

Department of the Navy

NAVSO P-2457

February 1993

AD-A268 969



DISTRIBUTION STATEMENT A
Approved for public release
Distribution Unlimited

RD&A Management Guide



DTIC
ELECTE
SEP 07 1993
S B D

12th Edition



0515LP2099100

93-18619 2918



The Guide's purpose is to help participants in DON RD&A understand the overall system and to provide a ready reference to governing instructions and other issuances. The Guide itself cannot be cited as authority for official actions.

93 8 10 217

**RD&A
Management Guide**

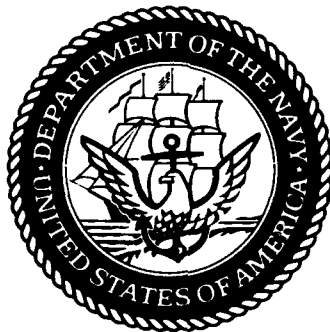

12th Edition

February 1993

NAVSO P-2457 (Rev. 2-93)

Approved for public release; distribution unlimited.



DEPARTMENT OF THE NAVY
 OFFICE OF THE ASSISTANT SECRETARY
 (Research, Development and Acquisition)
 WASHINGTON, D.C. 20350-1000

1 March 1993

FOREWORD

The twelfth edition of the Department of the Navy Research, Development and Acquisition Management Guide reflects extensive process improvements, which were promulgated in DOD Directive 5000.1 and DOD Instruction 5000.2 in response to the Defense Management Report and the Packard Commission. The Guide provides:

- a. An overview of the research, development and acquisition process to Department of Navy participants
- b. A ready reference to governing instructions and other issuances.

The guide is not to be used as an authoritative reference, because changes to governing instructions can be expected between editions of the guide.

The guide will be updated on an event-driven basis. Recommendations for changes are solicited and should be addressed to Director Strategic Planning (OASN(RD&A)), Washington D.C. 20350.

Edward C. Whitman
 Edward C. Whitman

DTIC QUALITY INSPECTED 1

Accession For	
NTIS GRA&I	<input checked="" type="checkbox"/>
DTIC TAB	<input type="checkbox"/>
Unannounced	<input type="checkbox"/>
Justification	
<i>periodic</i>	
By <i>mmma, 7 Sep 93</i>	
Distribution/	
Availability Codes	
Dist	Avail and/or Special
<i>A-1</i>	



DISTRIBUTION LIST

SNDL Part I

(1 copy each unless otherwise shown)

21A (Fleet Commanders in Chief and Detachments);
 22A (Fleet Commanders);
 23C3 (Commander Naval Reserve Force);
 24 (Type Commanders);
 26F (OPTEVFOR and Detachments -
 COMOPTEVFOR (10), all others (2));
 26G (FBM Operational Test Support Unit);
 29S (Research Submarine (Nuclear));
 42S (Air Test and Evaluation Squadrons);

SNDL Part II

(1 copy each unless otherwise shown)

A1 (Immediate Office of the Secretary (1) (except
 ASN(RD&A) 30));
 A2A (OGC) (5) (OLA, NAVCOMPT) (3),
 (CHINFO) (3), (OPA) (4), (DONPIC) (10),
 (ONR) (1);
 A3 (CNO);
 A6 (Headquarters U.S. Marine Corps) (40);
 B1 (OSD) (3);
 B2 (Defense Agencies);
 B2A (DSMC) (620);
 B3 (Colleges (2) - (except ICAF (30)));
 B5 (Coast Guard) (4);
 C1A (Naval Personnel at Army Activities);
 C2 (Naval Personnel at Air Force Activities);
 C3 (Naval Personnel at DoD or other Government
 Agencies);
 C4P (MARCORCOMMELECSOL);
 C49B (Naval Intelligence Operations Group and Unit
 Detachment);
 C5 (CHMAAG);
 C52B (NAVMEDRSCHU TWO DET MANILA
 RP) (2)
 C52C (NAVMEDRSCHINSTITUTE: (DET LIMA
 PE) (2), (TOX DET WPAFB) (6))
 C7 (USDAO);
 C20A (ONRDET);
 C20C (NRLDET; (USRD Orlando)) (15);
 C20D (ONRRESREP);
 C84P (NAVSURFWARCEN White Oak) (150);
 E2F (NAVACCTGFINCEN) (4);
 E3A (NRL) (325);
 E3B (ONRBRO);
 E3D11 (NAVENVPREDRSCHFAC) (5);
 E7A (NAVAUDSVCHQ) (5);
 E7B (NAVAUDSVC Regional Offices CAP (5), NE
 (5), SE (5), WEST (5))
 FA24 (COMNAVBASE, Charleston, SC);
 FA30 (LANTFLTWPNTAFAC) (5);

FB6 (NAF El Centro) (5);
 FD1 (COMNAVOCEANCOM) (20);
 FD2 (NAVOCEANO) (3);
 FE1 (COMNAVSECGRU) (2);
 FF1 (COMNAVDIST, Washington, DC);
 FF6 (NAV) (2);
 FF8 (PRESINSURV);
 FF17 (NAVOBSY FLAGSTAFFSTA);
 FF18 (NAVTACSUPPACT);
 FF36 (DEFREMANEDCEN) (6);
 FF38 (USNA) (12);
 FF42 (NAVPGSCOL) (20);
 FF44 (NAVWARCOL) (12);
 FF54 (COMNAVIMAGCOM) (2);
 FG1 (COMNAVTELCOM) (2);
 FH1 (COMNAVMEDECBM) (18);
 FH5 (NAVBIODYNLAB) (6),
 (NAVAEROMEDRSCHLAB) (50),
 (NAVSUBMEDRSCHLAB) (3);
 FH7 (NAVMEDRSCHINSTITUTE) (25);
 FH8 (NAVMEDRSCHU) (3 each);
 FH19 (NAVMEDRSCHDEVCOM) (25);
 FH20 (NAVHLTRSCHCEN) (8);
 FH22 (NAVDENTALRSCHINSTITUTE) (3);
 FH28 (NSHS);
 FKA1A (COMNAVAIRSYSCOM) (225);
 FKA1B (COMSPAWARSYSCOM) (150);
 FKA1C (COMNAVFACENGCOM) (10);
 FKA1F (COMNAVSUPSYSCOM) (6);
 FKA8F (DIR SPP) (5);
 FKM12 (NAVPETOFF);
 FKM13 (SPCC) (2);
 FKM15 (ASO BRASO) (5);
 FKM21 (NAVCLOTEXTRSCHFAC) (4);
 FKN1 (FACENGCOMDIV);
 FKN7 (NEESA);
 FKN11 (NAVCIVENGLAB) (45);
 FKP1B (WPNSTA) (Seal Beach only - Code 3143);
 FKP1E (NAVUSEAWARENGSTA) (15);
 FKP1F (NAVMINEWARENGACT) (4);
 FKP1J (NAVORDSTA) (5);
 FKP1M (NAVSUPPCEN: LOUISVILLE (10), CRANE
 (10));
 FKP2 (COMNAVSURFWARCEN) (10),
 (NAVUNSEAFWARCEN) (5);
 FKP3 (NAVPRO) (6);
 FKP4A (NAVSURFWARCEN COASTSYSTA) (50);
 FKP4B (NAVEODTEHCEN) (10);
 FKP4D (DTRCEN) (150)
 FKP4E (NAVSURFWARCENDIV: (PORT
 HUENEME) (15), (INDIAN HEAD) (15),
 (DAHLGREN) (175));
 FKP4F (NAVUNSEAWARCENDIV) (200);
 FKP6C (SEASPARROWPROJSUPPO);

FKP6D (NAVXDIVINGU);
 FKP14 (FLTCOMBATDIRSSACT) (2);
 FKP15 (INTCOMBATSYSTESTFAC) (2);
 FKP16 (NAVSSSES) (8);
 FKQ1 (NCCOSC) (5);
 FKQ2 (NAVELEXSECCEN);
 FKQ3A (NAVELEXCEN) (5);
 FKQ6C (NCCOSC RDTE DIV) (220);
 FKQ6D (NAVPERSRANDRCEND) (50);
 FKR2A (NAVPRO);
 FKR2B (NAVWPNENGSSUPACT) (5);
 FKR3I (NAVTRASYSSEN) (25);
 FKR6 (NAVAIRWARCENHDQTRS) (10);
 FKR6A (NAVAIRWARCENACDIV:
 (INDIANAPOLIS) (10), (LAKEHURST) (50),
 (PATUXENT RIVER) (100), (TRENTON)
 (19), (WARMINSTER) (125));
 FKR6B (NAVAIRWARCENWPNDIV: (PT MUGU)
 (145), (CHINA LAKE) (193));
 FKR7B (NAESU);
 FKR7C (NAVAIRTECHSERVFAC);
 FKR7E (NAVAVNDEPOTOPSCEN);
 FN1 (NAVSPACECOM) (20);
 FN3 (NAVSPASUR);
 FT1 (CNET) (5);
 FT2 (CNATRA) (2);
 FT5 (CNTECHTRA) (2);
 FT27 (NAVNUPWRTRAU);
 FT35 (NAVPHIBSCOL) (2);
 FT37 (NAVSCOLCECOFF);
 FT39 (NAVTECHTRACEN);
 FT43 SWOSCOLCOM;
 FT44 (NAVDIVESALVTRACEN);
 FT45 (NAVSCOLEOD);
 FT46 (FLEASWTRACEN) (2);
 FT49 (NAVGMSCOL);
 FT51 (FLEMINEWARTRACEN) (2);
 FT53 (NAVNUPWRSCOL);
 FT54 (NAVSUBSCOL);
 FT55 (NAVSCSCOL);
 FT72 (DPTNAVSCI);
 FT74 (NROTCU);
 FT76 (COMBATSYSTECHSCOLSCOM);
 FT78 (NETPMSA);
 FT85 (TRITRAFAC);

FT88 (EDOSCOL);
 V6 (CG, 4TH MAW);
 V11 (MCI);
 V12 (CG, MCCDC) (15);
 V13 (FLDMEDSERVSCOL);
 V28 (MARCORSYSCOM) (200);

Copy to: (1 copy unless otherwise shown)

SECDEF(USDA) (20);
 ASD(C³I) (5);
 ASD(PA&E) (5);
 ASD(PA) (3);
 CNO (N913) (300);
 COMSPAWARSYSCOM (SPAWAR-21) (40);
 NAVSEASYSYSCOM (06H) (420);
 NAVPGSCOL (Code AS/Lt) (500);
 Senior Member, Board of Inspection and
 Survey, Naval Air Warfare Center Aircraft
 Division,
 Patuxent River, MD 20670
 CCPO-CC Career Development Institute,
 Bldg. 150, Naval Station Anacostia,
 Washington, DC 20375-1502 (400)
 DTIC(ML) Defense Technical Information Center,
 Cameron Station, Alexandria, VA 22314;
 Commandant, U.S. Coast Guard Headquarters,
 Washington, DC 20593 (3);
 Library of Congress, Science and Technology Division,
 Referral Services Section, National Referral Center,
 Washington, DC 20540;
 Department of the Navy Library, Naval Historical
 Center, Washington Navy Yard,
 Washington, DC 20374;
 Logistics Management Institute
 Attention Librarian
 6400 Goldsboro Road
 Bethesda, MD 20817-5886 (3)
 DTIC Los Angeles Regional Office
 Attn: DTIC-BLNL
 222 N. Sepulveda, Blvd., Ste. 906
 El Segundo, CA 90245 (2)
 Commanding Officer USCG R&D Center
 Ivory Point
 Groton, CT 06340-6096 (3)

(For reordering information, see page x)

CONTENTS

FOREWORD BY EDWARD C. WHITMAN	iii
PREFACE	ix
Chapter 1 THE ACQUISITION PROCESS—AN OVERVIEW	1-1
Chapter 2 PLANNING AND PROCESS	2-1
Chapter 3 PROGRAMMING	3-1
Chapter 4 BUDGET PREPARATION AND JUSTIFICATION	4-1
Chapter 5 EXECUTION OF THE RDT&E BUDGET	5-1
Chapter 6 MANAGING ACQUISITION OF RD&A EFFORT	6-1
Chapter 7 TEST AND EVALUATION	7-1
Appendix A READINGS IN ACQUISITION MANAGEMENT	A-1
Appendix B THE NAVY AND DOD DIRECTIVE SYSTEMS	B-1
Appendix C INFORMATION CATEGORIZATION SYSTEMS	C-1
Appendix D TECHNICAL INFORMATION SERVICES	D-1
Appendix E ORGANIZATION AND RELATIONSHIPS	E-1
Appendix F TOPICS RELATED TO PLANNING AND CONDUCT OF RESEARCH, DEVELOPMENT, AND ACQUISITION	F-1
Appendix G RESEARCH, DEVELOPMENT AND ACQUISITION LABORATORIES AND CENTERS AND TEST AND EVALUATION ACTIVITIES	G-1
Appendix J GLOSSARY	J-1
MASTER REFERENCE LIST	MRL-1
INDEX	Index-1
ABBREVIATIONS	Abb-1

LIST OF EXHIBITS

2-1	Functional View of the Defense RD&A Process	2-1
2-2	Milestone Documentation Concept	2-6
2-3	Acquisition Milestones and Phases	2-7
2-4	Acquisition Phase and Milestone Decision Points	2-8
3-1	Basic Program Development Cycle (pt. 1)	3-4
3-1	Basic Program Development Cycle (pt. 2)	3-5
C-1	Research Program/Budget Structure	C-3
C-2	Naval Warfare Mission Areas and Corresponding 6.2 Program Mission Areas	C-5
C-3	Example of Program Element Numbering	C-9
E-1	Office of the Secretary of the Defense	E-2
E-2	DOD/DON Acquisition Relationships	E-10
E-3	Office of the Secretary of the Navy	E-11
E-4	Office of the Assistant Secretary of the Navy (Research, Development, and Acquisition)	E-11
E-5	Office of the Chief of Naval Operations	E-13
E-6	Naval Air Systems Command Headquarters	E-19
E-7	Naval Sea Systems Command Headquarters	E-20
E-8	Space and Naval Warfare Systems Command Headquarters	E-22
E-9	Marine Corps Systems Command Organization	E-24
E-10	Office of Naval Research	E-27
G-1	Warfare Centers/Laboratory	G-3
G-2	Naval Research Laboratory	G-4
G-3	Naval Air Warfare Center	G-6
G-4	Naval Command, Control and Ocean Surveillance Center	G-8
G-5	Naval Surface Warfare Center	G-11
G-6	Naval Undersea Warfare Center	G-14

PREFACE

The Navy's Management Guide for research, development, test and evaluation, acquisition activities serves both as an introduction to newcomers and as an aid to R&D procurement professionals. For newcomers, the Guide provides a comprehensive understanding of the Department of the Navy's research and development management system. For the professional, it is a rapid reference to general information and a summary of directives which contain fully developed and authoritative data on specific subjects.

It must be emphasized that this is a Guide. It is not a directive or a compilation of directives, notices, laws, or instructions. Neither is it to be cited as an authority for action. The Guide explains and provides references to directives and places them in perspective to provide the reader an understanding of the overall system. It also identifies directives and similar materials applicable to specific subjects and phases of the system. The reader is encouraged to consult the specific directive for a more comprehensive understanding of current status and to obtain official guidance.

Applicable directives, instructions and so forth are identified following each portion of the Guide. Those relating to an entire Section, such as Section 5.5, "Audits and Review," are outlined immediately following the introduction of the Section. References considered of greatest importance to each Chapter are indicated at the conclusion of that Chapter. There is also a master reference list.

Content and Organization

The Guide is outlined in seven Chapters and eight Appendixes. Chapters cover organization, planning, programming, budget preparation and execution, acquisition management and test and evaluation. All appendixes contain important information. However, the reader should give early attention to Chapter 1, for an understanding of the Navy's acquisition process is mandatory to comprehending and working with the system.

To assist in locating desired information rapidly, both a comprehensive Index and a detailed Table of Contents are provided; the latter preceding each Chapter. Index and Table of Content citations are presented primarily by location number rather than page number. For example, the definition of documentation is found at 2.2.4.2, indicating that this subject will be found as follows:

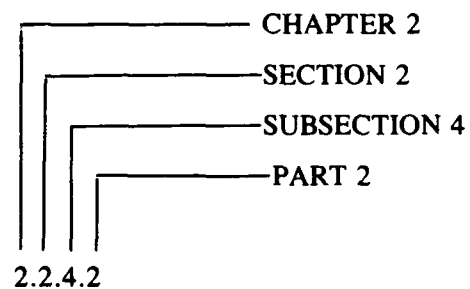

For ease in locating referenced paragraphs, the last and first paragraph numbers which appear on odd and even pages, respectively, are indicated at the top outer corner of those pages. The location number of material in an Appendix is preceded by the Appendix letter, e.g., E1.1.2.

The newcomer to research and development acquisition management, the audience for which this Guide primarily is intended, undoubtedly will experience difficulty with numerous acronyms and abbreviations. Unfortunately, they are the "tools of the trade"—the jargon of the culture—and must be understood! The reader is well advised to gain a very early familiarization with these abbreviations and terms. The first time an acronym or abbreviation appears in the Guide, it will be preceded by the complete phrase or expression. Also, all acronyms and abbreviations used in this edition will be found in alphabetical order at the end of the book.

Revisions, Expansion and Reader Comments

The research and development acquisition process is dynamic—responding constantly to

changes and improvements in the management structure, controls mechanism and systems procedures. Thus, it is important to appreciate that the Guide also is dynamic with possible near-term modifications indicated even in this edition.

Readers, be they newcomers or professionals, are asked to be analytical and critical in reading this material, and to provide their criticisms and recommended changes. Less specific comments—especially indications that certain portions appear weak, for whatever reason—will be useful and are greatly encouraged. Please direct such comments to:

Assistant Secretary of the Navy—
(Research Development and Acquisition)
ATTN: Director Strategic Planning
Rm. 5E715 Pentagon
Washington, DC 20350-1000

The Editor

OBTAINING ADDITIONAL COPIES

For this edition

Additional copies of NAVSO P-2457 can be requisitioned from the Navy Aviation Supply Office (ASO 1013), 5801 Tabor Avenue, Philadelphia, PA 19120-5099 through normal supply channels in accordance with NPFC Pub 2002D, NAVSUP P-437 or NAVSUP P-485 using AUTODIN, DAMES or milstrip message format to DAAS Dayton, OH. Cite stock number 0515LP2099100. The Guide is available to the general public through the Government Printing Office.

For the next edition

Submit requests to be placed on the distribution list, or for changes in the number of copies through automatic initial distribution, to the Office of Naval Research (Attn: ONR 011AO), 800 N. Quincy St., Arlington, VA 22217-5660.

Chapter 1
THE ACQUISITION PROCESS—AN OVERVIEW

TABLE OF CONTENTS

1.1 Overview	1-1
1.2 Acquisition Process Outline	1-3
1.3 Process Outline for Milestone Review Document Preparation	1-26

Chapter 1 THE ACQUISITION PROCESS—AN OVERVIEW

The latest changes in the way the Department of Defense (DOD) develops and procures new hardware have been driven by the July 1989 Defense Management report, a blueprint for implementing the acquisition reform recommendations made by the 1986 Packard Commission, led by former Deputy Secretary of Defense David Packard (see A2). A key goal was to introduce simplicity and consistency in the acquisition process across the military services and across all programs, i.e., those that require DOD review and approval and those that are service-reviewed and approved. One central theme of the reforms has been the definition of responsibility and accountability in the acquisition process, with clear lines that lead to a single decision-making authority.

1.1 OVERVIEW

Acquisition programs are divided into four categories, with different levels of decision-making authority for each. Those with anticipated total expenditures of more than \$300 million in research, development, test and evaluation (RDT&E) or \$1.8 billion in procurement (all in FY90 constant dollars) are termed Acquisition Category I (ACAT I) or major defense acquisition programs for which the Under Secretary of Defense, Acquisition [USD(A)] is the milestone decision authority (MDA) (ACAT ID). USD(A) may delegate this authority to the Component Head (ACAT IC), who may further delegate to the Component Acquisition Executive. Those valued at more than \$115 million in RDT&E or \$540 million in procurement (FY90 constant dollars) are referred to as ACAT II or major systems for which the ultimate decision makers are the civilian heads

of each military department. ACAT III and IV are lower levels of expenditure and authority. For the DON the MDA for ACAT IC, II, and III is ASN(RD&A) (delegable for AC III). For ACAT IV, the MDA is the Program Executive Officer (PEO), Direct Reporting Program Manager (DRPM), or SYSCOM Commander.

To help the milestone decision authority for major defense acquisition programs, i.e., ACAT I, two key organizations directly involved in the acquisition decision process are the military-led Joint Requirements Oversight Council (JROC), headed by the Vice Chairman of the Joint Chiefs of Staff (JCS) and the Defense Acquisition Board (DAB), headed by the USD(A). One of the JROC's central roles is as the first reviewer of proposed operational needs generated by the military services. The DAB, supported by conventional, strategic and C³I systems committees, is the final decision-making body for major defense acquisition programs.

Under the direction of the JROC and the DAB, each community now takes part in a continual examination of trade-offs between cost, schedules and performance during each phase of an acquisition program. With the establishment of separate thresholds and objectives during Milestone I, acquisition officials have more room to make meaningful cost, schedule, and performance trade-off choices, which help control program risks. Nevertheless the scope for change diminishes as the program progresses.

Typically a new system goes through a series of "milestone" decision points, each of which occurs before the system can proceed to the next phase. These points are:

Milestone 0 (M/S 0) – concept studies approval, after which a system can enter Phase 0, or concept exploration and definition. During this period, the Services can examine all possible technologies to achieve the particular capability identified in the Mission Need Statement (MNS).

Milestone I (M/S I) – concept demonstration approval, which precedes Phase I, demonstration and validation. Key performance thresholds and objectives are established at this milestone, which represents the formal start of a new acquisition program.

Milestone II (M/S II) – development approval, the prelude to Phase II, engineering and manufacturing development, formerly known as full-scale development. Phase II can also include low-rate initial production.

Milestone III (M/S III) – production approval which leads to Phase III, full-rate production and deployment of a system.

Milestone IV (M/S IV) – major modification approval, used on occasions when a system still in production is to be modified during regular life-cycle maintenance and support.

Note: upgrades to systems no longer in production are treated as new start initiations.

Before each milestone review can take place, exit criteria established at the previous milestone must be satisfied. The criteria can include such things as a specified level of performance during testing, or the adequacy of a new manufacturing process.

1.2 ACQUISITION PROCESS OUTLINE

The acquisition decision process outlines presented on the following pages are based on 23 February 1991 issue of DOD Directive (DODD) 5000.1, DOD Instruction (DODI) 5000.2, and the February 1991 issue of DOD Manual DOD Secretary of the Navy Instructions (SECNAVINST) 5000.2A and SECNAVINST 5420.188C.

The decision process outlines presented are as follows:

Pages 1-4 through 1-7 present the M/S O acquisition decision process for all ACATs.

Pages 1-8 through 1-21 present the M/S I through IV acquisition decision process for ACAT ID.

Pages 1-22 through 1-25 present the M/S I through IV acquisition decision process for ACAT IC, II, III and IV.

Pages 1-26 through 1-39 present the decision process outlines for the preparation of the milestone review documents which are submitted to the

milestone decision authority (MDA) for M/S review. These documents are required for all ACATs at M/Ss I through IV. In addition there are a number of other documents which may or may not be required at one or more milestone decision points for various ACATs. These are listed in SECNAV-INST 5000.2A, Part 11, Section C, Attachment 3 which details who prepares them, who reviews or endorses them, and who approves/validates them.

The processes are presented in the form of descriptive paragraphs and facing page flow charts. When appropriate, a "NOTE" has been added at the end of certain paragraphs to indicate that there are options to the action called for in that paragraph or to provide some other insight into the action described.

Also provided are selected page references as to where, in DODD 5000.1, DODI 5000.2 and DOD 5000.2-M, the paragraph subject matter is discussed in more detail.

Definitions of all abbreviations used in this presentation can be found on page 1-40.

ACQUISITION PROCESS OUTLINE
All ACATs
Milestone 0

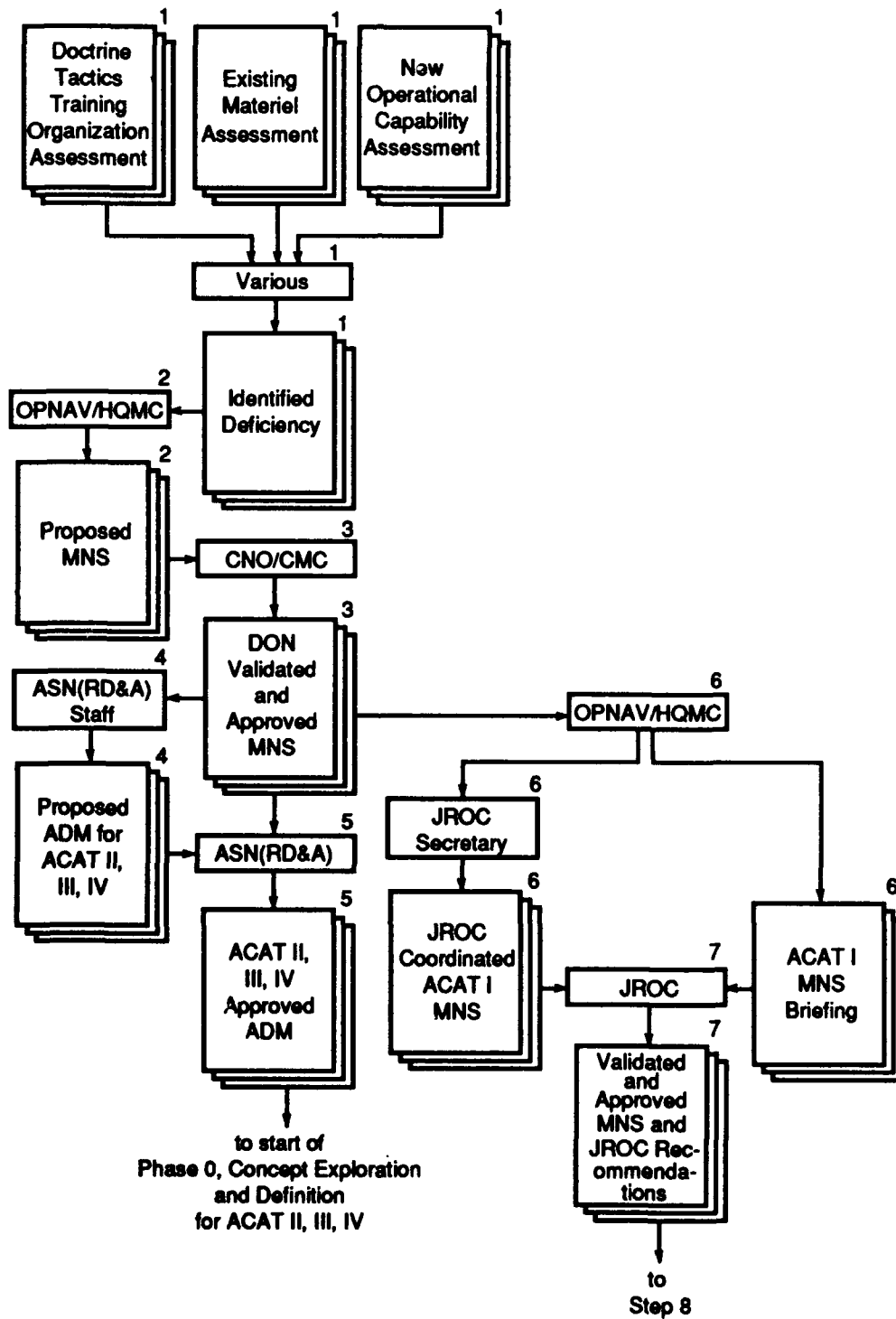

ACQUISITION PROCESS OUTLINE
All ACATs
Milestone 0

1. **Mission needs are identified as a direct result of continuing assessments of current and projected capabilities in the context of changing military threats and national defense policy. These assessments are conducted by various elements of the Department of the Navy (DON), the Unified and Specified Commands, the Office of the Secretary of Defense (OSD) and the Joint Chiefs of Staff (JCS). These assessments identify deficiencies that may result in a need to:**

- (1) **Change doctrine, tactics, training or organization;**
- (2) **Fix shortcomings in existing materiel; or**
- (3) **Introduce new operational capabilities.**

Ref: 5000.1, Part 2 page 3; 5000.2 Part 3 page 2, Part 4 Section B page 3, Part 11 Section C Attachment 1 page 2; and 5000.2-M, Part 2.

2. **An identified deficiency that could potentially result in the establishment of a new defense acquisition program is described in a Mission Need Statement (MNS). For identified DON needs, a proposed MNS is prepared by either the Office of the Chief of Naval Operations (OPNAV) or Headquarters, U.S. Marine Corps (HQMC).**
3. **The MNS is submitted by OPNAV/HQMC to either the Chief of Naval Operations (CNO) or to the Commandant of the Marine Corps (CMC) for review, approval and validation.**
4. **For a MNS that represents a potential ACAT II, III or IV program, the validated MNS is forwarded to the office of the Assistant Secretary of the Navy for Research, Development and Acquisition [ASN(RD&A)] which prepares a proposed Acquisition Decision Memorandum (ADM).**
5. **The potential ACAT II, III or IV MNS and proposed ADM is submitted to the ASN(RD&A) who, if in agreement, signs the ADM allowing the program to proceed into Phase 0, Concept Exploration and Definition, the Milestone (M/S) 0 decision.**
6. **Once validated within DON, a MNS for a potential ACAT ID or IC program is submitted, by OPNAV/HQMC, to the Joint Requirements Oversight Council (JROC) Secretary who reviews and coordinates the MNS through established JROC procedures. After coordination, OPNAV or HQMC briefs the JROC on the MNS contents.**

Ref: 5000.1, Part 2 page 4; 5000.2 Part 3 page 3, Part 13 Section D page 2.

7. **Based on the MNS and the briefing, the JROC determines the validity of the need, assigns a joint priority as appropriate and either approves or disapproves the MNS.**

Ref: 5000.2 Part 3 page 3 and Part 13 Section D page 2.

ACQUISITION PROCESS OUTLINE
 All ACATs
 Milestone 0

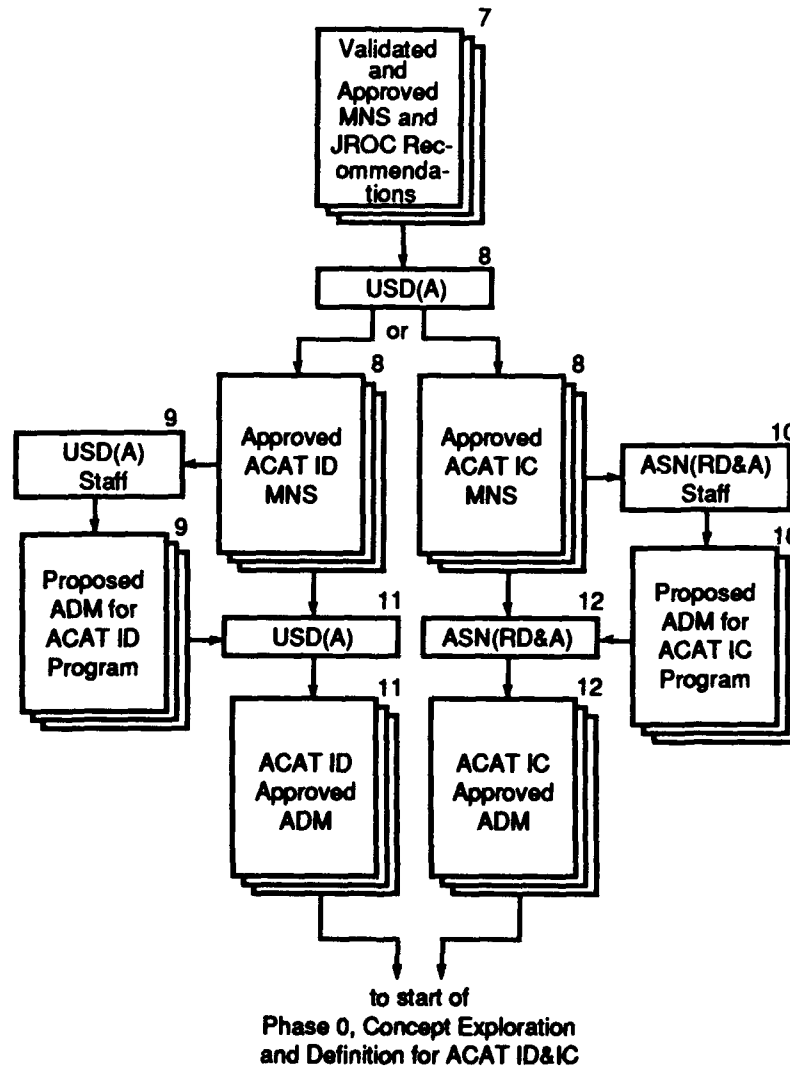

ACQUISITION PROCESS OUTLINE
All ACATs
Milestone 0

8. The MNS with the JROC's approval/disapproval is forwarded to the Under Secretary of Defense for Acquisition [USD(A)] who determines whether or not to hold a M/S 0 review and, in turn, initiate a Phase 0, Concept Exploration and Definition Phase.

NOTE: The USD(A) determines whether to convene the Defense Acquisition Board (DAB) to review and assess the MNS and make a recommendation concerning Concept Studies Approval.

Ref: 5000.1 Part 2 Section 2 page 4; 5000.2, Part 3 page 3, Part 13 Section A page 5.

9. For a MNS approved by the USD(A) for a program which has been designated a potential ACAT ID (a program requiring USD(A) milestone approval), the USD(A) staff prepares an ADM for USD(A) signature.

NOTE: An ADM documents a decision made by the milestone decision authority (MDA) and the exit criteria that must be met prior to the following milestone.

Ref: 5000.1 Part 2 page 5; 5000.2 Part 2 page 2, Part 11 Section C Attachment 1 page 2.

10. If the program has been designated as a potential ACAT IC program, the USD(A) delegates the milestone decision authority to the Secretary of the Navy (SECNAV). In turn, the SECNAV has designated the ASN(RD&A) as the MDA for Navy ACAT IC programs. In this case, the ADM is prepared by the ASN(RD&A)'s staff.

Ref: 5000.2 Part 2 page 2, Part 11 Section C Attachment 1 page 2.

11. For potential ACAT ID programs, the ADM is submitted to the USD(A) for review and approval. Once the ADM is approved, the M/S 0 decision, the potential program proceeds into Phase 0, Concept Exploration and Definition.

Ref: 5000.2 Part 2 page 2, Part 11 Section C Attachment 1 page 2.

12. For potential ACAT IC programs, the ADM is submitted to the ASD(RD&A) for review and approval. Once the ADM is approved, the M/S 0 decision, the potential program proceeds into Phase 0, Concept Exploration and Definition.

ACQUISITION PROCESS OUTLINE
 ACAT ID
 Milestone I through IV

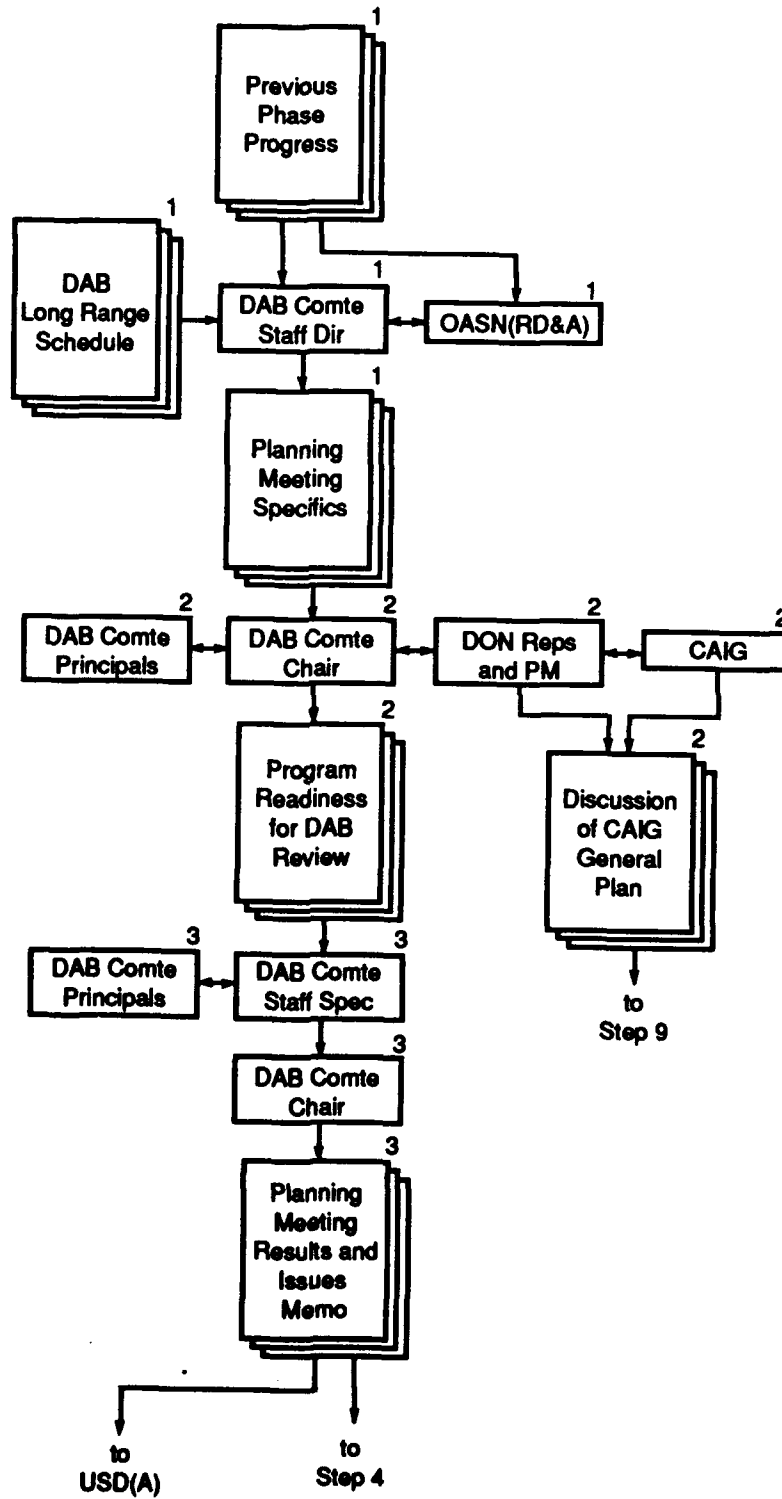

ACQUISITION PROCESS OUTLINE
ACAT ID
Milestone I through IV

1. Based on the previous phase progress and the long-range schedule published by the DAB Executive Secretary, the milestone review process is initiated at least 6 months prior to the scheduled DAB milestone review. At that time, informal discussions are conducted between Office of the USD(A) and Office of the ASN(RD&A). ASN(RD&A) is usually represented by the appropriate Deputy Assistant Secretary of the Navy (DASN), after consultation with the Program Manager (PM). Once a time is agreed to, the DAB Committee staff director prepares a memorandum to staff specialists in the DAB Committee member organizations announcing the specifics associated with the planning meeting (e.g., purpose, time, location, date, etc.). The memorandum will also indicate the approximate timeframe for the coming DAB Committee and DAB reviews.

NOTE: There are three DAB Committees: Strategic Systems; Conventional Systems; and Command, Control, Communications and Intelligence Systems.

Ref: 5000.2 Part 13 Section A page 2, Part 13 Section B page 2.

2. The planning meeting is chaired by the relevant DAB Committee Chair (or a representative) and will include representatives from each DAB Committee principal. Navy attendees are usually the appropriate DASN, representatives from OPNAV or HQMC and the Program Executive Officer (PEO)/Direct Reporting Program Manager (DRPM)/Systems Command (SYSCOM). In some cases the PM may also attend. The purpose of the meeting is to ascertain the readiness of the program for DAB review; to assess the plans for key milestone documents; and to determine the availability of test results. Included in the planning meeting is a discussion among the Cost Analysis and Improvement Group (CAIG), the Deputy PM (DPM), and representatives from the Naval Center for Cost Analysis (NCA) as to the CAIG's general plan.

Ref: 5000.2 Part 13 Section A page 6, Part 13 Section B page 2, Part 13 Section C page 1.

3. As a result of the planning meeting, the DAB Committee staff specialist prepares a memorandum which highlights the results of the planning meeting and identifies issues that should be addressed in the milestone documents. After coordination with the DAB Committee principals, (within 7 calendar days of the planning meeting) the memorandum is submitted to the DAB Committee Chair for signature and then forwarded to the USD(A) and the ASN(RD&A).

NOTE: At the same time, the DAB Committee staff specialist prepares a master milestone planning calendar which will be updated as required during the entire review process.

Ref: 5000.2 Part 13 Section A page 6, Part 13 Section B page 2.

ACQUISITION PROCESS OUTLINE
 ACAT ID
 Milestone I through IV

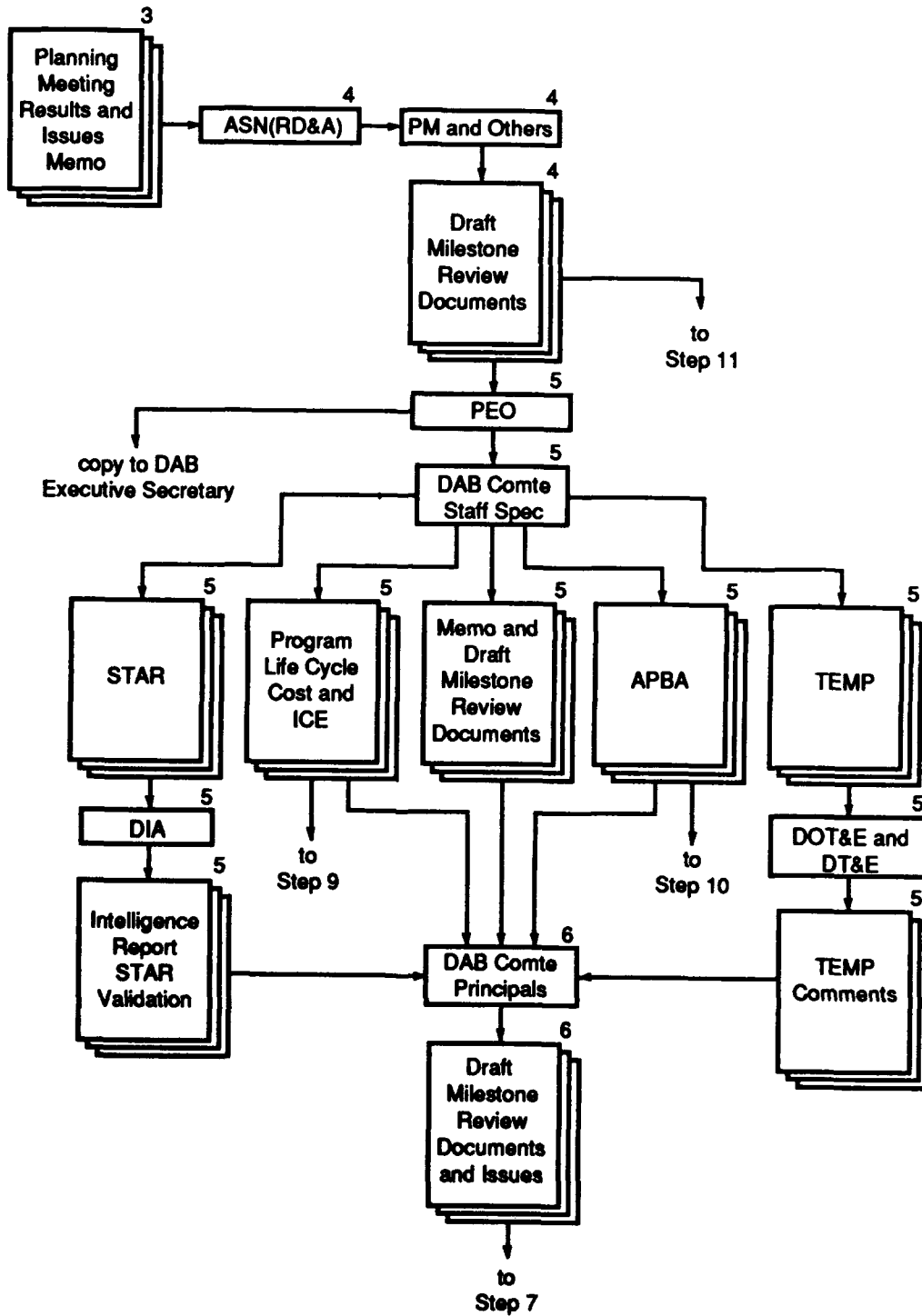

ACQUISITION PROCESS OUTLINE
ACAT ID
Milestone I through IV

4. The ASN(RD&A) [or the appropriate DASN acting for the ASN(RD&A)] forwards a copy to the PM who, along with others, uses it as one input during the preparation of the draft milestone review documents.

NOTE: See DODI 5000.2, Part 11, Section C, Attachment 1 for required milestone documentation. These draft documents are prepared and informally reviewed and/or endorsed as required by SECNAV Instruction 5000.2A, Enclosure 11, Part 11, Section C, Attachment 3.

NOTE: The DAB Committee staff specialist coordinates with the appropriate DASN to ensure delivery of the required numbers of copies of each document.

5. Drafts of the milestone review documents are addressed over the signature of the PEO/DRPM/SYSCOM, to the DAB Executive Secretary. One copy is provided to the DAB Executive Secretary with the remaining copies forwarded to the DAB Committee staff specialist, no later than 45 calendar days before the scheduled DAB Committee review. Upon receipt of the documents, the DAB Committee staff specialist prepares a cover memorandum and distributes the documents to appropriate DAB Committee members within 3 working days of receipt.

NOTE: One copy each of the draft Program Life Cycle Cost Estimate and the draft Independent Life Cycle Cost Estimate (ICE) are provided to the CAIG. One copy of the draft Acquisition Program Baseline Agreement (APBA) is provided to the JROC. One copy of the Test and Evaluation Master Plan (TEMP) is provided to the Director of Operational test and Evaluation (DOT&E) and one copy to the Director Test and Evaluation in the Office of the USD(A) (formerly DDDR&E(T&E)) for their review and comment. Prior to the submittal of the draft documentation, an advance copy of the System Threat Assessment Report (STAR) is provided by either the Naval Maritime Intelligence Center (NAVMIC) or the Marine Corps Intelligence Center (MCIC) to the Defense Intelligence Agency (DIA) for review so that a draft validation can be submitted with the STAR.

Ref: 5000.2 Part 4 Section A page 3, Part 10 Section A page 2, Part 11 Section C Attachment 1 page 3, Part 11 Section C Attachment 1 page 5, Part 11 Section C Attachment 1 page 6, Part 11 Section C Attachment 1 page 7, Part 11 Section C Attachment 1 page 10, Part 13 Section A page 7, Part 13 Section B page 3, Part 13 Section C page 2, Part 13 Section D page 2.

6. The DAB Committee principals, the CAIG, JROC, DOT&E and the DT&E, review the documents submitted to them and identify major issues, including the adequacy of the documents.

Ref: 5000.2 Part 13 Section A page 8.

ACQUISITION PROCESS OUTLINE
 ACAT ID
 Milestone I through IV

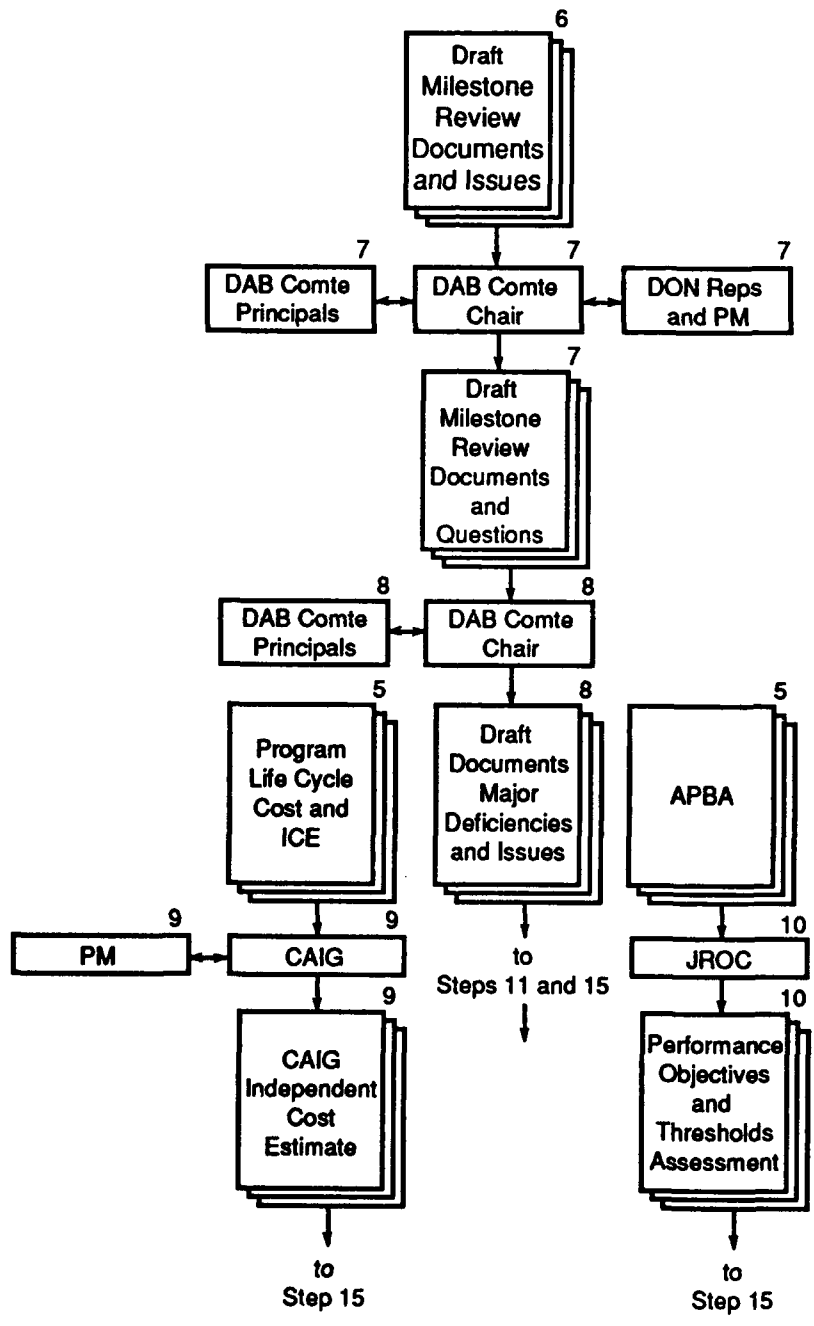

ACQUISITION PROCESS OUTLINE
ACAT ID
Milestone I through IV

7. No later than 30 calendar days before the scheduled DAB Committee review, a document review meeting is held. This meeting is chaired by the DAB Committee Chair (or a representative) and includes representatives of the DAB Committee principals and the PM, DASN(RD&A) staff, representatives of OPNAV/HQMC and PEO/DRPM/SYSCOM. The PM begins the meeting with an overall presentation of program technical content and risks, cost-effectiveness, threat, acquisition strategy, supportability and producibility, and test plans and results. The purpose of the review is to identify questions regarding the draft documents in preparation for making independent staff assessments and to reassess the readiness for DAB Committee and DAB reviews.

Ref: 5000.2 Part 13 Section A page 8, Part 13 Section B page 3.

8. The product of the document review is a memorandum to the ASN(RD&A) from the DAB Committee Chair which identifies, for the consideration of the ASN(RD&A), major deficiencies in the draft documents and major issues resulting from the review. This memorandum is coordinated with the DAB principals and issued within 5 calendar days of the review.

Ref: 5000.2 Part 13 Section A page 8, Part 13 Section B page 4.

9. No later than 21 calendar days before the DAB Committee review, the CAIG will meet to review independently the Program Life Cycle Cost Estimate and the ICE; to validate the methodology used to make these cost estimates; to determine whether additional analysis, which the CAIG may undertake itself, is required; and to be given an explanation of the Department of the Navy (DON) cost position. Representing the DON are usually the DPM and representatives of the DASN, OPNAV/HQMC, NCA and the PEO/DRPM/SYSCOM. The PM attends only if requested by the CAIG Chair and approved by the ASN(RD&A). The product of the review is a CAIG independent cost estimate for the program under review.

Ref: 5000.2 Part 10 Section A page 2, Part 11 Section C Attachment 1 page 5, Part 11 Section C Attachment 1 page 10, Part 13 Section A page 9, Part 13 Section B page 4, Part 13 Section C page 2.

10. No later than 14 calendar days before the DAB Committee review, the JROC holds a review with representatives of the DON, usually the PM if requested and approved by the ASN(RD&A), and representative of the DASN, PEO/DRPM/SYSCOM and OPNAV/HQMC. The purpose of this review is to confirm that the proposed performance objectives and thresholds in the APBA provide an operational capability that will satisfy the validated Operational Requirements Document (ORD). The product of the review is an assessment of the performance objectives and thresholds.

Ref: 5000.2 Part 11 Section C Attachment 1 page 2, Part 11 Section C Attachment 1 page 6, Part 13 Section A page 10, Part 13 Section B page 4, Part 13 Section D page 3.

ACQUISITION PROCESS OUTLINE
ACAT ID
Milestone I through IV

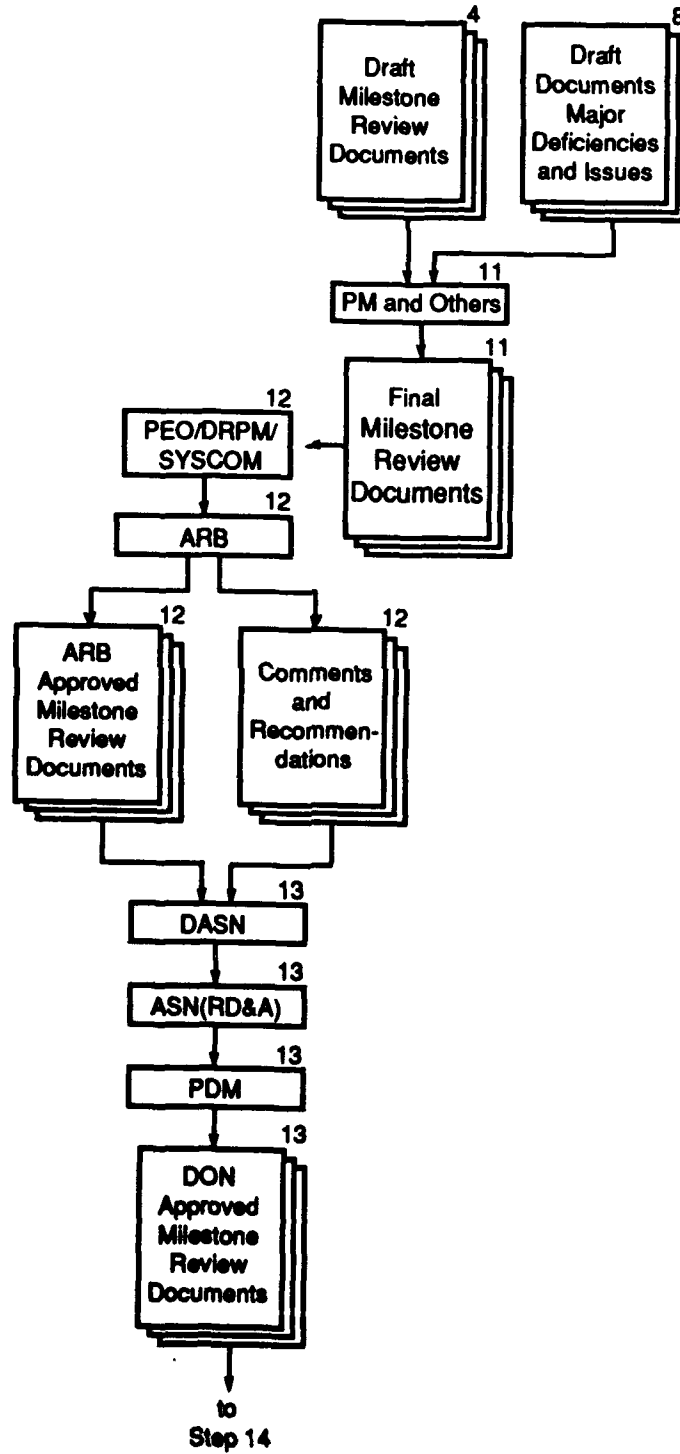

ACQUISITION PROCESS OUTLINE
ACAT ID
Milestones I through IV

11. Based on the draft milestone review documents and the identified major deficiencies and issues, the PM and others prepare the final milestone review documents. These documents will incorporate changes resulting from deficiencies and issues identified during the document review that the ASN(RD&A) agrees to accept.
12. In order to allow appropriate issues to be raised, addressed and potentially resolved prior to the Program Decision Meeting (PDM), the final milestone review documents are submitted to an Acquisition Review Board (ARB) chaired by the PEO/DRPM/SYSCOM. After the ARB, a letter forwarding the ARB's comments and recommendations is prepared.

NOTE: Cognizant PDM members shall be invited and attend or send a representatives to the ARB.

13. The ARB letter and the final milestone review documents are sent to the appropriate DASN who in turn schedules a PDM chaired by the ASN(RD&A). At the conclusion of the PDM, if all are in agreement, the milestone review documents are considered to be DON approved.

ACQUISITION PROCESS OUTLINE
ACAT ID
Milestone I through IV

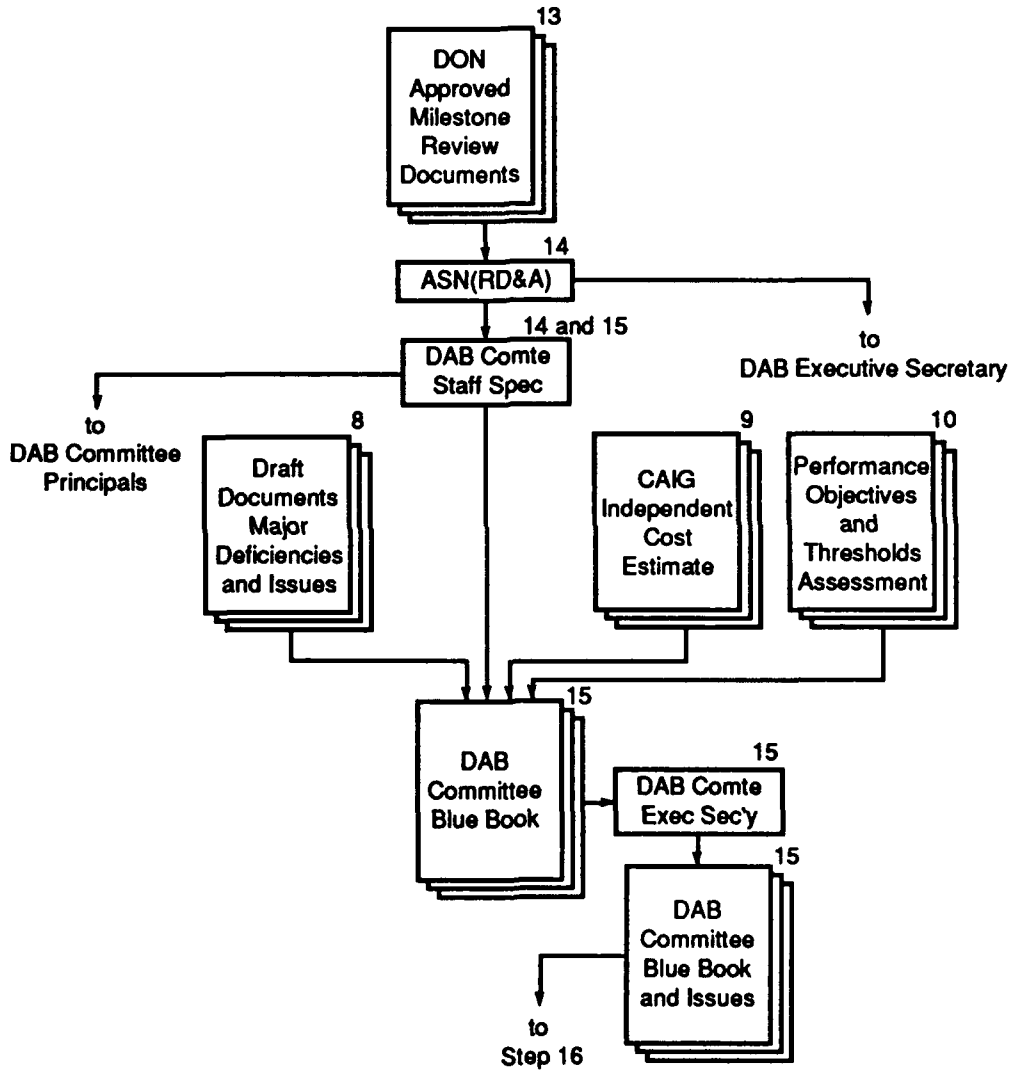

ACQUISITION PROCESS OUTLINE
ACAT ID
Milestone I through IV

14. No later than 10 calendar days prior to the scheduled DAB Committee milestone review, the PEO/DRPM/SYSCOM submits the final milestone review documents. The documents are submitted to the DAB Executive Secretary, under the signature of the ASN(RD&A), with copies to the Committee staff specialist who, in turn, distributes the documents to appropriate DAB Committee principals.

Ref: 5000.2 Part 13 Section A page 10, Part 13 Section B page 4.

15. At least 2 working days before the DAB Committee meeting, the DAB Committee staff specialist assembles the DAB Committee Blue Book and provides copies to the DAB Committee Executive Secretary. The Blue Book includes: inputs from the DON, e.g. the Integrated Program Summary (IPS) Executive Summary; assessments prepared by the various cognizant OSD offices in Steps 8, 9 and 10 above, e.g. the CAIG estimates; and the JROC assessment of the APBA. The blue book also identifies all outstanding program issues.

Ref: 5000.2 Part 11 Section C Attachment 1 page 4, Part 11 Section C Attachment 1 page 6, Part 13 Section A page 11, Part 13 Section B page 4, Part 13 Section B Attachment 2 page 1.

ACQUISITION PROCESS OUTLINE
 ACAT ID
 Milestone I through IV

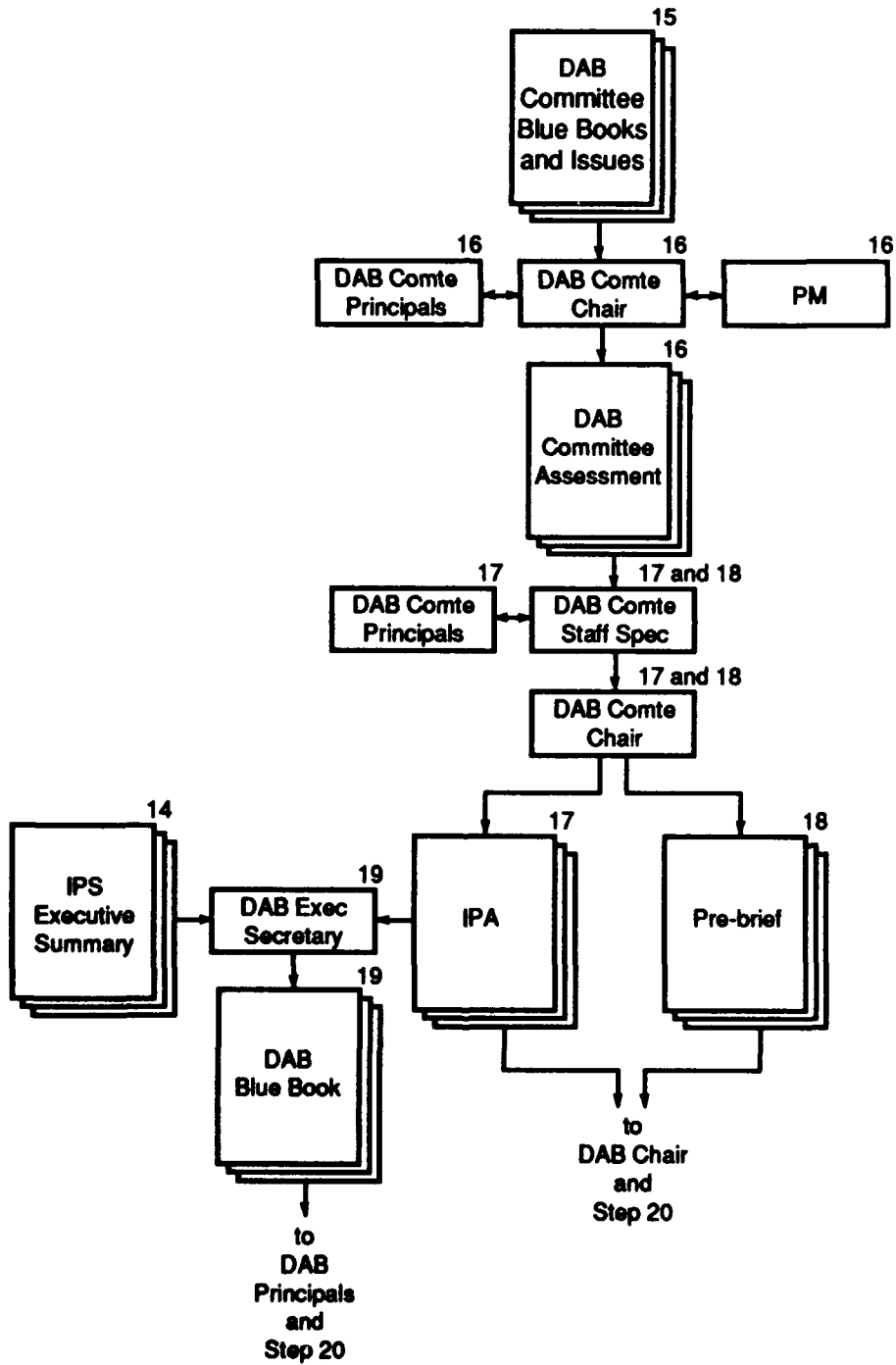

ACQUISITION PROCESS OUTLINE
ACAT ID
Milestone I through IV

16. The DAB Committee Executive Secretary provides the Blue Book to all DAB Committee principals in advance of the DAB Committee review identifying the issues to be discussed at the review. Based, in part, on the Blue Book, the cognizant DAB Committee Chair convenes a meeting to review the status of the program at least 14 days prior to the scheduled DAB milestone review, unless a shorter period of time is specifically authorized by the USD(A). The review includes presentations by the DAB Committee staff specialist, the PM and a review of the OSD staff offices' assessments. The PM briefs the Committee on the areas addressed in the IPS and on proposed cost-schedule-performance tradeoffs. The DAB Committee principals then present an assessment of the program in their functional areas, based on a review of the documents, and focusing on risk, risk management, affordability and proposed trade-offs. The purposes of this review are to ensure that all exit criteria and minimum required accomplishments have been satisfied or have been completed and to develop a recommendation to the DAB.

Ref: 5000.2 Part 11 Section C Attachment 1 page 5, Part 13 Section A page 11, Part 13 Section A page 12, Part 13 Section B page 6.

17. Upon conclusion of the Committee review, the Committee staff specialist prepares the Integrated Program Assessment (IPA) (i.e., the DAB Committee Chair's report), and a forwarding memorandum which are coordinated with the DAB Committee's principals within 2 working days. These documents are forwarded to the DAB Chair within 5 calendar days after the DAB Committee meeting. They include recommendations on the merits of proceeding with the program, proposed cost-schedule-performance trade-offs, and proposed exit criteria for the next acquisition phase.

Ref: 5000.2 Part 11 Section C page 4, Part 11 Section C Attachment 1 page 5, Part 13 Section A page 12, Part 13 Section B page 6; 5000.2-M, Part 4, page 4-4.

18. Three working days prior to the scheduled DAB meeting, the DAB Committee staff specialist prepares a pre-brief which the DAB Committee Chair provides to the DAB Chair. The pre-brief includes the purpose of the DAB, program highlights and/or background, results of the IPA, issues and trade-offs and recommendations.

Ref: 5000.2 Part 13 Section B page 6.

19. Two working days prior to the scheduled DAB, the DAB Executive Secretary will prepare the DAB Blue Book and provide a copy to all DAB principals. The Blue Book, which serves as a "read ahead", will include the IPS Executive Summary, the IPA and a summary of outstanding issues.

Ref: 5000.2 Part 11 Section C Attachment 1 page 4, Part 11 Section C Attachment 1 page 5, Part 13 Section A page 13, Part 13 Section B page 6.

ACQUISITION PROCESS OUTLINE
ACAT ID
Milestone I through IV

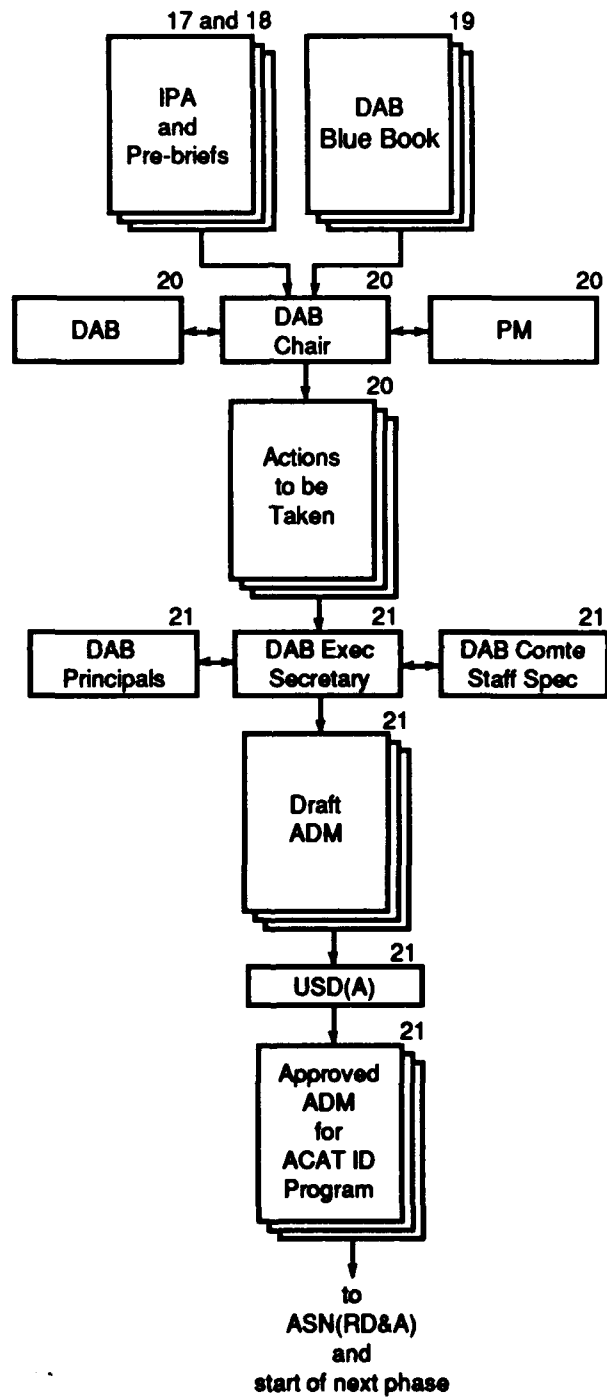

ACQUISITION PROCESS OUTLINE
ACAT ID
Milestone I through IV

20. Based on part of the Blue Book, the pre-brief, and the IPA, the DAB review will include the PM's highlighting of the overall status of the program; the DAB Committee Chair summarizing the DAB Committee's assessment and recommendations; followed by a full discussion of the issues, trade-offs and proposed exit criteria, after which the DAB Chair determines the actions to be taken. Also attending for the DON are the ASN(RD&A), DASN, OPNAV/HQMC representative and the PEO/DRPM/SYSCOM.

Ref: 5000.2 Part 11 Section C page 2, Part 13 Section A page 13, Part 13 Section B page 7.

21. Within 24 hours after the DAB review, the DAB Committee staff specialist assists the DAB Executive Secretary in preparing and staffing a proposed ADM. After review for accuracy by the DAB principals, the proposed ACAT ID ADM is presented for signature, within 48 hours after the DAB meeting, to the USD(A). Once signed by the USD(A), the program may proceed into the next phase.

Ref: 5000.2 Part 11 Section C Attachment 1 page 14, Part 13 Section A page 13, Part 13 Section B page 7.

ACQUISITION PROCESS OUTLINE
 ACAT IC, II, III, IV
 Milestones I through IV

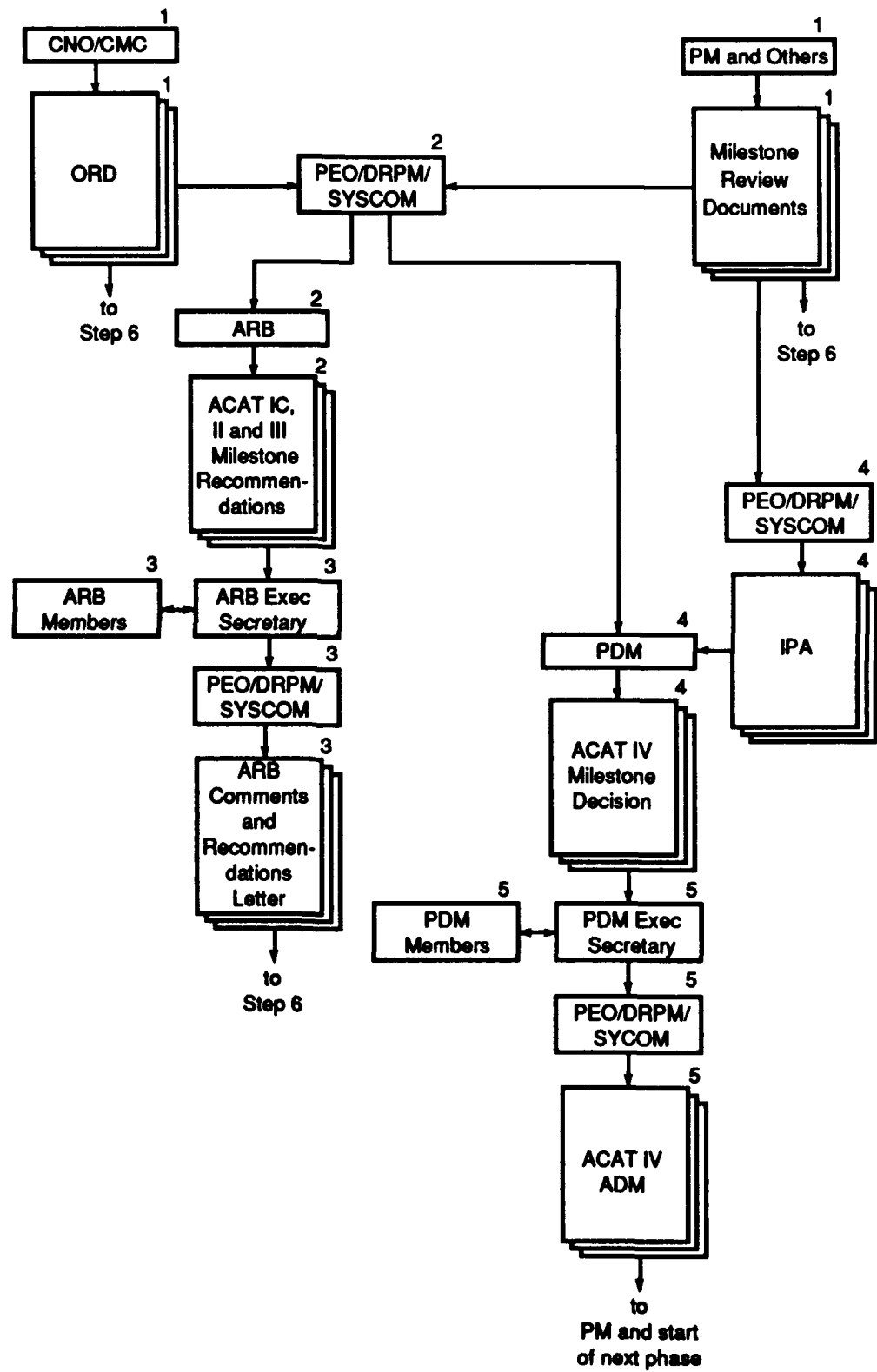

ACQUISITION PROCESS OUTLINE
ACAT IC, II, III, IV
Milestones I through IV

1. The milestone review documentation is prepared by the PM and others. At the same time the CNO/CMC is responsible for ensuring that a signed, current, valid and approved ORD exists which has been based in part, on the results of the Cost and Operational Effectiveness Analysis (COEA).
2. The ORD and milestone review documents are forwarded to the PEO/DRPM/SYSCOM who schedules an ARB for ACAT IC, II and III programs. The ARB, chaired by the PEO/DRPM/SYSCOM, is held to allow appropriate issues to be raised, addressed and potentially resolved and to develop a milestone recommendation prior to the PDM.

NOTE: No ARB is held for ACAT IV programs.

NOTE: Cognizant PDM members should be invited and attend or send a representative to the ARB.

3. After the ARB, a letter setting forth the ARB's comments and recommendations is prepared by the ARB executive secretary, reviewed by the ARB members and signed by the PEO/DRPM/SYSCOM.
4. In the case of an ACAT IV program, the PEO/DRPM/SYSCOM schedules only a PDM. The PDM, chaired by the PEO/DRPM/SYSCOM, reviews the milestone review documentation and the PEO/DRPM/SYSCOM staff prepared IPA to reach a milestone decision.

NOTE: The PEO/DRPM/SYSCOM designates a staff member as ARB Executive Secretary.

5. Based on the PDM results, the PDM Executive Secretary prepares a proposed ADM and reviews it with the PDM members. Once the proposed ADM has been reviewed, it is presented to the cognizant PEO/DRPM/SYSCOM for approval and signature. Once signed, the ADM is forwarded to the PM for the start of the next phase.

ACQUISITION PROCESS OUTLINE
ACAT IC, II, III, IV
Milestones I through IV

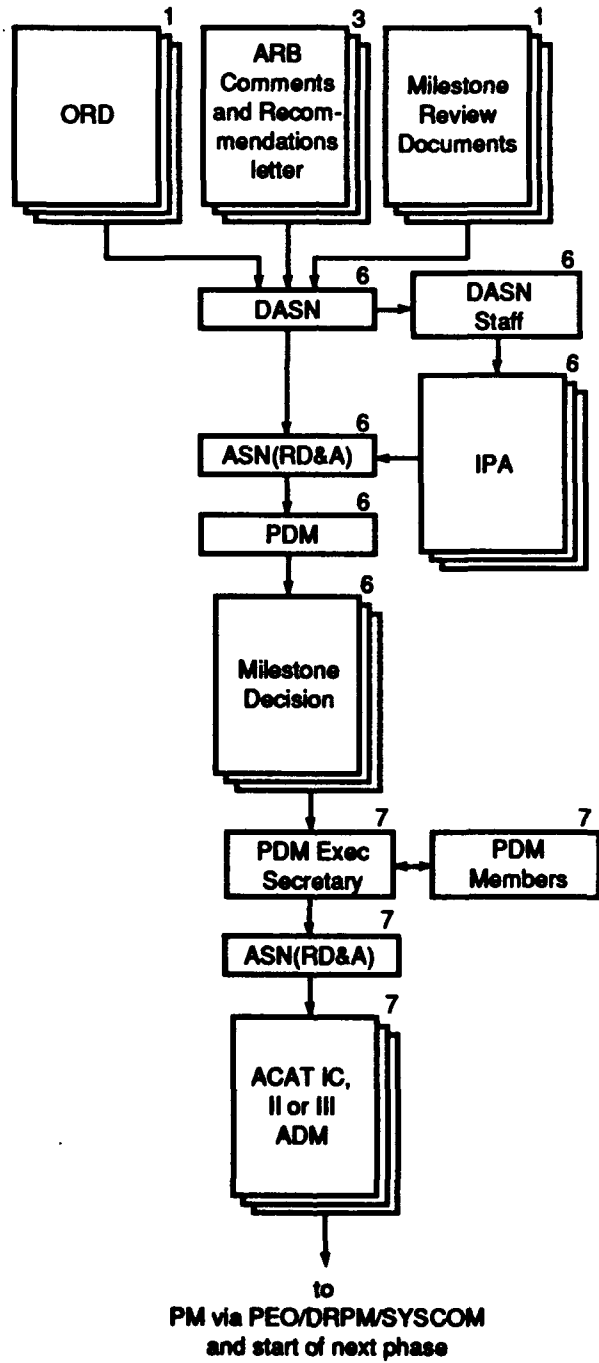

ACQUISITION PROCESS OUTLINE
ACAT IC, II, III, IV
Milestones I through IV

6. In the case of an ACAT IC, II or III program, the ARB's letter is forwarded to the appropriate DASN who schedules a PDM, after consultation with the ASN(RD&A). In addition, all milestone documentation should be submitted to the DASN prior to the scheduled PDM for the preparation of an IPA by the DASN's staff. The PDM, chaired by the ASN(RD&A), reviews the IPA, the milestone review documentation and the ARB's letter and comes to a milestone decision.

NOTE: ASN(RD&A) appoints an ASN(RD&A) staff member as Executive Secretary of the PDM.

7. At the conclusion of the PDM, the DASN is responsible for writing the proposed ADM which is coordinated with the PDM members. After the PDM members' review, the proposed ADM is presented to the ASN(RD&A) for approval and signature. Once signed by the ASN(RD&A), the ADM is forwarded to the PM via the PEO/DRPM/SYSCOM for the start of the next phase.

1.3 PROCESS OUTLINE FOR MILESTONE REVIEW DOCUMENT PREPARATION

System Threat Assessment Report (STAR)

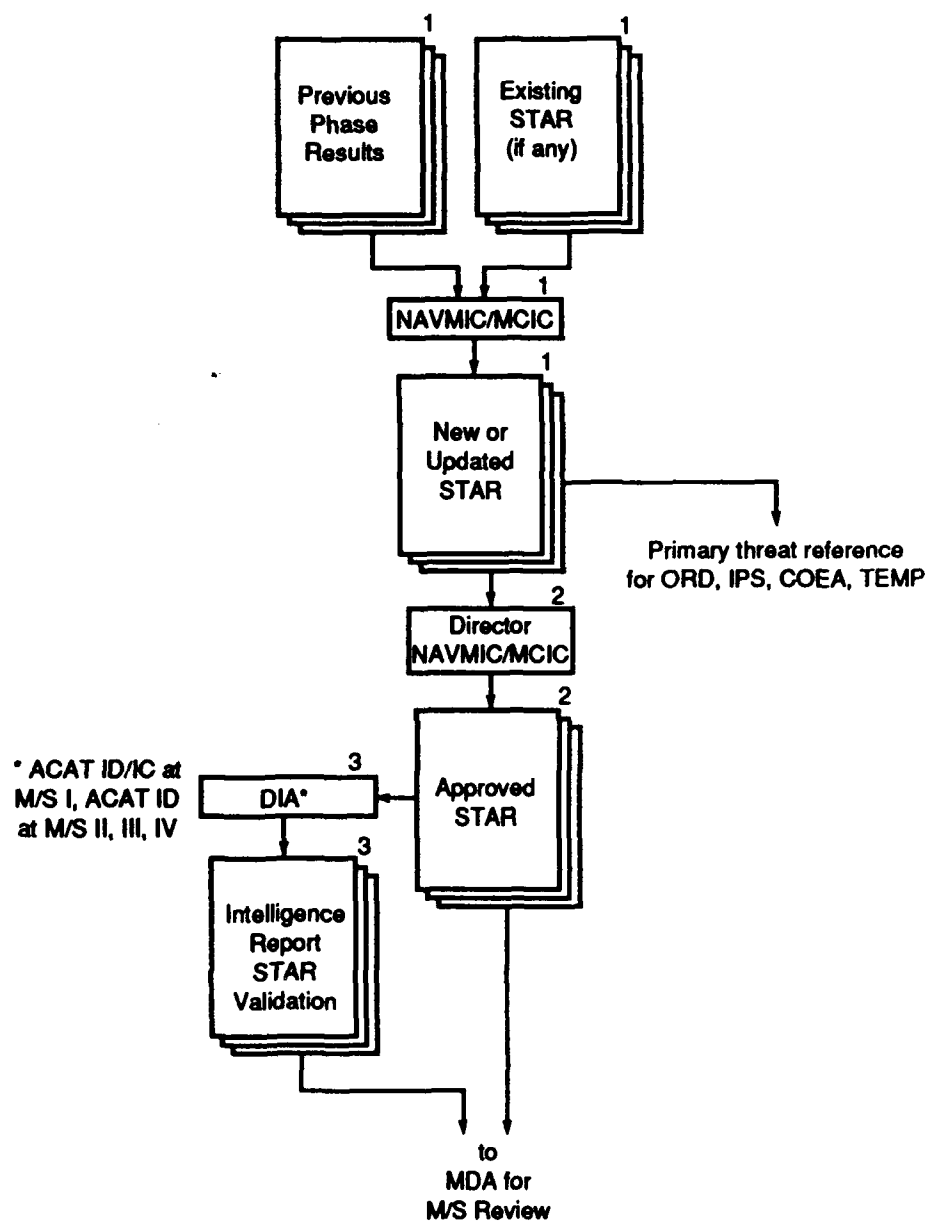

PROCESS OUTLINE FOR MILESTONE REVIEW DOCUMENT PREPARATION

System Threat Assessment Report (STAR)

Ref: 5000.2 Part 4 Section A pages 3 and 4, Part 11 Section C Attachment 2 page 2; and DOD 5000.2-M Part 5.

1. Based on the previous phase results, either the NAVMIC or MCIC prepares and/or updates the STAR.

NOTE: The STAR documents the DON threat assessment at the system level. The STAR is the primary threat document used in support of the milestone decision review and management of acquisition programs.

2. For all programs, the STAR is reviewed and approved by either Director of NAVMIC or the Director of MCIC.
3. After approval, ACAT ID/IC program STARS, at M/S I, and ACAT ID program STARS, at M/S II, III and IV, are submitted to the DIA for validation. After DIA validation, via the Intelligence Report, the updated STAR is submitted to USD(A) for M/S review. All other STARS are submitted to the MDA for M/S review.

NOTE: The STAR provides the primary threat reference for the ORD, IPS, COEA and TEMP.

PROCESS OUTLINE FOR MILESTONE REVIEW DOCUMENT PREPARATION

System Threat Assessment Report (STAR)

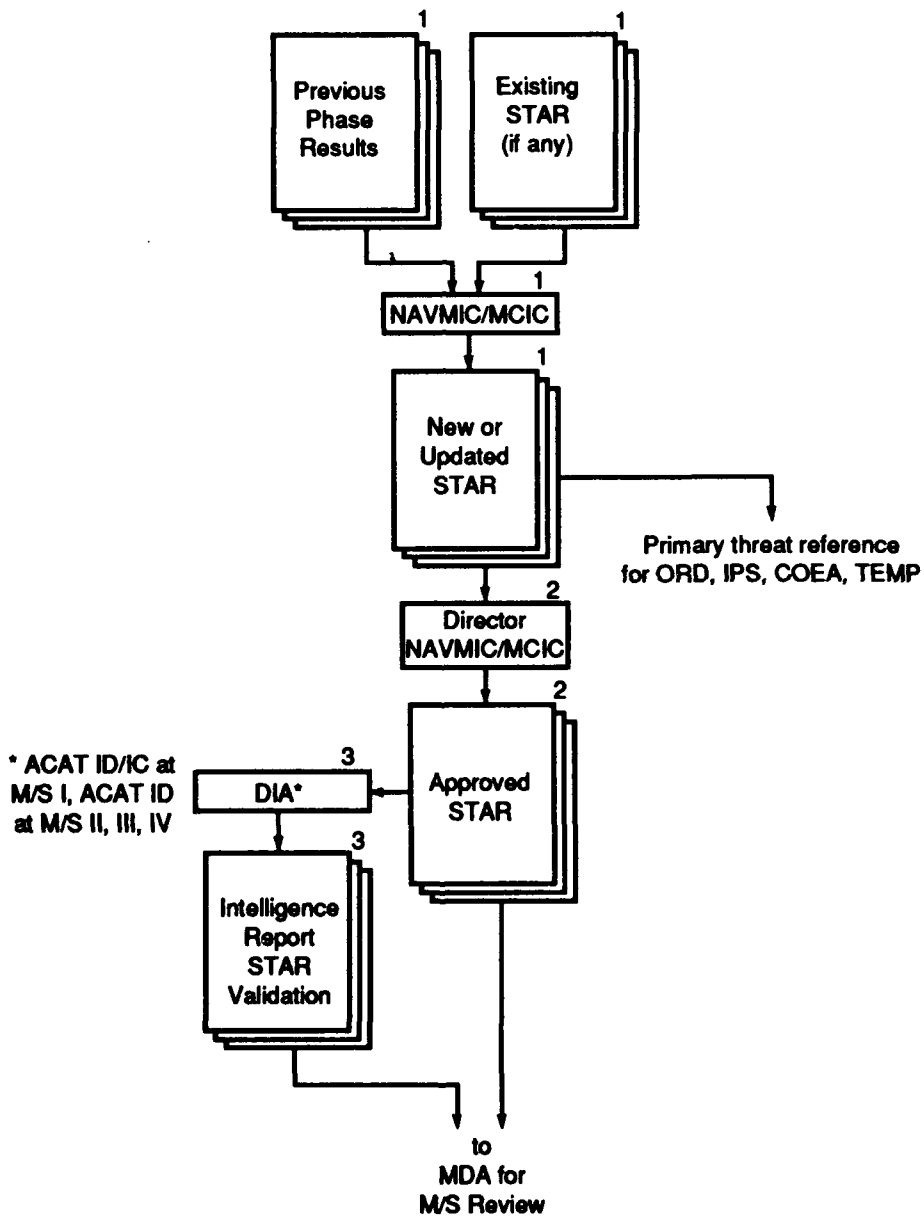

PROCESS OUTLINE FOR MILESTONE REVIEW DOCUMENT PREPARATION

System Threat Assessment Report (STAR)

Ref: 5000.2 Part 4 Section A pages 3 and 4, Part 11 Section C Attachment 2 page 2; and DOD 5000.2-M Part 5.

1. Based on the previous phase results, either the NAVMIC or MCIC prepares and/or updates the STAR.

NOTE: The STAR documents the DON threat assessment at the system level. The STAR is the primary threat document used in support of the milestone decision review and management of acquisition programs.

2. For all programs, the STAR is reviewed and approved by either Director of NAVMIC or the Director of MCIC.
3. After approval, ACAT ID/IC program STARs, at M/S I, and ACAT ID program STARs, at M/S II, III and IV, are submitted to the DIA for validation. After DIA validation, via the Intelligence Report, the updated STAR is submitted to USD(A) for M/S review. All other STARs are submitted to the MDA for M/S review.

NOTE: The STAR provides the primary threat reference for the ORD, IPS, COEA and TEMP.

PROCESS OUTLINE FOR MILESTONE REVIEW DOCUMENT PREPARATION

Integrated Program Summary (IPS)

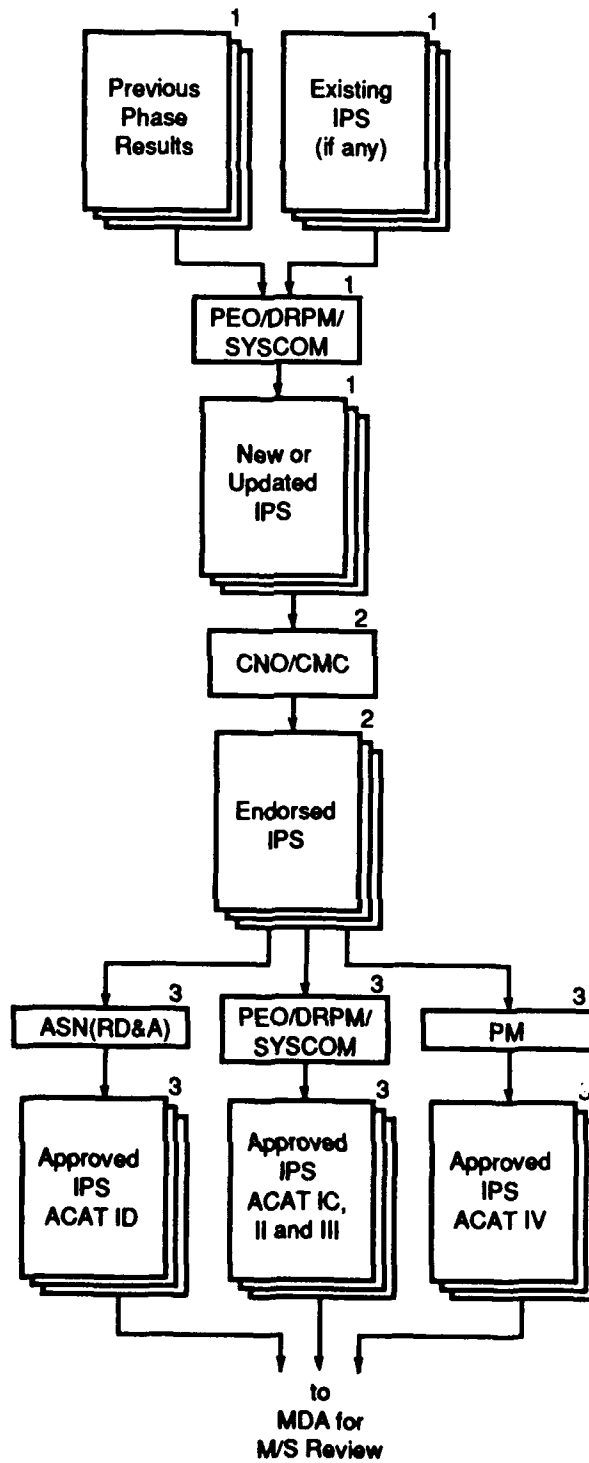

PROCESS OUTLINE FOR MILESTONE REVIEW DOCUMENT PREPARATION

Integrated Program Summary (IPS)

Ref: 5000.2 Part 2 page 7, Part 11 Section C Attachment 1 page 4, Part 11 Section C Attachment 2 page 3; and 5000.2-M Part 4.

1. Based on the previous phase results, the PEO/DRPM/SYSCOM prepares and/or updates the IPS.

NOTE: The IPS highlights the status of the critical areas and plans for future acquisition. The IPS with its annexes is the primary decision document used to facilitate top-level acquisition milestone decisions. It provides a comprehensive summary of program structure, status, assessment, plans and recommendations by the PEO and PM.

NOTE: The IPS is based in part on the ORD, STAR, COEA and APBA.

2. The IPS is submitted to either the CNO or CMC for concurrence and endorsement with regard to program structure only.
3. An IPS for an ACAT ID program is submitted to the ASN(RD&A) for approval. An IPS for an ACAT IC, II or III program is approved by the PEO/SYSCOM/DRPM. An IPS for an ACAT IV program is approved by the PM. After approval, the IPS is submitted to the MDA for M/S review.

NOTE: The IPS is prepared in parallel with the APBA.

PROCESS OUTLINE FOR MILESTONE REVIEW DOCUMENT PREPARATION

Program Life Cycle Cost Estimate

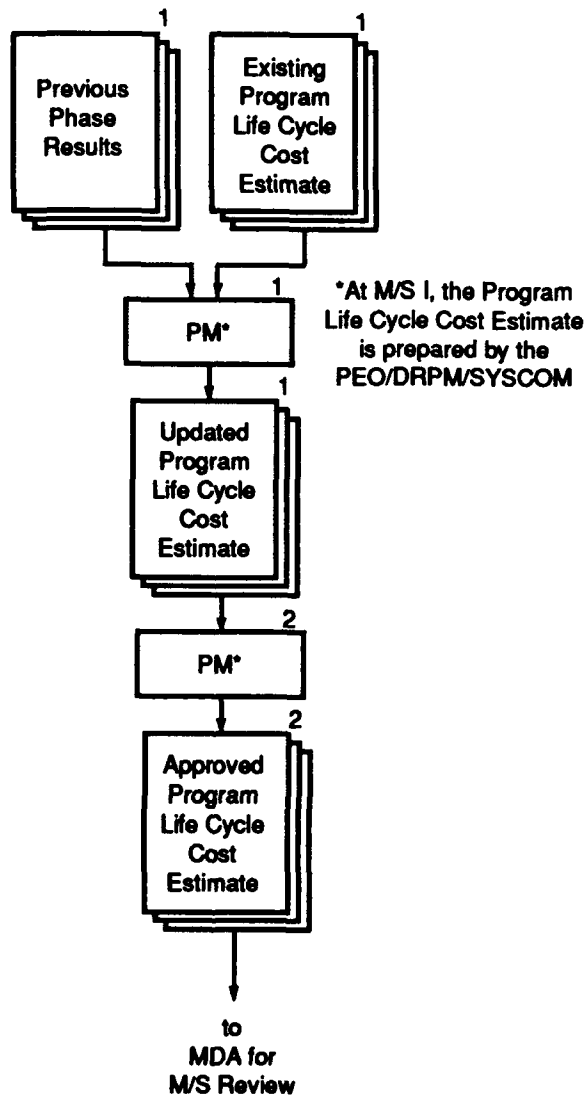

PROCESS OUTLINE FOR MILESTONE REVIEW DOCUMENT PREPARATION

Program Life Cycle Cost Estimate

Ref: 5000.2 Part 10 Section A page 1, Part 11 Section C Attachment 1 page 5, Part 11 Section C Attachment 2 page 4; 5000.2-M Part 15; SECNAV Instruction 5000.2.

1. The PEO/DRPM/SYSCOM prepares the Program Life Cycle Cost Estimate at M/S I. Based on the previous phase results, the PM updates the Estimate at M/S II, III and IV.

NOTE: The Program Life Cycle Cost Estimate documents the PM's life cycle cost estimate of the program. The Estimate also provides information about the methodology that was used to produce the Estimate.

2. The Program Life Cycle Cost Estimate is reviewed and approved by either the PEO/SYSCOM/DRPM at M/S I or the PM at M/S II, III and IV. After approval, the Program Life Cycle Cost Estimate is submitted to MDA for M/S review.

NOTE: A Program Life Cycle Estimate for an ACAT ID or IC program is also reviewed and commented on by the CAIG.

PROCESS OUTLINE FOR MILESTONE REVIEW DOCUMENT PREPARATION

Acquisition Program Baseline Agreement (APBA)

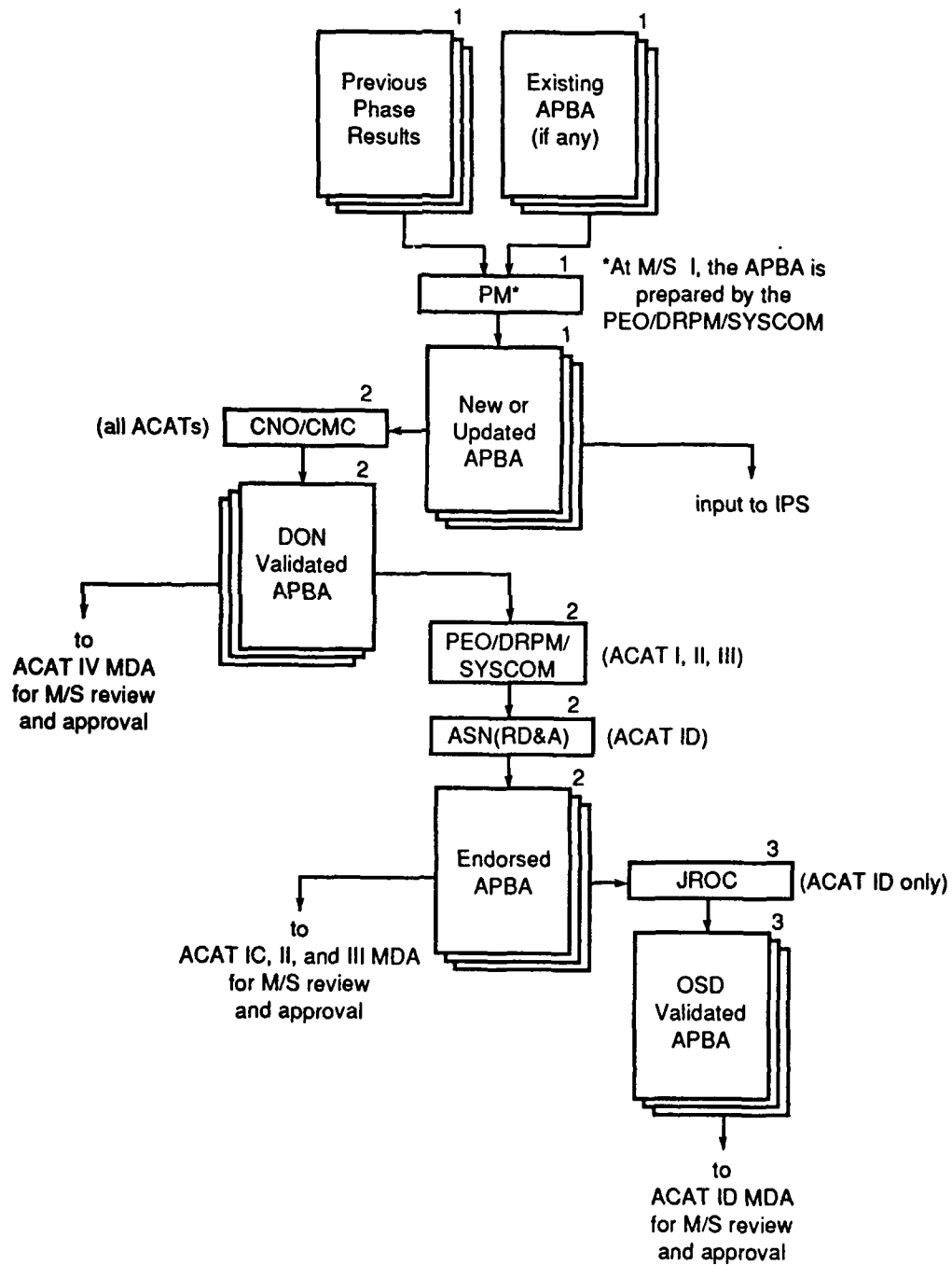

PROCESS OUTLINE FOR MILESTONE REVIEW DOCUMENT PREPARATION

Acquisition Program Baseline Agreement (APBA)

Ref: 5000.2 Part 4 Section B pages 5 and 6, Part 11 Section C Attachment 1 page 6, Part 11 Section C Attachment 2 page 4; and 5000.2-M Part 14.

1. The PEO/DRPM/SYSCOM prepares the APBA at M/S I. The PM, based on the previous phase results, updates the APBA at M/S II, III and IV.

NOTE: The APBA documents the cost, schedule and performance baseline agreement between the MDA and the PM.

NOTE: The APBA is based in part on the ORD, COEA and IPS.

2. All APBAs are reviewed and validated by the CNO/CMC. The APBAs for all ACAT I, II and III programs are reviewed and endorsed by the PEO/SYSCOM/DRPM. APBAs for ACAT ID programs are also endorsed by the ASN(RD&A).
3. ACAT ID program APBAs are validated by the JROC. After review and validation all APBAs are submitted to the MDA for M/S review and approval.

NOTE: The APBA serves as an input to the IPS.

PROCESS OUTLINE FOR MILESTONE REVIEW DOCUMENT PREPARATION

Test and Evaluation Master Plan (TEMP)

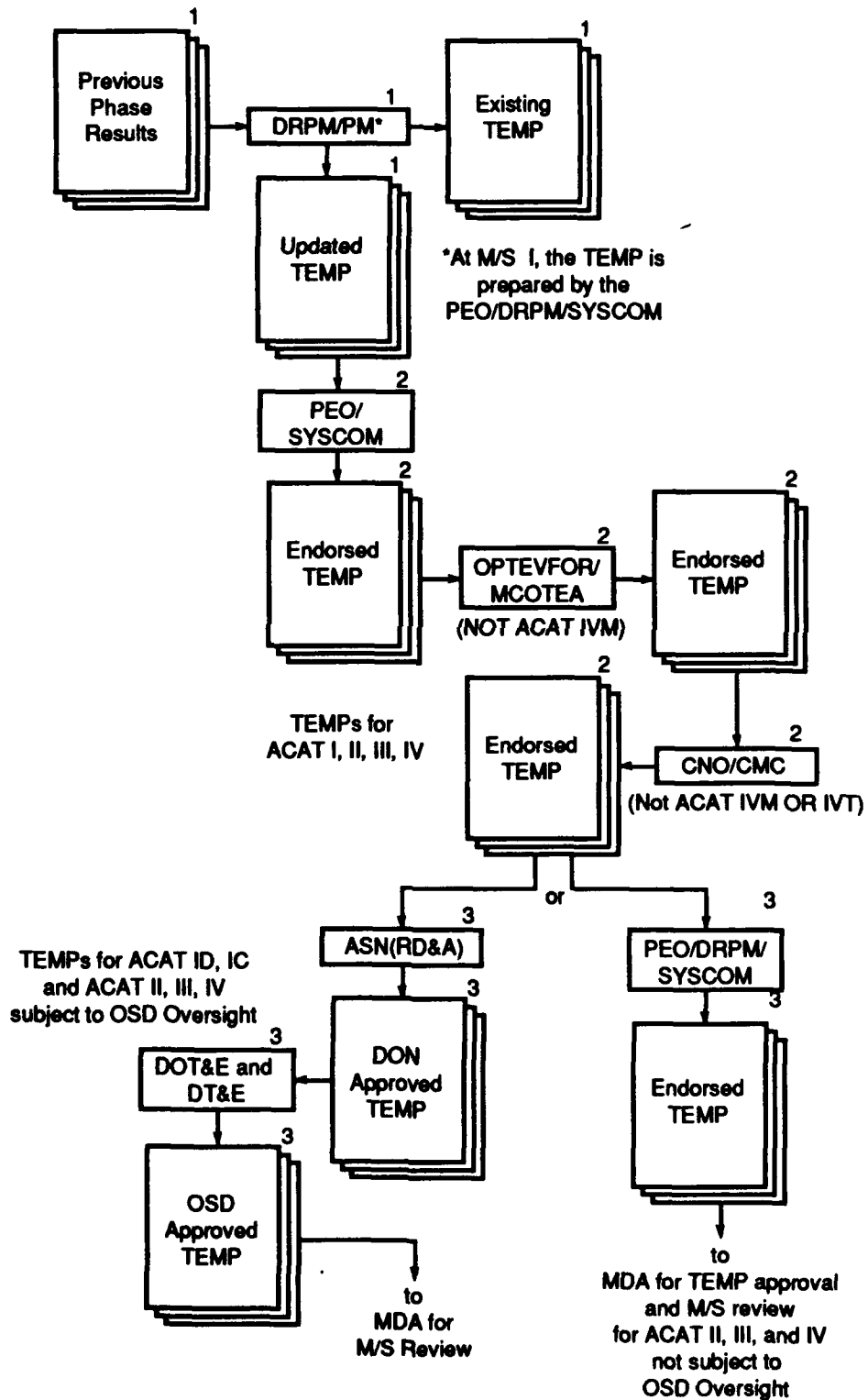

PROCESS OUTLINE FOR MILESTONE REVIEW DOCUMENT PREPARATION

Test and Evaluation Master Plan (TEMP)

Ref: 5000.2 Part 4 Section B page 5, Part 8 page 6, Part 11 Section C Attachment 2 page 4; and 5000.2-M Part 7.

1. At M/S I the PEO/DRPM/SYSCOM prepares the preliminary TEMP. At M/S II, III and IV, the DRPM/PM updates the TEMP based on the previous phase results.

NOTE: The TEMP documents the overall structure and objectives of the T&E program. The TEMP includes two levels of test criteria: (1) minimum acceptable operational performance requirements thresholds and objectives, which are the system level "measures of effectiveness" developed in the COEA and reflected in the ORD and APBA; and (2) critical technical parameters which are lower level technical "measures of effectiveness" developed in the COEA and which may also be reflected in the ORD and APBA. The TEMP outlines the T&E approach and methodology. It provides a frame work within which to generate detailed T&E plans and documents the schedule and resource implications associated with the T&E program.

2. All ACAT I, II, III and IVT program TEMPs are first submitted to the PEO/DRPM/SYSCOM and then to either the Commander, Operational Test and Evaluation Force (OPTEVFOR) or the Director of the Marine Corps Operational Testing and Evaluation Activity (MCOTEA). ACAT I, II, and III TEMPS then go to CNO and CMC for review and endorsement. ACAT IV TEMPS are not submitted to CNO and CMC for review and endorsement.
3. After endorsement, TEMPs for ACAT ID and IC programs and ACAT II, III and IV programs subject to OSD oversight are submitted to ASN(RD&A) for DON approval and forwarding to DOT&E and DT&E for OSD approval. TEMPs for ACAT II, III and IV programs not subject to OSD oversight are approved by the MDA. After approval, the TEMP is submitted to the MDA for M/S review.

PROCESS OUTLINE FOR MILESTONE REVIEW DOCUMENT PREPARATION

Cost and Operational Effectiveness Analysis (COEA)

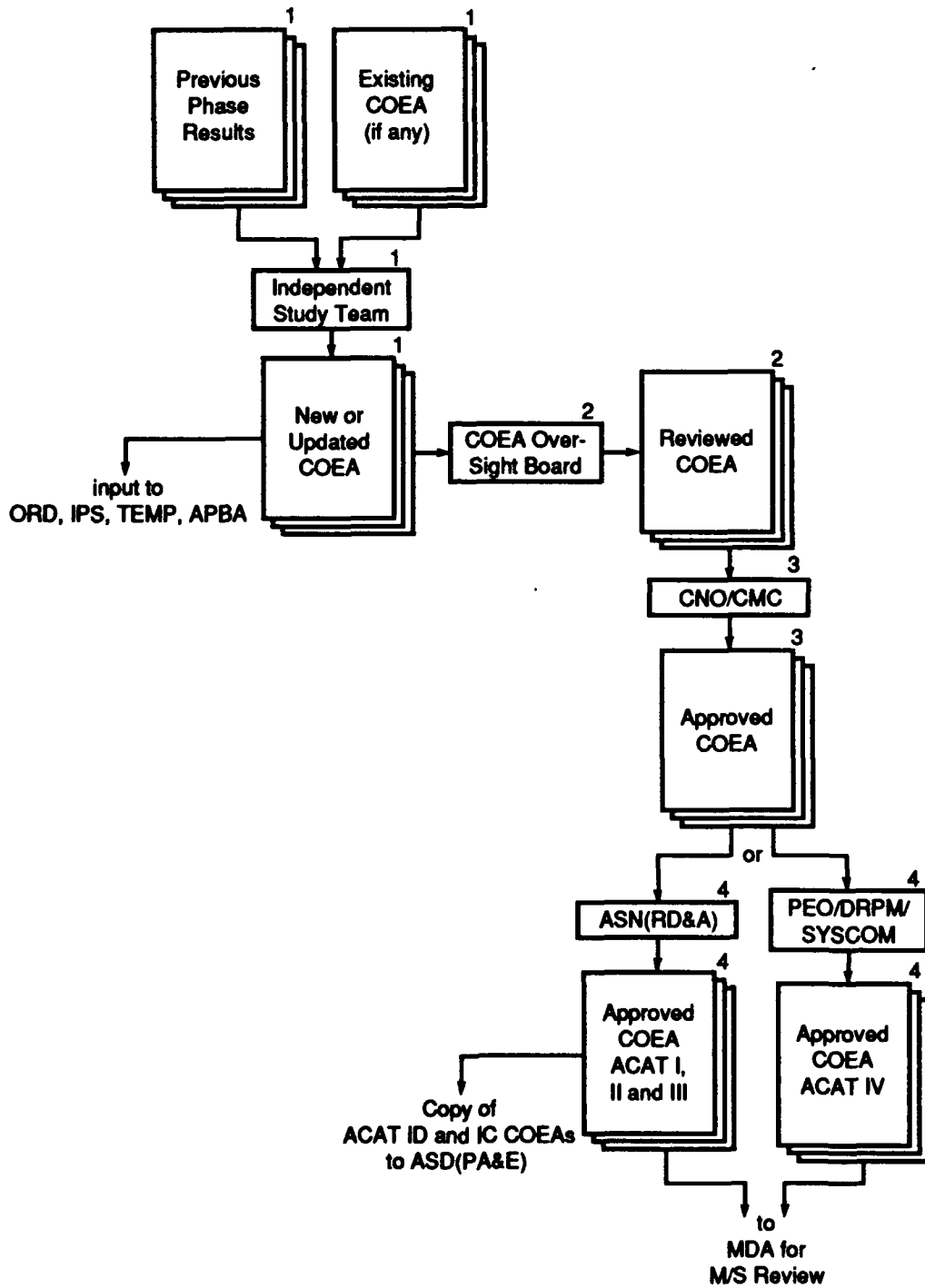

PROCESS OUTLINE FOR MILESTONE REVIEW DOCUMENT PREPARATION

Cost and Operational Effectiveness Analysis (COEA)

Ref: 5000.2 Part 4 Section E, Part 11 Section C Attachment 1 page 11, Part 11 Section C Attachment 2 page 6; and 5000.2-M Part 8.

1. Based on the previous phase results, an independent study team prepares and/or updates the COEA for all programs.

NOTE: The COEA evaluates the costs and benefits, i.e., the operational effectiveness or military utility, of alternative sources of action to meet recognized needs. The COEA analyzes the comparative cost effectiveness of alternatives at M/S I and II. At M/S III and IV, the analysis is an update of previous analyses, as required.

NOTE: The COEA is based in part on requirements stated in a MNS at M/S 0 and is an input to the development of the ORD for M/S I, II and III.

2. All COEAs are reviewed and endorsed by the DON COEA Oversight Board for ACAT I, II and III programs. An Oversight Board review is optional for ACAT IV programs.
3. All COEAs are submitted for approval to the CNO or CMC.
4. After CNO or CMC approval, ACAT I, II and III COEAs are submitted to the ASN(RD&A) for approval. Copies of ACAT ID and IC COEAs are also submitted to the OSD Office of the Assistant Secretary of Defense (Program Analysis and Evaluation) [ASD(PA&E)]. ACAT IV program COEAs are approved by the PEO/SYSCOM/DRPM. After approval, the COEA is submitted to the MDA for M/S review.

NOTE: The COEA serves as an input to the ORD, IPS, TEMP and APBA.

ABBREVIATIONS

ACAT	Acquisition Category
ADM	Acquisition Decision Memorandum
APBA	Acquisition Program Baseline Agreement
ARB	Acquisition Review Board
ASD(PA&E)	Assistant Secretary of Defense, Program Analysis and Evaluation
ASN(RD&A)	Assistant Secretary of the Navy for Research, Development and Acquisition
CAIG	Cost Analysis Improvement Group
CMC	Commandant of the Marine Corps
CNO	Chief of Naval Operations
COEA	Cost and Operational Effectiveness Analysis
DAB	Defense Acquisition Board
DASN	Deputy Assistant Secretary of the Navy
DIA	Defense Intelligence Agency
DODD	Department of Defense Directive
DODI	Department of Defense Instruction
DON	Department of the Navy
DOT&E	Director of Operational Test and Evaluation
DPM	Deputy Program Manager
DRPM	Direct Reporting Program Manager
DT&E	Director Test and Evaluation
HQMC	Headquarters, U.S. Marine Corps
ICE	Independent Cost Estimate
IPA	Integrated Program Assessment
IPS	Integrated Program Summary
JCS	Joint Chiefs of Staff
JROC	Joint Requirements Oversight Council
MCIC	Marine Corps Intelligence Center
MCOTEA	Marine Corps Operational Testing and Evaluation Activity
MDA	Milestone Decision Authority
MNS	Mission Need Statement
M/S	Milestone
NAVMIC	Naval Maritime Intelligence Center
NCA	Naval Center for Cost Analysis
OPNAV	Office of the Chief of Naval Operations
OPTEVFOR	Operational Test and Evaluation Force
ORD	Operational Requirements Document
OSD	Office of the Secretary of Defense
PDM	Program Decision Meeting
PEO	Program Executive Officer
PM	Program Manager
SECNAVINST	Secretary of the Navy Instruction
STAR	System Threat Assessment Report
SYSCOM	Systems Command
TEMP	Test and Evaluation Master Plan
USD(A)	Under Secretary of Defense for Acquisition

Chapter 2
PLANNING AND PROCESS

TABLE OF CONTENTS

2.1	Overview of the RD&A Process	2-1
2.1.1	Categories of RD&A Effort	2-2
2.1.1.1	Research	2-2
2.1.1.2	Exploratory Development	2-2
2.1.1.3	Advanced Development	2-2
2.1.1.4	Engineering and Manufacturing Development	2-2
2.1.1.5	Management and Support	2-2
2.1.1.6	Operational Systems Development	2-3
2.2	Planning for RD&A	2-3
2.2.1	Budget Category 6.1, Research	2-3
2.2.1.1	Principal participants	2-3
2.2.1.2	Documentation	2-3
2.2.1.3	Process and schedule	2-3
2.2.1.4	Decision criteria	2-3
2.2.2	Budget Category 6.2, Exploratory Development	2-4
2.2.2.1	Principal participants	2-4
2.2.2.2	Documentation	2-4
2.2.2.3	Process and schedule	2-4
2.2.2.4	Decision criteria	2-4
2.2.3	Budget Category 6.3A, Advanced Technology Development (ATD)	2-5
2.2.3.1	Principal participants	2-5
2.2.3.2	Documentation	2-5
2.2.3.3	Process and schedule	2-5
2.2.3.4	Decision criteria	2-5
2.2.4	Budget Categories 6.3B, 6.4, and "6.6," Advanced, Engineering, and Operational Systems Development	2-5
2.2.4.1	Principal participants	2-5
2.2.4.2	Documentation	2-5
2.2.4.3	Process and schedule	2-7
2.2.4.4	Decision criteria	2-7
2.3	Science and Technology Initiatives	2-7
2.3.1	Cooperation/Coordination in Science and Technology within DOD	2-7
2.3.2	Focus of Science and Technology	2-8
2.4	Test and Evaluation	2-9
2.4.1	Principal Participants	2-9
2.4.2	Documentation	2-9

Chapter 2 PLANNING AND PROCESS

Research and development, by its very nature, is uncertain in its success probability. Thus to attempt to assure reasonable success within a designated time and within budget constraints requires planning; possibly a higher degree of planning and evaluation of options than in any other field of management.

In this chapter the development of required plans is traced from their genesis in the interaction of scientific and technological possibilities, to their definitive expression in plans for systems under development and the test and evaluation required to prove that they meet the required need.

Unless one understands the essential function of planning, one might easily conclude that the time spent in documentation is disproportionate to its worth. However, the true value of documents—is in the process of their development and their ultimate use. Preparation of documents should catalyze decisions on critical issues, ensure

that problems are thought through, and record the results of an interactive decision process involving numerous inputs.

2.1 OVERVIEW OF THE RD&A PROCESS

Exhibit 2-1 is a functional view of the RD&A process in terms of five sequential phases. The first two blocks, Research and Exploratory Development, constitute the Technology Base. Combined with part of the third block, Advanced Technology Development (called informally 6.3A) they represent the DON Science and Technology (S&T) effort. The remainder of the third block (often referred to as 6.3B), by far the larger part of Advanced Development, represents development effort toward Demonstration and Validation of concept and system feasibility. The fourth block represents Engineering and Manufacturing Development and Operational Systems Development leading to the fifth block.

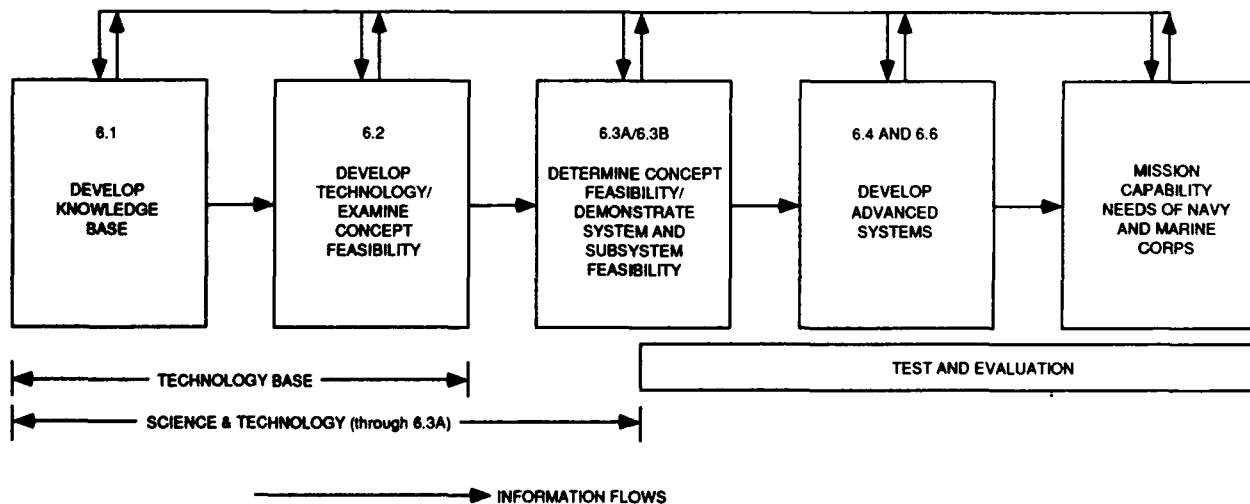

Exhibit 2-1 — Functional View of the Defense RD&A Process

2.1.1

Production and Deployment, the fielding of the system to provide mission capability needs of the Navy and Marine Corps. The double arrows at each link emphasize that the RD&A process is not a simple linear progression, but rather involves much iteration and feedback.

Test and Evaluation (T&E) is a vital constant, occurring in every phase of development and production. Formal T&E, governed by a carefully developed plan, begins in the Demonstration and Validation phase (referred to informally as 6.3B, see 2.1.1.3). Successful RD&A programs are invariably characterized by (1) effective use of T&E to manage risk and (2) early and effective communication and coordination among developers and prospective manufacturers and users of the system under development. T&E is a complex subject, which is discussed in detail in Chapter 7 and Appendix G of this Guide.

2.1.1 Categories of RD&A Effort. For planning, funding and review purposes, the Defense RDT&E Program is structured in six categories. These categories often are referred to by the numbers of the categories under the DOD Programming System. The six categories are described below.

*Ref: DON Budget Guidance Manual;
(NAVCOMPT 7102.2)*

2.1.1.1 Research. Budget Category 6.1, Research, includes all effort of scientific study and experimentation directed towards increasing knowledge and understanding in broad fields directly related to long-term DON needs. Research is conducted to ensure that both cutting-edge scientific discoveries and the general store of scientific knowledge are optimally utilized in the development of superior Naval equipment, strategies, and tactics. The 6.1 program is a major source of basic and applied research effort in electrical engineering, materials science, applied mathematics, and other disciplines (see C3.1.2) of importance to the DON.

2.1.1.2 Exploratory Development. Budget Category 6.2, Exploratory Development, includes effort directed toward the solution of specific Naval problems, short of major development projects. The role of the exploratory development program is to ensure that, as technological advances appear, they are investigated for possible development/exploration to determine applicability to future Naval programs. This type of effort may vary from fairly fundamental applied research to sophisticated bread-board hardware.

2.1.1.3 Advanced Development. Budget Category 6.3, Advanced Development, includes all projects which are characterized by the development of hardware for experimental test. The prime result of this type of effort is proof of design. At the core of the Advanced Development program is the imperative to develop and make available to the Fleet new and advanced technologies that will ensure the long-term superiority of U.S. forces. Advanced Development is further broken down into 6.3A and 6.3B effort. 6.3A projects are not related to specific ship or aircraft applications and are mostly developed as Advanced Technology Demonstrations (ATDs). Only highest risk/highest payoff efforts are selected as 6.3A projects. Many programs bypass this risk projection/risk assessment step and proceed directly into 6.3B programs which develop technologies intended for application on specific systems, e.g., ships or aircraft.

2.1.1.4 Engineering and Manufacturing Development. Budget Category 6.4, Engineering Development, includes programs that are typically in engineering and manufacturing development but have not yet received production approval.

2.1.1.5 Management and Support. Budget Category 6.5, Management and Support, includes support of installations or operations required for general research and development use. Included would be test ranges, military construction, maintenance support of laboratories, operations and maintenance of test aircraft and ships, and

studies and analyses in support of the R&D program.

2.1.1.6 Operational Systems Development. "6.6," Operational Systems Development, includes those projects still in Engineering and Manufacturing Development, but which have received approval for production or for which production funds have been included in the DOD budget submission for the budget or subsequent fiscal year. All work in this area is identified by major line item projects that appear as "RDT&E Costs of Weapon System Elements" in other programs, e.g., Program 1, Strategic Forces. Although Operational Systems Development is an official budget category, "6.6" is a term used for convenience in reference and discussion. Thus, there is no program element number 6.6xxx.

2.2 PLANNING FOR RD&A

For the categories of effort described above, except 6.5, this chapter will provide overviews of the following:

- **Principal Participants.** Provide a listing of the principal individuals and organizations involved in planning.
- **Documentation.** Describe the top-level documents used in planning and their purpose.
- **Process and Schedule.** Where a process for the development of planning for a category has been established, provide a brief description of the process. Provide an insight into the timing of the planning activities.
- **Decision Criteria.** Provide an overview of the decision criteria for each category.

2.2.1 Budget Category 6.1, Research.

2.2.1.1 Principal participants. The Chief of Naval Research (CNR) is responsible to the Secretary of the Navy (SECNAV), through

ASN(RD&A), for the overall investment strategy for the Research program and for developing research and technology programs which effectively address future operational naval needs and capabilities identified by the Chief of Naval Operations (CNO).

The Director, Science Directorate (ONR) is responsible to the CNR for managing the Research Program.

The CNO is represented by the Director, Test & Evaluation and Technology Requirements (N091), who acts as Resource Sponsor for planning, programming, and budgeting S&T and as representative of the user in establishing warfighting requirements for S&T.

2.2.1.2 Documentation. There are two key documents used during the development of the annual Research program:

(1) ONR Navy Research Investment Strategy which provides overall strategy for Naval research; and

(2) ONR Naval Needs & Science Opportunities which provides specific direction for allocation of Navy research resources.

2.2.1.3 Process and schedule. Long-range naval objectives and requirements are integrated with promising scientific opportunities into an annual program plan. CNR and N091 conduct an annual process of evaluation, prioritization, and selection of submitted research proposals for approval by ASN(RD&A).

2.2.1.4 Decision criteria. Decision criteria for approving 6.1 Research projects are:

- Does the project maintain a broad sustaining, versatile program in all science areas of potential naval relevance?
- Does the project emphasize core competencies in ocean sciences, advanced materials and information sciences to accelerate technology transition in DON high priority area?
- Does the project maintain balance in the program? Note: The 1992 program

2.2.2

Invested 60% of funding in evolutionary research, 15% in high risk/high payoff revolutionary effort, and 25% in research closely associated with Fleet applications.

- Does the project train students in science and engineering disciplines critically needed by the Navy in nurturing a strong and responsive in-house laboratory research capability?
- Does the project accelerate transitions to meet critical scientific gaps in essential Fleet programs?

2.2.2 Budget Category 6.2, Exploratory Development.

Ref: OCNR Instruction 3910.3

2.2.2.1 Principal participants. The Chief of Naval Research (CNR) is responsible to SECNAV, through ASN(RD&A), for the overall investment strategy for Exploratory Development for developing research and technology programs which effectively address future research and future operational naval needs and capabilities identified by the CNO.

The Director, Test & Evaluation and Technology (N091) acts as Resource Sponsor for planning, programming, and budgeting S&T and as representative of the user in establishing warfighting requirements for S&T.

The Director, Technology Directorate (ONR) is responsible to the CNR for managing the Exploratory Development program. He is assisted by the Science Directorate which helps to identify high-leveraged opportunities.

2.2.2.2 Documentation. The Exploratory Development program consists of a set of Block Programs which are documented in Block Program Plans, developed by Navy Laboratories and R&D Centers. A Block Program Plan is submitted for each Block Program. A Block Program is an integrated group of technology

projects with closely related applications and/or technical objectives. The Block Program Plan describes the program to be executed for the Execution year and Program Objectives Memorandum (POM) years.

2.2.2.3 Process and schedule. The Exploratory Development program development integrates the planning, programming, and budgeting processes. The process is carried out on an annual basis with each quarter of the fiscal year emphasizing a distinct portion of the process as follows:

- First Quarter: Accountability. Technology Directorate management reviews and assesses the previous and current years' programs.
- Second Quarter: Strategic Planning. The Investment and Mission Area Strategies are developed by the Technology Directorate.
- Third Quarter: Execution Planning. The Block Program Guidance is issued and the Block Plans for the following fiscal year are developed.
- Fourth Quarter: Block Program Plan reviews, modification, approval, and funding. Funding documents are promulgated by 30 September.

2.2.2.4 Decision criteria. The decision criteria for Exploratory Development programs are:

- Does the program help to maintain Navy technological superiority and provide the capability to counter new threats?
- Does the program provide technology opportunities that preserve the strategic Naval initiative and extend strategic flexibility?
- Does the program improve the effectiveness of the U.S. deterrent posture?
- Does the program present significant threats to U.S. adversaries?

- Does the program provide technology that reduces cost of acquisition and operation and maximizes system cost-effectiveness?

2.2.3 Budget Category 6.3A, Advanced Technology Development (ATD).

2.2.3.1 Principal participants. The Chief of Naval Research (CNR) is responsible to SECNAV, through ASN(RD&A) for the overall investment strategy for Advanced Technology Development and for developing research and technology programs which effectively address future operational naval needs and capabilities identified by the CNO.

The Director, Test & Evaluation and Technology Requirements (N091) acts as Resource Sponsor for planning, programming, and budgeting S&T and as representative of the user in establishing warfighting requirements for S&T.

The Director, Technology Directorate (ONR) is responsible to the CNR for managing the Advanced Technology Development program. He is assisted by the Science Directorate, which helps to identify high-leverage opportunities.

2.2.3.2 Documentation. Advanced Technology Development proposals prepared by Navy Laboratories, Warfare Centers and industry provide inputs for developing the 6.3A program.

2.2.3.3 Process and schedule. OPNAV (N091) establishes ATD requirements. Based on those requirements, CNR solicits proposed concepts, reviews the concepts, and submits its evaluation to N091. N091 reviews the concepts and submits its evaluation to ASN(RD&A).

After ASN(RD&A) review and concurrence, CNR requests that the proposers develop detailed concept papers for selected concepts.

The CNR in conjunction with the ATD executing organizations, evaluates the proposed concepts and develops a list of recommended ATD program for N091 to consider.

The ATDs program is updated and necessary Planning, Programming, and Budgeting System (PPBS) actions taken.

After PPBS and Congressional approval, CNR is authorized to proceed with the ATD execution.

2.2.3.4 Decision criteria. The design criteria for an ATD are:

- Is it responsive to priority warfighting requirements?
- Is it consistent with DDR&E guidance and coordinated with Project Reliance? (See 2.3.1.)
- Does it have medium to high risk but high transition potential and is it scheduled to be completed in 3 to 6 years?
- Does it have strong OPNAV sponsorship?

2.2.4 Budget Categories 6.3B, 6.4, and "6.6," Advanced, Engineering, and Operational Systems Development.

2.2.4.1 Principal participants. Program Executive Officers (PEOs), Direct Reporting Program Managers (DRPMs), Systems Command Commanders (SYSCOMs), and Program Managers (PMs) are responsible to the Navy Acquisition Executive (NAE) to plan and execute the programs.

Resource Sponsors within OPNAV (Surface Warfare, Submarine Warfare, and Air Warfare) are responsible for (1) representing the warfighter in the acquisition process and (2) representing the program in the PPBS.

*Ref: DOD Directive 5000.1, Part 3;
SECNAV Instruction 5000.2*

2.2.4.2 Documentation. Milestone reviews require rigorous assessments of a program's status and plans for the future. The information needs of the milestone decision authority and supporting staffs at each level, however, must be satisfied without creating an undue burden on the Program Manager. Accordingly, the milestone review

2.2.4.2

documentation concept, established by DOD Directive 5000.1, DOD Instruction 5000.2 and DOD 5000.2-M, provides for stand-alone supporting documentation and two standardized information displays, the Integrated Program Summary and the Integrated Program Assessment, as shown in Exhibit 2-2. DOD Instruction 5000.2, Parts 2 and 11, provides additional information on these documents, including who prepares, validates, and approves them. DOD 5000.2-M prescribes format and content.

Stand-Alone Supporting Documentation. The purposes of the stand-alone supporting documentation such as the Cost and Operational Effectiveness Analysis (COEA), Test and Evaluation Master Plan (TEMP), Acquisition

Program Baseline (APB), the Program and Independent Cost Estimates (PCE & ICE), and the Manpower Estimate Report, are to meet the information needs of the milestone decision authority, supporting staffs, and review forums.

Integrated Program Summary (IPS). The purpose of the IPS is to provide a succinct, integrated picture of the program's status, from the Program Manager's perspective, for use by the milestone decision authority, supporting staffs, and review forums.

Integrated Program Assessment (IPA). The IPA is a critique of the IPS and summarizes the results of the independent assessments conducted by the supporting staff and review groups. It is a

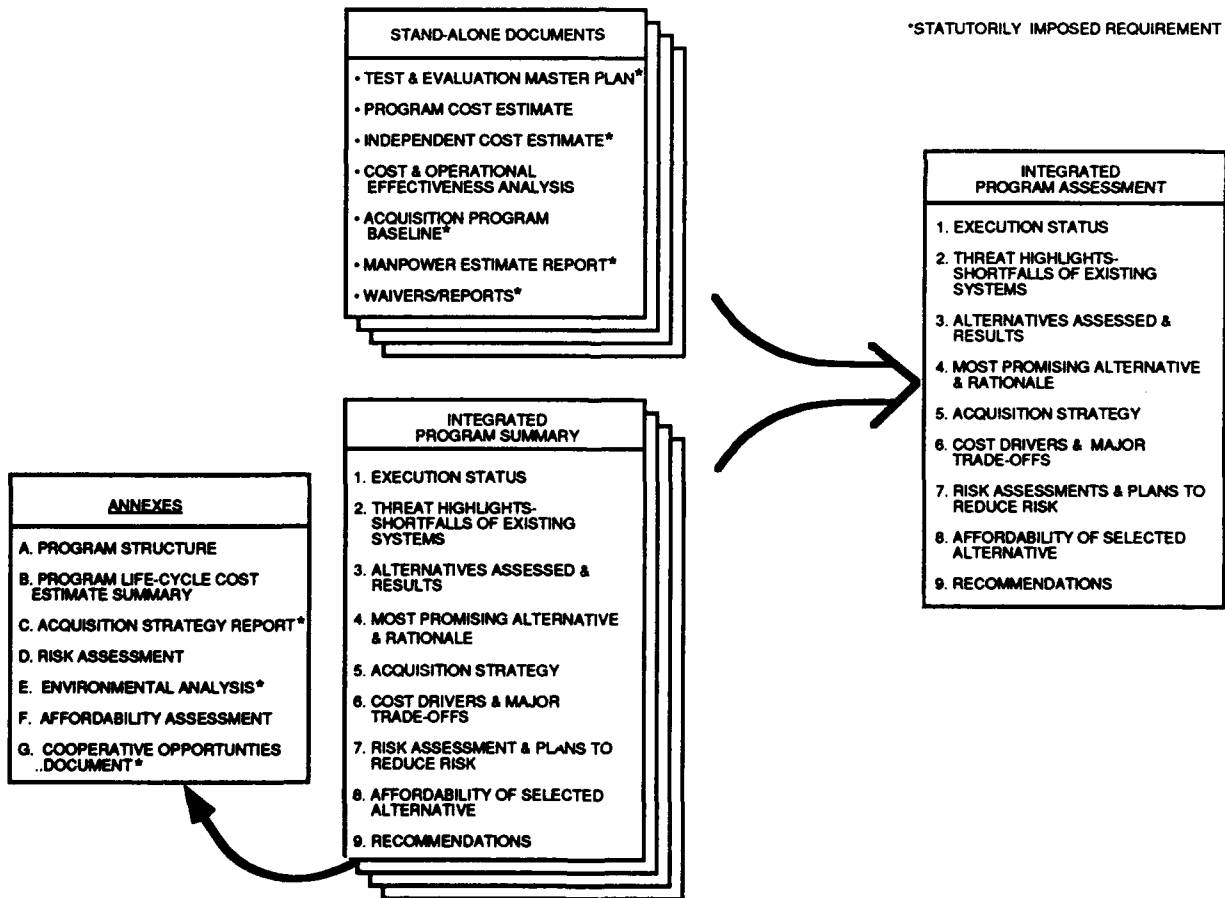

Exhibit 2-2 — Milestone Documentation Concept

major issue-oriented document and provides the basis for the milestone decision review agenda.

DOD Instruction 5000.2, Part 2 and Part 11, Section C; DOD 5000.2-M

2.2.4.3 Process and schedule. DOD Instruction 5000.2, Part 13, establishes the process for milestone reviews for Category ID by the Under Secretary of Defense for Acquisition once the Program Manager determines that the program has achieved all the objectives of the current acquisition phase and is ready to proceed into the next acquisition phase. Other acquisition categories, i.e., IC, II, III, and IV follow similar processes as established in SECNAV Instruction 5000.2 and OPNAV Instruction 5000.42.

Schedules for most programs have five milestone decision points and five phases during the acquisition process as illustrated in Exhibits 2-3 and 2-4. Low risk programs may not need a Demonstration-Validation phase, in which case Milestones I and II may be combined. These provide the basis for comprehensive management and the progressive decision-making associated with all programs.

Ref.: DOD Instruction 5000.2, Part 3

2.2.4.4 Decision criteria. The decision criteria are based on rigorous, objective assessments of a program's status and plans for managing risk during the next phase and the remainder of the program. The acquisition strategy and associated contracting activities explicitly link milestone decision reviews to events and demonstrated accomplishments in development, testing, and initial production.

Note: Chapter 1 of this Guide, "The Acquisition Process—an Overview," provides what might be termed a "map" of the official DOD acquisition process. The graphics are amplified by information on facing pages which identify the particular parts of DOD Directive 5000.1, DOD Instruction 5000.2, and DOD 5000.2-M that contain information on the documents, officials, and actions depicted in the graphics.

2.3 SCIENCE AND TECHNOLOGY INITIATIVES

The DON Science and Technology effort, which is managed by the Office of Naval Research, has been the subject of the recent Defense initiatives described below.

2.3.1 Cooperation/Coordination in Science and Technology within DOD. In late 1989, the Deputy Secretary of Defense challenged the Services to create a new approach to Science and

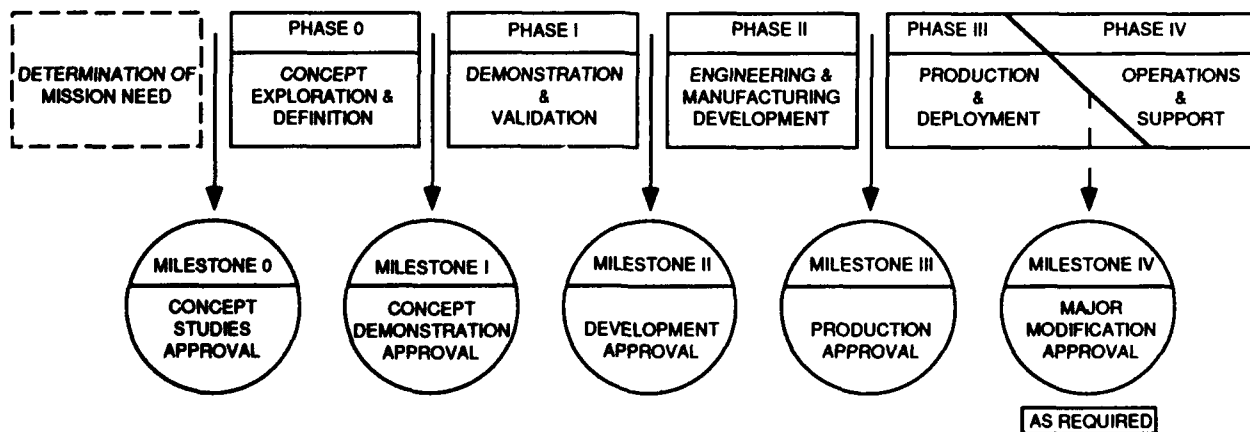

Exhibit 2-3 — Acquisition Milestones and Phases



Exhibit 2-4 — Acquisition Phase and Milestone Decision Points

Technology management, one that would eliminate inefficiencies, take advantage of joint considerations, and reduce unwarranted overlap in the RDT&E of each individual Service. That challenge resulted in the creation of the Tri Service Science and Technology Project Reliance. The goals of Project Reliance were to: enhance science and technology; ensure critical mass of resources to develop "world-class" products; reduce redundant capabilities and eliminate unnecessary duplication; gain efficiency through co-location and consolidation of in-house work when appropriate; and preserve the Services' mission-essential capabilities.

Project Reliance is a dynamic process. Its technical scope has expanded since its initiation. Currently, 31 broad technology areas are covered by Project Reliance some of which are:

1. Computers
2. Software

3. Sensors
4. Communications Networking
5. Electronic Devices
6. Environmental Effects
7. Materials and Processes
8. Energy Storage
9. Propulsion and Energy Conversion
10. Design Automation
11. Human-System Interfaces

2.3.2 Focus of Science and Technology. The mission of RD&A is to enhance the warfighting capabilities of U.S. forces. To optimize the focus of the S&T effort, the most pressing military and operational requirements have been broadly categorized into the following seven S&T Thrusts:

1. Global Surveillance and Communications
2. Precision Strike
3. Air Superiority and Defense

4. Sea Control and Undersea Superiority
5. Advanced Land Combat
6. Synthetic Environments
7. Technology for Affordability

2.4 TEST AND EVALUATION

T&E is not a discrete stage in RD&A, but an effort applied at every stage of development. It is classified in two types, Developmental Test and Evaluation (DT&E) and Operational Test and Evaluation (OT&E). DT&E is conducted by development activities and users to detect flaws in design, performance, and construction and confirm that specifications are met. OT&E is conducted, under conditions simulating as closely as possible the expected operating environment, to determine the suitability of the system for its purpose and to confirm that operational requirements are met. By law, OT&E must be conducted by an activity that is independent of developer and user.

DOD Instruction 5000.2, Part 8

2.4.1 Principal Participants. N091, as the principal T&E office within OPNAV, is responsible for oversight of all T&E effort.

DT&E is managed by the Program Manager and is conducted by design activities and participating laboratories and centers.

OT&E is conducted by the Operational Test and Evaluation Force (OPTEVFOR) or by the Marine Corps Operational Test and Evaluation

Activity (MCOTEA), the independent operational test organizations reporting, respectively, to the CNO or the CMC.

2.4.2 Documentation. The primary T&E document is the Test and Evaluation Master Plan (TEMP), first prepared for review during the Milestone I decision process and updated at each decision point thereafter. The TEMP is the governing document for the test and evaluation of a system.

Present acquisition policy emphasizes that the TEMP and the Cost and Operational Effectiveness Analysis (COEA) are aids to decision making. COEAs are analytic tools used to guide the program primarily at Milestones I and II. The TEMP aids the decision maker by verifying that a system has attained its technical performance specifications and objectives and is operationally effective and suitable for its intended use. A linkage has to exist between the COEA and TEMP particularly in the measures of effectiveness (MOE) and measures of performance (MOP) which define the military utility of the system.

Note: Chapter 7 of this Guide discusses the T&E participants, documentation, process, schedules, and decision criteria in detail. Additional information on T&E may be found in DOD Instruction 5000.2, Parts 4 and 8, DOD 5000.2-M, Part 7, and OPNAV Instruction 5000.42.

DOD Instruction 5000.2, Part 8; DOD 5000.2-M, Part 7

SELECTED REFERENCES ON PLANNING AND PROCESS

DOD Directive 3210.1, (OCNR 3900.11) "Administration and Support of Basic Research by the DOD."

DOD Directive 5000.1, "Defense Acquisition." Establishes fundamental overall policy for systems development and acquisition. The management principles in the directive are applicable to all programs.

DOD Instruction 5000.2, "Defense Acquisition Management Policies and Procedures." Detailed direction on nearly every aspect of systems development and acquisition.

DOD 5000.2-M, "DOD Manual: Defense Acquisition Management Documentation and Reports."

SECNAV 5000.2, "Implementation of Defense Acquisition Management Policies, Procedures, Documentation, and Reports."

OPNAV Instruction 5000.42, "OPNAV Responsibilities and Duties in the Acquisition Process."

MCO P5000.10, "Systems Acquisition Management Manual."

NOTE REGARDING DIRECTIVE NUMBERS

References to directives within this Guide are by series only; e.g., 3900.14, not to the effective edition within the series; e.g., 3900.14A

The "Master Reference List" indicates the version and issue date of each directive used in preparation of this edition of the Guide.

For recent information on the effective directive within a series, consult the "Department of the Navy Directives Issuance System: Consolidated Subject Index." (NAVPUBNOTE 5215).

Chapter 3 PROGRAMMING

TABLE OF CONTENTS

3.1	Objectives of DOD Programming System	3-1
3.2	DOD Future Years Defense Program	3-1
3.2.1	Program Element	3-1
3.2.2	Program	3-2
3.2.3	Major Programs	3-2
3.3	FY 1992-97 Planning, Programming and Budgeting	3-2
3.3.1	Navy Program Planning	3-2
3.3.2	OSD Planning	3-3
3.3.3	Navy Programming	3-3
3.3.4	OSD Program Review	3-3
3.3.5	Budget Formulation	3-3
3.4	Principal Documents for Programming and Budgeting	3-3
3.4.1	POM Serials	3-3
3.4.2	Joint Mission Area (JMA) and Support Area (SA) Assessments	3-3
3.4.3	Investment Balance Review (IBR)	3-6
3.4.4	Baseline Assessments	3-6
3.4.5	Integrated Priority List (IPL)	3-6
3.4.6	Sponsor Change and Program Proposal (SCP/SPP)	3-6
3.4.6.1	Sponsor Program Proposal Documentation	3-6
3.4.7	Post-SSP Program Assessments	3-6
3.4.8	DON Consolidated Planning and Programming Guidance (DNCPPG)	3-6
3.4.9	Program and Fiscal Guidance	3-7
3.4.10	National Military Strategy Document (NMSD)	3-7
3.4.11	Defense Planning Guidance (DPG)	3-7
3.4.12	Program Objectives Memorandum (POM)	3-7
3.4.13	Chairman's Program Assessment (CPA)	3-7
3.4.14	Program Decision Memorandum (PDM)	3-7
3.4.15	Program Budget Decision (PBD)	3-7
3.4.16	Major Budget Issues (MBI)	3-7

Chapter 3

PROGRAMMING

Programming, the subject of this Chapter, is the portion of the Planning, Programming and Budgeting System (PPBS) which links planning to budgeting. It is the process by which plans are converted into time-phased and fiscally constrained programs. The Department of the Navy Programming System is the process within which decisions are made by the Chief of Naval Operations, the Commandant of the Marine Corps, the Secretary of the Navy, and the Secretary of Defense concerning modernization (including R&D), force levels, readiness, and sustainability. For convenience this chapter includes material on planning and budget to provide a comprehensive picture of the PPBS. A more detailed discussion of budget formulation is reserved to Chapter 4. The justification of the budget to Congress is also addressed in the next chapter under 4.8.

It is important that the Department of Defense programming system be thoroughly understood. Its objectives and the manner in which it is developed are of particular importance to RD&A executives because the initiation of any system first must be approved, programmed and funded. To gain such approval and financing, the system must be justified in competition against optional means of achieving the proposed objectives and other uses for the same resources.

3.1 OBJECTIVES OF DOD PROGRAMMING SYSTEM

The DOD Programming System is designed primarily to accomplish the following eight objectives:

- Relate resources to Defense missions and requirements.

- Link planning to budgeting.
- Establish programs oriented to "Mission" rather than to department function.
- Provide a framework for Inter-Service competition to provide required mission forces.
- Establish a rational program structure which encompasses all Defense activities.
- Ensure that cost effectiveness studies support optional force structure or weapon system proposals.
- Evaluate programs on a continuous basis.
- Establish a single channel for major decisions on Defense programs.

3.2 DOD FUTURE YEARS DEFENSE PROGRAM

The Future Years Defense Program (FYDP) is a current summary of all Department of Defense programs. It relates manpower and financial resources to military programs. The FYDP describes accomplishments to date and future goals in support of national strategies. It includes program manpower, dollars, and force structure from the beginning of the PPBS in Fiscal Year 1962, through the current year plus data for each of the ensuing six fiscal years.

3.2.1 Program Element. The Program Element (PE) is the basic building block of the Future Years Defense Program (FYDP). It describes the mission, the responsible organization, and the estimated costs. Currently, there are approximately 3,000 Program Elements in the FYDP, including about 1,000 Navy Program Elements of

3.2.2

which about 300 are for RDT&E activities (see C7.2 and Exhibit C-3).

Ref.: DOD 7045.7-H

3.2.2 Program. A Program comprises several Program Elements developed to accomplish a defined objective. It specifies what is to be done, when, and the resources proposed to achieve it. Program Elements either complement or substitute for each other. It is important to distinguish between the meaning of "Program" as defined in the PPBS described here, and its definition in reference to the acquisition process which is discussed in Chapter 1.

3.2.3 Major Programs. There are 11 classifications of Major Programs. These classifications are listed in C7.1.

3.3 FY 1992-97 PLANNING, PROGRAMMING AND BUDGETING

The most recent cycle of the Planning, Programming and Budgeting System (PPBS) began in 1992, and will develop a program for the years FY 1996 through FY 2001. The flow of the programming process is depicted in Exhibit 3-1. Programming and budgeting for this cycle will culminate with submission of a two-year budget request to Congress for FY 1996 and FY 1997 in January 1995. The previous cycle was in its final stages in the Fall of 1992, and culminates with the submission of a two-year budget request to Congress for FY 1994 and FY 1995 in January 1993. The major processes and documentation scheduled in the FY 1996-2001 cycle include:

Navy Program Planning (July 1992 - December 1993)

- POM Serials
- Revised Joint Mission Area and Support Area Assessments and Investment Balance Review

- Baseline Assessments
- Integrated Priority List (IPL)
- Resources and Requirements Review Board discussions
- FY 95 Fiscal Guidance
- Sponsor Change Proposal (SCP) (Spring '93)

OSD Planning (February - November 1993)

- National Military Strategy Document
- Defense Planning Guidance

Navy Programming (December 1993 - July 1994)

- DON Consolidated Planning and Programming Guidance (DNCPPG) (Dec. '93)
- Programming and Fiscal Guidance (Jan. '94)
- Sponsor Program Proposals (Feb. '94)
- Sponsor Program Proposal Documentation (Feb. '94)
- Post-SPP Program Assessments (Mar. '94)
- Sponsor Pre-Briefs
- Program Objectives Memorandum (April '94)

OSD Program Review

- Chairman's Program Assessment (CPA)
- Program Decision Memorandum (PDM)

Budget Formulation (June 1994 - January 1995)

- Program Budget Decisions
- Major Budget Issues

3.3.1 Navy Program Planning. Navy Program Planning encompasses an initial round of Joint Mission Area (JMA) and Support Area (SA) Assessments and Investment Balance Review. After presentation of the JMA and SA Proposals, the Resources and Requirements Review Board (R³B) will conduct meetings to discuss the Investment Balance Review proposals. This

process commences in late 1992 and will continue through late 1993. Navy Program Planning is completed and Programming begun with the development and issuance in December 1993 of the DON Consolidated Planning and Programming Guidance by the SECNAV and of the Program and Fiscal Guidance.

3.3.2 OSD Planning. OSD planning begins with the issuance of the President's national security objectives and policies. The Chairman of the Joint Chiefs of Staff produces a fiscally constrained military strategy for review by the President. The Defense Planning Guidance (DPG) is drafted by OSD and commented upon by officials throughout the Department; then is revised as necessary and is issued by the Secretary of Defense. Fiscal guidance for POM formulation is also issued.

3.3.3 Navy Programming. Navy Programming commences upon the issuance of the DPG, the DON Consolidated Planning and Programming Guidance, and the Program and Fiscal Guidance. It includes Sponsor Program Proposals, program assessments, etc., and results in the submission of the Program Objectives Memorandum (POM).

3.3.4 OSD Program Review. The OSD Program Review provides an opportunity within the PPBS process for senior leadership (Defense Planning Resources Board) to review the results of program and policy initiatives and to assess the effectiveness of past problem solutions. The program review will focus on the contents of the Program Objectives Memorandum (POM):

- What capabilities are they providing?
- Are the capabilities consistent with the DPG and other guidance?
- What future changes in capabilities can be expected?

Findings from the program review will influence the future Defense program and the content of the PDM and will identify needs for special studies and lead to new directions for current efforts.

3.3.5 Budget Formulation. Upon completion of the POM submission, the Navy immediately begins development of a detailed budget based thereon. An internal Navy budget review is completed by August 1994, incorporating the results of the internal review and OSD direction in the PDM. Following an OSD review of the proposed budget and approval by the President the final budget amounts and supporting data are submitted to the Congress in January 1995.

3.4 PRINCIPAL DOCUMENTS FOR PROGRAMMING AND BUDGETING

A brief description of the principal documents used in the PPBS to update the Future Years Defense Program (FYDP) is provided below.

3.4.1 POM Serials. These memoranda form a set of instructions establishing Navy procedures for participation in the planning and programming processes of DOD. They are issued by the Director, Programming Division (N80), under the direction of the Chief of Naval Operations. The memoranda encompass CNO programming and fiscal guidance as well as procedural guidance. For the FY 1996-2001 PPB cycle they are numbered commencing with POM 96-1.

3.4.2 Joint Mission Area (JMA) and Support Area (SA) Assessments. The JMA and SA Assessments are intended to provide an overview of the current Navy structure. They are developed and defined through a series of special Process Action Team meetings. These Mission Areas will be the cornerstones of the POM process, replacing the "Warfare Area" and "Pillar" breakdowns of the Navy data-base as building blocks. The adoption of Joint Mission Areas will also move Navy POM development and analysis towards the organization and process used in the Joint Staff offices. The six Joint Mission Areas and two Support Areas are as follows:

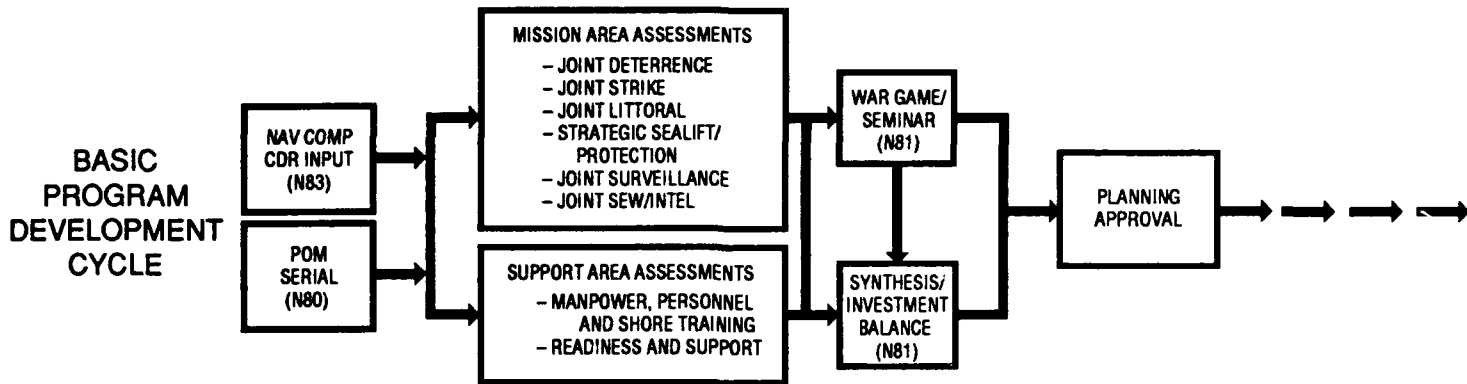

POST-ELECTION BUDGET REVISION	<ul style="list-style-type: none"> N83 COLLECTS COMPONENT CDR INPUT N80 ISSUES POM SERIAL TO DEFINE PROCESS AND SET SCHEDULE 	<ul style="list-style-type: none"> MACRO LOOK TO IDENTIFY NEW NEEDS INITIAL TEST OF TEAM CONCEPT 	<ul style="list-style-type: none"> SEMINAR EVALUATES MISSION AREAS IN ONE SCENARIO, FOCUS ON TECHNOLOGY/SENSORS, NOT PLATFORMS SYNTHESIS OF INDIVIDUAL AREA REVIEWS 	PLANNING DECISIONS TO GUIDE DETAILED WORK BY RSs: $R^3B \rightarrow CNO$ \uparrow PRCC
(DATES)	08 SEP 92	OCT - NOV 92	NOV - DEC 92	TBD
FY93 PROGRAM REVIEW	<ul style="list-style-type: none"> N83 COLLECTS COMPONENT CDR INPUT N80 ISSUES POM SERIAL TO DEFINE PROCESS AND SET SCHEDULE 	<ul style="list-style-type: none"> MORE INDEPTH LOOK AT JOINT MISSION AREAS PRIORITIES DEVELOPED 	<ul style="list-style-type: none"> N81 WAR GAME SYNTHESIS OF INDIVIDUAL AREA REVIEWS 	PLANNING DECISIONS TO GUIDE DETAILED WORK BY RSs: $R^3B \rightarrow CNO$ \uparrow PRCC
(DATES)	JAN 93	JAN - MAR 93	MAR 93	MAR - APR 93
POM 93	<ul style="list-style-type: none"> N83 COLLECTS COMPONENT CDR INPUT N80 ISSUES POM SERIAL TO DEFINE PROCESS AND SET SCHEDULE 	INDEPTH LOOK AT ALL AREAS DRAWING ON 2 PREVIOUS EFFORTS	<ul style="list-style-type: none"> N81 WAR GAME CONDUCTED N81 BALANCES INVESTMENT ACROSS ALL AREAS 	PLANNING DECISIONS TO GUIDE SPP BUILD: $R^3B \rightarrow CNO$ \uparrow PRCC
(DATES)	AUG 93	SEP - OCT 93	NOV 93	NOV 93

RESOURCES AND REQUIREMENTS REVIEW BOARD (R³B): (see E9.7.1)

N8(CHAIR), N80, N81, N82, N83, N84, N85, N86, N87, N88, N1B, N2B, N4B, N6B, N096 R&P, SYSCOMs, CNA

PROGRAM REVIEW AND COORDINATING COMMITTEE (PRCC): (see E9.7.2)

N80(CHAIR), N1B, N2B, N3/5B, N4B, N7B, N81, N82, N83, N84, N85, N86, N87, N88, N093B, N095B, N0986, N09B, R&P, SYSCOMs, PDASNs, OPA, NCS

DON PROGRAM STRATEGY BOARD (DPSB): (see E9.11)

SECNAV, CNO, CMC, USN, ASNs, N8, N80, N82, N83, OPA, R&P

Exhibit 3-1 — Basic Program Development Cycle (pt. 1)

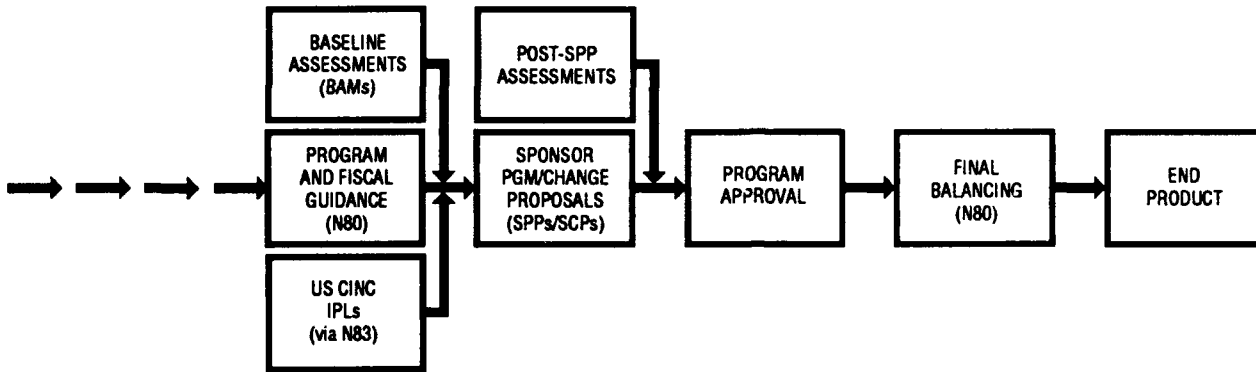

<ul style="list-style-type: none"> N80 DEV ELOPS PROGRAM AND FISCAL GUIDANCE WHICH REFLECTS PLANNING DECISIONS NO BAMs NO IPLs 	<ul style="list-style-type: none"> RSs DEVELOP SCPs TO MEET TOP LINE TOA NO POST-SPP ASSESSMENTS 	$R^3B \rightarrow CNO$ $\uparrow \quad \downarrow$ PRCC DPSB	N80 COLLATES CHANGES TO BUDGET SUBMISSION	NAVY BUDGET REDUCTION TO NAVCOMPT/OSD(C)
TBD	TBD	TBD	TBD	TBD
<ul style="list-style-type: none"> N80 DEV ELOPS PROGRAM AND FISCAL GUIDANCE WHICH REFLECTS PLANNING DECISIONS MINI- BAMs NO IPLs 	<ul style="list-style-type: none"> RSs DEVELOP SCPs TO REFLECT PROG CHANGES MINI POST-SPP ASSESSMENTS 	$R^3B \rightarrow CNO$ $\uparrow \quad \downarrow$ PRCC DPSB	N80 COLLATES CHANGES TO FY95 BUDGET	FY95 PROGRAM ADJUSTMENT TO NAVCOMPT
APR 93	APR- MAY 93	MAY 93	MAY 93	JUN 93
<ul style="list-style-type: none"> N80 DEV ELOPS PROGRAM AND FISCAL GUIDANCE WHICH REFLECTS PLANNING DECISIONS BAMs IPLs 	<ul style="list-style-type: none"> RSs DEVELOP SCPs POST-SPP ASSESSMENTS COMPLETED 	$R^3B \rightarrow CNO$ $\uparrow \quad \downarrow$ PRCC DPSB	N80 COMPLETES FINAL PRICING AND BALANCING ADJUSTMENTS	POM-96 TO NAVCOMPT AND OSD
DEC 93	DEC 93 - FEB 94	FEB - MAR 94	MAR 94	APR 94

BAM = BASLINE ASSESSMENT MEMORANDUM
 CDR = CRITICAL DESIGN REVIEW
 CNA = CENTER FOR NAVAL ANALYSES

DPSB = DoD PROGRAM STRATEGY BOARD
 INTEL = INTELLIGENCE
 IPL = INTEGRATED PRIORITY LIST
 PDASN = PRINCIPAL DEPUTY ASN

POM = PROGRAM OBJECTIVES MEMORANDUM
 PRCC = PROGRAM REVIEW AND COORDINATING COMMITTEE
 RS = RESOURCE SPONSOR

SCP = SPONSOR CHANGE PROPOSAL
 SEW = SPACE AND ELECTRONIC WARFARE
 SPP = SPONSOR PROGRAM PROPOSAL
 TOA = TOTAL OBLIGATION AUTHORITY

Exhibit 3-1 — Basic Program Development Cycle (pt. 2)

3.4.3

1. *Joint Strike*
2. *Joint Littoral Warfare*
3. *Joint Surveillance*
4. *Joint SEW/Intelligence*
5. *Joint Deterrence*
6. *Strategic Sealift/Protection*

1. *Readiness and Support and Infrastructure*
2. *Manpower, Personnel and Shore Training*

The JMA and SA assessment process, along with an Investment Balance Review, will be an ongoing process that continues throughout the planning and programming cycle. The Resource and Requirements Review Board (R³B) meetings are chaired by the Deputy Chief of Naval Operations for Resources, Warfare Requirements and Assessments (N8). This assessment/review process takes the place of the Warfare Appraisals, Summary Warfare Appraisal, and Readiness and Sustainability Appraisal.

3.4.3 Investment Balance Review (IBR). The IBR is conducted by the Assessment Division of the Deputy Chief of Naval Operations for Resources, Warfare Requirements and Assessments (N81) and is intended to provide a process to continually review and update key philosophical issues facing the Navy as they relate to the specified Joint Mission Areas and Support Areas. It will address overarching issues affecting the JMA and SA and key Navy capabilities and tradeoffs required with fiscal and other real-life constraints to combine assessment results into one complete Navy investment strategy.

3.4.4 Baseline Assessments. Baseline Assessments identify the minimum essential resources required to support a specific program or set of programs at a stated force level. They support program development by providing Resource Sponsors with rational baseline costs for projected force levels and by identifying support needs for particular programs. They provide a benchmark for determining the adequacy of resource allocation in Sponsor Change and Program Proposals (SCPs/SPPs).

3.4.5 Integrated Priority List (IPL). The IPL will be submitted by the Unified Commanders in the Fall of 1993 and will be the primary vehicle for input of their concerns into the development of the Program Objectives Memorandum (POM). Component Commanders will prepare point papers giving a programmatic focus to the IPLs. Official feedback will be provided to the Unified and Component Commanders documenting Navy response in the POM to their concerns.

3.4.6 Sponsor Change and Program Proposal (SCP/SPP). The SCPs and SPPs adjust the baseline FYDP to bring resource sponsor programs into compliance with CNO and higher level fiscal guidance. During the FY 1996-2001 PPBS cycle, SCPs will be prepared early in the cycle and in Spring 1993. SPPs will be prepared for the development of POM (December 1993 - February 1994).

3.4.6.1 Sponsor Program Proposal Documentation. The Sponsor Program Proposal Documentation (SPPD) highlights major changes to the resource sponsor's program in his SPP, and documents his response to fiscal and program guidance, baseline assessments, and inputs from CINCs/Component Commanders and Budget Submitting Offices.

3.4.7 Post-SPP Program Assessments. The Post-SPP Program Assessments will analyze the degree to which the SPP funding meets guidance and achieves the required program balance. Assessments are to be performed in such areas as manpower, personnel and training; logistics; ship maintenance/ modernization; physical security; and research, development and acquisition.

3.4.8 DON Consolidated Planning and Programming Guidance (DNCPPG). The DNCPPG states the decisions of SECNAV and CNO with respect to priorities and programming principles to be used in the development of the POM. Its issuance concludes the Navy Program Planning phase of the PPBS and begins the Programming phase. Development of the

DNCPPG in the Fall of 1993 will be based upon consideration of the continuing JMA and SA Assessments and Investment Balance Review process and of the CINC/Component Commander inputs. Issuance is scheduled for December 1993.

3.4.9 Program and Fiscal Guidance. Following the IBR, N8 publishes program guidance to the Resource Sponsors directing them to incorporate IBR decisions into their SPPs. Accompanying the program guidance is fiscal guidance establishing tentative sponsor "toplines," i.e., the allocation of total Navy resources among sponsors.

3.4.10 National Military Strategy Document (NMSD). The NMSD is developed by the Chairman of the Joint Chiefs of Staff (CJCS) for use in preparing the Defense Planning Guidance (see 3.4.11). It is a comprehensive military appraisal of the worldwide threat to United States interests and objectives, and includes recommended military objectives and strategies to achieve national goals.

3.4.11 Defense Planning Guidance (DPG). The DPG is the basic planning document upon which all Defense programming is based. It includes policy, strategy, force planning, planning scenarios, and discussions of major issues requiring top management attention. The DPG for the FY 1996-2001 PPBS cycle is developed in consultation among the SECDEF, the CJCS (see discussion of the NMSD in 3.4.10), the Service Secretaries, and the unified and specified commanders

3.4.12 Program Objectives Memorandum (POM). The POM is the document in which each military department and Defense Agency recommends and describes its total program within the resources and policy parameters specified by the DPG (see 3.4.11). It will provide the Department force level objectives approved by SECNAV for the six years of the FY 1996-2001 PPBS cycle and will describe major system new starts and significant base or force structure

changes for the ten year period beyond the year of the POM. Resource levels are similarly projected for six years (personnel, procurement, research and development, and operational programs). The POM is scheduled to be submitted to OSD on 1 April 1994.

3.4.13 Chairman's Program Assessment (CPA). The CPA is a risk assessment by the CJCS of the composite force recommendations in the POMs (see 3.4.12) submitted by the Services and Defense Agencies. It is a major input in the Defense Planning Resources Board (DPRB) consideration of the POM submissions and associated issues which leads to the issuance of the Program Decision Memorandum (PDM) (see 3.4.14).

3.4.14 Program Decision Memorandum (PDM). The PDM records SECDEF decisions on the POM (see 3.4.13) and forms the basis for the development of the budget request to Congress.

3.4.15 Program Budget Decision (PBD). OSD segregates the Service budgets into discrete segments for purposes of review and decision. A PBD is prepared by the OSD staff to provide SECDEF with an analysis of the funding and program in each of these segments along with one or more alternative recommendations. When approving a PBD, SECDEF selects the Service position or a staff alternative. The PBD highlights problems with program milestones or funding and permits SECDEF to examine DOD programs prior to meeting with the President and the Director of the Office of Management and Budget (OMB) to resolve final levels of Defense spending.

3.4.16 Major Budget Issues (MBI). MBI are identified by the Service Secretaries at the conclusion of the PBD review (see 3.4.15) and are discussed by SECDEF and the Service Secretaries at a special meeting provided for their resolution. Issues are restricted to those which have significant impact on the Services.

SELECTED REFERENCES ON THE PROGRAMMING PROCESS

Department of the Navy Programming Manual provides a broad overview of the PPBS process while its numerous appendixes and annexes contain detailed procedural guidance and reference information. It is currently out-of-date but still useful for definitions, etc.

DOD Instruction 7045.7, "Implementation of the Planning, Programming, and Budgeting System (PPBS)" establishes Navy responsibilities for processing and maintaining documents, records and reports for the DOD programming system. DOD Instruction 7045.7 provides procedural guidance for processing changes to the FYDP, for review, analysis and approval of new programs,

for maintaining and updating of the program structure.

DOD Directive 7045.14 establishes policy, procedures, and responsibilities for the PPBS system.

SECNAV Instruction 5000.16, "Department of the Navy Planning, Programming, and Budgeting System (PPBS)," establishes responsibilities of Navy organization in FYDP-related processes.

POM-(FY)-1, "Program Objective Memorandum Procedures for POM-(FY)" is the primary source for POM preparation information. It is issued each year by the Director, Programming Division (N80).

NOTE REGARDING DIRECTIVE NUMBERS

References to directives within this Guide are by series only; e.g., 3900.14, not to the effective edition within the series; e.g., 3900.14A

The "Master Reference List" indicates the version and issue date of each directive used in preparation of this edition of the Guide.

For recent information on the effective directive within a series, consult the "Department of the Navy Directives Issuance System: Consolidated Subject Index," (NAVPUBNOTE 5215).

Chapter 4
BUDGET PREPARATION AND JUSTIFICATION

TABLE OF CONTENTS

4.1	Place and Importance of Budgeting in the Management Process	4-1
4.2	Budgeting Terms and Concepts	4-1
4.3	Budgetary Structure	4-2
4.3.1	Appropriations	4-2
4.3.2	Budget Activities	4-2
4.3.3	Purpose of Appropriation Structure	4-2
4.4	The Budgetary Process	4-2
4.4.1	Biennial Budgeting	4-3
4.4.2	“Balanced Program”	4-3
4.4.3	Incremental Programming Policy	4-3
4.4.4	Justification and Appeal	4-3
4.4.5	Function and Source of Guidance	4-4
4.4.5.1	Procedural guidance	4-4
4.4.5.2	Substantive guidance	4-4
4.4.6	Congressional Budget and Impoundment Control Act of 1974 (PL93-344)	4-4
4.4.6.1	Concurrent Resolution	4-4
4.4.7	Research and Development Descriptive Summary (RDDS) (Form RD-5)	4-5
4.5	Supra-Navy Participants in the RDT&E Budgetary Process	4-5
4.5.1	Congress	4-5
4.5.2	The President	4-5
4.5.3	Office of Management and Budget (OMB)	4-5
4.5.4	Secretary of Defense (SECDEF)	4-6
4.6	Navy Participants in the R&D Budget Process	4-6
4.6.1	Secretary of the Navy	4-6
4.6.2	Navy Comptroller	4-6
4.6.3	Assistant Secretary of the Navy for Research, Development, and Acquisition	4-6
4.6.4	Chief of Naval Operations	4-6
4.6.4.1	Deputy Chief of Naval Operations for Resources, Warfare Requirements, and Assessments	4-6
4.6.4.2	Director, Test and Evaluation and Technology Requirements (N091)	4-7
4.6.5	Commandant of the Marine Corps	4-7
4.6.6	Chief of Naval Research	4-7

4.7	Justifying the Budget Before Congressional Committees	4-7
4.7.1	Guidelines for a Congressional Committee Witness	4-8
4.7.2	Hearing Preparation	4-8
4.7.3	Conduct of Hearing	4-9
4.7.4	Review and Editing the Transcript	4-9
4.7.5	Heartburns and Appeals	4-9
4.8	Late Appropriations	4-9

Chapter 4

BUDGET PREPARATION AND JUSTIFICATION

This chapter covers the development, presentation and justification of the budget, a process beginning more than 17 months before the start of the fiscal year and extending to passage of the Appropriation Acts.

This chapter concerns the objectives and mechanism of the RDT&E budgetary process, as well as the responsibilities of various executives and agencies involved in its development. The chronology of budget events carries a note of caution: no two years are ever exactly alike. The process of Congressional justification will be covered subsequently.

4.1 PLACE AND IMPORTANCE OF BUDGETING IN THE MANAGEMENT PROCESS

In the budget formulation process programs must compete for approval and implementation. Just as plans are meaningless unless they are approved for inclusion in the Future Years Defense Program (FYDP), programs are not valid until they achieve inclusion in the budget. In this continuous process, plans are translated into programs and programs are incorporated into budget items on a selected basis.

A program's appearance in the FYDP is not a guarantee that it will be funded because some programs normally are reduced or deleted when the budget is formulated. Programs may be adjusted or omitted to reduce the overall Defense or Federal budget, provide for other programs of higher priority or offset increased costs of other programs in the budget.

After approval, the budget becomes the framework for day-to-day management. The First Hoover Commission emphasized this in 1949 when it stated: "The budget and appropriation process is the heart of management and control of the executive branch."

4.2 BUDGETING TERMS AND CONCEPTS

Knowledge of the following terms and concepts is essential for an understanding of the budget process.

Budget—A planned program for a fiscal period in terms of a) estimated costs, obligations, and expenditures, b) source of funds for financing, including reimbursements anticipated and other resources to be applied, and c) explanatory and workload data on the projected programs and activities.

Mark-up—The process of modifying budget submissions; reducing, increasing, revising or eliminating items; and providing guidance resulting from the review process.

Reclama—A request for reversal of all or part of a budget mark made by a higher review level.

Appeal—Alternative term for reclama. The term appeal is used primarily during the congressional review phase.

Appropriation—An annual Act of Congress making specific funding authority available for specified purposes and to make payments out of the Treasury. Appropriations vary in the length of time the funds remain available for obligation.

4.3

Annual appropriations are available for only twelve months; multiyear appropriations for a definite period of two or more years; continuing or "no-year" appropriations are available until expended. The RDT&E,N appropriation is available for obligation for 24 months.

Project Listing—A display of an entire DON RDT&E Program by program elements, budget projects and associated dollars. It is used to support budget submissions to NAVCOMPT, OSD, OMB, and the Congress; and for POM submissions and apportionment requests.

*DON Programming Manual, Annex 4,
Part B*

NOTE: The DON Programming Manual contains extensive information, most of it now out of date. For some purposes, such as definitions, it is still useful.

4.3 BUDGETARY STRUCTURE

*FY 92 Cong. Appropriations Conference
Rpt.*

4.3.1 Appropriations. Congress appropriates Defense funds for a given fiscal year in an Appropriation Act, of which the principal seven subdivisions are:

- Title I: Military Personnel
- Title II: Operation and Maintenance
- Title III: Procurement
- Title IV: Research, Development, Test and Evaluation (RDT&E)
- Title V: Defense Business Operating Fund (DBOF)
- Title VI: Other DOD Programs
- Title VII: Related Agencies

4.3.2 Budget Activities. The Congressional Budget and Impoundment Control Act of 1974 (see

4.4.6) requires that budget submissions contain a presentation of "a detailed structure of national needs." Accordingly, mission-oriented budget activities have supplanted the hardware-oriented budget structure into which the RDT&E,N appropriation previously was classified. RDT&E budgets now are divided for Congressional presentation into the following budget activities:

- 1 Technology Base
 - 2 Advanced Technology Development
 - 3 Strategic Programs
 - 4 Tactical Programs
 - 5 Intelligence and Communications
 - 6 Defense-wide Mission Support.
-

*Ref.: DON Budget Guidance Manual
(NAVCOMPT 7102.2); NAVCOMPT
Manual (NAVSO P-1000-7, Vol. 7,
Chap. 074401)*

4.3.3 Purpose of Appropriation Structure. The appropriation structure provides the Congress a convenient means of correlating the RDT&E appropriation with various procurement appropriations. The structure also identifies the dollars relating to the major missions of the Navy. The budget presents the Congress with line items, at the program element level, comprising the programs for the ensuing or budget year.

4.4 THE BUDGETARY PROCESS

Programs in the POM submission (FYDP) are revised for Budgetary submission to reflect fiscal constraints, changes in threat assessment, Congressional action and so forth. Upon approval, this Budget submission reflects the decisions of SECDEF. The revised programs then are converted to the appropriation structure, consisting of the four-year period of the previously approved prior and current years and the two years being submitted for approval, to be presented in the budget and is supported by detailed lists of

items and dollars. Items including production schedules, prices, leadtime, activity rates, personnel grade structure and training requirements, among others, are required for the program proposed for budget inclusion.

4.4.1 Biennial Budgeting. Navy budgets are now prepared and submitted on a biennial basis, a change from the annual budgets prepared in past years. A complete set of budget-quality estimates is required for both budgeted fiscal years for all appropriations and accounts.

Each biennial budget cycle consists of a budget submission, supporting both fiscal years of the biennial cycle, followed by an apportionment review, which focuses on the second year. The apportionment review is the process of submission and review of updated estimates in anticipation of the allocation of funds.

Normally, under the biennial budgeting concept, preparation of the budget submission assumes completion of the DON POM. The programmatic adjustments contained in the POM normally form the basis for the budget estimates submitted for the DON budget review. Apportionment estimates are based on programs contained in the President's Budget submission, as amended.

4.4.2 "Balanced Program." A budget which provides optimum value for a given level of expenditure, i.e., "the best bang for the buck" is in a balanced condition. In other words, it is a condition in which all requirements identified in official guidance and included are adequately funded, no item being included which is less essential than any of the items excluded from the budget. To approach this ideal goal, program options must be evaluated carefully, and items competing for budget inclusion compared.

This list of requirements is reviewed by the next, higher organization which brings the list into balance by reducing or eliminating items considered marginal. This process is repeated through the various DOD and Congressional levels

until the Congress balances Defense requirements against other national needs.

4.4.3 Incremental Programming Policy. The Incremental Programming Policy's objective is to ensure that RDT&E,N effort be funded in increments coincident with the government fiscal year and that budget estimates be formulated accordingly. It is Navy policy to program and fund RDT&E work on an *annual incremental* basis instead of on a Procurement Appropriation's *fully funded* program basis.

*Ref.: NAVCOMPT Manual, Volume 7,
Chapter 074500*

4.4.4 Justification and Appeal. Justification is an integral part of the "Balanced Program" process (see 4.4.2). Each item in the budget estimate must be supported by written justification. The justification information both supports the inclusion of the proposed item and gives sufficient data to the next level of review authority concerning the details of the estimates to enable the reviewer to justify the item's inclusion to subsequent authority.

Budget justification demonstrates that the proposed item and its estimate is:

- Within the law and meets approved administrative guidelines.
- Essential to the effective performance of the assigned mission.
- The most economical and effective option to accomplishing its purpose.
- Feasible in terms of timing and the availability of resources.

"Appeal" is related closely to justification and mark-up (see 4.2). Appeal has a vital role in the process of attempting to achieve a "Balanced Program." The appeal aims at reversing a higher authority's mark-up of an item. A successful appeal usually requires improved justification making it possible to save worthwhile programs

4.4.5

earlier eliminated because of inadequate supporting information. Appeal instructions are usually provided by official guidance.

4.4.5 Function and Source of Guidance. Procedural and substantive "guidance" plays an important part in budget preparation.

4.4.5.1 Procedural guidance. Uniformity is essential for automated data processing equipment (ADPE) to summarize submissions from diverse organizations. One of the duties of the Comptroller of the Department of Defense is to establish "uniform terminologies, classifications and procedures" for use in all budgeting and accounting matters.

The means for presenting budget estimates is directed by higher authority. Justification material is required by the Office of Management and Budget (OMB) and is used to support budget estimates at each review level.

Budget Schedules and narrative are required by OMB in preparing Appendixes to the printed Federal budget. Backup Material is required by DOD COMPT. Annex Material is required by NAVCOMPT concurrent with his review. Budget Summary Table feeder data are required by NAVCOMPT for budget consolidation and publication and for use by Navy witnesses before Congress. The Office of Naval Research, in performing fiscal responsibilities as assigned by ASN(RD&A), issues procedural guidance for submission of RDT&E budgetary data by various Navy commands and offices.

*Ref.: DON Budget Guidance Manual
(NAVCOMPT 7102.2)*

4.4.5.2 Substantive guidance. Biennially, the Secretary of Defense issues the Defense Planning Guidance (DPG). The DPG is SECDEF's primary long-range planning document. It outlines national policy and military strategy themes. It is accompanied by fiscal

guidance to define the total financial constraints within which the DOD force structure will be developed and reviewed. Broad guidance from higher levels is translated into increasingly specific guidelines at lower levels. Another source of guidance is Congressional expressed and implied intent as stated in hearings on the authorization and appropriation requests and in reports accompanying the bills reported out by the various committees.

Ref.: DOD Instruction 7045.7

4.4.6 Congressional Budget and Impoundment Control Act of 1974 (PL93-344). Public Law 93-344 made extensive and important changes in the Federal Budget process. These include: (1) moved the start of the fiscal year from 1 July to 1 October; (2) created a Budget Committee in each House; (3) created the Congressional Budget Office; (4) required estimates of the President's budget for the budget year plus four additional years; (5) provided for "year ahead" authorization requests; (6) established a requirement for two Congressional concurrent resolutions; and (7) established the principle of the "Current Services" budget to be submitted by the President in advance of the annual request for new budget authority. In addition, the Act states:

The Budget ... shall contain a presentation of budget authority, proposed budget authority, outlays, proposed outlays, and descriptive information in terms of: 1) a detailed structure of national needs which shall be used to reference all agency missions and programs; 2) agency missions; and 3) basic programs.

To the extent practicable, each agency shall furnish information ... in support of its budget requests in accordance with its assigned missions in terms of Federal functions and subfunctions, including mission responsibilities of component organizations, and shall relate its programs to agency missions.

4.4.6.1 Concurrent Resolution. The Balanced Budget and Emergency Deficit Control

Act of 1985 (PL 99-177) (Gramm, Rudman, Hollings) replaced the two concurrent resolutions of the 1974 Act with a single concurrent resolution, due on 15 April, which establishes target amounts for the major functional categories; e.g., Defense, General Science, International Affairs, on the basis of which the authorizing and appropriating legislation is developed.

4.4.7 Research and Development Descriptive Summary (RDDS) (Form RD-5). The RDDS provides concise justification for each RDT&E program element. Each RDDS is to be a "stand alone" document covering purpose, structure, and activities to be funded. Originally strictly a budget back-up document for Congress, the RDDS now supports the POM, the DON budget and the President's budget. Individual RDDS are prepared by the Program Manager and submitted through the chain of command for collation into the overall RDDS document.

Ref.: DON Budget Guidance Manual (NAVCOMPT 7102.2); amplifying instructions are provided by the RDT&E, Navy Budget Submitting Office for each budget submission

4.5 SUPRA-NAVY PARTICIPANTS IN THE RDT&E BUDGETARY PROCESS

4.5.1 Congress. Article I of the United States Constitution assigns to the Congress the responsibility to "provide for the common defense" and to "provide and maintain a Navy." Section 9, Clause 7 of this Article further provides that "no money shall be drawn from the Treasury, but in consequence of appropriations made by law." In carrying out these responsibilities, Congress takes a keen interest in the content of military programs and their costs. Budget estimates are considered by the Armed Services Committees and the Appropriations Committees of both the House of Representatives and the Senate,

which hold formal hearings with OSD and Service representatives. The Armed Services Committees are responsible for preparing *authorizing* legislation to establish or renew programs and set funding ceilings; the Appropriations Committees are responsible for *appropriating* the funds. Full Congressional action is required to obtain an increase in authorization for a particular fiscal year once the authorization has been enacted.

The Budget Committees of the House and Senate, created by the Congressional Budget and Impoundment Control Act of 1974 (see 4.4.6), receive information from the standing committees of their respective Houses, including the Armed Services and Appropriations Committees, regarding required budget outlays and other fiscal matters falling within the jurisdiction of each. Based on this information, they draft and report to their Houses the required concurrent resolution (see 4.4.6.1). The Budget Committees are assisted in this process by the Congressional Budget Office (CBO), also established by the Act. The CBO is authorized by the Act to request (and receive) necessary information both from Congressional committees and from the Executive Branch.

4.5.2 The President. The President is responsible for presenting an Executive Budget to Congress. The President, through the OMB, reviews, revises, and approves the estimates of all departments and agencies. When consolidated, these estimates become a complete government-wide financial plan for the following fiscal year. The President is responsible for the integrity and validity of the estimates contained in the Executive Budget. By law (Budget and Accounting Act of 1921), no official of an executive department or agency may take any action or volunteer any opinion that is contrary to official budget policies as expressed by the President in his budget, except through proper official channels (see 4.7.1).

4.5.3 Office of Management and Budget (OMB). The OMB assists the President in preparing the budget and formulating the

4.5.4

Government's fiscal program. It also supervises and controls the administration of the budget.

Ref.: United States Government Organization Manual

4.5.4 Secretary of Defense (SECDEF). The Secretary of Defense participates actively in the budgetary process. Either the Secretary or his deputy issues all Program Budget Decisions (PBDs) reflecting major budgetary decisions. SECDEF also plays a major role in the justification of the budget before Congressional committees.

SECDEF is assisted in carrying out budgetary responsibilities by various officials and organizations discussed in Appendix E. They include: USD(A) (see E1.1), DOD Comptroller (see E1.4), ASD(PA&E) (see E1.5) and the Defense Planning and Resources Board (see E9.4).

4.6 NAVY PARTICIPANTS IN THE R&D BUDGET PROCESS

The development and justification of the Navy's budget for research, development, test and evaluation is a sequential and iterative process. Eight senior DON executives play major roles in this process.

*Ref.: SECNAV Instruction 5400.15;
OPNAV Instruction 5430.48*

4.6.1 Secretary of the Navy. The Secretary of the Navy (SECNAV) is responsible for preparing and submitting the Navy budget to the Secretary of Defense, the Office of Management and Budget (OMB) and the Congress. SECNAV is assisted in carrying out these duties by Navy Department operations, R&D and finance executives.

4.6.2 Navy Comptroller. Reporting to the SECNAV, and subject to policies of the DOD

Comptroller, the Navy Comptroller (NAV-COMPT) develops and establishes Navy Department fiscal principles and policies. He also prescribes procedures regarding budget preparation and administration, financial management and accounting, auditing, disbursing and reporting. NAVCOMPT assists the SECNAV by translating Navy and Marine Corps policies, plans and programs into the formal budget for presentation to SECDEF, the OMB and to the Congress. The NAVCOMPT also issues binding guidance to the various Commands and Offices concerning the forms and contents for submitting budget estimates and supporting data, and on the availability of funds and the purposes for which they may be spent.

4.6.3 Assistant Secretary of the Navy for Research, Development, and Acquisition. The Assistant Secretary of the Navy for Research, Development, and Acquisition (ASN(RD&A)) functions as the DON Acquisition Executive, as the Navy Senior Procurement Officer, and as the Senior DON Information Resource Management Official. The ASN (RD&A) represents the DON to DOD and Congress in matters related to acquisition policy and programs. The ASN(RD&A) establishes policy and procedures and manages all research, development, and acquisition.

4.6.4 Chief of Naval Operations. The Chief of Naval Operations (CNO) is responsible for determining and planning the material support needs of the Navy's operating forces, excluding those of the Marine Corps (see E3). The CNO acts as a principal advisor to SECNAV in the allocation of resources to meet Navy program requirements in the programming and budget processes. The CNO is responsible to determine and prioritize warfighting needs of the Navy and the requirements that must be met by the acquisition system to meet the needs.

4.6.4.1 Deputy Chief of Naval Operations for Resources, Warfare Requirements, and Assessments. The Deputy Chief of Naval

Operations for Resources, Warfare Requirements, and Assessments (N8) is responsible to ensure integration of planning, programming, budgeting, and appraisal within the Office of the CNO (see E3.7). This officer reviews programs, financial and manpower decisions, evaluates their impact on the total Navy activity, and recommends adjustments to restore desired balance. His Department of the Navy Program Information Center (DONPIC) is the primary OPNAV point of contact for program and budget matters .

4.6.4.2 Director, Test and Evaluation and Technology Requirements (N091). The Director Test and Evaluation and Technology Requirements carries out the responsibilities of the RDT&E,N appropriation sponsor. N091, with ASN(RD&A), CNR, and Commander, Marine Corps Systems Command, is a principal Navy witness before Congressional committees regarding RDT&E. N091 coordinates the preparation of appeals to Congressional budget markup actions and, within OPNAV, of testimony by DON officials before Congressional committees.

4.6.5 Commandant of the Marine Corps. The Commandant, Marine Corps (CMC) is responsible for determining and planning the material support needs of the Expeditionary Marine Forces, the Fleet Marine Forces Air Wings and other Marine activities. He is assisted by the Commander, MARCORSYSCOM, who assembles, integrates, prioritizes and coordinates the annual program, submitting it to the ASN(RD&A) and to the CNO for inclusion in the DON's Program and Project Listings of Navy and Marine Corps RDT&E Programs (see E6).

4.6.6 Chief of Naval Research. The Chief of Naval Research (CNR) assesses, promotes, coordinates and manages naval basic research, exploratory development, and advanced technology development. The Office of Naval Research (ONR) functions as the Budget Submitting Office and Responsible Office for the RDT&E,N appropriations.

The ONR Comptroller sets forth budget policies and procedures for the RDT&E,N program. In addition to providing budget preparation guidance and instructions to the various commands and offices, he coordinates preparation of budget estimates which, following review and approval of the ASN(RD&A), are submitted to the SECNAV, OSD, OMB and the Congress.

Ref.: SECNAV Instruction 5430.20

4.7 JUSTIFYING THE BUDGET BEFORE CONGRESSIONAL COMMITTEES

Following the President's Annual Budget Message, DOD budget estimates are sent to the Senate and House Armed Services and Appropriations Committees for review. Congressional review of the Defense portion of the President's budget is undertaken from the separate standpoints of authorization of programs and appropriation of funds. Authorizing legislation is prepared by the Senate and House Armed Services Committees, and appropriations legislation by the Defense Subcommittees of the Senate and House Appropriations Committees. The Congressional review process may involve hearings before these four committees and their appropriate subcommittees. The role of the Budget Committees primarily regards fiscal constraints. These committees were established by the Congressional Budget and Impoundment Control Act of 1974 (see 4.4.6). However, during the budget process the Budget Committees receive testimony, mostly of a general nature, both from the Service Chiefs and the DOD and Services' staffs. The Congressional Budget Office may request staff briefings of a more detailed nature on Defense programs.

For the RDT&E appropriation, the four committees receive a justification book containing R&D Descriptive Summaries (RDDS) and RDT&E Programs (R-1). The RDDS (see 4.4.7)

4.7.1

provide specific data on program elements and projects within each element.

Using this material, the committees conduct hearings to establish for the record the Services' position on major issues. Hearings on the RDT&E authorization are held by the R&D Subcommittee of the House Armed Services Committee. The recommendations of the full committee are acted upon by the full House. The Senate Armed Services Committee conducts its hearings in parallel with those of the House Committee, and the full committee reports recommendations on the Authorization Bill as passed by the House. Where there are differences between the bills passed by each body, the two committees meet in conference and arrive at an agreed joint position that is submitted to the two Houses for approval and enactment. The authorization as enacted establishes approved programs and recommends the maximum amount that may be appropriated by the Congress.

The procedure on the appropriation is similar in that the House Appropriations Committee generally acts first. The Defense Subcommittee holds hearings, and the full committee recommends an appropriation bill to the House. The Defense Subcommittee of the Senate Appropriations Committee holds hearings in parallel and recommends appropriate changes to the appropriations bill as passed by the House. Where differences exist between the Senate bill and the House bill, a conference meeting is held between representatives of each body, and a jointly agreed position is reported out.

Upon approval by both bodies and signature by the President, the bills become law.

Ref.: DOD Directive 5400.4; SECNAV Instruction 5730.5; NAVCOMPT Instruction 7121.3; Navy Witness Guide (NAVSO-3036)

4.7.1 Guidelines for a Congressional Committee Witness. A witness testifying on the budget before a Congressional Committee does so as a member of the Executive Branch supporting the "President's Budget." The witnesses are expected carefully to avoid volunteering views differing from the budget, either on or off the record. Direct questions must be answered frankly. However, should a witness feel compelled to express personal views inconsistent with the President's budget, the witness will emphasize that the President's judgment was reached from his overall perspective as head of the government and in view of overriding national policy. The witness should make clear that his personal comments are not to be construed as a request for additional funds.

Title 31, U.S. Code 1108 states the in part:

An officer or employee of an agency . . . may submit to Congress an appropriation estimate or request, a request for an increase in that estimate or request, or a recommendation meeting the financial needs of the government only at the request of either House of Congress.

It is imperative that Congressional Committee witnesses be thoroughly familiar and stay within the bounds of the foregoing Title 31 provision so that all testimony supports the President's budget.

4.7.2 Hearing Preparation. Preparation for hearings should assure that all members' questions may be answered using a minimum number of witnesses. Consequently, the few witnesses expected to provide the main testimony require extensive preparation.

Preliminary hearings liaison with the Appropriations Committees is the responsibility of NAVCOMPT, liaison with other committees is through the Navy's Office of Legislative Affairs. These contacts will determine areas of probable committee interest, estimates of hearings duration and, in some instances, specific questions which may be asked. Trends of prior hearings'

questioning may justify special preparation in certain areas. This is particularly true of questions developed in the hearings of other Services or of other Navy organizations. Current press or news articles may generate spontaneous questions for which the witness should be prepared. Thorough review of the previous years' testimony is mandatory.

Principal witnesses submit a prepared statement in advance of testimony. These statements receive careful Navy and OSD review prior to submission to the Committee; Committee receipt will be 48 hours before scheduled hearing.

4.7.3 Conduct of Hearing. The SECDEF and members of the Joint Chiefs of Staff testify on the overall program before the Authorization and Appropriations Committees. These are known as "Posture Hearings." The USD(A) is the principal DOD witness on RD&A programs before both Authorization and Appropriation Committees. The SECDEF may also testify at Appropriation Hearings.

The ASN(RD&A) is the principal witness concerning the DON RDT&E program and appropriation requests before both Authorization and Appropriation Committees. He is supported by the N091, COMMARCORSYSCOM, the CNR, the Navy's Oceanographer, and other senior advisors.

There is no rigid custom for the conduct of hearings, and the Committee Chairman may vary the procedure as he chooses. Generally, the principal witness provides a brief statement, submits a comprehensive statement for the record and responds to questions. Visual aids may be used to augment the prepared statement.

When a witness is not able to provide requested information or to respond adequately to a question the witness may request permission to "provide it for the record." The witness may request that sensitive or classified material be

bracketed in the transcript and not appear in the printed version.

4.7.4 Review and Editing the Transcript. Congressional Committees permit the witness to review and correct his testimony transcript. Corrections, however, are limited to grammar and obvious errors; the testimony's substance cannot be altered. "For the record" information is added in this process. Classified questions and testimony are bracketed, and do not appear in the printed version.

4.7.5 Heartburns and Appeals. "Heartburns" and "appeals" reclaims committee language or recommended program funding (see 4.2). "Heartburns" are those appeals of overriding importance.

Heartburns and appeals are submitted to the Authorization and Appropriation Committees in response to their actions on the Department's budget request. They must be in clear, concise, non-technical language, understandable by readers not familiar with the technology of the program.

*Ref.: DON Budget Guidance Manual
(NAVCOMPT 7102.2)*

4.8 LATE APPROPRIATIONS

In instances in which an appropriation has not been passed before the beginning of a fiscal year, the Congress normally passes a "continuing resolution" which permits agencies to spend at the lesser rate of (1) that achieved in the previous year or (2) that reflected in a prior action of Congress. During the period of operation under the continuing resolution, new starts, program buildup, and similar activities generally are not permitted.

SELECTED REFERENCES ON BUDGET PREPARATION AND JUSTIFICATION

OMB Circular No. A-11, "Instructions for the Preparation and Submission of Annual Budget Estimates." It is revised on a continuous basis.

SECNAV Instruction 5400.15, "Department of the Navy Research, Development, and Acquisition Responsibilities," assigns specific duties and responsibilities to the CNO, CMC, and SYSCOMS in implementing the ASN(RD&A) responsibilities.

DON Budget Guidance Manual (NAVCOMPT 7102.2) provides guidance for the preparation, submission and review of the budget estimates submitted to NAVCOMPT, OSD, OMB, and the Congress. Copies of this manual are provided to all

budget submitting offices, Appropriation and Resource Sponsors and other selected staff offices.

NAVCOMPT Instruction 7121.3, "Department of the Navy Annual Budget Hearings Before the Congressional Appropriations Committees; information for witnesses." In addition to useful information for witnesses, it also provides procedure for review of hearing transcripts prior to release.

Navy Witness Guide (NAVSO-3036). This guide is updated annually by the DON Office of Legislative Affairs.

NOTE REGARDING DIRECTIVE NUMBERS

References to directives within this Guide are by series only; e.g., 3900.14, not to the effective edition within the series; e.g., 3900.14A

The "Master Reference List" indicates the version and issue date of each directive used in preparation of this edition of the Guide.

For recent information on the effective directive within a series, consult the "Department of the Navy Directives Issuance System: Consolidated Subject Index." (NAVPUBNOTE 5215).

Chapter 5
EXECUTION OF THE RDT&E BUDGET

TABLE OF CONTENTS

5.1	Apportionment	5-1
5.1.1	Apportionment Request	5-1
5.1.2	RDT&E,N Apportionment Documentation	5-1
5.1.2.1	Apportionment (or Reapportionment) Schedule (DD Form 1105)	5-1
5.1.2.2	Investment Program/Fund Approval for Direct Obligation (SD Form 440)	5-2
5.1.2.3	RDT&E,N Budget Activity Allocations (NAVCOMPT Form 2058)	5-2
5.1.3	RDT&E,N Operating Budget Allocation Documentation (NAVCOMPT Form 2197)	5-2
5.1.4	Navy Actions Required by General Provisions	5-2
5.1.5	Administrating Deferrals	5-2
5.2	Obligation and Expenditure of Funds	5-2
5.3	Accounting for Research and Development	5-3
5.3.1	Objectives of R&D Accounting	5-3
5.3.2	Harmonizing Programming, Budgeting, and Accounting	5-3
5.3.3	Identification of RDT&E Costs	5-3
5.3.3.1	Expenses vs investments	5-4
5.3.3.2	Research and development cost definition	5-4
5.3.4	Distribution of Costs to Applicable R&D Projects	5-4
5.3.4.1	Defense Business Operating Fund	5-4
5.3.4.2	Operating budgets	5-4
5.4	Reprogramming	5-4
5.4.1	Reprogramming Procedures	5-6
5.4.2	Reprogramming Hearings	5-6
5.4.3	Reprogramming Reports	5-6
5.4.4	Internal Navy Reprogramming in RDT&E,N	5-6
5.5	Audits and Review	5-6
5.5.1	General Accounting Office	5-6
5.5.2	Navy Audit Program	5-7

Chapter 5 EXECUTION OF THE RDT&E BUDGET

The previous chapter described the RDT&E budget process from its initial preparation until its approval as part of the annual Appropriation Act by Presidential signature. This process requires more than 18 months to complete. This is not the conclusion of the budgetary activity. The process continues within the Congress, the Office of Management and Budget (OMB), the Office of the Secretary of Defense (OSD) and the Navy until specific funds are approved, released and obligated. Even following the expenditure of funds, in a sense the process still continues with auditing and control procedures. These matters are the subjects of this Chapter.

5.1 APPORTIONMENT

Funds must be apportioned before they can be obligated and spent. The Federal Government's apportionment process dates from the late 19th Century. Its purpose was to ensure that expenditures were spread throughout the year to avoid periodic needs for deficit appropriations.

Apportionment is a determination by the Director of OMB as to the amount of funds which may be obligated in a specific period under an appropriation, contract authorization or other statutory authorization. An apportionment may relate to all obligations within a single appropriations account to be incurred in a specific period or to obligations to be incurred for an activity project, program, function or object. Additional information is found in the Revised Statutes as amended (31 U.S.C. 1517).

*Ref.: DOD Directives 7110.1 and
7200.1*

5.1.1 Apportionment Request. NAVCOMPT submits the Apportionment Schedule (see 5.1.2.1) to the Comptroller of the Department of Defense within 5 days after passage of the Appropriations Act. The same Schedule is required by the OMB within 15 days subsequent to passage of the Act.

Upon receipt of the approved apportionment from OMB via OSD and considering the recommendations of OSD and the ASN(RD&A), NAVCOMPT allocates the RDT&E,N appropriation to the Chief of Naval Research (CNR) and Program Executive Officers/Direct Reporting Program Managers (PEOs/DRPMs). ONR makes further allocations to the various RDT&E,N administering offices.

Prior to the beginning of the fiscal year, the USD(A) transmits program guidance to the Services including his recommendations for program approvals. This is in response to the Services' program submissions in support of the Apportionment Request. The USD(A) also indicates the portion of the program which is not approved and the reason for his decision.

5.1.2 RDT&E,N Apportionment Documentation. NAVCOMPT notifies ASN(RD&A) of the RDT&E,N funds apportionment and the approved allocation by use of the following documents.

5.1.2.1 Apportionment (or Reapportionment) Schedule (DD Form 1105). The actions of

5.1.2.2

the NAVCOMPT, the OSD and the OMB regarding apportionment requests concerning RDT&E,N appropriation are recorded on this document. Appropriated funds are not available for the Navy's obligation until final authorization is completed by the OSD (See 5.1.2.2).

5.1.2.2 Investment Program/Fund Approval for Direct Obligation (SD Form 440). Signed jointly by the USD(A) and the DOD Comptroller, this document specifies the amounts approved and withheld (deferred) by OSD for each program element for obligation.

5.1.2.3 RDT&E,N Budget Activity Allocations (NAVCOMPT Form 2058). This document makes the allocation of funds to the CNR and PEOs/DRPMs from the NAVCOMPT. It reflects all actions contained on the SD 440 and any changes approved by NAVCOMPT. When appropriate, the NAVCOMPT will provide additional fiscal guidance.

5.1.3 RDT&E,N Operating Budget Allocation Documentation (NAVCOMPT Form 2197). The Chief of Naval Research uses this document to allocate approved funds to the various RDT&E administering organizations. Allocations are made in accordance with OMB, OSD and NAVCOMPT levels of allocations and apportionments. They also are based on CNR and Director, Test & Evaluation and Technology Requirements program guidance for their respective program areas.

5.1.4 Navy Actions Required by General Provisions. The Authorization and the Appropriation Acts, and reports on them, contain general provisions requiring Navy action. The Chief of Naval Operations, Programming Division (N80) reviews these data, and assigns specific responsibility for compliance and follow up.

Ref.: DOD Directive 5545.2; DOD Instruction 5545.3 (NAVCOMPT 7130.25); NAVCOMPT Instruction 7130.25

5.1.5 Administrating Deferrals. Deferrals of fund obligations initiated by the USD(A), DOD Comptroller, or Navy executives may be temporary or of indefinite duration. Temporary deferrals may require only the completion of Congressional action on the Appropriations Act or submission of additional program data. Indefinite deferrals normally require at least major program change.

In terms of day-to-day operations, as the fiscal year progresses, partially deferred programs may be jeopardized. In such situations, the need for additional incremental fund releases must be anticipated to avoid work stoppages and to preserve contractor relationships.

Some programs continue in a deferred status throughout the fiscal year because the USD(A) and/or the DOD Comptroller do not believe that justification for approval is adequate. These deferred program funds may be carried over into the next fiscal year, used for the original purpose when eventually approved or the funds may be reprogrammed to meet other programs' funding requirements.

5.2 OBLIGATION AND EXPENDITURE OF FUNDS

The apportionment, allocation and allotment process extends the authority to obligate funds down through the organization. The process makes it possible to issue orders, make contracts and take other actions establishing obligations for eventual funds expenditure. Obligation authority and program approval are the tools controlling budget execution.

Ref.: DOD Directive 7200.1

5.3 ACCOUNTING FOR RESEARCH AND DEVELOPMENT

The financial management system is dynamic. Change and improvement will continue to characterize the research and development accounting, reporting and resource management system.

Ref.: NAVSO P-3062 Financial Management of Resources, RDT&E,N; NAVCOMPT Instruction 7044.8

5.3.1 Objectives of R&D Accounting. The basic objectives of the R&D accounting system are to:

- Provide a standardized method and data base for collecting and reflecting finance oriented information used in programming, budgeting, accounting and control.
- Meet manager's reporting needs at all DOD echelons.
- Estimate and justify funds requirements for the implementation of plans.
- Comply with data requirements of the Congress, OMB, the Treasury and other government organizations.
- Identify all costs with specific programs, systems and other "end-product" and by performing activity.
- Conform with statutory requirements for financial management systems, including accounting principles and standards set forth by the U.S. Comptroller General and related legislation.
- Employ the most efficient information processing techniques, including optimum standardization of data elements and codes

and the use of electronic processing systems.

The purpose for accounting systems has undergone historic transition. When first established, the primary goal of such systems was to prevent breaches of trust and misappropriation of public funds. They were, therefore, concerned primarily with the purposes for which funds were appropriated and the status of unobligated monies.

While these objectives for the systems still exist, emphasis today is on resource management, i.e., using the accounting and control systems to help assure the most productive use of funds. Accordingly, the present R&D accounting and control system is designed to:

- Focus on resources used.
- Improve manager's accountability for the effective and efficient use of resources.
- Compare actual against planned performance.
- Use operating budgets as a basic management control device at each organization level.

The following paragraphs discuss the continuing evolution in accounting techniques aimed at interjecting more effectiveness and feedback into the planning, programming and budgeting phases of financial management.

5.3.2 Harmonizing Programming, Budgeting, and Accounting. A basic improvement in the accounting system has been collecting financial data through uniform accounting classifications used by all RDT&E,N managers. These classifications provide uniform techniques for data collection down to the lowest level of management concern, and are based on the structures used in programming and budgeting.

5.3.3 Identification of RDT&E Costs. Effective identification of RDT&E costs depends on:

- Distinguishing "investments" from "expense"

5.3.3.1

- Ensuring that the RDT&E,N appropriation is chargeable for all feasible and appropriate R&D costs.

Ref.: DOD Instruction 7040.5 (SEC-NAV 7040.6); DON Budget Guidance Manual (NAVCOMPT.7102.2); NAV-COMPT Manual

5.3.3.1 Expenses vs investments. Current instructions provide guidance for assigning costs to "expenses" or "investment" categories. The criteria consider (1) the qualities of the item, such as durability, in the case of an investment cost, or consumability, in the case of an operating cost; and (2) the circumstances under which an item is used or the way it is managed.

5.3.3.2 Research and development cost definition. Applicable instructions provide criteria to answer the question, "What is an RDT&E cost?" These instructions establish definitions and criteria used in specifying and classifying (1) R&D program resources of the Future Years Defense Plan (FYDP), (2) the programs and financial content of accounts concerning R&D accounts in the DOD budget and (3) the financial content of R&D accounts within the DOD management accounting system.

5.3.4 Distribution of Costs to Applicable R&D Projects. Several systems are used to distribute costs incurred by each RDT&E activity to the specific job. Large, complex RDT&E activities, such as the Naval Research Laboratory (NRL), employ working capital funds. Less complex activities employ operating budgets as alternative working capital arrangements. Small and relatively simple activities relate costs to results without such sophisticated accounting devices.

5.3.4.1 Defense Business Operating Fund. The Defense Business Operating Fund (DBOF) provides working capital for an industrial-type

activity, such as a shipyard, laboratory or aircraft-overhaul organization. Under DBOF, the activity pays its expenses—manpower, material, utilities, administration, etc.—from working capital, and charges its customers the *full* cost of its products or services. These costs, compared with industry and other industrially funded Government organizations, provide a measure of the organization's efficiency in the use of resources.

Ref.: DOD Directive 7410.4; NAV-COMPT Instruction 7133.1

5.3.4.2 Operating budgets. The operating budget is a tool for managing the financial resources available to the individual activity. In a single plan, the operating budget includes all direct and reimbursable funds, and provides annual budget estimates and periodic performance reports (against the estimate).

The operating budget divides an activity into "cost centers," an arrangement which pinpoints responsibility for effective use of resources.

Financial plans and accounting reports supporting the operating budget provide analyses of direct, indirect and general costs by cost center, and show the basis for and distribution of indirect and general costs to direct work. These techniques are used in facility management.

5.4 REPROGRAMMING

One of the principal functions of the R&D manager is making tradeoffs by moving resources among programs and projects to achieve their most productive use. The execution of the program, in the interest of maximum effectiveness, inevitably will require changes since the budget submission is based on plans that are generally at least 15 months old by the time execution begins.

While management effectiveness may demand shifting funds from a specific originally planned use to other more useful applications, the

maintenance of good faith with Congress requires that funds be spent for the purposes justified before Congress.

Congressional committees concerned with the Department of Defense Authorization and Appropriations Acts generally agree that rigid adherence to the amounts justified for individual budget activities or programs may unduly jeopardize the effective and economical accomplishment of planned programs, and that unforeseen occurrences may require some diversion of funds from the purposes for which they originally were intended.

Reprogramming procedures, developed in consultation with the committees, provide for retention of Congressional control over the use of Defense appropriations by making sure that the Congressional intent is carried out while, at the same time, this procedure provides a practical device for achieving flexibility in the execution of programs.

The Senate and House Armed Services and Appropriations Committees have directed that DOD adhere, within certain accepted variances, to the program justified in the budget. Before any changes which exceed established thresholds are made in a budget program, or any change is made in a "special interest" program, a reprogramming action (DD Form 1415) must be taken which provides both committees a description of significant variations from the justified amounts and purposes. The established procedures are as follows:

- Establish the base for reprogramming actions. All reprogramming actions are taken in relation to a "Base for Reprogramming Actions" established immediately after final Congressional authorization and appropriation action. It is submitted on DD Form 1414 through OSD to the Congressional committees and identifies the purposes in terms of program elements for the RDT&E appropriation, and the amounts for which funds have

been authorized and appropriated. It also reflects the specific application of adjustments made by the Congress. It is considered to be final only upon review and approval by the Congress.

- Specify actions requiring prior SECDEF and Armed Services and Appropriations Committees' approval. These include any reprogramming action involving:
 - the application of funds to items, programs, or functions in which the Congressional committees have expressed a special interest.
 - a transfer of funds between appropriations.
- Specify actions requiring prior SECDEF approval and notification to the Armed Services and Appropriations Committees. These include any reprogramming action involving:
 - an increase of four million dollars or more in any program element for a single program year.
 - a reduction of more than 10% or over four million dollars, whichever is greater, from the base for reprogramming.
 - a decrease from any activity to which funds were added during the annual appropriations process.
 - the addition of a new program element of two million dollars or more in a single fiscal year or estimated to cost ten million dollars or more over a three year period.
 - termination of any program which results in the elimination of a program element or of a subprogram or project of ten million dollars or more.

Ref.: NAVCOMPT Instruction 7133.1

5.4.1

5.4.1 Reprogramming Procedures. The request for Reprogramming Approval (DD Form 1415) includes an explanatory statement summarizing the need for the reprogramming. This statement contains all the information necessary for critical review by authorities and Congressional committees. The action must identify all compensating increases and decreases with the appropriation total so that there will be no addition or reduction in the individual reprogramming proposal. This does not apply when the reprogramming involves a transfer of funds into or out of the appropriation, a difference that would then result in a net change to the appropriation total.

All RDT&E reprogramming actions involving prior approval or notification of Congressional committees will be reviewed by USD(A) for concurrence or comment before being routed to the Secretary of Defense.

Advance notification of below-threshold reprogramming actions for new programs or line items not otherwise requiring prior approval (or notification action), will be made to the House and Senate Appropriations Committees. This notification will be made by letter directly to the committees by the DOD Component concerned, after coordination with the DOD Comptroller.

5.4.2 Reprogramming Hearings. Periodically, reprogramming hearings are conducted by Congressional committees.

5.4.3 Reprogramming Reports. Semi-annually, the "Report of Programs" (DD Form 1416) is submitted to Congressional committees, summarizing all reprogramming actions approved during the period, including those which did not, individually, require submission of reprogramming proposals to the Congressional committees.

5.4.4 Internal Navy Reprogramming in RDT&E,N. Reprogramming actions among R&D projects, within a program element and among program elements may be approved by the ASN(RD&A) within the restrictions imposed by Congress as provided in NAVSO P-3062-1,

Financial Management of Resources, RDT&E,N. ASN(RD&A) has delegated this authority in the Technology Base to the Chief of Naval Research. In the other four categories of the RDT&E,N appropriation and with the exception of Marine Corps programs therein this authority has been retained by ASN(RD&A). Similar authority for Marine Corps programs in categories 3 through 6 has been delegated to the Commander, Marine Corps Systems Command. However, any change to programs in Acquisition Categories I and II and other programs designated as "ASN(RD&A) special interest" requires the approval of ASN(RD&A). By ASN(R,E&S) Memorandum, dated March 1989, a further delegation of reprogramming authority has been made to the administering offices, empowering them to make cumulative changes to any project of up to \$500,000 in RDT&E,N categories 3 through 6, provided the change is within the overall Congressional limitations stated above and ACAT I, II and Congressional, OSD and ASN(RD&A) special interest items are not improperly affected. In the Technology Base the Chief of Naval Research delegates reprogramming authority at his own discretion.

*Ref.: NAVCOMPT Instruction 7133.1;
NAVSO P- 3062-1*

5.5 AUDITS AND REVIEW

Programming, reprogramming and accounting controls are supplemented by periodic audits and reviews conducted by certain offices inside and outside the Navy.

*Ref.: DOD Directives 7600.2, 7650.2;
SECNAV Instructions 5740.26, 7510.7*

5.5.1 General Accounting Office. The General Accounting Office (GAO) is an agency of the Congress completely independent of the Executive

Branch. It is the responsibility of the Comptroller General to investigate all matters relating to the receipt, disbursement and application of public funds. The Comptroller General makes an annual report to the Congress plus special reports as needed. These reports include "recommendations looking to greater economy or efficiency in public expenditures."

Section 313 of the Budget and Accounting Act of 1921 gives the Comptroller General the power to examine all Executive Branch records. This act states that:

... all departments and establishments shall furnish to the Controller General such information regarding the powers, duties, activities, organization, financial transactions, and methods of business of their respective offices as he may require ...

In the past, GAO audits tended to emphasize the legality of transactions. These audits focused on accounting matters, particularly whether expenditures were made in accordance with the law and intent of Congress. In recent times, emphasis increasingly has been on the question of how efficiently, effectively and economically government business is being conducted.

5.5.2 Navy Audit Program. The Navy Audit Program focuses on two distinct types of

audit—internal and contract. Internal audit is the independent appraisal of accounting, financial and related matters of an operating nature. It is concerned not only with detecting deficiencies which would be of interest to an external auditor—GAO, for instance—but also with providing management data it needs to improve the economy and effectiveness of operations. In short, internal audit is designed to provide management both protective and constructive services.

Title IV of the National Security Act 1949 amendments established offices of comptroller in the Department of Defense and in the Services, and established internal audit as a function of these offices. Within the DOD's Office of the Comptroller, there is an Assistant Comptroller for Audit. Within the Navy, the Comptroller is responsible for auditing; such functions being performed by the Navy's Auditor General.

Contract audit involves examining books and records of private contractors and verifying their cost representations insofar as Navy work is concerned. Contract audits also provide contracting officers with advice useful to them in negotiating contract prices. Both internal and contract audit are conducted under the Auditor General of the Navy.

SELECTED REFERENCES ON EXECUTION OF THE RDT&E BUDGET

DOD Directive 7200.1 (NAVCOMPT MANUAL Vol II), "Administrative Control of Appropriations," prescribes regulations to prevent obligation in excess of apportionment and to fix responsibility for creating an obligation or expenditure in excess of an "appropriation, apportionment, reapportionment, or subdivision thereof."

DOD Directive 7410.4 (NAVCOMPT MANUAL VOL V), "Industrial Fund Policy."

SECNAV Instruction 7510.7, "Department of the Navy Audit Manual for Management," together with its enclosures, **DOD Directive 7600.2**, "Department of Defense Audit Policies," and **DOD Instruction 7600.3**, "Internal Audit in the Department of Defense," describes basic policies and responsibilities for Department of the Navy auditing.

NAVSO P-3062, Parts 1 and 2, "Financial Management of Resources—Research, Development, Test and Evaluation, Navy."

NOTE REGARDING DIRECTIVE NUMBERS

References to directives within this Guide are by series only; e.g., 3900.14, not to the effective edition within the series; e.g., 3900.14A

The "Master Reference List" indicates the version and issue date of each directive used in preparation of this edition of the Guide.

For recent information on the effective directive within a series, consult the "Department of the Navy Directives Issuance System: Consolidated Subject Index," (NAVPUBNOTE 5215).

Chapter 6
MANAGING ACQUISITION OF RD&A EFFORT

TABLE OF CONTENTS

6.1	General Considerations	6-1
6.1.1	Fundamental Policy	6-1
6.1.2	Non-Development Items (NDI)	6-1
6.1.3	Basic Roles	6-1
6.1.4	Classes of Performers	6-2
6.1.4.1	In-house performers	6-2
6.1.4.2	Out-of-house performers	6-2
6.1.5	Other Execution Means	6-2
6.1.6	Major Laboratory/Center Functions	6-2
6.1.6.1	Technology Base	6-2
6.1.6.2	Advanced Development	6-3
6.1.6.3	Support for systems development	6-3
6.1.6.4	Source of technical advice	6-3
6.1.7	The In-House vs Contracting-Out Decision	6-3
6.2	Performance by In-House Organizations	6-3
6.2.1	Identifying Laboratory/Center Capability	6-4
6.2.2	Negotiating with Laboratories/Centers	6-4
6.2.3	Funding	6-4
6.2.4	“Contracting” with In-House Laboratories/Centers	6-4
6.2.5	Navy Laboratories/Centers IR/IED Program	6-4
6.3	Performance by Out-of-House Organizations	6-5
6.3.1	Federal Acquisition Regulation	6-5
6.3.2	Necessity for Visible Propriety	6-5
6.3.3	Role of Small Business	6-5
6.3.4	The Importance of Competition	6-5
6.3.5	Overview of Major Development Programs	6-6
6.3.6	Execution Functions	6-6
6.3.7	Acquisition Plan	6-6
6.3.7.1	Non-Development Items (NDI) in the AP	6-7
6.4	Contracting Technical Assistance	6-7
6.4.1	The Acquisition Team	6-7
6.4.2	Contracting Activities	6-7
6.5	Grants, Contracts and Other Acquisition Instruments	6-7
6.5.1	Grants	6-7
6.5.2	Contracts	6-7
6.5.2.1	Cost-sharing contract	6-7

6.5.2.2	Cost contract	6-7
6.5.2.3	Cost-plus-fixed-fee contract	6-7
6.5.2.4	Cost-plus-incentive-fee contract	6-8
6.5.2.5	Cost-plus-award-fee contract	6-8
6.5.2.6	Fixed-price-incentive contract	6-8
6.5.2.7	Firm-fixed-price contract	6-8
6.5.2.8	Purchase order	6-8
6.5.2.9	Letter contract	6-8
6.5.3	Contract Specifications	6-8
6.5.3.1	The Statement of Work	6-9
6.5.3.2	Technical Data Package	6-9
6.5.4	Other Contract Provisions	6-9
6.5.4.1	Patent rights	6-10
6.5.4.2	Data acquisition and data rights	6-10
6.5.4.3	Independent Research & Development (IR&D)	6-10
6.5.5	Contracting for the Technology Base and Advanced Technology	6-10
6.5.5.1	Full disclosure policy	6-11
6.5.5.2	Government equipment for universities and other nonprofit institutions	6-11
6.6	Soliciting R&D Competitive Bids and Proposals	6-11
6.6.1	Procurement Request	6-11
6.6.2	Solicitation Documents	6-11
6.6.3	Promulgation of Solicitation Documents	6-11
6.6.4	Evaluating Proposals and Bidders	6-12
6.6.5	Source Selection	6-12
6.6.6	The Broad Agency Announcement	6-13
6.7	Management Activities During Execution	6-13
6.7.1	Management Control Systems	6-13
6.7.2	Technical Reports	6-14
6.7.3	Progress Reports	6-14
6.7.4	Cost and Performance Reports	6-14
6.7.4.1	Cost Performance Report	6-14
6.7.4.2	Contractor Cost Data Reporting	6-14
6.7.4.3	Contract Funds Status Report	6-15
6.7.4.4	Cost/Schedule Status Report (C/SSR)	6-15
6.7.5	Administration of Contracts	6-15
6.7.6	Selected Acquisition Report	6-15
6.7.7	Other Reports	6-16
6.7.7.1	Research and Technology Work Unit Summary	6-16
6.7.7.2	RDT&E project listings	6-16
6.7.7.3	Reporting by Laboratories/Centers	6-16
6.7.8	Changes and Amendments to Contracts	6-16
6.8	Execution of Marine Corps R&D	6-16

6.8.1	Execution Approaches	6-16
6.8.2	Program Cognizance within the Marine Corps	6-16
6.8.3	Management of Acquisition	6-17
6.8.4	Role of Marine Corps Systems Command (MARCORSYSCOM)	6-17
6.8.5	Role of the Navy Laboratories	6-17
6.9	Program Management	6-17
6.10	Computer-Aided Acquisition and Logistics Support (CALs)	6-18

Chapter 6 MANAGING ACQUISITION OF RD&A EFFORT

This chapter discusses the arrangements under which the Navy's R&D work is accomplished.

6.1 GENERAL CONSIDERATIONS

6.1.1 Fundamental Policy. In the acquisition of research and development, it is fundamental Department of Defense policy to:

- Exploit the best scientific and technological sources to obtain the optimum balance in skills, quality, cost and schedule.
- Perform systems development only when the requirement cannot be met through use of Non-Development Items (see 6.1.2).
- Ensure maximum practical commonality in systems and equipment both within the Navy and among the Services.
- Encourage continuing competition, with multiple sources performing concurrent but separate development up through Engineering and Manufacturing Development (EMD) and dual competing sources for production.
- Ensure that contracts for development work permit an equitable and sensible sharing of risk. Risk will be reduced by controlling specifications and keeping program changes firmly under control.
- Continually strengthen the capability of the Government to competently plan and manage its R&D programs. Program Managers will be held accountable, will be

longer term, and will be better trained (see F3.3 and F3.4). Government facilities must carry a reasonable part of Research, and Exploratory and Advanced Development so as to be knowledgeable customers for later development by industry.

*Ref.: DOD Directive 5000.1, Part 1;
DOD Instruction 5000.2, Part 2;
SECNAV Instruction 5000.2*

6.1.2 Non-Development Items (NDI). NDI solutions to stated requirements must be pursued aggressively by each Program Manager throughout the acquisition process. Explicit consideration of NDI alternatives is required at all Milestone I, II, and III decision meetings, based on analysis and tradeoffs of performance, cost and schedule comparisons.

*Ref.: DOD Directive 5000.1; DOD
Instruction 5000.2, Parts 3, 6L, 10C;
SECNAV Instruction 5000.2*

6.1.3 Basic Roles. The acquisition process involves these essential roles in the Customer-Supplier dialogue and interaction (see F1.7):

- The "User" is the official or organization having the need, e.g., the Fleet, CINC. SYSCOM. This chapter is written from

6.1.4

the perspective of the Technical Customer who is the manager arranging for the research and development effort.

- The "Customer" may be the Technical Customer, i.e., the manager arranging for research, development, and acquisition effort, or may be CNO/CMC, representing the user. In some cases, the user, e.g., a SYSCOM, and customer may be the same.
- The "Performer" is the organization doing the work.
- The "Contracting Officer" has the basic responsibility for all contractual matters as described in the Federal Acquisition Regulation (FAR) and other regulations.

The "Customer" in the Customer-Supplier relationship may be the Technical Customer alone (in an in-house acquisition), or be the team of the Technical Customer and the Contracting Officer (when acquisition is by contract).

6.1.4 Classes of Performers. Performers of R&D can be divided into two general classes, in-house and out-of-house, with several subcategories in each class.

6.1.4.1 In-house performers. Government-owned, Government-operated (GOGO) (for brevity, "laboratory" is used to refer to Navy Warfare Centers, RDT&E Facilities, and laboratories) laboratories are the principal in-house performers. They account for approximately 30% of the DON R&D program.

In-house performance involves the least formal and time-consuming preliminaries. After an informal dialogue between the technical people on both sides, a general understanding is reached and the in-house equivalent of a contract is issued.

6.1.4.2 Out-of-house performers. They include:

- Commercial contractors account for the bulk of Engineering and Operational

Systems Development and about 65% of the DON R&D program.

- Educational and other nonprofit institutions whose primary purpose is the conduct of scientific research are the primary performers of fundamental or basic research.
- Federally Funded Research and Development Centers (FFRDC) operate like in-house laboratories but actually are contractor-operated facilities. The only current DON-sponsored FFRDC is the Center for Naval Analyses.

6.1.5 Other Execution Means. There are several other means for executing DON R&D work in addition to in-house laboratories and contractors. Such work may be done by another Government agency—such as NASA, Army, Air Force, National Institutes for Standards and Technology, Health and Human Services (HHS), National Academy of Sciences, National Institutes of Health or the National Security Agency. Interagency acquisitions must include an Economy Act determination in compliance with the FAR. (See FAR 17.5; DFARS 217.5). Under our Military Assistance Program, promising foreign research programs may receive cost sharing or aid contributions which entitle the DON to share in results, reports and other data. NATO-coordinated production arrangements which aid weapons standardization of our allies may provide Navy data and production items.

6.1.6 Major Laboratory/Center Functions. The role of the in-house laboratories spans the whole spectrum from research through operational support. While individual in-house laboratories have strong historical ties with individual Commands and Offices, the laboratories and "corporate assets" are available to all R&D managers and decision makers requiring their capabilities.

6.1.6.1 Technology Base. The DON in-house laboratories possess most of DON scientific and technological expertise. This

expertise is developed and maintained primarily through Research and Exploratory Development programs and is applied principally to advanced systems conceptions, weapon systems improvements, and resolution of fleet technology deficiencies.

Independent Research/Independent Exploratory Development (IR/IED) (see 6.2.5), plays a vital role in development of the DON Technology Base.

6.1.6.2 Advanced Development. The in-house laboratories also directly manage a large portion of Advanced Development, even though much of this work is performed by industry under contract. Laboratory responsibilities for these programs involve total program management, deputy project management or technical direction. The criteria for determining the scope of laboratory responsibility for Advanced Development relates to the labs involvement in the technology's development and in the concept of the system and to the availability of technical expertise.

6.1.6.3 Support for systems development. In-house laboratories also provide a wide range of services in support of major system developments. These services include (a) feasibility studies and other aspects of the concept exploration and definition process, (b) development of plans such as the Acquisition Plan, the Integrated Logistics Support (ILS) plan, etc., (c) development of specifications, (d) provision of experts for the proposal evaluation and source selection process, (e) development of subsystems for which industry does not have adequate capability, (f) systems development for selected programs, and (g) test and evaluation. Thus the laboratories ensure that DON can enter into contract negotiations as a knowledgeable buyer.

The laboratories also may help solve problems encountered during development.

6.1.6.4 Source of technical advice. The technical staffs of laboratories and other in-house organizations provide a source of advice and

consultation available to all Department of the Navy R&D managers. Such in-house technical competence is essential to protect against the situation where outside technical advice becomes de facto technical decision making. The laboratories also provide technical representatives to Acquisition Review Boards (ARBs), Program Decision Meetings (PDMs) and other forums, for independent technical assessments of programs.

6.1.7 The In-House vs Contracting-Out Decision. In some cases, the decision to conduct a project in-house or to contract it out is far from easy.

Government policy for R&D and acquisition implementation calls for performance of R&D effort by the class of institution—Government laboratory, educational or nonprofit institution, private contractor—which can perform the work most effectively and efficiently, subject to certain qualifications. For example, OMB Circular A-76 favors contracting out for commercial supplies or services (see FAR 7.3).

A series of actions to contract out important activities eventually could erode the Government's ability to manage its research and development programs. It is essential that Government laboratories gain substantial experience in relevant technologies if they are to be effective in carrying out their roles in the weapons acquisition process.

Another important consideration is the time required to get a project underway. The administrative steps in providing funds and program direction to in-house laboratories are far simpler than those in awarding a contract. In addition, the in-house laboratories have teams of technical experts aware of the technical threat and knowledgeable of DON problems and the operational environment.

6.2 PERFORMANCE BY IN-HOUSE ORGANIZATIONS

In-house organizations, particularly the in-house laboratories, constitute a base of scien-

6.2.1

tific, technological and engineering knowledge, and talent tailored to DON needs. This section discusses the kinds of tasks in-house organizations do best and describes processes for arranging, monitoring and funding such work.

6.2.1 Identifying Laboratory/Center Capability. Identifying the laboratories, or other in-house organizations, with the capabilities to meet a particular need is not difficult.

Appendix G identifies DON Warfare Centers and laboratories and provides brief statements of their missions. The three-volume RDT&E Center Management Briefs contain information on missions, facilities, programs, major accomplishments, organization, personnel, funds and responsibility of each RDT&E activity.

Another approach to identifying in-house DON capabilities is to request the Defense Technical Information Center to search its abstracts (DD 1498, "Research and Technology Work Unit Summary") to identify work most closely related to the technical need (see D3.1.1). The Technical Customer can then contact either the sponsor of the work or the Principal Investigator.

*Ref.: NAVAIR Instruction 5451.87;
RDT&E Center Management Briefs*

6.2.2 Negotiating with Laboratories/Centers.

When an in-house Laboratory is selected to perform a task, the process of "negotiating the contract" is relatively simple (see 6.1.4.1). The basic agreement is developed through informal negotiations. Once agreement has been reached, the proposed work is incorporated into the laboratory program and reported in the DOD Work Unit Information System (DD 1498). To fund the proposal or to modify it, the customer prepares a task assignment for the laboratory by letter or in a format specified by the individual Systems Command. Necessary funding documents

are forwarded to the activity in support of the task assignment.

The above documentation, essentially contractual in nature, provides statements of the work to be done, milestones, cost estimates, and funding.

6.2.3 Funding. DON major RDT&E activities operate under the Defense Business Operating Fund (DBOF) (5.3.4.1). When a DOD agency orders RDT&E work or services from a DBOF facility, a Work Request (NAVCOMPT form 2276A) is used. Funds to support work requests are obligated by the customer upon acceptance of the work by the DBOF activity.

For RDT&E activities not operating under DBOF, the management command issues an annual operating budget (5.3.4.2). This budget does not obligate the funds of the management command. Customers outside the management command may order work from these activities by using a work request. Acceptance of the document by the activity obligates the customer's funds.

6.2.4 "Contracting" with In-House Laboratories/Centers. Work requests fund an agreement with a laboratory or other in-house organization to perform a task. When placed with and accepted by the laboratory, the work request obligates funds in the same manner as a contract with a commercial concern. While the work request includes a brief technical description of the work, it is normally supplemented by an amplifying letter or task assignment document.

Ref.: DOD Directive 7410.4;

6.2.5 Navy Laboratories/Centers IR/IED Program. Under the IR/IED (Independent Research/ Independent Exploratory Development) Program, administered by the Office of Naval Research (ONR), funding is provided to each laboratory for projects initiated and managed by the laboratory. The principal objective of the

IR/IED Program is to capitalize immediately (i.e., outside the normal budget cycle and process) on in-house generated ideas for solution to Navy and Marine Corps problems.

6.3 PERFORMANCE BY OUT-OF-HOUSE ORGANIZATIONS

The process of executing a major program through contracting with industry is somewhat more formalized and complex.

6.3.1 Federal Acquisition Regulation. The Federal Acquisition Regulation (FAR) is the government-wide acquisition regulation containing policies, procedures, contract clauses and forms. Part 35 relates to R&D.

The FAR is supplemented by the DOD FAR Supplement (DFARS) and the Navy Acquisition Procedures Supplement (NAPS). Readers consulting FAR citations should consult corresponding sections in DFARS/NAPS for complete information.

6.3.2 Necessity for Visible Propriety. Contracting by the DON is public business and must be conducted with scrupulous regard for the rights of all competitors. Competitors have the right by law to be informed of the outcome of contracts, the basis of the award and the specific grounds for non-selection. This information legally must be maintained by the Navy and be available for review.

All individuals, including both government and contractor personnel, who are involved, even indirectly, with procurement, must take specific actions, e.g., signing a certification of compliance, in accordance with the Procurement Integrity Act (41 U.S.C. 423, as amended).

Prerenegotiation and postrenegotiation Business Clearance requirements prescribed in Navy Acquisition Procedures Supplement (NAPS 5201.690) must be fulfilled on each contract action.

Ref.: FAR 4.801; NAPS 5201.690

6.3.3 Role of Small Business. It is the policy of the Department of Defense to place a fair proportion of its total contracts for research and development supplies and services with small business concerns qualified to participate in Navy's programs.

Ref.: FAR 19.201 and 35.004(a); Navy Small and Disadvantaged Business Personnel Directory (NAVSO P-2485) provides contact points for small business firms concerning laboratories and other technical organizations

6.3.4 The Importance of Competition. Part 6 of the FAR deals with competition requirements in government contracting. Current law requires, with certain exceptions, that contracting officers use "full and open competition" in soliciting offers and awarding contracts. The competitive procedures involve: (a) sealed bids, (b) competitive proposals, (c) combination of competitive procedures and (d) other competitive procedures. Since research and development contracting generally is not suited to sealed bidding or combination procedures involving sealed bidding, competitive R&D contracts usually evolve from "competitive proposals" or "other competitive" procedures.

The "competitive proposal" procedure involves issuance of a Request for Proposals (RFP) (see 6.6.2). The "other competitive" procedure is used only for research and that development effort not related to specific system or hardware procurements, and involves a broad agency announcement.

It is important that competition primarily be based on performance, validated by testing and evaluation. DOD policy (See DODDIR 5000.1, Part 1C, SECNAVINST 5000.2) states that

6.3.5

Defense systems, subsystems, equipment, supplies, and services shall be acquired on a competitive basis to the extent practicable, as a means of achieving cost, schedule, and performance benefits.

The EMD contractors usually will then compete for annual production purchases, or "buys".

Despite the competition imperative, situations occasionally arise in R&D contracting where competition is not possible. FAR 6.302 identifies circumstances which permit other than full and open competition. Of these, three can pertain to R&D:

- Only one responsible source
- Unusual and compelling urgency
- Engineering, developmental or research work

Exceptions require written justifications and approvals (commonly called "J&A's"), which are prepared jointly by technical personnel and the Contracting Officer. Details on the requirements, content, approval, and availability of justifications are provided in FAR 6.303.

The Competition Advocate General is responsible for ensuring maximum effective, sustainable competition in DON programs.

Ref.: 10 U.S.C. 2304; 41 U.S.C. 253; FAR Part 6; DOD Directive 5000.1, Part 1C; DOD Instruction 5000.2, Part 5A; SECNAV Instructions 4210.10, 5000.2

6.3.5 Overview of Major Development Programs. A major program involves many tasks executed under a large number of different contracts and task orders. Although in-house laboratories seldom act as prime contractors on development contracts, they participate in most major programs.

For example, a major program such as a new fighter aircraft, in addition to the prime contract, will involve a number of industrial contracts for

both hardware and software. Hardware contracts cover various items of Government-furnished equipment (GFE). Engineering services and technical assistance may be provided under contract. In-house laboratories will be heavily involved in system definition, specifications preparation, proposal evaluation, performance monitoring, and in providing technical assistance. Major tasks, such as development of a brass-board model under Advanced Development, may be assigned to a laboratory, which in turn may contract all or portions of the work to an outside company.

6.3.6 Execution Functions. The following functions are basic to the execution of all R&D effort:

- Acquiring an adequate base of performer candidates.
- Selecting the best qualified participants.
- Establishing performance agreements.
- Conveying Government-furnished inputs.
- Performing the contract.
- Monitoring and reporting contract performance.
- Compensating performers.

6.3.7 Acquisition Plan. An Acquisition Plan (AP) is required when estimated development costs are \$5 million or more, or when annual production or services costs are 15 million or more for any fiscal year or 30 million or more for all years (DFARS 207-103(c)(i)).

The AP is used for in-depth program review and approval by the Head of the Contracting Activity, Program Executive Officer (PEO), Direct Reporting Program Manager (DRPM), SYSCOM Commander, or their designee. APs must meet the criteria of NAPS 5207. In general, a formal solicitation may not be issued prior to approval of the AP.

Acquisition Plan preparation should begin as soon as the need is identified. It is submitted for approval after the Acquisition Strategy is approved by the Milestone Decision Authority. The Program Manager and Contracting Officer are

responsible for the AP. APs are reviewed annually and updated when major changes occur or upon transition from one development phase to another.

Acquisition Plans include funding, methods of contracting, source selection, contract type, competition, cost, delivery, Government-furnished equipment and information, milestones, future requirements, and contract administration. The Acquisition Plan begins as a broad outline and is expanded and refined as the program progresses.

Ref.: DOD Instruction 5000.2, Part 11D; DFARS 7.1; NAPS 5207.1

6.3.7.1 Non-Development Items (NDI) in the AP. It is DOD policy that the use of NDI becomes the rule rather than the exception. APs must describe the extent to which NDI are planned for the proposed acquisitions, and justify where NDI are not feasible or cost effective (see 6.1.2).

Ref.: DOD Directive 5000.1, DOD Instruction 5000.2, Parts 3, 6, 10C; SECNAV Instruction 5000.2

6.4 CONTRACTING TECHNICAL ASSISTANCE

There are several major sources of technical assistance available to assist in the acquisition process.

6.4.1 The Acquisition Team. A complex acquisition requires not only the closest operation between the Technical Customer and the Contracting Officer, but also the assistance of a large number of specialists. These include legal and patent counsel, scientists and engineers knowledgeable in critical fields of technology, experts in integrated logistic support, etc. Where the Technical Customer's own organization does

not have the necessary skills available, such generally can be acquired from the laboratories.

6.4.2 Contracting Activities. Commands, Offices and many laboratories have contracts groups or contracts directorates which legally are responsible for all contracting activities, and provide staff advice and consultation to the Technical Customer. Generally, such assistance is available to meet the needs of acquisition planning and development of the procurement request (PR) long before actual contracting action begins.

6.5 GRANTS, CONTRACTS AND OTHER ACQUISITION INSTRUMENTS

6.5.1 Grants. The Department of Defense legally is permitted to use grants in support of basic research. Within the Department of the Navy, the Office of Naval Research has the authority to issue grants.

6.5.2 Contracts. A contract is an offer and acceptance backed by legal considerations. Types of contracts normally used to support RDT&E effort include:

Ref.: FAR Part 16; 35.006

6.5.2.1 Cost-sharing contract. Under a cost-sharing agreement the contractor is reimbursed for an agreed portion of his allowable costs, not to exceed an established ceiling. No fee is paid.

6.5.2.2 Cost contract. A cost contract involves payment of all allowable costs involved in executing a given research project. The contractor receives no fee. This type of contract establishes an estimate of the total cost for obligating current funds and establishes a ceiling beyond which the contractor cannot go (except at his own risk) without prior approval.

6.5.2.3 Cost-plus-fixed-fee contract. The cost-plus-fixed-fee contract is similar to the cost

6.5.2.4

contract in that it provides for payment of all allowable costs and establishes an estimate of the total cost. In addition, however, it provides for payment of a fixed fee based on the nature of the work and on other factors as stated in FAR 16.306.

6.5.2.4 Cost-plus-incentive-fee contract.

The cost-plus-incentive-fee contract is a cost-reimbursement-type agreement with provision for a fee which is adjusted by formula in accordance with the relationship of total allowable costs to target cost. Under this type of contract, there is negotiated initially a target cost, a target fee, a minimum and maximum fee and a fee adjustment formula. Factors other than cost, such as a performance and schedule, also can be used for contract incentives.

Ref.: FAR 16.3

6.5.2.5 Cost-plus-award-fee contract.

A cost-plus-award-fee contract is a cost-reimbursement contract that provides for a fee consisting of 1) a base amount fixed at the inception of the contract and 2) an award amount the contractor may earn in whole or in part during performance by excellence in quality, timeliness, technical ingenuity, cost-effective management, etc. The amount of award is based on the government's unilateral evaluation of contractor performance in terms of criteria stated in the contract and is not subject to the Disputes clause.

6.5.2.6 Fixed-price-incentive contract.

The fixed-price-incentive contract is a fixed-price-type contract with provision for adjustment of profit and establishment of the final contract price by a formula based on the relationship of final negotiated total cost to target costs. Under this type of incentive contract a target cost, a target profit, a price ceiling (but not a profit ceiling or floor), and a formula for

establishing final profit and price are negotiated at the outset.

6.5.2.7 Firm-fixed-price contract. The firm-fixed-price contract provides for a price which is not subject to any adjustment by reason of the contractor's cost experience in performing the work. This type of contract places maximum risk with the contractor. Because the contractor assumes full responsibility, in the form of profit or losses for all costs under or over the firm fixed price, he has a maximum profit incentive for effective cost control and contract performance. "The firm-fixed-price contract is suitable when definite design or performance specifications are available and whenever fair and reasonable prices can be established at the outset, or for level-of-effort work. DOD policy strictly limits use of fixed-price type contracts for R&D, since these conditions cannot be obtained (see DFARS 235.006).

6.5.2.8 Purchase order. An individual purchase order, DD Form 1155, may be used for fixed-price purchases under \$25,000.

6.5.2.9 Letter contract. A letter contract is a preliminary agreement which authorizes immediate start of work. Letter contracts are used only when a definitive contract cannot be negotiated and awarded soon enough to meet acquisition needs. Letter contracts are the least desirable contracting approach. DOD and DON policy limits their use.

Ref.: FAR 16.603; DFARS/NAPS 17.5

6.5.3 Contract Specifications. Specifications are clear and accurate descriptions of technical and other requirements established for supplies or services being procured. They also may spell out procedures for determining whether such requirements have been met. Requirements are sometimes defined by the work statement (see 6.5.3.1) or a "purchase description" when it is

impractical or uneconomical to prepare a specification.

There are two general types of specifications: *Function or performance specifications* define the end results, or capabilities sought, leaving how to achieve those results up to the performer. *Design specifications* prescribe *how* the results are to be achieved. Function or performance specifications are preferred when practicable.

6.5.3.1 The Statement of Work. The work statement is that portion of a contract describing the work to be done. While most other contract clauses primarily are the responsibility of the Contracting Officer, the work statement is of vital concern to the Technical Customer. Ideally, the work statement as set forth in the Procurement Request (6.6.1) will be suitable for use as the contract work statement. The Procurement Request is prepared by the Technical Customer.

The following elements are considered in preparing the work statement:

- The required objectives and desired results.
- Background information on the requirements and how they evolved.
- Elimination of performance requirements which yield only marginal military worth when compared to cost and/or risk, as certified by CNO/CMC.
- Maximum practical commonality.
- Technical considerations such as known specific phenomena or techniques.
- Personnel and environmental factors.
- A detailed description of the technical requirements and subordinate tasks.
- A description of reporting requirements and any other deliverable items, including data, experimental hardware, mockups and prototypes.
- Type of contract.
- Other special considerations, including streamlining and tailoring.

Acquisition streamlining is an important DOD initiative. The Program Manager is responsible for reviewing the requirements of the Technical Data Package (TDP) (see 6.5.3.2) and tailoring the solicitation to achieve the proper balance between military capability, cost, and other considerations.

Ref.: FAR 35.005(d); DOD Instruction 5000.2, Part 6; SECNAV Instruction 5000.2

6.5.3.2 Technical Data Package. The Technical Data Package (TDP) is a listing of technical data requirements in the contract which invoke documented technical requirements, manufacturing processes, design drawings, reports, etc., required to implement the contract. Federal or Military specifications and standards are reference documents in contract TDPs which establish government requirements for development and acceptance of material (FED or MIL-SPEC) or define acceptable manufacturing processes (MIL-STD). TDPs may also include Non-government Standard (NGS) or Commercial Item Description (CID) documents, which are commercial standards that have been adopted or modified to satisfy government requirements. The use of NGS or CID is intended to encourage the use of commercial products.

Formal specifications are available in two listings: the Index of Federal Specifications, Standards and Handbooks, and the military DOD Index of Specifications and Standards (DODISS). Both may be purchased from the Defense Printing Service (DPS).

6.5.4 Other Contract Provisions. Federal law and DOD and Service regulations require the inclusion of a variety of specific clauses in contracts. A number of these depend on the type of contract and contractor. Others are special contract requirements suited to the particular contract action. The majority of these clauses are drafted by the Contracting Officer with little or no direct input

6.5.4.1

from the Technical Customer. The following, however, are clauses of concern to the Technical Customer since they affect development and exploitation of technology.

6.5.4.1 Patent rights. Contracts relating to experimental, developmental or research work are required by FAR to include a patent rights clause. This clause defines the rights and obligations of the contracting parties regarding inventions that are conceived or first reduced to practice in the course of the contract. Such contracts require clauses permitting the Government to make contract results available to other agencies and to the private sector, consistent with national security and data rights as specified in the contract.

Ref.: FAR 27.2, 27.3; DFARS 227.3

6.5.4.2 Data acquisition and data rights. All RD&A contracts carefully must specify the data to be delivered. In planning a developmental acquisition, particularly when subsequent production contracts are contemplated, consideration should be given to the need and time required for obtaining the procurement package. The "procurement package" includes specific plans, drawings, specifications and other descriptive information necessary to achieve effective competition in production contracts.

Contracts in which the Government acquires technical data and computer software must identify the software and technical data requirements and must contain a "rights in computer software and technical data clause." The contract's computer software and technical data requirements appear in the "Contract Data Requirements List" (DD Form 1423), and set forth the technical data and computer software that are required to be furnished by a contractor. The "computer software and data clause" is a special contract clause defining the rights and obligations of the contracting parties with respect to such data and

software, and particularly the Government's right to use them.

Even though acquisition, maintenance and updating of computer software and data is an expensive process, it is general policy to acquire rather than than lease computer software and technical data necessary to meet needs of the overall acquisition strategy. This the strategy often requires acquisition of sufficient data to promote future competition.

Ref.: FAR 35.011; DFARS 227.4

6.5.4.3 Independent Research & Development (IR&D). Defense contractors may charge a share of independent research and development (IR&D) and Bid and Proposal (B&P) costs as overhead on Defense contracts to the extent that such costs are allocable, reasonable, and not otherwise unallowable. For major contractors, generally such costs may not exceed a five percent increase in each of three transitional years beginning 1 October 1992. (A major contractor is essentially one that allocated more than \$10 million in IR&D/BP costs to defense contracts in the preceding fiscal year.) Allowable IR&D/BP costs are limited to work of potential interest to DOD. Allowable cost limitations may be waived in special circumstances.

Ref.: DOD Instruction 3204.1; SEC-NAV Instruction 3900.40; FAR 31.205-18; DFARS 225, 231, 242

6.5.5 Contracting for the Technology Base and Advanced Technology. Research and that development effort not related to specific system and hardware procurements involve extending knowledge of nature's laws and of their useful applications. Since the results of such efforts normally cannot be foreseen, contracts for this work often call for the delivery of a *specified level*

of effort rather than the achievement of a specified result (see 6.5.2 on types of contracts).

Ref.: FAR 35.005(a), (b), (c)

6.5.5.1 Full disclosure policy. As noted earlier, R&D contracts are required to contain a clause permitting the Government to make contract results available to other Government agencies and the private sector, consistent with national security and data rights specified in the contract.

Ref.: FAR 35.010

6.5.5.2 Government equipment for universities and other nonprofit institutions. The Navy encourages education and nonprofit institutions to maintain a high level of effort in basic technologies to enhance our long-range scientific knowledge. Under the Short Form Research Contract (DFARS Part 235), title to property approved for purchase with contract funds is vested automatically in the universities or nonprofit institutions, with few exceptions.

Also, when the Government has property which is excess to its needs and which has been identified as "surplus," title may be transferred to educational and nonprofit institutions in accordance with existent disposal regulations.

Ref.: DOD Directive 3210.2

6.6 SOLICITING R&D COMPETITIVE BIDS AND PROPOSALS

Full and open competition is widely used in acquiring R&D. One technique is "competitive proposals" (see 6.3.4) and another is Broad Agency Announcements (BAA's) (see 6.6.6). The

key elements in the competitive proposals process are as follow:

6.6.1 Procurement Request. The Procurement Request (PR) is prepared by the Technical Customer to initiate the contracting process. This document provides a complete and technically adequate statement of what is required, which is used first in the solicitation document (RFP/RFQ) (see 6.6.2), and later in the contract work statement (see 6.5.3.1). Assistance generally is available from the contracts group to help the Technical Customer in its preparation.

The PR is coordinated and reviewed extensively before approval for initiation of the contract action since it is the basis for the commitment of funds. It certifies that the necessary funds are available and have been reserved for the proposed contract.

6.6.2 Solicitation Documents. The solicitation document advises prospective performers of Government needs. It takes the form either of a Request for Proposals (RFP) or a Request for Quotation (RFQ). The RFQ is used when bilateral negotiation will be conducted before a binding contract will exist. In the RFP, the Government reserves the option to award the contract on the basis of the proposal without further negotiation. Responsibility for preparing the RFP or the RFQ, which is part of the "bid package," rests with the Contracting Officer.

The technical heart of the solicitation document is the prospective work statement which provides the potential contractor a comprehensive understanding of technical factors, criteria, and/or problems which should be considered in preparing the proposal, and which the Government will use in proposal evaluation. This part of the PR must be comprehensive and clear to ensure that all contractors solicited have a common understanding of the requirement and the proposed method of evaluation.

6.6.3 Promulgation of Solicitation Documents. The RFP or the RFQ is sent to all organizations

6.6.4

known to have the requisite capabilities. Bidders Mailing Lists are maintained by the purchasing activities. In addition, the Technical Customer indicates in the PR the organizations known to have the technical capabilities required to carry out the work.

Since proposals may be both costly and wasteful of scientific and engineering manpower, FAR 35.007(a) limits initial solicitation to sources judged to have the basic technical qualifications to perform research or development in the specified field. The solicitation also is given public notice in the Commerce Business Daily, a Department of Commerce publication. Firms learning of the solicitation through the Commerce Business Daily may request an RFP or RFQ.

A pre-solicitation conference may be held with potential contractors prior to promulgation of the solicitation document to clarify questions concerning the proposed contract and to elicit the interest of prospective contractors.

The information in the solicitation may be supplemented by a "pre-proposal conference." This is a meeting of prospective offerors arranged by the Contracting Officer to answer questions of prospective offerors and assist them in understanding the Government's requirements.

Ref.: FAR Part 5, 15.409, 35.004, 35.007

6.6.4 Evaluating Proposals and Bidders.

Evaluation leading to selection of the performer involves the evaluation of proposals against the evaluation factors stated in the solicitation. The Technical Customer should play a major role in determining the appropriate evaluation factors and will usually play a major role in judging the capability of the bidders to successfully perform the technical work.

Cost/price must always be a factor. Additional potential considerations include the following:

- The contractor's understanding of the scope of the work as shown by the technical approach proposed.
- The availability and competence of experienced engineering, scientific and other technical personnel.
- The availability of necessary research, test and production facilities and the contractor's willingness to invest in production tooling and test equipment.
- Experience or pertinent innovative ideas in the applicable branch of science or technology.
- The contractor's willingness to devote resources to the proposed work with appropriate diligence.
- The contractor's management capabilities, quality and cost controls, and record of past performance.
- The contractor must be responsible, in such respects as financial stability and adequate security arrangements.

Ref.: DOD Instruction 5000.2, Part 10, Section B; SECNAV Instruction 5000.2; FAR 9.1 and 35.008; NAPS 5215.6 and 5215.8

6.6.5 Source Selection. The basis for the award of Defense contracts is the same, regardless of the method of acquisition, type of contract or nature of work. The overriding aim is a contract and contractor most advantageous to the government and confidence that the work will achieve desired objectives. FAR makes it clear that in awarding R&D contracts, the basic policy is to favor organizations including educational institutions, that propose the best ideas or concepts and have the highest competence in applicable fields of science or technology (see FAR 35.008(a)). Cost must be taken into consideration, not only to determine reasonableness, but also to determine under-

standing of the project, perception of risks, and ability to organize and perform the work.

Ref.: DOD Instruction 5000.2, Part 10, Section B; SECNAV Instruction 5000.2; FAR 15.80, 35.008; DFARS 215.804; NAPS 5215.6, 5215.804

6.6.6 The Broad Agency Announcement. A full and open competitive technique, used for research and that development effort not related to specific system or hardware procurements is the Broad Agency Announcement (BAA) described under "Other Competitive Procedures" in FAR 6.102(d)(2). This announcement identifies areas of broad research interest, lists criteria to be used in the selection process and solicits proposals from capable contractors.

BAA differs from the "competitive proposal" process in that there is not a work statement but only an announcement of general research interest. Proposals submitted in these general areas may vary widely and, as provided in the BAA, may be submitted either by a common date or any time during the announcement period. Proposals are not necessarily evaluated against each other, but are selected on the basis of individual scientific merit. Proposals receive scientific review, and the resulting awards are counted as full and open competition.

6.7 MANAGEMENT ACTIVITIES DURING EXECUTION

Subsequent to the contract award, the execution of the work involves a number of control, status and management systems. These must be carefully designed during early planning stages, well before contract award.

6.7.1 Management Control Systems. The contractor is responsible for timely and

satisfactory performance of his contract. However, the Government also monitors his performance to ensure that the desired results are accomplished as scheduled.

Management control information is generated from data used by the contractor's operating personnel, and provided to meet successively higher level management and monitoring requirements. Contractor management information and program control systems and reports should be used as much as practicable. Government imposed changes to contractor systems should be limited to those necessary to satisfy established DOD-wide standards.

Management control system and/or reporting requirements which can be contractually imposed are limited to those systems described in the "Acquisition Management Systems and Data Requirements Control List (AMSDL)." (DOD List 5010.12-L)

The AMSDL provides various listings of management system elements and advises the user in using the listings in preparation of solicitation documents.

Requirements for DOD-imposed acquisition management systems must be specified in the RFP and contract. These requirements must be included in the planning documents, solicitations and final contract. This list indicates possible "tailoring," provides a cross reference to sections of the contract where the "tailoring" is described, and, for deliverable data, cites appropriate Data Item Descriptions (DIDs) contained in the "Contract Data Requirements List," DD Form 1423. In other words, constraints exist upon DON acquisition managers both in the management systems that may be imposed and on data the contractor may be required to submit based on such systems.

The intent of the policies is to keep cost of monitoring and reporting to the minimum by limiting management control systems to those essential to fulfilling Government needs.

6.7.2

For significant contracts in all acquisition programs, evaluation of a contractor's management control system and demonstration of the internal systems against criteria contained in DOD Instruction 5000.2, Part 11B and Cost/Schedule Control Systems Criteria (C/SCSC) Joint Implementation Guide, NAVSO P3627 is required. Significant contracts are RDT&E contracts with a value of \$60 million or more or procurement contracts with a value of \$250 million or more (1990 constant dollars).

Ref.: DOD Directive 7750.5; DOD Instruction 5000.2, Part 11, Section B; SECNAV Instruction 5000.2; DOD 5010.12-L; OASN(S&L) pamphlet P3627, Cost/Schedule Control Systems

6.7.2 Technical Reports. Scientific and technical reports are written for the permanent record to document results of R&D effort. A completed "Report Documentation Page," DD Form 1473, must be included in each copy of a scientific or technical report required by the contract. Copies of all technical reports are furnished to the Defense Technical Information Center (DTIC). (See Appendix D for additional information on DTIC.)

DOD Directive 5230.24; SECNAV Instruction 3900.29; MIL-STD-847A (SECNAV Instruction 3900.29); FAR 35.010(b); DFARS 35.010

6.7.3 Progress Reports. Standard contract provisions require the contractor to submit reports on the status and results of all work. The contract defines a detailed reporting policy, and monthly reports in the form of letters often are required. Information submitted includes:

- The number and names of key personnel working on the project.
- Facilities used.
- Direction of the work, and present and anticipated problems.
- Experiments being conducted.
- The latest work done—scientific data, observations, predictions and plans.
- Financial information.

6.7.4 Cost and Performance Reports. The cost and performance reports listed below are applied to various levels and types of contracts as prescribed by DOD Instruction 5000.2, Part 11. For all, costs are reported against the standard work breakdown structures (WBS) prescribed by MIL-STD-881 (see C11). The reports are not required on firm-fixed-price contracts unless the Milestone Decision Authority determines that circumstances require particular cost/schedule visibility.

Ref.: DOD Instruction 5000.2, Part 11, Section D; DOD 5000.2-M, Part 20; SECNAV Instruction 5000.2

6.7.4.1 Cost Performance Report. The Cost Performance Report (CPR) provides the Program Manager a means of collecting summary level cost and schedule performance data. It is applicable to all contracts subject to C/SCSC criteria (see 6.7.1).

6.7.4.2 Contractor Cost Data Reporting. Contractor Cost Data Reporting (CCDR) provides a consistent, uniform historical cost data base for:

- Preparing independent cost estimates for weapon systems acquisitions to be reviewed by the Defense Acquisition Board (DAB).
- Developing cost estimates in support of analysis and contract negotiations.
- Tracking contractor's negotiated costs.

Through the use of standard definitions, standard WBS, uniform reporting and a cost

exchange system, the information collected provides a common data base for cost estimating within the DOD. CCDR is mandatory for all ACAT I programs and optional for others at the discretion of SECNAV, ASN(RD&A), or the milestone decision authority.

6.7.4.3 Contract Funds Status Report.

The Contract Funds Status Report (CFSR) supplies funding data that, along with other performance measurement inputs, provide DOD with information to assist in:

- Updating and forecasting contract fund requirements.
- Planning and decision-making on funding changes.
- Developing fund requirements and budget estimates in support of approved programs.
- Determining available funds in excess of contract needs.

CFSR normally applies to all contracts of over \$1 million and over 6 months..

6.7.4.4 Cost/Schedule Status Report (C/SSR). The Cost/Schedule Status Report is used to obtain contract cost and schedule performance information on contracts over 12 months in duration where application of the Cost Performance Report (see 6.7.4.1) is not appropriate.

6.7.5 Administration of Contracts. Responsibility for administration of contracts usually is delegated to contract administration offices upon contract award. These offices include those established by the Defense Contract Management Command (DCMC) of the DOD Defense Logistics Agency, and those established by the Navy within the Supervisor of Shipbuilding and Conversion (SUPSHIPS) organization.

The services these offices provide include contract administration, production and quality assurance, data and financial management

activities (and administration of the industrial security program) and contract compliance. They also provide access to small business/labor surplus area firms.

The Program Manager of a major program or of one meeting DOD Instruction 5000.2 cost thresholds is required to have representation at or near the contractor's site. This representation may be technical representatives assigned to existing DCMC offices or to Contract Administration Offices of other Services.

The handbook, DOD Directory of Contract Administration Services Components (DLAH 4105.4) identifies DOD organizations performing contract administration services.

Ref.: DLAH 4105.4

6.7.6 Selected Acquisition Report. The Selected Acquisition Report (SAR) is a standard, comprehensive, summary status report on major programs. The report's data meets the requirements of DOD management as well as the needs of Congressional review. Technical, schedule, and program cost sections are the heart of the SAR. These sections compare current estimates with the planning and development estimates in the approved Acquisition Program Baseline Agreement (APBA). Reasons for variance are required and demonstrated performance must be reported in the technical section.

SARs normally are prepared only for programs designated by the SECDEF as major Defense acquisition programs (Acquisition Category I). SARs are prepared by the Program Manager for submission through the SECNAV to the Secretary of Defense. SECDEF then forwards selected reports as requested to the Senate and House Armed Services and Appropriations Committees for information. The General Accounting Office also receives copies of the SARs.

6.7.7

Ref.: DOD Instruction 5000.2, Part 11, Section D; DOD 5000.2-M, Part 17; DOD 7000.3-G; SECNAV Instruction 5000.2

6.7.7 Other Reports. Several other reports are submitted by the Technical Customer.

6.7.7.1 Research and Technology Work Unit Summary. The R&T Work Unit Summary (DD Form 1498) is used to report ongoing effort at the work unit level. Work unit summaries are updated annually, or more frequently as significant changes occur.

Ref.: DOD 3200.12-R-1; SECNAV Instruction 3900.43

6.7.7.2 RDT&E project listings. RDT&E project listings were discussed in Chapter 4, "Budget Preparation and Justification" (see 4.2). Project listings are prepared during each year to support the May POM submission to OSD; the July budget submission to the Navy Comptroller; the September budget submission to OSD/OMB; and in December to reflect the President's budget. An additional listing is prepared by ONR Comptroller in May in support of the RDT&E Apportionment Requests.

6.7.7.3 Reporting by laboratories/centers. Reporting by the laboratories and centers consists of inputs to the DOD Work Unit Information System (DD Form 1498) and project and financial status reporting as agreed to between the laboratory/center and the customer.

6.7.8 Changes and Amendments to Contracts. Contract modifications, as defined by FAR 43.101, means any written change in the terms of a

contract. Changes must be accomplished by the Contracting Officer.

6.8 EXECUTION OF MARINE CORPS R&D

Ref.: MCO P5000.10, 5000.15

6.8.1 Execution Approaches. Execution of RD&A to meet Marine Corps needs is accomplished in a number of ways:

- By unilateral development of a system within the Marine Corps.
- By direct acquisition from a contractor or another Service.
- By transferring funds to another Service and "buying" a percentage of the management of a development program which the other Service conducts.
- By officially indicating interest in a development program which is totally funded by another service.
- By participation in a Joint Service Program.

The primary consideration determining the acquisition approach is whether the end product is required by the landing forces in amphibious or expeditionary operations. If so, the development is a Marine Corps responsibility and will be funded and controlled by the Marine Corps, either directly by procurement or a contractor's services or indirectly by transferring funds to another Service. If the end product is not peculiar to the needs of the landing forces, another Service will be formally requested to initiate, or modify, a development program to satisfy requirements of both the Marine Corps and the sponsoring Service.

6.8.2 Program Cognizance within the Marine Corps. Responsibility for program cognizance during the execution of R&D, acquisition and life-cycle management lies with the Office of the

Commander, Marine Corps Systems Command (COMMARCORSYSCOM) which coordinates and integrates the conduct of implementing actions. Additionally, COMMARCORSYSCOM serves as the point of contact for R&D and acquisition matters between the Marine Corps and external agencies.

6.8.3 Management of Acquisition. The total development effort managed by the Marine Corps greatly exceeds the amount supported with Marine Corps RDT&E funds. For example, a program totally funded by the Army can be as vital to future Marine Corps capability as a program financed by the Marine Corps. The Marine Corps devotes as much management attention to the former as to the latter.

6.8.4 Role of Marine Corps Systems Command (MARCORSYSCOM). MARCORSYSCOM is the primary field agency for the management of developmental efforts conducted on behalf of the Marine Corps. When such efforts are funded and controlled by the Marine Corps in execution of the Commandant's responsibility for the development of landing force weapons and equipments, or when the end product is being developed to satisfy a Marine Corps-peculiar requirement, MARCORSYSCOM's management role is active. When such efforts are conducted by another Service to satisfy requirements of both the Marine Corps and the sponsoring Service, MARCORSYSCOM's management role principally involves monitoring developmental efforts to ensure that Marine Corps requirements are satisfied and that any Marine Corps funds invested are appropriately utilized.

6.8.5 Role of the Navy Laboratories. Navy laboratory support of Marine Corps R&D includes:

- Identifying the development efforts (exploratory, advanced, engineering) and the technical requirements necessary to attain them.
 - Formulating (in conjunction with MARCORSYSCOM) tentative development programs to implement Marine Corps requirements.
 - Providing technical management of programs approved and funded to meet USMC requirements or the monitoring and providing of scientific/technical guidance on programs concerned with Marine Corps requirements but conducted by other Services.
- Assisting in developing and updating the Marine Corps Long-Range and Mid-Range Objective Plan, and the material objectives that flow from them.

6.9 PROGRAM MANAGEMENT

The Program Manager (PM) is responsible to the Program Executive Officer (PEO) or SYSCOM Commander (see E10.6), and is directly accountable for the successful implementation of the approved program.

PMs are responsible for ensuring that the program schedule and funding are consistent with the acquisition policies established in DOD Instruction 5000.2, as implemented by SECNAV Instruction 5000.2 from inception through completion. These elements of program management are to be adjusted as necessary throughout the acquisition cycle. Such adjustments shall be reflected in documents included in the PPBS process, decision-milestone process (i.e., ARBs, NPDM/MCPDM, DABs), in the Acquisition Strategy Report (ASR), in the AP, and in the APBA.

Changes in approved programs must be firmly controlled. Changes in baseline schedule, configuration, performance characteristics, or acquisition strategy which will increase funding requirements above the APBA thresholds of DOD Instruction 5000.2 and SECNAV Instruction 5000.2 must be presented for review in accordance with those Instructions.

*Ref.: DOD Instruction 5000.2, Part 11,
Section A; SECNAV Instruction 5000.2;
SECNAV Instruction 5420.188*

6.10 COMPUTER-AIDED ACQUISITION AND LOGISTICS SUPPORT (CALs)

CALs is a DOD initiative to transition from paper-intensive, nonintegrated weapon system design, manufacturing, and support processes to a highly automated and integrated mode of operation. The transition will be facilitated by acquiring, managing, and using technical data in

standardized digital form. This will be implemented between 1992 and 2010 by the development of an integrated technical data environment, the Integrated Weapon System Data Base (IWSDB).

SECDEF has directed that acquisition plans and solicitations give preference to contractor information systems and digital data, and ASN(RD&A) has directed that PEOs, DRPMs, and SYSCOMs aggressively incorporate CALs planning in acquisition strategy. CALs policy, plans, and coordination are established by N4.

*Ref.: DOD Instruction 5000.2, Part 6,
Section N; OPNAV Instruction 4120.5*

SELECTED REFERENCES ON MANAGING ACQUISITION OF RD&A EFFORT

Federal Acquisition Regulation (FAR)

DOD FAR Supplement (DFARS)

Navy Acquisition Procedures Supplement (NAPS)

DOD Instruction 5000.2, "Defense Acquisition Management Policies and Procedures."

DOD 5000.2-M, "Defense Acquisition Management Documentation and Reports."

SECNAV Instruction 5000.2, "Implementation of Defense Acquisition Management Policies, Procedures, Documentation and Reports."

NOTE REGARDING DIRECTIVE NUMBERS

References to directives within this Guide are by series only; e.g., 3900.14, not to the effective edition within the series; e.g., 3900.14A.

The "Master Reference List" shows the version and issue date of each directive used in preparation of this edition of the Guide.

For recent information on the effective directive within a series, consult "Department of the Navy Directives Issuance System: Consolidated Subject Index." (NAVPUBNOTE 5215)

Chapter 7
TEST AND EVALUATION

TABLE OF CONTENTS

7.1	Background	7-1
7.1.1	Nature of Test and Evaluation	7-1
7.1.2	T&E Functions	7-1
7.1.2.1	Information for development	7-1
7.1.2.2	Information for acquisition milestone decisions	7-1
7.1.2.3	Information for effective operational utilization	7-2
7.1.3	Policy on T&E	7-2
7.1.4	T&E in the Acquisition Cycle	7-2
7.1.5	Congressional Interest in Test and Evaluation	7-2
7.1.6	Waiver of T&E Requirements	7-3
7.1.7	Production Milestones	7-3
7.1.7.1	Approval for Full Rate Production (AFRP)	7-3
7.1.7.2	Low Rate Initial Production (LRIP)	7-3
7.1.8	T&E for Non-Development Items (NDI)	7-3
7.1.8.1	T&E of foreign systems	7-3
7.2	Organization for Test and Evaluation	7-4
7.2.1	T&E Responsibilities in OSD	7-4
7.2.1.1	Director, Test and Evaluation (DT&E)	7-4
7.2.1.2	Director of Operational Test and Evaluation	7-4
7.2.2	SECNAV's T&E Involvement	7-5
7.2.3	T&E Responsibilities in OPNAV	7-5
7.2.4	Board of Inspection and Survey	7-5
7.2.5	Operational Test and Evaluation Force (OPTEVFOR)	7-6
7.2.6	T&E Focal Points/Coordinators	7-6
7.2.7	Program Managers	7-6
7.2.8	T&E Coordination Group (TECG)	7-6
7.2.9	Test Planning Working Group (TPWG)	7-7
7.2.10	T&E Responsibilities in the Marine Corps	7-7
7.2.10.1	Marine Corps Operational Testing and Evaluation Activity (MCOTEA)	7-7
7.2.10.2	Fleet Marine Force (FMF)	7-7
7.3	Test and Evaluation Resources	7-7
7.3.1	T&E Field Activity Capabilities	7-7
7.3.2	Scheduling Use of Facilities	7-8
7.3.3	Obtaining New Facilities	7-8
7.3.4	Land-Based Test Sites (LBTS)	7-8
7.3.5	Major Range and Test Facility Base (MRTFB)	7-8

7.3.5.1	Elements of the MRTFB	7-8
7.3.5.2	Funding	7-9
7.3.6	Targets and EW Simulators	7-9
7.3.7	R&D Support	7-9
7.3.7.1	R&D support requirements	7-9
7.3.7.2	R&D support priorities	7-9
7.3.7.3	Scheduling R&D support	7-10
7.3.7.4	OT&E support for the Marine Corps	7-10
7.3.8	RDTE Platform Resources	7-10
7.4	Test and Evaluation Categories	7-10
7.4.1	Developmental Test and Evaluation (DT&E)	7-10
7.4.1.1	DT-I	7-10
7.4.1.2	DT-II	7-10
7.4.1.2.1	Technical Evaluation	7-11
7.4.1.3	DT-III	7-11
7.4.1.4	Production Acceptance T&E	7-11
7.4.2	Operational Test and Evaluation	7-11
7.4.2.1	OT-I	7-11
7.4.2.1.1	The Beyond Low Rate Initial Production Report	7-12
7.4.2.2	OT-II	7-12
7.4.2.3	OT-III	7-12
7.4.2.4	OT-IV	7-12
7.4.3	Board of Inspection and Survey Acceptance Trials	7-12
7.4.4	Joint Service Programs	7-13
7.4.4.1	Joint Test and Evaluation	7-13
7.4.4.2	Two-sided testing	7-13
7.4.4.3	Multiservice T&E	7-13
7.4.4.4	Funding of joint Service programs	7-13
7.4.5	Combined and/or Concurrent DT/OT	7-13
7.5	Planning for Test and Evaluation	7-13
7.5.1	Definition of Test Issues and Problems	7-14
7.5.2	Coordination with OPTEVFOR	7-14
7.5.3	Test and Evaluation Master Plan (TEMP)	7-14
7.5.4	Funding T&E	7-14
7.5.5	T&E Task Statements	7-15
7.5.6	Test Resource Planning	7-15
7.5.7	T&E Identification Number	7-15
7.6	Flow of Test & Evaluation Information to Users	7-15
7.6.1	T&E Information for Developers	7-15
7.6.2	Information for Program Managers	7-15

7.6.3	Information for Milestone Decisions	7-15
7.6.4	Information for Operating Forces	7-15
7.6.5	Information for the Board of Inspection and Survey	7-16
7.6.6	Formal T&E Reports and Their Availability	7-16
7.7	Test & Evaluation of Integrated Logistic Support	7-16
7.7.1	Requirements for ILS T&E	7-16
7.7.1.1	Operational Availability (Ao)	7-16
7.7.2	Timing of ILS T&E	7-17
7.7.3	Outputs of ILS T&E	7-17
7.7.4	Use of ILS T&E Results	7-17
7.8	Test & Evaluation for Ship Acquisition	7-17
7.8.1	Policies and Principles	7-18
7.8.2	Ship Acquisition T&E Planning	7-18
7.8.3	Organization for Ship T&E	7-19
7.8.4	Acceptance of Ships	7-19
7.8.5	Certification of Ship Aviation Facilities	7-19

Chapter 7

TEST AND EVALUATION

Department of the Navy research and development are discussed from the viewpoint of test and evaluation: policies, types of tests, facilities and resources, planning, execution, and utilization of results of test and evaluation (T&E).

7.1 BACKGROUND

This section, which provides a frame of reference for the rest of the chapter, covers the nature and purpose of test and evaluation and basic policy on T&E.

7.1.1 Nature of Test and Evaluation. While the terms "test" and "evaluation" most often are found together, they actually denote clearly distinguishable functions in the R&D process. "Test" is the examination of hardware/software—models, prototypes, production equipment, computer programs—to obtain data. "Evaluation" is the process in which data are logically assembled and analyzed to aid in making systematic decisions.

Test and evaluation involve the deliberate and rational generation of data useful to the technical and managerial personnel who control development. T&E may be defined broadly as all physical testing, experimentation and analyses performed during the course of research, development, introduction and employment of a weapon system or subsystem.

7.1.2 T&E Functions. Test and evaluation are integral to the development of systems and equipments. Testing provides information for a number of purposes and several classes of

information users. Principal purposes are described below.

7.1.2.1 Information for development. Testing of systems under development is used to determine whether thresholds have been met, and to identify and resolve technical uncertainties and problems. While information on such problems is generated primarily through testing by the developer, Government testing by the developing agency and the independent operational test agency is conducted during development to verify system performance status and efficacy of corrections to previously identified problems.

7.1.2.2 Information for acquisition milestone decisions. Many of the major milestone decisions, such as to initiate development or to conduct full-scale development, essentially are investment decisions. The decision makers are responsible for putting available resources to their most productive use. The issue in these milestone decisions is whether initiating, continuing, or committing additional resources to the acquisition will result in the most productive use of the required resources—money, material and personnel.

T&E provides information for these decisions, including data on operational effectiveness, operational suitability (including reliability, logistics, operational supportability, organization, doctrine and tactics for system deployment), needs for modifications or further development, and for estimating the probable cost of completing development, acquisition and ownership.

7.1.2.3

7.1.2.3 Information for effective operational utilization. The operating forces are another set of users of test information. An output of the operational evaluation effort is the development of tactics and doctrine for the most effective use of the system.

7.1.3 Policy on T&E. Development policy requires periodic performance demonstrations. Programs are structured and resources allocated to ensure that the demonstration of achievement of program objectives is the pacing function (see DOD Instruction 5000.2, Part 8, para 2 for "general policies").

A basic policy for operational test and evaluation is the concept of the "independent evaluation." An organization with a vested interest in "selling" the developing system is not to have unilateral control in establishing test requirements, the conduct of tests, or evaluation of results. The operating forces and the "buyer" of the system (for example, SECDEF for major programs) play a key role in determining test requirements and have access to an independent evaluation of test results.

Assessment of operational effectiveness and suitability through Initial Operational Test and Evaluation (IOT&E) is required before the Milestone III decision. IOT&E must be the product of an independent test organization: Operational Test and Evaluation Force (OPTEVFOR) or the Marine Corps Operational Test and Evaluation Activity (MCOTEA).

The principle of independent evaluation always has been fundamental to Navy development procedures. Evaluation for operational effectiveness and suitability, including a recommendation for fleet introduction, is performed by OPTEVFOR (see 7.4.2). Acceptance trials of vessels and aircraft are conducted by the Board of Inspection and Survey (see 7.4.3). Both organizations report directly to the Chief of Naval Operations for these purposes.

No new system or significant alteration to an existing system may be approved for production until it has been adequately tested and proved operationally effective and suitable (including logistical supportability).

Ref.: DOD Directive 5000.1; DOD Instruction 5000.2, Part 8; SECNAV Instruction 5000.2; OPNAV Instruction 5000.42; 10 U.S. Code 2399, 2400

7.1.4 T&E in the acquisition cycle. T&E is an essential part of the acquisition process. T&E begins in the earliest phase of RDT&E with experimental testing of scientific hypotheses and continues beyond completion of development where primary emphasis is on perfecting doctrine for the most effective employment of advanced weapons.

Ref.: DOD Directive 5000.1, SECNAV Instruction 5000.2

7.1.5 Congressional Interest in Test and Evaluation. The importance of test and evaluation, particularly Operational Test and Evaluation, in the eyes of Congress is reflected in the following passages from Title 10, United States Code:

2431. Weapons development and procurement schedules.

(a) The Secretary of Defense shall submit to Congress each calendar year ... a written report regarding development and procurement schedules for each weapon system for which ... funds for procurement are requested in that budget. The report shall include data on operational testing and evaluation ...

138. Director of Operational Test and Evaluation.

(a) (1) There is a Director of Operational Test and Evaluation in the Department of Defense, appointed ... by the President, by and with the advice and consent of the Senate ...

(c) The Director reports directly, without intervening review or approval, to the Secretary of Defense ...

(e) (1) The Secretary of a military department shall report promptly to the Director the results of all operational test and evaluation conducted by the military department and all studies conducted by the military department in connection with operation test and evaluation in the military department. ...

2399. Operational Test and Evaluation of defense acquisition programs.

(b) (4) A final decision within the Department of Defense to proceed with a major defense acquisition program beyond low-rate initial production may not be made until the Director has submitted to the Secretary of Defense the report with respect to that program under paragraph (2) and the Congressional defense committees have received that report.

7.1.6 Waiver of T&E Requirements. Waivers of the T&E requirement are rare, and the process purposely is difficult. Only the Secretary of Defense can grant such waivers to an approved Test and Evaluation Master Plan (TEMP) for a major program.

Ref.: DOD Instruction 5000.2, Part 8

7.1.7 Production Milestones. There may be several, "Production," decisions, particularly for very costly programs.

Ref.: SECNAV Instruction 5000.2

7.1.7.1 Approval for Full Rate Production (AFRP). AFRP at Milestone III signifies that:

- The system has demonstrated, through TECHEVAL, achievement of its technical thresholds.
- The system has demonstrated, through OPEVAL, achievement of operational thresholds and its operational effectiveness and operational suitability.
- The system has demonstrated, through ILS audit, that support planning is satisfactory.
- No additional development work is required.

7.1.7.2 Low Rate Initial Production (LRIP). LRIP is accomplished during Phase II.

LRIP quantity is determined by the milestone decision authority—for ACAT I programs in consultation with the DOT&E. Considerations include requirements for production-representative systems for OT&E and the need to preserve a production base for the system.

Ref.: 10 U.S. Code 2400

7.1.8 T&E for Non-Development Items (NDI). NDI strategies are preferred solutions as a matter of policy. In describing any NDI to be considered, the Developing Agency (DA), e.g., SYCOM, PEO, or DRPM, with the assistance of COMOPTEVFOR, will determine needed T&E and provide recommendations to the CNO.

Ref.: DOD Instruction 5000.2; OPNAV Instruction 5000.42

7.1.8.1 T&E of foreign systems. Deployment of selected foreign systems can make possible significant saving by avoiding duplicative R&D. The DOD manual on "Foreign Weapons

7.2

Evaluation and NATO Comparative Test Programs'' provides policy guidance and procedures for T&E of foreign nations' weapon systems, equipment, and technologies.

Ref.: DOD 5000.3-M-2

7.2 ORGANIZATION FOR TEST AND EVALUATION

Appendix G provides supplemental data to the summary information discussed herein.

7.2.1 T&E Responsibilities in OSD. T&E responsibilities in OSD are divided between the Director, Test and Evaluation and the Director, Operational Test and Evaluation.

Ref.: DOD Instruction 5000.2, Part 8

7.2.1.1 Director, Test and Evaluation (DT&E). The DT&E serves as the principal staff assistant and advisor to USD(A) on T&E within DOD. His responsibilities include:

- Overseeing all Developmental Test and Evaluation (DT&E) conducted with DOD, including designating RDT&E programs as major for such oversight. He provides advice and recommendations to SECDEF and guidance and consultation to Component Heads.
- Serving as OSD focal point for review, coordination, and approval of TEMPs. DT&E and the Director of Operational Test and Evaluation (see 7.2.1.2) are approval authorities for all DOD major program TEMPs.
- Monitoring and reviewing RDT&E to ensure adherence to policy, guidance, and standards.
- Providing the DAE and DAB principals at each major systems review a technical assessment of T&E conducted by Navy and other DOD organizations.

- Designating observers as required to be present at DT&E activities.
- Sponsoring joint and national test resource acquisition.
- Overseeing the DOD Major Range and Test Facility Base (MRTFB) (see 7.3.5); developing test resources.
- Serving as the OSD focal point for review, coordination, and approval of Live Fire Test and Evaluation (LFT&E) policy.
- Review of new major defense acquisition program requirements documents and integrated program summaries of DT&E implications, resource requirements, and providing comments to the DAE and the DAB principals.
- Administration of the Foreign Weapons Evaluation Program.
- Maintaining a DOD Test and Evaluation Master Library and Data Base.
- Confirming, with advice from the ATSD(AE) that nuclear survivability and hardness objectives are achieved during DT&E.

*Ref.: DOD Instruction 5000.2, Part 8;
DOD 5000.3-M-2*

7.2.1.2 Director of Operational Test and Evaluation. The Director of Operational Test and Evaluation (DOT&E) is the principal staff assistant and advisor to the Secretary of Defense on OT&E and is the DOD's principal OT&E official (see E1.3). His principal responsibilities include:

- Prescribing policies, procedures, and standards for OT&E.
- Providing guidance for conduct of OT&E in general and specific OT&E for major systems.
- Monitoring and reviewing all OT&E within DOD.
- Designating observers to be present during preparation for and conduct of the testing portion of OT&E.

- Controlling multiservice OT&E and coordinating OT&E conducted by more than one Military Department or Defense Agency.
- Providing DAE and DAB with OT&E comments relating to all DAB acquisition activities.
- Analyzing the results of major system acquisition OT&E. For major systems and DOT&E oversight programs, reporting to SECDEF and to Congressional Armed Services and Appropriations Committees that OT&E:
 - is adequate and
 - confirms effectiveness and suitability for combat of systems tested.
- Making recommendations to SECDEF on all budgetary and financial matters pertaining to OT&E, including facilities and equipment.
- Approving OT&E plans for major defense acquisition programs and DOT&E oversight programs.

*Ref.: DOD Instruction 5000.2, Part 8;
DOD Directive 5141.2*

7.2.2 SECNAV's T&E Involvement. The Secretary of the Navy, as head of the Department of the Navy, is responsible for the policies and control of the Navy, including weapon systems acquisition programs. SECNAV assigns general and specific Research and Development T&E responsibilities to the Assistant Secretary of the Navy (Research, Development and Acquisition) and T&E responsibilities to the Chief of Naval Operations.

Ref.: DOD Directive 5100.1 (SECNAV 5410.85); SECNAV Instructions 5410.85, 5430.7

7.2.3 T&E Responsibilities in OPNAV. The CNO has responsibility for ensuring the adequacy of the Navy's overall test and evaluation program. T&E policy and guidance are exercised through the Director, Test & Evaluation and Technology Requirements (N091) in accordance with overall policies of the Secretary of the Navy. (See E3.1.2.)

The Director, Test and Evaluation Division (N912) is responsible for implementing the responsibilities of N091 and for coordinating all test and evaluation associated with development of systems and equipment. The Director, RDT&E Facilities and Resources Division (N913) acts as the Resource Sponsor for Navy Major Range and Test Facility Base (MRTFB) components to ensure adequate range support of RDT&E projects (see 7.3.5). N913 is also the Resource Sponsor for COMPTEVFOR and some laboratory facilities, and for development of aerial and seaborne targets and EW simulators (see 7.2.5 and 7.3.6). The OPNAV Sponsor is responsible for establishment of acquisition program requirements and related system thresholds.

*Ref.: OPNAV Instructions 5000.42,
5430.48*

7.2.4 Board of Inspection and Survey. The Board of Inspection and Survey—"BIS" to the aviation community, "INSURV" in ship circles—is responsible for conducting acceptance trials of vessels and aircraft. The INSURV also conducts material inspections of vessels, surveys of vessels, and such other inspections and trials of naval vessels and aircraft as may be directed by the CNO (see G12.1).

The Board of Inspection and Survey consists of a permanent president (PRESINSURV) and small permanent staff. This cadre is augmented by personnel and resources from other organizations for the conduct of particular trials. For example, in performing INSURV trials of aircraft, test pilots and other personnel are assigned temporarily to the

7.2.5

Board of Inspection and Survey. The technical commands supply assistant inspectors for ship trials and inspections.

Ref.: Article 0321, U.S. Navy Regulations, 1973; OPNAV Instructions 5000.42, 5420.70

7.2.5 Operational Test and Evaluation Force (OPTEVFOR). OPTEVFOR is the Navy's independent operational test agency responsible for initial and follow-on OT&E. (See 7.4.2 and G12.2) Projects are assigned to OPTEVFOR by CNO, and COMOPTEVFOR reports for command directly to CNO. Results of OPTEVFOR evaluations are reported to CNO, SECNAV and, when appropriate, to CMC by the Commander, OPTEVFOR.

Having a relatively modest number of personnel and resources on the east and west coasts, COMOPTEVFOR relies heavily on the facilities, resources, and personnel of the operating forces, the developing agencies, and field activities for carrying out his mission. Close liaison is authorized and exercised with appropriate elements of the Systems Commands and other T&E organizations to facilitate test support.

OPTEVFOR is involved in varying degrees with all phases of R&D from earliest development to evaluation of newly developed equipment and appraisal of systems already in the Fleet. Involvement in early phases of research and development includes inputs to the Test and Evaluation Master Plan (TEMP), observing development testing, and conducting those phases of operational testing necessary to provide CNO or the CMC with an early and independent operational assessment.

Ref.: OPNAV Instructions 5000.42, 5440.47

7.2.6 T&E Focal Points/Coordinators.

Responsibility for coordination of T&E matters in OPNAV; the PEO, DRPMs, and designated PMs; Systems Commands; and DON Centers rests with a T&E focal point, which may or may not have a title, such as T&E Coordinator. Typical functions of the T&E focal point for a Systems Command include:

- Developing comprehensive information concerning availability of resources, timing, and requirements of test programs, and T&E workloads at various commands.
- Assisting in the preparation and review of the T&E portion of major planning documents such as MNS, ORDs, and TEMPs.
- Monitoring test program progress, and recommending program readiness to proceed through successive phases of development.
- Coordinating meetings on certification of readiness for OPEVAL, adjudication of internal systems problems, and internal reviews of TEMPs.

7.2.7 Program Managers. The Program Manager (PM) is responsible for developing and executing an adequate T&E program. His T&E responsibilities include:

- Defining, in collaboration with the CNO Test and Evaluation Coordinator and COMOPTEVFOR, a test program which will illuminate test issues and problems (see 7.5.1).
- Preparing and updating the TEMP (see 7.5.3).
- Arranging performance of required T&E.
- Budgeting and justifying the funding and resources necessary for performing the required T&E as contained in the Test and Evaluation Master Plan (TEMP).

7.2.8 T&E Coordination Group (TECG). Complex, multifaceted programs may require

extensive T&E coordination. To assist in this and resolve outstanding T&E issues, a TECG may be established by N091. The TECG will include the Requirements Officer, the Test and Evaluation Coordinator, and others as appropriate (such as a PRESINSURV representative for ship and aircraft programs). TECG recommendations may be included in the TEMP.

Ref.: OPNAV Instruction 5000.42

7.2.9 Test Planning Working Group (TPWG).

In order to establish early and effective communications with everyone in the test and evaluation team, the SYSCOM/PEO/DRPM/PM may establish a TPWG. The TPWG provides the forum for discussion of, coordination on, and resolution of test planning goals and issues. The TPWG should be chaired by the Program Manager. Membership should include the Requirements Officer, N912 T&E Coordinator, COMOPTEVFOR staff, program office DT representatives, SYSCOM T&E Division representatives, ASN(RD&A) staff, contractors, and others as appropriate.

Ref.: OPNAV Instruction 5000.42

7.2.10 T&E Responsibilities in the Marine Corps. The CMC has responsibility for ensuring the adequacy of testing and evaluation of all systems to be acquired by the Marine Corps. T&E policy and guidance are exercised through the Commander, Marine Corps Systems Command (COMMARCORSYSCOM) for development testing, in accordance with overall policies of the Secretary of the Navy and the Secretary of Defense (see G13).

Ref.: SECNAV Instruction 5000.2

7.2.10.1 Marine Corps Operational Testing and Evaluation Activity (MCOTEA).

As with other Services, Operational Testing, including IOT&E and FOT&E, must be conducted by a major field agency separate and distinct from both the using command and the command with development and/or procurement responsibilities. MCOTEA performs this function for and reports the results of its independent evaluation to the CMC (see G13.2). OT&E is conducted in phases appropriate to key decision points in the system acquisition process.

Ref.: MCO 3960.2

7.2.10.2 Fleet Marine Force (FMF). The FMF is responsible for conducting OT&E under the direction of MCOTEA, supporting DT&E in coordination with COMMARCORSYSCOM, and providing personnel or units to participate in joint T&E as assigned.

Ref.: MCOs P5000.10, 5000.11

7.3 TEST AND EVALUATION RESOURCES

This section describes the policies, organizations and responsibilities associated with the resources essential to T&E programs, including the range and test facility base, field RD&A support, new test capabilities, facilities, targets, and EW simulators.

7.3.1 T&E Field Activity Capabilities. The various capabilities of the Navy's T&E field activities can be found in referenced publications and by conferring with such agencies as the OPNAV RDT&E Facilities and Resources Division (N913), the T&E branch of the appropriate SYSCOM, and PMs.

Ref.: RDT&E Center Management Briefs; NAVSEA Test and Range

7.3.2

Facilities Catalog; Army Material Development and Readiness Command DARCOM 70-1, Army Test Facilities Register; Air Force Systems Command AFCP-80-3, Air Force Test Facilities Register

7.3.2 Scheduling Use of Facilities. Advanced scheduling is the key factor in obtaining use of test ranges and other facilities. Early liaison with facilities supervision will assist in the definition of a practical test plan to be incorporated in the TEMP, and will allow the facility the leadtime needed to provide required support. Funding of such tests is discussed in 7.5.4.

Ref.: DOD Directive 3200.11 (OPNAV 3900.25); OPNAV Instruction 3900.25; T&E Assets Database (available on TECNET)

7.3.3 Obtaining New Facilities. If the identification of T&E capabilities reveals that new facilities will be needed, extra long leadtimes may be necessary to obtain MILCON funding and to complete construction.

According to T&E funding policy (see 7.5.4), MILCON expenditures may be considered part of the institutional share, chargeable to the T&E facility.

Ref.: DOD Directive 3200.11; DOD 3200.11-D; OPNAV Instruction 3900.25

7.3.4 Land-Based Test Sites (LBTS). The complexity of modern systems and their attendant software and integration requirements have emphasized the value of the LBTS to the development, integration, test, configuration

management, and life-cycle support of many Navy systems. An LBTS is a facility duplicating or simulating a system's planned operational capability.

OT&E intended to support production decisions is required to be performed in an operational environment, rather than a LBTS, except when otherwise directed by CNO. Therefore, use of a LBTS, if in lieu of an actual host platform, must be justified based on cost-effectiveness and needed capability and requires N091 approval.

Ref.: OPNAV Instruction 5000.42

7.3.5 Major Range and Test Facility Base (MRTFB). The mission of the MRTFB is to provide a comprehensive range and test support base to all DOD Components and other authorized users responsible for R&D development and for operation of equipment and weapon systems.

The MRTFB is composed of 20 DOD major ranges and test facilities, which are managed by the Services and monitored for OSD by the Director, Test and Evaluation (see 7.2.1.1).

The Director, RDT&E Facilities and Resources Division (N913) is responsible for management of Navy elements of the MRTFB at the OPNAV level (see 7.2.3).

*Ref.: DOD Directive 3200.11;
DOD 3200.11-D;
OPNAV Instruction 3900.25*

7.3.5.1 Elements of the MRTFB. Each of the elements listed below is operated by one of the Services.

- Navy elements
 - Atlantic Undersea T&E Center
 - Naval Air Warfare Center Weapons Div., Pt. Mugu

- Naval Air Warfare Center Aircraft Div., Pax River
- Naval Air Warfare Center Weapons Div., China Lake (T&E portion only)
- Naval Air Warfare Center Aircraft Div., Trenton
- Army elements
 - Aberdeen Proving Ground (Material)
 - Dugway Proving Ground
 - Electronics Proving Ground
 - Kwajalein Missile Range
 - White Sands Missile Range
 - Yuma Proving Ground
- Air Force elements
 - Air Force Flight Test Center
 - Utah Test and Training Range
 - Air Force Development Test Center
 - Arnold Engineering Development Center
 - 45th Space Wing (Eastern Range)
 - 30th Space Wing (Western Range)
 - 6585th Test Group
 - Fighter Weapons Center
 - 4950th Test Wing

7.3.5.2 Funding. Most MRTFB activities operate under the DOD uniform funding policy, i.e., the user pays direct costs of services provided and the T&E activity pays indirect costs. This ensures that T&E is carried out at the best qualified activity, regardless of managing Service, by providing some cost uniformity among activities (see 7.5.4).

Early T&E program liaison is necessary to establish resource and schedule requirements needed to develop realistic cost estimates, including cost of new resources which may be "user unique" and, therefore, chargeable to the program.

7.3.6 Targets and EW Simulators. The Program Executive Officer for Cruise Missiles and Unmanned Aerial Vehicles Projects (PEO(CU)) (PMA 208) is responsible for developing, acquiring and managing the procurement of aerial

targets for support of T&E and Fleet training programs. The development, acquisition, and management of underwater and seaborne targets are the responsibility of NAVSEA (SEA 06U and PMS 300, respectively). The Program Manager REWSON is responsible for development, acquisition, and management of EW simulators.

7.3.7 R&D Support. R&D support encompasses the support provided by operational naval forces having a primary mission other than R&D to the DA, COMOPTEVFOR, PRESINSURV, or an R&D agency. There are three types of R&D support: dedicated support precludes employing the supporting unit in other missions; concurrent support permits employment of the supporting unit in activities other than R&D support, but will have an operational impact upon the unit's employment; and NIB (not-to-interfere basis) support permits employment of the supporting unit without interference from the R&D.

Ref.: OPNAV Instruction 5000.42

7.3.7.1 R&D support requirements. R&D support requirements include the following:

- Approved TEMP's (see 7.5.3)
- Requests for R&D support not related to specific acquisition programs
- COMOPTEVFOR test requirements.

Using these three inputs, updated by confirmation procedures, COMOPTEVFOR quarterly compiles and publishes "CNO Quarterly RDT&E Support Requirements" for the forthcoming quarter. This summary is used as a tool in the quarterly Fleet scheduling conferences.

7.3.7.2 R&D support priorities. N091 assigns a priority (applying to Fleet support only) to each R&D support task identified in the "CNO Quarterly RDT&E Support Requirements:"

- Priority ONE support tasks take precedence over normal Fleet operations.

7.3.7.3

- Priority TWO support tasks are equal to normal Fleet operations.
- Priority THREE support tasks take precedence after normal Fleet operations.

7.3.7.3 Scheduling R&D support. Fleet commanders-in-chief schedule support tasks indicated in the "CNO Quarterly RDT&E Support Requirement" in accordance with assigned priorities. COMOPTEVFOR coordinates R&D support scheduling for CNO and reports to CNO, quarterly, concerning the support provided.

7.3.7.4 OT&E support for the Marine Corps. The Marine Corps requests OPTEVFOR OT&E support from CNO, who then gives appropriate direction to COMOPTEVFOR. When such support is provided, OT&E planning is coordinated with CMC, and COMOPTEVFOR reports his independent evaluation to CMC and CNO. Operational Test & Evaluation planning for Navy programs having USMC application includes MCOTEA coordination, and MCOTEA is provided program documentation, test plans, and reports.

7.3.8 RDT&E Platform Resources. These resources include ships and aircraft that are dedicated to acquisition and nonacquisition programs. Ship assets are managed and supported by NAVSEA (SEA-05R), and the aircraft assets by the NAWC, Weapons Division.

7.4 TEST AND EVALUATION CATEGORIES

DOD classifies tests into two official categories: Developmental Test and Evaluation (DT&E) and Operational Test and Evaluation (OT&E).

The following paragraphs describe the general types of tests and provides examples of tests that are peculiar to specific types of equipment or platforms.

Ref.: DOD Instruction 5000.2; OPNAV Instruction 5000.42

7.4.1 Developmental Test and Evaluation (DT&E). DT&E is conducted to:

- Demonstrate that the engineering design and development processes are complete.
- Demonstrate that design risks have been minimized.
- Demonstrate that the system will meet specifications.
- Estimate the system's military utility when introduced.

DT&E is required for all acquisition programs. It is planned, conducted, and monitored by the Developing Agency (DA) or its designated organization. Objectives of each phase are developed by the DA and published in the TEMP.

Development Test and Evaluation is conducted in three major phases. If necessary, each phase may be divided into subphases, e.g., DT-III A, III B, etc.

7.4.1.1 DT-I. DT-I is conducted during the demonstration and validation (D&V) phase to support the Milestone II decision which leads to entry into Engineering and Manufacturing Development (EMD). Its principal purpose is to demonstrate that all technical risks have been identified and reduced to acceptable levels; that the best technical approaches have been selected; that engineering (rather than experimental) effort now is required and the required technology is available.

7.4.1.2 DT-II. DT-II is conducted during the EMD Phase to support the Milestone III decision which places the system into production. (This decision is the first decision to produce systems for permanent installation in Fleet organizations in Marine Corps units or for inventory.) It demonstrates that the design meets specifications regarding performance, reliability, maintain-

ability, logistics supportability, interoperability, survivability, vulnerability, and safety; the human factors; and the total spectrum of electromagnetic environmental effects.

7.4.1.2.1 Technical Evaluation. The final subphase of DT-II is Technical Evaluation (TECHEVAL). A TECHEVAL is conducted, with production-type hardware and software, to determine whether the system(s) functions in a technically acceptable manner, meets design and technical performance specification, and is technically and logistically ready for Operational Evaluation (OPEVAL). The Developing Agency is responsible for planning the test program and obtaining results of tests.

Following TECHEVAL, the DA certifies to the CNO and to COMOPTEVFOR the system's readiness for OPEVAL. However, OPEVAL does not commence until the CNO accepts the DA's certification of readiness in accordance with OPNAV Instruction 5000.42.

7.4.1.3 DT-III. DT-III is conducted after the production decision to verify that product improvements or correlation of design deficiencies identified during TECHEVAL, OPEVAL, FOT&E or Fleet employment, are effective. For aircraft programs, the final phase of DT-III is conducted by INSURV using production units. Aircraft DT-III is accomplished as early as possible, preferably prior to Initial Operational Capability.

7.4.1.4 Production Acceptance T&E. Production Acceptance Test & Evaluation (PAT&E) is testing conducted on production items to demonstrate that they meet contract specifications and requirements. Most PAT&E is the responsibility of the DA. However, acceptance trials of new ship construction or major ship conversions are the responsibility of PRESINSURV. The objectives of PAT&E are published in the TEMP.

7.4.2 Operational Test and Evaluation. Operational Test and Evaluation (OT&E) assesses a

system's operational effectiveness and suitability, identifies the need for modifications, and provides information on tactics. OT&E has three distinguishing characteristics: It is conducted in a realistic operational environment; using typical fleet-type personnel for operation and maintenance; against a simulated 'enemy, employing countermeasures.

OT&E is subdivided into two major categories: initial OT&E (IOT&E), which is all OT&E prior to the full production and fleet introduction decision; and follow-on OT&E (FOT&E), which is all OT&E following the production and fleet introduction decision. OT&E is also divided into four major phases (two IOT&E and two FOT&E) and may further be divided into subphases (e.g., OT-IIA, OT-IIB) if necessary.

The Navy is required to have one organization, separate and distinct from the developing, procuring, and using commands, which is responsible for *all* OT&E. The organization is the Operational Test and Evaluation Force (OPTEVFOR). OT&E is planned and conducted by COMOPTEVFOR who reports results direct to CNO.

Ref.: DOD Directive 5000.1; DOD Instruction 5000.2, Part 8; OPNAV Instruction 5000.42

7.4.2.1 OT-I. OT-I is that IOT&E conducted during the demonstration and validation phase to support the engineering and manufacturing decision. The objectives of OT-I are to provide an early assessment of the system's potential operational effectiveness (sufficient to justify continuation of development) and to provide operational information on system characteristics.

OT-I is not required for most programs. It is scheduled only for systems using new operational concepts or those involving significant operational risks. For a major defense acquisition program, if

7.4.2.1.1

the Milestone II decision includes committing procurement funds for long-lead items or entering Low Rate Initial Production (LRIP), the DOT&E must provide the DAE and the DAB principals an assessment of system operational effectiveness and suitability, based on Early Operational Assessment if required by the DAE.

7.4.2.1.1 The Beyond Low Rate Initial Production Report. The Beyond Low Rate Initial Production (LRIP) Report documents the Director, OT&E's assessment of the adequacy of OT&E and the combat effectiveness and suitability of a weapon system. It is provided to SECDEF and the Congress. The Beyond LRIP Report for any major defense acquisition program, or DOT&E oversight system, must be received by appropriate congressional committees prior to a decision by the Defense or Navy Acquisition Executive (DAE/NAE) to proceed beyond low-rate initial production.

DOD Directives 5000.1; DOD Instruction 5000.2, Part 3, 6-0; SECNAV Instruction 5000.2

7.4.2.2 OT-II. OT-II is that IOT&E phase conducted during the engineering and manufacturing development phase to support the production and Fleet introduction decision. OPEVAL is the final subphase of OT-II. Specific OT-II objectives include demonstrating the achievement of program objectives for operational effectiveness and suitability, and initiating or continuing tactics development. OPEVAL is conducted using production-representative hardware and begins no sooner than one month after TECHEVAL testing.

7.4.2.3 OT-III. OT-III is that FOT&E phase conducted after the production and fleet introduction decision. Specific OT-III objectives include testing of fixes to production systems,

completing any deferred or incomplete IOT&E, continuing tactics development, evaluating the system in different platform applications, and for block revisions to a system's software, verifying sustained, improved software performance.

For ship programs, OT-III is conducted with the lead ship during the period from delivery to the start of postshakedown availability (PSA).

7.4.2.4 OT-IV. OT-IV is that FOT&E conducted on fielded production systems. An initial objective of OT-IV is demonstration of the achievement of program objectives for production system operational effectiveness and suitability (especially reliability, maintainability, and logistic supportability). Other OT-IV objectives include OT&E of the system in new environments, in new applications, or against new threats.

For ship programs, OT-IV is conducted with the lead ship or designated follow ship after expiration of SCN funding authority to verify that critical deficiencies identified during previous T&E have been corrected and to complete FOT&E not accomplished in OT-III.

7.4.3 Board of Inspection and Survey Acceptance Trials. The Board of Inspection and Survey is responsible to the CNO for conducting acceptance trials of new ships prior to Navy acceptance from the contractor. They also monitor all DT&E testing of new model aircraft and conduct the final phase of DT-III testing.

Trials of ships are conducted to determine if they are suitable for their intended missions and if they have been constructed in accordance with contract specifications. After completion of acceptance trials, the Board documents material, performance, and design deficiencies and reports to the CNO its recommendation on the Navy's acceptance of the ship.

Ref.: OPNAV Instructions 5000.42, 5420.70; INSURV Instruction 13100.1

7.4.4 Joint Service Programs. Joint Service programs involve two or more Services or agencies.

*Ref.: DOD Instruction 5000.2, Part 8;
OPNAV Instruction 5000.42*

7.4.4.1 Joint Test and Evaluation. Joint Test & Evaluation (JT&E) programs are sponsored by OSD to obtain information required by Congress, OSD, Unified or Specified Commands, or DOD Components. They may be JDT&E, sponsored by DT&E, or JOT&E, sponsored by DOT&E. A lead Service is selected to plan and conduct the test, with participation by other Services as appropriate.

Ref.: DOD 5000.3-M-4

7.4.4.2 Two-sided testing. Two-sided operational testing involves testing one system against another in a realistic environment. Such tests evaluate system performance and operational suitability under realistic two-sided operational conditions, including free-play between offensive and defensive forces whenever possible.

7.4.4.3 Multiservice T&E. This is T&E conducted jointly by two or more Services for systems to be acquired by more than one Service, or for a Service's systems that have interfaces with equipment of another Service.

MultiService T&E is planned, conducted and reported under the procedures of the lead Service (or agency).

7.4.4.4 Funding of joint service programs. Most costs of joint tests are paid from a special RDT&E appropriation, "Director of Test and Evaluation, Defense," which is administered by the Director, Test and Evaluation (DT&E). Services pay the Operational & Maintenance

(O&M) participation costs for units/personnel involved.

*Ref.: DOD Instruction 5000.2, Part 8;
OPNAV Instruction 5000.42*

7.4.5 Combined and/or Concurrent DT/OT. DT&E and OT&E may be combined when cost and time benefits are significant and clearly identified, provided that test objectives are not compromised. TECHEVAL and OPEVAL may not be combined.

Whenever possible, DT/OT periods are conducted "concurrently" rather than "combined" since contractor participation in operational testing is limited by PL 99-661. Concurrent DT/OT permits contractor participation in DT events and still allows operational testing to be conducted autonomously.

*Ref.: DOD Instruction 5000.2, Part 8;
OPNAV Instruction 5000.42*

7.5 PLANNING FOR TEST AND EVALUATION

Requirements for test and evaluation are central to R&D planning. TEMPs (see 7.5.3) are organized around an orderly sequence of milestone decisions and the associated tests and demonstrations that provide information for those decisions (see 7.1.2). Effective planning provides groundwork for the necessary T&E to ensure that the equipment is ready for test and that test resources required to conduct the tests are available when needed.

Recognizing the need for adequate statistical test planning, design, and evaluation is essential to obtaining meaningful results.

The most important single source of T&E planning information is early and close collaboration with personnel of the prospective testing organization(s).

7.5.1

Ref.: DOD Instruction 5000.2; OPNAV Instruction 5000.42

7.5.1 Definition of Test Issues and Problems. A necessary first step in T&E planning is identifying the test issues to be addressed, for which tests and evaluations are to be designed and scheduled. This is accomplished in large degree by the incorporation in the TEMP of the Measures of Effectiveness (MOEs) and Measures of Performance (MOPs) documented in the Cost and Operational Effectiveness Analysis (COEA).

7.5.2 Coordination with OPTEVFOR. The Developing Agency (DA) maintains early and continuing liaison with COMOPTEVFOR to ensure that the DT&E program is understood and that OT&E requirements are identified and integrated into the program, including proper budgeting. The DA is required to provide COMOPTEVFOR all significant DT&E test data and analyses to assist in planning or interpreting OT&E. COMOPTEVFOR is responsible for monitoring all pertinent phases of DT&E.

7.5.3 Test and Evaluation Master Plan (TEMP). For each ACAT I, II, III, and IV program, the TEMP is the controlling test & evaluation management document.

The TEMP is reviewed annually and about three months prior to DAB or equivalent, and is updated on an event-driven schedule for milestone decisions, significant change to the program, threat changes, or significant test events.

The TEMP is prepared by the Developing Agency (DA) in cooperation with COMOPTEVFOR, PRESINSURV when appropriate, and, in the case of Automated Information Systems (AIS) programs, the Naval Computer and Telecommunications Station (NCTS), Pensacola. The DA is solely responsible for the DT&E and PAT&E sections and the COMOPTEVFOR for the OT&E section. However, early and close coordination between

the DA and OPTEVFOR is essential in the preparation of the DT&E section to ensure that data obtained in such areas as reliability and maintainability are statistically useful in the OT&E phase.

The current TEMP for ACAT III programs submitted by the DA through the Program Sponsor (ACNO/DCNO/DSO) to N091 for approval. Where higher-level approval is required—USD(A) for ACAT I, ASN(RD&A), for ACAT II—N091 coordinates such approvals. A TEMP, approved by OSD or ASN(RD&A), is required prior to each milestone decision for ACAT I or II programs. The DOT&E reviews all DOT&E oversight program TEMPs and, in conjunction with the DT&E, is the OSD approval authority for these TEMPs. For ACAT IV programs the TEMP is approved by the DA.

Approval of the TEMP (or TEMP revision) constitutes direction to conduct the T&E program, including the commitment of RDT&E support. Considerations for preparation of a Navy Training Plan (NTP) are addressed in the TEMP. The NTP should be approved prior to the earlier of Milestone II or certification of Readiness for OPEVAL.

Ref.: SECNAV Instruction 5000.2; OPNAV Instructions 1500.8, 5000.42

7.5.4 Funding T&E. DOD has directed that certain DOD T&E activities adopt a uniform funding policy. This policy requires customers to pay direct range costs for their test programs, while the test facility pays indirect and overhead costs with funds provided by its parent Service.

The objective of DOD's policy is to give greater visibility for the T&E program, to increase cost comparability among the various T&E activities, and to reduce cost biases in the placement of T&E work.

In keeping with DOD policy, funds for developing certain new testing facilities (MILCON) may be considered part of the

institutional share, chargeable to the T&E facility. This is to be negotiated with the facility staff. On the other hand, new test equipments needed for a specific project may be considered part of the industrial share and charged to the project funds.

OPTEVFOR receives funding from the CNO (N091) to oversee, manage, and conduct testing. Additionally, each program provides funding to satisfy testing requirements.

At the time of test execution, funds are transferred to the test activity based on current estimates of probable costs. If costs exceed estimates, additional funds must be provided; if they are less, the surplus is returned to the project.

The DA plans, programs, budgets and funds the costs of most resources identified in the approved TEMP. OPNAV Instruction 5000.42 contains specific funding guidelines.

7.5.5 T&E Task Statements. Task statements are used to advise technical and managerial test personnel what is to be tested, specific questions to be answered and other data the test should produce. Testing activities and the SYSCOMs usually have suggested or mandatory task statement formats to meet their testing procedures and requirements. Specific information on these requirements can be obtained through preliminary liaison with test activity personnel.

7.5.6 Test Resource Planning. The TEMP has a summary of the resources essential to accomplish the test program such as test articles, test activities to be utilized, special facilities and instrumentation, test platforms, and required fleet support services. Early identification and planning for these requirements is particularly important should new facilities be needed which require MILCON or assets such as new instrumentation or targets which need to be developed (see 7.3).

7.5.7 T&E Identification Number. N091 assigns a T&E identification number (TEIN) to each project assigned to a Developing Agency or COMOPTEVFOR for T&E. TEINs are sequential numbers assigned for the life of the program.

TEINs are the TEMP numbers for ACAT I, II, III, and IV programs.

Ref.: OPNAV Instruction 5000.42

7.6 FLOW OF TEST & EVALUATION INFORMATION TO USERS

This section covers the forms of information developed through T&E and its flow to users.

7.6.1 T&E Information for Developers. For T&E integral to the development process, development personnel normally are direct participants in tests and thus receive "instant feedback." They have little need for permanently documented information since changes in the evolving design occur and are rapidly evaluated in other experimental tests. However, for some development tests, formal technical reports are required.

7.6.2 Information for Program Managers. Much of the T&E information used in decisions of the Program Manager is based on personal contacts, telephone discussions with test personnel, and day-to-day dispatches on test results. The most important source of information is direct observation of and participation in important tests by the Program Manager and his staff. Formal technical reports usually are required (see 7.6.6).

7.6.3 Information for Milestone Decisions. Information required for major investment decisions (see Chapter 1) will be formal, documented, and based on extensive evaluation. In the evaluation process, information from tests will be integrated with information on other crucial information such as the continuing requirement for the system itself.

7.6.4 Information for Operating Forces. An important product of tests, particularly Operational Evaluation (see 7.4.2), will be doctrine and tactics for effective operation of the

7.6.5

system. COMOPTEVFOR publishes this information in a Tactics Guide. Additional information appears in such publications as NATOPS (Naval Air Training and Operating Procedures Standardization) manuals for the operation of aircraft and other tactical manuals. The results of T&E also are reflected in improvements in maintenance and support procedures and other technical information.

7.6.5 Information for the Board of Inspection and Survey. Test activities performing Service Acceptance tests for INSURV are required to submit test results in formal technical reports to INSURV. These reports form the basis for INSURV's reports and recommendation to CNO and SECNAV.

7.6.6 Formal T&E Reports and Their Availability. Formal reports of tests, other than development tests generally are prepared and filed in the Defense Technical Information Center (DTIC). These data then are available to all Need to Know users through normal DTIC distribution procedures (see D3, on DTIC).

7.7 TEST & EVALUATION OF INTEGRATED LOGISTIC SUPPORT

Navy's basic method to ensure that a system can be supported in the field is the Integrated Logistic Support (ILS) Planning System. The support system addresses operational and maintenance support concepts and requirements, and provides for the acquisition of the resources, e.g., needed personnel, data, spares, test equipment, and facilities (see F4.1).

A system's support effectiveness must be demonstrated in as realistic an operating environment as possible. Where practical, pilot or early production items and representative Fleet operators and maintainers are used. Where this is not possible, preproduction prototypes that are reasonably representative of future production designs are employed.

*Ref.: DOD Instruction 5000.42, Part 7,
Section A; SECNAV Instruction 5000.2*

7.7.1 Requirements for ILS T&E. ILS planning and products are subject to T&E just as is hardware. Operational availability (Ao) thresholds are established for all systems and equipments and documented in the TEMP. Objectives and criteria of the support system to support achievement of Ao thresholds also are established and documented in TEMPs. The ILS Manager (ILSM) assists in establishing these objectives and criteria. The ILSM also ensures adequate planning for logistic support of the test program.

7.7.1.1 Operational Availability (Ao). Ao is the basic readiness requirement for a system or equipment. It is expressed as the single Ao threshold the system or equipment must meet during both OPEVAL (at the end of development) and subsequently in the fleet. Ao is the percentage of time the system should be available for required use in its intended operational environment. Ao is established by the OPNAV warfare program sponsor in a system's earliest acquisition documentation.

Anticipating requirements to meet the projected threat, the OPNAV Program Sponsor analyzes and weighs performance characteristics, affordability, and supportability in calculating Ao. Ao is the quantitative link between readiness objectives and supportability. The SYSCOMs design and acquire systems and equipments to meet the established Ao threshold, and COMOPTEVFOR is responsible for assessing its achievement through OT&E.

As platforms for many different systems with multiple mission area responsibilities, aircraft do not lend themselves to a single value Ao. Therefore, aircraft readiness requirements shall be expressed in terms of Mission Capability by primary mission area (MCma) and Full Mission Capability (FMC) thresholds in lieu of Ao. This will permit early and continuous readiness

assessments during development and into deployment of the aircraft.

Ref.: OPNAV Instruction 3000.12

7.7.2 Timing of ILS T&E. Integrated Logistic Support Test and Evaluation should be time-phased and in harmony with the hardware system test and evaluation program. Initially, analytical study of hardware design and configuration should be employed to maintain surveillance over progress in achieving stated requirements. As design and fabrication progress, increasing levels of tests and demonstration on actual hardware are employed. These should culminate in a formal preplanned operational test and evaluation in which the production hardware and the operational and logistic support resources are used in validating the efficacy of the integrated logistic support planning process.

7.7.3 Outputs of ILS T&E. The test and evaluation of ILS:

- Determines the validity of established preventive maintenance concepts.
 - Validates the accuracy and adequacy of operating and maintenance instructions and other job performance aids.
 - Validates the need and demonstrates the performance support and test equipment for conducting operational and maintenance tasks.
 - Determines, with statistical confidence if possible, system reliability and maintainability against specified operational suitability goals.
 - Verifies the need and adequacy of facilities (shipboard and shore-based) provided for the systems' operation and maintenance.
 - Validates the quantitative and qualitative operator and maintenance personnel levels and planned training.
- Assesses the credibility of the spares and repair parts allowances established for operational units.
 - Evaluates the effectiveness of special handling, transportation, and storage devices proposed for the system.
 - Verifies, with statistical confidence if possible, achievement of quantitative values specified, such as turnaround times, servicing rates, maintenance manhours per operating hour, rearming rate, and restoration times.
 - Assesses qualitative values such as safety, human factors, environmental protection devices, accessibility, and interchangeability.

7.7.4 Use of ILS T&E Results. Results of the Test and Evaluation program are used to modify, as appropriate:

- IOC and MSD milestones
- Operational and maintenance planning
- Support and test equipment requirements and allowances
- Spares and repair part allowances
- Facility (shipboard and shore-based) adequacy, requirements, and arrangements
- Unit manning plans
- ILS planning documents
- Readiness measurement
- Advance to next program milestone.

7.8 TEST & EVALUATION FOR SHIP ACQUISITION

Ship acquisition, while subject to the same basic DOD and Navy T&E policies applied to other systems and equipment procurement, is an area in which special T&E applies. The accomplishment of ship T&E varies considerably from the normal test cycle due to the lengthy period for design, engineering, and construction of a

7.8.1

major ship, and because ship T&E includes both that conducted on the ship platform itself, as well as that conducted on the equipments and systems to be installed on the ship.

Ref.: DOD Instruction 5000.2, Parts 3 and 8; SECNAV Instruction 5000.2; OPNAV Instructions 5000.42, 4700.8; NAVSEA 0900-LP-095-2010, Ship Construction Tests and Trials Manual

7.8.1 Policies and Principles. Because the development and construction period for a major ship normally precludes completion of DT&E and IOT&E on the lead ship prior to the production decision for follow-on ships, successive phases of DT&E and IOT&E are accomplished as early as practicable to reduce risks and minimize the need for modification to follow-on units.

The CNO will determine when a new ship class requires total ship OPEVAL, i.e., a "prototype" ship program. The CNO also will determine (1) when combat or propulsion system complexity warrants construction of land-based test sites, and (2) when technological advances in hull or propulsion design require prototyping. When total ship OPEVAL is conducted, it is usually conducted in connection with FOT&E of the combat system or propulsion system.

DT&E and IOT&E prior to Milestone II generally consist only of T&E of the individual unproven shipboard systems and equipments. Such T&E, including validation of unproven shipboard test documentation, may be conducted on other ships or at land-based test sites.

For conventional ship acquisition programs (SCN-funded), DT&E and IOT&E between Milestones II and III consist of additional T&E of individual weapon systems, as well as T&E conducted at possible land-based test site(s). For prototype programs (RDT&E-funded), DT&E and IOT&E also includes T&E conducted on the lead ship itself.

For all classes of ships that require OT&E, continuing phases are accomplished on the lead ship at sea as early as possible in the acquisition process.

Ship Production Acceptance T&E must demonstrate that all systems are properly installed and operable in accordance with contract requirements and technical specifications. Because of the separation of milestones for delivery and operational readiness, and the segmented T&E periods that result, ship PAT&E is divided into two phases:

- The ship "construction" tests and trials phase includes all testing conducted on the ship during construction, including INSURV's Acceptance Trials. It also may include some earlier equipment PAT&E (such as factory acceptance tests) if imposed as a prerequisite to shipboard installation. For this phase, NAVSEA requires the development and conduct of an Integrated Test Package (ITP). The *Ship Construction Tests and Trials Manual* establishes procedures and organizational responsibilities for ship construction testing.
- The ship "post-delivery" tests and trials phase includes conventional tests and trials conducted on the ship from the time of ship delivery to and including INSURV's final contract trials and the post-shakedown availability. Post-delivery tests may include tactical trials, standardization trials, structural test firings, system qualification trials and operational readiness tests.

FOT&E, if conducted, usually occurs after the post-delivery test and trial period. TEMPS are required for ACAT II, III, and IV ship programs only when the CNO requires that COMOPTEVFOR conduct OT&E of the ship or overall combat system.

7.8.2 Ship Acquisition T&E Planning. The extensive coordination needed to plan and execute

T&E for the many systems and equipments involved in a ship acquisition program may be effected through the program's T&E Coordination Group (TECG).

The Ship Acquisition Program Manager (SHAPM) is the key NAVSEA representative for his respective TECG. He is responsible for developing, from OPNAV design requirements and his own risk analyses, definitive traceable test requirements necessary to demonstrate a progressive reduction of risk from initial factory T&E to land-based testing, ship construction tests and trials, and post-delivery tests and trials. To ensure effective planning and conformance to T&E policies, the SHAPM establishes early and continual liaison with OPTEVFOR and INSURV.

7.8.3 Organization for Ship T&E. Major participants in the planning and execution of ship T&E include:

- The Requirements Officer, representing the interests of the Resource Sponsor.
- The T&E Coordination Group (TECG), which establishes broad T&E requirements for a ship acquisition program and effects T&E coordination.

- The PM and/or SHAPM who, in collaboration with OPTEVFOR, develops the TEMP and is the key NAVSEA representative for the TECG.
- The Ship Design Manager, who is responsible to the SHAPM for production of the complete ship design, including test specifications.
- COMOPTEVFOR, who participates in the T&E planning and conducts all OT&E.

7.8.4 Acceptance of Ships. Navy acceptance of a ship is based on the CNO's decision, contingent upon the satisfactory completion of INSURV Acceptance Trials as determined by PRESINSURV.

7.8.5 Certification of Ship Aviation Facilities. All aviation facilities in new and overhauled naval ships which operate aircraft must be inspected and certified as meeting approved standards of adequacy and safety established by the Chief of Naval Operations.

Ref.: OPNAV Instruction 3120.28

SELECTED REFERENCES ON TEST AND EVALUATION

DOD Instruction 5000.2, "Defense Acquisition Management Policy and Procedures."

DOD 5000.3-M-4, "Joint Test and Evaluation Procedures Manual."

SECNAV Instruction 5000.2, "Implementation of Defense Acquisition Policies, Procedures, Documentation and Reports."

OPNAV Instruction 5000.42, "OPNAV Responsibilities and Duties in the Acquisition Process."

OPNAV Instruction 4700.8, "Trials, Acceptance, Commissioning, Fitting Out, Shakedown and Post Shakedown Availability of U.S. Naval Ships Undergoing Construction/Conversion/Modification."

NOTE REGARDING DIRECTIVE NUMBERS

References to directives are by series only; e.g., 3900.14, not to the effective edition within the series; e.g., 3900.14A.

The "Master Reference List" provides the version and issue date of each directive.

For recent information on the effective directive within a series, consult "Department of the Navy Directives Issuance System: Consolidated Subject Index." (NAVPUBNOTE 5215).

Appendix A
READINGS IN ACQUISITION MANAGEMENT

The following readings are provided to help Guide users understand some of the forces and considerations underlying the continuing evolution of the RD&A process as reflected in this publication.

TABLE OF CONTENTS

A1	“From the Sea: Preparing the Naval Service for the 21st Century,” A Navy and Marine Corps White Paper. Issued by the Secretary of the Navy, Mr. Sean O’Keefe; The Chief of Naval Operations, Admiral Frank B. Kelso II; and The Commandant of the Marine Corps, General C.E. Mundy, Jr., September 1992	A-1
A2	Excerpts from “Acquisition Organization and Procedures,” Chapter 3 of <i>A Quest for Excellence</i> , Final Report of the President’s Blue Ribbon Commission on Defense Management (Packard Commission), June 1986	A-8
A3	Excerpts from “Fiscal Realities and Their Impact on Weapons Systems, Acquisitions and Development Strategies,” An Address by Gerald A. Cann, Assistant Secretary of the Navy for Research, Development, and Acquisition, at the Fletcher School of Law and Diplomacy, Tufts University, November 18, 1992	A-10

Appendix A
READINGS IN ACQUISITION MANAGEMENT

A1 "FROM THE SEA: PREPARING THE NAVAL SERVICE FOR THE 21ST CENTURY," A NAVY AND MARINE CORPS WHITE PAPER. ISSUED BY THE SECRETARY OF THE NAVY, MR. SEAN O'KEEFE; THE CHIEF OF NAVAL OPERATIONS, ADMIRAL FRANK B. KELSO II; AND THE COMMANDANT OF THE MARINE CORPS, GENERAL C. E. MUNDY, JR., SEPTEMBER 1992

INTRODUCTION

The world has changed dramatically in the last two years, and America's national security policy has also changed. As a result, the priorities of the Navy and Marine Corps have shifted, leading to this broad assessment of the future direction of our maritime forces.

The fundamental shift in national security was first articulated by the President at the Aspen Institute on August 2, 1990. The new policy is reflected in the President's National Security Strategy and the "Base Force" concept developed by the Secretary of Defense and the Chairman of the Joint Chiefs of Staff.

The National Security Strategy has profound implications for the Navy and Marine Corps. Our strategy has shifted from a focus on a global threat to a focus on regional challenges and opportunities. While the prospect of global war has receded, we are entering a period of enormous uncertainty in regions critical to our national interests. Our forces can help to shape the future in ways favorable to our interests by underpinning

our alliances, precluding threats, and helping to preserve the strategic position we won with the end of the Cold War.

Our Naval Forces will be full participants in the principal elements of this strategy—strategic deterrence and defense, forward presence, crisis response, and reconstitution.

With a far greater emphasis on joint and combined operations, our Navy and Marine Corps will provide unique capabilities of indispensable value in meeting our future security challenges. American Naval Forces provide powerful yet unobtrusive presence; strategic deterrence; control of the seas; extended and continuous on-scene crisis response; project precise power from the sea; and provide sealift if larger scale warfighting scenarios emerge. These maritime capabilities are particularly well tailored for the forward presence and crisis response missions articulated in the President's National Security Strategy.

Our ability to command the seas in areas where we anticipate future operations allows us to resize our Naval Forces and to concentrate more on capabilities required in the complex operating environment of the "littoral" or coastlines of the earth. With the demise of the Soviet Union, the free nations of the world claim preeminent control of the seas and ensure freedom of commercial maritime passage. As a result, our national maritime policies can afford to de-emphasize efforts in some naval warfare areas. But the challenge is much more complex than simply reducing our present Naval Forces. We must structure a fundamentally different Naval Force to respond to strategic demands, and that new force

must be sufficiently flexible and powerful to satisfy enduring national security requirements.

The *new* direction of the Navy and Marine Corps team, both active and reserve, is to provide the nation:

Naval Expeditionary Forces—Shaped for Joint Operations Operating Forward From the Sea—Tailored for National Needs

This strategic direction, derived from the National Security Strategy, represents a fundamental shift away from open-ocean warfighting on the sea toward joint operations conducted from the sea. The Navy and Marine Corps will now respond to crises and can provide the initial, “enabling” capability for joint operations in conflict—as well as continued participation in any sustained effort. We will be part of a “sea-air-land” team trained to respond immediately to the Unified Commanders as they execute national policy.

In addition to our new direction, the Navy has a continuing obligation to maintain a robust strategic deterrent by sending nuclear ballistic submarines to sea. As long as the United States maintains a policy of nuclear deterrence, our highly survivable nuclear powered ballistic missile submarines will remain *critical* to national security. We also need to turn our attention and explore potential naval contributions to other forms of conventional strategic defense. In particular, we are carefully examining the naval capabilities which could contribute to theater missile defenses.

Beyond the shift in emphasis for the naval forces, there are some traditional naval missions for which we must redouble our efforts to improve our capability. Of particular importance, *sealift is an enduring mission for the Navy*. Our nation must remain capable of delivering heavy equipment and resupplying major ground and air combat power forward in crisis. Sealift is the key to force sustainment for joint operations and we are committed to a strong national sealift capability.

DEFINING THE NEW DIRECTION

Naval Expeditionary Forces

The restructured Naval Force must expand and capitalize upon its traditional *expeditionary* roles. “Expeditionary” implies a mind set, a culture, and a commitment to forces that are designed to operate forward and to respond swiftly. Specifically, Naval Expeditionary Forces are:

- **Swift to respond, on short notice, to crises in distant lands.** Naval Forces, deployed overseas, are poised to respond to national tasking. Recent examples include the initial rapid response to meet the requirements for Desert Shield and provide assistance to storm-battered Bangladesh and the war-torn Kurds following Desert Storm.
- **Structured to build power from the sea when required by national demands.** The Navy and Marine “sea-air-land” team is capable of a full range of action—from port visits and humanitarian relief to major offensive operations. Even as Desert Shield intensified, tailored Naval Forces responded to evacuation requirements in both Liberia and Somalia.
- **Able to sustain support for long-term operations.** Ships at sea in remote areas of the world have a healthy self-sufficiency. Naval Forces can remain on station for extended periods. Amphibious forces remained off Liberia for seven months. The USS Eisenhower task force remained in the Indian Ocean at sea for five months during the Iranian Hostage Crisis.
- **Unrestricted by the need for transit or overflight approval from foreign governments in order to enter the scene of action.** The international respect for freedom of the seas guarantees legal

access up to territorial waters of all coastal countries of the world. This affords Naval Forces the unique capability to provide peaceful presence in ambiguous situations before a crisis erupts.

In sum, Naval Expeditionary Forces provide unobtrusive forward presence which may be intensified or withdrawn as required on short notice.

Shaped for Joint Operations

The Navy and Marine Corps are full partners in joint operations. The battle field of the future will demand that everyone on the field be teammates. Such teamwork "enables" joint combat operations. Some examples of how Naval Forces will implement this concept include:

- As a highly sustainable force on scene, a Naval Force commander can command the joint task force while the operation is primarily maritime; and shift that command ashore if the campaign shifts landward at the discretion of the Unified Commander.
- Focusing on the littoral area, the Navy and Marine Corps can seize and defend an adversary's port, naval base or coastal air base to allow the entry of heavy Army or Air Force Forces. *The success of modern U.S. military strategy depends on forces organized, trained, and equipped for this division of combat labor.*
- Sealift will provide the maritime bridge to ensure heavy joint forces can arrive and fight effectively in major crisis.

Operating Forward, From the Sea

As the U.S. withdraws from overseas bases, Naval Forces will become even more relevant in

meeting American forward presence requirements.

The Navy and Marine Corps operate forward to project a positive American image, build foundations for viable coalitions, enhance diplomatic contacts, reassure friends, and demonstrate U.S. power and resolve. Naval Forces will be prepared to fight promptly and effectively, but they will serve in an equally valuable way by engaging day-to-day as peacekeepers in the defense of American interests. Naval Forces are unique in offering this form of international cooperation.

Operating forward, Naval Forces demonstrate United States commitment overseas and promote American interests. A scheduled, coalition-building multinational exercise involving U.S. Navy and Marine forces provides visible assurance to friends—and a warning to potential enemies. Humanitarian assistance and nation-building efforts have similar effects.

Naval Forces also *contain crises* through forward operations and rapid responses with flexible and sustainable sea-based forces. The seeds of conflict will continue to sprout in places where American interests are perceived as vulnerable. The art of managing crises in these areas is delicate and require the ability to orchestrate the appropriate response and to send precisely tailored diplomatic, economic, and military signals to influence the actions of adversaries.

Naval Forces provide a wide range of crisis response options, most of which have the distinct advantage of being easily reversible. If diplomatic activities resolve the crisis, Naval Forces can withdraw *without* action or build-up ashore.

If diplomacy fails, Naval Forces operating forward, as part of a joint U.S. military team, *can project United States combat power* as required.

Operating forward means operating in the littoral or "near land" areas of the world. As a

general *concept*, we can define the littoral as comprising two segments of the battlespace:

- Seaward: The area from the open ocean to the shore which must be controlled to support operations ashore.
- Landward: The area inland from shore that can be supported and defended directly from the sea.

The littoral region is frequently characterized by confined and congested water and air space occupied by friends, adversaries, and neutrals—making identification profoundly difficult. This environment poses varying technical and tactical challenges to Naval Forces. It is an area where our adversaries can concentrate and layer their defenses. In an era when arms proliferation means some third world countries possess sophisticated weaponry, there is a wide range of potential challenges.

For example, an adversary's submarines operating in shallow waters pose a particular challenge to Naval Forces. Similarly, coastal missile batteries can be positioned to "hide" from radar coverage. Some littoral threats—specifically mines, sea-skimming cruise missiles, and tactical ballistic missiles—tax the capabilities of our current systems and force structure. Mastery of the littoral should be presumed. It does not derive directly from command of the high seas. It is an objective which requires our focused skills and resources.

Tailored for National Needs

As Naval Forces shift from a Cold War, open ocean, blue water naval strategy to a regional, littoral, and expeditionary focus, *Naval organizations will change*. Responding to crises in the future will require great flexibility and new ways to employ our forces. As an example, the Naval Services will make available to Unified Commanders a notional Expeditionary Force Package from among the following:

- Aircraft carrier and air wing
- Amphibious ships with embarked Marines
- Surface combatants
- Navy Special Warfare Forces
- Submarines
- Maritime Patrol Aircraft
- Mine Warfare Forces

Under the aegis of the Unified Commander, these forces would be available for tasking in the full range of joint operations with the other services, thus providing a cohesive joint team capable of rapid and decisive action—from peacetime presence and exercises to joint strike in major crisis.

The Expeditionary Force Package can operate with other elements of joint or combined task forces, including:

- Air Force composite wing
- Army infantry, airborne, or air mobile forces
- Special Operations forces
- Surveillance, refueling, air defense assets
- Coast Guard assets
- Reserve Force in contributory support
- Allied forces and assets

Naval Forces can be continuously tailored to developing events. The answer to every situation may not be a carrier battle group. It may be an amphibious readiness group and a surface action group with Tomahawk missiles. It may be a group of minesweepers, with several guided missile frigates for defense. Or it may be the overwhelming power of a carrier battle group and an amphibious ready group with embarked Marines, operating with Air Force and Army forces. *The key is continuously tailoring our forces to anticipate and support national needs.*

Forces can be "shared" across theater boundaries to demonstrate capabilities, signal commitment to local leaders and promote

opportunities for regular exercises and exchanges with air, sea, and ground forces of our allies and coalition partners. Rapid movement of these forces across Unified Command boundaries will occur to forestall or respond to crises.

OPERATIONAL CAPABILITIES

All services are enhancing and streamlining their capabilities to maximize efficiency, particularly in joint and combined operations. The Naval Service will focus on complementing the capabilities of other Services, examine ways to minimize duplicative capabilities, and thereby efficiently meet the challenges of the new security environment. The shift in focus to littoral operations requires a corresponding shift of emphasis toward accelerating the adaption of existing forces to counter littoral threats.

In addition to our traditional operational capabilities of forward deployment, crisis response, strategic deterrence, and sealift, four key operational capabilities are required to successfully execute the *new direction of the Navy and Marine Corps*:

Command, Control, and Surveillance
Battlespace Dominance
Power Projection
Force Sustainment

Command, Control, and Surveillance

The Navy and Marine Corps will continue to structure command and control capabilities to promote efficient joint and combined operations as part of an overarching command, control, and communications architecture that can adapt from sea to shore. We will also exploit the *unique* contributions which Naval Forces bring to littoral operations.

Our surveillance efforts will continue to emphasize exploitation of space and electronic warfare systems to provide commanders with immediate information, while denying and/or managing the data available to our enemies.

Integrated information and netted sensors will allow us to use surveillance data from all sources—national and combined—and to target and strike from a variety of land, sea, and air platforms.

The Naval Force Commander will have the capability to command a joint task force and function as, or host, a Joint Force Commander. Command and control system capabilities enable domination of the battlespace and power projection, and are central to the precise application of power.

Particular emphasis will be placed on the ability to collect intelligence through covert surveillance early in crisis. Naval intelligence efforts will be directed to a regional focus.

Battlespace Dominance

The battlespace is the sea, air, and land environment where we will conduct our operations. The dominated battlespace expands and contracts and has limits. Dominating the battlespace presupposes effective command and control capabilities and serves as the logical prerequisite for the projection of power ashore. Battlespace dominance means that we can maintain access from the sea to permit the effective entry of equipment and resupply. This dominance implies that Naval Forces can bring to bear decisive power on and below the sea, on land, and in the air. We must use the full range of U.S., coalition and space-based assets to achieve dominance in space as well.

Naval Forces must also have the capability to deny access to a regional adversary, interdict the adversary's movement of supplies by sea, and control the local sea air. For the Naval Service, then dominating the battlespace means ensuring effective transition from open ocean to littoral areas, and from sea to land and back, to accomplish the full range of potential missions. This is the essence of naval adaptability and flexibility which are the keys to contingency

response. **Battlespace dominance is the heart of naval warfare.**

Power Projection

Power projection from the sea means bombs, missiles, shells, bullets, and bayonets. When Marines go ashore, naval aviation aboard aircraft carriers and—if required—land based expeditionary aircraft will provide them sustained, high-volume tactical air support ashore to extend the landward reach of our littoral operations. Rugged naval aircraft are well suited for expeditionary airfield operations. **These capabilities—the ability to generate high intensity power projection from the decks of our carriers and expeditionary airfields—are critical.** They must continue to be sufficiently available and ready to contribute to joint warfare and decisive victory.

Our carrier and cruise missile firepower can also operate independently to provide quick, retaliatory strike capability short of putting forces ashore. Remaining ready indefinitely to strike, this potential force *from the sea* is a critical tool for diplomacy and influence. The mere arrival of naval strike forces into an area of heightened U.S. interest sends a clear signal.

Joint operations between Naval and Air Force strike assets—including carrier-based aircraft, land-based naval expeditionary aircraft, land-based Air Force aircraft from both local and distant bases, and Tomahawk missiles from surface forces and attack submarines—have become standard.

Finally, forces projected ashore can maneuver and build up power rapidly deep in the objective area to disorient, divert, and disrupt the enemy.

Force Sustainment

America's influence depends on its ability to sustain military operations *around the globe*. The military options available can be extended indefinitely because sea-based forces can remain on station as long as required. Naval Forces

encompass the *full range* of logistics support that is the critical element of any military operation. It requires a comprehensive and responsive logistics support system, including air and sealift, replenishment ships, mobile repair facilities, and advanced logistic support hubs. It requires open sea lanes of communication so that passage of shipping is not impeded by an adversary.

In peace, naval logistics forces support the day-to-day forward operations of Naval Forces. During crisis, warfighting materiel afloat in maritime prepositioning ships enables the near-immediate projection of credible military power. Finally, during war, strategic sealift ships will deliver heavy equipment and resupply heavy ground and air combat forces. Forward logistics, prepositioning, and strategic sealift, coupled with strategic airlift, are the keys to force sustainment.

CONCLUSION

The Navy and Marine Corps Team is changing in response to the challenges of a new security environment. The shift is strategic landscape means that *Naval Forces will concentrate on littoral warfare and maneuver from the sea*. Maneuver from the sea, the tactical equivalent of maneuver warfare on land, provides a potent warfighting tool to the Joint Task Force Commander—a tool that is literally the key to success in many likely contingency scenarios.

The new direction of the Naval Service signals changes in doctrine, education, service integration, training, acquisition, infrastructure, operations, risk reduction, and other areas. Amplifying documents and policy statements will follow on these subjects.

Naval Forces must be both capable and affordable, supported by relevant concepts, doctrine, and training. These changes will refine and implement the operational capabilities of expeditionary warfare so that Naval Forces can help provide the Nation's leaders with a full range of options to preserve regional balances, lay the foundations for coalition operations, provide

assistance to Americans in danger, respond to crises of every type, and project decisive power ashore in conflict.

IMPLEMENTATION

Naval Doctrine Command

We are establishing a Naval Doctrine Command. Integration on the battlefield starts with integration of doctrine and training. The regional and littoral warfighting environment requires new doctrinal thinking to get the most out of integrating the Navy/Marine Corps and the joint sea-air-land team. The new Naval Doctrine Command, alternately commanded by a Navy Rear Admiral and a Marine Corps Major General, will provide for smooth integration of Naval Forces into joint operations at any level, close the gap between the air-land battle and amphibious warfare, and translate "operational maneuver from the sea" into naval doctrine. Above all, it will build doctrine for expeditionary warfare.

Examining Our Current Force

We will examine functions and capabilities, seeking to eliminate areas of redundancy and enhancing areas considered deficient in light of this shift in strategy. Navy and Marine Corps equipment design, tactical training, logistics support, and task force structure will be optimized for taking and holding objectives on or near the enemy's coastline. We specialize in maneuver warfare from over the horizon, using the ocean to project force at soft points in the enemy's defense. Our job during a regional conflict is to control the ocean adjacent to the littoral battlefield, the ground from the shore to our objectives, and the skies above both. We rely on Navy and Marine Corps strike assets to neutralize enemy threats that may engage us from outside of established defense perimeters. Our goal is to focus our procurement strategy on systems that best support the unique capabilities of the Navy and Marine Corps.

Immediate Tasks

Fiscal realities and a newly defined regional, littoral naval focus require new thinking, significant changes, and a commitment to undertake challenging tasks. The Navy and Marine Corps will:

- Restructure to accommodate the strategy outlined in this document.
- Link air, land, and naval warfare to ensure truly joint warfare.
- Develop naval doctrine consistent with the new direction and focus—including an examination of functions and capabilities.
- Organize, train, and implement new Naval Force packages for expeditionary operations. Train commanders and man their staffs for joint operations.
- Configure, train, and man numbered fleet and Marine expeditionary staffs to be able to command a joint task force and function as, or host, a Joint Force Air Component Commander.
- Enhance communications, command, and control.
- Establish Commander U.S. Naval Forces Central Command as a Vice Admiral billet; provide additional permanent staff billets and communications command and control capabilities necessary to execute his responsibilities.
- Provide the Marines with the medium-lift they require.
- Increase emphasis on generation of high intensity power projection, support of force ashore, and weapons necessary to fulfill the mission.
- Expand the integration of Navy and Marine Corps fixed-wing air capabilities.
- Fully integrate attack submarines, maritime patrol aircraft, and mine warfare assets into the expeditionary task forces.
- Resolve sealift deficiencies.

- Continue to reorient naval intelligence resources from the former Soviet Navy to regional, littoral threats.
- Structure the Naval Reserve for immediate crisis response and peacetime contributory support.
- Procure equipment systems to support this strategy and remain ahead of the global technological revolution in military systems.

A2 EXCERPTS FROM "ACQUISITION ORGANIZATION AND PROCEDURES," CHAPTER 3 OF A QUEST FOR EXCELLENCE, FINAL REPORT OF THE PRESIDENT'S BLUE RIBBON COMMISSION ON DEFENSE MANAGEMENT (PACKARD COMMISSION), June 1986

A major task of this Commission has been to evaluate the defense acquisition system, to determine how it might be improved, and to recommend changes that can lead to the acquisition of military equipment with equal or greater performance but at lower cost and with less delay. For this purpose, the Commission formed an Acquisition Task Force.

• • • •

We compared the defense acquisition system with other systems, both government and commercial, that develop and produce equipment of comparable complexity, in order to find success stories that could provide a model on which reforms of the defense acquisition system could be based. Defense acquisition represents the largest and, in our judgment, the most important business enterprise in the world. It deserves to be managed with the highest standards. We therefore conducted a "search for excellence" by examining organizations that had been most successful in acquisition, in order to find a model of excellence for defense acquisition.

Chances for meaningful improvement will come not from more regulation but only with major

institutional change. During the last decade or so a new theory of management has evolved. It has been developed by a limited number of U.S. companies, and it has flourished in Japan. These new management practices have resulted in much higher productivity and much higher quality in the products being produced. They involve the participation of all of the people in the organization in deciding among themselves how the job can best be done. They involve, above all, trust in people. They involve the belief that people in an organization want to do a good job, and that they will—if given the opportunity—all contribute their knowledge, skill, and enthusiasm to work together to achieve the aims and goals of their organization. Supervision can be minimized, and detailed review of work can be greatly reduced. A real sense of teamwork can be established. Every group in an organization can become a center of excellence, and in this way the entire organization achieves a level of excellence in every aspect of its work.

Centers of excellence have evolved here and there in the acquisition process, in the form of project teams that have developed and produced new weapons rapidly, efficiently, and with high quality performance. Unfortunately, this is not the way DOD typically operates. All too many people in DOD work in an environment of far too many laws, regulations, and detailed instructions about how to do their work. Far too many inspectors and auditors check their work, and there is a hierarchy of oversight in far too many layers, requiring much wasteful reporting and paperwork.

The quest for excellence in defense management will be successful only if a new management philosophy can replace the old. Instead of concentrating on the things that are being done wrong and trying to fix them with more laws, more regulations, and more inspectors, DOD should concentrate on those things that are done right and use them as models.

• • • •

All of our analysis leads us unequivocally to the conclusion that the defense acquisition system

has basic problems that must be corrected. These problems are deeply entrenched and have developed over several decades from an increasingly bureaucratic and overregulated process. As a result, all too many of our weapon systems cost too much, take too long to develop, and, by the time they are fielded, incorporate obsolete technology.

• • • •

Although each of the cases we examined has its own peculiarities, we identified a number of problems that frequently recurred: for example, government insistence on rigid customs specifications for products, despite the commercial availability of adequate alternative items costing much less.

• • • •

It is clear that major savings are possible in the development of weapon systems if DOD broadly emulates the acquisition procedures used in outstanding commercial programs. In a few programs, DOD has demonstrated that this can be done. The challenge is to extend the correct management techniques to all major defense acquisitions, and more widely realize the attendant benefits in schedule and costs.

• • • •

It is fundamental that we establish unambiguous authority for overall acquisition policy, clear accountability for acquisition execution, and plain lines of command for those with program management responsibilities. It is also imperative that we streamline acquisition procedures. This can be facilitated by a number of related actions:

- We strongly recommend creation by statute of the new position of Under Secretary of Defense (Acquisition).

• • • •

- The Army, Navy, and Air Force should each establish a comparable senior position filled by a top-level civilian Presidential appointee.

• • • •

- Each Service Acquisition Executive should appoint a number of Program Executive Officers.

Each Service Acquisition Executive should appoint a number of Program Executive Officers (PEO) who, like group general managers in industry, should be responsible for a reasonable and defined number of acquisition programs. Program managers for these programs should be responsible directly to their respective PEO, and, on program matters, report *only* to him. In other words, every major program should be set up as a center of excellence and managed with modern techniques. The Defense Acquisition Executive should insure that no additional layers are inserted into this program chain of command.

• • • •

We recommend a high priority on building and testing prototype systems to demonstrate that new technology can substantially improve military capability, and to provide a basis for realistic cost estimates prior to a full-scale development decision. Operational testing should begin early in advanced development, using prototype hardware. The early phase of R&D should employ extensive informal competition and use streamlined procurement processes.

• • • •

Rather than relying on excessively rigid military specifications, DOD should make greater use of components, systems, and services available "off-the-shelf." It should develop new or custom-made items only when it has been established that those readily available are clearly inadequate to meet military requirements.

Federal law and DOD regulations should provide for substantially increased use of commercial-style competition, emphasizing quality and established performance as well as price.

The caliber of uniformed military personnel engaged in program management has improved significantly of late. Military officers manage over 90 percent of DOD's roughly 240 program offices. Their ranks range from 0-5 (lieutenant colonel/commander) to 0-8 (major general/rear admiral). Each of the Services has established a well-defined acquisition career program for its officers. These include the Army's Materiel Acquisition Management (MAM) program, the Navy's Materiel Professional (MP) programs, and detailed career planning regulations for Air Force technical personnel and program managers. We strongly support these measures. We also support recent legislation that has further defined career paths for all program managers. In 1984, Congress established a minimum four-year tenure for program management assignments. The 1986 Authorization Act prescribed requisite qualification and training, including at least eight years of acquisition-related experience and appropriate instruction at the Defense Systems Management College (or equivalent training).

A3 EXCERPTS FROM "FISCAL REALITIES AND THEIR IMPACT ON WEAPONS SYSTEMS, ACQUISITIONS AND DEVELOPMENT STRATEGIES," AN ADDRESS BY GERALD A. CANN, ASSISTANT SECRETARY OF THE NAVY FOR RESEARCH, DEVELOPMENT, AND ACQUISITION, AT THE FLETCHER SCHOOL OF LAW AND DIPLOMACY, TUFTS UNIVERSITY, NOVEMBER 18, 1992

The challenge we face as we close this century is to carefully match an increasingly limited number of resources to clearly defined mission needs. In September of 1992, the Navy issued a white paper entitled... *From the Sea, Preparing the Naval Service for the 21st Century*. This revision to the Navy's maritime strategy documents a shift from focusing on a single global threat to regional challenges. It calls for the Navy to restructure its

forces to accommodate this new strategy. In turn, the acquisition process will focus on equipment and systems to support this strategy of littoral, regional warfare.

• • • •

The Navy will continue to rely on the tremendous force multiplier that high technology weapon systems provide. For the Navy, our changing national security objectives with the end of the Cold War call for a fundamentally different fleet. This fleet will be smaller, but must be highly flexible and technologically sophisticated. It is evident that down-sizing does not equate to simply cutting the number of ships and personnel in the fleet. Quite the contrary, to meet the challenges of the post Cold War world the navy needs to structure a fundamentally different force.

• • • •

The reality of the future is, however, that we must develop a flexible, effective force within constrained budgets, reflecting a world at reduced tensions, with economics a dominant force in the equation for international power.

• • • •

Under the current budget plan, the Defense budget has accelerated a trend that was started in 1985, the high watermark year of defense spending under the buildup of the early 1980's. Since 1985 there has been a decrease in total defense budget authority of 28.8 percent. The president's 1993 budget proposal continued this downward trend with a planned total decrease of 36.8 percent from the high watermark through 1997. During the same period defense procurement budget authority will have decreased by *over half*.

The Navy fiscal picture mirrors this overall DOD picture. Navy obligational authority peaked in 1988, at \$116 billion in constant FY92 dollars. Within five years, under current projections it will drop 36% to \$73.9 billion in FY92 dollars. Despite these reductions, a "Base Force" is planned to represent the minimum level of military capability believed necessary to keep the peace,

deter aggression, respond quickly where needed to defend our vital interests overseas.

It is likely that fiscal realities will continue to shift funds away from procurement toward operations and support. At the same time that overall procurement dollars are decreasing, the shift away from the Cold War emphasis on high rate productions and quick fielding of new weapons systems will increase the unit cost of the new systems that do enter the production process. Longer service lives through mid-life upgrades and technology insertions to existing systems combined with a slower replacement cycle are to be expected.

The downward trend in acquisition creates an opportunity and challenge for our research and technological development communities. The aggressive pursuit of technology, but more important, fieldable technology will be key to the Navy-Marine Corps team success in future conflicts. We must improve the process whereby these technologies transition from the laboratory development cycle to limited production cycles.

• • • •

In late 1989, the Deputy Secretary of Defense challenged the Service to create a new approach to S&T management, one that would eliminate inefficiencies, take advantage of joint considerations and reduce unwarranted overlap in the research, development, test and evaluation (RDT&E) of each individual Service. The Tri-Service S&T Reliance project was borne of this tasking and is one of the most comprehensive restructuring efforts involving technology base in over 40 years. The goals of S&T Reliance were to:

1. Enhance science and technology
2. Ensure critical mass of resources to develop "world class" products
3. Gain efficiency through collocation and consolidation of in-house work when appropriate
4. Preserve the Services' mission-essential capabilities

At the same time, each of the services began internal review and consolidation of its own technical organization, resulting in the Navy's recent consolidation of its R&D infrastructure into four Warfare Centers and a single Corporate Research Laboratory.

• • • •

Reliance is now fully operational. Reliance has produced a set of formal agreements among the Services for joint planning, collocation of in-house work, or lead Service agreements. These agreements cover the bulk of the non-Service-unique portion of the Services' 6.1, 6.2, and 6.3A programs. And, while the original focus of Reliance dealt with collocation of in-house work, as Reliance has been implemented, the joint planning process addresses *both* the in-house *and* the contract S&T programs.

• • • •

A major change in emphasis in the years ahead will be in DOD's science and technology (S&T) programs. Recognizing the substantial budget reductions expected in this decade, a need exists to continuously demonstrate viable technologies based on more rigorous "up front" technology development in order to reduce technical risk in the formal acquisition cycle. The vehicle used to show technology viability is the Advanced Technology Demonstration (ATD). The concept is not a new one. For example, in the recent past, the Have Blue aircraft demonstrated that stealth was feasible prior to the development and production of the F-117A. The Millimeter and Microwave Monolithic Integrated Circuits (MIMIC) program demonstrated the ability to produce low-cost integrated circuits. Some technology demonstrations will fail to be satisfactorily demonstrated in the laboratory and will be abandoned. Other demonstrations will lead to new capabilities that can be inserted into current systems and built into future programs. Still others will pass the test of laboratory maturity and can be

expected to transition to the traditional systems development process.

• • • •

At the same time greater emphasis must be placed on producibility of systems and their manufacturing processes. The S&T emphasis will be directed at seven broad areas of capability, or seven S&T Thrusts. Certainly there are goals and activities that do not comport with these Thrusts—the program is intended to focus where there is greater concern, not to equally balance the investment effort. These seven Thrusts represent the most pressing military and operational needs identified by our users. While the Thrusts may change, currently they are:

1. *Global Surveillance and Communication*

The ability to project power requires global surveillance and communications capability that can focus on a trouble spot, surge in capacity when needed, and respond to the needs of the commander.

2. *Precision Strike*

The requirement to reduce casualties, employ economy of force, and assure optimum weapon employment demands that we locate and destroy high-value targets in a timely manner.

3. *Air Superiority and Defense*

The need to defend deployed military forces and help defend allies and coalition partners from the growing threat of high performance aircraft and ballistic and cruise missiles, and the need to maintain decisive capabilities in air combat, interdiction, and close air support requires a strong effort in missile defense and air superiority.

4. *Sea Control and Undersea Superiority*

The ability to maintain overseas presence, conduct forcible entry and naval interdiction operations, and operate in littoral zones while keeping losses to a minimum presupposes a strong capability in sea control and undersea warfare.

5. *Advance Land Combat*

The ability to rapidly deploy our ground forces to a region, exercise a high degree of tactical mobility, and overwhelm the enemy quickly and with minimal casualties in the presence of a heavy armored threat and smart weaponry requires highly capable land combat systems.

6. *Synthetic Environment*

A broad range of information and human interaction technologies must be developed to synthesize present and future battlefields. We must therefore synthesize factory-to-battlefield environments with a mix of real and simulated objects and make them accessible from widely dispersed locations. Users, developers and testers must be able to interact effectively in the synthetic environment. The synthetic environment will better prepare our commanders and forces in the real battlefield.

7. *Technology for Affordability*

Technologies that reduce unit and life-cycle costs are essential to achieving significant performance and affordability improvements. Manufacturing process and product performance issues are integral parts of the program. Advances are particularly needed in technologies to support integrated product and process design, flexible manufacturing systems that decouple cost from volume, enterprise-wide information systems that improve program control and reduce overhead costs, and integrated software engineering environments.

ACQUISITION STRATEGIES

Advance Technology Demonstrations and concentration of R&D investment on high payoff, enabling technologies are designed to reduce technical risk; cost and schedule risk must similarly be reduced through more efficient management of program efforts. These efforts include mitigation of cost risk through a conservative contracting philosophy and better use of cost and schedule analysis. Greater emphasis on evaluation of cost and schedule progress as well as increased emphasis on scrutiny of technical indicators, such as weight growth in aircraft

programs, will be necessary to ensure that scarce defense resources are allocated to programs which are proceeding on schedule and within budget.

An event-based contracting procedure which is responsive to changing levels of risk through the life of a program is essential to today's defense marketplace. Current fiscal realities demand a thorough review of contract methodologies to make sure that contracts are awarded in the best interests of the government while they are realistic and achievable for the contractor. The *massive fixed-price development contracts of the 1980's* were a key factor that caused problems to the companies that attempted to carry them out in the face of reduced production requirements and burgeoning technical risk. This ultimately led to a number of major programs being canceled or contractors defaulting. In some cases, such events left valid military requirements unfilled. In the years ahead, excess capacity in the defense marketplace will provide pressure for companies to bid programs on very low margin in order to be competitive and survive in a downsizing market.

As weapons systems increase in cost, and limited production runs become the rule, future major acquisition programs need to share risk equitably between the customer and the producer as the degree of risk ebbs and flows through the various stages of development. The increased use of Advanced Technology Demonstrations is one answer to mitigation of technical risks. Contracts which provide an equitable and realistic apportionment of technical and financial risk between the Government and the contractor, and allow for a smooth transition to production are essential to mitigating cost risk. When properly structured in consonance with an aggressive design-to-cost activity, innovative, event based contracting methods will help us achieve a proper balance between development, production, operating and support costs and leave room for

profit in programs which may lead to limited production runs, or never enter a production phase.

Another area that gains increasing importance as budgets decrease and the advancement of commercial technologies continues to outpace military developments in areas such as computers and communications is the *increased use of commercial standards*, Commercial Off the Shelf (COTS) and Nondevelopmental Items (NDI). These strategies capitalize on technological successes of the commercial sector and allow rapid and cost effective insertion of state-of-the-art technology into our combat and support systems. Military-specific development of new capabilities can be costly and time consuming, as well as expensive to support over the life cycle of a system. Use of COTS and NDI have already proven highly successful in high technology fields such as computers and communications.

Just as the military can save money and time from adapting commercial products to military use, so too can the industrial base benefit from defense investment in dual use technologies, new manufacturing technologies, and infusion of defense related technology into the industrial base.

In Conclusion

The Navy and Marine Corps Team is changing in response to the dual challenges of a new threat environment and declining defense budget. New directions are signalled for doctrine, education, service integration, infrastructure, acquisition, research and development and other areas. Regardless of the dynamics of these processes, the peace we have paid so dearly to obtain, must be maintained through a well thought-out investment strategy followed through with a continued commitment to ensure that America's fighting forces remain second to none.

Appendix B
THE NAVY AND DOD DIRECTIVE SYSTEMS

TABLE OF CONTENTS

B1	Scope and Purpose	B-1
B2	Numbering of Navy Directives	B-1
B3	Identifying and Obtaining Instructions	B-1
	B3.1 Navy Consolidated Subject Index	B-2
B4	DOD Directive System	B-2
	B4.1 DOD Annual Listing	B-2

Appendix B

THE NAVY AND DOD DIRECTIVE SYSTEMS

The Department of the Navy Directives Issuance System consists primarily of two types of directives: instructions, which are directives of a continuing nature and are effective until cancelled; and notices, which are directives of a one-time nature, or are applicable for a brief period, usually 6 months or less. Notices contain a provision for their own cancellation.

B1 SCOPE AND PURPOSE

Directives serve two purposes. First, they prescribe or establish policy, organization, methods, or procedures; and second, they require action or contain information essential to the effective administration or operation of activities concerned. All Department of the Navy directives are issued in the Navy Directives Issuance System with the following required exceptions.

1. Top Secret directives
2. Joint Army-Navy-Air Force publications (JANAP's) which are numbered serially
3. Registered publications
4. Plans issued under the Navy Planning System

Optional exceptions to the Navy Directives System are:

1. Military operational releases
2. Book-type publications (manuals and technical publications)

3. Directives addressed to less than six addressees, including "Copy to" addressees. (In this connection primary consideration should be given to content rather than number of addressees.)

B2 NUMBERING OF NAVY DIRECTIVES

Navy Directives are numbered in accordance with the classification system described in SECNAV Instruction 5210.11, "Department of the Navy File Maintenance Procedures and Standard Subject Identification Codes (SSIC)." Additional information on this subject may be found in C9.

Numbers preceding the decimal point denote the subject of the directive, while the numbers following the decimal are consecutive numbers assigned by the issuing office. Letters following the consecutive number indicate the revision.

Ref.: SECNAV Instruction 5210.11

B3 IDENTIFYING AND OBTAINING INSTRUCTIONS

Identifying all directives concerning a particular subject matter may prove to be more difficult than anticipated. Once the required directives have been identified, obtaining copies is relatively easy. Each bureau, office and systems command maintains a directives control point for the purpose of supplying directives to their activity. Such points also are maintained by the

B3.1

Chief of Naval Operations and the Secretary of the Navy. When new directives arrive at an organization's directive control point, copies are routed to the various sections. Additional copies may be obtained as needed through the directive control point, or through the central stocking point, Naval Publications and Forms Directorate, Navy Aviation Supply Office, ASO Code 0344, 5801 Tabor Avenue, Philadelphia, Pennsylvania 19120-5099.

B3.1 Navy Consolidated Subject Index. The largest problem is identifying the specific directives which provide guidance on a particular subject. The primary aid for identifying directives pertaining to particular subjects is the current edition of NAVPUBINST 5215.1, "Consolidated Subject Index," which is issued annually. Each edition also includes a numerical list of effective instructions. This document provides a guide to the subject matter of unclassified instructions issued by DON components and distributed to addressees outside the originating office. It usually is effective in identifying directives dealing with listed subjects.

B4 DOD DIRECTIVE SYSTEM

The DOD directive numbering system is

based on issuing offices within the Office of the Secretary of Defense rather than on subject matter. Thus, there is no direct relationship between the DOD and the Navy systems.

Part IV of NAVPUBINST 5215.1, Navy Implementation of DOD Issuances, lists DOD directives, instructions, and other issuances. A column labeled "Implementation or Contact," identifies implementing Navy issuances and shows where the DOD issuances are included as enclosures.

Ref.: DOD Directive 5025.1

B4.1 DOD Annual Listing. The Office of the Secretary of Defense provides a publication, *DOD Directive System Annual Index* (DOD 5025.1-I). Part I is a numerical Index; Part II is a subject index.

Ref.: DOD 5025.1-I, DOD Directives System Annual Index issued by OASD (Administration), Directives Division, Correspondence and Directives Directorate

Appendix C
INFORMATION CATEGORIZATION SYSTEMS

TABLE OF CONTENTS

C1	Some Theoretical Aspects of Categorization Systems	C-1
C1.1	Function and Utility of Categorization Systems	C-1
C1.2	Criteria for Categorization Systems	C-1
C2	Qualities of Baseline Cost Estimates	C-2
C2.1	Estimates for Use in SARs	C-2
C2.2	Measures of Cost Estimate Confidence	C-2
C3	Naval Research Program Structure	C-2
C3.1	Program Building Blocks	C-3
C3.1.1	Program Elements	C-3
C3.1.2	Research Program Subelements	C-3
C3.1.3	Research Sponsor/Claimant Codes	C-3
C3.1.4	Research Project Number	C-3
C4	Exploratory Development Program Planning Structure	C-4
C4.1	Program Building Blocks	C-4
C4.1.1	Program Elements	C-4
C4.1.2	Technology Thrusts	C-4
C4.1.3	Block Program	C-4
C4.1.4	Project	C-5
C4.2	Exploratory Development Program Elements	C-5
C5	Mission Need Categorization Structures	C-6
C5.1	Marine Corps Planning Categories	C-6
C6	Appropriations Categories	C-7
C6.1	DOD Budget Structure	C-7
C6.2	RDT&E Budget Activities	C-7
C7	DOD Programming System Categories	C-8
C7.1	Major Programs	C-8
C7.2	Program Element	C-8
C8	Standard Cost Definitions	C-8
C9	Department of the Navy Standard Subject Identification Code	C-9
C9.1	Major Subject Groups	C-9
C9.2	Primary, Secondary, and Tertiary Numerical Subject Groups	C-10
C9.3	RDT&E Subject Groups	C-11

C10 Science and Technology Subject Categories	C-11
C10.1 Scientific and Technological Fields and Groups	C-11
C11 Work Breakdown Structure	C-12
C11.1 Expanded Ship Work Breakdown Structure (ESWBS)	C-12

Appendix C

INFORMATION CATEGORIZATION SYSTEMS

This section presents several categorization systems. Some are employed in RDT&E management and others affect RDT&E indirectly. These categorization systems provide perspectives of the Department of Defense from several points of view.

C1 SOME THEORETICAL ASPECTS OF CATEGORIZATION SYSTEMS

C1.1 Function and Utility of Categorization Systems. Categorization systems are critical to management. The more appropriate the categorization systems, the more manageable is the effort. Managers are responsible for achieving their mission goals using a fixed amount of resources; or, conversely, they are responsible for accomplishing a fixed task with minimum possible resources. To achieve such efficiency, managers must achieve optimum "balance" within their programs, i.e., the resources available to them must be employed in the most productive way. In other words, executives make "tradeoffs," or move resources within their programs to put them to their most productive use. Categorization systems provide both the key to detecting program imbalances and opportunities to increase effectiveness through tradeoffs (see 4.4.2).

A categorization system generally is designed to meet a specific need of a particular user. No single categorization system can be designed to meet the needs of all users. An understanding of categorization systems can aid program managers in selecting the system(s) that will best meet their needs.

C1.2 Criteria for Categorization Systems. Criteria useful for evaluating categorization systems include:

- It must be useful. It must display information in a manner which will permit a manager to make decisions with confidence that all relevant information is available and is accurately displayed.
- It must be simple.
- The elements of the system must be mutually exclusive; otherwise, decisions based on the system can be ambiguous.
- Elements must be symmetrical. This means that elements not conveying similar concepts should be discarded or replaced. For example, if one were to categorize materials and an element appeared which dealt with human factors, it would be readily apparent that it was out of place.
- Elements must cover the entire spectrum of the subject matter being categorized.
- The system should be expandable to accommodate new concepts and disciplines.
- The system must be convertible. This enables the decision maker to shift readily from one system to another and thereby deriving a different perspective concerning the same subject.
- It should lend itself to electronic or mechanical accumulation of data. As categorization systems pass from a higher to a lower organizational level the degree of detail in a specific area increases. In this transition the mass of data required to

fulfill the needs of the system increases to such an extent that it is essential that a categorization system be capable of computerization.

C2 QUALITIES OF BASELINE COST ESTIMATES

Cost judgments are made by comparing actual costs to a criterion termed a "baseline cost estimate." Categories have been established for rating the quality of these baseline estimates.

C2.1 Estimates for Use in SARs. In Selected Acquisition Reports (SARs), cost estimates are defined as follows:

- **Planning Estimate (PE)**—The SAR baseline estimate of program acquisition costs (by appropriation), schedule milestones, and performance characteristics that is approved before Milestone II.
- **Development Estimate (DE)**—The SAR baseline estimate of acquisition cost (by appropriation), schedule milestones, and performance characteristics that is approved at or subsequent to Milestone II, but before Milestone III.
- **Production Estimate (PdE)**—The SAR baseline estimate of program acquisition cost (by appropriation) that is approved at or subsequent to Milestone III.
- **Current Estimate (CE)**—A DOD Component's latest forecast of program acquisition cost, schedule milestone, and performance characteristics.

Ref.: DOD 5000.2-M, Part 17

C2.2 Measures of Cost Estimate Confidence. The following standards are used with cost estimate documents primarily in ship acquisition programs:

Class A—Detailed Cost Estimate (Post budget—contract estimates). Estimate based on contract plans and evaluation of firm quotations for major material items.

Class B—Bid Evaluation Cost Estimate (Post budget—contract estimates). Estimate based on contract plans and evaluation of contractor RFP-based bids.

Class C—Budget Quality Estimate. Estimate based on an engineering analysis of detailed characteristics of item under consideration.

Class D—Feasibility Estimate. Estimate based on technical feasibility studies and/or extrapolated from higher quality estimates of similar items.

Class E—Computer Estimate. Estimate developed using a computer model and based on cost estimating relationships and general total parameters.

Class F—"Ball Park" Estimate. Quick cost estimates prepared in absence of adequate design and cost information and based on general parameters.

Class X—Directed or Modified Cost Estimate. Estimate not developed by System Commands through normal cost estimating processes.

Ref.: DON Programming Manual, Appendix J

C3 NAVAL RESEARCH PROGRAM STRUCTURE

The structure for the Navy's Research (6.1) Program is issued by the Chief of Naval Research. The structure is set forth in OCNR letter 5000 ser 10P3/1044 of April 1989. It is used for planning and programming basic research throughout the Department of the Navy. The numbering system for specific elements is depicted graphically in Exhibit C-1.

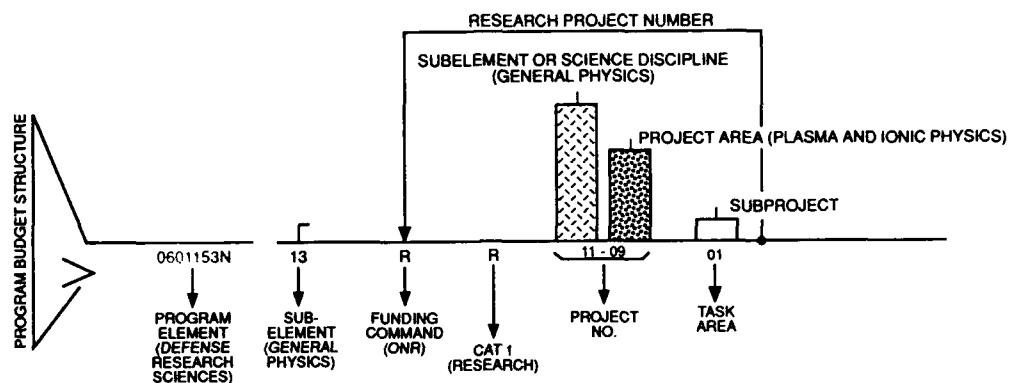

Exhibit C-1 — Research Program/Budget Structure

C3.1 Program Building Blocks.

C3.1.1 Program Elements. The Research Program Structure consists of two program elements (note that Research (6.1) Programs have a 0601 prefix):

- 0601152N—In-House Laboratory
Independent Research
- 0601153N—Defense Research Sciences

C3.1.2 Research Program Subelements. The program is structured around the following sixteen subelements:

- 11—General Physics
- 12—Radiation Sciences
- 13—Chemistry
- 14—Mathematics
- 15—Computer Sciences
- 21—Electronics
- 22—Materials
- 23—Mechanics
- 24—Energy Conversion
- 31—Ocean Sciences
- 32—Ocean Geophysics
- 33—Atmospheric Sciences
- 34—Astronomy and Astrophysics
- 41—Biological Science

- 42—Cognitive and Neural Sciences
- 52—Multidisciplinary Support

C3.1.3 Research sponsor/claimant codes. All elements of the Research Program are identified to sponsoring organizations by letter codes:

- M—Naval Medical Research and
Development Command
(NAVMEDRSCHDEVCOM)
- R—Office of Naval Research
(ONR)
- Y—Naval Facilities Engineering Command
(NAVFACENGCOM)

C3.1.4 Research Project Number. The Research Project Number is an eight digit number in which the first and second digits indicate the Funding Command and Budget Category (R for Category 1, Research). The third and fourth digits indicate the Naval Research Area (one of the sixteen subelements for Defense Research Sciences or In-House Laboratory Independent Research). The fifth and sixth digits indicate the specific research Project Area within the related Naval Research Area. The seventh and eighth digits further subdivide the Project into Subprojects (Task Areas) by each funding activity (Office or Command). (This is a two-digit

C4

numeric field that makes the Research Project Number unique to that claimant.) The third, fourth, fifth, and sixth digits together are referred to as the Project Number. For example:

RR - ONR, Research
RR-31 - Ocean Sciences
RR-31-01 - Ocean Engineering
02 - Oceanic Biology
03 - Physical Oceanography
RR-31-03-03 - Coastal Dynamics

C4 EXPLORATORY DEVELOPMENT PROGRAM PLANNING STRUCTURE

The Exploratory Development (6.2) Program Planning Structure is set forth by the Chief of Naval Research for use in planning and programming Navy-wide Exploratory Development. The Exploratory Development Program is managed by the Technology Directorate, an organization of the Office of Naval Research (ONR).

Ref.: OCNR Instruction 3910.3

C4.1 Program Building Blocks

C4.1.1 Program Elements. Program elements (PE) are the smallest subdivisions of the R&D program considered in the DOD programming system. The Exploratory Development Program, structured along naval mission area lines, budgets funding by program elements which approximate as closely as possible the mission areas. Naval warfare mission areas and corresponding Exploratory Development mission areas are shown in Exhibit C-2: (Note that Exploratory Development (6.2) programs have an 0602 prefix). Similar, or closely related warfare mission areas are funded under the same program element. Each mission area is subdivided by the technology thrusts required to meet its objectives. Technology thrusts, in turn, are supported by one

or more like technical projects, combinations of which are aggregated into a block program.

Program Element 0602XYZ

where:

X = 1 For AAW/ASUW/SAT
(Surface-Aerospace Technology)

2 For Support Technologies

3 For ASW/UT (Undersea
Technology)

9 For Corporate Programs, Plans,
and Budget Directorate

Y = 1 For warfare-related technology

2 For platform-related technology

3 For multi-application technology

Z = As required to ensure uniqueness of last
two characters of PE number for each
reference

Note: The above does not apply to PE 0602270
EW Technology.

Each project addresses one technology thrust.

See paragraph C4.2 for program elements
within the Exploratory Development Program.

C4.1.2 Technology Thrusts. Technology thrusts define the operational objectives to be achieved through a combination of technologies, and establish the objectives of the Block Program. Each technology thrust has a single operational and/or performance objective which supports the warfighting objectives of its mission area. A technology thrust may draw on several blocks and several projects within each of those blocks to meet its objectives.

C4.1.3 Block Program. A block program comprises an integrated group of technology projects with closely related applications and/or technical objectives. These are assigned to a given

WARFARE MISSION AREA	6.2 MISSION AREA	PROGRAM ELEMENT
AAW - Antiair Warfare	AAW	0602111N
ASU - Antisurface Ship Warfare	ASUW	0602111N
STW - Strike Warfare		
ELW - Electronic Warfare	EW	0602270N
ASW - Antisubmarine Warfare	ASW	0602314N
MIW - Mine Warfare	MW	0602315N
NSW - Naval Special Warfare	SPW	0602315N
AMW - Amphibious Warfare	AMW	0602131M
MOB - Mobility	Ships	0602121N
	Aircraft	0602122N
	Submarines	0602323N
	Nuclear Propulsion	0602324N
CCC - Command Control and Communications	C ³	0602232N
INT - Intelligence		
CON - Construction	Mission Support*	0602233N
FSO - Fleet Support Operations		
LOG - Logistics		
NCO - Noncombat Operations		
STS - Strategic Sealift		
NONE	Materials, Electronics and Computers	0602234N
	Lab Independent Exploratory Development	0602936N
	Oceanographic and Atmospheric	0602435N

* Includes Ocean and Atmospheric Support (P.E. 0602435N), Personnel Training and Simulation, CBD, and Logistic Technology Human Factors

Exhibit C-2 — Naval Warfare Mission Areas and Corresponding 6.2 Program Mission Areas

lead Navy Warfare Center, laboratory or Systems Command program manager. Typically, a Block program includes the overall Exploratory Development Program's efforts in a warfare technology area. The block is composed of a number of projects each of which may address a different technology thrust and/or mission area. Block programs are management entities designed to aggregate funding and program efforts to increase management efficiency and exploit the synergism of having similar tasks managed by a single Block Program Manager and within a single management structure.

C4.1.4 Project. A project is a sub-division of a block program and is a technology development which addresses the objectives of a single technology thrust. Thus, projects generally are defined as either specific technology or warfare

technology developments. The term *specific technologies* refers to an application of a science or engineering discipline, such as, radome material technology or laser communications technology. The term *warfare technology* refers to closely related warfare, weapons or platform objectives, such as, air-launched weaponry, surface ship technology, or airborne electronic warfare.

C4.2 Exploratory Development Program Elements. Program elements are listed by title below.

602111N	Surface/Aerospace Surveillance and Weapons Technology
0602270N	Electronic Warfare Technology
0602121N	Surface Ship Technology
0602122N	Aircraft Technology
0602131M	Marine Corps Landing Force Technology

C5

0602232N Command, Control and Communi-
cations Technology
0602233N Mission Support Technology
0602234N Materials, Electronic, and Computer
Technology
0602314N Undersea Surveillance and Weapons
Technology
0602315N Mine and Special Warfare
Technology
0602323N Submarine Technology
0602324N Nuclear Propulsion Technology
0602435N Ocean and Atmospheric Technology
0602936N Independent Exploratory Develop-
ment

MA 12 Intelligence
MA 15 Special Operations
MA 36 Electronic Warfare

Aviation Combat Element

MA 32 Antiair Warfare
Weapons
Surveillance
Control and Support Systems

MA 33 Assault Support

MA 35 Command and Control of A/C, Missiles
and UAVs

**C5 MISSION NEED CATEGORIZATION
STRUCTURES**

Mission need categorization structures (see F1.7.1) provide guidance for potential systems concepts and for developing the technology base. There is a number of such structures, developed more or less independently by organizations for their own purposes. Various efforts are underway to achieve some standardization of these structures, which if successful will benefit information flow and effective planning. An example in DOD is the Marine Corps structure of Mission Areas and capability sets. To illustrate the second-level structure, the capability sets under the first Mission Area in each major category are shown.

Ground Combat Element

MA 22 Ground Tactical Mobility/
Counter-mobility
Tactical Mobility
Mine Clearance Countermeasures
Obstacle Breaching
Counter-mobility

MA 23 Close Combat

MA 24 Fire Support

Combat Service Support Element

MA 41 Supply
Requests Determination Requisition,
Receipt, Storage & Distribution Salvage
& Reutilization Supply AIS

MA 42 Maintenance

MA 43 Transportation

MA 44 Expeditionary Engineering

MA 45 Health Services

C5.1 Marine Corps Planning Categories.
Marine Corps Mission Areas and capability sets
are set forth in the following categories:

Command Element

MA 11 Command and Control
Long-Range Communications
VHF Communications
Digital Communications
Position/Location Navigation

Additional MAs

FMF and Non FMF

MA 13	Security
MA 34	Offensive Air Support
MA 42	Maintenance
MA 46	Services

- Electronics and Communications
- Other Procurement
- Research, Development, Test, and Evaluation (see C6.2)
- Military Construction
- Trust Funds
- Trust Revolving Funds
- Military Functions
- Civil Functions
- Family Housing
- Revolving and Management Funds
- Other Accounts.

NonFMF

MA 51	Facilities Management
MA 52	Base Ops and Admin
MA 60	Training
MA 70	Manpower

*Ref.: DON Budget Guidance Manual
(NAVCOMPT 7102.2)*

C6 APPROPRIATIONS CATEGORIES

The appropriations categorization structure is used for budget development and budget presentation to the Congress.

C6.1 DOD Budget Structure. The following titles and subdivisions are used in budgetary and fiscal presentations:

- Military Personnel
 - Active Forces
 - Reserve Forces
- Operation and Maintenance
- Procurement
 - Aircraft
 - Missiles
 - Ships
 - Combat Vehicles, Weapons, and Torpedoes
 - Ordnance, Vehicles, and Related Equipment

C6.2 RDT&E Budget Activities. The RDT&E appropriation request is organized by mission-oriented budget activities in accordance with the Congressional Budget and Impoundment Control Act of 1974 (see 4.4.6). Definitions of budget activities are as follows:

1 Technology base. This activity finances basic research and exploratory development with the primary objective of increasing fundamental scientific knowledge adaptable to solving needs of widely varying future requirements.

2 Advanced technology development. This activity finances exploration of options and concepts prior to development of specific weapons systems. New technological developments are pursued which are not formally identified to specific operational requirements. This effort includes feasibility demonstrations of innovative concepts and emphasizes hardware competition in pursuit of optional solutions to potential military problems.

3 Strategic programs. This activity finances all R&D efforts on strategic offensive, defensive, and control systems.

4 Tactical programs. This activity finances advanced engineering and operational systems

C7

development related to all conflict levels of tactical warfare.

5 *Intelligence and communications.* This activity finances advanced, engineering, and operational systems development in intelligence and worldwide communications.

6 *Defense-wide mission support.* This activity finances efforts in support of installations or operations required for use in general research and development and not allocable to specific missions. Included are technical integration efforts, technical information activities, major test ranges, test facilities and general test instrumentation, target development, support of user tests, international cooperative R&D, and other R&D support.

*Ref.: NAVCOMPT Manual, Vol. 7,
Para. 074401*

C7 DOD PROGRAMMING SYSTEM CATEGORIES

C7.1 Major Programs.

- 1 Strategic Forces
- 2 General Purpose Forces
- 3 Intelligence and Communications
- 4 Airlift and Sealift
- 5 Guard and Reserve Forces
- 6 Research and Development
- 7 Central Supply and Maintenance
- 8 Training, Medical, and other General Personnel Activities
- 9 Administration and Associated Activities
- 10 Support of Other Nations
- 11 Special Operations Forces

Ref.: DON Programming Manual

C7.2 Program Element. A program element is the basic building block of the Defense Program. It describes the mission to be undertaken and identifies the organizational entities responsible for performing the mission. Elements may consist of forces, manpower, materials (both real and personal property), services, and associated costs. The list of Navy's program elements is detailed in the *DON Programming Manual*!

Program elements are identified by a eight-character symbol as shown graphically in Exhibit C-3.

C8 STANDARD COST DEFINITIONS

The unit procurement costs of weapon systems can vary substantially, depending on what factors are included in the cost figures. To eliminate confusion, the following standard cost definitions have been established:

- **Flyaway Cost**
 - Basic Unit (airframe, hull, chassis, frame and so forth.
 - Propulsion Equipment
 - Electronics/Avionics
 - Armament
 - Installed Government-Furnished Equipment
 - Other Level 3 Work Breakdown
 - Structure Hardware/Software
 - Subsystem Elements
 - System Project Management and System Test (as appropriate)
 - Nonrecurring and Recurring Production Costs
- **Weapon System Cost**
 - Flyaway Cost (see above) plus:
 - Peculiar Ground Support Equipment
 - Peculiar Training Equipment
 - Data (Publications, Technical)
 - Contractor Plant and Field Services
 - Installation and Checkout

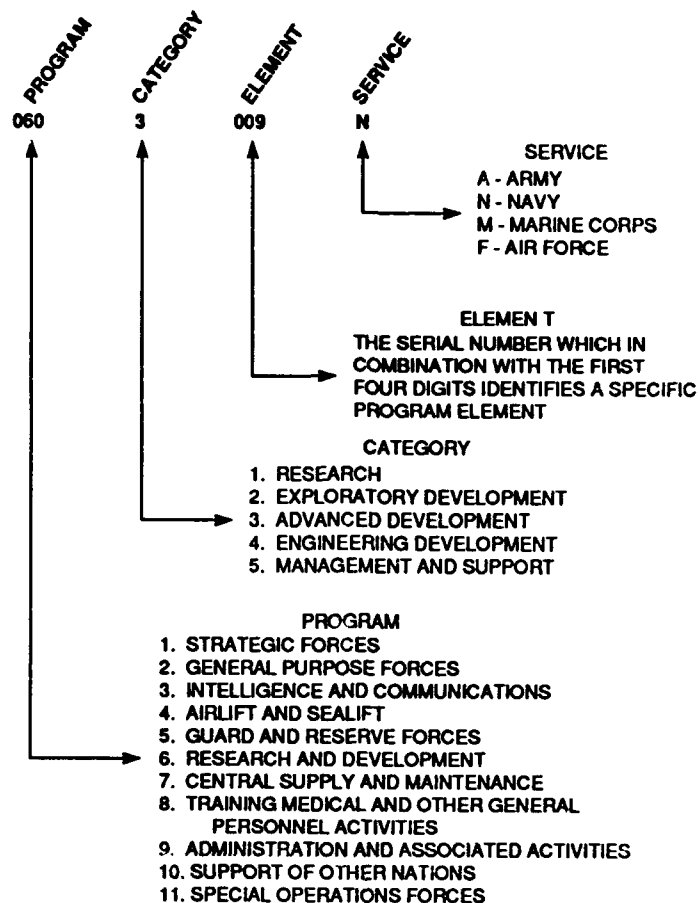

Exhibit C-3 — Example of Program Element Numbering

- Procurement Cost (as shown in SAR) includes:
Weapon System Cost (see above) plus:
Initial Spares
Outfitting Post Delivery, Cost
Growth, Escalation, and Ship
Contract Design (Navy
Shipbuilding Only)
- Program Acquisition Cost (as shown in SAR) includes:
Procurement Cost (see above) plus:
RDT&E
MILCON.

Ref.: DON Budget Guidance Manual (NAVCOMPT 7102.2)

C9 DEPARTMENT OF THE NAVY STANDARD SUBJECT IDENTIFICATION CODE

The Department of the Navy Standard Subject Identification Code provides a single coordinated system for classifying records, directives, correspondence, reports, forms, and other documents by subject.

Ref.: SECNAVINST 5210.11

C9.1 Major Subject Groups. The major fourteen subject groups of the Navy's Standard Subject Identification Code relate to:

1000 Series—Military Personnel. Administration of military personnel. (Civilian personnel are

C9.2

included in the 12000 series. General personnel—including both civilian and military personnel—are in the 5000 series.)

2000 Series—Telecommunications. General communication matters and communication systems and equipment.

3000 Series—Operations and Readiness. Operational plans, fleet operations, operational training and readiness, warfare techniques, operational intelligence, research and development, geophysical and hydrographic support.

4000 Series—Logistics. Logistical support of the Navy and Marine Corps, including procurement, supply control, property redistribution and disposal, travel and transportation, maintenance, construction and conversion, production and mobilization planning, and foreign military assistance.

5000 Series—General Administration and Management. The administration, organization, and management of the Department of the Navy, including general personnel matters (concerning both civilian and military personnel), records management, security, external and internal relations, audiovisual management, law and legal matters, office services, office automation, and publication and printing matters.

6000 Series—Medicine and Dentistry. Medical matters, such as physical fitness, general medicine, special or preventive medicine, dentistry, and medical equipment and supplies.

7000 Series—Financial Management. Financial administration of the Department of the Navy, including budgeting, disbursing, accounting, auditing, contract auditing, industrial and other special financing matters, and statistical reporting.

8000 Series—Ordnance Material. Ordnance material and weapons, including ammunition and explosives, guided missiles of all types, nuclear weapons, fire control and optics, combat vehicles,

underwater ordnance materials, and miscellaneous ordnance equipment.

9000 Series—Ships Design and Material. The design and characteristics of ships, and ships material and equipment.

10000 Series—General Material. General categories of materials not included in the specialized material groups. This group includes audiovisual/graphic/arts/photographic/television/video equipment and accessories, general machinery and tools, personnel (materials), and miscellaneous categories.

11000 Series—Facilities and Activities Ashore. Ashore structures and facilities, transportation facilities, heavy equipment, utilities and services, and other similar subjects.

12000 Series—Civilian Personnel. The administration of civilian personnel. (Military-personnel subjects are included in the 1000 series; general information relating to both civilian and military personnel is included in the 5000 series.)

13000 Series—Aeronautical and Astronautical Material. Aeronautical and astronautical material, including parts, accessories, and instruments; special devices, armament; aerological equipment, weapon systems, types of aircraft; and astronautic vehicles.

16000 Series—Coast Guard Missions. Administration and mission of the Coast Guard. Not to be used by Navy or Marine Corps activities.

C9.2 Primary, Secondary, and Tertiary Numerical Subject Groups. The foregoing fourteen major numerical subject groups are sub-divided into primary, secondary, and sometimes tertiary breakdowns. Primary subjects are designated by the last three digits of the code number. For example, the major subject of General Administration and Management, coded 5000, is subdivided into primary groups as follows:

- 5000 General Administration and Management
 - 5200 Management Programs and Techniques
 - 5300 Manpower/Personnel
 - 5400 Organization, Functions, and Status

Primary subjects are subdivided into secondary subjects by the last two digits of the numeric code. Tertiary breaks are indicated by the final digit. For example:

- 5200 Management Programs and Techniques
 - 5210 Records Management
 - 5211 Filing, Maintenance, Retrieval, and Privacy Act Systems

Some smaller subject groups are not sub-divided below the primary breakdown. Other larger subject groups are divided into many secondary and tertiary subjects, the extent depending upon the scope and complexity of the subject matter.

C9.3 RDT&E Subject Groups. The primary subject group, Research and Development, under major subject area, Operations and Readiness, (3000 series), is subdivided into four secondary groups as follows:

- 3000 Operations and Readiness
 - 3900 RDT&E, General
 - 3910 Plans
 - 3920 Programs
 - 3930 Projects
 - 3960 Tests and Evaluation.

C10 SCIENCE AND TECHNOLOGY SUBJECT CATEGORIES

A categorization system important in the reporting and retrieval of RDT&E information is that set forth in the Subject Categorization Guide for Defense Science and Technology (AD-A172-650). The Guide represents an

extensive revision of the previously used COSATI (Committee on Scientific and Technical Information) listing. It comprises 25 scientific and technical major subject fields, subdivided into more than 200 groups. It is in use by DOD, in conjunction with the Defense Technical Information Center (DTIC), for reporting and retrieval of information at the working level for all scientific and technical work (DD 1498) and for information on Independent Research and Development. The major subject headings are given below, with an example only of the subheadings under the first major subject. The numbering system shown is that used by DOD for task area, project, and work unit level reporting.

DTIC/TR-86/16 AD-A172-650

C10.1 Scientific and Technological Fields and Groups.

- 01 Aviation Technology
 - 01/01 Aerodynamics
 - 01/02 Military Aircraft Operations
 - 01/03 Aircraft
 - 01/04 Flight Control and Instrumentation
 - 01/05 Terminal Flight Facilities
- 02 Agriculture
- 03 Astronomy and Astrophysics
- 04 Atmospheric Sciences
- 05 Behavioral and Social Sciences
- 06 Biological and Medical Sciences
- 07 Chemistry
- 08 Earth Sciences and Oceanography
- 09 Electrotechnology and Fluidics
- 10 Power Production and Energy Conversion (Nonpropulsive)
- 11 Materials
- 12 Mathematical and Computer Science
- 13 Mechanical, Industrial, Civil, and Marine Engineering

- 14 Test Equipment, Research Facilities, and Reprography
- 15 Military Sciences
- 16 Guided Missile Technology
- 17 Navigation, Detection, and Counter-measures
- 18 Nuclear Science and Technology
- 19 Ordnance
- 20 Physics
- 21 Propulsion, Engines and Fuels
- 22 Space Technology
- 23 Biotechnology
- 24 Environmental Pollution and Control
- 25 Communications

- Central Integrated Checkout
- Antisubmarine Warfare
- Auxiliary Electronics Equipment
- Armament
- Auxiliary Armament/ Weapons Delivery Equipment
- Training
- Equipment
- Services
- Facilities

Ref.: MIL-STD-881; DOD Instruction 5000.2, Part 6, Section B

C11 WORK BREAKDOWN STRUCTURE

A work breakdown structure (WBS) is specified by DOD for application in contracting, planning, and reporting during the engineering development and subsequent stages of acquisition of a major system. A work breakdown structure is a product-oriented "family tree" composed of hardware, service, etc., which completely defines the project/program. It covers three levels of detail as illustrated by the partial sample of the Aircraft System summary WBS.

<u>Level 1</u>	<u>Level 2</u>	<u>Level 3</u>
Aircraft System	Air Vehicle	Airframe
		Power Plant
		Other Propulsion
		Communications
		Navigation/Guidance
		Fire Control
		Penetration Aids
		Reconnaissance
		Equipment
		Automatic Flight Control

C11.1 Expanded Ship Work Breakdown Structure (ESWBS). NAVSEA has developed a further, detailed structure based upon Appendix E of MIL-STD-881. Its major groupings are an extension of the Level 3 subheadings under the WBS Level 2 heading "Ship." The system is cross-indexed to the 9000 series of the Standard Subject Identification Code (See C9.1) and to the Bureau of Ships Consolidated Index (BSCI) (NAVSHIPS 0902-002-2000) which it supersedes, but which still is used in historical data. It provides a single language which is used through the life cycle of the ship. Its use is illustrated below:

<u>WBS Level 2</u>	<u>ESWBS Major Groups (WBS Level)</u>
Ship	000 General Guidance and Administration
	100 Hull Structure
	101 General Arrangement-Structure (Subgroup) (Element)
	110 Shell and Supporting Structure (Subgroup)
	111 Shell Plating, Surface Ship and Submarine

Pressure Hull
(Element)
112 Shell Plating,
Submarine Non-Pressure
Hull
120 Hull Structural Bulkheads

Ref.: NAVSEA
S9040-AA-IDX-010/SWBS-5D

Appendix D
TECHNICAL INFORMATION SERVICES

TABLE OF CONTENTS

D1	Scientific and Technical Information Program (STIP)	D-1
D2	Navy Technical Libraries	D-1
D3	Defense Technical Information Center (DTIC)	D-1
D3.1	DOD RDT&E Databases	D-2
D3.1.1	Work Unit Information System (WUIS) Database	D-2
D3.1.2	IR&D Database	D-2
D3.1.3	Technical Reports Database	D-2
D3.2	DTIC Products and Services	D-2
D3.2.1	Defense RDT&E On-Line Systems (DROLS)	D-2
D3.2.2	Notices of changes in classification, distribution, and availability	D-3
D3.2.3	Technical report secondary distribution services	D-3
D3.2.4	Automatic Document Distribution (ADD)	D-3
D3.2.5	Bibliographies	D-3
D3.2.6	WUIS and IR&D reports	D-4
D3.2.7	Referral service	D-4
D3.3	Obtaining DTIC Services	D-4
D4	Information Analysis Centers (IACs)	D-4
D4.1	IAC Listing	D-5
D4.2	Shock and Vibration Information Analysis Center (SAVIAC)	D-5
D5	Navy Acquisition, Research and Development Information Center (NARDIC)	D-6
D6	Navy Potential Contractor Program (NPCP)	D-6
D7	Government-Industry Data Exchange Program (GIDEP)	D-6
D8	National Technical Information Service (NTIS)	D-7

Appendix D

TECHNICAL INFORMATION SERVICES

Programs, facilities, services, and organizations are available to meet the information needs of Navy RD&A personnel and their contractors. The most important programs are described herein.

All Navy organizations performing, contracting, or authorizing scientific and technical work, studies are required by SECDEF and SECNAV to query the DOD RDT&E databases maintained at the Defense Technical Information Center (DTIC) prior to commencing new research or development activities (see D3.1.), and to submit work unit summaries at key points during such activities (see 3.1.1).

Ref.: DOD 3200.12-R-1

D1 SCIENTIFIC AND TECHNICAL INFORMATION PROGRAM (STIP)

The Department of Defense operates a comprehensive, coordinated STIP to ensure that such information contributes to the advancement of science and technology; permits timely and efficient conduct and management of DOD research, engineering, and studies programs; eliminates duplication of effort and waste of resources; and encourages and expedites the interchange and use of scientific and technical information (STI). The STIP provides for interchange of STI within and among DOD organizations and their contractors federal

agencies and their contractors, and the national and international scientific communities.

Ref.: DOD Directive 3200.12 (SECNAV 3900.43); SECNAV Instruction 3900.43

D2 NAVY TECHNICAL LIBRARIES

Navy (and DOD) technical libraries are vital to the RDT&E process. They are the access points to most of the major scientific and technical information services, provide direct access to reports, books, periodicals, a growing variety of electronic data bases, and other established library facilities and services tailored to users' technical needs.

Navy terminals for the Defense RDT&E On-Line System (DROLS) are located in the technical libraries, so that library staffs can assist RDT&E personnel. If a technical library does not have an online terminal to DTIC, the librarian will assist in formulating DOD RDT&E database queries, which are then sent to DTIC for processing. Search results are returned by mail.

As a general rule, information-gathering efforts should begin by discussions with the activity librarian.

D3 DEFENSE TECHNICAL INFORMATION CENTER (DTIC)

The DTIC provides STIP services to assist in carrying out STIP policy and administration,

D3.1

operates DOD-wide systems, and serves as a central coordinating point for DOD STI databases.

Among various reference tools available is IDA Paper P-1500, entitled *How to Get It—A Guide to Defense-Related Information Sources*. This reference guide identifies and helps acquire government-published documents, maps, patents, specifications or standards, and other resources of interest. Copies of this manual are available from most technical libraries.

Ref.: DOD Directive 3200.12 (SECNAV 3900.43)

D3.1 DOD RDT&E Databases. Three DOD RDT&E databases are operated by DTIC. These databases contain information summaries of on-going work, industry Independent Research and Development (IR&D), and technical reports.

D3.1.1 Work Unit Information System (WUIS) Database. This database provides information on on-going Defense-sponsored research and technology performed at DOD facilities or by contracts and grants or agreements. DOD organizations provide information described on Research and Technology Work Unit Summaries (DD Form 1498) in machine-readable form. Historical information also can be compiled from this database.

All Navy organizations performing, contracting, or authorizing scientific and technical work or studies are required to forward a complete, accurate work unit summary to DTIC upon the initiation of each work unit funded by Program 6. Revised work unit summaries must be submitted upon any major program change, milestone, completion, termination, or in any case within 12 months of the prior submission.

Ref.: DOD 3200.12-R-1; DOD 3200.12-M-1

D3.1.2 IR&D Database. This database contains proprietary information on Defense-related work from companies in the Independent Research and Development (IR&D) program. Because this information is proprietary, use is limited to authorized DOD personnel only. DOD contractors provide annual reports on their IR&D programs. Descriptions of individual projects are summarized on DTIC Form 271, which provides information similar to that shown on DD Form 1498.

Ref.: DOD Instruction 3204.1 (SECNAV 3900.40); SECNAV Instruction 3900.40

D3.1.3 Technical Reports Database. This database contains bibliographic citations with abstracts and other information on completed DOD-sponsored scientific and technical research reports submitted to DTIC. DOD organizations and contractors submit this information on Standard Form 298. DTIC also provides this Technical Reports database (unclassified information) on CD ROM.

In addition, DTIC also obtains, stores, retrieves, and provides secondary distribution of scientific and technical documents directly to registered users.

Ref.: SECNAV Instruction 3900.29; ANSI Std Z39.18

D3.2 DTIC Products and Services

D3.2.1 Defense RDT&E On-Line Systems (DROLS). Remote computer terminals provide online access to the above DOD RDT&E databases. Location of these Navy terminals can be obtained from technical libraries or from DTIC.

All DTIC-registered organizations may request DROLS searches directly from DTIC offices when such assistances cannot be obtained locally. DTIC facility addresses are:

DTIC HQ, Building 5, Cameron Station
Alexandria, Virginia 22034-6145

Telephone

Commercial: 703-274-6434

DSN (formerly AUTOVON): 284-6434

DTIC Los Angeles Regional Office

Attn: DTIC BLNL

222 North Sepulveda Blvd.

El Segundo, California, 90245-4320

Telephone

Commercial: 213-335-4170

DSN: 972-4170

DTIC Albuquerque Regional Office

Attn: DTIC BLNA,

Phillips Laboratory/SUL

Bldg 419, Kirtland AFB

Albuquerque, New Mexico, 87117-6008

Telephone

Commercial: 505-846-6797

DSN: 246-6797

DTIC Boston Regional Office

Attn: DTIC BLNB

Building 1103, Hanscom Air Force Base

Bedford, Massachusetts 01731-5000

Telephone

Commercial: 617-377-2413

DSN: 487-2413

DTIC MATRIS Office

Attn: DTIC-AM

Catalina Blvd., Bldg. 305

San Diego, California 92152-6800

Telephone

Commercial: 619-553-7000

DSN: 553-7000

D3.2.2 Notices of changes in classification, distribution, and availability. Notices are published quarterly on microfiche, with the fourth quarter being an annual cumulative issue.

D3.2.3 Technical report secondary distribution services. Registered users may obtain technical reports in either hard copy or microfilm. Documents may be ordered online via DROLS

(see D3.2.1), by phone, or by forwarding a Document Request (DTIC Form 1).

D3.2.4 Automatic Document Distribution (ADD). DTIC offers an Automatic Document Distribution service which provides microfiche copies of recent documents meeting a user's subject interest profile on a semimonthly basis.

D3.2.5 Bibliographies. These are listings of technical reports related to specific subjects. A computerized search is made of the DTIC collection listing applicable reports with control numbers, informative abstracts, and descriptive data.

The three main types of DTIC bibliographies offered are Demand, Current Awareness and Direct Response. They differ in depth of search, response time, and product format.

Demand Bibliography—A literature search on particular subject(s) resulting in a paper document and conducted at the request of a user. The bibliography usually covers the last 10 years or less, but expanded coverage may be justified by the user. Response time is about 10 days. Registered users may visit DTIC on 24 hours notice for direct contact with a retrieval specialist during a requested search.

Upon request, DTIC will make a computer search to locate technical reports pertinent to a user's research problem or project. The requesting organization specifies the time parameters of search.

Current Awareness Bibliography (CAB)—A customized, automated subscription bibliography service based on subject needs of DTIC users. Semimonthly, the user's subject interest profile is matched against information contained in newly accessioned documents. Paper documents containing unclassified citations to technical reports matching their subject interest profiles are sent free to CAB subscribers.

Direct Response Bibliography—A list of AD numbers and titles of technical reports which meet a specific information request by telephone, FAX, or letter. Written requests are required for more

D3.2.6

than 5 subject categories at one time. Response time for this free service is 24 hours.

D3.2.6 WUIS and IR&D reports. In a manner similar to bibliographies, reports from the Work Unit Information System (WUIS) (see D3.1.1) and/or Independent Research and Development (IR&D) reports (see D3.1.2) can be obtained either on a demand or recurring basis.

D3.2.7 Referral service. DTIC's referral service provides information concerning DOD-sponsored specialized sources of scientific and technical knowledge. When users require information exceeding DTIC data, this service directs them to other expertise sources.

The unclassified, hard-copy Referral Databank Directory is available from DTIC or NTIS. Activities included in the referral database include information analysis centers, specialized libraries, information exchanges and offices, depositories, laboratories, testing directorates and similar research facilities. The directory gives detailed descriptive information on the missions, subject areas, services and materials available, publications issued, key personnel, and access limitations of each activity. Entries are updated and verified by participating activities before publication of each new edition. Arrangement is alphabetical by organization, with indexes by Director/contact and by subject.

D3.3 Obtaining DTIC Services. Government research and development activities and their contractors, subcontractors, and grantees are eligible to receive most of the information from DTIC-based DOD databases. In addition, research and development organizations without current contracts may be eligible for service through the Potential Contractor Program with a military Service or the Defense Advanced Research Projects Agency (DARPA).

There are collections, however, which contain proprietary information compiled for the specific purpose of DOD management decisions

which are made available only to specified Defense activities.

All Navy (and DOD) activities must register with DTIC in order to obtain services. Normally, the Navy activity's librarian is the DTIC liaison.

To assist other organizations in acquiring DTIC services, the Center provides a Joint Services Regulation (DLAR 4185.10) and a manual (DLAM 4185.16), both entitled, "Certification and Registration for Access to DOD Scientific and Technical Information." This regulation provides the procedures and forms required for registration. Requests for the regulation or for additional information concerning DTIC should be addressed to:

Defense Technical Information Center
Attn: DTIC-O
Building No. 5, Cameron Station
Alexandria, VA 22304-6145
Telephone:
Commercial: 703-274-6871/72
DSN: 284-6871/72

Ref.: DLAR 4185.10; DLAM 4185.16

D4 INFORMATION ANALYSIS CENTERS (IACs)

The Defense Department supports twenty-three centers for analysis of scientific and technical information. Fourteen are contractor-operated IACs managed administratively by DTIC and funded by the Office of the Director, Acquisition Policy and Program Integration in the Office of the Undersecretary of Defense for Acquisition (OUSD(A)) through DTIC. Nine others are managed by other DOD activities. These Centers receive technical data from DOD laboratories and agencies possessing competence in the field of science and technology within which the particular Center functions. In addition, technical expertise is provided by scientists and engineers associated with appropriate research and development facilities.

Each center gathers information in its specialized area of interest; reviews, analyzes, evaluates, synthesizes, summarizes, and distributes it. These centers also provide critical reviews, state-of-the-art monographs, data compilations, answers to questions, and access to technical advice.

Most DOD IACs are on a service charge basis for both in-house and contract users. Information on the particular IAC most likely to have information for user problems may be obtained from DTIC or directly from the IACs through their reference and referral systems. Current information about IAC coverage and points of contact is provided by the DTIC-published *Directory of the Department of Defense Information Analysis Centers*, available from DTIC and the IACs. Other reference sources include the *The DTIC Referral Data Base Directory*, AD-A241 750, and from a technical report, *Information Analysis Centers in the Department of Defense*, Jul 87, AD-Ai84 002, available from DTIC or NTIS.

*DOD 3200.12-R-2; DTIC/ TR-87/17
(AD-A-184 002)*

D4.1 IAC Listing. Information on IACs may be obtained from the Program Manager for IACs, DTIC-DF, Tel. 274-6260, DSN (formerly AUTOVON): 284-6260. Data from certain IAC's, marked by *, can be obtained through the DTIC DROLS (see D3.2.1).

*Ceramics Information Analysis Center
Coastal Engineers Information Analysis Center
Chemical Propulsion Information Agency
*Chemical Warfare/Chemical-Biological Defense Information Analysis Center
Cold Regions Science and Technology Information Analysis Center
Concrete Technology Information Analysis Center

Crew Systems Ergonomics Information Analysis Center
Data Analysis Center for Software
DOD Nuclear Information Analysis Center
*Guidance and Control Information Analysis Center
*High Temperature Materials Information Analysis Center
Hydraulic Engineering Information Analysis Center
Infrared Information Analysis Center
*Manufacturing Technology Information Analysis Center
*Metals Information Analysis Center
*Metal Matrix Composites Information Analysis Center
*Nondestructive Testing Information Analysis Center
Pavement and Soils Trafficability Information Analysis Center
*Plastics Technical Evaluation Center
Reliability Analysis Center
Soil Mechanics Information Analysis Center
Survivability and Vulnerability Information Analysis Center
Tactical Technology Center

D4.2 Shock and Vibration Information Analysis Center (SAVIAC) . The SAVIAC is a new center, established under the sponsorship of a multiagency Technical Advisory Group with members from the Army, Navy, Air Force, NASA, and DOE laboratories. A successor to the former SVIC, which was located at the Naval Research Laboratory, its records date back to shortly after WW II. It is operated by Booz, Allen, and Hamilton and the Southwest Research Institute and monitored by the Navy.

SAVIAC serves as an information center for structural dynamics research, analysis, and testing. Its technical coverage includes all shock, vibration, blast, impact, and related effects. Its scope includes all air, land, sea, and space vehicles and structures subject to these dynamic forces. SAVIAC responds to technical inquiries, performs bibliographic searches, and maintains a technical

D5

information system. In addition, SAVIAC can perform research or other tasks for individual sponsors within the scope of its charter. SAVIAC services are available to all government agencies and contractors on a block funding or individual service charge basis. Requests for information on SAVIAC should be sent to:

The Shock and Vibration Information
Analysis Center
2711 Jefferson Davis Highway, Suite 600
Alexandria, VA 22202-4158
Telephone
Commercial: 703-769-7570
FAX: 703-685-6555

D5 NAVY ACQUISITION, RESEARCH AND DEVELOPMENT INFORMATION CENTER (NARDIC)

The NARDIC is the designated point within the Navy where R&D planning and requirements information is available for review by qualified representatives of industry. It was established because of the recognized benefit to the Navy of civilian participation in R&D relevant to Navy needs. The NARDIC maintains its office in Arlington, Virginia.

NARDIC's address is:
Navy Acquisition, Research and Develop-
ment Information Center
2211 Jefferson Davis Highway
Crystal Plaza 5, Room 802
Washington, DC 20360-5000
Telephone
Commercial: 703-602-9057
DSN: 703-332-9057

The NARDIC office provides reading rooms where representatives of authorized companies may review documents of interest.

NARDIC services are available to industrial, scientific, or other organizations registered for access to DOD (DTIC) information services. An organization may register for DOD information

services as either a contractor or prospective contractor.

D6 NAVY POTENTIAL CONTRACTOR PROGRAM (NPCP)

The NPCP informs the scientific and technical community, on a no-cost, controlled basis, of R&D problems confronting the DOD and DON.

Through NPCP agreements, classified and unclassified technical information on DON requirements and existing R&D is provided to nongovernment activities. NARDIC and DTIC services are available to NPCP participants. Participation is accomplished by executing a policy agreement with an NPCP focal point at a Navy R&D command. Firms or individuals with activities that have substantiated R&D capability and a reasonable potential for receiving and executing Navy contracts are eligible. Additional information can be obtained from the NARDIC office (see D5) or the Office of Naval Research, ONR 26, 800 North Quincy Street, Arlington, VA 22217-5000.

D7 GOVERNMENT-INDUSTRY DATA EXCHANGE PROGRAM (GIDEP)

GIDEP interchanges technical data related to parts, components, and materials used in military and space systems. GIDEP does not require generation of new data. It simply ensures that technical data required to be delivered under a contract and already paid for is available to other program participants to make cost savings possible on a reciprocal basis.

GIDEP is sponsored by the Joint Logistics Commanders (JLCs). By agreement of the JLCs, central management is assigned to the DON's representative to the JLCs. The GIDEP Program Manager is assigned to the Office of the Assistant Secretary of the Navy (Research, Development and Acquisition).

Although many organizations participate voluntarily, some government contracts require

that contractors participate in GIDEP. Contractors may be required to participate in accordance with MIL-STD-1556B, a contract clause, or a statement of work.

In DOD and NASA organizations, participation in GIDEP may be mandatory through application of one of the following regulations:

- Navy OPNAV Instruction 5200.29
- Army AMC Regulation 70-56
- Air Force Regulation 80-10
- NASA Management Instruction 5310.2

There are four GIDEP Data Interchanges:

a. Engineering Data Interchange—contains engineering evaluation and qualification test reports, nonstandard parts justification data, parts and materials specifications, manufacturing processes, and other related engineering data on parts, components, materials, and processes.

b. Reliability-Maintainability Data Interchange—contains failure rate/mode and replacement rate data on parts, components, and materials. Also includes reports on R&M practices and procedures.

c. Failure Experience Data Interchange—contains failure information on parts, components, processes, fluids, materials, and safety fire hazards. Also includes data from ALERT's as well as other problem information, failure analyses, and Diminishing Manufacturing Sources and Material Shortage (DMSMS) information.

d. Metrology Data Exchange—contains test equipment calibration procedures and metrology-related engineering data on test systems, calibration systems, and measurement technology.

An URGENT DATA REQUEST (UDR) system within GIDEP permits a participant with a specific technical problem to query rapidly the scientific and engineering expertise of all participating activities. A UDR form is initiated by the member and sent to the GIDEP Operations Center for distribution to all participants. Responses are provided directly to the person making the query and are also incorporated into the appropriate data interchange.

Further information on GIDEP may be obtained from:

GIDEP Operations Center
 Naval Warfare Assessment Center
 (Code QA50)
 Naval Weapons Station, Corona Annex
 Corona, CA 91718-8000
 Telephone
 Commercial: 714-273-4677/5324
 DSN (formerly AUTOVON): 933-4677/
 5324

Ref.: OPNAV Instruction 5200.29

D8 NATIONAL TECHNICAL INFORMATION SERVICE (NTIS)

The National Technical Information Service (NTIS) of the Department of Commerce is the primary activity within the Federal Government for the collection, announcement, and dissemination of unclassified technical reports and data on both U.S. and foreign government-sponsored R&D and engineering activities. Industry and the general public may purchase more than 50 products and services from NTIS, including

- Summaries and complete reports of such activities from 1964.
- Applications software, data files, and databases produced by Federal agencies.
- Assistance in identifying Federal laboratories in specific fields.
- Descriptions of ongoing U.S. government-sponsored research projects.
- Information on licensing of government-owned inventions.
- Online access to the NTIS database.

Current abstracts of NTIS documents and other records of interest are published in the twice-monthly *NTIS Alerts* bulletin. The *NTIS*

Products and Services Catalog, PR-27, may be obtained free of charge by calling 703-487-4650.

NTIS databases are accessible through commercial services. They can be searched at nominal cost through most Navy technical libraries.

Information on the NTIS services is available

from local technical libraries or from:

National Technical Information Service
U.S. Department of Commerce
Springfield, Virginia 22161
Telephone

Commercial: 703-487-4650.

DSN (formerly AUTOVON): 933-4677

SELECTED REFERENCES ON TECHNICAL INFORMATION SERVICES

DOD Directive 3200.12 (SECNAVINST 3900.43), "DOD Scientific and Technical Information Program (STIP)."

DOD 3200.12-R-1, "Research and Technology Work Unit Information System Regulation."

DOD 3200.12-R-2, "Centers for Analysis of Scientific and Technical Information Regulation."

DOD Instruction 3204.1 (SECNAV 3900.40), "Independent Research and Development."

DOD Instruction 5200.21 (SECNAV 3900.35), "Dissemination of DOD Technical Information."

ANSI Z39.18-1987, "Scientific and Technical Reports—organization, preparation, and production."

SECNAV Instruction 3900.29, "Standard Format Requirements for Scientific and Technical Reports."

SECNAV Instruction 3900.43, "Navy Scientific and Technical Information Program (STIP)."

NOTE REGARDING DIRECTIVE NUMBERS

References to directives within this Guide are by series only; e.g., 3900.14, not to the effective edition within the series; e.g., 3900.14A

The "Master Reference List" indicates the version and issue date of each directive used in preparation of this edition of the Guide.

For recent information on the effective directive within a series, consult the "Department of the Navy Directives Issuance System: Consolidated Subject Index," (NAVPUBNOTE 5215).

Appendix E
ORGANIZATION AND RELATIONSHIPS

TABLE OF CONTENTS

E1	Research, Development, and Acquisition Responsibilities of the Office of the Secretary of Defense	E-1
E1.1	Under Secretary of Defense (Acquisition) (USD(A))	E-1
E1.1.1	Director of Defense Research and Engineering (DDR&E)	E-3
E1.1.1.1	Assistant to the Secretary of Defense (Atomic Energy) (ATSD(AE))	E-3
E1.1.2	Assistant Secretary of Defense (Production and Logistics) (ASD(P&L))	E-4
E1.1.3	Director, Test and Evaluation (DT&E)	E-4
E1.1.4	Director, Strategic and Space Systems	E-4
E1.1.5	Director, Tactical Systems	E-4
E1.1.6	Director, Defense Procurement (DDP)	E-4
E1.1.7	Director, Acquisition Policy and Program Integration (D^AP&PI)	E-4
E1.1.8	Deputy Undersecretary of Defense for International Programs (DUSD(IP))	E-4
E1.2	Defense Acquisition Executive (DAE)	E-5
E1.3	Director of Operational Test and Evaluation (DOT&E)	E-5
E1.4	Comptroller of the Department of Defense	E-5
E1.5	Assistant Secretary of Defense, Program Analysis and Evaluation (ASD(PA&E))	E-5
E1.6	Assistant Secretary of Defense for Command, Control, Communications, and Intelligence (ASD(C31))	E-5
E1.7	Defense Agencies	E-6
E1.7.1	Defense Advanced Research Projects Agency (DARPA)	E-6
E1.7.2	Defense Nuclear Agency (DNA)	E-6
E1.7.3	Defense Information Systems Agency (DISA)	E-7
E1.7.4	Defense Contract Audit Agency (DCAA)	E-7
E1.7.5	Defense Intelligence Agency (DIA)	E-7
E1.7.6	Defense Logistics Agency (DLA)	E-7
E1.7.7	National Security Agency (NSA)	E-8
E1.7.8	Defense Mapping Agency (DMA)	E-8
E1.8	Joint Chiefs of Staff	E-8
E2	Research, Development and Acquisition Responsibilities of the Department of the Navy	E-8
E2.1	Secretary of the Navy	E-9

E2.1.1	Navy Acquisition Executive (NAE)	E-9
E2.1.2	Assistant Secretary of the Navy (Research, Development and Acquisition) (ASN(RD&A))	E-9
E2.1.3	Office of Program Appraisal (OPA)	E-12
E3	Office of the Chief of Naval Operations (OPNAV)	E-12
E3.1	Director of Test and Evaluation and Technology Requirements (N091, formerly OP-091)	E-14
E3.1.1	Science and Technology Requirements Division (N911, formerly OP-911)	E-14
E3.1.2	Test and Evaluation Programs Division (N912, formerly OP-912)	E-14
E3.1.3	RDT&E Facilities and Resources Division (N913, formerly OP-913)	E-14
E3.2	Deputy Chief of Naval Operations (Manpower and Personnel /Chief of Naval Personnel (N1, formerly OP-01) (DCNO(MP) formerly, DCNO(MPT))	E-14
E3.3	Director of Naval Intelligence (DNI) (N2, formerly OP-92)	E-15
E3.4	Deputy Chief of Naval Operations (Plans, Policy, and Operations) (N3/N5, formerly OP-06)	E-15
E3.5	Deputy Chief of Naval Operations (Logistics) (N4, formerly OP-04)	E-15
E3.6	Director of Space and Electronic Warfare, (N6, formerly OP-094)	E-15
E3.7	Deputy Chief of Naval Operations (Resources, Warfare Requirements, and Assessment) (N8, formerly OP-08)	E-16
E3.7.1	Director, Programming Division (N80, formerly OP-80)	E-16
E3.7.2	Director, Assessment Division (N81, formerly OP-81)	E-16
E3.7.3	Director, Surface Warfare Division (N86, formerly OP-03)	E-16
E3.7.4	Director, Submarine Warfare Division (N87, formerly OP-02)	E-16
E3.7.5	Director, Air Warfare Division (N88, formerly OP-05)	E-17
E3.8	Surgeon General of the Navy (N093, formerly OP-093)	E-17
E3.9	Oceanographer of the Navy (N096, formerly OP-096)	E-17
E3.10	Activities Reporting to CNO	E-17
E3.10.1	Naval Systems Commands	E-17
E3.10.2	Bureau of Medicine and Surgery	E-17
E3.10.3	Naval Oceanography Command	E-17
E4	Naval Systems Commands	E-17
E4.1	Material Support Responsibilities of Systems Commanders	E-17
E4.2	Naval Air Systems Command	E-18
E4.3	Naval Facilities Engineering Command	E-18
E4.4	Naval Sea Systems Command	E-18
E4.5	Naval Supply Systems Command	E-21
E4.6	Space and Naval Warfare Systems Command	E-21

E5	Defense Systems Management College (DSMC)	E-21
E6	Marine Corps Organization for Research, Development and Acquisition	E-23
E6.1	Commander, Marine Corps Systems Command (COMMARCORSSYSCOM)	E-23
E6.2	Commanding General, Marine Corps Combat Development Command (CG,MCCDC)	E-23
E6.3	HQMC Organization for RD&A	E-25
E6.3.1	Deputy Chief of Staff for Aviation (DC/S AVn)	E-25
E6.3.2	Deputy Chief of Staff for Manpower ((DC/S Mpr)	E-25
E6.3.3	Deputy Chief of Staff for Installation and Logistics (DC/S I&L)	E-25
E6.3.4	Deputy Chief of Staff for Requirements and Programs ((DC/S R&P)	E-25
E6.3.5	Director, Command and Control, Communications and Computers (DirC4)	E-25
E6.3.6	Director, Marine Corps Operational Test and Evaluation Activity (MCOTEA)	E-25
E6.4	Marine Corps RDT&E Liaison Organization	E-25
E6.5	Fleet Marine Forces (FMF)	E-25
E7	Office of Naval Research (ONR)	E-26
E8	Bureau of Medicine and Surgery (BUMED)	E-28
E8.1	Commanding Officer, Naval Medical Research and Development Command	E-28
E9	Boards and Other Groups	E-28
E9.1	Defense Science Board (DSB)	E-28
E9.2	Defense Acquisition Board (DAB)	E-28
E9.2.1	DAB Acquisition Committees	E-29
E9.3	Joint Requirements Oversight Council (JROC)	E-29
E9.4	Defense Planning and Resources Board (DPRB)	E-29
E9.5	Joint Services Automatic Testing-Executive Board (JSAT-EB)	E-29
E9.6	Naval Research Advisory Committee (NRAC)	E-30
E9.7	CNO Decision Process Groups	E-30
E9.7.1	Resource and Requirements and Review Board (R ³ B)	E-30
E9.7.1.1	Ship Characteristics Improvement Panel (SCIP)	E-30
E9.7.1.2	Air Characteristics Improvement Panel (ACIP)	E-31
E9.7.1.3	Nonnuclear Ordnance Requirement (NNOk) Panel	E-31
E9.7.2	Program Review and Coordinating Committee (PRCC)	E-31
E9.7.3	Navy Staff Executive Steering Committee	E-31
E9.7.4	Chief of Naval Operations Executive Steering Committee	E-31

E9.8	Navy and Marine Corps Program Decision Meetings (NPDM/MCPDM)	E-31
E9.9	Acquisition Review Board (ARB)	E-32
E9.10	Naval Studies Board—National Academy of Sciences	E-32
E9.11	DON Program Strategy Board (DPSB)	E-32
E9.12	Navy Laboratory/Center Coordinating Group (NLCCG)	E-32
E9.13	Navy Laboratory/Center Oversight Council (NLCOC)	E-32
E10	Participants in the Acquisition Process	E-32
E10.1	Appropriation Sponsor	E-32
E10.2	Program Sponsor	E-33
E10.3	Resource Sponsor	E-33
E10.4	Requirements Officer	E-33
E10.5	Program Executive Officer (PEO) and Direct Reporting Program Manager (DRPM)	E-33
E10.6	Program Manager (PM)	E-33
E10.7	Ship Acquisition Program Manager	E-33
E10.8	Acquisition Manager	E-33
E10.9	Contracting Officer	E-33

Appendix E ORGANIZATION AND RELATIONSHIPS

This appendix discusses the organizations and fundamental responsibilities of the principal agencies, departments, and executives involved in Research, Development, and Acquisition and how they work together to get the job done.

E1 RESEARCH, DEVELOPMENT, AND ACQUISITION RESPONSIBILITIES OF THE OFFICE OF THE SECRETARY OF DEFENSE

Department of Defense (DOD) functions and those of its departments and agencies are carried out under the direction, authority and control of the Secretary of Defense (SECDEF). The SECDEF serves under the direction of the President, who, as Commander-in-Chief of the Armed Forces, is responsible for final broad military decisions.

The Secretary of Defense is supported by the Office of the Secretary of Defense. The responsibilities of assistant secretaries with major involvement in RD&A are summarized in the following paragraphs with particular emphasis on the Under Secretary of Defense for Acquisition (see Exhibit E-1).

Ref.: DOD Directive 5100.1

E1.1 Under Secretary of Defense (Acquisition) (USD(A)). USD(A) is the senior, full-time acquisition executive of DOD and reports directly to the SECDEF and DEPSECDEF. USD(A) is the principal staff assistant and advisor to them for all matters relating to the acquisition system; research

and development; production; logistics; military construction; and procurement.

The USD(A) position was established by the FY 1987 Authorization Act (P.L. 99-661). Additional legislation regarding this office, which was contained in the Goldwater-Nichols Defense Reorganization Act of 1986, implemented certain recommendations of the President's Blue Ribbon Commission on Defense Management, otherwise known as the Packard Commission. Principal functions and responsibilities of the USD(A) include:

- Serving as the Defense Acquisition Executive (DAE) (see E1.2),
- Setting policy for acquisition matters,
- Serving as Chairman of the Defense Acquisition Board (DAB) (see E9.2),
- Reviewing proposed resources programs and budget estimates for acquisition programs. The Military Departments and other DOD Components must consult with the USD(A) on significant proposed changes to programs reviewed by the Defense Acquisition Board (DAB).
- Conducting the program for analyzing technology and industrial base.

USD(A)'s extensive authorities and relationships include direction of the Military Departments and Heads of other DOD Components on policy, procedure, and execution of the acquisition system.

Officials reporting directly or indirectly to USD(A) include:

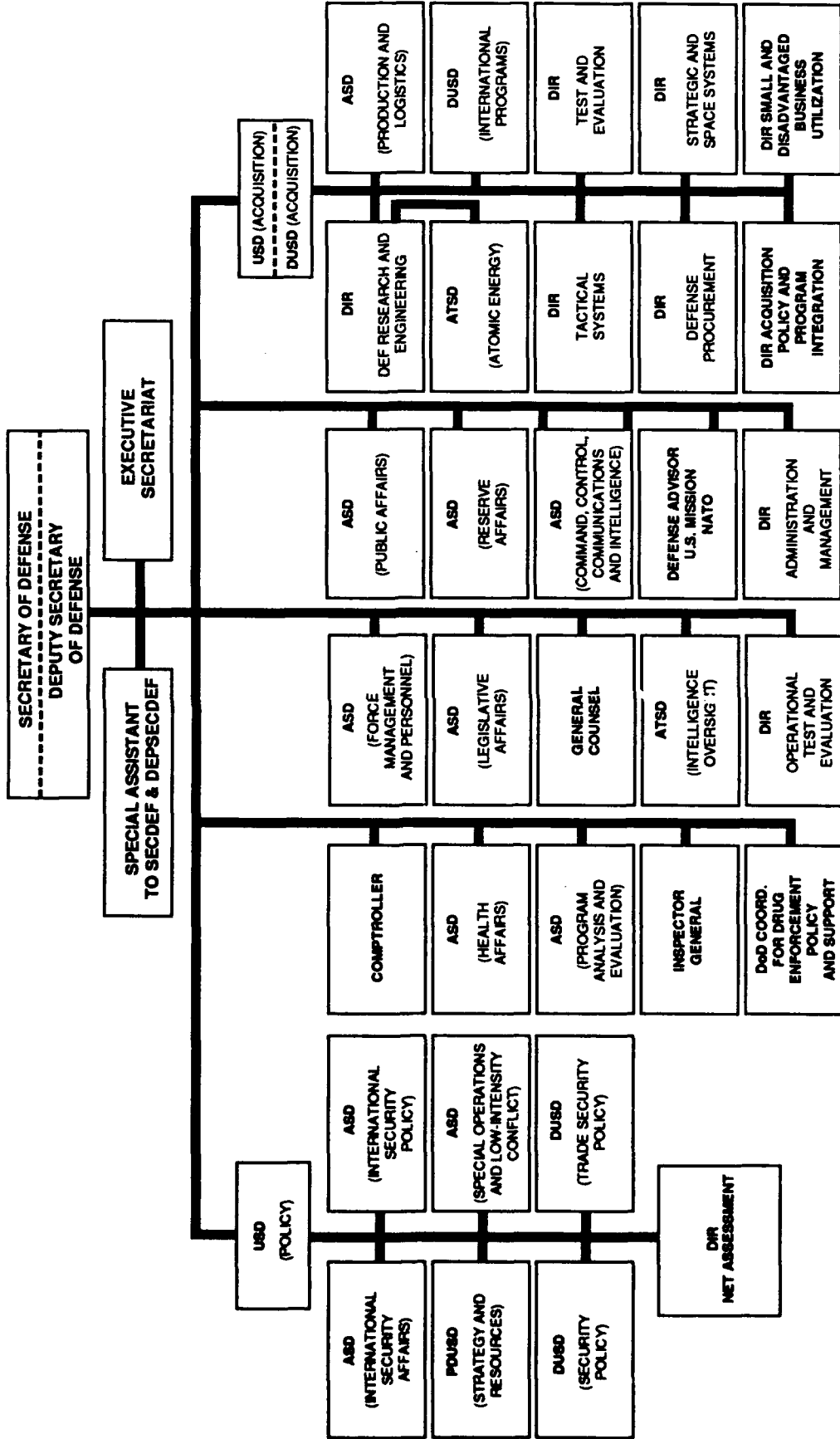

Exhibit E-1 — Office of the Secretary of the Defense

- Director of Defense Research and Engineering
- ASD (Production and Logistics)
- DUSD (International Programs)
- Director, Test and Evaluation
- Director, Acquisition Policy and Program Integration
- ASD (Command, Control, Communications, and Intelligence) for acquisition related activities
- Assistant to the Secretary of Defense (ATSD) (Atomic Energy) (through DDR&E).

Activities under USD(A) include DARPA (see E1.7.1), DNA (see E1.7.1), DLA (see E1.7.6), DSMC (see E5), and the Defense Acquisition University.

Note: OUSD(A) is currently under review and will probably experience major changes within the next few months.

Ref.: DOD Directive 5134.1

E1.1.1 Director of Defense Research and Engineering (DDR&E). DDR&E serves as the principal advisor and staff assistant to the USD(A) for DOD scientific and technical matters on all research and technology associated with (1) all laboratories and research, development, and engineering centers operated by the Services and other DOD Components and (2) Federally Funded Research and Development Centers (FFRDCs).

The DDR&E exercises line authority under the USD(A) with respect to activities funded under research (6.1), exploratory development (6.2), and Advanced Technology Development (6.3A), including authority to approve, modify, or disapprove research and development and other projects of the Services and Defense Agencies and

to make determinations regarding science and technology matters and research and development. The Assistant to the SECDEF (Atomic Energy), the Director, Defense Advanced Research Projects Agency (DARPA), and the Director, Defense Nuclear Agency (DNA) report to the DDR&E.

His responsibilities include:

- Conducting analyses, developing policies, providing advice, making recommendations, and issuing guidance on DOD plans and programs.
- Initiating programs, actions, and tasking to ensure adherence to DOD policies and national security objectives, and to ensure that programs are designed to accommodate operational requirements.
- Reviewing proposed resource programs, formulating budget estimates, recommending resource allocations, and monitoring implementation of approved programs.
- Reviewing and evaluating recommendations on requirements and priorities.
- Promoting coordination, cooperation, and mutual understanding within the Department of Defense and between the Department of Defense and other Federal Agencies and the civilian community.

Ref.: DOD Directive 5134.3

E1.1.1.1 Assistant to the Secretary of Defense (Atomic Energy) (ATSD(AE)). ATSD(AE), as principal staff assistant for Department of Defense atomic energy matters, is responsible to SECDEF, through DDR&E, for matters associated with: (1) nuclear and chemical weapons safety, security, and survivability; (2) nuclear survivability of strategic and theater nuclear forces and associated systems; (3) chemical and biological survivability of all DOD materiel; and (4) planning and implementation of

E1.1.2

modernization and upgrading of the nuclear and chemical weapons stockpile. Additionally, the ATSD(AE) serves as the single OSD focal point with responsibility for integrated management of all chemical stockpile destruction matters within DOD.

Ref.: DOD Directive 5148.2

E1.1.2 Assistant Secretary of Defense (Production and Logistics (ASD(P&L))). ASD(P&L) is the principal staff assistant and advisor to the USD(A) for management of DOD production, the National Defense Stockpile, logistics, installations, environmental programs, and other related matters.

Ref.: DOD Directive 5128.1

E1.1.3 Director, Test and Evaluation (DT&E). DT&E is the principal staff assistant to USD(A) for all test and evaluation matters, excluding Operational Test and Evaluation (OT&E) (see 7.2.1.1). This official is responsible for formulating T&E policy, approving the T&E Master Plans (TEMP) (see 7.5.3), and assessing test and evaluation results for the DAB (see E9.2).

E1.1.4 Director, Strategic and Space Systems. The Director, Strategic and Space Systems is the principal advisor and assistant to the USD(A) for the technical review, evaluation, and oversight of all DOD development and acquisition programs in the mission areas of Strategic Offense, Strategic and Theater Defense, Theater Nuclear Forces, Strategic Airlift, Space Launch Systems, Arms Control and Compliance, and relevant allied cooperative programs.

E1.1.5 Director, Tactical Systems. The Director, Tactical Systems is the principal assistant to the USD(A) for research and development of system specific items of equipment employed by conventional or tactical forces, but not involving

equipment end items pertaining to EW, BW/CW, or tactical nuclear forces.

E1.1.6 Director, Defense Procurement (DDP). The Director, Defense Procurement serves as the principal staff assistant and advisor to the USD(A) in the oversight of all contracting and procurement matters within DOD; directs the development, implementation, and management of integrated, coordinated, and uniform policies, and programs to govern DOD procurement worldwide; guides DOD managers in the conduct of business related activities to achieve effectiveness and efficiency; and directs the development and implementation of DOD policies and procedures for system acquisition business planning and strategies and reviews programs to assure compliance. In addition to other functions involved in carrying out these responsibilities, the Director provides advice to the Defense Acquisition Board (DAB) on defense systems procurement strategies and oversees the Defense Acquisition Regulations System.

E1.1.7 Director, Acquisition Policy and Program Integration (DAP&PI). The Director, Acquisition Policy and Program Integration is responsible for ensuring that the activities of OUSD(A) are integrated and directed toward accomplishing USD(A) responsibilities. The DAP&PI, among other specific functions, develops and codifies acquisition policy (in DOD 5000.1 and related issuances); ensures disciplined operation of the DAB and the Defense Acquisition Executive Summary (DAES) system; develops acquisition plans, strategies, guidance, and assessments in support of milestone reviews and PPBS processes; administers program status reporting systems; develops policy for contractor cost and schedule performance management and reporting systems; provides oversight of all OUSD(A) Congressional activities, and directs the Defense Technical Information Center (DTIC).

E1.1.8 Deputy Undersecretary of Defense for International Programs (DUSD(IP)). Within OUSD(A), the DUSD(IP) is the focal point for

coordination of all international defense cooperation issues, including security assistance, national disclosure policy, technology transfer, export control, travel; and cooperative research, development, production, and logistic support programs.

E1.2 Defense Acquisition Executive (DAE). The DAE is the principal advisor to the Secretary of Defense on all matters pertaining to the Department of Defense Acquisition System. The Under Secretary of Defense for Acquisition (USD(A)) is the DAE and:

- Establishes uniform policies and practices governing acquisition programs in general, and specific procedures, documentation requirements, and responsibilities for managing and reviewing major defense acquisition programs.
- Assures that the concepts, policies, and provisions of DOD Directive 5000.1 and OMB Circular A-109, "Major Systems Acquisition," are complied with and effectively administered throughout the Department of Defense.
- Chairs the Defense Acquisition Board (DAB).

Ref.: DOD Directives 5000.1, 5134.1

E1.3 Director of Operational Test and Evaluation (DOT&E). The DOT&E is the principal staff advisor and staff assistant to SECDEF on OT&E (see 7.2.1.2 for discussion of DOT&E responsibilities).

Ref.: DOD Directive 5141.2

E1.4 Comptroller of the Department of Defense. The Comptroller of the Department of Defense (DOD Comptroller) advises and assists the Secretary of Defense in the performance of the

Secretary's programming, budgetary, and fiscal functions; provides for the design and installation of resource management systems throughout DOD; and collects, analyzes, and reports resource management information for the Secretary of Defense and, as required, for the Office of Management and Budget, the Congress, the General Accounting Office, and other agencies outside the DOD. The DOD Comptroller supervises, directs, and reviews the preparation and execution of the DOD budget and is responsible for policy matters pertaining to automatic data processing and central data services. The DOD Comptroller is a permanent member of the DAB.

Ref.: DOD Directive 5118.3

E1.5 Assistant Secretary of Defense, Program Analysis and Evaluation (ASD(PA&E)). The Assistant Secretary of Defense, Program Analysis and Evaluation has prime responsibility within DOD for systems analysis, including responsibility for analysis of weapon systems and major material items and support systems. The ASD(PA&E) develops policies and provides guidance upon which planning and program projections are based; performs analyses and evaluations of plans, programs, and budget submissions; identifies issues; and evaluates alternative programs. The ASD(PA&E) has primary responsibility for assessing the adequacy of COEAs for ACAT ID programs. The ASD(PA&E) is a permanent member of the DAB.

Ref.: DOD Directive 5141.1; DOD Instruction 5000.2, Part 4, Section E

E1.6 Assistant Secretary of Defense for Command, Control, Communications, and Intelligence (ASD(C³I)). ASD(C³I) is the principal staff assistant and advisor to the Secretary of Defense for C³I policy, requirement, priorities, systems, resources, and programs, including related warning and reconnaissance activities, and

E1.7

those national programs and intelligence-related activities for which SECDEF has execution authority. ASD(C3I) reports to USD(A) for acquisition-related matters.

ASD(C³I) serves as the principal focus for staff coordination on all matters concerning these areas within the Department of Defense, with other Government Departments and Agencies, and with foreign governments and international organizations to which the United States is party. The ASD(C³I) also serves as principal staff assistant in carrying out the responsibilities of SECDEF as Executive Agent for the National Communications System (NCS) and is the principal DOD official responsible for preparing and defending the Department's C³I program before the Congress.

ASD(C³I)'s responsibilities include:

- Providing guidance and management and technical oversight for all C³I projects, programs, and systems being acquired by, or for use of, DOD and its Components.
- Participating in all DOD planning, programming, and budgeting activities, and reviewing proposed DOD resource programs, formulating budget estimates, recommending resource allocations, and monitoring implementation of approved programs. Activities under ASD(C³I) include the Defense Information Systems Agency (DISA) (see 1.7.3) and Defense Mapping Agency (DMA) (see 1.7.8).

Ref.: DOD Directive 5137.1

E1.7 Defense Agencies

E1.7.1 Defense Advanced Research Projects Agency (DARPA). DARPA is a separate agency under the Under Secretary of Defense (Acquisition), with a primary responsibility to maintain U.S. technological superiority over

potential adversaries. This mission includes responsibility to:

- Pursue imaginative and innovative research and development projects offering significant military utility.
- Manage and direct the conduct of basic and applied research and development that exploits scientific breakthroughs and demonstrates the feasibility of revolutionary approaches for improved cost and performance of advanced technology for future military applications.
- Stimulate greater emphasis on prototyping in defense systems by conducting prototype projects that embody technology that might be incorporated in joint programs, programs in support of deployed U.S. Forces (including the Unified and Specified Commands), or selected Military Department programs, and, on request, assist the Military Departments in their own prototyping programs.

Ref.: DOD Directive 5105.41

E1.7.2 Defense Nuclear Agency (DNA). DNA provides support for OSD, JCS, the Military Departments and other DOD Components, and other Federal Agencies on matters concerning nuclear weapons, nuclear weapons system acquisitions, nuclear weapons effects on weapon systems and forces, and nuclear weapons safety and security.

RD&A-related DNA responsibilities include:

- Managing DOD nuclear weapons effects research and test program.
- Conducting research through exploratory development and/or proof of principle to develop technology and techniques to improve the security and survivability of nuclear-weapon systems.

- Providing advice and assistance to DOD Components and Government Agencies in nuclear weapons-related matters.

Ref.: DOD Directive 5105.31

E1.7.3 Defense Information Systems Agency (DISA). DISA is responsible under ASD(C³I) for planning, developing, and supporting command, control, communications, and information systems that serve the needs of the National Command Authorities (NCA) under all conditions of peace and war. It provides guidance and support on technical and operational command, control, communications (C³), and information systems issues affecting the Office of the Secretary of Defense (OSD), the Military Departments, the Joint Chiefs of Staff (JCS) and the Joint Staff, the Unified and Specified Commands, and the Defense Agencies. It ensures the interoperability of the Worldwide Military Command and Control System (WWMCCS), the Defense Communications System (DCS), theater and tactical command and control systems, North Atlantic Treaty Organization (NATO) and/or allied C³ systems, and those national and/or international commercial systems that affect the DISA mission. It supports national security emergency preparedness (NSEP) telecommunications functions of the National Communications System (NCS).

Ref.: DOD Directive 5105.19

E1.7.4 Defense Contract Audit Agency (DCAA). The purpose of DCAA is to perform all necessary contract audit for the Department of Defense and to provide accounting and financial advisory services regarding contracts and subcontracts to all components of the Department of Defense who are responsible for procurement and contract administration. These services are provided in connection with the negotiation, administration, and settlement of contracts and

subcontracts. The agency also provides contract audit service to other government agencies under appropriate arrangements.

DCAA consists of an agency headquarters office and six regional offices. The regional offices manage over 300 field audit offices located throughout the United States and overseas. These field audit offices are called branch, resident, and procurement liaison offices. The agency headquarters exercises worldwide direction and control of the agency. The regional offices and their respective field audit offices are responsible for carrying out the contract audit program within their respective regions.

Ref.: DOD Directive 5105.36

E1.7.5 Defense Intelligence Agency (DIA). The mission of the DIA is to satisfy, or to ensure the satisfaction of, the foreign intelligence requirements of the Secretary of Defense, the Joint Chiefs of Staff, DOD Components and other authorized recipients, and to provide the military intelligence contribution to national intelligence. In carrying out this mission, the Director, DIA advises the Secretary of Defense on intelligence matters; participates in the DAB process by providing threat descriptions in support of systems acquisitions; acts as management authority for certain intelligence information systems; maintains a strong DOD scientific and technical intelligence program; and establishes, conducts, or recommends RD&A programs to carry out intelligence responsibilities. The Director, DIA assigns tasks and issues instructions or guidance, through the Secretary of Defense, to DOD Components as necessary to carry out functions assigned.

Ref.: DOD Directive 5105.21

E1.7.6 Defense Logistics Agency (DLA). The DLA mission is to function as an integral element of the DOD military logistics system to

E1.7.7

provide worldwide logistic support to the Military Departments, the Unified and Specified Commands, as well as other DOD Components and other customers. DLA reports to USD(A) through ASD(P&L).

Among DLA's many functions, it operates technical report data banks, oversees operation of contractor-operated DOD Information Analysis Centers; and provides scientific and technical information to DOD Components. (See Appendix D.)

Ref.: DOD Directive 5105.22

E1.7.7 National Security Agency (NSA). The National Security Agency has two primary missions—a security mission and an intelligence information mission. The responsibilities of the Director, National Security Agency include: (1) prescribing certain security principles, doctrines, and procedures for the U.S. Government; (2) organizing, operating, and managing certain activities and facilities for the production of intelligence information; (3) organizing and coordinating the research and engineering activities of the U.S. Government which are in support of the Agency's assigned functions; and (4) regulating certain communications in support of Agency missions.

Ref.: DOD Directive 5100.20

E1.7.8 Defense Mapping Agency (DMA). Under ASD(C³I), DMA provides support on matters of mapping, charting, and geodesy (MC&G) to the Office of the Secretary of Defense (OSD), the Military Departments, the Chairman, Joint Chiefs of Staff (CJCS) and the Joint Staff, the Unified and Specified Commands, and Defense Agencies.

RD&A-related DMA services and functions include:

- Providing advice and assistance on MC&G matters.
- Ensuring responsive support to MC&G requirements.
- Establishing DOD MC&G RDT&E requirements.

Ref.: DOD Directive 5105.40

E1.8 Joint Chiefs of Staff. The Joint Chiefs of Staff (JCS) constitute the Secretary of Defense's immediate military staff. The Chairman of the JCS is the principal military advisor to the President, the Secretary of Defense and the National Security Council. The Chairman acts as spokesman for Commanders of the Unified and Specified Combatant Commands, especially regarding operational requirements. He is responsible specifically for assessing defense acquisition program requirements.

E2 RESEARCH, DEVELOPMENT AND ACQUISITION RESPONSIBILITIES OF THE DEPARTMENT OF THE NAVY

The fundamental objectives of the Department of the Navy relate directly to its research, development, test and evaluation, and acquisition responsibilities. These fundamental objectives are:

- To organize, train, equip, prepare and maintain a high degree of readiness of Navy and Marine forces for the performance of military missions as directed by the President or the Secretary of Defense.
- To support Navy and Marine forces and the forces of other military departments, as directed by the Secretary of Defense, which are assigned to unified or specified commands. Support to include personnel,

material, administrative, and fiscal resources and technology through research and development efforts.

The Department of Navy is organized in a matrix, in which reporting relationships for R&D policy and Acquisition policy and practices are different, but complementary. The present DON organization structure for R&D and acquisition is shown in Exhibits E-2, E-3, and E-4.

Ref.: SECNAV Instructions 5400.15 and 5430.7

E2.1 Secretary of the Navy. The Secretary of the Navy (SECNAV) heads the Department of the Navy under the direction, authority and control of the Secretary of Defense. SECNAV is responsible for the policies and control of the Department of the Navy, including its organization, operations, administration and efficiency, and for assuring that the Navy has an effective research, development, test and evaluation program.

Ref.: DOD Directive 5100.1

E2.1.1 Navy Acquisition Executive (NAE).
The NAE shall:

- Exercise the power and discharge the responsibilities established by DOD Directive 5000.1, and Department of Defense policy for Service Acquisition Executives.
- Exercise all delegable powers and responsibilities in the area of acquisition that are assigned to the Secretary of the Navy by law and regulation.
- Be designated under Title 10, United States Code, Section 5014(c), as the single office or entity responsible for acquisition within the Office of the Secretary of the Navy.

- Assure that the concepts, policies, and applicable instructions are complied with and effectively administered throughout the Department of the Navy.
- Chair the DON POM Strategy Board (DPSB), as delegated, to ensure proper correlation between approved acquisition programs and the PPBS process. The DPSB shall advise the Secretary of the Navy on the POM and budget submissions to OSD and any adverse funding impact on approved acquisition programs.
- Approve selection of PMs for ACAT I programs and chair NPDM reviews for all ACAT I programs.

The Assistant Secretary of the Navy (Research, Development and Acquisition) serves as NAE.

Ref.: SECNAV Instruction 5000.2

E2.1.2 Assistant Secretary of the Navy (Research, Development and Acquisition) (ASN(RD&A)).

- Serving as the DON Acquisition Executive (NAE) and representing the DON to the USD(A) and Congress on all matters related to DON acquisition policy and programs.
- Serving as the Navy Senior Procurement Executive.
- Establishing acquisition policy and procedures and managing all DON research, development, production, shipbuilding, and logistics support programs.
- Managing the acquisition management structure and process within the DON in a manner consistent with, and supportive of, the policies and provisions of DOD Directive 5000.1 and other DOD policy.

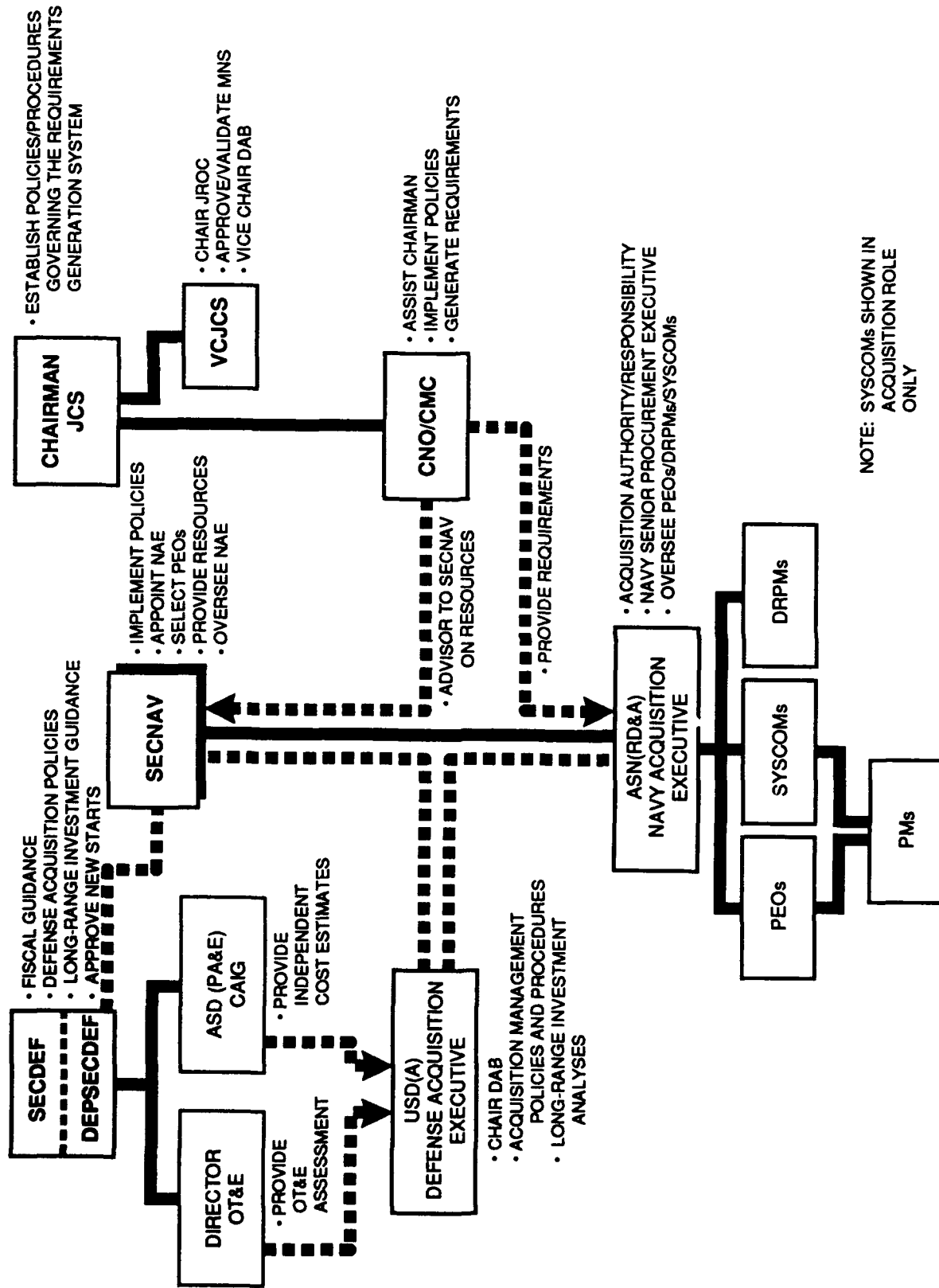

NOTE: SYSCOMs SHOWN IN ACQUISITION ROLE ONLY

Exhibit E-2 — DOD/DON Acquisition Relationships

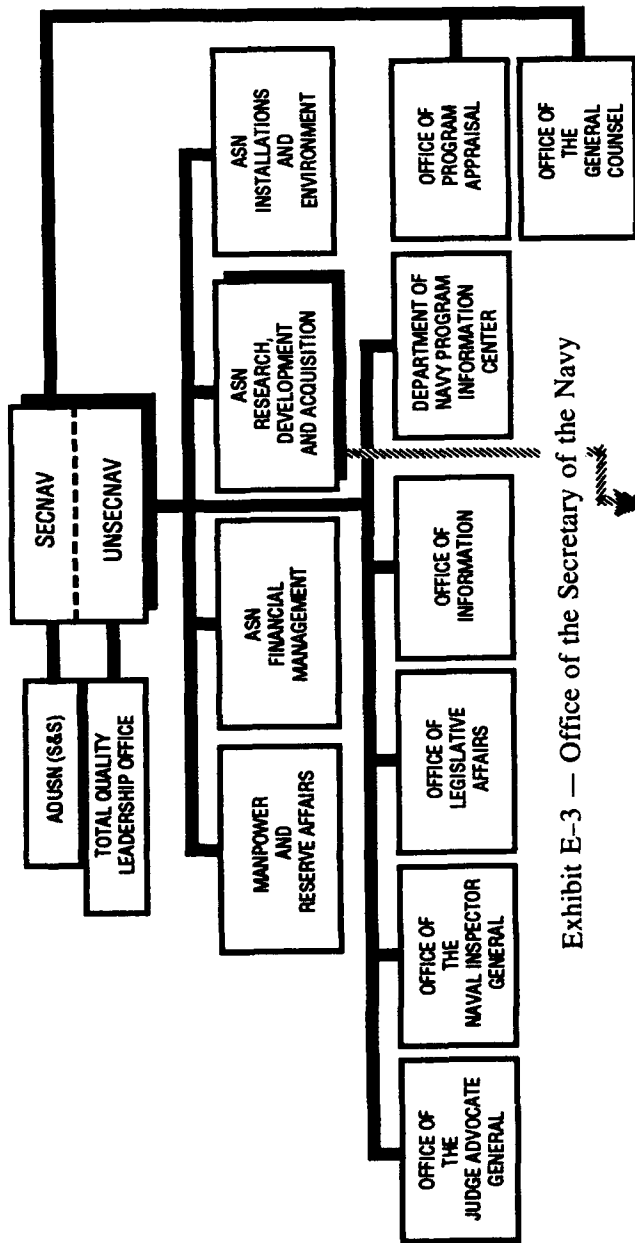

Exhibit E-3 — Office of the Secretary of the Navy

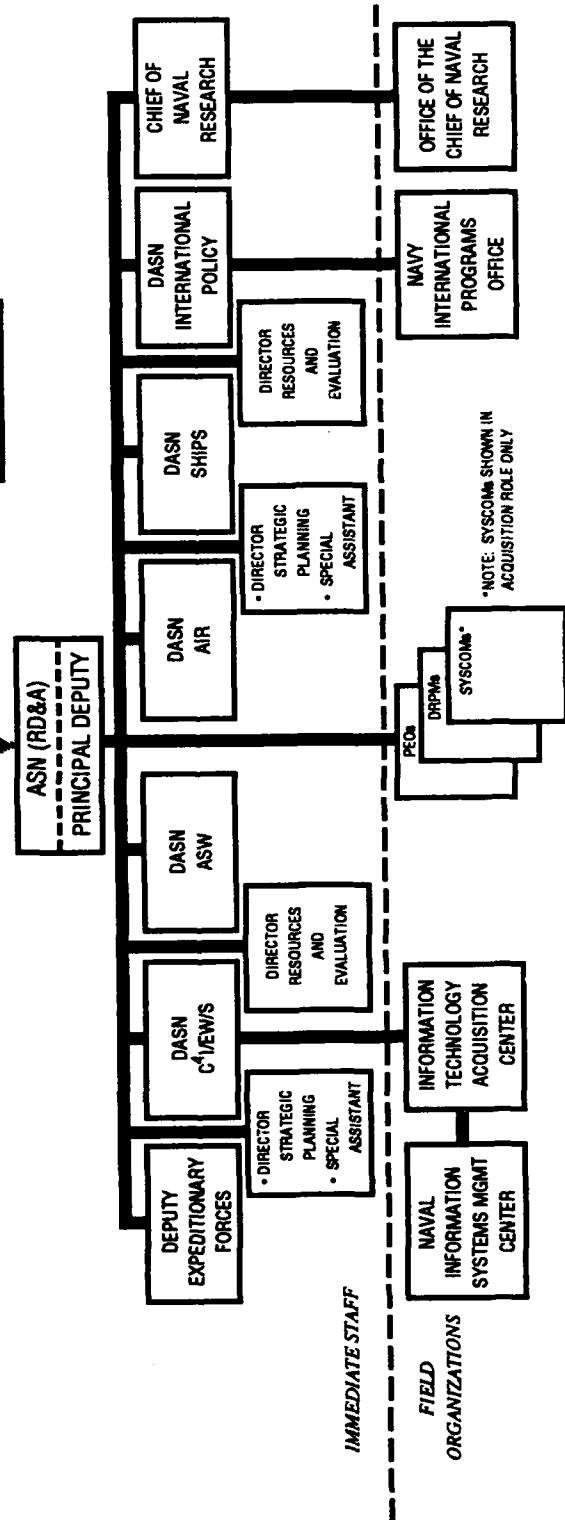

Exhibit E-4 — Office of the Assistant Secretary of the Navy (Research, Development, and Acquisition)

E2.1.3

- Recommending milestone decisions on ACAT ID programs and serving as program decision authority for ACAT IC, II, and III programs.
- Supervising the Program Executive Officers (PEOs) and Direct Reporting Program Managers (DRPMs).
- Performing as the DON Senior Information Resource Management (IRM) policy official. As such, ASN(RD&A) is responsible for all matters related to the acquisition and management of information systems and automated data processing systems and equipment.
- Nominating personnel to SECNAV for selection to serve as PEOs and major acquisition program PMs, after coordinating with the CNO or CMC.
- Developing policy for and providing management oversight of DON international RD&A efforts and technology transfer.
- Establishing DON policy, procedure and oversight concerning product integrity (including reliability, maintainability, quality assurance, acquisition streamlining, non-development items, standardization, and value engineering), procurement integrity, and accountability.
- Establish DON policy for acquisition workforce education and training.
- Establish policy and provide oversight for all matters pertaining to technology base, advanced technology development, Navy laboratories, and the Chief of Naval Research.

Ref.: SECNAV INSTRUCTION 5400.15

E2.1.3 Office of Program Appraisal (OPA). The Office of Program Appraisal

provides the Secretary of the Navy with a small appraisal staff to assist in assuring that existing and proposed Navy and Marine Corps programs provide the optimum means of achieving Department of the Navy objectives. The office conducts or coordinates studies, evaluates the responsiveness of the programming system to the needs of the Secretary, and provides recommendations as required.

Ref.: SECNAV Instruction 5430.60

E3 OFFICE OF THE CHIEF OF NAVAL OPERATIONS (OPNAV)

The Chief of Naval Operations (CNO) takes precedence over all other officers of the naval service in the performance of his duties within the Department of the Navy. CNO is the Navy member of the Joint Chiefs of Staff and the principal official of the Office of the Chief of Naval Operations (OPNAV) which is responsible, under law, to furnish professional advice and assistance to the Secretary, the Under Secretary, and the Assistant Secretaries of the Navy, and to the Chief of Naval Operations (see Exhibit E-5).

Subject to the authority, direction, and control of the Secretary of the Navy, the Chief of Naval Operations shall:

- preside over the Office of the Chief of Naval Operations;
- transmit the plans and recommendations of the Office of the Chief of Naval Operations to the Secretary and advise the Secretary with regard to such plans and recommendations;
- after approval of the plans or recommendations of the Office of the Chief of Naval Operations by the Secretary, act as the agent of the Secretary in carrying them into effect;

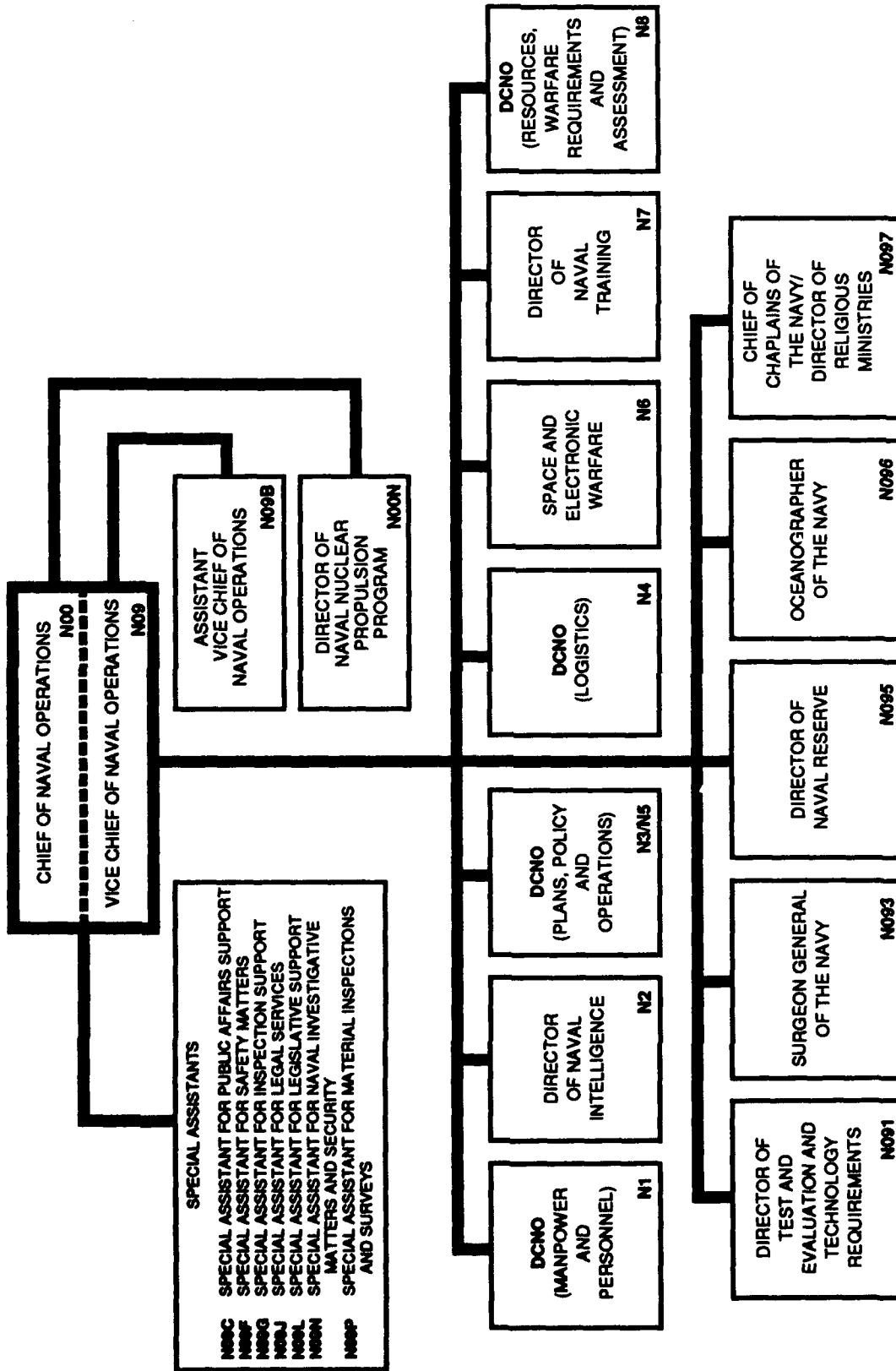

Exhibit E-5 -- Office of the Chief of Naval Operations

E3.1

- exercise supervision, consistent with the authority assigned to commanders of unified or specified combatant commands, over such of the members and organizations of the Navy and the Marine Corps as the Secretary determines;
- perform the duties prescribed for him under Public Law 99-433 and other provisions of law; and
- perform such other military duties, not otherwise assigned by law, as are assigned to him by the President, the Secretary of Defense, or the Secretary of the Navy.

In the research, development, and acquisition process, the CNO is responsible for determining requirements for military capabilities and overseeing test and evaluation of systems. (How these capabilities are achieved is a responsibility of the Systems Commands and other research, development, and acquisition organizations. (See E4, E7.)) In carrying out these responsibilities, the Office of the Chief of Naval Operations' duties center on the following:

- Define requirements essential to current and future mission capabilities of DON operating forces.
- Evaluate the military worth of capabilities which advancing science and technology make potentially attainable.
- Appraise research and development plans and efforts in terms of probable cost versus military worth.

*Ref.: OPNAV Instruction 5430.48,
OPNAV Organization Manual*

E3.1 Director of Test and Evaluation and Technology Requirements (N091, formerly OP-091). N091 implements CNO responsibilities to (1) establish and promulgate policy and

procedures for the conduct of Test and Evaluation (T&E); (2) establish requirements and prioritize and program resources in science and technology; (3) program resources for selected RDT&E field activities and other RDT&E programs as assigned; and (4) represent CNO in discussions with foreign navies regarding cooperative R&D projects.

Responsibilities of various officials and offices within N091 are detailed below.

E3.1.1 Science and Technology Requirements Division (N911, formerly OP-911). N911 executes N091 responsibilities for (1) establishing and promulgating Navy Science and Technology (S&T) requirements and (2) acting as Resource Sponsor for Navy S&T programs.

E3.1.2 Test and Evaluation Programs Division (N912, formerly OP-912). N912 executes N091 responsibilities for Navy T&E requirements, coordination, and procedures.

E3.1.3 RDT&E Facilities and Resources Division (N913, formerly OP-913). N913 executes N091 responsibilities for Navy T&E range facility resources and policies, and policies and procedures governing R&D requirements.

E3.2 Deputy Chief of Naval Operations (Manpower and Personnel)/Chief of Naval Personnel (N1, formerly OP-01) (DCNO(MP) formerly DCNO(MPT)). The mission of the DCNO(MP) is to implement the responsibilities of the CNO for the management of planning and programming of manpower and personnel (MP) resources, budgeting for military personnel, and appraisal of the Navy's total force MP programs; to develop systems for requirements determination of total MP resources and allocation of military personnel; to serve as principal advisor to the CNO on MP matters and exercise centralized coordination and control of professional standards criteria and human resource management.

In carrying out the above responsibilities the DCNO(MP) exercises joint responsibility with other sponsors for ensuring validity and feasibility of requirements for new equipment and weapon

systems. In addition, the DCNO(MP) determines RDT&E military requirements and monitors efforts in support of total force MP management. (Note: the term "total force" as used here encompasses active duty and reserve military, civilians, and contractors.)

Note: A major Staff Office under the Director of Training (N7) is now responsible for Navy training.

E3.3 Director of Naval Intelligence (DNI) (N2, formerly OP-92). The Director of Naval Intelligence implements CNO responsibilities for intelligence, cryptology (less signals security), special security, and foreign counter-intelligence; represents the DON in the national and foreign intelligence communities; provides intelligence foreign liaison and protocol support to SECNAV, CNO, OPNAV, and other Navy elements; and serves as sponsor for certain national defense and naval intelligence programs.

Among the DNI's functions is provision of threat support for DON weapon systems selection and planning.

E3.4 Deputy Chief of Naval Operations (Plans, Policy, and Operations) (N3/N5, formerly OP-06). The DCNO (Plans, Policy and Operations) serves as the principal advisor and OPNAV staff executive to CNO for JCS matters and implements CNO responsibilities for the development and dissemination of strategic plans and policies; serves as principal advisor to SECNAV and CNO on strategic planning, nuclear weapons systems, National Security Council affairs, and international politico-military matters; serves as principal advisor to the CNO on technology transfer, security assistance, foreign disclosure, and international program policy issues; and maintains the current operational status of Navy forces.

DCNO (Plans, Policy, and Operations) plays a major role in the development of the structure of long-range Navy capability objectives which are realized through development of required technological capabilities.

E3.5 Deputy Chief of Naval Operations (Logistics) (N4, formerly OP-04). The mission of the DCNO (Logistics) is to plan, determine, and provide for the logistic support needs of the operating forces and shore establishment of the Navy, except for those areas elsewhere assigned; and to serve as the principal advisor and executive to the Chief of Naval Operations on the conduct and assessment of the logistics affairs of the Department of the Navy.

E3.6 Director of Space and Electronic Warfare N6 (formerly OP-094). The mission of N6 is to exercise centralized coordination over policy, planning, and integrating of requirements for space and electronic warfare (SEW) including C³; space exploitation (except those requirements under the aegis of the Director, CIA), and space defense matters; reconnaissance; ocean surveillance (less Submarine Ocean Systems Underwater Surveillance (SOSUS)); electronic warfare (including C3CM and Cover and Deception) and information security (INFOSEC); to implement the responsibilities of the CNO with respect to determination of characteristics, development, appraisal, and coordination of program execution for SEW systems (including satellite communications, surveillance, navigation, and environmental sensing systems); to act as principal advisor to the CNO on tactical and non-tactical computer systems; to ensure optimum use of Navy information systems; to serve as principal advisor to CNO for Navy Records Management; to act as the CNO's representative to other services and government agencies for matters involving INFOSEC, communications, information systems, EW, space matters, Worldwide Military Command and Control System (WWMCCS), and Navy Electromagnetic Interference (EMI).

To exercise centralized advocacy of SEW systems engineering, configuration control, planning and requirements for fleet tactical readiness and force modernization. Included are responsibilities for integration and coordination of

E3.7

SEW programs at the battle and amphibious force level and for implementation of SEW tactics, doctrine, and training.

E3.7 Deputy Chief of Naval Operations (Resources, Warfare Requirements, and Assessment) (N8, formerly OP-08). N8 exercises centralized supervision and coordination of Navy determination of warfare requirements, allocation of resources, program planning and study efforts, in order to ensure the integration of planning, programming, budgeting, and appraisal within the Office of the Chief of Naval Operations and the management echelons subordinate to the Chief of Naval Operations.

As the CNO's principal staff executive for other than JCS matters, N8 is responsible for reviewing and evaluating programs in relation to the total Navy program and for recommending to the CNO or VCNO changes where needed. In addition, N8 directs the budget process for the CNO, including supervision of related financial management matters.

E3.7.1 Director, Programming Division (N80, formerly OP-80). N80, under the direction of N8, develops and operates the integrated program planning system for the Chief of Naval Operations; implements the responsibilities of the DCNO (Navy Program Planning) with regard to Navy programs and related plans; and coordinates, documents, and ensures implementation of CNO and VCNO decisions.

E3.7.2 Director, Assessment Division (N81, formerly OP-81). N81 is responsible to provide CNO, VCNO, and N8 with centralized analysis and assessment of joint mission and support areas and force-level requirements and resources; conduct long-range analysis and assessment of programs, plans, and alternatives; direct, sponsor and/or coordinate OPNAV-sponsored studies and analytical support provided by activities external to OPNAV; manage the DON Nonnuclear Ordnance Requirements (NNOR) and Noncombat Expenditure Requirements (NCER) programs;

coordinate, administer, assess, and validate acquisition programs; review R&D programs and provide priorities for Science and Technology programs; function as Resource Sponsor for N8-sponsored studies and analytical efforts; and review and validate analytical modeling, simulation, and wargaming.

E3.7.3 Director, Surface Warfare Division (N86, formerly OP-03). N86 determines shipboard requirements and major characteristics of surface ships (less carriers and submarine support ships) and surface warfare programs, including those in the Naval Reserve; fulfills responsibilities with respect to operational readiness, training and preparation for war of surface ships (less carriers and submarine support ships); acts as principal advisor on surface warfare matters involving relationships with other governmental agencies; exercises for the CNO centralized formulation, coordination, supervision, and execution of the Navy shipbuilding and conversion programs for all surface ships (less carriers and submarine support ships); directs programming and budgeting for all ship programs, including those of the Naval Reserve Force, and ensures that the programs are fully supported by timely planning and appraisal; formulates the characteristics of all naval surface ships (less carriers and submarine support ships) in order to fulfill and anticipate the requirements of naval operations; manages specific programs which the CNO may direct; and develops overall force levels and requirements related to surface warfare (less carriers and submarines).

E3.7.4 Director, Submarine Warfare Division (N87, formerly OP-02). N87 determines shipboard and related support requirements and major characteristics of programs pertaining to submarines, deep submergence systems, and undersea surveillance matters, and in such planning, preparation, and execution as are incident thereto; acts as the CNO's principal advisor on submarine, deep submergence systems, and undersea surveillance matters; fulfills

responsibilities in respect to readiness, training, and preparation for war; exercises centralized direction of all strategic submarine force planning, programming, and appraising in order to ensure integrated and effective Navy strategic submarine concepts and force levels; acts as representative in these matters involving relationships with other governmental agencies; and develops overall submarine force levels and requirements.

E3.7.5 Director, Air Warfare Division (N88, formerly OP-05). N88 implements the responsibilities of the Chief of Naval Operations with respect to naval aviation programs, including the Naval Air Reserves; determines the shipboard and related support requirements for aircraft carriers and specified aviation type ships; acts as the principal advisor on naval aviation matters, including air warfare, and as the representative in naval air operational matters involving relationships with other government and civil agencies; and develops overall naval aviation force levels and requirements.

(Note: The exact wording of the mission statements of the N8 Divisions is still under discussion. The above descriptions are essentially accurate.)

E3.8 Surgeon General of the Navy (N093, formerly OP-093). N093 provides, within OPNAV, centralized and coordinated guidance, direction, and oversight on all health related programs.

E3.9 Oceanographer of the Navy (N096, formerly OP-096). The mission of N096 is to plan, coordinate, and implement the responsibilities of the CNO with regard to naval oceanography (including oceanography, meteorology, mapping, charting, geodesy, astrometry, and precise time and time interval); to assist the ASN(RD&A) with respect to oceanography and related plans, programs, and policy matters; and to serve as the spokesman for naval oceanographic matters. N096 acts as resource sponsor for the Naval Oceanography Command and Naval

Observatory and as program sponsor for Naval Oceanography programs. As Oceanographer of the Navy, N096 acts for SECNAV and CNO in interagency and international matters involving Naval Oceanography.

E3.10 Activities Reporting to CNO.

E3.10.1 Naval Systems Commands. (See E4.)

E3.10.2 Bureau of Medicine and Surgery. (See E8.)

E3.10.3 Naval Oceanography Command. Located at Bay St. Louis, Mississippi, the Naval Oceanography Command is responsible for the management of assigned oceanographic; mapping, charting, and geodetic; and meteorological activities and efforts under the Naval Oceanographic Program. It provides technical guidance in such matters throughout the Department of the Navy.

Ref.: OPNAV Instruction 5450.165

E4 NAVAL SYSTEMS COMMANDS

E4.1 Material Support Responsibilities of Systems Commanders. Each Systems Command provides for and meets those material support needs of the Department of the Navy that are within the assigned "material support" responsibility of such command. This general responsibility includes specific responsibility for the research, design, development, logistics planning, test, technical evaluation, acquisition, procurement, contracting, production, construction, manufacture, inspection, fitting out, supply, maintenance, alteration, conversion, repair, overhaul, modification, advance base outfitting, safeguarding, distribution, and disposal of naval material for which the command is assigned responsibility. Individual Systems Commands are tasked to perform control, coordination, or service

E4.2

functions as designated Lead Systems Commands for particular programs or functions. In addition, each Systems Command is tasked to exercise command responsibility for the Naval Warfare Centers (NWCs) (see G4, 6, and 7) and to provide matrix support to any Program Executive Officers (PEOs) or Direct Reporting Program Managers (DRPMs) whose missions fall within the Systems Command's area responsibility.

For acquisition matters, the Systems Commanders report to the ASN(RD&A) in his capacity as Navy Acquisition Executive.

Representative material support responsibilities are listed in the following sections.

Ref.: SECNAV Instruction 5400.15

E4.2 Naval Air Systems Command. (See Exhibit E-6 and G4.)

- Navy and Marine Corps aircraft systems and components (including fuels and lubricants).
- Air-launched weapon systems and components (excluding torpedoes and mines).
- Other airborne and air-launched systems and components such as electronics, underwater sound, catapults, aircraft/missile range and evaluation instrumentation, mine countermeasures, targets, pyrotechnics, photographic and meteorological equipment, and training and support systems for the foregoing.

(Note: Where not otherwise assigned to the PEOs or DRPMs.)

E4.3 Naval Facilities Engineering Command.

- Shore facilities and fixed surface and subsurface ocean structures
- Floating cranes, amphibious pontoon equipment, fleet moorings, and lift docks

- Materials and equipment for advanced base functional components
- Tools, equipment, and techniques for construction and maintenance of fixed surface and subsurface ocean structures
- Materials and appliances for defense ashore against chemical, biological, and radiological warfare.

E4.4 Naval Sea Systems Command. (See Exhibit E-7 and G6.)

- Surface ships, submarines, submersibles, watercraft, and other seagoing platforms.
- Shipboard combat systems and expendable ordnance, including sensors, tactical data systems, surveillance and fire control radars, sonars, computers, guns, launchers, ammunition, guided missiles, mines, and torpedoes.
- Hull, mechanical, and electrical systems, including nuclear and non-nuclear propulsion, electrical generating equipment, auxiliary power generating and distribution systems, interior communications, navigation equipment, deck machinery, weapons and cargo handling, stowage, and damage control systems.
- Explosive ordnance disposal and explosive safety.
- Ship systems integration.
- Assigned small arms, infantry equipment, body protective armor, and inshore undersea warfare equipment.
- Chemical, biological, and radiological warfare defense materials and equipments.
- Respiratory protective devices, diving, submarine rescue, and salvage methods and equipment.

(Note: Where not otherwise assigned to the PEOs or DRPMs.)

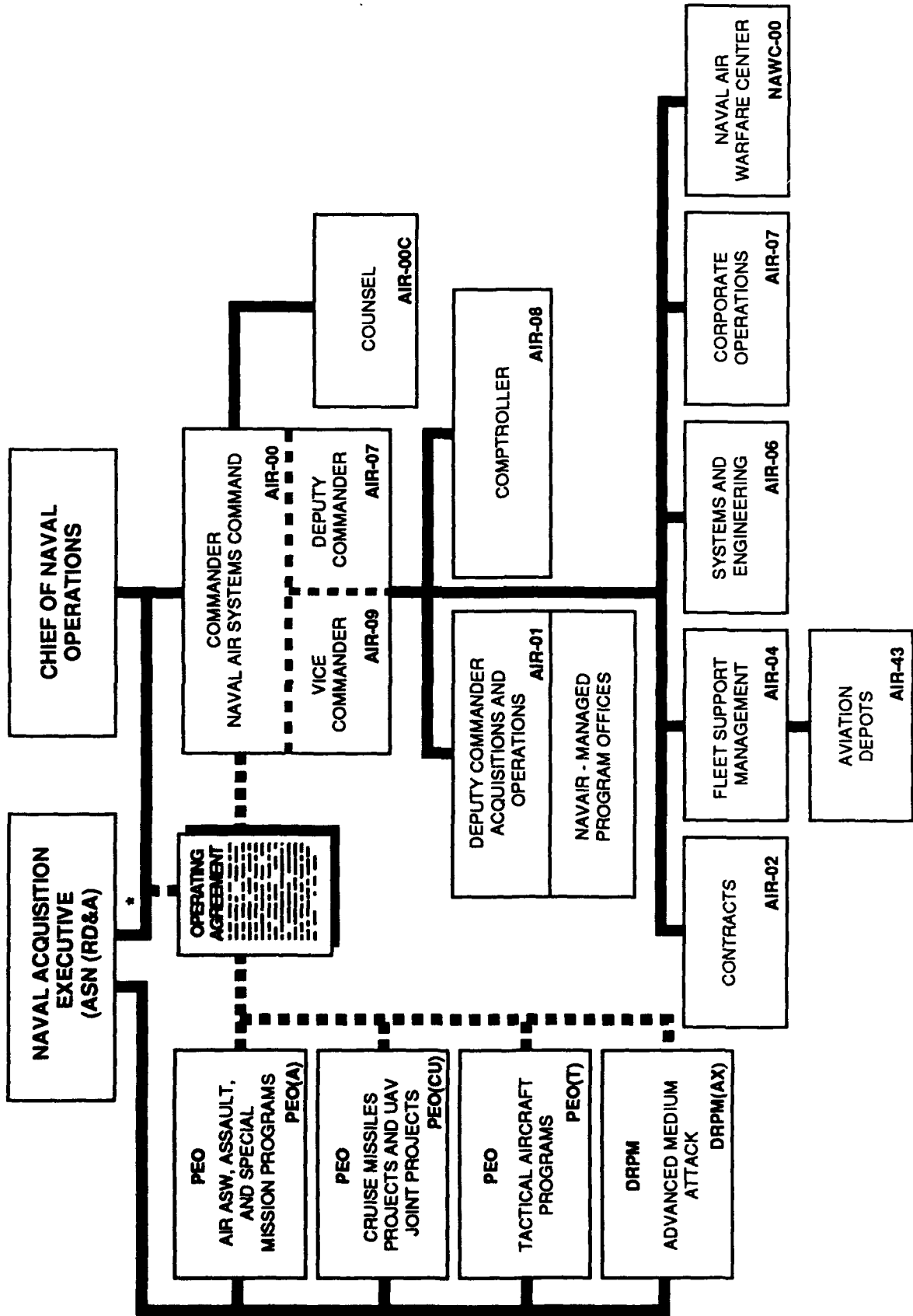

*NOTE: SYSCOM REPORTS TO NAE FOR ACQUISITION MATTERS ONLY

Exhibit E-6 — Naval Air Systems Command Headquarters

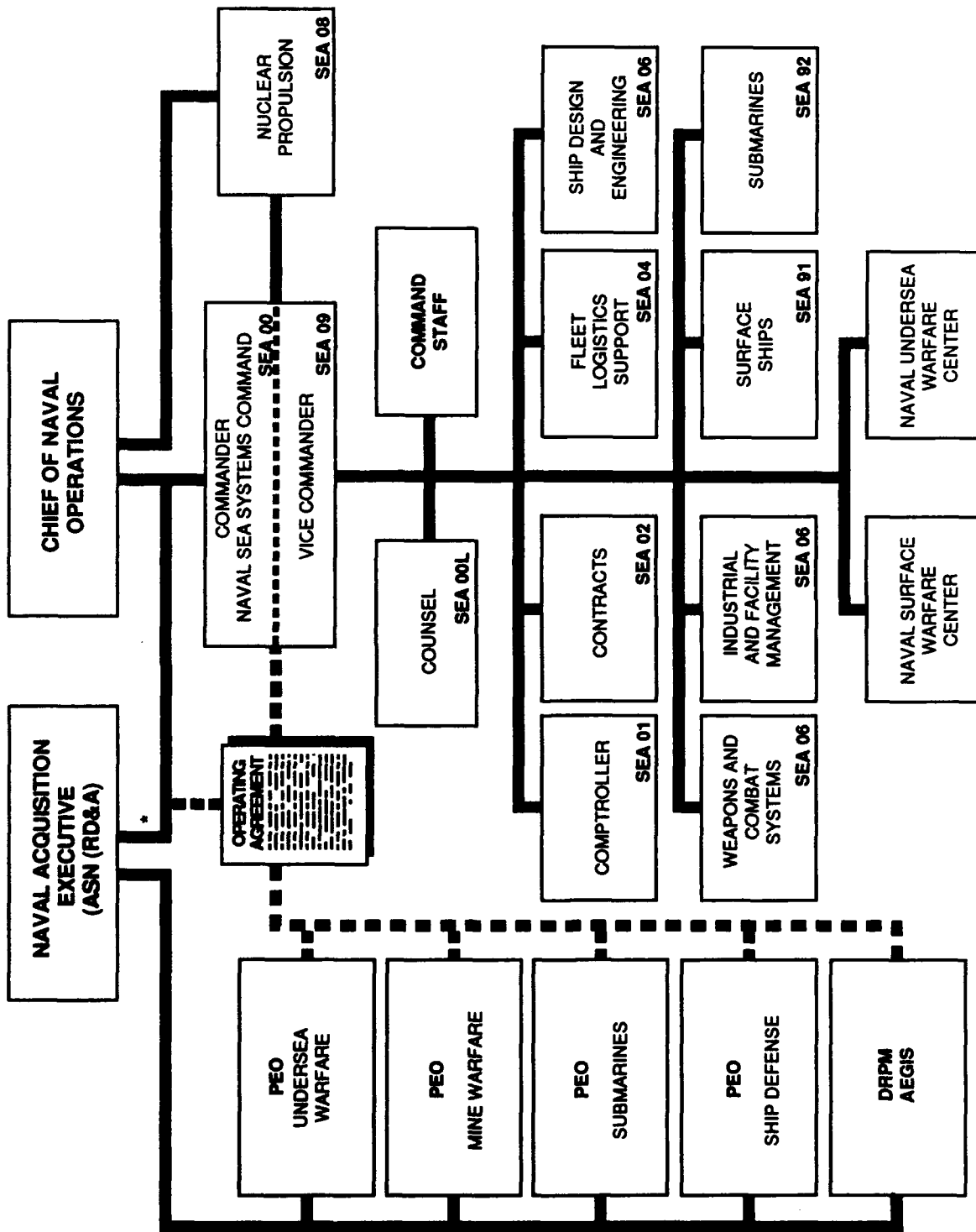

* NOTE: SYSCOM REPORTS TO NAE FOR ACQUISITION MATTERS ONLY

Exhibit E-7 — Naval Sea Systems Command Headquarters

E4.5 Naval Supply Systems Command.

- Serves as lead SYSCOM for logistics research and development.
- Weapon system program support.
- Materials-handling equipment not otherwise assigned.
- Special clothing not otherwise assigned.
- Automation of Navy technical data.
- Naval material for which responsibility is not otherwise assigned.

E4.6 Space and Naval Warfare Systems Command. (See Exhibit E-8 and G5.)

- Command/control/communications (C³) (platform to platform).
- Underseas and space surveillance (includes shore communications).
- Marine Corps expeditionary and amphibious electronics.
- Multiplatform electronic systems not otherwise assigned.
- Intelligence and intelligence-collection systems.
- Space systems.
- Cryptographic and cryptologic equipment.

(Note: Where not otherwise assigned to the PEO for Space, Communications, and Sensors.)

In addition, SPAWAR has DON-wide responsibility for force warfighting architecture and requirements integration among the total naval battle force; to provide similar material support for the Marine Corps; and to provide management of DON R&D and Engineering Centers.

E5 DEFENSE SYSTEMS MANAGEMENT COLLEGE (DSMC)

DSMC is a professional military educational institution operating under the direction of a Policy Guidance Council chaired by the Under Secretary of Defense (Acquisition).

The college offers more than 20 courses of instruction regarding management of defense systems acquisition. The College's Program Management Course (PMC) is the longest, at 20 weeks, and is required by law for individuals serving as program managers of designated major acquisition programs.

The mission of the DSMC is to promote and support the adoption and practice of sound systems management principles by the acquisition work force through education and training, research, consulting, and information dissemination.

The courses offered by the DSMC are intended to introduce the student to the world of systems acquisition and prepare him or her to function effectively within it. The content of each course and sub-course is continuously monitored and altered when necessary to reflect changing real-world conditions. DSMC also offers executive courses for senior professionals and technical courses in such areas as Total Quality Management and Technical Management. Additionally, new short courses developed from time to time answer the needs of a specific management group, or respond to requests from various government agencies, the Defense Acquisition University or Congress. To meet the need for regional courses, DSMC has established regional centers at Huntsville, Los Angeles, St. Louis, and Boston.

DSMC courses are conducted by a civilian and military faculty, whose efforts are complemented by guest lecturers from government, industry, and the academic communities. The College's non-attribution policy encourages guest lecturers to take part in open, candid discussions

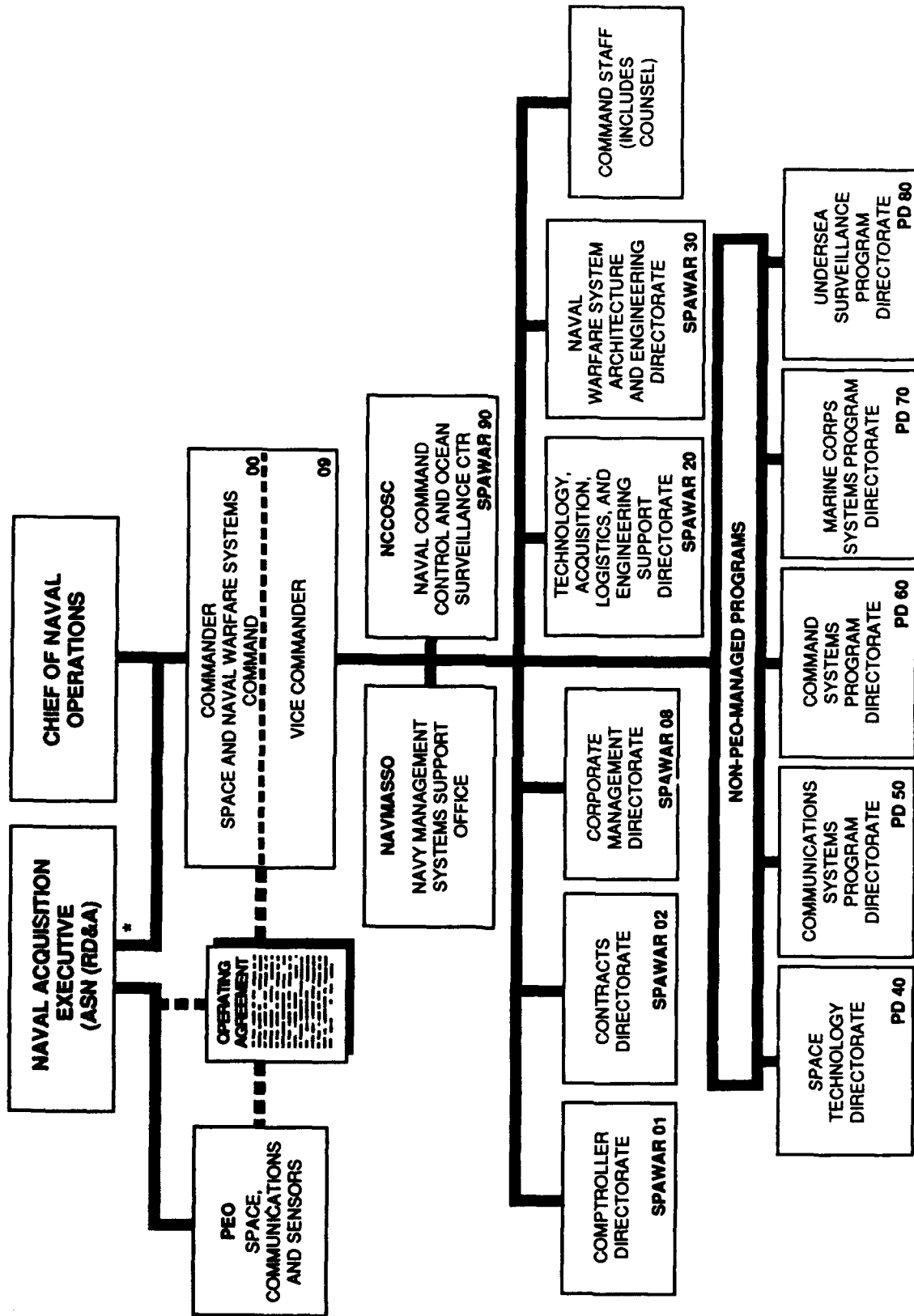

*NOTE: SYSCOM REPORTS TO NAE FOR ACQUISITION MATTERS ONLY

Exhibit E-8 — Space and Naval Warfare Systems Command Headquarters

with students. This enhances the real-world flavor of the DSMC experience. For specified information about the courses and course schedules call the Registrar at commercial (703) 805-2227 or DSN 655-2227.

The DSMC has produced a series of textbooks that cover various facets of the acquisition management business: program management, technical management, business and financial management, and special topics. These guidebooks are available for use throughout the acquisition community. For specific information about the guidebooks, call the Director of Publications at commercial (703) 664-5082 or DSN 354-5082.

Ref.: DOD Directive 5160.55

E6 MARINE CORPS ORGANIZATION FOR RESEARCH, DEVELOPMENT AND ACQUISITION

The Marine Corps is responsible for the development of equipment intended for use by landing forces in amphibious operations. The two Marine Corps organizations primarily concerned with acquisition matters are the Marine Corps Systems Command (MARCORSYSCOM) and the Marine Corps Combat Development Command (MCCDC), both located at Quantico, Virginia. Elements of the Marine Corps Headquarters organization support RD&A activities. In addition, individual personnel assigned to other DOD activities as Marine Corps Liaison Officers or Marine Corps Representatives and those occupying Marine Corps-sponsored billets in such activities are considered to be elements of the Marine Corps acquisition establishment.

Ref.: MCO P5000.10

E6.1 Commander, Marine Corps Systems Command (COMMARCORSYSCOM). (See

Exhibit E-9.) The Commander, Marine Corps Systems Command (COMMARCORSYSCOM) is tasked to conduct, supervise and/or monitor all Marine Corps related research, development and acquisition functions. COMMARCORSYSCOM plans and manages Marine Corps acquisition programs through all stages, from basic research through procurement and initial operational capability.

COMMARCORSYSCOM is a principal of the Marine Corps Program Decision Meeting (MCPDM) (see E9.7) serving as a member of ACAT IC, II, and III MCPDMs. He is Decision Authority for ACAT IV MCPDMs. Within the Marine Corps, he has overall responsibility for the review, coordination, and monitoring of all RDT&E and procurement activity.

Other functions include ensuring oversight and conduct of developmental test and evaluation of Marine Corps systems; developing and promulgating Marine Corps acquisition policy; implementing DOD, DON, and USMC financial management policy in support of acquisition programs; provision of equipment lifecycle management; and acting as appropriation sponsor for RDT&E,N and PMC.

COMMARCORSYSCOM reports directly to the ASN(RD&A) for acquisition matters.

Ref.: MCO 5000.19

E6.2 Commanding General, Marine Corps Combat Development Command (CG,MCCDC).

The Commanding General, Marine Corps Combat Development Command has been designated the field representative of the Commandant for development, in coordination with the other Services, of those phases of amphibious operations that pertain to the doctrines, tactics, and techniques used by landing forces. He serves as the Warfighting Proponent for the Commanding Generals, FMFLANT and

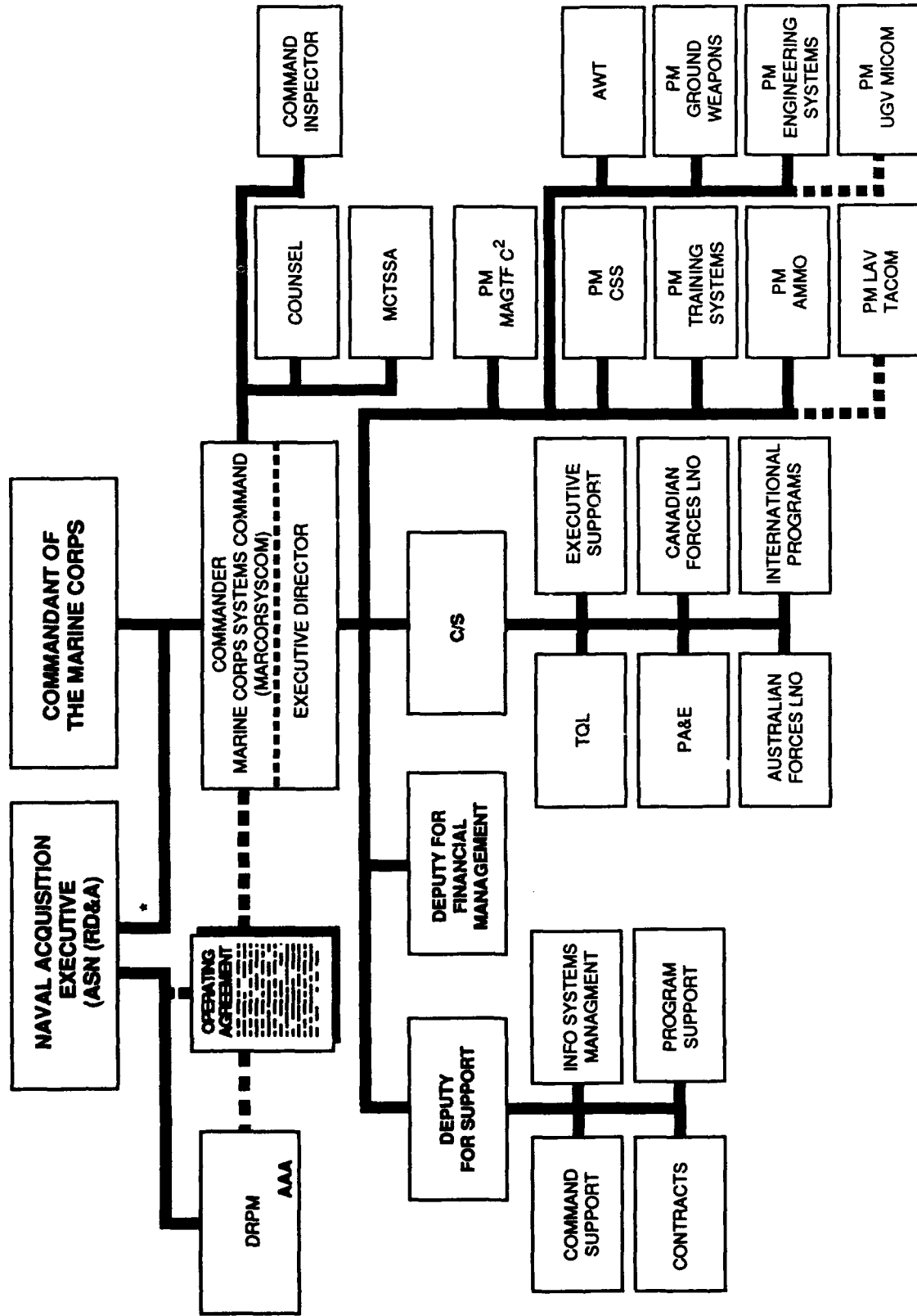

* NOTE: SYSCOM REPORTS TO NAE FOR ACQUISITION MATTERS ONLY

Exhibit E-9 — Marine Corps Systems Command Organization

FMFPAC, and in this capacity is responsible for developing operational requirements.

Representative functions performed by CG, MCCDC include: identifying required study areas and executing approved studies in support of Marine Corps mid- and long-range planning; developing, assessing, and promulgating concepts, plans and doctrine; acting as the Marine Corps focal point for war gaming; developing and implementing policy and programs for Marine Corps training and education; and preparing, coordinating, and reviewing operational requirements documentation.

E6.3 HQMC Organization for RD&A.

E6.3.1 Deputy Chief of Staff for Aviation (DC/S AVn). (DC/S AVn) is a principal member of the MCPDM. The DC/S AVn holds the position of Assistant Deputy Chief of Naval Operations (Marine Aviation), which enables him to function as an OPNAV sponsor for Navy programs involving Marine aviation.

E6.3.2 Deputy Chief of Staff for Manpower (DC/S Mpr). (DC/S Mpr) is responsible for military (Marine and Navy) and civilian manpower required to support the Marine Corps. The DC/S Mpr directs and supervises all aspects of manpower matters, including personnel research, manpower analysis and the development of manpower information systems. He is a MCPDM principal.

E6.3.3 Deputy Chief of Staff for Installation and Logistics (DC/S I&L). DC/S I&L exercises primary cognizance over all matters pertaining to installations and logistics support. The DC/S I&L is a principal member of the MCPDM.

E6.3.4 Deputy Chief of Staff for Requirements and Programs (DC/S R&P). DC/S R&P is responsible for coordinating Headquarters Marine Corps actions within the framework of the PPBS to provide the overall program requirements of the Fleet Marine Force,

the Supporting Establishment, and the Organized Marine Corps Reserve. The DC/S R&P ensures consistency, continuity, and compatibility of all approved requirements within available resources, and ensures HQMC staff application of appropriate analytical disciplines in requirements validation, program development, and program review. The DC/S R&P acts as final HQMC approval authority for Cost and Operational Effectiveness Analysis documents (COEAs). The DC/S R&P is a principal member of the MCPDM.

E6.3.5 Director, Command and Control, Communications, and Computers (DirC4). The DirC⁴ provides for planning, directing and coordinating staff activities relating to Marine Corps command and control, telecommunications and automated data systems and advises the CMC on JCS matters related to those activities. The DirC⁴ is a principal member of the MCPDM.

E6.3.6 Director, Marine Corps Operational Test and Evaluation Activity (MCOTEA). MCOTEA is a separate and independent operational testing activity. The Director, MCOTEA reports to the Commandant and supports the systems acquisition process by conducting operational tests and evaluations. The Director, MCOTEA is a principal member of the MCPDM.

E6.4 Marine Corps RDT&E Liaison Organization. RDT&E liaison functions for the Marine Corps are performed by a far-reaching network of Marines who are assigned to duty at or within the R&D organizations of DOD and the other Services; to joint-Service project/program offices; to industrial contractor's activities; and to FMF units in the field. Some of these personnel are clearly identified as Marine Corps Representatives/Liaison Officers/Project Officers, but many others occupy billets within the structure of the command to which they are assigned and are identified only by an appropriate billet title.

E6.5 Fleet Marine Forces (FMF). The Fleet Marine Forces figure prominently in the Marine

E7

Corps organization for RD&A by articulating operational requirements in coordination with CG, MCCDC, and providing a tailored vehicle for troop test and evaluation of material development in an operational environment.

E7 OFFICE OF NAVAL RESEARCH (ONR)

*SECNAV Notice 5430 of 4 December
1992*

The office of Naval Research (ONR) (see Exhibit E-10) was established by law in 1946 to plan, foster, and encourage scientific research in recognition of its paramount importance as related to the national security. ONR was charged to perform such duties as the Secretary of the Navy may prescribe relating to (1) the encouragement, promotion, planning, initiation, and coordination of naval research; (2) the conduct of naval research in augmentation of and in conjunction with the research and development conducted by other offices and agencies of the Department of the Navy; and (3) the supervision, administration, and control of activities within or for the Department of the Navy relating to patents, inventions, trademarks, copyrights, and royalty payments, and matters connected therewith.

The Office of Naval Research is commanded by the Chief of Naval Research. The Chief of Naval Research, as the Navy's science and technology executive, is a Deputy-Assistant Secretary-of-the-Navy-level official responsible for science and technology management, policy and oversight, and corporate Naval Research Laboratory policy and oversight for the Secretary of the Navy through the Assistant Secretary of the Navy (Research, Development and Acquisition (ASN(RD&A))).

The functions of ONR include:

- Assess, promote, coordinate, and manage naval basic research, exploratory development, and advanced technology development directed at transitioning new capabilities toward fleet utilization and increased naval warfare capability. Exploit Science and Technology (S&T) results for their developmental, tactical, or policy implications.
- Provide the Secretary of the Navy and DON Acquisition Executive (NAE) advice on policy matters concerning S&T. Serve as the senior scientific and technical advisor to the NAE.
- Provide policy direction and oversight to the Navy Corporate Laboratory.
- Provide policy, oversight, and executive management for programs funded in the 6.1, 6.2, and 6.3A Research, Development, Test, and Evaluation, Navy (RDT&E,N) categories.
- Maintain liaison with the Office of the Chief of Naval Operations regarding research and technology necessary to meet requirements for future fleet operations and capabilities.
- Represent the ASN(RD&A) on matters related to DON S&T programs of interest to OSD, DON, and other government agencies, institutions, industry, and individuals.
- Provide policy and direction to the patent program of the Navy.
- Acquire and assist science and technology through a contracts and grants program for ONR and the Naval Research Laboratory (NRL). Provide contracting services for other Navy, DOD, and Federal activities.

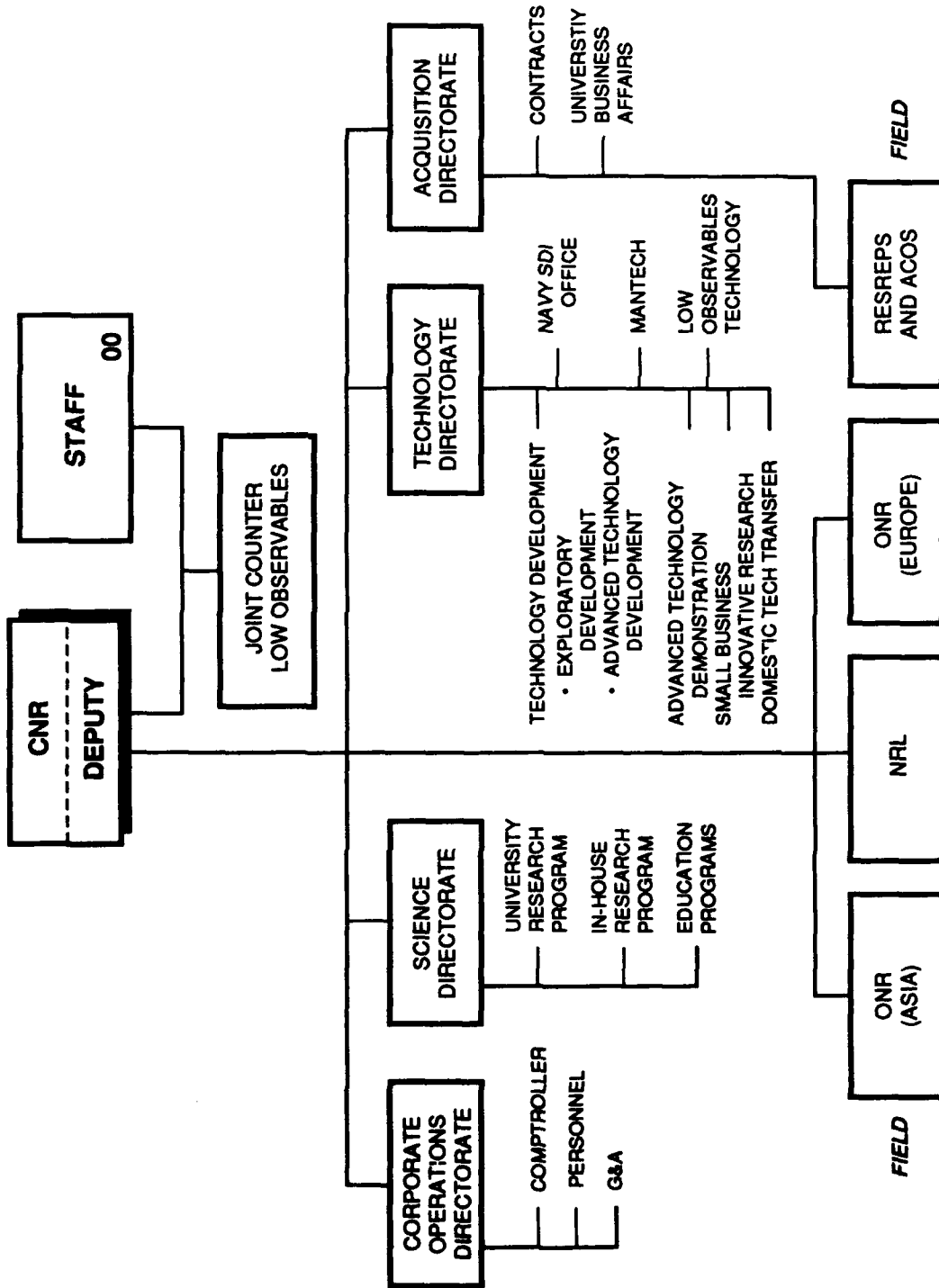

Exhibit E-10 — Office of Naval Research

- Manage the DON Small Business Research (SBIR) Program.
- Direct, as Technical Manager, the Naval Research Science and Technology Program.

E8 BUREAU OF MEDICINE AND SURGERY (BUMED)

R&D affairs within BUMED are the responsibility of the Assistant Chief for Readiness and Support (BUMED 02), as assisted by the Director for Readiness and Support (BUMED-26). Navy medical R&D is carried out under the direction of the Commanding Officer, Naval Medical Research and Development Command, Bethesda, Maryland.

Ref: NAVMEDCOMINSTS 5430.1, 5450.14

E8.1 Commanding Officer, Naval Medical Research and Development Command. The Commanding Officer, Naval Medical Research and Development Command manages and coordinates the Navy Medical Department Research, Development, Test, and Evaluation Program concerning the health, safety, and performance effectiveness of Navy and Marine Corps personnel.

In carrying out the above mission, the Commanding Officer, Naval Medical Research and Development Command commands the Navy Medical Department R&D laboratories; directs, plans, programs, budgets, and documents Navy Medical Department RDT&E efforts in response to Navy and Marine Corps RDT&E requirements; determines requirements for and recommends procurement, training, assignment, and distribution of R&D personnel; performs RDT&E staff functions for the Chief BUMED; provides professional medical and dental guidance in the

planning and conduct of Navy and Marine Corps weapon systems, life-support systems, and personnel protection; and coordinates Navy medical research efforts with the Navy Commands and Offices, other government agencies, civilian organizations, and foreign governments.

E9 BOARDS AND OTHER GROUPS

E9.1 Defense Science Board (DSB). The Defense Science Board, composed of members appointed from the public sector by the Secretary of Defense upon the recommendation of the Under Secretary of Defense for Acquisition, advises the Secretary of Defense, through the Under Secretary for Acquisition, on scientific and technical matters of interest to the Department of Defense.

Ref.: DOD Directive 5129.22

E9.2 Defense Acquisition Board (DAB). The DAB is the senior advisory body to the USD(A) to advise the USD(A) in enforcing policies and procedures governing the operations of the DOD Acquisition System. The DAB is the primary forum to advise the USD(A) on:

- Mission needs approved by the Joint Requirements Oversight Council (JROC) for Milestone 0 DAB review and possible Concept Exploration/Definition study effort.
- Milestone I through IV decision point reviews and program reviews of major defense acquisition programs subject to DAB review under DOD Directive 5000.1.

DAB members are: USD(A) (Chairman), Vice Chairman JCS, DDR&E, NAE and counterparts for the Army and Air Force, ASD(PA&E), DOD Comptroller, DOT&E, and the Chairs of DAB Acquisition Committees as appropriate. Responsible PMs and PEOs are

invited to DAB review sessions. The Chairman may invite representatives from DOD Components or other Government Agencies to participate in DAB activities on a case-by-case basis.

Ref.: DOD Directives 5000.1; 5000.49; DOD Instruction 5000.2, Part 13, Section A

E9.2.1 DAB Acquisition Committees. The DAB is supported by three Acquisition Committees that provide assistance in program review and policy formulation. The missions and membership of each committee can be found in their respective charters. The appropriate DAB Acquisition Committee reviews DAB programs prior to a DAB meeting. These sessions are to identify, and where possible, reach consensus on issues; determine issues to be brought before the DAB; and to formulate recommendations for DAB consideration.

The three Acquisition Committees are: Strategic Systems Committee (SSC); Command, Control, Communications, and Intelligence Committee (C³IC); and Conventional Systems Committee (CSC).

Ref.: DOD Directive 5000.1, DOD Instruction 5000.2, Part 13, Section A

E.9.3 Joint Requirements Oversight Council (JROC). The JROC reviews all Mission Need Statements that may necessitate major system development and makes recommendations to the DAB prior to DAB review at Milestone O. The JROC plays a continuing role in the validation of performance goals and baselines prior to DAB review of major reviews. The JROC also resolves functional, operational, and interoperability issues in joint and major programs that cannot be resolved via normal staffing.

Members of the JROC are the Vice Chairman, JCS (Chair); VCNO; Vice Chiefs of Staff, Army and Air Force; and Assistant CMC.

Ref.: DOD Instruction 5000.2, Part 13, Section A

E9.4 Defense Planning and Resources Board (DPRB). The DPRB exists as the primary forum to provide the Deputy Secretary of Defense the opportunity to receive the advice and recommendations of senior advisors on planning, programming, and budgeting matters and to develop stronger links among national security policy, military strategy, and the resources allocated to specific forces and programs.

DPRB members are DEPSECDEF (Chairman); Secretaries of the Army, Navy, and Air Force; Chairman, JCS; USD(A); USD(P); ASD(PA&E); DDR&E; and DOD Comptroller. The Chairman invites other senior military and civilian officials to participate as appropriate in the deliberations of the DPRB.

Ref.: DOD Directive 5126.48

E9.5 Joint Services Automatic Testing-Executive Board (JSAT-EB). The JSAT-EB was established to review the Services' development, selection, acquisition, and logistics policies as they relate to automatic testing; to establish a comprehensive program to improve that process, to include developing and implementing a long-range, definitive action program on automatic testing; and to oversee and advise the Automatic Testing Technology Standardization (ATTS) Program. Objectives of the JSAT-EB include:

- Reduce proliferation of automatic test equipment (ATE) and dependence on off-line ATE.
- Improve management of ATE development and acquisition, and institutionalize

E9.6

and integrate improvements into the weapon system management process.

- Improve communication and exchange of information among the Services and industry in the areas of management, acquisition, testing technology, and training.
- Assure development, transition, and application of advancing testing technology to testing problems.
- Enhance standardization of the Services' automatic testing programs, including development of appropriate standards and specifications.

Ref.: OPNAV Instruction 3960.13; MCO 4081.1

E9.6 Naval Research Advisory Committee (NRAC). As the Navy Department's senior research advisory group, the Committee advises the Secretary of the Navy, the CNO, the Commandant of the Marine Corps, and the CNR with respect to research and its utilization by the Navy, and on questions of policy on Navy-wide problems in science. It particularly advises on trends and potentialities of research relating to naval operations and administration of departmental research and development programs.

The fifteen members of the Committee are persons in civilian life who are preeminent in the fields of science, research, and development work. They are appointed by the Secretary of the Navy and serve for such term or terms as SECNAV may specify. One member must be from the field of medicine.

An Executive Committee, reporting to ASN(RD&A), is responsible for identification and formulation of proposed NRAC efforts. The Executive Committee consists of the Director of Test & Evaluation and Technology Requirements

N091, CNR, COMMARCORSYSCOM, and two ASN(RD&A) staff officers: the Principal Deputy ASN(RD&A) and the Director Acquisition Management, International Programs, and Congressional Support.

Ref.: SECNAV Instruction 5420.79

E9.7 CNO Decision Process Groups. The groups described below constitute a series of forums for making decisions and forming policy. Issues flow through a hierarchy of these forums until resolved at the lowest appropriate level. They replace the former CNO Executive Board (CEB) process.

Ref.: OPNAV Instruction 5420.2

E9.7.1 Resource and Requirements and Review Board (R³B). The purpose of the R³B is to develop warfare requirements and resource issues that will have a significant impact on the Navy's future. The R³B has four working-level panels, the Ship Characteristics Improvement Panel (SCIP), the Air Characteristics Improvement Panel (ACIP), the Nonnuclear Ordnance Requirement (NNOR) Panel and the Program Review and Coordinating Committee (PRCC).

The President of the Center for Naval Analyses (CNA), and senior representatives of N80 and N81 serve as advisors.

The Permanent members of the R3B are N8 (Chair), N80, N81, N82, N83, N85, N86, N87, N88, N89, N12, N2B, N4B, N6B, N7B, N091, N095, N096, USMC DC/S (AVn), USMC DC/S (R&P), NAVAIR, NAVSEA, SPAWAR, CHINFO, OLA.

E9.7.1.1 Ship Characteristics Improvement Panel (SCIP). The SCIP assists the R³B in meeting those responsibilities pertaining to ship acquisition and improvement by coordinating formulation of ship building and conversion programs. It staffs all aspects, including

coordination of necessary planning, programming, budgeting, and support.

Membership of the SCIP includes N86 (Chair) and representatives of N4, N6, N80, N81, N83, N85, N87, N88, N091, NAVSEA, USMC DC/S (R&P), SPAWAR, ASN(RD&A), ADEPUNSECNAV (Safety and Survivability).

E9.7.1.2 Air Characteristics Improvement Panel (ACIP). The ACIP assists the R³B in meeting those responsibilities pertaining to aircraft acquisition and improvement by coordinating the formulation of Engineering Change Proposals (ECP's), future requirements, modifications, cost control, and all other matters pertaining to aircraft, aircraft systems, and air-launched weapons. The ACIP also staffs all aspects of aircraft acquisition and improvement including ILS and Navy Training Plan issues in order to provide recommendations to the R³B. The ACIP is responsible for coordination of the planning, programming, budgeting, and support necessary for efficient and cost effective execution of those responsibilities.

Members of the ACIP are N88 (Chair), and representatives of ASN(RD&A), USMC DC/S (AVn), N4, N6, N091, N09F, N80, N81, and NAVAIR.

E9.7.1.3 Nonnuclear Ordnance Requirement (NNOR) Panel. The NNOR Panel assists the R³B in determining nonnuclear ordnance requirements to ensure maximum readiness and substantiality to counter the current and projected threat. It translates ordnance requirements to programming and planning objectives and conducts comprehensive review of weapon lethality and effectiveness for each resource sponsor.

Members of the NNOR Panel are N81 (Chair) and representatives of N3/N5, N4, N80, N82, N83, N85, N86, N87, N88, N091, USMC DC/S (AVn), NAVAIR, and NAVSEA.

E9.7.2 Program Review and Coordinating Committee (PRCC). The purpose of the PRCC is

to assist with the development of the Navy Program Objectives Memorandum by serving as a review committee for Sponsor Program Proposals and other tasks as assigned by N8.

Members of the PRCC are representatives of N80 (chair) N81, N82, N83, N85, N86, N87, N88, N12, N2B, N4B, N51, N6B, N7B, N091, N095, and USMC DC/S (R&P).

E9.7.3 Navy Staff Executive Steering Committee. The Navy Staff Executive Steering Committee reviews and directs the development of issues to be considered by the CNO Executive Steering Committee.

Members of the Navy Staff Executive Steering Committee are the VCNO (Chair), N1, N2, N3/N5, N4, N6, N7, N8, N093, N095, all SYSCOMS, OLA, CHINFO, COMMSC, OJAG, MCPON.

E.9.7.4 Chief of Naval Operations Executive Steering Committee. The CNO Executive Steering Committee reviews and develops the uniformed Service position in issues and policies of vital importance to operating the Navy of today and shaping the Navy of the future.

Members of the CNO Executive Steering Committee are the CNO (Chair), the VCNO, CINCPACFLT, CINCLANTFLT, CINCUSNAVEUR.

E9.8 Navy and Marine Corps Program Decision Meetings (NPDM/MCPDM). The NPDM/MCPDM is the DON forum for acquisition program milestone decisions and for program reviews.

Attendance at NPDMs and MCPDMs is determined on a case-by-case basis by the responsible DASN/Deputy/Director, except that individuals on a core list or their representatives are invited to all ACAT I, II, III PDMs. The core lists for ACAT I-III programs include: ASN(RD&A) (Chair); ASNs (FM), (M&RA), and (I&E); the OPNAV or USMC Sponsor; PEO, DRPM, or SYSCOM; N80, 81, 82; the

E9.9

responsible OASN(RD&A) DASN/Director; the OASN Action Officer; General Counsel; Program Manager; Executive Secretary.

NPDMs add: OPA, COMOPTEVFOR, and N1, N4, N6, N8, N091. MCPDMs add FDMC, DC/S I&L, Mpr, R&P, and PP&O; and Director, MCOTEA.

For Automated Information System programs the core lists differ slightly. Detailed core attendance lists are contained in SECNAV Instruction 5420.188.

Ref.: SECNAV Instruction 5420.188

E9.9 Acquisition Review Board (ARB). The ARB, normally convened by a SYSCOM, reviews acquisition programs, provides advice and guidance to acquisition managers, and recommends alternative courses of action. For ACAT IV programs, the SYSCOM ARB is the single decision forum. ARB activities are intended to complement the review processes established by higher headquarters for major programs and selectively provide SYSCOM-level review for acquisition programs of all categories.

E9.10 Naval Studies Board-National Academy of Sciences. With appropriate attention to the influence of domestic economy, national objectives, social imperatives, and anticipated military requirements, the Board for Naval Studies of the National Academy of Sciences conducts and reports upon surveys and studies in the field of scientific research and development applicable to the operation and function of the Navy. Each particular project undertaken by the Board within this mission is precisely defined and mutually agreed to by the Board and the Director, Test and Evaluation and Technology Requirements N091 acting for the Assistant Secretary of the Navy (RD&A).

E9.11 DON Program Strategy Board (DPSB). The DPSB, chaired by SECNAV, develops strategies, resolves issues, and reviews programs

at the top level of DON management. Members are SECNAV; UNDERSECNAV; CNO; CMC; N8, N80, N82, N83, OPA; DC/S(R&P) Marine Corps; ASN(RD&A); ASN(M&RA); and ASN(FM).

POM Serial Yr-1

E9.12 Navy Laboratory/Center Coordinating Group (NLCCG). The NLCCG, chartered by ASN(R&D), resolves Laboratory/Center issues within the authority of its members and identifies issues for ASN(RD&A) through the NLCOC (see E9.13). Members are the Commanders and Technical Directors of the Warfare Centers and of the Naval Research Laboratory.

E9.13 Navy Laboratory/Center Oversight Council (NLCOC). The NLCOC, chartered by SECNAV, provides corporate oversight of the DON RDT&E, engineering, and fleet support communities contained in the Warfare Centers and Laboratory. The Council provides high-level advocacy for improving productivity and effectiveness in the communities. Core membership includes ASN(RD&A) (Chair), VCNO, Assistant CMC. Members at large include COMMARCORSYSCOM, ASN(FM), ASN-(M&RA), ASN(I&E), DON General Counsel, AND N091.

E10 PARTICIPANTS IN THE ACQUISITION PROCESS

The acquisition of a major system requires a well coordinated effort. Responsibilities of some of the principals are as follows:

Ref.: DON Programming Manual, Appendix NB

E10.1 Appropriation Sponsor. The Appropriation Sponsor is a Deputy Chief of Naval Operations (DCNO), Assistant Chief of

Naval Operations (ACNO) or Commander, Marine Corps Systems Command (COMMARCORSSYSCOM) charged with supervisory control over an appropriation. N091 is the Appropriation Sponsor for the RDT&E,N appropriation relating to research and development.

E10.2 Program Sponsor. The Program Sponsor is the DCNO or Director, Staff Office (DSO) responsible for determining program objectives, timephasing and support requirements, and for appraising progress, readiness, and military worth for a given weapon system function or task. He or she is the CNO's or CMC's agent concerning the program. The Marine Corps program sponsor is the same executive as the appropriation sponsor.

E10.3 Resource Sponsor. A Resource Sponsor is the DCNO or DSO responsible for a group of programs and resources constituting certain warfare and supporting warfare tasks. In liaison with Program and Appropriation Sponsors, he prepares and justifies a Navy position on resource allocation within the assigned group of tasks to assure a fiscally effective and balanced program.

E10.4 Requirements Officer. The OPNAV Requirements Officer (RO) serves as the contact point within OPNAV for matters related to platform and system requirements, test and evaluation and resources. The RO represents the Program and Resource Sponsors with the naval acquisition organization and keeps Program and Resource Sponsors informed on program status. The RO is explicitly precluded from exercising line authority in the acquisition process.

E10.5 Program Executive Officer (PEO) and Direct Reporting Program Manager (DRPM). The PEO has authority and responsibility for all major programs within his area, as well as other programs designated by SECNAV. The PEO

reports directly to the NAE with regard to his programs, and the PEO. Some large, complex, or critical programs are managed by DRPMs, who report directly to the NAE.

There are currently eight PEOs for: Air ASW, Assault, and Special Mission Programs; Cruise Missiles Project and UAV Project; Tactical Aircraft Programs; Space, Communications, and Sensors; Submarines; Undersea Warfare; Mine Warfare; and Ship Defense. There are currently four DRPMs for: AEGIS, Strategic Systems, Advanced Medium Attack (AX), and Advanced Amphibious Assault.

E10.6 Program Manager (PM). A Program Manager is responsible for executing an approved program. The term is restricted to the manager of a relatively major effort who has been designated PM in a program charter. He is responsible to the Program Executive Officer (PEO) or SYSCOM Commander and reports only to him on program matters. Thus, no manager will have more than one level of supervision between him and the Navy Acquisition Executive, and no more than two organization echelons between him and the Defense Acquisition Executive.

E10.7 Ship Acquisition Program Manager. A Ship Acquisition Program Manager (SHAPM) is a NAVSEA Program Manager responsible for the development, design, construction, and conversion of assigned ship types. SHAPM operates under a charter from Commander, Naval Sea Systems Command.

E10.8 Acquisition Manager. An Acquisition Manager performs the functions of a Program Manager for acquisitions which do not require the degree of visibility and status of program management.

E10.9 Contracting Officer. The Contracting Officer has legal responsibility for all contractual matters related to an acquisition.

**SELECTED REFERENCES ON
RD&A ORGANIZATION MATTERS**

DOD Directive 5000.1, "Defense Acquisition."

Components," provides a basic statement of the responsibilities of various organizations and officials within the Department of Defense.

DOD Instruction 5000.2, "Defense Acquisition Management and Policies."

DOD Directive 5100.1, "Functions of the Department of Defense and its Major

SECNAV Instruction 5400.15, "Department of the Navy Research, Development and Acquisition Responsibilities."

Appendix F
TOPICS RELATED TO PLANNING AND CONDUCT OF RESEARCH,
DEVELOPMENT, AND ACQUISITION

TABLE OF CONTENTS

F1	Overview of the RD&A Process	F-1
F1.1	Output of the RD&A Process	F-1
F1.2	Nature of the R&D Process	F-1
F1.3	Threat Information	F-2
F1.4	Studies, Analyses and Systems Engineering	F-2
	F1.4.1 Studies and analyses	F-2
	F1.4.2 Engineering management	F-2
	F1.4.3 Systems engineering process	F-2
F1.5	RD&A as a Subsystem	F-2
F1.6	“Invention” and “Innovation”	F-3
F1.7	The Customer-Supplier Dialogue	F-3
	F1.7.1 “Needs” and “requirements”	F-3
	F1.7.2 “Technology push” and “requirements pull”	F-3
	F1.7.3 Patents as an aid to coupling	F-4
	F1.7.4 Domestic Technology Transfer	F-4
F2	Process Integration	F-4
F2.1	Coordination and Focus	F-4
F2.2	Advising Boards, Panels and Committees	F-4
F2.3	Scientific and Technical Information	F-5
F3	Program Management	F-5
F3.1	Characteristics of Program Management	F-5
F3.2	Establishing the Program	F-5
F3.3	Staffing the Program Office	F-6
F3.4	Matériel Professional Program	F-6
F4	Logistics and Resources	F-6
F4.1	Integrated Logistics Support (ILS)	F-6
F4.2	New Facilities for RDT&E	F-7
F4.3	Personnel	F-7
F4.4	Cost Considerations	F-7
	F4.4.1 Economic Analysis	F-8
	F4.4.2 Design-to-Cost	F-8
	F4.4.3 Cost Estimation and Analysis	F-8
	F4.4.3.1 Cost analysis responsibilities	F-8
	F4.4.3.2 Cost estimating methodologies	F-8
	F4.4.3.3 Classes of baseline cost estimates	F-8
	F4.4.3.4 Standard weapon system costs	F-9

F4.4.3.5	Navy Headquarters Programming System/Navy Headquarters Budget System	F-9
F4.4.3.6	Life Cycle Cost (LCC)	F-9
F4.4.4	Incremental Acquisition Strategy	F-9
F4.4.5	Cost Measurement and Reporting	F-9
F5	Milestones for Ship Programs	F-10

APPENDIX F

TOPICS RELATED TO PLANNING AND CONDUCT OF RESEARCH, DEVELOPMENT, AND ACQUISITION

In this appendix, various topics are discussed of which readers who are involved in the planning and conduct of research development, and acquisition should be aware.

F1 OVERVIEW OF THE RD&A PROCESS

In this section, the RD&A process is examined, both as it relates to the larger process of planning and managing improvement in the Navy's ability to carry out its mission, and in terms of its internal workings.

F1.1 Output of the RD&A Process. It is not uncommon for people to equate RD&A with the development of hardware, a view which is as limited as it is erroneous. The product of the RD&A effort is an operational capability. Weapons hardware is but one subsystem of operational capability. This point must be re-emphasized: The objective of RD&A is operational capability, not hardware *per se*.

The elements of the total system required to provide an operational capability include:

- Equipment—system hardware plus equipment (trainers, support equipment, etc.) required for its effective utilization and support.
- People—trained crews and maintenance personnel plus the support system required for their continuing development and the training of their replacements.
- Facilities.
- Material—consumables, spares, etc.

- Information—technical maintenance data, operating tactics, maintenance procedures, etc.

F1.2 Nature of the R&D Process. The function of R&D in the development of operational capabilities is the production of the information required to achieve such capabilities. Some needed capabilities can be achieved without new information, and hence are not R&D problems. RD&A is a multistage information generation and conversion process characterized by the integration and conversion of information within stages and information flow coupling between stages.

R&D is a way of progressively reducing uncertainty by buying information. In the earliest stages of the R&D process, uncertainty usually is very high regarding probable results and the value of the results. Decisions on what and on what not to do are made on the basis of expected value—the predicted value of the payoff if successful, multiplied by the probability of success. Judicious decisions must be made on how much to pay for uncertainty—reducing information before making particular R&D investment decisions. In the case of major weapon systems, a very substantial investment usually is justified.

Fortunately, costs and uncertainty are inversely related in the RD&A process. In the research phase, uncertainty usually is high, but the cost relatively low. In the systems development phase of the process, cost per project can be extremely high while uncertainty is relatively low.

F1.3

The RD&A manager, like all managers, is accountable for putting the resources subject to his discretion to their most productive use. The obligation will cause the RD&A manager to "bet on longshots" where costs are low relative to payoff. He will invest significantly to reduce uncertainties where large investments are at stake.

F1.3 Threat Information. Threat is the capability of a potential enemy to limit or negate a Navy mission or capability. The interface of threat with each weapon system is continuous throughout the life of the system. In each system's program it is required that specific plans be included for obtaining and using threat intelligence for the life cycle of the program.

System Threat Assessment Reports (STAR) are required to be updated at each decision Milestone (see Chapter 1, p. 1-29). If a development is not threat-related, that point must be explained by the program sponsor in the appropriate requirements document.

Ref.: DOD Instruction 5000.2, Part 4, Section A; DOD Manual 5000.2-M, Part 5; OPNAV Instruction 3811.1

F1.4 Studies, Analyses and Systems Engineering. Optimizing the use of resources requires a clear understanding of (1) what is needed, (2) means of achieving desired results and (3) the advantages and disadvantages of the alternatives. Studies, analyses and systems engineering are means for producing such information.

F1.4.1 Studies and analyses. Studies and analyses lead to critical examination and investigation of a subject, resulting in conclusions or recommendations that make substantive contributions to planning, programming and decision making.

Studies and analyses typically are "paper-and-pencil" efforts to organize and evaluate available data to provide greater

understanding of alternative organizations, tactics, doctrines, policies, strategies, procedures, systems, or programs. It is DOD policy that studies and analyses be used as essential management tools. They are an integral part of executive or command responsibility. Studies and analyses undertaken in connection with specific programs take place, for the most part, as part of the COEA process (see Chapter 1, p. 1-39).

Studies and analyses may be conducted by in-house organizations, by affiliated organizations or by outside organizations under contract or grant.

Ref.: DOD Directive 4205.2; SECNAV Instruction 4200.31; OPNAV Instruction 5000.37

F1.4.2 Engineering management. Engineering management is the effort needed to transform a military requirement into an operational system. It includes system engineering to define system performance criteria and configuration, the planning and control of program tasks, integrations of engineering specialties, and the management of a totally integrated effort, including design engineering, special engineering, test engineering, logistics engineering and production engineering to meet cost, technical performance, supportability and schedule objectives.

F1.4.3 System engineering process. The system engineering process is a logical sequence of activities and decisions followed to transform an operational need into system performance parameters and a preferred system configuration.

Ref.: MIL-STD-499A, "Engineering Management"

F1.5 RD&A as a Subsystem. It is the function of RD&A to help provide capabilities needed to carry out most effectively the Navy's mission. The determination of future operational capabilities is

not part of the RD&A process, but rather of the overall Navy planning process. While it is the function of higher level planning to decide what capabilities are desired, it is the function of R&D to determine what will be *possible* to achieve, how they can be achieved, and to develop and organize the new knowledge required to accomplish the task. It is the function of acquisition activities to provide those capabilities. Thus RD&A constitutes an important subsystem of the overall operational capability development system.

F1.6 "Invention" and "Innovation." Achieving new capabilities, which is a principal justification of R&D effort, requires both invention and innovation. Invention is the development of new options; innovation with developing and putting into use the capabilities such options make possible. Generally, innovation is many times more costly than the invention part of the process.

In general, effort categorized as Research (6.1) or Exploratory Development (6.2) is part of the inventive process, while Advanced Development (6.3), Engineering Development (6.4) and Operational Systems Development (6.6) are primarily innovative.

F1.7 The Customer-Supplier Dialogue. Efficient coupling requires that the Supplier, as spokesman for means, and that the Customer, as spokesman for ends, coordinate their work. The Customer primarily is responsible for determining what needs to be done while the Supplier is primarily responsible for determining how results can be achieved. Together, through an active dialogue they hammer out the best compromise between what is desirable and what is possible (see 6.1.3). The formal part of this dialogue occurs incident to the COEA process (see Chapter 1, p. 1-39).

*Ref.: DOD Instruction 5000.2, Part 4,
Section E*

F1.7.1 "Needs" and "requirements." A variety of terms is used concerning desired capabilities—e.g., "need," "objective," "target," "problem," "requirement," etc. While all of these terms denote capabilities of value in accomplishing a mission, they differ in what they imply about the Customer's commitment to spend resources for their attainment. The whole Customer-Supplier dialogue is tempered by the obligation of both Customer and Supplier to apply government resources to yield the optimum overall benefit in mission capability.

"Need" is used by DOD in a specific sense, as set forth by OMB in Circular A-109. Under the Circular, when analyses indicate a deficiency in existing capabilities, an opportunity to establish new capabilities, or an opportunity to reduce significantly ownership costs or increase effectiveness of existing material, a "mission need" exists. A mission need is described in a Mission Need Statement (MNS) submitted by OPNAV to the Navy Acquisition Executive (ASN(RD&A)) and, for major programs, to the Joint Requirements Oversight Council (JROC), as described in Chapter 1.

A "requirement" generally is outlined in a document by which the Customer, CNO/CMC, describes to the Supplier—normally the technical establishment—a specific mission need for resolution. A requirement is documented by an Operational Requirement Document (ORD) as described in Chapter 1.

F1.7.2 "Technology push" and "requirements pull." The concepts of "technology push" and "requirements pull" relate to the influence of "supply" (technology push) and "demand" (requirements pull) on shaping research and development programs. Technology push is a matter of what is technologically feasible and of the eagerness of the R&D community to do what can be done; while requirements pull concerns what needs doing to

F1.7.3

solve problems barring attainment of needed operational capabilities.

F1.7.3 Patents as an aid to coupling. The United States Patent Office has copies of more than three million domestic patents, seven million foreign patents, and countless pieces of trade literature classified by technical categories. A review of this information should provide familiarization with any prior approaches to resolve a particular problem, or to identify approaches which may be covered by patents. The knowledge can result in cost savings by avoiding the unnecessary expense of duplicating prior efforts and possible patent infringements. ONR is responsible for ensuring that patent issues are properly managed in Navy RD&A.

F1.7.4 Domestic Technology Transfer. Technology developed under military programs has made great contributions to the ability of U.S. high-technology products to compete in world markets. The Navy Military-Civilian Technology Transfer and Cooperative Development Program was established to strengthen this relationship between Navy R&D and the civilian economy.

Philosophical and programmatic changes have resulted from the Stevenson-Wydler Technology Innovation Act of 1980 (PL 96-480), the Federal Technology Transfer Act of 1986 (PL 99-502) and Executive Order 12591 of April 1987. Essentially, Navy domestic technology transfer has moved from an all-volunteer, "first-come, first-served" effort to a more structured endeavor. The changes also enhance financial return to both individual inventors and R&D activities from royalties received from benefiting organizations.

The objectives of this program are to (1) facilitate the flow of Navy-developed technology into civilian applications and (2) provide for cooperative development of technologies of importance to both the Department of the Navy and the civilian economy.

*Ref.: DOD Regulation 3200.12-R-4;
SECNAV Instruction 5700.16*

F2 PROCESS INTEGRATION

Research & development and acquisition management is a multi-stage information generation and conversion process with integration of the data among the various stages. The productivity of the overall process depends as much on efficient information coordination among the stages in the process as on good research or development work within the stages. Various mechanisms exist which facilitate the integration process.

F2.1 Coordination and Focus. Few activities require greater intellectual and management discipline than research, development, test, and evaluation. Planning, execution, management, and control must be closely focused to be effective. Focus implies, for example among other things, striking the essential balance between the important encouragement of creative, innovative thinking and experimentation, and the equally necessary requirement that scarce RDT&E resources be focused on relatively specific areas applicable to DON missions. A most important mechanism by which such focus is achieved is early, effective, and frequent inter- and intra-stage coordination and information flow.

F2.2 Advising Boards, Panels and Committees. Face-to-face groups of individuals, having disparate responsibilities but related functions and objectives are primary forums for providing essential information flow and coordination. These groups within the Navy's research, development, and acquisition structure include boards and panels which provide information, analyses, and experienced advice and guidance to decision-makers, as well as committees of senior officials, which formulate policy and effect

decisions. All are related to an orderly flow of information (see E9).

F2.3 Scientific and Technical Information. One of the basic "products" of the research and development and acquisition process is Scientific and Technical Information (STI). This product results from the Navy's ability to (1) provide R&D and acquisition managers and appropriate personnel necessary STI, (2) collect and store such information and (3) make STI available when required. Several organizations within Navy have been established expressly to collect, analyze, store, maintain and disseminate scientific and technical data. The functions and activities of these organizations—and their "products"—are integrated to aid in improving overall RD&A effectiveness in the Scientific and Technical Information Program (STIP) (see Appendix D for further information on STIP and STI).

Ref.: DOD Directive 3200.12; SECNAV Instruction 3900.43

F3 PROGRAM MANAGEMENT

Program Management consists of planning, organizing, coordinating, directing and controlling the combined efforts of participating civilian and military Navy personnel and contracting agencies in successfully accomplishing a program. Program Management, without reservation, is one of the most important and critically necessary functions of Navy research and development and acquisition.

The National Security Decision Directive, which put into effect certain recommendations of the President's Blue Ribbon Commission on Defense Management, specified that, in organizations for acquisition, "no Program Manager would have more than one level of supervision between himself and his Service Acquisition Executive."

Thus, in the Department of the Navy, the Program Manager (PM) reports to a Program Executive Officer (PEO) who reports to the Navy Acquisition Executive (NAE). For programs under the cognizance of the Defense Acquisition Executive (DAE) i.e. ACAT ID programs, the Navy Acquisition Executive reports directly to the DAE, who is the Under Secretary of Defense (Acquisition).

Ref.: DOD Directive 5000.1; DOD Instruction 5000.2; SECNAV Instruction 5000.2

F3.1 Characteristics of Program Management Program Management is "product-driven." Consequently, the Program Manager (PM) is highly oriented toward the end-product of the Program—hardware or software. In comparison, our laboratories, many of the participating universities and industries and the other organizational components which constitute the Navy's RDT&E and acquisition system have less specifically defined product goals, but rather are engaged in continuous, "building block" efforts to improve the process and to achieve longer term, more general scientific and technical goals; goals often times much less specific and clear-cut than those of the Program Manager, and frequently less certain, especially in the research part of the spectrum. These organizations are structured, consequently, around skills, disciplines or function; frequently in a cooperative, matrix environment.

Both types of organizations are essential to achieving effective and economical research and development and acquisition results. They complement each other in significantly affecting the quality of Navy and Marine Corps state of readiness.

F3.2 Establishing the Program. Managers of most designated programs operate under charters issued by the respective Program Executive Officers (see E10.5 and E10.6). These charters,

F3.3

issued as 5400 series instructions, set forth the authority, responsibility and operating relationships of the Program Manager.

F3.3 Staffing the Program Office. An approved program is staffed with the caliber and number of people required to get the job done. These people possess both management and technical skills and experience required to support the Program Manager (PM) in carrying out the PM's responsibilities successfully.

Effective performance by the Program Manager requires both the authority of military rank and the confidence of technical and business knowledge and experience. As a general rule, the Navy Program Manager will be a Marine Colonel, a Navy Captain or a civilian official of equivalent grade, with the most important and critical programs headed by a flag officer or civilian equivalent. Sometimes a Senior Executive Service (SES) civilian manager will be the PM.

Personnel considered for assignment as senior members of a Project Manager's staff should be individuals expected to be available for at least three years, with major Program Managers serving four-year tours.

Training and development of PMs and senior staff members is a vital and ongoing function (see F3.4 on the Material Professional program). The manager of a major program is required by law (Section 1622 (b)(1) of Title 10, United States Code) to complete successfully the Program Management Course (PMC) at the Defense Systems Management College, or a comparable program management course, prior to assignment as a program manager. In addition, the senior program office staff members should be graduates of the PMC course or have equivalent education or experience. Effective July 1, 1990, Section 1623(b) of Title 10, requires that general and flag officers assigned procurement commands meet the education and experience requirements prescribed for program managers in Section 1622(b).

SES personnel assigned to program offices normally will have had broad experience and

training. Key staff subordinates are selected by the Program Manager and must be highly qualified by training or experience to manage one or more important elements of the program.

Ref.: DOD Directive 5000.52; SECNAV Instructions 12920.1, 12950.11; OPNAV Instruction 1211.8

F3.4 Materiel Professional Program. The Materiel Professional (MP) Program was established to sustain superiority in naval system management by improving career development, assignment and use of personnel involved in systems acquisition, logistics, technology, support, facilities, materiel maintenance, and materiel readiness. There are parallel Navy programs for military and civilian MPs.

The MP career path provides for formal education, developmental training and assignment to appropriate positions of increasing responsibility.

Over 100 high-level positions have been specifically designated as MP billets. Examples of billets designated for military MPs include SYSCOM Commanders, N091, DCNO Logistics, Laboratory COs and Program Managers.

Ref.: DOD Directive 5000.52; OPNAV Instruction 1040.9; SECNAVINSTS 5300.33, 5300.34

F4 LOGISTICS AND RESOURCES

F4.1 Integrated Logistics Support (ILS). Integrated Logistic Support (ILS) is the management and technical activity aimed at integrating readiness and support considerations into system design, schedule, cost and acquisition.

Readiness is achieved through creating the design/support interface, developing maintenance

planning, and implementing cost-effective life-cycle support. ILS planning influences design and evolves life-cycle support through Logistics Support Analysis (LSA). Resources to achieve readiness and availability are given equal weight with performance considerations during competitive source selections. ILS assessment and subsequent tradeoffs serve to provide the required support during the operations phase at minimum cost.

The elements of logistic support, planned in an integrated manner, are:

- Maintenance
- Manpower and personnel
- Equipment
- Supply
- Technical data
- Training
- Computer resources
- Facilities
- Packaging, handling, storage and transportation information
- Design interface.

Program Managers are required to document the management approach, decisions, and plans associated with logistics planning efforts in an Integrated Logistics Support Plan (ILSP). The plan will be the basis for coordinating logistics planning efforts and ensuring that each ILS element is addressed and integrated with the other elements throughout the program and will include planning for deployment and post-production support.

Ref.: DOD Instruction 5000.2, Part 7, Section A; SECNAV Instruction 5000.2

F4.2 New Facilities for RDT&E. Construction of new facilities required to support RDT&E projects involves special problems. The funds for constructing facilities are provided by the Military Construction (MILCON) appropriation. Except for very minor construction or modifications, it is

illegal to use RDT&E funds to pay for construction. Thus, the need for RDT&E facilities must be anticipated long in advance, and measures taken to meet the requirements for obtaining funds through the MILCON appropriation.

Ref.: DOD Instruction 7040.4 (SECNAV 7045.9)

F4.3 Personnel. Personnel needed for development or deployment of a new system are a special planning problem owing to the leadtimes involved. Often training may take longer than development and production of the hardware they are to operate.

In addition to the training leadtimes, controls necessitate advance preparation. All personnel levels are tightly controlled within the Future Years Defense Program (FYDP). Thus requirements must be anticipated long in advance and the measures taken to secure timely authorizations.

Ref.: OPNAV Instructions 1500.8 and 5000.50

F4.4 Cost Considerations. It is the obligation of Defense management to provide the highest mission capability possible within the resource limits the country chooses to allocate to Defense. DOD Directive 5000.1 states that a cost-effective balance must be achieved among acquisition costs, ownership costs ..., and system effectiveness in terms of the mission to be performed.

This section deals with RDT&E and acquisition concepts, policies and institutional arrangements related to cost considerations of mission effective, cost-effective and affordable weapons.

Ref.: DOD Directive 5000.4; DOD Instructions 5000.2 and 7041.3; SECNAV Instruction 5000.2

F4.4.1

F4.4.1 Economic Analysis. Economic analysis is a means of systematically considering benefits and cost in decision-making, particularly in investment decisions. In conducting economic analysis cost and benefit, objectives, and alternatives are identified and compared through the use of an appropriate analytical framework.

Economic analyses are required to support the acquisition of major systems. The results of these analyses are summarized in the COEA, and provide the basis for subsequent program evaluation.

F4.4.2 Design-to-Cost. In the planning of development programs, cost parameters reflect the cost of acquisition and ownership. Discrete cost projections (e.g., unit production cost, operating and support cost) are established as "design-to" requirements. System development is continuously evaluated against these design-to-cost goals. Design-to-cost applies to most systems to be produced in significant quantities.

*Ref.: DOD Instruction 5000.2, Part 6,
Section K*

F4.4.3 Cost Estimation and Analysis. Much emphasis is placed on improving estimates of probable cost of developing, procuring, operating and supporting proposed systems. Cost estimating dominates every phase of Navy planning, programming and budgeting. Development and acquisition costs, along with recurring ownership costs, must be estimated accurately if realistic Navy programming and decision-making are to result.

F4.4.3.1 Cost analysis responsibilities. Cost estimates for a proposed program are prepared by the Program Manager and are updated annually. Independent cost estimates are made by the Naval Center for Cost Analysis (NCA) for ACAT I and II programs. For ACAT ID or IC programs, the DOD Cost Analysis Improvement Group (CAIG) then provides the DAB or ASN(RD&A)

respectively, with a review and evaluation of both the estimates prepared by the PM and the independent estimate prepared by NCA.

F4.4.3.2 Cost estimating methodologies.

For estimating costs of weapon systems, the three most common approaches are: Engineering or "bottom-up," parametric, and analogy. Each relies on a work breakdown structure (WBS) that defines the work required to develop, procure, operate, and support the system. The WBS, described in MIL-STD-881, is outlined in C11.

Engineering estimates are based on detailed system specifications and drawings, industrial engineering standards, etc.; total cost is estimated by summing the estimated costs for individual elements of the effort being analyzed. These estimates are sensitive to design and manufacturing changes and can identify cost driving elements. Because they require detailed information, engineering estimates are less useful for systems that are not fully defined.

Parametric estimates, based on relationships derived from "actual" costs, use system or program parameters (e.g., size, complexity, development time) to estimate costs. These statistically derived estimates require historical cost data on similar systems. They are sensitive to major design or program changes and can evaluate cost drivers and give quick results. Normally less detailed than engineering estimates, they can be as accurate.

Cost estimates by analogy rely on relationships to costs experienced for similar items (e.g., ratio of hardware to engineering costs based on ratios experienced in similar programs). These estimates require limited historical data and can be adjusted for differences between systems. Accuracy depends on similarity to historical programs and adequacy of adjustments. Analogies may not identify cost drivers, so may not assess the impact of design or program changes.

F4.4.3.3 Classes of baseline cost estimates.

Often, what are erroneously termed "cost overruns" result from comparing the actual cost of

developing a system against cost estimates made before either the system was fully defined or the number to be procured was established.

The term "cost growth" refers to the increase in an estimate. When it occurs the bases of the current and previous estimates must be carefully examined. Cost changes resulting from such causes as system design change, inflation, etc. should be called cost growth, rather than "cost overruns." A cost overrun results when the incurred cost of a program exceeds the target cost.

F4.4.3.4 Standard weapon system costs. Confusion frequently results from the release of cost estimates of weapon systems that were based on different cost elements. To eliminate this confusion, standard definitions are used for "Flyaway Cost," "Weapon System Cost," "Procurement Cost" and "Program Acquisition Cost" (see C8).

F4.4.3.5 Navy Headquarters Programming System/Navy Headquarters Budget System. The Navy Headquarters Programming System/Navy Headquarters Budget System (NHPS/NHBS) is essentially a data bank to provide and display Navy program and cost information in a variety of reports. Data are expressed either in appropriation structure or in DOD programming structure, using computerized data processing.

Ref.: NAVCOMPT Instruction 7102.2

F4.4.3.6 Life Cycle Cost (LCC). Life cycle cost is the total cost to the government for a system's development, acquisition, operation and logistic support over a defined life span. Life cycle cost estimates are part of economic analysis, and thus are required for all major programs (see discussion of economic analysis in paragraph F4.4.1).

F4.4.4 Incremental Acquisition Strategy. Even with the ultimate ability to project true program cost, there still is great uncertainty associated with the technical performance, i.e., what can be achieved, how long it will take, how much it will cost and what will be the value of resulting operational capabilities. Thus, it is policy to pursue development programs through an incremental strategy under which program decisions on further work are made on the basis of successfully passing Milestones. Programs are structured and resources allocated so that demonstration of achievement objectives is the pacing function. Further, as the advancing program yields improved information, practical tradeoffs are made between system capability, cost and schedule.

A demonstration milestone funding strategy, also sometimes required by Congress, requires submission of the latest test results along with requests for funds for procurement of weapons.

F4.4.5 Cost Measurement and Reporting. As programs unfold, costs are collected and cost information is reported to various monitors and decision makers. For selected major programs, one primary report is the SAR (Selected Acquisition Report). The SAR is designed for the Office of the Secretary of Defense, and for OSD to furnish information to the Congress and the GAO.

SARs include past information on costs, schedule and technical achievements, and "current estimates" of the system's operational/technical characteristics, as well as when it is likely to be available and its probable cost.

SARs are submitted annually with the President's Budget and quarterly if (1) a total program increases or decreases by 5%, (2) a schedule slips by six months, or (3) a major Milestone decision occurs.

Other cost measurement and reports are discussed in Chapter 6 (6.7.4).

F5 MILESTONES FOR SHIP PROGRAMS

RD&A programs for systems acquisition progress through a series of decision milestones, which are described in detail in Chapters 1 and 2. Ship building/acquisition programs have traditionally some unique applications of the terminology. Shipbuilding program Milestone II

is the decision for low-rate initial production for naval vessels and contract award for detail design and construction of the lead ship. Milestone III is the decision for Full-Rate Production. In many instances, this may occur after contracts for the entire class of ships have been awarded,, due to the long time required from ship award until a full Operational Evaluation can be completed.

Appendix G
RESEARCH, DEVELOPMENT AND ACQUISITION
LABORATORIES AND CENTERS
AND TEST AND EVALUATION ACTIVITIES

TABLE OF CONTENTS

G1	Role of the In-House Research, Development and Acquisition Laboratories/Centers	G-1
G2	Recent Developments	G-2
G3	CNR Laboratory (DON Corporate Laboratory)	G-4
G3.1	Naval Research Laboratory (NRL)	G-4
G4	COMNAVAIR Activities	G-4
G4.1	Naval Air Warfare Center (NAWC)	G-4
G4.1.1	Naval Air Warfare Center Aircraft Division (NAWCAD)	G-5
G4.1.2	Naval Air Warfare Center Weapons Division (NAWCWPNS)	G-6
G5	COMSPAWAR Activities	G-7
G5.1	Naval Command, Control and Ocean Surveillance Center (NCCOSC)	G-7
G5.1.1	Naval Command, Control and Ocean Surveillance Center, RDT&E Division, San Diego	G-7
G5.1.2	Naval Command, Control and Ocean Surveillance Center West Coast ISE Division (NISE WEST)	G-8
G5.1.3	Naval Electronic Systems Engineering Center, Portsmouth (NESEC, Portsmouth)	G-8
G5.1.4	Naval Electronic Systems Engineering Center, Charleston (NESEC, Charleston)	G-8
G5.1.5	Naval Electronic Systems Engineering Activity, St. Inigoes (NESEA, St. Inigoes)	G-8
G5.1.6	Naval Electronic Systems Security Engineering Center, Washington, DC (NESSEC, Washington, DC)	G-9
G6	COMNAVSEA Activities	G-9
G6.1	Naval Surface Warfare Center (NSWC)	G-9
G6.1.1	NSWC Carderock Division	G-9
G6.1.2	NSWC, Crane Division	G-11
G6.1.3	NSWC, Dahlgren Division	G-11
G6.1.4	NSWC Indian Head, Division	G-11
G6.1.5	NSWC Port Hueneme Division	G-12

G6.2	Naval Undersea Warfare Center (NUWC)	G-12
G6.2.1	Naval Undersea Warfare Center Division, Keyport	G-12
G6.2.2	Naval Undersea Warfare Center Division, Newport	G-13
G6.3	Naval Explosive Ordnance Disposal Technology Center (NAVEODTECHCEN)	G-14
G7	CHBUMED Laboratories	G-14
G7.1	Naval Medical Research Development Command (NMRDC)	G-14
G7.1.1	Naval Medical Research Institute (NMRI)	G-14
G7.1.2	Naval Submarine Medical Research Laboratory (NSMRL)	G-14
G7.1.3	Naval Medical Research Unit No. 2	G-14
G7.1.4	Naval Medical Research Unit No. 3	G-14
G7.1.5	Naval Health Research Center (NHRC)	G-14
G7.1.6	Naval Dental Research Institute (NDRI)	G-15
G7.1.7	Naval Aerospace Medical Research Laboratory (NAMRL)	G-15
G7.1.8	Naval Biodynamics Laboratory (NBDL)	G-15
G8	COMNAVFAC Laboratory	G-15
G8.1	Naval Civil Engineering Laboratory (NCEL)	G-15
G9	COMNAVSUP Laboratory	G-15
G9.1	Navy Clothing and Textile Research Facility (NCTRF)	G-15
G10	CHBUPERS Laboratory	G-15
G10.1	Navy Personnel Research and Development Center (NPRDC)	G-15
G11	Not-for-Profit Activities Supporting Naval R&D	G-16
G11.1	Marine Physical Laboratory, Scripps Institution of Oceanography	G-16
G11.2	Applied Research Laboratory, Pennsylvania State University	G-16
G11.3	Applied Research Laboratories, The University of Texas at Austin	G-16
G11.4	Applied Physics Laboratory, The University of Washington	G-16
G11.5	Johns Hopkins Applied Physics Laboratory	G-16
G11.6	Center for Naval Analyses (CNA)	G-17
G12	T&E Activities Reporting to CNO	G-17
G12.1	Board of Inspection and Survey	G-17
G12.1.1	General Responsibilities	G-17
G12.1.2	Organization	G-17
G12.2	Operational Test and Evaluation Force (OPTEVFOR)	G-17
G12.2.1	Missions and Tasks	G-17
G12.2.2	OPTEVFOR Organization	G-18
G12.2.3	OPTEVFOR Subordinate Commands	G-18
G12.2.3.1	Air Test and Evaluation Squadron One (VX-1)	G-18
G12.2.3.2	Air Test and Evaluation Squadron Four (VX-4)	G-18
G12.2.3.3	Air Test and Evaluation Squadron Five (VX-5)	G-19

G12.3 Atlantic Fleet Weapons Training Facility	G-19
G13 T&E Activities Reporting to Commandant Marine Corps	G-19
G13.1 Marine Corps Systems Command (MARCORSYSCOM)	G-19
G13.2 Marine Corps Operational Testing and Evaluation Activity (MCOTEA)	G-19
G14 Major Range and Test Facility Base (MRTFB)	G-20

APPENDIX G
RESEARCH, DEVELOPMENT AND ACQUISITION
LABORATORIES AND CENTERS
AND TEST AND EVALUATION ACTIVITIES

The Navy's extensive in-house laboratory complex provides an important portion of its research and development competence. This complex is woven deeply into the Navy's heritage. For example, the Naval Undersea Warfare Center evolved from the Newport Naval Torpedo Station, founded in 1869. The roots of the Naval Surface Weapons Center, Carderock Division were the Experimental Model Basin (1899) and Engineering Experiment Station (1905). The Naval Research Laboratory, the first Navy laboratory devoted primarily to basic research in the military sciences, was an outgrowth of recommendations of the Naval Consulting Board of World War I, headed by Thomas A. Edison.

**G1 ROLE OF THE IN-HOUSE
RESEARCH, DEVELOPMENT
AND ACQUISITION LABORATORIES
/CENTERS**

The basic purpose of the Navy's in-house laboratories—and of all other Navy RDT&E effort—is to assure that the Nation has the best, most up-to-date, capable, and effective Fleet and Marine Corps forces which modern technology can provide for the resources available.

To fulfill their obligation to the Fleet and further enhance their overall value to the Navy, the laboratories/centers must not only be on-going producers of science and technology, but they must also be thoroughly alert to the present and future operational requirements of the Fleet. To satisfy this requirement, it is mandatory that first, the laboratories understand the operational problems of the Fleet, potential threats, and the capabilities and limitations of its personnel and its organi-

zation; and, secondly, the activities be so placed and so used that they have an important voice in systems decisions and planning.

Over the years the Navy has succeeded in building up laboratories of high quality and demonstrable effectiveness. Moreover, the Navy has been fortunate in recruiting and retaining within these laboratories/centers first-rate scientists and engineers who have developed extensive knowledge and understanding of naval problems. In trying out new ideas, scientists have often joined the operating forces to work side by side with military personnel. Many projects which have led to improved weapons and operating equipment were inspired and made practical by such close contact with Fleet units.

It is the policy of the Navy to develop and maintain Navy research and development laboratories/centers of acknowledged excellence in those fields of science and technology pertinent to its needs in order to:

- Develop and prosecute scientific and technical laboratory programs having as their prime objective the improvement of Navy and Marine Corps capabilities, equipments, and systems.
- Maintain a sufficient base of scientific and engineering talent, experienced in Navy and Marine Corps matters, to preclude the possibility of "technological surprise" due to unforeseen applications of science and technology by potential enemies.
- Enable the Navy to enter the marketplace in the acquisition of new weapons and weapon systems as sophisticated buyers, with technical experience and expertise in

the disciplines relevant to the development of such systems.

- Maintain a technical memory of past technical problems and their solutions to assist in the support of deployed equipment and its improvement while in service.
- Have continuously available the capability to exploit new technical opportunities on a quick reaction basis, often under tight security controls, for the solution of Navy and Marine Corps problems.

ASN(RD&A) is responsible for all matters related to RD&A within the DON.

G2 RECENT DEVELOPMENTS

On 2 January 1992, the most significant realignment since 1966 of Navy field activities engaged in research, development and systems acquisition occurred. In 1989 guidance to Secretary of Defense Cheney, the President asked that a plan be developed to accomplish full implementation of the Packard Commission

Report and the Goldwater-Nichols DOD Reorganization Act of 1986. The result was the Defense Management Report (DMR), which was followed by issuance by the DOD Comptroller of Defense Management Report Decisions (DMRDs). DMRD 922 proposed savings in the FY91-FY95 budgets by consolidating R&D and T&E activities to reduce overhead, streamline operations, and centralize professional staff associated with specific technology areas.

In the DON, under the Assistant Secretary of the Navy (Research, Development and Acquisition) (ASN(RD&A)), a concept was developed which would organizationally combine 36 field activities, including laboratories, T&E activities, and in-service engineering centers to form four large Centers and a strengthened corporate laboratory structure. Three Centers' missions address, respectively, air, sea, and undersea warfare; the fourth is focused on command, control, and ocean surveillance. The Warfare Centers are placed under the Systems Commands with whose missions they are aligned (see Exhibit G-1). This places the Naval Air

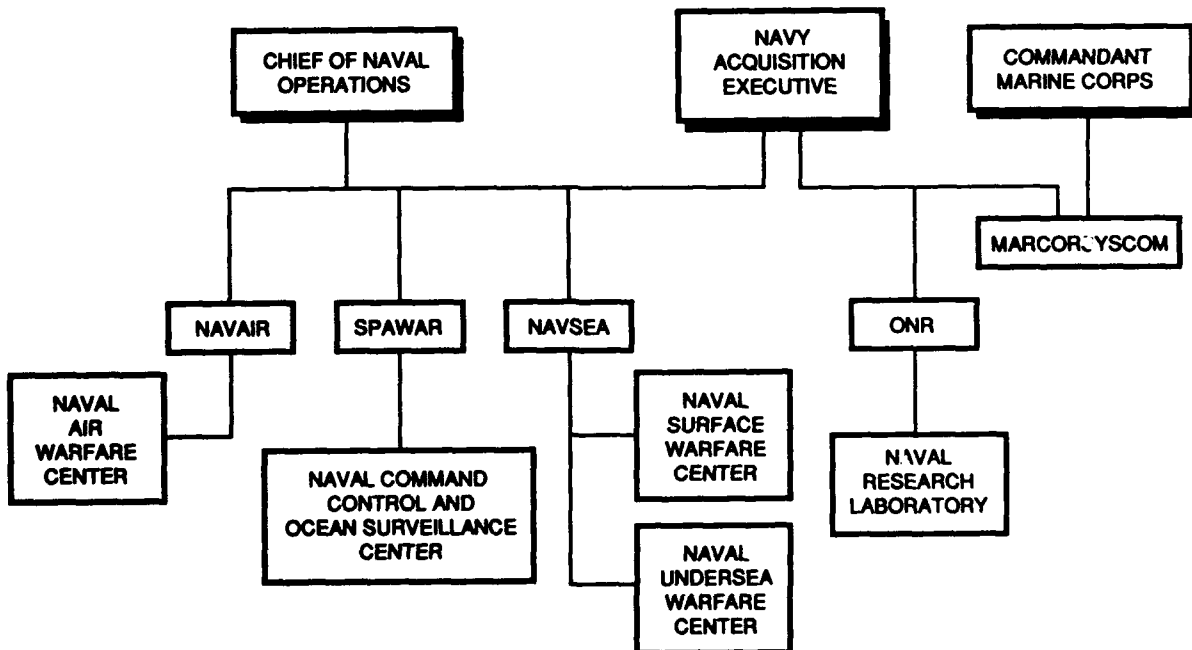

Exhibit G-1. Warfare Centers/Laboratory

Warfare Center (NAWC) under Naval Air Systems Command (see G4), the Naval Command, Control, and Ocean Surveillance Center (NCCOSC) under the Space and Naval Warfare Systems Command (see G5), and the Surface Warfare Center (NSWC) and Naval Undersea Warfare Center (NUWC) under Naval Sea Systems Command (see G6). The Naval Research Laboratory (NRL) continues to report to the Office of Naval Research (see G3). The position of Director of Naval Laboratories was disestablished.

Initial establishment of the Warfare Centers and implementation of the realignments associated with the Naval Research Laboratory were effective on 2 January 1992. Final implementation of the Warfare Center plan is scheduled to be completed by the close of FY97. A central objective of this reorganization is to realign workload consistent with the respective missions and leadership areas of the new Warfare Centers. Realization of this objective requires a redistribution of work assignments and supporting resources among the Centers, closure of some activities, and downsizing of others, all of which is ongoing on a high priority basis. When these major alterations to the Navy's longstanding RDT&E and engineering field infrastructure are finally in place, the objectives of the DMR in this area will have been achieved and the Navy will have a more sharply focused research, development, and acquisition support in-house capability which will readily accommodate fluctuations in the Navy's budget over the foreseeable future.

Oversight of the activities of the Warfare Centers and Naval Research Laboratory is accomplished through two newly formed committees. The Navy Laboratory/Center Coordinating Group (NLCCG) (see E9.12) was chartered by ASN(RD&A) to "address cross-center/laboratory operations and investment issues, potential unwarranted duplication, and inter-command cooperation. The NLCCG will resolve issues within its collective authorities and identify issues for the Assistant Secretary of the Navy (Research, Development and Acquisition)

(ASN(RD&A)) through the Navy Laboratory/Center Oversight Council (NLCOC)." NLCCG membership includes the Commanders and Technical Directors of the Warfare Centers and the Commanding Officer and Director of Research of the Naval Research Laboratory. The NLCOC (see E9.13), chartered by the Secretary of the Navy, is charged with providing "corporate oversight of the Department of the Navy RDT&E, engineering and Fleet support communities contained in the Warfare Centers and Laboratory. The Council will ensure strong advocacy of and commitment to providing an environment for improving productivity and effectiveness exists at the highest levels in the Navy." The ASN(RD&A) serves as the NLCOC Chairman. Other core members include the Vice Chief of Naval Operations and the Assistant Commandant of the Marine Corps. Members at large include the Commanders of the Systems Commands; Chief of Naval Research; Commander, Marine Corps System Command; Assistant Secretary of the Navy (Financial Management); Assistant Secretary of the Navy (Manpower and Reserve Affairs); Assistant Secretary of the Navy (Installations and Environment); DON General Counsel; and the Director of Navy Test and Evaluation and Technology Requirements (N091).

The Navy's biomedical laboratories remain under the Naval Medical Research and Development Command. All medical research conducted by the Services is coordinated by the DOD Armed Services Biomedical Research, Evaluation, and Management Committee. A realignment and reorganization similar to that described above is occurring in the medical research community, transferring responsibilities and resources among the Services to achieve the same goals of focused and efficient research.

SECNAV Instruction 5400.16

G3

G3 CNR LABORATORY (DON Corporate Laboratory)

G3.1 Naval Research Laboratory (NRL) (see Exhibit G-2).

Location: Washington, D.C. 20375-5320

Telephone:

Commercial: 202-767-3200

DSN: 297-3200

Mission: To operate the Navy's full spectrum corporate laboratory to conduct a broadly based multidisciplinary program of scientific research and advanced technological development directed toward maritime applications of new and improved materials, techniques, equipment, systems and ocean, atmospheric, and space sciences and related technologies.

Other Sites:

Naval Research Laboratory
(formerly Naval Oceanographic
and Atmospheric Research Laboratory)

Location: Stennis Space Center
Bay St. Louis, MS 39529-5004

Telephone:

Commercial: 601-688-4010

DSN: 485-4010

Naval Research Laboratory
(formerly Naval Environmental
Prediction Research Facility)

Location: Monterey, CA 93943-5006

Telephone:

Commercial: 408-647-4731

DSN: 878-4731

Naval Research Laboratory

Location: P.O.Box 8337

Orlando, FL 32856-8337

Telephone:

Commercial: 407-857-5230

G4 COMNAVAIR ACTIVITIES

G4.1 Naval Air Warfare Center (NAWC) (see Exhibit G-3).

Location: Washington, DC 20361-6000

Telephone:

Commercial: 703-746-7730

DSN: 286-7730

Mission: To be the Navy's full spectrum research, development, test and evaluation, engineering, and Fleet support center for air platforms, autonomous air vehicles, missiles and missile subsystems, weapons systems associated with air warfare, and for sensor systems used to conduct antisubmarine warfare from air platforms. To manage the Naval Element of the major Range and Test Facility Base for N913 (see 7.3.5).

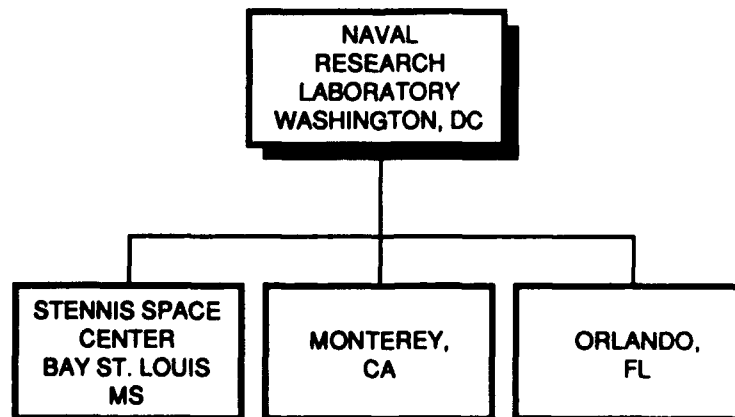

Exhibit G-2 — Naval Research Laboratory

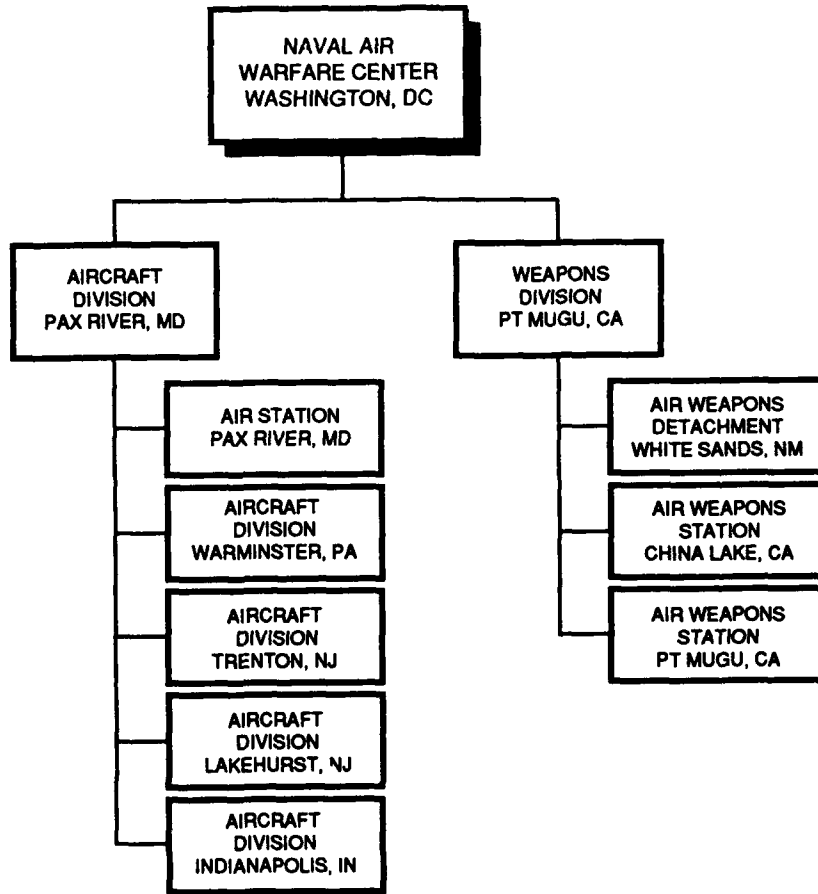

Exhibit G-3 — Naval Air Warfare Center

G4.1.1 Naval Air Warfare Center Aircraft Division (NAWCAD).

Location: Patuxent River, MD
20670-5304

Telephone:
Commercial: 301-863-1108
DSN: 326-1108

Field Sites:

Location: NAWCAD
Indianapolis, IN 46219-2189

Telephone:
Commercial: 317-353-7001
DSN: 369-7001

Location: NAWCAD

Lakehurst, NJ 08733-5000
Telephone:
Commercial: 908-323-2380
DSN: 624-2380

Location: NAWCAD
Trenton, NJ 08628-0176
Telephone:
Commercial: 609-538-6602
DSN: N/A

Location: NAWCAD
Warminster, PA 18974-5000
Telephone:
Commercial: 215-441-2235
DSN: 441-2235

Location: NAWCAD

G4.1.2

Patuxent River, MD 20670

Telephone:

Commercial: 301-863-1020

DSN: 326-1020

Mission: To be the Navy's principal research, development, test, evaluation, engineering, and Fleet support activity for Naval aircraft, engines, avionics, aircraft support systems, and ship/shore/air operations. This mission includes: research and development of manned and unmanned air vehicles, air vehicle propulsion systems, core and mission-unique avionics including air ASW systems, airborne surveillance systems, aircraft launch and recovery systems, aviation support equipment, and related functions such as aircraft modeling and analysis and aircraft active and passive signatures; systems integration of all air platform subsystems; conduct of test and evaluation for these same aircraft, propulsion, avionics, and support systems, as well as aircraft electronics warfare throughout the spectrum of the life cycle to ensure successful operational performance; maintain aircraft test and evaluation ranges; assure an effective transition to production, including manufacturing production support and pilot/emergency production, to maintain a responsive industrial base; and perform in-service engineering of aircraft, avionics, and launch/recovery systems.

G4.1.2 Naval Air Warfare Center Weapons Division (NAWCWPNS).

Location: Point Mugu, CA 93042-5000
and China Lake, CA 93555-6001

Telephone (Point Mugu):

Commercial: 805-989-7113

DSN: 351-7113

Telephone: (China Lake)

Commercial: 619-939-2201

DSN: 437-2201

Field Sites:

Naval Air Weapons Station

Location: Point Mugu, CA 93042-5000

Telephone:

Commercial: 805-989-7903

DSN: 351-7903

Naval Air Weapons Station

Location: China Lake, CA 93555-6001

Telephone:

Commercial: 619-939-2211

DSN: 437-2211

NAWCWPNS Detachment

Location: White Sands, NM 88002-5510

Telephone:

Commercial: 505-678-2101

DSN: 258-2101

Mission: To conduct research, design, development, test and evaluation of air weapons and associated aircraft systems into strike, anti-surface warfare (ASUW), and anti-air warfare (AAW) aircraft. To conduct research, design, development, test and evaluation of tactical missiles for any navy platform. To operate, maintain, and improve the Naval Western Test Range Complex (NWTRC) air, land, and sea test ranges for weapons and weapons systems testing and evaluation. To provide development and operation of aerial and surface targets. To provide production support, in-service engineering support, and production improvement for air weapons systems and tactical missiles. To provide development and test, and continuing support of electronic combat systems and electronic devices for airborne electronic warfare. To complete studies of naval warfare systems for strike, ASUW, AAW, and other warfare areas. To provide support to Navy nuclear weapons programs. To insure continued promotion and maintenance of fundamental research and the

technology base to support the above mission areas.

and ocean surveillance and the integration of those systems which overarch multiplatforms.

G5 COMSPAWAR ACTIVITIES

G5.1 Naval Command, Control and Ocean Surveillance Center (NCCOSC) (see Exhibit G-4).

Location: San Diego, CA 92147-5042

Telephone:

Commercial: 619-553-0170

DSN: 553-0170

Mission: To be the Navy's full spectrum research, development, test and evaluation, engineering, and Fleet support center for command, control and communication systems

G5.1.1 Naval Command, Control and Ocean Surveillance Center, RDT&E Division, San Diego

Location: San Diego, CA 92152-5000

Telephone:

Commercial: 619-553-3000

DSN: 553-3000

Field Sites:

NCCOSC RDT&E Division Detachment,
Kailua

Location: P.O. Box 997

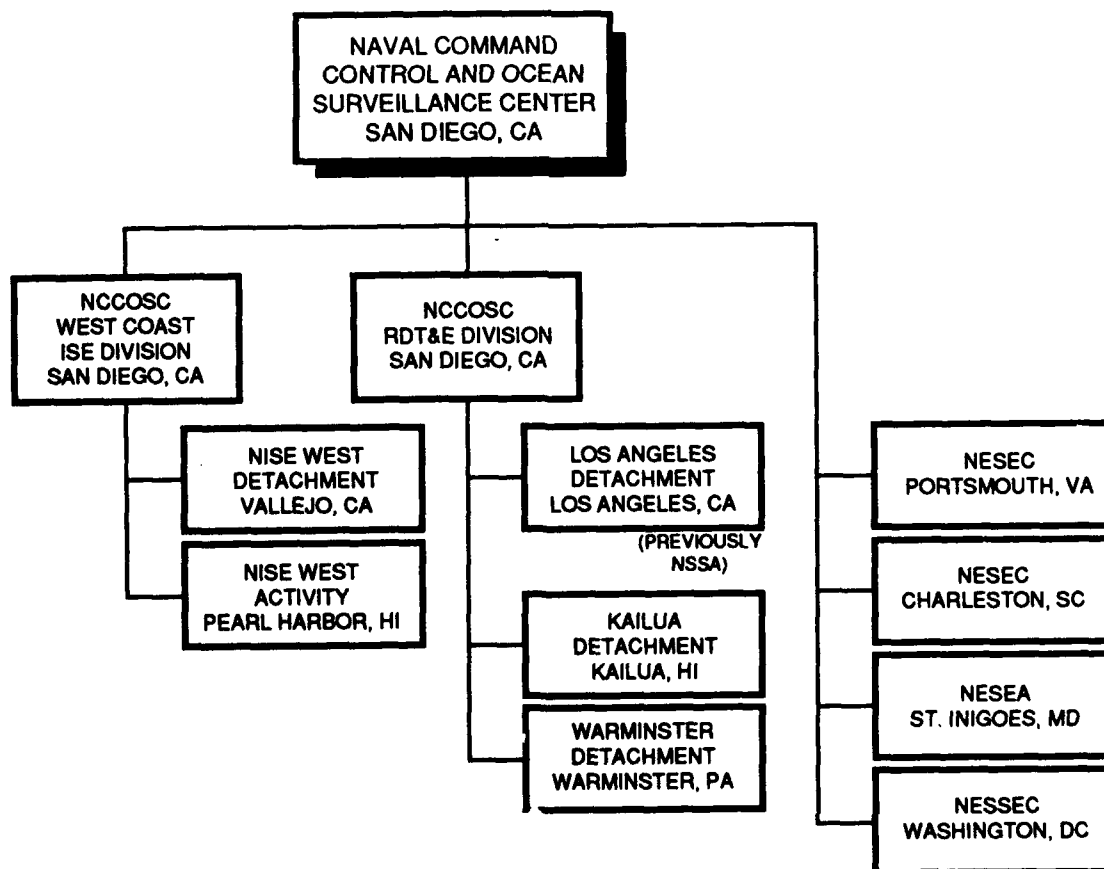

Exhibit G-4 — Naval Command, Control and Ocean Surveillance Center

G5.1.2

Kailua, HI 96734-0997

Telephone:

Commercial: 808-257-5244
DSN: 225-9801 (switchboard)
then 457-5243

NCCOSC RDT&E Division Detachment,
Los Angeles

Location: Los Angeles, CA 90009-2960

Telephone:

Commercial: 310-363-1824
DSN: 833-1824

NCCOSC RDT&E Division Detachment,
Warminster

Location: Warminster, PA 18974-5000

Telephone:

Commercial: 215-441-2350
DSN: 441-2350

Mission: To be the Navy's research, development, test and evaluation center for command, control, and communication systems and ocean surveillance and the integration of those systems which overarch multiplatforms.

G5.1.2 Naval Command, Control and Ocean Surveillance Center West Coast ISE Division (NISE WEST). (Note: ISE = in-service engineering.)

Location: San Diego, CA 92138-3288

Telephone:

Commercial: 619-524-2000
DSN: 524-2000

Field Sites:

NISC West Detachment Center, Vallejo

Location: Vallejo, CA 94592-5017

Telephone:

Commercial: 707-646-8631
DSN: 253-5403

NISE West Activity, Pearl Harbor

Location: Pearl Harbor, HI 96860

Telephone:

Commercial: 808-474-9279
DSN: 695-9801

Mission: To be the Navy's engineering and Fleet support center for assigned command, control and communication systems and ocean surveillance and the integration of those systems which overarch multiplatforms.

G5.1.3 Naval Electronic Systems Engineering Center, Portsmouth (NESEC, Portsmouth).

Location: Portsmouth, VA 23705-0055

Telephone:

Commercial: 804-396-3131
DSN: 961-3131

Mission: To provide electronics material support for systems and equipment for which the Naval Command, Control, and Ocean Surveillance Center is assigned responsibility, and to perform such other functions as may be directed by the Commander, Naval Command, Control, and Ocean Surveillance Center.

G5.1.4 Naval Electronic Systems Engineering Center, Charleston (NESEC, Charleston)

Location: Charleston, SC 29418-6504

Telephone:

Commercial: 803-745-4900
DSN: 563-2030

Mission: To provide electronics material support for systems and equipment for which the Naval Command, Control, and Ocean Surveillance Center is assigned responsibility, and to perform such other functions as may be directed by the Commander, Naval Command, Control, and Ocean Surveillance Center.

G5.1.5 Naval Electronic Systems Engineering Activity, St. Inigoes (NESEA, St. Inigoes).

Location: St. Inigoes, MD 20684-0010

Telephone:

Commercial: 301-862-8004

DSN: 326-3512, X8004

Mission: To provide electronics material support for systems and equipment for which the Naval Command, Control, and Ocean Surveillance Center is assigned responsibility; and to perform such other functions as may be directed by the Commander, Naval Command, Control, and Ocean Surveillance Center.

G5.1.6 Naval Electronic Systems Security Engineering Center, Washington, DC (NESSEC, Washington, DC).

Location: Washington, DC 20393-5270**Telephone:**

Commercial: 202-282-0609

DSN: 292-0609

Mission: To provide engineering support and technical services on cryptographic, cryptologic, and signal security systems and equipment; to provide life-cycle electronic material support for systems and equipment under the cognizance of the Naval Command, Control, and Ocean Surveillance Center; and to perform such other functions as may be directed by the Commander, Naval Command, Control, and Ocean Surveillance Center.

G6 COMNAVSEA ACTIVITIES

G6.1 Naval Surface Warfare Center (NSWC) (see Exhibit G-5).

Location: Washington, DC 20362-5160**Telephone:**

Commercial: 703-602-0632

DSN: 332-0632

Mission: To operate the Navy's full spectrum research, development, test and evaluation, engineering, and Fleet support center for ship hull, mechanical, and electrical systems, surface ship combat systems, coastal warfare systems, and other offensive and defensive systems associated with surface warfare.

G6.1.1 NSWC, Carderock Division.

Location: Bethesda, MD 20084-5000**Telephone:**

Commercial: 301-227-1628

DSN: 287-1628

Field Sites:

NSWC Carderock Division Detachment,
Bayview

Location: Bayview, ID 83803-0129**Telephone:**

Commercial: 208-683-2321

NSWC Carderock Division Detachment,
Annapolis

Location: Annapolis, MD 21402-1198**Telephone:**

Commercial: 410-267-2536

DSN: 281-2536

NSWC Carderock Division Detachment,
Bremerton

Location: Bremerton, WA 98314-5215**Telephone:**

Commercial: 206-476-4335

DSN: 439-4335

Naval Ship Systems Engineering Station,
Carderock Division, NSWC

Location: Philadelphia, PA 19112-5083**Telephone:**

Commercial: 215-897-7005

DSN: 443-7005

NSWC Carderock Division Detachment,
Memphis

Location: Memphis, TN 38113-0428**Telephone:**

Commercial: 901-947-3117

Mission: To provide research, development, test and evaluation, Fleet support, and in-service engineering for surface and undersea vehicle hull, mechanical and electrical systems, and propulsors; provide logistics R&D; and to provide support to

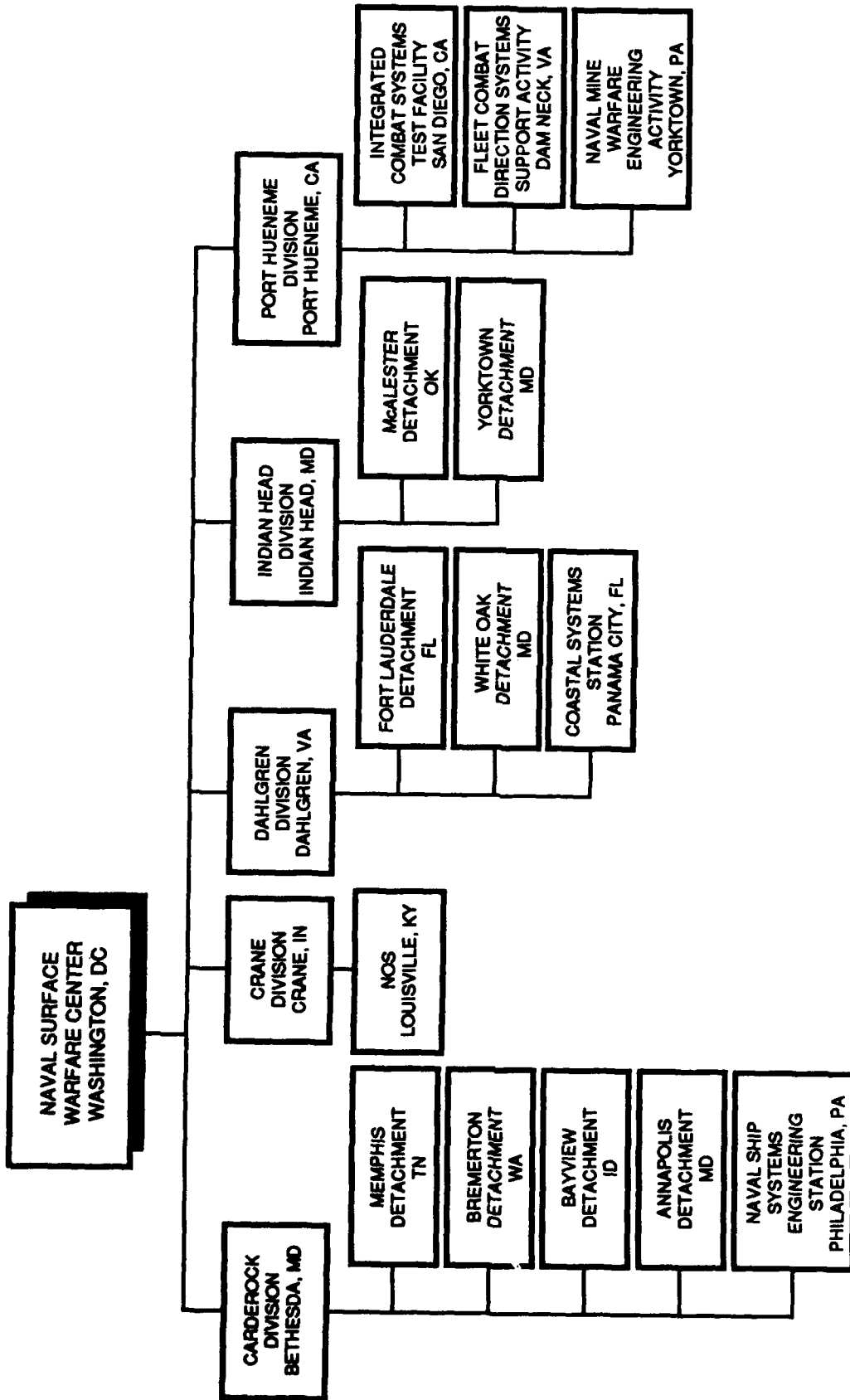

Exhibit G-5 — Naval Surface Warfare Center

the Maritime Administration and the maritime industry. To execute other responsibilities as assigned by the Commander, Naval Surface Warfare Center.

G6.1.2 NSWC, Crane Division.

Location: Crane, IN 47522-5000

Telephone:

Commercial: 812-854-3666

DSN: 482-3666

Field Site:

Naval Ordnance Station, Crane Division,
NSWC

Location: Louisville, KY 40214-5001

Telephone:

Commercial: 502-364-5211

DSN: 989-5211

Mission: To provide engineering and industrial base support of weapon systems, subsystems, equipments, and components with principal emphasis on industrial and product engineering associated with surface warfare systems in the areas of electronics, ordnance, pyrotechnics, gun systems, microwave technology, small arms, and surface ship electronic warfare in-service engineering. To execute other responsibilities as assigned by the Commander, Naval Surface Warfare Center.

G6.1.3 NSWC, Dahlgren Division.

Location: Dahlgren, VA 22448-5000

Telephone:

Commercial: 703-663-8531

DSN: 249-8531

Field Sites:

NSWC Dahlgren Division Detachment,
Fort Lauderdale

Location: Fort Lauderdale, FL
33315-3528

Telephone:

Commercial: 305-359-7228

DSN: 483-7228

NSWC Dahlgren Division Detachment,
White Oak

Location: Silver Spring, MD 20903-5000

Telephone:

Commercial: 301-394-1796

DSN: 290-1796

Coastal Systems Station, Dahlgren
Division, NSWC

Location: Panama City, FL 32407-5000

Telephone:

Commercial: 904-234-4201

DSN: 436-4201

Mission: To provide research, development, test and evaluation, engineering, and fleet support for surface warfare systems, surface ship combat systems, ordnance, mines, amphibious warfare systems, mine countermeasures, special warfare systems, and strategic systems. To execute other responsibilities as assigned by the Commander, Naval Surface Warfare Center.

G6.1.4 NSWC Indian Head Division.

Location: Indian Head, MD 20640-5035

Telephone:

Commercial: 301-743-4276

DSN: 354-4276

Field Sites:

NSWC Indian Head Division Detachment,
McAlester

Location: McAlester, OK 74501-5190

Telephone:

Commercial: 918-421-2582

DSN: 956-6582

NSWC Indian Head Division Detachment,
Yorktown

G6.1.5

Location: Yorktown, VA 23691-5110

Telephone:

Commercial: 804-887-4762

DSN: 953-4762

Mission: To provide primary technical capability in Energetics for all Warfare Centers through engineering, Fleet and operational support, manufacturing technology, limited production, industrial base support, and secondary technical capability through research, development, test, and evaluation for energetic materials, ordnance devices and components, and related ordnance engineering standards to include chemicals, propellants and their propulsion systems, explosives, pyrotechnics, warheads, and simulators. To provide support including special weapons support, explosive safety and ordnance environmental support to all Warfare Centers, Military Departments and the ordnance industry. To execute other responsibilities as assigned by Commander, Naval Surface Warfare Center.

G6.1.5 NSWC Port Hueneme Division.

Location: Port Hueneme, CA 93043-4307

Telephone:

Commercial: 805-982-8242

DSN: 551-8242

Field Sites:

Integrated Combat Systems Test Facility,
Port Hueneme Division, NSWC

Location: San Diego, CA 92152-6900

Telephone:

Commercial: 619-553-3146

DSN: 553-3146

Fleet Combat Direction Systems Support
Activity, Dam Neck, NSWC,
Port Hueneme Division

Location: Virginia Beach, VA
23461-5300

Telephone:

Commercial: 804-433-6311

DSN: 433-6311

Naval Mine Warfare Engineering Activity,
NSWC, Port Hueneme Division

Location: Yorktown, VA 23691-5076

Telephone:

Commercial: 804-888-3602

DSN: 953-3602

Mission: To provide test and evaluation, in-service engineering, and integrated logistic support for surface and mine warfare combat systems, system interface, weapons systems and subsystems, unique equipments, and related expendable ordnance of the Navy surface Fleet. To execute other responsibilities as assigned by the Commander, Naval Surface Warfare Center.

G6.2 Naval Undersea Warfare Center (NUWC) (see Exhibit G-6)

Location: Newport, RI 02841-1708

Telephone:

Commercial: 401-841-6761

DSN: 948-6761

Mission: To operate the Navy's full spectrum research, development, test and evaluation, engineering and Fleet support center for submarines, autonomous underwater systems, and offensive and defensive weapons systems associated with undersea warfare.

G6.2.1 Naval Undersea Warfare Center Division, Keyport.

Location: Keyport, WA 98345-0580

Telephone:

Commercial: 206-396-2345

DSN: 744-2345

Mission: To support the mission of the Naval Undersea Warfare Center by providing test and evaluation, in-service engineering, maintenance and repair, Fleet, support, and industrial base support for undersea warfare systems, undersea weapon systems, countermeasures and sonar systems. To execute other responsibilities as

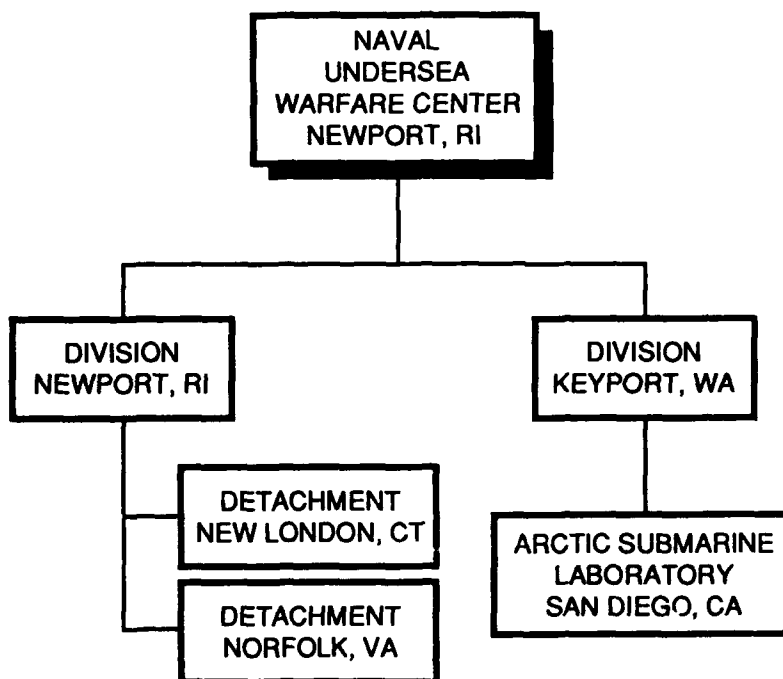

Exhibit G-6 — Naval Undersea Warfare Center

assigned by the Commander, Naval Undersea Warfare Center.

Field Site:

Arctic Submarine Laboratory

Location: San Diego, CA 72152-5000

Telephone:

Commercial: 619-553-7441

DSN: 553-0190

G6.2.2 Naval Undersea Warfare Center Division, Newport.

Location: Newport, RI 02841-5047

Telephone:

Commercial: 401-841-3344

DSN: 948-3344

Mission: To support the mission of the Naval Undersea Warfare Center by providing research, development, test and evaluation, engineering, and Fleet support for submarines, autonomous underwater systems, undersea offensive and

defensive weapon systems and countermeasures associated with undersea warfare. To execute other responsibilities as assigned by the Commander, Naval Undersea Warfare Center.

Field Sites:

NUWC Detachment, New London

Location: New London, CT

06320-5594

Telephone:

Commercial: 203-440-4313

DSN: 636-4313

NUWC Detachment, Norfolk

Location: Norfolk, VA 23511-5698

Telephone:

Commercial: 804-444-9101

DSN: 564-9101

NUWC Detachment, Atlantic Undersea Test and Evaluation Center (AUTEC)

G6.3

Location: West Palm Beach, FL
33402-7517
Telephone:
Commercial: 407-832-8566, x7200
DSN: 483-7200

G6.3 Naval Explosive Ordnance Disposal Technology Center (NAVEODTECHCEN).

Location: Indian Head, MD 20640-5070
Telephone:
Commercial: 301-743-6803/6804
DSN: 364-6803/6804

Mission: To provide research and development and logistic support of specialized equipment, tools, techniques, and procedures required to support operational explosive ordnance disposal (EOD) units of all Services, worldwide, in the location, identification, render-safe, removal, exploitation, and/or disposal of surface and underwater explosive ordnance.

G7 CHBUMED LABORATORIES

G7.1 Naval Medical Research and Development Command (NMRDC)

Mission: To manage and coordinate the Navy Medical Department research, development, test, and evaluation program concerning the health, safety, and performance effectiveness of Navy and Marine Corps personnel.

G7.1.1 Naval Medical Research Institute (NMRI).

Location: National Naval Medical Center
Bethesda, MD 20889-5607
Telephone:
Commercial: 301-295-0021
DSN: 295-0021

Detachments in Dayton, Ohio, and
Lima, Peru.

Areas of Responsibility: To conduct basic and applied research and development concerned

with the health, safety, and efficiency of naval personnel.

G7.1.2 Naval Submarine Medical Research Laboratory (NSMRL).

Location: Naval Submarine Base
Groton, CT 06349-5900
Telephone:
Commercial: 203-449-3263
DSN: 241-3263

Areas of Responsibility: To conduct medical research and development on problems peculiar to shipboard, submarine, and diving medicine.

G7.1.3 Naval Medical Research Unit No. 2.

Location: Djakarta, Indonesia
Telephone:
62-21-420-7854
Mail Address: FPO AP 96520-5000

Detachments in Manila, Republic of
Phillippines.

Areas of Responsibility: To perform medical research on diseases of military importance that are endemic and epidemic in the Far East.

G7.1.4 Naval Medical Research Unit No. 3.

Location: Cairo, Egypt
Telephone:
20-2-284-1375
Mail Address: PSC 452 Box 5000
FPO AE 09835-0007

Areas of Responsibility: To perform medical research on diseases of military importance that are endemic and epidemic in the Middle East.

G7.1.5 Naval Health Research Center (NHRC).

Location: PO Box 85122
San Diego, CA 92138-5122
Telephone:
Commercial: 619-553-8400
DSN: 553-8400

Areas of Responsibility: To conduct research and development on the medical and psychological aspects of health and performance of naval service personnel.

G7.1.6 Naval Dental Research Institute (NDRI)

Location: Naval Base
Great Lakes, IL 60088-5259
Telephone:
Commercial: 708-688-4678
DSN: 792-4678

Detachments in Bethesda, Maryland, and
San Antonio, Texas.

Areas of Responsibility: To conduct research, development, test and evaluation on problems of dental and oral health in the Navy and Marine Corps population, and on problems of fleet and field dentistry.

G7.1.7 Naval Aerospace Medical Research Laboratory (NAMRL)

Location: Naval Air Station
Pensacola, FL 32508-5700
Telephone:
Commercial: 904-452-3286
DSN: 922-3286

Areas of Responsibility: To conduct research, development, test, and evaluation in aerospace medicine and related scientific areas applicable to aerospace systems.

G7.1.8 Naval Biodynamics Laboratory (NBDL).

Location: PO Box 29407
New Orleans, LA 70189-0407
Telephone:
Commercial: 504-257-3917
DSN: 485-2297

Areas of Responsibility: To conduct biomedical research on the effects of the mechanical forces encountered in ships and aircraft on naval personnel, establish human tolerance limits for these forces, and develop methods to protect personnel from such forces.

G8 COMNAVFAC LABORATORY**G8.1 Naval Civil Engineering Laboratory (NCEL).**

Location: 560 Laboratory Drive,
Port Hueneme, CA 93043-4328
Telephone:
Commercial: 805-982-4980
DSN: 551-4980

Mission: To provide innovative technology products and services required to improve the acquisition, operation, and maintenance of Navy shore and ocean facilities and to enhance the Seabees and the Marine Corps operational readiness capabilities. To conduct RDT&E, transfer technology, and provide specialized engineering services.

G9 COMNAVSUP LABORATORY**G9.1 Navy Clothing and Textile Research Facility (NCTRF).**

Location: PO Box 59
Natick, MA 01760-0001
Telephone:
Commercial: 508-651-4172
DSN: 256-4172

Mission: To conduct RDT&E and provide engineering support in clothing, textiles, and related fields associated with service clothing and environmental protective clothing.

G10 CHBUPERS LABORATORY**G10.1 Navy Personnel Research and Development Center (NPRDC).**

Location: San Diego, CA 92152-6800
Telephone:
Commercial: 619-553-7897
DSN: 553-7897

Mission: To conduct research and development to improve the performance of

G11

individuals, teams, and organizations within the Navy and Marine Corps. To provide products and services specifically directed at improving Department of the Navy personnel planning, testing, acquisition, selection, classification, training, utilization, motivation, organization, management, and other contemporary issues.

G11 NOT-FOR-PROFIT ACTIVITIES SUPPORTING NAVAL R&D

G11.1 Marine Physical Laboratory, Scripps Institution of Oceanography.

Location: San Diego, CA 92152

Telephone:

Commercial: 619-534-1803

DSN: 933-7259

Contractor: Scripps Institution of Oceanography, University of California.

Mission: To generate knowledge about the ocean and its boundaries and application of this knowledge to the solution of Navy undersea problems.

G11.2 Applied Research Laboratory, Pennsylvania State University.

Location: PO Box 30

State College, PA 16804

Telephone:

Commercial: 814-865-6343

Mission: To serve as a center of excellence in undersea science and technology; conduct basic and applied research, exploratory development, and advanced development in support of the Navy's undersea technology base and related mission areas: contribute to the educational objectives, research goals, and scholarly reputation of Penn State; and promote the transfer of advanced technology and training to the governmental and industrial sectors.

G11.3 Applied Research Laboratories, The University of Texas at Austin.

Location: PO Box 8029

Austin, TX 78701-8029

Telephone:

Commercial: 512-835-3200

Mission: To (1) conduct research, development, engineering, testing, evaluation, assessment, and technical field support to provide effective solutions to DOD problems; (2) contribute to fundamental scientific advances in acoustics, electromagnetics, and computer engineering; and (3) interpret and transition basic and applied research results from academia to Government Agencies and industry.

G11.4 Applied Physics Laboratory, The University of Washington.

Location: 1013 N.E. 40th Street

Seattle, WA 98105

Telephone:

Commercial: 206-543-1300

Mission: To conduct a university-based program of fundamental research, technology advancement, engineering, and education emphasizing naval applications of ocean science, ocean acoustics, and ocean engineering.

G11.5 Johns Hopkins University Applied Physics Laboratory.

Location: Johns Hopkins Road

Laurel, MD 20723-6099

Telephone:

Commercial: 301-953-5000

Mission: To provide essential engineering, research, development, and test and evaluation capabilities in support of programs to improve the efficiency and assure the availability of current and future Navy strategic and tactical forces; and to conduct related scientific and technical programs on behalf of other military and civilian agencies of the government.

G11.6 Center for Naval Analyses (CNA).

Location: 4401 Ford Avenue
 Alexandria, VA 22302-0268
Telephone:
 Commercial: 703-824-2000
 DSN: 289-2638

Mission: The primary mission of CNA is to provide the DON with an independent, authoritative source of applied research and analysis that is focused upon the major present and future needs and issues of the Navy and Marine Corps. CNA's continuing program of research is primarily concentrated along specific broad categories of study that address major DON issues. Other portions of the research program are devoted to the utilization of CNA headquarters professional staff to provide quick-response analytic support and the assignment of professional staff members as field representatives to various Navy, Marine Corps, and Unified and Specified Commanders.

G12 T&E ACTIVITIES REPORTING TO CNO**G12.1 Board of Inspection and Survey.**

OPNAV Instruction 5420.70

G12.1.1 General Responsibilities. The responsibilities of the Board of Inspection and Survey are set forth in Chapter 3, U.S. Navy Regulations, 1973. The following article covers the Board's T&E responsibilities:

0321. President Board of Inspection and Survey.

The President, of the Board of Inspection and Survey, assisted by such other officers and such permanent and semipermanent subboards as may be designated by the Secretary of the Navy, shall:

a. Conduct acceptance trials and inspections of all ships and service craft prior to acceptance for naval service.

b. Conduct acceptance trials and inspections on one or more aircraft of each type or model prior to final acceptance for naval service.

c. Examine at least once every three years, if practicable, each naval ship to determine its material condition and, if found unfit for continued service, report to higher authority.

d. Perform such inspections and trials of naval ships, service craft, and aircraft as may be directed by the Chief of Naval Operations.

G12.1.2 Organization. The work of the Board of Inspection and Survey is accomplished through several permanent and semipermanent groups; BIS, Washington, DC; Sub-BIS Aviation Board Atlantic, Norfolk, Virginia; Sub-BIS Pacific, San Diego, California; Sub-BIS Aviation Board, Patuxent River, Maryland; and semipermanent Boards at inactive ship maintenance facilities, naval districts, and various overseas locations. In addition, other sub-Boards may be convened as required by the President.

G12.2 Operational Test and Evaluation Force (OPTEVFOR).

OPNAV Instruction 5440.47

G12.2.1 Missions and Tasks.

Mission: It is the mission of OPTEVFOR to operationally test and evaluate specific weapon systems, ships, aircraft, and equipments, including procedures and tactics, where required; and, when directed by CNO, to assist development agencies in the accomplishment of necessary development test and evaluation.

Tasks:

1. Carry out assigned responsibilities as an independent test agency for required operational test and evaluation under the command of CNO

G12.2.2

and serve as principal advisor to the CNO for all Department of the Navy matters pertaining to operational test and evaluation.

2. Provide the results of operational test and evaluation to the Defense Acquisition Board (DAB) production decision review(s) and to other reviews as directed by CNO.

3. Conduct operational tests on weapon systems including ships, aircraft, and automated information systems.

4. Evaluate the operational effectiveness, suitability, and capability of tested weapon systems to meet the stated needs and performance criteria, reporting the results to CNO.

5. Develop tactics and procedures for the employment of specific weapon systems as directed by the CNO.

6. At times assist the various development agencies in the conduct of developmental test and evaluation including the coordination, scheduling, and conduct of Fleet services. Report results of such assists, including assessment of operational suitability and ability to meet specified needs, to the development agency and CNO.

7. Review the T&E planning for new weapon systems, reporting to the CNO on the adequacy of the plan to address and resolve critical issues.

8. Monitor and report on such other tests and evaluation efforts as are directed by the CNO.

9. Assist in the COEA process.

G12.2.2 OPTEVFOR Organization. The Operational Test and Evaluation Force, with headquarters at Norfolk, Virginia, is a fleet force under:

- The Chief of Naval Operations for technical control and budgetary program guidance in the field of development, test, and evaluation.
- CINCLANTFLT/CINCPACFLT for all operational matters under the purview of CINCLANT/CINCPAC.

At the Headquarters, the OPTEVFOR staff is organized along lines which give primary consideration to types of warfare and to project administration rather than along the lines of a standard Navy staff. Under this type of organization, evaluation of equipment or systems is carried out within staff divisions manned by personnel with experience peculiar to the type of warfare for which their division is named. Resource Sponsor for OPTEVFOR is N912.

G12.2.3 OPTEVFOR Subordinate Commands. The Operational Test and Evaluation Force comprises the following subordinate commands:

G12.2.3.1 Air Test and Evaluation Squadron One (VX-1).

Location: Naval Air Station
Patuxent River, MD 20670

Telephone:

Commercial: 301-863-3607

DSN: 356-3607

The function of Air Test and Evaluation Squadron One, located at Naval Air Station, Patuxent River, Maryland, is to test and/or evaluate airborne antisubmarine weapon systems, support systems, components, and equipment, and to develop tactics for their use. Tests are conducted using land- and carrier-based, fixed- and rotary-wing aircraft.

G12.2.3.2 Air Test and Evaluation Squadron Four (VX-4).

Location: Naval Air Weapons Station
Point Mugu, CA 93042

Telephone:

Commercial: 805-982-7518

DSN: 351-7518

The function of Air Test and Evaluation Squadron Four, located at Point Mugu, California, is to test and/or evaluate all-weather fighter weapon systems and air-launched guided missile weapon systems including associated equipment and aircraft, as directed by Commander, Operational Test and Evaluation Force. Tests and evaluations are carried out with aircraft assigned to

the squadron for that purpose and with the assistance of Pacific Fleet units assigned by the Commander in Chief, U.S. Pacific Fleet, when required for specific projects. The squadron works in close cooperation with the NAWC Weapons Division, Point Mugu.

G12.2.3.3 Air Test and Evaluation Squadron Five (VX-5).

Location: Naval Air Weapons Station
China Lake, CA 93555

Telephone:

Commercial: 619-939-5274

DSN: 437-5274

The function of Air Test and Evaluation Squadron Five is to develop airborne attack weapon systems and support systems and to evaluate aircraft tactics, techniques, and procedures for the delivery of airborne special weapons. This evaluation is carried out by operational tests with aircraft assigned to the squadron for that purpose and with the assistance of Pacific Fleet units assigned by Commander in Chief, U.S. Pacific Fleet, when required for specific projects. The squadron works in close cooperation with the NAWC Weapons Division at China Lake.

G12.3 Atlantic Fleet Weapons Training Facility.

Location: Roosevelt Roads, Puerto Rico

Mail: FPO Miami, FL 34051

Telephone:

Commercial: 809-863-2000

Detachments:

Three-Dimensional Underwater Range
St. Croix, Virgin Islands

Drone Control Site

Roosevelt Roads, Puerto Rico

Drone Control Site

St. Thomas, Virgin Islands

Drone Control Site

St. Croix, Virgin Islands

Air Impact and Close Air Support
Range, Vieques Island

Mission: To operate, maintain, and develop weapons range facilities and services in direct support of the training of Fleet forces and other activities and for the development, test, and evaluation of weapon systems.

G13 T&E ACTIVITIES REPORTING TO COMMANDANT MARINE CORPS.

G13.1 Marine Corps Systems Command (MARCORSYSCOM).

Location: Quantico, VA 22134-5080

Telephone:

Commercial: 703-640-4471

DSN: 278-4471

Mission: COMMARCORSYSCOM is responsible to ensure that all Development Test and Evaluation (DT&E) of Marine Corps systems is effectively and safely planned, conducted, and reported, including Live Fire Test. MARCORSYSCOM will represent the Marine Corps in all Joint DT&E matters, including Joint Commanders' Group (Test and Evaluation).

G13.2 Marine Corps Operational Testing and Evaluation Activity (MCOTEA).

Location: Quantico, VA 22134-5010

Telephone:

Commercial: 703-640-3141

DSN: 278-3141

Mission: To support the material acquisition process by managing the Marine Corps Operational Test and Evaluation (OT&E) program for acquisition categories (ACAT) I through IV, less the OT&E of aircraft, and to perform such other functions as may be directed by the Commandant of the Marine Corps.

Ref.: Marine Corps Order 3960.2

**G14 MAJOR RANGE AND TEST
FACILITY BASE (MRTFB).**

The MRTFB comprises 20 DOD activities, which are managed by the Services and monitored for OSD by the Director, Test and Evaluation (see 7.2.1.1). Its mission is to provide a

comprehensive and range support base to DOD Components and other authorized users. The MRTFB is described in detail in 7.3.5.

*Ref.: DOD Directive 3200.11; OPNAV
Instruction 3900.25*

**SELECTED REFERENCES ON RESEARCH AND DEVELOPMENT
LABORATORIES, CENTERS, AND T&E ACTIVITIES**

DOD Directive 3201.1, "Management of DOD Research and Development Laboratories," establishes policy and guidance for the management of DOD laboratories/centers, assigns responsibilities for the management of DOD laboratories.

DOD Instruction 3201.3, "DOD Research and Development Laboratories," sets forth goals and objectives of DOD R&D Laboratories.

SECNAV Instruction 3910.3, "Navy Research and Development Laboratories," states policy and guidance and assigns responsibilities for the management of Navy research and development (R&D) laboratories.

SECNAV Instruction 5400.16, "Department of the Navy Warfare Centers and Corporate Laboratory." Describes the organization and functions of the Navy Warfare Centers and Naval Research Laboratory.

RDT&E Center Management Briefs, three volumes containing information on the missions, facilities, programs, major accomplishments, organization, personnel, funds, and functions/responsibilities of each of the 20-plus DON RDT&E organizations covered. (Published

annually by COMSPAWARSYSCOM). Copies may be obtained by sending a request to

Naval Surface Warfare Center, Dahlgren
Code D11
Dahlgren, VA 22448-5000

Department of Defense In-house RDT&E Activities. A compendium of information on DOD RDT&E field activities issued annually by the Office of the Director, Defense REsearch and Engineering (DDR&E). In addition to the missions, it provides data on finances, manpower, facilities and major programs for all designated DOD RDT&E field activities. Copies may be obtained by sending a request to

Office of the Secretary of Defense
Director, Defense Research and
Engineering
Pentagon, Room 3E118
Washington, DC 20301-3080

or

I-NET, Inc.
Attn: CSG-8920
6430 Rockledge Drive
Suite 600
Bethesda, MD 20817

Appendix J GLOSSARY

In addition to terms defined in this glossary, terms defined in Part 15, "Definitions," of DOD Instruction 5000.2, are also listed and referenced.

The terms defined below were selected from directives and other official documents.

Most of these definitions came originally from directives which bore a disclaimer along these lines: "As used in this directive, the following definitions will apply." Thus these definitions are presented with the following words of caution:

WARNING: The following definitions are presented for information only. It cannot be assumed that directive and manual writers using these terms in any particular instance are attempting to convey the precise meanings contained in these definitions.

Abbreviations and acronyms are listed at the end of the book.

ACCEPTANCE TRIALS—Trials and material inspection conducted underway by the trial board for ships constructed in a private shipyard to determine suitability for acceptance of a ship.

ACCRUED EXPENDITURES—Costs incurred during a given period representing liabilities incurred for goods and services received, other assets acquired, and performance accepted, whether or not payment has been made.

ACQUISITION—The process consisting of planning, designing, producing, and distributing a weapon systems/equipments. Acquisition in this sense includes the conceptual, validation, full-scale development, production, and deployment/operational phases of the weapon systems/

equipments project. For those weapon systems/equipments not being procured by a project manager, it encompasses the entire process from inception of the requirement through the operational phase.

Acquisition Categories (DODI 5000.2, Part 15, #1)

Acquisition Category 1 (DODI 5000.2, Part 15, #1a)

Acquisition Category 2 (DODI 5000.2, Part 15, #1b)

Acquisition Category III and IV (DODI 5000.2, Part 15, #1c)

Acquisition Decision Memorandum (ADM) (DODI 5000.2, Part 15, #2)

Acquisition Plan (DODI 5000.2, Part 15, #3)

Acquisition Planning (DODI 5000.2, Part 15, #4)

Acquisition Program (DODI 5000.2, Part 15, #5)

Acquisition Strategy (DODI 5000.2, Part 15, #6)

Acquisition Strategy Report (DODI 5000.2, Part 15, #7)

Acquisition Streamlining (DODI 5000.2, Part 15, #8)

ADVANCED DEVELOPMENT (Budget Category 6.3)—Includes all projects which have moved into the development of hardware for test.

Affordability (DODI 5000.2, Part 15, #9)

Agency Acquisition Executive (DODI 5000.2, Part 15, #10)

AGENCY COMPONENT—A major organizational subdivision of an agency. For example: the Army, Navy, Air Force, and Defense Supply Agency

are agency components of the Department of Defense. The Federal Aviation, Urban Mass Transportation, and the Federal Highway Administrations are agency components of the Department of Transportation.

AGENCY MISSIONS—Those responsibilities for meeting national needs assigned to a specific agency.

ALLOCATION—An authorization by a designated official of a component of the Department of Defense making funds available within a prescribed amount to an operating agency for the purpose of making allotments; i.e., the first subdivision of an apportionment.

ANALYSIS—The qualitative and/or quantified evaluation of information requiring technical knowledge and judgment.

APPORTIONMENT—A determination by the Office of Management and Budget as to the amount of obligations which may be incurred when the nature of the work involved prevents the preparation of definitive requirements, specifications, or cost data. Sometimes called letter of intent.

APPROPRIATION—A part of an Appropriation Act by Congress providing a specified amount of funds to be used for designated purposes. Appropriations include: (1) research, development, test, and evaluation, RDT&E; (2) reserve personnel, RP; (3) military personnel, MP; (4) military construction, MILCON; (5) weapons procurement, WP; (6) operations and maintenance, O&M; (7) aircraft procurement, AP; (8) other procurement, OP; (9) shipbuilding and conversion, SC; (10) family housing, Defense, FHD; (11) claims, Defense, CD; (12) retired pay, Defense, RPD; (13) procurement, Marine Corps, PMC.

APPROPRIATION SPONSOR—DCNO or a Director of a Staff Office charged with supervisory control over an appropriation.

AUTHORIZATION—Basic substantive legislation enacted by Congress which sets up a Federal program or agency either indefinitely or for a given period of

time. Such legislation sometimes sets limits on the amount that can subsequently be appropriated, but does not usually provide budget authority.

AUTOMATIC TEST EQUIPMENT (ATE)—An equipment that is designed to automatically conduct analysis of functional or static parameters and to evaluate the degree of performance degradation and perform fault isolation of unit malfunctions.

Availability (DODI 5000.2, Part 15, #11)

BASELINE, APPROVED—The combination of approved program schedule, configuration, performance characteristics, acquisition, strategy, and other business aspects which constitute the variables reflected in either the appropriate acquisition milestone approval for that acquisition category or as reflected in the latest approved program management proposal action.

BENEFIT-COST ANALYSIS—An analytical approach to solving problems of choice. It requires the definition of objectives, identification of alternative ways of achieving each objective, and the identification, for each objective, of that alternative which yields the required level of benefits at the lowest cost. This same analytical process is often referred to as cost-effectiveness analysis when the benefits or outputs of the alternatives cannot be quantified in terms of dollars.

BUDGET—A planned program for a fiscal period in terms of (a) estimated costs, obligations and expenditures, (b) source of funds for financing, including reimbursements anticipated and other resources to be applied, and (c) explanatory and workload data on the projected programs and activities.

BUDGET AUTHORITY—Authority provided by the Congress, mainly in the form of appropriations, which allows Federal agencies to incur obligations to spend or lend money. (Budget in Brief)

BUDGETING—The process of translating approved resource requirements (Manpower & Material) into timephased financial requirements.

BUDGET MARK-UP—Revision of a budget in detail, at a review level, based on consideration of policies, programs, scheduling, cost factors, and other pertinent data, as a basis for approval or obligation authorization.

Capstone Test and Evaluation Master Plan (Capstone TEMP) (DODI 5000.2, Part 15, #12)

CHART, FLOW—A graphic presentation using symbols to show the step-by-step sequence of operations or procedures.

CHOP—Expression indicating concurrence.

COMBAT SYSTEM—The equipment, computer programs, people and documentation organic to the accomplishment of the mission of an aircraft, surface ship, or submarine; excludes the structure, material, propulsion, power and auxiliary equipment, transmissions and propulsion, fuels and control systems, and silencing inherent in the construction and operation of aircraft, surface ships and submarines.

COMBAT SYSTEM TEST INSTALLATION—A collection of subsystems including weapon, sensor, and information processing equipment together with their interfaces installed, for the purposes of early testing prior to the availability of a first production item, at a test facility designed to simulate the essential parts of the production item.

COMMITMENT—A firm administrative reservation of funds, based upon firm procurement directives, orders, requisitions, authorizations to issue travel orders, or requests which authorize the recipient to create obligations without further recourse to the official responsible for certifying the availability of funds.

COMMUNICATIONS-ELECTRONICS (C-E)—The specialized field concerned with the use of electronic devices and systems for the acquisition or acceptance, processing, storage, display, analysis, protection, disposition, and transfer of information. C-E systems include communications, radar,

navigation, and all other systems which use the electromagnetic spectrum.

Component Acquisition Executive (DODI 5000.2, Part 15, #13)

COMPUTER-AIDED ACQUISITION AND LOGISTIC SUPPORT (CALs)—A DOD initiative to transition from paper-intensive, non-integrated weapon systems design, manufacturing, and support processes to a highly automated and integrated mode of operation. This transition will be facilitated by acquiring, managing, and using technical data in standardized digital form.

Computer Resources (DODI 5000.2, Part 15, #14)

Computer Software (or Software) (DODI 5000.2, Part 15, #15)

Computer Software Documentation (DODI 5000.2, Part 15, #16)

Configuration (DODI 5000.2, Part 15, #17)

Configuration Item (DODI 5000.2, Part 15, #18)

Configuration Management (DODI 5000.2, Part 15, #19)

Constant Year Dollars (DODI 5000.2, Part 15, #20)

CONTRACT—An agreement, enforceable by law, between two or more competent parties, to do or not to do something not prohibited by law, for a legal consideration.

CONTRACT, COST—A contract which provides for payment to the contractor of allowable costs, to the extent prescribed in the contract, incurred in performance of the contract.

CONTRACT, COST-PLUS-A-FIXED-FEE—A cost-reimbursement-type contract which provides for the payment of a fixed fee to the contractor. The fixed fee, once negotiated, does not vary with actual cost, but may be adjusted as a result of any subsequent changes in the scope of work or services to be performed under the contract.

CONTRACT, COST-PLUS-INCENTIVE-FEE—A cost-reimbursement-type contract with provision for a fee which is adjusted by formula in accordance with the relationship which total allowable costs bear to target costs. The provision for increase or decrease in the fee, depending upon allowable costs of contract performance, is designed as an incentive to the contractor to increase the efficiency of performance.

CONTRACT, COST-REIMBURSEMENT TYPE—A type of contract which provides for payment to the contractor of allowable costs incurred in the performance of the contract, to the extent prescribed in the contract.

CONTRACT, COST-SHARING—A cost-reimbursement-type contract under which the contractor receives no fee but is reimbursed only for an agreed portion of its allowable costs.

Contract Data Requirements List (CDRL) (DODI 5000.2, Part 15, #21)

Contract Data Requirement (DODI 5000.2, Part 15, #22)

CONTRACT, FIRM-FIXED-PRICE—A contract which provides for a price which is not subject to any adjustment by reason of the cost experience of the contractor in the performance of the contract.

CONTRACT, FIXED-PRICE—A type of contract which generally provides for a firm price, or under appropriate circumstances may provide for an adjustable price, for the supplies or services which are being procured.

CONTRACT, FIXED-PRICE WITH ESCALATION—A fixed-price type of contract which provides for the upward and downward revision of the stated contract price upon the occurrence of certain contingencies (such as fluctuations in the material prices and labor rates) which are specifically defined in the contract.

CONTRACT, TASK-TYPE—A master contract for research and development work, consisting of two parts, one of which sets forth general provisions and

the other which is represented by one or more task orders issued thereunder.

CONTRACTOR SUPPORT—An arrangement during initial development or production of end-items whereby a contractor furnishes required material and maintenance of an end-item or system pending assumption of supply support by the military service.

CONTROL—The act of evaluating, through the use of reports or records or by inspection of operations, current performance of assigned responsibilities as compared with planned objectives or established standards.

COST ANALYSIS—An analytical process employed to predict the resource requirements for weapon systems and programs.

COST ANALYSIS IMPROVEMENT GROUP (CAIG)—The principal advisory group to the DAB on matters related to costs.

COST CATEGORY—One of three types of costs into which the total cost of a program element is divided: (1) research and development, (2) investment, and (3) operating.

COST CENTER—An administrative unit selected for the purpose of accumulating and controlling costs. It usually: (1) consists of a natural grouping of machines, methods, processes, or operations; (2) is identified with single management responsibility; and (3) is made up of elements which have common cost characteristics.

Cost and Operational Effectiveness Analysis (DODI 5000.2, Part 15, #24)

Cost Effectiveness (DODI 5000.2, Part 15, 23)

COST GROWTH—A term related to the net change of an estimated or actual amount over a base figure previously established. The base must be relatable to a program, project or contract and be clearly identified including source, approval authority, specific items included, specific assumptions made, date and the amount.

COST MODELS—A method for making rapid estimates of dollar and manpower requirements to

support force structure which are accurate enough to detect significant differences in the cost-effectiveness of alternatives. This is done by using an assembled set of Navy program factors and a computerized set of estimating relationships to compute statistical averages.

Critical Design Review (DODI 5000.2, Part 15, #25)

Critical Intelligence Parameter (DODI 5000.2, Part 15, #26)

CRITICAL ISSUES—Those aspects of a system's capability, either operational, technical, or other, that must be questioned before a system's overall worth can be estimated, and that are of primary importance to the decision authority in reaching a decision to allow the system to advance into the next acquisition phase.

Critical Operational Issue (DODI 5000.2, Part 15, #27)

CURRENT ESTIMATE (CE)—(See C2.1)

DAE BASELINE—A program baseline established by the DOD component and approved by the DAE in accordance with DOD Directive 5000.45.

DATA—Any representations such as characters or analog quantities to which meaning may be assigned. Data may be expressed in digital, graphic, or symbolic form.

DATA SYSTEM—Combinations of personnel efforts, forms, formats, instructions, procedures, data elements and related data codes, communications facilities, and automatic data processing equipment, which provide an organized and interconnected means, either automated, manual, or a mixture of these for recording, collecting, processing and communicating data.

Defense Acquisition Board (DAB) (DODI 5000.2, Part 15, #28)

Defense Acquisition Board Committee (DODI 5000.2, Part 15, #29)

Defense Planning and Resources Board (DPRB) (DODI 5000.2, Part 15, #30)

DEFENSE PROGRAM—The official document which summarizes the SECDEF-approved plans and programs for the Department of Defense. It is published at least once annually.

DEFENSE RESEARCH—Scientific study and experimentation directed toward increasing knowledge and understanding in those fields of the physical, engineering, environmental, biological-medical, and behavioral-social sciences directly related to explicitly-stated long-term national security needs.

DEMONSTRATION AND VALIDATION DECISION—Milestone I decision by which the SECDEF reaffirms the mission need and approves one or more selected alternatives for competitive demonstration and validation.

Department of Defense Acquisition System (DODI 5000.2, Part 15, #31)

Design Control Activity (DODI 5000.2, Part 15, #32)

DETERMINATIONS AND FINDINGS (D&F)—Documents (signed by (1) the Secretary of a Department, (2) the Head of a Procuring Activity, or (3) the Contracting Officer) that justify the use of the authority to enter into contracts by negotiation.

DEVELOPMENT ESTIMATE (DE)—(See C2.1)

DISTRIBUTION STATEMENT—A statement used in marking a technical document to denote the conditions of its availability for distribution, release, or disclosure at the initiation of a component of the DOD.

DOCUMENT—Any recorded information or data regardless of physical form or characteristics, including but not limited to the following:

- (1) Written or printed material: (whether handwritten, printed or typed);
- (2) Data processing cards or tapes;
- (3) Maps, charts, photographs, negatives, moving or still films, or film strips;

(4) Paintings, drawings, engravings, or sketches;

(5) Sound or voice recordings;

(6) Reproductions of the foregoing by any means or process.

DOD Components (DODI 5000.2, Part 15, #33)

DOD Component Acquisition Executive (DODI 5000.2, Part 15, 34)

Early Operational Assessment (DODI 5000.2, Part 15, #35)

ECONOMIC ANALYSIS—A systematic approach to the problem of choosing how to employ scarce resources and an investigation of the full implications of achieving a given objective in the most efficient and effective manner.

EFFECTIVENESS—The performance or output received from an approach or a program. Ideally, it is a quantitative measure which can be used to evaluate the level of performance in relation to some standard, set of criteria, or end objective.

Electronic Counter-Countermeasures (ECCM) (DODI 5000.2, Part 15, #36)

Environment (DODI 5000.2, Part 15, #37)

Evaluation Criteria (DODI 5000.2, Part 15, #38)

Exit Criteria (DODI 5000.2, Part 15, #39)

EXPENDITURES—Charges against available funds. They are evidenced by vouchers, claims, or other documents approved by competent authority. Expenditures represent the actual payment of funds.

EXPENSES—Costs of resources consumed in use.

Firmware (DODI 5000.2, Part 15, #40)

Follow-On Operational Test and Evaluation (DODI 5000.2, Part 15, #41)

Full Operational Capability (FOC) (DODI 5000.2, Part 15, #42)

Full Rate Production (DODI 5000.2, Part 15, #43)

Highly Sensitive Classified Programs (DODI 5000.2, Part 15, #44)

Human Factors (DODI 5000.2, Part 15, #45)

Human Performance (DODI 5000.2, Part 15, #46)

Implementation (DODI 5000.2, Part 15, #47)

Independent Cost Analysis (DODI 5000.2, Part 15, #48)

Independent Cost Estimate (DODI 5000.2, Part 15, #49)

Industrial Base (DODI 5000.2, Part 15, #50)

Industrial Mobilization (DODI 5000.2, Part 15, #51)

INFORMATION ANALYSIS CENTER—A DOD-wide service directed toward collecting technical information in a specific area of effort and its evaluation and filtering into the form of condensed data, summaries or state-of-the-art reports.

INFORMATION RETRIEVAL SYSTEM—A system for locating and selecting, on demand, certain documents or other graphic records relevant to a given information requirement from a file of such material. Examples of information retrieval systems are classification, indexing, and machine searching systems.

INFORMATION SYSTEM—The network of all communication methods within an organization. It includes information exchanges upward, downward, or laterally to accomplish the objectives of the organization as well as information fed back to be used in management appraisal, progressing, controlling, scheduling, planning and also in replanning, rescheduling and other phases, to assure the appropriate end result.

Initial Operational Capability (DODI 5000.2, Part 15, #52)

Initial Operational Test and Evaluation (IOT&E) (DODI 5000.2, Part 15, #53)

Integrated Logistic Support (DODI 5000.2, Part 15, #54)

Integrated Logistic Support (ILS) Elements (DODI 5000.2, Part 15, #55)

Maintenance Planning (DODI 5000.2, Part 15, #55a)

Manpower and Personnel (DODI 5000.2, Part 15, #55b)

Supply Support (DODI 5000.2, Part 15, #55c)

Support Equipment (DODI 5000.2, Part 15, #55d)

Technical Data (DODI 5000.2, Part 15, #55e)

Training and Training Support (DODI 5000.2, Part 15, #55f)

Computer Resources Support (DODI 5000.2, Part 15, #55g)

Facilities (DODI 5000.2, Part 15, #55h)

Packaging, Handling, Storage, and Transportation (DODI 5000.2, Part 15, #55i)

Design Interface (DODI 5000.2, Part 15, #55j)

Integrated Program Assessment (IPA) (DODI 5000.2, Part 15, #56)

Integrated Program Summary (IPS) (DODI 5000.2, Part 15, #57)

Intelligence Report (DODI 5000.2, Part 15, #58)

INTERNAL AUDIT—An independent appraisal, performed in accordance with Department of the Navy audit standards, of the diverse operations and controls within an organization or program. Internal audits determine whether acceptable policies and procedures are followed, established standards are met, resources are used efficiently, and organization or program objectives are met.

Interoperability (DODI 5000.2, Part 15, #59)

INVESTMENT COSTS—Costs of real property and equipment.

Joint Program (DODI 5000.2, Part 15, #61)

Joint Requirements Oversight Council (JROC) (DODI 5000.2, Part 15, #60)

LABORATORY—A government-operated installation at which an important fraction of the work is research and development.

LAND-BASED TEST SITE (LBTS)—A facility duplicating/simulating as many conditions as possible of a system's planned operational installation and utilization.

LEAD-TIME, PROCUREMENT—The time interval between the initiation of procurement action and the receipt into the supply system of material purchased as a result of such action.

LEAD-TIME, PRODUCTION—The time interval between the placement of a contract and receipt into the supply system of material acquired.

Life-Cycle Cost (DODI 5000.2, Part 15, #62)

LIFE CYCLE COSTING—Life Cycle Costing (LCC) is an acquisition or procurement technique which considers operating, maintenance, and other costs of ownership as well as acquisition price in the award of contracts for hardware and related support.

LOGISTICS SUPPORT—The supply and maintenance of material essential to proper operation of a system in the force.

Logistic Supportability (DODI 5000.2, Part 15, #63)

Logistics Support Analysis (DODI 5000.2, Part 15, #64)

Low-Rate Initial Production (LRIP) (DODI 5000.2, Part 15, #65)

Maintainability (DODI 5000.2, Part 15, #66)

MAINTENANCE ENGINEERING—That activity of equipment maintenance which develops concepts, criteria and technical requirements during the conceptual and acquisition phases to be applied and maintained in a current status during the operational phase to assure timely, adequate and economic maintenance support of weapons and equipments.

Major Defense Acquisition Program (DODI 5000.2, Part 15, #67)

Major Program (DODI 5000.2, Part 15, #68)

Major System (DODI 5000.2, Part 15, #69)

MANAGEMENT AND SUPPORT (Budget Category 6.5)—Includes effort directed toward support of installations or operations required for general research and development use.

Manufacturing (DODI 5000.2, Part 15, #70)

MANUFACTURING TECHNOLOGY—Any action undertaken which has as its objective (1) the timely establishment or improvement of the manufacturing processes, techniques, or equipment required to support current and projected programs, and (2) the assurance of the ability to produce, reduce leadtime, insure economic availability of end items, reduce costs, increase efficiency, improve reliability, or to enhance safety and antipollution measures.

METROLOGY—The science of weights and measures used to determine conformance to technical requirements including the development of standards and systems for absolute and relative measurements.

Metric System of Measurement (DODI 5000.2, Part 15, #71)

MILITARY INTER-DEPARTMENTAL PURCHASE REQUEST (MIPR)—A procurement order issued by one Military Service on another Military Service to procure, produce or deliver services, supplies or equipment to or for the ordering Service.

Minimum Acceptable Operational Requirement (DODI 5000.2, Part 15, #72)

Minimum Required Accomplishments (DODI 5000.2, Part 15, #73)

MISSION AREA—A major subdivision of a mission, so extracted that it generally parallels the traditional naval warfare and support areas.

MISSION AREA—A segment of the Defense mission as established by the SECDEF.

Mission Critical System (DODI 5000.2, Part 15, #74)

Mission Need (DODI 5000.2, Part 15, #75)

Mission Reliability (DODI 5000.2, Part 15, #76)

Model (DODI 5000.2, Part 15, #77)

NAVAL VEHICLES—Self-propelled, boosted, or towed conveyances used for the strategic and tactical deployment of forces, weapons, materials, and supplies in support of naval warfare.

NEW OBLIGATIONAL AUTHORITY (NOA)—Authority becoming newly available for a given year, provided by current and prior actions of the Congress, enabling Federal Agencies to obligate the government to pay out money.

Nondevelopment Item (DODI 5000.2, Part 15, #82)

Nonmajor Defense Acquisition Program (DODI 5000.2, Part 15, #78)

Nuclear Biological, and Chemical Contamination (DODI 5000.2, Part 15, #79)

Nuclear (N) Contamination (DODI 5000.2, Part 15, #79a)

Biological (B) (DODI 5000.2, Part 15, #79b)

Chemical (C) Contamination (DODI 5000.2, Part 15, #79c)

Nuclear Biological, and Chemical Contamination Survivability (DODI 5000.2, Part 15, #80)

Hardness (DODI 5000.2, Part 15, #80a)

Decontamination (DODI 5000.2, Part 15, #80b)

Compatibility (DODI 5000.2, Part 15, #80c)

Negligible Contamination Level (DODI 5000.2, Part 15, #81)

Nuclear Hardness (DODI 5000.2, Part 15, #83)

Nuclear Survivability (DODI 5000.2, Part 15, #84)

Nuclear Survivability Characteristics (DODI 5000.2, Part 15, #85)

OBLIGATION—The amount of an order placed, contract awarded, service received, or other transaction which legally reserves a specified amount of an appropriation or fund for expenditure.

OPERABILITY—The design characteristic of the system/equipment that will assure personnel

feasibility and optimum utilization of operator personnel.

OPERATING BUDGET, APPROVED—An authorization to an R&D field activity on NAVCOMPT Form 2189-1 (Approved Operating Budget) that constitutes authority to that activity for incurring obligations within the amount authorized for each direct program R&D effort assigned therein.

Operational Assessment (DODI 5000.2, Part 15, #86)

OPERATIONAL AVAILABILITY (Ao)—An index of a weapon system *material readiness*, including system software where applicable, in a *mission* environment. It is a measure of the probability of an item's being in a condition, generally referred to as "up", such that it can perform its intended function, within acceptable limits of degradation, when called upon.

OPERATIONAL CAPABILITY—A subdivision of a mission area which more specifically delineates appropriate operational functions.

Operational Effectiveness (DODI 5000.2, Part 15, #87)

Operational Reliability and Maintainability Value (DODI 5000.2, Part 15, #88)

Operational Suitability (DODI 5000.2, Part 15, #89)

OPERATIONAL TEST AND EVALUATION (OT&E)—The field test under realistic combat conditions, of any item (or key component of) weapons, equipment, or munitions for the purpose of determining the effectiveness and suitability of the weapons, equipment, or munitions for use in combat by typical military users; and the evaluation of the results of such test.

OUTLAYS—Expenditures or the actual amount of funds that must be drawn from the Treasury for goods and services received during the fiscal year under review.

PARAMETRIC COST ESTIMATE—An estimate which predicts costs by means of explanatory variables such as performance characteristics, physical characteristics, and characteristics relevant to the development process, as derived from experience on logically related systems. (Report of Commission on Government Procurement.)

Performance (DODI 5000.2, Part 15, #90)

PILOT PRODUCTION—The controlled manufacture of limited numbers of an item for service test and evaluation purposes using manufacturing drawings and specifications which have been developed for quantity production and with tooling that is representative of that to be used in unlimited production.

PLANNING ESTIMATE (PE)—(See C2.1)

PLANNING / PROGRAMMING / BUDGETING SYSTEM (PPBS)—An integrated system for the establishment, maintenance, and revision of the SYDP and the DOD budget.

Post-Deployment Software Support (PDSS) (DODI 5000.2, Part 15, #92)

Post-Production Support (DODI 5000.2, Part 15, #91)

Preliminary Design Review (DODI 5000.2, Part 15, #93)

Prime Contractor (DODI 5000.2, Part 15, #94)

PROCUREMENT—Includes purchasing, renting, leasing, or otherwise obtaining supplies or services. It also includes all functions that pertain to the obtaining of supplies and services, including description but not determination of requirements, selection and solicitation of sources, preparation and award of contracts, and all phases of contract administration.

Producibility (DODI 5000.2, Part 15, #95)

PRODUCTION ESTIMATE (PE)—(See C2.1)

Production Planning (DODI 5000.2, Part 15, #96)

Production Readiness (DODI 5000.2, Part 15, #97)

PROGRAM (Acquisition version)—A plan or scheme of action designed for the accomplishment of a definite objective which is specific as to the time-phasing of the work to be done and the means proposed for its accomplishment, particularly in quantitative terms, with respect to manpower, material, and facilities requirements.

PROGRAM (PPBS version)—A combination of program elements designed to express the accomplishment of a definite objective or plan which is specified as to the time-phasing of what is to be done and the means proposed for its accomplishment. Programs are aggregations of program elements and, in turn, aggregate to the total Future-Years Defense Program (FYDP).

PROGRAM ACQUISITION COST (PAC)—The development, procurement, and system specific construction cost to acquire the defense system.

PROGRAM BASELINE—A formal agreement between a PM and a PEO, SAE, or the DAE that briefly summarizes factors critical to the success of a program, such as functional specifications, cost, and schedule objectives and requirements, against which the program will subsequently be evaluated.

PROGRAM/BUDGET DECISION (PBD)—A Secretary of Defense decision, in prescribed format, authorizing changes to a submitted budget estimate and the FYDP.

PROGRAM CHANGE DECISION (PCD)—A Secretary of Defense decision, in prescribed format, authorizing changes to the FYDP.

PROGRAM CHANGE REQUEST (PCR)—Proposal, in prescribed format, for out-of-cycle changes to the approved data in the FYDP.

PROGRAM DECISION MEMORANDUM (PDM)—A document which provides decisions of the Secretary of Defense on POMs.

PROGRAM ELEMENT—The basic building block of the Defense Program, the program element is a description of a mission by the identification of the organizational entities and resources needed to

perform the assigned mission. Resources consist of forces, manpower, material quantities, and costs, as applicable.

PROGRAM EVALUATION—Economic analysis of on-going actions to determine how best to improve approved program/project based on actual performance. Program evaluation studies entail a comparison of actual performance with the approved program/project.

Program Executive Officer (PEO) (DODI 5000.2, Part 15, #98)

PROGRAM MANAGEMENT—Management of a project, using organizational or procedural alignments, which will permit varying degrees of intensified direction. This may apply to management of a complete system or any portion thereof, and it may include all phases of development, production, and distribution, or be limited to a single phase, e.g., development.

Program Manager PM (DODI 5000.2, Part 15, #99)

PROGRAM MANAGER CHARTER—A document approved by the appropriate authority stating the program manager's responsibility, authority, and accountability in the management of a major system acquisition project.

PROGRAMMING (DOD PROGRAMMING SYSTEM)—The process of translating planned military force requirements into time-phased manpower and material resource requirements.

PROJECTED OPERATIONAL ENVIRONMENT (POE)—Statement of projected conditions of operations of each class of naval unit used in establishment of manning requirements. The POE statement includes wartime and peacetime operating conditions as well as other information pertinent to developing the Ship Manning Document (SMD).

PROJECT ORDER—A specific, definite and certain order issued under the authority contained in 41 U.S.C. 23 for the manufacture of materials, supplies, and equipment, or for other work or services which,

when placed with and accepted by a separately managed and financed Government-owned and operated establishment, serves to obligate appropriations in the same manner as orders or contracts placed with commercial enterprises.

PROVISIONING, INITIAL—The process of determining the range and quantity of items (i.e., spares and repair parts, special tools, test equipment and support equipment) required to support and maintain an end item of material for an initial period of service.

PROVISIONING, PHASED—A management refinement to the provisioning process whereby procurement of all or part of the total computed quantity of selected items is deferred until the later stages of production, thereby enhancing the ability of the provisioning activity to predict requirements more reliably.

QUALITY ASSURANCE—A planned and systematic pattern of all actions necessary to provide adequate confidence that material conforms to established technical requirements and achieves satisfactory performance in service.

R&D RESPONSIBILITY CENTER—A designated organizational element or a major subdivision thereof such as a laboratory, an operating division, or a service center at an R&D installation for which overall responsibility for specified operations has been assigned to one individual and for which a separate budget has been established.

RDT&E PROGRAM—Consists of all efforts funded from the RDT&E appropriation regardless of program category or program element.

REIMBURSABLE ORDER—An order for work or services accepted by a government office/activity which is initially financed by the performing activity. All cost incurred will result in reimbursement to the performing appropriation.

Reliability (DODI 5000.2, Part 15, #100)

Repair Parts (DODI 5000.2, Part 15, #101)

REPROGRAMMING/REPROGRAMMING ACTIONS—Changes in the application of financial resources from the purposes originally contemplated and budgeted for, testified to, and described in the justification submitted to the Congressional Committees in support of fund authorizations and budget requests.

RESEARCH (Budget Category 6.1)—Includes all effort of scientific study and experimentation directed toward increasing knowledge and understanding in those fields of the physical, engineering, environmental and life sciences related to long-term national security needs. It provides fundamental knowledge required for the solution of military problems. It forms a part of the base for (a) subsequent exploratory and advanced developments in Defense-related technologies, and (b) new and improved military functional capabilities in areas such as communications, detection, tracking, surveillance, propulsion, mobility, guidance and control, navigation, energy conversion, materials and structures, and personnel support.

Risk (DODI 5000.2, Part 15, #102)

Risk Management (DODI 5000.2, Part 15, #103)

Robust Design (DODI 5000.2, Part 15, #104)

SCIENTIFIC AND TECHNICAL INFORMATION (STI)—Communicable knowledge or information resulting from or pertaining to the conduct and management of R&E efforts. STI is used by administrators, managers, scientists, and engineers engaged in scientific and technological efforts and is the basic intellectual resource for and result of such effort.

SELECTED ACQUISITION REPORT (SARs)—Standard, comprehensive summary status reports on selected DOD acquisition programs for external reporting to Congress.

Senior Procurement Executive (SPE) (DODI 5000.2, Part 15, #105)

Service Acquisition Executive (SAE) (DODI 5000.2, Part 15, #106)

SHOULD-COST STUDY—A comprehensive, in-depth, management analysis, which involves examination and evaluation of all phases of a contractor's operation, done by a team of specialists in engineering, pricing, audit, management, and plant facilities, etc. The primary objective is to identify instances of omission or commission in the management and performance of planned or existing work which could compromise attainment of realistic schedule, performance, and cost objectives. A realistic price is one which is based on an attainable cost estimate; that is, an estimate of what it should cost if the contractor operates with reasonable economy and efficiency.

Simulation (DODI 5000.2, Part 15, #107)

Simulator (DODI 5000.2, Part 15, #108)

Software Support (DODI 5000.2, Part 15, #109)

SOURCE SELECTION—The process wherein the requirements, facts, recommendations, and government policy relevant to an award decision in a competitive procurement of a system/project are examined and the decision is made.

Spare Acquisition Integrated with Production (SAIP) (DODI 5000.2, Part 15, #112)

Spare Parts (DODI 5000.2, Part 15, #110)

Spares (DODI 5000.2, Part 15, #111)

SPECIFICATION—A document intended primarily for use in procurement, which clearly and accurately describes the essential technical requirements by which it will be determined that the requirements have been met. Specifications for items and materials may also contain preservation, packaging, packing, and marking requirements.

STANDARD—An established or accepted rule, measure, or model by which the degree of satisfactoriness of a product or act is determined.

STANDARDIZATION—The process of establishing by common agreement engineering criteria, terms, principles, practices, materials, items, processes, equipment, parts, subassemblies, and

assemblies to achieve the greatest practicable uniformity of items of supply and engineering practices, to insure the minimum feasible variety of such items and practices, and to effect optimum interchangeability of equipment parts and components.

STUDIES AND ANALYSES—Critical examination and investigation of a subject, often requiring sophisticated analytical techniques to integrate a variety of factors, leading to conclusions or recommendations making substantive contributions to planning, programming and decision making. Unlike experimentally-oriented research and development activities, studies and analyses are typically "pencil and paper" efforts (often computer-assisted) which usually do not generate new scientific knowledge *per se*. Studies are designed to organize and evaluate data and information already available (or which can be inferred or extrapolated from existing data) to provide greater understanding or relevant alternative policies, systems or programs.

SUNK COST—A cost which is irrevocably committed to a project; such costs have no bearing on the results of comparative cost studies.

Supplementation (DODI 5000.2, Part 15, #113)

Supportability (DODI 5000.2, Part 15, #114)

Surge (DODI 5000.2, Part 15, #115)

Survivability (DODI 5000.2, Part 15, #116)

Susceptibility (DODI 5000.2, Part 15, #117)

SYSTEM—An assembly of procedures, processes, methods, routines, or techniques united by some form of regulated interaction to form an organized whole.

SYSTEM ACQUISITION PROCESS—A sequence of specified decision events and phases of activity directed to achievement of established program objectives in the acquisition of Defense systems and extending from approval of a mission need through successful deployment of the Defense system or termination of the program.

SYSTEM EFFECTIVENESS—A measure of the extent to which a system can be expected to complete

its assigned mission within an established timeframe under stated environmental conditions.

SYSTEM ENGINEERING, DEFENSE—That portion of the acquisition process dealing with the transformation of an operational need into an optimal set of system performance parameters and a preferred system configuration. It includes engineering/technical management, definition of system and program, design engineering, support engineering, the integration of the engineering specialties, and other such factors that affect the development, production, deployment, operation, and disposal of the system.

SYSTEM ENGINEERING PROCESS—A logical sequence of activities and decisions transforming an operational need into a description of system performance parameters and a preferred system configuration.

System Readiness Objective (DODI 5000.2, Part 15, #118)

System Reliability and Maintainability Parameter (DODI 5000.2, Part 15, #119)

System Safety (DODI 5000.2, Part 15, #120)

System Threat Assessment (DODI 5000.2, Part 15, #121)

TAILORING—The process of evaluating individual potential requirements to determine their pertinence and cost effectiveness for a specific system or equipment acquisition, and modifying these requirements to ensure that each contributes to an optimal balance between need and cost.

Technical Data (DODI 5000.2, Part 15, #122)

Technical Data Package (DODI 5000.2, Part 15, #123)

TECHNICAL EVALUATION (TECHEVAL)—The final sub-phase of Development Test and Evaluation II (DT-II), the purpose of which is to certify that the design meets specified requirements and is ready for Operational Evaluation (OPEVAL).

Technical Manual (TM) (DODI 5000.2, Part 15, #124)

TECHNICAL SERVICES—Those services associated with the installation, operation, and maintenance of aircraft and shipboard weapons, equipment and systems and performed by in-house and contract personnel qualified and trained in engineering and technical disciplines.

TECHNOLOGICAL LIFE—The estimated number of years before technology will make the existing or proposed equipment or facilities obsolete.

Testbed (DODI 5000.2, Part 15, #125)

TEST CRITERIA—Standards by which test results and outcome are judged.

THREAT—The sum of the potential strength, capabilities, and intentions of an enemy which can limit or negate mission accomplishment or reduce force, system, or equipment effectiveness.

THRESHOLDS—Monetary, time, or resource limitations placed on a program, to be used as guides as the program progresses and the breaching of which is cause for careful review of at least some aspects of the program.

THRESHOLDS (DOD PROGRAMMING SYSTEM)—A set of criteria which, if met or exceeded, requires the submission of a Program Change Request to the Office of the Secretary of Defense.

TIME LINE—A schedule line showing key dates and planned events.

TOTAL OBLIGATIONAL AUTHORITY (TOA)—The total financial requirements of the FYDP or any component thereof required to support the approved program of a given fiscal year.

TOTAL QUALITY LEADERSHIP (TQL)—is the application of *quantitative methods* and *people* to assess and improve: (1) materials and services supplied to the organization, (2) all significant processes within the organization, and (3) meeting the needs of the customer, now and in the future. (Also known as "Total Quality Management (TQM).")

Transportability (DODI 5000.2, Part 15, #126)

UNDERWAY TRIALS (UT)—Trials and material inspection conducted underway by the Trial Board for all ships constructed in a naval shipyard or converted/modernized in a naval or private shipyard to determine suitability for delivery and whether the ship is ready for active fleet duty.

UNSOLICITED PROPOSAL—A research or development proposal which is made to the Government by a prospective contractor without prior formal or informal solicitation from a purchasing activity.

VALUE ENGINEERING DISCIPLINE—A sequential process for systematically analyzing the functional requirements of DOD systems, equipment, facilities, procedures, and material to achieve the essential functions at the lowest total cost of effective ownership, consistent with requirements for performance, reliability, quality, maintainability, and safety.

Vulnerability (DODI 5000.2, Part 15, #127)

Weapon System (DODI 5000.2, Part 15, #128)

WORK BREAKDOWN STRUCTURE—A product-oriented family tree division of hardware, software, services and other work tasks which organizes, defines and graphically displays the product to be produced as well as the work to be accomplished to achieve the specified product.

WORK UNIT—The smallest segment into which research or technology efforts are divided for local administration or control. Each work unit has a specific objective, finite duration, and results in an end product. It is technically distinct in scope, objective, and duration from other research or technology efforts with which it may be aggregated for either financial, administrative, or contracting purposes.

GLOSSARY REFERENCE LIST

Glossary: Defense Acquisition Acronyms and Term. Published by the Defense Systems Management College with updates approximately every two years. For sale by the Superintendent of Documents.

JCS Pub. 1-02, Department of Defense Dictionary of Military and Associated Terms.

NOTE REGARDING DIRECTIVE NUMBERS

References to directives within this Guide are by series only; e.g., 3900.14, not to the effective edition within the series; e.g., 3900.14A.

The Master Reference List shows the version and issue date of each directive used in preparation of this edition of the Guide.

MASTER REFERENCE LIST

This master reference list provides a consolidated listing of directives and instructions, showing modifications and date of issue, used in preparation of this edition of the **DON RDA Management Guide**. Numbers in parentheses following the citation show specific sections and paragraphs affected by that directive.

DOD

DODDIR 3200.11 of 9/29/80 (OPNAV 3900.25), MAJOR RANGE AND TEST FACILITY BASE. (7.3.2; 7.3.3; 7.3.5; G14)

DOD 3200.11-D of 6/83, MAJOR RANGE AND TEST FACILITY BASE SUMMARY OF CAPABILITIES. (7.3.3; 7.3.5)

DODDIR 3200.12 of 2/15/83 (SECNAV 3900.43), DOD SCIENTIFIC AND TECHNICAL INFORMATION PROGRAM. (D; D1; D3; F2.3)

DOD 3200.12-M-1 of 8/84, RESEARCH AND TECHNOLOGY WORK UNIT INFORMATION SYSTEM MANUAL. (D3.1.1)

DOD 3200.12-R-1 of 8/83, RESEARCH AND TECHNOLOGY WORK UNIT INFORMATION SYSTEM REGULATION. (6.7.7.1; D; D3.1.1)

DOD 3200.12-R-2 of 1/85, CENTERS FOR ANALYSIS OF SCIENTIFIC AND TECHNICAL INFORMATION REGULATION. (D; D4)

DOD 3200.12-R-4 of 12/88, DOMESTIC TECHNOLOGY TRANSFER PROGRAM REGULATION. (F1.7.4)

DODDIR 3201.1 of 3/9/81 (SECNAV 3910.3), MANAGEMENT OF DOD RESEARCH AND DEVELOPMENT LABORATORIES. (G)

DODINST 3201.3 of 3/31/81 (SECNAV 3910.3), DOD RESEARCH AND DEVELOPMENT LABORATORIES. (G)

DODINST 3204.1 of 12/1/83 (SECNAV 3900.40), INDEPENDENT RESEARCH AND DEVELOPMENT. (6.5.4.3; D; D3.1.2)

DODDIR 3210.1 of 10/26/61 (OCNR 3900.11), ADMINISTRATION AND SUPPORT OF BASIC RESEARCH BY THE DOD. (2)

DODDIR 3210.2 of 4/22/77, RESEARCH GRANTS AND TITLE TO EQUIPMENT PURCHASED UNDER GRANTS. (6.5.5.2)

DOD 4205.2 of 2/10/92, ACQUIRING AND MANAGING CONTRACTED ADVISORY ASSISTANCE SERVICES (CAAS). (F1.4.1)

DODDIR 5000.1 of 2/23/92, DEFENSE ACQUISITION.*

DODINST 5000.2 of 2/23/91, DEFENSE ACQUISITION MANAGEMENT POLICIES AND PROCEDURES.*

DOD 5000.2-M of 2/91, DEFENSE ACQUISITION MANAGEMENT DOCUMENTATION AND REPORTS.*

*Note: This directive is so extensively cited in the Guide that specific citation locations are not listed.

DOD 5000.3-M-2 of 8/88, FOREIGN WEAPONS EVALUATION AND NATO COMPARATIVE TEST. (7.1.8.1; 7.2.1.1)

DOD 5000.3-M-4 of 8/88, JOINT TEST AND EVALUATION PROCEDURES MANUAL. (7, 7.4.4.1)

DODDIR 5000.4 of 10/30/80, OSD COST ANALYSIS IMPROVEMENT GROUP. (F4.4)

DODDIR 5000.49 of 9/11/89, DEFENSE ACQUISITION BOARD. (E9.2)

DODDIR 5000.52 of 10/25/91, DEFENSE ACQUISITION EDUCATION, TRAINING AND CAREER DEVELOPMENT PROGRAM. (F3.3; 3.4)

DOD 5010.12-L of 4/89, ACQUISITION MANAGEMENT SYSTEMS AND DATA REQUIREMENTS CONTROL LIST. (6.7.1)

DOD 5025.1-I, DOD DIRECTIVES SYSTEM ANNUAL INDEX. (B4.1)

DODDIR 5025.1 of 12/23/88, DEPARTMENT OF DEFENSE DIRECTIVES SYSTEM. (B4)

DODDIR 5100.1 of 9/25/87 (SECNAV 5410.85), FUNCTIONS OF THE DEPARTMENT OF DEFENSE AND ITS MAJOR COMPONENTS. (7.2.2; E; E1; E2.1)

DODDIR 5100.20 of 12/31/71, THE NATIONAL SECURITY AGENCY AND THE CENTRAL SECURITY SERVICE. (E1.7.7)

DODDIR 5105.19 of 6/25/91, DEFENSE INFORMATION SYSTEMS AGENCY (DISA). (E1.7.3)

DODDIR 5105.21 of 5/19/77, DEFENSE INTELLIGENCE AGENCY. (E1.7.5)

DODDIR 5105.22 of 12/6/88, DEFENSE LOGISTICS AGENCY. (E1.7.6)

DODDIR 5105.31 of 1/24/91, DEFENSE NUCLEAR AGENCY (DNA). (E1.7.2)

DODDIR 5105.36 of 6/8/78, DEFENSE CONTRACT AUDIT AGENCY. (E1.7.4)

DODDIR 5105.40 of 12/6/90, DEFENSE MAPPING AGENCY (DMA). (E1.7.8)

DODDIR 5105.41 of 1/25/89, DEFENSE ADVANCED RESEARCH PROJECTS AGENCY. (E1.7.1)

DODDIR 5118.3 of 6/24/91, COMPTROLLER OF THE DEPARTMENT OF DEFENSE. (E1.4)

DODDIR 5126.48 of 4/13/92, DEFENSE PLANNING AND RESOURCES BOARD (DPRB). (E9.4)

DODDIR 5128.1 of 2/9/89, ASSISTANT SECRETARY OF DEFENSE (PRODUCTION AND LOGISTICS). (E1.1.2)

DODDIR 5129.22 of 6/26/78, DEFENSE SCIENCE BOARD. (E9.1)

DODDIR 5134.1 of 8/8/89, UNDER SECRETARY OF DEFENSE (ACQUISITION). (E1.1; E1.2)

DODDIR 5134.3 of 1/9/89, DIRECTOR OF DEFENSE RESEARCH AND ENGINEERING. (E.1.1.1)

DODDIR 5137.1 of 3/27/90, ASSISTANT SECRETARY OF DEFENSE FOR COMMAND, CONTROL, COMMUNICATIONS AND INTELLIGENCE. (E1.6)

DODDIR 5141.1 of 2/1/89, ASSISTANT SECRETARY OF DEFENSE (PROGRAM ANALYSIS AND EVALUATION). (E1.5)

DODDIR 5141.2 of 4/2/84, DIRECTOR OF OPERATIONAL TEST AND EVALUATION. (7.2.1.2; E1.3)

DODDIR 5148.2 of 2/4/86, ASSISTANT TO THE SECRETARY OF DEFENSE (ATOMIC ENERGY). (E1.1.1.1)

DODDIR 5160.55 of 8/22/88, DEFENSE SYSTEMS MANAGEMENT COLLEGE (DSMC). (E5)

DODINST 5200.21 of 9/27/79 (SECNAV 3900.35), DISSEMINATION OF DOD TECHNICAL INFORMATION. (D)

DODDIR 5230.24 of 3/18/87, DISTRIBUTION STATEMENTS ON TECHNICAL DOCUMENTS. (6.7.2)

DODDIR 5400.4 of 1/30/78, PROVISION OF INFORMATION TO CONGRESS. (4.8)

DODDIR 5545.2 of 8/20/79, DOD POLICY FOR CONGRESSIONAL AUTHORIZATION AND APPROPRIATION ACTIONS. (5.1.4)

DODINST 5545.3 of 7/5/79 (NAVCOMPTINST 7130.25), DOD PROCEDURES FOR CONGRESSIONAL AUTHORIZATION AND APPROPRIATION ACTIONS. (5.1.4)

DOD 7000.3-G of 5/80, PREPARATION AND REVIEW OF SELECTED ACQUISITION REPORTS. (6.7.6)

DODINST 7040.4 of 3/5/79 (SECNAV 7045.9), MILITARY CONSTRUCTION AUTHORIZATION AND REPORTING. (F4.2)

DODINST 7040.5 of 9/1/66 (SECNAV 7040.6), DEFINITIONS OF EXPENSES AND INVESTMENT COSTS. (5.3.3)

DODINST 7041.3 of 10/18/72 (SECNAV 7000.14), ECONOMIC ANALYSIS AND PROGRAM EVALUATION FOR RESOURCE MANAGEMENT. (F4.4)

DODINST 7045.7 of 5/23/84, IMPLEMENTATION OF THE PLANNING, PROGRAMMING, AND BUDGETING SYSTEM (PPBS). (3; 4.4.5.2)

DOD 7045.7-H, of 2/91, FYDP PROGRAM STRUCTURE. (3.2.1)

DODDIR 7045.14 of 5/22/84, THE PLANNING, PROGRAMMING, AND BUDGETING SYSTEM (PPBS). (3)

DODINST 7110.1 of 10/30/80, DOD BUDGET GUIDANCE. (5.1)

DODDIR 7200.1 of 5/7/84, ADMINISTRATIVE CONTROL OF APPROPRIATIONS. (5; 5.1; 5.2)

DODDIR 7410.4 of 7/1/88, INDUSTRIAL FUND POLICY. (5; 5.3.4.1; 6.2.4)

DODDIR 7600.2 of 2/2/91, AUDIT POLICIES. (5.5)

DODDIR 7650.2 of 7/19/85, GENERAL ACCOUNTING OFFICE AUDITS AND REPORTS. (5.5)

DODDIR 7750.5 of 8/7/86, MANAGEMENT AND CONTROL OF INFORMATION REQUIREMENTS. (6.7.1)

INSURV

INSURVINST 13,100.1D of 4/15/87, POLICIES, RESPONSIBILITIES, AND PROCEDURES FOR INSURV AIRCRAFT TRIALS. (7.4.3)

MARINE CORPS

MCO 3960.2A of 12/20/89, MARINE CORPS OPERATIONAL TEST AND EVALUATION ACTIVITY. (7.2.10.1; G13.2)

MCO 4081.1 of 10/1/87, JOINT SERVICES AUTOMATIC TESTING—EXECUTIVE BOARD. (E9.5)

MCO P5000.10C of 4/1/89, SYSTEMS ACQUISITION MANAGEMENT MANUAL. (2; 6.8; 7.2.10.2; E6)

MCO 5000.11A of 7/2/79, TESTING AND EVALUATION OF SYSTEMS AND EQUIPMENT FOR THE MARINE CORPS. (7.2.10.2)

MCO 5000.15 of 2/19/85, MARINE CORPS SYSTEMS ACQUISITION MANAGEMENT POLICY. (6.8)

MCO 5000.19 of 2/13/92, MARINE CORPS SYSTEMS COMMAND. (E6.1)

NAVAIR

NAVAIRINST 5451.87B of 6/6/89, TECHNICAL SUPPORT ASSIGNMENTS TO NAVAL AIR SYSTEMS COMMAND (NAVAIR) FIELD ACTIVITIES AND SPACE AND NAVAL WARFARE SYSTEMS COMMAND (SPAWAR) RESEARCH AND DEVELOPMENT (R&D) CENTERS. (6.2.1)

NAVCOMPT

NAVCOMPTINST 7044.8 of 6/25/74, REIMBURSABLE ORDERS CITING THE RESEARCH, DEVELOPMENT, TEST AND EVALUATION, NAVY (RDT&E,N) APPROPRIATION. (5.3)

NAVCOMPTINST 7102.2A of 8/15/85, GUIDANCE FOR THE PREPARATION, SUBMISSION AND REVIEW OF DEPARTMENT OF THE NAVY (DON) BUDGET ESTIMATES. (Promulgates *DON Budget Guidance Manual*. Distribution limited primarily to major claimants for funds.) (2.1.1; 4; 4.3.2; 4.4.5.1; 4.4.7; 4.7.5; 5.3.3; C6.1; C8; F4.4.3.5)

NAVCOMPTINST 7121.3D of 10/6/67, DEPARTMENT OF THE NAVY ANNUAL BUDGET HEARINGS BEFORE THE CONGRESSIONAL APPROPRIATIONS COMMITTEES; INFORMATION FOR WITNESSES. (4; 4.7)

NAVCOMPTINST 7130.25D of 11/9/79, PROCEDURES FOR THE ANNUAL REVIEW AND IMPLEMENTATION OF CONGRESSIONAL ACTIONS ON AUTHORIZATION AND APPROPRIATION ACTS AFFECTING DOD AND RELATED CONGRESSIONAL REPORTS. (5.1.4)

NAVCOMPTINST 7133.1C of 5/8/80, PROCEDURES AND REPORTING REQUIREMENTS RELATED TO THE REPROGRAMMING OF APPROPRIATED FUNDS; IMPLEMENTATION OF. (5.3.4.1; 5.4; 5.4.4)

NAVMEDCOM

NAVMEDCOMINST 5430.1B of 5/18/88, NAVAL MEDICAL COMMAND ORGANIZATION MANUAL. (E8)

NAVMEDCOMINST 5450.14 of 5/16/83, NAVAL MEDICAL RESEARCH AND DEVELOPMENT COMMAND, BETHESDA, MARYLAND; MISSION AND FUNCTIONS OF. (E8)

NAVPUB

NAVPUBINST 5215.1C of 10/1/91, DEPARTMENT OF THE NAVY DIRECTIVES ISSUANCE SYSTEM CONSOLIDATED SUBJECT INDEX. (B3.1)

OCNR/ONR

OCNRINST 3900.11 of 5/8/89, ADMINISTRATION AND SUPPORT OF BASIC RESEARCH WITHIN THE DEPARTMENT OF THE NAVY. (2)

OCNRINST 3910.3 of 3/11/87, EXPLORATORY DEVELOPMENT PROGRAM POLICIES, PROCEDURES, AND RESPONSIBILITIES. (2.2.2; C4)

OPNAV

OPNAVINST 1040.9 of 4/20/85, MATERIEL PROFESSIONAL (MP) PROGRAM. (F3.4)

OPNAVINST 1211.8A of 2/9/80, MANPOWER POLICY IN THE WEAPON SYSTEMS ACQUISITION MANAGEMENT FIELD. (F3.3)

OPNAVINST 1500.8M of 9/18/86, NAVY TRAINING PLANNING PROCESS. (7.5.3; F4.3)

OPNAVINST 3000.12 of 12/29/87, OPERATIONAL AVAILABILITY OF EQUIPMENT AND WEAPON SYSTEMS. (7.7.1.1)

OPNAVINST 3120.28B of 10/21/91, CERTIFICATION OF AVIATION FACILITIES IN NAVAL SHIPS OPERATING AIRCRAFT. (7.8.5)

OPNAVINST 3811.1B of 2/24/87, THREAT SUPPORT TO WEAPON SYSTEMS SELECTION AND PLANNING. (F1.3)

OPNAVINST 3900.25B of 6/19/81, MAJOR RANGE AND TEST FACILITY BASE. (7.3.2; 7.3.3; 7.3.5; G14)

OPNAVINST 3960.13 of 10/1/87, JOINT SERVICE AUTOMATIC TESTING—EXECUTIVE BOARD. (E9.5)

OPNAVINST 4120.5 of 7/1/92, DON COMPUTER-AIDED ACQUISITION AND LOGISTIC SUPPORT (CAL) POLICY AND STRATEGIC PLAN. (6.10)

OPNAVINST 4700.8H of 12/5/90, TRIALS, ACCEPTANCE, COMMISSIONING, FITTING OUT, SHAKEDOWN AND POST SHAKEDOWN AVAILABILITY OF U.S. NAVAL SHIPS UNDERGOING CONSTRUCTION/CONVERSION/MODERNIZATION. (7; 7.8)

OPNAVINST 5000.37A of 4/20/79, THE MANAGEMENT AND CONDUCT OF STUDIES AND ANALYSES. (F1.4.1)

OPNAVINST 5000.42C of 5/10/86, RESEARCH, DEVELOPMENT AND ACQUISITION PROCEDURES.*

OPNAVINST 5000.50A of 8/12/87, NAVY TRAINING SIMULATOR AND DEVICE ACQUISITION AND MANAGEMENT. (F4.3)

OPNAVINST 5200.29 of 2/24/87, PARTICIPATION IN GOVERNMENT-INDUSTRY DATA EXCHANGE PROGRAM. (D7)

OPNAVINST 5410.12D of 10/13/78, DEFENSE COMMUNICATIONS AGENCY (DCA). (E1.6.2)

OPNAVINST 5420.2Q of 1/26/93, RESOURCES AND REQUIREMENTS REVIEW BOARD. (9.7)

OPNAVINST 5420.70B of 8/24/92, MISSION, ORGANIZATION AND FUNCTIONS OF THE BOARD OF INSPECTION AND SURVEY. (7.2.4; 7.4.3; G12.1)

OPNAVINST 5430.48C of 9/2/88, OFFICE OF CHIEF OF NAVAL OPERATIONS (OPNAV) ORGANIZATION MANUAL. (4.6; 7.2.3; E3)

OPNAVINST 5440.47F of 5/21/84, MISSION AND FUNCTIONS OF OPERATIONAL TEST AND EVALUATION FORCE (OPTEVFOR). (7.2.5; G12.2)

OPNAVINST 5450.165C of 6/27/89, MISSION AND FUNCTIONS OF COMMANDER, NAVAL OCEANOGRAPHIC COMMAND. (E3.10.3)

SECNAV

SECNAVINST 3900.29C of 3/19/91, STANDARD FORMAT REQUIREMENTS FOR SCIENTIFIC AND TECHNICAL REPORTS. (6.7.2; D; D3.1.3)

*Note This instruction is so extensively cited in the Guide that specific citation locations are not listed. It is designed to be interleaved with DOD Instruction 5000.2 and DOD 5000.2-M.

SECNAVINST 3900.35C of 7/31/80,
DISSEMINATION OF DEPARTMENT OF
DEFENSE TECHNICAL INFORMATION. (D)

SECNAVINST 3900.40B of 4/30/87, POLICY
AND ASSIGNMENT OF RESPONSIBILITIES
OF THE INDEPENDENT RESEARCH AND
DEVELOPMENT PROGRAM. (6.5.4.3; D;
D3.1.2)

SECNAVINST 3900.43 of 12/29/83, NAVY
SCIENTIFIC AND TECHNICAL
INFORMATION PROGRAM (STIP). (6.7.7.1;
D; D1; D3; F2.3)

SECNAVINST 3910.3 of 4/6/82, NAVY
RESEARCH AND DEVELOPMENT
LABORATORIES. (G)

SECNAVINST 4200.31B of 9/8/87,
CONTRACT SUPPORT SERVICES (CSS).
(F1.4.1)

SECNAVINST 4210.10 of 7/18/88,
COMPETITION IN ACQUISITION. (6.3.4)

SECNAVINST 5000.2A of 12/9/92,
IMPLEMENTATION OF DEFENSE
ACQUISITION MANAGEMENT POLICIES,
PROCEDURES, DOCUMENTATION, AND
REPORTS.*

SECNAVINST 5000.16E of 3/31/86,
DEPARTMENT OF THE NAVY PLANNING,
PROGRAMMING, AND BUDGETING
SYSTEM (PPBS). (3)

SECNAVINST 5000.28E of 1/23/84,
DEFENSE SYSTEMS MANAGEMENT
COLLEGE (DSMC). (E5)

SECNAVINST 5000.32 of 2/21/85,
ADDITIONAL REPORTING
RESPONSIBILITIES OF THE ASSISTANT
SECRETARY OF THE NAVY
(SHIPBUILDING AND LOGISTICS) AND
ASSISTANT SECRETARY OF THE NAVY

(RESEARCH, ENGINEERING AND
SYSTEMS).

SECNAVINST 5210.11D of 10/20/87,
DEPARTMENT OF THE NAVY FILE
MAINTENANCE PROCEDURES AND
STANDARD SUBJECT IDENTIFICATION
CODES (SSIC). (B2; C9)

SECNAVINST 5300.33 of 5/2/91, MATERIEL
PROFESSIONAL PROGRAM. (F3.4)

SECNAVINST 5300.34 of 8/6/91,
DEPARTMENT OF THE NAVY
ACQUISITION WORKFORCE PROGRAM.
(F3.4)

SECNAVINST 5400.15 of 8/5/91,
DEPARTMENT OF THE NAVY RESEARCH,
DEVELOPMENT, AND ACQUISITION
RESPONSIBILITIES. (4.6; E; E2; E2.1.2;
E4.1)

SECNAVINST 5400.16 of 12/18/92,
DEPARTMENT OF THE NAVY WARFARE
CENTERS AND CORPORATE
LABORATORY. (G; G2)

SECNAVINST 5410.85C of 3/26/91,
FUNCTIONS OF THE DEPARTMENT OF
DEFENSE AND ITS MAJOR COMPONENTS.
(7.2.2)

SECNAVINST 5420.79C of 2/17/84, THE
NAVAL RESEARCH ADVISORY
COMMITTEE. (E9.6)

SECNAVINST 5420.188C of 7/16/92, NAVY
AND MARINE CORPS PROGRAM
DECISION MEETINGS (PDM). (1.2; 6.9; A;
E9.8)

SECNAVINST 5430.7L of 6/7/79,
ASSIGNMENT OF RESPONSIBILITIES TO
AND AMONG THE CIVILIAN EXECUTIVE
ASSISTANTS TO THE SECRETARY OF THE
NAVY. (7.2.2; E2)

*Note: This instruction is so extensively cited in the Guide that specific citation locations are not listed. It is designed to be interleaved with DOD Instruction 5000.2 and DOD 5000.2-M.

SECNAVINST 5430.20 of 3/7/91, OFFICE OF NAVAL RESEARCH. (4.6.6; E7)

SECNAVINST 5430.60B of 8/1/75, OFFICE OF PROGRAM APPRAISAL; RESPONSIBILITIES OF. (E2.1.3)

SECNAVINST 5700.16 of 10/27/89, DOMESTIC TECHNOLOGY TRANSFER. (F1.7.4)

SECNAVINST 5730.5G of 8/24/81, PROCEDURE FOR HANDLING OF NAVAL LEGISLATIVE AFFAIRS AND CONGRESSIONAL RELATIONS. (4.7)

SECNAVINST 5740.26 of 3/24/86, RELATIONS WITH THE GENERAL ACCOUNTING OFFICE (GAO). (5.5)

SECNAVINST 7040.6B of 1/2/80, DEFINITIONS OF EXPENSE AND INVESTMENT COSTS. (5.3.3)

SECNAVINST 7045.9B of 3/6/80, MILITARY CONSTRUCTION AUTHORIZATION AND APPROPRIATION. (F4.2)

SECNAVINST 7510.7E of 10/11/91, DEPARTMENT OF THE NAVY INTERNAL AUDIT. (5; 5.5)

SECNAVINST 12920.1B of 12/23/86, SENIOR EXECUTIVE SERVICE (SES). (F3.3)

SECNAVINST 12950.11 of 8/21/74, DEPARTMENT OF THE NAVY CIVILIAN WEAPON SYSTEMS ACQUISITION MANAGER CAREER MANAGEMENT PROGRAM. (F3.3)

ABBREVIATIONS

AAW	Antiair Warfare	CFSR	Contract Funds Status Report
ACAT	Acquisition Category	CG (---)	Commanding General (-----)
ACIP	Air Characteristics Improvement Panel	C ³ I	Command, Control, Communications, and Intelligence
ACNO(---)	Assistant Chief of Naval Operations for (-----)	CIA	Central Intelligence Agency
ACO	Administrative Contracting Officer	CIMP	Component Information Management Plan
ACPB	Acquisition Career Program Board	CINC (---)	Commander in Chief. (-----)
ADD	Automatic Document Distribution	CJCS	Chairman, Joint Chiefs of Staff
ADL	Authorized Data List	CMC	Commandant of the Marine Corps
ADM	Acquisition Decision Memorandum	CNA	Center for Naval Analyses
ADM	Advanced Development Model	CNO	Chief of Naval Operations
ADPE	Automated Data Processing Equipment	CNR	Chief of Naval Research
AFP	Approval for Full Production	COEA	Cost and Operational Effectiveness Analysis
AFRP	Approval for Full Rate Production	COM(---)	Commander, (---)
AFSC	Air Force Systems Command	COMMARCORSSYSCOM	Commander, Marine Corps Systems Command
AIS	Automated Information Systems	COMOPTEVFOR	Commander, Operational Test and Evaluation Force
ALP	Approval for Limited Production	COSATI	Committee on Scientific and Technical Information
ALRIP	Approval for Low Rate Initial Production	COTR	Contracting Officer's Technical Representative
AMC	Army Materiel Command	CPA	Chairman's Program Assessment
AMRAD	DOD Air Munitions Requirements and Development Committee	CPAM	CNO Program Analysis Memorandum
AMSDL	Acquisition Management Systems and Data Requirements Control List	CPFF	Cost Plus Fixed Fee
Ao	Operational Availability	CPFG	CNO Program and Fiscal Guidance
AP	Acquisition Plan	CPIF	Cost Plus Incentive Fee
AP	Acquisition Professional	CPR	Cost Performance Report
APB	Acquisition Program Baseline	CPS	Competitive Prototyping Strategy
APBA	Acquisition Program Baseline Agreement	CSC	Conventional Systems Committee
APL	Applied Physics Laboratory	C/SCSC	Cost/Schedule Control Systems Criteria
ARB	Acquisition Review Board	CSS	Contract Support Services
ARC	Acquisition Review Council	C/SSR	Cost/Schedule Status Report
ASD (---)	Assistant Secretary of Defense for (-----)	CSTAP	CNO Study and Analysis Program
ASN (---)	Assistant Secretary of the Navy for (-----)	DA	Developing Agency
ASN(RD&A)	Assistant Secretary of the Navy (Research, Development and Acquisition)	DAB	Defense Acquisition Board
ASR	Acquisition Strategy Report	DACM	Director Acquisition Career Management
ASUW	Antisurface Warfare	DAE	Defense Acquisition Executive
ASW	Antisubmarine Warfare	DAES	Defense Acquisition Executive Summary
AT	Acceptance Trials	D&F	Determinations and Findings
ATD	Advanced Technology Demonstration	D&V	Demonstration and Validation
ATD	Advanced Technology Development (Program)	DARPA	Defense Advanced Research Projects Agency
ATE	Automatic Test Equipment	DASN(---)	Deputy Assistant Secretary of the Navy for (---)
ATP	Advanced Technology Panel	DBOF	Defense Business Operating Fund
ATSD (---)	Assistant to the Secretary of Defense for (---)	DC	Development Coordinator
ATTS	Automatic Testing Technology Standardization (Program)	DCA	Defense Communications Agency
AUTEC	Atlantic Undersea Test and Evaluation Center	DCAA	Defense Contract Audit Agency
AWP	Acquisition Workforce Program	DCAS	Defense Contract Administration Services
BAA	Broad Agency Announcements	DCMC	Defense Contract Management Command
B&P	Bid and Proposal	DCNO (---)	Deputy Chief of Naval Operations for (-----)
BIS	Board of Inspection and Survey	DCS	Defense Communications System
BT	Builder's Trials	DC/S (---)	Deputy Chief of Staff Marine Corps for (-----)
CAIG	Cost Analysis Improvement Group		
CALS	Computer-Aided Acquisition and Logistics Support		
CBO	Congressional Budget Office		
CBR	Chemical, Biological, Radiological		
CCDR	Contractor Cost Data Reporting		
CE	Current Estimate		
CFE	Contractor-Furnished Equipment		

DDR&E	Director, Defense Research and Engineering	ILS	Integrated Logistic Support
DE	Development Estimate	ILSM	ILS Manager
DEP (---)	Deputy (-----)	ILSP	Integrated Logistic Support Plan
DFARS	DOD FAR Supplement	INFOSEC	Information Security
DIA	Defense Intelligence Agency	INO	Institute for Naval Oceanography
DID	Data Item Description	INS	Institute of Naval Studies
DISA	Defense Information Systems Agency	INSURV	Board of Inspection and Survey
DLA	Defense Logistics Agency	IOC	Initial Operational Capability (date)
DMA	Defense Mapping Agency	IOT&E	Initial Operational Test and Evaluation
DMRD	Defense Management Report Decisions	IPA	Integrated Program Assessment
DNA	Defense Nuclear Agency	IPL	Integrated Priority Lists
DNCPPG	DON Consolidated Planning and Programming Guidance	IPR	In-Process Review
DNFYF	Department of the Navy Future Years Program	IPS	Integrated Program Summary
DNI	Director of Naval Intelligence	IR&D	Independent Research and Development
DOD	Department of Defense	IR/IED	Independent Research/Independent Exploratory Development
DODISS	DOD Index of Specifications and Standards	IRM	Information Resource Management
DON	Department of the Navy	ISE	In-Service Engineering
DONPIC	Department of Navy Program Information Center	IWSDB	Integrated Weapon System Data Base
DOT&E	Director Operational Test and Evaluation	JANAP	Joint Army-Navy-Air Force Publication
DPA&E	Director Program Analysis and Evaluation	JCS	Joint Chiefs of Staff
DP&E	Director, Planning and Evaluation	JDT&E	Joint Development T&E
DPG	Defense Planning Guidance	JLC	Joint Logistics Commanders
DPI	Director, Program Integration	JLRSA	Joint Long-Range Strategic Appraisal
DPRB	Defense Planning and Resources Board	JMA	Joint Mission Area
DPSB	DON Program Strategy Board	JOT&E	Joint Operational T&E
DROLS	Defense RDT&E On-Line Systems	JROC	Joint Requirements Oversight Council
DRPM	Direct Reporting Program Manager	JSAT-EB	Joint Services Automatic Testing-Executive Board
DSB	Defense Science Board	JSP	Joint Service Program Plan
DSMC	Defense Systems Management College	JSPS	Joint Strategic Planning System
DSN	Defense Switch Network	JT&E	Joint Test and Evaluation
DSO	Director Staff Office	JSNS	Justification for System New Start
DT	Development Testing	LBTS	Land-Based Test Sites
DT&E	Developmental Test and Evaluation	LCC	Life Cycle Cost
DT&E	Director, Test and Evaluation	LFT&E	Livefire Test and Evaluation
DTC	Design-to-Cost	LRFP	Logistics Requirements and Funding Plan
DTIC	Defense Technical Information Center	LRG	Logistics Review Group
DUSD (---)	Deputy Under Secretary of Defense for (-----)	LRIP	Low Rate Initial Production
ECCM	Electronic Counter Countermeasures	LSA	Logistics Support Analysis
ECM	Electronic Countermeasures	MARCORSYSCOM	Marine Corps System Command
ECP	Engineering Change Proposal	MAS	Mission Area Strategies
ED	Exploratory Development	MBI	Major Budget Issues
EDM	Engineering Development Model	MC&G	Mapping, Charting, and Geodesy
EMC	Electromagnetic Compatibility	MCCDC	Marine Corps Combat Development Command
EMD	Engineering and Manufacturing Development	MCCR	Mission Critical Computer Resources
EMI	Electromagnetic Interference	MCIC	Marine Corps Intelligence Center
ESWBS	Expanded Ship Work Breakdown Structure	MCOTEA	Marine Corps Operational Testing and Evaluation Activity
EW	Electronic Warfare	MCPDM	Marine Corps Program Decision Meeting
FAR	Federal Acquisition Regulation	MDA	Milestone Decision Authority
FFP	Firm Fixed Price	MEWS	Mission-Essential Weapon System
FFRDC	Federally Funded Research and Development Centers	MI/DS	Management Information/Data Systems
FMF	Fleet Marine Forces	MILCON	Military Construction (appropriation)
FOT&E	Follow-on Operational Test and Evaluation	MIL-SPEC	Military Specification
FPI	Fixed-Price Incentive	MIL-STD	Military Standard
FRP	Full Rate Production	MIPR	Military Inter-Departmental Purchase Request
FY	Fiscal Year	MIS	Metrology Information Service
FYDP	Future Years Defense Program	MM&SC	Major Mission & Support Category
GAO	General Accounting Office	MNS	Mission Need Statement
GFE	Government-Furnished Equipment	MOE	Measures of Effectiveness
GFM	Government-Furnished Material	MOP	Measures of Performance
GIDEP	Government-Industry Data Exchange Program	MOU	Memorandum of Understanding
GOCO	Government-Owned, Contractor-Operated	MP	Materiel Professional (program)
GOGO	Government-Owned, Government-Operated	MP	Manpower and Personnel
GPO	Government Printing Office	MRTFB	Major Range and Test Facility Base
HQMC	Headquarters Marine Corps	MTBF	Mean Time Between Failures
IAC	Information Analysis Center	MTTR	Mean Time to Repair
IBR	Investment Balance Review	MUL	Master Urgency List
ICE	Independent Cost Estimates	MYP	Multi-Year Procurement
IDA	Institute for Defense Analyses	NADEC	Navy Decision Center
		NAE	Navy Acquisition Executive

NAMRL	Naval Aerospace Medical Research Laboratory	OASN(RD&A)	Office of the Assistant Secretary of the Navy (Research, Development and Acquisition)
NAPDD	Non-Acquisition Program Definition Document	OJCS	Organization of the Joint Chiefs of Staff
NAPS	Navy Acquisition Procedures Supplement	OLA	Office of Legislative Affairs
NARDIC	Navy Acquisition Research and Development Information Center	OMB	Office of Management and Budget
NAVAIR	Naval Air Systems Command	ONR	Office of Naval Research
NAVCOMPT	Office of the Comptroller of the Navy	OPA	Office of Program Appraisal
NAVEODTEHCEN	Naval Explosive Ordnance Disposal Technology Center	OPEVAL	Operational Evaluation
NAVFAC	Naval Facilities Engineering Command	OPN	Other Procurement, Navy (Appropriation)
NAVSEA	Naval Sea Systems Command	OPNAV	Office of the Chief of Naval Operations
NAVSUP	Naval Supply Systems Command	OPTEVFOR	Operational Test and Evaluation Force
NAWC	Naval Air Warfare Center	ORD	Operational Requirements Document
NAWCAD	Naval Air Warfare Center Aircraft Division	OSD	Office of the Secretary of Defense
NAWCWPNS	Naval Air Warfare Center Weapons Division	OSN	Office of the Secretary of the Navy
NBC	Nuclear, Biological, and Chemical	OT	Operational Testing
NBDL	Naval Biodynamics Laboratory	OTA	Operational Test Agency
NCA	Naval Center for Cost Analysis	OT&E	Operational Test and Evaluation
NCCOSC	Naval Command, Control, and Ocean Surveillance Center	OUSD(A)	Office of the Undersecretary of Defense for Acquisition
NCEL	Naval Civil Engineering Laboratory	PAMN	Procurement of Aircraft and Missiles, Navy (Appropriation)
NCTRF	Naval Clothing and Textile Research Facility	PAT&E	Production Acceptance Test and Evaluation
NCTS	Navy Computer and Telecommunications Station	PBD	Program Budget Decision
NDI	Non-Development Item	PCAD	Program Change Approval Document
NDRI	Naval Dental Research Institute	PCE	Program Cost Estimate
NESEA	Naval Electronic Systems Engineering Activity	PCR	Program Change Request
NESEC	Naval Electronic Systems Engineering Center	PD	Program Director
NESSEC	Naval Electronic Systems Security Engineering Center	PDA	Principal Development Activity
NHBS	Navy Headquarters Budget System	PDA	Program Decision Authority
NHPS	Navy Headquarters Programming System	PDASN	Principal Deputy Assistant Secretary of the Navy
NHRC	Naval Health Research Center	PdE	Production Estimate
NLCCG	Navy Laboratory/Center Coordinating Group	PDM	Program Decision Memorandum
NLCOG	Navy Laboratory/Center Oversight Council	PDR	Program Deviation Report
NMRDC	Naval Medical Research and Development Command	PDRC	Program Development Review Committee
NMRI	Naval Medical Research Institute	PDS	Primary Development Service/Agency
NMSD	National Military Strategy Document	PE	Program Element
NNOR	Nonnuclear Ordnance Requirements	PE	Planning Estimate
NOA	New Obligational Authority	PE	Procurement Executive
NPCP	Navy Potential Contractor Program	PEM	Program Endorsement Memorandum
NPDM	Navy Program Decision Meeting	PEO	Program Executive Officer
NPPO	Navy Program Planning Office	PES	Program Evaluation Summary
NPRDC	Navy Personnel Research and Development Center	P ³ I	Preplanned Product Improvement
NRAC	Naval Research Advisory Committee	PIC	Navy Department Program Information Center
NRL	Naval Research Laboratory	PM	Program Manager
NSA	National Security Agency	PMC	Program Management Course
NSC	National Security Council	POL	Petroleum, Oil, and Lubricants
NSEP	National Security Emergency Preparedness	POM	Program Objectives Memorandum
NSMRL	Naval Submarine Medical Research Laboratory	PPBS	Planning, Programming, and Budgeting System
NTE	Not-to-Exceed (contract price)	PPI	Pom Preparation Index
NTIS	National Technical Information Service	PR	Procurement Request
NTP	Naval Training Plan	PRCC	Program Review and Coordinating Committee
NTSC	Naval Training Systems Center	PRDR	Production Reliability Design Review
O&MN	Operation and Maintenance, Navy (Appropriation)	PRESINSURV	President, Board of Inspection and Survey
		PSA	Post Shakedown Availability
		QMR	Qualitative Material Requirements (Army)
		QPL	Qualified Products List
		RAD	Resource Allocation Display
		RAM	System Reliability, Availability, and Maintainability
		R&D	Research and Development
		R&M	Reliability and Maintainability
		R ³ B	Resource and Requirements and Review Board
		RD&A	Research, Development, and Acquisition
		RDDS	RDT&E Descriptive Summary
		RDT&E	Research, Development, Test, and Evaluation
		RDT&E.N	Research, Development, Test and Evaluation, Navy (Appropriation)
		RFP	Request for Proposal
		RFQ	Request for Quotation

RSI	Rationalization, Standardization, and Interoperability	SSIC	Standard Subject Identification Codes
RTF	Release to the Fleet	SSPO	Strategic Systems Program Office
SA	Support Area	SSSG	Surface Ship Survivability Group
SAE	Service Acquisition Executive	STAR	System Threat Assessment Report
S&T	Science and Technology	STI	Scientific and Technical Information
SAP	Ship Acquisition Plan	STIP	Scientific and Technical Information Program
SAR	Selected Acquisition Report	SYSCOM	Systems Command
SAVIAC	Shock and Vibration Information Analysis Center	TAB	Technical Abstracts Bulletin
SCIP	Ship Characteristics and Improvement Panel	TAD	Technology Area Description
SCN	Shipbuilding and Conversion, Navy (Appropriation)	T&E	Test and Evaluation
SCP	Sponsor Change Proposal	TDP	Technical Data Package
SECDEF	Secretary of Defense	TECG	Test and Evaluation Coordination Group
SECNAV	Secretary of the Navy	TECHEVAL	Technical Evaluation
SES	Senior Executive Service	TEIN	T&E Identification Number
SEW	Space and Electronic Warfare	TEMP	Test and Evaluation Master Plan
SHAPM	Ship Acquisition Program Manager	TLWR	Top Level Warfare Requirement
SIOP	Single Integrated Operational Plan	TOA	Total Obligation Authority
SLEP	Service Life Extension Program	TPWG	Test Planning Working Group
SNDL	Standard Navy Distribution List	UAV	Unmanned Aerial Vehicle
SOSUS	Submarine Ocean Systems Underwater Surveillance	USD(A)	Under Secretary of Defense (Acquisition)
SPAWAR	Space and Naval Warfare (systems command)	USD(P)	Under Secretary of Defense (Policy)
SPP	Sponsor Program Proposal	USN	Under Secretary of the Navy
SPPD	Sponsor Program Proposal Documentation	VCNO	Vice Chief of Naval Operations
SSA	Source Selection Authority	WBS	Work Breakdown Structure
SSAC	Source Selection Advisory Council	WSA	Warfare Systems Architecture (standards)
SSC	Strategic Systems Committee	WSE	Warfare Systems Engineering (standards)
SSEB	Source Selection Evaluation Board	WUIS	Work Unit Information System
		WWMCCS	Worldwide Military Command and Control System

INDEX

A

- Acceptance Trials, defined J
- Accounting systems for RDT&E 5.3
- Accrued expenditures, defined J
- ACIP
(Air Characteristics Improvement Panel) E9.7.1.2
- Acquisition
 - Alternative means of 6.1.4,6.1.5
 - AP (Acquisition Plan) 6.3.7
 - Basic roles in 6.1.3
 - Categories (ACAT) 1.1
 - Competition in 6.3.4
 - Decision Memorandum (ADM) 1.2
 - Defined J
 - Executive
 - Defense E1.2
 - Navy E2.1.1
 - Management Systems and Data Requirements
 - Control List (AMSDL) 6.7.1
 - Manager E10.8
 - Milestones, Decision Ch. 1
 - Ship programs F5
 - Of R&D, fundamental policy 6.1.1
 - Participants in process E10
 - Phases 1.1
 - Policy on selection of
 - performers 6.1.1,6.1.7
 - Process Outline Charts 1.2
 - Program Baseline Agreement (APBA) 1.2,1.3
 - Review Board (ARB) 1.2,E9.9
 - Strategy, Incremental F4.4.4
 - Team 6.4.1
 - Technical assistance for 6.4
- Advanced Development (6.3) 2.2.4
 - Defined 2.1.1.3,J
 - Demonstration and validation phase 2.1
 - Functions of 2.1
 - Role of Laboratories in 6.1.6.2
- Advanced Technology Demonstration
(ATD) (6.3A) 2.1.1.3
- Advanced Technology Development
(ATD) 2.2.3
- Advocate General
 - Competition 6.3.4
- Agency Component, defined J
- Agency Mission, defined J
- Air Characteristics Improvement
Panel (ACIP) E9.7.1.2
- Allocation, defined J
- AMSDL (Acquisition Management Systems
and Data Requirements Control List) 6.7.1
- Analysis, defined J
- AP (Acquisition Plan) 6.3.7
 - NDI in 6.3.7.1
- APBA (see Acquisition Program
Baseline Agreement)
- Appeal
 - Defined 4.2
 - Use of in budget process 4.4.4,4.7.5
- Apportionment 5.1
 - Defined 5.1,J
 - Documentation of 5.1.2
 - Request 5.1.1
- Appropriations
 - Act, responses to 5.1.1
 - Actions on general provisions of act 5.1.4
 - Categories used for C6
 - Committees 4.5.1,4.7
 - Defined 4.2,J
 - Duration of availability 4.2
 - Hearings, Congressional 4.5.1,4.7
 - Late 4.8
 - Listed 4.3.1
 - RDT&E,N Ch. 4,Ch. 5
 - Sponsor E10.1
 - Defined J
 - Structure, purpose of 4.3.3
- Approval
 - For full-rate production 7.1.7.1
 - For low rate initial production 7.1.7.2
- Armed Services Committees
 - Authorization hearings on budget 4.5.1,4.7
- Assessments (JMA&SA) and Investment Balance
Review 3.3.3,3.1,3.4.2
- Assistant Secretary of Defense
(Command, Control, Communications,
and Intelligence (ASD(C³I)) E1.6
(Production and Logistics) (ASD(P&L)) E1.1.2
(Program Analysis and Evaluation)
(ASD(PA&E)) E1.5
- Assistant Secretary of the Navy
(Research, Development, and Acquisition)
(ASN(RD&A)) E2.1.2
- Duties and responsibilities E2.1.2
- Navy Acquisition Executive E2.1.1
- Organization of office of E2.1.2
- RD&A responsibilities E2.1.2
- Role in preparation/justification of budget 4.6.3
- T&F responsibilities of 7.2.2

Assistant Secretary of the Navy (RD&A) (*Con't*)
 Witness for Appropriation hearing 4.7.3
 Assistant to the Secretary of Defense
 (Atomic Energy) (ATSD(AE)) E1.1.1.1
 ATD (Advanced Technology
 Demonstration) 2.1.1.3
 ATD (Advanced Technology
 Development) (6.3A) 2.2.3
 ATE (Automatic Test Equipment) E9.5
 Atlantic Undersea Test and Evaluation
 Center (AUTEK) G6.2.2
 Atlantic Fleet Weapons Training Facility G12.3
 Audit Program, Navy 5.5.2
 Contract 5.5.2
 Internal 5.5.2
 Audits and reviews 5.5
 AUTEK (Atlantic Undersea Test and
 Evaluation Center) G6.2.2
 Authorization, defined J
 Authorization hearings
 (Congressional) 4.5.1,4.7
 Automatic Document Distribution (ADD) D3.2.4
 Automatic Test Equipment (ATE) E9.5
 Defined J
 Automatic Testing, Joint Services
 Executive Board E9.5

B

Balanced program
 Concept of 4.4.2
 Baseline, Approved, defined J
 Baseline Assessments 3.4.4
 Baseline cost estimates F4.4.3.3
 Qualities of C2
 Benefit-Cost Analysis, defined J
 Bibliographies D3.2.5
 Bid and Proposal cost 6.5.4.3
 Bid package
 Defined 6.6.2
 Bidders
 Conference 6.6.3
 Evaluation of 6.6.4
 Mailing lists 6.6.3
 Board of Inspection and Survey
 (BIS) (INSURV) 7.2.4,G12.1
 Acceptance trials 7.4.3
 Board, Naval Studies of the National
 Academy of Sciences E9.10
 Boards and Other Groups E9
 Broad Agency Announcement
 Technique 6.6.6
 Budget Ch. 4,Ch. 5
 Activities (RDT&E)
 Defined C6.2
 Listed 4.3.2,C6.2
 Annex material 4.4.5.1
 Backup material 4.4.5.1
 CNR responsibilities 4.6.6
 Current Services 4.4.6
 Budget, defined J

Budget (*Con't*)
 Budget Authority, defined J
 Budgeting, defined 4.2.J
 Budget Mark-Up, defined 4.2.J
 Justification before Congress 4.7
 Justification material 4.4.5.1
 Operating 5.3.4.2
 Preparation and justification of Ch. 4
 Procedural guidance 4.4.5.1
 Process 4.4
 Navy participants in 4.6
 Supra-Navy participants in 4.5
 Relation to FYDP 4.1
 Role in management process 4.1
 Structure 4.3,C6.1
 Substantive guidance 4.4.5.2
 Summary Table 4.4.5.1
 Terms and Concepts 4.2
 Budget and Impoundment Control Act
 of 1974 4.4.6
 Bureau of Medicine and Surgery E3.10.2,E8
 Activities G7
 Bureau of Naval Personnel G10
 Laboratory G10.1

C

CAIG (DOD Cost Analysis Improvement
 Group) 1.2,F4.4.3.1
 CALS (Computer-Aided Acquisition
 and Logistics Support) 6.10
 Categories (FYDP) of RDT&E 2.1.1
 Categorization Systems App. C
 Criteria for C1.2
 Functions of C1.1
 Categorizations used for Appropriations C6
 CCDR (Contractor Cost Data Reporting) 6.7.4.2
 Center for Naval Analyses (CNA) G11.6
 Certification of ship aviation facilities 7.8.5
 CFSR (Contract Funds Status Report) 6.7.4.3
 Chairman's Program Assessment (CPA) 3.4.13
 Chart, Flow, defined J
 Charters for designated programs E10.6,F3.2
 Chief of Naval Operations (see CNO)
 Chief of Naval Research (see CNR)
 Chop, defined J
 Circular A-109, OMB F1.7.1
 Civil Engineering Laboratory G8.1
 CNA (Center for Naval Analyses) G11.6
 CNO (Chief of Naval Operations) E3
 Decision Process Groups E9.7
 Executive Steering Committee E9.7.4
 Role in budget process 4.6.4
 T&E organizations reporting to G12
 T&E responsibilities of 7.2.3
 CNR (Chief of Naval Research) E7
 Activities reporting to G3
 As a principal advisor to
 ASN(RD&A) E7
 RD&A responsibilities E7
 Role in preparation/justification of
 budget 4.6.6

COEA (Cost and Operational Effectiveness Analysis)	1.2,1.3,2.4.2,F1.4.1,F1.7,F4.4.1
Colleges and universities	
Class of RDT&E performers	6.1.4.2
Combat System, defined	J
Combat System Test Installation, defined	J
Commandant of the Marine Corps (CMC)	
Role in preparation/justification of budget	4.6.5
T&E organizations reporting to	G13
Commander, Marine Corps System	
Command (COMMARCORSYSCOM)	E6.1
Commerce Business Daily	
Synopsising of Solicitations in	6.6.3
Commitment, defined	J
Communications-Electronics, defined	J
COMOPTVFOR	7.2.5
T&E information from	7.6.4
Competition	
Acquisition of R&D via	6.6
Advocate General	6.3.4
As fundamental policy	6.1.1
Impact of data rights on	6.5.4.2
Importance of	6.3.4
Comptroller of the Department of Defense	E1.4
Comptroller of the Navy (NAVCOMPT)	4.6.2
Comptroller of ONR	4.6.6
Computer-Aided Acquisition and Logistics Support (CALs)	
Defined	J
Concept Demonstration/Validation Phase	2.1
Concept Exploration/Definition Phase	1.1
Conceptual effort	
Role of Laboratories in	6.1.6.3
Concurrent resolutions	4.4.6.1
Congress(ional)	
Budget committees	4.4.6,4.5.1
Budget Office (CBO)	4.4.6,4.5.1
Concurrent resolutions	4.4.6.1
Hearings	4.7
Conduct of	4.7.3
Guidelines for witnesses	4.7.1
Preparation for	4.7.2
Review and editing of transcript	4.7.4
Used as budget guidance	4.4.5.2
Interest in OT&E	7.1.5
Role in preparation/justification of budget	4.5.1
Consolidated Subject Index, Navy Directives	B3.1
Continuing resolution	
Use of with late appropriations	4.8
Contract(s)	
Administration of	6.7.5
And other acquisition instruments	6.5
Changes and amendments to	6.7.8
Data Requirements List (DD form 1423)	6.7.1
Contract(s) (Con't)	
Defined	6.5.2.J
Funds Status Report (CFSR)	6.7.4.3
General provisions	6.5.4
Grants	6.5.1
In-house laboratory work request	6.2.4
Types of	6.5.2
Cost	6.5.2.2
Defined	J
Cost-plus-Award-fee	6.5.2.5
Cost-plus-fixed-fee	6.5.2.3
Defined	J
Cost-plus-incentive-fee	6.5.2.4
Defined	J
Cost-Reimbursable Type	
Defined	J
Cost-sharing	6.5.2.1
Defined	J
Firm-fixed-price	6.5.2.7
Defined	J
Fixed-Price, defined	J
Fixed-price incentive	6.5.2.6
Fixed-Price with escalation, defined	J
Letter contract	6.5.2.9
Purchase order	6.5.2.8
Task-type, defined	J
Work statement	6.5.3.1
Contracting	
Activities	6.4.2
For Research and Exploratory Development	6.5.5
Officer	6.1.3,E10.9
Right of losers to information	6.3.2
Role of small business	6.3.3
Source selection	6.6.5
Contractor Support, defined	J
Contractor Cost Data Reporting (CCDR)	6.7.4.2
Control, defined	J
Cost	
Allocation to R&D projects	5.3.4
Analysis	F4.4.3
Defined	J
Improvement Group (CAIG)	1.2,F4.4.3.1
Defined	J
Responsibilities	F4.4.3.1
Assignment of to expenses vs investment	5.3.3.1
Bid and Proposal	6.5.4.3
Category, defined	J
Center, defined	J
Considerations	F4.4
Criteria and definitions for assignment of	5.3.3.2
Design to	F4.4.2
Estimates	
Baseline. Classes of	C2,F4.4.3.3
For DAB	F4.4.3.1
For use in SAR	C2.1
Independent	F4.4.3.1
Measures of confidence	C2.2

Cost (Con't)	
Estimates (Con't)	
Parametric	F4.4.3.2
Qualities of	C2
Estimation	F4.4.3
Data for	6.7.4.2
Growth defined	F4.4.3.3,J
Headquarters Budget System	F4.4.3.5
Headquarters Programming System	F4.4.3.5
Identification of	5.3.3
Life cycle	F4.4.3.6
Measurement	F4.4.5
Methodologies	F4.4.3.2
Models, defined	J
Overruns defined	F4.4.3.3
Performance Report (CPR)	6.7.4.1
Reporting	F4.4.5
Standard definitions	C8,F4.4.3.4
Cost and Operational Effectiveness	
Analysis (COEA)	1.2,1.3,2.4.2,F1.4.1,F1.7,F4.4.1
Cost/Schedule Control Systems Criteria	
C/SCSC	6.7.1
Cost/Schedule Status Report	
(C/SSR)	6.7.4.4
Coupling	F1.7
Customer-Supplier dialogue	
as framework for	F1.7
Panels, Committees, Boards, etc.,	
as an aid to	F2.2
CPA (Chairman's Program Assessment)	3.4.13
CPR (Cost Performance Report)	6.7.4.1
Critical Issues, defined	J
C/SCSC (Cost/Schedule Control Systems	
Criteria)	6.7.1
C/SSR (Cost/Schedule Status Report)	6.7.4.4
Current effort	
Identification of	6.2.1,D3.1.1,D3.1.2
Current Estimates (CE) for SAR,	
defined	C2.1
Customer-Supplier dialogue	F1.7
Customer functions in	F1.7
In acquisition	6.1.3
Supplier functions in	F1.7
D	
DAB (see Defense Acquisition Board)	
DAE Baseline, defined	J
DARPA (Defense Advanced Research	
Projects Agency)	E1.7.1
Data acquisition and data rights	6.5.4.2
Data, defined	J
Data exchange	
Government-Industry Program	
(GIDEP)	D7
Data system, defined	J
D&F (see Determinations & Findings)	
DBOF (Defense Business Operating	
Fund)	5.3.4.1
Use by laboratories	6.2.3
DCAA (Defense Contract Audit Agency)	E1.7.4
DCMC (Defense Contract Management	
Command)	6.7.5
DCNO (Deputy Chief of Naval Operations)	
Logistics (N4)	E3.5
Manpower and Personnel/Chief	
of Naval Personnel (DCNO(MP)) (N1)	E3.2
Plans, Policy and Operation (N3/N5)	E3.4
Resources, Warfare Requirements,	
and Assessments (N8)	4.6.4.1,E3.7
DD Forms	
1'05 Approved Apportionment and/or	
Reapportionment Schedule	5.1.2.1
1155 Purchase Order	6.5.2.8
1414 Base for Reprogramming Actions	5.4
1415 Reprogramming Action	5.4,5.4.1
1416 Report of Programs	5.4.3
1423 Contractor Data Requirements	
List	6.5.4.2,6.7.1
1473 Report Documentation Page	6.7.2
1498 Research and Technology Work Unit	
Summary	6.7.7.1
WUIS Data Base	D3.1.1
Role in identifying relevant work	6.2.1
DDR&E (Director Defense Research	
and Engineering)	E1.1.1
Defense Acquisition Board (DAB)	Ch. 1,E9.2
Acquisition Committees	E9.2.1
Defense Acquisition Executive (DAE)	E1.2
Defense Advanced Research Projects Agency	
(DARPA)	E1.7.1
Defense Agencies	E1.7
Defense Business Operating Fund	
(DBOF)	5.3.4.1
Use by laboratories	6.2.3
Defense Contract Audit	
Agency (DCAA)	E1.7.4
Defense Contract Management	
Command (DCMC)	6.7.5
Defense Information Systems	
Agency (DISA)	E1.7.3
Defense Intelligence Agency (DIA)	E1.7.5
Defense Logistics Agency (DLA)	E1.7.6
Defense Mapping Agency (DMA)	E1.7.8
Defense Nuclear Agency (DNA)	E1.7.2
Defense Planning and Resources Board	
(DPRB)	E9.4
Defense Planning Guidance (DPG)	3.3,3.3.2,3.3.3,3.4.11
Defense Program, defined	J
Defense RDT&E On-Line Systems	
(DROLS)	D3.2.1
Defense Research, defined	J
Defense Research Sciences	C3.1.1
Defense Science Board (DSB)	E9.1
Defense Systems Management	
College (DSMC)	E5
Training of Program Managers	E5
Defense Technical Information Center	
(DTIC)	D3
Services	D3.2
T&E reports available through	7.6.6

Deferrals	
Administration of	5.1.5
Demonstration and Validation phase	
of weapons life cycle	1.1
Decision, defined	J
Demonstration of performance	
Policy on	7.1.3
Department of the Navy Objectives	E2
Deputy Assistant Secretary of	
the Navy (DASN)	1.2, App. E
Deputy Chief of Naval Operations (see DCNO)	
Deputy Under Secretary of Defense	
(International Programs) (DUSD(IP))	E1.1.8
Design specifications	6.5.3
Design to cost (DTC)	F4.4.2
Designated Programs	F3.2
Determination and Findings (D&F), defined	J
Development Estimates (DE) for SAR,	
defined	C2.1
Development Test and Evaluation	
(DT&E)	7.4.1
DIA (Defense Intelligence Agency)	E1.7.5
Direct Reporting Program Manager	
(DRPM)	1.2, E10.5
Directives	
DOD, how to obtain	B4
Navy, how to obtain	B3
Numbering of Navy	B2, C9
System, described	App. B
Director,	
Air Warfare (N88)	E3.7.5
Assessments (N81)	E3.7.2
Naval Intelligence (N2)	E3.3
Programming (N80)	E3.7.1
Space and Electronic Warfare (N6)	E3.6
Submarine Warfare (N87)	E3.7.4
Surface Warfare (N86)	E3.7.3
Test and Evaluation and Technology	
Requirements (N091)	E3.1
role in budget process	4.6.4.2
Director, (in OSD)	
Acquisition Policy and Program	
Integration	E1.1.7
Defense Procurement	E1.1.6
Defense Research and	
Engineering (DDR&E)	E1.1.1
Operating Test and	
Evaluation (DOT&E)	7.2.1.2, E1.3
Strategic and Space Systems	E1.1.4
Tactical Systems	E1.1.5
Test and Evaluation (DT&E)	7.2.1.1, E1.1.3
DISA (Defense Information Systems	
Agency)	E1.7.3
Distribution Statement, defined	J
DLA (Defense Logistics Agency)	E1.7.6
DMA (Defense Mapping Agency)	E1.7.8
DNA (Defense Nuclear Agency)	E1.7.2
DNCPPG (Department of the Navy	
Consolidated Planning and	
Programming Guidance)	3.4.8
DNCPPG (Department of the Navy (<i>Con't</i>))	
Documents used in updating	3.4
Document(s)	
Defined	J
Identifying	D3.2.5
Obtaining copies	D3.2.4
DOD Budget structure	C6.1
DODISS (DOD Index of Specifications	
and Standards)	6.5.3.2
DOT&E (Director, Operational Test and	
Evaluation)	1.2, 7.2.1.2, E1.3
DPG (Defense Planning Guidance)	3.4.11
DPRB (Defense Planning and Resources	
Board)	E9.4
DPSB (DON Program Strategy Board)	E9.11
DROLS (Defense RDT&E On-Line	
Systems)	D3.2.1
DRPM (Direct Reporting Program	
Manager)	1.2, E10.5
DSB (Defense Science Board)	E9.1
DT&E (Development Test and	
Evaluation)	2.4, 7.4.1
DTC (Design to Cost)	F4.4.2
DTIC (see Defense Technical Information Center)	
E	
Economic analysis	F4.4.1
Defined	J
Educational and nonprofit institutions	
<i>Government equipment for</i>	6.5.5.2
Effectiveness, defined	J
Engineering Development (6.4)	2.2.4
Defined	2.1.1.4
Engineering management	F1.4.2
Evaluation	
Defined	7.1.1
Execution of R&D, fundamental	
policy for	6.1.1
Expenditure of funds	5.2
Expenditures, defined	J
Expenses, defined	J
Expertise	
Identification of	6.2.1, D3.2.7
Exploratory Development (6.2)	2.2.2
Block Program	
Defined	C4.1.3
Guidance	2.2.2.3
Plans	2.2.2
Project, defined	C4.1.4
Contracting for	6.5.5
Defined	2.1.1.2
Investment Strategy	2.2.2.3
Mission Area Strategy	2.2.2.3
Planning documentation	2.2.2.2
Planning process	2.2.2.3
Program	2.2.2
Program building blocks	C4.1
Program elements	C4.1.1
Listed	4.2
Program planning structure	C4

F

Facilities	
Engineering Command (NAVFAC)	E4.3
Funding through MILCON	
appropriation	F4.2
Planning for	F4.2
FAR (Federal Acquisition Regulation)	6.3.1
Feasibility Studies	
Role of laboratories in	6.1.6.3
Federal Acquisition Regulation (FAR)	6.3.1
Federally Funded Research	
and Development	6.1.4.2
Fiscal Year	4.4.6
Fleet Marine Force (FMF)	7.2.10.2,E6.5
Fleet RDT&E Support	7.3.7
Priorities	7.3.7.2
Requirements	7.3.7.1
Flyaway Cost	F4.4.3.4
Definition of	C8
Foreign Systems	
Test and Evaluation of	7.1.8.1
FOT&E (Follow-on OT&E)	7.4.2,7.4.2.3,7.4.2.4
Full disclosure policy in R&D contracts	6.5.5.1
Full-Rate Production Approval for (AFRP)	7.1.7.1
Function Specifications	6.5.3
FYDP (Future Years Defense Program)	3.2
Annual updating process	3.3
Description of	3.2
Documents used in updating	3.4
Major programs listed	C7.1
Program element, defined	C7.2
Relation to budget	4.1

G

GAO (General Accounting Office)	5.5.1
GFE (Government-Furnished Equipment)	6.3.5
GIDEP (Government-Industry Data Exchange	
Program)	D7
GOGO (Government-Owned, Government	
Operated)	6.1.4.1
Government-furnished equipment (GFE)	6.3.5
Government-Industry Data Exchange Program	
(GIDEP)	D7
Government-Owned, Government	
Operated (Laboratory/Center) (GOGO)	6.1.4.1
Grants	6.5.1
Guidance procedural and substantive	4.4.5

H

Harmonizing programming, budgeting,	
and accounting	5.3.2
Heartburns and Appeals	4.7.5

I

IAC (Information Analysis Centers)	D4
IBR (Investment Balance Review)	3.4.3
ICE (Independent Cost Estimates)	1.2

ILS (Integrated Logistic Support)	F4.1
Concept	F4.1
Elements of	F4.1
Plan	
Role of laboratories in preparation of	6.1.6.3
T&E of	7.7
Timing of	7.7.2
Utilization of	7.7.4
Incremental Acquisition Strategy	F4.4.4
Incremental funding (see Incremental	
programming)	
Incremental programming	4.4.3
Independent Cost Estimates (ICE)	1.2
Independent Research and	
Development (see IR&D)	
Independent Research and Independent	
Exploratory Development (see IR/IED)	
Information Analysis Centers (IAC)	D4
Defined	J
Information flow	
In RDT&E process	F1.2
Information Retrieval System, defined	J
Information System, defined	J
In-house performance, acquisition	
through	6.1.4.1.6.2
In-house vs contracting out decision	6.1.7
Initial Operational Test and Evaluation	
(see IOT&E)	
Innovation	
Concept of	F1.6
Differentiated from invention	F1.6
INSURV (Board of Inspection	
and Survey)	7.2.4,G12.1
Acceptance trials	7.4.3
Integrated Logistic Support (see ILS)	
Integrated Priority List (IPL)	3.4.5
Integrated Program Assessment (IPA)	1.2,2.2.4.2
Integrated Program Summary (IPS)	1.2,1.3.2.2.4.2
Integrated Weapon System Data	
Base (IWSDB)	6.10
Internal Audit, defined	J
Invention	
Concept of	F1.6
Different from innovation	F1.6
Investment	
As FYDP cost category	5.3.3.2
Cost, defined	J
Investment Balance Review (IBR)	3.4.3
IOT&E (Initial Operational Test and	
Evaluation)	7.4.2
Defined	7.4.2
OPEVAL as	7.4.2.2
Policy on timing of	7.1.3
IPA (see Integrated Program Assessment)	
IPL (see Integrated Priority List)	
IPS (see Integrated Program Summary)	
IR&D (Independent Research and	
Development)	6.5.4.3
Data base of DTIC	D3.1.2

IR/IED (Independent Research and Independent
Exploratory Development) 6.2.5
Role in technology base development 6.1.6.1
IWSDB (Integrated Weapon System
Data Base) 6.10

J

JCS (Joint Chiefs of Staff)
RD&A responsibilities E1.8
Joint Mission Area (JMA) 3.4.2
Joint Requirements Oversight
Council (JROC) 1.2,E9.3
Joint Service Programs 7.4.4
Funding of 7.4.4.4
Joint Services Automatic Testing
Executive Board (JSAT-EB) E9.5
Joint Test and Evaluation (JT&E) 7.4.4.1
Justification
Role in budget process 4.4.4
Of budget before Congress 4.7

L

Laboratories/Centers App. G
Defined J
Functions in execution of RDT&E 6.1.6
Funding of work 6.2.3
Identification of capabilities of 6.2.1
IR/IED 6.2.5
Monitoring of work performed by 6.2.2
Naval Laboratories and Centers
Atlantic Fleet Weapons Training
Facility G12.3
Atlantic Undersea Test and
Evaluation Center (AUTECE) G6.2.2
Naval Aerospace Medical
Research Laboratory G7.1.7
Naval Air Warfare Center (NAWC) G4.1
Aircraft Division (NAWCAD) G4.1.1
Weapons Division (NAWCWPNS) G4.1.2
Naval Biodynamics Laboratory G7.1.8
Naval Civil Engineering Laboratory G8.1
Naval Command, Control, and Ocean
Surveillance Center (NCCOSC) G5.1
RDT&E Division G5.1.1
ISE Division West G5.1.2
NESEC, Portsmouth G5.1.3
NESEC, Charleston G5.1.4
NESEA, St. Inigoes G5.1.5
NESSEC, Washington, D.C. G5.1.6
Naval Dental Research Institute G7.1.6
Naval Explosive Ordnance Disposal
Technology Center (NAVEODTECHCEN) .. G6.3
Naval Medical Research Institute G7.1.1
Naval Medical Research Units G7.1.3,G7.1.4
Naval Research Laboratory (NRL) G3.1
NRL, Bay St. Louis G3.1
NRL, Monterey G3.1
NRL, Orlando G3.1

Laboratories/Centers (Cont')
Naval Laboratories and Center (Con't)
Naval Submarine Medical Research
Laboratory G7.1.2
Naval Surface Warfare Center (NSWC) G6.1
NSWC, Carderock Division G6.1.1
NSWC, Crane Division G6.1.2
NSWC, Dahlgren Division G6.1.3
NSWC, Indian Head Division G6.1.4
NSWC, Port Hueneme Division G6.1.5
Naval Undersea Warfare Center (NUWC) G6.2
NUWC Division, Keyport G6.2.1
NUWC Division, Newport G6.2.2
Navy Clothing and Textile Research
Facility G9.1
Navy Personnel Research and
Development Center G10.1
Negotiation with 6.2.2
Not-for-Profit-Activities G11
Applied Physics Laboratories,
Johns Hopkins Univ. G11.5
Univ. of Washington G11.4
Applied Research Laboratories,
Penn State Univ. G11.2
Univ. of Texas, Austin G11.3
Center for Naval Analyses (CNA) G11.6
Marine Physical Laboratory, Scripps
Institution of Oceanography G11.1
Performance of RDT&E effort by 6.1.4.1,6.2
Reporting by 6.7.7.3
Reporting to ONR G3
Role in Advanced Development 6.1.6.2
Role in execution of Marine Corps
RDT&E 6.8.5
Role in RDT&E G1
Role in systems definition 6.1.6.3,6.3.5
Staffing for acquisition team
source of 6.4.1
Support for systems development 6.4.1
Technical advice
Source 6.1.6.4
Land-Based Test Site (LBTS), defined 7.3.4.J
LCC (Life Cycle Cost) F4.4.3.6
Lead-Time, Procurement, defined J
Lead-Time, Production, defined J
Letter contracts 6.5.2.9
Libraries
Technical D2
Life Cycle, weapons 1.1
Life-Cycle Cost (LCC) F4.4.3.6
Defined J
Logistics Support, defined J
Logistics and Resources F4
Low Rate Initial Production (LRIP) 7.1.7.2,7.4.2.1.1

M

Maintenance Engineering, defined J
Major Budget Issues (MBI) 3.4.16
Major Programs (FYDP)
Listed C7.1

Major Range and Test Facility Base (see MRTFB)	
Management and Support (6.5)	
Defined	2.1.1.5,J
Management control systems	
In contracting	6.7.1
Manufacturing Technology, defined	J
Marine Corps	
Alternative means for executing RD&A	6.8.1
Combat Development Command (MCCDC)	E6.2
Deputy Chief of Staff (DC/S) for	
Aviation	E6.3.1
Manpower	E6.3.2
Installations and Logistics	E6.3.3
Requirements and Programs	E6.3.4
Director, Command, Control	
Communications and Computers	E6.3.5
Execution of RD&A	6.8
Fleet Marine Forces (FMF)	7.2.10.2,E6.5
Liaison organization	E6.4
Management of RD&A acquisition	6.8.3
Organization for RD&A	E6
Program cognizance within	6.8.2
Program Decision Meetings (MCPDM)	E9.8
Role of laboratories in RD&A	6.8.5
Mark-up	
As budgeting term, defined	4.2
Materiel Professional (MP) Program	F3.4
MBI (Major Budget Issues)	3.4.16
MCOTEA (Marine Corps Test and Evaluation Activity)	7.1.3,7.2.10.1,G13.2
MCPDM (Marine Corps Program Decision Meeting)	E9.8
Measures of Effectiveness (MOE)	2.4.2
Measures of Performance (MOP)	2.4.2
Medical Research and Development	
Command	E8.1
Activities	G7
Medicine and Surgery, Bureau of	E8
Metrology, defined	J
MILCON	
As a T&E cost	7.3.3,7.5.4
As element of program acquisition cost	C8
Funding of RDT&E-related construction	F4.2
Milestones, acquisition decision	
0 - Concepts Study Approval	1.1,1.2
I - Concept Demonstration Approval	1.1,1.2
II - Development Approval	1.1,1.2
III - Production Approval	1.1,1.2
IV - Major Modification Approval	1.1,1.2
for Ship Programs	F5
Process charts	
ACAT I and II programs	1.2
ACT III programs	1.2
ACAT IV programs	1.2
T&E information inputs into	7.1.2.2
Military Inter-Departmental Purchase Request (MIPR), defined	J
MIL-STD-499A, Engineering	
Management	F1.4.2,F1.4.3
MIL-STD-847A, Format Requirements for Scientific and Technical Reports Prepared by and for the DOD	6.7.2
MIL-STD-881, Work Breakdown Structure	C11,F4.4.3.2
Missions and functions of laboratories and centers	
Information on	6.2.1,App. G
Mission Area, defined	J
Mission Need Categorization Structures	C5
Mission Need Determination (Milestone 0)	Ch. 1
Mission Need Statement (MNS)	1.1,1.2,1.3
MRTFB (Major Range and Test Facility Base)	7.3.5,G14
Elements of: Army, Navy, Air Force	7.3.5.1
N	
N091 Director, Test and Evaluation and Technology Requirements	7.2.3,E3.1
N911 Science and Technology Requirements Division	E3.1.1
N912 Test and Evaluation Programs Division	7.2.3,E3.1.2
N913 RDT&E Facilities and Resources Division	7.2.3,7.3.5,E3.1.3
N093 Surgeon General of the Navy	E3.8
N096 Oceanographer of the Navy	E3.9
N1 DCNO (Manpower and Personnel)	E3.2
N2 Director of Naval Intelligence	E3.3
N3/N5 DCNO (Plans, Policy, and Operations)	E3.4
N4 DCNO (Logistics)	E3.5
N6 Director of Space and Electronic Warfare	E3.6
N8 DCNO (Resources Warfare Requirements, and Assessments)	3.4.2,3.4.9,E3.7
N80 Programming Division	3.4.1,E3.7.1
N81 Assessment Division	3.4.3,E3.7.2
N86 Surface Warfare Division	E3.7.3
N87 Submarine Warfare Division	E3.7.4
N88 Air Warfare Division	E3.7.5
NAE (Navy Acquisition Executive)	E2.1.1
NAPS (Navy Acquisition Procedures Supplement)	6.3.1
NARDIC (Navy Acquisition, Research and Development Information Center)	D5
National Academy of Sciences	
Naval Studies Board	E9.10
National Military Strategy Document (NMSD)	3.4.10
National Security Agency (NSA)	E1.7.7
National Technical Information Service (NTIS)	D8
NAVAIR (Naval Air Systems Command)	E4.2
Activities	G4
Naval Explosive Ordnance Disposal Technology Center (NAVEODTEHCEN)	G6.3

Naval Laboratories and T&E activities (see Laboratories/Centers)	
Naval Oceanography Command	E3.10.3
Naval Research Advisory Committee (NRAC)	E9.6
Naval Research Program	
Element (FYDP)	C3.1.1
Planning of	2.2.1
Structure	C3
Subelements of Defense Research Sciences	C3.1.2
Naval Vehicles, defined	J
NAVCOMPT (Comptroller of the Navy)	
Role in preparation/justification of budget	4.6.2
NAVEODTECHCEN (Naval Explosive Ordnance Disposal Technology Center)	G6.3
NAVFAC (Naval Facilities Engineering Command)	E4.3
Laboratory	G8
NAVSEA (Naval Sea Systems Command)	E4.4
Activities	G6
NAVSUP (Naval Supply Systems Command)	E4.5
Laboratory	G9
Navy Acquisition Executive (NAE)	E2.1.1
Navy Acquisition, Research & Development Information Center (NARDIC)	D5
Navy Consolidated Subject Index (NAVPUBINST 5215.1)	B3.1
Navy Headquarters Budget System (NHBS)	F4.4.3.5
Navy Headquarters Programming System (NHPS)	F4.4.3.5
Navy Laboratory/Center Coordinating Group (NLCCG)	E9.12
Navy Laboratory/Center Oversight Council (NLCOC)	E9.13
Navy/Marine Corps Program Decision Meeting (NPDM/MCPDM)	E9.8
Navy Potential Contractor Program (NPCP)	D6
Navy Procurement Executive	E2.1.2
Navy Staff Executive Steering Committee	E9.7.3
NDI (Non-Development Item)	
Acquisition Plan	6.3.7.1
Milestone decisions	6.1.2
Policy on	6.1.1
T&E for	7.1.8
Needs	
As used by OSD	F1.7.1
Differentiated from "requirements,"	F1.7.1
New Obligation Authority (NOA), defined	J
NLCCG (Navy Laboratory/Center Coordinating Group)	E9.12
NLCOC (Navy Laboratory/Center Oversight Council)	E9.13
NMSP (National Military Strategy Document)	3.4.10
Non-Development Item (see NDI)	
Nonnuclear Ordnance Requirement Panel (NNOR)	E9.7.1.3
Not-for-profit laboratories (see Laboratories/Centers)	
NPCP (Navy Potential Contractor Program)	D6
NPDM (Navy Program Decision Meeting)	E9.8
NRAC (Naval Research Advisory Committee)	E9.6
NRL (Naval Research Laboratory)	G3.1
NSA (National Security Agency)	E1.7.7
NTIS (National Technical Information Service)	D8
Q	
Obligation and expenditure of funds	5.2
Obligation, defined	J
Oceanographer of the Navy	E3.9
Office of Chief of Naval Operations (see OPNAV)	
Office of Naval Research	E7
Authorized to issue grants	6.5.1
Budgetary guidance, promulgation of	4.6.6
Organization and mission of	E7
Role in preparation/justification of budget	4.6.6
Office of Program Appraisal (OPA)	E2.1.3
Office of the Secretary of Defense (see OSD)	
OMB (Office of Management and Budget)	
Circular A-109	F1.7.1
Role in preparation/justification of budget	4.5.3
Support of President in preparation/justification of budget	4.5.2
OPA (Office of Program Appraisal)	E2.1.3
Operability, defined	J
Operating budgets	5.3.4.2
Approved, defined	J
Role in funding work by laboratories	6.2.3
Operational Availability (Ao)	7.7.1.1
Defined	J
Operational Capability	
Concept of	F1.1
Defined	J
Elements of	F1.1
RDT&E as a subsystem of	F1.5
Operational Evaluation (OPEVAL)	7.4.2.2
Operational Requirements Document (ORD)	1.2.1.3
Operations and Support Phase (of weapons life cycle)	1.1.2.2.4.3
Operational Systems Development (6.6)	2.2.4
Defined	2.1.1.6

Operational Test and Evaluation	
(OT&E)	7.4.2
Defined	J
Director OT&E	7.2.1.2,E1.3
Force (see OPTEVFOR)	
OPEVAL (Operational Evaluation)	7.4.2.2
OPNAV (Office of Chief of Naval	
Operations)	E3
OPTEVFOR (Operational Test and Evaluation	
Force)	7.2.5,G12.2
Early coordination with	7.5.2
Independent OT&E organization	7.2.5
Mission	G12.2.1
Subordinate commands	G12.2.3
T&E responsibilities	7.2.5
ORD (Operational Requirements Document)	1.2,1.3
Organization for RD&A	App. E
OSD (Office of Secretary of Defense)	E1
Organization for RD&A	E1
OT&E (Operational Test and	
Evaluation) (see also OPTEVFOR)	2.4,7.4.2
Congressional interest in	7.1.5
Director (DOT&E)	7.2.1.2,E1.3
Outlays, defined	J

P

Parametric Cost Estimate, defined	J
PAT&E (Production Acceptance Test and	
Evaluation)	7.4.1.4
Patents	
As aid to coupling	F1.7.3
Contract provisions on rights	6.5.4.1
PBD (Program Budget Decision)	3.4.15,4.5.4
PDM (Program Decision	
Memorandum	3.4.14
PEO (Program Executive Officer)	1.2,E10.5
Performance specification	
Defined	6.5.3
Performers of RDT&E	
Classes of	6.1.4
Commercial contractors	6.1.4.2,6.3
Definition of as used in	
this Guide	6.1.4
Educational and nonprofit	6.1.4.2
In-house	6.1.4.1
Out-of-house	6.1.4.2
Personnel, Bureau of	G10
Personnel support, planning for	F4.3
Pilot Production, defined	J
Planning Estimate (PE) for SAR	
Defined	C2.1
Planning, Programming and Budgeting	
System (PPBS)	Ch. 3
Defined	J
Platform resources, RDT&E	7.3.8
PM (Program Manager)	6.9,E10.6

POM (Program Objectives	
Memorandum)	3.4.12
PDM as decision document	3.4.14
Post-SPP Program Assessments	3.4.7
PPBS (Planning, Programming and Budgeting	
System)	Ch. 3
PR (Procurement Request)	6.6.1
President, role in budget process	4.5.2
Presolicitation Conference	6.6.3
Process Outline charts	
Acquisition process	1.2
Milestone document preparation	1.3
Procurement	
Cost, defined	C8
Defined	J
Request (PR)	6.6.1
Production Acceptance Test and	
Evaluation (PAT&E)	7.4.1.4
Production and Deployment Phase	1.1
Production, approval for	
Full rate	7.1.7.1
Low rate initial	7.1.7.2
Production Estimate (PdE) for SAR, defined	C2.1
Production Milestones	7.1.7
Program	
FYDP described	3.2
Major listed	C7.1
Program (acquisition version), defined	J
Program (PPBS version), defined	3.2.2,J
Program Acquisition Cost	F4.4.3.4
Defined	C8,J
Program and Fiscal Guidance	
(POM dev.)	3.4.9
Program Baseline, defined	J
Program Budget Decision (PBD)	3.4.15,4.5.4
Defined	J
Program changes, control of	6.9
Program Change Decision (PCD), defined	J
Program Change Request (PCR), defined	J
Program Decision Memorandum (PDM)	1.2,3.4.14
Defined	J
Program element	3.2.1,C4.1.1,C7.2
Defined	J
Program Evaluation, defined	J
Program Executive Officer (PEO)	E10.5
Program Life Cycle Cost Estimate	1.2,1.3
Program management	6.9,F3
Characteristics of	F3.1
Program management (of RD&A performance)	6.9
Defined	J
Program Manager	E10.6
Charter, defined	J
Direct Reporting	E10.5
Selection of	F3.3
Ship Acquisition	E10.7
T&E information for	7.6.2
T&E responsibilities of	7.2.7
Training of	F3.3

Program Objectives Memorandum (see POM)	
Program Review and Coordinating Committee (PRCC)	E9.7.2
Program Sponsor	E10.2
Program Structure	
Naval Research	C3
Exploratory Development	C4
Programming (DOD Programming System)	
Defined	J
Objectives	3.1
Programming	Ch. 3
Division (N80)	E3.7.1
Incremental	4.4.3
Programs, designated	
Charters	F3.2
Establishment of	F3.2
Staffing of	F3.3
Progress reports	6.7.3
Project	
Exploratory Development, defined	C4.1.4
Project listings, RDT&E	4.2,6.7.7.2
Projected Operational Environment, defined	J
Project Order, defined	J
Proposals	
Evaluation of	6.6.4
Request for (see RFP)	
Provisioning, Initial, defined	J
Provisioning, Phased, defined	J
Purchase Description	
As substitute for specifications	6.5.3
Purchase Order	6.5.2.8

Q

Quality Assurance, defined	J
----------------------------	---

R

R ³ B (Resources and Requirements Review Board)	3.3,3.3.1,3.4.2,E9.7.1
R&D Responsibility Center, defined	J
Range and Test Facility Base, Major (see MRTFB)	
Ranges, Test	
Atlantic Fleet Weapons Training Facility	G12.3
AUTEK	G6.2.2
Naval Air Weapons Station, China Lake	G4.1.2
Naval Surface Warfare Center, Dahlgren Division	G6.1.3
RD&A (Research, Development, and Acquisition)	
As a subsystem	F1.5
Committees and Boards concerned with	E9,F2.2
Coordination and Focus	F2.1
Cost	F4.4
DON responsibilities for	E2
Fleet support	7.3.7
Functional view of process	2.1
FYDP categories defined	2.1.1
Marine Corps planning categories listed	C5.1
Nature of process	F1.2
Output of process	F1.1
Overview of process	F1

RD&A (Research, Development, and Acquisition) (Con't)	
Performers	
Classes of	6.1.4
Policy on selection of	6.1.7
Personnel	F4.3
Process Integration	F2
RDDS (RDT&E Descriptive Summary)	4.4.7
RDT&E (Research, Development, Test, and Evaluation)	
Accounting for	5.3
Appropriation	
Budget activities of	4.3.2,C6.2
Descriptive Summary (RDDS)	4.4.7
As element of Program Acquisition	
Cost	C8
Field activities	App. G
Program, defined	J
Project listings	4.2.6.7.7.2
RDT&E,N appropriation	Ch. 4,Ch. 5
Reclama, defined	4.2
Reimbursable Order, defined	J
Reliance, Project	2.3.1
Reporting by laboratories/centers	6.7.7.3
Reports, progress	6.7.3
Reports, technical	6.7.2
Announcement of	D3.2.2
Identifying	D3.2.5
Obtaining copies	D3.2.2,D3.2.4,D3.2.6
Reprogramming/Reprogramming Actions	
Base for	5.4
Defined	J
DD Form 1415, use in	5.4.1
Hearing for	5.4.2
Internal Navy for RDT&E,N	5.4.4
Procedures for	5.4.1
Reports	5.4.3
Request for Proposals (RFP)	6.6.2.6.6.3
Request for Quotations (RFQ)	6.6.2.6.6.3
Requirements	
Differentiated from needs	F1.7.1
For ILS T&E	7.7.1
Officer	E10.4
Requirements pull	F1.7.2
Research and Technology Work Unit Summary (see DD Form 1498)	
Research (Budget Category 6.1)	2.2.1
Contracting for	6.5.5
Defined	2.1.1.1,J
Program building blocks	C3.1
Program elements	C3.1.1
Program Subelements	C3.1.2
Sponsor Codes	C3.1.3
Resource and Requirements and Review Board (R ³ B)	3.3,3.3.1,3.4.2,E9.7.1
Resource Sponsor	E10.3
Responsibilities	
ASN(RD&A)	E2.1.2
CNO	E3
CNR	E7
COMMARCORSSYSCOM	E6.1

Responsibilities (Con't)	
DDR&E	E1.1.1
Defense Acquisition Executive	E1.2
Department of the Navy	E2
JCS	E1.8
SECDEF	E1
SECNAV	E2.1
RFP (Request for Proposals)	6.6.2,6.6.3
RFP/RFQ, promulgation of	6.6.2,6.6.3

S

SA (Support Area)	3.3,3.4.2,3.4.3
SAR (Selected Acquisition Report)	6.7.6,F4.4.5
SAVIAC (Shock and Vibration Information Analysis Center)	D4.2
Science and Technology	
Resource Sponsor (N091)	2.2.1.1,2.2.2.1,2.2.3.1
Subject Categories	C10
Thrusts	2.3.2,C4.1.2
Scientific and Technical	
Information (STI)	F2.3
Defined	J
Program	D1
Reports	6.7.2
SCIP (Ship Characteristics and Improvement Panel)	E9.7.1.1
SCP (Sponsor Change Proposal)	3.4.6
Sea Systems Command (NAVSEA)	E4.4
SECDEF (Secretary of Defense)	E1
RD&A responsibilities	E1
Role in preparation/justification of budget	4.5.4
SECNAV (Secretary of the Navy)	E2.1
RD&A responsibilities	E2.1
Role in preparation/justification of budget	4.6.1
T&E responsibilities	7.2.2
Selected Acquisition Report (SAR)	6.7.6,F4.4.5
Defined	J
Ship Acquisition Program Manager (SHAPM)	7.8.2,E10.7
Ship Characteristics and Improvement Panel (see SCIP)	
Ship Design Manager	7.8.3
Ships	
Acceptance of	7.8.4
Certification of aviation facilities	7.8.5
Expanded Ship Work Breakdown Structure (ESWBS)	C11.1
Program Milestones	F5
T&E of	7.8
Organization for	7.8.3
Planning for	7.8.2
Policies and principles	7.8.1
Shock and Vibration Information Analysis Center (SAVIAC)	D4.2
Should-Cost Study, defined	J

Small business	
Contracting policy on	6.3.3
Sole Source	6.3.4
Solicitation documents	6.6.2
Promulgation of	6.6.3
Source selection	6.6.5
Defined	J
Space and Naval Warfare Systems	
Command (SPAWAR)	E4.6
Specifications and Standards	6.5.3
Acquisition streamlining	6.5.3.1
Catalogs of	6.5.3.2
Defined	6.5.3.J
Federal	6.5.3.2
Listings of	
DOD Index of Specification and Standards (DODISS)	6.5.3.2
Federal Specifications, Standards and Handbooks	6.5.3.2
Military	6.5.3.2
Obtaining copies of	6.5.3.2
Role in contracting	6.5.3
Role of laboratories in development of	6.1.6.3
Sponsor	
Appropriations	E10.1
Program	E10.2
Resource	E10.3
Sponsor Change Proposal (SCP)	3.3,3.4.6
Sponsor Program Proposal (SPP)	3.3,3.4.6
Documentation (SPPD)	3.4.6.1
Standard Subject Identification Code, Navy	B2,C9
Standard weapons systems costs	F4.4.3.4
Standardization, defined	J
STAR (see System Threat Assessment Report)	
State-of-the-art	
Obtaining information on	D4
STI (see Scientific and Technical Information)	
Studies and analyses	F1.4.1
Defined	J
Sunk Cost, defined	J
Supply Systems Command (NAVSUP)	E4.5
Support Area (SA)	3.3,3.4.2,3.4.3
Support, logistics planning for	F4
Supportability, T&E and	7.7
Surgeon General of the Navy	E3.8
System, defined	J
System Acquisition Process, defined	J
System Effectiveness, defined)	J
System Engineering, Defense, defined	J
System Threat Assessment Report (STAR)	1.2.1.3,F1.3
Systems Commanders	
Material support responsibilities of	E4.1
Systems Commands	E3.10.1,E4
Systems engineering	F1.4
Process, defined	F1.4.3.J

T

Tailoring, defined J
 Targets for T&E and training 7.3.6
 T&E (Test and Evaluation) Ch. 7
 Acceptance trials, INSURV 7.4.3
 Acquisition cycle, in the 7.1.4
 And supportability 7.7
 Capability, identification of 7.3.1
 Combined DT/OT 7.4.5
 Concurrent DT/OT 7.4.5
 Congressional policy on 7.1.5
 Coordination Group (TECG) 7.2.8
 Ships 7.8.2,7.8.3
 Coordinators 7.2.6
 Defined 7.1.1
 Director, Operational Test and
 Evaluation (DOT&E) 7.2.1.2,E1.3
 DT&E 7.4.1
 Evaluation, defined 7.1.1
 Facilities 7.3, App. G
 Acquisition of 7.3.3
 Scheduling of 7.3.2
 Field activities, capabilities of 7.3.1
 Fleet support for 7.3.7
 Priorities 7.3.7.2
 Requirements 7.3.7.1
 Scheduling 7.3.7.3
 Focal Points 7.2.6
 Foreign Systems, of 7.1.8.1
 Functions of 7.1.2
 Funding of 7.5.4
 Identification Number (TEIN) 7.5.7
 ILS 7.7
 Independent evaluation policy 7.1.3
 Information flow 7.6
 Information for
 BIS/INSURV 7.6.5
 Developers 7.6.1
 Development 7.1.2.1
 Milestone decisions 7.1.2.2,7.6.3
 Operating forces 7.1.2.3,7.6.4
 Program Managers 7.6.2
 Integral aspect of acquisition process 2.1,2.4,7.1.4
 IOT&E, policy on timing of 7.1.3
 Joint T&E (JT&E) 7.4.4.1
 LBTS (Land-Based Test Sites) 7.3.4
 Major Range and Test Facility
 Base (MRTFB) 7.3.5
 Listing of Elements 7.3.5.1
 Master Plan (TEMP) 1.2,1.3,2.4.2,7.5.3
 Ships 7.8.1,7.8.3
 Multiservice testing 7.4.4.3
 Nature of 7.1.1
 Organization (see T&E)
 Organization for 7.2
 OT&E 7.4.2
 Congressional interest in 7.1.5
 Planning for 7.5
 Policy on 7.1.3

T&E (Test and Evaluation) (Con't)

Ranges (see Ranges, Test)
 Ranges and test facilities 7.3
 Reports 7.6.6
 Requirements, waiver of 7.1.6
 Resources 7.3
 Responsibilities 7.2
 ASN(RD&A) 7.2.2
 CNO 7.2.3
 DOT&E 7.2.1.2,E1.3
 DT&E 7.2.1.1
 INSURV 7.2.4,G12.1
 Marine Corps 7.2.10,G13
 MCOTEA 2.4.1,7.2.10.1,G13.2
 FMF (Fleet Marine Forces) 7.2.10.2
 N091 7.2.3,E3.1
 N912 7.2.3,E3.1.2
 N913 7.2.3,E3.1.3
 OPTEVFOR 7.2.5,G12.2
 OSD 7.2.1
 Program Managers 7.2.7
 SECNAV 7.2.2
 Ship acquisition, for 7.8
 Tactics and doctrine, inputs for 7.1.2.3
 Targets for 7.3.6
 Task statements for 7.5.5
 T&E Division (N912) 7.2.3
 TECG (T&E Coordination Group) 7.2.8
 Test, defined 7.1.1
 Test issues and problems, definition of 7.5.1
 Two-sided testing 7.4.4.2
 TECHEVAL (Technical Evaluation) 7.4.1.2.1
 Technical customer
 Definition as used in this Guide 6.1.3
 Technical Evaluation (TECHEVAL) 7.4.1.2.1
 Defined J
 Technical libraries D2
 Technical reports 6.7.2
 Announcement service D3.2.2
 Copy service, DTIC D3.2.3,D3.2.4
 Standard Form 298 database D3.1.3
 Technical Services, defined J
 Technological Life, defined J
 Technology base
 Identification of current efforts D3.1,D4
 Role of laboratories in development of 6.1.6.1
 Technology push F1.7.2
 Technology transfer
 Domestic program F1.7.4
 TEIN (T&E Identification Number) 7.5.7
 TEMP (T&E Master Plan) 1.2,1.3,2.4.2,7.5.3
 PM responsibility for preparation 7.2.7
 Ships 7.8.1,7.8.3
 Terminals, remote on-line D3.2.1
 Test
 Acceptance trials, INSURV 7.4.3
 And evaluation (see T&E)
 Criteria, defined J
 Resource planning 7.5.6
 Test Planning Working Group (TPWG) 7.2.9

Threat, defined J
 Threat information F1.3
 Thresholds, defined J
 Thresholds (DOD Programming System)
 defined J
 Thrusts, S&T 2.3.2, C4.1.2
 Time Line, defined J
 Total Obligation Authority (TOA), defined J
 Total Quality Leadership (TLQ), defined J
 TPWG (Test Planning Working
 Group) 7.2.9

U

Underway Trials, defined J
 Unsolicited Proposal, defined J
 USD(A) Under Secretary of Defense
 (Acquisition) E1.1
 Principal witness for RDT&E 4.7.3
 RD&A responsibilities E1.1
 T&E responsibilities 7.2.1.1

V

Validation Phase, Demonstration and 2.1
 Value Engineering Discipline, defined J
 VX-1, detachment of OPEVFOR G12.2.3.1
 VX-4, detachment of OPEVFOR G12.2.3.2
 VX-5, detachment of OPEVFOR G12.2.3.3

W

Waiver of T&E requirements 7.1.6
 WBS (Work Breakdown Structure)
 As categorization system C11
 Defined J
 Ships, Extended (ESWBS) C11.1
 Structure for costing F4.4.3.2
 Use in cost reporting 6.7.4
 Weapon system cost, standard C8, F4.4.3.4
 Weapon system test (joint) 7.4.4.1
 Witnesses before Congressional committees,
 guidelines for 4.7.1
 Work Breakdown Structure (see WBS)
 Work request, in-house laboratory 6.2.4
 Work statement, contract 6.5.3.1
 Work unit, defined J
 Database D3.1.1
 Work Unit Information System (WUIS) D3.1.1
 Working capital fund 5.3.4.1