

AD-A275 335

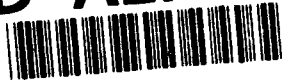

2

ARMY RESEARCH LABORATORY



EMP Design and Test Guidelines for Systems in Mobile Shelters

edited by Stephen C. Sanders

ARL-SR-1

December 1993

DTIC
ELECTE
FEB 04 1994
S B D

Approved for public release; distribution unlimited.

94 2 03 137

9586 94-03923



The findings in this report are not to be construed as an official Department of the Army position unless so designated by other authorized documents.

Citation of manufacturer's or trade names does not constitute an official endorsement or approval of the use thereof.

Destroy this report when it is no longer needed. Do not return it to the originator.

REPORT DOCUMENTATION PAGE			Form Approved OMB No. 0704-0188	
Public reporting burden for this collection of information is estimated to average 1 hour per response, including the time for reviewing instructions, searching existing data sources, gathering and maintaining the data needed, and completing and reviewing the collection of information. Send comments regarding this burden estimate or any other aspect of this collection of information, including suggestions for reducing this burden, to Washington Headquarters Services, Directorate for Information Operations and Reports, 1215 Jefferson Davis Highway, Suite 1204, Arlington, VA 22202-4302, and to the Office of Management and Budget, Paperwork Reduction Project (0704-0188), Washington, DC 20503.				
1. AGENCY USE ONLY (Leave blank)	2. REPORT DATE December 1993	3. REPORT TYPE AND DATES COVERED Final		
4. TITLE AND SUBTITLE EMP Design and Test Guidelines for Systems in Mobile Shelters			5. FUNDING NUMBERS PE: 62120	
6. AUTHOR(S) edited by Stephen C. Sanders				
7. PERFORMING ORGANIZATION NAME(S) AND ADDRESS(ES) U.S. Army Research Laboratory 2800 Powder Mill Road Adelphi, MD 20783			8. PERFORMING ORGANIZATION REPORT NUMBER ARL-SR-1	
9. SPONSORING/MONITORING AGENCY NAME(S) AND ADDRESS(ES) U.S. Army Research Laboratory Attn AMSRL-WT-ND 2800 Powder Mill Road Adelphi, MD 20783			10. SPONSORING/MONITORING AGENCY REPORT NUMBER	
11. SUPPLEMENTARY NOTES AMS code: 612120.H250011 ARL project: 3FE7E4				
12a. DISTRIBUTION/AVAILABILITY STATEMENT Approved for public release; distribution unlimited.			12b. DISTRIBUTION CODE	
13. ABSTRACT (Maximum 200 words) This document addresses the unique electromagnetic characteristics of metallic enclosures, commonly referred to as signal, communications, or box-body shelters, and identifies what system developers should do to optimize the electronic survivability of equipment placed in these shelters. Since nuclear-induced high-altitude EMP is but one of possibly many nonionizing hostile environments that the shelter electronics must survive, this document treats EMP survivability in terms familiar to the design engineer.				
14. SUBJECT TERMS EMP guidelines, design test, shelters			15. NUMBER OF PAGES 96	
			16. PRICE CODE	
17. SECURITY CLASSIFICATION OF REPORT Unclassified	18. SECURITY CLASSIFICATION OF THIS PAGE Unclassified	19. SECURITY CLASSIFICATION OF ABSTRACT Unclassified	20. LIMITATION OF ABSTRACT UL	

Foreword

The technical staff of the North Atlantic Treaty Organization (NATO), Defence Support Division, has prepared a series of documents that address the nuclear weapons effects (NWE) survivability of tri-service military equipment. These effects include air blast, thermal radiation, initial nuclear radiation, and electromagnetic pulse (EMP). The series of reports, Allied Engineering Publications (AEPs), is further described in this document (in the Executive Summary), which was prepared by Panel VIII and its Technical Sub-Panel. The members are

Lt. Col J. Blakiston (Chairman)

R. Monguilan (Secretary)

EMP Working Group

Belgium: Capt. M. Ir. Piette

Canada: Dr. F. P. Szabo

France: ICETA G. Mayoux (Chairman)

ECSC J. J. Rodaro

Msr. M. Tessot (Past Chairman)

Germany: Dr. J. Nitsch

Dr. R. Sturm

Netherlands: Ir. R. Middelkoop

United Kingdom: Mr. D. Robson

United States: Mr. S. Sanders (Editor)

Dr. J. Ingram

Mr. R. Pfeffer

DTIC QUALITY INSPECTED 6

Accession For	
NTIS GRA&I	<input checked="" type="checkbox"/>
DTIC TAB	<input type="checkbox"/>
Unannounced	<input type="checkbox"/>
Justification	
By _____	
Distribution/	
Availability Codes	
Dist	Avail and/or Special
A-1	

Contents

	page
Foreword	3
Executive Summary	11
1. Introduction	13
1.1 <i>General</i>	13
1.2 <i>System Conditions</i>	13
1.3 <i>Scope</i>	14
2. Mobile Shelters	16
2.1 <i>Use of Shelters</i>	16
2.1.1 <i>Configurations</i>	16
2.1.2 <i>Operation</i>	17
2.1.3 <i>Interface Protection</i>	17
2.2 <i>Shelter Design</i>	18
2.2.1 <i>Shielding</i>	18
2.2.2 <i>Construction</i>	18
2.2.3 <i>Grounding Connections</i>	19
2.2.4 <i>Wiring Configuration</i>	20
3. Functional Analysis	21
3.1 <i>Hierarchy</i>	21
3.2 <i>Function Analysis</i>	21
3.3 <i>Failure Effects Analysis</i>	21
3.4 <i>Fault Tree Analysis</i>	22
3.5 <i>Test Guidelines</i>	22
4. Hardening Principles	24
4.1 <i>Zoning Concept</i>	24
4.2 <i>Guidelines</i>	26
4.3 <i>Relation of Guidelines</i>	27
4.4 <i>Hardening Assurance Program</i>	30
5. External Stress Guidelines	31
5.1 <i>Configurations</i>	31
5.2 <i>Grounding</i>	32
5.3 <i>Guideline Levels</i>	32
5.4 <i>Modifications to Guideline Levels</i>	34
5.5 <i>Shield Density Currents</i>	34
5.6 <i>Currents Inside External Cables</i>	35
6. Internal Stress Guidelines	36
6.1 <i>General</i>	36
6.2 <i>Conducted Interference</i>	37
7. Protection Guidelines	39
7.1 <i>General</i>	39
7.2 <i>Shield Protection</i>	39
7.2.1 <i>Shielding Guideline Modifications</i>	40
7.2.2 <i>Special Components of Shielding</i>	41
7.3 <i>Linear Penetrations</i>	42
7.3.1 <i>Waveguides and Vents</i>	42
7.3.2 <i>Cable Shield and Grounding Terminations</i>	43

Contents

	page
7.3.3 Penetrating Pipes	45
7.3.4 Fiber-Optic Tubes	46
7.4 <i>Cable Protection</i>	46
7.4.1 General.....	46
7.4.2 Coaxial Cable Guidelines	48
7.5 <i>Circuit Entry Protection</i>	48
7.5.1 Telecommunications Lines.....	48
7.5.2 Local Control	49
7.6 <i>Power Entry Protection</i>	50
7.6.1 Guidelines for Protection	50
7.6.2 Guidelines for Power Cables	51
8. Susceptibility Design and Test Guidelines	52
8.1 <i>General</i>	52
8.2 <i>Susceptibility Analysis and Tests</i>	52
8.3 <i>Grouping Guidelines</i>	53
8.4 <i>Evaluation of Critical Equipment</i>	54
8.4.1 Electromagnetic Compatibility	54
8.4.2 Circuit Operating Levels	54
8.4.3 Manufacturer's Data	55
8.4.4 Semiconductor Analysis	55
8.4.5 Shield Entry Tests	57
8.5 <i>Testing Guidelines</i>	58
8.5.1 Stress Guidelines	58
8.5.2 Conducted Currents	58
9. Acceptance Test Methods	60
9.1 <i>General</i>	60
9.1.1 Coupling Configuration Tested	60
9.1.2 Test Objectives and Schedules	60
9.2 <i>Shield Protection</i>	61
9.2.1 Principles and Methods	61
9.2.2 Test Equipment	62
9.2.3 Test Configuration	63
9.2.4 Shielding Tests	65
9.2.5 Evaluations	66
9.3 <i>Passive Penetration Protection</i>	67
9.3.1 Principles and Methods	67
9.3.2 Test Equipment	67
9.3.3 Test Configuration	67
9.3.4 Passive Penetration Tests	68
9.3.5 Evaluations	69
9.4 <i>RF Penetration Protection</i>	69
9.4.1 Principles and Methods	70
9.4.2 Quarter-Wave Stub	70
9.4.3 Nonlinear Protection	72
9.4.4 Filters	74
9.4.5 Evaluations	75
9.5 <i>Control/Signal Penetration Protection</i>	75

Contents

	page
9.5.1 Principles and Methods	75
9.5.2 Test Equipment	76
9.5.3 Circuit Tests	76
9.5.4 Evaluation	76
9.6 <i>Power Penetration Protection</i>	77
9.6.1 Principles and Methods	77
9.6.2 Test Equipment	77
9.6.3 Test Configuration	77
9.6.4 Power-Line Tests	77
9.6.5 Evaluation	79
9.7 <i>Susceptibility Tests</i>	79
9.7.1 Principles and Methods	79
9.7.2 Conducted Tests	80
9.7.3 Radiated Tests (Bounded or Free)	81
9.7.4 Evaluation	84
10. Mobile Shelters in a Nuclear Source Region	85
10.1 <i>General</i>	85
10.1.1 External Source-Region Coupling	85
10.1.2 Internal EMP (IEMP)	85
10.2 <i>Source-Region Effects</i>	86
10.2.1 External SREMP Coupling to Mobile Shelters	86
10.2.2 Box IEMP	87
10.2.3 Cable-IEMP	88
10.2.4 Summary of Data	88
10.3 <i>Consequences of Hardening</i>	88
Glossary	91
Appendix A.— Guideline Summary	95
Distribution	99

Figures

	page
1. Guideline terms	14
2. Shelter connections	17
3. Grounding connections	19
4. Fault tree	23
5. Perfect shield	24
6. Imperfect shield	24
7. Protected shield	25
8. Zoning cases	25
9. Maintenance guidelines	28
10. Statistical guidelines	28
11. Protection methods	29
12. Shelter interconnections	31
13. External current range	33
14. Cable protection	37
15. Internal current spectrum	38
16. Shield wall	39
17. Shield protection	40
18. Waveguide cutoff	42
19. Waveguide installation	43
20. Grounding to shield	44
21. Stress division	44
22. Linear protection	44
23. Incorrect waveguide	45
24. Correct waveguide	45
25. Coaxial entry protection	49
26. Wire entry protection	50
27. PPD schematic	50
28. HEMP stresses	52
29. Coupled transient	53
30. Functional analysis	53
31. Wunsch factor	56
32. Statistical error	58
33. Device damage/upset spectrum	59
34. Test scheduling	61
35. Shield test setup	63
36. Antenna positions	64
37. PPD entry panel	68
38. Quarter-wave stub	71
39. RF entry test	71
40. Voltage test setup	72
41. PPD parameter tests	73
42. Gap extinction test	73
43. Power circuit test	78
44. Power PPD test setup	78
45. Power test setup	78
46. Direct injection	80

Figures

	page
47. Pin sinusoid injection	80
48. Cable sinusoid injection	81
49. Gap extinction test	82
50. Injected pulse spectrum	83

Tables

1. Analysis sequence	23
2. Cable and antenna currents	33
3. External current guidelines	33
4. Internal field guidelines	36
5. Internal currents	37
6. Shelter shielding	40
7. Cable shielding	41
8. Penetration protection	49
9. Device operating levels	54
10. Damage/upset guidelines	59
11. Antenna characteristics	62
12. Antenna positions	64

Executive Summary

AC/225 (Panel VII/TSP) has been directed by AC/225 (Panel VII) to prepare a series of NATO documents that address the nuclear weapons effects (NWE) survivability of tri-service military equipment. NWE, qualitatively speaking, includes air blast, thermal radiation, initial nuclear radiation, and electromagnetic pulse (EMP). Where possible, these NWE survivability documents are NATO Unclassified, or at the lowest possible security classification level, in order to maximize their use by equipment designers or managers and government personnel. The documents are designed to assure NATO a consistent affordable approach to NWE survivability.

NWE survivability can be achieved in a number of ways, which include redundancy, timely resupply, mitigation techniques, software modification, and equipment hardening. These NWE survivability documents emphasize equipment hardening, since the other options are often not defined until the equipment is fielded; however, the other options will be discussed where appropriate.

The approach adopted in developing this survivability series is to first identify the key equipment classes found on the battlefield and then develop relevant survivability documents for each. Some of the most important equipment classes found on the battlefield today are topics of the series. They include

- a. Ground-based command, control, communication, computer, and intelligence (C⁴I) systems,
- b. Ground-based weapon delivery systems,
- c. Air-based systems, and
- d. Sea-based systems.

To date, Panel VII and its Technical Sub-Panel (TSP) have developed documents addressing several different aspects of NWE survivability. We identify these documents and state what survivability aspect each emphasizes in the following list.

Allied Engineering Publications (AEP)	Related Standards
AEP-4, Annex A (Land), B (Navy), C (Air), Nuclear Hardening Criteria Installations	STANAG 4145
AEP-9, NATO Manual of Simulators of Nuclear Weapons Effects	
AEP-14, Guidance for the Armored Fighting Vehicle Designer to Improve Nuclear Radiation Protection	STANAG 4328
AEP-18, NATO User's Guide to EMP Testing and Simulation	
AEP-19, Nuclear Protection Design Considerations for Mobile Shelters	
AEP-20, NATO EMP Test Procedures for Systems in Mobile Shelters	
AEP-21, NATO EMP Calibration Procedures	
AEP-22, Guide to Transient Radiation Effects on Electronics (TREE) at Tactical Level	
AEP-25, Nuclear Blast/Thermal Test Methods and Procedures	

This document, AEP-20, addresses the unique electromagnetic characteristics of metallic enclosures, commonly referred to as signal, communications, or box-body shelters, and identifies what system developers should do to optimize the electronic survivability of equipment placed in these shelters. Since nuclear-induced high-altitude EMP is but one of possibly many nonionizing hostile environments that the shelter electronics must survive, this document treats EMP survivability in terms familiar to the design engineer.

1. Introduction

1.1 General

Various types of shelters are used to contain equipment for modern armies in a wide variety of applications:

- communications,
- weapons control,
- command posts, and
- mobile laboratories.

The design of a shelter considers the functions and conditions in which it is to be used:

- single or multi-purpose use,
- vehicle, pad, or ground mounted,
- open or closed to personnel, and
- time/mobility configurations.

1.2 System Conditions

The electromagnetic pulse (EMP) guidelines defined in this document are for general or typical system functions and conditions. The program director using these guidelines needs to ensure that the hardening decisions are compatible with specific system details and possible eventualities of design, production, and testing. The system manufacturer needs to consider the EMP stress and the system design strengths as he selects hardening protection and specifies acceptance tests.

The following terms are the guidelines used throughout the text, so it is useful for the reader to be familiar with them before proceeding. A glossary at the end of this report defines other symbols and terms.

A	logic for acceptable damage,
\bar{A}	unacceptable damage
AC_n^i	externally conducted current (A)
AR	externally radiated field (V/m)
CC_n^i	internally conducted current (A)
CR_{ni}	internally radiated fields (V/m)
DC_{ni}	device damage from conducted current (A)
DR_{ni}	device damage from radiated fields (V/m)
F	logic for a critical function; \bar{F} = a noncritical function
i,j	superscript to indicate zones

m, n	subscript to indicate index of guideline level
M	logic for critical equipment; \bar{M} = noncritical equipment
P	logic for acceptable upset; \bar{P} = unacceptable upset
PC_n^{ij}	cable shielding protection (dB)
PD_{inn}^{ij}	nonlinear penetration protective device, where m is the index for applied current (A), and n is the index for the resultant current (A)
PJ_n^{ij}	shielding protection from current density on the shield from external cable current transfer (dB)
PL_n^{ij}	linear PPD (dB)
PR_n^{ij}	enclosure shielding protection (dB)
UC_n^i	device upset from circuit voltage (V)
UR_n^i	for device upset from radiated fields (V/m)

Figure 1 shows the technical guideline terms in use.

1.3 Scope

This document takes account of EMP hardening at system conception and its evolution to a hardened prototype system; it also identifies production acceptance procedures.

The purpose is to

- define EMP hardening in system design,
- obtain a hardened prototype system, and
- standardize protection and testing.

Figure 1. Guideline terms.

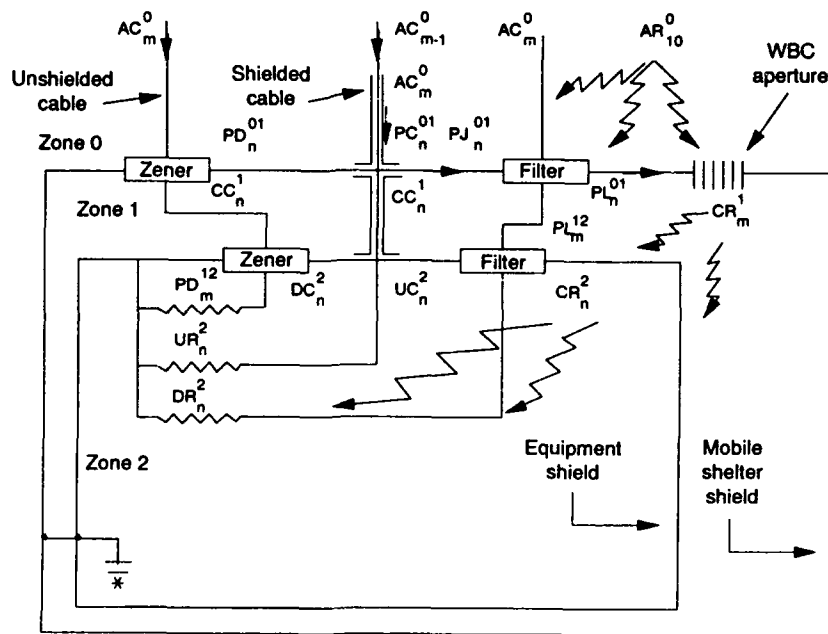

This document is intended for

- program managers responsible for installing systems into shelters,
- contractors and manufacturers of these systems, and
- persons in charge of testing these systems.

We discuss hardening to high-altitude EMP (HEMP) as described in AEP-4. Shelters are described in detail in AEP-19. Other threat environments can modify the protection methods and technologies used for EMP hardening. The effects of low-altitude nuclear explosions are not considered, except for their influence on the choices of hardening methods to enable other electromagnetic effects to be taken into account (see sect. 10 for internal and system-generated EMP (IEMP) and (SGEMP)).

In this document a hardening method is defined and designated that is based on stress, susceptibility, and protection guidelines, and verified by acceptance testing. The application of principles and considerations for the development of a prototype in no way constitutes a guarantee of its hardness. This must be proven by qualification tests on the production prototype. At the stage of commercial manufacture a recognized plan of quality control will have to be instituted and acceptance tests will have to be performed. It is preferred that maintenance procedures be established early in the design to determine realistic hardening characteristics.

Proposed methods for hardening mobile facilities use both single (global) and zoned (distributed) hardening (see sect. 4), while requirements for Supreme Headquarters, Allied Powers Europe (SHAPE) fixed facilities invoke only single hardening as described in the Allied Command Europe Standard, SHAPE 1460-3, November 1989. Using either hardening method to design equipment does not guarantee hardening; that should be demonstrated by the qualification tests to be described by AEP-18. AEP-21 provides calibration procedures for AEP-18 and for tests described in section 9 of this document.

A plan for quality evaluation and testing is needed early in the design phase of a system to assure its EMP hardening. Sustaining hardness over time also requires a maintenance plan prepared during the design phase, to include surveillance and retest as needed.

This document does not seek to establish hardening designs, but is limited to providing guidelines (stress, susceptibility, and protection) and methods to allow a clear assessment of necessary hardening. To achieve this, we need to examine the principal designs for shelter-mounted systems so as to be able to select the types that are suitable as models.

2. Mobile Shelters

2.1 Use of Shelters

Electronic systems are sensitive to damage or upset from external electromagnetic transients such as lightning, radar, static electric discharge, switching spikes, and nuclear EMP. The shelter that protects equipment from the weather can also protect against electromagnetic transients. Shelters are increasing in use among all armed forces, since they can easily be adapted to form a Faraday shield against fields and a boundary for transient suppression on conductors without adverse effect on normal equipment operation. The following is a partial list of the functions of a shelter.

A shelter provides:

- maximum concentration of weight,
- mechanical ease of handling and transport,
- wind, temperature, and humidity control, and it also protects against
- electromagnetic interference (EMI),
- lightning,
- signal intelligence (TEMPEST) suppression,
- dirt and blast fragments,
- biological and chemical contaminants, and
- nuclear thermal radiation, blast, and EMP.

The following must be considered when hardening is being designed into a shelter-based system:

- configurations of deployment,
- operating modes,
- interfaced equipment, and
- location of protective elements (such as current sinks, bunkers, and caves).

2.1.1 *Configurations*

There are many configurations for shelters. Two of them are

- fixed or semi-fixed pattern (on the ground) and
- mobile shelters (on vehicles).

2.1.2 Operation

Shelter-based systems, which may be operated by personnel or automatically, may be mounted on vehicles or on the ground. Various protective systems can be used. If manned, a degree of interruption in the operation is generally acceptable. Automatic operation requires equipment to monitor the system remotely, so that upset can be serviced.

2.1.3 Interface Protection

Equipment that is accessory to the system and may be connected to the shelter includes

- lifting jacks,
- radio and radar masts and antennas,
- vehicles,
- remote controls and consoles,
- telephones and intercoms, and
- systems and subsystems.

These accessories may enhance electromagnetic field coupling and conduct intense electric transients into the system. Multi-shelter centers can minimize these transients using a star or in-line configuration for their connections through

- power lines,
- telephone and data transmission lines,
- rf lines, and
- pneumatic, hydraulic, and optical lines.

Figure 2 shows three types of connections.

Figure 2. Shelter connections.

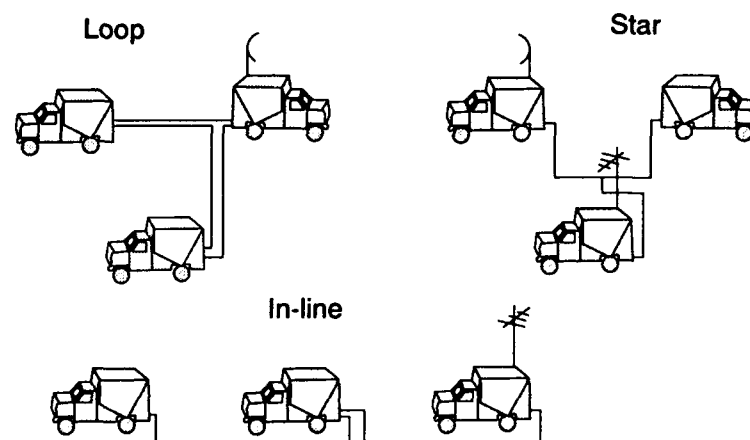

In order to reduce circulating currents, all cables should be connected at one single collecting plate on the shelter that is linked directly to the earth ground. This system absorbs the energy coupled into the conductors and diverted by the protective device. The quality of the connection to earth is very relevant for transients strong in frequencies below 10 MHz.

The wall penetrations contribute to a loss of shielding effectiveness for the shelter. These penetrations consist of

- ventilation grills,
- doors and hatches,
- signal, power, and rf entry panels,
- hydraulic and pneumatic lines, and
- mechanical drives.

These penetrations are subject to wear from the weather and should be designed and serviced to maintain their electromagnetic protection over several years of such exposure.

2.2 Shelter Design

2.2.1 *Shielding*

Shielding against penetration from electromagnetic fields is built into an enclosure in a number of ways so as to provide total hardening. Interface penetrations are accounted for in maintaining shielding for design and verification tests. While methods of shielding are not prescribed, electromagnetic properties should be consistent, stable, and easy to maintain through simple periodic inspection and correction procedures.

2.2.2 *Construction*

Construction of the shelter depends on the compartments, racks, and consoles to be included and on the way internal equipment is accessed. A shelter can be built with several zones of protection to accommodate different functions with different hardening requirements. For example, the services compartment contains the electric power, an environmental control unit, and possibly a nuclear, biological, chemical (NBC) filtering system, while the operations compartment houses such electronic equipment as computers, consoles, and radio transceivers. As a general rule, the different compartments have different electromagnetic sensitivities and operating levels.

The equipment can be set up on frames or racks or in containers. These may be enclosed by a separate shield to give additional protection against EMP. The systems may be mounted on the floor, on walls, or in corners of the shelter with mountings that may be rigid or flexible so as to absorb shock.

2.2.3 Grounding Connections

Internal systems are electrically connected to one another or to a bus by connections dedicated for electrical safety. All shields become part of this grounding system. Other grounding systems, if possible, are isolated from this system and from each other; this holds true for the alternating current power neutral, the direct current return, the analog signal return, the digital signal return, and the high-frequency signal return. Each uses somewhat different approaches in its design, as illustrated by almost any electronics handbook. Except for the safety ground, each must provide some protection at shielding interfaces and should come together at only one point in the total system.

The inner skin of the shelter is usually aluminum and serves as the reference surface for safety, cable shields, racks, and protective devices. Mechanical connections can be implemented as follows:

- Each item of equipment connects to the chassis or rack,
- Each chassis or rack connects to the shield, and
- Short straps of low impedance are used for connections.

Figure 3 shows how to establish a grounding reference (fishtail type) with only one point of connection on the shelter frame as close as possible to the cable entry plate where the external grounding of the shelter is found. External grounding is made to a post, rod, water pipe, or buried plate, again using a low-inductance short strap.

Figure 3. Grounding connections.

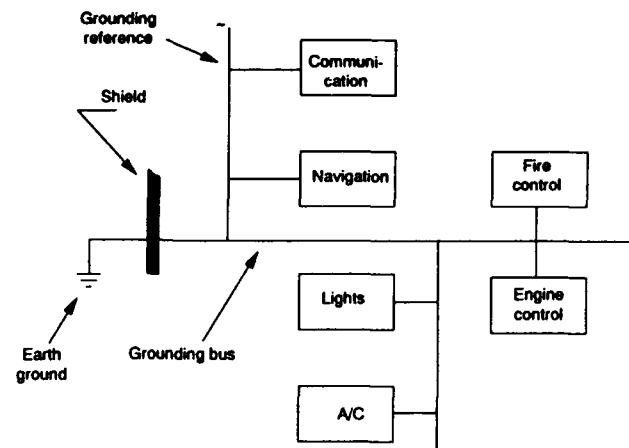

The other grounding references use different designs, but connect into this network at a single point at the cable entry panel in order to provide electromagnetic compatibility and decoupling of noise by common impedance.

2.2.4 *Wiring Configuration*

Wiring may or may not be shielded for electromagnetic isolation, but is usually run close to the shielding surfaces. Unshielded cables are less rigid but produce substantial interference. Cables close to one another yield high (1:2) mutual induction for cross-talk, and with diverse end impedances may produce interference factors of from one to five.

Shielded cables are more rigid but yield very little interference. If shields are properly terminated to the reference ground using quality connectors, the transfer impedance is very small. Coupling of the considerable currents on the cable shield from environmental transients onto the conductors within can range from small (1:100) for terminations of large impedance, to negligible (1:10,000) for small impedances.

3. Functional Analysis

3.1 Hierarchy

The functional analysis of a shelter-mounted system identifies critical circuits and parts that may require protection to perform essential functions during and after an EMP event. Such an analysis begins with a mission and an implementing function. It proceeds with the system or subsystem providing that function and works down to the circuits and equipment of that subsystem. Finally it arrives at the most critical parts and the components most important to the function. This logically deductive analysis of the system, which identifies hardness critical items, is evaluated against internal strengths for susceptibility levels of a critical function to EMP. These susceptibility levels are extrapolated to a testable interface where they can be compared to specified guideline levels. Further analysis will indicate any need for hardening. Tests will provide data to compare to the guidelines for a decision whether to validate the equipment as hard or susceptible.

3.2 Function Analysis

A logically deductive analysis of the functions of a shelter-mounted system (for instance, a command, control, and communications terminal) partitions the function and its equipment into subfunctions and equipment that support each operational element or integrated combination. In this instance, command and control would be combined into an operational element that is supported by tactical computers, displays that present information, and an interface that receives user instructions. The other operational element—communications—is implemented with receivers, transmitters, encoding devices, user interfaces, and antennas that perform specific subfunctions for required operation. This division of functions, with inter-relationships and associated equipment, proceeds through several hierarchical levels of analysis until a discrete item of equipment is identified as important enough to analyze further.

3.3 Failure Effects Analysis

The functional hierarchy and associated equipment list establishes the circuits or parts that are important. Logically inductive analysis evaluates and organizes failure threshold levels (strengths) for specific parts so as to accumulate them upward through the equipment hierarchy. Failure Mode Effect and Criticality Analysis first evaluates individual component characteristics independent of their

function in the system and using inductive analysis then evaluates the reliability of the system composed of these individual components. Failure modes (strengths or threshold failure levels) extrapolated to accessible equipment interfaces are compared with established standards for that equipment interface to determine susceptibility. This analysis fails when more than two function hierarchies are interleaved. The complexity from the variability in possible failure modes becomes excessive.

For a typical communications shelter, the hierarchies would begin at the device (semiconductor, inductor, and IC) level, would proceed to the plug-in (printed circuit board and connector) level, and conclude at the (maintenance) line replaceable unit, such as an antenna, crypto-unit, or radio set. It is at the line replaceable unit interface where the maximum safe EMP-coupled transient stress levels (guidelines) are specified. These guidelines include a confidence factor to provide a statistical safety margin. They are discussed in sections 5, 6, and 8.

3.4 Fault Tree Analysis

Additional analysis can determine the effect of equipment degradation or upset on the function of a system according to its mission requirements. This allows a decision to be made as to what hardness is required to meet operational specifications. Fault Tree Analysis is a technique used to determine the effects of lower level system functions on the more global functions of the system. The objective is to confirm the criticality of assemblies identified by the Function Tree Analysis. This process uses deductive analysis by assuming a macro-operational failure and then determining all possible micro-failures that could produce it. The Fault Tree Analysis method starts with a functional capability such as communications and using Boolean logic proceeds to identify sub-functions (and associated hardware) whose failure could produce the communications failure. Figure 4 illustrates this logic for the communications function.

3.5 Test Guidelines

A complete functional analysis identifies critical functions and equipment that must survive the effects of EMP. For each piece of critical equipment that is identified, a set of susceptibility restrictions, or test guidelines, is established based on the requirements for the equipment to recover without manual intervention and to continue to operate without degradation or transient upset. Critical equipment that is permitted to stop until manual intervention or may tolerate transient upsets is designated *AP*. Critical equipment

that must automatically recover, but is designed to allow for a transient upset is designated $\bar{A}P$. Critical equipment that must not be allowed to stop or have a transient upset condition is designated $\bar{A}\bar{P}$.

Table 1 shows a matrix of the allowed susceptibility restrictions plotted against the allowed susceptibility analysis methods. A sequence is given for examining the transient guidelines defined in sections 5, 6, and 8. A piece of critical equipment that has a guideline restriction that is $\bar{A}P$ can be validated to test guideline level 1 using electromagnetic compatibility (EMC) design considerations. To be validated for the fourth test sequence, the equipment must have explicitly incorporated EMP hardening designs and validation tests. Alternative methods to validate equipment to the guideline test levels are discussed in section 8.3.

Figure 4. Fault tree.

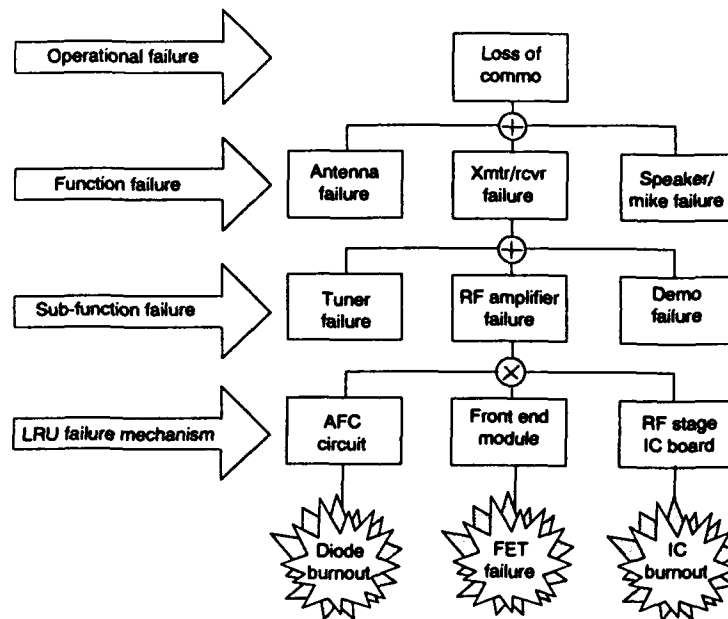

Table 1. Analysis sequence.

Eq. state analysis	AP	$\bar{A}P$	$\bar{A}\bar{P}$
EMC coupling	—	—	1st
Function level	—	—	2nd
Component data	1st	1st	—
Susceptibility	2nd	2nd	—
Tests	3rd	3rd	3rd
Hardening	4th	4th	4th

4. Hardening Principles

4.1 Zoning Concept

EMP protection relies on an electromagnetic barrier around essential elements of the system to be protected. An electromagnetic barrier is a closed surface that separates two volumes electromagnetically. As illustrated in figure 5, the volume inside the surface is protected from sources outside by the barrier. The electromagnetic barrier must be sufficiently impervious to electromagnetic fields produced by the EMP source that circuits or other elements inside the barrier are not adversely affected.

An ideal barrier might be a completely closed perfectly conducting shield; such a shield would allow no electromagnetic fields from external sources to penetrate the volume inside the shield.

Practical electromagnetic shields are made from common metals and must accommodate information transfer across the barrier (input and output data), energy supply lines for operating power, means for waste heat removal, and other functions necessary to support the protected system and make it useful. Holes and penetrating conductors severely compromise the shield, as shown in figure 6.

EMP protection generally consists of two parts:

- shielding the vulnerable equipment and
- installing protection on penetrations.

Thus, the practical electromagnetic barrier is fabricated from metal shields and includes elements shown in figure 7, such as surge arrestors, filters, and waveguides below cutoff at openings for wires, plumbing, and ventilation apertures.

One global shield around the protected area creates a single boundary that is easy to define and maintain. This protected area is

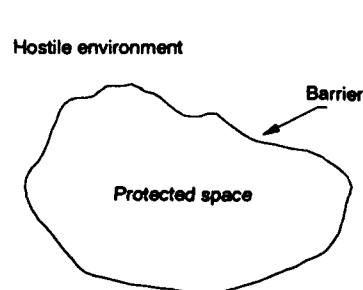

Figure 5. Perfect shield.

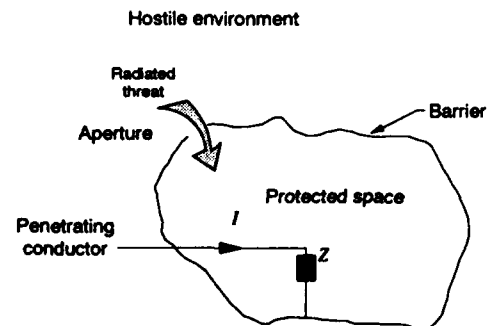

Figure 6. Imperfect shield.

referred to as zone 1; zone 0 is the external region containing the threat. Additional shielding of very sensitive equipment may be needed. It is more economical to create an extra protective area, zone 2, for this equipment than it is to upgrade the much larger shield to a higher level of protection. The shielding may be tailored to the needs of the equipment under consideration.

It is important to define the functions or parts of systems that need to be protected from EMP. Placement of electromagnetic barriers depends on the location of critical equipment. Practical factors also need to be considered, such as providing easy access for maintenance and limiting the volume, weight, insertion loss, and energy capacity of protection devices. For example, figure 8 shows the location of penetration protective devices (PPDs) for a link between the two zones of a system.

A steel, aluminum, or copper shield can provide much greater EMP protection than is necessary for most systems if the shield is continuous, closed, and at least a few tenths of a millimeter thick. For example, inside a closed 10-m shield 1-mm thick, the peak voltage induced in a 10-m radius loop (just inside the shield) by high-altitude EMP (HEMP) is only 4 mV for steel or copper and 12 mV for

Figure 7. Protected shield.

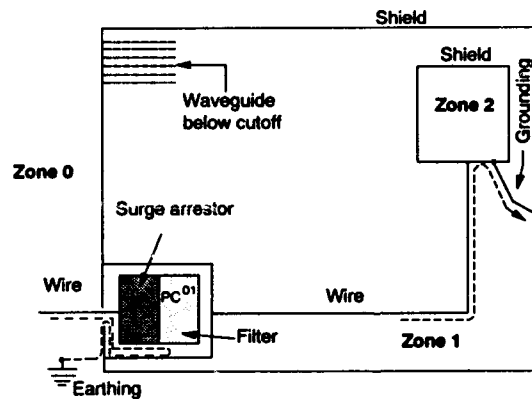
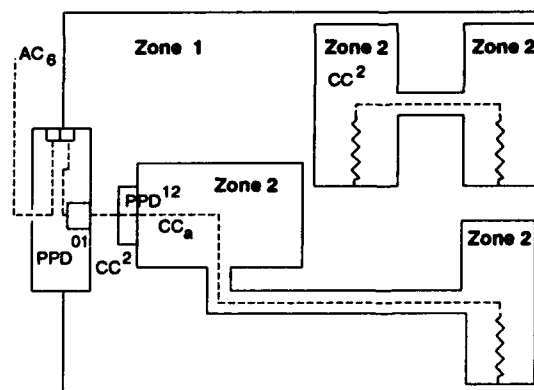

Figure 8. Zoning cases.



aluminum. The continuous metal shield permits EMP protection to be focused on the openings in the shield and on ways to minimize EMP penetrations at these openings. Once the integrity of the shield is established, the verification of EMP protection simplifies to verification of the effectiveness of the treatments at the openings. The function of these treatments is to deviate, reflect, or absorb the EMP-induced energy that propagates along the conducting penetrating line to the shielded area.

In an ideal situation, as long as the shield encloses all parts of the system that must be protected, the barrier may have any size, shape, or location. In practice, the shape or form of the barrier may affect the shielding effectiveness, the ease with which it can be installed, and its resistance to degradation.

4.2 Guidelines

In order to define and test the level of EMP hardening that a piece of equipment requires, a set of guidelines is needed. These guidelines implement the protection philosophy outlined in section 4.1:

- P_n^i is a guideline defining the total classification for the shelter; n provides an index to the level of overall protection in decibels, and i is the innermost zone with n index level protection.

To evaluate the shielding, the following radiated levels are needed:

- AR_{10}^0 is the external radiated field level 10 (or 100 kV/m) in zone 0, expressed in pulse shape and field strength.
- CR_n^i is the internal radiated field level, n , that is tolerated in zone i , also expressed in pulse shape and field strength.

For penetration and protection hardening the following conducted levels are needed:

- AC_n^i is the external conducted current level, n , in zone i , expressed in amperes on a cable or other conductor. This parameter follows as a consequence of AR_{10}^0 coupling to the conductor. It can be measured or calculated.
- CC_n^i is the internal conducted current level, n , that is tolerated in zone i , expressed in amperes on a conductor.

Two other parameters are needed to evaluate the hardening. The first of these is the susceptibility level of the equipment in the protected zones. Depending on operational demands, two different levels can be distinguished: (1) a level where the equipment is permanently damaged by radiation, DR_n , or current, DC_n , and (2) a

level at which upset or malfunction occurs by radiation, UR_n , or current, UC_n , but the equipment can be reset.

- DC_n^i or conducted current levels, which result in damage to a device, expressed as A,
- DR_n^i or radiated field levels, which result in damage to a device, expressed as V/m,
- UC_n^i or conducted current levels, which result in upset to a circuit, expressed as A,
- UR_n^i or radiated field levels, which result in upset to a device, expressed as V/m.

DC_n^i and DR_n^i values are usually found in equipment specifications.

Values for UC_n^i and UR_n^i are mostly an order of magnitude lower and have to be determined experimentally.

Five hardening guidelines are needed to evaluate the hardening required for equipment. They provide the protection level that is needed, expressed as a relation of the threat level to the guideline. These are

- PR^{ij} , or the protection level for the shielded enclosure,
- PC^{ij} , or the protection level for shielded cables,
- PJ^{ij} , or the protection level for current densities on shielded enclosures due to currents from cables,
- PD^{ij} , or the protection level provided by a nonlinear device, and
- PL^{ij} , or the protection level provided by a linear device.

4.3 Relation of Guidelines

Hardening requirements can be determined from the set of guidelines discussed in section 4.2. Measuring the values of the parameters mentioned verifies the protection levels. Equation (1) states that the external stress level AR_{10}^0 modified by the protection level PR_n^{ij} should be equal to the internal stress guideline level CR_n^{ij} plus a safety margin, SM . Similar considerations on PJ_n^{ij} apply for the external cables.

$$20 \log AR_n^0 - PR_m^{01} = 20 \log CR_p^1 + SM, \quad (1)$$

where $n - m = p + k$,

with k an integer magnitude of SM .

Due to aging and usage EMP protection degrades with time as shown in the lower part of figure 9. Periodic checks are needed to monitor this potential problem. How frequent these checks need to be depends on the materials, usage, design, and guidelines. As soon as the protected level is lower than the internal guideline, repair is necessary.

In practice, variations occur in the parameters between individual copies of the same equipment. This can be accounted for through a statistical approach. A variance in the parameters shows a relation as presented in figure 10 for a Gaussian distribution. This variance is due to the

- accuracy of the measurements or data evaluation and
- reproducibility of susceptibility tests and protection evaluation tests.

Testing a few samples of the same equipment allows variance in parameters to be assessed: the smaller the variance in equipment susceptibility and protection level, the smaller the safety margin that can be allowed. However, multiple sample testing can be very expensive and time-consuming.

Figure 9. Maintenance guidelines.

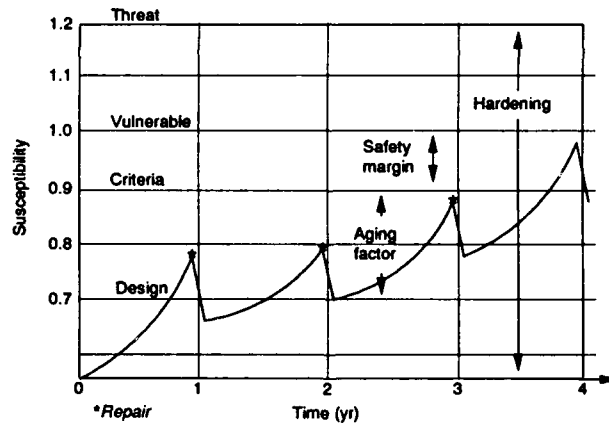
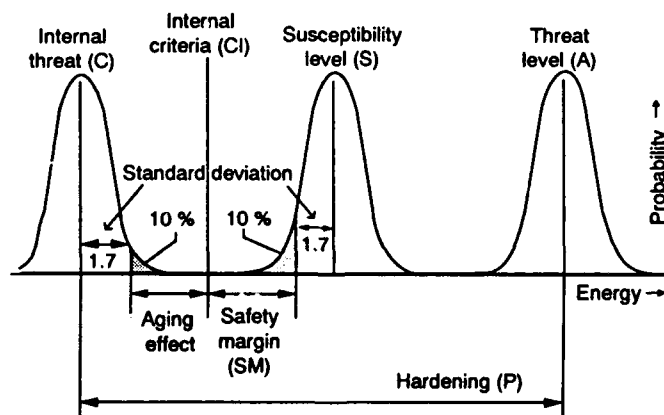

Figure 10. Statistical guidelines.



How wide, exactly, the safety margin needs to be depends on the requirements of a given project and the judgment of the technical project manager. Without specific information on the variance of a parameter, the project manager can use, as an empirical rule, the fixed parameter values, add 10 dB to create a safety margin, and add 20 dB for aging if necessary.

Equation (1) can be used for all electromagnetic barriers considered. As a general guideline, the more information on the statistics of a parameter that is known, the better a safety margin can be determined. The variance can be estimated if at least 10 independent values of the same parameter are known. The safety margin can be chosen such that 10 percent of the susceptibility level is in the safety margin of figure 10, and just 10 percent of the internal threat is allowed in the aging margin. If after time this percentage falls fully within the safety margin due to aging, no overlap with the susceptibility level is allowed. This means that the safety margin should be at least the width of both 10-percent regions together:

$$SM \geq 1.7 \sigma_c + 1.7 \sigma_s , \quad (2)$$

where σ_c = variance of internal threat, and σ_s = variance of susceptibility.

Figure 11 shows several zones and their guidelines. If equipment placed in zone 1 cannot be permitted to suffer upset, the necessary hardening can be found from

$$\begin{aligned} 20 \log AR^0 - PR^{01} &= 20 \log CR^1 . \\ 20 \log AC^0 - PC^{01} &= 20 \log CC^1 . \end{aligned} \quad (3)$$

Figure 11. Protection methods.

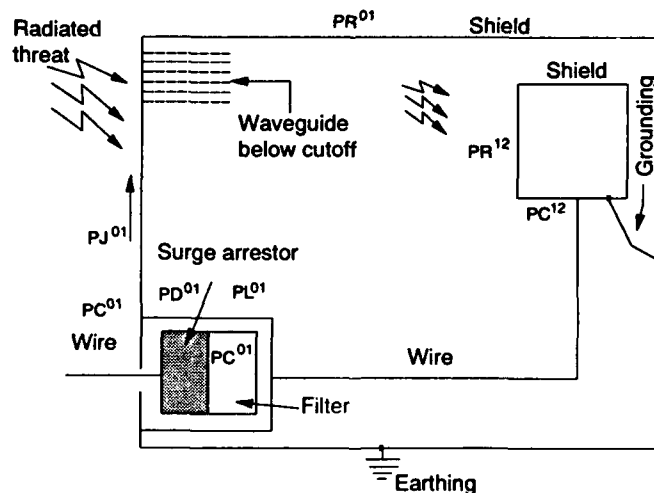

In this example, CR^1 and CC^1 are internal stress guidelines without safety margins. PR^{01} and PC^{01} designate the protection from zone 0 to zone 1 for radiation and for conduction, respectively. Likewise:

$$\begin{aligned} 20 \log CR^1 - PR^{12} &= 20 \log CR^2 \leq 20 \log UR^2 - SM , \\ 20 \log CC^1 - PC^{12} &= 20 \log CC^2 \leq 20 \log UC^2 - SM . \end{aligned} \quad (4)$$

Equations (3) and (4) relate the environment of zone 0 to zone 1 and that of zone 1 to zone 2. Equation (5) relates zone 0 through zone 2.

$$\begin{aligned} 20 \log AR^0 - PR^{01} - PR^{12} &= 20 \log CR^2 \leq 20 \log UR^2 - SM . \\ 20 \log AC^0 - PC^{01} - PC^{12} &= 20 \log CC^2 \leq 20 \log UC^2 - SM . \end{aligned} \quad (5)$$

For a numerical example, assume an electric field in zone 0 of $AR^0 = 60$ kV/m or 96 dB (V/m). The protection offered by the first shield, PR^{01} , is 50 dB. The equipment in zone 2 may be subjected to a field of $UR^2 = 6$ V/m without causing upset. The safety margin is chosen as $SM = 10$ dB. We calculate the protection needed from the second shield, PR^{12} , by equation (5).

$$\begin{aligned} 20 \log 60 \text{ (kV/m)} - 50 - PR^{12} &\leq 20 \log 6 \text{ (V/m)} - 10 . \\ 96 - 50 - PR^{12} &\leq 15 - 10 . \end{aligned} \quad (6)$$

So the second shield should offer 41 dB $\leq PR^{12}$ upset protection.

4.4 Hardening Assurance Program

A simple program can be developed to preserve the EMP hardness of equipment through production:

- *Define the specifications.* In general, values need to be assigned to all parameters mentioned in section 4.2. Usually this will involve some experimenting to determine the susceptibility levels of the system components.
- *Design the prototype.* Determine the necessary protection and integrate the protective means into the design of the system.
- *Test the prototype.* If necessary, it can be modified. Additional tests, as necessary, should precede qualification testing of the prototype system.
- *Control production.* The configuration and parts procurement must be controlled to assure that the hardness of the produced system resembles that of the qualified prototype system. Occasional tests on production copies may be considered.

5. External Stress Guidelines

5.1 Configurations

In this section we describe the test guidelines that represent the maximum expected coupling of EMP-generated electromagnetic energy onto typical shelter configurations. We also establish guideline classes for the external electromagnetic transients at the transition boundary between zone 0 and zone 1 (see sect. 4 for a discussion of zones).

Only isolated, star- or line-configured shelters should be considered. Loop-configured systems must be avoided, unless the cables form parallel runs with a separation of less than 50 cm, as shown in figure 12. The external cables connect to the external surface of the shelter at an entry panel in the lower part of one of the four sides of the shield.

Multiple shelters and external equipment such as antenna masts or diesel generators connect to earth ground by means of electrodes in accordance with established standards for personnel safety. It is preferable to ground external cable shields to a buried metal plate separated from the shelter shield to decrease the currents circulating on the shelter itself.

Since a major function of the shelter is to decouple electromagnetic energy from the outside of the shelter to the equipment inside, attenuations of more than 40 dB must be maintained. Also, the impedances associated with the shelter configuration, grounding, and cable shield terminations are such that the induced EMP transients are characterized as short-circuit loads to the cable-coupled transients. Those penetrations that are protected by nonlinear devices also require an estimate of early-time voltage transients because it takes a few seconds for short-circuit loading to occur.

Figure 12. Shelter interconnections.

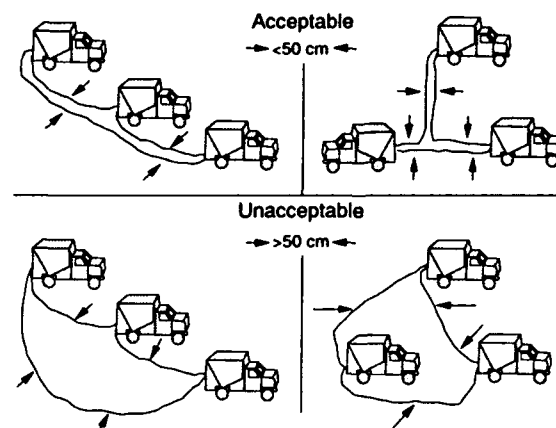

5.2 Grounding

A shelter is usually connected to an earth penetrating electrode by a conductor about 200 cm long, that provides about a 1- μ H inductance. While the resistive impedance is about 2 m Ω , the inductive reactance is 6 Ω at a frequency of 1 MHz and 24 Ω at 4 MHz.

For a shelter with a floor area of 30 m² and supported 0.5 m aboveground, the capacitive reactance to ground is 120 Ω at a frequency of 1 MHz and 30 Ω at 4 MHz.

The total impedance for these conditions would be:

6 Ω at a frequency of 1 MHz

12 Ω at a frequency of 4 MHz

The significance of these data is that protection measures that divert an EMP transient to ground would raise the voltage of the shield substantially across critical parts of the spectrum for each ampere of current being diverted. Some resonance would exist for frequencies above 4 MHz with peak values limited by minimum impedances. Collectors of large transients would produce risetimes greater than 100 ns, with associated frequency content below 3.5 MHz. The characteristic impedance of such cables (60 to 400 Ω) is significantly larger than the grounding impedances, which could be as high as 20 Ω . Actual currents are less than the short-circuit currents. This results in a small over-estimation of current.

5.3 Guideline Levels

External electromagnetic fields are defined as plane waves with an impedance (E/H) of 377 Ω . The field is a function of time as expressed in AEP-4. The wave shape in AEP-4 is an envelope of a wide variety of EMP environments which, when simulated, can be used in systems tests to investigate the responses and hardening effectiveness of the system.

The electromagnetic field penetrates into the shelter through openings and through induction on cables with variable source impedances according to the distance from the opening and the cable. The shelter constitutes a cavity that can generate standing waves, which amplify the coupling into circuits. Electromagnetic energy coupled onto external cables can penetrate the shield and re-radiate complex fields, which couple onto additional cables.

Due to the complexity of these phenomena, it is essential to express guidelines for these fields that are easy to produce for tests and compare with guidelines for internal coupled currents. Assume that the

only guideline for zone 0 is $AR_{10}^0 = 100 \text{ kV/m}$ and the corresponding magnetic field is calculated as the electric field divided by 377Ω in amperes/meter.

Table 2 summarizes the peak common mode currents that can be induced by HEMP on external cables and antennas. This table provides a gross estimate of the magnitude of transient currents for general cable or antenna coupling. We can obtain refined values and waveforms by modifying these currents for particular shelter features. Table 3 shows the guidelines for maximum transient currents coupled to external cables and antennas from EMP.

Each guideline is chosen as a set of values that forms a reasonable envelope of the transient peak levels predicted for multiple cable and antenna configurations described in table 2.

The frequency range for these four levels has the idealized appearance shown in figure 13.

Table 2. Cable and antenna currents.

Configured	Length (m)	Height (m)	I_{pk} (A)
Cable	<100	<5	600
Elevated	—	<5	1500
Horizontal	>100	>5	600
	—	>5	3000
Cable	<25	—	200
Underground	>25	—	600
Antenna	<1	—	10
Vertical	<5	—	200
Monopole	<10	—	800
	>30	—	6000
Horn Antenna	Area	1 m^2	10

Table 3. External current guidelines.

Guide-line	Level (A)	Rise (ns)	Fall (s)
AC ₇	3000	100	10
AC ₆	1000	30	10
AC ₅	300	30	10
AC ₄	100	10	10

Figure 13. External current range.

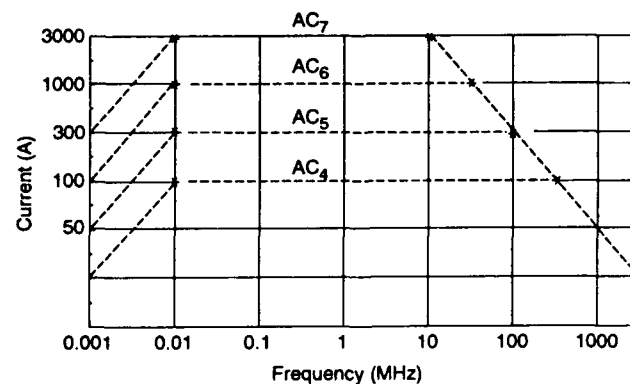

In the figure, the two axes are logarithmic scales; the first breakpoint for each level is associated with the decay time, while the second breakpoint is associated with the risetime.

5.4 Modifications to Guideline Levels

The guidelines from table 3 are for in-line configured shelters and must be modified to account for currents from the equipment on the end of the cable and for cross-cable coupling. Currents transferred onto a cable due to a shelter or generator will increase the standard level by something close to 200 A. If the end system is on the ground the influence of the total current on the cable will be negligible and the guideline will be unmodified.

Early-time coupling between external cables induces energy to or from the cables whenever they are to each other, such as at an entry panel. A coupling factor of about one third can be used for cables for early times or high frequencies. If the shelter sits on the ground, this coupling reduces the standard level by a factor of 10. Using a raised grounding plate for the entry panel to earth ground permits a reduction of coupling to the shelter and a reduction of coupling between cables. Late time (greater than 100 ns) coupling levels for each cable of a system equal the sum of the currents referenced to the cable entry from all the remaining cables. This sum is determined by circuit analysis—usually, the current in the cable divided by the sum of the inverse ground impedances located before the cable entry point.

Star-configured multiple shelters share the coupling for all end-system equipment by reducing the number of grounding systems located before the equipment. A system can use an AC_5 standard in a cable, an AC_4 in a cable that is close to other cables, and an AC_3 in a cable between shelters on the ground or in a star configuration.

Transient currents conducted onto a shelter are assumed to be equal to the sum of the estimated currents of the individual cables connected to the shelter. This total current is divided by the number of grounds. Similarly, the current in the grounding system of the shelter is equal to the sum of the estimated current in each cable.

5.5 Shield Density Currents

Cable connections do not change the guidelines other than to change the lower frequency limit for an unattenuated peak value from 1 MHz to 100 kHz.

5.6 Currents Inside External Cables

Transient currents coupled to the inside wires of an exterior cable are determined for three cases:

- 1—Unshielded cables
- 2—Shielded cables linking two shelters
- 3—Shielded cables connected to an antenna

Case 1. The modified guidelines for the bulk (common-mode) current for an unshielded multi-wire bundle have been established in section 5.3. The differential mode between two wires of an unshielded bundle is negligible for balanced terminations at both ends. If terminations are unbalanced, the differential mode current is assumed to be equal to the common-mode current.

Case 2. For shielded cables the common mode current on the interior wire bundle of a shielded cable is given by equation (7):

$$\begin{aligned} \text{Early time } I_a &= \frac{I_g (Z_{xfr} S + 2Z_{tc})}{2Z_c} , \\ \text{Late time } I_a &= \frac{I_g (Z_{xfr} S + 2Z_{tc})}{\Sigma Z_l + j\omega S Z_c / v} , \end{aligned} \quad (7)$$

where I_a = interior bulk current (A),
 I_g = exterior shield current (A),
 Z_{xfr} = cable transfer impedance/length (Ω/m),
 Z_{tc} = connector transfer impedance (Ω),
 Z_c = characteristic impedance (Ω),
 Z_l = cable load impedance (Ω),
 S = length of cable (m),
 L = inductance of cable (H/m),
 v = speed of propagation (m/s), and
 $j\omega$ = characteristic frequency (rads/s).

Case 3. The guidelines for transient currents on the interior of a shielded cable assume a shielding attenuation of 10 dB. The guideline is decreased by one index value from the exterior shield guideline between cables in a single bundle. For coaxial cables linked to the antenna, the core current is determined by the current coupled by the antenna plus the current transferred to the core from the shield.

6. Internal Stress Guidelines

6.1 General

Hardened zones can be protected against the effects of EMP by

- electromagnetic shielding and
- shelter penetration protection.

Despite the use of high-performance technology, some interference will remain in different zones of the shelter. This interference is partly from radiated electromagnetic waves and partly from conducted current transients. The levels of these interference transients are directly related to the efficiency of the coupling and the protection used. The linear protection of a system by a Faraday shield is measured as a shielding effectiveness, or efficiency (SE), quantity, which is the ratio between the level of the threat field and the resulting field inside the shield. For nonlinear protection devices there is some arbitrary level below which there is no significant protection and above which there is substantial protection. Table 4 lists the guidelines, CR_n^i , for internal field stress.

In order to ease the design of hardening, this section will define for each zone different classes of guidelines for maximum acceptable internal currents, designated CC , where n is between 4 and 8 (the higher class representing a more severe environment). Each class is further subdivided into

- CR_n of radiated internal interference levels and
- CC_n of conducted internal interference levels.

Due to the interrelation of the phenomena, the two latter guidelines must relate as $CR_n = CC_{(n+7)}$. For example, good shielding would provide an internal criterion of class CR_1 , and the conductive current may result in a class CC_8 . These guidelines must be the same class to provide a consistent overall level of hardness. It is necessary either to choose a new, more efficient conduction protection device or to

Table 4. Internal field guidelines.

Guidelines	Ampl. (V/m)	Rise (ns)	Fall (μ s)
CR_8^i	10000	10	0.5
CR_7^i	3000	10	0.5
CR_6^i	1000	10	0.5
CR_5^i	300	10	0.5
CR_4^i	100	10	0.5

adopt a more relaxed class of guidelines for shielding. The latter measure would require a higher level of susceptibility guidelines for the equipment being hardened.

A threat that can be tolerated must be of a class of guidelines such that its amplitude is greater than ambient interference but less than the susceptibility guidelines, or test guidelines, decreased by the required safety margins.

6.2 Conducted Interference

EMP effects conducted by internal cables to protected areas can be coupled by

- residual electromagnetic fields to all circuits,
- residual currents from protected penetrations of the shield, and
- common currents from connections between circuits.

Table 5 lists the guidelines for conducted currents, which involve the following penetrations:

- unshielded cables or harnesses,
- conduit or cable connectors, and
- outer coaxial sheaths or cable shields.

The transient amplitude within coaxial or shielded cables is usually less, but can be greater, than that of the shield or outer sheath. Experience in sustainment of hardening over time shows that a factor of 20 dB should be added to the cable shielding effectiveness, or transfer function (I_{crc}/I_{shld}) to offset aging degradation of hardness. Figure 14 shows different examples of various cable protection designs.

In the same way as for radiated fields, the form of conducted transient is defined by seven evenly increasing classes of guidelines.

Table 5. Internal currents.

Guidelines	Ampl. (A)	Rise (ns)	Fall (μ s)
CC ₄	100	10	10
CC ₃	30	10	10
CC ₂	10	10	10
CC ₁	3	10	10
CC ₀	1	10	10
CC ₋₁	0.3	10	10
CC ₋₂	0.1	10	10

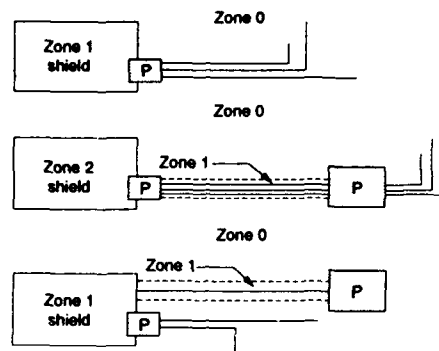

Figure 14. Cable protection.

The form of the EMP transient as a function of time is specified by equation (8):

$$I_{(t)} = I_0 e^{-\pi f t / Q} \sin(2\pi f t + \Phi), \text{ where}$$

I_0 = guideline level (amperes), (8)

Φ = phase (radians), and

$Q = 15 \pm 5$ (damping factor).

Amplitude I_0 is determined from the maximum for each level of guideline; its spectral density is constant within the frequencies between 1 and 100 MHz, and decreases by 20 dB per decade above and below this range. Figure 15 shows that the range of frequencies between 100 kHz and 100 MHz is of concern, including the low-frequency transients from long external lines and high-frequency resonances from internal wiring of the shelter.

Protective devices attached to long cables often require the capacity for additional low-frequency current. An additional 20 dB may be considered for frequencies below 1 MHz to enable any filter following a protective device to accommodate the residual energy within the protective device.

When a cable circuit is connected to a low impedance, only the value of the current will be taken into account for heat capacity. High impedance terminations require that the voltage be considered for dielectric strength.

After the EMP transient that can be tolerated within the protected area is defined, it is necessary to (1) compare it to the residual values of the output of the protection device (sect. 7), and (2) choose the appropriate susceptibility guideline level (sect. 8).

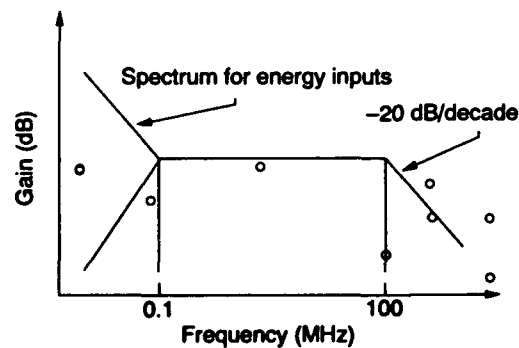

Figure 15. Internal current spectrum.

7. Protection Guidelines

7.1 General

In this section we establish the guidelines to which manufacturer's equipment and devices will be classified. Test methods described in the NATO Green Book, NATO 1460/3 (August 1990), and outlined in section 9, use external stress levels determined by the procedures of section 5 and internal stress levels identified in section 6. Generally, EMP protection is separated into linear and nonlinear categories. Linear protection includes Faraday shields, braids, and devices such as filters, waveguides, grounding, and bonding—anything that responds to stress in a continuous way. Nonlinear protection consists of spark gaps, metal oxide varistors, or any device that responds to stress in a continuous way to a threshold level, and then responds abruptly in another way, such as a changed impedance. When sufficiently stressed, even linear devices perform nonlinearly, by arcing or corona.

7.2 Shield Protection

The shield is usually built into the wall of a shelter using a conductive material such as aluminum, steel, or copper screen. Composite shelters may use carbon/boron or other modest conducting materials for weight concerns, but will not be able to achieve the same shielding effectiveness without some additional treatment. Very reliable shields require double layers (fig. 16) to provide redundancy for fault tolerance, and very effective shields may require steel plate with welded seams for 100-dB maintainable hardness. Both extremes have substantial weight penalties. In addition to EMP transients, a shelter wall should be designed to withstand lightning, blast and flash, and fragments, and they perhaps should provide isolated environments for signal intelligence (radio silence) or protection against TEMPEST and high-power microwaves (directed energy).

Figure 16. Shield wall.

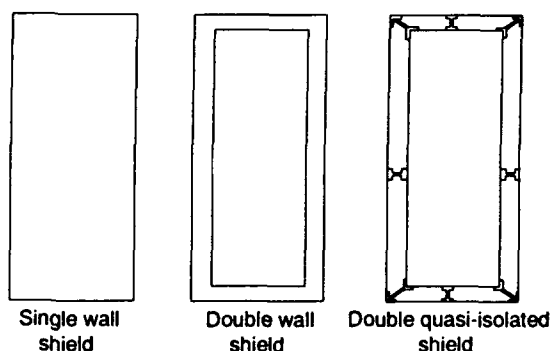

7.2.1 Shielding Guideline Modifications

Guidelines for basic shelter configurations are shown in table 6. These attenuation levels are used to relate the identified external stress (AR_{10}^0 from sect. 5) to the allowable internal radiated residual stress (CR_n^i from sect. 6). Seven levels of guidelines are identified for shielding effectiveness.

PR_n is the protection criterion for an isolated shelter. The absence of external conducted transients results in only the direct EMP field generating surface currents on the shield. In this case, the allowed attenuation begins above 80 dB and rolls off below 1 MHz with a reduction of 20 dB per decade of descending frequency. Figure 17 shows the guideline ranges.

PC_n is the protection guideline for a shelter connected by shielded cable to other shelters. External conductors connected to the shield couple low-frequency surface currents. The guidelines are the same except that the roll-off extends below 100 kHz and again reduces the effectiveness by 20 dB per decade of descending frequency. For example, a combination of two residual internal stresses, CR_5 and CR_4 , result from the previously identified AC_{10} and AR_{10} external stresses after attenuation by guidelines PJ_5 and PR_6 . The combined internal radiated stress is the larger of the two guidelines (i.e., CR_5). PC_n and PJ_n are shown in table 7 and are equal to PR_n and PL_n , except that levels attenuate below 0.1 MHz for PC_n and PJ_n .

Table 6. Shelter shielding.

Guide	Amplitude (dB)	High frequency (MHz)	Low frequency (MHz)
PR_6PL_6	60	100	1
PR_5PL_5	50	100	1
PR_4PL_4	40	100	1
PR_3PL_3	30	100	1
PR_2PL_2	20	100	1
PR_1PL_1	10	100	1
PR_0PL_0	0	100	1

Figure 17. Shield protection.

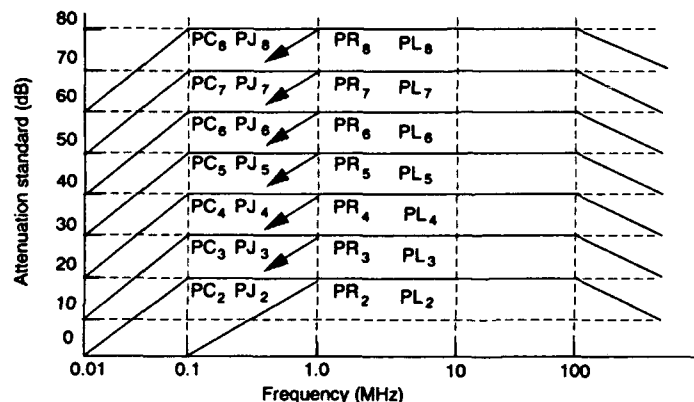

Table 7. Cable shielding.

Guide	Amplitude (dB)	High frequency (MHz)	Low frequency (MHz)
PJ ₈ PC ₈	80	100	0.0
PJ ₇ PC ₇	70	100	0.1
PJ ₆ PC ₆	60	100	0.1
PJ ₅ PC ₅	50	100	0.1
PJ ₄ PC ₄	40	100	0.1
PJ ₃ PC ₃	30	100	0.1
PJ ₂ PC ₂	20	100	0.1
PJ ₁ PC ₁	10	100	0.1
PJ ₀ PC ₀	0	100	0.1

7.2.2 *Special Components of Shielding*

The shielding effectiveness of a shelter depends upon many special components and how the conductive bonding of those components is maintained over time. These components are the door seams, aperture honeycomb, panel joints, and connector seals. The effectiveness of these devices in preserving the shielding effectiveness is determined by the conductivity of the mating surface between the device and the shelter. Conductivity changes can occur due to chemical or galvanic corrosion, mechanical deformation, or collection of dirt, grease, or paint at the juncture. Choosing dissimilar metals should be avoided, or galvanic effects should be mitigated by intermediate metals. Corrosion prevention treatments should be considered. Weather gaskets should be used to isolate any rf gaskets from the external weather. Doors or panels that are repeatedly opened should use these guidelines. Periodic inspection with servicing can maintain the original effectiveness. Active testing is preferred over visual inspection, since shielding degradation is not always visible. Seams should be designed for easy access to facilitate maintenance. Replacement parts and tools should be available within the shelter in order to facilitate prompt repair.

Because the shielding effectiveness of access panels and entry doors rapidly degrades over time or through frequent use, the guideline for the shield of a used shelter should be reduced by 20 dB between annual periods of maintenance to the shield and its ancillary components.

7.3 Linear Penetrations

7.3.1 Waveguides and Vents

For all linear penetrations such as waveguides or filters, cable shields should be attached to the shield so that effectiveness is not compromised. Waveguides are used to channel microwave signals into the shelter. "Waveguide beyond cutoff" pipes can be used to pass nonconducting materials or to serve as air vents. They are designed to attenuate all frequencies below the cutoff frequency of the waveguide. This frequency depends on the geometry of the waveguide design. Rectangular or cylindrical waveguide attenuations are given in equation (9) and illustrated in figure 18.

$$SE \text{ (dB)} = 27.3 \frac{1}{b} \sqrt{1 - \left(\frac{f}{f_c}\right)^2}$$

For square b , For round d ,

$$f_c = \frac{15}{b} \text{ (GHz)} \quad f_c = \frac{17.6}{d} \text{ (GHz)} \quad (9)$$

b = side cm. d = diameter cm.

Connections between an effective shield and the "waveguide below cutoff" metal must be bonded in a manner that assures the continuity of the basic shielding surface. Generally these connections should be welded using compatible metals. Figure 19 shows a typical installation detail for a waveguide. Waveguides are a cost-effective way to attenuate the EMP threat fields.

Honeycomb vents should be constructed so there is electrical connectivity between all adjacent cells along the entire length of each cell. The array of cells and the frame can be dip brazed, or the cells can be crimped together along the entire length of each cell and then brazed to the frame. This assembly should be gasketed with RFI gasket and bolted, brazed, soldered, or welded to the shelter shield. Each cell must have at least a 4:1 length-to-diameter (effective) ratio

Figure 18. Waveguide cutoff.

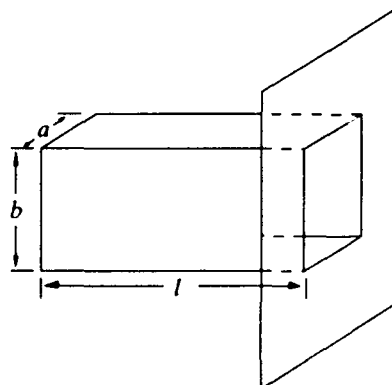
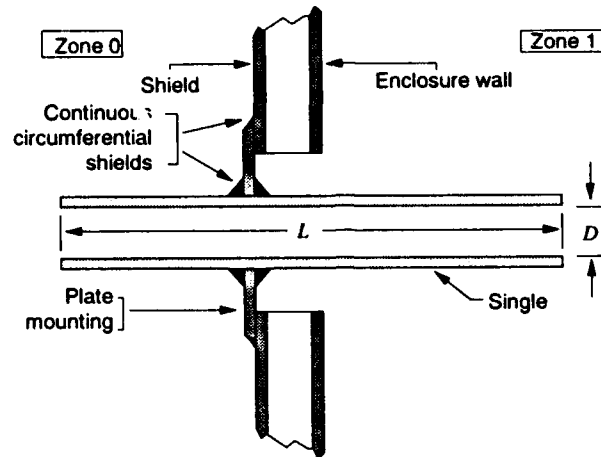

Figure 19. Waveguide installation.



and a diameter of less than 2 cm. The array should not be larger than 0.50 m².

Water pipe penetrations must conform to the waveguide guidelines. They are typically located at the main entry panel. Additional information is presented in section 7.3.3.

7.3.2 Cable Shield and Grounding Terminations

Wherever a grounding connector or a cable shield attaches to pass through the shield, the connection must minimize the transient current passing into the protected zone. You can do this by circumferentially bonding the stud or connector to the shield as shown in figure 19. It is recommended that the interior bonding of the stud or connector be offset from the exterior bonding to minimize the penetration of residual current into the interior, as shown in figure 20.

Despite the circumferential bonding for cable shields, some current penetrates the zone, but this should be limited to the internal conducted guidelines discussed in section 6. This residual depends on the current division through the impedance of the bond and the internal circuit as shown in figure 21. A short-circuit termination is generally the case. The impedance of the circuit will then be the characteristic impedance of the cable for early time and will be the inductive impedance of the short circuit loop for late time. The minimum protection is expressed by equation (10):

$$\begin{aligned}
 I_s &< CC_m, \\
 PL_p &= 20 \log AC_n - 20 \log CC_m; \\
 \text{the guideline subscripts must relate as } p &= n - m.
 \end{aligned}
 \tag{10}$$

From the external stress guidelines given in section 5, and the internal stress guidelines given in section 6, the range of attenuation, in decibels, of PL_n , PR_n , PC_n and PD_n is shown in figure 22.

Figure 20. Grounding to shield.

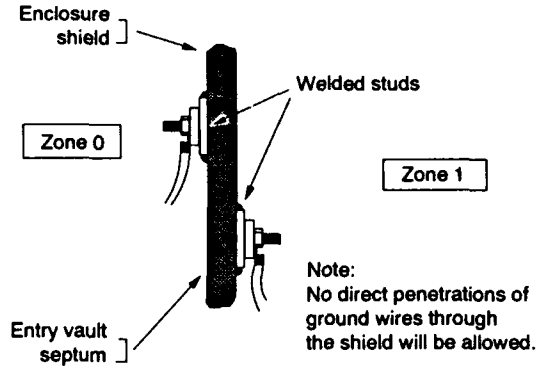

Figure 21. Stress division.

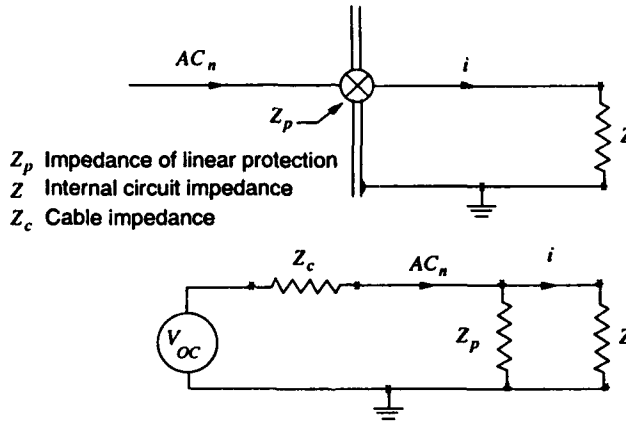
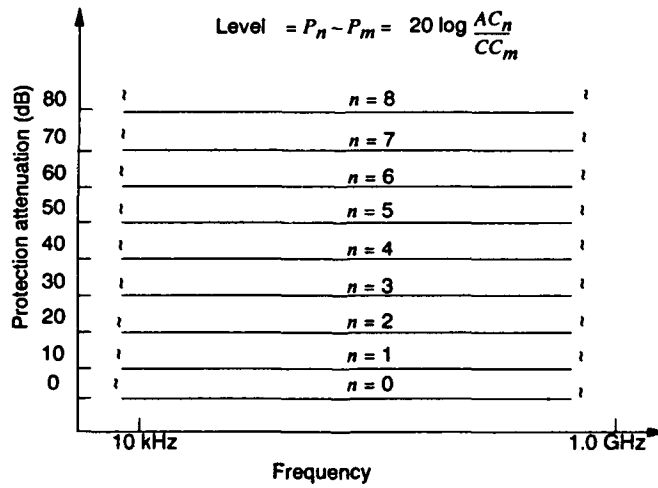

Figure 22. Linear protection.



7.3.3 Penetrating Pipes

Because of the finite conductivity of water and sewage, their penetrations through a shield must be electromagnetically protected to ensure that external stresses are not transmitted inside the shield. The conducting fluid should enter the shelter through a metallic pipe. The insulating pipe shown in figure 23 should be avoided. Instead, a metallic "waveguide below cutoff" should connect the pipe through the shelter so the conducting fluid can contact the shield penetration protection and the stress currents can be diverted to the shield exterior, as shown in figure 24.

Figure 23. Incorrect waveguide.

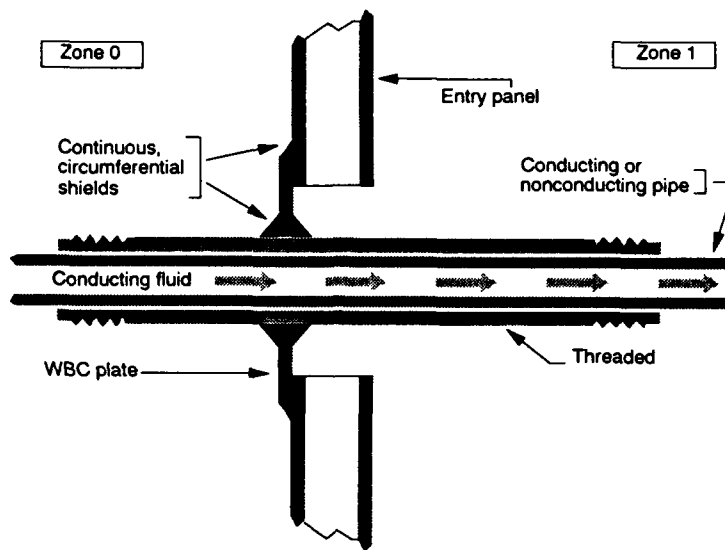
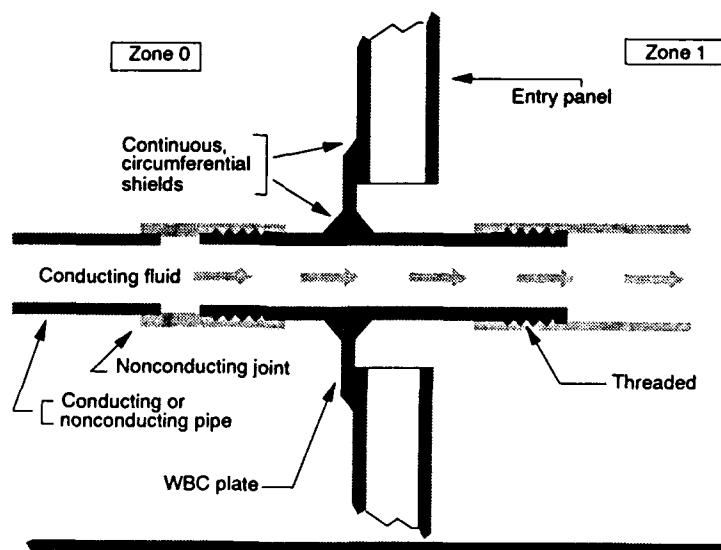

Figure 24. Correct waveguide.



7.3.4 Fiber-Optic Tubes

Waveguides may also be used to pass fiber-optic lines through the shield. Several precautions are required. Some fiber-optic sheaths may contain metal strands for mechanical strength, and such cables should not penetrate the waveguide. The metallic strands should be removed from the fiber-optic line and terminated on the shield. Highly conductive plastic should also be stripped from the fiber-optic lines and bonded to the shield by any conductive attachment means which provide permanence.

7.4 Cable Protection

7.4.1 General

Any conductor that penetrates a shield must be hardened to prevent a threat-induced transient into the shielded volume. A coaxial cable can be hardened by circumferential bonding of the outer shield or conductor to the outer surface of the enclosure shield. A spark gap and filter can be combined to protect a conductive penetration that cannot be grounded. Generally an rf penetration should be coaxial cable treated with a penetration protection device (PPD) at the shelter shield. Figure 25 (sect. 7.4.2) shows a generic antenna line hardened against threat-coupled transients.

PPDs attenuate, shunt, absorb, or reflect transient current at the shield to levels that are tolerated by equipment in zone 1 (see sect. 6 for the zone concept). The amount of attenuation required varies according to the cable type, geometry, and loading. PPD designs consist of combinations of nonlinear surge arrestors and linear filters. They are typically complex. Specific designs require detailed engineering.

Figure 25. Coaxial entry protection.

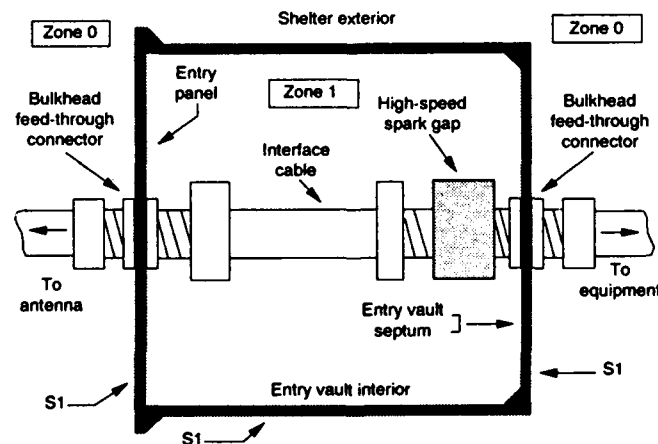

Three general PPD applications arise due to the operating frequency of the penetrating cable. In one, the frequency of operation is well below the principal frequencies of the stress (less than 10 kHz). Low-pass filtering is effective. In another, the cable operates at a high frequency (greater than 100 MHz). In the third, dominant frequencies of stress fall within the operating frequency of the equipment. A band-pass filter may be used, and existing couplers or pre-selectors may serve as band-pass filters. Limiting devices may be added in order to limit the dielectric stress on the filter, but must not clip the operating signal.

In each of these three situations, if the external stress is large, a surge arrester is required between the filter and the transient source to divert large energy pulses, and an insertion impedance may be required to prevent the fast limiting device from preempting the switching of the surge arrester and burning out the limiting device. If the stress rise time is slow (longer than 0.1 μ s) the surge arrester alone will suffice to protect the equipment.

Other general guidelines for the design, selection, and application of PPDs include the following:

1. The PPD chosen should not interfere with normal operation of the circuit. Insertion losses should typically be less than 1/2 dB. Intermodulation products on rf circuits should be below 100 dB of operating levels and voltage standing wave ratios (VSWRs) should be less than a factor of 1.2. These guidelines are typical; specific systems may have other requirements.
2. Shunt capacitance for nonlinear devices is critical to the operation of high-frequency circuits. These parasitic capacitances of the device should be below the maximum defined by equation (11):

$$C_{shnt} = \frac{1}{2\pi f Z_c} , \quad (11)$$

where

C_{shnt} is the maximum shunt capacitance,

f is the highest operating frequency, and

Z_c is the characteristic impedance of the line.

Shunt capacitance concerns generally require a spark gap configured in a coaxial package or strip-line designs.

3. Leakage current for solid-state nonlinear devices should be minimal to reduce possible electromagnetic interference effects.
4. Very slow (near dc) voltage levels for nonlinear clamping should be between 1.2 and 1.5 times the peak operating voltage of the line. Devices should be chosen that maintain the voltage at the highest operating frequency.
5. It is wise to make all nonlinear devices dual, for common switching.
6. Using one circuit for two signals (at different times or frequencies) should be avoided due to the possibility of intermodulation effects from the protective devices. The designer should be informed on the use of suppression devices in any antenna line so that his design can adjust to minimize the impact of parasitic and nonlinear effects.
7. A minimum number of nonlinear devices should be used to simplify the predictability of a system's response and to reduce maintenance costs.
8. Nonlinear PPDs should be on the unprotected side of a filter, except when a small limiter of the band-pass transients is desired.
9. The reduction of parasitic inductance by using the shortest possible leads to parts is critical to the proper operation of equipment and protective devices. Shunt connections should be kept under 2 cm. Wide strap leads or foils are preferred, with a length-to-width ratio of less than five to one.
10. Filters should be multistage and lossy. If the filter input is capacitive, an inductor or resistor may be needed to avoid voltage amplification when a surge arrester switches nonlinear. Filters should be able to withstand the overshoot of the threat modified by PPDs.
11. Filter cases should be part of the shield and should provide good electrical connections with the entry vault by use of rf gaskets or metal-to-metal bonding.

7.4.2 Coaxial Cable Guidelines

Figure 25 shows an entry vault for coaxial lines. (Protection for coaxial cable penetration may involve a nonlinear element.) The guideline PL_n is used to identify the attenuation levels for linear devices such as a filter, and are scaled in decibels as found in table 6. The guideline PD_{mn} is used to identify the nonlinear attenuation levels. These are given with the first index, m , identifying the applied current, AC_m (table 3 for external cables) or CC_m (table 5 for internal cables). Voltage at this current for the nonlinearity region must also

be considered. Voltage in the nonlinear region is the sum of the standoff (Zener) voltage and the potential of the bulk resistance due to the diverted current ($V_{tot} = V_{znr} + I_s R_b$). The index n identifies the external stress AC_n , discussed in section 5. The residual current values of PD_n are listed in table 8.

7.5 Circuit Entry Protection

7.5.1 Telecommunications Lines

Telecommunications lines include both telephone pairs and data pairs. These circuits should be hardened by a three-electrode spark gap sharing a common chamber, and followed by a resistor and filter on each line. When a shielded multi-conductor cable penetrates the shield, a connector with rf backshell should be used to provide circumferential continuity as described in section 7.3. The individual wires of the multi-conductor cable are each protected as separate wires using the spark gap and filter combination.

Besides coaxial lines, three other types of cables may penetrate the shelter's shield. These are telecommunications, local control, and power lines. Main-power-line protection is further discussed in section 7.6. Figure 26 shows an entry vault layout for telecommunications lines, with the lines protected by a nonlinear electronic surge arrester (discussed in sect. 7.4.2) that is combined with a filter or other linear device. Figure 27 shows the basic schematic.

7.5.2 Local Control

Local control circuits consist of data or command lines. Data and low-voltage control lines are protected the same as the circuits discussed in the previous section. High-voltage control lines use the same technique as that protecting the prime power entry, described in section 7.6.

Table 8. Penetration protection.

Guide	Current (A)	Rise (ns)	Fall (μ s)
PD _{m6}	1000	10	10
PD _{m5}	300	10	10
PD _{m4}	100	10	10
PD _{m3}	30	1	10
PD _{m2}	10	1	10
PD _{m1}	3	1	10
PD _{m0}	1	1	10

Figure 26. Wire entry protection.

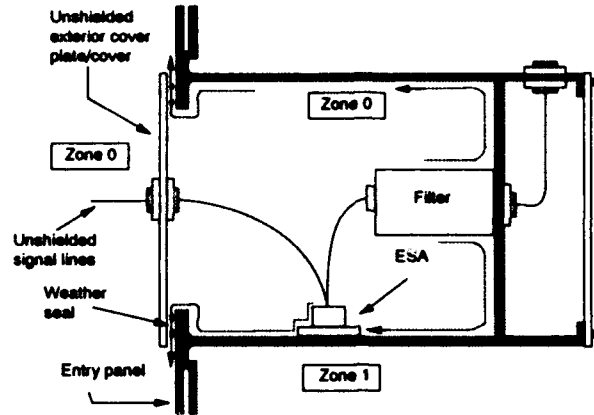

7.6 Power Entry Protection

7.6.1 Guidelines for Protection

Power lines are protected by a spark gap followed by a filter as shown in figure 27. The input stages of the filter must withstand threat-induced common-mode voltages whose levels are given in section 5. The input stage of the power filter should be a shunt capacitor (of 1 μF or greater) to increase the rise-time of the transient. This improves the effectiveness of the spark gap by allowing time for sparking and by lowering the threshold of voltage to fire.

The filter should not appreciably change attenuation or spectrum for impedance mismatch. Tolerance is achieved by multi-sections and lossyness. The filters should contain at least three stages. L-type filters are not tolerant of variable impedances on the input or output but can control over-voltages from oscillation.

Pi section filters are more tolerant, but tend to oscillate. *T*-filters are undesirable because of the tendency for arcing at the input of the inductor. Butterworth filters are excellent, but cost more.

The spark gap, usually a lightning protection type, can be replaced by a self-extinguishing gap if the expected surge currents are limited to a few kilo-amperes.

The voltage threshold of the spark gap should be greater than the peak value of the power-line voltage. If the RMS voltage is 100 V, the peak is a factor of $\sqrt{2}$ more than this, and a value of 150 V would be safe. The dielectric strength of the filter input capacitor should be at least twice this value for a minimum safety factor of two.

When spark gaps are used on power lines, they should be capable of being extinguished after the transient has passed, even though the

Figure 27. PPD schematic.

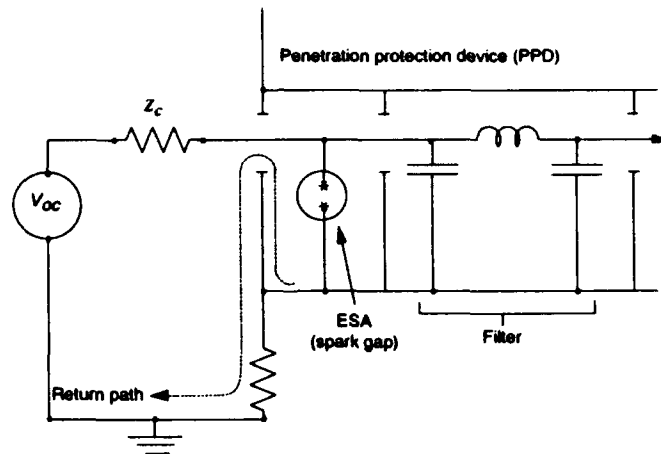

power is still applied to the spark gap. The device has to dissipate the energy of the transient and the line before it is extinguished. A varistor is sometimes placed in series with the spark gap to ensure time for the gap to extinguish during an ac crossing of zero potential. The varistor needs to be power rated for its share of the transient and power duty cycle.

A filter and spark gap combination should be used for each phase and neutral of the power line. It is recommended that the spark gap and filter be contained within a shielded enclosure. The case of both filter and spark gap should be bonded electrically with the walls of the shield. All leads should be short and broad to minimize parasitic inductance.

7.6.2 Guidelines for Power Cables

Attenuation for power cable protection devices is the same as for other entries described in section 7.6.1.

8. Susceptibility Design and Test Guidelines

8.1 General

The electromagnetic stress on the equipment inside the shelter is threefold: an electromagnetic field penetrating through apertures and coupling onto equipment, a current transient penetrating through a cable to equipment, or a current transient penetrating on a cable and reradiating to cables within. Figure 28 illustrates these three modes of EMP energy penetration. It is essential to know how much amplitude and energy the equipment will be exposed to and what threshold to damage the equipment can withstand; then protection measures may be selected to be included in the design to reduce the stress at the equipment to levels it can withstand. It may be necessary to increase the strength of the equipment for transients which are unavoidable. The designer must identify these stresses, strengths, and attenuations in order to design the equipment to be hard against EMP.

8.2 Susceptibility Analysis and Tests

Nuclear EMP effects are simulated by an analytic expression that includes the time amplitude (and the spectral density amplitude) and is easily generated by existing test equipment. This analytic expression is given as equation (12).

$$A(t) = \sum_{i=0}^n A_i e^{-\pi f_i t / Q_i} \sin(2\pi f_i t + \Phi_i) , \quad (12)$$

where A_i is the i^{th} amplitude factor, Q_i is the i^{th} decay factor, f_i is the i^{th} frequency factor, and Φ_i is the i^{th} phase angle.

Equipment designers should modify this equation to meet the equipment specifications. It is usually sufficient to deal with only a

Figure 28. HEMP stresses.

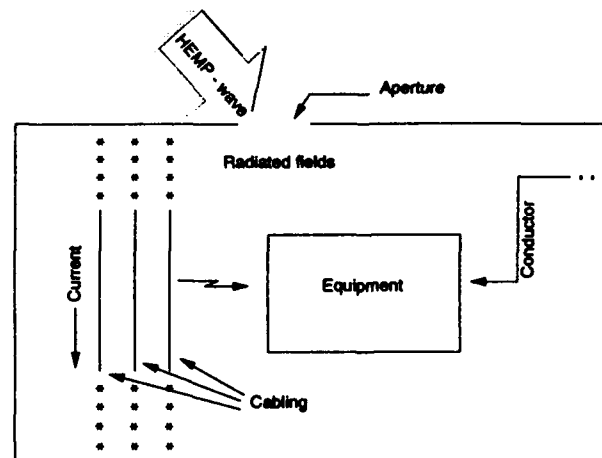

few of the i factors. The resulting EMP simulation may have complex structures but will approximate the threat as generated by incident HEMP fields, diffracted HEMP fields, and cable-coupled current from HEMP fields.

Figure 29 shows an example of such a transient. Every analytic or experimental investigation of the susceptibility of the circuits and equipment aids the designer's ability to harden the system. This experience allows the selecting of rules appropriate to the equipment based on the results from several sources:

- comparison of responses to different threats,
- comparison of residual transients from PPDs, and
- applying zoning concepts with different protection measures.

A hardening approach should be the outcome of the analysis and test program using the above rules.

8.3 Grouping Guidelines

Figure 30 is a functional analysis schematic summary that shows the logic from section 3 using the notation defined in the glossary. Note that the function F is critical, and the function \bar{F} is not critical. The last step subdivides only the critical equipment in A , \bar{A} , P , and \bar{P} . The next subsection considers critical equipment.

Figure 29. Coupled transient.

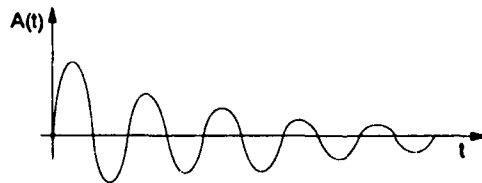
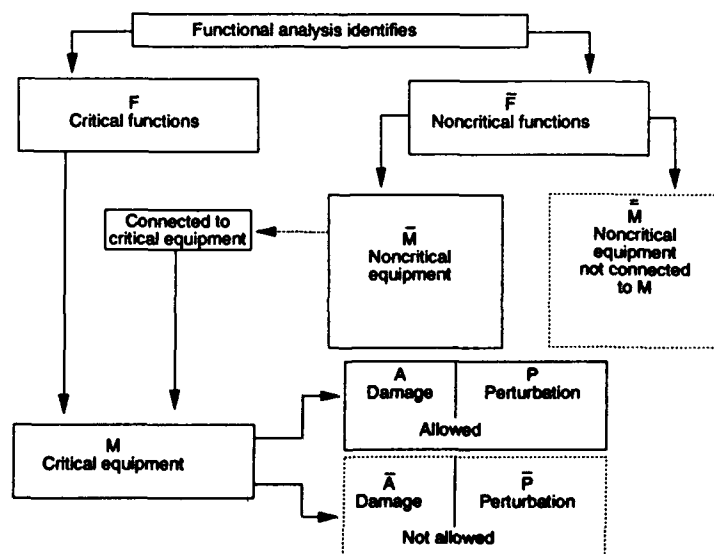

Figure 30. Functional analysis.



8.4 Evaluation of Critical Equipment

For information on the susceptibility of critical equipment, we evaluate the results from different measurement methods. Some methods were shown in table 1, with the responses of the equipment as shown. Guidelines are selected from the numbers shown in the table. If the levels for the stress on or in the equipment are known or specified, the designer may proceed step by step through the table numbers. Otherwise the designer is free to choose a susceptibility level plus some safety margin as a design goal and, making sure that the specification is met, describe his equipment as hardened to that level.

8.4.1 Electromagnetic Compatibility

We usually perform electromagnetic compatibility (EMC) tests with continuous wave (cw) excitation, selecting single-frequency steps over the range of the spectrum of interest, but we have also added broadband pulse excitation to the EMC test procedures. EMP tests complement EMC tests in that the shielding and penetration protection for EMP also provides the barrier for EMC.

8.4.2 Circuit Operating Levels

Equipment components usually have a threshold level of upset or damage moderately above their operating levels; the specific threshold varies statistically from sample to sample, but is generally about twice the operating range. Assuming that the device survives the operating levels in an ambient environment, these levels provide truncations of the electrical over-stress threshold. Table 9 shows three logic types and the upper and lower operating voltages. The rated operating characteristics of a typical device apply to steady-state operation. Susceptibility analysis requires the corresponding equivalent threshold values for square and damped sine waves. Rectangular pulse levels are obtained with equation (13).

$$V_p = V_0 \left(\frac{\tau}{t_p} \right)^{1/2},$$

where τ = mean duration and t_p = pulse duration . (13)

Table 9. Device operating levels.

Type	Low level (V)	High level (V)
RTL	<1	<2
TTL	1.6	3.5
DTL	1.6	3.5

Excitation of a damped sine wave can also be analytically described by equation (14).

$$V_{(t)}^{\sin} = V_{pk} e^{-\pi ft/Q} \sin(2\pi ft) ,$$

where Q = damping factor .

The sine duration $T = \frac{1}{f} = 2t_p$.

(14)

To provide a minimum for the failure threshold of a device, the designer can convert the operating voltage level (V_o) into a square pulse level by choosing a V_{sin} approximately equal in power using an energy equivalent of the rectangular pulse. The damped sine wave of period T is defined in equation (14).

These equations calculate the "operating levels" for two different pulses. They provide the minimum bound of the device's failure threshold.

8.4.3 *Manufacturer's Data*

The equipment manufacturer should perform a swept spectrum network analysis of his equipment to determine the permissible transient current and voltage input short of causing damage.

8.4.4 *Semiconductor Analysis*

We can use pulse susceptibility analysis to determine the maximum current and the maximum voltage that is less than failure current and failure voltage. Levels of current that may result in damage are identified analytically by the Wunsch-Bell model. This model identifies the threshold failure level of a semiconductor due to pulsed voltages. This model is based on the assumption that applied rectangle pulses with durations of from 0.1 to 20 μ s can adequately determine the junction temperature using linear heat flow theory.

$$P/A = K_1 t_p^{-1} + K_2 t_p^{-1/2} + K_3 t_p^0 ,$$

where

$$K_2 = \sqrt{\pi k \rho C_{\mu} [T_m - T_i]} ,$$

K = Wunsch exponent ,

ρ = density ,

C = specific heat ,

T_m = melting point, and

T_i = ambient temperature .

(15)

Figure 31 shows the Wunsch-Bell semi-empirical model for a wide range of pulse durations. For HEMP failure thresholds the curve is divided into three regimes. The first corresponds to adiabatic heating of the susceptible region of the device and is inversely proportional to the pulse width. The second corresponds to a quasi-adiabatic heating and is proportional to $t_p^{-1/2}$ (the model appropriate to EMP transients). The third corresponds to a steady-state function where the heat flow away equals the heat conversion and the duration of the pulse is not relevant. The device is specified to operate at a steady-state level less than the failure threshold level; this operation level also provides a safe lower bound on the device for long pulse widths. This lower bound becomes safer as the pulse width decreases into the quasi-adiabatic and adiabatic regions of the model.

The advantage of knowing the damage levels of a semiconductor device is that, along with other data stored in data banks (e.g., the SCORCH data base), the device can be modeled in computer circuit analysis codes with both operating and damage behavior simulated. For us to model the behavior of the device, including damage, to a wide range of pulse widths, it is sufficient to know the failure power level applied to different devices for only one rectangular pulse width.

Computer codes probably require more information, which can be extracted from equivalent circuit models for the devices, equivalent circuit parameters for the specific semiconductor devices, and the calculated amplitude and waveform of transient stress appearing at some (input) node of the circuit model.

In studying this special transient, the computer analysis calculations are correlated with the semiconductor failure measurements so as to estimate the failure level of a semiconductor device. These correlations are especially useful in the circuit design phase of equipment because the circuit reliability can be increased if we include protec-

Figure 31. Wunsch factor.

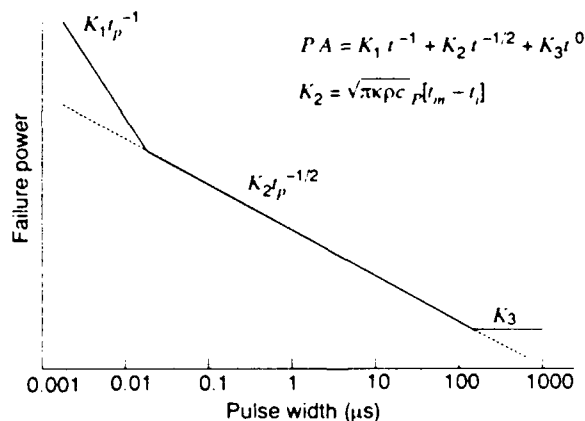

tion. The computer model allows us to calculate currents, voltages, and watts to failure along with other properties of a device under any given rectangular pulse stress. It is of value to correlate this rectangular pulse data to damped sine wave data. These are usually provided by the manufacturer.

There are several techniques for performing waveform conversion. An accurate analytic approach is a convolution technique for converting square pulse failure power (watts) into other equivalent failure waveforms.

Equation (16) provides a method of obtaining a new waveform when the square pulse is given. The value of T that maximizes the convolution integral is found; then with T known, we calculate the power amplitude P_0 of the new waveform needed to fail the device. The failure current I_0 and the failure voltage V_0 are then obtained from circuit parameters. The convolution waveform is derived from the following conversion technique.

- (a) $P_{sq} = At_p^{-K}$ square pulse failure,
- (b) $P(t) = P_0 F(t)$, where $F(t)$ is the pulse shape, and
- (c) $\int_0^T F(t) (T - t)^{K-1} dt$.
- (d) Find T , which maximizes the integral. (16)
- (e) Solve $P_0 = \frac{A}{KI_0^T}$, where A = junction area.
- (f) Find I_0 , V_0 circuit parameters.
- (g) K is the Wunsch exponent of t (fig. 31).

The sine wave period is often chosen to be $T = 5T_p$, and the Q -factor is restricted to $Q \leq 25$. These numerical and semi-empirical methods are of major benefit to the designer, since they are conducted in the production design phase and permit desensitizing the point of entry of the shield and predictions for test values.

A simpler but less accurate conversion is to use equations (13) and (14) and the failure data from tests or specifications.

Expected discrepancies between theoretical results and those obtained in appropriate experiments are about ± 10 dB. Figure 32 shows the corresponding statistical curve.

8.4.5 Shield Entry Tests

It is recommended that the designer test all points of entry for his equipment before finalizing designs. These tests should be

Figure 32. Statistical error.

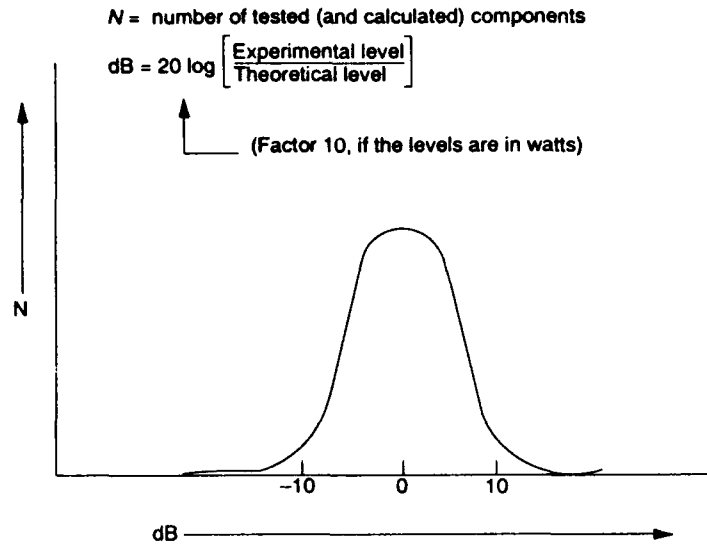

performed using several rectangular and damped sine wave stresses with and without the equipment powered on. Discrepancies of several tested networks of similar types may help determine a standard deviation that can be used to choose a suitable safety margin.

8.5 Testing Guidelines

8.5.1 Stress Guidelines

The form of the electric field that should be radiated on the equipment under test is that of the following exponential equation (17):

$$\begin{aligned}
 E_{(t)} &= E_0 e^{-\alpha t} & \alpha &= \pi \frac{f}{Q} \\
 E_0 &= \frac{AR_{10}}{10^\delta} \text{ for guideline } n. \\
 n &= 6 - 2\delta & \delta &= \text{either 1 or 2} \\
 f &= 4 \text{ MHz} & Q &= \text{decay rate}
 \end{aligned}
 \tag{17}$$

A safety margin may be added depending on the statistical variance of the equipment, the confidence level needed for criticality, the complexity of the product, and possible aging effects.

8.5.2 Conducted Currents

The shape of the conducted transient currents (common mode and differential mode) to inject into the pins of equipment is given by equation (18). Figure 33 shows the different susceptibility guidelines.

Long cables collect considerable current. Depending on the protection measures and the load, these currents can penetrate the sheltered zone and cross-couple to other cables. This leads to a severe stress on the devices, which should be tested in common mode (and differential mode) by injecting on the pins a current given by the CC_n guidelines and equation (18).

$$I_{(t)} = I_0 e^{-\pi f t / Q} \sin(2\pi f t + \Phi) , \quad (18)$$

$$I_0 = \frac{10 \text{ (amps)}}{10^{1/2\delta}} ,$$

where Φ is phase = 0, f is the range between $0.1 \text{ MHz} \leq f \leq 100 \text{ MHz}$, Q is ≈ 16 , and d is chosen from table 10 (DC_n or UC_n).

Figure 33 shows the range of the test guidelines for protective devices.

A suggested choice for the boundary frequencies is

$$F_1 = 1 \text{ MHz, and } F_2 = 100 \text{ MHz,}$$

but this bandwidth can be altered if dictated by the equipment. The total spectrum should include operating frequencies of the equipment as well as low (kHz) frequencies of any connected PPD responses.

Figure 33. Device damage/upset spectrum.

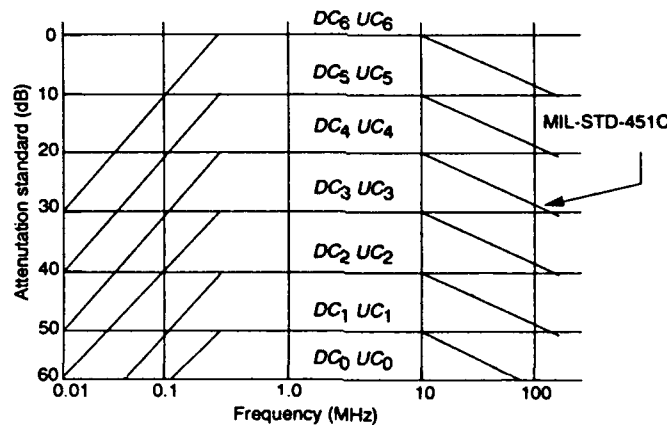

Table 10. Damage/upset guidelines.

Suscept. class	Delta	DC_n (A)	UC_n (V)
$n = 4$	$\delta = -2$	100	100
$n = 3$	$\delta = -1$	30	30
$n = 2$	$\delta = 0$	10	10
$n = 1$	$\delta = 1$	3	3
$n = 0$	$\delta = 2$	1	1
$n = -1$	$\delta = 3$	0.3	0.3
$n = -2$	$\delta = 4$	0.1	0.1

9. Acceptance Test Methods

9.1 General

9.1.1 *Coupling Configuration Tested*

Test methods for the following coupling configurations are considered in this section:

- Shelters with doors, panels, and apertures, but without equipment or penetrations,
- Penetrators with linear circuits,
- Penetrators for rf signals,
- Penetrators for controls/signals with nonlinear PPDs,
- Penetrations for power supplies, and
- Internal equipment.

Tests for each configuration should be adapted to the required objective of the equipment. Tests are proposed that comply with a plan that includes the following analyses:

- Principles and methods
- Test equipment
- Test configuration
- Test procedure
- Evaluation

9.1.2 *Test Objectives and Schedules*

Tests are applied at four stages of development for equipment, according to the objectives and the responsible organization concerned. Figure 34 shows the interrelationships of these tests.

Type No. 1, Parts tests: Undertaken by the manufacturer to determine the characteristics of parts and subassemblies, parts tests are followed by manufacturer's data sheets, product classification, and hardening measures development.

Type No. 2, Parts qualification: Directed by the prime contractor or agency, and performed on one or several subassemblies in order to develop prototypes, these tests ensure the compatibility of products with each other and with the requirements.

Type No. 3, Prototype tests: Performed on one or several prototype systems to show that the designs and materials meet specifications.

Figure 34. Test scheduling.

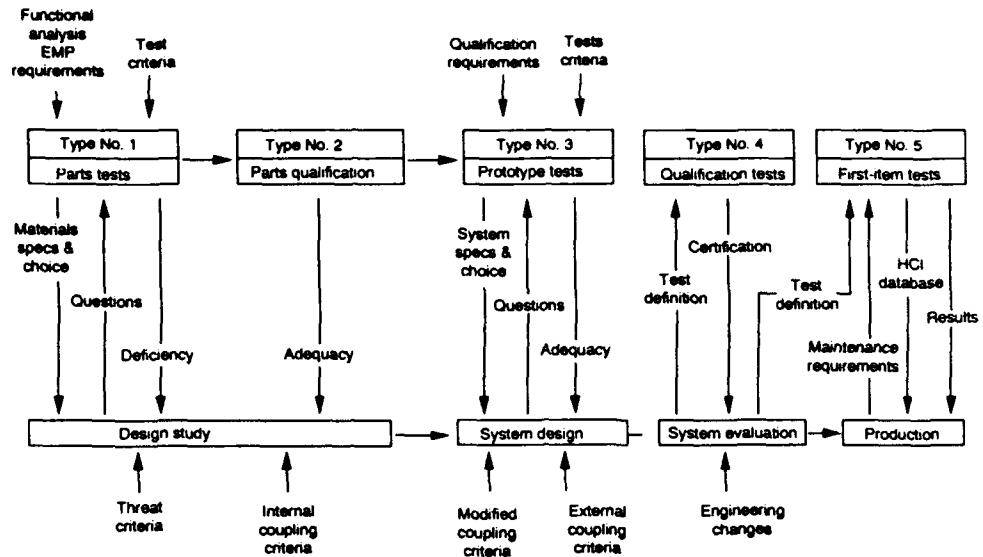

Type No. 4, Qualification tests: Performed on a system or set of sub-systems by each equipment manufacturer. The prime contractor or agency is responsible to coordinate and evaluate these tests.

Type No. 5, First-item tests: Defined by the results of the previous tests and analyses. They are performed on a production model of the total system and include checks to guarantee hardness of a system taken from the production line in accordance with the specified guideline in the system operational requirements.

9.2 Shield Protection

9.2.1 Principles and Methods

Shelters protect equipment from electromagnetic fields by attenuating the energy incident on the equipment or conducted on cables. Attenuation is measured at a nondestructive low level. High-level nonlinearity problems such as saturation, arcing, or clamping can become an additional source of threat, so measurements are required to demonstrate that they are under control.

These measurements consist of determining the field attenuation (ratio of the field inside to the field outside the shield) using instruments configured identically with and without the shield. This is done for several locations. The least attenuation is used to specify shielding effectiveness. Other methods are MIL-STD-285, IEEE-299, and the Small Loop Test.

These methods can also be applied to internal shields to create additional zones of protection. These guidelines have considered MIL-STD-285D.

Attenuation should be measured for magnetic fields between 10 kHz and 1 MHz; electric fields for 200 kHz, 1 MHz, and 18 MHz; and plane-wave fields for 450 MHz and 1 GHz.

Some adaptations are necessary to represent EMP fields, since the frequency spectrum ranges from 10 kHz to 1 GHz, with wavelengths corresponding to the dimensions of the shelters or attached cables. It is necessary to

- locate any conductive gaps in the shield using a high-frequency set of transmitter, receiver, and antennas,
- measure the magnetic field attenuation and correct any poor electric bonds, and
- estimate the attenuation of gaps.

9.2.2 Test Equipment

MIL-STD-285 recommends the use of different antennas depending on the frequencies being used for the test (table 11 lists several suitable antennas and their characteristics). Different types of equipment to generate and amplify rf signals are available commercially.

Several characteristics are important for EMP tests:

- Frequency stability,
- Level stability,
- Power from 20 to 50 W, and
- Harmonic distortion.

Receivers generally should contain their own power supply (preferably batteries) and be located inside a shelter. Sensitivity levels depend on the required dynamics and the transmitted power. The filter bandwidth of the receiver affects the noise at the input and the rejection of electromagnetic disturbances. For ease of measurement, narrow-band filters should not be used.

Table 11. Antenna characteristics.

Frequency	Transmit	Receive	Mode
10 kHz	Loop, 30 cm R	Loop, 30 cm R	Rectilinear polarization
1 MHz	single turn	single turn	
100 MHz	Passive whip	Active tuned	Rectilinear polarization
18 MHz	dipole 2 × 1 m	whip, dipole	
20 MHz	Bicone or	Active tuned	Rectilinear polarization
200 MHz	dipole	whip, dipole, or bicone	
~1 GHz	Spiral log	Tuned dipole	Circular

9.2.3 Test Configuration

Figure 35 shows a setup for a double measurement of low-level linear testing of shielding effectiveness. The first of the double measurement is without the item under test, and the second is with the item under test between the antennas. Equation (19) shows the difference in received level expressed as decibels of attenuation:

$$SE = 20 \log V_{(with\ shield)} - 20 \log V_{(without\ shield)} \quad (19)$$

Table 12 lists the recommended positions of the antenna for a few measurements within the shelter. Three configurations are commonly used for low-frequency tests (fig. 36).

- Panel tests: Loop antennas, co-planar to one another, are located 30 cm from the wall and successively oriented, first in a parallel, and then in an orthogonal position.
- Edge tests: The co-planar loop antennas are 30 cm from the side walls in the edge of the shelter. Only one direction is required, and should be oriented to provide the maximum coupling expected for the largest dimension of the shield. When the distance between the inside loop antenna and a third panel is less than 40 cm, the corner test is used.
- Corner tests: Two co-planar loop antennas are located on the axis bisecting the corner angle, forming an angle of 54° with each corner edge. The test uses two orthogonal directions of the loop antennas. The distance between the loops and the corner is 30 cm.

Very-high-frequency tests ($f < 20$ MHz) are carried out using dipole or bicone antennas, generally about 30 cm from the shelter wall. The

Figure 35. Shield test setup.

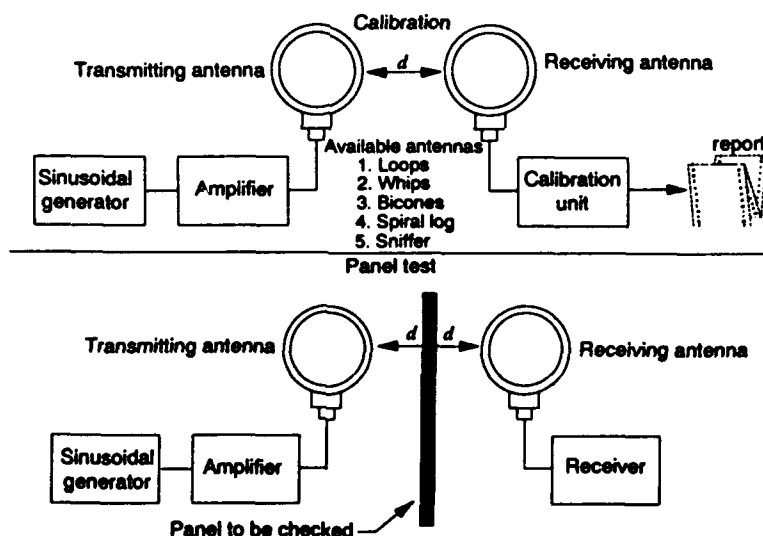
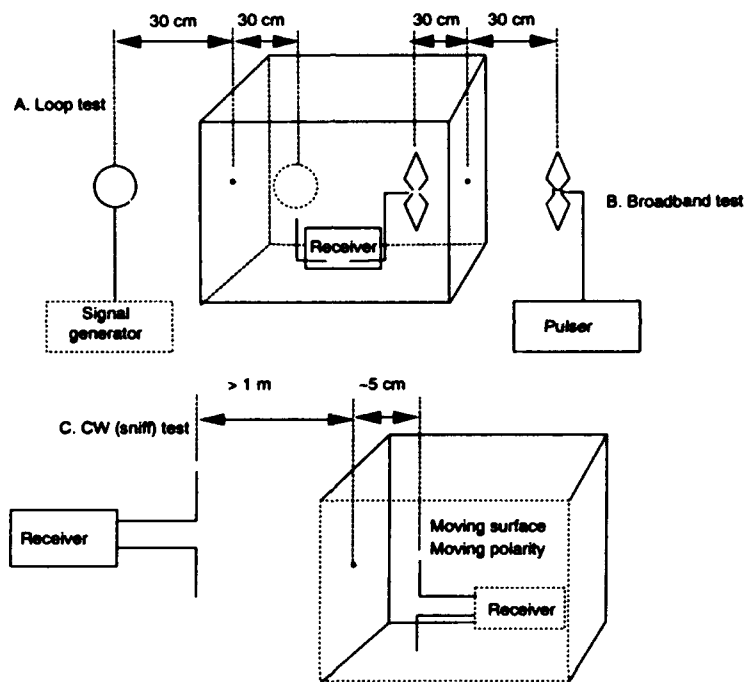

Table 12. Antenna positions.

Antenna	Doors, apertures	Edge tests	Corner tests
Loop distance 30 cm perp. to panel	Xmt 30 cm Rcv 30 cm horizontal and vertical	see figure 36, A	see figure 36, A
Bicone parallel to panel	Xmt ≥ 30 cm Rcv ≥ 30 cm horizontal and vertical	see figure 36, B	
Spiral log perp. to panel	Xmt ≥ 1 m Rcv 5 cm horizontal and vertical	see figure 36, C	

Figure 36. Antenna positions.



reception antenna should be located and adjusted to obtain the maximum pickup, but should be at about 30 cm. Obstacles between the antennas should be at least 20 cm away from the line of sight. The axes of the two antennas should be parallel and oriented for maximum reception.

Ultra-high-frequency tests ($f > 200$ MHz) should use a spiral log antenna for transmission and a tuned dipole antenna for reception. The axis of the transmission antenna should be perpendicular to the wall. The receiving antenna should be oriented for maximum reception. The transmitting antenna should be some distance from the wall, about 3 m if the wall is 3×3 m. The receiving antenna should

be parallel to and about 5 cm from any breaks in the internal wall of the shelter, and should be moved along the break to find maximum reception. The antennas should be face to face on either side of a break, such as honeycomb material, doors, panels, seals, casing welds, or other critical points.

Scales of measurement are set to a value modestly higher than the predicted measurement of the shielding attenuation. A curve can be plotted which, when repeated over time, can identify amplitude and frequency drifts. Drift should not vary the level by more than 3 dB over one hour.

9.2.4 *Shielding Tests*

A shield can be characterized by tests of three areas: panels, seams, and structures.

- *Panel tests:* A single ultra-high-frequency test reading is followed by tests defined in MIL-STD-285. If the panels have been previously qualified, only one needs to be tested.
- *Seam tests:* An ultra-high-frequency test is carried out on welds and seals to detect any flaws in conductivity that would leak rf energy. The tests are performed according to MIL-STD-285. Flaws are corrected until all tests are passed and the material is qualified as homogeneous. Nondestructive mechanical-optical checks (dye, ultrasonics, and x-rays) may be done before these electromagnetic tests.
- *Structure tests:* The shelter equipment (doors, vents, and panels) is tested as specified in section 9.2.2. An initial ultra-high-frequency check is carried out on any detail work to identify what corrections are needed, such as reducing gaps, tightening bolts, and fitting doors. The MIL-STD-285 tests for panels and seams are performed every 50 cm for the full structure with equipment fitted, and the panel tests are performed at the center of the structure.

The above tests will be performed in the following ways:

Types No. 1 and No. 2, Parts tests and Parts qualification: The shield, without electronic equipment, but with hardware (doors, air conditioning, and connector panels) shall have all openings (except waveguides) electromagnetically covered to provide shielding greater than the specified shielding of the shelter. The material and bonding to the shield of the covers requires attention to provide the conductivity needed. The shelter is tested. Each opening or piece of fitted equipment is then uncovered and the opening is tested. Design or workmanship is corrected and retested until the opening can be qualified as adequate. Type No. 1 is for characterization and

Type No. 2 for qualification. Different configurations or operating conditions requiring that the specification be met will also be tested.

Types No. 3 and No. 4, Prototype tests and Qualification tests: A prototype of the shelter, equipped and stressed by shock, vibration, temperature, and moisture is given the structure test above (with cables attached but unterminated at the far end). Type No. 3 is for characterization and Type No. 4 for qualification.

Type No. 5, First-item tests: One of the first shelters from the production line after system checkouts should be tested the same as the prototype test, except for a reduced number of test points (based on qualified equipment) in both the power down and the system operating modes. A full test plan and test report should be prepared and reviewed. The results of this test will provide engineering change proposals to the design and production plan, and contribute to a quality assurance plan for controlling changes to the production and provide for the field maintenance of the shelter, which may improve or degrade its EMP hardness.

Additional tests can be defined according to the results of the Type No. 5 production shelter tests. Special consideration could be given to aging, compatibility of different metals, corrosion, creep-strain, and other wear that could degrade hardness if design of materials and bonding techniques are not tested and incorporated. Producibility considerations may require tests. A very thin aluminum skin can provide adequate panel shielding but cannot be mated to other panels or hardware. A thicker panel, while heavier, is required for such connection. Tests would allow the thinnest (lightest) shielding material to be selected consistent with the mechanical and electrical bonding required for many years of hard use.

Responsibilities may be delegated by the primary contractor or agency to the various manufacturers or special laboratories, but the primary contractor or agency must verify EMP hardness, both through an independent observer-evaluator and through direct participation with a complete test on the production shelter.

9.2.5 *Evaluations*

The classes of guidelines are defined in section 7.3.1. AR_n , AC_n , CR_n , and CC_n produce the attenuation levels, PR_n and PJ_n , which are assigned to the shelter. If the equipment has been subject to aging tests, the protection guidelines may be reduced by one category. Measured attenuations are to be plotted against frequency and the changes compared on a graph with those of the guideline spectrum. Any insufficient measurements should be explained or corrected.

Satisfactory measurements are noted. They qualify the equipment to the class of hardness and the threat level specified.

9.3 Passive Penetration Protection

9.3.1 Principles and Methods

Passive lines are nonpowered connections to the shelter such as waveguides, coaxial outer conductors, or plumbing or mechanical metal. They are grounded to the outer shield of the shelter or controlled by a passive PPD and grounded to a rack. Attenuation by PPD is necessary to avoid high values of currents that can induce failure or damage on the electronic system.

We measure attenuation using low-level tests on prototype lines, omitting the nonlinear effects. This attenuation is equal to the current on the load side of the PPD divided by the current on the line side, as defined in section 9.4.3.

9.3.2 Test Equipment

Both pulse and cw tests are conducted. The equipment used may vary to include automatic controlled digitizing instruments or conventional manual instruments equivalent to

- Pulse generator, >10 A short circuit, risetime ≤ 10 ns,
- Two bulk current probes, >30 A, 0.03 Ω in, 50 Ω out,
- Hookup cables, connectors, and attenuators, 50 Ω ,
- Oscilloscope, >200-MHz bandwidth, 2-mV/div sensitivity,
- Camera and digitizer, 1-ns intervals, 2- μ s duration,
- Sinusoidal signal generator-amplifier, >10 W, 10 kHz to 100 MHz, 50 Ω out,
- Selective voltmeter, 10-kHz to 100-MHz bandwidth, 50 Ω in, sensitivity better than 100 μ V.

The measurements proposed (10 kHz to 100 MHz) have dynamic sensitivity and insertion losses that adapt to the cases discussed in section 7.3. Measurements qualified as correct should be recorded in digital form as the test data base.

9.3.3 Test Configuration

Figure 37 illustrates the test setup for a PPD mounted in an entry panel. Test cables should be less than 1 m long. Active line penetrations should include at least a 1-cm sample of the line through the

Figure 37. PPD entry panel.

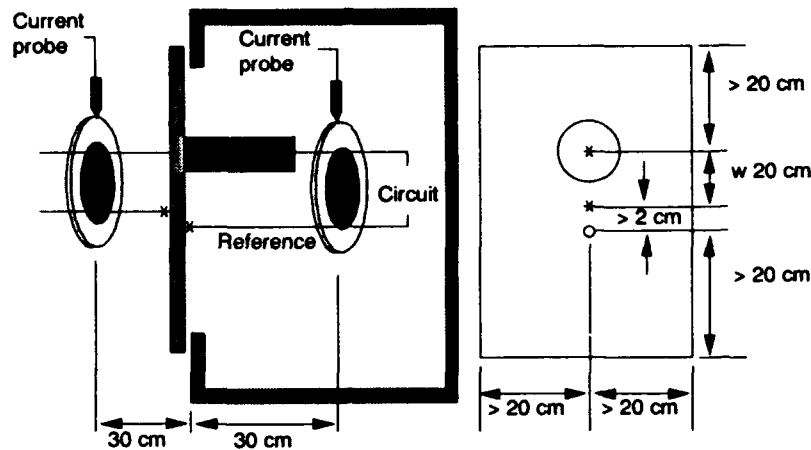

panel-mounted PPD. Passive lines should include at least a 1-cm sample welded or soldered to the panel and penetrating it. External and internal passive lines should be separated by more than two diameters of distance. Internal lines should be tested with the designed loads—a short-circuit load and an open-circuit load.

9.3.4 Passive Penetration Tests

Pulse- and cw-injected currents are applied for three types of tests:

Type No. 1, Parts tests: The line current inside a panel, divided by the current applied to the line outside the panel, should equal or exceed the guidelines for shielding effectiveness for each of the loading conditions (design, short, and open). The pulse injector is connected to the outside and the measurement probe to the inside. This test applies to plumbing, shields, or wire and may use a special (grounded) panel without attachment to the shelter.

Type No. 3, Prototype tests: Type No. 1 tests are repeated with a panel of proposed design, mounted to a prototype shelter. Pulse and cw levels should be to the specified stress guidelines.

Type No. 5, First-item tests: The tests for Type No. 3 are repeated with fewer frequencies and the designed loads. A quality assurance analysis should be performed to identify the over-test required to compensate for aging effects.

All tests should

- Calibrate probes and drivers.
- Validate setup and connections by end-to-end checks.
- Provide a load, an operating state, an isolation of the PPD (Test Nos. 1 or 2) or a connected PPD (Test Nos. 3, 4, or 5).

- Validate measurement by reversing the probe polarity and noting a reversed polarity repeatable data. Any absolute value that repeats less than 10% should be remeasured or explained in terms of non-repeatable phenomenon.
- Check measurement for reasonableness with predictions. Any deviation over a factor of two should be corrected with a better measurement or better prediction.
- Check for probe insertion loss for the design load by adding an additional probe and inject with 0.1 MHz or a pulse. The change in level should be less than 1% (time signature for pulse) and the change in phase should be less than $\pm 10^\circ$ (Fourier signature for pulse).
- Calculate system qualification class, PL_n , for the normal configuration by equation (20).

$$PL_n^i \leq Attn_{(w)} = 20 \log \frac{\text{Fourier transform of } I_{external(t)}}{\text{Fourier transform of } I_{internal(t)}} \quad (20)$$

$$n = \log \frac{I_{external(w)}}{I_{internal(w)}}, \text{ rounded low .}$$

9.3.5 Evaluations

The guideline for the production test is PL_n (attenuation) as chosen in section 7.3.2. This guideline is diminished by the appropriate aging effect (sect. 4.3) for those systems subjected to aging tests.

Measurements should be Fourier transformed and the graph annotated to indicate half-power frequencies, energy, and any compromising evidence such as saturation, discontinuity, or other phenomena that indicate abnormal behavior. As an exception, retest, reconfiguration, redesign, or reporting may be required. These graphs are compared to the guidelines to classify the equipment for acceptance and qualify compliance with the specifications for hardening.

9.4 RF Penetration Protection

PPDs are used on rf lines to reduce transient levels below thresholds of damage or upset. PPDs must be selected so that the parasitic capacitance or inductance inserted into the tuned circuit does not cause the frequency, bandwidth, and efficiency to degrade unacceptably. Three types of devices are used: tuned quarter-wave stub, clamping device, or filter. Coordinated devices are discussed in section 9.6.

9.4.1 Principles and Methods

RF circuits are usually 50- Ω characteristic impedance. Test configurations should include 50- Ω terminations on all cables and devices. Tests measure the dielectric strength (except for quarter-wave stubs) of the insulation, the surge arrestors, and the continuity of the circuit, as well as attenuation.

A high-voltage (5-kV), high impedance (1-M Ω) dc source is monitored while the voltage is slowly increased from 0 to 5 kV. This voltage is recorded and reported. An ohmmeter that can read as little as 0.05 Ω is used to measure end-to-end continuity on the circuit. Allowing for soldered connections, contact connections, or small fuses, the resistance of a circuit should be less than 0.1 Ω . Attenuation is measured as described in section 9.4.3.

The following parameters should be measured or obtained to verify the adequacy of Zener and spark-gap PPDs:

- C_p , the parasitic capacitance, which can de-tune an rf circuit.
- V_s , the static voltage of the PPD, for clamping protection. This must be safely more than the operating voltage, and less than half of the dielectric voltage breakdown.
- V_d , dynamic clamping voltage, is usually higher than V_s .
- I_{mx} , the maximum current to be shunted by the PPD before protection fails.
- V_r , the residual voltage across the PPD while the transient is being clamped.
- I_e , the extinction current, which allows a gas-filled spark gap to deionize and resume its V_s stand-off voltage rating.

Filter circuits are tested by pulse injection at progressively higher voltages until a 10-percent change of the transfer function or the current leakage is recorded. The attenuation transfer function is measured as the ratio of the output to the input in the frequency domain. Current leakage and in-band insertion losses are also of concern. MIL-STD-220A serves as the test guide and input ringing is a particular problem with excessive voltage peaks. Tests should be loaded with 5 Ω , 50 Ω , 500 Ω , and the circuit load (<5 Ω for power lines).

9.4.2 Quarter-Wave Stub

A tuned appendage to a circuit that is one-fourth of an electrical wavelength long can cause energy of that wavelength to be reflected

back upon the source. This property effectively protects against transients within a narrow band-pass. Figure 38 illustrates this PPD.

Test Equipment

Signal generator, sinusoid, 10 W, variable 1 to 200 MHz,

Two power splitters, 50 Ω ,

Attenuator, 20 dB, 50 Ω ,

Coaxial load, 50 Ω resistive, 5 W,

Ohmmeter, 0.05- Ω sensitivity, 1-A current, and

Selective voltmeter, 50 Ω , bandwidth to 200 MHz.

Test Configuration.—Figure 39 illustrates the test setup for quarter-wave PPD tests.

Stub Test Procedures.—Quarter-wave stub PPDs require measurement of attenuation and continuity.

Type No. 1, *Parts tests*, should preferably be tested to simulate the actual load, but a 50- Ω termination may be used if necessary. The circuit is not linear, so a pulse test is necessary.

Type No. 2, *Parts qualification*, must use the actual load. Specified component tests are required.

Type No. 3, *Prototype tests*, are not applicable.

Type No. 4, *Qualification tests*, are not applicable.

Type No. 5, *First-item tests*, are not applicable.

Figure 38. Quarter-wave stub.

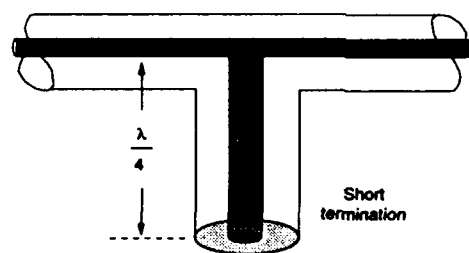
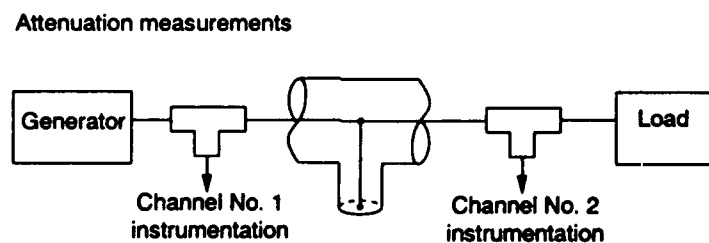

Figure 39. RF entry test.



9.4.3 Nonlinear Protection

Test Configuration.—Figure 40 illustrates the setup for voltage tests on thresholds of nonlinearity. To test the insulation of the circuit, nonlinear PPDs must be disconnected. Figure 41 shows the equipment setup for parameter tests, including capacitance and measurements.

The circuit is tested both with and without the PPD installed. Figure 42 illustrates the voltage to time traces recorded on the oscilloscope. When the PPD is tested alone, the measurement is compared to data from a properly functioning similar PPD. The extinction voltage for spark gaps is measured using a current-controlled power supply and oscilloscope.

Figure 40. Voltage test setup.

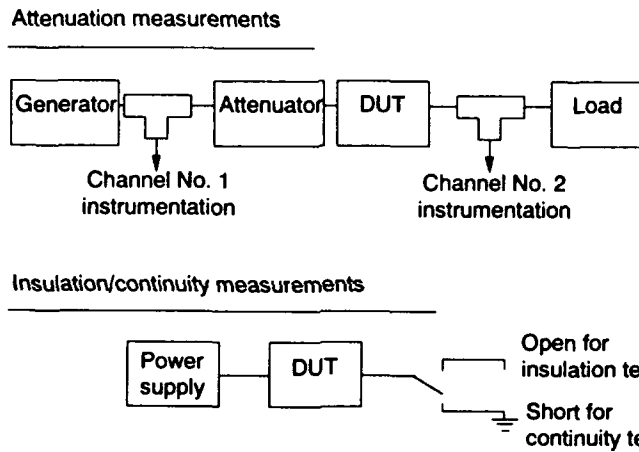

Figure 41. PPD parameter tests.

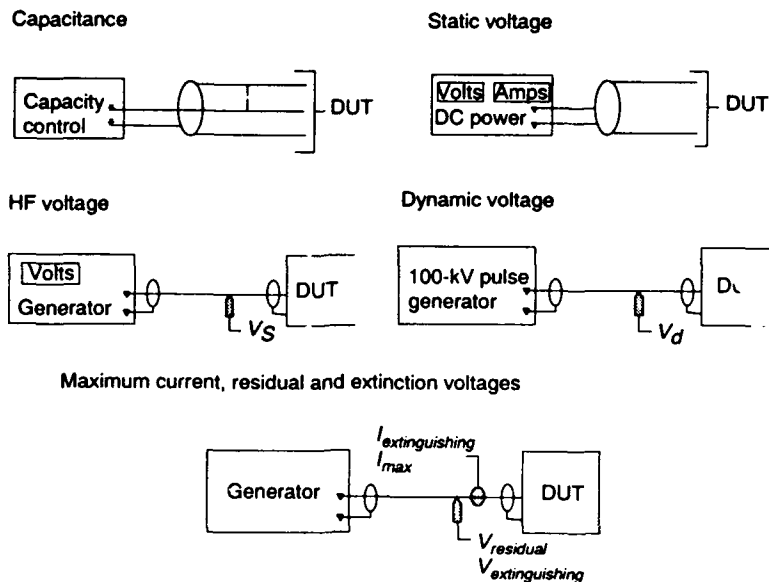
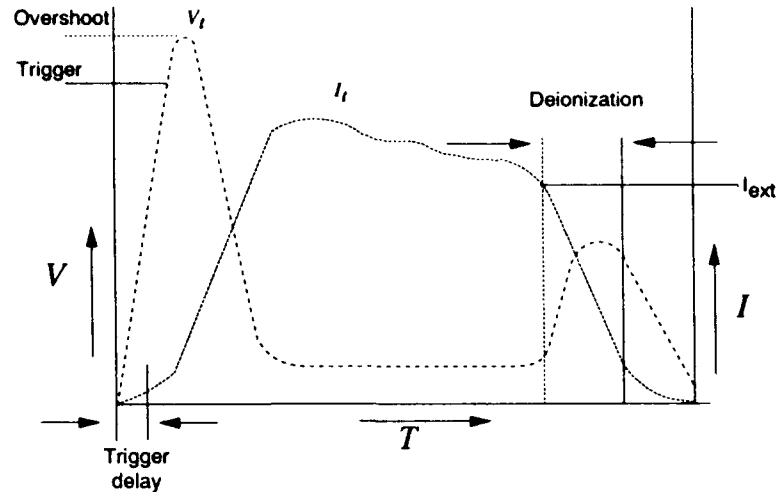

Figure 42. Gap extinction test.



Test Equipment

DC power supply, variable from 100 to 5000 V, with 1-m Ω output

Pulse power supply, variable from 1 to 10 kV, with 10-ns risetime and 1- μ s fall time; 12- Ω source impedance

Two power splitters, 50 Ω

Attenuator, 20 dB, 50 Ω

Load, 50 Ω , 5 W

Voltmeter, >10 k Ω /V, 1- to 5000-V range

Two voltage probes, 10 kV

Two current probes, 3 kA

Capacitance bridge, 1 to 1000 pF

Oscilloscope, 200-MHz bandwidth

Nonlinear Test Procedures.—The following procedures are used for nonlinear PPDs.

Type No. 1, Parts tests: The circuit is tested in its normal state with the PPD removed, then with the PPD installed. V_s , V_d , I_{mx} , V_r , I_e , and V_e are recorded (see sect. 9.4.1 for an explanation of terms).

Type No. 2, Parts qualification: V_d , I_{mx} , V_r , I_e , and V_e are recorded. V_e and I_e require a pulse generator protected for short circuits.

Type No. 3, Prototype tests: These tests can be limited to V_s measurements if a quality assurance plan provides for all parts and subassemblies to be qualified by Type No. 1 and No. 2 tests.

Type No. 4, Qualification tests: These are based on the results of previous tests.

Static voltage is measured by progressively increasing the voltage until breakdown. Dynamic voltage is measured by recording voltage breakdown for different risetimes of voltage from zero to twice V_s . We test maximum current (we do not measure, but qualify) by allowing the rated current through the PPD while it is in the nonlinear state. Residual voltage is measured 50 ns after breakdown. We test current extinction by applying the maximum current after breakdown and backing down the current until the standoff voltage returns.

9.4.4 Filters

Test Configuration.—The test setup for filter PPDs has been illustrated, as well as that for quarter-wave stubs.

Test Equipment

DC power supply, variable from 100 to 5000 V, with 1-m Ω output,

Signal generator, sinusoid, 10 W variable, 1 to 200 MHz,

Two power splitters, 50 Ω ,

Attenuator, 20 dB, 50 Ω ,

Load, 50 Ω , resistive, 5 W,

Two voltage probes, 10 kV,

Two current probes, 3 kA,

Capacitance bridge, 1 to 1000 pF,

Oscilloscope, 200-MHz bandwidth.

Filter Test Procedures.—Filter tests are done in conformance to MIL-STD-220A.

Type No. 1, Parts tests: These tests are done with the rated load simulated.

Type No. 2, Parts qualification: These tests should use the actual load. The applied pulse can be oscillating (damped by 20) so as to reproduce cable ringing.

Types No. 3 and 4, Prototype tests and Qualification tests: This series requires only a functional test and an attenuation test.

Type No. 5, First-item tests: This series requires a functional test and an attenuation test.

9.4.5 Evaluations

Linear line protection devices (quarter-wavelength stub and filters) are described by the guideline PL_n , where n is the class of attenuation. Nonlinear PPDs (Zener, MOV, or spark gap) are described by the guideline PD_{mn} , where m is the class of external levels of current to the PPD and n is the class of internal levels (residual) of current from the PPD. If the internal cables have been hardened, n may be increased two levels. If the rated capacity of the circuit is less than n , the next lower guideline level should be used to classify the equipment. If the equipment tested was previously aged (environment tested), the guideline class may be reduced, except for filter circuits.

The values of each measured parameter should be evaluated for compatibility with the function of the equipment and for its protection.

- V_s should be between operating voltage and damage voltage,
- V_d should be below damage voltage,
- I_{max} should be more than the guideline PD_{mn} or PL_n , although m may be increased one level for shielded cables on external lines, and
- I_e should be below the internal guideline PD_{mn} or PL_n .

9.5 Control/Signal Penetration Protection

9.5.1 Principles and Methods

Protection for signal and control lines usually includes a limiter (such as a Zener diode) and a low-pass filter (RFI type, $f < 100$ kHz). These PPDs attenuate the unwanted transients enough to protect the circuit devices without compromising the circuit's function. Sections 9.4.3 and 9.4.4 discuss the test methods involved. In addition to functional compatibility checkouts, the following characteristics are measured under low-level and high-level broad-band pulse stress:

- Line voltage drop,
- Leakage current,
- Parasitic capacity and inductance,
- Insertion impedance, and
- Secondary ringing or transients.

Simple circuits are tested to determine the adequacy of the protection and the susceptibility margin of the circuit. More complex circuits are tested as a black box by direct pulse to determine the transfer function and the susceptibility margin. Limiters may be spark gap, varistor, or Zener, tested for the static breakdown voltage or clamping voltage.

Direct injection on the PPD by the threat-criteria-level pulse with the voltage and current measured allows the functional characteristics of the PPDs to be identified.

9.5.2 *Test Equipment*

The following instruments are recommended:

- Pulse generator, variable from 10 to 100 kV, 10-ns risetime, 200-ns half level, and about 90- Ω source impedance,
- Pulse generator, variable from 1 to 10 kV, $I_{mx} > 3$ kA, 50-ns risetime, 10- μ s half level, and about 3.3- Ω source impedance,
- Voltage probe, 10 kV, $C < 10$ pF, $Z_{in} > 1$ k Ω , and
- Current probe, 3 kA, $Z_{in} < 0.001$ Ω .

9.5.3 *Circuit Tests*

Voltage and currents should be recorded for both the input (line) and output (load) of the interface, including the PPD. Additional measurements are needed for the following types of tests.

Type No. 1, Parts tests: These tests apply and measure high voltages and currents through any nonlinearity.

Type No. 2, Parts qualification: These are performed on finalized parts using simulated line and simulated load (real line or load are satisfactory).

Type No. 3, Prototype tests: These tests should verify system function compatibility and the PPD clamping or breakdown voltage.

Type No. 4, Qualification tests: This test requires full system function compatibility and PPD static and dynamic voltage verification.

Type No. 5, First-item tests: These are the same as for Type No. 4, except the test item is taken from the production line.

9.5.4 *Evaluation*

The category for the equipment is defined by the guideline PL_n (or PD_{mn}) in section 7.3.2. Either this classification is met, redesign is required, or the classification must be redefined to a new PL_n . The results of the test are self-evident. Implications to the design or classification are direct; i.e., failure to function could relate to a large parasitic capacitance, a low clamping voltage, or an inappropriate bandpass.

9.6 Power Penetration Protection

9.6.1 Principles and Methods

Power-line protection works on the same principles as control and signal protection, discussed in section 9.5.1. The basic difference for power lines is the presence of substantial power continuously on the line and the substantially greater transient current coupled to the line. Direct injection of the PPD with the threat guideline level of current accounts for the latter, while power-up of the line during tests accounts for the former. Both input and output current are measured for pre-pulse, breakdown, and post-pulse recovery.

9.6.2 Test Equipment

Power circuit tests require the following test equipment:

- AC power supply, 3 ϕ Y, able to supply the equipment-rated voltage, current, frequency, and kVAs,
- Power load bank, 3 ϕ Y, and equipment-rated kVAs,
- Three pulse generators, synchronously triggered, variable from 1 to 10 kV, $I_{mx} \geq 3$ kA, ≈ 50 -ns risetime, 2- μ s half level, ≈ 3 - Ω source,
- Two voltage probes, 10 kV,
- Two current probes, 3 kA, and
- Two oscilloscopes, 200-MHz bandwidth, dual-channel digitizer.

9.6.3 Test Configuration

Figure 43 illustrates the setup of test equipment for power-line tests. All three phases are powered and synchronously pulsed while the input and output voltages and currents are measured for each phase separately or collectively, as convenient. The voltage and current probes connect to each oscilloscope (not shown) provided with some means of digitizing both channels. Automatic data processing equipment should also be a part of this configuration, so the test results and objective may be evaluated before changing probes to another line.

9.6.4 Power-Line Tests

Common-mode current and voltages are measured on each power PPD, as shown in figure 44. The power lines with PPDs are simultaneously loaded and powered as shown in figure 45.

Figure 43. Power circuit test.

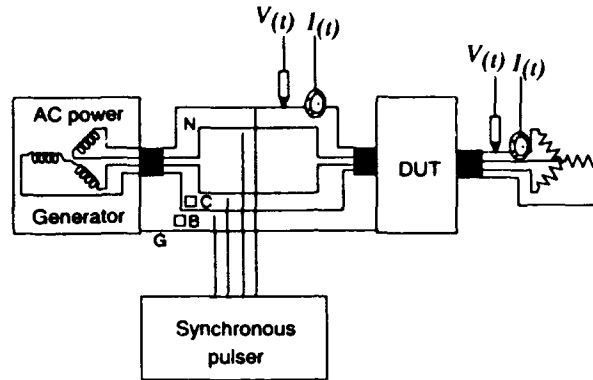

Figure 44. Power PPD test setup.

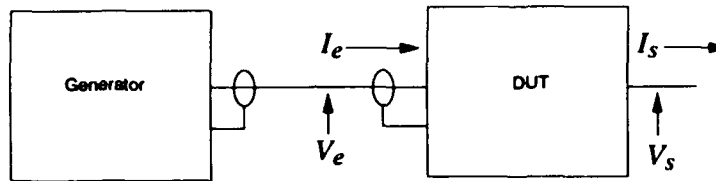
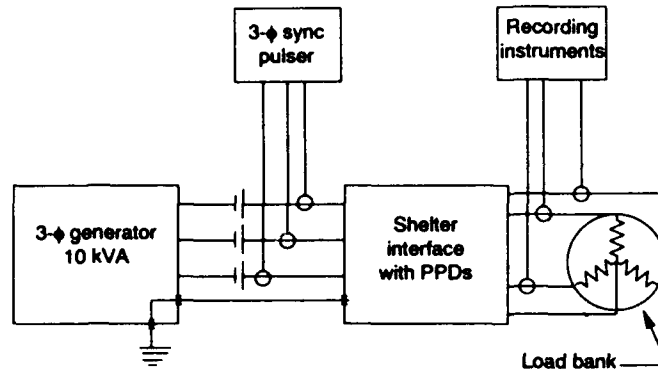

Figure 45. Power test setup.



Type No. 1, Parts tests, are not applicable.

Type No. 2, Parts qualification, of the PPD with line and load impedances simulated and rated power applied is performed for static voltages, transfer function, and extinction current.

Type No. 3, Prototype tests, are not applicable.

Type No. 4, Qualification tests, require, in addition to the measurements of Type No. 2, measurement of the parasitic capacitance (shunt), inductance (series), resistance (shunt), and admittance (series) values.

Type No. 5, First-item tests, are performed on each line with power-up and actual line and load circuits, for static voltages, transfer function, and extinction current.

The phases of the synchronous pulse applied to each line should be varied by 0° , 90° , and 180° , while the other lines are held at 0° (pulse start to pulse peak = $90^\circ \approx 50$ ns). Qualification data should not vary by more than 10 percent.

9.6.5 *Evaluation*

The attenuation class is defined by PL_n (or PD_n) in section 7.3.2. It is not modified for aging effects. The results of these tests can be directly used to indicate redesign, reselection, or qualification decisions. Lines are classified by the level of the guideline that is qualified in test Type No. 4 and confirmed in test Type No. 5.

9.7 **Susceptibility Tests**

9.7.1 *Principles and Methods*

Mobile shelter equipment is subjected to stress from two types of transients, radiated (AR_n) and conducted (AC_n). Susceptibility tests are designed around electromagnetic field stress (simulating an EMP pulse environment) and current injection stress (simulating the coupled energy from the EMP pulse onto external cables).

Radiated tests are conducted on the shelter enclosure and as much cable extension as the test volume allows. The system being tested is operated during the test and the effects of the illumination are observed. If a bounded wave simulator is used, the driving generator should simulate the ground reflection cancellation. Using a biconic dipole requires the free-field EMP to be radiated. A thorough check-out and calibration is performed before and after each test to identify any degradation (damage) not observed during the test (upset).

Conducted tests may simulate the response of the cable to EMP, or, if the cable is attached, may simulate the coupling onto the cable. It is preferred, but not necessary, that this test be conducted synchronously with the radiation test. Injection is either directly onto the pin or shield or, preferably, coupled by an inductive test fixture. A pulse of the shape of the threat guideline is applied with the cable attached, and a damped sinusoidal transient to simulate the cable's electrical length (half-wave length) and lossiness is used in the absence of the cable. The source impedance should match the characteristic impedance of the cable.

9.7.2 Conducted Tests

Test Equipment.—For conduction tests, use the following.

- Pulse generator, from 10 kV adjustable to 100 kV, 90- Ω source, >25 J, 10-ns risetime into <1- Ω load.
- Damped sinusoid generator, from 1 kV adjustable to 10 kV, 3- Ω source, >25 J, frequency from 0.1 MHz adjustable to 100 MHz, damped at 10 percent adjustable to 50 percent.
- Current probe, electrostatic shielded, bandwidth from 10 kHz to 100 MHz, rated >1000 A, 50- Ω output.
- Inductive current driver.
- Recording equipment, bandwidth \geq 100 MHz, digitizing increment \leq 5 ns, 1024 digital samples over 5 μ s.
- Line impedance stabilizing network, $L = 5 \mu$ H.

Test Configuration.—Figure 46 shows the test setup for the direct injection test onto a cable. Figure 47 shows a sinusoidal injection of a pin, and figure 48 shows the same for a cable.

Figure 46. Direct injection.

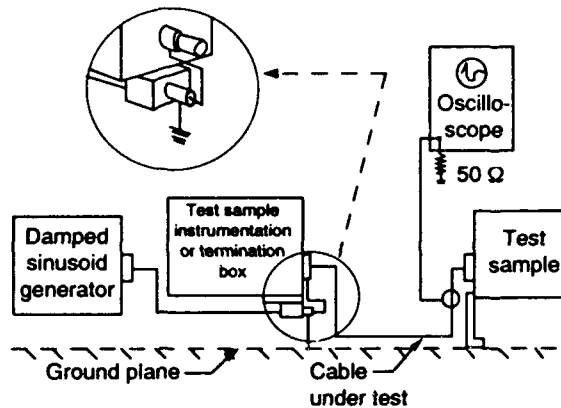

Figure 47. Pin sinusoid injection.

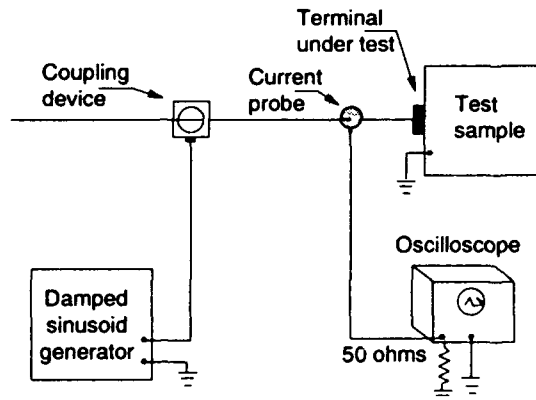
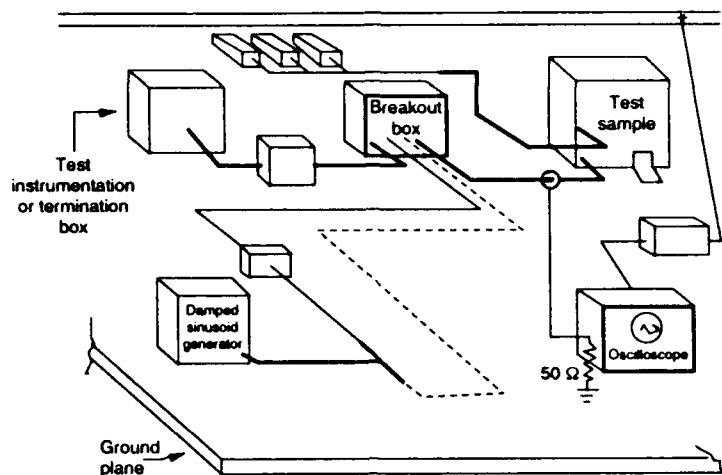

Figure 48. Cable sinusoid injection.



The system with cables should be terminated and grounded as in normal operation. Cables should be 5 cm above the ground plane to protect the dielectric of the cable. The facility and instruments should be isolated or protected from the driving pulse. Probes should be placed at least 15 cm from the shelter. Leads should be kept as short as possible.

Injection Test Procedure.—DC and AC power leads, signal leads, control leads, ground leads, and shields are injected.

Figure 49 provides the amplitudes and spectrum for the pulse to be applied for different guideline levels as described by section 8.5.2. Additional test frequencies for damped sinusoidal injection should be applied for any resonance (oscillator or tuned circuit) in the circuit.

Cable length resonance can be calculated as a tuned half-wave dipole from equation (21).

$$f(\text{resonance}) = \frac{v10^9}{2L} \text{ Hz} , \quad (21)$$

where v varies from 0.5 to 0.9 and represents the propagation velocity on the cable as a fraction of the speed of light. L is the length of the cable in meters.

Each pulse should be calibrated and applied for both polarities to each test point sequentially.

Figure 49. Gap extinction test.

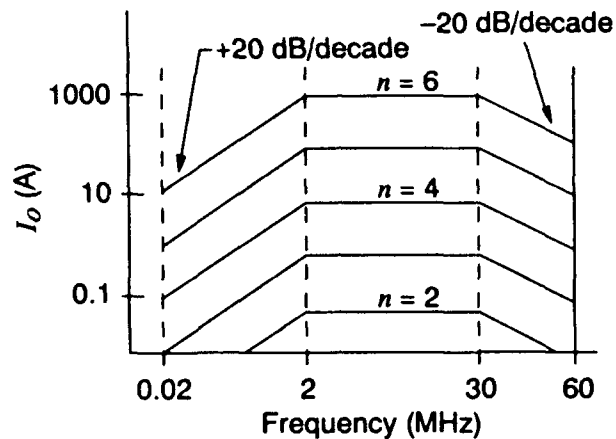

9.7.3 Radiated Tests (Bounded or Free)

Test Equipment.—For tests within a confined or radiated field, the equipment to be used follows.

- Parallel plate (bounded wave) simulator of $\approx 100 \Omega$ and a test volume with height, length, and depth each about twice that of the shelter to be tested. The electric field should resemble the threat guideline and be adjustable from 50 to 100 percent of the maximum level. It should be driven by a pulse generator with an output similar to AEP-4, Edition 4, Annex A (Land).
- Biconic dipole (free-field) simulator that allows a 15° to 45° angle aboveground, an off-centerline target or tilted antenna to provide $\approx 30^\circ$ polarity, and an incident (without reflection) field meeting the test guidelines. The maximum E field should be adjustable from 10 to 100 percent of the guideline and be shaped like that of the bounded wave simulator.
- Field monitor—differential electric or magnetic field sensor—should be connected to an integrator ($\approx 1\text{-}\mu\text{s}$ time constant) and recording equipment (specified per AEP-21) to verify each pulse for conformance to the guideline.
- Telemetry system of shielded coaxial cable or fiber-optic system, specified and calibrated per AEP-21.

Test Configuration.—Figure 50 illustrates the test setup for a bounded wave radiation test, with the connections to the test item shown.

Three orientations of the shelter and cables within the radiated volume would be tested with power off, power on, and any significant

Figure 50. Injected pulse spectrum.

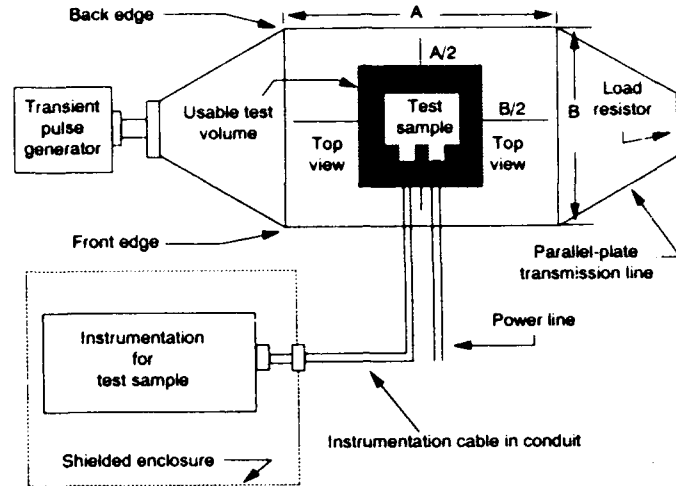

changes in operating mode (i.e., transmit/receive). Modular systems should be tested in the most complete configuration and if possible each modular configuration.

Radiated Test Procedures.—The following test procedures are recommended.

Type No. 1, Parts test: Radiation testing is not performed for small parts.

Type No. 2, Parts qualification: These tests are performed on the unit level by the main contractor.

Type No. 3, Prototype tests: These tests are performed on the prototype.

Type No. 4, Qualification tests: These tests are performed on the final prototype, along with cable injection tests.

Type No. 5, First-item tests: These tests are performed on the first item of production along with cable injection tests.

Fields should be adjusted to the required peak level as measured by the monitor in the center of the test volume.

The system is placed in the volume and connected according to the operational installation.

The cables are connected and placed parallel to the electric field vector and looped as necessary to fit in the volume, with the loop perpendicular to the magnetic field vector.

The system is subjected to a minimum of 10 pulses. Any permanent or temporary malfunction, degradation, or deviation of the equipment is identified and reported.

9.7.4 Evaluation

The results are presented in the form of a summary table with the ordinate showing the different configurations that were examined (at least three orientations each) and the abscissa showing the presence or absence of any susceptibility, the amplitude of the applied stress, the operating mode of the system, and the nature of any failure or upset.

A comparison of the results and guidelines leads to the classification of the equipment.

10. Mobile Shelters in a Nuclear Source Region

10.1 General

The preceding sections addressed the design and testing of mobile shelters that protect contained equipment against the electromagnetic fields from a high-altitude nuclear burst (HEMP). This section, however, is somewhat outside the scope of the document, since it introduces the use of shelters that operate within the source region (see also AEP-19 and AEP-22) and are therefore subjected to the entire nuclear environment: nuclear radiation, blast, thermal radiation, Compton currents, air conductivity, and the electromagnetic pulse. In keeping with the concept of balanced hardening, these shelters are assumed to be at such a range from the nuclear source that a human operator can survive the most far-reaching effects and complete his mission. The system is thus hardened to resist the levels of all the effects when reduced by that range. However, at the resulting levels of gamma radiation, a shelter that has been designed to protect equipment against HEMP may still give insufficient protection against source region EMP (SREMP). In this section, we consider each SREMP coupling mechanism in turn.

10.1.1 External Source-Region Coupling

The interaction of gamma rays with air molecules releases Compton electrons, which radiate from the burst point and so generate an electric field by charge separation. Subsequent interaction of these Compton electrons with the air produces secondary electrons, causing air conductivity (both electronic and ionic). The presence of the earth's surface then creates a horizontal magnetic field and a vertical electric field. (We have very briefly described the free electromagnetic environment of the source region; i.e., in the absence of equipment, it will induce an EMP in any system immersed within it.)

10.1.2 Internal EMP (IEMP)

When gamma rays directly interact with a system, the released Compton electrons produce a complex electromagnetic environment that includes external and internal fields and currents induced on surfaces and within cables. Field generation within the shelter and subsequent coupling to cables is called box IEMP. Current generation within cables by gamma radiation is known as cable IEMP or direct radiation drive on cables. Electromagnetic shielding at the skin of the shelter does not prevent the gamma rays from generating these effects within the shelter.

To enable readers to understand the relative magnitudes of the effects, Maxwell's equations have been applied in a time-domain finite-difference code to calculate a typical level of gamma radiation; the results are presented in this section.

10.2 Source-Region Effects

To simplify the discussion, shelters are assumed to have no external connections such as antennas, power cables, or other conductors. This enables comparison of the signals induced in internal cables by each of the three coupling mechanisms: external source-region coupling, box IEM, and cable IEMP. It should be understood that coupling to external cables may well be the dominant effect in the source region.

10.2.1 External SREMP Coupling to Mobile Shelters

For reasons of mechanical construction, the metal used in shelter walls is usually thick enough that the diffusion through it of electromagnetic fields or surface currents is negligible when compared to the leakage penetration through seams, gasketed doors, or other apertures. When the seam aperture has some metal-to-metal contact:

$$\begin{aligned} V_i &= R_s j_x \text{ for source driver,} \\ V_i &= L_s \frac{dj_x}{dt} \text{ for open seams, and} \\ V_i &= Z_t j_x \text{ transfer impedance,} \end{aligned} \quad (22)$$

where

V_i = internal voltage,

R_s = seam resistance (Ω) for the length,

L_s = seam inductance (H) for the length,

j_x = external current density perpendicular to the long dimension, and

Z_t = total impedance (Ω).

$$\begin{aligned} I_{(t)}^{0c} &= \mu H_{(t)} A / L , \\ V_{(t)}^{0c} &= Z_{trm} \cdot mA (dH/dt) . \end{aligned} \quad (23)$$

For a small shelter (3 m long \times 1.8 m high \times 2.1 m wide), elevated 1.2 m above soil having relative permittivity and conductivity of 10 and 0.0125 S/m, respectively, the peak external electromagnetic field and magnetic field were calculated as

35 kV/m for the E-field and 190 A/m for the H-field.

For a larger shelter (with dimensions of 4.2 \times 2.1 \times 2.1 m), the corresponding results are increased to

40 kV/m for the E-field and 240 A/m for the H-field.

In practice, shelters in service for one year but with no visible damage are measured to be worse than this (typically 60-dB magnetic shielding effectiveness). The open-circuit voltages and short-circuit currents induced in cables by these internal fields were calculated using Telegrapher's equations, giving

$I_{sc} = 6\text{-mA}$ peak approximation and

$V_{oc} = 60\text{-mV}$ peak approximation.

10.2.2 Box IEMP

Gamma-ray interaction with the shelter walls and with the internal air molecules generates electromagnetic fields within the shelter. These fields were calculated as

$E = 6\text{ kV/m}$ (small shelter) and

$E = 6.5\text{ kV/m}$ (large shelter).

These are maximum peak values, symmetric about the shelter midpoint and decreasing away from the walls.

$H = 70\text{ A/m}$ in each case, maximum but asymmetric.

The internal fields are much larger for box IEMP than for external source-region coupling.

Using the above value of magnetic field and assuming maximum coupling to a cable forming a loop with an area of 1 m², the induced short-circuit current is predicted to be

$I_{sc} = 17.6\text{ A}$.

For two representative values of cable transfer impedance, the open-circuit voltages within the cables are

$V_{oc} = 9\text{ V}$ for Z_t of 0.5 Ω/m and

$V_{oc} = 0.9\text{ V}$ for Z_t of 0.05 Ω/m .

These calculated values of short-circuit currents and open-circuit voltages are significantly greater than for external source-region coupling.

10.2.3 Cable-IEMP

Gamma radiation inside the shelter will penetrate the shields of cables, driving Compton currents toward internal conductors and inducing voltages, and causing currents to flow into terminating circuits. Since this is a very complex process that depends on cable type and geometry factors, experimental measurement is the only reliable way to determine the response.

For the level of gamma radiation previously assumed, the induced voltages were measured as

50 to 500 mV for coaxial cables and

1 to 10 V for multiwire cables.

The values of voltage for multiwire cables are comparable to those previously calculated from box IEMP.

10.2.4 Summary of Data

Currents induced on cables within the shelter are greater for box and cable IEMP than for external source-region coupling to the shelter (provided coupling to external conductors is neglected).

The magnitudes of box IEMP electric fields and consequent induced cable currents increase in proportion to the shelter dimensions presented to the incident gamma flux.

Electric fields are largest near the center of the incident wall. Magnetic fields are largest at the ends of the shelter for broadside incidence.

Grounding the shelter does not reduce the box IEMP or cable IEMP responses.

10.3 Consequences of Hardening

Mobile metallic shelters can be expected to provide about 60 dB of electromagnetic shielding, with protection at points of entry reducing externally generated voltages to the levels shown in section 10.2.3. For the levels of voltage on cable cores calculated above for both box and cable IEMP (i.e., 1 to 10 V), it is probable that transient upset would occur but permanent damage is unlikely.

If the hardening specifications for transient-radiation electromagnetic effects require that no permanent damage, power disturbance, or transient upset should occur, then it may be necessary to modify the EMP hardening approach. An obvious way to lessen the box IEMP effects would be by reducing the total enclosed volume of the shelter or to divide it into smaller, screened compartments, with protection applied at boundaries. If, however, a choice is made to improve the quality of coaxial cables so as to reduce box IEMP induced voltages, then the overall protection from external source region coupling may become greater than is required (if the shelter HEMP screening specification is retained) for balanced hardening. A more difficult problem would be to reduce cable IEMP induced voltages to below about 1 V, especially for multi-conductor cables; it may well be easier to increase the system's signal levels. This would also reduce the problems from box IEMP.

If the TREE hardening specification prevents permanent damage or power reduction by using circumvention, and allows transient upset to occur, then the required reduction of IEMP and cable IEMP induced voltages may be achieved by cable selection.

Cautionary note: While the information presented in this section results from careful consideration of predicted and measured data, the reader should realize that the subject is less well advanced than for other weapon effects. It may well be that the hardening advice will change and be refined as more information becomes available.

Glossary

ac	alternating current (50- to 60-Hz power)
adiabatic	condition of accumulated, not outflowing, energy
AEP	Allied Engineering Publication (NATO)
arrestors	devices to limit voltage or current
attenuation	reduction in level
band-pass	range of frequencies for low attenuation
bicone	a broad-band antenna
bonding	establishing permanent electrical conductivity
Boolean	logic allowing "and/or" selective choices
Butterworth	an efficient filter design
clamping	limiting (Zener) or eliminating (spark gap) volts
classification	EMP hardness description for a mobile system
common mode	voltage or current on all conductors of a cable
Compton	free electrons stripped from atoms by gamma/x-rays that spiral in the earth's field to generate EMP
coupling	transfer of energy from an electromagnetic field to an electric conductor
cross-talk	current on a wire induced from another wire
DUT	device under test
dc	direct current
differential	small ratio; B-dot is the differential dB/dt
dipole	two-element (1-W) EM coupling antenna electrical field vector in volts/meter
EM	electromagnetic
EMP	electromagnetic pulse—a broadband EM transient field from a nuclear burst
EMC	electromagnetic compatibility—a spectrum of environments caused by electronic equipment radiation
fall time	the time elapsed while a value changes from 90 percent of its peak value to 10 percent of its steady state
Faraday shield	conductive enclosure that reflects most of an electromagnetic field at the mismatch between its low (<0.01 Ω) impedance and space (377 Ω) impedance
fiber optic	a light-carrying glass fiber used to transport information with light emitting/detecting diodes
Fourier transform	a method of transforming data from <i>t</i> to <i>f</i>
free field	electromagnetic radiation where the target does not affect the radiating source
Gaussian	a probable distribution of values for many samples
guidelines	voluntary standards for performance
ground	a conductor able to receive charge without changing voltage, often the earth

H	magnetic field vector in ampere-turns/meter ²
HEMP	high-altitude EMP
IEEE	Institute of Electrical and Electronic Engineers
IEMP	internal EMP
injection	applied (direct or induced) pulse, as opposed to radiation
inter-modulation	cross-talk, frequencies modulating each other
linearity	direct relationship between an independent and a dependent variable
load	impedance on a conductor
lossy	transmitting medium that absorbs some energy
monopole	one-element (1-W) EM antenna
MOV	metal oxide varistor, a PPD used to shunt current to ground when a specified voltage is exceeded
NATO	North Atlantic Treaty Organization
NWE	nuclear weapons effects
orthogonal	extending at right angles into multi-dimensions
over-test	applying greater stress than designed for
parasitic	intrinsic, unavoidable parameters
permittivity	property (ϵ) of a material which affects the linear response of a material to an electric field
POE	point of entry
PPD	penetration protection device, also known as TPD
residual	ambient or remaining after attenuation or clamping
rf	radio frequency
RFI	radio frequency interference, or self-jamming
rise time	the time for a value to change from 10 to 90 percent of peak value
RMS	root-mean-square (V or A level for average power)
rolloff	the change of value with change in frequency
SE	shielding effectiveness, shielding efficiency, or the ratio (dB) of external to internal fields due to a shield
SGEMP	system-generated electromagnetic pulse
SM	safety margin, or the discretionary extra protection provided for contingency and confidence
source impedance	the impedance seen by, but not of, the circuit
spark gap	a multi-electrode, usually gas filled, chamber designed to short when a voltage is exceeded
splitters	matched impedance power dividers to branch signals
SREMP	source-region electromagnetic pulse
strength	the ability of a material to withstand both high potential (volts) and high energy (joules)
susceptibility	a measure of a circuit or function to degrade or fail when exposed to a specified environment
Thévenin	an equivalent circuit of lumped parameters
TPD	terminal protection device

transient	a short, unwanted broad-band impulse
varistor	variable resistor, which protects a circuit by diverting current to ground above some voltage
VSWR	virtual standing wave ratio
vulnerability	the probability of equipment to fail or not fail when exposed to a specified environment
waveguides	a metal enclosed path along which an rf field can travel, without frequencies below designed cutoff
waveshape	the pattern of data on a time plot
Wunsch	the constant in the Wunsch-Bell equation to relate device damage to time
Zener	a diode with a nondestruct property of breaking down (standoff) above a designed voltage level
B	exponential damping factor, related to Q
C	capacitance in farads (p = parasitic, c = characteristic, n = circuit element)
e	base of the natural log system (2.71828)
f	frequency as an independent variable in hertz
$F(t)$	analytic function dependent on variable t
i	zone index
I	current in amps
L	inductance in henrys
m	guideline index along with n and p
n	guideline index, along with m and p
P	power, or I^2R , in watts
p	guideline index, along with m and n
Q	damping factor, dimensionless
S	length in meters or feet
t	independent variable in seconds
v	velocity of electrical propagation, as meters/second (c), or as a fraction of the speed of light
Z	complex impedance, in Ω
α	double exponential $E(t)$ exponent driving rise time
β	double exponential $E(t)$ exponent driving fall time
δ	relates index to order of magnitude
Φ	angle of incidence in radians or degrees
Σ	symbol for summing
σ	standard deviation for statistical descriptions
τ	period (seconds) or convolution interval (seconds)

Appendix A.—Guideline Summary

Appendix A.—Guideline Summary

Guide- line	AC_n 5.3	CR_n 6.1	CC_n 6.2	PR_nPL_n 7.2.1	PJ_nPC_n 7.2.2	PD_{mn} 7.4
$n = 8$	—	10 kV/m	—	—	—	—
Rise ns		10				
Fall μ s		0.5				
$n = 7$	3 kA	3 kV/m	—	—	—	—
Rise ns	100	10				
Fall μ s	10	0.5				
$n = 6$	1 kA	1 kV/m	—	60 dB	60 dB	1000 A
Rise ns	30	10		100 MHz	100 MHz	1
Fall μ s	10	0.5		1 MHz	0.1 MHz	
$n = 5$	300 A	300 V/m	—	50 dB	50 dB	300 A
Rise ns	10	10		100 MHz	100 MHz	1
Fall μ s	10	0.5		1 MHz	0.1 MHz	
$n = 4$	100 A	100 V/m	100 A	40 dB	40 dB	100 A
Rise ns	10	10	10	100 MHz	100 MHz	1
Fall μ s	10	0.5	10	1 MHz	1 MHz	
$n = 3$	—	—	30 A	30 dB	30 dB	30 A
Rise ns			10	100 MHz	100 MHz	1
Fall μ s			10	1 MHz	0.1 MHz	
$n = 2$	—	—	10 A	20 dB	20 dB	10 A
Rise ns			10	100 MHz	100 MHz	1
Fall μ s			10	1 MHz	0.1 MHz	
$n = 1$	—	—	3 A	10 dB	10 dB	3 A
Rise ns			10	100 MHz	100 MHz	1
Fall μ s			10	1 MHz	0.1 MHz	
$n = 0$	—	—	1 A	0 dB	0 dB	1 A
$n = -1$	—	—	0.3 A	—	—	—
$n = -2$	—	—	0.1 A	—	—	—

Distribution

Administrator
Defense Technical Information Center
Attn: DTIC-DDA (2 copies)
Cameron Station, Building 5
Alexandria, VA 22304-6145

Director
Defense Intelligence Agency
Attn: DIO/SPRD, D. Spohn
Attn: RTS-2A, Technical Library
Washington, DC 20301

Defense Nuclear Agency
Attn: RAEE Electronics Effects Div
Attn: RAEV Electromagnetic Applications
Div
Attn: TISI-Scientific Information Div
6801 Telegraph Road
Alexandria, VA 22310-3398

Deputy Director for Research and Engineering
(Science and Technology)
Attn: Room 3E118
Pentagon
Washington, DC 20301-3080

Commander
US Army Materiel Command
Attn: MCAM-CN
5001 Eisenhower Avenue
Alexandria, VA 22333-0001

Director
US Army Missile Command (USAMICOM)
Attn: AMSMI-RD-CS-R, Documents
Redstone Arsenal, AL 35898-5400

Commander
US Army Nuclear and Chemical Agency
Attn: MONA-NU, R. Pfeffer
Attn: MONA-NU, Adam Renner
7500 Backlick Road, Building 5073
Springfield, VA 22150-3198

Commander
US Army White Sands Missile Range
Attn: STEWS-IM-ST, Technical Library
White Sands Missile Range, NM 88002-5030

Naval Research Laboratory
Attn: 4700, Plasma Physics Division
Attn: 5700, Tactical Electronic Warfare
Division
Attn: 6800, Electronic Science & Technology
Division
Attn: Code 4820, Technical Info Div
4555 Overlook Avenue SW
Washington, DC 20375-5000

Naval Surface Warfare Center, Dahlgren
Division
Attn: Code E231, Technical Library
Dahlgren, VA 22448-5020

Air Force Phillips Laboratory
Attn: PL/WSR, C. Baum
Albuquerque, NM 87116-008

Department of the Air Force
Attn: HQUSAF/DFSELD
USAF Academy, CO 80840-5701

Sandia National Laboratories
Attn: Organization 3141, Reports Acquisition
PO Box 5800
Albuquerque, NM 87185

National Institute of Standards and
Technology
Attn: V. Ulbrecht, Research Information
Center
Room E01, Building 101
Gaithersburg, MD 20899

US Army Research Laboratory
Attn: AMSRL-OP-CI-AD, Library (3 copies)
Attn: AMSRL-OP-CI-AD, Mail & Records
Mgmt

Distribution

US Army Research Laboratory (cont'd)

Attn: AMSRL-OP-CI-AD, Tech Pub

Attn: AMSRL-WT, Dir Exec

Attn: AMSRL-WT, Chief Scientist

Attn: AMSRL-WT-N, Chief

Attn: AMSRL-WT-N, Deputy Chief

Attn: AMSRL-WT-N, Senior Research
Scientist

US Army Research Laboratory (cont'd)

Attn: AMSRL-WT-P, Chief

Attn: AMSRL-WT-T, Chief

Attn: AMSRL-WT-W, Chief

Attn: AMSRL-SL-ND, Chief

Attn: AMSRL-SS-F, Chief

Attn: AMSRL-SS-S, Chief

Attn: AMSRL-WT-ND, S. Sanders (4 copies)