

Office of
Space Transportation
Systems

Flammability, Odor, And Offgassing
Requirements And Test Procedures
For Materials In Environments
That Support Combustion

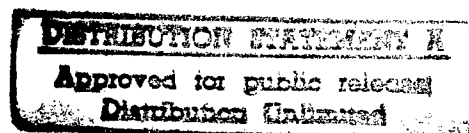

19980309 314

DTIC QUALITY INSPECTED 4

NASA
National Aeronautics and
Space Administration

PLEASE RETURN TO:
BMD TECHNICAL INFORMATION CENTER
BALLISTIC MISSILE DEFENSE ORGANIZATION
7100 DEFENSE PENTAGON
WASHINGTON D.C. 20301-7100

U5583

Accession Number: 5583

Publication Date: May 01, 1988

Title: Flammability, Odor, And Offgassing Requirements and Test Procedures for Materials in Environments that Support Combustion

Corporate Author Or Publisher: NASA, Office of Space Transportation Systems Report Number: NHB 8060.1B

Descriptors, Keywords: OSTS NASA Flammability Odor Offgassing Requirement Test Procedure Environment Combustion

Pages: 00050

Cataloged Date: Mar 28, 1995

Document Type: HC

Number of Copies In Library: 000001

Record ID: 29794

PREFACE

Date: September 1981

This publication establishes uniform material selection, evaluation and control criteria for all materials that are under consideration for use in and around space vehicles, ground support equipment and facilities during assembly, test and flight operations. It supersedes the February 1974 issue of NHB 8060.1A. Included herein are revised criteria for material applications in high pressure LOX/GOX systems and in combustion supporting environments other than oxygen. Also included are revised criteria for offgassing testing of materials, a new procedure for black box testing, and other clarification changes. This publication provides:

- a. Standard requirements for control of flammability, odor and offgassing of materials to be used in the design, development, and testing of manned space vehicles, and of payloads and their related equipment which will fly in habitable portions within such vehicles.
- b. Guidelines and directions for material selection.
- c. Testing procedures for the candidate materials.

The provisions of this handbook are applicable to the NASA installations responsible for hardware design, development and testing of hardware described above under item a.

Provisions of this handbook will be included as applicable in all future contracts and programs involving space vehicles and payloads, and their equipment which will fly in habitable portions within such vehicles. However, the supply of this document within NASA is limited. Therefore, for those procurement actions involving only a certain portion (or portions) of this handbook, the cognizant NASA installations shall abstract or reproduce only such portions as applicable to a given RFP or contract action in lieu of furnishing copies of this handbook.

Any questions or comments concerning the provisions of this document should be directed to Reliability, Quality and Safety (Code MR), NASA Headquarters.

NHB 8060.1A dated February 1974 is cancelled.



L. Michael Weeks
Acting Associate Administrator
for Space Transportation Systems

The use in this Handbook of trade names of commercially available products does not constitute an endorsement of the product by the National Aeronautics and Space Administration and does not imply that there are no other suitable products available.

CONTENTS

<u>Par.</u>	<u>CHAPTER 1: INTRODUCTION</u>	<u>Page</u>
100	Scope	1-1
101	Approach	1-1
102	Relation to NASA Centers Material Programs	1-1
103	Abbreviations and Acronyms	1-2
104	Related Documents	1-2

CHAPTER 2: REQUIREMENTS

200	Materials Selection	2-1
201	Batch/Lot Approval	2-2
202	Material Categories and Requirements	2-2
203	Stowed/Life Support Equipment Interface	2-9
204	Acceptance Criteria	2-9
205	System Flammability Requirements	2-13
206	Spacecraft Offgassing Requirements	2-14
207	Related Considerations	2-14
208	Test Discipline, Records and Reporting	2-14

CHAPTER 3: MATERIALS PROGRAM MANAGEMENT

300	General	3-1
301	Material Control Program Plan	3-2
302	Quality Assurance (QA) Provisions	3-4

CHAPTER 4: REQUIRED TESTS

400	General	4-1
401	Test 1 - Upward Propagation Test	4-1
402	Test 2 - Downward Propagation Rate Test	4-6
403	Test 3 - Flash and Fire Point Test	4-7
404	Test 4 - Electrical Wire Insulation and Accessory Flammability Test	4-11
405	Test 5 - Electrical Connector Potting and Conformal Coatings Flammability Test	4-18
406	Test 6 - Odor Test	4-25
407	Test 7 - Determination of Offgassed Products Test	4-33
408	Test 8 - Flammability Test for Materials in Vented Containers	4-41
409	Test 9 - Electrical Overload Test for Sealed Containers	4-45
410	Test 10 - Simulated Crew Bay, Panel or Major Assembly Flammability Test	4-47
411	Test 11 - Deleted and Combined with Test 10	4-50

<u>Par.</u>		<u>Page</u>
412	Test 12 - Total Spacecraft Cabin Offgassing Test	4-50
413	Test 13 - Ambient Liquid Oxygen and Pressurized Liquid and Gaseous Oxygen Mechanical Impact Test	4-52
414	Test 14 - Gaseous Oxygen Pneumatic Impact Test	4-79
415	Test 15 - Compatibility of Materials with Type "J" fluids	4-84
416	Test 16 - Determination of Offgassed Products from Assembled Articles	4-89

FIGURES

2-1	Typical Test Record Sample Form	2-16
4-1	WSTF Flash & Fire Point Test Apparatus & Control System	4-9
4-2	Typical Oscilloscope Displays	4-14 & 4-15
4-3	Potting Flammability Test Equipment Schematic	4-19
4-4	Sample Configuration	4-20
4-5	Conformal Coating Sample Configuration	4-23
4-6	Odor Test Sample Form	4-32
4-7	Schematic of Chamber Vacuum & Pressurization Equipment	4-39
4-8	Offgassed Products Test Form	4-40
4-9	ABMA Impact Tester	4-55 & 4-56 & 4-57
4-10	Details of Striker, Sample Cup & Sample	4-58
4-11	Samples in Test Cups	4-60
4-12	Grease Insert Cup Holder	4-62
4-13	Sample Freezing Box	4-63
4-14	Typical Free-fall Timing Circuit	4-64
4-15	Dye Penetrant Rack	4-68
4-16	Typical Mechanical Impact Test Chamber	4-76
4-17	Pneumatic Impact Test System	4-80
4-18	Schematic-Pneumatic Impact Test System	4-81
4-19	Category "J" Test Data Form	4-87 & 4-88
4-20	Offgassed Products from Assembled Article Test	4-93

TABLES

2-1	Test Materials Quantity Requirements	2-3
2-2	Materials Usage Types and Materials Group Classifications	2-5
4-1	Drop Height Schedule for Energy Threshold Value Determination Using a 20LB (9.00kg) Plummets	4-71

APPENDICES

APPENDIX A	Abbreviations and Acronyms	A-1
APPENDIX B	Related Documents	B-1
APPENDIX C	Precision Cleaning Guidelines	C-1
	Type D and Type J Test Specimens and Oxygen Impact Test Apparatus	
APPENDIX D	Maximum Allowable Concentrations of Atmospheric Contaminants in Manned Spacecraft and Usage Guidelines	D-1

CHAPTER 1: INTRODUCTION

100 SCOPE

This publication establishes the criteria for selection of materials used in space vehicles, associated GSE and test facilities. It establishes the flammability, odor, and offgassing limitations for testing candidate materials. Chapter 2 provides material selection criteria and evaluation requirements for the various material usage categories. It also relates the various test techniques to the applicable material usage categories. Detailed procedures to be utilized for screening candidate materials are provided in Chapter 4. The major elements of a Materials Control Program are presented in Chapter 3. It is intended that the cognizant NASA center program office and Material specialists shall select the appropriate elements of this publication and establish a materials control program tailored to the needs of the specific programs.

Note: The designer and materials engineer must exercise care in evaluating the data from the tests specified herein since final acceptance of materials depends on their application. Generally, the materials are tested in their final configuration or a thorough analysis is performed of the test data in relation to the applications of the materials to assure that no hazards exist.

101 APPROACH

1. The selection of materials which are used in and around manned spacecraft during flight and test operations must include consideration of the flammability properties and offgassing limitations of the candidate materials. The materials evaluation should be conducted in a manner equivalent to the condition of actual use including the most hazardous gas mixture and pressure conditions anticipated for the application environment. This should be established by the responsible NASA center program office in accord with the Program requirements.
2. The material selection is to be based on the following general fire control criteria:
 - a. The probability of ignition shall be reduced to a minimum by initial design or practical modifications that include elimination of materials which exhibit low flash and/or fire points.
 - b. Any potential fire shall be restricted to minimum well defined isolated areas without propagation paths.
 - c. The rate and magnitude of pressure and temperature increase in any potential fire shall not cause structural damage to the vehicle.

102 RELATION TO NASA CENTERS MATERIAL PROGRAMS

1. The NASA Manned Space Flight Centers (George C. Marshall Space Flight

Center, Johnson Space Center, and John F. Kennedy Space Center) shall use this document and develop implementation plans for Center-peculiar operations to ensure the disciplines specified herein are standardized.

2. Implementation of the requirements of this document are considered the responsibility of the appropriate NASA center materials representative and the cognizant center program office. Revisions to this publication shall be approved by the various NASA Center Materials Representative and NASA Headquarters (Code MR) .
3. NHB 1700.7, Safety Policy and Requirements for Payloads Using the Space Transportation System (STS), requires compliance to NHB 8060.1B.

103 ABBREVIATIONS AND ACRONYMS

Abbreviations and acronyms used in this publication are included in Appendix A.

104 RELATED DOCUMENTS

1. Appendix B lists the documents that form a part of this publication to the extent specified herein. Unless otherwise indicated, the issue in effect on date of invitation for bids or request for proposals shall apply.
2. Copies of specifications, standards, drawings, and publications required by contractors in connection with specific procurement functions should be obtained from the procuring activity or as directed by the contracting officer.

CHAPTER 2: REQUIREMENTS

200 MATERIALS SELECTION

1. GENERAL

- a. All materials used in habitable areas of spacecraft for flight operations, including the materials of the spacecraft, stowed equipment and experiments, shall be evaluated for flammability, odor and offgassing characteristics. All materials used in other areas of the vehicle and nonflight and ground support equipment (GSE) that is designed for use in, or is close enough to, the spacecraft to present a fire propagation hazard, shall be evaluated for flammability characteristics. Materials shall be evaluated in accordance with the applicable requirements which are specified in this document. Material application previously tested and approved by NASA shall be considered in order to minimize additional testing.
- b. Materials in Type D (High Pressure LOX/GOX systems) and J (Combustion-Supporting Environments) applications which can also be exposed to the pertinent fluid as the result of a single barrier failure must be reported. An engineering evaluation and analysis of test data shall be provided to justify the use of the materials or a configuration test must be performed. A single-barrier failure is defined in paragraph 205-7.
- c. Failures of structural parts such as pressure lines and tanks are not considered single-barrier failures. These structural parts shall be reviewed on an individual design basis.

2. MATERIALS GROUPING AND RESTRICTIONS

Materials considered for use shall be grouped as follows based upon the results of screening tests and shall be approved for specific applications by the NASA Center responsible for the spacecraft/hardware development:

- a. GROUP I - Materials that are noncombustible or self-extinguishing when tested for flammability properties in accordance with Test 1 (page 2-9) in the minimum use thickness. Group I materials will be verified in end item configuration and/or full-scale tests in accordance with paragraph 205 unless it can be shown by the rationale resulting from an engineering evaluation and analysis of test data that configuration/full-scale tests are not required. Such certification is required to be supported by independent test results to include the type of test employed and all results thereof. In addition, these materials shall also meet the requirements of Tests 6 and 7 if used in the habitable areas of the spacecraft.

Note: There are no restrictions on Group I materials in design.

- b. Group II - Materials that do not meet the Group I flammability requirement. Group II materials shall not be used unless functional requirements preclude the use of Group I types and they are specifically approved by the materials specialist from the cognizant NASA Center on an individual basis. Should it be imperative to use Group II materials

in habitable environments, the functionally-acceptable material with the lowest flame propagation rate shall be used. The Group II materials shall be subjected to the applicable required test (including Tests 6 and 7) for use in all habitable areas of the spacecraft. All pertinent tests and design data including drawings, photographs, specifications, environmental and functional requirements shall be submitted to the cognizant NASA Center for review and approval. Materials samples shall be submitted in accordance with Table 2.1. Systems using Group II materials in the design shall be subjected to configuration testing in accordance with Paragraph 205.

201 BATCH/LOT APPROVAL

Unless specified otherwise by the procuring activity, all materials considered for use in environments which support combustion shall be batch/lot tested in their minimum use thickness until such time as reactivity characteristics traceable to batch/lot variations are determined. Batch/lot test data shall be specified by the NASA procuring activity. Where batch/lot controls have been deemed necessary by NASA, an approved traceability control system shall be implemented. Batch/lot verification data shall be part of the data pack for the hardware.

202 MATERIAL CATEGORIES AND REQUIREMENTS

Table 2-2, Material Usage Types and Material Group Classifications, presents the relationship of material usage types and material group classifications with respect to each required test. Material usage is categorized as follows:

1. TYPE A MAJOR EXPOSED MATERIALS

This category shall include the material applications that are unlimited with respect to quantity, proximity to ignition sources, or exposure to the crew bay atmosphere and/or are used extensively in the spacecraft. To prevent flame propagation, these materials in their applications must be self-extinguishing (Group I) as defined herein.

2. TYPE B SPECIAL MATERIALS APPLICATIONS AND MINOR EXPOSED MATERIALS

- a. This category includes those materials applications in the spacecraft arranged in discrete locations and exposed to an atmosphere that supports combustion. The amount and arrangement of materials shall be limited to prevent the spread of fire in the vehicle.
- b. Materials, whether Group I or Group II, shall be shown to be nonpropagation in their usage configuration by test or analysis.

3. TYPE C LOW PRESSURE OXYGEN SUPPLY MATERIALS

This category includes those materials used in the systems exposed to less than 25 psia oxygen. It includes those materials in the suit loop, emergency oxygen mask and the oxygen delivery system exposed to the crew bay environment.

TABLE 2-1 TEST MATERIAL QUANTITY REQUIREMENTS (8060.1/8060.1A/8060.1B)

(All Requirements Based on One Test Atmosphere and Pressure)

Test Name & Number	Sheet Type (paper, Cloth, etc.)	Liquids, Lubes, Heat Transfer Fluids, etc.	Coatings Paints, Inks, etc.	Foams	Insulated Electrical Wire	Potting & Molding Compounds
1. Upward Propagation	4 each, 6.4 x 30.5 cm (2-1/2" x 12") x "as received" thickness	240 cc (1/2 pint)	Sufficient to cover 4 each, 6.4 x 30.5 cm (2-1/2" x 12") x required thickness	4 each, 6.4 x 30.5 cm (2-1/2" x 12") x required thickness	121 cm (48")	Sufficient to cover 4 each, 6.4 x 30.5 cm (2-1/2" x 12") x 0.3 cm (1/8") deep
2. Downward Propagation	4 each, 6.4 x 30.5 cm (2-1/2" x 12") x "as received" thickness	240 cc (1/2 pint)	Sufficient to cover 4 each, 6.4 x 30.5 cm (2-1/2" x 12") x required thickness	4 each, 6.4 x 30.5 cm (2-1/2" x 12") x required thickness	121 cm (48")	Sufficient to cover 4 each, 6.4 x 30.5 cm (2-1/2" x 12") x 0.3 cm (1/8") deep
3. Flash & Fire	(4 each, 1/2-gram samples or 1.25 cm (1/2") diameter by 1.25 cm (1/2") high cylinder)					
4. Electrical Wire Flammability	N/A	N/A	N/A	N/A	Minimum of 305 cm (120") of wire per run, 914 cm (360") total for 3 runs	N/A
5. Electrical Connector Flammability	N/A	N/A	N/A	N/A	N/A	At least 480 cc (1.0 pint) of material when cored.
6. Odor Note 1	2000 cm ² (318 In. ²) (both sides)	40 grams (1.41 oz.)	2000 cm ² (310 In. ²) (both sides) or 1.0 pint	500 cm ² (Surface) (77.5 In. ²)	40 grams (1.41 oz.)	40 grams (1.41 oz.)
7. Trace gas Analysis Notes 1 & 2	2000 cm ² (310 In. ²) (both sides)	40 grams (1.41 oz.)	2000 cm ² (310 In. ²) (both sides) or 1.0 pint	500 cm ² (Surface) (77.5 In. ²)	40 grams (1.41 oz.)	40 grams (1.41 oz.)
8., 9., 10., 11., 12.	N/A					

TABLE 2-1 TEST MATERIAL QUANTITY REQUIREMENTS (Continued)

(All Requirements Based on One Test Atmosphere and Pressure)

Test Name & Number	Sheet Type (paper, Cloth, etc.)	Liquids, Lubes, Heat Transfer Fluids, etc.	Coatings Paints, Inks, etc.	Foams	Insulated Electrical Wire	Potting & Molding Compounds
13. GOX Impact & (Mech. & Pneu.)	MHB8060.1 LOX/GOX-Mech. 240 Specimens 1.75 cm (11/16") dia. Max. thickness -.35 cm (1/8")	120 cc (4 oz.)	120 cc (4 oz.)	MHB8060.1 LOX/GOX-Mech. 240 Specimens 1.75 cm (11/16") dia. Max. thickness -.35 cm (1/8")	30.5 cm (12")	120 cc (4 oz.)
14. GOX Pneumatic	GOX Pneumatic 80 Samples .475 cm (3/16") dia. Max. thickness -.35 cm (1/8")			GOX Pneumatic 80 Samples .475 cm (3/16") dia. Max. thickness -.35 cm (1/8")		
15. Category J Fluids Constant Temperature Immersion Test	4 each 5.1 cm x .64 cm x .64 cm (2" x 1/4" x 1/4") 4 each total surface area = 13.6 cm ² (2.1 in. ²)	280 gm (10 oz.)	480 cc (1.0 pint)	4 each 5.1 cm x .64 cm (2" x 1/4" x 1/4") 4 each total surface area = 13.6 cm ² (2.1 in. ²)	305 cm (120")	4 each 5.1 cm x .64 cm (2" x 1/4" x 1/4") 4 each total surface area = 13.6 cm ² (2.1 in. ²)
Note 3				Quantities listed are for testing at one pressure.		

- 1 Amounts and quantities given are for a 4 liter container for odor and for a 4-liter container for Test No. 7.
- 2 Due to WSTF safety criteria, test No. 7 must be performed before any odor test can be performed, except in special cases where only one item is available for testing. Therefore, enough material must be submitted for both Test No. 6 & Test No. 7 in order to perform any Odor Test.
- 3 Quantities include enough materials to conduct WSTF screening test.

Table 2 - 2 Materials Usages Types and Materials Group Classifications

Material Usages Categorization	Group I Materials Required Tests (See Notes 1 & 6)	Group II Materials (NASA Center Approval for Use Required) Required Tests (See Notes 1 & 6)
Type A - Exposed Materials in the Crew Bay Environments	Electrical - 1, 4, 6, 7 OR /10 & 16/* Potting - 1, 5, 6, 7 OR /10 & 16/* Other - 1, 6, 7 OR /10 & 16/* * (See Note 4)	None (See Note 5)
Type B - Special Applications and Minor Exposed Materials	Electrical - 1, 4, 6, 7 OR /10 & 16/* Potting - 1, 5, 6, 7 OR /10 & 16/* Other - 1, 6, 7 OR /10 & 16/* * (See Note 4)	2, 3, 6 & 7 or /10 & 16/
Type C - Low Pressure Oxygen Supply Materials	Electrical - 1, 4, 6, 7 OR/10 or 11&16/** Potting - 1, 5, 6, 7 OR/10 or 11&16/** Other - 1, 6, 7 OR /10 or 11 & 16/** ** (See Note 2)	2, 3, 6 & 7 or /10 & 16/ (See Note 2)
Type D - Materials in High Pressure LOX/GOX/Systems	Electrical - 1, 4, 13 (See Note 2) Other - 13 or 14 as applicable (See Note 2)	None (See Note 5)
Type E - Sealed Containers		2, 3, & 9 (See Note 3)
Type F - Vented Containers	1, 6, 7 or 8 & 16	2&3, 6, 7 or 8 & 16 (See Note 3)
Type G - Materials Applications in Nonflight Equipment	Electrical - 1, 4. Potting - 1, 5 Other - 1	2&3
Type H - Material in Unpressurized Portions of the Spacecraft	Electrical - 1, 4 Potting Cpd. - 1,5 Other - 1	Tests 2 & 3
Type J - Materials in Combustion Supporting Environments Other than Oxygen	Test 15	None (See Note 5)

- NOTE: 1. End item configuration-type test 10 or 11 and 12 or an analysis required for final materials acceptance for use in manned spacecraft except type H for which Test 12 is not required.
2. Test 6 and 7 applicable to LOX systems which could affect crew atmosphere.
3. Tests 2 and 3 applicable to material selection and not End Item Sealed or Vented Container
4. Both test 1 and 5 are applicable to potting compounds and conformal coatings. Also both 1 and 4 are applicable to electrical wire insulation
5. Normally, only Group I materials may be used in these applications. When Group II materials must be used, specific program office approval is required. The materials are then subjected to the tests required for the Type Application.
6. Tests 6, 7, 16 are applicable for habitable areas of Spacecraft ONLY.

All materials used in this category shall meet Group I requirements except in those special cases where authorization is given by the center program office to use Group II materials which shall then be shown to be nonpropagating in their usage configuration by test or analysis.

4. TYPE D MATERIALS IN HIGH PRESSURE LOX/GOX SYSTEMS

As a goal, the design should not have an ignition source normally interfacing with the media. If the design does not meet this goal in the particular system it is mandatory that configuration tests be run, or that a comprehensive configuration analysis showing that no hazard exists be submitted to NASA for approval. This test shall be conducted at minimum use thickness and maximum use pressure and temperature.

- a. This category shall include those materials used in greater than 25 psia oxygen systems and materials used in both flight and GSE oxygen storage and delivery systems and those portions of pressurization systems that may come in contact with oxygen. All materials considered for use shall be batch tested until the capability of the material to meet the requirements of this category is established. They shall also meet the requirements of Test 13, Part 1 "Ambient LOX," as a minimum. Data for materials previously tested to the requirements of Test 13, Part 1, are listed in NASA MSFC publication TMX 64711.

Candidate materials which meet the requirements of Test 13, Part 1, and are proposed for use in high pressure LOX/GOX systems shall also meet the acceptance requirements of Test 13, Part 2 or Test 14 in the thickness equal to (or less than) that intended for use at the maximum service pressure and temperature. Materials which do not meet the acceptance criteria of paragraph 413-2 and remain candidates shall undergo threshold determinations at the actual thickness intended for use and at the maximum use pressure and temperature in accordance with Test 13, Part 2.

All Type D materials shall be approved by the procuring activity prior to use in design.

- b. The acceptance criteria for mechanical LOX/GOX impact tests are given in paragraph 413-2.
- c. In addition, materials intended to be used in proximity to sources of electrical energy shall be evaluated in configuration using "worst case" electrical and environmental conditions applying to techniques of Test 4. To be acceptable, materials must be self-extinguishing in accordance with Test 1. If additional information (especially where pneumatic impact loading is possible) is required, Test 14 shall be used. Materials that do not meet the requirements of the above tests and which are essential to the application shall be analyzed and the approximate energy levels, to which they can be exposed, calculated to form the basis for additional testing and/or rationale.

- d. Materials which will be used in high pressure environments (such as pressurized air) containing oxygen and some inert gas at an oxygen partial pressure of or greater than 20 psia shall be evaluated according to Test 13, Part 2 only, in the use environment in the actual thickness intended for use and at maximum use pressure and temperature.

5. TYPE E MATERIALS IN SEALED CONTAINERS

- a. This category shall include those material applications inside sealed containers, sealed with an inert gas (maximum leakage rate of less than 1×10^{-4} cc/sec), and/or potting compound inside, with no method of receiving or replenishing a supply of combustion supporting atmosphere.
- b. Where the evaluation analysis of existing data are inadequate, all materials used in sealed containers shall meet the requirements of Test 9.
- c. Tests 6 and 7 are not required for materials applications inside sealed containers.

6. TYPE F MATERIALS IN VENTED CONTAINERS

- a. This category shall include those materials applications used/stowed inside unsealed containers with or without an internal ignition source. Removal of stowed materials shall be for limited operational use only, nominally not to exceed 2 hours in any 8 hour period.
- b. Where the evaluation analyses of existing data are inadequate, materials applications used in closed (but not sealed) containers shall meet the requirement of Test 8. The container shall not rupture or permit the escape of flames or burning debris. The container shall not emit gasses and heat to an extent that would cause a pressure rise in the module or vehicle which might cause structural damage.
- c. Tests 6 and 7 or 16 are required for materials applications in vented containers used in habitable areas of the spacecraft.

7. TYPE G MATERIAL APPLICATIONS IN NONFLIGHT EQUIPMENT AND GSE

- a. This category shall include materials used in nonflight and/or ground support equipment designed for use in the interior compartments, or is close enough to the spacecraft to present a fire propagation hazard.
- b. Type G materials shall meet the requirements of Group I (refer to Paragraph 200-2) in their use configuration.

8. TYPE H MATERIAL IN UNPRESSURIZED PORTIONS OF THE SPACECRAFT

- a. The material applications included in this category shall be those in uninhabited portions of the spacecraft.

- b. Materials outside the crew bay area shall meet the requirements specified herein, as applicable. The use of materials that fail to meet the applicable flammability requirements shall require design measures to minimize fire hazards. The materials shall be self-extinguishing in 14.7 psia air when evaluated in accordance with the applicable flammability tests. The details of the design measures (drawings, specifications, photographs, etc.), the rationale for use of the material, and the experimental proof of acceptability under the worst practical conditions shall be approved by the procuring activity prior to inclusion of the materials in the design. The data based on ASTM, Underwriters Laboratory (references listed in Appendix B) and FAA flammability procedures may be used as a basis for determining the flammability characteristics of materials in unpressurized areas of the spacecraft provided the test atmosphere is at least as severe as that proposed for use.

9. TYPE J MATERIALS FOR COMBUSTION SUPPORTING ENVIRONMENTS OTHER THAN OXYGEN

- a. As a goal, the design should not have an ignition source normally interfacing with the media. If materials screening tests indicate a potential hazard when used within approximately 1 inch of an ignition source, it is mandatory that configuration tests be run or that a comprehensive configuration analysis showing that no hazard exists be submitted to NASA for approval/disapproval.
- b. This category shall include all materials exposed to fluids other than oxygen such as N_2O_4 , N_2H_4 and other oxidizers and fuels that are theoretically capable of undergoing reactions with the environment in which used.
- c. Materials used at nominally ambient temperature shall be shown to be compatible with the environment in question at a maximum use temperature or 160° F, whichever is higher. Materials used at temperatures higher than 160°F shall be tested at the maximum use temperature. A material is considered compatible if exposure of the material to that environment at the test temperature (under maximum use pressure) for a period of 48 hours does not result in chemical or physical changes such as tackiness, flaking, complete dissolution, etc. (Data obtained according to general guidelines similar to that of Test 15 are included in the Titan II Storage Propellant Handbook and are considered directly applicable.) Materials shown to be incompatible at temperatures less than 160°F shall be considered unacceptable. All materials for which no compatibility data exists shall be evaluated using the procedure of Test 15.
- d. If the materials are exposed to a source of energy such as mechanical impact, pneumatic impact, heat source, etc., then a configuration test or a special test applicable to the unique conditions shall be devised and performed to ensure the material's compatibility. A configuration analysis may be performed to ensure adequate compatibility.

NOTE: Not all the detailed test procedures can be provided for this category due to the wide variation in the chemical behavior of the environments involved. In the design of specific test equipment for each environment, care must be taken to ensure compatibility of all exposed instrumentation.

203 STOWED/LIFE SUPPORT EQUIPMENT INTERFACE

All equipment programmed for spacecraft mission usage that is stowed in containers (such as life support and experiment equipment) must conform to the applicable requirements specified in this publication.

204 ACCEPTANCE CRITERIA

The following is a summary of acceptance criteria for Tests presented in Chapter 4, when tested in the most hazardous use environment.

1. TEST 1 - UPWARD PROPAGATION TEST

Materials shall be considered nonflammable or self-extinguishing if, less than 6 inches of the minimum use thickness sample is consumed, and the time of burning does not exceed 10 minutes. There shall be no sparking, sputtering or dripping of flaming particles from the test sample.

Note: If any sample self-extinguishes after burning more than 3 inches, but less than the sample's full length, subsequent samples shall be tested in a chamber having a volume of at least 250 liters to assure oxygen starvation has not occurred. If only one test specimen is available for test, it must be tested in a chamber having a volume of at least 250 liters for the same reason.

2. TEST 2 - DOWNWARD PROPAGATION RATE TEST

Materials failing to comply with the requirements of Test 1 shall be ignited at the top of a vertically oriented specimen and the flame propagation rate shall be determined if the material burn length is 6 inches or more. The occurrence of a spark, sputter, drip, or transfer of solid mass during burning shall be recorded. Test results will be used in conjunction with results from Test 1 so that the flame propagation rates and the extinguishing characteristics of the test material are considered together in providing a relative ranking for material review and selection. Acceptance of the material is based on the use of the material in a specific configuration.

3. TEST 3 - FLASH AND FIRE POINT TEST

Group II materials shall be evaluated according to Test No. 3 and shall be acceptable for design if they exhibit a flash point above 400°F and a fire point above 450°F.

4. TEST 4 - ELECTRICAL WIRE INSULATION AND ACCESSORY FLAMMABILITY TEST

Materials shall be nonflammable in the test atmosphere during the application of current overloads up to the melting point of the conductor. In addition, the configuration shall meet the requirements of Test 1.

5. TEST 5 - ELECTRICAL CONNECTOR POTTING FLAMMABILITY TEST

Materials used as potting compounds shall be nonflammable in the test atmosphere during the application of current overloads up to the melting point of the conductor. In addition, the configuration shall meet the requirements of Test 1.

6. TEST 6 - ODOR TEST

The nature and quantity of odor products as measured in the test chamber for a given sample size shall not exceed the rating of 2.5 as expressed in paragraph 406.2.c, Odor Evaluations and Acceptance Criteria. This test shall determine the odor characteristics of materials. The results of Test 7 shall be reviewed before conducting this test so that members of the odor team are not inadvertently exposed to toxic offgassing products.

7. TEST 7 - DETERMINATION OF OFFGASSED PRODUCTS TEST

- a. The quantity of each offgassed product, as determined from either a standard quantity of a material or the actual quantity used in the spacecraft, shall not result in a projected offgassed material concentration in excess of the MAC value for that product shown in Appendix D.
- b. The toxicological summation of the total offgassed products of a material shall be evaluated for potential toxicity in accordance with the MAC guidelines of Appendix D by the responsible NASA medical office.
- c. Final acceptance of a material shall be determined by the responsible NASA medical office from an assessment of the potential toxicity of the total quantity of offgassed products from all contaminant generating items for a given mission.

8. TEST 8 - FLAMMABILITY TEST FOR MATERIALS IN VENTED CONTAINERS

In the event of an internal fire, the container:

- a. Shall not rupture or permit the escape of flames, burning debris or the scattering of flaming contents outside the container.
- b. Shall not permit flames or burning materials to be emitted through vents.

- c. Shall not emit gases and heat to the extent that a rise in pressure (measured in the test chamber when related to a corresponding rise in the module or vehicle) might be sufficient to cause rupture of the walls of the habitable areas of the spacecraft.

9. TEST 9 - ELECTRICAL OVERLOAD TEST FOR SEALED CONTAINERS

The sealed container shall not rupture and emit flame, burning particles, smoke or gas as a result of the test.

10. TEST 10 - SIMULATED CREW BAY, PANEL OR MAJOR ASSEMBLY FLAMMABILITY TEST

The results of the test should demonstrate that there can be no propagation of the fire to adjacent equipment by radiation, conduction, or mass transfer. There shall be no sputter, drip, or release of hot or burning particles.

11. TEST 11 - DELETED AND COMBINED WITH TEST 10. (Old title was "Guidelines for Simulated Crew Bay Configuration Flammability Verification Test")

12. TEST 12 - TOTAL SPACECRAFT OFFGASSING TEST

The results of this test along with other sources of trace contaminants and other available data shall be evaluated against the performance of the spacecraft ECLSS by the responsible NASA engineering office and the data provided to the responsible NASA center toxicology organization for analysis and approval. The safety of the spacecraft atmosphere shall be established with respect to the measured contaminants. A report confirming the acceptability of the spacecraft atmosphere shall be forwarded to the cognizant NASA program office by the approving toxicology organization.

13. TEST 13 - AMBIENT LOX AND PRESSURIZED LOX AND GOX MECHANICAL IMPACT TEST

- a. The material shall be subjected to 20 successive impact tests at 72 ft. lbs. using the equipment described in paragraph 413-3. More than one reaction in 20 impacts rejects the material. If there is no more than one reaction in 20 impacts, the material shall be subjected to 40 additional impacts. No further reactions shall place the material in the acceptable category. The material shall show none of the following reactions:

- (1) Audible explosion
- (2) Flash (electronically or visually detected)
- (3) Evidence of burning (obvious charring)
- (4) Major discoloration (due to ignition only rather than other phenomena).

NOTE: A burnt odor alone is not considered sufficient proof that a reaction has occurred. If any reaction occurs (including those during rebound of plummet) it shall be reported as evidence of sensitivity. Inclusion of rebounds applies to ambient LOX impact test only.

- b. All type D materials that fail paragraph 413.2.a criteria and remain a candidate for use must be subjected to LOX or GOX mechanical impact energy threshold determinations in the thickness of actual use. (See paragraph 413.3.q on page 4-71.)

14. TEST 14 - GASEOUS OXYGEN PNEUMATIC IMPACT TEST

- a. A candidate material shall exhibit no reactions at the specified use pressure; and maximum temperature to which it can be exposed in the thickness intended for use.
- b. If a material does react at the test pressure and temperature, a review will be required to ascertain the level of pneumatic impact conditions that exist within the system in which the material is applied.

15. TEST 15 - CONSTANT TEMPERATURE IMMERSION OF MATERIALS IN TYPE J FLUIDS

The criteria for acceptability is based on exposure to a test environment consisting of a 48-hour conditioning period in the test fluid at maximum use temperature or 160° F whichever is higher. All materials are to be tested at their maximum use pressure and temperature. A material is considered to be compatible with the test fluid if exposure of the material to these conditions results in no obvious changes in the material; i.e., dissolution, separation, dimensional, hardness or tensile strength degradation, etc. Materials shown to be incompatible at test fluid temperatures of less than 160° F are also considered incompatible and testing at 160° F is not required.

16. TEST 16 - DETERMINATION OF OFFGASSED PRODUCTS FROM ASSEMBLED ARTICLES

- a. The quantity of each offgassed product of an assembled article shall not result in a projected spacecraft concentration in excess of the MAC (Maximum Allowable Concentration) value for that product.
- b. The toxicological summation of the total offgassed products of an assembled article shall be evaluated for potential toxicity in accordance with MAC guidelines of Appendix D by the responsible NASA toxicology group.
- c. Final acceptance of an assembled article shall be determined by the responsible NASA toxicology group from an assessment of the potential toxicity of the total quantity of offgassed products from all contaminant generating items for a given mission.

205 SYSTEM FLAMMABILITY REQUIREMENTS

Materials shall be verified in end item configuration (such as stowage in vented containers and simulated crew bay configuration) unless the vendor certifies through evaluation, analyses and rationale of all test data that the materials application will not introduce any flammability hazards that may jeopardize the mission. Such certification by the vendor is required to be supported by independent test results including the type of test employed and all results thereof. Prior to initiating test, the cognizant design organization shall submit to the cognizant NASA Center for review and approval, specific and detailed proposals that include drawings, photographs, specifications test plans, and procedures for all items that require system tests. Systems tests shall duplicate contiguous material and "worst case" operating conditions. The test plan shall identify the worst probable failure modes and the proposed test shall reflect the use of these modes. Test analyses and documentary records that include instrumentation data, photographic coverage, etc., shall be provided the cognizant NASA Center at the conclusion of each systems test for review and approval. Test 10 shall be used in planning the system flammability test. For required systems or configuration tests, the use of a piece of functional equipment is not mandatory. Nonfunctioning electronic components and other mechanical parts can be simulated with respect to mass and geometry. The simulation must be approved by the cognizant NASA Center. Any assembly may be selected for test based on "worst case" shall include consideration of geometry, spatial relationships and material quantities. "Worst case" is defined as materials or an assembly of materials that present a maximum potential ignition/propagation hazard as indicated by analyses. This selection must consider:

1. Proximity of potential ignition hazards.
2. Propagation paths formed by proximal materials.
3. The quantity of flammable material in any given area.
4. The most hazardous oxidizing atmosphere and pressure to which it will be exposed.
5. Consequences of ignition.
6. Heat sink effects.
7. Single-barrier failures shall be limited to and defined as potential leaks within a component that permit the fluid to directly contact the materials behind the barrier; for example, leaks from a fluid enclosure to an adjacent enclosure such as through the following:
 - a. Welded or brazed joints.
 - b. Mechanical joints (e.g., B-nuts).
 - c. O-rings, gaskets and bladders.
 - d. Metal and nonmetal diaphragms.

Redundant seals in series which have been acceptance pressure tested individually prior to flight shall not be considered.

8. Single barrier failure analysis shall also consider the ability of the container behind the barrier to contain the system pressure. If the container cannot contain the system pressure, then a fracture analysis must be made to assure that the container leaks before rupturing and will not produce fragments which could be a hazard to the crew or vehicle.

206 SPACECRAFT OFFGASSING REQUIREMENTS

A total spacecraft offgassing test shall be conducted on the spacecraft or its individual modules. The individual offgassed components shall be identified and measured, and the total quantity of the products shall be reported to the responsible NASA medical office. The test shall be conducted at the lowest habitable operating pressure. Where it is not feasible, as determined by the procuring center, to test a complete spacecraft or a specified module, an analysis of the data obtained from offgassing tests on systems, modules, and spacecraft that contain the same or similar materials should be performed by the cognizant design activity and NASA medical office to establish the safety of the spacecraft atmosphere.

207 RELATED CONSIDERATIONS

1. METALLIC MATERIALS

Metallic materials used in the design of equipment that will be exposed to the habitable environments shall be nonflammable or self-extinguishing in the designated spacecraft atmosphere and actual use thickness when determined by Test 1 and, if used in an oxygen system, they shall be oxygen compatible when tested in accordance with Test 13.

2. ISOLATION OF GROUP II MATERIALS

All efforts shall be made to isolate Group II materials from the crew bay environment and potential ignition sources by suitable design means. The resulting design shall meet Group I criteria when tested in accordance with the required tests.

3. ELECTRICAL/ELECTROMECHANICAL EQUIPMENT

Electrical or electromechanical devices such as motors, heaters, control panels, lights, etc., shall meet the requirements of the applicable flammability, odor, and offgassing configuration tests.

208 TEST DISCIPLINE, RECORDS, AND REPORTING

1. TEST DISCIPLINE

- a. Test plans and procedures will be written before each test and submitted to the cognizant NASA center and testing agency.

- b. Each test rationale, plan and procedure will be approved by the cognizant NASA center before tests start.
- c. Each test shall be directed by the cognizant Test Engineer/Conductor or appointed alternate.
- d. The Test Engineer/Conductor shall ensure that testing is accomplished in accordance with approved test plans and procedures and that recording of data and test results is complete and accurate. Each material to be tested shall be identified through one of the following:
 - (1) Manufacturer's Certification or Identification.
 - (2) NASA Certification or Identification.
- e. The test setup shall simulate the actual conditions that the materials under test will be subjected to during flight or ground tests.

NOTE: If response is not received in (time as specified in the contract) days following receipt of the test plans/procedures by the cognizant NASA center, test programs may be initiated and test approval assumed.

2. TEST RECORDS

Complete test records shall be prepared by the contractor or NASA design/test activity for each material or system tested. The test conductor assigned for the conduct of each test is responsible for the acquisition, recording, and control of all test data. Records of applicable data are presented on a Test Record form similar to Figure 2-1. The test record format is flexible; however, all pertinent test data are to be recorded and maintained for test history purposes on all materials tested.

3. TEST REPORTING

Complete test records and additional supporting data, which could influence the acceptability of the material, shall be submitted to the cognizant center program office before use or stowage in space vehicles. Test records shall be available not later than hardware delivery to a contractor/NASA center. The hardware cognizant NASA center shall ensure that test data is distributed to all interested centers. Specific test data required for each test are presented in Chapter 4.

Test Title	Upward Propagation Test	Test Agency	WSTF
Test Conductor	Jack Stradling	Test Number	80-12374
Test Team Member		Date	1-8-80
Quality Assurance			
Safety			
Material (Chemical) Genesis	PR 1538 Adhesive		
Chemical Composition			
Manufacturer	Products Research		
Sample Size (including Thickness in inches)	12 x 2.5 x 0.05 in.		
Power			
Igniter			
Chamber Volume in liters	50 Liters	Media	N ₂ /O ₂
		Vacuum	
		Top Ignition	Bottom Ignition
Sample Number	No. 3		
GOX (%)	30% O ₂		
Chamber Pressure, (psia)	9.0 psia		
Sample Weight (grams)	11.12 gms		
Time to Ignition (seconds)			
Total Burning Time (seconds)	47.8 sec.		
Time to Propagate, 5 inches (seconds)			
Self-Extinguishing	yes		
Weight Consumed (grams)			
Burning Length (inches)	6.5 in.		
Time to Propagate 12 inches (seconds)			
Flame Propagation Rate (inch/seconds)	0.14 in/sec		
Camera Coverage PPS/CPS	WSTF #0280-0197		
Combustion Pressure			
Increase (psia)			
Description of Test (Narrative)			

Figure 2-1 Typical Test Record Sample Form

CHAPTER 3: MATERIALS PROGRAM MANAGEMENT

300 GENERAL

The total materials control program involves the complete identification, evaluation, and resolution of potential flammability and offgassing hazards resulting from the use of materials in manned or test spacecraft and associated test equipment. The major elements of a total program are:

1. MATERIALS IDENTIFICATION

Identification and documentation of all materials used, both in original design and in any change, including weights, surface areas and applications both inside and outside the spacecraft.

2. USAGE EVALUATION

Documentation of material applications and the comparison of test data to establish selection and test requirements to identify potential hazards.

3. TESTING

Logic, procedures, and data documentation for the test program to support evaluation and full-scale verification of modules, vehicles, or experiments, if warranted.

4. HAZARD REMOVAL

Procedures involved in the removal of identified hazards.

5. DEVIATION PROCEDURES

Procedures involved in documenting materials that do not meet the established requirements but are proposed for use in the spacecraft must be approved by the cognizant NASA center program office.

6. AS-BUILT CONTROL

Procedures involved in assuring that no material hazards are introduced between initial design and mission completion.

7. FORMAL REVIEW PROCEDURES

Procedures used to summarize the status of materials to permit certification of acceptability of a given design or a given configuration.

8. NEW TECHNOLOGY

Identify areas of new test technology or technique improvement for consideration.

301 MATERIAL CONTROL PROGRAM PLAN

Preparation and implementation of material control program plans are the joint responsibility of the cognizant NASA centers and their respective contractors of contractor-furnished equipment and experiments. The final control plan shall be approved by the NASA center assigned program responsibility. The contractor/supplier shall define in the control plan a systematic and continuing program to report and control material use, status, test, evaluation, substitution, and verification. The plan shall also contain detailed procedures for submitting deviation requests including drawing numbers, weights, surface areas as applicable, location, environment, etc. Before any evaluation testing is conducted, the applicable NASA center program office must review and approve the need for the test. Such control plans shall contain as a minimum:

1. TEST FACILITIES

Before initiation of a test program, each facility must demonstrate to the cognizant NASA center that equipment to be used is properly calibrated and will produce the same or equivalent results as related equipment used by other testing agencies. Equivalence in testing will also be demonstrated by each facility performing tests on standard material samples furnished by the cognizant NASA center.

2. TEST ENVIRONMENT

All tests shall be conducted at the most hazardous test pressure and gas mixture conditions designated for the applicable program environment. A definition of these conditions shall be included as part of the program plan.

3. SYSTEM VERIFICATION AND TESTING

Materials requiring system verification shall be tested and accepted in accordance with paragraph 205. Test plans shall be prepared for all contemplated configuration tests, simulated crew bay configuration tests, and total spacecraft tests. These test plans shall be submitted to the appropriate NASA center program office for approval before initiation of test. If verification testing is required the representative usage configuration and assemblies shall be tested.

4. NONFLIGHT EQUIPMENT

The contractor shall implement a materials control program encompassing all nonflight equipment used on, in, and around the vehicle.

5. MATERIALS EVALUATION

Materials used in the design, fabrication and testing of manned spacecraft, GSE, facilities, payloads and their related equipment must be evaluated against the requirements of the proper groups (refer to paragraph 200-2). Materials that do not meet the criteria of the pertinent material screening test shall be processed by one of the following selections:

- a. The materials shall be rejected and substitute materials selected and tested.
- b. The material shall be subjected to configuration testing or analysis (except for category D and category J applications)
- c. A request for a deviation shall be provided to the NASA center program office for the following cases:
 - (1) Category D & J applications:
 - (a) Materials that fail the screening test (Test No. 13 or 15) but passed a configuration test.
 - (b) Materials that fail the screening test (Test No. 13 or 15) and the configuration test or are judged hazardous.
 - (2) Category A, B, C, E, F and G applications.
 - (a) The materials at the configuration level will not pass the required application test and analysis based on similarity to other test configurations which indicates a possible hazard exists.
 - (b) The material will not be subjected to a configuration test and the analyses are inconclusive.

6. PROCEDURES AND REQUIREMENTS CHANGE CONTROL

Procedures shall be established to resolve materials questions, problems, and waiver requests.

7. CONFIGURATION CONTROL

The contractor/supplier shall identify the activities that involve review of post design release documentation, control of material access to the flight hardware and periodic physical examinations by NASA/contractor materials specialists. Post release documentation review should include material review dispositions and test preparation sheets which introduce materials without an engineering order, discrepancy reports, standard repair practices, and all applicable process specifications. Periodic examinations of the flight hardware at various stages of manufacture shall be conducted by NASA/contractor materials specialists to identify hazardous material usages.

8. FORMAL REVIEW PROCEDURES

A formal review procedures shall be established by the contractor as part of the materials control program to verify materials acceptability. The data package shall include applicable drawings, complete material identification, usage and location, verification of drawing review,

material approval status, deviation status, applicable test data, and hazard removal status. The designated NASA materials control representative of the cognizant NASA center will evaluate the test data and approve the materials/systems based on the criteria established herein.

302 QUALITY ASSURANCE (QA) PROVISIONS

Unless otherwise specified in the contract or order, the cognizant NASA center is responsible for the performance of all test requirements as specified herein (performance of tests may be delegated to a test activity approved by NASA). The NASA or its designated representative reserves the right to perform any or all of the tests set forth in this specification where such tests are deemed necessary to assure that materials and systems conform to the prescribed requirements. If other than NASA test facilities are used, the contractor shall be responsible to the cognizant NASA center for assuring that the testing agency conducts the tests in accordance with the following requirements:

1. All instrumentation used in these tests shall be in current calibration and shall bear appropriate documentation to this effect from an approved calibration laboratory.
2. All materials tested shall be accompanied by manufacturer's identification and the test specimens shall represent the materials proposed for use in construction of the spacecraft.
3. If assemblies or subassemblies are to be tested, the supplier shall certify that the test articles contain identical materials and potential ignition sources with equivalent geometrical configurations to those produced for use in the spacecraft or that they are identical to the installed equipment.
4. The testing capability of the laboratories and personnel involved shall be certified in accordance with cognizant NASA center certification requirements that relate to the requirements of this document.
5. The complete results of each test shall be recorded in accordance with instructions contained in paragraph 208 on a form similar to Figure 2-1.
6. Where and when deemed necessary, NASA reserves the right to have one or more representatives observe what it considers to be critical material tests when conducted by non-NASA organizations.

CHAPTER 4: REQUIRED TESTS

400 GENERAL

Table 2-1 identifies the required tests for material usage types and materials group classifications. The test procedures and related test disciplines for Tests 1 through 16 are presented in paragraphs 401 through 416.

401 TEST 1 - UPWARD PROPAGATION TEST

1. PURPOSE

The purpose of the upward propagation test is to determine the flammability characteristics of candidate materials when exposed along the bottom edge to an ignition source. Determination shall be made during the tests of such factors as the sample's combustibility, propagation rate, self-extinguishing properties, and total burn time.

2. CRITERIA OF ACCEPTABILITY

Materials shall be considered noncombustible, or self-extinguishing if, less than 6 inches of the minimum use thickness sample is consumed, and the time of burning does not exceed 10 minutes. There shall be no sparking, sputtering, or dripping of flaming particles from the test sample. A minimum of 3 samples shall be tested. A failure of any one of the 3 samples constitutes failure of the material. The burn rates shall be reported as the average of the samples which have a burn length of 6 inches or greater.

NOTE: If any sample self-extinguishes after burning more than 3 inches but less than sample's full length, subsequent samples shall be tested in a chamber having a volume of at least 250 liters to assure oxygen starvation has not occurred. If only one test specimen is available for test, it must be tested in a chamber having a volume of at least 250 liters for the same reason.

3. TEST CONDITIONS - PRESSURES AND ATMOSPHERE

The test pressure and gas mixture conditions for the pertinent materials category shall be designated by the center program office. These conditions shall represent the most hazardous atmosphere anticipated in the spacecraft.

4. TEST EQUIPMENT

Materials applied in nonoxygen enriched atmospheres (such as air, 79% + 21% O₂) at 14.7 psia may be tested in a hood or in a chamber similar to that described in subparagraph a. The chamber described below is used for testing materials in oxygen or oxygen enriched atmospheres at other than the above pressure.

- a. Chamber. The test chamber shall have a volume sufficient to assure complete combustion of the sample under test. It shall have a minimum volume of 98 liters and shall be suitably constructed and protected to ensure safe operation. A window or viewing port for visual observation shall be included. The test chamber shall contain inlets for vacuum, ignition wire, instrumentation, air, oxygen, test gas mixtures, and suitable elements for heating the chamber when required. The chamber shall be fully protected against the possibility of operator injury in the event of explosive rupture. Organic materials used in the construction of the chamber, such as gaskets and seals, shall not contribute to the flammability of test material. The chamber shall be equipped with necessary ventilation features to prevent personnel exposure to potentially hazardous combustion by-products. A vertical sample holder as specified in subparagraph e shall be positioned within the test chamber.
- b. Pressure Gage. A pressure gage capable of measuring operating pressures with an accuracy of 0.2 psia or a pressure transducer and recorder with comparable capability shall be used.
- c. Oxygen Supply. Oxygen used in conducting the test shall be commercially available and shall conform to Specification MIL-O-27210, Type 1, or MIL-P-25508, Type 1. Equipment used to transfer the oxygen to the test chamber shall be efficient and safe and conform to Type D requirements.
- d. Gas Supply. Test gases, other than oxygen, shall conform to the appropriate specifications as required. Efficient and safe equipment shall be used for measuring the gas flow and for transferring the gas to the test chamber.
- e. Sample Holder. The sample holder shall consist of a vertically mounted steel clamp that overlaps 1/4 inch on each side of a specimen along the full 12 inch minimum length of the sample, leaving a 2 inch wide by 12 inch long exposed center section. The sample material shall be located in the sample holder such that the bottom of the sample material is located at least 3 inches from the chamber base to preclude the aid in propagation derived from a buildup of burning residue. For materials such as thread, tie cord and ropes test shall be made by impaling the material on a needle rake with needles approximately 3 inches apart. The needles should be such that they are not a significant heat sink. This needle rake configuration should also be used for thin films where the standard clamp configuration is a significant heat sink and interferes with the results. Nonstandard test specimens shall be mounted in a manner which will not inhibit flame propagation.
- f. Ignition Source. Ignition of the sample shall be accomplished by employing a regulated energy source. The ignition source shall consist of a length of No. 20 gage bare nickel-chromium wire which has a nominal resistivity of 0.7 ohms per foot, sufficient to wind a minimum of three turns around a standard Cleanweld "B" igniter.

The nominal diameter of this igniter is 0.125" with a length of 1 inch +0.25". The flame temperature is 2000^oF +200^oF and burns for a duration of 25 +5 seconds. At least one inch of wire shall be left at each end to permit fastening to the power lugs. The ignition of the igniter shall be accomplished by employing a regulated direct current power source. The upper edge of the igniter surface shall be placed 0.25 inch from the bottom edge of the sample. Cleanweld "B" igniters can be procured from Clean Weld Incorporated, Alhambra, California. For Type "G" and "H" materials which involve tests conducted in atmospheres which are not oxygen enriched, such as air, a Bunsen Burner, which provides required temperature and burn time may be employed in lieu of the Cleanweld Type "B" igniter.

- g. Propagation Indicators. When requested by the center program office, motion picture records shall be made and retained on propagation tests. The camera shall be 16mm or equivalent, operating at a rate suitable to provide an accurate indication of the test. The equipment shall be calibrated to the manufacturer's specifications and shall be positioned such that an accurate determination of the total burn characteristics can be made from the films. As an alternative, a pulse camera may be used in conjunction with the stopwatch used in subparagraph h.
- h. Propagation Timers. All burning tests shall be visually observed for ignition and combustion characteristics. Timers shall be started at the first visual indication of combustion and stopped when the flame ceases to propagate upward. The total burn time will also be measured.

5. SAMPLE PREPARATION

Samples shall be prepared for test as follows:

- a. Inspection and Cleaning. Material samples shall be evaluated in the thickness intended for use whenever possible and shall be free of cuts, abrasions, or other flaws as determined by close visual inspection. Before testing, the samples shall be cleaned by the particular specification or procedure appropriate for the end item they represent.
- b. Sizing. Sizing shall be accomplished in accordance with the following:
 - (1) Films, fabrics, sheets, and composites shall be tested in the "as received" condition. Samples shall be cut in the form of rectangles 2 1/2 inches wide by 12 inches long minimum. Foams and high bulk materials shall be tested in the "as applied" thickness and have the same minimum dimensions as specified above.
 - (2) Primers, coating materials, paints, viscous greases, and pressure sensitive tapes shall be applied on the substrate material intended for use, if known. The coatings shall be applied in a thickness equivalent to normal use then cured in accordance with prescribed manufacturing practices. If the spacecraft substrate

material is not available, the coatings shall be applied to 2.5 x 12.0 x 0.003 inch aluminum foil.

- (3) Fluids shall be applied to a suitable noncombustible substrate such as 0.010 inch thick fiberglass cloth. The substrate shall be allowed to soak in the fluid for a period of 30 minutes, then drained to remove excess fluid.

NOTE: Materials and components that will be used in irregular size or shape shall be tested in the "as purchased" configuration. Such samples shall be attached to the sample holder by fiberglass or metal threads when the sample cannot be held by the sample holder. This includes coaxial cable, thermocouple wire, other low energy signal wiring, and electrical wiring. Nonstandard (e.g., configuration) samples shall be mounted in a manner which will not inhibit flame propagation.

6. PRETEST PROCEDURE

The following pretest checks shall be performed before test start:

- a. Verify that all test equipment is clean and is in current calibration, and that analytical equipment is calibrated and operative.
- b. Observe placement of motion picture camera(s).
- c. Verify that all other instrumentation is operative.
- d. Verify that oxygen conforms to the classification specified in subparagraph 4c and other gases are certified as required.
- e. Verify that sample is correctly identified.
- f. Prepare (3) samples as specified in subparagraph 5.
- g. If samples are irregularly shaped, describe the shapes.
- h. Clean and weigh the samples and record the weight.
- i. Record volume of test chamber in liters verifying that it has a volume of at least 98 liters.
- j. Mount the sample in the sample holder and verify that the exposed center section is 2.0 ± 0.1 inches wide (for standard non-configuration type samples).
- l. Place the igniter horizontally with its top surface 0.25 ± 0.03 inches from the bottom of the sample at the midpoint of the (2 inch) exposed width and centered on the material's thickness.

7. TEST PROCEDURES

Testing of the candidate samples shall be accomplished in accordance with the following basic procedure for materials which will be applied in atmospheres at pressures less or greater than 14.7 psia. Materials applied in atmosphere at 14.7 psia (such as air) may be tested in the chamber but the leak check steps can be deleted. These materials may also be tested in a hood but precautions must be taken to baffle the test sample from drafts. The applicable steps of the procedure shall then be followed.

- a. Evacuate the chamber to 0.2 psia or less.
- b. Isolate the chamber and monitor the pressure for one minute. Testing shall not begin until all leaks are corrected (a leak is indicated if an increase in pressure of more than 0.2 psia occurs in 2 minutes).
- c. Pressurize the chamber with test gas mixtures at the maximum use pressure using techniques that assure mixture accuracy within 0.5% of the specified valve oxygen concentration.
- d. Allow the chamber to stabilize at the test pressure, then soak the samples in test gas mixture for a period of at least 3 minutes.
- e. Verify that the chamber pressure is the desired test pressure, then isolate the chamber.
- f. Start the motion picture camera and other applicable instruments.
- g. Apply current to the ignition wire until the igniter ignites, then stop current flow.
- h. Record whether sample is noncombustible or self-extinguishing, and/or extent of burning.
- i. Note combustion characteristics (nature and color of flame, soot, residue and other pertinent observations).
- j. Record the final pressure in the chamber.

8. REPORTING

The data shall be reported in accordance with instructions contained in paragraph 208 on a form similar to Figure 2-1. The following special data are required:

- a. Test pressure.
- b. Test atmosphere.
- c. Sample size.

- d. Combustion Characteristics. Distance that flame progressed before extinguishing, flame phenomena, etc. For samples having a burn length of more than 6 inches, the flame propagation rate shall be reported. If all three samples have a burn length greater than 6.0 inches and were tested in the same chamber, the average flame propagation rate for the three samples may also be reported.

402 TEST 2 - DOWNWARD PROPAGATION RATE TEST

1. PURPOSE

The purpose of this test is to determine the downward propagation rate of materials which fail to meet the requirements of Test 1.

2. CRITERIA OF ACCEPTABILITY

Materials failing to comply with the requirements of Test 1 shall be ignited at the top of a vertically oriented specimen and the flame propagation rate shall be determined. A minimum of three samples shall be tested. A failure of any one of the three to self-extinguish in 6 inches or less constitutes failure of the material. The burn rates shall be reported as the average of the three samples. The occurrence of a spark, sputter, drip, or transfer of solid mass during burning shall be recorded. Flame propagation rates may be used to provide relative rankings for material review and selection.

3. TEST CONDITIONS - PRESSURES AND ATMOSPHERE

The test pressure and gas mixture conditions for the pertinent materials category shall be designated by the program office. These conditions shall be representative of the most hazardous atmosphere anticipated in the spacecraft.

4. TEST EQUIPMENT

The test equipment shall be the same as that in paragraph 401-4. The material shall be tested in a chamber having a volume greater than or equal to that utilized in Test 1.

5. PROPAGATION RATE INDICATORS

Any suitable propagation rate indicator may be used that will provide an accuracy of at least 5%. Typical propagation rate indicators include thermocouple rakes, motion pictures, stopwatch, etc.

6. SAMPLE PREPARATION

Samples shall be prepared in the same manner as described in paragraph 401-5.

7. PRETEST PROCEDURE

The pretest procedure shall be the same as that described in paragraph 401-6.

8. TEST PROCEDURE

The test procedure shall be the same as that described in paragraph 401-7, except that the bottom edge or surface of the igniter wire shall be placed approximately 0.10 inch above, with the igniter rod parallel to the top edge of the sample and centered on material's width and thickness.

9. REPORTING

Test data shall be reported in accordance with instructions contained in paragraph 208 on a form similar to Figure 2-1. The special information shall be the same as required under paragraph 401-8.

403 TEST 3 - FLASH AND FIRE POINT TEST

1. PURPOSE

The flash and fire test is designed to evaluate the spark ignition characteristics of materials selected for application in and around manned spacecraft.

2. CRITERIA OF ACCEPTABILITY

Flash and fire points shall be measured and recorded. Candidate materials shall be acceptable for design if they exhibit a flash point above 400°F and a fire point above 450°F. A minimum of three samples shall be tested. The flash point and fire point reported will be that of the lowest flash point and fire point of the three samples tested.

3. TEST CONDITIONS - PRESSURE AND ATMOSPHERE

The test pressure and gas mixture conditions for the pertinent materials category shall be designated by the center program office. These conditions shall represent the most hazardous atmosphere anticipated in the spacecraft.

4. DEFINITIONS

- a. Flash Point. The flash point is the lowest temperature at which the mixture of vapors from the surface of the material and the test atmosphere will provide a non-self-sustaining flash or flame when exposed to an ignition source.
- b. Fire Point. The fire point is the lowest temperature at which the mixture of vapors from the surface of the material and the test atmosphere continue to burn after ignition. A self-sustaining self-propagating glow shall be considered equivalent to flaming combustion.

5. TEST EQUIPMENT

- a. Test Chamber. The test chamber shall be the same or equivalent to that shown in figure 4-1.

- b. Spark Ignition Equipment. Spark needles shall be made of 0.09 inch diameter 304 stainless steel shaped to a 45^o-95^o conical point having a 0.004 inch radius tip. Spark energy shall be supplied to the electrodes using the high voltage spark generator circuit. The total spark energy per pulse shall be 50 \pm 20 millijoules with a spark duration of 2 \pm 1 milliseconds.
- c. Gas Systems. The gas mixture delivery system shall consist of corrosion resistant steel tubing of suitable size. When oxygen is used in conducting the test, it shall conform to specification MIL-0-27210 Type I, or MIL-P-25508 Type I. Equipment used to transfer the oxygen to the test chamber shall be efficient and safe and conform to the requirements of Type D.
- d. Flash and Fire Sensor Unit. Flash and fire events shall be determined visually or with confirmation by a sensor unit constructed as specified in the NASA WSTF drawing 251-12092.

6. TEST SPECIMEN PREPARATION

- a. The desired test specimen weight is 0.500 \pm 0.025 grams. If this specimen weight cannot be realized within the volume limitation of the sample cup, then decrease the sample weight to 0.400 \pm 0.025 grams (or 0.300 \pm 0.025 grams, etc.).
- b. Bulk materials, films, fabrics, and foams shall be cut to a cylindrical shape of 0.6 inch diameter and may be stacked in sufficient height to make up the required specimen weight.
- c. Liquids, powders, lubricants, greases, or small solid items shall be poured or otherwise transferred into the cup to make up the test specimen.
- d. Electrical wire insulation shall be stripped from the wire, cut to 1/4 inch lengths, and placed in the cup to make up the test specimen.
- e. Paints, coatings, adhesives, and other such materials that require curing before testing are to be applied to Teflon in the "normal usage" thickness and then cured, stripped from the Teflon, and cut to the test configuration (i.e., discs). The material shall then be stacked in the specimen cup to provide the required sample weight.
- f. Materials not suited to testing in the forms described above shall be tested in the most feasible manner. In any event, the test specimen weight shall not exceed 0.500 \pm 0.025 grams and the distance between the specimen surface and the electrodes shall be maintained to 0.750 \pm 0.025 inches.
- g. The specimens shall be cleaned by blowing with dry, filtered nitrogen or air.

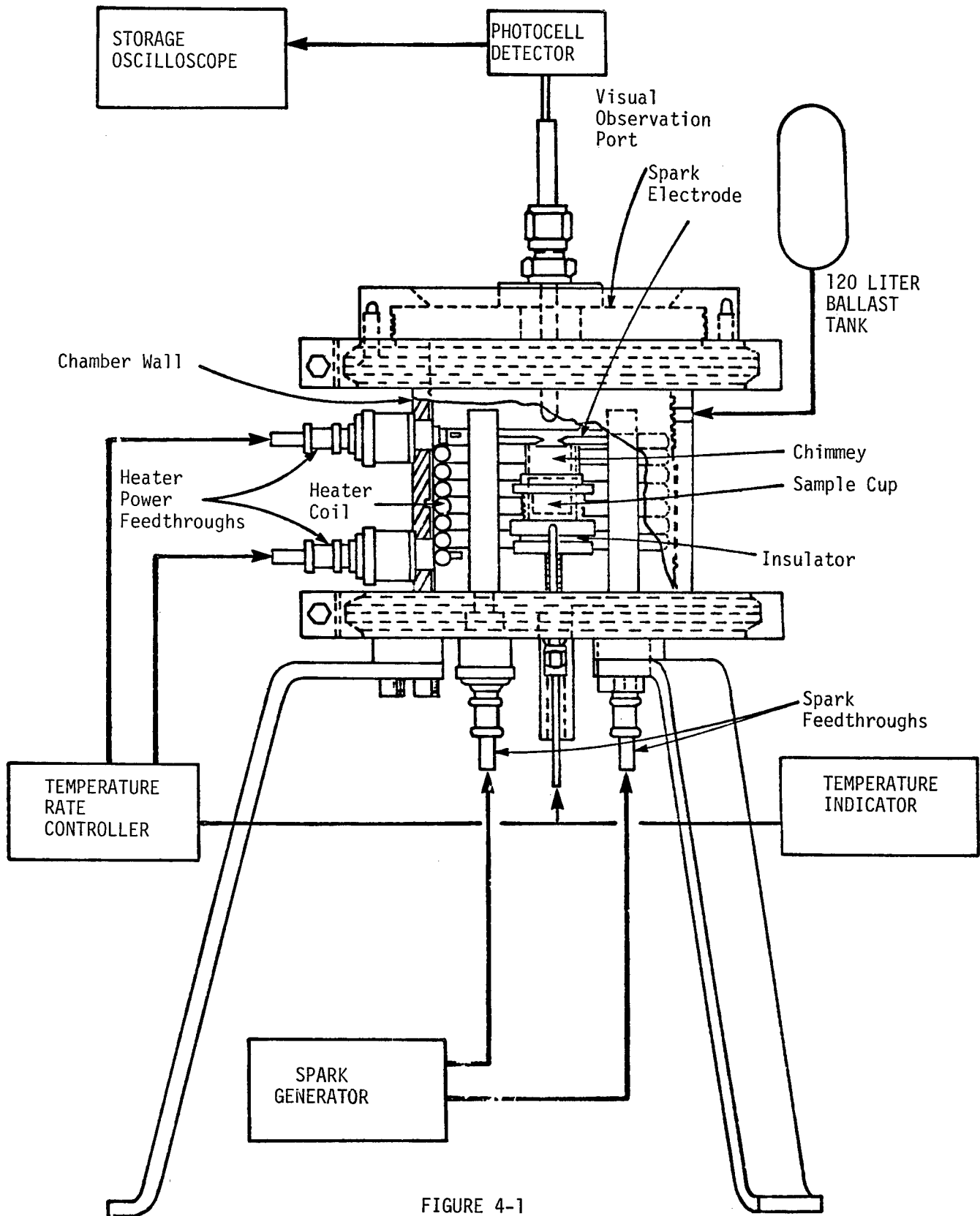

FIGURE 4-1
 WSTF FLASH & FIRE POINT TEST
 APPARATUS & CONTROL SYSTEM
 WSTF DWG 251-12092
 4-9

7. TEST PROCEDURE

- a. The test chamber shall be thoroughly cleaned before each test. Chamber surfaces must be free of cleaning agent residues after cleaning.
- b. Place the prepared test specimen into the cup.
- c. Place the cup in the cup assembly.
- d. Insert the spark electrodes and adjust the spark gap to 0.125 ± 0.025 inches.
- e. Adjust the specimen cup assembly so that the distance between the specimen surface and the spark gap is 0.750 ± 0.025 inches and the electrodes are touching the top of the chimney.
- f. Seal the test chamber and evacuate to at least 0.2 psia.

NOTE: A pressure rise greater than 0.2 psia in 2 minutes indicates a leak that must be corrected before proceeding with the test.

- g. Pressurize the chamber to the desired test atmosphere and pressure, using techniques that assure mixture accuracy within 0.5% of the specified value. Allow sample to soak in test atmosphere for 3 minutes prior to starting test.
- h. Allow the spark to discharge across the electrode, during the 3 minute soak time, approximately 20 times before initiating thermal programming. This step will establish spark uniformity.
- i. Heat the specimen at the rate of $25 \pm 5^{\circ}\text{F}$ per minute. A single spark shall be discharged once for each 10^{+3} seconds.
- j. Record flash and fire points as detected.
- k. Testing for flash and fire points shall be stopped when the fire point is reached or a maximum temperature of 1000°F is attained.
- l. Depressurize and cool the chamber to ambient temperature.
- m. Thoroughly clean the interior of the chamber and clean or replace the sample cup. Ensure cleaning agent/solvent used to clean the sample and test system do not cause the test hardware itself to exhibit a flash point.
- n. Repeat steps subparagraphs a through m until the required number of samples have been tested.

8. ELECTRONIC DETECTION OF FLASH AND FIRE

A major advantage of the test system shown in Figure 4-1 is that sensitive instrumentation and visual observation are both used to monitor flash

occurrences within the chamber. Some materials exhibit an apparent flash which has been defined as a "halo". The system described in subparagraph 5 records this halo effect and differentiates between the halo effect and a true flash point. This is accomplished by means of an oscilloscope, operated in the storage mode so that the spark output can be analyzed and retained on the scope's display console after its occurrence. Typical spark energy outputs observed on the oscilloscope are presented in Figure 4-2. The basic spark output is characterized as shown in "A" of Figure 4-2. When a material that exhibits the halo is being tested, the amplitude of the basic spark output generally increases by some small increment with each spark after a certain temperature is reached as shown in "B" and "D" of Figure 4-2. During a period when the halo is being observed, the displacement (horizontal) axis is vertically constant; only the energy in the amplitude increases. The halo does not propagate as does an actual flash. The halo appears like an ionized gas that adds energy to the spark only for the duration of the spark. An actual flash self-propagates for a time period longer than the spark time; hence, an increase in the time displacement will be observed. This is illustrated in "C" and "D" of Figure 4-2. Characteristics exhibited by materials as illustrated in "C" and "D" of Figure 4-2 are difficult to differentiate visually from the halo; however, the instrumentation display clearly indicates the occurrence of a flash. Examples "E" and "F" of Figure 4-2 illustrates the shape of flashes that can easily be distinguished. A sustained flash shall be considered as the fire point.

9. REPORTING

The test data shall be reported in accordance with instructions contained in Paragraph 208 on a form similar to Figure 2-1. The following special information shall be reported:

- a. Maximum test temperature.
- b. Flash point temperature °F.
- c. Fire point temperature °F.
- d. Test pressure.
- e. Test atmosphere.
- f. Sample weight.
- g. Observations (temperature at which halo is observed, sample discoloration, etc.).

404 TEST 4 - ELECTRICAL WIRE INSULATION AND ACCESSORY FLAMMABILITY TEST

1. PURPOSE

This test is designed to screen wire insulation and electrical accessory material for flammability characteristics. Electrical accessory material

consists of wire bundle sleeving, heat shrinkable tubing, solder sleeves, bundle ties, cable clamps, identification tags, etc.

2. CRITERIA OF ACCEPTABILITY

Electrical wire insulation and accessories shall be noncombustible or self-extinguishing in the test atmosphere during the application of current overloads up to the melting point of the electrical conductor. A minimum of 3 test specimen shall be used. Failure of any one specimen will constitute failure of the component. If the component passes this test it must also be tested in accordance with Test 1.

3. TEST CONDITIONS - PRESSURES AND ATMOSPHERES

The test pressure and gas mixture conditions for the pertinent materials category shall be designated by the center program office. These conditions shall represent the most hazardous atmosphere anticipated in the spacecraft.

4. TEST EQUIPMENT

The test equipment shall be the same as that described in paragraph 401-4, items a through d.

- a. Sample Holder. The sample holder shall consist of two horizontally mounted electrical connections, i.e., knurled bolts, spaced 13 inches apart. Three nonflammable center supports shall be provided to support the center and end of the sample wire bundle. The electrical terminals shall be connected to the ignition power source.
- b. Ignition Source. An external electrical power supply shall be provided which is capable of providing a large steady current through one wire of the sample bundle so that a high temperature will be achieved quickly. The power source must be capable of supplying a current 10% above the nominal fusion current for the gage wire being tested in accordance with the following schedule.

<u>Wire Gage No.</u>	<u>Initial Test Current* (Amps)</u>	<u>Increment of Current Current Increase (Amps)</u>	<u>Nominal Fusion Current (Amps)</u>
28	5	1	15
26	10	2	20
24	15	3	30
22	30	4	40
20	40	5	60
18	60	8	80
16	80	10	120
14	120	15	160
12	160	25	225
10	220	30	300
8	350	45	475
6	500	65	675
4	725	95	950

<u>Wire Gage No.</u>	<u>Initial Test Current* (Amps)</u>	<u>Increment of Current Current Increase (Amps)</u>	<u>Nominal Fusion Current (Amps)</u>
2	1000	135	1350
0	1400	200	1900

* NOTE: Values shown are for copper. For other conductor materials, the numbers should be changed accordingly.

5. SAMPLE PREPARATION

a. Wire Insulation Samples

- (1) Insulated wire samples shall be free of cuts, abrasions, or other flaws as determined by close visual inspection.
- (2) Prior to testing, the samples shall be cleaned of foreign matter and residue using a method compatible with the insulation being tested.
- (3) A test bundle of seven insulated wires, six of which are 12 inches in length and the seventh wire 13 inches in length, shall be tightly bound together, using Bently-Harris STFE-30 lacing tape or equivalent or the appropriate bundle ties to be tested, in five places approximately 3 inches apart. The 13 inch length wire shall be positioned on the interior of the bundle in intimate contact with adjacent wires and shall be stripped of 1/2 inch of insulation on each end. A crimp spade lug terminal shall be used at each end to terminate the overload wire and provide a heat sink. The wires shall be laid up parallel to each other and one end of the bundle shall be twisted 180° relative to the other. Electrical harnesses and accessories as used in actual applications, including connectors, may be used in lieu of the above configuration. The mating connector with electrical wiring to power electrode must be either ceramic insulated wire or bare copper wire of lower gage number than that used in the test bundle.

b. Electrical Wire Accesories

- (1) Accessory specimens shall be free of cuts, abrasions or other flaws as determined by close visual inspection.
- (2) Accessory specimens shall be installed over or adjacent to wire bundles, prepared per subparagraph a in the manner in which they are intended to be installed in the spacecraft.

6. PRETEST PROCEDURE

- a. Verify that all test equipment is clean and in current calibration.
- b. Verify gas certification.

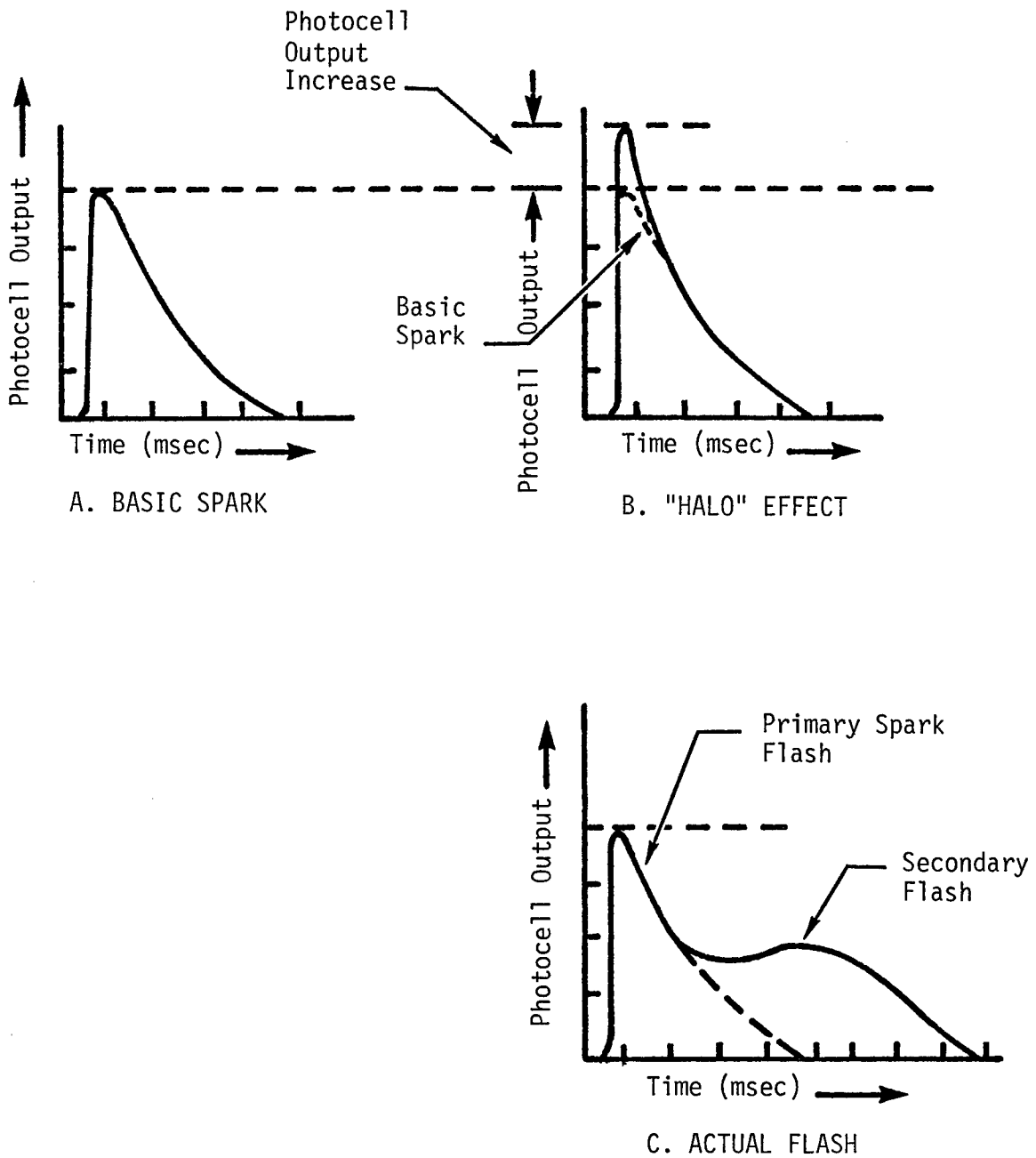

- NOTES: 1. Photocell output scale determined by vertical gain setting of the oscilloscope.
 2. Time base shown is 0.5 milliseconds/division.
 3. The vertical span of the basic spark should be adjusted for approximately $\frac{1}{4}$ the available scope display at ambient temperature.

FIGURE 4-2 Typical Oscilloscope Displays (Sheet 1 of 2 sheets)

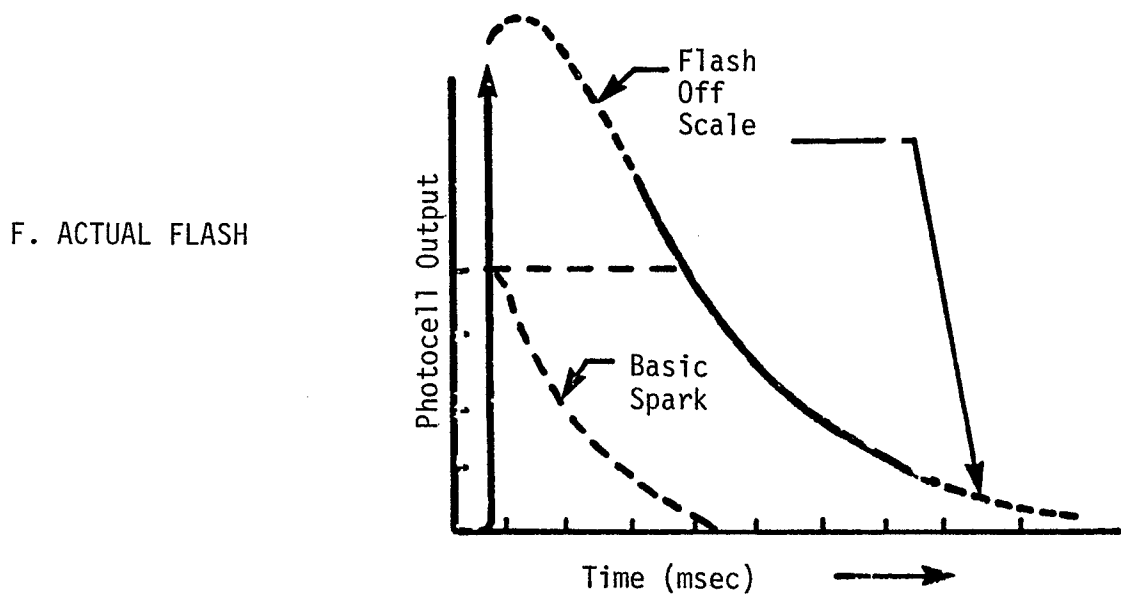
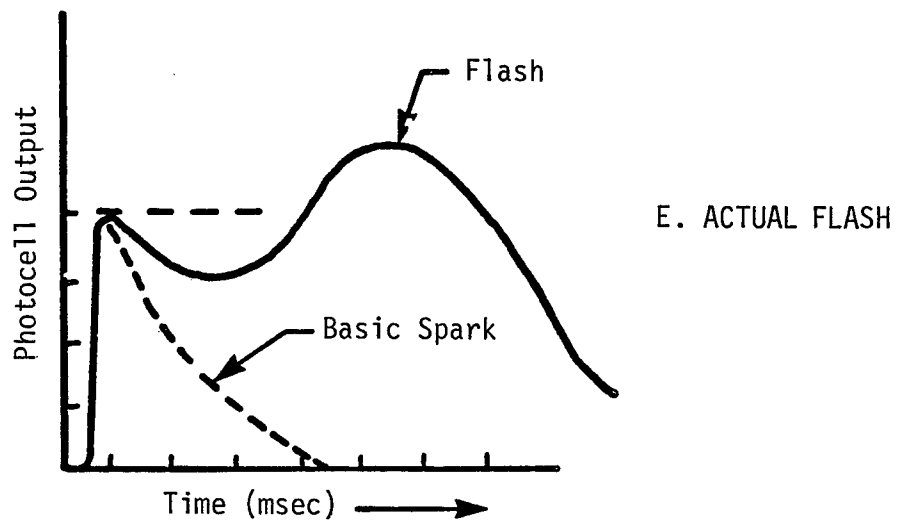
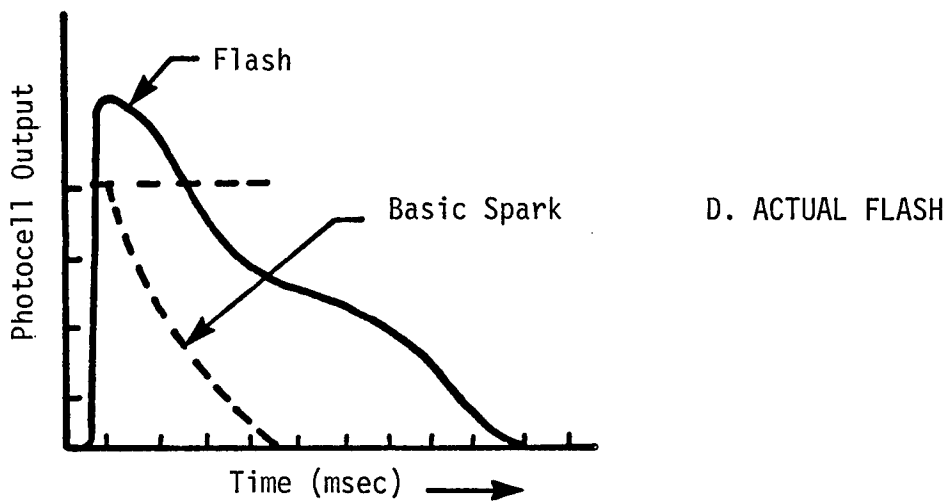

FIGURE 4-2 TYPICAL OSCILLOSCOPE DISPLAYS (Sheet 2 of 2 Sheets)

- c. Visually inspect each sample (there shall be no cuts, abrasions, or other flaws).
- d. Prepare three samples per paragraph 404-5a.
- e. Install wire accessories per paragraph 404-5b. Document installation configuration details.
- f. The sample bundle shall be mounted in the sample holder and positioned within the test chamber by fastening one end of the stripped wire to each of the electrical connection posts. The sample bundle shall be supported in the middle by a center support constructed with a non-flammable material.
- g. Record wire gage number.
- h. Record power supply current capability in amps. Power supply must meet the requirement of paragraph 404-4b for the gage wire being tested.
- i. Record thickness of wire insulation in mm.
- j. Record volume of chamber in liters.

7. TEST PROCEDURE

Testing of the candidate samples shall be accomplished in accordance with the following basic procedure for materials which will be used in atmospheres at pressures other than 14.7 psia. Materials used in an atmosphere at 14.7 psia (such as air) may be tested in the chamber but the leak check steps can be deleted. These materials may also be tested in a hood but precautions must be taken to baffle the test samples from drafts. The applicable steps of the procedure shall then be followed.

- a. Evacuate the chamber to 0.2 psia or less.
- b. Allow the chamber to stand for 2 minutes. A leak is indicated if an increase in the test chamber pressure of greater than 0.2 psia is observed at the end of that time. If a leak occurs, the chamber will be brought to atmospheric pressure, leak corrected, and steps in subparagraphs a and b repeated. Repressurize the chamber to test pressure with the test gas, using techniques that assure oxygen concentration within 0.5% of the specified value.
- c. After the chamber has stabilized at test pressure, soak the specimen for at least 3 minutes. Record soak time.
- d. Verify that the chamber pressure is at the desired test pressure, then isolate the chamber from the pressurization and vacuum sources.
- e. Apply a current per initial test current of paragraph 404-4b to the wire. If ignition is not obtained in 1 minute, the current shall be increased as specified in paragraph 404-4b. If the wire

fails, the voltage shall remain applied to the overloaded wire until it is positively established that current does not flow.

- f. Record current level at which ignition occurred or the wire failed. Record if combustion was sustained or halted upon removal of ignition source. Record any other observations such as melting, dripping, sputtering, discoloration, etc.
- g. Return the chamber to the normal state.

8. REPORTING

Test data shall be reported in accordance with instructions contained in paragraph 208 on a form similar to Figure 2-1. The following special data shall be reported:

- a. Configuration of the test item.
- b. Combustion characteristics and phenomena; self-extinguishing or burned.
- c. Current level at end of test.
- d. Test pressure.
- e. Test atmosphere.

405 TEST 5 - ELECTRICAL CONNECTOR POTTING AND CONFORMAL COATINGS
FLAMMABILITY TEST

1. PURPOSE

This test evaluates the flammability characteristics of spacecraft potting and coating compounds in a specific gas atmosphere environment. It is designed to simulate a short circuit or dielectric breakdown of current carrying wires, or connector contacts within the potting or coating used to environmentally seal electrical connectors and circuit boards.

2. CRITERIA OF ACCEPTABILITY

Connector potting and coating compounds shall be noncombustible in the test atmosphere during the application of current overloads up to the melting point of the electrical conductor. In addition, the material must be tested in accordance with Test 1. A minimum of three samples shall be tested.

3. TEST CONDITIONS - PRESSURES AND ATMOSPHERES

The test pressure and gas mixture conditions for the pertinent materials category shall be designated by the center program office. The conditions shall represent the most hazardous atmosphere anticipated in the spacecraft.

4. TEST EQUIPMENT

The test equipment shall be the same as that described in paragraph 401-4, items a through d.

a. Sample Holder and Connector Mount. The sample holder shall consist of two horizontally mounted electrical connections (bolt with knurled nuts) spaced 13 inches apart. The electrical terminals shall be connected to the ignition power source. A central connector consisting of a vertical panel drilled to receive a horizontal Bendix PT07-Jam Nut Receptacle or equivalent shall be provided. See Figures 4-3 and 4-4.

b. Ignition Source. An external power supply shall be provided which is capable of providing a large steady current so a high temperature will be achieved quickly. The power source must be capable of supplying 100 amperes of current through the No. 18 AWG overload conductor.

5. SAMPLE PREPARATION FOR POTTING COMPOUNDS

a. Prepare three samples for each candidate potting compound per subparagraphs b through j.

NOTE: Electrical harness and accessories as used in actual applications including connectors may be used in lieu of the hardware called out below. A direct short must be built into this system.

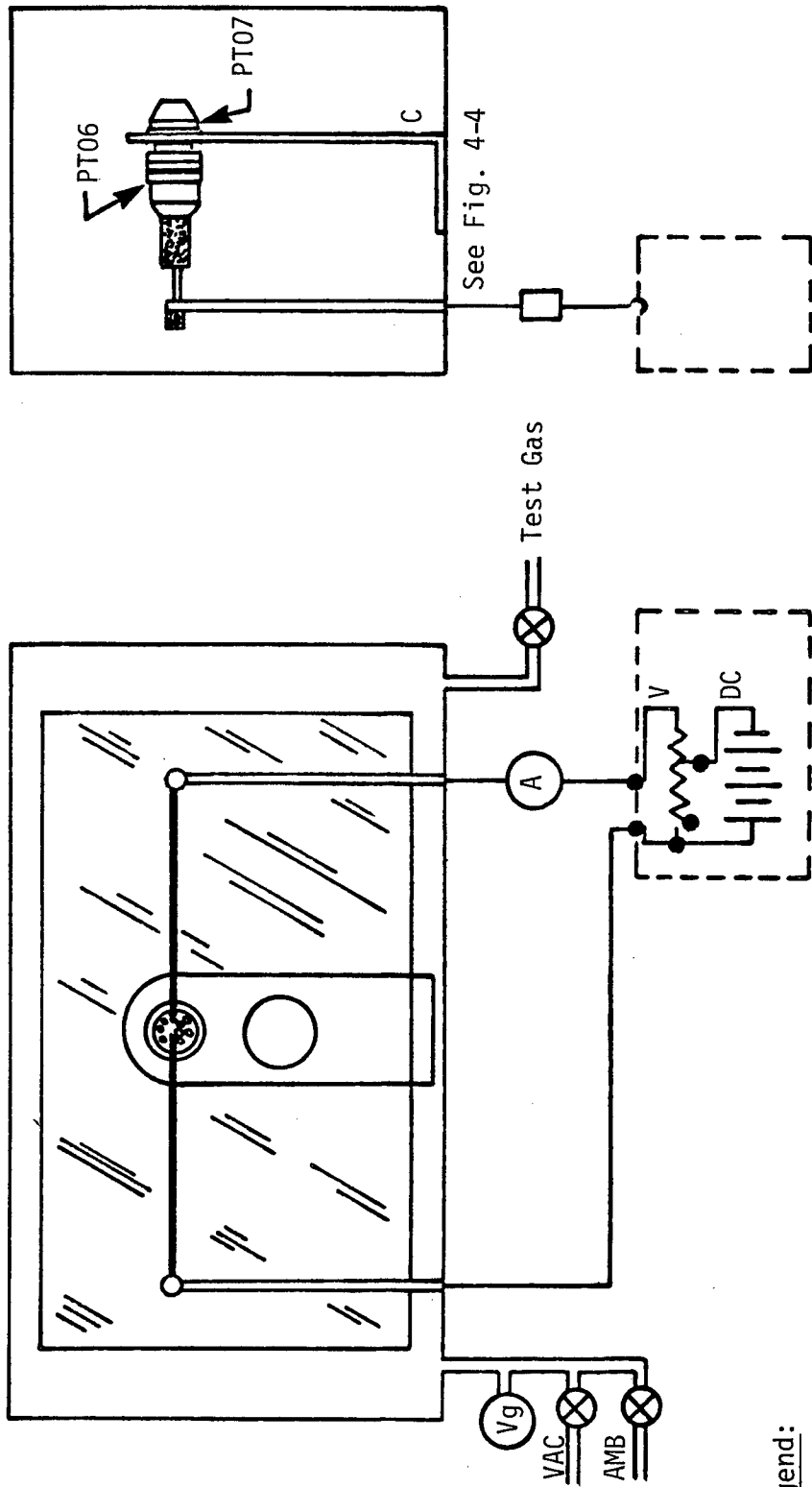

Legend:

Vg = Vacuum Gage

DC = 28 vdc Power Supply

V = Variable Resistor

A = 0 to 100 Amp Ammeter

C = Central Connector Mount

PT06 = Bendix PT 06-CP-18-11P Straight Plug

PT07 = Bendix PT 07-CP-18-11S Jam Nut Receptacle

Figure 4-3 Potting Flammability Test Equipment Schematic

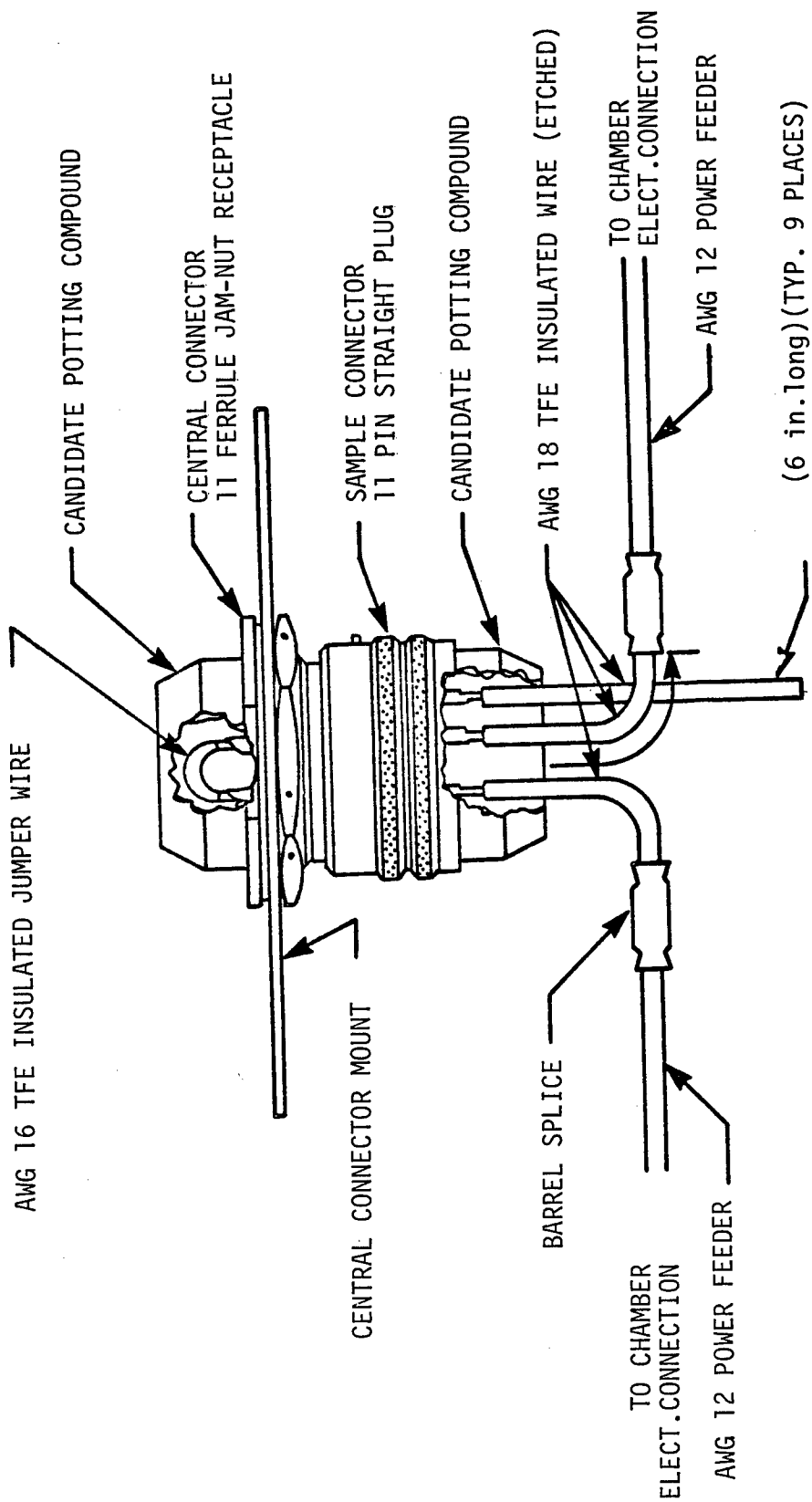

FIGURE 4-4. SAMPLE CONFIGURATION

- b. Prepare a 6 inch length of AWG 18 white Teflon insulated wire (MIL-W-16878, Type E, or MIL-W-22759, Type MS21985) as follows:
 - (1) Form a U-bend in the middle of the wire and etch the center 4 inches per JSC Specification Q-3.
 - (2) Strip 1/4 inch insulation from each end.
 - (3) Cut the wire in half such that 2 inches of etched insulation remain on the unstripped end of each 3 inch length.
- c. Prepare two 6 inch lengths of AWG 12 white TFE Teflon insulated wire. Strip 1/2 inch of insulation from one end of each wire and 1/4 inch from the other end of each wire.
- d. Crimp the 1/4 inch exposed AWG 12, 6 inch wire to the 1/4 inch exposed AWG 18, 3 inch wire using a standard copper barrel crimp sleeve. Repeat for the second wire.
- e. Slide a 1 inch length of FEP Teflon heat shrinkable sleeving over each barrel crimp; shrink using a hot air gun.
- f. Obtain a Bendix Pygmy PT06CP-18-11P Straight Plug or equivalent. Take the wires prepared and stripped per subparagraph b above and crimp one wire to contact K and the second wire to adjacent contact L (see Figure 4-4).
- g. Crimp nine etched white AWG 18 Teflon insulated wires, each 6 inches long, in the remaining contacts.
- h. Place the potting boot on the connector and fill with the candidate potting compound per the manufacturer's instructions. Ensure that the potting compound is within the recommended shelf life. Ensure that all steps are followed exactly as they would be in flight hardware, including cleaning and priming of connector rear insert for bondable capability, degassing potting compound, proper humidity control, etc.
- i. Cure per applicable user's procedure or manufacturer's recommended time/temperature for optimum properties.
- j. Remove potting boot.

6. CENTRAL CONNECTOR PREPARATION

- a. Prepare three central connectors per subparagraph b through e.
- b. Obtain a Bendix Pygmy PT07CP-18-11S Jam Nut Receptacle or equivalent. Crimp a short AWG 16 Teflon insulated jumper between contact K and contact L (see Figure 4-4).
- c. Place the potting boot on the connector and fill with the compound to be tested.

d. Cure per manufacturer's instruction.

e. Remove potting boot.

7. SAMPLE PREPARATION FOR COATING COMPOUNDS

a. Prepare three samples for each candidate conformal coating compound as follows:

- (1) Obtain an eight lug NAS1066-3-8 terminal block. Mount to a 4 x 15 x 0.020 inch aluminum base plate. See Figure 4-5.
- (2) Prepare a 14 inch length of AWG 18 white Teflon insulated wire (MIL-W-22759, Type MS21985) as follows:
 - (a) Form a U-bend in the middle of the wire and etch the center 4 inches per JSC-SPEC- Q-3.
 - (b) Cut the wire in half and strip 1/2 inch of insulation from all four ends.
- (3) Etch 2 inches of one end of each of six additional AWG 18 Teflon insulated wires, each 6 inches long, per JSC-SPEC-Q-3. Strip 1/2 inch of insulation from the etched ends.
- (4) Form a U-bend in the middle of a 10 inch length of AWG 20 white Teflon insulated wire and etch the center 4 inches per JSC-SPEC-Q-3. Cut the etched portion of the wire to obtain a jumper 3 inches long, all of which is etched. Strip 1/2 inch from each end.
- (5) Obtain ten MS20659 terminal lugs and crimp per manufacturer's instructions to conductors at etched ends of wire prepared per subparagraphs (3) and (4).
- (6) Fasten the nine wires to the terminal block as shown in Figure 4-5, using standard terminal board hardware.
- (7) Overcoat the base plate, terminal block, wire lugs, and wire insulation to within 1/8 inch of the end of the etched portion with the candidate primer (if applicable) and conformal coating compound, applied to recommended thickness and in accordance with recommended application techniques.
- (8) Cure per recommended time/temperature process.

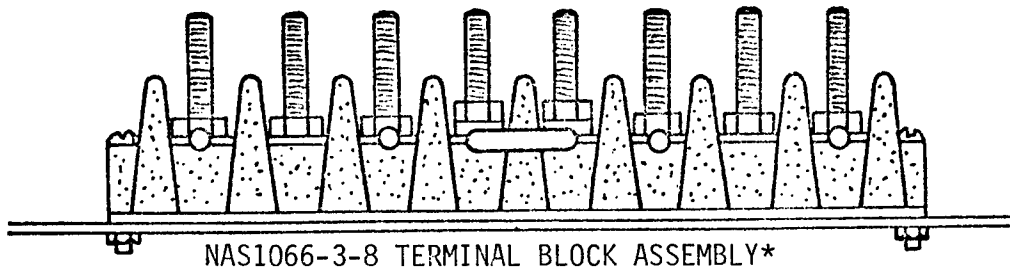
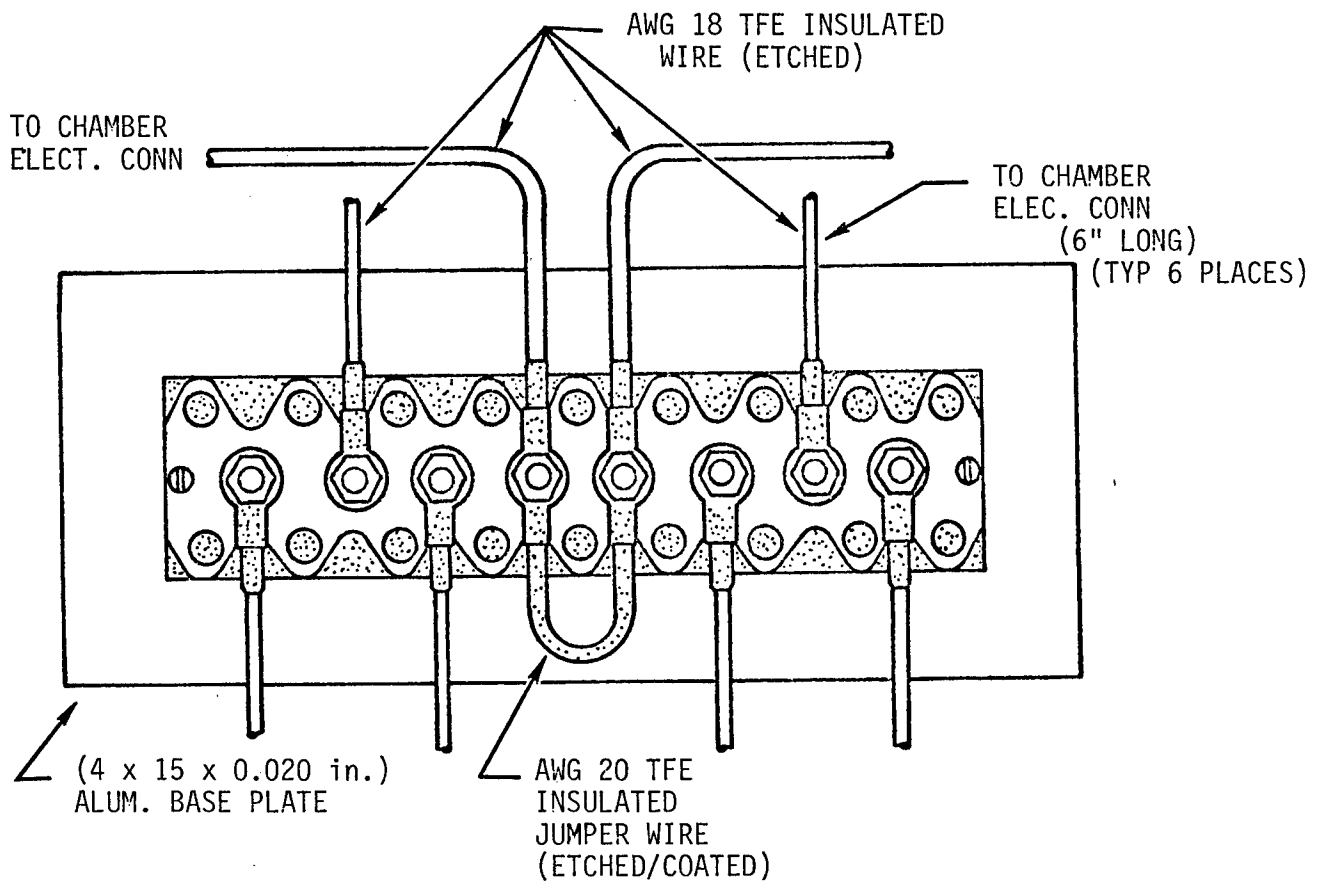

*Procurable from Olympic Plastic Co.,
 3471 So. La Cienega Blvd., Los Angeles, Calif.,
 or Seastrom Mfg. Co., 701 Sonora, Glendale, Calif.

Note: Shaded areas to be coated with candidate conformal coating.

FIGURE 4-5. CONFORMAL COATING SAMPLE CONFIGURATION

8. TEST PROCEDURE FOR POTTED CONNECTORS

Testing of the candidate connector samples shall be accomplished in accordance with the following basic procedures for materials which will be applied in atmospheres at pressures other than 14.7 psia. Materials applied in ambient air atmosphere at 14.7 psia may be tested in the chamber but the leak check (step b.) can be deleted. These materials may also be tested in a hood but precautions must be taken to baffle the test samples from drafts. The applicable steps of the procedure shall then be followed.

- a. After verifying the test gas certification, the sample prepared per subparagraphs 5 and 6 shall be mounted in the sample holder by locking the PT06CP plug to the PT07CP receptacle which has been placed in the vertical panel provided for it, and fastened with a threaded locknut. The stripped ends of the lengths of wire crimped into the plug shall be fastened to the current supply terminals of the sample holder.
- b. The test chamber shall be evacuated to a pressure of 0.2 psia or less. Allow the chamber to stand for 2 minutes. A leak is indicated if an increase in test chamber pressure greater than 0.2 psia is observed at the end of that time. If a leak occurs, the system shall be brought to atmosphere pressure and the leak corrected before any additional tests are carried out. Repeat the above procedure until leaks are corrected, then pressurize the test chamber with the test gas using techniques that assure oxygen concentration within 0.5% of the specified value.
- c. After the test chamber has been stabilized at the test pressure, soak the specimens 3 to 10 minutes. Apply a current of 55 amperes to the wire. If ignition or considerable degradation is not obtained in 4 minutes, the current shall be increased 5 amperes per minute (i.e., from 55 to 60 and 60 to 65, etc.) until such time as the wire fails or ignition occurs. If the wire fails, voltage shall remain applied to the open wire for 1 minute to establish that current does not flow by bridging the gap to adjacent conductors.
- d. Three samples of each potting compound shall be tested. The failure of any one sample to meet the criteria of subparagraph 2 shall be cause for rejection of that compound.
- e. The chamber shall be returned to the normal state at the conclusion of the test.

9. TEST PROCEDURE FOR COATING COMPOUNDS

Testing of the candidate coating samples shall be accomplished in accordance with the following basic procedure for materials which will be applied in atmospheres at pressures less than 14.7 psia. Materials applied in an atmosphere at 14.7 psia may be tested in the chamber but the leak check (step 6) can be deleted. These materials may also be tested in a hood but precautions must be taken to baffle the test samples from drafts. The applicable steps of the procedure shall then be followed.

- a. The sample, prepared per subparagraph 7, shall be placed in the chamber and the stripped end of each 7 inch wire shall be fastened to a chamber electrical connection.
- b. After verifying the test gas certification, the chamber shall be evacuated to a pressure of 0.2 psia or less. Allow the chamber to stand for 2 minutes. A leak is indicated if an increase in test chamber pressure greater than 0.2 psia is observed during the 2-minute period after the vacuum pump is closed off from the system. The system shall be brought to atmospheric pressure and the leak corrected before any additional tests are carried out. Repeat the above procedure until leaks are corrected, then pressurize the test chamber with the test gas using techniques that assure oxygen concentration within 0.5% of the specified value.
- c. After the test chamber has been stabilized at the test pressure, soak the specimens 3 to 10 minutes. Apply a current of 40 amperes to the wire. If ignition or considerable degradation is not observed in 1 minute, the current shall be increased 5 amperes per minute (i.e., from 40 to 45 to 50, etc.) until such time as the wire fails or ignition occurs. If the wire fails, voltage shall remain applied to the open wire until it is positively established that current does not flow by bridging the gap to adjacent conductors.
- d. Three samples of each candidate conformal coating shall be tested. The failure of any one sample to meet the criteria of subparagraph 2 shall be cause for rejection of that coating.

10. REPORTING

Test data shall be reported in accordance with instructions contained in paragraph 208 on a form similar to Figure 2-1. The following special information shall be reported.

- a. Current level at the end of the test.
- b. Results of each test including combustion phenomena if ignition occurs.
- c. Test pressure.
- d. Test atmosphere.
- e. Configuration of the test item.

406 TEST 6 - ODOR TEST

1. PURPOSE

The purpose of this test is to determine the odor characteristics of materials. A material that fails these requirements shall not be used.

NOTE: The results of Test 7 shall be evaluated before conducting this test so that members of the odor team are not exposed to unacceptable levels of toxic offgassed products.

2. ODOR TEST REQUIREMENTS AND CRITERIA

a. Prerequisites to Selection of Odor Evaluation Test Panel

- (1) Review NMI 7100.8 "Human Research Policy and Procedures" to determine applicable procedure.
- (2) Prepare protocol and authorization of human research where required by paragraph 8, NMI 7100.8.
- (3) Prepare voluntary consent forms for signature of test panel members where required by paragraph 6, NMI 7100.8.

b. Selection of Test Panel for Odor Evaluation

- (1) The test conductor shall establish a pool of medically qualified personnel.
- (2) Where contractor personnel are used, NASA contracts shall include human research activity within the statements of work in order that applicable state worker's compensation statutes will apply in the event of injury.
- (3) Each member of the pool shall be capable of detecting seven basic odor standards from the following solutions:

<u>Primary Odor</u>	<u>Standard Compound</u>	<u>Amount Dilution in Distilled or Deionized Water</u>
Ethereal	1,2-Dichloroethane	400 u1 in 500 ml
Camphoraceous	1,8-Cineole	5 u1 in 500 ml
Musky	15-Hydroxypentadecanoic acid lactone	1 mg in 1000 ml
Floral	1-Methyl-1-ethyl-2-phenyl propanol-1	75 u1 in 500 ml
Minty	Methone (d1)	2 u1 in 333 ml
Pungent	Formic acid	25 ml of 90% solution in 500 ml
Putrid	Methyl disulfide (Methyl dithiomethane)	1 u1 in 10,000 ml

- (4) Members of the pool shall be given three odorless solutions along with the seven primary standards for detection of odor.

- (5) The solutions shall be freshly prepared once a month or as needed and stored in closed glass-stoppered bottles away from heat sources and direct sunlight.
- (6) The established pool for odor evaluation shall be requalified every 4 months for olfactory sensitivity.
- (7) A panel of at least five members shall be selected from the pool for odor evaluations.
- (8) Odor panel members shall receive a nose and throat examination by a medical staff member within 1 hour prior to each odor test for nasal irritation or other abnormal conditions, and between 2 and 4 hours after each odor test.
- (9) Members of the pool shall not participate on the panel if their sense of smell is affected in any manner such as by recent smoking, ingestion of highly flavored foods, or exposure to pungent vapors.
- (10) At least one of the seven odors shall be presented to the panel as a standard for verifying the ability to detect odor before evaluation of odors from any sample material.
- (11) Panel members shall not be permitted to see the material, know the gas sample being evaluated for odor, or see the ratings of the other panelists prior to being subjected to the odor.
- (12) Odor evaluation on sample materials shall be performed in a room actively ventilated and free from extraneous odors.
- (13) Odor evaluations shall be performed on every new bottle of oxygen, nitrogen, or premixed test gas used for the test atmosphere.
- (14) Provisions shall be made for flushing the face mask of residual odors and for sanitizing.

c. Odor Evaluations and Acceptance Criteria

<u>Member's Rating</u>	<u>Test Conductor's Rating</u>
Undetectable	0
Barely Detectable	1
Easily Detectable	2
Objectionable	3
Irritating	4

An average rating of 2.5 or lower on the undiluted odor sample of any sample material by the panel members signifies the material passes the odor test.

3. TEST CONDITIONS - PRESSURES AND ATMOSPHERE

The test pressure and gas atmosphere conditions for the pertinent materials type shall be designated by the center program office. For this test, these conditions will normally be 11.8 to 12.0 psia (conditioning pressure), 49°C, and 25.9% oxygen (balance nitrogen).

4. TEST EQUIPMENT

a. Test Chamber

The test chamber shall normally be made of Pyrex glass and its internal volume shall be 2 liters minimum. The test chamber shall have the following:

- (1) A gas tight removable cover.
- (2) A sampling valve.
- (3) A sampling port capable of being sealed with a septum. A laboratory vacuum desiccator may be used as a test chamber.

b. Chamber Vacuum and Pressurization Equipment

The equipment shall consist of the items specified in Test 7, paragraph 5b.

c. Heating Source

The heating unit or oven shall maintain the test chamber at the designated test temperature +3°C. The temperature during sample thermal conditioning shall be recorded.

d. Sample Transfer Equipment

Glass syringes of 30 cm³ capacity shall be used for measuring and transferring sample atmospheres from the test chambers to the panel member's face mask.

e. Mask

The mask shall consist of an odorless, flexible material which can be applied to a panel member's face to cover the nose and mouth.

f. Odor Testing Equipment

Applicable odor testing equipment (test chamber, syringe, mask, test atm., regulators, etc.) shall be free of extraneous odors.

5. TEST SPECIMEN PREPARATION

a. Material Classification

All the materials to be tested shall be classified into one of four categories, surface, volume, weight, or specialized items.

b. Samples Based on Surface

- (1) This classification is defined as all those materials that are essentially two dimensional. This would include films, fabrics, coatings, finishes, inks, primers, adhesives, thin film lubricants, tapes, and electrical insulating materials.
- (2) The sample tested shall have a surface of 46.5 ± 2.5 square inches per liter of test chamber. Coatings, finishings, etc., shall be coated on a clean aluminum substrate of 0.020 ± 0.001 inch thickness. Material thickness, curing process, and method of application shall be in accordance with the manufacturer's recommendations. Material may be coated on both sides of the aluminum panel. Tapes and other similar materials with an adhesive surface shall be fastened to a similar aluminum panel. In all cases, only the outer surfaces of a material on the aluminum panel is counted in the surface area determinations. Films, fabrics, and similar materials shall be cut to give 46.5 ± 2.5 square inches surface. Because these materials are two surfaced in use, both the top and bottom surface shall be counted in determining total surface area. Heat shrinkable tubing shall be applied and shrunk to simulate actual use configuration.

c. Samples Based on Volume

- (1) This classification is defined as all those materials having a definite volume but having a large real surface area due to surface convolutions or matting. These shall include foams and other blown or foamed materials and insulation padding.
- (2) Samples of these materials shall be cut to a thickness of 0.50 ± 0.05 inch unless the existing thickness is less than 0.50 inch. In this case, the existing thickness shall be used. The material shall be cut to such a size as to give 7.75 ± 0.75 square inches of total surface per liter of test container volume. All surfaces, tops, bottoms, and sides shall be used to compute total surface area. In cases where the natural thickness is such that the material cut would be too large to be placed into the container, two or more pieces may be cut as long as the total surface area requirement is met.

d. Samples Based on Weight

- (1) This classification is defined as all those materials having a definite bulk and not falling into the volume classification.

This shall include potting compounds, molding compounds, cast or formed objects, solid wires, and thick plastics. Liquids that are not used or applied as coatings or thin films shall be included.

- (2) The samples shall be used as much as possible in the supplied configuration and cut to give 5.0 ± 0.25 grams per liter of chamber volume. Potted or molded materials shall be prepared and cured per manufacturer's directions and cut to weight. Liquids shall be placed in suitable nonreactive dishes 2.25 ± 0.25 inches in diameter. Sample weight shall be 5.0 ± 0.25 grams per liter of test chamber volume.

e. Specialized Items

It must be recognized that some materials will not meet the above classifications and must be specially handled. This will most often occur with nonhomogeneous materials. These materials will be tested in the manner designated by the Test Conductor. The manner of testing and sample preparation shall be fully reported.

6. SAMPLE CHAMBER PREPARATION

a. Cleaning

The chamber shall be cleaned using procedures that remove residual odors. Cleaning shall include a distilled water rinse and thorough drying.

b. Leak Check

The glass chamber and lid should be visually examined for chips or scratches that might allow leakage.

7. PRE-TEST PROCEDURE

Before odor testing, candidate materials must have been tested for levels of toxic offgassed components (Test 7) so that odor panel members are not exposed to unacceptable levels of toxic components. The method for determining toxic level shall be approved by the responsible NASA toxicology organization.

8. TEST PROCEDURE

- a. Place a clean, weighed specimen in the test chamber. Use an adequate amount of Dow Corning III vacuum grease (or equivalent) sealant on the ground glass surfaces of the container to effect a gas seal.
- b. Connect the chamber to the vacuum and pressurization system shown in Figure 4-6. Evacuate the chamber to 1.0 ± 0.1 psia and backfill with the test atmosphere to 10.0 ± 0.1 psia. Check the vacuum seal for leaks and readjust if necessary. Reevaluate to 0.2 ± 0.05 psia and backfill, using techniques that assure oxygen concentration within 0.5% of the specified value, to a pressure such that the

chamber interior will be at test pressure when the atmosphere is at test temperature. The test atmosphere composition may be obtained by partial pressure addition of oxygen and nitrogen during the leading step or by use of a cylinder of premixed test atmosphere.

- c. Heat the chamber to test temperature $+ 3^{\circ}\text{C}$ for a period of $72 + 1$ hours. The odor evaluation must not be made until the toxicological evaluation of the sample has been made. The odor test must be performed within 72 hours of the conclusion of thermal treatment.
- d. Following the isothermal exposure, the test chamber shall be removed from the oven and allowed to cool to room temperature.
- e. The pressure in the test chamber shall be measured and recorded after cooling to room temperature.
- f. The test chamber shall be pressurized to ambient atmospheric pressure with the test atmosphere.
- g. Odor Test - Known volumes of sample atmosphere shall be extracted from the test chamber by means of a syringe and diluted with fresh gas in the following proportions:
 - (1) One cm^3 of sample atmosphere to 29 cm^3 of test atmosphere.
 - (2) Three cm^3 of sample atmosphere to 27 cm^3 of test atmosphere.
 - (3) Thirty cm^3 of sample atmosphere to 0 cm^3 of test atmosphere.

NOTE: The order of administering the above samples shall not be known by the panel members.

9. REPORTING

Test data shall be reported in accordance with instructions contained in Paragraph 208 on a form similar to Figure 4-6. The following specific information shall be reported.

- a. Average rating numbers for each dilution determined by the panel members.
- b. Material classification and size per paragraph 5.

ODOR TEST SAMPLE FORM

TEST AGENCY WSTF DATE 1-12-78

TEST NUMBER 78-9757

TEST CONDUCTOR(S) Jack Stradling

QUALITY ASSURANCE _____

SAFETY _____

MANUFACTURER'S MATERIAL NOMENCLATURE Dacron cloth style 15292

MANUFACTURER'S LOT NUMBER _____

MANUFACTURER Stern and Stern

MATERIAL CHEMICAL NOMENCLATURE Polyester

SAMPLE NUMBER _____

SAMPLE WEIGHT N/A

SAMPLE SIZE (INCLUDING THICKNESS) 46.5 sq. in.

MATERIAL CLASSIFICATION Based on surface

TEST CHAMBER TEMPERATURE 120°F

TEST CHAMBER PRESSURE 12.3 psia

TEST CHAMBER ATMOSPHERE Shuttle

TEST CHAMBER VOLUME (liters)	MATERIAL PER LITER OF TEST CHAMBER VOLUME	TOTAL SOAK TIME (hrs.)	SAMPLE WITHDRAWAL (psia)
2 liters	300 sq. cm.	72 hr.	12.3 psia

ODOR SAMPLE CONCENTRATION AND TEST RESULTS

1 part to 29 parts matrix gas	1 part to 9 parts matrix gas	No dilution
<u>0.0</u>	<u>0.2</u>	<u>1.2</u>

REMARKS:

407 TEST 7 - DETERMINATION OF OFFGASSED PRODUCTS TEST

1. PURPOSE

This establishes the criteria for a screening test to determine the suitability of nonmetallic materials for use in the space vehicle crew compartment environments. The criteria are established with respect to production of potentially toxic volatile offgassed products.

2. DEFINITIONS

The following definitions apply to the terms as used in this test procedure:

- a. Offgassing. The evolution of gaseous products from a liquid or solid material.
- b. Offgassed Product. An organic or inorganic compound evolved from a liquid or solid material.
- c. Maximum Allowable Concentration (MAC). The maximum concentration of an offgassed product that is allowed in the spacecraft for a specified flight duration. MAC values for manned spacecraft are contained in Appendix D.

3. CRITERIA FOR ACCEPTABILITY

- a. The quantity of each offgassed product, as determined from either a standard quantity of a material or the actual quantity used in the spacecraft, shall not result in a projected spacecraft concentration in excess of the MAC value for that product.
- b. The toxicological summation of the total offgassed products of a material shall be evaluated for potential toxicity in accordance with the MAC guidelines of Appendix D by the responsible NASA toxicology group.
- c. Final acceptance of material shall be determined by the responsible NASA medical office from an assessment of the potential toxicity of the total quantity of offgassed products from all contaminant generating items for a given mission. (Anodized metal panels and other similar protective treatments and untreated metal panels do not require testing for toxicity.)

4. TEST CONDITIONS - TEMPERATURE, PRESSURE AND ATMOSPHERE

The test pressure, temperature and gas mixture conditions for the pertinent materials type shall be designated by the cognizant center program office. These conditions shall represent the most hazardous atmosphere anticipated in the spacecraft. The test atmosphere shall be the worse case atmosphere as defined by the applicable program office except that the pressure shall be slightly below ambient at the test laboratory.

5. TEST EQUIPMENT

- a. Test Chamber. The test chamber shall have a minimum volume of two liters. It shall have a configuration and be fabricated of materials which allow ready cleaning. Valves and seals used shall contain no soft goods that contribute detectable offgassing to the chamber. Appropriate instrumentation will be used to provide and monitor the required temperature and pressure in the test chamber. The chamber shall be constructed so as to permit direct gas sample introduction from the chamber to the analytical equipment.
- b. Chamber Vacuum, Pressurization and Thermal Cleaning Equipment. The equipment shall consist of the following items (Figure 4-6) and/or any other equipment that the test laboratory requires to assure chamber certification as specified in subparagraph 6.
- (1) Vacuum pump with a free air displacement of at least 100 liters per minute and an ultimate vacuum capability of 1.0×10^{-3} Torr or lower pressure.
 - (2) Pressure gage accurate to ± 0.03 psia; 0 to 15 psia range (nominal).
 - (3) Vacuum gage capable of measuring 10^{-4} Torr.
 - (4) Manifold with valves for interconnection of the chamber, vacuum pump, pressure gage, vacuum gage and K-bottles.
 - (5) Heat gun rated at 1000 watts (nominal).
 - (6) Liquid nitrogen dewar.
 - (7) K-bottles (commercially supplied bottles) of oxygen and nitrogen with suitable regulators. Oxygen and nitrogen used shall be of sufficient purity to minimize analytical interferences. Oxygen and nitrogen complying with MIL-O-27210, Type 1 and MIL-P-27401C, Type 1, Grade A, respectively, as amended below, have been found suitable for this use. Cylinders of premixed test atmospheres should meet the requirements below.

Recommended Maximum Limits (ppm by volume) for
selected Impurities in Oxygen and Nitrogen

	<u>Oxygen</u>	<u>Nitrogen</u>
Carbon Monoxide	2.0	2.0
Carbon Dioxide	10.0	10.0
Total Hydrocarbons, as CH ₄	2.0	2.0
Halogenated Compounds	0.5	0.5
Water	7.0	7.0

- c. Heating Source. The heating unit or oven shall maintain the test chamber at the designated test temperature $\pm 5^{\circ}\text{F}$. The temperature during sample thermal conditioning shall be recorded.
- d. Analytical Equipment. The analytical equipment shall consist of the following types of equipment and any other instruments the test laboratory requires to assure accuracy and precision in the offgassed products analyses:
 - (1) Gas Chromatograph System. The gas chromatography system shall employ detectors capable of responding to the offgassing products listed in Appendix D. As supplementary detectors, the following are recommended: electron capture, flame photometric, nitrogen/phosphorus flame ionization, and photoionization detectors. The separatory columns shall have the capability of separating light organic and inorganic gases, organic sulfides and mercaptans, halogenated hydrocarbons, representative aliphatic and aromatic hydrocarbons including aldehydes, ketones, alcohols, and esters.
 - (2) Recording Infrared Spectrophotometer with 10-Meter or Greater Pathlength Infrared Gas Cell. The cell shall have provisions for heating to test temperature and maintaining temperature to $\pm 5^{\circ}\text{F}$.
 - (3) Mass Spectrometer. The mass spectrometer range shall be 10 to at least 600 amu; resolution shall be at least 1200 at mass 600 (resolution is defined as $m/\Delta m$ when Δm is measured at peak half height). The sensitivity shall be such that a 10 nanogram/second sample will produce identifiable spectra of acetone or toluene.
 - (4) Gas sampling system suitable for the transfer of measured volumes of gas samples from the test chamber to the analytical instruments.
 - (5) Calibration standards as required to calibrate detectors. The calibration gas used with flame ionization detectors shall be propane; working standards shall be referenced to propane standards from the National Bureau of Standards.

6. SAMPLE CHAMBER CERTIFICATION

- a. Cleaning. The sample container shall be cleaned, heated, and purged with air or nitrogen by some suitable method to reduce residual container contamination (background).
- b. Leak Check. Connect the chamber to the vacuum and pressurization system (see Figure 4-7). The chamber shall be evacuated to less than 1 Torr and checked for leaks. The chamber shall be acceptable for use if the pressure rise due to leaks does not exceed 2 millitorr per minute.

- c. Cleanliness Certification. Before loading the sample into the chamber, the chamber shall be filled with the test atmosphere or nitrogen to 6.0 psia and conditioned for 72 ± 1 hour at test temperature. Alternatively the container may be conditioned for 24 ± 1 hour at test temperature plus 35°F . The chamber atmosphere shall then be analyzed for residual contamination (background). The chamber shall be certified as clean for use if the concentrations of the residual volatiles (background) are sufficiently low to permit detection and quantitation of offgassed products from the test specimen (see paragraph 8).

7. TEST SPECIMENS PREPARATION

- a. Categories. All the materials to be tested shall be classified into two categories: weight and specialized items.
- b. Samples Based on Weight
- (1) Materials which are essentially two dimensional and require application to a substrate (e.g., films, coatings, primers, inks, paints, adhesives, tapes, thin film lubricants, etc.) shall be applied to clean aluminum substrates 0.003- to 0.020-inch thickness. Samples may be applied to both sides of the substrate. A sufficient number of substrates with sample shall be prepared so as to provide a net sample weight of 5.0 ± 0.25 grams per liter of test chamber volume. The approximate total sample surface area shall be reported.
- NOTE: In some cases (e.g., inks and other very thin film) it may not be possible to attain the required weight of 5.0 ± 0.25 grams per liter of test chamber volume. In these cases, the maximum practical quantity of sample less than 5.0 ± 0.25 grams per liter of test chamber volume shall be tested.
- (2) Materials which are essentially two dimensional and are not applied to a substrate (e.g., fabrics, photographic film and similar materials) shall be cut to convenient test dimensions. Heat shrinkable tubing shall be shrunk to simulate actual use configuration. A sufficient quantity of sample shall be cut so as to provide a sample weight of 5.0 ± 0.25 grams per liter of test chamber volume.
- (3) Materials which are essentially three dimensional (e.g., foams, insulation padding, potting and molding compounds, cast or formed objects, thick plastics, liquids, etc.) shall be tested as closely as possible to the use configuration and cut to provide a sample weight of 5.0 ± 0.25 grams per liter of test chamber volume. Liquids shall be placed in suitable nonreactive dishes.

- c. Specialized Items. It must be recognized that some materials may not meet the above requirements and must be specially handled. This will most often occur with nonhomogeneous materials. These

materials will be tested in the manner designated by the Test Engineer in charge. The manner of testing and sample preparation shall be fully reported. The desirable ratio of test material weight to test chamber volume is 5 ± 0.25 grams per liter.

8. TEST PROCEDURE

- a. Place a clean, weighed specimen prepared per subparagraph 7 in the test chamber.
- b. Connect the chamber to the vacuum and pressurization system shown in Figure 4-6. Evacuate the chamber to 0.2 ± 0.05 psia and backfill with the test atmosphere to 2.0 ± 0.05 psia. Reevacuate to 0.2 ± 0.05 psia and backfill with test atmosphere to a pressure such that the chamber will be at test pressure when the test atmosphere is at test temperature. The test atmosphere composition may be obtained by partial pressure addition of oxygen and nitrogen during the loading step or by use of a premixed test gas.
- c. Heat the chamber to test temperature $\pm 3^{\circ}\text{C}$ for a period of 72 ± 1 hour.
- d. Connect the chamber to the analytical system and measure and record the chamber pressure.

NOTE: The pressure gage or transducer may be an integral part of the chamber or it may be integral with the analytical system. The gage or transducer shall be accurate to ± 0.1 psia.

- e. Sample and analyze the offgassed products in the chamber at room temperature. The quantitative analysis shall be initiated within 72 ± 1 hour; conditioning period. Any non-compliance to the time or temperature shall be reported with the test data.
- f. The identity and quantity of each analyzable offgassed product, excluding water vapor and carbon dioxide, shall be recorded on the reporting format.

NOTE: Some offgassed components may be present at levels too minute for identification. These shall be reported as "unidentified component" and the quantities expressed in micrograms per gram of sample.

- g. All charts, equipment calibration information and test data will be retained in the event that further identification or evaluation is necessary.

9. REPORTING

Test data shall be reported in accordance with instructions contained in paragraph 208 on a form similar to Figure 4-8 and will include the identity of organic and inorganic offgassed products and their quantities in micrograms/gram from the material. Water and carbon dioxide shall

not be reported. All pertinent test conditions shall be reported. Data to be reported must be verified by an authorized center quality assurance office.

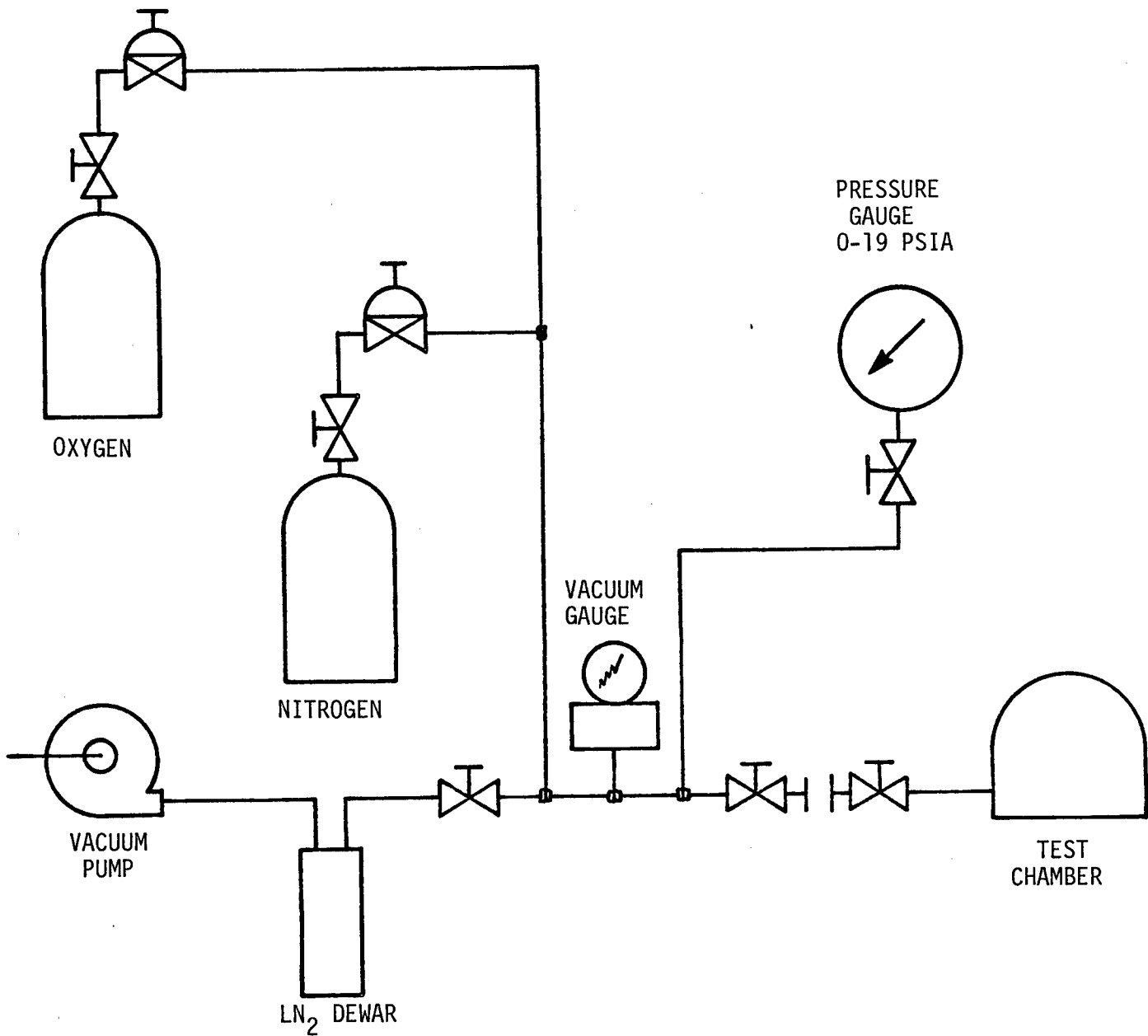

FIGURE 4-7 SCHEMATIC OF CHAMBER VACUUM & PRESSURIZATION EQUIPMENT

OFFGASSED PRODUCTS TEST FORM

TEST AGENCY WSTF DATE 6-6-79

TEST NUMBER 79-11705

TEST CONDUCTOR(S) Jack Stradling

QUALITY ASSURANCE _____

SAFETY _____

MANUFACTURER'S MATERIAL NOMENCLATURE Epoxy Enamel Paint #66208

MANUFACTURER'S LOT NUMBER _____

MANUFACTURER Sears, Roebuck & Co.

MATERIAL CHEMICAL NOMENCLATURE _____

SAMPLE NUMBER _____

SAMPLE WEIGHT 20.2786 gm.

SAMPLE SIZE (INCLUDING THICKNESS) 6" x 12"

TEST CHAMBER FREE VOLUME 4 liters

TEST CHAMBER TEMPERATURE 120°F

TEST CHAMBER PRESSURE 12.0 psia

TEST CHAMBER ATMOSPHERE 74.1% N₂/25.9% O₂

OFFGASSED PRODUCTS:

<u>IDENTITY</u>	<u>QUANTITY (MICROGRAMS PER GRAM OF SAMPLE)</u>
<u>CO</u>	<u>30</u>
<u>C5 Aldehyde</u>	<u>3</u>
<u>C6 Aldehyde</u>	<u>3</u>
<u>Styrene</u>	<u>42</u>
<u>Aliphatic hydrocarbons</u>	<u>10</u>

FIGURE 4-8

408 TEST 8 - FLAMMABILITY TEST FOR MATERIALS IN VENTED CONTAINERS

1. PURPOSE

- a. This test describes the method for determining the ability of a closed (unsealed) container to withstand the effects of a fire internal or external to the containers. This test is applicable to containers with either internal ignition sources or external ignition sources.
- b. Potentially hazardous materials, or instruments containing such materials, that are removed from the container for a period longer than established between the center program offices and Flight Crew Operations (normally not to exceed 2 hours per 8 hour period) must meet the requirements for Group I materials.

2. CRITERIA FOR ACCEPTABILITY

In the event of an internal fire, the container:

- a. Shall not rupture or permit the escape of flames, burning debris or the scattering of flaming contents outside the container.
- b. Shall not permit flames or burning materials to be emitted through vents.
- c. Shall not emit gases and heat to the extent that a rise in pressure (measured in the test chamber when related to a corresponding rise in the module or vehicle) might be sufficient to cause rupture of the walls of the habitable areas of the spacecraft.

3. TEST CONDITIONS - PRESSURES AND ATMOSPHERES

The test shall be performed on materials configured in a container in the same manner as the flight item. The most hazardous ("worst case") configuration of materials shall be determined and used in the test. The test pressure and gas mixture conditions shall be designated by the center program office. These conditions shall represent the most hazardous atmosphere anticipated in the spacecraft.

4. TEST EQUIPMENT

- a. Test Chamber. The test chamber shall be the same or similar to that described in paragraph 401-4a.
- b. Thermal Characteristics Indicators: Temperature Monitoring. Thermocouple readings may be monitored by multiple point recorders or any equally accurate method. The desired accuracy is $\pm 10^{\circ}\text{F}$. The thermocouples may be placed inside the container spaced one inch apart along and in contact with the conductor selected for overloading. Where the external igniter is used, the thermocouples shall be placed on and around the material selected for ignition in accordance with the test engineer's direction. Additional thermocouples shall be placed approximately at the center of the top, bottom, and four

sides of the interior. Thermocouples shall be placed on the exterior of the container against the top, bottom, and four sides, approximately in the middle of each panel.

- c. Pressure Gage. A pressure gage capable of measuring operating pressures with an accuracy of ± 0.2 psia, or a pressure transducer and recorder with comparable capability, shall be used to monitor test chamber pressure.
- d. Motion or still pictures of the test are required.

5. IGNITION SOURCE

- a. Internal Ignition. Ignition of the materials in the container with electrical wiring shall be accomplished by using a power supply that is capable of providing a large current through one wire of the conductor bundle so a high temperature will be achieved quickly. The power source must be capable of supplying a current for that gage wire being tested. Refer to Test 4, paragraph 404-4.b, for the initial test current for wire gage number 28 through 12. Materials in a nonelectrical container shall be treated as described in subparagraph b.
- b. External Ignition. Ignition of materials in a container without an internal ignition source shall be accomplished in the following manner. A Cleanweld B igniter or equivalent which is representative of the highest possible temperature source shall be placed outside the container at a point closest to the most combustible material in the test configuration. Sufficient energy shall be supplied to ignite the igniter. The igniter shall be left in contact with the container until the igniter burns out. The contractor shall furnish analyses to support the selection of ignition sources other than Cleanweld B igniters.

NOTE: In the event that the worst service condition specified above cannot be determined, the igniter shall be appropriately placed inside the container to serve as the ignition source.

6. SAMPLE PREPARATION

- a. The container shall be the same size, geometry, and material as the flight container.
- b. The equipment to be tested shall be the same as the flight equipment, with regard to nonmetallics. Electronic parts and similar expensive metallic or ceramic entities may be simulated.
- c. The equipment shall be packaged and positioned in the container in the same manner as in the flight article. Thermocouples shall be exited through bushings or any adequately sealable means.

7. PRETEST PROCEDURE

- a. Verify that all test equipment is in current calibration.
- b. Verify that the container is the required item.
- c. Verify proper attachment of thermocouples in the designated area.
- d. Verify proper packaging and positioning of the materials and equipment.
- e. Verify the gas certification.
- f. Position the container in the chamber.
- g. Verify the placing of the ignition wire in the designated spot in the container or that the conductor to be overloaded is hooked up to the proper, high current power supply.
- h. Observe that the ignition wire, thermocouples and other instrument leads are hooked up to the pertinent outlets.

8. TEST PROCEDURE

Testing of the containers shall be accomplished in accordance with the following basic procedures for containers which will be exposed to atmospheres at pressure other than 14.7 psia. Materials applied in an atmosphere at 14.7 psia may be tested in the chamber but the leak check steps (a and b) below can be omitted. These containers may also be tested in a hood but precautions must be taken to baffle the test area from drafts. The applicable steps of the procedure shall then be followed.

- a. The chamber shall be evacuated to a minimum of 0.2 psia.
- b. Isolate the chamber and monitor the pressure for 2 minutes to check for leaks. A pressure rise of more than 0.2 psia during that time indicates a leak that must be rectified before going to the next step.
- c. Pressurize the chamber to test pressure with the test atmosphere using techniques that assure oxygen concentration within 0.5% of the specified value.
- d. After the chamber has stabilized at the proper pressure, permit the container to equilibrate for at least 3 minutes.
- e. Start all applicable instruments.
- f. For containers with an internal ignition source such as an electrical conductor, current shall be applied to the conductor at the amperage shown for that size conductor in the table paragraph 404-4.b. If positive indication of ignition (e.g., flame) is not observed, the current shall be increased in 5 ampere steps at 1 minute intervals

until the wire fails, the power supply limit is reached, or positive indication of ignition is observed.

- g. For containers requiring external ignition, apply current to the igniter until ignition occurs or will not occur.
- h. Observe all phenomena occurring in and around the container.

NOTE: The test shall be terminated if the container ruptures or if obviously excessive quantities of fire and smoke are emitted from the vents.

- i. Record any pressure rise and the final pressure in the chamber.
- j. Remove the container from the test chamber and examine it and its contents and record all observations.

9. REPORTING

Test data shall be reported in accordance with instructions contained in paragraph 208 on a form similar to Figure 2-1. The following special test data and information shall be reported.

- a. Identification by generic name of all the materials tested in the container.
- b. Vendor and vendor designation for the materials.
- c. Construction and source of container.
- d. Presence or absence of flame or ignition failure.
- e. Color of flame.
- f. Evolution of smoke from the vents.
- g. Evolution of flame from the vents.
- h. Length of time flame persisted from the container.
- i. Length of time smoke evolved.
- j. Rate of test article temperature rise and final test article temperature. The rate of test chamber pressure rise and final test chamber pressure shall also be reported.
- k. Condition of container after the test.
- l. Condition of contents of the container after the test.
- m. Test pressure.
- n. Test atmosphere.

409 TEST 9 - ELECTRICAL OVERLOAD TEST FOR SEALED CONTAINERS

1. PURPOSE

This procedure describes the method for testing materials packaged in sealed containers and the ability of the container to withstand, without rupturing, the effects of a fire initiated within the container as a result of an electrical overload. For containers with no internal electrical energy sources, the ignition system described in paragraph 408-5b shall be used.

2. CRITERIA FOR ACCEPTABILITY

The sealed container shall not rupture or emit flame, burning particles, smoke or gas as a result of the test.

3. TEST CONDITIONS - PRESSURES AND ATMOSPHERES

The test conditions shall be the same as those described in paragraph 408-3.

4. TEST EQUIPMENT

- a. Test Chamber. The test chamber shall be the same or similar to that described in paragraph 401-4a.
- b. Thermal Characteristics Indicators. The temperature monitoring shall be the same as described in paragraph 408-4b.
- c. Motion picture camera(s) shall film the phenomena in case the container distorts or ruptures.

5. IGNITION SOURCE

The ignition of the materials shall be accomplished in the same manner as described in paragraph 407-5.

6. SAMPLE PREPARATION

The samples preparation shall be the same as that described in paragraph 408-6.

7. PRETEST PROCEDURES

The pretest procedure shall be the same as described in paragraph 408-7.

8. TEST PROCEDURE

The test procedure shall be the same as that in paragraph 408-8 except that the "Note" under paragraph 408-8h shall be changed to read, "The test shall be terminated if the container ruptures."

9. REPORTING

Test data shall be reported in accordance with instructions contained in paragraph 208 on a form similar to Figure 2-1. The following special test data and information shall be reported:

- a. Identification by generic and trade names of all the materials contained in the tested container.
- b. Construction, configuration, and source of the container.
- c. Presence or absence of ignition or fusion of the conductor.
- d. Temperature changes inside the container and those measured on the outer walls of the container.
- e. Phenomena associated with rupture of container, if rupture occurred:
 - (1) Presence or absence of flame and smoke.
 - (2) Extent of scatter of burning or smoking materials.
 - (3) Part of container where rupture occurred.
 - (4) Pressure rise in chamber.
 - (5) Presence of gases and method of detection.
- f. Condition of container after the test
- g. Condition of the contents after the test.
- h. Test pressure.
- i. Test atmosphere.

410 TEST 10 - SIMULATED CREW BAY, PANEL OR MAJOR ASSEMBLY FLAMMABILITY TEST

1. PURPOSE

This procedure describes the method for determining the combustion characteristics, particularly the propagation rate, of a number of different sizes and areas of nonmetallic materials of similar or different types. These include an entire crew module or a functional assembly, subsystem, or system in the spacecraft. (Each item usually requires a specifically developed procedure. Guidelines for establishing the parameters of the test follow.) The purpose of flammability tests on assemblies is to determine the behavior of the crew module or assembly under the particular test conditions which shall be representative of the most hazardous situation to which they will be exposed.

2. CRITERIA FOR ACCEPTABILITY

The results of the test should demonstrate that there can be no propagation of the fire to adjacent equipment by radiation, conduction, or mass transfer. There shall be no sputter, drip, or release of hot or burning particles.

3. TEST CONDITIONS

- a. Pressure and Atmosphere. The test shall be conducted at the most hazardous pressure and gas mixture conditions designated for the materials applications.
- b. Test Parameters
 - (1) Configuration and materials of the test assembly will be a duplicate (or very high fidelity reproduction) of the flight article.
 - (2) Test assembly (combustion element) will be oriented in the chamber as it will be in the operational spacecraft at launch.
 - (3) The test chamber volume for assemblies will be sufficient to provide for complete combustion and to assure that O₂ starvation cannot occur per the fire hazard analysis, and to accommodate the largest assembly to be tested with adequate space around the assembly to allow observation of the extent of projection of burning pieces due to sputtering and expansion of gases internal to the burning mass.
 - (4) For assemblies containing substitute materials or new designs, the test configuration need not be operational unless economically feasible. The materials shall be configured as in the flight article. Expensive components may be simulated, but the basic material, geometry, and simulated mass of the components must be the same as in the flight assembly.
 - (5) All thermal interfaces will be simulated.

- (a) Cold plates.
 - (b) Structure.
 - (c) Convection due to the cabin fan.
 - (d) Cabin radiation characteristics.
- c. Instrumentation. Instrumentation requirements for each test assembly will be determined on an individual basis as part of overall combustion hazard analysis.
- (1) Temperature Measurement. Temperatures will be continuously recorded during test.
 - (a) Temperature measuring and recording equipment will have response times equal to or greater than the rate of change of temperature at the location being measured as predicted by thermal calculations.
 - (b) Locations of temperature measurement devices will depend on the configuration of the assembly being tested. These should provide a temperature profile of the assembly and location of ignition sites.
 - (c) Measure chamber gas temperature.
 - (d) Measure chamber wall temperature.
 - (2) Pressure Measurement. Continuously measure and record the chamber gas pressure.
 - (3) Determine quantity and composition of combustion gas generated. Use gas chromatography, mass spectrometry, and other applicable methods as outlined in Test 7, paragraph 407-5d.

4. IGNITION SOURCE

In general, two modes of ignition must be considered.

- a. Ignition from an internal source; i.e., wire overload or short circuit.
- b. Ignition from an external source; i.e., flame or fire propagated from another nearby burning entity. The standard igniter described in paragraph 408-5 should be used as an external ignition source.

5. PRETEST PROCEDURE

- a. Define or select the test assembly. This should be a portion of the spacecraft which is a meaningful and convenient package for fire hazard testing and analysis. The portion selected shall be that definable area vulnerable to a potential fire.

- b. Perform a fire hazard analysis on the test assembly.
 - (1) Material inventory.
 - (2) Configuration analysis.
 - (3) Thermal analysis.
- c. Design the flammability test to obtain the required information. The experimental design will be based on the fire hazard analysis.

6. PRETEST PROCEDURES

The pretest procedures will describe, step-by-step, the preparation of the chamber and the assembly and configuration of the materials within the vehicle or assembly. Ignition locations and test termination criteria shall be established. The pretest documents shall be prepared by the contractor and submitted to the testing agency and the center program office for concurrence before the test is run.

7. TEST PROCEDURE

- a. Ignition. The ignition source shall be that detailed in Test 8 paragraph 408-5. Ignition will be accomplished at appropriate sites (determined by combustion hazard analysis) and will simulate the following fire conditions:
 - (1) Momentary heat source produced by any suitable method other than the burning igniter.
 - (2) Ignition source with continuous heat input (internal).
 - (3) External heat input. A rationale justifying selection of ignition points will accompany each test report.
- b. Post Test Inspection. The following test data will be obtained before and after the test:
 - (1) Color still photographs.
 - (2) Visual inspection.
 - (3) Motion pictures as required.

8. REPORTING

Test data shall be reported in accordance with instructions contained in paragraph 208 on a form similar to Figure 2-1. The following special test data and information shall be reported:

- a. Identification by generic name of all materials.
- b. Vendor and vendor designation for the materials.

- c. Weight and surface area for the nonmetallic materials.
- d. Combustion characteristics (burning rate, sparks, dripping, flame color and size, etc.).
- e. Initial point of ignition.
- f. Flame propagation paths.
- g. Heat transport paths.
- h. Total heat generated.
- i. Quantity and composition of combustion product gases.
- j. Evaluation of the effects of the fire on the performance of the assembly according to spacecraft hazard categories.
- k. Test chamber size.
- l. Rise in test chamber pressure and temperature during the test.
- m. Test pressure.
- n. Test atmosphere.

411 TEST 11 - DELETED AND COMBINED WITH TEST 10

412 TEST 12 - TOTAL SPACECRAFT CABIN OFFGASSING TEST

1. PURPOSE

The purpose of this test is to identify and measure the quantities of contaminant gases offgassed into the crew cabin areas prior to a space mission. The results of this test will be used to assess the toxicological safety of the spacecraft for manned flight.

2. CRITERIA FOR ACCEPTABILITY

The results of this test along with other sources of trace contaminants and other available data shall be evaluated against the performance of the Spacecraft ECLSS by the responsible NASA engineering office and the data provided to the responsible NASA medical office for analysis and approval. The safety of the spacecraft atmosphere shall be established with respect to the measured contaminants. A report confirming the spacecraft atmosphere shall be forwarded to the cognizant center program office by the approving medical office.

3. TEST CONDITIONS

- a. A test period shall be established for a given spacecraft based upon the designated space mission duration and the limits of detection for the analytical instrumentation used to analyze gaseous samples obtained during the test. Samples shall be taken of the spacecraft cabin atmosphere in sets of three gas cylinders. Cylinder volume shall be at least 500 ml each. The cylinders shall be filled with samples to at least 100 psia.
- b. Sample sets shall be obtained at intervals sufficient to establish a plot of the offgassing trend. This will depend upon the overall length of the test.
- c. The spacecraft hatch shall be closed. This is to prevent any exchange of cabin atmosphere with the outside air.
- d. All possible flight hardware shall be onboard the spacecraft at the time of the test. All flight hardware not available must be subjected to Test 16.
- e. All possible heat producing equipment shall be turned on and at operating temperature prior to the initiation of the test.
- f. The environmental control life support system (ECLSS) shall be operated if requested by the responsible NASA engineering office. If operation is requested, the time for start-up and total operating time for the ECLSS will be established by the NASA engineering office.
- g. The spacecraft may or may not be manned for the test.

4. PRE-TEST PROCEDURES

- a. All sampling equipment shall be cleaned and tested to assure that no interference will result from wall effects (i.e., contamination) for acceptability for trace gas analyses.
- b. All gas sampling cylinders shall be tested for leaks. (Leak rate shall be no greater than 1×10^{-8} Torr-liters/sec.)
- c. The gas sampling pump shall be capable of producing pressures of at least 120 psia.

5. TEST PROCEDURES

- a. The sampling pump shall be located outside the spacecraft. A gas sampling line shall extend from the pump either to a spacecraft penetration or through a special provision in a temporary door. The sampling line shall extend into the crew cabin area.
- b. Samples shall be taken at predesignated times.

6. POST-TEST REQUIREMENT

Gas sampling cylinders shall be returned to the appropriate laboratory for analyses. The analytical data shall be reported to the responsible NASA medical office within 3 days after the test.

7. REPORTING

- a. The tests shall be directed by the cognizant test engineer or appointed alternate. Approval of the test and verification of data transcribed to the data sheets shall be indicated at the end of the test procedure by the responsible test engineer's signature.
- b. The removal capability of the spacecraft environmental control and life support system will be evaluated using the trace contaminant generation data provided by the test as well as other sources (such as crew) which will be present for the assigned mission to establish projected contaminant levels for the mission. These levels will be evaluated against the criteria of Appendix D.

413 TEST 13 - AMBIENT LIQUID OXYGEN AND PRESSURIZED LIQUID AND GASEOUS OXYGEN MECHANICAL IMPACT TEST

i. PURPOSE

- a. The purpose of this test is to determine the impact sensitivity of materials exposed to liquid or gaseous oxygen (LOX or GOX).
- b. The test is applicable to materials selected for use in both ambient and high pressure LOX or GOX systems.

The test methods are separated as follows:

- (1) Ambient LOX Mechanical Impact. (Part 1)
- (2) Pressurized LOX or GOX Mechanical Impact. (Part 2)

2. CRITERIA FOR ACCEPTABILITY FOR AMBIENT LOX AND PRESSURIZED AND LOX AND GOX MECHANICAL IMPACT TEST.

- a. To meet the requirements for acceptability, the material shall show no reaction when being subjected to 20 successive impact tests at 10 kg-m (72 ft. lbs.) using the equipment described in paragraph 3. More than one reaction in 20 impacts rejects the material. If there is only one reaction in the 20 impacts, the material shall be subjected to 40 additional impacts and if there is no further reaction, the material shall be placed in the acceptable category. During any of the tests, the material shall show none of the following reactions:

- (1) Audible explosion.
- (2) Flash (electronically or visually detected).

- (3) Evidence of burning (obvious charring).
- (4) Major discoloration (due to ignition only rather than other phenomena).

NOTE: A burnt odor alone is not considered sufficient proof that a reaction has occurred. If a reaction occurs (including those during rebound of plummet) it shall be reported as evidence of sensitivity. Inclusion of rebounds applies to ambient LOX mechanical impact tests only.

- b. All Type D materials that fail subparagraph a criteria and remain a candidate for use must be subjected to LOX or GOX mechanical impact energy threshold determinations in the thickness of actual use. (See paragraph 413-3q on page 4-71.)
- c. The material to be tested must be traceable back to the actual manufacturer and to a specific batch and/or lot number.
- d. A final report containing the complete evaluation and analysis of the test results and data and the recommendations of the NASA medical office shall be submitted to the appropriate center program office.

3. PART 1 - AMBIENT LOX MECHANICAL IMPACT SCREENING TEST

a. Sample Preparation

(1) Sampling

- (a) Sufficient material shall be available to permit preparation and testing of 140 separate 11/16-inch diameter disc samples. Sheet materials up to 1/4 inch in thickness shall be tested as 11/16-inch diameter discs in the thickness intended for actual use. Materials normally used in thicknesses greater than 1/4 inch shall be sized and tested as 11/16-inch diameter discs of the thickness 0.060 ± 0.005 inch. Failure of samples to meet requirements of this specification shall be cause for rejection of the material. Greases, fluids, and other materials, whose thicknesses are dictated by conditions of use, shall be tested as 0.050 ± 0.005 inch layers in test cups. Materials not readily available in sheet form shall be tested in the available configuration.
- (b) Stainless steel inserts shall be used as a false bottom in the aluminum specimen cups when testing all materials with the exception of greases, oils, liquids, dye penetrants, coatings, and solders. The latter materials shall be tested as specified in other sections of this specification.

NOTE: Specimens shall be free of ragged edges, fins, or other irregularities.

- (2) O-rings. Each size from each batch of O-rings and/or O-ring materials shall be sampled and tested as follows unless it can be demonstrated that test results on different sizes and batches are comparable when tested as specified in subparagraph o.
 - (a) Extruded O-rings. 140 Sample discs 11/16 inch diameter by thickness of O-rings shall be cut from a strip after the chopping operation. The discs shall be similarly processed and deflashed with the same equipment used for the O-rings. The discs shall be cleaned as specified for the material and its use and tested after precooling as specified in subparagraph i.
 - (b) Molded O-rings. 140 Sample discs 11/16 inch diameter by the thickness of the O-rings, and which have been similarly processed and deflashed, shall be furnished.
 - (c) O-rings from standard stock or where above procedures are impractical. O-rings 1/2 inch outside diameter or less shall be sampled and tested as a complete o-ring. O-rings larger than 1/2 inch outside diameter shall be tested as one segment (approximately 3/4 inch long) on a stainless steel insert. The samples shall be cleaned and precooled as specified in Appendix C and subparagraph i, respectively. If a sample is not impacted during testing, it shall be placed in a new cup with a stainless steel insert and precooled prior to re-testing. As an alternative, sufficient samples may be prepared to account for the normal impact misses.

b. Test Equipment

- (1) ABMA Impact Tester (see Figure 4-9). The impact tester shall have a rugged structural frame with three vertical guides capable of maintaining accurate vertical alignment under repeated shock conditions, a mechanism for dropping a plummet which weighs 20 ± 0.05 pounds through a distance of 43.3 ± 0.2 inches (this will transmit to the test sample an approximate impact energy of 72 foot-pounds), a striker pin (see Figure 4-9) 1/2 inch in diameter and 2 inches long, and test cup (see Figure 4-11) approximately 7/8 inch inside diameter by approximately 7/8 inch inside depth made of 1/16 inch thick aluminum alloy. The initial alignment and subsequent operation of the impact tester shall be such that the plummet falls uniformly under essentially friction-free conditions. This shall be verified by suitable means on each drop to assure that $\pm 3\%$ of the theoretical drop time is attained. Measurement shall be made as close to the striker pin as possible.

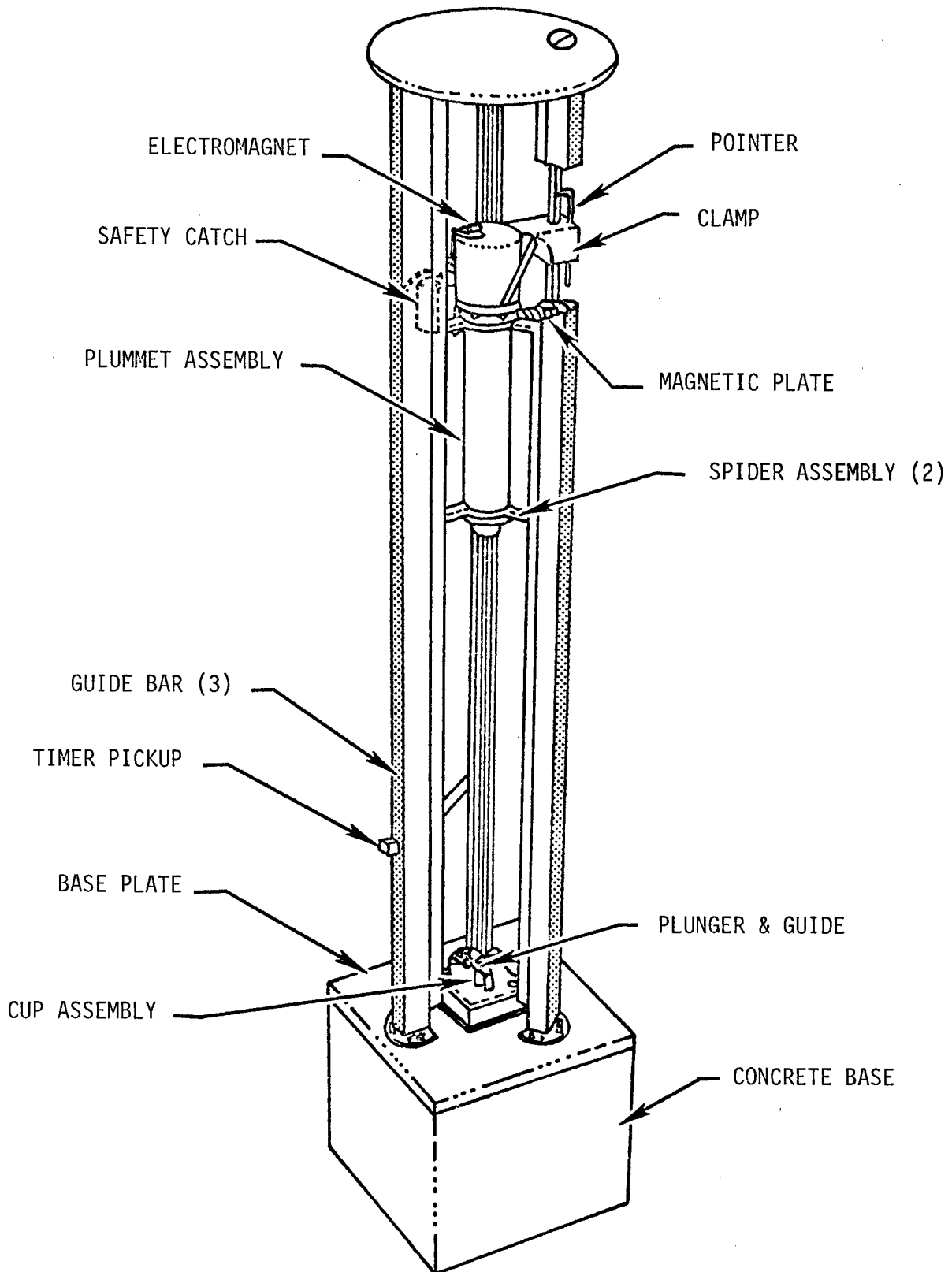

FIGURE 4-9 ABMA IMPACT TESTER
MSFC DRAWING NO. A-E-0 (SHEET NO. 1)

PRINT INDEX FOR IMPACT TESTER

A-E-0	ASSEMBLY, ABMA IMPACT TESTER
A-A-1	FOUNDATION COVER
A-C-2	BASE PLATE
A-C-3	STRUT ASSEMBLY
A-C-4	CLAMPBAR ASSEMBLY
A-B-5	BAR-PLUMMET GUIDE
A-B-6	PLATE-TOP
B-D-1	ANVIL REGION ASSEMBLY
B-C-2	PRE-COOLING MOAT
B-A-3	ALIGNING PIN
B-A-4	STRIKER-PIN GUIDE
B-A-5	STRIKER-PIN GUIDE
B-A-6	GUIDE STRIKER PIN
B-A-7	STRIKER PIN
C-D-1	PLUMMET-ASSEMBLY
C-C-2	PLUMMET
C-B-3	NOSE-PLUMMET
C-C-4	SPIDER-PLUMMET
C-A-5	NUT-PLUMMET
C-B-6	TOP PLATE PLUMMET-ASSEMBLY
C-A-7	SPIDER SCREW
D-D-1	ELECTROMAGNET HOUSING ASSEMBLY
D-C-2	SHEET 1 OF 3 - WELDMENT ASSEMBLY
	SHEET 2 OF 3 - CLAMP
	SHEET 3 OF 3 - ELECTROMAGNETIC HOUSING
D-B-3	BRACKET-ELECTROMAGNET
D-B-4	SCREW-HAND
D-C-5	ELECTROMAGNET HOUSING
D-B-6	ELECTROMAGNET ASSEMBLY
D-B-7	CORE-ELECTROMAGNET
D-B-8	INSULATOR CORE-ELECTROMAGNET
D-B-9	START PLATE
D-A-10	POINTER
E-D-1	FREEZING BOX
E-B-2	SPECIMEN CUP HOLDER
E-A-3	SPECIMEN CUP
E-A-4	SPECIMEN PLATE
E-A-5	SPECIMEN CUP
E-A-6	TEFLON SLEEVE
F-C-1	ANVIL REGION ASSEMBLY
F-C-2	ANVIL PLATE
F-B-3	SHEET 1 OF 2 - HOLDER - TWO PIECE SPECIMEN CUP
	SHEET 2 OF 2 - HOLDER - SPECIMEN CUP

Figure 4-9 ABMA IMPACT TESTER

PRINT INDEX FOR IMPACT TESTER

F-A-4 SLEEVE-HOLD DOWN SPECIMEN CUP HOLDER
F-A-5 ALIGNING PIN
F-A-7 TOE-HOLD DOWN SPECIMEN CUP HOLDER

Print Index for ABMA Impact Tester MSFC
Drawing No. A-E-0 (Sheet No. 2)

Figure 4-9 ABMA IMPACT TESTER

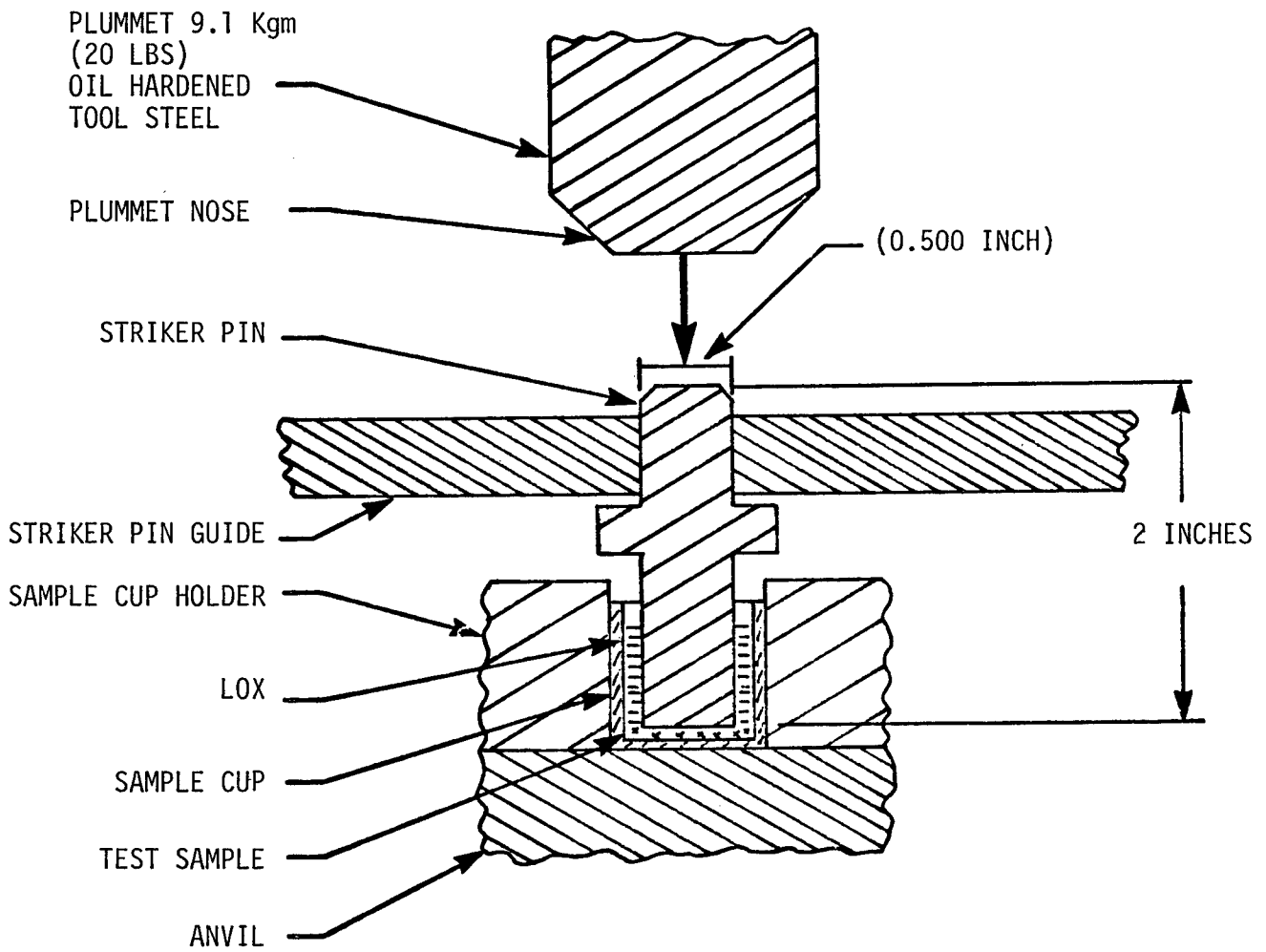
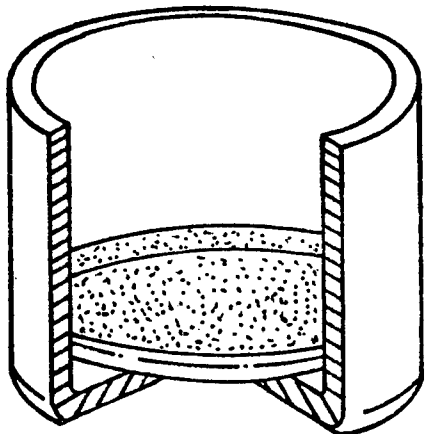
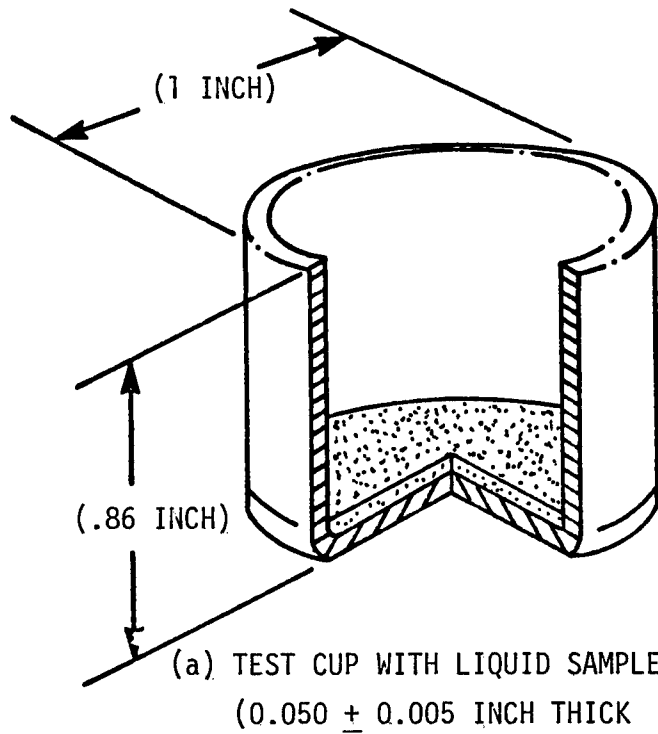

FIGURE 4-10 DETAILS OF STRIKER, SAMPLE CUP, AND SAMPLE
(IMPACT SENSITIVITY SYSTEM)

NOTE: The weight times the drop-height specified is not duplicated for the purposes of this test by combinations other than 20 ± 0.05 pounds and 43.3 ± 0.2 inches. For example, doubling the weight and halving the drop height would not duplicate the specified requirement. Drop height shall be measured from the nose of the plummet to the top of the striker pin with the cup and stainless steel disc in position.

c. Drop Tester Components

- (1) Electromagnet. The electromagnet (if used) shall be designed with a sufficient safety factor to hold over 20 pounds of weight with a minimum energizing wattage. Mechanical suspension/release devices shall be designed with a sufficient safety factor to positively hold a 20 pound plummet.
- (2) Safety Catch. The solenoid-operated safety catch shall be designed to hold the plummet near the base of the magnet in the event of a power failure.
- (3) Base Plate. The base plate shall be constructed from 1-inch (minimum) thick stainless steel plate and shall rest solidly and level on a 2-foot cube (minimum) base of reinforced concrete. Four stainless steel foundation bolts shall be used to anchor the plate to the concrete.
- (4) Anvil Plate and Specimen Cup Holder. A stainless steel, type 440B heat treated anvil plate 5 by 5 by 2 inches thick, shall be bolted to the base plate in the center of the machine. This plate shall center the specimen cup holder and provide the base plate with protection from denting upon impact. A 5 by 5 inch stainless steel specimen cup holder, 1 inch thick, shall be bolted on top of the anvil plate. The specimen cup holder shall have a slightly tapered hold into which the test cup can be placed.
- (5) Specimen Cups (see Figure 4-10). One-piece specimen cups shall be made of any 3000 or 5000 series aluminum alloy. A special insert cup made of any 3000 or 5000 series aluminum alloy (see Figure 4-11) with an inside depth of 0.050 ± 0.005 inch shall also be used when testing semisolid materials. These special insert cups shall be placed inside the one-piece specimen cups.
- (6) Striker Pins. The striker pins shall be made from 17-4 PH stainless steel with hardness in accordance with the applicable detail drawings. A sufficient number of pins shall be provided for testing and discard.
- (7) Auxiliary Equipment. The auxiliary equipment shall consist of stainless steel forceps for handling the specimen cups and striker pins, stainless steel spatulas, and LOX Handling



(b) TEST CUP WITH GREASE SAMPLE SHOWING INSERT CUP

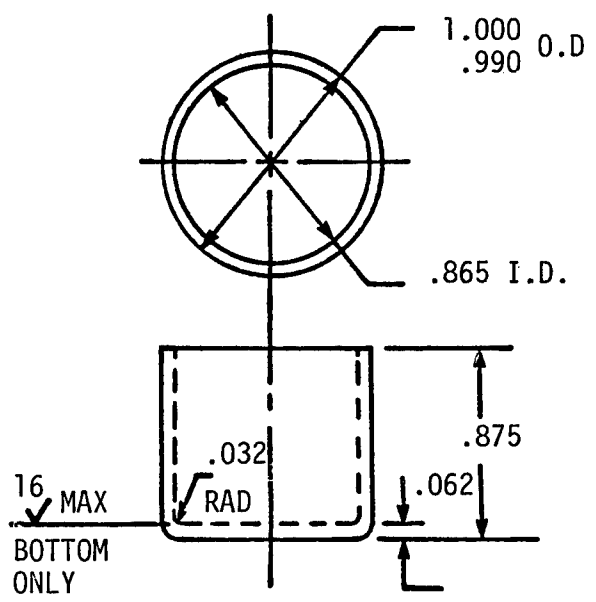

SPECIMEN CUP (32)
CUP IS FORMED BY DEEP DRAWING. THICKNESS AND PARALLELNESS OF CUP BOTTOM TO BE CONTROLLED TO .0610-.0630 BY COINING.
SCALE 2/1

FIGURE 4-11 SAMPLES IN TEST CUPS

equipment (e.g., stainless steel Dewar flasks, fireproof lintless laboratory coats, safety goggles, gloves, and LOX storage containers). Additional handling equipment shall include a grease insert cup holder (see Figure 4-12) sample freezing box (see Figure 4-13), striker pin baskets, specimen cup trays, microburettes, syringes, a test cell for the impact tester with a protective window for observation of test drops, a control panel for the operator to activate the safety catch and electromagnet, and timing instrumentation to measure the drop time of the plummet or its velocity just before impact.

- (8) Timer. A Berkely Universal counter and timer, Model 5500, or approved equal, shall be used to measure drop time. The overall drop time shall be measured and recorded for each test drop for any given height. The timer shall be calibrated periodically to ensure that the rated accuracy of the equipment is maintained. A typical timing circuit is shown on Figure 4-14.
- (9) Test Cell. The impact tester shall be housed in a test cell with a concrete floor. Walls shall be constructed of reinforced concrete or metal to provide protection from explosion or fire hazards. The cell shall contain a shatterproof-glass observation window. It shall be darkened sufficiently for observation of flashes. Continuous ventilation shall provide fresh air to the test cell. Construction of the test cell shall be directed at providing a facility that can be economically maintained at a high level of good housekeeping.

d. Materials

- (1) Liquid Oxygen. LOX used in the performance of this test shall conform to the requirements of Specification MIL-P-25508 or MIL-O-27210 Type II.
- (2) Liquid Nitrogen. Liquid nitrogen used in the performance of this test shall conform to the requirements of Specification BB-N-411 or MIL-P-27401.
- (3) Trichloroethylene. Trichloroethylene used in the performance of this test shall conform to the requirements of Specification MSFC-SPEC-217.
- (4) Alkaline Cleaner. A nonetch-type alkaline cleaner shall be used.
- (5) Trichlorotrifluoroethane (Freon TF). Freon TF used in the performance of the test shall conform to the requirements of Specification MIL-C-81302, Type II.

e. Preparation of Equipment for Testing

- (1) Impact Tester. The guide tracks, plummet, anvil plate, striker pin guide, sample cup holder, and base plate of the impact

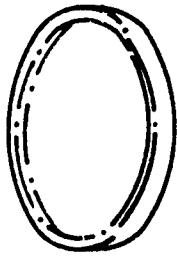

(a) GREASE INSERT CUP INSIDE DEPTH

$(0.050 \pm 0.005 \text{ INCH})$

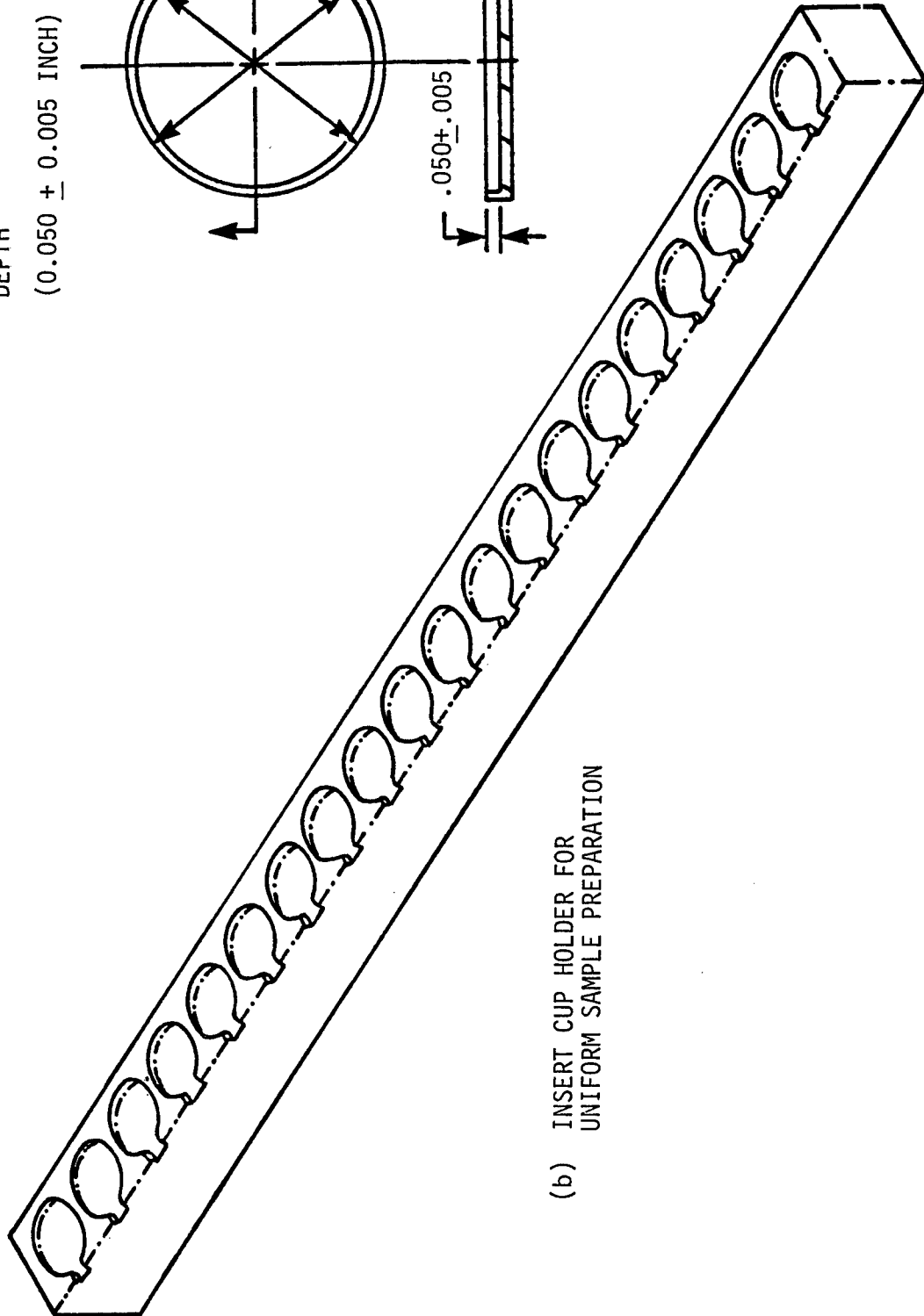
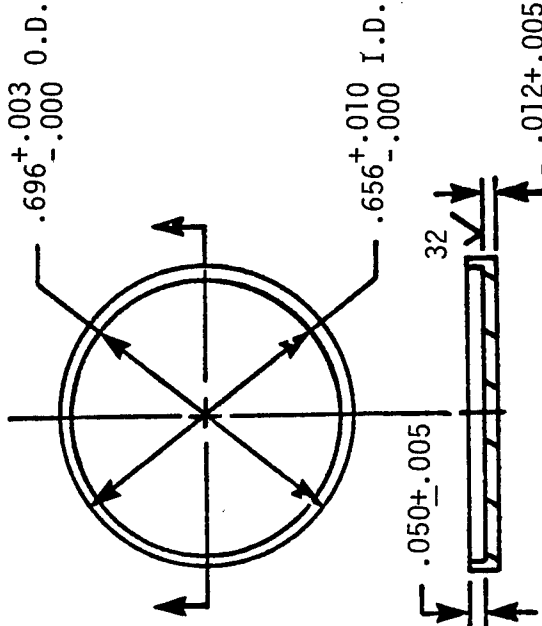

(b) INSERT CUP HOLDER FOR UNIFORM SAMPLE PREPARATION

FIGURE 4-12 GREASE INSERT CUP HOLDER

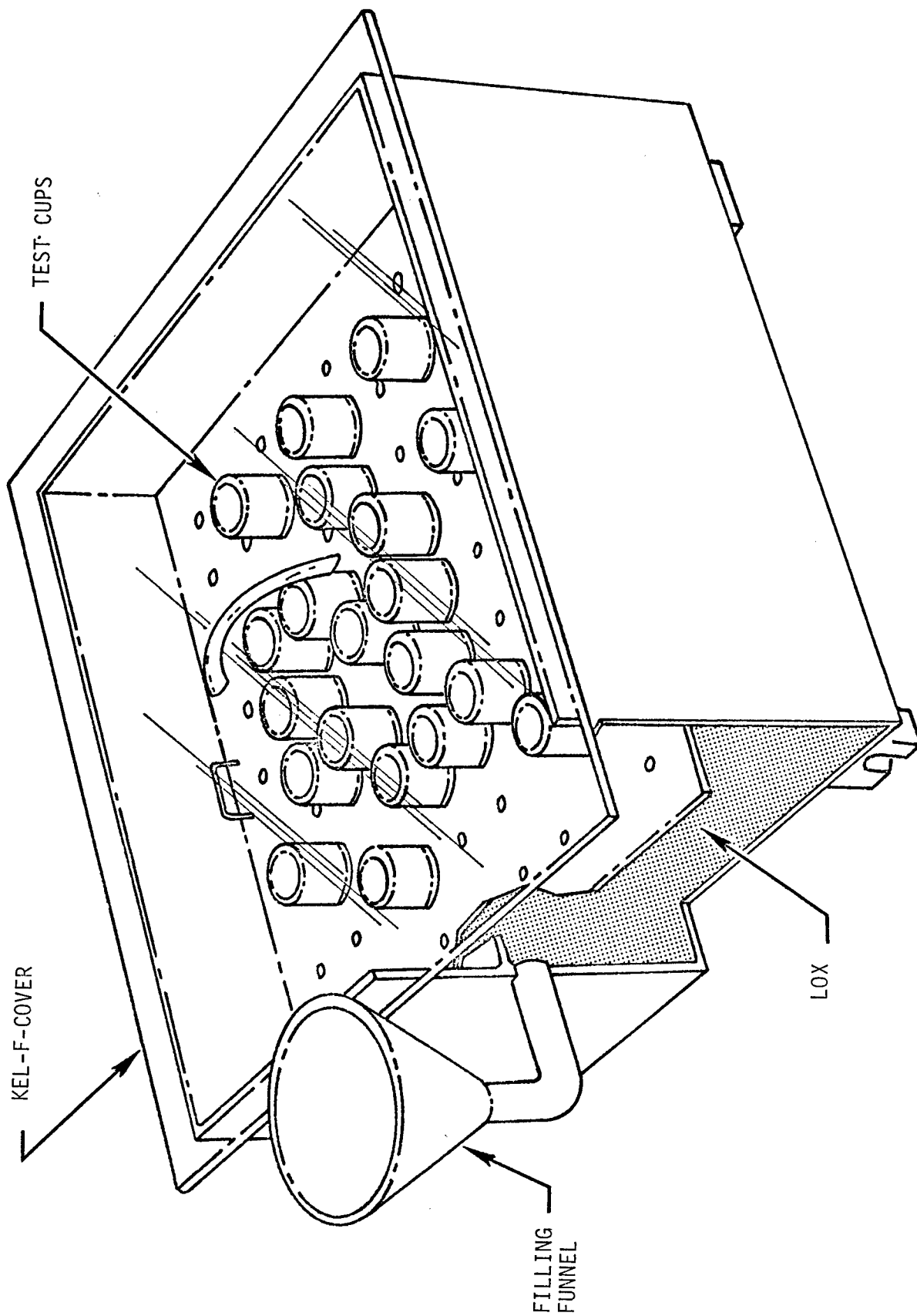

FIGURE 4-13 SAMPLE FREEZING BOX

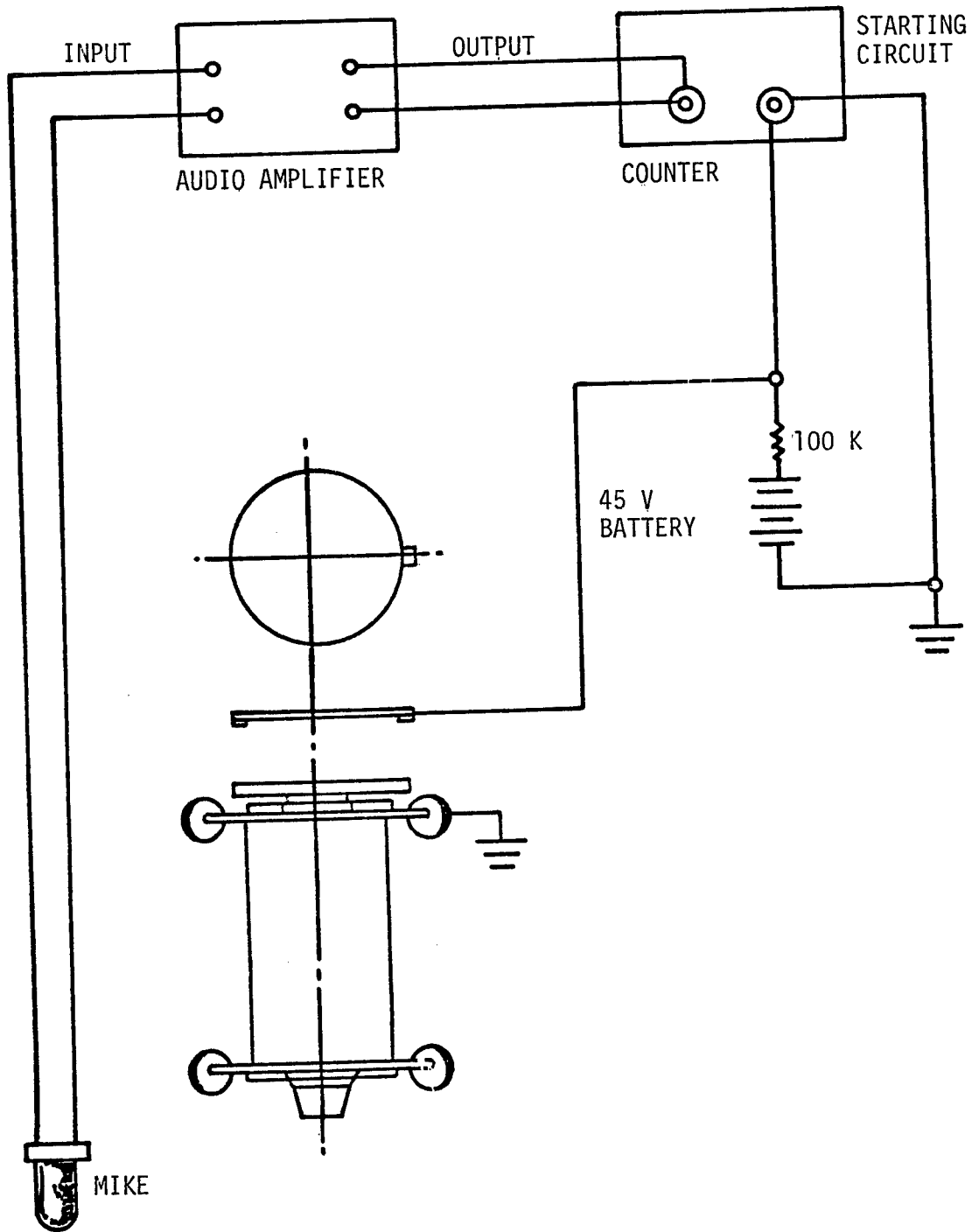

FIGURE 4-14 TYPICAL FREE-FALL TIMING CIRCUIT

tester shall be cleaned thoroughly at the start of each test and between tests of different materials, and shall be rinsed with clean trichlorotrifluoroethane or equivalent at least after impact test of every tenth sample. After completion of testing for the day, the impact tester shall be thoroughly cleaned. Cleanliness shall be maintained throughout any series of impact tests to minimize erroneous results.

- (2) **Striker Pins.** Striker pins shall be used only once and then cleaned. Before each test the striker pins shall be checked for dimensional conformance to the applicable drawing and then examined to ensure freedom from scratches, nicks, metallic slivers, and other imperfections. When required, the pins shall be remachined to ensure freedom from scratches and pits. All striker pins shall be cleaned, dried and stored in a suitable container to maintain cleanliness. Cleaning shall be done in accordance with Appendix C, paragraph 5.5.
 - (3) **Remachined Striker Pins.** The length of remachined striker pins shall be 2.000 (plus 0.010 or minus 0.100) inches. Striker pins shall be remachined if the striking area exhibits scratches or pits or both. It may be necessary to remachine pins that are bent or flattened during impact tests. Badly bent and remachined pins, in which the diameter near the striking area is greater than 0.505 inches or is less than 0.495 inch, shall be discarded.
 - (4) **Type 347 Stainless Steel Inserts.** Type 347 stainless steel inserts shall be cleaned in accordance with the method specified for striker pins. Inserts shall be used only once and then discarded.
 - (5) **Specimen Cups.** A test cup shall be used only once and discarded. Prior to use, specimen cups shall be cleaned, dried and stored in a suitable container. Cleaning shall be in accordance with Appendix C, paragraph 5.5
- f. **Blank Test.** The effectiveness of any cleaning procedure used to clean sample cups and striker pins shall be checked by testing at the 72 foot-pound level with a series of 20 blank cups (filled with LOX) and striker pins, cleaned per the enclosed procedure. In addition to these blank tests, four blank tests shall be made at random during any 8-hour period of testing. Additional blank tests may be made at the discretion of the operator. The striker pins and sample cups shall be handled by forceps or tongs and kept out of contact with the operator's hands or other sources of contamination.
- g. **Cleaning Procedure for Auxiliary Equipment**
- (1) **Test Cell.** The interior surfaces of the test cell shall be maintained in a sufficiently clean condition to preclude biasing of the test data which might occur due to introduction of local contamination onto the test materials or apparatus.

- (2) Stainless Steel Ware. Stainless steel ware, such as striker pin baskets, forceps, tongs, spatulas, and inserts, shall be cleaned in the same manner as the striker pins. Once integrated into the handling procedure, a thorough rinse of the stainless steel ware with clean trichlorotrifluoroethane or equivalent should be the only cleaning necessary.
- (3) Glassware Check. Any glassware, such as microburettes, beakers, and syringes, shall be cleaned, dried and stored in a suitable container to maintain cleanliness. Cleaning shall be in accordance with Appendix C, paragraph 5.1.

h. Preparation of Test Samples

- (1) Number of Samples. At least 20 samples shall be used for each series of test drops. It may be desirable to prepare more than 20 samples because of rejection due to samples floating or breaking up during precooling.
- (2) Liquid Samples. Liquid samples shall be applied to form a layer in the bottom of the specimen cups 0.050 ± 0.010 inch thick.
- (3) Greases and Semisolids. Grease samples shall be prepared as follows:
 - (a) Special specimen cups with inside depths of 0.050 ± 0.005 inch shall be provided (see Figure 4-12).
 - (b) The special specimen cups shall be cleaned as specified in subparagraph e.
 - (c) Place special cups into the cup holder (see Figure 4-12). Press sufficient sample material into the special cups with a clean, stainless steel spatula to form a sample that is free of air bubbles and void spots.
 - (d) Scrape off the excess sample with the spatula until a smooth surface, level with the edge of the cup, is achieved.
 - (e) Remove the special cup from the holder and place it inside the regular specimen cups.
- (4) Solid Samples. Solid samples shall be cleaned, rinsed, dried as specified below, and placed in the bottom of the specimen cups.
- (5) Metallic and Solvent-Resistant Samples. Metallic and solvent-resistant samples shall be cleaned as specified in Appendix C, paragraph 4.0. If received in a clean condition, they shall be tested in that condition.
- (6) Nonmetallic Samples. Nonmetallic samples shall be cleaned as specified in Appendix C, paragraph 4.0. If received in

a cleaned condition, they shall be tested in that condition.

(7) Coatings

- (a) Paints and Dry Film Lubricants. Coating samples, such as paints and dry film lubricants, shall be cured according to applicable instructions and prepared as follows:
- (i) Apply the coating to 11/16 inch diameter stainless steel inserts in the same manner and to the same thickness that is intended for hardware application.
 - (ii) After the samples have dried, place them in the regular specimen cups and test.
- (b) Elastomerics. Elastomeric coating samples shall be applied as a coating to 11/16 inch diameter stainless steel inserts, cured according to applicable instructions, and prepared as follows:
- (i) METHOD 1 (Single Dip Coat). Dip coat inserts to specified thickness and place on clean aluminum foil or on PTFE to air dry. The coated insets shall be removed from the foil and turned over after 30 minutes to allow both sides to dry. The specimens shall be cured as specified prior to testing. The coating thickness shall be checked on at least four samples and recorded.
 - (ii) METHOD 2 (Brush Coat). Apply material using a single brush stroke with a soft nonshedding brush. Apply in single brush coats until specified thickness is attained. Cure each coat or finished coating as specified. Each specimen shall be visually examined for contamination (especially bristles from the brush) following application of each coat. The coated specimens shall be air dried for a minimum of 24 hours following application of the final coat before testing.
- (8) Leak Check Compounds, Dyes, and Dye Penetrant Systems. Clean, unsealed, sulfuric-acid-anodized, 6061-TC aluminum alloy discs (or any other substrate specified by the manufacturer or Test Requester) 11/16 inch in diameter by 0.063 inch thick shall be used as a carrier. Prior to use, the discs shall be cleaned in accordance with Appendix C, paragraph 5.5. To check the effectiveness of the cleaning procedure, a minimum of 20 blank discs shall be tested as specified in subparagraph f. The discs shall then be soaked in the leak check compound, dye, dye penetrant, emulsifier, or developer for 15 minutes, drained for 15 minutes at an angle of 90 degrees in the fixture shown on Figure 4-15 and tested by placing the specimen discs on stainless steel inserts in the bottom of the test cups.

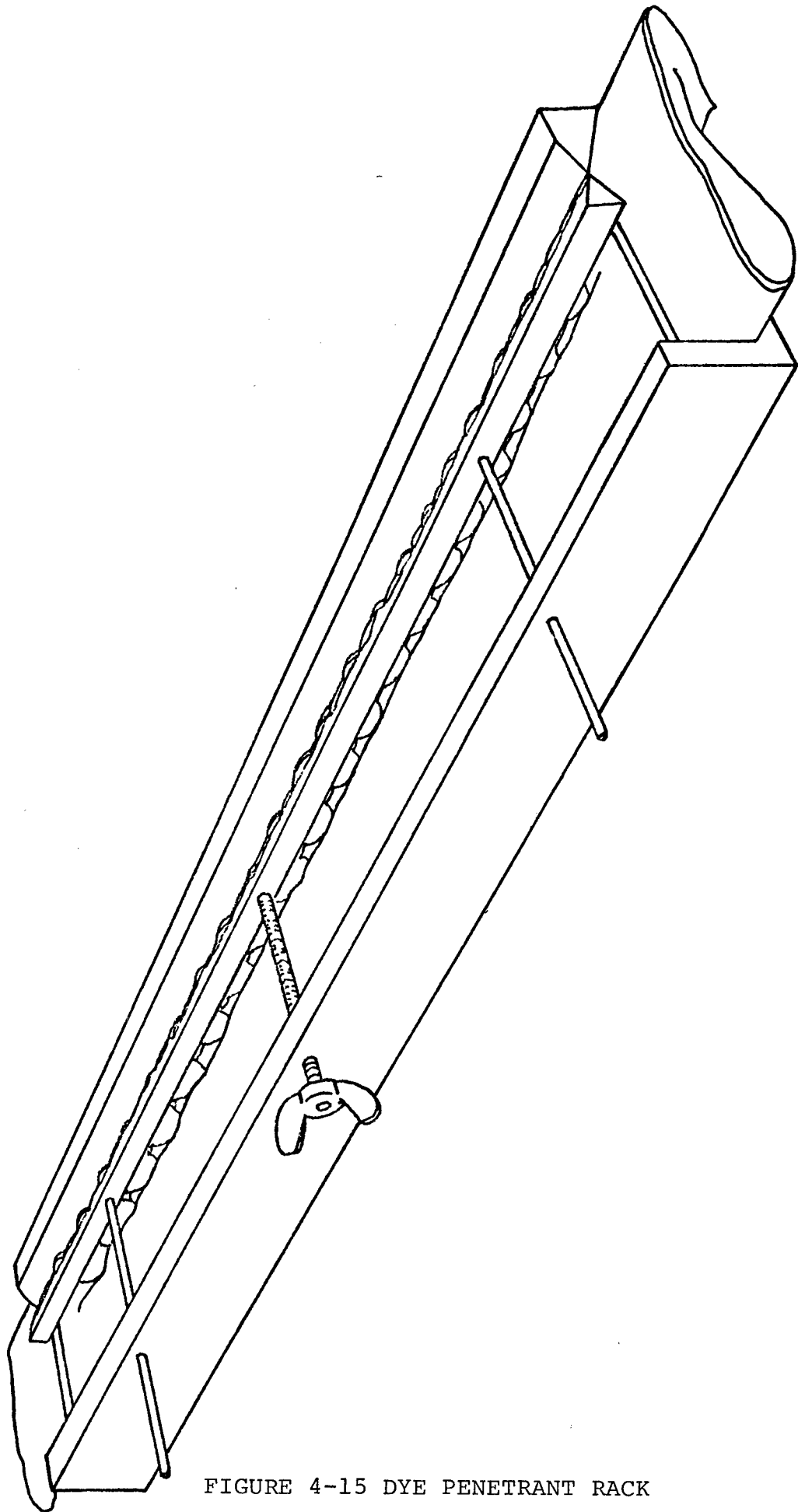

FIGURE 4-15 DYE PENETRANT RACK

- (9) Solders. Solders shall be tested as flat sheets. The sheets shall be prepared by melting and casting the solders to form ingots and by rolling the ingots into sheets of 0.020 ± 0.005 inch in thickness. Discs 11/16 inch in diameter shall be punched from the sheets, cleaned as outlined in Appendix C and tested by placing the discs on stainless steel inserts in the bottom of the test cups. If rosin core solder is used, care should be taken to ensure that the rosin is burned off or completely removed prior to test.
- i. Precooling. Precooling shall be accomplished by lowering the temperature of the material to the boiling point of LOX at atmospheric pressure.
- j. Dewar Flasks. Stainless Steel Dewar flasks shall be precooled by slowly pouring LOX into the flask until the LOX ceases to boil. When cooled, the flask shall be filled with LOX and covered with clean aluminum foil or a stainless steel cover. Since glass Dewar flasks are easily broken, they should not be used.
- k. Specimen Cups
- (1) Blank Specimen Cups. The clean, blank specimen cups shall be precooled by slowly pouring LOX into a sample trap until the LOX covers and fills the cups.
- (2) Specimen Cups Containing Sample Material. To minimize cracking of the samples during freezing, the cups containing the samples shall be precooled slowly by using the freezing box shown on Figure 4-13. The box should be leveled prior to use. The procedure shall be as follows:
- (a) Place approximately 40 specimen cups over the holes in the retainer plate.
- (b) Using an automatic delivery tube with 25-liter Dewar flask, pressurize the Dewar flask to approximately 2.5 pounds per square inch gage (psig) with oil-free oxygen.
- (c) While maintaining the pressure at approximately 2.5 psig, open the discharge valve approximately halfway and start to fill the freezing box.
- (d) As an alternate, a nonpressurized hand Dewar may be used. The time required to fill the cups and the freezing box 1/8 inch from the top shall be 35 to 40 minutes. After this step, a careful inspection shall be made. Any sample that separates from the bottom of the cup and floats shall be forcibly submerged in LOX during conditioning. Any sample that shatters due to thermal shock shall be discarded. The samples shall be transferred to a suitable (precooled) container for storage until tested. Additions of LOX shall be made, as necessary, while tests are in progress to ensure that each sample cup is completely filled at time of testing.

- l. Striker Pins. Cleaned striker pins shall be precooled by placing pins in a Dewar flask and adding liquid nitrogen to the flask until the pins are covered with liquid nitrogen.
- m. Specimen Cup Holder and Base Plate. The specimen cup holder and anvil plate shall be precooled by adding liquid nitrogen to the stainless steel moat surrounding the specimen cup holder and base plate. The moat should be filled with liquid nitrogen to approximately 1/2 inch below the top of the specimen cup holder. Time should be allowed to bring base plate and anvil to equilibrium temperature before starting test.
- n. Pretest Procedure
 - (1) Critical test parameters shall be as follows:
 - (a) Plummet Weight. Plummet weight shall be 20 ± 0.05 pounds.
 - (b) Drop Height. Drop height shall be adjusted to the specified height ± 0.2 inch.
 - (c) Striker Pin Diameter. Striker pin diameter near the striking area shall be 0.500 ± 0.005 inch.
 - (d) Energy Loss. The energy loss due to friction shall be controlled by measuring and recording the drop time of each drop of any given height. The observed plummet drop time shall not deviate more than 3 percent from the theoretical drop time.
 - (2) Blank Drop. The effectiveness of the cleaning procedure shall be checked by testing blank cups as outlined in subparagraph f.
- o. Test Procedure for Ambient LOX Mechanical Impact Determination
 - (1) The magnet shall be adjusted to proper drop height (see Table 4-1).
 - (2) Clean tongs shall be used to set the precooled specimen cups into the specimen cup holder.
 - (3) A visual check shall be made to assure that the frozen sample is fully submerged in LOX. Samples that float shall be restrained under the LOX surface by the striker pin.
 - (4) Place the striker pin in the cup and hold it in place by the striker pin guide.
 - (5) Add the LOX to the specimen cup to ensure that the specimen cup is full.
 - (6) Cover the exposed container of LOX.

- (7) Allow the plummet to impact the striker pin while observing necessary safety precautions.
 - (8) Observe visually or electronically and record the results of the impact reaction as defined in subparagraph 2.
 - (9) Verify that the drop time of the plummet was within specified tolerance (see subparagraph n (1)(d)).
- p. Interpretation of Results. A material proposed for use in LOX systems or subject to direct contact with LOX shall conform to the requirements of subparagraph 2.
- q. Energy Threshold Levels. For materials sensitive at 72 foot-pounds, it may be desirable to determine threshold values. The approximate threshold value shall be obtained by testing 20 samples at each of the drop heights listed in Table 4-1. The first height at which no reactions are obtained in 20 drops shall be the approximate threshold value. The definitive threshold value shall be determined by 20 tests at drop-height increments of 3 inches starting at a height of 6 inches above the approximate threshold value. The definitive threshold value shall be the higher of the two adjacent heights at which no reaction was obtained.
- r. Rejection and Retest. Failure of any sample to meet the requirements of this specification shall be cause for rejection of the LOX represented. Rejected materials shall not be submitted for approval without full details being furnished concerning the previous rejection and measures taken to correct the defects. If not more than one test unit of the original test sample fails to meet the test requirements specified herein, the manufacturer may request a retest. If all test units of the retest meet the requirements specified herein, the material shall be considered compatible for use in LOX systems.

TABLE 4-1. DROP HEIGHT SCHEDULE FOR ENERGY THRESHOLD VALUE DETERMINATION USING A 20LB (9.00kg) PLUMMET

<u>ENERGY</u> <u>(Ft Lbs)</u>	<u>DROP HEIGHT</u> <u>(Inches)</u>
72	43.3
65	39.0
60	36.0
55	33.0
50	30.0
45	27.0
40	24.0
35	21.0
30	18.0
25	15.0
20	12.0
15	9.0
10	6.0

4. PART 2 - TEST METHOD FOR PRESSURIZED LOX OR GOX MECHANICAL IMPACT

- a. Purpose. This procedure determines the compatibility of materials used in pressurized LOX or GOX systems.
- b. Criteria of Acceptability. The material when subjected to mechanical impacts at the maximum use pressure and temperature shall meet the criteria described in subparagraph 2. Materials which fail to meet those criteria shall be subjected to threshold determinations in LOX or GOX at maximum use pressure and temperature at the drop heights shown in Table 4-1.
- c. Test Atmosphere. Candidate materials shall be tested in 95_{-0}^{+5} percent LOX or GOX (MIL-0-27210C).
- d. Test Equipment. All tests shall be performed utilizing the basic ABMA impact tester described in subparagraph 3b with appropriate modifications.
- e. Sample Identification. The following information shall accompany each material submitted for test.
 - (1) Generic name.
 - (2) Manufacturer and manufacturer's designation.
 - (3) Composition.
 - (4) Batch/lot number.
 - (5) Previous cleaning and conditioning processes.
 - (6) Test pressure.
 - (7) Test temperature.
 - (8) Test thickness.
- f. Sample Preparation. The materials samples shall be prepared according to the procedures described in subparagraph 3c.
- g. Sample Cleanliness. Materials submitted shall be cleaned in accordance with the cleaning guidelines established for the material and its application.
- h. Pre-Test Procedure. Verify that all test equipment is in current calibration. The ABMA test equipment, fixtures, striker pins, etc., shall be thoroughly cleaned before each test according to the procedure utilized by the testing agency. If such a procedure has not been established, the cleaning guidelines outlined in Appendix C shall be followed.

i. Test Procedures

- (1) Place the sample in position within the sample retainer cavity. Verify that the sample is contained in a specimen holder and cup assembly which will allow for the transfer of impact energy to the subject specimen in a repetitious manner. Verify that the sample is submerged in LOX prior to performing impact tests.
- (2) Adjust the plummet drop height. The plummet's weight shall be standardized at 20 pounds and dropped from heights shown in Table 4-1. Set rebound catcher.
- (3) Pass gaseous oxygen from the high pressure oxygen source into the chamber and pressurize the test chamber to the applicable test pressure.
- (4) Adjust the chamber pressures to the specified levels.
- (5) Maintain the pressures in the test chamber ± 3 percent of the specified pressure.
- (6) Counterload the equalizer chamber to permit the striker pin to "float" in the test chamber.
- (7) Maintain the temperature at ± 10 percent of the specified temperature.
- (8) Activate the plummet release mechanism. Verify that the plummet impacts the striker pin once and is restrained by the rebound catcher.
- (9) Record the pressure and temperature in the chamber before, during, and after the test.
- (10) Record any flashes electronically or visually detected.
- (11) At the conclusion of the test, release the residual GOX pressure in the assembly.
- (12) Disassemble the test apparatus.
- (13) Examine the sample specimen and cup specimen holder for visible signs of reaction.
- (14) Record all observations; photographs of a visual change in the sample specimen shall be at the discretion of the test engineer.
- (15) Repeat the above procedure, each time employing a new sample and assuring cleanliness requirements are maintained until the total number of samples are tested.

- j. Threshold Level Determination. Materials sensitive at 10 Kg-m (72 ft. lbs.) shall be subjected to threshold level determination according to the procedure detailed in subparagraph 3q. The determinations shall be made starting at the maximum use pressure and temperature.
- k. Reporting. Test data shall be reported in accordance with instructions contained in paragraph 208 on a form similar to Figure 2-1. The following special test data and information shall be reported:
 - (1) Lot/batch numbers of each material.
 - (2) Impact energy for each test.
 - (3) Condition of sample after test.
 - (4) Number of mechanical impacts.
 - (5) Number of failures versus number of samples tested.
 - (6) Definitive threshold value.
 - (7) Pertinent comments and observations of test.
 - (8) Test pressure.
 - (9) Test temperature.
 - (10) Test media (LOX or GOX).

5. PART 3 - CALIBRATION OF THE ABMA MECHANICAL IMPACT TESTER

- a. Purpose. This procedure provides a means to assess performance of the ABMA mechanical impact tester.
- b. Criteria of Acceptability. The energy delivered to a calibration specimen shall be verified for the basic ABMA tester. A calibration curve for each tester shall be established initially by determining the penetration function (defined in paragraph 413.5.g) at each integral energy level. The annual verification shall be performed by determining the penetration function at the 1, 4, 7, and 10 kg-m energy levels. The calibration and verification curves must have a slope greater than 0.100 and must have a correlation coefficient greater than 0.985.
- c. Test Atmosphere. This procedure utilizes liquid nitrogen as the fluid medium.
- d. Test Equipment. All tests shall be performed utilizing the basic ABMA impact tester described in subparagraph 3b with appropriate modifications as follows:
 - (1) The standard striker shall be used with the tip remachined into a 0.500 ± 0.005 inch diameter hemisphere having an 8 microinch or better surface finish.

- (2) The calibration specimen shall be 304 SS annealed to MIL-H-6875F, 0.688 ± 0.010 inch diameter, 0.350 ± 0.010 inch thick, and a 16 microinch or better surface finish.
- (3) No sample cups shall be used.

TYPICAL MECHANICAL IMPACT TEST CHAMBER

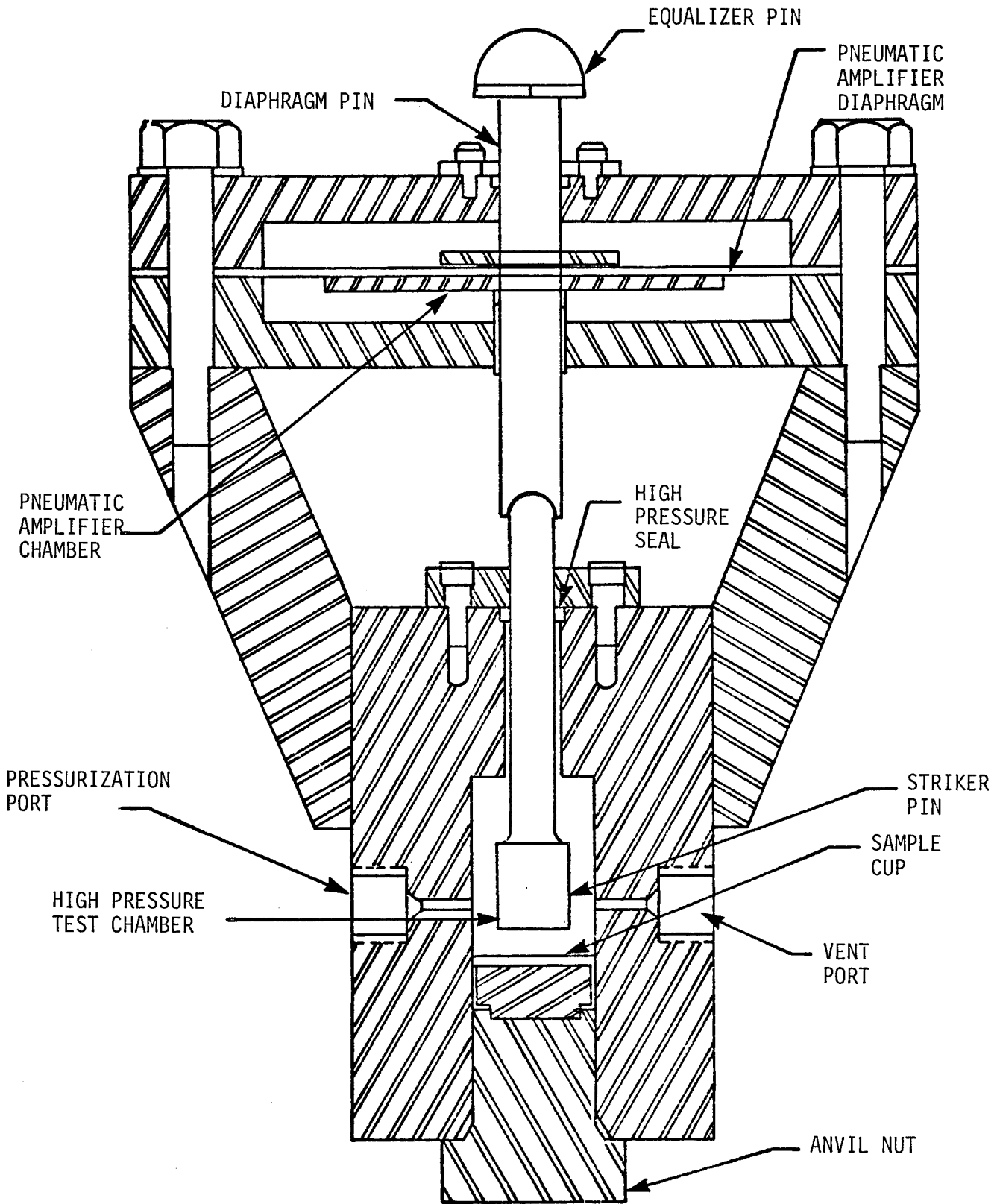

FIGURE 4-16

e. Pre-Test Procedure. Verify all test equipment is in current calibration.

f. Test Procedure

- (1) Pre-cool strikers, specimens, and cavity with liquid nitrogen.
- (2) Place the calibration specimen in the center of the cavity.
- (3) Install the remachined striker pin.
- (4) Perform standard drop test and prevent rebound for a total of 5 tests at each appropriate energy level.
- (5) Prior to reuse, verify that no deformation of striker pins has occurred. Striker pin deformation may occur due to repetitive reuse at higher energy levels.
- (6) Determine the diameter of the indentation in the calibration specimen to the nearest 0.0005 inch by averaging two readings taken 90° apart.

g. INTERPRETATION OF RESULTS

- (1) The penetration function is determined as follows:

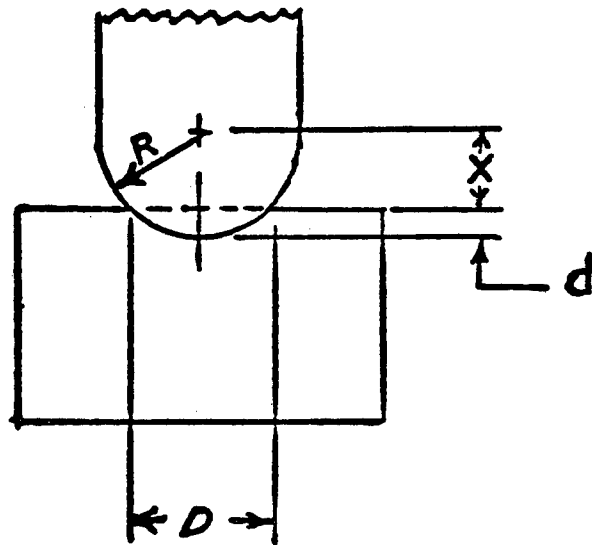

R - Striker Radius (6.35 mm)

D - Dent Diameter (mm)

d - Penetration

d^2 - Penetration Function

$$d = R - X$$

$$d^2 = R^2 - 2XR + X^2$$

$$X^2 = R^2 - (D/2)^2$$

$$d^2 = R^2 - 2R(R^2 - (D/2)^2)^{1/2} + R^2 - (D/2)^2$$

$$= 2R^2 - (D/2)^2 - 2R(R^2 - (D/2)^2)^{1/2}$$

$$= 80.645 - 0.25D^2 - 12.7(40.3225 - 0.25D^2)^{1/2}$$

- (2) Plot the penetration function versus energy level using a linear least-squares curve fit forced through the origin and determine the correlation coefficient for this line.
- h. Verification Failure. If the minimum requirements are not met (slope > 0.100 , correlation coefficient > 0.985), all testing must be terminated until the problems are rectified.

414 TEST 14 - GASEOUS OXYGEN PNEUMATIC IMPACT TEST

1. PURPOSE

This test is performed to determine the sensitivity of materials in contact with gaseous oxygen, whether directly or as the result of a single barrier failure when subjected to pneumatic impact. The materials are tested over the pressure range as directed by program requirements.

2. CRITERIA FOR ACCEPTABILITY

- a. A candidate material shall exhibit no reactions at the specified use pressure and maximum temperature to which it can be exposed in the thickness intended for use.
- b. If a material does react at the test pressure and temperature, a review will be required to ascertain the level of pneumatic impact conditions that exist within the system in which the material is applied.

3. TEST CONDITIONS - PRESSURES AND ATMOSPHERES

- a. Candidate materials shall be tested in 95⁺⁵ percent GOX (MIL-0-27210C) at the specified use pressure and ⁻⁰temperature. Pressure increments of 500 psia will normally be used.
- b. Standard test conditions employed in performance of the pneumatic impact test are as follows: (other conditions require special notation).
 - (1) Test chamber temperature $70 \pm 10^{\circ}\text{F}$ (or maximum use temperature).
 - (2) Five pneumatic impact cycles within 60 seconds, automatically timed.
 - (3) The pressure in the test chamber shall be raised to 95 percent of test pressure within 50 milliseconds.
- c. The pneumatic test equipment is presented schematically in Figures 4-17 and 4-18.

4. SAMPLE IDENTIFICATION

The following information shall accompany each material submitted for test:

- a. Generic name.
- b. Manufacturer and manufacturer's designation.
- c. Composition.
- d. Batch/lot number.
- e. Previous cleaning and conditioning processes.

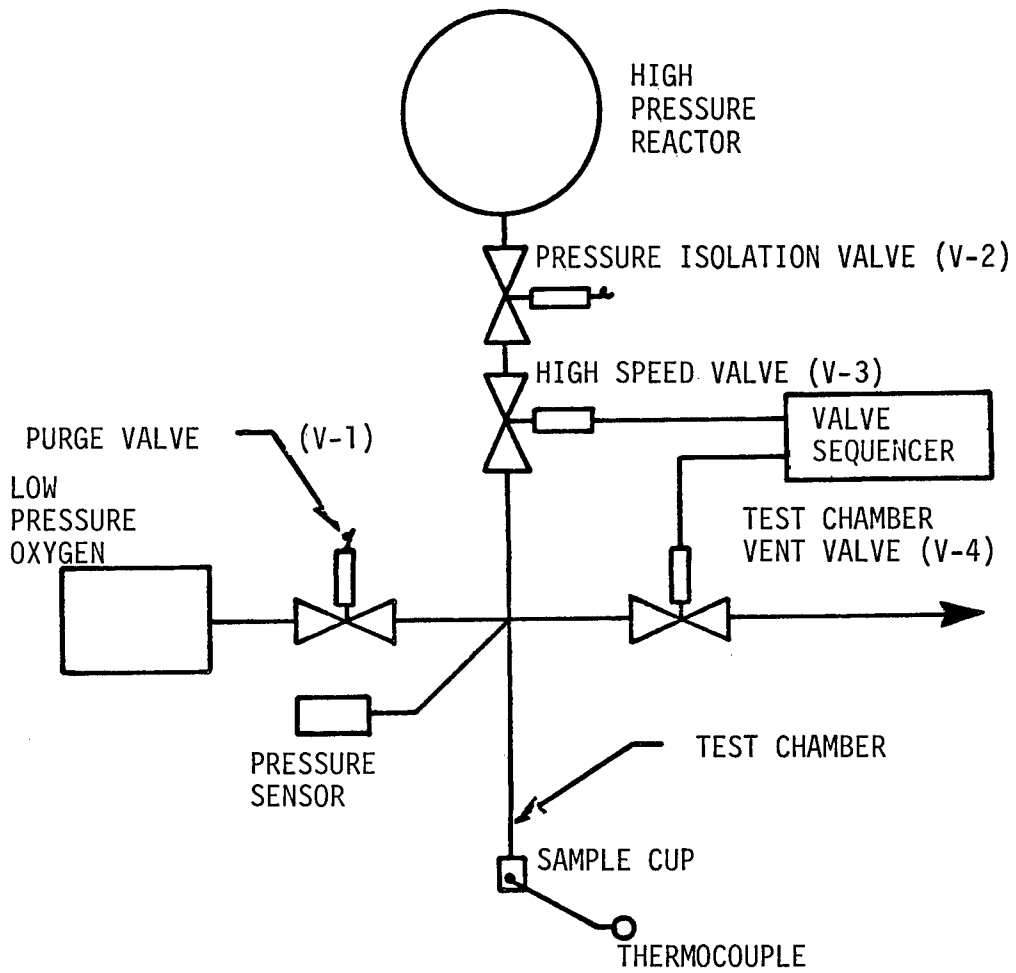
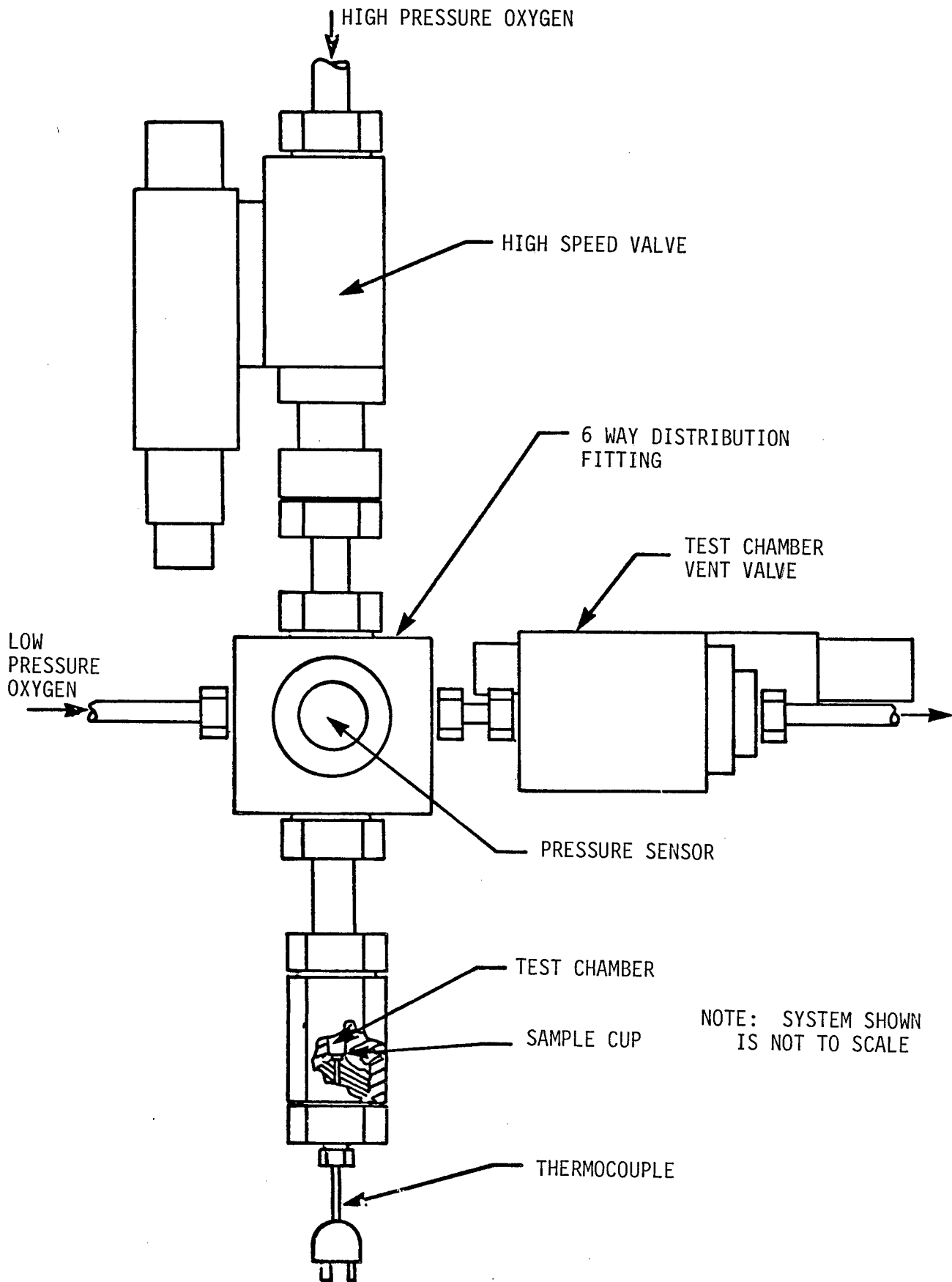

FIGURE 4-17
 PNEUMATIC IMPACT TEST SYSTEM
 WSTF DWG 523-10379



NOTE: SYSTEM SHOWN IS NOT TO SCALE

FIGURE 4-18
 SCHEMATIC-PNEUMATIC IMPACT TEST SYSTEM
 WSTF DWG t23-10379

- f. Test pressure.
- g. Test temperature.
- h. Test thickness.

5. SAMPLE PREPARATION

Material samples shall be 3/16 inch diameter by use thickness (unless prevented by use configuration) and shall be prepared according to the procedures described in paragraph 413-3a. Eighty specimens of each material shall be prepared unless otherwise specified.

- a. Sample Cleanliness. Materials submitted shall be cleaned in accordance with the cleaning guidelines described in Appendix C.

6. TEST PROCEDURE

- a. Place the sample in position within the sample cup.
- b. Loosely install the sample cup in the test chamber.
- c. Purge the test chamber and sample cup with low pressure oxygen by opening purge valve V-1 to ensure that a 95^{+5}_{-0} percent oxygen environment is established within the test chamber.
- d. Wrench-tighten sample cup.
- e. Pressurize the high pressure accumulator to the desired test pressure with oxygen.
- f. Stabilize the test chamber temperature at the desired test conditions.
- g. Subject the material specimen to cyclic high pressure oxygen as follows:
 - (1) Ensure purge valve V-1 is closed.
 - (2) Open vent valve V-4 until chamber pressure sensor indicates atmospheric pressure, then close V-4.
 - (3) Open pressure isolation valve V-2.
 - (4) Cycle high speed valve V-3 open until test chamber pressure sensor indicates the same pressure as the accumulator, then close.
 - (5) Maintain pressure in test chamber for 5 seconds.
 - (6) Open vent valve V-4 for 5 seconds to allow the test chamber pressure to decay to atmosphere pressure, then close the vent valve.

- (7) Repeat Steps (4), (5), and (6) until five complete cycles have been accomplished.
 - (8) Close pressure isolation valve V-2.
 - (9) Open vent valve V-4 and high speed valve V-3.
 - (10) When test chamber pressure sensor indicates atmospheric pressure, close V-3 and V-4.
- h. Remove sample cup from test chamber.
 - i. Remove the material specimen and examine for evidence of reaction.
 - j. Record all observations on the data sheet. Photographs of a visual change in the sample shall be at the discretion of the test engineer.
 - k. Repeat the above sequence to obtain data on a total of 20 specimens at each specified test pressure.

7. REPORTING

Test data shall be reported in accordance with instructions contained in paragraph 208 on a form similar to Figure 2-1. The following special test data and information shall be reported:

- a. Lot/batch number.
- b. Test pressure.
- c. Occurrence of pressure change due to reaction.
- d. Test temperature.
- e. Temperature change due to reaction.
- f. Condition of sample after test.
- g. Number of test cycles.
- h. Number of failures versus number of samples tested.
- i. Pertinent comments and observations of the test agency.
- j. Test atmosphere.

415 TEST 15 - COMPATIBILITY OF MATERIALS WITH TYPE "J" FLUIDS

1. PURPOSE

The purpose of this test is to determine the gross compatibility of materials with Type J fluids.

2. SCOPE

This test is applicable for materials being considered for use in all Type J fluids. The test technique is hazardous in nature and requires remote propellant handling and control.

3. CRITERIA FOR ACCEPTABILITY

- a. The criteria for acceptability is based on exposure to a test environment consisting of a 48-hour conditioning period in the test fluid. All materials are to be tested at their maximum use pressure and temperature. Materials used at ambient temperature and below shall be tested at 160°F. A material is considered to be compatible with the test fluid if exposure of the material to these conditions results in no deleterious changes in the material, i.e., dissolution, separation, dimensional, hardness or tensile strength degradation, etc.
- b. Materials shown to be incompatible at test fluid temperatures of less than 160°F are also considered incompatible and testing at 160°F is not required.

4. TEST CONDITIONS

- a. The test materials will be exposed to either liquid or vapor-phase test fluids as required by the requester.
- b. The test pressure will be adjusted to simulate maximum applied system use pressure, if known. If the test pressures are not specified, the testing agency will select a pressure not to exceed 1000 psia.
- c. Test temperature, unless otherwise stated by the test requester, will be 160°F, +5.5°F, -0°F.
- d. Exposure time will be 48 ± 1 hour unless otherwise specified. For test purposes, test timing will commence when the test pressure and temperature conditions are established in the test chamber. Test timing will be stopped when post-test cooling is initiated.
- e. If required, physical properties test such as dimensional change, hardness, tensile strength and chemical analysis of the fluid media and test materials will be performed.

5. TEST EQUIPMENT

- a. The test chamber shall be constructed of 300 series stainless steel or equivalent. It shall contain a rupture disc suitable for protecting personnel and test equipment in the event a high order reaction occurs. The test chamber shall have penetrations for fluid media filling and draining, and pressure and temperature monitoring.
- b. The test chamber shall provide a total volume of at least 2 liters including a minimum of 1-liter volume as ullage. This configuration will permit the option of testing in either liquid or vapor-phase fluid media.

6. SAMPLE PREPARATION

Test materials include solids, semisolids, and liquids. Each type of material requires different treatment with regard to preparation and test. The following guidelines shall be considered when submitting a material for testing.

a. Solids (includes foam materials).

- (1) Prepare three samples, each with an exposed surface area of approximately 2.0 square inches.
- (2) Cleaning will be performed in accordance with Appendix C guidelines.

b. Semisolids and Liquids.

- (1) A 300 series stainless steel cup shall be used to contain a 0.050 ± 0.010 inch layer of the test material having an exposed surface area of 6.0 ± 0.2 square inches.
- (2) Generally, a semisolid will be exposed only to vapor-phase fluid media. Liquids can only be exposed to vapor-phase.
- (3) If test materials are of the same generic class, several materials may be simultaneously evaluated in the same test chamber.

7. TEST PROCEDURE

- a. Verify that all test equipment is in current calibration.
- b. Verify that all test equipment which will be exposed to the test fluid media is clean to the level specified by the test agency.
- c. Position test materials in the test chamber.
- d. Complete test chamber assembly (with rupture disc) and perform helium leak test at the specified test pressure. (Leakage in excess of 0.1 psia per minute must be repaired.)

- e. Install test chamber into an oven and connect chamber to fluid media supply and instrumentation systems.
- f. Load test chamber with the test fluid, maintaining approximately 50% internal volume as ullage.
- g. Energize oven heater. Temperature rise shall be $20 \pm 5^{\circ}\text{F}$ per hour.
- h. Start recording instrumentation (pressure and temperature) when fluid media bulk temperature reaches the requested specified test temperature.
- i. Pressurize test chamber to the test pressure with helium as required.
- j. Continue the immersion test for the requested specified test duration (normally 48 ± 1 hour). Adjust pressure and temperature as required during test.
- k. After test, de-energize oven heaters, vent and drain the test chamber, and de-energize recording instrumentation.
- l. Disassemble the test chamber, photograph and remove samples from the test chamber. Perform physical and chemical tests as required.

WARNING: Handling of materials exposed to Type J fluids may be extremely hazardous due to changes which may have occurred in the material due to exposure to the test fluid media. Procedures such as mechanical impact testing of small post test samples should be established to evaluate the hazards associated with handling the material after test.

- m. Record all observations on the data sheet. Recorded observations shall include comments pertaining to any sample color changes, physical deformation, dissolution characteristics, separation, apparent size change, etc. Physical properties and chemical analysis will also be provided when required.
- n. Test chamber and allied hardware shall be decontaminated and cleaned per the applicable test agency requirements.

8. REPORTING

Test data shall be reported in accordance with the instructions contained in paragraph 208. An example of an acceptable form is shown in Figure 4-19.

BEAKER TESTED & APPROVED FOR CAT.J TEST IN FLUID ON DATE DATE: / /

76-8133	TYPE J TEST AUTHORIZATION	
TEST AGENCY ID	REQUESTER ID	CONT NASA
MAT'L. NAME/MFG'S. ID & BATCH/LOT NO.		CHEMICAL CLASS OF MATERIAL
AMS 3238 Butyl Rubber		
APPLICABLE TEST DOCUMENT		GENERIC NAME OF MATERIAL
NHB 8060.1B		

TEST CONDITIONS		MATERIAL PREPARATION	
Test Samples per _____		Prep. per: <u>OCP-200-022</u>	
Test Name: <u>CONSTANT TEMPERATURE IMMERSION</u>		Special Instructions: <u>See Page 2</u>	
Test Fluid: <u>NH₃</u>		PREPARED SAMPLE APPROVALS	
Special instructions: _____		TECH.	ENGR.
			NASA Q.A.

TEST DATA

Test Sample Description: Black Rubber

Material Quantity (gms.): 68.46 Container Volume (ml.): 2,000

Media Volume (ml.): 650 Media Exposure Time (hrs.): 48 ± 1

Test Chamber Pressure: 250 psia Media Exposure Temp. (°F): 160 + 5.5, -0

OBSERVATIONS

Pre-Test Warm-up & Pressurization Test

T Deviation: _____ °F Temperature Deviation: _____ °F

P Deviation: _____ psid

BULK CHARACTERISTICS/Pre-Test Post-Test			SURFACE CHARACTERISTICS/Pre-Test Post-Test		
Shape	<u>Rectangular</u>	<u>Same</u>	Smooth	<u>Yes</u>	<u>Yes</u>
Flexible	<u>Yes</u>	<u>Yes</u>	Rough	<u>No</u>	<u>No</u>
Pigid	<u>No</u>	<u>No</u>	Wrinkled	<u>No</u>	<u>No</u>
Soft	<u>No</u>	<u>No</u>	Pitted	<u>No</u>	<u>No</u>
Hard	<u>No</u>	<u>No</u>	Woven	<u>No</u>	<u>No</u>
Friable	<u>No</u>	<u>No</u>	Matted	<u>No</u>	<u>No</u>
Remarks:	_____		Tacky	<u>No</u>	_____
	_____		Remarks:	_____	

VISUAL CHARACTERISTICS/Pre-Test Post-Test			POST-TEST GROSS COMPATIBILITY			
Color	<u>Black</u>	<u>Black</u>	Burned:	<u>No</u>	Cracked:	<u>No</u>
Opaque	<u>Yes</u>	<u>Yes</u>	Charred:	<u>No</u>	Separated:	<u>No</u>
Translucent	<u>No</u>	<u>No</u>	Dissolved:	<u>No</u>	Swelled:	<u>No</u>
Transparent	<u>No</u>	<u>No</u>	Fractured:	<u>No</u>	Shrunk:	<u>No</u>
Remarks:	_____		Remarks:	_____		

POST-TEST MATERIAL'S SPECIAL TESTS, PHOTOGRAPHS AND RESULTS:

Grab Sample Impact Test at 367 ft-lb/in² - No Reaction

DATE	TEST TECH.	CHECKED BY	CONT. ENG' RG.	NASA Q.A.	OTHER

SPECIAL PREPARATION INSTRUCTIONS

N/A

MATERIAL PREPARATION HISTORY

Sample cut/sized per _____ Step _____
Sample cleaned per Step _____

CURE HISTORY: _____

SPECIAL TEST INSTRUCTIONS

Soak for 45 day period in ammonia vapor phase

TEMPORARY PROCEDURE DEVIATIONS

PROCEDURE	PAGE	STEP	CHANGE	AUTHORIZATION	
				CONT.	NASA
			N/A		

416 TEST 16 - DETERMINATION OF OFFGASSED PRODUCTS FROM ASSEMBLED ARTICLES

1. PURPOSE

This test establishes the criteria for a screening test to determine the suitability of assembled articles for use in space vehicle crew compartment environments. The criteria are established with respect to production of potentially toxic volatile offgassed products.

2. DEFINITIONS

The following definitions apply to the terms as used in this test procedure:

- a. Assembled Article. Any component "black box", or assembly of components which represents the article to be used in a spacecraft.
- b. Offgassing. The evolution of gaseous products from an assembled article.
- c. Offgassed Product. An organic or inorganic compound evolved from a liquid or solid material.
- d. Maximum Allowable Concentration (MAC). The maximum concentration of an offgassed product that is allowed in the spacecraft for a specified flight duration. MAC values for manned spacecraft are contained in Appendix D.

3. CRITERIA FOR ACCEPTABILITY

- a. The quantity of each offgassed product of an assembled article shall not result in a projected spacecraft concentration in excess of the MAC value for that product.
- b. The toxicological summation of the total offgassed products of an assembled article shall be evaluated for potential toxicity in accordance with the MAC guidelines of Appendix D by the responsible toxicology group.
- c. Final acceptance of an assembled article shall be determined by the responsible NASA medical office from an assessment of the potential toxicity of the total quantity of offgassed products from all contaminant generating items for a given mission.

4. TEST CONDITIONS - TEMPERATURE, PRESSURE, ATMOSPHERE, SAMPLING FREQUENCY, AND ASSEMBLY OPERATION

The test conditions for the pertinent materials category shall be designated by the cognizant NASA center program office. These test variables shall represent the most hazardous condition anticipated in the spacecraft.

5. TEST EQUIPMENT

- a. Test Chamber. The test chamber shall have a minimum volume of two liters. It shall have a configuration and be fabricated of materials which allow ready cleaning. A fan shall be installed in the chamber when practical to insure uniform distribution of the offgassed products. The fan shall not contribute detectable offgassing to the chamber. Valves and seals used shall not contain any soft goods that could contribute detectable offgassing to the chamber.
- b. Chamber Vacuum, Pressurization and Thermal Cleaning Equipment. The equipment shall consist of the following items or equivalent (Figure 4-7) and/or any other equipment that the test laboratory requires to assure chamber certification as specified in subparagraph 6.
- (1) Vacuum pump with a free air displacement of at least 100 liters per minute and an ultimate vacuum capability of 1.0×10^{-3} Torr or lower.
 - (2) Pressure gage accurate to ± 0.03 psia; 0 to 15 psia range (nominal).
 - (3) Vacuum gage capable of measuring 10^{-4} Torr.
 - (4) Manifold with valves for interconnection of the chamber, vacuum pump, pressure gage, vacuum gage and K-bottles.
 - (5) Heat gun rated at 1000 watts (nominal).
 - (6) Liquid nitrogen dewar.
 - (7) K-bottles of test gas (mixture of oxygen and nitrogen) with suitable regulators. The test gas shall conform to the requirements of Test 7, paragraph 407-5b(7).
- c. Heating Source. The heating unit or oven shall maintain the test chamber at the designated test temperature $\pm 5^{\circ}\text{F}$. The temperature during thermal conditioning of the assembled article shall be recorded.
- d. Analytical Equipment. The analytical equipment shall consist of the following types of equipment any any other instruments that the test laboratory requires to assure accuracy and precision in the offgassed products analyses:
- (1) Gas Chromatograph System. The gas chromatography system shall employ detectors capable of responding to a wide variety of offgassed products as listed in Appendix D. As supplementary detectors, the following are recommended: electron capture, flame photometric, nitrogen/phosphorus flame ionization, and photoionization detectors. The separatory columns shall have the capability of separating light organic and inorganic gases, organic sulfides and mercaptans, halogenated hydrocarbons, representative aliphatic and aromatic hydrocarbons including aldehydes, ketones, alcohols, and esters.

- (2) Recording Infrared Spectrophotometer with 10-Meter or Greater Path Length Gas Cell. The cell shall have provisions for heating to test temperature and maintaining temperature to $\pm 5^{\circ}\text{F}$.
- (3) Mass Spectrometer. The mass spectrometer range shall be 10 to at least 600 amu; resolution shall be at least 1200 at mass 600. (Resolution is defined as m/m when m is measured at peak half height.) The sensitivity shall be such that a 10 nanogram/second sample will produce identifiable spectra of acetone or toluene.
- (4) Gas sampling system suitable for the transfer of measured volumes of gas samples from the test chamber to the gas chromatograph.
- (5) Calibration standards as required to calibrate detectors. The calibration gas used with flame ionization detectors shall be propane; working propane standards shall be certified by reference to propane standards from the National Bureau of Standards.

6. SAMPLE CHAMBER CERTIFICATION

- a. Cleaning. The sample chamber shall be cleaned, heated, and purged with air or nitrogen by some suitable method to reduce residual chamber contamination (background).
- b. Leak Check. Connect the chamber to the vacuum and pressurization system (see Figure 4-7). The chamber shall be evacuated to less than 1 Torr and checked for leaks. The chamber shall be acceptable for use if the pressure rise due to leaks does not exceed 2 millitorr per minute.
- c. Cleanliness Certification. Before loading the assembled article into the chamber, the chamber shall be filled with the test atmosphere or nitrogen to 6.0 ± 0.1 psia and conditioned for 72 ± 1 hour at test temperature or for 24 ± 1 hours at test temperature plus 35°F . The chamber shall then be analyzed for residual contamination (background). The chamber shall be certified as clean for use if the concentrations of the residual volatiles are sufficiently low to permit detection and quantitation of offgassed products from the assembled article (see subparagraph 7).

7. TEST PROCEDURE

- a. Place the weighed assembly in the chamber and connect the assembly if required to the electrical feedthrough.
- b. The free volume of the chamber shall be determined by removing or adding a known volume of nitrogen and noting the change in chamber pressure after stabilization. Alternatively, the free volume may be determined by use of a known amount of a tracer gas with gas

chromatographic or other analysis of its concentration in the chamber containing the test article.

- c. Connect the chamber to the vacuum and pressurization system shown in Figure 4-7. Evacuate the chamber to 0.2 ± 0.05 psia and backfill with the test atmosphere to 2.0 ± 0.05 psia. Reevacuate to 0.2 ± 0.05 psia and backfill with test atmosphere to a pressure such that the chamber will be at test pressure when the test atmosphere is at test temperature. The test atmosphere composition may be obtained by partial pressure addition of oxygen and nitrogen during the loading step or by use of a premixed test gas. If the assembled article cannot be exposed to a vacuum, a pressurization-vent cycle must be utilized that assures at least 95% of the existing atmosphere has been replaced by the test atmosphere.
- d. Heat the chamber per specified conditions, e.g., temperature ($\pm 5^{\circ}\text{F}$), pressure, time, test atmosphere, etc.
- e. Connect the chamber to the analytical system and measure and record the chamber pressure.

NOTE: The pressure gage or transducer may be an integral part of the chamber or it may be integral with the analytical system. The gage or transducer shall be accurate to ± 0.03 psia.

- f. Sample and analyze the offgassed products at intervals specified.
- g. The identity and quantity of each analyzable offgassed product, excluding water vapor and carbon dioxide, shall be recorded on the reporting format.
- h. All charts, equipment calibration information and test data shall be retained and be traceable in the event that further identification or evaluation is necessary.

NOTE: Some offgassed components may be present at levels too minute for identification. These shall be reported as "unidentified component" and the quantity expressed in micrograms as propane.

8. REPORTING

Test data shall be reported in accordance with instructions contained in paragraph 208 on a form similar to Figure 4-20 and will include the identity of organic and inorganic offgassed products and their quantities in micrograms. Water and carbon dioxide shall not be reported. All pertinent test conditions shall be reported.

OFFGASSED PRODUCTS FROM ASSEMBLED ARTICLE TEST

TEST AGENCY WSTF DATE 3-20-79

TEST NUMBER 79-11449

TEST CONDUCTOR(S) Jack Stradling

QUALITY ASSURANCE _____

SAFETY _____

MANUFACTURER'S ARTICLE NAME Tektronix Oscilloscope

MANUFACTURER'S MODEL NUMBER 466

MANUFACTURER'S SERIAL NUMBER S/N B136531

MANUFACTURER Tektronix

NASA ARTICLE IDENTITY 0772

TEST CHAMBER VOLUME 95 liters

TEST CHAMBER TEMPERATURE 120°F

TEST CHAMBER PRESSURE 12.0 psia

TEST CHAMBER ATMOSPHERE _____

OFFGASSED PRODUCTS:

<u>IDENTITY</u>	<u>QUANTITY (MICROGRAMS)</u>
<u>Butane</u>	<u>0.011</u>
<u>C5 Aliphatic hydrocarbon</u>	<u>0.905</u>
<u>MEK</u>	<u>0.090</u>
<u>Toluene</u>	<u>0.009</u>
<u>Xylene</u>	<u>0.071</u>
<u>C9-C10 aromatic & aliphatic hydrocarbon</u>	<u>0.062</u>
<u>CO</u>	<u>0.102</u>

FIGURE 4-20

APPENDIX A - ABBREVIATIONS AND ACRONYMS

ABMA	Army Ballistic Missile Agency
amps	amperes
ASTM	American Society for Testing Materials
AWG	American Wire Gage
ECLSS	Environmental Control and Life Support System
FAA	Federal Aviation Administration
FAR	Federal Aviation Regulation
FEP	Fluorinated Ethylene Propylene
GFE	Government Furnished Equipment
GSE	Ground Support Equipment
GOX	Gaseous Oxygen
JSC	Johnson Space Center
KSC	John F. Kennedy Space Center
LOX	Liquid Oxygen
MAC	Maximum Allowable Concentration
MR	Reliability, Quality and Safety (OSTS), NASA Headquarters
MSFC	George C. Marshall Space Flight Center
N ₂ O ₄	Nitrogen tetroxide
N ₂ H ₄	Hydrazine
OSTS	Office of Space Transportation Systems
ppm	parts per million
psia	pounds per square inch absolute
PTFE	Polytetrafluoroethylene (teflon)
QA	Quality Assurance
RFP	Request for Proposal

SBF	Single Barrier Failure
SPEC	Specification
TFE	polytetrafluoroethylene resin
Vg	Vacuum Gage
WSTF	White Sands Test Facility

APPENDIX B - RELATED DOCUMENTS

The following publications contain applicable information relating to the selected requirements and criteria prescribed herein:

SPECIFICATIONS

Military

AFSC DH 1-7	Aerospace Materials
MIL-W-22759	Wire, Electrical, Fluorocarbon-Insulated, Copper and Copper Alloy
MIL-P-25508	Propellant Oxygen, Type I
MIL-O-27210	Oxygen, Aviators Breathing, Liquid and Gas, Type I

Lyndon B. Johnson Space Center (JSC)

JSC-SPEC-Q3	Pretreatment (Etching) of Teflon Surfaces prior to Potting Processes, Specification for
JSC-02681	Nonmetallic Materials Design Guidelines and Test Data Handbook
JSC-C-020A	Water, High Purity and Distilled
JSC-C-23	Surface Cleanliness Levels for Sampling Equipment

American Society for Testing Materials (ASTM)

ASTM-D56	Standard Method of Test for Flash Point by Tag closed Tester
ASTM-D568	Standard Method of Test for Flammability of Flexible Plastics
ASTM-D635	Standard Method of Test for Flammability of Self-Supporting Plastics

PUBLICATIONS

George C. Marshall Space Flight Center (MSFC)

TMX 64711	Compatibility of Materials with Liquid Oxygen - Volume I
MSFC-SPEC-234A	Nitrogen, Space Vehicle Grade

Federal Aviation Administration (FAA)

FAR25	Airworthiness Standards (Part 25)
-------	-----------------------------------

APPENDIX C - PRECISION CLEANING GUIDELINES
TYPE D AND TYPE J TEST SPECIMENS AND OXYGEN
IMPACT TEST APPARATUS

1.0 PURPOSE

These requirements are written to assure that materials testing is performed under uniformly clean conditions. These cleaning guidelines shall assure that nonmetallic materials specimens are subjected to uniform cleaning methods which are repeatable. The method is intended to remove hydrocarbons which contaminate the surface during manufacturing, handling, processing, and shipping.

2.0 SCOPE

These guidelines describe methods of cleaning material test specimens. The constraints implied by cleaning and the techniques of cleaning are only generally covered. Particulate contamination shall be controlled by assuring freshly prepared cleaning solutions. These guidelines are not an operating procedure or job instruction which details every specific step required to perform a cleaning operation. These operating procedures/job instructions are the responsibility of the operating element and are not within the scope of this document.

3.0 VISUAL EXAMINATION

3.1 All material specimens shall be visually inspected to detect signs of contamination. Methods employed within the sample preparation area shall be those which can be utilized during inspection and verification to determine the amount of precleaning required. Any contamination shall be cause for recleaning (see Section 4.0). Observations must be made with the unaided eye and light of sufficient intensity to illuminate the area being inspected during the initial material cleanliness inspection.

3.2 All material specimens shall be free of cuts, abrasions, and other flaws as determined by close visual inspection without magnification.

4.0 CLEANING

4.1 Before any materials test, the material specimens shall be cleaned as specified in this appendix.

4.2 Some solids, most semisolids and all liquids shall be tested in their "as used" condition; that is, no special cleaning processes other than those used to prepare the material for the specified test are required.

4.3 Applicable test specimens shall be subjected to the following general cleaning provisions consisting of the removal of such gross surface contaminants as scale, grease marks, manufacturing residues, excess plasticizers, corrosion and oxidation products, etc., prior to final precision cleaning per this specification. Solvent cleaning shall be limited to water and mild detergent since further solvent action can change the physical and chemical properties of materials by leaching or solvent absorption. The cleaning method proposed here is uniformly applied to all materials prior to performing required tests and correlates with existing contractor cleanliness specifications.

4.4 Rubber gloves or equivalent shall be worn during all cleaning operations. Cleaned surfaces shall not be handled with bare hands. Clean (low-lint) white nylon gloves or equivalent shall be worn when handling cleaned items. During and subsequent to cleaning, care shall be taken not to recontaminate parts. Cleaned parts shall be placed and sealed in a polyethylene or equivalent package which has been cleaned in accordance with JSC-C-23, Level 1.

4.5 Cleaning and inspection processes per this specification are designed not to be detrimental to nonmetallic materials or test apparatus parts. When a procedure herein is not directly applicable to nonmetallic material specimens, those specimens shall not be processed per this specification.

4.6 CLEANING MATERIALS

4.6.1 Rinse Water

Rinse water shall be of the distilled or deionized variety conforming to the following:

Conductivity: 50,000 ohm-cm minimum resistance at 25C

pH: 5.0 - 7.5

Chlorides: 1.0 ppm by weight (maximum)

Surface Tension: 71.71 dynes per cm (minimum)

at 20°C.

4.6.2 Detergent

Detergent shall be added to deionized or distilled water in accordance with concentration requirements of Section 4.7.3 and then passed through a 25 micron (absolute) filter, or better, prior to use, for flushing/decontamination purposes. The following detergent types are acceptable: Liqui-Det #2, Turco 4215S, Ivory liquid detergent.

4.6.3 Cleaning Solvents

Cleaning solvent shall be trichlorotrifluoroethane (Freon 113) for cleaning test fixture and apparatus and shall be filtered through a 4.5 micron (absolute) filter, or better, prior to use. The NVR content of the solvent shall not exceed 1.0 mg per 200 ml. Nonmetallic materials shall be suitably cleaned with water and mild detergent solution.

4.6.4 Nitrogen

Gaseous nitrogen used for drying purposes shall conform to the following:

- Purity: 99.5% by volume (minimum).
- Oxygen Content: 0.5% by volume (maximum).
- Hydrocarbons,
as Methane: 58.3 ppm by volume
(maximum).
- Moisture Content: 26.3 ppm by volume (maximum).
- Filtration: 25 microns or less.

4.7 CLEANING PROCEDURE

4.7.1 Samples shall be first inspected for any signs of abrasion, etc., and brushed clean, using a nylon brush.

4.7.2 The material specimens shall then be decontaminated, using cold tap water. Flush with water until pH of effluent is within 0.5 pH unit of influent, but do not flush less than 2 minutes.

4.7.3 Perform detergent cleaning using 1/2 to 1 oz. of detergent/gallon of deionized water. Assist cleaning with nylon brush. Immersion time shall be 5 + 1 minutes at bath temperature of 120^o-150^oF. Agitation, not ultrasonic, shall be effected for a period not less than 30 seconds prior to removal from detergent bath.

4.7.4 Soak and agitate for not less than 2 minutes with deionized water (see Section 4.6.1) 140^oF maximum until no evidence of detergent solution is apparent when checked by a suitable ASTM or equivalent method.

4.7.5 Rinse-spray using deionized water for at least ten thorough applications.

4.7.6 Place samples in clean Petri dish.

4.7.7 Purge for 5 minutes with nitrogen (GN₂) conforming to Section 4.6.4, filtered through a membrane filter not exceeding a 4.5 micron pore size, and package in a polyethylene or equivalent package.

4.7.8 Samples have now been uniformly cleaned and are ready for testing.

5.0 TEST APPARATUS

5.1 Prior to performing any GOX impact test, the test chamber and components shall be degreased in a solution of detergent and demineralized water or Freon 113 depending upon the contaminants. Rinsing or flushing shall be thorough, followed by adequate drying, such as passage of dry nitrogen, air, or inert gas over the components.

5.2 Application of any cleaning solution must be restricted to usages where problems subsequent to cleaning will not occur as a result of the application; e.g., corrosion from entrapped cleaning fluids that might alter a material's GOX impact characteristics, etc.

5.3 All steps in any procedure must progress in an uninterrupted series of operations through the final rinse and drying operation. Precautions must be taken to assure that cleanliness is maintained until testing commences.

5.4 The cleaning requirements for Type J fluid test systems are beyond the scope of this document.

5.5 Corrosion resistant steel components, including striker pins and inserts should be cleaned as follows after physically removing any gross contamination adhering to the striker pins from prior usage.

- a. Immerse in a bath of an approved inhibited nonetch alkaline cleaning solution (Turco 4215 - 10 ± 2 ounces per gallon, or equal) at 160 ± 10°F, for a minimum of 10 minutes.
- b. Flush thoroughly with large quantities of tap water for a minimum of 10 minutes at room temperature.
- c. Immerse in a bath of 10 ± 2% Nitric acid, at 170 to 190°F for a minimum of 5 minutes and a maximum of 10 minutes.
- d. Flush thoroughly with large quantities of demineralized water for a minimum of 10 minutes. The demineralized water shall contain no particle over 175 microns in any dimension and no more than five particles from 100 to 175 microns in size when a 500 milliliter sample is tested by an approved particle count procedure. The minimum specific resistance of the water shall be 50,000 ohms with a pH between 6.0 and 8.0

e. Dry the components thoroughly with a drying gas or by a vacuum drying process.

5.6 Aluminum alloy components, specimen cups, and grease cups should be cleaned as follows:

- a. Immerse in a bath of an approved inhibited nonetch alkaline cleaning solution (Turco 4215, 10 ± 2 ounces per gallon, or equal) at $160 \pm 10^{\circ}\text{F}$, for a minimum of 10 minutes.
- b. Flush thoroughly with large quantities of tap water for a minimum of 10 minutes at room temperature.
- c. Immerse in a bath of 3 to 5% nitric acid at a temperature of 85 to 95°F for a minimum of 5 minutes and a maximum of 7 minutes. A solution of $5 \pm 0.5\%$ of phosphoric acid at 160 to 180°F may be used in place of or after HNO_3 for removing heavy contamination that cannot be removed with the nitric acid solution. If used, immerse in the phosphoric acid solution for a minimum of 5 minutes and a maximum of 7 minutes.
- d. Flush thoroughly with large quantities of demineralized water for 10 minutes. The quality of the water should be equal to that described for use in flushing stainless steel components in paragraph d of the preceding sequence.
- e. Dry the aluminum alloy components thoroughly with a drying gas, or by a vacuum drying process.

5.7 After cleaning and drying, the components are checked for nonvolatile residue and particulate contamination using trichlorotrifluoroethane (Freon 113) as a test solvent. The nonvolatile residue content of the test solvent shall be no greater than 0.010 gram per 500 milliliters and shall have no particles over 175 microns in any dimension and no more than five particles from 10 to 100 microns in size. A sufficient quantity of the component is selected so that the combined surface area will be 1 square foot, and this quantity is treated with 500 milliliters of the test solvent. The test solvent is analyzed for nonvolatile residue and a particle size distribution obtained. The nonvolatile residue contamination on the surface of the components for oxygen testing shall be no greater than 0.001 gram per square foot. Particles of contamination per square foot of component surface area shall not exceed the following limits:

- a. No particles greater than 500 microns in any dimension.
- b. One particle between 350 and 500 microns.
- c. Five particles between 100 and 350 microns.

The test solvent "Freon 113" normally has a nonvolatile residue content of less than 1.5 milligrams per 500 milliliters of solvent.

The drying gas (if used) should have a total hydrocarbon content no greater

than 5 ppm as compared to a methane standard, and the particulate contamination no more than 25 particles in the 25 to 100 micron range and none greater than 100 microns on a standard 30 cubic foot sample.

NOTE: Procedures other than those specified in paragraphs 5.5 and 5.6 may be utilized for cleaning corrosion resistant steel and aluminum alloy components, provided the cleanliness level attained is equal to or better than that required by the procedures of paragraphs 5.5 and 5.6.

APPENDIX D - MAXIMUM ALLOWABLE CONCENTRATIONS (MACs)
OF
ATMOSPHERIC CONTAMINANTS IN MANNED SPACECRAFT AND USAGE GUIDELINES

I. Maximum Allowable Concentrations (MACs) of Contaminants for Missions up to 7 Days*

	<u>Mol. Wt.</u>	<u>MACs</u> <u>7-Day</u> <u>ppm (mg/M³)</u>
**1. <u>Alcohols</u>		
allyl alcohol (2-propen-1-ol)	58.08	0.5 (1)
n-amyl alcohol (1-pentanol)	88.15	35 (126)
isobutyl alcohol (2-methyl-1-propanol)	74.12	40 (121)
n-butyl alcohol (1-butanol)	74.12	40 (121)
sec-butyl alcohol (2-butanol)	74.12	40 (121)
tert-butyl alcohol (2-methyl-2-propanol)	74.12	40 (121)
cyclohexanol	100.2	30 (123)
ethyl alcohol (ethanol)	46.07	50 (94)
ethylene glycol (1,2-ethanediol)	62.07	50 (127)
2-hexyl alcohol (2-hexanol)	102.2	40 (167)
methyl alcohol (methanol)	32.04	40 (52.4)
octyl alcohol (1-octanol)	130.2	40 (213)
phenol	94.11	2 (7.7)
n-propyl alcohol (1-propanol)	60.09	40 (98.3)
isopropyl alcohol (2-propanol)	60.09	40 (98.3)
**2. <u>Aldehydes</u>		
acetaldehyde (ethanal)	44.05	30 (54.0)
acrolein (propenal)	56.06	0.05 (0.11)
benzaldehyde (benzenecarbal)	106.1	40 (173)

*For missions longer than 7 days consult the NASA Toxicologist for MAC values.
 **See Paragraph II.d., Page D-12.

	<u>Mol. Wt.</u>	<u>MACs</u> <u>7-Day</u> <u>ppm (mg/M³)</u>
butyraldehyde (butanal)	72.10	40 (118)
crotonaldehyde (trans-2-butenal)	70.09	0.6 (1.7)
formaldehyde (methanal)	30.03	0.1 (0.12)
furfural (2-furancarboxal)	96.08	2 (7.9)
propionaldehyde (propanal)	58.08	40 (95.0)
valeraldehyde (pentanal)	86.13	30 (106)
**3. <u>Aromatic hydrocarbons</u>		
benzene	78.11	0.1 (0.32)
cumene (isopropylbenzene)	120.2	15 (73.7)
decalin (decahydronaphthalene)	138.2	2 (11)
ethylbenzene	106.2	20 (86.8)
1,2-ethylmethylbenzene (1-ethyl-2-methylbenzene)	120.2	5 (25)
indene (indonaphthene)	116.1	2 (9.5)
mesitylene (1,3,5-trimethylbenzene)	120.2	3 (15)
methyl styrene (2-phenylpropene)	118.2	30 (145)
naphthalene	128.2	2 (10)
propylbenzene	120.1	10 (49.1)
pseudocumene (1,2,4-trimethylbenzene)	120.2	3 (15)
styrene (ethenylbenzene)	104.1	10 (42.6)
toluene (methylbenzene)	92.13	20 (75.3)
m-xylene (1,3-dimethylbenzene)	106.2	20 (86.8)
o-xylene (1,2-dimethylbenzene)	106.2	20 (86.8)
p-xylene (1,4-dimethylbenzene)	106.2	20 (86.8)
**4. <u>Esters</u>		
n-amy] acetate	130.2	30 (160)

	<u>Mol. Wt.</u>	<u>MACs</u> <u>7-Day</u> <u>ppm (mg/M³)</u>
n-butyl acetate	116.2	40 (190)
cellosolve acetate (2-ethoxyethyl acetate)	132.2	30 (162)
ethyl acetate	88.10	50 (180)
ethyl formate	74.08	30 (90.9)
ethyl lactate	118.1	40 (193)
isobutyl acetate	116.2	40 (190)
isopropyl acetate	102.1	50 (209)
methyl acetate	74.08	40 (121)
methyl butyrate	102.1	20 (83.5)
methyl methacrylate	100.1	25 (102)
n-propyl acetate	102.1	40 (167)

**5. Ethers

2,5-dimethylfuran	96.12	0.04 (0.16)
m-dioxane (1,3-dioxane)	88.11	5 (18)
ethyl butyl ether (1-ethoxybutane)	102.2	80 (334)
ethyl ether (diethyl ether)	74.12	80 (242)
furan (1,4-epoxy-1,3-butadiene)	68.07	0.04 (0.11)
2-methylfuran	82.10	0.04 (0.13)
methyl vinyl ether (methoxyethene)	58.08	50 (119)
isopropyl ether (diisopropyl ether)	102.2	50 (209)
tetrahydrofuran (1,4-epoxybutane)	72.10	40 (118)

HALOCARBONS

6. Chlorocarbons

butyl chloride (1-chlorobutane)	92.57	40 (151)
carbon tetrachloride (tetrachloromethane)	153.8	2 (13)

	<u>Mol. Wt.</u>	<u>MACs</u> <u>7-Day</u> <u>ppm (mg/M³)</u>	
chloroacetone (1-chloro-2-propanone)	92.53	0.05	(0.19)
chlorobenzene	112.6	10	(46.0)
chloroform (trichloromethane)	119.4	1	(4.9)
o-dichlorobenzene (1,2-dichlorobenzene)	147.0	5	(30)
ethyl chloride (chloroethane)	64.50	100	(263.7)
ethylene chloride (1,2-dichloroethane)	98.97	10	(40.5)
ethylidene chloride (1,1-dichloroethane)	98.97	25	(101)
isopropyl chloride (2-chloropropane)	78.54	85	(273)
methyl chloride (chloromethane)	50.49	20	(41.3)
methyl chloroform (1,1,1-trichloroethane)	133.4	30	(164)
methylene chloride (dichloromethane)	84.94	25	(86.8)
perchloroethylene (tetrachloroethene)	165.8	5	(34)
n-propyl chloride (1-chloropropane)	78.54	30	(96)
propylene dichloride (1,2-dichloropropane)	113.0	10	(42.2)
beta-trichloroethane (1,1,2-trichloroethane)	133.4	1	(5.5)
trichloroethylene (trichloroethene)	131.4	0.1	(0.54)
vinyl chloride (chloroethene)	62.50	0.1	(0.26)
vinylidene chloride (1,1-dichloroethene)	96.95	2	(7.9)

7. Chlorofluorocarbons

chlorofluoromethane	68.48	50	(140)
chlorotrifluoroethane (1-chloro-1,2, 2-trifluoroethane)	118.5	100	(484.5)
chlorotrifluoroethylene (chloro-tri- fluoroethene)	116.5	100	(476.4)
dichlorodifluoroethylene (1,2-dichloro- 1,2-difluoroethene)	133.0	25	(136)
Freon 11 (trichlorofluoromethane)	137.4	100	(561.8)

	<u>Mol. Wt.</u>	<u>MACs</u> <u>7-Day</u> <u>ppm (mg/M³)</u>	
Freon 12 (dichlorodifluoromethane)	120.9	100	(494.4)
Freon 21 (dichlorofluoromethane)	102.9	5	(21)
Freon 22 (chlorodifluoromethane)	86.47	100	(353.6)
Freon 112 (1,1,2,2-tetrachloro-1,2-difluoroethane)	204.0	100	(834.2)
Freon 113 (1,1,2-trichloro-1,2,2-trifluoroethane)	187.4	50	(383)
Freon 114 (1,2-dichloro-1,1,2,2-tetrafluoroethane)	171.9	100	(702.9)
monochlorofluoroethylene (1-chloro-2-fluoroethene)	80.46	25	(82.2)
Freon FE1301 (Halon 1301) (bromotrifluoromethane)	148.9	100	(608.8)
8. <u>Fluorocarbons</u>			
Freon 23 (trifluoromethane)	70.01	100	(286.3)
perfluoroethylene (tetrafluoroethene)	100.0	50	(204)
**9. <u>Hydrocarbons</u>			
acetylene (ethyne)	26.04	500	(532.4)
allene (propadiene)	40.07	50	(81.9)
isobutane (2-methylpropane)	58.12	100	(237.6)
n-butane (butane)	58.12	100	(237.6)
1-butene	56.10	200	(458.0)
cis-2-butene	56.10	100	(229.4)
trans-2-butene	56.10	100	(229.4)
1,3-butadiene	54.09	100	(221.2)
isobutylene (2-methylpropene)	56.10	500	(1147)
citrene (limonene(d))	136.2	100	(557.0)
cyclohexane	84.16	60	(206)

	<u>Mol. Wt.</u>	<u>MACs</u> <u>7-Day</u> <u>ppm (mg/M³)</u>
cyclohexene	82.14	60 (201)
cyclopentane	70.13	60 (172)
cyclopentene	68.12	60 (167)
cyclopropane	42.08	60 (103)
n-decane (decane)	142.3	40 (233)
1,1-dimethylcyclohexane	112.2	25 (115)
trans-1,2-dimethylcyclohexane	112.2	25 (115)
2,2-dimethylbutane	86.18	25 (88.1)
n-dodecane (dodecane)	170.3	40 (278)
ethane	30.07	1000 (1230)
ethylacetylene (1-butyne)	54.09	80 (177)
trans-1-methyl-3-ethylcyclohexane	126.2	25 (129)
ethylene (ethene)	28.05	300 (344.1)
n-heptane (heptane)	100.2	50 (205)
1-heptene	98.19	50 (201)
1-hexene	84.16	50 (172)
n-hexane (hexane)	86.18	50 (176)
isoprene (2-methyl-1,3-butadiene)	68.11	200 (557.0)
*methane	16.04	2700 (1771)
methylacetylene (propyne)	40.06	250 (409.5)
2-methyl-1-butene	70.13	500 (1434)
methylcyclohexane	98.18	15 (60.2)
4-methylcyclohexene	96.17	100 (393.2)
methylcyclopentane	84.16	15 (51.6)
3-methylpentane	86.17	500 (1762)
n-nonane (nonane)	128.3	60 (315)

	<u>Mol. Wt.</u>	<u>MACs</u> <u>7-Day</u> <u>ppm (mg/M³)</u>	
1-nonene	126.2	50	(258)
n-octane (octane)	114.2	75	(350)
1-octene	112.2	50	(229)
isopentane (2-methylbutane)	72.15	100	(295.0)
n-pentane (pentane)	72.15	200	(590.0)
1-pentene	70.13	65	(186)
2-pentene	70.13	65	(186)
*propane	44.09	500	(901.4)
*propylene (propene)	42.08	500	(860.3)
tetradecane	198.4	50	(406)
1,1,3-trimethylcyclohexane	126.2	25	(129)
2,3,4-trimethylhexane	128.1	50	(262)
undecane (hendecane)	156.3	50	(319)
**10. <u>Inorganic Acids</u>			
chlorine	70.91	0.3	(0.87)
hydrochloric acid (hydrogen chloride)	36.47	1	(1.5)
hydrofluoric acid (hydrogen fluoride)	20.01	0.1	(0.082)
**11. <u>Ketones</u>			
acetone (2-propanone)	58.08	300	(712.5)
acetylbenzene (acetophenone)	120.1	50	(245)
cyclohexanone	98.15	15	(60.2)
diisobutyl ketone (2,6-dimethyl-4-heptanone)	142.2	10	(58.1)
mesityl oxide (4-methyl-3-penten-2-one)	98.15	10	(40.1)
methyl butyl ketone (2-hexanone)	100.2	10	(41.0)
methyl ethyl ketone (2-butanone)	72.10	20	(59.0)

	<u>Mol. Wt.</u>	<u>MACs</u> <u>7-Day</u> <u>ppm (mg/M³)</u>	
methyl hexyl ketone (2-octanone)	128.2	20	(105)
methyl isobutyl ketone (4-methyl-2-pentanone)	100.2	20	(82.0)
methyl isopropyl ketone (3-methyl-2-butanone)	86.13	20	(70.4)
methyl propyl ketone (2-pentanone)	86.13	20	(70.4)
phorone (2,6-dimethyl-2,5-heptadiene-4-one)	138.2	20	(113)
12. <u>Mercaptans and Sulfides</u>			
carbon bisulfide (carbon disulfide)	76.14	5	(16)
carbon oxysulfide (carbonyl sulfide)	60.07	5	(12)
ethyl mercaptan (ethanethiol)	62.13	0.1	(0.25)
ethyl sulfide (diethyl sulfide)	90.18	0.1	(0.37)
hydrogen sulfide	34.08	2	(2.8)
methyl sulfide (dimethyl sulfide)	62.13	1	(2.5)
methyl mercaptan (methanethiol)	48.1	0.1	(0.20)
**13. <u>Nitrogen Oxides</u>			
nitric oxide	30.01	5	(6.1)
nitrogen dioxide	46.01	0.5	(0.94)
nitrogen tetroxide	92.02	0.5	(1.9)
nitrous oxide	44.01	500	(899.8)
**14. <u>Organic Acids</u>			
acetic acid (ethanoic acid)	60.05	3	(7.4)
butyric acid (butanoic acid)	88.10	5	(18)
caprylic acid (octanoic acid)	144.2	25	(147)
propionic acid (propanoic acid)	74.08	5	(15)
pyruvic acid (2-oxo-propanoic acid)	88.06	1	(3.6)

	<u>Mol. Wt.</u>	<u>MACs</u> <u>7-Day</u> <u>ppm (mg/M³)</u>	
valeric acid (pentanoic acid)	102.1	25	(104)
15. <u>Organic Nitrogens</u>			
acetonitrile (ethanenitrile)	41.05	4	(6.7)
carbodiimide (cyanamide)	42.04	0.8	(1.4)
uns-dimethyl hydrazine (1,1-dimethyl hydrazine)	60.10	0.1	(0.25)
indole (1-benzo[b]pyrrole)	117.1	0.1	(0.48)
monomethyl hydrazine (methylhydrazine)	46.07	0.04	(0.075)
skatole (3-methyl indole)	131.2	0.1	(0.54)
**16. <u>Miscellaneous</u>			
ammonia	17.03	25	(17.4)
carbon monoxide	28.01	25	(28.6)
hexamethylcyclotrisiloxane	222.4	25	(227)
hydrogen	2.016	3000	(247.3)
hydrogen cyanide (hydrocyanic acid)	27.06	1	(1.1)
sulfur dioxide	64.07	1	(2.6)

II. Usage Guidelines For MAC Values of Atmospheric Contaminants In Manned Spacecraft

The maximum allowable concentration (MAC) of most compounds listed above is the maximum concentration of that contaminant allowed in the spacecraft atmosphere, only if that compound exists alone. The spacecraft atmosphere, however, consists of a homogeneous mixture of compounds, many of which have similar effects that are additive. These potential additive effects must be considered in the assessment of the toxicological hazard of contaminant mixtures. The following guidelines for MAC usage provide for the potential summation of toxic effects of contaminants and must be observed in the application of MAC values to evaluate the safety of the spacecraft atmosphere.

- a. The concentration of each contaminant in the spacecraft atmosphere must not exceed its MAC value.
- b. For contaminants designated by an asterisk, each MAC value is valid when the contaminant is either alone or in mixtures of contaminants. These contaminants will be evaluated individually.
- c. For each of the groups of contaminants, a group-limit concept will be utilized to evaluate the toxicological hazard of the group. In each group, the summation (T) of the ratios of concentration to MAC value of each member of the group (except asterisked members) must not exceed one. The following formula will be used:

$$\frac{C_1}{MAC_1} + \frac{C_2}{MAC_2} + \frac{C_3}{MAC_3} + \dots = T < 1$$

- d. In addition, the interaction of contaminant groups that have potential additive effects must be evaluated toxicologically. These groups are identified by a double asterisk in the above table. For this evaluation, the summation (ΣT) of the T values of these groups must not exceed one, as shown by the following formula.

$$T_1 + T_2 + T_3 + \dots = \Sigma T < 1$$

- e. MAC values for several compounds listed in the above table were established on the basis of limited toxicity data and must be considered provisional and subject to revision as more data become available.

- f. The above guidelines are general guidelines to be used by the NASA toxicologist for evaluation of the toxic hazards of a homogeneous mixture of contaminants in the spacecraft atmosphere. Because of the complexity of this mixture, only general guidelines, and not fixed rules, for this evaluation are possible. In many instances a more comprehensive analysis of the data than is provided by these guidelines will be necessary for a valid toxicological evaluation.