



NUWC Division Keyport

Report No. 2254

Copy No.

THE HISTORY OF THE NAVAL TORPEDO TRACKING RANGES AT KEYPORT

August 1998

NAVAL UNDERSEA WARFARE CENTER DIVISION KEYPORT
TEST & TRAINING ENVIRONMENTS DEPARTMENT
Keyport, Washington 98345-7610

Approved for Public Release; Distribution Unlimited

Measurement Technologies Division
Code 523

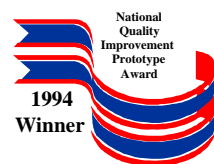



DEPARTMENT OF THE NAVY
NAVAL UNDERSEA WARFARE CENTER DIVISION
610 DOWELL STREET
KEYPORT, WASHINGTON 98345-7610

L.J. CARTER
CAPT, USN
COMMANDER NUWC, KEYPORT

R.C. ROGERS
CDR, USN
CHIEF STAFF OFFICER

D.M. VICCIONE
EXECUTIVE DIRECTOR

ADMINISTRATIVE STATEMENT

NUWC Division Keyport Report 2254, The History Of The Naval Torpedo Tracking
Ranges At Keyport

By Charles R. Gundersen

Reviewed for
technical content by

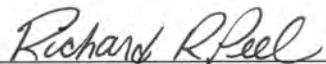
Richard R. Peel
Ocean Engineering Division

Approved by

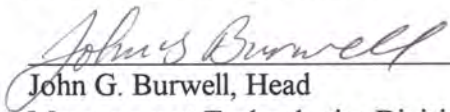
John G. Burwell, Head
Measurement Technologies Division

Released by

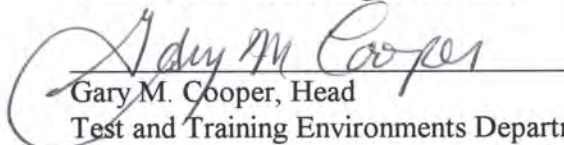
Gary M. Cooper, Head
Test and Training Environments Department

Date: 14 AUG 1998

REPORT DOCUMENTATION PAGE

Form Approved
OMB No. 0704-0188

Public reporting burden for this collection of information is estimated to average 1 hour per response, including the time for reviewing instructions, searching existing data sources, gathering and maintaining the data needed, and completing and reviewing the collection of information. Send comments regarding this burden estimate or any other aspect of this collection of information, including suggestions for reducing this burden, to Washington Headquarters Services, Directorate for Information Operations and Reports, 1215 Jefferson Davis Highway, suite 1204, Arlington, 22202-4302, and to the Office of Management and Budget, Paperwork Reduction Project (0704-0188), Washington, DC 20503.

1. AGENCY USE ONLY (Leave blank)	2. REPORT DATE August 1998	3. REPORT TYPE AND DATES COVERED Final report	
4. TITLE AND SUBTITLE The History of the Naval Torpedo Tracking Ranges at Keyport		5. FUNDING NUMBERS	
6. AUTHOR(S) Charles R. Gundersen			
7. PERFORMING ORGANIZATION NAME(S) AND ADDRESS(ES) Naval Undersea Warfare Center Division Keyport Test & Training Environments Department 610 Dowell Street Keyport, WA 98345-7610		8. PERFORMING ORGANIZATION REPORT NUMBER Report No. 2254	
9. SPONSORING/MONITORING AGENCY NAME(S) AND ADDRESS(ES) Naval Undersea Warfare Center Division Keyport Test & Training Environments Department 610 Dowell Street Keyport, WA 98345-7610		10. SPONSORING/MONITORING AGENCY REPORT NUMBER	
11. SUPPLEMENTARY NOTES			
12a. DISTRIBUTION AVAILABILITY STATEMENT Approved for Public Release; Distribution Unlimited		12b. DISTRIBUTION CODE	
13. ABSTRACT (Maximum 200 words) This report chronicles the history and technology of the U.S. Navy's undersea tracking range developments, particularly the facilities at Keyport, Washington and at other sites in the Pacific Northwest. These developments, ongoing since the early 1900's, were driven by significant challenges in the testing & evaluation of torpedoes and ever more complex undersea weapons, as well as by notorious weapon failures during their use by the fleet. Nearly a century of invention and evolution of tracking range instrumentation is described, along with the differing concepts and techniques employed to acoustically track underwater objects.			
14. SUBJECT TERMS Undersea tracking ranges Acoustic signals Hydrophone arrays		15. NUMBER OF PAGES 107	
		16. PRICE CODE	
SECURITY CLASSIFICATION OF REPORT UNCLASSIFIED	SECURITY CLASSIFICATION OF THIS PAGE UNCLASSIFIED	SECURITY CLASSIFICATION OF ABSTRACT UNCLASSIFIED	LIMITATION OF ABSTRACT UL



USS SKATE Class Submarine Operating on the Dabob Bay Underwater Tracking Range

The History of the Naval Torpedo Tracking Ranges at Keyport



Charles R. Gundersen, Code 523

**Measurement Technologies Division
Naval Undersea Warfare Center Division Keyport
Keyport, Washington**

August 1998

Prepared for the

**Naval Undersea Museum
Keyport, Washington**

The History of the Naval Torpedo

Tracking Ranges at Keyport

Executive Summary

With the realization, at the turn of the last century, that our nation was soon to take on a two-ocean responsibility, the Navy decided to set up a west coast site for the preparation and testing of a new weapon, the torpedo, destined for service on board ships and submarines operating in the Pacific Ocean. The reason was simple, a west coast torpedo station would avoid the need to transport these new weapons across the continent of the United States, to the east coast, in order to obtain torpedo services. One important function assigned to the new torpedo station was to assess the performance of the weapon through actual in-water testing in a controlled environment on a tracking range. At Keyport, Washington, there was an ideal body of relatively shallow water in which torpedoes could be tested: Port Orchard Inlet.

However, to determine the success or failure of a torpedo run required direct observation, difficult at best within the waters of Puget Sound. Nevertheless, a network of buoys and observation platforms, manned by technicians armed only with stopwatches, were set up along the centerline of the new range. From visual observations of the torpedo as it sped down the range past the observers, a determination was made as to the success of the run. Occasionally a net was lowered in the water for the torpedo to penetrate in an attempt to determine depth. As would be later shown, under combat conditions, this limited testing was just not adequate to fully understand the performance of these weapons, or to uncover potential problems; even though in wartime service they were designed to make a single straight run toward a target at a specified depth until the warhead detonated (either on contact or influenced by the target's hull). Testing deficiencies became apparent as serious torpedo problems surfaced during actual wartime use. This quickly resulted in the application of new technologies to the process of weapons testing and contributed to the eventual deployment of a very successful torpedo.

Acoustic based tracking systems were installed during the last year of World War II, just as the Navy began to shift emphasis away from torpedo attacks solely against surface ships, to include torpedo attacks against deep diving enemy submarines. It can be readily appreciated that a new generation of deep diving and highly maneuverable torpedoes, able to seek out submerged targets, would spawn a new generation of tracking technologies, and the need for a new body of deep water in which these new technologies could be applied. This need was fulfilled with the installation of a new range in the deeper waters of Dabob Bay, a range designed to allow tracking in all three dimensions. The new range in Dabob Bay was the very first tracking range capable of accurate 3-D tracking and is still considered one of the quietest and most secure instrumented underwater ranges in the world. At first, acoustic signals of several hundred kiloHertz were used, being received and transmitted by special acoustic transponders installed in all exercise participants. The transponder in the test torpedo received the bottom-mounted array's interrogating pulse and sent out a reply pulse back to the array of hydrophones which provided the information necessary to determine the transponder's exact position relative to the array. The first attempt to track using this approach turned out to be very successful and timely, with a system ready-to-go and able to meet the tracking requirements of a new breed of torpedo (the Anti-Submarine Warfare torpedo). However, as the weapons needing testing matured, several limitations to this tracking approach became apparent.

Resolving these limitations resulted in the next jump in range tracking technologies, that of advanced bottom-mounted hydrophone arrays and later new acoustic tracking codes and telemetry signals, all operating at a new lower frequency. With some modernization, this represents the current generation of tracking technologies. In addition, new range sites appeared in the deeper waters off Vancouver Island, British Columbia, Canada at a place called Nanoose and in the shallow waters off the coast of Washington at Quinault.

A consistent and predominate theme in Keyport's mission statement has always been the Test and Evaluation (proofing and qualification) of torpedoes, targets, countermeasures and other undersea vehicles. This formal program of production acceptance testing (proofing) and the need to satisfy the research and development (R&D) community by testing advanced and upgraded weapon systems (in a controlled environment against a known target) have been the traditional uses of undersea ranges. However, shortly after the first range operations began there emerged unexpected and beneficial new uses for tracking ranges. For example, two major new range programs were started, a program to align a ship's fire control system (called Weapon System Accuracy Trials, WSAT), and an acoustic measurement and analysis program to support noise signature acquisition from a variety of undersea vehicles.

With the expanded usefulness of Keyport's undersea tracking ranges came the requirement for added capability. This led to the development of new range systems, which included:

- Bottom and surface torpedo recovery systems (weapons are recovered intact, since the ranges are not deep enough to crush a weapon's hulls),
- Special multi-purpose range craft that can support a full spectrum of range operations, beyond just launching the test vehicle,
- Fixed and mobile targets and countermeasure emulators to avoid the expense and scheduling difficulties of using actual Fleet assets,
- Integration of the in-air portion of a weapon's trajectory with the underwater track to produce a true 3-D picture of the entire run of air dropped weapons,
- Linking all range sites to a Range Information Display Center (RIDC) at Keyport where operations can be efficiently viewed, controlled, and analyzed in real time.

One critical, near term tracking effort involves returning to the acoustically harsh environment of shallow water, the increasingly important littoral areas of the world's oceans. Supplementing this important work will be investments in the areas of information connectivity, computer modeling and simulation, continued development of transportable range technologies, and programs to provide improvement and modernization of range tracking equipment.

The central thread throughout this report is the development of technologies to accomplish undersea tracking at Keyport's undersea range sites, rather than providing a general overview of the many aspects of a modern undersea range facility.

Table of Contents

Abbreviations and Definitions	x
Foreword	xiii
Introduction	1
The Early Range at Keyport	2
A New Torpedo for the Fleet	6
Torpedo Problems Experienced During World War II	7
The First Keyport Acoustic Range	8
Early Acoustic Ranging in Hood Canal	19
The 3-D Range at Dabob Bay	23
Low Frequency Experiment in Alaska	29
High Frequency Ranging at Dabob Bay	32
The Shift to Low Frequency Tracking at Dabob Bay	35
Related Activity at Other Navy Range Sites	38
A New Range Site Develops at Nanoose	41
Types of Tracking Arrays	45
High Frequency Buoyant Array	45
Low Frequency Buoyant Array	45
Semi-Rigid Array	47
Rigid-Rigid Array	48
How a Tracking Range Determines Positions	49
Long Baseline Tracking	50
Short Baseline Tracking	54
New Tracking Signals for New Tracking Capabilities	56
The Development of PSK Tracking	56
The Development of SFSK Tracking	62
The Shallow Water Range at Quinault	67
On to the Future	74
References	77
Appendix A Wartime Problems with the MK 14 Torpedo	80
Appendix B Development of Weapon Recovery Systems	90
Appendix C Time-Line of Torpedo Tracking Range Events at Keyport	97

List of Figures

Frontispiece	USS SKATE Class Submarine Operating on the Dabob Bay Underwater Tracking Range	iv
Figure 1	Torpedo Ranging in Port Orchard Inlet	3
Figure 2	Range Operations in Port Orchard Inlet	4
Figure 3	Launching Torpedoes Down Port Orchard Inlet	9
Figure 4	Keyport Acoustic Range Layout (Circa 1957)	11
Figure 5	The Firing Tube and Submersible Elevator at Pier 1	13
Figure 6	Keyport Acoustic Range Control Console	15
Figure 7	Keyport Acoustic Range Tracking Concept	17
Figure 8	Three-Dimensional Range Installation in Hood Canal	21
Figure 9	High Frequency Tracking Range Concept	22
Figure 10	High Frequency Buoyant Array	26
Figure 11	Low Frequency Buoyant Array	30
Figure 12	High Frequency Array Installation	33
Figure 13	Dabob Bay 3-D Tracking Range Layout	37
Figure 14	Long and Short Baseline Tracking Arrays	40
Figure 15	Nanoose 3-D Tracking Range Layout	44
Figure 16	Rigid-Rigid Array	49
Figure 17	Synchronous Spherical Tracking Equation	51
Figure 18	Asynchronous Hyperbolic Tracking Equation	53
Figure 19	Tone Burst and Phase-Shift Keying (PSK) Signal Characteristics	58
Figure 20	Spaced Frequency-Shift Keying (SFSK) Signal Characteristics	65
Figure 21	Technical Comparison of Tracking Technologies	66
Figure 22	Shallow Water Range Acoustic Test	69
Figure 23	Quinault Shallow Water Tracking Range Layout	72
Figure B-1	Weapon Recovery Using SORD	92
Figure B-2	The Pisces Manned Submersibles	94

Abbreviations and Definitions

2-D	Two-dimensional
3-D	Three-Dimensional
ADCAP	Advanced Capability MK 48 torpedo
AFWTF	Atlantic Fleet Weapons Training Facility, St. Croix, U.S. Virgin Islands
ALWT	Advanced Lightweight Torpedo (redesignated as the MK 50)
APL/UW	Applied Physics Laboratory, University of Washington
Array	A rigid structure resting on the seafloor, usually with an electrical signal cable connecting it with a computer facility on shore, containing one or more acoustic receiving hydrophones for the purpose of tracking an underwater vehicle or for receiving the ambient noise signature from that vehicle.
ASTOR	Anti-Submarine Torpedo, MK 45
ASW	Anti-Submarine Warfare
AUTEC	Atlantic Undersea Test and Evaluation Center, Tongue of the Ocean (TOTO), Andros Island, Bahamas
BARSTUR	Barking Sands Tactical Underwater Range, Hawaii
BSURE	Barking Sands Underwater Range Expansion, Hawaii
BuOrd	Bureau of Ordnance, United States Navy
BuShips	Bureau of Ships, United States Navy
CD-ROM	Compact Disk-Read Only Memory
CNO	Chief of Naval Operations
COMOPTEVFOR	Commander, Operational Test and Evaluation Force, United States Navy
COT	Consolidated Operability Test
CTD	Conductivity, Temperature, and Depth
CURV	Cable-Controlled Underwater Recovery Vehicle
CWO	Chief Warrant Officer
dB	Decibel
DEC	Digital Equipment Corporation
Electrolytic release	A type of release which separates an array from its anchor through an electrolysis action where an electric current is passed through a corrosive strength member to dissolve it away by rapid corrosion.
FORACS	Fleet Operational Readiness Accuracy Check Site
FSK	Frequency-Shift Keying
GPS	Global Positioning System
H₂O₂	Hydrogen peroxide
HAIUR	Hawaiian Islands Underwater Range
I₀	The computer's time interval between position calculations
K/B Dock	Keyport/Bangor pier on the east side of Hood Canal, Washington

kHz	KiloHertz, one thousand cycles per second
LBL	Long baseline. Refers to the spacing between the tracking system's receiving hydrophones and is approximately 2,000 yards.
Mod	Modification
Navol	A solution of 70% hydrogen peroxide (H ₂ O ₂) and 30% water
NAVSEA	Naval Sea Systems Command, United States Navy
NOL	Naval Ordnance Laboratory
NOTS	Naval Ordnance Test Station, Pasadena Annex, Pasadena, California.
NTS	Naval Torpedo Station, either Newport, Rhode Island or Keyport, Washington
NTV	NUWES Test Vehicle
NUOS	Naval Underwater Ordnance Station, Newport, Rhode Island
NUWC	Naval Undersea Warfare Center
NUWES	Naval Undersea Warfare Engineering Station, Keyport, Washington
OPEVAL	Operational Evaluation
ORL/PSU	Ordnance Research Laboratory, Pennsylvania State University
PMS	Program Manager, Naval Sea Systems Command
Proofing	A formal program of weapon production acceptance testing following delivery of the weapon to the Government by the manufacturer
PSK	Phase-Shift Keying
R&D	Research and Development
RF	Radio Frequency telemetry
RIDC	Range Information Display Center
S/N	Signal-to-noise ratio
SBL	Short baseline. Refers to the spacing between the tracking system's receiving hydrophones. Spacings of 10 and 30 feet have been used on Keyport arrays.
SCIUR	San Clemente Island Underwater Range, California
SCORE	Southern California Offshore Range, California
SFSK	Spaced Frequency-Shift Keying (see FSK)
SINKEX	Sink exercise where a ship is intentionally sunk to test the effectiveness of a weapon.
SOLARIS	Submerged Object Locating and Recovery/Inspection System
SORD	Submerged Object Recovery Device
SPV	Special Purpose Vehicle
SST	Submarine Sensor Tracking
STVP	Salinity, Temperature, sound Velocity, and Pressure
SWARTV	Shallow Water Acoustic Range Test Vehicle
SWIFT	Shallow Water Inexpensive Flexible Tracking
SWR	Shallow Water Range
Sync clock	Synchronous clock. A tracking projector on the vehicle being tracked that is synchronized in time with the main tracking computer at the range control site.
T&E	Test and Evaluation

TECHEVAL	Technical Evaluation
TNT	Tri-nitro-toluene – an explosive
Torpex	Torpedo explosive
TRB	Torpedo retriever boat
TROV-N	Tethered Remotely Operated Vehicle – Navy
TTAT	Torpedo Tube Acceptance Trials
UUV	Unmanned undersea vehicles
WSAT	Weapon System Accuracy Trials

Foreword

The material contained in this report was originally gathered for use in developing the script for the undersea tracking range display at the Naval Undersea Museum, Keyport, Washington. In some ways it could be considered a supplement to that script. This work may be of interest to the technically curious visitor who, having just toured the torpedo exhibit, is now standing in front of the range display with its high frequency tracking array and wonders how it all got started and is interested in obtaining more details about this history than is offered in the text of the range display script. However, it is hoped that this work will also benefit new and existing employees at NUWC Division, Keyport, involved in the development of range systems, to give them an idea of the rich background upon which they are building.

It is the intent of this work to trace the history of the various techniques used at Keyport to track torpedoes and other craft on our ranges rather than to be a comprehensive study of the development of the entire undersea range system here at Keyport.

A grateful thank you must be extended to those people who took the time to review this report and provided so many worthwhile comments. In addition, the author wishes to thank Nik Lauer, Vitro Corp., whose range history document (see References) inspired this work.

The History of the Naval Torpedo Tracking Ranges at Keyport

Introduction

This report presents an overview of the evolution and technology of the underwater torpedo tracking ranges developed and operated by Naval Undersea Warfare Center Division, Keyport located in the Pacific Northwest. Tracking range sites are located both in the state of Washington and in the province of British Columbia, Canada, and (together with land-based test facilities and portable tracking range hardware) are collectively known as the Northwest Range. The Northwest Range plays an integral role within the U.S. Navy by providing realistic and controlled environments to test a variety of undersea weapons. One aspect of this testing, called “proofing,” is crucial since it is the process by which weapons are accepted into the Navy’s undersea arsenal. Weapon systems testing is also necessary to uncover problem areas, assess performance of upgraded or modified weapons, to aid in the development of entirely new weapon systems, and, of course, it has a motivating effect on the contractor manufacturing the weapon. Addressing these critical testing requirements is the principal function of an underwater tracking range.

The establishment of the Northwest Range had its inception in the years following the Spanish-American War when U.S. Navy warships began steaming into the Pacific Ocean in ever increasing numbers. Most of these warships carried a recently introduced underwater weapon, the “automobile torpedo.” But, the Navy’s only station dedicated to the overhaul and testing of these torpedoes was located on the east coast. A new west coast torpedo station would eliminate the need to transport torpedoes to the east coast, thus saving considerable time and money.

This history both begins and ends with the range testing of torpedoes designed to seek out their targets in shallow water. Early torpedoes operated at a constant depth of only a few feet below the surface, and ran straight and true toward their target in order to strike the hull of the target vessel. To test a weapon with this type of performance, the Navy established several tracking ranges in shallow water; one was installed in Port Orchard Inlet on the west side of Puget Sound. Years later the threat posed by the Soviet Union’s “blue water” fleet of submarines made it necessary to install new ranges, first in Hood Canal and Dabob Bay, then in the Strait of Georgia, Canada. Currently, the end of the Cold War and the break-up of the Soviet Union has once again focused attention on shallow water areas, where many submarines belonging to less-than-friendly third world countries could pose a significant challenge to the free passage of international commerce between nations.

The appendices in this report include a review of the problems that plagued our torpedoes in World War II, a discussion of our capability to recover ordnance from the sea floor, and a time-line history of the significant events relating to torpedo tracking at this Division of the Naval Undersea Warfare Center.

The Early Range at Keyport

Beginning in 1909 the Navy started to investigate the coastal waters between British Columbia, Canada and San Diego, California for a suitable location to establish a west coast torpedo station to test and service torpedoes for the Pacific Fleet. The land and waters around Keyport, Washington were surveyed in June 1909 and were found to be ideal for the desired still-water range. One reason for selecting the site was its shallow depth, only 90 feet at its deepest point, which would make it possible for divers to recover the torpedoes that did not surface at the end of their test runs. Plus, the location offered excellent shipping facilities to all points in the Pacific and it was close to the Puget Sound Naval Shipyard at Bremerton. In June 1910 Congress authorized the purchase of the peninsula near Keyport as the site for the new Pacific Coast Torpedo Station with a charter to store, modify, repair and test torpedoes (\$145,000 was appropriated for this purpose). While the Secretary of the Navy, Josephus E. Daniels, was visiting the Puget Sound area in July 1913 he stopped at Keyport to inspect the site for the new station and was favorably impressed with its potential. It was during that same year that a modest beginning was made when torpedoes from battleships being overhauled at Puget Sound Naval Shipyard were taken aboard the torpedo boat, USS GOLDSBOROUGH (TB 20), and brought to Keyport for test firing in Port Orchard Inlet in an area destined to become the Station's first torpedo tracking range.

The Pacific Coast Torpedo Station was formally commissioned on 14 November 1914 with Commander H. N. Jenson, USN, as the Station's first Commanding Officer. Whitehead torpedoes, manufactured in about 1896 by the E. W. Bliss Company of Brooklyn, New York, were the first torpedoes the Station prepared for the Fleet. In those early days, three or four men would obtain a torpedo from its storage on one side of Building 1, transfer it by hand to the other side of the shop, break it down, overhaul it, and then reassemble it. The torpedo would then be hauled down Pier 1 (the Torpedo Dock, built in 1915) by hand cart, and loaded on board USS LAWRENCE (DD 8), a "flush-deck, four pipe" destroyer, for test firing down the inlet. The ship stayed at Keyport during the summers of 1915 and 1916 to provide compressed air and power for the launching of more torpedoes until a power plant at the Station could be completed.

It was not until April 1916 that a 7,000 yard range was laid out along the inlet and inaugurated by USS SOUTH DAKOTA (Armored Cruiser No. 9) with a test firing of torpedoes. The torpedo range installation consisted of the placement of six buoys in Port Orchard Inlet to define the range centerline and establish precise distances down the range in 1,000 yard increments. To complete the range installation a pair of torpedo tubes was mounted on a "firing float" with the torpedo tubes facing straight down the range and parallel to the centerline. This 40-foot by 40-foot barge was tied off the south side of the Torpedo Dock, as shown in Figure 1. The overall range concept is illustrated in Figure 2. With the 1917 installation of a narrow gage railway line from Building 1 to the end of the Torpedo Dock, test torpedoes could be brought to the firing float on battery powered electric carts.



A torpedo makes the rounds at Keyport in 1918.
From the torpedo shop ...



... to the pier and firing float ...



... to the firing range in Port Orchard Inlet, just
south of the Station's industrial area ...



... and hoisted back on the pier after a test run.

Torpedo Ranging In Port Orchard Inlet

Figure 1



Testing torpedoes was quite different in the 1940's from what it is today. As the diagram shows, above, torpedo speed and depth measurements were made by a visual system at the Keyport range. Barges were set up at each 1000-yard point on the range and buoys were set at specified distances between those barges. Observers on the barge would time torpedoes as they passed between buoys. Originally, a rough, visual estimate was used to determine the depth the 'tin fish' swam. Later, depth was determined with the use of nets placed strategically to allow torpedoes to pass through them. The location of the hole made by a torpedo indicated how deep it had gone.

Range Operations In Port Orchard Inlet

Figure 2

As early as 1916, “ranging” was conducted within Port Orchard Inlet, but without the use of any tracking instruments on the bottom or along the shore to evaluate the progress of the torpedo. All in-water torpedo testing was conducted from the firing float and it was left up to “experts” watching the event to tell whether or not the test was a success. However, not all the torpedoes made a straight run down the range, some exhibited rather strange behavior. For example, Herb Hindle, one of the Station’s first employees describes two runs that went awry. He wrote “a torpedo left the tube, made a right turn, followed the shore line, passed between the end of the bar running to Radio Hill and the beach, and ended up in the south lagoon.” The other run “cut straight across the bay. There were some Indians working on fish nets on the beach and this fish (torpedo) came roaring out of the water and landed in the middle of the works. They were very much surprised.” Eventually, these constant ranging and calibrating efforts led to a straight running torpedo.

In 1920 the two torpedo tubes on the firing float were replaced with a single triple torpedo tube mount to test the torpedoes developed by Bliss-Leavitt. These included the following types of torpedoes:

- MK 7, the Navy's first “steam” torpedo,
- MK 8, the big 21-inch diameter by 21-foot long destroyer-launched torpedo,
- MK 9, a torpedo launched from battleships,
- MK 10, a fast (36 knots), short-range torpedo with, for its day, a most potent warhead (500 pounds of TNT).

(It is interesting to note that approximately 600 of the MK 8 torpedoes were issued to Great Britain for use with the 50 “flush-deck, four pipe” U.S. destroyers provided to them as part of the “lend-lease” arrangement in the early days of World War II.)

As mentioned above six buoys provided a general reference line down the range, but soon two floats were moored on the range, one at the midpoint (3,500 yards) and the other at the most extreme point (7,000 yards). Communication between the personnel on the floats and the personnel at the Torpedo Dock was initially accomplished through a system of flags, then in 1919 a large surplus of deep-sea submarine cable was obtained and the flags were replaced by field telephones. This cable lasted for about 20 years, until several sets of radio receivers and transmitters were purchased for more reliable range communications. A tall observation tower was built on the Torpedo Dock in 1938 to provide an 11-foot by 13-foot observation room at a height of 40 feet above the pier. Most likely the only tracking instrument in the tower, which acted as a range control station, was a “spotting glass.” One important function performed in the tower was to use the spotting glass to follow the track (wake) of the torpedo during its run down the range to gauge the amount of deflection or deviation from a straight run down the range centerline. If the track was nice and straight the run would have been judged a success and the weapon “proofed.”

The torpedo testing business did not change very much over these 20 years, except for a new name for the Station. In 1930 the name was changed to U.S. Naval Torpedo Station. The main function of the range at Keyport remained the same: To allow torpedoes, like the MK 9 battleship torpedo, to make a 7,000 yard straight-away run at a speed between 27 and 28 knots with an air charge of 1,900 pounds per square inch in the air flask. This is an example of a

proofing requirement. “Proofing” is a very important concept, so now it will be more formally introduced: Proofing is that part of torpedo production acceptance testing which includes an in-water test of the complete end-item torpedo under realistic operating conditions, usually on a sample basis, as a condition of government final acceptance of the torpedo matériel.

The tracking instrumentation used in those years could best be described as visual, consisting of the spotting glass at the head of the range to determine deflection away from the range centerline and to estimate initial run depth, and several stopwatches to determine torpedo speed. Just before World War II the number of floats was increased in order to have one float moored at each 1,000 yard point near the range centerline, with a corresponding marker buoy moored at a specified distance on the other side of the range centerline. Observers on the floats started their stopwatches the instant the torpedo was fired and then stopped their stopwatches when the torpedo was observed to pass between the float they were on and the marker buoy. This would determine the torpedo's speed. Torpedo deflection was judged satisfactory if the torpedo passed between two other buoys placed near the end of the range. Depth was estimated by the “Mark 1 eyeball” of the observer on each float, but at times nets were lowered into the water and the run depth was estimated a little more precisely from the location of the hole made by the torpedo as it passed through the net. In one novel approach toward finding torpedo speed and deflection, the section of the torpedo containing the warhead was replaced with a shell section containing a device to inflate a number of balloons during the run down the range. The balloons were released at predetermined intervals and rapidly popped up to the surface to give the observers a good indication of the speed and deflection of the torpedo. The distance between the balloons gave the torpedo's speed, and the deflection was determined by triangulating on each balloon to find its location on the range. Experience from these limited testing techniques showed that the torpedoes would generally make a good run down the range (“good” in speed and deflection), if they were properly prepared and if they did not hit the bottom upon launch.

A New Torpedo for the Fleet

The Bureau of Ordnance, BuOrd, introduced a new weapon system to the Fleet in 1941, the MK 14 steam driven torpedo with its MK 6 magnetic influence exploder, both of which were developed at the U.S. Naval Torpedo Station, Newport, Rhode Island. This new torpedo was designed to detonate under the keel of the target vessel, thus breaking its back and quickly sinking it (overcoming the ever greater side wall armor protection being installed on the newer warships of that time). BuOrd was very proud of the new MK 6 exploder, since it would minimize the number of torpedoes used by exploding under an enemy warship's vulnerable keel. However, they subjected it to an excessive degree of security.

The MK 6 exploder was only explosively tested once, in May 1926, and then under ideal conditions. Testing of the MK 14 torpedo was limited to non-explosive testing to confirm that the torpedo ran straight and true with very little deflection (run depth was not a priority). The overriding criterion in the testing program was the safe recovery of the torpedo; each MK 14 torpedo cost \$10,000 and BuOrd thought that they were too expensive to waste in a test where the torpedo would blow up. No warshot tests of the MK 14 were conducted in the 1930s; and when World War II began there was no one in the Navy who had ever seen, or heard, a torpedo detonate.

Prior to World War II, BuOrd had concentrated all torpedo production at Newport, which resulted in not enough torpedoes being procured to meet training and testing needs. In fact Newport enjoyed a virtual monopoly on torpedo construction from 1869 to 1940. There was no rush to build up a stockpile of torpedoes as war came closer to America, which resulted in an early shortage of torpedoes. To compensate for this shortage, submarine commanders were told to use their few torpedoes very sparingly and were sometimes sent out on patrol without a full load of torpedoes.

It should be noted that the U.S. submarine service received relatively little combat experience in World War I; in fact U.S. Navy submarines sank no enemy ships before 1941. Submarine commanders (most at a relatively advanced age) exercised extreme caution during Fleet exercises in the 1930s. The preferred attack position was from a depth of 100 feet using a fire control solution based solely on the passive sonar hydrophones. This attack posture was based on the commanders' fear of antisubmarine aircraft. Being "sunk" during one of these exercises was hazardous to the career of the commander, contributing to a culture of caution.

Torpedo Problems Experienced During World War II

Although torpedo testing had long included the ranging of test torpedoes, the naval tracking range as we know it today had its inception in the torpedo reliability problems experienced by submarine commanders during World War II. The limited torpedo testing conducted during the 1920s and 1930s set the stage for a high torpedo failure rate in actual combat, and that is precisely what happened in World War II, when submarine commanders were chagrined to learn that there was little connection between torpedo presets and the performance of the new MK 14 torpedo. Despite an exact run depth preset into the torpedo prior to launch, torpedoes often seemed to run either under the target or run into it with no effect. In many cases the torpedoes either failed to explode or exploded prematurely. Although submarine commanders reported frequent torpedo problems in their patrol reports, and obviously believed that torpedo performance was largely responsible for the extremely low percentages of hits and effective explosions, senior officials were reluctant to believe them. Other factors complicated the situation. Unwarranted faith was placed in the expected effectiveness of the MK 6 exploder, and as a result, single torpedoes were often fired when spreads of torpedoes (salvos) would have been more appropriate. Officers commanding submarines at the outset of the war, who were trained in peacetime, often turned out to be entirely too timid in combat. The position taken by BuOrd, to all of this, was that the weapons experts were all in BuOrd, and if the torpedoes they issued to the Fleet were not sinking ships, the fault had to be elsewhere. Despite numerous complaints from many commanders, the most frequent result of the myriad of problems surrounding the MK 14 torpedo was the early relief of the submarine commander (40 times in 1942 alone).

The lack of a thorough testing program during the development of this new weapon system severely curtailed its usefulness in the early years of the war, and prevented its full potential from being realized during the war. However, as events were later to unfold, this situation was never going to happen again and the MK 14 torpedo went on to become a very successful weapon with an exceptionally long service life of over 40 years. This is a very important issue, for it was the need to resolve these torpedo problems that were uncovered during

the war and the need to ensure that all future torpedoes issued to the Fleet had proved themselves by being successfully fired on a tracking range that led to the upgrading of torpedo testing technology and the introduction of new tracking techniques, all beginning in the later stages of the war. The reader is encouraged to refer to the references and Appendix A for more insight into the problems that plagued the MK 14 torpedo during the first two years of the war.

The First Keyport Acoustic Range

Meanwhile, starting in about 1940, the launching of exercise torpedoes from the firing float stationed at Keyport's Pier 1 was being replaced by torpedo launchings from one of several sets of torpedo tubes installed on the south end of the pier. These torpedo tubes were on rotating mounts and could be accurately aimed down the range. As the testing continued into the winter months, there was nothing to shelter the tubes from the elements or to shelter the men preparing and loading the torpedoes into the tubes. Finally, in 1943, Building 99 was constructed over these torpedo tube mounts. The building's design included three areas for the launching of torpedoes. The center location contained a triple mount of 21-inch diameter torpedo tubes, the east side of the building contained a dual mount consisting of one 21-inch and one 18-inch diameter torpedo tube, and the west side contained a single 18-inch diameter torpedo tube. The torpedo tube mounts rotated so that the ends of each set of torpedo tubes swung out of the building through large sliding doors, built into the south and south-east side of the building, in order for the tubes to point down range. These tubes also rotated inboard and the sliding doors closed for torpedo tube maintenance or when the tubes were unused, which was very seldom by 1944. During that year approximately 7,000 torpedoes were ranged (proofed) on the Keyport Range (using the "visual" method of tracking described previously). As shown in Figure 2 an additional firing float was also used in order to achieve this very high torpedo proofing rate. This barge was previously the Keyport to Poulsbo ferry. A unique observation area was located near the point of torpedo launch on the south side of the converted ferry boat. From this spot an observer watched the torpedo being launched directly below him (getting thoroughly drenched in the process) and then used a large spotting glass to follow the course of the torpedo's bubbles all the way down the range (as shown in Figure 3).

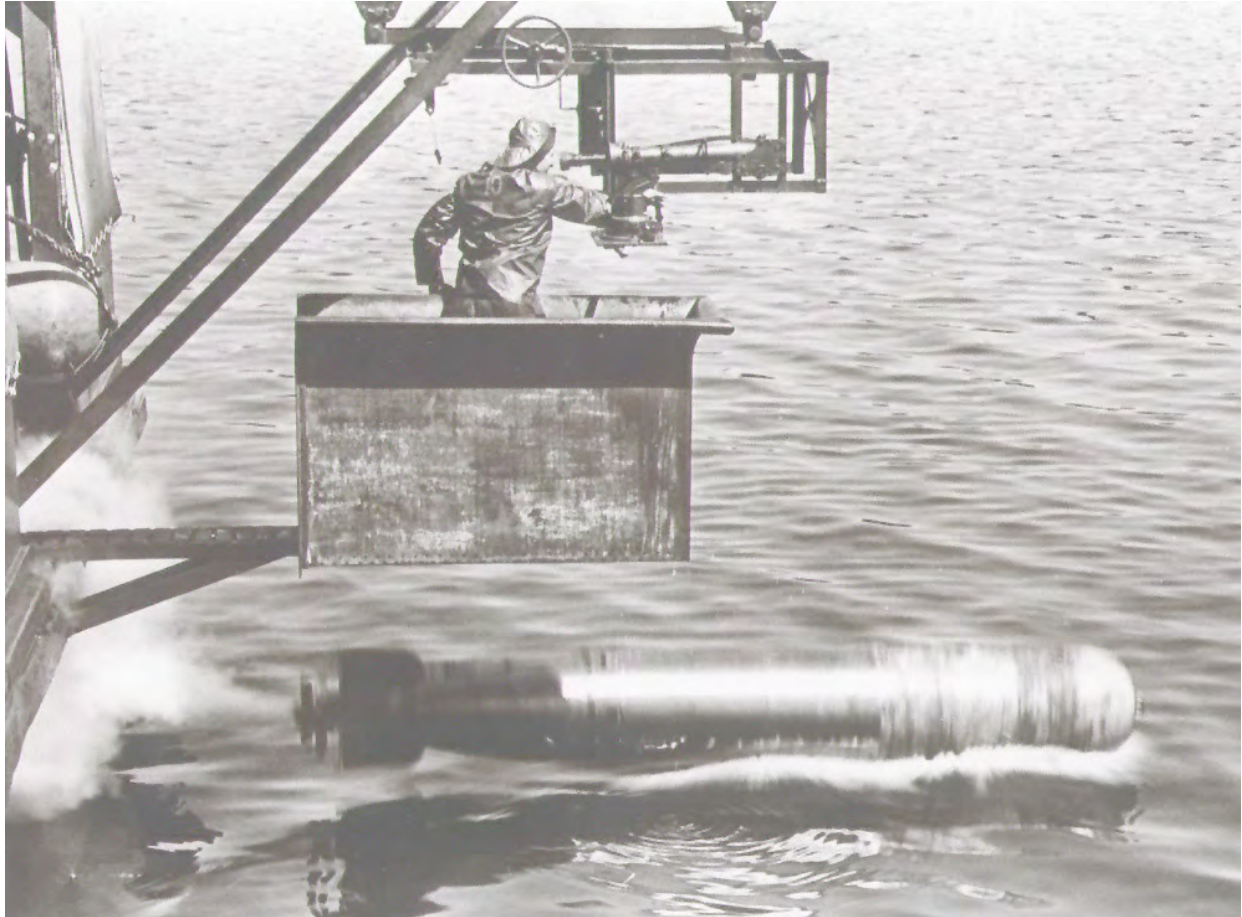

Keyport mechanics constructed this device, used to observe the launch of aircraft torpedoes, from salvaged metal. Chief Torpedoman E.E. Blackwell, decked out in his rain slicker, is prepared for the shower of spray that is about to drench him.

(Photo by Art Forde / Seattle Times, 1943)

Launching Torpedoes Down Port Orchard Inlet

Figure 3

Because of the torpedo reliability problems uncovered in the early years of World War II (Appendix A), BuOrd was finally persuaded that better methods of weapons testing were required, testing where the conditions could be carefully controlled and the operations continuously monitored, in order to obtain accurate information concerning the performance of the weapons. In his own words, the Chief of the Bureau of Ordnance directed “that as a matter of permanent policy, no service torpedo device ever be adopted as standard until it has been tested under conditions simulating as nearly as possible those which will be encountered in battle.” Not only did this statement reemphasize the need to proof all new production torpedoes, but it also had a dramatic impact on the development of new torpedo ranging techniques.

In January 1944 the Naval Ordnance Laboratory (NOL) was requested by BuOrd to survey areas near Piney Point, Maryland, and Keyport, Washington, to determine the feasibility of building an acoustic tracking range at one of these locations. In May BuOrd allocated \$100,000 for the purpose of installing one of these ranges in Port Orchard Inlet. This acoustic tracking range, designed by John Treadwell of the Naval Ordnance Laboratory, was to provide a measurement of torpedo speed near the launch point and at 500 yards down range; then measurements of both speed and deflection angle at 1,000, 2,000, 3,000, 4,000, 5,000, and 6,000 yards. The tracking range was based on the first acoustic tracking range installed by NOL during the summer of 1943 at the Naval Torpedo Station, Newport. Since the Newport installation had shown that consistent, and accurate, speed and deflection data could be obtained, BuOrd decided to build a second acoustic range and selected the Keyport site. Eventually a third acoustic range was built at Piney Point.

At the same time the acoustic tracking range was being designed and installed, Professor Joe Henderson of the University of Washington organized the Applied Physics Laboratory (APL/UW) to begin investigating new exploder designs, an effort which would eventually lead to the MK 9 exploder. Although this new exploder (a combination contact and magnetic gradient-field influence exploder) would not be available until the war was over, this and other problems with the MK 14 torpedo served to raise the interest level in weapons testing within APL/UW and initiated a long association between the U.S. Navy and APL/UW.

The new acoustic tracking range designated for Keyport was installed at the site of the existing range in Port Orchard Inlet, as shown in the range diagram of Figure 4. It was called an acoustic range because the noise generated by the torpedo (mainly its propulsion system) was used as the tracking signal, and this signal was picked up by several sets of bottom-mounted hydrophones. The Keyport Acoustic Range initially measured only the speed of the exercise torpedo as it ran down the 6,000 yard range centerline and its deflection (or angle away from the range centerline). Later the depth of the torpedo was also measured.

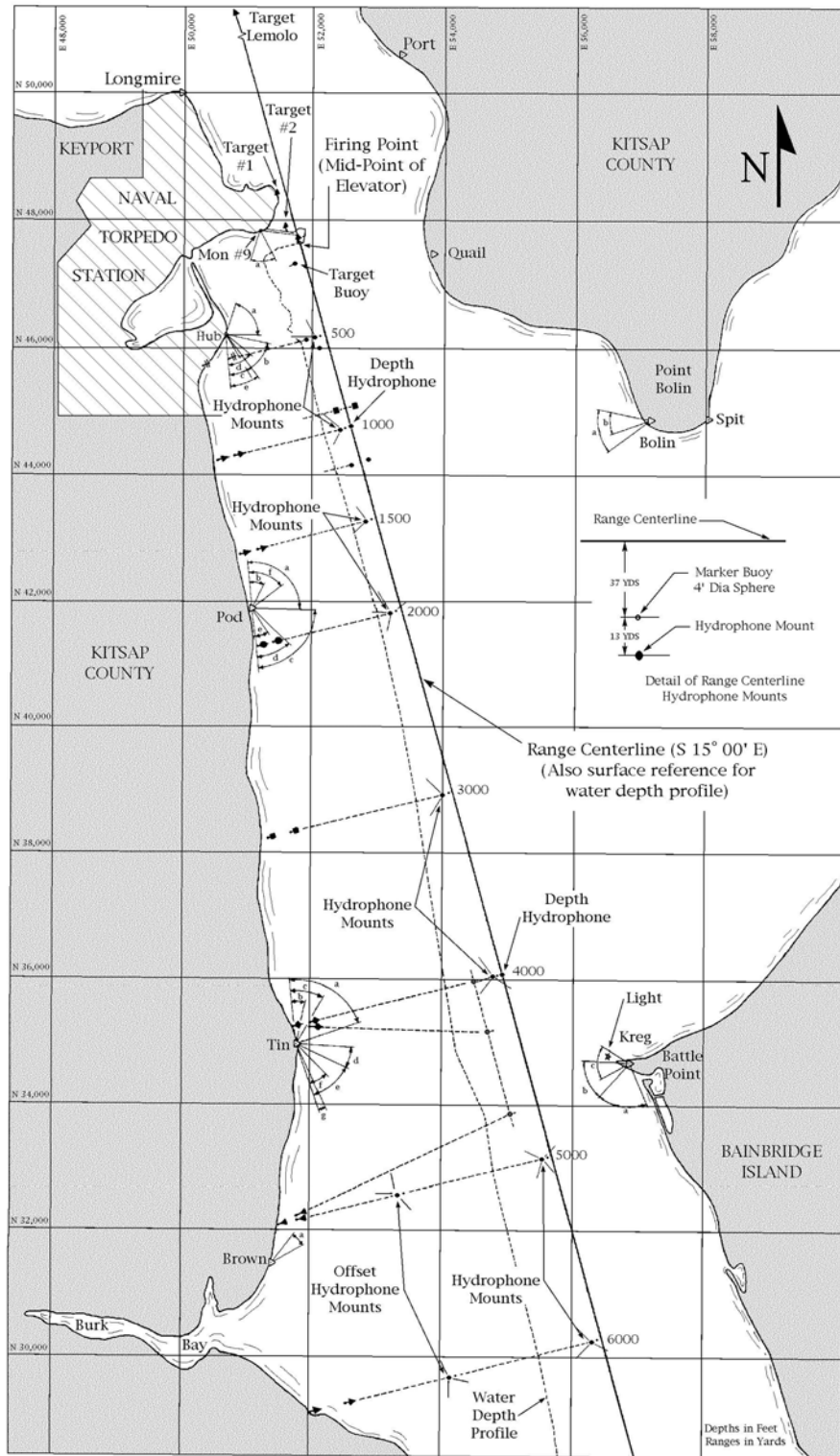

Keyport Acoustic Range Layout (Circa 1957)

Figure 4

Installation of the acoustic range began in June 1944 and was completed in September. Then in 1945 the single 18-inch diameter torpedo tube and mounting base were removed from inside Building 99 to make room for a unique underwater elevator and submersible torpedo tube. A spare torpedo tube, suitable for this application, had just become available with the decommissioning of the old Fleet submarine USS BASS (SS 164). One of its 21-inch diameter torpedo tubes was removed and shipped to Keyport just before the old submarine was scuttled as a sonar target off Block Island. The torpedo tube was installed in a small building attached to the south side of Building 99 and in this structure was built a rather unique elevator arrangement. The elevator was designed so that the test torpedo could be loaded into the torpedo tube when the elevator and tube were in the raised position out of the water, but then fired from the tube when it was submerged underwater (as shown in Figure 5). At the same time, the Acoustic Range Control Room was added on top of Building 99 to control the acoustic tracking range. The range, its new control room, and the loading/firing apparatus on the submersible elevator were pronounced ready for operations in the spring of 1945. However, two serious design and material problems quickly became evident: (1) water leakage (attributed to inefficient water seals) began to dissolve some of the crystal elements in the hydrophones, with a corresponding loss of sensitivity, and (2) dezincification of the naval brass in the hydrophone mounts caused deterioration of the mounting rings. Subsequent repairs featured more rigid and better sealed hydrophones, and the hydrophone mounts were made of a more corrosion resistant naval bronze or phosphor bronze. During the immediate post-war years, reduced funding for war-related efforts precipitated a reduction in torpedo testing, and maintenance of the range was discontinued from 1947 to 1950.



The Firing Tube and Submersible Elevator at Pier 1

Figure 5

Torpedoes run on this range were straight-running, shallow depth torpedoes (without any homing capability) that had been developed during World War II, and included the following types:

- MK 13, the first torpedo specifically designed for aircraft launching,
- MK 14, the primary submarine-launched, anti-surface ship torpedo used in World War II,
- MK 15, a destroyer-launched torpedo,
- MK 16, a “chemical” torpedo using Navol, a solution of 70% hydrogen peroxide (H_2O_2) and water, as an oxidizer instead of air (speed 46 knots, range 11,000 yards),
- MK 18, a wakeless, electric torpedo to supplement the MK 14.

The Korean conflict restored interest in military matters, and the Keyport Acoustic Range became fully operational again in 1951. In that same year, BuOrd tasked Keyport to fabricate 40 additional redesigned hydrophones as spares and replacement hydrophones for all three of the acoustic ranges: Newport, Keyport, and Piney Point. Torpedo testing increased, and additional features were added to the Keyport Acoustic Range as their needs became apparent. Additional hydrophones to measure speed and deflection angle were added in 1954-55 to facilitate testing of the first passive acoustic homing torpedo, the submarine launched, anti-escort MK 27 torpedo and another anti-surface ship torpedo, the MK 35. A depth hydrophone was added along the range centerline at the 1,000 yard point in 1955 and another at the 4,000 yard point in 1956. Track offset stations were installed to evaluate the circular run pattern of the “chemical” MK 16 torpedo. These two offset stations were located 800 yards west of the range centerline, one at the 5,000 yard point, and the other at 6,000 yards. In June 1959 a new Control Panel (Figure 6) was installed that utilized a paper tape recording mechanism.

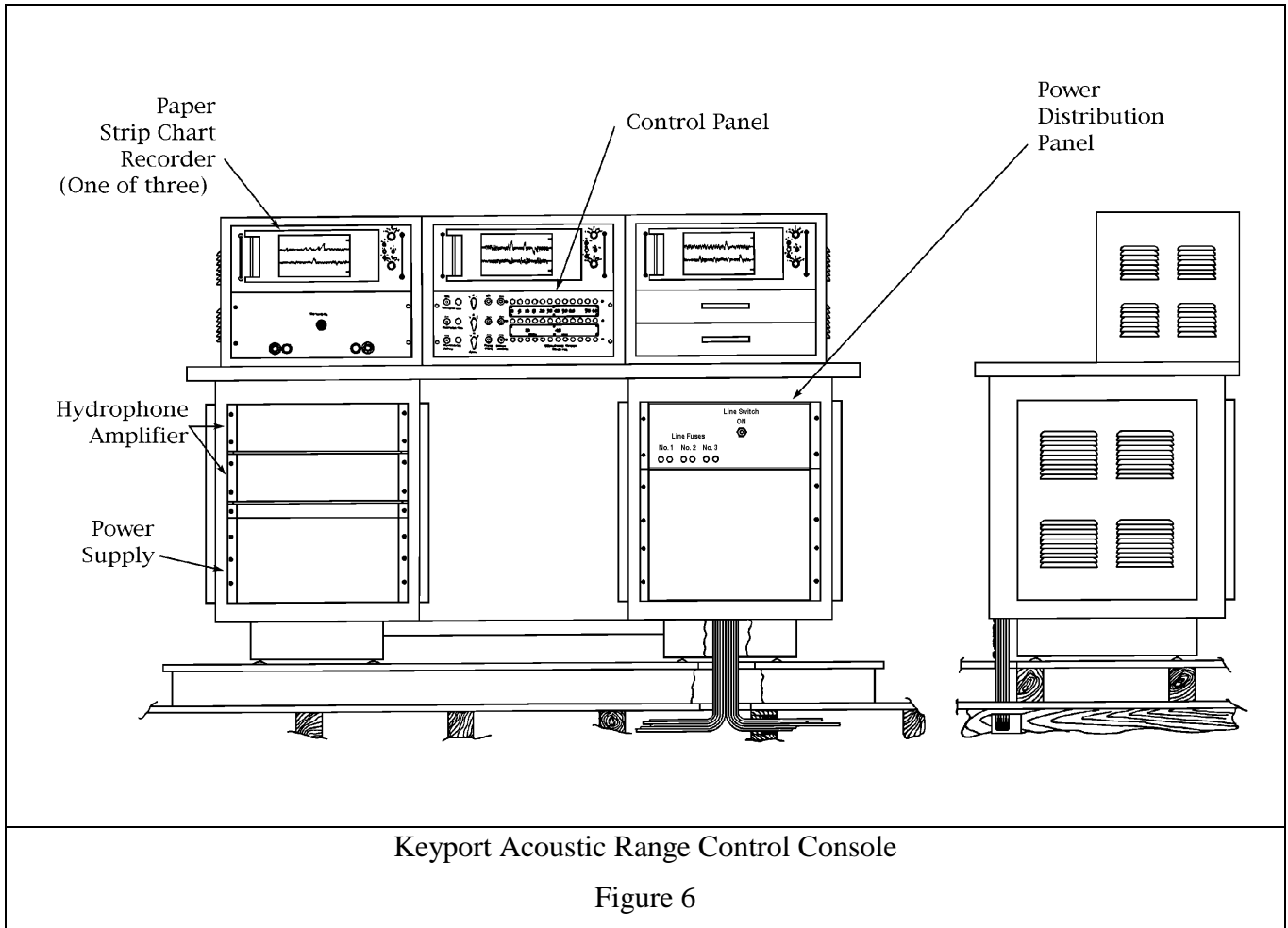

In its final configuration (about 1959) the range consisted of eight hydrophone stations, placed in a straight line 50 yards west of range centerline, extending for 7,000 yards down Port Orchard Inlet from Keyport's Pier 1 (plus two depth and two offset hydrophones). Each station consisted of two bottom-mounted hydrophones for determining torpedo speed and deflection. The modern equivalent of this hydrophone pair is called an "array."

The hydrophones used at each station were made by the Brush Development Company, Cleveland, Ohio and were cylindrical tubes several feet long employing 24 Rochelle salt crystal elements spaced 1.91 inches apart. The operating frequency of the range was initially between 15 and 20 kiloHertz (kHz), but after the 1959 upgrade the receivers were tuned to 14.5 kHz. The hydrophones were essentially line arrays, which resulted in a very unique sensitivity pattern, or directivity. The hydrophones were most sensitive to sound energy coming from directions perpendicular to the longitudinal axis of the hydrophones, i.e., in a thin 10° wedge shaped disk. The speed measuring hydrophone at each station was mounted with its sensitivity pattern perpendicular to the line of fire of the torpedo, i.e., the range centerline, and the hydrophone for measuring deflection was mounted with its sensitivity pattern 45° to the line of torpedo fire (as shown in Figure 7). During range installation long bronze pilings were driven into the bottom of the inlet, at precisely surveyed points, and two hydrophones (mounted to a single brass transit-like base) were attached to the top of each piling at a point three feet off the bottom. Divers, exercising great care, oriented the hydrophones to the proper angles with respect to range centerline by using hand held magnetic compasses (which explains why the pilings were made of a nonmagnetic material).

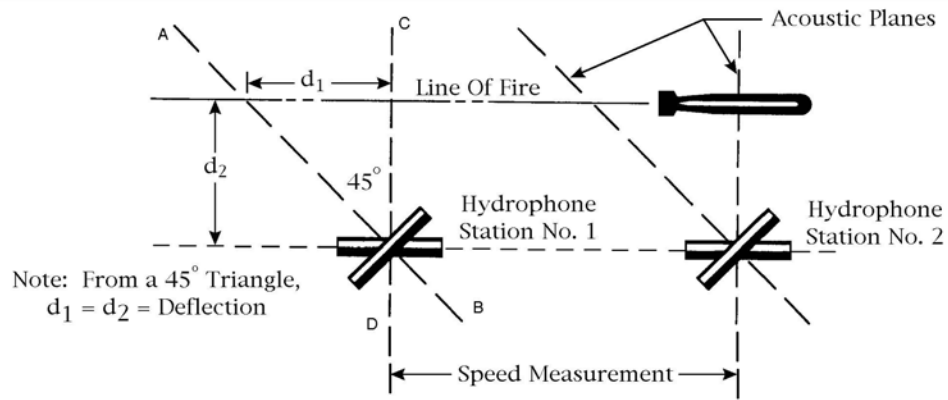

Orientation Of Hydrophone Acoustic Planes For Speed And Deflection Measurement

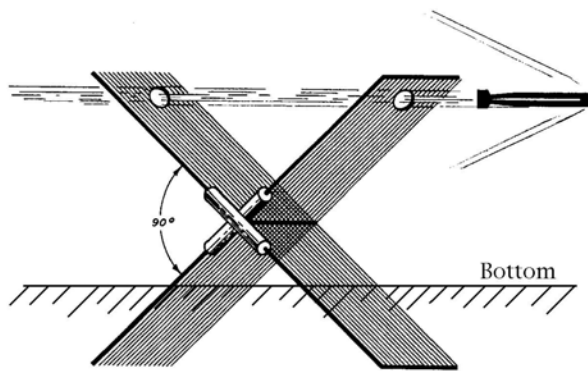

Operation Of Acoustic Planes For Depth Measurement

Typical Acoustic Range Recording

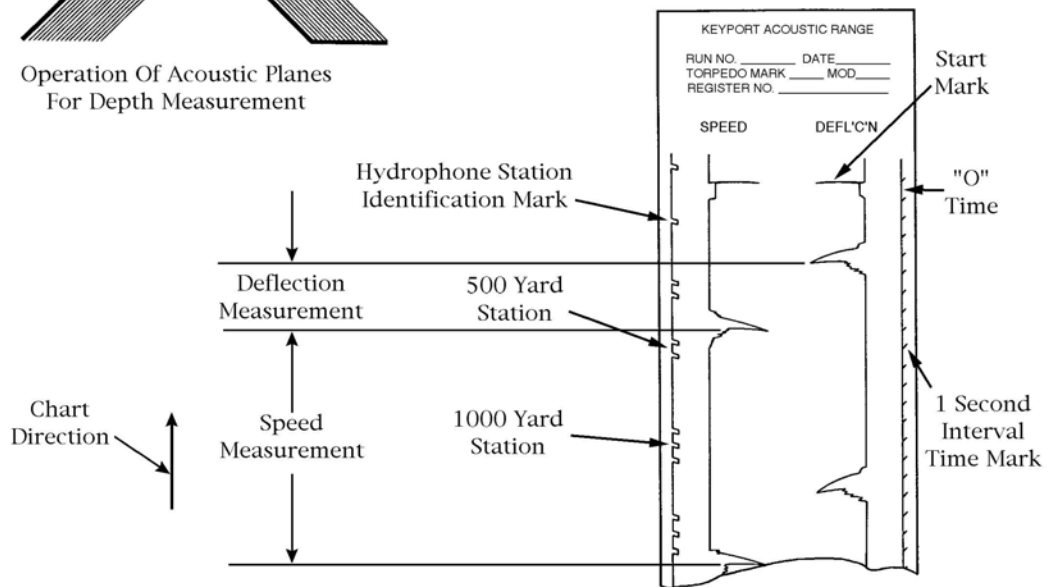

Keyport Acoustic Range Tracking Concept

Figure 7

As the torpedo passed each station, these unidirectional hydrophones picked up the torpedo's noise signature, amplified the signal, and sent it to the Control Panel located in the control room atop Building 99. At the Control Panel this signal caused a mark to be made on a rotating paper tape recorder. The technique is illustrated in Figure 7. Two such marks from two different stations provided the torpedo's speed between the stations, since the distance between the stations was known and the time it took the torpedo to transit this distance was recorded on the paper tape. To determine the deflection, or distance away from an individual station, both of the station's hydrophones were used. Here the torpedo first ensonified one hydrophone and then the next as it passed through each hydrophone's axis of maximum sensitivity. Two additional marks were made on the paper tape to record the time at which the torpedo passed through these sensitive regions of the two hydrophones. This time was multiplied by the speed of the torpedo (as previously determined) to get a distance traveled, which was equal to the distance away from the hydrophone (the amount of deflection). When plotted on the range chart, it was a simple matter to measure the deflection of the torpedo from its intended course along the range centerline. In this manner each station provided the information needed to calculate deflection, but two adjacent stations were required to find speed. The paper tape was read with the aid of a calibrated scale (measured in seconds as the paper chart speed was constant), and these times were entered into a series of tables to obtain the values of speed and deflection. Each succeeding hydrophone station was turned on manually at the Control Panel by the operator as soon as the torpedo's signature was received (and recorded) by the previous station. Speed was measured quite accurately, with a maximum error of under 1%, but the deflection error was about $\pm 4\%$.

To find the depth at the two depth stations along the range centerline, the depth hydrophone pair was used. These two hydrophones were oriented 90° to each other so that their acoustic planes formed a large figure "X" (again, refer to Figure 7). The depth was determined from the transit time through the top two legs of the "X" in a manner similar to that used to calculate deflection.

One limitation of the range was that torpedoes were restricted to running in a straight line trajectory at a shallow depth. The range was not suitable to test weapons with onboard guidance systems or with a reattack capability. The timing system was not very accurate (to the nearest tenth of a second) and depended upon finding the time of a pulse by reading needle marks off a paper tape. The system was not "positional" in that it did not give the position of the torpedo, but rather only an indication of its speed and how far it was drifting away from the range centerline (later depth measurements were also provided). The range required operator attention to switch recording from one hydrophone station to the next as the torpedo sped down the range (while, at the same time, trying to guess the new value for system gain – by observing the amplitude of the previous mark – and quickly making the proper adjustment). Finally, the tracking signal came from torpedo generated noise and not from a dedicated acoustic tracking device carried by the torpedo. However, this tracking concept had the advantage of not requiring any tracking aids in the torpedo and did not depend upon a knowledge of the speed of sound in water.

In July of 1963 the submersible torpedo tube, along with the entire elevator platform, was removed and taken to Puget Sound Naval Shipyard for refurbishment at a cost of \$25,000. It was subsequently reinstalled and used infrequently until a range inspection conducted during the

summer of 1969 found the range to be non-operational due to faults in the underwater cable. The elevator platform was finally removed in 1981.

Early Acoustic Ranging in Hood Canal

Shortly after World War II the U.S. Navy began to deploy acoustic homing torpedoes on board submarines for use against enemy submarines and surface ships. These torpedoes were significantly different than those used during the war. The new torpedoes could dive deeper, change course, and steer themselves toward the target rather than just run in a straight line (or maneuver according to a well defined pattern) like all previous torpedoes. These new torpedoes also had improved versions of the contact exploder.

By 1948-49 it became apparent to the Navy that Keyport's torpedo range in Port Orchard Inlet was much too shallow to test these new deep diving, acoustic Anti-Submarine Warfare (ASW) weapons that were coming off the drawing boards. In response to this, a nationwide search began for a protected body of salt water suitable for testing the new torpedoes. As a result of this search, Keyport began to shift torpedo testing operations to Hood Canal and the deeper Dabob Bay. In late 1949 the Navy received official permission from the U.S. Army Corps of Engineers to use parts of Dabob Bay and Hood Canal for "non-explosive torpedo ranging."

Following successful development of the MK 9 exploder, APL/UW turned its energies toward the development of underwater weapons, components, and evaluation systems. In 1952 APL/UW requested funding from BuOrd to investigate the feasibility of designing and building a three-dimensional (3-D) high frequency tracking range in Dabob Bay capable of simultaneously and accurately tracking two high speed moving objects, such as an exercise torpedo and its target. Such a system would provide an additional and independent source of torpedo performance data, beyond that available from the torpedo's internal tape recorder. Besides providing a check on the internal recorder, a tracking range affords the opportunity to gather much more data than can be provided by the recorder. This will be made clear in later sections of this report. It was desired to accomplish this tracking objective in real time over a distance of about 1,000 feet, to a relative accuracy of one foot. By using a time-share scheme it was hoped that the range could track the two objects simultaneously. BuOrd agreed with APL/UW, and feasibility studies, basic engineering design work, and the building of individual components for such a range began at APL/UW. Since authority for underwater operations in Hood Canal had already been granted, Hood Canal was selected as the location to demonstrate this new ranging concept before final installation in Dabob Bay. But, would this new development be in time? The new MK 27 acoustic homing torpedo was beginning to arrive at Keyport and needed range testing and proofing.

In fact, when the first MK 27 Mod 4 torpedoes (redesigned from the Mod 0 anti-escort version into an ASW weapon) arrived on Station in 1951 there was no suitably instrumented range available where the torpedoes could operate at a variety of depths. They could not be fully tested on the existing acoustic range at Keyport because the depth was too shallow. So, they would have to be tested in Hood Canal, range or no range! A firing tube, with a small control tower built above it, was set up on an existing pier on the east side of Hood Canal at Bangor, called the Keyport/Bangor Dock. Torpedoes were fired from this tube in the general direction of a target lowered into the water from a barge stationed out in the canal. The target consisted of an

acoustic projector that transmitted a signal to attract the attention of the torpedo's passive sonar. This provided something for the test torpedo to attack. There was not much one could do to evaluate the success of such a run except to watch the torpedo being launched and then wait for it to come back up to the surface. If it surfaced near the target then it probably was a success, if not, then it could be considered a failure. There was no way to tell what happened in between or to tell how well the torpedo attacked the target, if it found the target at all. About 200 MK 27 Mod 4 torpedoes were tested this way during 1951. From only a few visual observations, the limited data recorded in the torpedo during the run, and some educated guesswork, the proofing engineers had to piece together a picture of the run and make a judgment as to the performance of the weapon. In addition, in late 1951 there were numerous air drops of the MK 34 Mod 1 torpedo conducted in Hood Canal. At one time during 1953 the total rate of proofing at Keyport reached a high of 900 torpedoes per month at the three range sites (Port Orchard Inlet, Hood Canal, and Dabob Bay). Clearly, the solution offered by APL/UW could not come too soon.

However, it would not be easy to set up a new tracking range in an environment where existing tracking systems such as optical instruments, radar, and radio equipment would not work; and where the medium posed such technical challenges as natural and man-made noise, boundary reflections of the acoustic signals, thermal gradients, underwater currents, high pressure, and corrosion. Consequently, it was several years before an experimental 3-D tracking range, designed by Dr. David S. Potter and Stanley R. Murphy of APL/UW, among others, was finally established in Hood Canal. That happened in January 1955 when APL/UW installed their 3-D tracking array in 275 feet of water 1,700 feet west of K/B Dock. The array cable came ashore near K/B Dock and terminated at the recently completed Advanced Undersea Weapons building. Figures 8 and 9 show how a 3-D tracking range operates and illustrate the major tracking system components. In Figure 8 the MK 27 Mod 4 torpedo is shown being tracked by the hydrophone array in the foreground with the experimental computer shown in the upper left insert. The exercise torpedo is attacking (homing on) the target's transducer suspended below the float at the left. The target's transducer provides the acoustic sound source to entice the torpedo into attacking it, in order to test the torpedo's passive homing logic. This target, designated Target MK 1 Mod 0, was developed in 1955 by the Ordnance Research Laboratory at Pennsylvania State University (ORL/PSU) and has led to an ongoing development effort to produce artificial targets that are required by the increasingly complex terminal homing characteristics of modern torpedoes. As of this writing, the Target MK 1 is still in use, although it is now up to the Mod 3 version.



Three-Dimensional Range Installation in Hood Canal

Figure 8

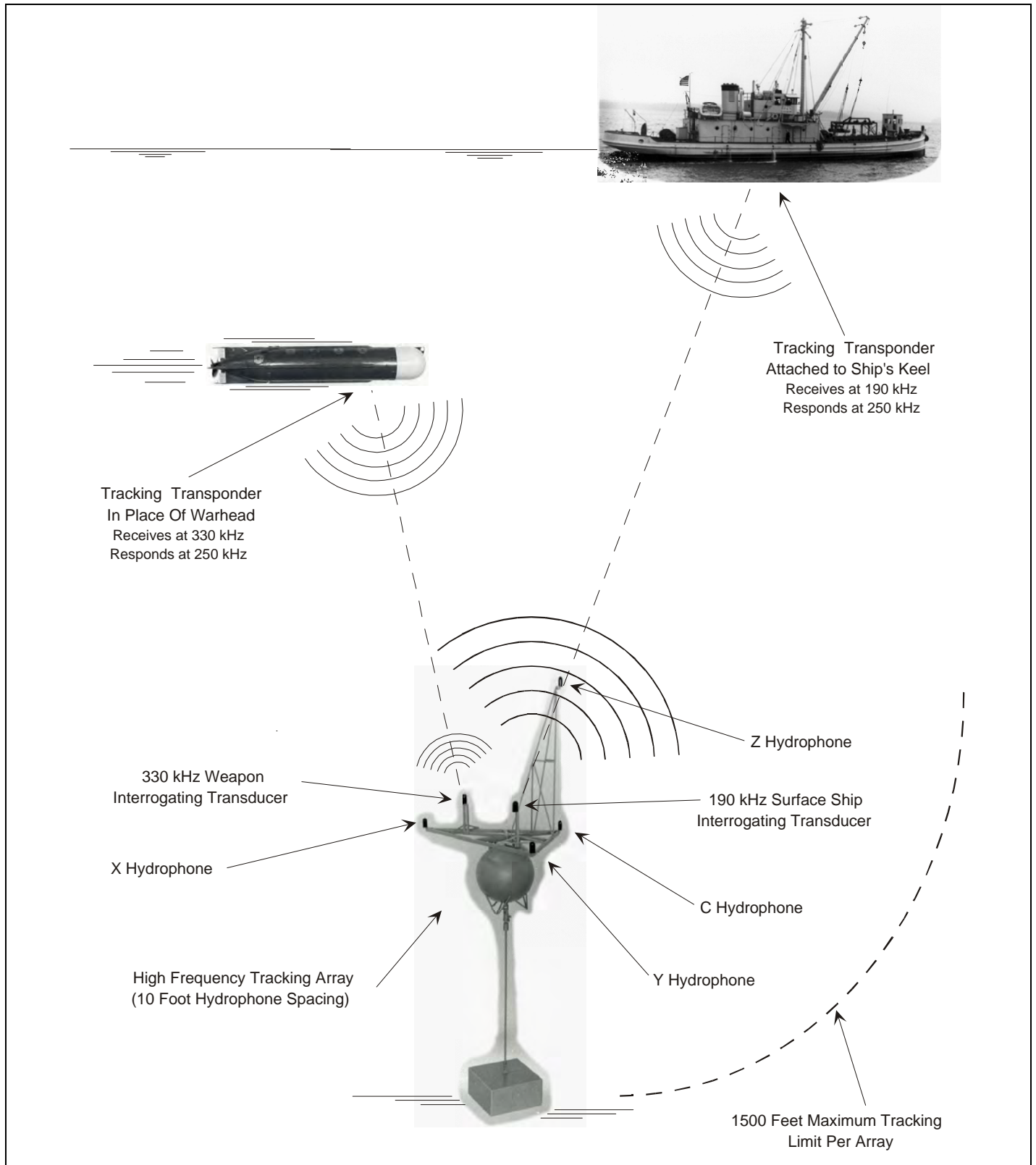

High Frequency Tracking Range Concept

Figure 9

The experimental range in Hood Canal consisted of the single bottom-mounted array, containing a cluster of four receiving hydrophones as well as two interrogating transducers. (Incidentally, the very first array, installed in March 1954, subsequently failed and was lost when the recovery attempt yielded only a frayed cable stump.) The torpedoes and other objects to be tracked by the array were instrumented with a tracking transponder prior to the test run (as shown in Figure 9). These early APL/UW designed transponders were vacuum-tube devices that were powered by the torpedo's main propulsion battery. It was believed, initially, that extremely precise weapon position information was both required and achievable, so high frequency transponders (250 kHz) were used (this high frequency was well above the torpedo's homing frequency).

During 1955 several operations were conducted on this experimental tracking range. On 7 December 1955 a MK 35 Mod 3 exercise torpedo was launched from one of the Station's firing craft and was tracked by the range as it went into a circular pattern near the array. Then on 14 December 1955 a MK 27 Mod 4 exercise torpedo was fired from the Firing Pier at K/B Dock to attack a surface target, the ex-LST 17. This hulk was used as a target for over a year, eventually being sunk by USS RAZORBACK (SS 394) in August 1956 during a "SINKEX" conducted 90 miles northwest of Neah Bay, Washington. By this time the old target had been badly dented after absorbing many hits from all the exercise torpedoes sent after it, all with contact exploders. This SINKEX was the first live warshot test of the MK 16 Mod 6 torpedo with the new MK 9 Mod 4 exploder.

The array in Hood Canal remained in operation until 1957 when the array was recovered and the experimental computer was returned to APL/UW; but during its two years of operation a total of 40 torpedo operations were conducted on the range. As was discovered during this time, the short ranges obtainable (1,500 feet slant range) imposed substantial limitations on the usefulness of the results. Still, the system worked, after a fashion, and the early results encouraged continued efforts.

The 3-D Range at Dabob Bay

As mentioned previously, APL/UW began working on concepts for a 3-D underwater tracking system for the Navy in 1952. The need for this development grew out of a mutual desire by Keyport and APL/UW to resolve several key torpedo tracking issues:

- Keyport needed a tracking range to test (and proof) the various deep diving ASW torpedoes that operated in all three dimensions. This capability was necessary to determine what was happening underwater in the vicinity of the target (i.e., during terminal homing as the torpedo attacked and re-attacked the target). Obtaining this type of information was just not possible with the existing method of shooting blind off K/B dock. The torpedo/target interaction, deep underwater, was becoming much more important than just looking at a straight line shot to see what deflection existed.
- APL/UW needed to find a suitable place to do developmental testing of the long range, deep diving MK 45 Mod 0 ASTOR torpedo they were developing. Plus the weapon's Technical Evaluation (TECHEVAL) and proofing programs

would require a 3-D range. The existing “uninstrumented” ranging area in Dabob Bay would suffice if a method to track the torpedo in three dimensions could be found.

- APL/UW also needed to evaluate the “miss distance” of its new MK 9 Mod 4 influence exploder recently designated for use in the MK 16 Mod 6 torpedo.

Also contributing to the decision by BuOrd to fund APL/UW were the recommendations of several studies at the national level (beginning with a National Research Council study in 1948), and the fact that the U.S. was involved in another war (the Korean War).

The miss distance or “stand-off” distance of APL/UW's new MK 9 exploder was important to the proper functioning of the influence exploder; therefore, it was desirable to know this parameter to within 10% (the stand-off distance being defined as the desired distance from the target to the torpedo's fuze at the time of warhead detonation). It was not practical to instrument the target ship because the torpedo might approach the target ship anywhere along its length.

The desire to assess the miss distance performance of the influence exploder combined with the other tracking system needs mentioned above led to the necessity of constructing an underwater acoustic tracking range in Dabob Bay (where limited torpedo testing had been ongoing since about 1949). Even as early as 1948 Dabob Bay was being considered as the site for a future deep water tracking range. Until a tracking range could be installed in Dabob Bay, the only measurement of torpedo performance came from observers in Navy helicopters flying above the bay during the exercises.

Dabob Bay was a perfect site for the Navy's first deep water, high accuracy 3-D tracking range because of its unique geography and environment. At 600 feet, it was the nation's deepest protected body of salt water in the continental United States. The bay had excellent conditions for weapon testing with little tidal and temperature changes, low natural and man-made noise, and the bottom consisted of soft silt and mud to reduce acoustic reverberation. The surrounding hills provided very good visual sighting for in-air tracking of surface vessels and air dropped or airborne weapon systems. The maneuvering area was approximately seven nautical miles long by one and a half nautical miles wide; and Dabob Bay was close to engineering, production, and naval support facilities at Keyport, the Naval Ammunition Depot at Bangor, and Puget Sound Naval Shipyard.

The overall plan for the range was similar to the Hood Canal experiment. Both the exercise torpedo and the target would be temporarily equipped with an acoustic transponder facing down toward the bottom-mounted hardware. Four listening hydrophones, installed on a bottom-mounted array frame, would measure the times of arrival of the “tracking pulses.” The raw signals would be sent to a computer, through an underwater electrical cable, where the positions of both the torpedo and target would be calculated and displayed in real time. The hydrophone array would also have two interrogating transducers (at two different frequencies) to interrogate the transponders aboard the moving torpedo and target. The figure at the frontispiece of this report illustrates the overall range concept at Dabob Bay, where a submarine is shown as the target for a homing ASW torpedo.

At the time the range was being designed (1952-57) digital computers were so new that they did not exist outside of computer research laboratories. Because of this APL/UW chose a computation process that required only vacuum-tube analog computers due to their long experience in designing and building these computers. Plus, analog computers had the ability to produce a direct graphical readout. But, the computational power of analog computers was not very extensive, so a tracking concept had to be devised which only required the solutions to some very simple equations (i.e., solving three separate one-dimensional equations rather than three simultaneous equations). Three separate one dimensional analog computers would be used, one for each coordinate direction. This drove the decision to place the four hydrophones along the edges of an imaginary cube with one hydrophone at the corner of the cube (the C hydrophone) and the other three along the X, Y, and Z axes (in a Cartesian coordinate system). The solutions to the tracking equations were presented in analog form as the output voltages from a double integration process; the X, Y, and Z coordinate values were proportional to the output voltages of three identical analog integrators. The computational scheme used by an individual analog computer (a pair of integrators) took the timing information from the array that provided the range to the torpedo and the timing information that provided the bearing information relative to one of the three axes, multiplied the two together, and generated an output voltage proportional to this product. This in turn was proportional to one of the three coordinate values of the torpedo's position. Plotters were used to provide real time displays of these coordinate values as a function of time.

The separation distance between the corner hydrophone and any of the other three was driven by the frequency of the acoustic tracking signal (and the need to have an array of manageable size). At 250 kHz the separation spacing was 10 feet. This high frequency was chosen because it was desired to maximize the timing accuracy of the signal detection process. This process was called "leading edge detection," where the higher the frequency of the tone burst tracking signal the sharper the leading edge, and the sharper the leading edge the better the processor was at extracting an accurate value for the time of signal reception at a particular hydrophone. For this tracking concept to work, the exact location and orientation of the array had to be known. An acoustic survey would have to be performed after the array was placed on the bottom to accurately determine its location and orientation. Figure 10 shows a typical high frequency array.

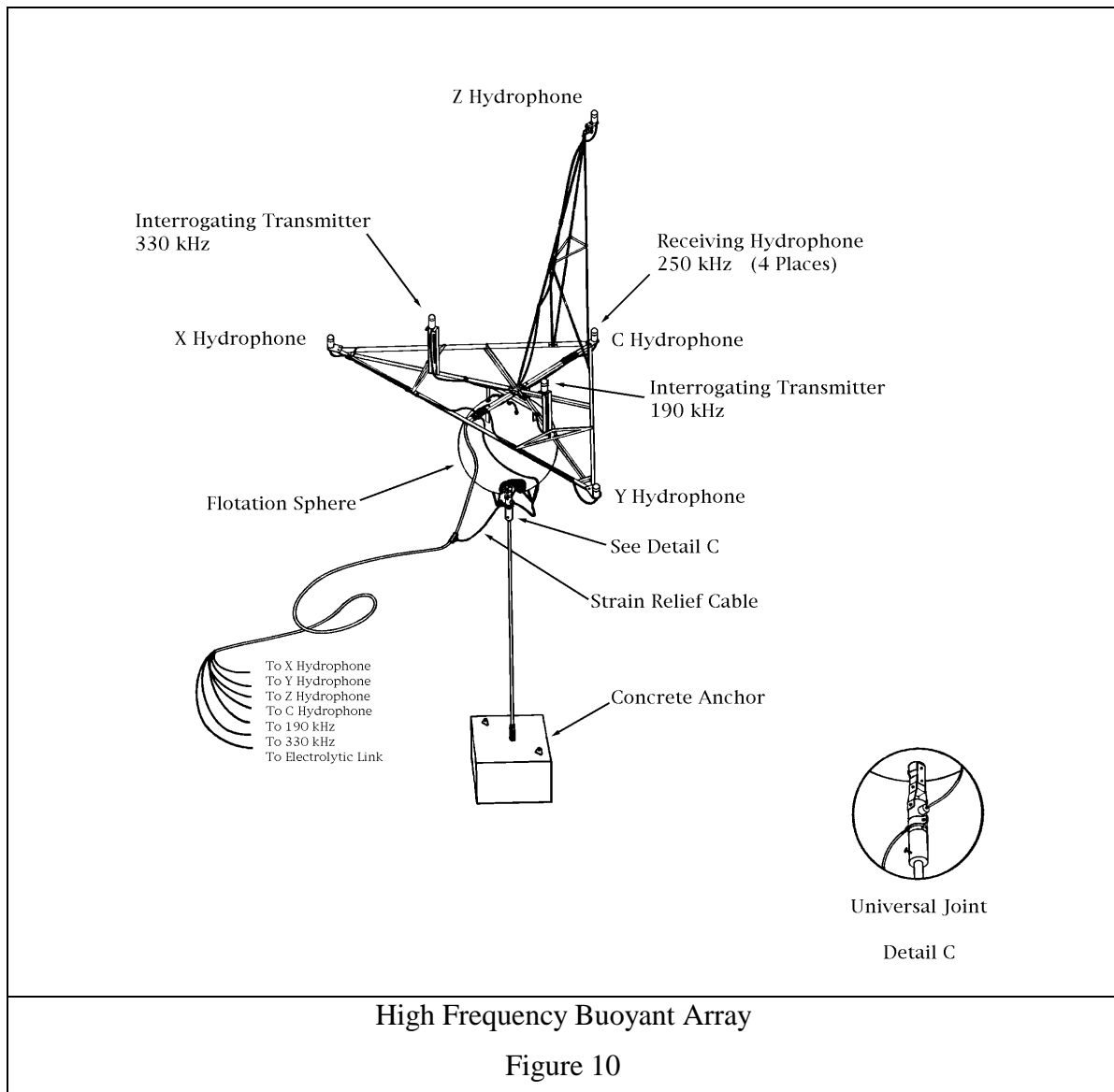

Following the initial experiments conducted by APL/UW at their Lake Union dock in Seattle and the successful “proof of concept” experiments in Hood Canal, it was time to find a computer site along the shores of Dabob Bay. Therefore, Keyport and APL/UW moved rapidly to secure a long term lease from the Washington State Department of Fisheries for the use of a site near the Washington State Shellfish Laboratory at Whitney Point to establish a control facility for the new tracking range. This facility, completed in September 1956, was the home of the new APL/UW analog computer, with its maze of vacuum tubes; a computer “programmed,” or more precisely, especially assembled, to act as a range tracking computer.

In early May 1957 installation of the new 3-D tracking range began off Whitney Point in Dabob Bay with the deployment of a single four-sensor “short baseline” array in 620 feet of

water. By late-May the first torpedo, a MK 27 Mod 4, was successfully tracked on the range, accompanied by boat sirens wailing away during the launch to warn beachcombers. The short range of the high frequency tracking signal, however, required the installation of more arrays in order to obtain a reasonably sized tracking area. This caused the Dabob Bay range to quickly grow from the single array to 10 arrays. The next year Keyport began taking over responsibility from APL/UW for the high frequency range with full operational responsibility assumed in early 1959 (however, APL/UW retained design cognizance). The range computer building at Whitney Point was soon enlarged, tripling its size, to accommodate habitability improvements and new ORL/PSU sound measuring equipment (to measure the sound, or noise, being radiated from a vehicle being tracked by the range).

Also, in 1958, the torpedo testing barge YTT 6 was towed from Newport, Rhode Island through the Panama Canal to Keyport. This self-contained barge was fitted out with a full torpedo preparation facility, an underwater firing tube, and a prototype Angle Solver Mark 18 (a fire control console for the MK 45 ASTOR torpedo). After refurbishment at Keyport and Puget Sound Naval Shipyard the barge was anchored on the range centerline off Bolton Peninsula in April 1959 for the ASTOR Range Evaluation program.

In the early 1960s high speed film cameras were installed at various locations around the range to provide tracking of the in-air portion of aircraft launched weapons, before the track was picked up by the underwater arrays upon weapon impact with the water surface. Two of these sites near Whitney Point, the North CZR Building and the South CZR Building, each contained three fixed cameras installed in 1961 by the Sandia Corporation. These were Bowen ribbon-frame cameras – quite unique cameras, as their negatives were 5.25 inches wide, but only 0.95 inches high. They provided the exact location of launch and water entry, and were used during the TERNE III ASW rocket tests to produce range tables of the rocket's trajectory. Another camera frequently used was the 35-mm Mitchell motion picture camera, a type widely used by Hollywood in the 1930s and 1940s. Sandia Corporation bolted this camera to a ME 16 tracking mount and installed both in a large dome on the beach at Whitney Point. Then, in 1963, Keyport installed three very accurate German Askania cinetheodolites (originally these 35-mm cameras were used during the development of the German A-4 rocket or “ballistic missile”). The Mitchell camera and one of the Askania cameras were set up on the beach at Zelatched Point for a while until a mud slide swept them into Dabob Bay. These cameras, combined with the underwater tracking arrays, provided a complete and integrated picture of the trajectory from weapon launch to the location of the weapon at end-of-run.

Although there were growing pains, it quickly became clear that a 3-D tracking range was a brand new tool with uses far beyond those initially envisioned; such as observing the attack and re-attack modes of homing torpedoes, measuring the accuracy of wire guidance, accurately determining the noise level of ships and torpedoes, and, ultimately, obtaining information for tactical use. Indeed, the new facility at Dabob Bay was the world's first fully instrumented deep water tracking range. Early range work at this new 3-D tracking range involved testing the following types of torpedoes:

- MK 14, which maintained its presence at Keyport well into the mid-1960s,
- MK 27, a post-war, acoustic homing torpedo (the Mod 4 version was an ASW torpedo),

- MK 34, an aircraft launched, acoustic homing, ASW torpedo (a post-war improvement of the World War II MK 24 “mine”),
- MK 37, a wire guided, submarine-launched, ASW weapon,
- MK 39, the first wire guided torpedo (a modification of the MK 27 Mod 4),
- MK 43, the first lightweight, low cost, aircraft launched, acoustic homing, ASW torpedo,
- MK 44, a second-generation lightweight, low cost, ASW torpedo,
- MK 45 (or ASTOR), a long range, wire guided, submarine launched torpedo,
- The Norwegian TERNE III ASW rocket using a special shock-resistant tracking transponder to withstand the impact of water entry.

The range, as initially installed, used the transponding acoustic signal concept in which the object being tracked contained an acoustic transponder that only emitted a pulse upon receiving the proper interrogating acoustic signal from the array. In other words, the transponder waited until it received a command from the array before it responded by transmitting a pulse of a different frequency back to the array. The transponder was mounted in the torpedo's exercise section, which replaced the warhead during range testing. This reply pulse was projected from a “flush mount” transducer installed in the bottom of the exercise section and flush with the torpedo's outer surface.

When the torpedo was running on the range and within the array's coverage “zone” it was capable of receiving the array's 330 kHz interrogation signal. Immediately upon validating the interrogation signal the vehicle's transponder responded with an acoustic pulse at 250 kHz directed down to the array. Surface ships and other test participants (such as targets) were interrogated in turn at 190 kHz, and all responded back to the array with the same 250 kHz pulse.

The interrogating signal was not always sent up to the torpedo by an acoustic pulse from the tracking array. Beginning with the early wire guided torpedoes (MK 39 and MK 45 ASTOR) the transponder's interrogation signal was frequently sent down the guide wire. The range tracking computer sent the interrogating signal to a radio transmitter at the computer site, which relayed the signal out to the firing craft on the range. The firing craft received this signal and passed it to the torpedo fire control panel where it was sent down to the torpedo over the guide wire. At the torpedo the interrogating signal was stripped off the guide wire and routed to the transponder. After the transponder validated the signal, it sent out an acoustic reply signal to the array as before. This alternate interrogation process overcame the noise generated by the vehicle, which often made it difficult to receive an acoustic interrogation signal from the array.

The arrays were installed with overlapping tracking coverage areas (500 feet of overlap) to provide a continuous track. The defined tracking volume of each array was a volume of water the shape of a cylinder, 2,000 feet in diameter, extending from the surface down 600 feet to the depth of the array. However, each high frequency array was able to track an object out to a maximum slant range of about 1,500 feet, slightly beyond the defined tracking volume.

The range at Dabob Bay produced excellent tracks with ± 1 foot point-to-point accuracy within a given array and ± 5 feet true space accuracy using a .661 second pulse repetition period.

To attain maximum tracking accuracy a program was used to correct every position measurement for a variety of effects. These included the oceanographic effects of sound ray bending (which depended upon salinity, temperature, and depth); the physical effects of array tilt and array rotation; and the instrumentation effects of receiver unbalance and instrumentation time delay. An IBM 650 computer at Puget Sound Naval Shipyard made these correction computations after the exercise.

It was soon realized that this new range would have the ability to evaluate a complete ASW weapon system from its early development phase through operational testing and into production (proofing). However, two major deficiencies soon came to light: (1) the self-noise (including cavitation) generated by the vehicles (surface ship, submarine, or high speed torpedoes) participating in the test made reception of the interrogating 330 kHz or 190 kHz pulses very difficult, and (2) the high frequency (250 kHz) acoustic energy was subject to high attenuation in the water resulting in a very short range for the tracking signal. In water depths of 600 feet the arrays could only be spaced 1,500 feet apart. To increase the size of the range many more arrays would be needed (using a significant quantity of very expensive array-to-shore electrical cable). APL/UW was to solve the first of these problems by installing synchronous transmitters ("sync clocks" driven by stable crystal-controlled oscillators) in the vehicles to be tracked on the range, and installing a master sync clock at the range computer site. Tracking devices using these new transmitters produced a tracking pulse at a precisely known time, when synchronized with the range computer master clock, rather than relying on the reception and decoding of an interrogating pulse before a tracking pulse could be transmitted. Also, there was one less signal in the water to worry about. Lowering the acoustic tracking frequency to 75 kHz eventually solved the second problem (short ranges). But, a lower tracking signal frequency would require that the spacing of the receiving hydrophones on the bottom-mounted arrays be increased significantly to preserve the tracking accuracy. Hence, the installation of new and much larger arrays would be required.

Low Frequency Experiment in Alaska

In 1958 a decision was made to investigate the feasibility of using lower tracking frequencies; in effect, to accept slightly reduced accuracy as a trade-off for increased range and depth, and to reduce the number of arrays. In addition, there were some impending test objectives that could only be satisfied in water deeper than 600 feet. High frequency arrays were spaced 500 yards apart, but new low frequency arrays could be spaced up to 2,000 yards apart to create a much larger range with fewer arrays and less cabling. The new low frequency 3-D acoustic arrays (Figure 11) would operate at 75 kHz and have over three times the range of the high frequency arrays then in place at Dabob Bay. This frequency was selected after careful consideration of such interacting variables as attenuation of the signal in seawater, tracking accuracy, baseline length, the noise environment, Doppler considerations, water depth, and mutual interference with other systems and with the torpedo sonar frequency. The resultant, larger array was designed with the hydrophones spaced 30 feet apart.

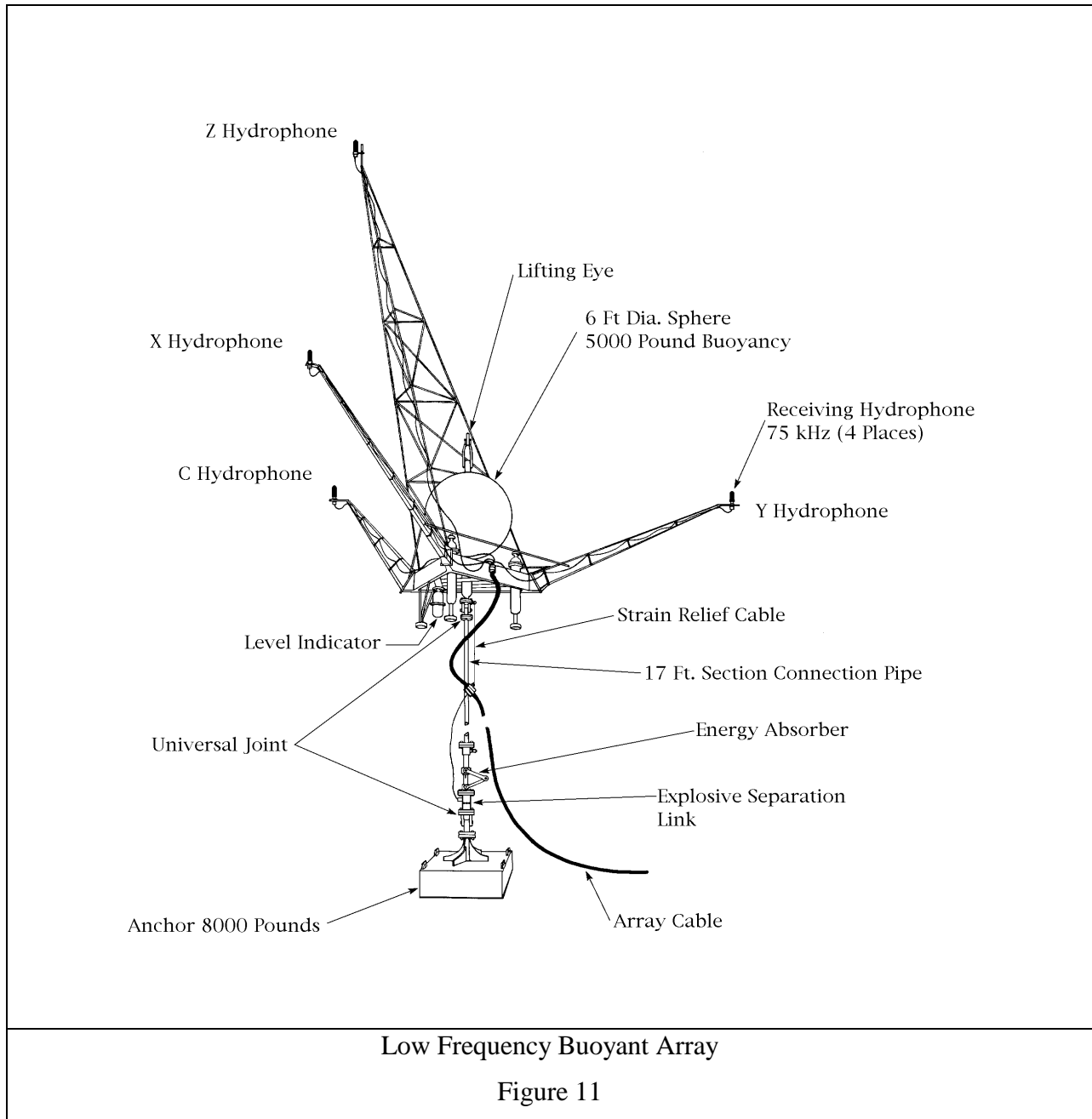

To find a suitable site (deep, quiet, and private) to test the concept of a low frequency tracking signal, Keyport and APL/UW jointly conducted a survey of southern Alaskan waters in the summer of 1958 (this survey also looked at Behm Canal, Alaska and Jervis Inlet, British Columbia). Waterfall Cove, in the southern portion of Chatham Strait, was selected because the water depth near shore reached 2,000 feet. The geography at Chatham Strait was such that when the array was lowered to the bottom there would be only a short cable run to the support vessel anchored near shore. Due to the temporary nature and mission of this tracking range (testing new deep diving torpedoes) the tracking computer hardware was placed aboard one of Keyport's range craft.

In July 1959 a small, three-vessel convoy steamed north to Chatham Strait for the expedition. The three ships consisted of YF 885 with the tracking computer in its hold and the new APL/UW designed array disassembled on its deck, YFRT 451 with the test torpedoes loaded in its hold, and torpedo retriever TR 31. Upon arriving at the selected site all of the array components were transferred to YFRT 451 for assembly, which took three days. YFRT 451 then deployed the large delicate array and laid the array electrical cable to an off-range anchoring site in Waterfall Cove where YF 885 lay waiting in moor. The array cable actually came ashore at "Z" Island and was secured to the trunk of a tree with a cable clamp. Initially the exercise (coordinated from YF 885) got off to a bad start when the array failed to release from the ship's crane. A newly developed release mechanism would not let go of the array when the release lanyard was pulled. After several unsuccessful attempts the array was hauled back on the deck and the release mechanism was replaced with some manila line, tying the array to the hook of the ship's crane. When the array was again swung over the side and ready for deployment the manila line was parted by several well aimed rifle shots.

One MK 45 Mod 0, five MK 39 Mod 1, and three MK 37 Mod 0 torpedoes were fired by YFRT 451, tracked successfully by the array, and recovered. The entire expedition was considered quite successful, clearly proving the utility of the lower frequency tracking signal and the practicality of a semi-mobile tracking range, the Navy's first "portable range." In addition, operation of the torpedoes in deeper water made apparent a design flaw in the MK 37 torpedo when it was discovered that the torpedo would not home on targets when running at depths in excess of 750 feet. Seawater pressure at that depth desensitized the magnetostrictive sonar transducer in the nose of the torpedo. Subsequent testing provided the torpedo's designers with enough information to correct this "deafness."

The array was recovered following five days of ranging and brought back to Keyport. On the way home an "evaluation" of the operation was held in Juneau at the Red Dog Saloon. Music, fire hose sprays, and the BOQ's portable bar greeted the returning fleet at Keyport. CWO Cox took the fisherman's award for his 140-pound halibut caught in Waterfall Cove on the first night. However, the weather in Alaska was apparently not what one expects to find during the summer months as confirmed by the fact that of the 105 cases of beer sent up with the crew 80 were returned, unopened.

The immediate result of the successful Alaskan venture was the attention of the Navy research and development establishment, in particular the Naval Ordnance Test Station (NOTS) Pasadena Annex, Pasadena, California. NOTS persuaded the Navy to remove the Alaskan array, the APL/UW analog computer, and associated electronics from Keyport's custody and install them at San Clemente Island (off the coast of San Diego, California) in an operation called DEEPTRACK. This project was to demonstrate the feasibility of developing a larger, permanent range consisting of seven tracking arrays. The array was installed in March 1960 on the east side of the island near Station South Point in 1,500 feet of water and the tracking computer was located in a van parked alongside the existing range control building at South Point. DEEPTRACK successfully tracked both surface and subsurface targets and demonstrated an accuracy of ± 5 feet. The array was installed on a slope overlooking deeper water, providing an opportunity to track the test vehicle down to 2,000 feet, 500 feet below the X-Y plane of the array. Following this period of calibration and testing it was decided not to install the range due to funding constraints and the fact that the impending deep water range to be eventually

established in the Strait of Georgia, British Columbia would meet the Navy's requirements for a testing and proofing range. The array off San Clemente Island saw no further testing and remains in place and unused to this day.

It is not often that such a brand new testing technology springs to life, and those who took part in the exciting effort at APL/UW and at Keyport to exploit this new dimension in underwater ranging can take pride in its development and look back on a fun filled career.

High Frequency Ranging at Dabob Bay

During the first few years following the high frequency range installation (between 1958 and 1964) a succession of developments helped further exploit the concept of 3-D acoustic tracking, despite the limitations imposed by the tracking signal's high frequency. The first priority was to increase the tracking area of the high frequency instrumented range by increasing the number of arrays from 10 arrays to 12 arrays. By the time the last high frequency array was installed in June 1964 the range had grown to 15 arrays with an overall acoustic tracking area of slightly more than one square nautical mile. Figure 12 shows sailors struggling to tend the signal cable of a high frequency array about to be lowered to the bottom in Dabob Bay. Another important task was to increase the reliability of the range components. During this time, ship, submarine, and torpedo testing operations continued at Dabob Bay and range utilization dramatically increased to a total of 2,400 range exercises in 1960, as the range proved to be more and more useful and its capabilities increased. These operations included a few runs where the exercise torpedo was set to hit a target submarine, runs to gather tactical data concerning the weapon, runs of experimental units, as well as proofing runs. Furthermore, by this time BuOrd began to specify that torpedo proofing had to include runs on the Dabob Bay range (beginning with the MK 37 Mod 0 and MK 45 Mod 0). The year 1964 was the busiest year yet for the new range with 4,556 units ranged. The range was an invaluable tool in the development, testing, and improvement of nearly every underwater weapon system in the Navy. It could determine values for such parameters as velocity, acceleration, turn radius, reach, advance, transfer, and dive/climb angle; all with an accuracy, and at a depth, never before realized. Naturally, such achievement attracted considerable attention to the shores of Dabob Bay where APL/UW director Joe Henderson hosted salmon barbecues, complete with all the trimmings. In 1959 several distinguished visitors came to Keyport, including Senator Henry M. Jackson with Vice Admiral H. G. Rickover in tow (or vice versa).



High Frequency Array Installation

Figure 12

One new capability brought on line during this period was noise monitoring to determine the level of self-noise generated by ships or weapons being tested on the range. In addition to four noise measuring platforms (also called “arrays”), installed and operated by ORL/PSU, Keyport operated several sound boats which deployed hydrophones over the side to record the noise levels. These systems measured how much noise was emitted (radiated) by a vehicle or submarine on the range, as too much emitted noise could alert a potential adversary to your location and make you the unhappy target for one of his weapons!

Another new mission for the range was that of checking the accuracy of the fire control system on a ship or submarine by employing the unique capabilities of the 3-D range. This started in about 1960 when Fleet commanders complained that torpedoes fired in open sea exercises were not hitting their targets due to torpedo defects (again?). However, when word of this reached APL/UW, they suspected that the problem was not due to any torpedo deficiency but that the ship's sonar and other weapons aiming equipment (the fire control system) was at the heart of the problem. At about this same time APL/UW was testing a modified torpedo exploder against an LST, but the torpedo missed the target due to a misalignment between the submarine's heading and the torpedo's course setting mechanism. Further tests on Dabob Bay involving both destroyers and submarines quickly proved this misalignment to be the problem. In response, APL/UW proposed a shipboard equipment alignment and calibration program to measure the bearing and range accuracy of ship sensors. This program was eventually taken over by Keyport and combined with APL/UW's acceptance trials of new or overhauled torpedo tubes (Torpedo Tube Acceptance Trials, TTAT), and called the Weapon System Accuracy Trials (WSAT) program. In essence, the WSAT program evaluated the operability and accuracy of the entire ASW weapons system suite on submarines and surface ships. WSAT range operations look for sonar range and bearing errors, and gyrocompass, radar, and fire control transmission errors. Ships participating in this program are either new construction or ships that recently completed a major overhaul or conversion. The information obtained during the trials is fed back to the ship and to naval technical bureaus so that corrective actions can be taken. WSAT-type exercises, begun in 1965 at Dabob Bay with USS PERMIT (SSN 594), were to become major range events and have continued as such ever since. Also, out of these tests would grow other sensor-oriented programs such as Consolidated Operability Tests (COT), and Fleet Operational Readiness Accuracy Check Sites (FORACS). These programs have since become important users of range time. At some FORACS installations, there has even been a blending of sensor accuracy testing programs and range tracking programs, as 3-D tracking capabilities have been added to these FORACS locations.

Many improvements were made to the range during these early years including new electronic navigation gear for the range craft (called RAYDIST), upgrades to much of the computer site electronics hardware, and additional optical tracking equipment. It was during this time that APL/UW developed and introduced a transistorized version of the early vacuum-tube transponder, then later moved away from transponders all together with the 1959 development of the “synchronous clock.” As mentioned previously, this innovation allowed the use of synchronized tracking, where the tracking projector in the torpedo (colloquially known as a “sync clock”) transmitted the tracking signal at a predetermined, or synchronized, time. This was especially important in noisy vehicles which had difficulty decoding the interrogating signal projected up from the array.

In synchronous tracking all range events were synchronized to the computer site's time base, a timing pulse – not actual time of day – generated every 1.310720 seconds and called I_0 ¹ (the I_0 period was later changed to 2.0 seconds and obtained from the Global Positioning System (GPS) along with the actual time of day.) One method to accomplish synchronization, when the torpedo was loaded in the torpedo tube and ready for launching, was to send a synchronizing signal by a radio link (RF telemetry). This message was received on board the firing craft, passed through the torpedo tube door, and then on into the torpedo's tracking projector (sync clock) by way of a breakaway cable, which separated from the torpedo upon launch. This radio link technique was also particularly effective with noisy surface vessels when cavitation was present or with noisy wire-guided torpedoes. Using this arrangement the range tracking computer knew ahead of time when each torpedo tracking pulse would be sent, and then the computer just waited for its reception at the hydrophones on the array.

It should be emphasized that knowledge of the exact time that the tracked vehicle emitted the tracking pulse was critical to maintaining a good and consistent track. There were three ways to accomplish this: (1) the interrogating transponder technique used in the high frequency range, (2) the above mentioned transmission of the signal over a radio link to the firing craft, or other surface craft being tracked on the range, and (3) the installation of a very stable sync clock in the weapon, or other submerged vehicle being tracked. As each hydrophone on the array picked up the short, continuous wave, tone burst signal, the computer determined exactly the time of arrival of the signal and computed the difference between the time that the tracking signal left the torpedo and the time it arrived at each of the hydrophones on the 3-D array. With these sets of time differences, several tracking options were available and these will be discussed in the section titled How A Tracking Range Determines Positions.

The high frequency range remained operational well into 1970. But by 1974, the Whitney Point computer site had closed down and during that summer a concerted effort was made to remove the high frequency arrays before they became a safety hazard in case a self release brought an array to the surface. This recovery effort was not entirely successful, as evidenced by the fact that, as of this writing, one additional high frequency array remains to be recovered (after being found in November 1995).

The Shift to Low Frequency Tracking at Dabob Bay

In 1962 construction began on a temporary computer van site on the beach at Zelatched Point to test new transistorized shore equipment and to control the South Dabob Bay range exercises. One of the high frequency arrays (Array 109) was actually terminated at Zelatched Point with the signal being relayed over to Whitney Point. With this arrangement it was hoped that two separate small scale range operations could be conducted simultaneously at both the North and South Dabob Bay range sites, while the combined areas could be used for a single, large range exercise. This plan never came to fruition because no more high frequency arrays were installed after 1964, and the impending shift to low frequency arrays would create a tracking range that would encompass nearly the entire bay. Instead, the future tendency would be

¹This odd number resulted from taking the output of a commercially available stable crystal-controlled oscillator (an oscillating signal at a frequency of 100 kHz) and dividing it by two, electronically, a total of 17 times to arrive at a signal somewhere near one cycle per second, the desired synchronization rate.

toward larger tracking areas as the newer weapons, with their ever increasing range and endurance, needed more maneuvering room. This, and the program to check the accuracy of a ship's combat system, made "small scale range operations" less likely.

Starting in March 1965 Dabob Bay saw the deployment of new low frequency, 75 kHz, tracking arrays being installed "over the top" of the old 250 kHz high frequency arrays. In design, these first low frequency arrays were just scaled up versions of the high frequency arrays. At this time both high frequency and low frequency tracking operations were possible at Dabob Bay with the low frequency system resulting in a much larger tracking area while using fewer arrays. Tracking operations at the North Dabob Bay range site, controlled from Whitney Point, began to be phased out with the shift to the new low frequency tracking signal and with the 1965 completion of a permanent computer building, located high on the bluff overlooking Zelatched Point. This building was soon to be the new quarters for the first generation of digital computers at Keyport, the Scientific Data Systems, Model SDS-920. Figure 13 is a diagram of the Dabob Bay range showing the coverage areas of both the high frequency and low frequency arrays. As of this writing there are seven bottom-mounted arrays in Dabob Bay (only five of which are shown in Figure 13) with an acoustic coverage area of about nine square miles.

Until 1963 Dabob Bay was the only source of 3-D underwater tracking range services in the world. Then, in the period between 1964 and 1968, four new underwater ranges were constructed.

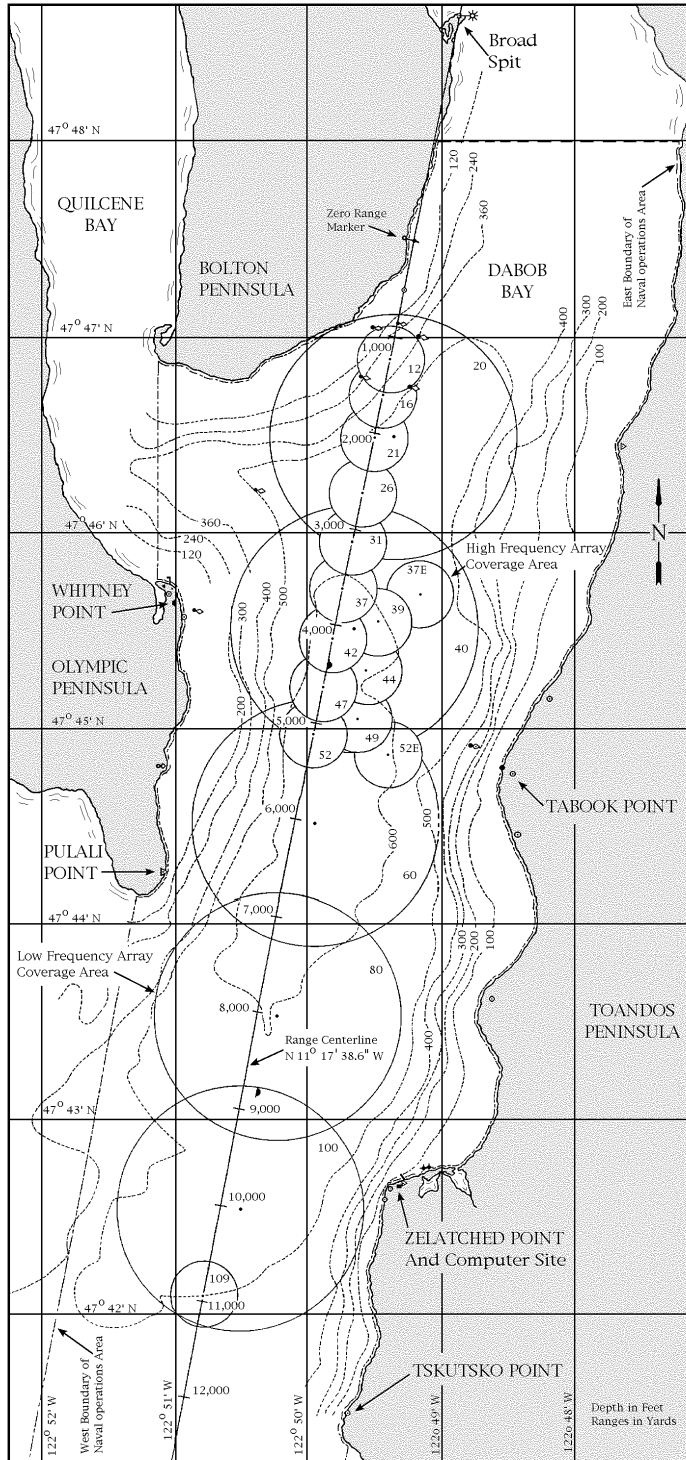

Dabob Bay 3-D Tracking Range Layout
 (Showing both High and Low Frequency Array Coverage Areas)

Figure 13

Related Activity at Other Navy Range Sites

While these early efforts in underwater tracking were taking place at Keyport, other elements in the Navy were attempting to evaluate the long range requirements in the field of 3-D acoustic tracking. In 1957, as a part of its Long Range Plan for Research and Development, the Bureau of Ordnance formulated the requirements for a deep water range with 3-D tracking capabilities, both in-air and in-water, which would effectively simulate open ocean conditions to provide adequate testing for advanced ASW weapons and weapon systems. A survey of possible sites for this proposed range was made by the Naval Underwater Ordnance Station (the former Naval Torpedo Station, Newport, later NUWC Division, Newport), and in December 1957 NUOS forwarded a preliminary report to BuOrd with a site recommendation of Andros Island and the Tongue of the Ocean (TOTO) in the Bahamas.

In 1959, the Secretary of the Navy requested that the Chief of Naval Operations (CNO) and the Bureau of Ships (BuShips) establish the Atlantic Undersea Test and Evaluation Center (AUTEK) at TOTO. NUOS was designated as the lead activity and assigned technical responsibility for establishing the range. The David Taylor Model Basin (later the Naval Surface Warfare Center Carderock Division) and the Naval Underwater Sound Laboratory (later NUWC Detachment, New London) were assigned responsibilities in sonar and acoustics. With the concurrence of the Bahamian government, an agreement was signed with the United Kingdom whereby the U.S. Navy would have the use of territory in the Bahamas for purposes of installing test facilities, and the U.K. would have equal access to these facilities. In 1964, with the services of contractors Arthur D. Little, ITT, and Delco, construction began on the AUTEK range.

By the time RADM Charles K. Bergin was appointed Commander, Operational Test and Evaluation Force (COMOPTEVFOR) in 1961, the need for Navy underwater tracking ranges was generally accepted. AUTEK, with its proposed long baseline range, was already in the budget, having been authorized in 1960. AUTEK, however, was not expected to be operational until 1966, and RADM Bergin's schedule for the MK 46 torpedo included Operational Evaluation (OPEVAL) in 1964, so a search began for an alternate location for a range which could be operational sooner. APL/UW and Keyport, as the Navy's range experts, were enlisted for the job, in cooperation with Marine International, a private Seattle-based contractor. RADM Bergin preferred a location near Key West, Florida, where good Navy support facilities already existed, but the combination of distance to deep water, severe current conditions, and shipping density made it a poor choice, so an alternate location was sought.

After surveying several possibilities, St. Croix, U.S. Virgin Islands was selected, and construction began on the Atlantic Fleet Weapons Range, Underwater Tracking Range. The range equipment that had been used in the Chatham Strait experiment, and later taken to San Clemente Island, formed the basis for the short baseline arrays installed at St. Croix. Some improvements to the system were included at St. Croix, including a primitive digital computer (Scientific Data Systems SDS-910 with a memory of 4,096 24-bit words). The initial installation consisted of four arrays, which were installed off the western shore of St. Croix in 3,000 feet of water in March 1964 providing six square nautical miles of underwater tracking area. Base frequency for the new St. Croix range was 75 kHz. Only tone burst tracking (1.5 ms wide tones), without any pulse coding, was available at the time, so there was no telemetry superimposed on the signal. Up to eight objects could be tracked simultaneously without

introducing track ambiguity. The synchronized projectors developed by APL/UW for the Keyport ranges were used to ensure proper range timing.

This new short baseline range installation, managed by Dr. Wayne Sandstrom, APL/UW, was completed as planned in time for the MK 46 OPEVAL in 1964. The deep water AUTEK long baseline range was dedicated in 1966, becoming operational in 1967.

During the 1967 expansion of the Atlantic Fleet Weapons Range the number of arrays was increased to 13 providing a 21 square nautical mile coverage area. A unique feature of these new arrays was a fifth hydrophone (added for redundancy) located on a 30-foot arm in the X-Y plane midway between the X-axis and Y-axis. The four original arrays were eventually modified to incorporate this fifth hydrophone. Additionally, a multiplexer was added to each array to allow the signals from the hydrophones to be sent to the computer site via a single coaxial cable, instead of a more expensive multiconductor cable. Preamplifiers were used at the hydrophones to amplify the signals well above any noise level anticipated in the cable between the array and the input to the shore-based receivers. In the mid-1970s a MODCOMP IV general purpose digital computer was installed to replace the SDS-925, which had replaced the SDS-910 in 1968.

The range facility was renamed the Atlantic Fleet Weapons Training Facility (AFWTF) in 1975. Then during the 1980s the AFWTF range was switched over to a totally long baseline, synchronous system using a 13 kHz Phase-Shift Keying (PSK) coded pulse, converting it into an "AUTEK-type range." This greatly enlarged the total underwater tracking area to 450 square nautical miles.

Note that the spacing between short baseline arrays is typically 2,000 yards (determined by the "hearing distance" or propagation range of the frequency used), but each hydrophone pair on a short baseline array is separated by only 30 feet. Long baseline systems, on the other hand, use single-hydrophone sensors (or platforms) spaced such that the pulses emitted by the vehicle can be heard by at least two but preferably three platforms. Since long baseline ranges are generally in deep ocean waters, the arrays are typically spaced over 2,000 yards apart. (See Figure 14 for an illustration of long baseline and short baseline array structures).

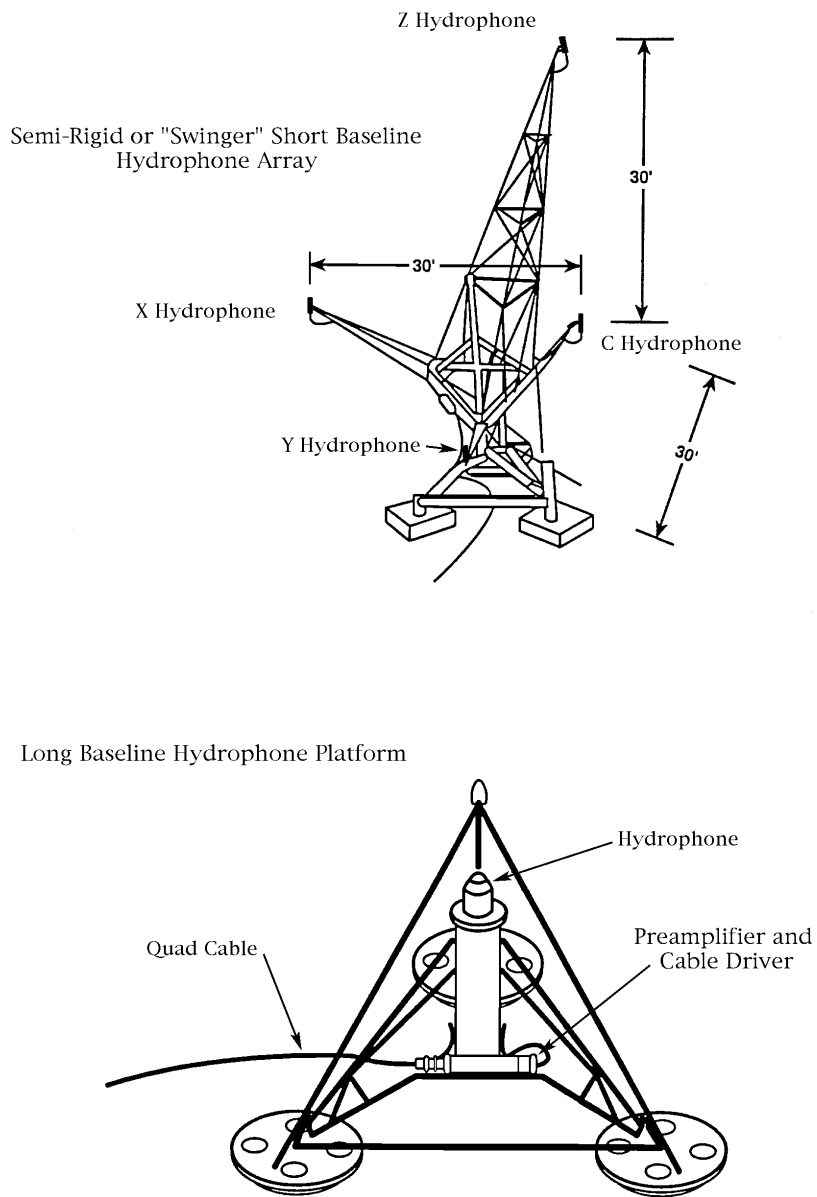

Long and Short Baseline Tracking Arrays

Figure 14

A New Range Site Develops at Nanoose

During the early 1960s, several separate efforts were simultaneously underway to expand the possibilities of underwater tracking ranges. In the Pacific Northwest, Keyport, which still had the high frequency (250 kHz) range installation at Dabob Bay, began an effort to locate a large, secure, and acoustically quiet place to install a low frequency (75 kHz) range. For a brief period, installation of a range was attempted at Patos Island, west of Bellingham, WA. The waters off Patos Island offered a much greater expanse than the physically restricted waters of Dabob Bay, an important consideration when selecting a site to proof advanced ASW torpedoes like the MK 44. These torpedoes carried new sonar systems with longer acquisition ranges that would have been acoustically limited by the confines of Dabob Bay. The effort to set up a range at Patos Island began in June 1961 with the installation of one array in 700 feet of water (slightly deeper than the 600 foot water depth of Dabob Bay). The array cable came ashore on the island and terminated at a computer van (more array installations were planned, depending upon the successful operation of this one array). During August and September a number of torpedoes were fired, but surface and sub-surface water conditions were not favorable. The strong tidal currents near the bottom caused the array to tilt severely (often in excess of 5°), and surface conditions were generally too rough for safe torpedo recovery or to land float planes carrying range support personnel. After approximately four months of operation the Patos Island range was disestablished.

There was one positive result from this effort: It provided additional impetus to establish a range in the Strait of Georgia, British Columbia. Before the Strait of Georgia site was selected, other potential tracking range sites in Alaska and Canada were considered; but none of them offered the combined advantages of a large volume of water with a water depth that would not crush a torpedo should it find itself on the bottom, good weather conditions for nearly year around operations, and a reasonably close proximity to Keyport where the torpedoes were prepared and where the results of the runs were analyzed.

In 1961, negotiations were begun with Canada for the installation and joint operation of an acoustic range near Ballenas Island, in the Strait of Georgia. After several exploratory trips were made to Ballenas and Winchelsea Islands, construction of the range, based on the low frequency 75 kHz tracking signal, was begun near Nanoose Harbour in 1962. Following the installation of three arrays, the range was pronounced ready for operation in 1963. The array cables were temporarily terminated at a trailer on South Ballenas Island that contained the range tracking computer and served as a range control site. After one year of operation at South Ballenas Island, the tracking center was moved into a new facility constructed on Winchelsea Island. Cooperation between Canada and the U.S. was spelled out in an International Agreement, signed in 1965, which stipulated that the Canadian Navy would provide the building facilities, range support craft, and communications equipment; while the U.S. Navy would provide the computer tracking system and arrays, range firing craft, targets, and recovery services.

This new range at Nanoose, which also used a multiplexed signal transmission technique with the short baseline arrays, quickly proved invaluable. By 1967 the range had been expanded from three arrays to 10, increasing the length of the range to 28,000 yards. During these early

years of range operation at Nanoose, the weapons to be tested (mainly lightweight torpedoes) were loaded on the firing craft at Keyport, over 130 miles to the south of the range. The firing craft would then transit to the range and fire the weapons, which were recovered by a torpedo retriever boat (TRB) and brought back to Keyport. Later, helicopters and float planes were briefly used in an effort to expedite the transportation of torpedoes between Keyport and Nanoose. The civilian version of the Bell "Huey" helicopter could even handle the large MK 48 torpedo, representing a total load of 3,500 pounds. The main advantage was the quick turn around of the torpedo; from Keyport to Ranch Point in Nanoose Harbour, then onto the range, and back to Keyport – all in the same day. Float planes were used to ferry personnel from Keyport to Nanaimo, which also served as a staging area for the small boats. Eventually a support facility at Ranch Point was established. On 17 December 1967 the range suffered a setback when lightning struck Winchelsea Island and caused severe damage to the underwater tracking equipment and surfaced several of the buoyant arrays when their explosive releases fired. But this event began a major effort to protect range electronics by using lightning arrestors.

Overall range utilization at both the Dabob Bay and Nanoose tracking range sites increased to over 3,000 range exercise firings in 1968. This year also saw some expansion and improvement at the range control center on Winchelsea Island, including a new computer system (Scientific Data Systems SDS-930 with a memory of 8,192 24-bit words). In addition, impending advances in the fields of acoustics and electronics, all applicable to 3-D acoustic ranging, would bring about many more changes, and in particular, the availability of fast digital computers would remove the need for a tightly controlled array geometry (as explained in the next section).

Two cine-sextant optical tracking systems were installed in 1969 to obtain in-air trajectory data for correlation with the 3-D acoustic data. Each cine-sextant system included two separate cameras, a 35-mm camera to the left of the operator and a 70-mm camera to the operator's right. The data from the two cine-sextant sites consisted of two elevation angles and two azimuth angles to provide a 3-D location of the airborne object by triangulation. As was the case at Dabob Bay, with its integrated optical and acoustic tracking capability, the Nanoose range site was also able to integrate the in-air portion of the trajectory with both the surface and underwater track to produce a complete picture of the exercise. This provided an important capability that was truly unique to these Keyport tracking range sites.

Shortly after the cine-sextant cameras were installed at Nanoose they played an instrumental role in determining the reason why MK 44 torpedoes were failing to run after being air dropped on the range. Some of the first pictures ever taken by these cine-sextant cameras were of the MK 44 torpedoes being torn apart as their parachutes opened, yanking the afterbody away from the torpedo and spilling the battery.

Deflection measurements from the early range days were not completely forgotten. In 1969 a deflection measurement system was developed that was based on taking a photograph of the bearing to a shore target from the firing craft at the moment the weapon was launched in order to measure the exact firing angle. The YF 520 had one of the German Askania cameras for this purpose. When warships were operating on the range, a picture was taken of the fire control panel. At night this was done using a red strobe light to not interfere with the night time red lighting in the compartment, as the crew would be at General Quarters during these exercises. In

addition, many WSAT operations were conducted at the new range site; with the final weapons launching occurring at Nanoose, after preliminary surface WSAT operations were completed at Dabob Bay.

In 1970 the Nanoose tracking range was doubled in size to provide about 32 square nautical miles of acoustic tracking which provided enough room to fully evaluate the new MK 48 torpedo. The next year it was expanded again to cover over 36 square nautical miles of tracking area (as shown in Figure 15). Then again in 1992, the range was further expanded to 44 square nautical miles, employing 29 bottom-mounted arrays. A “shallow-water” array was added near Winchelsea Island in 1995 to support torpedo R&D in shallow, rough-bottom conditions.

The main emphasis at Nanoose was on the testing (proofing) of new production torpedoes just entering the Fleet from the manufacturer. The significance of this tracking range site can be better understood from the comment made by the Naval Sea Systems Command's Program Executive Officer for Undersea Warfare: “The single most important core facility is the instrumented underwater test range facility at Nanoose, British Columbia, operated by NUWC Division, Keyport.” This is due to the ability of the Nanoose site to provide critical Test and Evaluation (T&E) services to current and future generations of undersea weapons. These include the lightweight torpedoes, MK 46 and MK 50, the heavyweight torpedoes, MK 48 and MK 48 ADCAP, as well as various mine warfare systems.

Proofing was also done at Dabob Bay, but the workload at Dabob Bay was more related to weapon's R&D programs and to WSAT testing. Other, larger, Navy ranges were developed as exercise and training ranges to be used to conduct major Fleet exercises involving numerous ships, submarines, and aircraft.

A major advantage offered by the Nanoose range site (as with the site at Dabob Bay) was that a torpedo could always be recovered intact, even when the torpedo sank to the bottom. The 3-D tracking capability (backed up by a long-life, free-running, 45 kHz acoustic locating pinger in the torpedo) provided the torpedo's location on the range bottom where it sank, and the depth at the bottom of the range was not great enough to crush the weapon (see Appendix B for a discussion of Keyport's torpedo recovery capabilities).

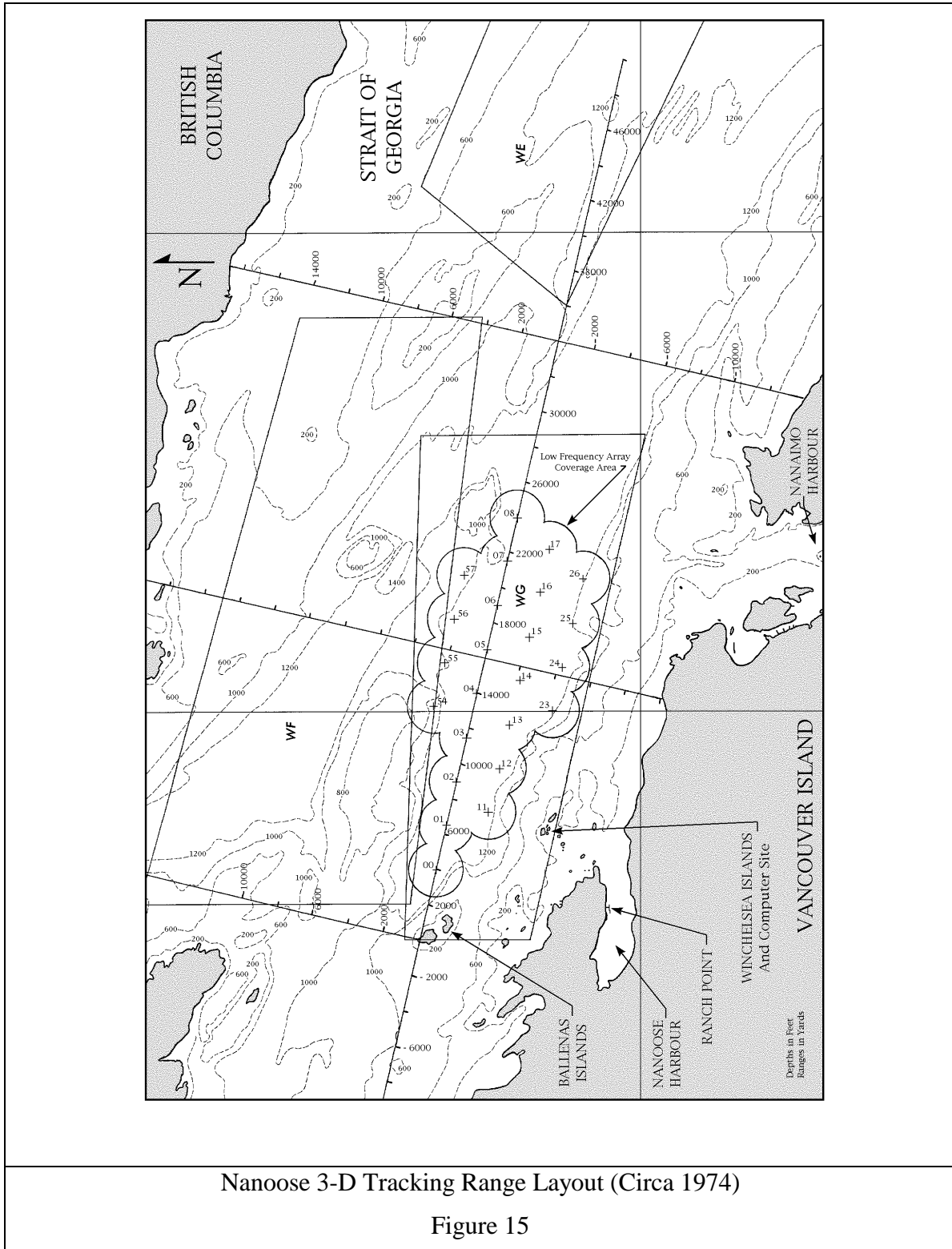

Nanoose 3-D Tracking Range Layout (Circa 1974)

Figure 15

Types of Tracking Arrays

Four different types of array frames have been used to hold the four receiving hydrophones needed for short-baseline tracking at the various Keyport range sites. The first two types were referred to as floating or buoyant arrays, one type for the 250 kHz high frequency signal and the other type for the 75 kHz low frequency tracking signal. The other two array types, called “semi-rigid” (or “swinger”) and “rigid-rigid,” were used only with the 75 kHz low frequency signal. In all cases the four hydrophones were attached to the array in such a manner as to form a Cartesian coordinate system, with one hydrophone at the origin (the C hydrophone) and the other three located orthogonally along the three axes (in the X, Y, and Z directions).

- High Frequency Buoyant Array

These APL/UW designed arrays, the first devices to provide a complete 3-D solution to the tracking of underwater objects, were only used in Dabob Bay and Hood Canal. In this type of array the structure holding the hydrophones was allowed to rotate about the X and Y axes, but the array could not rotate about the vertical axis (Figure 10). Tilt of the X-Y plane was necessary to ensure that the three hydrophones in that plane would remain truly horizontal following array deployment, regardless of the bottom slope. Preventing rotation about the Z axis was necessary to ensure that a consistent bearing angle was maintained to the object being tracked relative to the array.

A flotation sphere supported the frame holding the four hydrophones, which were spaced 10 feet apart. The buoyancy provided by this sphere forced the array frame into the proper attitude where the three lower hydrophones were maintained in the level X-Y plane and the fourth hydrophone was held directly above the coordinate system origin. A second function of the flotation sphere was to provide a simple means to recover the array. A concrete anchor held the array in place on the bottom and was attached to the array by a rigid, non-rotating tube with a universal linkage mechanism that allowed array tilt but prevented rotation. In order to obtain a correct tracking solution it was very important that the array not rotate about its vertical axis. The linkage mechanism also contained an electrolytic release device (corrosive link) to allow separation at the universal joint when the array was commanded to come up to the surface for recovery. After the electrical current was applied to the corrosive link it would take only a few hours for the link to be eaten away and have the flotation sphere carry the array to the surface.

- Low Frequency Buoyant Array

Essentially these were “times three” scaled-up versions of the high frequency buoyant arrays, with a 30-foot spacing between the low frequency receiving hydrophones (Figure 11). To provide buoyancy to compensate for the longer and heavier array arms, the flotation sphere had to be much larger than the sphere used with the smaller high frequency arrays. In addition, the flotation sphere (a large six-foot diameter spherical steel “pressure hull”) had to withstand the seawater pressures at the bottom of the Navy's deep ranges at Nanoose and St. Croix. As a consequence these arrays were very cumbersome to handle and expensive to build. They were used predominately at the Nanoose and Dabob Bay sites, with some being built for off-station

use at St. Croix and other deep water range sites. The test array used in the low frequency experiment in Chatham Strait, Alaska was of this type.

An important step in preparing these arrays for use was the land-based hydrophone and array survey. During array assembly an optical alignment and verification process was conducted to adjust the spacing of the hydrophones with respect to each other to exact specified values. This determined the X, Y, and Z spacings between the hydrophones (plus, in-air leveling of the array was also accomplished). Then just prior to array installation, and while the deployment barge was still pierced, the array was lowered into the water and divers positioned lead weights on the lower arms in the X-Y plane to level, as nearly as possible, the orthogonal coordinate system. This established a true horizontal plane for the three lower hydrophones. Finally, after the array was installed, and when all settling motions had died out, an acoustic survey was conducted to determine the exact location of the array on the range and the three-dimensional orientation of the array with respect to the range centerline (position, tilt, and array rotation). This final survey was conducted with the help of a range craft maneuvering along a designated path on the surface. The range craft was equipped with an acoustic projector that transmitted the tracking signal (or survey signal) down to the array while the craft maneuvered overhead, within the array's area of coverage. The exact positions of this range craft were determined optically by using theodolites mounted along the shoreline. A statistically based algorithm mathematically positioned the array to agree with the range craft locations. The result was a transformation of each individual array's coordinate system into a unified range coordinate system. The purpose of a single unified coordinate system was to make the track continuous when the object being tracked left one array's coverage area and entered the coverage area of another array.

In a manner similar to that used on the high frequency buoyant arrays, universal joints in the connecting pipe between the buoyancy sphere and the concrete anchor allowed these low frequency arrays to self-level (in tilt), but would not allow them to rotate about the vertical axis. The 3-inch diameter connecting pipe also contained a shock absorber system that dampened the shock experienced by the array upon hitting the bottom. (The array was usually dropped from a few feet above the bottom to help plant the array firmly in the bottom sediment.) A tilt sensor on the array measured any remaining tilt, with respect to the horizontal plane, resulting from local tidal currents along the bottom of the range. These values of tilt (in both the X and Y direction) were sent to the range control center via signals on the underwater array cable and were read and entered into the tracking computer before each torpedo was run on range (later this became unnecessary as computer hardware and software programming improved). These values for array tilt were very important in arriving at a proper tracking solution. Array tilt, of even a few degrees, was significant enough to produce noticeable errors in the positions of the torpedo being tracked by the array.

This arrangement proved fairly successful, but in light of several problems this design was eventually replaced with a more rigid array type. An example of one of the problem areas, although infrequent, was the unexpected surfacing of one or more arrays during a lightning storm. The lightning caused an electrical voltage spike to be sent down the cable, which activated the recovery device. These arrays did not use the electrolytic corrosive link of the high frequency arrays, instead they used an explosive bolt to release the standpipe from the concrete anchor and allow the array to float to the surface. On more than one occasion, as a range craft entered the range, the Craftmaster would have to report that an array was on the surface. A good

example is the lightning storm at Nanoose on 17 December 1967 which resulted in the surfacing of several arrays, and put a halt to many Christmas plans as Keyport personnel and range craft had to work through the Christmas holidays to clear the shipping channel of large spheres with awkwardly protruding arms. This lightning strike occurred during the daytime while workmen were constructing the concrete pads for the optical cine-sextant tracking system on Winchelsea Island. The lightning bolt could be seen traveling down the roadway between the two workmen. In 1973 a similar lightning strike at AFWTF in St. Croix also brought one of their arrays to the surface.

Another problem with this type of array was the annoying fact that sometimes the concrete anchor would land directly on the array signal cable during array installation, which always caused an array cable failure when the array was later recovered. The high maintenance requirements, the significant problems caused by cable leaks, and the need to constantly enter the tilt values into the computer all contributed to the abandonment of the buoyant arrays. The last array of this type was recovered and retired in the late 1980s.

- Semi-Rigid Array

Arrays of this type were also called “swingers” as the upper array structure, holding the hydrophones, was allowed to swing under the action of gravity in order to orient the array coordinates to the local vertical. It was the weight of the hydrophone structure, rather than buoyancy, that caused the hydrophones to seek a level orientation. In this new design the array frame and arms from the buoyant array were retained, but the concrete anchor and standpipe were not used. Also, a pivoting tripod assembly replaced the buoyancy sphere in order to provide a single point from which to hang the upper array frame and arms.

As with the buoyant array, this array type was not allowed to rotate, the only motion allowed was the tilting of the hydrophone structure about the X and Y axes to compensate for any bottom slope. An acoustic survey was also conducted, after the deployment motions had settled out, to determine the final array location and orientation. These semi-rigid arrays also had a tilt sensor to send the final array tilt value, with respect to the horizontal plane, to the range control center.

Beginning in 1968 these Keyport manufactured arrays began to replace the buoyant arrays as the latter failed in service. The arrays were not recovered for periodic maintenance; instead they were left down until they failed. However, during range checkout and before a range exercise firing, the arrays were checked from shore through the array cable to test the hydrophones and cable. To periodically pick up the arrays for maintenance would have been too impractical and expensive.

One other major reason for switching to this semi-rigid design was that these new arrays were easier to fabricate than the low frequency buoyant arrays. Even though the semi-rigid arrays weighed about the same as the buoyant arrays (six tons) and were only six to eight feet shorter (being 30 feet by 30 feet by 42 feet high), they were easier to deploy than the low frequency buoyant arrays. The slightly shorter height made a difference in handling the arrays and also made it easier to pass under low bridges when the arrays were deck loaded on a range craft.

Another advantage of the semi-rigid arrays over the buoyant arrays was that the hydrophone arms could be locked in place by firing “squibs,” or explosively actuated locking pins (in 1995 this was changed to have the seawater pressure at the depth of the array wedge the locking pins in place). The array could be set down on a mildly sloping surface (up to 15°) and, after the arms were pulled into alignment by gravity, the locking pins would be fired to form a rigid structure. The array was allowed to settle in the bottom mud for a week or two before being “locked up” and surveyed. Usually this resulted in the hydrophone plane being level to within 2° to 3° . During array assembly the hydrophones were mounted on the 30-foot arms to within an accuracy of 1/8 inch and arranged orthogonally so that the angle between the arms was $90^\circ \pm 20$ seconds of arc. Even though the array arms were locked in place, the value of tilt was occasionally read to determine if the array had moved or shifted its position. Array recovery was accomplished by having one of Keyport's unmanned recovery vehicles attach a strong line to a lifting eye located on the array.

Initially, it was necessary to have the hydrophones as level as possible since the tracking software algorithm could only tolerate a small angle of array miss-alignment from a true horizontal plane. Later, as more powerful computers became available, new mathematical algorithms eliminated the need to have the array hydrophones held in a nearly level orientation by a cumbersome flotation (or gravity based) system. A software based vertical reference program was developed to handle any orientation of the array coordinate system no matter what attitude the array finally assumed. This new software approach, coupled with the relatively high maintenance required by the semi-rigid arrays (especially those with the early explosively actuated squibs), led to a decision that this array design did not need to be used at most of the installation sites and that the array structure could be even simpler. However, the semi-rigid array would still be used in cases where the bottom slope was moderately severe (taking care to chose a site so that the array could level up without “two blocking” the array frame against the tripod stand).

- Rigid-Rigid Array

The structure for this type of array does not require a flotation or gravity system to orient the hydrophones nor does it require a mechanism to lock the hydrophones in place. In fact, not only does this array design prevent rotation; but, as its name implies, it also prevents any tilting of the X-Y plane (as shown in Figure 16). In addition, this array type can be installed on the bottom without regard to any misalignments of the array coordinates from the range coordinate system. The only requirement concerning the slope of the bottom is to ensure that the array does not slide out of position down the slope. The array overlap areas are constantly monitored to see if any of the arrays have slipped out of position. The orientation of the hydrophones is “software based” meaning that a perfectly oriented hydrophone array is set up in computer memory rather than actually having to exist on the array. This is possible due to faster digital computers now available to do the coordinate conversions. As usual, an acoustic survey is needed to gather information that the computer uses to determine the array's actual orientation, and location on the bottom. It should be noted that these arrays are not suitable for bottom contours that show a steep slope as then the array structure could shadow the hydrophones and interfere with the tracking signal (in these cases the semi-rigid array would be used). Tilt sensors are still used, but

now their function is limited to the installation phase where they are used to determine the final resting slope of the array.

The life expectancy of an array is 10 years. However, many last much longer and when an array does fail it is brought up to the surface and replaced with a completely refurbished array.

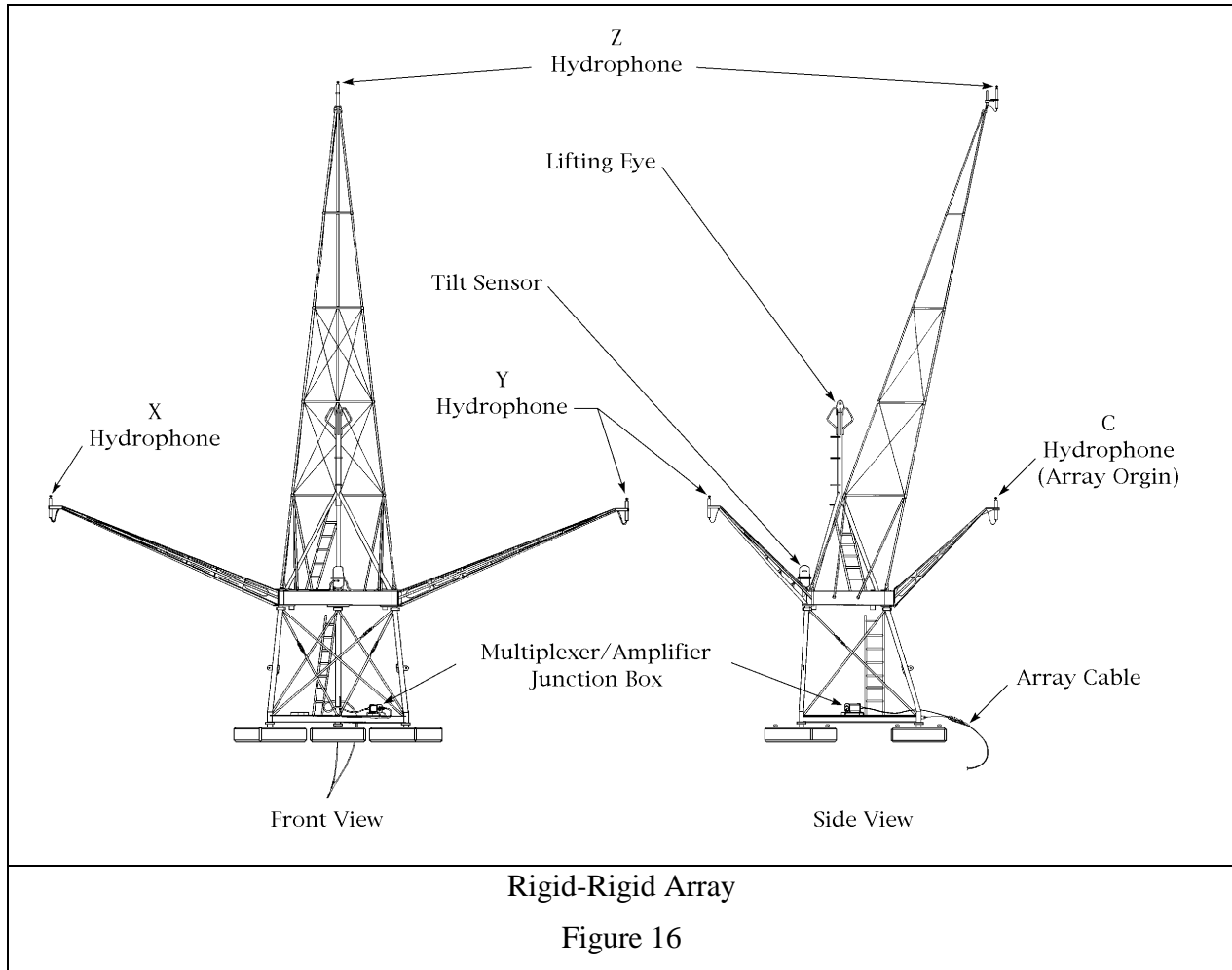

How a Tracking Range Determines Positions

As mentioned on page 35, a set of time differences is generated from the measurements of the time interval it takes for an acoustic pulse to travel from the synchronized tracking projector in the torpedo to each of the hydrophones on the array. Using these time differences, it is possible to determine the position of the torpedo by either of two different methods, depending upon how the hydrophones are spaced on the range floor. One method is called long baseline (LBL) tracking and the other is called short baseline (SBL) tracking. In long baseline tracking the hydrophones are widely spaced apart, on the order of thousands of yards; whereas, in short

baseline tracking all the hydrophones required for a tracking solution are mounted on a single structure (remember that Keyport's original high frequency short baseline array had hydrophones spaced only 10 feet apart). In the long baseline case, tracking is accomplished within the dimensions of the "array" (in this context it may be helpful to think of the "array" as a group of widely separated single-hydrophone platforms); and in the short baseline case, tracking is accomplished outside the dimensions of a single array structure. Long baseline tracking is used at the deep water Navy ranges such as the Barking Sands Tactical Underwater Range (BARSTUR) and the Southern California Offshore Range (SCORE) in the Pacific Ocean, and the Atlantic Undersea Test and Evaluation Center (AUTEC) and the Atlantic Fleet Weapons Training Facility (AFWTF) in the Atlantic Ocean. It is also used at the Quinault shallow water range site and for transportable ranges based on the Quinault range technology. Short baseline tracking is used at the Dabob Bay and Nanoose sites of the Northwest Range.

- Long Baseline Tracking

The long baseline tracking concept can be used with tracking projectors that are either synchronized with the range tracking computer or are free running and not synchronized (called asynchronous). Even though LBL tracking is normally used in deep water, Keyport developed a shallow water version for use at the Quinault range site off the coast of Washington.

Using Synchronous Tracking Projectors: Long baseline tracking requires reception of the tracking pulse by a minimum of three widely spaced hydrophone platforms (one hydrophone per platform). These signals are sent to the shore site tracking computer, usually in near real time. The computer compares the pulse's arrival time at each of the three hydrophones with the time the same pulse left the tracking projector in order to compute three time intervals for that pulse. The time intervals are the measured elapsed times the sound took to propagate through the water from the vehicle's tracking projector to the receiving hydrophone on each platform. These time intervals are converted into slant ranges (distances from the projector to the hydrophones) by multiplying the time intervals by the speed of sound in water.

A slant range can be thought of physically as the radius of a sphere centered at the receiving hydrophone. Knowing the slant range from the vehicle to just one of the hydrophones only provides the fact that the vehicle being tracked is somewhere on the surface of a sphere at a particular distance (radius) from the hydrophone. By calculating the second slant range to another hydrophone (from the same pulse emitted by the vehicle) a solution is produced that has the vehicle located at any point along the intersection of the two spheres (anywhere along a circle). Some of these points may fall below the range floor, above the water surface, or at some distance away from the range; so the vehicle being tracked cannot be at any of these locations. If the depth is known, as it is for vehicles operating on the surface, this will provide a tracking solution², and it is called a two-dimensional (2-D) solution. However, two slant ranges do not provide enough information for a full 3-D solution, because the two slant ranges only produce a line of position along the intersection of the two spheres. It takes one more slant range, to the third hydrophone, to compute the location of the vehicle. The intersection of the three spheres

²Actually, it will produce two possible locations for the vehicle carrying the projector. However, previous tracking positions will generally enable one of the two to be eliminated.

provides a complete 3-D solution. Figure 17 is an illustration of synchronous tracking and the associated mathematical equation.

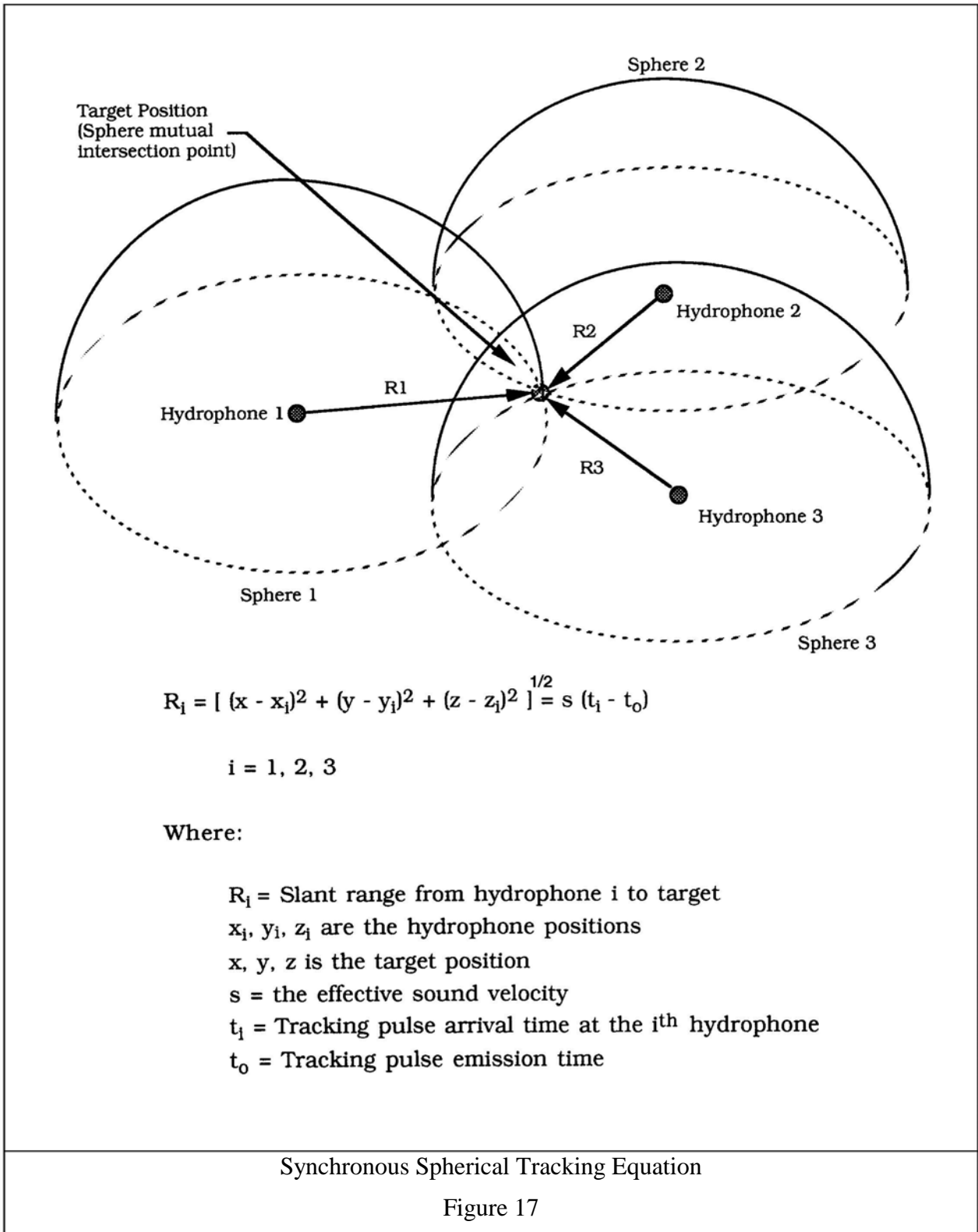

A variation of this technique is often useful when only the 2-D solution is available, but the depth of the vehicle must be known (possibly sent to the computer site by way of an acoustic communication link – as in the telemetry portion of the tracking signal). To arrive at a complete 3-D tracking solution in this case, the depth can be thought of as a plane that passes through the two spheres of the 2-D solution with the location of the vehicle being at the intersection of the plane and the two spheres.

Using Asynchronous Tracking Projectors: When the range tracking projector is not synchronized with the tracking facility's computer time base prior to an operation, the tracking process is asynchronous (or sometimes referred to as non-synchronous). In this form of tracking, the difference in the arrival time of a tracking pulse at a pair of receiving hydrophones is used to define a hyperbolic surface of position for the tracking projector. Two additional pairs of hydrophones are used to define two additional hyperbolic surfaces, and the intersection of the three surfaces defines the position of the tracking projector. Note that in synchronous tracking only one hydrophone is needed to get the range (or radius) out to the solution sphere, but in asynchronous tracking it takes two hydrophones to obtain one solution hyperboloid. Since only the time differences between pairs of hydrophones are used, rather than the slant ranges, the exact time of transmission of the pulse is not needed. For a complete 3-D solution, reception by at least four hydrophones is required. The outputs from the asynchronous tracking algorithms are the X and Y distances from the hydrophones' origin, the depth of the vehicle, and the "pulse emission time" (the time the signal should have left the tracking projector on the vehicle). If signal reception at four hydrophones is not possible, the vehicle being tracked must either operate at a set (known) depth or the vehicle must transmit its depth to the tracking center through an underwater acoustic communication link (as mentioned above). Hence, as in the synchronous case, it is possible to arrive at a complete 3-D solution from signal reception at three hydrophones, if the depth of the vehicle is known, by passing a depth plane through the intersection of the two hyperboloids.

Most of the deep water ranges have the capability to track asynchronously, and in fact use tracking projectors that do not require the time consuming process of synchronization. After tracking in the asynchronous mode for a short period of time these ranges can benefit from the more precise synchronous tracking approach by determining the time at which a synchronized tracking pulse should have been emitted by the vehicle being tracked in order to produce the same tracking solution. This calculated "pulse emission time" can then be used in a "pseudo-synchronous" tracking approach to emulate a synchronized system and take advantage of the more accurate synchronous tracking algorithms and the ability to use one less receiving hydrophone.

Both synchronous and asynchronous long baseline tracking are used at the different range sites, each with its advantages and disadvantages. Synchronous tracking is more accurate, and does not require reception by as many hydrophones, but it does require that additional synchronization cables be connected to the tracking projector in the vehicle and it requires the extra step of prelaunch synchronization. Asynchronous tracking is a simpler system, and more appropriate for use at large area and/or deep water ranges (because fleet participants can start their tracking projectors at any time without the need for range technicians to synchronize the tracking projectors). However, asynchronous tracking does sacrifice some accuracy. Figure 18 is an illustration of asynchronous hyperbolic tracking and the associated mathematical equation.

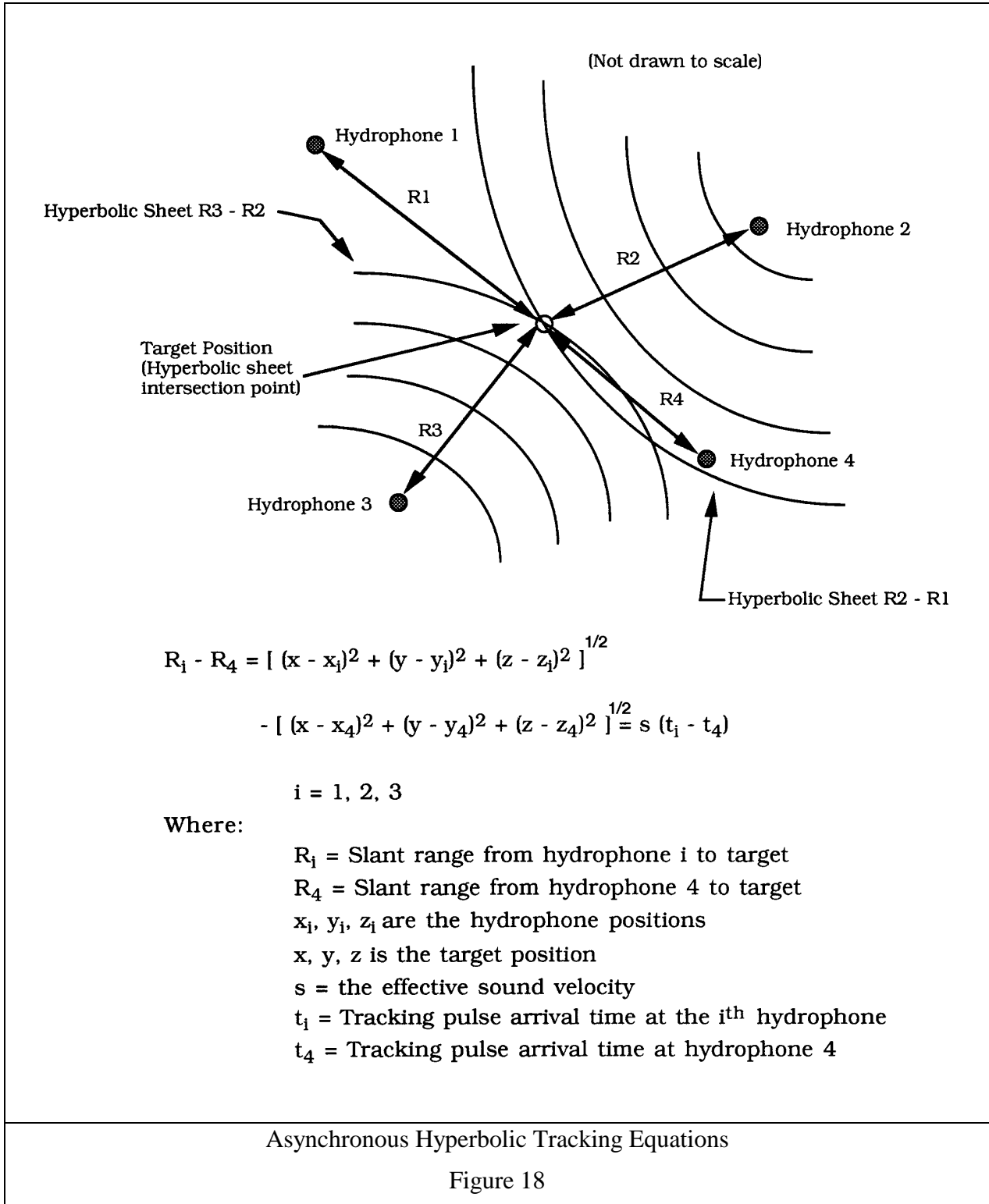

The Shallow Water Case: Even though both synchronous and asynchronous tracking concepts work in shallow water, the shallow depths of these waters impose a severe handicap on the tracking system. It is very difficult for the tracking system to determine the depth, or Z-coordinate, solution in order to arrive at a complete 3-D position. The reason is that the three solution spheres are intersecting nearly tangentially which makes minute errors in measuring the time of arrival of the signal significantly change the calculated depth of the vehicle. Note that in shallow water the diameter of the spheres is usually much greater than the water depths so the underwater portion of the spheres look more like cylinders. Since the intersection of these three cylinders becomes a vertical straight line from the bottom to the surface, all that is known is the horizontal location of the object being tracked (the X and Y positions). Therefore, in shallow water, a 2-D tracking solution is produced from the acoustic tracking algorithms.

This 2-D solution is combined with the known depth of the vehicle to provide enough information to determine the 3-D position of the vehicle. But, it is necessary for the vehicle being tracked to have an acoustic telemetry capability and be able to measure the surrounding seawater pressure. This pressure (depth) data is continuously encoded in the telemetry portion of the tracking pulse and acoustically transmitted to the bottom-mounted hydrophones. At the range computer site this telemetry data is decoded to give an indication of the vehicle's depth in real time. Another way to obtain the depth is to just assume that it is fixed, like a submarine operating at periscope depth. This depth data is fed into the tracking program where it can be thought of as producing a depth plane that passes through the intersection of the three cylinders of the 2-D solution. The complete 3-D tracking solution is at the intersection of this plane and the three cylinders of the 2-D solution. This method of 2-D synchronous tracking with depth telemetry is the method of tracking used for transportable shallow water ranges and at the Quinault site of the Northwest Range.

- Short Baseline Tracking

Using Synchronous Tracking Projectors: This method of tracking uses a cluster of hydrophones (usually four) mounted on a single array frame (for example, the original high frequency array, with its 10 foot hydrophone spacing; and the low frequency array, with its 30 foot hydrophone spacing). The tracking approach used with a short baseline array is to make time measurements of the acoustic tracking pulse as it sweeps through the array, then compute a direction vector and trace it back to the origin of the signal (the tracking projector on the vehicle). This vector not only points in the direction of the vehicle, but the length of the vector defines the distance between the array and vehicle; thus providing a complete 3-D position of the vehicle.

The geometry of the array makes it possible to find the three-dimensional angle (the vector angle) of the incoming sound ray by noting how the wave front interacts with the hydrophones. As the wave front of the acoustic pulse arrives at the array, the hydrophone closest to the vehicle being tracked detects the pulse first, and the hydrophone farthest from the vehicle detects it last. Each different direction of this wavefront forms a unique set of times when the four hydrophones detect the pulse. By the use of simple formulas, these time values can be very precisely converted into a direction (or three-dimensional angle) to the tracking projector, i.e., the "sound ray path" from the array of hydrophones to the projector. For this method of tracking to be accurate the array location, tilt, and rotation with respect to the range coordinate system must

have been precisely determined by an array survey, and the sound velocity profile of the surrounding water must be accurately measured. One of the reasons for arranging the hydrophones at the corners of a cube, as was done on the first short baseline arrays, was to ensure that tracking could be accomplished using rather simple mathematical operations. Other array geometries would have required the computation of square roots. This operation may be taken for granted these days, but in the 1950s and early 1960s calculating square roots in real time was not an easy task for the early analog computers.

The sound ray path back to the tracking projector is never a straight line because the velocity of sound in the water between the hydrophone and the projector is not constant. The ray path actually bends slightly in response to the variations in sound velocity caused by local changes in the water temperature, salinity, and density with increasing depth (pressure). To correct for these effects, in a sense straightening out the ray path, sound velocity data (ray path corrections) are obtained and entered into the computer to calculate the actual direction of the tracking projector with respect to the array coordinate axes. Note that short baseline tracking works well only when a direct acoustic path exists between the projector and the array. Sound rays arriving at the array after reflecting off the surface (or bottom) generate unacceptable errors in determining the projector position.

But how far away, back along this ray path, is the tracking projector? Since the system is synchronous, this distance is determined by measuring the time it takes the signal to travel from the tracking projector to the array. This time interval is then converted into a slant range by multiplying the time interval by the speed of sound in water (again taking into account the sound ray path corrections; that is, the variation in the velocity of sound as a function of depth).

The position of the tracking projector (and vehicle being tracked) is defined once both the three-dimensional angle and the slant range between the array and the tracking projector are determined. The computer first finds the position of the projector in array coordinates, then transforms the position into range coordinates using the data from the array survey.

Using Asynchronous Tracking Projectors: In the asynchronous case, the length of the direction vector is not known (the acoustic data only provides the three-dimensional angle). And by itself, this will not provide much tracking information at all. Not even a useful 2-D plot could be produced from this limited data. Again it is the vehicle's depth that allows a tracking solution to be found. The complete 3-D position of the vehicle is found by following the ray path up toward the vehicle and stopping at the telemetered depth (or at the surface).

Each short baseline array operates independently of its neighboring arrays, and tracks the projector until it moves out of "reliable" acoustic range. As long as only one array is tracking the projector, the track will usually be smooth. It is when the track transitions to a neighboring array that slight discontinuities in the track become noticeable. In this tracking overlap area, between the two arrays, it is usual for the two tracks to not perfectly coincide due to small measurement errors.

As mentioned above, in order to produce an accurate track it is necessary to know the sound velocity profile of the water where the exercise is conducted. In 1969 a program called NUTRAK was installed on the digital computers at both the Nanoose and Dabob Bay range tracking sites. This program made use of the oceanographic data returned from an STVP probe lowered into the seawater from one of the range craft. The STVP probe measured the Salinity,

Temperature, sound Velocity, and Pressure at various depths. Incorporating this information into the tracking solution significantly improved the tracking accuracy at the Dabob Bay and Nanoose tracking sites. Later, a CTD probe was used to provide Conductivity and Temperature, as a function of Depth, in order to produce the sound velocity profile.

New Tracking Signals for New Tracking Capabilities

- **The Development of PSK Tracking**

In the mid and late 1960s, a serious look was taken at the possibility of using ranges tactically for the reconstruction of Fleet exercises, in hopes that range data could be used to resolve the “who shot whom” problems. The use of a tracking range for this new application was a promising prospect, but no range then in existence seemed to provide the right combination of features. Water deeper than available at the Northwest Range was desired, but AUTEK (at 6,000 feet) would be too deep for a 75 kHz “Northwest Range” style of range to function satisfactorily. Various areas were evaluated, and finally a location off the coast of Lanai, in the Hawaiian Islands, was chosen. Unfortunately, the political clout mustered by the pineapple growers on Lanai combined with the fact that the government already owned an abandoned Air Force Base (Bonham) on Kauai, quickly brought an end to that proposal. The site off the west coast of Kauai was then selected, and construction began on the Barking Sands Tactical Underwater Range (BARSTUR). Because of the water depth at BARSTUR (between 2,400 and 6,000 feet), an AUTEK-style (long baseline) range was installed. Completed in 1967, BARSTUR provided an underwater tracking area of 120 square miles with 37 hydrophones. Tone burst tracking signals were used at BARSTUR with frequencies ranging from 13 kHz to 50 kHz (different frequencies represent different objects tracked).

BARSTUR was expanded significantly in 1976 with the addition of BSURE (Barking Sands Underwater Range Extension). The requirement for BSURE was primarily generated by the necessity to test longer range weapons over a greater tactical area. The BSURE tracking area was to cover 880 square miles in water depths from 6,000 to 15,000 feet. While the four-hydrophone hyperbolic system of tracking simple tone burst signals was used to provide three-dimensional information at BARSTUR, such a system at BSURE was not practical because of the large number of hydrophones that would have been required to cover the 880 square miles.

The key to the solution at BSURE was a new tracking signal developed by Bunker-Ramo, which provided two new features: (1) the ability to track multiple objects, and (2) the ability to transmit telemetry information. The existing tone burst tracking approach measured differences in arrival time at multiple bottom-mounted hydrophones of short (approximately 1.28 millisecond) continuous wave pulses. In fact, a tone burst pulse, the simplest form of signal modulation, can only convey timing information. But before any timing information can be extracted from the signal it must first be validated as a true timing signal rather than a noise event. This validation process required that the tone burst pulse remain above a designated threshold for a prescribed length of time, usually 400 microseconds. Typically, tone burst systems were susceptible to noise and required a signal-to-noise ratio of at least 15 dB in order to produce reliable tracking. But, signal detection using the new tracking signal, called Phase-Shift Keying (PSK), did not rely on assigning a time to the instant a pulse exceeded some designated

threshold level. Instead the tracking system compared the received signal's digital bit pattern (code) with a stored replica and looked for a match. This correlation was done in real time so that the instant a match was made, the signal's arrival time at the hydrophone was very accurately determined.

PSK offered significantly improved performance by minimizing pulse ambiguity, especially important in the presence of countermeasures. Typically, PSK signal validation could be obtained with a signal-to-noise ratio as low as 5 dB. The inherent digital coding of the PSK tracking pulse also facilitated sending acoustic telemetry as part of the tracking signal. At BSURE, 2-D position data was derived directly from reception of the transmitted PSK pulse, while depth information was encoded in the pulse telemetry. Tracking projectors used on the BSURE range transmitted the PSK code at 13 kHz. This coding system turned out to be a major development in range technology and has been upgraded and improved upon many times to enhance range utilization. Since its introduction at BSURE in 1976, PSK (or a PSK derivative) has become the standard system at most Navy ranges. See Figure 19 for a comparison of the tone burst and PSK tracking signals.

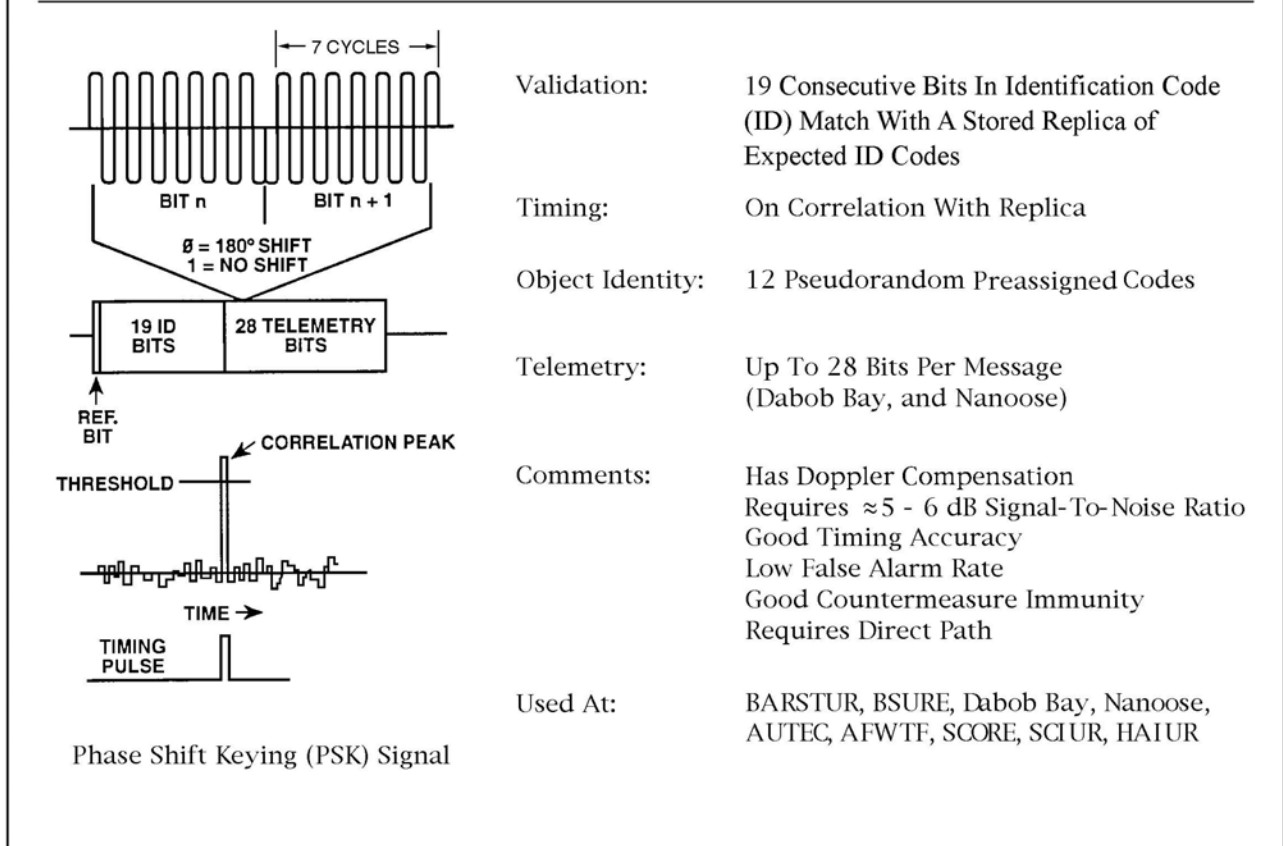
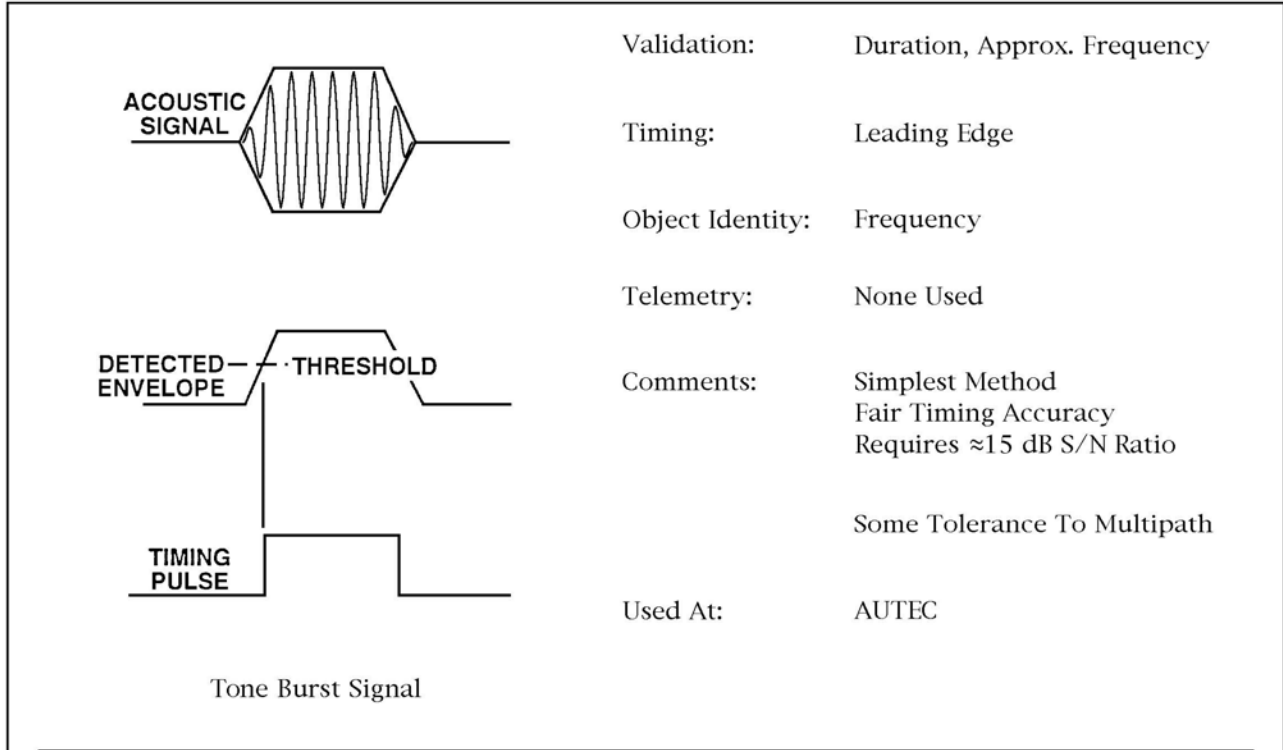

Tone Burst and Phase-Shift Keying (PSK) Signal Characteristics

Figure 19

As the number of ranges operated by the Navy increased in the 1960s, and the spectrum of applications increased as well, it became clear that Keyport needed to review its current level of range technology. As a consequence, several internal studies were conducted in the early 1970s to define existing range limitations in light of current and expected future Navy range requirements. A number of recommendations were made as a result of these studies. One of the study findings noted that most of the problems stemmed from a conscious decision made many years earlier to expedite getting the 3-D range system on line, and now (in the early 1970s) the consequences of those earlier decisions were beginning to restrict the usefulness of the range. It turned out that the ultimate importance of the range exceeded the original expectations. Some of the problems (other than failed components or maintenance) uncovered by the studies were related to a failure to keep up with the state-of-the-art. For instance, one report noted that “too many human hands and minds are required at too many stages” in the gathering, transmitting, analyzing, and the dissemination of the data. A classic example of this problem was the “post-run mode assign process” where it took human intervention to determine which track point belonged to which object (torpedo, target, or launcher). Major conclusions from these studies pointed out the need to implement more automation, use a coded tracking pulse (to replace the tone burst pulse), and form an in-house applied research group to lessen the reliance on APL/UW for technical assistance.

As a direct result of these studies, Keyport set out to develop its own version of a coded tracking signal that could be used for telemetry and unit discrimination at the low frequency (75 kHz), short baseline range sites of Nanoose and Dabob Bay. The Bunker-Ramo PSK signal could not be directly implemented at either Dabob Bay or Nanoose because it worked at too low of a frequency (13 kHz) and had too long of a pulse repetition period (time between pulses). Any implementation of a new tracking signal would have to be at 75 kHz because of the large investment in 75 kHz hardware already installed on the bottom at the two range sites. The important aspect of the PSK signal was its ability to encode information within the oscillations of the transmitted waveform. The PSK pulse developed for use at Keyport consisted of an oscillating waveform 4.6 milliseconds long, which contains 48 bits of object identification and telemetry information. The PSK signal was composed of a pulsed stream of zeros and ones (“bits”) that create a unique code. Every seven cycles, of the 75 kHz PSK signal, a 180° phase shift may occur within the waveform, representing a logic “0” bit, or the signal phase may remain unchanged, representing a logic “1” bit. In addition to the 20 (19 + 1 reference) identification bits, up to 28 bits of telemetry were included in the pulse. Twelve standard, pseudo-random, identification codes (the same ones used for the Bunker-Ramo system) were provided giving the range the ability to track 12 objects at once using a single frequency. These codes were selected for their desirable characteristics of low cross-correlation with interfering signals (noise) and other PSK codes in the set (other vehicles), and narrow auto-correlation to maximize the timing accuracy of the desired code.

It turned out that the short baseline arrays used at Keyport were adaptable to a coded pulse system such as PSK. Since the hydrophones are so close together, however, determining pulse arrival times would be critical, and timing measured in microseconds (as opposed to milliseconds for a long baseline range) would be necessary. Other factors, such as Doppler compensation, would also need to be considered. But, if a PSK coding scheme could be implemented, then each torpedo and every ship participating in the exercise could be equipped

with a projector set to a unique PSK code. The computer could then “tag” and keep track of each vehicle, allowing multiple vehicles to be tracked at once, in addition to computing and storing performance parameters such as the speed and heading of each participant. This challenge provided Keyport with an early application of modern signal theory, with its emphasis on digital processing techniques. The Keyport effort was ultimately successful, and a patent for the process was granted to two Keyport engineers³. Both Dabob Bay and Nanoose were converted to PSK tracking, as were most of the other ranges – long baseline or short.

This shift to PSK alleviated several serious deficiencies inherent in the tone burst system. Among the issues resolved were:

- Even though the tone burst tracking signal was simple and fairly reliable in quiet situations, all tracked objects transmitted exactly the same signal and it was often difficult to sort them out. To correct for this problem the PSK signal was designed to allow the selection of any one of 12, unique, binary-coded, signals. These provided a clear digital identification code for up to 12 different object, which completely eliminated the ambiguity between their tracks. This solved the “mode assign” problem.
- PSK provided a six to 10 times improvement in timing accuracy which resulted in a much smoother and more accurate track.
- The PSK system was more reliable than the tone-burst system, and provided a significant improvement in signal detection, allowing the tracking projector's signals to be detected in spite of a much lower signal-to-noise ratio. That is, PSK signals could be detected even when they were not much louder than the background acoustic noise (or interfering signals). Tracking with PSK can be accomplished at a signal-to-noise ratio as low as 5 dB. This led to an increase in the detection range and became an important consideration when acoustic countermeasure devices were part of the test.
- The ability to transmit digital data to shore (like torpedo depth, inertial position data, or other weapon internal information) within the tracking signal code was a valuable feature. When internally-determined vehicle position data is available, sending this position data encoded in the acoustic telemetry signal can allow the vehicle to be “tracked” using a single range hydrophone. This can provide a much larger range for a given number of hydrophones.
- Besides improvements due to better signal processing, the use of PSK resulted in up to 12.5% more track points being available for processing compared to the former tone burst tracking system. The reason for this increase in data was due to a design feature in the tone burst system that prevented every eighth tracking signal from being projected. This signal drop-out feature produced an intentional gap in the track at set intervals; a gap that could be later used as an alignment marker. The reason for producing this marker was to help the post-run analysts align the data recorded inside the torpedo with the torpedo

³ “Doppler Compensated PSK Signal Processor,” Alan L. Lindstrum, Supervisory Electronics Engineer, and Jay V. Chase, Electronics Engineer, Applied Research Division, Patent No. 4,187,491, dated 5 February 1980.

track as determined by the tracking system. Since an alignment mark could be created in the PSK code by toggling one of the telemetry bits, there was no longer a need to blank out any of the tracking signals.

- PSK provides a faster update rate. Tracking data rates were increased from the tone burst rate of one track point per range timing interval (the original standard tracking interval was about every 1.3 seconds) to as many as four points per second for PSK.

An additional problem solved by the implementation of PSK was called the “hull coupling” problem. This problem stems from the fact that the tone burst tracking signal, after originating in the transducer, travels down the hull of the torpedo (at a speed greater than the speed of sound through water) and is re-radiated into the water at various points along the torpedo's hull. Too frequently, this hull-coupled tone, radiating from the nose or tail of the torpedo, arrived at the tracking array slightly before the direct path signal from the projector. This false, hull coupled, signal resulted in false (early) validations at the hydrophones and position errors, or “jitter,” in the tone burst tracking solutions.

The problem was solved because the PSK receiver only processed the strongest signal received at any given time. Hull-coupled signals are weaker, even though their energy may arrive at the tracking array slightly before the acoustic projector's stronger signal. As the processor matches the incoming signal with a stored replica (using the correlation process) the PSK bit decisions (whether the bit is a 1 or 0) are being made based on the phase changes of the strongest signal. When any two signals overlap, the largest signal determines which phase is detected. In the case of PSK tracking, as long as the PSK signal exceeds other signals, or noise, by at least 5 dB, the tracking system will clearly detect it. (This S/N ratio is much smaller than that needed for detecting tone burst signals, hence there is better tracking in the presence of noise or countermeasures.)

So, when a strong, slightly-delayed signal (compared to the weaker hull-coupled signal), starts marching through the PSK correlator shift register, its bits are the ones that matter. The weaker signal is effectively ignored after the stronger one starts controlling the bit decisions and lines up with the stored replica being matched. The few bits of the weaker signal that might already have been detected are just treated like noise. With torpedo length vehicles, any hull coupled signal would not be completely received before the main (direct path) signal started to arrive.

As an added bonus, the shift to PSK did not require new tracking arrays, nor any additional underwater cables. No changes to the array multiplexers were necessary, nor were any changes needed to the hydrophones or their spacing. Also, this shift did not require new tracking transducers in the torpedoes being tracked (although the transducers were screened to pick the ones most PSK-compatible).

However, all these advantages did have some price. New sync clocks would be needed to drive the tracking transducers in the torpedoes and new tracking signal receivers would be needed at the range computer centers. But, most significantly, new range computers would be needed since the old SDS computers could not process the volume of information associated with a PSK coded signal (i.e., track up to 12 separately identifiable objects and also transfer telemetry data). The new computers, MODCOMP IVs, were first installed at the Nanoose range

computer site on Winchelsea Island in June 1979, and for about a year the range underwent a slow conversion from the tone burst tracking signal to the new PSK tracking signal. Shortly thereafter the Dabob Bay range site was also changed over to the PSK tracking signal and the computer site at Zelatched Point received new MODCOMP IV computers. Due to its superior performance and proven design, PSK technology became the clear choice for any range implementation where multipath interference is not a problem.

—

Both the Dabob Bay and Nanoose sites of the Northwest Range offer ranging in water depths where the vehicles can be easily recovered should they end their run by sinking to the bottom; both sites support a variety of fixed and mobile targets for advanced weapons to home on (as a low cost alternative to the use of actual submarines and surface ships as targets); and both sites support a wide spectrum of in-water acoustic measurements. To provide complete range services at the Northwest Range, additional support systems have been developed over the years, such as above water tracking (optical, GPS, and radar), range timing and synchronization systems, dedicated torpedo firing and surface recovery craft, and range computer site hardware to calculate and plot the position, in real time, of each vehicle (surfaced or submerged) or aircraft operating on the range.

A wide variety of comprehensive data products are routinely produced by the instrumentation at the various Northwest Range sites, and during transportable range operations at remote sites away from the fixed ranges. This information is transmitted to the Range Information Display Center (RIDC) located at the main Keyport facility. Secure communication links (microwave and land-lines) provide encrypted video, audio, and digital tracking data inputs into the RIDC in real time. This allows engineers and test observers to avoid the cost and time involved in traveling to the site of the operation; it also facilitates rapid evaluation of range exercises. Using large screen video and associated monitors, the RIDC provides real time displays and fusion of range data (tracking plots, acoustics, and telemetry data, plus two-way video and communications) from all Northwest Range sites. The facility also provides playback capabilities for detailed analyses of recorded data. All the data products can be merged together in Compact Disk-Read Only Memory (CD-ROM) format and used by range customers for interactive analyses on their office desktop computers.

- The Development of SFSK Tracking

The development of the Spaced Frequency-Shift Keying (SFSK) tracking signal grew out of the need to once again track torpedoes in shallow water. This time it was the Navy's newest ASW weapon, the Advanced Lightweight Torpedo (ALWT), now designated the MK 50, that spurred the development effort.

The outstanding feature of the SFSK tracking signal, another implementation of a coded tracking signal, is that it will allow tracking in the severe multipath environment found in shallow water, indeed multipath reverberation is one of the most predominant acoustic features of shallow water. Reverberation can be defined as the scattering of sound in the sea from all of its boundaries, inhomogeneities, and particles. It is most easily recognized as the long, slowly decaying, quivering tone following the ping of an active sonar system. Of the three types of

reverberation (volume reverberation or back-scattering, sea-surface reverberation, and bottom reverberation), the two that most challenge the ability to conduct ranging operations in shallow water are surface and bottom reverberation. These two combine to make what is called a multipath acoustic environment. Tracking systems set up in most littoral areas of the world will experience this severe multipath phenomenon in the propagation of any acoustic signal. What this means to a tracking system set up in shallow water is that the tracking signals will arrive at the hydrophones after suffering severe degradation. The signals received at the hydrophones (after reflecting off the bottom and the surface) will consist of many replicas of the transmitted signal all overlapping with each other, but decaying over time. The resultant destructive and constructive interference of the multiple overlapping signals often makes tracking signal detection and the decoding of phase-based acoustic telemetry information extremely difficult. This constant interference destroys information concerning phase changes (so important in PSK signal detection and identification) and distorts tone burst signals, rendering these techniques only usable in shallow water when the hydrophones are placed extremely close together.

Most tracking systems in deeper water depend upon a direct path signal from the vehicle being tracked to the tracking range hydrophones. In a shallow water environment, a direct acoustic path (i.e., one without reflections off the surface or bottom) between the vehicle being tracked and the tracking hydrophones often does not exist beyond several hundred yards. This would result, if a deeper water range concept were to be used, in the hydrophones being spaced so closely together that the cost would be prohibitive for a large range area. Another problem area concerns the overall shallow water range configuration where the bottom-mounted tracking hydrophones are virtually in the same horizontal plane as the vehicles being tracked. This complicates the acoustic tracking solution in the vertical (Z) direction, and essentially prevents the acoustic tracking system from providing a complete three-dimensional solution (where depth is included as part of the track), based on acoustic signal timing alone. Vehicle generated depth information can, however, be effectively carried by acoustic telemetry incorporated in the tracking signal.

The SFSK signal overcomes these problems and provides excellent vehicle identification along with the transmission of accurate telemetry information. It is a time expanded version of Frequency-Shift Keying (FSK) modulation where the frequency signifies a logic state (a "0" or "1" bit). SFSK looks like a series of short tone burst pulses; however, the overall signal is correlated just like a PSK signal to determine the tracking signal's arrival time.

In the time expanded SFSK signal the bits are spaced apart in time to allow the reflected signals to sufficiently decay before that frequency is used again. The net result is a much longer signal with SFSK than with PSK. The SFSK signal may contain the same information, but it is up to 100 times longer in duration than the PSK pulse (depending upon the level of reverberation to be accommodated). The time expansion allows each received tone burst bit and its reverberation to decay about 6 dB before that frequency is used again, permitting successful bit detection. Also, due to the fact that SFSK detection is based upon a bit by bit decision as to the relative levels of two frequencies used for a "1" or "0" (not absolute levels or levels compared to noise), the SFSK signal is inherently rather immune to noise or acoustic countermeasures. The SFSK tracking signal makes use of the fact that multipaths exist and the geometry is such that travel time variations over the different paths are relatively unimportant. Note that the signal

frequency is preserved even if the signal amplitude, phase, and pulse duration are distorted when propagating through the multipath environment.

In the Keyport SFSK system, a tracking projector in the torpedo is programmed to operate in one of three frequency bands identified as the low, mid, and high frequency bands contained in the range between 30 kHz and 50 kHz. The use of three bands allows simultaneous tracking of three different objects, one in each band, without mutual interference (or six objects can be tracked by time sharing the frequencies that are assigned to the three bands). The low and mid frequency bands are intended for higher velocity vehicles and include acoustic telemetry, such as depth, inertial position data, or an internal status indication. The high band is intended for slower moving surface craft and/or those vehicles without the need for acoustic telemetry. Digital information is encoded by using four frequencies within each band; two for detection and object identification (using the same type of 19-bit code as is used in PSK), and two for acoustic telemetry. Acoustic telemetry signals are transmitted simultaneously with the tracking signals, but simply shifted slightly in time to utilize the delay period between tracking code bits to send the telemetry code message. Thus unique identification codes and digital data (telemetry) can be transmitted, even though signal amplitude and duration are distorted and signal phase is garbled due to the many reflections. System timing is based on correlation with a stored replica of the transmitted signal, and signal validation occurs when 17 of the 19 bits in the code match the replica. Bit patterns and frequencies can be modified to support specific vehicle identification and telemetry requirements. Also, the bit spacing can be adjusted to match reverberation decay times associated with different acoustic environments. Figure 20 shows SFSK signal characteristics. Figure 21 is a technical comparison of tracking technologies.

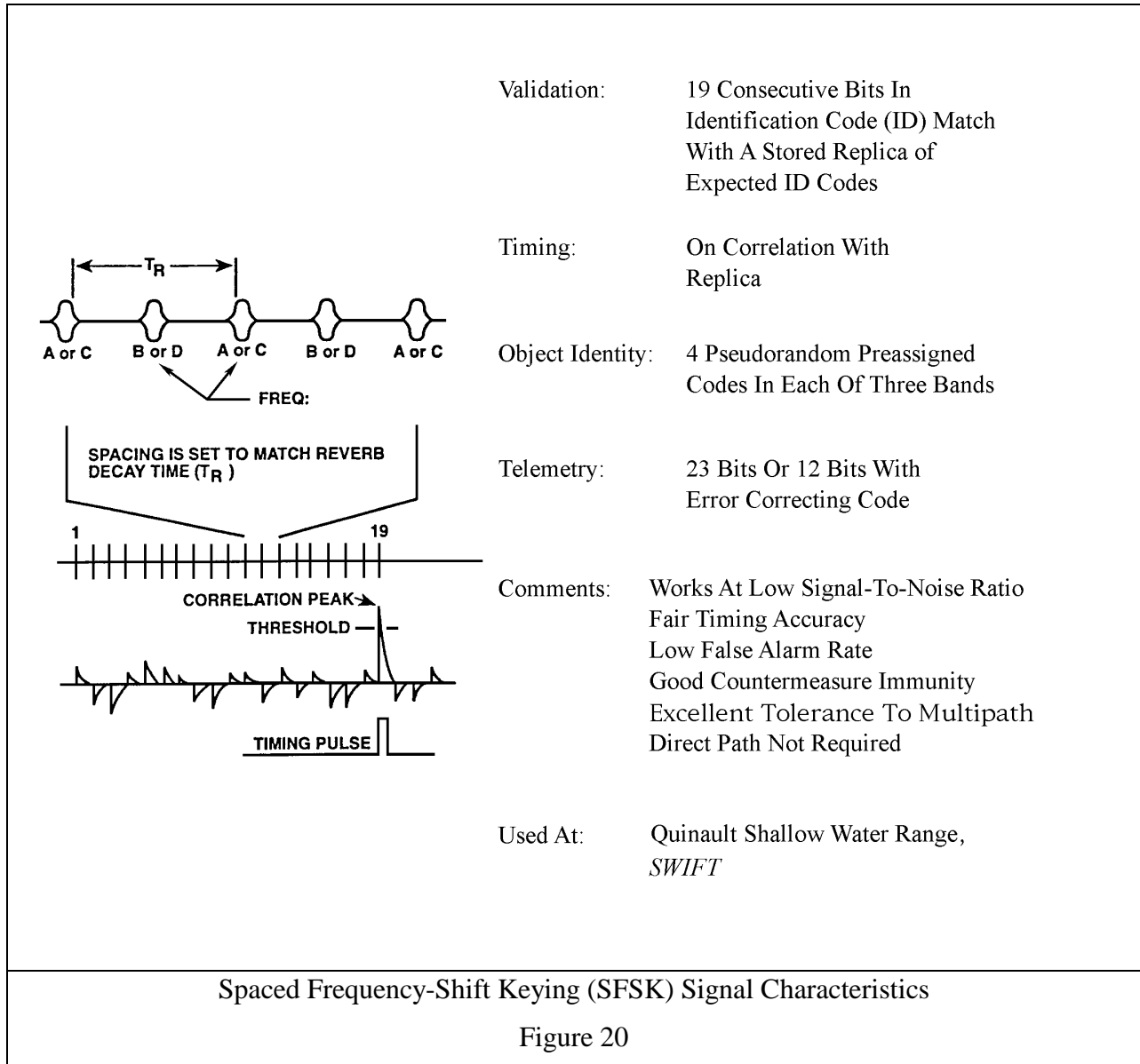

System	Advantages	Disadvantages
<u>Acoustic Signals</u>		
Tone Burst	<ul style="list-style-type: none"> • Simplicity and Low Cost. 	<ul style="list-style-type: none"> • Poor Interference Rejection.
PSK	<ul style="list-style-type: none"> • Good Interference Rejection. • Each Object Tracked Identified. 	<ul style="list-style-type: none"> • Poor Multipath Rejection.
SFSK	<ul style="list-style-type: none"> • Good Interference and Multipath Rejection. • Each Object Tracked Identified. 	<ul style="list-style-type: none"> • Reduced Repetition Period. • Less Efficient Use of Frequency Spectrum for Multi-object Tracking, Compared to PSK. • Longer Pulse Length. • Higher Power Drain.
<u>Array Baseline</u>		
Long	<ul style="list-style-type: none"> • Simplicity and Low Cost. 	<ul style="list-style-type: none"> • Poor Depth Accuracy (in Shallow Water).
Short	<ul style="list-style-type: none"> • Tracking Signal Frequency Out of Torpedo Operating Frequency Band, for Non-Interference with Torpedo Sonar. • High Pulse Repetition Period Produces More Detailed Track. • Better Z-Coordinate Track. 	<ul style="list-style-type: none"> • Complex, and Difficult to Deploy and Recover.
<u>Timing Mode</u>		
Synchronous	<ul style="list-style-type: none"> • High Accuracy and Reception by One Fewer Sensor Required. • Allows Direct Measurement of Distance to Object Being Tracked. 	<ul style="list-style-type: none"> • More Operational Complexity.
Asynchronous	<ul style="list-style-type: none"> • No Pre-Op Synchronization and No Cable Connections to Internal Tracking Projector. • No Submarine Rider Required to Perform Synchronization. 	<ul style="list-style-type: none"> • Less Accuracy, and Reception by One More Sensor Required.
<p>Technical Comparison of Tracking Technologies</p> <p>Figure 21</p>		

The Shallow Water Range at Quinault

The need to test the performance of the new MK 50 ASW torpedo in shallow water is another case of weapon requirements driving range developments. In this case it led to the development of the Quinault site of the Northwest Range. Located in an existing Navy operating area off the Washington coast near Kalaloch, Washington, the Quinault site presented a whole new set of problems, including open ocean, shallow water (less than 150 feet), a sand bottom (acoustically reflective), high sea states, and high reverberation. In addition, any tracking system installed there would be required to perform in the presence of countermeasures. Real time tracking was also required to ensure weapon security, prevent weapon loss, and to position all the range craft during the complicated test scenarios. In establishing such a ranging facility, the main challenge was the shallow water depths where the tracking hydrophones would be virtually in the same horizontal plane as the torpedo being tested; thus making acoustic depth tracking infeasible. Hence, any tracking system designed for use in shallow water would require that the tracking signal provide depth telemetry from the vehicle. Tracking systems in existence at the time depended upon a direct path signal from the vehicle being tracked to the hydrophone. But, as mentioned earlier, in a shallow water environment a direct acoustic path between the vehicle being tracked and the tracking hydrophone does not exist beyond several hundred yards.

It was obvious that a new system would have to be developed, one which would perform satisfactorily after several reflections and multiple arrivals of the transmitted signal. During a series of open ocean tests involving many different candidate tracking signals, the SFSK tracking signal was found to perform very satisfactorily (i.e., frequency was preserved). Following these tests the SFSK signal was selected as the tracking signal for the new range at Quinault. The successful development of the new signal resulted in another Keyport patent⁴. The actual range development program occurred in several phases, as discussed in the following sections.

Preliminary Requirements: As early as 1976 Keyport began assessing the need for a real time tracking range in shallow water, while at the same time several studies were begun to look into the various tracking concepts that could work in that environment. These studies eventually included at-sea acoustic tracking and telemetry experiments, the development and testing of a new torpedo exercise section with dual mounted tracking projectors (one pointing out each side) rather than just one tracking projector pointing straight down, and the development of various hardware and software systems suited to shallow water ranging. In 1977 the Advanced Lightweight Torpedo (ALWT) Project Manager (NAVSEA PMS 406) tasked Keyport to develop unique shallow water ranging capabilities to support the ALWT system trials, as no suitable shallow water instrumented test range existed. This type of testing was necessary since torpedo guidance systems sometimes have trouble in shallow water distinguishing between the ocean's surface or bottom and a target (i.e., the torpedo cannot figure out where the target echo came from). Keyport had to start from scratch and develop the first modern instrumented shallow water tracking range. The range was to be in 120 feet of water with a sandy bottom encompassing an area of two by four nautical miles in an open ocean environment with the capability to track six underwater objects simultaneously. Due to the potentially high ocean

⁴ "Tracking and Telemetry System for Severe Multipath Acoustic Channels," Jay V. Chase, Electronics Engineer, Applied Research Division, Patent No. 4,463,452, dated 31 July 1984.

swells (sea state) only a long baseline range configuration would be possible (as short baseline arrays were deemed too fragile and too large).

Ocean Acoustic Tests of 1978: The shallow water range development effort began with a series of tests conducted off the coast of Washington near Pacific Beach. On one brief visit to the site in April oceanographic data for the site selection process was collected. But gathering acoustic background data and conducting quiet acoustic studies during this trip was hampered by the noise generated by the range craft. To conduct such studies in the future would require a special purpose platform (or buoy system).

In September, a two-week acoustic tracking and telemetry operation was conducted. During this at-sea period various signal coding techniques (tone burst, Phase-Shift Keying, and Frequency-Shift Keying (FSK) – but, not yet SFSK) were tested over different distances and at different water depths. Acoustic frequencies from 12.5 kHz to as high as 250 kHz were evaluated. The experimental signals were transmitted from a transducer deployed from the surface support craft (IX 308) and received at a unique and acoustically quiet hydrophone platform (a spar buoy-shaped device made from MK 46 fuel tanks and anchored to the bottom, named RASABUOY I). The signals were relayed back to the IX 308 using an analog RF link. Figure 22 shows how the experimental equipment was deployed for this operation. Test engineers on the IX 308 observed and recorded the signals. The results of these tests eventually led to the choice of the FSK-type tracking signal: Spaced Frequency-Shift Keying, SFSK.

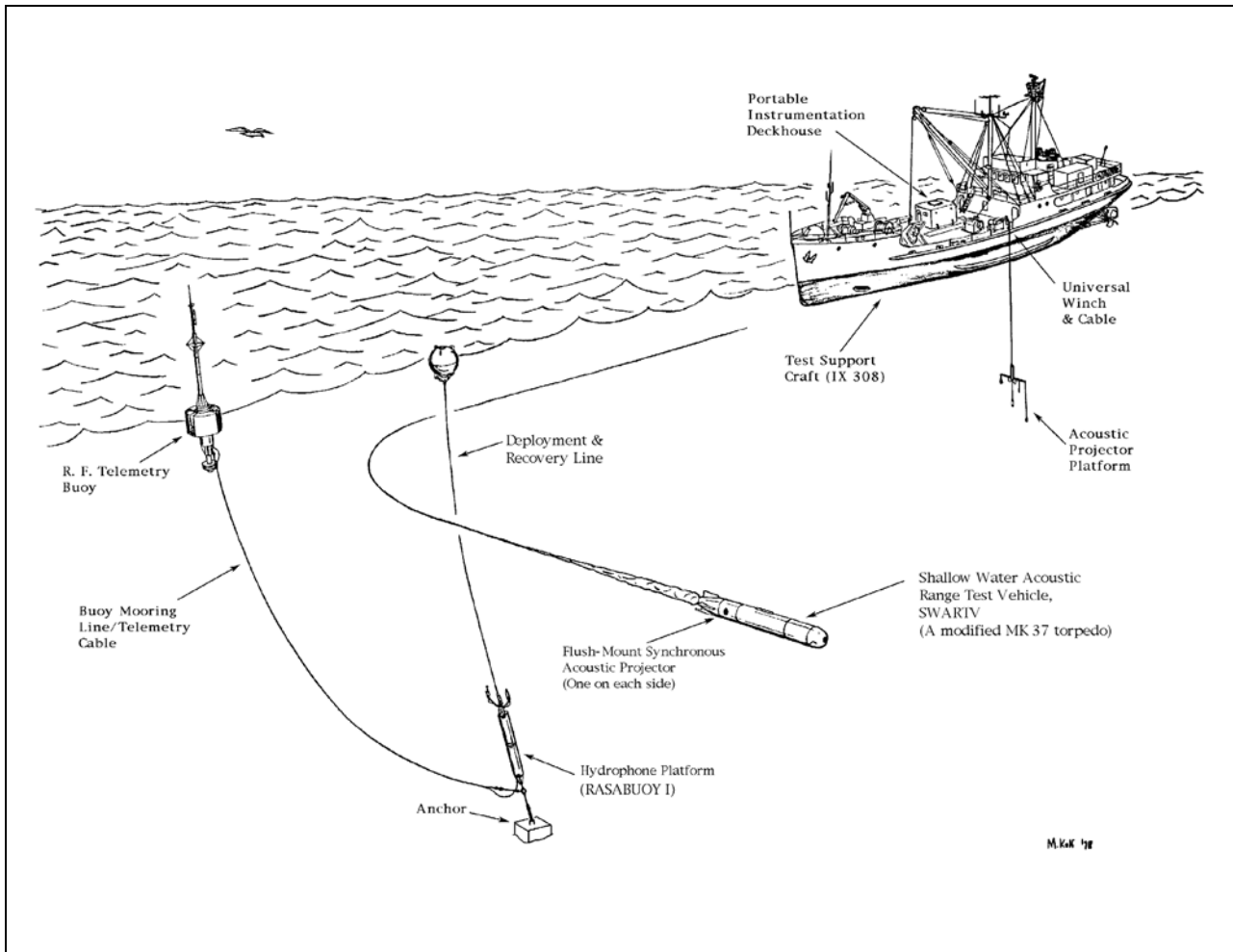

Shallow Water Range Acoustic Test
(Using RASABUOY I)

Figure 22

One objective of this exercise was to form a two sensor tracking range (one hydrophone on RASABUOY I and the other on the IX 308), then launch a free-swimming vehicle to transmit a test signal. The test vehicle was made from parts of a MK 37 torpedo and named the Shallow Water Acoustic Range Test Vehicle (SWARTV). The vehicle was not quite ready when the IX 308 deployed for the operation so it had to be taken out to the site on a Torpedo Retriever boat. The weather was not very cooperative and the seas were beginning to build as the retriever transited to the site and pulled alongside the IX 308. During the attempt to transfer the vehicle to the IX 308 the vehicle began to swing like a pendulum due to the ship's motions. At one point the nose of the vehicle crashed against the side of the tracking van (earning it a new name, the "anti-van torpedo"). In order to regain control of the swinging torpedo-like vehicle and stop its motion the vehicle was rapidly lowered to the deck (but not before one of the line handling sailors, attempting to stabilize the swinging vehicle, was injured when he fell into the ship's

hold). The vehicle hit the deck on top of the narrow torpedo loading hatch, but came to rest lying across the open hatch (perpendicular to the hatch opening). Most everyone within sight of the vehicle jumped on it to prevent it from rolling around and it was quickly chained down to the deck. However, now the open hatch could not be covered and the seas continued to increase. As a result of this incident the test vehicle needed to be taken to Aberdeen, Washington, and returned to Keyport for a thorough checkout. The seas continued to build during the transit into port with water coming over the bow and washing down into the open hatch.

Upon reaching port, late Friday afternoon, the vehicle was trucked to Keyport to be refurbished and checked out (“turned around”). The torpedo shop at Keyport worked that weekend to complete the task and the vehicle was trucked back to Aberdeen on Sunday. Monday morning the IX 308 sailed back out to the operating area to complete the exercise as shown in Figure 22. This was the second portable tracking exercise conducted by Keyport (as the initial low frequency experiment in Chatham Strait, Alaska can be considered the first portable range exercise). Valuable experience was gained in 1978 about working in the ocean swells found in the coastal waters off Washington.

Keyport Experimental Range: In October 1978 the decision was made to install an experimental version of a shallow water range at the old Keyport Acoustic Range site in Port Orchard Inlet (essentially coming full circle back to again conducting range operations in shallow water). Four long baseline sensors were deployed on the range, which created a tracking area about 2.3 miles long by 0.6 miles wide in water depths of 60 feet. Individual cables from each sensor terminated at a small, eight-foot by 20-foot, tracking center van (the “blue van”) located at the end of Pier 1 beside the building which, many years ago, housed the old Acoustic Range control station. The tracking signals were first processed by an experimental SFSK receiver and then passed to a Digital Equipment Corporation (DEC) Micro VAX PDP 11 computer for track generation and plotting. The critical telemetry decoding function (for depth, etc.) was accomplished with the aid of a Hewlett Packard HP 9820 calculator. By February 1979 the range was up and running and range operations resumed in Port Orchard Inlet with the SWARTV. In March 1979 (only five months from project initiation) real time X-Y tracking was demonstrated for the first time using the newly developed SFSK tracking signal. Full 3-D tracking was accomplished the next month with the transmission of depth telemetry data. The purpose of reviving the range was to verify that the various systems developed by Keyport for a shallow water range would perform properly when taken to the open ocean range site.

Ocean Experimental Range: The exact location of the new range was determined during an April 1979 site survey which showed that the best site within the existing Navy operating area was in an area seven miles offshore, between Point Grenville and Kalaloch. In August and September 1979 an expedition was mounted to this site to try out this new shallow water tracking scheme. Four long baseline sensor platforms were deployed in about 100 feet of water with the sensor cables coming together at a surface buoy. This new surface buoy, named RASABUOY II, relayed the data via an RF link to the tracking center van (the “blue van”) located 20 miles south of Kalaloch at the Point Grenville Loran station. Range testing at this site, using both a towed depressor and the SWARTV, evaluated and optimized the candidate acoustic tracking and telemetry techniques, confirming that the SFSK signal was a good choice. Underwater UQC voice communication (telephone) in shallow water was also demonstrated.

Quinault Range Site: The installation of the new range at Quinault began in the summer of 1980 with the deployment of the range cable (and two spare cables) by a civilian contractor (Jacobson Brothers, Seattle, Washington) and the Seabees (CBU 418) from the Naval Submarine Base, Bangor, Washington. These three cables were deployed from the Kalaloch Lodge beach area out about seven miles to the site of a multiplexer unit (junction box). Each cable consisted of a seven mile section of single armored SB-H coaxial transoceanic telephone cable spliced to 3,900 feet of double armored SB-A/C coaxial cable which was installed through the surf zone. This effort was soon followed by the installation of the junction box and four low profile, bottom-mounted, long baseline sensor platforms spaced 2,000 yards apart. The quad, four wire, cables from each sensor platform were connected to the junction box, which multiplexed the signals for transmission to shore on the larger SB cable. Testing of this new shallow water range, using the revolutionary SFSK tracking signal, began in August 1980. A new and larger, eight by 40-foot, mobile range control van (the Shallow Water Range (SWR) van) was trucked to the range site, and parked near a water treatment facility at the Kalaloch Ranger Station. The SWR van contained a MODCOMP IV computer to handle the real time tracking calculations.

Range installation continued during the summer of 1981 after the four original test sensors were recovered for evaluation following their one year of exposure to the shallow water environment. New hydrophones were mounted to the platforms and they were reinstalled on the seafloor along with nine new sensor platforms for a total of 13 sensors. Each sensor platform had to be connected to the junction box, which was also recovered and replaced with a new junction box. The first operations on this new range were devoted to range surveying and system testing. The full 13 sensor range was ready by mid-1981 and fulfilled its mission of developmental test and operational evaluation support for the new MK 50 torpedo. The range was later expanded to 32 sensors covering an area of 45 square nautical miles as shown in Figure 23.

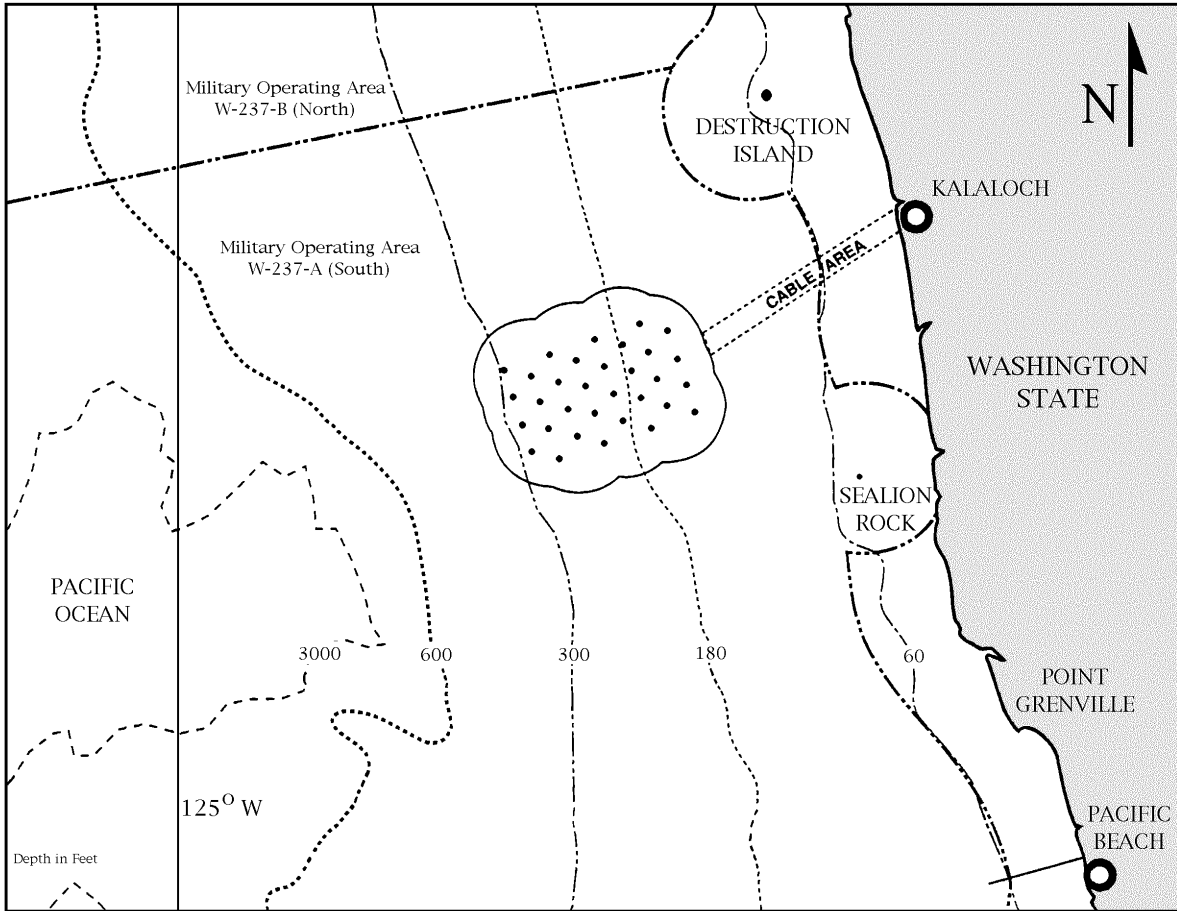

Quinault Shallow Water Tracking Range Layout

Figure 23

The Environmental and Regulations Impact: The installation of this new range at Quinault brought with it a new set of issues to resolve. It turned out that the relatively small amount of construction involved, that of laying three cables across the beach, crossed the jurisdictional lines of at least six federal agencies, eight state agencies, one county agency, and one private interest (the local lodge owner). The at-sea range site itself was already in a Navy operating area, so it was only the cable across the beach that was the issue as far as the permit process was concerned. And that consisted of just 2,000 feet of cable on shore, from the beach to the control van.

The federal agencies involved were the:

- U.S. Army Corps of Engineers (which had to issue the permit),
- Western Division, Naval Facilities Engineering Command (which had to obtain all the right-of-ways),
- National Park Service,
- Fish and Wildlife Service,
- Environmental Protection Agency,
- National Oceanic and Atmospheric Administration.

The state agencies involved were the:

- Washington Department of Ecology,
- Department of Fisheries,
- Department of Game, Wildlife Habitat Management Division,
- Department of Transportation,
- Department of Social and Health Services, Water Supply and Waste Section,
- Department of Natural Resources, Marine Land Management Office,
- State Parks and Recreation Commission,
- Office of Archaeology and Historic Preservation.

The county agency involved was the:

- Jefferson County Commissioners.

Finally the local interest was the:

- Kalaloch Lodge owner.

The key agency was the U.S. Army Corps of Engineers which had to issue the permit to lay the cable, and no permit would be issued until all objections – by any interested party – were satisfactorily answered. One interested party was the Sierra Club which was the only organization to launch a formal objection with the U.S. Army Corps of Engineers. In an attempt to resolve the Sierra Club's objections John Veatch, then Head of the Applied Research Division at Keyport, went to the University of Washington to discuss the issue with a professor, who was also a high ranking official in the Sierra Club and responsible for the club's objection to the U.S.

Army Corps of Engineers. As the meeting began John was asked if he knew of a Fred Veatch, a former Sierra Club member who was well acquainted with the professor. Yes, John knew Fred; indeed Fred was his father. The meeting grew more informal as the professor tried to reminisce about Fred while John tried to describe the size of the cables involved and how they would be buried deep under the beach and would not be visible to the public. The Sierra Club's objection was withdrawn the next day.

—

With the demand for range tracking services continuing to increase, the 1980s saw a move toward increasing capabilities at installations used for other purposes. In 1983, the FORACS I site at San Clemente Island added 3-D tracking capability and came under the cognizance of NUWC Site San Diego as the San Clemente Island Underwater Range (SCIUR). In similar fashion, the FORACS III site at Nanakuli, Hawaii, added 3-D tracking in 1987 and became the Hawaiian Islands Underwater Range (HAIUR).

On to the Future

Underwater vehicle tracking does not always have to be accomplished with massive amounts of hardware installed on the bottom of the range and miles of cables strung out on the ocean floor. Usually the most expensive parts of a tracking range consist of this underwater hardware that has to be installed and maintained on the floor of the range. For several years Keyport has been developing tracking systems which minimize the amount of this expensive and maintenance intensive hardware. Three of these systems are the Inertial Measurement Underwater Tracking System, the Shallow Water Inexpensive Flexible Tracking (*SWIFT*) system, and the Submarine Sensor Tracking (SST) system.

Inertial Measurement Underwater Tracking System: The inertial tracking range concept, another range system patented by Keyport⁵, overcomes the problem of expensive bottom-mounted hardware by having the vehicle itself generate the position data and relay it to the range control site. The vehicle determines its positions from an on board inertial navigation system. An acoustic transmitter takes this positional information, formats the data, and transmits it to shore, in real time, by an acoustic telemetry link. Only one hydrophone is needed in this concept, unlike the three or four required for conventional acoustic tracking. A computer at the range control site decodes these inertial measurements and computes the vehicle's position with respect to an initialized reference point. A pressure sensor measures the vehicle's depth to augment the tracking solution. Data is also recorded on board the vehicle for post-run analysis. As an option, the telemetry link from the vehicle can be received by a surface vessel or a buoy for further relaying to the shore site.

The concept was successfully tested in June 1979 using the NUWES Test Vehicle (NTV) on the Keyport Experimental Range off Pier 1. It was the first test involving real time acoustic telemetry of X-Y positions from an underwater vehicle. The X-Y acoustic telemetry track agreed very well with the 2-D SFSK track. Further testing was conducted at the Quinault Range site.

⁵ "Inertial Measurement Underwater Tracking System," Jay V. Chase, Electronics Engineer, Applied Research Division, Patent No. 4,315,326, dated 9 February 1982.

A tracking system of this type would be useful in several situations, in very large ranges where it would be too expensive to install bottom-mounted arrays, as a complement to shallow water tracking ranges, or where it is necessary to install a quick response range to meet a short term tracking requirement. All range position data is generated on board the vehicle and all that is necessary on the range is a suitable hydrophone to receive this tracking data. This concept of inertial tracking may be used in the large (500 square miles) Shallow Water Training Ranges being proposed for both the east and west coasts of the United States.

Shallow Water Inexpensive Flexible Tracking: In response to the increased emphasis on Naval operations in littoral ocean environments, Keyport has developed a family of tracking range components collectively called Shallow Water Inexpensive Flexible Tracking (*SWIFT*) Ranges. *SWIFT* Ranges provide integrated, real time tracking of multiple exercise participants, such as ships, submarines, torpedoes, targets, and aircraft. It usually takes only a day or two to install a *SWIFT* Range, which can then provide range services from a few days to a few years in water depths as shallow as two feet to over 5,000 feet. Key features include rapid deployment, lightweight hardware, flexible communications links, and the use of a variety of tracking signals (i.e., PSK or SFSK for underwater tracking and GPS for above-water tracking), with control of the range possible from any remote location onshore or aboard ship.

In one *SWIFT* Range configuration, a surface buoy was cabled to eight bottom-mounted hydrophones. The buoy was in a two point moor with one leg of the moor holding the buoy on station and the other leg preventing the buoy from rotating and provided an attachment point for the underwater cables coming up from the hydrophones. The buoy received the tracking signals (SFSK), backed up the raw data on a digital data storage medium, and relayed the encrypted data in real time over a cellular telephone to the users on shore. The range users monitored the events at a remote range control center where the data was decrypted, processed, and displayed using desktop computers.

SWIFT Ranges can be configured with the hydrophones cabled to a moored craft in place of the termination and telemetry buoy described above, or with individual radio-link buoys connected to each hydrophone. The latter method can support rapid deployments, of relatively short duration, at lower cost. Potential *SWIFT* range applications include Fleet exercises at off-range sites, weapons testing and evaluations at remote locations, and to extend the tracking areas of existing ranges.

Submarine Sensor Tracking: Another tracking technology developed at Keyport is used to determine the terminal homing track of exercise torpedoes as they approach a target submarine. In this case, the idea is to make the submarine itself the carrier of a tracking range with the tracking hydrophones selected from those already existing on board the target submarine. It is not necessary to install a tracking projector in the exercise torpedo since the terminal homing signals transmitted by the torpedo's active sonar can be used as the tracking signals. One such system is called Submarine Sensor Tracking (SST). Because there is no tracking projector installed in the torpedo, SST is a non-synchronous tracking system. The torpedo's sonar pings must be received by at least four submarine hydrophones (usually the BQA-8B hydrophones) to give a full 3-D solution. The "array survey," in this case, is done in the library where the precise locations of the ship's hydrophones are determined from the ship's drawings.

It should be noted that the Northwest Range has for many years been the primary T&E agent for many undersea weapon systems (torpedoes, mobile mines, torpedo self-defense systems, and mobile targets) throughout their entire acquisition process and in-service life. For many years this effort emphasized high rate production acceptance testing (proofing), weapon developmental and operational testing, and the associated product improvement and upgrade program requirements. However, customer T&E interest has shifted toward evaluating emerging and upgraded weapon systems in new and different ways. Driven by the need to test these systems in more realistic environments, there has been increasing interest, for instance, in weapons testing against third-world threat-type submarines in littoral waters. There were other drivers as well, such as the need to test high endurance unmanned undersea vehicles (UUVs), very quiet vehicles, or underwater vehicles that operate at very high speeds. To meet these requirements Keyport began development of several non-traditional range technologies. Some examples include:

Portable Range Technologies: Due to the increased need to test in a variety of ocean environments, multi-purpose operations are becoming popular, (i.e., combining weapons testing with Fleet training exercises at forward deployed Fleet operating areas). A new concept called “drive by” testing can even catch the Fleet while in transit to these operating areas. The emphasis here is on providing flexibility to meet specific test requirements through the use of transportable range instrumentation that can be quickly set up at sites remote from the Northwest Range to support a test and/or training mission. The *SWIFT* concept, described above, is aimed in this direction.

Connectivity, Modeling and Simulation: Undersea weapons developers are placing increasing importance on modeling and simulation and, in order to realize its many benefits, Keyport is embarking on a program to provide essential connectivity (to network test and evaluation data) among the various assets of: (1) the Northwest Range system, (2) Fleet ships and submarines stationed in the Puget Sound area, and (3) modeling and simulation sites at other Navy laboratories and universities. Exercises conducted within a “modeling and simulation” framework allow the participation of widely distributed exercise participants (for example, ships in port, in transit, or already at their assigned patrol stations) with their shore based partners at simulation sites, land-based test facilities, and at underwater tracking range sites. This close integration allows the Navy to benefit from the cost and time saving potential offered by an increased use of modeling and simulation, along with its capability to broaden the scope of a test exercise and to simulate different threat situations.

Improvement and Modernization: As all this is brought together, it is essential to avoid the obsolescence of Keyport's existing tracking range test capability. This will be prevented because the normal technology progression in weapon system upgrading will foster concurrent improvements to the range tracking systems here at Keyport, with the goal of continuing to provide testing environments that realistically approximate warfighting environments.

References

Acoustic Torpedo Range, U.S. Naval Station, Keyport, Washington, NOL Report No. 925, 1 March 1945.

U.S. Navy Bureau of Ordnance in World War II, by Buford Rowland and William B. Boyd, Bureau of Ordnance, Department of the Navy, Washington, D.C. 1953.

A Description of the Three-Dimensional Deep Water Range for Torpedo Tracking, by S. R. Murphy, APL/UW/TE/54-42, 30 September 1954.

The Three-Dimensional Tracking Range : 1, by S. R. Murphy, APL/UW/TE/56-13, 15 August 1956.

An Introduction to the Three-Dimensional Underwater Tracking Range, APL/UW/TE/58-3, 31 January 1958.

Application of the Three-Dimensional Tracking Range to Torpedo Proofing, by R. L. Higgins, NTS Report No. 171, January 1959.

Keyport Acoustic Torpedo Range, by S. M. Hanson, NTS Report No. 182, July 1959.

Keyport Acoustic Range, Brief history of, NTS Engineering Division Memo 859, of 21 August 1959.

Reverberations, Vol. III, No. 9, Applied Physics Laboratory, University of Washington, 25 September 1959.

History, U.S. Naval Torpedo Station, Keyport, WA, prepared by A. Carpinella, 13ND-NTS-P5750/1, 1960 and 1974.

A Brief History of the High-Frequency Three-Dimensional Tracking Range, Dabob Bay, Washington (U), by J.E. Camp, APL/UW/TE 60-20, Applied Physics Laboratory/University of Washington, 2 June 1961.

The St. Croix Three-Dimensional Underwater Tracking Range, by J.E. Camp and R.W. Minto, APL/UW 6421, Applied Physics Laboratory/University of Washington, 12 December 1964.

Underwater Platform, by Peter L. Balise, U.S. Patent No. 3,161,255, 15 December 1964.

A Brief Survey of U.S. Underwater Acoustic Tracking Ranges, by P.R. Wessel and J.R. Cunningham, NOLTR 67-2, Naval Ordnance Laboratory, White Oak, Maryland, 9 January 1967.

Pre-Stressed Spherical Electro-Acoustic Transducer, by Rudolph E. Corwin and Elbert A. Pence, U.S. Patent No. 3,317,762, 2 May 1967.

Air and Underwater Trajectories of the TERNE III Rocket, by Kjar G. Willey, NTS Report No. 313, May 1962.

NAVTORPSTA Keyport Range Complex and Associated Data, Technical Manual, Operations Instructions, NAVORD OD 41964, 1 May 1970.

Range Development Study Group Report, Naval Undersea Warfare Engineering Station, Keyport, WA. W. M. Sandstrom, Chairman, April 1972.

U.S. Navy Underwater Tracking Range at Atlantic Fleet Weapons Training Facility St. Croix, U.S.V.I., by A. N. Roberts, 1 October 1978.

Inertial Measurement Underwater Tracking System, by Jay V. Chase, U.S. Patent No. 4,315,326, 9 February 1982.

Torpedo Technology, by Louis C. Gerken, American Scientific Corp. 1989.

Torpedo Town U.S.A., A History of the Naval Undersea Warfare Engineering Station, 1914-1989, by Lisa Poole with Dianne Robinson, Diamond Anniversary Publishing, 1989.

Improved Tracking Methods for Short Baseline Hydrophone Arrays, by Larry Anderson, NUWC-KPT Report 2066, October 1993.

A Technical History of Northwest Navy Range Tracking Systems, Appendix C to the Northwest Range Tracking Systems Program Management Plan, by Nik Lauer, Vitro Corp. 1993.

Underwater Tracking Range Implementation Using Spaced-Frequency-Shift Keyed (SFSK) Signals, Undersea Ranges Department Technical Note 95-2, by Reid Johnson, February 1995.

Hellions of the Deep, The Development of American Torpedoes in World War II, by Robert Gannon, The Pennsylvania State University Press, University Park, Pennsylvania, 1996.

Range Users Guide, preliminary version

Plus personal interviews, oral histories, informal communications, and various unpublished sources. Too numerous to list were the many issues of Warhead and Keynotes, the Station's newspapers, that were very helpful.

Appendix A

Wartime Problems with the MK 14 Torpedo

The New MK 14 Submarine Torpedo

The United States Navy Bureau of Ordnance, BuOrd, introduced a new weapon system to the Fleet in 1941, the MK 14 steam driven torpedo with its MK 6 magnetic influence exploder. Both were developed at the U.S. Naval Torpedo Station, Newport, Rhode Island (established in 1869 as the world's first naval station dedicated to the development of the torpedo). This new weapon was designed to detonate under the keel of the target vessel and break its back (through the action of the expanding and collapsing sphere of gas), thus quickly sinking the ship. As an additional advantage, a detonation under the keel would overcome the ever greater side wall armor protection then being installed on the newer capital warships of that era. To achieve warhead detonation the magnetic influence exploder sensed the variations in the intensity and direction of the earth's magnetic field adjacent to the target's hull. It was hoped that this would minimize the number of torpedoes expended by getting at an enemy warship's vulnerable underbelly. BuOrd was very proud of the new magnetic Exploder MK 6, and subjected it to very tight security. Few operational commanders knew of its existence. There was no Fleet training using the MK 6, and the technical manuals were even locked away. Security was so tight that any defects were sure to be hidden from the very people who imposed the tight security and from those capable of providing a remedy. However, to many of the world's navies the inherent problems associated with magnetic influence detonation were already well known. In the case of Japan this kind of exploder was considered unreliable and the Japanese Navy rejected the use of magnetic exploders.

An experimental version of the influence exploder was only tested once, on 8 May 1926, and then under ideal conditions (not in a simulated wartime environment). An obsolete submarine hulk (the ex-L 8) was towed to sea and sunk by a warshot torpedo, but the torpedo was not fired from a submarine. The exploder activated at the proper instant and the target sank. It was a great success, so great that any further at sea testing of the new exploder was deemed unnecessary. However, the exploder was subjected to further testing at Newport, with at least one report back to BuOrd that the exploder exhibited a tendency to prematurely activate. But, BuOrd took no significant action and the exploder was repackaged into a version that would fit into the MK 14 torpedo and designated the Exploder MK 6. The only testing of the MK 14 torpedo itself was on a tracking range to determine that the torpedo ran straight and true with very little deflection for the specified distance at the specified speed. Depth measurements were not made, and wartime conditions were not simulated. The thought of destroying a new MK 14 in a warshot test was deemed too wasteful by BuOrd, since each MK 14 cost \$10,000 in those days. Testing had to emphasize the safe return of the torpedo. No warshot tests of the MK 14 were conducted in the 1930s; and when World War II began there was no one in the Navy who had ever seen, or heard, a torpedo detonate.

Conditions Ripe For A Disaster

Looking back on that period of time it is possible to list a number of contributing factors, all interacting with each other, which set the stage for the ensuing torpedo disaster.

Production Problems: Prior to World War II, BuOrd had concentrated all torpedo production at Newport, partly in response to the Washington Naval Conference of 1922 where an agreement was reached to reduce the overall number of warships capable of firing torpedoes. In fact Newport enjoyed a virtual monopoly on torpedo production from 1869 to 1940. In 1937 torpedoes were produced at a rate of about 2.5 per day which resulted in not enough torpedoes being available to meet training and testing needs. It is important to realize that the torpedoes being built at the time were not designed with mass production as an objective. The tolerances were much tighter than those practiced by commercial companies and many torpedo components were considered tool room jobs rather than assembly line tasks. How do you, with production line automation, duplicate what had traditionally been made through hand worked precision? One could say they were actually designed for meticulous, small scale manufacture – at the Naval Torpedo Station at Newport. Politics came into play when BuOrd tried to open another torpedo production facility before the war broke out. The local state politicians cried foul as they feared that such a move would threaten jobs in Rhode Island. Hence, no plans were realized for mass production. Early in the war the building of torpedo firing craft actually outstripped the capacity to build torpedoes for them.

Naval War Fighting Doctrine: There is another reason why torpedoes were not produced in mass quantity before the war. The U.S. Navy was not going to practice “unrestricted submarine warfare” against the international commerce of any nation, as was practiced by the German U-boats in World War I. Our submarines were to support the battle Fleet and act as scouts in accordance with War Plan Orange. U.S. Navy submarines conducted only scattered ASW patrol operations during World War I. In fact in the entire 41 years of existence of the submarine service in the U.S. Navy no ship had ever been sunk by a U.S. Navy submarine before 1941. But, the next war was sure to be different. It would mark the first use by the U.S. Navy of this new combination – submarines firing anti-ship torpedoes.

With no rush to build up a stockpile of MK 10 or MK 14 torpedoes as war came closer to America, an early shortage of torpedoes resulted (only to be made worse by the loss of Manila Bay, along with nearly half of the remaining torpedoes, to the advancing Japanese early in World War II). During the Japanese air raid against the Cavite Naval Shipyard on 10 December over 200 MK 14 torpedoes were destroyed. To compensate for this shortage, submarine commanders were told to use their few remaining torpedoes very sparingly and were sometimes sent out on patrol with less than a full load.

The National Economy: During the depression, precious little funding was available for torpedo testing, for mass torpedo production just to create a stockpile, or for realistic training. BuOrd could not sanction the destruction of a \$10,000 torpedo just to see if it worked (after all, torpedoes with exercise sections substituted for the warheads were regularly tested on the torpedo ranges at Newport and Keyport).

With the unrealistic Fleet training available to them (especially lacking were any live warshot exercises), submarine commanders began exercising extreme caution during Fleet

maneuvers in the 1930s. The preferred attack position was from a depth of 100 feet using a fire control solution based solely on passive sonar. This attack posture was based on the commanders' fear of antisubmarine aircraft. Moreover, being "sunk" during one of these exercises was very hazardous to the career of the commander, which contributed to this culture of caution. At the outset of the war this cautious nature of officers commanding submarines produced commanders who were entirely too timid in combat.

The lack of proper training and the limited torpedo testing programs during the 1920s and 1930s directly led to the high torpedo failure rate early in the war when submarine commanders realized that there was little connection between torpedo presets and torpedo performance. Torpedoes often seemed to either run under the target or run into it, depending upon presets, with no effect. In many cases the torpedoes either failed to explode or exploded prematurely. Although submarine commanders reported frequent torpedo problems in their patrol reports, and obviously believed that torpedo performance was largely responsible for the extremely low percentages of hits and effective explosions, senior officials were reluctant to believe them.

Overconfidence in the Magnetic Exploder MK 6: Unwarranted faith was placed in the expected effectiveness of the MK 6 magnetic exploder, after its one and only live fire test. No further testing was done at locations with varying magnetic field strengths or to determine a statistical failure rate. The position taken by BuOrd was that the weapons experts were all in BuOrd, and if the torpedoes they issued to the Fleet were not sinking ships, the fault was with the Fleet.

Magnetic Exploder MK 6 Security Policy: Security surrounding the MK 6 was too tight. The Fleet didn't begin to receive torpedoes with the MK 6 until the fall of 1941, and then only in limited quantities. It could be argued that no relaxation of security is ever a good policy, but the lid kept on the MK 6 exploder was entirely too tight. Even as negative reports were reaching BuOrd concerning the unreliability, or outright rejection, of magnetic influence detonators by many foreign powers, BuOrd still kept a clamp on its security.

Inaccurate Fleet Feedback: Initial reports reaching BuOrd on the performance of the weapons they issued were mixed, as far as the MK 14 torpedo was concerned. Some reports even indicated success with the MK 6 exploder. A few commanders submitted patrol reports indicating successes with the MK 14 torpedo all the while concealing the fact that they had to deactivate the influence feature of the MK 6 exploder in order to obtain such results (clearly providing misleading information to BuOrd).

In the face of this contradictory feedback BuOrd initiated no program to rebuild or replace the exploder in the early years of the war. They maintained their faith in the underlying principles of the exploder and in its ultimate success.

Torpedo Problems – A Review Of The Sequence Of Events

Although several types of torpedo malfunction were observed, the complaints of the commanders most frequently centered on two areas: torpedo run depth and the exploder mechanism, which seemed to fail in two ways, exploding either prematurely or not at all. The first problem noticed was premature explosions, the torpedoes detonated too far away from their targets. This was quickly attributed to defective magnetic influence exploders. But when the

magnetic influence feature of the exploder was disconnected (against BuOrd's directives), thus relying solely on the contact exploder, the "miss" situation did not improve. For example, USS SARGO fired 13 torpedoes at 6 different targets with no results (even after dismantling the magnetic influence feature of the MK 6 exploder). Further use of the torpedo (resulting in more misses) suggested that the torpedo was running too deep (considerably deeper than the depth settings) and was passing harmlessly under the target.

It was the experimental work done by the Fleet that identified the problem. In 1942, Rear Admiral Charles A. Lockwood, commander of submarines in the Southwest Pacific, became convinced that the torpedoes were in fact the main cause of the low hit totals for his submarines. BuOrd officially disagreed, and, in effect, accused the submarine skippers of using imaginary torpedo defects as an excuse for poor marksmanship. RADM Lockwood, enraged at this response, decided to take matters into his own hands. In June of 1942, he began a series of experiments involving nets in the waters south of Fremantle, Western Australia. USS SKIPJACK fired three exercise torpedoes at a large 500-foot long fishing net placed at a distance of 850 yards from the submarine. In another demonstration near Albany, Western Australia USS SAURY fired three torpedoes at a net. The holes made by the torpedoes as they passed through the nets proved to be a rudimentary but fairly effective method of determining the torpedoes deflection angle and run depth. The run depth and deflection angle, computed from the location of the hole, were then compared with preset values from the depth spindle and the gyro setting indicator-regulator. The tests showed no serious problem with deflection angle, but the torpedoes ran as much as 11 feet deeper than the set run depth. BuOrd was unimpressed and initially responded with scorn for the test methods. Persistence paid off, however, and eventually Admiral King (the Chief of Naval Operations) ordered the bureau to run proper tests. A series of tests were conducted on the Newport tracking range in Narragansett Bay which convinced BuOrd to admit, in August 1942, that the new MK 14 torpedo ran 10 feet deeper than set (a new depth control mechanism was later introduced). Although the reason for the erratic run depths would not be identified until some time later, mere knowledge of what was happening to torpedo run depths at least allowed firing submarines to compensate for this when pre-setting the run depth.

When the depth error was finally appreciated and the submarine commanders were instructed to subtract 10 feet from the depth settings (while keeping the magnetic influence feature active), the problem of premature explosions became more evident. Despite repeated complaints, official support for the magnetic exploder forced the Fleet to keep it in use until July 1943 when Admiral Nimitz officially ordered the magnetic influence feature deactivate on all torpedoes aboard Pacific Fleet submarines. The Southwest Pacific Fleet submarines (now under the command of one of the principle advocates and originators of the MK 6 exploder) finally deactivated the device on their torpedoes in January 1944. The southern hemisphere is far from an ideal magnetic environment for a device that was essentially designed to work in the earth's magnetic field found in Narragansett Bay, Rhode Island. Still, with the MK 6 exploder deactivated the productivity of the submarines did not increase, instead a new problem surfaced.

Erratic performance of the magnetic influence feature was not the only problem displayed by the exploders. Even when the torpedoes were set to hit, the contact exploder would sometimes fail, and the torpedoes would clang harmlessly against the target vessels. Frustration of the submarine commanders may be typified by a 1943 log entry made by the commanding officer of USS WAHOO, CDR Dudley "Mush" Morton, following a three-day period in which

he had experienced 10 consecutive torpedo failures: “Damn the torpedoes!” This new problem of duds was verified when a torpedo hit the target but failed to explode on contact.

An outstanding example of this is represented by the experience of USS TINOSA (which had the magnetic exploder deactivated on all 16 of its torpedoes). The commander spotted a large tanker, the *Tonan Maru No. 3*, (a 19,000 ton converted whale factory ship) doing 13 knots and preceded to pump 15 torpedoes into her. Of the 13 torpedoes that hit the tanker, only one detonated (some sources say two detonated). His position was considered perfect, exactly 90° from the target at a range of just 875 yards. The commander took the last torpedo home in disgust while a Japanese tug towed the crippled tanker to Truk Island where her cargo was salvaged. This incident occurred on 24 July 1943, the very day the magnetic influence feature was deactivated from torpedoes aboard ships based at Pearl Harbor. (Note that a large water splash will result from a dud due to the air flask bursting and could be mistaken for a high order detonation of the warhead.)

Persuaded by the TINOSA experience that there was also a defect in the contact exploder, the submarine force commander (RADM Lockwood again, now in Pearl Harbor) ordered the force gunnery officer to find out what was wrong. Testing was conducted by firing a series of warshot torpedoes at a submerged sheer cliff on the island of Kahoolawe. The first two exploded; the third was a dud. Brave souls retrieved the dud from a depth of 55 feet and brought it on board USS WIDGEON, a submarine rescue vessel, for examination. What they found was that crushing of the warhead on impact caused a deformation of the firing pin guide lines, which prevented the firing pin from operating. Subsequent testing revealed that the binding was most likely to cause failure on a “perfect” 90° impact, showing once again that the exploder had been improperly designed and inadequately tested. Subsequent tests by BuOrd confirmed these results, and stimulated efforts to design a new exploder. In the meantime, modifications to the existing exploders enabled the submarines to improve their hit percentages and tonnage totals.

It wasn't until October 1943 that the problems with the MK 14 torpedo were resolved and the submarine service began to show an improved performance record.

The Three Main Torpedo Problem Areas

As indicated, torpedo problems were reported early in the war by the submarine commanders, but were usually met with disbelief. BuOrd and SubPac staff officers placed the blame for the low number of sinkings everywhere but on the torpedo. They blamed the captain's cautious tactics, a bad case of nerves, incompetence, improper handling and/or operation of the weapon, crew inexperience, and poor torpedo maintenance. BuOrd, with its vested interest in the exploder, did not believe the torpedo problem reports, and in general resisted the need to do any comprehensive testing and make changes. Toward the end of the first year of World War II nearly a third of the submarine commanders were replaced for poor performance or unsuitability. Many were criticized for lack of aggressiveness and unproductive patrols.

But, the torpedo problems were very real and can be broken down into three separate areas: (1) the depth-control mechanism, (2) the new magnetic influence feature, and (3) its backup contact exploder. The last two problem areas were buried in the new MK 6 exploder.

These problems were not uncovered all at once, and as soon as one problem was resolved the next one showed up.

The Depth Problem: Two separate issues contributed to make the MK 14 torpedo run deeper than the torpedo preset depth.

1. The hydrostatic device which measured the surrounding sea water pressure (used to find depth) was not placed on the torpedo in a location where it could faithfully measure the sea water pressure. It was placed well aft, in the “afterbody,” near the diving control surfaces (diving planes) which it controlled. Due to the hydrodynamics of the water flowing over the skin of the torpedo at that location, the pressure was actually less than the pressure of the sea water just a few inches away from the skin of the torpedo (Bernoulli’s principle). So, while the torpedo was running, it always registered a lower pressure, which produced an inaccurate depth measurement (a depth shallower than the actual depth of the torpedo). This inaccurate depth was transmitted to the depth control surfaces causing the torpedo to dive to a deeper depth than the depth set before launch.

2. The warhead, filled with TNT (then later Torpex), was heavier than the exercise section used during torpedo testing on the tracking range. Plus, it was made increasingly heavier, at the request of the Fleet, as BuOrd added more explosives; bringing the total up from 507 pounds of TNT to 668 pounds of Torpex by the fall of 1942. This effect exaggerated the difference between the warhead weight and the exercise section weight. This problem originated early in the development of the MK 14 torpedo by the need to test the torpedo without any explosive charge in the warhead; instead water was substituted for the explosive charge during in-water runs on the Newport tracking range (to ensure torpedo recovery). At the end of the run the water was expelled and the torpedo surfaced for recovery. Before the war the exercise sections weighed about the same as the warheads, but as more explosive charge was added to the warhead during the war the weight difference was magnified.

Also contributing to the depth sensor problem was the fact that the depth sensor was calibrated using the lighter weight exercise section. Since the lighter weight exercise section produced a torpedo of less density than an actual warshot torpedo, an inaccurate value for torpedo weight and trim was provided to the Fleet. During actual wartime service, with the heavier weight warhead, the torpedo ran deeper than it did on the Newport tracking range (but, at that time, the range couldn't measure depth anyway).

Almost every time the Fleet reported an error in the running depth of the MK 14 torpedo BuOrd would quickly send out a representative to investigate. But all too often the report was to place the fault everywhere but on the torpedo (inadequate maintenance, improper handling, etc.).

The Magnetic Exploder Problem: The problems with the MK 6 exploder concerned the submarine crew more than the problems of deep running torpedoes for they caused either a premature detonation or a dud, either of which caught the attention of the targeted vessel with reprisals sure to follow. Especially irritating were the torpedoes that detonated as soon as they encountered the slightest deviation in the magnetic field around them, which was, in some cases, just a few yards from the torpedo tube.

Too often, when the torpedo was set to run deep and pass under the keel in order to have the magnetic influence exploder detonate the warhead, nothing would happen. But when the

torpedo was set at a shallow depth to have the back up contact exploder detonate the warhead, the magnetic influence exploder would detonate the warhead prematurely (if it chose to work at all). When the MK 6 detonated the warhead prematurely the submarine commander sometimes mistook it for a hit or a sinking. At least it looked like a hit through the periscope, and so would be reported as such.

Many people considered the MK 6 exploder extremely complex, with a flawless unit only a far off pipe dream. Three separate explosive actions were required to detonate the warhead in the torpedo. In the first action a firing pin struck a primer cap, which in turn set off a detonator in the base of the booster charge, finally the shock wave from the booster detonated the TNT (or Torpex). One of the mechanisms that activated the firing pin received its signal by sensing the earth's magnetic field, the magnetic influence component of the MK 6 exploder.

The magnetic field under a ship was initially presumed to be a hemisphere and a torpedo set at the proper depth would intersect this field at its lowest point, directly under the keel. But, the magnetic field may have been much more flattened than originally presumed, resembling a thick disk. The torpedo would then encounter the strong magnetic field from this disk at some distance from the hull and detonate the warhead before the torpedo was under the keel. Unless the exploder was perfectly adjusted, it would activate at distances from 50 feet to 150 feet from the hull. It appears that these premature detonations were more prevalent when attacking larger targets, such as aircraft carriers, where the warhead would encounter the necessary activating flux density while still some distance from the keel. In other words, the thing was just too sensitive and the Fleet began to seriously distrust the MK 14 torpedo.

There is another possible explanation. The passive feature of the exploder relied on the target's magnetic signature and was fooled by local changes in the earth's magnetic field. The exploder was tested in Narragansett Bay, and the properties of the earth's magnetic field in that area are not the same as the magnetic field properties in the South Pacific Ocean.

BuOrd did not believe any of this and insisted that nothing could be wrong with its creation, until the problem erupted into a major scandal. The operating forces were initially told not to disable the exploder, nor to conduct tests on it. It turned out that the greatest debate between the submarine force and BuOrd was over the MK 6 magnetic influence exploder. Other than deactivating the magnetic influence feature, no solution to this problem made its way into the Pacific Theater during the war.

Instead of being a device which could reduce the number of torpedoes fired against a target, the real effect was an excessive use of the MK 14 in order to get an explosion at the target (making a weapon already in short supply even scarcer).

The Contact Exploder Problem: In June 1943, after many of the boats disconnected the magnetic feature of the MK 6 exploder, the problem of duds intensified. The contact exploder device was a backup to the magnetic feature of the exploder, but it too was flawed because it frequently failed to detonate the warhead when the torpedo struck the ship's hull. It failed most often when impacting at right angles (a perfect 90° angle to the target ship's centerline), the optimum position. The better job the submarine commander did in aligning the target, according to the preferred tactic, the greater the chances were of a dud!

To find this problem the Fleet conducted the series of tests in mid 1943 involving firing several warshot torpedoes at a submerged vertical cliff-face in Hawaii. These tests showed that the weak exploder mechanism was crushed in a perfect 90° shot. To find out why, some drop tests were conducted using concrete filled dummy warheads. When the warheads were set to hit a steel plate head-on most of the exploders failed, but when the plate was tilted 45° there were fewer failures.

This turned out to be a simple mechanical problem: the firing pin jammed. The direction of motion of the firing pin (activated by a spring) was not along the axis of the MK 14 torpedo but lay perpendicular to it. Under the shock of torpedo impact, sufficient friction was created between the firing pin and its guide walls to slow down the action of the pin against the primer cap, that is, if the impact shock didn't break the pin and/or guides first. The pin did not always travel far enough or fast enough to strike the primer cap with enough energy to activate it. More than just a stronger spring would be needed, the firing pin had to be redesigned.

At Pearl Harbor the solution was to produce a lighter weight firing pin. They were able to find enough high strength, lightweight metal from the propeller blades of downed Japanese Pearl Harbor raiders (a novel method of recycling).

By the fall of 1943 solutions had been found to the major problems with the MK 14 torpedo. But, a few more issues needed to be resolved. There was a tendency for some torpedoes to immediately make a circular run upon launch with unfortunate consequences for the submarine (at least one submarine fell victim to this problem). And there was a problem with the wake generated by the steam driven propulsion system which could alert the target (the MK 18 electric torpedo resolved this problem).

All the bugs were eventually worked out and the MK 14 torpedo did prove effective. The MK 14, and to some extent its successor the MK 18, sent to the bottom some 5 million tons of enemy shipping and damaged 2.5 million tons more. The MK 14 itself sent 4 million tons of Japanese war material to the bottom. Mass production was eventually achieved with a total of 13,000 MK 14 torpedoes being produced during war. According to BuOrd, January 1944 saw this particular controversial chapter in its history draw to a close.

Actions Taken By BuOrd To Resolve The Torpedo Problems

Continue Range Testing: BuOrd continued funding, and authorizing, range testing of torpedoes (but not enough emphasis was placed on tracking the depth of the torpedo). The range at Newport used aircraft to look for any erratic performance and to observe torpedo deflections. BuOrd even used submerged nets on a few occasions but found the results misleading and the effort very expensive and cumbersome. The nets did not hang straight down, but swung up from the vertical in the most mild current; and the distance from the top of the net to the hole made by the torpedo was not the same in water as it was when the net was taken out of the water. So when the net results differed from the depths recorded by the torpedo, the data from the net testing was ignored.

In the summer of 1943 BuOrd conducted a series of test firings of torpedoes against steel plates lowered in the water and reproduced the problem of the sticky firing pins. They were

working on their own solution when word came of the approach taken by Pearl Harbor (and they quietly left that issue alone).

As a direct result of the feedback from the Fleet on the operating capabilities of the MK 14 torpedo and its MK 6 exploder, BuOrd decided it had to improve the method of tracking torpedoes. The tracking range at Newport was eventually improved during the later stages of the war through the use of several sets of acoustic tracking hydrophones that allowed both the speed and deflection of a torpedo to be monitored during its run down the range (but still without the capability to monitor depth). A similar acoustic tracking range was established at Keyport, Washington.

Continue To Improve The MK 14 Torpedo: BuOrd continued making modifications to the MK 14 torpedo and to the MK 6 exploder, always maintaining faith in the ultimate success of the MK 6. It was even redesigned once to remove a small electrical generator in favor of a battery as the power source, and the arming distance was increased.

It can be appreciated that efforts to improve the exploder (and BuOrd's credibility) really took off in the summer of 1943 when the entire Pacific Fleet (submarines and destroyers) refused to use the magnetic influence feature. BuOrd hoped a modified and reliable exploder could eventually be "sold" to its only customer, the operating forces.

Continue New Torpedo Development: Efforts continued toward developing the MK 18 electric torpedo as a replacement for the MK 14. By late 1944 the MK 18 (modeled after a German G7e recovered from the captured U-570 and some that were found intact on U.S. east coast beaches in 1942) entered Fleet service. The new torpedo eliminated the bubbles that followed in the wake of the MK 14 torpedo, but was much slower, and occasionally there were fires or hydrogen explosions from its batteries.

A Matter Of Priority: As important as the MK 14 was, it was not given the highest priority at Newport by BuOrd. The aircraft launched MK 13 torpedo had the highest priority – and had its greatest hour of glory on 7 April 1945 when it was used to sink the battleship *Yamato* and several other Japanese warships, but such success came only after years of working out its bugs. There was also work to be done on the MK 15 surface launched torpedo for destroyers, although it had a lower priority than the MK 13 and MK 14.

References

Operations of the Fremantle Submarine Base 1942-1945, by David Creed, The Naval Historical Society of Australia, Garden Island, N.S.W., nd.

U.S. Navy Bureau of Ordnance in World War II, by Buford Rowland and William Boyd, Bureau of Ordnance, Dept. of the Navy, Washington, D.C., 1953.

War Under the Pacific, by Keith Wheeler, Time-Life Books Inc., 1980.

U.S. Subs in Action, Warships No. 2, by Robert C. Stern, Squadron/Signal Publications, Inc., 1983.

The Devil's Device, Robert Whitehead and the History of the Torpedo, by Edwin Gray, U.S. Naval Institute Press, Annapolis, MD, 1991.

The Mk-XIV Torpedo: Lessons for Today, Technical Paper, Naval History, Page 34, U.S. Naval Institute, Annapolis, MD, Winter 1992.

Stealth at Sea, The History of the Submarine, by Dan van der Vat, Houghton Mifflin Co., New York, 1995.

The Great Torpedo Scandal, 1941-43, by Frederick J. Milford, The Submarine Review, October 1996.

Hellions of the Deep, The Development of American Torpedoes in World War II, by Robert Gannon, The Pennsylvania State University Press, University Park, Pennsylvania, 1996.

Appendix B

Development of Weapon Recovery Systems

In the early days of torpedo testing, recovery of weapons which had gone to the bottom was accomplished by surface vessels using nets, snares, and grapnels. Later, magnetic detection gear and hard hat divers were used to recover torpedoes, a reasonably satisfactory method, given the shallow waters used at the time for weapons testing. When it became necessary to test large numbers of weapons in relatively deep waters, however, such methods were no longer practical and torpedoes that did not surface at the end of their run remained on the bottom, out of reach of conventional diving methods.

With the installation of the tracking range at Dabob Bay, the need finally arose to recover weapons in water depths up to 600 feet. The first recovery opportunity took place in May 1958 (just one year after ranging operations began on the new 3-D range) and its success greatly hastened the “acceptance” of the torpedo tracking range concept. This was the recovery of an errant MK 37 Mod 0 torpedo which, while being tracked, sank to the bottom of the bay in 614 feet of water. The torpedo was negatively buoyant and was damaged during its launch from the submarine firing the torpedo. The 3-D range accurately tracked the torpedo on its way to the bottom as the after compartment flooded with seawater. It ended up in a vertical orientation with its tail 18 inches in the bottom sediment where it remained for the next 23 days.

Shortly after that, rumors of this “lost” torpedo reached Jacobson Brothers, a Seattle company devoted to marine construction, cable laying, and undersea salvage. In a letter to the Commander of the Naval Torpedo Station, Keyport, they offered their services. Following acceptance of their offer they quickly readied their new Jacobson Submerged Television and Recovery (J-STAR) system, on board their research craft the SONAR BELLE, and steamed to Keyport in an attempt to find the downed torpedo. This new recovery system consisted of a metal frame lowered in the water by a strong electrical cable onto which was mounted an underwater television camera, some hydraulic grappling gear (“ice tongs”), and a range tracking projector to provide position data. On 29 May 1958, during their first day on the range, J-STAR was lowered to the exact spot of the downed torpedo, as determined by the 3-D range, and succeeded in recovering the sunken torpedo. Since the maximum visibility was only a foot or two, the successful recovery of the torpedo demonstrated that the whole scheme (ranging and recovery) was “for real” and that no longer were “sinkers” (torpedoes whose flotation devices didn't work) “lost and gone forever.” During the preceding nine years of torpedo proofing operations at Hood Canal and Dabob Bay other torpedoes failed to surface at the end of their runs and were lost, with little chance of recovery, because of the lack of an accurate 3-D tracking system and a recovery capability. This new recovery capability was to prove to be very important in the future, especially in the first pre-production runs of new torpedo designs. Range exercises involving new weapons could safely be conducted at Keyport because developmental torpedoes could sink to the bottom without being destroyed by the pressure, making recovery worthwhile; such was not the case at AUTECH, in the Bahamas.

The routine firing and recovery of negatively buoyant warshot weight torpedoes proved to be invaluable. For instance, in the testing of the MK 37 torpedo, comparison firings of warshot weight and exercise weight torpedoes revealed a problem not previously identified. The MK 37 torpedo used a forward looking transducer mounted in the nose of the torpedo to home on targets. In exercise configuration, the torpedo was positively buoyant, and as a consequence ran with a constant down angle to maintain depth. Even when running at a shallow depth, the torpedo didn't "see" the surface acoustically. Tests at Dabob Bay using warshot weight torpedoes, however, showed that the warshot torpedoes, which were negatively buoyant, ran with an up angle to maintain depth, and had a strong tendency to home on surface chop. This phenomenon, known as "surface capture," led to the development of an anti-capture modification to the MK 37.

The success of the J-STAR vehicle lay in its ability to maneuver on the bottom. J-STAR did not rely on thrusters for propulsion, but instead used a system of wires to pull itself along the bottom. The process is called kedging and is shown in Figure B-1. Three kedge wires are shown in the figure extending from the surface craft down to the recovery vehicle and over to the mooring buoys. Motion along the bottom is accomplished by paying out and taking in wires from a pair of these kedge wires to haul the vehicle in the direction desired. Typically systems using this method of maneuvering do not have much search capability and must be positioned nearly directly above the object to be recovered. On 26 December 1961 Jacobson Brothers received a patent on the kedging principle of controlling an underwater television camera titled "Underwater Television Device."

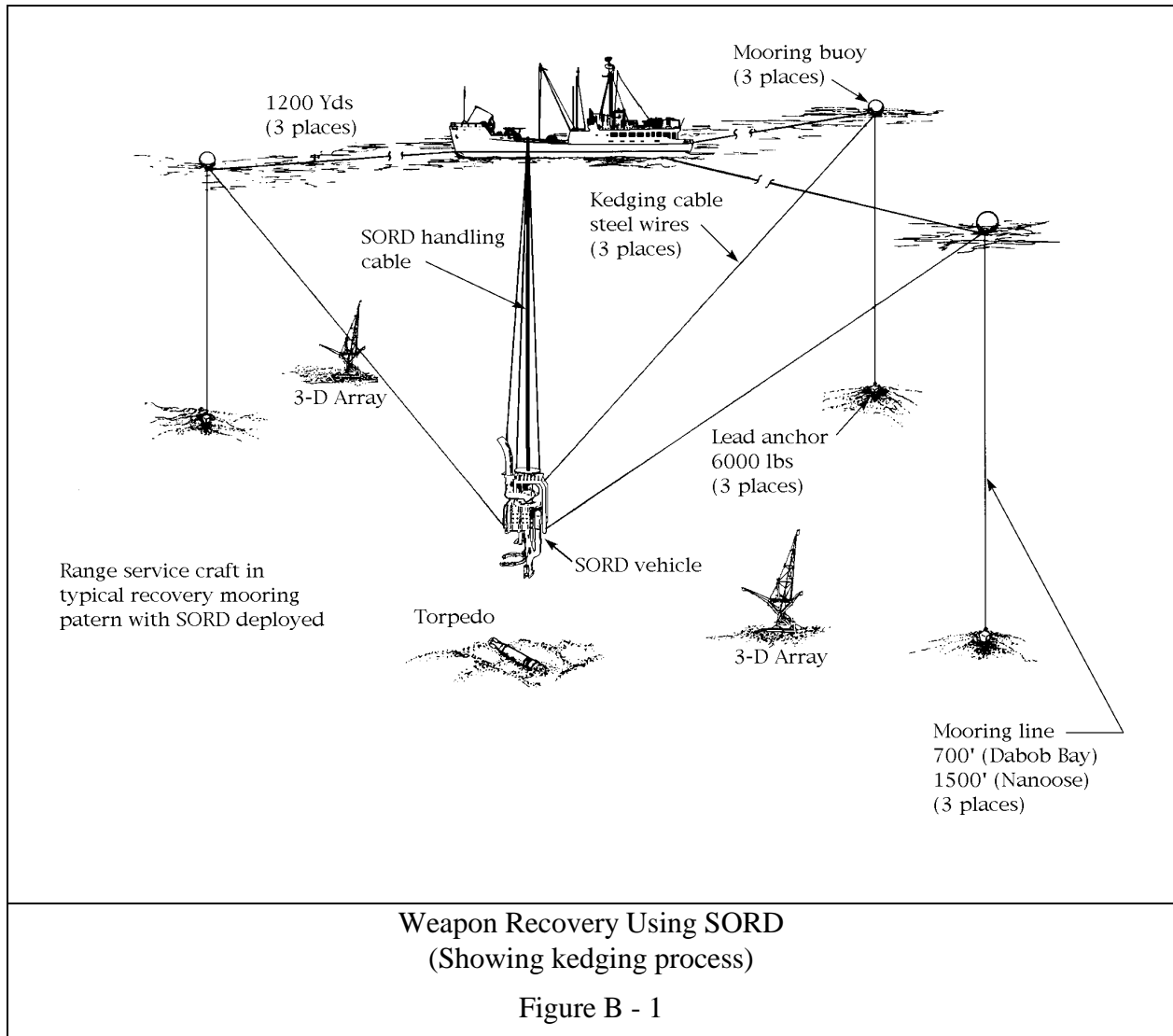

In 1959, the Navy contracted with Vitro Corporation, Silver Springs, Maryland for the design and manufacture of an unmanned submersible apparatus to be used for bottom recovery of torpedoes. This vehicle, called SOLARIS (Submerged Object Locating and Recovery/Inspection System), was delivered in November 1960, and testing began in 1961. As originally delivered SOLARIS was quite unstable. As soon as the claw, located at the very bottom of the vehicle, touched the sea floor or a downed torpedo the vehicle would have a tendency to tip over. This was corrected the next year by removing the two thrusters at the top of the vehicle and replacing them with a kedge wire system. In 1962, the first successful torpedo recovery using SOLARIS was accomplished in Dabob Bay. The original vehicle cost \$145,000 and contained both an underwater television camera and a torpedo recovery claw, both of which were controlled from one of Keyport's range craft, the YF 885. SOLARIS had a lifting capability of 8,000 pounds with its hydraulically operated claw. During its short career it recovered more than 125 torpedoes, principally in Dabob Bay. In 1968 when CURV IIA was installed on the YF 885, SOLARIS was

removed and retired (after having provided Keyport's "recovery" engineers with a most valuable learning experience).

Jacobson Brothers was not too pleased when they learned of the existence of SOLARIS, in fact on 15 March 1962 they filed a law suit against the Navy claiming a patent infringement for the alleged use of their kedging invention on SOLARIS. The Navy contended that the patent was invalid because of a legal term called "obviousness." Was or was not such a maneuvering scheme obvious to a person having ordinary skill in the art of underwater salvage work? The court considered the prior art and determined that the kedging principle had been a part of the prior art since as early as 1934. In the opinion filed on 6 November 1974 the court found in favor of the Navy and dismissed the claim.

Notwithstanding all this legal maneuvering, Jacobson Brothers was under a nearly continuous contract with Keyport for about 17 years following the 1958 recovery. On 18 April 1962 they recovered their first MK 46 torpedo from the bottom of the Nanoose range site. It was considered essential to recover the MK 46 in order to determine what caused the torpedo to sink. In addition they recovered 37 air dropped devices that buried themselves in the bottom of Dabob Bay. And finally, MK 48s were recovered starting in the early 1970s. During their first 10 years of recover work for Keyport, Jacobson Brothers picked up more than 400 units, some buried under 20 feet of bottom mud, representing a weapons savings of several million dollars.

During this time underwater weapon recovery was also provided by a manned submersible. International Hydrodynamics, Vancouver, B.C, was contracted to provide bottom search and recovery services at the Nanoose range site with its PISCES two-man submersible vehicle. Figure B-2 shows three of the PISCES vehicles equipped with torpedo recovery claws. PISCES performed admirably by making four recoveries from the bottom during its first 8-hour dive. This highly maneuverable small submersible was limited to recovering the lightweight MK 44 and MK 46 torpedoes.

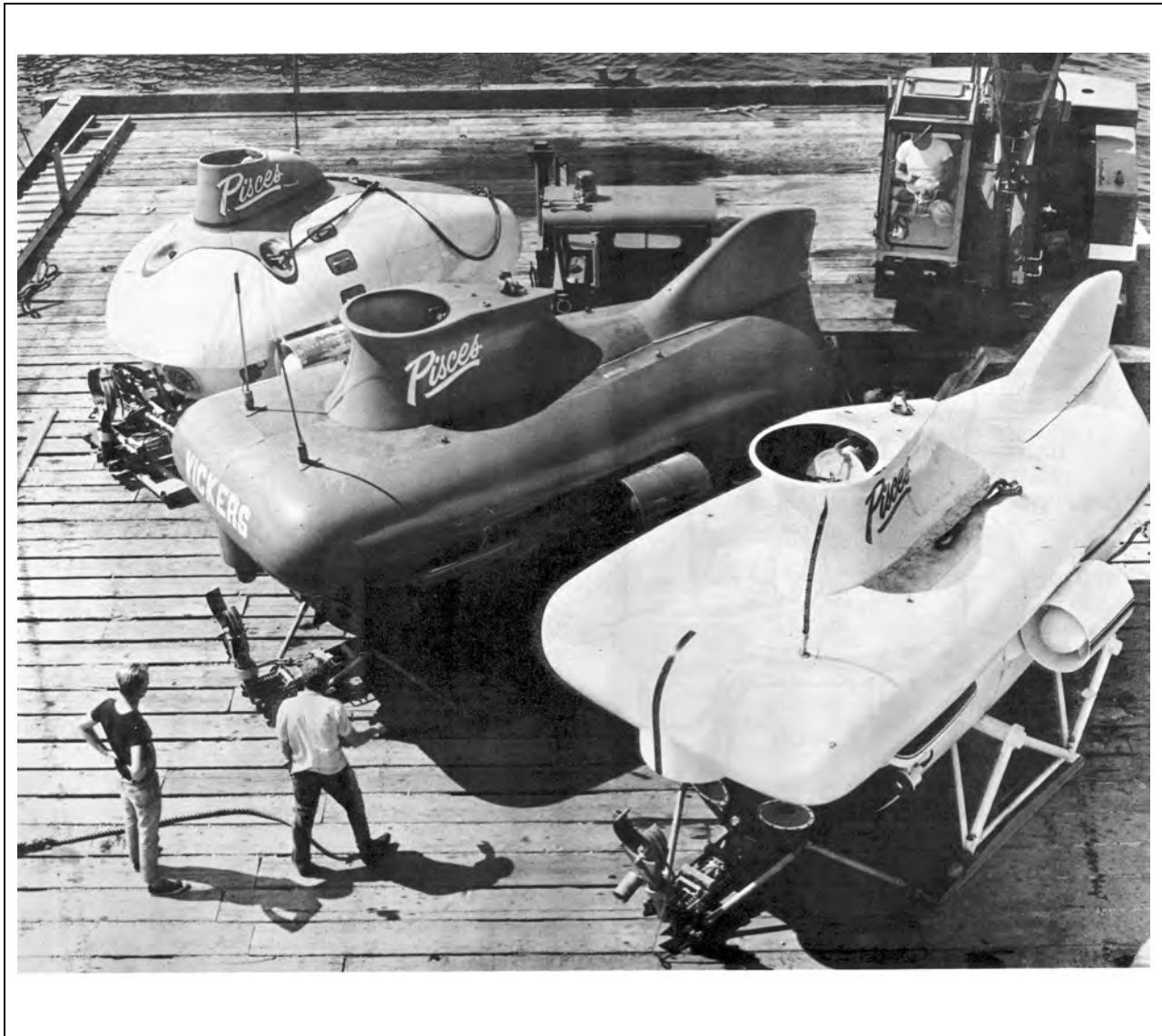

The Pisces Manned Submersible
(Note the torpedo recovery clamps)

Figure B-2

In 1964 a new unmanned, remotely-controlled recovery system, SORD (Submerged Object Recovery Device), was designed and built at Keyport under the direction of Jack Green, then Head of the Design Division, Research and Engineering Department, for recovery operations in the deeper waters of the Nanoose range and at Jervis Inlet. It recovered a torpedo from a depth of 525 feet on its initial test in 1965, and was immediately placed in service for use at both Dabob Bay and Nanoose. However, there was an immediate need for bottom recovery services at AFWTF in St. Croix to recover nine MK 46 torpedoes from a depth of 3,000 feet following exercises in which the torpedoes were set to hit a target submarine. These torpedoes

were tracked during the exercise and on their way to the bottom by the 3-D range, until they reached hull crush depth. SORD was deployed at these final 3-D range positions and recovered all nine torpedoes in June 1966. During 1968 a total of 43 bottom recoveries were accomplished on Keyport's ranges using SORD. One limitation on SORD operations, however, was the requirement that the operating craft be in a firm three point moor with control of SORD being accomplished by the kedge wire system. SORD had the ability to recovery an object weighing up to 10,000 pounds in water depth of 6,500 feet. The original SORD was retained in operation until its replacement by SORD IV. Building upon the success of this recovery concept a second SORD vehicle was designed. This new vehicle, SORD II, was built in 1968 as an improved version of SORD I and served Keyport's recovery needs until its retirement in 1990. SORD II was capable not only of bottom recovery, but, like all the SORD vehicles, it also had an integral wash-out eductor to remove bottom sediment and permit recovery of objects buried as deep as 30 feet. The most recent vehicle of this type, SORD IV, was developed in 1984 and is similar to previous SORD vehicles in many respects, but has an improved bottom silt removal capability. It is able to recover an object buried as deep as 30 feet in water depths to 5000 feet. As in the case of other SORD vehicles, SORD IV requires the supporting surface craft to be in a three-point moor.

Successful recovery of bottomed torpedoes depends upon how well the 3-D tracking range tracks the unit all the way down to the bottom and whether or not the unit contains a "minipinger." This small 45 kHz recovery pinger was designed at Keyport and is installed on all submerged vehicles operating on Keyport ranges. The "minipinger" transmits a pulse every second for up to 90 days to provide the recovery team with an acoustic homing signal.

While SORD was being perfected, other agencies were developing underwater recovery devices as well. In 1968 Keyport received from the Naval Undersea Warfare Center (NUWC), Pasadena, California a remotely operated deep sea submersible vehicle with a 3000 foot operating depth, called CURV IIA (Cable-Controlled Underwater Recovery Vehicle). Although CURV IIA also imposed limitations on the surface vessel operating as a mother craft, these limitations were much less restrictive than those imposed by SORD. A three-point moor was not required, but the support craft had to use its main propulsion system and bow thruster in order to station keep above the vehicle. A set of thrusters mounted on CURV IIA and controlled from the surface vessel (the YF 885) maneuvered the vehicle along the bottom toward the torpedo to be recovered. This vehicle operated until a 1977 update in flotation, frame, and electronics extended its operating depth to 5000 feet (a limitation imposed by the length of its umbilical cable). In 1995 the vehicle underwent a further refurbishment by adding an electro-optic slip ring assembly to transmit the television signal to the surface support ship through the fiber optic conductors in the tether cable.

The next evolution in recovery systems, TROV-N (Tethered Remotely Operated Vehicle - Navy) was procured by Keyport in 1979. Like CURV IIA, TROV-N is a free swimming vehicle, controlled from a supporting surface vessel by a tether. TROV-N does have a small silt eductor for sediment removal, but it is capable of removing only two feet of sediment, mainly to help lessen the need to use the more expensive SORD vehicle. TROV-N has an operating depth of 3000 feet, a hover capability, and is capable of lifting a 10,000 pound load. TROV-N and CURV IIA are now identical in operating characteristics, and have on occasion been used together in complex recoveries. One such operation occurred in the winter of 1980 off Whidbey

Island where the two vehicles were used to recover a downed EA6-B aircraft. While TROV-N was on station a winter storm swept through the area and severely damaged TROV-N. It took two years of work by both the original manufacturer and Keyport to finally get TROV-N operational again.

The newest recovery vehicle, the Triumph Special Purpose Vehicle (SPV), was obtained in 1989 and has both a wash-out capability (similar to TROV-N) and a limited ordnance recovery capability to depths of 3000 feet. With its modular design it can easily be configured to support a variety of special projects

Present Keyport recovery capabilities include:

- Multipurpose manipulators,
- Flyaway capability for rapid response,
- Sonar, video, and still camera capabilities, with pan and tilt features,
- Recovery of objects buried as deep as thirty feet.

Future goals include:

- Higher resolution sonar and other sensor systems,
- Upgrade hydraulics to decrease their interference with acoustic systems,
- Improved turbid condition viewing capabilities,
- Improved over-the-side handling characteristics,
- GPS linked to acoustic tracking of vehicles,
- Incorporate a fiber optic control link to the vehicles.

Appendix C

Time-Line of Torpedo Tracking Range Events at Keyport

Date	Early 1900's	1913	1914	1916	1919-1920	1930	1941
Event							
Security Issue/ Global Situation	Show the flag in the Pacific Ocean following the Spanish-American War.		World War I begins in Europe.	World War I	World War I ends.		World War II begins in the Pacific.
U.S. National Response	Increase U.S. Navy presence in the Pacific Ocean.		Authorize funding for a new torpedo station.				U.S. enters the war.
U.S. Navy Action *	Increase naval activity along U.S. Pacific Coast.		Pacific Coast Torpedo Station established.				Offensive action against Japan.
Impact On Keyport *	Build a torpedo station on the west coast so the Pacific Fleet would no longer have to transport torpedoes to and from Newport, Rhode Island to obtain torpedo services.	USS GOLDSBOROUGH launches the first torpedo down Port Orchard Inlet.	Construct facilities for the storage, modification, repair and testing of torpedoes.	Torpedo testing range laid out in Port Orchard Inlet.	Torpedo tubes installed on a firing float at the end of Pier 1 (at the head of the new range).	Name changed to U.S. Naval Torpedo Station.	Increase torpedo production, torpedo training, and torpedo testing on range.
Type of Torpedo						Torpedoes ranged at Keyport: MK 7, MK 8, MK 9, MK 10.	Torpedo shortages, and initial problems with the MK 14 torpedo and its MK 6 exploder (fuze).

* As related to the task of testing torpedoes on the tracking ranges at Keyport

Date	1944	1944	1944	1945	1947 - 50	1951
Event						
Security Issue/ Global Situation	World War II.	World War II.	World War II.	World War II ends.		Korean War.
U.S. National Response				Nation demobilizes from war effort.		Nation renews military effort.
U.S. Navy Action *		Initial torpedo problems resulted in a need for better testing methods.	An improved torpedo exploder mechanism needed.	Cutbacks in weapons and weapons testing.	Funding cutbacks.	New generation of post-W.W.II acoustic homing torpedoes need testing.
Impact On Keyport *	Delivered 7000 MK 14 torpedoes to the Fleet. Ranging exceeded 100 units per day.	New Acoustic Range installed in Port Orchard Inlet.	APL/UW develops the MK 9 exploder and begins long association with Keyport.	Workforce reduced. New Acoustic Range becomes operational.	Range maintenance discontinued for Acoustic Range. Tracking experiments begin at Dabob Bay and in Hood Canal.	Testing resumes on the Keyport Acoustic Range.
Type of Torpedo	MK 14 torpedo problems resolved by 1943.	Torpedoes ranged at Keyport: MK 13, MK 14, MK 15, MK 18.				A new torpedo arrives on station: The MK 27, and becomes the first acoustic homing torpedo ranged at Keyport.

* As related to the task of testing torpedoes on the tracking ranges at Keyport

Date	1952	1955	1956	1957	1958	1959
Event						
Security Issue/ Global Situation	Korean War.	The Cold War period.		The Cold War continues.		
U.S. National Response		Counter increased Soviet military threat.		Counter increased Soviet submarine threat.		
U.S. Navy Action *		Increase emphasis on Anti-Submarine Warfare (ASW).		Develop a lightweight, low cost, ASW weapon (launched from a helicopter)		
Impact On Keyport *	Three-Dimensional (3-D) acoustic tracking range designed by APL/UW.	Install the APL/UW designed 3-D acoustic tracking array in Hood Canal. Range uses a 250 kHz tracking signal and transponders.	Improvements made to the Keyport Acoustic Range in Port Orchard Inlet.	First 3-D acoustic tracking array installed in Dabob Bay using the 250 kHz tracking signal.	First bottom recovery of a downed torpedo. USS SARGO became the first nuclear powered submarine to test fire a torpedo on Dabob Bay.	Experimental low frequency (75 kHz) array installed in Chatham Strait, Alaska for a brief demonstration of a new low frequency tracking signal. Dabob Bay range switched to synchronous clock pingers instead of transponders.
Type of Torpedo		MK 27 acoustic homing torpedo.	MK 16, MK 27 Mod 4, MK 35.	MK 27 Mod 4, MK 37 Mod 0, MK 39 Mod 1, the first wire guided torpedo, MK 45 Mod 0.	MK 37, MK 44, the second generation of lightweight ASW torpedoes.	MK 37, MK 39, MK 43.

* As related to the task of testing torpedoes on the tracking ranges at Keyport

Date	1963	1965	1970	1972	1979	1981
Event						
Security Issue/ Global Situation						
U.S. National Response						
U.S. Navy Action *						
Impact On Keyport *	Installation begins on a new low frequency (75 kHz) 3-D tracking range at Nanoose in British Columbia, Canada.	New low frequency (75 kHz) tracking arrays installed “over the top” of the existing 250 kHz arrays at Dabob Bay.	Nanoose range expanded to over 40 square miles of tracking area.	Keyport develops the Phase-Shift Keyed (PSK) tracking signal for use at Dabob Bay and Nanoose.	Keyport develops the Spaced Frequency-Shift Keyed (SFSK) tracking signal for shallow water environments.	Shallow water range installed off coast of Washington state in 120 feet of water using new SFSK tracking signal.
Type of Torpedo	A post-war record number of range exercises were conducted this year (over 4000). MK 46, the third generation of lightweight ASW torpedoes.	MK 37, MK 46.	MK 48			MK 50, the fourth generation of lightweight ASW torpedoes. MK 48 ADCAP.

* As related to the task of testing torpedoes on the tracking ranges at Keyport

Date	Early-1990s	Mid-1990s	Late-1990s and beyond
Event			
Security Issue/ Global Situation	The Cold War Ends.	Post Cold War period.	Regional conflicts, terrorists activities and unknown threats.
U.S. National Response	Counter third world threat from small diesel electric submarines.	Defense downsizing.	Enhance current systems and develop new capabilities to meet the challenge.
U.S. Navy Action *	Enhance the MK 50 with a shallow water capability.	Budget restraints. Requirement to transport a range system to any remote exercise location.	Significant increase in specialized weapons testing.
Impact On Keyport *	Develop the Submarine Sensor Tracking (SST) system.	Develop the <i>SWIFT</i> family of range technologies.	Extend existing range capabilities, and develop new range technologies to support weapon tracking in any ocean environment.
Type of Torpedo	MK 50.	MK 48 ADCAP and special purpose vehicles.	MK 54 Lightweight Hybrid Torpedo and Follow-on torpedoes. MK 48 ADCAP MODS

* As related to the task of testing torpedoes on the tracking ranges at Keyport