

Aspire

**easyStore H341/H342
Service Guide**

PRINTED IN TAIWAN

Revision History

Please refer to the table below for the updates made on Aspire easyStore H341/342 service guide.

Date	Chapter	Updates

Copyright

Copyright © 2010 by Acer Incorporated. All rights reserved. No part of this publication may be reproduced, transmitted, transcribed, stored in a retrieval system, or translated into any language or computer language, in any form or by any means, electronic, mechanical, magnetic, optical, chemical, manual or otherwise, without the prior written permission of Acer Incorporated.

Disclaimer

The information in this guide is subject to change without notice.

Acer Incorporated makes no representations or warranties, either expressed or implied, with respect to the contents hereof and specifically disclaims any warranties of merchantability or fitness for any particular purpose. Any Acer Incorporated software described in this manual is sold or licensed "as is". Should the programs prove defective following their purchase, the buyer (and not Acer Incorporated, its distributor, or its dealer) assumes the entire cost of all necessary servicing, repair, and any incidental or consequential damages resulting from any defect in the software.

Acer is a registered trademark of Acer Corporation.

Intel is a registered trademark of Intel Corporation.

Other brand and product names are trademarks and/or registered trademarks of their respective holders.

Conventions

The following conventions are used in this manual:

SCREEN MESSAGES	Denotes actual messages that appear on screen.
NOTE	Gives additional information related to the current topic.
WARNING	Alerts you to any physical risk or system damage that might result from doing or not doing specific actions.
CAUTION	Gives precautionary measures to avoid possible hardware or software problems.
IMPORTANT	Reminds you to do specific actions relevant to the accomplishment of procedures.

Service Guide Coverage

This Service Guide provides you with all technical information relating to the BASIC CONFIGURATION decided for Acer's "global" product offering. To better fit local market requirements and enhance product competitiveness, your regional office MAY have decided to extend the functionality of a machine (e.g. add-on card, modem, or extra memory capability). These LOCALIZED FEATURES will NOT be covered in this generic service guide. In such cases, please contact your regional offices or the responsible personnel/channel to provide you with further technical details.

FRU Information

Please note WHEN ORDERING FRU PARTS, that you should check the most up-to-date information available on your regional web or channel. If, for whatever reason, a part number change is made, it will not be noted in the printed Service Guide. For ACER-AUTHORIZED SERVICE PROVIDERS, your Acer office may have a DIFFERENT part number code to those given in the FRU list of this printed Service Guide. You MUST use the list provided by your regional Acer office to order FRU parts for repair and service of customer machines.

Table of Contents

System Tour	1
Features	1
System Tour	2
Front Panel	2
Rear Panel	3
Internal Components	4
System LED Indicators	5
System Utilities	9
AMI BIOS Setup Utility	9
Entering the BIOS Setup Utility	10
Navigating Through the Setup Utility	11
Setup Utility Menus	12
System Disassembly	19
Disassembly Requirements	19
Pre-disassembly Procedure	20
Main Unit Disassembly	21
Removing the Hard Disk	22
Removing the System Cover	25
Removing the Front Bezel	26
Removing the Front I/O Board	28
Removing the Backplane Board	30
Removing the Power Supply	33
Removing the Fan	36
Removing the Memory Module	37
Removing the Mainboard	39
Removing the HDD Access LED cables	40
System Troubleshooting	41
Hardware Diagnostic Procedure	41
System Check Procedures	42
Power system check	42
System external inspection	42
System internal inspection	42
System Diagnosis	43
Hardware diagnostic program	43
Debug card	44
POST Code Checkpoints	45
Viewing BIOS checkpoints	45
POST code checkpoints list	45
System Status Error Codes	50
BIOS Recovery	51
Clearing CMOS	52
Undetermined Problems	53
System Block Diagram and Board Layout	55
System Block Diagram	55
Board Layout	56
Mainboard	56
System Jumpers	57

FRU (Field Replaceable Unit) List**59**

Exploded Diagram

60

FRU List

62

Technical Specifications**65**

System Tour

Features

Below is a brief summary of the home server's many features:

NOTE: The features listed in this section are for your reference only. The exact configuration of the server depends on the model purchased.

Processor

- ❑ Onboard Intel Atom D410/D510 processor

Chipset

- ❑ Intel 82801IR I/O Controller Hub (ICH 9R) (Southbridge)

Memory subsystem

- ❑ Supports DDR2 unbuffered SDRAM

Media storage

- ❑ Up to four 3.5-inch hot-swappable SATA hard disk drives

Networking

- ❑ One Gigabit Ethernet LAN port (RJ-45)

I/O ports

- ❑ USB 2.0 ports (1 front and 4 rear)
- ❑ Gigabit LAN port
- ❑ eSATA port

Power supply

- ❑ 220-watts (100/240 Vac) Energy Star compliant power supply

Operating system and software

- ❑ Operating system:
 - Windows Home Server
- ❑ Applications
 - Windows Home Server Connector
 - Lights Out Client
 - Software Update
 - Server Recovery
 - PC Recovery

Physical dimensions







- ❑ WxHxD: 200 x 180 x 212 mm
- ❑ Weight (without HDD): 4.5 kg (with 1 HDD): 5.1 kg

System Tour

This section is a virtual tour of the system's interior and exterior components.

Front Panel



No.	Icon	Component
1		Power button/power indicator
2		Network indicator
3		Hard disk drive (HDD) status indicator
4		System status indicator
5		USB backup button/USB backup indicator
6		USB 2.0 port
7		Front door Open the door to access the hot-swappable HDDs.
8		HDD access indicators

Rear Panel



No.	Icon	Component
1	▶◀	Recovery/reset button
2	e SATA	eSATA port
3	⌘	Gigabit Ethernet port
4	USB+	USB ports
5		Power connector
6		Power fan

Internal Components

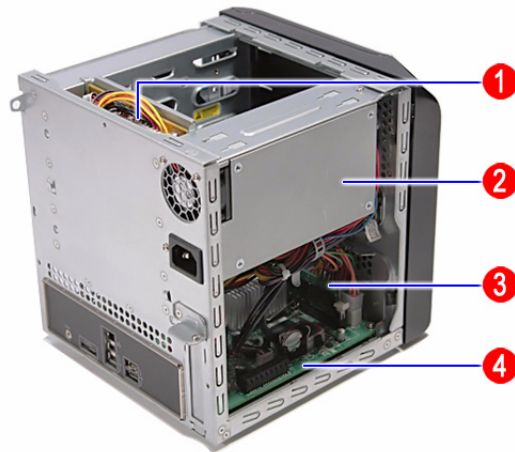



No.	Component
1	Backplane board
2	Power supply
3	Memory module
4	Mainboard



System LED Indicators

Front panel



This section describes the different system LED indicators.

No.	LED indicator	Color	LED status	Description
1		Blue	On	System is connected to the power supply and turned on and ready for use.
			Random blink	<ul style="list-style-type: none"> System is booting System is in S3 sleep state (suspend to memory)
		None	Off	<ul style="list-style-type: none"> System is not powered on System initialize operation in progress
2		Blue	On	Link between system and network
			Random blink	Network access
		None	Off	Network disconnected
3		Purple	On	<ul style="list-style-type: none"> System not initialized HDD is not mounted into the drive bay
			Random blink	<ul style="list-style-type: none"> HDD is mounted into the drive bay and is in the process of being manually added into the server storage HDD is in the process of being removed from the server storage.
		Blue	On	HDD is mounted into the drive bay and added into the server storage
		Red	Random blink	<ul style="list-style-type: none"> HDD failure Windows Home Server cannot find HDD
		None	Off	No HDD mounted in the drive bay

No.	LED indicator	Color	LED status	Description
4	System status 	Blue	Random blink	<ul style="list-style-type: none"> System is booting System is shutting down
			On	System initialize operation completed.
		Blue and purple	Random blink	System is booting from a USB device (Reserved for BIOS update while boot block has been active)
		Red	On	May indicate the following states: <ul style="list-style-type: none"> System failure HDD failure SATA controller failure USB controller failure LAN controller failure Fan failure Memory failure Boot device not found Refer to “System Status Error Codes” on page 50 for more information.
		Random blink	System recovery or reset is in progress	
5	USB device backup 	Blue	On	<ul style="list-style-type: none"> USB storage device is connected to the USB port Backup completed
			Random blink	System is backing up files from a USB storage device
		None	Off	USB storage device unmounted
6	HDD access	Blue	Blink	HDD is in use
		None	Off	No HDD activity

Rear panel



No.	LED indicator	Color	LED status	Description
1	LAN port network speed LED	Amber	On	1000 Mbps network access
		Green	On	100 Mbps link network access
		None	Off	10 Mbps link network access
2	LAN port activity LED	Green	On	Active network link
			Random blink	Transmit or receive activity
		None	Off	No network connection

System Utilities

AMI BIOS Setup Utility

BIOS setup is a hardware configuration program built into the system's Basic Input/Output System (BIOS). Since most systems are already properly configured and optimized, there is no need to run this utility. You will need to run this utility under the following conditions.

- When changing the system configuration settings
- When redefining the communication ports to prevent any conflicts
- When modifying the power management configuration
- When changing the password or making other changes to the security setup
- When a configuration error is detected by the system and you are prompted ("Run Setup" message) to make changes to the BIOS setup

NOTE: If you repeatedly receive Run Setup messages, the battery may be bad. In this case, the system cannot retain configuration values in CMOS. Ask a qualified technician for assistance.

BIOS setup loads the configuration values in a battery-backed nonvolatile memory called CMOS RAM. This memory area is not part of the system RAM which allows configuration data to be retained when power is turned off.

Before you run the AMI BIOS Setup Utility, make sure that you have saved all open files. The system reboots immediately after you close the Setup.

NOTE: AMI BIOS Setup Utility will be simply referred to as "Setup" or "Setup utility" in this guide.

The screenshots used in this guide display default system values. These values may not be the same those found in your system.

Entering the BIOS Setup Utility

Before you begin, prepare the following:

- Wrist grounding strap and conductive mat for preventing electrostatic discharge
- Philips screwdriver
- Debug card - Refer to page 44 for details about the debug card.
- Debug card cable

1. Turn off the computer and all attached devices.
2. Remove the cover. See “Removing the System Cover” on page 25.
3. Connect the debug card cable to the debug card cable connector on the mainboard.

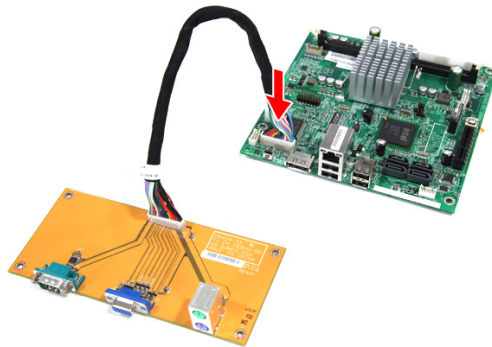

4. Locate the JP1 Debug/User mode jumper on the mainboard.

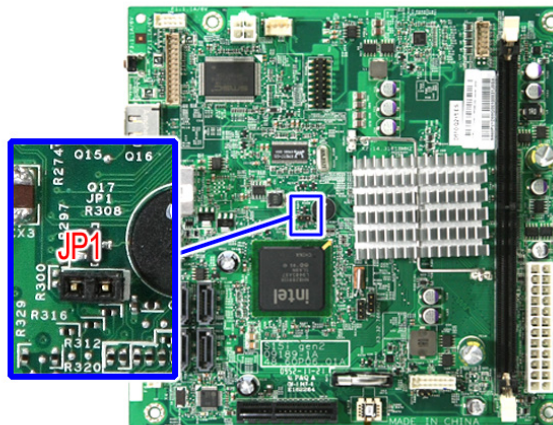

5. Close the jumper to enable system for debug mode.
6. Connect the power cable to the rear panel.
7. Connect a PS/2 keyboard to the PS/2 keyboard port on the debug card.
8. Connect a monitor to the VGA port on the debug card.
9. Restart the system.
10. Turn on the monitor.
11. During POST, press <Delete>.

If you fail to press <Delete> before POST is completed, you will need to restart the system.

When the Setup Utility screen displays, use the left and right arrow keys to move through the menus.

Navigating Through the Setup Utility

Use the following keys to move around the Setup utility.

- Left** and **Right** arrow keys – Move between selections on the menu bar.
- Up** and **Down** arrow keys – Move the cursor to the field you want.
- Pg Up** and **Pg Dn** keys – Move the cursor to the previous and next page of a multiple page menu.
- Home** – Move the cursor to the first page of a multiple page menu.
- End** – Move the cursor to the last page of a multiple page menu.
- +** and **-** keys – Select a value for the currently selected field (only if it is user-configurable). Press these keys repeatedly to display each possible entry, or the **Enter** key to choose from a pop-up menu.

NOTE: Grayed-out fields are not user-configurable.

- Enter** key – Display a submenu screen.

NOTE: Availability of submenu screen is indicated by a (>).

- Esc** – If you press this key:
 - On one of the primary menu screens, the Exit menu displays.
 - On a submenu screen, the previous screen displays.
 - When you are making selections from a pop-up menu, closes the pop-up without making a selection.
- F1** – Display the BIOS setup General Help panel.
- F2** or **F3** – Press to change setup menu colors.
- F7** – Press to discard changes.
- F9** – Press to load optimized default system values.
- F10** – Save changes made the Setup and close the utility.

Setup Utility Menus

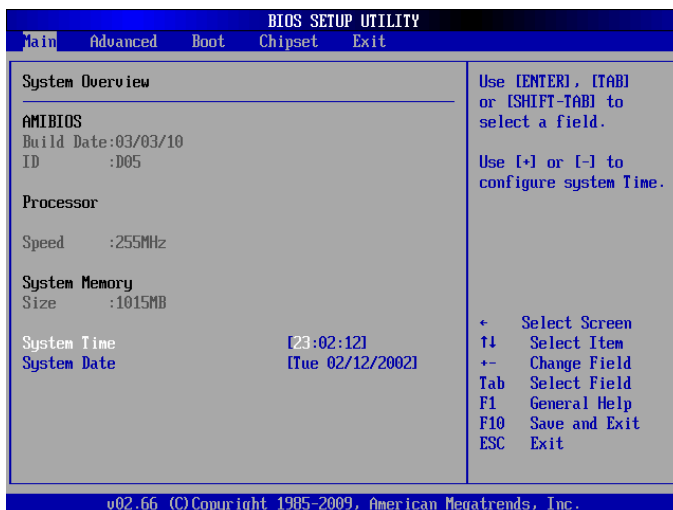

The Setup Main menu includes the following main setup categories.

- Main
- Advanced
- Boot
- Chipset
- Exit

In the descriptive table following each of the menu screenshots, settings in **boldface** are the default and suggested settings.

Main

The Main menu displays basic information about the system and lets you set the system date and time.

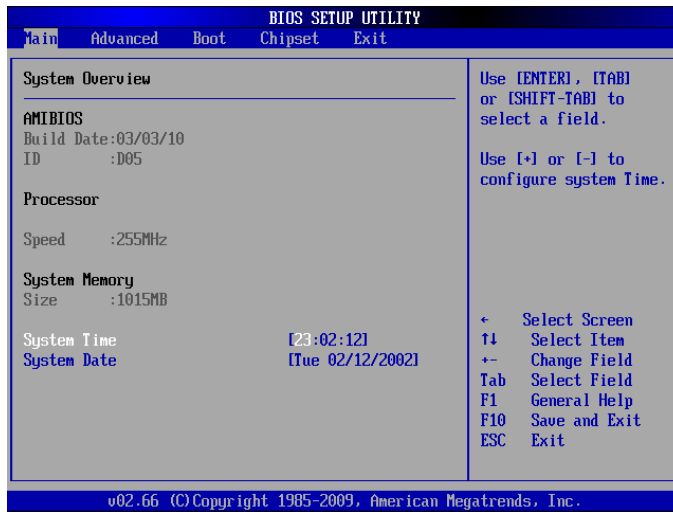

Parameter	Description
AMIBIOS Build Date ID	Version number of the BIOS Setup Utility. Date when the BIOS Setup Utility was created.
Processor Speed	Displays the processor speed in MHz.
System Memory	Total size of system memory detected during POST.
System Time	Set the system time following the hour-minute-second format.
System Date	Set the date following the month-day-year format.

Advanced

The Advanced menu display submenu options for configuring the function of various hardware components. Select a submenu item, then press <Enter> to access the related submenu screen.



Parameter	Description
IDE Configuration	Press <Enter> to select options for the IDE Configuration settings.
Hardware Health Configuration	Press <Enter> to select options for the Hardware Health Configuration.
ACPI Configuration	Press <Enter> to select options for ACPI Configuration settings.
AHCI Configuration	Press <Enter> to select options for AHCI Configuration settings.

Boot

Use the Boot menu to specify the boot sequence from available devices. Select a submenu item, then press <Enter> to access the related submenu screen.



Chipset

Use the Chipset menu to configure the south bridge chipset. Select the submenu item, then press <Enter> to access the submenu screen.



Parameter	Description
South Bridge Configuration	Press <Enter> to select options for the South Bridge Configuration settings.

Exit

The Exit menu lists options for quitting the Setup Utility. Highlight any of the exit options, then press <Enter>.

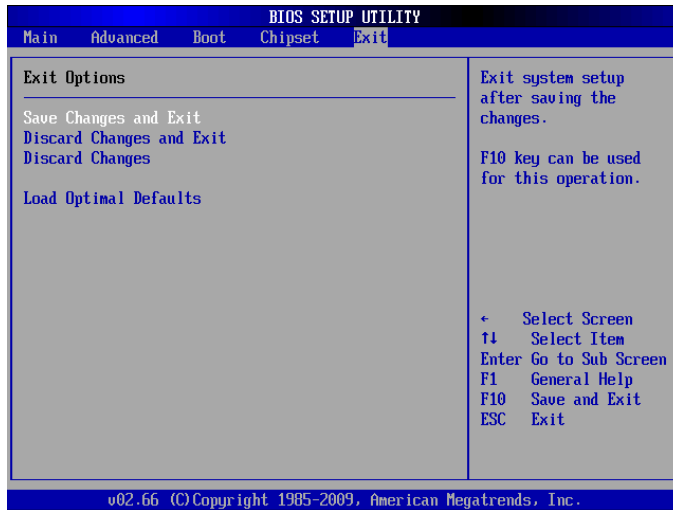

Parameter	Description
Save Changes and Exit	Saves changes made and closes the utility. Keyboard shortcut: F10
Discard Changes and Exit	Discards changes made and closes the utility.
Discard Changes	Discards all changes made to the utility and load previous configuration settings.
Load Optimal Defaults	Loads the factory default settings for all setup parameters. Keyboard shortcut: F9 Setup Defaults are quite demanding in terms of resources consumption. If you are using low-speed memory chips or other kinds of low-performance components and you choose to load these settings, the system might not function properly.

System Disassembly

This chapter contains step-by-step procedures on how to disassemble the desktop computer for maintenance and troubleshooting.

Disassembly Requirements

To disassemble the computer, you need the following tools:

- Wrist grounding strap and conductive mat for preventing electrostatic discharge
- Flat-blade screwdriver
- Philips screwdriver
- Hex screwdriver
- Plastic flat-blade screwdriver
- Plastic tweezers

NOTE: The screws for the different components vary in size. During the disassembly process, group the screws with the corresponding components to avoid mismatch when putting back the components.

Pre-disassembly Procedure

Before proceeding with the disassembly procedure, perform the steps listed below:

1. Turn off the system and all the peripherals connected to it.
2. Unplug the power cord from the power outlets.
3. Unplug the power cord from the system.
4. Unplug all peripheral cables from the system.
5. Place the system unit on a flat, stable surface.

Main Unit Disassembly

MAIN UNIT DISASSEMBLY

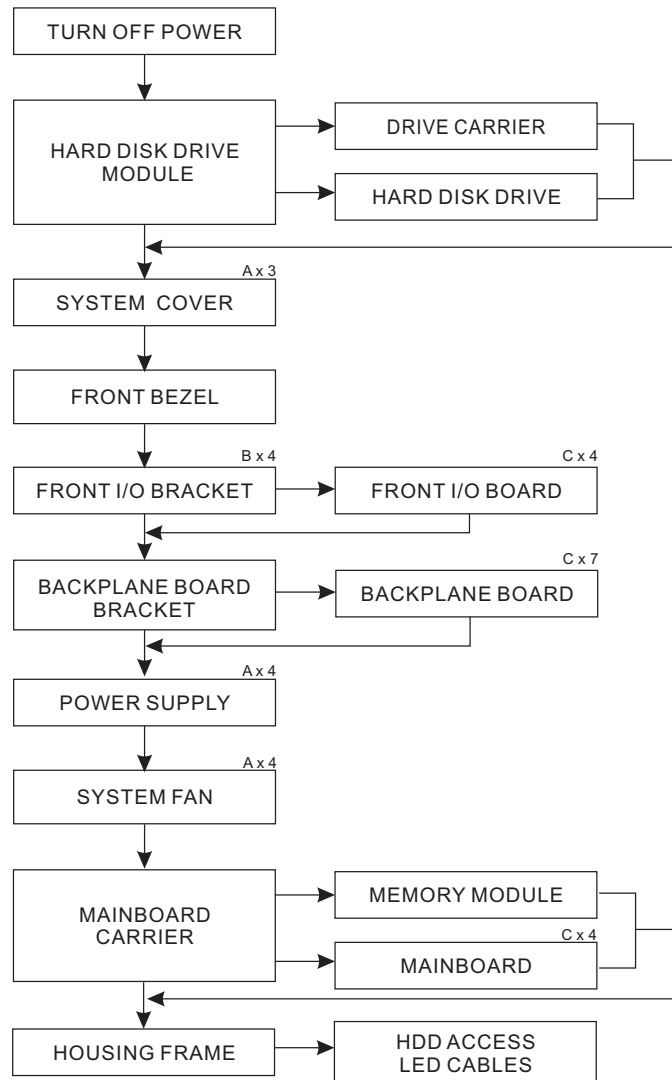

Screw List

Code	Screw	Part No.
A	M3-0.5*4	86.1A524.4R0
B	M3*6L	86.VA524.6R0
C	M3*0.5*4L	86.19534.4R0

Removing the Hard Disk

1. Open the front panel.



2. Press to release the hard drive carrier handle.



3. Flex the carrier handle.



4. Slide the hard drive carrier out of the HDD bay.



-
5. Remove the carrier by gently prying open the left rail of the carrier (1) and lift the hard disk off the carrier (2) .

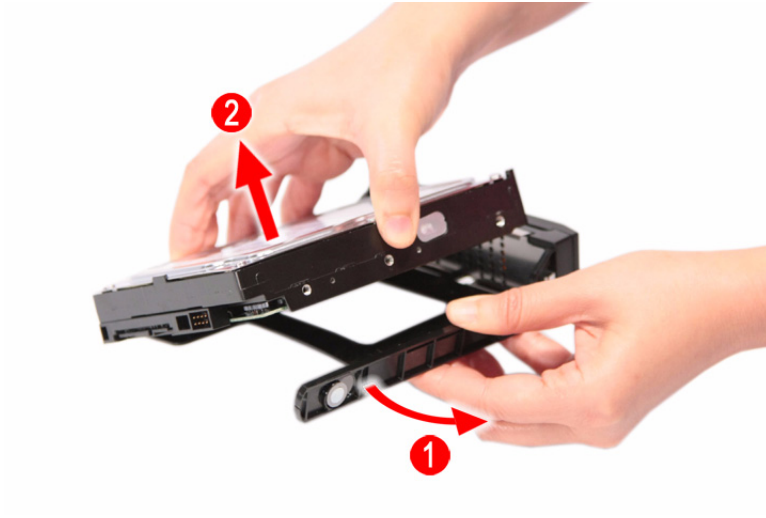

Removing the System Cover

1. Perform the pre-disassembly procedure described on page 20.
2. Remove the three screws (A) that secure system cover.



Screw (Quantity)	Color	Torque	Part No.
M3-0.5*4 (3)	Silver	5.1 to 6.9 kgf-cm	86.1A524.4R0

3. Slide the system cover toward the back of the chassis until the tabs on the cover disengage with the slots on the chassis.
4. Lift the side panel away from the server and put it aside for reinstallation later.

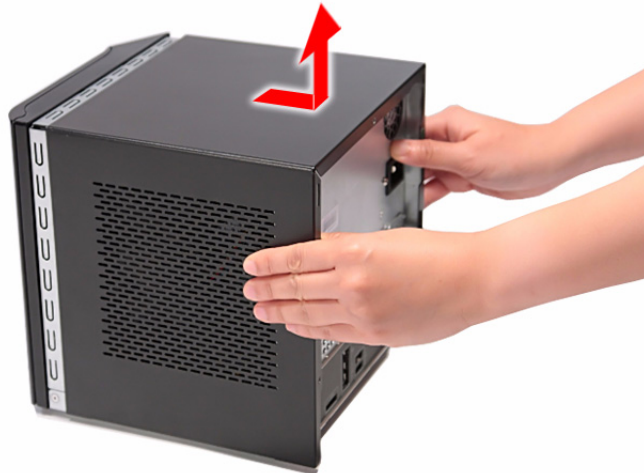

Removing the Front Bezel

1. Remove the system cover. Refer to the previous section for instructions.
2. Release the front bezel retention tabs from the chassis interior.

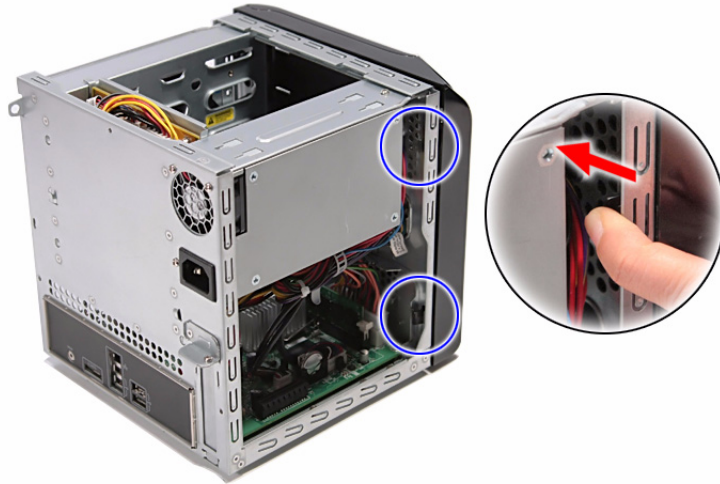

3. Pull the bezel slightly outward, then disconnect the front I/O board cable.

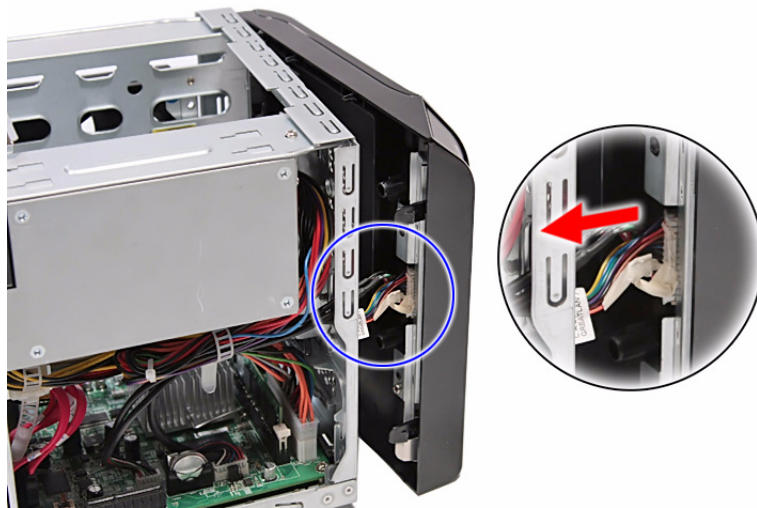

-
4. Pull the bezel away from the chassis.

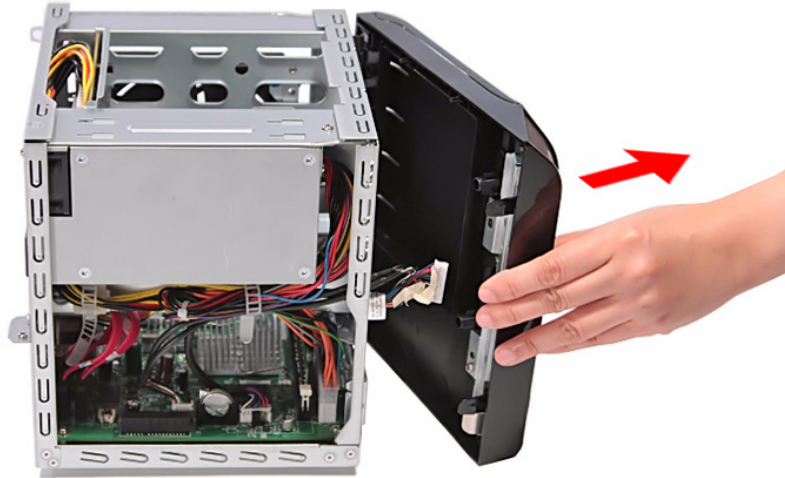

Removing the Front I/O Board

1. See “Removing the System Cover” on page 25.
2. See “Removing the Front Bezel” on page 26.
3. Remove the four screws (**B**) that secures the front I/O bracket.

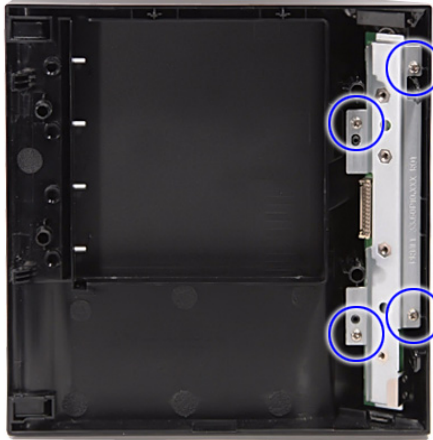

Screw (Quantity)	Color	Torque	Part No.
M3*6L (4)	Silver	5.1 to 6.9 kgf-cm	86.VA524.6R0

4. Remove the bracket.



5. Remove the four screws (C) that secure the front I/O board.



Screw (Quantity)	Color	Torque	Part No.
M3*0.5*4L (4)	Silver	5.1 to 6.9 kgf-cm	86.19534.4R0

6. Remove the front I/O board.

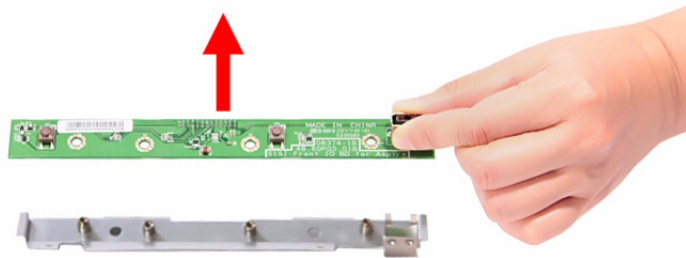

Removing the Backplane Board

1. See “Removing the Hard Disk” on page 22.
2. See “Removing the System Cover” on page 25.
3. Disconnect the fan (1), LED (2), and power (3) cables from their backplane board connectors.

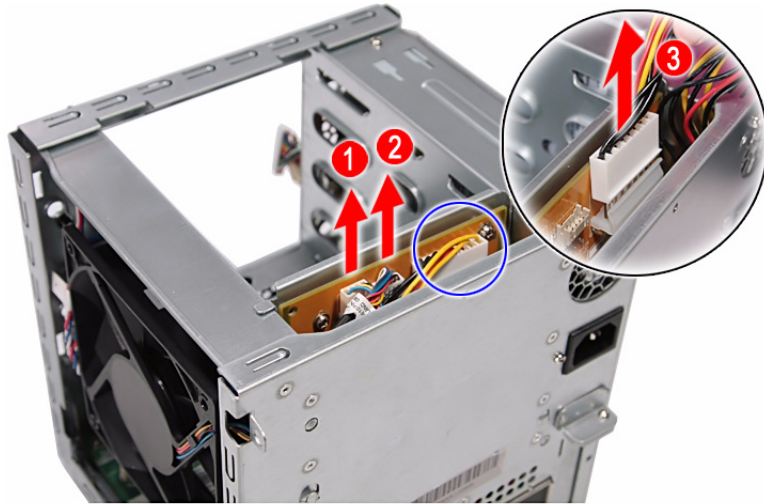

4. Disconnect the four HDD SATA cables from their mainboard connectors.

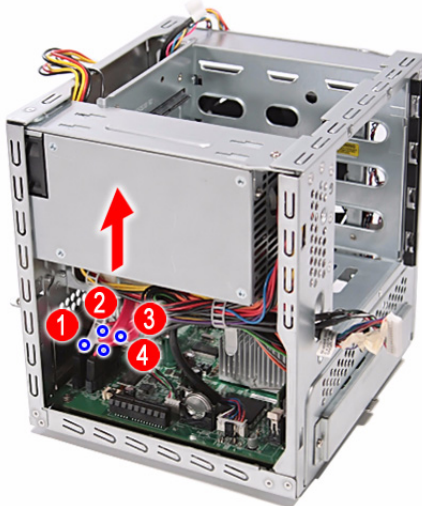

5. Pull the backplane board bracket out of the chassis.

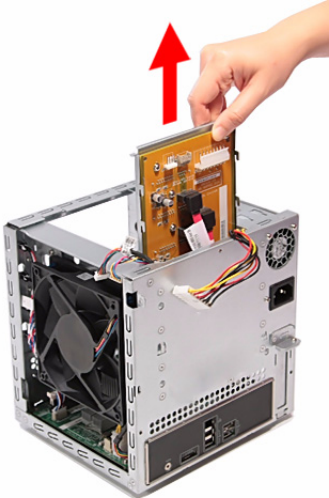

6. Detach the four HDD SATA cables from their backplane board connectors.

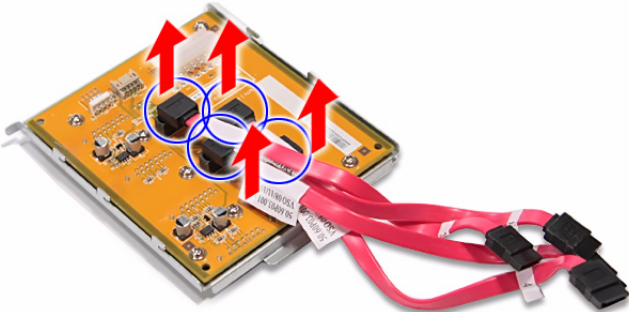

7. Remove the seven screws (C) that secure the backplane board.

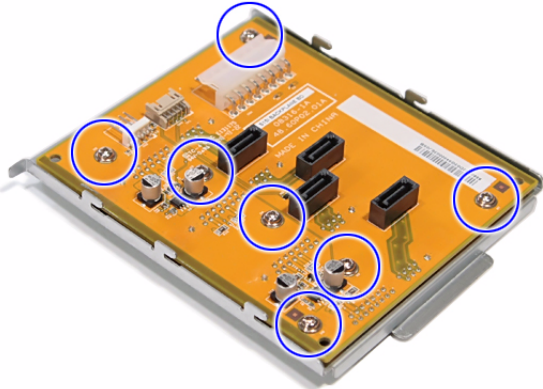

Screw (Quantity)	Color	Torque	Part No.
M3*0.5*4L (7)	Silver	5.1 to 6.9 kgf-cm	86.19534.4R0

8. Lift the backplane board off the bracket.

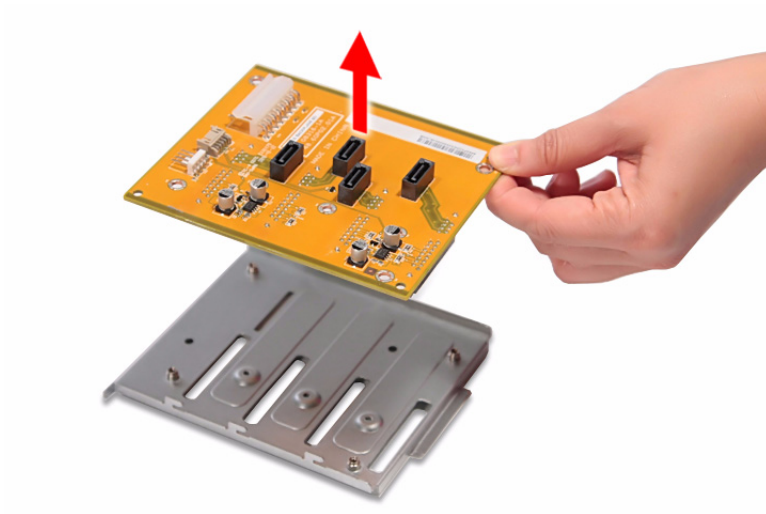

Removing the Power Supply

1. See “Removing the Hard Disk” on page 22.
2. See “Removing the System Cover” on page 25.
3. See “Removing the Backplane Board” on page 30.
4. Release the power cables from the cable ties, as shown.

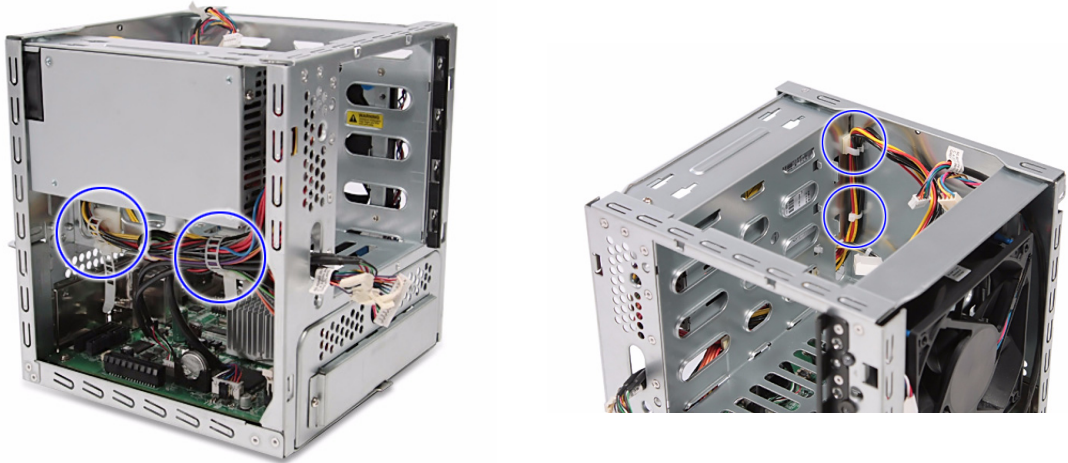

5. Disconnect the 4-pin power cable from its mainboard connector.

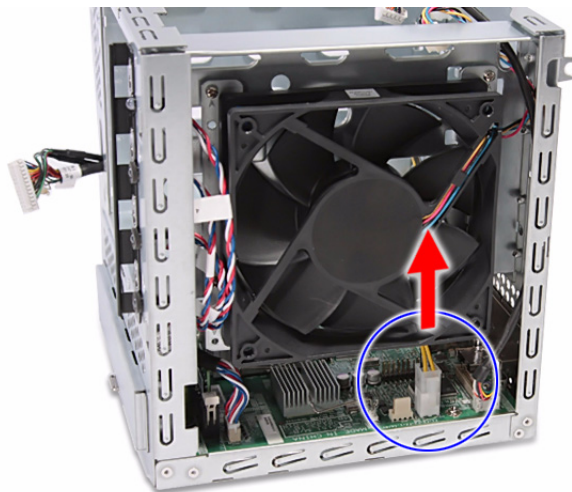

6. Remove the four screws (A) that secure the power supply.



Screw (Quantity)	Color	Torque	Part No.
M3-0.5*4 (4)	Silver	5.1 to 6.9 kgf-cm	86.1A524.4R0

7. With the thumb in the thumb hole, press the tab to release the mainboard carrier from the chassis.

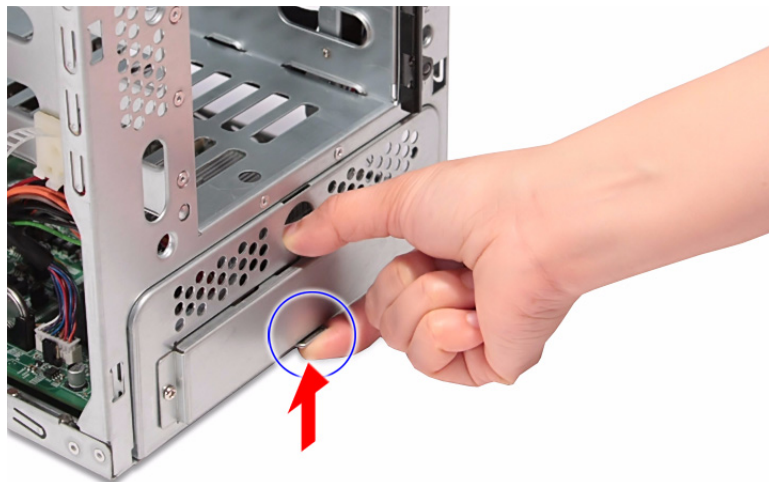

- Slide the mainboard carrier out slightly, until you have access to the power cable.

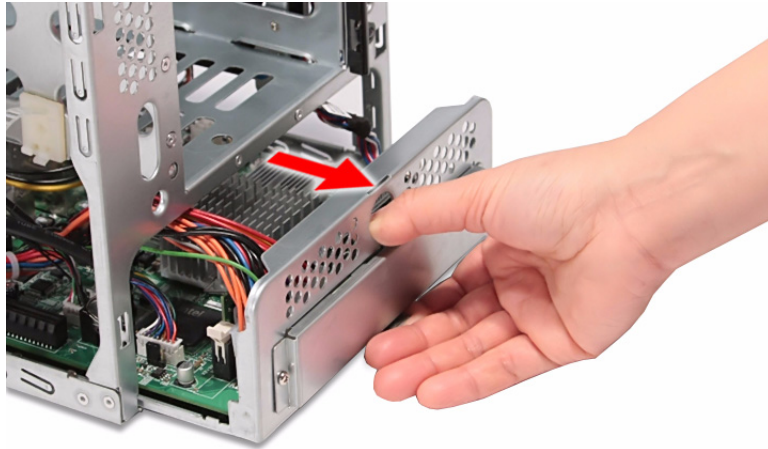

- While pressing the tab on the 24-pin power cable, pull the cable off the mainboard connector.

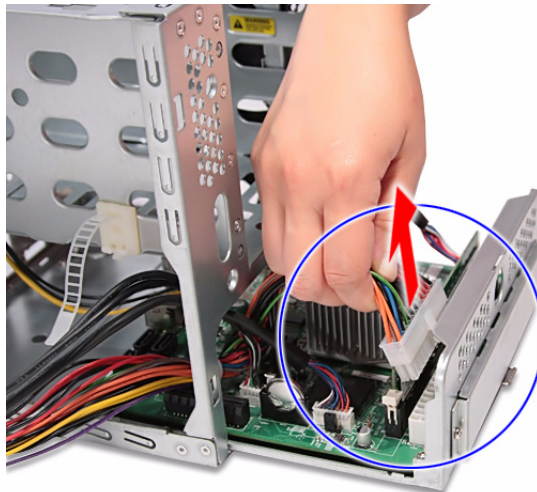

- Pull the power supply out of the chassis.



Removing the Fan

1. See “Removing the Hard Disk” on page 22.
2. See “Removing the System Cover” on page 25.
3. See “Removing the Backplane Board” on page 30.
4. Remove the four screws (A) that secure the fan.

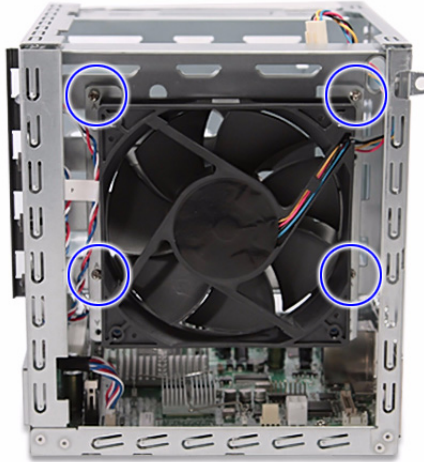

Screw (Quantity)	Color	Torque	Part No.
M3-0.5*4 (3)	Silver	5.1 to 6.9 kgf-cm	86.1A524.4R0

5. Remove the fan.



Removing the Memory Module

1. See “Removing the Hard Disk” on page 22.
2. See “Removing the System Cover” on page 25.
3. See “Removing the Front Bezel” on page 26.
4. See “Removing the Backplane Board” on page 30.
5. See “Removing the Power Supply” on page 33.
6. See “Removing the Fan” on page 36.
7. Disconnect the HDD access LED cable from its mainboard connector.

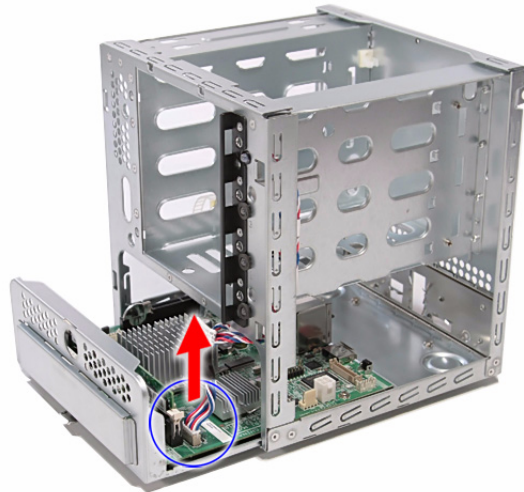

8. Pull the mainboard carrier out of the chassis.



-
9. Press the holding clips on both sides of the DIMM slot outward to release the DIMM (1).
 10. Gently pull the DIMM upward to remove it from the DIMM slot (2).

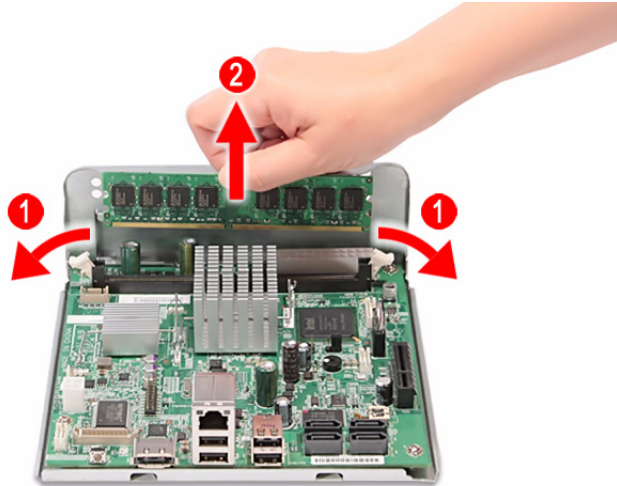

Removing the Mainboard

1. See “Removing the Hard Disk” on page 22.
2. See “Removing the System Cover” on page 25.
3. See “Removing the Front Bezel” on page 26.
4. See “Removing the Backplane Board” on page 30.
5. See “Removing the Power Supply” on page 33.
6. See “Removing the Fan” on page 36.
7. Remove the four screws (C) that secure the mainboard.

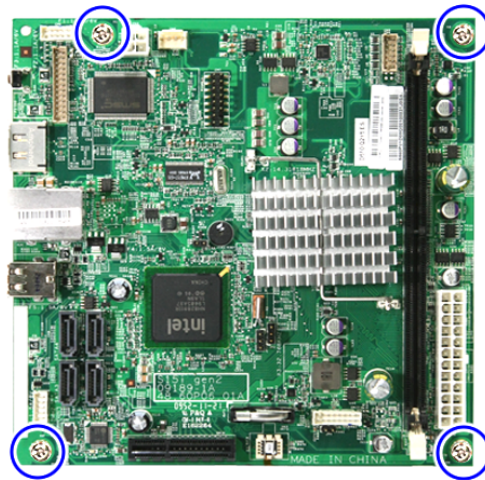

Screw (Quantity)	Color	Torque	Part No.
M3*0.5*4L (4)	Silver	5.1 to 6.9 kgf-cm	86.19534.4R0

8. Lift the mainboard off the mainboard carrier.

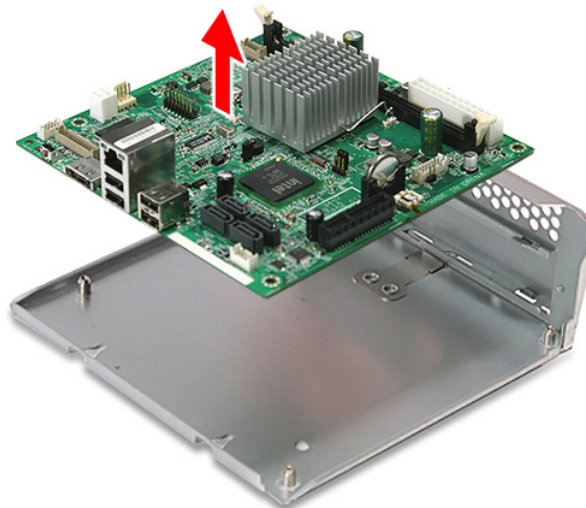

Removing the HDD Access LED cables

1. See “Removing the Hard Disk” on page 22.
2. See “Removing the System Cover” on page 25.
3. See “Removing the Front Bezel” on page 26.
4. See “Removing the Backplane Board” on page 30.
5. See “Removing the Power Supply” on page 33.
6. See “Removing the Fan” on page 36.
7. See “Removing the Mainboard” on page 39.
8. Press the release tabs on the HDD access LED cables, then detach the cables.

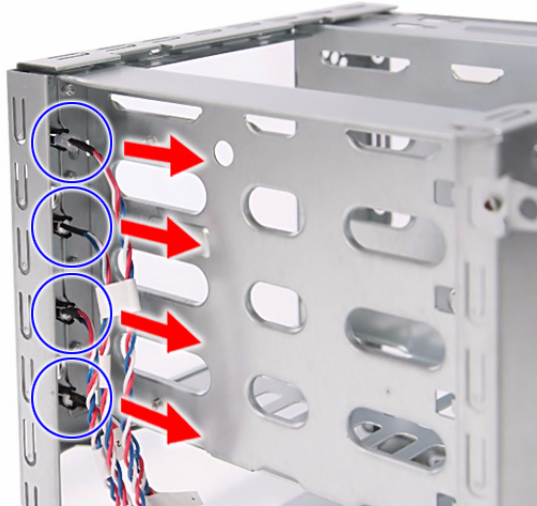

System Troubleshooting

This chapter provides instructions on how to troubleshoot system hardware problems.

Hardware Diagnostic Procedure

The system's diagnostic function monitors system activity and performs

IMPORTANT: The diagnostic tests described in this chapter are only intended to test Acer products. Non-Acer products, prototype cards, or modified options can give false errors and invalid system responses.

1. Obtain the failing symptoms in as much detail as possible.
2. Verify the symptoms by attempting to recreate the failure by running the diagnostic tests or repeating the same operation. Refer to the "System Diagnosis" on page 43 for more information.
3. Refer to the table below to determine which corrective action to perform.
 - System Check Procedures
 - System Diagnosis
 - Checkpoints
 - Undertermined Problems

System Check Procedures

Power system check

If the system will power on, skip this section. Refer to System External Inspection.

If the system will not power on, check if the power cable is properly connected to the system and AC source.

System external inspection

1. Inspect the LED indicators on the front panel, which can indicate the malfunction. For the LED locations and description of their behaviour, see “System LED Indicators” on page 5.
2. Make sure that air flow is not blocked.
3. Make sure nothing in the system is making contact that could short out power.
4. If the problem is not evident, continue with System Internal Inspection.

System internal inspection

1. Turn off the system and all the peripherals connected to it.
2. Unplug the power cord from the power outlets.
3. Unplug the power cord from the system.
4. Unplug all peripheral cables from the system.
5. Place the system unit on a flat, stable surface.
6. Remove the system cover. For instructions on removing system cover, refer to “Removing the System Cover” on page 25.
7. Verify that components are properly seated.
8. Verify that all cable connectors inside the system are firmly and correctly attached to their appropriate connectors.
9. Verify that all components are Acer-qualified and supported.
10. Replace the system cover.
11. Power on the system.
12. If the problem with the system is not evident, you can try viewing the POST messages and BIOS event logs during the system startup.

System Diagnosis

Hardware diagnostic program

The purpose of the hardware diagnostic program is to check hardware problems. It executes simple tests of each hardware component to make sure the hardware is not the source of the problem. If hardware problems, such as a fan, LED board, hard disk drive, memory; are confirmed, the diagnostic program can detect the specific component causing the problem. The program needs to be saved in a bootable USB device.

To run the diagnostic program:

1. Turn off the system.
2. Prepare a bootable USB device by copying or downloading the “**ANNIE.GHO**” diagnostic utility to the USB device. The diagnostic utility may be obtained from the CD that came with the system.
3. Plug the bootable USB device to any USB port on the rear of the system.
4. Power on the system. The system status indicator blinks blue.
5. Immediately press and release the Recovery/reset button with the paper clip end. The system status indicator blinks red and immediately starts the diagnostic process:
 - a. Onboard memory flash check
 - b. HDD account check
 - c. Memory size check (1024 or 2048 MB)
 - d. Fan speed check
 - e. CPU temperature check
 - f. MB voltage check
 - g. Backplane board temperature check
 - h. PQAF system test
 - i. PQAF memory test
 - j. PQAF HDD test
 - k. Read SN from DMI data check
 - l. End test

During the diagnostic process, the result of the test displays on the HDD status indicators. The indicator(s) blinks blue when the system has passed each diagnostic test and blinks red when an error condition occurs. After the system has completed the diagnostic procedure the HDD status indicators light purple.

Test Items	HDD LED status (normal)				HDD LED status (failed)			
	HDD 0	HDD 1	HDD 2	HDD 3	HDD 0	HDD 1	HDD 2	HDD 3
Onboard memory flash check	Blue				Red			
HDD account check		Blue						
Memory size check	Blue	Blue			Red	Red		
Fan speed check			Blue				Red	
CPU temperature check	Blue		Blue		Red		Red	
MB voltage check		Blue	Blue			Red	Red	

Test Items	HDD LED status (normal)				HDD LED status (failed)			
Boot from USB disk	HDD 0	HDD 1	HDD 2	HDD 3	HDD 0	HDD 1	HDD 2	HDD 3
Backplane board temperature check	Blue	Blue	Blue	White	Red	Red	Red	White
PQAF system test	White	White	White	Blue	White	White	White	Red
PQAF memory test	Blue	White	White	Blue	Red	White	White	Red
PQAF HDD test	White	Blue	White	Blue	White	Red	White	Red
Read SN from DMI data check	Blue	Blue	White	Blue	Red	Red	White	Red
End test	Purple	Purple	Purple	Purple	White	White	White	White

- After the diagnostic routine is completed, the HDD status indicator lights purple indicating the system has passed all diagnostic tests.
- A copy of the test result will be saved as a log file (i.e., 66380AC3.LOG) and stored in the Results folder. The name of the log file is based on the last 8 bytes of the serial number

Debug card

The debug card is a diagnostic tool for technicians to configure the system BIOS settings and conveniently troubleshoot various problems. This card can help you track the progress of a Power-On Self Test (POST) and discover the cause of errors during system operations. The debug card connects to the system via its debug card cable connector. It includes a VGA port for connecting an external monitor to view BIOS output checkpoints. The debug card also provides a PS/2 mouse port, PS/2 keyboard port and a serial port.

Identifying the components

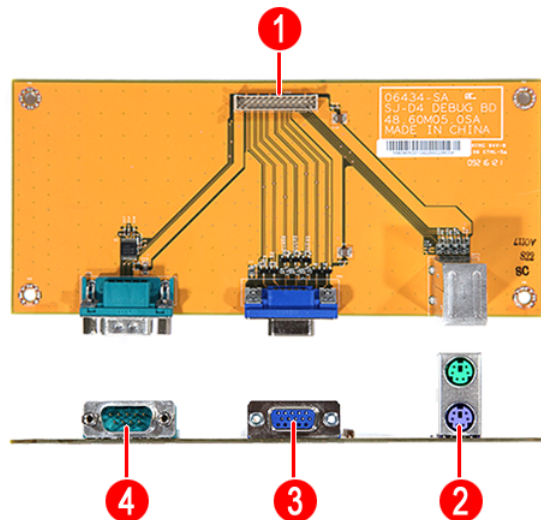

No.	Component
1	Debug card cable connector
2	PS/2 mouse and keyboard port
3	VGA/monitor port
4	Serial port

For more information on how to connect the debug card to the system, refer to “Entering the BIOS Setup Utility” on page 10.

POST Code Checkpoints

The Power-On Self Test (POST) is a BIOS procedure that boots the system, initializes and diagnoses the system components, and controls the operation of the power-on password option. If POST discovers errors in system operations at power-on, it displays error messages, generates a checkpoint code at port 80h or even halts the system if the error is fatal.

The main components on the system board that must be diagnosed and/or initialized by POST to ensure system functionality are as follows:

- Microprocessor with built-in numeric coprocessor and cache memory subsystem
- Direct memory access (DMA) controller (8237 module)
- Interrupt system (8259 module)
- Three programmable timers (system timer and 8254 module)
- ROM subsystem
- RAM subsystem
- CMOS RAM subsystem and real time clock/calendar with battery backup

When POST executes a task, it uses a series of preset numbers called checkpoints to be latched at port 80h, indicating the stages it is currently running. This latch can be read and shown on an external monitor connected to the debug card.

Viewing BIOS checkpoints

Viewing all checkpoints generated by the BIOS requires a debug card and an external monitor. Checkpoints may appear on the bottom right corner of the screen during POST.

POST code checkpoints list

Bootblock initialization code checkpoint

The following table describes the Award common tasks carried out by POST. An unique checkpoint number denotes each task. .

Checkpoint	Description
Before D1	Early chipset initialization is done. Early super I/O initialization is done including RTC and keyboard controller. NMI is disabled.
D1	Perform keyboard controller BAT test. Check if waking up from power management suspend state. Save power-on CPUID value in scratch CMOS.
D0	Go to flat mode with 4GB limit and GA20 enabled. Verify the bootblock checksum.
D2	Disable CACHE before memory detection. Execute full memory sizing module. Verify that flat mode is enabled.
D3	If memory sizing module not executed, start memory refresh and do memory sizing in Bootblock code. Do additional chipset initialization. Re-enable CACHE. Verify that flat mode is enabled.
D4	Test base 512KB memory. Adjust policies and cache first 8MB. Set stack.
D5	Bootblock code is copied from ROM to lower system memory and control is given to it. BIOS now executes out of RAM.
D6	Both key sequence and OEM specific method is checked to determine if BIOS recovery is forced. Main BIOS checksum is tested. If BIOS recovery is necessary, control flows to checkpoint E0. See Bootblock Recovery Code Checkpoints section of document for more information.

Checkpoint	Description
D7	Restore CPUID value back into register. The Bootblock-Runtime interface module is moved to system memory and control is given to it. Determine whether to execute serial flash.
D8	The Runtime module is uncompressed into memory. CPUID information is stored in memory.
D9	Store the Uncompressed pointer for future use in PMM. Copying Main BIOS into memory. Leaves all RAM below 1MB Read-Write including E000 and F000 shadow areas but closing SMRAM.
DA	Restore CPUID value back into register. Give control to BIOS POST (ExecutePOSTKernel). See POST Code Checkpoints section of document for more information.

Bootblock recovery code checkpoints

The Bootblock recovery code gets control when the BIOS determines that a BIOS recovery needs to occur because the user has forced the update or the BIOS checksum is corrupt. The following table describes the type of checkpoints that may occur during the Bootblock recovery portion of the BIOS:

Checkpoint	Description
E0	Initialize the floppy controller in the super I/O. Some interrupt vectors are initialized. DMA controller is initialized. 8259 interrupt controller is initialized. L1 cache is enabled.
E9	Set up floppy controller and data. Attempt to read from floppy.
EA	Enable ATAPI hardware. Attempt to read from ARMD and ATAPI CDROM.
EB	Disable ATAPI hardware. Jump back to checkpoint E9.
EF	Read error occurred on media. Jump back to checkpoint EB.
E9 no EA	Determine information about root directory of recovery media.
F0	Search for pre-defined recovery file name in root directory.
F1	Recovery file not found.
F2	Start reading FAT table and analyze FAT to find the clusters occupied by the recovery file.
F3	Start reading the recovery file cluster by cluster.
F5	Disable L1 cache.
FA	Check the validity of the recovery file configuration to the current configuration of the flash part.
FB	Make flash write enabled through chipset and OEM specific method. Detect proper flash part. Verify that the found flash part size equals the recovery file size.
F4	The recovery file size does not equal the found flash part size.
FC	Erase the flash part.
FD	Program the flash part.
FF	The flash has been updated successfully. Make flash write disabled. Disable ATAPI hardware. Restore CPUID value back into register. Give control to F000 ROM at F000:FFF0h.

POST code checkpoints

The POST code checkpoints are the largest set of checkpoints during the BIOS pre-boot process. The following table describes the type of checkpoints that may occur during the POST portion of the BIOS:

Checkpoint	Description
03	Disable NMI, Parity, video for EGA, and DMA controllers. Initialize BIOS, POST, Runtime data area. Also initialize BIOS modules on POST entry and GPNV area. Initialized CMOS as mentioned in the Kernel Variable "wCMOSFlags."
04	Check CMOS diagnostic byte to determine if battery power is OK and CMOS checksum is OK. Verify CMOS checksum manually by reading storage area. If the CMOS checksum is bad, update CMOS with power-on default values and clear passwords. Initialize status register A. Initializes data variables that are based on CMOS setup questions. Initializes both the 8259 compatible PICs in the system.
05	Initializes the interrupt controlling hardware (generally PIC) and interrupt vector table.
06	Do R/W test to CH-2 count reg. Initialize CH-0 as system timer. Install the POSTINT1Ch handler. Enable IRQ-0 in PIC for system timer interrupt. Traps INT1Ch vector to "POSTINT1ChHandlerBlock."
08	Initializes the CPU. The BAT test is being done on KBC. Program the keyboard controller command byte is being done after Auto detection of KB/MS using AMI KB-5.
0A	Initializes the 8042 compatible Key Board Controller.
0B	Detects the presence of PS/2 mouse.
0C	Detects the presence of Keyboard in KBC port.
0E	Testing and initialization of different Input Devices. Also, update the Kernel Variables. Traps the INT09h vector, so that the POST INT09h handler gets control for IRQ1. Uncompress all available language, BIOS logo, and Silent logo modules.
13	Early POST initialization of chipset registers.
24	Uncompress and initialize any platform specific BIOS modules.
30	Initialize System Management Interrupt.
2A	Initializes different devices through DIM. See DIM Code Checkpoints section of document for more information.
2C	Initializes different devices. Detects and initializes the video adapter installed in the system that have optional ROMs.
2E	Initializes all the output devices.
31	Allocate memory for ADM module and uncompress it. Give control to ADM module for initialization. Initialize language and font modules for ADM. Activate ADM module.
33	Initializes the silent boot module. Set the window for displaying text information.
37	Displaying sign-on message, CPU information, setup key message, and any OEM specific information.
38	Initializes different devices through DIM. See DIM Code Checkpoints section of document for more information.
39	Initializes DMAC-1 & DMAC-2.
3A	Initialize RTC date/time.
3B	Test for total memory installed in the system. Also, Check for DEL or ESC keys to limit memory test. Display total memory in the system.
3C	Mid POST initialization of chipset registers.
40	Detect different devices (Parallel ports, serial ports, and coprocessor in CPU, ... etc.) successfully installed in the system and update the BDA, EBDA...etc.

Checkpoint	Description
50	Programming the memory hole or any kind of implementation that needs an adjustment in system RAM size if needed.
52	Updates CMOS memory size from memory found in memory test. Allocates memory for Extended BIOS Data Area from base memory.
60	Initializes NUM-LOCK status and programs the KBD typematic rate.
75	Initialize Int-13 and prepare for IPL detection.
78	Initializes IPL devices controlled by BIOS and option ROMs.
7A	Initializes remaining option ROMs.
7C	Generate and write contents of ESCD in NVRam.
84	Log errors encountered during POST.
85	Display errors to the user and gets the user response for error.
87	Execute BIOS setup if needed / requested.
8C	Late POST initialization of chipset registers.
8E	Program the peripheral parameters. Enable/Disable NMI as selected
90	Late POST initialization of system management interrupt.
A0	Check boot password if installed.
A1	Clean-up work needed before booting to OS.
A2	Takes care of runtime image preparation for different BIOS modules. Fill the free area in F000h segment with 0FFh. Initializes the Microsoft IRQ Routing Table. Prepares the runtime language module. Disables the system configuration display if needed.
A4	Initialize runtime language module.
A7	Displays the system configuration screen if enabled. Initialize the CPU's before boot, which includes the programming of the MTRR's.
A8	Prepare CPU for OS boot including final MTRR values.
A9	Wait for user input at config display if needed.
AA	Uninstall POST INT1Ch vector and INT09h vector. Deinitializes the ADM module.
AB	Prepare BBS for Int 19 boot.
AC	End of POST initialization of chipset registers.
B1	Save system context for ACPI.
00	Passes control to OS Loader (typically INT19h).

Device Initialization Manager code checkpoints

The Device Initialization Manager (DIM) module gets control at various times during BIOS POST to initialize different BUSES. The following table describes the main checkpoints where the DIM module is accessed:

Checkpoint	Description
2A	Initialize different buses and perform the following functions: Reset, Detect, and Disable (function 0); Static Device Initialization (function 1); Boot Output Device Initialization (function 2). Function 0 disables all device nodes, PCI devices, and PnP ISA cards. It also assigns PCI bus numbers. Function 1 initializes all static devices that include manual configured onboard peripherals, memory and I/O decode windows in PCI-PCI bridges, and noncompliant PCI devices. Static resources are also reserved. Function 2 searches for and initializes any PnP, PCI, or AGP video devices.

Checkpoint	Description
38	Initialize different buses and perform the following functions: Boot Input Device Initialization (function 3); IPL Device Initialization (function 4); General Device Initialization (function 5). Function 3 searches for and configures PCI input devices and detects if system has standard keyboard controller. Function 4 searches for and configures all PnP and PCI boot devices. Function 5 configures all onboard peripherals that are set to an automatic configuration and configures all remaining PnP and PCI devices.

While control is in the different functions, additional checkpoints are output to port 80h as a word value to identify the routines under execution. The low byte value indicates the main POST Code Checkpoint. The high byte is divided into two nibbles and contains two fields. The details of the high byte of these checkpoints are as follows:

HIGH BYTE XY

The upper nibble 'X' indicates the function number that is being executed. 'X' can be from 0 to 7.

- 0 = func#0, disable all devices on the BUS concerned.
- 1 = func#1, static devices initialization on the BUS concerned.
- 2 = func#2, output device initialization on the BUS concerned.
- 3 = func#3, input device initialization on the BUS concerned.
- 4 = func#4, IPL device initialization on the BUS concerned.
- 5 = func#5, general device initialization on the BUS concerned.
- 6 = func#6, error reporting for the BUS concerned.
- 7 = func#7, add-on ROM initialization for all BUSES.
- 8 = func#8, BBS ROM initialization for all BUSES.

The lower nibble 'Y' indicates the BUS on which the different routines are being executed. 'Y' can be from 0 to 5.

- 0 = Generic DIM (Device Initialization Manager).
- 1 = On-board System devices.
- 2 = ISA devices.
- 3 = EISA devices.
- 4 = ISA PnP devices.
- 5 = PCI devices

System Status Error Codes

NOTE: Perform the FRU replacement or actions in the sequence shown in FRU/Action column, if the FRU replacement does not solve the problem, put the original part back in the computer. Do not replace a non-defective FRU.

The error messages in the following table indicate the error signals on the HDD access LED indicators on the front panel and the error symptoms.

Operating condition	HDD LED error codes				Description
	1	2	3	4	
System is booting	■				SATA controller failed
		■			USB controller failed
	■	■			LAN controller failed
			■		Fan failed
	■		■		Memory failed
		■	■		Boot device not found
System has booted	■	■	■	■	Disk failure

BIOS Recovery

Perform the BIOS recovery if the BIOS flash ROM has become corrupted. The following sections provide instructions on how to recover BIOS settings.

To create a BIOS Recovery disk:

1. Prepare a USB storage device.
2. Connect the USB storage device to a USB port on your computer.
3. Copy the target BIOS ROM file to a USB storage device.
4. Rename the target BIOS to “**AMIBoot.ROM**”.
5. Unplug the device.

To perform a BIOS recovery:

1. Create the BIOS Recovery disk as described in the previous section.
2. Connect the BIOS Recovery disk on the USB port on the system.
3. Depending on the current state of the system, do either of the following:
 - If the system has crashed:
Power on the system. The system initializes the BIOS recovery process and the system will reboot automatically after the flash update is completed.
 - If the system has not crashed or if you want to revert BIOS to previous settings:
During POST, press <Ctrl> + <Home> during POST. This action will flash the BIOS from the USB storage device to the system and reboot automatically after the flash update is completed.
4. Remove the BIOS Recovery disk.

Clearing CMOS

To clear the BIOS configuration you need to short the JP3 Clear CMOS jumper on the mainboard.

1. Turn off the computer and all attached devices.
2. Remove the system cover. See “Removing the System Cover” on page 25.
3. Locate the JP3 Clear CMOS jumper on the mainboard.
4. Remove the jumper from the default position.
5. Replace the jumper to connect the 2nd and 3rd pins.
6. Access the BIOS Setup Utility by connecting a debug card, keyboard, and a monitor to the system. Perform steps 3 and 7 through 10 of the “Entering the BIOS Setup Utility” on page 10.
7. Press <F9> to load the system default values.
8. Press <F10> to save the changes made and close the Setup Utility.

Undetermined Problems

The diagnostic problems does not identify which adapter or device failed, which installed devices are incorrect, whether a short circuit is suspected, or whether the system is inoperative.

NOTE: Verify that all attached devices are supported by the computer.

NOTE: Verify that the power supply being used at the time of the failure is operating correctly. (See “Power system check” on page 42.)

Follow procedures below to isolate the failing FRU. Do not isolate non-defective FRU.

1. Power off the computer.
2. Visually check them for damage. If any problems are found, replace the FRU.
3. Remove or disconnect all of the following devices:
 - Non-Acer devices
 - Printer, mouse, and other external devices
 - Hard disk drive
 - DIMM
 - CD/DVD-ROM drive
 - Adapter cards
4. Power on the computer.
5. Determine if the problem has been resolved.
6. If the problem does not recur, reconnect the removed devices one at a time until you find the failed FRU.
7. If the problem persists, replace the FRU one at a time. Do not replace a non-defective FRU.

System Block Diagram and Board Layout

System Block Diagram

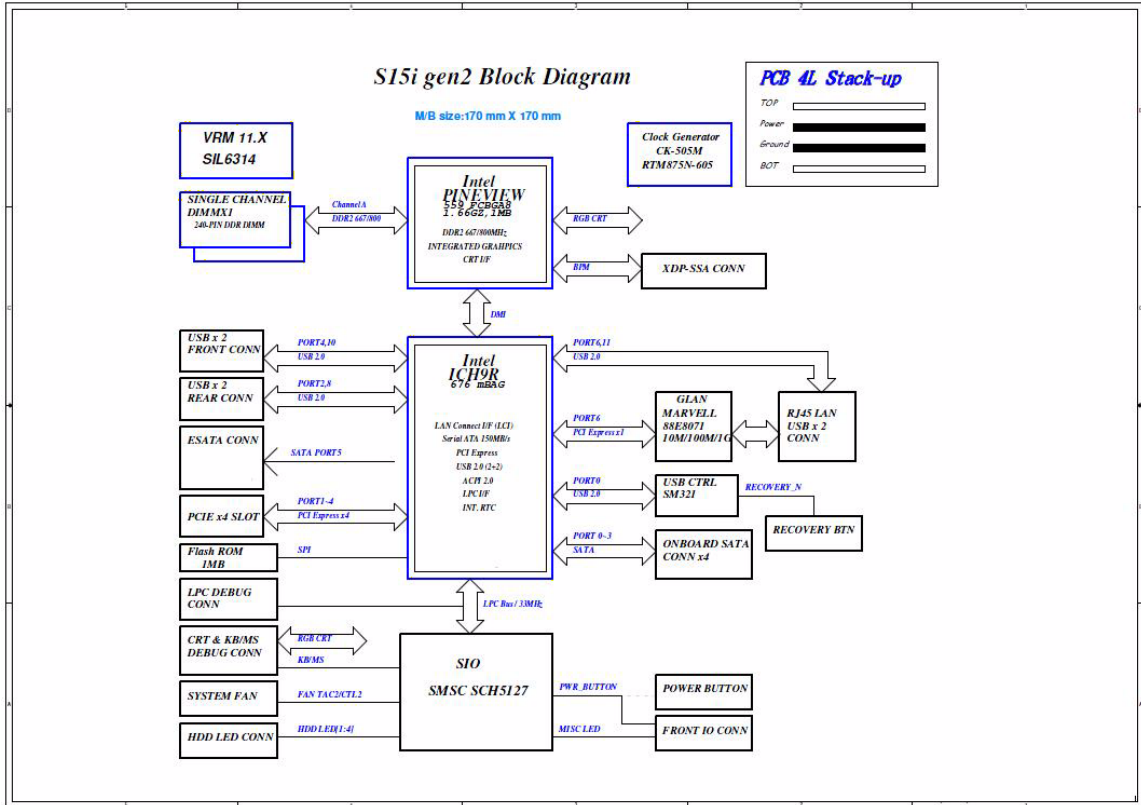

Board Layout

Mainboard

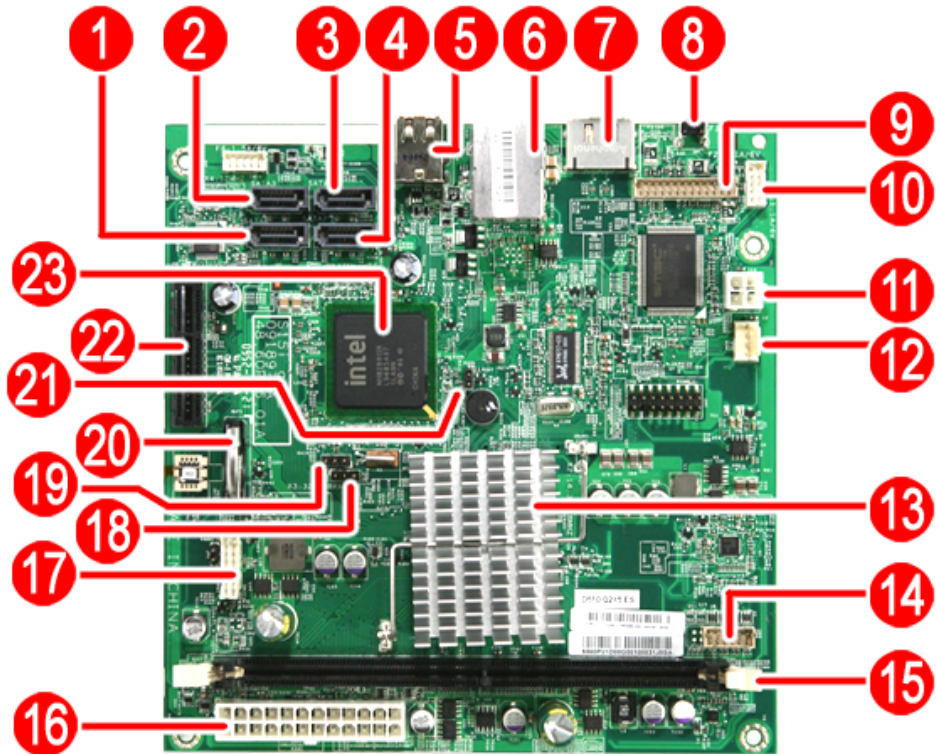

No	Description	No	Description
1	SATA 1 port	13	Intel Atom D410/D510 processor
2	SATA 3 port	14	HDD access LED cable connector
3	SATA 4 port	15	DDR2 DIMM slot
4	SATA 2 port	16	24-pin power cable connector
5	USB ports	17	Front I/O board cable connector
6	Gigabit Ethernet port (top) USB ports (bottom)	18	System type select jumper
7	eSATA port	19	Clear CMOS jumper
8	Recovery/reset button	20	Battery
9	Debug card cable connector	21	Debug/user mode jumper
10	Backplane board LED cable connector	22	x1 PCI Express slot
11	4-pin power cable connector	23	Intel ICH9R chipset (south bridge)
12	Fan cable connector (reserved)		

System Jumpers

Name	Location	Settings
Clear CMOS jumper	JP3	1-2 Normal (default) 2-3 Clear CMOS
System type select jumper	JP2	1-2 Aspire system (default) 2-3 Other model
Debug/user mode jumper	JP1	Open User mode enabled (default) Closed Debug mode enabled

FRU (Field Replaceable Unit) List

This chapter offers the FRU (Field Replaceable Unit) list in global configuration of the home server. Refer to this chapter whenever ordering the parts to repair or for RMA (Return Merchandise Authorization).

NOTES:



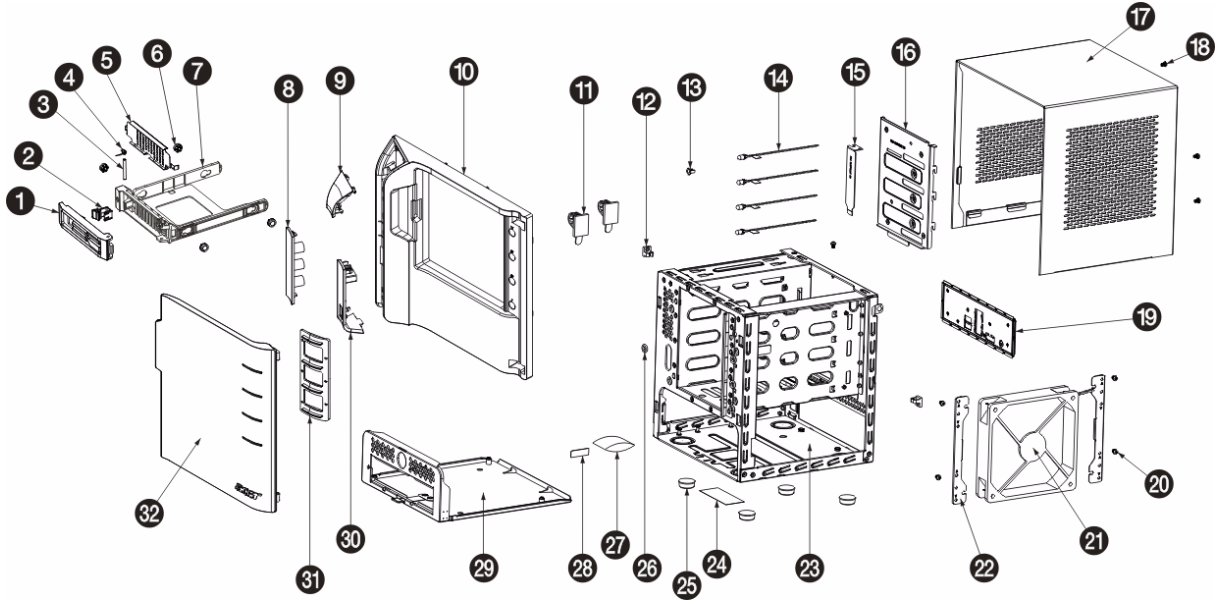

- ❑ When ordering FRU parts, check the most up-to-date information available on your regional web or channel. For whatever reasons a part number is changed, it will NOT be noted on the printed Service Guide. For Acer authorized service providers, your Acer office may have a different part number code from those given in the FRU list of this printed Service Guide. You MUST use the local FRU list provided by your regional Acer office to order FRU parts for service.
- ❑ To scrap or to return the defective parts, follow the local government ordinance or regulations on how to dispose it properly, or follow the rules set by your regional Acer office on how to return it.
- ❑ This document will be updated as more information about the FRU list becomes available.

Exploded Diagram





Item	Part No.	Part Name	QTY.
1	42.60P02.001	Handle HDD carrier HT-361	1
2	42.60P03.001	Latch HDD carrier HT-361	1
3	34.60P07.001	Axis HDD carrier HT-361	1
4	34.60P05.001	SPG HDD carrier HT-361	1
5	34.60P04.001	EMI HDD carrier HT-361	1
6	47.60M06.001	HDD ear rubber pin HT-360	4
7	42.60P01.001	HDD carrier HT-361	1
8	40.60P04.001	PLT as Icon HT-361	1
9	40.60P03.001	PLT as power HT-361	1
10	41.60P02.001	Bezel as main HT-361	1
11	42.55S13.001	Tie mount HU-139	1
12	42.91F07.001	Wire saddle CHF-8 HU122G	2
13	42.5E309.001	LED housing CLED-1A	4
14	50.60P04.001	C.A. HDD LED B/R HT-361	1
15	33.60P09.001	BRKT PCI LP dummy HT-361	1
16	33.60P05.001	BRKT BP HT-361	1
17	30.60P02.001	CAS UP HT-361	1
18	86.1A524.4R0	SCRW MACH PAN M3-0.5*4 NI	4
19	60.60P14.001	ASSY rear I/O cover HT-361	1
20	86.1A524.4R0	SCRW MACH PAN M3-0.5*4 NI	4
21	60.60P11.001	ASSY fan 120x120x25 S15	1
22	33.60P04.001	BRKT fan HT-361	2
23	60.60P02.001	ASSY main chassis HT-361	1
24	45.00049.001	Label spec dummy art UB series	1
25	42.60P11.001	Rubber foot R1907 19D7H	4
26	47.60P05.001	Sponge HDD LED HT-361	4
27	38.09008.001	Dessicant silica gel 30G H25	1
28	40.60P07.001	LBL 24*8MM warning HT-361	2
29	60.60P03.001	ASSY MB tray HT-361	1
30	40.60P06.001	PLT AS USB HT-361	1
31	42.60P17.001	Lens as door HT-361	1
32	42.60P16.001	Door as bezel HT-361	1

FRU List

Component	QTY	Part Name	Description	Acer Part Number
Board				
Front I/O board 	1	FRONT I/O BOARD	S15I ASPIRE FRONT I/O BD DIP	55.R3601.002
Backplane board 	1	BACKPLANE BOARD	S15I BACKPLANE BOARD DIP	55.R3601.001
Cable				
Backplane board cable	1	BACKPLANE BOARD CABLE	C.A. 2CON 10PIN HT361	50.R3601.001
HDD SATA cable	1	HDD SATA CABLE	C.A. HDD SATA CABLE HT-361	50.R3601.003
Front I/O board cable	1	FRONT I/O BOARD CABLE	C.A. 2CON 26PIN HT361	50.R3601.002
HDD access LED cable		HDD LED CABLE	C.A. HDD LED B/R HT-361	50.R3601.004
Power cord	1	POWER CORD 2.5A 250V 1800MM BLACK UK SING	CORD AC UK/SING 2.5A250V 1800	27.R3601.003
	2	POWER CORD 1800MM BLACK EUR	CORD PWR AC LINE EUR 1.8M BLK	27.R3601.002
		POWER CORD 7A 125V 1800MM BLACK US	CORD SVT 10A 125V 1800MM BLK	27.R3601.001
		POWER CORD 7A 125V JAPAN	CORD VCTF 3G 7A/125V(JAPAN)	27.01518.181
		POWER CORD 250V 10A 1800MM SWISS	CORD 250V 10A 1800MM SWISS	27.01518.251
		EXTERNAL ETHERNET CAT5E CABLE BLACK 2M	C.A. CAT5E STRAI BLACK_2M BIZ	50.R3601.005
Case/Cover/Bracket Assembly				
Front I/O dummy bracket	1	FRONT I/O DUMMY BRACKET	BRKT FRONT I/O HT-361	33.R3601.003
Power supply support bracket	1	POWER SUPPLY SUPPORT BRACKET	BRKT PSU SUPPORT HT-361	33.R3601.002
Front bezel 	1	FRONT BEZEL W/KEY LOCK&KEY	ASSY ASPIRE BEZEL HT-361	60.R3601.002
Housing frame 	2	ASSEMBLY CHASSIS W/HDD LED CABLE&FAN&UPPER CASE&LOWER CASE&HDD BRACKET&MAIN BOARD CARRIRE&FAN BRACKET	HOUSING ASSY HT-361	60.R3601.001

Component	QTY	Part Name	Description	Acer Part Number
Front I/O bracket 		FRONT I/O BOARD BRACKET	ASSY BRKT AS FRONT I/O HT-361	33.R3601.001
HDD carrier 		HDD CARRIER	ASSY HDD CARRIER HT-361	42.R3601.001
Backplane bracket 		Backplane bracket	BRKT BP HT361	N/A
Mainboard carrier 		Mainboard carrier	ASSY MB TRAY HT-361	N/A
System cover 		System cover	CAS UP HT-361	N/A
Key		MASTER KEY	DK103-KY05 MASTER KEY HT-361	33.R3601.004
Fan				
		FAN W/FAN RUBBER	ASSY FAN 120X120X25 S15	23.R3601.001
Hard disk drive				
	1	HDD SEAGATE 3.5" 7200RPM 1000GB ST31000333AS BRINKS SATA II LF F/W:SD45	HDD 1TB SGT ST31000333AS 7.2KR	KH.01K01.005
	1	HDD SEAGATE 3.5" 7200RPM 640GB ST3640623AS BRINKS SATA II 16MB LF F/W:SD43	HDD 640GB 3.5" SGT ST3640623AS	KH.64001.001
Mainboard				
	1	MAINBOARD S15I INTEL ATOM D410/D510 ICH9R V1.0 LF FOR ASPIRE/ALTOS ESAYSTORE W/ CPU&HEATSINK	S15I GEN2 MAIN BOARD W/O CPU,DIMM D	MB.TIA01.001 MB.T1B01.001

Component	QTY	Part Name	Description	Acer Part Number
Memory				
	1	MEMORY UNIFOSA UNB-DIMM DDRII 800 1GB GU341G0ALEPR6B2C6CE LF	DIMM 1G GU341G0ALEPR6B2C6CE	KN.51203.034
	1	MEMORY UNIFOSA UNB-DIMM DDRII 800MHZ 1GB GU341G0ALEPR6B2C6CE LF	DIMM 1G GU341G0ALEPR6B2C6CE	KN.1GB0H.009
Power supply				
	1	PSU DELTA GPS-200AB B 200W 100-240V S1	SPS 200W 1U DELTA GPS-200AB B	PY.20009.001
Screws				
	1	SCRW TAP PAN M3*6L 2LEAD NI	SCRW TAP PAN M3*6L 2LEAD NI	86.VA524.6R0
	1	SCRW MACH P/WS M3*0.5*4L NI	SCRW MACH P/WS M3*0.5*4L NI	86.19534.4R0
	1	SCRW MACH PAN M3-0.5*4 NI	SCRW MACH PAN M3-0.5*4 NI	86.1A524.4R0

Technical Specifications

This section provides technical specifications for the system.

Processor

Item	Specification	
Type	Onboard Intel Atom series	
Model number	D410	D510
Core	1	2
Threads	2	4
Clock speed (GHz)	1.66	1.66
L2 cache size	512 KB	1 MB
Bus type	DMI	DMI
Manufacturing tech (CMOS)	45 nm	45 nm
Max TDP (W)	10	13
Socket type	Micro-FCBGA8559	Micro-FCBGA8559
Embedded	Yes	Yes

System Board Major Chips

Item	Specification
System core logic	Intel Atom D410/D510 processor + Intel ICH9R
Storage controller	Intel ICH9R
Graphics memory controller	Integrated in the Intel Atom D410/D510 processor
Flash disk controller	Intel ICH9R + SM321
LAN controller	Intel ICH9R + Marvell Yukon 88E8071
Hardware sensors monitor	Intel ICH9R + SMSC SCH5127 Super I/O

System Memory

Item	Specification
Memory type	DDR2-800 unbuffered DIMM
Organization	Unbuffered, non-ECC
Pin count	240
DIMM sockets	1
DIMM size	1 GB or 2 GB
Minimum memory	1 GB
Maximum memory	2 GB
Vendor	Unifosa
Model name	GU341G0ALEPR6B2C6CE GU342G0ALEPR692C6CE

System BIOS

Item	Specification
BIOS vendor	AMI
BIOS version	D05
Flash memory	256 MB

PCI Interface

Item	Specification
PCI Express controller	Intel ICH9R
Number of slots	One PCI Express x 1 slot

Network Interface

Item	Specification
LAN controller	Intel ICH9R + Marvell Yukon 88E8071
Supports LAN protocol	10/100/1000 Mbps
LAN connector type	RJ45

SATA Interface

Item	Specification
SATA controller	SATA: Intel ICH9R eSATA: Intel ICH7R + Marvell 88SE6111
Connectors	<ul style="list-style-type: none">• Four SATA ports• One eSATA port (optional)