

6Gb/s SATA RAID Cards

ARC-1203 series

(PCIe 2.0 to 6Gb/s SATA RAID Controllers)

User Manual

Version: 1.3

Issue Date: February, 2020

Copyright and Trademarks

The information regarding products in this manual is subject to change without prior notice and does not represent a commitment on the part of the vendor, who assumes no liability or responsibility for any errors that may appear in this manual. All brands and trademarks are the properties of their respective owners. This manual contains materials protected under International Copyright Conventions. All rights reserved. No part of this manual may be reproduced in any form or by any means, electronic or mechanical, including photocopying, without the written permission of the manufacturer and the author.

FCC Statement

This equipment has been tested and found to comply with the limits for a Class B digital device, pursuant to part 15 of the FCC Rules. These limits are designed to provide reasonable protection against interference in a residential installation. This equipment generates, uses, and can radiate radio frequency energy and, if not installed and used in accordance with the instructions, may cause harmful interference to radio communications. However, there is no guarantee that interference will not occur in a particular installation.

Manufacturer's Declaration for CE Certification

We confirm ARC-1203 series has been tested and found compliant with the requirements in the council directive relating to the EMC Directive 2004/108/EC. Regarding to the electromagnetic compatibility, the following standards were applied:

EN 55022: 2006, Class B
EN 61000-3-2: 2006
EN 61000-3-3: 1995+A1: 2001+A2: 2005

EN 55024:1998+A1:2001=A2:2003
IEC61000-4-2: 2001
IEC61000-4-3: 2006
IEC61000-4-4: 2004
IEC61000-4-5: 2005
IEC61000-4-6: 2006
IEC61000-4-8: 2001
IEC61000-4-11: 2004

Contents

1. Introduction	12
1.1 Overview	12
1.2 Features	14
2. Hardware Installation	17
2.1 Before You First Installing.....	17
2.2 Board Layout.....	18
2.3 Installation.....	19
2.4 SATA Cables	25
2.4.1 Internal Min SAS 4i to SATA Cable	25
2.4.2 Internal Min SAS 4i (SFF-8087) to Internal Min SAS 4i (SFF-8087) cable	26
2.5 LED Cables.....	27
2.6 Summary of the installation.....	31
3. McBIOS RAID Manager	34
3.1 Starting the McBIOS RAID Manager	34
3.2 McBIOS RAID manager	35
3.3 Configuring Raid Sets and Volume Sets	36
3.4 Designating Drives as Hot Spares.....	36
3.5 Using Quick Volume /Raid Setup Configuration	37
3.6 Using Raid Set/Volume Set Function Method	38
3.7 Main Menu	40
3.7.1 Quick Volume/Raid Setup	41
3.7.2 Raid Set Function	45
3.7.2.1 Create Raid Set	46
3.7.2.2 Delete Raid Set	47
3.7.2.3 Expand Raid Set.....	48
3.7.2.4 Offline Raid Set	49
3.7.2.5 Activate Incomplete Raid Set.....	50
3.7.2.6 Create Hot Spare.....	51
3.7.2.7 Delete Hot Spare	51
3.7.2.8 Rescue Raid Set	52
3.7.2.9 Raid Set Information	53
3.7.3 Volume Set Function	53
• Volume Name	56
• Raid Level	57
• Capacity	57
• Stripe Size	59
• SCSI ID	60

• SCSI LUN	60
• Cache Mode	61
• Write Protect	61
• Tag Queuing	62
3.7.3.2 Create Raid30/50/60 (Volume Set 30/50/60)	62
3.7.3.3 Delete Volume Set	63
3.7.3.4 Modify Volume Set	64
3.7.3.4.1 Volume Growth	64
3.7.3.4.2 Volume Set Migration	65
3.7.3.5 Check Volume Set	66
3.7.3.6 Stop Volume Set Check	66
3.7.3.7 Display Volume Set Info.	66
3.7.4 Physical Drives	67
3.7.4.1 View Drive Information	67
3.7.4.2 Create Pass-Through Disk	68
3.7.4.3 Modify Pass-Through Disk	69
3.7.4.4 Delete Pass-Through Disk	69
3.7.4.5 Set Disk To Be Failed	70
3.7.4.6 Activate Failed Disk	70
3.7.4.7 Identify Selected Drive	71
3.7.4.8 Identify Enclosure	71
3.7.5 Raid System Function	72
3.7.5.1 Mute The Alert Beeper	72
3.7.5.2 Alert Beeper Setting	73
3.7.5.3 Change Password	73
3.7.5.4 JBOD/RAID Function	74
3.7.5.5 Background Task Priority	74
3.7.5.6 Maximum SATA Mode	75
3.7.5.7 HDD Read Ahead Cache	76
3.7.5.8 Volume Data Read Ahead	76
3.7.5.9 Empty HDD Slot LED	77
3.7.5.10 Auto Activate Raid Set	78
3.7.5.11 Disk Write Cache Mode	78
3.7.5.12 Write Same Support	79
3.7.5.13 Capacity Truncation	79
3.7.6 More System Functions	80
3.7.6.1 Smart Option For HDD	81
3.7.6.2 Smart Polling Interval	81
3.7.6.3 Hot Plugged Disk For Rebuilding	82
3.7.7 HDD Power Management	83
3.7.7.1 Stagger Power On	84
3.7.7.2 Time To Hdd Low Power Idle	85

3.7.7.3 Time To Low RPM Mode	85
3.7.7.4 Time To Spin Down Idle Hdd	86
3.7.8 Ethernet Configuration	86
3.7.8.1 DHCP Function	86
3.7.8.2 Local IP address	87
3.7.8.3 HTTP Port Number	88
3.7.8.4 Telnet Port Number	88
3.7.8.5 SMTP Port Number	89
3.7.8.6 Ethernet Address	90
3.7.9 Alert By Mail Config	90
3.7.10 View System Events	91
3.7.11 Clear Events Buffer	91
3.7.12 Hardware Monitor	92
3.7.13 System Information	92
4. Driver Installation	93
4.1 Creating the Driver Diskettes	93
4.2 Driver Installation for Windows	94
4.2.1 Installing Windows on a RAID Volume	94
4.2.2 Installing Controller on an Existing Windows	96
4.2.3 Uninstall controller from Windows	97
4.3 Driver Installation for Linux	98
4.4 Driver Installation for FreeBSD	98
4.5 Driver Installation for Solaris	99
4.6 Driver Installation for Mac X	99
4.6.1 Installation Procedures	100
4.6.2 Making Volume Sets Available to Mac OS X	102
5. ArchHTTP Proxy Server Installation	104
5.1 For Windows	105
5.2 For Linux	110
5.3 For FreeBSD	112
5.4 For Solaris 10	112
5.5 For Mac OS X	112
5.6 ArchHTTP Configuration	113
6. Web Browser-based Configuration	118
6.1 Start-up McRAID Storage Manager	118
• Start-up from Windows/Mac Local Administration	119
• Start-up McRAID Storage Manager from Linux/FreeBSD/Solaris Local Administration	119
• Start-up from Ethernet Port (Out-of-Band)	120
6.2 McRAID Storage Manager	121
6.3 Main Menu	122

6.4 Quick Function	122
6.5 Raid Set Functions	123
6.5.1 Create Raid Set	123
6.5.2 Delete Raid Set	124
6.5.3 Expand Raid Set	124
6.5.4 Offline Raid Set	125
6.5.5 Rename Raid Set	126
6.5.6 Activate Incomplete Raid Set	126
6.5.7 Create Hot Spare	127
6.5.8 Delete Hot Spare	128
6.5.9 Rescue Raid Set	128
6.6 Volume Set Functions	129
6.6.1 Create Volume Set (0/1/10/3/5/6)	129
6.6.2 Create Raid 30/50/60 (Volume Set 30/50/60)	133
6.6.3 Delete Volume Set	134
6.6.4 Modify Volume Set	134
6.6.4.1 Volume Growth	135
6.6.4.2 Volume Set Migration	136
6.6.5 Check Volume Set	136
6.6.6 Schedule Volume Check	137
6.6.7 Stop Volume Set Check	138
6.7 Security Function	139
6.7.1 Create SED RAID Set	139
6.7.2 Delete SED RAID Set	140
6.7.3 Delete ISE RAID Set	140
6.7.4 Security Key Setup	141
6.7.4.1 SED Key Management-Creation	141
6.7.4.2 SED Key Management-Modification	142
6.7.5 Import Security Key	143
6.7.6 Erase Failed Disk	144
6.7.7 RevertSP	144
6.8 Physical Drive	145
6.8.1 Create Pass-Through Disk	145
6.8.2 Modify Pass-Through Disk	145
6.8.3 Delete Pass-Through Disk	146
6.8.4 Clone Disk	146
6.8.4.1 Clone And Replace	147
6.8.4.2 Clone Only	148
6.8.5 Abort Cloning	148
6.8.6 Set Disk To Be Failed	148
6.8.7 Activate Failed Disk	148
6.8.8 Identify Enclosure	149

6.8.9 Identify Drive	149
6.9 System Controls	150
6.9.1 System Config	150
• System Beeper Setting	150
• JBOD/RAID Configuration	150
• Max SATA Mode Supported	151
• HDD Read Ahead Cache	151
• Volume Data Read Ahead	151
• Empty HDD Slot LED	151
• Max Command Length	152
• Auto Activate Incomplete Raid	152
• Disk Write Cache Mode	152
• Write Same For Initialization	152
• Hot Plugged Disk For Rebuilding	152
• Disk Capacity Truncation Mode	153
• Smart Option For HDD	153
• Smart Polling Interval	154
6.9.2 Advanced Configuration.....	155
• TLER Setting	155
• Timeout Setting	156
• Number of Retries	156
• Buffer Threshold	156
• Amount of Read Ahead	156
• Read Ahead Count.....	157
• Read Ahead Requests	157
• Number of AV Stream	157
• Optimize AV Recording.....	158
• Read Performance Margin.....	158
• Write Performance Margin	158
• Read And Discard Parity Data	160
• Fail Disk For Any Timeout.....	160
• Hitachi/WDC/Seagate SATA HDD Speed	160
• BIOS Selection.....	161
• PCIE Link Down Reset.....	161
• Active Cable Management	161
• Host Command Queue Mode.....	161
• End Device Frame Buffering.....	162
• PCIE Command Queue Depth.....	162
• Write Cache Amount.....	162
• Save SED Key In Controller	162
• Dual Path Usage	163
• Ext Connector#1 Speed Limit	163

• Ext Connector#2 Speed Limit	163
• Fail Disk For Reading Error	163
6.9.3 HDD Power Management	165
• Stagger Power On Control	165
• Time To Hdd Low Power Idle	166
• Time To Spin Down Idle HDD	166
• SATA Power Up In Standby	166
6.9.4 Ethernet Configuration	166
• DHCP Function.....	167
• Local IP address.....	167
• Gateway IP address.....	168
• Subnet Mask	168
• HTTP Port Number.....	168
• Telnet Port Number	168
• SMTP Port Number	168
6.9.5 Alert By Mail Configuration	168
6.9.6 SNMP Configuration	169
6.9.7 NTP Configuration	169
• NTP Sever Address	170
• Time Zone.....	170
• Automatic Daylight Saving.....	170
6.9.8 View Events/Mute Beeper	171
6.9.9 Generate Test Event	171
6.9.10 Clear Events Buffer	172
6.9.11 Modify Password.....	172
6.9.12 Update Firmware	173
6.10 Information	174
6.10.1 Raid Set Hierarchy	174
6.10.2 System Information	174
6.10.3 Hardware Monitor	175
Appendix A	176
Upgrading Flash ROM Update Process.....	176
A-1 Overview	176
A-2 Upgrading Firmware Through McRAID Storage Manager ...	177
A-3 Upgrading Firmware Through nflash DOS Utility	178
A-4 Upgrading Firmware Through CLI.....	179
Appendix B	180
Battery Backup Module (ARC-6120BA-T121-12G).....	180
Appendix C	184
SNMP Operation & Installation.....	184
C-1 Overview	184

C-2 SNMP Definition.....	184
C-3 SNMP Installation	185
C-3-1 Using ArchHTTP.....	187
C-3-2 Using Onboard NIC Installation.....	187
C-3-3 Using In-band PCIe + SNMP extension agent Installation	189
C-3-4 SNMP Extension Agent Installation	190
C-3-4-1 Windows.....	190
C-3-4-2 Linux	193
C-3-4-3 FreeBSD	194
Appendix D.....	195
Appendix E	199
Self-Encrypting Disk (SED) Encryption.....	199
Appendix F	205
RAID Concept	205
RAID Set.....	205
Volume Set.....	205
Ease of Use Features.....	206
• Foreground Availability/Background Initialization	206
• Online Array Roaming	206
• Online Capacity Expansion.....	206
• Online RAID Level and Stripe Size Migration	208
• Online Volume Expansion	209
High Availability	209
• Global/Local Hot Spares	209
• Hot-Swap Disk Drive Support.....	210
• Auto Declare Hot-Spare	210
• Auto Rebuilding	211
• Adjustable Rebuild Priority.....	211
High Reliability	212
• Hard Drive Failure Prediction.....	212
• Auto Reassign Sector	212
• Consistency Check	213
Data Protection	214
• Battery Backup	214
• Recovery ROM	214
Appendix G.....	215
Understanding RAID	215
RAID 0.....	215
RAID 1.....	216
RAID 10(1E).....	217

RAID 3	217
RAID 5	218
RAID 6	219
RAID x0	219
JBOD	220
Single Disk (Pass-Through Disk)	220
Summary of RAID Levels	221

INTRODUCTION

1. Introduction

This section presents a brief overview of the 6Gb/s SATA RAID controller, ARC-1203-4i/8i. (PCIe 2.0 to 6Gb/s SATA RAID controllers)

1.1 Overview

The ARC-1203-4i/8i internal PCIe 2.0 host RAID controllers are a cost-effective solutions for connecting up to 4/8 6Gb/s SATA peripheral devices. The RAID controllers are based on the same RAID kernel of field-proven internal/external RAID controller and same device driver architecture with widely used 3Gb/s and 6Gb/s SAS/SATA RAID controller. Applications that benefit most features from these controllers include NAS, server RAID solutions, web servers, near-line backup, security systems and streaming applications. ARC-1203 series support directly attached 4/8 internal 6Gb/s SATA ports via 1/2 SFF-8087 connector.

The ARC-1203 series 6Gb/s RAID controllers are low-profile PCI cards, ideal for 1U and 2U rack-mount systems. These controllers utilize the same RAID kernel that has been field-proven in existing external RAID controller products, allowing Areca to quickly bring stable and reliable PCIe 2.0 6Gb/s SATA RAID controllers to the market.

Unparalleled Flexibility

Embedded with ARM-based storage I/O processor makes those products a pure hardware RAID controller and raise the standard to higher performance levels with several enhancements including 6Gb/s SATA ports, on-board 1GB SDRAM memory and high performance PCIe 2.0 x8 lane host interface bus interconnection. The ARC-1203 series RAID card with a dedicated processor and cache memory that offloads the parity calculations from the CPU, as this means you can pair it with a slow, lower power processor, the cost to benefit ratio for this cost-effective RAID adapter is negligible. With several port configuration options 4 internal and 8 internal ARC-1203 series RAID can be easily integrated into a variety of hardware and software platforms, and are ideal for cost-effective, high-capacity NAS, DVR and cold storage market.

Unsurpassed Data Availability

As storage capacities continue to rapidly increase, users need greater level of disk drive fault tolerance, which can be implemented without doubling the investment in disk drives. The RAID 6 can offer fault tolerance greater than RAID 1 or RAID 5 but only consumes the capacity of 2 disk drives for distributed parity data. Areca entry-level RAID controllers incorporate onboard storage processors to deliver true hardware RAID. Hardware RAID cards have their own local RAID processor onboard, plus dedicated onboard cache for full hardware offloading of RAID-processing functions. The ability of hardware RAID controllers to rebuild an array in the event of a drive failure is superior to what software RAID controllers offer.

The ARC-1203 series 6Gb/s SATA RAID controllers can also provide RAID levels 0, 1, 1E, 3, 5, 6, 10, 30, 50, 60, Single Disk or JBOD for maximum configuration flexibility. Its high data availability and protection derives from Areca Technology's advanced features: Online RAID Capacity Expansion, Array Roaming, Online RAID Level / Stripe Size Migration, Global Online Spare, Automatic Drive Failure Detection, Automatic Failed Drive Rebuilding, Disk Hot-Swap, Online Background Rebuilding, Instant Availability/Background Initialization, Auto Reassign Sector, Redundant Flash Image and Battery Backup Module. The optional battery backup module provides power to the cache if it contains data not yet written to the drives when power is lost.

Maximum Interoperability

The ARC-1203 series 6Gb/s SATA RAID adapters support broad operating system including Windows 10/8/server 2012/2008/Vista/2003/XP(64-bit), Linux (Open Source), FreeBSD (Open Source), VMware, Solaris (Open Source), Mac and more, along with key system monitoring features such as enclosure management (Serial bus & SGPIO) and SNMP function. Our products and technology are based on extensive testing and validation process; same as Areca 3Gb/s and 6Gb/s SAS/SATA RAID adapter field-proven compatibility with operating systems, motherboards, applications and device drives.

INTRODUCTION

Easy RAID Management

The controllers contain an embedded McBIOS RAID manager that can access via hot key at M/B BIOS boot-up screen. This pre-boot McBIOS RAID manager can use to simplify the setup and management of RAID controller. The controller firmware also contains a browser-based McRAID storage manager which can be accessed through the Ethernet port or ArcHttp proxy server in Windows, Linux, FreeBSD and more environments. The McRAID storage manager allows local and remote to create and modify RAID set, volume set, and monitor RAID status from standard web browser. The ArcSAP quick manager can scan for multiple RAID units in the local and remote systems and provide an effective mechanism to configure and monitor your RAID units.

1.2 Features

Controller Architecture

- ARM_based 1066MHz storage I/O processor
- 512MB on-board DDR3-1066 SDRAM with ECC protection
- PCIe 2.0 x4 lanes host interface
- Support up to 4/8 x 6Gb/s SATA HDDs/SSD
- Multi-adapter support for large storage requirements
- BIOS boot support for greater fault tolerance
- BIOS PnP (plug and play) and BBS (BIOS boot specification) support
- Boot support for the uEFI host BIOS
- NVRAM for RAID event & transaction log
- Redundant flash image for controller availability
- Battery Backup Module (BBM) ready (optional)
- RoHS compliant

RAID Features

- RAID level 0, 1, 10(1E), 3, 5, 6, 30, 50, 60, Single Disk or JBOD
- Multi-level RAID 0 and RAID 10 (R00 and R100)
- Support up to 1MB stripe size
- Multiple RAID selection
- Online array roaming
- Online RAID level/stripe size migration
- Online capacity expansion and RAID level migration simultaneously

INTRODUCTION

- Online volume set growth
- Instant availability and background initialization
- Support global and dedicated hot spare
- Automatic drive insertion/removal detection and rebuilding
- Greater than 2TB capacity per disk drive support
- Greater than 2TB per volume set (64-bit LBA support)
- SED (self-encrypting drives) function support
- Support intelligent power management to save energy and extend service life
- Support for native 4K and 512 byte sector SATA devices
- Multiple pairs SSD/HDD disk clone function
- SSD automatic monitor clone (AMC) support
- Support HDD firmware update

Monitors/Notification

- System status indication through global HDD activity/fault connector, individual fault connector, LCD/serial bus connector and alarm buzzer
- SMTP support for email notification
- SNMP support for remote manager
- Enclosure management (Serial bus & SGPIO) ready

RAID Management

- Field-upgradeable firmware in flash ROM

In-Band Manager

- Hot key "boot-up" McBIOS RAID manager via M/B BIOS
- Web browser-based McRAID storage manager via ArchHTTP proxy server for all operating systems
- Support Command Line Interface (CLI)
- API library for customer to write manager utility
- Single Admin Portal (ArcSAP) quick manager utility

Out-of-Band Manager

- Firmware-embedded web browser-based McRAID storage manager, SMTP manager, SNMP agent and Telnet function via Ethernet port
- Out-of-Band API sample and functional code for customer to quickly customize its AP
- Support push button and LCD display panel (optional)

INTRODUCTION

Operating System

- Windows 10/8/2012/7/2008/Vista/XP(64-bit)/2003
- Linux
- FreeBSD
- VMware (Driver 6.x support CLI in-band management utility)
- Solaris 10/11 x86/x86_64
- Mac OS 10.5.x or higher

6Gb/s SATA RAID controllers		
Model name	ARC-1203-4i	ARC-1203-8i
I/O Processor	ARM_based 1066MHz storage I/O processor	
Form Factor (H x L)	Low Profile: 64.4 x 168 mm	
Host Bus Type	PCIe 2.0 x4 Lanes	
Driver Connector	1xSFF-8087	2xSFF-8087
Drive Support	Up to 4 x 6Gb/s SATA HDDs/SSD	Up to 8 x 6Gb/s SATA HDDs/SSD
RAID Level	0, 1, 1E, 3, 5, 6, Single Disk, and JBOD	0, 1, 1E, 3, 5, 6, 10, 30, 50, 60, Single Disk, and JBOD
On-Board Cache	512 MB on-board DDR3-1066 SDRAM with ECC protection	
Management Port	In-Band: PCIe / Out-of-Band: LCD, and LAN Port	
Enclosure Ready	Individual Faulty Header, SGPIO, and Serial bus	

Note:

Low-profile bracket has included on the low profile board shipping package.

2. Hardware Installation

This section describes the procedures for installing the 6Gb/s SATA RAID controllers.

2.1 Before You First Installing

Thanks for purchasing the 6Gb/s SATA RAID controller as your RAID data storage subsystem. This user manual gives simple step-by-step instructions for installing and configuring the 6Gb/s SATA RAID controller. To ensure personal safety and to protect your equipment and data, reading the following information package list carefully before you begin installing.

Package Contents

If your package is missing any of the items listed below, contact your local dealers before you install. **(Disk drives and disk mounting brackets are not included)**

- 1 x 6Gb/s SATA RAID controller in an ESD-protective bag
- 1 x Installation CD – containing driver, relative software, an electronic version of this manual and other related manual
- 1 x Quick start guide
- 1 x Low-profile bracket

System Requirement

The 6Gb/s SATA RAID controller can be installed in an universal PCIe slot and requires a motherboard that:

ARC-1203 series 6Gb/s SATA RAID controller requires:

- Comply with the PCIe 2.0 x4 lanes
It can work on the PCIe 2.0 x1, x4 and x8 signal with x4 or x8 slot M/B.
- Backward-compatible with PCIe 1.0

HARDWARE INSTALLATION

2.2 Board Layout

The RAID controllers can support a family SATA interface included 4/8 internal ports with 6Gb/s capability. This section provides the board layout and connector/jumper for the 6Gb/s SATA RAID controller.

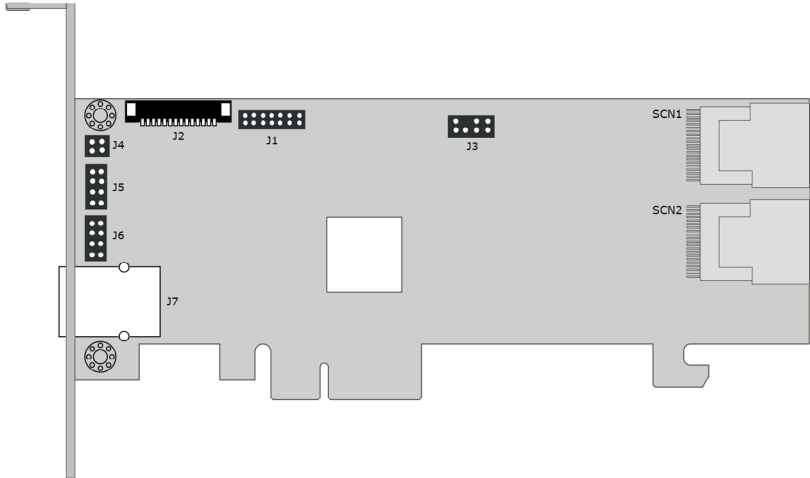

Figure 2-1, ARC-1203-4i/8i 6Gb/s SATA RAID controller

Connector	Type	Description
1. (J1)	Manufacture Purpose Port	14-pin header
2. (J2)	Battery Backup Module Connector	14-pin box header
3. (J3)	I ² C/LCD Connector	7-pin header
4. (J4)	Global Fault/Activity LED	4-pin header
5. (J5)	Individual Activity LED (1-8 Ports) Header	8-pin header
6. (J6)	Individual Fault LED (1-8 Ports) Header	8-pin header
7. (J7)	Ethernet port	RJ45
8. (SCN1)	SATA 1-4 Ports	SFF-8087
9. (SCN2)	SATA 5-8 Ports (for ARC-1203-8i)	SFF-8087

Table 2-1, ARC-1203-4i/8i connectors

HARDWARE INSTALLATION

2.3 Installation

Use the following instructions below to install a PCIe 2.0 6Gb/s SATA RAID controller.

Step 1. Unpack

Unpack and remove the PCIe 2.0 6Gb/s SATA RAID controller from the package. Inspect it carefully, if anything is missing or damaged, contact your local dealer.

Step 2. Power PC/Server Off

Turn off computer and remove the AC power cord. Remove the system's cover. For the instructions, please see the computer system documentation.

Step 3. Install the PCIe 6Gb/s SATA RAID Cards

To install the 6Gb/s SATA RAID controller, remove the mounting screw and existing bracket from the rear panel behind the selected PCIe 2.0 slot. Align the gold-fingered edge on the card with the selected PCIe 2.0 slot. Press down gently but firmly to ensure that the card is properly seated in the slot, as shown on Figure 2-2. Then, screw the bracket into the computer chassis. ARC-1203 series controllers require a PCIe 2.0 x4/x8 slot.

Figure 2-2, Insert into a PCIe slot

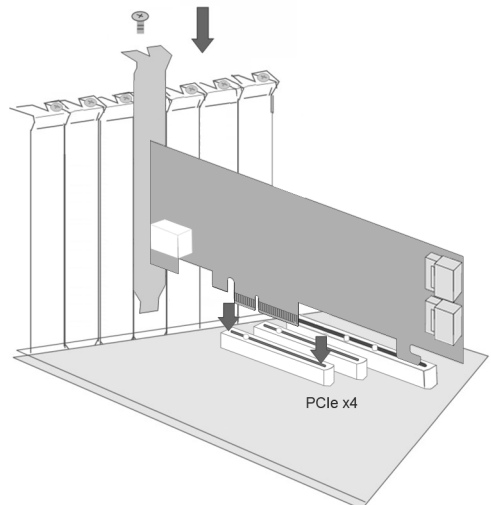

HARDWARE INSTALLATION

Step 4. Mount the Drives

You can connect the SATA drives to the controller through direct cable and backplane solutions. In the direct connection, SATA drives are directly connected to 6Gb/s SATA RAID controller port with SATA cables. The 6Gb/s SATA RAID controller can support up to 8 ports. Remove the front bezel from the computer chassis and install the cages or SATA drives in the computer chassis. Loading drives to the drive tray if cages are installed. Be sure that the power is connected to either the cage backplane or the individual drives.

In the backplane solution, SATA drives are directly connected to 6Gb/s SATA system backplane. The number of SATA drives is limited to the number of slots available on the system backplane.

Step 5. Install SATA Cable

This section describes SATA cable how to connect on controller.

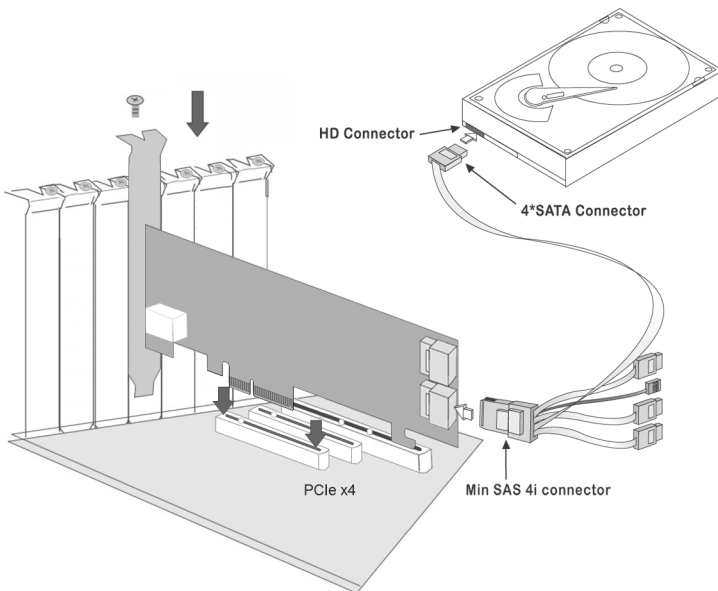

Figure 2-3, Connecting to HDD

HARDWARE INSTALLATION

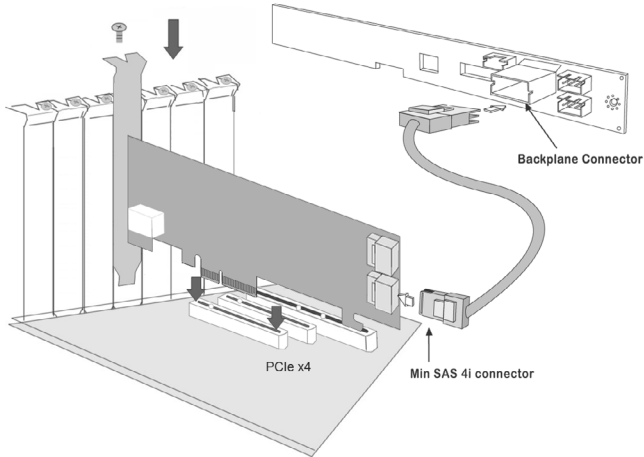

Figure 2-4, Connecting to Backplane

Step 6. Install the LED Cable (Optional)

The preferred I/O connector for server backplanes is the internal SFF-8087 connector. This connector has eight signal pins to support four SATA drives and six pins for the SGPIO (Serial General Purpose Input/Output) side-band signals. The SGPIO bus is used for efficient LED management and for sensing drive Locate status. See SFF 8485 for the specification of the SGPIO bus. For backplane without SGPIO supporting, Please refer to Section 2.6 LED cables for fault/activity LED cable installation.

LED Management: The backplane may contain LEDs to indicate drive status. Light from the LEDs could be transmitted to the outside of the server by using light pipes mounted on the SATA drive tray. A small microcontroller on the backplane, connected via the SGPIO bus to a 6Gb/s SATA RAID controller, could control the LEDs. Activity: blinking 5 times/second and Fault: solid illuminated

Drive Locate Circuitry: The location of a drive may be detected by sensing the voltage level of one of the pre-charge pins before and after a drive is installed.

The following signals define the SGPIO assignments for the Min SAS 4i internal connector (SFF-8087) in the 6Gb/s SATA RAID controller.

HARDWARE INSTALLATION

PIN	Description	PIN	Description
SideBand0	SClock (Clock signal)	SideBand1	SLoad (Last clock of a bit stream)
SideBand2	Ground	SideBand3	Ground
SideBand4	SDataOut (Serial data output bit stream)	SideBand5	SDataIn (Serial data input bit stream)
SideBand6	Reserved	SideBand7	Reserved

Step 7. Adding a Battery Backup Module (Optional)

Please refer to Appendix B Battery Backup Module (ARC-6120BA-T121) for installing the BBM in your 6Gb/s SATA RAID controller.

Step 8. Re-check Fault LED Cable Connections (Optional)

Be sure that the proper failed drive channel information is displayed by the fault LEDs. An improper connection will tell the user to “Hot Swap” the wrong drive. This can result in removing the wrong disk (one that is functioning properly) from the controller. This can result in failure and loss of system data.

Step 9. Power up the System

Thoroughly check the installation, reinstall the computer cover, and reconnect the power cord cables. Turn on the power switch at the rear of the computer (if equipped) and then press the power button at the front of the host computer.

Step 10. Install the Controller Driver

For a new system:

- Driver installation usually takes places as part of operating system installation. Please refer to Chapter 4 “Diver Installation” for the detailed installation procedure.

For an existing system:

- To install the controller driver into the existing operating system. For the detailed installation procedure, please refer to the Chapter 4, “Driver Installation”.

HARDWARE INSTALLATION

Step 11. Install ArcHTTP Proxy Server

The ARC-1203 firmware has embedded the web-browser McRAID storage manager. ArcHTTP proxy server will launch the web-browser McRAID storage manager. It provides all of the creation, management and monitor ARC-1203 series RAID controller status. Please refer to the Chapter 5 for the detail "ArcHTTP Proxy Server Installation". For SNMP agent function, please see the "SNMP Operation & Installation" section in the Appendix C of the user manual.

Step 12. Configure Volume Set

With Areca series RAID cards, there are 4 methods to manage your ARC-1203 series RAID controller. It can be configured by using the LCD with keypad, McBIOS RAID manager (terminal emulation) or McRAID storage manager (via LAN port and ArcHTTP proxy utility).

- **Method 1: Internal PCIe Connection (McBIOS RAID Manager)**
The ARC-1203 series RAID controller can be configured via a BIOS start up McBIOS manager. The McBIOS RAID manager is firmware-based and is used to configure RAID sets and volume sets. Because the utility resides in the ARC-1203 series RAID controller firmware, operation is independent of any operating systems on your computer. For additional information on using the BIOS on-screen to configure the RAID subsystem see the Chapter 3 of "BIOS Configuration" of the user manual.
- **Method 2: Internal PCIe Connection (McRAID Storage Manager)**
You're now ready to use the McRAID storage manager to set up RAID volumes. Your ARC-1203 series RAID controller can be configured by using McRAID storage manager (launched by ArcHTTP proxy server). ARC-1203 RAID controller has embedded the TCP/IP & web browser-based RAID manager in the firmware. User can use the standard web browsers to manage the RAID controller using ArcHTTP proxy server installed. For additional information on using the McRAID storage manager to configure the RAID controller see the Chapter 6 of "Web Browser-Based Configuration" of the user manual.
- **Method 3: LAN Port Connection (McRAID Storage Manager)**
The ARC-1203 RAID controller has embedded the TCP/IP & web

HARDWARE INSTALLATION

browser-based RAID manager in the firmware. User can remote manage the RAID controller without adding any user specific software (platform independent) via standard web browsers directly connected to the 10/100Mbps RJ45 LAN port. For additional information on using the LAN port to configure the RAID subsystem see the Chapter 6 of “Web Browser-Based Configuration” of the user manual.

- **Method 4: Front LCD Panel with Keypad (Optional)**
You can use LCD front panel and keypad function to simply create the RAID volume. The LCD status panel also informs you of the disk array’s current operating status at a glance. For additional information on using the LCD to configure the RAID controller see the ARC1000_LCD manual on the shipping CD. The LCD provides a system of screens with areas for information, status indication, or menus. The LCD screen displays up to two lines at a time of menu items or other information.

Step 13. Format, Partition and Mount the ARC-1203 RAID Controller Volumes

After the volume set is ready for system accesses, it needs to be partitioned, formatted, and mounted by the operating system. There are various steps, depending on what operating system you are using (Windows, Linux, FreeBSD or Mac, etc.). Detailed steps for each operating system are provided on their disk utility. After that, the ARC-1203 series RAID controller can be fully used.

Step 14. Determining the Boot Sequences

The ARC-1203 series RAID controller is a bootable device. You can use it as primary boot drive or secondary storage drive. If your system already contains a bootable device with an installed operating system, you can set up your system to boot a second operating system from the new ARC-1203 series RAID controller volume.

For PC system:

To add a second bootable controller, you may need to enter setup of motherboard BIOS and change the device boot sequence so that the new ARC-1203 series RAID controller volume heads the list. If the system BIOS setup does not allow this change, your system

HARDWARE INSTALLATION

may be not configurable to allow the new ARC-1203 RAID controller volume to act as a second boot device.

For Apple Mac Pro system:

Areca controller has supported the uEFI BIOS on the PCIe 2.0 6Gb/s SATA RAID controller. You have other alternatively to add volumes on the Intel-based Mac bootable device listing. You can follow the following procedures to add 6Gb/s SATA RAID controller on the Mac bootable device listing.

1. Set the BIOS selection in System Controls: Advance Configuration to "uEFI" option for Intel_based MacPro boot.
2. Ghost (such as Carbon Copy Cloner ghost utility) the Mac OS X system disk on the Intel-based Mac to the external 6Gb/s SATA RAID controller volume set. Carbon Copy Cloner is an archival type of back up software. You can take your whole Mac OS X system and make a carbon copy or clone to Areca volume similar as an other hard drive.
3. Power up Intel-based Mac, it will take about 30 seconds for controller firmware ready. Areca volume will be added in the bootable device automatically.

2.4 SATA Cables

You can connect the end devices to each other through direct cables or through the SATA backplane connections. The following is an example of some internal SATA cables.

2.4.1 Internal Min SAS 4i to SATA Cable

The Min SAS 4i to SATA cables are used for connection between the 6Gb/s SATA RAID controller internal connectors and connectors on the SATA disk drives or SAS/SATA connector backplane. The 6Gb/s SATA controllers have 1-4 Min SAS 4i (SFF-8087) internal connectors, each of them can support up to four SATA drives.

These controllers can be installed in a server RAID enclosure with standard SATA/SAS connectors backplane. The following diagram

HARDWARE INSTALLATION

shows the picture of Min SAS 4i to 4*SATA cables. Backplane supports SGPIO header can leverage the SGPIO function on the 6Gb/s SATA RAID controller through the sideband cable.

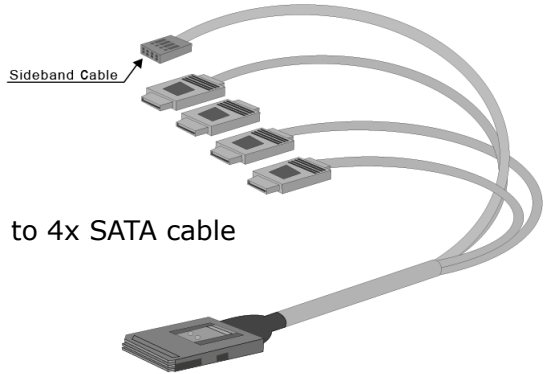

Figure 2-5, SFF-8087 to 4x SATA cable

The SFF-8448 sideband signals cable is reserved for the backplane with header on it.

2.4.2 Internal Min SAS 4i (SFF-8087) to Internal Min SAS 4i (SFF-8087) cable

The 6Gb/s SATA RAID controllers have 1-4 Min SAS 4i internal SFF-8087 connectors, each of them can support up to four SATA signals. These controllers can be installed in a server RAID enclosure with Min SAS 4i internal connectors backplane. This Min SAS 4i cable has eight signal pins to support four SATA drives and six pins for the SGPIO (Serial General Purpose Input/Output) sideband signals. The SGPIO bus is used for efficient LED management and for sensing drive Locate status.

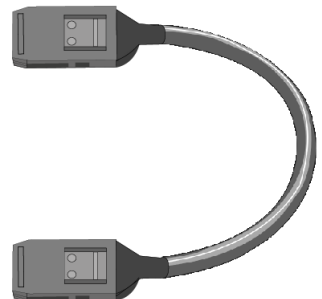

Figure 2-6, SFF-8087 cable

HARDWARE INSTALLATION

2.5 LED Cables

There is no SGPIO supported in the most of old version SATA backplane. The 6Gb/s SATA controller also provides two kinds of alternative LED cable header to support the fault/activity status for those backplanes. The global indicator connector is used by the server/desktop system global indicator LED.

The following electronics schematic is the 6Gb/s SATA RAID controller logical of fault/activity header. The signal from EPLD CTL output pin is cathode (-) side.

The following diagrams and descriptions describe each type of connector.

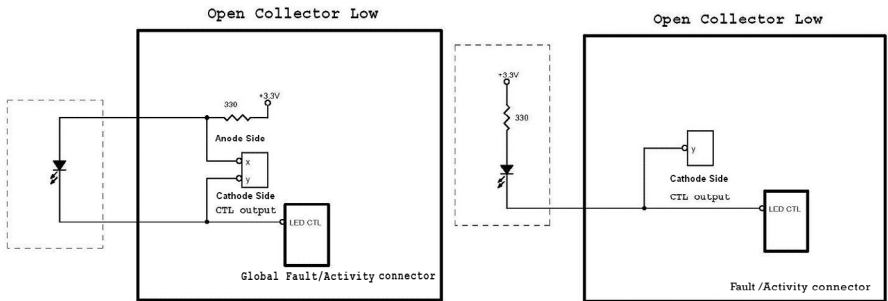

Note:

A cable for the global indicator comes with your computer system. Cables for the individual drive LEDs may come with a drive cage, or you may need to purchase them.

A: Individual Fault LED and Global Activity/Fault Indicator Connector

Most of the backplanes have supported the HDD activity from the HDD. The 6Gb/s SATA RAID controller also provides the fault activity for fault LED. Connect the cables for the drive fault LEDs between the backplane of the cage and the respective connector on the 6Gb/s SATA RAID controller.

The following table is the fault LED signal behavior.

HARDWARE INSTALLATION

LED	Normal Status	Problem Indication
Fault LED	<ol style="list-style-type: none"> When the fault LED is solid illuminated, there is no disk present. When the fault LED is off, then disk is present and status is normal. 	<ol style="list-style-type: none"> When the fault LED is slow blinking (2 times/sec), that disk drive has failed and should be hot-swapped immediately. When the activity LED is illuminated and fault LED is fast blinking (10 times/sec) there is rebuilding activity on that disk drive.

If the system will use only a single global indicator, attach the LED to the two pins of the global activity/fault connector. The global fault pin pair connector is the overall fault signal. This signal will light up in any disk drive failure.

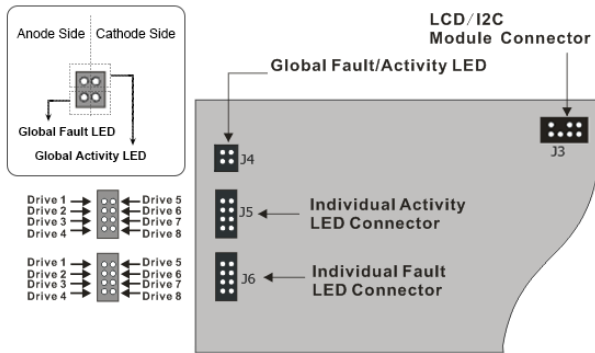

Figure 2-7, ARC-1203-4i/8i LED Indicator Connector

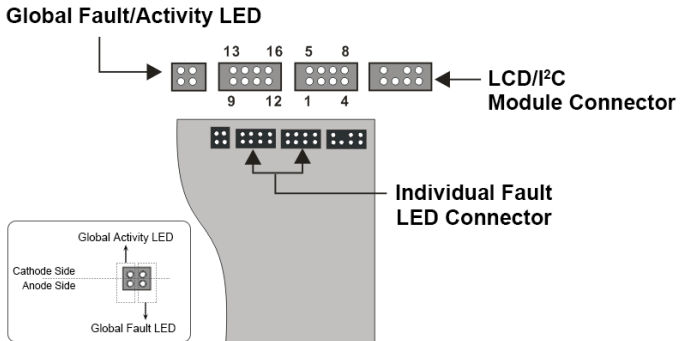

Figure 2-8, ARC-1203-12i/16i LED Indicator Connector

HARDWARE INSTALLATION

B: Areca Serial Bus Connector

The serial bus connector can add optional accessories to add RAID controller more functions. You can connect this interface to Areca LCD module for information, status indication, or menus or Card LED indicator for status message. This interface can also cascade to another Areca serial bus accessories for the additional status display.

The following picture and table is the serial bus signal name description for the LCD/I²C Module Connector (J3).

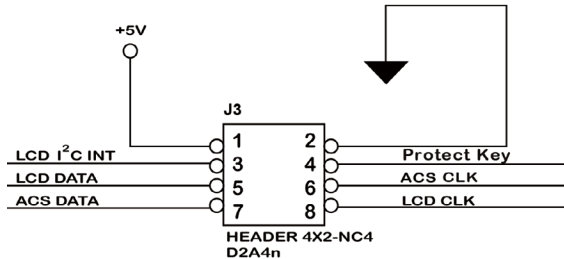

PIN	Description	PIN	Description
1	Power (+5V)	2	GND
3	LCD Module Interrupt	4	Protect Key
5	LCD Module Serial Data	6	Fault/Activity Clock
7	Fault/Activity Serial Data	8	LCD Module Clock

You can use one optional LCD front panel and keypad function to simply create the RAID volume. The LCD status panel also informs you the disk array's current operating status at a glance. The LCD configuration is described in a separate manual: RAID Card_LCD manual. The LCD housed in a 5¼-inch half-height or 3.5-inch canister.

HARDWARE INSTALLATION

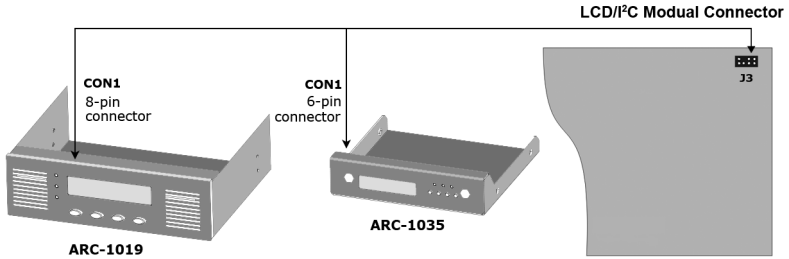

Figure 2-9, Connect to LCD Status Panel

You can use one optional Card LED indicator connected serial bus interface to display fault/activity status on I/O bracket or 3.5-inch canister. This LED provides indications about the operational state of the HDD on the RAID controller.

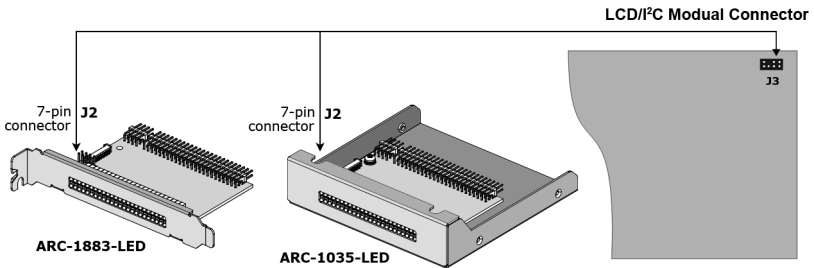
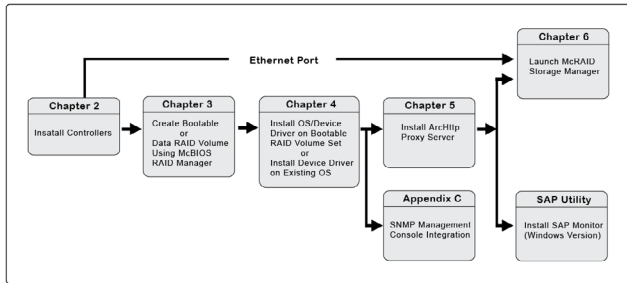

Figure 2-10, Connect to LED Indicator

HARDWARE INSTALLATION

2.6 Summary of the installation

The flow chart below describes the installation procedures for 6Gb/s SATA RAID controllers.



These procedures includes hardware installation, the creation and configuration of a RAID volume through the McBIOS/McRAID manager, OS installation and installation of 6Gb/s SATA RAID controller software.

The software components configure and monitor the 6Gb/s SATA RAID controllers as following table.

Configuration Utility	Operating System Supported
McBIOS RAID Manager	OS-Independent
McRAID Storage Manager (Via ArchTTP proxy server)	Windows 10/8/2012/7/2008/Vista/ XP(64-bit)/2003, Linux, FreeBSD, So- laris and Mac
McRAID Storage Manager (Via Ethernet port)	OS-Independent
SAP Monitor (Single Admin Portal to scan for multiple RAID units in the net- work, via ArchTTP proxy server)	Windows 10/8/2012/7/2008/Vista/ XP(64-bit)/2003
SNMP Manager Console Integration	Windows 10/8/2012/7/2008/Vista/ XP(64-bit)/2003, Linux and FreeBSD

HARDWARE INSTALLATION

McRAID Storage Manager

Before launching the firmware-embedded web browser, McRAID storage manager through the PCIe bus, you need first to install the ArchHTTP proxy server on your server system. If you need additional information about installation and start-up of this function, see the McRAID Storage Manager section in Chapter 6 of the user manual.

ArchHTTP Proxy Server

ArchHTTP has to be installed for GUI RAID console (MRAID storage manager) to run. It is used to launch the web browser McRAID storage manager. It also runs as a service or daemon in the background that allows capturing of events for mail and SNMP traps notification. If you need additional information about installation and start-up of this function, see the ArchHTTP Proxy Server Installation section in Chapter 5 of the user manual.

CLI Utility

CLI (Command Line Interface) lets you set up and manage RAID controller through a command line interface. CLI performs many tasks at the command line. You can download CLI manual from Areca website or software CD <CDROM>\DOCS directory.

SNMP Manager Console Integration

There are two ways to transport SNMP data on the ARC-1203 RAID controller: in-band PCIe host bus interface or out-of-band built-in LAN interface. Enter the "SNMP Tarp IP Address" option on the firmware-embedded SNMP configuration function for user to select the SNMP data agent-side communication from the out-of-band built-in LAN interface. To use in-band PCIe host bus interface, keep blank on the "SNMP Tarp IP Address" options.

- **Out of Band-Using LAN Port Interface**

Out-of-band interface refers to transport SNMP data of 6Gb/s SATA controllers from a remote station connected to the controller through a network cable. Before launching the SNMP manager on the clinet, you need firstly to enable the firmware-embedded SNMP agent function and no additional agent

HARDWARE INSTALLATION

software inquired on your server system. If you need additional information about installation and start-up this function, see the section 6.8.4 SNMP Configuration of the user manual.

- **In-Band-Using PCIe Host Bus Interface**

In-band interface refers to management of the SNMP data of 6Gb/s SATA controllers from a PCIe host bus. In-band interface is simpler than out-of-band interface for it requires less hardware in its configuration. Since the 6Gb/s SATA RAID controller is already installed in the host system, no extra connection is necessary. Just load the necessary in-band Areca SNMP extension agent for the controllers. Before launching the SNMP agent in the sever, you need first to enable the firmware-embedded SNMP community configuration and install Areca SNMP extension agent in your server system. If you need additional information about installation and start-up the function, see the SNMP Operation & Installation section in the Appendix C of the user manual.

Single Admin Portal (ArcSAP) Monitor

This utility can scan for multiple RAID units in the local and remote systems and provide an effective mechanism to configure and monitor your RAID units. For additional information, see the utility manual (ArcSAP) in the packaged CD or download it from the web site **<http://www.areca.com.tw>**

BIOS CONFIGURATION

3. McBIOS RAID Manager

The system mainboard BIOS automatically configures the following 6Gb/s SATA RAID controller parameters at power-up:

- I/O Port Address
- Interrupt Channel (IRQ)
- Controller ROM Base Address

Use McBIOS RAID manager to further configure the 6Gb/s SATA RAID controller to suit your server hardware and operating system.

3.1 Starting the McBIOS RAID Manager

This section explains how to use the McBIOS RAID manager to configure your RAID system. The McBIOS RAID manager is designed to be user-friendly. It is a menu-driven program, residing in the firmware, which allows you to scroll through various menus and sub-menus and select among the predetermined configuration options.

When starting a system with a 6Gb/s SATA RAID controller installed, it will display the following message on the monitor during the start-up sequence (after the system BIOS startup screen but before the operating system boots):

```
ARC-1203 PCIe4/5.0G RAID Controller - DRAM: 1024(MB) / #Channels: 8
BIOS: V1.23 / Date: 2015-12-10 - F/W: V1.52 / Date: 2015-11-10

▶ Bus/Dev/Fun= 8/0/0, I/O-Port=FBEA0000h, IRQ=10, BIOS=CA00 : 0h
▶▶ ID-LUN#00-0, Vol="Areca ARC-1203-VOL#000R001", Size=3.6 (TB)
▶▶ ID-LUN#00-1, Vol="Areca ARC-1203-VOL#001R001", Size=3.6 (TB)
▶▶ ID-LUN#00-2, Vol="Areca ARC-1203-VOL#002R001", Size=3.6 (TB)
▶▶ RAID controller BIOS not installed
▶▶ Press <Tab/F6> to enter SETUP menu. 9 second(s) left <ESC to Skip>..
```

The McBIOS RAID manager message remains on your screen for about nine seconds, giving you time to start the configuration menu by pressing **Tab** or **F6**. If you do not wish to enter configuration menu, press **ESC** to skip configuration immediately. When activated, the McBIOS RAID manager window appears showing a selection dialog box listing the 6Gb/s SATA RAID controllers that are installed in the system. The legend at the bottom of the screen shows you what keys are enabled for the windows.

BIOS CONFIGURATION

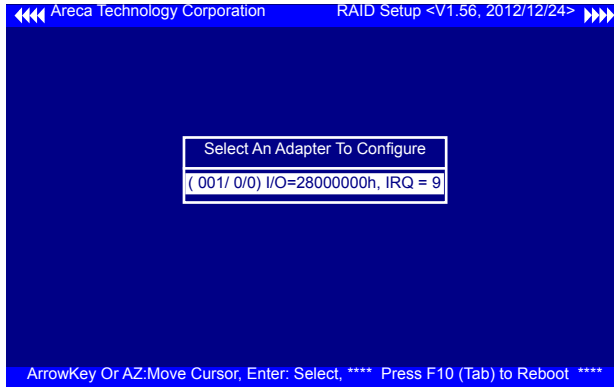

Use the **Up** and **Down** arrow keys to select the controller you want to configure. While the desired controller is highlighted, press the **Enter** key to enter the main menu of the McBIOS RAID manager.

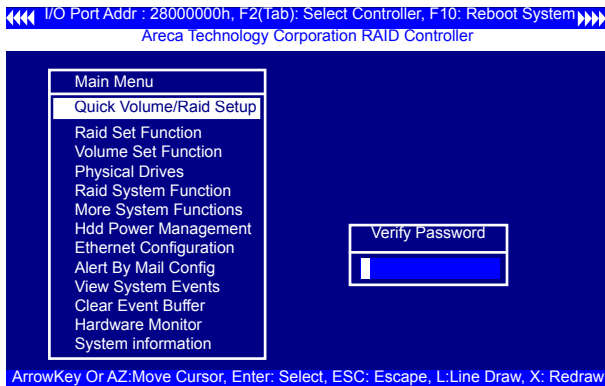

Note:

The manufacture default password is set to **0000**; this password can be modified by selecting **Change Password** in the **Raid System Function** section.

3.2 McBIOS RAID manager

The McBIOS RAID manager is firmware-based and is used to configure RAID sets and volume sets. Because the utility resides in the 6Gb/s SATA RAID controller firmware, operation is independent of any operating systems on your computer. This utility can be used to:

- Create RAID sets,
- Expand RAID sets,

BIOS CONFIGURATION

- Add physical drives,
- Define volume sets,
- Modify volume sets,
- Modify RAID level/stripe size,
- Define pass-through disk drives,
- Modify system functions and
- Designate drives as hot spares.

3.3 Configuring Raid Sets and Volume Sets

You can configure RAID sets and volume sets with McBIOS RAID manager automatically. Using "Quick Volume/Raid Setup" or manually using "Raid Set/Volume Set Function". Each configuration method requires a different level of user input. The general flow of operations for RAID set and volume set configuration is:

Step	Action
1	Designate hot spares/pass-through drives (optional).
2	Choose a configuration method.
3	Create RAID sets using the available physical drives.
4	Define volume sets using the space available in the RAID set.
5	Initialize the volume sets and use volume sets (as logical drives) in the host OS.

3.4 Designating Drives as Hot Spares

Any unused disk drive that is not part of a RAID set can be designated as a hot spare. The "Quick Volume/Raid Setup" configuration will add the spare disk drive and automatically display the appropriate RAID level from which the user can select. For the "Raid Set Function" configuration option, the user can use the "Create Hot Spare" option to define the hot spare disk drive.

When a hot spare disk drive is being created using the "Create Hot Spare" option (in the "Raid Set Function"), all unused physical devices connected to the current controller appear:

Choose the target disk by selecting the appropriate check box. Press **Enter** key to select a disk drive, and press **Yes** in the "Create Hot Spare" to designate it as a hot spare.

BIOS CONFIGURATION

3.5 Using Quick Volume /Raid Setup Configuration

“Quick Volume / Raid Setup configuration” collects all available drives and includes them in a RAID set. The RAID set you created is associated with exactly one volume set. You will only be able to modify the default RAID level, stripe size and capacity of the new volume set. Designating drives as hot spares is also possible in the “Raid Level” selection option. The volume set default settings will be:

Parameter	Setting
Volume Name	ARC-1203-VOL#00
SCSI Channel/SCSI ID/SCSI LUN	0/0/0
Cache Mode	Write-Back
Tag Queuing	Yes

The default setting values can be changed after configuration is completed. Follow the steps below to create arrays using the “Raid Set / Volume Set” method:

Step	Action
1	Choose “Quick Volume /Raid Setup” from the main menu. The available RAID levels with hot spare for the current volume set drive are displayed.
2	<p>It is recommended that you use drives of the same capacity in a specific array. If you use drives with different capacities in an array, all drives in the RAID set will be set to the capacity of the smallest drive in the RAID set.</p> <p>The numbers of physical drives in a specific array determines which RAID levels that can be implemented in the array.</p> <p>RAID 0 requires 1 or more physical drives.</p> <p>RAID 1 requires at least 2 physical drives.</p> <p>RAID 10(1E) requires at least 3 physical drives.</p> <p>RAID 3 requires at least 3 physical drives.</p> <p>RAID 5 requires at least 3 physical drives.</p> <p>RAID 3 +Spare requires at least 4 physical drives.</p> <p>RAID 5 + Spare requires at least 4 physical drives.</p> <p>RAID 6 requires at least 4 physical drives.</p> <p>RAID 6 + Spare requires at least 5 physical drives.</p> <p>Highlight the desired RAID level for the volume set and press the Enter key to confirm.</p>

BIOS CONFIGURATION

3	The capacity for the current volume set is entered after highlighting the desired RAID level and pressing the Enter key. The capacity for the current volume set is displayed. Use the UP and DOWN arrow keys to set the capacity of the volume set and press the Enter key to confirm. The available stripe sizes for the current volume set are then displayed.
4	Use the UP and DOWN arrow keys to select the current volume set stripe size and press the Enter key to confirm. This parameter specifies the size of the stripes written to each disk in a RAID 0, 1, 10(1E), 5 or 6 volume set. You can set the stripe size to 4KB, 8KB, 16KB, 32KB, 64KB, 128KB, 256KB, 512KB, or 1024KB. A larger stripe size provides better read performance, especially when the computer preforms mostly sequential reads. However, if the computer preforms random read requests more often, choose a smaller stripe size.
5	When you are finished defining the volume set, press the Yes key to confirm the "Quick Volume And Raid Set Setup" function.
6	Foreground (Fast Completion) Press Enter key to define fast initialization or selected the Background (Instant Available) or No Init (To Rescue Volume). In the "Background Initialization", the initialization proceeds as a background task, the volume set is fully accessible for system reads and writes. The operating system can instantly access to the newly created arrays without requiring a reboot and waiting the initialization complete. In "Foreground Initialization", the initialization proceeds must be completed before the volume set ready for system accesses. In "No Init", there is no initialization on this volume.
7	Initialize the volume set you have just configured
8	If you need to add additional volume set, using main menu "Create Volume Set" function.

3.6 Using Raid Set/Volume Set Function Method

In "Raid Set Function", you can use the "Create Raid Set" function to generate a new RAID set. In "Volume Set Function", you can use the "Create Volume Set" function to generate an associated volume set and configuration parameters.

If the current controller has unused physical devices connected, you can choose the "Create Hot Spare" option in the "Raid Set Function" to define a global hot spare. Select this method to configure new RAID sets and volume sets. The "Raid Set/Volume Set Function" configuration option allows you to associate volume sets with partial and full RAID sets.

BIOS CONFIGURATION

Step	Action
1	To setup the hot spare (option), choose "Raid Set Function" from the main menu. Select the "Create Hot Spare" and press the Enter key to define the hot spare.
2	Choose "Raid Set Function" from the main menu. Select "Create Raid Set" and press the Enter key.
3	The "Select a Drive For Raid Set" window is displayed showing the SATA drives connected to the 6Gb/s SATA RAID controller.
4	<p>Press the UP and DOWN arrow keys to select specific physical drives. Press the Enter key to associate the selected physical drive with the current RAID set.</p> <p>It is recommended that you use drives of the same capacity in a specific array. If you use drives with different capacities in an array, all drives in the RAID set will be set to the capacity of the smallest drive in the RAID set.</p> <p>The numbers of physical drives in a specific array determines which RAID levels that can be implemented in the array.</p> <p>RAID 0 requires 1 or more physical drives. RAID 1 requires at least 2 physical drives. RAID 10(1E) requires at least 3 physical drives. RAID 3 requires at least 3 physical drives. RAID 5 requires at least 3 physical drives. RAID 6 requires at least 4 physical drives. RAID 30 requires at least 6 physical drives. RAID 50 requires at least 6 physical drives. RAID 60 requires at least 8 physical drives.</p>
5	After adding the desired physical drives to the current RAID set, press the Enter to confirm the "Create Raid Set" function.
6	An "Edit The Raid Set Name" dialog box appears. Enter 1 to 15 alphanumeric characters to define a unique identifier for this new RAID set. The default RAID set name will always appear as Raid Set. #. Press Enter key to finish the name editing.
7	Press the Enter key when you are finished creating the current RAID set. To continue defining another RAID set, repeat step 3. To begin volume set configuration, go to step 8.
8	Choose the "Volume Set Function" from the main menu. Select "Create Volume Set" and press the Enter key.
9	Choose a RAID set from the "Create Volume From Raid Set" window. Press the Yes key to confirm the selection.

BIOS CONFIGURATION

10	Choosing Foreground (Fast Completion) Press Enter key to define fast initialization or selected the Background (Instant Available) or No Init (To Rescue Volume). In the "Background Initialization", the initialization proceeds as a background task, the volume set is fully accessible for system reads and writes. The operating system can instantly access to the newly created arrays without requiring a reboot and waiting the initialization complete. In "Foreground Initialization", the initialization proceeds must be completed before the volume set ready for system accesses. In "No Init", there is no initialization on this volume.
11	If space remains in the RAID set, the next volume set can be configured. Repeat steps 8 to 10 to configure another volume set.

3.7 Main Menu

The main menu shows all functions that are available for executing actions, which is accomplished by clicking on the appropriate link.

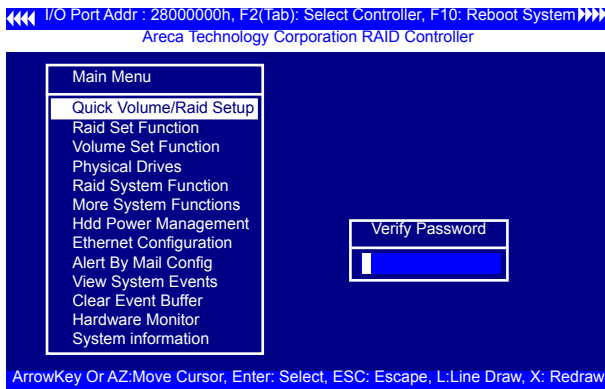

Note:

The manufacture default password is set to **0000**; this password can be modified by selecting "Change Password" in the "Raid System Function" section.

BIOS CONFIGURATION

Option	Description
Quick Volume/Raid Setup	Create a default configuration based on the number of physical disk installed
Raid Set Function	Create a customized RAID set
Volume Set Function	Create a customized volume set
Physical Drives	View individual disk information
Raid System Function	Setup the RAID system configuration
Hdd Power Management	Manage HDD power based on usage patterns
Ethernet Configuration	LAN port setting
View System Events	Record all system events in the buffer
Clear Event Buffer	Clear all information in the event buffer
Hardware Monitor	Show the hardware system environment status
System Information	View the controller system information

This password option allows user to set or clear the RAID controller's password protection feature. Once the password has been set, the user can only monitor and configure the RAID controller by providing the correct password. The password is used to protect the RAID controller from unauthorized entry. The controller will prompt for the password only when entering the main menu from the initial screen. The RAID controller will automatically return to the initial screen when it does not receive any command in five minutes.

3.7.1 Quick Volume/Raid Setup

"Quick Volume/Raid Setup" is the fastest way to prepare a RAID set and volume set. It requires only a few keystrokes to complete. Although disk drives of different capacity may be used in the RAID set, it will use the capacity of the smallest disk drive as the capacity of all disk drives in the RAID set. The "Quick Volume/Raid Setup" option creates a RAID set with the following properties:

1. All of the physical drives are contained in one RAID set.
2. The RAID level, hot spare, capacity, and stripe size options are selected during the configuration process.
3. When a single volume set is created, it can consume all or a portion of the available disk capacity in this RAID set.

BIOS CONFIGURATION

4. If you need to add an additional volume set, use the main menu "Create Volume Set" function.

The total number of physical drives in a specific RAID set determine the RAID levels that can be implemented within the RAID set. Select "Quick Volume/Raid Setup" from the main menu; all possible RAID level will be displayed on the screen.

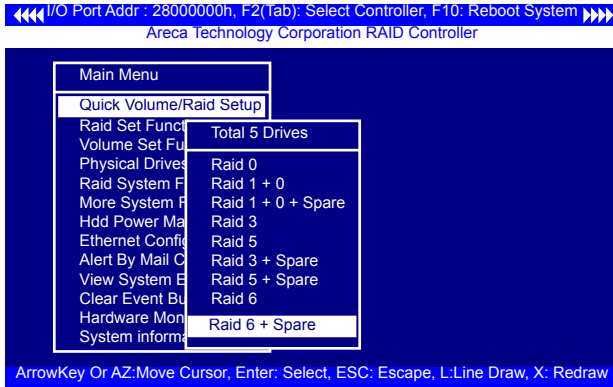

If volume capacity will exceed 2TB, controller will show the "Greater Two TB Volume Support" sub-menu.

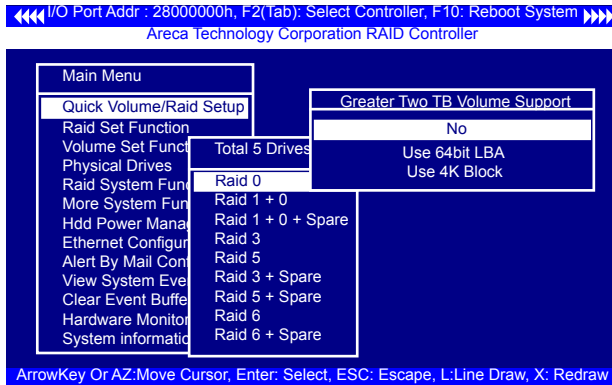

- **No**

It keeps the volume size with max. 2TB limitation.

BIOS CONFIGURATION

- **Use 64bit LBA**

This option use 16 bytes CDB instead of 10 bytes. The maximum volume capacity up to 512TB. For any hard disk drives working in the 4K native mode in the Raid set, the volume set directly sets and exposes 4KB sector size to the operating system. This option works on different OS which supports 16 bytes CDB. Such as:

Windows 2003 with SP1 or later

Linux kernel 2.6.x or later

- **Use 4K Block**

This option uses 16 bytes CDB and changes the sector size from default 512 bytes to 4k bytes. Windows XP only supports maximum volume capacity is up to 16TB.

A single volume set is created and consumes all or a portion of the disk capacity available in this RAID set. Define the capacity of volume set in the "Available Capacity" popup. The default value for the volume set, which is 100% of the available capacity, is displayed in the selected capacity. Use the **UP** and **DOWN** arrow key to set capacity of the volume set and press **Enter** key to accept this value. If the volume set uses only part of the RAID set capacity, you can use the "Create Volume Set" option in the main menu to define additional volume sets.

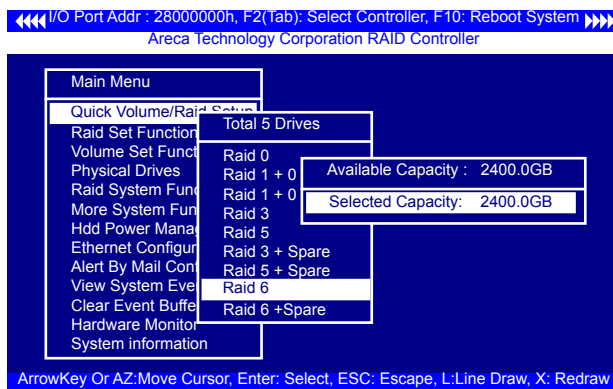

BIOS CONFIGURATION

Stripe Size This parameter sets the size of the stripe written to each disk in a RAID 0, 1, 1E, 10, 5, or 6 logical drive. You can set the stripe size to 4KB, 8KB, 16KB, 32KB, 64KB, 128KB, 256KB, 512KB, or 1024KB.

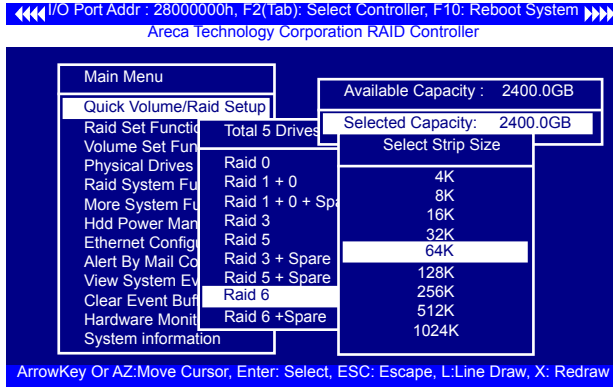

A larger stripe size produces better-read performance, especially if your computer does mostly sequential reads. However, if you are sure that your computer performs random reads more often, select a smaller stripe size.

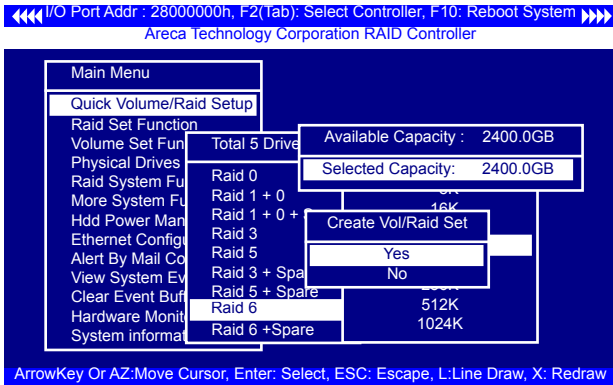

Press **Yes** key in the "Create Vol/Raid Set" dialog box, the RAID set and volume set will start to initialize it.

BIOS CONFIGURATION

Select "Foreground (Faster Completion)" or "Background (Instant Available)" for initialization and "No Init (To Rescue Volume)" for recovering the missing RAID set configuration.

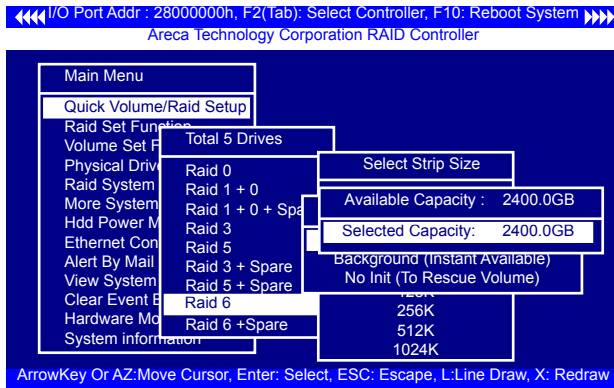

3.7.2 Raid Set Function

Manual configuration gives complete control of the RAID set setting, but it will take longer to configure than "Quick Volume/Raid Setup" configuration. Select "Raid Set Function" to manually configure the RAID set for the first time or delete existing RAID sets and reconfigure the RAID set.

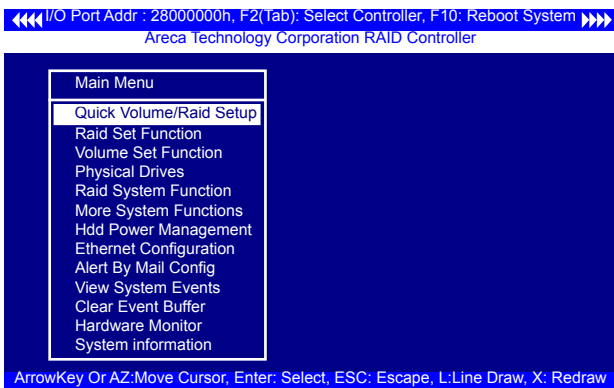

BIOS CONFIGURATION

3.7.2.1 Create Raid Set

The following summaries are the RAID set features for the 6Gb/s SATA RAID controller.

1. Up to 16 disk drives can be included in a single RAID set.
2. Up to 16 RAID sets can be created per controller, but RAID level 30 50 and 60 only can support two sub-volumes (RAID set).

To define a RAID set, follow the procedures below:

- (1). Select "Raid Set Function" from the main menu.
- (2). Select "Create Raid Set" from the "Raid Set Function" dialog box.
- (3). A "Select IDE Drive For Raid Set" window is displayed showing the SATA drives connected to the current controller. Press the **UP** and **DOWN** arrow keys to select specific physical drives. Press the **Enter** key to associate the selected physical drive with the current RAID set. Repeat this step; the user can add as many disk drives as are available to a single RAID set. When finished selecting SATA drives for RAID set, press **Esc** key. A "Create Raid Set Confirmation" screen will appear, select the **Yes** option to confirm it.

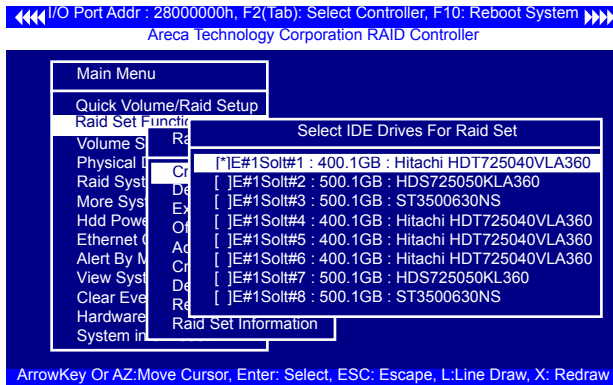

- (4). An "Edit The Raid Set Name" dialog box appears. Enter 1 to 15 alphanumeric characters to define a unique identifier for the RAID set. The default RAID set name will always appear as Raid Set #.
- (5). Repeat steps (3) to define another RAID sets.

BIOS CONFIGURATION

Note:

To create RAID 30/50/60 volume, you need create multiple RAID sets first with the same disk numbers on each RAID set. The max no. disk drives per volume set: 16 for RAID 0/10(1E)/3/5/6/30/50/60

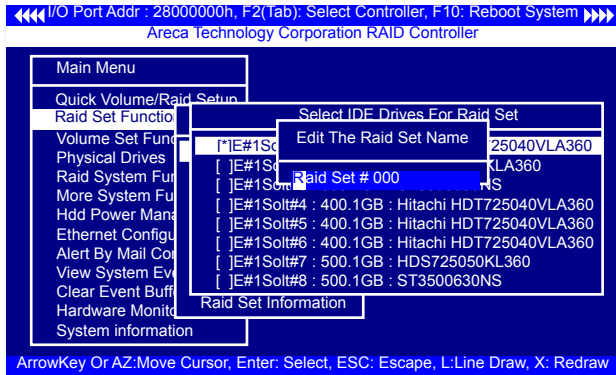

3.7.2.2 Delete Raid Set

To completely erase and reconfigure a RAID set, you must first delete it and re-create the RAID set. To delete a RAID set, select the RAID set number that you want to delete in the "Select Raid Set To Delete" screen. Then "Delete Raid Set" dialog box will appear, press the **Yes** to delete it. Warning, data on RAID set will be lost if this option is used. But for deleting RAID set with the Raid 30/50/60 volume, firstly, you need to delete the volumes belonging those RAID sets.

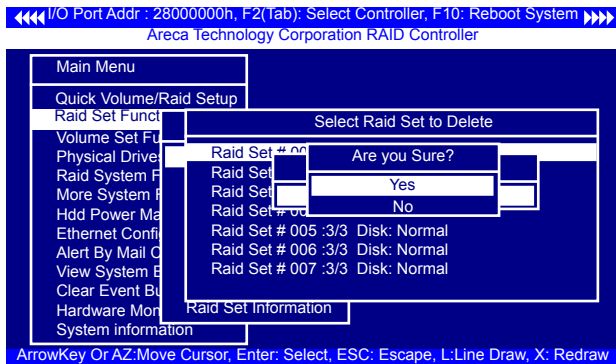

BIOS CONFIGURATION

3.7.2.3 Expand Raid Set

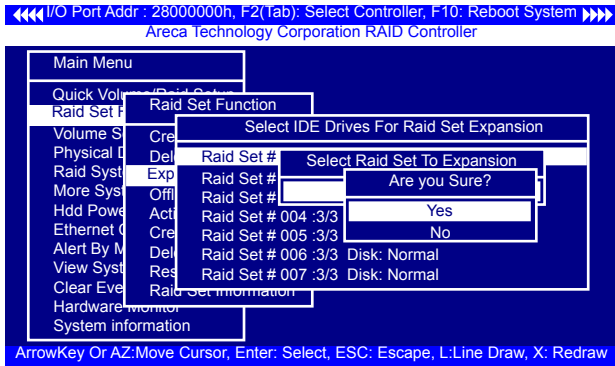

Instead of deleting a RAID set and recreating it with additional disk drives, the "Expand RAID Set" function allows the users to add disk drives to the RAID sets that have already been created.

To expand a RAID set:

1. Select the "Expand RAID Set" option. If there is an available disk, then the "Select SATA Drives For RAID Set Expansion" screen appears.
2. Select the target RAID set by clicking on the appropriate radius button. Select the target disk by clicking on the appropriate check box.
3. Press the **Yes** key to start the expansion on the RAID set.

The new additional capacity can be utilized by one or more volume sets. The volume sets associated with this RAID set appear for you to have chance to modify RAID level or stripe size. Follow the instruction presented in the "Modify Volume Set" to modify the volume sets; operation system specific utilities may be required to expand operating system partitions.

Caution:

RAID set expansion is a quite critical process, we strongly recommend customer backup data before expand. Unexpected accident may cause serious data corruption.

BIOS CONFIGURATION

Note:

1. Once the "Expand Raid Set" process has started, user can not stop it. The process must be completed.
2. If a disk drive fails during RAID set expansion and a hot spare is available, an auto rebuild operation will occur after the RAID set expansion completes.
3. RAID 30/50/60 doesn't support the "Expand Raid Set".

● Migrating

Migration occurs when a disk is added to a RAID set. Migrating state is displayed in the RAID state area of "The Raid Set Information" screen when a disk is being added to a RAID set. Migrating state is also displayed in the associated volume state area of the "Volume Set Information" which belongs this RAID set.

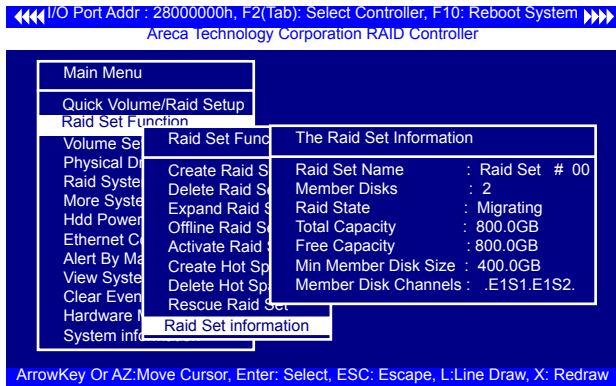

3.7.2.4 Offline Raid Set

This function is for customer being able to unmount and re-mount a multi-disk volume. All Hdds of the selected RAID set will be put into offline state and spun down and fault LED will be in fast blinking mode.

BIOS CONFIGURATION

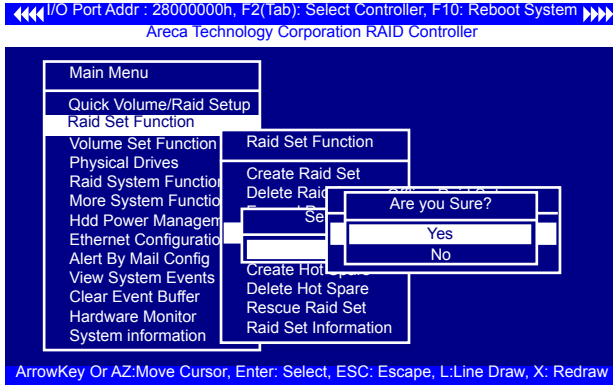

3.7.2.5 Activate Incomplete Raid Set

The following screen is used to activate the RAID set after one of its disk drive was removed in the power off state. When one of the disk drives is removed in power off state, the RAID set state will change to "Incomplete State". If user wants to continue to work while the 6Gb/s SATA RAID controller is powered on, the user can use the "Activate Incomplete Raid Set" option, the RAID state will change to "Degraded Mode" and start to work.

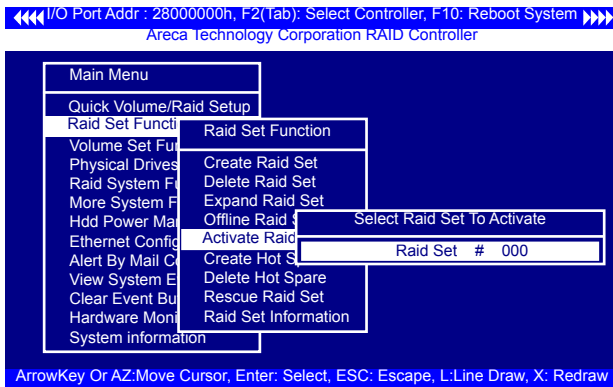

BIOS CONFIGURATION

3.7.2.6 Create Hot Spare

When you choose the "Create Hot Spare" option in the "Raid Set Function", all unused physical devices connected to the current controller will result in the screen.

Select the target disk by clicking on the appropriate check box. Press the **Enter** key to select a disk drive and press **Yes** in the "Create Hot Spare" to designate it as a hot spare.

The "Create Hot Spare" gives you the ability to define a global or dedicated hot spare. Unlike "Global Hot Spare" which can be used with any RAID sets, "Dedicated Hot Spare" can only be used with a specific RAID set or Enclosure. Under "Global For SSD or HDD" option, SSD hot spare is used to rebuild failed SSD and HDD hot spare for rebuild failed HDD. When a disk drive fails in the RAID set or enclosure with a dedicated hot spare is pre-set, data on the disk drive is rebuild automatically on the dedicated hot spare disk.

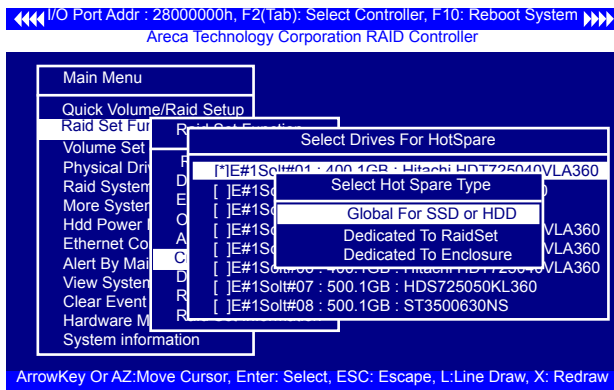

3.7.2.7 Delete Hot Spare

Select the target hot spare disk to delete by clicking on the appropriate check box.

Press the **Enter** key to select a hot spare disk drive, and press **Yes** in the "Delete Hot Spare" screen to delete the hot spare.

BIOS CONFIGURATION

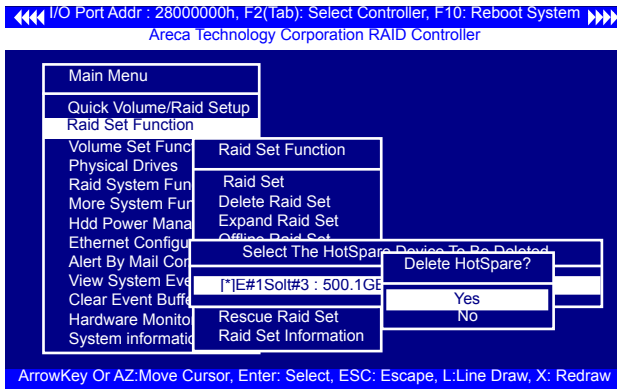

3.7.2.8 Rescue Raid Set

When the system is powered off in the RAID set update/creation period, it possibly could disappear due to this abnormal condition. The "RESCUE" function can recover the missing RAID set information. The RAID controller uses the time as the RAID set signature. The RAID set may have different time after the RAID set is recovered. The "SIGANT" function can regenerate the signature for the RAID set.

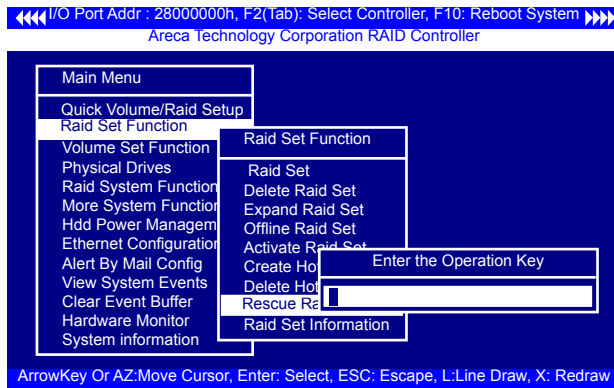

Caution:

Please contact us to make sure if you need to use rescue function. Improperly usage may cause configuration corruption.

BIOS CONFIGURATION

Once can manually fail a drive, which is useful in kill-off slow speed disk. There is nothing physically wrong with the disk. A manually failed the drive can be rebuilt by the hot spare and brought back on-line.

3.7.2.9 Raid Set Information

To display RAID set information, move the cursor bar to the desired RAID set number, then press the **Enter** key. The "Raid Set Information" will appear. You can only view information for the RAID set in this screen.

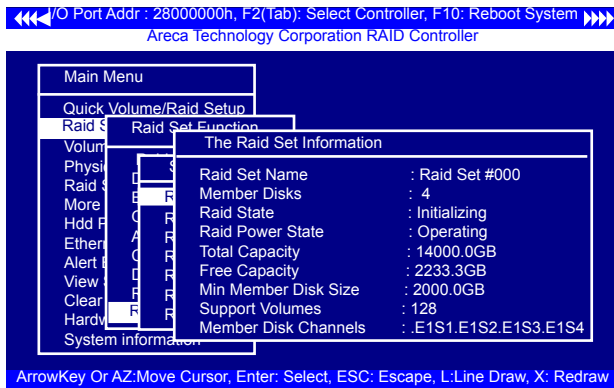

3.7.3 Volume Set Function

A volume set is seen by the host system as a single logical device; it is organized in a RAID level within the controller utilizing one or more physical disks. RAID level refers to the level of data performance and protection of a volume set. A volume set can consume all of the capacity or a portion of the available disk capacity of a RAID set. Multiple volume sets can exist on a RAID set. If multiple volume sets reside on a specified RAID set, all volume sets will reside on all physical disks in the RAID set. Thus each volume set on the RAID set will have its data spread evenly across all the disks in the RAID set rather than one volume set using some of the available disks and another volume set using other disks.

BIOS CONFIGURATION

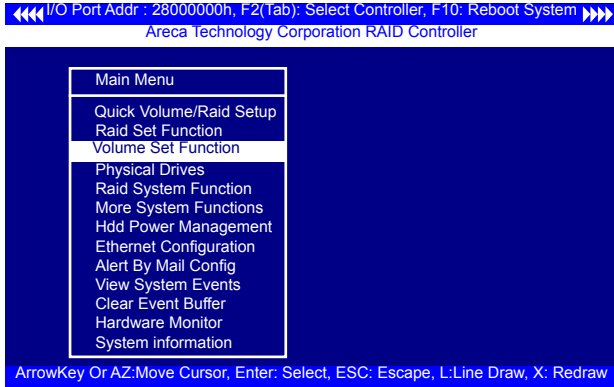

The following summaries are the volume set features for the 6Gb/s SATA RAID controller.

1. Volume sets of different RAID levels may coexist on the same RAID set and up to 128 volume sets per controller.
2. Up to 128 volume sets can be created in a RAID set.
3. The maximum addressable size of a single volume set is not limited to 2TB, because the controller is capable of 64-bit LBA mode. However the operating system itself may not be capable of addressing more than 2TB.

3.7.3.1 Create Volume Set (0/1/10/3/5/6)

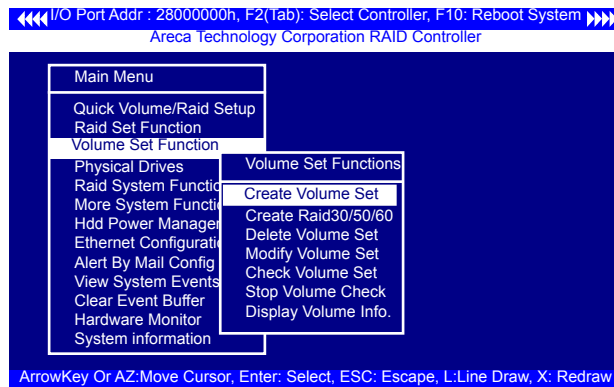

BIOS CONFIGURATION

To create a volume set, following the steps:

1. Select the "Volume Set Function" from the main menu.
2. Choose the "Create Volume Set" from "Volume Set Functions" dialog box screen.
3. The "Create Volume From Raid Set" appears. This screen displays the existing arranged RAID sets. Select the RAID set number and press the **Enter** key. The "Volume Creation" dialog is displayed in the screen.
4. The new create volume set attribute allows user to select the Volume Name, Raid level, Capacity, Strip Size, SCSI Channel/ SCSI ID/SCSI Lun, Cache Mode, and Tagged Command Queuing.

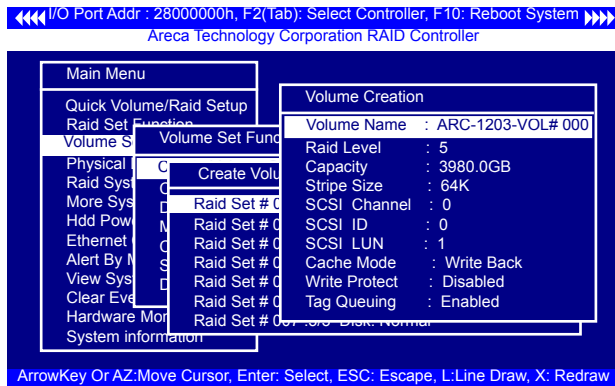

5. After completed the modification of the volume set, press the **Esc** key to confirm it. An "Initialization Mode" screen appears.
 - Select "Foreground (Faster Completion)" for faster initialization of the selected volume set.
 - Select "Background (Instant Available)" for normal initialization of the selected volume set.
 - Select "No Init (To Rescue Volume)" for no initialization of the selected volume.

BIOS CONFIGURATION

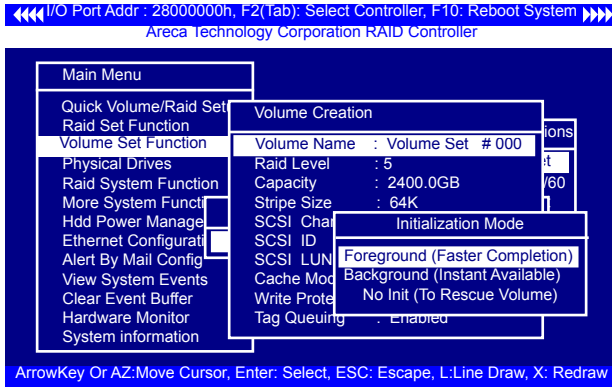

- Repeat steps 3 to 5 to create additional volume sets.
- The initialization percentage of volume set will be displayed at the bottom line.

Note:

Controller starts to initialize the volume in two conditions

- Stay in controller bios manager or
- Boot into OS and the controller driver loaded.

● Volume Name

The default volume name will always appear as ARC-1203-VOL #. You can rename the volume set providing it does not exceed the 15 characters limit.

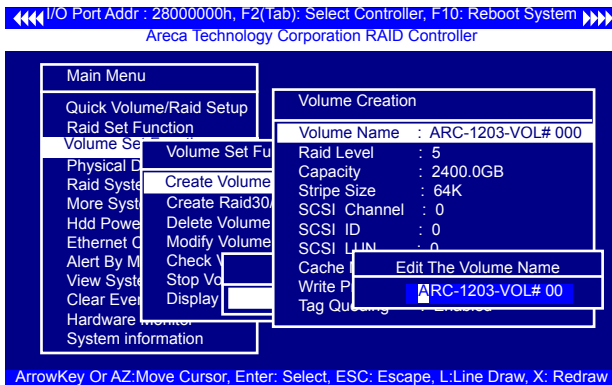

BIOS CONFIGURATION

● Raid Level

Set the "Raid Level" for the volume set. Highlight "Raid Level" and press the **Enter** key. The available RAID levels for the current volume set are displayed. Select a RAID level and press the **Enter** key to confirm.

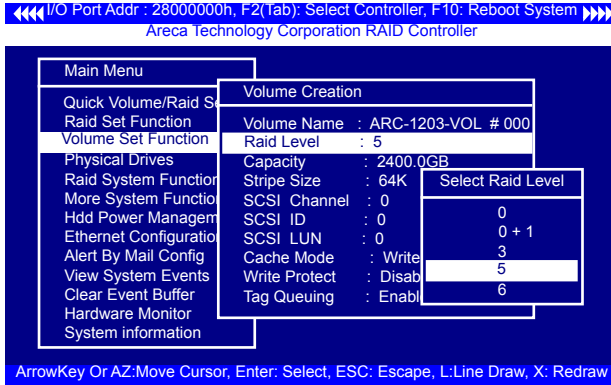

● Capacity

The maximum available volume size is the default value for the first setting. Enter the appropriate volume size to fit your application. The capacity value can be increased or decreased by the **UP** and **DOWN** arrow keys. The capacity of each volume set must be less than or equal to the total capacity of the RAID set on which it resides.

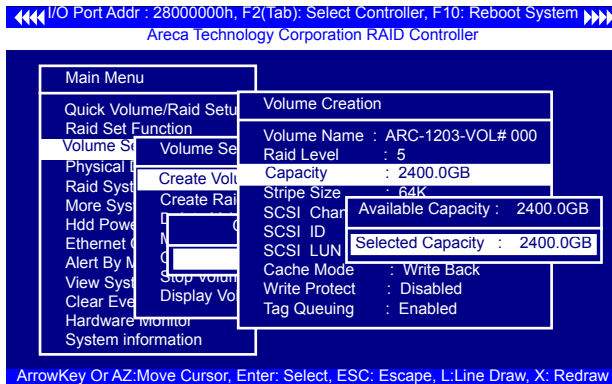

BIOS CONFIGURATION

If volume capacity will exceed 2TB, controller will show the "Greater Two TB Volume Support" sub-menu.

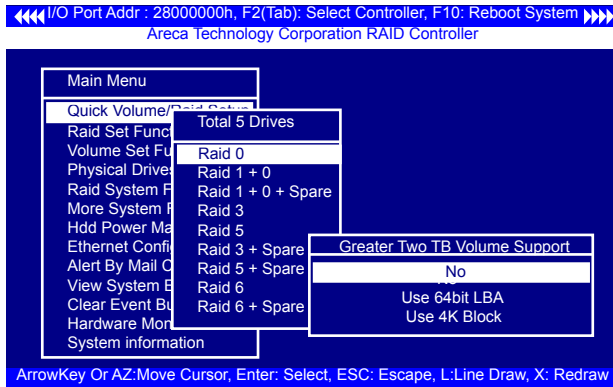

- No

When this option is enabled, it keeps the volume size with max. 2TB limitation. For any hard disk drives working in the 4K native mode in the Raid set, the volume set directly sets and exposes 4KB sector size to the operating system.

- Use 64bit LBA

This option use 16 bytes CDB instead of 10 bytes. The maximum volume capacity up to 512TB. For any hard disk drives working in the 4K native mode in the Raid set, the volume set directly sets and exposes 4KB sector size to the operating system. This option works on different OS which supports 16 bytes CDB. Such as:

Windows 2003 with SP1 or later

Linux kernel 2.6.x or later

- Use 4K Block

This option uses 16 bytes CDB and changes the sector size from default 512 bytes to 4k bytes. Windows XP only supports maximum volume capacity is up to 16TB.

BIOS CONFIGURATION

● Stripe Size

This parameter sets the size of segment written to each disk in a RAID 0, 1, 1E, 10, 5, 6, 50 or 60 logical drive. You can set the stripe size to 4KB, 8KB, 16KB, 32KB, 64KB, 128KB, 256KB, 512KB, or 1024KB.

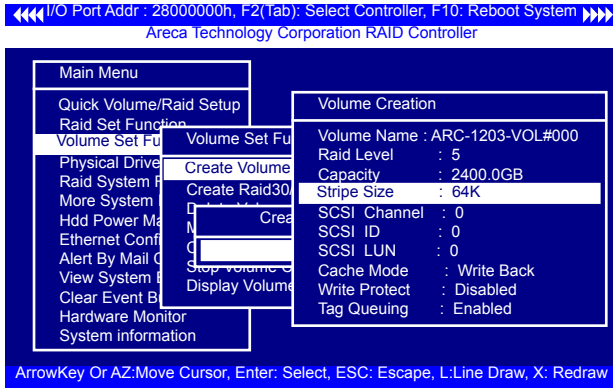

The 6Gb/s SATA RAID controller function simulates an external SCSI RAID controller. The host bus represents the SCSI channel. Choose the "SCSI Channel". A "Select SCSI Channel" dialog box appears; select the channel number and press the **Enter** key to confirm it.

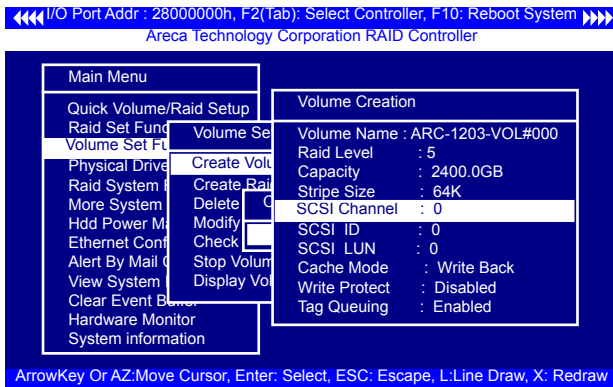

BIOS CONFIGURATION

● SCSI ID

Each device attached to the 6Gb/s SATA RAID controller, as well as the 6Gb/s SATA RAID controller itself, must be assigned a unique SCSI ID number. A SCSI channel can connect up to 15 devices. It is necessary to assign a SCSI ID to each device from a list of available SCSI IDs.

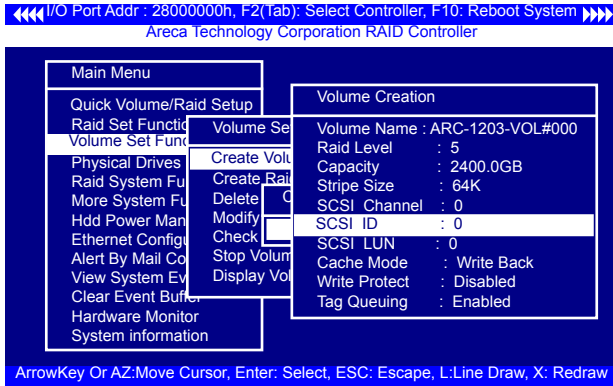

● SCSI LUN

Each SCSI ID can support up to 8 LUNs. Most 6Gb/s SATA controllers treat each LUN as if it were a SATA disk.

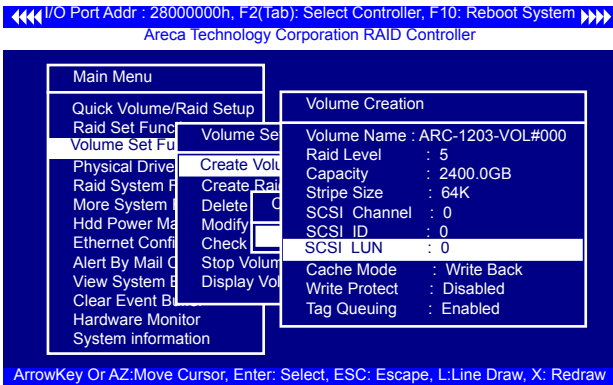

BIOS CONFIGURATION

● Cache Mode

User can set the cache mode to either "Write Through" or "Write Back".

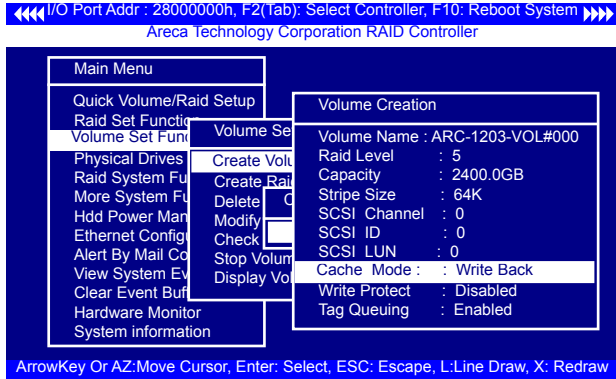

● Write Protect

When "Write Protect" is enabled on the "Create Volume Set", host commands fail if they are issued to a volume in that RAID controller and attempt to modify a volume's data or attributes. "Write Protection" is used primarily for customer-initiated disaster recovery testing.

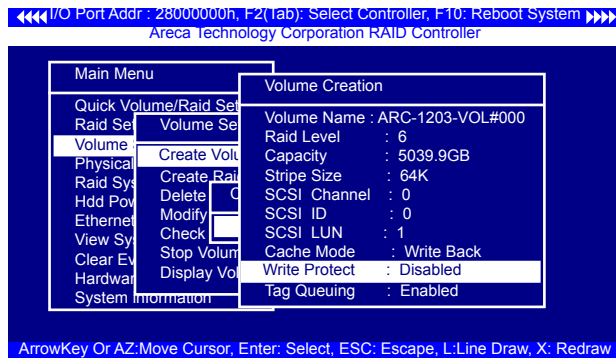

BIOS CONFIGURATION

• Tag Queuing

This option, when enabled, can enhance overall system performance under multi-tasking operating systems. The Command Tag (Drive Channel) function controls the SATA command tag queuing support for each drive channel. This function should normally remain be enabled. Disabled this function only when using older drives that do not support command tag queuing.

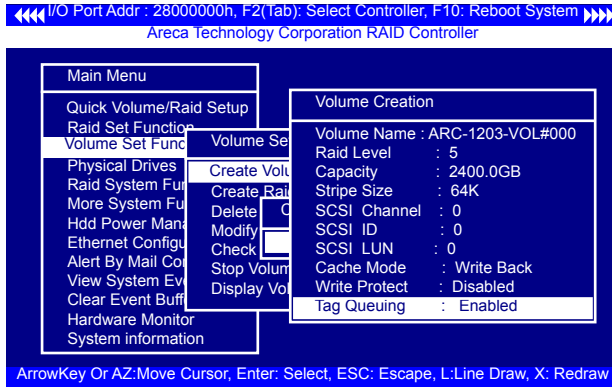

3.7.3.2 Create Raid30/50/60 (Volume Set 30/50/60)

To create 30/50/60 volume set from RAID set group, move the cursor bar to the main menu and click on the "Create Raid30/50/60" link. The "Select The Raid Set To Create Volume On It" screen will show all RAID set number. Tick on the RAID set numbers (same disk No per RAID set) that you want to create and then click on it.

The created new volume set attribute option allows users to select the Volume Name, Capacity, Raid Level, Strip Size, SCSI ID/ LUN, Cache Mode, and Tagged Command Queuing. The detailed description of those parameters can refer to section 3.7.3.1. User can modify the default values in this screen; the modification procedures are in section 3.7.3.4.

BIOS CONFIGURATION

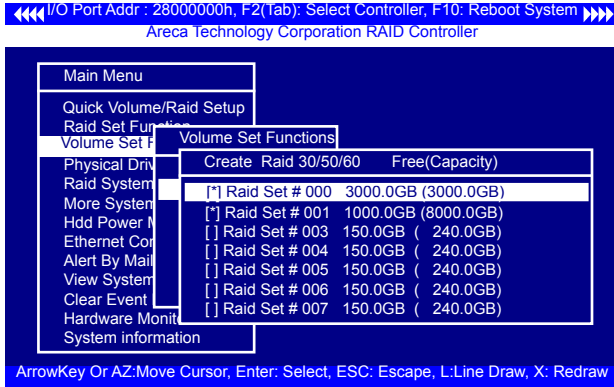

Note:

Raid Level 30 50 and 60 can support up to eight RAID sets (four pairs).

3.7.3.3 Delete Volume Set

To delete volume set from a RAID set, move the cursor bar to the "Volume Set Functions" menu and select the "Delete Volume Set" item, then press the **Enter** key. The "Volume Set Functions" menu will show all Raid Set # items. Move the cursor bar to a RAID set number, then press the **Enter** key to show all volume sets within that RAID set. Move the cursor to the volume set number that is to be deleted and press the **Enter** key to delete it.

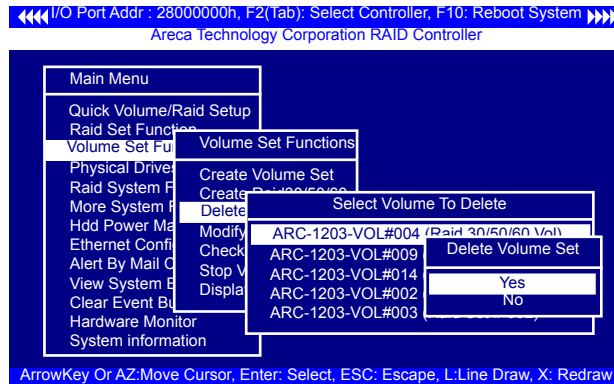

BIOS CONFIGURATION

3.7.3.4 Modify Volume Set

Use this option to modify volume set configuration. To modify volume set values from RAID set system function, move the cursor bar to the "Modify Volume Set" item, then press the **Enter** key. The "Volume Set Functions" menu will show all RAID set items. Move the cursor bar to a RAID set number item, then press the **Enter** key to show all volume set items. Select the volume set from the list to be changed, press the **Enter** key to modify it.

As shown, volume information can be modified at this screen. Choose this option to display the properties of the selected volume set. But user can only modify the last volume set capacity.

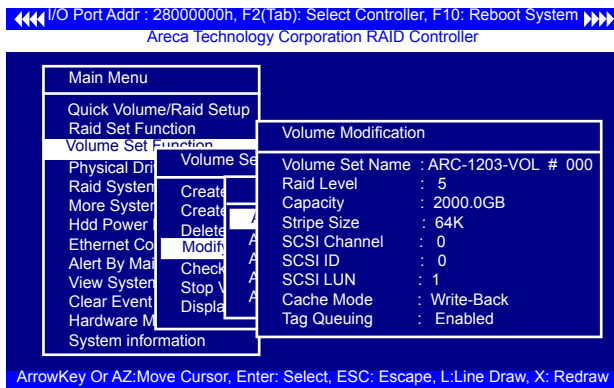

3.7.3.4.1 Volume Growth

Use "Expand Raid Set" function to add disk to a RAID set. The additional capacity can be used to enlarge the last volume set size or to create another volume set. The "Modify Volume Set" function can support the "Volume Modification" function. To expand the last volume set capacity, move the cursor bar to the "Capacity" item and entry the capacity size. When finished the above action, press the **ESC** key and select the **Yes** option to complete the action. The last volume set starts to expand its capacity.

BIOS CONFIGURATION

To expand an existing volume noticed:

- Only the last volume can expand capacity.
- When expand volume capacity, you can't modify stripe size or modify RAID level simultaneously.
- You can expand volume capacity, but can't reduce volume capacity size.
- After volume expansion, the volume capacity can not be decreased.

For greater 2TB expansion:

- If your system installed in the volume, don't expand the volume capacity greater 2TB; except your OS and RAID controller can support boot up from a greater 2TB capacity device.
- Expand over 2TB used 64bit LBA mode. Please make sure your OS supports 64bit LBA before expand it.

3.7.3.4.2 Volume Set Migration

Migrating occurs when a volume set is migrating from one RAID level to another, when a volume set strip size changes, or when a disk is added to a RAID set. Migration state is displayed in the volume state area of the "Volume Set Information" screen.

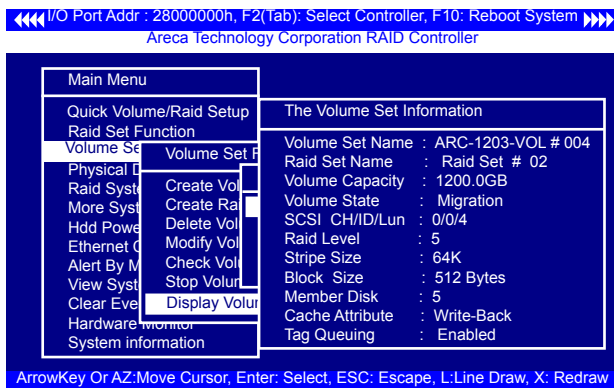

Note:

Power failure may damage the migration data. Please back-up the RAID data before you start the migration function.

BIOS CONFIGURATION

3.7.3.5 Check Volume Set

Use this option to verify the correctness of the redundant data in a volume set. For example, in a system with a dedicated parity disk drive, a volume set check entails computing the parity of the data disk drives and comparing those results to the contents of the dedicated parity disk drive. To check volume set, move the cursor bar to the "Check Volume Set" item, then press the **Enter** key. The "Volume Set Functions" menu will show all RAID set number items. Move the cursor bar to a RAID set number item and then press the **Enter** key to show all volume set items. Select the volume set to be checked from the list and press **Enter** key to select it. After completed the selection, the confirmation screen appears, press **Yes** to start the check.

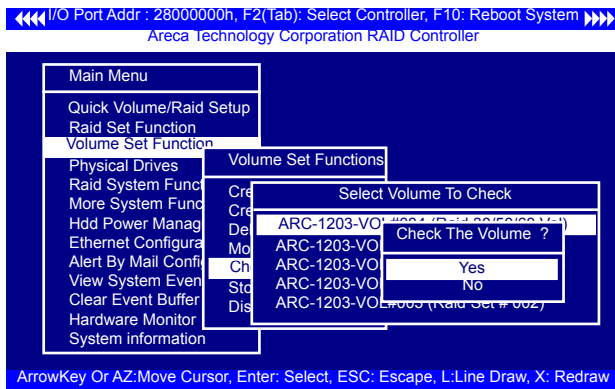

3.7.3.6 Stop Volume Set Check

Use this option to stop all of the "Check Volume Set" operations.

3.7.3.7 Display Volume Set Info.

To display volume set information, move the cursor bar to the desired volume set number and then press the **Enter** key. The "Volume Set Information" screen will be shown. You can only view the information of this volume set in this screen, but can not modify it.

BIOS CONFIGURATION

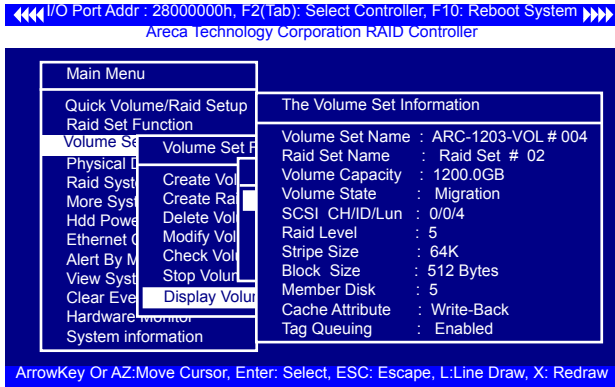

3.7.4 Physical Drives

Choose this option from the main menu to select a physical disk and perform the operations listed above. Move the cursor bar to an item, then press **Enter** key to select the desired function.

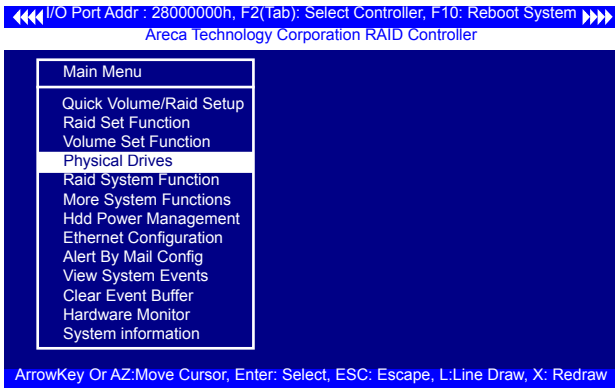

3.7.4.1 View Drive Information

When you choose this option, the physical disks connected to the 6Gb/s SATA RAID controller are listed. Move the cursor to the desired drive and press **Enter** key to view drive information.

BIOS CONFIGURATION

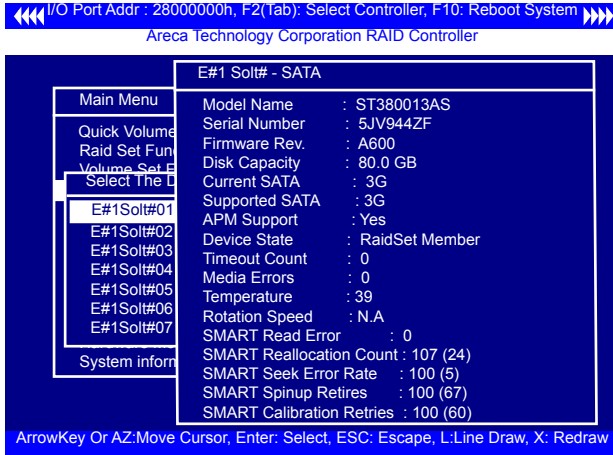

3.7.4.2 Create Pass-Through Disk

A pass-through disk is not controlled by the 6Gb/s SATA RAID controller firmware and thus cannot be a part of a volume set. The disk is available directly to the operating system as an individual disk. It is typically used on a system where the operating system is on a disk not controlled by the 6Gb/s SATA RAID controller firmware. The SCSI Channel/SCSI ID/SCSI LUN, Cache Mode, Write Protect and Tag Queuing must be specified to create a pass-through disk.

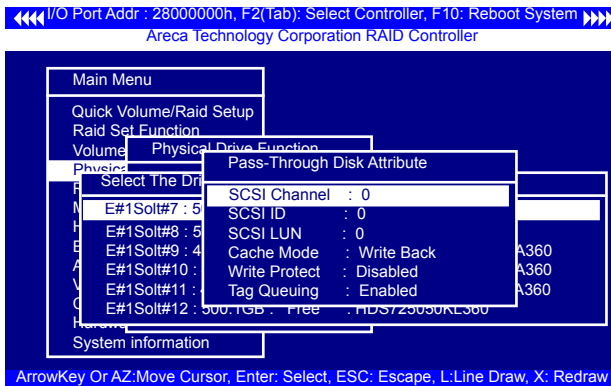

BIOS CONFIGURATION

3.7.4.3 Modify Pass-Through Disk

Use this option to modify "Pass-Through Disk Attributes". To select and modify a pass-through disk from the pool of pass-through disks, move the "Modify Pass-Through Drive" option and then press the **Enter** key. The "Physical Drive Function" menu will show all pass-through drive number options. Move the cursor bar to the desired number and then press the **Enter** key to show all pass-through disk attributes. Select the parameter from the list to be changed and then press the **Enter** key to modify it.

3.7.4.4 Delete Pass-Through Disk

To delete a pass-through drive from the pass-through drive pool, move the cursor bar to the "Delete Pass-Through Drive" item, then press the **Enter** key. The "Delete Pass-Through confirmation" screen will appear; select **Yes** to delete it.

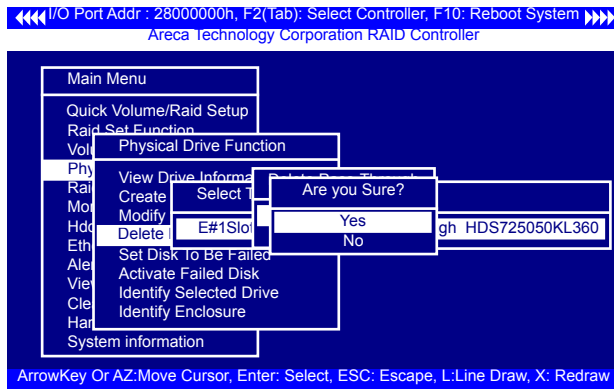

BIOS CONFIGURATION

3.7.4.5 Set Disk To Be Failed

It sets a normal working disk as “failed” so that users can test some of the features and functions.

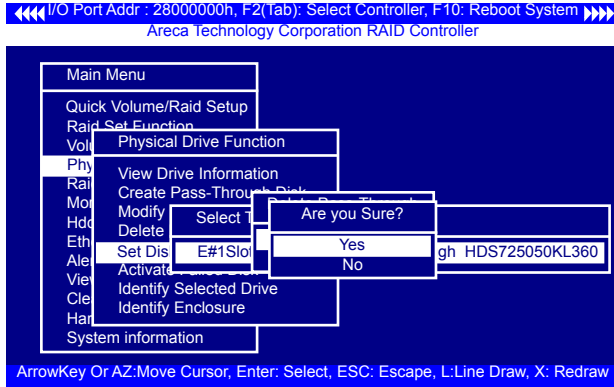

3.7.4.6 Activate Failed Disk

It forces the current “failed” disk in the system to be back on-line. “Activate Failed Disk” function has no effect on the removed disks, because a “removed” disk does not give the controller a chance to mark it as “failure”.

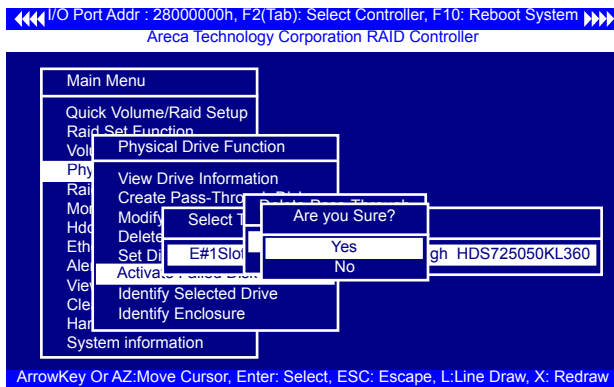

BIOS CONFIGURATION

3.7.4.7 Identify Selected Drive

To prevent removing the wrong drive, the selected disk fault LED indicator will light for physically locating the selected disk when the "Identify Selected Device" is selected.

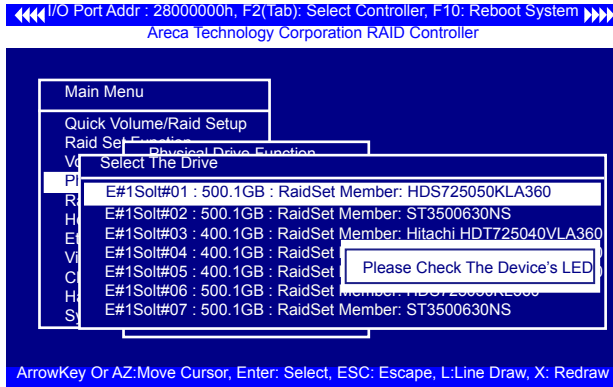

3.7.4.8 Identify Enclosure

To prevent removing the wrong enclosure, the selected Areca expander enclosure all disks fault LED indicator will light for physically locating the selected enclosure when the "Identify Enclosure" is selected. This function will also light the enclosure LED indicator, if it is existed.

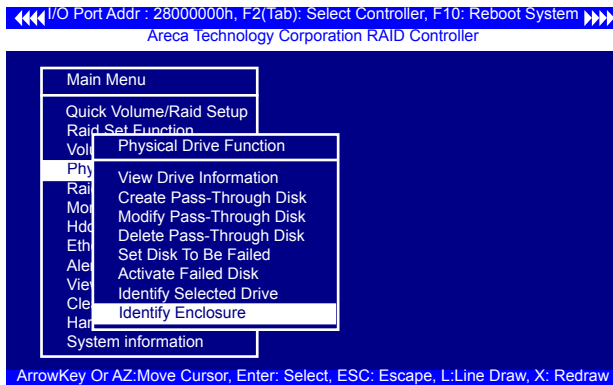

BIOS CONFIGURATION

3.7.5 Raid System Function

To set the "Raid System Function", move the cursor bar to the main menu and select the "Raid System Function" item and then press **Enter** key. The "Raid System Function" menu will show multiple items. Move the cursor bar to an item, then press **Enter** key to select the desired function.

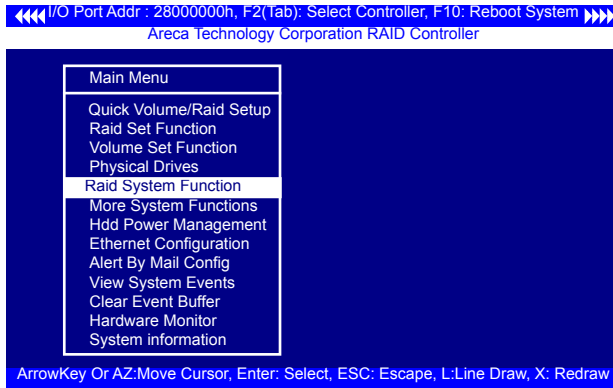

3.7.5.1 Mute The Alert Beeper

The "Mute The Alert Beeper" function item is used to control the SATA RAID controller beeper. Select **Yes** and press the **Enter** key in the dialog box to turn the beeper off temporarily. The beeper will still activate on the next event.

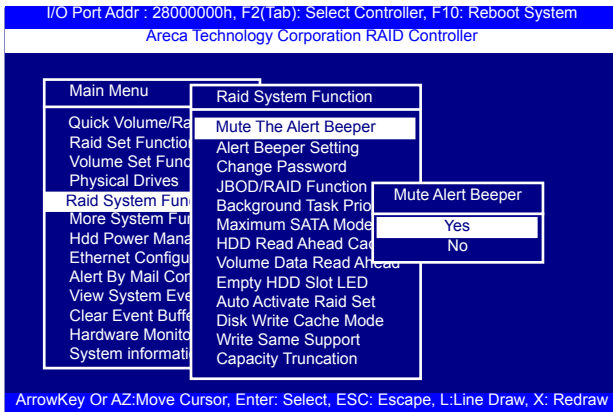

BIOS CONFIGURATION

3.7.5.2 Alert Beeper Setting

The "Alert Beeper Setting" function item is used to "Disabled" or "Enabled" the SATA RAID controller alarm tone generator. Select "Disabled" and press the **Enter** key in the dialog box to turn the beeper off.

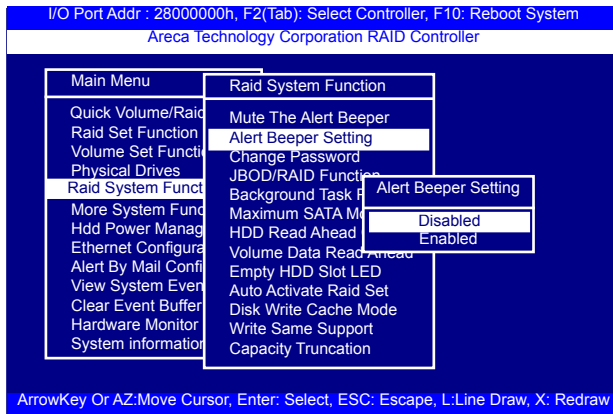

3.7.5.3 Change Password

The manufacture default password is set to 0000.

The password option allows user to set or clear the password protection feature. Once the password has been set, the user can monitor and configure the controller only by providing the correct password. This feature is used to protect the internal RAID system from unauthorized access. The controller will check the password only when entering the main menu from the initial screen. The system will automatically go back to the initial screen if it does not receive any command in 5 minutes.

To set or change the password, move the cursor to "Raid System Function" screen, press the "Change Password" item. The "Enter New Password" screen will appear. Do not use spaces when you enter the password. If spaces are used, it will lock out the user. To disable the password, only press **Enter** key in both the "Enter New Password" and "Re-Enter New Password" column. The existing password will be cleared. No password checking will occur when entering the main menu.

BIOS CONFIGURATION

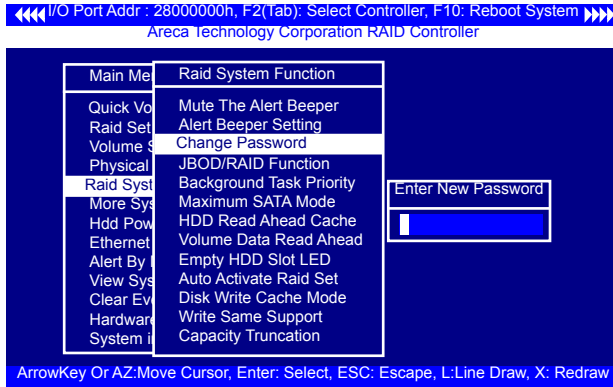

3.7.5.4 JBOD/RAID Function

JBOD is an acronym for “Just a Bunch Of Disk”. A group of hard disks in a RAID box are not set up as any type of RAID configuration. All drives are available to the operating system as an individual disk. JBOD does not provide data redundancy. User needs to delete the RAID set, when you want to change the option from the RAID to the JBOD function.

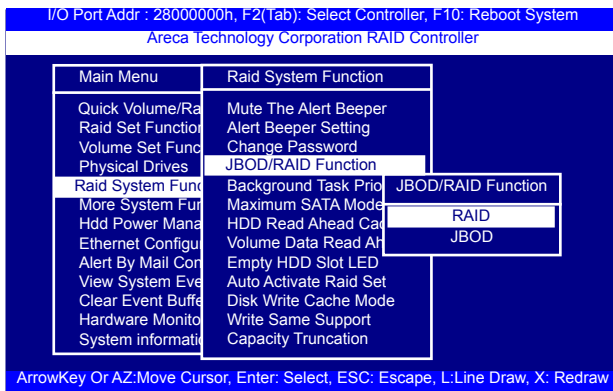

3.7.5.5 Background Task Priority

The “Background Task Priority” is a relative indication of how much time the controller devotes to a rebuild operation. The 6Gb/s SATA RAID controller allows the user to choose the rebuild priority (UltraLow, Low, Normal, High) to balance volume set access and rebuild tasks appropriately.

BIOS CONFIGURATION

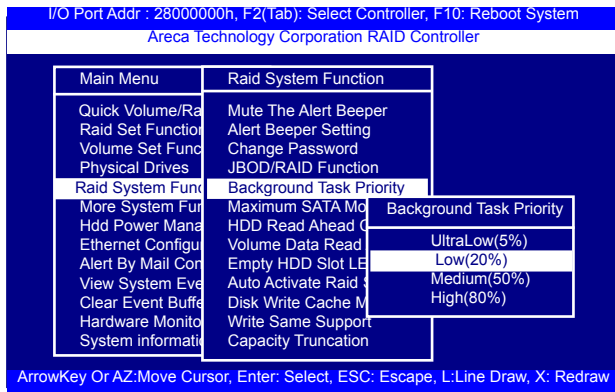

3.7.5.6 Maximum SATA Mode

The controller drive channel can support up to SATA III, which runs up to 600MB/s. NCQ is a command protocol in Serial ATA that can only be implemented on native Serial ATA hard drives. It allows multiple commands to be outstanding within a drive at the same time. Drives that support NCQ have an internal queue where outstanding commands can be dynamically rescheduled or re-ordered, along with the necessary tracking mechanisms for outstanding and completed portions of the workload. The RAID subsystem allows user to choose the SATA Mode: SATA150, SATA150+NCQ, SATA300, SAT300+NCQ, SATA600, SATA600+NCQ.

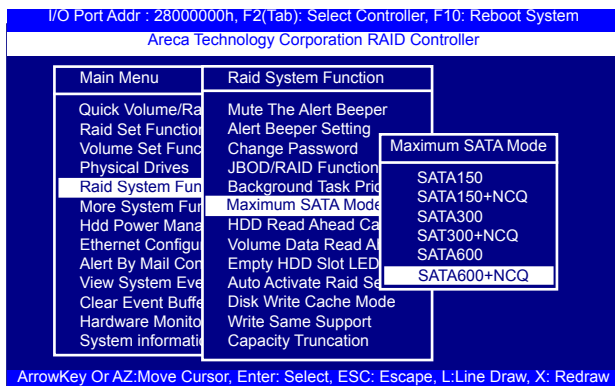

BIOS CONFIGURATION

3.7.5.7 HDD Read Ahead Cache

Allow Read Ahead (Default: Enabled)—When "Enabled", the drive's read ahead cache algorithm is used, providing maximum performance under most circumstances.

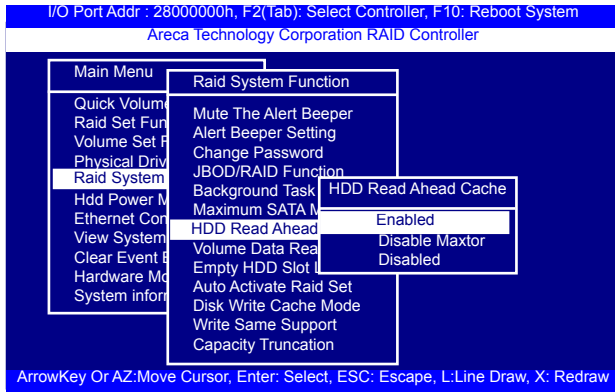

3.7.5.8 Volume Data Read Ahead

The volume read data ahead parameter specifies the controller firmware algorithms which process the read ahead data blocks from the disk. The "Volume Data Read Ahead" parameter is normal by default. To modify the value, you must set it from the "Raid System Function" using the "Volume Data Read Ahead" option. The default "Normal" option satisfies the performance requirements for a typical volume. The "Disabled" value implies no read ahead. The most efficient value for the controllers depends on your application. The "Aggressive" value is optimal for sequential access but it degrades random access.

BIOS CONFIGURATION

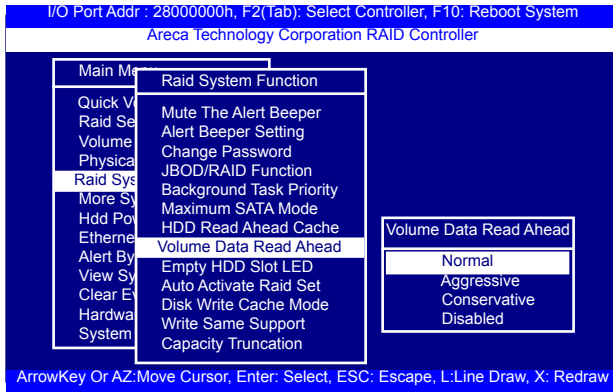

3.7.5.9 Empty HDD Slot LED

The firmware has added the "Empty HDD Slot LED" option to setup the fault LED light "ON" or "OFF" when there is no HDD installed. When each slot has a power LED for the HDD installed identify, user can set this option to "OFF". Choose option "ON", the 6Gb/s SATA RAID controller will light the fault LED; if no HDD installed.

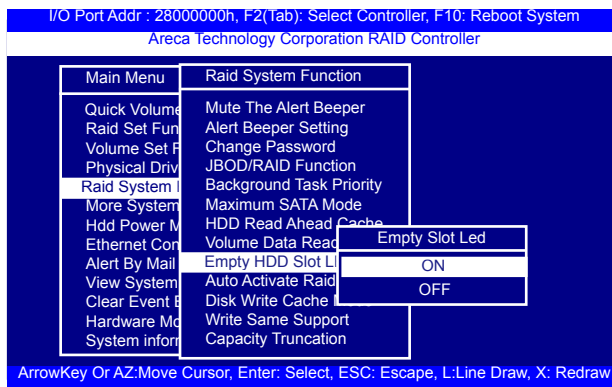

BIOS CONFIGURATION

3.7.5.10 Auto Activate Raid Set

When some of the disk drives are removed in power off state or boot up stage, the RAID set state will change to "Incomplete State". But if a user wants to automatically continue to work while the 6Gb/s SATA RAID controller is powered on, then user can set the "Auto Activate Raid Set" option to "Enabled". The RAID state will change to "Degraded Mode" while it powers on.

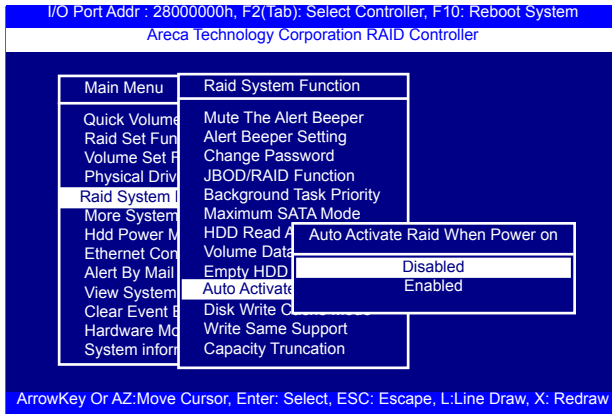

3.7.5.11 Disk Write Cache Mode

User can set the "Disk Write Cache Mode" to Auto, Enabled, or Disabled. "Enabled" increases speed, "Disabled" increases reliability.

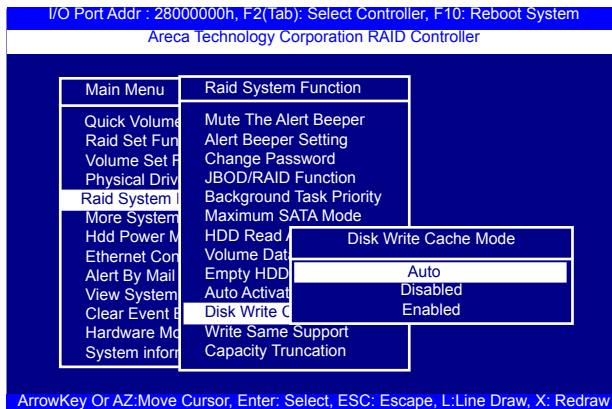

BIOS CONFIGURATION

3.7.5.12 Write Same Support

Drives that support the Write Same feature (SCT) can write to multiple drive sectors at once, improving initialization time. To take advantage of this feature, all the drives in the unit must support Write Same. User can set the "Enabled" or "Disabled" for the controller initialization.

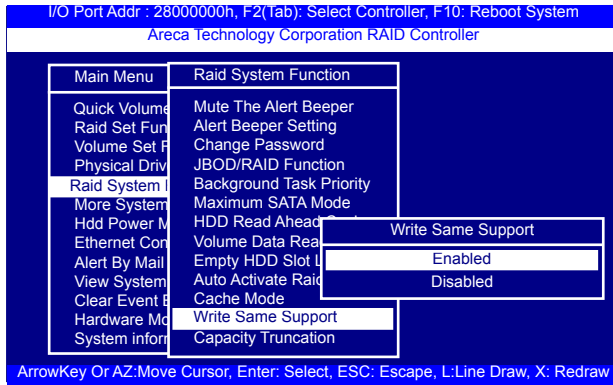

3.7.5.13 Capacity Truncation

The 6Gb/s SATA RAID controller uses drive truncation so that drives from different vendors are more likely to be usable as spares for one another. Drive truncation slightly decreases the usable capacity of a drive that is used in redundant units. The controller provides three truncation modes in the system configuration: Multiples Of 10G, Multiples Of 1G and Disabled.

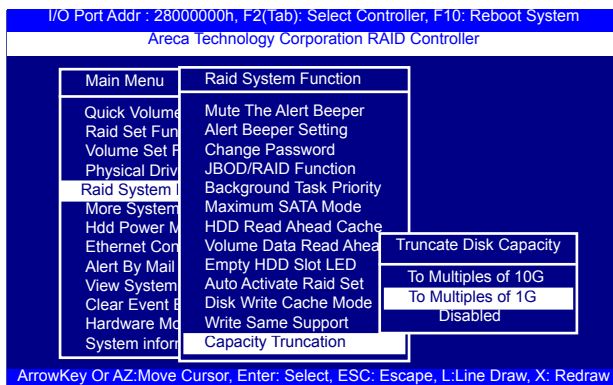

BIOS CONFIGURATION

Multiples Of 10G: If you have 120 GB drives from different vendors; chances are that the capacity varies slightly. For example, one drive might be 123.5 GB, and the other 120 GB. "Multiples Of 10G" truncates the number under tens. This makes the same capacity for both of these drives so that one could replace the other.

Multiples Of 1G: If you have 123 GB drives from different vendors; chances are that the capacity varies slightly. For example, one drive might be 123.5 GB, and the other 123.4 GB. "Multiples Of 1G" truncates the fractional part. This makes the same capacity for both of these drives so that one could replace the other.

Disabled: It does not truncate the capacity.

3.7.6 More System Functions

To set the "More System Functions", move the cursor bar to the main menu and select the "More System Functions" item and then press Enter key. The "More System Functions" menu will show multiple items. Move the cursor bar to an item, then press **Enter** key to select the desired function.

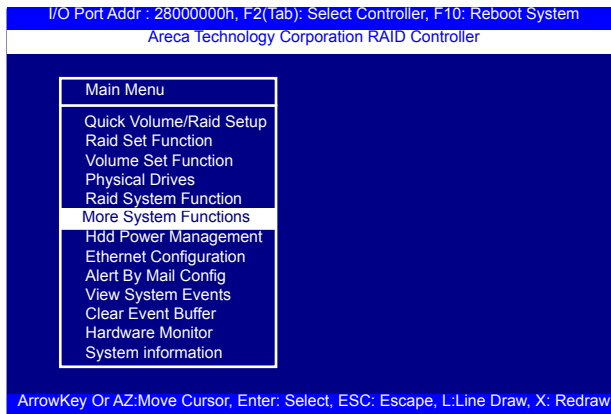

BIOS CONFIGURATION

3.7.6.1 Smart Option For HDD

This option is used to increase the reliability of SSDs/HDDs by automatically copying data from a drive with potential to fail to a designated hot spare or newly inserted drive. The options are: "Failed The Drive", "Failed The Drive If Hot Spare Exist", and "Alert Only". The default is "Alert Only".

"Failed The Drive"- controllers kill off the SMART fail drive immediately.

"Failed The Drive If Hot Spare Exist" – controllers kill off the SMART fail disk if hot spare drive is existed.

"Alert Only" – it will trigger alert when there happens a SMART fail drive.

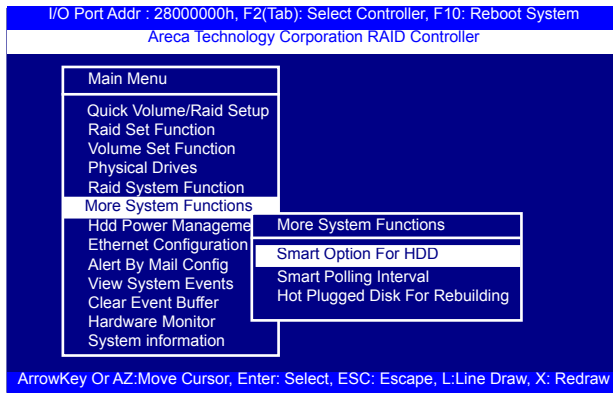

3.7.6.2 Smart Polling Interval

Besides the scheduled volume check, user can define the Smart Polling Interval to pull the SMART status of each disk. The default is "on demand".

User can schedule every certain period of time interval to pull the SMART status of each disk. When SMART polling is executed, disk activity will be temporarily halted until the SMART parameter reading is finished. That is why you don't want to set the Interval too frequent. What to use is up to the users to decide based on their applications and experiment results.

BIOS CONFIGURATION

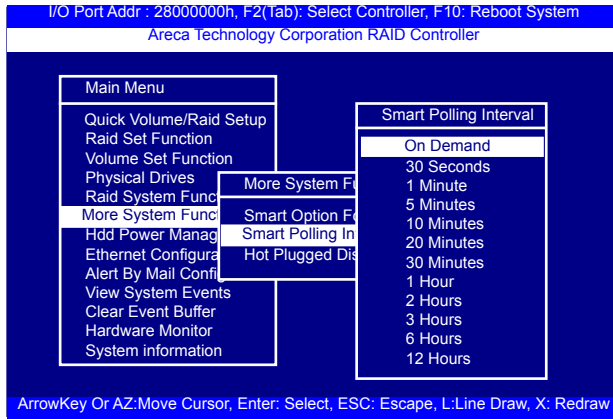

3.7.6.3 Hot Plugged Disk For Rebuilding

It defines if the RAID array volume should start rebuilding or not when detects a disk is inserted/re-inserted during online. The options are: "Blank Disk Only", "Always", and "Disable". The default is "Blank Disk Only".

"Blank Disk Only"-it will trigger the rebuilding if and only if the inserted disk has not been in the RAID array before, which has no RAID signature on it. So when a previously removed disk is self re-inserted, it won't trigger the degraded RAID array to rebuild, and so that the administrator has a chance to identify this mis-behaving disk and replaces it.

"Always" – it is what it was before. Whenever a disk is inserted/re-inserted whether new or previously existed, it always trigger a rebuilding for the Degraded RAID set/Volume.

"Disable" – it will not trigger rebuilding regardless what sort of disk plugging in. When "Disable" and/or "Blank Disk Only" is selected, the re-inserted/previously removed disk will be identified as a disk in a separate RAID set with duplicated RAIDset# and with all the rest of RAID members missing.

BIOS CONFIGURATION

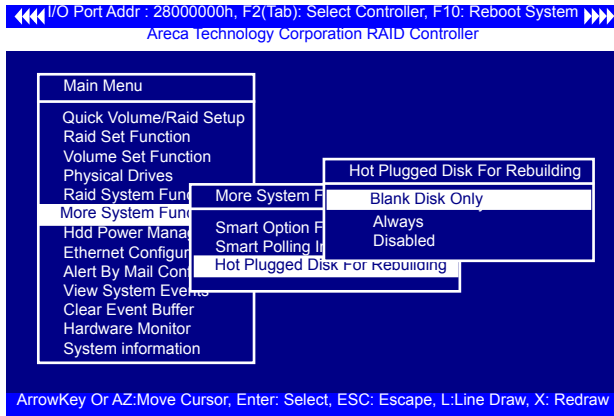

3.7.7 HDD Power Management

The 6Gb/s SATA RAID controller has automated the ability to manage HDD power based on usage patterns. The "HDD Power Management" allows you to choose a "Stagger Power On", "Low Power Idle", "Low RPM" and completely "Spins Down HDD". It is designed to reduce power consumption and heat generation on idle drives.

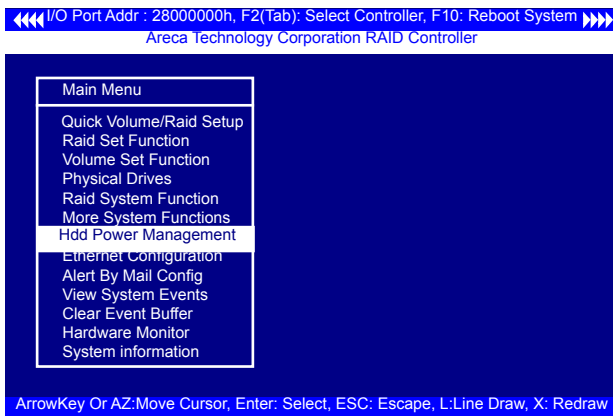

BIOS CONFIGURATION

3.7.7.1 Stagger Power On

In a PC system with only one or two drives, the power can supply enough power to spin up both drives simultaneously. But in systems with more than two drives, the startup current from spinning up the drives all at once can overload the power supply, causing damage to the power supply, disk drives and other system components. This damage can be avoided by allowing the host to stagger spin-up of the drives. The SATA drives have supported the staggered spin-up capabilities to boost reliability. The staggered drive spin-up is a very useful feature for managing multiple disk drives in a storage subsystem. It gives the host the ability to spin up the disk drives sequentially or in groups, allowing the drives to come ready at the optimum time without straining the system power supply. The staggered drive spin-up in a multiple drive environment also avoids the extra cost of a power supply designed to meet short-term startup power demand as well as steady state conditions.

The 6Gb/s SATA RAID controller has included the option for customer to select the disk drives sequentially staggered power up value. The values can be selected from 0.4s to 6s per step which powers up one group of drives.

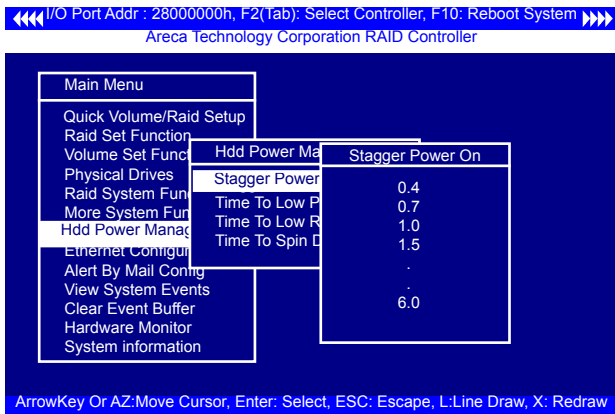

BIOS CONFIGURATION

3.7.7.2 Time To Hdd Low Power Idle

This option delivers lower power consumption by automatically unloading recording heads during the setting idle time. The values can be selected "Disabled" or within the range 2 to 7 minutes.

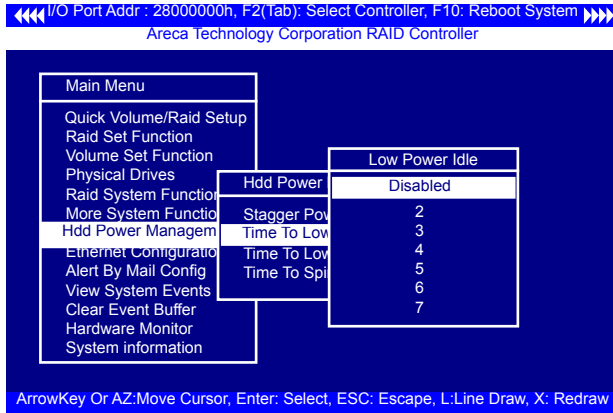

3.7.7.3 Time To Low RPM Mode

This function can automatically spin disks at lower RPM if there have not been used during the setting idle time. The values can be selected "Disabled" or within the range 10 to 60 minutes.

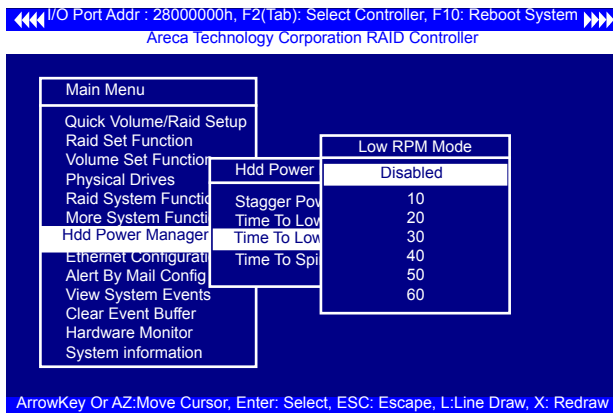

BIOS CONFIGURATION

3.7.7.4 Time To Spin Down Idle Hdd

This function can automatically spin down the drive if it hasn't been accessed for a certain amount of time. This value is used by the drive to determine how long to wait (with no disk activity, before turning off the spindle motor to save power). The values can be selected "Disabled" or within the range 1 to 60 minutes.

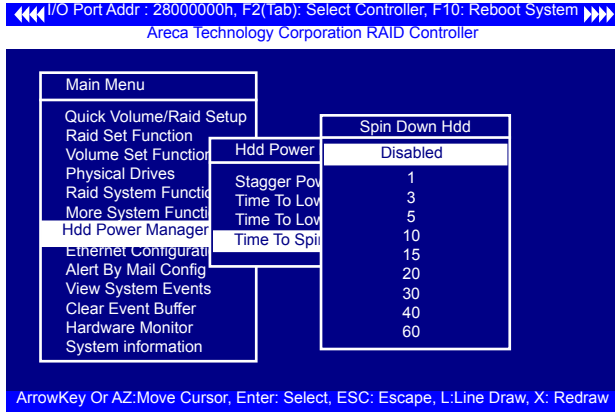

3.7.8 Ethernet Configuration

Use this feature to set the controller Ethernet port configuration. It is not necessary to create reserved disk space on any hard disk for the Ethernet port and HTTP service to function; these functions are built into the controller firmware. Move the cursor bar to the main menu "Ethernet Configuration Function" item and then press the **Enter** key. The "Ethernet Configuration" menu appears on the screen. Move the cursor bar to an item, then press **Enter** key to select the desired function.

3.7.8.1 DHCP Function

DHCP (Dynamic Host Configuration Protocol) allows network administrators centrally manage and automate the assignment of IP (Internet Protocol) addresses on a computer network. When using the TCP/IP protocol (Internet protocol), it is necessary for a computer to have a unique IP address in order to communicate to other computer systems. Without DHCP, the IP address

BIOS CONFIGURATION

must be entered manually at each computer system. DHCP lets a network administrator supervise and distribute IP addresses from a central point. The purpose of DHCP is to provide the automatic (dynamic) allocation of IP client configurations for a specific time period (called a lease period) and to minimize the work necessary to administer a large IP network.

To manually configure the IP address of the controller, move the cursor bar to DHCP Function item, then press **Enter** key to show the DHCP setting. Select the "Disabled" or "Enabled" option to enable or disable the DHCP function. If DHCP is disabled, it will be necessary to manually enter a static IP address that does not conflict with other devices on the network.

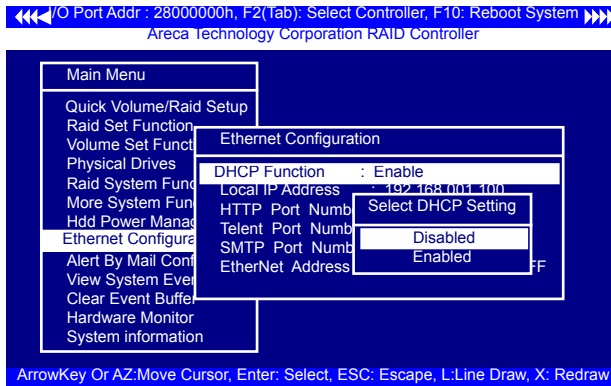

3.7.8.2 Local IP address

If you intend to set up your client computers manually (no DHCP), make sure that the assigned IP address is in the same range as the default router address and that it is unique to your private network. However, it is highly recommend to use DHCP if that option is available on your network. An IP address allocation scheme will reduce the time it takes to set-up client computers and eliminate the possibilities of administrative errors and duplicate addresses. To manually configure the IP address of the controller, move the cursor bar to Local IP address item, then press the **Enter** key to show the default address setting in the RAID controller. You can then reassign the static IP address of the controller.

BIOS CONFIGURATION

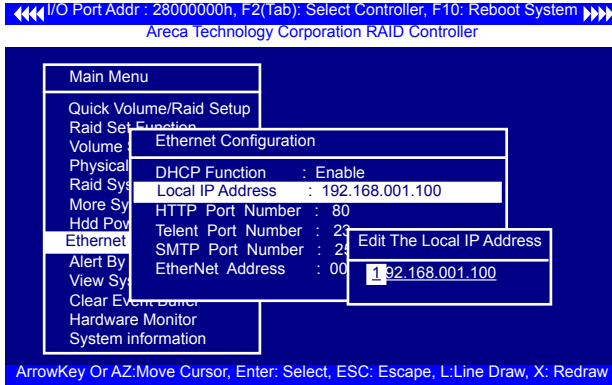

3.7.8.3 HTTP Port Number

To manually configure the "HTTP Port Number" of the controller, move the cursor bar to "HTTP Port Number" item, then press the **Enter** key to show the default address setting in the RAID controller. Then you can reassign the default "HTTP Port Number" of the controller.

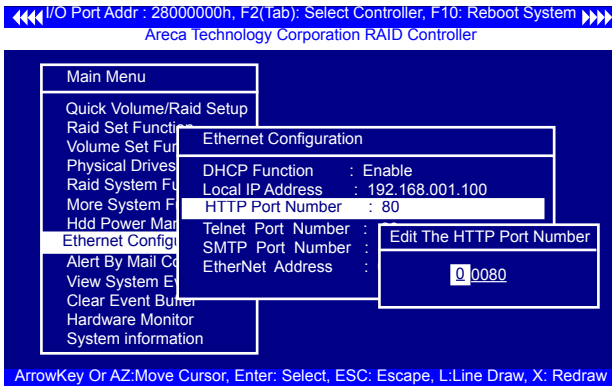

3.7.8.4 Telnet Port Number

To manually configure the "Telnet Port Number" of the controller, move the cursor bar to "Telnet Port Number" item, then press the **Enter** key to show the default address setting in the RAID controller. You can then reassign the default "Telnet Port Number" of the controller.

BIOS CONFIGURATION

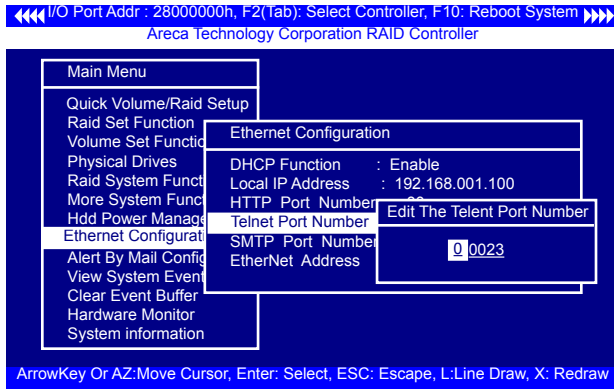

3.7.8.5 SMTP Port Number

To manually configure the “SMTP Port Number” of the controller, move the cursor bar to the main menu “Ethernet Configuration” function item and then press **Enter** key. The “Ethernet Configuration” menu appears on the screen. Move the cursor bar to “SMTP Port Number” item, then press **Enter** key to show the default address setting in the RAID controller. You can then reassign the default “SMTP Port Number” of the controller.

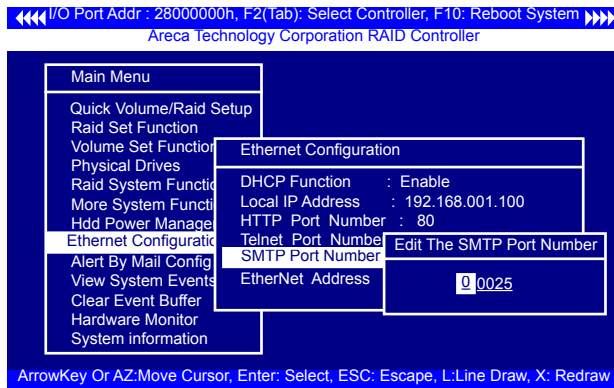

BIOS CONFIGURATION

3.7.8.6 Ethernet Address

Each Ethernet port has its unique Mac address, which is also factory assigned. Usually, Ethernet address is used to uniquely identify a port in the Ethernet network.

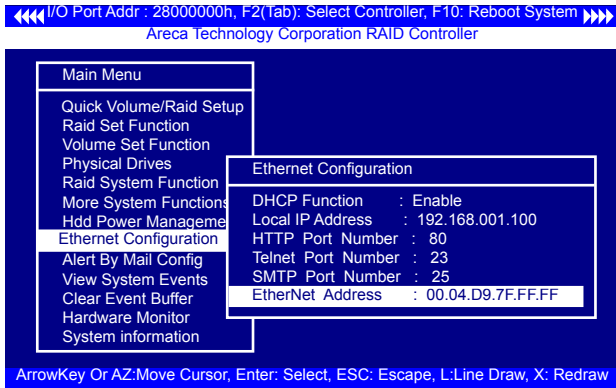

3.7.9 Alert By Mail Config

To configure the 6Gb/s SATA RAID controller e-mail function, move the cursor bar to the main menu and click on the "Alert By Mail Config" link. The "Alert By Mail Config" menu will show all items. Move the cursor bar to the "Alert By Mail Config" item, then select the desired function.

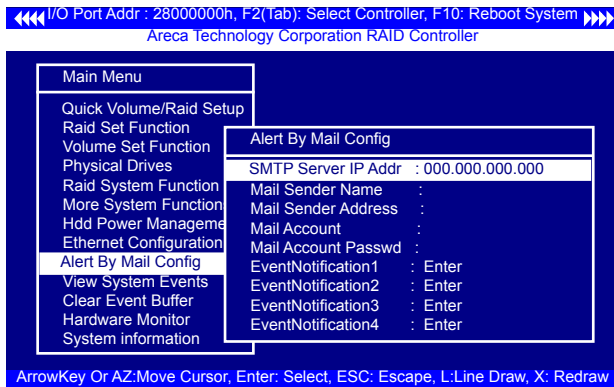

BIOS CONFIGURATION

3.7.10 View System Events

To view the 6Gb/s SATA RAID controller's system events information, move the cursor bar to the main menu and select the "View System Events" link, then press the **Enter** key. The 6Gb/s SATA RAID controller's events screen appear.

Choose this option to view the system events information: Timer, Device, Event type, Elapsed Time, and Errors. The SATA RAID controller does not have a build-in real time clock. The time information is the relative time from the 6Gb/s SATA RAID controller powered on.

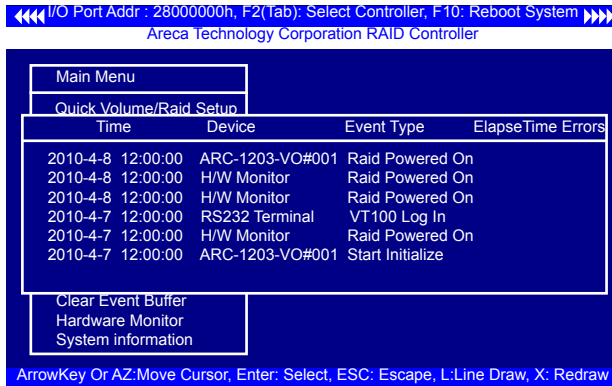

3.7.11 Clear Events Buffer

Use this feature to clear the entire events buffer.

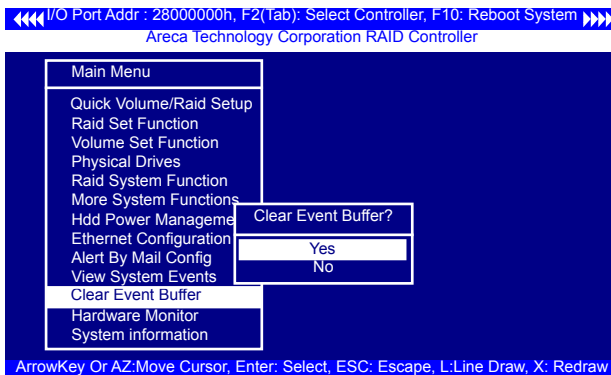

BIOS CONFIGURATION

3.7.12 Hardware Monitor

To view the RAID controller's hardware monitor information, move the cursor bar to the main menu and click the "Hardware Monitor" link. The "Controller H/W Monitor" screen appears. The "Controller H/W Monitor" provides the CPU temperature, controller temperature and voltage of the 6Gb/s SATA RAID controller.

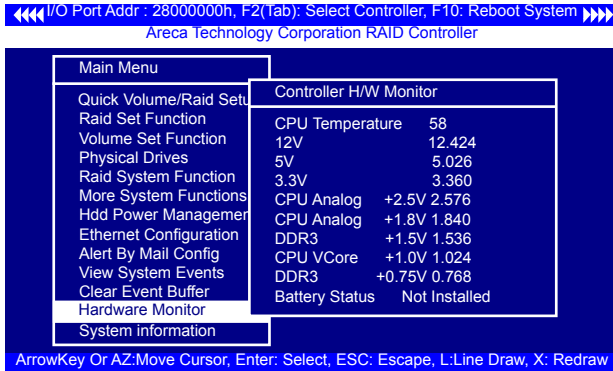

3.7.13 System Information

Choose this option to display controller name, firmware version, BOOT ROM version, SATA firmware version, serial number, main processor, CPU instruction cache and data cache size, system memory, and current IP address. To check the system information, move the cursor bar to "System Information" item, then press **Enter** key. All relevant controller information will be displayed.

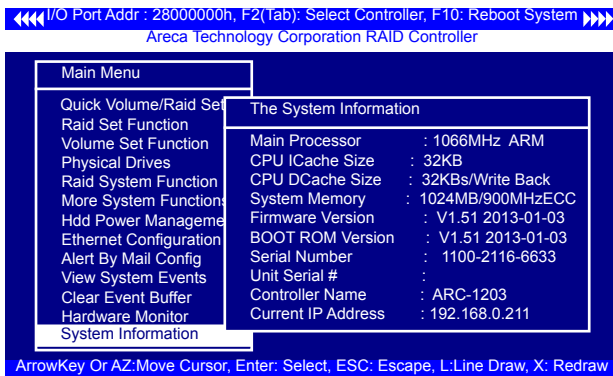

4. Driver Installation

This chapter describes how to install the SATA RAID controller driver to your operating system. The installation procedures use the following terminology:

Installing operating system on SATA controller's volume

If you have a new drive configuration without an operating system and want to install operating system on a disk drive managed by the SATA RAID controller. The driver installation is a part of the operating system installation.

Installing SATA RAID controller into an existing operating system

The computer has an existing operating system installed and the SATA RAID controller is being installed as a secondary controller.

Have all required system hardware and software components on hand before proceeding with the setup and installation.

Materials required:

- Microsoft Windows, Linux, FreeBSD, Solaris and Mac OS X installation CD
- SATA RAID controller software CD
- SATA RAID controller

4.1 Creating the Driver Diskettes

The software CD disc shipped with the 6Gb/s RAID controller is included driver files for Windows, Linux, FreeBSD, Solaris and Mac OS X/macOS.

If you do not have the software CD disc with the package, contact your local dealers or you can also download the latest version drivers from Areca web site at <http://www.areca.com.tw>

These driver files are intended for use with new operating system installations. You can copy the driver file to USB device and installed from it. Determine the correct kernel version and identify

DRIVER INSTALLATION

which files contain drivers for that kernel, and a screen with several choices will be displayed.

The driver disk is ready now. Proceed the following installation with the instructions for your operating system.

4.2 Driver Installation for Windows

The SATA RAID controller can be used with Microsoft Windows 10/8/Server 2012/7/2008/Vista/XP(64-bit)/2003 with StorPort Drivers.

4.2.1 Installing Windows on a RAID Volume

For completed details on installing Windows, see the Windows User's Manual. The following procedures detail installing the SATA RAID controller driver while installing Windows 10/8/Server 2012/7/2008/Vista/XP(64-bit)/2003. Have your bootable Microsoft Windows CD and follow the required procedure below to install SATA RAID controller:

1. Make sure you follow the instructions in Chapter 2 "Hardware Installation" to install the controller and connect the disk drives or enclosure.
2. Start the system and then press **Tab** or **F6** to access the Mc BIOS RAID manager. Use the McBIOS RAID manager to create the RAID set and volume set to which you will install Windows. For details, see Chapter 3 "McBIOS RAID manager". Once a volume set is created and configured, continue with next step to install the operating system.
3. Insert the Windows setup CD and reboot the system to begin the Windows installation.
4. Follow the on-screen instructions to begin the Windows installation.
5. When prompted to specify a location for Windows, select "**Load Driver**".

DRIVER INSTALLATION

6. Insert the USB driver disk or floppy drive, browse to the driver location, then click "**OK**".
7. Window will check the floppy; select the correct card and CPU type for your hardware from the listing and press "**Next**" to install it.
8. Click on "**Next**" again to accept the default partition configuration, or refer to your Windows documentation to configure partitions manually.
9. From this point on, simply follow the Microsoft Windows installation procedure. Follow the on-screen instructions, responding as needed, to complete the installation.
10. After the installation is completed, reboot the system to load the new driver/operating system.
11. See Chapter 5 in this manual to customize your RAID volume sets using McRAID storage manager.

After you finish creating additional volume, the following steps show how to make any new volumes or independent disks accessible to Windows.

- (a). Click "**Start**" ==> right-click "**Computer**" and select "**Manage**".
- (b). Click "**Disk Management**" in the left pane.
- (c). Scroll down to the bottom of the middle pane.
Windows will display a list of new drives attached to your system with a label such as "Disk 1" or "Disk 2", etc.
- (d). Right-click on the drive you want to partition and then again to format it
- (e). Once it's formatted, Windows automatically assigns the next available drive letter to it and then it will appear in Windows Explorer.

DRIVER INSTALLATION

4.2.2 Installing Controller on an Existing Windows

In this scenario, you are installing the controller in an existing Windows system. To install the driver:

1. Follow the instructions in Chapter 2, the Hardware Installation Chapter, to install the controller and connect the disk drives or enclosure.
2. Start the system and then press **Tab** or **F6** to enter the controller McBIOS RAID manager. Use the configuration utility to create the RAID set and volume set. For details, see Chapter 3, McBIOS RAID Manager. Once a volume set is created and configured, continue with installation of the driver.
3. Re-Boot Windows and the OS will recognize the SATA RAID controller and launch the "Found New Hardware Wizard", this guides you in installing the SATA RAID driver.
4. The Windows will pop-up and provide a choice of how to proceed. so that you can choose a specific driver.
5. When the next screen queries the user about utilizing the currently installed driver, click on the "**Have Disk**" button.
6. Insert the SATA RAID controller driver media to locate the correct path. Click on the "**Next**" button.
7. Windows automatically copies the appropriate driver files and rebuilds its driver database.
8. The summary screen appears; click on the "**close**" button.
9. Restart the computer to load the new drivers.
10. See Chapter 5 in this manual for information on customizing your RAID volumes using McRAID storage manager.

After you finish creating additional volume, the following steps show how to make any new volumes or independent disks acces-

DRIVER INSTALLATION

sible to Windows.

- (a). Click "**Start**" = => right-click "**Computer**" and select "**Manage**".
- (b). Click "**Disk Management**" in the left pane.
- (c). Scroll down to the bottom of the middle pane.
Windows will display a list of new drives attached to your system with a label such as "Disk 1" or "Disk 2", etc.
- (d). Right-click on the drive you want to partition and then again to format it
- (e). Once it's formatted, Windows automatically assigns the next available drive letter to it and then it will appear in Windows Explorer.

4.2.3 Uninstall controller from Windows

To remove the SATA RAID controller driver from the Windows system, follow the instructions below.

1. Ensure that you have closed all applications and are logged in with administrative rights.
2. Open "Control Panel" and start the "Add/Remove Program" icon and uninstall and software for the SATA RAID controller.
3. Go to "Control Panel" and select "System". Select the "Hardware" tab and then click the "Device Manager" button. In device manager, expand the "SCSI and RAID Controllers" section. Right click on the SATA RAID controller and select "Uninstall".
4. Click **Yes** to confirm removing the SATA RAID driver. The prompt to restart the system will then be displayed.

DRIVER INSTALLATION

4.3 Driver Installation for Linux

This chapter describes how to install the SATA RAID controller driver to Red Hat Linux, SuSE and other versions of Linux. Before installing the SATA RAID driver to the Linux, complete the following actions:

1. Install and configure the controller and hard disk drives according to the instructions in Chapter 2 Hardware Installation.
2. Start the system and then press **Tab** or **F6** to enter the McBIOS RAID manager configuration utility. Using the McBIOS RAID manager to create the RAID set and volume set. For details, see Chapter 3, McBIOS RAID Manager.

If you are using a Linux distribution for which there is not a compiled driver available from Areca, you can copy the source from the SAS software CD or download the source from the Areca website and compile a new driver.

Compiled and tested drivers for Red Hat and SuSE Linux are included on the shipped CD. You can download updated versions of compiled and tested drivers for RedHat or SuSE Linux from the Areca web site at <http://www.areca.com.tw>. Included in these downloads is the Linux driver source, which can be used to compile the updated version driver for RedHat, SuSE and other versions of Linux. Please refer to the "readme.txt" file on the included SATA RAID controller CD or website to make driver diskette and install driver to the system.

4.4 Driver Installation for FreeBSD

This chapter describes how to install the SATA RAID controller driver to FreeBSD. Before installing the SATA RAID driver to FreeBSD, complete following actions:

1. Install and configure the controller and hard disk drives according to the instructions in Chapter 2, Hardware Installation.
2. Start the system and then press **Tab** or **F6** to enter the McBIOS RAID Manager configuration utility. Use the McBIOS RAID man-

DRIVER INSTALLATION

ager to create the RAID set and volume set. For details, see Chapter 3, McBIOS RAID Manager.

The supplied software CD that came with the SATA RAID controller includes compiled and tested drivers for FreeBSD 7.x (7.2 and onwards), 8.x (8.0 and onwards) and 9.x (9.0 and onwards). To check if a more current version driver is available, please see the Areca web site at <http://www.areca.com.tw>.

Please refer to the "readme.txt" file on the SATA RAID controller software CD or website to make driver diskette and install driver to the system.

4.5 Driver Installation for Solaris

This chapter describes how to install the SATA RAID controller driver to Solaris. Before installing the SATA RAID driver to Solaris, complete following actions:

1. Install and configure the controller and hard disk drives according to the instructions in Chapter 2, Hardware Installation.
2. Start the system and then press **Tab** or **F6** to enter the McBIOS RAID Manager configuration utility. Use the McBIOS RAID manager to create the RAID set and volume set. For details, see Chapter 3, McBIOS RAID Manager.

The supplied software CD that came with the SATA RAID controller includes compiled and tested drivers for Solaris 10/11 x86/x86_64. Please refer to the "readme.txt" file on the software CD or website: <http://www.areca.com.tw> to make driver diskette and install driver to the system.

4.6 Driver Installation for Mac X

After hardware installation, the SATA disk drives connected to the SATA RAID controller must be configured and the volume set units initialized by the controller before they are ready to use by the system.

DRIVER INSTALLATION

4.6.1 Installation Procedures

This section describes detailed instructions for installing the Areca Mac driver & utility for the 6Gb/s SATA RAID controller on your Intel_based Mac Pro. You must have administrative level permissions to install Mac driver & utility. You can use the MRAID installer to install Mac driver & utility (MRAID) at once or “Custom” to install special components.

To follow the process to install driver & utility on Intel-based Mac as below:

1. Insert the Areca Software CD that came with your Areca SATA RAID controller.
2. Double-click on the “install_mraid.zip” file that resides at <CD-ROM>\packages\MacOS to add the installer on the Finder.
3. Launch the installer by double-clicking the install_mraid on the Finder.
4. Follow the installer on-screen steps, responding as needed, to complete the Areca driver and MRAID (ArcHTTP and CLI utility) installation.

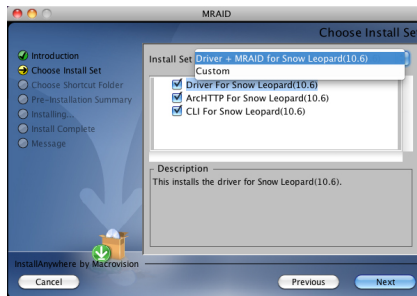

- **Driver** is required for the operating system to be able to interact with the Areca RAID controller.

Important:

Be sure to update the ArcMSR.kext driver shipping with Mac OS X to V1.3.7 or later from the software CD or from the Areca website.

DRIVER INSTALLATION

- **ArcHTTP** has to be installed for GUI RAID console (MRAID storage manager) to run. It also runs as a service or daemon in the background that allows capturing of events for mail and SNMP traps notification. Refer to the section 5.6 ArcHTTP Configuration, for details about the mail and SNMP traps configuration.
 - **Command Line Interface (CLI)** lets you set up and manage RAID controller through a command line interface. CLI performs many tasks at the command line. You can download CLI manual from Areca website or software CD <CDROM>\DOCS directory.
5. A reboot is required to complete the installation (This will start the ArcHTTP so RAID Console can be used).
 6. Normally ArcHTTP64 and CLI are installed at the same time on SATA RAID controller. Once ArcHTTP and CLI have been installed, the ArcHTTP background task automatically starts each time when you start your computer.

There is one "MRAID" icon showing on your desktop. Double-click on the "MRAID" icon to locate your ArcHTTP utility and CLI program file folder.

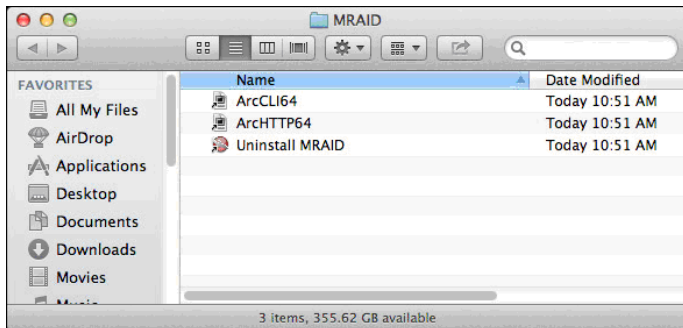

When you double-click on the "ArcHTTP64", it shows all RAID storages available on the system and create an individual RAID storage icon located on left column of the "ArcHTTP Configurations" screen.

DRIVER INSTALLATION

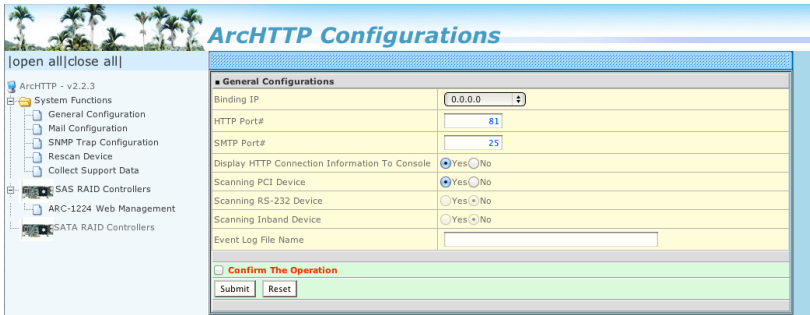

Locate “ARC-1203 Web Management” and launch the selected McRAID storage manager. Enter RAID storage default User Name “admin” and the Password “0000” when the login page prompted for it. After logging in, the McRAID storage manager process starts.

If there is any RAID adapter missed on the system start-up, you can use the “Rescan Device” function. See chapter 5 in this manual for information on customizing your RAID volumes using McRAID storage manager.

4.6.2 Making Volume Sets Available to Mac OS X

When you create a volume through McRAID storage manager, the Mac OS X recognizes that a new disk is avail, and displays a message asking what you next want to do. If the message does not show up, start the “Disk Utility” manually from the “Finder”, use the “Go” menu and open the “Utilities” folder. Double-click on the “Disk Utility” program. Follow the on-screen prompts to create a volume set and to assign a disk drive letter.

To initialize and partition your unit

1. When the Disk Utility window opens, find and select the desired drive in the sidebar that represents your RAID storage and click on the “Partition” button.
2. In the Partition Layout column, click on the “Current” to show the drop-down menu and select the number of partitions that you want your RAID storage to have. Each partition will appear as a separate drive on your computer.

DRIVER INSTALLATION

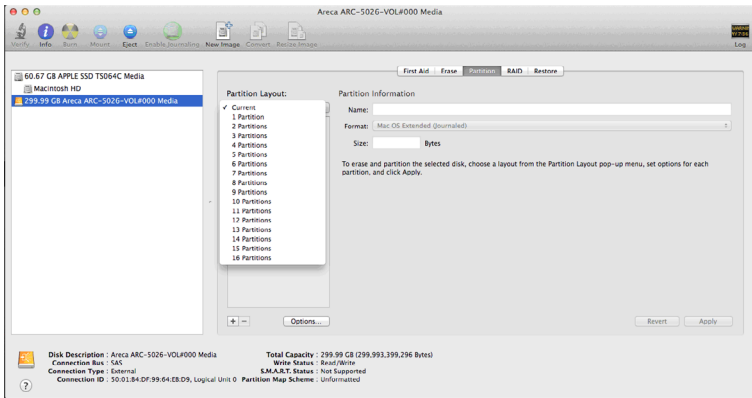

3. Specify your Partition Information, Option setting and click on the "Apply" button.

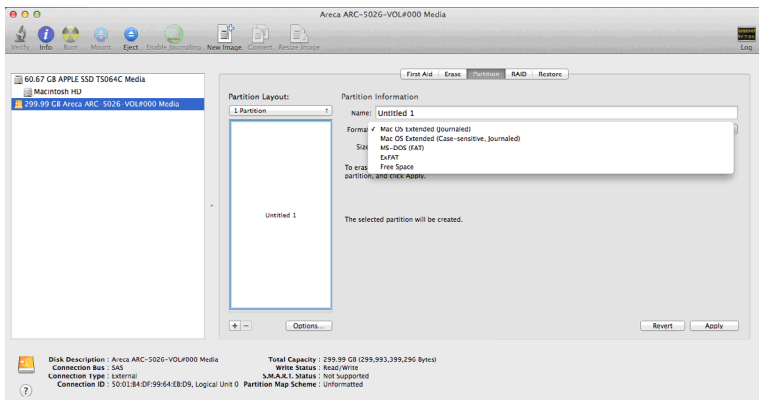

If you're not sure which format to use, choose Mac OS X Extended (Journaled).

4. When a message asks you to confirm you want to partition the disk, click on the "Partition" button. This may take a couple of minutes, depending on the size of the drives in your RAID storage. When the partitioning is complete, icons for each new partition show up on your desktop. They are now ready to use.

ARCHTTP PROXY SERVER INSTALLATION

5. ArchHTTP Proxy Server Installation

Overview

After hardware installation, the SATA disk drives connected to the SATA RAID controller must be configured and the volume set units initialized before they are ready to use.

The user interface for these tasks can be accessed through the built-in configuration that resides in the controller's firmware. It provides complete control and management of the controller and disk arrays, eliminating the need for additional hardware or software.

In addition, a software utility to configure the SATA RAID controller is provided on the software CD delivered with SATA RAID controller. This software CD contains the software utility that can monitor, test, and support the SATA RAID controller. The software utility and McRAID storage manager can configure and monitor the SATA RAID controller via ArchHTTP proxy server interface. The following table outlines their functions:

Configuration Utility	Operating System Supported
McBIOS RAID Manager	OS-Independent
McRAID Storage Manager (Via ArchHTTP proxy server)	Windows, Linux, FreeBSD, Solaris and Mac OS X
SAP Monitor (Single Admin Portal to scan for multiple RAID units in the network, Via ArchHTTP proxy server)	Windows

The HTTP management software (ArchHTTP) runs as a service or daemon, and have it automatically start the proxy for all controllers found. This way the controller can be managed remotely without having to sign in the server. The HTTP management software (ArchHTTP) also has integrated the email notification and SNMP extension agent. The email notification can be configured in local or remote standard web browser.

Note:

If your controllers have onboard LAN port, you do not need to install ArchHTTP proxy server, you can use McRAID storage manager directly.

ARCHTTP PROXY SERVER INSTALLATION

5.1 For Windows

This section describes how to install the MRAID software to your operating system. The software installation includes ArchHTTP and CLI utility.

In this scenario, you are installing the MRAID software in an existing Windows system. You can use the installer to install ArchHTTP and CLI at once or "Custom" to install special components. Follow the steps below to install the utility for Windows.

1. Download the install_mraid installer from the website at "<https://www.areca.com.tw/support/downloads.html>", the file name begins with "install_mraid" followed by the version control.
2. Double-click on the zipped file that comes from the website to unzip it. Double-click on the "setup.exe" file for installing MRAID.
3. The screen shows Preparing to Install.

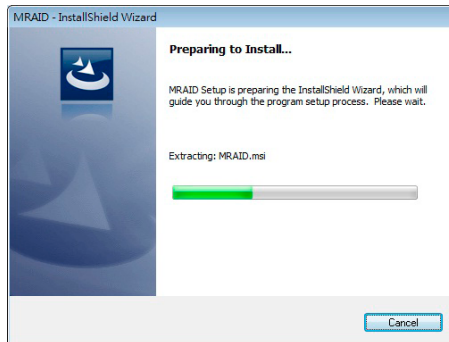

4. The MRAID Installer (or InstallShield Wizard) opens, preparing to install and click on the "**Next**" button to continue.

ARCHTTP PROXY SERVER INSTALLATION

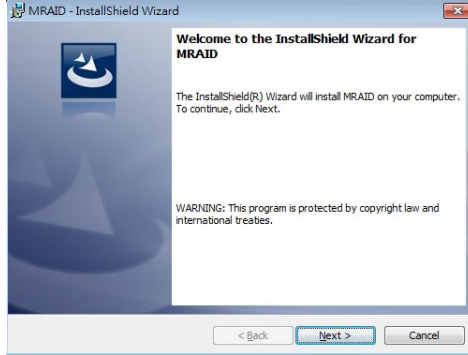

5. When the License Agreement screen appears, read and agree to the license information; then let the InstallShield Wizard guide you through the installation process.

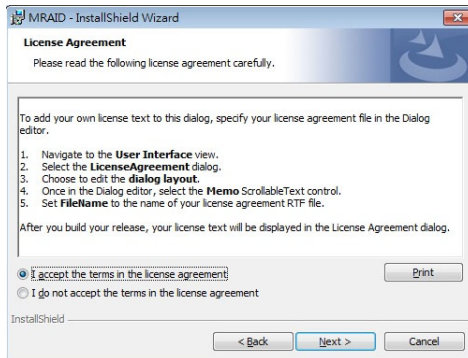

6. On the Setup Type screen, use the settings to specify these things: and click on the "Next" button to continue.

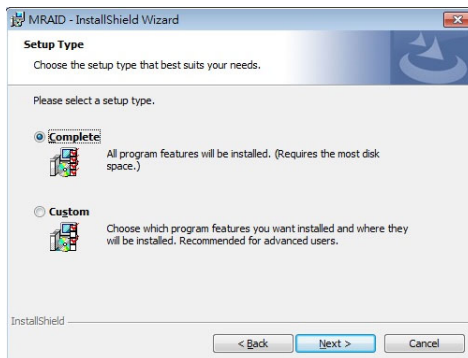

ARCHTTP PROXY SERVER INSTALLATION

- “Complete” to install ArchHTTP and CLI utility at once, check the first box.
 - “Custom” to install special components and change the program directory. When this “**Custom**” check box is checked, go to the Custom Setup screen.
- 6-1. On the Custom Setup screen, click on an icon to install special components and click on the “**Next**” button to continue.

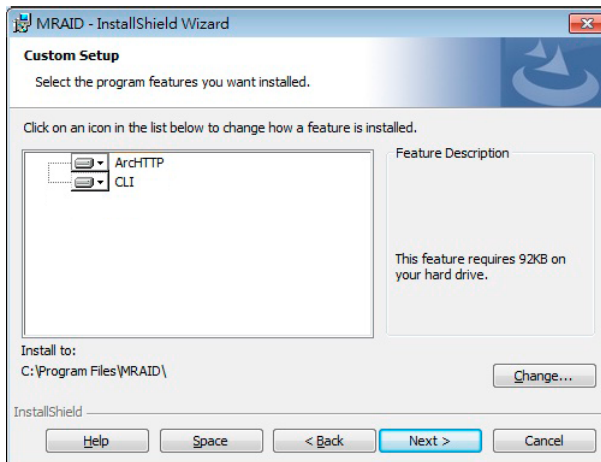

- **ArchHTTP** has to be installed for GUI RAID console (McRAID storage manager) to run. It also runs as a service or daemon in the background that allows capturing of events for mail and SNMP traps notification. Refer to the chapter 3 ArchHTTP Configuration on ARC-1883 user manual, for details about the mail and SNMP traps configuration.
- **CLI (Command Line Interface)** provides the functionality available in MRAID storage manager through a Command Line Interface. You can set up and manage RAID storage inline. CLI performs many tasks at the command line. You can download CLI manual from Areca website.

ARCHTTP PROXY SERVER INSTALLATION

- When you reach the installation page, click on the **“Install”** button to continue.

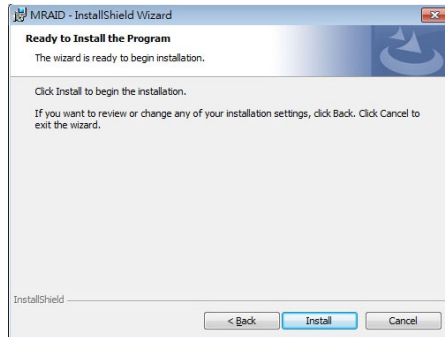

- A program bar appears that measures the progress of the driver installation.

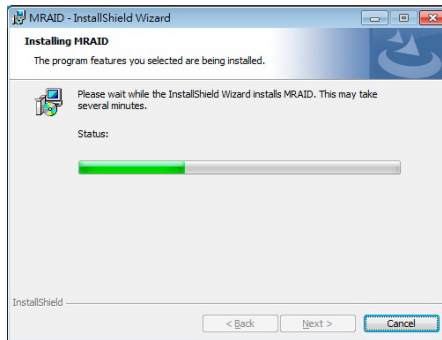

When this screen completes, you have completed the MRAID installation. If you have no ARC-1883 yet installed a “MRAID Installer Information” message displays.

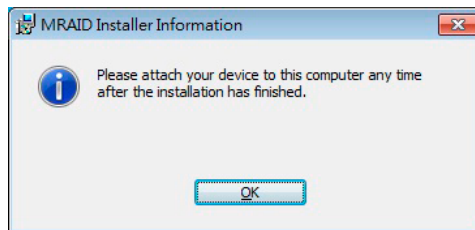

- After installation is complete, click on the **“Finish”** button to exit the InstallShield Wizard.

ARCHTTP PROXY SERVER INSTALLATION

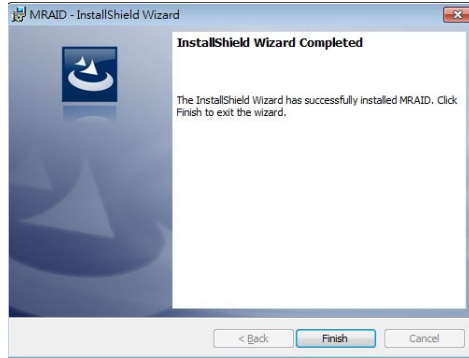

10. Once ArchHTTP and CLI have been installed, the ArchHTTP background task automatically starts each time when you start your computer. There is one MRAID icon showing on your "Programs" folder. This icon is for you to start up the McRAID storage manager (by ArchHTTP) and CLI utility.



The "**ArcHTTP Taskbar**" icon shows on the button of system tray by default. Double click "ArcHTTP Taskbar" to launch the ArchHTTP Configuration screen. It automatically scans the local-host RAID units on the system and creates an individual RAID storage icon located in the left column screen. When you double click on a selected element the left column screen, child element belonged parent element appears. Locate "ARC-1203 Web Management" and launch the McRAID storage manager.

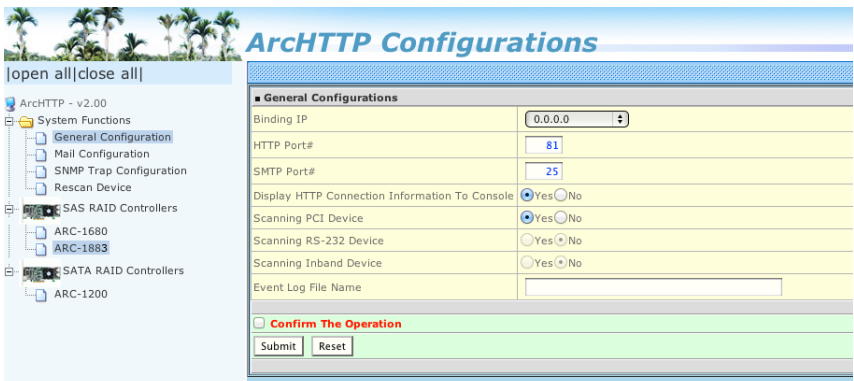

ARCHTTP PROXY SERVER INSTALLATION

1. See the next chapter detailing the McRAID Storage Manager to customize your RAID volume set.
2. If you need to configure the "System Function" of ArchHTTP, please refer to section 5.6 ArchHTTP Configuration.

5.2 For Linux

You should have administrative level permissions to install SATA RAID software. This procedure assumes that the SATA RAID hardware and Linux are installed and operational in your system.

The following installation procedure explains how to install the SATA RAID software for Linux. The ArchHTTP proxy server is provided on the software CD delivered with SATA RAID controller card or download from the www.areca.com.tw. The firmware embedded McRAID storage manager can configure and monitor the SATA RAID controller via ArchHTTP proxy server.

1. Login as root. Copy the ArchHTTP file to a local directory.
 - (a). Insert the SATA RAID controller CD in the CD-ROM drive.
 - (b). Copy <CD-ROM>\PACKAGES\Linux\http directory to local (Ex:/usr/local/sbin). or
 - (c). Download from the www.areca.com.tw or from the email attachment.
2. You must have administrative level permissions to install SATA RAID controller ArchHTTP proxy server software. This procedure assumes that the SATA RAID hardware and driver are installed and operational in your system.

The following details are the installation procedure of the SATA RAID controller for Linux ArchHTTP proxy server software.

- (a). Run the ArchHTTP proxy server by using the following command:
Usage: ./archttp32 (TCP_PORT) or ./archttp64 (TCP_PORT).
It depends on your OS version.
Parameters: TCP_PORT value= 1~65535 (If TCP_PORT

ARCHTTP PROXY SERVER INSTALLATION

assigned, ArchHTTP will start from this port. Otherwise, it will use the setting in the archttpsrv.conf or default 81). This is the port address assigning for the ArchHTTP configuration (Cfg Assistant). Such as: archttp64 1553

- (b). ArchHTTP server console started, Controller card detected then ArchHTTP proxy server screen appears.

Copyright (c) 2004 Areca, Inc. All Rights Reserved.
Areca HTTP proxy server V2.4.0 for Areca RAID controllers.

Controller(s) list

```
-----  
Cfg Assistant : Listen to port[1553].  
Controller[1](PCI) : Listen to port[1554].  
Binding IP:[0.0.0.0]  
Note: IP[0.0.0.0] stands for any ip bound to this host.  
-----
```

```
#####  
Press CTRL-C to exit program!!  
#####  
Controller [1] Http: New client [9] accepted  
Controller [1] Http: New Recv 243 bytes  
Controller [1] Http: Send [174] bytes back to the client
```

- (c). If you need the "Cfg Assistant", please refer to section 5.6 ArchHTTP Configuration.
- (d). For detailing about McRAID storage manager to customize your RAID volume set is discussed in Chapter 6.

For Mozilla user:

Because our management need Java support, so user may need upgrade to version 1.6 or later.

ARCHTTP PROXY SERVER INSTALLATION

5.3 For FreeBSD

You must have administrative level permissions to install SATA RAID software. This procedure assumes that the SATA RAID hardware and FreeBSD are installed and operational in your system. The following installation procedure explains how to install the SATA RAID software for FreeBSD.

1. Insert the SATA RAID controller software CD in the CD-ROM drive.
2. Login as root. Copy <CD-ROM>\PACKAGES\FreeBSD\http ArchHTTP file to a local directory. The next steps are same as Linux. Please see section 5.2 For Linux.

5.4 For Solaris 10

You must have administrative level permissions to install SATA RAID software. This procedure assumes that the SATA RAID hardware and Solaris are installed and operational in your system. The following installation procedure explains how to install the SATA RAID software for Solaris.

1. Insert the SATA RAID controller software CD in the CD-ROM drive.
2. Login as root. Copy <CD-ROM>\PACKAGES\Solaris\http ArchHTTP file to a local directory. The next steps are same as Linux. Please see section 5.2 For Linux.

5.5 For Mac OS X

The firmware embedded McRAID storage manager can configure and monitor the SATA RAID controller via ArchHTTP proxy server. The ArchHTTP proxy server for Mac OS X has combined with the CLI and driver on the install_mraid installer, please refer to Chapter 4.6 Driver Installation for Mac OS X.

ARCHTTP PROXY SERVER INSTALLATION

5.6 ArchHTTP Configuration

The ArchHTTP proxy server will automatically assign one additional port for setup its configuration. If you want to change the "archttpsrv.conf" setting up of ArchHTTP proxy server configuration, for example: General Configuration, Mail Configuration, and SNMP Configuration, please start Web Browser `http://localhost: Cfg Assistant`. Such as `http://localhost: 81`. The port number for the first controller McRAID storage manager is ArchHTTP proxy server configuration port number plus 1.

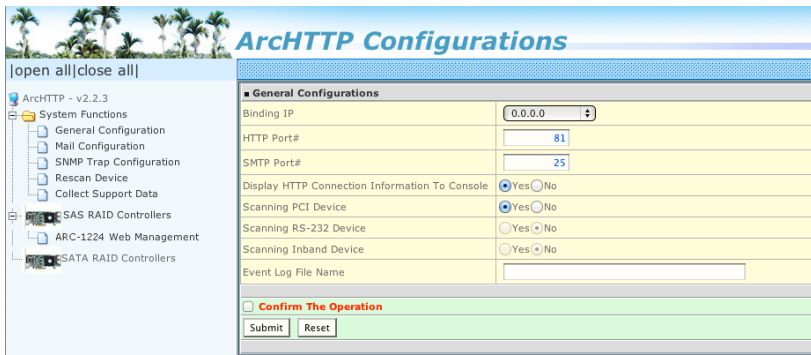

● **General Configuration:**

Binding IP: Restrict ArchHTTP proxy server to bind only single interface (If more than one physical network in the server).

HTTP Port#: Value 1~65535.

Display HTTP Connection Information To Console: Select "Yes" to show Http send bytes and receive bytes information in the console.

Scanning PCI Device: Select "Yes" for ARC-1XXX series controller.

Scanning RS-232 Device: No.

Scanning Inband Device: No.

● **Mail (alert by Mail) Configuration:**

Many users require that email notifications be sent to the appropriate administrators when an alert is detected. To set up your mail servers, click on the "Mail Configuration" link. The "SMTP Server Configurations" allows you to define settings for your mail server. This setup screen is shown as below:

ARCHTTP PROXY SERVER INSTALLATION

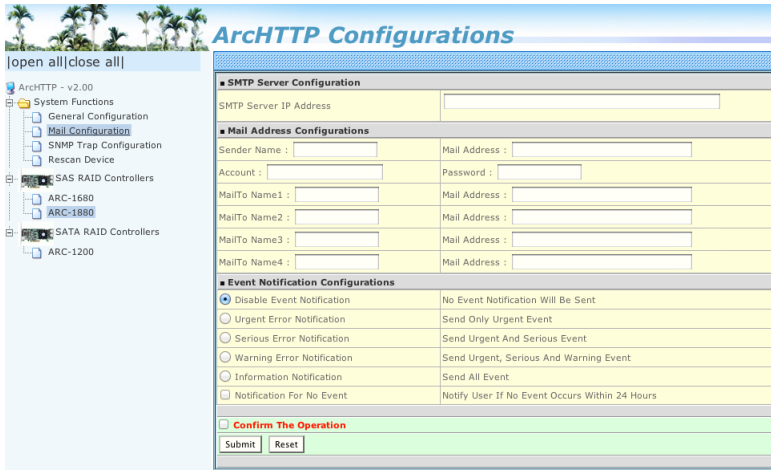

The following article describes a best practice methodology for setting this up in the "SMTP Server Configurations".

1. SMTP Server Configuration:

SMTP Server IP Address: Enter IP address of the SMTP server to configure your mail program correctly.
Ex: 192.168.0.2.

2. Mail Address Configurations:

Sender Name: This is the sender name that the e-mail alerts will appear to be coming from.

Ex: RaidController_1.

Mail address: This is the mail address that the e-mail alerts will appear to be coming from, but don't type IP to replace domain name.

Ex: RaidController_1@areca.com.tw.

Account: Enter the valid account if your SMTP mail server requires authentication.

Password: Enter the valid password if your SMTP mail server requires authentication.

3. Event Notification Configurations:

This step involves setting up of notification rules. Notification rules instruct ArchHTTP on the notifications that should be sent when certain types of alerts are detected.

ARCHTTP PROXY SERVER INSTALLATION

MailTo Name: Enter the alert receiver name that will be shown in the outgoing mail.

Mail Address: Enter the receiver's e-mail address. This is the address you want the e-mail alerts sent to.

Ex: admin@areca.com.tw.

According to your requirement, set the corresponding event level:

Disable Event Notification: No event notification will be sent.

Urgent Error Notification: Send only urgent events.

Serious Error Notification: Send urgent and serious events.

Warning Error Notification: Send urgent, serious and warning events.

Information Notification: Send all events.

Notification For No Event: Notify user if no event occurs within 24 hours.

● **SNMP Traps Configuration:**

This section discusses how to enable the SNMP traps on your RAID storage, and how to control the sending of SNMP traps from the ArchHTTP. To send the SNMP traps to client SNMP manager such as Net-SNMP manager using the IP address assigned to the operating system, you can simply use the SNMP function on the ArchHTTP. The ArchHTTP only provides one direction to send the trap to the SNMP manager without needing to install the SNMP extension agent on the host. If SNMP manager requests to query the SNMP information from RAID storage, please refer the Appendix D "SNMP Operation & Installation".

To set up SNMP traps sending function, click on the "SNMP Configuration" link. SNMP Traps Configurations are set up on this page. This setup screen is shown as below:

ARCHTTP PROXY SERVER INSTALLATION

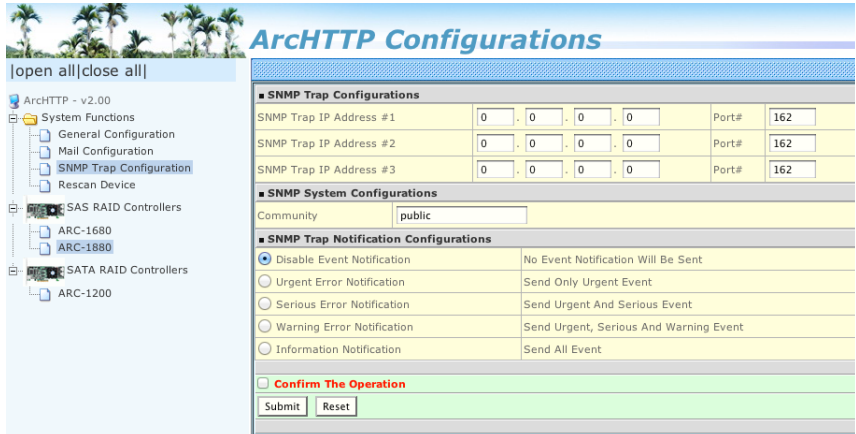

The following article describes a best practice methodology for setting this up in the "SNMP Traps Configurations".

1. SNMP Trap Configurations

Enter the SNMP trap IP address.

2. SNMP System Configurations

Community name acts as a password to screen accesses to the SNMP agent of a particular network device. Type the community names of the SNMP agent in this field. Most network devices use "public" as default of their community names. This value is case-sensitive.

3. SNMP Trap Notification Configurations

Event Notification Table refers to Appendix E. Before the client side SNMP manager application accepts the RAID storage traps, it is necessary to integrate the MIB into the management application's database of events and status indicator codes. Ensure the compilation process successfully integrates the contents of the `areca_sata.mib` file into the traps database. Please refer to Appendix D of "SNMP Operation & Installation". The MIBs file resides at: `<CD-ROM>\packages\SNMP_MIBs` on the software CD.

ARCHTTP PROXY SERVER INSTALLATION

Note:

After you confirm and submit configurations, you can use "Generate Test Event" feature to make sure these settings are correct.

● **Rescan Device Configuration:**

The ArcHTTP scans the RAID controllers on the system and creates an individual RAID controller icon located on left column of the "ArcHTTP Configurations" screen. If any RAID controller is missed at system start-up, then you can use the "Rescan Device" function to rescan the targets to allow a missed RAID storage to be added.

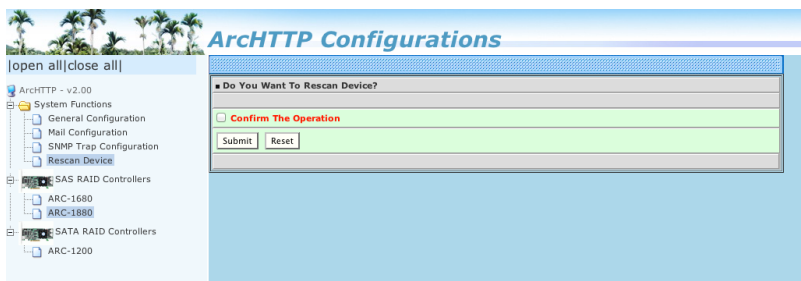

● **Collect Support Data:**

The "Collect Support Data" option on the ArcHTTP is used to download all controller's information (system information, configuration, disk information and event log) to a supported file (file name:ctrlxx-xxxxx.log). It will be automatically started when ERROR or SERIOUS event has occurred.

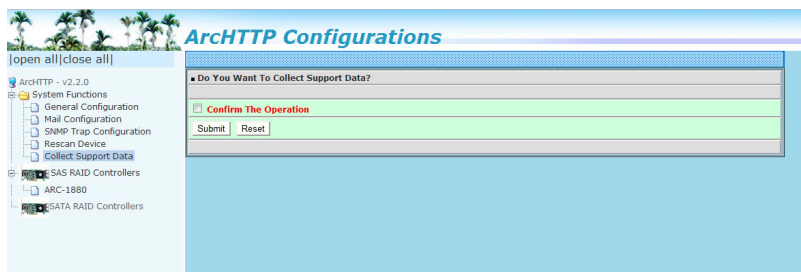

WEB BROWSER-BASED CONFIGURATION

6. Web Browser-based Configuration

Before using the firmware-based browser McRAID storage manager, do the initial setup and installation of this product. If you need to boot up the operating system from a RAID volume set, you must first create a RAID volume by using McBIOS RAID manager. Please refer to section 3.3 Using Quick Volume /Raid Setup Configuration for information on creating this initial volume set.

The McRAID storage manager is firmware-based utility, which is accessible via the web browser installed on your operating system. The web browser-based McRAID storage manager is a HTML-based application, which utilizes the browser (IE, Chrome and Mozilla etc.) installed on your monitor station.

It can be accessed through the in-band PCIe bus or out-of-band LAN port. ArchHTTP is used to launch the in-band web browser-based McRAID storage manager. The firmware-embedded web browser-based McRAID storage manager allows local or remote to access it from any standard internet browser via a LAN or WAN with no software or patches required. The firmware contains SMTP manager monitors all system events and user can select either single or multiple user notifications to be sent via LAN with "Plain English" e-mails. The firmware-embedded SNMP agent allows remote to monitor events via LAN with no SNMP agent required. Use the McRAID storage manager to:

- Create RAID set
- Expand RAID set
- Define volume set
- Add physical drive
- Modify volume set
- Modify RAID level/stripe size
- Define pass-through disk drives
- Modify system function
- Update firmware
- Designate drives as hot spares

6.1 Start-up McRAID Storage Manager

With McRAID storage manager, you can:

WEB BROWSER-BASED CONFIGURATION

- Locally manage a system containing a supported RAID storage that has Windows or Mac OS X, ArcHTTP and a supported browser.
- Remote and managed systems must have a TCP/IP connection.
- **Start-up from Windows/Mac Local Administration**

Once ArcHTTP and CLI have been installed, the ArcHTTP - background task automatically starts each time when you start your computer. There is one MARID icon showing on Mac "Desktop"



or one "ArcHTTP Taskbar" icon showing on Windows system tray. This icon is for you to start up the ArcHTTP (launch the McRAID storage manager). When you click on the ArcHTTP64 from MRAID or "ArcHTTP Taskbar" from system tray, it shows all RAID controllers available on the host system and create an individual RAID controller icon located on left column of the "ArcHTTP Configurations" screen. This RAID controller icon is for user to launch the selected RAID controller web browser McRAID storage manager.

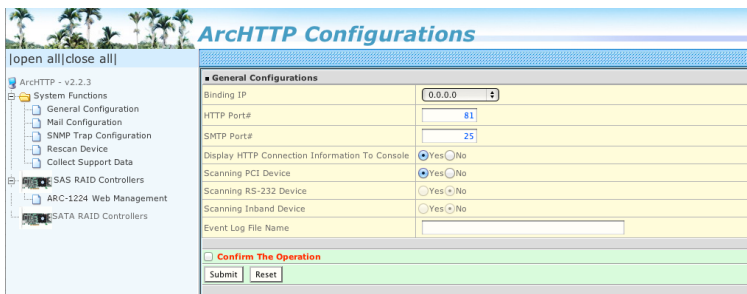

The "Enter Network Password" dialog screen appears, type the User Name and Password. The RAID controller default User Name is "admin" and the Password is "0000". After entering the user name and password, press **Enter** key to access the McRAID storage manager.

- **Start-up McRAID Storage Manager from Linux/FreeBSD/Solaris Local Administration**

To configure the internal SATA RAID controller. You need to

WEB BROWSER-BASED CONFIGURATION

know its IP address. You can find the IP address assigned by the ArchHTTP proxy server installation: Binding IP:[X.X.X.X] and controller listen port.

1. You can click on the individual adapter icon located on left column of the "ArchHTTP Configurations" screen or Launch your McRAID storage manager by entering `http://[Computer IP Address]:[Port Number]` in the web browser.
2. When connection is established, the "System Login" screen appears. The SATA RAID controller default user name is "admin" and the password is "0000".

● Start-up from Ethernet Port (Out-of-Band)

The SATA RAID controller also offers an alternative out-of-band method for McRAID storage manager. User can access the built-in configuration without running the ArchHTTP proxy server on the host system. The web browser-based McRAID storage manager is a HTML-based application, which utilizes the browser installed on your remote system. To ensure proper communications between the SATA RAID controller and McRAID storage manager, please connect the SATA RAID controller LAN port to any LAN switch port.

The RAID storage has embedded the TCP/IP & web browser based McRAID storage manager in the firmware. User can remote manage the SATA RAID controller without adding any user specific software (platform independent) via standard web browsers directly connected to the 10/100Mbit RJ45 LAN port.

To configure SATA RAID controller on a remote machine, you need to know its IP address. The IP address is default shown on the LCD initial start-up screen. Launch your McRAID storage manager by entering `http://[IP Address]` in the web browser.

Note:

You can find controller Ethernet port IP address in McBIOS RAID manager "System Information" option.

WEB BROWSER-BASED CONFIGURATION

6.2 McRAID Storage Manager

The following login screen is displayed in the browser. This screen displays the initial start-up configuration.

The screenshot shows the Areca Technology Corporation web browser-based configuration interface. The interface is divided into a left-hand navigation menu and a main content area. The navigation menu includes options like "Raid System Console", "Quick Function", "RAID Set Functions", "Volume Set Functions", "Security Functions", "Physical Drives", "System Controls", "Information", "RAID Set Hierarchy", "System Information", and "Hardware Monitor". The main content area displays the "RAID Set Hierarchy" section, which includes a table for "RAID Set # 000" and a table for "Enclosure#1: ARE CA SATA RAID V1.0".

RAID Set	Devices	Volume Set(Ch/Id/Lun)	Volume State
Raid Set # 000	E#1Slot#1	ARC_1202_V04_#000(0/0/0)	Normal
	E#1Slot#2	ARC_1201_V04_#001(0/0/1)	Normal
	E#1Slot#3	ARC_1203_V04_#002(0/0/2)	Normal
	E#1Slot#4	ARC_1201_V04_#003(0/0/3)	Normal
		ARC_1203_V04_#004(0/0/4)	Normal

Device	Usage	Capacity	Model
Slot#(0)	Raid Set # 000 (0B)	200.1GB	HCS725550KLA360
Slot#(1)	Raid Set # 000 (0A)	2000.4GB	WDC WD2003FYFS-02W0B0
Slot#(2)	Raid Set # 000 (0B)	500.1GB	WDC WD5000YS-01MR00
Slot#(3)	Raid Set # 000 (0A)	2000.4GB	WDC WD2003FYFS-02W0B0
Slot#(4)	Free	2000.4GB	WDC WD1003P-YYF-02W0B0
Slot#(5)	Free	2000.4GB	WDC WD2002FYFS-02W3B0
Slot#(6)	Free	2000.4GB	WDC WD1003P-YYF-02W0B0

The RaidSet Hierarchy displays the "Raid Set List", "Volume Set List", and "Physical Disk List". The RAID set information, volume set information, and drive information can also be viewed by clicking on the "RAID Set Hierarchy" on the main menu screen.

- To display RAID set information, move the mouse cursor to the desired RAID set number, then click on it. The RAID set information will be displayed.
- To display volume set information, move the mouse cursor to the desired volume set number, then click on it. The volume set information will be displayed.
- To display drive information, move the mouse cursor to the desired physical drive number, then click on it. The drive information will be displayed.

WEB BROWSER-BASED CONFIGURATION

6.3 Main Menu

The main menu shows all available functions, accessible by clicking on the appropriate link.

Individual Category	Description
Quick Function	Create a default configuration, which is based on the number of physical disks installed; it can modify the volume set Capacity, Raid Level, and Stripe Size.
Raid Set Functions	Create a customized RAID set.
Volume Set Functions	Create customized volume sets and modify the existed volume sets parameter.
Physical Drives	Create pass through disks and modify the existing pass through drives parameters. Also provides the function to identify disk drives (blinking fault LED).
System Controls	Setting the RAID system configuration.
Information	Viewing the controller information. The Raid Set Hierarchy can be viewed through the "Raid Set Hierarchy" item.

6.4 Quick Function

The screenshot shows the 'Quick Create Raid/Volume Set' configuration page. The interface includes a navigation menu on the left with options like 'Raid System Console', 'Quick Function', 'Quick Create', 'RAID Set Functions', 'Volume Set Functions', 'Security Functions', 'Physical Drives', 'System Controls', and 'Information'. The main content area is titled 'Quick Create Raid/Volume Set' and contains the following fields:

- Total Number Of Disks: 16
- Select Raid Level: Raid 5 + Spare (dropdown)
- Maximum Capacity Allowed: 420 GB
- Select Capacity: 420 GB
- Volume Initialization Mode: Foreground Initialization (dropdown)
- Select Stripe Size: 64 kBBytes (dropdown)
- RaidSet Mode: Max 128 Volumes (dropdown)

At the bottom, there is a 'Confirm The Operation' checkbox and 'Submit' and 'Reset' buttons.

The number of physical drives in the 6Gb/s SATA RAID controller determines the Raid Levels that can be implemented with the RAID set. You can create a RAID set associated with exactly one volume set. The user can change the Raid Level, Capacity, Initialization Mode and Stripe Size. A hot spare option is also created, depending on the exist configuration. Click the "Confirm The Operation" check box and click on the "Submit" button in the "Quick Create" screen, the RAID set and volume set will start to initialize.

WEB BROWSER-BASED CONFIGURATION

Note:

In "Quick Create", your volume set is automatically configured based on the number of disks in your system. Use the "Raid Set Functions" and "Volume Set Functions" if you prefer to customize your volume set, or RAID 30/50/60 volume set.

6.5 Raid Set Functions

Use the "Raid Set Function" and "Volume Set Function" if you prefer to customize your volume set. Manual configuration can provide full control of the RAID set settings, but it will take longer to complete than the "Quick Volume/Raid Setup" configuration. Select the "Raid Set Function" to manually configure the RAID set for the first time or delete and reconfigure existing RAID sets. (A RAID set is a group of disks containing one or more volume sets.)

6.5.1 Create Raid Set

To create a RAID set, click on the "Create Raid Set" link. A "Select The Drive For RAID Set" screen is displayed showing the drive(s) connected to the current controller and enclosures. Click on the selected physical drives within the current RAID set. Enter 1 to 15 alphanumeric characters to define a unique identifier for a RAID set. The default RAID set name will always appear as "Raid Set #". Click the "Confirm The Operation" check box and click on the "Submit" button on the screen; the RAID set will start to initialize. If you have available disk member, you can repeat above procedures to define another RAID sets.

The screenshot shows the "Areca Technology Corporation" web interface. On the left is a navigation tree with options like "Raid System Console", "Quick Function", "RAID Set Functions", "Volume Set Functions", "Security Functions", "Physical Drives", "System Controls", and "Information". The main content area is titled "Select The Drives For RAID Set" and shows "Enclosure#1 : ARECA SATA RAID V1.0". It contains a table of physical drives:

Slot	Capacity	Model
Slot#5	2000.4GB	WDC WD2003FYYS-02W0B0
Slot#6	2000.4GB	WDC WD2002FYPS-02W3B0
Slot#7	2000.4GB	WDC WD2003FYYS-02W0B0
Slot#8	1000.2GB	WDC WD1001FALS-00J7B0

Below the table, there are input fields for "Raid Set Name" (set to "Raid Set #001") and "RaidSet Mode" (set to "Max 128 Volumes"). A "Confirm The Operation" checkbox is checked. At the bottom are "Submit" and "Reset" buttons.

WEB BROWSER-BASED CONFIGURATION

128 volumes is the default mode for SATA RAID controller, the 16 volumes mode is used for support roaming this raidset to 3Gb/s SATA RAID controllers. The 3Gb/s SATA RAID controller is designed to support up to 16 volumes only. You have to use "Max 16 volumes" on the raidset mode if you plan to roam this raidset between 6Gb/s SATA RAID controller and 3Gb/s SATA RAID controller.

Note:

To create RAID 30/50/60 volume, you need create multiple RAID sets first with the same disk numbers on each RAID set. The max no. disk drives per RAID set: 16 for RAID 0/10(1E)/3/5/6/30/50/60.

6.5.2 Delete Raid Set

To delete a RAID set, click on the "Deleted Raid Set" link. A "Select The RAID Set To Delete" screen is displayed showing all exist RAID sets in the current controller. Click the RAID set number which you want to delete in the select column on the delete screen. Then, click the "Confirm The Operation" check box and click on the "Submit" button in the screen to delete it. The volume sets included in the "Delete RAID Set". It will be deleted by this action. But for the Raid 30/50/60, you need to delete the volumes belonging to those RAID sets.

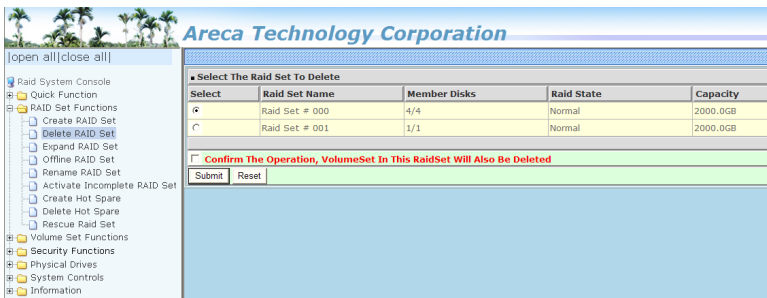

6.5.3 Expand Raid Set

Instead of deleting a RAID set and recreating it with additional disk drives, the "Expand Raid Set" function allows the users to add disk drives to the RAID set that have already been created. To expand a RAID set:

WEB BROWSER-BASED CONFIGURATION

Select the "Expand Raid Set" option. If there is an available disk, then the "Select SATA Drives For Raid Set Expansion" screen appears.

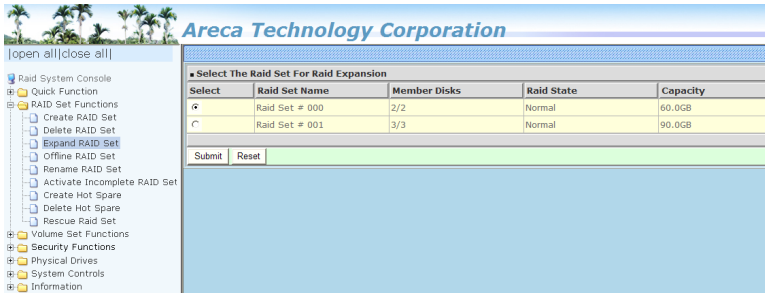

Select the target RAID set by clicking on the appropriate radio button. Select the target disk by clicking on the appropriate check box. Click on the "Submit" button to start the expansion on the RAID set. The new additional capacity can be utilized by one or more volume sets. The volume sets associated with this RAID set appear for you to have chance to modify RAID level or stripe size. Follow the instruction presented in the "Modify Volume Set " to modify the volume sets; operation system specific utilities may be required to expand operating system partitions.

Note:

1. Once the "Expand Raid Set" process has started, user can not stop it. The process must be completed.
2. If a disk drive fails during RAID set expansion and a hot spare is available, an auto rebuild operation will occur after the RAID set expansion completes.
3. RAID 30/50/60 does not support the "Expand Raid set".
4. RAID set expansion is a quite critical process, we strongly recommend customer backup data before expand. Unexpected accident may cause serious data corruption.

6.5.4 Offline Raid Set

This function is for customer being able to unmount and remount a multi-disk volume. All Hdds of the selected RAID set will be put into offline state, spun down and fault LED in fast blinking mode. User can remove those Hdds and insert new Hdds on those empty slots without needing power down the controller.

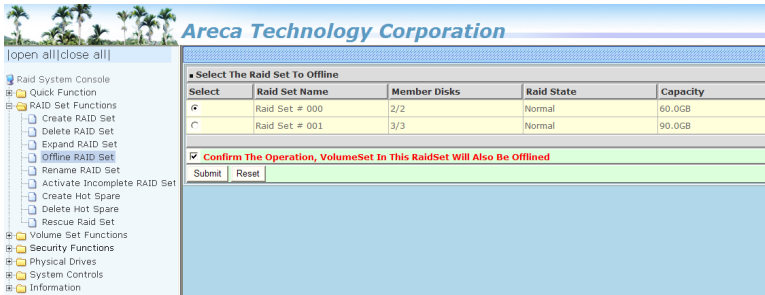

6.5.5 Rename Raid Set

The default RAID set name will always appear as "Raid Set #" when it is first created by the controller. The "Rename Raid Set" function is for customer to rename the default RAID set name.

To rename a RAID set from a group of RAID sets:

- (1). Click on the "Rename Raid Set" link.
- (2). Click the RAID set check box from the list that you wish to rename. Click the "Submit" button. The following screen appears. Use this option to rename the RAID set name.

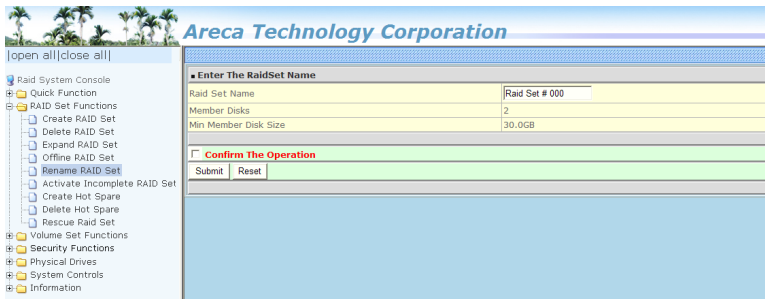

6.5.6 Activate Incomplete Raid Set

If one of the disk drives is removed in power off state, the RAID set state will change to "Incomplete State". If the user wants to continue to operate the controller without power-off the 6Gb/s SATA RAID controller, the user can use the "Activate Incomplete Raid Set" option to active the RAID set. After the user completes this function, the Raid State will change to "Degraded Mode" and start to work.

To activate the incomplete the RAID set, click on the "Activate Raid Set" link. A "Select The RAID SET To Activate" screen is

WEB BROWSER-BASED CONFIGURATION

displayed showing all RAID sets existing on the current controller. Click the RAID set number to activate in the select column. Click on the "Submit" button on the screen to activate the RAID set that had a disk removed (or failed) in the power off state. The 6Gb/s SATA RAID controller will continue to work in degraded mode.

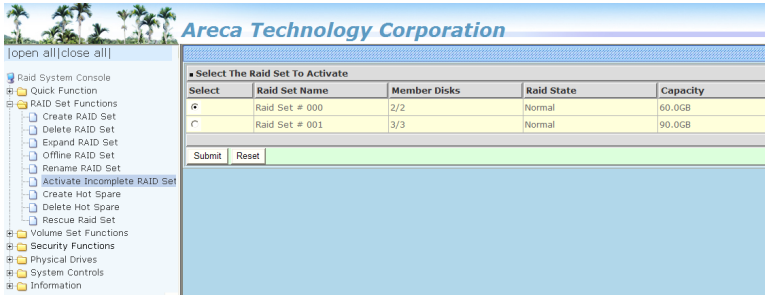

6.5.7 Create Hot Spare

When you choose the "Create Hot Spare" option in the "Raid Set Function", all unused physical devices connected to the current controller appear. Select the target disk by clicking on the appropriate check box. Click the "Confirm The Operation" check box and click the "Submit" button in the screen to create the hot spares. The "Create Hot Spare" gives you the ability to define a global or dedicated hot spare. Unlike "Global Hot Spare" which can be used with any RAID sets, "Dedicated Hot Spare" can only be used with a specific RAID set or Enclosure. Under "Global For SSD or HDD" option, SSD hot spare is used to rebuild failed SSD and HDD hot spare for rebuild failed HDD. When a disk drive fails in the RAID set or enclosure with a dedicated hot spare is pre-set, data on the disk drive is rebuild automatically on the dedicated hot spare disk.

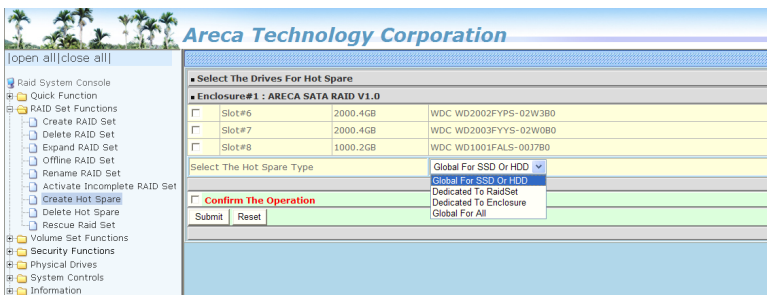

WEB BROWSER-BASED CONFIGURATION

6.5.8 Delete Hot Spare

Select the target hot spare disk to delete by clicking on the appropriate check box. Click the “Confirm The Operation” check box and click the “Submit” button on the screen to delete the hot spares.

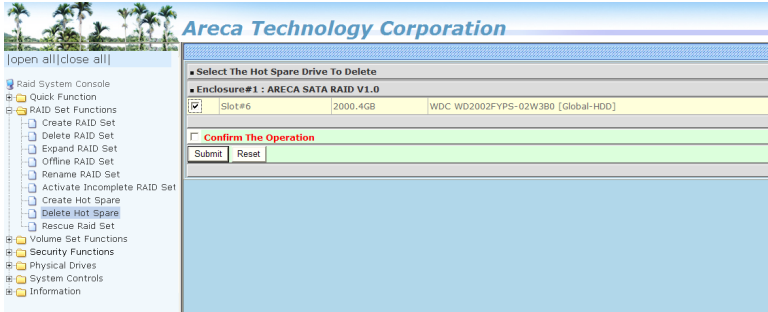

6.5.9 Rescue Raid Set

When the system is powered off in the RAID set update/creation period, the configuration possibly could disappear due to this abnormal condition. The “RESCUE” function can recover the missing RAID set information. The RAID controller uses the time as the RAID set signature. The RAID set may have different time after the RAID set is recovered. The “SIGANT” function can regenerate the signature for the RAID set.

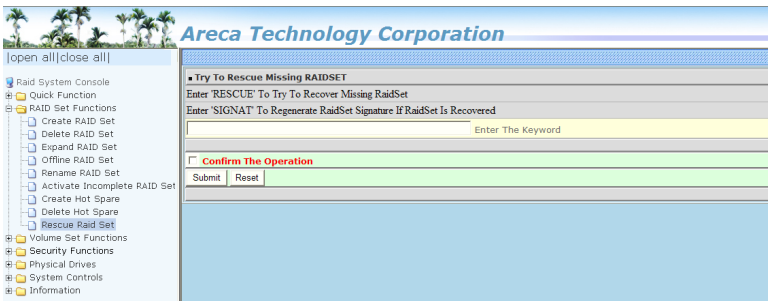

Caution:

Please contact us to make sure if you need to use rescue function. Improperly usage may cause configuration corruption.

6.6 Volume Set Functions

A volume set is seen by the host system as a single logical device. It is organized in a RAID level with one or more physical disks. RAID level refers to the level of data performance and protection of a volume set. A volume set capacity can consume all or a portion of the disk capacity available in a RAID set. Multiple volume sets can exist on a group of disks in a RAID set. Additional volume sets created in a specified RAID set will reside on all the physical disks in the RAID set. Thus each volume set on the RAID set will have its data spread evenly across all the disks in the RAID set.

The following summaries are the volume set features for the 6Gb/s SATA RAID controller.

1. Volume sets of different RAID levels may coexist on the same RAID set and up to 128 volume sets per controller.
2. Up to 128 volume sets can be created in a RAID set.
3. The maximum addressable size of a single volume set is not limited to 2TB, because the controller is capable of 64-bit LBA mode. However the operating system itself may not be capable of addressing more than 2TB.

6.6.1 Create Volume Set (0/1/10/3/5/6)

To create volume set from RAID set system, move the cursor bar to the main menu and click on the "Create Volume Set" link. The "Select The Raid Set To Create On It" screen will show all RAID set number. Tick on a RAID set number that you want to create and then click on the "Submit" button.

The new create volume set attribute allows user to select the Volume Name, RAID Level, Capacity, Greater Two TB Volume Support, Initialization Mode, Strip Size, Cache Mode, Tagged Command Queuing, and SCSI Channel/SCSI ID/SCSI LUN.

WEB BROWSER-BASED CONFIGURATION

The screenshot shows the 'Enter The Volume Attribute' configuration page. The left sidebar contains a navigation tree with categories like 'Raid System Console', 'Quick Function', 'RAID Set Functions', 'Volume Set Functions', 'Security Functions', 'Physical Drives', 'System Controls', and 'Information'. The main content area is a form with the following fields:

Volume Name	ARC-1224-VOL008
Member Disks	8
Volume Raid Level	Raid 5
Max. Capacity Allowed	185.6 GB
Select Volume Capacity	185.6 GB
Greater Two TB Volume Support	No
Volume Initialization Mode	Foreground Initialization
Volume Stripe Size	64 KBytes
Volume Cache Mode	Write Back
Volume Write Protection	Disabled
Volume IO Mode	Cached IO
Tagged Command Queuing	Enabled
SCSI Channel:SCSI ID:SCSI Lun	0 : 1 : 0
Volumes To Be Created	1

At the bottom, there is a 'Confirm The Operation' checkbox and 'Submit' and 'Reset' buttons.

- **Volume Name**

The default volume name will always appear as "ARC-1203-VOL". You can rename the volume set providing it does not exceed the 15 characters limit.

- **Volume Raid Level**

Set the Raid Level for the volume set. Highlight the desired RAID Level from the available RAID levels option.

There are two circumstances when you choose RAID level 1 function:

RAID 1-Simple Mirroring is also known as "**two disk mirror**"; If your RAID set has two disks, data written on one disk drive is simultaneously written to another disk drive.

RAID 1-Multi Mirroring is also known as "**triple disk mirror**"; If your RAID set has three disks, data written on one disk drive is simultaneously written to another two disk drives.

- **Capacity**

The maximum volume size is the default initial setting. Enter the appropriate volume size to fit your application.

- **Greater Two TB Volume Support**

If volume capacity will exceed 2TB, controller will show the "Greater Two TB Volume Support" sub-menu. Greater Two TB Volume Support option: "No", "64bit LBA" and "4K Block".

WEB BROWSER-BASED CONFIGURATION

- **No**

When this option is enabled, it keeps the volume size with max. 2TB limitation. For any hard disk drives working in the 4K native mode in the Raid set, the volume set directly sets and exposes 4KB sector size to the operating system.

- **64bit LBA**

This option uses 16 bytes CDB instead of 10 bytes. The maximum volume capacity up to 512TB. For any hard disk drives working in the 4K native mode in the Raid set, the volume set directly sets and exposes 4KB sector size to the operating system.

This option works on different OS which supports 16 bytes CDB.

- **4K Block**

This option uses 16 bytes CDB and changes the sector size from default 512 bytes to 4k bytes. Windows XP only supports maximum volume capacity is up to 16TB.

● **Initialization Mode**

This option is used to define "Background Initialization", "Foreground Initialization" or "No Init (To Rescue Volume)". When "Background Initialization", the initialization proceeds as a background task, the volume set is fully accessible for system reads and writes. The operating system can instantly access to the newly created arrays without requiring a reboot and waiting the initialization complete. When "Foreground Initialization", the initialization proceeds must be completed before the volume set ready for system accesses. There is no initialization happened when you select "No Init" option. "No Init" is for customer to rescue volume without losing data in the disk.

Note:

Controller starts to initialize the volume in two conditions

1. Stay in controller bios manager or
2. Boot into OS and the controller driver loaded.

WEB BROWSER-BASED CONFIGURATION

- **Stripe Size**

This parameter sets the size of the stripe written to each disk in a RAID 0, 1, 10, 5, 6, 50 or 60 logical drive. You can set the stripe size to 4KB, 8KB, 16KB, 32KB, 64KB, 128KB, 256KB, 512KB, or 1024KB. A larger stripe size produces better read performance, especially if your computer does mostly sequential reads. However, if you are sure that your computer does random reads more often, select a smaller stripe size.

Note:

RAID level 3 and 30 can't modify the cache strip size.

- **Cache Mode**

The 6Gb/s SATA RAID controller supports "Write Through" and "Write Back" cache.

- **Volume Write Protection**

When "Volume Write Protection" is enabled on the "Modify Volume Set", host commands fail if they are issued to a volume in that RAID controller and attempt to modify a volume's data or attributes. Volume Write Protection is used primarily for customer-initiated disaster recovery testing.

- **Tagged Command Queuing**

The "Enabled" option is useful for enhancing overall system performance under multi-tasking operating systems. The Command Tag (Drive Channel) function controls the SATA command tag queuing support for each drive channel. This function should normally remain "Enabled". "Disabled" this function only when using SATA drives that do not support command tag queuing.

- **SCSI Channel/SCSI ID/SCSI Lun**

SCSI Channel: The 6Gb/s SATA RAID controller function is simulated as an external SCSI RAID controller. The host bus is represented as a SCSI channel. Choose the SCSI Channel.
SCSI ID: Each SCSI device attached to the SCSI card, as well as the card itself, must be assigned a unique SCSI ID number. A SCSI channel can connect up to 15 devices. The 6Gb/s SATA RAID controller is a large SCSI device. Assign an ID from a list of SCSI IDs.

WEB BROWSER-BASED CONFIGURATION

SCSI LUN: Each SCSI ID can support up to 8 LUNs. Most 6Gb/s SATA controllers treat each LUN like a SATA disk.

6.6.2 Create Raid 30/50/60 (Volume Set 30/50/60)

To create 30/50/60 volume set from RAID set group, move the cursor bar to the main menu and click on the "Create Raid 30/50/60" link. The "Select The Raid Set To Create Volume On It" screen will show all RAID set number. Tick on the RAID set numbers (same disk No per RAID set) that you want to create and then click on the "Submit" button.

The new create volume set attribute allows user to select the Volume Name, Raid Level, Capacity, Greater Two TB Volume Support, Initialization Mode, Strip Size, Cache Mode, Tagged Command Queuing, and SCSI Channel/SCSI ID/SCSI Lun. Please refer to above section for details description of each item.

Note:

RAID level 30 50 and 60 can support up to eight RAID set (four pairs), but it can not support expansion and migration.

Areca Technology Corporation

open all | close all

- Raid System Console
 - Quick Function
 - RAID Set Functions
 - Volume Set Functions
 - Create Volume Set
 - Create Raid30/50/60**
 - Delete Volume Set
 - Modify Volume Set
 - Check Volume Set
 - Schedule Volume Check
 - Stop Volume Check
 - Security Functions
 - Physical Drives
 - System Controls
 - Information

Enter The Volume Attribute

Volume Name	ARC-1224-VOL#001
Member Disks	2x4
Volume Raid Level	50
Max Capacity Allowed	30 GB
Select Volume Capacity	50 GB
Greater Two TB Volume Support	No
Volume Initialization Mode	Foreground Initialization
Volume Stripe Size	64 Kbytes
Volume Cache Mode	Write Back
Tagged Command Queuing	Enabled
SCSI Channel:SCSI ID:SCSI Lun	0 : 0 : 0

Confirm The Operation

Submit Reset

WEB BROWSER-BASED CONFIGURATION

6.6.3 Delete Volume Set

To delete a volume from RAID set, move the cursor bar to the main menu and click on the "Delete Volume Set" link. The "Select The Raid Set To Delete" screen will show all RAID set numbers. Click a RAID set number and the "Confirm The Operation" check box and then click the "Submit" button to show all volume set items in the selected RAID set. Click a volume set number and the "Confirm The Operation" check box and then click the "Submit" button to delete the volume set.

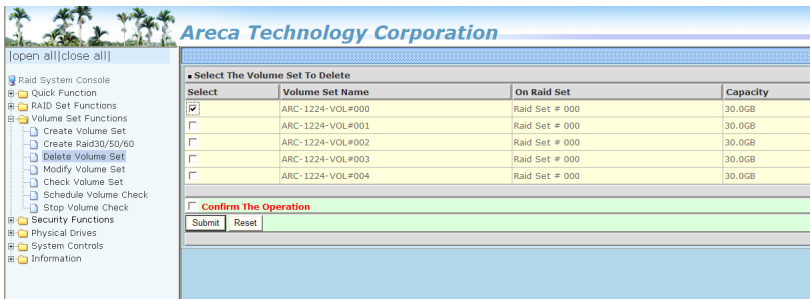

6.6.4 Modify Volume Set

To modify a volume set from a RAID set:

1. Click on the "Modify Volume Set" link.
2. Click the volume set check box from the list that you wish to modify. Click the "Submit" button. The following screen appears.

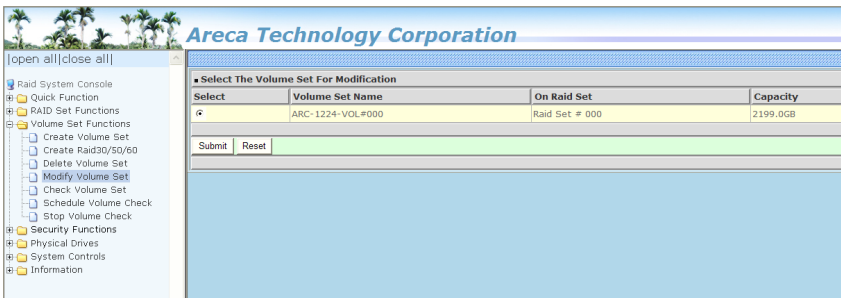

WEB BROWSER-BASED CONFIGURATION

Use this option to modify the volume set configuration. To modify volume set attributes, move the cursor bar to the volume set attribute menu and click it. The "Enter The Volume Attribute" screen appears. Move the cursor to an attribute item and then click the attribute to modify the value. After you complete the modification, click the "Confirm The Operation" check box and click the "Submit" button to complete the action. The user can only modify the last volume set capacity.

6.6.4.1 Volume Growth

Use "Expand RAID Set" function to add disk to a RAID set. The additional capacity can be used to enlarge the last volume set size or to create another volume set. The "Modify Volume Set" function can support the "Volume Modification" function. To expand the last volume set capacity, move the cursor bar to the "Capacity" item and entry the capacity size. When finished the above action, click on the "Submit" button to complete the action. The last volume set starts to expand its capacity.

To expand an existing volume noticed:

- Only the last volume can expand capacity.
- When expand volume capacity, you can't modify stripe size or modify RAID level simultaneously.
- You can expand volume capacity, but can't reduce volume capacity size.
- After volume expansion, the volume capacity can't be decreased.

For greater 2TB expansion:

- If your system installed in the volume, don't expand the volume capacity greater 2TB; except your OS and RAID controller can support boot up from a greater 2TB capacity device.
- Expand over 2TB used LBA64 mode. Please make sure your OS supports LBA64 before expand it.

WEB BROWSER-BASED CONFIGURATION

6.6.4.2 Volume Set Migration

Migrating occurs when a volume set is migrating from one RAID level to another, when a volume set strip size changes, or when a disk is added to a RAID set. Migration state is displayed in the volume state area of the “Volume Set Information” screen.

The screenshot displays the "RAID Set Information" screen for an Areca Technology Corporation system. The interface includes a navigation menu on the left and a main content area with two tables. The top table, "RAID Set", shows a RAID set #000 in a "Migrating (2.9%)" state. The bottom table, "Enclosure #1 : ARECA SATA RAID V1.0", lists various disks with their usage, capacity, and model.

RAID Set	Devices	Volume Set(CH/SS/Lan)	Volume State	Capacity
RAID Set # 000	ES100E1, ES100E2, ES100E3, ES100E4, ES100E5, ES100E6	ARC-1224-VOL_#500(0,0,0)	Migrating (2.9%)	100,000

Device	Usage	Capacity	Model
ES100E1	RAID Set # 000	400,000	HITACHI HUSML400AS6000
ES100E2	RAID Set # 000	400,000	HITACHI HUSML400AS6000
ES100E3	RAID Set # 000	400,000	HITACHI HUSML400AS6000
ES100E4	RAID Set # 000	400,000	HITACHI HUSML400AS6000
ES100E5	RAID Set # 000	36,700	HITACHI HUS51430VLS300
ES100E6	RAID Set # 000	36,700	SEAGATE ST320027ES
ES100E7	RAID Set # 000	72,400	SEAGATE ST3724AS40
ES100E8	RAID Set # 000	36,700	HITACHI HUS51430VLS300

Note:

1. If the volume is RAID level 30, 50, or 60, you can not change the volume to another RAID level. If the volume is RAID level 0, 1, 10(1E), 3, 5 or 6, you can not change the volume to RAID level 30, 50, or 60.
2. Power failure may damage the migration data. Please backup the RAID data before you start the migration function.

6.6.5 Check Volume Set

To check a volume set from a RAID set:

1. Click on the “Check Volume Set” link.
2. Click on the volume set from the list that you wish to check.

Click on “Confirm The Operation” and click on the “Submit” button. Use this option to verify the correctness of the redundant data in a volume set. For example, in a system with dedicated parity, volume set check means computing the parity of the data disk drives and comparing the results to the contents of the dedicated parity disk drive. The checking percentage can also be viewed by clicking on “RAID Set Hierarchy” in the main menu.

WEB BROWSER-BASED CONFIGURATION

6.6.6 Schedule Volume Check

A volume check is a process that verifies the integrity of redundant data. To verify RAID 3, 5, 6, 30, 50 or 60 redundancy, a volume check reads all associated data blocks, computes parity, reads parity, and verifies that the computed parity matches the read parity.

Volume checks are very important because they detect and correct parity errors or bad disk blocks in the drive. A consistency check forces every block on a volume to be read, and any bad blocks are marked; those blocks are not used again. This is critical and important because a bad disk block can prevent a disk rebuild from completing. We strongly recommend that you run consistency checks on a regular basis—at least once per week (set on 'Scheduler'). Volume checks degrade performance, so you can also run them when the system is idle (set by "Checking After System Idle").

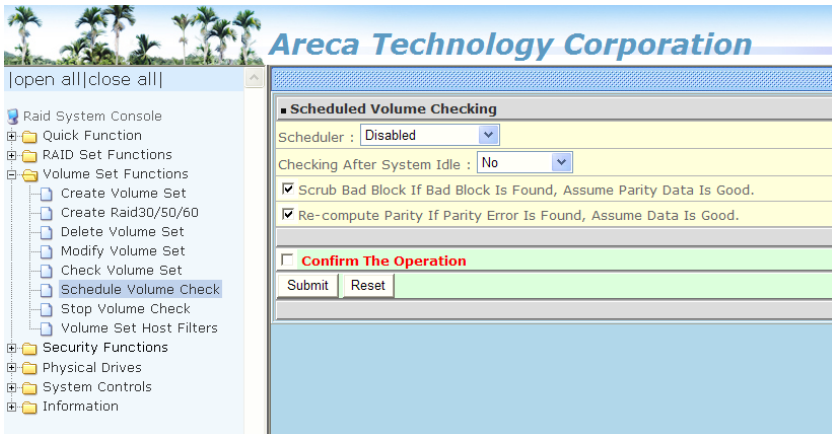

Note:

Please make sure of the inconsistency source generated by parity error or bad block before you click the recovery method. Otherwise, you will lose the recovery data.

WEB BROWSER-BASED CONFIGURATION

6.6.7 Stop Volume Set Check

Use this option to stop the "Check Volume Set" function.



6.7 Security Function

The “Security Function” on the new firmware supports Self-Encrypting Disks (SED) for protection of data against loss or theft of SEDs. Protection is achieved by the use of encryption technology on the drives. The McRAID storage management allows SED keys to be created and managed as well as create/delete RAID sets. The following section provides the “Security Function” instructions to perform the custom configuration tasks. All SED functions are integrated into the intuitive and user friendly McRAID manager interface for easy access. Choose this option from the main menu and then perform the operations listed below.

6.7.1 Create SED RAID Set



To create a SED RAID set, click on the “Create SED Raid Set” link. A “Select The Drive For SED RAID Set” screen is displayed showing the SED drive(s) connected to the current controller and enclosures. Click on the selected physical drives within the current RAID set. Enter 1 to 15 alphanumeric characters to define a unique identifier for a SED RAID set. The default RAID set name will always appear as “Raid Set #”. Tick on the “Confirm The Operation” check box and click on the “Submit” button on the screen; the RAID set will start to initialize. If you have available disk member, you can repeat above procedures to define another RAID sets. The Max 128 Volumes is the default mode for RAID controller.

WEB BROWSER-BASED CONFIGURATION

6.7.2 Delete SED RAID Set



A SED RAID Set is a RAID Set that has been locked on a controller that holds a security key. When you delete existing SED RAID sets, there has one option available to perform an Instant Secure Erase. The "Secure Erase The Member Disks" function is the process of permanently erasing all data on the SED disks and resetting the security attributes. The data on the SED disk is lost.

To delete a SED RAID set, click on the "Deleted Raid Set" link; a "Select The SED RAID Set To Delete" screen is displayed showing all exist SED RAID sets in the current controller. Click on the SED RAID set number which you want to delete in the select column on the delete screen. Then, tick on the "Confirm The Operation" check box and click on the "Submit" button in the screen to delete it. The volume sets included in the "Delete SED RAID Set". It will be deleted by this action. But for the Raid 30/50/60, you need to delete the volumes belonging to those SED RAID sets.

6.7.3 Delete ISE RAID Set



WEB BROWSER-BASED CONFIGURATION

Instant Secure Erase (ISE) or Crypto Erase allows a drive to be instantly erased using industry-standard commands and options. An ISE RAID Set is a RAID Set that has been created by a group of ISE only SAS hard disks on a controller. When you delete existing SED RAID sets, there has one option available to perform an Instant Secure Erase. The "Secure Erase The Member Disks" function is the process of permanently erasing all data on the ISE disks and resetting the security attributes. The data on the ISE disk is lost.

To delete an ISE RAID set, click on the "Deleted ISE Raid Set" link. A "Select The ISE RAID Set To Delete" screen is displayed showing all exist ISE RAID sets in the current controller. Click on the RAID set num-ber which you want to delete in the select column on the delete screen. Then, tick on the "Confirm The Operation" check box and click on the "Submit" button in the screen to delete it. The volume sets included in the "Delete ISE RAID Set". It will be deleted by this action. But for the Raid 30/50/60, you need to delete the volumes belonging to those ISE RAID sets.

6.7.4 Security Key Setup

The Areca RAID controllers support Self-Encrypting Disks (SED) for protection of data against loss or theft of SEDs. Protection is achieved by the SED hard drive that automatically and continuously encrypts the data on the drive without any user interaction. There is one SED key per controller. You can manage the SED key under McRAID manager. Local SED key management in the controller firmware is designed to protect data from security breaches with minimal cost and complexity. The key can be escrowed in to a file using McRAID manager. Creating and managing SED key is an important part of the cryptographic process. The key must be kept secret from anyone who should not decrypt your data. This section describes how to generate and manage keys.

6.7.4.1 SED Key Management-Creation

There is one SED key per controller which stores in the controller flash memory. Areca provides both automatically or password methods to generate a key.

WEB BROWSER-BASED CONFIGURATION

1. SED Key is generated automatically by internal random number for a SED RAID set use without needing a password input.
2. SED Key is generated by user supplied password for a SED RAID set use.



6.7.4.2 SED Key Management-Modification

If you have evidence that the SED key is known to unauthorized users, you can change the SED key again. The 'Disable SED Key' function is used to clear SED key on controller and RAID set members.



In some cases, you may want to export a SED key to store on removable media or to use on a different computer. If you want to create a backup copy of the SED key or use it on another computer, you must first export the SED key. Exporting the SED key puts it in a file (filename.bin) that you can then transfer to another computer or put in a safe place.

WEB BROWSER-BASED CONFIGURATION

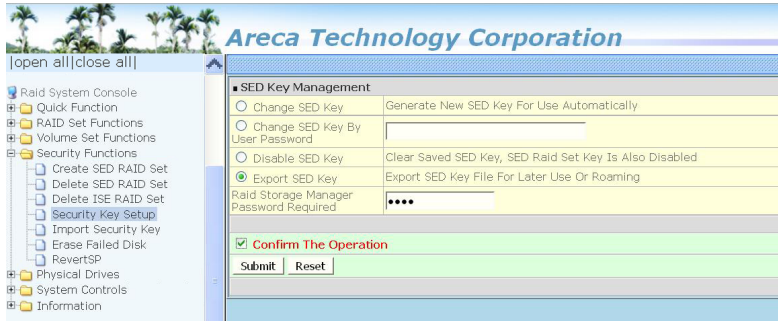

6.7.5 Import Security Key

SED RaidSet created on an Areca RAID adapters can be migrated to another RAID adapter. If you are importing a RaidSet originally secured with a SED key, you need to import the foreign SED key files to secure or unlock that RaidSet. The "Import Security Key" file is for Raidset Roaming or Change SED Key function. If you roam a RaidSet from old controller to another new (with Security Functions support), the foreign SED key file must be imported before it can be used.

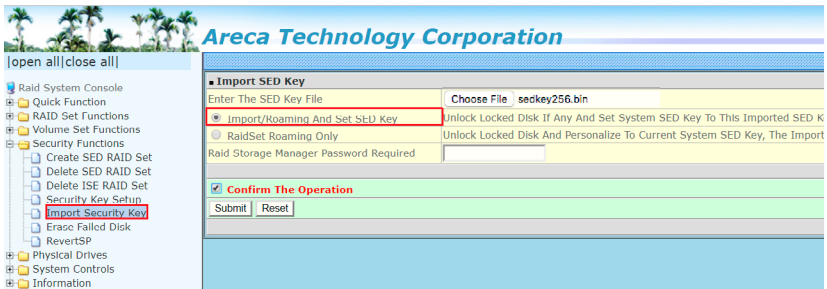

1. Select the "Import/Roaming And Set SED Key" option to unlock the locked disk and change to foreign SED key.
2. Select the "RaidSet Roaming Only" option to unlock the locked disk and personalize to new controller's SED key. If there is an existing SED key on new controller, RaidSet is updated with the new security key. If there is not an existing SED key on new controller, RaidSet is updated to unlock RaidSet.

WEB BROWSER-BASED CONFIGURATION

6.7.6 Erase Failed Disk

To erase the failed encryption-capable physical disk, move the cursor bar to the main menu and click on the "Erase Failed Disk" link. The "Select The Device To Erase" screen will show all failed encryption-capable physical disks. Tick on the failed disk that you want to erase and then click on the "Submit" button. In case controller successfully performs an Instant Secure Erase, it will erase all data on the encryption-capable physical disk disks and reset the security attributes. The data on the encryption-capable physical disk is lost.

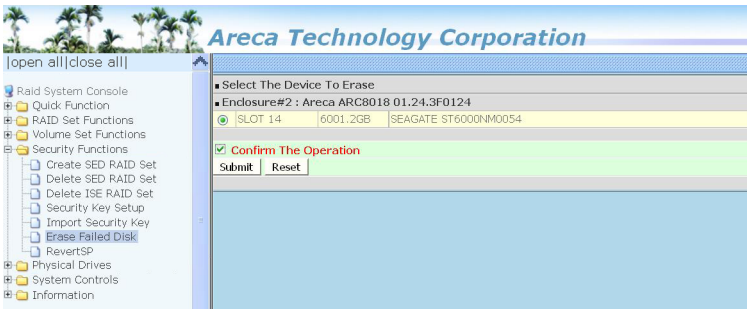

6.7.7 RevertSP

SED models will support the RevertSP feature which erases all data in all bands on the device and returns the contents of all SPs (Security Providers) on the device to their original factory state. In order to execute the RevertSP method the unique PSID (Physical Secure ID) printed on the drive label must be provided. PSID is not electronically accessible and can only be manually read from the drive label.



6.8 Physical Drive

Choose this option to select a physical disk from the main menu and then perform the operations listed below.

6.8.1 Create Pass-Through Disk

To create pass-through disk, move the mouse cursor to the main menu and click on the "Create Pass-Through" link. The relative setting function screen appears. A pass-through disk is not controlled by the 6Gb/s SATA RAID controller firmware; it can't be a part of a volume set. The disk is available to the operating system as an individual disk. It is typically used on a system where the operating system is on a disk not controlled by the RAID firmware. The user can also select the Volume Cache Mode, Write Protection, Tagged Command Queuing, and SCSI channel/SCSI_ID/SCSI_LUN for this pass-through disk.

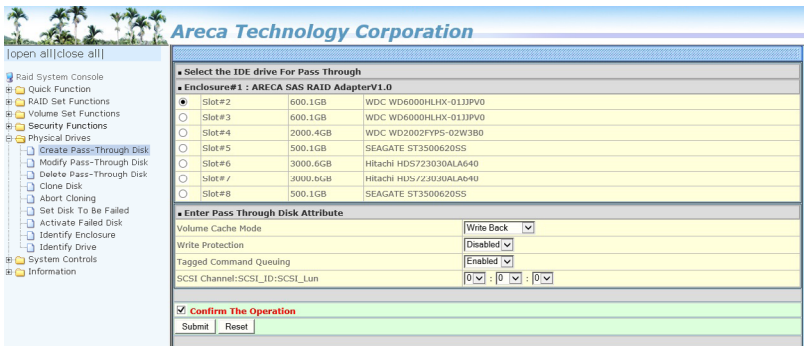

6.8.2 Modify Pass-Through Disk

Use this option to modify the pass-through disk attribute. The user can modify the Cache Mode, Tagged Command Queuing, and SCSI Channel/ID/LUN on an existing pass-through disk.

To modify the pass-through drive attribute from the pass-through drive pool, move the mouse cursor and click on the "Modify Pass-Through" link. The "Select The Pass Through Disk For Modification" screen appears mark the check box for the pass-through disk from the pass-through drive pool and click on the "Submit" button to select drive. When the "Enter Pass-Through Disk Attri-

WEB BROWSER-BASED CONFIGURATION

bute” screen appears, modify the drive attribute values, as you want. After you complete the selection, mark the check box for “Confirm The Operation” and click on the “Submit” button to complete the selection action.

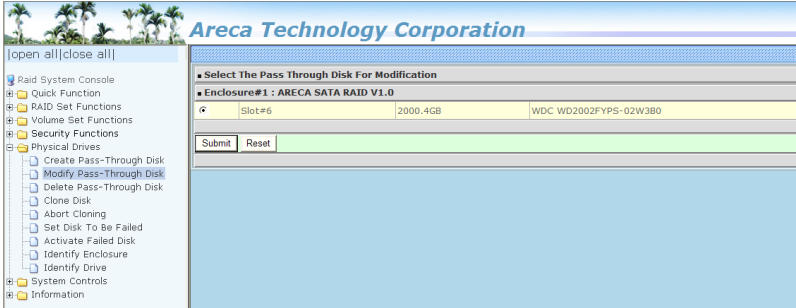

6.8.3 Delete Pass-Through Disk

To delete a pass-through drive from the pass-through drive pool, move the mouse cursor bar to the main menus and click the “Delete Pass Through” link. After you complete the selection, mark the check box for “Confirm The Operation” and click the “Submit” button to complete the delete action.

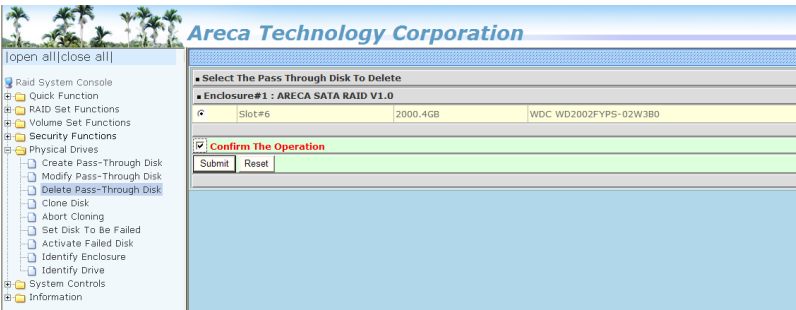

6.8.4 Clone Disk

Instead of deleting a RAID set and recreating it with larger disk drives, the “Clone Disk” function allows the users to replace larger disk drives to the RAID set that have already been created. Click the “Clone Disk” option on the “Physical Drives” link to enable the clone function. If there is an available disk, then the “Select The Drives For Cloning” screen appears. There are two “Clone Disk” function options: “Clone And Replace” and “Clone Only.”

WEB BROWSER-BASED CONFIGURATION

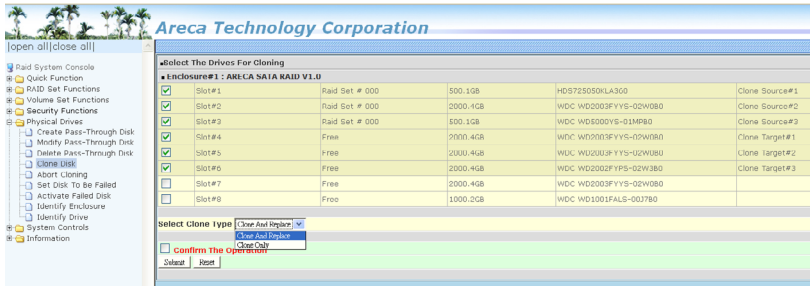

Clone Disk Procedure

1. Select one of the members as the "Clone Source" (status indicated as Raid Set #) by clicking on the appropriate check box.
2. Select a "Clone Target" (status indicated as Free or Hot Spare) by clicking on the appropriate check box.
3. If you have available disk member, you can repeat above procedures to define another clone pair.
4. Select Clone Type.

The pair number for both the "Clone Source" and the "Clone Target" will be indicated in the screen. Click the "Confirm The Operation" check box and click on the "Submit" button on the screen; the controller will automatically start the cloning process using the existing "stand-by" (Free or Hot Spare drive) to clone the source drive (the Raid Set member drive). The cloning process percentage will be indicated in the "Volume State" area of the "Volume Set Information" screen. Completion of the Clone function process will be indicated by a notification message on the event log.

6.8.4.1 Clone And Replace

You can enlarge your logical drives by copying and replacing all member drives with drives of higher capacity. The existing data in the logical drives is copied onto the new drives, and then the original members are marked as "Offlined".

WEB BROWSER-BASED CONFIGURATION

6.8.4.2 Clone Only

The stand-by disk will clone the logical drives without substituting it. The status of the stand-by drive will be marked as "Offline" after the cloning process. The source drive will remain a member of the logical drive.

6.8.5 Abort Cloning

Use this function to stop the ongoing clone disk action.

6.8.6 Set Disk To Be Failed

It sets a normal working disk as "failed" so that users can test some of the features and functions.

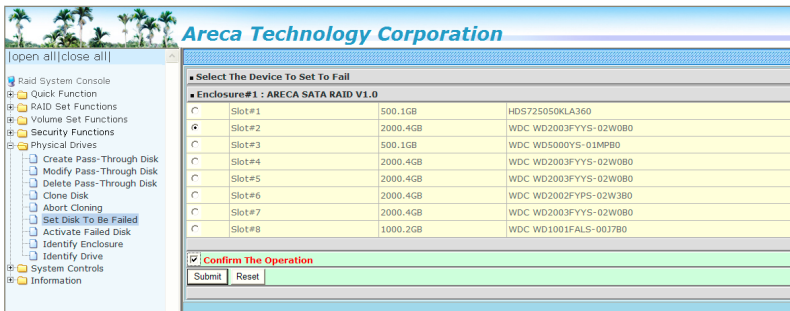

6.8.7 Activate Failed Disk

It forces the current "failed" disk in the system to be back online. "Activate Failed Disk" function has no effect on the removed disks, because a "removed" disk does not give the controller a chance to mark it as "failure".

Followings are considered as "Removed-Disk":

1. Manually removed by user
2. Losing PHY connection due to bad connector, cable, backplane
3. Losing PHY connection due to disk fail

Basically, in the eyes of the controller, the disk suddenly disappears due to whatever reason.

WEB BROWSER-BASED CONFIGURATION

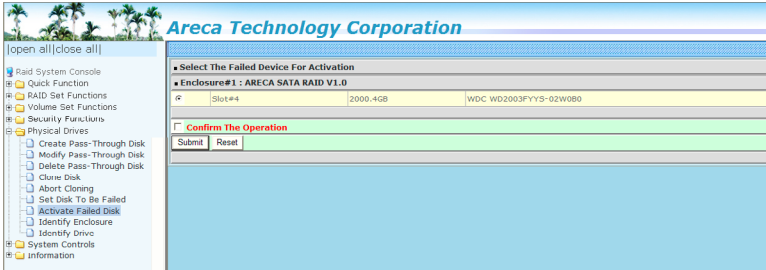

6.8.8 Identify Enclosure

To prevent removing the wrong enclosure, the selected Areca expander enclosure all disks fault LED indicator will light for physically locating the selected enclosure when the "Identify Enclosure" is selected. This function will also light the enclosure LED indicator, if it is existed.

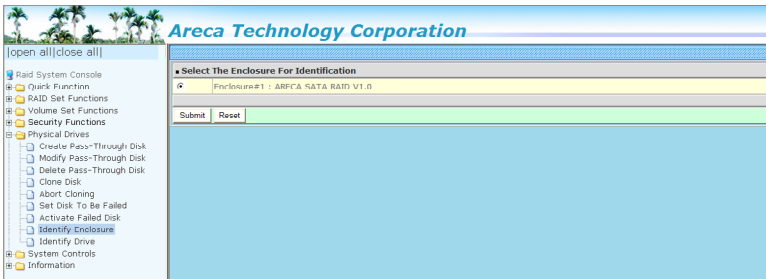

6.8.9 Identify Drive

To prevent removing the wrong drive, the selected disk fault LED indicator will light for physically locating the selected disk when the "Identify Selected Device" is selected.

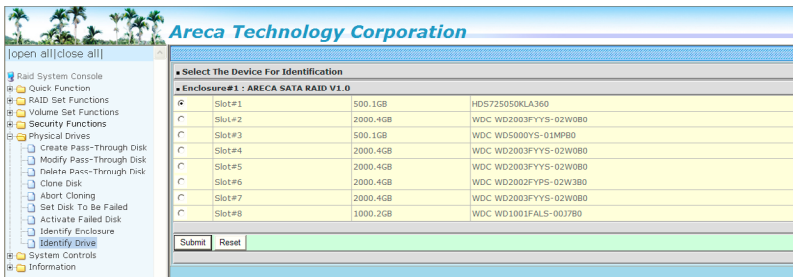

6.9 System Controls

6.9.1 System Config

To set the RAID system function, move the cursor to the main menu and click the "System Controls" link. The "Raid System Function" menu will show all items, and then select the desired function.



- **System Beeper Setting**

The "System Beeper Setting" function is used to "Disabled" or "Enabled" the 6Gb/s SATA RAID controller alarm tone generator.

- **Background Task Priority**

The "Background Task Priority" is a relative indication of how much time the controller devotes to a rebuild operation. The 6Gb/s SATA RAID controller allows the user to choose the rebuild priority (UltraLow, Low, Medium and High) to balance volume set access and rebuild tasks appropriately. For high array performance, specify a "Low" value.

- **JBOD/RAID Configuration**

JBOD is an acronym for "Just a Bunch Of Disk". A group of hard disks in a RAID box are not set up as any type of RAID configuration. All drives are available to the operating system as an individual disk. JBOD does not provide data redundancy.

WEB BROWSER-BASED CONFIGURATION

User needs to delete the RAID set, when you want to change the option from the RAID to the JBOD function.

- **Max SATA Mode Supported**

The controller drive channel can support up to SATA III, which runs up to 600MB/s. NCQ is a command protocol in Serial ATA that can only be implemented on native Serial ATA hard drives. It allows multiple commands to be outstanding within a drive at the same time. Drives that support NCQ have an internal queue where outstanding commands can be dynamically rescheduled or re-ordered, along with the necessary tracking mechanisms for outstanding and completed portions of the workload. The RAID subsystem allows user to choose the SATA Mode: SATA150, SATA150+NCQ, SATA300, SAT300+NCQ, SATA600, SATA600+NCQ.

- **HDD Read Ahead Cache**

Allow Read Ahead (Default: Enabled)—When Enabled, the drive's read ahead cache algorithm is used, providing maximum performance under most circumstances.

- **Volume Data Read Ahead**

The volume read data ahead parameter specifies the controller firmware algorithms which process the Read Ahead data blocks from the disk. The read ahead parameter is normal by default. To modify the value, you must set it from the command line using the Read Ahead option. The normal option satisfies the performance requirements for a typical volume. The disabled value implies no read ahead. The most efficient value for the controllers depends on your application. Aggressive read ahead is optimal for sequential access but it degrades random access.

- **Empty HDD Slot LED**

The firmware has added the "Empty HDD Slot LED" option to setup the fault LED light "ON "or "OFF" when there is no HDD installed. When each slot has a power LED for the HDD installed identify, user can set this option to "OFF". Choose option "ON", the 6Gb/s SATA RAID controller will light the fault LED; if no HDD installed.

WEB BROWSER-BASED CONFIGURATION

- **Max Command Length**

Max Command Length is used to set a "best" IO size for the RAID controller.

- **Auto Activate Incomplete Raid**

When some of the disk drives are removed in power off state or boot up stage, the RAID set state will change to "Incomplete State". But if a user wants to automatically continue to work while the 6Gb/s SATA RAID controller is powered on, the user can set the "Auto Activate Incomplete Raid" option to enable. The RAID state will change to "Degraded Mode" while it powers on.

- **Disk Write Cache Mode**

User can set the "Disk Write Cache Mode" to Auto, Enabled, or Disabled. "Enabled" increases speed, "Disabled" increases reliability.

- **Write Same For Initialization**

Drives that support the Write Same feature (SCT) can write to multiple drive sectors at once, improving initialization time. To take advantage of this feature, all the drives in the unit must support Write Same. User can set the "Enabled" or "Disabled" for the controller initialization.

- **Hot Plugged Disk For Rebuilding**

It defines if the RAID array volume should start rebuilding or not when detects a disk is inserted/re-inserted during online. The options are: "Blank Disk Only", "Always", and "Disable". The default is "Blank Disk Only".

"Blank Disk Only" - it will trigger the rebuilding if and only if the inserted disk has not been in the RAID array before, which has no RAID signature on it. So when a previously removed disk is self re-inserted, it won't trigger the degraded RAID array to rebuild, and so that the administrator has a chance to identify this miss-behaving disk and replace it.

"Always" - it is what it was before. Whenever a disk is inserted/re-inserted whether new or previously existed, it always triggers a rebuilding for the Degraded RAID set/Volume.

WEB BROWSER-BASED CONFIGURATION

“Disable” – it will not trigger rebuilding regardless what sort of disk plugging in. When “Disable” and/or “Blank Disk Only” is selected, the re-inserted/previously removed disk will be identified as a disk in a separate RAID set with duplicated RAID-set# and with all the rest of RAID members missing.

- **Disk Capacity Truncation Mode**

Areca RAID controller uses drive truncation so that drives from differing vendors are more likely to be able to be used as spares for each other. Drive truncation slightly decreases the usable capacity of a drive that is used in redundant units. The controller provides three truncation modes in the system configuration: “**Multiples Of 10G**”, “**Multiples Of 1G**”, and “**Disabled**”.

Multiples Of 10G: If you have 120 GB drives from different vendors; chances are that the capacity varies slightly. For example, one drive might be 123.5 GB, and the other 120 GB. Multiples Of 10G truncates the number under tens. This makes same capacity for both of these drives so that one could replace the other.

Multiples Of 1G: If you have 123 GB drives from different vendors; chances are that the capacity varies slightly. For example, one drive might be 123.5 GB, and the other 123.4 GB. Multiples Of 1G truncates the fractional part. This makes capacity for both of these drives so that one could replace the other.

Disabled: It does not truncate the capacity.

- **Smart Option For HDD**

This option is used to increase the reliability of SSDs/HDDs by automatically copying data from a drive with potential to fail to a designated hot spare or newly inserted drive. The options are: “Failed The Drive”, “Failed The Drive If Hot Sapre Exist”, and “Alert Only”. The default is “Alert Only”

“Failed The Drive” – controllers kill off the SMART fail drive immediately.

WEB BROWSER-BASED CONFIGURATION

"Failed The Drive If Hot Sapre Exist" – controllers kill off the SMART fail disk if hot sapre dive is existed.

"Alert" – it will trigger alert when there happens a SMART fail drive.

- **Smart Polling Interval**

Besides the scheduled volume check, user can define the Smart Pulling Interval to pull the SMART status of each disk. The default is "on demand". User can schedule every certain period of time interval to pull the SMART status of each disk. When SMART pulling is executed, disk activity will be temporarily halted until the SMART parameter reading is finished. That is why you don't want to set the " Smart Polling Interval" too frequent. What to use is up to the users to decide based on their applications and experimental results.

WEB BROWSER-BASED CONFIGURATION

6.9.2 Advanced Configuration

To set the RAID system function, move the cursor to the main menu and click the "Advanced Configuration" link. The "Advanced Configuration" menu will show all items, and then select the desired function.

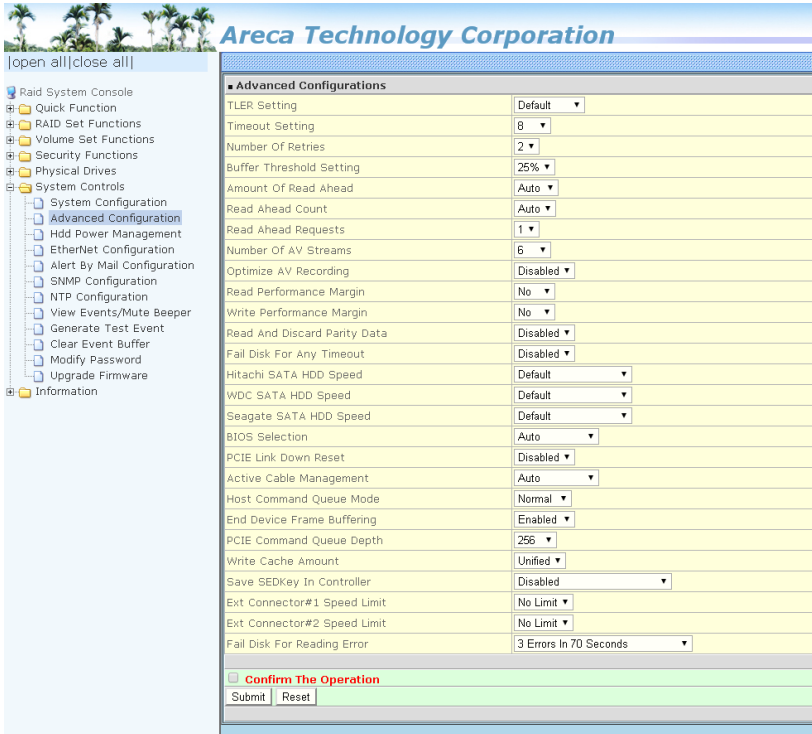

• TLER Setting

TLER (time-limited error recovery) functions provide support for WD Caviar RE (RAID) series disks. This is a new option from WD to support RAID features that were traditionally missing from standard desktop drives. TLER is a method of signaling the system RAID controller in the event that an error recovery process is taking longer than time-out specifications allow. This prevents the RAID controller from dropping the drive from the array during this period. Default value is manufacture setting. You can select between 5, 6 and 7 second. This feature is to setup the HDD internal timeout value.

WEB BROWSER-BASED CONFIGURATION

- **Timeout Setting**

Disk time-out is a registry setting that defines the time that RAID controller will wait for a hard disk to respond to a command. You can modify the retry value by entering a new value in the edit box beside this button and then selecting the button. Normally you should not need to modify this value. Default value is 8 seconds: You can select between 3~8 second.

- **Number of Retries**

This setting determines the number of access that will be attempted before the current command from the RAID controller to the disk drive is aborted. You can modify the retry value by entering a new value in the edit box beside this button and then selecting the button. Normally you should not need to modify this value. There are two selections, either 2 retry or 3 retry.

- **Buffer Threshold**

This new feature there are 3 options; 25%, 50%, 75%. The percentage represents how much data should be kept in resident cache memory (how full cache should get) before controller starts to flush data onto the hard drives. If the buffer is set for 25%, then all 25% will be cached and is used for writing data. The remaining cache memory will be used for reading incoming write and other system overhead. Write buffer threshold for 5% is added for video recording. This option will push data to disk early.

This feature gives controller extra buffer time in case of slow response from the hard drives within a given time. Consequently, this can prevent a pause in data flow and there will be continues data access and stream. This feature is very useful for the video streaming applications where there is high demand for constant non-stop data flow with no interruption due to lower performance of specific hardware.

- **Amount of Read Ahead**

Read-Ahead data is buffered in the RAID controller cache, however, thereby cutting down on the amount of I/O traffic to the disk. The Amount of Read Ahead defines how many data of reading at a time, making more efficient use of the RAID sub system. This makes it possible to locate and re-issue the data

WEB BROWSER-BASED CONFIGURATION

without repetitive hard parsing activities. The Amount of Read Ahead parameter is used to allocate an amount of memory in the cache memory the frequently executed queries and return the result set back to the host without real disk read execution. Default value is Auto: Controller will base on the HDD number to set the amount of Read Ahead value. You can select between 512KB ~ 16MB.

- **Read Ahead Count**

The Read Ahead count is used to define how many times (1, 2, 3,, 10) of the "Amount of Read Ahead X Read Ahead Requests" data reading at a time. Default value is Auto: Controller will base on the HDD number to set the amount of Read Ahead Count value. You can select between Auto, 1, 2, or 10.

- **Read Ahead Requests**

The Read Ahead Requests is used to define how many times (1, 2, 3) of the "Amount of Read Ahead " data reading at a time. Default value is 1. You can select between 1, 2, or 3.

- **Number of AV Stream**

RAID controllers are required to have not only the function of processing ordinary data but also the function of dealing with AV (audio/video) stream data needing real-time processing. Since the bus cycle used in RAID controller was designed to transfer the computer data exactly, it was unsuitable for the transfer of AV stream needing great band widths. They are required to do some setting for the handshaking during the processing of stream data. This setting is an object of transferring stream data efficiently on an existing RAID controller. Normally you should not need to modify this value. Default value is 6. You can select between 6~256.

To decide how to set AV stream payout parameter, you need to check the Number of Stream, Amount of Read Ahead, and Total Cache Memory during runtime. You can try to adjust the three numbers to get the best performance as your requirement. Number of Stream shows the number of stream added to the system, Amount of Read Ahead shows the amount of Read Ahead data taken from the cache without real disk execution, and total cache memory shows the total available memory being installed in the RAID controller.

WEB BROWSER-BASED CONFIGURATION

- **Optimize AV Recording**

AV recording option is for video recording (no time limit), but if used in normal operation, performance may be degraded. This new feature there are 4 options; Disabled, Mode1, Mode2 and Mode 3. Default value is Disabled. Our controller cache uses LRU method, there have no special memory capacity reserved for read or write. The Mode 1, 2 and 3 are used to define the command sorting method. The default sorting method is helpful for normal applications, but not useful for AV applications, so we have defined three different sorting methods for these special applications. To decide how to optimize AV stream recording parameter, you need to adjust the Optimize AV Recording, and Write Buffer Threshold during runtime.

- **Read Performance Margin**

The "Read Performance Margin" is for controller to reserve n% read margin during AV stream recording.

- **Write Performance Margin**

The "Write Performance Margin" is for controller to reserve n% write margin AV stream recording.

AJA Mode Usage:

1. Controller needs to reboot when you adjust the following settings.
 - (1). Optimize For AV Recording: change any setting
 - (2). Read Performance Margin : No <-> X%
 - (3). Write Performance Margin : No <-> X%
2. The following setting is changed for AJA mode, and reboot is required for the setting to take effect.

Setting and Usage			
Optimize AV	Read Margin	Write margin	Description
Mode 3	Any	Any	R/W AJA mode with throttling, no sorting
Mode Disabled/1/2	X%	X%	R/W AJA mode with throttling and sorting
Mode Disabled/1/2	X%	No	Read AJA mode with throttling and sorting
Mode Disabled/1/2	No	X%	Write AJA mode with throttling and sorting

WEB BROWSER-BASED CONFIGURATION

- <a>. Under Optimize For AV Recording mode: 3
Read Performance Margin and Write Performance Margin are enabled with "No" setting is 0%, reboot is not required to change Read Performance Margin and Write Performance Margin

- . If Read Performance Margin or Write Performance Margin are changed to X%, reboot is not required to change X% to Y%.

- <c>. For NON-VIDEO application, the following setting is recommended
Buffer Threshold Setting: 25%
Optimize AV Recording: disabled

Example:

- (1). Only write throttling is required
 - (a). Buffer Threshold Setting: 5%
 - (b). Optimize For AV Recording Mode left unchanged (Disabled)
 - (c). Read Performance Margin left unchanged (No)
 - (d). Write Performance Margin set to X%
 - (e). Reboot
 - (f). Adjust Write Performance Margin to fine tune the result (no reboot required)

- (2). Read/Write Throttling is required and sorting is to be disabled
 - (1). Buffer Threshold Setting: 5%
 - (2). Optimize For AV Recording Mode set to 3
 - (3). Reboot
 - (4). Adjust Read/Write Performance Margin to fine tune the result (no reboot required)

WEB BROWSER-BASED CONFIGURATION

The screenshot shows the Areca Technology Corporation web browser-based configuration interface. The navigation tree on the left includes categories like RAID System Console, Quick Function, RAID Set Functions, Volume Set Functions, Security Functions, Physical Drives, and System Controls. The 'Advanced Configuration' option is selected. The main configuration area lists various settings with their current values and default options. The 'Read And Discard Parity Data' setting is highlighted, showing it is set to 'No'. Other settings include 'Hitachi SATA HDD Speed' at 8%, 'WDC SATA HDD Speed' at 10%, and 'Seagate SATA HDD Speed' at 12%. A 'Confirm The Operation' dialog is visible at the bottom of the configuration area.

Setting	Value	Default
TLER Setting	Default	Default
Timeout Setting	8	
Number Of Retries	2	
Buffer Threshold Setting	25%	
Amount Of Read Ahead	Auto	
Read Ahead Count	Auto	
Read Ahead Requests	1	
Number Of AV Streams	6	
Optimize AV Recording	Disabled	
Read Performance Margin	No	
Write Performance Margin	No	
Read And Discard Parity Data	No	
Fail Disk For Any Timeout	6%	
Hitachi SATA HDD Speed	8%	
WDC SATA HDD Speed	10%	
Seagate SATA HDD Speed	12%	
BIOS Selection	14%	
PCIE Link Down Reset	16%	
Active Cable Management	18%	
Host Command Queue Mode	20%	
End Device Frame Buffering	22%	
PCIE Command Queue Depth	24%	
Write Cache Amount	26%	
Save SEDKey In Controller	28%	
Ext Connector#1 Speed Limit	30%	
Ext Connector#2 Speed Limit	32%	
Fail Disk For Reading Error	34%	
	36%	
	38%	
	No Limit	
	3 Errors In 70 Seconds	

- **Read And Discard Parity Data**

This function is used to determine if parity data is to be read and discarded.

- **Fail Disk For Any Timeout**

Imaging system products expect to have constant speed for writing raw data to the storage by constant speed without any data loss whenever a drive becomes failure in RAID system. This function is the option that RAID controller will kill off the HDD for any time out. It can reduce the write cache size to buffer the raw data.

- **Hitachi/WDC/Seagate SATA HDD Speed**

The purpose of this setting is to provide alternative method to change the interface speed of a SATA HDD speed so that it can be successfully utilized in some compatible condition. Reboot is required for this setting to take effect.

WEB BROWSER-BASED CONFIGURATION

- **BIOS Selection**

It combines the "Legacy BIOS", "UEFI BIOS" and "EFI BIOS" into a single BIOS, and provides BIOS option in the GUI. In the old days, Areca provided separate BIOS files for each, and need to manually flash it in. Now flashing BIOS for different BIOS type is no longer needed, just make the BIOS selection in System Controls: Advance Configuration: BIOS Option.

The controller provides three BIOS options.

Legacy: for PC motherboards that are using regular BIOS boot.

UEFI: for PC motherboards using UEFI boot.

EFI: for Intel-based Mac boot

Disable: disable controller BIOS at POST (set to 0xFF)

==> If BIOS is to be disabled --> All data are 0xFF

- **PCIE Link Down Reset**

If SAS RAID adapters is experiencing problems with link down issue in some host M/B , please try to set the "PCIE Link Down Reset".

Enable: The RAID-on-Chip (ROC) PCIe link will be down and need to be re-initialized to get the link up.

Disable: The RAID-on-Chip (ROC) PCIe link will ignore the "PCIE link Down Reset" command.

- **Active Cable Management**

An active cable requires power for circuitry that is integral to any of the TX/RX high speed serial channels supported by the cable. In addition, the active cable requires power to operate the management interface. There is one E2prom on the AOC cable that records the AOC capability 6 or 12 Gb/s, optical or non optical. This setting is for user to disable the E2prom value that it writes the wrong value. If select "Auto", it only works with the 8644 cable that has been programmed.

- **Host Command Queue Mode**

This option is used to solve the the problem with reads stalling that causes by out of order command completion. Choose the "Host Command Queue Mode" option="Ordered" on the "Advanced Configuration" if you want similar read/write throughputs. There the read and write get the same priority as they are scheduled and the reads are not pushed back.

WEB BROWSER-BASED CONFIGURATION

- **End Device Frame Buffering**

Using the 12Gb/s SAS technology, including End Device Frame Buffering (EDFB) technology, the ROC and expander are designed to help ease the industry's transition to 12Gb/s SAS-enabled systems by enabling customers to take advantage of 12Gb/s speeds while using existing 6Gb/s drives and backplane infrastructure. This technology allows the expander to perform aggregation, essentially allowing two devices to share one port on the expander.

- **PCIe Command Queue Depth**

This parameter is adjusted the commands per queue of PCIe bus which transmits multiple commands to a single target without waiting for the initial command to complete. User can set the "PCIe Command Queue Depth" to 256, 512, or 1024.

- **Write Cache Amount**

The "Write Cache Amount" is for controller to configure how much cache SDRAM dedicated for read, and how much for write. By default (Unified), the size of read or write cache is automatically assigned by the controller firmware. If your server application has significantly more reads than writes or more writes than reads, you might need to change this setting to adjust the read/write cache ratio for improving performance. Reboot is required for the setting to take effect. The optimal ratio setting is application-dependent.

- **Save SED Key In Controller**

<a> If enable --> disable, clear SED Key saved in setup
 If disable --> enable, if key exists, save to setup

If enable--->disable, the key will not remain in the flash. So that next time power up again, it will need to input the key from the CLI or McRAID manager. You can also import the key file (Import Security Key) or key-in the password (Enter SED Key By Password) from the GUI interface.

WEB BROWSER-BASED CONFIGURATION

- **Dual Path Usage**

This option is only available on the ARC-1883X with dual path firmware.

- **Load Balance By Slot** is the method for distributing command requests across a group of slots. Going down the list of slots, the controller forwards a command request to each slot in turn.
- **Load Balance By Round Robin** is the method for distributing command requests across two ports of each slot. Going down the list of ports in the slot, the controller forwards a command request to each port in turn.
- **Active Standby** is the method for distributing command requests on across the SFF-8644 SAS 1-4 ports and the other SFF-8644 SAS 5-8 ports as standby. If the active SAS cable fails, traffic fails over to a standby cable.

- **Ext Connector#1 Speed Limit**

This option is only available on the ARC-1883X/1883LP. It is used to limit the external connector speed in case of compatible issue on low speed connected enclosure.

- **Ext Connector#2 Speed Limit**

This option is only available on the ARC-1883X. It is used to limit the external connector speed in case of compatible issue on low speed connected enclosure.

- **Fail Disk For Reading Error**

This option is available to improve the fail disk function if the disk has too many reading errors. This function is the option that RAID controller will kill off the HDD for reading error account setting value.

- 3 errors in 70 seconds: this option also includes 4 errors in 100 seconds, 5 errors in 120 seconds
- 6 errors in 2 minutes: this option also includes 8 errors in 180 seconds, 10 errors in 240 seconds
- 9 errors in 3 minutes: this option also includes 12 errors in 270 seconds, 15 errors in 360 seconds
- Reading Error Does Not Fail Disk

WEB BROWSER-BASED CONFIGURATION



Areca Technology Corporation

|open all|close all|

- 🔗 Raid System Console
- 📁 Quick Function
- 📁 RAID Set Functions
- 📁 Volume Set Functions
- 📁 Security Functions
- 📁 Physical Drives
- 📁 System Controls
 - 📁 System Configuration
 - 📁 **Advanced Configuration**
 - 📁 Hdd Power Management
 - 📁 EtherNet Configuration
 - 📁 Alert By Mail Configuration
 - 📁 SNMP Configuration
 - 📁 NTP Configuration
 - 📁 View Events/Mute Beeper
 - 📁 Generate Test Event
 - 📁 Clear Event Buffer
 - 📁 Modify Password
 - 📁 Upgrade Firmware
- 📁 Information

Advanced Configurations

TLER Setting	Default ▾
Timeout Setting	8 ▾
Number Of Retries	2 ▾
Buffer Threshold Setting	25% ▾
Amount Of Read Ahead	Auto ▾
Read Ahead Count	Auto ▾
Read Ahead Requests	1 ▾
Number Of AV Streams	6 ▾
Optimize AV Recording	Disabled ▾
Read Performance Margin	No ▾
Write Performance Margin	No ▾
Read And Discard Parity Data	Disabled ▾
Fail Disk For Any Timeout	Disabled ▾
Hitachi SATA HDD Speed	Default ▾
WDC SATA HDD Speed	Default ▾
Seagate SATA HDD Speed	Default ▾
BIOS Selection	Auto ▾
PCIe Link Down Reset	Disabled ▾
Active Cable Management	Auto ▾
Host Command Queue Mode	Normal ▾
End Device Frame Buffering	Enabled ▾
PCIe Command Queue Depth	256 ▾
Write Cache Amount	Unified ▾
Save SEDKey In Controller	Disabled ▾
Ext Connector#1 Speed Limit	No Limit ▾
Ext Connector#2 Speed Limit	No Limit ▾
Fail Disk For Reading Error	3 Errors In 70 Seconds ▾
<input type="checkbox"/> Confirm The Operation	3 Errors In 70 Seconds
	6 Errors In 2 Minutes
	9 Errors In 3 Minutes
	Reading Error Does Not Fail Disk
<input type="button" value="Submit"/> <input type="button" value="Reset"/>	

6.9.3 HDD Power Management

The 6Gb/s SATA RAID controller has automated the ability to manage HDD power based on usage patterns. The “HDD Power Management” allows you to choose a “Stagger Power On Control”, “Low Power Idle”, “Low RPM” and completely “Spins Down Idle HDD”. It is designed to reduce power consumption and heat generation on idle drives.

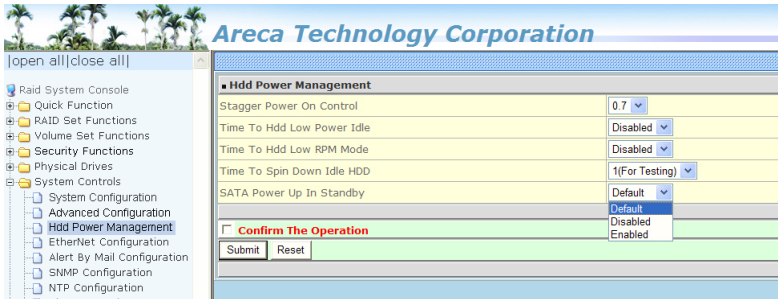

● Stagger Power On Control

In a PC system with only one or two drives, the power can supply enough power to spin up both drives simultaneously. But in systems with more than two drives, the startup current from spinning up the drives all at once can overload the power supply, causing damage to the power supply, disk drives and other system components. This damage can be avoided by allowing the host to stagger the spin-up of the drives. The SATA drives have supported the staggered spin-up capabilities to boost reliability. The staggered drive spin-up is a very useful feature for managing multiple disk drives in a storage subsystem. It gives the host the ability to spin up the disk drives sequentially or in groups, allowing the drives to come ready at the optimum time without straining the system power supply. The staggered drive spin-up in a multiple drive environment also avoids the extra cost of a power supply designed to meet short-term startup power demand as well as steady state conditions.

The 6Gb/s SATA RAID controller has included the option for customer to select the disk drives sequentially staggered power up value. The values can be selected from 0.4 to 6 seconds per step which powers up one drive.

WEB BROWSER-BASED CONFIGURATION

- **Time To Hdd Low Power Idle**

This option delivers lower power consumption by automatically unloading recording heads during the setting idle time. The values can be selected "Disabled" or within the range 2 to 7 minutes.

- **Time To Hdd Low RPM Mode**

This function can automatically spin disks at lower RPM if there have not been used during the setting idle time. The values can be selected "Disabled" or within the range 10 to 60 minutes.

- **Time To Spin Down Idle HDD**

This function can automatically spin down the drive if it hasn't been accessed for a certain amount of time. This value is used by the drive to determine how long to wait (with no disk activity, before turning off the spindle motor to save power). The values can be selected "Disabled" or within the range 1 to 60 minutes.

- **SATA Power Up In Standby**

SATA Power Up In Standby (power management 2 mode, PM2) is a SATA disk drive configuration which prevents the drive from automatic spinup when power is applied. "Enabled" option allows the drive to be powered-up into the Standby power management state to minimize inrush current at power-up and to allow the controller to sequence the spinup of devices. It is mainly for server/workstation environments operating in multiple-drive configurations.

6.9.4 Ethernet Configuration

Use this feature to set the controller Ethernet port configuration. A customer doesn't need to create a reserved space on the arrays before the Ethernet port and HTTP service are working. The firm-ware-embedded web browser-based RAID manager can access it from any standard internet browser or from any host computer either directly connected or via a LAN or WAN with no software or patches required.

WEB BROWSER-BASED CONFIGURATION

To configure the RAID controller Ethernet port, move the cursor bar to the main menu and click on the "System Controls" link. The "System Controls" menu will show all items. Move the cursor bar to the "Ethernet Configuration" item, and then select the desired function.

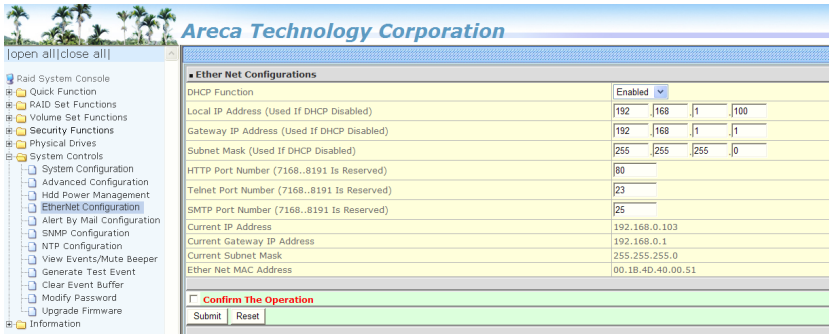

Note:

If you configure the HTTP port number to 0, the HTTP console will be closed.

• DHCP Function

DHCP (Dynamic Host Configuration Protocol) is a protocol that lets network administrators manage centrally and automate the assignment of IP (Internet Protocol) configurations on a computer network. When using the internet's set of protocols (TCP/IP), in order for a computer system to communicate to another computer system, it needs a unique IP address. Without DHCP, the IP address must be entered manually at each computer system. DHCP lets a network administrator supervise and distribute IP addresses from a central point. The purpose of DHCP is to provide the automatic (dynamic) allocation of IP client configurations for a specific time period (called a lease period) and to eliminate the work necessary to administer a large IP network.

• Local IP address

If you intend to set up your client computers manually (no DHCP), make sure that the assigned IP address is in the same range as the default router address and that it is unique to

WEB BROWSER-BASED CONFIGURATION

your private network. However, it is highly recommend to use DHCP if that option is available on your network. An IP address allocation scheme will reduce the time it takes to set-up client computers and eliminate the possibilities of administrative errors and duplicate addresses. To manually configure the IP address of the controller, move the cursor bar to Local IP address item, then reassign the static IP address of the controller.

- **Gateway IP address**

A gateway is a node (a router) on a TCP/IP network that serves as an access point to another network. A default gateway is the node on the computer network that the network software uses when an IP address does not match any other routes in the routing table.

- **Subnet Mask**

A Subnet mask is a 32-bit number that masks an IP address, and divides the IP address into network address and host address.

- **HTTP Port Number**

To manually configure the "HTTP Port Number" of the controller, move the cursor bar to "HTTP Port Number" item, then reassign the default "HTTP Port Number" of the controller.

- **Telnet Port Number**

To manually configure the "Telnet Port Number" of the controller, move the cursor bar to "Telnet Port Number" item, then reassign the default "Telnet Port Number" of the controller.

- **SMTP Port Number**

To manually configure the "SMTP Port Number" of the controller, Move the cursor bar to "SMTP Port Number" item, then reassign the default "SMTP Port Number" of the controller.

6.9.5 Alert By Mail Configuration

To configure the 6Gb/s SATA RAID controller e-mail function, move the cursor bar to the main menu and click on the "System Controls" link. The "System Controls" menu will show all items.

WEB BROWSER-BASED CONFIGURATION

Move the cursor bar to the “Alert By Mail Configuration” item, then select the desired function. This function can only be set via web-based configuration.

The firmware contains a SMTP manager monitoring all system events. Single or multiple user notifications can be sent via “Plain English” e-mails with no software required. (Please refer to section 5.6 “ArcHTTP Configuration” of SMTP Sever Configuration, Mail Address Configuration and Event Notification Configuration.)

The screenshot shows the "SMTP Server Configuration" page in the Areca Technology Corporation web interface. The left sidebar contains a tree view with "Alert By Mail Configuration" selected. The main content area is divided into several sections:

- SMTP Server IP Address:** A field for the IP address, currently showing "0.0.0.0".
- Mail Address Configurations:** A table with columns for "Sender Name", "Mail Address", and "Function". There are four rows for configuration.
- Event Notification Configurations:** A list of notification types with checkboxes and descriptions:
 - Disable Event Notification: No event notification will be sent
 - Urgent Error Notification: Send Only Urgent Event
 - Serious Error Notification: Send Urgent And Serious Event
 - Warning Error Notification: Send Urgent, Serious And Warning Event
 - Information Notification: Send All Event
 - Notification For No Event: Notify User If No Event Occurs Within 24 Hours
- Confirm The Operation:** "Submit" and "Reset" buttons.

6.9.6 SNMP Configuration

Please refer to Appendix C of SNMP Operation & Installation.

The screenshot shows the "SNMP Trap Configurations" page in the Areca Technology Corporation web interface. The left sidebar contains a tree view with "SNMP Configuration" selected. The main content area is divided into several sections:

- SNMP Trap Configurations:** A table with columns for "SNMP Trap IP Address #1", "SNMP Trap IP Address #2", "SNMP Trap IP Address #3", "Port", and "Trap". There are three rows for configuration.
- SNMP System Configurations:** Fields for "Community", "sysContact.0", "sysName.0", and "sysLocation.0".
- SNMP Trap Notification Configurations:** A list of notification types with checkboxes and descriptions:
 - Usable SNMP Trap: No SNMP Trap Will Be Sent
 - Urgent Error Notification: Send Only Urgent Event
 - Serious Error Notification: Send Urgent And Serious Event
 - Warning Error Notification: Send Urgent, Serious and Warning Event
 - Information Notification: Send All Event
 - SNMP Through PCI Inband: Ethernet SNMP Is Disabled
- Confirm The Operation:** "Submit" and "Reset" buttons.

6.9.7 NTP Configuration

The Network Time Protocol (NTP) is used to synchronize the time of a computer client or server to another server or reference time source, such as a radio or satellite receiver or modem. It provides

WEB BROWSER-BASED CONFIGURATION

accuracies typically within a millisecond on LANs and up to a few tens of milliseconds on WANs relative to Coordinated Universal Time (UTC) via a Global Positioning Service (GPS) receiver, for example:

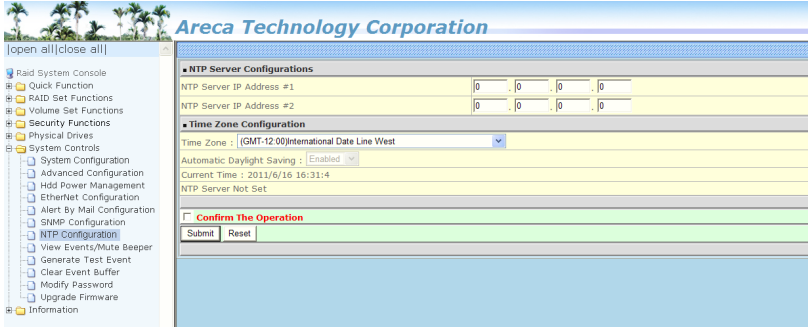

- **NTP Server Address**

The most important factor in providing accurate, reliable time is the selection of NTP servers to be used in the configuration file. Typical NTP configurations utilize multiple redundant servers and diverse network paths in order to achieve high accuracy and reliability. Our NTP configuration supports two existing public NTP synchronization subnets.

- **Time Zone**

Time Zone conveniently runs in the system tray and allows you to easily view the date and time in various locations around the world. You can also quickly and easily add your own personal locations to customize time zone the way you want.

- **Automatic Daylight Saving**

Automatic Daylight Saving will normally attempt to automatically adjust the system clock for daylight saving changes based on the computer time zone. This tweak allows you to disable the automatic adjustment.

Note:

NTP feature works through onboard Ethernet port. So you must make sure that you have connected onboard Ethernet port.

WEB BROWSER-BASED CONFIGURATION

6.9.8 View Events/Mute Beeper

To view the 6Gb/s SATA RAID controller's event information, click on the "View Event/Mute Beeper" link. The 6Gb/s SATA RAID controller "System events Information" screen appears. The mute beeper function automatically enable by clicking on "View Events/Mute Beeper".

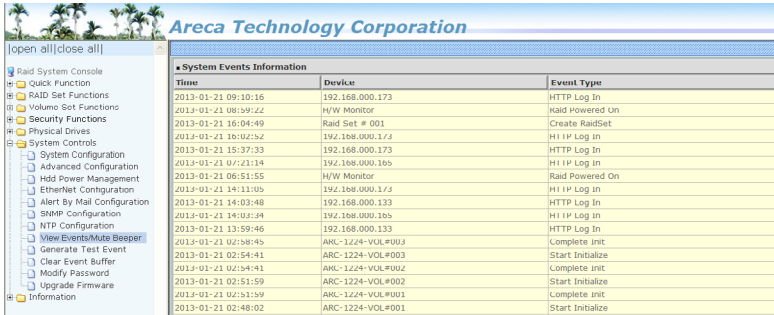

The screenshot shows the 'System Events Information' screen with a table of events. The table has three columns: Time, Device, and Event Type. The events listed include RAID Set # 001, H/W Monitor, RAID Powered On, and various HTTP Log In events.

Time	Device	Event Type
2013-01-21 09:10:16	192.168.000.173	HTTP Log In
2013-01-21 08:59:22	H/W Monitor	RAID Powered On
2013-01-21 16:04:49	Raid Set # 001	Create RaidSet
2013-01-21 18:02:52	192.168.000.173	HI I/F Log In
2013-01-21 15:37:33	192.168.000.173	HTTP Log In
2013-01-21 07:21:14	192.168.000.166	HI I/F Log In
2013-01-21 06:51:55	H/W Monitor	Raid Powered On
2013-01-21 14:11:05	192.168.000.173	HI I/F Log In
2013-01-21 14:03:48	192.168.000.133	HTTP Log In
2013-01-21 14:03:24	192.168.000.166	HI I/F Log In
2013-01-21 13:59:46	192.168.000.133	HTTP Log In
2013-01-21 02:58:45	ARC-1224-VOL#003	Complete Init
2013-01-21 02:54:41	ARC-1224-VOL#003	Start Initialize
2013-01-21 02:54:41	ARC-1224-VOL#002	Complete Init
2013-01-21 02:51:59	ARC-1224-VOL#002	Start Initialize
2013-01-21 02:51:59	ARC-1224-VOL#001	Complete Init
2013-01-21 02:48:02	ARC-1224-VOL#001	Start Initialize

Select this option to view the system events information: Time, Device, Event Type, Elapse Time and Errors. The RAID controller does not have a built-in real time clock. The time information is the relative time from the system time setting. The maximum event no. is 256 per controller.

6.9.9 Generate Test Event

Use this feature is generate events for testing purposes.

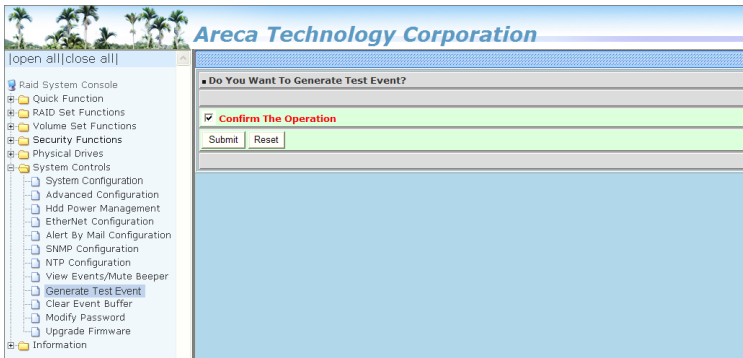

The screenshot shows the 'Do You Want To Generate Test Event?' dialog box. It has a checkbox labeled 'Confirm The Operation' which is checked. Below the checkbox are 'Submit' and 'Reset' buttons.

Do You Want To Generate Test Event?

Confirm The Operation

Submit Reset

WEB BROWSER-BASED CONFIGURATION

6.9.10 Clear Events Buffer

Use this feature to clear the entire events buffer information.

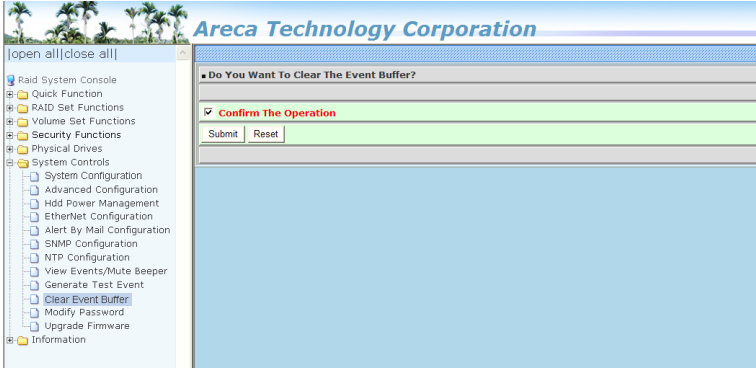

6.9.11 Modify Password

To set or change the 6Gb/s SATA RAID controller password, select "System Controls" from the menu and click on the "Modify Password" link. The "Modify System Password" screen appears.

The manufacture default password is set to 0000.

The password option allows user to set or clear the 6Gb/s SATA RAID controller's password protection feature. Once the password has been set, the user can only monitor and configure the 6Gb/s SATA RAID controller by providing the correct password. The password is used to protect the 6Gb/s SATA RAID controller from unauthorized entry. The controller will check the password only when entering the main menu from the initial screen. The 6Gb/s SATA RAID controller will automatically go back to the initial screen when it does not receive any command in 5 minutes. Do not use spaces when you enter the password, If spaces are used, it will lock out the user.

To disable the password, leave the fields blank. Once the user confirms the operation and clicks the "Submit" button, the existing password will be cleared. Then, no password checking will occur when entering the main menu from the starting screen.

WEB BROWSER-BASED CONFIGURATION

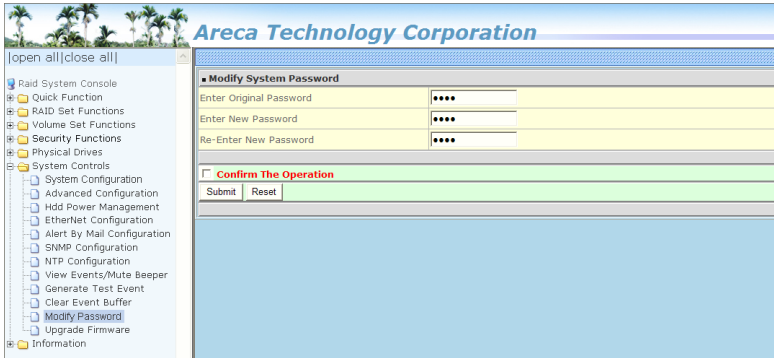

6.9.12 Update Firmware

Please refer to the appendix A "Upgrading Flash ROM Update Process".

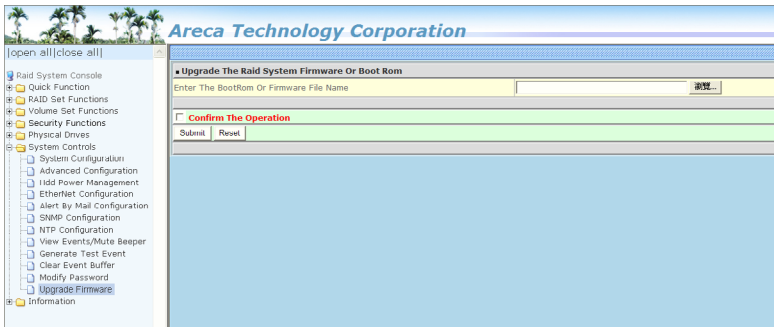

APPENDIX

6.10 Information

6.10.1 Raid Set Hierarchy

Use this feature to view the 6Gb/s SATA RAID controller current RAID set, current volume set and physical disk information. The volume state and capacity are also shown on this screen.

The screenshot shows the RAID Set Hierarchy screen. The left sidebar contains a navigation menu with options like 'Raid System Console', 'Quick Function', 'RAID Set Functions', 'Volume Set Functions', 'Security Functions', 'Physical Drives', 'System Controls', 'Information', 'RAID Set Hierarchy', 'System Information', and 'Hardware Monitor'. The main content area is titled 'Areca Technology Corporation' and displays the following information:

RAIDset Hierarchy

RAID Set	Devices	Volume Set(Ch/Id/Lun)	Volume State
Raid Set # 000	e#1slot1	ABC-1224_VOL#500(0/0/0)	Normal
	e#1slot2	ABC-1224_VOL#501(0/0/1)	Normal
	e#1slot3	ABC-1224_VOL#502(0/0/2)	Normal
	e#1slot4	ABC-1224_VOL#503(0/0/3)	Normal
	e#1slot5	ABC-1224_VOL#504(0/0/4)	Normal

Enclosure#1 : ARECA SATA RAID V1.0

Device	Usage	Capacity	Model
Slot#1(0)	Raid Set # 000 (0B)	500.1GB	H0C72550KLA360
Slot#2(1)	Raid Set # 000 (0A)	2000.4GB	WDC WD2003FYYS-02W0B0
Slot#3(2)	Raid Set # 000 (0B)	500.1GB	WDC WD5000YS-01MR00
Slot#4(3)	Raid Set # 000 (0A)	2000.4GB	WDC WD2003FYYS-02W0B0
Slot#5(4)	Free	2000.4GB	WDC WD2003FYYS-02W0B0
Slot#6(5)	Free	2000.4GB	WDC WD2003FYYS-02W0B0
Slot#7(6)	Free	2000.4GB	WDC WD2003FYYS-02W0B0

6.10.2 System Information

To view the 6Gb/s SATA RAID controller's system information, move the mouse cursor to the main menu and click on the "System Information" link. The 6Gb/s SATA RAID controller "RAID Subsystem Information" screen appears.

Use this feature to view the 6Gb/s SATA RAID controller's system information. The controller name, controller firmware version, Boot ROM version, SATA firmware version, serial number, main processor, CPU instruction/data cache size, system memory size/speed and current IP address appear in this screen.

The screenshot shows the RAID Subsystem Information screen. The left sidebar is the same as in the previous screenshot, with 'System Information' selected. The main content area is titled 'Areca Technology Corporation' and displays the following information:

RAID Subsystem Information

Controller Name	ARC-1224-8i
Firmware Version	V1.51 2013-01-15
BOOT ROM Version	V1.51 2013-01-03
Serial Number	1100-2116-6633
Unit Serial #	
Main Processor	900MHz ARM
CPU ICache Size	32KBytes
CPU DCache Size	32KBytes/Write Back
CPU SCache Size	512KBytes/Write Back
System Memory	1024MB/900MHz/ECC
Current IP Address	192.168.0.211

6.10.3 Hardware Monitor

The hardware monitor information of this controller is shown on this screen.

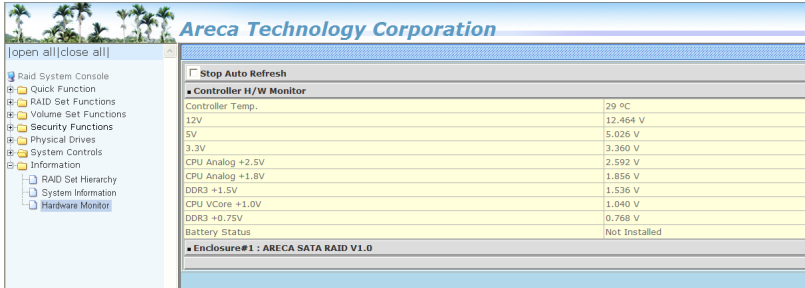

The screenshot displays the RAID System Console interface for Areca Technology Corporation. The left sidebar shows a tree view with 'Hardware Monitor' selected. The main window displays the 'Controller H/W Monitor' section, which includes a 'Stop Auto Refresh' button and a table of hardware metrics. Below this, the 'Enclosure#1 : ARECA SATA RAID V1.0' section is visible but empty.

■ Controller H/W Monitor	
Controller Temp.	29 °C
12V	12.464 V
5V	5.026 V
3.3V	3.360 V
CPU Analog +2.5V	2.592 V
CPU Analog +1.8V	1.856 V
DDR3 +1.5V	1.536 V
CPU VCore +1.0V	1.040 V
DDR3 +0.75V	0.768 V
Battery Status	Not Installed

■ Enclosure#1 : ARECA SATA RAID V1.0

APPENDIX

Appendix A

Upgrading Flash ROM Update Process

A-1 Overview

Since the ARC-1203 RAID controllers feature flash ROM firmware, it is not necessary to change the hardware flash chip in order to upgrade the RAID firmware. The user can simply re-program the old firmware through the in-band PCIe bus or out-of-band Ethernet port McRAID Storage manager and nflash DOS utility. New releases of the firmware are available in the form of a DOS file on the shipped CD or Areca website. The files available at the FTP site for each model contain the following files in each version:

ARC1203NNNN.BIN Software Binary Code ("NNNN" refers to the software code type)

ARC1203BIOS.BIN:→ PCIe 2.0 BIOS for system board using

ARC1203BOOT.BIN:→ RAID controller hardware initialization

ARC1203FIRM.BIN:→ RAID kernel program

ARC1203MBR0.BIN:→ Master Boot Record for supporting Dual Flash Image in the 6Gb/s SATA RAID controller

README.TXT contains the history information of the software code change in the main directory. Read this file first to make sure you are upgrading to the proper binary file. Select the right file for the upgrade. Normally, user upgrades the ARC1203BIOS.BIN for system M/B compatibility and ARC1203FIRM.BIN for RAID function. All these files in the firmware package are a part of the firmware. You should update all files in the package, no special update order needed. New firmware works after a system restart not instant available, so you can update all files before restart the system. The controller firmware is independent of the array, and update firmware does not touch anything you stored in the array.

Note:

Please update all binary code (BIOS, BOOT FIRM and MBR0) before you reboot system. Otherwise, a mixed firmware package may hang the controller.

A-2 Upgrading Firmware Through McRAID Storage Manager

Get the new version firmware for your 6Gb/s SATA RAID controller. For example, download the bin file from your OEM's web site onto the C: drive.

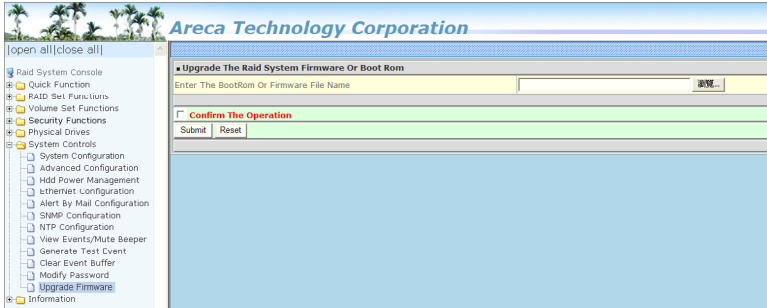

1. To upgrade the 6Gb/s SATA RAID controller firmware, move the mouse cursor to "Upgrade Firmware" link. The "Upgrade The Raid System Firmware or Boot Rom" screen appears.
2. Click "Browse". Look in the location to which the Firmware upgrade software was downloaded. Select the file name and click "Open".
3. Click "Confirm The Operation" and press the "Submit" button.
4. The web browser begins to download the firmware binary to the controller and start to update the flash ROM.
5. After the firmware upgrade is complete, a bar indicator will show "Firmware Has Been Updated Successfully".
6. After the new firmware package completes downloading, find a chance to restart the controller/computer for the new firmware to take effect.

The web browser-based McRAID storage manager can be accessed through the in-band PCIe bus or out-of-band LAN port. The in-band method uses the ArchHTTP proxy server to launch the McRAID storage manager. The out-of-band method allows local or

APPENDIX

remote to access the McRAID storage manager from any standard internet browser via a LAN or WAN with no software or patches required.

Controller with onboard LAN port, you can directly plug an Ethernet cable to the controller LAN port, then enter the McBIOS RAID manager to configure the network setting. After network setting configured and saved, you can find the current IP address in the McBIOS RAID manager "System Information" page.

From a remote pc, you can directly open a web browser and enter the IP address. Then enter user name and password to login and start your management. You can find the firmware update feature from the "Raid System Console" on the "System Controls" option.

A-3 Upgrading Firmware Through nflash DOS Utility

Areca now offers an alternative means communication for the 6Gb/s SATA RAID controller – Upgrade the all files (BIOS, BOOT, FIRM and MBR0) without necessary system starting up to running the ArchHTTP proxy server. The nflash utility program is a DOS application, which runs in the DOS operating system. Be sure of ensuring properly to communicate between 6Gb/s SATA RAID controller and nflash DOS utility. Please make a bootable DOS floppy diskette or USB devices from other Windows operating system and boot up the system from those bootable devices.

- **Starting the nflash Utility**

You do not need to short any jumper cap on running nflash utility. The nflash utility provides an on-line table of contents, brief descriptions of the help sub-commands. The nflash utility put on the <CD-ROM>\Firmware directory. You can run the <nflash> to get more detailed information about the command usage. Typical output looks as below:

```
A:\nflash
Raid Controller Flash Utility
V1.52 2013-11-07
Command Usage:
NFLASH FileName
NFLASH FileName /cn --> n=0,1,2,3 write binary to controller#0
FileName May Be ARC1203FIRM.BIN or ARC1203*
For ARC1203* Will Expand To ARC1203BOOT /FIRM/BIOS.BIN
```

```
A:\>nflash arc120~1.bin
Raid Controller Flash Utility
V1.52 2013-11-07
MODEL : ARC-1203
MEM FE620000 FE7FF000
File ARC120~1.BIN : >>*** => Flash OK
```

A-4 Upgrading Firmware Through CLI

This Command Line Interface (CLI) provides you to configure and manage the 6Gb/s SATA RAID controller components in Windows, Linux, FreeBSD and more environments. The CLI is useful in environments where a graphical user interface (GUI) is not available. Through the CLI, you perform firmware upgrade that you can perform with the McRAID storage manager GUI. The controller has added protocol on the firmware for user to update the controller firmware package (BIOS, BOOT, FIRM and MBR0) through the utility.

To update the controller firmware, follow the procedure below:

```
Parameter: <path=<PATH_OF_FIRMWARE_FILE>>
Fn: Firmware Updating.
Ex: Update Firmware And File Path Is In [C:\FW\ARC1203FIRM.BIN.]
Command: sys updatefw path=c:\fw\ARC1203firm.bin [Enter]
```

APPENDIX

Appendix B

Battery Backup Module (ARC-6120BA-T121-12G)

B-1 Overview

The 12Gb/s SAS RAID controller operates using cache memory. The Battery Backup Module is an add-on module that provides power to the 12Gb/s SAS RAID controller cache memory in the event of a power failure. The Battery Backup Module monitors the write back cache on the 12Gb/s SAS RAID controller, and provides power to the cache memory if it contains data not yet written to the hard drives when power failure occurs.

B-2 BBM Components

This section provides the board layout and connector/jumper for the BBM.

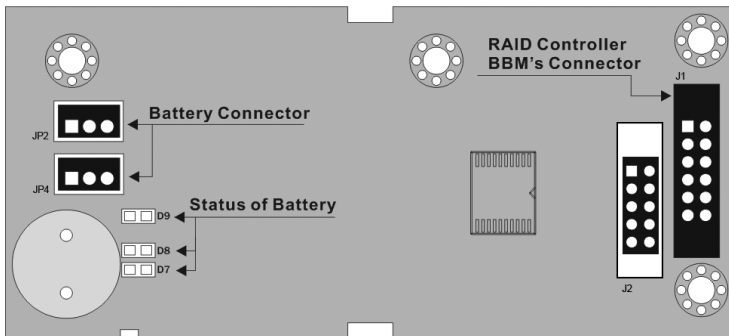

B-3 Status of BBM

- D7 (Green) : light when BBM activated
- D8 (Green) : light when BBM normal
- D9 (Red) : light when BBM charging

Note:

The BBM status will be shown on the web browser of "Hardware Monitor Information" screen.

B-4 Installation

1. Make sure all power to the system is disconnected.
2. The 12Gb/s SAS RAID controller's battery connector is available for the optional battery backup module. Connect the BBM cable to the 14-pin battery connector on the controller.
3. Integrators may provide pre-drilled holes in their cabinet for securing the BBM using its three mounting positions.
4. Low profile bracket also provided.
5. The BBM will occupy one PCI slot on the host backplane.

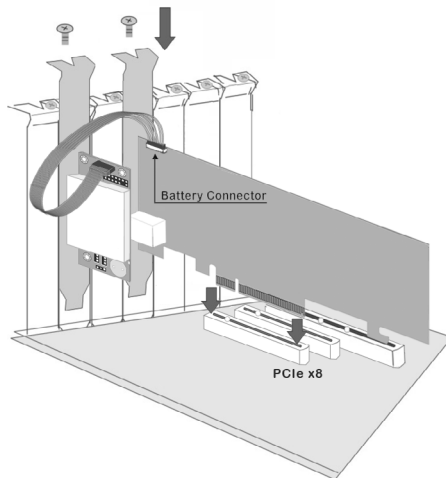

B-5 Battery Backup Capacity

Battery backup capacity is defined as the maximum duration of a power failure for which data in the cache memory can be maintained by the battery. The BBM's backup capacity varied with the memory chips that installed on the 12Gb/s SAS RAID controller.

APPENDIX

B-6 Operation

1. Battery conditioning is automatic. There are no manual procedures for battery conditioning or preconditioning to be performed by the user.
2. In order to make sure of all the capacity is available for your battery cells, allow the battery cell to be fully charged when installed for the first time. The first time charge of a battery cell takes about 24 hours to complete.

B-7 Changing the Battery Backup Module

At some point, the LI-ION battery will no longer accept a charge properly. LI-ION battery life expectancy is anywhere from approximately 1 to 5 years.

1. Shutdown the operating system properly. Make sure that cache memory has been flushed.
2. Disconnect the BBM cable from 12Gb/s SAS RAID controller's battery connector.
3. Disconnect the battery pack cable from JP2 on the BBM.
4. Install a new battery pack and connect the new battery pack to JP2.
5. Connect the BBM to 12Gb/s SAS RAID controller's battery connector.

Note:

Do not remove BBM while system is running.

B-8 Battery Functionality Test Procedure:

1. Writing amount of data into controller volume, about 5GB or bigger.
2. Waiting for few seconds, power failed system by remove the power cable.
3. Check the battery status, make sure the D9 is bright light, and battery beeps every few seconds.
4. Power on system, and press Tab/F6 to login controller.
5. Check the controller event log, make sure the event shows controller boot up with power recovered.

B-9 BBM Specifications

Mechanical

- Module Dimension (W x H x D): 37.3 x 13 x 81.6 mm
- BBM Connector: 2 x 6 box header

Environmental

- Operating Temperature
 - * Temperature:
 - 0° C to +40° C (Charge)
 - 0° C to +55° C (Discharge)
 - * Humidity: 45-85%, non-condensing
- Storage Temperature
 - * Temperature:
 - 20° C to +20° C (storing for less than 1year)
 - 20° C to +40° C (storing for less than 3months)
 - 20° C to +55° C (storing for less than 1month)
 - * Humidity: 45-85%, non-condensing

Electrical

- Input Voltage
 - +3.6VDC
- On Board Battery Capacity
 - 1880mAH (1 x 1880mAH) for ARC-1883 series boards

APPENDIX

Appendix C

SNMP Operation & Installation

C-1 Overview

The McRAID storage manager includes a firmware-embedded Simple Network Management Protocol (SNMP) agent for the Areca RAID controller. An SNMP-based management application (also known as an SNMP manager) can monitor the disk array. An example of a SNMP management application is Hewlett-Packard's Open View, Net-SNMP or SNMPc. The SNMP extension agent can be used to augment the Areca RAID controller through PCIe host bus interface if you are already running an SNMP management application at your site.

C-2 SNMP Definition

SNMP, an IP-based protocol, has a set of commands for getting the status of target devices. The SNMP management platform is called the SNMP manager, and the managed devices have the SNMP agent loaded. Management data is organized in a hierarchical data structure called the Management Information Base (MIB). These MIBs are defined and sanctioned by various industry associations. Each type of device on your network has its own specific MIB file. The MIB file defines the device as a set of managed objects — values that can be read or changed by the SNMP manager. The MIB file enables the SNMP manager to interpret trap messages from devices. To make sense out of a trap that's sent by a device, the SNMP manager needs to have access to the MIB that describes the format and content of the possible traps that the device can send. The objective is for all vendors to create products in compliance with these MIBs so that inter-vendor interoperability can be achieved. To be available for the SNMP manager, a command adds the MIB file for each of devices to the MIB database. This enables the devices to be managed via the SNMP manager.

The following figure illustrates the various components of an SNMP-based management architecture.

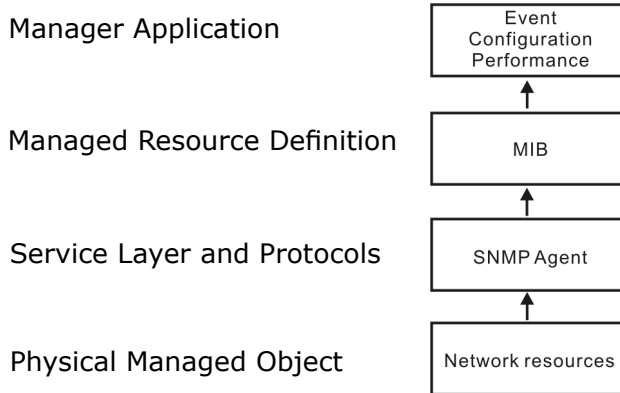

C-3 SNMP Installation

Perform the following steps to install the Areca RAID controller SNMP function into the SNMP manager. The installation of the SNMP manager is accomplished in several phases:

Step 1. Installing the SNMP manager software on the client

Installing the SNMP manager software on the client. This installation process is well-covered in the User's Guide of your SNMP manager application.

Step 2. Compiling the MIB description file with the management

Placing a copy of the RAID controller's MIBs file in a directory which is accessible to the management application and compile the MIB description file with the SNMP management application database. Before the manager application accesses the Areca RAID controller, it is necessary to integrate the MIB into the management application's database of events and status indicator codes. This process is known as "compiling" the MIB into the application. This process is highly vendor-specific and should be well-covered in the User's Guide of your SNMP manager application. Ensure the compilation process successfully integrates the contents of the `areca_SATA.mib` file into the traps database. The MIBs file resides at: `<CD-ROM>\packages\SNMP_MIBs` on the software CD or download from <http://www.areca.com.tw>.

APPENDIX

Each RAID controller needs to have its own MIBs file. Areca provide 4 adapters MIBs file for users. User can request it if more controllers install on one system.

Note:

1. The MIB compiler may be not installed by default with SNMP manager.
2. Some SNMP managers have unique rule on the format of MIB files, you may need to refer the error message to mo-dify the mib file to be able to met the software requirement.

Step 3. SNMP Service Method

With Areca series RAID cards, there are 3 service methods to get SNMP:
ArchHTTP, onboard NIC and in-band PCIe + SNMP extension agent.

1. Service Method-1: using ArchHTTP proxy server
Pay attention to these:
 - Do not check mark the option: "SNMP Through PCI".
 - Make sure you have the latest driver and ArchHTTP, from this URL <http://www.areca.com.tw/support/>
 - ArchHTTP supports sending "traps" only, do not support the "get" command.
2. Service Method-2: using onboard NIC.
Pay attention to these:
 - Do not check mark the option: "SNMP Through PCI".
 - Do need to fill out the "SNMP Trap Config".
3. Service Method-3: using in-band PCIe + SNMP extension agent.
Pay attention to these:
 - Download the SNMP extension agent from Areca URL.
 - The agent is to be installed on the system which has the Areca controller.
 - Check Mark the option: "SNMP Through PCI".
 - To use in-band PCIe host bus interface, keep space (or zero) on all "SNMP Tarp IP Address" options.

C-3-1 Using ArcHTTP

The HTTP management software (ArcHTTP) runs as a service or daemon, and has it automatically start the proxy for all controllers found. This way the controller can be managed remotely without having to sign in the server. The ArcHTTP has also integrated the ability of sending SNMP trap. Please reference the manual Chapter 3 "ArcHTTP Proxy Server Installation" section to install and setup its configuration.

To enable the controller to send the SNMP traps to client SNMP manager using the IP address assigned to the operating system, such as Net-SNMP manager, you can simply use the SNMP function on the ArcHTTP proxy server utility. To enable the RAID controller SNMP traps sending function, configure the "SNMP Traps Configuration" options on the "ArcHTTP Configurations". The ArcHTTP proxy only provides one direction to send the trap to the SNMP manager without needing to install the SNMP extension agent on the host. For detailed information on using ArcHTTP proxy server utility to send the SNMP traps, please see "SNMP Traps Configuration" section on 5.6 "ArcHTTP Configuration".

If SNMP manager requests to query the SNMP information from RAID controller, please refer the C-3-2 section - Using Onboard NIC and C-3-3 section - Using In-band PCIe+ SNMP extension agent.

C-3-2 Using Onboard NIC Installation

By using the built-in LAN port on the RAID controller- RAID controller using built-in LAN interface. You can use the browser-based manager or CLI SNMP configuration to setup the firmware-based SNMP configuration. The following screen is the firmware-embedded SNMP configuration setup screen using browser-based manager:

To launch the above browser-based RAID controller SNMP function, click on the "System Controls" link. The "System Controls" menu will show available items. Select the "SNMP Configuration" item. The firmware-embedded SNMP agent manager monitors all system events and the SNMP function becomes functional with no agent software required.

APPENDIX

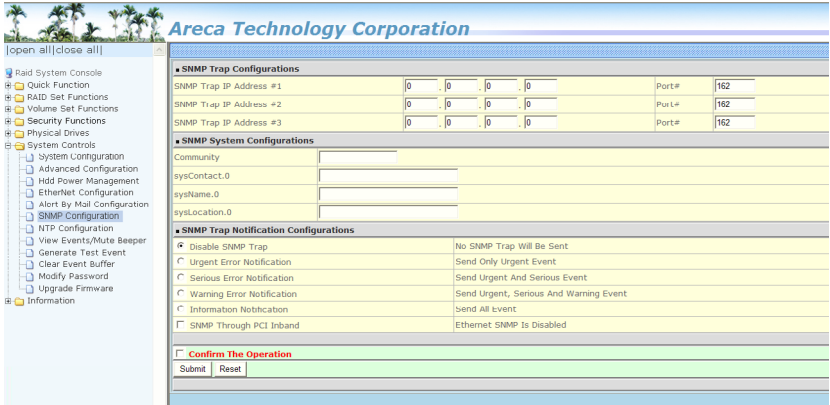

When you open the “SNMP Configuration” link, you will see the following settings:

1. SNMP Trap Configurations

Enter the SNMP Trap IP Address.

2. SNMP System Configurations

Community name acts as a password to screen accesses to the SNMP agent of a particular network device. Type in the community names of the SNMP agent. Before access is granted to a request station, this station must incorporate a valid community name into its request; otherwise, the SNMP agent will deny access to the system. Most network devices use “public” as default of their community names. This value is case-sensitive. The system Contact, Name and Location that will be shown on the outgoing SNMP trap.

3. SNMP Trap Notification Configurations

Please refer to Appendix D “Event Notification Configurations”.

Note:

After you confirm and submit configurations, you can use “Generate Test Event” feature to make sure these settings are correct.

C-3-3 Using In-band PCIe + SNMP extension agent Installation

By using the IP address assigned to the operating- RAID controller using Areca SNMP extension agent through PCIe host bus interface.

1. Set only "Community" field and keep space (or zero) on all "SNMP Trap IP Address" options on the firmware-embedded SNMP configuration function. There is no function to set other fields on "SNMP System Configuration".

The SNMP "Community" and "SNMP Trap IP Address" can setup by using browser-based manager or CLI SNMP configuration. To launch the browser-based RAID controller SNMP function, click on the "System Controls" link. The "System Controls" menu will show available items. Select the "SNMP Configuration" item. The following "SNMP System Configuration" screen is launched by browser-based manager.

*SNMP Trap Configurations	
SNMP Trap IP Address #1	Port: 162
SNMP Trap IP Address #2	Port: 162
SNMP Trap IP Address #3	Port: 162

*SNMP System Configurations	
Community	
sysContact.O	
sysName.O	
sysLocation.O	

*SNMP Trap Notification Configurations	
<input checked="" type="checkbox"/> Disable SNMP Trap	No SNMP Trap Will Be Sent
<input type="checkbox"/> Urgent Error Notification	Send Only Urgent Event
<input type="checkbox"/> Serious Error Notification	Send Urgent And Serious Event
<input type="checkbox"/> Warning Error Notification	Send Urgent, Serious And Warning Event
<input type="checkbox"/> Information Notification	Send All Event
<input type="checkbox"/> SNMP Through PCI Inband	Ethernet SNMP Is Disabled

Confirm The Operation

Submit | Reset

About community, Community name acts as a password to screen accesses to the SNMP agent of a particular network device. Type in the community names of the SNMP agent. Before access is granted to a request station, this station must incorporate a valid community name into its request; otherwise, the SNMP agent will deny access to the system.

Most network devices use "public" as default of their community names. This value is case-sensitive.

APPENDIX

2. Mark the check box on the "SNMP Through PCI Inband" setting and keep space (or zero) on all "SNMP Tarp IP Address" options.
3. Installing the SNMP extension agent on the server which has the Areca controller.

Please refer to next section of "SNMP Extension Agent Installation" for different operation system such as Windows, Linux and FreeBSD.

C-3-4 SNMP Extension Agent Installation

The SNMP extension agent on the device is able to return meaningful, highly useful information to the SNMP manager. The Areca RAID controllers have supported the extension agent for Windows, Linux and FreeBSD. This section is the detail procedures for those extension agent installations.

C-3-4-1 Windows

You must have administrative level permission to install 6Gb/s SATA RAID controller extension agent software. This procedure assumes that the RAID hardware and Windows are both installed and operational in your system.

To enable the SNMP agent for Windows, configure Windows for TCP/IP and SNMP services. The Areca SNMP extension agent file is ARCSNMP.DLL. Screen captures in this section are taken from a Windows XP installation. If you are running another version of Windows, your screens may look different, but the Areca SNMP extension agent installation is essentially the same.

1. Insert the Areca RAID controller software CD in the CD-ROM drive.
2. Run the setup.exe file that resides at: <CD-ROM>\packages\windows\SNMP\setup.exe on the CD. (If SNMP service was not installed, please install SNMP service first.)

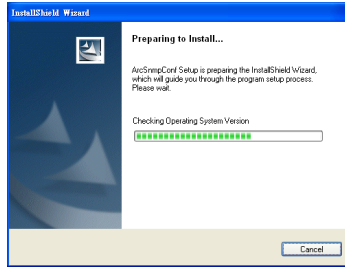

3. Click on the "setup.exe" file then the welcome screen appears.

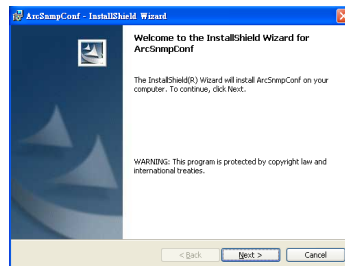

4. Click the "Next" button and then the "Ready Install the Program" screen will appear. Follow the on-screen prompts to complete Areca SNMP extension agent installation.

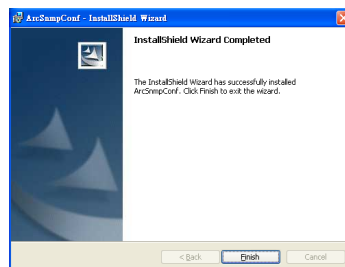

5. A Progress bar appears that measures the progress of the Areca SNMP extension agent setup. When this screen completes, you have completed the Areca SNMP extension agent setup.

APPENDIX

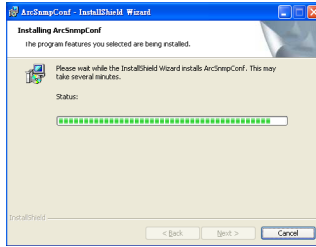

6. After a successful installation, the "Setup Complete" dialog box of the installation program is displayed. Click the "Finish" button to complete the installation.

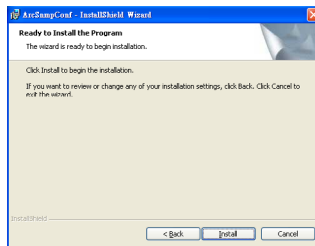

Starting SNMP Trap Notification Configurations

To start "SNMP Trap Notification Configurations", there have two methods. First, double-click on the "Areca RAID Controller".



Second, you may also use the "Taskbar Start/programs/Areca Technology Corp/ArcSnmpConf" menus shown below.

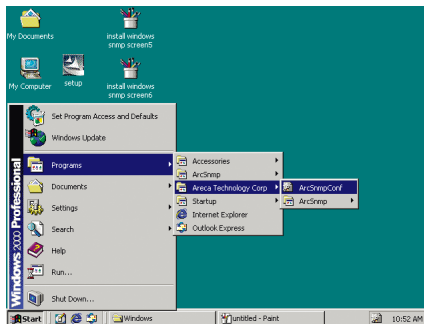

SNMP Community Configurations

About community, Community name acts as a password to screen accesses to the SNMP agent of a particular network device. Type in the community names of the SNMP agent. Before access is granted to a request station, this station must incorporate a valid community name into its request; otherwise, the SNMP agent will deny access to the system. Most network devices use "public" as default of their community names. This value is case-sensitive.

SNMP Trap Notification Configurations

The "Community Name" should be the same as firmware-embedded SNMP Community. The "SNMP Trap Notification Configurations" includes level 1: Serious, level 2: Error, level 3: Warning and level 4: Information. The level 4 covers notification events such as initialization of the controller and initiation of the rebuilding process; Level 3 includes events which require the issuance of warning messages; Level 2 covers notification events which once have happen; Level 1 is the highest level, and covers events the need immediate attention (and action) from the administrator.

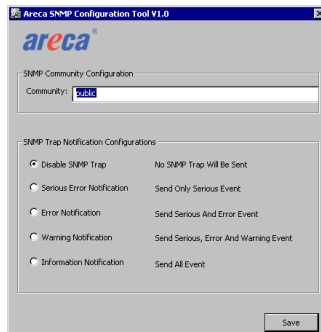

C-3-4-2 Linux

You must have administrative level permission to install Areca RAID software. This procedure assumes that the Areca RAID hardware and Linux are installed and operational in your system. The old version agent has to modify the open source project, integrate the changes from Areca manually, then take the modified binaries and manually deploy them. Users need to change source code from the linux distribution and then maintain it by themselves.

APPENDIX

The new version agent provides the way to integrate with those codes into snmpd/snmptrapd and create a sub agent for user easy to install it. The new version SNMP extension agent installation for Linux procedure, please refer to <CD-ROM>\packages\Linux\SNMP\readme.txt or download from ftp://ftp.areca.com.tw/RaidCards/AP_Drivers/Linux/SNMP/V4.1/ .

C-3-4-3 FreeBSD

You must have administrative level permission to install Areca RAID software. This procedure assumes that the Areca RAID hardware and FreeBSD are installed and operational in your system. The old version agent has to modify the open source project, integrate the changes from Areca manually, then take the modified binaries and manually deploy them. Users need to change source code from the linux distribution and then maintain it by themselves.

The new version agent provides the way to integrate with those codes into snmpd/snmptrapd and create a sub agent for user easy to install it. The new version SNMP extension agent installation for FreeBSD procedure, please refer to <CD-ROM>\packages\FreeBSD\SNMP\readme.txt or download from ftp://ftp.areca.com.tw/RaidCards/AP_Drivers/FreeBSD/SNMP/V4.1/ .

Appendix D

Event Notification Configurations

The controller classifies disk array events into four levels depending on their severity. These include level 1: Urgent, level 2: Serious, level 3: Warning and level 4: Information. The level 4 covers notification events such as initialization of the controller and initiation of the rebuilding process; Level 2 covers notification events which once have happen; Level 3 includes events which require the issuance of warning messages; Level 1 is the highest level, and covers events that need immediate attention (and action) from the administrator. The following lists sample events for each level:

A. Device Event

Event	Level	Meaning	Action
Device Inserted	Warning	HDD inserted	
Device Removed	Warning	HDD removed	
Reading Error	Warning	HDD reading error	Keep Watching HDD status, may be it caused by noise or HDD unstable.
Writing Error	Warning	HDD writing error	Keep Watching HDD status, may be it caused by noise or HDD unstable.
ATA Ecc Error	Warning	HDD ECC error	Keep Watching HDD status, may be it caused by noise or HDD unstable.
Change ATA Mode	Warning	HDD change ATA mode	Check HDD connection
Time Out Error	Warning	HDD time out	Keep Watching HDD status, may be it caused by noise or HDD unstable.
Device Failed	Urgent	HDD failure	Replace HDD
PCI Parity Error	Serious	PCI parity error	If only happen once, it may be caused by noise. If always happen, please check power supply or contact to us.
Device Failed(SMART)	Urgent	HDD SMART failure	Replace HDD

APPENDIX

PassThrough Disk Created	Inform	Pass Through Disk created	
PassThrough Disk Modified	Inform	Pass Through Disk modified	
PassThrough Disk Deleted	Inform	Pass Through Disk deleted	

B. Volume Event

Event	Level	Meaning	Action
Start Initialize	Warning	Volume initialization has started	
Start Rebuilding	Warning	Volume rebuilding has started	
Start Migrating	Warning	Volume migration has started	
Start Checking	Warning	Volume parity checking has started	
Complete Init	Warning	Volume initialization completed	
Complete Rebuild	Warning	Volume rebuilding completed	
Complete Migrate	Warning	Volume migration completed	
Complete Check	Warning	Volume parity checking completed	
Create Volume	Warning	New volume created	
Delete Volume	Warning	Volume deleted	
Modify Volume	Warning	Volume modified	
Volume Degraded	Urgent	Volume degraded	Replace HDD
Volume Failed	Urgent	Volume failure	
Failed Volume Revived	Urgent	Failed volume revived	
Abort Initialization	Warning	Initialization been abort	
Abort Rebuilding	Warning	Rebuilding aborted	
Abort Migration	Warning	Migration aborted	
Abort Checking	Warning	Parity check aborted	
Stop Initialization	Warning	Initialization stopped	
Stop Rebuilding	Warning	Rebuilding stopped	
Stop Migration	Warning	Migration stopped	
Stop Checking	Warning	Parity check stopped	

C. RAID Set Event

Event	Level	Meaning	Action
Create RaidSet	Warning	New RAID set created	
Delete RaidSet	Warning	Raidset deleted	
Expand RaidSet	Warning	Raidset expanded	
Rebuild RaidSet	Warning	Raidset rebuilding	
RaidSet Degraded	Urgent	Raidset degraded	Replace HDD

D. Hardware Monitor Event

Event	Level	Meaning	Action
DRAM 1-Bit ECC	Urgent	DRAM 1-Bit ECC error	Check DRAM
DRAM Fatal Error	Urgent	DRAM fatal error encountered	Check the DRAM module and replace with new one if required.
Controller Over Temperature	Urgent	Abnormally high temperature detected on controller	Check air flow and cooling fan of the enclosure, and contact us.
Hdd Over Temperature	Urgent	Abnormally high temperature detected on Hdd (over 55 degree)	Check air flow and cooling fan of the enclosure.
Fan Failed	Urgent	Cooling Fan # failure or speed below 1700RPM	Check cooling fan of the enclosure and replace with a new one if required.
Controller Temp. Recovered	Serious	Controller temperature back to normal level	
Hdd Temp. Recovered	Serious	Hdd temperature back to normal level	
Raid Powered On	Warning	RAID power on	
Test Event	Urgent	Test event	
Power On With Battery Backup	Warning	RAID power on with battery backed up	
Incomplete RAID Discovered	Serious	Some RAID set member disks missing before power on	Check disk information to find out which channel missing.

APPENDIX

HTTP Log In	Serious	a HTTP login detected	
Telnet Log	Serious	a Telnet login detected	
API Log In	Serious	a API login detected	
Lost Rebuilding/ MigrationLBA	Urgent	Some rebuilding/ migration raidset member disks missing before power on.	Reinserted the missing member disk back, controller will continued the incompleted rebuilding/migration.

Appendix E

Self-Encrypting Disk (SED) Encryption

The “Security Function” on the firmware supports Self-Encrypting Disks (SED) for protection of data against loss or theft of SEDs. Protection is achieved by the use of encryption technology on the drives. The McRAID storage management allows SED keys to be created and managed as well as create/delete RAID sets.

Self-Encrypting Disk (SED) Encryption Flow Chart

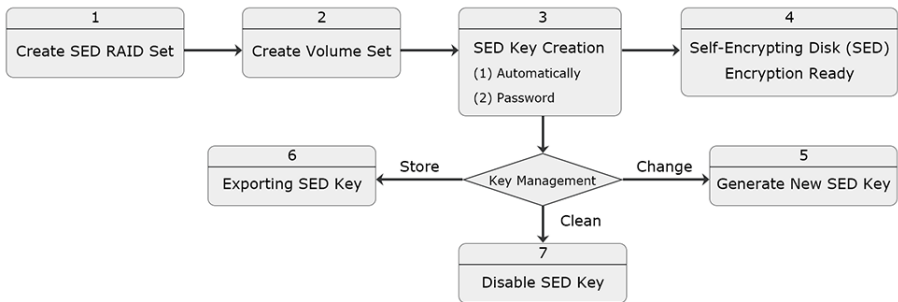

Step 1. Create SED RAID Set

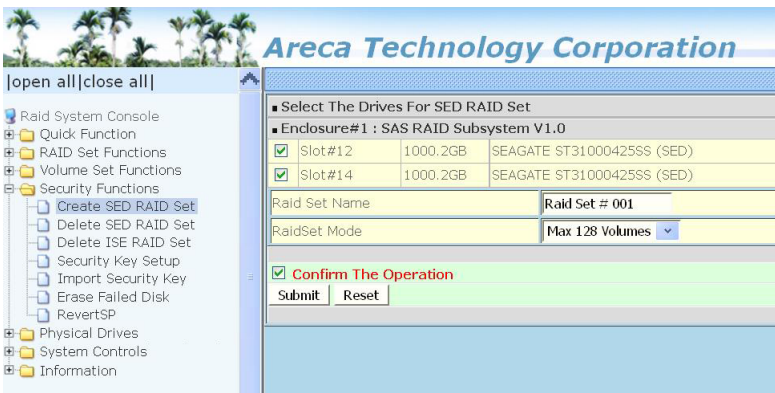

APPENDIX

Step 2. Create Volume Set

Create volume set in the web management.

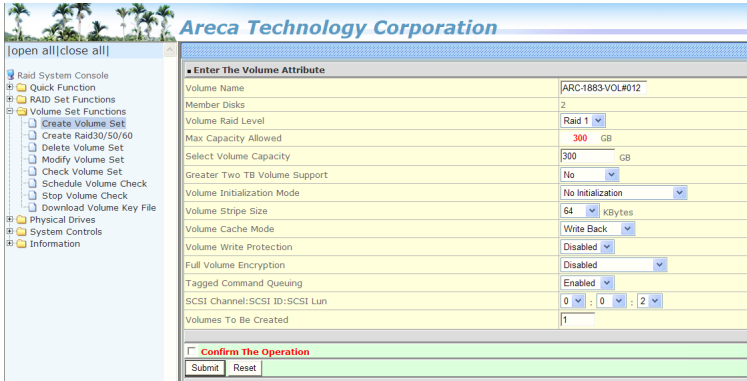

Step 3. SED Key Creation

There is one SED key per controller. You can create the SED key under McRAID manager. The key can be escrowed in to a file using McRAID manager. There is one SED key per controller which stores in the controller flash memory. Areca provides both automatically or password methods to generate a key.



Step 4. Self-Encrypting Disk (SED) Ready

Now, whenever you write data to the drive (e.g. create a file and save it to the SED volume), it gets encrypted with the SED key. And whenever you read data from the drive (e.g. access a file stored on the SED), it's decrypted with the same SED key.

Step 5. Generate New SED Key

If you have evidence that the SED key is known to unauthorized users, you can change the SED key again. Areca provides both automatically or password methods to generate a New key to replace the foreign SED key.

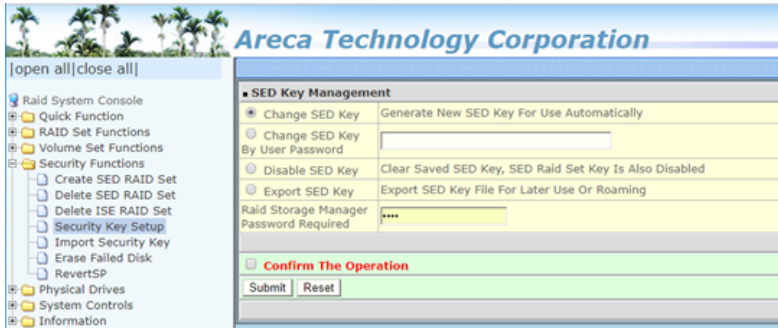

Step 6. Exporting SED Key

In some cases, you may want to export a SED key to store on removable media or to use on a different computer. If you want to create a backup copy of the SED key or use it on another computer, you must first export the SED key.



APPENDIX

Exporting the SED key puts it in a file (SEDKEY256.BIN) that you can then transfer to another computer or put in a safe place.

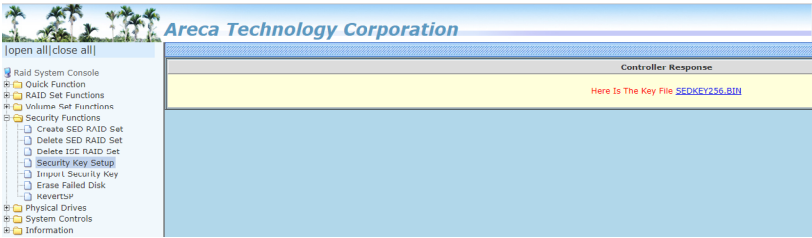

The key file (SEDKEY256.BIN) is stored on the specific location.

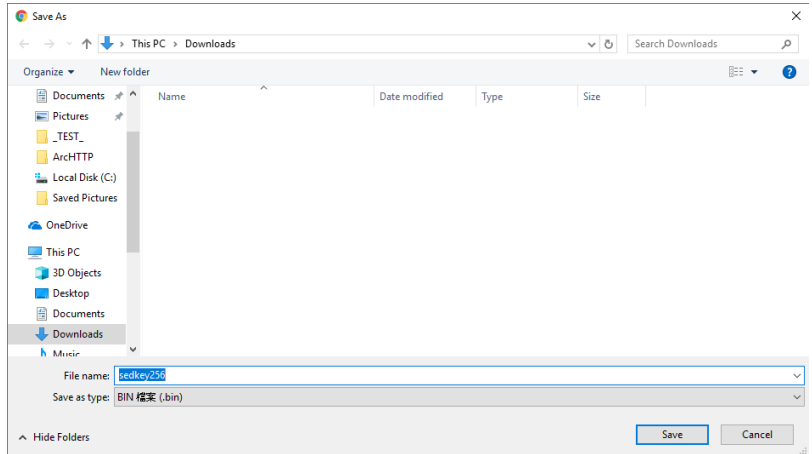

Without the proper authentication key (SED key), even if the SED RAID set is removed and placed in another new RAID controller, the data remains inaccessible.

Step 7. Clean Saved SED Key

The 'Disable SED Key' function is used to clear SED key on controller and RAID set members.

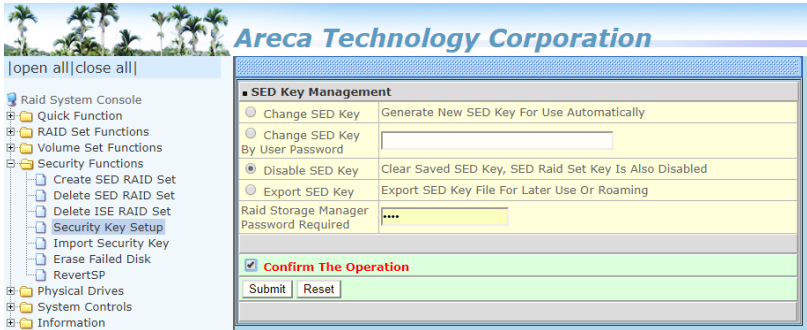

● Save SEDKey In Controller

There is one SED key per controller which stores in the controller flash memory. You can disable the SED Key saved in controller flash using "Save SEDKey In Controller" on the Advanced Configurations. So that next time power up again, it will ask for key again.

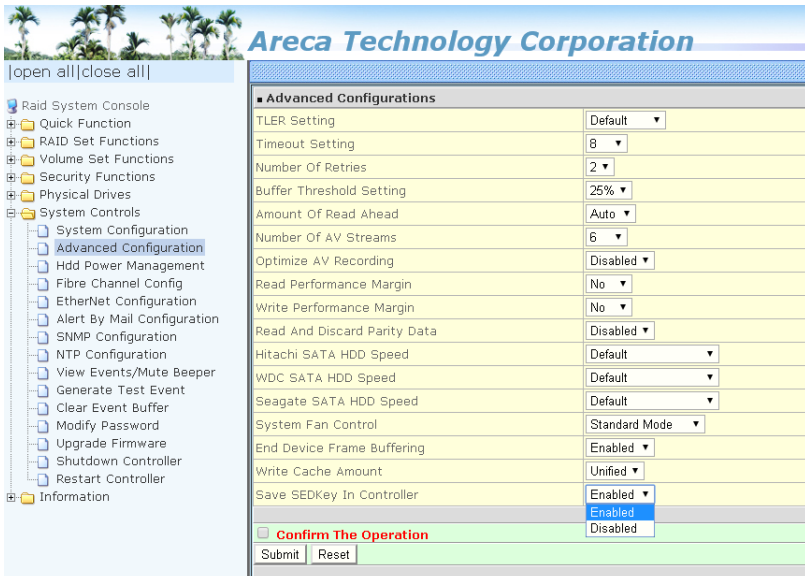

APPENDIX

- <a> If enable --> disable, clear SED Key saved in setup
- If disable --> enable, if key exists, save to setup

If you setup from enable--->disable, the key will not remain in the flash. So that next time power up again, it will need to input the key from the CLI or McRAID manager again. The controller volume will be in the lock stage. It will be not available to the OS.

After your run the CLI to upload the key, volume will be unlocked and available to the OS. You can also import the key file (Import Security Key) or keyin the password (Enter SED Key By User Password) from the GUI interface.

(1) Import Security Key

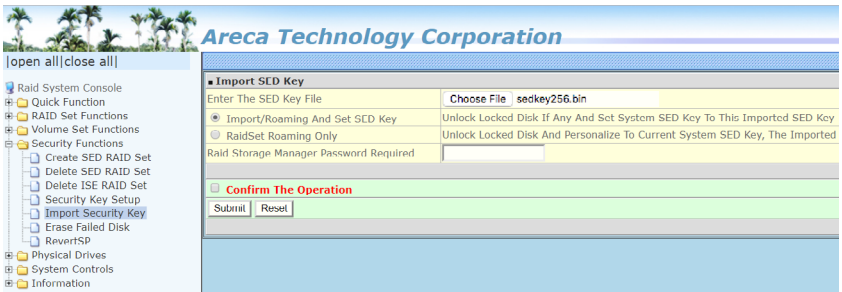

(2) Enter SED Key By User Password

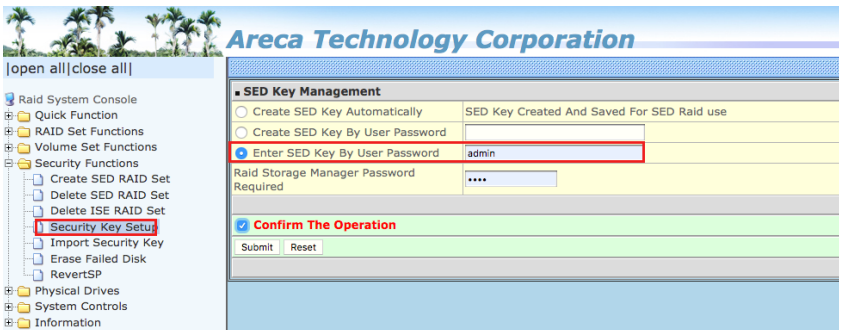

Appendix F

RAID Concept

RAID Set

A RAID set is a group of disks connected to a RAID controller. A RAID set contains one or more volume sets. The RAID set itself does not define the RAID level (0, 1, 1E, 3, 5, 6, 10, 30, 50, 60, etc); the RAID level is defined within each volume set. Therefore, volume sets are contained within RAID sets and RAID Level is defined within the volume set. If physical disks of different capacities are grouped together in a RAID set, then the capacity of the smallest disk will become the effective capacity of all the disks in the RAID set.

Volume Set

Each volume set is seen by the host system as a single logical device (in other words, a single large virtual hard disk). A volume set will use a specific RAID level, which will require one or more physical disks (depending on the RAID level used). RAID level refers to the level of performance and data protection of a volume set. The capacity of a volume set can consume all or a portion of the available disk capacity in a RAID set. Multiple volume sets can exist in a RAID set. For the RAID controller, a volume set must be created either on an existing RAID set or on a group of available individual disks (disks that are about to become part of a RAID set). If there are pre-existing RAID sets with available capacity and enough disks for the desired RAID level, then the volume set can be created in the existing RAID set of the user's choice.

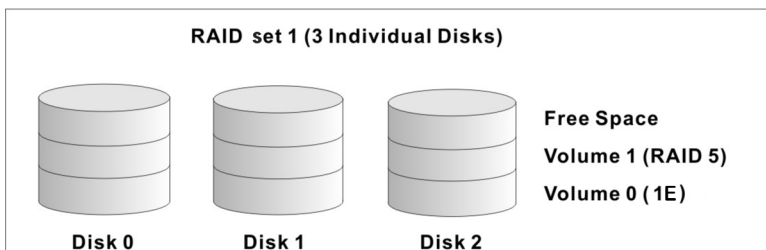

APPENDIX

In the illustration, volume 1 can be assigned a RAID level 5 of operation while volume 0 might be assigned a RAID level 1E of operation. Alternatively, the free space can be used to create volume 2, which could then be set to use RAID level 5.

Ease of Use Features

- **Foreground Availability/Background Initialization**

RAID 0 and RAID 1 volume sets can be used immediately after creation because they do not create parity data. However, RAID 3, 5, 6, 30, 50 or 60 volume sets must be initialized to generate parity information. In Background Initialization, the initialization proceeds as a background task, and the volume set is fully accessible for system reads and writes. The operating system can instantly access the newly created arrays without requiring a reboot and without waiting for initialization to complete. Furthermore, the volume set is protected against disk failures while initialing. If using Foreground Initialization, the initialization process must be completed before the volume set is ready for system accesses.

- **Online Array Roaming**

RAID controllers store RAID configuration information on the disk drives. The controller therefore protects the configuration settings in the event of controller failure. Online array roaming allows the administrators the ability to move a complete RAID set to another system without losing RAID configuration information or data on that RAID set. Therefore, if a server fails, the RAID set disk drives can be moved to another server with an Areca RAID controllers and the disks can be inserted in any order.

- **Online Capacity Expansion**

Online Capacity Expansion makes it possible to add one or more physical drives to a volume set without interrupting server operation, eliminating the need to backup and restore after reconfiguration of the RAID set. When disks are added to a RAID set, unused capacity is added to the end of the

RAID set. Then, data on the existing volume sets (residing on the newly expanded RAID set) is redistributed evenly across all the disks. A contiguous block of unused capacity is made available on the RAID set. The unused capacity can be used to create additional volume sets.

A disk, to be added to a RAID set, must be in normal mode (not failed), free (not spare, in a RAID set, or passed through to host) and must have at least the same capacity as the smallest disk capacity already in the RAID set.

Capacity expansion is only permitted to proceed if all volumes on the RAID set are in the normal status. During the expansion process, the volume sets being expanded can be accessed by the host system. In addition, the volume sets with RAID level 1, 10, 3, 5 or 6 are protected against data loss in the event of disk failure(s). In the case of disk failure, the volume set changes from "migrating" state to "migrating+degraded" state. When the expansion is completed, the volume set would then transition to "degraded" mode. If a global hot spare is present, then it further changes to the "rebuilding" state.

The expansion process is illustrated as following figure.

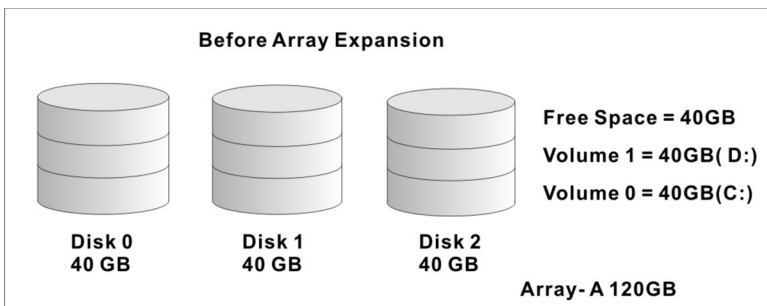

RAID controller redistributes the original volume set over the original and newly added disks, using the same fault-tolerance configuration. The unused capacity on the expand RAID set can then be used to create an additional volume set, with a different fault tolerance setting (if required by the user.)

APPENDIX

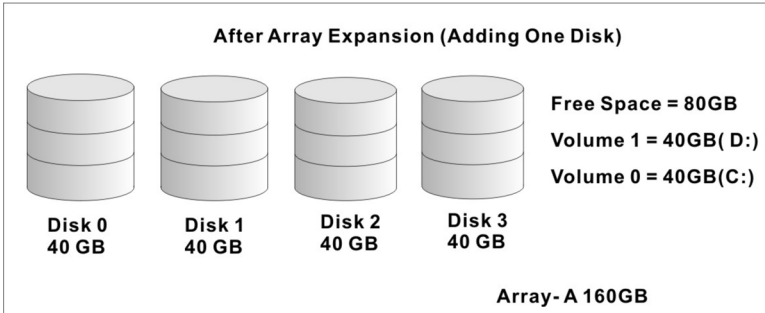

● Online RAID Level and Stripe Size Migration

For those who wish to later upgrade to any RAID capabilities, a system with online RAID level/stripe size migration allows a simplified upgrade to any supported RAID level without having to reinstall the operating system.

The RAID controllers can migrate both the RAID level and stripe size of an existing volume set, while the server is on-line and the volume set is in use. Online RAID level/stripe size migration can prove helpful during performance tuning activities as well as when additional physical disks are added to the RAID controller. For example, in a system using two drives in RAID level 1, it is possible to add a single drive and add capacity and retain fault tolerance. (Normally, expanding a RAID level 1 array would require the addition of two disks). A third disk can be added to the existing RAID logical drive and the volume set can then be migrated from RAID level 1 to 5. The result would be parity fault tolerance and double the available capacity without taking the system down. A fourth disk could be added to migrate to RAID level 6. It is only possible to migrate to a higher RAID level by adding a disk; disks in an existing array can't be reconfigured for a higher RAID level without adding a disk.

Online migration is only permitted to begin, if all volumes to be migrated are in the normal mode. During the migration process, the volume sets being migrated are accessed by the host system. In addition, the volume sets with RAID level 1, 1E, 10, 3, 5 or 6 are protected against data loss in the event

of disk failure(s). In the case of disk failure, the volume set transitions from migrating state to (migrating+degraded) state. When the migration is completed, the volume set transitions to degraded mode. If a global hot spare is present, then it further transitions to rebuilding state.

● **Online Volume Expansion**

Performing a volume expansion on the controller is the process of growing only the size of the latest volume. A more flexible option is for the array to concatenate an additional drive into the RAID set and then expand the volumes on the fly. This happens transparently while the volumes are online, but, at the end of the process, the operating system will detect free space at after the existing volume.

Windows, NetWare and other advanced operating systems support volume expansion, which enables you to incorporate the additional free space within the volume into the operating system partition. The operating system partition is extended to incorporate the free space so it can be used by the operating system without creating a new operating system partition.

You can use the Diskpart.exe command line utility, included with Windows Server 2003 or the Windows 2000 Resource Kit, to extend an existing partition into free space in the dynamic disk.

Third-party software vendors have created utilities that can be used to repartition disks without data loss. Most of these utilities work offline. Partition Magic is one such utility.

High Availability

● **Global/Local Hot Spares**

A hot spare is an unused online available drive, which is ready for replacing the failure disk. The hot spare is one of the most important features that RAID controllers provide to deliver a high degree of fault-tolerance. A hot spare is a spare physical drive that has been marked as a hot spare and therefore

APPENDIX

is not a member of any RAID set. If a disk drive used in a volume set fails, then the hot spare will automatically take its place and the data previously located on the failed drive is reconstructed on the hot spare.

Dedicated hot spare is assigned to serve one specified RAID set. Global hot spare is assigned to serve all RAID set on the RAID controller. Dedicated hot spare has higher priority than the global hot spare. For this feature to work properly, the hot spare must have at least the same capacity as the drive it replaces. The hot spare function only works with RAID level 1, 1E, 3, 5, 6, 10, 30, 50, or 60 volume set.

The "Create Hot Spare" option gives you the ability to define a global/dedicated hot spare disk drive. To effectively use the hot spare feature, you must always maintain at least one drive that is marked as a global hot spare.

Important:

The hot spare must have at least the same capacity as the drive it replaces.

● **Hot-Swap Disk Drive Support**

The RAID controller chip includes a protection circuit that supports the replacement of SATA hard disk drives without having to shut down or reboot the system. A removable hard drive tray can deliver "hot swappable" fault-tolerant RAID solutions. This feature provides advanced fault tolerant RAID protection and "online" drive replacement.

● **Auto Declare Hot-Spare**

If a disk drive is brought online into a system operating in degraded mode, the RAID controllers will automatically declare the new disk as a spare and begin rebuilding the degraded volume. The Auto Declare Hot-Spare function requires that the smallest drive contained within the volume set in which the failure occurred.

In the normal status, the newly installed drive will be reconfigured an online free disk. But, the newly-installed drive is automatically assigned as a hot spare if any hot spare disk was used to rebuild and without new installed drive replaced it. In this condition, the Auto Declare Hot-Spare status will be disappeared if the RAID subsystem has since powered off/on.

The Hot-Swap function can be used to rebuild disk drives in arrays with data redundancy such as RAID level 1, 1E, 3, 5, 6, 10, 30, 50 and 60.

● **Auto Rebuilding**

If a hot spare is available, the rebuild starts automatically when a drive fails. The RAID controllers automatically and transparently rebuild failed drives in the background at user-definable rebuild rates.

If a hot spare is not available, the failed disk drive must be replaced with a new disk drive so that the data on the failed drive can be automatically rebuilt and so that fault tolerance can be maintained.

RAID controllers will automatically restart the system and rebuilding process if the system is shut down or powered off abnormally during a reconstruction procedure condition.

When a disk is hot swapped, although the system is functionally operational, the system may no longer be fault tolerant. Fault tolerance will be lost until the removed drive is replaced and the rebuild operation is completed.

During the automatic rebuild process, system activity will continue as normal, however, the system performance and fault tolerance will be affected.

● **Adjustable Rebuild Priority**

Rebuilding a degraded volume incurs a load on the RAID subsystem. The RAID controllers allow the user to select the rebuild priority to balance volume access and rebuild tasks

APPENDIX

appropriately. The Background Task Priority is a relative indication of how much time the controller devotes to a background operation, such as rebuilding or migrating.

RAID controller allows user to choose the task priority (Ultra Low (5%), Low (20%), Medium (50%), High (80%)) to balance volume set access and background tasks appropriately. For high array performance, specify an Ultra Low value. Like volume initialization, after a volume rebuilds, it does not require a system reboot.

High Reliability

● Hard Drive Failure Prediction

In an effort to help users avoid data loss, disk manufacturers are now incorporating logic into their drives that acts as an "early warning system" for pending drive problems. This system is called SMART. The disk integrated controller works with multiple sensors to monitor various aspects of the drive's performance, determines from this information if the drive is behaving normally or not, and makes available status information to 6Gb/s SATA RAID controller firmware that probes the drive and look at it.

The SMART can often predict a problem before failure occurs. The controllers will recognize a SMART error code and notify the administer of an impending hard drive failure.

● Auto Reassign Sector

Under normal operation, even initially defect-free drive media can develop defects. This is a common phenomenon. The bit density and rotational speed of disks is increasing every year, and so are the potential of problems. Usually a drive can internally remap bad sectors without external help using cyclic redundancy check (CRC) checksums stored at the end of each sector.

The RAID controller drives perform automatic defect re-assignment for both read and write errors. Writes are always

completed - if a location to be written is found to be defective, the drive will automatically relocate that write command to a new location and map out the defective location. If there is a recoverable read error, the correct data will be transferred to the host and that location will be tested by the drive to be certain the location is not defective. If it is found to have a defect, data will be automatically relocated, and the defective location is mapped out to prevent future write attempts.

In the event of an unrecoverable read error, the error will be reported to the host and the location will be flagged as being potentially defective. A subsequent write to that location will initiate a sector test and relocation should that location prove to have a defect. Auto Reassign Sector does not affect disk subsystem performance because it runs as a background task. Auto Reassign Sector discontinues when the operating system makes a request.

● **Consistency Check**

A consistency check is a process that verifies the integrity of redundant data. To verify RAID 3, 5, 6, 30, 50 or 60 redundancy, a consistency check reads all associated data blocks, computes parity, reads parity, and verifies that the computed parity matches the read parity.

Consistency checks are very important because they detect and correct parity errors or bad disk blocks in the drive. A consistency check forces every block on a volume to be read, and any bad blocks are marked; those blocks are not used again. This is critical and important because a bad disk block can prevent a disk rebuild from completing. We strongly recommend that you run consistency checks on a regular basis—at least once per week. Note that consistency checks degrade performance, so you should run them when the system load can tolerate it.

APPENDIX

Data Protection

- **Battery Backup**

The RAID controllers are armed with a Battery Backup Module (BBM). While a Uninterruptible Power Supply (UPS) protects most servers from power fluctuations or failures, a BBM provides an additional level of protection. In the event of a power failure, a BBM supplies power to retain data in the RAID controller's cache, thereby permitting any potentially dirty data in the cache to be flushed out to secondary storage when power is restored.

The batteries in the BBM are recharged continuously through a trickle-charging process whenever the system power is on. The batteries protect data in a failed server for up to three or four days, depending on the size of the memory module. Under normal operating conditions, the batteries last for three years before replacement is necessary.

- **Recovery ROM**

RAID controller firmware is stored on the flash ROM and is executed by the I/O processor. The firmware can also be updated through the RAID controllers PCIe 2.0 bus port or Ethernet port without the need to replace any hardware chips. During the controller firmware upgrade flash process, it is possible for a problem to occur resulting in corruption of the controller firmware. With our Redundant Flash Image feature, the controller will revert back to the last known version of firmware and continue operating. This reduces the risk of system failure due to firmware crash.

Appendix G

Understanding RAID

RAID is an acronym for Redundant Array of Independent Disks. It is an array of multiple independent hard disk drives that provides high performance and fault tolerance. The RAID controller implements several levels of the Berkeley RAID technology. An appropriate RAID level is selected when the volume sets are defined or created. This decision should be based on the desired disk capacity, data availability (fault tolerance or redundancy), and disk performance. The following section discusses the RAID levels supported by the RAID controller.

The RAID controllers makes the RAID implementation and the disks' physical configuration transparent to the host operating system. This means that the host operating system drivers and software utilities are not affected, regardless of the RAID level selected. Correct installation of the disk array and the controller requires a proper understanding of RAID technology and the concepts.

RAID 0

RAID 0, also referred to as striping, writes stripes of data across multiple disk drives instead of just one disk drive. RAID 0 does not provide any data redundancy, but does offer the best High-speed data throughput. RAID 0 breaks up data into smaller blocks and then writes a block to each drive in the array. Disk striping enhances performance because multiple drives are accessed simultaneously; the reliability of RAID level 0 is less because the entire array will fail if any one disk drive fails.

APPENDIX

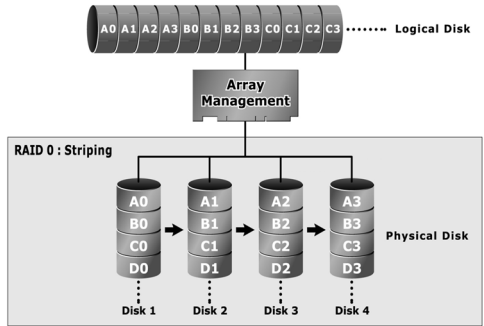

RAID 1

RAID 1 is also known as “disk mirroring”; data written on one disk drive is simultaneously written to another disk drive. Read performance will be enhanced if the array controller can, in parallel, access both members of a mirrored pair. During writes, there will be a minor performance penalty when compared to writing to a single disk. If one drive fails, all data (and software applications) are preserved on the other drive. RAID 1 offers extremely high data reliability, but at the cost of doubling the required data storage capacity.

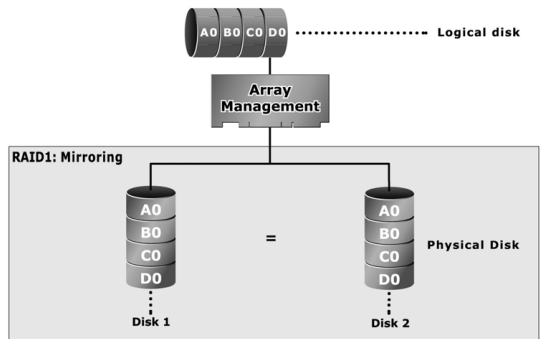

RAID 10(1E)

RAID 10(1E) is a combination of RAID 0 and RAID 1, combining striping with disk mirroring. RAID Level 10 combines the fast performance of Level 0 with the data redundancy of level 1. In this configuration, data is distributed across several disk drives, similar to Level 0, which are then duplicated to another set of drive for data protection. RAID 10 has been traditionally implemented using an even number of disks, some hybrids can use an odd number of disks as well. Illustration is an example of a hybrid RAID 10(1E) array comprised of five disks; A, B, C, D and E. In this configuration, each strip is mirrored on an adjacent disk with wrap-around. Areca RAID 10 offers a little more flexibility in choosing the number of disks that can be used to constitute an array. The number can be even or odd.

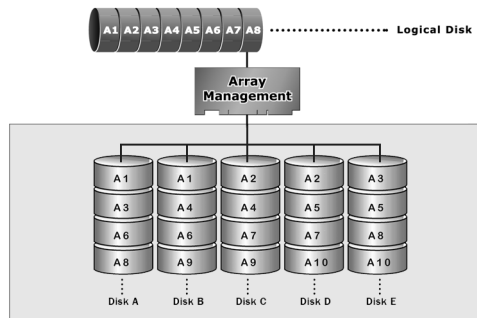

RAID 3

RAID 3 provides disk striping and complete data redundancy through a dedicated parity drive. RAID 3 breaks up data into smaller blocks, calculates parity by performing an exclusive-or on the blocks, and then writes the blocks to all but one drive in the array. The parity data created during the exclusive-or is then written to the last drive in the array. If a single drive fails, data is still available by computing the exclusive-or of the contents corresponding strips of the surviving member disk. RAID 3 is best for applications that require very fast data-transfer rates or long data blocks.

APPENDIX

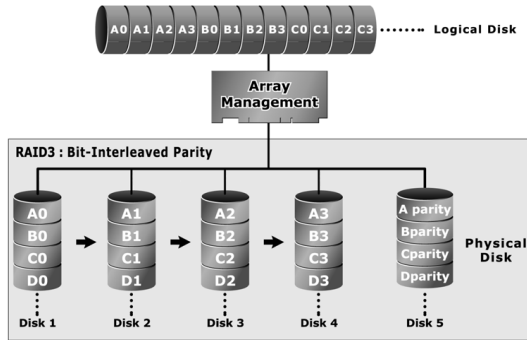

RAID 5

RAID 5 is sometimes called striping with parity at byte level. In RAID 5, the parity information is written to all of the drives in the controllers rather than being concentrated on a dedicated parity disk. If one drive in the system fails, the parity information can be used to reconstruct the data from that drive. All drives in the array system can be used for seek operations at the same time, greatly increasing the performance of the RAID system. This relieves the write bottleneck that characterizes RAID 4, and is the primary reason that RAID 5 is more often implemented in RAID arrays.

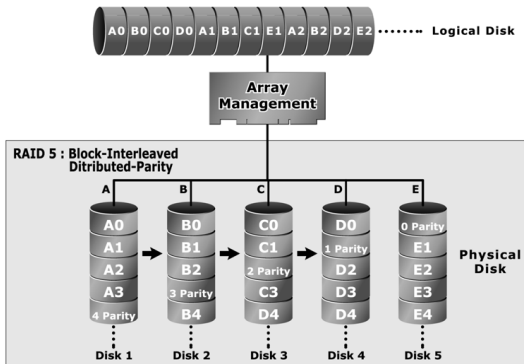

RAID 6

RAID 6 provides the highest reliability. It is similar to RAID 5, but it performs two different parity computations or the same computation on overlapping subsets of the data. RAID 6 can offer fault tolerance greater than RAID 1 or RAID 5 but only consumes the capacity of 2 disk drives for distributed parity data. RAID 6 is an extension of RAID 5 but uses a second, independent distributed parity scheme. Data is striped on a block level across a set of drives, and then a second set of parity is calculated and written across all of the drives.

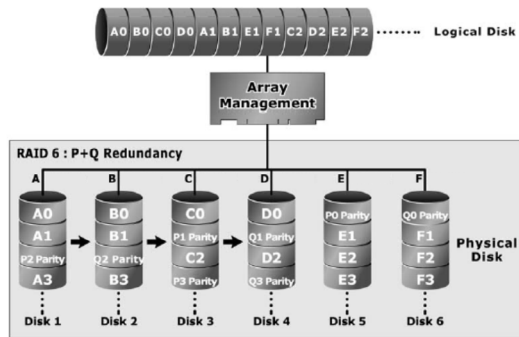

RAID x0

RAID level-x0 refers to RAID level 00, 100, 30, 50 and 60. RAID x0 is a combination multiple RAID x volume sets with RAID 0 (striping). Striping helps to increase capacity and performance without adding disks to each RAID x array. The operating system uses the spanned volume in the same way as a regular volume. Up to one drive in each sub-volume (RAID 3 or 5) may fail without loss of data. Up to two drives in each sub-volume (RAID 6) may fail without loss of data. RAID level x0 allows more physical drives in an array. The benefits of doing so are larger volume sets, increased performance, and increased reliability.

The following illustration is an example of a RAID level x0 logical drive.

APPENDIX

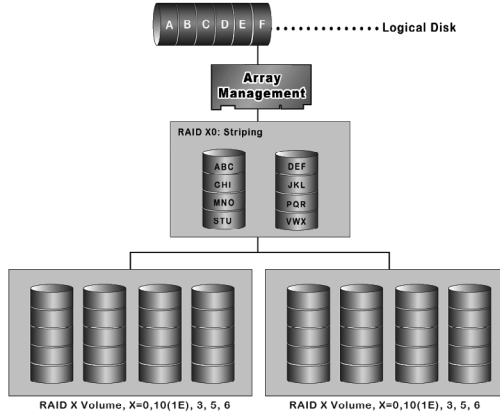

Important:

RAID level 00, 100, 30, 50 and 60 can support up to eight RAID set. If volume is RAID level 00, 100, 30, 50, or 60, you can't change the volume to another RAID level. If volume is RAID level 0, 1, 10(1E), 3, 5, or 6, you can't change the volume to RAID level 00, 100, 30, 50, or 60.

JBOD

(Just a Bunch Of Disks) A group of hard disks in a RAID box are not set up as any type of RAID configuration. All drives are available to the operating system as an individual disk. JBOD does not provide data redundancy.

Single Disk (Pass-Through Disk)

Pass through disk refers to a drive that is not controlled by the RAID firmware and thus can not be a part of a RAID volume. The drive is available to the operating system as an individual disk.

Summary of RAID Levels

6Gb/s SATA RAID controller supports RAID Level 0, 1, 10(1E), 3, 5, 6, 30, 50 and 60. The following table provides a summary of RAID levels.

RAID Level Comparison			
RAID Level	Description	Disks Requirement (Minimum)	Data Availability
0	Also known as striping. Data distributed across multiple drives in the array. There is no data protection.	1	No data Protection
1	Also known as mirroring. All data replicated on 2 separated disks. N is almost always 2. Due to this is a 100 % duplication, so is a high costly solution.	2	Up to one disk failure
10(1E)	Also known as mirroring and striping. Data is written to two disks simultaneously, and allows an odd number or disk. Read request can be satisfied by data read from wither one disk or both disks.	3	Up to one disk failure in each sub-volume
3	Also known Bit-Interleaved Parity. Data and parity information is subdivided and distributed across all data disks. Parity information normally stored on a dedicated parity disk.	3	Up to one disk failure
5	Also known Block-Interleaved Distributed Parity. Data and parity information is subdivided and distributed across all disk. Parity information normally is interspersed with user data.	3	Up to one disk failure
6	RAID 6 provides highest reliability, but not widely used. Similar to RAID 5, but does two different parity computations or the same computation on overlapping subsets of the data. The RAID 6 can offer fault tolerance greater that RAID 1 or RAID 5 but only consumes the capacity of 2 disk drives for distributed parity data.	4	Up to two disk failure

APPENDIX

30	RAID 30 is a combination multiple RAID 3 volume sets with RAID 0 (striping)	6	Up to one disk failure in each sub-volume
50	RAID 50 is a combination multiple RAID 5 volume sets with RAID 0 (striping)	6	Up to one disk failure in each sub-volume
60	RAID 60 is a combination multiple RAID 6 volume sets with RAID 0 (striping)	8	Up to two disk failure in each sub-volume