

# Essential Surge Protector





Models P5BT-FR, P5BV-FR, P5BT-IT, P5BV-IT, P5BT-SP, P5BV-SP, P5BT-GR, P5BV-GR, P5BT-RS and P5BV-RS

Thank you for purchasing APC's P5 series surge protector. Please complete and mail the Warranty Registration card, or complete the Warranty Registration form online at www.apc.com. **Note:** for the purposes of this manual, only one "T" model and one "V" model are shown.

## Safety

- Do not install this device during a lightning storm.
- For indoor use only.
- Do not install the surge protector in a hot or excessively moist location; do not use with aquarium equipment.

## Installation

1. Plug the surge protector into a grounded outlet only.
2. Plug the power cord from your computer and/or other electrical equipment into the surge protector outlets **1**.  
**Note:** Verify the device to be protected operates correctly before plugging it into the surge protector.
3. For P5BT-FR, P5BT-GR, P5BT-RS, P5BT-IT and P5BT-SP models, connect a modular telephone cord between the telephone wall outlet and the surge protector jack **2** marked . Connect another modular telephone cord between the surge protector jack **3** marked  and the telephone, modem or fax machine.
4. For P5BV-FR, P5BV-GR, P5BV-RS, P5BV-IT and P5BV-SP models, connect a coaxial cable from the cable source to the connector **4** marked . Connect the supplied coaxial cable from the connector **5** marked  to the equipment to be protected (CATV box, VCR, TV, cable modem).
5. Place the Power switch **6** to the ON position.

**Protection Indicator** - The P5B-FR, P5B-GR, P5B-RS, P5B-IT, and P5B-SP Protection Indicator **7** is marked **220-240V~ 10 A MAX**. When the unit is plugged in and turned on, the green Protection Indicator illuminates to show the surge protector is capable of protecting equipment from harmful electrical surges. If the indicator does not illuminate when the unit is plugged in and turned on, the unit has sustained damage and is no longer capable of protecting your equipment. It should be returned according to the instructions provided by APC Technical Support.

**Grounding OK Indicator** - When the surge protector is plugged in and power is turned on, the Grounding OK Indicator **8** illuminates (green) to show that the power source outlet is properly grounded. If the Grounding OK Indicator does not illuminate, there is a problem with the building wiring. Employ a qualified and licensed electrician to correct the problem.

**Cord Management Guide** **9** - is provided for keeping power cords connected to the unit neat and organized, and can also be wall-mounted with the surge protector (see below).

**Pivoting Strain Relief** **10** - allows the power cord 180-degrees of top-to-bottom rotation to extend the life of the power cord and the surge protector.

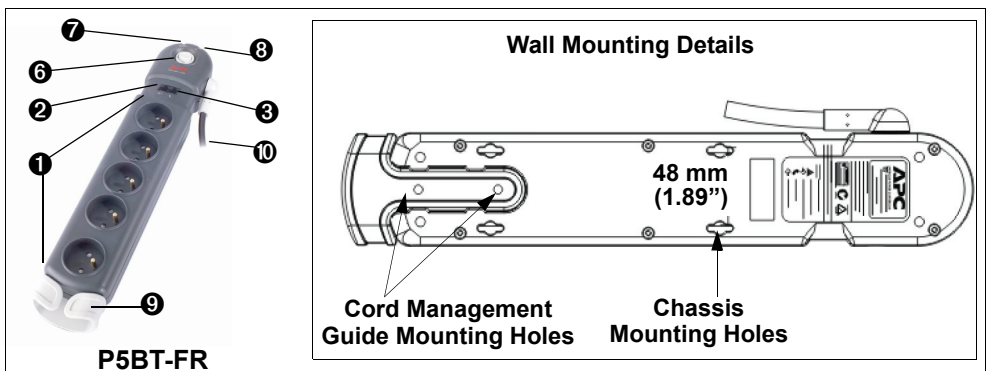

## Specifications

Nominal Operating Voltage	220-240 Vac, 10 A MAX
Operating Frequency	50- 60 Hz
Operating Temperature	0 to 40° C (32 to 104° F)
Operating Relative Humidity	0 to 95%, non-condensing

## Limited Warranty

APC warrants its products to be free from defects in materials and workmanship under normal use and service by the original owner for the lifetime of the product, (in Germany the period is 30 years from the purchase date of the product). For units purchased and/or used in countries not belonging to the European Community, the warranty period is 5 years from the date of purchase. The APC obligation under this warranty is limited to repairing or replacing, at its sole option, any such defective products. To obtain service under warranty you must obtain a Returned Material Authorization (RMA) number from APC or an APC Service Center with transportation charges prepaid and must be accompanied by a brief description of the problem and proof of date and place of purchase. This warranty applies only to the original purchaser.

THIS POLICY IS NOT A WARRANTY. REFER TO APC LIMITED WARRANTY FOR INFORMATION CONCERNING THE WARRANTY FOR YOUR APC PRODUCT. THE LIMITATIONS AND CONDITIONS CONTAINED IN THIS POICY DO NOT AFFECT THE TERMS OF THE WARRANTY.

**"Equipment Protection Policy"**

The policy is valid in all European Union state members. It is also valid in Norway, Switzerland, Iceland, and Liechtenstein. If your electronic equipment is damaged by power line transients on an AC power line (230V – see Note below) while directly and properly connected to a standard APC product covered by the Equipment Protection Policy ("connected equipment"), and if all the remaining conditions specified below are met, APC will, at APC's sole option, during the period specified below only, replace the APC product and either a) pay for the repair of the connected equipment or b) reimburse you for the fair market value, as determined by the then current price list of the Boston Computer Exchange (or equivalent), of the connected equipment, in an amount not to exceed the dollar limits stated below, if APC determines that the damage was caused by the failure of the APC product to protect against power line transients and/or where applicable, telephone or CATV (Cable Television) line transients. Power line transients that APC products have been designed to protect against, as recognized by industry standards, include spikes and surges on AC power lines. Protection from telephone line transients applies only to APC products which offer modem or fax line protection, and in cases in which such protection is available, telephone service equipment must include a properly installed and operating "primary protection" device at the service entrance (such devices are normally added during telephone installation) in order to be covered for telephone line transients. Protection of CATV connected equipment from transients applies only to APC products which offer such protection, and in such cases, the CATV service must be properly grounded according to the codes set forth in the all applicable national and local electrical and safety codes in order to be covered for CATV transients.

**"Data Recovery Policy"**

If data is lost from the hard drive in the protected computer due to a malfunction of a properly connected APC product, APC will, at its sole discretion, provide data recovery services from Ontrack® data recovery labs. This warranty will be offered to customers to the extent commercially reasonable, as determined by APC at its sole discretion. Ontrack will make every commercially reasonable effort to retrieve customer data, however, due to the nature of data loss, recovery is not guaranteed. The data recovery warranty is available on all APC products mentioned in the chart that follows with the exception of APC's Basic Surge Protector models. Data recovery is limited to physical hard drives within protected computing equipment. Expressly excluded from this warranty are any type of external storage devices.

APC reserves the right to determine whether the damage to the connected equipment is due to APC product failure by requesting that damaged equipment be sent to APC for inspection. This policy is in excess of, and applies only to the extent necessary beyond, any coverage for the connected equipment provided by other sources, including, but not limited to, any manufacturer's warranty, and any extended warranty coverage.

**Equipment Protection Policy Dollar and Period Limits:**

For customers that meet the qualifications and conditions set forth in this policy, APC will provide reimbursements (cost of repair or fair market value) during the period limits and up to the dollar limit stated as follows:

Product	Amount	Period
P5BT-FR, P5BT-IT, P5BT-GR, P5BT-RS, P5BT-SP, P5BV-FR, P5BV-IT, P5BV-GR, P5BV-RS, P5BV-SP	35,000 GBP/50,000 Euros	Lifetime

**Note:** "Lifetime" period is the life of the product while owned by the original purchaser ("you" or "purchaser"). Other period limitations are from the date of purchase.

**Eligibility for coverage under the Equipment Protection Policy:**

- You must register the product by returning to APC the warranty card provided with the product within 10 days of purchase. All information must be filled in, and you should retain a copy for your records.
- All connected equipment must have a CE mark.
- The APC product must be plugged into properly wired and grounded outlets; no extension cords, adapters, other ground wires, or electrical connections may be used, with the sole exception of other standard APC 230V products. The installation must not include power protection products by any manufacturer other than APC. The installation must comply with all applicable local electrical and safety codes.
- Any claim under the Equipment Protection Policy must be made within 10 days of the day of alleged damage to the connected equipment.
- The Equipment Protection Policy covers only those product models listed above and is valid in all Eurpean Union state members, as well as Norway, Switzerland, Iceland, and Liechtenstein.

**What is not covered under the Equipment Protection Policy:**

- DAMAGE TO ELECTRONIC EQUIPMENT RESULTING FROM TRANSIENTS ON DATA LINES IS NOT COVERED.
- Restoration of lost data and reinstallation of software are not covered.
- This policy does not cover damage from a cause other than AC power line transients, except for damage due to telephone line or CATV transients, which is covered only if the APC product offers such protection.
- DAMAGE CAUSED BY FAILURE TO PROVIDE A SUITABLE INSTALLATION ENVIRONMENT FOR THE PRODUCT (INCLUDING, BUT NOT LIMITED TO, LACK OF A PROPER SAFETY GROUND).
- Damage caused by the use of the APC product for purposes other than those for which it was designed.
- Damage caused by accidents, or disasters such as fire, flood, or wind.
- Damage caused by abuse, misuse, alternation, modification, or negligence.
- This policy is null and void if, in APC's view, the APC product has been tampered with or altered in any way.
- EXCEPT AS EXPRESSLY PROVIDED IN THIS POLICY, IN NO CASE SHALL APC BE LIABLE UNDER THE TERMS OF THIS POLICY FOR ANY DAMAGES WHATSOEVER, INCLUDING, BUT NOT LIMITED TO, DIRECT, INDIRECT, SPECIAL, INCIDENTAL, CONSEQUENTIAL, OR MULTIPLE DAMAGES ARISING OUT OF THE USE OF THE APC PRODUCT OR DAMAGE TO THE CONNECTED EQUIPMENT, REGARDLESS OF THE LEGAL THEORY ON WHICH SUCH CLAIM IS BASED, EVEN IF ADVISED OF THE POSSIBILITY OF SUCH DAMAGE. SUCH DAMAGES INCLUDE BUT ARE NOT LIMITED TO, LOSS OF PROFITS, LOSS OF SAVINGS OR REVENUE, LOSS OF USE OF THE APC PRODUCT OR THE CONNECTED EQUIPMENT OR ANY ASSOCIATED EQUIPMENT, LOSS OF SOFTWARE, COST OF CAPITAL, COST OF ANY SUBSTITUTE EQUIPMENT, FACILITIES OR SERVICES, DOWNTIME, THE CLAIMS OF THIRD PARTIES, INCLUDING CUSTOMERS, AND INJURY TO PROPERTY.

**Submitting an Equipment Protection Policy Claim:**

- If all of the conditions for coverage are satisfied, call the APC customer service department (see list at the end of the document for respective phone numbers) and obtain an EPP RMA (Equipment Protection Policy Returned Material Authorization) number. APC will forward you an Equipment Protection Policy claim form, which must be completed and filed within 30 days.
- Mark the Equipment Protection Policy RMA number on the product you are returning.
- Pack the APC product in its original packaging (or request packing materials from APC if the packaging has been discarded). Enclose the completed Equipment Policy claim form and a copy of your sales receipt for the APC product in box.
- Mark the EPP RMA number clearly on the outside of box.
- Ship the product (one way shipping charges paid by you) to:  
American Power Conversion, Technical Support, Ballybrit Business Park, Galway, Ireland  
Tel. +353 91 702000.
- APC will evaluate the product to determine its level of functionality, and will examine the product for evidence of damage from AC line transients (telephone line or CATV transients, if applicable). (A) If APC's evaluation provides no evidence of damage from power line transients (telephone line or CATV transients, if applicable), APC will send to the customer (i) a report summarizing the tests performed and (ii) a rejection of claim notice. (B) If the APC product shows evidence of damage from power line transients (telephone line or CATV transients, if applicable), APC will request that all connected equipment for which an Equipment Protection Policy claim has been submitted, be sent for evaluation to either APC or an authorized service center. If it is determined that the connected equipment has been damaged from AC power line transients (telephone line or CATV transients, if applicable), APC will, in its discretion, either authorize you to have the equipment repaired or reimburse you for the fair market value of the damaged equipment, up to the dollar limits stated above.
- If you are authorized by APC to have the connected equipment repaired, the repair must be performed at a service center that is authorized by the manufacturer of the connected equipment. APC reserves the right to contact the authorized service centre directly to discuss repair costs and damage to the connected equipment to determine if it was caused by AC power line transients (telephone line or CATV transients, if applicable) and the right to request that the service centre forward the connected equipment or components to APC for inspection.
- APC will, after determining that the damage was caused by the failure of the APC product to protect against AC power line transients (telephone line or CATV transients, if applicable), issue payment to you, in its sole discretion, for either costs of repair of the fair market value of the connected equipment, up to the dollar limits stated above. APC reserves the right to require you to transfer title and deliver the connected equipment to APC if it chooses to reimburse you for the fair market value of the connected equipment.
- Unless modified in a writing signed by APC and you, the terms of this policy are understood to be the complete and exclusive agreement between the parties, superseding all prior agreements, oral and written, and all other communications between the parties relating to the subject matter of this agreement. No employee of APC or any other party is authorized to make any



**CE Declaration of Conformity**

**2004**  
Date of product declaration

We, the undersigned, declare under our sole responsibility that the equipment specified below conforms to the following standards and directives:

<b>Harmonized Standards:</b>	IEC 60884; IEC 61643-1:1998+A1:2001; IEC 61643-11:2002
<b>Applicable Council Directives:</b>	73/23/EEC
<b>Type of Equipment:</b>	Five Outlet AC Power Surge Protector; Single Line Telephone Surge Protector; Coaxial Cable Surge Protector
<b>Model Numbers:</b>	P5BT-FR; P5BT-IT; P5BT-SP; P5BT-GR; P5BT-RS; P5BV-FR; P5BV-IT; P5BV-SP; P5BV-GR; P5BV-RS

<b>Manufacturers:</b>	American Power Conversion Ballybritt Business Park Galway, Ireland	American Power Conversion 2nd Street PEZA, Cavite Economic Zone Rosario, Cavite Philippines	APC (Suzhou) UPS Co., Ltd 339 Suhong Zhong Lu Suzhou Industrial Park Suzhou Jiangsu 215021 P. R. China
-----------------------	--	---	--

American Power Conversion Breaffy Rd. Castlebar Co Mayo, Ireland	American Power Conversion Lot 10, Block 16, Phase 4 PEZA, Rosario, Cavite Philippines	APC Power Infrastructure Co., Ltd 1678, Ji Xian Road, Tong An Xiamen, P. R. China 361100
---	--	---

American Power Conversion 132 Fairgrounds Rd. West Kingston, RI 02892 USA	American Power Conversion Lot 3, Block 14, Phase 3 PEZA, Rosario, Cavite Philippines
---	---

American Power Conversion 1600 Division Rd. West Warwick, RI 02892 USA	APC Brazil LTDA. Al. Xingu, 850 Barueri Alphaville/Sao Paulo 06455-030 Brazil
--	---

APC India Pvt. Ltd. 187/3, 188/3, Jigani Industrial Area, Jigani Bangalore, 562106 Karnataka India
--

<b>Importer:</b>	American Power Conversion (A. P. C.) b. v. Ballybritt Business Park Galway, Ireland
------------------	---

<b>Place:</b>	Galway, Ireland	Ray S. Ballard, Managing Director, Europe
---------------	-----------------	---

 5 Jan 04

990-1965A

Entire contents copyright 2007 American Power Conversion Corporation. All rights reserved. Reproduction in whole or in part without permission is prohibited. APC, the APC logo, and Back-UPS are trademarks of American Power Conversion Corporation. All other trademarks, product names, and corporate names are the property of their respective owners and are used for informational purposes only.