



Catalog
D 11

Edition
2023

MOTION CONTROL DRIVES

SINAMICS G130













Converter Built-in Units

SINAMICS G150

Converter Cabinet Units

[siemens.com/d11](https://www.siemens.com/d11)

Related catalogs

<p>SINAMICS G180 D 18.1 Converters – Compact Units, Cabinet Systems, Cabinet Units Air-Cooled and Liquid-Cooled</p> <p>E86060-K5518-A111-A3-7600</p>		<p>Industrial Controls IC 10 SIRIUS</p> <p>PDF (E86060-K1010-A101-B5-7600)</p>	
<p>SINAMICS S120 D 21.3 Chassis Format Converter Units Chassis-2 Format Converter Units Cabinet Modules, Cabinet Modules-2</p> <p>SINAMICS S150 Converter Cabinet Units PDF (E86060-K5521-A131-A8-7600)</p>		<p>Industrial Communication IK PI SIMATIC NET</p> <p>E86060-K6710-A101-B8-7600</p>	
<p>Motion Control Drives D 21.4 SINAMICS S120 and SIMOTICS</p> <p>E86060-K5521-A141-A1-7600</p>		<p>Low-Voltage Power Distribution and Electrical Installation Technology LV 10 SENTRON • SIVACON • ALPHA</p> <p>PDF (E86060-K8280-A101-B7-7600)</p>	
<p>Motion Control Drives D 31.1 SINAMICS Inverters for Single-Axis Drives Built-In Units</p> <p>PDF (E86060-K5531-A111-A4-7600)</p>		<p>SiePortal Information and Ordering Platform on the Internet</p> <p>sieportal.siemens.com</p>	
<p>Motion Control Drives D 31.2 SINAMICS Converters for Single-Axis Drives Distributed Converters</p> <p>PDF (E86060-K5531-A121-A3-7600)</p>		<p>The Engineering Manual SINAMICS Low Voltage Engineering Manual</p> <p>Engineering Manual for</p> <ul style="list-style-type: none"> - SINAMICS G130 Converter Built-in Units, - SINAMICS G150 Converter Cabinet Units, - SINAMICS S120 Chassis Units, - SINAMICS S120 Cabinet Modules, - SINAMICS S150 Converter Cabinet Units <p>This manual offers users comprehensive support with the configuring of drives and associated system components. The first three chapters deal mainly with the fundamental physical principles of variable-speed drives and with directives and basic information for EMC and include general system descriptions and general engineering information. The other chapters then discuss in detail questions relating to th dimensioning of drives as well as the selection of suitable motors.</p> <p>Note: The manual is not available in hard copy form, but only as an electronic file in PDF format.</p>	
<p>SINAMICS Drives D 35 SINAMICS G120P and SINAMICS G120P Cabinet pump, fan, compressor converters</p> <p>PDF (E86060-K5535-A101-A5-7600)</p>			
<p>Motion Control System PM 21 SIMOTION Equipment for Production Machines</p> <p>E86060-K4921-A101-A4-7600</p>			

SINAMICS G130 Converter Built-in Units

SINAMICS G150 Converter Cabinet Units

Motion Control Drives



Catalog D 11 · 2023

Supersedes:
Catalog D 11 · 2015

Refer to SiePortal for current updates of this catalog:
sieportal.siemens.com

Please contact your local Siemens branch.

© Siemens 2023

System overview

1

Highlights

2

SINAMICS G130 converter built-in units
75 kW to 800 kW

3

SINAMICS G150 converter cabinet units
75 kW to 2700 kW

4

Tools and configuration

5

Services and documentation

6

Appendix

7



The products and systems described in this catalog are manufactured/distributed under application of a certified quality management system in accordance with EN ISO 9001 and EN ISO 14001 (Certified Registration No. 002241 QM UM). The certificate is recognized by all IQNet countries.

Digitalization in drive technology

From the digital world to the real world

[siemens.com/digital-drives](https://www.siemens.com/digital-drives)

Increase your transparency and productivity by digitalizing your drive technology

Many drives are used in the manufacturing and process industries. They produce lots of data anyway – why not use them to increase the availability and productivity of machines and plants?

Drive technology offers the ideal entry point into the world of digitalization – for plant and machine builders as well as for users.

The digitalization portfolio for the drive train spans over the complete life cycle – from the design phase to realization and optimization – in the digital and the real world.

Our portfolio contains drive simulation solutions and efficient engineering tools, comprehensive connectivity that allows drives to be easily linked to the relevant platforms as well as smart analytics (e.g. cloud and edge apps) and drive system services.

These solutions enable you to gain a better understanding of processes, states and utilization. The health status of the drive train can be monitored and analyzing drive data enables an early detection of anomalies and reduces downtimes. This way, availability and productivity of machines and plants can be increased and the actual maintenance demand can be identified. Furthermore, data-based business models and service offerings are facilitated.

Our digitalization portfolio covers all phases of the life cycle: from the design phase to realization and optimization. It covers the digital and the real drive train.

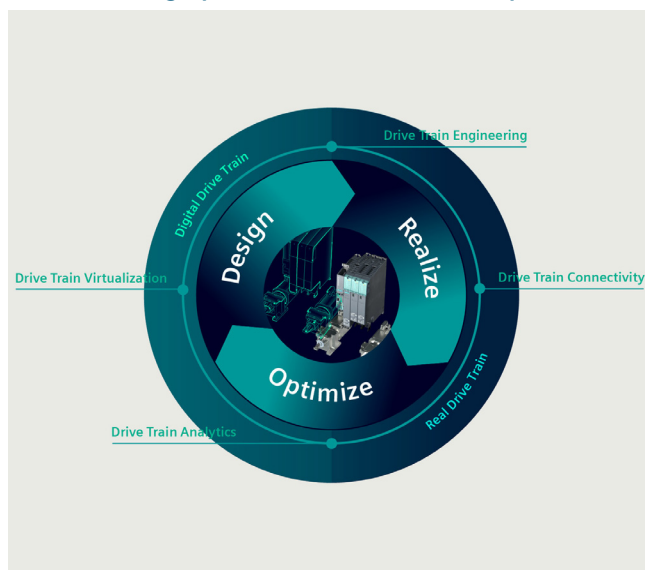

Design: By creating a digital twin of the drives, machine builders can shorten their time-to-market since they can design, simulate and optimize their machine before ordering any material or products. Together with other tools from the engineering box, simulation can also speed up the engineering phase of drives and entire machines, for example by virtual commissioning of the PLC.

Realize: Once the machine is in operation, the drives can be connected to other platforms, for example to the cloud and Industrial Edge. This creates transparency in terms of what is going on inside the drive train, e.g. with regard to the actual current, torque and speed.

Optimize: To understand the collected data, our drive train analytics portfolio provides algorithms and analysis tools to unlock the potential of the data and turn the gained transparency into insights and valuable knowledge. These insights can then again be used in the design phase of the next life cycle, thus closing the loop.

Benefits of drive train digitalization

Machine builders



Availability



Increase the availability of your machines

Speed



Shorten time-to-market

Business models



Develop new service and business models

Machine operators



Productivity



Increase the productivity of your production

Flexibility



Increase the flexibility of your production

Efficiency



Identify potential for optimization

Benefits for machine and plant builders

- Increased availability of machines and plants – thanks to digital options for checking and implementing design improvements and comprehensive monitoring of drive systems
- Shorter time-to-market and faster development times – thanks to practical software tools and a continuous database for concurrent development processes as well as virtual simulations, tests, and commissioning of machines and plants
- New options for future service and business models – ranging from customized application solutions and digital services to contractually guaranteed availabilities of machines and plants

Benefits for machine and plant operators

- Increased availability and productivity of production, fewer unscheduled downtimes – through the early detection of deviations and emerging risks thanks to digital drive monitoring
- More flexible production down to batch size 1 – through more effective use of knowledge from existing production lines thanks to transparent utilization, states, locations, and capacities down to the drive level
- Identification of potential for optimization to make production faster, better, and more efficient thanks to data-based transparency – for example, for faster modifications, simpler quality control, and the early prediction of maintenance demand as well as demand-oriented maintenance



TIA Selection Tool – quick, easy, smart configuration

For you to get the most out of our portfolio quickly and easily.

Do you always need the optimum configuration for planning your project?

For your application we offer the TIA Selection Tool to support all project planners, beginners and experts alike.

No detailed portfolio knowledge is necessary.

TIA Selection Tool is available for download as a free desktop version or a cloud variant.

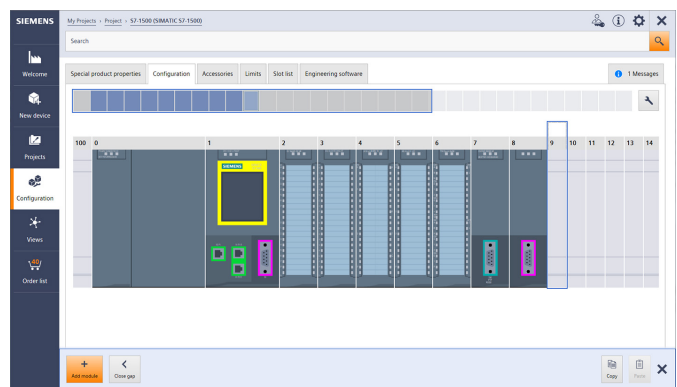

Your Advantages

Quick

- Configure a complete project with just a few entries – without a manual, without special knowledge
- Import and export of hardware configuration to TIA Portal or other systems
- Ideal visualization of the projects to be configured

Easy

- Tool download either as desktop version or web-based cloud version
- Technically always up-to-date about product portfolio and innovative approaches
- Highly flexible, secure, cross-team work in the cloud
- Direct ordering in SiePortal

Smart

- Smart selection wizard for error-free configuration and ordering
- Configuration options can be tested and simulated in advance
- Library for archiving sample configurations

The TIA Selection Tool is a completely paperless solution.

Download it now:

www.siemens.com/tst

For more
information,
scan the
QR code



System overview



1/2	The SINAMICS converter family
1/2	Integration in automation
1/2	Applications
1/3	Innovative, energy-efficient and reliable drive systems and applications as well as services for the entire drive train
1/3	Energy efficiency
1/4	Variants
1/4	Platform concept
1/4	Quality management according to EN ISO 9001
1/4	Integrated system configuration
1/5	Industry Online Support app
1/6	Drive selection
	SINAMICS selection guide – typical applications
1/6	Overview
1/6	More information
1/7	SIMOTICS motors
1/7	Overview
1/8	SINAMICS G130 / SINAMICS G150
	The universal drive solution for single-motor drives with a high power rating
1/8	Overview
1/8	Benefits
1/8	Application
1/8	Design
1/9	Integration

System overview

The SINAMICS converter family

Overview

Integration in automation

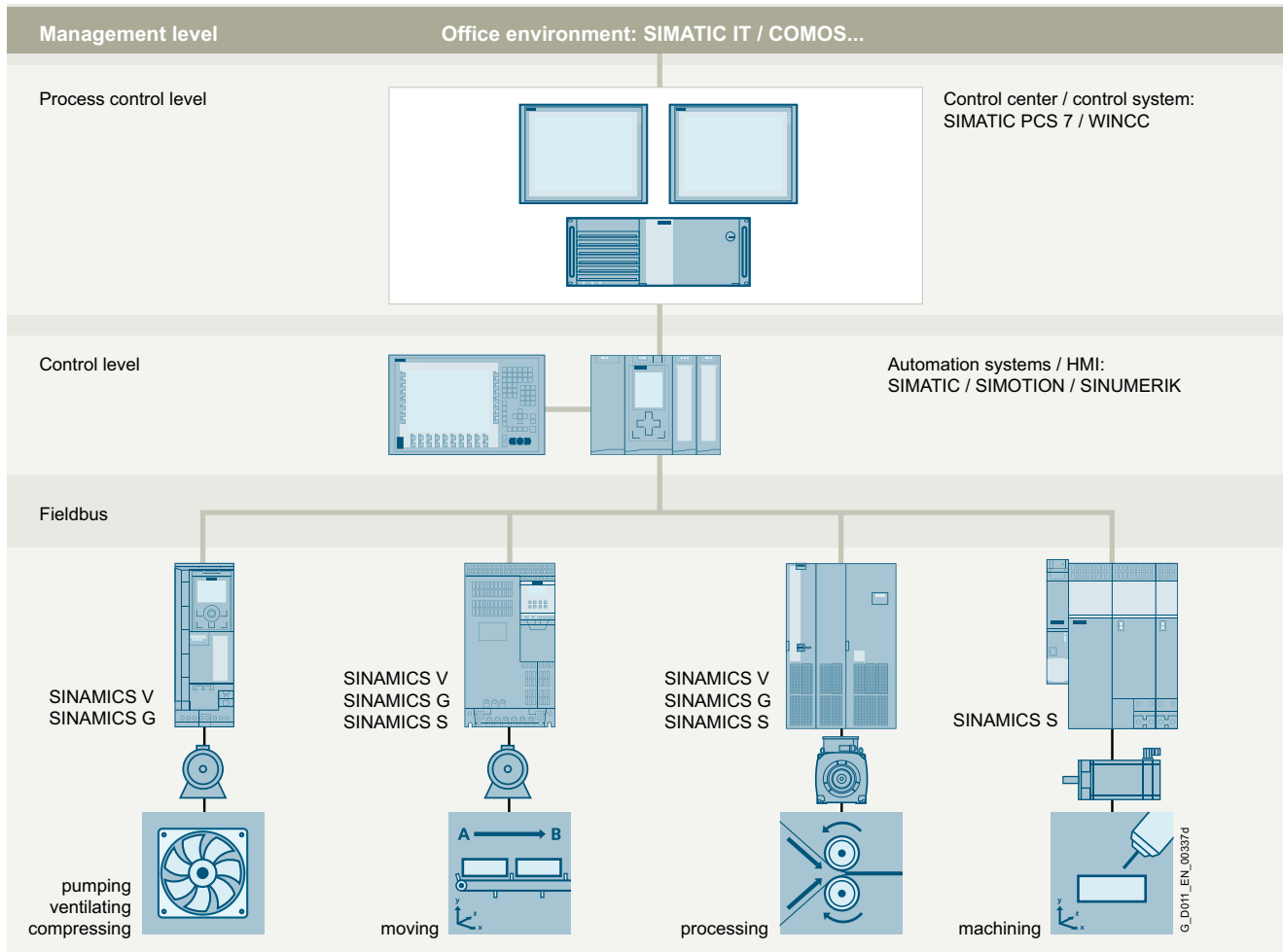

SINAMICS in automation

Totally Integrated Automation and communication

SINAMICS is an integral component of the Siemens "Totally Integrated Automation" concept. Integrated SINAMICS systems covering configuration, data storage, and communication at automation level ensure low-maintenance solutions with the SIMATIC, SIMOTION and SINUMERIK control systems.

Depending on the application, the appropriate variable frequency converters can be selected and incorporated in the automation concept. With this in mind, the converters are clearly subdivided into their different applications. A wide range of communication options (depending on the converter type) are available for establishing a communication link to the automation system:

- PROFINET
- PROFIBUS
- EtherNet/IP
- Modbus TCP
- Modbus RTU
- AS-Interface
- BACnet MS/TP

Applications

SINAMICS is the comprehensive converter family from Siemens designed for machine and plant engineering applications. SINAMICS offers solutions for all drive tasks:

- Simple pump and fan applications in the process industry
- Demanding single drives in centrifuges, presses, extruders, elevators, as well as conveyor and transport systems
- Drive line-ups in textile, plastic film, and paper machines as well as in rolling mill plants
- Highly dynamic servo drives for machine tools, as well as packaging and printing machines

Overview



SINAMICS as part of the Siemens modular automation system

Innovative, energy-efficient and reliable drive systems and applications as well as services for the entire drive train

The solutions for drive technology place great emphasis on the highest productivity, energy efficiency and reliability for all torque ranges, performance and voltage classes.

Siemens offers not only the right innovative variable frequency converter for every drive application, but also a wide range of energy-efficient low-voltage motors, geared motors, explosion-protected motors and high-voltage motors for combination with SINAMICS.

Furthermore, Siemens supports its customers with global pre-sales and after-sales services, with over 295 service points in 130 countries – and with special services e.g. application consulting or motion control solutions.

Energy efficiency

Energy management process

Efficient energy management consultancy identifies the energy flows, determines the potential for making savings and implements them with focused activities.

Almost two thirds of the industrial power requirement is from electric motors. This makes it all the more important to use drive technology permitting energy consumption to be reduced effectively even in the configuration phase, and consequently to optimize plant availability and process stability. With SINAMICS, Siemens offers powerful energy efficient solutions which, depending on the application, enable a significant reduction in electricity costs.

Up to 70 % potential for savings using variable-speed operation

SINAMICS enables great potential for savings to be realized by controlling the motor speed. In particular, huge potential savings can be recovered from pumps, fans and compressors which are operated with mechanical throttle and valves. Here, changing to variable-speed drives brings enormous economic advantages. In contrast to mechanical control systems, the power consumption at partial load operation is always immediately adjusted to the demand at that time. So energy is no longer wasted, permitting savings of up to 60 % – in exceptional cases even up to 70 %. Variable-speed drives also offer clear advantages over mechanical control systems when it comes to maintenance and repair. Current spikes when starting up the motor and strong torque surges become things of the past – and the same goes for pressure waves in pipelines, cavitation or vibrations which cause sustainable damage to the plant. Smooth starting and ramp-down relieve the load on the mechanical system, ensuring a significantly longer service life of the entire drive train.

System overview

The SINAMICS converter family

Overview

Regenerative feedback of braking energy

In conventional drive systems, the energy produced during braking is converted to heat using braking resistors. Energy produced during braking is efficiently recovered to the supply system by versions of SINAMICS G and SINAMICS S converters with regenerative feedback capability and these devices do therefore not need a braking resistor. This permits up to 60 % of the energy requirement to be saved, e.g. in lifting applications. Energy which can be reused at other locations on a machine. Furthermore, this reduced power loss simplifies the cooling of the system, enabling a more compact design.

Energy transparency in all configuration phases

Early on, in the configuration phase, the SIZER for Siemens Drives engineering tool provides information on the specific energy requirement. The energy consumption across the entire drive train is visualized and compared with different plant concepts.

SINAMICS in combination with energy-saving motors

The consistency of the engineering extends beyond the SINAMICS converter family to the higher-level automation systems as well as to a wide range of energy-efficient motors in a wide variety of performance classes, which are up to 10 % more efficient than previous motors.

Variants

Depending on the area of application, the SINAMICS converter family offers an optimally tailored variant for any drive task.

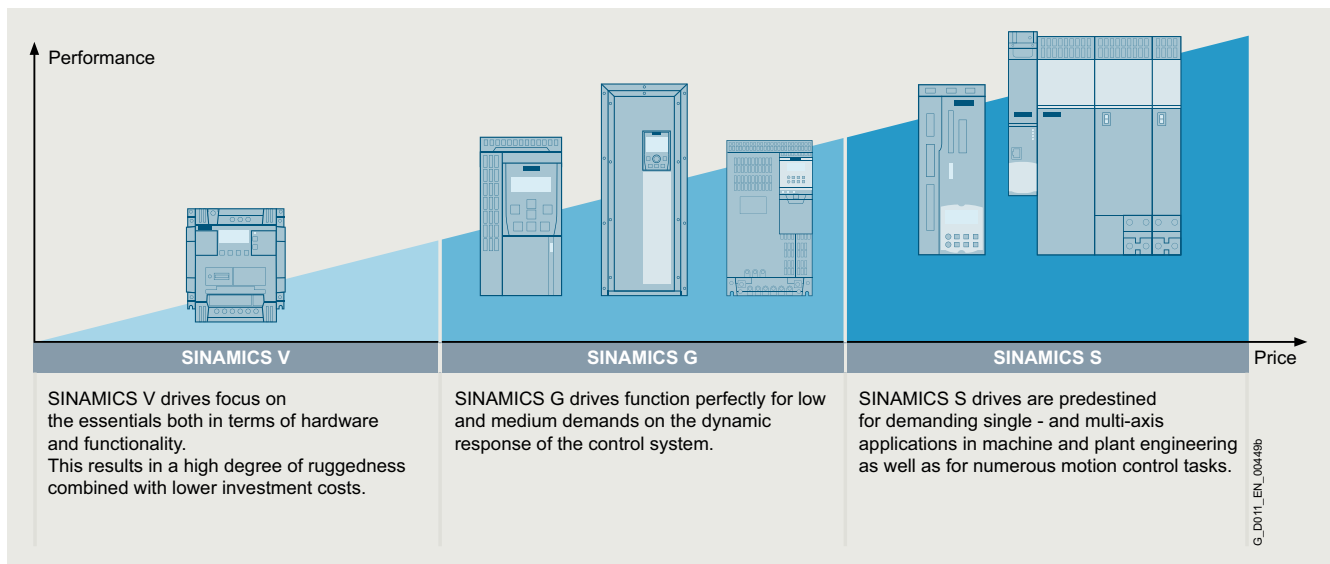

Platform concept

All SINAMICS variants are based on a platform concept. Joint hardware and software components, as well as standardized tools for dimensioning, configuration, and commissioning tasks ensure high-level integration across all components. SINAMICS handles a wide variety of drive tasks with no system gaps. The different SINAMICS variants can be easily combined with each other.

Quality management according to EN ISO 9001

SINAMICS conforms to the most exacting quality requirements. Comprehensive quality assurance measures in all development and production processes ensure a consistently high level of quality.

Of course, our quality management system is certified by an independent authority in accordance with EN ISO 9001.

Integrated system configuration

Siemens offers perfectly matched drive components with which you can meet your requirements. The drive components reveal their true strengths over the full range of engineering and commissioning through to operation: Integrated system configuration is performed using the Siemens Product Configurator: Just select a motor and a converter and design them with the SIZER for Siemens Drives (integrated in the TIA Selection Tool) engineering tool. The STARTER and SINAMICS Startdrive commissioning tools integrate the motor data and at the same time simplify efficient commissioning. All drive components are incorporated in the TIA Portal – this simplifies engineering, commissioning and diagnostics.

Overview

Industry Online Support app





With the Industry Online Support app, you can access more than 300000 documents for Siemens Industry products – any time and from anywhere.

Main functions at a glance:

- Scanning of product codes and EAN codes to directly display all of the technical and graphical data (e.g. CAX data) of the product
- Sending of product information or entries via e-mail to further process the information at the workstation

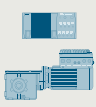
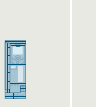
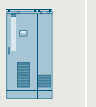
- Conveniently send inquiries to Technical Support. Detailed information can be conveniently completed using the scan or photo function
- Save the favorites on the device using the offline cache function. These articles, products and conferences can then be called even without network access.
- Transfer of PDF documents to an external library
- The contents and interfaces are available in six languages (German, English, French, Italian, Spanish and Chinese) - including a temporary switchover to English.

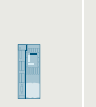
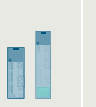
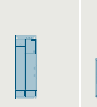
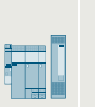
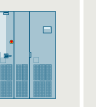
You can find additional information on the internet at:
www.siemens.com/sinamics-assistant

Low voltage											Direct voltage
Standard performance frequency converters		Distributed frequency converters	Industry-specific frequency converters		Servo converters			High performance frequency converters			DC converters
											
SINAMICS V20 G120C G120	SINAMICS G130 G150	SINAMICS G115D G120D SIMATIC ET 200pro FC-2	SINAMICS G120X	SINAMICS G180	SINAMICS V90 S200	SINAMICS S110	SINAMICS S210 S210 (New)	SINAMICS G220	SINAMICS S120 S120M	SINAMICS S150	SINAMICS DCM DCP ¹⁾
0.12 kW to 250 kW	75 kW to 2700 kW	0.37 kW to 7.5 kW	0.75 kW to 630 kW	2.2 kW to 6600 kW	0.05 kW to 7 kW	0.55 kW to 132 kW	0.05 kW to 7 kW	0.55 kW to 55 kW	0.55 kW to 5700 kW	75 kW to 1200 kW	6 kW to 30 MW
Pumps, fans, compressors, conveyor belts, mixers, mills, spinning machines, textile machines, refrigerated display counters, fitness equipment, ventilation systems, single-axis positioning applications in machine and plant engineering	Pumps, fans, compressors, conveyor belts, mixers, mills, extruders	Conveyor technology, single-axis positioning applications (G120D)	Pumps, fans, compressors, building management systems, process industry, HVAC, water/waste water industries	Pumps, fans, compressors, conveyor belts, extruders, mixers, mills, kneaders, centrifuges, separators	Handling machines, packaging machines, automatic assembly machines, metal forming machines, printing machines, winding and unwinding units	Single-axis positioning applications in machine and plant engineering	Packaging machines, handling equipment, feed and withdrawal devices, stacking units, automatic assembly machines, laboratory automation, wood, glass and ceramics industry, digital printing machines	Pumps, fans, compressors, conveyor belts, mixers, mills, spinning machines, textile machines, refrigerated display counters, fitness equipment, ventilation systems, single-axis positioning applications in machine and plant engineering	Production machines (packaging, textile and printing machines, paper machines, plastic processing machines), machine tools, plants, process lines and rolling mills, marine drives, test bays	Test bays, cross cutters, centrifuges	Rolling mill drives, wire-drawing machines, extruders and kneaders, cableways and lifts, test bay drives
Catalog D 31.1	Catalog D 11	Catalog D 31.2	Catalog D 31.5	Catalog D 18.1	Catalog D 33 D 37.1	Catalog D 31.1	Catalog D 32	Catalog D 36.1	Catalogs D 21.3, D 21.4 NC 62	Catalog D 21.3	Catalog D 23.1, SiePortal

Engineering tools (e.g. Siemens Product Configurator, TIA Selection Tool, SINAMICS DriveSim Basic/Advanced, STARTER and SINAMICS Startdrive)

¹⁾ DC/DC controllers, see SiePortal.

System overview

Drive selection

1

Overview

SINAMICS selection guide – typical applications

Use	Requirements for torque accuracy/speed accuracy/position accuracy/coordination of axes/functionality					
	Continuous motion			Non-continuous motion		
	Basic	Medium	High	Basic	Medium	High
Pumping, ventilating, compressing	Centrifugal pumps Radial/axial fans Compressors	Centrifugal pumps Radial/axial fans Compressors	Eccentric screw pumps	Hydraulic pumps Metering pumps	Hydraulic pumps Metering pumps	Descaling pumps Hydraulic pumps
	V20 G120C G120X	G120X G130/G150 G180 ¹⁾ DCM	G220 S120	G120/G220	S110	S120
Moving	Conveyor belts Roller conveyors Chain conveyors	Conveyor belts Roller conveyors Chain conveyors Lifting/lowering devices Elevators Escalators/moving walkways Indoor cranes Marine drives Cable railways	Elevators Container cranes Mining hoists Excavators for open-cast mining Test bays	Acceleration conveyors Storage and retrieval machines	Acceleration conveyors Storage and retrieval machines Cross-cutters Reel changers	Storage and retrieval machines Robotics Pick & place Rotary indexing tables Cross-cutters Roll feeds Engagers/disengagers
	V20 G115D G120C ET 200pro FC-2 ²⁾	G120/G220 G120D G130/G150 G180 ¹⁾	G220 S120 S150 DCM	V90 S200 G120/G220 G120D	S110 S210 DCM	S120 S210 DCM
Processing	Mills Mixers Kneaders Crushers Agitators Centrifuges	Mills Mixers Kneaders Crushers Agitators Centrifuges Extruders Rotary furnaces	Extruders Winders/unwinders Lead/follower drives Calenders Main press drives Printing machines	Tubular bagging machines Single-axis motion control such as • Position profiles • Path profiles	Tubular bagging machines Single-axis motion control such as • Position profiles • Path profiles	Servo presses Rolling mill drives Multi-axis motion control such as • Multi-axis positioning • Cyclic cams • Interpolations
	V20 G120C	G120/G220 G130/G150 G180 ¹⁾	G220 S120 S150 DCM	V90 S200 G120/G220	S110 S210	S120 S210 DCM
Machining	Main drives for • Turning • Milling • Drilling	Main drives for • Drilling • Sawing	Main drives for • Turning • Milling • Drilling • Gear cutting • Grinding	Axis drives for • Turning • Milling • Drilling	Axis drives for • Drilling • Sawing	Axis drives for • Turning • Milling • Drilling • Lasering • Gear cutting • Grinding • Nibbling and punching
	S110	S110 S120	S120	S110	S110 S120	S120

Using the SINAMICS selection guide

The varying range of demands placed on modern variable frequency converters requires a large number of different types. Selecting the optimum converter is becoming a significantly more complex process. The application matrix shown simplifies this selection process considerably, by suggesting the ideal SINAMICS converter for examples of typical applications and requirements.

- The application type is selected from the vertical column
 - Pumping, ventilating, compressing
 - Moving
 - Processing
 - Machining
- The quality of the motion type is selected from the horizontal row
 - Basic
 - Medium
 - High

More information

More information about SINAMICS is available on the internet at www.siemens.com/sinamics

Practical application examples and descriptions are available on the internet at www.siemens.com/sinamics-applications

¹⁾ Industry-specific converters.

²⁾ Information on the SIMATIC ET 200pro FC-2 frequency converter is available in Catalog D 31.2 and at www.siemens.com/et200pro-fc

Overview

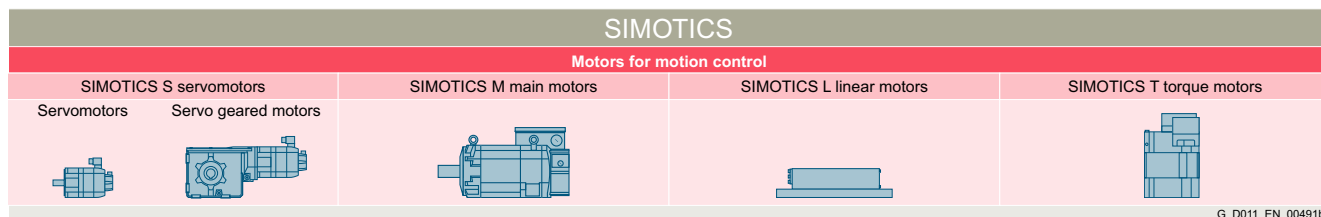
**SIMOTICS stands for**

- 150 years of experience in building electric motors
- The most comprehensive range of motors worldwide
- Optimum solutions in all industries, regions and power/performance classes
- Innovative motor technologies of the highest quality and reliability
- Highest dynamic performance, precision and efficiency together with the optimum degree of compactness
- Our motors can be integrated into the drive train as part of the overall system
- A global network of skill sets and worldwide service around the clock

A clearly structured portfolio

The entire SIMOTICS product portfolio is transparently organized according to application-specific criteria in order to help users select the optimum motor for their application.

The product range extends from standard motors for pumps, fans and compressors to highly dynamic, precise motion control motors for positioning tasks and motion control in handling applications, as well as production machinery and machine tools, to DC motors and powerful high-voltage motors. Whatever it is that you want to move – we can supply the right motor for the task.

www.siemens.com/simotics

An outstanding performance for any job

A key characteristic of all SIMOTICS motors is their quality. They are robust, reliable, dynamic and precise to assure the requisite performance level for any process and deliver exactly the capabilities demanded by the application in hand. Thanks to their compact design, they can be integrated as space-saving units into installations. Furthermore, their impressive energy efficiency makes them effective as a means of reducing operating costs and protecting the environment.

A dense network of skill sets and servicing expertise around the world

SIMOTICS offers not only a wealth of sound experience gleaned from a development history which stretches back over around 150 years, but also the know-how of hundreds of engineers. This knowledge and our worldwide presence form the basis for a unique proximity to industries which feeds through in tangible terms to the specific motor configuration which is tailored to suit your application.

Our specialists are available to answer all your queries regarding any aspect of motor technology. At any time – wherever you are in the world. When you choose SIMOTICS, therefore, you reap the benefits of a global service network which is continuously accessible, thereby helping to optimize response times and minimize downtimes.

Perfection of the complete drive train

SIMOTICS is perfectly coordinated with other Siemens product families. In combination with the SINAMICS integrated converter family and the SIRIUS complete portfolio of industrial controls, SIMOTICS fits seamlessly as part of the complete drive train into automation solutions which are based on the SIMATIC, SIMOTION and SINUMERIK control systems.

System overview

SINAMICS G130 / SINAMICS G150

1

SINAMICS G130 / SINAMICS G150

Overview



SINAMICS G130 converter built-in unit and SINAMICS G150 converter cabinet unit

SINAMICS G130 converter built-in units and SINAMICS G150 converter cabinet units are designed for variable-speed drives in mechanical engineering and plant construction.

They have been specially designed to meet the requirements of drives with square-wave and constant load characteristics, with medium performance requirements, and without regenerative feedback capability.

The control accuracy of the sensorless vector control is suitable for most applications, which means that an additional actual speed value encoder is not required.

However, SINAMICS G130/SINAMICS G150 converters are optionally available with an encoder evaluation function in order to handle applications that require an encoder for system-specific reasons.

SINAMICS G130 and SINAMICS G150 offer an economic drive solution that can be matched to customers' specific requirements using the wide range of available components and options.

Benefits

- Particularly quiet and compact converters due to the use of state-of-the-art IGBT power semiconductors and an innovative cooling concept.
- All device modules are easily accessible, making them extremely service-friendly.
- Can be easily integrated into automation solutions using a PROFIBUS or PROFINET interface and various analog and digital interfaces.
- Individual modules and power components can be replaced quickly and easily, which ensures a higher level of plant availability.
- Simple commissioning and parameterization using interactive menus on the AOP30 Advanced Operator Panel with graphic LCD and plain-text display.

Application

Variable-speed drives are ideal for all applications that involve moving, conveying, pumping or compressing solids, liquids or gases.

Key applications include:

- Pumps and fans
- Compressors
- Extruders and mixers
- Mills

Design

SINAMICS G130

The SINAMICS G130 provides machine builders and plant constructors with a modular drive system that can be tailored to specific applications.

SINAMICS G130 essentially consists of two modular, stand-alone components

- Power Module and
- Control Unit

They may be located separately from one another or combined in a single unit. The Power Module contains a slot for the Control Unit.

The AOP30 Advanced Operator Panel can be used for commissioning and local operation.

Predefined interfaces, via terminal block or the CU320-2 Control Unit with either PROFIBUS or PROFINET, make commissioning and control of the drive much easier. The Control Unit interfaces can be expanded with add-on modules.

SINAMICS G150

SINAMICS G150 is a ready-to-connect AC/AC converter in a standard control cabinet.

It can be adapted to individual requirements by selecting from an extensive range of options.

It is available in widths from 400 mm, which then increase in intervals of 200 mm, and can be ordered with various degrees of protection up to IP54 in two design versions.

• **Version A**

offers sufficient space for all the options available.

The different versions allow the line and motor connections to be arranged at the top or bottom, as required. This results in excellent flexibility in terms of location in the plant. This version is also available with power units connected in parallel.

• **Version C**

is a particularly space-saving version designed for applications where the power supply components are accommodated in a central low-voltage distribution unit and need not be provided again in the control cabinet.

The AOP30 Advanced Operator Panel is fitted as standard in the cabinet door for both versions.

Integration

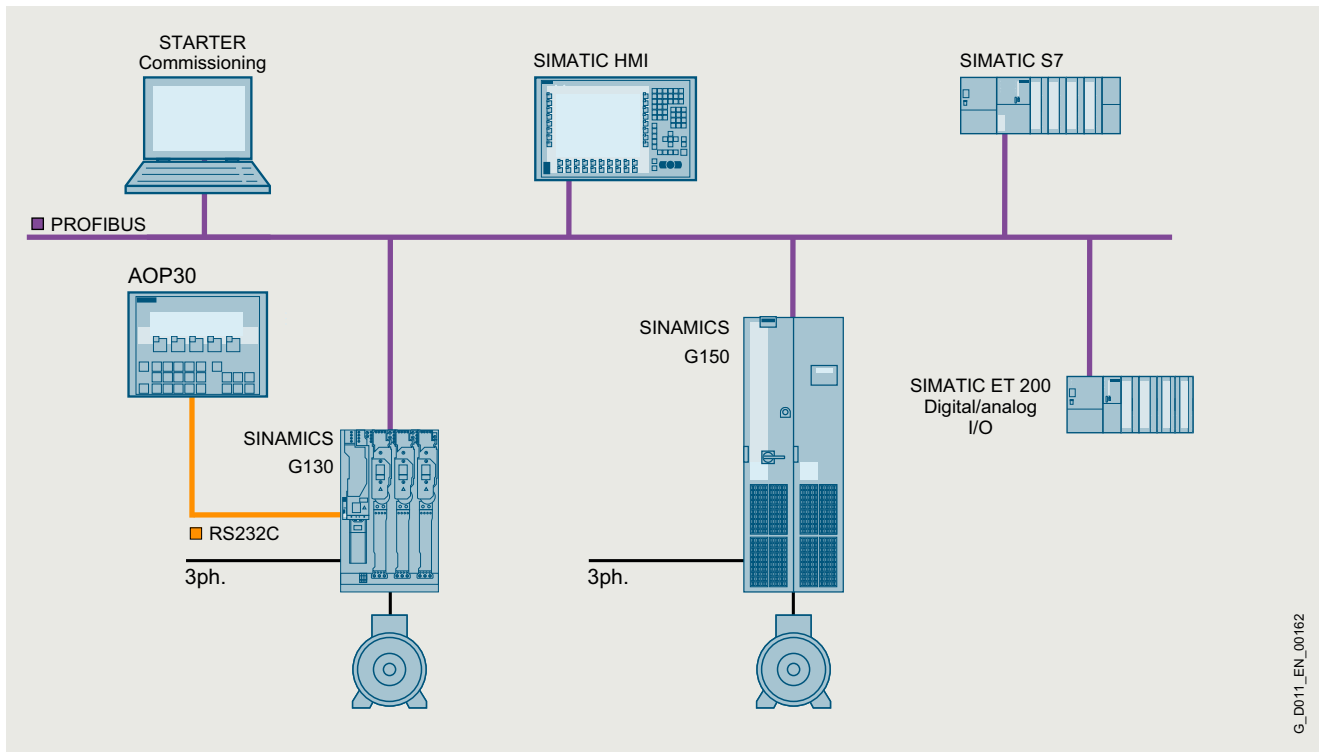

SINAMICS G130 and SINAMICS G150 configuration example with SIMATIC S7

System overview

Notes

1

Highlights



2/2	Safety Integrated
2/2	Overview
2/3	Function
2/14	Safety Integrated for SINAMICS G130 and SINAMICS G150
2/14	Overview
2/15	Function
2/16	Energy efficiency classes according to IEC 61800-9-2
2/16	Overview
2/19	Communication
2/19	Overview
2/20	PROFIBUS
2/21	PROFINET
2/24	Industrial Ethernet
2/25	PROFIdrive
2/26	EtherNet/IP
2/26	Modbus TCP

Highlights

Safety Integrated

Overview



Legal framework

Machine manufacturers and plant construction companies must ensure that their machines or plants cannot cause danger due to malfunctions in addition to the general risks of electric shock, heat or radiation.

In Europe, for example, compliance with the Machinery Directive 2006/42/EC is legally stipulated by the EU framework directive for occupational safety. In order to ensure compliance with this directive, it is recommended that the corresponding harmonized European standards are applied. This triggers the "assumption of conformity" and gives manufacturers and operators the legal security in terms of compliance with both national regulations and EU directives. The machine manufacturer uses the CE marking to document compliance with all relevant directives and regulations in the free movement of goods.

Safety-related standards

Functional safety is specified in various standards. For example, EN ISO 12100 specifies standards pertaining to machine safety (risk assessment and risk reduction). IEC 61508 specifies basic requirements for electronic and programmable safety-related systems. EN 62061 (only applicable for electrical and electronic control systems) and EN ISO 13849-1 define the functional and safety-related requirements of safety-oriented control systems.

The above-mentioned standards define different safety requirements that the machine has to satisfy in accordance with the risk, frequency of a dangerous situation, probability of occurrence and the opportunities for recognizing impending danger.

- EN ISO 13849-1: Performance Level PL a ... e; Category B, 1 ... 4
- EN 62061: Safety Integrity Level SIL 1 ... 3

Trend toward integrated safety systems

The trend toward greater complexity and higher modularity of machines has seen a shift in safety functions away from the classical central safety functions (for example, shutdown of the complete machine using a main disconnecting means) and into the machine control system and the drives. This is often accompanied by a significant increase in productivity because the setup times are shortened. Depending on the type of machine, it may even be possible to continue manufacturing other parts while the setup is in progress.

Safety Integrated Functions act much faster than those of a conventional design. The safety of a machine is increased further with Safety Integrated. Furthermore, thanks to the faster method of operation, safety measures controlled by integrated safety systems are perceived as less of a hindrance by the machine operator, therefore significantly reducing the motivation to consciously bypass safety functions.

Function

Safety functions integrated in SINAMICS drives

SINAMICS drives are characterized by a large number of Safety Integrated Functions. In combination with the sensors and safety control required for the safety functionality, they ensure that highly-effective protection for persons and machines is implemented in a practice-oriented manner.

They comply with the requirements of the following safety categories:

- PL d and Category 3 according to EN ISO 13849-1
- SIL 2 according to IEC 61508 and IEC 61800-5-2

The Safety Integrated functions of SINAMICS drives are certified by independent institutions. You can obtain the corresponding test certificates and manufacturer's declarations from your Siemens contacts.

Note:

The Safe Brake Test (SBT) diagnostic function meets the requirements for Category 2 according to EN ISO 13849-1. The PM240-2 Power Modules, frame sizes FSD to FSG additionally offer STO acc. to IEC 61508 SIL 3 and EN ISO 13489-1 PL e and Category 3.

The Safety Integrated functions are generally certified by independent institutes. You can obtain the corresponding test certificates and manufacturer's declarations from your Siemens contacts.

The Safety Integrated Functions that are currently available are described below. Their functional safety satisfies the requirements defined in the international standard IEC 61800-5-2 for variable-speed drive systems.

The safety functions integrated into the SINAMICS drive system can be roughly divided into four categories:

- **Functions for safely stopping a drive**
 - Safe Torque Off (STO)
 - Safe Stop 1 (SS1)
 - Safe Stop 2 (SS2)
 - Safe Operating Stop (SOS)
- **Functions for safe brake management**
 - Safe Brake Control (SBC)
 - Safe Brake Test (SBT) (this diagnostic function exceeds the scope of IEC 61800-5-2)
- **Functions for safely monitoring the motion of a drive**
 - Safely-Limited Speed (SLS)
 - Safe Speed Monitor (SSM)
 - Safe Direction (SDI)
 - Safely-Limited Acceleration (SLA)
- **Functions for safely monitoring the position of a drive**
 - Safely-Limited Position (SLP)
 - Safe Position (SP) (this function exceeds the scope of IEC 61800-5-2)
 - Safe Cam (SCA)

Safe Torque Off (STO)

The STO function is the most common and basic drive-integrated safety function. It ensures that no torque-generating energy can continue to affect a motor and prevents unintentional start-ups.

Effect

This function is a mechanism that prevents the drive from restarting unexpectedly, in accordance with EN 60204-1, Section 5.4. The STO function suppresses the drive pulses (corresponds to Stop Category 0 according to EN 60204-1). The drive is reliably torque-free. This state is monitored internally in the drive.

Application

STO has the immediate effect that the drive cannot supply any torque-generating energy. STO can be used wherever the drive will naturally reach a standstill due to load torque or friction in a sufficiently short time or when "coasting down" of the drive will not have any relevance for safety.

STO makes it possible for persons to work safely when the protective door is open (restart interlock) and is used on machines/installations with moving axes, e.g. on handling or conveyor systems.

Customer benefits

Some of the advantages of the Safety Integrated Function STO over conventional safety technology with electromechanical switchgear include the elimination of separate components as well as of the work that would be required to wire and service them, i.e. no wearing parts as a result of the electronic shutdown. Because of the fast electronic switching times, the function provides a shorter reaction time than the conventional solution comprising electromechanical components. When STO is triggered, the converter remains connected to the network and can be fully diagnosed.

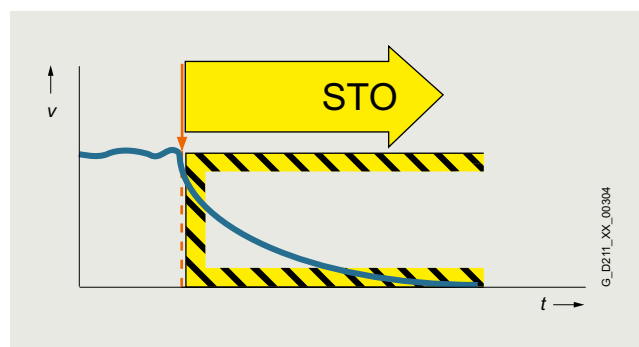

Highlights

Safety Integrated

Function

Safe Stop 1 (SS1)

The SS1 function causes a motor to stop rapidly and safely and switches the motor to torque-free mode after coming to a standstill by activating STO.

Effect

The SS1 function can safely stop the drive in accordance with EN 60204-1, Stop Category 1. When the SS1 function is selected, the drive brakes autonomously along a quick-stop ramp and automatically activates the Safe Torque Off and Safe Brake Control functions (if configured) when the parameterized safety delay time expires.

If the variant "SS1 with external stop (SS1E)" is parameterized, the drive does not brake autonomously when the function is selected. In this case, the higher-level control must bring the drive to a standstill within a parameterized STO transition time. The SBR (Safe Brake Ramp) and SAM (Safe Acceleration Monitor) functions are not active. SS1E is a useful function for drives that need to be stopped as a group by the Motion Control system in order to prevent potential damage to the machine or product.

Application

The SS1 function is used when, in the event of a safety-relevant incident, the drive must stop as quickly as possible with a subsequent transition into the STO state (e.g. EMERGENCY STOP). It is thus used to bring large centrifugal masses to a stop as quickly as possible for the safety of the operating personnel, or to brake motors at high speeds as quickly as possible. Examples of typical applications are saws, grinding machine spindles, centrifuges, winders and storage and retrieval machines.

Customer benefits

The targeted stopping of a drive by means of SS1 reduces the risk of danger, increases the productivity of a machine, and allows the safety clearances in a machine to be reduced. The principle is to bring the drive actively to a standstill, compared with just using the STO function. Complex mechanical brakes that are susceptible to wear are normally not required to brake the motor.

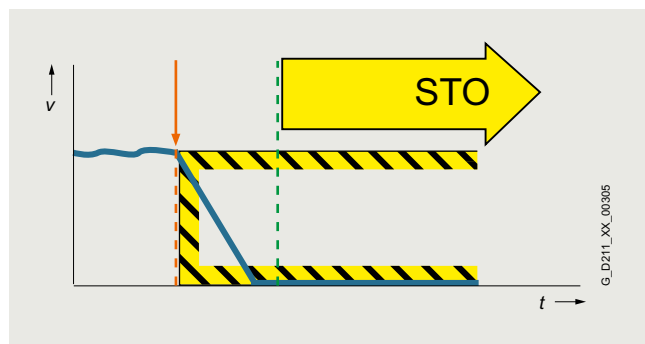

Safe Stop 2 (SS2)

The SS2 function brings the motor to a standstill quickly and safely and then activates the SOS function once the motor has stopped.

Effect

The Safe Stop 2 function can safely stop the drive in accordance with EN 60204-1, Stop Category 2. When the SS2 function is selected, the drive brakes autonomously along a quick stop ramp. In contrast to SS1, the drive control remains operational afterwards, i.e. the motor can supply the full torque required to maintain zero speed. Standstill is safely monitored (Safe Operating Stop function).

If the variant "SS2 with external stop (SS2E)" is parameterized, the drive does not brake autonomously when the function is selected. In this case, the higher-level control must bring the drive to a standstill within a parameterized Safe Operating Stop transition time. The SBR (Safe Brake Ramp) and SAM (Safe Acceleration Monitor) functions are not active. SS2E is a useful function for drives that need to be stopped as a group by the Motion Control system in order to prevent potential damage to the machine or product.

Application

As with SS1, the SS2 function ensures the quickest possible deceleration of the motor. However, the motor power is not switched off. Instead, a control system prevents it from leaving the standstill position – even if it is affected by external forces. Typical applications for SS2 include machine tools, for example.

Customer benefits

The SS2 function ensures a rapid axis stop. Because the control remains active, after the safety function is deselected, productive operation can continue without referencing. This ensures short setup and standstill times and high productivity.

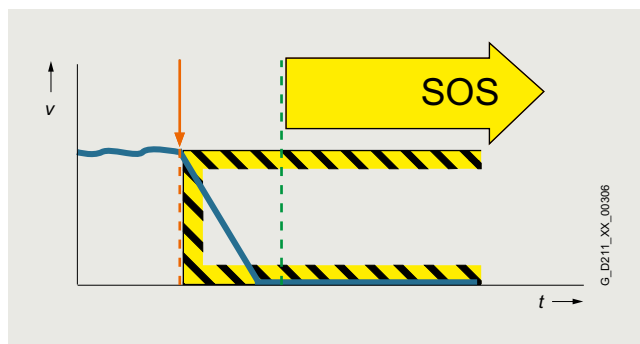

Function**Safe Operating Stop (SOS)**

With the SOS function, the stopped motor is held in position by the drive control system and its position is monitored.

Effect

The SOS function constitutes safe standstill monitoring. The drive control remains in operation. The motor can therefore deliver the full torque to hold the current position. The actual position is reliably monitored. In contrast to safety functions SS1 and SS2, the speed setpoint is not influenced autonomously. After SOS has been activated, the higher-level control must bring the drive to a standstill within a parameterized time and then hold the position setpoint.

Application

SOS is an ideal solution for all those applications for which the machine or parts of the machine must be at a safe standstill for certain steps, but the drive must also supply a holding torque. It is ensured that despite counter torque the drive remains in its current position. In contrast to SS1 and SS2, the drive does not brake autonomously in this case. It expects the higher-level controller to ramp down the relevant axes as a coordinated group within an adjustable delay time. This can be used to prevent any damage to the machine or product. Typical applications for SOS include winders, converting and packaging machines and machine tools.

Customer benefits

No mechanical components are necessary to keep the axis in position despite any counterforce that may occur. Due to the short switching times and the fact that the drive control always remains active, setup and downtimes are reduced. Recalibration of the axis after exiting the SOS function is not necessary. The axis can immediately be moved again after deactivation of the SOS function.

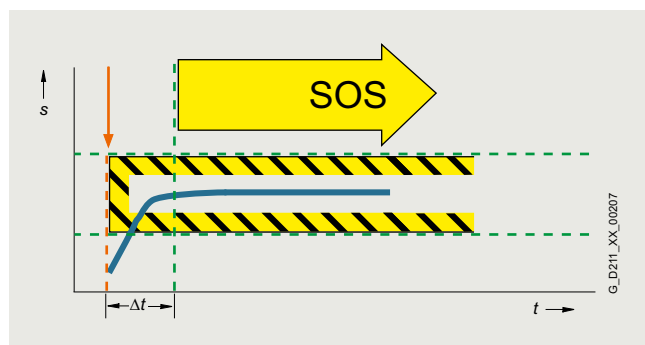
**Safe Brake Control (SBC)**

The SBC function permits the safe control of a holding brake. SBC is always activated in parallel with STO.

Effect

A holding brake which is active in a de-energized state is controlled and monitored using safe two-channel technology. Due to the two-channel control, the brake may still be activated in the event of an insulation fault in the control cable. Errors of this kind are detected early by means of test pulses.

Note:

Safe Brake Control does not detect mechanical faults in the brake itself, such as worn brake linings. For Motor Modules in booksize format, the terminals for the motor brake are integrated. An additional Safe Brake Relay is required for Power Modules in blocksize format. An additional Safe Brake Adapter is necessary for Power Modules in chassis format.

Application

The SBC function is used in conjunction with the functions STO or SS1 to prevent the movement of an axis in the torque-free state, e.g. because of gravity.

Customer benefits

Again, the function saves the use of external hardware and the associated wiring.

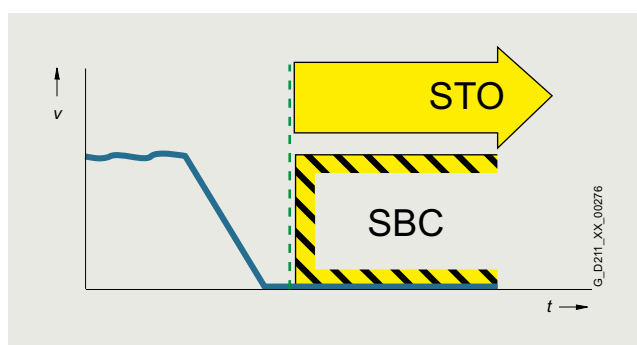

Highlights

Safety Integrated

Function

Safe Brake Test (SBT)

The SBT diagnostic function carries out a brake function test at regular intervals or before personnel enter the danger zone.

Effect

A good way to check the proper functioning of brakes that have become worn is to apply a torque to the closed brake. Drive systems that have two brakes, e.g. motor brake and external brake, can be tested with different torque values.

Application

The SBT diagnostic function is suitable for implementing a safe brake in combination with the SBC function.

Customer benefits

The function detects faults or wear in the brake mechanics. Automatically testing the effectiveness of brakes reduces maintenance costs and increases the safety and availability of the machine or plant.

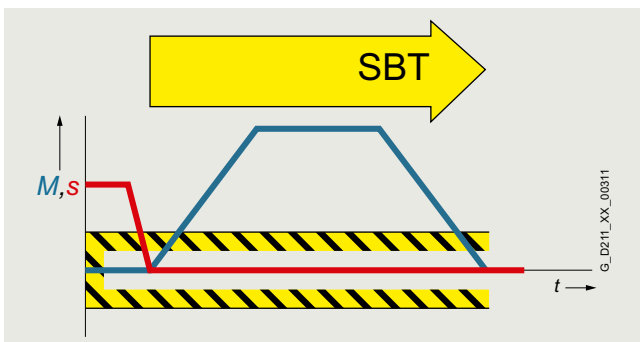

Safely-Limited Speed (SLS)

The SLS function monitors the drive to ensure that it does not exceed a preset speed or velocity limit.

Effect

The SLS function monitors the drive against a parameterized speed limit. Four different limit values can be selected. As in the case of SOS, the speed setpoint is not influenced independently. After SLS has been selected, the higher-level control must bring the drive down below the selected speed limit within a parameterizable time. If the speed limit is exceeded, a customizable drive-integrated fault reaction occurs.

The SLS limit stage 1 can be multiplied by a factor that is transferred in 16-bit resolution via PROFIsafe. This allows an almost unlimited number of limits to be specified.

Application

The SLS function is used if people are in the danger zone of a machine and their safety can only be guaranteed by reduced speed. Typical application cases include those in which an operator must enter the danger zone of the machine for the purposes of maintenance or setting up, such as a winder in which the material is manually threaded by the operator. To prevent injury to the operator, the roller may only spin at a safely reduced speed. SLS is often also used as part of a two-stage safety concept. While a person is in a less critical zone, the SLS function is activated, and the drives are only stopped safely in a smaller area with higher potential risk. SLS can be used not only for operator protection, but also for machinery protection, e.g. if a maximum speed must not be exceeded.

Customer benefits

The SLS function can contribute to a significant reduction in downtime, or greatly simplify or even accelerate setup. The overall effect achieved is a higher availability of the machine. Moreover, external components such as speed monitors can be omitted.

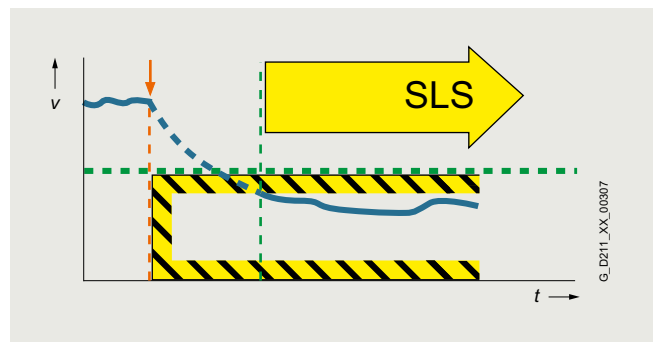

Function

Safe Speed Monitor (SSM)

The SSM function warns when a drive is working below an adjustable speed limit. As long as it remains below the threshold, the function issues a safety-related signal.

Effect

If a speed value drops below a parameterized limit, a safety-related signal is generated. This can, for example, be processed in a safety control unit to respond to the event by programming, depending on the situation.

Application

With the SSM function, in the simplest case, a safety door can be unlocked if the speed drops below a non-critical level. Another typical example is that of a centrifuge that may be filled only when it is operating below a configured speed limit.

Customer benefits

Unlike SLS, there is no drive-integrated fault reaction when the speed limit is exceeded. The safe feedback can be evaluated in a safety control unit, allowing the user to respond appropriately to the situation.

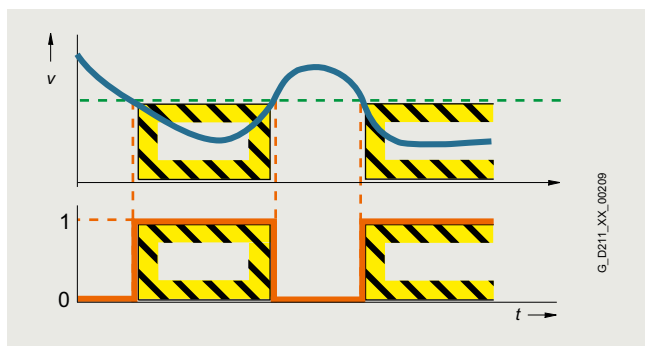

Safe Direction (SDI)

The SDI function ensures that the drive can only move in the selected direction.

Effect

Deviation from the direction of motion currently being monitored is detected reliably and the configured drive-integrated fault reaction is initiated. It is possible to select which direction of rotation is to be monitored.

Application

The SDI function is used when the drive may only move in one direction. A typical application is to permit the operator access to a danger zone, as long as the machine is rotating in the safe direction, i.e. away from the operator. In this state, the operator can feed material into the work zone or remove material from the work zone without danger.

Customer benefits

The function saves the use of external components such as speed monitors and the associated wiring. The release of a danger zone while the machine is moving away from the operator increases productivity. Without the SDI function, the machine must be safely stopped during material loading and removal.

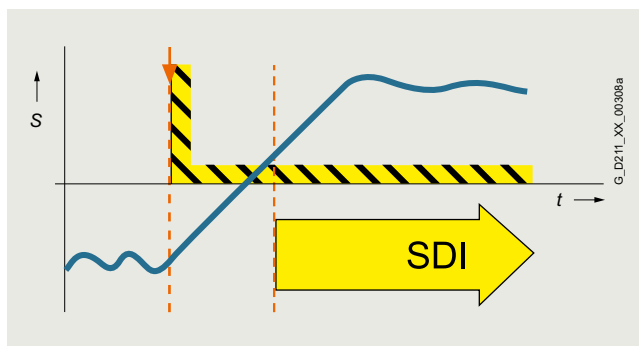

Highlights

Safety Integrated

Function

Safely-Limited Acceleration (SLA)

The SLA function monitors that the drive does not exceed a preset acceleration limit value.

Effect

The SLA function monitors that the motor does not violate the defined acceleration limit (e.g. in setup mode). SLA detects early on whether the speed is increasing at an inadmissible rate (the drive accelerates uncontrollably) and initiates the stop response.

Application

The SLA function is used, e.g., for SIMATIC Safe Kinematics. SLA can only be used in safety systems with an encoder.

Customer benefits

The function monitors for maximum permissible acceleration in setup mode and safe monitoring of the tool center point with different kinematics.

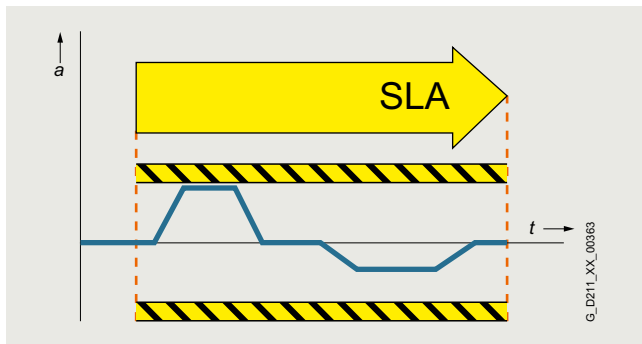

Safely-Limited Position (SLP)

The SLP function monitors the axis to ensure that it remains within the permissible traversing range.

Effect

When SLP is activated, the traversing range limited by the configured software limit switches is safely monitored. If the permitted traversing range is exited, a configurable fault reaction occurs. It is possible to toggle between two traversing ranges, even when the machine is in operation.

Application

SLP is used for applications in which machine operators have to enter a protection area, e.g. for feeding in and removing material. Safe monitoring of the axis position ensures that the axis cannot move into the protection area released for operators and so place them in danger, for example, on storage and retrieval machines, gantry cranes or machining centers.

Customer benefits

SLP can be used for highly-effective protection area monitoring. The function does away with the use of external components such as hardware limit switches and the associated wiring expense. Due to the short reaction time following a limit overshoot, safety clearances can be reduced.

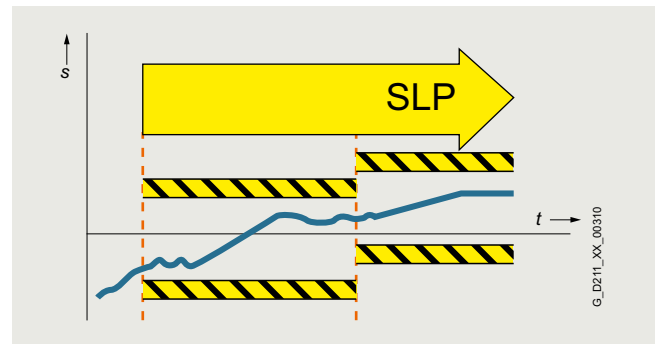

Function

Safe Position (SP)

The SP function transfers the actual position values determined safely in the drive over safe PROFIsafe communication to a safety control.

Effect

In contrast to the SLP function that monitors the current actual position value against a limit and, in the case of an overshoot, activates a drive-integrated fault reaction, SP transfers the current actual position values to the safety control. Position monitoring is implemented in the safety program of the control. Extended PROFIsafe telegrams are available for transferring the position values. The position values can be transferred in 16-bit or 32-bit resolution, as required. A time stamp is also transferred with the position values.

Application

Tailor-made safety concepts can be created using the SP function. It is ideal for use on machines that require flexible safety functions. It is extremely versatile and can be used, for example, to implement safe, axis-specific range detection by means of safe cams. The SP function can also be used to implement multi-axis safety concepts, multi-dimensional protection areas and zone concepts.

Customer benefits

Position monitoring or speed monitoring is implemented in the safety program of the control, so the user has the flexibility for implementing tailor-made safety functions. The reaction to a limit overshoot must also be specified in the safety program. This means a higher initial programming outlay, but it does offer the opportunity for initiating different fault reactions depending on the situation.

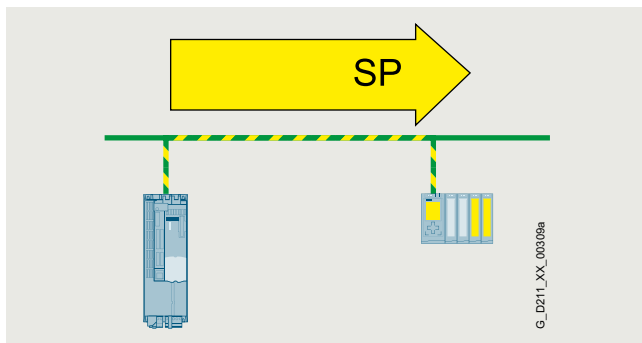

Safe Cam (SCA)

The SCA function enables safety-related monitoring of the position.

Effect

The SCA function outputs a safe signal if the drive is within a specified position range. It facilitates the realization of safe axis-specific range detection. Up to 30 safe cams can be parameterized per axis.

Application

It is only permissible that a protective door is opened if a drive is in a certain position range. The drive may only be traversed with reduced speed when it is located in a certain position range.

Customer benefits

The function enables safety-related switchover of safety functions. With SCA, safe electronic cam controllers can be implemented without additional hardware. With SCA, work and protection zone delimitations are reliably detected.

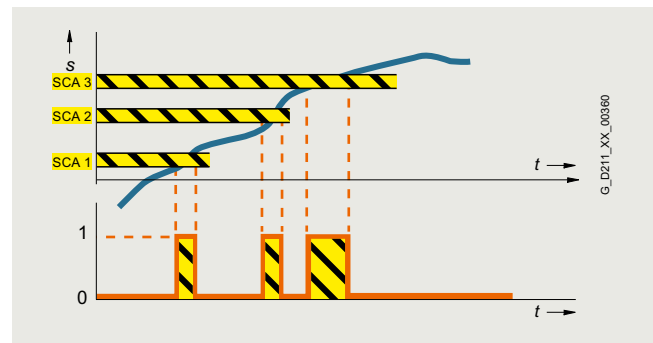

Highlights

Safety Integrated

Function

Basic Functions, Extended Functions, and Advanced Functions

With SINAMICS G converters, the safety functions are basically implemented without encoders.

With SINAMICS S drives, the safety functions are implemented with encoders – individual safety functions can also be operated without encoders.

The Safety Integrated Functions are grouped into Basic Functions, Extended Functions, and Advanced Functions.

The Basic Functions are included in the standard scope of supply.

The Extended Functions must be activated by a license. The Advanced Functions for SINAMICS S120 must also be activated via a license.

The electronic Certificate of License is the paperless delivery form for runtime options for SINAMICS and contains information about the type of rights of use purchased for the software.

- Basic Functions
 - Safe Torque Off (STO)
 - Safe Brake Control (SBC)
 - Safe Stop 1 (SS1)
- Extended Functions
 - Safe Stop 1 with external stop (SS1E)
 - Safe Stop 1 (SS1) with SBR or SAM
 - Safe Stop 2 with external stop (SS2E)
 - Safe Stop 2 (SS2) with SBR or SAM
 - Safe Operating Stop (SOS)
 - Safely-Limited Speed (SLS)
 - Safe Speed Monitor (SSM)
 - Safe Direction (SDI)
 - Safely-Limited Acceleration (SLA)
 - Safe Brake Test (SBT) diagnostic function
- Advanced Functions
 - Safely-Limited Position (SLP)
 - Safe Position (SP)
 - Safe Cam (SCA)

The license for Safety Integrated Advanced Functions also includes the license for Safety Integrated Extended Functions.

For the Extended Functions SS1 and SS2 with SAM, Safe Acceleration Monitor (SAM) is performed during braking to identify any faults already during the braking phase.

With SS1 and SS2, a Safe Brake Ramp (SBR) can be configured as an alternative.

The Basic Functions – activated via on-board terminals on the device, TM54F Terminal Module (only for SINAMICS S) or via PROFIsafe – do not require an encoder.

Activation of the Safety Integrated Functions

The safety functions for SINAMICS drives can be activated via terminals, e.g. for use of a conventional safety circuit.

For standalone safety solutions for small to medium-sized applications, it is frequently sufficient that the various sensing components are directly hardwired to the drive.

For integrated safety solutions, the safety-relevant sequences are generally processed and coordinated in the fail-safe SIMATIC controller. Here, the system components communicate via the PROFINET or PROFIBUS fieldbus. The safety functions are controlled via the safe PROFIsafe communication protocol.

SINAMICS drives can be easily integrated into the plant or system topology.

PROFIsafe

SINAMICS drives support the PROFIsafe profile based on PROFINET as well as on PROFIBUS.

PROFIsafe is an open communications standard that supports standard and safety-related communication over the same communication path (wired or wireless). A second, separate bus system is therefore not necessary. The telegrams that are sent are continually monitored to ensure safety-relevant communication.

Possible errors such as telegrams that have been lost, repeated or received in the incorrect sequence are avoided. This is done by consecutively numbering the telegrams in a safety-relevant fashion, monitoring their reception within a defined time and transferring an ID for transmitter and receiver of a telegram. A CRC (cyclic redundancy check) data security mechanism is also used.

The operating principle of Safety Integrated

Two independent switch-off signal paths

Two independent switch-off signal paths are available. All switch-off signal paths are low active. This ensures that the system is always switched to a safe state if a component fails or in the event of cable breakage. If a fault is discovered in the switch-off signal paths, the STO or SS1 function (depending on parameter settings) is activated and a system restart inhibited.

Two-channel monitoring structure

All the main hardware and software functions for Safety Integrated are implemented in two independent monitoring channels (e.g. switch-off signal paths, data management, data comparison). A cyclic crosswise comparison of the safety-relevant data in the two monitoring channels is carried out.

The monitoring functions in each monitoring channel work on the principle that a defined state must prevail before each action is carried out and a specific acknowledgement must be made after each action. If these expectations of a monitoring channel are not fulfilled, the drive coasts to a standstill (two channel) and an appropriate message is output.

Forced dormant error detection using test stop

The functions and switch-off signal paths must be tested at least once within a defined time in order to meet requirements as per EN ISO 13849-1 and IEC 61508 in terms of timely fault detection. This must be implemented either in cyclic manual mode or the test stop must be automatically initiated as part of the process. The test stop cycle is monitored, and after a specific time has been exceeded, an alarm is output. A test stop does not require a POWER ON. The acknowledgment is set by canceling the test stop request.

Examples of when forced dormant error detection must be performed:

- When the drives are at a standstill after the system has been switched on
- Before the protective door is opened
- At defined intervals (e.g. every 8 hours)
- In automatic mode, time and event-driven

Function

Safe speed/position sensing without/with encoder

Safe actual value sensing without encoder

A drive monitor with encoder is necessary for operation of a series of safety functions.

For applications with encoderless mode or with encoders that have no safety capability, the safety functions can also be implemented without encoder. It is not possible to use all safety functions in this case.

For devices in Chassis format, encoderless safety functions can only be implemented when certain boundary conditions apply (see [SINAMICS S120 Safety Integrated](#) and [SINAMICS G130, G150, S120 Chassis, S120 Cabinet Modules, S150; Safety Integrated Function Manuals](#)).

In operation without encoder, the actual speed values are calculated from the measured electrical actual values. This means that speed monitoring is also possible during operation without an encoder.

Safety Integrated Extended Functions "without encoder" must **not** be used if the motor, after it has been switched off, can still be accelerated by the mechanical elements of the connected machine component.

Safe actual value sensing with encoder

Incremental encoders or absolute encoders can be used for safe sensing of the position values on a drive.

Safe actual value sensing relies on redundant evaluation of the incremental tracks A/B that supply sin/cos signals of $1 V_{pp}$. Only encoders of the type whose A/B track signals are created and processed using purely analog techniques can be used.

HTL/TTL incremental encoders may also be used. In this case, safe actual value sensing is achieved by using two independent encoders. The minimum possible speed resolution must also be taken into account. The encoder signals are input via the Sensor Module Cabinet-Mounted SMC30 (for cabinet options **K50, K52**).

The encoder signals are input via Sensor Modules.

As an alternative, motors with an integrated DRIVE-CLiQ interface can be used. The speed or position actual values are generated directly in the motor as safe values and are transferred to the Control Unit over safe communication via DRIVE-CLiQ.

Certified built-on rotary encoders with DRIVE-CLiQ interface may also be used (see <https://support.industry.siemens.com/cs/document/65402168>).

The encoder must be mechanically attached in such a manner that the encoder shaft is unable to unplug or slide off. For notes on this, see IEC 61800-5-2: 2016, Table D.16.

A list of Siemens motors that fulfill the electrical and mechanical requirements is available at: <https://support.industry.siemens.com/cs/document/33512621>

The following can be used for safe speed/position sensing:

- Single-encoder systems or
- Dual-encoder systems

Single-encoder system

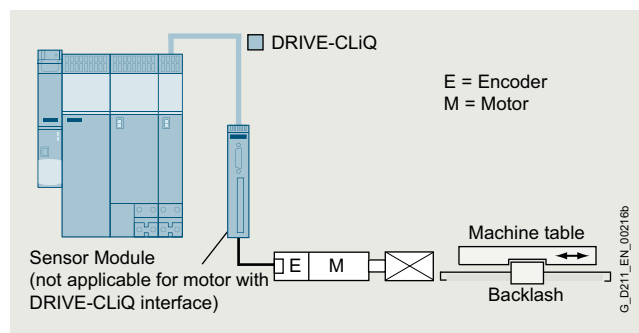

Example: Single-encoder system

In a single-encoder system, the motor encoder is used exclusively for safe actual value sensing.

Dual-encoder system

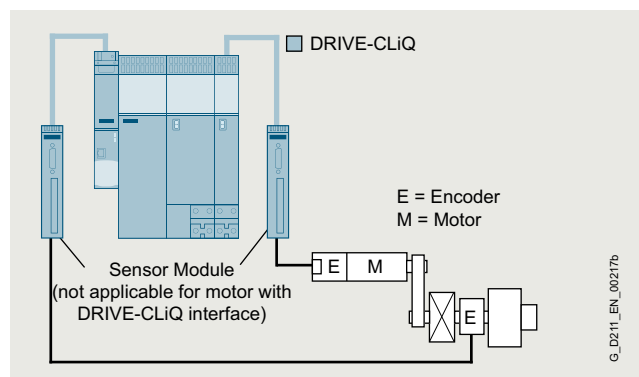

Example: Dual-encoder system

In the case of the dual-encoder system, the safe actual values for a drive are provided by two separate encoders. The actual values are transferred to the Control Unit over DRIVE-CLiQ. When motors without a DRIVE-CLiQ connection are used, a Sensor Module must be provided.

HTL/TTL incremental encoders can be used as an alternative with a dual-encoder system. Either two HTL/TTL encoders, one dual-HTL/TTL encoder or one HTL/TTL encoder and one sin/cos encoder can be used.

Highlights

Safety Integrated

Function

The safety functions are listed below with criteria for actual value sensing:

	Functions	Abbreviation	With encoder	Without encoder	Description
Basic Functions	Safe Torque Off	STO	Yes	Yes	Safe Torque Off
	Safe Stop 1	SS1	Yes	Yes ¹⁾	Safe stopping process in accordance with stop category 1
	Safe Brake Control	SBC	Yes	Yes	Safe Brake Control
Extended Functions	Safe Torque Off	STO	Yes	Yes	Safe Torque Off
	Safe Stop 1	SS1	Yes	Yes ¹⁾	Safe stopping process in accordance with stop category 1
	Safe Brake Control	SBC	Yes	Yes	Safe Brake Control
	Safe Operating Stop	SOS	Yes	No	Safe monitoring of the standstill position
	Safe Stop 2	SS2	Yes	No	Safe stopping process in accordance with stop category 2
	Safely-Limited Speed	SLS	Yes	Yes ¹⁾	Safe monitoring of the maximum speed
	Safe Speed Monitor	SSM	Yes	Yes ¹⁾	Safe monitoring of the minimum speed
	Safe Direction	SDI	Yes	Yes ¹⁾	Safe monitoring of the direction of motion
	Safely-Limited Acceleration	SLA	Yes	No	Safely-Limited Acceleration
	Safe Brake Test	SBT	Yes	No	Diagnostic function for safe testing of the required holding torque of a brake
Advanced Functions	Safely-Limited Position	SLP	Yes	No	Safely-Limited Position
	Safe Position	SP	Yes	Yes ²⁾	Safe transfer of position values
	Safe Cam	SCA	Yes	No	Safe cams

¹⁾ The use of this safety function without encoder is permitted with asynchronous (induction) motors, synchronous motors from the SIEMOSYN series, or with SIMOTICS reluctance motors.

²⁾ Only for the transmission of relative position values. An encoder is required to transmit absolute position values.

Integration

The safety functions integrated in SINAMICS drives are listed below.

Safety Integrated	Low voltage Standard Performance frequency converters SINAMICS						Distributed frequency converters SINAMICS		
	V20	G120C	G120		G130 G150	CU320-2	G115D wall and motor-mounted	G120D	CU250D-2
Functions			CU230P-2	CU240E-2	CU250S-2			CU240D-2	CU250D-2
STO	–	✓	–	✓	✓	✓	✓	✓	✓
SS1	–	–	–	✓ ¹⁾	✓	✓	–	✓ ¹⁾	✓ ¹⁾
SS2	–	–	–	–	–	✓ ²⁾	–	–	–
SOS	–	–	–	–	–	✓ ²⁾	–	–	–
SBC	–	–	–	–	✓	✓	–	–	–
SBT	–	–	–	–	–	✓ ²⁾	–	–	–
SLS	–	–	–	✓ ¹⁾	✓ ²⁾	✓ ²⁾	✓ ²⁾	✓ ¹⁾	✓ ¹⁾
SSM	–	–	–	✓ ¹⁾	✓ ²⁾	✓ ²⁾	–	✓ ¹⁾	✓ ¹⁾
SDI	–	–	–	✓ ¹⁾	✓ ²⁾	✓ ²⁾	–	✓ ¹⁾	✓ ¹⁾
SLA	–	–	–	–	–	✓ ²⁾	–	–	–
SLP	–	–	–	–	–	–	–	–	–
SP	–	–	–	–	–	–	–	–	–
SCA	–	–	–	–	–	–	–	–	–
Control									
PROFIsafe	–	✓	–	✓	✓	✓	✓	✓	✓
F-DI	–	✓	–	✓	✓	✓	✓	✓	✓

More information

The Safety Integrated Function Manual contains detailed information about the safety functions
<https://support.industry.siemens.com/cs/document/109781722>

Further manuals pertaining to Safety Integrated in drive systems can be found on the internet at
<https://support.industry.siemens.com/cs/ww/en/ps/13206/man>

More information about Safety Integrated in SINAMICS can be found on the internet at
www.siemens.com/safety-drives

¹⁾ With fail-safe Control Unit.

²⁾ With Safety Extended license.

Highlights

Safety Integrated for SINAMICS G130 and SINAMICS G150

Overview

The safety functions integrated into the drive can greatly reduce the effort required to implement safety concepts.

The Safety Integrated functions are implemented electronically and therefore offer short response times in comparison to solutions with externally implemented monitoring functions.

As an alternative to controlling via terminals and/or PROFIsafe, there is also the option to parameterize several Safety Integrated functions without selection. In this mode, after parameterization and a POWER ON, these functions are permanently selected.

Example

"SLS without selection" can be used, for example, to monitor the maximum velocity to prevent the drive from exceeding a mechanical speed limit. For this purpose, use of the "SLS without selection" function means that an F-DI is not needed.

Safety Integrated with and without encoder

The Safety Integrated Basic Functions STO, SBC and SS1 can be operated without encoder: two safety-capable incremental encoders (HTL or TTL) are required for utilization of the Safety Integrated Extended Functions SLS, SDI and SSM. Each of these is connected to an SMC30 Sensor Module Cabinet (with SINAMICS G150: first SMC30 option **K50**, second SMC30 option **K52**). The minimum possible velocity resolution for an HTL/TTL encoder system must be taken into account.

Further information can be found in the [Safety Integrated Function Manual](#).

Licensing

No license is required for the Basic Functions.

The Extended Functions require one license for each axis with safety functions. It is of no consequence here which Safety Integrated functions are used and how many.

The license for SINAMICS G130 devices can be ordered as option **F01** at the same time as the memory card. An upgrade license for the Control Unit Kit is available.

The license required for SINAMICS G150 can be ordered as option **K01** at the same time.

Safe Brake Adapter

The SBC function requires a Safe Brake Adapter (option **K88** for SINAMICS G150).

The Safe Brake Adapter allows safe control of electro-mechanical motor brakes.

The Safe Brake Adapter controls 230 V AC brakes. The SBC function monitors the control of the brake, however, not its functioning.

The converter controls the connected brake using the motor holding brake function.

External surge suppressors are not required. The cable harnesses for connection to the Power Module are included in the scope of supply.

The brake is controlled in accordance with IEC 61508 SIL 2 and EN ISO 13849-1 PL d and Category 3.

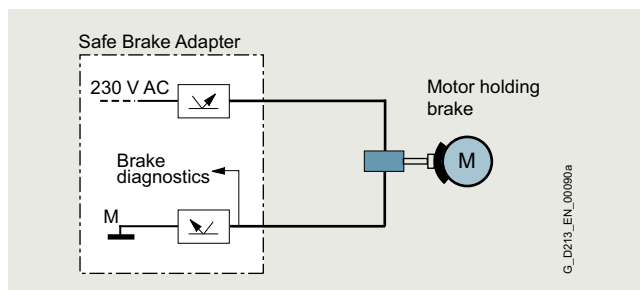

Safe Brake Control (SBC)

G_DZ13_EN_00090a

Safety Integrated for SINAMICS G130 and SINAMICS G150

Function

Function	Control	Underlying function	Reaction to limit overshoot	External setpoint input effective	Encoder required ¹⁾	License required
Basic Functions						
STO	<ul style="list-style-type: none"> • EP terminals on Power Module • Terminal module (option K82) • PROFIsafe 	SBC (if activated)	–	No	No ²⁾	No ³⁾
SBC	<ul style="list-style-type: none"> • Via Safe Brake Adapter 	–	–	–	No	No
SS1	<ul style="list-style-type: none"> • EP terminals on Power Module • Terminal module (option K82) • PROFIsafe 	STO following expiry of the parameterized delay time, SBC (if activated)	STO	Can be parameterized	No	No
Extended Functions						
STO	<ul style="list-style-type: none"> • F-DI on TM54F • PROFIsafe 	SBC (if activated)	–	No	Yes ²⁾	Yes ³⁾
SS1 with SBR/SAM	<ul style="list-style-type: none"> • F-DI on TM54F • PROFIsafe 	Safe Acceleration Monitor (SAM) or Safe Brake Ramp (SBR) during braking. STO and SBC (if activated) following expiry of the parameterized delay time or if the speed falls below the minimum speed limit	STO	Can be parameterized	No	Yes
SS2	<ul style="list-style-type: none"> • F-DI on TM54F • PROFIsafe 	Safe Acceleration Monitor (SAM) or Safe Brake Ramp (SBR) during braking. Following expiry of the parameterized SOS delay time	SS1 → STO	No	Yes	Yes
SLS encoderless	<ul style="list-style-type: none"> • F-DI on TM54F • PROFIsafe • Continuously activated 	–	STO, SS1 (can be parameterized)	Yes	No	Yes
SLS	<ul style="list-style-type: none"> • F-DI on TM54F • PROFIsafe • Continuously activated 	–	STO, SS1 (can be parameterized)	Yes	Yes	Yes
SOS	<ul style="list-style-type: none"> • F-DI on TM54F • PROFIsafe 	–	SS1 → STO	Yes	Yes	Yes
SSM	<ul style="list-style-type: none"> • Always active, if configured 	–	Signals that the speed has fallen below a specified value	Yes	No	Yes
SDI	<ul style="list-style-type: none"> • F-DI on TM54F • PROFIsafe • Continuously activated 	–	STO, SS1 (can be parameterized)	Yes	No	Yes
SLA	<ul style="list-style-type: none"> • F-DI on TM54F • PROFIsafe 	–	STO, SS1, SS2 (can be parameterized)	Yes	Yes	Yes
SBT	<ul style="list-style-type: none"> • F-DI on TM54F • PROFIsafe 	–	Signals test result. Warning if test failed	Yes	Yes	Yes

¹⁾ Encoderless Safety Extended Functions can be implemented only on request.

²⁾ Activation using terminals on the TM54F requires an encoder.

³⁾ Activation using terminals on the TM54F requires a license.

Highlights

Energy efficiency classes according to IEC 61800-9-2

Overview

Step by step to more efficiency

One of the core objectives of the European Union is a sustainable power industry. In industrial plants today, around 70 % of the power demand is from electrically driven systems. This high percentage contains huge potential for saving energy in electrical drives. For that reason, the European Union introduced minimum requirements for the energy efficiency of electric motors in the form of a statutory motor regulation as early as 2011.

These activities are expanded by EU Directive 2019/1781, which deals with more stringent requirements for DOL motors (Direct On Line) and defines the efficiency limits for frequency converters. The directive offers a legal basis for technical content in terms of the efficiency of specific products and services. However, standardization plays a leading role in determining the range and available market technology.

Improving energy efficiency is supported by a systematic selection of the most efficient converter and drive system technologies on the IEC 61800-9 series of standards. Part 1 specifies the methodology to determine the energy efficiency index of an application on the basis of the expanded product approach (EPA) and semi-analytical models (SAMs), whereas part 2 entails indicators for the evaluation of the energy efficiency performance and classification of converters and drive systems.

First of all, the consideration of eight application-relevant operating points is introduced as mandatory, in order to take the different applications into account in a targeted manner. Determination of loss values at these eight points and definition of efficiency classes are laid down by the standard in a uniform way. This enables data relevant to operation, such as application-specific load profiles, to now be taken into account more easily in the energy efficiency analysis.

The standard is especially important for variable-speed drives of the following types:

- for AC/AC converters without energy recovery functionality
- for motors with integrated converters
- for supply voltages of 100 V to 1000 V
- for power ratings of 0.12 kW to 1000 kW

To cover all applications of driven machines, the IEC 61800-9-2 standard defines operating points in full-load and partial-load operation, at which the losses of the motor and drive systems have to be determined. Based on the loss data at the operating points in partial-load operation, variable-speed drives can be explicitly considered in more detail. This makes their advantages especially clear.

Centrifugal pumps, fans

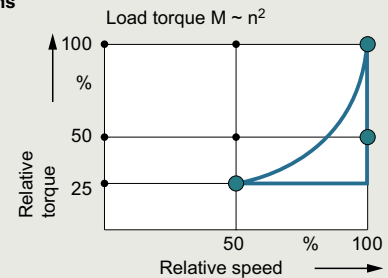

Hoisting gear, extruders, conveyor belts

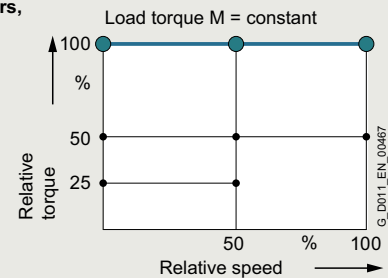

Winders, coilers

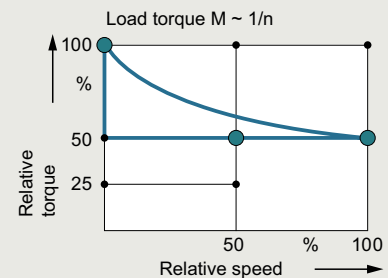

Duty cycles for different driven machines

Moreover, frequency converters and motor systems are classified in efficiency classes, which permit an initial rough estimate of the potential saving. Definition of reference systems is a key aspect of this because they provide standard reference values. The positioning of these reference systems defines the efficiency class. The relative distance from the reference system can be used as an absolute measure of the efficiency at the operating point in question.

Overview

Advantages of the detailed loss consideration of IEC 61800-9-2 over the previous consideration of efficiencies and maximum loss values

For motors, the efficiency consideration was previously only defined for operation without a converter at 50/60 Hz. It provides a good way of comparing the energy efficiency of motors from different manufacturers for this use case.

The more detailed loss analysis of IEC 61800-9-2, on the other hand, is aimed at speed-controlled operation and therefore now also includes motors especially designed for converter operation in the energy analysis. These were previously not covered by the applicable standards.

Moreover, a loss analysis over the entire setting and load range of the motor is possible. This is done in accordance with the standard IEC 61800-9-2 with typical values.

For holistic consideration, it is essential to include all the relevant components of a drive system. The IEC 61800-9-2 standard defines this in detail. The standardized expression of power loss data as a percentage makes comparison considerably easier and more transparent.

The method also makes it possible to consider a motor that produces a holding torque at speed zero, for example. In this case, the efficiency is zero, but a power loss from current producing magnetization and holding torque does occur. In summary, the key advantage of standard IEC 61800-9-2 is the ability to perform the energy analysis of an electrical drive system based on standardized load profiles in all operating ranges due to uniform general conditions. This provides the user with complete transparency irrespective of the manufacturer.

Establishing efficiency classes of frequency converters (Complete Drive Modules CDM)

To avoid overmodulation and to ensure comparability between makes, which cannot be achieved otherwise, the efficiency classes of CDMs refer to the 90/100 operating point (90 % motor stator frequency, 100 % torque current).

Standard IEC 61800-9-2 defines the relative losses of a CDM in efficiency classes IE0 to IE2. With reference to the value of a CDM of efficiency class IE1 (reference converter), a CDM of efficiency class IE2 has 25 % lower losses and a CDM of efficiency class IE0 has 25 % higher losses.

The publication of EU Directive 2019/1781 makes compliance with the eco-design requirements for the product declaration of conformity mandatory.

AC/AC transformers, that belong to the aforementioned categories (specific voltage and performance level without regenerative feedback capability), must meet efficiency class IE2, in order to be authorized for installation/use within the EU.

Operating points for CDMs

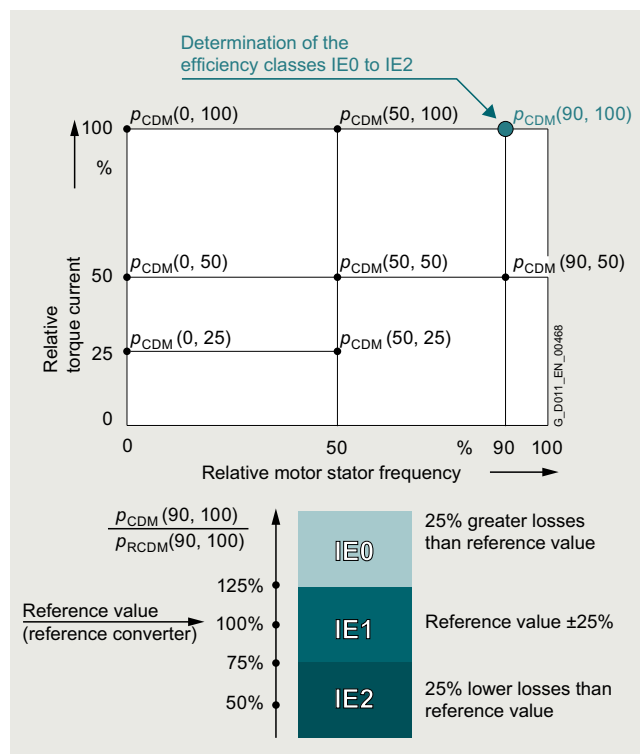

Complete Drive Module (CDM) – determining the efficiency class

Establishing the efficiency classes of drive systems (Power Drive Systems PDS)

What is possible for the individual systems, of course, also applies to the entire electrical PDS (frequency converter plus motor). Detailed comparisons are now possible at this level, too. The reference values for the reference system provide clear indications of the energy performance of the PDS.

Because targeted matching of the motor and CDM provides additional potential for optimization in electrical drive systems, it is especially important for the user to consider the entire drive system.

For the efficiency class of a PDS, too, a specific load point is defined. In this case, the reference point used is the 100/100 operating point (100 % motor stator frequency, 100 % torque).

Standard IEC 61800-9-2 defines the relative losses of a PDS in efficiency classes IES0 to IES2. With reference to the value of a PDS of efficiency class IES1 (reference drive), a PDS of efficiency class IES2 has 20 % lower losses and a PDS of efficiency class IES0 has 20 % higher losses.

Highlights

Energy efficiency classes according to IEC 61800-9-2

Overview

Operating points for PDS

2

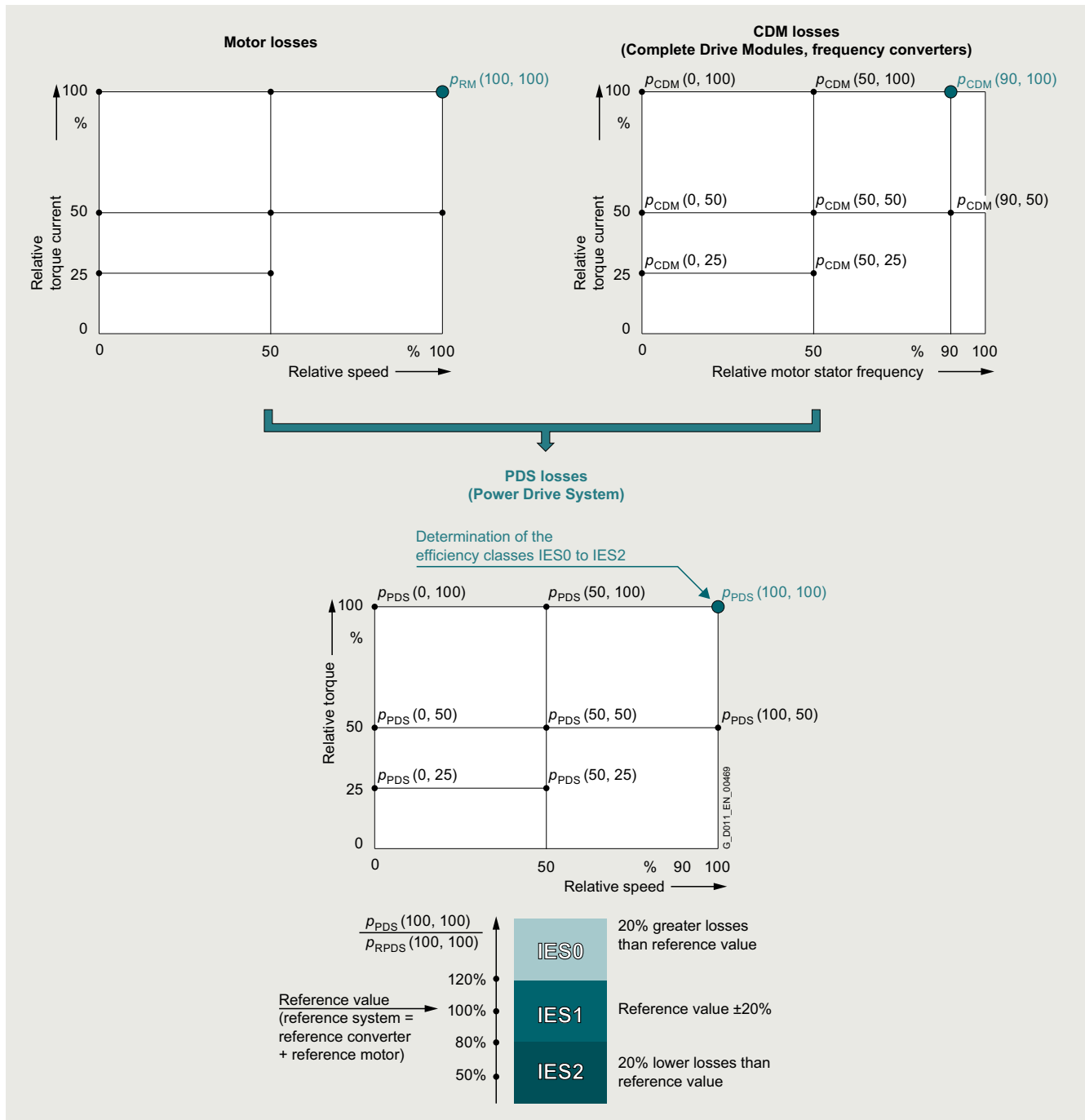

Power Drive System (PDS) – determining the efficiency class

More information

An example of a highly efficient drive system with efficiency class IES2 is the new synchronous inductance drive system with SIMOTICS reluctance motors and SINAMICS drives. More information is available on the internet at www.siemens.com/drivesystem-reluctance, www.siemens.com/simotics-gp, www.siemens.com/simotics-sd

Power loss data of SINAMICS converters for single-axis drives are available on the internet at <https://support.industry.siemens.com/cs/document/94059311>. More information on current laws and standards, new standards, and mandatory guidelines is available on the internet at www.siemens.com/legislation-and-standards

Overview

Communication overview

Digital bus systems are commonly used in industrial automation today. These handle communication between the control level, the machine control, the sensors and actuators. The SINAMICS product family offers integrated communication interfaces in all product groups – which can be used to connect the most important fieldbus systems in the simplest possible way.

The CU320-2 Control Unit offers the following options:

- PROFIBUS DP
 - PROFIBUS DP equidistance and isochronous mode
 - PROFIBUS DP device-to-device communication
- PROFINET
 - PROFINET RT
 - PROFINET IRT isochronous
 - PROFINET IRT non-isochronous
 - PROFINET Shared Device
 - PROFINET media redundancy MRP (surge prone)
 - PROFINET media redundancy MRPD (surge free)
 - PROFIsafe
 - PROFIenergy
 - PROFIdrive application class 1
 - PROFIdrive application class 3
 - PROFIdrive application class 4
- USS
- EtherNet/IP
- Modbus TCP
- Web server

Highlights

Communication > PROFIBUS

Overview



PROFIBUS – the proven, rugged bus system for automation engineering applications

The requirements of users for an open, non-proprietary communication system have resulted in the specification and standardization of the PROFIBUS protocol.

PROFIBUS defines the technical and functional features of a serial fieldbus system, with which the distributed field automation devices in the lower area (sensor/actuator level) can be networked up to the mid performance range (cell level).

Standardization according to IEC 61158/EN 50170 secures your investments for the future.

Using the conformity and interoperability test performed by the test laboratories authorized by PROFIBUS & PROFINET International (PI) and the certification of the devices by PI, users have the security of knowing that the quality and functionality is guaranteed, even in multi-vendor installations.

PROFIBUS versions

Two different PROFIBUS versions have been defined in order to comply with the widely varying requirements at field level:

PROFIBUS FMS (Fieldbus Message Specification) – the universal solution for communication tasks at the field and cell levels in the industrial communication hierarchy.

PROFIBUS PA (Process Automation) – the version for applications in process automation. PROFIBUS PA uses the intrinsically safe transmission technology specified in IEC 61158-2.

PROFIBUS DP (Distributed Periphery) – this version, which is optimized for speed, is specifically tailored to the communication of automation systems with distributed I/O stations and drives. PROFIBUS DP sets itself apart as a result of very short response times and high noise immunity, and replaces cost-intensive, parallel signal transfer with 24 V and measured value transfer utilizing 0/4 ... 20 mA technology.

Design

Bus participants on PROFIBUS DP

PROFIBUS DP makes a distinction between two different master classes and one device class:

DP master class 1

For PROFIBUS DP, DP master class 1 is the central component. In a defined and continually repeating message cycle the central master station exchanges information with distributed stations (DP devices).

DP master class 2

Devices of this type (programming, configuring or operator control devices) are used during commissioning, for configuring the DP system, for diagnostics or for operating the active plant or system. A DP master class 2 can, for example, read input, output, diagnostic and configuration data of the devices.

DP device

A DP device is an I/O device which receives output information or setpoints from the DP master, and as response, returns input information, measured values and actual values to the DP master. A DP device never sends data automatically, but only when requested by the DP master.

The quantity of input and output information depends on the device, and for each DP device in each send direction can be a maximum of 244 bytes.

Function

Functional scope in DP masters and DP devices

The functional scope can differ between DP masters and DP devices. The different functional scopes are classified as DP-V0, DP-V1 and DP-V2.

DP-V0 communication functions

The DP-V0 master functions consist of "Configuration", "Parameter Assignment" and "Reading Diagnostics Data", as well as cyclic reading of input data/actual values and writing output data/setpoints.

DP-V1 communication functions

The DP-V1 function expansions make it possible to perform acyclic read and write functions as well as processing cyclic data communication. This type of device must be supplied with extensive parameterization data during start-up and during normal operation. These acyclically transferred parameterization data are only rarely changed in comparison to the cyclic setpoints, actual values, and measured values, and are transferred at lower priority in parallel with the cyclic high-speed user data transfer. Detailed diagnostic information can be transferred in the same way.

DP-V2 communication functions

The extended DP-V2 master functions mainly comprise functions for isochronous operation and device-to-device communication between DP devices.

- **Isochronous mode:**
Isochronous mode is implemented by means of an equidistant signal in the bus system. This cyclic, equidistant cycle is sent by the DP master to all bus nodes in the form of a Global Control Telegram. Master and devices can then synchronize their applications with this signal. The signal jitter between cycles is less than 1 µs.
- **Device-to-device communication:**
The "publisher/subscriber" model is used to implement device-to-device communication. Devices declared as publishers make their input data/actual values and measured values available to other devices, the subscribers, for reading. This is performed by sending the response frame to the master as a broadcast. Device-to-device communication is therefore a cyclic process.

PROFIBUS with SINAMICS

SINAMICS uses the PROFIBUS DP protocol.

SINAMICS drives can only be used as DP devices.

Overview

**PROFINET – the Ethernet standard for automation**

PROFINET is the world's leading Industrial Ethernet standard for automation with more than 40 million nodes installed worldwide.

PROFINET makes companies more successful, because it speeds up processes and raises both productivity and plant availability.

2

Your advantages at a glance

Flexibility	Efficiency	Performance
Tailor-made plant concepts	Optimal use of resources	Increased productivity
<ul style="list-style-type: none"> ▶ Industrial Wireless LAN ▶ Safety ▶ Flexible topologies ▶ Open standard ▶ Web tools ▶ Expandability 	<ul style="list-style-type: none"> ▶ One cable for everything ▶ Device/network diagnostics ▶ Energy efficiency ▶ Simple wiring ▶ Fast device replacement ▶ Ruggedness/stability 	<ul style="list-style-type: none"> ▶ Speed ▶ High precision ▶ Large quantity structures ▶ High transmission rate ▶ Redundancy ▶ Fast start-up

G_IK10_XX_10304

Flexibility

Short response times and optimized processes are the basic requirements for competitiveness in global markets because the product lifecycles are becoming shorter and shorter.

PROFINET ensures maximum flexibility in plant structures and production processes, and it enables you to implement innovative machine and plant concepts. For example, mobile devices can also be integrated at locations that are difficult to access.

Flexible topologies

In addition to the linear structure characterized by the established fieldbuses, PROFINET also enables the use of star, tree and ring structures. This is made possible by switching technology via active network components, such as Industrial Ethernet switches and media converters, or by integrating switch functionality into the field devices. This results in increased flexibility in the planning of machines and plants, as well as savings in cabling.

The PROFINET network can be installed without any specialist knowledge at all and meets all requirements that are relevant to the industrial environment. The "PROFINET Installations Guidelines" assist manufacturers and users with network planning, installation and commissioning. Symmetrical copper cables or RFI-resistant fiber-optic cables are used, depending on the application. Devices from different manufacturers are easily connected via standardized and rugged plug-in connectors (up to IP65/IP67 degree of protection).

By integrating switch functionality into the devices, linear topologies can be created that are directly oriented toward an existing machine or plant structure. This reduces cabling overhead and cuts down on components such as external switches.

IWLAN

PROFINET also supports wireless communication with Industrial Wireless LAN, thus opening up new fields of application. For example, technologies subject to wear, such as trailing cables, can be replaced and automated guided vehicle systems and mobile operator panels can be used.

Safety

The PROFIsafe safety profile, which has been tried and tested with PROFIBUS and which permits the transmission of standard and safety-related data on a single bus cable, can also be used with PROFINET. No special network components are necessary for fail-safe communication, which means that standard switches and standard network transitions can continue to be used without any restrictions. In addition, fail-safe communication is equally possible via Industrial Wireless LAN (IWLAN).

Open standard

PROFINET, the open multi-vendor standard (IEC 61158/IEC 61784), is supported by PROFIBUS and PROFINET International (PI). It stands for maximum transparency, open IT communication, network security and simultaneous real-time communication.

Highlights

Communication > PROFINET

Overview

Thanks to its openness, PROFINET provides the basis for a standardized automation network in the plant, to which all other machines and devices can be connected. Even the integration of existing plant components, for example using PROFIBUS, presents no problems due to the use of network transitions.

Use of web tools

Thanks to the unrestricted support of TCP/IP, PROFINET permits the use of standard web services such as web servers. Irrespective of the tool used, information from the automation level can be accessed from virtually any location using a commercially available internet browser. This considerably simplifies commissioning and diagnostics. Users can then decide for themselves how much openness to the IT world they want to allow for their machine or plant. This means that PROFINET can be used simply as an isolated plant network or connected via appropriate Security Modules, such as the SCALANCE S modules, to the office network or the internet. In this way, new remote maintenance concepts or the high-speed exchange of production data become possible.

Expandability

On the one hand, PROFINET facilitates the integration of existing systems and networks without any great effort. In this way, PROFINET safeguards investments in existing plant components that communicate via PROFIBUS and other fieldbuses such as AS-Interface. On the other hand, additional PROFINET nodes can be added at any time. By using additional network components, network infrastructures can be expanded using cabling or wireless methods – even while the plant is operating.

Efficiency

Greater global competition means that companies must use their resources economically and efficiently. This applies in particular to production. This is where PROFINET ensures greater efficiency. Simple engineering guarantees fast commissioning, while reliable devices ensure a high level of plant availability. Comprehensive diagnostic and maintenance concepts help to reduce plant downtimes and keep maintenance costs to a minimum.

One cable for everything

PROFINET permits simultaneous fieldbus communication with isochronous mode and standard IT communication (TCP/IP) on one cable. This real-time communication for the transmission of user/process data and diagnostic data takes place on a single cable. Specific profile communication (PROFIsafe, PROFIdrive and PROFlenergy) can be integrated without any additional cabling. This solution offers a wide scope of functions at a low level of complexity.

Device and network diagnostics

By retaining the tried and tested PROFIBUS device model, the same diagnostics information is available with PROFINET. In addition, module-specific and channel-specific data can also be read out from the devices during device diagnostics, enabling faults to be located quickly and easily. Apart from the availability of device information, the reliability of network operation has top priority in the network management.

In existing networks the Simple Network Management Protocol (SNMP) has established itself as the de facto standard for the maintenance and monitoring of the network components and their functions. PROFINET uses this standard and gives users the opportunity to maintain their networks with tools that are familiar to them, such as the SINEMA Server network management software.

For easier maintenance of PROFINET devices, both on-site and remotely via a secure VPN connection, application-specific websites can be set up on the web server of the field devices using the familiar HTML standard.

Energy efficiency

Moving toward the green factory: PROFlenergy is a profile that provides functions and mechanisms for PROFINET field devices that support energy-efficient production.

The profile, which is defined by the PNO and is independent of any manufacturers or devices, enables energy demand and costs to be significantly reduced: Using PROFlenergy, any specific loads that are not currently being used can be switched off. This achieves a noticeable reduction in energy costs during breaks in production. PROFlenergy permits the simple, automated activation and deactivation of technologically related plant components. It is coordinated centrally by means of a higher-level controller and is networked via PROFINET. This ensures that as much energy as possible is saved during long breaks. Temporarily switching off plant components contributes to the even distribution and most efficient use of energy.

The use of PROFlenergy is made easy for the machine builder by its integration into familiar series of products. In addition, PROFlenergy is defined in such a way that the necessary function blocks can easily be integrated into existing automation systems at a later stage.

Simple wiring

Particularly stringent demands are made on the installation of cables in the industrial environment. In addition, there is a requirement to set up industry-standard networks in the shortest possible time without any special knowledge.

With FastConnect, Siemens offers a high-speed installation system that meets all of these requirements. FastConnect is the standard-compliant, industry-standard cabling system consisting of cables, connectors and assembly tools for PROFINET networks. The time required for connecting terminals is minimized by the simple installation method using just a single tool, while installation errors are prevented by the practical color-coding. Both copper cables and glass fiber optic cables can be easily assembled on site in this way.

Fast device replacement

PROFINET devices are identified by means of a name assigned during configuration. When replacing a defective device, a new device can be recognized from its topology information by the IO controller and a new name can be assigned to it automatically. This means that no engineering tool is necessary for the replacement of equipment.

This mechanism can even be used for the initial commissioning of a complete system. This speeds up commissioning, particularly in the case of series machines.

Ruggedness

An automation network must be able to withstand most external sources of interference. The use of Switched Ethernet prevents faults in one section of the network from affecting the entire plant network. For areas that are particularly prone to radio frequency interference (RFI), PROFINET allows the use of fiber optic cables.

Overview

Performance

Productivity and product quality determine the level of success in the market. Precise motion control, dynamic drives, high-speed controllers and the deterministic synchronization of devices are therefore key factors in achieving superior production. They facilitate high production rates and optimum product quality at the same time.

Speed and precision

Fast motion control applications demand precise and deterministic exchange of data. This is implemented by means of drive controllers using isochronous real time (IRT).

With IRT and isochronous mode, PROFINET permits fast and deterministic communication. This synchronizes the various cycles of a system (input, network, CPU processing and output), even in the case of parallel TCP/IP traffic. The short cycle times of PROFINET make it possible to raise the productivity of machines and plants and to guarantee the product quality and high level of precision.

The standardized PROFIdrive profile permits vendor-independent communication between CPUs and drives.

Large quantity structures

The use of PROFINET makes it possible to overcome the existing restrictions regarding the scope of machines and systems that can be implemented. In one network, several different controllers can interact with their assigned field devices. The number of field devices per PROFINET network is virtually unlimited – the entire range of IP addresses is available.

High data rate

By using 100 Mbit/s in full duplex mode, PROFINET achieves a significantly higher data rate than previous fieldbuses. This means that other plant data can be transmitted over TCP/IP without any problems, in addition to the process data. PROFINET therefore meets the combined industrial demands for simultaneously transmitting high-speed IO data and large volumes of data for additional sections of the application. Even the transmission of large volumes of data, such as that from cameras, has no adverse effect on the speed and precision of the IO data transmission, thanks to PROFINET mechanisms.

Media redundancy

A higher plant availability can be achieved with a redundant installation (ring topology). The media redundancy can be implemented not only with the aid of external switches, but also by means of integrated PROFINET interfaces. Using the media redundancy protocol (MRP), reconfiguration times of 200 ms can be achieved. If the communication is interrupted in just one part of the ring installation this means that a plant standstill is prevented and any necessary maintenance or repair work can be performed without any time pressure.

For motion control applications, PROFINET with IRT in ring topologies offers extended media redundancy for planned duplication (MRPD) which operates in a bumpless mode without any reconfiguration time. If communication is interrupted (e.g. a cable break) the process can continue operating without interruption.

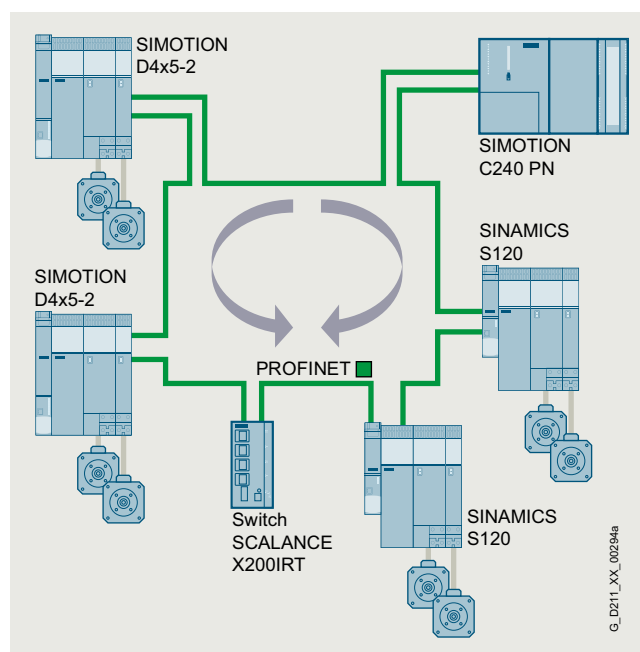

Bumpless media redundancy illustrated by example of SINAMICS S120 with SIMOTION and SCALANCE X200IRT

Benefits

- PROFINET is the open Industrial Ethernet standard for automation
- PROFINET is based on Industrial Ethernet
- PROFINET uses TCP/IP and IT standards
- PROFINET is real-time Ethernet
- PROFINET enables seamless integration of fieldbus systems
- PROFINET supports fail-safe communication via PROFIsafe and also via IWLAN

More information

More information is available on the internet at:
www.siemens.com/profinet

Highlights

Communication > Industrial Ethernet

Overview



Ethernet is the basic internet technology for worldwide networking. The many possibilities of intranet and internet, which have been available for office applications for a long time, are now utilized for production automation with Industrial Ethernet.

Apart from the use of information technology, the deployment of distributed automation systems is also on the increase. This entails breaking up complex control tasks into smaller, manageable and drive-based control systems. This increases the demand for communication and consequently a comprehensive and powerful communication system.

Industrial Ethernet provides a powerful area and cell network for the industrial field, compliant with the IEEE 802.3 (ETHERNET) standard.

Benefits

Ethernet enables a very fast data transfer (10/100 Mbit/s, 1/10 Gbit/s) and at the same time has full-duplex capability. It therefore provides an ideal basis for communication tasks in the industrial field. With a share of over 90 %, Ethernet is the number one network worldwide and offers important features which have essential advantages:

- Fast commissioning thanks to the simplest connection method
- High availability since existing networks can be extended without any adverse effects
- Almost unlimited communication performance because scalable performance is available through switching technology and high data rates when required
- Networking of different application areas such as office and production areas
- Company-wide communication based on WAN (Wide Area Network) technology or the internet
- Investment protection due to continuous compatibility with further developments
- Wireless communication using Industrial Wireless LAN

In order to make Ethernet suitable for industrial applications, considerable expansions with respect to functionality and design are required:

- Network components for use in harsh industrial environments
- Fast assembly of the RJ45 connectors
- Fail-safety through redundancy
- Expanded diagnostics and message concept
- Use of future-oriented network components (e.g. switches)

SIMATIC NET offers corresponding network components and products.

Overview



PROFIdrive – the standardized drive interface for PROFINET and PROFIBUS

PROFIdrive defines the device behavior and technique to access internal device data for electric drives connected to PROFINET and PROFIBUS – from basic frequency converters up to high-performance servo controllers.

It describes in detail the practical use of communication functions – device-to-device communication, equidistance and clock cycle synchronization (isochronous mode) in drive applications. In addition, it specifies all device characteristics which influence interfaces connected to a controller over PROFINET or PROFIBUS. This also includes the state machine (sequence control), the encoder interface, scaling of values, definition of standard telegrams, access to drive parameters, etc.

The PROFIdrive profile supports both central as well as distributed motion control concepts.

What are profiles?

For devices and systems used in automation technology, profiles define properties and modes of behavior. This allows manufacturers and users to define common standards. Devices and systems that comply with such a cross-manufacturer profile, are interoperable on a fieldbus and, to a certain degree, can be interchanged.

Are there different types of profiles?

A distinction is made between what are known as application profiles (general or specific) and system profiles:

- Application profiles (also device profiles) predominantly refer to devices (e.g. drives) and include an agreed selection regarding bus communication as well as specific device applications.
- System profiles describe classes of systems, including master functionality, program interfaces and integration resources.

Is PROFIdrive fit for the future?

PROFIdrive has been specified by the PROFIBUS and PROFINET International (PI) user organization, and is specified as a standard that is fit for the future through standard IEC 61800-7.

The basic philosophy: Keep it simple

The PROFIdrive profile tries to keep the drive interface as simple as possible and free from technology functions. As a result, referencing models as well as the functionality and performance of the PROFINET/PROFIBUS master have either no or only little influence on the drive interface.

One drive profile – different application classes

The integration of drives into automation solutions depends very strongly on the particular drive application. In order to be able to address the complete, huge bandwidth of drive applications – from basic frequency converters up to synchronized multi-axis systems with a high dynamic performance – using just one profile, PROFIdrive defines six application classes, to which most drive applications can be assigned:

- Class 1 – standard drives (pumps, fans, agitators, etc.)
- Class 2 – standard drives with technological functions
- Class 3 – positioning drives
- Class 4 – motion control drives with central, higher-level motion control intelligence and the patented "Dynamic Servo Control" positioning concept
- Class 5 – motion control drives with central, higher-level motion control intelligence and position setpoint interface
- Class 6 – motion control drives with distributed motion control intelligence integrated in the drives

Design

The device model of PROFIdrive

PROFIdrive defines a device model comprising function modules, which interoperate inside the device and which reflect the intelligence of the drive system. These modules have objects assigned to them which are described in the profile and are defined with respect to their functions. The overall functionality of a drive is therefore described through the sum of its parameters.

In contrast to other drive profiles, PROFIdrive defines only the access mechanisms to the parameters as well as a subset of profile parameters (approx. 30) such as the fault buffer, drive control and device identification.

All other parameters are vendor-specific which gives drive manufacturers great flexibility with respect to implementing control functions. The elements of a parameter are accessed acyclically over data records.

As a communication protocol, PROFIdrive uses DP-V0, DP-V1, and the DP-V2 expansions for PROFIBUS including the functions "Device-to-Device Communication" and "Isochronous Operation", or PROFINET IO with real-time classes RT and IRT.

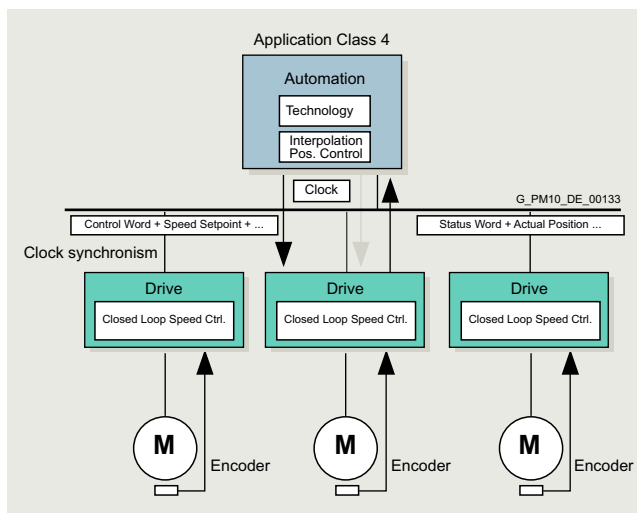

More information

More information on PROFINET and PROFIBUS is available at: www.profibus.com

See under Download / Technical description & books / PROFIdrive – Technology and Application - System Description.

Highlights

Communication > EtherNet/IP

Overview



Ethernet Industrial Protocol (EtherNet/IP) is an open standard for industrial networks. EtherNet/IP is used to transmit cyclic I/O data and acyclic parameter data. EtherNet/IP was developed by the ODVA (Open DeviceNet Vendor Association) and belongs to the international standard series IEC 61158.

Communication > Modbus TCP

Overview



The Ethernet protocol Modbus TCP is an open standard for industrial networks. Modbus TCP is used to transmit acyclic register data. Modbus TCP has been standardized in the international series of standards IEC 61158 since 2007.

SINAMICS G130 converter built-in units



3/2	Overview
3/3	Benefits
3/3	Application
3/3	Design
3/6	Function
3/8	Technical specifications
3/9	General technical specifications
3/10	Characteristic curves
3/10	Derating data
3/12	Overload capability
3/12	More information
3/13	Power Modules
3/21	Line-side power components
3/21	Line filters
3/24	Line Harmonics Filter
3/26	Line reactors
3/30	Recommended line-side system components
3/32	DC link components
3/32	Braking Modules
3/35	Braking resistors
3/37	Load-side power components
3/37	Motor reactors
3/41	dv/dt filters plus VPL
3/46	dv/dt filters compact plus VPL
3/50	Sine-wave filters
3/52	Control Unit and Control Unit Kit CU320-2
3/55	CompactFlash card for CU320-2
3/56	Supplementary system components
3/56	BOP20 Basic Operator Panel
3/57	AOP30 Advanced Operator Panel
3/59	CBE20 Communication Board
3/60	TB30 Terminal Board
3/62	TM31 Terminal Module
3/65	TM54F Terminal Module
3/68	TM150 Terminal Module
3/70	VSM10 Voltage Sensing Module
3/72	Safe Brake Adapter SBA
3/74	SMC30 Sensor Module Cabinet-Mounted
3/75	Signal cables

SINAMICS G130

Converter built-in units

75 kW to 800 kW

Overview



SINAMICS G130 converter built-in units, frame sizes FX and HX

The SINAMICS G130 is a converter that can be combined very flexibly with the associated system components and installed into customer-specific control cabinets or directly into machines.

SINAMICS G130 converter built-in units are available for the following voltages and power ratings:

Line voltage	Power
380 ... 480 V 3 AC	110 ... 560 kW
500 ... 600 V 3 AC	110 ... 560 kW
660 ... 690 V 3 AC	75 ... 800 kW

A wide range of add-on electrical components allow the drive system to be optimized for specific requirements. Configuration and commissioning are greatly simplified by predefined interfaces.

The control accuracy of the sensorless vector control is suitable for most applications, which means that an additional actual speed value encoder is not required.

However, encoder evaluation units are available for the SINAMICS G130 converters so that they can address applications that require an encoder for plant-specific reasons.

Communication between the Control Unit, the Power Module and other active SINAMICS components is performed via DRIVE-CLiQ, the drive's internal interface. The DRIVE-CLiQ connections, which are available as pre-assembled cables of different lengths, allow a complete converter system to be put together quickly.

For communication with the process control system, with the CU320-2 Control Unit either a PROFIBUS or a PROFINET interface is available as standard. The interface can also be expanded with digital and analog inputs and outputs. The TM31 Terminal Module and TB30 Terminal Board are provided for this purpose. Additional expansion cards can also be installed to allow communication via EtherNet/IP and Modbus TCP.

Benefits

- Particularly quiet and compact converters due to the use of state-of-the-art IGBT power semiconductors and an innovative cooling concept.
- Individual modules and power components can be replaced quickly and easily, which ensures a higher level of plant availability. Replaceable components have been designed so that they can be quickly and easily replaced. In addition, the "Spares On Web" Internet tool makes it easy to view the spare parts that are available for the particular order (www.siemens.com/sow).
- Easy integration in automation solutions by means of a standard communications interface as well as a range of analog and digital interfaces.
- Simple commissioning and parameterization using interactive menus on the AOP30 Advanced Operator Panel with graphic LCD and plain-text display, or PC-supported using the STARTER commissioning tool (www.siemens.com/starter).
- Preset software functions make it easier to adapt the converter to the individual plant.
- All components, from individual parts to the ready-to-connect cabinet, undergo rigorous testing throughout the entire production process. This guarantees a high level of functional reliability during installation and commissioning, as well as in operation.

Application

Variable-speed drives are ideal for all applications that involve moving, conveying, pumping or compressing solids, liquids or gases.

Key applications include:

- Pumps and fans
- Compressors
- Extruders and mixers
- Mills

Design

The SINAMICS G130 converter built-in units provide machine builders and plant constructors with a modular drive system that can be tailored to specific applications.

SINAMICS G130 converter built-in units mainly consist of the following modular, stand-alone components:

- Power Module
- Control Unit

They may be located separately from one another or combined in a single unit. The Power Module contains a slot for the Control Unit.

The Power Modules are supplied with a DRIVE-CLiQ cable for communication and a cable for the 24 V supply to the Control Unit. These cables are pre-assembled for installing the Control Unit in the Power Module. If the two units are installed in separate locations, the cables must be ordered in the appropriate lengths.

The AOP30 Advanced Operator Panel and the numeric BOP20 Basic Operator Panel can be used for commissioning and local operation.

Predefined interfaces, via terminal block or the CU320-2 Control Unit with either PROFIBUS or PROFINET, make commissioning and control of the drive much easier. The interfaces of the CU320-2 Control Unit can be supplemented with add-on modules, such as the plug-in TB30 Terminal Board or the TM31 Terminal Module.

If further customer interfaces are required for the communication with the drive, an external 24 V supply must be provided.

The following two figures provide assistance when assembling the required converter components. The first figure shows the design and individual components of a SINAMICS G130 drive. The second figure is a flowchart containing the decision and selection criteria required for the individual components.

SINAMICS G130

Converter built-in units

75 kW to 800 kW

Design

3

3 AC supply

Line-side power components
e.g.
Switch disconnectors
Line contactors
Line filters
Line reactors
Line harmonics filters



Connection system

Signal cables



SINAMICS G130 components

Power Modules



Control Unit Kit

CU320-2 Control Unit
with CompactFlash card



Supplementary system components
e.g.

Terminal Board
Terminal Module
Sensor Module
Advanced
Operator Panel
PROFINET board



DC link components

Braking Modules
with braking resistors



Motor-side power components

Motor reactors
Sine-wave filters
dv/dt-filter plus VPL
dv/dt-filter compact plus VPL



Motors

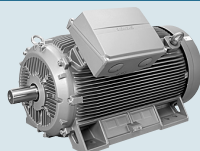

G_D011_EN_00163b

Design

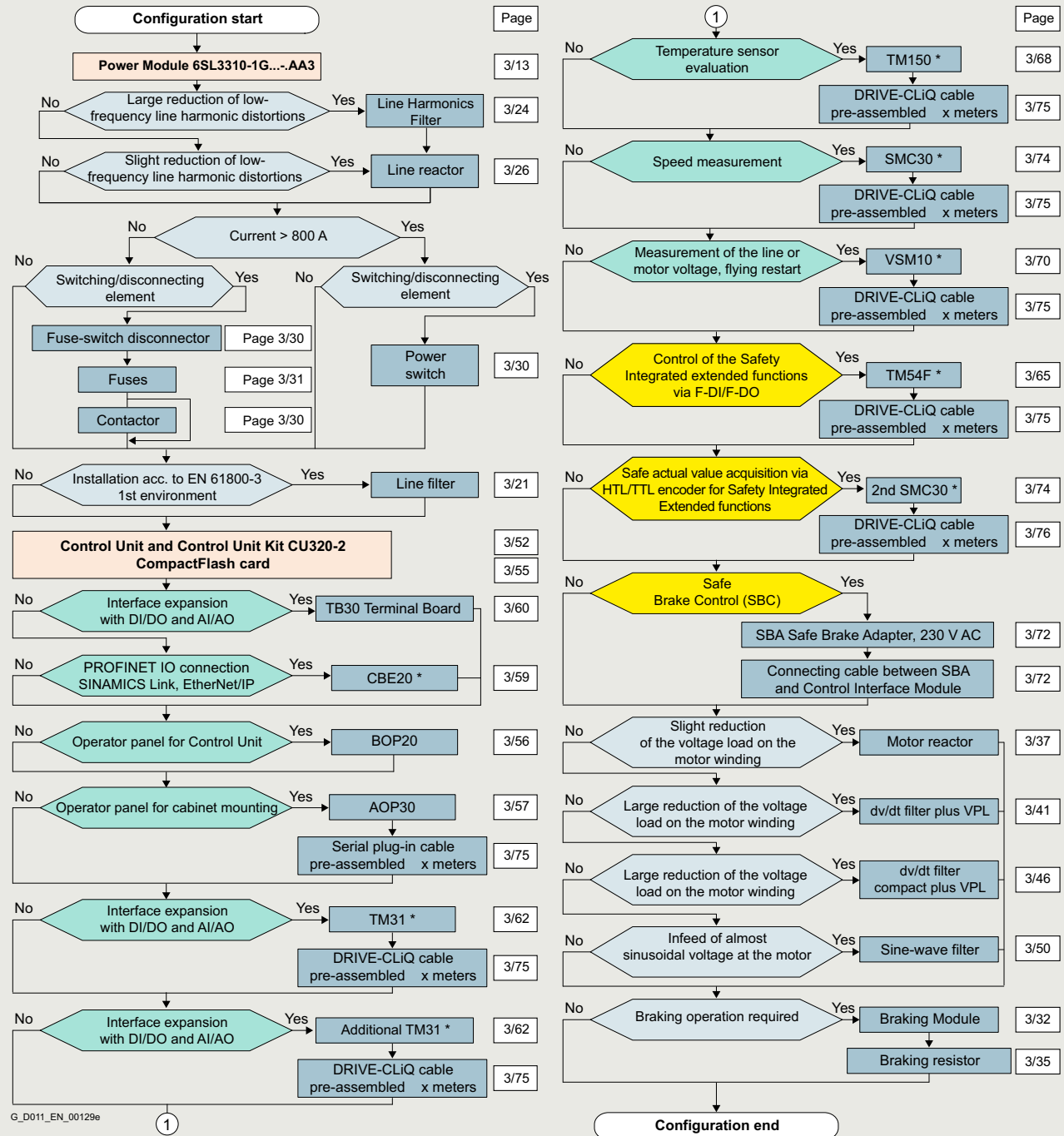

Note:
The use of an external 24 V supply must be checked for the components marked with *.
For further information, please refer to the SINAMICS Low Voltage Engineering Manual.

SINAMICS G130

Converter built-in units

75 kW to 800 kW

Design

Coated modules

The following converter components are equipped as standard with coated modules:

- Power Modules
- Control Units
- Sensor Modules
- Terminal Modules
- Advanced Operator Panel (AOP30)

The coating on the modules protects the sensitive SMD components against corrosive gases, chemically active dust and moisture.

Nickel-plated busbars

All copper busbars of the Power Modules are nickel-plated in order to achieve the best possible immunity to environmental effects. The bare copper connections also do not have to be cleaned for customer connections.

Function

Communication with higher-level controller and customer terminal block

A PROFIBUS or PROFINET communication interface is provided as standard on the CU320-2 Control Unit for use as a customer interface to the controller; there are also expansions such as the TM31 Terminal Module, the TB30 Terminal Board and modules to support EtherNet/IP, Modbus TCP or SINAMICS Link communication.

These interfaces can be used to connect the system to the higher-level controller using analog and digital signals, or to connect additional devices.

To simplify configuration and commissioning of the drive, the TM31 Terminal Module can be preset with a variety of factory settings.

[For further information, please refer to the SINAMICS Low Voltage Engineering Manual.](#)

Open-loop and closed-loop control functions

The converter control contains a high-quality vector control with speed and current control as well as motor and converter protection.

Function

Software and protective functions

The software functions available as standard are described below:

Software and protective functions	Description
Setpoint specification	The setpoint can be specified both internally and externally; internally as a fixed setpoint, motorized potentiometer setpoint or jog setpoint, externally via the communication interface or an analog input on the customer terminal block. The internal fixed setpoint and the motorized potentiometer setpoint can be switched or adjusted via control commands from any interface.
Motor identification	The automatic motor identification function makes commissioning faster and easier and optimizes closed-loop control of the drive.
Ramp-function generator	A user-friendly ramp-function generator with separately adjustable ramp-up and ramp-down times, together with adjustable rounding times in the lower and upper speed ranges, allows the drive to be smoothly accelerated and braked. As a consequence, this avoids the drive train from being overloaded and reduces the stress on mechanical components. The down ramps can be parameterized separately for quick stop.
V_{dc max} controller	The V _{dc max} controller automatically prevents overvoltages in the DC link, if the set down ramp is too short, for example. This may also extend the set ramp-down time.
V_{dc min} control	For brief line supply failures, the kinetic energy of the rotating drive is used to buffer the DC link and therefore prevents fault trips. The converter remains operational as long as the drive can provide regenerative energy as a result of its motion and the DC-link voltage does not drop below the shutdown threshold. When the line supply recovers within this time, the drive is again accelerated up to its speed setpoint.
Automatic restart ¹⁾	The automatic restart switches the drive on again when the power is restored after a power failure, and ramps up to the current speed setpoint.
Flying restart ¹⁾	The flying restart function allows the converter to be switched to a motor that is still turning. With the voltage sensing capability provided by the optional VSM10 Voltage Sensing Module, the flying restart time for large induction motors can be significantly reduced because the motor does not need to be de-magnetized.
Technology controller	The technology controller function module allows simple control functions to be implemented, e.g. level control or volumetric flow control. The technology controller is designed as a PID controller. The differentiator can be switched to the control deviation channel or to the actual value channel (factory setting). The P, I, and D components can be set separately.
Free function blocks	Using the freely programmable function blocks, it is easy to implement logic and arithmetic functions for controlling the SINAMICS G130. The blocks can be programmed by means of an operator panel or the STARTER commissioning tool.
Drive Control Chart (DCC)	Drive Control Chart (DCC) is an additional tool for the easy configuration of technology functions for the SINAMICS G130. The block library contains a large selection of control, arithmetic and logic blocks as well as extensive open-loop and closed-loop control functions. The user-friendly DCC editor enables easy graphics-based configuration, allows control loop structures to be clearly represented and provides a high degree of reusability of charts that have already been created. DCC is an add-on to the STARTER commissioning tool.
Rt detection for motor protection	A motor model stored in the converter software calculates the motor temperature based on the current speed and load. More exact sensing of the temperature, which also takes into account the influence of the ambient temperature, is possible by means of direct temperature sensing using Pt1000/KTY84 sensors in the motor winding.
Motor temperature evaluation	Motor protection by evaluating a type KTY84, PTC, Pt100 or Pt1000 temperature sensor. When a KTY84 sensor is connected, the limit values can be set for alarm or shutdown. When a PTC thermistor is connected, the system reaction to triggering of the thermistor (alarm or trip) can be defined.
Motor blocking protection	A blocked motor is detected and protected against thermal overloading by a fault trip.
Essential service mode	Special converter operating mode that increases the availability of the drive system, e.g. in the event of a fire.
Bypass	This circuit allows the motor to be operated via the converter or directly on the line supply.
Brake control	"Simple brake control" for control of holding brakes: The holding brake is used to secure drives against unwanted motion when deactivated. "Extended brake control" function module for complex brake control, e.g. for motor holding brakes and operational brakes: When braking with a feedback signal, the brake control reacts to the feedback signal contacts of the brake.
Write protection	Write protection to prevent unintentional changing of the setting parameters (without password function).
Know-how protection	Know-how protection for encrypting stored data, e.g. to protect configuration know-how, and to protect against changes and duplication (with password function).
Web server	The integrated web server provides information about the drive unit via its web pages. The web server is accessed using an internet browser via unsecured (http) or secured transmission (https).
Power unit protection	Description
Ground fault monitoring at the output	A ground fault at the output is detected by a total current monitor and results in shutdown in grounded systems.
Electronic short-circuit protection at the output	A short-circuit at the output (e.g. at the converter output terminals, in the motor cable or in the motor terminal box) is detected and the converter shuts down with a "fault".
Thermal overload protection	An alarm is issued first when the overtemperature threshold responds. If the temperature rises further, the device either shuts down or independently adjusts the pulse frequency or output current so that a reduction in the thermal load is achieved. Once the cause of the fault has been eliminated (e.g. cooling has been improved), the original operating values are automatically resumed.

¹⁾ Factory setting: Not activated (can be parameterized)

SINAMICS G130

Converter built-in units

75 kW to 800 kW

Technical specifications

The most important directives and standards are listed below. These are used as basis for the SINAMICS G130 converter built-in units and they must be carefully observed to achieve an EMC-compliant configuration that is safe both functionally and in operation.

European directives	
2006/42/EC	Machinery directive: Directive of the European Parliament and Council of May 17, 2006 on machinery and for changing Directive 95/16/EC (amendment)
2014/35/EU	Low-voltage directive: Directive of the European Parliament and Council of February 26, 2014 for the harmonization of the laws of the member states relating to the provision of electrical equipment designed for use within certain voltage limits on the market (amended version)
2014/30/EU	EMC directive: Directive of the European Parliament and Council of February 26, 2014 for the harmonization of the laws of the member states relating to electromagnetic compatibility (amended version)
2011/65/EU	RoHS directive Directive of the European Parliament and Council of June 8, 2011 on the restriction of the use of certain hazardous substances in electrical and electronic equipment
(EU) 2019/1781	Ecodesign Regulation – requirements in accordance with the Ecodesign Directive Commission Regulation of October 1, 2019 laying down ecodesign requirements for electric motors and variable speed drives pursuant to Directive 2009/125/EC of the European Parliament and of the Council
European standards	
EN ISO 3744	Acoustics – Determination of the sound power level and sound energy level for noise sources that result from sound pressure measurements – envelope surface procedure of the accuracy class 2 for a largely free sound field over a reflecting plane
EN ISO 13849-1	Safety of machinery – Safety-related parts of control systems Part 1: General design principles (ISO 13849-1:2006) (replaced EN 954-1)
EN 60146-1-1	Semiconductor converters – General requirements and line-commutated converters Part 1-1: Specification of basic requirements
EN 60204-1	Electrical equipment of machines Part 1: General definitions
EN 60529	Degrees of protection provided by enclosures (IP code)
IEC 61508-1	Functional safety of electrical/electronic/programmable electronic safety-related systems Part 1: General requirements
IEC 61508-2	Functional safety of electrical/electronic/programmable electronic safety-related systems Part 2: Requirements for electrical/electronic/programmable electronic safety-related systems
IEC 61508-3	Functional safety of electrical/electronic/programmable electronic safety-related systems Part 3: Software requirements
IEC 61800-2	Adjustable speed electrical power drive systems Part 2: General requirements – Rating specifications for the measurement of low-voltage adjustable frequency AC power drive systems
EN 61800-3	Adjustable speed electrical power drive systems Part 3: EMC product standard including special test procedure
EN 61800-5-1	Adjustable speed electrical power drive systems Part 5: Safety requirements Main section 1: Electrical and thermal requirements
EN 61800-5-2	Adjustable speed electrical power drive systems Part 5-2: Safety requirements – Functional safety (IEC 61800-5-2:2007)
North American standards	
UL508A	Industrial Control Panels
UL508C	Power Conversion Equipment
UL 61800-5-1	Adjustable Speed Electrical Power Drive Systems
CSA C22.2 No. 14	Industrial Control Equipment
Certificates of suitability	
cULus, cURus	Testing by UL (Underwriters Laboratories, www.ul.com) according to UL and CSA standards

Certification marks: (see Approvals)

Technical specifications
General technical specifications

Electrical specifications			
Line voltages and power ranges	<ul style="list-style-type: none"> • 380 ... 480 V 3 AC ±10% (-15% <1 min) 110 ... 560 kW • 500 ... 600 V 3 AC ±10% (-15% <1 min) 110 ... 560 kW • 660 ... 690 V 3 AC ±10% (-15% <1 min) 75 ... 800 kW 		
Line system configurations	Grounded TN/TT systems or ungrounded IT systems (a grounded line conductor is not permissible in 690 V line supplies)		
Line frequency	47 ... 63 Hz		
Output frequency	0 ... 550 Hz ¹⁾		
Line power factor	<ul style="list-style-type: none"> • Fundamental > 0.96 • Total 0.75 ... 0.93 		
Efficiency	> 98%		
Overvoltage category	III according to EN 61800-5-1		
Rated short-circuit current according to IEC, in conjunction with the specified fuses	<ul style="list-style-type: none"> • 1.1 ... 447 kW 65 kA • 448 ... 671 kW 84 kA • 672 ... 1193 kW 170 kA • >1194 kW 200 kA 		
Rated short-circuit current SCCR (Short Circuit Current Rating) according to UL508C (up to 600 V), in conjunction with the specified fuses or circuit breakers	<ul style="list-style-type: none"> • 1.1 ... 447 kW 65 kA • 448 ... 671 kW 84 kA • 672 ... 1193 kW 170 kA • >1194 kW 200 kA 		
Control method	Vector control with and without encoder or V/f control		
Fixed speeds	15 fixed speeds plus 1 minimum speed, parameterizable (in the default setting, 3 fixed setpoints plus 1 minimum speed are selectable using terminal strip/PROFIBUS/PROFINET)		
Speed ranges that can be skipped	4, parameterizable		
Setpoint resolution	0.001 rpm digital 12-bit analog		
Braking operation	By means of additional Braking Modules and braking resistors		
Mechanical specifications			
Degree of protection	IP00 or IP20 depending on type		
Protection class	I according to EN 61800-5-1		
Touch protection	EN 50274 / DGUV regulation 3 when used as intended		
Cooling method	Forced air cooling AF according to EN 60146		
Ambient conditions	Storage ¹⁾	Transport ¹⁾	Operation
Ambient temperature	-25 ... +55 °C (-13 ... 131 °F)	-25 ... +70 °C (-13 ... 158 °F) as of <u>-40 °C (-40 °F)</u> for 24 hours	0 ... +40 °C (32 ... 104 °F) up to +55 °C (131 °F), see derating data
Relative humidity (condensation not permissible)	5 ... 95% Class 1K4 acc. to IEC 60721-3-1 (1997)	5 ... 95% at 40 °C (104 °F) Class 2K3 acc. to IEC 60721-3-2 (1997)	5 ... 95% Class 3K3 acc. to IEC 60721-3-3 (2002)
Environmental class / harmful chemical substances	Class 1C2 acc. to IEC 60721-3-1 (1997)	Class 2C2 acc. to IEC 60721-3-2 (1997)	Class 3C2 acc. to IEC 60721-3-3 (2002)
Organic/biological influences	Class 1B1 acc. to IEC 60721-3-1 (1997)	Class 2B1 acc. to IEC 60721-3-2 (1997)	Class 3B1 acc. to IEC 60721-3-3 (2002)
Mechanically active substances	Class 1S1 acc. to IEC 60721-3-1 (1997)	Class 2S1 acc. to IEC 60721-3-1 (1997)	Class 3S1 acc. to IEC 60721-3-1 (2002)
Degree of pollution	2 according to EN 61800-5-1		
Installation altitude	Up to 2000 m (6562 ft) above sea level without derating; > 2000 m (6562 ft) see derating data		
Mechanical stability	Storage ¹⁾	Transport ¹⁾	Operation
Vibratory load	1.5 mm (0.06 in) at 5 ... 9 Hz 5 m/s ² (16.4 ft/s ²) at > 9 ... 200 Hz Class 1M2 acc. to IEC 60721-3-1 (1997)	3.1 mm (0.12 in) at 5 ... 9 Hz 10 m/s ² (32.8 ft/s ²) at > 9 ... 200 Hz Class 2M2 acc. to IEC 60721-3-2 (1997)	0.075 mm (0.00 in) at 10 ... 58 Hz 10 m/s ² (32.8 ft/s ²) at > 58 ... 200 Hz -
Shock load	40 m/s ² (131 ft/s ²) for 22 ms Class 1M2 acc. to IEC 60721-3-1 (1997)	100 m/s ² (328 ft/s ²) for 11 ms Class 2M2 acc. to IEC 60721-3-2 (1997)	100 m/s ² (328 ft/s ²) for 11 ms Class 3M4 acc. to IEC 60721-3-3 (2002)

For footnotes, see page 3/10

SINAMICS G130

Converter built-in units

75 kW to 800 kW

Technical specifications

Compliance with standards

Conformances/certificates of suitability, according to

CE (EMC Directive No. 2014/30/EU, Low Voltage Directive No. 2014/35/EU and Machinery Directive No. 2006/42/EC for functional safety)
RCM, RoHS II, UKCA
SEMI F47
cULus (only for devices connected to line supply voltages 380 ... 480 V 3 AC and 500 ... 600 V 3 AC)

Radio interference suppression

The SINAMICS G130 converter systems are not designed for connection to the public power network ("first environment"). Radio interference suppression is compliant with the EMC product standard for variable-speed drives EN 61800-3, "Second environment" (industrial networks). EMC disturbances can occur when connected to the public power networks. However, if additional measures are taken (e.g. line filter), it can also be operated in the "first environment".²⁾

Deviations from the specified classes are underlined.

Characteristic curves

Derating data

SINAMICS G130 built-in units and the associated system components are rated for an ambient temperature of 40 °C and installation altitudes up to 2000 m above sea level.

At ambient temperatures > 40 °C, the output current must be reduced. Ambient temperatures above 55 °C are not permissible.

At installation altitudes > 2000 m above sea level, it must be taken into account that the air pressure, and therefore air density, decreases as the height increases. As a consequence, the cooling efficiency and the insulation capacity of the air also decrease.

Due to the reduced cooling efficiency, it is necessary, on the one hand, to reduce the ambient temperature and on the other hand, to reduce the heat loss in the built-in unit by reducing the output current, whereby ambient temperatures lower than 40 °C may be offset to compensate.

The following table lists the permissible output currents depending on the installation altitude and ambient temperature. The specified values already include a permitted compensation in respect of installation altitude and ambient temperatures < 40 °C (temperature at the air intake of the built-in unit).

The values apply under the precondition that a cooling air flow through the devices is guaranteed as specified in the technical specifications.

As additional measure for installation altitudes from 2000 m up to 5000 m, an isolating transformer is required in order to reduce transient overvoltages according to EN 60664-1.

For further information, please refer to the [SINAMICS Low Voltage Engineering Manual](#).

Current derating factors for built-in units depending on the ambient / air intake temperature and the installation altitude

Installation altitude above sea level m	Current derating factor (as a percentage of the rated current) for an ambient / air intake temperature of							
	20 °C	25 °C	30 °C	35 °C	40 °C	45 °C	50 °C	55 °C
0 ... 2000						93.3%	86.7%	80%
2001 ... 2500					96.3%			
2501 ... 3000		100%		98.7%				
3001 ... 3500								
3501 ... 4000			96.3%					
4001 ... 4500		97.5%						
4501 ... 5000	98.2%							

¹⁾ The output frequency is also affected by the selected control method and the pulse frequency. For further information, please refer to the [SINAMICS Low Voltage Engineering Manual](#).

²⁾ Applies to motor cable lengths < 100 m (328 ft).

Characteristic curves

Current derating depending on the pulse frequency

To reduce motor noise or to increase output frequency, the pulse frequency can be increased relative to the factory setting (1.25 kHz or 2 kHz). When the pulse frequency is increased, the derating factor of the output current must be taken into account. This derating factor must be applied to the currents specified in the technical specifications.

For further information, please refer to the SINAMICS Low Voltage Engineering Manual.

Derating factor of the output current depending on the pulse frequency for devices with a rated pulse frequency of 2 kHz

Article No.	Type rating	Output current at 2 kHz	Derating factor for pulse frequency				
			2.5 kHz	4 kHz	5 kHz	7.5 kHz	8 kHz
6SL3310-...	kW	A					
380 ... 480 V 3 AC							
1GE32-1AA3	110	210	95%	82%	74%	54%	50%
1GE32-6AA3	132	260	95%	83%	74%	54%	50%
1GE33-1AA3	160	310	97%	88%	78%	54%	50%
1GE33-8AA3	200	380	96%	87%	77%	54%	50%
1GE35-0AA3	250	490	94%	78%	71%	53%	50%

Derating factor of the output current depending on the pulse frequency for devices with a rated pulse frequency of 1.25 kHz

Article No.	Type rating	Output current at 1.25 kHz	Derating factor for pulse frequency				
			2 kHz	2.5 kHz	4 kHz	5 kHz	7.5 kHz
6SL3310-...	kW	A					
380 ... 480 V 3 AC							
1GE36-1AA3	315	605	83%	72%	64%	60%	40%
1GE37-5AA3	400	745	83%	72%	64%	60%	40%
1GE38-4AA3	450	840	87%	79%	64%	55%	40%
1GE41-0AA3	560	985	92%	87%	70%	60%	50%
500 ... 600 V 3 AC							
1GF31-8AA3	110	175	92%	87%	70%	60%	40%
1GF32-2AA3	132	215	92%	87%	70%	60%	40%
1GF32-6AA3	160	260	92%	88%	71%	60%	40%
1GF33-3AA3	200	330	89%	82%	65%	55%	40%
1GF34-1AA3	250	410	89%	82%	65%	55%	35%
1GF34-7AA3	315	465	92%	87%	67%	55%	35%
1GF35-8AA3	400	575	91%	85%	64%	50%	30%
1GF37-4AA3	500	735	87%	79%	64%	55%	35%
1GF38-1AA3	560	810	83%	72%	61%	55%	35%
660 ... 690 V 3 AC							
1GH28-5AA3	75	85	93%	89%	71%	60%	40%
1GH31-0AA3	90	100	92%	88%	71%	60%	40%
1GH31-2AA3	110	120	92%	88%	71%	60%	40%
1GH31-5AA3	132	150	90%	84%	66%	55%	35%
1GH31-8AA3	160	175	92%	87%	70%	60%	40%
1GH32-2AA3	200	215	92%	87%	70%	60%	40%
1GH32-6AA3	250	260	92%	88%	71%	60%	40%
1GH33-3AA3	315	330	89%	82%	65%	55%	40%
1GH34-1AA3	400	410	89%	82%	65%	55%	35%
1GH34-7AA3	450	465	92%	87%	67%	55%	35%
1GH35-8AA3	560	575	91%	85%	64%	50%	35%
1GH37-4AA3	710	735	87%	79%	64%	55%	35%
1GH38-1AA3	800	810	83%	72%	61%	55%	35%

Note:

The derating factors for pulse frequencies in the range between the specified fixed values can be determined by linear interpolation.

SINAMICS G130

Converter built-in units

75 kW to 800 kW

Characteristic curves

Overload capability

The SINAMICS G130 converters have an overload reserve in order to overcome breakaway torques, for example. If larger surge loads occur, this must be taken into account in the configuration. For drives with overload requirements, the appropriate base load current must, therefore, be used as a basis for the required load.

The criterion for overload is that the drive is operated with its base load current before and after the overload occurs on the basis of a duty cycle duration of 300 s.

The base load current for a low overload I_L is based on a duty cycle of 110% for 60 s or 150% for 10 s.

The base load current for a high overload I_H is based on a duty cycle of 150% for 60 s or 160% for 10 s.

More information

Documentation

The device documentation consists of the following parts:

- Operating instructions

The documentation is available in English, Chinese, French, German, Italian, Russian and Spanish.

3

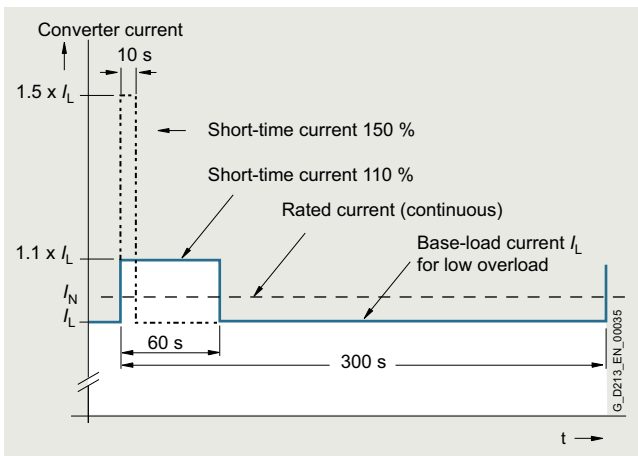

Low overload

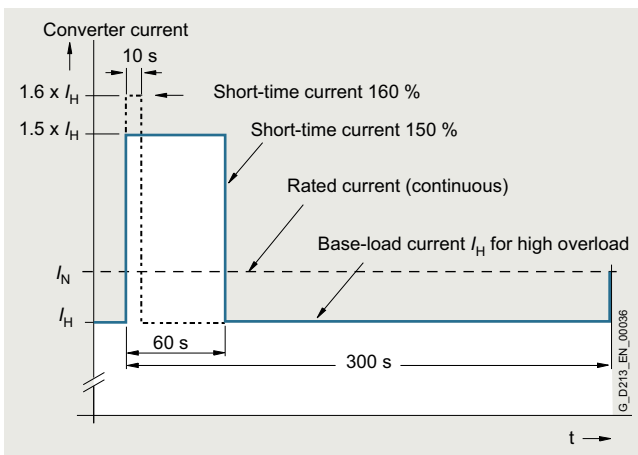

High overload

Overview

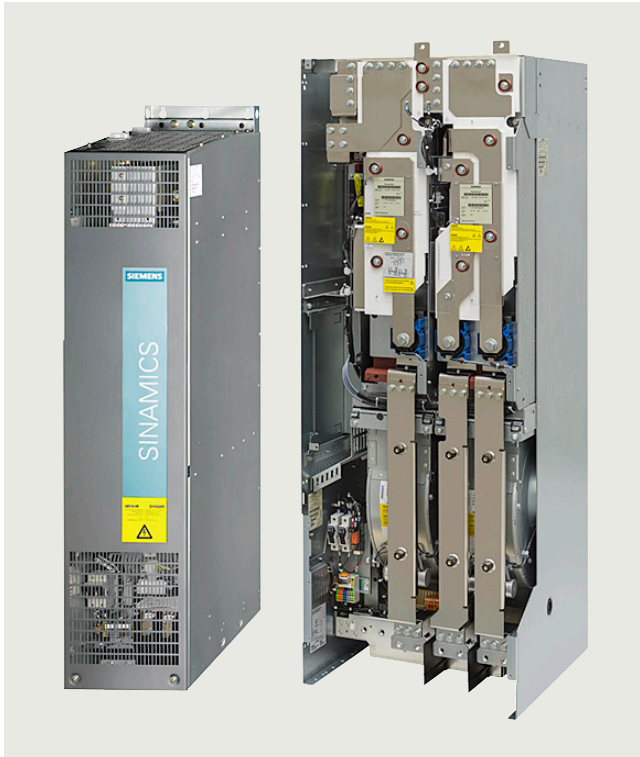

The Power Module contains:

- The line-side 6-pulse rectifier
- The DC-link capacitors
- The inverter in IGBT technology
- The associated control and monitoring electronics
- The precharging circuit for the DC link
- The control and power supply for the fans in the Power Module

Design

As standard, the Power Module has the following interfaces:

- 1 line supply connection
- 1 motor connection
- 1 connection for Braking Module
- 1 connection for dv/dt filter or dv/dt filter compact plus VPL
- 1 connection for external 24 V DC supply
- 24 V power supply (max. 2.5 A) for
 - CU320-2 Control Unit
 - AOP30 Advanced Operator Panel
 - Further DRIVE-CLiQ components
- 3 DRIVE-CLiQ sockets
- 1 temperature sensor input (KTY84-130, PTC, Pt100 or Pt1000)
- 1 connection for Safe Brake Adapter
- 1 connection for Safety Integrated
- 2 PE/protective conductor connections

DRIVE-CLiQ cables for connections to further DRIVE-CLiQ devices can be ordered pre-assembled and cut to length as required (see [Section Supplementary system components](#) → [Signal cables](#)).

The scope of supply of the Power Modules includes:

- 1 DRIVE-CLiQ cable for connection to the Control Unit
- 1 set of warning labels in 30 languages (BG, CN, CZ, DE, DK, EE, ES, FI, FR, GB, GR, HU, IE, IS, IT, JP, KR, LT, LV, MT, NL, NO, PL, PT, RO, RU, SE, SI, SK, TR)

Selection and ordering data

Type rating		Rated output current	Power Module
at 50 Hz 400 V, 500 V or 690 V	at 60 Hz 460 V or 575 V		
kW	hp	A	Article No.
380 ... 480 V 3 AC			
110	150	210	6SL3310-1GE32-1AA3
132	200	260	6SL3310-1GE32-6AA3
160	250	310	6SL3310-1GE33-1AA3
200	300	380	6SL3310-1GE33-8AA3
250	400	490	6SL3310-1GE35-0AA3
315	500	605	6SL3310-1GE36-1AA3
400	600	745	6SL3310-1GE37-5AA3
450	700	840	6SL3310-1GE38-4AA3
560	800	985	6SL3310-1GE41-0AA3
500 ... 600 V 3 AC			
110	150	175	6SL3310-1GF31-8AA3
132	200	215	6SL3310-1GF32-2AA3
160	250	260	6SL3310-1GF32-6AA3
200	300	330	6SL3310-1GF33-3AA3
250	400	410	6SL3310-1GF34-1AA3
315	450	465	6SL3310-1GF34-7AA3
400	600	575	6SL3310-1GF35-8AA3
500	700	735	6SL3310-1GF37-4AA3
560	800	810	6SL3310-1GF38-1AA3
660 ... 690 V 3 AC			
75		85	6SL3310-1GH28-5AA3
90		100	6SL3310-1GH31-0AA3
110		120	6SL3310-1GH31-2AA3
132		150	6SL3310-1GH31-5AA3
160		175	6SL3310-1GH31-8AA3
200		215	6SL3310-1GH32-2AA3
250		260	6SL3310-1GH32-6AA3
315		330	6SL3310-1GH33-3AA3
400		410	6SL3310-1GH34-1AA3
450		465	6SL3310-1GH34-7AA3
560		575	6SL3310-1GH35-8AA3
710		735	6SL3310-1GH37-4AA3
800		810	6SL3310-1GH38-1AA3

Note: The power data in hp units is based on the NEC/CEC standards for the North American market.

SINAMICS G130

Converter built-in units

Power Modules

Integration

The Power Module communicates with the CU320-2 Control Unit via DRIVE-CLiQ and receives its control information via this route.

3

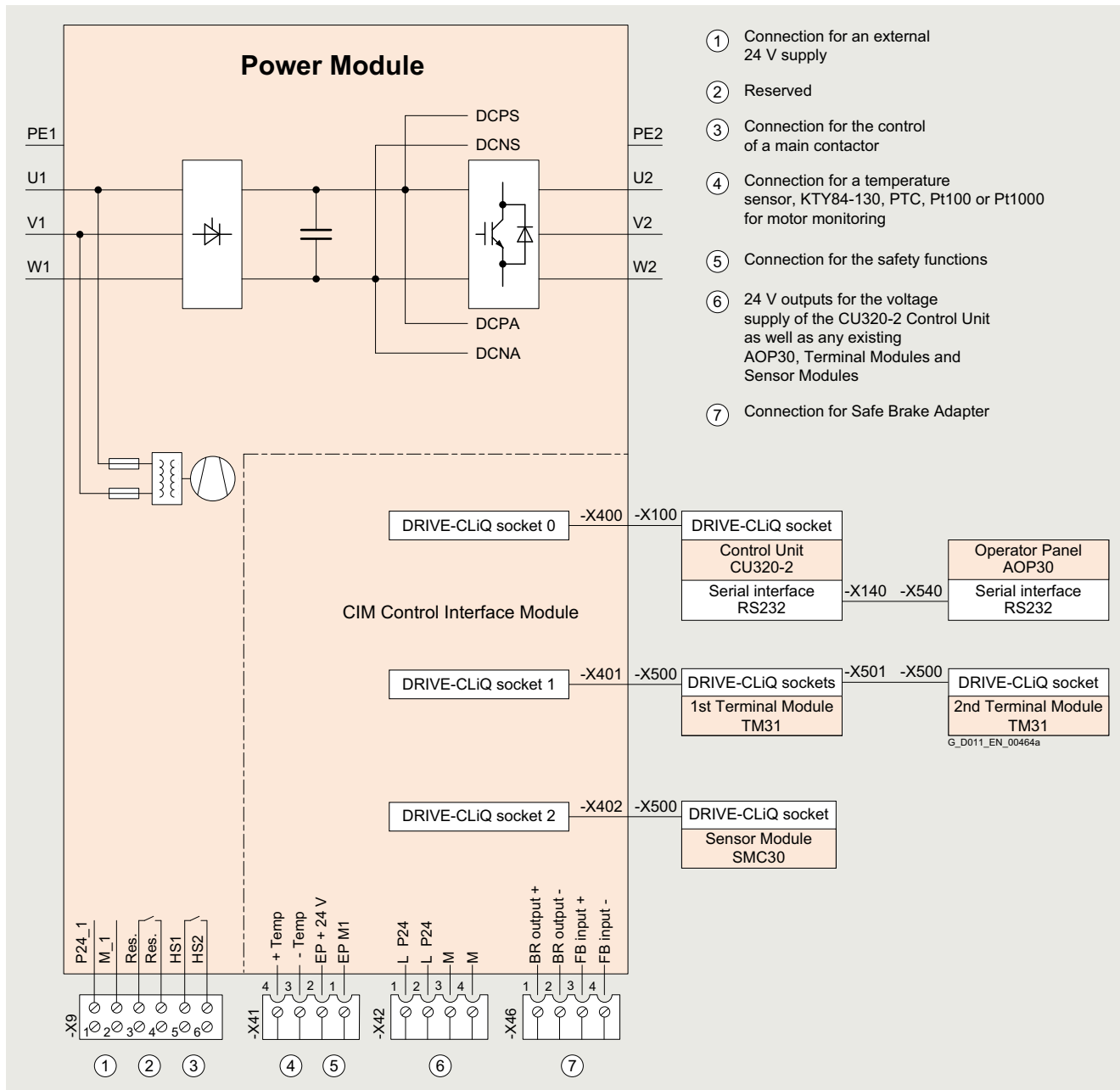

Connection example of a Power Module

Technical specifications

Line voltage 380 ... 480 V 3 AC		Power Modules				
		6SL3310-1GE32-1AA3	6SL3310-1GE32-6AA3	6SL3310-1GE33-1AA3	6SL3310-1GE33-8AA3	6SL3310-1GE35-0AA3
Type rating						
• For I_L at 50 Hz 400 V ¹⁾	kW	110	132	160	200	250
• For I_H at 50 Hz 400 V ¹⁾	kW	90	110	132	160	200
• For I_L at 60 Hz 460 V ²⁾	hp	150	200	250	300	400
• For I_H at 60 Hz 460 V ²⁾	hp	150	200	200	250	350
Output current						
• Rated current I_N	A	210	260	310	380	490
• Base-load current I_L ³⁾	A	205	250	302	370	477
• Base-load current I_H ⁴⁾	A	178	233	277	340	438
Input current						
• Rated input current	A	229	284	338	395	509
• Input current, max.	A	335	410	495	606	781
• Current requirement, 24 V DC auxiliary power supply ⁵⁾	A	0.8	0.8	0.9	0.9	0.9
Minimum short-circuit current ⁶⁾	A	3000	3600	4400	4400	8000
Power loss, max. ⁷⁾						
• At 50 Hz 400 V	kW	2.4	3.2	3.9	4.3	5.6
• At 60 Hz 460 V	kW	2.6	3.3	4.4	4.9	6.1
Cooling air requirement	m ³ /s (ft ³ /s)	0.17 (6.00)	0.23 (8.12)	0.36 (12.7)	0.36 (12.7)	0.36 (12.7)
Cable length, max. between Power Module and motor ⁸⁾						
• Shielded	m (ft)	300 (984)	300 (984)	300 (984)	300 (984)	300 (984)
• Unshielded	m (ft)	450 (1476)	450 (1476)	450 (1476)	450 (1476)	450 (1476)
Degree of protection		IP20	IP20	IP20	IP20	IP20
Sound pressure level L_{pA} (1 m) at 50/60 Hz	dB	64/67	71/71	69/73	69/73	69/73
Line connection U1, V1, W1		M10 screw	M10 screw	M10 screw	M10 screw	M10 screw
• Conductor cross section, max. (IEC)	mm ²	2 × 185	2 × 185	2 × 240	2 × 240	2 × 240
Motor connection U2/T1, V2/T2, W2/T3		M10 screw	M10 screw	M10 screw	M10 screw	M10 screw
• Conductor cross section, max. (IEC)	mm ²	2 × 185	2 × 185	2 × 240	2 × 240	2 × 240
PE1/GND connection		M10 screw	M10 screw	M10 screw	M10 screw	M10 screw
• Conductor cross section, max. (IEC)	mm ²	2 × 185	2 × 185	2 × 240	2 × 240	2 × 240
PE2/GND connection		M10 screw	M10 screw	M10 screw	M10 screw	M10 screw
• Conductor cross section, max. (IEC)	mm ²	2 × 185	2 × 185	2 × 240	2 × 240	2 × 240
Dimensions						
• Width	mm (in)	326 (12.8)	326 (12.8)	326 (12.8)	326 (12.8)	326 (12.8)
• Height	mm (in)	1400 (55.1)	1400 (55.1)	1533 (60.4)	1533 (60.4)	1533 (60.4)
• Depth	mm (in)	356 (14.0)	356 (14.0)	545 (21.5)	545 (21.5)	545 (21.5)
Weight, approx.	kg (lb)	104 (229)	104 (229)	176 (388)	176 (388)	176 (388)
Frame size		FX	FX	GX	GX	GX

Note: The power data in hp units is based on the NEC/CEC standards for the North American market.

¹⁾ Rated output of a typical 6-pole standard induction motor based on I_L or I_H for 3 AC 50 Hz 400 V.

²⁾ Rated output of a typical 6-pole standard induction motor based on I_L or I_H for 3 AC 60 Hz 460 V.

³⁾ The base-load current I_L is based on a load cycle of 110% for 60 s or 150% for 10 s with a load cycle duration of 300 s (see [Technical specifications](#) → [Overload capability](#)).

⁴⁾ The base-load current I_L is based on a load cycle of 150% for 60 s or 160% for 10 s with a load cycle duration of 300 s (see [Technical specifications](#) → [Overload capability](#)).

⁵⁾ If the auxiliary supply is to be fed in separately from the load supply, e.g. if the control should be able to continue communication when the line voltage fails.

⁶⁾ The minimum current required to reliably trigger 3NE1 protective devices.

⁷⁾ The specified power losses are the maximum values for a utilization of 100%. The values are lower under normal operating conditions.

⁸⁾ Longer cable lengths for specific configurations are available on request.

SINAMICS G130

Converter built-in units

Power Modules**Technical specifications**

Line voltage 380 ... 480 V 3 AC		Power Modules				
		6SL3310-1GE36-1AA3	6SL3310-1GE37-5AA3	6SL3310-1GE38-4AA3	6SL3310-1GE41-0AA3	
Type rating						
• For I_L at 50 Hz 400 V ¹⁾	kW	315	400	450	560	
• For I_H at 50 Hz 400 V ¹⁾	kW	250	315	400	450	
• For I_L at 60 Hz 460 V ²⁾	hp	500	600	700	800	
• For I_H at 60 Hz 460 V ²⁾	hp	350	450	600	700	
Output current						
• Rated current I_N	A	605	745	840	985	
• Base-load current I_L ³⁾	A	590	725	820	960	
• Base-load current I_H ⁴⁾	A	460	570	700	860	
Input current						
• Rated input current	A	629	775	873	1024	
• Input current, max.	A	967	1188	1344	1573	
• Current requirement, 24 V DC auxiliary power supply ⁵⁾	A	1	1	1	1.25	
Minimum short-circuit current ⁶⁾		A	10000	10500	16000	18400
Power loss, max. ⁷⁾						
• At 50 Hz 400 V	kW	7.2	8.5	9.1	12.7	
• At 60 Hz 460 V	kW	8.1	9.4	10.2	14.5	
Cooling air requirement		m ³ /s (ft ³ /s)	0.78 (27.5)	0.78 (27.5)	0.78 (27.5)	1.48 (52.3)
Cable length, max. between Power Module and motor ⁸⁾						
• Shielded	m (ft)	300 (984)	300 (984)	300 (984)	300 (984)	
• Unshielded	m (ft)	450 (1476)	450 (1476)	450 (1476)	450 (1476)	
Degree of protection			IP00	IP00	IP00	
Sound pressure level L_{pA} (1 m) at 50/60 Hz		dB	70/73	70/73	70/73	72/75
Line connection U1, V1, W1			2 × M12 screws	2 × M12 screws	2 × M12 screws	3 × M12 screws
• Conductor cross section, max. (IEC)	mm ²	4 × 240	4 × 240	4 × 240	6 × 240	
Motor connection U2/T1, V2/T2, W2/T3			2 × M12 screws	2 × M12 screws	2 × M12 screws	3 × M12 screws
• Conductor cross section, max. (IEC)	mm ²	4 × 240	4 × 240	4 × 240	6 × 240	
PE1/GND connection			M12 screw	M12 screw	M12 screw	2 × M12 screws
• Conductor cross section, max. (IEC)	mm ²	2 × 240	2 × 240	2 × 240	4 × 240	
PE2/GND connection			2 × M12 screws	2 × M12 screws	2 × M12 screws	3 × M12 screws
• Conductor cross section, max. (IEC)	mm ²	4 × 240	4 × 240	4 × 240	6 × 240	
Dimensions						
• Width	mm (in)	503 (19.8)	503 (19.8)	503 (19.8)	909 (35.8)	
• Height	mm (in)	1506 (59.3)	1506 (59.3)	1506 (59.3)	1510 (59.4)	
• Depth	mm (in)	540 (21.3)	540 (21.3)	540 (21.3)	540 (21.3)	
Weight, approx.		kg (lb)	294 (648)	294 (648)	294 (648)	530 (1168)
Frame size			HX	HX	HX	JX

Note: The power data in hp units is based on the NEC/CEC standards for the North American market.

¹⁾ Rated output of a typical 6-pole standard induction motor based on I_L or I_H for 3 AC 50 Hz 400 V.

²⁾ Rated output of a typical 6-pole standard induction motor based on I_L or I_H for 3 AC 60 Hz 460 V.

³⁾ The base-load current I_L is based on a load cycle of 110% for 60 s or 150% for 10 s with a load cycle duration of 300 s (see [Technical specifications](#) → [Overload capability](#)).

⁴⁾ The base-load current I_L is based on a load cycle of 150% for 60 s or 160% for 10 s with a load cycle duration of 300 s (see [Technical specifications](#) → [Overload capability](#)).

⁵⁾ If the auxiliary supply is to be fed in separately from the load supply, e.g. if the control should be able to continue communication when the line voltage fails.

⁶⁾ The minimum current required to reliably trigger 3NE1 protective devices.

⁷⁾ The specified power losses are the maximum values for a utilization of 100%. The values are lower under normal operating conditions.

⁸⁾ Longer cable lengths for specific configurations are available on request.

Technical specifications

Line voltage 500 ... 600 V 3 AC		Power Modules				
		6SL3310-1GF31-8AA3	6SL3310-1GF32-2AA3	6SL3310-1GF32-6AA3	6SL3310-1GF33-3AA3	6SL3310-1GF34-1AA3
Type rating						
• For I_L at 50 Hz 500 V ¹⁾	kW	110	132	160	200	250
• For I_H at 50 Hz 500 V ¹⁾	kW	90	110	132	160	200
• For I_L at 60 Hz 575 V ²⁾	hp	150	200	250	300	400
• For I_H at 60 Hz 575 V ²⁾	hp	150	200	200	250	350
Output current						
• Rated current I_N	A	175	215	260	330	410
• Base-load current I_L ³⁾	A	171	208	250	320	400
• Base-load current I_H ⁴⁾	A	157	192	233	280	367
Input current						
• Rated input current	A	191	224	270	343	426
• Input current, max.	A	279	341	410	525	655
• Current requirement, 24 V DC auxiliary power supply ⁵⁾	A	0.9	0.9	0.9	0.9	1
Minimum short-circuit current ⁶⁾	A	2400	3000	3600	5200	5200
Power loss, max. ⁷⁾						
• At 50 Hz 500 V	kW	2.8	3.2	3.7	4.6	6.1
• At 60 Hz 575 V	kW	3.2	3.6	4.1	5.1	7.1
Cooling air requirement	m ³ /s (ft ³ /s)	0.36 (12.7)	0.36 (12.7)	0.36 (12.7)	0.36 (12.7)	0.78 (27.5)
Cable length, max. between Power Module and motor ⁸⁾						
• Shielded	m (ft)	300 (984)	300 (984)	300 (984)	300 (984)	300 (984)
• Unshielded	m (ft)	450 (1476)	450 (1476)	450 (1476)	450 (1476)	450 (1476)
Degree of protection		IP20	IP20	IP20	IP20	IP00
Sound pressure level L_{pA} (1 m) at 50/60 Hz		69/73	69/73	69/73	69/73	70/73
Line connection U1, V1, W1		M10 screw	M10 screw	M10 screw	M10 screw	2 × M12 screws
• Conductor cross section, max. (IEC)	mm ²	2 × 240	2 × 240	2 × 240	2 × 240	4 × 240
Motor connection U2/T1, V2/T2, W2/T3		M10 screw	M10 screw	M10 screw	M10 screw	2 × M12 screws
• Conductor cross section, max. (IEC)	mm ²	2 × 240	2 × 240	2 × 240	2 × 240	4 × 240
PE1/GND connection		M10 screw	M10 screw	M10 screw	M10 screw	M12 screw
• Conductor cross section, max. (IEC)	mm ²	2 × 240	2 × 240	2 × 240	2 × 240	2 × 240
PE2/GND connection		M10 screw	M10 screw	M10 screw	M10 screw	2 × M12 screws
• Conductor cross section, max. (IEC)	mm ²	2 × 240	2 × 240	2 × 240	2 × 240	4 × 240
Dimensions						
• Width	mm (in)	326 (12.8)	326 (12.8)	326 (12.8)	326 (12.8)	503 (19.8)
• Height	mm (in)	1533 (60.4)	1533 (60.4)	1533 (60.4)	1533 (60.4)	1506 (59.3)
• Depth	mm (in)	545 (21.5)	545 (21.5)	545 (21.5)	545 (21.5)	540 (21.3)
Weight, approx.	kg (lb)	176 (388)	176 (388)	176 (388)	176 (388)	294 (648)
Frame size		GX	GX	GX	GX	HX

Note: The power data in hp units is based on the NEC/CEC standards for the North American market.

¹⁾ Rated output of a typical 6-pole standard induction motor based on I_L or I_H for 3 AC 50 Hz 500 V.

²⁾ Rated output of a typical 6-pole standard induction motor based on I_L or I_H for 3 AC 60 Hz 575 V.

³⁾ The base-load current I_L is based on a load cycle of 110% for 60 s or 150% for 10 s with a load cycle duration of 300 s (see [Technical specifications](#) → [Overload capability](#)).

⁴⁾ The base-load current I_L is based on a load cycle of 150% for 60 s or 160% for 10 s with a load cycle duration of 300 s (see [Technical specifications](#) → [Overload capability](#)).

⁵⁾ If the auxiliary supply is to be fed in separately from the load supply, e.g. if the control should be able to continue communication when the line voltage fails.

⁶⁾ The minimum current required to reliably trigger 3NE1 protective devices.

⁷⁾ The specified power losses are the maximum values for a utilization of 100%. The values are lower under normal operating conditions.

⁸⁾ Longer cable lengths for specific configurations are available on request.

SINAMICS G130

Converter built-in units

Power Modules

Technical specifications

Line voltage 500 ... 600 V 3 AC		Power Modules			
		6SL3310-1GF34-7AA3	6SL3310-1GF35-8AA3	6SL3310-1GF37-4AA3	6SL3310-1GF38-1AA3
Type rating					
• For I_L at 50 Hz 500 V ¹⁾	kW	315	400	500	560
• For I_H at 50 Hz 500 V ¹⁾	kW	250	315	450	500
• For I_L at 60 Hz 575 V ²⁾	hp	450	600	700	800
• For I_H at 60 Hz 575 V ²⁾	hp	450	500	700	700
Output current					
• Rated current I_N	A	465	575	735	810
• Base-load current $I_L^{(3)}$	A	452	560	710	790
• Base-load current $I_H^{(4)}$	A	416	514	657	724
Input current					
• Rated input current	A	483	598	764	842
• Input current, max.	A	740	918	1164	1295
• Current requirement, 24 V DC auxiliary power supply ⁵⁾	A	1	1	1.25	1.25
Minimum short-circuit current ⁶⁾	A	6200	8400	10500	10400
Power loss, max. ⁷⁾					
• At 50 Hz 500 V	kW	6.7	7.9	11	12.1
• At 60 Hz 575 V	kW	7.7	8.9	12.9	14
Cooling air requirement	m ³ /s (ft ³ /s)	0.78 (27.5)	0.78 (27.5)	1.48 (52.3)	1.48 (52.3)
Cable length, max. between Power Module and motor ⁸⁾					
• Shielded	m (ft)	300 (984)	300 (984)	300 (984)	300 (984)
• Unshielded	m (ft)	450 (1476)	450 (1476)	450 (1476)	450 (1476)
Degree of protection		IP00	IP00	IP00	IP00
Sound pressure level L_{pA} (1 m) at 50/60 Hz		dB	70/73	73/75	73/75
Line connection U1, V1, W1					
• Conductor cross section, max. (IEC)	mm ²	2 × M12 screws 4 × 240	2 × M12 screws 4 × 240	3 × M12 screws 6 × 240	3 × M12 screws 6 × 240
Motor connection U2/T1, V2/T2, W2/T3					
• Conductor cross section, max. (IEC)	mm ²	2 × M12 screws 4 × 240	2 × M12 screws 4 × 240	3 × M12 screws 6 × 240	3 × M12 screws 6 × 240
PE1/GND connection					
• Conductor cross section, max. (IEC)	mm ²	M12 screw 2 × 240	M12 screw 2 × 240	2 × M12 screws 4 × 240	2 × M12 screws 4 × 240
PE2/GND connection					
• Conductor cross section, max. (IEC)	mm ²	2 × M12 screws 4 × 240	2 × M12 screws 4 × 240	3 × M12 screws 6 × 240	3 × M12 screws 6 × 240
Dimensions					
• Width	mm (in)	503 (19.8)	503 (19.8)	909 (35.8)	909 (35.8)
• Height	mm (in)	1506 (59.3)	1506 (59.3)	1510 (59.4)	1510 (59.4)
• Depth	mm (in)	540 (21.3)	540 (21.3)	540 (21.3)	540 (21.3)
Weight, approx.		kg (lb)	294 (648)	530 (1168)	530 (1168)
Frame size		HX	HX	JX	JX

Note: The power data in hp units is based on the NEC/CEC standards for the North American market.

¹⁾ Rated output of a typical 6-pole standard induction motor based on I_L or I_H for 3 AC 50 Hz 500 V.

²⁾ Rated output of a typical 6-pole standard induction motor based on I_L or I_H for 3 AC 60 Hz 575 V.

³⁾ The base-load current I_L is based on a load cycle of 110% for 60 s or 150% for 10 s with a load cycle duration of 300 s (see [Technical specifications](#) → [Overload capability](#)).

⁴⁾ The base-load current I_L is based on a load cycle of 150% for 60 s or 160% for 10 s with a load cycle duration of 300 s (see [Technical specifications](#) → [Overload capability](#)).

⁵⁾ If the auxiliary supply is to be fed in separately from the load supply, e.g. if the control should be able to continue communication when the line voltage fails.

⁶⁾ The minimum current required to reliably trigger 3NE1 protective devices.

⁷⁾ The specified power losses are the maximum values for a utilization of 100%. The values are lower under normal operating conditions.

⁸⁾ Longer cable lengths for specific configurations are available on request.

Technical specifications

Line voltage 660 ... 690 V 3 AC		Power Modules					
		6SL3310-1GH28-5AA3	6SL3310-1GH31-0AA3	6SL3310-1GH31-2AA3	6SL3310-1GH31-5AA3	6SL3310-1GH31-8AA3	6SL3310-1GH32-2AA3
Type rating							
• For I_L at 50 Hz 690 V ¹⁾	kW	75	90	110	132	160	200
• For I_H at 50 Hz 690 V ¹⁾	kW	55	75	90	110	132	160
Output current							
• Rated current I_N	A	85	100	120	150	175	215
• Base-load current I_L ²⁾	A	80	95	115	142	171	208
• Base-load current I_H ³⁾	A	76	89	107	134	157	192
Input current							
• Rated input current	A	93	109	131	164	191	224
• Input current, max.	A	131	155	188	232	279	341
• Current requirement, 24 V DC auxiliary power supply ⁴⁾	A	0.8	0.8	0.8	0.8	0.9	0.9
Minimum short-circuit current ⁵⁾	A	1050	1050	1200	1600	2400	3000
Heat loss, max. ⁶⁾ at 50 Hz 690 V	kW	1.3	1.6	1.8	2.3	3	3.5
Cooling air requirement	m ³ /s (ft ³ /s)	0.17 (6.00)	0.17 (6.00)	0.17 (6.00)	0.17 (6.00)	0.36 (12.7)	0.36 (12.7)
Cable length, max. between Power Module and motor ⁷⁾							
• Shielded	m (ft)	300 (984)	300 (984)	300 (984)	300 (984)	300 (984)	300 (984)
• Unshielded	m (ft)	450 (1476)	450 (1476)	450 (1476)	450 (1476)	450 (1476)	450 (1476)
Degree of protection		IP20	IP20	IP20	IP20	IP20	IP20
Sound pressure level L_{pA} (1 m) at 50/60 Hz	dB	64/67	64/67	64/67	64/67	69/73	69/73
Line connection U1, V1, W1		M10 screw	M10 screw	M10 screw	M10 screw	M10 screw	M10 screw
• Conductor cross section, max. (IEC)	mm ²	2 × 185	2 × 185	2 × 185	2 × 185	2 × 240	2 × 240
Motor connection U2/T1, V2/T2, W2/T3		M10 screw	M10 screw	M10 screw	M10 screw	M10 screw	M10 screw
• Conductor cross section, max. (IEC)	mm ²	2 × 185	2 × 185	2 × 185	2 × 185	2 × 240	2 × 240
PE1/GND connection		M10 screw	M10 screw	M10 screw	M10 screw	M10 screw	M10 screw
• Conductor cross section, max. (IEC)	mm ²	2 × 185	2 × 185	2 × 185	2 × 185	2 × 240	2 × 240
PE2/GND connection		M10 screw	M10 screw	M10 screw	M10 screw	M10 screw	M10 screw
• Conductor cross section, max. (IEC)	mm ²	2 × 185	2 × 185	2 × 185	2 × 185	2 × 240	2 × 240
Dimensions							
• Width	mm (in)	326 (12.8)	326 (12.8)	326 (12.8)	326 (12.8)	326 (12.8)	326 (12.8)
• Height	mm (in)	1400 (55.1)	1400 (55.1)	1400 (55.1)	1400 (55.1)	1533 (60.4)	1533 (60.4)
• Depth	mm (in)	356 (14.0)	356 (14.0)	356 (14.0)	356 (14.0)	545 (21.5)	545 (21.5)
Weight, approx.	kg (lb)	104 (229)	104 (229)	104 (229)	104 (229)	176 (388)	176 (388)
Frame size		FX	FX	FX	FX	GX	GX

Note: The power data in hp units is based on the NEC/CEC standards for the North American market.

¹⁾ Rated output of a typical 6-pole standard induction motor based on I_L or I_H for 3 AC 50 Hz 690 V.

²⁾ The base-load current I_L is based on a load cycle of 110% for 60 s or 150% for 10 s with a load cycle duration of 300 s.

³⁾ The base-load current I_L is based on a load cycle of 150% for 60 s or 160% for 10 s with a load cycle duration of 300 s (see [Technical specifications](#) → [Overload capability](#)).

⁴⁾ If the auxiliary supply is to be fed in separately from the load supply, e.g. if the control should be able to continue communication when the line voltage fails.

⁵⁾ The minimum current required to reliably trigger 3NE1 protective devices.

⁶⁾ The specified power losses are the maximum values for a utilization of 100%. The values are lower under normal operating conditions.

⁷⁾ Longer cable lengths for specific configurations are available on request.

SINAMICS G130

Converter built-in units

Power Modules**Technical specifications**

Line voltage 660 ... 690 V 3 AC		Power Modules						
		6SL3310-1GH32-6AA3	6SL3310-1GH33-3AA3	6SL3310-1GH34-1AA3	6SL3310-1GH34-7AA3	6SL3310-1GH35-8AA3	6SL3310-1GH37-4AA3	6SL3310-1GH38-1AA3
Type rating								
• For I_L at 50 Hz 690 V ¹⁾	kW	250	315	400	450	560	710	800
• For I_H at 50 Hz 690 V ¹⁾	kW	200	250	315	400	500	560	710
Output current								
• Rated current I_N	A	260	330	410	465	575	735	810
• Base-load current I_L ²⁾	A	250	320	400	452	560	710	790
• Base-load current I_H ³⁾	A	233	280	367	416	514	657	724
Input current								
• Rated input current	A	270	343	426	483	598	764	842
• Input current, max.	A	410	525	655	740	918	1164	1295
• Current requirement, 24 V DC auxiliary power supply ⁴⁾	A	0.9	0.9	1	1	1	1.25	1.25
Minimum short-circuit current ⁵⁾	A	3600	5200	5200	6200	8400	10500	10400
Heat loss, max. ⁶⁾ at 50 Hz 690 V	kW	4	5	6.7	7.3	8.6	12.1	13.4
Cooling air requirement	m ³ /s (ft ³ /s)	0.36 (12.7)	0.36 (12.7)	0.78 (27.5)	0.78 (27.5)	0.78 (27.5)	1.48 (52.3)	1.48 (52.3)
Cable length, max. between Power Module and motor ⁷⁾								
• Shielded	m (ft)	300 (984)	300 (984)	300 (984)	300 (984)	300 (984)	300 (984)	300 (984)
• Unshielded	m (ft)	450 (1476)	450 (1476)	450 (1476)	450 (1476)	450 (1476)	450 (1476)	450 (1476)
Degree of protection		IP20	IP20	IP00	IP00	IP00	IP00	IP00
Sound pressure level L_{pA} (1 m) at 50/60 Hz		dB	69/73	69/73	70/73	70/73	73/75	73/75
Line connection U1, V1, W1		M10 screw	M10 screw	2 × M12 screws	2 × M12 screws	2 × M12 screws	3 × M12 screws	3 × M12 screws
• Conductor cross section, max. (IEC)	mm ²	2 × 240	2 × 240	4 × 240	4 × 240	4 × 240	6 × 240	6 × 240
Motor connection U2/T1, V2/T2, W2/T3		M10 screw	M10 screw	2 × M12 screws	2 × M12 screws	2 × M12 screws	3 × M12 screws	3 × M12 screws
• Conductor cross section, max. (IEC)	mm ²	2 × 240	2 × 240	4 × 240	4 × 240	4 × 240	6 × 240	6 × 240
PE1/GND connection		M10 screw	M10 screw	M12 screw	M12 screw	M12 screw	2 × M12 screws	2 × M12 screws
• Conductor cross section, max. (IEC)	mm ²	2 × 240	2 × 240	2 × 240	2 × 240	2 × 240	4 × 240	4 × 240
PE2/GND connection		M10 screw	M10 screw	2 × M12 screws	2 × M12 screws	2 × M12 screws	3 × M12 screws	3 × M12 screws
• Conductor cross section, max. (IEC)	mm ²	2 × 240	2 × 240	4 × 240	4 × 240	4 × 240	6 × 240	6 × 240
Dimensions								
• Width	mm (in)	326 (12.8)	326 (12.8)	503 (19.8)	503 (19.8)	503 (19.8)	909 (35.8)	909 (35.8)
• Height	mm (in)	1533 (60.4)	1533 (60.4)	1506 (59.3)	1506 (59.3)	1506 (59.3)	1510 (59.4)	1510 (59.4)
• Depth	mm (in)	545 (21.5)	545 (21.5)	540 (21.3)	540 (21.3)	540 (21.3)	540 (21.3)	540 (21.3)
Weight, approx.	kg (lb)	176 (388)	176 (388)	294 (648)	294 (648)	294 (648)	530 (1168)	530 (1168)
Frame size		GX	GX	HX	HX	HX	JX	JX

Note: The power data in hp units is based on the NEC/CEC standards for the North American market.

¹⁾ Rated output of a typical 6-pole standard induction motor based on I_L or I_H for 3 AC 50 Hz 690 V.

²⁾ The base-load current I_L is based on a load cycle of 110% for 60 s or 150% for 10 s with a load cycle duration of 300 s.

³⁾ The base-load current I_L is based on a load cycle of 150% for 60 s or 160% for 10 s with a load cycle duration of 300 s (see [Technical specifications](#) → [Overload capability](#)).

⁴⁾ If the auxiliary supply is to be fed in separately from the load supply, e.g. if the control should be able to continue communication when the line voltage fails.

⁵⁾ The minimum current required to reliably trigger 3NE1 protective devices.

⁶⁾ The specified power losses are the maximum values for a utilization of 100%. The values are lower under normal operating conditions.

⁷⁾ Longer cable lengths for specific configurations are available on request.

Overview

Line-side power components protect the connected components against transient or continuous overvoltages and ensure that specified limit values are maintained.

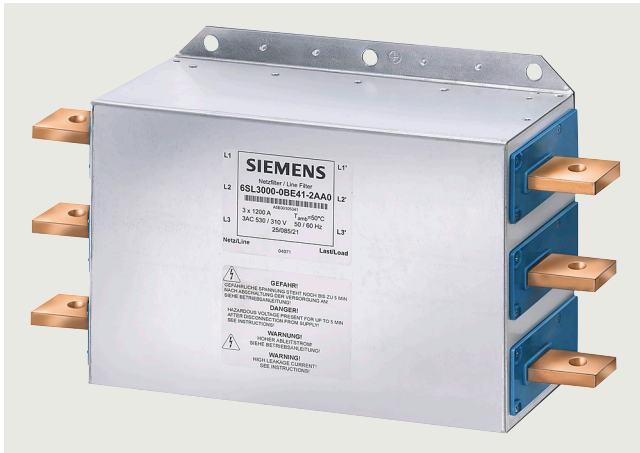

To limit the emitted interference, the converters are equipped as standard with a radio interference suppression filter that conforms to the limits defined in Category C3. SINAMICS G130 converters equipped with a line filter also meet the limits for use in the first environment (Category C2) according to EN 61800-3¹⁾.

SINAMICS G130 converters comply with the noise immunity requirements defined in this standard for the first and second environments.

In conjunction with line reactors, line filters limit the conducted interference emitted by the Power Modules to the limit values of Category C2 defined in product standard EN 61800-3. Provided that the system has been set up in accordance with the EMC installation guidelines, the limit values at the installation location will be in accordance with the requirements for environment 1.

The line filters are suitable for grounded systems (TN or TT systems with grounded neutral point).

Selection and ordering data

Suitable for Power Module	Type rating of the Power Module at 400 V, 500 V or 690 V kW	Line filter
		Article No.
380 ... 480 V 3 AC		
6SL3310-1GE32-1AA3	110	6SL3000-0BE32-5AA0
6SL3310-1GE32-6AA3	132	6SL3000-0BE34-4AA0
6SL3310-1GE33-1AA3	160	
6SL3310-1GE33-8AA3	200	
6SL3310-1GE35-0AA3	250	6SL3000-0BE36-0AA0
6SL3310-1GE36-1AA3	315	6SL3000-0BE41-2AA0
6SL3310-1GE37-5AA3	400	
6SL3310-1GE38-4AA3	450	
6SL3310-1GE41-0AA3	560	
500 ... 600 V 3 AC		
6SL3310-1GF31-8AA3	110	6SL3000-0BG32-5AA0
6SL3310-1GF32-2AA3	132	
6SL3310-1GF32-6AA3	160	6SL3000-0BG34-4AA0
6SL3310-1GF33-3AA3	200	
6SL3310-1GF34-1AA3	250	
6SL3310-1GF34-7AA3	315	6SL3000-0BG36-0AA0
6SL3310-1GF35-8AA3	400	6SL3000-0BG41-2AA0
6SL3310-1GF37-4AA3	500	
6SL3310-1GF38-1AA3	560	
660 ... 690 V 3 AC		
6SL3310-1GH28-5AA3	75	6SL3000-0BG32-5AA0
6SL3310-1GH31-0AA3	90	
6SL3310-1GH31-2AA3	110	
6SL3310-1GH31-5AA3	132	
6SL3310-1GH31-8AA3	160	
6SL3310-1GH32-2AA3	200	
6SL3310-1GH32-6AA3	250	6SL3000-0BG34-4AA0
6SL3310-1GH33-3AA3	315	
6SL3310-1GH34-1AA3	400	
6SL3310-1GH34-7AA3	450	6SL3000-0BG36-0AA0
6SL3310-1GH35-8AA3	560	6SL3000-0BG41-2AA0
6SL3310-1GH37-4AA3	710	
6SL3310-1GH38-1AA3	800	

For further information about EMC-compliant plant construction, please refer to the SINAMICS Low Voltage Engineering Manual.

¹⁾ Applies to motor cable lengths < 100 m.

SINAMICS G130

Converter built-in units

Line-side power components > Line filters**Technical specifications**

Line voltage 380 ... 480 V 3 AC		Line filter			
		6SL3000-0BE32-5AA0	6SL3000-0BE34-4AA0	6SL3000-0BE36-0AA0	6SL3000-0BE41-2AA0
Rated current	A	250	440	600	1200
Power loss	kW	0.015	0.047	0.053	0.119
Line/load connection		1 × hole for M10	1 × hole for M10	1 × hole for M10	1 × hole for M12
• Conductor cross section, max. (IEC)	mm ²	Provided for busbar connection	Provided for busbar connection	Provided for busbar connection	Provided for busbar connection
PE connection		Hole for M8	Hole for M8	Hole for M10	Hole for M10
Degree of protection		IP00	IP00	IP00	IP00
Dimensions					
• Width	mm (in)	360 (14.17)	360 (14.17)	400 (15.75)	425 (16.73)
• Height	mm (in)	240 (9.45)	240 (9.45)	265 (10.43)	265 (10.43)
• Depth	mm (in)	116 (4.57)	116 (4.57)	140 (5.51)	145 (5.71)
Weight, approx.	kg (lb)	12.3 (27.1)	12.3 (27.1)	19 (41.9)	25.8 (56.9)
Certificates of suitability, according to		cURus	cURus	cURus	cURus
Suitable for Power Module		6SL3310-1GE32-1AA3 (110 kW)	6SL3310-1GE32-6AA3 (132 kW) 6SL3310-1GE33-1AA3 (160 kW) 6SL3310-1GE33-8AA3 (200 kW)	6SL3310-1GE35-0AA3 (250 kW)	6SL3310-1GE36-1AA3 (315 kW) 6SL3310-1GE37-5AA3 (400 kW) 6SL3310-1GE38-4AA3 (450 kW) 6SL3310-1GE41-0AA3 (560 kW)

Line voltage 500 ... 600 V 3 AC		Line filter			
		6SL3000-0BG32-5AA0	6SL3000-0BG34-4AA0	6SL3000-0BG36-0AA0	6SL3000-0BG41-2AA0
Rated current	A	250	440	600	1200
Power loss	kW	0.015	0.047	0.053	0.119
Line/load connection		1 × hole for M10	1 × hole for M10	1 × hole for M10	1 × hole for M12
• Conductor cross section, max. (IEC)	mm ²	Provided for busbar connection	Provided for busbar connection	Provided for busbar connection	Provided for busbar connection
PE connection		Hole for M8	Hole for M8	Hole for M10	Hole for M10
Degree of protection		IP00	IP00	IP00	IP00
Dimensions					
• Width	mm (in)	360 (14.17)	360 (14.17)	400 (15.75)	425 (16.73)
• Height	mm (in)	240 (9.45)	240 (9.45)	265 (10.43)	265 (10.43)
• Depth	mm (in)	116 (4.57)	116 (4.57)	140 (5.51)	145 (5.71)
Weight, approx.	kg (lb)	12.3 (27.1)	12.3 (27.1)	19 (41.9)	25.8 (56.9)
Certificates of suitability, according to		cURus	cURus	cURus	cURus
Suitable for Power Module		6SL3310-1GF31-8AA3 (110 kW) 6SL3310-1GF32-2AA3 (132 kW)	6SL3310-1GF32-6AA3 (160 kW) 6SL3310-1GF33-3AA3 (200 kW) 6SL3310-1GF34-1AA3 (250 kW)	6SL3310-1GF34-7AA3 (315 kW)	6SL3310-1GF35-8AA3 (400 kW) 6SL3310-1GF37-4AA3 (500 kW) 6SL3310-1GF38-1AA3 (560 kW)

Technical specifications

Line voltage 660 ... 690 V 3 AC		Line filter			
		6SL3000-0BG32-5AA0	6SL3000-0BG34-4AA0	6SL3000-0BG36-0AA0	6SL3000-0BG41-2AA0
Rated current	A	250	440	600	1200
Power loss	kW	0.015	0.047	0.053	0.119
Line/load connection		1 × hole for M10	1 × hole for M10	1 × hole for M10	1 × hole for M12
• Conductor cross section, max. (IEC)	mm ²	Provided for busbar connection	Provided for busbar connection	Provided for busbar connection	Provided for busbar connection
PE connection		Hole for M8	Hole for M8	Hole for M10	Hole for M10
Degree of protection		IP00	IP00	IP00	IP00
Dimensions					
• Width	mm (in)	360 (14.17)	360 (14.17)	400 (15.75)	425 (16.73)
• Height	mm (in)	240 (9.45)	240 (9.45)	265 (10.43)	265 (10.43)
• Depth	mm (in)	116 (4.57)	116 (4.57)	140 (5.51)	145 (5.71)
Weight, approx.	kg (lb)	12.3 (27.1)	12.3 (27.1)	19 (41.9)	25.2 (55.6)
Certificates of suitability, according to		cURus	cURus	cURus	cURus
Suitable for Power Module		6SL3310-1GH28-5AA3 (75 kW) 6SL3310-1GH31-0AA3 (90 kW) 6SL3310-1GH31-2AA3 (110 kW) 6SL3310-1GH31-5AA3 (132 kW) 6SL3310-1GH31-8AA3 (160 kW) 6SL3310-1GH32-2AA3 (200 kW)	6SL3310-1GH32-6AA3 (250 kW) 6SL3310-1GH33-3AA3 (315 kW) 6SL3310-1GH34-1AA3 (400 kW)	6SL3310-1GH34-7AA3 (450 kW)	6SL3310-1GH35-8AA3 (560 kW) 6SL3310-1GH37-4AA3 (710 kW) 6SL3310-1GH38-1AA3 (800 kW)

SINAMICS G130

Converter built-in units

Line-side power components > Line Harmonics Filters**Overview**

Line Harmonics Filters reduce the low-frequency harmonic effects of converters to a level that can otherwise only be achieved using 12-pulse rectifiers.

The stringent limit values of IEEC 519: 2014 are complied with without any exceptions (precondition: $u_k \leq 5\%$ or $RSC \geq 20$).

Design

Line Harmonics Filters are supplied as stand-alone components in a rugged housing. They are installed between the customer's low-voltage distribution panel and the converter. The voltage is disconnected and fused in the customer's low-voltage switchgear, as is the power supply cable.

The Line Harmonics Filters have no fans (natural convection cooling). This means that no external auxiliary power supply is required.

The Line Harmonics Filters are equipped with a floating thermostatic switch, which can be monitored externally, for the monitoring thermal overloads, e.g. as a result of insufficient cooling air being supplied.

Note:

The converter must have a line reactor in order to use a Line Harmonics Filter.

Notice:

To ensure the converter will function, the R_{SC} (Relative Short-Circuit Power) of the infeed grid must have a value of $RSC \geq 10$ or $u_k \leq 10\%$.

Selection and ordering data

Suitable for Power Module	Type rating of the Power Module at 400 V, 500 V or 690 V kW	Line Harmonics Filter
		Article No.
380 ... 480 V 3 AC		
6SL3310-1GE33-1AA3	160	6SL3000-OJE36-1AA0
6SL3310-1GE33-8AA3	200	
6SL3310-1GE35-0AA3	250	
6SL3310-1GE36-1AA3	315	
6SL3310-1GE37-5AA3	400	6SL3000-OJE38-4AA0
6SL3310-1GE38-4AA3	450	
6SL3310-1GE41-0AA3	560	6SL3000-OJE41-0AA0
500 ... 600 V 3 AC		
6SL3310-1GF31-8AA3	110	6SL3000-OJH33-3AA0
6SL3310-1GF32-2AA3	132	
6SL3310-1GF32-6AA3	160	
6SL3310-1GF33-3AA3	200	
6SL3310-1GF34-1AA3	250	6SL3000-OJH34-7AA0
6SL3310-1GF34-7AA3	315	
6SL3310-1GF35-8AA3	400	6SL3000-OJH35-8AA0
6SL3310-1GF37-4AA3	500	6SL3000-OJH38-1AA0
6SL3310-1GF38-1AA3	560	
660 ... 690 V 3 AC		
6SL3310-1GH31-8AA3	160	6SL3000-OJH33-3AA0
6SL3310-1GH32-2AA3	200	
6SL3310-1GH32-6AA3	250	
6SL3310-1GH33-3AA3	315	
6SL3310-1GH34-1AA3	400	6SL3000-OJH34-7AA0
6SL3310-1GH34-7AA3	450	
6SL3310-1GH35-8AA3	560	6SL3000-OJH35-8AA0
6SL3310-1GH37-4AA3	710	6SL3000-OJH38-1AA0
6SL3310-1GH38-1AA3	800	

For further information on Line Harmonics Filters, please refer to the [SINAMICS Low Voltage Engineering Manual](#).

Technical specifications

Line voltage 380 ... 415 V 3 AC (50 Hz) 440 ... 480 V 3 AC (60 Hz)		Line Harmonics Filter		
		6SL3000-0JE36-1AA0	6SL3000-0JE38-4AA0	6SL3000-0JE41-0AA0
Rated current ¹⁾	A	500	700	900
Power loss	kW	3.09	4.54	5.6
Line/load connection				
• Conductor cross section, max. (IEC)	mm ²	4 × 240	4 × 240	4 × 240
PE connection				
		3 × M12 studs	3 × M12 studs	3 × M12 studs
Degree of protection				
		IP21	IP21	IP21
Dimensions				
• Width	mm (in)	600 (23.6)	800 (31.5)	1000 (39.4)
• Height	mm (in)	1700 (66.9)	1700 (66.9)	1700 (66.9)
• Depth	mm (in)	540 (21.3)	540 (21.3)	540 (21.3)
Weight, approx.	kg (lb)	460 (1014)	600 (1323)	900 (1984)
Paint finish				
		RAL 7035	RAL 7035	RAL 7035
Suitable for Power Module				
		6SL3310-1GE33-1AA3 (160 kW) 6SL3310-1GE33-8AA3 (200 kW) 6SL3310-1GE35-0AA3 (250 kW) 6SL3310-1GE36-1AA3 (315 kW)	6SL3310-1GE37-5AA3 (400 kW) 6SL3310-1GE38-4AA3 (450 kW)	6SL3310-1GE41-0AA3 (560 kW)

Line voltage 500 ... 600 V 3 AC 660 ... 690 V 3 AC		Line Harmonics Filter			
		6SL3000-0JH33-3AA0	6SL3000-0JH34-7AA0	6SL3000-0JH35-8AA0	6SL3000-0JH38-1AA0
Rated current ¹⁾	A	290	400	520	710
Power loss	kW	3.11	4.62	5.69	7.97
Line/load connection					
• Conductor cross section, max. (IEC)	mm ²	4 × 240	4 × 240	4 × 240	4 × 240
PE connection					
		3 × M12 studs	3 × M12 studs	3 × M12 studs	3 × M12 studs
Degree of protection					
		IP21	IP21	IP21	IP21
Dimensions					
• Width	mm (in)	600 (23.6)	800 (31.5)	1000 (39.4)	1000 (39.4)
• Height	mm (in)	1700 (66.9)	1700 (66.9)	1700 (66.9)	1700 (66.9)
• Depth	mm (in)	540 (21.3)	540 (21.3)	540 (21.3)	540 (21.3)
Weight, approx.	kg (lb)	450 (992)	600 (1323)	830 (1830)	830 (1830)
Paint finish					
		RAL 7035	RAL 7035	RAL 7035	RAL 7035
Suitable for Power Module					
		6SL3310-1GF31-8AA3 (110 kW) 6SL3310-1GF32-2AA3 (132 kW) 6SL3310-1GF32-6AA3 (160 kW) 6SL3310-1GH31-8AA3 (160 kW) 6SL3310-1GF33-3AA3 (200 kW) 6SL3310-1GH32-2AA3 (200 kW) 6SL3310-1GF32-6AA3 (250 kW) 6SL3310-1GH33-3AA3 (315 kW)	6SL3310-1GF34-1AA3 (250 kW) 6SL3310-1GF34-7AA3 (315 kW) 6SL3310-1GH34-1AA3 (400 kW) 6SL3310-1GH34-7AA3 (450 kW)	6SL3310-1GF35-8AA3 (400 kW) 6SL3310-1GH35-8AA3 (560 kW)	6SL3310-1GF37-4AA3 (500 kW) 6SL3310-1GF38-1AA3 (560 kW) 6SL3310-1GH37-4AA3 (710 kW) 6SL3310-1GH38-1AA3 (800 kW)

¹⁾ The rated current of the Line Harmonics Filters is defined according to the active power. It can therefore be lower than the rated input current of the associated Power Module.

SINAMICS G130

Converter built-in units

Line-side power components > Line reactors

Overview

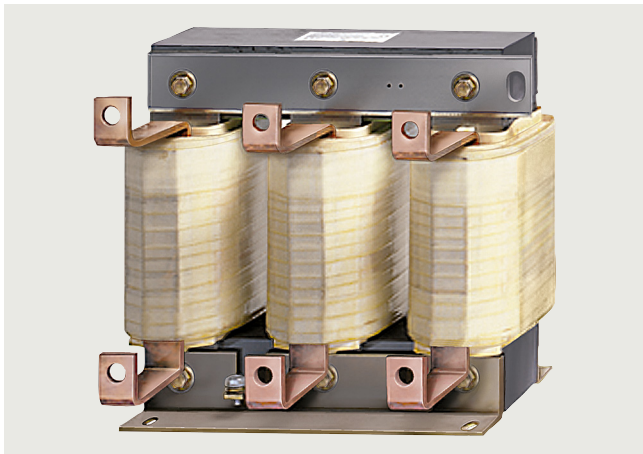

A line reactor is needed for high short-circuit power levels, partly to protect the actual converter against excessive harmonic currents, and thus against overload, and partly to limit the line harmonics to the permissible values. The harmonic currents are limited by the complete inductance comprising the line reactor and line supply cable inductance. Line reactors can be omitted if the line supply cable inductance is increased sufficiently, i.e. the RSC value must be sufficiently small.

RSC = Relative Short-Circuit power: Ratio of short-circuit power $S_{K\text{ line}}$ at the supply connection point to fundamental apparent output S_{conv} of the connected converters (according to IEC 60146-1-1).

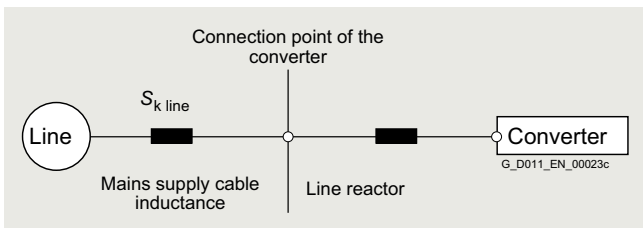

The following applies for SINAMICS G130 converter built-in units:

Power	Line reactor can be omitted	Line reactor required
kW	For RSC	For RSC
< 200	≤ 43	> 43
200 ... 500	≤ 33	> 33
> 500	≤ 20	> 20

It is recommended that a line reactor is always connected on the line side of the converter, as in practice, it is often not known on which supply configuration individual converters are to be operated, i.e. which supply short-circuit power is present at the converter connection point.

A line reactor can only be omitted when the value for RSC is less than the values listed in the above table. This is the case, when the converter, as shown in the following figure, is connected to the line supply via a transformer with the appropriate rating.

Notice:

However, a line reactor is always required when a line filter is used.

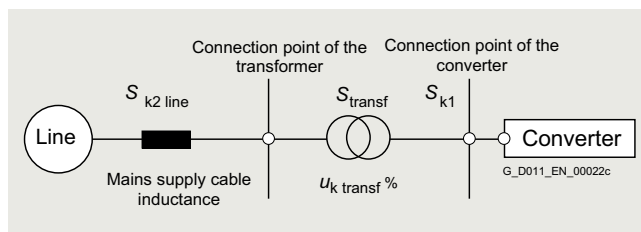

In this case, the line short-circuit power S_{K1} at the connection point of the converter is approximately:

$$S_{K1} = S_{\text{transf}} / (u_{k\text{ transf}} + S_{\text{transf}} / S_{k2\text{ line}})$$

Formula symbols	Meaning
S_{transf}	Transformer power rating
$S_{k2\text{ line}}$	Short-circuit power of the higher-level voltage
$u_{k\text{ transf}}$	Per-unit short-circuit voltage

3

Selection and ordering data

Suitable for Power Module	Type rating of the Power Module at 400 V, 500 V or 690 V kW	Line reactor Article No.
380 ... 480 V 3 AC		
6SL3310-1GE32-1AA3	110	6SL3000-OCE32-3AA0
6SL3310-1GE32-6AA3	132	6SL3000-OCE32-8AA0
6SL3310-1GE33-1AA3	160	6SL3000-OCE33-3AA0
6SL3310-1GE33-8AA3	200	6SL3000-OCE35-1AA0
6SL3310-1GE35-0AA3	250	
6SL3310-1GE36-1AA3	315	6SL3000-OCE36-3AA0
6SL3310-1GE37-5AA3	400	6SL3000-OCE37-7AA0
6SL3310-1GE38-4AA3	450	6SL3000-OCE38-7AA0
6SL3310-1GE41-0AA3	560	6SL3000-OCE41-0AA0
500 ... 600 V 3 AC		
6SL3310-1GF31-8AA3	110	6SL3000-0CH32-2AA0
6SL3310-1GF32-2AA3	132	
6SL3310-1GF32-6AA3	160	6SL3000-0CH32-7AA0
6SL3310-1GF33-3AA3	200	6SL3000-0CH33-4AA0
6SL3310-1GF34-1AA3	250	6SL3000-0CH34-8AA0
6SL3310-1GF34-7AA3	315	
6SL3310-1GF35-8AA3	400	6SL3000-0CH36-0AA0
6SL3310-1GF37-4AA3	500	6SL3000-0CH38-4AA0
6SL3310-1GF38-1AA3	560	
660 ... 690 V 3 AC		
6SL3310-1GH28-5AA3	75	6SL3000-0CH31-1AA0
6SL3310-1GH31-0AA3	90	
6SL3310-1GH31-2AA3	110	6SL3000-0CH31-6AA0
6SL3310-1GH31-5AA3	132	
6SL3310-1GH31-8AA3	160	6SL3000-0CH32-2AA0
6SL3310-1GH32-2AA3	200	
6SL3310-1GH32-6AA3	250	6SL3000-0CH32-7AA0
6SL3310-1GH33-3AA3	315	6SL3000-0CH33-4AA0
6SL3310-1GH34-1AA3	400	6SL3000-0CH34-8AA0
6SL3310-1GH34-7AA3	450	
6SL3310-1GH35-8AA3	560	6SL3000-0CH36-0AA0
6SL3310-1GH37-4AA3	710	6SL3000-0CH38-4AA0
6SL3310-1GH38-1AA3	800	

SINAMICS G130

Converter built-in units

Line-side power components > Line reactors

Technical specifications

Line voltage 380 ... 480 V 3 AC		Line reactor			
		6SL3000-OCE32-3AA0	6SL3000-OCE32-8AA0	6SL3000-OCE33-3AA0	6SL3000-OCE35-1AA0
$I_{th\ max}$	A	224	278	331	508
Nominal inductance L_N	μH	76	62	52	42
Power loss	kW	0.274	0.247	0.267	0.365
Line/load connection		1 × hole for M10	1 × hole for M10	1 × hole for M10	1 × hole for M12
• Conductor cross section, max. (IEC)	mm ²	Provided for busbar connection	Provided for busbar connection	Provided for busbar connection	Provided for busbar connection
PE connection		M6 screw	M6 screw	M6 screw	M6 screw
Degree of protection		IP00	IP00	IP00	IP00
Dimensions					
• Width	mm (in)	270 (10.63)	270 (10.63)	270 (10.63)	300 (11.81)
• Height	mm (in)	248 (9.76)	248 (9.76)	248 (9.76)	269 (10.59)
• Depth	mm (in)	200 (7.87)	200 (7.87)	200 (7.87)	212.5 (8.37)
Weight, approx.	kg (lb)	24.5 (54.0)	26 (57.3)	27.8 (61.3)	38 (83.8)
Certificates of suitability, according to		cURus	cURus	cURus	cURus
Suitable for Power Module		6SL3310-1GE32-1AA3 (110 kW)	6SL3310-1GE32-6AA3 (132 kW)	6SL3310-1GE33-1AA3 (160 kW)	6SL3310-1GE33-8AA3 (200 kW) 6SL3310-1GE35-0AA3 (250 kW)

Line voltage 380 ... 480 V 3 AC		Line reactor			
		6SL3000-OCE36-3AA0	6SL3000-OCE37-7AA0	6SL3000-OCE38-7AA0	6SL3000-OCE41-0AA0
$I_{th\ max}$	A	628	773	871	1060
Nominal inductance L_N	μH	27	22	19	16
Power loss	kW	0.368	0.351	0.458	0.498
Line/load connection		1 × hole for M12	1 × hole for M12	1 × hole for M12	1 × hole for M12
• Conductor cross section, max. (IEC)	mm ²	Provided for busbar connection	Provided for busbar connection	Provided for busbar connection	Provided for busbar connection
PE connection		M6 screw	M6 screw	M6 screw	M6 screw
Degree of protection		IP00	IP00	IP00	IP00
Dimensions					
• Width	mm (in)	300 (11.81)	300 (11.81)	350 (13.78)	350 (13.78)
• Height	mm (in)	269 (10.59)	269 (10.59)	321 (12.64)	321 (12.64)
• Depth	mm (in)	212.5 (8.37)	212.2 (8.35)	211.5 (8.33)	211.5 (8.33)
Weight, approx.	kg (lb)	41.4 (91.3)	51.3 (113)	63.2 (139)	69.6 (153)
Certificates of suitability, according to		cURus	cURus	cURus	cURus
Suitable for Power Module		6SL3310-1GE36-1AA3 (315 kW)	6SL3310-1GE37-5AA3 (400 kW)	6SL3310-1GE38-4AA3 (450 kW)	6SL3310-1GE41-0AA3 (560 kW)

Line voltage 500 ... 600 V 3 AC		Line reactor			
		6SL3000-OCH32-2AA0	6SL3000-OCH32-2AA0	6SL3000-OCH32-7AA0	6SL3000-OCH33-4AA0
$I_{th\ max}$	A	215	215	270	342
Nominal inductance L_N	μH	150	150	100	81
Power loss	kW	0.24	0.275	0.277	0.27
Line/load connection		1 × hole for M10	1 × hole for M10	1 × hole for M10	1 × hole for M10
• Conductor cross section, max. (IEC)	mm ²	Provided for busbar connection	Provided for busbar connection	Provided for busbar connection	Provided for busbar connection
PE connection		M6 screw	M6 screw	M6 screw	M6 screw
Degree of protection		IP00	IP00	IP00	IP00
Dimensions					
• Width	mm (in)	270 (10.63)	270 (10.63)	270 (10.63)	270 (10.63)
• Height	mm (in)	248 (9.76)	248 (9.76)	248 (9.76)	248 (9.76)
• Depth	mm (in)	200 (7.87)	200 (7.87)	200 (7.87)	200 (7.87)
Weight, approx.	kg (lb)	31.1 (68.6)	31.1 (68.6)	27.9 (61.5)	38.9 (85.8)
Certificates of suitability, according to		cURus	cURus	cURus	cURus
Suitable for Power Module		6SL3310-1GF31-8AA3 (110 kW)	6SL3310-1GF32-2AA3 (132 kW)	6SL3310-1GF32-6AA3 (160 kW)	6SL3310-1GF33-3AA3 (200 kW)

Technical specifications

Line voltage 500 ... 600 V 3 AC		Line reactor		
		6SL3000-0CH34-8AA0	6SL3000-0CH36-0AA0	6SL3000-0CH38-4AA0
$I_{th\ max}$	A	482	597	840
Nominal inductance L_N	μH	65	46	40
Power loss	kW	0.48	0.485	0.618
Line/load connection		1 × hole for M10	1 × hole for M12	1 × hole for M12
• Conductor cross section, max. (IEC)	mm^2	Provided for busbar connection	Provided for busbar connection	Provided for busbar connection
PE connection		M6 screw	M6 screw	M6 screw
Degree of protection		IP00	IP00	IP00
Dimensions				
• Width	mm (in)	350 (13.78)	350 (13.78)	410 (16.14)
• Height	mm (in)	321 (12.64)	321 (12.64)	385 (15.16)
• Depth	mm (in)	232.5 (9.15)	232.5 (9.15)	224 (8.82)
Weight, approx.	kg (lb)	55.6 (123)	63.8 (141)	98 (216)
Certificates of suitability, according to		cURus	cURus	cURus
Suitable for Power Module		6SL3310-1GF34-1AA3 (250 kW) 6SL3310-1GF34-7AA3 (315 kW)	6SL3310-1GF35-8AA3 (400 kW)	6SL3310-1GF37-4AA3 (500 kW) 6SL3310-1GF38-1AA3 (560 kW)

Line voltage 660 ... 690 V 3 AC		Line reactor			
		6SL3000-0CH31-1AA0	6SL3000-0CH31-6AA0	6SL3000-0CH32-2AA0	6SL3000-0CH32-7AA0
$I_{th\ max}$	A	107	155	230	270
Nominal inductance L_N	μH	310	220	150	100
Power loss	kW	0.252	0.279	0.275	0.277
Line/load connection		1 × hole for M10	1 × hole for M10	1 × hole for M10	1 × hole for M10
• Conductor cross section, max. (IEC)	mm^2	Provided for busbar connection	Provided for busbar connection	Provided for busbar connection	Provided for busbar connection
PE connection		M6 screw	M6 screw	M6 screw	M6 screw
Degree of protection		IP00	IP00	IP00	IP00
Dimensions					
• Width	mm (in)	270 (10.63)	270 (10.63)	270 (10.63)	270 (10.63)
• Height	mm (in)	248 (9.76)	248 (9.76)	248 (9.76)	248 (9.76)
• Depth	mm (in)	200 (7.87)	200 (7.87)	200 (7.87)	200 (7.87)
Weight, approx.	kg (lb)	24.4 (53.8)	25.9 (57.1)	31.1 (68.6)	27.9 (61.5)
Certificates of suitability, according to		cURus	cURus	cURus	cURus
Suitable for Power Module		6SL3310-1GH28-5AA3 (75 kW) 6SL3310-1GH31-0AA3 (90 kW)	6SL3310-1GH31-2AA3 (110 kW) 6SL3310-1GH31-5AA3 (132 kW)	6SL3310-1GH31-8AA3 (160 kW) 6SL3310-1GH32-2AA3 (200 kW)	6SL3310-1GH32-6AA3 (250 kW)

Line voltage 660 ... 690 V 3 AC		Line reactor			
		6SL3000-0CH33-4AA0	6SL3000-0CH34-8AA0	6SL3000-0CH36-0AA0	6SL3000-0CH38-4AA0
$I_{th\ max}$	A	342	482	597	840
Nominal inductance L_N	μH	81	65	46	40
Power loss	kW	0.27	0.48	0.485	0.618
Line/load connection		1 × hole for M10	1 × hole for M10	1 × hole for M12	1 × hole for M12
• Conductor cross section, max. (IEC)	mm^2	Provided for busbar connection	Provided for busbar connection	Provided for busbar connection	Provided for busbar connection
PE connection		M6 screw	M6 screw	M6 screw	M6 screw
Degree of protection		IP00	IP00	IP00	IP00
Dimensions					
• Width	mm (in)	270 (10.63)	350 (13.78)	350 (13.78)	410 (16.14)
• Height	mm (in)	248 (9.76)	321 (12.64)	321 (12.64)	385 (15.16)
• Depth	mm (in)	200 (7.87)	232 (9.13)	232 (9.13)	224 (8.82)
Weight, approx.	kg (lb)	38.9 (85.8)	55.6 (123)	63.8 (141)	98 (216)
Certificates of suitability, according to		cURus	cURus	cURus	cURus
Suitable for Power Module		6SL3310-1GH33-3AA3 (315 kW)	6SL3310-1GH34-1AA3 (400 kW) 6SL3310-1GH34-7AA3 (450 kW)	6SL3310-1GH35-8AA3 (560 kW)	6SL3310-1GH37-4AA3 (710 kW) 6SL3310-1GH38-1AA3 (800 kW)

SINAMICS G130

Converter built-in units

Line-side power components > Recommended line-side system components**Selection and ordering data**

The table below lists recommended ratings for input-side switching and fuse protection elements according to IEC standards.

Further information about the main contactors, switch disconnectors, fuses and circuit breakers specified in the table can be found in Catalog LV 10.

Type rating (for 400V, 500V or 690V)	Rated input current	Assignment to Power Module	Line contactor	Fixed-mounted circuit breaker	Switch disconnector for cable protection fuses incl. semiconductor protection of type 3NE1
kW	A	Type 6SL3310-...	Article No.	Article No.	Article No.
380 ... 480 V 3 AC					
110	229	1GE32-1AA3	3RT1456-.....	–	3KF3325-0MF51
132	284	1GE32-6AA3	3RT1466-.....	–	3KF4340-0MF51
160	338	1GE33-1AA3	3RT1466-.....	–	3KF4340-0MF51
200	395	1GE33-8AA3	3RT1476-.....	–	3KF5363-0MF51
250	509	1GE35-0AA3	3RT1476-.....	–	3KF5363-0MF51
315	629	1GE36-1AA3	3RT1476-.....	–	3KF5380-0MF51
400	775	1GE37-5AA3	3RT1466-..... (3 units)	–	3KF5380-0MF51
450	873	1GE38-4AA3	–	3WA1110-... *)	–
560	1024	1GE41-0AA3	–	3WA1112-... *)	–
500 ... 600 V 3 AC					
110	191	1GF31-8AA3	3RT1456-.....	–	3KF3325-0MF51
132	242	1GF32-2AA3	3RT1456-.....	–	3KF3325-0MF51
160	270	1GF32-6AA3	3RT1466-.....	–	3KF4340-0MF51
200	343	1GF33-3AA3	3RT1466-.....	–	3KF4340-0MF51
250	426	1GF34-1AA3	3RT1476-.....	–	3KF5363-0MF51
315	483	1GF34-7AA3	3RT1476-.....	–	3KF5363-0MF51
400	598	1GF35-8AA3	3RT1476-.....	–	3KF5380-0MF51
500	764	1GF37-4AA3	3RT1466-..... (3 units)	–	3KF5380-0MF51
560	842	1GF38-1AA3	–	3WA1110-... *)	–
660 ... 690 V 3 AC					
75	93	1GH28-5AA3	3RT1446-.....	–	3KF2312-0MF51
90	109	1GH31-0AA3	3RT1446-.....	–	3KF2312-0MF51
110	131	1GH31-2AA3	3RT1446-.....	–	3KF3325-0MF51
132	164	1GH31-5AA3	3RT1456-.....	–	3KF3325-0MF51
160	191	1GH31-8AA3	3RT1456-.....	–	3KF3325-0MF51
200	224	1GH32-2AA3	3RT1456-.....	–	3KF3325-0MF51
250	270	1GH32-6AA3	3RT1466-.....	–	3KF4340-0MF51
315	343	1GH33-3AA3	3RT1466-.....	–	3KF4340-0MF51
400	426	1GH34-1AA3	3RT1476-.....	–	3KF5363-0MF51
450	483	1GH34-7AA3	3RT1476-.....	–	3KF5363-0MF51
560	598	1GH35-8AA3	3RT1476-.....	–	3KF5380-0MF51
710	764	1GH37-4AA3	3RT1466-..... (3 units)	–	3KF5380-0MF51
800	842	1GH38-1AA3	–	3WA1110-... *)	–

^{*)} The circuit breakers must always be switched ON and OFF by the sequence control. An interlocking set 3WA9111-0BA21 as described in Catalog LV 10 should be provided for the circuit breakers in order to exclude the risk of unintentional manual operation. Manual operation bypasses the pre-charging circuit and can therefore destroy the Power Module.

Selection and ordering data

Type rating (for 400V, 500V or 690V)	Rated input current	Assignment to Power Module	Cable protection fuse ¹⁾		Cable protection fuse incl. semiconductor protection ²⁾	
			Article No.	Rated current A	Article No.	Rated current A
380 ... 480 V 3 AC						
110	229	1GE32-1AA3	3NA3144	250	3NE1230-2	315
132	284	1GE32-6AA3	3NA3250	300	3NE1331-2	350
160	338	1GE33-1AA3	3NA3254	355	3NE1334-2	500
200	395	1GE33-8AA3	3NA3260	400	3NE1334-2	500
250	509	1GE35-0AA3	3NA3372	630	3NE1436-2	630
315	629	1GE36-1AA3	3NA3475	800	3NE1438-2	800
400	775	1GE37-5AA3	3NA3475	800	3NE1448-2	850
450	873	1GE38-4AA3	3NA3365	2 × 500	3NE1436-2	2 × 630
560	1024	1GE41-0AA3	3NA3472	2 × 630	3NE1437-2	2 × 710
500 ... 600 V 3 AC						
110	191	1GF31-8AA3	3NA3244-6	250	3NE1227-2	250
132	242	1GF32-2AA3	3NA3252-6	315	3NE1230-2	315
160	270	1GF32-6AA3	3NA3354-6	355	3NE1331-2	350
200	343	1GF33-3AA3	3NA3365-6	500	3NE1334-2	500
250	426	1GF34-1AA3	3NA3365-6	500	3NE1334-2	500
315	483	1GF34-7AA3	3NA3252-6	2 × 315	3NE1435-2	560
400	598	1GF35-8AA3	3NA3354-6	2 × 355	3NE1447-2	670
500	764	1GF37-4AA3	3NA3365-6	2 × 500	3NE1448-2	850
560	842	1GF38-1AA3	3NA3365-6	2 × 500	3NE1334-2	2 × 500
660 ... 690 V 3 AC						
75	93	1GH28-5AA3	3NA3132-6	125	3NE1022-2	125
90	109	1GH31-0AA3	3NA3132-6	125	3NE1022-2	125
110	131	1GH31-2AA3	3NA3136-6	160	3NE1224-2	160
132	164	1GH31-5AA3	3NA3240-6	200	3NE1225-2	200
160	191	1GH31-8AA3	3NA3244-6	250	3NE1227-2	250
200	224	1GH32-2AA3	3NA3252-6	315	3NE1230-2	315
250	270	1GH32-6AA3	3NA3354-6	355	3NE1331-2	350
315	343	1GH33-3AA3	3NA3365-6	500	3NE1334-2	500
400	426	1GH34-1AA3	3NA3365-6	500	3NE1334-2	500
450	483	1GH34-7AA3	3NA3252-6	2 × 315	3NE1435-2	560
560	598	1GH35-8AA3	3NA3354-6	2 × 355	3NE1447-2	670
710	764	1GH37-4AA3	3NA3365-6	2 × 500	3NE1448-2	850
800	842	1GH38-1AA3	3NA3365-6	2 × 500	3NE1334-2	2 × 500

¹⁾ The specified 3NA3... fuses can be used for the additional cable protection.

²⁾ Only 3NE1... fuses should be used to protect the devices. These must be located as close as possible to the converter.

SINAMICS G130

Converter built-in units

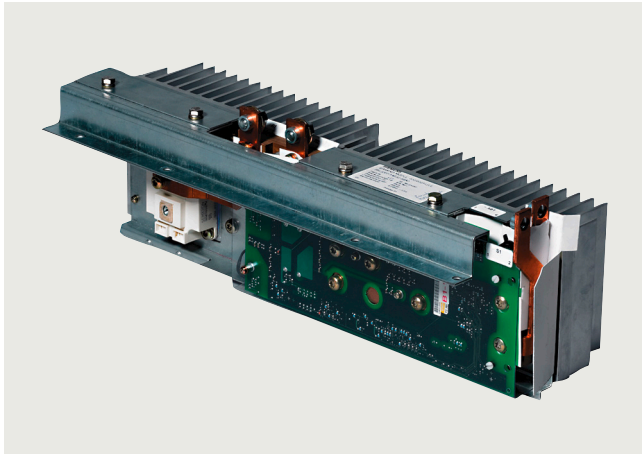
DC link components > Braking Modules**Overview**

A Braking Module and the associated braking resistor are required when the drive is to be braked or specifically stopped, e.g. for an EMERGENCY STOP.

The Braking Module includes the power electronics and the associated control circuit. The supply voltage for the electronics is taken from the DC link.

During operation, the DC-link power is converted into heat loss in an external braking resistor.

The Braking Module works independently of the converter control. If more braking power is required than provided by the Braking Modules listed here, then braking units may be connected in parallel for higher converter outputs (on request). In this case, a Braking Module is assigned to each braking resistor.

The activation threshold of the Braking Module can be adjusted by means of a DIP switch. The braking power values specified in the technical specifications apply to the upper activation threshold.

Design

The Braking Module is inserted in a slot inside the Power Module; it is force-cooled by the Power Module fan.

Several Braking Modules can be used for Power Modules with more than one power block:

- Frame size HX: 2 Braking Modules
- Frame size JX: 3 Braking Modules

Each Braking Module is always assigned a dedicated braking resistor.

The Braking Module is connected to the DC link by means of the busbar sets or flexible cables contained in the scope of delivery.

The Braking Module has the following interfaces as standard:

- DC-link connection
- Braking resistor connection
- 1 digital input (block Braking Module / acknowledge error)
- 1 digital output (Braking Module faulty)
- 1 DIP switch for adjusting the activation threshold

Information about Braking Module activation thresholds as well as further configuration information is contained in the SINAMICS Low Voltage Engineering Manual.

Selection and ordering data

Suitable for Power Module	Type rating of the Power Module at 400 V, 500 V or 690 V kW	Braking Module	
		Article No.	
380 ... 480 V 3 AC			
6SL3310-1GE32-1AA3	110	6SL3300-1AE31-3AA0	
6SL3310-1GE32-6AA3	132		
6SL3310-1GE33-1AA3	160	6SL3300-1AE32-5AA0	
6SL3310-1GE33-8AA3	200		
6SL3310-1GE35-0AA3	250		
6SL3310-1GE36-1AA3	315	6SL3300-1AE32-5BA0	
6SL3310-1GE37-5AA3	400		
6SL3310-1GE38-4AA3	450		
6SL3310-1GE41-0AA3	560		
500 ... 600 V 3 AC			
6SL3310-1GF31-8AA3	110	6SL3300-1AF32-5AA0	
6SL3310-1GF32-2AA3	132		
6SL3310-1GF32-6AA3	160		
6SL3310-1GF33-3AA3	200		
6SL3310-1GF34-1AA3	250	6SL3300-1AF32-5BA0	
6SL3310-1GF34-7AA3	315		
6SL3310-1GF35-8AA3	400		
6SL3310-1GF37-4AA3	500		
6SL3310-1GF38-1AA3	560		
660 ... 690 V 3 AC			
6SL3310-1GH28-5AA3	75	6SL3300-1AH31-3AA0	
6SL3310-1GH31-0AA3	90		
6SL3310-1GH31-2AA3	110		
6SL3310-1GH31-5AA3	132		
6SL3310-1GH31-8AA3	160	6SL3300-1AH32-5AA0	
6SL3310-1GH32-2AA3	200		
6SL3310-1GH32-6AA3	250		
6SL3310-1GH33-3AA3	315		
6SL3310-1GH34-1AA3	400	6SL3300-1AH32-5BA0	
6SL3310-1GH34-7AA3	450		
6SL3310-1GH35-8AA3	560		
6SL3310-1GH37-4AA3	710		
6SL3310-1GH38-1AA3	800		

Integration

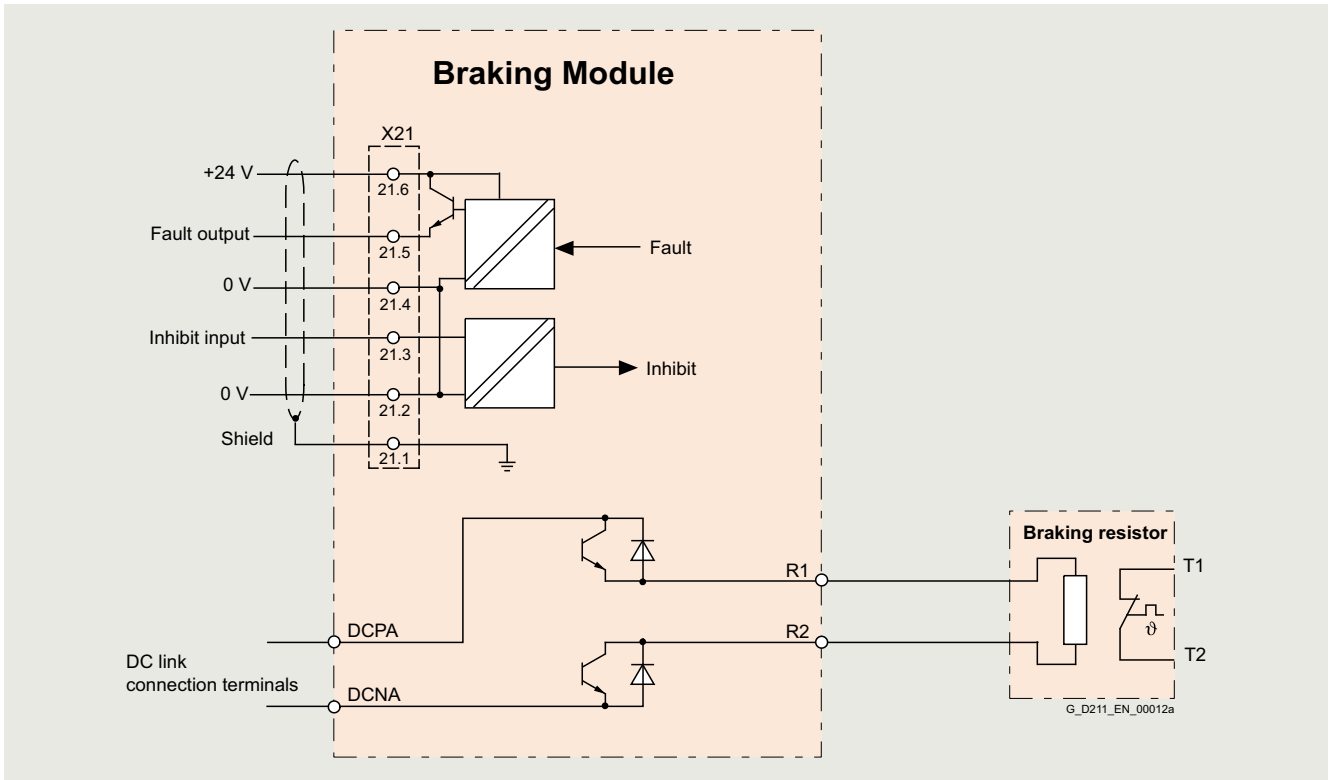

Connection diagram for Braking Module

Characteristic curves

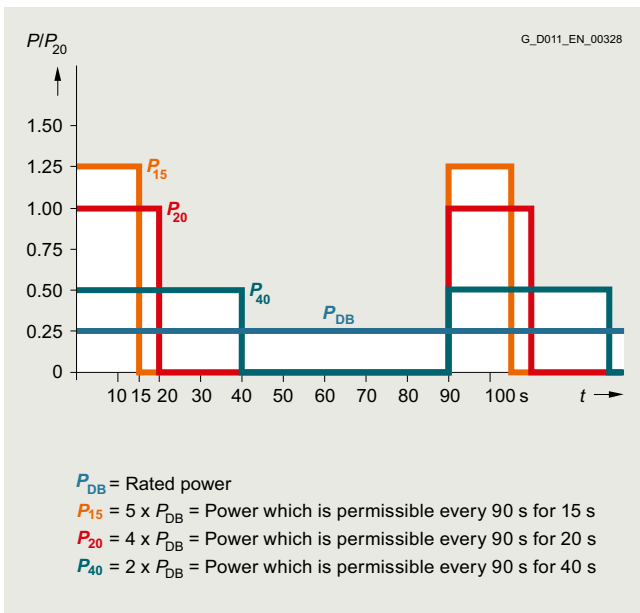

Load diagram for Braking Modules and braking resistors

3

SINAMICS G130

Converter built-in units

DC link components > Braking Modules

Technical specifications

		Braking Module					
		6SL3300-1AE31-3AA0	6SL3300-1AE32-5AA0 6SL3300-1AE32-5BA0	6SL3300-1AF32-5AA0 6SL3300-1AF32-5BA0	6SL3300-1AH31-3AA0	6SL3300-1AH32-5AA0 6SL3300-1AH32-5BA0	
Line voltage		380 ... 480 V 3 AC		500 ... 600 V 3 AC	660 ... 690 V 3 AC		
Rated power P_{DB}	kW	25	50	50	25	50	
Peak power P_{15}	kW	125	250	250	125	250	
Power P_{20}	kW	100	200	200	100	200	
Power P_{40}	kW	50	100	100	50	100	
Activation thresholds (adjustable via DIP switch)	V	774 (factory setting) or 673	774 (factory setting) or 673	967 (factory setting) or 841	1158 (factory setting) or 1070	1158 (factory setting) or 1070	
Digital inputs							
• Voltage	V	24	24	24	24	24	
• Low level (an open digital input is interpreted as "low")	V	-3 ... +5	-3 ... +5	-3 ... +5	-3 ... +5	-3 ... +5	
• High level	V	15 ... 30	15 ... 30	15 ... 30	15 ... 30	15 ... 30	
• Current consumption at 24 V DC, typ.	mA	10	10	10	10	10	
• Conductor cross section, max. (IEC)	mm ²	1.5	1.5	1.5	1.5	1.5	
Digital outputs (continuously short-circuit-proof)							
• Voltage	V	24	24	24	24	24	
• Load current per digital output, max.	mA	500	500	500	500	500	
• Conductor cross section, max. (IEC)	mm ²	1.5	1.5	1.5	1.5	1.5	
Design conforms to		UL and IEC	UL and IEC	UL and IEC	IEC	IEC	
R1/R2 connection		M8 nut	M8 nut	M8 nut	M8 nut	M8 nut	
• Conductor cross section, max. (IEC)	mm ²	35	50	50	35	50	
Weight, approx.	kg (lb)	3.6 (7.94)	7.3 (16.1) (6SL3300-1AE32-5AA0) 7.5 (16.5) (6SL3300-1AE32-5BA0)	7.3 (16.1) (6SL3300-1AF32-5AA0) 7.5 (16.5) (6SL3300-1AF32-5BA0)	3.6 (7.94)	7.3 (16.1) (6SL3300-1AH32-5AA0) 7.5 (16.5) (6SL3300-1AH32-5BA0)	
Certificates of suitability, according to		cULus	cULus	cULus	–	–	
Braking Module		6SL3300-1AE31-3AA0	6SL3300-1AE32-5AA0	6SL3300-1AF32-5AA0	6SL3300-1AH31-3AA0	6SL3300-1AH32-5AA0	
Suitable for Power Module		6SL3310-1GE32-1AA3 (110 kW) 6SL3310-1GE32-6AA3 (132 kW)	6SL3310-1GE33-1AA3 (160 kW) 6SL3310-1GE33-8AA3 (200 kW) 6SL3310-1GE35-0AA3 (250 kW)	6SL3310-1GF31-8AA3 (110 kW) 6SL3310-1GF32-2AA3 (132 kW) 6SL3310-1GF32-6AA3 (160 kW) 6SL3310-1GF33-3AA3 (200 kW)	6SL3310-1GH28-5AA3 (75 kW) 6SL3310-1GH31-0AA3 (90 kW) 6SL3310-1GH31-2AA3 (110 kW) 6SL3310-1GH31-5AA3 (132 kW)	6SL3310-1GH31-8AA3 (160 kW) 6SL3310-1GH32-2AA3 (200 kW) 6SL3310-1GH32-6AA3 (250 kW) 6SL3310-1GH33-3AA3 (315 kW)	
Braking Module		–	6SL3300-1AE32-5BA0	6SL3300-1AF32-5BA0	–	6SL3300-1AH32-5BA0	
Suitable for Power Module		–	6SL3310-1GE36-1AA3 (315 kW) 6SL3310-1GE37-5AA3 (400 kW) 6SL3310-1GE38-4AA3 (450 kW) 6SL3310-1GE41-0AA3 (560 kW)	6SL3310-1GF34-1AA3 (250 kW) 6SL3310-1GF34-7AA3 (315 kW) 6SL3310-1GF35-8AA3 (400 kW) 6SL3310-1GF37-4AA3 (500 kW) 6SL3310-1GF38-1AA3 (560 kW)	–	6SL3310-1GH34-1AA3 (400 kW) 6SL3310-1GH34-7AA3 (450 kW) 6SL3310-1GH35-8AA3 (560 kW) 6SL3310-1GH37-4AA3 (710 kW) 6SL3310-1GH38-1AA3 (800 kW)	

Overview



Excess energy in the DC link is dissipated via the braking resistor.

The braking resistor is connected to a Braking Module. The braking resistor is positioned outside the cabinet or switchgear room. This enables the resulting heat loss around the Power Modules to be dissipated. This reduces the level of air conditioning required.

Two braking resistors with different rated and peak power values are available for the devices.

The braking resistor is monitored on the basis of the duty factor. A temperature switch (NC contact) is also fitted. This responds when the maximum permissible temperature is exceeded and can be evaluated by a controller. The maximum permissible cable length between the Braking Module and braking resistor is 100 m.

Information about possible duty cycles of the braking resistors as well as other configuration information is contained in the SINAMICS Low Voltage Engineering Manual.

Selection and ordering data

P_{DB} rated power kW	Suitable for Braking Module	Braking resistor Article No.
Line voltage 380 ... 480 V 3 AC		
25	6SL3300-1AE31-3AA0	6SL3000-1BE31-3AA0
50	6SL3300-1AE32-5.A0	6SL3000-1BE32-5AA0
Line voltage 500 ... 600 V 3 AC		
50	6SL3300-1AF32-5.A0	6SL3000-1BF32-5AA0
Line voltage 660 ... 690 V 3 AC		
25	6SL3300-1AH31-3AA0	6SL3000-1BH31-3AA0
50	6SL3300-1AH32-5.A0	6SL3000-1BH32-5AA0

Characteristic curves

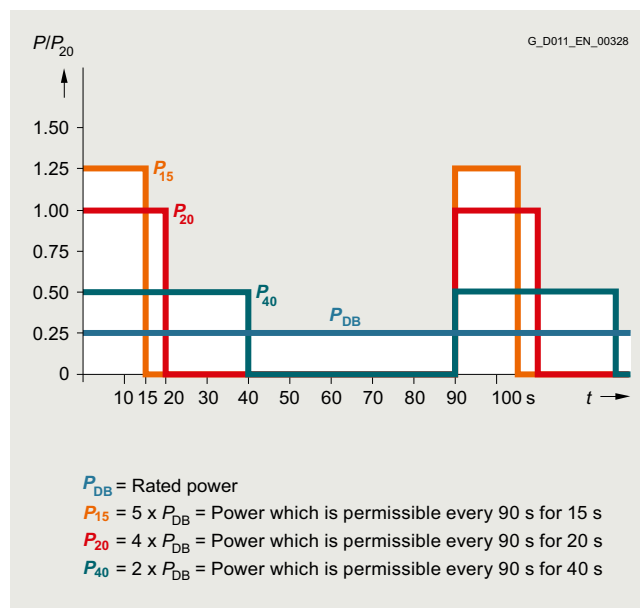

Load diagram for Braking Modules and braking resistor

Technical specifications

Line voltage 380 ... 480 V 3 AC		Braking resistor	
		6SL3000-1BE31-3AA0	6SL3000-1BE32-5AA0
Resistance	Ω	4.4 ($\pm 7.5\%$)	2.2 ($\pm 7.5\%$)
P_{DB} rated power (continuous braking power)	kW	25	50
P_{15} power	kW	125	250
P_{20} power	kW	100	200
P_{40} power	kW	50	100
Current, max.	A	189	378
Conductor cross section, max. (IEC)	mm ²	50	70
Power connection		M10 stud	M10 stud
Degree of protection		IP20	IP20
Dimensions			
• Width	mm (in)	740 (29.13)	810 (31.89)
• Height	mm (in)	600 (23.62)	1325 (52.17)
• Depth	mm (in)	486 (19.13)	486 (19.13)
Weight, approx.	kg (lb)	50 (110)	120 (265)
Certificates of suitability, according to		cURus	cURus
Suitable for Braking Module		6SL3300-1AE31-3AA	6SL3300-1AE32-5.A0

SINAMICS G130

Converter built-in units

DC link components > Braking resistors**Technical specifications**

Line voltage 500 ... 600 V 3 AC		Braking resistor
		6SL3000-1BF32-5AA0
Resistance	Ω	3.4 (±7.5%)
P_{DB} rated power (continuous braking power)	kW	50
P_{15} power	kW	250
P_{20} power	kW	200
P_{40} power	kW	100
Current, max.	A	255
Conductor cross section, max. (IEC)	mm ²	70
Power connection		M10 stud
Degree of protection		IP20
Dimensions		
• Width	mm (in)	810 (31.89)
• Height	mm (in)	1325 (52.17)
• Depth	mm (in)	486 (19.13)
Weight, approx.	kg (lb)	120 (265)
Certificates of suitability, according to		cURus
Suitable for Braking Module		6SL3300-1AF32-5.A0

Line voltage 660 ... 690 V 3 AC		Braking resistor	
		6SL3000-1BH31-3AA0	6SL3000-1BH32-5AA0
Resistance	Ω	9.8 (±7.5%)	4.9 (±7.5%)
P_{DB} rated power (continuous braking power)	kW	25	50
P_{15} power	kW	125	250
P_{20} power	kW	100	200
P_{40} power	kW	50	100
Current, max.	A	125	255
Conductor cross section, max. (IEC)	mm ²	50	70
Power connection		M10 stud	M10 stud
Degree of protection		IP20	IP20
Dimensions			
• Width	mm (in)	740 (29.13)	810 (31.89)
• Height	mm (in)	600 (23.62)	1325 (52.17)
• Depth	mm (in)	486 (19.13)	486 (19.13)
Weight, approx.	kg (lb)	50 (110)	120 (265)
Certificates of suitability, according to		cURus	cURus
Suitable for Braking Module		6SL3300-1AH31-3AA0	6SL3300-1AH32-5.A0

Overview

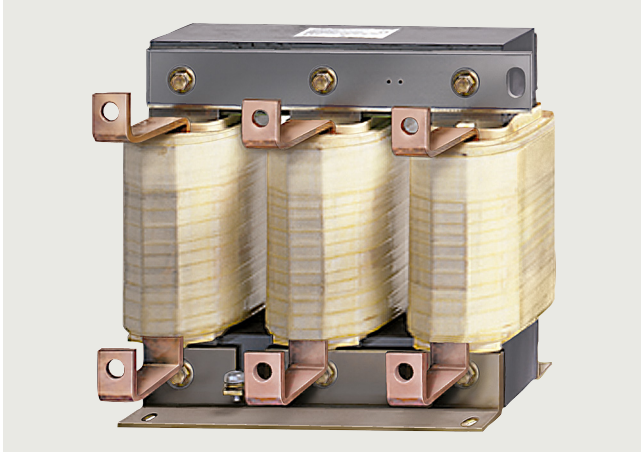

Motor reactors reduce the voltage load on the motor windings by reducing the voltage gradients at the motor terminals that occur during converter operation. At the same time, the capacitive charge/discharge currents that place an additional load on the converter output when long motor cables are used, are reduced. The maximum permissible output frequency when a motor reactor is used is 150 Hz.

The motor reactor must be installed as close as possible to the Power Module.

Selection and ordering data

Suitable for Power Module	Type rating of the Power Module at 400 V, 500 V or 690 V kW	Motor reactor
		Article No.
380 ... 480 V 3 AC		
6SL3310-1GE32-1AA3	110	6SL3000-2BE32-1AA0
6SL3310-1GE32-6AA3	132	6SL3000-2BE32-6AA0
6SL3310-1GE33-1AA3	160	6SL3000-2BE33-2AA0
6SL3310-1GE33-8AA3	200	6SL3000-2BE33-8AA0
6SL3310-1GE35-0AA3	250	6SL3000-2BE35-0AA0
6SL3310-1GE36-1AA3	315	6SL3000-2AE36-1AA0
6SL3310-1GE37-5AA3	400	6SL3000-2AE38-4AA0
6SL3310-1GE38-4AA3	450	
6SL3310-1GE41-0AA3	560	6SL3000-2AE41-0AA0
500 ... 600 V 3 AC		
6SL3310-1GF31-8AA3	110	6SL3000-2AH31-8AA0
6SL3310-1GF32-2AA3	132	6SL3000-2AH32-4AA0
6SL3310-1GF32-6AA3	160	6SL3000-2AH32-6AA0
6SL3310-1GF33-3AA3	200	6SL3000-2AH33-6AA0
6SL3310-1GF34-1AA3	250	6SL3000-2AH34-5AA0
6SL3310-1GF34-7AA3	315	6SL3000-2AH34-7AA0
6SL3310-1GF35-8AA3	400	6SL3000-2AH35-8AA0
6SL3310-1GF37-4AA3	500	6SL3000-2AH38-1AA0
6SL3310-1GF38-1AA3	560	
660 ... 690 V 3 AC		
6SL3310-1GH28-5AA3	75	6SL3000-2AH31-0AA0
6SL3310-1GH31-0AA3	90	
6SL3310-1GH31-2AA3	110	6SL3000-2AH31-5AA0
6SL3310-1GH31-5AA3	132	
6SL3310-1GH31-8AA3	160	6SL3000-2AH31-8AA0
6SL3310-1GH32-2AA3	200	6SL3000-2AH32-4AA0
6SL3310-1GH32-6AA3	250	6SL3000-2AH32-6AA0
6SL3310-1GH33-3AA3	315	6SL3000-2AH33-6AA0
6SL3310-1GH34-1AA3	400	6SL3000-2AH34-5AA0
6SL3310-1GH34-7AA3	450	6SL3000-2AH34-7AA0
6SL3310-1GH35-8AA3	560	6SL3000-2AH35-8AA0
6SL3310-1GH37-4AA3	710	6SL3000-2AH38-1AA0
6SL3310-1GH38-1AA3	800	

SINAMICS G130

Converter built-in units

Load-side power components > Motor reactors**Technical specifications**

Line voltage 380 ... 480 V 3 AC		Motor reactor (for pulse frequencies of 2 kHz to 4 kHz)				
		6SL3000-2BE32-1AA0	6SL3000-2BE32-6AA0	6SL3000-2BE33-2AA0	6SL3000-2BE33-8AA0	6SL3000-2BE35-0AA0
Rated current	A	210	260	310	380	490
Power loss						
• At 50 Hz	kW	0.436	0.454	0.422	0.477	0.448
• At 150 Hz	kW	0.486	0.5	0.47	0.5	0.5
Load connection		1 × hole for M10	1 × hole for M10	1 × hole for M10	1 × hole for M10	1 × hole for M12
PE connection		M8 screw	M8 screw	M8 screw	M8 screw	M8 screw
Cable length, max. between motor reactor and motor ¹⁾						
• Shielded	m (ft)	300 (984)	300 (984)	300 (984)	300 (984)	300 (984)
• Unshielded	m (ft)	450 (1476)	450 (1476)	450 (1476)	450 (1476)	450 (1476)
Degree of protection		IP00	IP00	IP00	IP00	IP00
Dimensions						
• Width	mm (in)	300 (11.81)	300 (11.81)	300 (11.81)	300 (11.81)	300 (11.81)
• Height	mm (in)	285 (11.22)	315 (12.40)	285 (11.22)	285 (11.22)	365 (14.37)
• Depth	mm (in)	257 (10.12)	277 (10.91)	257 (10.12)	277 (10.91)	277 (10.91)
Weight, approx.	kg (lb)	60 (132)	66 (146)	62 (137)	73 (161)	100 (220)
Certificates of suitability, according to		cURus	cURus	cURus	cURus	cURus
Suitable for Power Module		6SL3310-1GE32-1AA3 (110 kW)	6SL3310-1GE32-6AA3 (132 kW)	6SL3310-1GE33-1AA3 (160 kW)	6SL3310-1GE33-8AA3 (200 kW)	6SL3310-1GE35-0AA3 (250 kW)

Line voltage 380 ... 480 V 3 AC		Motor reactor (for pulse frequencies of 1.25 kHz to 2.5 kHz)			
		6SL3000-2AE36-1AA0	6SL3000-2AE38-4AA0		6SL3000-2AE41-0AA0
Rated current	A	605	840	840	985
Power loss					
• At 50 Hz	kW	0.798	0.75	0.834	0.939
• At 150 Hz	kW	0.9	0.84	0.943	1.062
Load connection		1 × hole for M12	1 × hole for M12	1 × hole for M12	1 × hole for M12
PE connection		M10 screw	M10 screw	M10 screw	M10 screw
Cable length, max. between motor reactor and motor ¹⁾					
• Shielded	m (ft)	300 (984)	300 (984)	300 (984)	300 (984)
• Unshielded	m (ft)	450 (1476)	450 (1476)	450 (1476)	450 (1476)
Degree of protection		IP00	IP00	IP00	IP00
Dimensions					
• Width	mm (in)	410 (16.14)	410 (16.14)	410 (16.14)	410 (16.14)
• Height	mm (in)	392 (15.43)	392 (15.43)	392 (15.43)	392 (15.43)
• Depth	mm (in)	292 (11.50)	292 (11.50)	292 (11.50)	302 (11.89)
Weight, approx.	kg (lb)	130 (287)	140 (309)	140 (309)	146 (322)
Certificates of suitability, according to		cURus	cURus	cURus	cURus
Suitable for Power Module		6SL3310-1GE36-1AA3 (315 kW)	6SL3310-1GE37-5AA3 (400 kW)	6SL3310-1GE38-4AA3 (450 kW)	6SL3310-1GE41-0AA3 (560 kW)

Technical specifications

Line voltage 500 ... 600 V 3 AC		Motor reactor (for pulse frequencies of 1.25 kHz to 2.5 kHz)				
		6SL3000-2AH31-8AA0	6SL3000-2AH32-4AA0	6SL3000-2AH32-6AA0	6SL3000-2AH33-6AA0	6SL3000-2AH34-5AA0
Rated current	A	175	215	260	330	410
Power loss						
• At 50 Hz	kW	0.357	0.376	0.389	0.4	0.481
• At 150 Hz	kW	0.403	0.425	0.441	0.454	0.545
Load connection		1 × hole for M10	1 × hole for M10	1 × hole for M10	1 × hole for M10	1 × hole for M10
PE connection		M8 screw	M8 screw	M8 screw	M8 screw	M8 screw
Cable length, max. between motor reactor and motor ¹⁾						
• Shielded	m (ft)	300 (984)	300 (984)	300 (984)	300 (984)	300 (984)
• Unshielded	m (ft)	450 (1476)	450 (1476)	450 (1476)	450 (1476)	450 (1476)
Degree of protection		IP00	IP00	IP00	IP00	IP00
Dimensions						
• Width	mm (in)	300 (11.81)	300 (11.81)	300 (11.81)	300 (11.81)	350 (13.78)
• Height	mm (in)	285 (11.22)	285 (11.22)	285 (11.22)	285 (11.22)	330 (12.99)
• Depth	mm (in)	212 (8.35)	212 (8.35)	212 (8.35)	212 (8.35)	215 (8.46)
Weight, approx.	kg (lb)	34 (75)	34 (75)	40 (88.2)	43 (94.8)	56 (123)
Certificates of suitability, according to		cURus	cURus	cURus	cURus	cURus
Suitable for Power Module		6SL3310-1GF31-8AA3 (110 kW)	6SL3310-1GF32-2AA3 (132 kW)	6SL3310-1GF32-6AA3 (160 kW)	6SL3310-1GF33-3AA3 (200 kW)	6SL3310-1GF34-1AA3 (250 kW)

Line voltage 500 ... 600 V 3 AC		Motor reactor (for pulse frequencies of 1.25 kHz to 2.5 kHz)			
		6SL3000-2AH34-7AA0	6SL3000-2AH35-8AA0	6SL3000-2AH38-1AA0	
Rated current	A	465	575	810	810
Power loss					
• At 50 Hz	kW	0.631	0.705	0.78	0.877
• At 150 Hz	kW	0.723	0.801	0.91	1.003
Load connection		1 × hole for M12	1 × hole for M12	1 × hole for M12	1 × hole for M12
PE connection		M8 screw	M8 screw	M8 screw	M8 screw
Cable length, max. between motor reactor and motor ¹⁾					
• Shielded	m (ft)	300 (984)	300 (984)	300 (984)	300 (984)
• Unshielded	m (ft)	450 (1476)	450 (1476)	450 (1476)	450 (1476)
Degree of protection		IP00	IP00	IP00	IP00
Dimensions					
• Width	mm (in)	410 (16.14)	410 (16.14)	410 (16.14)	410 (16.14)
• Height	mm (in)	392 (15.43)	392 (15.43)	392 (15.43)	392 (15.43)
• Depth	mm (in)	292 (11.50)	292 (11.50)	279 (10.98)	279 (10.98)
Weight, approx.	kg (lb)	80 (176)	80 (176)	146 (322)	146 (322)
Certificates of suitability, according to		cURus	cURus	cURus	cURus
Suitable for Power Module		6SL3310-1GF34-7AA3 (315 kW)	6SL3310-1GF35-8AA3 (400 kW)	6SL3310-1GF37-4AA3 (500 kW)	6SL3310-1GF38-1AA3 (560 kW)

SINAMICS G130

Converter built-in units

Load-side power components > Motor reactors

Technical specifications

Line voltage 660 ... 690 V 3 AC		Motor reactor (for pulse frequencies of 1.25 kHz to 2.5 kHz)						
		6SL3000-2AH31-0AA0		6SL3000-2AH31-5AA0		6SL3000-2AH31-8AA0	6SL3000-2AH32-4AA0	6SL3000-2AH32-6AA0
Rated current	A	100	100	150	150	175	215	260
Power loss								
• At 50 Hz	kW	0.215	0.269	0.237	0.296	0.357	0.376	0.389
• At 150 Hz	kW	0.26	0.3	0.26	0.332	0.403	0.425	0.441
Load connection		1 × hole for M10	1 × hole for M10	1 × hole for M10	1 × hole for M10	1 × hole for M10	1 × hole for M10	1 × hole for M10
PE connection		M6 screw	M6 screw	M6 screw	M6 screw	M8 screw	M8 screw	M8 screw
Cable length, max. between motor reactor and motor ¹⁾								
• Shielded	m (ft)	300 (984)	300 (984)	300 (984)	300 (984)	300 (984)	300 (984)	300 (984)
• Unshielded	m (ft)	450 (1476)	450 (1476)	450 (1476)	450 (1476)	450 (1476)	450 (1476)	450 (1476)
Degree of protection		IP00	IP00	IP00	IP00	IP00	IP00	IP00
Dimensions								
• Width	mm (in)	270 (10.63)	270 (10.63)	270 (10.63)	270 (10.63)	300 (11.81)	300 (11.81)	300 (11.81)
• Height	mm (in)	248 (9.76)	248 (9.76)	248 (9.76)	248 (9.76)	285 (11.22)	285 (11.22)	285 (11.22)
• Depth	mm (in)	200 (7.87)	200 (7.87)	200 (7.87)	200 (7.87)	212 (8.35)	212 (8.35)	212 (8.35)
Weight, approx.	kg (lb)	25 (55.1)	25 (55.1)	25.8 (56.9)	25.8 (56.9)	33 (72.8)	35 (77.2)	40 (88.2)
Certificates of suitability, according to		–	–	–	–	–	–	–
Suitable for Power Module		6SL3310-1GH28-5AA3 (75 kW)	6SL3310-1GH31-0AA3 (90 kW)	6SL3310-1GH31-2AA3 (110 kW)	6SL3310-1GH31-5AA3 (132 kW)	6SL3310-1GH31-8AA3 (160 kW)	6SL3310-1GH32-2AA3 (200 kW)	6SL3310-1GH32-6AA3 (250 kW)

Line voltage 660 ... 690 V 3 AC		Motor reactor (for pulse frequencies of 1.25 kHz to 2.5 kHz)					
		6SL3000-2AH33-6AA0	6SL3000-2AH34-5AA0	6SL3000-2AH34-7AA0	6SL3000-2AH35-8AA0	6SL3000-2AH38-1AA0	
Rated current	A	330	410	465	575	810	810
Power loss							
• At 50 Hz	kW	0.4	0.481	0.631	0.705	0.78	0.877
• At 150 Hz	kW	0.454	0.545	0.723	0.801	0.91	1.003
Load connection		1 × hole for M10	1 × hole for M10	1 × hole for M12	1 × hole for M12	1 × hole for M12	1 × hole for M12
PE connection		M8 screw	M8 screw	M8 screw	M8 screw	M8 screw	M8 screw
Cable length, max. between motor reactor and motor ¹⁾							
• Shielded	m (ft)	300 (984)	300 (984)	300 (984)	300 (984)	300 (984)	300 (984)
• Unshielded	m (ft)	450 (1476)	450 (1476)	450 (1476)	450 (1476)	450 (1476)	450 (1476)
Degree of protection		IP00	IP00	IP00	IP00	IP00	IP00
Dimensions							
• Width	mm (in)	300 (11.81)	350 (13.78)	410 (16.14)	410 (16.14)	410 (16.14)	410 (16.14)
• Height	mm (in)	285 (11.22)	330 (12.99)	392 (15.43)	392 (15.43)	392 (15.43)	392 (15.43)
• Depth	mm (in)	212 (8.35)	215 (8.46)	292 (11.50)	292 (11.50)	279 (10.98)	279 (10.98)
Weight, approx.	kg (lb)	43 (94.8)	56 (123)	80 (176)	80 (176)	146 (322)	146 (322)
Certificates of suitability, according to		–	–	–	–	–	–
Suitable for Power Module		6SL3310-1GH33-3AA3 (315 kW)	6SL3310-1GH34-1AA3 (400 kW)	6SL3310-1GH34-7AA3 (450 kW)	6SL3310-1GH35-8AA3 (560 kW)	6SL3310-1GH37-4AA3 (710 kW)	6SL3310-1GH38-1AA3 (800 kW)

¹⁾ Longer cable lengths for specific configurations are available on request

Overview

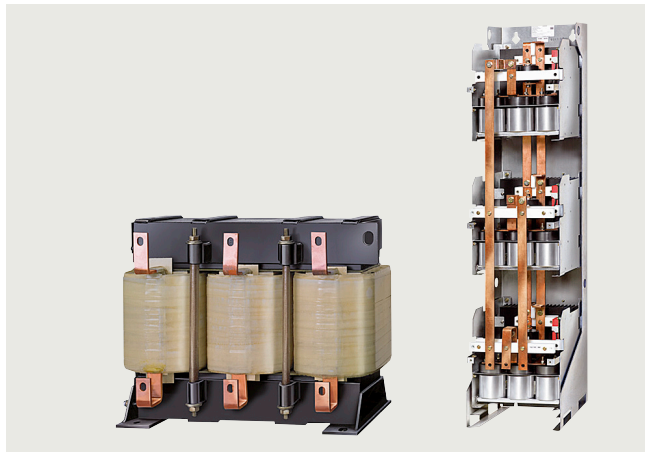

dv/dt filter plus VPL (**V**oltage **P**eak **L**imiter) limit the voltage rate of rise dv/dt to values $< 500 \text{ V}/\mu\text{s}$ and the typical peak voltage to the following values in accordance with the limit value curve according to IEC/TS 60034-17: 2006:

- $< 1000 \text{ V}$ at $U_{\text{line}} < 575 \text{ V}$
- $< 1250 \text{ V}$ at $660 \text{ V} < U_{\text{line}} < 690 \text{ V}$

Standard motors with standard insulation and without insulated bearings with a supply voltage of up to 690 V can be used for converter operation if a dv/dt filter plus VPL is used.

dv/dt filters plus VPL are designed for the following maximum motor cable lengths:

- Shielded cables: 300 m (e.g. Protodur NYCWY)
- Unshielded cables: 450 m (e.g. Protodur NYY)

For shorter cable lengths (100 m shielded, 150 m unshielded), refer to [dv/dt filter compact plus VPL](#).

Notice:

The max. permissible cable length between the dv/dt filter and Power Module is 5 m.

Design

The dv/dt filter plus VPL consists of two components, which are also supplied as separate mechanical units:

- dv/dt reactor
- Voltage limiting network, which cuts-off the voltage peaks and feeds the energy back to the DC link.

Selection and ordering data

Suitable for Power Module	Type rating of the Power Module at 400 V, 500 V or 690 V kW	dv/dt filter plus VPL
		Article No.
380 ... 480 V 3 AC		
6SL3310-1GE32-1AA3	110	6SL3000-2DE32-6AA0
6SL3310-1GE32-6AA3	132	
6SL3310-1GE33-1AA3	160	6SL3000-2DE35-0AA0
6SL3310-1GE33-8AA3	200	
6SL3310-1GE35-0AA3	250	
6SL3310-1GE36-1AA3	315	6SL3000-2DE38-4AA0
6SL3310-1GE37-5AA3	400	
6SL3310-1GE38-4AA3	450	
6SL3310-1GE41-0AA3	560	6SL3000-2DE41-4AA0
500 ... 600 V 3 AC		
6SL3310-1GF31-8AA3	110	6SL3000-2DH32-2AA0
6SL3310-1GF32-2AA3	132	
6SL3310-1GF32-6AA3	160	6SL3000-2DH33-3AA0
6SL3310-1GF33-3AA3	200	
6SL3310-1GF34-1AA3	250	6SL3000-2DH34-1AA0
6SL3310-1GF34-7AA3	315	6SL3000-2DH35-8AA0
6SL3310-1GF35-8AA3	400	
6SL3310-1GF37-4AA3	500	6SL3000-2DH38-1AA0
6SL3310-1GF38-1AA3	560	
660 ... 690 V 3 AC		
6SL3310-1GH28-5AA3	75	6SL3000-2DH31-0AA0
6SL3310-1GH31-0AA3	90	
6SL3310-1GH31-2AA3	110	6SL3000-2DH31-5AA0
6SL3310-1GH31-5AA3	132	
6SL3310-1GH31-8AA3	160	6SL3000-2DH32-2AA0
6SL3310-1GH32-2AA3	200	
6SL3310-1GH32-6AA3	250	6SL3000-2DH33-3AA0
6SL3310-1GH33-3AA3	315	
6SL3310-1GH34-1AA3	400	6SL3000-2DH34-1AA0
6SL3310-1GH34-7AA3	450	6SL3000-2DH35-8AA0
6SL3310-1GH35-8AA3	560	
6SL3310-1GH37-4AA3	710	6SL3000-2DH38-1AA0
6SL3310-1GH38-1AA3	800	

For further information on dv/dt filters, please refer to the [SINAMICS Low Voltage Engineering Manual](#).

SINAMICS G130

Converter built-in units

Load-side power components > dv/dt filters plus VPL**Technical specifications**

Line voltage 380 ... 480 V 3 AC		dv/dt filter plus VPL			
		6SL3000-2DE32-6AA0	6SL3000-2DE35-0AA0	6SL3000-2DE38-4AA0	6SL3000-2DE41-4AA0
I_{th max}	A	260	490	840	1405
Degree of protection		IP00	IP00	IP00	IP00
Cable length, max. between dv/dt filter and motor ¹⁾					
• Shielded	m (ft)	300 (984)	300 (984)	300 (984)	300 (984)
• Unshielded	m (ft)	450 (1476)	450 (1476)	450 (1476)	450 (1476)
Certificates of suitability, according to		cURus	cURus	cURus	cURus
dv/dt reactor					
Power loss					
• At 50 Hz	kW	0.701	0.874	1.106	1.111
• At 60 Hz	kW	0.729	0.904	1.115	1.154
• At 150 Hz	kW	0.78	0.963	1.226	1.23
Connections					
• To Power Module		1 × hole for M10	1 × hole for M12	1 × hole for M12	2 × holes for M12
• To load		1 × hole for M10	1 × hole for M12	1 × hole for M12	2 × holes for M12
• PE		M6 screw	M6 screw	M6 screw	M6 screw
Dimensions					
• Width	mm (in)	410 (16.14)	460 (18.11)	460 (18.11)	445 (17.52)
• Height	mm (in)	370 (14.57)	370 (14.57)	385 (15.16)	385 (15.16)
• Depth	mm (in)	229 (9.02)	275 (10.83)	312 (12.28)	312 (12.28)
Weight, approx.	kg (lb)	66 (146)	122 (269)	149 (329)	158 (348)
Voltage Peak Limiter (VPL)					
Power loss					
• At 50 Hz	kW	0.029	0.042	0.077	0.134
• At 60 Hz	kW	0.027	0.039	0.072	0.125
• At 150 Hz	kW	0.025	0.036	0.066	0.114
Connections					
• To dv/dt reactor		M8 nut	70 mm ² terminals	1 × hole for M8	1 × hole for M10
• To DC link		M8 nut	70 mm ² terminals	1 × hole for M8	1 × hole for M10
• PE		M8 stud	35 mm ² terminals	M8 stud	M8 stud
Dimensions					
• Width	mm (in)	263 (10.35)	392 (15.43)	309 (12.17)	309 (12.17)
• Height	mm (in)	265 (10.43)	285 (11.22)	1312.5 (51.67)	1312.5 (51.67)
• Depth	mm (in)	188 (7.40)	210 (8.27)	400 (15.75)	400 (15.75)
Weight, approx.	kg (lb)	6 (13.2)	16 (35.3)	48 (106)	72 (159)
Suitable for Power Module		6SL3310-1GE32-1AA3 (110 kW) 6SL3310-1GE32-6AA3 (132 kW)	6SL3310-1GE33-1AA3 (160 kW) 6SL3310-1GE33-8AA3 (200 kW) 6SL3310-1GE35-0AA3 (250 kW)	6SL3310-1GE36-1AA3 (315 kW) 6SL3310-1GE37-5AA3 (400 kW) 6SL3310-1GE38-4AA3 (450 kW)	6SL3310-1GE41-0AA3 (560 kW)

Note: Two dv/dt reactors are required for Power Modules with a type rating of 560 kW.

The listed technical specifications refer to one dv/dt reactor.

¹⁾ Longer cable lengths for specific configurations are available on request.

Technical specifications

Line voltage 500 ... 600 V 3 AC		dv/dt filter plus VPL				
		6SL3000-2DH32-2AA0	6SL3000-2DH33-3AA0	6SL3000-2DH34-1AA0	6SL3000-2DH35-8AA0	6SL3000-2DH38-1AA0
$I_{th\ max}$	A	215	330	410	575	810
Degree of protection		IP00	IP00	IP00	IP00	IP00
Cable length, max. between dv/dt filter and motor ¹⁾						
• Shielded	m (ft)	300 (984)	300 (984)	300 (984)	300 (984)	300 (984)
• Unshielded	m (ft)	450 (1476)	450 (1476)	450 (1476)	450 (1476)	450 (1476)
Certificates of suitability, according to		cURus	cURus	cURus	cURus	cURus
dv/dt reactor						
Power loss						
• At 50 Hz	kW	0.578	0.595	0.786	0.862	0.828
• At 60 Hz	kW	0.604	0.62	0.826	0.902	0.867
• At 150 Hz	kW	0.645	0.661	0.884	0.964	0.927
Connections						
• To Power Module		1 × hole for M10	1 × hole for M10	1 × hole for M12	1 × hole for M12	2 × holes for M12
• To load		1 × hole for M10	1 × hole for M10	1 × hole for M12	1 × hole for M12	2 × holes for M12
• PE		M6 screw	M6 screw	M6 screw	M6 screw	M6 screw
Dimensions						
• Width	mm (in)	460 (18.11)	460 (18.11)	460 (18.11)	460 (18.11)	445 (17.52)
• Height	mm (in)	360 (14.17)	360 (14.17)	385 (15.16)	385 (15.16)	385 (15.16)
• Depth	mm (in)	275 (10.83)	275 (10.83)	312 (12.28)	312 (12.28)	312 (12.28)
Weight, approx.	kg (lb)	83 (183)	135 (298)	147 (324)	172 (379)	160 (353)
Voltage Peak Limiter (VPL)						
Power loss						
• At 50 Hz	kW	0.032	0.042	0.051	0.063	0.106
• At 60 Hz	kW	0.03	0.039	0.048	0.059	0.1
• At 150 Hz	kW	0.027	0.036	0.043	0.054	0.091
Connections						
• To dv/dt reactor		70 mm ² terminals	70 mm ² terminals	1 × hole for M8	1 × hole for M8	1 × hole for M10
• To DC link		70 mm ² terminals	70 mm ² terminals	1 × hole for M8	1 × hole for M8	1 × hole for M10
• PE		35 mm ² terminals	35 mm ² terminals	M8 stud	M8 stud	M8 stud
Dimensions						
• Width	mm (in)	392 (15.43)	392 (15.43)	309 (12.17)	309 (12.17)	309 (12.17)
• Height	mm (in)	285 (11.22)	285 (11.22)	1312.5 (51.67)	1312.5 (51.67)	1312.5 (51.67)
• Depth	mm (in)	210 (8.27)	210 (8.27)	400 (15.75)	400 (15.75)	400 (15.75)
Weight, approx.	kg (lb)	16 (35.3)	16 (35.3)	48 (106)	48 (106)	72 (159)
Suitable for Power Module		6SL3310-1GF31-8AA3 (110 kW)	6SL3310-1GF32-6AA3 (160 kW)	6SL3310-1GF34-1AA3 (250 kW)	6SL3310-1GF34-7AA3 (315 kW)	6SL3310-1GF37-4AA3 (500 kW)
		6SL3310-1GF32-2AA3 (132 kW)	6SL3310-1GF33-3AA3 (200 kW)		6SL3310-1GF35-8AA3 (400 kW)	6SL3310-1GF38-1AA3 (560 kW)

Note: Two dv/dt reactors are required for Power Modules with a type rating of 500 kW and 560 kW.

The listed technical specifications refer to one dv/dt reactor.

¹⁾ Longer cable lengths for specific configurations are available on request.

SINAMICS G130

Converter built-in units

Load-side power components > dv/dt filters plus VPL**Technical specifications**

Line voltage 660 ... 690 V 3 AC		dv/dt filter plus VPL			
		6SL3000-2DH31-0AA0	6SL3000-2DH31-5AA0	6SL3000-2DH32-2AA0	6SL3000-2DH33-3AA0
$I_{th\ max}$	A	100	150	215	330
Degree of protection		IP00	IP00	IP00	IP00
Cable length, max. between dv/dt filter and motor ¹⁾					
• Shielded	m (ft)	300 (984)	300 (984)	300 (984)	300 (984)
• Unshielded	m (ft)	450 (1476)	450 (1476)	450 (1476)	450 (1476)
Certificates of suitability, according to		cURus	cURus	cURus	cURus
dv/dt reactor					
Power loss					
• At 50 Hz	kW	0.49	0.389	0.578	0.595
• At 60 Hz	kW	0.508	0.408	0.604	0.62
• At 150 Hz	kW	0.541	0.436	0.645	0.661
Connections					
• To Power Module		1 × hole for M10	1 × hole for M10	1 × hole for M10	1 × hole for M10
• To load		1 × hole for M10	1 × hole for M10	1 × hole for M10	1 × hole for M10
• PE		M6 screw	M6 screw	M6 screw	M6 screw
Dimensions					
• Width	mm (in)	350 (13.78)	350 (13.78)	460 (18.11)	460 (18.11)
• Height	mm (in)	320 (12.60)	320 (12.60)	360 (14.17)	360 (14.17)
• Depth	mm (in)	227 (8.94)	227 (8.94)	275 (10.83)	275 (10.83)
Weight, approx.	kg (lb)	48 (106)	50 (110)	83 (183)	135 (298)
Voltage Peak Limiter (VPL)					
Power loss					
• At 50 Hz	kW	0.016	0.02	0.032	0.042
• At 60 Hz	kW	0.015	0.019	0.03	0.039
• At 150 Hz	kW	0.013	0.018	0.027	0.036
Connections					
• To dv/dt reactor		M8 nut	M8 nut	70 mm ² terminals	70 mm ² terminals
• To DC link		M8 nut	M8 nut	70 mm ² terminals	70 mm ² terminals
• PE		M8 stud	M8 stud	35 mm ² terminals	35 mm ² terminals
Dimensions					
• Width	mm (in)	263 (10.35)	263 (10.35)	392 (15.43)	392 (15.43)
• Height	mm (in)	265 (10.43)	265 (10.43)	285 (11.22)	285 (11.22)
• Depth	mm (in)	188 (7.40)	188 (7.40)	210 (8.27)	210 (8.27)
Weight, approx.	kg (lb)	6 (13.2)	6 (13.2)	16 (35.3)	16 (35.3)
Suitable for Power Module		6SL3310-1GH28-5AA3 (75 kW) 6SL3310-1GH31-0AA3 (90 kW)	6SL3310-1GH31-2AA3 (110 kW) 6SL3310-1GH31-5AA3 (132 kW)	6SL3310-1GH31-8AA3 (160 kW) 6SL3310-1GH32-2AA3 (200 kW)	6SL3310-1GH32-6AA3 (250 kW) 6SL3310-1GH33-3AA3 (315 kW)

¹⁾ Longer cable lengths for specific configurations are available on request.

Technical specifications

Line voltage 660 ... 690 V 3 AC		dv/dt filter plus VPL			
		6SL3000-2DH34-1AA0	6SL3000-2DH35-8AA0	6SL3000-2DH38-1AA0	
$I_{th\ max}$	A	410	575	810	
Degree of protection		IP00	IP00	IP00	
Cable length, max. between dv/dt filter and motor ¹⁾					
• Shielded	m (ft)	300 (984)	300 (984)	300 (984)	
• Unshielded	m (ft)	450 (1476)	450 (1476)	450 (1476)	
Certificates of suitability, according to		cURus	cURus	cURus	
dv/dt reactor					
Power loss					
• At 50 Hz	kW	0.786	0.862	0.828	
• At 60 Hz	kW	0.826	0.902	0.867	
• At 150 Hz	kW	0.884	0.964	0.927	
Connections					
• To Power Module		1 × hole for M12	1 × hole for M12	2 × holes for M12	
• To load		1 × hole for M12	1 × hole for M12	2 × holes for M12	
• PE		M6 screw	M6 screw	M6 screw	
Dimensions					
• Width	mm (in)	460 (18.11)	460 (18.11)	445 (17.52)	
• Height	mm (in)	385 (15.16)	385 (15.16)	385 (15.16)	
• Depth	mm (in)	312 (12.28)	312 (12.28)	312 (12.28)	
Weight, approx.		kg (lb)	147 (324)	172 (379)	160 (353)
Voltage Peak Limiter (VPL)					
Power loss					
• At 50 Hz	kW	0.051	0.063	0.106	
• At 60 Hz	kW	0.048	0.059	0.1	
• At 150 Hz	kW	0.043	0.054	0.091	
Connections					
• To dv/dt reactor		1 × hole for M8	1 × hole for M8	1 × hole for M10	
• To DC link		1 × hole for M8	1 × hole for M8	1 × hole for M10	
• PE		M8 stud	M8 stud	M8 stud	
Dimensions					
• Width	mm (in)	309 (12.17)	309 (12.17)	309 (12.17)	
• Height	mm (in)	1312.5 (51.67)	1312.5 (51.67)	1312.5 (51.67)	
• Depth	mm (in)	400 (15.75)	400 (15.75)	400 (15.75)	
Weight, approx.		kg (lb)	48 (106)	48 (106)	72 (159)
Suitable for Power Module		6SL3310-1GH34-1AA3 (400 kW)	6SL3310-1GH34-7AA3 (450 kW) 6SL3310-1GH35-8AA3 (560 kW)	6SL3310-1GH37-4AA3 (710 kW) 6SL3310-1GH38-1AA3 (800 kW)	

Note: Two dv/dt reactors are required for Power Modules with a type rating of 710 kW and 800 kW.
 The listed technical specifications refer to one dv/dt reactor.

¹⁾ Longer cable lengths for specific configurations are available on request.

SINAMICS G130

Converter built-in units

Load-side power components > dv/dt filters compact plus VPL

Overview

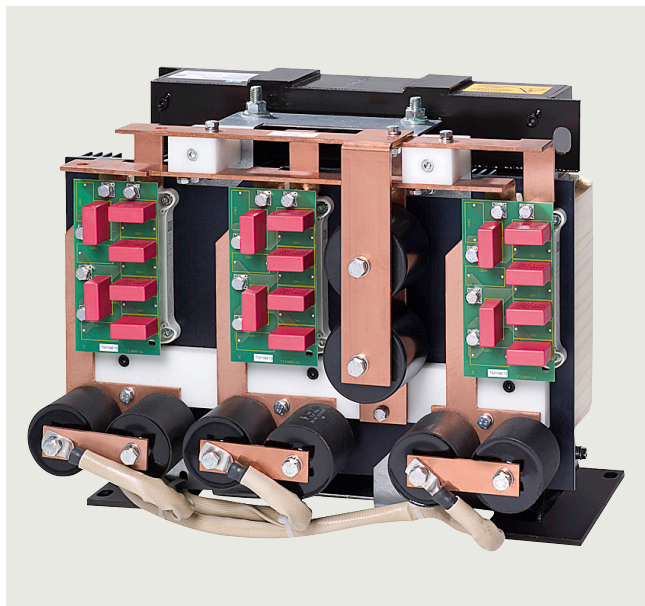

dv/dt filters compact plus VPL (**V**oltage **P**eak **L**imiter) limit the voltage rate of rise dv/dt to values of $< 1600 \text{ V}/\mu\text{s}$ and the typical peak voltage to the following values in accordance with the limit value curve A according to IEC 60034-25: 2007:

- $< 1150 \text{ V}$ at $U_{\text{line}} < 575 \text{ V}$
- $< 1400 \text{ V}$ at $660 \text{ V} < U_{\text{line}} < 690 \text{ V}$

Standard motors with standard insulation and without insulated bearings with a supply voltage of up to 690 V can be used for converter operation if a dv/dt filter compact plus VPL is used.

dv/dt filters compact plus VPL are designed for the following maximum motor cable lengths:

- Shielded cables: 100 m (e.g. Protodur NYCWY)
- Unshielded cables: 150 m (e.g. Protodur NYY)

For longer cable lengths ($> 100 \text{ m}$ shielded, $> 150 \text{ m}$ unshielded) refer to [dv/dt filter plus VPL](#).

Notice:

- The max. permissible cable length between the dv/dt filter and Power Module is 5 m.
- Operation with output frequencies $< 10 \text{ Hz}$ is permissible for max. 5 min.

Design

The dv/dt filter compact plus VPL consists of two components, which are supplied together as a compact mechanical unit:

- dv/dt reactor
- Voltage limiting network, which cuts-off the voltage peaks and feeds the energy back to the DC link.

Selection and ordering data

Suitable for Power Module	Type rating of the Power Module at 400 V, 500 V or 690 V kW	dv/dt filter compact plus VPL
		Article No.
380 ... 480 V 3 AC		
6SL3310-1GE32-1AA3	110	6SL3000-2DE32-6EA0
6SL3310-1GE32-6AA3	132	
6SL3310-1GE33-1AA3	160	6SL3000-2DE35-0EA0
6SL3310-1GE33-8AA3	200	
6SL3310-1GE35-0AA3	250	
6SL3310-1GE36-1AA3	315	6SL3000-2DE38-4EA0
6SL3310-1GE37-5AA3	400	
6SL3310-1GE38-4AA3	450	
6SL3310-1GE41-0AA3	560	6SL3000-2DE41-4EA0
500 ... 600 V 3 AC		
6SL3310-1GF31-8AA3	110	6SL3000-2DG32-2EA0
6SL3310-1GF32-2AA3	132	
6SL3310-1GF32-6AA3	160	6SL3000-2DG33-3EA0
6SL3310-1GF33-3AA3	200	
6SL3310-1GF34-1AA3	250	6SL3000-2DG34-1EA0
6SL3310-1GF34-7AA3	315	6SL3000-2DG35-8EA0
6SL3310-1GF35-8AA3	400	
6SL3310-1GF37-4AA3	500	6SL3000-2DG38-1EA0
6SL3310-1GF38-1AA3	560	
660 ... 690 V 3 AC		
6SL3310-1GH28-5AA3	75	6SL3000-2DG31-0EA0
6SL3310-1GH31-0AA3	90	
6SL3310-1GH31-2AA3	110	6SL3000-2DG31-5EA0
6SL3310-1GH31-5AA3	132	
6SL3310-1GH31-8AA3	160	6SL3000-2DG32-2EA0
6SL3310-1GH32-2AA3	200	
6SL3310-1GH32-6AA3	250	6SL3000-2DG33-3EA0
6SL3310-1GH33-3AA3	315	
6SL3310-1GH34-1AA3	400	6SL3000-2DG34-1EA0
6SL3310-1GH34-7AA3	450	6SL3000-2DG35-8EA0
6SL3310-1GH35-8AA3	560	
6SL3310-1GH37-4AA3	710	6SL3000-2DG38-1EA0
6SL3310-1GH38-1AA3	800	

For further information on dv/dt filters compact, please refer to the [SINAMICS Low Voltage Engineering Manual](#).

Technical specifications

Line voltage 380 ... 480 V 3 AC		dv/dt filter compact plus VPL			
		6SL3000-2DE32-6EA0	6SL3000-2DE35-0EA0	6SL3000-2DE38-4EA0	6SL3000-2DE41-4EA0
Rated current	A	260	490	840	1405
$I_{th\ max}$	A	260	490	840	1405
Power loss, max.					
• At 50 Hz 400 V	kW	0.21	0.29	0.518	Reactor: 1.027 VPL: 0.127 Total: 1.154
• At 60 Hz 460 V	kW	0.215	0.296	0.529	Reactor: 1.077 VPL: 0.12 Total: 1.197
• At 150 Hz 400 V	kW	0.255	0.344	0.609	Reactor: 1.354 VPL: 0.09 Total: 1.444
Power connection, input and output side		Hole for M10	Hole for M10	Hole for M12	2 x elongated holes, 14 x 18 mm (0.55 x 0.71 in)
• Conductor cross section, max. (IEC)		Provided for busbar connection	Provided for busbar connection	Provided for busbar connection	Provided for busbar connection
DC-link connection, DCPS, DCNS		Threaded socket M8	Threaded socket M8	Hole for M8	Hole for M8
• Conductor cross section, max. (IEC)	mm ²	16	25	50	95
PE/GND connection		Threaded socket M6	Threaded socket M6	Threaded socket M6	Threaded socket M6 (reactor and VPL)
Cable length, max. between dv/dt filter and motor					
• Shielded	m (ft)	100 (328)	100 (328)	100 (328)	100 (328)
• Unshielded	m (ft)	150 (492)	150 (492)	150 (492)	150 (492)
Degree of protection		IP00	IP00	IP00	IP00
Dimensions					
• Width	mm (in)	310 (12.20)	350 (13.78)	440 (17.32)	Reactor: 430 (16.93) VPL: 277 (10.91)
• Height	mm (in)	283 (11.14)	317 (12.48)	369 (14.53)	Reactor: 385 (15.16) VPL: 360 (14.17)
• Depth	mm (in)	238 (9.37)	260 (10.24)	311 (12.24)	Reactor: 323 (12.72) VPL: 291 (11.46)
Weight, approx.	kg (lb)	41 (90.4)	61 (135)	103 (227)	Reactor: 168.8 (372) VPL: 19.2 (42.3) Total: 188 (415)
Certificates of suitability, according to		cURus	cURus	cURus	cURus
Suitable for Power Module		6SL3310-1GE32-1AA3 (110 kW) 6SL3310-1GE32-6AA3 (132 kW)	6SL3310-1GE33-1AA3 (160 kW) 6SL3310-1GE33-8AA3 (200 kW) 6SL3310-1GE35-0AA3 (250 kW)	6SL3310-1GE36-1AA3 (315 kW) 6SL3310-1GE37-5AA3 (400 kW) 6SL3310-1GE38-4AA3 (450 kW)	6SL3310-1GE41-0AA3 (560 kW)

SINAMICS G130

Converter built-in units

Load-side power components > dv/dt filters compact plus VPL**Technical specifications**

Line voltage 500 ... 690 V 3 AC		dv/dt filter compact plus VPL			
		6SL3000-2DG31-0EA0	6SL3000-2DG31-5EA0	6SL3000-2DG32-2EA0	6SL3000-2DG33-3EA0
Rated current	A	100	150	215	330
$I_{th\ max}$	A	100	150	215	330
Power loss, max.					
• At 50 Hz 500/690 V	kW	0.227	0.27	0.305	0.385
• At 60 Hz 575 V	kW	0.236	0.279	0.316	0.399
• At 150 Hz 500/690 V	kW	0.287	0.335	0.372	0.48
Power connection, input and output side		Hole for M10	Hole for M10	Hole for M10	Hole for M10
• Conductor cross section, max. (IEC)		Provided for busbar connection	Provided for busbar connection	Provided for busbar connection	Provided for busbar connection
DC-link connection, DCPS, DCNS		Threaded socket M8	Threaded socket M8	Hole for M8	Hole for M8
• Conductor cross section, max. (IEC)	mm ²	16	16	25	25
PE/GND connection		Threaded socket M6	Threaded socket M6	Threaded socket M6	Threaded socket M6
Cable length, max. between dv/dt filter and motor					
• Shielded	m (ft)	100 (328)	100 (328)	100 (328)	100 (328)
• Unshielded	m (ft)	150 (492)	150 (492)	150 (492)	150 (492)
Degree of protection		IP00	IP00	IP00	IP00
Dimensions					
• Width	mm (in)	310 (12.20)	310 (12.20)	350 (13.78)	350 (13.78)
• Height	mm (in)	283 (11.14)	283 (11.14)	317 (12.48)	317 (12.48)
• Depth	mm (in)	238 (9.37)	238 (9.37)	260 (10.24)	260 (10.24)
Weight, approx.	kg (lb)	34 (75)	36 (79.4)	51 (112)	60 (132)
Certificates of suitability, according to		cURus	cURus	cURus	cURus
Suitable for Power Module					
• 500 ... 600 V 3 AC		–	–	6SL3310-1GF31-8AA3 (110 kW) 6SL3310-1GF32-2AA3 (132 kW)	6SL3310-1GF32-6AA3 (160 kW) 6SL3310-1GF33-3AA3 (200 kW)
• 660 ... 690 V 3 AC		6SL3310-1GH28-5AA3 (75 kW) 6SL3310-1GH31-0AA3 (90 kW)	6SL3310-1GH31-2AA3 (110 kW) 6SL3310-1GH31-5AA3 (132 kW)	6SL3310-1GH31-8AA3 (160 kW) 6SL3310-1GH32-2AA3 (200 kW)	6SL3310-1GH32-6AA3 (250 kW) 6SL3310-1GH33-3AA3 (315 kW)

Technical specifications

Line voltage 500 ... 690 V 3 AC	dv/dt filter compact plus VPL			
		6SL3000-2DG34-1EA0	6SL3000-2DG35-8EA0	6SL3000-2DG38-1EA0
Rated current	A	410	575	810
$I_{th\ max}$	A	410	575	810
Power loss, max.				
• At 50 Hz 500/690 V	kW	0.55	0.571	Reactor: 0.88 VPL: 0.084 Total: 0.964
• At 60 Hz 575 V	kW	0.568	0.586	Reactor: 0.918 VPL: 0.08 Total: 0.998
• At 150 Hz 500/690 V	kW	0.678	0.689	Reactor: 1.137 VPL: 0.059 Total: 1.196
Power connection, input and output side		Hole for M12	Hole for M12	2 x elongated holes, 14 x 18 mm (0.55 x 0.71 in)
• Conductor cross section, max. (IEC)		Provided for busbar connection	Provided for busbar connection	Provided for busbar connection
DC-link connection, DCPS, DCNS		Hole for M8	Hole for M8	Hole for M8
• Conductor cross section, max. (IEC)	mm ²	50	50	95
PE/GND connection		Threaded socket M6	Threaded socket M6	Threaded socket M6 (reactor and VPL)
Cable length, max. between dv/dt filter and motor				
• Shielded	m (ft)	100 (328)	100 (328)	100 (328)
• Unshielded	m (ft)	150 (492)	150 (492)	150 (492)
Degree of protection		IP00	IP00	IP00
Dimensions				
• Width	mm (in)	440 (17.32)	440 (17.32)	Reactor: 430 (16.93) VPL: 277 (10.91)
• Height	mm (in)	369 (14.53)	369 (14.53)	Reactor: 385 (15.16) VPL: 360 (14.17)
• Depth	mm (in)	311 (12.24)	311 (12.24)	Reactor: 323 (12.72) VPL: 291 (11.46)
Weight, approx.	kg (lb)	87 (192)	100 (220)	Reactor: 171.2 (377) VPL: 18.8 (41.5) Total: 190 (419)
Certificates of suitability, according to		cURus	cURus	cURus
Suitable for Power Module				
• 500 ... 600 V 3 AC		6SL3310-1GF34-1AA3 (250 kW)	6SL3310-1GF34-7AA3 (315 kW) 6SL3310-1GF35-8AA3 (400 kW)	6SL3310-1GF37-4AA3 (500 kW) 6SL3310-1GF38-1AA3 (560 kW)
• 660 ... 690 V 3 AC		6SL3310-1GH34-1AA3 (400 kW)	6SL3310-1GH34-7AA3 (450 kW) 6SL3310-1GH35-8AA3 (560 kW)	6SL3310-1GH37-4AA3 (710 kW) 6SL3310-1GH38-1AA3 (800 kW)

SINAMICS G130

Converter built-in units

Load-side power components > Sine-wave filters

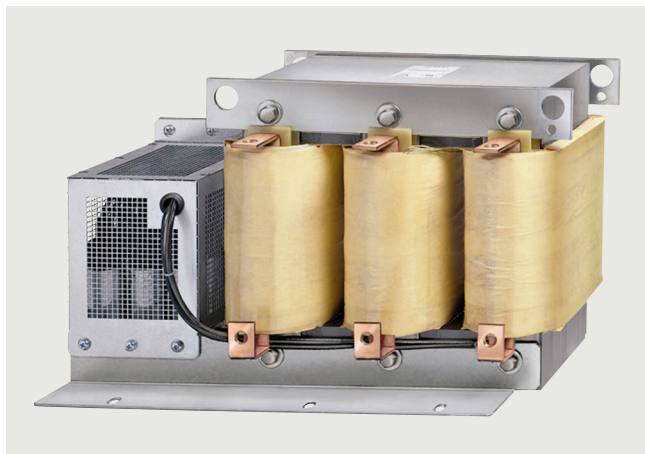
Overview

Sine-wave filters are available in the voltage range 380 V to 480 V up to a type rating of 250 kW, and in the voltage range 500 V to 600 V up to a type rating of 132 kW.

The sine-wave filter at the converter output supplies almost perfect sinusoidal voltages on the motor so that standard motors can be used without special cables or power derating. Standard cables can be used.

Note the following when a sine-wave filter is used:

- The output frequency is limited to max. 150 Hz (at 380 to 480 V) and 115 Hz (at 500 to 600 V).
- The maximum output voltage is limited to approx. 85% of the input voltage.
- Maximum permissible motor cable lengths:
 - Unshielded cable: 450 m
 - Shielded cable: 300 m
- During commissioning, the pulse frequency is increased to double the factory setting. This induces current derating, which must be applied to the built-in units' rated currents listed in the technical specifications.

Note:

The reduced voltage at the motor terminals compared to the rated motor voltage means that the motor reaches the field weakening range earlier.

The sine-wave filter may be operated only when the motor is connected; sine-wave filters are not no-load-proof!

For further information on sine-wave filters, please refer to the [SINAMICS Low Voltage Engineering Manual](#).

Selection and ordering data

Suitable for Power Module	Type rating of the Power Module at 400 V or 500 V kW	Sine-wave filter	
		Article No.	
380 ... 480 V 3 AC			
6SL3310-1GE32-1AA3	110	6SL3000-2CE32-3AA0	
6SL3310-1GE32-6AA3	132		
6SL3310-1GE33-1AA3	160	6SL3000-2CE32-8AA0	
6SL3310-1GE33-8AA3	200	6SL3000-2CE33-3AA0	
6SL3310-1GE35-0AA3	250	6SL3000-2CE34-1AA0	
500 ... 600 V 3 AC			
6SL3310-1GF31-8AA3	110	6SL3000-2CF31-7AA0	
6SL3310-1GF32-2AA3	132		

Technical specifications

Line voltage 380 ... 480 V 3 AC		Sine-wave filter			
		6SL3000-2CE32-3AA0	6SL3000-2CE32-8AA0	6SL3000-2CE33-3AA0	6SL3000-2CE34-1AA0
Rated current ¹⁾	A	225	276	333	408
Power loss	kW	0.6	0.69	0.53	0.7
Connections					
• Load		1 × hole for M10	1 × hole for M10	1 × hole for M10	1 × hole for M10
• PE		1 × hole for M10	1 × hole for M10	1 × hole for M10	1 × hole for M10
Cable length, max. between sine-wave filter and motor					
• Shielded		m (ft) 300 (984)	300 (984)	300 (984)	300 (984)
• Unshielded		m (ft) 450 (1476)	450 (1476)	450 (1476)	450 (1476)
Degree of protection		IP00	IP00	IP00	IP00
Dimensions					
• Width		mm (in) 620 (24.41)	620 (24.41)	620 (24.41)	620 (24.41)
• Height		mm (in) 300 (11.81)	300 (11.81)	370 (14.57)	370 (14.57)
• Depth		mm (in) 320 (12.60)	320 (12.60)	360 (14.17)	360 (14.17)
Weight, approx.	kg (lb)	124 (273)	127 (280)	136 (300)	198 (437)
Certificates of suitability, according to		cURus	cURus	cURus	cURus
Suitable for Power Module		6SL3310-1GE32-1AA3 (110 kW) 6SL3310-1GE32-6AA3 (132 kW)	6SL3310-1GE33-1AA3 (160 kW)	6SL3310-1GE33-8AA3 (200 kW)	6SL3310-1GE35-0AA3 (250 kW)

Line voltage 500 ... 600 V 3 AC		Sine-wave filter			
		6SL3000-2CF31-7AA0			
Rated current ²⁾	A	188			
Power loss	kW	0.8			
Connections					
• Load		1 × hole for M10			
• PE		1 × hole for M10			
Cable length, max. between sine-wave filter and motor					
• Shielded		m (ft) 300 (984)			
• Unshielded		m (ft) 450 (1476)			
Degree of protection		IP00			
Dimensions					
• Width		mm (in) 620 (24.41)			
• Height		mm (in) 370 (14.57)			
• Depth		mm (in) 360 (14.17)			
Weight, approx.	kg (lb)	210 (463)			
Certificates of suitability, according to		cURus			
Suitable for Power Module		6SL3310-1GF31-8AA3 (110 kW) 6SL3310-1GF32-2AA3 (132 kW)			

¹⁾ Output current of the Power Module at an adapted pulse frequency of 4 kHz.

²⁾ Output current of the Power Module at an adapted pulse frequency of 2.5 kHz.

SINAMICS G130

Converter built-in units

Control Unit and Control Unit Kit CU320-2

Overview



The communication, open-loop and closed-loop control functions for the Power Modules are executed in a CU320-2 Control Unit. Communication with the higher-level control system is performed via PROFIBUS DP or PROFINET.

The CU320-2 Control Unit and the associated CompactFlash card can be ordered separately or as Control Unit Kit. The Control Unit Kit comprises the CU320-2 Control Unit, a CompactFlash card and the stored drive software.

Design

The CU320-2 Control Unit features the following connections and interfaces as standard:

- Fieldbus interface:
 - CU320-2 PN: 1 PROFINET interface with 2 ports (RJ45 sockets) with PROFIdrive V4 profile
 - CU320-2 DP: 1 PROFIBUS interface with PROFIdrive V4 profile
- 4 DRIVE-CLiQ sockets for communication with other DRIVE-CLiQ devices, e.g. Power Modules, Terminal Modules
- 12 parameterizable digital inputs (floating)
- 8 parameterizable bidirectional digital inputs/outputs (non-floating)
- 1 serial RS232 interface
- 1 interface for the BOP20 Basic Operator Panel
- 1 slot for the CompactFlash card on which firmware and parameters are stored
- 1 slot to install an option module for the interface expansion
- 2 rotary coding switches for manually setting the PROFIBUS address
- 1 Ethernet interface for commissioning and diagnostics
- 3 measuring sockets and one reference ground for commissioning support
- 1 connection for the electronics power supply via the 24 V DC supply connector
- 1 PE/protective conductor connection
- 1 ground connection

A shield connection for the signal cable shield of the option module is located on the CU320-2 Control Unit.

The available option slot is used to expand the interfaces, e.g. number of terminals.

The status of the CU320-2 Control Unit is indicated via multi-color LEDs.

As the firmware and set parameters are stored on a plug-in CompactFlash card, the Control Unit can be changed without the need for tools.

Selection and ordering data

Description	Article No.
CU320-2 PN Control Unit without CompactFlash card	6SL3040-1MA01-0AA0
CU320-2 DP Control Unit without CompactFlash card	6SL3040-1MA00-0AA0
PROFINET Control Unit Kit comprising:	6SL3040-1GA01-1AA0
<ul style="list-style-type: none"> • CU320-2 PN Control Unit • CompactFlash card with the latest firmware • STARTER commissioning tool on DVD-ROM 	
PROFIBUS DP Control Unit Kit comprising:	6SL3040-1GA00-1AA0
<ul style="list-style-type: none"> • CU320-2 DP Control Unit • CompactFlash card with the latest firmware • STARTER commissioning tool on DVD-ROM 	

Accessories

For CU320-2 PN: Industrial Ethernet FC	
• RJ45 plug 145 (1 unit)	6GK1901-1BB30-0AA0
• RJ45 plug 145 (10 units)	6GK1901-1BB30-0AB0
• Stripping tool	6GK1901-1GA00
• Standard cable GP 2x2	6XV1840-2AH10
• Flexible cable GP 2x2	6XV1870-2B
• Trailing cable GP 2x2	6XV1870-2D
• Trailing cable 2x2	6XV1840-3AH10
• Marine cable 2x2	6XV1840-4AH10
For CU320-2 DP: PROFIBUS connector	
• <u>Without</u> PG/PC connection	6ES7972-0BA42-0XA0
• <u>With</u> PG/PC connection	6ES7972-0BB42-0XA0
STARTER commissioning tool on DVD-ROM	6SL3072-0AA00-0AG0

Accessories for re-ordering

Dust protection blanking plugs (50 units) for sealing unused DRIVE-CLiQ ports	6SL3066-4CA00-0AA0
--	---------------------------

For further information on the CU320-2 Control Unit, please refer to the SINAMICS Low Voltage Engineering Manual.

Integration

Communication between a CU320-2 Control Unit and the connected components takes place via DRIVE-CLiQ.

A DRIVE-CLiQ cable for connecting the CU320-2 to the SINAMICS G130 converter is included in the scope of delivery of the Power Module.

The BOP20 Basic Operator Panel can also be snapped onto the CU320-2 Control Unit during operation for diagnostic purposes.

Integration

The CU320-2 Control Unit and other connected components are commissioned and diagnosed with the STARTER commissioning tool and the installed SINAMICS Support Package.

The CU320-2 PN Control Unit requires a CompactFlash card with firmware as of V4.4.
The CU320-2 DP Control Unit requires a CompactFlash card with firmware as of V4.3.

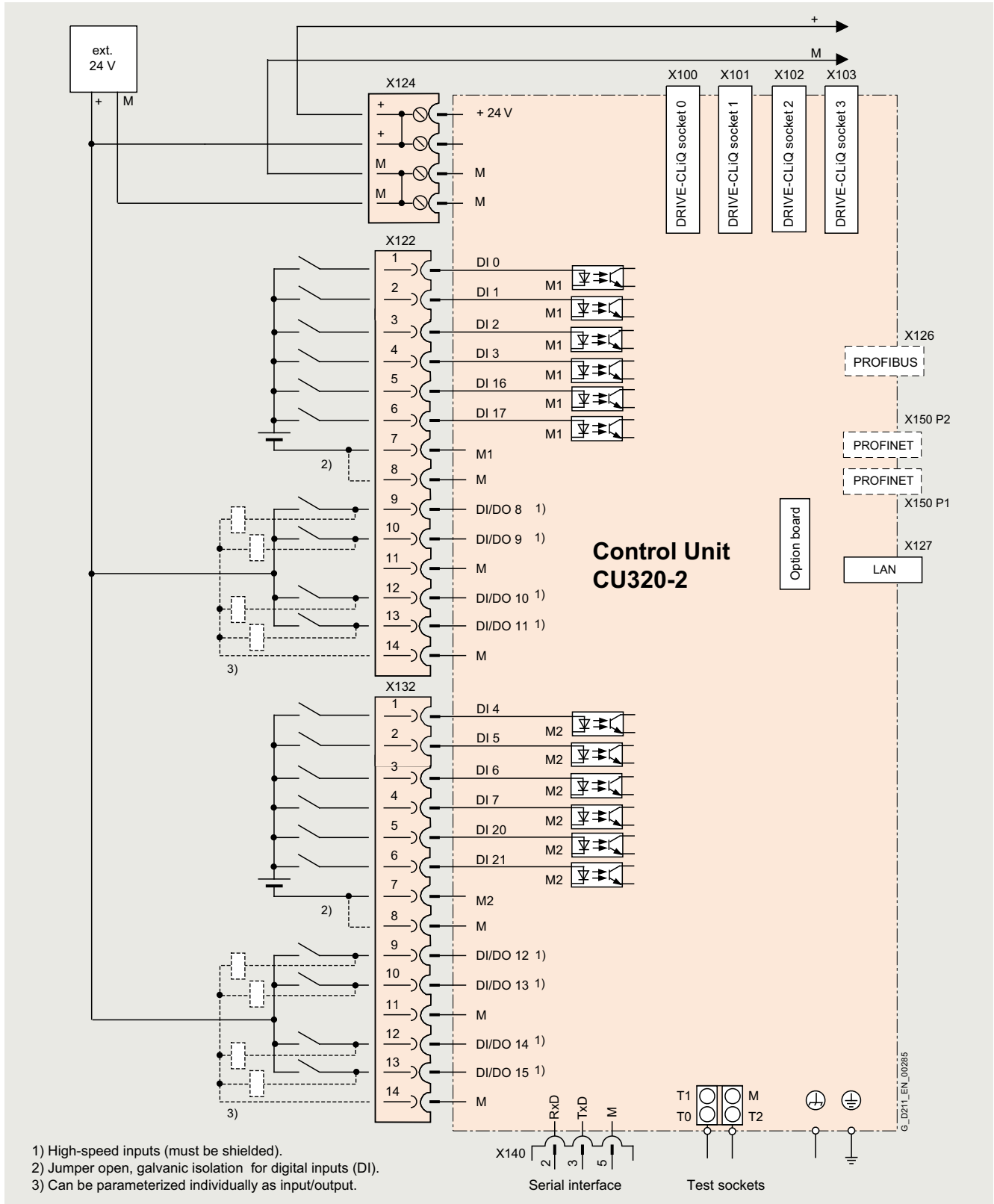

- 1) High-speed inputs (must be shielded).
- 2) Jumper open, galvanic isolation for digital inputs (DI).
- 3) Can be parameterized individually as input/output.

Connection example of a CU320-2 Control Unit

3

SINAMICS G130

Converter built-in units

Control Unit and Control Unit Kit CU320-2**Technical specifications**

	Control Unit CU320-2 6SL3040-1MA0 . -0AA0
Current requirement, max. at 24 V DC, typ. without taking into account digital outputs, expansion option slot and DRIVE-CLiQ supply	1 A
• Conductor cross section, max.	2.5 mm ²
• Fuse protection, max.	20 A
Digital inputs according to IEC 61131-2 Type 1	12 floating digital inputs 8 bidirectional non-floating digital inputs/outputs
• Voltage	-3 ... +30 V
• Low level (an open digital input is interpreted as "low")	-3 ... +5 V
• High level	15 ... 30 V
• Current consumption at 24 V DC, typ.	9 mA
• Delay time of digital inputs, approx. ¹⁾	
- L → H	50 μs
- H → L	100 μs
• Delay time of high-speed digital inputs, approx. ¹⁾	
- L → H	5 μs
- H → L	50 μs
• Conductor cross section, max.	1.5 mm ²
Digital outputs (continuously short-circuit-proof)	8 bidirectional non-floating digital inputs/outputs
• Voltage	24 V DC
• Load current per digital output, max.	500 mA
• Delay time, typ./max.	
- L → H	150/400 μs
- H → L	75/100 μs
• Conductor cross section, max.	1.5 mm ²
Power loss	24 W
PE connection	M5 screw
Ground connection	M5 screw
Dimensions	
• Width	50 mm (1.97 in)
• Height	300 mm (11.8 in)
• Depth	226 mm (8.90 in)
Weight, approx.	2.3 kg (5.07 lb)
Certificate of suitability, according to	cULus

¹⁾ The specified delay times refer to the hardware. The actual reaction time depends on the time slot in which the digital input or output is processed.

Overview



The CompactFlash card contains the firmware and set parameters. The CompactFlash card is inserted into the appropriate slot of the CU320-2 Control Unit.

Design

A CU320-2 Control Unit can process the communication, open-loop and closed-loop control functions of the power units. The computing capacity requirement increases in proportion to the number of power units and system components and in relation to the dynamic response required. The computing capacity requirement and utilization of the CU320-2 Control Unit can be calculated with the SIZER for Siemens Drives engineering tool.

In addition to the firmware, the CompactFlash card also contains license keys which are required to enable firmware options, e.g. for the Safety Integrated extended functions. The Safety Integrated extended functions must be ordered for each axis via order codes (**F..**) in addition to the article number.

Converter cabinets with a Control Unit already contain the CompactFlash card with the current firmware. The Safety license can be added as a cabinet option.

The firmware options can be also enabled subsequently. You require the serial number of the CompactFlash card and the article number of the firmware license to be enabled. With this information, you can purchase the associated license key via a license database to enable the firmware option. The license key is only valid for the identified CompactFlash card and cannot be transferred to other CompactFlash cards.

A PDF guide for the purchase of the license key can be found at the following link at Usage Guide / Demonstration www.siemens.com/automation/license

Selection and ordering data

Description	Article No.
CompactFlash card for CU320-2 Control Unit without safety license	6SL3054-3-0-1BA0
CompactFlash card for CU320-2 Control Unit with safety license	6SL3054-3-0-1BA0-Z F01
• For one axis	
<u>Firmware version</u>	↑↑
V4.8	E J
V5.1	F B
V5.2	F C
	↑
Service Pack SP1 ¹⁾	1
Service Pack SP3 ²⁾	3
Firmware license	
• Safety Integrated extended functions option including Certificate of License for one axis for upgrading the license of a CompactFlash card.	6SL3074-0AA10-0AA0
• SINAMICS DCB extension option Runtime license as of firmware V4.6 including Certificate of License for upgrading the license of a CompactFlash card (see Section Tools and configuration, Drive Control Chart engineering software).	6SL3077-0AA00-0AB0

The current firmware version at the time of publication of this catalog is version V5.2 SP3.

¹⁾ Applies only to firmware version 5.1.

²⁾ Applies only to firmware version 5.2.

SINAMICS G130

Converter built-in units

Supplementary system components > BOP20 Basic Operator Panel

Overview



BOP20 Basic Operator Panel

Parameters can be set, diagnostics information (e.g. alarm and fault messages) read out and faults acknowledged using the BOP20 Basic Operator Panel.

Design

The BOP20 Basic Operator Panel has a backlit two-line display area with six keys.

The integrated plug connector on the rear of the BOP20 Basic Operator Panel provides its power and establishes communication with the Control Unit.

Integration

CU310-2 PN Control Unit with inserted BOP20 Basic Operator Panel



CU320-2 PN Control Unit with inserted BOP20 Basic Operator Panel

Selection and ordering data

Description	Article No.
BOP20 Basic Operator Panel	6SL3055-0AA00-4BA0

Overview

The AOP30 Advanced Operator Panel is an input/output device for converters of the SINAMICS series, preferably for cabinet installation.

It has the following characteristics:

- Graphical backlit LCD display for plain text display and a bar display of process variables
- LEDs for display of the operating states
- Help function describing causes of and remedies for faults and alarms
- Keypad for operational control of a drive
- Local/remote switchover for selecting the operating location (control priority assigned to operator panel or customer terminal strip/communication channel)
- Numeric keypad for input of setpoint or parameter values
- Function keys for guided navigation in the menu
- Two-stage safety concept to protect against accidental or unauthorized changes to settings.
 - Operation of the drive from the operator panel can be disabled by the keyboard lock so that only parameter values and process variables can be displayed on the operator panel.
 - A password can be used to prevent the unauthorized modification of converter parameters.
- Front panel with degree of protection IP55

The AOP30 and SINAMICS drive communicate via the RS232 serial interface with PPI protocol.

The AOP30 may be omitted if the drive is only operated via PROFIBUS, for example, and no local display is required on the cabinet. The AOP30 can then be used simply for commissioning purposes and to obtain diagnostic information, in which case, it is plugged into the RS232 interface on the CU320-2 Control Unit. In this case, an external 24 V power supply (max. current requirement 200 mA) is required.

AOP30
 X540

 9-pole SUB-D
 RxD 2
 TxD 3
 M 0V 5

CU320-2
 X140

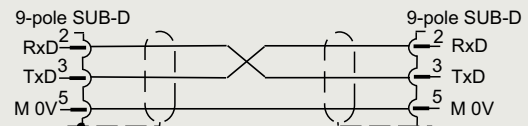
 9-pole SUB-D
 RxD 2
 TxD 3
 M 0V 5

G_D011_EN_00068

Assignment of the serial plug-in cable

Design

The AOP30 is an operator panel with graphical display and membrane keyboard. The device can be installed in a cabinet door which is between 2 mm and 4 mm thick.

Features:

- Display with green backlighting, resolution 240 × 64 pixels
- Membrane keyboard with 26 keys
- Connection for a 24 V power supply
- RS232 interface
- Time and date memory with internal battery backup
- 4 LEDs to indicate the operating state of the drive:
 - RUN green
 - ALARM yellow
 - FAULT red
 - Local/Remote green

SINAMICS G130

Converter built-in units

Supplementary system components > AOP30 Advanced Operator Panel**Selection and ordering data**

Description	Article No.
AOP30 Advanced Operator Panel	6SL3055-0AA00-4CA5
<i>Accessories</i>	
RS232 plug-in cable for connecting the AOP30 to the CU320-2	
1 m (3.28 ft) long	6FX8002-1AA01-1AB0
2 m (6.56 ft) long	6FX8002-1AA01-1AC0
3 m (9.84 ft) long	6FX8002-1AA01-1AD0
4 m (13.1 ft) long	6FX8002-1AA01-1AE0
5 m (16.41 ft) long	6FX8002-1AA01-1AF0
6 m (19.7 ft) long	6FX8002-1AA01-1AG0
7 m (23.0 ft) long	6FX8002-1AA01-1AH0
8 m (26.2 ft) long	6FX8002-1AA01-1AJ0
9 m (29.5 ft) long	6FX8002-1AA01-1AK0
10 m (32.8 ft) long	6FX8002-1AA01-1BA0

For SINAMICS G150, the AOP30 Advanced Operator Panel is installed in the cabinet door as standard.

Technical specifications

	AOP30 Advanced Operator Panel 6SL3055-0AA00-4CA5
Power supply	24 V DC (20.4 ... 28.8 V DC)
Current requirement	
• Without backlighting	< 100 mA
• For max. backlighting	< 200 mA
Data interface	RS232 interface, PPI protocol
Backup battery	3 V lithium CR2032
Operating temperature	0 ... 55 °C (32...131 °F)
Storage and transport temperature	-25 ... +70 °C (-13 ... +158 °F)
Degree of protection	IP20 for the inside of the cabinet IP55 for the outside of the cabinet
Dimensions	
• Width	212 mm (8.35 in)
• Height	156 mm (6.14 in)
• Depth	31 mm (1.22 in)
Weight, approx.	0.55 kg (1.21 lb)
Certificate of suitability	cULus

Overview

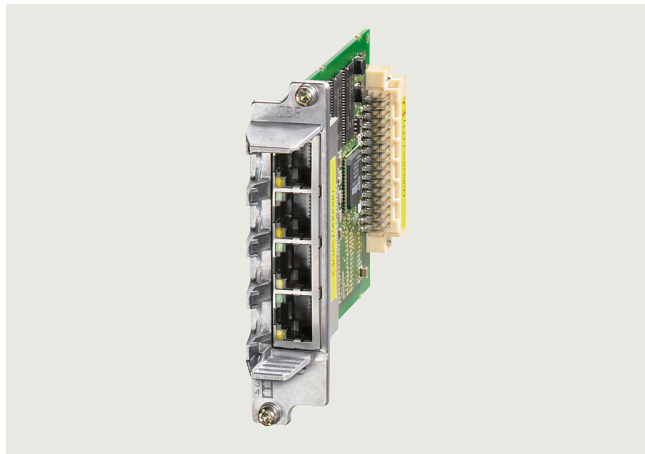

The CBE20 Communication Board is required when:

- A SINAMICS G130 or SINAMICS G150 converter, equipped with a CU320-2 DP (PROFIBUS) Control Unit, is to be connected to a PROFINET IO network
- SINAMICS Link is to be used to directly exchange data between several CU320-2 DP (PROFIBUS) or CU320-2 PN (PROFINET) Control Units without using a higher-level control system
- EtherNet/IP is to be supported
- Modbus TCP is to be supported in a CU320-2 DP

With the CBE20 Communication Board, SINAMICS G130 or SINAMICS G150 is a PROFINET IO device in the sense of PROFINET and offers the following functions:

- PROFINET IO device
- 100 Mbit/s full duplex
- Supports real-time classes of PROFINET IO:
 - RT (Real-Time)
 - IRT (Isochronous Real-Time), minimum send cycle 500 μ s
- Connects to controllers as a PROFINET IO device according to the PROFIdrive profile
- Standard TCP/IP communication for engineering processes using the STARTER commissioning tool
- Integrated 4-port switch with four RJ45 sockets based on the PROFINET ASIC ERTEC400. The optimum topology (line, star, tree) can therefore be configured without additional external switches.

Integration

The CBE20 Communication Board is inserted into the option slot of the CU320-2 Control Unit.

SINAMICS Link

SINAMICS Link is to be used to directly exchange data between several CU320-2 DP (PROFIBUS) or CU320-2 PN (PROFINET) Control Units without using a higher-level control system. In this case, the CBE20 Communication Board is required. Possible applications for the SINAMICS Link include:

- Torque distribution for several drives
- Setpoint cascading for several drives
- Load distribution for drives coupled through a material web
- Couplings between SINAMICS G or SINAMICS S with CU320-2 and SINAMICS DC Master with CUD

Nodes other than the SINAMICS CU320-2 Control Units and the CUD Control Units of the SINAMICS DC MASTER cannot be integrated into this communication network.

SINAMICS Link is activated by appropriately parameterizing the Control Units of the nodes.

Selection and ordering data

Description	Article No.
CBE20 Communication Board	6SL3055-0AA00-2EB0

Accessories

Industrial Ethernet FC

• RJ45 plug 145 (1 unit)	6GK1901-1BB30-0AA0
• RJ45 plug 145 (10 units)	6GK1901-1BB30-0AB0
• Stripping tool	6GK1901-1GA00
• Standard cable GP 2x2	6XV1840-2AH10
• Flexible cable GP 2x2	6XV1870-2B
• Trailing cable GP 2x2	6XV1870-2D
• Trailing cable 2x2	6XV1840-3AH10
• Marine cable 2x2	6XV1840-4AH10

For SINAMICS G150, the CBE20 Communication Board can be ordered as an option by specifying order code **G33**.

More information about connectors and cables can be found in

- Section MOTION-CONNECT connection system
- Catalog IK PI
- Siemens Industry Mall:
www.siemens.com/industrymall

Technical specifications

	CBE20 Communication Board 6SL3055-0AA00-2EB0
Current requirement at 24 V DC	0.16 A
Power loss, max.	2.4 W
Weight, approx.	0.1 kg (0.22 lb)
Certificate of suitability	cULus

SINAMICS G130

Converter built-in units

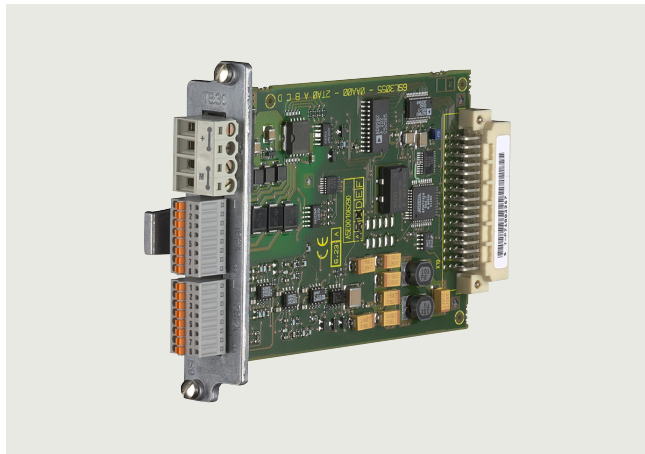
Supplementary system components > TB30 Terminal Board**Overview**

TB30 Terminal Board

The TB30 Terminal Board supports the addition of digital inputs/digital outputs and analog inputs/analog outputs to a Control Unit.

Design

The following are located on the TB30 Terminal Board:

- Power supply for digital inputs/digital outputs
- 4 digital inputs
- 4 digital outputs
- 2 analog inputs
- 2 analog outputs

A shield connection for the signal cable shield is located on the Control Unit.

Selection and ordering data

Description	Article No.
TB30 Terminal Board	6SL3055-0AA00-2TA0

For the SINAMICS G150, the TB30 Terminal Board can be ordered as an option by specifying order code **G62**.

Technical specifications

TB30 Terminal Board 6SL3055-0AA00-2TA0	
Power requirement, max. at 24 V DC via Control Unit CU320-2 without taking account of digital outputs	0.05 A
<ul style="list-style-type: none"> • Conductor cross-section, max. • Fuse protection, max. 	2.5 mm ² 20 A
Digital inputs In accordance with IEC 61131-2 Type 1	
<ul style="list-style-type: none"> • Voltage • Low level (an open digital input is interpreted as "low") • High level • Current consumption at 24 V DC, typ. • Delay time of digital inputs ¹⁾, approx. <ul style="list-style-type: none"> - L → H - H → L • Conductor cross-section, max. 	-3 ... +30 V -3 ... +5 V 15 ... 30 V 6 mA 50 μs 100 μs 0.5 mm ²
Digital outputs (continuously short-circuit-proof)	
<ul style="list-style-type: none"> • Voltage • Load current per digital output, max. • Delay time of digital outputs ¹⁾, approx. • Conductor cross-section, max. 	24 V DC 500 mA 150 μs 0.5 mm ²
Analog inputs (difference)	
<ul style="list-style-type: none"> • Voltage range (an open analog input is interpreted as 0 V) • Internal resistance R_i • Resolution ²⁾ • Conductor cross-section, max. 	-10 ... +10 V 65 kΩ 13 bits + sign 0.5 mm ²
Analog outputs (continuously short-circuit-proof)	
<ul style="list-style-type: none"> • Voltage range • Max. load current • Resolution • Settling time, approx. • Conductor cross-section, max. 	-10 ... +10 V -3 ... +3 mA 11 bits + sign 200 μs 0.5 mm ²
Power loss, max.	3 W
Weight, approx.	0.1 kg (0.22 lb)
Certificate of suitability	cULus

¹⁾ The specified delay times refer to the hardware. The actual reaction time depends on the time slice in which the digital input/output is processed.

²⁾ If the analog input is to be operated in the signal processing sense with continuously variable input voltage, the sampling frequency $f_a = 1/t_{\text{time slice}}$ must be at least twice the value of the highest signal frequency f_{max} .

Integration

The TB30 Terminal Board is inserted in the slot to optionally expand the CU320-2 Control Unit.

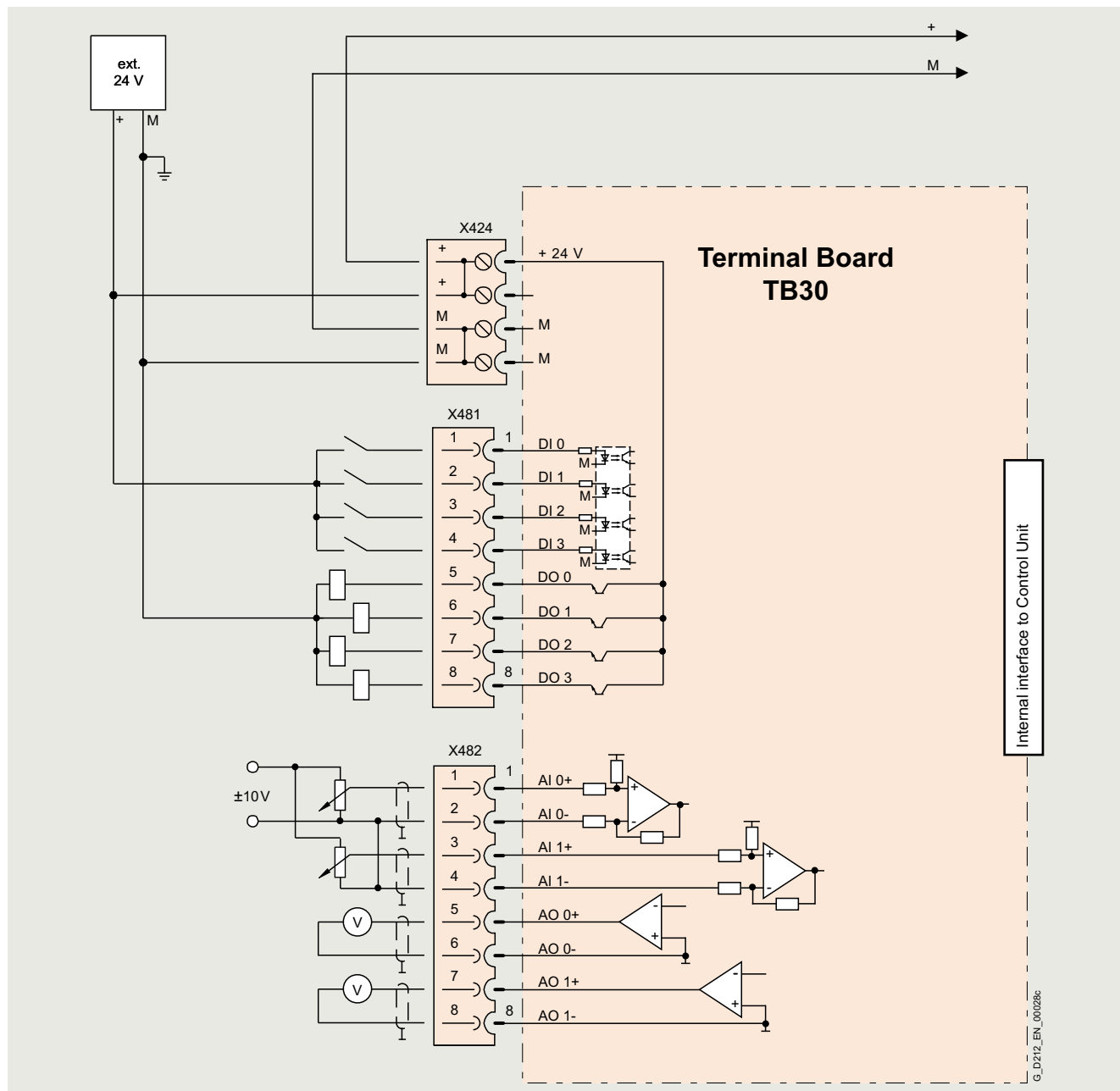

Connection example of a TB30 Terminal Board

SINAMICS G130

Converter built-in units

Supplementary system components > TM31 Terminal Module

Overview



TM31 Terminal Module

With the TM31 Terminal Module, the number of available digital inputs and outputs and the number of analog input and outputs within a drive can be expanded.

The TM31 Terminal Module also features relay outputs with changeover contact and a temperature sensor input.

Design

The following are located on the TM31 Terminal Module:

- 8 digital inputs
- 4 bidirectional digital inputs/outputs
- 2 relay outputs with changeover contact
- 2 analog inputs
- 2 analog outputs
- 1 temperature sensor input for KTY84-130, Pt1000 or PTC (Pt1000 can be used from firmware V4.7 HF17 and higher)
- 2 DRIVE-CLiQ sockets
- 1 connection for the electronics power supply via the 24 V DC supply connector
- 1 PE/protective conductor connection

The status of the TM31 Terminal Module is indicated via a multi-color LED.

The TM31 Terminal Module can be snapped onto a TH 35 standard mounting rail in accordance with EN 60715 (IEC 60715).

The signal cable shield can be attached to the TM31 Terminal Module via a shield connection terminal, e.g. type SK8 supplied by Phoenix Contact or type KLBÜ CO 1 supplied by Weidmüller. The shield connection terminal must not be used as a strain relief mechanism.

Selection and ordering data

Description	Article No.
TM31 Terminal Module Without DRIVE-CLiQ cable	6SL3055-0AA00-3AA1
<i>Accessories for re-ordering</i>	
Dust protection blanking plugs (50 units) For DRIVE-CLiQ port	6SL3066-4CA00-0AA0

For the SINAMICS G150, the TM31 Terminal Module can be ordered as an option by specifying order code **G60** or **G61**.

Technical specifications

	TM31 Terminal Module 6SL3055-0AA00-3AA1	TM31 Terminal Module 6SL3055-0AA00-3AA1
Power requirement, max. At 24 V DC without taking account of the digital outputs and DRIVE-CLiQ supply	0.5 A	
<ul style="list-style-type: none"> Conductor cross-section, max. Fuse protection, max. 	2.5 mm ² 20 A	
Digital inputs In accordance with IEC 61131-2 Type 1		
<ul style="list-style-type: none"> Voltage Low level (an open digital input is interpreted as "low") High level Current consumption at 24 V DC, typ. Delay times of digital inputs ¹⁾, approx. <ul style="list-style-type: none"> - L → H - H → L Conductor cross-section, max. 	-3 ... +30 V -3 ... +5 V 15 ... 30 V 9 mA 50 μs 100 μs 1.5 mm ²	
Digital outputs (continuously short-circuit-proof)		
<ul style="list-style-type: none"> Voltage Load current per digital output, max. Total current of digital outputs, max. Delay times of digital outputs ¹⁾ <ul style="list-style-type: none"> - Typ. - Max. Conductor cross-section, max. 	24 V DC 100 mA 400 mA 150 μs with 0.5 A resistive load 500 μs 1.5 mm ²	
Analog inputs a switch is used to toggle between voltage and current input		
<ul style="list-style-type: none"> As voltage input <ul style="list-style-type: none"> - Voltage range - Internal resistance R_i - Resolution ²⁾ As current input <ul style="list-style-type: none"> - Current ranges - Internal resistance R_i - Resolution ²⁾ Conductor cross-section, max. 	-10 ... +10 V 100 kΩ 11 bits + sign 4 ... 20 mA, -20 ... +20 mA, 0 ... 20 mA 250 Ω 10 bits + sign 1.5 mm ²	
Analog outputs (continuously short-circuit-proof)		
<ul style="list-style-type: none"> Voltage range Max. load current Current ranges Load resistance, max. Resolution Conductor cross-section, max. 	-10 ... +10 V -3 ... +3 mA 4 ... 20 mA, -20 ... +20 mA, 0 ... 20 mA 500 Ω in the range -20 ... +20 mA 11 bits + sign 1.5 mm ²	
Relay outputs CO contacts		
<ul style="list-style-type: none"> Max. load current Operational voltage, max. Switching capacity, max. <ul style="list-style-type: none"> - At 250 V AC - At 30 V DC Required minimum current Conductor cross-section, max. 	8 A 250 V AC, 30 V DC 2000 VA (cos φ = 1) 750 VA (cos φ = 0.4) 240 W (resistive load) 100 mA 2.5 mm ²	
Power loss, max.	10 W	
PE connection	M4 screw	
Dimensions		
<ul style="list-style-type: none"> Width Height Depth 	50 mm (1.97 in) 150 mm (5.91 in) 111 mm (4.37 in)	
Weight, approx.	0.49 kg (1.08 lb)	
Certificate of suitability	cULus	

¹⁾ The specified delay times refer to the hardware. The actual reaction time depends on the time slice in which the digital input/output is processed.

²⁾ If the analog input is to be operated in the signal processing sense with continuously variable input voltage, the sampling frequency $f_a = 1/t_{\text{time slice}}$ must be at least twice the value of the highest signal frequency f_{max} .

SINAMICS G130

Converter built-in units

Supplementary system components > TM31 Terminal Module

Integration

The TM31 Terminal Module can communicate via DRIVE-CLiQ with the following Control Units.

- CU310-2 Control Unit
- CU320-2 Control Unit
- SINUMERIK Control Unit
- SIMOTION D Control Unit
- SINAMICS DCM Advanced CUD

3

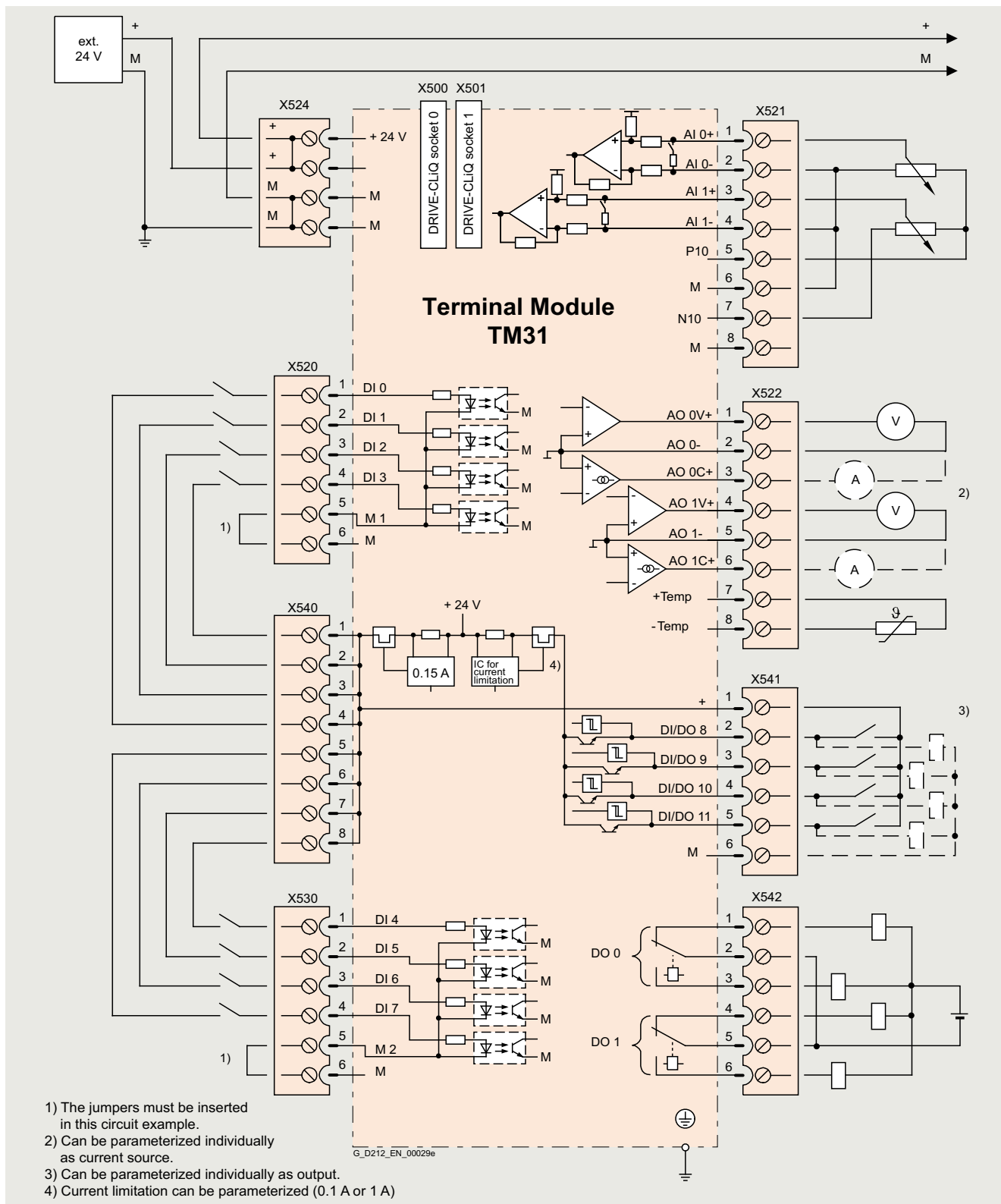

Connection example of TM31 Terminal Module

Overview



TM54F Terminal Module

The TM54F Terminal Module is a dual-processor I/O interface with four fail-safe digital outputs and ten fail-safe digital inputs for utilization of the Safety Integrated functions of the SINAMICS drive system via external actuators and sensors.

Every available safety function integrated in the drive can be controlled via the fail-safe digital inputs on the TM54F Terminal Module. In the event that the parameterized safety functions of several drives operated together on a Control Unit are to be executed together, then these drives can be grouped in the TM54F Terminal Module. The advantage of this approach is that only one fail-safe digital input needs to be connected for these drives.

The fail-safe digital inputs and outputs have two channels and are redundantly configured with an internal data cross-check using the two processors. A fail-safe digital output consists of one P-switching and one M-switching output as well as one digital input to read back the switching state. A fail-safe digital input consists of two digital inputs.

Safety sensors can be connected over two switchable 24 V sensor supplies and can be evaluated over the fail-safe digital inputs. The switchable 24 V sensor supply ensures that the fail-safe digital inputs can be dynamized to detect dormant errors (this dynamization is used to check the shutdown paths). An unswitchable 24 V sensor supply is additionally provided by the TM54F Terminal Module for connecting undynamizable safety sensors.

The TM54F Terminal Module must be directly connected to a Control Unit via a DRIVE-CLiQ cable. Only one TM54F Terminal Module can be assigned to each Control Unit. It is not permissible to make the TM54F connection via another DRIVE-CLiQ device, e.g. a Power Module, a Motor Module or a Line Module.

Design

The following are located on the TM54F Terminal Module:

- 4 fail-safe digital outputs
- 10 fail-safe digital inputs
- 4 LEDs, single color for indicating the status of the read back channel of the fail-safe digital outputs
- 4 LEDs, dual-color for indicating the status of the fail-safe digital outputs
- 20 LEDs, dual-color for indicating the status of the fail-safe digital inputs
- 3 LEDs, single color for indicating the status of the 24 V sensor supplies
- 2 DRIVE-CLiQ sockets
- 2 connections for 24 V sensor supply, switchable
- 1 connection for 24 V sensor supply, not switchable
- 1 connection for the electronics power supply via the 24 V DC supply connector
- 1 connection for the 24 V power supply to digital outputs and sensors
- 1 PE/protective conductor connection

The status of the TM54F Terminal Module is indicated via a multi-color LED.

The TM54F Terminal Module can be snapped onto a TH 35 standard mounting rail in accordance with EN 60715 (IEC 60715).

The signal cable shield can be attached to the TM54F Terminal Module via a shield connection terminal, e.g. type SK8 supplied by Phoenix Contact or type KLBÜ CO 1 supplied by Weidmüller. The shield connection terminal must not be used as a strain relief mechanism.

Pins for connector coding are included in the TM54F Terminal Module scope of supply.

Selection and ordering data

Description	Article No.
TM54F Terminal Module Without DRIVE-CLiQ cable	6SL3055-0AA00-3BA0
<i>Accessories for re-ordering</i>	
Dust protection blanking plugs (50 units) For DRIVE-CLiQ port	6SL3066-4CA00-0AA0

For the SINAMICS G150, the TM54F Terminal Module can be ordered as an option by specifying order code **K87**.

SINAMICS G130

Converter built-in units

Supplementary system components > TM54F Terminal Module**Technical specifications**

	TM54F Terminal Module 6SL3055-0AA00-3BA0	TM54F Terminal Module 6SL3055-0AA00-3BA0
Current requirement (X524 at 24 V DC) without DRIVE-CLiQ supply	0.2 A	
• Conductor cross-section, max.	2.5 mm ²	
• Fuse protection, max.	20 A	
Max. current requirement ext. 24 V for supplying the digital outputs and 24 V sensor supply (X514 at 24 V DC)	4 A	
• Conductor cross-section, max.	2.5 mm ²	
• Fuse protection, max.	20 A	
I/O		
• Number of fail-safe digital inputs	10	
• Number of fail-safe digital outputs	4	
• 24 V sensor supply	3, of which 2 can be temporarily shut down using an internal test routine for dynamizing fail-safe digital inputs, current carrying capacity 0.5 A each	
• Cables and connections	Plug-in screw-type terminals	
• Conductor cross-section, max.	1.5 mm ²	
Digital inputs in accordance with IEC 61131-2 Type 1, with galvanic isolation		
• Voltage	-3 ... +30 V	
• Low level (an open digital input is interpreted as "low")	-3 ... +5 V	
• High level	15 ... 30 V	
• Current consumption at 24 V DC, typ.	>3.2 mA	
• Delay time of digital inputs, approx. ¹⁾		
- L → H, typ.	30 μs	
- H → L, typ.	60 μs	
• Safe state	Low level (for inputs that can be inverted: without inversion)	
		Digital outputs (continuously short-circuit-proof)
		• Voltage
		24 V DC
		• Load current per fail-safe digital output, max. ²⁾
		0.5 A
		• Delay times (resistive load) ¹⁾
		- L → H, typ.
		300 μs
		- H → L, typ.
		350 μs
		• Safe state
		Output switched off
		Scanning cycle t_{SI} for fail-safe digital inputs or fail-safe digital outputs
		4 ... 25 ms (adjustable)
		Power loss, max. At 24 V
		4.5 W
		PE connection
		M4 screw
		Dimensions
		• Width
		50 mm (1.97 in)
		• Height
		151 mm (5.94 in)
		• Depth
		110 mm (4.33 in)
		Weight, approx.
		0.9 kg (1.98 lb)
		Certificate of suitability
		cULus
		Safety Integrated
		Acc. to IEC 61508 SIL 2 and EN ISO 13849-1 PL d and Category 3

Integration

The TM54F Terminal Module can communicate via DRIVE-CLiQ with the following Control Units.

- CU310-2 Control Unit
- CU320-2 Control Unit
- SINUMERIK 828D
- Numeric Control Extensions NX10.3
- Numeric Control Extensions NX15.3
- SIMOTION D Control Unit or Controller Extension

¹⁾ The specified delay times refer to the hardware. The actual reaction time depends on the time slice in which the digital input/output is processed.

²⁾ The total current of all fail-safe digital outputs must not exceed 5.33 A.

SINAMICS G130

Converter built-in units

Supplementary system components > TM150 Terminal Module**Overview**

TM150 Terminal Module

The TM150 Terminal Module is a DRIVE-CLiQ component for temperature evaluation. The temperature is measured in a temperature range from -99 °C to +250 °C for the following temperature sensors:

- Pt100 (with monitoring for wire breaks and short-circuits)
- Pt1000 (with monitoring for wire breaks and short-circuits)
- KTY84 (with monitoring for wire breaks and short-circuits)
- PTC (with monitoring for short-circuit)
- Bimetallic NC contact (without monitoring)

For the temperature sensor inputs, for each terminal block the evaluation can be parameterized for 1×2-wire, 2×2-wire, 3-wire or 4-wire. There is no galvanic isolation in the TM150 Terminal Module.

The temperature channels can be subdivided into 3 groups and evaluated together.

Design

The following are located on the TM150 Terminal Module:

- 6 ... 12 temperature sensor inputs
- 2 DRIVE-CLiQ sockets
- 1 connection for the electronics power supply via the 24 V DC supply connector
- 1 PE/protective conductor connection

The status of the TM150 Terminal Module is indicated via a multi-color LED.

The TM150 Terminal Module can be snapped onto a TH 35 standard mounting rail in accordance with EN 60715 (IEC 60715).

Selection and ordering data

Description	Article No.
TM150 Terminal Module Without DRIVE-CLiQ cable	6SL3055-0AA00-3LA0
Accessories for re-ordering	
Dust protection blanking plugs (50 units) For DRIVE-CLiQ port	6SL3066-4CA00-0AA0

For the SINAMICS G150, the TM150 Terminal Module can be ordered as an option by specifying order code **G51**.

Technical specifications

	TM150 Terminal Module 6SL3055-0AA00-3LA0
Power requirement, max. at 24 V DC	0.5 A
• Conductor cross section, max.	2.5 mm ²
• Fuse protection, max.	20 A
Temperature sensor inputs The inputs can be parameterized individually for the evaluation of sensors	
• Conductor cross section, max.	1.5 mm ²
• Measuring current per sensor, approx.	0.8 mA
Power loss	1.6 W
PE connection	M4 screw
Dimensions	
• Width	30 mm (1.18 in)
• Height	150 mm (5.91 in)
• Depth	111 mm (4.37 in)
Weight, approx.	0.41 kg (0.90 lb)
Certificate of suitability	cULus

Integration

The TM150 Terminal Module can communicate via DRIVE-CLiQ with the following Control Units.

- CU310-2 Control Unit
- CU320-2 Control Unit
- SINAMICS DCM Advanced CUD

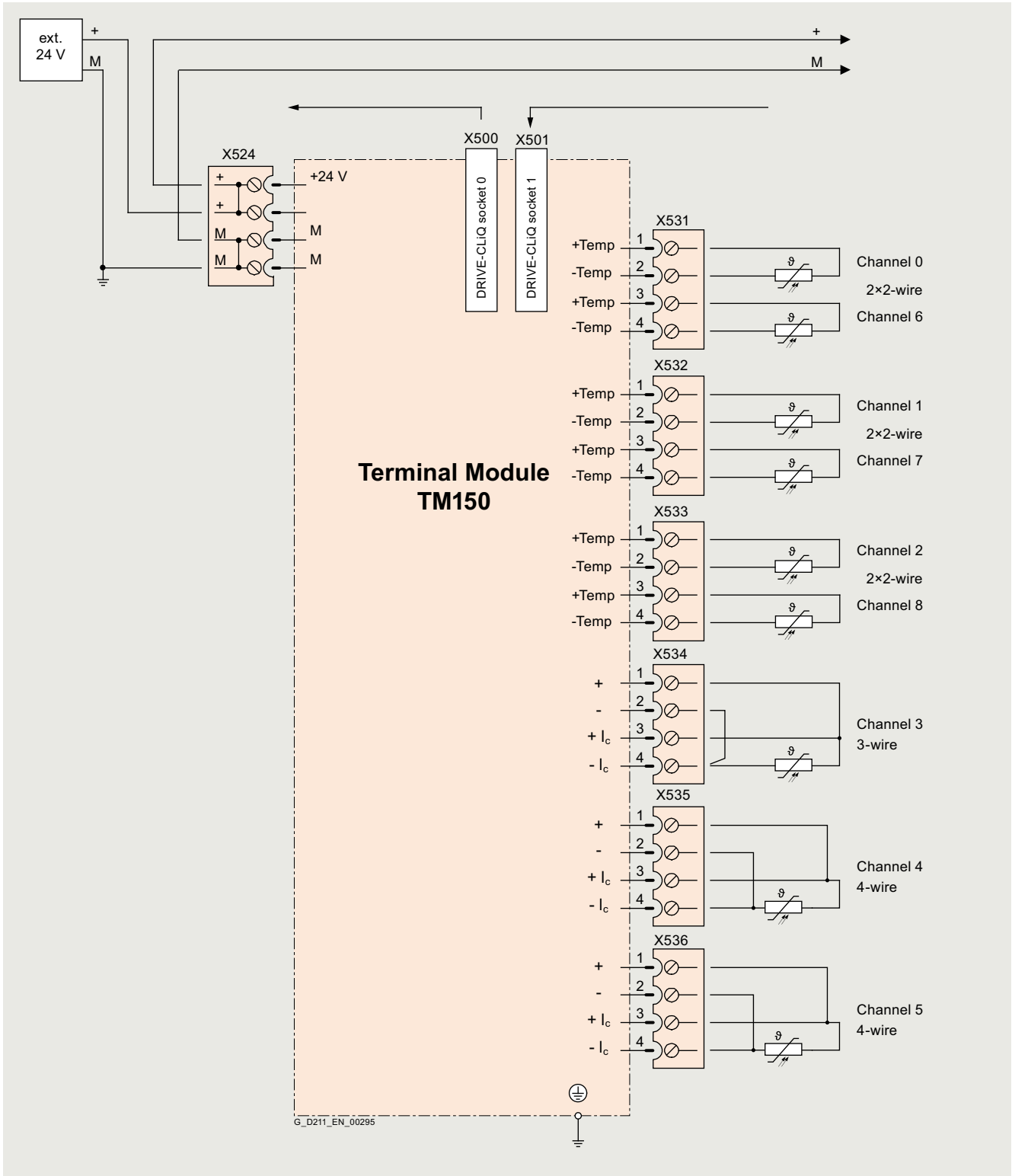

Connection example of a TM150 Terminal Module

SINAMICS G130

Converter built-in units

Supplementary system components > VSM10 Voltage Sensing Module**Overview**

The VSM10 Voltage Sensing Module enables the line or motor voltage characteristic to be measured precisely. The phase differential voltage can be measured, either grounded (in the delivery state with jumper plugged in) or isolated.

In addition, the VSM10 Voltage Sensing Module is used to connect to rotating synchronous motors – or for a "quick flying restart" of rotating induction motors.

Design

The VSM10 Voltage Sensing Module has the following interfaces:

- 1 connection for direct voltage sensing up to 690 V
- 1 connection for voltage sensing using voltage transformers, maximum voltage 100 V
- 1 temperature sensor input for KTY84-130, Pt1000 or PTC (Pt1000 can be used from firmware V4.7 HF17)
- 1 DRIVE-CLiQ socket
- 1 connection for the electronics power supply via the 24 V DC supply connector
- 1 plug-in jumper for either grounded (delivery state) or isolated measurement
- 1 PE/protective conductor connection

The status of the VSM10 Voltage Sensing Module is indicated by a two-color LED.

The VSM10 Voltage Sensing Module can be snapped onto a TH 35 mounting rail according to EN 60715 (IEC 60715).

Selection and ordering data

Description	Article No.
VSM10 Voltage Sensing Module Without DRIVE-CLiQ cable	6SL3053-0AA00-3AA1
<i>Accessories for re-ordering</i>	
Dust protection blanking plugs (50 units) For DRIVE-CLiQ port	6SL3066-4CA00-0AA0

For the SINAMICS G150, the VSM10 Voltage Sensing Module can be ordered as an option with order code **K51** to implement the flying restart function.

Technical specifications

VSM10 Voltage Sensing Module 6SL3053-0AA00-3AA1	
Power requirement, max. at 24 V DC	0.2 A
• Conductor cross section, max.	2.5 mm ²
Power loss, max.	10 W
Line voltage detection	
• Insulation resistance neutral point - ground when the jumper is not inserted	> 10 MΩ
• Input resistance	
- Terminal X521	> 362 kΩ/phase
- Terminal X522	> 2.5 MΩ/phase
Analog inputs (reserved for monitoring an Active Interface Module in chassis format)	
• Internal resistance, approx. (between differential inputs)	100 kΩ
• Resolution	12-bit + sign
PE connection	M4 screw
Dimensions	
• Width	50 mm (1.97 in)
• Height	150 mm (5.91 in)
• Depth	111 mm (4.37 in)
Weight, approx.	1 kg (2.21 lb)
Certificate of suitability	cULus

Integration

The VSM10 Voltage Sensing Module communicates with the CU320-2 Control Unit via DRIVE-CLiQ.

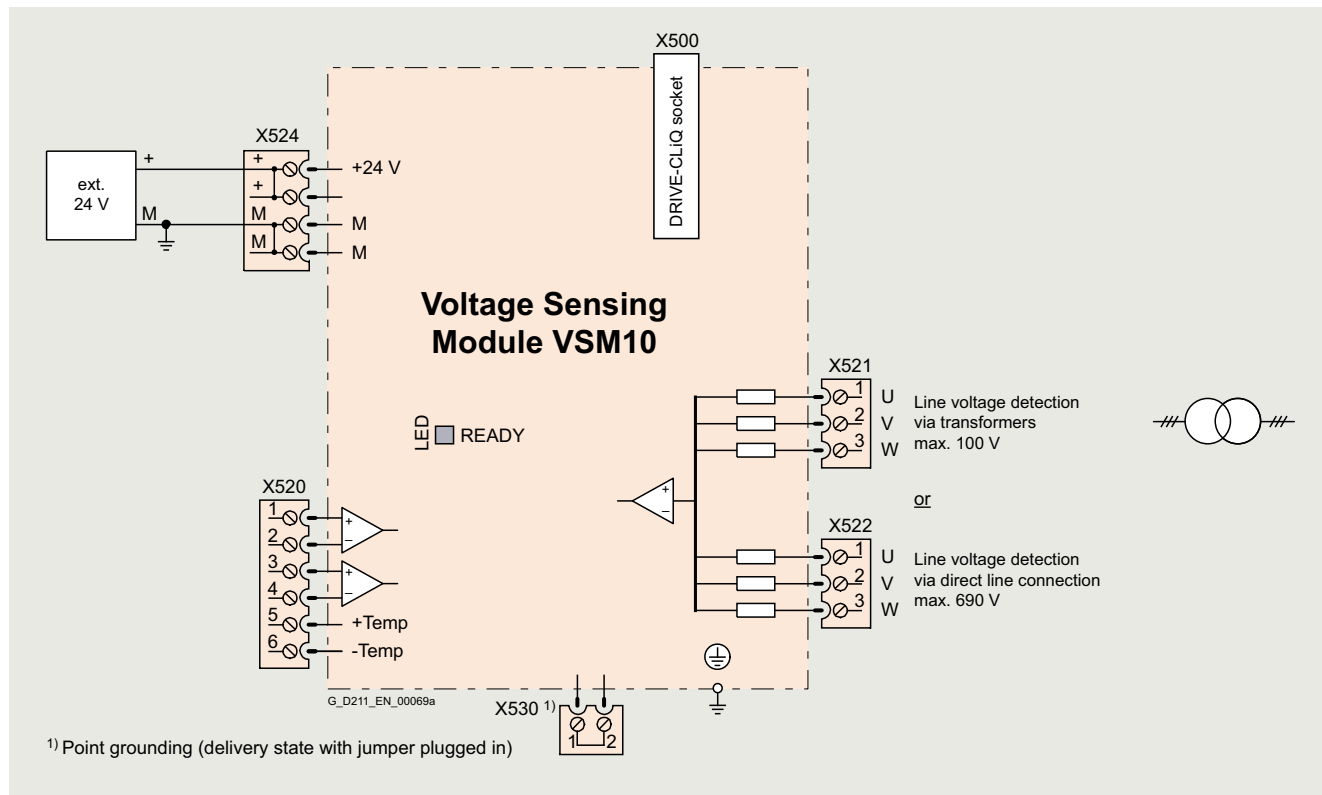

Connection example of a VSM10 Voltage Sensing Module

SINAMICS G130

Converter built-in units

Supplementary system components > Safe Brake Adapter SBA**Overview**

Safe Brake Adapter SBA

The Safe Brake Adapter SBA is required to implement a Safe Brake Control (Safety Integrated function "SBC") in conjunction with Motor Modules and Power Modules in chassis format in accordance with IEC 61800-5-2.

The Safe Brake Adapter is available for a 230 V AC brake control voltage.

Note:

The SBA is approved for the IEC area. Safe Brake Adapter with UL approval are available on request. The UL approval is valid for a maximum permissible current consumption of 1.5 A (inductive).

Design

The Safe Brake Adapter SBA has the following connections and interfaces:

- 1 connection for the connecting cable to the Power Module/Motor Module (X11)
- 1 connection for the external 230 V AC supply (X12)
- 1 connection for the motor holding brake (X14)
- 1 connection for quick de-excitation of the operating coil (X15)

The Safe Brake Adapter is designed for attachment to a support rail in accordance with EN 60715.

Selection and ordering data

Description	Article No.
Safe Brake Adapter 230 V AC/2 A	6SL3355-2DX00-1AA0
Accessories	
Connecting cable Pre-assembled interface cable to connect the SBA to the electronics module Control Interface Module in the Motor Module/Power Module (4 m)	6SL3060-4DX04-0AA0

Technical specifications

Safe Brake Adapter 6SL3355-2DX00-1AA0	
Electronics power supply	
• Supply voltage (via the Control Interface Module)	24 V DC (20.4 ... 28.8 V)
Supply voltage of the motor holding brake	230 V AC
Current consumption, max permitted	
• Motor holding brake	2 A
• Fast de-excitation	2 A
Cable length, max.	
• To the Control Interface Module	10 m (32.8 ft)
• To the brake	300 m (984 ft)
Conductor cross-section, max., respectively	2.5 mm ²
Dimensions	
• Width	75 mm (2.95 in)
• Height	111 mm (4.37 in)
• Depth	89 mm (3.50 in)
Weight, approx.	0.25 kg (0.55 lb)
Safety Integrated	Acc. to IEC 61508 SIL 2 and EN ISO 13849-1 PL d and Category 3

Integration

The control and feedback signal regarding the switching state of the SBA relay is implemented via terminals of the electronic module Control Interface Module (CIM) in the Motor Module/ Power Module. The excitation coil of the holding brake is connected directly at the SBA.

The SBA can be ordered as an additional component for SINAMICS G130 built-in units.

For SINAMICS G150 cabinet units, it is available as an option (**K88**).

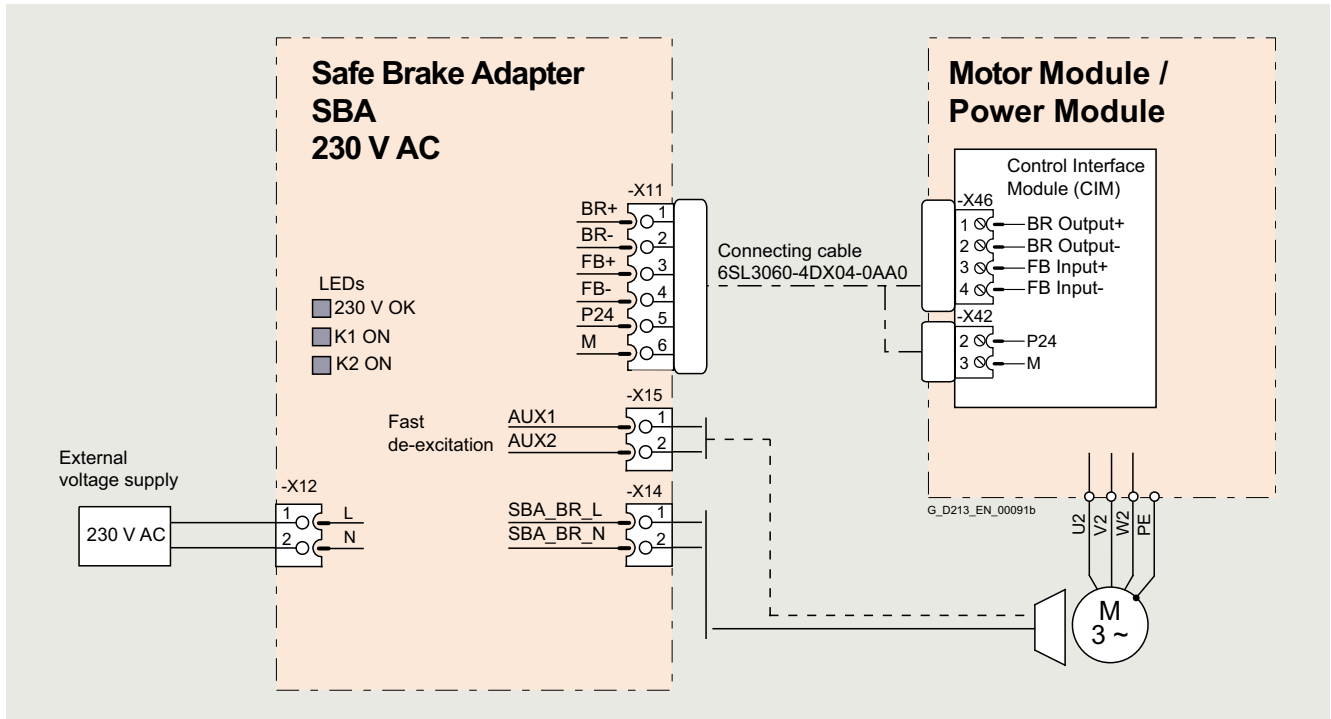

Connection example of a Safe Brake Adapter SBA

SINAMICS G130

Converter built-in units

Supplementary system components > SMC30 Sensor Module Cabinet-Mounted

Overview

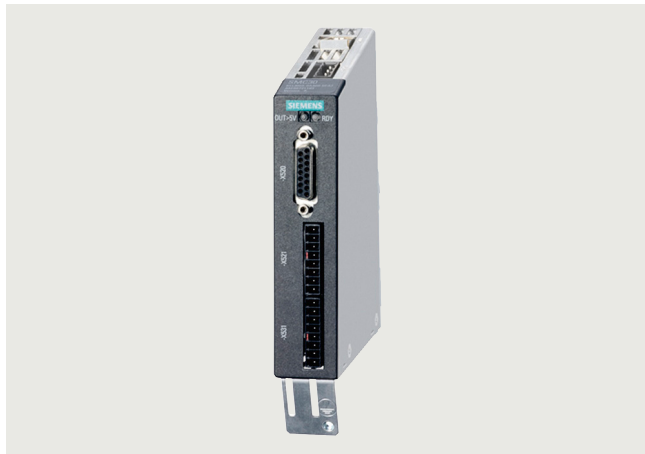

SMC30 Sensor Module Cabinet-Mounted

The SMC30 Sensor Module Cabinet-Mounted is required to evaluate the encoder signals of motors without a DRIVE-CLiQ interface. External encoders can also be connected via the SMC30.

The following encoder signals can be evaluated:

- Incremental encoders TTL/HTL with/without open-circuit detection (open-circuit detection is only available with bipolar signals)
- SSI encoder with TTL/HTL incremental signals
- SSI encoder without incremental signals

The motor temperature can also be sensed using a PTC thermistor KTY84-130, Pt1000 or PTC.

Design

The SMC30 Sensor Module Cabinet-Mounted features the following connections and interfaces as standard:

- 1 encoder connection including motor temperature sensing (KTY84-130, Pt1000 or PTC) either via SUB-D connector or via terminals
- 1 DRIVE-CLiQ interface
- 1 connection for the electronics power supply via the 24 V DC supply connector
- 1 PE/protective conductor connection

The status of the SMC30 Sensor Module Cabinet-Mounted is indicated via a multi-color LED.

The SMC30 Sensor Module Cabinet-Mounted can be snapped onto a TH 35 standard mounting rail in according to EN 60715 (IEC 60715).

The maximum encoder cable length between SMC30 modules and encoders is 100 m. For HTL encoders, this length can be increased to 300 m if the A+/A- and B+/B- signals are evaluated and the power supply cable has a minimum cross-section of 0.5 mm².

The signal cable shield can be connected to the SMC30 Sensor Module Cabinet-Mounted via a shield connection terminal, e.g., Phoenix Contact type SK8 or Weidmüller type KLBÜ CO 1. The shield connection terminal must not be used as a strain relief mechanism.

Integration

SMC30 Sensor Modules Cabinet-Mounted communicate with a Control Unit via DRIVE-CLiQ.

Selection and ordering data

Description	Article No.
SMC30 Sensor Module Cabinet-Mounted	6SL3055-0AA00-5CA2
Without DRIVE-CLiQ cable	
<i>Accessories for re-ordering</i>	
Dust protection blanking plugs (50 units)	6SL3066-4CA00-0AA0
For DRIVE-CLiQ port	

For the SINAMICS G150, the SMC30 Sensor Module Cabinet-Mounted can be ordered as an option by specifying order code **K50**.

A second SMC30 can be ordered as an option with the order code **K52** for reliable actual value acquisition when using the Safety Integrated Extended Functions.

Technical specifications

	SMC30 Sensor Module Cabinet-Mounted 6SL3055-0AA00-5CA2
Current requirement, max. at 24 V DC, without taking encoder into account	0.2 A
• Conductor cross-section, max.	2.5 mm ²
• Fuse protection, max.	20 A
Power loss, max.	10 W
Encoders which can be evaluated	<ul style="list-style-type: none"> • Incremental encoder TTL/HTL • SSI encoder with TTL/HTL incremental signals • SSI encoder without incremental signals
• Input current range TTL/HTL	4 ... 20 mA (typ. 10 mA)
• Encoder supply	24 V DC/0.35 A or 5 V DC/0.35 A
• Encoder frequency, max.	500 kHz
• SSI baud rate	100 ... 1000 kBaud
• Resolution absolute position SSI	30 bits
• Cable length, max.	
- TTL encoder	100 m (328 ft) (only bipolar signals permitted) ¹⁾
- HTL encoder	100 m (328 ft) for unipolar signals 300 m (984 ft) for bipolar signals ¹⁾
- SSI encoder	100 m (328 ft)
PE connection	M4 screw
Dimensions	
• Width	30 mm (1.18 in)
• Height	150 mm (5.91 in)
• Depth	111 mm (4.37 in)
Weight, approx.	0.45 kg (0.99 lb)
Certificate of suitability	cULus

¹⁾ Signal cables twisted in pairs and shielded

Overview



Signal cables are required for the DRIVE-CLiQ connection between different components. Signal cables are pre-assembled and are sold by the meter. The following signal cables are available:

- DRIVE-CLiQ signal cables
- MOTION-CONNECT DRIVE-CLiQ signal cables
- MOTION-CONNECT pre-assembled signal cables

Type of delivery for pre-assembled signal cables

Pre-assembled signal cables are available in units of 10 cm. Cables up to 30 kg or 100 m are supplied as coils; above this, they are supplied on drums.

Application

DRIVE-CLiQ signal cables

DRIVE-CLiQ signal cables are used to connect components with DRIVE-CLiQ connections, which have a separate or external 24 V DC power supply.

MOTION-CONNECT DRIVE-CLiQ signal cables

MOTION-CONNECT DRIVE-CLiQ signal cables are used whenever components with DRIVE-CLiQ connections must meet high requirements such as mechanical stress and oil resistance, e.g. where a connection is made outside the cabinet between

- Power Modules and Sensor Modules
- Power Modules and motors with DRIVE-CLiQ interface

MOTION-CONNECT DRIVE-CLiQ signal cables have 24 V DC cores.

Serial plug-in cable for connecting the AOP30 to the CU320-2

The AOP30 Advanced Operator Panel is connected to the CU320-2 Control Unit via a serial plug-in cable (RS232C cable).

The maximum cable length is 10 m. To guarantee disturbance-free communication, a shielded cable is recommended, and the cable shield should be connected to both connector housings.

Selection and ordering data

Signal cable	Length m (ft)	Article No.
Pre-assembled DRIVE-CLiQ signal cables (without 24 V DC cores)	0.11 (0.36)	6SL3060-4AB00-0AA0
	0.16 (0.52)	6SL3060-4AD00-0AA0
Connectors with degree of protection IP20/IP20	0.21 (0.69)	6SL3060-4AF00-0AA0
	0.26 (0.85)	6SL3060-4AH00-0AA0
	0.36 (1.18)	6SL3060-4AM00-0AA0
	0.41 (1.35)	6SL3060-4AP00-0AA0
	0.60 (1.97)	6SL3060-4AU00-0AA0
	0.95 (3.12)	6SL3060-4AA10-0AA0
	1.20 (3.94)	6SL3060-4AW00-0AA0
	1.45 (4.76)	6SL3060-4AF10-0AA0
	1.60 (5.25)	6SL3060-4AG10-0AA0
	2.10 (6.89)	6SL3060-4AB20-0AA0
	2.40 (7.87)	6SL3060-4AE20-0AA0
	2.80 (9.19)	6SL3060-4AJ20-0AA0
	5.00 (16.4)	6SL3060-4AA50-0AA0

SINAMICS G130

Converter built-in units

Supplementary system components > Signal cables

Integration

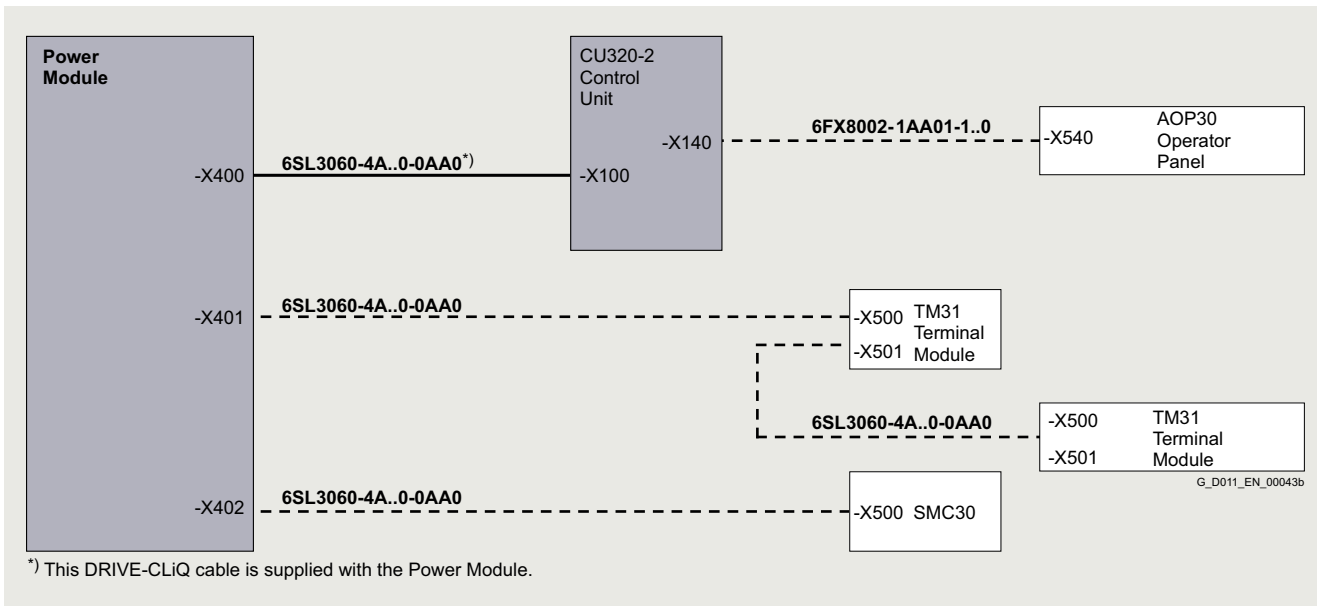

Connection example of a CU320-2 Control Unit

3

SINAMICS G150 converter cabinet units

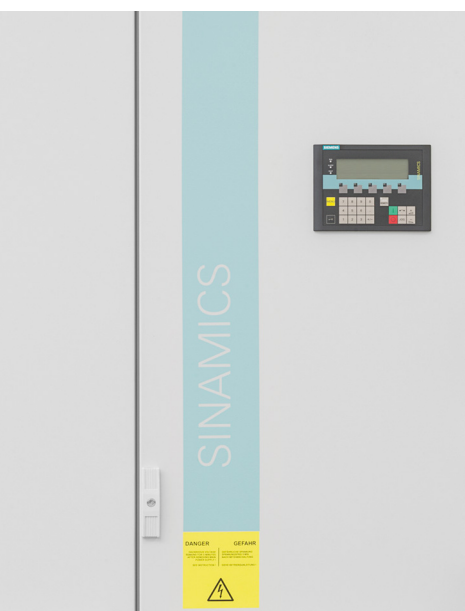

4/2	Overview
4/3	Benefits
4/3	Application
4/3	Design
4/6	Function
4/9	Selection and ordering data
4/9	Single connection
4/9	Parallel connection
4/10	Options
4/13	Option selection matrix
4/14	Ordering examples
4/15	Description of options
4/29	Technical specifications
4/30	General technical specifications
4/31	Single connection
4/35	Parallel connection
4/37	Characteristic curves
4/37	Derating data
4/40	Overload capability
4/41	Configuration
4/41	Cable cross-sections and connections
4/41	Single connection
4/42	Parallel connection
4/42	Minimum motor cable lengths for operation with power units connected in parallel
4/43	Cable cross-sections for line and motor connection
4/43	Grounding and protective conductor cross-section
4/44	Line-side power components
4/44	Recommended fuses

SINAMICS G150

Converter cabinet units

75 kW to 2700 kW

Overview



SINAMICS G150 converter cabinet units, versions A and C

With its SINAMICS G150 converter cabinet units, a drive system is available on which all line-side and motor-side components are integrated together with the Power Module extremely compact into a specially designed cabinet enclosure. This approach minimizes the effort and expense required to configure and install them.

SINAMICS G150 has been specially designed to meet the requirements of drives with square-wave and constant load characteristics, with medium performance requirements, and without regenerative feedback capability.

The control accuracy of the sensorless vector control is suitable for most applications, which means that an additional actual speed value encoder is not required.

SINAMICS G150 converter cabinet units are optionally available with an encoder evaluation function in order to handle applications that require an encoder for plant-specific reasons.

SINAMICS G150 converter cabinet units offer an economic drive solution that can be adapted to customer-specific requirements through a wide range of components and options.

SINAMICS G150 is available in two versions:

- Version A**
 All optionally available line connection components, such as the main switch, circuit breakers, line contactor, line fuses, line filter or motor-side components and additional monitoring devices, can be installed as required. This version is also available with power units connected in parallel.
- Version C**
 Offers an extremely space-optimized structure without line-side components. This particularly slimline version can be used, for example, when line connection components are accommodated in a central low-voltage distribution panel (MCC) in the plant.

The following voltages and power ratings are available:

Line voltage	Power range single connection (versions A and C)	Power range parallel connection (version A)
380 ... 480 V 3 AC	110 ... 560 kW	630 ... 900 kW
500 ... 600 V 3 AC	110 ... 560 kW	630 ... 1000 kW
660 ... 690 V 3 AC	75 ... 800 kW	1000 ... 2700 kW

Degrees of protection are IP20 (standard) and optionally IP21, IP23, IP43 and IP54.

Benefits

- Particularly quiet and compact converters thanks to state-of-the-art IGBT power semiconductors and an innovative cooling concept.
- Individual modules and power components can be replaced quickly and easily, which ensures a higher level of plant availability. Replaceable components have been designed so that they can be quickly and easily replaced. In addition, the "Spares On Web" Internet tool makes it easy to view the spare parts that are available for the particular order at all times.
- Can be easily integrated in automation solutions by means of a standard communications interface as well as a range of analog and digital interfaces.
- Easy commissioning and parameterization using interactive menus on the AOP30 Advanced Operator Panel with graphic LCD and plain-text display, or PC-supported using the STARTER commissioning tool (see [Chapter Tools and configuration](#)).
- Preset software functions make it easier to adapt the converter to the individual plant. For example, the key functions for controlling pumps are stored as a preprogrammed macro in the drive.
- With regard to EMC, the devices are subdivided into various zones, and as a consequence, they are extremely insensitive to disturbances and are very reliable in operation. With the help of simulated conditions, partitions have been designed to act as air guides and to help dissipate heat.
- Special measures used in the construction of the cabinets ensure that they remain mechanically durable over their entire life cycle. All components, from individual parts to the ready-to-connect cabinet, undergo rigorous testing throughout the entire production process. This guarantees a high level of functional reliability during installation and commissioning, as well as in operation.

Application

Variable-speed drives are ideal for all applications that involve moving, conveying, pumping or compressing solids, liquids or gases.

Key applications include:

- Pumps and fans
- Compressors
- Extruders and mixers
- Mills

Design

SINAMICS G150 converter cabinet units are characterized by their compact, modular and service-friendly design.

A wide range of options is available depending on the cabinet version which permit optimum adaptation of the drive system to the respective requirements (see [Options](#)).

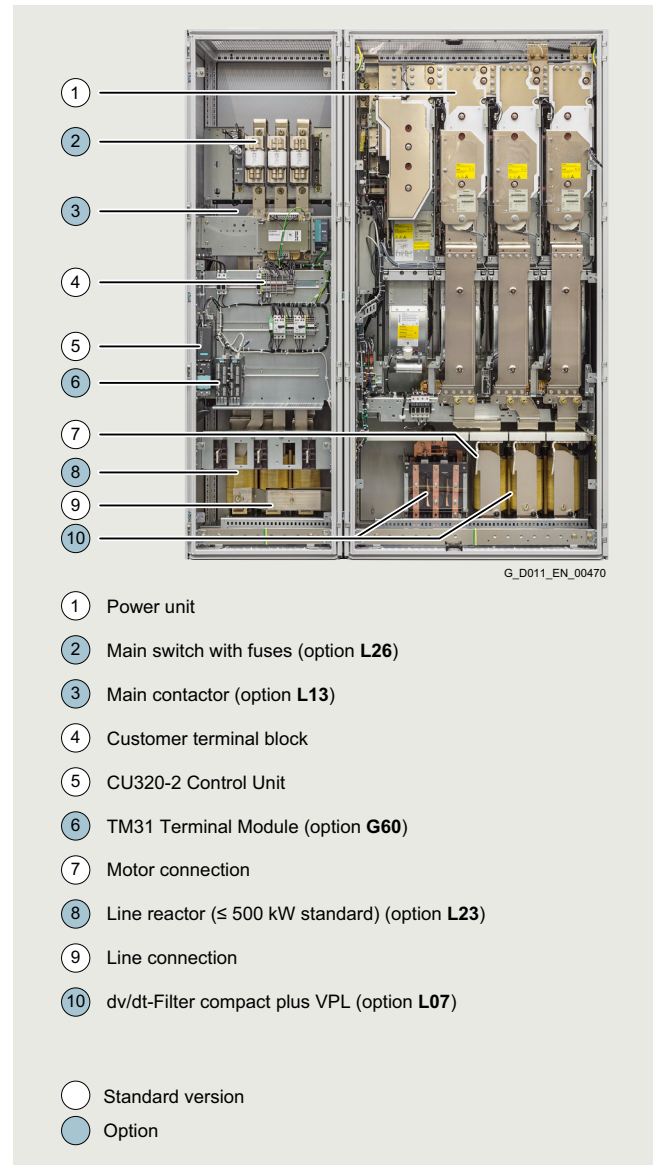

Example of the design of a SINAMICS G150 converter cabinet unit, version A

SINAMICS G150

Converter cabinet units

75 kW to 2700 kW

Design

4

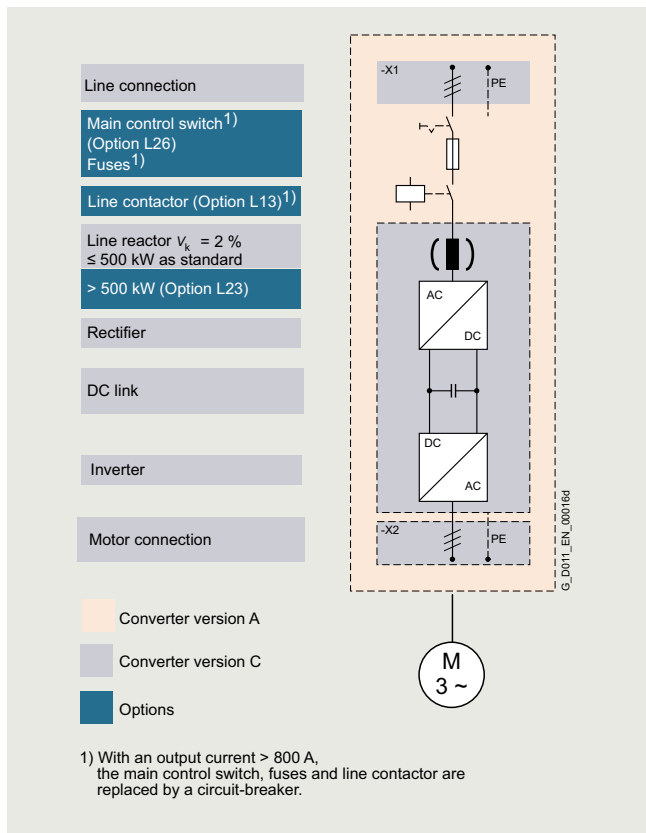

Basic design of a SINAMICS G150 converter cabinet unit with several essential options

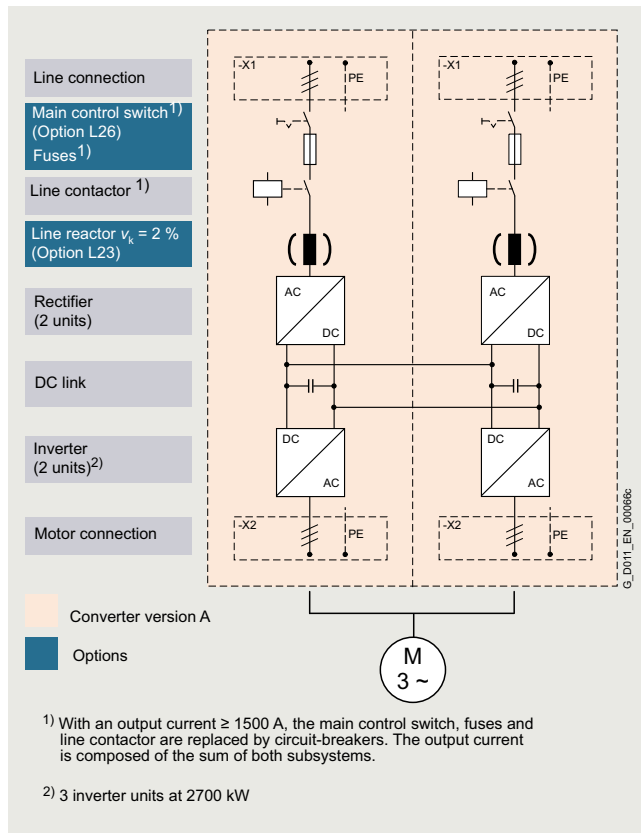

Basic design of a SINAMICS G150 converter cabinet unit in parallel connection in order to increase the power rating, with several essential options

Design

Coated modules

The following converter components are equipped as standard with coated modules:

- Power Modules
- Control Units
- Sensor Modules
- Terminal Modules
- Advanced Operator Panel (AOP30)

The coating on the modules protects the sensitive SMD components against corrosive gases, chemically active dust and moisture.

Nickel-plated busbars

All of the copper busbars used in the converter cabinet are nickel-plated in order to achieve the best possible immunity to environmental effects. The bare copper connections also do not have to be cleaned for customer connections.

Note:

With some options, parts of the copper busbars cannot be nickel-plated for technical reasons.

Degrees of protection of the cabinet units

The EN 60529 standard covers the protection of electrical equipment by means of housings, covers or equivalent, and includes:

- Protection of persons against accidental contact with live or moving parts within the housing and protection of the equipment against the ingress of solid foreign bodies (touch protection and protection against ingress of solid foreign bodies)
- Protection of the equipment against the ingress of water (water protection)
- Abbreviations for the internationally agreed degrees of protection

The degrees of protection are specified by abbreviations comprising the code letters IP and two digits.

Degrees of protection for the converter cabinet unit	First digit (touch protection and protection against ingress of foreign solid bodies)	Second digit (protection of the equipment against the ingress of water)
IP20 (standard)	Protected against solid foreign bodies with a diameter ≥ 12.5 mm	No water protection
IP21 (option M21)	Protected against solid foreign bodies with a diameter ≥ 12.5 mm	Protected against drip water Vertically falling water drops must not have any harmful effects.
IP23 (option M23)	Protected against solid foreign bodies with a diameter ≥ 12.5 mm	Protected against spray water Water sprayed on at an angle of up to 60° both sides of the vertical must not have any harmful effects.
IP43 (option M43)	Protected against solid foreign bodies with a diameter ≥ 1 mm	Protected against spray water Water sprayed on at an angle of up to 60° both sides of the vertical must not have any harmful effects.
IP54 (option M54)	Dust protected. Ingress of dust is not totally prevented, but dust must not be allowed to enter in such quantities that the functioning or safety of the equipment is impaired.	Protected against splash water Water splashing onto the housing from any direction must not have any harmful effects.

SINAMICS G150

Converter cabinet units

75 kW to 2700 kW

Function

AOP30 Advanced Operator Panel



An AOP30 Advanced Operator Panel is located in the cabinet door of the converter for the operator control and monitoring as well as for the commissioning.

The AOP30's two-stage safety concept prevents unintentional or unauthorized changes to settings. Operation of the drive from the operator panel can be disabled by the keyboard lock so that only parameter values and process variables can be displayed on the operator panel. The OFF key is factory-set to "active", but can be deactivated by the customer. A password can be used to prevent the unauthorized changing of converter parameters.

The user is guided by interactive menus through the drive commissioning screens. When commissioning the drive for the first time, only six motor parameters (which can be found on the motor rating plate) have to be entered on the AOP30. The closed-loop control is then optimized automatically to adapt the converter to the motor.

German, English, French, Italian, Spanish and Chinese are stored on the CU320-2 Control Unit CompactFlash card as operator panel languages. The desired language must be downloaded to the AOP30 prior to commissioning. In addition to these preinstalled languages, **Russian and Portuguese (Brazil)** are also available for subsequent installation. Further languages are available on request.

Examples of plain-text displays during various phases of operation are shown below.

The **first commissioning** is performed via the operator panel.

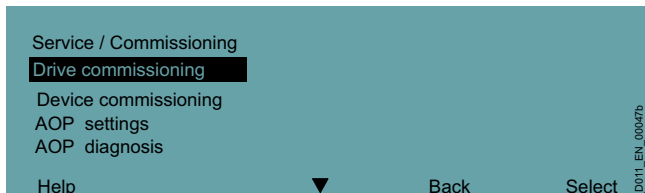

Only six motor parameters have to be entered:

Power, speed, current, cos φ, voltage and frequency of the motor.

This information can be found on the motor rating plate, and must be entered in the screens on the display by following a short, menu-assisted procedure. The motor cooling method must also be specified.

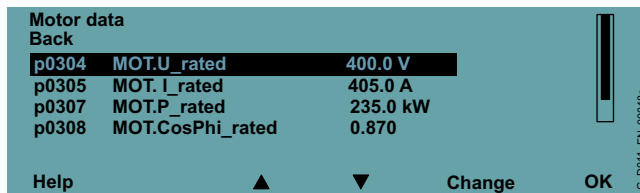

The next screen contains the parameter values that are used to automatically optimize the control.

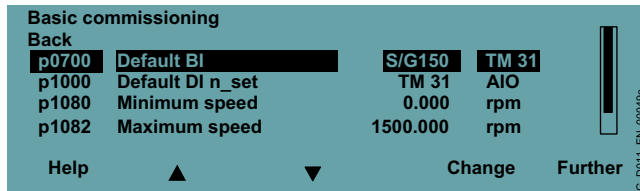

During **operation**, the display shows current data, such as setpoints and actual values as absolute values or it is possible to parameterize up to three process variables as a quasi-analog bar display.

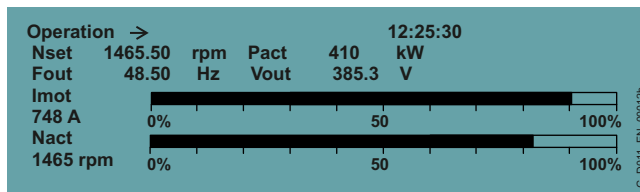
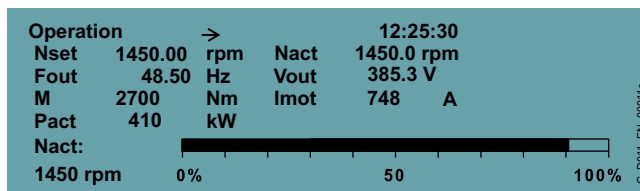

Any **alarms** which occur are signaled by the flashing of the yellow "ALARM" LED, **faults** by the lighting up of the red "FAULT" LED. There is also an indication of the cause displayed in plain text on the display's status line.

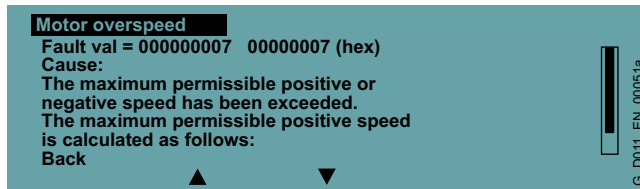
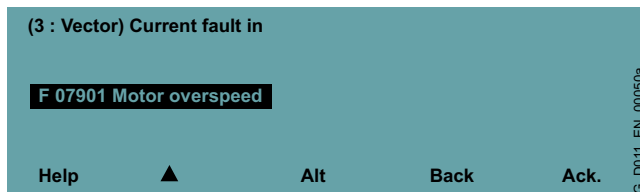

Function

Communication with higher-level controller and customer terminal block

A PROFIBUS interface on the CU320-2 DP Control Unit is provided as standard as the customer interface for the controller.

When using the CU320-2 PN (PROFINET) Control Unit (option **K95**), communication is via PROFINET in accordance with the PROFIdrive profile.

The Control Unit can be connected to the higher-level controller via its digital inputs and outputs to exchange digital signals.

The inputs and outputs available as standard can be optionally expanded using a TB30 Terminal Board (option **G62**) and/or up to two TM31 Terminal Modules (option **G60** or **G61**).

To simplify configuration and commissioning of the drive, the optional TM31 Terminal Module can be preset with a variety of factory settings.

For further information, please refer to the [SINAMICS Low Voltage Engineering Manual](#).

Open-loop and closed-loop control functions

The converter control contains a high-quality sensorless vector control with speed and current control as well as motor and converter protection.

Software and protective functions

The software functions available as standard are described below:

Software and protective functions	Description
Setpoint specification	The setpoint can be specified both internally and externally; internally as a fixed setpoint, motorized potentiometer setpoint or jog setpoint, externally via the communications interface or an analog input on the customer terminal block. The internal fixed setpoint and the motorized potentiometer setpoint can be switched or adjusted via control commands from any interface.
Motor identification	The automatic motor identification function makes commissioning faster and easier and optimizes closed-loop control of the drive.
Ramp-function generator	A user-friendly ramp-function generator with separately adjustable ramp-up and ramp-down times, together with adjustable rounding times in the lower and upper speed ranges, allows the drive to be smoothly accelerated and braked. As a consequence, this avoids the drive train from being overloaded and reduces the stress on mechanical components. The down ramps can be parameterized separately for quick stop.
V_{dc max} controller	The V _{dc max} controller automatically prevents overvoltages in the DC link, if the set down ramp is too short, for example. This may also extend the set ramp-down time.
V_{dc min} control	For brief line supply failures, the kinetic energy of the rotating drive is used to buffer the DC link and therefore prevents fault trips. The converter remains operational as long as the drive can provide regenerative energy as a result of its motion and the DC-link voltage does not drop below the shutdown threshold. When the line supply recovers within this time, the drive is again accelerated up to its speed setpoint.
Automatic restart ¹⁾	The automatic restart switches the drive on again when the power is restored after a power failure, and ramps up to the current speed setpoint.
Flying restart ¹⁾	The flying restart function allows the converter to be switched to a motor that is still turning. With the voltage sensing capability provided by the optional VSM10 Voltage Sensing Module, the flying restart time for large induction motors can be significantly reduced because the motor does not need to be de-magnetized.
Technology controller	The technology controller function module allows simple control functions to be implemented, e.g. level control or volumetric flow control. The technology controller is designed as a PID controller. The differentiator can be switched to the control deviation channel or to the actual value channel (factory setting). The P, I, and D components can be set separately.
Free function blocks	Using the freely programmable function blocks, it is easy to implement logic and arithmetic functions for controlling the SINAMICS G150. The blocks can be programmed by means of an operator panel or the STARTER commissioning tool.
Drive Control Chart (DCC)	Drive Control Chart (DCC) is an additional tool for the easy configuration of technology functions for the SINAMICS G150. The block library contains a large selection of control, arithmetic and logic blocks as well as extensive open-loop and closed-loop control functions. The user-friendly DCC editor enables easy graphics-based configuration, allows control loop structures to be clearly represented and provides a high degree of reusability of charts that have already been created. DCC is an add-on to the STARTER commissioning tool.
Pt detection for motor protection	A motor model stored in the converter software calculates the motor temperature based on the current speed and load. More exact measurement of the temperature, which also takes into account the influence of the ambient temperature, is possible by means of direct temperature measurement using Pt1000/KTY84 sensors in the motor winding.
Motor temperature evaluation	Motor protection by evaluating a KTY84, PTC, Pt100 or Pt1000 temperature sensor. When a KTY84 sensor is connected, the limit values can be set for alarm or shutdown. When a PTC thermistor is connected, the system reaction to triggering of the thermistor (alarm or trip) can be defined.
Motor blocking protection	A blocked motor is detected and protected against thermal overloading by a fault trip.
Essential service mode	Special converter operating mode that increases the availability of the drive system, e.g. in the event of a fire.
Bypass	This circuit allows the motor to be operated via the converter or directly on the line supply.
Brake control	"Simple brake control" for control of holding brakes: The holding brake is used to secure drives against unwanted motion when deactivated. "Extended brake control" function module for complex brake control, e.g. for motor holding brakes and operational brakes: When braking with a feedback signal, the brake control reacts to the feedback signal contacts of the brake.
Write protection	Write protection to prevent unintentional changing of the setting parameters (without password function).

¹⁾ Factory setting: Not activated (can be parameterized).

SINAMICS G150

Converter cabinet units

75 kW to 2700 kW

Function

Software and protective functions	Description
Know-how protection	Know-how protection for encrypting stored data, e.g. to protect configuration know-how, and to protect against changes and duplication (with password function).
Web server	The integrated web server provides information about the drive unit via its web pages. The web server is accessed using an Internet browser via unsecured (http) or secured transmission (https).
Power unit protection	Description
Ground fault monitoring at the output	A ground fault at the output is detected by a total current monitor and results in shutdown in grounded systems.
Electronic short-circuit protection at the output	A short-circuit at the output (e.g. at the converter output terminals, in the motor cable or in the motor terminal box) is detected and the converter shuts down with a "fault".
Thermal overload protection	An alarm is issued first when the overtemperature threshold responds. If the temperature rises further, the device either shuts down or independently adjusts the pulse frequency or output current so that a reduction in the thermal load is achieved. Once the cause of the fault has been eliminated (e.g. cooling has been improved), the original operating values are automatically resumed.

Selection and ordering data

Single connection

Type rating		Rated output current	SINAMICS G150 converter cabinet units, versions A and C (Article No. supplement, see below)
at 50 Hz 400 V, 500 V or 690 V	at 60 Hz 460 V or 575 V		
kW	hp	A	Article No.
380 ... 480 V 3 AC			
110	150	210	6SL3710-1GE32-1 A3
132	200	260	6SL3710-1GE32-6 A3
160	250	310	6SL3710-1GE33-1 A3
200	300	380	6SL3710-1GE33-8 A3
250	400	490	6SL3710-1GE35-0 A3
315	500	605	6SL3710-1GE36-1 A3
400	600	745	6SL3710-1GE37-5 A3
450	700	840	6SL3710-1GE38-4 A3
560	800	985	6SL3710-1GE41-0 A3
500 ... 600 V 3 AC			
110	150	175	6SL3710-1GF31-8 A3
132	200	215	6SL3710-1GF32-2 A3
160	250	260	6SL3710-1GF32-6 A3
200	300	330	6SL3710-1GF33-3 A3
250	400	410	6SL3710-1GF34-1 A3
315	450	465	6SL3710-1GF34-7 A3
400	600	575	6SL3710-1GF35-8 A3
500	700	735	6SL3710-1GF37-4 A3
560	800	810	6SL3710-1GF38-1 A3
660 ... 690 V 3 AC			
75		85	6SL3710-1GH28-5 A3
90		100	6SL3710-1GH31-0 A3
110		120	6SL3710-1GH31-2 A3
132		150	6SL3710-1GH31-5 A3
160		175	6SL3710-1GH31-8 A3
200		215	6SL3710-1GH32-2 A3
250		260	6SL3710-1GH32-6 A3
315		330	6SL3710-1GH33-3 A3
400		410	6SL3710-1GH34-1 A3
450		465	6SL3710-1GH34-7 A3
560		575	6SL3710-1GH35-8 A3
710		735	6SL3710-1GH37-4 A3
800		810	6SL3710-1GH38-1 A3

Article No. supplement

- **Version A**
All available options can be installed as required
- **Version C**
Especially space-saving design

A
C

Note: The power data in hp units is based on the NEC/CEC standards for the North American market.

Parallel connection

Type rating		Rated output current	SINAMICS G150 converter cabinet units, version A
at 50 Hz 400 V, 500 V or 690 V	at 60 Hz 460 V or 575 V		
kW	hp	A	Article No.
380 ... 480 V 3 AC			
630	900	1120	6SL3710-2GE41-1AA3
710	1000	1380	6SL3710-2GE41-4AA3
900	1250	1560	6SL3710-2GE41-6AA3
500 ... 600 V 3 AC			
630	900	860	6SL3710-2GF38-6AA3
710	1000	1070	6SL3710-2GF41-1AA3
1000	1250	1360	6SL3710-2GF41-4AA3
660 ... 690 V 3 AC			
1000		1070	6SL3710-2GH41-1AA3
1350		1360	6SL3710-2GH41-4AA3
1500		1500	6SL3710-2GH41-5AA3
1750		1729	6SL3710-2GH41-8EA3
1950		1948	6SL3710-2GH42-0EA3
2150		2158	6SL3710-2GH42-2EA3
2400		2413	6SL3710-2GH42-4EA3
2700		2752	6SL3710-2GH42-7EA3

Note: The power data in hp units is based on the NEC/CEC standards for the North American market.

SINAMICS G150

Converter cabinet units

75 kW to 2700 kW

Options

When ordering a converter with options, add the suffix **"-Z"** to the article number and then the order code(s) for the desired option(s).

Example:
6SL3710-1GE32-1CA3-Z
+M07+D60+...

See also ordering examples.

Available options	Order code	Version A	Version C
Input-side options			
Use in the first environment according to EN 61800-3 Category C2 (TN systems or TT systems with grounded neutral point) ¹⁾	L00	✓	–
Clean Power version with integrated Line Harmonics Filter compact ²⁾	L01	✓	–
Line contactor (for currents ≤ 800 A for single connection)	L13	✓	–
Surge suppression	L21	✓	–
Scope of delivery without line reactor (for converters ≤ 500 kW)	L22	✓	✓
Line reactor $u_k = 2\%$ (for converters > 500 kW)	L23	✓	✓
Main switch incl. fuses or circuit breakers	L26	✓	–
Quick start (for option L01)	L76	✓	–
EMC shield bus ³⁾ (cable connection from below)	M70	✓	✓
PE busbar ^{3) 6)} (cable connection from below)	M75	–	✓
Output-side options			
dv/dt filter compact plus Voltage Peak Limiter	L07	✓	–
Motor reactor	L08	✓	–
dv/dt filter plus Voltage Peak Limiter	L10	✓	–
Sine-wave filter (up to 250 kW at 380 ... 480 V, up to 132 kW at 500 ... 600 V)	L15	✓	–
EMC shield bus ³⁾ (cable connection from below)	M70	✓	✓
PE busbar ^{3) 6)} (cable connection from below)	M75	–	✓
Motor protection and safety functions			
EMERGENCY OFF pushbutton installed in the cabinet door	L45	✓	–
EMERGENCY OFF category 0	L57	✓	–
EMERGENCY STOP Category 1, 230 V AC ⁴⁾	L59	✓	–
EMERGENCY STOP Category 1, 24 V DC ⁴⁾	L60	✓	–
Thermistor motor protection (alarm)	L83	✓	–
Thermistor motor protection (trip)	L84	✓	–
Pt100 evaluation unit	L86	✓	–
Insulation monitoring	L87	✓	–
Degree of protection increase			
Degree of protection IP21	M21	✓	✓
Degree of protection IP23	M23	✓	✓
Degree of protection IP43	M43	✓	✓
Degree of protection IP54	M54	✓	✓
Mechanical options			
Base 100 mm high, RAL 7022	M06	✓	✓
Cable-marshaling compartment 200 mm high, RAL 7035	M07	✓	✓
Line connection from above ²⁾	M13	✓	–
Motor connection from above ²⁾	M78	✓	–
Crane transport assembly (top-mounted)	M90	✓	✓

✓ Option can be ordered

– Option cannot be ordered

Please refer to the selection matrix for information about possible option combinations.

¹⁾ Applies to motor cable lengths < 100 m.

²⁾ Not available for converters > 1500 kW with power units connected in parallel.

³⁾ This option is listed for the input- and output-side options, but is only required once.

⁴⁾ This option is contained as standard in version A.

⁵⁾ The stopping requirements must be taken into account with this option. Additional braking units may be required.

Options

Available options	Order code	Version A	Version C
Safety Integrated			
Safety license for one axis	K01	✓	–
Additional SMC30 Sensor Module Cabinet-Mounted	K52	✓	–
Terminal module for controlling the "Safe Torque Off" and "Safe Stop 1" safety functions	K82	✓	–
TM54F Terminal Module	K87	✓	–
SBA Safe Brake Adapter, 230 V AC	K88	✓	–
Other options			
CBE20 Communication Board	G33	✓	✓
TM150 temperature sensor evaluation unit	G51	✓	–
TM31 Terminal Module	G60	✓	✓
Additional TM31 Terminal Module	G61	✓	–
TB30 Terminal Board	G62	✓	✓
SMC30 Sensor Module Cabinet-Mounted	K50	✓	✓
VSM10 Voltage Sensing Module	K51	✓	–
Auxiliary power supply, 230 V AC	K74	✓	–
CU320-2 PN Control Unit	K95	✓	✓
Connection for external auxiliary equipment	L19	✓	–
Cabinet lighting with service socket	L50	✓	–
Cabinet anti-condensation heating	L55	✓	✓
Braking unit 25 kW (P_{20} power: 100 kW)	L61	✓	–
Braking unit 50 kW (P_{20} power: 200 kW)	L62	✓	–
Marking of all control cable conductor ends	M91	✓	✓
Special cabinet paint finish ¹⁾	Y09	✓	✓
One-line label for system identification, 40 × 80 mm ¹⁾	Y31	✓	✓
Two-line label for system identification, 40 × 180 mm ¹⁾	Y32	✓	✓
Four-line label for system identification, 40 × 180 mm ¹⁾	Y33	✓	✓
Production flowcharts			
Documentation, production flowchart: Created once	B43	✓	✓
Documentation, production flowchart: Created every two weeks	B44	✓	✓
Documentation, production flowchart: Updated every month	B45	✓	✓
Packaging options			
Generation of a preliminary and a final packing list (shipping)	B55	✓	✓
Packed items labeled with a customized label	B56	✓	✓
Photo documentation of the ordered units	B57	✓	✓
Documentation (standard: English/German)			
Additional documentation in German	D00	✓	✓
Customer documentation (circuit diagram, layout diagram, dimensional drawing, spare parts list) in EPLAN format	D01	✓	✓
Customer documentation (circuit diagram, terminal diagram, layout diagram) in DXF format	D02	✓	✓
Preliminary version of customer documentation	D14	✓	✓
Additional documentation in Russian	D56	✓	✓
Documentation language: English/French	D58	✓	✓
Documentation language: English/Spanish	D60	✓	✓
Additional documentation in Italian	D72	✓	✓
Additional documentation in English	D76	✓	✓
Additional documentation in French	D77	✓	✓

✓ Option can be ordered

– Option cannot be ordered

Please refer to the selection matrix for information about possible option combinations.

¹⁾ The order code Y.. requires data in plain text.

SINAMICS G150

Converter cabinet units

75 kW to 2700 kW

Options

Available options	Order code	Version A	Version C
Additional documentation in Spanish	D78	✓	✓
Documentation language: English/Italian	D80	✓	✓
Additional documentation in Chinese	D84	✓	✓
Documentation language English/Chinese	D91	✓	✓
Documentation language English/Russian	D94	✓	✓
Rating plate language (standard: English/German)			
Rating plate data in English/French	T58	✓	✓
Rating plate data in English/Spanish	T60	✓	✓
Rating plate data in English/Italian	T80	✓	✓
Rating plate data in English/Russian	T85	✓	✓
Rating plate data in English/Chinese	T91	✓	✓
Options specific to the chemical industry			
NAMUR terminal block	B00	✓	–
Protective separation for 24 V supply (PELV)	B02	✓	–
Outlet for external auxiliary equipment (uncontrolled)	B03	✓	–
Options specific to the shipbuilding industry			
Marine version	M66	✓	✓
Individual certificate from Lloyds Register (LR)	E21	✓	✓
Individual certificate from Bureau Veritas (BV)	E31	✓	✓
Individual certificate from DNV GL	E51	✓	✓
Individual certificate from American Bureau of Shipping (ABS)	E61	✓	✓
Individual certificate from Chinese Classification Society (CCS)	E71	✓	✓
Converter acceptance in presence of customer			
Visual acceptance	F03	✓	✓
Function test without connected motor	F71	✓	✓
Function test with test bay motor under no-load conditions	F75	✓	✓
Insulation test	F77	✓	✓
Customer-specific acceptance inspections (on request)	F97	✓	✓
Converter acceptance without the customer present			
Function test without connected motor	F72	✓	✓
Function test with test bay motor under no-load conditions	F74	✓	✓
Insulation test	F76	✓	✓
Warranty extension for converter			
Extension of the warranty period by 12 months to a total of 24 months (2 years) after delivery	Q80	✓	✓
Extension of the warranty period by 18 months to a total of 30 months (2½ years) after delivery	Q81	✓	✓
Extension of the warranty period by 24 months to a total of 36 months (3 years) after delivery	Q82	✓	✓
Extension of the warranty period by 30 months to a total of 42 months (3½ years) after delivery	Q83	✓	✓
Extension of the warranty period by 36 months to a total of 48 months (4 years) after delivery	Q84	✓	✓
Extension of the warranty period by 48 months to a total of 60 months (5 years) after delivery	Q85	✓	✓

✓

Option can be ordered

–

Option cannot be ordered

Please refer to the selection matrix for information about possible option combinations.

Options

Option selection matrix

Certain options are mutually exclusive. The tables below only provide an overview. Please refer to the descriptions of the individual options for a precise description of the options and other exclusions.

Electrical options

	G33	G51	G61	G62	K50	K51	K87	L00	L01	L13	L22	L23	L26	L57	L59	L60	L61	L62	L86	L87
G33		✓	✓	–	✓	✓	✓	✓	✓	✓	✓	✓	✓	✓	✓	✓	✓	✓	✓	✓
G51	✓		✓	✓	✓	✓	✓	✓	✓	✓	✓	✓	✓	✓	✓	✓	✓	✓	–	✓
G61	✓	✓		✓	✓	✓	4)	✓	✓	✓	✓	✓	✓	✓	✓	✓	✓	✓	✓	✓
G62	–	✓	✓		✓	✓	✓	✓	✓	✓	✓	✓	✓	✓	✓	✓	✓	✓	✓	✓
K50	✓	✓	✓	✓		–	✓	✓	✓	✓	✓	✓	✓	✓	✓	✓	✓	✓	✓	✓
K51	✓	✓	✓	✓	–		✓	✓	✓	✓	✓	✓	✓	✓	✓	✓	✓	✓	✓	✓
K87	✓	✓	4)	✓	✓	✓		✓	✓	✓	✓	✓	✓	✓	✓	✓	✓	✓	✓	✓
L00	✓	✓	✓	✓	✓	✓	✓		✓	✓	–	1)	✓	✓	✓	✓	✓	✓	✓	–
L01	✓	✓	✓	✓	✓	✓	✓	✓		✓	–	–	✓	✓	✓	✓	✓	✓	✓	✓
L13	✓	✓	✓	✓	✓	✓	✓	✓	✓		✓	✓	2)	3)	3)	3)	✓	✓	✓	✓
L22	✓	✓	✓	✓	✓	✓	✓	–	–	✓		–	✓	✓	✓	✓	✓	✓	✓	✓
L23	✓	✓	✓	✓	✓	✓	✓	1)	–	✓	–		✓	✓	✓	✓	✓	✓	✓	✓
L26	✓	✓	✓	✓	✓	✓	✓	✓	✓	2)	✓	✓		3)	3)	3)	✓	✓	✓	✓
L57	✓	✓	✓	✓	✓	✓	✓	✓	✓	3)	✓	✓	3)		–	–	✓	✓	✓	✓
L59	✓	✓	✓	✓	✓	✓	✓	✓	✓	3)	✓	✓	3)	–		–	✓	✓	✓	✓
L60	✓	✓	✓	✓	✓	✓	✓	✓	✓	3)	✓	✓	3)	–	–		✓	✓	✓	✓
L61	✓	✓	✓	✓	✓	✓	✓	✓	✓	✓	✓	✓	✓	✓	✓	✓		–	✓	✓
L62	✓	✓	✓	✓	✓	✓	✓	✓	✓	✓	✓	✓	✓	✓	✓	✓	–		✓	✓
L86	✓	–	✓	✓	✓	✓	✓	✓	✓	✓	✓	✓	✓	✓	✓	✓	✓	✓		✓
L87	✓	✓	✓	✓	✓	✓	✓	–	✓	✓	✓	✓	✓	✓	✓	✓	✓	✓	✓	✓

✓	Options can be combined
–	Options are mutually exclusive

1) For converters ≤ 500 kW / 700 hp, the line reactor (order code **L23**) is included in the converter scope of delivery. For converters > 500 kW / 700 hp, option **L23** must be ordered separately when the converter is to be operated on line supplies with high short-circuit power ($R_{SC} > 20$) or when a line filter is used (option **L00**).

2) Combination **L13/L26** only possible for currents < 800 A. As of 800 A, circuit breakers are used that also include the function of options **L13** and **L26**.

3) The options **L57**, **L59** and **L60** always require electrical separation from the line supply, this means for converters in a single circuit, for converter currents ≤ 800 A, option **L13** and for converter currents > 800 A, option **L26**. For converters with power units connected in parallel, electrical separation from the line supply is included as standard.

4) A combination of options **G61** and **K87** as a special version is available on request.

SINAMICS G150

Converter cabinet units

75 kW to 2700 kW

Options

Mechanical options / electrical options

	E21	E31	E51	E61	E71	L00	L01	L07	L08	L10	L15	M06	M07	M13	M21	M23	M43	M54	M66	M70	M78	
E21		✓	✓	✓	✓	✓	✓	✓	✓	✓	✓	✓	✓	✓	–	1)	✓	✓	1)	✓	✓	
E31	✓		✓	✓	✓	✓	✓	✓	✓	✓	✓	✓	✓	✓	–	1)	✓	✓	1)	✓	✓	
E51	✓	✓		✓	✓	✓	✓	✓	✓	✓	✓	✓	✓	✓	–	1)	✓	✓	1)	✓	✓	
E61	✓	✓	✓		✓	✓	✓	✓	✓	✓	✓	✓	✓	✓	–	1)	✓	✓	1)	✓	✓	
E71	✓	✓	✓	✓		✓	✓	✓	✓	✓	✓	✓	✓	✓	–	1)	✓	✓	1)	✓	✓	
L00	✓	✓	✓	✓	✓		✓	✓	✓	✓	✓	✓	✓	✓	✓	✓	✓	✓	✓	✓	2)	✓
L01	✓	✓	✓	✓	✓	✓		✓	✓	✓	✓	✓	✓	✓	✓	✓	✓	✓	✓	–	✓	✓
L07	✓	✓	✓	✓	✓	✓	✓		–	–	–	✓	✓	✓	✓	✓	✓	✓	✓	✓	✓	–
L08	✓	✓	✓	✓	✓	✓	✓	–		–	–	✓	✓	✓	✓	✓	✓	✓	✓	✓	✓	–
L10	✓	✓	✓	✓	✓	✓	✓	–	–		–	✓	✓	✓	✓	✓	✓	✓	✓	✓	✓	–
L15	✓	✓	✓	✓	✓	✓	✓	–	–	–		✓	✓	✓	✓	✓	✓	✓	✓	✓	✓	–
M06	✓	✓	✓	✓	✓	✓	✓	✓	✓	✓	✓		–	✓	✓	✓	✓	✓	✓	✓	✓	✓
M07	✓	✓	✓	✓	✓	✓	✓	✓	✓	✓	✓	–		✓	✓	✓	✓	✓	✓	✓	✓	✓
M13	✓	✓	✓	✓	✓	✓	✓	✓	✓	✓	✓	✓	✓		–	✓	✓	✓	✓	✓	3)	✓
M21	–	–	–	–	–	✓	✓	✓	✓	✓	✓	✓	✓	–		–	–	–	–	–	✓	–
M23	1)	1)	1)	1)	1)	✓	✓	✓	✓	✓	✓	✓	✓	✓	–		–	–	1)	✓	✓	
M43	✓	✓	✓	✓	✓	✓	✓	✓	✓	✓	✓	✓	✓	✓	–	–		–	✓	✓	✓	✓
M54	✓	✓	✓	✓	✓	✓	✓	✓	✓	✓	✓	✓	✓	✓	–	–	–		✓	✓	✓	✓
M66	1)	1)	1)	1)	1)	✓	–	✓	✓	✓	✓	✓	✓	✓	–	1)	✓	✓		✓	✓	✓
M70	✓	✓	✓	✓	✓	2)	✓	✓	✓	✓	✓	✓	✓	3)	✓	✓	✓	✓	✓	✓		3)
M78	✓	✓	✓	✓	✓	✓	✓	–	–	–	–	✓	✓	✓	–	✓	✓	✓	✓	✓	3)	✓

✓

Options can be combined

–

Options are mutually exclusive

1) Option **M66** includes option **M23**.
Options **E21**, **E31**, **E51**, **E61**, **E71** include option **M66**.

2) Option **L00** includes option **M70**.

3) If the line connection (option **M13**) and the motor connection (option **M78**) are from above, the EMC shield bus (option **M70**) is not required in the lower cabinet area.

Ordering examples

Example 1

Task:

A converter cabinet unit is required to control the fan speed for a 380 kW fan drive connected to an existing 400 V MCC outgoing feeder. The rated speed of the fan is 975 rpm. Due to the prevailing ambient conditions, the converter must be mounted on a 100 mm cabinet base and have IP54 degree of protection. The installation altitude is < 1000 m above sea level, the ambient temperature is 45 °C.

Solution:

Because an MCC outgoing feeder already exists, line connection components, such as main switch, line contactor and line fuses, can be omitted and the space-saving version C can be selected. If we take into account the derating factors for the IP54 degree of protection and the increased ambient temperature, a 450 kW, 400 V converter cabinet unit with options **M06** (cabinet base 100 mm) and **M54** (IP54 degree of protection) must be selected for this constellation.

The ordering data is as follows:

6SL3710-1GE38-4CA3-Z
+M06 +M54

Rating plate data

	T58	T60	T80	T85	T91
T58		–	–	–	–
T60	–		–	–	–
T80	–	–		–	–
T85	–	–	–		–
T91	–	–	–	–	

Example 2

Task:

A 280 kW pump to control pressure compensation is to be supplied via a converter for a completely new district heating pumping station. A 690 V supply is available. The installation altitude is 350 m above sea level and the ambient temperature is 40 °C. The rated speed of the pump is 740 rpm. The pump unit and motor are located in an unmanned substation, so the winding temperature of the motor must be monitored by Pt100 resistance thermometers and evaluated by the converter. The color of the converter cabinet units is to be RAL 3002.

Solution:

A converter cabinet unit with 315 kW, 690 V in the version A with the following options should be selected:

L26 (main switch including fuses),
L13 (line contactor),
L86 (Pt100 evaluation unit) and
Y09 (special cabinet paint finish).

The ordering data is as follows:

6SL3710-1GH33-3AA3-Z
+L26 +L13 +L86 +Y09
cabinet color RAL 3002

Options

Description of options

Further descriptions of the options are provided in the SINAMICS Low Voltage Engineering Manual.

B00, B02, B03

Options compliant with NAMUR requirements

Exclusion list with other options:

The following restrictions and exclusions applicable to the NAMUR terminal block **B00** with regard to other available options must be taken into account.

Remark on the option	Reason
L57, L59, L60	An EMERGENCY OFF Category 0 is already provided in the NAMUR version. The forced line supply disconnection is connected at terminal -A1-X2: 17, 18.
L83, L84	A thermistor evaluation unit (trip) is already included as standard with option B00 .
L19	Alternatively, option B03 can be selected. This means that a reduced scope is available for external auxiliaries.
L87	The insulation monitor monitors the complete electrically coupled network. This combination is available on request. An insulation monitor can also be provided on site.
G60	A TM31 Terminal Module is already included as standard with option B00 .

With options such as **L50, L55, L86**, the connection is made as described in the standard. There is no wiring to the NAMUR terminal block.

Notice:

In addition to option **B00** for supply disconnection, option **L13** for currents ≤ 800 A or option **L26** for currents > 800 A must be ordered. For converters with power units connected in parallel, electrical separation from the line supply is included as standard.

B00

NAMUR terminal block

The terminal block has been designed and implemented in accordance with the requirements and guidelines of the Standards Working Group for Instrumentation and Control in the Chemical Industry (NAMUR Recommendation NE37), i.e. certain functions of the device are assigned to specified terminals. The inputs and outputs connected to the terminals fulfill PELV requirements ("protective extra-low voltage with protective separation").

The terminal block and associated functions have been reduced to the necessary minimum. Unlike the NAMUR recommendation, optional terminals are not available.

Terminal -A1-X2:	Meaning	Default	Remark
10	DI	ON (dynamic) / ON/OFF (static)	The effective mode can be encoded using a wire jumper at terminal -A1-400:9; 10.
11	DI	OFF (dynamic)	
12	DI	Faster	
13	DI	Slower	
14	DI	RESET	
15	DI	Interlock	
16	DI	Counter-clockwise	"0" signal for CW rotating field "1" signal for CCW rotating field
17, 18		Supply disconnection	EMERGENCY OFF circuit
30, 31		Ready	Relay output (NO contact)
32, 33		Motor is turning	Relay output (NO contact)
34	DO (NO)	Fault	Relay output (changeover contact)
35	DO (COM)		
36	DO (NC)		
50, 51	AI 0/4-20 mA	Speed setpoint	
60, 61	AO 0/4-20 mA	Motor frequency	
62, 63	AO 0/4-20 mA	Motor current	Motor current is default setting; can be reparameterized for other variables

The 24 V supply is provided on the plant side via terminals -A1-X2:1-3 (fused in the converter with 1 A). It must be ensured that the PELV safety requirements are fulfilled (protective extra-low voltage with protective separation).

Terminal -A1-X2:	Meaning	
1	M	Reference conductor
2	P24	24 V DC supply
3	P24	24 V DC outgoing feeder

For temperature monitoring of explosion-proof motors, option **B00** includes a PTC thermistor evaluation unit. Exceeding the limit value causes a shutdown. The associated PTC sensor is connected to terminal -A1-X3:90, 91.

Terminal -A1-X3:	Meaning	
90, 91	AI	Connection of PTC sensor

In parallel to operation via the NAMUR terminal block, there is also the option to operate the converter via the communication interface provided as standard on the CU320-2 Control Unit. The PROFIdrive profile "Process engineering" employed in the chemical industry can be selected by macros.

SINAMICS G150

Converter cabinet units

75 kW to 2700 kW

Options

B02

Protective separation for 24 V supply (PELV)

If no protective separation for 24 V supply (PELV) is available at the customer site, this option is used to provide a second power supply to guarantee compliance with the PELV voltage. (Terminal assignments as for option **B00**, 24 V supply at terminals -A1-X1:1, 2, 3 is not required)

Note:

Option **B02** is only possible in conjunction with option **B00**.

B03

Outgoing feeder for external auxiliaries (uncontrolled)

If a motor fan is to be supplied with power from the plant, option **B03** provides an uncontrolled external outgoing feeder with a 10 A fuse. As soon as the supply voltage is present at the converter input, a voltage is also present at these terminals. This corresponds to the converter input voltage ($U = U_{line}$). You must take this into account when configuring an external fan.

Terminal -A1-X1:	Meaning
1, 2, 3, PE	Outgoing feeder for external auxiliary equipment

Note:

Option **B03** is only possible in conjunction with option **B00**.

B43, B44, B45

Production flowcharts

Production flowcharts are provided with options **B43**, **B44** and **B45**. After the order has been clarified, these are emailed as a dual language (English/German) PDF file.

Order code	Description
B43	Documentation, production flowchart: Created once
B44	Documentation, production flowchart: Updated every two weeks
B45	Documentation, production flowchart: Updated every month

B55

Generation of a preliminary and a final packing list (shipping)

This option provides the electronically editable packing list (possibly predefined from the factory) with the following information in Excel format:

- Number of individual packages
- Type of package (pallet, crate, etc.)
- Weight (unpacked and packed)
- Dimensions (unpacked and packed)
- Delivery location
- Label for package item (when option B56 is ordered)
- Description of what is in the package

A first packing list is generated after complete technical clarification with preliminary data. When shipped, a final packing list is provided with the actual data.

B56

Packed items labeled with a customized label

With this option, customized labels are attached to the unpacked and packed packaged units. Internal customers must provide two labels at least 2 weeks before the shipping date (printout to the factory logistics department, specifying the article number).

B57

Photographic documentation of the ordered units

This option provides digital photographic documentation with the following content:

- 1 photo diagonally from the front
- 1 photo diagonally from the rear (opposite)
- 1 photo with the packed item on which the label is legible

The listed photos of the packed items are taken in both an unpacked and a packed state in each position (a total of 6 photos per packed item).

D00, D56, D72, D76, D77, D78, D84

Additional documentation

The documentation is also available in a single language, to enable other language combinations to be ordered, for example.

If a further language is required in addition to the standard documentation in English/German, the option **D74** (documentation in English/German) must also be ordered in addition to that language.

Order code	Description
D00	German
D56	Russian
D72	Italian
D76	English
D77	French
D78	Spanish
D84	Chinese

D01

Customer documentation (circuit diagram, layout diagram, dimensional drawing, spare parts list) in EPLAN format

If option **D01** is ordered, the last version of the cabinet circuit diagram, layout diagram, dimensional drawing and spare parts list is delivered digitally in EPLAN format.

D02

Customer documentation (circuit diagram, terminal diagram, layout diagram) in DXF format

This option can be used to order documents such as circuit diagrams, terminal diagrams, layout diagrams, and dimension drawings in DXF format, in order to process them further in CAD systems, for example.

D14

Preliminary version of customer documentation in PDF format

If documents such as circuit diagrams, terminal diagrams, layout diagrams and dimension drawings are required in advance for the purpose of system engineering (integration of drive into higher-level systems, interface definition, installation, building planning, etc.), it is possible to order a draft copy of the documentation when ordering the Cabinet Modules. These documents are then supplied electronically a few working days following receipt of the order. If the order includes options that fall outside the scope of standard supply, these will not be covered by the documentation due to the obvious time constraints.

The client is sent the documentation relating to the order by email. The recipient's email address must be specified with the order for this purpose. In the email, the recipient will receive a link (internet address) for downloading order-specific documentation.

With the option **D02**, the documents are also transmitted in DXF format.

Options

D58, D60, D80, D91, D94 Documentation language

Order code	Language
D58	English/French
D60	English/Spanish
D80	English/Italian
D91	English/Chinese
D94	English/Russian

Note:

If a documentation option is not selected, the relevant documentation is supplied as standard in English/German.

E21 to E71 Individual certification of the converter

The individual certification of the converter by the relevant certification body contains the expansions described in option M66.

Order code	Description
E21	Individual certificate from Lloyds Register (LR)
E31	Individual certificate from Bureau Veritas (BV)
E51	Individual certificate from Det Norske Veritas (DNV)
E61	Individual certificate from American Bureau of Shipping (ABS)
E71	Individual certificate from Chinese Classification Society (CCS)

Note:

It is not possible to combine several individual certificates.

F03, F71, F75, F77, F97 Converter acceptance tests with the customer present

F72, F74, F76 Converter acceptance tests without the customer present

Option	Description
F03	<p>Visual acceptance</p> <p>The tests are carried out with the converter de-energized.</p> <p>The following is included in the scope of the acceptance tests:</p> <ul style="list-style-type: none"> • Check of degree of protection • Check of equipment (components) • Check of equipment identifiers • Check of clearance and creepage distances • Check of cables • Check of customer documentation • Submission of the acceptance report
F71, F72	<p>Function test without connected motor</p> <p>After the visual acceptance with the converter switched off, the converter is connected to rated voltage. No current at the converter output end.</p> <p>The following is included in the scope of the acceptance tests:</p> <ul style="list-style-type: none"> • Visual acceptance as described for option F03 • Check of power supply • Check of protective and monitoring devices (simulation) • Check of fans • Pre-charging test • Function test without connected motor • Submission of the acceptance report

Option	Description
F74, F75	<p>Function test with test bay motor under no-load conditions</p> <p>After the visual acceptance with the converter switched off, the converter is connected to rated voltage. A small current flows at the converter output end in order to operate the test bay motor under no-load conditions.</p> <p>The following is included in the scope of the acceptance tests:</p> <ul style="list-style-type: none"> • Visual acceptance as described for option F03 • Check of power supply • Check of protective and monitoring devices (simulation) • Check of fans • Function test with test bay motor under no-load conditions • Submission of the acceptance report
F76, F77	<p>Acceptance of the converter insulation test</p> <p>The following is included in the scope of the acceptance tests:</p> <ul style="list-style-type: none"> • High-voltage test • Measurement of the insulation resistance • Submission of the acceptance report
F97	<p>Customer-specific system acceptance tests (on request)</p> <p>If acceptance tests are desired which are not covered by the options F03, F71/F72, F74/F75 or F76/F77, customer-specific acceptance tests / supplementary tests can be ordered using order code F97 on request and following technical clarification.</p>

G33 CBE20 Communication Board

The CBE20 Communication Board is required when:

- A SINAMICS G130 or SINAMICS G150 converter, equipped with a CU320-2 DP (PROFIBUS) Control Unit, is to be connected to a PROFINET IO, Ethernet IP or Modbus TCP network
- SINAMICS Link is to be used to directly exchange data between several CU320-2 DP (PROFIBUS) or CU320-2 PN (PROFINET) Control Units without using a higher-level control system.

With the CBE20 Communication Board, a SINAMICS G130 or a SINAMICS G150 is a PROFINET IO device in the sense of PROFINET and offers the following functions:

- PROFINET IO device
- 100 Mbit/s full duplex
- Supports real-time classes of PROFINET IO:
 - RT (Real-Time)
 - IRT (Isochronous Real-Time), minimum send cycle 500 µs
- Connects to controllers as a PROFINET IO device according to the PROFIdrive profile
- Standard TCP/IP communication for engineering processes using the STARTER commissioning tool
- Integrated 4-port switch with four RJ45 sockets based on the PROFINET ASIC ERTEC400. The optimum topology (line, star, tree) can therefore be configured without additional external switches.

The CBE20 Communication Board is inserted into the option slot of the CU320-2 Control Unit.

For a description of the CBE20 Communication Board, see SINAMICS G130 converter built-in units, Supplementary system components.

SINAMICS G150

Converter cabinet units

75 kW to 2700 kW

Options

G51

TM150 temperature sensor evaluation unit

The TM150 Terminal Module is a DRIVE-CLiQ component that is used to acquire and evaluate data from several temperature sensors. The temperature is measured in a temperature range from -99 °C to +250 °C for the following temperature sensors:

- Pt100 (with monitoring for wire breakage and short-circuit)
- Pt1000 (with monitoring for wire breakage and short-circuit)
- KTY84 (with monitoring for wire breakage and short-circuit)
- PTC (with monitoring for short-circuit)
- Bimetallic NC contact (without monitoring)

For the temperature sensor inputs, for each terminal block the evaluation can be parameterized for 1 × 2-wire, 2 × 2-wire, 3-wire or 4-wire. There is no galvanic isolation in the TM150 Terminal Module.

A maximum of 12 temperature sensors can be connected to the TM150 Terminal Module.

For a description of the TM150 Terminal Module, see [SINAMICS G130 converter built-in units, Supplementary system components](#).

G60

TM31 Terminal Module

The TM31 Terminal Module is used to extend the customer terminals on the CU320-2 Control Unit.

The following additional interfaces are available:

- 8 digital inputs
- 4 bidirectional digital inputs/outputs
- 2 relay outputs with changeover contact
- 2 analog inputs
- 2 analog outputs
- 1 temperature sensor input (KTY84-130/Pt1000/PTC)
- 2 DRIVE-CLiQ sockets
- 1 connection for the electronics power supply via the 24 V DC supply connector
- 1 PE/protective conductor connection

To simplify configuration and commissioning of the drive, the optional TM31 Terminal Module can already be preset to a variety of factory settings, which can then be selected during commissioning.

For further information, please refer to the [SINAMICS Low Voltage Engineering Manual](#).

For a description of the TM31 Terminal Module, see [SINAMICS G130 converter built-in units, Supplementary system components](#).

G61

Additional TM31 Terminal Module

With option **G61**, the number of digital inputs/outputs, as well as the number of analog inputs/outputs in the drive system can be expanded using a second TM31 Terminal Module (in addition to the TM31 Terminal Module that can be selected using option **G60**).

Note:

Option **G61** requires option **G60**.

For a description of the TM31 Terminal Module, see [SINAMICS G130 converter built-in units, Supplementary system components](#).

G62

TB30 Terminal Board

The TB30 Terminal Board is inserted into the option slot of the Control Unit and offers the possibility of expanding the CU320-2 Control Unit by four digital inputs/outputs each as well as two analog inputs/outputs each.

Note:

Option **G62** cannot be combined with option **G33** (Communication Board CBE20).

For a description of the TB30 Terminal Board, see [SINAMICS G130 converter built-in units, Supplementary system components](#).

K01

Safety license for one axis

The Safety Integrated Basic Functions do not require a license. However, the Safety Integrated Extended Functions require a license for each axis equipped with safety functions. It is irrelevant which safety functions are used and how many. Option **K01** contains the license for one axis.

Subsequent licensing is possible in the internet via the WEB License Manager by generating a license key: www.siemens.com/automation/license

K50

SMC30 Sensor Module Cabinet-Mounted

The SMC30 Sensor Module Cabinet-Mounted can be used to evaluate the encoders of motors without a DRIVE-CLiQ interface. External encoders can also be connected via the SMC30.

The following encoder signals can be evaluated:

- Incremental encoders TTL/HTL with and without wire break detection (wire break detection is only available with bipolar signals)
- SSI encoders with TTL/HTL incremental signals
- SSI encoders without incremental signals

The motor temperature can also be measured using KTY84-130, Pt1000 or PTC thermistors.

For a description of the SMC30 Sensor Module Cabinet-Mounted, see [SINAMICS G130 converter built-in units, Supplementary system components](#).

K51

VSM10 Voltage Sensing Module Cabinet-Mounted

The VSM10 Voltage Sensing Module is used to measure the voltage characteristic on the motor side, so that the following function can be implemented:

- Operation of a permanent-magnet synchronous motor without encoder with the requirement to be able to connect to a motor that is already running (flying restart function).
- Quick flying restart of large induction motors: The time for the demagnetization of the motor is eliminated through the measurement of the voltage.

For a description of the VSM10 Voltage Sensing Module Cabinet-Mounted, see [SINAMICS G130 converter built-in units, Supplementary system components](#).

K52

Second SMC30 Sensor Module Cabinet-Mounted

With option **K50**, the converter cabinet contains an SMC30 Sensor Module Cabinet-Mounted. An additional SMC30 Sensor Module enables reliable actual-value acquisition when using Safety Integrated Extended Functions (requires a license: Option **K01**).

Options

K74

Provision of a cabinet-internal 230 V AC auxiliary power supply

If there is no 230 V AC power supply in the plant, option **K74** can be used to provide a cabinet-internal auxiliary power supply for the required auxiliary voltages of the external control circuits of the cabinet unit. The auxiliary voltages are generated by a transformer.

Note:

If there is no 230 V AC power supply in the plant, it is essential to select option **K74** in order to ensure proper functioning of the following SINAMICS G150 cabinet units:

- Type 6SL3710-2...
- Type 6SL3710-1... for options **B00, G61, K50, L13, L26 > 800 A, L57, L59, L60, L83, L84, L86** and **L87** for cabinet version A

Options **L50** and **L55** always require an external supply voltage and must not be supplied via option **K74**.

K82

Terminal module for controlling the Safe Torque Off and Safe Stop 1 safety functions

The terminal module controls the Safety Integrated Basic Functions Safe Torque Off (STO) and Safe Stop 1 (SS1) (time-controlled) over a voltage of 24 V DC/AC (terminology as defined in IEC 61800-5-2). The relays used here are permitted up to an installation altitude of 2000 m. The use of this option for requirements that go beyond this is possible upon request.

The integrated safety functions, starting from the Safety Integrated (SI) input terminals of the components (Control Unit and Motor Module), satisfy the requirements of EN 61800-5-2, EN 60204-1, EN ISO 13849-1 Category 3 for Performance Level (PL) d and IEC 61508 SIL 2.

With option **K82**, the requirements specified in EN 61800-5-2, EN 60204-1, EN ISO 13849-1 Category 3 for Performance Level (PL) d and IEC 61508 SIL 2 are fulfilled.

The Safety Integrated functions using option **K82** are only available in conjunction with certified components and software versions.

The Safety Integrated functions of SINAMICS are generally certified by independent institutes. An up-to-date list of certified components is available on request from your local Siemens office.

K87

TM54F Terminal Module

The TM54F Terminal Module is a terminal expansion module with safe digital inputs and outputs for controlling the Safety Integrated Functions.

The TM54F provides four fail-safe digital outputs and ten fail-safe digital inputs. A fail-safe digital output consists of one 24 V DC switching output, one output switching to ground and one digital input to check the switching state. A fail-safe digital input consists of two digital inputs.

For a description of the TM54F Terminal Module, see [SINAMICS G130 converter built-in units, Supplementary system components](#).

K88

SBA Safe Brake Adapter, 230 V AC

Safe Brake Control (SBC) is a safety function that is used in safety-related applications. In the no-current state, the brake acts on the drive motor using spring force. The brake is released when current flows in it (low active).

The SBA Safe Brake Adapter is installed in the converter cabinet in the factory. An infeed is connected to terminal -X12 on the SBA Safe Brake Adapter for the power supply. For control, a connection is also made between the SBA and the Control Interface Module in the factory using a cable harness.

On the plant side, to control the brake, a connection must be made between terminal -X14 on the SBA Safe Brake Adapter and the brake.

For a description of the SBA Safe Brake Adapter, see [SINAMICS G130 converter built-in units, Supplementary system components](#).

K95

CU320-2 PN Control Unit (PROFINET)

Instead of the CU320-2 DP Control Unit (PROFIBUS) supplied as standard, the converter is supplied with a CU320-2 PN (PROFINET).

For a description of the CU320-2 Control Unit, see [SINAMICS G130 converter built-in units, Supplementary system components](#).

L00

Use in the first environment according to EN 61800-3, Category C2 (TN systems or TT systems with grounded neutral point)

To limit the **emitted interference**, the converters are equipped as standard with a radio interference suppression filter that conforms to the limits defined in Category C3. SINAMICS G150 converters equipped with a line filter also meet the limits for use in the first environment (Category C2) according to EN 61800-3¹⁾.

SINAMICS G150 units comply with the **noise immunity** requirements defined in this standard for the first and second environments.

In conjunction with line reactors, line filters also limit the conducted interference emitted by the Power Modules to the limit values of Category C2 defined in product standard EN 61800-3. For converter power ratings >500 kW, option **L23** must be additionally ordered (not required when option **L01** is selected).

To allow the power cable shield to be connected in conformance with EMC requirements, an additional EMC shield bus (option **M70**) is installed at the converter input and output. A separate order is not required in this case.

¹⁾ Applies to motor cable lengths < 100 m.

SINAMICS G150

Converter cabinet units

75 kW to 2700 kW

Options

L01

Clean Power version with integrated Line Harmonics Filter compact



Instead of the line reactor, a Line Harmonics Filter is integrated in the control cabinet; this minimizes the harmonics that occur due to the principle of operation. As a consequence, the unit fully complies with the limit values stipulated in standard IEEE 519: 2014 without any exceptions (precondition: $u_k \leq 5\%$ or $RSC \geq 20$).

Notice:

To ensure the converter will function, the RSC (Relative Short-Circuit Power) of the infeed grid must have a value of $RSC \geq 10$ or $u_k \leq 10\%$.

Option **L01** always requires electrical separation from the line supply, i.e. for converters in a single connection for converter currents ≤ 800 A, option **L13** and for converter currents > 800 A, option **L26**. Options **L13** and **L26** have to be ordered in addition for version A.

For converters with power units connected in parallel, electrical separation from the line supply is included as standard.

SINAMICS G150 Clean Power with integrated Line Harmonics Filter is available for power ratings up to 1500 kW in all available degrees of protection up to IP54 (see options **M21** to **M54**).

Notice:

When using option **L01** on 60 Hz line supplies, a restricted voltage tolerance of +8% applies!

Note:

Option **L01** is not available for converters > 1500 kW with power units connected in parallel and cannot be combined with the following options:

- **L22** (without line reactor)
- **L23** (line reactor $u_k = 2\%$)
- **M66** (marine version)

Power loss, width and weight of the SINAMICS G150 Clean Power converter cabinet units

SINAMICS G150 Clean Power 6SL3710-...	Type rating	Power loss at 50 Hz/60 Hz ¹⁾	Width	Weight
Z = +L01	kW	kW	mm	kg
380 ... 480 V 3 AC				
1GE32-1AA3-Z	110	5.36/4.52	1200	685
1GE32-6AA3-Z	132	6.26/5.34	1200	685
1GE33-1AA3-Z	160	7.38/6.57	1200	940
1GE33-8AA3-Z	200	8.28/7.17	1400	940
1GE35-0AA3-Z	250	10.03/9.01	1400	955
1GE36-1AA3-Z	315	12.77/12.2	1800	1115
1GE37-5AA3-Z	400	15.22/14.5	1800	1170
1GE38-4AA3-Z	450	15.72/15	1800	1200
1GE41-0AA3-Z	560	22.07/21.45	2200	1580
2GE41-1AA3-Z	630	25.34/24.4	3600	2430
2GE41-4AA3-Z	710	30.24/29	3600	2550
2GE41-6AA3-Z	900	31.14/30	3600	2970
500 ... 600 V 3 AC				
1GF31-8AA3-Z	110	6.93/6.5	1200	705
1GF32-2AA3-Z	132	7.33/6.9	1200	705
1GF32-6AA3-Z	160	9.68/8.95	1200	755
1GF33-3AA3-Z	200	10.78/9.95	1200	755
1GF34-1AA3-Z	250	13.97/13.1	1800	1130
1GF34-7AA3-Z	315	13.67/13.9	1800	1130
1GF35-8AA3-Z	400	16.07/16.2	1800	1270
1GF37-4AA3-Z	500	19.32/19.6	2200	1730
1GF38-1AA3-Z	560	20.72/20.9	2200	1730
2GF38-6AA3-Z	630	27.14/27.8	3600	2460
2GF41-1AA3-Z	710	31.94/32.4	3600	2460
2GF41-4AA3-Z	1000	37.04/39.2	4400	3780
660 ... 690 V 3 AC				
1GH28-5AA3-Z	75	3.71	1200	655
1GH31-0AA3-Z	90	4.11	1200	655
1GH31-2AA3-Z	110	4.96	1200	695
1GH31-5AA3-Z	132	5.06	1200	695
1GH31-8AA3-Z	160	6.93	1200	935
1GH32-2AA3-Z	200	7.33	1200	935
1GH32-6AA3-Z	250	9.68	1200	975
1GH33-3AA3-Z	315	10.78	1200	975
1GH34-1AA3-Z	400	13.97	1800	1150
1GH34-7AA3-Z	450	14.97	1800	1150
1GH35-8AA3-Z	560	18.17	1800	1250
1GH37-4AA3-Z	710	20.12	2200	1900
1GH38-1AA3-Z	800	21.32	2200	1940
2GH41-1AA3-Z	1000	36.04	3600	2560
2GH41-4AA3-Z	1350	39.84	4400	3780
2GH41-5AA3-Z	1500	42.24	4400	3860

¹⁾ Associated voltages for 50 Hz/60 Hz, see Section Technical specifications.

Options

L07

dv/dt filter compact plus Voltage Peak Limiter

dv/dt filters compact plus VPL (Voltage Peak Limiter) limit the voltage rate of rise dv/dt to values of $<1600 \text{ V}/\mu\text{s}$ and the typical voltage peaks to the following values in accordance with the limit value curve A according to IEC 60034-25: 2007:

- $< 1150 \text{ V}$ at $U_{\text{line}} < 575 \text{ V}$
- $< 1400 \text{ V}$ at $660 \text{ V} < U_{\text{line}} < 690 \text{ V}$

The dv/dt filter compact plus VPL functionally consists of two components that are supplied as a compact mechanical unit, the dv/dt reactor and the voltage limiting network (VPL), which limits voltage peaks and feeds back the energy to the DC link. It is so compact that it can be completely integrated into the cabinet, even for high power ratings. A supplementary cabinet is not required.

By using a dv/dt filter compact plus VPL, standard motors with standard insulation and without insulated bearings can be used with supply voltages up to 690 V in converter operation.

dv/dt filters compact plus VPL are designed for the following maximum motor cable lengths:

- Shielded cables: 100 m (e.g. Protodur NYCWY)
- Unshielded cables: 150 m (e.g. Protodur NYY)

For longer cable lengths ($> 100 \text{ m}$ shielded, $> 150 \text{ m}$ unshielded), the dv/dt filter plus VPL (option **L10**) should be used.

Notice:

- Operation with output frequencies $< 10 \text{ Hz}$ is permissible for max. 5 min.
- The maximum permissible output frequency is 150 Hz.

The appropriate information in the SINAMICS Low Voltage Engineering Manual should also be carefully observed.

Note:

Option **L07** cannot be combined with the following options:

- **L08** (motor reactor)
- **L10** (dv/dt filter plus VPL)
- **L15** (sine-wave filter)
- **M78** (motor connection from above)

L08

Motor reactor

Motor reactors reduce the voltage load on the motor windings by reducing the voltage gradients at the motor terminals that occur during converter operation. At the same time, the capacitive charge/discharge currents that place an additional load on the converter output when long motor cables are used, are reduced. The maximum permissible output frequency when a motor reactor is used is 150 Hz.

Motor reactors are designed for the following maximum motor cable lengths:

- Shielded cables: 300 m (e.g. Protodur NYCWY)
- Unshielded cables: 450 m (e.g. Protodur NYY)

Note:

Option **L08** cannot be combined with the following options:

- **L07** (dv/dt filter compact plus VPL)
- **L10** (dv/dt filter plus VPL)
- **L15** (sine-wave filter)
- **M78** (motor connection from above)

L10

dv/dt filter plus Voltage Peak Limiter

dv/dt filters plus VPL (Voltage Peak Limiter) limit the voltage rate of rise dv/dt to values $<500 \text{ V}/\mu\text{s}$ and the typical voltage peaks to the following values in accordance with the limit value curve according to IEC/TS 60034-17: 2006:

- $< 1000 \text{ V}$ at $U_{\text{line}} < 575 \text{ V}$
- $< 1250 \text{ V}$ at $660 \text{ V} < U_{\text{line}} < 690 \text{ V}$

The dv/dt filter plus VPL functionally consists of two components, the dv/dt reactor and the voltage limiting network (VPL), which limits voltage peaks and feeds the energy back to the DC link.

Depending on the converter power, option **L10** can be accommodated in the converter cabinet unit or an additional cabinet is required with a width of 400 mm or 600 mm.

Voltage range V	Installation of the dv/dt filter plus VPL within the converter cabinet unit kW	Installation of the dv/dt filter plus VPL in an additional cabinet kW
380 ... 480	110 ... 250	315 ... 900
500 ... 600	110 ... 200	250 ... 1000
660 ... 690	75 ... 315	400 ... 2700

By using a dv/dt filter plus VPL, standard motors with standard insulation and without insulated bearings can be used with supply voltages up to 690 V in converter operation.

dv/dt filters plus VPL are designed for the following maximum motor cable lengths:

- Shielded cables: 300 m (e.g. Protodur NYCWY)
- Unshielded cables: 450 m (e.g. Protodur NYY)

For cable lengths $< 100 \text{ m}$ shielded or $< 150 \text{ m}$ unshielded, the dv/dt filter compact plus VPL (option **L07**) can be advantageously used.

The appropriate information in the SINAMICS Low Voltage Engineering Manual should also be carefully observed.

Note:

Option **L10** cannot be combined with the following options:

- **L07** (dv/dt filter compact plus VPL)
- **L08** (motor reactor)
- **L15** (sine-wave filter)
- **M78** (motor connection from above)

SINAMICS G150

Converter cabinet units

75 kW to 2700 kW

Options

L13

Line contactor (for currents ≤ 800 A for single connection)

SINAMICS G150 converter cabinet units in a single connection do not have a line contactor as standard. Option **L13** is required if a switching element is required for disconnecting the cabinet from the supply (required for EMERGENCY OFF). The contactor is controlled and powered inside the converter. For devices with rated input currents > 800 A in single connection, the function of option **L13** is provided by option **L26**.

Note:

For converters with power units connected in parallel, the line contactor is included as standard.

Terminal -X50:	Meaning
4	Checkback contact (NO contact), contactor closed
5	Checkback contact (NC contact), contactor closed
6	Common potential

L15

Sine-wave filter

Sine-wave filters are available in the voltage range 380 V to 480 V up to a type rating of 250 kW, and in the voltage range 500 V to 600 V up to a type rating of 132 kW.

The sine-wave filter at the converter output supplies almost perfect sinusoidal voltages to the motor so that standard motors can be used without special insulation and without insulated bearings. The sine-wave filter also reduces the converter-related supplementary motor noise. The maximum permissible motor supply cable length is limited to 300 m.

Notice:

In conjunction with the option **L15**, the pulse frequency of the converter must be increased. This reduces the power available at the converter output (for the derating factor, see [SINAMICS Low Voltage Engineering Manual](#)). The modulation depth of the output voltage decreases to approx. 85% (380 V to 480 V) or approx. 83% (500 V to 600 V). The maximum output frequency is 150 Hz (for 380 V to 480 V) or 115 Hz (for 500 V to 600 V). It should be noted that the reduced voltage at the motor terminals compared to the rated motor voltage means that the motor switches to field weakening mode earlier.

Note:

Option **L15** cannot be combined with the following options:

- **L07** (dv/dt filter compact plus VPL)
- **L08** (motor reactor)
- **L10** (dv/dt filter plus VPL)
- **M78** (motor connection from above)

L19

Connection for external auxiliary equipment

An outgoing, controlled feeder fused with max. 10 A for external auxiliary equipment (e.g. motor external fan).

The voltage is tapped at the converter input upstream of the main contactor / circuit breaker and, therefore, has the same level as the supply voltage.

The outgoing feeder can be controlled internally by the converter or externally.

Terminal -X155:	Meaning	Range
1	L1	380 ... 690 V AC
2	L2	380 ... 690 V AC
3	L3	380 ... 690 V AC
11	Contactor control	230 V AC
12	Contactor control	230 V AC
13	Feedback signal, circuit breaker	230 V AC / 0.5 A; 24 V DC / 2 A
14	Feedback signal, circuit breaker	230 V AC / 0.5 A; 24 V DC / 2 A
15	Feedback signal, contactor	230 V AC / 6 A
16	Feedback signal, contactor	230 V AC / 6 A
PE	PE	

L21

Surge suppression

In ungrounded IT systems, the line voltage is not permanently connected to the ground potential because of the missing ground connection of the supply network. Therefore, when a ground fault occurs during operation, a voltage against ground increased by a factor of 2 can occur. For this reason, it is recommended that a surge suppression against ground be installed for operation on IT systems. The surge suppression option includes the installation of line-side surge arresters and upstream fuses for each system phase. The signaling contacts of the surge arresters are connected in series for the monitoring and connected to a customer interface.

Note:

Option **L21** does not include the installation of an insulation monitor for the IT system. An insulation monitor should always be ordered separately as option **L87** when the supplying IT system is not monitored at another position (e.g. at the transformer outgoing feeder). Only one insulation monitor can be used in each galvanically coupled network.

Option **L21** also does not include the factory-side removal of the metal bracket which establishes the connection to ground of the radio interference suppression filter installed as standard. The metal bracket should therefore be removed during the installation or commissioning of the converter if the device is to be operated on an ungrounded IT system.

Options

L22

Scope of delivery without line reactor (for converters ≤ 500 kW)

L23

Line reactor $u_k = 2\%$ (for converters > 500 kW)

The line reactor is included as standard in converters up to 500 kW. For converter power ratings > 500 kW, including the parallel connections, the line reactor ($u_k = 2\%$) is optionally available, as in this power range, the converter is often connected to the medium-voltage line supply via transformers that are adapted to the converter rating.

A line reactor is needed for high short-circuit power levels, partly to protect the actual converter against excessive harmonic currents, and thus against overload, and partly to limit the line harmonics to the permissible values. The harmonic currents are limited by the complete inductance comprising the line reactor and line supply cable inductance. Line reactors can be omitted if the line supply cable inductance is increased sufficiently, i.e. the RSC value must be sufficiently small.

RSC = Relative Short-Circuit power: Ratio of short-circuit power $S_{K \text{ line}}$ at the line connection point to fundamental apparent power S_{conv} of the connected converters (according to EN 60146-1-1).

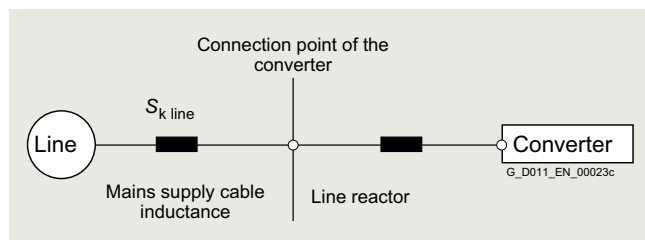

The following applies for SINAMICS G150 converter cabinet units:

Type rating kW	Line reactor can be omitted		Line reactor required	
	For RSC	Order code (option)	For RSC	Order code (option)
< 200	≤ 43	L22	> 43	–
200 ... 500	≤ 33	L22	> 33	–
≥ 500	≤ 20	–	> 20	L23

It is recommended that a line reactor is always connected on the line side of the converter, as in practice, it is often not known on which supply configuration individual converters are to be operated, i.e. which supply short-circuit power is present at the converter connection point.

The line reactor can only be omitted (option **L22**) if the values for RSC are lower than those shown in the table. This is the case, as shown in the following diagram, when the converter is connected to the line supply via a transformer with the appropriate rating.

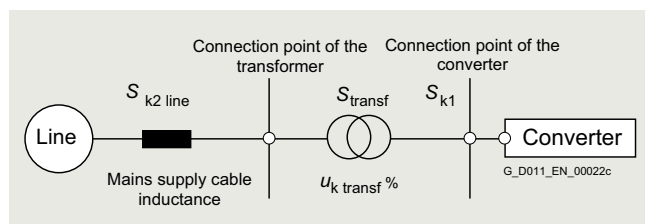

As high-rating converters are usually connected to medium-voltage supply systems via transformers to reduce their harmonic effects on the supply, cabinet units over 500 kW are not equipped with line reactors as standard.

A line reactor (option **L23**) is always required when

- For cabinet units > 500 kW, the RSC ratio is > 20 , or
- Several converters are connected to the same line connection point
- For cabinet units in a parallel connection, the line supply is not fed-in through a three-winding transformer, or
- A line filter is used

For further information, please refer to the SINAMICS Low Voltage Engineering Manual.

Note:

When option **L01** is selected, a line reactor is not required (options **L22/L23** and **L01** cannot be combined).

L26

Main switch incl. fuses or circuit breakers

A switch disconnecter with fuses is available as main switch for converters in single connection with ratings up to 800 A. With currents above 800 A, a circuit breaker is used instead of a switch disconnecter. The circuit breaker is controlled and supplied within the converter.

Option **L26** is included as standard for converters with power units connected in parallel and a rated input current of ≥ 1500 A.

Circuit breakers are installed in this case. For rated input currents < 1500 A, by selecting option **L26**, main switches including fuses are installed in addition to the line contactors provided as standard.

L45

EMERGENCY OFF pushbutton installed in the cabinet door

Option **L45** only includes the EMERGENCY OFF pushbutton. This is fitted with a protective collar in the cabinet door of the converter. The contacts of the pushbutton are brought out and connected to a terminal block. The EMERGENCY OFF functions, Category 0 or 1, can be activated in conjunction with options **L57**, **L59** and **L60**.

Notice:

By pressing the EMERGENCY OFF pushbutton, in compliance with IEC 60204-1 (VDE 0113), the motor is stopped – either uncontrolled or controlled depending on the selected Category 0 or 1 – and the converter disconnected from the line supply. Auxiliary voltages such as the supply for an external fan or anti-condensation heating may still be present. Certain areas within the converter also remain live (under voltage), such as the control or auxiliary equipment. If complete disconnection of all voltages is required, the EMERGENCY OFF pushbutton must be incorporated into a protective system to be implemented by the customer. For this purpose, an NC contact is provided at terminal -X120.

The EMERGENCY OFF button is preconfigured at the factory only when one of the options **L57** to **L60** is selected simultaneously. Other circuit arrangements must be implemented by the customer.

SINAMICS G150

Converter cabinet units

75 kW to 2700 kW

Options

L50

Cabinet lighting with service socket

With option **L50**, cabinet lighting is included with an additional service socket for a SCHUKO connector (connector type F) according to CEE 7/4. The power supply for the cabinet lighting and the service socket is external and must be fuse-protected for max. 10 A.

The cabinet lighting consists of an LED hand lamp with On/Off switch and with magnetic fasteners on an approx. 3 m long connecting cable. The lamp is factory-positioned in the cabinet door at a defined marking, and the connecting cable is wound on the associated mount.

L55

Anti-condensation heating for cabinet

The anti-condensation heating is recommended at low ambient temperatures and high levels of humidity to prevent condensation. A 100 W cabinet heater is installed in each cabinet section (two heaters are installed per cabinet with cabinet section widths of between 800 mm and 1200 mm).

The power supply for the anti-condensation heating (110 V to 230 V AC, at terminal block -X240) must be provided externally and fused with max. 16 A.

Terminal -X240:	Meaning
1	L1 (110 ... 230 V AC)
2	N
3	PE

L57

EMERGENCY OFF Category 0

EMERGENCY OFF Category 0 for uncontrolled stopping according to EN 60204-1.

The function includes interrupting the power feed for the converter via the line contactor and bypassing the microprocessor controller using a safety combination according to EN 60204-1. The motor coasts down.

Notice:

Option **L57** always requires electrical separation from the line supply, i.e. for converters in a single connection for converter currents ≤ 800 A, option **L13** and for converter currents > 800 A, option **L26**. For converters with power units connected in parallel, electrical separation from the line supply is included as standard.

Terminal -X120:	Meaning
7	Loop in the EMERGENCY OFF pushbutton from the plant side; remove jumper 7-8!
8	Loop in the EMERGENCY OFF pushbutton from the plant side; remove jumper 7-8!
15	"On" for monitored start; remove jumper 15-16!
16	"On" for monitored start; remove jumper 15-16!
17	Checkback signal, "Safety combination has tripped"
18	Checkback signal, "Safety combination has tripped"

L59

EMERGENCY STOP Category 1, 230 V AC

EMERGENCY STOP Category 1 for controlled stopping according to EN 60204-1.

The function stops the drive using a fast stop along a down ramp that is parameterized by the user. The power supply to the converter is then interrupted as described for EMERGENCY OFF Category 0.

In order to maintain the specified stopping times, it may be necessary to use a braking unit.

Notice:

Option **L59** always requires electrical separation from the line supply, i.e. for converters in a single connection for converter currents ≤ 800 A, option **L13** and for converter currents > 800 A, option **L26**. For converters with power units connected in parallel, electrical separation from the line supply is included as standard.

Terminal -X120:	Meaning
7	Loop in the EMERGENCY OFF pushbutton from the plant side; remove jumper 7-8!
8	Loop in the EMERGENCY OFF pushbutton from the plant side; remove jumper 7-8!
15	"On" for manual start; remove jumper 15-16!
16	"On" for manual start; remove jumper 15-16!
17	Checkback signal, "Safety combination has tripped"
18	Checkback signal, "Safety combination has tripped"

L60

EMERGENCY STOP Category 1, 24 V DC

EMERGENCY STOP Category 1 for controlled stopping according to EN 60204-1.

The function stops the drive using a fast stop along a down ramp that is parameterized by the user. The power supply to the converter is then interrupted as described for EMERGENCY OFF Category 0.

In order to maintain the specified stopping times, it may be necessary to use a braking unit.

Notice:

Option **L60** always requires electrical separation from the line supply, i.e. for converters in a single connection for converter currents ≤ 800 A, option **L13** and for converter currents > 800 A, option **L26**. For converters with power units connected in parallel, electrical separation from the line supply is included as standard.

Terminal -X120:	Meaning
7	Loop in the EMERGENCY OFF pushbutton from the plant side; remove jumper 7-8!
8	Loop in the EMERGENCY OFF pushbutton from the plant side; remove jumper 7-8!
15	"On" for manual start; remove jumper 15-16!
16	"On" for manual start; remove jumper 15-16!
17	Checkback signal, "Safety combination has tripped"
18	Checkback signal, "Safety combination has tripped"

Options

L61, L62 Braking units

Braking units may be required for drives in which motors might operate in generator mode, but have no facility for feeding energy back into the supply system.

The braking unit comprises two components:

- A Braking Module that is installed in the converter cabinet
- A braking resistor to be mounted externally (IP20 degree of protection).

The braking unit functions as an autonomous unit, and does not require an external power supply. The braking energy is converted into heat in the braking resistor that must be mounted externally.

A max. cable length of 100 m is permissible between the Braking Module and the braking resistor. This allows the braking resistor to be mounted externally so that heat losses can be dissipated outside the converter enclosure.

The braking resistor is connected to terminal block –X5 on the converter cabinet unit:

Terminal -X5:	Meaning
1	Braking resistor connection
2	Braking resistor connection

Characteristic curves

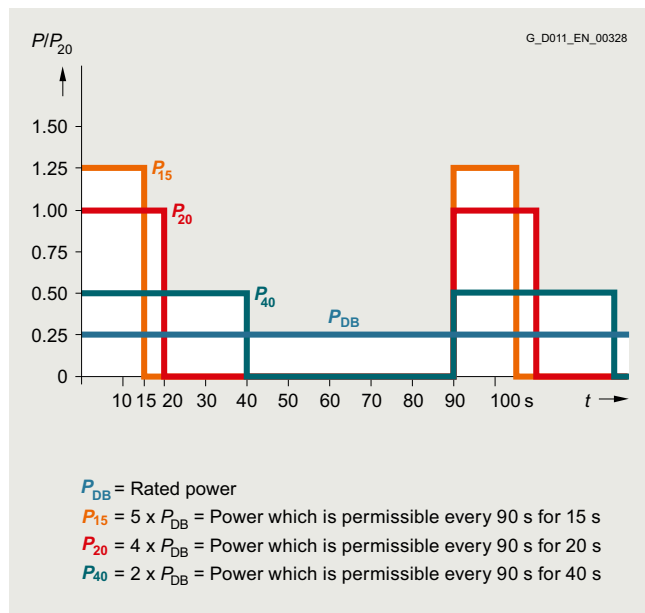

Load diagram for Braking Modules and braking resistors

Information about possible duty cycles of the braking units and other configuration notes are contained in the SINAMICS Low Voltage Engineering Manual.

The following braking units are available for SINAMICS G150 converters – depending on the converter type:

Option	SINAMICS G150 converter cabinet units Type rating kW	Braking Module				Braking resistor R_B Ω
		P_{DB} kW	P_{40} kW	P_{20} kW	P_{15} kW	
380 ... 480 V 3 AC						
L61	110 ... 132	25	50	100	125	4.4 ±7.5%
L62	160 ... 900	50	100	200	250	2.2 ±7.5%
500 ... 600 V 3 AC						
L62	110 ... 1000	50	100	200	250	3.4 ±7.5%
660 ... 690 V 3 AC						
L61	75 ... 132	25	50	100	125	9.8 ±7.5%
L62	160 ... 2700	50	100	200	250	4.9 ±7.5%

P_{DB} : Rated power (continuous braking power)

P_{40} : 40 s power in relation to a braking interval of 90 s

P_{20} : 20 s power in relation to a braking interval of 90 s

P_{15} : 15 s power in relation to a braking interval of 90 s

A second 50 kW braking unit can be used in converters with power units connected in parallel in order to increase the braking power. In this case, a Braking Module is assigned to each braking resistor. You can order a second braking unit by selecting option **L62** twice.

If more braking power is required than provided by the braking units listed here, then braking units may be connected in parallel for higher converter outputs (on request).

For further information, please refer to the SINAMICS Low Voltage Engineering Manual.

L76

Quick start (for option L01)

If **L01** (Line Harmonics Filter) is in use, after the converter has been switched off, as a result of the principle of operation, a waiting period of at least 30 seconds must be allowed to elapse before switching on again. With option **L76**, the wait time is shortened to approx. 3 s.

L83

Thermistor motor protection device (alarm)

Thermistor motor protection device for PTC thermistors (PTC resistors, type A) for alarm. The thermistor motor protection device is supplied with power and evaluated internally in the converter.

Terminal -B127:	Meaning
T1	Sensor circuit connection
T2	Sensor circuit connection

SINAMICS G150

Converter cabinet units

75 kW to 2700 kW

Options

L84

Thermistor motor protection device (trip)

Thermistor motor protection device for PTC thermistors (PTC resistors, type A) for trip. The thermistor motor protection device is supplied with power and evaluated internally in the converter.

Terminal -B125:	Meaning
T1	Sensor circuit connection
T2	Sensor circuit connection

L86

Pt100 evaluation unit

The Pt100 evaluation unit can monitor up to six sensors. The sensors can be connected using a two-wire or three-wire system. The limit values can be freely programmed for each channel.

In the factory setting, the measuring channels are subdivided into two groups, each with three channels. With motors, for example, this means that three Pt100s in the stator windings and two Pt100s in the motor bearings can be monitored. Unused channels can be hidden via parameters.

The output relays are integrated into the internal fault and shutdown sequence of the converter.

L87

Insulation monitoring

An insulation monitor must be used if the converter is connected to an ungrounded line supply. The device monitors the entire galvanically coupled circuit for insulation faults.

An alarm is output in the event of a fault.

Notice:

Only **one** insulation monitor can be used in each galvanically coupled network.

As there are different response strategies when a ground fault occurs in an ungrounded system, output relays of the insulation monitor are provided for integration in a plant-side control. It is also possible to integrate the outputs into the converter monitoring system on the plant side.

Insulation monitoring can be supplied on request for converter cabinet units with power units connected in parallel.

M06

Base 100 mm high, RAL 7022

The additional cabinet base allows larger bending radii for cables (cable inlet from below) and enables them to be routed within the cabinet base.

The cabinet base is supplied in RAL 7022 as standard. A special paint finish is not available for the base. It is delivered completely assembled with the cabinet. The height of the operator panel changes accordingly.

M07

Cable marshalling space 200 mm high, RAL 7035

The cable marshalling space is made of strong sheet steel and allows cables to be connected more flexibly (entry from below). It also allows routing of cables within the marshalling compartment. It is delivered completely assembled with the cabinet. The height of the operator panel changes accordingly.

Note:

The cable compartment is painted as standard with RAL 7035. If a special color is requested for the cabinet (order code **Y09**), the cable-marshaling space is also painted in this color.

M13

Line connection from above

The control cabinet is provided with an additional roof section to allow a line connection from above. The connection lugs for the power cables, the clamping bar for mechanically securing the cables, an EMC shield bus, and a PE busbar are located within this roof section.

This increases the cabinet height by 405 mm. The busbars for the connection from above are delivered completely pre-installed. For transport reasons, the roof sections are delivered separately and must be fitted on site. Crane transport assemblies (option **M90**) can still be used.

However, they must be removed on site before the roof sections can be installed. Use of rope spreaders should be considered in the case of small crane hook heights.

An undrilled aluminum mounting plate (5 mm thick) is provided in the roof section for feeding in the cables. Depending on the number of cables and the cross-sections used, holes for attaching cable glands for feeding in the cables must be drilled in this mounting plate on site.

Notice:

The control cables are still connected from below. When option **M13** is selected, the standard line connection from below is omitted.

The degree of protection of the roof sections is IP21. In combination with options **M23**, **M43** and **M54**, additional plastic ventilation grilles and filter elements are provided.

Note:

The roof sections are painted in RAL 7035 as standard. If a special color is requested for the cabinet (order code **Y09**), the roof sections are also painted in this color. Ventilation grilles used with IP23, IP43 and IP54 degrees of protection are in RAL 7035 and cannot be painted.

Option **M13** is not available for converters > 1500 kW with power units connected in parallel.

Options

M21

Degree of protection IP21

Cabinet version in IP20, but with additional top cover or canopy. This increases the cabinet height by 250 mm.

For transport reasons, the top covers or canopies are delivered separately and must be fitted on site.

Note:

The top covers or canopies are painted in RAL 7035 as standard. If a special color is requested for the cabinet (order code **Y09**), the top covers or canopies will also be painted this color.

M23/M43/M54

Degree of protection IP23/IP43/IP54

When **M23**, **M43** or **M54** is selected, the converter is equipped with a roof section. This increases the cabinet height by 400 mm.

For transport reasons, the roof sections are delivered separately and must be fitted on site.

Note:

The roof sections are painted in RAL 7035 as standard. If a special color is requested for the cabinet (order code **Y09**), the roof sections are also painted in this color. The molded plastic parts (e.g. ventilation grilles) are in RAL 7035 and cannot be painted.

M66

Marine version

For compliance with the requirements of the classification institutes:

- Lloyds Register
- American Bureau of Shipping
- Bureau Veritas
- Det Norske Veritas
- Chinese Classification Society

This option includes a strengthened mechanical version of the cabinet, handles (handrail) below the operator panel and mechanical locking of the cabinet doors. The cabinet has degree of protection IP23 (option **M23**) and includes a cabinet anti-condensation heater (option **L55**). To attach the converter to the ship's deck, a welding frame (5 mm high) is supplied separately.

Note:

A combination with options **M21**, **M23** and **L01** or **L55** is not possible. If the converter is used for a safety-relevant drive on a ship, then individual certification is also required (see options **E21** to **E71**) – these include option **M66**.

M70

EMC shield bus (cable connection from below)

The EMC shield bus is used to connect shielded line and motor supply cables. The EMC shield bus is included as standard with option **L00** (RFI suppression filter).

M75

PE busbar (cable connection from below)

The PE busbar is used to connect and secure PE cables. The PE busbar is contained as standard in version A. For version C, the PE busbar can be ordered separately as option **M75**.

M78

Motor connection from above

The control cabinet is provided with an additional roof section for a motor connection from above. The connection lugs for the power cables, the clamping bar for mechanically securing the cables, an EMC shield bus, and a PE busbar are located within this roof section.

This increases the cabinet height by 405 mm. The busbars for the connection from above are delivered completely pre-installed. For transport reasons, the roof sections are delivered separately and must be fitted on site. Crane transport assemblies (option **M90**) can still be used. However, they must be removed on site before the roof sections can be installed.

An undrilled aluminum mounting plate (5 mm thick) is provided in the roof section for feeding in the cables. Depending on the number of cables and the cross-sections used, holes for attaching cable glands for feeding in the cables must be drilled in this mounting plate on site.

Note:

The control cables are still connected from below. When option **M78** is selected, the standard motor connection from below is omitted. A combination with motor-side options **L07**, **L08**, **L10** and **L15** is not possible. If option **L61** or **L62** is selected at the same time as option **M78**, the braking-resistor should also be connected from above.

The degree of protection of the roof sections is IP21. In combination with options **M23**, **M43** and **M54**, additional plastic ventilation grilles and filter elements are provided.

Note:

The roof sections are painted in RAL 7035 as standard. If a special color is requested for the cabinet (order code **Y09**), the roof sections are also painted in this color. Ventilation grilles used with IP23, IP43 and IP54 degrees of protection are in RAL 7035 and cannot be painted.

Option **M78** is not available for converters > 1500 kW with power units connected in parallel.

M90

Crane transport assembly (top-mounted)

For single cabinets up to a width of 600 mm, the crane transport assembly consists of transport eyebolts. For cabinet widths of 800 mm and wider, transport rails are used.

Rope spreaders should be used for low crane hook heights.

SINAMICS G150

Converter cabinet units

75 kW to 2700 kW

Options

M91

Marking of all control cable conductor ends

When this option is selected, all control cables or conductor ends (including all customer-specific options) are labeled throughout the cabinet.

Q80, Q81, Q82, Q83, Q84, Q85

Warranty extension for converter

Order code	Additional text
Q80	Extension of the warranty period by 12 months to a total of 24 months (2 years) after delivery
Q81	Extension of the warranty period by 18 months to a total of 30 months (2½ years) after delivery
Q82	Extension of the warranty period by 24 months to a total of 36 months (3 years) after delivery
Q83	Extension of the warranty period by 30 months to a total of 42 months (3½ years) after delivery
Q84	Extension of the warranty period by 36 months to a total of 48 months (4 years) after delivery
Q85	Extension of the warranty period by 48 months to a total of 60 months (5 years) after delivery

T58, T60, T80, T85, T91

Rating plate data

The standard version of the rating plate is in English/German.

A rating plate in another language can be selected using the following order code for the option.

Order code	Rating plate language
T58	English/French
T60	English/Spanish
T80	English/Italian
T85	English/Russian
T91	English/Chinese

Y09

Special cabinet paint finish

The converter cabinet units are delivered in RAL 7035 as standard. The special paint finish must be specified in plain text when ordering. All RAL colors which are available as powder coatings can be selected.

Note:

If options such as cable marshalling space (order code **M07**), top covers or canopies (order code **M21**), roof sections (order codes **M23/M43/M54**) or cable connection from above (order codes **M13/M78**) are ordered for the converter cabinet units, they will also be supplied in the paint finish specified in the order. The molded plastic parts (e.g. ventilation grilles) are in RAL 7035 and cannot be painted.

Y31

One-line label for system identification, 40 × 80 mm

Resopal labels (white with black lettering) for identifying the control cabinets are available. The labels are stuck to the cabinet door.

Dimensions H × W: 40 × 80 mm

The text must be specified in plain text when ordering.

Field 1: Max. 9 characters, font size 10 mm.

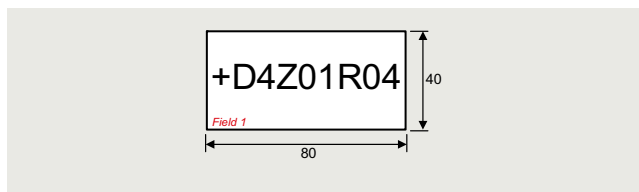

Y32

Two-line label for system identification, 40 × 180 mm

Resopal labels (white with black lettering) for identifying the control cabinets are available. The labels are stuck to the cabinet door.

Dimensions H × W: 40 × 180 mm

The text must be specified in plain text when ordering.

Field 1: Max. 9 characters, font size 10 mm

Field 2: Max. 9 characters, font size 10 mm

Field 3: Max. 20 characters, font size 10 mm

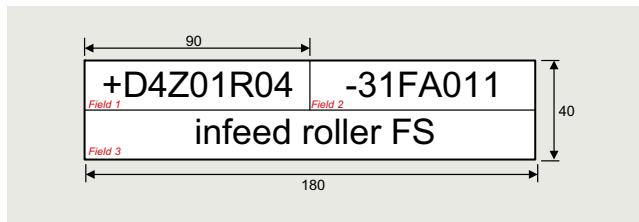

Y33

Four-line label for system identification, 40 × 180 mm

Resopal labels (white with black lettering) for identifying the control cabinets are available. The labels are stuck to the cabinet door.

Dimensions H × W: 40 × 180 mm

The text must be specified in plain text when ordering.

Field 1: Max. 9 characters, font size 10 mm

Field 2: Max. 20 characters, font size 6 mm

Field 3: Max. 20 characters, font size 6 mm

Field 4: Max. 20 characters, font size 6 mm

Field 5: Max. 20 characters, font size 6 mm

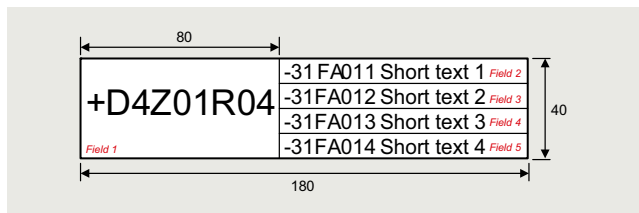

Technical specifications

The most important directives and standards are listed below. These are used as basis for the SINAMICS G150 converter cabinet units and they must be carefully observed to achieve an EMC-compliant configuration that is safe both functionally and in operation.

European directives	
2006/42/EC	Machinery directive: Directive of the European Parliament and Council of May 17, 2006 on machinery and for changing Directive 95/16/EC (amendment)
2014/35/EU	Low-voltage directive: Directive of the European Parliament and Council of February 26, 2014 for the harmonization of the laws of the member states relating to the provision of electrical equipment designed for use within certain voltage limits on the market (amended version)
2014/30/EU	EMC directive: Directive of the European Parliament and Council of February 26, 2014 for the harmonization of the laws of the member states relating to electromagnetic compatibility (amended version)
2011/65/EU	RoHS directive Directive of the European Parliament and Council of June 8, 2014 on the restriction of the use of certain hazardous substances in electrical and electronic equipment
(EU) 2019/1781	Ecodesign Regulation - requirements in accordance with the Ecodesign Directive Commission Regulation of October 1, 2019 laying down ecodesign requirements for electric motors and variable speed drives pursuant to Directive 2009/125/EC of the European Parliament and of the Council
European standards	
EN ISO 3744	Acoustics – Determination of the sound power level and sound energy level for noise sources that result from sound pressure measurements – envelope surface procedure of the accuracy class 2 for a largely free sound field over a reflecting plane
EN ISO 13849-1	Safety of machinery – Safety-related parts of control systems Part 1: General design principles (ISO 13849-1:2006) (replaced EN 954-1)
EN 60146-1-1	Semiconductor converters – General requirements and line-commutated converters Part 1-1: Specification of basic requirements
EN 60204-1	Electrical equipment of machines Part 1: General definitions
EN 60529	Degrees of protection provided by enclosures (IP code)
IEC 61508-1	Functional safety of electrical/electronic/programmable electronic safety-related systems Part 1: General requirements
IEC 61508-2	Functional safety of electrical/electronic/programmable electronic safety-related systems Part 2: Requirements placed on safety-related electrical/electronic/programmable electronic systems
IEC 61508-3	Functional safety of electrical/electronic/programmable electronic safety-related systems Part 3: Software requirements
EN 61800-2	Adjustable speed electrical power drive systems Part 2: General requirements – Rating specifications for the measurement of low-voltage adjustable frequency AC power drive systems
EN 61800-3	Adjustable speed electrical power drive systems Part 3: EMC product standard including special test procedure
EN 61800-5-1	Adjustable speed electrical power drive systems Part 5: Safety requirements Main section 1: Electrical and thermal requirements
EN 61800-5-2	Adjustable speed electrical power drive systems Part 5-2: Safety requirements – Functional safety (IEC 61800-5-2:2007)

SINAMICS G150

Converter cabinet units

75 kW to 2700 kW

Technical specifications

General technical specifications

Electrical specifications		Single connection	Parallel connection	
Line voltages and power ranges	<ul style="list-style-type: none"> • 380 ... 480 V 3 AC ±10% (-15% < 1 min) • 500 ... 600 V 3 AC ±10% (-15% < 1 min) • 660 ... 690 V 3 AC ±10% (-15% < 1 min) 	110 ... 560 kW 110 ... 560 kW 75 ... 800 kW	630 ... 900 kW 630 ... 1000 kW 1000 ... 2700 kW	
Line system configurations	Grounded TN/TT systems or ungrounded IT systems (a grounded line conductor is not permissible in 690 V line supplies)			
Line frequency	47 ... 63 Hz			
Output frequency	0 ... 550 Hz ¹⁾			
Line power factor	<ul style="list-style-type: none"> • Fundamental > 0.96 • Total 0.75 ... 0.93 			
Efficiency	> 98%			
Overvoltage category	III according to EN 61800-5-1			
Control method	Vector control with and without encoder or V/f control			
Fixed speeds	15 fixed speeds plus 1 minimum speed, parameterizable (in the default setting, 3 fixed setpoints plus 1 minimum speed are selectable using terminal strip/PROFIBUS/PROFINET)			
Speed ranges that can be skipped	4, parameterizable			
Setpoint resolution	0.001 rpm digital 12-bit analog			
Braking operation	Optional via braking unit			
Mechanical specifications				
Degree of protection	IP20 (higher degrees of protection up to IP54 optional)			
Protection class	I according to EN 61800-5-1			
Touch protection	EN 50274 / DGUV regulation 3 when used as intended			
Cabinet system	Rittal TS 8, doors with double-bit key, three-section base plates for cable entry			
Paint finish	RAL 7035 (indoor requirements)			
Cooling method	Forced air cooling AF according to EN 60146			
Ambient conditions		Storage	Transport	Operation
Ambient temperature		-25 ... +55 °C (-13 ... 131 °F)	-25 ... +70 °C (-13 ... +158 °F) from -40 °C (-40 °F) for 24 hours	0 ... +40 °C (32 ... 104 °F) to +50 °C (122 °F) see derating data
Relative humidity (condensation not permissible)		<u>5 ... 95%</u> Class 1K4 acc. to IEC 60721-3-1 (1997)	5 ... 95% at 40 °C (104 °F) Class 2K3 acc. to IEC 60721-3-2 (1997)	<u>5 ... 95%</u> Class 3K3 acc. to IEC 60721-3-3 (2002)
Environmental class / harmful chemical substances		Class 1C2 acc. to IEC 60721-3-1 (1997)	Class 2C2 acc. to IEC 60721-3-2 (1997)	Class 3C2 acc. to IEC 60721-3-3 (2002)
Organic/biological influences		Class 1B1 acc. to IEC 60721-3-1 (1997)	Class 2B1 acc. to IEC 60721-3-2 (1997)	Class 3B1 acc. to IEC 60721-3-3 (2002)
Mechanically active substances		Class 1S1 acc. to IEC 60721-3-1 (1997)	Class 2S1 acc. to IEC 60721-3-2 (1997)	Class 3S1 acc. to IEC 60721-3-3 (2002)
Degree of pollution		2 according to EN 61800-5-1		
Installation altitude		Up to 2000 m (6562 ft) above sea level without derating; > 2000 m (6562 ft) see derating data		
Mechanical stability		Storage	Transport	Operation
Vibratory load		Class 1M2 acc. to IEC 60721-3-1 (1997)	Class 1M2 acc. to IEC 60721-3-1 (1997)	–
<ul style="list-style-type: none"> • Deflection • Acceleration 		1.5 mm (0.06 in) at <u>5 ... 9 Hz</u> 5 m/s ² (16.4 ft/s ²) at > 9 ... 200 Hz	<u>3.1 mm (0.12 in) at 5 ... 9 Hz</u> 10 m/s ² (32.8 ft/s ²) at > 9 ... 200 Hz	0.075 mm (0.00 in) at 10 ... 58 Hz 9.8 m/s ² (32.2 ft/s ²) at >58 ... 200 Hz
Shock load		Class 1M2 acc. to IEC 60721-3-1 (1997)	Class 2M2 acc. to IEC 60721-3-2 (1997)	Class 3M1 acc. to IEC 60721-3-3 (2002)
<ul style="list-style-type: none"> • Acceleration 		40 m/s ² (131 ft/s ²) for 22 ms	100 m/s ² (328 ft/s ²) for 11 ms	Test values acc. to EN 60068-2-27 Test Ea: 5 g, 30 ms, 3 shocks
Compliance with standards				
CE marking	According to EMC Directive No. 2014/30/EU, Low-Voltage Directive No. 2014/35/EU, Machinery Directive No. 2006/42/EC for functional safety and Ecodesign Regulation - requirements as per Ecodesign Directive (EU) 2019/1781, SEMI F47			
Radio interference suppression	The SINAMICS G150 converter systems are not designed for connection to the public power network ("first environment"). Radio interference suppression is compliant with the EMC product standard for variable-speed drives EN 61800-3, "Second environment" (industrial networks). EMC disturbances can occur when connected to the public power networks. However, if supplementary measures are taken (e.g. line filter, see option L00) operation in the "first environment" is possible. ²⁾			

Deviations from the specified classes are underlined.

¹⁾ The output frequency is also affected by the selected control method and the pulse frequency. For further information, please refer to the SINAMICS Low Voltage Engineering Manual.

²⁾ Applies to motor cable lengths < 100 m (328 ft).

Technical specifications
Technical specifications for single connection

Line voltage 380 ... 480 V 3 AC		SINAMICS G150 converter cabinet units 6SL3710-1GE...-....								
		32-1.A3	32-6.A3	33-1.A3	33-8.A3	35-0.A3	36-1.A3	37-5.A3	38-4.A3	41-0.A3
Single connection										
Type rating										
• For I_L at 50 Hz 400 V ¹⁾	kW	110	132	160	200	250	315	400	450	560
• For I_H at 50 Hz 400 V ¹⁾	kW	90	110	132	160	200	250	315	400	450
• For I_L at 60 Hz 460 V ²⁾	hp	150	200	250	300	400	500	600	600	800
• For I_H at 60 Hz 460 V ²⁾	hp	125	150	200	250	350	350	450	500	700
Output current										
• Rated current I_N	A	210	260	310	380	490	605	745	840	985
• Base-load current $I_L^{(3)}$	A	205	250	302	370	477	590	725	820	960
• Base-load current $I_H^{(4)}$	A	178	233	277	340	438	460	570	700	860
Input current										
• Rated input current ⁵⁾	A	229	284	338	395	509	629	775	873	1024
• Input current, max.	A	335	410	495	606	781	967	1188	1344	1573
• Current requirement, 24 V DC auxiliary power supply ⁶⁾	A	1.1	1.1	1.35	1.35	1.35	1.4	1.4	1.4	1.5
Rated short-circuit current according to IEC ⁷⁾	kA	65	65	65	65	65	65	65	84	84
Minimum short-circuit current ⁸⁾	A	3000	3600	4400	4400	8000	10000	10500	16000/1800 ⁹⁾	18400/2000 ⁹⁾
Power loss, max. ¹⁰⁾										
• At 50 Hz 400 V	kW	2.9	3.8	4.4	5.3	6.4	8.2	9.6	10.1	14.4
• At 60 Hz 460 V	kW	2.54	3.36	4.07	4.67	5.96	8.3	9.7	10.2	14.7
Cooling air requirement	m ³ /s (ft ³ /s)	0.17 (6.00)	0.23 (8.12)	0.36 (12.7)	0.36 (12.7)	0.36 (12.7)	0.78 (27.5)	0.78 (27.5)	0.78 (27.5)	1.48 (52.3)
Sound pressure level L_{pA} (1 m) at 50/60 Hz	dB	67/68	69/73	69/73	69/73	69/73	70/73	70/73	70/73	72/75
Cable lengths between converter and motor ¹¹⁾										
• Shielded	m (ft)	300 (984)	300 (984)	300 (984)	300 (984)	300 (984)	300 (984)	300 (984)	300 (984)	300 (984)
• Unshielded	m (ft)	450 (1476)	450 (1476)	450 (1476)	450 (1476)	450 (1476)	450 (1476)	450 (1476)	450 (1476)	450 (1476)
Dimensions										
• Width for version A/C	mm (in)	800/400 (31.50/ 15.75)	800/400 (31.50/ 15.75)	800/400 (31.50/ 15.75)	1000/400 (39.37/ 15.75)	1000/400 (39.37/ 15.75)	1200/600 (47.24/ 23.62)	1200/600 (47.24/ 23.62)	1200/600 (47.24/23.62)	1600/1000 (62.99/39.37)
• Height ¹²⁾	mm (in)	2000 (78.74)	2000 (78.74)	2000 (78.74)	2000 (78.74)	2000 (78.74)	2000 (78.74)	2000 (78.74)	2000 (78.74)	2000 (78.74)
• Depth	mm (in)	600 (23.62)	600 (23.62)	600 (23.62)	600 (23.62)	600 (23.62)	600 (23.62)	600 (23.62)	600 (23.62)	600 (23.62)
Weight, approx. (degree of protection IP20, without options) for version A/C	kg (lb)	460/225 (1014/496)	460/225 (1014/496)	670/300 (1477/661)	670/300 (1477/661)	670/300 (1477/661)	750/670 (1653/ 1477)	750/670 (1653/ 1477)	780/670 (1720/1477)	1100/880 (2425/1940)

Note: The power data in hp units is based on the NEC/CEC standards for the North American market.

For information on the line connection, motor connection and cabinet grounding, see Section Configuration.

¹⁾ Rated output of a typical 6-pole standard induction motor based on I_L or I_H for 3 AC 50 Hz 400 V.

²⁾ Rated output of a typical 6-pole standard induction motor based on I_L or I_H for 3 AC 60 Hz 460 V.

³⁾ The base-load current I_L is based on a load cycle of 110% for 60 s or 150% for 10 s with a load cycle duration of 300 s. See [Characteristic curves, Section Overload capability](#).

⁴⁾ The base-load current I_H is based on a duty cycle of 150% for 60 s or 160% for 10 s with a duty cycle duration of 300 s. See [Characteristic curves, Section Overload capability](#).

⁵⁾ The currents listed here are based on the rated output current.

⁶⁾ If the drive control is to remain active after a main infeed failure, the converter must be externally supplied with 24 V DC.

The following must also be taken into account:

– CU320-2: 1 A

– TM31: 0.5 A

– AOP30: 0.2 A

– SMC: 0.6 A

– Current requirement of digital inputs/outputs.

⁷⁾ In conjunction with the specified fuses or circuit breakers.

⁸⁾ Minimum current required for reliably triggering the protective devices.

⁹⁾ For option **L26** (version A) the low value applies.

¹⁰⁾ The specified power losses are the maximum values for a utilization of 100%. The values are lower under normal operating conditions. Typical values according to IEC 61800-9-2. The values apply for converters without an integrated line filter.

More information can be found on the internet at <https://support.industry.siemens.com/cs/document/94059311>

¹¹⁾ Longer cable lengths for specific configurations are available on request.

¹²⁾ Version A: The cabinet height increases by
– 250 mm (9.84 in) for degree of protection IP21
– 400 mm (15.75 in) for degrees of protection IP23, IP43 and IP54
– 405 mm (15.94 in) for options **M13** and **M78**
Version C: The cabinet height increases by
– 250 mm (9.84 in) for degree of protection IP21
– 400 mm (15.75 in) for degrees of protection IP23, IP43 and IP54

SINAMICS G150

Converter cabinet units

75 kW to 2700 kW

Technical specifications

Line voltage 500 ... 600 V 3 AC		SINAMICS G150 converter cabinet units 6SL3710-1GF-.....								
		31-8.A3	32-2.A3	32-6.A3	33-3.A3	34-1.A3	34-7.A3	35-8.A3	37-4.A3	38-1.A3
Single connection										
Type rating										
• For I_L at 50 Hz 500 V ¹⁾	kW	110	132	160	200	250	315	400	500	560
• For I_H at 50 Hz 500 V ¹⁾	kW	90	110	132	160	200	250	315	450	500
• For I_L at 60 Hz 575 V ²⁾	hp	150	200	250	300	400	450	600	700	800
• For I_H at 60 Hz 575 V ²⁾	hp	150	200	200	250	350	450	500	700	700
Output current										
• Rated current I_N	A	175	215	260	330	410	465	575	735	810
• Base-load current $I_L^{(3)}$	A	171	208	250	320	400	452	560	710	790
• Base-load current $I_H^{(4)}$	A	157	192	233	280	367	416	514	657	724
Input current										
• Rated input current ⁵⁾	A	191	224	270	343	426	483	598	764	842
• Input current, max.	A	279	341	410	525	655	740	918	1164	1295
• Current requirement, 24 V DC auxiliary power supply ⁶⁾	A	1.35	1.35	1.35	1.4	1.4	1.4	1.4	1.5	1.5
Rated short-circuit current according to IEC ⁷⁾	kA	65	65	65	65	65	65	65	84	84
Minimum short-circuit current ⁸⁾	A	2400	3000	3600	5200	5200	6200	8400	10500	10400/1800 ⁹⁾
Power loss, max. ¹⁰⁾										
• At 50 Hz 500 V	kW	3.8	4.2	5	6.1	8.1	7.8	8.7	12.7	14.1
• At 60 Hz 575 V	kW	3.2	3.6	4.1	5.1	6.7	7.5	8.4	12.5	13.8
Cooling air requirement	m ³ /s (ft ³ /s)	0.36 (12.7)	0.36 (12.7)	0.36 (12.7)	0.36 (12.7)	0.78 (27.5)	0.78 (27.5)	0.78 (27.5)	1.48 (52.3)	1.48 (52.3)
Sound pressure level L_{pA} (1 m) at 50/60 Hz	dB	69/73	69/73	69/73	69/73	72/75	72/75	72/75	72/75	72/75
Cable lengths between converter and motor ¹¹⁾										
• Shielded	m (ft)	300 (984)	300 (984)	300 (984)	300 (984)	300 (984)	300 (984)	300 (984)	300 (984)	300 (984)
• Unshielded	m (ft)	450 (1476)	450 (1476)	450 (1476)	450 (1476)	450 (1476)	450 (1476)	450 (1476)	450 (1476)	450 (1476)
Dimensions										
• Width for version A/C	mm (in)	800/400 (31.50/ 15.75)	800/400 (31.50/ 15.75)	800/400 (31.50/ 15.75)	800/400 (31.50/ 15.75)	1200/600 (47.24/ 23.62)	1200/600 (47.24/ 23.62)	1200/600 (47.24/ 23.62)	1600/1000 (62.99/ 39.37)	1600/1000 (62.99/39.37)
• Height ¹²⁾	mm (in)	2000 (78.74)	2000 (78.74)	2000 (78.74)	2000 (78.74)	2000 (78.74)	2000 (78.74)	2000 (78.74)	2000 (78.74)	2000 (78.74)
• Depth	mm (in)	600 (23.62)	600 (23.62)	600 (23.62)	600 (23.62)	600 (23.62)	600 (23.62)	600 (23.62)	600 (23.62)	600 (23.62)
Weight, approx. (degree of protection IP20, without options) for version A/C	kg (lb)	460/300 (1014/661)	460/300 (1014/661)	460/300 (1014/661)	460/300 (1014/661)	750/670 (1653/ 1477)	750/670 (1653/ 1477)	860/670 (1896/ 1477)	1150/940 (2535/ 2072)	1150/960 (2535/2116)

Note: The power data in hp units is based on the NEC/CEC standards for the North American market.

For information on the line connection, motor connection and cabinet grounding, see Section Configuration.

¹⁾ Rated output of a typical 6-pole standard induction motor based on I_L or I_H for 3 AC 50 Hz 500 V.

²⁾ Rated output of a typical 6-pole standard induction motor based on I_L or I_H for 3 AC 60 Hz 575 V.

³⁾ The base-load current I_L is based on a load cycle of 110% for 60 s or 150% for 10 s with a load cycle duration of 300 s. See [Characteristic curves](#), [Section Overload capability](#).

⁴⁾ The base-load current I_H is based on a duty cycle of 150% for 60 s or 160% for 10 s with a duty cycle duration of 300 s. See [Characteristic curves](#), [Section Overload capability](#).

⁵⁾ The currents listed here are based on the rated output current.

⁶⁾ If the drive control is to remain active after a main infeed failure, the converter must be externally supplied with 24 V DC.

The following must also be taken into account:

- CU320-2: 1 A
- TM31: 0.5 A
- AOP30: 0.2 A
- SMC: 0.6 A
- Current requirement of digital inputs/outputs.

⁷⁾ In conjunction with the specified fuses or circuit breakers.

⁸⁾ Minimum current required for reliably triggering the protective devices.

⁹⁾ For option **L26** (version A) the low value applies.

¹⁰⁾ The specified power losses are the maximum values for a utilization of 100%. The values are lower under normal operating conditions.

¹¹⁾ Longer cable lengths for specific configurations are available on request.

¹²⁾ Version A: The cabinet height increases by
– 250 mm (9.84 in) for degree of protection IP21
– 400 mm (15.75 in) for degrees of protection IP23, IP43 and IP54
– 405 mm (15.94 in) for options **M13** and **M78**
Version C: The cabinet height increases by
– 250 mm (9.84 in) for degree of protection IP21
– 400 mm (15.75 in) for degrees of protection IP23, IP43 and IP54

Technical specifications

Line voltage 660 ... 690 V 3 AC		SINAMICS G150 converter cabinet units 6SL3710-1GH...-....						
Single connection		28-5.A3	31-0.A3	31-2.A3	31-5.A3	31-8.A3	32-2.A3	32-6.A3
Type rating								
• For I_L at 50 Hz 690 V ¹⁾	kW	75	90	110	132	160	200	250
• For I_H at 50 Hz 690 V ¹⁾	kW	55	75	90	110	132	160	200
Output current								
• Rated current I_N	A	85	100	120	150	175	215	260
• Base-load current I_L ²⁾	A	80	95	115	142	171	208	250
• Base-load current I_H ³⁾	A	76	89	107	134	157	192	233
Input current								
• Rated input current ⁴⁾	A	93	109	131	164	191	224	270
• Input current, max.	A	131	155	188	232	279	341	410
• Current requirement, 24 V DC auxiliary power supply ⁵⁾	A	1.1	1.1	1.1	1.1	1.35	1.35	1.35
Rated short-circuit current according to IEC ⁶⁾	kA	65	65	65	65	65	65	65
Minimum short-circuit current ⁷⁾	A	1500	1500	1200	1600	2400	3000	3600
Power loss, max. ⁸⁾ at 50 Hz 690 V	kW	1.7	2.1	2.7	2.8	3.8	4.2	5
Cooling air requirement	m ³ /s (ft ³ /s)	0.17 (6.00)	0.17 (6.00)	0.17 (6.00)	0.17 (6.00)	0.36 (12.7)	0.36 (12.7)	0.36 (12.7)
Sound pressure level L_{pA} (1 m) at 50/60 Hz	dB	67/68	67/68	67/68	67/68	67/73	67/73	67/73
Cable lengths between converter and motor ⁹⁾								
• Shielded	m (ft)	300 (984)	300 (984)	300 (984)	300 (984)	300 (984)	300 (984)	300 (984)
• Unshielded	m (ft)	450 (1476)	450 (1476)	450 (1476)	450 (1476)	450 (1476)	450 (1476)	450 (1476)
Dimensions								
• Width for version A/C	mm (in)	800/400 (31.50/15.75)	800/400 (31.50/15.75)	800/400 (31.50/15.75)	800/400 (31.50/15.75)	800/400 (31.50/15.75)	800/400 (31.50/15.75)	800/400 (31.50/15.75)
• Height ¹⁰⁾	mm (in)	2000 (78.74)	2000 (78.74)	2000 (78.74)	2000 (78.74)	2000 (78.74)	2000 (78.74)	2000 (78.74)
• Depth	mm (in)	600 (23.62)	600 (23.62)	600 (23.62)	600 (23.62)	600 (23.62)	600 (23.62)	600 (23.62)
Weight, approx. (degree of protection IP20, without options) for version A/C	kg (lb)	460/225 (1014/496)	460/225 (1014/496)	460/225 (1014/496)	460/225 (1014/496)	670/300 (1477/661)	670/300 (1477/661)	670/300 (1477/661)

Note: The power data in hp units is based on the NEC/CEC standards for the North American market.

For information on the line connection, motor connection and cabinet grounding, see Section Configuration.

¹⁾ Rated output of a typical 6-pole standard induction motor based on I_L or I_H for 3 AC 50 Hz 690 V.

²⁾ The base-load current I_L is based on a load cycle of 110% for 60 s or 150% for 10 s with a load cycle duration of 300 s. See [Characteristic curves](#), [Section Overload capability](#).

³⁾ The base-load current I_H is based on a duty cycle of 150% for 60 s or 160% for 10 s with a duty cycle duration of 300 s. See [Characteristic curves](#), [Section Overload capability](#).

⁴⁾ The currents listed here are based on the rated output current.

⁵⁾ If the drive control is to remain active after a main infeed failure, the converter must be externally supplied with 24 V DC.

The following must also be taken into account:
 – CU320-2: 1 A
 – TM31: 0.5 A
 – AOP30: 0.2 A
 – SMC: 0.6 A
 – Current requirement of digital inputs/outputs.

⁶⁾ In conjunction with the specified fuses or circuit breakers.

⁷⁾ Minimum current required for reliably triggering the protective devices.

⁸⁾ The specified power losses are the maximum values for a utilization of 100%. The values are lower under normal operating conditions.

⁹⁾ Longer cable lengths for specific configurations are available on request.

¹⁰⁾ Version A: The cabinet height increases by
 – 250 mm (9.84 in) for degree of protection IP21
 – 400 mm (15.75 in) for degrees of protection IP23, IP43 and IP54
 – 405 mm (15.94 in) for options **M13** and **M78**
 Version C: The cabinet height increases by
 – 250 mm (9.84 in) for degree of protection IP21
 – 400 mm (15.75 in) for degrees of protection IP23, IP43 and IP54

SINAMICS G150

Converter cabinet units

75 kW to 2700 kW

Technical specifications

Line voltage 660 ... 690 V 3 AC		SINAMICS G150 converter cabinet units 6SL3710-1GH...-....					
Single connection		33-3.A3	34-1.A3	34-7.A3	35-8.A3	37-4.A3	38-1.A3
Type rating							
• For I_L at 50 Hz 690 V ¹⁾	kW	315	400	450	560	710	800
• For I_H at 50 Hz 690 V ¹⁾	kW	250	315	400	450	560	710
Output current							
• Rated current I_N	A	330	410	465	575	735	810
• Base-load current I_L ²⁾	A	320	400	452	560	710	790
• Base-load current I_H ³⁾	A	280	367	416	514	657	724
Input current							
• Rated input current ⁴⁾	A	343	426	483	598	764	842
• Input current, max.	A	525	655	740	918	1164	1295
• Current requirement, 24 V DC auxiliary power supply ⁵⁾	A	1.35	1.4	1.4	1.4	1.5	1.5
Rated short-circuit current according to IEC ⁶⁾	kA	65	65	84	84	85	85
Minimum short-circuit current ⁷⁾	A	5200	5200	6200	8400	10500	10400/2000 ⁸⁾
Power loss, max. ⁹⁾ at 50 Hz 690 V	kW	6.1	8.1	9.1	10.8	13.5	14.7
Cooling air requirement	m ³ /s (ft ³ /s)	0.36 (12.7)	0.78 (27.5)	0.78 (27.5)	0.78 (27.5)	1.48 (52.3)	1.48 (52.3)
Sound pressure level L_{pA} (1 m) at 50/60 Hz	dB	67/73	72/75	72/75	72/75	72/75	72/75
Cable lengths between converter and motor ¹⁰⁾							
• Shielded	m (ft)	300 (984)	300 (984)	300 (984)	300 (984)	300 (984)	300 (984)
• Unshielded	m (ft)	450 (1476)	450 (1476)	450 (1476)	450 (1476)	450 (1476)	450 (1476)
Dimensions							
• Width for version A/C	mm (in)	800/400 (31.50/15.75)	1200/600 (47.24/23.62)	1200/600 (47.24/23.62)	1200/600 (47.24/23.62)	1600/1000 (62.99/39.37)	1600/1000 (62.99/39.37)
• Height ¹¹⁾	mm (in)	2000 (78.74)	2000 (78.74)	2000 (78.74)	2000 (78.74)	2000 (78.74)	2000 (78.74)
• Depth	mm (in)	600 (23.62)	600 (23.62)	600 (23.62)	600 (23.62)	600 (23.62)	600 (23.62)
Weight, approx. (degree of protection IP20, without options) for version A/C	kg (lb)	670/300 (1477/661)	780/670 (1720/1477)	780/670 (1720/1477)	840/670 (1852/1477)	1320/940 (2910/2072)	1360/980 (2998/2161)

Note: The power data in hp units is based on the NEC/CEC standards for the North American market.

For information on the line connection, motor connection and cabinet grounding, see Section Configuration.

¹⁾ Rated output of a typical 6-pole standard induction motor based on I_L or I_H for 3 AC 50 Hz 690 V.

²⁾ The base-load current I_L is based on a load cycle of 110% for 60 s or 150% for 10 s with a load cycle duration of 300 s. See [Characteristic curves](#), [Section Overload capability](#).

³⁾ The base-load current I_H is based on a duty cycle of 150% for 60 s or 160% for 10 s with a duty cycle duration of 300 s. See [Characteristic curves](#), [Section Overload capability](#).

⁴⁾ The currents listed here are based on the rated output current.

⁵⁾ If the drive control is to remain active after a main infeed failure, the converter must be externally supplied with 24 V DC.

The following must also be taken into account:

- CU320-2: 1 A
- TM31: 0.5 A
- AOP30: 0.2 A
- SMC: 0.6 A
- Current requirement of digital inputs/outputs.

⁶⁾ In conjunction with the specified fuses or circuit breakers.

⁷⁾ Minimum current required for reliably triggering the protective devices.

⁸⁾ For option **L26** (version A) the low value applies.

⁹⁾ The specified power losses are the maximum values for a utilization of 100%. The values are lower under normal operating conditions.

¹⁰⁾ Longer cable lengths for specific configurations are available on request.

¹¹⁾ Version A: The cabinet height increases by
– 250 mm (9.84 in) for degree of protection IP21
– 400 mm (15.75 in) for degrees of protection IP23, IP43 and IP54
– 405 mm (15.94 in) for options **M13** and **M78**
Version C: The cabinet height increases by
– 250 mm (9.84 in) for degree of protection IP21
– 400 mm (15.75 in) for degrees of protection IP23, IP43 and IP54

Technical specifications

Technical specifications for parallel connection

Parallel connection	SINAMICS G150 converter cabinet units, version A 6SL3710-2GE...-....			SINAMICS G150 converter cabinet units, version A 6SL3710-2GF...-....			
	41-1AA3	41-4AA3	41-6AA3	38-6AA3	41-1AA3	41-4AA3	
Line voltage	380 ... 480 V 3 AC			500 ... 600 V 3 AC			
Type rating							
• For $I_L^{(1)}$	kW	630	710	900	630	710	1000
• For $I_H^{(1)}$	kW	500	560	710	560	630	800
• For I_L at 60 Hz 460 V or 575 V ⁽²⁾	hp	900	1000	1250	900	1000	1250
• For I_H at 60 Hz 460 V or 575 V ⁽²⁾	hp	700	900	1000	800	900	1000
Output current							
• Rated current $I_N^{(3)}$	A	1120	1380	1560	860	1070	1360
• Base-load current $I_L^{(3)(4)}$	A	1092	1340	1516	836	1036	1314
• Base-load current $I_H^{(3)(5)}$	A	850	1054	1294	770	950	1216
Input current							
• Rated input current ⁽³⁾⁽⁶⁾	A	1174	1444	1624	904	1116	1424
• Input current, max.	A	1800	2215	2495	1388	1708	2186
• Current requirement, 24 V DC auxiliary power supply ⁽⁷⁾	A	2.8	2.8	3	2.8	2.8	3
Rated short-circuit current according to IEC ⁽⁸⁾	kA	2 × 65	2 × 65	2 × 65	2 × 65	2 × 65	2 × 84
Minimum short-circuit current⁽⁹⁾	A	2 × 1000	2 × 10500	2 × 1800	2 × 6200	2 × 8400	2 × 10500
Power loss, max.⁽¹⁰⁾							
• At 50 Hz 400 V / 500 V	kW	16.2	19	19.9	15.4	17.2	23.8
• At 60 Hz 460 V / 575 V	kW	16.6	19.4	20.4	15	16.8	25
Cooling air requirement	m ³ /s (ft ³ /s)	1.56 (55.1)	1.56 (55.1)	1.56 (55.1)	1.56 (55.1)	1.56 (55.1)	2.96 (105)
Sound pressure level L_{pA} (1 m) at 50/60 Hz	dB	73/76	73/76	73/76	75/78	75/78	75/78
Cable lengths between converter and motor ⁽¹¹⁾							
• Shielded	m (ft)	300 (984)	300 (984)	300 (984)	300 (984)	300 (984)	300 (984)
• Unshielded	m (ft)	450 (1476)	450 (1476)	450 (1476)	450 (1476)	450 (1476)	450 (1476)
Dimensions							
• Width ⁽¹²⁾	mm (in)	2400 (94.49)	2400 (94.49)	2400 (94.49)	2400 (94.49)	2400 (94.49)	3200 (125.98)
• Height ⁽¹³⁾	mm (in)	2000 (78.74)	2000 (78.74)	2000 (78.74)	2000 (78.74)	2000 (78.74)	2000 (78.74)
• Depth	mm (in)	600 (23.62)	600 (23.62)	600 (23.62)	600 (23.62)	600 (23.62)	600 (23.62)
Weight, approx. (degree of protection IP20, without options)	kg (lb)	1700 (3748)	1710 (3770)	2130 (4696)	1700 (3748)	1700 (3748)	2620 (5776)

Note: The power data in hp units is based on the NEC/CEC standards for the North American market.

For information on the line connection, motor connection and cabinet grounding, see Section Configuration.

¹⁾ Rated output of a typical 6-pole standard induction motor based on I_L or I_H at 3 AC 50 Hz 400 V, 500 V or 690 V.

²⁾ Rated output of a typical 6-pole standard induction motor based on I_L or I_H at 3 AC 60 Hz 460 V or 575 V.

³⁾ The currents specified here are the total current of both converter sections.

⁴⁾ The base-load current I_L is based on a load cycle of 110% for 60 s or 150% for 10 s with a load cycle duration of 300 s. See [Characteristic curves](#), [Section Overload capability](#).

⁵⁾ The base-load current I_H is based on a duty cycle of 150% for 60 s or 160% for 10 s with a duty cycle duration of 300 s. See [Characteristic curves](#), [Section Overload capability](#).

⁶⁾ The currents listed here are based on the rated output current.

⁷⁾ If the drive control is to remain active after a main infeed failure, the converter must be externally supplied with 24 V DC.

The following must also be taken into account:

– CU320-2: 1 A

– TM31: 0.5 A

– AOP30: 0.2 A

– SMC: 0.6 A

– Current requirement of digital inputs/outputs.

⁸⁾ In conjunction with the specified fuses or circuit breakers.

⁹⁾ Minimum current required for reliably triggering the protective devices.

¹⁰⁾ The specified power losses are the maximum values for a utilization of 100%. The values are lower under normal operating conditions.

¹¹⁾ Longer cable lengths for specific configurations are available on request.

¹²⁾ The power units connected in parallel are supplied as two transport units.

¹³⁾ The cabinet height increases by
– 250 mm (9.84 in) for degree of protection IP21
– 400 mm (15.75 in) for degrees of protection IP23, IP43 and IP54
– 405 mm (15.94 in) for options **M13** and **M78**

SINAMICS G150

Converter cabinet units

75 kW to 2700 kW

Technical specifications

		SINAMICS G150 converter cabinet units, version A 6SL3710-2GH...-....							
Parallel connection		41-1AA3	41-4AA3	41-5AA3	41-8EA3	42-0EA3	42-2EA3	42-4E A3	42-7E A3
Line voltage		660 ... 690 V 3 AC							
Type rating									
• For I_L ¹⁾	kW	1000	1350	1500	1750	1950	2150	2400	2700
• For I_H ¹⁾	kW	900	1200	1350	1500	1750	1950	2150	2400
• For I_L at 60 Hz 460 V or 575 V ²⁾	hp	–	–	–	–	–	–	–	–
• For I_H at 60 Hz 460 V or 575 V ²⁾	hp	–	–	–	–	–	–	–	–
Output current									
• Rated current I_N ³⁾	A	1070	1360	1500	1729	1948	2158	2413	2752
• Base-load current I_L ³⁾⁴⁾	A	1036	1314	1462	1720	1940	2150	2390	2685
• Base-load current I_H ³⁾⁵⁾	A	950	1216	1340	1547	1742	1930	2158	2463
Input current									
• Rated input current ³⁾⁶⁾	A	1116	1424	1568	1800	2030	2245	2510	2865
• Input current, max.	A	1708	2186	2406	2765	3115	3450	3860	4400
• Current requirement, 24 V DC auxiliary power supply ⁷⁾	A	2.8	2.8	3	4.7	4.7	4.7	4.7	6
Rated short-circuit current according to IEC ⁸⁾	kA	2 × 65	2 × 84	2 × 84	2 × 85	2 × 85	2 × 85	2 × 85	2 × 85
Minimum short-circuit current⁹⁾	A	2 × 8400	2 × 10500	2 × 1800	2 × 1800	2 × 2000	2 × 2300	2 × 2500	2 × 3000
Power loss, max.¹⁰⁾ at 50 Hz 690 V	kW	21.3	26.6	29	35	38	40	46	52
Cooling air requirement	m ³ /s (ft ³ /s)	1.56 (55.1)	2.96 (105)	2.96 (105)	3.67 (130)	3.67 (130)	3.67 (130)	3.67 (130)	5.15 (182)
Sound pressure level L_{pA} (1 m) at 50/60 Hz	dB	75/78	75/78	75/78	75/78	75/78	75/78	75/78	75/78
Cable lengths between converter and motor ¹¹⁾									
• Shielded	m (ft)	300 (984)	300 (984)	300 (984)	300 (984)	300 (984)	300 (984)	300 (984)	300 (984)
• Unshielded	m (ft)	450 (1476)	450 (1476)	450 (1476)	450 (1476)	450 (1476)	450 (1476)	450 (1476)	450 (1476)
Dimensions									
• Width ¹²⁾	mm (in)	2400 (94.49)	3200 (125.98)	3200 (125.98)	3600 (141.73)	3600 (141.73)	3600 (141.73)	3600 (141.73)	4400 (173.23)
• Height ¹³⁾	mm (in)	2000 (78.74)	2000 (78.74)	2000 (78.74)	2000 (78.74)	2000 (78.74)	2000 (78.74)	2000 (78.74)	2000 (78.74)
• Depth	mm (in)	600 (23.62)	600 (23.62)	600 (23.62)	600 (23.62)	600 (23.62)	600 (23.62)	600 (23.62)	600 (23.62)
Weight, approx. (degree of protection IP20, without options)	kg (lb)	1700 (3748)	2620 (5776)	2700 (5952)	3010 (6636)	3010 (6636)	3070 (6768)	3860 (8510)	4580 (10097)

Note: The power data in hp units is based on the NEC/CEC standards for the North American market.

For information on the line connection, motor connection and cabinet grounding, see Section Configuration.

¹⁾ Rated output of a typical 6-pole standard induction motor based on I_L or I_H at 3 AC 50 Hz 400 V, 500 V or 690 V.

²⁾ Rated output of a typical 6-pole standard induction motor based on I_L or I_H at 3 AC 60 Hz 460 V or 575 V.

³⁾ The currents specified here are the total current of both converter sections.

⁴⁾ The base-load current I_L is based on a load cycle of 110% for 60 s or 150% for 10 s with a load cycle duration of 300 s. See [Characteristic curves](#), [Section Overload capability](#).

⁵⁾ The base-load current I_H is based on a duty cycle of 150% for 60 s or 160% for 10 s with a duty cycle duration of 300 s. See [Characteristic curves](#), [Section Overload capability](#).

⁶⁾ The currents listed here are based on the rated output current.

⁷⁾ If the drive control is to remain active after a main infeed failure, the converter must be externally supplied with 24 V DC.

The following must also be taken into account:

- CU320-2: 1 A
- TM31: 0.5 A
- AOP30: 0.2 A
- SMC: 0.6 A
- Current requirement of digital inputs/outputs.

⁸⁾ In conjunction with the specified fuses or circuit breakers.

⁹⁾ Minimum current required for reliably triggering the protective devices.

¹⁰⁾ The specified power losses are the maximum values for a utilization of 100%. The values are lower under normal operating conditions.

¹¹⁾ Longer cable lengths for specific configurations are available on request.

¹²⁾ The power units connected in parallel are supplied as two transport units.

¹³⁾ The cabinet height increases by
 – 250 mm (9.84 in) for degree of protection IP21
 – 400 mm (15.75 in) for degrees of protection IP23, IP43 and IP54
 – 405 mm (15.94 in) for options **M13** and **M78**

Characteristic curves

Derating data

SINAMICS G150 converter cabinet units and the associated system components are rated for an ambient temperature of 40 °C and installation altitudes up to 2000 m above sea level.

At ambient temperatures > 40 °C, the output current must be reduced. Ambient temperatures above 50 °C are not permissible.

At installation altitudes > 2000 m above sea level, it must be taken into account that the air pressure, and therefore air density, decreases as the height increases. As a consequence, the cooling efficiency and the insulation capacity of the air also decrease.

Due to the reduced cooling efficiency, it is necessary, on the one hand, to reduce the ambient temperature and on the other hand, to lower heat loss in the converter cabinet unit by reducing the output current, whereby ambient temperatures lower than 40 °C may be offset to compensate.

The following table lists the permissible output currents depending on the installation altitude and ambient temperature for the various degrees of protection. The specified values already include a permitted compensation in respect of installation altitude and ambient temperatures < 40 °C (temperature at the air intake of the converter cabinet unit).

The values apply under the precondition that it is guaranteed that the cooling air, as specified in the technical data, flows through the units as a result of the cabinet arrangement.

As additional measure for installation altitudes from 2000 m up to 5000 m, an isolating transformer is required in order to reduce transient overvoltages according to EN 60664-1.

For further information, please refer to the [SINAMICS Low Voltage Engineering Manual](#).

Current-derating factors for converter cabinet units depending on the ambient / air intake temperature, the installation altitude and the degree of protection

Degree of protection	Installation altitude above sea level m	Current derating factor (as a percentage of the rated current) for an ambient / air intake temperature of						
		20 °C	25 °C	30 °C	35 °C	40 °C	45 °C	50 °C
IP20, IP21, IP23 and IP43	0 ... 2000						93.3%	86.7%
	2001 ... 2500					96.3%		
	2501 ... 3000		100%		98.7%			
	3001 ... 3500							
	3501 ... 4000			96.3%				
	4001 ... 4500		97.5%					
IP54	4501 ... 5000	98.2%						
	0 ... 2000					93.3%	86.7%	80%
	2001 ... 2500		100%		96.3%	89.8%		
	2501 ... 3000				98.7%	92.5%		
	3001 ... 3500				94.7%			
	3501 ... 4000		96.3%	90.7%				
	4001 ... 4500	97.5%	92.1%					
4501 ... 5000	93%							

SINAMICS G150

Converter cabinet units

75 kW to 2700 kW**Characteristic curves**Current derating depending on the pulse frequency

To reduce motor noise or to increase output frequency, the pulse frequency can be increased relative to the factory setting (1.25 kHz or 2 kHz). When the pulse frequency is increased, the derating factor of the output current must be taken into account. This derating factor must be applied to the currents specified in the technical specifications.

For further information, please refer to the SINAMICS Low Voltage Engineering Manual.

Derating factor of the output current depending on the pulse frequency for devices with a rated pulse frequency of 2 kHz

SINAMICS G150	Type rating	Output current at 2 kHz	Derating factor	
			for pulse frequency 2.5 kHz	4 kHz
6SL3710-...	kW	A		
380 ... 480 V 3 AC				
1GE32-1 . A3	110	210	95%	82%
1GE32-6 . A3	132	260	95%	83%
1GE33-1 . A3	160	310	97%	88%
1GE33-8 . A3	200	380	96%	87%
1GE35-0 . A3	250	490	94%	78%

Derating factor of the output current depending on the pulse frequency for devices with a rated pulse frequency of 1.25 kHz

SINAMICS G150	Type rating	Output current at 1.25 kHz	Derating factor		
			for pulse frequency 2 kHz	2.5 kHz	4 kHz
6SL3710-...	kW	A			
380 ... 480 V 3 AC					
1GE36-1 . A3	315	605	83%	72%	64%
1GE37-5 . A3	400	745	83%	72%	64%
1GE38-4 . A3	450	840	87%	79%	64%
1GE41-0 . A3	560	985	92%	87%	70%
2GE41-1AA3	630	1120	83%	72%	64%
2GE41-4AA3	710	1380	83%	72%	64%
2GE41-6AA3	900	1560	87%	79%	64%
500 ... 600 V 3 AC					
1GF31-8 . A3	110	175	92%	87%	70%
1GF32-2 . A3	132	215	92%	87%	70%
1GF32-6 . A3	160	260	92%	88%	71%
1GF33-3 . A3	200	330	89%	82%	65%
1GF34-1 . A3	250	410	89%	82%	65%
1GF34-7 . A3	315	465	92%	87%	67%
1GF35-8 . A3	400	575	91%	85%	64%
1GF37-4 . A3	500	735	87%	79%	64%
1GF38-1 . A3	560	810	83%	72%	61%
2GF38-6AA3	630	860	92%	87%	67%
2GF41-1AA3	710	1070	91%	85%	64%
2GF41-4AA3	1000	1360	87%	79%	64%

Characteristic curves

SINAMICS G150 6SL3710-...	Type rating kW	Output current at 1.25 kHz A	Derating factor for pulse frequency		
			2 kHz	2.5 kHz	4 kHz
660 ... 690 V 3 AC					
1GH28-5 . A3	75	85	93%	89%	71%
1GH31-0 . A3	90	100	92%	88%	71%
1GH31-2 . A3	110	120	92%	88%	71%
1GH31-5 . A3	132	150	90%	84%	66%
1GH31-8 . A3	160	175	92%	87%	70%
1GH32-2 . A3	200	215	92%	87%	70%
1GH32-6 . A3	250	260	92%	88%	71%
1GH33-3 . A3	315	330	89%	82%	65%
1GH34-1 . A3	400	410	89%	82%	65%
1GH34-7 . A3	450	465	92%	87%	67%
1GH35-8 . A3	560	575	91%	85%	64%
1GH37-4 . A3	710	735	87%	79%	64%
1GH38-1 . A3	800	810	83%	72%	61%
2GH41-1AA3	1000	1070	91%	85%	64%
2GH41-4AA3	1350	1360	87%	79%	64%
2GH41-5AA3	1500	1500	83%	72%	61%
2GH41-8EA3	1750	1729	92%	87%	67%
2GH42-0EA3	1950	1948	91%	86%	64%
2GH42-2EA3	2150	2158	87%	79%	55%
2GH42-4EA3	2400	2413	87%	79%	55%
2GH42-7EA3	2700	2752	91%	86%	64%

SINAMICS G150

Converter cabinet units

75 kW to 2700 kW

Characteristic curves

Overload capability

The SINAMICS G150 converter cabinet units have an overload reserve in order to overcome breakaway torques, for example. If larger surge loads occur, this must be taken into account in the configuration. For drives with overload requirements, the appropriate base load current must, therefore, be used as a basis for the required load.

The criterion for overload is that the drive is operated with its base load current before and after the overload occurs on the basis of a duty cycle duration of 300 s.

The base load current for a low overload I_L is based on a duty cycle of 110% for 60 s or 150% for 10 s.

The base load current for a high overload I_H is based on a duty cycle of 150% for 60 s or 160% for 10 s.

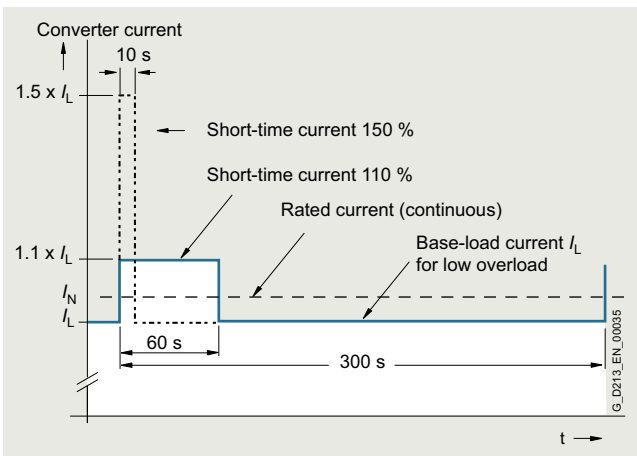

Low overload

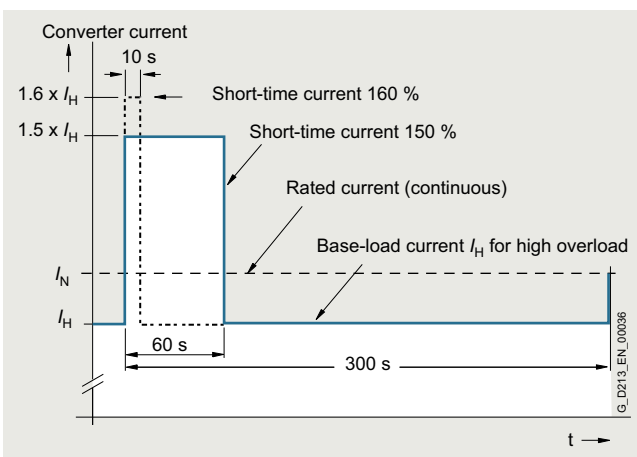

High overload

Configuration

Cable cross-sections and connections

The following tables list the recommended and maximum possible cable connections at the line and motor ends for a single connection (versions A and C) and a parallel connection (version A).

The recommended cross-sections are based on the specified fuses. They are valid for a three-conductor copper cable routed horizontally in air with PVC insulation and a permissible

conductor temperature of 70 °C (e.g. Protodur NYY or NYCWY) at an ambient temperature of 40 °C and individual routing.

For deviating conditions (cable routing, cable accumulation, ambient temperature), the appropriate correction factors according to IEC 60364-5-52 must be taken into account.

For further information, please refer to the [SINAMICS Low Voltage Engineering Manual](#).

Single connection

Type rating	Converter cabinet unit	Line connection			Motor connection			Cabinet grounding	
		Recommended cross-section ¹⁾	Maximum cable cross-section	Fixing screws	Recommended cross-section ¹⁾	Maximum cable cross-section	Fixing screws	Fixing screws	Remark
kW	SINAMICS G150, versions A and C 6SL3710-...	IEC mm ²	IEC mm ²		IEC mm ²	IEC mm ²			
380 ... 480 V 3 AC									
110	1GE32-1 . A3	2 × 70	4 × 240	M12	2 × 50	2 × 150	M12	M12	
132	1GE32-6 . A3	2 × 95	4 × 240	M12	2 × 70	2 × 150	M12	M12	
160	1GE33-1 . A3	2 × 120	4 × 240	M12	2 × 95	2 × 150	M12	M12	
200	1GE33-8 . A3	2 × 120	4 × 240	M12	2 × 95	2 × 150	M12	M12	
250	1GE35-0 . A3	2 × 185	4 × 240	M12	2 × 150	2 × 240	M12	M12	
315	1GE36-1 . A3	2 × 240	4 × 240	M12	2 × 185	4 × 240	M12	M12	
400	1GE37-5 . A3	3 × 185	4 × 240	M12	2 × 240	4 × 240	M12	M12	Cu busbar
450	1GE38-4 . A3	4 × 150	8 × 240	M12	3 × 185	4 × 240	M12	M12	Cu busbar
560	1GE41-0 . A3	4 × 185	8 × 240	M12	4 × 185	6 × 240	M12	M12	Cu busbar
500 ... 600 V 3 AC									
110	1GF31-8 . A3	120	4 × 240	M12	95	2 × 150	M12	M12	
132	1GF32-2 . A3	2 × 70	4 × 240	M12	120	2 × 150	M12	M12	
160	1GF32-6 . A3	2 × 95	4 × 240	M12	2 × 70	2 × 185	M12	M12	
200	1GF33-3 . A3	2 × 120	4 × 240	M12	2 × 95	2 × 240	M12	M12	
250	1GF34-1 . A3	2 × 185	4 × 240	M12	2 × 120	4 × 240	M12	M12	
315	1GF34-7 . A3	2 × 185	4 × 240	M12	2 × 150	4 × 240	M12	M12	
400	1GF35-8 . A3	2 × 240	4 × 240	M12	2 × 185	4 × 240	M12	M12	
500	1GF37-4 . A3	3 × 185	8 × 240	M12	2 × 240	6 × 240	M12	M12	Cu busbar
560	1GF38-1 . A3	4 × 150	8 × 240	M12	3 × 185	6 × 240	M12	M12	Cu busbar
660 ... 690 V 3 AC									
75	1GH28-5 . A3	50	4 × 240	M12	35	2 × 70	M12	M12	
90	1GH31-0 . A3	50	4 × 240	M12	50	2 × 150	M12	M12	
110	1GH31-2 . A3	70	4 × 240	M12	70	2 × 150	M12	M12	
132	1GH31-5 . A3	95	4 × 240	M12	70	2 × 150	M12	M12	
160	1GH31-8 . A3	120	4 × 240	M12	95	2 × 150	M12	M12	
200	1GH32-2 . A3	2 × 70	4 × 240	M12	120	2 × 150	M12	M12	
250	1GH32-6 . A3	2 × 95	4 × 240	M12	2 × 70	2 × 185	M12	M12	
315	1GH33-3 . A3	2 × 120	4 × 240	M12	2 × 95	2 × 240	M12	M12	
400	1GH34-1 . A3	2 × 185	4 × 240	M12	2 × 120	4 × 240	M12	M12	
450	1GH34-7 . A3	2 × 185	4 × 240	M12	2 × 150	4 × 240	M12	M12	
560	1GH35-8 . A3	2 × 240	4 × 240	M12	2 × 185	4 × 240	M12	M12	
710	1GH37-4 . A3	3 × 185	8 × 240	M12	3 × 150	6 × 240	M12	M12	Cu busbar
800	1GH38-1 . A3	4 × 150	8 × 240	M12	3 × 185	6 × 240	M12	M12	Cu busbar

¹⁾ The recommendations for the North American market in AWG or MCM must be taken from the appropriate NEC (National Electrical Code) and CEC (Canadian Electrical Code) standards.

SINAMICS G150

Converter cabinet units

75 kW to 2700 kW**Configuration**

Parallel connection

Type rating	Converter cabinet unit	Line connection			Motor connection			Cabinet grounding	
		Recom- mended cross- section ¹⁾	Maximum cable cross- section	Fixing screws	Recom- mended cross- section ¹⁾	Maximum cable cross- section	Fixing screws	Fixing screws	Remark
kW	SINAMICS G150, version A 6SL3710-...	IEC mm ²	IEC mm ²		IEC mm ²	IEC mm ²			
380 ... 480 V 3 AC									
630	2GE41-1AA3	2 × 240	4 × 240	M12	2 × 185	4 × 240	M12	M12	
710	2GE41-4AA3	3 × 185	4 × 240	M12	2 × 240	4 × 240	M12	M12	Cu busbar
900	2GE41-6AA3	4 × 150	8 × 240	M12	2 × 240	4 × 240	M12	M12	Cu busbar
500 ... 600 V 3 AC									
630	2GF38-6AA3	2 × 185	4 × 240	M12	2 × 150	4 × 240	M12	M12	
710	2GF41-1AA3	2 × 240	4 × 240	M12	2 × 185	4 × 240	M12	M12	
1000	2GF41-4AA3	3 × 185	8 × 240	M12	2 × 240	6 × 240	M12	M12	Cu busbar
660 ... 690 V 3 AC									
1000	2GH41-1AA3	2 × 240	4 × 240	M12	2 × 185	4 × 240	M12	M12	
1350	2GH41-4AA3	3 × 185	8 × 240	M12	3 × 150	6 × 240	M12	M12	Cu busbar
1500	2GH41-5AA3	4 × 150	8 × 240	M12	3 × 185	6 × 240	M12	M12	Cu busbar
1750	2GH41-8EA3	4 × 150	8 × 240	M12	3 × 185	6 × 240	M12	M12	Cu busbar
1950	2GH42-0EA3	4 × 150	8 × 240	M12	3 × 185	6 × 240	M12	M12	Cu busbar
2150	2GH42-2EA3	4 × 150	8 × 240	M12	3 × 185	6 × 240	M12	M12	Cu busbar
2400	2GH42-4EA3	4 × 150	8 × 240	M12	3 × 185	6 × 240	M12	M12	Cu busbar
2700 ²⁾	2GH42-7EA3	4 × 150	8 × 240	M12	3 × 185	6 × 240	M12	M12	Cu busbar

Note:

The recommended and maximum conductor cross-sections refer to one of the two converter sections in the parallel connection.

Minimum motor cable lengths for operation with power units connected in parallel

When using power units connected in parallel, the following motor cable lengths must be observed if a motor is connected with only one winding system and no motor-side reactors or filters are used:

Type rating	SINAMICS G150 converter cabinet unit version A	Minimum cable length
kW		m
380 ... 480 V 3 AC		
630	6SL3710-2GE41-1AA3	13
710	6SL3710-2GE41-4AA3	10
900	6SL3710-2GE41-6AA3	9
500 ... 600 V 3 AC		
630	6SL3710-2GF38-6AA3	18
710	6SL3710-2GF41-1AA3	15
1000	6SL3710-2GF41-4AA3	13
660 ... 690 V 3 AC		
1000	6SL3710-2GH41-1AA3	20
1350	6SL3710-2GH41-4AA3	18
1500	6SL3710-2GH41-5AA3	15
1750	6SL3710-2GH41-8EA3	12
1950	6SL3710-2GH42-0EA3	10
2150	6SL3710-2GH42-2EA3	8
2400	6SL3710-2GH42-4EA3	8
2700	6SL3710-2GH42-7EA3	8

¹⁾ The recommendations for the North American market in AWG or MCM must be taken from the appropriate NEC (National Electrical Code) and CEC (Canadian Electrical Code) standards.

²⁾ The motor-side inverter comprises three Motor Modules connected in parallel.

Configuration

Cable cross-sections for line and motor connection

It is generally recommended to use shielded 3-conductor three-phase cables between the converter and motor – and for higher power ratings, symmetrical cables where possible. If required, several of these cables can be connected in parallel. There are two main reasons for this:

- Only then can the high IP55 degree of protection at the motor terminal box be easily achieved. The reason for this is that cables are routed into the terminal box through glands, and the number of possible glands is restricted by the terminal box geometry. Therefore single cables are less suitable.
- With symmetrical, 3-conductor, three-phase cables, the summed ampere-turns over the cable outer diameter are equal to zero and they can be routed in conductive, metal cable ducts or racks without any significant currents (ground current or leakage current) being induced in these conductive, metal connections. The danger of induced leakage currents and thus of increased cable sheath losses is significantly higher with single-conductor cables.

The cable cross-section required depends on the current being conducted in the cable. The permissible current load capability of cables is defined, for example in IEC 60364-5-52. It depends partly on the ambient conditions such as temperature, but also on the routing method. It should be taken into account whether cables are individually routed with relatively good cooling, or whether several cables are routed together; in this case, cable ventilation is significantly poorer, which can therefore result in higher cable temperatures. Regarding this topic, reference is made to the corresponding correction factors for these secondary conditions in IEC 60364-5-52.

For 3-conductor copper and aluminum cables with PVC insulation and a permissible conductor temperature of 70 °C (158 °F) (e.g. Protodur NYY or NYCWY), as well as an ambient temperature of 40 °C (104 °F), the cross-sections can be determined from the following table, which is based on IEC 60364-5-52.

Current-carrying capacity according to IEC 60364-5-52 at 40 °C

Cross-section of 3-conductor cable mm ²	Copper cable		Aluminum cable	
	Individual routing	Several cables next to one another ¹⁾	Individual routing	Several cables next to one another ¹⁾
3 × 2.5	22	17	17	13
3 × 4	30	23	23	18
3 × 6	37	29	29	22
3 × 10	52	41	40	31
3 × 16	70	54	53	41
3 × 25	88	69	68	53
3 × 35	110	86	84	65
3 × 50	133	104	102	79
3 × 70	171	133	131	102
3 × 95	207	162	159	124
3 × 120	240	187	184	144
3 × 150	278	216	213	166
3 × 185	317	247	244	190
3 × 240	374	292	287	224

¹⁾ Maximum nine cables may be routed directly next to one another horizontally on a cable tray.

Cables must be connected in parallel for higher currents.

Note:

The recommendations for the North American market in AWG or MCM must be taken from the appropriate NEC (National Electrical Code) and CEC (Canadian Electrical Code) standards.

Grounding and protective conductor cross-section

The protective conductor must be dimensioned taking into account the following data:

- In the case of a ground fault, no impermissibly high contact voltages resulting from voltage drops on the PE conductor caused by the ground fault current may occur (< 50 V AC or < 120 V DC, IEC 61800-5-1, IEC 60364, IEC 60543).
- The protective conductor must not be excessively loaded by any ground fault current it carries.
- If it is possible for continuous currents to flow through the PE conductor when a fault occurs, the PE conductor cross-section must be dimensioned for this continuous current.
- The protective conductor cross-section must be selected according to EN 60204-1, EN 60439-1, IEC 60364.

Cross-section, line conductor mm ²	Minimum cross-section, external protective conductor mm ²
Up to 16	Minimum cross-section of line conductor
16 ... 35	16
As of 35	Minimum half the cross-section of line conductor

Note:

The recommendations for the North American market in AWG or MCM must be taken from the appropriate NEC (National Electrical Code) and CEC (Canadian Electrical Code) standards.

- Switchgear and motors are usually grounded separately via a local grounding electrode. With this constellation, the ground fault current flows via the parallel ground connections and is divided. In spite of the relatively low protective conductor cross-sections used in accordance with the table above, no inadmissible touch voltages occur with this grounding system. However, from experience gained with different grounding constellations, we recommend that the ground cable from the motor returns directly to the converter. For EMC reasons and to prevent bearing currents, symmetrical 3-conductor, three-phase cables should be used where possible instead of 4-conductor cables, especially on drives in the higher power range. For 3-conductor cables, the protective or PE conductor must be routed separately or arranged symmetrically in the motor cable. The symmetry of the PE conductor is achieved using a conductor surrounding all phase conductors or using a cable with a symmetrical arrangement of the three phase conductors and three ground conductors. [For more detailed information on this topic, please refer to the SINAMICS Low Voltage Engineering Manual.](#)
- Through their high-speed control, the converters limit the load current (motor and ground fault currents) to an rms value corresponding to the rated current. Based on this, we recommend that the cross-section of the protective conductor to ground the cabinets be the same as for the line conductor.

SINAMICS G150

Converter cabinet units

Line-side power components > Recommended fuses

Selection and ordering data

The fuses specified below are the recommended types for protecting the unit on the low-voltage distribution panel. If option **L26** (main switch or circuit breaker) has been selected, the converter already has integrated semiconductor protection. In this case, a fuse of type 3NA can be used on the distribution panel.

If option **L26** has not been selected, we strongly advise that type 3NE fuses are used ¹⁾.

Further information on the fuses is provided in Catalog LV 10.

Single connection

Type rating		SINAMICS G150 converter cabinet units	Fuse with existing fuse switch disconnecter (option L26)			Fuse (incl. semiconductor protection) without fuse switch disconnecter		
at 50 Hz, 400 V, 500 V or 690 V	at 60 Hz, 460 V or 575 V		Rated current	Frame size acc. to IEC 60269-2	Article No.	Rated current	Frame size acc. to IEC 60269-2	Article No.
kW	hp	Versions A and C 6SL3710-...	A		A			
380 ... 480 V 3 AC								
110	150	1GE32-1 . A3	3NA3144	250	2	3NE1230-2	315	1
132	200	1GE32-6 . A3	3NA3250	300	2	3NE1331-2	350	2
160	250	1GE33-1 . A3	3NA3254	355	3	3NE1334-2	500	2
200	300	1GE33-8 . A3	3NA3260	400	3	3NE1334-2	500	2
250	400	1GE35-0 . A3	3NA3372	630	3	3NE1436-2	630	3
315	500	1GE36-1 . A3	3NA3475	800	4	3NE1438-2	800	3
400	600	1GE37-5 . A3	3NA3475	800	4	3NE1448-2	850	3
450	600	1GE38-4 . A3	3NA3365	2 × 500	3	3NE1436-2	2 × 630	3
560	800	1GE41-0 . A3	3NA3472	2 × 630	3	3NE1437-2	2 × 710	3
500 ... 600 V 3 AC								
110	150	1GF31-8 . A3	3NA3244-6	250	2	3NE1227-2	250	1
132	200	1GF32-2 . A3	3NA3252-6	315	2	3NE1230-2	315	1
160	250	1GF32-6 . A3	3NA3354-6	355	3	3NE1331-2	350	2
200	300	1GF33-3 . A3	3NA3365-6	500	3	3NE1334-2	500	2
250	400	1GF34-1 . A3	3NA3365-6	500	3	3NE1334-2	500	2
315	450	1GF34-7 . A3	3NA3352-6	2 × 315	3	3NE1435-2	560	3
400	500	1GF35-8 . A3	3NA3354-6	2 × 355	3	3NE1447-2	670	3
500	700	1GF37-4 . A3	3NA3365-6	2 × 500	3	3NE1448-2	850	3
560	800	1GF38-1 . A3	3NA3365-6	2 × 500	3	3NE1343-2	2 × 500	2
660 ... 690 V 3 AC								
75		1GH28-5 . A3	3NA3132-6	125	1	3NE1022-2	125	00
90		1GH31-0 . A3	3NA3132-6	125	1	3NE1022-2	125	00
110		1GH31-2 . A3	3NA3136-6	160	1	3NE1224-2	160	1
132		1GH31-5 . A3	3NA3240-6	200	2	3NE1225-2	200	1
160		1GH31-8 . A3	3NA3244-6	250	2	3NE1227-2	250	1
200		1GH32-2 . A3	3NA3252-6	315	2	3NE1230-2	315	1
250		1GH32-6 . A3	3NA3354-6	355	3	3NE1331-2	350	2
315		1GH33-3 . A3	3NA3365-6	500	3	3NE1334-2	500	2
400		1GH34-1 . A3	3NA3365-6	500	3	3NE1334-2	500	2
450		1GH34-7 . A3	3NA3352-6	2 × 315	3	3NE1435-2	560	3
560		1GH35-8 . A3	3NA3354-6	2 × 355	3	3NE1447-2	670	3
710		1GH37-4 . A3	3NA3365-6	2 × 500	3	3NE1448-2	850	3
800		1GH38-1 . A3	3NA3365-6	2 × 500	3	3NE1334-2	2 × 500	2

Note: The power data in hp units is based on the NEC/CEC standards for the North American market.

¹⁾ The double function fuses (3NE1) for cable and semiconductor protection are recommended to protect the converter. These fuses are specially adapted to the requirements of the semiconductors in the input rectifier

- Superfast
- Adapted to the limit current integral of the semiconductor
- Lower arc voltage
- Improved current limiting

²⁾ The specified 3NA3 fuses can be used for the additional cable protection.

³⁾ Only 3NE1... fuses should be used to protect the devices. These must be located as close as possible to the converter.

Selection and ordering data

Parallel connection (data for each converter subsystem)

Type rating		SINAMICS G150 converter cabinet units	Fuse with existing fuse switch disconnecter (option L26) ¹⁾			Fuse (incl. semiconductor protection) without fuse switch disconnecter ²⁾		
at 50 Hz, 400 V, 500 V or 690 V	at 60 Hz, 460 V or 575 V		Version A	Rated current	Frame size acc. to IEC 60269-2	Rated current	Frame size acc. to IEC 60269-2	
kW	hp	6SL3710-...	Article No.	A	Article No.	A		
380 ... 480 V 3 AC								
630	900	2GE41-1AA3	3NA3475	800	4	3NE1438-2	800 3	
710	1200	2GE41-4AA3	3NA3475	800	4	3NE1448-2	850 3	
900	1200	2GE41-6AA3	3NA3365	2 × 500	3	3NE1436-2	2 × 630 3	
500 ... 600 V 3 AC								
630	900	2GF38-6AA3	3NA3352-6	2 × 315	3	3NE1435-2	560 3	
710	1000	2GF41-1AA3	3NA3365-6	2 × 500	3	3NE1447-2	670 3	
1000	1600	2GF41-4AA3	3NA3365-6	2 × 500	3	3NE1448-2	850 3	
660 ... 690 V 3 AC								
1000		2GH41-1AA3	3NA3354-6	2 × 355	3	3NE1447-2	670 3	
1350		2GH41-4AA3	3NA3365-6	2 × 500	3	3NE1448-2	850 3	
1500		2GH41-5AA3	3NA3365-6	2 × 500	3	3NE1334-2	2 × 500 2	
1750		2GH41-8EA3	3NA3365-6	2 × 500	3	3NE1435-2	2 × 560 3	
1950		2GH42-0EA3	3NA3362-6	3 × 425	3	3NE1436-3	2 × 630 3	
2150		2GH42-2EA3	3NA3365-6	3 × 500	3	3NE1334-2	3 × 500 2	
2400		2GH42-4EA3	3NA3365-6	3 × 500	3	3NE1334-2	3 × 500 2	
2700		2GH42-7EA3	3NA3372	3 × 630	3	3NE1436-3	3 × 630 3	

Note: The power data in hp units is based on the NEC/CEC standards for the North American market.

¹⁾ The specified 3NA3... fuses can be used for the additional cable protection.

²⁾ Only 3NE1... fuses should be used to protect the devices. These must be located as close as possible to the converter.

SINAMICS G150

Notes

4

Tools and configuration



5/2	Siemens Product Configurator
5/3	SinaSave energy efficiency tool
5/4	SIZER for Siemens Drives engineering tool (integrated in the TIA Selection Tool)
5/5	STARTER commissioning tool
5/7	SINAMICS DCC (STARTER)
5/8	SINAMICS Startdrive commissioning tool
5/10	Drive ES engineering software
5/12	Configuration with EPLAN
5/14	Engineering Manual

Cybersecurity information

Siemens provides products and solutions with industrial cybersecurity functions that support the secure operation of plants, systems, machines and networks.

In order to protect plants, systems, machines and networks against cyber threats, it is necessary to implement – and continuously maintain – a holistic, state-of-the-art industrial cybersecurity concept. Siemens' products and solutions constitute one element of such a concept.

Customers are responsible for preventing unauthorized access to their plants, systems, machines and networks. Such systems, machines and components should only be connected to an enterprise network or the internet if and to the extent such a connection is necessary and only when appropriate security measures (e.g. firewalls and/or network segmentation) are in place.

For additional information on industrial cybersecurity measures that may be implemented, please visit

www.siemens.com/cybersecurity-industry

Siemens' products and solutions undergo continuous development to make them more secure. Siemens strongly recommends that product updates are applied as soon as they are available and that the latest product versions are used. Use of product versions that are no longer supported, and failure to apply the latest updates may increase customer's exposure to cyber threats.

To stay informed about product updates, subscribe to the Siemens Industrial Cybersecurity RSS Feed under

www.siemens.com/cert

Tools and configuration

Siemens Product Configurator

Overview

The Siemens Product Configurator helps you to configure the optimum drive technology products for a number of applications. The product portfolio comprises the full drive technology range of gearbox, motor, converter and connection system as well as corresponding controller with suitable software license. The intuitive user interface in conjunction with product-specific preliminary selectors makes it simple, fast and efficient to configure products. The result is a bill of materials with extensive documentation consisting of technical data sheets, motor characteristic curves, 2D dimensional drawings / 3D CAD models, EPLAN macros and much more. You can order the products directly by transferring the bill of materials to the shopping cart of SiePortal.



Siemens Product Configurator at a glance

- Quick and easy configuration of drive products and associated components – gearboxes, motors, converters, controllers, connection systems
- Extensive documentation for all products and components, such as
 - Data sheets in up to 12 languages
 - Motor characteristic curves
 - 2D dimensional drawings / 3D CAD models in different formats
 - Terminal box drawing and terminal connection diagram
 - Certificates
 - EPLAN macros
- Ability to order products directly through SiePortal

Access to the Siemens Product Configurator

The Siemens Product Configurator can be accessed without the need for registration or logging in:

www.siemens.com/spc

Overview

SinaSave determines the energy saving potential and payback time based on your application setup. SinaSave is a web tool which is intuitive to operate and supports you in an investment decision:

- Is it worthwhile to use more energy efficient systems?
- When will my investment pay off?

SinaSave supports you to find the optimum solution: technically, economically, and ecologically.

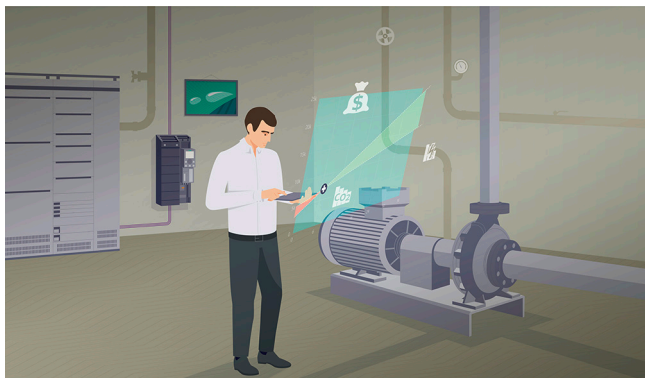

In which cases can SinaSave support you?

- Motors
 - Calculate your potential energy savings and amortization times with SIMOTICS motors
- Pump systems
 - Calculate your potential energy and CO2 savings with our pump drive systems
- Fan systems
 - Calculate your potential energy and CO2 savings with our fan drive systems

Access to the SinaSave energy efficiency tool

SinaSave can be accessed without the need for registration or logging in:

www.siemens.com/sinasave

Benefits

- **Transparency of overall savings potential and individual amortization plan**
 - SinaSave calculates the expected energy consumption and the resulting savings of energy, CO2 and energy cost, based on your individual energy prices, operating times and load profiles.
- **Support to find the optimum solution to make easy decision**
 - SinaSave directly compares your existing motors with SIMOTICS motors of various energy efficiency classes, for new systems and retrofits.
- **Ease of use and self-explanatory user guidance to calculate savings potential on overall system level**
 - SinaSave compares different drive system configurations for pump or fan applications. Regardless of greenfield or brownfield projects, SinaSave offers the flexibility to choose from different motor types and control modes, including variable speed drives and softstarters.
- **Well-structured SinaSave projects give you transparency of the savings potential of your entire facility**
 - SinaSave lets you combine several items in a single project. That means it's possible to reflect entire facilities and identify the savings potential they offer.

Function

- Determine savings potential for energy, power costs, and CO2
- Estimate expected amortization and Total Costs of Ownership (TCO)
- Output of system power losses for motor inverter systems as per IEC 61800-9-2
- Calculate possible financing, such as energy performance contracting (EnPC)
- Take government subsidies into account
- Simple design with intuitive usability
- Results presented in graphic form
- Save and load, share a handout e.g with your customer or decision-maker
- Eight languages, 14 currencies, IEC and NEMA standards
- Direct transfer to next processes, e.g. product configuration

More information

Further information about the amortization calculator for energy-efficient drive systems is available on the internet at:

www.siemens.com/tools-sinasave

Further information about services for energy saving is available on the internet at:

www.siemens.com/energy-saving

www.siemens.com/energy-efficiency

Tools and configuration

SIZER for Siemens Drives engineering tool (integrated in the TIA Selection Tool)

Overview

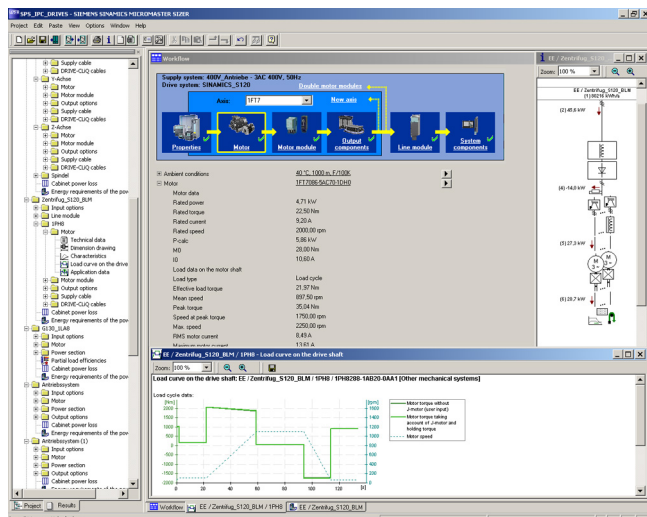

The following drives and controls can be engineered in a user-friendly way using the SIZER for Siemens Drives engineering tool:

- SIMOTICS low-voltage motors, including servo geared motors
- SIMOGEAR geared motors
- SINAMICS low-voltage drive systems
- Motor starters
- SINUMERIK CNC
- SIMOTION Motion Control controller
- SIMATIC controller

It provides support when selecting the technologies involved in the hardware and firmware components required for a drive task. SIZER for Siemens Drives covers the full range of operations required to configure a complete drive system, from basic single drives to demanding multi-axis applications.

SIZER for Siemens Drives supports all of the engineering steps in one workflow:

- Configuring the power supply
- Designing the motor and gearbox, including calculation of mechanical transmission elements
- Configuring the drive components
- Compiling the required accessories
- Selecting the line-side and motor-side power options, e.g. cables, filters, and reactors

When SIZER for Siemens Drives was being designed, particular importance was placed on a high degree of usability and a universal, function-based approach to the drive application. The extensive user guidance makes it easy to use the tool. Status information keeps you continually informed about the progress of the configuration process.

The drive configuration is saved in a project. In the project, the components and functions used are displayed in a hierarchical tree structure.

The project view permits the configuration of drive systems and the copying/inserting/modifying of drives already configured.

The configuration process produces the following results:

- A parts list of the required components (export to Excel, use of the Excel data sheet for import to SAP)
- Technical specifications of the system
- Characteristic curves
- Comments on line harmonic distortions
- Mounting arrangement of drive and control components and dimensional drawings of motors
- Energy requirements of the configured application

These results are displayed in a results tree and can be reused for documentation purposes.

Support is provided by the technological online help menu:

- Detailed technical specifications
- Information about the drive systems and their components
- Decision-making criteria for the selection of components
- Online help in English, French, German, Italian, Chinese and Japanese

System requirements

- PG or PC, with Pentium III min. 800 MHz (recommended > 1 GHz)
- 512 MB RAM (1 GB RAM recommended)
- At least 2 GB of free hard disk space
- An additional 100 MB of free hard disk space on Microsoft Windows system drive
- Screen resolution 1024 × 768 pixels
- Operating system:
 - Microsoft Windows 7 (32/64-bit) Professional, Enterprise, Ultimate, Home
 - Microsoft Windows 8.1 (32/64-bit) Professional, Enterprise, Ultimate, Home
 - Microsoft Windows 365
 - Microsoft Windows 10 (64-bit) Professional, Enterprise
- Microsoft Office 2003/2007/2010/2013/2016/365
- Microsoft Internet Explorer V8.0
- Microsoft .NET Framework 2.0
- OpenGL 2.1

More information

Drive dimensioning in the TIA Selection Tool

Application-specific requirements can be determined using drive technology dimensioning in the TIA Selection Tool. This can include motors, gearboxes and converters. The tool supports the configuration and dimensioning of control functions with an open and closed control loop. The technical documentation with features of the technical drive system, as well as a product list for ordering via SiePortal can also be compiled.

You can find more information on the SIZER for Siemens Drives engineering tool at

<https://support.industry.siemens.com/cs/ww/en/ps/13434/dl>

You can find more information about the TIA Selection Tool at: www.siemens.com/tia-selection-tool

Overview

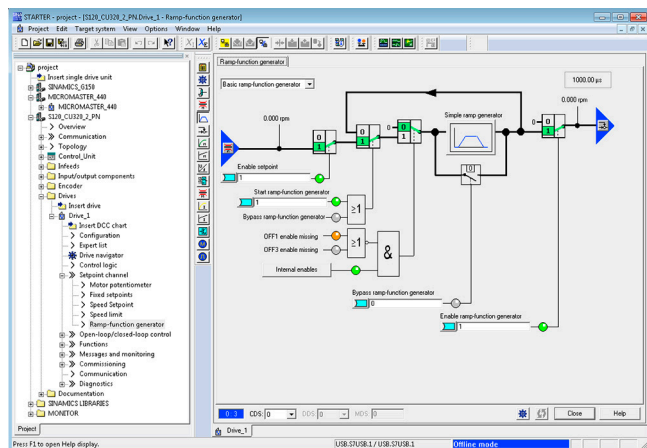

The user-friendly STARTER commissioning tool can be used for:

- Commissioning
- Optimization
- Diagnostics

This software can be operated as a standalone PC application, or integrated as a TIA-compatible program in SIMATIC STEP 7, or highly integrated into the SCOUT Engineering System (for SIMOTION). The basic functions and handling are the same in both cases.

In addition to the SINAMICS drives, STARTER also supports MICROMASTER 4 devices.

The project wizards can be used to create the drives within the structure of the project tree.

Beginners are supported by solution-based dialog guidance, whereby a standard graphics-based display maximizes clarity when setting the drive parameters.

First commissioning is guided by a wizard which makes all the basic settings in the drive. Therefore, getting a motor up and running is merely a question of setting a few of the drive parameters as part of the drive configuration process.

The individual settings required are made using graphics-based parameterization screens, which also precisely visualize the principle of operation of the drive.

Examples of individual settings that can be made include:

- Use of terminals
- Bus interface
- Setpoint channel (e.g. fixed setpoints)
- Closed-loop speed control (e.g. ramp-function generator, limits)
- BICO interconnections
- Diagnostics

For experts, the expert list can be used to specifically and quickly access individual parameters at any time. An individual compilation of frequently used parameters can be saved in dedicated user lists and watch tables.

In addition, the following functions are available for optimization purposes:

- Self-optimization of the controller settings (depending on drive unit)
- Setup and evaluation of trace recordings¹⁾
 - Tool function for recording 2 × 8 signals with
 - Measuring cursor function
 - Extensive trigger functions
 - Several Y scales
 - Sampling times in the current controller cycle clock

Diagnostics functions provide information about:

- Control/status words
- Parameter status
- Operating conditions
- Communication states

Performance features

- User-friendly: Only a small number of settings need to be made for successful first commissioning: The motor starts to rotate
- Solution-oriented dialog-based user guidance simplifies commissioning
- Self-optimization functions reduce manual effort for optimization.

System requirements

The following minimum requirements must be complied with:

- Hardware
 - PG or PC with Pentium III min. 1 GHz (recommended >1 GHz)
 - Work memory 2 GB (4 GB recommended)
 - Screen resolution 1024 × 768 pixels, 16-bit color depth
 - Free hard disk memory: min. 5 GB
- Software
 - Microsoft Internet Explorer V6.0 or higher
 - 64-bit operating systems:
 - Microsoft Windows Server 2019
 - Microsoft Windows Server 2022
 - Microsoft Windows 10 Pro
 - Microsoft Windows 10 Enterprise
 - Microsoft Windows 11 Pro
 - Microsoft Windows 11 Enterprise

Supported virtualization platforms

STARTER (V5.1 SP1 and higher) can be installed on a virtual machine. For this purpose, one of the following virtualization platforms in the specified version or a newer version can be used:

- VMware vSphere Hypervisor (ESXi) 6.7 Update 2
- VMware Workstation pro V16.2.4
- VMware Player V16.2.4
- Microsoft Windows Server 2019 Hyper-V

You can use the following guest operating systems to install STARTER within the selected virtualization platform:

- Microsoft Windows 10 Professional/Enterprise (64 bit)
- Microsoft Windows 11 Professional/Enterprise (64 bit)

¹⁾ Depending on drive unit. Not supported for MICROMASTER 4, SINAMICS G110, SINAMICS G120 <firmware V4.4, SINAMICS G110D and SINAMICS G120D <firmware V4.5.

Tools and configuration

STARTER commissioning tool

Integration

Data can be exchanged (depending on the version) via PROFIBUS or PROFINET/Ethernet or via a serial interface.

For commissioning and service, a PG/PC can be connected to the CU320-2 Control Unit via PROFIBUS. A PROFIBUS connection must be available with a connecting cable at the PG/PC.

Further, communication between a CU320-2 Control Unit and PG/PC can also be established via Ethernet, either via an (optional) CBE20 Communication Board or the Ethernet interface -X127 on the CU320-2 Control Unit.

Note:

The terminal strip -X127 is suitable as a communication link to the PG/PC only for the purposes of servicing and commissioning.

Selection and ordering data

Description	Article No.
STARTER commissioning tool	
Single license and certificate of license	
English, French, German, Italian, Spanish	
• On DVD-ROM	6SL3072-0AA00-0AG0
• Software download (email address required for delivery)	6SL3072-0AA00-0AK0

Note:

In addition to the STARTER commissioning tool, SINAMICS Drive Control Chart (SINAMICS DCC) can be installed. This allows the device functionality in the SINAMICS drive system to be expanded with dedicated technology functions as required.

Further information about SINAMICS DCC can be found in the section SINAMICS DCC (Drive Control Chart) with STARTER.

Accessories

Depending on the version of the Control Unit (CU), the Control Unit of the drive unit can communicate with the programming device (PG) or PC via PROFIBUS or PROFINET/Ethernet or via a serial interface. The following accessories are available for the particular drive system as listed in the following table.

Description	Recommended accessories
	For communication between the drive unit and the programming device or PC
	Article No.
SINAMICS G130 and SINAMICS G150	
• PROFIBUS	CP 5711 communication module
	USB adapter for connecting a PG or notebook to PROFIBUS or MPI
	USB cable (2 m (6.56 ft)) included in scope of supply
	SIMATIC DP plug-in cable
	12 MBaud, for PG connection, pre-assembled with 2 x 9-pin SUB D connector, 3 m (9.84 ft)
	6GK1571-1AA00
	6ES7901-4BD00-0XA0
• PROFINET/ Ethernet	Standard CAT5 Ethernet cable or PROFINET cable
	–

More information

The STARTER commissioning tool is also available on the internet under www.siemens.com/starter

Overview

SINAMICS DCC (Drive Control Chart) is a technological expansion for the SINAMICS S120/S150/G130/G150/MV/DCM/DCP drive systems. This allows the device functions of the SINAMICS drive system to be expanded individually with freely available closed-loop control, arithmetic and logic blocks. SINAMICS DCC for STARTER enables simple, graphic configuration of these blocks and integrates them in the drive unit.

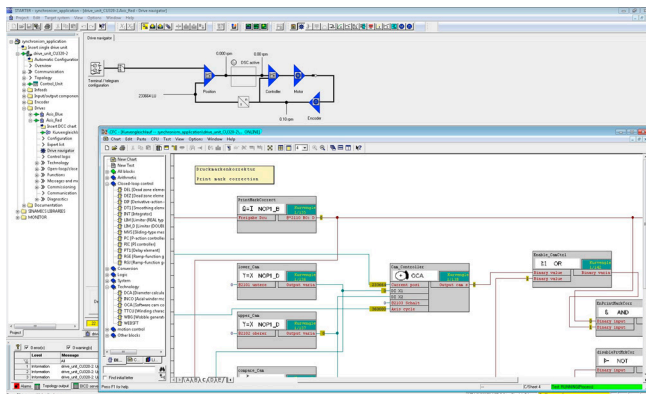

A comprehensive standard library is available for the configuration, which can be expanded by additional libraries, the so-called DCB Extension.

Via the Siemens application support, a range of example applications (winder, synchronous operation, cross-cutter, etc.) are available for download on the basis of SINAMICS DCC with STARTER and can be used as a ready-to-use solution or be individually adapted or expanded.

Minimum hardware and software requirements

See [STARTER commissioning tool](#).

Minimum software requirements for existing SIMATIC CFC Editor

The installation of STARTER V5.4 SP2 and SINAMICS DCC V3.4 SP2 results in the following minimum requirements:

- when using STEP7 OEM V5.7 in the standalone installation: SIMATIC CFC Editor V9.0 SP5 Upd4
- when using STEP7 V5.7 full version (with monitoring of application integrity): SIMATIC CFC Editor V9.0 SP5 Upd4
- when using STEP7 V5.7 full version (without monitoring of application integrity): SIMATIC CFC Editor V9.0 SP3 Upd4
- when using STEP7 V5.6 SPx full version: SIMATIC CFC Editor V9.0 Upd1

Please check the minimum requirements in relation to the product SIMATIC CFC when installing STEP7 or SIMATIC PCS 7.

Selection and ordering data

SINAMICS DCC consists of a graphic configuration tool (DCC Editor based on SIMATIC CFC) and the standard library. SINAMICS DCC is installed as an add-on to the STARTER commissioning tool.

The SINAMICS DCC V3.4 SP2 software package is a component of STARTER V5.4 SP2.

The necessary license key (floating license) for the configuration of SINAMICS DCC V3.4 SP2 must be ordered separately.

The included DCB standard library of SINAMICS DCC V3.4 SP2 does not require a runtime license. Existing licenses for SINAMICS DCC V2.1 and higher can also be used for SINAMICS DCC V3.4 SP2.

An upgrade variant for the application in STARTER V5.4 SP2 and SINAMICS DCC V3.4 SP2 is available for an existing license key of SINAMICS DCC V2.0 SPx.

Description	Article No.
SINAMICS DCC V3.4 SP2 License Key for SINAMICS DCC V3.4 and V3.4 SP2	6AU1810-1HA34-0XB0 6AU1810-1HA34-0XF0
<ul style="list-style-type: none"> • License key on USB flash drive • Upgrade license key on USB flash drive 	
SINAMICS DCB Extension license Runtime license for license upgrading with firmware version V4.6 or later (can also be ordered in conjunction with the CompactFlash card, see CompactFlash card for CU310-2 and CU320-2 Control Units)	6SL3077-0AA00-0AH0
<ul style="list-style-type: none"> • Electronic license 	
SINAMICS DCB Studio V2.3 Development tool for programming blocks that can be imported as an additional library (DCB Extension) for SINAMICS DCC in STARTER or in the TIA Portal	On request

Further information about SINAMICS DCB Extension and SINAMICS DCB Studio can be found in the section [SINAMICS DCC \(Drive Control Chart\)](#) in the TIA Portal.

Tools and configuration

SINAMICS Startdrive commissioning tool

Overview

SINAMICS Startdrive is integrated in the TIA Portal and is a tool for the configuration, commissioning and diagnostics of the SINAMICS family of converters.

The SINAMICS Startdrive commissioning tool has been optimized with regard to user friendliness and consistent use of the TIA Portal benefits of a common working environment for PLC, HMI and drives. Time-saving and guided step-by-step commissioning with maximum flexibility is complemented by user-friendly graphic function views for all drive functions, including functional safety (Safety Integrated) and drive-based technology functions (e.g. EPos). The automatic message display, the powerful real-time trace and the context-sensitive online help make converter diagnostics very easy.

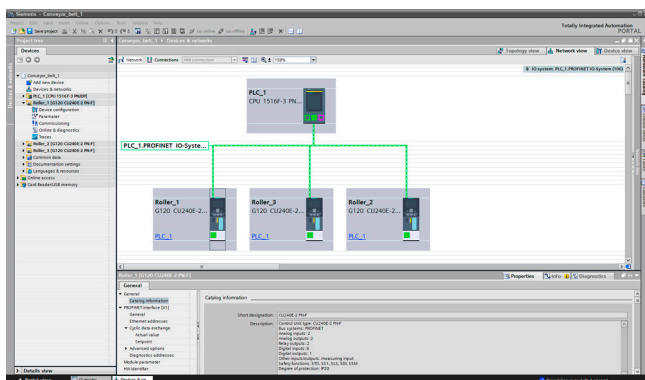

The software packages based on the TIA Portal are harmonized with each other and offer important benefits, the main advantage being a shared project storage. The TIA Portal enables simple integration of SINAMICS converters in your automation solution. Thanks to the standardization of operator actions and the integration in general TIA Portal operating concepts (e.g. UMAC, Openness) as well as standard TIA Portal functions (e.g. Undo/Redo), familiarization is easy both for drive experts as well as SIMATIC users. Special focus is placed on the interaction between SIMATIC and SINAMICS, especially when connecting the SINAMICS drives to SIMATIC technology objects.

Integration

Supported frequency converters

SINAMICS Startdrive Basic enables complete commissioning, diagnostics, parameterization, optimization and connection to the PLC for the following SINAMICS converters integrated in SINAMICS Startdrive:

- SINAMICS G120, G120C, G120D, G120P
- SINAMICS G115D
- SINAMICS G130, G150
- SINAMICS G220 (as of V18 SP2)
- SINAMICS S120 ¹⁾, S150
- SINAMICS S200 (as of V18 SP2)
- SINAMICS S210 and SINAMICS S210 (New) (as of V18 SP1)
- SINAMICS MV

SINAMICS Startdrive Advanced

With SINAMICS Startdrive Advanced (available as of V15) you benefit from powerful engineering functions that save you considerable time and ultimately costs.

- Safety acceptance test:
 - Guided acceptance test wizard for all drive-based Safety Integrated functions
 - Automatic and safety function-specific generation of traces to analyze the machine behavior
 - Generation of an acceptance report as Excel file (xlsx format, can also be used with OpenOffice)
 - Safety Activation Test
- Improved optimization options in the drive: Extended measuring functions (available for CU320-2 PN/DP and CU310-2 PN as of V5.2 SP3, SINAMICS S210 (New) as of V6.1 and SINAMICS S200 as of V6.2), long-term trace
- Also contains all Startdrive Basic functions
- Only license key required, no additional installation

New in V19

Startdrive Basic V19

- Support of the shared device functionality for SINAMICS S210, S120, G220 for separate control of the drives by separate controllers
- Improvement of the library function for individual drive objects in the multi-axis system
- Integration of the decentralised SINAMICS S120M drives
- Integration of the drive version V6.3 for SINAMICS S200 and SINAMICS S210 (New):
 - Introduction of the positioning function EPos for SINAMICS S210 (New)

Startdrive Advanced V19

- Long-term trace functionality for CU320-2 PN/DP and CU310-2 PN-based drive units

¹⁾ Includes SINAMICS S220 Smart Line Modules booksize format as of SINAMICS Startdrive V17 Update 1.

Integration

Installation versions

SINAMICS Startdrive can be installed as an optional package to SIMATIC STEP 7 or as a stand-alone application (without SIMATIC STEP 7).

System requirements

The following table shows the recommended hardware and system equipment for the operation of SINAMICS Startdrive.

Hardware	Recommendation
Computer	As of SIMATIC FIELD PG M6 Comfort (or comparable PC)
Processor	Intel Core i5-8400H (2.5 ... 4.2 GHz; 4 cores + hyper-threading; 8 MB Smart Cache)
RAM	16 GB or more (32 GB for large projects)
Hard disk	SSD with at least 50 GB available memory
Screen resolution	15.6" Full HD display (1920 × 1080 or larger)
Operating systems	<ul style="list-style-type: none"> • Microsoft Windows 10 (64 bit) <ul style="list-style-type: none"> - Windows 10 Professional Version 22H2 - Windows 10 Enterprise 21H2, 22H2 - Windows 10 Enterprise 2016 LTSC - Windows 10 Enterprise 2019 LTSC - Windows 10 Enterprise 2021 LTSC • Microsoft Windows 11 (64 bit) <ul style="list-style-type: none"> - Windows 11 Home Version 21H2, 22H2 - Windows 11 Professional Version 21H2, 22H2 - Windows 11 Enterprise 21H2, 22H2 • Microsoft Windows Server (64 bit) <ul style="list-style-type: none"> - Windows Server 2016 Standard (full installation) - Windows Server 2019 Standard (full installation) - Windows Server 2022 Standard (full installation)

Compatibility with other products

- SINAMICS Startdrive V19 operates with STEP 7, WinCC and Scout TIA V19 in one framework
- SINAMICS Startdrive V19 can be installed on the same computer in parallel with other versions of SINAMICS Startdrive V12 to V18
- SINAMICS Startdrive can be installed on the same computer as SINAMICS MICROMASTER STARTER

Supported virtualization platforms

SINAMICS Startdrive can be installed in a virtual machine. For this purpose, one of the following virtualization platforms in the specified version or a newer version can be used:

- VMware vSphere Hypervisor (ESXi) 6.7
- VMware Workstation 15.5.0
- VMware Player 15.5.0
- Microsoft Hyper-V Server 2019

Supported safety programs

The following safety programs have been tested with SINAMICS Startdrive V19:

- Virus scanners:
 - Symantec Endpoint Protection 14.6
 - Trend Micro OfficeScan 14.0
 - McAfee Endpoint Security (ENS) 10.6 and 10.7
 - Microsoft Defender
 - Qihoo 360 "Safe Guard 12.1" + "Virus Scanner"
- Encryption software:
 - Microsoft Bitlocker
- Host-based Intrusion Detection System
 - McAfee Application Control 8.3.3

Selection and ordering data

Description	Article No.
SINAMICS Startdrive Basic V19 commissioning tool Single license and certificate of license English, French, German, Italian, Spanish, Chinese Simplified • Software download (email address required for delivery)	6SL3072-4KA02-0XG0
SINAMICS Startdrive Advanced V19 commissioning tool License key (floating license) English, French, German, Italian, Spanish, Chinese Simplified • On DVD-ROM with license key on USB flash drive • Software download incl. license key (email address required for delivery)	6SL3072-4KA02-0XA5 6SL3072-4KA02-0XG5
Upgrade SINAMICS Startdrive Advanced V15 ... V18 to V19 • On DVD-ROM with license key on USB flash drive • Software download incl. license key (email address required for delivery)	6SL3072-4KA02-0XE5 6SL3072-4KA02-0XK5
Software Update Service with SINAMICS Startdrive Advanced in the TIA Portal Delivery is performed according to the number of ordered SUS products (e.g. 10 upgrade license keys (floating license) with 10 DVD-ROMs, 10 USB flash drives, etc.) • On DVD-ROM with upgrade license key on USB flash drive • Software download incl. license key (email address required for delivery)	6SL3072-4AA02-0XL8 6SL3072-4AA02-0XY8

More information

The SINAMICS Startdrive Basic commissioning tool is available for free on the internet at:
www.siemens.com/startdrive

Tools and configuration

Drive ES engineering software

Overview

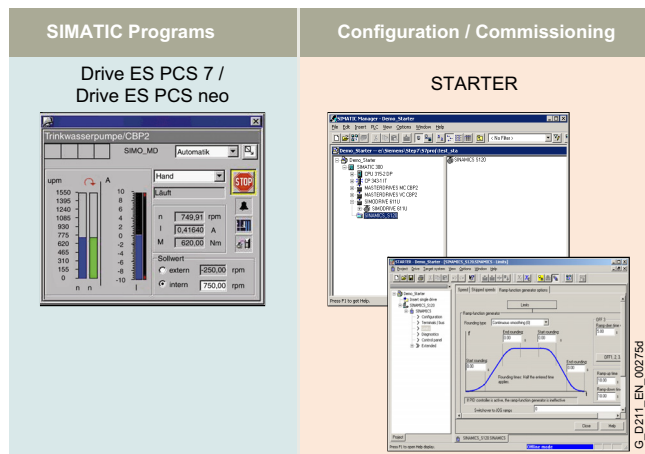

Drive ES/STARTER is the engineering system used to integrate the communication, configuration and data management functions of Siemens drive technology into the SIMATIC automation world easily, efficiently and cost-effectively.

The following software packages are available for selection:

- STARTER
- Drive ES PCS 7 / Drive ES PCS neo

The Drive ES (**Drive Engineering Software**) fully integrates drives from Siemens into the world of Totally Integrated Automation (STEP 7 V5.x).

Design

The following software packages are available for selection:

- **STARTER**
- **Drive ES PCS 7** (APL Style or Classic Style) / **Drive ES PCS neo**

STARTER

The STARTER commissioning tool is for first-time users of the world of Totally Integrated Automation and the basic software for setting the parameters of the SINAMICS and MICROMASTER 4 drives online and offline in this environment. The STARTER integration enables both the automation system and the drives to be handled using the SIMATIC Manager software. STARTER is the starting point for common data archiving in complete projects and for extending the use of the routing and the SIMATIC teleservice to drives. STARTER provides the configuration tools for the Motion Control functions – device-to-device communication, equidistance and isochronous operation with PROFIBUS DP and ensures that drives with PROFINET IO are simply integrated into the SIMATIC environment.

Drive ES PCS 7 (APL Style or Classic Style)

Drive ES PCS 7 links the drives with a PROFIBUS DP interface into the SIMATIC PCS 7 process control system, and it requires that SIMATIC PCS 7, V6.1 and higher has first been installed. Drive ES PCS 7 provides a block library with blocks for the drives and the corresponding faceplates for the operator station, which enables the drives to be operated from the PCS 7 process control system. From V6.1 and higher, drives will also be able to be represented in the PCS 7 Maintenance Station.

From Drive ES PCS 7 V8.0 and higher, two versions of the library are available: The APL (Advanced Process Library) variant and the previous version in the so-called Classic Style.

Detailed contents of the Drive ES PCS 7 (APL Style or Classic Style)

- **Block library for SIMATIC PCS 7** Faceplates and control blocks for SIMOVERT MASTERDRIVES VC and MC, as well as MICROMASTER/MIDIMASTER of the third and fourth generation and SIMOREG DC MASTER and SINAMICS
- **STEP 7 V5.x slave object manager** for user-friendly configuration of drives and non-cyclic PROFIBUS DP communication with the drives
- **STEP 7 V5.x device object manager** for easy configuration of drives with PROFINET-IO interfaces (V8.0 SP1 and higher)
- **SETUP program** for installing the software in the SIMATIC PCS 7 environment

Drive ES PCS neo

Siemens SINAMICS drives can be controlled via SIMATIC PCS neo and operated and monitored on the OCM client with the SINAMICS library Drive ES PCS neo. The drive ES PCS neo faceplates make the data relevant for system operation available on the OCM client. The STARTER commissioning tool on the engineering server can also be used for parameter assignment, commissioning and detailed diagnostics of the SINAMICS drives.

Selection and ordering data

Description	Article No.
Drive ES PCS 7 V8.2 SPx ¹⁾ Block library for PCS 7 for the integration of drives in Classic Style (as predecessor) Requirement: PCS 7 V8.2 and higher Type of delivery: CD-ROM Languages: en, de, fr, it, es With electronic documentation <ul style="list-style-type: none"> • Single-user license incl. 1 runtime license • Runtime license (without data storage medium) • Update service for single-user license 	6SW1700-8JD00-2AA0 6SW1700-5JD00-1AC0 6SW1700-0JD00-0AB2
Drive ES PCS 7 APL V8.2 SPx ¹⁾ Block library for PCS 7 for the integration of drives in APL Style (Advanced Process Library) Requirement: PCS 7 V8.2 and higher Type of delivery: CD-ROM Languages: en, de, fr, it, es With electronic documentation <ul style="list-style-type: none"> • Single-user license incl. 1 runtime license • Runtime license (without data storage medium) • Update service for single-user license 	6SW1700-8JD01-2AA0 6SW1700-5JD00-1AC0 6SW1700-0JD01-0AB2
Drive ES PCS 7 V9.0 SPx ¹⁾ Block library for PCS 7 for the integration of drives in Classic Style (as predecessor) Requirement: PCS 7 V9.0 or higher Type of delivery: CD-ROM Languages: en, de, fr, it, es With electronic documentation <ul style="list-style-type: none"> • Single-user license incl. 1 runtime license • Runtime license (without data storage medium) • Update service for single-user license • Upgrade from V6.x/V7.x/V8.x/V9.x to V9.0 SPx ¹⁾ 	6SW1700-1JD00-0AA0 6SW1700-5JD00-1AC0 6SW1700-0JD00-0AB2 6SW1700-1JD00-0AA4
Drive ES PCS 7 APL V9.0 SPx ¹⁾ Block library for PCS 7 for the integration of drives in APL Style (Advanced Process Library) Requirement: PCS 7 V9.0 or higher Type of delivery: CD-ROM Languages: en, de, fr, it, es With electronic documentation <ul style="list-style-type: none"> • Single-user license incl. 1 runtime license • Runtime license (without data storage medium) • Update service for single-user license • Upgrade of APL V8.x, V9.x to V9.0 SPx ¹⁾ or Drive ES PCS 7 V6.x, V7.x, V8.x, V9.x classic to Drive ES PCS 7 APL V9.0 SPx ¹⁾ 	6SW1700-1JD01-0AA0 6SW1700-5JD00-1AC0 6SW1700-0JD01-0AB2 6SW1700-1JD01-0AA4
Drive ES PCS 7 V9.1 SPx ¹⁾ Block library for PCS 7 for the integration of drives in Classic Style (as predecessor) Requirement: PCS 7 V9.1 or higher Type of delivery: DVD-ROM Languages: en, de, fr, it, es With electronic documentation <ul style="list-style-type: none"> • Single-user license incl. 1 runtime license • Runtime license (without data storage medium) • Update service for single-user license • Upgrade from V6.x/V7.x/V8.x/V9.x to V9.1 SPx ¹⁾ 	6SW1700-2JD00-0AA0 6SW1700-5JD00-1AC0 6SW1700-0JD00-0AB2 6SW1700-2JD00-0AA4

Description	Article No.
Drive ES PCS 7 APL V9.1 SPx ¹⁾ Block library for PCS 7 for the integration of drives in APL Style (Advanced Process Library) Requirement: PCS 7 V9.1 or higher Type of delivery: DVD-ROM Languages: en, de, fr, it, es With electronic documentation <ul style="list-style-type: none"> • Single-user license incl. 1 runtime license • Runtime license (without data storage medium) • Update service for single-user license • Upgrade of APL V8.x, V9.x to V9.1 SPx ¹⁾ or Drive ES PCS 7 V6.x, V7.x, V8.x, V9.x classic to Drive ES PCS 7 APL V9.1 SPx ¹⁾ 	6SW1700-2JD01-0AA0 6SW1700-5JD00-1AC0 6SW1700-0JD01-0AB2 6SW1700-2JD01-0AA4
Drive ES PCS neo V3.0 / V3.1 / V4.0 Block library for SIMATIC PCS neo for the integration of SINAMICS drives Requirement: PCS neo V3.0 or higher Type of delivery at V3.0: The SINAMICS library is a component of the SIMATIC PCS neo V3.0 product. Type of delivery at V3.1 / V4.0: Integration via the import of a SINAMICS device type file (product support). License reference for the license code and the Certificate of License for the Drive ES PCS neo SINAMICS library via OSD Languages: de, en <u>License for the Drive ES PCS neo SINAMICS library (engineering and runtime software)</u> Floating license for 1 engineering user on the engineering server A runtime license for a PCS neo Controller (single license for 1 installation) <u>Runtime license Drive ES PCS neo SINAMICS library</u> To execute the function blocks for a SIMATIC PCS neo Controller Language-neutral, single license for 1 installation Type of delivery: Electronic Certificate of License (OSD)	6SW1700-1JE01-0AH0 6SW1700-1JE00-1AH0

Options

Drive ES PCS 7 Software Update Service

A software update service can also be purchased for the Drive ES PCS 7 software. The user will automatically receive the latest software, service packs and full versions for one year after ordering.

The update service can only be ordered in addition to an existing (i.e. previously ordered) full version.

- Period of update service: 1 year

The update service is automatically extended by 1 further year unless canceled up to 6 weeks prior to expiration.

Description	Article No.
Drive ES PCS 7 <ul style="list-style-type: none"> • Update service for single-user license 	6SW1700-0JD00-0AB2
Drive ES PCS 7 APL <ul style="list-style-type: none"> • Update service for single-user license 	6SW1700-0JD01-0AB2

More information

Further information is available on the internet at:
www.siemens.com/drive-es

¹⁾ Orders are automatically supplied with the latest Service Pack (SP).

Tools and configuration

Configuration with EPLAN

Overview

Configuring with EPLAN

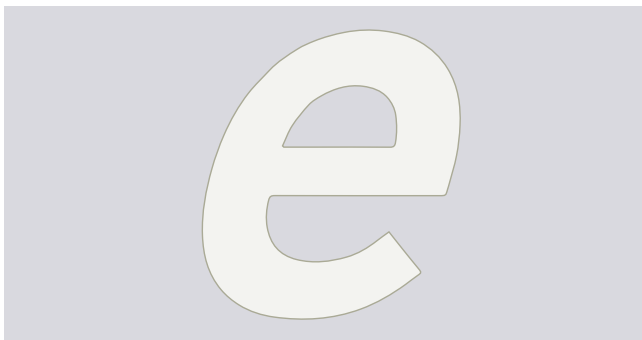

EPLAN is an engineering software for configuring electrical installations. The EPLAN platform combines expert systems for various disciplines, such as electrical, fluid and EMC engineering (EMC = electrical, measuring and control engineering) as well as control cabinet and plant engineering. It provides the wiring information required to determine the optimal laying routes, connection lengths, bundle diameters, and design of the cable tree.

EPLAN Electric P8 – an EPLAN module – is CAE software specifically for configuring documentation and managing electrical automation projects for machines and systems. EPLAN Electric P8 offers the following functions:

- Creating circuit diagrams for control cabinets
- Managing article master data
- Automatic generation of bills of materials, terminal plans, PLC diagrams and overviews
- Preparation of the documentation for the configured system
- Design of the mechanical control cabinet configuration

EPLAN macros for SINAMICS components

EPLAN Electric P8 macros are available as downloads without charge, so that SINAMICS components can be easily and cost-effectively integrated into an EPLAN project. Macros are available for the following components:

- SINAMICS G120P, PM330 Power Modules
- SINAMICS G130 built-in units
- SINAMICS S120 chassis units
- SINAMICS DCM DC converters
- Line and motor-side components
- DC link components
- Control Units
- Supplementary system components

Using EPLAN Electric P8 macros substantially shortens the configuration time. All the necessary information about a component is supplied at the press of a button. This ensures that the data is up-to-date and correct – and mistakes/errors can be avoided.

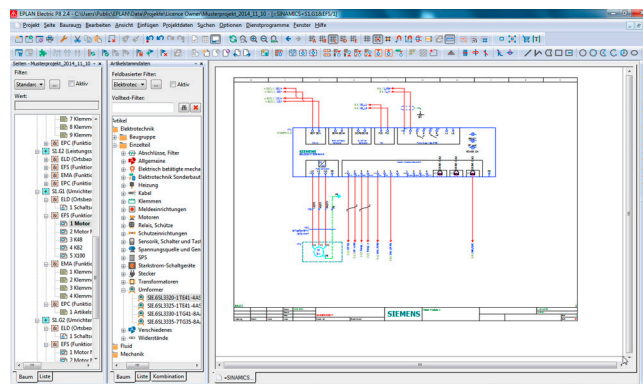

EPLAN user interface

The macros are provided in the file format EDZ (EPLAN Data Archived Zipped). An EDZ file is an archive for article master data, CAX data and macros. A macro in EDZ format contains the following data:

- Internal circuit diagrams
- Wiring diagrams
- Product master data
- Product images
- Data sheets

EPLAN Electric P8 macros for SINAMICS components are available in the following tools:

- Siemens Product Configurator (www.siemens.com/spc)
- CAX Onlinemanager
- Image database (download)

EPLAN projects for SINAMICS converter cabinet units

EPLAN projects are available for SINAMICS converter cabinet units, that simplify the configuration, and save time throughout the entire engineering process. EPLAN projects are available for the following converter cabinet units:

- SINAMICS G120P Cabinet
- SINAMICS G150
- SINAMICS S120 Cabinet Modules
- SINAMICS S150

The complete EPLAN project is digitally delivered. The order is made by selecting the additional option **D01**.

Tools and configuration

Engineering Manual

Overview



To correctly select and configure the devices listed in this catalog, we would like to refer to the SINAMICS Low Voltage Engineering Manual. This supplements the Catalogs D 11 and D 21.3, and is intended to simplify the handling of SINAMICS series devices.

This manual is only available in electronic form and only in German and English. It is available as a PDF in the Information and Download Center:

<https://support.industry.siemens.com/cs/document/83180185>

The Engineering Manual contains general information on the basics of variable-speed electric AC drives, as well as detailed system descriptions and direct specifications for the following SINAMICS series devices:

- SINAMICS G130 Converter Built-in Units (Catalog D 11)
- SINAMICS G150 Converter Cabinet Units (Catalog D 11)
- SINAMICS S120 Modular Built-in Units (Catalogs D 21.3 and D 21.4)
- SINAMICS S120 Modular Cabinet Modules (Catalog D 21.3)
- SINAMICS S150 Converter Cabinet Units (Catalog D 21.3)

For the device-specific topics for the SINAMICS S120 Chassis-2 and SINAMICS S120 Cabinet Modules-2 series of devices, Catalog D 21.3 is supplemented by the SINAMICS Low Voltage SINAMICS S120 Chassis-2 and Cabinet Modules-2 Engineering Manual.

The Engineering Manual contains general information on the basics of variable-speed electric AC drives, as well as detailed system descriptions and direct specifications for the following SINAMICS series devices:

- Modular Built-in Units SINAMICS S120 Chassis-2 (Catalog D 21.3)
- Modular Cabinet Units SINAMICS S120 Cabinet Modules-2 (Catalog D 21.3)

The manual is available only in electronic form in German and English:

<https://support.industry.siemens.com/cs/document/109791862>

The Engineering Manual is divided into several sections with different layouts.

The first chapter – Basics and system description – essentially explains the physical basics of variable-speed electric AC drives and provides a generally valid system description of the SINAMICS series devices.

The second chapter – EMC design guideline – discusses the topic of **E**lectromagnetic **C**ompatibility (EMC) and provides all the information required to configure and install drives with the specified SINAMICS devices in compliance with EMC guidelines.

The following chapters – Configuration of the SINAMICS G130, G150, S120 built-in units, S120 Cabinet Modules and S150 devices – discuss device-specific topics, which go beyond the contents of the generally valid system descriptions.

The information provided addresses technically qualified and trained personnel. It is the responsibility of the configuration engineer to evaluate the completeness of the information provided for the respective application. This person also has the final system responsibility for the entire drive or the plant.

Services and documentation



6/2	Partner at Siemens
6/3	Industry Services
6/4	Portfolio
6/6	Online Support
6/7	Service & Support
6/7	Extension of warranty
6/9	SITRAIN – Digital Industry Academy
6/11	SINAMICS range of training courses
6/12	Spares on Web
6/13	Industry Online Support / myDocumentation
6/14	Documentation

Services and documentation

Partners

Partners at Siemens

At your service locally, around the globe for consulting, sales, training, service, support, spare parts on the entire portfolio of Siemens.

Your partner can be found in our Personal Contacts Database at: www.siemens.com/automation-contact

You start by selecting

- the required competence,
- products and branches,
- a country and a city

or by a

- location search or free text search.

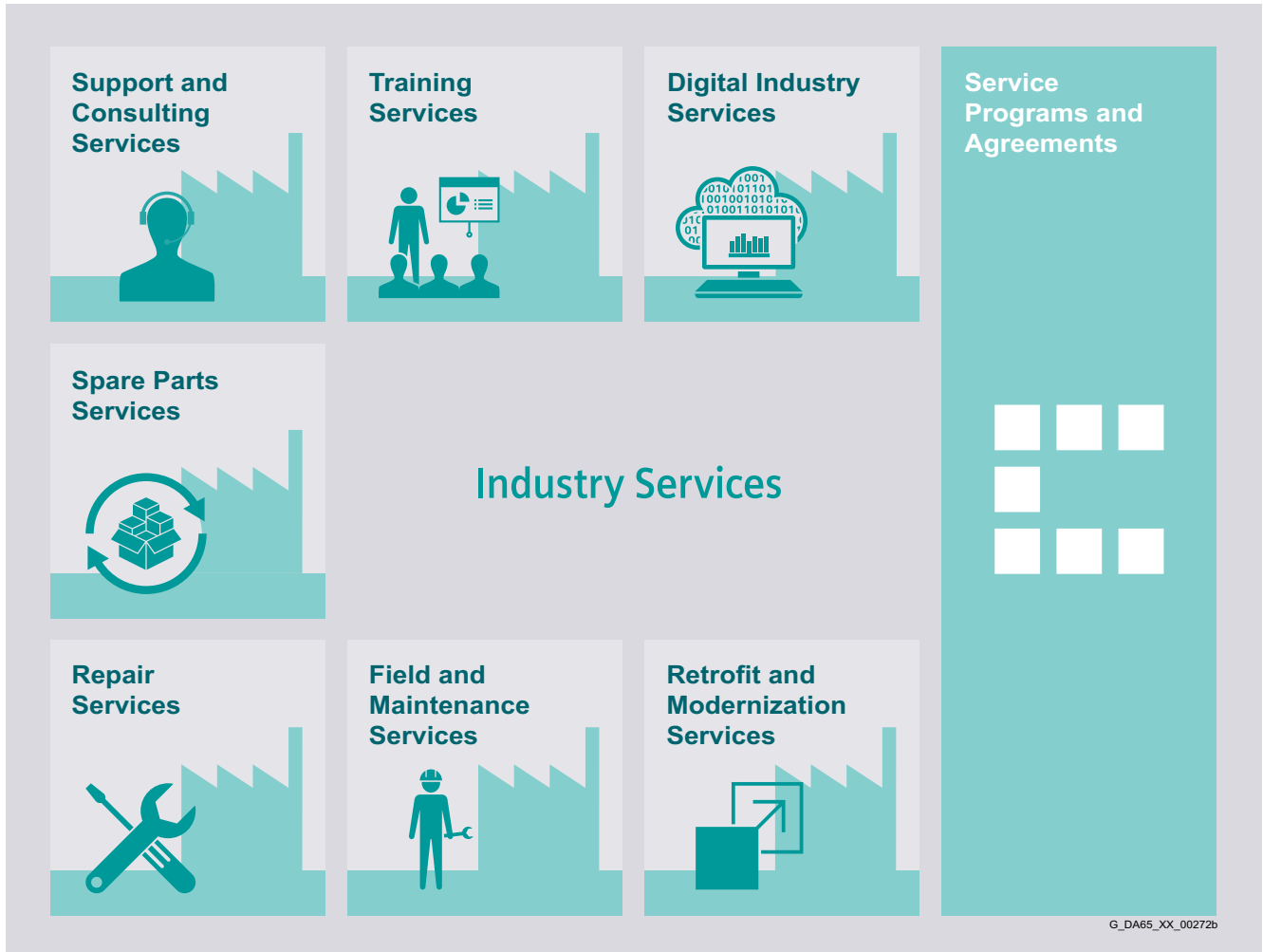
Overview

Keep your business running and shaping your digital future – with Industry Services

Optimizing the productivity of your equipment and operations can be a challenge, especially with constantly changing market conditions. Working with our service experts makes it easier. We understand your industry's unique processes and provide the services needed so that you can better achieve your business goals.

You can count on us to maximize your uptime and minimize your downtime, increasing your operations' productivity and reliability. When your operations have to be changed quickly to meet a new demand or business opportunity, our services give you the flexibility to adapt. Of course, we take care that your production is protected against cyber threats. We assist in keeping your operations as energy and resource efficient as possible and reducing your total cost of ownership. As a trendsetter, we ensure that you can capitalize on the opportunities of digitalization and by applying data analytics to enhance decision making: You can be sure that your plant reaches its full potential and retains this over the longer lifespan.

You can rely on our highly dedicated team of engineers, technicians and specialists to deliver the services you need – safely, professionally and in compliance with all regulations. We are there for you, where you need us, when you need us.

www.siemens.com/industryservices

Services and documentation

Industry Services

Industry Services – Portfolio overview

Overview



Digital Industry Services make your industrial processes transparent to gain improvements in productivity, asset availability, and energy efficiency.

Production data is generated, filtered and translated with intelligent analytics to enhance decision-making.

This is done whilst taking data security into consideration and with continuous protection against cyber-attack threats.

www.siemens.com/global/en/products/services/industry/digital-industry-services.html

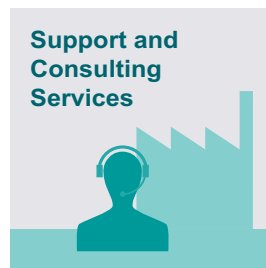

Industry Online Support site for comprehensive information, application examples, FAQs and support requests.

Technical and Engineering Support for advice and answers for all inquiries about functionality, handling, and fault clearance. The Service Card as prepaid support for value added services such as Priority Call Back or Extended Support offers the clear advantage of quick and easy purchasing.

Information & Consulting Services, e.g. SIMATIC System Audit; clarity about the state and service capability of your automation system or Lifecycle Information Services; transparency on the lifecycle of the products in your plants.

<https://support.industry.siemens.com/cs/ww/en/sc/2235>



From the basics and advanced to specialist skills, SITRAIN courses provide expertise right from the manufacturer – and encompass the entire spectrum of Siemens products and systems for the industry.

Worldwide, SITRAIN courses are available wherever you need a training course in more than 170 locations in over 60 countries.

<https://support.industry.siemens.com/cs/ww/en/sc/2226>



Spare Parts Services are available worldwide for smooth and fast supply of spare parts – and thus optimal plant availability. Genuine spare parts are available for up to ten years. Logistic experts take care of procurement, transport, custom clearance, storage and order management. Reliable logistics processes ensure that components reach their destination as needed.

Since not all spare parts can be kept in stock at all times, Siemens offers a preventive measure for spare parts provisioning on the customer's premises with optimized **Spare Parts Packages** for individual products, custom-assembled drive components and entire integrated drive trains – including risk consulting.

Asset Optimization Services help you design a strategy for parts supply where your investment and carrying costs are reduced and the risk of obsolescence is avoided.

<https://support.industry.siemens.com/cs/ww/en/sc/2110>

Overview

Repair Services



Repair Services are offered on-site and in regional repair centers for fast restoration of faulty devices' functionality.

Also available are extended repair services, which include additional diagnostic and repair measures, as well as emergency services.

<https://support.industry.siemens.com/cs/ww/en/sc/2154>

Retrofit and Modernization Services



Provide a cost-effective solution for the expansion of entire plants, optimization of systems or upgrading existing products to the latest technology and software, e.g. migration services for automation systems.

Service experts support projects from planning through commissioning and, if desired over the entire extended lifespan, e.g. Retrofit for Integrated Drive Systems for an extended lifetime of your machines and plants.

<https://support.industry.siemens.com/cs/ww/en/sc/2286>

Field and Maintenance Services



Siemens specialists are available globally to provide expert field and maintenance services, including commissioning, functional testing, preventive maintenance and fault clearance. All services can be included in customized service agreements with defined reaction times or fixed maintenance intervals.

<https://support.industry.siemens.com/cs/ww/en/sc/2265>

Service Programs and Agreements



A technical Service Program or Agreement enables you to easily bundle a wide range of services into a single annual or multi-year agreement.

You pick the services you need to match your unique requirements or fill gaps in your organization's maintenance capabilities.

Programs and agreements can be customized as KPI-based and/or performance-based contracts.

<https://support.industry.siemens.com/cs/ww/en/sc/2275>

Services and documentation

Industry Services

Online Support

Overview

Online Support – fast, intuitive, whenever you want, wherever you need

Web

www.siemens.com/online-support

App

Scan the QR code for information on our Online Support app.

- FAQ / Application examples**
Information about industrial products, programming and configuration as well as application examples
- Technical information**
Videos, documentation, manuals, updates, product notes, compatibility tool, certificates, planning data such as dimensional drawings, product data, 3D models
- Forum**
Exchange information and experience with other users and experts

Online Support for Siemens Industry Products

Siemens Industry and Online Support with some 1.7 million visitors per month is one of the most popular web services provided by Siemens. It is the central access point for comprehensive technical know-how about products, systems and services for automation and drives applications as well as for process industries.

In connection with the challenges and opportunities related to digitalization you can look forward to continued support with innovative offerings.

Overview
SINAMICS G130
Service Protect

Service Protect allows our customers to purchase extended manufacturer's liability of up to 5 years.

Extended warranty

For SINAMICS G130, Siemens offers an extended warranty of up to 6½ years:

SINAMICS G150

For SINAMICS G150, we provide the option of extending the warranty beyond the normal liability period. The normal warranty period as listed in our standard service and delivery terms is 12 months.

1. Extension of the warranty period when ordering new products

When ordering new products, it is possible to extend the standard warranty period for an additional price. Various extension periods can be selected.

Warranty extension for converters

Additional ordering data -Z with order code	Additional text
Q80	Extension of the warranty period by 12 months to a total of 24 months (2 years) after delivery
Q81	Extension of the warranty period by 18 months to a total of 30 months (2½ years) after delivery
Q82	Extension of the warranty period by 24 months to a total of 36 months (3 years) after delivery
Q83	Extension of the warranty period by 30 months to a total of 42 months (3½ years) after delivery
Q84	Extension of the warranty period by 36 months to a total of 48 months (4 years) after delivery
Q85	Extension of the warranty period by 48 months to a total of 60 months (5 years) after delivery

- 12-month standard warranty
- Optional extension via Service Protect
 - Free for the first 6 months after registering the product at: <https://myregistration.siemens.com/>
 - Available at a cost for 3 or 5 additional years.

The correct service MLFB must be chosen with an assignment list on the basis of the hardware product.

For more information, see:

<https://support.industry.siemens.com/cs/ww/en/sc/4842>

2. Extension of the warranty period after the product has been delivered

If a product has already been delivered, an extended warranty can be ordered as long as the original warranty period has not yet expired. In addition to the article number specified on the rating plate, the serial number must also be stated in the order.

The following article numbers are used:

Warranty extension for converters	
Article No.	Text
9LD1730-0AA24	Extension of the warranty period by 12 months to a total of 24 months (2 years) after delivery
9LD1730-0AA30	Extension of the warranty period by 18 months to a total of 30 months (2½ years) after delivery
9LD1730-0AA36	Extension of the warranty period by 24 months to a total of 36 months (3 years) after delivery
9LD1730-0AA42	Extension of the warranty period by 30 months to a total of 42 months (3½ years) after delivery
9LD1730-0AA48	Extension of the warranty period by 36 months to a total of 48 months (4 years) after delivery
9LD1730-0AA60	Extension of the warranty period by 48 months to a total of 60 months (5 years) after delivery

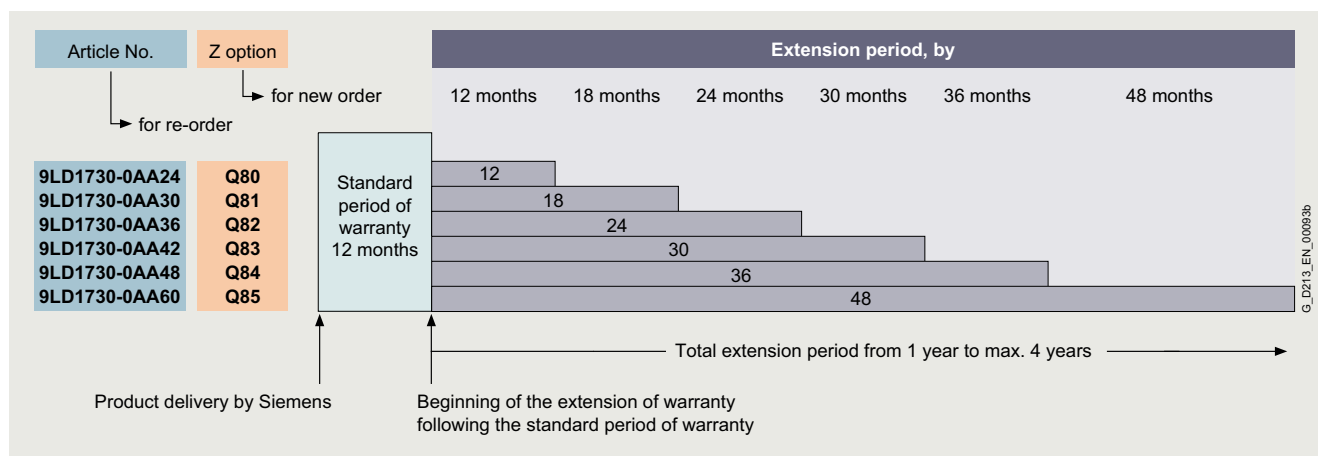
Warranty extension overview

Services and documentation

Service & Support

Extension of warranty

Overview

Conditions for an extension of the warranty period:

1. The liability for defects period can be extended only once, i.e. it is not possible to extend an extension. If a product has already been delivered, an extended warranty can only be ordered if the original warranty period has not yet expired.
2. The scope of services provided by an extended warranty period includes all material and work expenditure by Siemens for rectification of the damage and, where applicable, all travel costs and expenses.
3. For all periods of an extended warranty for new products and products that have already been delivered, the final destination of the product must be known (region in which the equipment will ultimately be installed). Please contact your Siemens representative for the purpose of providing this information.
4. The general storage conditions described in the operating instructions must be adhered to, especially the specifications for long-term storage. These specifications must be requested separately from Siemens if necessary.
5. Commissioning must be performed by appropriately qualified personnel. When making warranty claims, it might sometimes be necessary to submit the commissioning report to the department making the decision.
6. For all periods of the extended warranty, all of the regular maintenance intervals must be complied with according to the specifications in the operating instructions. When ordering the appropriate maintenance, this must be carried out by Siemens or by personnel authorized by Siemens. The corresponding maintenance records must be submitted when making warranty claims.
7. The operating conditions correspond to the specifications and data provided in the operating instructions, in the engineering manual or special conditions specified in the specific contract.
8. The extended warranty excludes wearing parts such as fans and filters. This does not apply if it can be clearly proven that the failure is a premature one.
9. Otherwise, the general warranty terms apply as agreed in the delivery contract.

Introduction



SITRAIN – DIGITAL INDUSTRY ACADEMY
The Future of Learning starts now

SITRAIN - Digital Industry Academy stands for a modern learning culture that focuses on the needs of learners and the demands of innovative companies.

SITRAIN offers a comprehensive range of knowledge on Siemens industrial products and, under the vision "Future of Learning", pursues a holistic approach that combines different forms and methods of learning. Different learning formats allow for more effective, flexible and continuous learning depending on the type of learning.

Education and training directly from the manufacturer



Industrial Automation Systems SIMATIC

Training available for: SIMATIC S7-1500, TIA Portal, SIMATIC S7-300/400, SIMATIC S7-1200



Drive Technology

Training available for: SINAMICS S120 and SINAMICS G120 low-voltage converters, SINAMICS G130 / G150 / G180 / S150



SINUMERIK CNC automation system

Training available for: SINUMERIK 840D, SINUMERIK 840D sl and SINUMERIK ONE



Process Control Systems

Training available for: SIMATIC PCS 7, SIMATIC PCS neo



Digital Enterprise

Training available for: Openness, SIMIT, OPC UA, Industrial Edge, Virtual commissioning



Industrial Communications

Training available for: OPC UA, PROFINET, SCALANCE, RUGGEDOM, Industrial Ethernet, Fieldbus communication, Industrial Security, Remote communication



Identification and Locating

Training available for: RFID, RTLS systems



Operator Control and Monitoring Systems

Training available for: SIMATIC WinCC Unified in TIA Portal, SIMATIC WinCC in TIA Portal, SIMATIC WinCC V7x

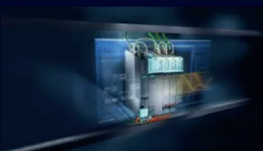

Motion Control System SIMOTION

Training available for: SIMOTION (Programming, Commissioning, Diagnostics, Service)



Smart Infrastructure

Training available for: SIRIUS, SENTRON, SIVACON, ALPHA, SIMOCODE, Circuit breakers



Process Analytics & Instrumentation

Training is available for process analytics and instrumentation, explosion protection, process gas chromatographs



Additional training offer

SIMOVE with Automated Guided Vehicles (AGV), SIPLUS CMS, Guidelines and standards for control cabinets

Services and documentation

SITRAIN – Digital Industry Academy

Introduction

Different learning formats and methods for maximum learning success

Face-to-face training in the training center or in the virtual classroom, with fixed dates and course times, learning in a group with a learning consultant? Or digital training, on your own responsibility and location-independent, on demand, 24/7?

With the learning formats "Learning Journey", "Learning Membership" and "Learning Event", SITRAIN offers a wide range of different learning options in connection with didactically effective methods and modular possibilities.



Learning Journey

The combination for sustainable learning success

- The optimal mix of self-study units and guided live modules
- Includes a Learning Membership to work through the self-study modules and access on-demand content
- The SITRAIN learning consultant is available for questions and one-on-one consultations
- Ideal integration into the daily work routine and adaptation to one's own learning pace.

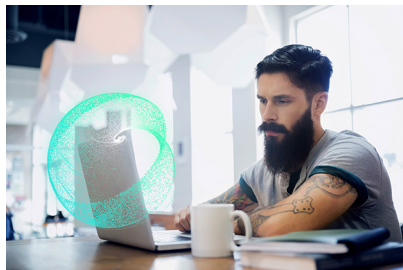

Learning Membership

Securing knowledge through continuous learning on your own responsibility

- With access to the comprehensive and constantly growing range of self-study units on SITRAIN access, the digital learning platform
- Search and find specific learning content or simply have a look around – anytime and anywhere
- A modern learning culture through continuous learning on your own responsibility and transparency about your learning success in the team or company.



Learning Event

Acquire theoretical and practical knowledge in a compact and guided format

- You achieve a defined learning goal in the shortest possible time
- The learning consultant guides you through the practical exercises and is also exclusively available to you during the theoretical sessions for the entire duration
- Focused learning, outside of the daily work routine, in a protected learning environment – virtually, in the training center, or at your company.



Live

Learn together with others, simultaneously and guided by a learning consultant. Online, in the SITRAIN training center or at your company.



Self-reliant

Expand your knowledge self-determined and work on your learning units at your own pace and according to your own schedule.



On demand

Get the knowledge you need, exactly when you need it. Be it to answer a current question or to work on a special topic.

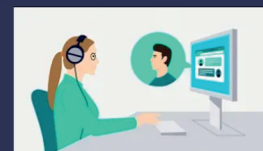

Individually

Talk directly with the learning consultant, clarify detailed questions and get personal coaching for transferring the learned topics to your own application.

6



Training cases catalog

<https://www.siemens.com/sitrain-catalog-training-cases>

Find your local offer here



SITRAIN – Digital Industry Academy worldwide

You will find the regional knowledge offer in the country selection. One click will take you to the corresponding website.

Overview

Training courses for SINAMICS G150/G130/S150

Here you will find an overview of the training courses available for the SINAMICS G150/G130/S150.

The courses are modular in design and are intended for a variety of target groups as well as individual customer requirements.

The system overview will acquaint decision-makers and sales personnel with the system very quickly.

The basic and follow-up courses are guaranteed to provide all of the technical knowledge that service personnel will need for commissioning and service.

All courses contain as many practical exercises as possible in order to enable intensive and direct training on the drive system and with the tools in small groups.

You will find further information about course contents and dates in Catalog ITC and on the Internet.

Title (all courses are available in English and German)	Target group			Duration	Course code
	Sales personnel, planners, decision makers	Commissioning engineers, programmers	Service personnel, maintenance technicians		
SINAMICS system overview	✓	–	–	2 days	DR-SN-UEB
Integrated drive systems - introduction and basic information	✓	–	–	3 days	DR-IDS
SIMOTICS induction motors - planning and configuration	✓	–	–	3 days	DR-ASM-PL
SINAMICS G150/G130/S150 - diagnostics and service	–	✓	✓	5 days	DR-G15-DG
SINAMICS on PROFINET and PROFIBUS - diagnostics and service	–	–	✓	3 days	DR-NET-DG

Services and documentation

Spares on Web

Overview

Spares on Web – online identification of spare parts

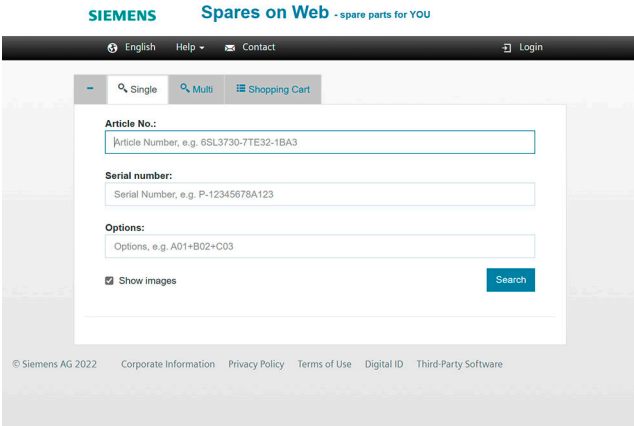

The screenshot displays the Siemens Spares on Web interface. At the top, the Siemens logo is followed by the text "Spares on Web - spare parts for YOU". Below this is a navigation bar with "English", "Help", "Contact", and "Login" links. The main search area features a "Single" search mode selected, with "Multi" and "Shopping Cart" options. The search form includes three input fields: "Article No." (with a placeholder "Article Number, e.g. 6SL3730-7TE32-1BA3"), "Serial number:" (with a placeholder "Serial Number, e.g. P-12345678A123"), and "Options:" (with a placeholder "Options, e.g. A01+B02+C03"). A "Show images" checkbox is checked, and a "Search" button is located to the right of the options field. At the bottom of the page, there is a footer with the text "© Siemens AG 2022" and links for "Corporate Information", "Privacy Policy", "Terms of Use", "Digital ID", and "Third-Party Software".

Spares on Web is a web-based tool for identifying spare parts. After you have entered the Article No. and serial number, the spare parts available for the relevant unit are displayed.

www.siemens.com/sow

Overview

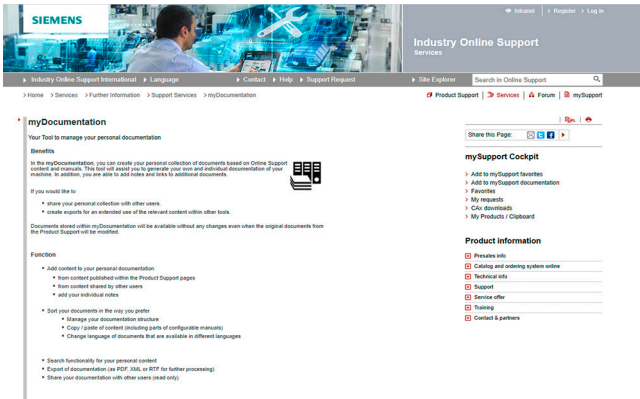

myDocumentation – customized information

myDocumentation offers all Motion Control customers an innovation with extended usability: Machine manufacturers and end users are not only able to assemble their own customized technical documents for a specific product or system on the internet, they can also generate complete libraries with individually configured contents. The content that matches your topic can be selected from the full range of fully configurable manuals stored under product support using the operator interface and assembled using drag & drop into application-based libraries, generated and even combined with your own documentation. The self-generated collections can be saved in the commonly used RTF and PDF formats or even in XML format.

You must register for configuring and generating/managing (the existing login can be used, e.g. SiePortal)
sieportal.siemens.com

Benefits

With myDocumentation, a personal collection of documents can be compiled from the documents and manuals in product support. In this way, your own and individual plant/system documentation is efficiently generated. This can be supplemented by personal notes and links to further documents.

For use beyond the personal area, it is possible

- to share content with other persons
- to use your own relevant content outside the tool via an export function

Design

myDocumentation is the web-based system to generate personalized documentation based on standard documents. It is part of the Industry Online Support.

Function

Opening myDocumentation

myDocumentation can be opened in several ways

- Search in the Service & Support Portal
<https://support.industry.siemens.com>
 Corresponding manuals are marked as "fully configurable". Click on "Display and configure" or "Configure" to open myDocumentation. The selected document is displayed as the current document.
- Using the direct link from the Service & Support Portal
<https://www.automation.siemens.com/docconf/>
 After login/registration, the online help is displayed as current document.
- Click on the "My Documentation" tile in mySupport
<https://support.industry.siemens.com/cs/my?lc=en-WW>

Adding content to personal documentation

- Directly from the product support
- From content provided by other users
- Creating personal notes

Storage of the content relevant to you in your personal structure

- Maintenance of the storage structure
- Copy/paste of content (including excerpts from configurable manuals)
- Language selection for multilingual content

Search in personal documentation

Export documentation (as PDF, XML or RTF for further processing)

Share documentation with other users (read access to your content)

More information

You will find further information on the internet at
<https://support.industry.siemens.com/cs/ww/en/sc/4960>

Services and documentation

Documentation

Overview

SINAMICS G130 converter built-in units

Comprehensive documentation is available for the SINAMICS G130 converter built-in units ranging from Operating Instructions through List Manuals to the Engineering Manual.

Information is available in the following formats:

- PDF file
- Documents/documentation for the configuration and for downloading at:

<https://support.industry.siemens.com/cs/ww/en/ps/13226/man>

SINAMICS G150 converter cabinet units

The documentation is provided only in digital format, and comprises the following sections:

- Description
- Installation instructions
- Commissioning guide
- Description of functions
- Maintenance information

as well as device-specific documentation such as circuit diagrams, dimensional drawings, spare parts lists, layout diagrams and terminal diagrams.

Documentation in English/German is supplied as standard with the device (in PDF format).

If one of the languages subsequently listed is required, when ordering this should be specified using the corresponding option order code (see [Description of options](#)):

Language	Order code
English/French	D58
English/Spanish	D60
English/Italian	D80
English/Chinese	D91
English/Russian	D94

Documents/documentation for the configuration and for downloading at:

<https://support.industry.siemens.com/cs/ww/en/ps/13227/man>

Application

Explanations for the manuals:

- **Operating Instructions**
contain all the information needed for the installation and for the electrical connection of the components, information about commissioning and a description of the converter functions.
Phases of use: Control cabinet construction, commissioning, operation, maintenance and servicing.
- **List Manual**
describes all parameters, function diagrams and faults/alarms for the product/system as well as their meaning and setting options. It contains parameter data and fault/alarm descriptions with functional correlations.
Phases of use: Commissioning of components that have already been connected, configuration of system functions, fault cause/diagnostics.
- **Function Manual**
contains all the relevant information about individual drive functions.
Phases of use: Commissioning of components that have already been connected, configuration of system functions.

Appendix



7/2	Certificates of suitability (approvals)
7/4	Software Licenses
7/6	Conversion tables
7/8	Conditions of sale and delivery

Appendix

Certificates of suitability (approvals)





Overview

Many of the products in this Catalog fulfill requirements, e.g. for UL, CSA or FM and are labeled with the corresponding approval designation.

All of the certificates of suitability, approvals, certificates, declarations of conformity, test certificates, e.g. CE, UL, Safety Integrated etc. have been performed with the associated system components as they are described in the Catalogs and Configuration Manuals.





The certificates are only valid if the products are used with the described system components, are installed according to the Installation Guidelines and used for their intended purpose.

In other cases, the vendor of these products is responsible for arranging for the issue of new certificates.

Test code	Tested by	Device series/ Component	Test standard	Product category/ File-No.
UL: Underwriters Laboratories Independent public testing body in North America				
	UL according to UL standard	SINUMERIK	Standard UL 508, CSA C22.2 No. 142	NRAQ/7.E164110 NRAQ/7.E217227
		SIMOTION	Standard UL 508, CSA C22.2 No. 142	NRAQ/7.E164110
	UL according to CSA standard	SINAMICS	Standard UL 508, 508C, 61800-5-1 CSA C22.2 No. 142, 274	NRAQ/7.E164110, NMMS/2/7/8.E192450, NMMS/2/7/8.E203250, NMMS/7.E214113, NMMS/7.E253831
				NMMS/2/7/8.E121068 NMMS/7.E355661 NMMS/7.E323473
	UL according to UL and CSA standards	SIMODRIVE	Standard UL 508C, CSA C22.2 No. 274	NMMS/2/7/8.E192450 NMMS/7.E214113
				SIMOTICS
	UL according to UL and CSA standards	Line/motor reactors	Standard UL 508, 506, 5085-1, 5085-2, 1561, CSA C22.2 No. 14, 47, 66.1-06, 66.2-06	XQNX2/8.E257859 NMTR2/8.E219022 NMMS2/8.E333628 XPTQ2/8.E257852 XPTQ2/8.E103521 NMMS2/8.E224872 XPTQ2/8.E354316 XPTQ2/8.E198309 XQNX2/8.E475972
				Line filters, dv/dt filters, sine-wave filters
		Resistors	UL 508, 508C, CSA C22.2 No. 14, 274	NMTR2/8.E224314 NMMS2/8.E192450 NMTR2/8.E221095 NMTR2/8.E226619
TUV: TÜV Rheinland of North America Inc. Independent public testing body in North America, Nationally Recognized Testing Laboratory (NRTL)				
TÜV: TÜV SÜD Product Service Independent public testing body in Germany, Nationally Recognized Testing Laboratory (NRTL) for North America				
	TUV according to UL and CSA standards	SINAMICS	NRTL listing according to standard UL 508C	U7V 12 06 20078 013 U7 11 04 20078 009 U7 11 04 20078 010 U7 11 04 20078 011
		SIMOTION	NRTL listing according to standard UL 508	U7V 13 03 20078 01
		SIMODRIVE	NRTL listing according to standard UL 508C, CSA C22.2. No. 14	CU 72090702
		Motion Control Encoder	NRTL listing according to UL 61010-1 CSA C22.2 No. 61010-1	U8V 10 06 20196 024

Certificates of suitability (approvals)

Overview

Test code	Tested by	Device series/ Component	Test standard	Product category/ File-No.
CSA: Canadian Standards Association Independent public testing body in Canada				
	CSA according to CSA standard	SINUMERIK	Standard CSA C22.2 No. 142	2252-01 : LR 102527
FMRC: Factory Mutual Research Corporation Independent public testing body in North America				
	FM according to FM standard	SINUMERIK	Standard FMRC 3600, FMRC 3611, FMRC 3810, ANSI/ISA S82.02.1	-
EAC: Ivanovo-Certificate Independent public testing body in the Russian Federation				
	EAC in accordance with the EAC Directive	SINAMICS SINUMERIK SIMOTION	Standard IEC 61800-5-1/-2, IEC 61800-3	-
RCM: Australian Communications and Media Authority Independent public testing body in Australia				
	RCM according to EMC standard	SINAMICS SINUMERIK SIMOTION	Standard IEC AS 61800-3, EN 61800-3	-
KC: National Radio Research Agency Independent public testing body in South Korea				
	KC according to EMC standard	SINAMICS SINUMERIK SIMOTION	Standard KN 11	-
BIA Federal Institute for Occupational Safety				
-	Functional safety	SINAMICS SINUMERIK SIMOTION	Standard EN 61800-5-2	-
TÜV SÜD Rail				
-	Functional safety	SINAMICS SINUMERIK SIMOTION	Standard EN 61800-5-2	-

More information about certificates can be found online at:
<https://support.industry.siemens.com/cs/ww/en/ps/cert>

Appendix

Overview

Software types

Software requiring a license is categorized into types. The following software types have been defined:

- Engineering software
- Runtime software

Engineering software

This includes all software products for creating (engineering) user software, e.g. for configuring, programming, parameterizing, testing, commissioning or servicing.

Data generated with engineering software and executable programs can be duplicated for your own use or for use by third-parties free-of-charge.

Runtime software

This includes all software products required for plant/machine operation, e.g. operating system, basic system, system expansions, drivers, etc.

The duplication of the runtime software and executable programs created with the runtime software for your own use or for use by third-parties is subject to a charge.

You can find information about license fees according to use in the ordering data (e.g. in the catalog). Examples of categories of use include per CPU, per installation, per channel, per instance, per axis, per control loop, per variable, etc.

Information about extended rights of use for parameterization/configuration tools supplied as integral components of the scope of supply can be found in the readme file supplied with the relevant product(s).

License types

Siemens Digital Industries and Smart Infrastructure offers various types of software license:

- Floating license
- Single license
- Rental license
- Rental floating license
- Trial license
- Demo license
- Demo floating license

Floating license

The software may be installed for internal use on any number of devices by the licensee. Only the concurrent user is licensed. The concurrent user is the person using the program. Use begins when the software is started. A license is required for each concurrent user.

Single license

Unlike the floating license, a single license permits only one installation of the software per license.

The type of use licensed is specified in the ordering data and in the Certificate of License (CoL). Types of use include for example per instance, per axis, per channel, etc.

One single license is required for each type of use defined.

Rental license

A rental license supports the "sporadic use" of engineering software. Once the license key has been installed, the software can be used for a specific period of time (the operating hours do not have to be consecutive).

One license is required for each installation of the software.

Rental floating license

The rental floating license corresponds to the rental license, except that a license is not required for each installation of the software. Rather, one license is required per object (for example, user or device).

Trial license

A trial license supports "short-term use" of the software in a non-productive context, e.g. for testing and evaluation purposes. It can be transferred to another license.

Demo license

The demo license support the "sporadic use" of engineering software in a non-productive context, for example, use for testing and evaluation purposes. It can be transferred to another license. After the installation of the license key, the software can be operated for a specific period of time, whereby usage can be interrupted as often as required.

One license is required per installation of the software.

Demo floating license

The demo floating license corresponds to the demo license, except that a license is not required for each installation of the software. Rather, one license is required per object (for example, user or device).

Certificate of License (CoL)

The CoL is the licensee's proof that the use of the software has been licensed by Siemens. A CoL is required for every type of use and must be kept in a safe place.

Downgrading

The licensee is permitted to use the software or an earlier version/release of the software, provided that the licensee owns such a version/release and its use is technically feasible.

Delivery versions

Software is constantly being updated. The following delivery versions

- PowerPack
- Upgrade

can be used to access updates.

Existing bug fixes are supplied with the ServicePack version.

PowerPack

PowerPacks can be used to upgrade to more powerful software. The licensee receives a new license agreement and CoL (Certificate of License) with the PowerPack. This CoL, together with the CoL for the original product, proves that the new software is licensed.

A separate PowerPack must be purchased for each original license of the software to be replaced.

Upgrade

An upgrade permits the use of a new version of the software on the condition that a license for a previous version of the product is already held.

The licensee receives a new license agreement and CoL with the upgrade. This CoL, together with the CoL for the previous product, proves that the new version is licensed.

A separate upgrade must be purchased for each original license of the software to be upgraded.

Overview

ServicePack

ServicePacks are used to debug existing products. ServicePacks may be duplicated for use as prescribed according to the number of existing original licenses.

License key

Siemens Digital Industries and Smart Infrastructure supplies software products with and without license keys.

The license key serves as an electronic license stamp and is also the "switch" for activating the software (floating license, rental license, etc.).

The complete installation of software products requiring license keys includes the program to be licensed (the software) and the license key (which represents the license).

Software Update Service (SUS)

As part of the SUS contract, all software updates for the respective product are made available to you free of charge for a period of one year from the invoice date. The contract will automatically be extended for one year if it is not canceled three months before it expires.

The possession of the current version of the respective software is a basic condition for entering into an SUS contract.

You can download explanations concerning license conditions from https://mall.industry.siemens.com/legal/ww/en/terms_of_trade_en.pdf

Appendix

Conversion tables

Rotary inertia (to convert from A to B, multiply by entry in table)

A \ B	lb-in ²	lb-ft ²	lb-in-s ²	lb-ft-s ² slug-ft ²	kg-cm ²	kg-cm-s ²	gm-cm ²	gm-cm-s ²	oz-in ²	oz-in-s ²
lb-in ²	1	6.94×10^{-3}	2.59×10^{-3}	2.15×10^{-4}	2.926	2.98×10^{-3}	2.92×10^3	2.984	16	4.14×10^{-2}
lb-ft ²	144	1	0.3729	3.10×10^{-2}	421.40	0.4297	4.21×10^5	429.71	2304	5.967
lb-in-s ²	386.08	2.681	1	8.33×10^{-2}	1.129×10^3	1.152	1.129×10^6	1.152×10^3	6.177×10^3	16
lb-ft-s ² slug-ft ²	4.63×10^3	32.17	12	1	1.35×10^4	13.825	1.355×10^7	1.38×10^4	7.41×10^4	192
kg-cm ²	0.3417	2.37×10^{-3}	8.85×10^{-4}	7.37×10^{-5}	1	1.019×10^{-3}	1000	1.019	5.46	1.41×10^{-2}
kg-cm-s ²	335.1	2.327	0.8679	7.23×10^{-2}	980.66	1	9.8×10^5	1000	5.36×10^3	13.887
gm-cm ²	3.417×10^{-4}	2.37×10^{-6}	8.85×10^{-7}	7.37×10^{-8}	1×10^{-3}	1.01×10^{-6}	1	1.01×10^{-3}	5.46×10^{-3}	1.41×10^{-5}
gm-cm-s ²	0.335	2.32×10^{-3}	8.67×10^{-4}	7.23×10^{-5}	0.9806	1×10^{-3}	980.6	1	5.36	1.38×10^{-2}
oz-in ²	0.0625	4.34×10^{-4}	1.61×10^{-4}	1.34×10^{-5}	0.182	1.86×10^{-4}	182.9	0.186	1	2.59×10^{-3}
oz-in-s ²	24.13	0.1675	6.25×10^{-2}	5.20×10^{-3}	70.615	7.20×10^{-2}	7.09×10^4	72.0	386.08	1

Torque (to convert from A to B, multiply by entry in table)

A \ B	lb-in	lb-ft	oz-in	N-m	kg-cm	kg-m	gm-cm	dyne-cm
lb-in	1	8.333×10^{-2}	16	0.113	1.152	1.152×10^{-2}	1.152×10^3	1.129×10^6
lb-ft	12	1	192	1.355	13.825	0.138	1.382×10^4	1.355×10^7
oz-in	6.25×10^{-2}	5.208×10^{-3}	1	7.061×10^{-3}	7.200×10^{-2}	7.200×10^{-4}	72.007	7.061×10^4
N-m	8.850	0.737	141.612	1	10.197	0.102	1.019×10^4	1×10^7
kg-cm	0.8679	7.233×10^{-2}	13.877	9.806×10^{-2}	1	10^{-2}	1000	9.806×10^5
kg-m	86.796	7.233	1.388×10^3	9.806	100	1	1×10^5	9.806×10^7
gm-cm	8.679×10^{-4}	7.233×10^{-5}	1.388×10^{-2}	9.806×10^{-5}	1×10^{-3}	1×10^{-5}	1	980.665
dyne-cm	8.850×10^{-7}	7.375×10^{-8}	1.416×10^{-5}	10^{-7}	1.0197×10^{-6}	1.019×10^{-8}	1.019×10^{-3}	1

Length (to convert from A to B, multiply by entry in table)

A \ B	inches	feet	cm	yd	mm	m
inches	1	0.0833	2.54	0.028	25.4	0.0254
feet	12	1	30.48	0.333	304.8	0.3048
cm	0.3937	0.03281	1	1.09×10^{-2}	10	0.01
yd	36	3	91.44	1	914.4	0.914
mm	0.03937	0.00328	0.1	1.09×10^{-3}	1	0.001
m	39.37	3.281	100	1.09	1000	1

Force (to convert from A to B, multiply by entry in table)

A \ B	lb	oz	gm	dyne	N
lb	1	16	453.6	4.448×10^5	4.4482
oz	0.0625	1	28.35	2.780×10^4	0.27801
gm	2.205×10^{-3}	0.03527	1	1.02×10^{-3}	N.A.
dyne	2.248×10^{-6}	3.59×10^{-5}	980.7	1	0.00001
N	0.22481	3.5967	N.A.	100000	1

Mass (to convert from A to B, multiply by entry in table)

A \ B	lb	oz	gm	kg	slug
lb	1	16	453.6	0.4536	0.0311
oz	6.25×10^{-2}	1	28.35	0.02835	1.93×10^{-3}
gm	2.205×10^{-3}	3.527×10^{-2}	1	10^{-3}	6.852×10^{-5}
kg	2.205	35.27	10^3	1	6.852×10^{-2}
slug	32.17	514.8	1.459×10^4	14.59	1

Rotation (to convert from A to B, multiply by entry in table)

A \ B	r/min	rad/s	degrees/s
r/min	1	0.105	6.0
rad/s	9.55	1	57.30
degrees/s	0.167	1.745×10^{-2}	1

Power (to convert from A to B, multiply by entry in table)

A \ B	hp	Watts
hp (English)	1	745.7
(lb-in) (deg./s)	2.645×10^{-6}	1.972×10^{-3}
(lb-in) (r/min)	1.587×10^{-5}	1.183×10^{-2}
(lb-ft) (deg./s)	3.173×10^{-5}	2.366×10^{-2}
(lb-ft) (r/min)	1.904×10^{-4}	0.1420
Watts	1.341×10^{-3}	1

Temperature Conversion

°F	°C	°C	°F
0	-17.8	-10	14
32	0	0	32
50	10	10	50
70	21.1	20	68
90	32.2	30	86
98.4	37	37	98.4
212	100	100	212
subtract 32 and multiply by $\frac{5}{9}$		multiply by $\frac{9}{5}$ and add 32	

Mechanism Efficiencies

Acme-screw with brass nut	~0.35–0.65
Acme-screw with plastic nut	~0.50–0.85
Ball-screw	~0.85–0.95
Chain and sprocket	~0.95–0.98
Preloaded ball-screw	~0.75–0.85
Spur or bevel-gears	~0.90
Timing belts	~0.96–0.98
Worm gears	~0.45–0.85
Helical gear (1 reduction)	~0.92

Friction Coefficients

Materials	μ
Steel on steel (greased)	~0.15
Plastic on steel	~0.15–0.25
Copper on steel	~0.30
Brass on steel	~0.35
Aluminum on steel	~0.45
Steel on steel	~0.58
Mechanism	μ
Ball bushings	<0.001
Linear bearings	<0.001
Dove-tail slides	~0.2++
Gibb ways	~0.5++

Material Densities

Material	lb-in ³	gm-cm ³
Aluminum	0.096	2.66
Brass	0.299	8.30
Bronze	0.295	8.17
Copper	0.322	8.91
Hard wood	0.029	0.80
Soft wood	0.018	0.48
Plastic	0.040	1.11
Glass	0.079–0.090	2.2–2.5
Titanium	0.163	4.51
Paper	0.025–0.043	0.7–1.2
Polyvinyl chloride	0.047–0.050	1.3–1.4
Rubber	0.033–0.036	0.92–0.99
Silicone rubber, without filler	0.043	1.2
Cast iron, gray	0.274	7.6
Steel	0.280	7.75

Wire Gauges¹⁾

Cross-section mm ²	Standard Wire Gauge (SWG)	American Wire Gauge (AWG)
0.2	25	24
0.3	23	22
0.5	21	20
0.75	20	19
1.0	19	18
1.5	17	16
2.5	15	13
4	13	11
6	12	9
10	9	7
16	7	6
25	5	3
35	3	2
50	0	1/0
70	000	2/0
95	00000	3/0
120	0000000	4/0
150	–	6/0
185	–	7/0

¹⁾ The table shows approximate SWG/AWG sizes nearest to standard metric sizes; the cross-sections do not match exactly.

Appendix

Conditions of sale and delivery

1. General Provisions

By using this catalog you can purchase hard- and software products as well as services (together hereinafter referred to as "products") described therein from Siemens Aktiengesellschaft subject to the following Terms and Conditions of Sale and Delivery (hereinafter referred to as "T&C"). Note, for products purchased from any Siemens entity having a registered office outside of Germany, the respective terms and conditions of sale and delivery of the respective Siemens entity apply exclusively. The following T&C apply exclusively for orders placed with Siemens Aktiengesellschaft, Germany.

1.1 For customers with a seat or registered office in European Union

For customers with a seat or registered office in European Union, the following terms and conditions apply subordinate to T&C:

- for products, which include specific terms and conditions in the text of the product description, these specific terms and conditions shall apply and subordinate thereto,,
- for stand-alone software products and software products forming a part of a product or project, the "General Conditions for Software Products for Infrastructure & Industry Business (German law)"¹⁾ and/or
- for consulting services the "Allgemeine Geschäftsbedingungen für Beratungsleistungen für Infrastructure & Industry Geschäft (Deutsches Recht)"¹⁾ (available only in German) and/or
- for other services, the „Supplementary Terms and Conditions for Services for Infrastructure & Industry Business (German Law) ("BL")"¹⁾ and/or
- for other products the "General Conditions for the Supply of Products and Services of the Electrical and Electronics Industry"¹⁾.
In case such products should contain Open Source Software, the conditions of which shall prevail over the "General Conditions for the Supply of Products and Services of the Electrical and Electronics Industry"¹⁾, the Product will be given a note as to which special conditions apply to this open source software. This shall apply mutatis mutandis for notices referring to other third-party software components.

1.2 For customers with a seat or registered office outside European Union

For customers with a seat or registered office outside European Union, the following terms and conditions apply subordinate to T&C:

- for products, which include specific terms and conditions in the description text, these specific terms and conditions shall apply and subordinate thereto,
- for consulting services the "Standard Terms and Conditions for Consulting Services for Infrastructure & Industry Business (Swiss Law)"¹⁾ and/or
- for other services the "International Terms & Conditions for Services"¹⁾ supplemented by "Software Licensing Conditions"¹⁾ and/or
- for other products the "International Terms & Conditions for Products"¹⁾ supplemented by "Software Licensing Conditions"¹⁾

1.3 For customers with master or framework agreement

To the extent products offered are covered by an existing master or framework agreement, the terms and conditions of that agreement shall apply instead of T&C.

2. Prices

The prices are in € (Euro) ex point of delivery, exclusive of packaging.

The sales tax (value added tax) is not included in the prices. It shall be charged separately at the respective rate according to the applicable statutory legal regulations.

Prices are subject to change without prior notice. We will charge the prices valid at the time of delivery.

To compensate for variations in the price of raw materials (e.g. silver, copper, aluminum, lead, gold, dysprosium and neodym), surcharges are calculated on a daily basis using the so-called metal factor for products containing these raw materials.

A surcharge for the respective raw material is calculated as a supplement to the price of a product if the basic official price of the raw material in question is exceeded.

The metal factor of a product indicates the basic official price (for those raw materials concerned) as of which the surcharges on the price of the product are applied, and with what method of calculation. The metal factor, provided it is relevant, can be found in the respective product description.

An exact explanation of the metal factor can be downloaded at: https://mall.industry.siemens.com/legal/ww/en/terms_of_trade_en.pdf

To calculate the surcharge (except in the cases of copper, dysprosium and neodym), the official price from the day prior to that on which the order was received or the release order was effected is used.

To calculate the surcharge applicable to copper, the official price from two days prior to that on which the order was received or the release order was effected is used.

To calculate the surcharge applicable to dysprosium and neodym ("rare earths"), the corresponding three-month basic average price in the quarter prior to that in which the order was received or the release order was effected is used with a one-month buffer (details on the calculation can be found in the explanation of the metal factor).

3. Additional Terms and Conditions

The dimensions are in mm. In Germany, according to the German law on units in measuring technology, data in inches apply only to devices for export.

Illustrations are not binding.

Insofar as there are no remarks on the individual pages of this catalog – especially with regard to data, dimensions and weights given – these are subject to change without prior notice.

¹⁾ The text of the Terms and Conditions of Siemens AG can be downloaded at https://mall.industry.siemens.com/legal/ww/en/terms_of_trade_en.pdf

4. Export Control and Sanctions Compliance

4.1 General

Customer shall comply with all applicable sanctions, embargoes and (re-)export control laws and regulations, and, in any event, with those of the European Union, the United States of America and any locally applicable jurisdiction (collectively "Export Regulations").

4.2 Checks for Products

Prior to any transaction by customer concerning products (including hardware, documentation and technology) delivered by Siemens, or products (including maintenance and technical support) performed by Siemens with a third party, customer shall check and certify by appropriate measures that

- (i) the customer's use, transfer, or distribution of such products, the brokering of contracts or the provision of other economic resources in connection with products will not be in violation of any Export Regulations, also taking into account any prohibitions to circumvent these (e.g., by undue diversion)
- (ii) the products are not intended or provided for prohibited or unauthorized non-civilian purposes (e.g. armaments, nuclear technology, weapons, or any other usage in the field of defense and military);
- (iii) customer has screened all direct and indirect parties involved in the receipt, use, transfer, or distribution of the products against all applicable restricted party lists of the Export Regulations concerning trading with entities, persons and organizations listed therein and
- (iv) products within the scope of items-related restrictions, as specified in the respective annexes to the Export Regulations, will not, unless permitted by the Export Regulations, be
 - (a) exported, directly or indirectly (e.g., via Eurasian Economic Union (EAEU) countries), to Russia or Belarus, or
 - (b) resold to any third party business partner that does not take a prior commitment not to export such products to Russia or Belarus.

4.3 Non-Acceptable Use of Software and Cloud Services

Customer shall not, unless permitted by the Export Regulations or respective governmental licenses or approvals,

- (i) download, install, access or use the products from or in any location prohibited by or subject to comprehensive sanctions or subject or to license requirements according to the Export Regulations;
 - (ii) grant access to, transfer, (re-)export (including any "deemed (re-)exports"), or otherwise make available the products to any entity, person, or organization identified on a restricted party list of the Export Regulations;
 - (iii) use the products for any purpose prohibited by the Export Regulations (e.g. use in connection with armaments, nuclear technology or weapons);
 - (iv) upload to a products platform any customer content unless it is non-controlled (e.g. in the EU: AL = N; in the U.S.: ECCN = N or EAR99);
 - (v) facilitate any of the afore mentioned activities by any user.
- Customer shall provide all users with all information necessary to ensure compliance with the Export Regulations.

4.4 Semiconductor Development

Customer will not, without advance written authorization from Siemens, use offerings for the development or production of integrated circuits at any semiconductor fabrication facility located in China meeting the criteria specified in the U.S. Export Administration Regulations, 15 C.F.R. 744.23.

4.5 Information

Upon request by Siemens, customer shall promptly provide Siemens with all information pertaining to users, the intended use and the location of use or the final destination (in the case of hardware, documentation and technology) of the products. Customer will notify Siemens prior to customer disclosing any information to Siemens that is defense-related or requires controlled or special data handling pursuant to applicable government regulations, and will use the disclosure tools and methods specified by Siemens.

4.6 Reservation

Siemens shall not be obligated to fulfill this agreement if such fulfillment is prevented by any impediments arising out of national or international foreign trade or customs requirements or any embargoes or other sanctions. Customer acknowledges that Siemens may be obliged under the Export Regulations to limit or suspend access by customer and/or users to products.

5. Miscellaneous

Errors excepted and subject to change without prior notice.

Appendix

Notes

Selection and ordering at Siemens SiePortal – Ordering products and downloading catalogs

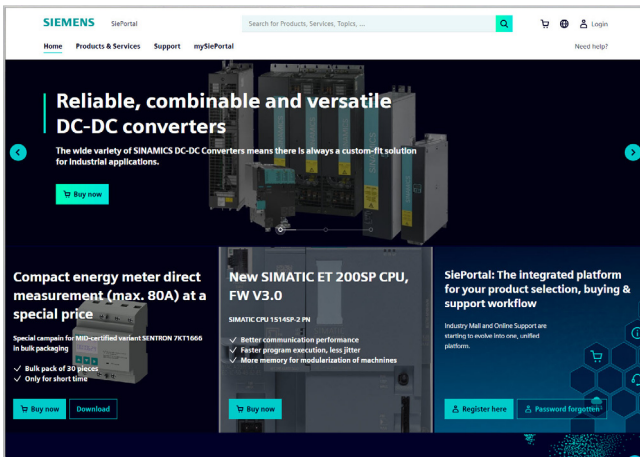

Easy product selection and ordering with SiePortal

SiePortal > Products & Services

The internet ordering platform of Siemens AG is located in SiePortal. It provides you with online access to a comprehensive product spectrum that is presented in an informative, well-organized way.

Powerful search functions help you select the required products, while configurators enable you to configure complex product and system components quickly and easily. CAX data are also available for you to use.

Data transfer allows the entire procedure, from selection through ordering to tracking and tracing, to be carried out online. Availability checks, individual customer discounting, and quotation preparation are also possible.

sieportal.siemens.com

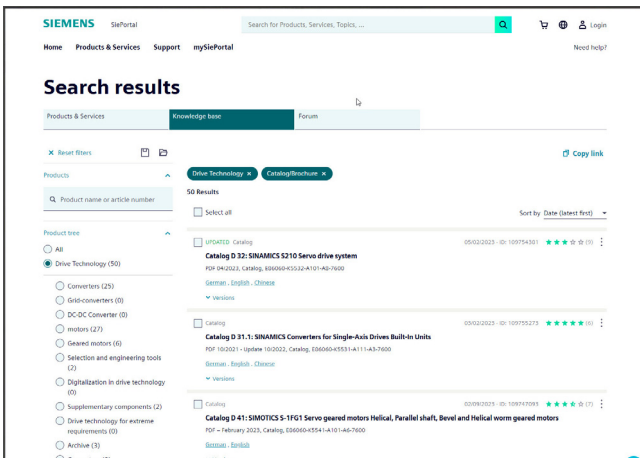

Downloading catalogs

SiePortal > Support > Knowledge base

You can download catalogs and brochures in PDF format from Siemens Industry Online Support without having to register.

The filter box makes it possible to perform targeted searches.

sieportal.siemens.com

Get more information

SINAMICS G130
Converter Built-in Units
www.siemens.com/sinamics-g130

SINAMICS G150
Converter Cabinet Units
www.siemens.com/sinamics-g150

SINAMICS converter family:
www.siemens.com/sinamics

Local partners worldwide:
www.siemens.com/automation-contact

Published by
Siemens AG

Digital Industries
Motion Control
Postfach 31 80
91050 Erlangen, Germany

For the U.S. published by
Siemens Industry Inc.

100 Technology Drive
Alpharetta, GA 30005
United States

PDF (E86060-K5511-A101-A7-7600)
V6.MKKATA.GMC.500
KG 1123 204 En
Produced in Germany
© Siemens 2023

Cybersecurity information

Siemens provides products and solutions with industrial cybersecurity functions that support the secure operation of plants, systems, machines and networks.

In order to protect plants, systems, machines and networks against cyber threats, it is necessary to implement – and continuously maintain – a holistic, state-of-the-art industrial cybersecurity concept. Siemens' products and solutions constitute one element of such a concept.

Customers are responsible for preventing unauthorized access to their plants, systems, machines and networks. Such systems, machines and components should only be connected to an enterprise network or the internet if and to the extent such a connection is necessary and only when appropriate security measures (e.g. firewalls and/or network segmentation) are in place.

For additional information on industrial cybersecurity measures that may be implemented, please visit

www.siemens.com/cybersecurity-industry.

Siemens' products and solutions undergo continuous development to make them more secure. Siemens strongly recommends that product updates are applied as soon as they are available and that the latest product versions are used. Use of product versions that are no longer supported, and failure to apply the latest updates may increase customer's exposure to cyber threats.

To stay informed about product updates, subscribe to the Siemens Industrial Cybersecurity RSS Feed under
www.siemens.com/cert

Subject to changes and errors. The information given in this document only contains general descriptions and/or performance features which may not always specifically reflect those described, or which may undergo modification in the course of further development of the products. The requested performance features are binding only when they are expressly agreed upon in the concluded contract.

All product designations may be trademarks or product names of Siemens AG or other companies whose use by third parties for their own purposes could violate the rights of the owners.