

DISTRIBUTED BY

**Best MATERIALS**.com<sup>®</sup>

**DEWALT**<sup>®</sup>

**ANCHORS & FASTENERS**



## BUYERS GUIDE

**DEWALT**

**Powers**  
FASTENING INNOVATIONS

**ELCO**

ANCHORS

LIGHT DUTY

ADHESIVES

INSTALLATION SYSTEMS

DIRECT FASTENING

ELCO SCREWS

SOFTWARE



# THE COMPLETE SOFTWARE FOR ANCHORING TO CONCRETE



**DESIGN**



**COMPARE**



**DOCUMENT**



**ANCHOR**

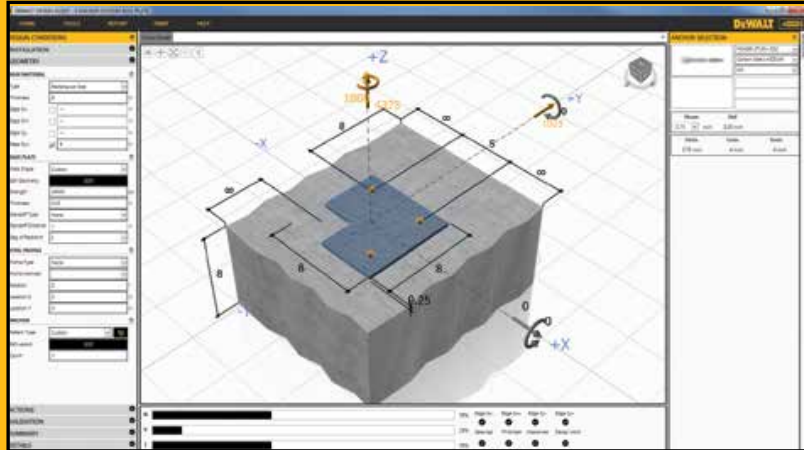

## Building with steel and concrete takes vision, power, and structural design without limits.

DEWALT Design Assist is a free structural design software that streamlines, automates and optimizes DEWALT anchoring products in accordance with ACI318, anchor design provisions of the Canadian Standards Association (CSA A23.3-14), and optional metric units of measurement.

### ANCHOR TYPES:



**Cast-in-Place**



**Mechanical**



**Adhesives**

DOWNLOAD AT [DEWALT.COM/DDA](http://DEWALT.COM/DDA)

**DEWALT**

<b>MECHANICAL ANCHORS</b>	4
EXPANSION ANCHORS	6
UNDERCUT ANCHORS	13
BOLT/SHIELD ANCHORS	14
SCREW ANCHORS	16
CAST-IN-PLACE ROD HANGER ANCHORS	22
ROD HANGER ANCHORS	24
PIN/NAIL ANCHORS	34
LIGHT DUTY ANCHORS	38
<b>ADHESIVE ANCHORS</b>	43
ACRYLIC ADHESIVES	44
EPOXY ADHESIVES	46
FOAM / SEALANTS	48
<b>INSTALLATION TOOLS</b>	50
<b>INSTALLATION ACCESSORIES</b>	56
DRILL BITS	56
HAND TOOLS	59
DRILLING ACCESSORIES	60
POWER TOOL ACCESSORIES	60
ADHESIVE ACCESSORIES	61
<b>DIRECT FASTENING</b>	68
CORDLESS CONCRETE NAILING SYSTEM	68
POWDER ACTUATED FASTENING SYSTEM	70
<b>POWERS FASTENERS</b>	
GAS FASTENING	80
ROOFING	82
<b>ELCO CONSTRUCTION PRODUCTS</b>	
DRILIT® DRILL SCREWS	86
TAPFAST®	92
ROOF CLIP FASTENERS	92
DRIL-FLEX®	92
TAP-FLEX®	94
ALUMI-FLEX®	94
BI-FLEX®	95
FAB-LOK®	96
CON-FLEX®	96
RAPIDSET TOOLS	98



# DEWALT®

## OUR HISTORY OF GUARANTEED TOUGH.®

### 1900'S

### 1922

Raymond DeWalt, then superintendent of Seabrook Farms, perfects the first woodworking machine for the purpose of increasing productivity and versatility.



### 1924

DeWALT Products Company's first plant and offices are located in Leola, Pennsylvania.



### 1955

Over the next two years, adds 40,000 sq. ft. of manufacturing space to the plant in order to keep up with consumer demand



### 1994

DeWALT kickstarts a revolutionary system of over 30 new cordless tools, including the most powerful cordless tool at the time, the 14.4 volt cordless drill/driver and 5-3/8" cordless saw.

DeWALT cordless system included drill/drivers, screwdrivers, impact drivers, impact wrench, saws, flashlights, and the first combination drill/driver/hammer drill.



**14.4  
VOLT**

### 1923

First DeWALT tool, a radial arm saw, sold.



### 1941

The DeWALT firm begins a period of rapid expansion to meet the demands of government orders in connection with national defense and wartime machinery requirements.



### 1992

DeWALT introduces its first line of portable electric power tools and accessories designed specifically for residential contractors, remodelers, and professional woodworkers.



**2000'S**

**2010**

DeWALT introduces the new 12V MAX\* system of lithium ion tools designed to incorporate comfort and compact design with the power and industry-leading features contractors need on the jobsite.



**2012**

DeWALT launches Perform and Protect™ line of products designed to provide a high level of one or more of the following: control, dust containment or low vibration, without sacrificing performance.



**2015**

DeWALT introduces Tool Connect™, which allows users with Bluetooth®-enabled DeWALT products to connect and track their tools from anywhere with real-time updates from the field.



**2017**

DeWALT has always delivered GUARANTEED TOUGH® products. That legacy is continued with our upcoming digital solutions. DeWALT Jobsite WiFi is tough enough for the jobsite with simple setup and adaptability for construction.



**18 VOLT**

**2011**

DeWALT expands its lithium ion tools offering with the introduction of the new 20V MAX\* system. DeWALT also continues to support its 69 million 18V cordless system battery users with new 18V products.



**2013**

In 2013, DeWALT introduces its cordless 20V MAX\* XR® line of Brushless power tools which include brushless motors and high capacity lithium ion batteries.



**2016**

DeWALT launches DeWALT FLEXVOLT®, the world's first battery that automatically changes voltage when the user changes tools, offering both increased power and runtime for the jobsite.

**DEWALT FLEXVOLT**



**2018**

April 2018 marks the 100th anniversary of the Product Service Division of Stanley Black & Decker. Repair, parts, and accessories are available at 64 centers across the United States and 830 authorized service centers.



**" YOU BUY A MACHINE AND WHAT YOU REALLY GET IS SATISFACTION, ENTIRE SATISFACTION."**

**- RAYMOND DeWALT**







**EXPANSION ANCHORS**

**Power-Stud® + SD1**

Type	Wedge Expansion Anchor
Approvals	ICC-ES ESR-2818 (Concrete) ESR-2966 (Masonry) IBC & IRC 2018, 2015, 2012, 2009 Recognition in cracked & uncracked concrete including seismic and wind loading (Category 1 Anchors) Full FM & UL listings in product brochure or at <a href="http://www.DEWALT.com">www.DEWALT.com</a>
Description	Fully threaded Torque controlled
Base Materials	Normal and sand-light-weight concrete, concrete over metal deck, grouted concrete masonry (CMU)
Anchor Material	Carbon steel body & expansion clip

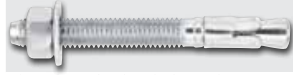

POWER-STUD+ SD1 CARBON STEEL BODY & EXPANSION CLIP				
CAT #	SIZE	THREAD LEN	CTN	MSTR
7400SD1*	1/4" x 1-3/4"	3/4"	100	600
7402SD1	1/4" x 2-1/4"	1-1/4"	100	600
7404SD1	1/4" x 3-1/4"	2-1/4"	100	600
7410SD1*	3/8" x 2-1/4"	7/8"	50	300
7412SD1*	3/8" x 3-1/4"	1-3/8"	50	300
7413SD1	3/8" x 3"	1-5/8"	50	300
7414SD1	3/8" x 3-1/2"	2-1/8"	50	300
7415SD1	3/8" x 3-3/4"	2-3/8"	50	300
7416SD1	3/8" x 5"	3-5/8"	50	300
7417SD1	3/8" x 7"	5-5/8"	50	200
7420SD1*	1/2" x 2-3/4"	1"	50	200
7422SD1	1/2" x 3-3/4"	2"	50	200
7423SD1	1/2" x 4-1/2"	2-3/4"	50	200
7424SD1	1/2" x 5-1/2"	3-3/4"	50	150
7426SD1	1/2" x 7"	5-1/4"	25	100
7427SD1	1/2" x 8-1/2"	6-3/4"	25	100
7428SD1	1/2" x 10"	8-1/4"	25	100
7430SD1*	5/8" x 3-1/2"	1-1/2"	25	100
7432SD1	5/8" x 4-1/2"	2-1/2"	25	100
7433SD1	5/8" x 5"	3"	25	100
7434SD1	5/8" x 6"	4"	25	75
7436SD1	5/8" x 7"	5"	25	75
7438SD1	5/8" x 8-1/2"	6-1/2"	25	50
7439SD1	5/8" x 10"	8"	25	50
7440SD1*	3/4" x 4-1/4"	1-3/4"	20	60
7441SD1*	3/4" x 4-3/4"	2-1/4"	20	60
7442SD1	3/4" x 5-1/2"	3"	20	60
7444SD1	3/4" x 6-1/4"	3-3/4"	20	60
7446SD1	3/4" x 7"	4-1/2"	20	60
7448SD1	3/4" x 8-1/2"	6"	10	40
7449SD1	3/4" x 10"	7-1/2"	10	40
7451SD1	3/4" x 12"	9-1/2"	10	20
7450SD1*	7/8" x 6"	2-3/4"	10	40
7452SD1	7/8" x 8"	4-3/4"	10	40
7454SD1	7/8" x 10"	6-3/4"	10	20
7461SD1*	1" x 6"	2-3/8"	10	30
7463SD1	1" x 9"	5-3/8"	10	20
7465SD1	1" x 12"	8-3/8"	5	10
7473SD1	1-1/4" x 9"	4-3/4"	5	10
7475SD1	1-1/4" x 12"	7-3/4"	5	10

\*For Power-Stud+ SD1 Less than the minimum standard anchor length for strength design. Published length is the overall length of the anchor. Allow for fixture thickness plus one anchor diameter for the nut and washer thickness when selecting a length. Packaged with nuts and washers.  
1/4" diameter Power-Stud+ SD1 and Tie-Wire Power-Stud for uncracked concrete only



TIE-WIRE POWER-STUD					
CAT #	SIZE	WIRE HOLE	MIN EMBED	CTN	MSTR
7409SD1*	1/4" x 2"	9/32"	1-1/8"	100	600

RECOMMENDED INSTALLATION POWER TOOLS		
CAT #	TYPE	PAGE
DCH273P2DH0, DCH293R2DH, DCH133M2, DCH263R2DH, D25263K, D25333K	SDS+ Rotary Hammers	50
DCH481X2, DCH733X2	SDS Max FlexVolt Cordless Rotary Hammers	51
D25481K, D25604K, D25733K	SDS Max Combination Hammers	51



ACCESSORIES		
TYPE		PAGE
SDS+ Carbide Drill Bits	by diameter/length	56
SDS Max Carbide Drill Bits	by diameter/length	57
Hollow Drill Bit	by diameter/length	58
Hammer	refer to page	59
Torque Wrench	refer to page	59
Socket	refer to page	59



**GUARANTEED TOUGH.®**

**EXPANSION ANCHORS**

**Power-Stud® +SD2**

Type	Wedge Expansion Anchor
Approvals	ICC-ES ESR-2502 (Concrete); IBC & IRC 2018, 2015, 2012, 2009    
Description	Recognition in cracked & uncracked concrete including seismic and wind loading (Category 1 Anchors) Full FM & UL listings in product brochure or at www.DeWALT.com
Description	Fully threaded Torque controlled
Base Materials	Normal and sand-lightweight concrete, concrete over metal deck, grouted concrete masonry (CMU)
Anchor Material	Carbon steel body w. ss expansion clip



**POWER-STUD+ SD2 CARBON STEEL BODY & SS EXPANSION CLIP**

CAT #	SIZE	THREAD LEN	CTN	MSTR
7413SD2	3/8" x 3"	1-5/8"	50	300
7414SD2	3/8" x 3-1/2"	2-1/4"	50	300
7415SD2	3/8" x 3-3/4"	2-1/2"	50	300
7416SD2	3/8" x 5"	3-3/4"	50	300
7422SD2	1/2" x 3-3/4"	2-1/8"	50	200
7424SD2	1/2" x 5-1/2"	3-7/8"	50	150
7426SD2	1/2" x 7"	5-3/8"	25	100
7427SD2	1/2" x 8-1/2"	6-7/8"	25	100
7435SD2	5/8" x 4-3/4"	2-7/8"	25	100
7433SD2	5/8" x 5"	3-1/8"	25	100
7434SD2	5/8" x 6"	4-1/8"	25	75
7436SD2	5/8" x 7"	5-1/8"	25	75
7438SD2	5/8" x 8-1/2"	6-5/8"	25	50
7442SD2	3/4" x 5-1/2"	3-1/4"	20	60
7444SD2	3/4" x 6-1/4"	4"	20	60
7446SD2	3/4" x 7"	4-3/4"	20	60
7448SD2	3/4" x 8-1/2"	6-1/4"	10	40

**RECOMMENDED INSTALLATION POWER TOOLS**

CAT #	TYPE	PAGE
DCH273P2DH0, DCH293R2DH, DCH133M2, DCH263R2DH, D25263K, D25333K	SDS+ Rotary Hammers	50
DCH481X2, DCH733X2	SDS Max FlexVolt Cordless Rotary Hammers	51
D25481K, D25604K, D25733K	SDS Max Combination Hammers	51
D25481K, D25604K, D25733K	SDS Max Combination Hammers	

**ACCESSORIES**

TYPE		PAGE
SDS+ Carbide Drill Bits	by diameter/length	56
SDS Max Carbide Drill Bits	by diameter/length	57
Hollow Drill Bit	by diameter/length	58
Hammer	refer to page	59
Torque Wrench	refer to page	59
Socket	refer to page	59

**Power-Stud® + SD4/SD6**

Type	Wedge Expansion Anchor
Approvals	ICC-ES ESR-2502 (Concrete) IBC & IRC 2018, 2015, 2012, 2009    
Description	Recognition in cracked & uncracked concrete including seismic and wind loading (Category 1 Anchors)
Description	Fully threaded Torque controlled
Base Materials	Normal and sand-lightweight concrete, grouted concrete masonry (CMU)
Anchor Material	SD4: Type 304 stainless steel anchor body with type 316 expansion clip and hex nut SD6: Type 316 stainless steel anchor body, expansion clip and hex nut



**POWER-STUD+ SD4 (304 SS)**

CAT #	SIZE	THREAD LEN	CTN	MSTR
7300SD4*	1/4" x 1-3/4"	3/4"	100	600
7302SD4	1/4" x 2-1/4"	1-1/4"	100	600
7304SD4	1/4" x 3-1/4"	2-1/4"	100	600
7313SD4	3/8" x 3"	1-5/8"	50	300
7315SD4	3/8" x 3-3/4"	2-3/8"	50	300
7316SD4	3/8" x 5"	3-5/8"	50	300
7322SD4	1/2" x 3-3/4"	2"	50	200
7323SD4	1/2" x 4-1/2"	2-3/4"	50	200
7324SD4	1/2" x 5-1/2"	3-3/4"	50	150
7326SD4	1/2" x 7"	5-1/4"	25	100
7333SD4	5/8" x 5"	3"	25	100
7334SD4	5/8" x 6"	4"	25	75
7338SD4	5/8" x 8-1/2"	6-1/2"	25	50
7342SD4	3/4" x 5-1/2"	3-1/8"	20	60
7348SD4	3/4" x 8-1/2"	6-1/8"	10	40



**POWER-STUD+ SD6 (316SS)**

CAT #	SIZE	THREAD LEN	CTN	MSTR
7600SD6*	1/4" x 1-3/4"	3/4"	100	600
7602SD6	1/4" X 2-1/4"	1-1/4"	100	600
7604SD6	1/4" X 3-1/4"	2-1/4"	100	600
7610SD6*	3/8" x 2-1/4"	7/8"	50	300
7612SD6	3/8" X 2-3/4"	1-3/8"	50	300
7613SD6	3/8" X 3"	1-5/8"	50	300
7614SD6	3/8" X 3-1/2"	2-1/8"	50	300
7615SD6	3/8" X 3-3/4"	2-3/8"	50	300
7316SD6	3/8" X 5"	3-5/8"	50	300
7617SD6	3/8" X 7"	5-5/8"	50	200
7620SD6*	1/2" x 2-3/4"	1"	50	200
7622SD6	1/2" x 3-3/4"	2"	50	200

**POWER-STUD+ SD6 (316SS)**

CAT #	SIZE	THREAD LEN	CTN	MSTR
7623SD6	1/2" x 4-1/2"	2-3/4"	50	200
7624SD6	1/2" x 5-1/2"	3-3/4"	50	150
7626SD6	1/2" x 7"	5-1/4"	25	100
7630SD6*	5/8" x 3-1/2"	1-1/2"	25	100
7632SD6	5/8" x 4-1/2"	2-1/2"	25	100
7633SD6	5/8" x 5"	3"	25	100
7634SD6	5/8" x 6"	4"	25	75
7636SD6	5/8" x 7"	5"	25	75
7638SD6	5/8" x 8-1/2"	6-1/2"	25	50
7640SD6*	3/4" x 4-1/4"	1-7/8"	20	60
7641SD6*	3/4" x 4-3/4"	2-3/8"	20	60
7642SD6	3/4" x 5-1/2"	3-1/8"	20	60
7644SD6	3/4" x 6-1/4"	3-7/8"	20	60
7646SD6	3/4" x 7"	4-5/8"	20	60
7648SD6	3/4" x 8-1/2"	6-1/8"	10	40
7649SD6	3/4" x 10"	7-5/8"	10	40

**RECOMMENDED INSTALLATION POWER TOOLS**

CAT #	TYPE	PAGE
DCH273P2DH0, DCH293R2DH, DCH133M2, DCH263R2DH, D25263K, D25333K	SDS+ Rotary Hammers	50
DCH481X2, DCH733X2	SDS Max FlexVolt Cordless Rotary Hammers	51
D25481K, D25604K, D25733K	SDS Max Combination Hammers	51

**ACCESSORIES**

TYPE		PAGE
SDS+ Carbide Drill Bits	by diameter/length	56
SDS Max Carbide Drill Bits	by diameter/length	57
Hollow Drill Bit	by diameter/length	58
Hammer	refer to page	59
Torque Wrench	refer to page	59
Socket	refer to page	59

\* For Power-Stud+ SD4 and SD6: Less than the minimum standard anchor length for strength design. Published length is the overall length of the anchor. Allow for fixture thickness plus one anchor diameter for the nut and washer thickness when selecting a length. Packaged with nuts and washers.

1/4" diameter Power-Stud+ SD4 and SD6 for uncracked concrete only



**EXPANSION ANCHORS**

**Power-Stud® HD5**

Type	Wedge Expansion Anchor
Approvals	
Description	Torque controlled Fully threaded Hot-Dip (zinc) galvanized coating
Base Materials	Concrete, grouted concrete masonry (CMU)
Anchor Material	Carbon steel anchor body, nut and washer Type 304 stainless steel expansion wedge (clip) Zinc galvanized according to ASTM A 153 Class C or D



**HOT-DIP GALVANIZED POWER-STUD**

CAT #	SIZE	MIN EMBED	THREAD LEN	CTN	MSTR
7713HD5	3/8" x 3"	1-1/2"	1-1/2"	50	300
7715HD5	3/8" x 3-3/4"	1-1/2"	2-3/8"	50	300
7716HD5	3/8" x 5"	1-1/2"	3-1/2"	50	300
7717HD5	3/8" x 7"	1-1/2"	5-1/2"	50	200
7720HD5	1/2" x 2-3/4"	2"	1"	50	200
7722HD5	1/2" x 3-3/4"	2"	2"	50	200
7723HD5	1/2" x 4-1/2"	2"	2-3/4"	50	200
7724HD5	1/2" X 5-1/2"	2"	3-3/4"	50	150
7726HD5	1/2" X 7"	2"	5-1/4"	25	100
7730HD5	5/8" X 3-1/2"	2-3/8"	1-1/2"	25	100
7733HD5	5/8" x 5"	2-3/8"	3"	25	100
7734HD5	5/8" x 6"	2-3/8"	4"	25	75
7738HD5	5/8" x 8-1/2"	2-3/8"	6-1/2"	25	50
7741HD5	3/4" x 4-3/4"	3-3/8"	2-1/4"	20	60
7742HD5	3/4" x 5-1/2"	3-3/8"	3"	20	60
7746HD5	3/4" x 7"	3-3/8"	4-1/2"	20	60
7748HD5	3/4" x 8-1/2"	3-3/8"	6"	10	40

**RECOMMENDED INSTALLATION POWER TOOLS**

CAT #	TYPE	PAGE
DCH273P2DH0, DCH293R2DH, DCH133M2, DCH263R2DH, D25263K, D25333K	SDS+ Rotary Hammers	50

DCH481X2, DCH733X2	SDS Max FlexVolt Cordless Rotary Hammers	51
D25481K, D25604K, D25733K	SDS Max Combination Hammers	51

**ACCESSORIES**

TYPE		PAGE
SDS+ Carbide Drill Bits	by diameter/length	56
SDS Max Carbide Drill Bits	by diameter/length	57
Hollow Drill Bit	by diameter/length	58
Hammer	refer to page	59
Torque Wrench	refer to page	59
Socket	refer to page	59

**PERFORM  
PROTECT™**

DeWALT'S PERFORM & PROTECT™ line of tools is designed to provide a high level of one or more of the following: control, dust containment or low vibration, without sacrificing performance.

## YOUR FIRST LINE OF DEFENSE.™

DUST

CONTROL

VIBRATION

[DeWALT.com/PERFORMANDPROTECT](http://DeWALT.com/PERFORMANDPROTECT)

**GUARANTEED TOUGH®**

**EXPANSION ANCHORS**

**Domestic Wedge Anchors**

Type	Wedge Expansion Anchor
Approvals	Tested to ASTM E488
Description	Fully threaded Torque controlled Carbon steel and stainless steel wedge expansion made in the U.S.A., nut and washer made in Taiwan or China*
Base Materials	Normal and sand-light-weight concrete
Anchor Material	Carbon steel – plated with commercial bright zinc and a supplementary chromate treatment in accordance with ASTM Specification B 633, SC1, Type III. Type 303 stainless steel – Manufactured from AISI Type 303 stainless steel which is passivated. Type 316 stainless steel



CARBON STEEL WEDGE ANCHOR					
CAT #	SIZE	THREAD LEN	CTN	MSTR	
7400USA	1/4" x 1-3/4"	3/4"	100	600	
7402USA	1/4" x 2-1/4"	3/4"	100	600	
7404USA	1/4" x 3-1/4"	3/4"	100	600	
7410USA	3/8" x 2-1/4"	7/8"	50	300	
7412USA	3/8" x 2-3/4"	1-1/8"	50	300	
7413USA	3/8" x 3"	1-1/8"	50	300	
7414USA	3/8" x 3-1/2"	1-1/8"	50	300	
7415USA	3/8" x 3-3/4"	1-1/8"	50	300	
7416USA	3/8" x 5"	1-1/8"	50	300	
7417USA	3/8" x 6-1/2"	1-1/8"	50	200	
7420USA	1/2" x 2-3/4"	1-1/4"	50	200	
7422USA	1/2" x 3-3/4"	1-1/4"	50	200	
7423USA	1/2" x 4-1/4"	1-1/4"	50	200	
7424USA	1/2" x 5-1/2"	1-1/4"	50	150	
7428USA	1/2" x 10"	1-1/4"	25	100	
7430USA	5/8" x 3-1/2"	2"	25	100	
7432USA	5/8" x 4-1/2"	3"	25	100	
7433USA	5/8" x 5"	2"	25	100	
7434USA	5/8" x 6"	2"	25	75	
7436USA	5/8" x 7"	2"	25	75	
7440USA	3/4" x 4-1/4"	2"	20	60	
7441USA	3/4" x 4-3/4"	2"	20	60	
7442USA	3/4" x 5-1/2"	2"	20	60	
7444USA	3/4" x 6-1/4"	2"	20	60	
7446USA	3/4" x 7"	2"	20	60	
7449USA	3/4" x 10"	2"	10	30	
7461USA	1" x 6"	2"	10	30	
7475USA	1-1/4" x 12"	2"	5	10	

TYPE 303 STAINLESS STEEL WEDGE ANCHOR					
CAT #	SIZE	THREAD LEN	CTN	MSTR	
7300USA	1/4" x 1-3/4"	3/4"	100	500	
7304USA	1/4" x 3-1/4"	3/4"	100	500	
7312USA	3/8" x 2-3/4"	1-1/8"	50	250	
7313USA	3/8" x 3"	1-1/8"	50	250	
7314USA	3/8" x 3-1/2"	1-1/8"	50	250	
7315USA	3/8" x 3-3/4"	1-1/8"	50	250	
7316USA	3/8" x 5"	1-1/8"	50	250	
7320USA	1/2" x 2-3/4"	1-1/4"	50	200	
7323USA	1/2" x 4-1/4"	1-1/4"	50	200	
7324USA	1/2" x 5-1/2"	1-1/4"	50	150	
7326USA	1/2" x 7"	1-1/4"	25	100	
7332USA	5/8" x 4-1/2"	2"	25	100	
7341USA	3/4" x 4-3/4"	2"	20	60	
7348USA	3/4" x 8-1/2"	2"	10	40	
7349USA	3/4" x 10"	2"	10	30	

TYPE 316 STAINLESS STEEL WEDGE ANCHOR					
CAT #	SIZE	THREAD LEN	CTN	MSTR	
7600USA	1/4" x 1-3/4"	3/4"	100	500	
7602USA	1/4" x 2-1/4"	1-1/8"	100	500	
7610USA	3/8" x 2-1/4"	1-1/8"	50	250	
7612USA	3/8" x 2-3/4"	1-1/8"	50	250	
7613USA	3/8" x 3"	1-1/8"	50	250	
7614USA	3/8" x 3-1/2"	1-1/8"	50	250	
7615USA	3/8" x 3-3/4"	1-1/8"	50	250	
7616USA	3/8" x 5"	1-1/8"	50	250	
7626USA	1/2" x 7"	1-1/4"	25	100	
7630USA	5/8" x 3-1/2"	2"	25	100	
7632USA	5/8" x 4-1/2"	2"	25	100	
7633USA	5/8" x 5"	2"	25	100	
7634USA	5/8" x 6"	2"	25	75	
7636USA	5/8" x 7"	2"	25	75	
7638USA	5/8" x 8-1/2"	2"	25	75	
7642USA	3/4" x 5-1/2"	2"	20	60	
7646USA	3/4" x 7"	2"	20	60	

RECOMMENDED INSTALLATION POWER TOOLS		
CAT #	TYPE	PAGE
DCH273P2DHO, DCH293R2DH, DCH133M2, DCH263R2DH, D25263K, D25333K	SDS+ Rotary Hammers	50
DCH481X2, DCH733X2	SDS Max FlexVolt Cordless Rotary Hammers	51
D25481K, D25604K, D25733K	SDS Max Combination Hammers	51

ACCESSORIES		
TYPE		PAGE
SDS+ Carbide Drill Bits	by diameter/length	56
SDS Max Carbide Drill Bits	by diameter/length	57
Hollow Drill Bit	by diameter/length	58
Hammer	refer to page	59
Torque Wrench	refer to page	59
Socket	refer to page	59



\* Domestic nut and washer available upon request.



**EXPANSION ANCHORS**

**Stainless Steel Power-Stud®**

Type Wedge Expansion Anchor

Approvals  
   
 Federal GSA Specification – Meets the descriptive and proof load requirements of CID A-A-1923A, Type 4  
 Full UL listings in product brochure or at www.DEWALT.com

Description Torque controlled Fully threaded

Base Materials Normal weight concrete, Lightweight concrete, grouted concrete masonry (CMU)

Anchor Material Stainless steel

The published length is the overall length of the anchor. Allow for fixture thickness plus one anchor diameter for the nut and washer thickness when selecting a length



**ROD HANGER POWER-STUD**

CAT #	ROD SIZE	ANCHOR SIZE	DRILL DIA	MIN EMBED	THREAD DEPTH	CTN	MSTR
07806	3/8"	1/2" x 2-3/8"	1/2"	2-1/4"	3/4"	100	500



**TYPE 304 STAINLESS STEEL POWER-STUD**

CAT #	SIZE	MIN EMBED	THREAD LEN	CTN	MSTR
07300	1/4" x 1-3/4"	1-1/8"	3/4"	100	500
07302	1/4" x 2-1/4"	1-1/8"	1-1/4"	100	500
07304	1/4" x 3-1/4"	1-1/8"	2-1/4"	100	500
07310	3/8" x 2-1/4"	1-5/8"	1-1/4"	50	250
07312	3/8" x 2-3/4"	1-5/8"	1-5/8"	50	250
07313	3/8" x 3"	1-5/8"	1-7/8"	50	250
07314	3/8" x 3-1/2"	1-5/8"	2-3/8"	50	250
07315	3/8" x 3-3/4"	1-5/8"	2-5/8"	50	250
07316	3/8" x 5"	1-5/8"	3-1/8"	50	250
07320	1/2" x 2-3/4"	2-1/4"	1-3/8"	50	200
07322	1/2" x 3-3/4"	2-1/4"	2-3/8"	50	200
07323	1/2" x 4-1/2"	2-1/4"	3-1/8"	50	200
07324	1/2" x 5-1/2"	2-1/4"	4-1/8"	50	150
07326	1/2" x 7"	2-1/4"	5-5/8"	25	100
07330	5/8" x 3-1/2"	2-3/4"	2"	25	100
07332	5/8" x 4-1/2"	2-3/4"	3"	25	100
07333	5/8" x 5"	2-3/4"	3-1/2"	25	100
07334	5/8" x 6"	2-3/4"	4-1/2"	25	75
07336	5/8" x 7"	2-3/4"	5-1/2"	25	75
07338	5/8" x 8-1/2"	2-3/4"	7"	25	75
07340	3/4" x 4-1/4"	3-3/8"	2-3/8"	20	60
07341	3/4" x 4-3/4"	3-3/8"	2-7/8"	20	60
07342	3/4" x 5-1/2"	3-3/8"	3-5/8"	20	60
07344	3/4" x 6-1/4"	3-3/8"	4-3/8"	20	60
07346	3/4" x 7"	3-3/8"	5-1/8"	20	60
07348	3/4" x 8-1/2"	3-3/8"	6-5/8"	10	40
07349	3/4" x 10"	3-3/8"	8-1/8"	10	30
07352	7/8" x 8"	3-7/8"	4-3/4"	10	40
07361	1" x 6"	4-1/2"	2-3/8"	10	30
07363	1" x 9"	4-1/2"	5-3/8"	10	30
07365	1" x 12"	4-1/2"	8-3/8"	5	15

**TYPE 316 STAINLESS STEEL POWER-STUD**

CAT #	SIZE	MIN EMBED	THREAD LEN	CTN	MSTR
07600	1/4" x 1-3/4"	1-1/8"	3/4"	100	500
07602	1/4" x 2-1/4"	1-1/8"	1-1/4"	100	500
07604	1/4" x 3-1/4"	1-1/8"	2-1/4"	100	500
07610	3/8" x 2-1/4"	1-5/8"	1-1/4"	50	250
07612	3/8" x 2-3/4"	1-5/8"	1-5/8"	50	250
07613	3/8" x 3"	1-5/8"	1-7/8"	50	250
07614	3/8" x 3-1/2"	1-5/8"	2-3/8"	50	250
07615	3/8" x 3-3/4"	1-5/8"	2-5/8"	50	250
07616	3/8" x 5"	1-5/8"	3-1/8"	50	250
07620	1/2" x 2-3/4"	2-1/4"	1-3/8"	50	200
07622	1/2" x 3-3/4"	2-1/4"	2-3/8"	50	200
07623	1/2" x 4-1/2"	2-1/4"	3-1/8"	50	200
07624	1/2" x 5-1/2"	2-1/4"	4-1/8"	50	150
07626	1/2" x 7"	2-1/4"	5-5/8"	25	100
07630	5/8" x 3-1/2"	2-3/4"	2"	25	100
07332	5/8" x 4-1/2"	2-3/4"	3"	25	100
07633	5/8" x 5"	2-3/4"	3-1/2"	25	100
07634	5/8" x 6"	2-3/4"	4-1/2"	25	75
07636	5/8" x 7"	2-3/4"	5-1/2"	25	75
07638	5/8" x 8-1/2"	2-3/4"	7"	25	75
07640	3/4" x 4-1/4"	3-3/8"	2-3/8"	20	60
07641	3/4" x 4-3/4"	3-3/8"	2-7/8"	20	60
07642	3/4" x 5-1/2"	3-3/8"	3-5/8"	20	60
07644	3/4" x 6-1/4"	3-3/8"	4-3/8"	20	60
07646	3/4" x 7"	3-3/8"	5-1/8"	20	60
07648	3/4" x 8-1/2"	3-3/8"	6-5/8"	10	40

**RECOMMENDED INSTALLATION POWER TOOLS**

CAT #	TYPE	PAGE
DCH273P2DHO, DCH293R2DH, DCH133M2, DCH263R2DH, D25263K, D25333K	SDS+ Rotary Hammers	50
DCH481X2, DCH733X2	SDS Max FlexVolt Cordless Rotary Hammers	51
D25481K, D25604K, D25733K	SDS Max Combination Hammers	51

**ACCESSORIES**

TYPE		PAGE
SDS+ Carbide Drill Bits	by diameter/length	56
SDS Max Carbide Drill Bits	by diameter/length	57
Hammer	refer to page	59
Torque Wrench	refer to page	59
Socket	refer to page	59

**GUARANTEED TOUGH.**

**EXPANSION ANCHORS**

**Power-Bolt®+**

Type	Heavy Duty Sleeve Anchor
Approvals	ICC-ES ESR-3260 (Concrete); 1/2", 5/8" & 3/4" IBC & IRC 2018, 2015, 2012, 2009 Recognition in cracked & uncracked concrete including seismic and wind loading (Category 1 Anchors)
Description	Torque controlled Low profile finished hex head
Base Materials	Normal and lightweight concrete
Anchor Material	Carbon steel, Grade 8 bolt (equivalent)



CARBON STEEL HEX HEAD POWER-BOLT+					
CAT #	SIZE	DRILL DIA	CTN	MSTR	
6902SD	1/4" x 1-3/4"	1/4"	100	600	
6906SD	1/4" x 3"	1/4"	100	600	
6911SD	3/8" x 1-7/8"	3/8"	50	300	
6910SD	3/8" x 2-1/4"	3/8"	50	300	
6913SD	3/8" x 3"	3/8"	50	300	
6914SD	3/8" x 3-1/2"	3/8"	50	300	
6916SD	3/8" x 4"	3/8"	50	300	
6930SD*	1/2" x 2-3/4"	1/2"	50	200	
6932SD	1/2" x 3-1/2"	1/2"	50	200	
6934SD	1/2" x 4-3/4"	1/2"	25	150	
6936SD	1/2" x 5-3/4"	1/2"	25	150	
6940SD*	5/8" x 3"	5/8"	20	120	
6942SD	5/8" x 4"	5/8"	15	90	
6944SD	5/8" x 5"	5/8"	15	90	
6945SD	5/8" x 6"	5/8"	15	60	
6947SD	5/8" x 8-1/2"	5/8"	10	40	

\*Less than the minimum standard anchor length for strength design or not included in ESR-3260. The published size includes the diameter and the length which is measured from below the washer to the end of the anchor. Allow for fixture thickness when selecting a length.

CARBON STEEL HEX HEAD POWER-BOLT+				
CAT #	SIZE	DRILL DIA	CTN	MSTR
6950SD	3/4" x 3-1/4"	1/4"	15	90
6952SD	3/4" x 4-1/2"	3/4"	10	60
6954SD	3/4" x 5-1/4"	3/4"	10	50
6956SD	3/4" x 7-1/4"	3/4"	10	40
6957SD	3/4" x 8-1/4"	3/4"	10	40

RECOMMENDED INSTALLATION POWER TOOLS		
CAT #	TYPE	PAGE
DCH273P2DHO, DCH293R2DH, DCH133M2, DCH263R2DH, D25263K, D25333K	SDS+ Rotary Hammers	50

DCH481X2, DCH733X2	SDS Max FlexVolt Cordless Rotary Hammers	51
D25481K, D25604K, D25733K	SDS Max Combination Hammers	51

ACCESSORIES		
TYPE		PAGE
SDS+ Carbide Drill Bits	by diameter/length	56
SDS Max Carbide Drill Bits	by diameter/length	57
Hollow Drill Bit	by diameter/length	58
Hammer	refer to page	59
Torque Wrench	refer to page	59
Socket	refer to page	59

**Power-Bolt®**

Type	Heavy Duty Sleeve Anchor
Approvals	Full UL listings in product brochure or at www.DeWALT.com
Description	Finished hex head or flat head
Base Materials	Concrete, block, brick and stone
Anchor Material	Type 304 stainless steel & carbon steel (flat head)



304 STAINLESS STEEL HEX HEAD POWER-BOLT					
CAT #	SIZE	DRILL DIA	MIN DEPTH	QTY	MSTR
05902	1/4" x 1-3/4"	1/4"	1-1/4"	100	600
05906	1/4" x 3"	1/4"	1-1/4"	100	600
05910	3/8" x 2-1/4"	3/8"	2"	50	300
05914	3/8" x 3-1/2"	3/8"	2"	50	300
05916	3/8" x 4"	3/8"	2"	50	300
05930	1/2" x 2-3/4"	1/2"	2-1/2"	50	200
05934	1/2" x 4-3/4"	1/2"	2-1/2"	25	150

\*Published length is measured from under the washer to the end of the anchor.

CARBON STEEL FLAT HEAD POWER-BOLT					
CAT #	SIZE	DRILL DIA	MIN DEPTH	QTY	MSTR
06983	3/8" x 6"	3/8"	2"	50	250
06984	1/2" x 5"	1/2"	2-1/2"	25	125
06987	5/8" x 5-1/2"	5/8"	2-3/4"	15	90

Published length is the overall length of the anchor.

RECOMMENDED INSTALLATION POWER TOOLS		
CAT #	TYPE	PAGE
DCH273P2DHO, DCH293R2DH, DCH133M2, DCH263R2DH, D25263K, D25333K	SDS+ Rotary Hammers	50

DCH481X2, DCH733X2	SDS Max FlexVolt Cordless Rotary Hammers	51
D25481K, D25604K, D25733K	SDS Max Combination Hammers	51

ACCESSORIES		
TYPE		PAGE
SDS+ Carbide Drill Bits	by diameter/length	56
SDS Max Carbide Drill Bits	by diameter/length	57
Hollow Drill Bit	by diameter/length	58
Hammer	refer to page	59
Torque Wrench	refer to page	59
Socket	refer to page	59

**PB-PRO**

Type	Metric Heavy Duty Sleeve Anchor
Approvals	
Description	Large diameter Torque controlled Finished hex head
Base Materials	Concrete
Anchor Material	Carbon steel



CARBON STEEL HEX HEAD PB-PRO					
CAT #	SIZE	DRILL DIA	LENGTH	QTY	MSTR
PFM1220650	24-M16 x 148mm	24mm	148mm	5	20
PFM1220700	24-M16 x 178mm	24mm	178mm	5	20
PFM1220750	28-M20 x 170mm	28mm	170mm	5	15
PFM1220800	28-M20 x 190mm	28mm	190mm	5	10
PFM1220850	28-M20 x 220mm	28mm	220mm	5	10

\*Published length is measured from under the washer to the end of the anchor.

DRILL BITS					
CAT #	SIZE	DRILL DIA	LENGTH	USABLE LENGTH	QTY
PFA1330220	24mm x 340mm	24mm	340mm	200mm	1
PFM1330290	28mm x 380mm	28mm	380mm	250mm	1

DESCRIPTION			SIZE	PG
SDS+ Carbide Drill Bits		by diameter/length		56
SDS Max Carbide Drill Bits		by diameter/length		57

ACCESSORIES		
CAT #	DESCRIPTION	QTY
	Hammer	refer to page
	Torque Wrench	refer to page
	Socket	refer to page

DWM174581	M24	1/2"	Drive Manual Socket
DWM174585	M28	1/2"	Drive Manual Socket

**MECHANICAL ANCHORS 11**



**EXPANSION ANCHORS**

**Lok-Bolt AS®**

Type	Sleeve Expansion Anchor
Approvals	
Description	Pre-assembled single unit sleeve anchor Extension sleeves create longer lengths AS refers to all-steel sleeve
Base Materials	Concrete, block, brick
Anchor Material	Carbon steel & stainless steel



Hex Nut Lok-Bolt: Published length measured from below the washer to the end of the anchor.  
Acorn Nut Lok-Bolt: The published length is measured from below the washer to the end of the anchor.  
Combo and Threshold Flat Head Lok-Bolt: These parts do not have a compression ring.

HEX NUT LOK-BOLT AS CARBON STEEL						
CAT #	SIZE	DRILL DIA	MIN EMBED	CTN	MSTR	
05005S	5/16" x 1-1/2"	5/16"	1"	100	600	
05010S	5/16" x 2-3/8"	5/16"	1"	100	500	
05015S	3/8" x 1-7/8"	3/8"	1-1/4"	50	300	
05020S	3/8" x 3"	3/8"	1-1/4"	50	250	
05022S	3/8" x 4"	3/8"	1-1/4"	50	250	
05025S	1/2" x 2-1/2"	1/2"	1-1/2"	25	150	
05030S	1/2" x 3"	1/2"	1-1/2"	25	150	
05034S	1/2" x 3-3/4"	1/2"	1-1/2"	25	150	
05033S	1/2" x 5-1/4"	1/2"	1-1/2"	25	125	
05032S	1/2" x 6"	1/2"	1-1/2"	10	50	
05035S	5/8" x 2-1/2"	5/8"	2"	25	125	
05038S	5/8" x 3"	5/8"	2"	25	100	
05040S	5/8" x 4-1/4"	5/8"	2"	10	60	
05045S	5/8" x 5-3/4"	5/8"	2"	10	50	
05050S	3/4" x 2-3/4"	3/4"	2-1/4"	10	60	
05055S	3/4" x 4-1/4"	3/4"	2-1/4"	10	40	
05060S	3/4" x 6-1/4"	3/4"	2-1/4"	10	30	
05065S	3/4" x 8-1/4"	3/4"	2-1/4"	10	20	

HEX NUT LOK-BOLT AS 304 STAINLESS STEEL						
CAT #	SIZE	DRILL DIA	MIN EMBED	CTN	MSTR	
06152S	3/8" x 1-7/8"	3/8"	1-1/4"	50	300	
06153S	3/8" x 3"	3/8"	1-1/4"	50	250	
06156S	1/2" x 2-1/2"	1/2"	1-1/2"	25	150	
06157S	1/2" x 3"	1/2"	1-1/2"	25	150	
06160S	1/2" x 3-3/4"	1/2"	1-1/2"	25	150	
06164S	5/8" x 4-1/4"	5/8"	2"	10	60	
06168S	3/4" x 4-1/4"	3/4"	2-1/4"	10	40	



ACORN NUT LOK-BOLT AS CARBON STEEL						
CAT #	SIZE	DRILL DIA	MIN EMBED	CTN	MSTR	
05125S	1/4" x 5/8"	1/4"	1/2"	100	1000	
05150S	1/4" x 1-3/8"	1/4"	1/2"	100	600	
05175S	1/4" x 2-1/4"	1/4"	1/2"	100	600	

ACORN NUT LOK-BOLT AS 304 STAINLESS STEEL						
#	SIZE	DRILL DIA	MIN EMBED	CTN	MSTR	
06150S	1/4" x 1-3/8"	1/4"	1/2"	100	600	

The published length is measured from below the washer to the end of the anchor.



ROUND HEAD LOK-BOLT AS CARBON STEEL						
CAT #	SIZE	DRILL DIA	MIN EMBED	CTN	MSTR	
05205S	1/4" x 1-3/8"	1/4"	1/2"	100	1000	
05210S	1/4" x 2-1/4"	1/4"	1/2"	100	600	
05215S	1/4" x 3"	1/4"	1/2"	100	600	
05240S	3/8" x 3-3/4"	3/8"	1-1/4"	50	250	

ROUND HEAD LOK-BOLT AS 304 STAINLESS STEEL						
CAT #	SIZE	DRILL DIA	MIN EMBED	CTN	MSTR	
06180S	1/4" x 2-1/4"	1/4"	1/2"	100	600	



COMBO FLAT HEAD LOK-BOLT AS CARBON STEEL						
CAT #	SIZE	DRILL DIA	MIN EMBED	CTN	MSTR	
05305S	1/4" x 1-1/2"	1/4"	1/2"	100	1000	
05310S	1/4" x 2-1/4"	1/4"	1/2"	100	600	
05315S	1/4" x 3"	1/4"	1/2"	100	600	
05320S	1/4" x 4"	1/4"	1/2"	100	600	

CAT #	SIZE	DRILL DIA	MIN EMBED	CTN	MSTR
05325S	1/4" x 5-1/4"	1/4"	1/2"	100	600
05330S	5/16" x 2-1/4"	5/16"	1"	100	600
05340S	3/8" x 2-3/4"	3/8"	1-1/4"	50	300
05345S	3/8" x 4"	3/8"	1-1/4"	50	250
05350S	3/8" x 5"	3/8"	1-1/4"	50	250
05360S	3/8" x 6"	3/8"	1-1/4"	50	250

COMBO FLAT HEAD LOK-BOLT AS 304 STAINLESS STEEL						
CAT #	SIZE	DRILL DIA	MIN EMBED	CTN	MSTR	
06170S	1/4" x 2-1/4"	1/4"	1/2"	100	600	
06172S	1/4" x 3"	1/4"	1/2"	100	600	
06174S	3/8" x 4"	3/8"	1-1/4"	50	250	
06175S	3/8" x 5"	3/8"	1-1/4"	50	250	
06176S	3/8" x 6"	3/8"	1-1/4"	50	250	



THRESHOLD FLAT HEAD LOK-BOLT AS						
CAT #	SIZE	DRILL DIA	MIN DEPTH	CTN	MSTR	
05500S	1/4" x 2"	1/4"	1/2"	100	600	



ROD HANGER LOK-BOLT AS CARBON STEEL						
CAT #	SIZE	DRILL DIA	MIN DEPTH	CTN	MSTR	
05810S	1/4" x 1-1/2"	5/16"	1/2"	50	300	
05815S	3/8" x 1-7/8"	3/8"	1-1/4"	50	300	
05825S	1/2" x 2-1/4"	1/2"	1-1/2"	25	150	



TIE-WIRE LOK-BOLT AS						
CAT #	SIZE	DRILL DIA	MIN DEPTH	CTN	MSTR	
05700S	5/16" x 1-1/2"	5/16"	1"	100	600	



LOK-BOLT AS EXTENDERS CARBON STEEL						
CAT #	SIZE	DRILL DIA	MIN EMBED	CTN	MSTR	
05684	3/8" x 1-1/4"	3/8"	1/2"	50	500	

RECOMMENDED INSTALLATION POWER TOOLS		
CAT #	TYPE	PAGE
DCH273P2DHO, DCH293R2DH,	SDS+ Rotary Hammers	50
DCH133M2, DCH263R2DH,		
D25263K, D25333K		

ACCESSORIES		
TYPE		PAGE
SDS+ Carbide Drill Bits	by diameter/length	56
SDS Max Carbide Drill Bits	by diameter/length	57
Hammer	refer to page	59
Torque Wrench	refer to page	59
Socket	refer to page	59

**GUARANTEED TOUGH.**

**UNDERCUT ANCHORS**

**Atomic+ Undercut®**

Type	Heavy Duty Undercut Anchor
Approvals	ICC-ES ESR-3067 (Concrete) IBC & IRC 2018, 2015, 2012, 2009 Recognition in cracked & uncracked concrete including seismic and wind loading (Category 1 Anchors)
Description	Standard and through-bolt applications  Transfers load mainly through bearing, not dependent upon friction between the expansion sleeve and the concrete
Base Materials	Normal and sand-lightweight concrete, concrete over metal deck
Anchor Material	Zinc plated a 36 carbon steel, zinc plated high strength A 193 grade B7 steel, type 316 stainless steel



STD = Standard Type  
TB = Through-Bolt Type



**ATOMIC+ UNDERCUT ANCHOR A 36 STEEL**

CAT #	NOM DIA	LENGTH	UNDERCUT BIT #	STOP BIT #	TYPE	CTN
03100SD	3/8"	5-1/2"	03200SD	03220SD	STD	20
03102SD	3/8"	5-1/2"	03200SD	*	TB	20
03108SD	1/2"	7"	03201SD	03222SD	STD	15
03110SD	1/2"	7"	03201SD	*	TB	15
03120SD	5/8"	7-3/4"	03202SD	03222SD	STD	10
03122SD	5/8"	7-3/4"	03202SD	*	TB	10
03132SD	3/4"	8-5/8"	03203SD	03228SD	STD	8



**ATOMIC+ UNDERCUT HIGH STRENGTH A 193, GRADE B7 STEEL**

CAT #	NOM DIA	LENGTH	UNDERCUT BIT #	STOP BIT #	TYPE	CTN
03104SD	3/8"	6-3/4"	03200SD	03221SD	STD	20
03106SD	3/8"	6-3/4"	03200SD	*	TB	20
03112SD	1/2"	8"	03201SD	03223SD	STD	10
03114SD	1/2"	8"	03201SD	*	TB	15
03116SD	1/2"	9-3/4"	03201SD	03224SD	STD	15
03118SD	1/2"	9-3/4"	03201SD	*	TB	15
03124SD	5/8"	10-3/4"	03202SD	03226SD	STD	10
03126SD	5/8"	10-3/4"	03202SD	*	TB	10
03128SD	5/8"	12-1/4"	03202SD	03227SD	STD	10
03130SD	5/8"	12-1/4"	03202SD	*	TB	10
03136SD	3/4"	13-5/8"	03203SD	03229SD	STD	8
03138SD	3/4"	13-5/8"	03203SD	*	TB	8



**ATOMIC UNDERCUT+ TYPE 316 STAINLESS STEEL - CLASS 1**

CAT #	NOM DIA	LENGTH	UNDERCUT BIT #	STOP BIT #	TYPE	CTN
03600SD	3/8"	5-1/2"	03200SD	03220SD	STD	20
03602SD	3/8"	5-1/2"	03200SD	*	TB	20
03608SD	1/2"	7"	03201SD	03222SD	STD	15
03610SD	1/2"	7"	03201SD	*	TB	15
03620SD	5/8"	7-3/4"	03202SD	03225SD	STD	10
03622SD	5/8"	7-3/4"	03202SD	*	TB	10
03632SD	3/4"	8-5/8"	03203SD	03228SD	STD	8
03634SD	3/4"	8-5/8"	03203SD	*	TB	8



**ATOMIC UNDERCUT+ TYPE 316 STAINLESS STEEL - CLASS 2**

CAT #	NOM DIA	LENGTH	UNDERCUT BIT #	STOP BIT #	TYPE	CTN
03609SD	1/2"	8"	03201SD	03222SD	STD	15
03613SD	1/2"	8"	03201SD	*	TB	15
03635SD	5/8"	10-3/4"	03202SD	03225SD	STD	10
03639SD	5/8"	10-3/4"	03202SD	*	TB	10
03648SD	3/4"	12-5/8"	03203SD	03228SD	STD	8
03649SD	3/4"	12-5/8"	03203SD	*	TB	8



**STOP DRILL BITS**

CAT #	NOM STOP BIT DIA	FOR NOM ANCHOR DIA	MAX DRILL DEPTH	SHANK	TUBE
03220SD	5/8"	3/8"	3-1/8"	SDS+	1
03221SD	5/8"	3/8"	4-3/8"	SDS+	1
03222SD	3/4"	1/2"	4-1/4"	SDS+	1
03223SD	3/4"	1/2"	5-1/4"	SDS+	1
03224SD	3/4"	1/2"	7"	SDS+	1
03225SD	1"	5/8"	5"	SDS-Max	1
03226SD	1"	5/8"	8"	SDS-Max	1
03227SD	1"	5/8"	9-1/2"	SDS-Max	1
03228SD	1-1/8"	3/4"	5-13/16"	SDS-Max	1
03229SD	1-1/8"	3/4"	10-13/16"	SDS-Max	1



**UNDERCUT DRILL BITS**

CAT #	NOM STOP BIT DIA	FOR NOM ANCHOR DIA	MAX DRILL DEPTH	SHANK	TUBE
03200SD	5/8"	3/8"	9"	SDS	1
03201SD	3/4"	1/2"	10-1/4"	SDS	1
03202SD	1"	5/8"	12-1/4"	SDS-Max	1
03203SD	1-1/8"	3/4"	13-1/2"	SDS-Max	1



**SETTING SLEEVE**

CAT #	FOR NOMINAL ANCHOR DIA	TUBE
03210SD	3/8"	1
03211SD	1/2"	1
03218SD	5/8"	1
03213SD	3/4"	1



**CUTTER BLADE REPLACEMENTS FOR UNDERCUT BIT**

CAT #	DESCRIPTION	TUBE
03205SD	Atomic+ (3/8") Cutter Blade - 5/8"	1
03206SD	Atomic+ (1/2") Cutter Blade - 3/4"	1
03208SD	Atomic+ (5/8") Cutter Blade - 1"	1
03209SD	Atomic+ (3/4") Cutter Blade - 1-1/8"	1



**REPLACEMENT BOW JAWS FOR UNDERCUT BIT**

CAT #	DESCRIPTION	TUBE
03212SD	3/8" Bow Jaw for 5/8" Hole	1
03215SD	1/2" Bow Jaw for 3/4" Hole	1
03216SD	5/8" Bow Jaw for 1" Hole	1
03217SD	3/4" Bow Jaw for 1-1/8" Hole	1

**RECOMMENDED INSTALLATION POWER TOOLS**

CAT #	TYPE	PAGE
DCH481X2, DCH733X2	SDS Max FlexVolt Cordless Rotary Hammers	51
D25481K, D25604K, D25733K	SDS Max Combination Hammers	51

**ACCESSORIES**

TYPE	PAGE
Hammer	refer to page 59
Torque Wrench	refer to page 59
Socket	refer to page 59



**BOLT/SHIELD ANCHORS**

**Double Expansion Anchor**

Type	Shell Expansion Anchor
Approvals	Federal GSA Specification – Meets the proof load requirements CID A-A 1923A, Type 3
Description	Dual expansion machine bolt anchor
Base Materials	Concrete
Anchor Material	Zamac alloy



**DOUBLE**

CAT #	SIZE	ANCHOR LEN	DRILL DIA	MIN HOLE DEPTH	CTN	MSTR
09510	1/4"	1-3/8"	1/2"	1-1/4"	50	500
09515	5/16"	1-5/8"	5/8"	1-1/2"	50	500
09520	3/8"	2"	3/4"	1-3/4"	50	250
09525	1/2"	2-1/2"	7/8"	2-1/4"	25	250
09530	5/8"	2-3/4"	1"	2-1/2"	25	100
09535	3/4"	3-15/16"	1-1/4"	3-1/2"	10	50

**RECOMMENDED INSTALLATION POWER TOOLS**

CAT #	TYPE	PAGE
DCH273P2DHO, DCH133M2, D25263K	SDS+ Rotary Hammers	50

**Single Expansion Anchor**

Type	Shell Expansion Anchor
Approvals	Federal GSA Specification – Meets the proof load requirements CID A-A 1923A, Type 2
Description	Machine bolt anchor
Base Materials	Concrete
Anchor Material	Zamac alloy



**SINGLE**

CAT #	SIZE	ANCHOR LEN	DRILL DIA	MIN HOLE DEPTH	CTN	MSTR
09650	1/4"	1-5/16"	1/2"	1-3/8"	50	250
09655	5/16"	1-1/2"	5/8"	1-5/8"	50	250
09665	3/8"	1-1/2"	5/8"	1-5/8"	50	250
09675	1/2"	2-1/16"	7/8"	2-1/2"	25	125
09685	5/8"	2-5/8"	1"	2-3/4"	25	125

**RECOMMENDED INSTALLATION POWER TOOLS**

CAT #	TYPE	PAGE
DCH273P2DHO, DCH133M2, D25263K	SDS+ Rotary Hammers	50

**Lag Shield™**

Type	Shell Expansion Anchor
Approvals	Federal GSA Specification – Meets the proof load requirements CID A-A 1923A, Type 1 Tested in accordance with ASTM E 488
Description	For Lag Bolts Short style for harder base materials, long for softer materials
Base Materials	Concrete and mortar joints of block and brick
Anchor Material	Zamac alloy



**LAG SHIELD**

CAT #	SIZE	DRILL DIA	MIN HOLE DEPTH	CTN	MSTR
01051	1/4" Short	1/2"	1"	50	500
01055	1/4" Long	1/2"	1-1/2"	50	500
01101	5/16" Short	1/2"	1-1/4"	50	500
01105	5/16" Long	1/2"	1-3/4"	50	500
01151	3/8" Short	5/8"	1-3/4"	50	500
01155	3/8" Long	5/8"	2-1/2"	50	250
01201	1/2" Short	3/4"	2"	50	500
01205	1/2" Long	3/4"	3"	50	200
01251	5/8" Short	7/8"	2"	25	125
01255	5/8" Long	7/8"	3-1/2"	25	125

CAT #	SIZE	DRILL DIA	MIN HOLE DEPTH	CTN	MSTR
01301	3/4" Short	1"	2"	25	125
01305	3/4" Long	1"	3-1/2"	25	100

**RECOMMENDED INSTALLATION POWER TOOLS**

CAT #	TYPE	PAGE
DCH273P2DHO, DCH133M2, D25263K	SDS+ Rotary Hammers	50

**Calk-In™**

Type	Machine Bolt Anchor
Approvals	Federal GSA Specification – Meets the proof load requirements CID A-A 1923A, Type 3
Description	Calking type machine bolt anchor
Base Materials	Concrete, block and brick
Anchor Material	Zamac alloy and lead



**CALK-IN**

CAT #	SIZE	DRILL DIA	MIN HOLE DEPTH	CTN	MSTR
09205	8-32	5/16"	1/2"	100	1000
09210	10-24	3/8"	5/8"	100	1000
09220	1/4"-20	1/2"	7/8"	100	600
09225	5/16"-18	5/8"	1"	50	300
09230	3/8"-16	3/4"	1-1/4"	50	300
09240	1/2"-13	7/8"	1-1/2"	50	300
09250	3/4"-10	1-1/4"	2-1/4"	50	-

**MASTER PACK**

CAT #	SIZE	DRILL DIA	MIN HOLE DEPTH	MSTR
09222	1/4"-20	3/8"	7/8"	1000



**CALK-IN SETTING TOOLS PURCHASED SEPARATELY**

CAT #	SIZE	CTN	MSTR
09201	8	1	-
09211	10	1	100
09221	1/4"	1	100
09226	5/16"	1	100
09231	3/8"	1	50
09241	1/2"	1	50
09251	3/4"	1	-

**RECOMMENDED INSTALLATION POWER TOOLS**

CAT #	TYPE	PAGE
DCH273P2DHO, DCH133M2, D25263K	SDS+ Rotary Hammers	50



**GUARANTEED  
TOUGH.®**



**CUSTOMIZABLE**



**PORTABLE**



**VERSATILE**

The **TOUGHSYSTEM**® range stacks up to any jobsite and completes the total jobsite solution. It is the ultimate in customizable, portable, and versatile storage and flexes to meet your needs to deliver INFINITE POSSIBILITIES™. With our lockable security and weather resistant features, the **TOUGHSYSTEM**® products are able to withstand what you throw at them. From the workshop, to the van, to the jobsite, bring this stackable system wherever the job takes you. Stack up, then move out.

Discover INFINITE POSSIBILITIES™ with **TOUGHSYSTEM**® Storage.

**DEWALT.COM/TOUGHSYSTEM**

**MECHANICAL ANCHORS 15**



**SCREW ANCHORS**

**Screw-Bolt™+**

Type	High Performance Screw Anchor
Approvals	ICC-ES ESR-3889 (Concrete), ESR-4042 (Masonry) IBC & IRC 2018, 2015, 2012, 2009 Recognition in cracked & uncracked concrete including seismic and wind loading (Category 1 Anchors)
Description	Uses standard ANSI tolerance drill bits One-piece, finished head Tough threads tap high strength concrete Head ratchet teeth lock against fixture
Base Materials	Normal and sand-lightweight concrete, concrete over metal deck, grouted concrete masonry (CMU), clay brick masonry
Anchor Material	Carbon steel



ZINC PLATED HEX HEAD SCREW-BOLT+			
CAT #	SIZE	CTN	MSTR
PFM1411000	1/4" x 1-1/4"	100	600
PFM1411020	1/4" x 1-3/4"	100	600
PFM1411060	1/4" x 2-1/4"	100	600
PFM1411080	1/4" x 2-5/8"	100	500
PFM1411100	1/4" x 3"	100	500
PFM1411160	3/8" x 1-3/4"	50	300
PFM1411220	3/8" x 2-1/2"	50	300
PFM1411240	3/8" x 3"	50	250
PFM1411280	3/8" x 4"	50	250
PFM1411300	3/8" x 5"	50	250
PFM1411320	3/8" x 6"	50	150
PFM1411340	1/2" x 2"	50	200
PFM1411360	1/2" x 2-1/2"	50	200
PFM1411380	1/2" x 3"	50	150
PFM1411420	1/2" x 4"	50	150
PFM1411460	1/2" x 5"	25	100
PFM1411480	1/2" x 6"	25	75
PFM1411520	1/2" x 8"	25	100
PFM1411540	5/8" x 3"	25	100
PFM1411580	5/8" x 4"	25	100
PFM1411600	5/8" x 5"	25	75
PFM1411640	5/8" x 6"	25	75
PFM1411680	5/8" x 8"	25	50
PFM1411700	3/4" x 3"	20	60
PFM1411720	3/4" x 4"	20	60
PFM1411760	3/4" x 5"	20	60
PFM1411800	3/4" x 6"	20	60
PFM1411840	3/4" x 8"	10	40
PFM1411880	3/4" x 10"	10	20



MECHANICALLY GALVANIZED SCREW-BOLT+			
CAT #	SIZE	CTN	MSTR
PFM1461240	3/8" x 3"	50	250
PFM1461280	3/8" x 4"	50	250
PFM1461300	3/8" x 5"	50	250
PFM1461320	3/8" x 6"	50	150
PFM1461420	1/2" x 4"	50	150
PFM1461460	1/2" x 5"	25	100
PFM1461480	1/2" x 6"	25	75
PFM1461520	1/2" x 8"	25	100
PFM1461600	5/8" x 5"	25	75
PFM1461640	5/8" x 6"	25	75
PFM1461680	5/8" x 8"	25	50
PFM1461800	3/4" x 6"	20	60
PFM1461850	3/4" x 8"	10	40

RECOMMENDED INSTALLATION POWER TOOLS		
CAT #	TYPE	PAGE
DCH293R2DH, DCH133M2, DCH263R2DH, D25333K, D25263K	SDS+ Rotary Hammers	50
DCH481X2, DCH733X2	SDS Max FlexVolt Cordless Rotary Hammers	51
D25481K, D24604K, D25733K	SDS Max Combination Hammers	51
DCF890M2, DCF894P2, DCF899P2	Cordless Impact Wrenches	52









ACCESSORIES		
TYPE		PAGE
SDS+ Carbide Drill Bits	by diameter/length	56
SDS Max Carbide Drill Bits	by diameter/length	57
Hollow Drill Bit	by diameter/length	58
Impact Rated Socket	by diameter	59

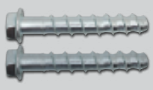

ZINC PLATED FLAT HEAD SCREW-BOLT+			
CAT #	SIZE	CTN	MSTR
PFM1411105	1/4" x 3"	100	500
PFM1411225	3/8" x 2-1/2"	50	300
PFM1411245	3/8" x 3"	50	250
PFM1411285	3/8" x 4"	50	250
PFM1411385	1/2" x 3"	50	150
PFM1411425	1/2" x 4"	50	150
PFM1411465	1/2" x 5"	25	100

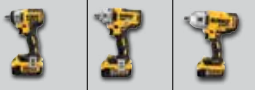

**GUARANTEED TOUGH.**

<b>Screw-Bolt™ + Installation System</b>													
Zinc Plated Screw-Bolt™ Mechanically Galvanized Screw-Bolt™					20V Max** SDS Plus Rotary Hammers			SDS Plus Rotary Hammers	SDS Rotary Hammer	Flexvolt® SDS Max	20V Max** Impact Wrenches		
													
ZINC PLATED CATALOG #	GALVANIZED CATALOG #	ANCHOR DIA X LEN	HOLE SIZE	SOCKET SIZE	DCH273P2DH 1"	DCH133M2 1"	DCH293R2DH 1-1/8"	D25333K 1-1/8"	D25263K 1-1/8"	DCH481X2 1-9/16"	DCF890M2 3/8"	DCF894HP2 1/2"	DCF899P2 HIGH TORQUE 1/2"
													
					<b>DW5517</b>	<b>DW5417</b>	DW5417			-	<b>DWMT74479B</b>	-	-
PFM1411000	-	1/4" x 1-1/4"	1/4"	7/16"	<b>DW5517</b>	<b>DW5417</b>	DW5417			-	<b>DWMT74479B</b>	-	-
PFM1411020	-	1/4" x 1-3/4"	1/4"	7/16"	<b>DW5517</b>	<b>DW5417</b>	DW5417			-	<b>DWMT74479B</b>	-	-
PFM1411060	-	1/4" x 2-1/4"	1/4"	7/16"	<b>DW5517</b>	<b>DW5417</b>	DW5417			-	<b>DWMT74479B</b>	-	-
PFM1411080	-	1/4" x 2-5/8"	1/4"	7/16"	<b>DW5517</b>	<b>DW5417</b>	DW5417			-	<b>DWMT74479B</b>	-	-
PFM1411100	-	1/4" x 3"	1/4"	7/16"	<b>DW5517</b>	<b>DW5417</b>	DW5417			-	<b>DWMT74479B</b>	-	-
*PFM1411160	-	3/8" x 1-3/4"	3/8"	9/16"	<b>DW5527</b>	<b>DW5427</b>	DW5427			-	-	<b>DWMT75122B</b>	-
PFM1411220	-	3/8" x 2-1/2"	3/8"	9/16"	<b>DW5527</b>	<b>DW5427</b>	DW5427			-	-	<b>DWMT75122B</b>	-
PFM1411240	PFM1461240	3/8" x 3"	3/8"	9/16"	<b>DW5527</b>	<b>DW5427</b>	DW5427			-	-	<b>DWMT75122B</b>	-
PFM1411280	PFM1461280	3/8" x 4"	3/8"	9/16"	<b>DW5527</b>	<b>DW5427</b>	DW5427			-	-	<b>DWMT75122B</b>	-
PFM1411300	PFM1461300	3/8" x 5"	3/8"	9/16"	<b>DW5529</b>	<b>DW5429</b>	DW5429			-	-	<b>DWMT75122B</b>	-
PFM1411320	PFM1461320	3/8" x 6"	3/8"	9/16"	<b>DW5529</b>	<b>DW5429</b>	DW5429			-	-	<b>DWMT75122B</b>	-
*PFM1411340	-	1/2" x 2"	1/2"	3/4"	<b>DW5537</b>	<b>DW5437</b>	<b>DW5437</b>			-	-	<b>DWMT75113B</b>	-
PFM1411360	-	1/2" x 2-1/2"	1/2"	3/4"	<b>DW5537</b>	<b>DW5437</b>	<b>DW5437</b>			-	-	<b>DWMT75113B</b>	-
PFM1411380	-	1/2" x 3"	1/2"	3/4"	<b>DW5537</b>	<b>DW5437</b>	<b>DW5437</b>			-	-	<b>DWMT75113B</b>	-
PFM1411420	PFM1461420	1/2" x 4"	1/2"	3/4"	<b>DW5537</b>	<b>DW5437</b>	<b>DW5437</b>			-	-	<b>DWMT75113B</b>	-
PFM1411460	PFM1461460	1/2" x 5"	1/2"	3/4"	<b>DW5538</b>	<b>DW5438</b>	<b>DW5438</b>			-	-	<b>DWMT75113B</b>	-
PFM1411480	PFM1461480	1/2" x 6"	1/2"	3/4"	<b>DW5538</b>	<b>DW5438</b>	<b>DW5438</b>			-	-	<b>DWMT75113B</b>	-
PFM1411520	PFM1461520	1/2" x 8"	1/2"	3/4"	<b>DW5538</b>	<b>DW5438</b>	<b>DW5438</b>			-	-	<b>DWMT75113B</b>	-
*PFM1411540	-	5/8" x 3"	5/8"	15/16"	DW5471	<b>DW5446</b>	<b>DW5471</b>			<b>DW5806</b>	-	-	<b>DWMT75104B</b>
PFM1411580	-	5/8" x 4"	5/8"	15/16"	DW5471	<b>DW5446</b>	<b>DW5471</b>			<b>DW5806</b>	-	-	<b>DWMT75104B</b>
PFM1411600	PFM1461600	5/8" x 5"	5/8"	15/16"		<b>DW5446</b>	<b>DW5471</b>			<b>DW5806</b>	-	-	<b>DWMT75104B</b>
PFM1411640	PFM1461640	5/8" x 6"	5/8"	15/16"		<b>DW5446</b>	<b>DW5471</b>			<b>DW5806</b>	-	-	<b>DWMT75104B</b>
PFM1411680	PFM1461680	5/8" x 8"	5/8"	15/16"		<b>DW5447</b>	<b>DW5471</b>			<b>DW5806</b>	-	-	<b>DWMT75104B</b>
*PFM1411700	-	3/4" x 3"	3/4"	1-1/8"		DW5453	<b>DW5474</b>			<b>DW5810</b>	-	-	<b>DWMT75125B</b>
*PFM1411720	-	3/4" x 4"	3/4"	1-1/8"		DW5453	<b>DW5474</b>			<b>DW5810</b>	-	-	<b>DWMT75125B</b>
PFM1411760	-	3/4" x 5"	3/4"	1-1/8"		DW5453	<b>DW5474</b>			<b>DW5810</b>	-	-	<b>DWMT75125B</b>
PFM1411800	PFM1461800	3/4" x 6"	3/4"	1-1/8"		DW5453	<b>DW5474</b>			<b>DW5810</b>	-	-	<b>DWMT75125B</b>
PFM1411840	PFM1461850	3/4" x 8"	3/4"	1-1/8"		DW5455	<b>DW5474</b>			<b>DW5810</b>	-	-	<b>DWMT75125B</b>
PFM1411880	-	3/4" x 10"	3/4"	1-1/8"		DW5455	<b>DW5475</b>			<b>DW5812</b>	-	-	<b>DWMT75125B</b>

\* denotes sizes which are less than the minimum standard anchor length for Strength Design. The published size length of the anchor is measured from under the head.

**MECHANICAL ANCHORS 17**



**SCREW ANCHORS**

**316 Stainless Steel Wedge-Bolt**

Type	Screw Anchor
Approvals	Tested in accordance with ASTM E488, AC106 criteria and AC193 criteria
Description	Uses special matched tolerance Wedge-Bit™ One-piece, finished head Additional corrosion resistance Head ratchet teeth lock against fixture
Base Materials	Concrete, grouted concrete masonry (CMU)
Anchor Material	316 Stainless steel



316 STAINLESS STEEL WEDGE-BOLT SCREW ANCHOR			
CAT #	DIA & LENGTH	CTN	MSTR
07870	1/4" x 2"	100	600
07872	1/4" x 3"	100	500
07876	1/4" x 4"	100	500
07878	1/4" x 5"	100	500
07880	3/8" x 2-1/2"	50	300
07882	3/8" x 3"	50	250
07884	3/8" x 4"	50	250
07886	3/8" x 5"	50	250
07888	1/2" x 3"	50	150
07890	1/2" x 4"	50	150
07892	1/2" x 5"	25	100
07894	1/2" x 6"	25	75

WEDGE-BITS			
CAT #	SIZE	USABLE LENGTH	QTY MSTR
01312	SDS 1/4" x 4"	2"	1
01314	SDS 1/4" x 6"	4"	1
01315	SDS 1/4" x 8"	6"	1
01316	SDS 3/8" x 6"	4"	1
01318	SDS 3/8" x 10"	6"	1
01332	SDS 3/8" x 12"	10"	1
01319	SDS 3/8" x 18"	16"	1

CAT #	SIZE	USABLE LENGTH	QTY	MSTR
01320	SDS 1/2" x 6"	4"	1	
01322	SDS 1/2" x 10"	8"	1	5
01334	SDS 1/2" x 12"	10"	1	5
01335	SDS 1/2" x 18"	16"	1	5
01340	Spline 1/2" x 13"	8"	1	15
01342	Spline 1/2" x 16"	11"	1	14
01354	SDS-Max 1/2" x 13"	8"	1	20
01370	HD Straight Shank 1/4" x 4"	2-3/4"	1	25
01372	HD Straight Shank 1/4" x 6"	4"	1	25
01380	HD Straight Shank 3/8" x 6"	4"	1	25
01384	HD Straight Shank 3/8" x 13"	11"	1	5
01390	HD Straight Shank 1/2" x 6"	4"	1	25
01394	HD Straight Shank 1/2" x 13"	11"	1	5

RECOMMENDED INSTALLATION POWER TOOLS		
CAT #	TYPE	PAGE
DCH273P2DHO, DCH293R2DH, DCH133M2, D25333K, D25263K	SDS+ Rotary Hammers	50
DCF890M2, DCF894P2, DCF899P2	Impact Wrenches	52

ACCESSORIES	
TYPE	PAGE
Hand Pump/-Dust Blower	61
Impact Rated Sockets	by diameter 59

**UltraCon®+**

Type	Concrete Screw
Approvals	ICC-ES ESR-3068 (Concrete), ICC-ES ESR-3196 (Masonry-CMU), MIAMI-DADE COUNTY FBC FLORIDA BUILDING CODE ICC-ES ESR-3042 (Wood-to-Wood), ICC-ES ESR-3213 (Chemically Treated Lumber), Miami-Dade NOA Florida Building Code
Description	Stalgard® Coating Blue, White Silver or Bronze
Base Materials	Concrete, Block, Brick, Wood, Pressure Treated Lumber
Anchor Material	Carbon Steel



ULTRACON+ HEX WASHER HEAD - BLUE			
CAT #	SIZE	CTN	MSTR
DFM12700*	3/16" x 1-1/4"	100	500
DFM12700B*	3/16" x 1-1/4"	5000	-
DFM12702*	3/16" x 1-3/4"	100	500
DFM12702B*	3/16" x 1-3/4"	3000	-
DFM12704	3/16" x 2-1/4"	100	500
DFM12704B	3/16" x 2-1/4"	2000	-
DFM12706	3/16" x 2-3/4"	100	500
DFM12706B	3/16" x 2-3/4"	1500	-
DFM12708	3/16" x 3-1/4"	100	500
DFM12708B	3/16" x 3-1/4"	1000	-
DFM12710	3/16" x 3-3/4"	100	500
DFM12710B	3/16" x 3-3/4"	1000	-
DFM12712	3/16" x 4"	100	500
DFM12712B	3/16" x 4"	1000	-
DFM12715*	1/4" x 1"	100	500
DFM12720*	1/4" x 1-1/4"	100	500
DFM12720B*	1/4" x 1-1/4"	2000	-
DFM12722*	1/4" x 1-3/4"	100	500
DFM12722B*	1/4" x 1-3/4"	2000	-
DFM12724	1/4" x 2-1/4"	100	500
DFM12724B	1/4" x 2-1/4"	1500	-
DFM12726	1/4" x 2-3/4"	100	500
DFM12726B	1/4" x 2-3/4"	1000	-
DFM12728	1/4" x 3-1/4"	100	500
DFM12728B	1/4" x 3-1/4"	1000	-
DFM12730	1/4" x 3-3/4"	100	500
DFM12730B	1/4" x 3-3/4"	500	-
DFM12732	1/4" x 4"	100	500
DFM12732B	1/4" x 4"	500	-
DFM12734	1/4" x 5"	100	500
DFM12734B	1/4" x 5"	500	-

ULTRACON+ HEX WASHER HEAD - BLUE, CONTINUED			
CAT #	SIZE	CTN	MSTR
DFM12735	1/4" x 6"	100	500
DFM12735B	1/4" x 6"	500	-



ULTRACON+ PHILLIPS FLAT HEAD - BLUE			
CAT #	SIZE	CTN	MSTR
DFM12740*	3/16" x 1-1/4"	100	500
DFM12740B*	3/16" x 1-1/4"	5000	-
DFM12742*	3/16" x 1-3/4"	100	500
DFM12742B*	3/16" x 1-3/4"	3000	-
DFM12744	3/16" x 2-1/4"	100	500
DFM12744B	3/16" x 2-1/4"	2500	-
DFM12746	3/16" x 2-3/4"	100	500
DFM12746B	3/16" x 2-3/4"	1500	-
DFM12748	3/16" x 3-1/4"	100	500
DFM12748B	3/16" x 3-1/4"	1000	-
DFM12750	3/16" x 3-3/4"	100	500
DFM12750B	3/16" x 3-3/4"	1000	-
DFM12752	3/16" x 4"	100	500
DFM12752B	3/16" x 4"	1000	-
DFM12760*	1/4" x 1-1/4"	100	500
DFM12760B*	1/4" x 1-1/4"	2500	-
DFM12762*	1/4" x 1-3/4"	100	500
DFM12762B*	1/4" x 1-3/4"	2500	-
DFM12764	1/4" x 2-1/4"	100	500
DFM12764B	1/4" x 2-1/4"	1500	-
DFM12766	1/4" x 2-3/4"	100	500
DFM12766B	1/4" x 2-3/4"	1000	-
DFM12768	1/4" x 3-1/4"	100	500
DFM12768B	1/4" x 3-1/4"	1000	-
DFM12770	1/4" x 3-3/4"	100	500
DFM12770B	1/4" x 3-3/4"	500	-
DFM12772	1/4" x 4"	100	500
DFM12772B	1/4" x 4"	500	-

**18 MECHANICAL ANCHORS**

www.DEWALT.com

**GUARANTEED TOUGH.**

**SCREW ANCHORS**

**UltraCon®+ Continued**

Type	Concrete Screw
Approvals	ICC-ES ESR-3068 (Concrete), ICC-ES ESR-3196 (Masonry-CMU), ICC-ES ESR-3042 (Wood-to-Wood), ICC-ES ESR-3213 (Chemically Treated Lumber) Miami-Dade NOA Florida Building Code
Description	Stalgard® Coating Blue, White Silver or Bronze
Base Materials	Concrete, Block, Brick, Wood, Pressure Treated Lumber
Anchor Material	Carbon Steel



\*Sizes which are less than the minimum standard anchor length for strength design.



**ULTRACON+ PHILLIPS FLAT HEAD - BLUE, CONTINUED**

CAT #	SIZE	CTN	MSTR
DFM12774	1/4" x 5"	100	500
DFM12776	1/4" x 6"	100	500



**ULTRACON+ HEX WASHER HEAD - WHITE**

CAT #	SIZE	CTN	MSTR
DFM2ELD200*	3/16" x 1-1/4"	5000	-
DFM2ELD210*	3/16" x 1-3/4"	3000	-
DFM2ELD220	3/16" x 2-1/4"	2500	-
DFM2ELD230	3/16" x 2-3/4"	1500	-
DFM2ELD240	3/16" x 3-1/4"	1000	-
DFM2ELD250*	1/4" x 1-1/4"	2500	-
DFM2ELD195*	1/4" x 1-3/4"	2000	-
DFM2ELD205	1/4" x 2-1/4"	1500	-
DFM2ELD215	1/4" x 2-3/4"	1000	-
DFM2ELD225	1/4" x 3-1/4"	1000	-
DFM2ELD235	1/4" x 3-3/4"	500	-
DFM2ELD245	1/4" x 4"	500	-
DFM2ELD255	1/4" x 5"	500	-
DFM2ELD265	1/4" x 6"	500	-



**ULTRACON+ PHILLIPS FLAT HEAD - WHITE**

CAT #	SIZE	CTN	MSTR
DFM2ELD320*	3/16" x 1-1/4"	5000	-
DFM2ELD330*	3/16" x 1-3/4"	3000	-
DFM2ELD340	3/16" x 2-1/4"	2500	-
DFM2ELD350	3/16" x 2-3/4"	1500	-
DFM2ELD360	3/16" x 3-1/4"	1000	-
DFM2ELD370	3/16" x 3-3/4"	1000	-
DFM2ELD385*	1/4" x 1-1/4"	2500	-
DFM2ELD386*	1/4" x 1-3/4"	2000	-
DFM2ELD387	1/4" x 2-1/4"	1500	-
DFM2ELD388	1/4" x 2-3/4"	1000	-
DFM2ELD389	1/4" x 3-1/4"	1000	-



**ULTRACON+ HEX FLANGE HEAD - WHITE**

CAT #	SIZE	CTN	MSTR
DFM2ELD270*	1/4" x 1-1/4"	2000	-
DFM2ELD275*	1/4" x 1-3/4"	1500	-
DFM2ELD285	1/4" x 2-1/4"	1000	-
DFM2ELD295	1/4" x 2-3/4"	1000	-
DFM2ELD305	1/4" x 3-1/4"	500	-



**ULTRACON+ PHILLIPS TRIMFIT HEAD - WHITE**

CAT #	SIZE	CTN	MSTR
DFM2ELD400*	1/4" x 1-3/4"	2000	-
DFM2ELD410	1/4" x 2-1/4"	1500	-
DFM2ELD420	1/4" x 2-3/4"	1000	-
DFM2ELD430	1/4" x 3-1/4"	1000	-
DFM2ELD440	1/4" x 3-3/4"	500	-
DFM2ELD450	1/4" x 4"	500	-



**ULTRACON+ HEX WASHER HEAD - SILVER**

CAT #	SIZE	CTN	MSTR
DFM2ELG340*	1/4" x 1-1/4"	2500	-
DFM2ELG341*	1/4" x 1-3/4"	2000	-

**ULTRACON+ HEX WASHER HEAD - SILVER, CONTINUED**

CAT #	SIZE	CTN	MSTR
DFM2ELG371	1/4" x 2-1/4"	1500	-
DFM2ELG401	1/4" x 2-3/4"	1000	-
DFM2ELG431	1/4" x 3-1/4"	1000	-



**ULTRACON+ PHILLIPS FLAT HEAD - SILVER**

CAT #	SIZE	CTN	MSTR
DFM2ELG521*	3/16" x 1-1/4"	5000	-
DFM2ELG551*	3/16" x 1-3/4"	3000	-
DFM2ELG581	3/16" x 2-1/4"	2500	-
DFM2ELG611	3/16" x 2-3/4"	1500	-
DFM2ELG641	3/16" x 3-1/4"	1000	-
DFM2ELG671	3/16" x 3-3/4"	1000	-



**ULTRACON+ PHILLIPS FLAT TRIMFIT HEAD - SILVER**

CAT #	SIZE	CTN	MSTR
DFM2ELG770*	1/4" x 1-1/4"	2500	-
DFM2ELG771*	1/4" x 1-3/4"	2000	-
DFM2ELG801	1/4" x 2-1/4"	1500	-
DFM2ELG831	1/4" x 2-3/4"	1000	-
DFM2ELG861	1/4" x 3-1/4"	1000	-
DFM2ELG891	1/4" x 3-3/4"	500	-
DFM2ELG921	1/4" x 4"	500	-



**ULTRACON+ HEX FLANGE HEAD - SILVER**

CAT #	SIZE	CTN	MSTR
DFM2ELC145*	1/4" x 1-3/4"	1500	-
DFM2ELC151	1/4" x 2-1/4"	1000	-
DFM2ELC160	1/4" x 2-3/4"	1000	-
DFM2ELC170	1/4" x 3-1/4"	1000	-
DFM2ELG510*	1/4" x 1-3/4"	1500	-
DFM2ELG512	1/4" x 2-1/4"	1000	-



**ULTRACON+ HEX WASHER HEAD - BRONZE**

CAT #	SIZE	CTN	MSTR
DFM2ELE465	1/4" x 4"	500	-



**ULTRACON+ PHILLIPS FLAT TRIMFIT HEAD - BRONZE**

CAT #	SIZE	CTN	MSTR
DFM2ELG612	3/16" x 2-3/4"	1500	-
DFM2ELG832	1/4" x 2-3/4"	1000	-
DFM2ELG862	1/4" x 3-1/4"	1000	-
DFM2ELG892	1/4" x 3-3/4"	500	-

**RECOMMENDED INSTALLATION POWER TOOLS**

CAT #	TYPE	PAGE
DCH273P2DHO, DCH133M2,	SDS+ Rotary Hammers	50

**ACCESSORIES**

CAT #	DESCRIPTION	USABLE LENGTH
DW5366	Installation kit installs 3/16" and 1/4" UltraCon+ anchor diameters	
DW5381	SDS+ 2-Cutter drill bit, 5/32" x 7"	4"
DW5382	SDS+ 2-Cutter drill bit, 3/16" x 7"	4"



**SCREW ANCHORS**

**UltraCon®**

Type	Concrete Screw
Approvals	Miami-Dade NOA Florida Building Code
Description	Silver Stalgard® Coating
Base Materials	Concrete, brick, block
Anchor Material	Carbon steel



**ULTRACON HEX WASHER HEAD**

CAT #	SIZE	CTN	MSTR
DFM5ELG481	5/16" x 1-3/4"	1000	-
DFM5ELG486	5/16" x 2-1/4"	1000	-
DFM5ELG491	5/16" x 2-3/4"	500	-
DFM5ELG496	5/16" x 3-1/4"	500	-
DFM5ELG501	5/16" x 3-3/4"	500	-
DFM5ELG506	5/16" x 4"	500	-
DFM5ELG511	5/16" x 5"	250	-
DFM5ELG516	5/16" x 6"	250	-



**ULTRACON PHILLIPS FLAT TRIMFIT HEAD**

CAT #	SIZE	CTN	MSTR
DFM5ELG945	5/16" x 2-1/4"	1500	-
DFM5ELG955	5/16" x 2-3/4"	1000	-
DFM5ELG965	5/16" x 3-1/4"	500	-
DFM5ELG972	5/16" x 3-3/4"	500	-
DFM5ELG976	5/16" x 4"	500	-
DFM5ELG991	5/16" x 5"	250	-



**ULTRACON HEX TRIMFIT HEAD**

CAT #	SIZE	CTN	MSTR
DFM5ELG482	5/16" x 1-3/4"	1500	-
DFM5ELG487	5/16" x 2-1/4"	1000	-
DFM5ELG492	5/16" x 2-3/4"	1000	-
DFM5ELG497	5/16" x 3-1/4"	500	-
DFM5ELG502	5/16" x 3-3/4"	500	-



**ULTRACON PHILLIPS FLAT OVERSIZE HEAD**

CAT #	SIZE	CTN	MSTR
DFM5ELG203	5/16" x 3"	50	250
DFM5ELG204	5/16" x 4"	50	250
DFM5ELG205	5/16" x 5"	50	250
DFM5ELG206	5/16" x 6"	50	250

**RECOMMENDED INSTALLATION POWER TOOLS**

CAT #	TYPE	PAGE
DCH273P2DHO, DCH133M2	SDS+ Rotary Hammers	50



**ULTRACON PHILLIPS FLAT HEAD**

CAT #	SIZE	CTN	MSTR
DFM5ELG941	5/16" x 2-1/4"	1000	-
DFM5ELG948	5/16" x 2-3/4"	500	-
DFM5ELG960	5/16" x 3-1/4"	500	-
DFM5ELG979	5/16" x 4"	500	-
DFM5ELG992	5/16" x 5"	500	-
DFM5ELG998	5/16" x 6"	250	-

**ACCESSORIES**

CAT #	DESCRIPTION	USABLE LENGTH
DW5417	SDS+ 2-Cutter drill bit, 1/4" x 6"	4"
DW5418	SDS+ 2-Cutter drill bit, 1/4" x 8-1/2"	6-1/2"
DW5420	SDS+ 2-Cutter drill bit, 1/4" x 12"	10"
DW5421	SDS+ 2-Cutter drill bit, 1/4" x 14"	12"

**UltraCon® SS4**

Type	Concrete Screw
Approvals	Miami-Dade NOA Florida Building Code
Description	Silver Stalgard® Coating 410 Stainless Steel provides enhanced corrosion resistance and ductility over carbon steel fasteners
Base Materials	Concrete, brick, block
Anchor Material	410 Stainless Steel



**ULTRACON SS4 HEX WASHER HEAD**

CAT #	SIZE	CTN	MSTR
DFM4EUH310	1/4" x 1-1/4"	100	500
DFM4EUH315	1/4" x 1-3/4"	100	500
DFM4EUH325	1/4" x 2-1/4"	100	500
DFM4EUH335	1/4" x 2-3/4"	100	500
DFM4EUH345	1/4" x 3-1/4"	100	500
DFM4EUH355	1/4" x 3-3/4"	100	500
DFM4EUH365	1/4" x 4"	100	500
DFM4EUH375	1/4" x 5"	100	500
DFM4EUH385	1/4" x 6"	100	500

**RECOMMENDED INSTALLATION POWER TOOLS**

CAT #	TYPE	PAGE
DCH273P2DHO, DCH133M2	SDS+ Rotary Hammers	50

**ACCESSORIES**

CAT #	DESCRIPTION	USABLE LENGTH
DW5382	SDS+ 2-Cutter drill bit, 3/16" x 7"	4"



**ULTRACON SS4 PHILLIPS FLAT HEAD**

CAT #	SIZE	CTN	MSTR
DFM4EUF310	1/4" x 1-1/4"	100	500
DFM4EUF315	1/4" x 1-1/4"	100	500
DFM4EUF325	1/4" x 1-3/4"	100	500
DFM4EUF335	1/4" x 2-3/4"	100	500
DFM4EUF345	1/4" x 3-1/4"	100	500
DFM4EUF355	1/4" x 3-3/4"	100	500
DFM4EUF365	1/4" x 4"	100	500

**GUARANTEED TOUGH®**

**SCREW ANCHORS**

**Crete-Flex®**

Type	Concrete Screw
Approvals	Miami-Dade NOA Florida Building Code
Description	Silver Stalgard® Coating 410 Stainless Steel provides enhanced corrosion resistance and ductility for outstanding performance
	Larger .201 root diameter provides exceptionally high shear values
Base Materials	Concrete, brick, block
Anchor Material	410 Stainless Steel



CRETE-FLEX HEX WASHER HEAD			
CAT #	SIZE	CTN	MSTR
DFM4EMH500	3/16" x 1-1/4"	100	500
DFM4EMH510	3/16" x 1-3/4"	100	500
DFM4EMH530	3/16" x 2-1/4"	100	500
DFM4EMH550	3/16" x 2-3/4"	100	500
DFM4EMF310	#14 x 1-1/4"	100	500
DFM4EMF330	#14 x 1-3/4"	100	500
DFM4EMF350	#14 x 2-1/4"	100	500
DFM4EMF370	#14 x 2-3/4"	100	500
DFM4EMF390	#14 x 3-1/4"	100	500
DFM4EMF410	#14 x 3-3/4"	100	500
DFM4EMF430	#14 x 4"	100	500
DFM4EMF450	#14 x 5"	100	500
DFM4EMF470	#14 x 6"	100	500



CRETE-FLEX PHILLIPS FLAT HEAD			
CAT #	SIZE	CTN	MSTR
DFM4EMF610	3/16" x 1-1/4"	100	500
DFM4EMF620	3/16" x 1-3/4"	100	500
DFM4EMF630	3/16" x 2-1/4"	100	500
DFM4EMF640	3/16" x 2-3/4"	100	500
DFM4EMF650	3/16" x 3-1/4"	100	500
DFM4EMF690	#14 x 1-1/4"	100	500
DFM4EMF710	#14 x 1-3/4"	100	500
DFM4EMF730	#14 x 2-1/4"	100	500
DFM4EMF750	#14 x 2-3/4"	100	500
DFM4EMF770	#14 x 3-1/4"	100	500
DFM4EMF790	#14 x 3-3/4"	100	500
DFM4EMF810	#14 x 4"	100	500
DFM4EMF830	#14 x 5"	100	500
DFM4EMF850	#14 x 6"	100	500

RECOMMENDED INSTALLATION POWER TOOLS		
CAT #	TYPE	PAGE
DCH273P2DHO, DCH133M2	SDS+ Rotary Hammers	50



CRETE-FLEX HEX FLANGE HEAD			
CAT #	SIZE	CTN	MSTR
DFM4EMF340	#14 x 1-3/4"	100	500
DFM4EMF360	#14 x 2-1/4"	100	500



CRETE-FLEX PHILLIPS TRIMFIT HEAD			
CAT #	SIZE	CTN	MSTR
DFM4EMF510	#14 x 1-3/4"	100	500
DFM4EMF530	#14 x 2-1/4"	100	500
DFM4EMF550	#14 x 2-3/4"	100	500

ACCESSORIES		
CAT #	DESCRIPTION	USABLE LENGTH
DW5381	SDS+ 2-Cutter drill bit, 5/32" x 7"	4"
DW5410	SDS+ 2-Cutter drill bit, 7/32" x 6"	4"
DW5412	SDS+ 2-Cutter drill bit, 7/32" x 10"	

**Aggre-Gator®**

Type	Concrete Screw
Approvals	Miami-Dade NOA High Velocity Hurricane Zone Florida Building Code
Description	Corrosion resistant
	High strength and ductility Galvanic compatibility in dissimilar metal applications involving aluminum Silver Stalgard® GB (Galvanic Barrier) Coating
Base Materials	Concrete, brick, block, ACQ- treated lumber
Anchor Material	Bi-Metal 300 Series Stainless Steel

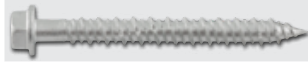

AGGRE-GATOR HEX WASHER HEAD			
CAT #	SIZE	CTN	MSTR
DFM3EML300	1/4" x 1-1/4"	50	300
DFM3EML315	1/4" x 1-3/4"	50	300
DFM3EML325	1/4" x 2-1/4"	50	300
DFM3EML335	1/4" x 2-3/4"	50	300
DFM3EML345	1/4" x 3-1/4"	50	300
DFM3EML365	1/4" x 4"	50	300

RECOMMENDED INSTALLATION POWER TOOLS		
CAT #	TYPE	PAGE
DCH273P2DHO, DCH133M2	SDS+ Rotary Hammers	50

ACCESSORIES		
CAT #	DESCRIPTION	USABLE LENGTH
DW5382	SDS+ 2-Cutter drill bit, 3/16" x 7"	4"
(is the adaptor sold seperately?)		



AGGRE-GATOR PHILLIPS TRIMFIT HEAD			
CAT #	SIZE	CTN	MSTR
DFM3EMM340	1/4" x 3-1/4"	50	300
DFM3EMM300	1/4" x 1-1/4"	50	300
DFM3EMM310	1/4" x 1-3/4"	50	300
DFM3EMM320	1/4" x 2-1/4"	50	300
DFM3EMM330	1/4" x 2-3/4"	50	300
DFM3EMM360	1/4" x 4"	50	300

ACCESSORIES		
CAT #	DESCRIPTION	USABLE LENGTH
DW5382	SDS+ 2-Cutter drill bit, 3/16" x 7"	4"



**CAST-IN-PLACE  
ROD HANGER**

**DDI+™ (DEWALT DECK INSERT)**

Type	Rod Hanging Anchor
Approvals	ICC-ES ESR-3958 (Concrete) Recognition in cracked & uncracked concrete including seismic and wind loading (Category 1 Anchors) Full FM & UL listings in product brochure or at www.DEWALT.com
Description	Installs through predrilled pan deck used to support MEP attachments in poured concrete slabs
Base Materials	Normal and lightweight concrete over steel deck
Anchor Material	Plain and zinc plated carbon steel



DDI+ #	ANCHOR/ROD SIZE	DRILL DIA	INSERT QTY
PFM2511100	3/8"	7/16"	20
PFM2511110	1/2"	9/16"	20
PFM2511120	5/8"	11/16"	20
PFM2511130*	3/4"	13/16"	12
PFM2511140*	7/8"	15/16"	12

\* Parts not included in ESR-3958

RECOMMENDED INSTALLATION POWER TOOLS		
CAT #	TYPE	PAGE
DCD996P2	Cordless Hammerdrill	
DCF991P2	Cordless Drill /Driver	

ACCESSORIES		
CAT #	TYPE	SIZE
D180014IR	Impact Rated Hole Saw	7/8"
DWA1786IR	Impact Rated Step Drill Bit	3/16" - 7/8"
DW2218IR	Impact Rated Magnetic Nut Driver	1/4" x 1-7/8"
DWA2221IR	Impact Rated Cleanable Nut Driver	1/4"



**AUTOMATE THE PLACEMENT AND DESIGN OF MEP HANGERS AND SEISMIC BRACING**

**Plug-in for Autodesk® Revit®**

Achieve significant BIM workflow efficiencies and cost savings.

- **PREFABRICATION SPOOLS**  
Generate all hanger prefab spool sheets directly from the BIM with a single click.
- **POINT LOADS & SEISMIC BRACING**  
Point loads are calculated based on system weights and seismic bracing is accurately placed based on your project specified rules.
- **BILLS OF MATERIAL**  
Create material quantity schedules directly from the BIM.
- **FIELD LAYOUT POINTS**  
Export hanger points in CSV file format to any robotic total station for streamlined field layout.

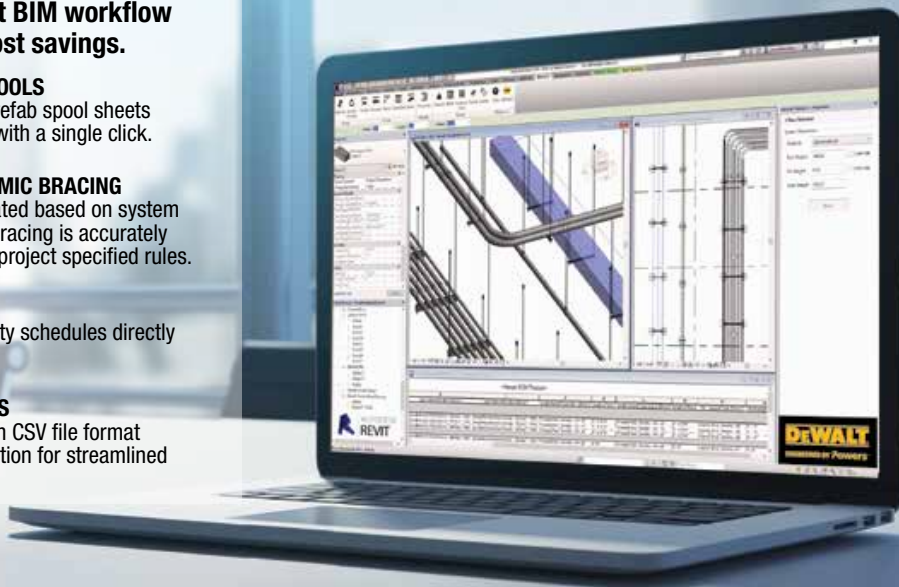

LEARN MORE AT [DEWALT.COM/HANGERWORKS](http://DEWALT.COM/HANGERWORKS)

Autodesk® and Revit® are registered trademarks of Autodesk, Inc.



**GUARANTEED TOUGH.**

**CAST-IN-PLACE ROD HANGER**

**Wood-Knocker® II+**

Type	Cast-In-Place Concrete Insert
Approvals	ICC-ES ESR-3657 (Concrete) IBC & IRC 2018, 2015, 2012, 2009  Recognition in cracked & uncracked concrete including seismic and wind loading (Category 1 Anchors) Full FM & UL listings in product brochure or at www.DeWALT.com
Description	Installs onto forms used to support MEP attachments in poured concrete slabs
Base Materials	Normal and lightweight concrete
Anchor Material	Carbon steel and engineered plastic



WOOD-KNOCKER II+ LOW PROFILE			
CAT #	ROD SIZE	COLOR	QTY
PFM2500014	1/4"	Brown	100
PFM2500038	3/8"	Green	100
PFM2501438	1/4" & 3/8"	Yellow	100
WOOD-KNOCKER II+ SINGLE THREAD			
CAT #	ROD SIZE	COLOR	QTY
PFM2521100	1/4"	Brown	100
PFM2521150	3/8"	Green	100
PFM2521200	1/2"	Yellow	100
PFM2521250	5/8"	Red	100
PFM2521300	3/4"	Purple	100
WOOD-KNOCKER II+ DOUBLE THREAD			
CAT #	ROD SIZE	COLOR	QTY
PFM2521438	1/4" & 3/8"	White	100
PFM2521350	3/8" & 1/2"	Grey	100
PFM2525834	5/8" & 3/4"	Black	50

WOOD-KNOCKER II+ TRIPLE THREAD			
CAT #	ROD SIZE	COLOR	QTY
PFM253143812	1/4" & 3/8" & 1/2"	Teal	100
PFM253381258	3/8" & 1/2" & 5/8"	Orange	50
PAN-KNOCKER II+ (NO NAIL)			
CAT #	ROD SIZE	COLOR	QTY
PFM253143812NN	1/4" & 3/8" & 1/2"	Teal	100
PFM2525834NN	5/8" & 3/4"	Black	100
ACCESSORIES			PAGE
TYPE			
Hammer	refer to page		59

**Bang-It® +**

Type	Cast-In-Place Concrete Insert
Approvals	ICC-ES ESR-3657 (Concrete) IBC & IRC 2018, 2015, 2012, 2009  Recognition in cracked & uncracked concrete including seismic and wind loading (Category 1 Anchors) Full FM & UL listings in product brochure or at www.DeWALT.com
Description	Installs through predrilled pan deck used to support MEP attachments in poured concrete slabs
Base Materials	Normal and lightweight concrete
Anchor Material	Carbon steel and engineered plastic



BANG-IT+ SINGLE THREAD			
CAT #	ROD SIZE	COLOR	QTY
07540	1/4"	Brown	100
07542	3/8"	Green	100
07544	1/2"	Yellow	100
07546	5/8"	Red	50
07548	3/4"	Purple	50
BANG-IT+ DOUBLE THREAD			
CAT #	ROD SIZE	COLOR	QTY
PFM3521438	1/4" & 3/8"	White	100
07543	3/8" & 1/2"	Grey	100
PFM3525834	5/8" & 3/4"	Black	50
BANG-IT+ TRIPLE THREAD			
CAT #	ROD SIZE	COLOR	QTY
PFM353143812	1/4" & 3/8" & 1/2"	Teal	50
PFM353381258	3/8" & 1/2" & 5/8"	Orange	50

RECOMMENDED INSTALLATION POWER TOOLS			
CAT #	TYPE		PAGE
DCF887D2	Cordless Impact Driver		53
DCD996P2	Cordless Hammerdrill		53
DCD991P2	Cordless Drill Driver		53
ACCESSORIES			
CAT #	TYPE	SIZE	QTY
D180014IR	Impact Rated Hole Saw	7/8"	
D180020IR	Impact Rated Hole Saw	1-1/4"	
DWA1786IR	Impact Rated Step Drill Bit	3/16" - 7/8"	
07560	Bang-It Stand Up Pole Tool	29"	1
07562	Carbide Hole Saw	13/16"	10
07564	Carbide Hole Saw	1-3/16"	10
07566	Centerbit with Spring Replacement		1





**ROD HANGER ANCHORS**

**Mini-Undercut+™**

Type	Undercut Anchor
Approvals	ICC-ES ESR-3912 (Concrete); IBC & IRC 2018, 2015, 2012, 2009 Recognition in cracked & uncracked concrete including seismic and wind loading (Category 1 Anchors)
Description	Transfers load mainly through bearing, not dependent upon friction between the expansion sleeve and the concrete.
Base Materials	Post-tension concrete (PT slabs), hollow-core precast concrete, normal-weight concrete, sand-lightweight concrete and concrete over steel deck
Anchor Material	Carbon steel



MINI UNDERCUT ANCHOR					
CAT #	ANCHOR SIZE	ROD DIA	DRILL DIA	QTY	MSTR QTY
PFM2111820	3/8" x 3/4"	3/8"	5/8"	100	600



ACCU-BIT					
CAT #	STOP BIT SIZE	ROD DIA	DRILL DIA	DRILL DEPTH	QTY
PPA2431720	5/8" x 3/4"	3/8"	5/8"	3/4"	1



SDS SETTING TOOL			
CAT #	SETTING TOOL SIZE	ROD DIA	QTY
PFM2101720	5/8" x 3/4"	3/8"	10

RECOMMENDED INSTALLATION POWER TOOLS		
CAT #	TYPE	PAGE
DCH273P2DH0, DCH293R2DH, D25263K	SDS+ Rotary Hammer	50



ACCESSORIES	
CAT #	TYPE
DWH050K	Dust Extraction Hole Cleaning
DWH003SBH	Stop Bit Head Nozzle Kit
DWH002SBH	Stop Bit Head Replacement 3-Pack



**GUARANTEED TOUGH.**

**ROD HANGER ANCHORS**

**Snake+®**

Type	Internally Threaded Screw Anchor
Approvals	ICC-ES ESR-2272 (Concrete) IBC & IRC 2018, 2015, 2012, 2009 Recognition in cracked & uncracked concrete including seismic and wind loading (Category 1 Anchors) Full FM listings in product brochure or at www.DEWALT.com
Description	Self-tapping
Base Materials	Normal and sand-light-weight concrete, concrete over metal deck
Anchor Material	Carbon steel



CAT #	SIZE	MIN HOLE DEPTH	INTERNAL THREAD DEPTH	QTY	MSTR
6400SD	1/4"	1-5/8"	22/32"	100	1000
6401SD	3/8"	1-5/8"	11/16"	50	500
6403SD	1/2"	2-1/2"	29/32"	50	300

One setting tool included per box



EXTRA SNAKE+ SNAKE+ SETTING TOOLS			
CAT #	SIZE	QTY	MSTR
6402SD	1/4"	1	100
6407SD	3/8"	1	250
6404SD	1/2"	1	250

RECOMMENDED INSTALLATION POWER TOOLS		
CAT #	TYPE	PAGE
DCH293R2DH, DCH133M2, D25263K	SDS+ Rotary Hammers	50
DCF890M2, DCF894P2, DCF880M2	Cordless Impact Wrenches	52

ACCESSORIES		
TYPE		PAGE
SDS+ Carbide Drill Bits	by diameter/length	56

**Smart DI Anchor (Drop-In)**

Type	Internally Threaded Expansion Anchor
Approvals	Full FM & UL listings in product brochure or at www.DEWALT.com
Description	Patented plug design yields more expansion at anchor bottom Smart Drill and DI tool reduce drilling/setting effort
Base Materials	Concrete
Anchor Material	Carbon steel



SMART DI			
CAT #	SIZE	QTY	MSTR
6304SD	1/4"	100	1000
6306SD	3/8"	50	500
6308SD	1/2"	50	300



DI REPLACEMENT PARTS		
CAT #	FITS TOOL	KIT CONTENTS
00426SD	00425SD	1 Rubber Spring Plug, 2 Guide Screws
00428SD	00427SD	Rubber Spring Plug, 2 Guide Screws
00430SD	00430SD	Rubber Spring Plug, 2 Guide Screws



DI TOOL			
CAT #	SIZE	QTY	MSTR
00425SD	1/4"	1	6
00427SD	3/8"	1	6
00429SD	1/2"	1	6



DRILL			
CAT #	SIZE	QTY	MSTR
00391SD	3/8" (for 1/4" Smart DI)	1	12
00397SD	1/2" (for 3/8" Smart DI)	1	12
00410SD	5/8" (for 1/2" Smart DI)	1	12

SMART DI AVAILABLE IN JARS		
CAT #	SIZE	QTY
J6304SD	1/4"	100
J6306SD	3/8"	50
J6308SD	1/2"	50

RECOMMENDED INSTALLATION POWER TOOLS		
CAT #	TYPE	PAGE
DCH293R2DH, DCH133M2, D25263K	SDS+ Rotary Hammers	50

ACCESSORIES		
CAT #	TYPE	
DWH003SBH	Stop Bit Head Nozzle Kit	
DWH002SBH	Stop Bit Head Replacement 3-Pack	

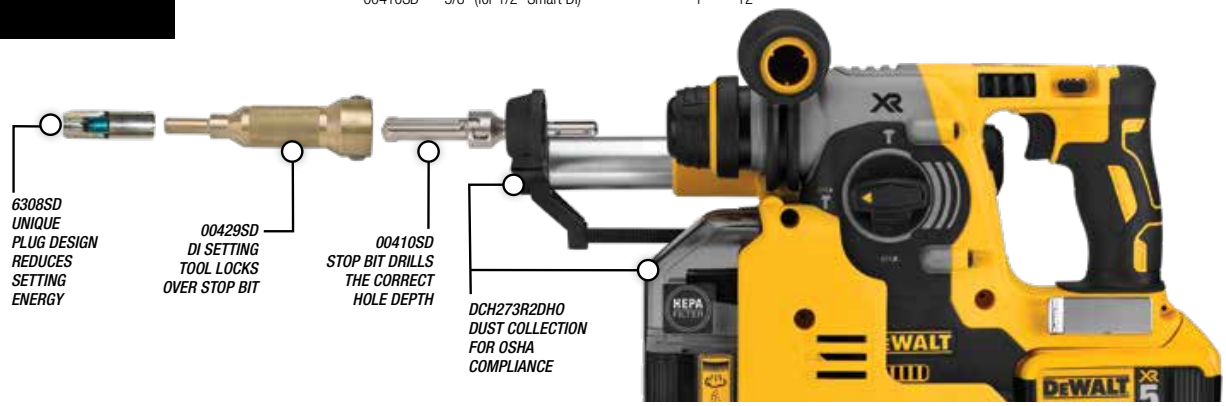

**MECHANICAL ANCHORS 25**



**ROD HANGER ANCHORS**

**Hollow-Set® Drop-In**

Type	Internally Threaded Expansion Anchor
Approvals	Full UL listings in product brochure or at <a href="http://www.DEWALT.com">www.DEWALT.com</a>
Description	For anchoring in hollow base materials. Overcomes spalling issues.
Base Materials	Concrete, block, brick, pre-cast hollow core plank and stone
Anchor Material	Zamac alloy with carbon or stainless steel cones



**ZAMAC BODY WITH CARBON STEEL CONE**

CAT #	SIZE	DRILL DIA	OVERALL LEN	SLEEVE LEN	QTY	MSTR
09320	1/4"	3/8"	7/8"	5/8"	100	1000
09330	5/16"	5/8"	1-5/16"	15/16"	50	300
09340	3/8"	5/8"	1-5/16"	15/16"	50	300
09350	1/2"	3/4"	1-3/4"	1-1/4"	50	250
09360	5/8"	1"	2"	1-1/2"	25	125

**ZAMAC BODY WITH STAINLESS STEEL CONE**

CAT #	SIZE	DRILL DIA	OVERALL LEN	SLEEVE LEN	QTY	MSTR
09420	1/4"	3/8"	7/8"	5/8"	100	1000
09440	3/8"	5/8"	1-5/16"	15/16"	100	500



**SOLID BASE MATERIAL SETTING TOOLS**

CAT #	SIZE	QTY	MSTR
09322	1/4"	1	200
09342	5/16" & 3/8"	1	50
09352	1/2"	1	25
09362	5/8"	1	-



**HOLLOW BASE MATERIAL SETTING TOOLS**

CAT #	SIZE	QTY	MSTR
09323	1/4"	1	50
09333	5/16"	1	50
09343	3/8"	1	50
09353	1/2"	1	50
09363	5/8"	1	-

**RECOMMENDED INSTALLATION POWER TOOLS**

CAT #	TYPE	PAGE
DCH293R2DH, DCH133M2, D25263K	SDS+ Rotary Hammers	50

**ACCESSORIES**

TYPE		PAGE
SDS+ Carbide Drill Bits	by diameter/length	56
Hammer	refer to page	59
Torque Wrench	refer to page	59



**POWER OF FREEDOM™**



Our DeWALT FLEXVOLT® tools are made to deliver the power needed for tough jobs, while eliminating the hassle of a cord.

DeWALT FLEXVOLT® batteries automatically switch voltage when you change tools. Get maximum runtime with 20V MAX\* tools and the power of corded with 60V MAX\* and 120V MAX\* tools.

**GUARANTEED TOUGH.**

**ROD HANGER ANCHORS**

**Mini Dropin™**

Type	Internally Threaded Expansion Anchor
Approvals	Full FM listings in product brochure or at <a href="http://www.DeWALT.com">www.DeWALT.com</a>
Description	Machine bolt anchor for shallow embedment applications
Base Materials	Pre-cast hollow core plank, concrete
Anchor Material	Carbon steel



**MINI DROP-IN**

CAT #	SIZE	DRILL DIA	MIN DEPTH	THREAD DEPTH	QTY	MSTR
06335	1/4"	3/8"	5/8"	3/8"	100	1000
06322	3/8"	1/2"	3/4"	13/32"	100	1000
06337	1/2"	5/8"	1"	5/8"	50	250



**SETTING TOOLS FOR MINI DROP-IN ANCHORS**

CAT #	SIZE	QTY	MSTR
06336	1/4"	1	50
06323	3/8"	1	50
06338	1/2"	1	50



**SDS-PLUS ACCU-BIT FOR MINI DROP-IN**

CAT #	SIZE	QTY
DWA5491	SDS-Plus 3/8" for 1/4" Mini Drop-In	1
DWA5492	SDS-Plus 1/2" for 3/8" Mini Drop-In	1
DWA5494	SDS-Plus 5/8" for 1/2" Mini Drop-In	1

**RECOMMENDED INSTALLATION POWER TOOLS**

CAT #	TYPE	PAGE
DCH293R2DH, DCH133M2, D25333K, D25263K	SDS+ Rotary Hammers	50

**ACCESSORIES**

TYPE	PAGE
SDS+ Carbide Drill Bits by diameter/length	56
DWH003SBH Stop Bit Head Nozzle Kit	
DWH002SBH Stop Bit Head Replacement 3-Pack	

**Steel-Dropin™**

Type	Internally Threaded Expansion Anchor
Approvals	Full UL listings in product brochure or at <a href="http://www.DeWALT.com">www.DeWALT.com</a>
Description	Machine bolt anchor
Base Materials	Solid concrete, solid block, hard stone
Anchor Material	Carbon Steel, Type 303 Stainless Steel and Type 316 Stainless Steel Coil thread version available for forming applications



**CARBON STEEL DROP-IN (SMOOTH WALL)**

CAT #	SIZE	DRILL DIA	MIN DEPTH	THREAD DEPTH	QTY	MSTR
06304	1/4"	3/8"	1"	7/16"	100	1000
06306	3/8"	1/2"	1-9/16"	5/8"	50	500
06308	1/2"	5/8"	2"	13/16"	50	300
06320	5/8"	7/8"	2-1/2"	1-3/16"	25	125
06312	3/4"	1"	3-3/16"	1-3/8"	10	50

**CARBON STEEL FLANGED DROP-IN (LIPPED)**

CAT #	SIZE	DRILL DIA	MIN DEPTH	THREAD DEPTH	QTY	MSTR
06324	1/4"	3/8"	1"	7/16"	100	1000
06326	3/8"	1/2"	1-9/16"	5/8"	50	500
06328	1/2"	5/8"	2"	13/16"	50	300

**CARBON STEEL KNURLED WALL DROP-IN**

CAT #	SIZE	DRILL DIA	OVERALL LEN	THREAD DEPTH	QTY	MSTR
06340	1/4"	3/8"	1"	7/16"	100	1000
06342	3/8"	1/2"	1-9/16"	5/8"	50	500
06344	1/2"	5/8"	2"	13/16"	50	250

**TYPE 303 STAINLESS STEEL DROP-IN**

CAT #	SIZE	DRILL DIA	MIN DEPTH	THREAD DEPTH	QTY	MSTR
06204	1/4"	3/8"	1"	7/16"	100	1000
06206	3/8"	1/2"	1-9/16"	5/8"	50	500
06208	1/2"	5/8"	2"	13/16"	50	300
06210	5/8"	7/8"	2-1/2"	1-3/16"	25	125
06212	3/4"	1"	3-3/16"	1-3/8"	10	50

**TYPE 316 STAINLESS STEEL DROP-IN**

CAT #	SIZE	DRILL DIA	MIN DEPTH	THREAD DEPTH	QTY	MSTR
06224	1/4"	3/8"	1"	7/16"	100	1000
06226	3/8"	1/2"	1-9/16"	5/8"	50	500
06228	1/2"	5/8"	2"	13/16"	50	300
06230	5/8"	7/8"	2-1/2"	1-3/16"	25	125
06232	3/4"	1"	3-3/16"	1-3/8"	10	50

**CARBON STEEL COIL THREAD DROP-IN**

CAT #	SIZE	DRILL DIA	MIN DEPTH	THREAD DEPTH	QTY	MSTR
06330	1/2"	5/8"	2"	13/16"	50	300
06332	3/4"	1"	3-3/16"	1-3/8"	10	50

**DROP-IN 304SS AND 316SS**

CAT #	TYPE	SIZE	CTN	MSTR
6204USA	303SS	1/4"	100	1000
6206USA	303SS	3/8"	50	500

CAT #	TYPE	SIZE	CTN	MSTR
6208USA	303SS	1/2"	50	300
6210USA	303SS	5/8"	25	125
6212USA	303SS	3/4"	10	50
6224USA	316SS	1/4"	100	1000
6226USA	316SS	3/8"	50	500
6228USA	316SS	1/2"	50	300
6230USA	316SS	5/8"	25	125
6304USA	Carbon Steel	1/4"	100	1000
6306USA	Carbon Steel	3/8"	50	500
6308USA	Carbon Steel	1/2"	50	300
6320USA	Carbon Steel	5/8"	25	125
6312USA	Carbon Steel	3/4"	10	50

**STEEL DROP-IN (AVAILABLE IN JARS)**

CAT #	SIZE	QTY
J6304SD	1/4"	100
J6306SD	3/8"	50
J6308SD	1/2"	50



**SETTING TOOLS FOR STEEL DROP-IN ANCHORS**

CAT #	SIZE	QTY	MSTR
06305	1/4"	1	250
06307	3/8"	1	100
06309	1/2"	1	100
06311	5/8"	1	50
06313	3/4"	1	25

**SDS-PLUS STOP BIT FOR DROP-IN**

CAT #	SIZE	QTY
DWA5491	3/8" for 1/4" Drop-In	1
DWA5493	1/2" for 3/8" Drop-In	1
DWA5495	5/8" for 1/2" Drop-In	1

**RECOMMENDED INSTALLATION POWER TOOLS**

CAT #	TYPE	PAGE
DCH293R2DH, DCH133M2, D25333K, D25263K	SDS+ Rotary Hammers	50

**ACCESSORIES**

TYPE	PAGE
SDS+ Carbide Drill Bits by diameter/length	56
Hammer refer to page	59



**ROD HANGER ANCHORS**

**Hangermate®+ for Concrete**

Type	Rod Hanging Anchor
Approvals	ICC-ES ESR-3889 (Concrete); IBC & IRC 2018, 2015, 2012, 2009   Recognition in cracked & uncracked concrete including seismic and wind loading (Category 1 Anchors) Full FM listings in product brochure or at www.DEWALT.com
Description	Rod hanging anchors
Base Materials	Concrete
Anchor Material	Carbon steel



**HANGERMATE+ FOR CONCRETE - INTERNALLY THREADED - VERTICAL**

CAT #	ROD DIA	DESCRIPTION	CTN	MSTR
PFM2211100	1/4"	1/4" x 1-5/8"	25	125
PFM2211200	3/8"	1/4" x 1-5/8"	25	125
PFM2211250	3/8"	1/4" x 2-1/2"	25	125
PFM2211260	3/8"	3/8" x 1-5/8"	25	125
PFM2211270	3/8"	3/8" x 2"	25	125
PFM2211280	1/2"	3/8" x 2"	25	125

**INSTALLATION DRIVERS AND ACCESSORIES:**

**HANGERMATE+ FOR CONCRETE - INTERNALLY THREADED - VERTICAL**

CAT #	SOCKET SIZE	DRIVE	CTN	MSTR
PFM1491050	3/8"	1/4" Hex	5	25
PFM1491100	1/2"	1/4" Hex	5	25
07198	11/16"	1/4" Hex	5	25
By Diameter	3/8" - 11/16"	3/8" Square		See Page X



**HANGERMATE+ FOR CONCRETE - EXTERNALLY THREADED - VERTICAL**

CAT #	ROD DIA	DESCRIPTION	CTN	MSTR
PFM1421000	3/8"	1/4" x 1-5/8"	25	125
PFM1421050	3/8"	1/4" x 2-1/2"	25	125

**INSTALLATION DRIVERS AND ACCESSORIES:**

**HANGERMATE+ FOR CONCRETE - EXTERNALLY THREADED - VERTICAL**

CAT #	SOCKET SIZE	DRIVE	CTN	MSTR
DWMT19052B	1/2" (Deep)	3/8" Square	1	50
CAT #	DESCRIPTION	CTN	MSTR	
PFM2201050	3/8" to 1/2" Adaptor <sup>1</sup>	25	125	

1. The 3/8" to 1/2" adaptor has a 3/8-16 external thread and a 1/2-13 internal thread.

**RECOMMENDED INSTALLATION POWER TOOLS**

**HANGERMATE+ FOR CONCRETE**

CAT #	TYPE	PAGE
DCH273P2DHO, DCH293R2DH	SDS+ Rotary Hammers	50
DCH133M2, D25263K		
DCF890M2	Cordless Impact Wrenches	52
DCF887D2	Cordless Impact Driver	53

**Hangermate® for Concrete**

Type	Rod Hanging Anchor
Approvals	Full FM listings in product brochure or at www.DEWALT.com 
Description	Rod hanging anchors
Base Materials	Concrete
Anchor Material	Carbon steel



**HANGERMATE BASIC FOR CONCRETE - INTERNALLY THREADED - VERT.**

CAT #	ROD DIA	DESCRIPTION	CTN	MSTR
PFM2217171	1/4"	1/4" x 1-1/4"	100	600
PFM2217173	3/8"	1/4" x 1-1/2"	100	600

**INSTALLATION DRIVERS AND ACCESSORIES:**

**HANGERMATE BASIC FOR CONCRETE - INTERNALLY THREADED - VERT.**

CAT #	SOCKET SIZE	DRIVE	CTN	MSTR
PFM1491050	3/8"	1/4" Hex	5	25
PFM1491100	1/2"	1/4" Hex	5	25
By Diameter	3/8" - 1/2"	3/8" Square		



**HANGERMATE FOR CONCRETE - INTERNALLY THREADED - PIVOT**

CAT #	ROD DIA	DESCRIPTION	CTN	MSTR
PFM2281300	3/8"	1/4" x 2"	25	125

**INSTALLATION DRIVERS AND ACCESSORIES:**

**HANGERMATE FOR CONCRETE - INTERNALLY THREADED - PIVOT**

CAT #	DRIVE	CTN	MSTR
PFM2201250	1/4" Hex	5	25

**OTHER ACCESSORIES:**

**HANGERMATE FOR CONCRETE**

CAT #	DESCRIPTION	CTN	MSTR
PFM2201050	3/8" to 1/2" Adaptor <sup>1</sup>	25	125

1. The 3/8" to 1/2" adaptor has a 3/8-16 external thread and a 1/2-13 internal thread.

**RECOMMENDED INSTALLATION POWER TOOLS**

CAT #	TYPE	DETAILS PAGE
DCH273P2DHO	Rotary Hammer	
DCF887D2	Impact Driver	
DCF890M2	Impact Wrench	
DCS350D2	Rod Cutter	

**RECOMMENDED INSTALLATION POWER TOOLS**

**HANGERMATE+ FOR CONCRETE**

CAT #	TYPE	PAGE
DCH273P2DHO, DCH293R2DH	SDS+ Rotary Hammers	50
DCH133M2, D25263K		
DCF890M2	Cordless Impact Wrenches	52
DCF887D2	Cordless Impact Driver	53

**Suspender® for Concrete**

Type	Rod Hanging Anchor
Approvals	Full FM listings in product brochure or at www.DEWALT.com 
Description	Rod hanging anchors
Base Materials	Concrete
Anchor Material	Carbon steel

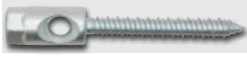

**SUSPENDER FOR CONCRETE - DUAL-DIRECTIONAL**

CAT #	DESCRIPTION	DRIVER	CTN	MSTR
PFM2271050	5/16" x 2-1/4"	PFM2201300	25	125

**RECOMMENDED INSTALLATION POWER TOOLS**

**HANGERMATE+ FOR CONCRETE**

CAT #	TYPE	PAGE
DCH273P2DHO, DCH293R2DH	SDS+ Rotary Hammers	50
DCH133M2, D25263K		
DCF890M2	Cordless Impact Wrenches	52
DCF887D2	Cordless Impact Driver	53

**INSTALLATION DRIVERS AND ACCESSORIES:**

**SUSPENDER FOR CONCRETE - DUAL-DIRECTION**

CAT #	SOCKET SIZE	DRIVE	CTN	MSTR
PFM2201300	1/4" Hex	5	25	25

**OTHER ACCESSORIES:**

**SUSPENDER FOR CONCRETE**

CAT #	DESCRIPTION	CTN	MSTR
PFM2201050	3/8" to 1/2" Adaptor <sup>1</sup>	25	125

1. The 3/8" to 1/2" adaptor has a 3/8-16 external thread and a 1/2-13 internal thread.

**GUARANTEED TOUGH®**

**ROD HANGER ANCHORS**

**Hangermate®+ and Hangermate® for Concrete Systems**

							APPROVALS				
							UL	FM APPROVED		ICC-ES	
								PIPE SIZE	LOAD		PIPE SIZE
<b>HANGERMATE+ FOR CONCRETE - INTERNALLY-THREADED - VERTICAL</b>											
CAT #	HANG	ROD DIA	DESCRIPTION	SOCKET SIZE	DRIVER	PIPE SIZE	LOAD	PIPE SIZE	LOAD	ICC-ES	
PFM2211100	Vertical	1/4"	1/4" x 1-5/8"	3/8"	PFM1491050	-	-	4"	1,475	ESR-3889	
PFM2211200	Vertical	3/8"	1/4" x 1-5/8"	1/2"	PFM1491100	-	-	4"	1,475	ESR-3889	
PFM2211250	Vertical	3/8"	1/4" x 2-1/2"	1/2"	PFM1491100	-	-	4"	1,475	ESR-3889	
PFM2211260	Vertical	3/8"	3/8" x 1-5/8"	1/2"	PFM1491100						
PFM2211270	Vertical	3/8"	3/8" x 2"	1/2"	PFM1491100						
PFM2211280	Vertical	1/2"	3/8" x 2"	11/16"	07198						
<b>HANGERMATE FOR CONCRETE - EXTERNALLY THREADED VERTICAL</b>											
CAT #	HANG	ROD DIA	DESCRIPTION	SOCKET SIZE	DRIVER	PIPE SIZE	LOAD	PIPE SIZE	LOAD	ICC-ES	
PFM1421000	Vertical	3/8"	1/4" x 1-5/8"	1/2"	DWMT19052B	-	-	4"	1,475	ESR-3889	
PFM1421050	Vertical	3/8"	1/4" x 2-1/2"	1/2"	DWMT19052B	-	-	4"	1,475	ESR-3889	
<b>HANGERMATE BASIC FOR CONCRETE - INTERNALLY THREADED - VERTICAL</b>											
CAT #	HANG	ROD DIA	DESCRIPTION	SOCKET SIZE	DRIVER	PIPE SIZE	LOAD	PIPE SIZE	LOAD	ICC-ES	
PFM2217171	Vertical	1/4"	1/4" x 1-1/4"	3/8"	PFM1491050			4"		-	
PFM2217173	Vertical	3/8"	1/4" x 1-1/2"	1/2"	PFM1491100	-	-	4"	1,475	-	
<b>HANGERMATE FOR CONCRETE - INTERNALLY THREADED - PIVOT</b>											
CAT #	HANG	ROD DIA	DESCRIPTION	DRIVER	PIPE SIZE	LOAD	PIPE SIZE	LOAD	ICC-ES		
PFM2281300	Variable	3/8"	1/4" x 2"	PFM2201250	-	-	-	-	-		
<b>SUSPENDER FOR CONCRETE - DUAL-DIRECTIONAL</b>											
CAT #	HANG	ROD DIA	DESCRIPTION	DRIVER	PIPE SIZE	LOAD	PIPE SIZE	LOAD	ICC-ES		
PFM2271050	Vertical & Horizontal	3/8"	5/16" x 2-1/4"	PFM2201300	-	-	-	-	-		





**ROD HANGER ANCHORS**

**Hangermate® for Wood**

Type	Rod Hanging Anchor
Approvals	
Description	Rod hanging anchors in a wide range of styles
Base Materials	Wood
Anchor Material	Carbon steel



**HANGERMATE FOR WOOD - INTERNALLY THREADED - VERTICAL**

CAT #	ROD DIA	DESCRIPTION	CTN	MSTR
PFM2251000	1/4"	1/4" x 2"	25	125
PFM2251050	3/8"	1/4" x 1"	25	125
PFM2251100	3/8"	1/4" x 2"	25	125
PFM2251150	3/8"	5/16" x 2-1/2"	25	125
PFM2251200	3/8"	1/4" x 3"	25	125
PFM2251250	3/8"	1/4" x 4"	25	125
PFM2251300	1/2"	15/16" x 2-1/2"	25	125



**HANGERMATE FOR WOOD - INTERNALLY THREADED - HORIZONTAL**

CAT #	ROD DIA	DESCRIPTION	CTN	MSTR
PFM2261000	1/4"	1/4" x 1"	25	125
PFM2261050	3/8"	1/4" x 1"	25	125
PFM2261100	3/8"	1/4" x 2"	25	125
PFM2261150	3/8"	5/16" x 2-1/2"	25	125



**HANGERMATE FOR WOOD - INTERNALLY THREADED - PIVOT**

CAT #	ROD DIA	DESCRIPTION	CTN	MSTR
PFM2281100	3/8"	1/4" x 2"	25	125



**HANGERMATE - WOOD - ACOUSTICAL CEILING SCREW EYELET**

CAT #	HOLE DIA	DESCRIPTION	CTN	MSTR
PFM2251500	3/16"	1/4" x 3-1/4"	25	125

**INSTALLATION DRIVERS AND ACCESSORIES:**

**HANGERMATE FOR WOOD - INTERNALLY THREADED - VERTICAL**

CAT #	SOCKET SIZE	DRIVE	CTN	MSTR
PFM2201150	5/8"	1/4" Hex	5	25

**INSTALLATION DRIVERS AND ACCESSORIES:**

**HANGERMATE FOR WOOD - INTERNALLY THREADED - HORIZONTAL**

CAT #	SOCKET SIZE	DRIVE	CTN	MSTR
PFM2201150	5/8"	1/4" Hex	5	25

**INSTALLATION DRIVERS AND ACCESSORIES:**

**HANGERMATE FOR WOOD - INTERNALLY THREADED - PIVOT**

CAT #	DRIVE	CTN	MSTR
DW22862	1/4" Hex	5	25

**INSTALLATION DRIVERS AND ACCESSORIES:**

**HANGERMATE FOR WOOD - CEILING SCREW EYELET**

CAT #	DRIVE	CTN	MSTR
DW22862	1/4" Hex	5	25

**OTHER ACCESSORIES:**

**HANGERMATE FOR WOOD**

CAT #	DESCRIPTION	CTN	MSTR
PFM2201050	3/8" to 1/2" Adaptor <sup>1</sup>	25	125
PFM2201100	Hangermate Pole Tool Kit <sup>2</sup>	25	125

1. The 3/8" to 1/2" adaptor has a 3/8-16 external thread and a 1/2-13 internal thread.  
 2. The Hangermate pole tool kit is designed for use with standard 1/2" steel conduit tubing (conduit not included) and can be customized to various lengths and ceiling heights. Compatible with standard steel and wood Hangermate.

**RECOMMENDED INSTALLATION POWER TOOLS:**

**HANGERMATE FOR WOOD**

CAT #	TYPE	PAGE
DCD991P2	Cordless Drill/Drivers	53
DCF887D2	Cordless Impact Driver	53

**Suspender® for Wood**

Type	Rod Hanging Anchor
Approvals	
Description	Rod hanging anchors in a wide range of styles
Base Materials	Wood
Anchor Material	Carbon steel



**SUSPENDER FOR WOOD - DUAL-DIRECTIONAL**

CAT #	ROD DIA	DESCRIPTION	CTN	MSTR
PFM2271000	3/8"	5/16" x 2-1/4"	25	125

**INSTALLATION DRIVERS AND ACCESSORIES:**

**SUSPENDER FOR WOOD - IDUAL DIRECTION**

CAT #	DRIVE	CTN	MSTR
DW22862	1/4" Hex	5	25

**OTHER ACCESSORIES:**

**SUSPENDER FOR WOOD**

CAT #	DESCRIPTION	CTN	MSTR
PFM2201050	3/8" to 1/2" Adaptor <sup>1</sup>	25	125
PFM2201100	Hangermate Pole Tool Kit <sup>2</sup>	25	125

1. The 3/8" to 1/2" adaptor has a 3/8-16 external thread and a 1/2-13 internal thread.  
 2. The Hangermate pole tool kit is designed for use with standard 1/2" steel conduit tubing (conduit not included) and can be customized to various lengths and ceiling heights. Compatible with standard steel and wood Hangermate.

**RECOMMENDED INSTALLATION POWER TOOLS:**

**SUSPENDER FOR WOOD**

CAT #	TYPE	PAGE
DCD792D2, DCD980M2, DCD991P2	Cordless Drill/Drivers	53
DCF887D2	Cordless Impact Driver	53



**GUARANTEED TOUGH.®**

**ROD HANGER ANCHORS**



**Hangermate® for Wood**

						APPROVALS			
						UL		FM APPROVED	
<b>HANGERMATE FOR WOOD - INTERNALLY THREADED - VERTICAL</b>									
CAT #	HANG	ROD DIA	DESCRIPTION	SOCKET SIZE DRIVER	PIPE SIZE	LOAD	PIPE SIZE	LOAD	
PFM2251000	Vertical	1/4"	1/4" x 2"	5/8"	PFM2201150	-	-	-	-
PFM2251050	Vertical	3/8"	1/4" x 1"	5/8"	PFM2201150	-	-	-	-
PFM2251100	Vertical	3/8"	1/4" x 2"	5/8"	PFM2201150	3"	1,050	-	-
PFM2251150	Vertical	3/8"	5/16" x 2-1/2"	5/8"	PFM2201150	4"	1,500	4"	1,475
PFM2251200	Vertical	3/8"	1/4" x 3"	5/8"	PFM2201150	3"	1,050	-	-
PFM2251250	Vertical	3/8"	1/4" x 4"	5/8"	PFM2201150	3"	1,050	-	-
PFM2251300	Vertical	1/2"	15/16" x 2-1/2"	5/8"	PFM2201150	-	-	-	-
<b>HANGERMATE FOR WOOD - INTERNALLY THREADED - HORIZONTAL</b>									
CAT #	HANG	ROD DIA	DESCRIPTION	SOCKET SIZE DRIVER	PIPE SIZE	LOAD	PIPE SIZE	LOAD	
PFM2261000	Horizontal	1/4"	1/4" x 1"	5/8"	PFM2201150	-	-	-	-
PFM2261050	Horizontal	3/8"	1/4" x 1"	5/8"	PFM2201150	-	-	-	-
PFM2261100	Horizontal	3/8"	1/4" x 2"	5/8"	PFM2201150	3"	1,050	-	-
PFM2261150	Horizontal	3/8"	5/16" x 2-1/2"	5/8"	PFM2201150	3"	1,050	-	-
<b>HANGERMATE PIVOT FOR WOOD - INTERNALLY THREADED - PIVOT</b>									
CAT #	HANG	ROD DIA	DESCRIPTION	DRIVER	PIPE SIZE	LOAD	PIPE SIZE	LOAD	
PFM2281100	Variable	3/8"	1/4" x 2"	PFM2201250	-	-	-	-	-
<b>HANGERMATE SUSPENDER FOR WOOD - CEILING SCREW EYELET</b>									
CAT #	HANG	HOLE DIA	DESCRIPTION	DRIVER	PIPE SIZE	LOAD	PIPE SIZE	LOAD	
PFM2251500	-	3/16"	1/4" x 3-1/4"	PFM2201350	4"	1,500	4"	1,475	
<b>SUSPENDER FOR WOOD - DUAL-DIRECTION</b>									
CAT #	HANG	ROD DIA	DESCRIPTION	DRIVER	PIPE SIZE	LOAD	PIPE SIZE	LOAD	
PFM2271000	Vertical and Horizontal	3/8"	5/16" x 2-1/4"	PFM2201300	-	-	-	-	-



**ROD HANGER ANCHORS**

**Hangermate® for Steel**

Type	Rod Hanging Anchor
Approvals	Full FM & UL listings in product brochure or at <a href="http://www.DeWALT.com">www.DeWALT.com</a>
Description	Rod hanging anchors in a wide range of styles
Base Materials	Steel
Anchor Material	Carbon steel



**HANGERMATE FOR STEEL - INTERNALLY THREADED - VERTICAL**

CAT #	ROD DIA	DESCRIPTION	QTY	MSTR
PFM2231000	1/4"	1/4"-20 x 1" #3	25	125
PFM2231100	3/8"	1/4"-20 x 1" #3	25	125
PFM223110N	3/8"	1/4"-20 x 1" #3 w/ Nut	25	125
PFM2231150	3/8"	1/4"-20 x 1-1/2" #5	25	125
PFM223115N	3/8"	1/4"-20 x 1-1/2" #5 w/ Nut	25	125
PFM2231200	3/8"	1/4"-20 x 1-1/2" #3	25	125
PFM223120N	3/8"	1/4"-20 x 1-1/2" #3 w/ Nut	25	125
PFM2231250	3/8"	1/4"-20 x 2" #3	25	125



**HANGERMATE FOR STEEL - INTERNALLY THREADED - HORIZONTAL**

CAT #	ROD DIA	DESCRIPTION	QTY	MSTR
PFM2241100	3/8"	1/4"-20 x 1" #3	25	125
PFM224110N	3/8"	1/4"-20 x 1" 3 w/ Nut	25	125
PFM2241150	3/8"	1/4"-20 x 1-1/2" #3	25	125
PFM224115N	3/8"	1/4"-20 x 1-1/2" #3 w/ Nut	25	125
PFM2241200	3/8"	1/4"-20 x 1-1/2" #5	25	125
PFM224120N	3/8"	1/4"-20 x 1-1/2" #5 w/ Nut	25	125

**HANGERMATE FOR STEEL - INTERNALLY THREADED - PIVOT**

CAT #	ROD DIA	DESCRIPTION	QTY	MSTR
PFM2281150	3/8"	1/4"-20 x 1" #3	25	125
PFM2281200	3/8"	1/2"-20 x 1-3/4" #5	25	125
PFM2281250	3/8"	1/4"-14 x 1" #3	25	125



**HANGERMATE FOR STEEL - CEILING SCREW EYELET**

CAT #	HOLE DIA	DESCRIPTION	QTY	MSTR
PFM2231500	3/8"	1/4" x 2"	25	125
PFM2231550	3/8"	1/4" x 3-1/4"	25	125

**INSTALLATION DRIVERS AND ACCESSORIES: HANGERMATE FOR STEEL - INTERNALLY THREADED - VERTICAL**

CAT #	SOCKET SIZE	DRIVE	CTN	MSTR
PFM2201200	1/2"	1/4" Hex	5	25

**INSTALLATION DRIVERS AND ACCESSORIES: HANGERMATE FOR STEEL - INTERNALLY THREADED - HORIZONTAL**

CAT #	SOCKET SIZE	DRIVE	CTN	MSTR
PFM2201200	1/2"	1/4" Hex	5	25

**INSTALLATION DRIVERS AND ACCESSORIES: HANGERMATE FOR STEEL - INTERNALLY THREADED - PIVOT**

CAT #	DRIVE	CTN	MSTR
PFM2201250	1/4" Hex	5	25

**INSTALLATION DRIVERS AND ACCESSORIES: HANGERMATE FOR STEEL - CEILING SCREW EYELET**

CAT #	DRIVE	CTN	MSTR
PFM2201350	1/4" Hex	5	25

**OTHER ACCESSORIES: HANGERMATE FOR STEEL**

CAT #	DESCRIPTION	CTN	MSTR
PFM2201050	3/8" to 1/2" Adaptor <sup>1</sup>	25	125
PFM2201100	Hangermate Pole Tool Kit <sup>2</sup>	25	125

1. The 3/8" to 1/2" adaptor has a 3/8-16 external thread and a 1/2-13 internal thread.  
2. The Hangermate pole tool kit is designed for use with standard 1/2" steel conduit tubing (conduit not included) and can be customized to various lengths and ceiling heights. Compatible with standard steel and wood Hangermate.

**RECOMMENDED INSTALLATION POWER TOOLS HANGERMATE FOR STEEL**

CAT #	TYPE	PAGE
DCD887D2	Cordless Drill / Driver	53

**Suspender® for Steel**

Type	Rod Hanging Anchor
Approvals	Full FM & UL listings in product brochure or at <a href="http://www.DeWALT.com">www.DeWALT.com</a>
Description	Rod hanging anchors in a wide range of styles
Base Materials	Steel
Anchor Material	Carbon steel



**SUSPENDER FOR STEEL - DUAL-DIRECTIONAL**

CAT #	ROD DIA	DESCRIPTION	CTN	MSTR
PFM227110N	3/8"	1/4"-20 x 1" #3 w/ Nut	25	125
PFM227120N	3/8"	1/4"-29 x 1-1/2" #3 w/ Nut	25	125
PFM227130N	3/8"	1/4"-20 x 1-1/2" #5 w/ Nut	25	125

**INSTALLATION DRIVERS AND ACCESSORIES: SUSPENDER FOR STEEL - CEILING SCREW EYELET**

CAT #	DRIVE	CTN	MSTR
DW22862	1/4" Hex	5	25

**OTHER ACCESSORIES: SUSPENDER FOR STEEL**

CAT #	DESCRIPTION	CTN	MSTR
PFM2201050	3/8" to 1/2" Adaptor <sup>1</sup>	25	125
PFM2201100	Hangermate Pole Tool Kit <sup>2</sup>	25	125

1. The 3/8" to 1/2" adaptor has a 3/8-16 external thread and a 1/2-13 internal thread.  
2. The Hangermate pole tool kit is designed for use with standard 1/2" steel conduit tubing (conduit not included) and can be customized to various lengths and ceiling heights. Compatible with standard steel and wood Hangermate.

**RECOMMENDED INSTALLATION POWER TOOLS SUSPENDER FOR STEEL**

CAT #	TYPE	PAGE
DCD887D2	Cordless Drill / Driver	53

**GUARANTEED TOUGH®**

**ROD HANGER ANCHORS**



**Hangermate® for Steel System**

									APPROVALS			
									UL		FM	
									PIPE SIZE	UL THICK.	PIPE SIZE	FM THICK.
									PIPE SIZE	UL THICK.	PIPE SIZE	FM THICK.
<b>HANGERMATE FOR STEEL - INTERNALLY THREADED - VERTICAL</b>												
CAT #	HANG	ROD DIA	DESCRIPTION	SOCKET SIZE	DRIVER	MIN THICKNESS	MAX THICKNESS	LOAD DIRECTION	PIPE SIZE	UL THICK.	PIPE SIZE	FM THICK.
PFM2231000	Vertical	1/4"	1/4"-20 x 1" #3	1/2"	PFM2201200	0.060"	0.210"	Vertical	-	-	-	-
PFM2231100	Vertical	3/8"	1/4"-20 x 1" #3	1/2"	PFM2201200	0.060"	0.210"	Vertical	4"	0.060"	-	-
PFM223110N	Vertical	3/8"	1/4"-20 x 1" #3 w/ Nut	1/2"	PFM2201200	0.060"	0.210"	Vertical	4"	0.125"	4"	0.105"
PFM2231150	Vertical	3/8"	1/4"-20 x 1-1/2" #5	1/2"	PFM2201200	0.125"	0.500"	Vertical	4"	0.060"	4"	0.060"
PFM223115N	Vertical	3/8"	1/4"-20 x 1-1/2" #5 w/ Nut	1/2"	PFM2201200	0.125"	0.500"	Vertical	4"	0.125"	4"	0.105"
PFM2231200	Vertical	3/8"	1/4"-20 x 1-1/2" #3	1/2"	PFM2201200	0.060"	0.210"	Vertical	4"	0.060"	-	-
PFM223120N	Vertical	3/8"	1/4"-20 x 1-1/2" #3 w/ Nut	1/2"	PFM2201200	0.060"	0.210"	Vertical	4"	0.060"	-	-
PFM2231250	Vertical	3/8"	1/4"-20 x 2" #3	1/2"	PFM2201200	0.060"	0.210"	Vertical	4"	0.125"	-	-
<b>HANGERMATE FOR STEEL - INTERNALLY THREADED - HORIZONTAL</b>												
CAT #	HANG	ROD DIA	DESCRIPTION	SOCKET SIZE	DRIVER	MIN THICKNESS	MAX THICKNESS	LOAD DIRECTION	PIPE SIZE	UL THICK.	PIPE SIZE	FM THICK.
PFM2241100	Horizontal	3/8"	1/4"-20 x 1" #3	1/2"	PFM2201200	0.060"	0.210"	Horizontal	-	-	-	-
PFM224110N	Horizontal	3/8"	1/4"-20 x 1" 3 w/ Nut	1/2"	PFM2201200	0.060"	0.210"	Horizontal	4"	0.060"	4"	0.060"
PFM2241150	Horizontal	3/8"	1/4"-20 x 1-1/2" #3	1/2"	PFM2201200	0.060"	0.210"	Horizontal	-	-	-	-
PFM224115N	Horizontal	3/8"	1/4"-20 x 1-1/2" #3 w/ Nut	1/2"	PFM2201200	0.060"	0.210"	Horizontal	4"	0.060"	4"	0.060"
PFM2241200	Horizontal	3/8"	1/4"-20 x 1-1/2" #5	1/2"	PFM2201200	0.125"	0.500"	Horizontal	-	-	-	-
PFM224120N	Horizontal	3/8"	1/4"-20 x 1-1/2" #5 w/ Nut	1/2"	PFM2201200	0.125"	0.500"	Horizontal	4"	0.060"	4"	0.060"
<b>HANGERMATE FOR STEEL - INTERNALLY THREADED - PIVOT</b>												
CAT #	HANG	ROD DIA	DESCRIPTION	DRIVER	MIN THICKNESS	MAX THICKNESS	LOAD DIRECTION	PIPE SIZE	UL THICK.	PIPE SIZE	FM THICK.	
PFM2281150	Variable	3/8"	1/4"-20 X 1" #3	PFM2201250	0.060	0.188	Vertical 45°	-	-	-	-	
PFM2281200	Variable	3/8"	1/2"-20 X 1-3/4" #5	PFM2201250	0.125	0.500	Vertical 45°	-	-	-	-	
PFM2281250	Variable	3/8"	1/4"-14 X 1" #3	PFM2201250	0.060	0.188	Vertical 45°	-	-	-	-	
<b>HANGERMATE FOR STEEL - CEILING SCREW EYELET</b>												
CAT #	HANG	HOLE DIA	DESCRIPTION	DRIVER	MIN THICKNESS	MAX THICKNESS	LOAD DIRECTION	PIPE SIZE	UL THICK.	PIPE SIZE	FM THICK.	
PFM2231500	-	3/8"	1/4" x 2"	PFM2201350	0.060"	0.105"	-	-	-	-	-	
PFM2231550	-	3/8"	1/4" x 3-1/4"	PFM2201350	0.06	0.105"	-	-	-	-	-	
<b>SUSPENDER FOR STEEL - DUAL-DIRECTION</b>												
CAT #	HANG	ROD DIA	DESCRIPTION	DRIVER	MIN THICKNESS	MAX THICKNESS	LOAD DIRECTION	PIPE SIZE	UL THICK.	PIPE SIZE	FM THICK.	
PFM227110N	Vertical and Horizontal	3/8"	1/4"-20 x 1" #3 w/ Nut	PFM2201300	0.060"	0.188"	Vertical Horizontal	4"	0.060"	4"	0.060"	
PFM227120N	Vertical and Horizontal	3/8"	1/4"-29 x 1-1/2" #3 w/ Nut	PFM2201300	0.125"	0.500"	Vertical Horizontal	4"	0.060"	4"	0.060"	
PFM227130N	Vertical and Horizontal	3/8"	1/4"-20 x 1-1/2" #5 w/ Nut	PFM2201300	0.060"	0.188"	Vertical	4"	0.060"	4"	0.060"	

Loads vary depending on steel thickness. Contact DEWALT for more information.



**PIN/NAIL ANCHORS**

**Heli-Pin™**

Type	Façade anchor
Approvals	Tested in accordance with CSA70
Description	Helical wall tie system Anchors existing brick veneers to back-up structural members without exposed hardware
Base Materials	Concrete, block, brick, stone clay tile and wood
Anchor Material	304 stainless steel



HELI-PIN ANCHOR				HELI-PIN SETTING TOOL			
CAT #	SIZE	CTN	MSTR	CAT #	DESCRIPTION	CTN	MSTR
08341	8mm (5/16") x 6"	100	600	08345	SDS Setting Tool	1	2
08342	8mm (5/16") x 8"	100	300				
08343	8mm (5/16") x 10"	100	400				
08344	8mm (5/16") x 12"	50	100				

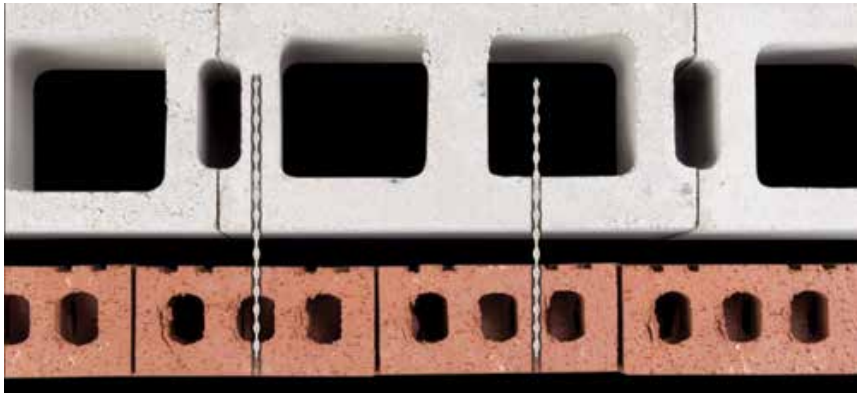

**Safe-T+® Pin**

Type	Nail Anchor
Approvals	Tested in accordance with ASTM E 488 Tested in accordance with ICC-ES AC193 for use in structural concrete
Description	Improved alternative to Zamac Nailin anchors where overhead use is not recommended
Base Materials	Normal and structural sand-lightweight concrete, grout-filled concrete and brick masonry
Anchor Material	Zinc plated carbon steel



SAFE-T PIN ANCHOR				
CAT #	SIZE	DRILL DIA	CTN	MSTR
2800SD	6mm (1/4") x 1-3/8"	6mm	100	600



ADDITIONAL SAFE-T PIN DRILL BIT ALSO AVAILABLE SEPARATELY				
CAT #	SIZE	USABLE LEN	CTN	MSTR
02800	6mm	3-1/4"	250	-

RECOMMENDED INSTALLATION POWER TOOLS			PAGE
CAT #	TYPE		
DCH273P2DHO, DCH293R2DH, D25263K	SDS+ Rotary Hammers		50

**GUARANTEED TOUGH.**

**PIN/NAIL ANCHORS**

**Spike®**

Type	Pin Anchor
Approvals	Tested in accordance with ASTM E488 and AC01 criteria
Description	One Piece Tamper-proof Pre-Expanded; no secondary tightening operation
Base Materials	Concrete and block
Anchor Material	Carbon steel and Type 316 stainless steel



**MUSHROOM HEAD GRADE 8.2 CARBON STEEL SPIKE**

CAT #	SIZE	DRILL DIA	MIN HOLE DEPTH	CTN	MSTR
05502	3/16" x 1"	3/16"	7/8"	100	1000
05503	3/16" x 1-1/4"	3/16"	7/8"	100	1000
05504	3/16" x 1-1/2"	3/16"	1-1/4"	100	1000
05506	3/16" x 2"	3/16"	1-1/4"	100	1000
05508	3/16" x 2-1/2"	3/16"	1-1/4"	100	600
05510	3/16" x 3"	3/16"	1-1/4"	100	600
05511	3/16" x 3-1/2"	3/16"	1-1/4"	100	600
05512	3/16" x 4"	3/16"	1-1/4"	100	600
05522	1/4" x 1"	1/4"	7/8"	100	1000
05523	1/4" x 1-1/4"	1/4"	1"	100	1000
05524	1/4" x 1-1/2"	1/4"	1-1/4"	100	1000
05526	1/4" x 2"	1/4"	1-1/4"	100	600
05528	1/4" x 2-1/2"	1/4"	1-1/4"	100	600
05530	1/4" x 3"	1/4"	1-1/4"	100	600
05531	1/4" x 3-1/2"	1/4"	1-1/4"	100	600
05532	1/4" x 4"	1/4"	1-1/4"	100	600
05546	3/8" x 2"	3/8"	1-3/4"	25	250
05548	3/8" x 2-1/2"	3/8"	1-3/4"	25	150
05550	3/8" x 3"	3/8"	1-3/4"	25	150
05551	3/8" x 3-1/2"	3/8"	1-3/4"	25	150
05552	3/8" x 4"	3/8"	1-3/4"	25	150
05554	3/8" x 5"	3/8"	1-3/4"	25	150
05556	3/8" x 6"	3/8"	1-3/4"	25	125
05569	1/2" x 2-3/4"	1/2"	2-1/2"	50	200
05571	1/2" x 3-1/2"	1/2"	2-1/2"	50	150
05572	1/2" x 4"	1/2"	2-1/2"	25	125
05574	1/2" x 5"	1/2"	2-1/2"	25	125
05577	1/2" x 6-1/2"	1/2"	2-1/2"	25	100

The published length is measured from below the head to the end of the anchor



**MUSHROOM HEAD 316 STAINLESS STEEL SPIKE**

CAT #	SIZE	DRILL DIA	MIN HOLE DEPTH	CTN	MSTR
06602	3/16" x 1"	3/16"	7/8"	100	600
06603	3/16" x 1-1/4"	3/16"	7/8"	100	600
06604	3/16" x 1-1/2"	3/16"	1-1/4"	100	600
06606	3/16" x 2"	3/16"	1-1/4"	100	1000
06623	1/4" x 1-1/4"	1/4"	1"	100	1000
06624	1/4" x 1-1/2"	1/4"	1-1/4"	100	600
06626	1/4" x 2"	1/4"	1-1/4"	100	600
06628	1/4" x 2-1/2"	1/4"	1-1/4"	100	600
06630	1/4" x 3"	1/4"	1-1/4"	100	600
06646	3/8" x 2"	3/8"	1-3/4"	25	250
06648	3/8" x 2-1/2"	3/8"	1-3/4"	25	250
06650	3/8" x 3"	3/8"	1-3/4"	25	250

The published length is the overall length of the anchor



**FLAT HEAD GRADE 8.2 CARBON STEEL SPIKE**

CAT #	SIZE	DRILL DIA	MIN HOLE DEPTH	CTN	MSTR
05608	3/16" x 2-1/2"	3/16"	1-1/4"	100	600
05610	3/16" x 3"	3/16"	1-1/4"	100	600
05612	3/16" x 4"	3/16"	1-1/4"	100	600
05624	1/4" x 1-1/2"	1/4"	1-1/4"	100	1000
05626	1/4" x 2"	1/4"	1-1/4"	100	600
05628	1/4" x 2-1/2"	1/4"	1-1/4"	100	600
05630	1/4" x 3"	1/4"	1-1/4"	100	600
05631	1/4" x 3-1/2"	1/4"	1-1/4"	100	600
05632	1/4" x 4"	1/4"	1-1/4"	100	500



**SPECIAL APPLICATION ROD HANGING PIPE SPIKE GRADE 8.2 CARBON STEEL**

CAT #	SIZE	DRILL DIA	MIN HOLE DEPTH	CTN	MSTR
03755	1/4"	3/16"	1-1/4"	100	600
03758	3/8"	1/4"	1-3/4"	50	300



**SPECIAL APPLICATION- SUSPENDED CEILING TIE-WIRE SPIKE GRADE 8.2 CARBON STEEL**

CAT #	SIZE	DRILL DIA	MIN HOLE DEPTH	CTN	MSTR
03756	3/16"	3/16"	1-1/4"	100	600
03758	1/4"	1/4"	1-1/4"	50	600



**SPECIAL APPLICATION CONCRETE FORMING FORMING SPIKE GRADE 8.2 CARBON STEEL**

CAT #	SIZE	DRILL DIA	MIN HOLE DEPTH	CTN	MSTR
03795	3/16" x 1-1/2"	3/16"	1-1/4"	100	600
03796	3/16" x 2"	3/16"	1-1/4"	100	600
03797	3/16" x 2-3/4"	3/16"	1-1/4"	100	600
03794	1/4" x 2-3/4"	1/4"	1-1/4"	100	500



**SPIKE INSTALLATION TOOLS**

CAT #	DESCRIPTION	TIP O.D.	CTN	MSTR
03790	Spike Driver 1000	1/2"	1	-

**RECOMMENDED INSTALLATION POWER TOOLS**

CAT #	TYPE	PAGE
DCH273P2DHO, DCH133M2, D25263K,	SDS+ Rotary Hammers	50



**ACCESSORIES**

TYPE	PAGE
SDS+ Carbide Drill Bits	by diameter/length 56
Hammer	refer to page 59



**PIN/NAIL ANCHORS**

**Drive®**

Type	Split Pin Pre-Expanded Anchor
Approvals	Full FM & UL listings at www.DeWALT.com
	 
Description	One Piece Tamper-proof Pre-Expanded; no secondary tightening operation
Base Materials	Concrete
Anchor Material	Carbon steel



**ROUND HEAD DRIVE**

CAT #	SIZE	DRILL DIA	MIN HOLE DEPTH	CTN	MSTR
03211	1/4" x 1-1/4"	1/4"	1-1/8"	100	1000
03241	1/4" x 1-1/2"	1/4"	1-1/8"	100	1000
03271	1/4" x 2"	1/4"	1-1/8"	100	600
03301	1/4" x 2-1/2"	1/4"	1-1/8"	100	600
03601	3/8" x 2"	3/8"	1-7/8"	25	250
03631	3/8" x 2-1/2"	3/8"	1-7/8"	25	150
03691	3/8" x 3-1/2"	3/8"	1-7/8"	25	150
03781	1/2" x 3"	1/2"	2-5/8"	25	150



**FLAT HEAD GRADE 8.2 CARBON STEEL SPIKE**

CAT #	SIZE	DRILL DIA	MIN HOLE DEPTH	CTN	MSTR
03092	3/16" x 1-1/2"	3/16"	7/8"	100	1000
03122	3/16" x 2"	3/16"	7/8"	100	1000
03152	3/16" x 2-1/2"	3/16"	7/8"	100	600
03162	3/16" x 3"	3/16"	7/8"	100	600
03242	1/4" x 1-1/2"	1/4"	1-1/8"	100	1000
03272	1/4" x 2"	1/4"	1-1/8"	100	600
30302	1/4" x 2-1/2"	1/4"	1-1/8"	100	600
03332	1/4" x 3"	1/4"	1-1/8"	100	600
03362	1/4" x 3-1/2"	1/4"	1-1/8"	100	600
03392	1/4" x 4"	1/4"	1-1/8"	100	600



**TIE-WIRE DRIVE (13/64" TIE-WIRE HOLE)**

CAT #	SIZE	DRILL DIA	MIN HOLE DEPTH	CTN	MSTR
03244	1/4" x 1-3/4"	1/4"	1-1/8"	500	-
03245	1/4" x 1-3/4"	1/4"	1-1/8"	100	1000

**RECOMMENDED INSTALLATION POWER TOOLS**

CAT #	TYPE	PAGE
DCH273P2DHO, DCH133M2, D25263K	SDS+ Rotary Hammers	50

**ACCESSORIES**

TYPE	PAGE
Hammer	Refer to page 59

**Zamac Hammer-Screw® Anchor**

Type	Nail Anchor
Approvals	Federal GSA Specification— Meets the proof load requirements of CID A-A 1925A, Type 1
	
Description	One-step anchor Phillips head with internal screw Removable
Base Materials	Concrete, block brick and stone
Anchor Material	Zamac alloy with carbon steel or Perma-Seal drive screw



**ZAMAC HAMMER-SCREW - MUSHROOM HEAD / NO. 2 PHILLIPS TYPE SCREW CARBON STEEL**

CAT #	SIZE	DRILL DIA	CTN	MSTR
02839	1/4" x 3/4"	1/4"	500	500
02840	1/4" x 1"	1/4"	500	500
02842	1/4" x 1-1/4"	1/4"	500	500
02844	1/4" x 1-1/2"	1/4"	500	500
02846	1/4" x 2"	1/4"	500	500
02848	1/4" x 2-1/4"	1/4"	500	250
02850	1/4" x 3"	1/4"	500	500

**MASTER PACK**

CAT #	SIZE	DRILL DIA	CTN	MSTR
02839	1/4" x 3/4"	1/4"	500	500
02939	1/4" x 3/4"	1/4"	-	500
02940	1/4" x 1"	1/4"	-	500
02942	1/4" x 1-1/4"	1/4"	-	500
02944	1/4" x 1-1/2"	1/4"	-	500
02946	1/4" x 2"	1/4"	-	250
02948	1/4" x 2-1/4"	1/4"	-	500
02949	1/4" x 3"	1/4"	-	-

**RECOMMENDED INSTALLATION POWER TOOLS**

CAT #	TYPE	PAGE
D25263K	SDS+ Rotary Hammer	50

**GUARANTEED TOUGH®**

**PIN/NAIL ANCHORS**

**Zamac Nailin® Anchor**

Type	Drive Pin Anchor
Approvals	Federal GSA Specification Meets the proof load requirements of CID A-A 1925A, Type 1 (mushroom head) & Type 2 (flat head) <sup>1</sup>
	
Description	Tamper-proof Nail drive anchor
Base Materials	Concrete, block brick and stone
Anchor Material	Zamac alloy with carbon or stainless steel screw



MUSHROOM HEAD ZAMAC NAILIN CARBON STEEL NAIL					
CAT #	SIZE	DRILL DIA	CTN	MSTR	
02802	3/16" x 7/8"	3/16"	100	500	
02806	1/4" x 3/4"	1/4"	100	500	
02808	1/4" x 1"	1/4"	100	500	
02814	1/4" x 1-1/4"	1/4"	100	500	
02820	1/4" x 1-1/2"	1/4"	100	500	
02826	1/4" x 2"	1/4"	100	500	
02804	1/4" x 3"	1/4"	100	500	
MASTER PACK					
CAT #	SIZE	DRILL DIA	CTN	MSTR	
02803	3/16" x 7/8"	3/16"	1000	500	
02807	1/4" x 3/4"	1/4"	1000	500	
02809	1/4" x 1"	1/4"	1000	500	
02815	1/4" x 1-1/4"	1/4"	1000	500	
02821	1/4" x 1-1/2"	1/4"	1000	500	
02827	1/4" x 2"	1/4"	1000	500	
02805	1/4" x 3"	1/4"	1000	500	



MUSHROOM HEAD ZAMAC NAILIN STAINLESS STEEL NAIL					
CAT #	SIZE	DRILL DIA	CTN	MSTR	
02858	1/4" x 1"	1/4"	100	500	
02864	1/4" x 1-1/4"	1/4"	100	500	
02870	1/4" x 1-1/2"	1/4"	100	500	
02876	1/4" x 2"	1/4"	100	500	

RECOMMENDED INSTALLATION POWER TOOLS		
CAT #	TYPE	PAGE
DCH273P2DHO, DCH293R2DH, D25263K	SDS+ Rotary Hammers	50

ACCESSORIES		
TYPE		PAGE
SDS+ Carbide Drill Bits by diameter/length		56
Hammer	refer to page	59



FLAT HEAD ZAMAC NAILIN CARBON STEEL NAIL					
CAT #	SIZE	DRILL DIA	CTN	MSTR	
02836	1/4" x 1-1/2"	1/4"	100	500	
02838	1/4" x 2"	1/4"	100	500	

**Nylon Nailin® Anchor**

Type	Plastic Drive Pin Anchor
Approvals	Federal GSA Specification Meets the proof load requirements of CID A-A 1925A, Type 1 (mushroom head) & Type 2 (flat head) <sup>1</sup>
	
Description	Tamper-proof Nail drive anchor
Base Materials	Concrete, block brick and stone
Anchor Material	Engineered nylon with carbon or stainless steel drive pin



ROUND HEAD NYLON NAILIN - CARBON STEEL NAIL					
CAT #	SIZE	DRILL DIA	CTN	MSTR	
02431	3/16" x 1"	3/16"	100	1000	
02451	3/16" x 1-1/2"	3/16"	100	1000	
02521	1/4" x 1"	1/4"	100	1000	
02541	1/4" x 1-1/2"	1/4"	100	1000	



MUSHROOM HEAD NYLON NAILIN STAINLESS STEEL NAIL					
CAT #	SIZE	DRILL DIA	CTN	MSTR	
02528	1/4" x 1"	1/4"	100	1000	
02548	1/4" x 1-1/2"	1/4"	100	1000	



FLAT HEAD NYLON NAILIN- CARBON STEEL NAIL					
CAT #	SIZE	DRILL DIA	CTN	MSTR	
02542	1/4" x 1-1/2"	1/4"	100	1000	
02562	1/4" x 2"	1/4"	100	1000	



MUSHROOM HEAD BODIES ONLY					
CAT #	SIZE	DRILL DIA	CTN	MSTR	
02574	1/4" x 3"	1/4"	2500	-	

RECOMMENDED INSTALLATION POWER TOOLS		
CAT #	TYPE	PAGE
DCH273P2DHO, DCH293R2DH, D25263K	SDS+ Rotary Hammers	50

ACCESSORIES		
TYPE		PAGE
SDS+ Carbide Drill Bits by diameter/length		56
Hammer	refer to page	59



MUSHROOM HEAD NYLON NAILIN CARBON STEEL NAIL					
CAT #	SIZE	DRILL DIA	CTN	MSTR	
02433	3/16" x 1"	3/16"	100	1000	
02513	1/4" x 3/4"	1/4"	100	1000	
02523	1/4" x 1"	1/4"	100	1000	
02543	1/4" x 1-1/2"	1/4"	100	1000	
02563	1/4" x 2"	1/4"	100	1000	
02573	1/4" x 3"	1/4"	100	1000	
02583	1/4" x 4"	1/4"	100	1000	



**LIGHT DUTY ANCHORS**

**Wall Dog®**

Type	Universal Light-Duty Anchor
Approvals	
Description	Smooth entry, clean cutting; strong hold Self-drills in wallboard and in plywood Install with Phillips® Screwdriver
Base Materials	Concrete, grout-filled concrete masonry, hollow concrete masonry, brick masonry, Wallboard, plywood Plaster
Anchor Material	Carbon steel <small>Screws with a white finish have a white head and a zinc body</small>



**WALL-DOG LIGHT DUTY ANCHOR - COMBO HEX WASHER HEAD**

CAT #	DESCRIPTION	BOX	CTN	MSTR
2265	1-1/4" Combo HWH Zinc Bulk			5000
2271	1-1/4" Combo HWH Zinc	100	1000	N/A



**WALL-DOG LIGHT DUTY ANCHOR - OVAL HEAD**

CAT #	DESCRIPTION	BOX	CTN	MSTR
2314	1-1/4" Zinc Oval Head	100	1000	N/A
2328	1-1/4" White Oval Head	100	1000	N/A



**WALL-DOG LIGHT DUTY ANCHOR - WAFER HEAD**

CAT #	DESCRIPTION	BOX	CTN	MSTR
2277	1/4" x 1-1/2" White Wafer Head	100	500	N/A
2278	1/4" x 2" White Wafer Head	100	500	N/A
2279	1/4" x 2-1/4" White Wafer Head	100	500	N/A
2280	1/4" x 2-1/2" White Wafer Head	100	500	N/A



**WALL-DOG LIGHT DUTY ANCHOR - PAN HEAD**

CAT #	DESCRIPTION	BOX	CTN	MSTR
2316	1-1/4" Zinc Pan Head	100	1000	N/A
2330	1-1/4" White Pan Head	100	1000	N/A
2273	1-1/2" White Pan Head	100	600	N/A
2274	1-1/2" Bronze Pan Head	100	600	N/A
2275	1-1/2" Zinc Pan Head	100	600	N/A
2276	1-1/2" Black Pan Head	100	600	N/A
2286	1-1/4" Black Pan Head	100	500	N/A
2294	1-1/4" Brass Pan Head	100	500	N/A
2315	1-1/4" Zinc Pan Head Bulk			5000
2331	1-1/4" White Pan Head Bulk			5000
2298	1-1/4" Black Pan Head Bulk			5000



**WALL-DOG LIGHT DUTY ANCHOR - ROBERTSON HEAD**

CAT #	DESCRIPTION	BOX	CTN	MSTR
2281	1-1/4" Zinc Robertson Head			5000
2266	1-1/4" Zinc Robertson Head	100	1000	N/A

Phillips® is a registered trademark of Phillips Consumer Electronics Corporation.

**RECOMMENDED INSTALLATION POWER TOOLS**

CAT #	TYPE	PAGE
DCD996P2	Cordless Drill Driver	53

**Scru-Lead**

Type	Wall Anchor
Approvals	
Description	Use with sheet metal or wood screws Performance is dependent on the integrity of the base material
Base Materials	Normal-weight concrete, concrete masonry, brick masonry
Anchor Material	Lead alloy



**SCRU-LEAD**

CAT #	SIZE	DRILL DIA	CTN	MSTR
09409	#6 - #8 x 3/4"	1/4"	100	1000
09414	#6 - #8 x 1"	1/4"	100	1000
09419	#6 - #8 x 1-1/2"	1/4"	100	500
09429	#10 - #14 x 1	5/16"	100	1000
09439	#10 - #14 x 1-1/2"	5/16"	100	600
09460	#16 - #18 x 1-1/2"	3/8"	25	250

**RECOMMENDED INSTALLATION POWER TOOLS**

CAT #	TYPE	PAGE
DCD996P2	Cordless Drill Driver	53



**GUARANTEED TOUGH.**

**LIGHT DUTY ANCHORS**

**Polly**

Type	Hollow Wall Anchor
Approvals	Federal GSA Specification – Meets the descriptive requirements of FF-B-588D, Type III, Class A (Standard Polly) and Class B (Drive Polly)
Description	Sleeve type hollow wall anchor Allows fixture and screw removal and re-anchoring
Base Materials	Wallboard, plywood
Anchor Material	Carbon steel



**COMBINATION SLOTTED PHILLIPS HEAD POLLY**

CAT #	SIZE	SCREW LENGTH	DRILL DIA	WALL THICKNESS	CTN	MSTR
02100	1/8" XS	1-1/16"	5/16"	1/8"-1/4"	100	500
02101	1/8" S	1-3/4"	5/16"	3/8"-1/2"	100	500
02102	1/8" L	2-1/4"	5/16"	5/8"-1"	100	500
02111	3/16" S	2"	3/8"	3/8"-5/8"	50	250
02112	3/16" L	2-1/2"	3/8"	3/4"-1-1/8"	50	250
02121	1/4" S	2-1/4"	7/16"	3/8"-1/2"	50	250
02122	1/4" L	2-3/4"	7/16"	5/8"-1-1/8"	50	250

XS - Extra Short S - Short L - Long XL - Extra Long

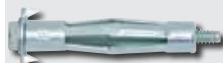

**SLOTTED HEX HEAD POLLY**

CAT #	SIZE	SCREW LENGTH	DRILL DIA	WALL THICKNESS	CTN	MSTR
02105	1/8" S	1-3/4"	5/16"	3/8"-1/2"	100	500



**DRIVE POLLY**

CAT #	SIZE	SCREW LENGTH	WALL THICKNESS	CTN	MSTR
02182	1/8" S	2"	3/8"-1/2"	100	500
02184	1/8" L	2-3/8"	1/2"-3/4"	100	500



**POLLY SETTING TOOL (FITS ALL SIZES)**

CAT #	DESCRIPTION	CTN	MSTR
02150	Polly Setting Tool	1	-

**RECOMMENDED INSTALLATION POWER TOOLS**

CAT #	TYPE	PAGE
DCD996P2	Cordless Drill Driver	53

**Toggle Bolt**

Type	Hollow Wall Anchor
Approvals	
Description	Two-part assembly consisting of a machine screw and a spring wing toggle Variety of head styles and lengths
Base Materials	Wallboard, plaster, hollow concrete masonry
Anchor Material	Carbon Steel



**COMBO MUSHROOM HEAD**

CAT #	SIZE	DRILL DIA.	BOX	CTN
04023	1/8" x 2"	3/8"	50	500
04033	1/8" x 3"	3/8"	50	500
04133	3/16" x 3"	1/2"	50	500
04143	3/16" x 4"	1/2"	50	500
04233	1/4" x 3"	5/8"	50	500
04243	1/4" x 4"	5/8"	50	500



**SLOTTED HEX HEAD**

CAT #	SIZE	DRILL DIA.	BOX	CTN
04038	1/8" x 3"	3/8"	50	500



**FLAT HEAD**

CAT #	SIZE	DRILL DIA.	BOX	CTN
04132	3/16" x 3"	1/2"	50	500
04142	3/16" x 4"	1/2"	50	500
04232	1/4" x 3"	5/8"	50	500



**TOGGLE WINGS ONLY**

CAT #	SIZE	DRILL DIA.	BOX	CTN
04000	1/8"	3/8"	100	500
04020	3/16"	1/2"	100	1000
04220	1/4"	5/8"	100	1000
04330	5/16"	7/8"	50	500
04430	3/8"	7/8"	50	500
04540	1/2"	1-1/4"	25	-



**COMBO ROUND HEAD**

CAT #	SIZE	DRILL DIA.	BOX	CTN
04021	1/8" x 2"	3/8"	50	500
04031	1/8" x 3"	3/8"	50	500
04041	1/8" x 4"	3/8"	50	500
04121	3/16" x 2"	1/2"	50	500
04131	3/16" x 3"	1/2"	50	500
04141	3/16" x 4"	1/2"	50	500
04151	3/16" x 5"	1/2"	50	500
04161	3/16" x 6"	1/2"	50	500
04231	1/4" x 3"	5/8"	50	500
04241	1/4" x 4"	5/8"	50	500
04251	1/4" x 5"	5/8"	50	500
04261	1/4" x 6"	5/8"	50	500
04341	5/16" x 4"	7/8"	25	250
04431	3/8" x 3"	7/8"	25	250
04441	3/8" x 4"	7/8"	25	250
04451	3/8" x 5"	7/8"	25	125
04461	3/8" x 6"	7/8"	25	125
04541	1/2" x 4"	1-1/4"	25	25



**TIE-WIRE ACOUSTICAL TOGGLE**

CAT #	SIZE	TIE WIRE HOLE SIZE	DRILL DIA	BOX	CTN
04247	1/4" x 4"	7/32"	5/8"	100	-
04257	1/4" x 5"	7/32"	5/8"	100	-

**RECOMMENDED INSTALLATION POWER TOOLS**

CAT #	TYPE	PAGE
DCD996P2	Cordless Drill Driver	53



**LIGHT DUTY ANCHORS**

**Legs**

Type	Wallboard Anchor
Approvals	
Description	Expansion anchor Pierce point; no pre-drilling
Base Materials	Wallboard
Anchor Material	Zinc plated carbon steel



LEGS WALLBOARD ANCHOR				
CAT.NO.	DESCRIPTION	BOX	CTN	
02336	Legs Wallboard Anchor	100	1000	
02335	Legs Anchor w/ No.8 x 1" Screw	100	1000	
MASTER PACK				
CAT #	DESCRIPTION	MASTER CTN		
02338	Legs Wallboard Anchor	5000		

**Zip-All®**

Type	Wallboard Anchor
Approvals	
Description	Self drilling Use No. 6 or No. 8 screws
Base Materials	Wallboard
Anchor Material	Zamac alloy



ZIP-ALL				
CAT #	WALL THICKNESS	DESCRIPTION	CTN	MSTR
02296	3/8" to 1"	Zinc - no screws	100	1000
02297	3/8" to 1"	Zinc - with screws	100	1000

**Sharkie**

Type	Plastic Wall Anchor
Approvals	
Description	Light duty Suitable for screws with various thread sizes and styles
Base Materials	Concrete, Brick, Cinder Block, Wood, Masonry, Ceramic Tile, Plaster, Stone, Stucco, Aerated Concrete, Flakeboard, Drywall
Anchor Material	Engineered plastic



SHARKIE ANCHOR				
CAT #	DESCRIPTION	CTN	MSTR	
07580	Sharkie Anchor Flange #4-#10	100	1000	
07582	Sharkie Anchor Flange #6-#12	100	1000	
07584	Sharkie Anchor Flange #8-#14	100	500	

**Strap-Toggle™**

Type	Hollow Wall Anchor
Approvals	Federal GSA Specification – Meets the descriptive requirements of FF-B-588D, Type V for a captive toggle (superseded)
Description	Heavy duty
	Small installation hole; removable
	Accommodates range of wall thicknesses
Base Materials	Wallboard, hollow concrete masonry
Anchor Material	Engineered plastic and carbon steel wings

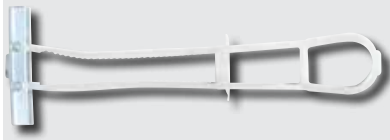

STRAP-TOGGLE (not packed with screws)					
CAT #	SIZE	DRILL DIA	WALL THICKNESS	CTN	MSTR
04052	3/16" x 4	1/2"	3/8" - 2-1/2"	50	300
04054	1/4" x 4-1/2"	1/2"	3/8" - 2-1/2"	50	300
04056	3/8" x 4"	3/4"	3/8" - 2-1/2"	25	150
04058	1/2" x 4	3/4"	3/8" - 2-1/2"	25	150



SELF-DRILLING STRAP-TOGGLE				
CAT #	SIZE	CTN	MSTR	
PFM4561500	3/16" x 4	50	300	
PFM4561600	1/4" x 4"	50	300	



STRAP-TOGGLE INSTALLATION

**GUARANTEED TOUGH®**

**LIGHT DUTY ANCHORS**

**Zip-It® and Zip-It® Jr.**

Type	Wallboard Anchor
Approvals	
Description	Light duty
Base Materials	Wallboard
Anchor Material	Engineered Plastic or Zamac Alloy



NYLON ZIP-IT					
CAT #	WALL THICKNESS	DESCRIPTION	CTN	MSTR	
02345	3/8" to 1"	Nylon Zip-It, no screws	100	1000	
02348	3/8" to 1"	Nylon Zip-It, with No.8 x 1" screws	100	1000	
02355	3/8" to 1"	Nylon Zip-It, no screws (master carton)	-	5000	



ZINC ZIP-IT					
CAT #	WALL THICKNESS	DESCRIPTION	CTN	MSTR	
02346Z	3/8" to 1"	Zinc Zip-It, no screws	100	1000	
02349Z	3/8" to 1"	Zinc Zip-It, with No. 8 x 1" screws	100	1000	
02356Z	3/8" to 1"	Zinc Zip-It, no screws (master carton)	-	1000	



ZIP-IT KITS					
CAT #	ANCHOR	DESCRIPTION	CTN	MSTR	
02368	Nylon Zip-It	50 anchors & No. 8 x 1" screws	1	10	
02369Z	Zinc Zip-It	50 anchors & No. 8 x 1" screws	1	10	



NYLON ZIP-IT JR.					
CAT #	WALL THICKNESS	DESCRIPTION	CTN	MSTR	
02351	3/8"-5/8"	Nylon Zip-It Jr. & No. 6 x 1" screws	100	1000	



ZINC ZIP-IT JR.					
CAT #	WALL THICKNESS	DESCRIPTION	CTN	MSTR	
02362Z	3/8"-5/8"	Zinc Zip-It Jr., no screws	100	1000	
02364Z	3/8"-5/8"	Zinc Zip-It Jr., No. 8 x 1" screws	100	1000	
02363Z	3/8"-5/8"	Zinc Zip-It Jr., no screws (master carton)	-	5000	



ZIP-IT JR. KITS					
CAT #	MATERIAL	DESCRIPTION	CTN	MSTR	
02367	Nylon	50 Anchors, No. 6 x 1" screws & No. 2 Phillips Driver Bit	1	10	



**Zinc Zip-Toggle®**

Type	Hollow Wall Anchor
Approvals	
Description	Heavy duty Fastens fixtures up to 3/4"
Base Materials	Wallboard
Anchor Material	Zinc



CAT #	SIZE	SCREWS	CTN	MSTR	
02295	Metal Zip-Toggle with screws	No. 6 x 2"	50	250	

**Poly-Toggle®**

Type	Plastic Hollow Wall Anchor
Approvals	Federal GSA Specification – Meets the descriptive requirements of FF-B-588D, Type IV (superseded)
Description	Light duty
Base Materials	Solid base materials Wallboard, hollow concrete masonry
Anchor Material	Engineered plastic



CAT #	SIZE	WALL THICKNESS	DRILL DIA	CTN	MSTR
02302	Mini	1/8"	5/16"	100	1000
02303	Short	3/8"	5/16"	100	1000
02304	Medium	1/2"	5/16"	100	1000
02305	Long	5/8"	5/16"	100	1000

RECOMMENDED INSTALLATION POWER TOOLS			
CAT #	TYPE		PAGE
DCD996P2	Cordless Drill Driver		53



**LIGHT DUTY ANCHORS**

**Pop-Toggle**

Type	Hollow Wall Anchor
Approvals	
Description	Light to medium duty Pre-installs without a screw; easy placement and removal
Base Materials	Wallboard, plaster, plywood
Anchor Material	Engineered plastic

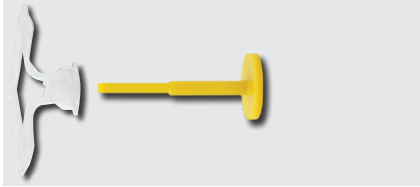

**POP-TOGGLE**

CAT #	DESCRIPTION	CTN	MSTR
04060	Pop-Toggle Small	100	1000
04062	Pop-Toggle Medium	100	1000
04064	Pop-Toggle Large	100	1000

**RECOMMENDED INSTALLATION POWER TOOLS**

CAT #	TYPE	PAGE
DCD996P2	Cordless Drill Driver	53

**Fluted Plastic Anchor**

Type	Plastic Wall Anchor
Approvals	
Description	Light duty Use with sheet metal or wood screw
Base Materials	Normal-weight concrete
Anchor Material	Engineered plastic



**FLUTED PLASTIC ANCHOR**

CAT #	SIZE	COLOR	DRILL DIA	MIN DEPTH	CTN	MSTR
07500	#4-#6 x 1"	White	3/16"	100	1,000	5000
07510	#10-#12 x 1"	Green	1/4"	100	1,000	5000
07515	#10-#12 x 1-1/4"	Green	1/4"	100	1,000	1000
07520	#10-#12 x 1-1/2"	Green	1/4"	100	1,000	1000
07530	#14 x 1-1/2"	Blue	5/16"	100	1,000	1000

**RECOMMENDED INSTALLATION POWER TOOLS**

CAT #	TYPE	PAGE
DCD996P2	Cordless Drill Driver	53

**Bantam Plug**

Type	Plastic Wall Anchor
Approvals	
Description	Light duty Use with sheet metal or wood screw
Base Materials	Normal-weight concrete, solid or hollow concrete masonry, solid or hollow brick masonry, gypsum wallboard
Anchor Material	Engineered plastic

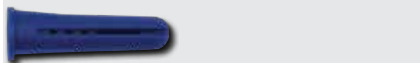

**BANTAM PLUG (not packed with screws)**

CAT #	SIZE	DRILL DIA	MIN DEPTH	CTN	MSTR
07559	#6 -#8 x 3/4"	3/16"	100	1,000	1000
07569	#8 -#10 x 7/8"	3/16"	100	1,000	5000
07579	#10 -#12 x 1"	1/4"	100	5,000	5000
07589	#14 -#16 x 1-1/2"	5/16"	50	2,500	2500

**MASTER PACK**

CAT #	KIT #	ANCHOR SIZE	SCREW SIZE	ANCHORS & SCREWS	CTN	MSTR
08934	B-8	#8 -#10	#8 x 1"	100	1	10
08936	B-10	#10 - #12	#10 x 1"	100	1	10
08938	B-12	#10 - #12	#12 x 1"	100	1	10



**BANTAM KITS**

CAT #	DESCRIPTION	CTN	MSTR
08933	#6 Combo Plastic Anchor Kit: 6-8 x 3/4" Bantam Anchors (Qty?) #6 x 1" Pan Head Screws (Qty?) 3/16 x 4 Masonry Bit (Qty?)	1	10
008937	#10 x 1-1/4" Pan Head Anchor Kit: 10 - 12 Bantam Anchors (100 qty.) 10 x 1-1/4" Tapping Pan Combo Screws (100 qty.) 1/4 C/T Drill Bit (1 qty.)	1	10
008939	#10 x 1-1/4" Hex Head Anchor Kit: 10 x 1-1/4" Bantam Anchors (100 qty.) 10 x 1-1/4" Hex Washer Hd Screws (100 qty.) 1/4 C/T Drill Bit (1 qty.) 5/16 Hex Driver (1 qty.)	1	10
008941	#10 x 1" Hex Head Anchor Kit: 10 x 1" Bantam Anchors (100 qty.) 10 x 1" Hex Washer Head Screws (100 qty.) 1/4 C/T Drill Bit (1 qty.) 5/16 Hex Driver (1 qty.)	1	10
008948	#10 Super Yellow Anchor Kit: #10-12 Yellow Ribbed Anchors (Qty?) #10 x 1" Pan Hd Screws (Qty?) 1/4 x 4 Masonry Bit (Qty?)	1	10

**RECOMMENDED INSTALLATION POWER TOOLS**

CAT #	TYPE	PAGE
DCD996P2	Cordless Drill Driver	





**ACRYLIC ADHESIVES**

**AC200+®**

**Type** High Performance Two-Component Acrylic

**Approvals**  
 ICC-ES ESR-4027 (Concrete & PIR)  
 Conforms to AC308 / ACI 355.4  
 NSF  
 DT  
 DUST X+  
 Compliant with NSF/ANSI Standard 61 for drinking water system components  
 Department of Transportation listings

**Base Materials** Normal-weight concrete, grouted concrete masonry, brick  
 Installation conditions: Dry concrete, water-saturated concrete, water-filled holes

**Size Range** 3/8" to 1-1/4" diameter threaded rod, No.3 to No.10 rebar

Bonds threaded rod and reinforcing bar hardware elements  
 Wide installation temperature range with small edge distances and spacings  
 Optimized curing adhesive; reliable installation yet easy to dispense  
 High bond strength values  
 Embedment depths from 4d to 20d



**AC200+ CARTRIDGES**

CAT #	DESCRIPTION	QTY	MSTR	PALLET
PFC1271050	9.5 fl. oz. Quik-Shot*	12	36	648
PFC1271150	28 fl. oz. Dual Cartridge*	8	-	240

**AC200+ EXTRA MIXING NOZZLES**

CAT #	FITS CARTRIDGE	CTN	MSTR
PFC1641600	PFC1271050 and PFC1271150	2	24

**DISPENSERS**

CAT #	TYPE	PAGE
08437	Standard Quik-Shot Manual - 9oz / 9.5oz	61
08479	High Performance Quik-Shot Manual - 9oz / 9.5oz	61
DCE560B	20V Quik-Shot Adhesive Dispenser Bare	61
DCE560D1	20V Quik-Shot Adhesive Dispenser Kit	61
08494	Standard Manual 10:1 - 28oz	61
DCE595B	20V Acrylic Dispenser 10:1 28oz Bare	61
DCE595D1	20V Acrylic Dispenser 10:1 28oz Kit	61
08496SD	Pneumatic 10:1 Dispenser - 28oz	61

**RECOMMENDED HOLE DRILLING POWER TOOLS**

CAT #	TYPE	PAGE
DCH481X2,	SDS Max FlexVolt	
DCH733X2	Rotary Hammer	51
D25481K, D25604K	SDS Max Combination Hammer	51

**CLEANING ACCESSORIES**

CAT #	TYPE	PAGE
by diameter/length	SDS Max Hollow Drill Bits	58
08292	Air Nozzle W/Extension	62
by diameter/length	Premium Brushes (required for max load values)	61
DWW012	Dust Extractor	60
DWH050K	Large Hammer Dust Extraction	60

**DISPENSING ACCESSORIES**

CAT #	TYPE	PAGE
by diameter/length	Premium Piston Plugs	62
PFC1640600	Flex Tubing	62

**AC100+ Gold®**

**Type** Two-Component Acrylic

**Approvals**  
 ICC-ES ESR-2582 (Concrete); ICC-ES ESR-3200 (Masonry); ESR-4105 (Unreinforced Masonry (URM))  
 Compliant with NSF/ANSI Standard 61 for drinking water system components  
 Conforms to ASTM C 881 and AASHTO M235, Types I, II, IV and V, Grade 3, Classes A & B  
 Department of Transportation listings

**Base Materials** Normal-weight concrete, grouted and hollow concrete masonry (CMU, unreinforced masonry, brick  
 Installation conditions: Dry concrete, water-saturated concrete, water-filled holes

**Size Range** 3/8" to 1-1/4" diameter threaded rod, No.3 to No.10 rebar

Bonds threaded rod and reinforcing bar hardware elements  
 Consistent performance in low and high strength concrete  
 Evaluated and recognized for freeze/thaw performance and for a range of embedments in interior and exterior applications  
 Evaluated and recognized for long term and short term loading  
 Versatile low odor formula with quick cure time

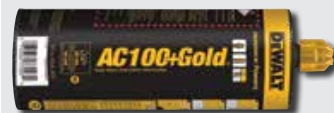

**AC100+GOLD CARTRIDGES**

CAT #	DESCRIPTION	QTY	MSTR	PALLET
8478SD	9.5 fl. oz. Quik-Shot*	12	36	684
8486SD	11.5 fl. oz. Dual Cartridge*	12	-	540
8490SD	28 fl. oz. Dual Cartridge*	8	-	240

**AC100+GOLD EXTRA MIXING NOZZLES**

CAT #	FITS CARTRIDGE	QY	MSTR
08293	8478SD and 8486SD	2	24
08294	8490SD	2	24

**DISPENSERS**

CAT #	TYPE	PAGE
08437	Standard Manual - 9oz / 9.5oz	49
08479	High Performance Manual - 9oz / 9.5oz	49
DCE560B	20V Quik-Shot Adhesive Dispenser Bare	49
DCE560D1	20V Quik-Shot Adhesive Dispenser Kit	49
08485	Standard Manual - 11.5oz	49
08494	Standard 10:1 Manual - 28oz	49
DCE595B	20V Acrylic Dispenser 10:1 28oz Bare	49
DCE595D1	20V Acrylic Dispenser 10:1 28oz Kit	49
08496SD	Pneumatic 10:1 Dispenser - 28oz	49

**RECOMMENDED HOLE DRILLING POWER TOOLS**

CAT #	TYPE	HOLE SIZE	PAGE
DCH293R2DH	SDS+ Rotary Hammer	5/8" - 7/8"	50
DCH133M2	SDS Max Rotary Hammer	5/32" - 5/8"	50
DCH481X2	Flexvolt SDS Max Rotary Hammer	5/8" - 1-1/8"	51
DCH733X2	Flexvolt SDS Max Rotary Hammer		51
D25481K, D25604K, D25733K	SDS Max Rotary Hammers		51

**DRILLING ACCESSORIES**

DRILL BIT	PAGE
Standard Carbide Bit by diameter/length	56/57
Hollow Drill Bit by diameter/length	58

**CLEANING ACCESSORIES**

CAT #	TYPE	PAGE
by diameter/length	Standard Brushes	61
08280	Hand Pump/Blower	61

**DISPENSING ACCESSORIES**

TYPE	CAT #	PAGE
Standard Piston Plugs	by diameter/length	62
Flex Tubing	PFC1640600	62

\* One mixing nozzle packaged with each cartridge. AC200+ and AC100+ Gold nozzles must be used to ensure complete and proper mixing of the adhesive.

**GUARANTEED TOUGH.**

**ACRYLIC ADHESIVES**

**AC50™**

Type	Two-Component Acrylic
Approvals	Conforms to ASTM C 881 and AASHTO M235, Types I, II, IV and V, Grade 3, Classes A & B Department of Transportation listings 
Base Materials	Normal and lightweight concrete Installation conditions: Dry concrete
Size Range	3/8" to 1" diameter threaded rod, No.3 to No.8 rebar

Bonds threaded rod and reinforcing bar into hardened concrete  
Evaluated for installation and use in dry holes  
Can be installed in a range of base material temperatures (as low as 5°F)



AC50 CARTRIDGES				
CAT #	DESCRIPTION	QTY	MSTR	PALLET
08497	28 fl. oz. Dual Cartridge*	8	-	240

AC50+ MIXING NOZZLES			
CAT #	FITS CARTRIDGE	QTY	MSTR
08294	8497	2	24

DISPENSERS		
CAT #	TYPE	PAGE
08494	Standard 10:1 Manual - 28oz	
DCE595B	20V Acrylic Dispenser 10:1 28oz Bare	
DCE595D1	20V Acrylic Dispenser 10:1 28oz Kit	
08496SD	Pneumatic 10:1 Dispenser - 28oz	

**RECOMMENDED HOLE DRILLING POWER TOOLS**

CAT #	TYPE	HOLE SIZE	PAGE
DCH293R2DH	SDS+ Rotary Hammer	5/8" - 7/8"	50
DCH133M2	SDS Max Rotary Hammer	5/32" - 5/8"	50
DCH481X2	Flexvolt SDS Max Rotary Hammer	5/8" - 1-1/8"	51
DCH733X2	Flexvolt SDS Max Rotary Hammer		51
D25733K, D25481K, D25604K	SDS Max Rotary Hammers		51

**CLEANING ACCESSORIES**

CAT #	TYPE	PAGE
by diameter/length	Standard Brushes	61
08280	Hand Pump/Blower	

**DISPENSING ACCESSORIES**

CAT #	TYPE	PAGE
by diameter/length	Standard Piston Plugs	62
PFC1640600	Flex Tubing	62

\*One mixing nozzle packaged with each cartridge. AC50+ nozzles must be used to ensure complete and proper mixing of the adhesive.



**CAPSULE ADHESIVES**

**Hammer-Capsule**

Type	Drive-In Capsule Adhesive
Approvals	Department of Transportation listings 
Base Materials	Normal weight concrete and grouted concrete masonry
Size Range	3/8" to 1" diameter threaded rod, No.3 to No.8 rebar

Fast, easy installation - no special adapters required for setting  
Excellent chemical resistance  
Components are mixed during installation of rod or rebar  
Pre-measured chemical component volumes – no waste and simplified placement



HAMMER-CAPSULE				
CAT #	DESCRIPTION	QTY	MSTR	
06702	3/8" Hammer-Capsule	10	500	
06703	1/2" Hammer-Capsule	10	200	
06704	5/8" Hammer-Capsule	10	100	
06705	3/4" Hammer-Capsule	6	60	
06706	7/8" Hammer-Capsule	6	60	
06707	1" Hammer-Capsule	6	60	

**RECOMMENDED HOLE DRILLING POWER TOOLS**

CAT #	TYPE	HOLE SIZE	PAGE
DCH293R2DH	SDS+ Rotary Hammer	5/8" - 7/8"	50
DCH133M2	SDS+ Rotary Hammer	5/32" - 5/8"	50
DCH481X2	Flexvolt SDS Max Rotary Hammer	5/8"-1-1/8"	51
D25481K, D25604K	SDS Max Combination Hammer		51

**CLEANING ACCESSORIES**

CAT #	TYPE	PAGE
by diameter/length	Standard Brushes	61
08280	Hand Pump/Blower	61



**EPOXY ADHESIVES**

**Pure110+®**

Type	Two-Component High Strength Epoxy Adhesive
Approvals	ICC-ES ESR-3298 (Concrete & PIR) Conforms to ASTM C 881 and AASHTO M235, Types I, II, IV and V, Grade 3, Classes B & C Compliant with NSF/ANSI 61 for drinking water system components Department of Transportation listings
Base Materials	Normal and lightweight concrete, grouted concrete masonry and hollow concrete masonry Installation conditions: Dry concrete, water-saturated concrete, water-filled holes, submerged concrete
Size Range	3/8" to 1-1/4" diameter threaded rod, No.3 to No.11 rebar

Bonds threaded rod and reinforcing bar into hardened concrete | Evaluated for installation and use in dry and wet holes, including water filled and underwater | Can be installed in a wide range of base material temperatures | Same bond strength at room temperature and at 110°F.



**PURE110+ 1:1 MIX RATIO CARTRIDGES**

CAT #	DESCRIPTION	QTY	MSTR	PALLET
08310SD	9 fl. oz. Quik-Shot*	12	36	648
08321SD	20.5 fl. oz. dual cartridge*	12	-	360
08351SD	50.5 fl. oz. dual cartridge*	5	-	150

**PURE110+ MIXING NOZZLES**

CAT #	FITS CARTRIDGE	QTY	MSTR
PFC1641600	08310SD	2	24
08609	08321SD,08351SD	2	24

**DISPENSERS**

CAT #	TYPE	PAGE
08437	Standard Quik-Shot Manual - 9oz / 9.5oz	61
08479	High Performance Quik-Shot Manual - 9oz / 9.5oz	61
DCE560B	20V Quik-Shot Adhesive Dispenser Bare	61
DCE560D1	20V Quik-Shot Adhesive Dispenser Kit	61
08409	Standard Manual 1:1 - 20.5oz	61
08421	High Performance 1:1 Manual - 20.5oz	61
DCE591B	20V Epoxy Dispenser 1:1 20.5oz Bare	61
DCE591D1	20V Epoxy Dispenser 1:1 20.5oz Kit	61
08459	Pneumatic 1:1 Dispenser - 20.5oz	61
08438	Pneumatic Dispenser - 50.5oz	61

**RECOMMENDED HOLE DRILLING POWER TOOLS**

CAT #	TYPE	HOLE SIZE	PAGE
DCH293R2DH	SDS+ Rotary Hammer	5/8" - 7/8"	50
DCH133M2	SDS+ Rotary Hammer	5/32" - 5/8"	50
DCH481X2	Flexvolt SDS Max Rotary Hammer	5/8" - 1-1/8"	51
DCH733X2	Flexvolt SDS Max Rotary Hammer		51
D25733K	SDS Max Rotary Hammer		51
D25481K, D25604K	SDS Max Combination Hammer		51

**CLEANING ACCESSORIES**

CAT #	TYPE	PAGE
by diameter/length	Standard Brushes	61
DWV012	Dust Extractor	60
by diameter/length	Hollow Drill Bits	58

**DISPENSING ACCESSORIES**

CAT #	TYPE	PAGE
by diameter/length	Premium Piston Plugs	62
PFC1640600	Flex Tubing	62

**Pure50+™**

Type	Two-Component Epoxy Adhesive
Approvals	ICC-ES ESR-3576 (Concrete) Conforms to ASTM C 881 and AASHTO M235, Types I, II, IV and V, Grade 3, Classes B & C (also meets Type III except for elongation) Compliant with NSF/ANSI Standard 61 for Drinking Water System Components Department of Transportation listings
Base Materials	Normal and lightweight concrete Installation conditions: Dry concrete, water-saturated concrete, water-filled holes
Size Range	3/8" to 1-1/4" diameter threaded rod, No.3 to No.10 rebar

Bonds threaded rod and reinforcing bar into hardened concrete | Evaluated for installation and use in dry and wet holes, including water filled | Can be installed in a wide range of base material temperatures



**PURE50+ CARTRIDGES**

CAT #	DESCRIPTION	QTY	MSTR	PALLET
08600	9 fl. oz. Quik-Shot*	12	36	648
08605	20.5 fl. oz. dual cartridge*	12	-	360
08651	50.5 fl. oz. dual cartridge*	5	-	150

**PURE50+ MIXING NOZZLES**

CAT #	FITS CARTRIDGE	QTY	MSTR
PFC1641600	08600	2	24
08294	08605	2	24
08609	08651	2	24

**DISPENSERS**

CAT #	TYPE	PAGE
08437	Standard Quik-Shot Manual - 9oz / 9.5oz	61
08479	High Performance Quik-Shot Manual - 9oz / 9.5oz	61
DCE560B	20V Quik-Shot Adhesive Dispenser Bare	61
DCE560D1	20V Quik-Shot Adhesive Dispenser Kit	61
08409	Standard 1:1 Manual - 20.5oz	61
08421	High Performance 1:1 Manual - 20.5oz	61
DCE591B	20V Epoxy Dispenser 1:1 20.5oz Bare	61
DCE591D1	20V Epoxy Dispenser 1:1 20.5oz Kit	61
08459	Pneumatic 1:1 Dispenser - 20.5oz	61
08438	Pneumatic 1:1 Dispenser - 50.5oz	61

**RECOMMENDED HOLE DRILLING POWER TOOLS**

CAT #	TYPE	HOLE SIZE	PAGE
DCH293R2DH	SDS+ Rotary Hammer	5/8" - 7/8"	50
DCH133M2	SDS+ Rotary Hammer	5/32" - 5/8"	50
DCH481X2	Flexvolt SDS Max Rotary Hammer	5/8" - 1-1/8"	51
DCH733X2	Flexvolt SDS Max Rotary Hammer		51
D25733K	SDS Max Rotary Hammer		51
D25481K, D25604K	SDS Max Combination Hammer		51

**DRILLING ACCESSORIES**

DRILL BIT	TYPE	PAGE
Standard Carbide Bit	by diameter/length	56/57
Hollow Drill Bit	by diameter/length	58

**CLEANING ACCESSORIES**

CAT #	TYPE	PAGE
by diameter/length	Standard Brushes	61
DWV012	Dust Extractor	60
by diameter/length	Hollow Drill Bits	58

**DISPENSING ACCESSORIES**

CAT #	TYPE	PAGE
by diameter/length	Premium Piston Plugs	50
PFC1640600	Flex Tubing	50



**EPOXY ADHESIVES**

**PE1000+®**

Type	Two-Component High Strength Epoxy Adhesive
Approvals	<p>ICC-ES ESR-2583 (Concrete)</p> <p>Compliant with NSF/ANSI Standard 61 for drinking water system components</p> <p>Conforms to ASTM C 881 and AASHTO M235, Types I, II, IV and V, Grade 3, Classes B &amp; C</p> <p>Department of Transportation listings</p>
Base Materials	<p>Normal and light-weight concrete, grouted concrete masonry (CMU)</p> <p>Installation conditions: Dry concrete, water-saturated concrete, water-filled holes</p>
Size Range	3/8" to 1-1/4" diameter threaded rod, No. 3 to No. 10 rebar

For use with threaded rod and reinforcing bar hardware elements | Consistent performance in low and high strength concrete  
 Recognized for freeze/thaw performance; for long term and short term loading and for variable embedments | Cartridge design allows for multiple uses using extra mixing nozzles | Easy dispensing reduces applicator fatigue



**PE1000+ CARTRIDGES**

CAT #	DESCRIPTION	QTY	MSTR	PALLET
0500SD	13 fl.oz. Dual Cartridge	12	-	624
0502SD	19.5 fl.oz. Dual Cartridge	12	-	360

One mixing nozzle packaged with each cartridge. PE1000+ nozzles must be used to ensure complete and proper mixing of the adhesive.

**PE1000+ MIXING NOZZLES**

CAT #	FITS CARTRIDGE	QTY	MSTR
08294	0500SD, 0502SD	2	24

**DISPENSERS**

CAT #	TYPE	PAGE
08298	Standard 3:1 Manual - 13oz & 19.5oz	61
DCE593B	20V Epoxy Dispenser 3:1 13/19.5oz Bare	61
DCE593D1	20V Epoxy Dispenser 3:1 13/19.5oz Kit	61
08497SD	Pneumatic 3:1 Dispenser - 13oz & 19.5oz	61

**RECOMMENDED HOLE DRILLING POWER TOOLS**

CAT #		HOLE SIZE	PAGE
DCH293R2DH	SDS+ Rotary Hammer	5/8" - 7/8"	50
DCH133M2	SDS+ Rotary Hammer	5/32" - 5/8"	50
DCH481X2	Flexvolt SDS Max Rotary Hammer	5/8" - 1-1/8"	51
DCH733X2	Flexvolt SDS Max Rotary Hammer		51
D25733K	SDS Max Rotary Hammer		51
D25481K	SDS Max Combination Hammer		51
D25604K	SDS Max Combination Hammer		51

**DRILLING ACCESSORIES**

DRILL BIT		PAGE
by diameter/length	Standard Carbide Bit	56/57
by diameter/length	Hollow Drill Bit	58

**DISPENSING ACCESSORIES**

CAT #	TYPE	PAGE
by diameter/length	Standard Piston Plugs	62
PFC1640600	Flex Tubing	62





**FOAM ADHESIVES**

**TriggerFoam™ Pro**

Type	Expanding Polyurethane Foam
Approvals	ICC-ES ESR-3263 Thermal and Moisture Protection and annular space protection for wood fire blocking: FireBlock Formula, Window & Door Formula, All Season Formula Full UL listings in product brochure or at www.DEWALT.com
Base Materials	Concrete, masonry, wood and metal

Professional, gun applied, normal expansion polyurethane foam sealant with an extended temperature range which allows for use at temperatures as low as 23°F. It is designed to seal gaps, insulate and deaden sound. Recommended for use in heating and air conditioning, electrical and plumbing applications.



TRIGGERFOAM PRO DISPENSERS			
CAT #	TYPE	QTY	MSTR
08126	20" Dispensing tool	1	-
08128	Deluxe metal gun	1	10
08139	Deluxe plastic gun	1	10

DISPENSING ACCESSORIES			
CAT #	TYPE	QTY	MSTR
08147	TriggerFoam Pro Cleaner 17 fl. oz.	1	6

TRIGGERFOAM PRO			
CAT #	DESCRIPTION	CTN	PALLET
08133P	Fire Block Formula 29 oz.	12	612
08134P	Window & Door Formula 29 oz.	12	612
08135P	All Season Formula 29 oz.	12	612
08136N	Standard Formula 29 oz.	12	612



**PowerFoam™**

Type	Expanding Polyurethane Foam
Approvals	Full UL listings in product brochure or at www.DEWALT.com
Base Materials	Concrete, masonry, wood and metal

One-part polyurethane expanding foam that sets and cures into its final form by reacting to moisture and humidity present in the air. PowerFoam's exceptional ability to bond allows it to be applied to various building elements including the surfaces of concrete, brick, block, wood, steel, aluminum and other miscellaneous metals. As it is being dispensed, PowerFoam has a neutral odor. Cured foam is standard yellow.



POWERFOAM			
CAT #	DESCRIPTION	CTN	PALLET
08130N	PowerFoam 12 oz.	12	1020
08132N	PowerFoam 29 oz.	12	612

**ADHESIVE SEALANT**

**PowerStick™**

Type	Adhesive Sealant
Base Materials	Concrete, masonry, metals, wood, plastics

One component universal adhesive/sealant based on proprietary MS Polymer chemistry. PowerStick is the first professional grade product on the market that delivers high bond strength and superior flexibility.



POWERSTICK				
CAT #	DESCRIPTION	COLOR	CTN	PALLET
08166N	PowerStick 10 oz.	White	12	1200
08168N	PowerStick 10 oz.	Gray	12	1200

**GUARANTEED TOUGH.**

# THE FIRST CORDLESS ADHESIVE ANCHOR INSTALLATION SYSTEM

OSHA TABLE 1 COMPLIANT AND ICC-ES APPROVED TESTED ANCHOR INSTALLATION SYSTEM BY DEWALT

**DUST X+**  
ANCHOR INSTALLATION SYSTEM

## DRILL + EXTRACT + ANCHOR



# GET COMPLIANT WITH DEWALT

220+ WAYS TO BECOME TABLE 1 OSHA COMPLIANT (1926.1153)

## TABLE 1

**OSHA COMPLIANT**  
1926.1153

### SOLUTIONS



TOOLS | SHROUDS & ACCESSORIES | DUST EXTRACTORS

Visit [DEWALT.com/DUST](http://DEWALT.com/DUST) to see all OSHA Compliant Solutions

ADHESIVES 49



**SDS+ ROTARY HAMMERS**



1" SDS+ Rotary Hammer

1-1/8" L-Shape SDS+ Rotary Hammer

1" SDS+ Rotary Hammer

**DCH273P2DHO**

**DCH293R2DH**

**DCH133M2**

Optimal Concrete Drilling	5/32" to 5/8"	1/4" to 7/8"	5/32" to 5/8"
Joules of Impact Energy	2.1	3.5	2.6
RPM	0-1,100	950	0-1,100
BPM	0-4,600	0-4,320	0-4,600
Torque Control	Integral clutch	E-Clutch® and Integral Clutch	
Voltage	20V MAX*	20V MAX*	20V MAX*
Battery Ah	5	6	4
Weight, Tool Only (lbs.)	6.8	6.8	5.5
Vibration Control	Yes, Shocks™	Yes, Shocks™	No
Vibration	6.6 m/s²	7.5 m/s²	
Cordless Dust Collection	Yes	Yes	D25301D
Suitable Anchors	PB+, Power-Bolt Power-Stud Lok-Bolt AS, Mini-Undercut Screw-Bolt+, Wedge-Bolt 316, Snake+ Smart DI, Hollow-Set Drop-In, Steel Drop-In, Mini Drop-In Hangermate+ Concrete Spike, Drive, Safe-T Pin, Nail-In	PB+, Power-Bolt Power-Stud Lok-Bolt AS, Mini-Undercut Screw-Bolt+, Wedge-Bolt 316 Snake+, Smart DI, Hollow-Set Drop-In, Steel Drop-In, Mini Drop-In Hangermate+ Concrete Spike, Drive, Safe-T Pin, Nail-In	PB+, Power-Bolt Power-Stud Lok-Bolt AS, Screw-Bolt+, Wedge-Bolt 316 Snake+, Smart DI, Hollow-Set Drop-In, Steel Drop-In, Hangermate+ Concrete

\*Maximum initial battery voltage (measured without a workload) is 20 volts. Nominal voltage is 18.



1-1/8" Rotary Hammer

1-1/8" SDS+ Rotary Hammer

1-1/8" SDS+ Rotary Hammer

**DCH263R2DH**

**D25333K**

**D25263K**

Optimal Concrete Drilling	1/4" to 3/4"	1/4" to 7/8"	1/4" to 3/4"
Joules of Impact Energy	3.0	3.5	3.0
RPM / BPM	0 - 4300 BPM	0-1,000 / 0-4,480	0-1,450 / 0-5,350
Torque Control		Integral Clutch	Integral Clutch
Voltage	20V MAX*		
Amps		8.5	8.5
Weight (lbs.)	5.95	8.1	6.8
Vibration Control	Yes, Shocks™	Yes, Shocks™	Yes, Shocks™
Vibration		7.5 m/s²	9.8 m/s²
Dust Collection Accessory (Requires Dust Extractor)	Yes	DWH304DH	D25301D
Suitable Anchors	PB+, Power-Bolt Power-Stud+ Lok-Bolt AS Screw-Bolt+ Adhesive Anchors	PB+, Power-Bolt Power-Stud Lok-Bolt AS, Screw-Bolt+, Wedge-Bolt 316 Mini Drop-In, Steel Drop-In	PB+, Power-Bolt Power-Stud Lok-Bolt AS, Mini-Undercut Screw-Bolt+, Wedge-Bolt 316, Snake+ Smart DI, Hollow-Set Drop-In, Steel Drop-In, Mini Drop-In Hangermate+ Concrete, Hangermate Wood, Safe-T Pin, Spike, Drive Hammer-Screw, Nail-In

**50 INSTALLATION TOOLS**

[www.DEWALT.com](http://www.DEWALT.com)

**GUARANTEED TOUGH.®**

**FLEXVOLT®  
SDS MAX  
ROTARY  
HAMMERS**



1-9/16" SDS Max Combination Hammer

1-7/8" SDS MAX Combination Hammer

	<b>DCH481X2</b>	<b>DCH733X2</b>
Optimal Concrete Drilling	1/2" to 1-1/8"	3/4" to 1-7/8"
Joules of Impact Energy	6.1	13.3
RPM	0-540	177-355
BPM	0-3,150	2,705
Torque Control	E-Clutch® and Integral Clutch	E-Clutch® and Integral Clutch
Voltage	60V MAX**	60V MAX**
Battery Ah	9	9
Weight, Tool Only (lbs.)	11.9	20
Vibration Control	Yes, Shocks™	Yes, Shocks™
Vibration	9.4 m/s <sup>2</sup>	9.0 m/s <sup>2</sup>
Dust Collection Accessory	DWH050K	DWH050K
Suitable Anchors	PB+, Power-Bolt Power-Stud Screw-Bolt+ Undercut Anchors Adhesive Anchors	PB+, Power-Bolt Power-Stud Screw-Bolt+ Undercut Anchors Adhesive Anchors

\*\*60V MAX- maximum initial battery voltage (measured without a workload) is 60 volts. Nominal voltage is 54.

**SDS MAX  
ROTARY  
HAMMERS**



1-9/16" SDS Max Combination Hammer

1-3/4" SDS Max Combination Hammer

1-7/8" SDS Max Rotary Hammer

	<b>D25481K</b>	<b>D25604K</b>	<b>D25733K</b>
Optimal Concrete Drilling	1/2" to 1-1/8"	5/8" to 1-1/4"	3/4" to 1-3/4"
Joules of Impact Energy	6.1	8	13.3
RPM / BPM	0-540 / 0-3,150	210-415 / 1,430-2,840	177-355 / 1,350-2,705
Torque Control	Integral Clutch	E-Clutch® and Integral Clutch	E-Clutch® and Integral Clutch
Amps	10.5	13.5	15
Weight (lbs.)	13	15.1	15
Vibration Control	Yes, Shocks™	Yes, Shocks™	Yes, Shocks™
Vibration	9.4 m/s <sup>2</sup>	9.1 m/s <sup>2</sup>	9.6 m/s <sup>2</sup>
Dust Collection Accessory (Requires Dust Extractor)	DWH050K	DWH050K	DWH050K
Suitable Anchors	PB+, Power-Bolt Power-Stud Screw-Bolt+ Undercut Anchors Adhesive Anchors	PB+, Power-Bolt Power-Stud Screw-Bolt+ Undercut Anchors Adhesive Anchors	PB+, Power-Bolt Power-Stud Screw-Bolt+ Undercut Anchors Adhesive Anchors

**INSTALLATION TOOLS 51**



**CORDLESS  
IMPACT  
WRENCHES**



3/8" Cordless Compact Impact Wrench

**DCF890M2**



1/2" Cordless Impact Wrench

**DCF894P2**



1/2" Cordless High Torque Impact Wrench

**DCF899P2**

No Load Speed	0-3,200	3 Mode	400 / 1200 / 1900
Impacts/Minute	0-2,700	0-3,100	2400
Tool Length / Tool Weight	5.5" / 2 Lbs	6.95" / 3.48 Lbs	8.81" / 7.2 Lbs
Charge/Batteries	20V MAX* Lithium Ion 4.0 Ah	20V MAX* Lithium Ion 5.0 Ah	20V MAX* Lithium Ion 5.0 Ah
Suitable Anchors	Screw-Bolt+, Wedge-Bolt 316 Snake+ Hangermate+ (Concrete)	Screw-Bolt+ Wedge-Bolt 316 Snake+	Screw-Bolt+ Wedge-Bolt 316 Hangermate+ Concrete



1/2" Cordless Impact Wrench

**DCF880M2**

No Load Speed	0-2,300
Impacts/Minute	0-2,700/2400
Tool Length / Tool Weight	5.70" / 3.4 Lbs
Charge/Batteries	20V MAX* Lithium Ion 5.0 Ah
Suitable Anchors	Snake+



**GUARANTEED TOUGH.**

**CORDLESS IMPACT DRIVERS**



1/4" Cordless Impact Driver

**DCF887D2**

Anvil Type / Chuck Type	1/4" Hex / Quick Release
No Load Speed	0-1,000/ 2,800/ 3,250
Impacts/Minute	3,600
Torque	0-240/ 1,500/1,825 In-lbs
Tool Length	5.3"
Charge/Batteries	Fast Charger / (2) 20V MAX* XR Lithium Ion (4.0 Ah)
Suitable Anchors	Hangermate+ Concrete, Hangermate Steel, Bang-It+

**CORDLESS DRILL DRIVERS**



1/2" Cordless Hammerdrill

**DCD996P2**

Chuck Size/Type	1/2" / Metal Ratcheting
Clutch Settings	11
No Load Speed	0-450 / 0-1,300 / 0-2,000 (drill mode) 0-500/0-1500/0-2250 (hammerdrill mode)
Max Power	820 UWO
Speed Settings	3
Charge/Batteries	(2) 20V MAX* XR Lithium Ion (5.0 Ah)
Suitable Anchors	Hangermate Steel / Wood, Bang-It, DDI+, Poly-Toggle, Pop-Toggle, Fluted Plastic Anchor, Bantam, Wall Dog, Scru-Lead, Polly, Toggle Bolt



1/2" Cordless Drill Driver

**DCD991P2**

Chuck Size/Type	1/2" / Metal Ratcheting
No Load Speed	0-450 / 0-1300 / 0-2000
Max Power	820 UWO
Speed Settings	3
Tool Weight	4.6lbs
Charge/Batteries	Fast Charger / (2) 20V MAX* XR Lithium Ion (4.0 Ah)
Suitable Anchors	Hangermate Steel / Wood Bang-It, DDI+

\*Maximum initial battery voltage (measured without a workload) is 20 volts. Nominal voltage is 18.



**INSTALLATION TOOLS 53**



# MANAGE YOUR TOOLS. ANYWHERE.™

Tool Connect™ is a three-part inventory management solution designed to help you save time and money.



## PRODUCTS

Tool Connect™ Tools, Batteries, Tags and Connectors with Bluetooth® technology.



## MOBILE APP

Use the mobile app to pair with Tool Connect™ assets on the jobsite.



## INVENTORY MANAGER

Inventory Manager Online Portal tracks your assets across multiple jobsites using data received from Tool Connect™ mobile apps.

**DEWALT.COM/TC**



Tool Connect™ Tag

### DCE041

Bluetooth® Range	100 ft
Coin Cell Life	3 yrs
Tool Length / Height	2-1/5" / 1/2"
Tool Weight (Tool Only)	0.6 oz

Also Available  
 DCE041-4 (4) Tool Connect™ Tags  
 DCE041-10 (10) Tool Connect™ Tags  
 DCE041-10 (25) Tool Connect™ Tags



Tool Connect™ Connector

### DCE040

Voltage	20VMAX*
IP Rating	IP68
Bluetooth® Range	100 ft
Coin Cell Life	Rechargeable
Tool Weight (Tool Only)	4.1 oz



**GUARANTEED TOUGH.®**

**PERFORM  
PROTECT™**

**YOUR FIRST LINE  
OF DEFENSE.™**

FOR MORE INFORMATION:  
[www.DeWALT.com/PNP](http://www.DeWALT.com/PNP)



**LANYARD  
READY™**

### A PERFORM & PROTECT™ FEATURE FOR CORDED & CORDLESS TOOLS

DeWALT® LANYARD READY™ integrated solutions offer options to tether select corded and cordless tools to rigid structures on jobsites when working at height with a maximum lanyard length of 2m, helping to secure the tool in case it is dropped.



The integrated lanyard attachment point works with any multi-action carabiner

2-stage carabiner for a secure hold, yet can be un-hooked from attachment point to charge battery

The integrated lanyard strap has a lanyard that secures the battery to the tool

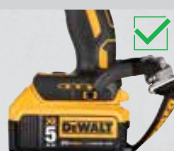

Any permanent stretch to the attachment point exposing the red internal coils indicates it has been compromised and must be serviced prior to reuse.

DeWALT's PERFORM & PROTECT™ line of Power Tools is designed to provide a high level of one or more of the following: control, dust containment, or low vibration, without sacrificing performance.

**INSTALLATION TOOLS 55**



**SDS+ DRILL BITS**



**SDS+ Full Head Carbide**

Shank / Tip		CAT #	DIAMETER	USABLE LENGTH	OVERALL LENGTH	CAT #	DIAMETER	USABLE LENGTH	OVERALL LENGTH
Tool	Rotary hammer with SDS + (slotted drive shaft) type chuck	DW5502	3/16"	2"	4-1/2"	DW5526	5/16"	10"	12"
		DW5503	3/16"	4"	6-1/2"	DW5527	3/8"	4"	6-1/2"
Base Materials	Concrete, block, brick and soft stone	DW5504	3/16"	5"	8-1/2"	DW5529	3/8"	8"	10"
		DW5506	3/16"	10"	12"	DW55300	3/8"	10"	12"
Size Range	5/32" x 6-1/2" to 1-1/8" x 18"	DW5512	7/32"	8"	10"	DW5531	3/8"	16"	18"
		DW5517	1/4"	4"	6"	DW5537	1/2"	4"	6"
Description	High Impact Tip Open Head Elongated 4 Flute Design	DW5518	1/4"	6"	8-1/2"	DW5538	1/2"	8"	10-1/2"
		DW55200	1/4"	10"	12"	DW5539	1/2"	10"	12"
		DW5521	1/4"	12"	14"	DW5540	1/2"	16"	18"
		DW5524	5/16"	4"	6"				



**SDS+ 4-Cutter Carbide**

Shank / Tip		CAT #	DIAMETER	USABLE LENGTH	OVERALL LENGTH	CAT #	DIAMETER	USABLE LENGTH	OVERALL LENGTH
Tool	Rotary hammer with SDS + (slotted drive shaft) type chuck	DW5471	5/8"	8"	10"	DW5479	1"	8"	10"
		DW5472	5/8"	16"	18"	DW5480	1"	16"	18"
Base Materials	Concrete, block, brick and soft stone	DW5474	3/4"	8"	10"	DW5481	1-1/8"	8"	10"
		DW5475	3/4"	16"	18"	DW5482	1-1/8"	6"	18"
Size Range	5/8" x 10" to 1-1/8" x 18"	DW5477	7/8"	8"	10"				
		DW5478	7/8"	16"	18"				
Description	High Impact Tip Open Head Elongated 4 Flute Design								



**SDS+ Carbide 2-Cutter**

Shank / Tip		CAT #	DIAMETER	USABLE LENGTH	OVERALL LENGTH	CAT #	DIAMETER	USABLE LENGTH	OVERALL LENGTH
Tool	Rotary hammer with SDS + (slotted drive shaft) type chuck	DW5401	5/32	4-1/2	6-1/2	DW5438	1/2	8	10
		DW5400	5/32	2	4	DW5439	1/2	10	12
Base Materials	Concrete, block, brick and soft stone	DW5403	3/16	4-1/2	6-1/2	DW5440	1/2	16	18
		DW5404	3/16	6-1/2	8-1/2	DW5441	1/2	22	24
Size Range	5/32" x 6-1/2" to 1-1/8" x 16"	DW5407	3/16	12	14	DW5442	9/16	4	6
		DW5408	3/16	14	16	DW5443	9/16	10	12
Description	Carbide Tip Four Flute Helix Increased Steel	DW5406	3/16	10	12	DW5444	9/16	16	18
		DW5405	3/16	8	10	DW5445	9/16	22	24
		DW5402	3/16	2	4	DW5446	5/8	6	8
		DW5410	7/32	4	6	DW5448	5/8	16	18
		DW5412	7/32	4	6	DW5447	5/8	10	12
		DW5416	1/4	2	4	DW5450	11/16	6	8
		DW5417	1/4	4	6	DW5449	5/8	22	24
		DW5418	1/4	6-1/2	8-1/2	DW5455	3/4	10	12
		DW5420	1/4	10	12	DW5453	3/4	6	8
		DW5421	1/4	12	14	DW5456	3/4	16	18
		DW5424	5/16	4	6	DW5457	3/4	22	24
		DW5426	5/16	10	12	DW5460	7/8	6	8
		DW5432	3/8	22	24	DW5458	27/32	6	8
		DW5430	3/8	10	12	DW5433	7/16	4	6
		DW5427	3/8	4	6	DW5462	7/8	16	18
		DW5429	3/8	8	10	DW5464	1	8	10
		DW5431	3/8	16	18	DW5466	1	16	18
		DW5435	7/16	10	12	DW5468	1 1/8	8	10
		DW5437	1/2	4	6	DW5469	1 1/8	16	18
		DW5436	7/16	16	18				

**GUARANTEED TOUGH.**

**SDS-MAX DRILL BITS**



**SDS-Max 4-Cutter Carbide**

Shank / Tip		CAT #	DIAMETER	USABLE LENGTH	OVERALL LENGTH	CAT #	DIAMETER	USABLE LENGTH	OVERALL LENGTH
Tool	Rotary hammer with SDS Max (slotted drive shaft) type chuck	DW5806	5/8"	8"	13-1/2"	DW5817	27/32"	16"	21-1/2"
		DW5809	5/8"	16"	21-1/2"	DW5818	1"	8"	13-1/2"
Base Materials	Concrete, block, brick and soft stone	DW5807	5/8"	31"	36"	DW5819	1"	16"	21-1/2"
		DW5808	11/16"	16"	21-1/2"	DW5852	1"	24"	29"
Size Range	5/8" x 13-1/2" to 1-1/4" x 22-1/2"	DW5810	S3/4"	8"	13-1/2"	DW5820	1"	31"	36"
		DW5812	3/4"	16"	21-1/2"	DW5821	1-1/8"	10"	15"
Description	Open Head U-Flute Design	DW5813	3/4"	31"	36"	DW5822	1-1/8"	18"	22-1/2"
		DW5814	13/16"	16"	21-1/2"	DW5853	1-1/8"	24"	29"
		DW5815	7/8"	8"	13-1/2"	DW5854	1-1/8"	31"	36"
		DW5816	7/8"	16"	21-1/2"	DW5824	1-1/4"	10"	15"
		DW5851	7/8"	31"	36"	DW5825	1-1/4"	18"	22-1/2"



**SDS-Max Carbide**

Shank / Tip		CAT #	DIAMETER	USABLE LENGTH	OVERALL LENGTH	CAT #	DIAMETER	USABLE LENGTH	OVERALL LENGTH
Tool	Rotary hammer with SDS Max (slotted drive shaft) type chuck	DW5801	9/16"	8"	13-1/2"	DW5875	7/8"	16"	21-1/2"
		DW5802	9/16"	16"	21-1/2"	DW5876	1"	8"	13-1/2"
Base Materials	Concrete, block, brick and soft stone	DW5803	1/2"	8"	13-1/2"	DW5877	1"	16"	21-1/2"
		DW5804	1/2"	16"	21-1/2"	DW5878	1-1/8"	10"	15"
Size Range	9/16" x 13-1/2" to 1-1/4" x 22-1/2"	DW5870	5/8"	8"	13-1/2"	DW5879	1-1/8"	18"	22-1/2"
		DW5871	5/8"	16"	21-1/2"	DW5880	1-1/4"	10"	15"
Description	Open Head U-Flute Design	DW5872	3/4"	8"	13-1/2"	DW5881	1-1/4"	18"	22-1/2"
		DW5873	3/4"	16"	21-1/2"				
		DW5874	7/8"	8"	13-1/2"				

**NO BREAK GUARANTEE™**



**INSTALLATION ACCESSORIES 57**



**HOLLOW  
DRILL BITS**

**SDS-Plus and SDS-Max Carbide Hollow Drill Bit**

Approvals



Shank / Tip

SDS+



SDS Max



Tool

Rotary hammer with SDS + or SDS Max type chuck

Base Materials

Concrete, Block, Brick and Soft Stone

Size Range

1/2" x 14-1/2" to 1-1/2" x 47-1/4"

Description

Hollow Bit conducts dust away from drill hole via DeWALT DustX+ System

**SDS+**

CAT #	DIA	OVERALL LENGTH	USABLE LENGTH
DWA54012	1/2"	14-1/2"	9-3/4"
DWA54916	9/16"	14-1/2"	9-3/4"
DWA54058	5/8"	14-1/2"	9-3/4"
DWA54034	3/4"	14-1/2"	9-3/4"

**SDS MAX**

CAT #	DIA	OVERALL LENGTH	USABLE LENGTH
DWA58058	5/8"	23-5/8"	15-3/4"
DWA58034	3/4"	23-5/8"	15-3/4"
DWA58078	7/8"	23-5/8"	15-3/4"
DWA58001	1"	23-5/8"	15-3/4"
DWA58116	1 1/16"	23-5/8"	15-3/4"
DWA58118	1-1/8"	23-5/8"	15-3/4"
DWA58958	5/8"	47-1/4"	39-3/8"
DWA58934	3/4"	47-1/4"	39-3/8"
DWA58978	7/8"	47-1/4"	39-3/8"
DWA58901	1"	47-1/4"	39-3/8"
DWA58918	1-1/8"	47-1/4"	39-3/8"
DWA58114	1-1/4"	47-1/4"	39-3/8"
DWA58138	1-3/8"	47-1/4"	39-3/8"
DWA58112	1-1/2"	47-1/4"	39-3/8"



**GUARANTEED TOUGH®**

**ANCHOR ACCESSORIES**

**Installation Hand Tools and Accessories**



**HAMMER/SLEDGE**

CAT #	DESCRIPTION	QTY
DWHT51064	22Oz. One-Piece Steel Hammer Head Length 5-1/2"; Head Weight 22Oz. Overall Length 16", Overall Weight 2 Lbs.	1
J1433G	Proto 2.5lb Sledge Hammer	1



**MICROMETER TORQUE WRENCHES**

CAT #	DRIVE SIZE	TORQUE RANGE	HEAD WIDTH	HEAD DEPTH	OVERALL LENGTH	QTY
DWMT75463	3/8"	20-100 ft-lbs	1-9/16"	78	17-5/16"	1
DWMT75462	1/2"	50-250 ft-lbs	-	1	27-1/2"	1



**DRIVE IMPACT RATED UNIVERSAL SOCKETS SET**

CAT #	DESCRIPTION	QTY
DWMT19228	3/8 in Drive Impact Universal Socket Set (12pc): SAE 5/16, 3/8, 7/16, 1/2, 9/16, 5/8, 11/16, 3/4, 13/16, 7/8, 15/16, 1	1
DWMT19240	1/2" Drive 6pt Impact Socket Set (19pc): SAE 3/8, 7/16, 1/2, 9/16, 5/8, 11/16, 3/4, 13/16, 7/8, 15/16, 1, 1-1/16, 1-1/8, 1-3/16, 1-1/4, 1-5/16, 1-3/8, 1-7/16, 1-1/2.	1



**MANUAL SOCKETS FOR ATOMIC UNDERCUT+ AND POWER-STUDS**

CAT #	ANCHOR DIAMETER	SOCKET SIZE	SOCKET DRIVE	QTY
DWMT88977	1/4"	7/16"	3/8" Drive	1
DWMT86443	1/4"	7/16"	1/2" Drive	1
DWMT88979	3/8"	9/16"	3/8" Drive	1
DWMT86445	3/8"	9/16"	1/2" Drive	1
DWMT88982	1/2"	3/4"	3/8" Drive	1
DWMT86449	1/2"	3/4"	1/2" Drive	1
DWMT19573	5/8"	15/16"	3/8" Drive	1
DWMT86453	5/8"	15/16"	1/2" Drive	1
DWMT86457	3/4"	1-1/8"	1/2" Drive	1
DWMT17211	7/8"	1-15/16"	1/2" Drive	1
DWMT17227	1"	1-1/2"	1/2" Drive	1
DWMT74658	1-1/4"	1/7/8"	1/2" Drive	1

**MANUAL SOCKETS FOR POWER BOLTS**

DWMT88980	1/2"	5/8"	3/8" Drive	1
DWMT88766	1/2"	5/8"	1/2" Drive	1
DWMT88982	5/8"	3/4"	3/8" Drive	1
DWMT86449	5/8"	3/4"	1/2" Drive	1
DWMT19573	3/4"	15/16"	3/8" Drive	1
DWMT86453	3/4"	15/16"	1/2" Drive	1

**MANUAL SOCKETS FOR LOK BOLT ACORN NUT & HEX HEAD**

DWMT88976	1/4"	3/8"	3/8" Drive	1
DWMT88977	5/16"	7/16"	3/8" Drive	1
DWMT88978	3/8"	1/2"	3/8" Drive	1
DWMT88979	1/2"	9/16"	3/8" Drive	1
DWMT88982	5/8"	3/4"	3/8" Drive	1
DWMT19573	3/4"	15/16"	3/8" Drive	1



**IMPACT RATED SOCKETS FOR SCREW-BOLT+ AND WEDGE-BOLT 316 SS**

CAT #	ANCHOR DIAMETER	SOCKET SIZE	SOCKET DRIVE	QTY
DWMT74479	1/4"	7/16"	3/8" Drive	1
DWMT75122	3/8"	9/16"	1/2" Drive	1
DWMT75113	1/2"	3/4"	1/2" Drive	1
DWMT75104	5/8"	15/16"	1/2" Drive	1
DWMT75125	3/4"	1-1/8"	1/2" Drive	1



**IMPACT RATED DEEP SOCKET FOR HANGER MATE+ EXTERNALLY THREADED CONCRETE ANCHOR**

CAT #	NOM ANCHOR SIZE	SOCKET SIZE	QTY
DWMT73934	3/8"	1/2"	1



**IMPACT RATED SOCKET FOR HANGER MATE+ EXTERNALLY THREADED CONCRETE ANCHOR**

CAT #	NOM ANCHOR SIZE	SOCKET SIZE	QTY
DW2286	3/8"	3/8"	1



**20V MAX\* THREADED ROD CUTTER KIT**

CAT #	DESCRIPTION	QTY
DCS350D1	Kit Includes: DCS371B Threaded Rod Cutter DCB203 2 Ah Lithium Ion Battery, DCB112 Charger(2) DCS3501B3 4 Sided Cutting Dies, Cutting Die, Adjustment Wrench 1 Cuts 1/4", 3/8", 1/2" Mild Steel Coarse Threaded Rod and 1/4", 3/8" Stainless Steel Coarse Threaded Rod	1



**20V MAX\* LITHIUM ION BAND SAW KIT**

CAT #	DESCRIPTION	QTY
DCS371P1	Kit Includes: DCS371P1 Band Saw, DCB205 - 20V MAX* Premium Xr 5.0Ah Lithium Ion Battery Pack DCB101 - 12V MAX* - 20V MAX* Lithium Ion Battery Charger DW3982, DW3983, DW3984C and DW3986C Bi Metal Cordless Bandsaw Blades, Blade Tracking, Kit Bag 2-1/2" Cutting Capacity	1



**20V MAX\* BRUSHLESS DEEP CUT BAND SAW KIT**

CAT #	DESCRIPTION	QTY
DCS374P2	Kit Includes: DCS374 20V MAX* Band Saw (2) DCB205 20V MAX* 5.0Ah batteries DCB101 - 12V MAX* - 20V MAX* Lithium Ion Battery Charger Kit Box, 18TPI Band Saw Blade 5" Cutting Capacity	1

\*Maximum initial battery voltage (measured without a workload) is 20 volts. Nominal voltage is 18.



**DRILLING  
ACCESSORIES**

**Dust Management**



DUST EXTRACTOR		
CAT #	DESCRIPTION	QTY
DWW012	10 Gallon Wet/Dry HEPA/RRP Dust Extractor	1
DWW9402	Fleece bag (5 pack) for DEWALT Dust Extractors	5
DWW9316	Replacement Anti-Static Hose	1
DWW9320	Replacement HEPA Filter Set (Type 1)	1
DWW9000	Air Lock Connector	1



DUST EXTRACTION ATTACHMENTS		
CAT #	DESCRIPTION	QTY
DWH302DH	Filter Box Fits DWH303DH	1
DWH303DH	Dust Extractor Fits DCH273P2 1" 20V MAX* SDS Rotary Hammer	1
DCH273P2DHO	1" 20V MAX* SDS Rotary Hammer Combo Kit Kit Includes: (2) DCB205 5.0Ah Batteries (1) DCB101 Charger, 360 Degree Side Handle, Depth Rod, Retractable Utility Hook, Extractor HEPA Filter	1
DCH293R2DH	1-1/8" 20V MAX* SDS Rotary Hammer Combo Kit Includes Tool and Dust Extractor	1
DCH304DH	Dust Extractor Fits DCH293R2 1-1/8" 20V MAX* SDS Rotary Hammer	1
DWH001SDH	Standard Bit Head for Onboard Dust Extractor Replacement 3-Pack	1
DWH002SBH	Stop Bit Head for Onboard Dust Extractor Replacement 3-Pack	1
DWH003SBH	Stop Bit Head Nozzle Kit for Onboard Dust Extractor	1



LARGE HAMMER DUST EXTRACTION - HOLE CLEANING		
CAT #	DESCRIPTION	QTY
DWH050K	Kit Includes: 5/16" Hole Cleaning Tube, 9/16" Hole Cleaning Tube, 1-1/2" Hole Drilling Head Attachment, 2" Hole Drilling Head Attachment Dust Extractor Body, Kit Box	1
Two interchangeable drilling heads for optimum dust removal. One for holes up to 1-1/2" and one for holes up to 2"		

**POWER TOOL  
ACCESSORIES**

**Power Source Accessories**



POWER STATION CHARGER		
CAT #	DESCRIPTION	QTY
DCB1800B	1800 Watt Portable Power Station & Parallel Battery Charger	1

BATTERIES		
CAT #	DESCRIPTION	QTY
DCB609	20V/60V MAX* Flexvolt 9.0Ah Battery	1
DCB609-2	20V/60V MAX* Flexvolt 9.0Ah Battery 2 Pack	2
DCB612	20V/60V MAX* Flexvolt 12.0Ah Battery	1

CAT #	DESCRIPTION	QTY
DCB206	20V MAX* XR 6.0Ah Lithium Ion Battery Pack	1
DCB206-2	20V MAX* XR 6.0Ah Lithium Ion Battery Pack 2 Pack	2
DCB205	20V MAX* XR 5.0Ah Lithium Ion Battery Pack	1
DCB205-2	20V MAX* XR 5.0Ah Lithium Ion Battery Pack 2 Pack	2
DCB204	20V MAX* XR Lithium Ion Battery Pack	1
DCB204-2	20V MAX* R Lithium Ion Battery Pack	2
DCB203	20V MAX* Compact Lithium Ion Battery Pack	1
DCB203-2	20V MAX* Compact Lithium Ion Battery Pack	2
DCB200	20V MAX* Lithium Ion Battery Pack (3.0 Ah)	1
DCB200-2	20V MAX* Lithium Ion Battery Pack (3.0 Ah)	2
DCB115	Charger for all DEWALT 12V-20V MAX* Li-Ion Batteries	1
DCB118	20V MAX* Flexvolt Fast Charger	1

\*Maximum initial battery voltage (measured without a workload) is 20 volts. Nominal voltage is 18.

**GUARANTEED TOUGH.**

**ADHESIVE ACCESSORIES**

**Hole Cleaning Tools and Accessories**



**STEEL PREMIUM BRUSHES (REQUIRED FOR AC200+)**

CAT #	DESCRIPTION	QTY
PFC1671050	Steel Premium Brush For 7/16" Hole	1
PFC1671100	Steel Premium Brush For 1/2" Hole	1
PFC1671150	Steel Premium Brush For 9/16" Hole	1
PFC1671200	Steel Premium Brush For 5/8" Hole	1
PFC1671225	Steel Premium Brush For 11/16" Hole	1
PFC1671250	Steel Premium Brush For 3/4" Hole	1
PFC1671300	Steel Premium Brush For 7/8" Hole	1
PFC1671350	Steel Premium Brush For 1" Hole	1
PFC1671400	Steel Premium Brush For 1-1/8" Hole	1
PFC1671450	Steel Premium Brush For 1-3/8" Hole	1
PFC1671500	Steel Premium Brush For 1-1/2" Hole	1
PFC1671000	Premium Manual Brush Wood Handle	1
PFC1671010	Premium Brush Extension	1
PFC1671820	Premium Steel Brush Extension 12"	1
PFC1671830	Premium Steel Brush SDS Adapter	1
PFC1671960	Premium Steel Brush Drill Chuck Adapter	1



**WIRE BRUSHES**

CAT #	DESCRIPTION	QTY
08275	Wire Brush For 5/8" ANSI Hole, No. 4 Rebar	1
08284	Wire Brush For 7/16" ANSI Hole	1
08287	Wire Brush For 7/8" ANSI Hole	1
08285	Wire Brush For 9/16" ANSI Hole	1
08278	Wire Brush For 3/4" ANSI Hole	1
08286	Wire Brush For 11/16 In ANSI Hole	1
08288	Wire Brush For 1" ANSI Hole	1
08289	Wire Brush For 1-1/8" ANSI Hole	1

CAT #	DESCRIPTION	QTY
08290	Wire Brush For 1-3/8" ANSI Hole	1
08291	Wire Brush For 1-1/2" ANSI Hole	1
08299	Wire Brush For 1-3/4" Hole, No. 11 Rebar	1
08282	Brush Extension 12"	1
08283	SDS Plus Adapter For Wire Brush	1
08296	Jacobs Chuck Adapter	1



**NYLON BRUSHES**

CAT #	DESCRIPTION	QTY
07931	Nylon Brush For 7/16" ANSI Hole	1
07932	Nylon Brush For 9/16" ANSI Hole	1
07933	Nylon Brush For 3/4" ANSI Hole	1
07934	Nylon Brush For 1" to 1-1/8" ANSI Hole	1
07935	Nylon Brush For 1-1/4" ANSI Hole	1
52073	Adhesive Cleaning Kit	1



**AIR NOZZLE**

CAT #	DESCRIPTION	QTY
08292	Air Nozzle W/Extension	1



**HAND PUMP**

CAT #	DESCRIPTION	QTY
08280	Hand Pump / Dust Blower 25oz.	1

**Dispensing Tools**



**CORDLESS 20V DISPENSERS**

CAT #	DESCRIPTION	QTY	MSTR
DCE560B	20V Quik-Shot Dispenser Bare	1	63
DCE560D1	20V Quik-Shot Dispenser Kitte	1	66
DCE593B	20V Epoxy Dispenser 3:1 13/19.5oz Bare	1	63
DCE593D1	20V Epoxy Dispenser 3:1 13/19.5oz Kit	1	48
DCE591B	20V Epoxy Dispenser 1:1 20.5oz Bare	1	63
DCE591D1	20V Epoxy Dispenser 1:1 20.5oz Kit	1	48
DCE595B	20V Acrylic Dispenser 10:1 28oz Bare	1	63
DCE595D1	20V Acrylic Dispenser 10:1 28oz Kit	1	48



**STANDARD MANUAL DISPENSERS**

CAT #	DESCRIPTION	QTY	MSTR
08437	Standard Quik-Shot Manual Dispenser 9/9.5oz	1	432
08485	Standard 10:1 Manual Dispenser 11.5 oz	1	144
08298	Standard 3:1 Manual Dispenser 13oz & 19.5oz	1	80
08409	Standard 1:1 Manual Dispenser 20.5oz	1	96
08494	Standard 10:1 Manual Dispenser 28oz	1	60



**HIGH PERFORMANCE DISPENSERS**

CAT #	DESCRIPTION	QTY	MSTR
08421	High Performance 1:1 Manual Dispenser 20.5oz	1	10
08479	High Performance Quik-Shot Dispenser 9/9.5oz	1	12



**PNEUMATIC DISPENSERS**

CAT #	DESCRIPTION	QTY	MSTR
8497SD	Pneumatic 3:1 Dispenser 13oz & 19.5oz	1	20
08459	Pneumatic 1:1 Dispenser 20.5oz	1	
8496SD	Pneumatic 10:1 Dispenser 28oz	1	20
08438	Pneumatic 1:1 Dispenser 50.5	1	

1-800-4 DEWALT

ACCESSORIES / TOOLS FOR ADHESIVES

61



**ADHESIVE ACCESSORIES**

**Mixing Nozzles and Nozzle Extensions**



**MIXING NOZZLES**

CAT #	DESCRIPTION	QTY	MSTR
PFC1641600	Mixing Nozzle for AC200+	2	21
08609	Extra High Flow Mixing Nozzle	2	24
08293	Mixing Nozzle for AC100+ Gold 10 & 12 oz	2	24
08294	Mixing Nozzle	2	24
08281	8" Extension	1	12



**FLEXIBLE EXTENSIONS**

CAT #	DESCRIPTION	QTY	MSTR
08297	Flex Extension Tubing for Piston Plug	1	12
PFC1640600	Flexible Extension Hose 25 Ft	1	12

**Adhesive Piston Plugs**



**STANDARD PISTON PLUGS**

CAT #	DESCRIPTION	ANSI BIT DIA	ROD DIA	REBAR SIZE	QTY
08302	9/16" Plug	9/16"	1/2"	#4	10
08304	5/8" Plug	5/8"	-	#4	10
08258	11/16" Plug	11/16"	5/8"	#5	10
08259	3/4" Plug	3/4"	5/8"	#5	10
08300	7/8" Plug	7/8"	3/4"	#6	10
08301	1" Plug	1"	7/8"	#7	10
08303	1-1/8" Plug	1-1/8"	1"	#8	10
08305	1-3/8" Plug	1-3/8"	1-1/4"	#9	10
08309	1-1/2" Plug	1-1/2"	-	#10	10



NEW!

**PREMIUM PISTON PLUGS**

CAT #	DESCRIPTION	ANSI BIT DIA	ROD DIA	REBAR SIZE	QTY
PFC1691510	Premium Plug	5/8" Hole	-	#4	5
PFC1691520	Premium Plug	3/4" Hole	5/8"	#5	5
PFC1691530	Premium Plug	7/8 Hole	3/4"	#6	5
PFC1691540	Premium Plug	1" Hole	7/8"	#7	5
PFC1691550	Premium Plug	1-1/8" Hole	1"	#8	5
PFC1691560	Premium Plug	1-3/8" Hole	1-1/4"	#9	5
PFC1691570	Premium Plug	1-1/2" Hole	-	#10	5
PFC1691580	Premium Plug	1-3/4" Hole	1-1/2"	#11	5

**Screen Tubes**



**PLASTIC SCREEN TUBES**

CAT #	DESCRIPTION	DRILL DIA	QTY
08470	1/4" x 1-3/4"	1/2"	25
08310	3/8" x 3-1/2"	9/16"	25
08311	3/8" x 6"	9/16"	25
08313	3/8" x 8"	9/16"	25
08315	1/2" x 3-1/2"	3/4"	25
08317	1/2" x 6"	3/4"	25
08321	5/8" x 6"	7/8"	25
08323	3/4" x 6"	1"	10



**STAINLESS STEEL SCREEN TUBES**

CAT #	DESCRIPTION	DRILL DIA	QTY
07960	1/4" x 2"	3/8"	25
07862†	1/4" x 6"	3/8"	25
07864†	1/4" x 8"	3/8"	25
07866	1/4" x 10"	3/8"	25
07856	3/8" x 2"	1/2"	25
07961†	3/8" x 3-1/2"	1/2"	25
07962†	3/8" x 6"	1/2"	25
07963†	3/8" x 8"	1/2"	25
07964†	3/8" x 10"	1/2"	25
07959†	3/8" x 12"	1/2"	25
07857	1/2" x 2"	5/8"	25
07965	1/2" x 3-1/2"	5/8"	25
07966†	1/2" x 6"	5/8"	25
07967†	1/2" x 8"	5/8"	25
07968†	1/2" x 10"	5/8"	25
07858	5/8" x 2"	3/4"	25
07969	5/8" x 4-1/2"	3/4"	20
07970	5/8" x 6"	3/4"	20
07971†	5/8" x 8"	3/4"	20
07972†	5/8" x 10"	3/4"	20
07859	3/4" x 2"	7/8"	25
07973	3/4" x 6"	7/8"	10
07977	3/4" x 8"	7/8"	10
07974	3/4" x 10"	7/8"	10
07975	3/4" x 13"	7/8"	10
07978	3/4" x 17"	7/8"	10
07855	15/16" x 2"	1"	25
07865	15/16" x 8"	1"	10
07867	15/16" x 13"	1"	25
07869†	15/16" x 18"	1"	10

† Includes extension tubes



**GUARANTEED  
TOUGH.**

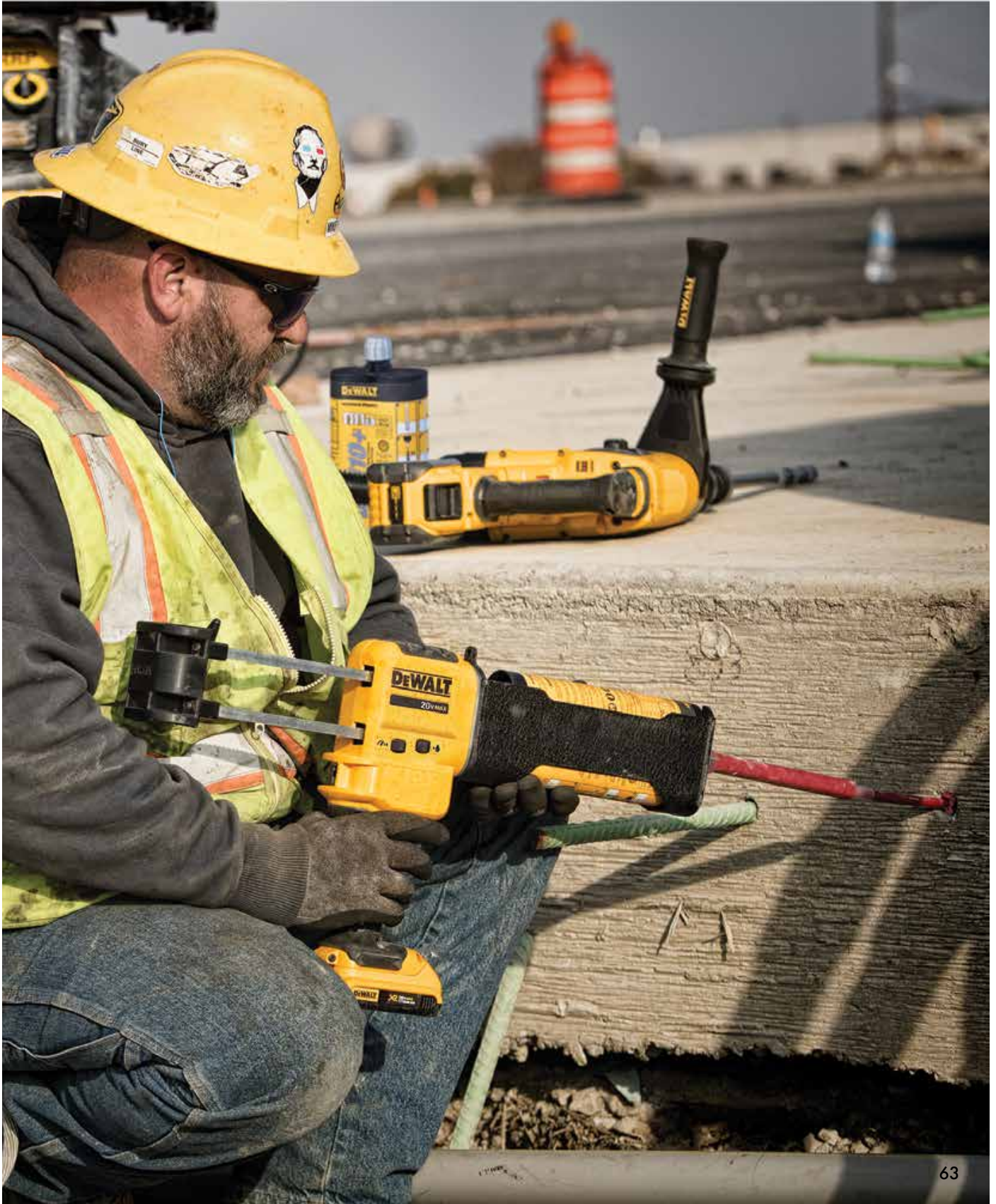



**ADHESIVE ACCESSORIES**

**Adhesive Installation System: Drill Bits**

			20V MAX* SDS Plus Rotary Hammers Drill Bits			Flexvolt® SDS Max Drill Bits	SDS Max Combination Hammer (Corded) Drill Bits
*For 20V MAX* Maximum initial battery voltage measured without a workload is 20 volts. Nominal voltage is 18.							
ROD/REBAR SIZE	HOLE SIZE	EMBEDMENT	DCH273P2 1" L-SHAPE	DCH133M2 1" D-HANDLE	DCH293R2 1-1/8" L-SHAPE W/ E-CLUTCH	DCH481X2 1-9/16" W/ E-CLUTCH	D25603K 1-3/4" / CORDED
			SDS+	SDS+	SDS+	SDS MAX	
3/8" or #3	1/2"	4"	DW5537	DW5437	DW5537		
3/8" or #3	1/2"	8"	DW5538	DW5438	DW5538		
3/8" or #3	1/2"	10"	DW5539	DW5439	DW5539		
3/8" or #3	1/2"	16"	DW5540	DW5440	DW5540		
3/8" or #3	1/2"	22"	DW55410	DW5441	DW55410		
1/2"	5/8"	6"	DW5471	DW5446	DW5471		DW5806
1/2" or #4	5/8"	8"	DW5471	DW5447	DW5471		DW5806
1/2" or #4	5/8"	16"	DW5472	DW5448	DW5472		DW5809
1/2" or #4"	5/8"	22"		DW5449			DW5807
1/2" or #4	5/8"	31"					DW5807
5/8" or #5	3/4"	6"	DW5474	DW5453	DW5474		DW5810
5/8" or #5	3/4"	10"	DW5475	DW5447	DW5475		DW5812
5/8" or #5	3/4"	16"	DW5475	DW5447	DW5475		DW5812
5/8" or #5	3/4"	22"		DW5457			DW5813
3/4" or #6	7/8"	6"	DW5477	DW5460	DW5477		DW5815
3/4" or #6	7/8"	10"	DW5478	DW5461	DW5478		DW5816
3/4" or #6	7/8"	16"	DW5478	DW5462	DW5478		DW5816
7/8" or #7	1"	8"	DW5479	DW5464	DW5479		DW5818
7/8" or #7	1"	16"	DW5480	DW5466	DW5480		DW5819
7/8" or #7	1"	24"					DW5852
7/8" or #7	1"	31"					DW5820
1" or #8	1-1/8"	8"	DW5481	DW5468	DW5481		DW5821
1" or #8	1-1/8"	16"	DW5482	DW5469	DW5482		DW5822
1" or #8	1-1/8"	24"					DW5853
1" or #8	1-1/8"	31"					DW5854

\* 7/16" may be needed in some circumstance for 3/8" rod      \*\* 9/16" may be needed in some circumstance for 1/2" rod

**GUARANTEED TOUGH®**

Adhesive Installation System: Hollow Drill Bits												Accessories			
			20V MAX* SDS Plus Rotary Hammers Hollow Drill Bit			Flexvolt® SDS Max Hollow Drill Bit	SDS Max Combination Hammer (Corded) Hollow Drill Bit								
ROD/ REBAR SIZE	HOLE SIZE	EMBED.	DCH273P2 1" L-SHAPE	DCH133M2 1" D-HANDLE	DCH293R2 1-1/8" L-SHAPE W/ E-CLUTCH	DCH481X2 1-9/16" W/ E-CLUTCH	D25603K 1-3/4" / CORDED		PREMIUM PISTON PLUGS	STANDARD PISTON PLUGS	PREMIUM BRUSH	STANDARD BRUSH			
3/8" or #3	1/2"	4"	DWA54012	DWA54012	DWA54012				08302-PWR	PFC1671100					
3/8" or #3	1/2"	8"	DWA54012	DWA54012	DWA54012				08302-PWR	PFC1671100					
3/8" or #3	1/2"	10"	DWA54012	DWA54012	DWA54012				08302-PWR	PFC1671100					
3/8" or #3	1/2"	16"							08302-PWR	PFC1671100					
3/8" or #3	1/2"	22"							08302-PWR	PFC1671100					
1/2"	5/8"	6"	DWA54058	DWA54058	DWA54058	DWA58058	DWA58058	PFC1691510	08258-PWR	PFC1671200	08275-PWR				
1/2" or #4	5/8"	8"	DWA54058	DWA54058	DWA54058	DWA58058	DWA58058	PFC1691510	08258-PWR	PFC1671200	08275-PWR				
1/2" or #4	5/8"	16"	DWA54058	DWA54058	DWA54058	DWA58058	DWA58058	PFC1691510	08258-PWR	PFC1671200	08275-PWR				
1/2" or #4"	5/8"	22"				DWA58958	DWA58958	PFC1691510	08258-PWR	PFC1671200	08275-PWR				
1/2" or #4	5/8"	31"				DWA58958	DWA58958	PFC1691510	08258-PWR	PFC1671200	08275-PWR				
5/8" or #5	3/4"	6"	DWA54034	DWA54034	DWA54034	DWA58034	DWA58034	PFC1691520	08259-PWR	PFC1671250	08278-PWR				
5/8" or #5	3/4"	10"	DWA54034	DWA54034	DWA54034	DWA58034	DWA58034	PFC1691520	08259-PWR	PFC1671250	08278-PWR				
5/8" or #5	3/4"	16"				DWA58034	DWA58034	PFC1691520	08259-PWR	PFC1671250	08278-PWR				
5/8" or #5	3/4"	22"				DWA58934	DWA58934	PFC1691520	08259-PWR	PFC1671250	08278-PWR				
3/4" or #6	7/8"	6"				DWA58078	DWA58078	PFC1691530	08300-PWR	PFC1671300	08287-PWR				
3/4" or #6	7/8"	10"				DWA58078	DWA58078	PFC1691530	08300-PWR	PFC1671300	08287-PWR				
3/4" or #6	7/8"	16"				DWA58078	DWA58078	PFC1691530	08300-PWR	PFC1671300	08287-PWR				
7/8" or #7	1"	8"				DWA58001	DWA58001	PFC1691540	08301-PWR	PFC1671350	08288-PWR				
7/8" or #7	1"	16"				DWA58001	DWA58001	PFC1691540	08301-PWR	PFC1671350	08288-PWR				
7/8" or #7	1"	24"				DWA58901	DWA58901	PFC1691540	08301-PWR	PFC1671350	08288-PWR				
7/8" or #7	1"	31"				DWA58901	DWA58901	PFC1691540	08301-PWR	PFC1671350	08288-PWR				
1" or #8	1-1/8"	8"				DWA58118	DWA58118	PFC1691550	08303-PWR	PFC1671400	08288-PWR				
1" or #8	1-1/8"	16"				DWA58118	DWA58118	PFC1691550	08303-PWR	PFC1671400	08288-PWR				
1" or #8	1-1/8"	24"				DWA58918	DWA58918	PFC1691550	08303-PWR	PFC1671400	08288-PWR				
1" or #8	1-1/8"	31"				DWA58918	DWA58918	PFC1691550	08303-PWR	PFC1671400	08288-PWR				



# ELIMINATE 100% OF TRADITIONAL HOLE CLEANING STEPS WITH DUST X+\*

## DRILL + EXTRACT + ANCHOR



Screw-Bolt™+ Power-Stud®+ SD1 Power-Stud®+ SD2 Power-Stud®+ SD4/6 Power-Bolt®+ PFC1271050 08310SD 08600

A TESTED ANCHOR INSTALLATION SYSTEM BY DeWALT THAT IS OSHA TABLE 1 COMPLIANT AND ICC-ES APPROVED

HOLLOW DESIGN THAT ALLOWS THE DUST TO BE REMOVED WHEN DRILLING PROVIDING INCREASED DRILLING SPEED.



WIDEST VARIETY OF DIAMETERS AND LENGTHS FOR THE MOST COMMON ANCHOR AND REBAR INSTALLATIONS.

### RECOMMENDED HAMMER SELECTION BY HOLLOW DRILLBIT DIAMETER\*

BIT DIA	SDS + HAMMERS				SDS MAX HAMMERS		
	DCH133	D25263K / DCH263	DCH293	D25333K	D25481K / DCH481	D25604K	D25733K / DCH733
3/8"	✓	✓	✓	✓	×	×	×
1/2"	✓	✓	✓	✓	✓	×	×
5/8"	✓	✓	✓	✓	✓	✓	×
3/4"	✓	✓	✓	✓	✓	✓	✓
7/8"	×	✓	✓	✓	✓	✓	✓
1"	×	✓	✓	✓	✓	✓	✓
1-1/8"	×	×	×	×	✓	✓	✓
1-1/4"	×	×	×	×	✓	✓	✓
1-3/8"	×	×	×	×	✓	✓	✓
1-1/2"	×	×	×	×	×	✓	✓

✓ OPTIMUM    ✓ MAXIMUM    × NOT RECOMMENDED

\*Based on 15-3/4" of embedment. For deeper holes go up in hammer size.

\*These claims are abbreviated instructions which may vary by application. Review and follow the instructions accompanying the product or refer to the product technical manual located at anchors.DEWALT.com

# DEWALT®

ENGINEERED BY **POWERS™**

- **GAS-FREE OPERATION:**  
Runs on DEWALT 20V MAX\* battery.
- **1" MAGAZINE:** Reduces weight vs. DCN890 and allows for improved access into deep track. Interchangeable with 2-1/4" magazine.
- **BRUSHLESS MOTOR:** Comparable application speed to gas concrete nailers.
- **FIELD SERVICEABLE PISTON:** Can be replaced by user in the field in under 2 minutes



## 20V MAX\* 1" Magazine Cordless Concrete Nailer



DCN891P2

\* Maximum initial battery voltage (measured without a workload) is 20 volts. Nominal voltage is 18.  
\*\* 2-1/4" magazine and pins also available





**DIRECT FASTENING**

**Cordless Concrete Nailing System**

Type	Cordless Direct Fastening System
Approvals	ICC-ES ESR-4076
Base Materials	Hollow block, concrete and steel
Anchor Size Range	1/2" - 2-1/4" length .102 to .145 diameter
Tool Platform	DeWALT 20V MAX*

\*Maximum initial battery voltage (measured without a workload) is 20 volts. Nominal voltage is 18.



TOOL	
CAT #	DESCRIPTION
DCN891P2	20V MAX* Cordless Concrete Nailer  (2) DCB205 20V MAX* Premium Lithium Ion Batteries (5Ah) DCN8907 1" Magazine DCN8904 Standard / Drywall Nose Piece Charger Kitbox
DCN891B	20V MAX* Cordless Concrete Nailer  DCN8907 1" Magazine, DCN8904 Standard / Drywall Nose Piece Kitbox



TOOL	
CAT #	DESCRIPTION
DCN890P2	20V MAX* Cordless Concrete Nailer  (2) DCB205 20V MAX* Premium Lithium Ion Batteries (5Ah) DCN8906 2-1/4" Magazine DCN8904 Standard / Drywall Nose Piece Charger Kitbox



CONCRETE PINS		
CAT #	DESCRIPTION	QTY
DCN890075	CCN Pin 3/4" x .102" (Z)	1000
DCN8912075	CCN Pin 3/4" x .120" (Z)	1000
DCN891075	CCN Pin 3/4" x .145" (Z)	1000
DCN890100	CCN Pin 1" x .102" (Z)	1000
DCN890125	CCN Pin 1-1/4" x .102" (Z)	1000
DCN890150	CCN Pin 1-1/2" x .102" (Z)	1000
DCN890225	CCN Pin 2-1/4" x .137" (T Z)	500



STEEL PINS		
CAT #	DESCRIPTION	QTY
DCN8910500	CCN PIN 1/2" x .120" (T Z)	1000



CONCRETE / STEEL / HYBRID PINS		
CAT #	DESCRIPTION	QTY
DCN8910680	CCN Pin .680" x .120" / .102" (S YZ)	1000
DCN8917300	CCN Pin .730" x .120" / .102" (S YZ)	1000
DCN8907804	CCN Pin .780" x .102" / .088" (K S Z)	1000
DCN8941380	CCN Pin 1-3/8" x .108" (K Z)	1000

K: Knurled S: Step T: Tapered Z: Zinc YZ: Yellow Zinc



ACCESSORIES	
CAT #	DESCRIPTION
DCN8901	Replacement Piston
DCN8902	Magnetic Stick-E™ Nose Piece
DCN8903	Stick-E™ Nose Piece
DCN8904	Standard / Drywall Nose Piece
DCN8905	Pole Tool
DCN8906	2-1/4" Magazine
DCN8907	1" Magazine

**DIRECT FASTENING**

**Cordless Concrete Nailing System**



**STICK-E WASHERS**



CAT #	DESCRIPTION	WASHER DIA	CTN	MSTR
DFD405101	Lathing Washer	1"	100	1000
DFD405100	Lathing Washer (Washer Only)	1"	100	1000
DFD405716	Insulation Washer	1-7/16"	100	1000
DFD405112	Strap Metal Washer	1/2"	100	1000
DFD405610	Square Washer	1"	100	1000
DFD405901	Fiberglass Sheathing Washer	1-1/4"	250	2500
DFD405102	Stainless Steel Sealing Washer	3/4"	100	1000

**STICK-E CEILING CLIP ASSEMBLIES**



CAT #	CLIP ANGLE	WIRE HOLE	CTN	MSTR
DFD405550	90°	5/16"	100	1000
DFD405530	60°	5/16"	100	1000

**STICK-E CONDUIT CLIP ASSEMBLIES**



CAT #	CABLE DIAMETER	CTN	MSTR
DFD405338	3/8"	100	1000

**STICK-E CONDUIT STRAP ASSEMBLIES**

CAT #	CONDUIT DIAMETER	CTN	MSTR
DFD405312R	1/2"	100	1000
DFD405334R	3/4"	100	1000
DFD405310R	1"	100	1000

R = Ribbed

**STICK-E CONDUIT CLAMP ASSEMBLIES**

CAT #	CONDUIT DIAMETER	CTN	MSTR
DFD405412	1/2"	50	200
DFD405434	3/4"	50	200
DFD405410	1"	50	100

**STICK-E ROD HANGING ASSEMBLIES**



**STICK-E ROD HANGER CLIPS**

CAT #	ROD DIAMETER	CTN	MSTR
DFD405214	1/4"	100	1000
DFD405238	3/8"	100	1000

**STICK-E CEILING CLIPS WITH POST NUT**

CAT #	ROD DIAMETER	CTN	MSTR
DFD405215	1/4"	100	1000
DFD405239	3/8"	100	1000

**OTHER STICK-E ASSEMBLIES**



**STICK-E REBAR CLIP**

CAT #	REBAR SIZE	CTN	MSTR
DFD405300	#3	100	1000

**STICK-E CABLE TIE DONUT**

CAT #	DIAMETER	CTN	MSTR
DFD405902	1-1/4"	100	1000

**STICK-E BRIDLE RING ASSEMBLIES**

CAT #	DIAMETER	CTN	MSTR
55094-PWR	1-1/4"	100	1000
55096-PWR	2"	100	1000



**SELECTION GUIDE**

	Dimensions		Base				DEWALT Tools										Other Tools					ICC-ES Approvals			
	Shank Length	Shank Diameter	Concrete	Lightweight Concrete	Grout-filled CMU	Steel	DFD270	P1000	T1000	P2201	P35s	P3500/PA3500	P3600	Sniper	SA270	Cobra	Viper / Viper 4	XT540	DX35	DX351	DX2		DX460 / DX5		
<b>Pins</b>	<b>Spiral CSI Drive Pins</b>	1/2" to 1-1/2"	0.157"	●	○	○	●	●	●	●	○	●		●	●	●	●	●	●	●	●	●	●	ESR-2024	
	<b>Spiral CSI Drive Pins</b>	2" to 2-7/8"	0.157"	●	○	○	●	●	●	●	●			●				●	●	●	●	●	●	ESR-2024	
	<b>Spiral CSI Drive Pins Collated</b>	5/8" to 2"	0.157"					●							●			●		○		●		ESR-2024	
	<b>Spiral CSI Drive Pins with Washer</b>	3/4" to 2-7/8"	0.157"	●	○	○	●	●	●	●	●	○			●			○		●	●	●	●	●	ESR-2024
<b>0.300" Head Drive Pins</b>	<b>0.300" Head Drive Pins</b>	1/2" to 1-1/2"	0.145"	●	●	○	○	●	●	●	●	●		●	●	●	●	●	●	●	○	●	●	ESR-2024	
	<b>0.300" Head Drive Pins</b>	1-3/4" to 3"	0.145"	●	●	○		●	●	●	●	●		●				●		●	●	●	●	ESR-2024	
	<b>0.300" Head Drive Pins with Top Hat</b>	1/2" to 1"	0.145"	●	●	○	○	●	●	●	●	●		●	●	●	●	●	●	●	○	●	●	ESR-2024	
	<b>0.300" Head Drive Pins with Washer</b>	3/4" to 1-1/2"	0.145"	●	●	○	○	●	●	●	●	●		●	●	●	●	●	●	●	●	●	●	●	ESR-2024
	<b>0.300" Head Drive Pins with Washer</b>	2" to 3"	0.145"	●	●	○		●	●	●	●	●			●			●		●	●	●	●	●	ESR-2024
	<b>8mm Head Drive Pins</b>	<b>8mm Head Drive Pins with Top Hat</b>	5/8" to 1"	0.145"	●	●	○	○	●	●	●	●	●		●	●	●	●	●	●	●	●	●	●	ESR-2024
	<b>8mm Head Drive Pins with Washer</b>	1" to 1-1/2"	0.145"	●	●	○	○	●	●	●	●	●		●	●	●	●	●	●	●	●	●	●	ESR-2024	
	<b>8mm Head Drive Pins with Washer</b>	2" to 2-7/8"	0.145"	●	●	○	○	●	●	●	●	●			●			●		●	●	●	●	ESR-2024	
<b>Threaded Studs</b>	<b>1/4"-20 Threaded Studs</b>	1/2" to 1-1/4"	0.145"	●	●	○	●	●	●	●	●	●		●	●	●	●	●	●	●	●	●	●	ESR-2024	
	<b>3/8"-16 Threaded Studs</b>	3/4" to 1-1/4"	0.205"	●	●	○	●					●												ESR-2024	
<b>Rod Hangers</b>	<b>Rod Hangers and Post Nut Hangers (0.300", 8mm)</b>	1-1/8" to 1-1/4"	0.145"	●	●	○	○	●	●	●	○	●	●	●	●	●	●	●	●	●	●	●	●	ESR-2024	
<b>Clips &amp; Assemblies</b>	<b>Drive Pins with Ceiling Clip (0.300", 8mm)</b>	1" to 1-1/4"	0.145" 0.157"	●	●	○	○	●	●	●	●	●		●	●	●	●	●	●	●	●	●	●	ESR-2024	
	<b>Drive Pins with BX-EMT Conduit Clip (0.300", 8mm)</b>	1" to 1-1/4"	0.145"	●	●	○	○	●	●	●	●	●		●	●	●	●	●	●	●	●	●	●		
	<b>Drive Pins with Rebar Basket Clip (8mm)</b>	2-7/16", 2-7/8"	0.145"	●	●	○	○	●	●	●	●	●			●	●		●		●	●	●	●		

● Suitable ○ May Be Suitable

	Load Power					DEWALT Tools							Examples of Other Tools*										
	Gray-Level 1	Brown-Level 2	Green-Level 3	Yellow-Level 4	Red-Level 5	P1000 / T1000	P2201	P35s	P3500/PA3500	P3600	Sniper	DFD270	SA270	Cobra / Cobra+	Viper / Viper 4	DX E37	DX600N	DX35	DX351	DX460 / DX5	DX2		
<b>Loads</b>	<b>.22 Caliber Single (Short) Loads</b>	●	●	●	●		●	●								●							
	<b>.27 Caliber Single (Long) Loads</b>					●											●						
	<b>.25 Caliber 10-Load Strip</b>			●	●	●		●										●					
	<b>.27 Caliber 10-Load Safety Strip</b>		●	●	●	●			●	●	●	●	●	●	●	●					●	●	●

\* The indicated powder loads are generally compatible for form and fit in the examples given.



**POWDER ACTUATED**

**P1000 Tool**

Description	Hammer-Actuated Semi-Automatic Powder-Actuated Tool Tool Length: 13" Tool Weight: 3.0 lbs.
Load Type	.22 Caliber (Short) Loads Gray (1), Brown (2), Green (3), Yellow (4)
Pin Type	0.300" and 8mm Head Drive Pins, 1/4"-20 Threaded Studs
Pin Length	1/2" – 3"



P1000			
CAT #	DESCRIPTION	CTN	MSTR
DDF211000P	P1000 (Blister Pack)	1	10

ACCESSORIES		PAGE
DESCRIPTION		
0.300" Head Drive Pins		75
8mm Head Drive Pins		76
1/4"-20 Threaded Studs		77
.22 Caliber Single Loads		74

**T1000 Tool**

Description	Trigger-Actuated Semi-Automatic Powder-Actuated Tool Tool Length: 13" Tool Weight: 3.0 lbs.
Load Type	.22 Caliber (Short) Loads Gray (1), Brown (2), Green (3), Yellow (4)
Pin Type	0.300" and 8mm Head Drive Pins, 1/4"-20 Threaded Studs
Pin Length	1/2" – 3"



P1000			
CAT #	DESCRIPTION	CTN	MSTR
DDF211010P	T1000 (Blister Pack)	1	10

ACCESSORIES		PAGE
DESCRIPTION		
0.300" Head Drive Pins		75
8mm Head Drive Pins		76
1/4"-20 Threaded Studs		77
.22 Caliber Single Loads		74

**P2201 Tool**

Description	Trigger-Actuated Semi-Automatic Powder-Actuated Tool Tool Length: 12-1/2" Tool Weight: 4.3 lbs.
Load Type	.22 Caliber (Short) Loads Gray (1), Brown (2), Green (3), Yellow (4)
Pin Type	0.300" and 8mm Head Drive Pins, 1/4"-20 Threaded Studs
Pin Length	1/2" – 3"



P35s			
CAT #	DESCRIPTION	CTN	MSTR
DDF211022P	P2201 (Blister Pack)	1	10

ACCESSORIES			
CAT #	DESCRIPTION	QTY	PAGE
52522	Replacement Driver Piston for P2201	1	
52510	Replacement Nose Piece for P2201	1	
52512	Replacement Piston Reset Pins for P2201	1	
	0.300" Head Drive Pins		75
	8mm Head Drive Pins		76
	1/4"-20 Threaded Studs		77
	.22 Caliber Single Loads		74

**Powder Actuated Tool Operation:** Powder actuated tools may be used only by properly trained and licensed operators as described in ANSI Standard A 10.3. For complete tool operation details, completely review the tool manual and contact your local DEWALT branch office or distributor for training.



**POWDER ACTUATED**

**P35s Tool**

Description	Trigger-Actuated Semi-Automatic Powder-Actuated Tool Tool Length: 11-1/4" Tool Weight: 4.3 lbs.
Load Type	.25 Caliber Load Strips Green (3), Yellow (4), Red (5)
Pin Type	0.300" and 8mm Head Drive Pins, 1/4"-20 Threaded Studs
Pin Length	1/2" – 1-1/2"



P35s			
CAT #	DESCRIPTION	CTN	MSTR
52002	P35s (Deluxe Kit)	1	-

ACCESSORIES			
CAT #	DESCRIPTION	QTY	PAGE
50065	6' Pole Tool	1	-
50066	8' Pole Tool	1	-
52200	Replacement Driver Piston for P35s	1	-
52204	Replacement Guide for P35s	1	-
52206	Replacement Baseplate for P35s	1	-
	0.300" Head Drive Pins		75
	8mm Head Drive Pins		76
	1/4"-20 Threaded Studs		77
	.25 Caliber Strip Loads		74

**P3500 Tool**

Description	Trigger-Actuated Semi-Automatic Powder-Actuated Tool Tool Length: 13-5/8" Tool Weight: 5.0 lbs.
Load Type	.27 Caliber (Short) Load Safety Strips Brown (2), Green (3), Yellow (4), Red (5)
Pin Type	0.300" and 8mm Head Drive Pins, 1/4"-20 Threaded Studs
Pin Length	1/2" – 3"



P3500			
CAT #	DESCRIPTION	CTN	MSTR
DDF212035P	P3500 (Blister Pack)	1	-
52000	P3500 (Deluxe Kit)	1	-

ACCESSORIES			
CAT #	DESCRIPTION	QTY	PAGE
50065	6' Pole Tool	1	-
50066	8' Pole Tool	1	-
52102	Replacement Driver Piston for P3500 (for .300" Head Drive Pins)	1	-
52100	Replacement Driver Piston for P3500 (for 8mm Head Drive Pins)	1	-

CAT #	DESCRIPTION	QTY	PAGE
52108	Replacement Guide for P3500, PA3500	1	-
52110	Replacement Baseplate for P3500, PA3500	1	-
52120	Replacement Shear Clip for P3500, PA3500	1	-
52112	Replacement Piston Stop for P3500, PA3500, P3600	1	-
52122	Replacement Steel Annular Ball for P3500, PA3500	1	-
52106	Replacement Piston Ring for P3500	1	-
<i>Limited Access Accessories for Applications in Tight Areas:</i>			
52114	Limited Access Guide for P3500, PA3500	1	-
52116	Limited Access Baseplate for P3500, PA3500	1	-
	0.300" Head Drive Pins		75
	8mm Head Drive Pins		76
	1/4"-20 Threaded Studs		77
	.27 Caliber Load Safety Strips		74

**PA3500 Tool**

Description	Trigger-Actuated Semi-Automatic Powder-Actuated Tool with Adjustable Power Tool Length: 13-5/8" Tool Weight: 5.0 lbs.
Load Type	.27 Caliber (Short) Load Safety Strips Brown (2), Green (3), Yellow (4), Red (5)
Pin Type	0.300" and 8mm Head Drive Pins, 1/4"-20 Threaded Studs
Pin Length	1/2" – 3"



PA3500			
CAT #	DESCRIPTION	CTN	MSTR
52019	PA3500 (Deluxe Kit)	1	-

ACCESSORIES			
CAT #	DESCRIPTION	QTY	PAGE
50065	6' Pole Tool	1	-
50066	8' Pole Tool	1	-
52103	Replacement Driver Piston for PA3500 (for .300" Head Drive Pins)	1	-
52108	Replacement Guide for P3500, PA3500	1	-
52110	Replacement Baseplate for P3500, PA3500	1	-
52120	Replacement Shear Clip for P3500, PA3500	1	-
52112	Replacement Piston Stop for P3500, PA3500, P3600	1	-
52122	Replacement Steel Annular Ball for P3500, PA3500	1	-
<i>Limited Access Accessories for Applications in Tight Areas:</i>			
52114	Limited Access Guide for P3500, PA3500	1	1
52116	Limited Access Baseplate for P3500, PA3500	1	1
	0.300" Head Drive Pins		75
	8mm Head Drive Pins		76
	1/4"-20 Threaded Studs		77
	.27 Caliber Load Safety Strips		74

**Powder Actuated Tool Operation:** Powder actuated tools may be used only by properly trained and licensed operators as described in ANSI Standard A 10.3. For complete tool operation details, completely review the tool manual and contact your local DEWALT branch office or distributor for training.

**GUARANTEED TOUGH.**

**POWDER ACTUATED**

**P3600 Tool**

Description	Trigger-Actuated Semi-Automatic Powder-Actuated Tool Tool Length: 13-5/8" Tool Weight: 5.0 lbs.
Load Type	.27 Caliber (Short) Load Safety Strips Brown (2), Green (3), Yellow (4), Red (5)
Pin Type	0.300" and 10mm Head Drive Pins, 3/8" Head Drive Pins, 3/8" Threaded Studs
Pin Length	1/2" – 3"



P3600			
CAT #	DESCRIPTION	CTN	MSTR
52010	3600 (Deluxe Kit)	1	-

**ACCESSORIES**

CAT #	DESCRIPTION	QTY	PAGE
50065	6' Pole Tool	1	-
50066	8' Pole Tool	1	-
52578	Replacement Driver Piston for P3600	1	-
52579	Replacement Guide for P3600	1	-
52112	Replacement Piston Stop for P3500, PA3500, P3600	1	-
	3/8"-16 Threaded Studs		77
	.27 Caliber Load Safety Strips		74

**Sniper™ Tool**

Description	Bump-Fire Powder-Actuated Tool for Over-head Applications Tool Length: 17" Tool Weight: 4.0 lbs.
Load Type	.27 Caliber (Short) Load Safety Strips Brown (2), Green (3), Yellow (4), Red (5)
Pin Type	0.300" and 8mm Head Drive Pins
Pin Length	1/2" – 1-1/2"



SNIPER TOOL			
CAT #	DESCRIPTION	CTN	MSTR
52051	Sniper (Deluxe Kit)	1	-

**ACCESSORIES**

CAT #	DESCRIPTION	QTY	PAGE
52053	6' Pole Tool for Sniper Tool	1	-
52061	8' Pole Tool for Sniper Tool	1	-
	0.300" Head Drive Pins		75
	8mm Head Drive Pins		76
	.27 Caliber Load Safety Strips		74

**DFD270 Tool**

Description	Trigger-Actuated Fully-Automatic Powder-Actuated Tool Tool Length: 18" Tool Weight: 7.1 lbs.
Load Type	.27 Caliber (Short) Load Safety Strips Brown (2), Green (3), Yellow (4), Red (5)
Pin Type	0.300" and 8mm Head Drive Pins, 1/4"-20 Threaded Studs
Pin Length	1/2" to 2-7/8"



P35s			
CAT #	DESCRIPTION	CTN	MSTR
DFD270SK	DFD270 (Single Shot Kit)	1	-
DFD270MK	DFD270 (Magazine and Single Shot Kit)	1	-



**ACCESSORIES**

CAT #	DESCRIPTION	QTY	PAGE
DFD2701	Driver Piston for DFD270 (for .300" Head Drive Pins)	1	-
DFD2705	Driver Piston for DFD270 (for 8mm Head Drive Pins)	1	-
DFD2702	Single Shot Nose Piece for DFD270	1	-
DFD2703	Magazine Nose Piece for DFD270	1	-
DFD2704	Cleaning Kit for DFD270	1	-
	0.300" Head Drive Pins		75
	8mm Head Drive Pins		76
	1/4"-20 Threaded Studs		77
	.27 Caliber Safety Strip Loads		74



**DIRECT FASTENING 73**



**POWDER  
ACTUATED**

**Accessories**

ACCESSORIES			CAT #	DESCRIPTION	CTN
52018	5mm Allen Wrench	1	52070	Tool Cleaning Kit (P3500 / P35s)	1
52024	5/32" Allen Wrench	1	52072	Tool Cleaning Kit (P2200)	1
52034	Spray Lubricant	1	50065	6' Di-Electric Pole Tool Fits: P35s, P3500, PA3500, P3600	1
			50066	8' Di-Electric Pole Tool Fits: P35s, P3500, PA3500, P3600	1



**PAT POWDER  
LOADS**

**Powder Loads**



**.22 CALIBER (SHORT) LOADS**

CAT #	SIZE	POWER LEVEL	CTN	MSTR
50502	.22 Short	Brown (2)	100	10,000
50504	.22 Short	Green (3)	100	10,000
50506	.22 Short	Yellow (4)	100	10,000

**.27 CALIBER (LONG) LOADS**

CAT #	SIZE	POWER LEVEL	CTN	MSTR
50612	.27 Long	Red (5)	100	10,000

**.25 CALIBER STRIP LOADS**

CAT #	SIZE	POWER LEVEL	CTN	MSTR
50570	.25 strip	Green (3)	100	10,000
50574	.25 strip	Yellow (4)	100	10,000
50578	.25 strip	Red (5)	100	10,000

**.25 CALIBER STRIP LOADS (BULK)**

50572	.25 strip	Green (3)	1,000	10,000
50576	.25 strip	Yellow (4)	1,000	10,000
50580	.25 strip	Red (5)	1,000	10,000

**.27 CALIBER STRIP LOADS**

CAT #	SIZE	POWER LEVEL	BOX	CTN	MSTR
50620	.27 Safety Strip	Brown (2)	100	10,000	-
50622	.27 Safety Strip	Green (3)	100	10,000	-
50626	.27 Safety Strip	Yellow (4)	100	10,000	-
50630	.27 Safety Strip	Red (5)	100	10,000	-

**.27 CALIBER STRIP LOADS (BULK)**

50624	.27 Safety Strip	Green (3)	-	1,000	10,000
50628	.27 Safety Strip	Yellow (4)	-	1,000	10,000
50632	.27 Safety Strip	Red (5)	-	1,000	-

**GUARANTEED TOUGH.**

**POWDER ACTUATED**

**0.300" Head Drive Pins**

Type	Fasteners for Powder Actuated Tools
Approvals	ICC-ES ESR-2024 (Concrete)
	
Description	<p>For permanent fastening</p> <p>Knurled shank for increased performance in steel base materials</p> <p>Top hat pins for fastening drywall track to concrete or steel. Top hat provides extra bearing surface against the drywall track.</p> <p>Washed pins provide resistance to pullover. Pre-assembled with 14 gauge metal washers.</p> <p>Mechanically galvanized pins for fastening through pressure treated lumber. Available with washer for increased pullover resistance</p>
Base Materials	Concrete, some types of masonry and A36 structural steel

K = Knurled  
BO = Black Oxide



**0.300" HEAD DRIVE PINS**

CAT #	SIZE	HEAD DIA	SHANK DIA	CTN	MSTR
50012	1/2" (K)	0.300"	.145"	100	5000
50016	5/8" (K)	0.300"	.145"	100	5000
50022	3/4"	0.300"	.145"	100	5000
50023	3/4" (BO)	0.300"	.145"	100	5000
50026	1"	0.300"	.145"	100	5000
50032	1-1/4"	0.300"	.145"	100	1000
50034	1-1/2"	0.300"	.145"	100	1000
50038	2"	0.300"	.145"	100	1000
50040	2-1/4"	0.300"	.145"	100	1000
50044	2-1/2"	0.300"	.145"	100	1000
50048	3"	0.300"	.145"	100	1000



**0.300" DIAMETER HEAD DRIVE PINS (MECHANICALLY GALVANIZED)**

CAT #	SIZE	HEAD DIA	SHANK DIA	CTN	MSTR
50034MG	1-1/2"	0.300"	.145"	100	1000
50038MG	2"	0.300"	.145"	100	1000
50045MG	2-1/2"	0.300"	.145"	100	1000
50047MG	3"	0.300"	.145"	100	1000



**0.300" DIAMETER HEAD DRIVE PINS WITH TOP HAT**

CAT #	SIZE	HEAD DIA	SHANK DIA	CTN	MSTR
50136	1/2" (K)	0.300"	.145"	100	5000
50138	5/8" (K)	0.300"	.145"	100	5000
50140	3/4"	0.300"	.145"	100	5000
50144	1"	0.300"	.145"	100	5000



**0.300" DIAMETER HEAD BALLISTIC POINT DRIVE PINS**

CAT #	SIZE	HEAD DIA	SHANK DIA	CTN	MSTR
50057	1-7/8"	0.300"	.181/.150"	100	1000

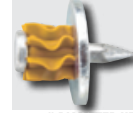

**0.300" DIAMETER HEAD DRIVE PINS WITH 3/4" WASHER**

CAT #	SIZE	HEAD DIA	SHANK DIA	CTN	MSTR
50070	3/4"	0.300"	.145"	100	1000

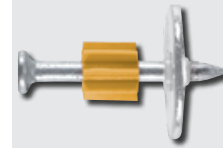

**0.300" DIAMETER HEAD DRIVE PINS WITH 7/8" WASHER**

CAT #	SIZE	HEAD DIA	SHANK DIA	CTN	MSTR
50090	1"	0.300"	.145"	100	1000
50092	1-1/4"	0.300"	.145"	100	1000
50094	1-1/2"	0.300"	.145"	100	1000
50096	2"	0.300"	.145"	100	1000
50098	2-1/2"	0.300"	.145"	100	1000
50100	3"	0.300"	.145"	100	1000

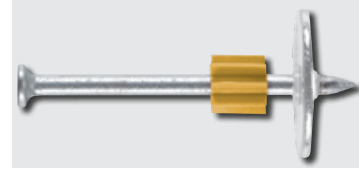

**0.300" DIAMETER HEAD DRIVE PINS WITH 1" WASHER**

CAT #	SHANK LEN	WASHER TYPE	HEAD DIA	SHANK DIA	CTN	MSTR
50120	3"	1" square	0.300"	.145"	100	1000
50108	1-1/4"		0.300"	.145"	100	1000
50110	1-1/2"		0.300"	.145"	100	1000
50112	2"		0.300"	.145"	100	1000
50114	2-1/2"		0.300"	.145"	100	1000
50116	3"		0.300"	.145"	100	1000

**0.300" DIAMETER HEAD DRIVE PINS WITH 1" WASHER (MECHANICALLY GALVANIZED)**

CAT #	SIZE	HEAD DIA	SHANK DIA	CTN	MSTR
50110MG	1-1/2"	.300	.145	100	1000
50112MG	2"	.300	.145	100	1000
50113MG	2-1/2"	.300	.145	100	1000
50115MG	3"	.300	.145	100	1000

**0.300" DIAMETER HEAD DRIVE PINS WITH 1-7/8" INSULATION WASHER**

CAT #	SHANK LEN	HEAD DIA	SHANK DIA	CTN	MSTR
50122	1-1/2"	0.300"	.145"	100	1000
50126	2-1/2"	0.300"	.145"	100	1000

**DIRECT FASTENING 75**



**POWDER  
ACTUATED**

**CSI Spiral and 8mm Head Drive Pins**

Type Fasteners for Powder Actuated Tools

Approvals ICC-ES ESR-2024 (Concrete)



Description For permanent fastening  
Knurled shank for increased performance in steel base materials  
Top hat pins for fastening drywall track to concrete or steel. Top hat provides extra bearing surface against the drywall track.  
Washer pins provide resistance to pullover. Pre-assembled with 14 gauge metal washers.  
CSI Spiral (Concrete, Steel and I-Beam) pins have a knurled shank for consistent optimized performance in steel base materials

Base Materials Concrete, some types of masonry and A36 or A572 structural steel

K = Knurled  
MG = Mechanically Galvanized



**CSI SPIRAL DRIVE PINS (8MM HEAD DIAMETER)**

CAT #	SIZE	HEAD DIA	SHANK DIA	CTN	MSTR
50178	13mm (1/2")	8mm	.145"	100	1000
50181	16mm (5/8")	8mm	.145"	100	1000
51201	16mm (5/8")	8mm	.157"	100	1000
50203	19mm (3/4")	8mm	.157"	100	1000
50204	22mm (7/8")	8mm	.157"	100	1000
50205	27mm (1")	8mm	.157"	100	1000
50208	32mm (1-1/4")	8mm	.157"	100	1000
50207	37mm (1-1/2")	8mm	.157"	100	1000
50209	52mm (2")	8mm	.157"	100	1000
50241	62mm (2-1/2")	8mm	.157"	100	1000
50211	72mm (2-7/8")	8mm	.157"	100	1000



**CSI SPIRAL DRIVE PINS WITH WASHER (8MM HEAD DIAMETER)**

CAT #	SIZE	HEAD DIA	SHANK DIA	WASHER	CTN	MSTR
50245	3/4" (19mm)	8mm	.157"	3/4"	100	1000
50247	1" (27mm)	8mm	.157"	3/4"	100	1000
50261	1-1/4" (32mm)	8mm	.157"	1"	400	1000
50263	2-1/2" (62mm)	8mm	.157"	1"	400	1000
50265	2-7/8" (72mm)	8mm	.157"	1"	400	1000



**CSI SPIRAL DRIVE PINS COLLATED (8MM HEAD DIAMETER)**

CAT #	SHANK LEN	HEAD DIA	SHANK DIA	CTN	MSTR
50238N	13mm (1/2")	8mm	.145"	100	1000
50241N	16mm (5/8")	8mm	.145"	100	1000
51450	16mm (5/8") (K)	8mm	.157"	100	1000
50452	19mm (3/4") (K)	8mm	.157"	100	1000
50454	22mm (7/8") (K)	8mm	.157"	100	1000
50456	27mm (1") (K)	8mm	.157"	100	1000

**CSI SPIRAL10-FASTENER COLLATION**

CAT #	SHANK LEN	HEAD DIA	SHANK DIA	CTN	MSTR
50458	32mm (1-1/4") (K)	8mm	.157"	100	1000
50460	37mm (1-1/2") (K)	8mm	.157"	100	1000
50461	42mm (1-5/8") (K)	8mm	.157"	100	1000
50462	52mm (2") (K)	8mm	.157"	100	1000
50463	62mm (2-1/2") (K)	8mm	.157"	100	1000



**8MM DIAMETER HEAD DRIVE PINS WITH TOP HAT**

CAT #	SHANK LEN	HEAD DIA	SHANK DIA	CTN	MSTR
50210	16mm (5/8") (K)	8mm	.145"	100	5000
50214	22mm (7/8")	8mm	.145"	100	5000
50216	27mm (1")	8mm	.145"	100	5000



**8MM DIAMETER HEAD DRIVE PINS WITH 1" WASHER**

CAT #	SHANK LEN	HEAD DIA	SHANK DIA	CTN	MSTR
50220	27mm (1")	8mm	.145"	100	1000
50222	32mm (1-1/4")	8mm	.145"	100	1000
50224	37mm (1-1/2")	8mm	.145"	100	1000
50226	52mm (2")	8mm	.145"	100	1000
50228	62mm (2-1/2")	8mm	.145"	100	1000
50230	72mm (2-7/8")	8mm	.145"	100	1000
50229	72mm (2-7/8") MG	8mm	.145"	100	1000



**GUARANTEED TOUGH.®**

**POWDER ACTUATED**

**Threaded Studs**

**Type** Fasteners for Powder Actuated Tools

**Approvals** ICC-ES ESR-2024 (Concrete)  

**Description** Removeable  
Accommodates shimming  
Knurled shank for increased performance in steel base materials

**Base Materials** Concrete and A36 structural steel



**1/4"-20 THREADED STUDS (UNC THREAD)**

CAT #	THREAD LEN	SHANK LEN	THREAD DIA	SHANK DIA	CTN	MSTR
50322	3/4"	1/2" (K)	1/4"	.145"	100	1000
50326	3/4"	3/4"	1/4"	.145"	100	1000
50328	1/2"	1"	1/4"	.145"	100	1000
50330	3/4"	1"	1/4"	.145"	100	1000
50336	3/4"	1-1/4"	1/4"	.145"	100	1000
50338	1-1/4"	1-1/4"	1/4"	.145"	100	1000



**3/8"-16 THREADED STUDS (UNC THREAD)**

CAT #	THREAD LEN	SHANK LEN	THREAD DIA	SHANK DIA	CTN	MSTR
50340	1-1/4"	3/4" (K)	3/8"	.205"	100	1000
50342	1-1/4"	1"	3/8"	.205"	100	1000
50344	1-1/4"	1-1/4"	3/8"	.205"	100	1000

K = Knurled

**Hammer Drive Pins**

**Type** Fasteners for Standard Hand Tools

**Description** Permanent Fastening  
Not to be used in a powder actuated tool  
Washer mounted over point retains the pin in the fastener guide of the tool during driving

**Base Materials** Concrete and some types of masonry



**1/4" HAMMER DRIVE PINS**

CAT #	SHANK LEN	HEAD DIA	SHANK DIA	CTN	MSTR
50294	3/4"	1/4"	.140"	100	5000
50296	1"	1/4"	.140"	100	5000
50298	1-1/4"	1/4"	.140"	100	1000



**HAMMER DRIVE SETTING TOOL**

CAT #	CTN	MSTR
50310	1	11

**ACCESSORIES**

TYPE	PAGE
Hammer	refer to page

K = Knurled

**PAT ASSEMBLIES**

**Ceiling Clip Assemblies**

**Type** Drive Pins Pre-assembled with Stamped Steel Clips

**Approvals** ICC-ES ESR-2024 (Concrete)  

**Description** For suspending acoustical ceiling systems or light fixtures  
A dome mechanism or top hat holds the pin in the clip

**Base Materials** Concrete and some types of masonry



**0.300" HEAD DRIVE PINS WITH CEILING CLIPS**

CAT #	SHANK LEN	HEAD DIA	SHANK DIA	WIRE HOLE	CTN	MSTR
50364	1"	0.300"	.145"	0.278"	100	1000
50368†	1-1/8"	0.300"	.145"	0.278"	100	1000
50370	1-1/4"	0.300"	.145"	0.278"	100	1000
50374	1-1/4"	0.300"	.145"	.0278	100	1000



**0.300" HEAD DRIVE PINS WITH EXTENDED LENGTH CEILING CLIPS**

CAT #	SHANK LEN	HEAD DIA	SHANK DIA	WIRE HOLE	CTN	MSTR
DFD3373	1"	0.300"	.145"	0.278"	100	1000
DFD3374	1-1/8"	0.300"	.145"	0.278"	100	1000
50366	7/8"	0.300"	.150	0.313"	100	1000



**8MM HEAD DRIVE PINS WITH CEILING CLIPS**

CAT #	SHANK LEN	CLIP ANGLE	HEAD DIA	SHANK DIA	WIRE HOLE	CTN	MSTR
50272	27mm	90°	8mm	.145"	0.278"	100	1000
50274	32mm	90°	8mm	.145"	0.278"	100	1000
50206	37mm	90°	8mm	.177"	0.313"	100	1000



**CSI SPIRAL DRIVE PINS WITH CEILING CLIPS**

CAT #	SHANK LEN	CLIP ANGLE	HEAD DIA	SHANK DIA	WIRE HOLE	CTN	MSTR
50212	7/8" (22mm) TH	90°	8mm	.157"	0.313"	100	1000
50213	1" (27mm) TH	90°	8mm	.157"	0.313"	100	1000
50218	1-1/4" (32mm) TH	90°	8mm	.157"	0.313"	100	1000



**BALLISTIC POINT DRIVE PINS WITH CEILING CLIPS**

CAT #	SHANK LEN	CLIP ANGLE	HEAD DIA	SHANK DIA	WIRE HOLE	CTN	MSTR
50058	1-1/4"	60°	0.300"	.181/.150"	0.278"	100	1000
50366	7/8"		0.300"	.150"	0.313"	100	1000

† TH = Top Hat  
† 60° Angle Economy Clip

**DIRECT FASTENING 77**



**POWDER  
ACTUATED**

**BX & EMT Conduit Clip Assemblies**

Type	Drive pins pre-assembled with stamped steel Clips
Description	For the electrical trade, BX and EMT conduit clips are provided in various sizes for attaching conduit to base materials.
Base Materials	Concrete and some types of masonry

TH = Top Hat  
EMT = Electrical Metallic Tube



**0.300" HEAD DRIVE PINS WITH BX CABLE STRAPS**

CAT #	CLIP DIA	HEAD DIA	SHANK LEN	SHANK DIA	BOX	CTN
50150	3/8" BX	0.300"	1" TH	.145"	100	1000



**0.300" HEAD DRIVE PINS WITH CONDUIT CLIPS**

CAT #	CLIP DIA	SHANK LEN	HEAD DIA	SHANK DIA	BOX	CTN
50382	1/2" EMT	1"	.300"	.145"	100	1000
50384	3/4" EMT	1-1/4"	.300"	.145"	100	1000
50385	3/4" EMT	1" TH	.300"	.145"	100	1000
50386	3/4" EMT	1-1/8"	.300"	.145"	100	1000
50388	1" EMT	1" TH	.300"	.145"	25	250



**8MM HEAD DRIVE PINS WITH EMT CONDUIT CLIPS**

CAT #	CLIP DIA	SHANK LEN	HEAD DIA	SHANK DIA	BOX	CTN
50276	1/2" EMT	27mm TH	8mm	.145"	100	1000
50278	3/4" EMT	27mm TH	8mm	.145"	100	500
50280	1" EMT	27mm TH	8mm	.145"	25	250

**Rod Hanging Clip Assemblies**

Type	Drive pins pre-assembled with stamped steel clips
Description	For the mechanical, electrical, and plumbing trades, rod hanging clips are provided in various sizes for attaching threaded rod to base materials.
Base Materials	Concrete and some types of masonry

TH = Top Hat  
EMT = Electrical Metallic Tube  
XL = Extended Length



**CSI SPIRAL AND 8MM HEAD DRIVE PINS WITH ROD HANGER (UNC THREAD)**

CAT #	ROD DIA	SHANK LEN	SHANK DIA	BOX	CTN
50221	1/4"-20	32mm (1-1/4")	.145"	100	1000
50219	3/8"-16	32mm (1-1/4")	.145"	100	1000
50215	1/4"-20	32mm (1-1/4")	.157"	100	1000



**0.300" HEAD DRIVE PINS WITH POST NUT ROD HANGER (UNC THREAD)**

CAT #	ROD DIA	SHANK LEN	CLIP ANGLE	SHANK DIA	BOX	CTN
50376	1/4"-20	1-1/8"	90°	.145"	100	1000
50378	1/4"-20	1-1/4"	90°	.145"	100	1000
55379	3/8"	1-1/2"	90°	.157"	50	500



**0.300" HEAD DRIVE PINS WITH EXTENDED LENGTH POST NUT ROD HANGER (UNC THREAD)**

CAT #	ROD DIA	SHANK LEN	CLIP ANGLE	SHANK DIA	BOX	CTN
DFD3388	1/4"-20	1"	90°	.145"	50	500
DFD3389	1/4"-20	1-1/4"	90°	.145"	50	500

**Rebar/Dowel Basket Assemblies**

Type	Drive Pins Pre-assembled with Stamped Steel Clips
Description	Holds support baskets for reinforcing bars in place while the concrete is being poured. For #3 rebar and wire baskets.
Base Materials	Concrete and some types of masonry

TH = Top Hat

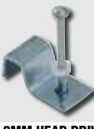

**8MM HEAD DRIVE PINS WITH REBAR/DOWEL BASKET CLIPS**

CAT #	DESCRIPTION	HEAD DIA	SHANK DIA	BOX	CTN
50704	37mm (1-1/2") TH	8mm	.145"	100	500
50712	52mm (2") TH	8mm	.145"	100	500
50716	62mm (2-1/2")	8mm	.145"	100	500
50718	72mm (2-7/8")	8mm	.145"	100	500

**Ceiling Clips Without Pins**

Type	90° Ceiling clips
Description	3/4" wide, 14 ga. thick Long leg: 1-1/4" long; 7/32" hole Short leg: 5/8" long; 5/16" hole



**CEILING CLIPS WITHOUT PINS**

CAT #	CLIP ANGLE	HOLE DIA	BOX	CTN
50400	90°	7/32" & 5/16"	100	1000



**GAS FASTENING** 80

**ROOFING** 82

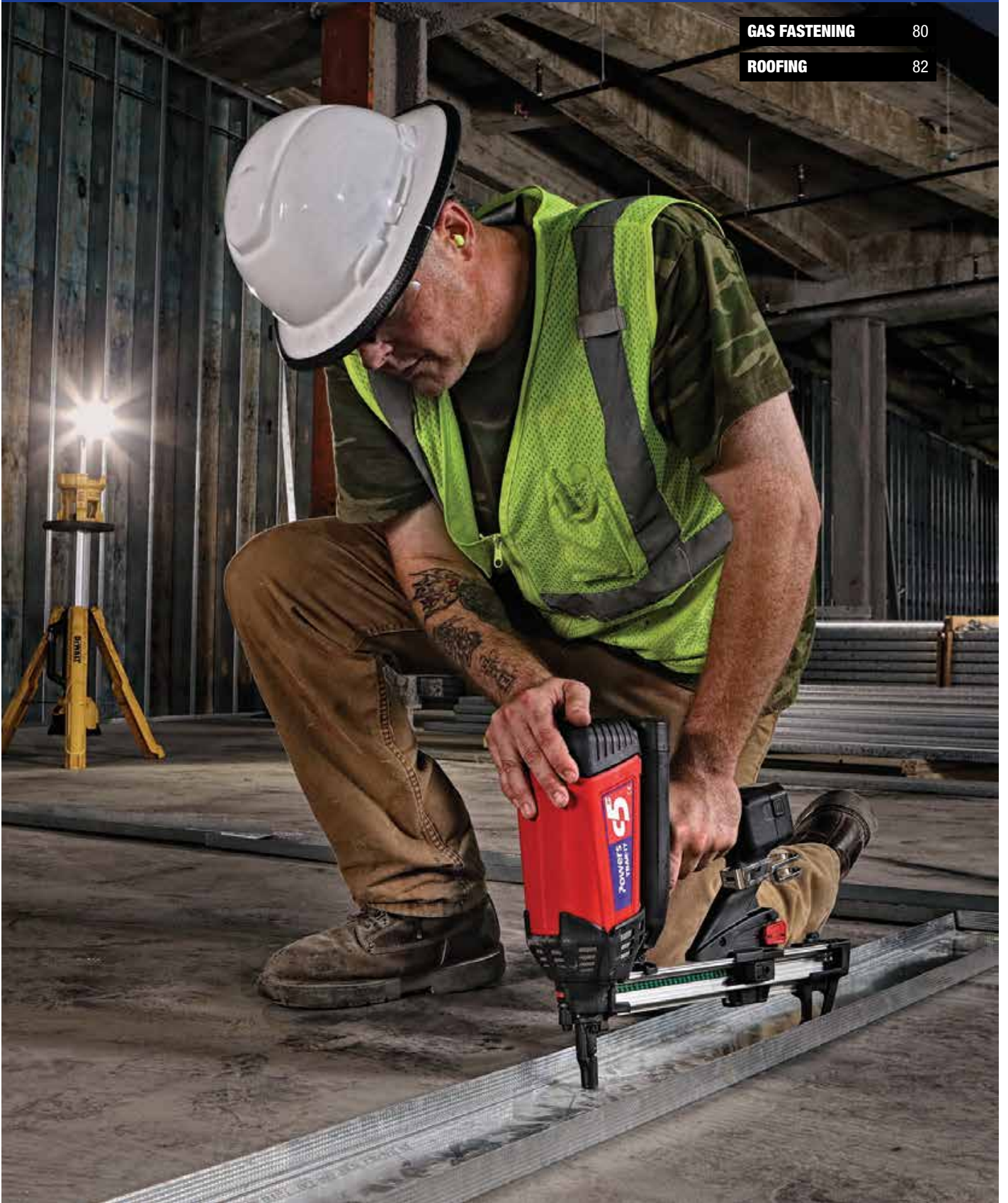



	Page	Dimensions		Base Material										ICC-ES Code Recognition				
		Diameter	Length	Concrete	High Strength / Concrete Concrete	Pre-cast Concrete	Lightweight Concrete	Lightweight Concrete On Metal Deck	Wood Sill Plate to Concrete	Grouted Concrete Masonry	Hollow Concrete Masonry	Brick Masonry	Plywood to Light Gauge Steel		A36/A572 Steel	Wood to Steel	Stick-E Accessories	
<b>Straight Pins (Smooth Shank)</b>	80	0.102"	3/4" - 1-1/2"	●						○	○	○					●	ESR-3275
<b>Straight Pins (Smooth Shank)</b>	80	0.120"	3/4"	●	●	●	●			●	●	●						
<b>Straight Pins (Smooth Shank)</b>	80	0.145"	3/4" - 1"	●	○	●	●			○	○		○					ESR-3275
<b>Step Shank Pins</b>	80	0.102" - 0.120"	1-1/2" - 0.780"															
<b>Step Shank Pins</b>	80	0.145"	7/8" - 1-1/2"	●	●					○	○							ESR-3275
<b>Stick-E Pins (Step Shank)</b>	81	0.120" - 0.088"	0.780"	●	○	●	●			●	●	○					●	
<b>Plywood to Steel Pins (Special Knurl Shank Rolled Point)</b>	XX	0.102"	1-3/8"										●				Denz-Glass Washer	

● Suitable ○ May be Suitable

### Trak-It® C5

Gas Fastening System

**BASE MATERIAL**

Concrete, Lightweight Concrete, Hollow and Grouted CMU, Masonry & Steel

The fuel injected Trak-It C5 cordless concrete pin nailer is the lightest and smallest tool in its class, resulting in less operator fatigue and a better overall ergonomic feel. C5 has a high power output at 105 Joules, which allows for shooting into even the hardest concrete. It is able to shoot pins .102, .108, .120 and .145 diameter pins up to 1-1/2" in length. Safety training and licencing not required to use this system.



**TRAK-IT C5 TOOL**

CAT #	DESCRIPTION	BOX	CTN
55142	Trak-It C5 Tool w/ Deep Track (1-1/4" Pin) - 42 Pin Capacity	1	-
55144	Trak-It C5 Tool w/ Short Track (1-1/2" Pin) - 22 Pin Capacity	1	-
55148	Trak-It C5 Tool w/ Long Track (1-1/2" Pin) - 42 Pin Capacity	1	-
55302	Trak-It C5 Fuel Cell	20	80
55583	Trak-It C5 Battery	1	-
55618	Trak-It C5 Charger Base	1	-
55619	Trak-It C5 110V Adapter Cord	1	-
56347	Trak-It C5 Pole Tool Full System	1	3
56348	Trak-It C5 Pole Tool 3' Extension	1	20
56342	Accessory Deep Track for Trak-It C5 (Up to 1-1/4" Pins - 42 Pin Capacity)	1	-
55346	Accessory Short Track for Trak-It C5 (Up to 1-1/2" Pins - 22 Pin Capacity)	1	-
56344	Accessory Long Track for Trak-It C5 (Up to 1-1/2" Pins - 42 Pin Capacity)	1	-

### Trak-It® C5 Pins



**CODE LISTED**  
ICC-ES ESR-3275

**TRAK-IT C5 STANDARD 0.102" STRAIGHT PINS**

CAT #	SHANK DIA.	LENGTH	STEP DIA.	FINISH	KNURL/ SPIRAL	BOX	CTN
55325	0.120"	1/2"	-	Zinc	-	800	4,000
55310	0.102"	3/4"	-	Zinc	-	800	4,000
55312	0.102"	1"	-	Zinc	-	800	4,000
55314	0.102"	1-1/4"	-	Zinc	-	800	4,000
55316	0.102"	1-1/2"	-	Zinc	-	800	4,000



**TRAK-IT C5 STANDARD 0.120" STRAIGHT PINS**

CAT #	SHANK DIA.	LENGTH	STEP DIA.	FINISH	BOX	CTN
55343	0.120", Tapered	3/4"	-	Zinc	800	4,000



**TRAK-IT C5 STANDARD 0.145" STRAIGHT PINS**

CAT #	SHANK DIA.	LENGTH	STEP DIA.	FINISH	KNURL/ SPIRAL	BOX	CTN
55318	0.145"	3/4"	-	Zinc	-	800	4,000
55320	0.145"	1"	-	Zinc	-	800	4,000



**TRAK-IT C5 STRUCTURAL CONCRETE AND STEEL PINS**

CAT #	SHANK DIA.	LENGTH	STEP DIA.	FINISH	KNURL/ SPIRAL	BOX	CTN
55336	0.145"	7/8"	0.120"	Zinc	K	800	4,000
55338	0.145"	1-1/8"	0.120"	Zinc	K	800	4,000
55322	0.145"	1-1/4"	0.102"	Zinc	-	800	4,000
55324	0.145"	1-1/2"	0.102"	Zinc	-	800	4,000



**TRAK-IT C5 SPECIALTY SHORT PINS**

CAT #	SHANK DIA.	LENGTH	STEP DIA.	FINISH	KNURL/ SPIRAL	BOX	CTN
55325	0.120"	1/2"	-	Zinc	-	800	4,000
55328	0.120"	0.680"	0.102"	Zinc	K	800	4,000
55330	0.120"	0.730"	0.102"	Zinc	K	800	4,000
55342	0.102"	0.780"	0.088"	Zinc	K	800	4,000



**TRAK-IT C5 SPECIALTY SPIRAL KURL PINS**

CAT #	SHANK DIA.	LENGTH	FINISH	KNURL/ SPIRAL	BOX	CTN
55340	0.108"	1-3/8"	Zinc	K	800	4,000



## STICK-E ASSEMBLIES

Stick-E assemblies are specially designed components for various fastening attachments into concrete, concrete masonry block and steel. They are used in conjunction with pins driven by the Trak-It C5 tools for various light duty applications.

### STICK-E WASHERS



CAT #	DESCRIPTION	WASHER DIAMETER	CTN	MSTR
DFD405101	Lathing Washer	1"	100	1000
DFD405100	Lathing Washer (Washer Only)	1"	100	1000
DFD405716	Insulation Washer	1-7/16"	100	1000
DFD405112	Strap Metal Washer	1/2"	100	1000
DFD405610	Square Washer	1"	100	1000
DFD405901	Fiberglass Sheathing Washer	1-1/4"	250	2500
DFD405102	Stainless Steel Sealing Washer	3/4"	100	1000



CAT #	CLIP ANGLE	WIRE HOLE	CTN	MSTR
DFD405550	90°	0.313"	100	1000
DFD405530	60°	0.313"	100	1000

### STICK-E CONDUIT CLIP ASSEMBLIES

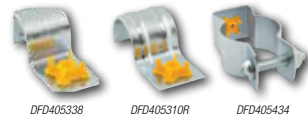

CAT #	CABLE DIAMETER	CTN	MSTR
DFD405338	3/8"	100	1000

### STICK-E CONDUIT STRAP ASSEMBLIES

CAT #	CONDUIT DIAMETER	CTN	MSTR
DFD405312R	1/2"	100	1000
DFD405334R	3/4"	100	1000
DFD405310R	1"	100	1000

R = Ribbed

### STICK-E CONDUIT CLAMP ASSEMBLIES

CAT #	CONDUIT DIAMETER	CTN	MSTR
DFD405412	1/2"	50	200
DFD405434	3/4"	50	200
DFD405410	1"	50	100

### STICK-E ROD HANGING ASSEMBLIES



CAT #	ROD DIAMETER	CTN	MSTR
DFD405214	1/4"	100	1000
DFD405238	3/8"	100	1000

### STICK-E CEILING CLIPS WITH POST NUT

CAT #	ROD DIAMETER	CTN	MSTR
DFD405215	1/4"	100	1000
DFD405239	3/8"	100	1000

### OTHER STICK-E ASSEMBLIES



CAT #	REBAR SIZE	CTN	MSTR
DFD405300	#3 (3/8")	100	1000

### STICK-E CABLE TIE DONUT

CAT #	DIAMETER	CTN	MSTR
DFD405902	1-1/4"	100	1000

### STICK-E BRIDLE RING ASSEMBLIES

CAT #	DIAMETER	CTN	MSTR
55094-PWR	1-1/4"	100	1000
55096-PWR	2"	100	1000



	Page	Base Material				Insulation Thickness														Coating/Material	
		Steel Deck	Wood Deck	Concrete Deck	Lightweight Concrete Deck	1"	2"	3"	4"	5"	6"	7"	8"	9"	10"	11"	12"	13"	14"	Perma-Seal Coated Carbon Steel	Galvalume
<b>Perma-Seal Roofing Spike</b>	82			●	○	●	●	●	●	●	●	●	●	●	●	●	●	●	●	●	●
<b>Deck Screws</b>	82	●	●			●	●	●	●	●	●	●	●	●	●	●	●	●	●	●	●
<b>Stress Plates</b>	83	Used with Roofing Spike & Deck Screws																			●

● Suitable ○ May be Suitable



### Roofing Spike

Roofing Anchor

BASE MATERIAL

Concrete

SIZE RANGE

1/4" x 1-1/4" to 1/4" x 14"

ANCHOR MATERIAL

Perma-Seal Coated Carbon Steel

For roofing applications, the Spike is a one-piece, vibration resistant anchor available for use to fasten insulation, single-ply membrane, wood, and metal to structural concrete roof decks. This version of the Spike has a Perma-Seal™ coating, and is designed for use in conjunction with Powers stress plates for insulation and membrane attachments.

#### PERMA-SEAL SPIKE

CAT #	ANCHOR SIZE	DRILL DIA.	MIN. EMBED.	BOX	CTN
3811	1/4" x 1-1/4"	1/4"	7/8"	500	-
3723	1/4" x 1-1/2"	1/4"	7/8"	500	-
3725	1/4" x 2"	1/4"	1-1/4"	500	-
3727	1/4" x 2-1/2"	1/4"	1-1/4"	500	-
3729	1/4" x 3"	1/4"	1-1/4"	500	-
3731	1/4" x 3-1/2"	1/4"	1-1/4"	500	-
3733	1/4" x 4"	1/4"	1-1/4"	500	-
3735	1/4" x 4-1/2"	1/4"	1-1/4"	500	-
3737	1/4" x 5"	1/4"	1-1/4"	500	-
3739	1/4" x 5-1/2"	1/4"	1-1/4"	500	-
3741	1/4" x 6"	1/4"	1-1/4"	250	-
3743	1/4" x 6-1/2"	1/4"	1-1/4"	250	-
3745	1/4" x 7"	1/4"	1-1/4"	250	-
3747	1/4" x 7-1/2"	1/4"	1-1/4"	250	-
3749	1/4" x 8"	1/4"	1-1/4"	250	-
3753	1/4" x 9"	1/4"	1-1/4"	250	-
3757	1/4" x 10"	1/4"	1-1/4"	250	-
3765	1/4" x 11"	1/4"	1-1/4"	100	-
3769	1/4" x 12"	1/4"	1-1/4"	100	-
3773	1/4" x 13"	1/4"	1-1/4"	100	-
3777	1/4" x 14"	1/4"	1-1/4"	100	-



#### SPIKE INSTALLATION TOOLS FOR ROOFING APPLICATIONS

CAT #	DESCRIPTION	GUIDE ID.	BOX
3790	SPIKE Driver 1000	1/2"	1



### Deck Screws

Roofing Anchor

BASE MATERIAL

Steel or Wood Deck

SIZE RANGE

No. 12 x 1-5/8" to No. 12 x 8"

ANCHOR MATERIAL

Perma-Seal Coated Carbon Steel

Deck Screws are designed for attaching rigid insulation board, single-ply membrane, and wood blocking to steel and wood decks. Available in carbon steel with a Perma-Seal™ coating. The deck screws are used in conjunction with insulation or membrane plates and can also be used with batten bar. For corrosion protection the screws are coated with Perma-Seal, which meets the requirements of FM Global Standard 4470.

#### PERMA-SEAL COATED NO.12 PH DECK SCREW

CAT #	SIZE	THREAD LENGTH	BOX	CTN
02613	No. 12 x 1-5/8"	1-1/2"	1000	-
02618	No. 12 x 2-1/4"	2"	1000	-
02624	No. 12 x 2-7/8"	2-5/8"	1000	-
02530	No. 12 x 3-1/4"	3"	1000	-
02632	No. 12 x 3-3/4"	3"	1000	-
02636	No. 12 x 4-1/2"	3"	1000	-
02640	No. 12 x 5"	3"	1000	-
02648	No. 12 x 6"	4"	1000	-
02656	No. 12 x 7"	4"	500	-
02664	No. 12 x 8"	4"	500	-

### Stress Plates

BASE MATERIAL

Insulation, Single-Ply Roofing Materials

SIZE RANGE

2" and 3" Round

ANCHOR MATERIAL

Galvalume Coated Carbon Steel Disk

Stress plates are designed for use with Deck Screws and Spike anchors. Stress plates can be grouped into two categories; insulation plates and membrane plates. Insulation plates, as the term implies, are used when mechanically attaching rigid foam insulation to roof decks. They are manufactured in a 3" diameter for use with No. 12 Deck Screws™ and 1/4" Spike anchors. For corrosion resistance, a Galvalume coating is applied to the carbon steel plates. Membrane plates, sometimes called lap plates, are used when mechanically attaching single ply material in the area of the lap or seam. They are manufactured in a 2" diameter for use with No. 12 Deck Screws and 1/4" Spike anchors.



INSULATION PLATES				
CAT #	SIZE	PLATE THICKNESS	MATERIAL	CTN
03880	3" round	.019"	Galvalume	500

MEMBRANE PLATES				
CAT #	SIZE	PLATE THICKNESS	MATERIAL	CTN
03878	2" round barbed	.034"	Galvalume	1000

**Stainless Steel Sealing Washers**

Stainless Steel Sealing Washers are typically used with 1/4" diameter anchors for roof flashing, termination bar and dissimilar metal applications.



SEALING WASHER TYPE 304 STAINLESS STEEL WITH EPDM SEAL			
CAT NO.	SIZE	BOX	CTN
2896	5/16" (ID) x 1-1/8" (OD)	100	1000



ROOFING



<b>DRILIT® DRILL SCREWS</b>	86
<b>TAPFAST®</b>	92
<b>ROOF CLIP FASTENERS</b>	92
<b>DRIL-FLEX®</b>	92
<b>TAP-FLEX®</b>	94
<b>ALUMI-FLEX®</b>	94
<b>BI-FLEX®</b>	95
<b>FAB-LOK®</b>	96
<b>CON-FLEX®</b>	96
<b>RAPIDSET TOOLS</b>	98



**Stalgard® High-Performance Protective Coatings**  
Provide consistent, high corrosion resistance

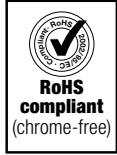

Stalgard® durable, multi-layer, corrosion-resistant coatings are engineered to provide optimal performance in demanding construction applications. These environmentally-friendly finishes are free of chromates and silicates and any process, like electroplating, that might induce hydrogen embrittlement, preventing structural failures.

- Maximizes fastener performance
- Salt spray at 1000+ hours with no red rust per ASTM B117
- Uniform thickness
- Low coefficient of friction – eliminates the need for post-coating lubricants to ease installation
- Does not use processes that introduce hydrogen – will not cause brittle failures like those caused by electroplating
- Durable tough finish – doesn't come off during handling
- Clean and dry – no oily residue
- Eliminates the plating process, resulting in a more environmentally-friendly product than those with plated zinc or other finishes
- Grey Stalgard is ACQ-compatible
- Maintains drilling and tapping performance

**STALGARD® Stalgard Coating for Induction Heat-Treated Fasteners**  
Outstanding Corrosion Protection

Proven, outstanding corrosion resistance for most construction applications, including metal and wood. Salt spray resistance: 1000 hours per ASTM B117. Available colors: silver and gray.

**STALGARD® GB Stalgard GB (Galvanic Barrier) Coating**  
Galvanic Barrier Corrosion Protection

Standard on all Elco stainless steel fasteners  
Prevents a galvanic reaction between the stainless steel and dissimilar application materials, which could lead to fastener and/or joint failure. Available color: Silver

**STALGARD® SUB Stalgard SUB Ultimate Barrier Coating**  
Ultimate Barrier Corrosion Protection

For more severely-corrosive environments. Salt spray 2,000 hours per ASTM B117. Available color: Silver



**Drilit® Standard Drill Screws**

Self-drilling fasteners in the most popular sizes

Self-drilling fasteners eliminate separate drilling and tapping operations for faster, more economical installations.

**Specifications**

- Diameters: #6 to 5/16"
- Lengths: 1/2" to 4"
- Drill Points: Drilit® forged
- Drive Systems: Hex and phillips
- Material: Carbon steel
- Finishes: Stalgard® coating or zinc

**Features & Benefits**

- ICC ESR-3294 available on some SKUs
- Eliminates separate drilling and tapping operations
- Fasteners coated with Stalgard finish typically show no red rust or other base metal corrosion on significant surfaces even after 1000 hours of 5% neutral salt spray exposure (per ASTM B117)

Cat #	Description	ICC Appr.	FM Appr.	Point	Finish	Ctn Qty	Ctn Wt	Case Qty	Case Wt
-------	-------------	-----------	----------	-------	--------	---------	--------	----------	---------



**#6 DIAMETER, 1/4" HEX WASHER HEAD**

EDA135-I-100	6-20 x 3/8	-	-	#2	Zinc	100	0.3	1000	3
EDA140-I-100	6-20 x 1/2	-	-	#2	Zinc	100	0.4	1000	4
EDA146-I-100	6-20 x 5/8	-	-	#2	Zinc	100	0.4	1000	4
EDA160-I-100	6-20 x 3/4	-	-	#2	Zinc	100	0.4	1000	4
EDA190-I-100	6-20 x 1	-	-	#2	Zinc	100	0.5	1000	5

Drill Screw Head Styles		Product Line
Hex Washer Head		Drilit® / Drilit® Flo-Seal® Drill Screws / Dril-Flex® / Bi-Flex® Alumi-Flex® / TapFast® / Tap-Flex®
Phillips Pan Head		Drilit® / Dril-Flex® / Bi-Flex®
Phillips Wafer Head		Drilit® Wood-to-Metal / Dril-Flex®
Phillips Flat Head		Drilit® Wood-to-Metal / Bi-Flex® Wood-to-Metal
Phillips Pancake Head		Architectural Roof Clip Fasteners / Bi-Flex®
Phillips Undercut Flat Head		Dril-Flex® / Bi-Flex® / Alumi-Flex®

**Point Size Selection**

Maximum Combined Material Thickness By Point Type

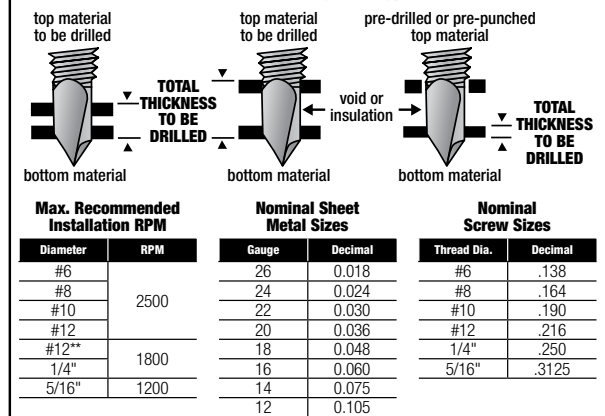

\*\* Applies to #12 diameter screws with point types 4, 4.5 and 5



Cat #	Description	ICC Appr.	FM Appr.	Point	Finish	Ctn Qty	Ctn Wt	Case Qty	Case Wt
-------	-------------	-----------	----------	-------	--------	---------	--------	----------	---------



**#8 DIAMETER, 1/4" HEX WASHER HEAD**

EDA235-I	8-18 x 1/2	-	-	#2	Zinc	10000	32.19	-	-
EDA235-I-100	8-18 x 1/2	-	-	#2	Zinc	100	0.4	1000	4
EDA236-I	8-18 x 1/2	-	-	#2	Stalgard®	10000	40	-	-
EDA236-I-100	8-18 x 1/2	-	-	#2	Stalgard®	100	0.4	1000	4
EDA250-I-100	8-18 x 5/8	-	-	#2	Zinc	100	0.4	1000	4
EDA260-I	8-18 x 3/4	-	-	#2	Zinc	8000	40	-	-
EDA260-I-100	8-18 x 3/4	-	-	#2	Zinc	100	0.5	1000	5
EDA261-I	8-18 x 3/4	-	-	#2	Stalgard®	8000	40	-	-
EDA261-I-100	8-18 x 3/4	-	-	#2	Stalgard®	100	0.5	1000	5
EDA285-I-100	8-18 x 1	-	-	#2	Zinc	100	0.5	1000	5
EDA286-I	8-18 x 1	-	-	#2	Stalgard®	5000	25	-	-
EDA290-I-100	8-18 x 1-1/4	-	-	#2	Zinc	100	0.8	1000	8
EDA295-I-100	8-18 x 1-1/2	-	-	#2	Zinc	100	0.9	1000	9



**#8 DIAMETER, #2 PHILLIPS PAN HEAD**

EDD251-I	8-18 x 1/2	-	-	#2	Stalgard®	10000	31.85	-	-
EDD251-I-100	8-18 x 1/2	-	-	#2	Stalgard®	100	3	1000	0.3
EDD266-I	8-18 x 3/4	-	-	#2	Stalgard®	10000	40	-	-
EDD291-I	8-18 x 1	-	-	#2	Stalgard®	8000	40	-	-



**#10 DIAMETER, 5/16" HEX WASHER HEAD**

EDA431-I-100	10-16 x 1/2	-	-	#2	Stalgard®	100	0.6	1000	6
EDB600-I-100	10-24 x 1/2	-	-	#2	Zinc	100	0.7	1000	7
EDB401-I	10-16 x 1/2	Y	-	#2	Stalgard®	5000	35	-	-
EDB401-I-100	10-16 x 1/2	Y	-	#2	Stalgard®	100	0.7	1000	7
EDB426-I	10-16 x 5/8	Y	-	#3	Stalgard®	6000	48	-	-
EDB426-I-100	10-16 x 5/8	Y	-	#3	Stalgard®	100	0.8	1000	8
EDC450-I	10-16 x 3/4	Y	Y	#1	Stalgard®	5000	40	-	-
EDC450-I-500	10-16 x 3/4	Y	Y	#1	Stalgard®	500	4	5000	40
EDB445-I-100	10-16 x 3/4	-	-	#3	Zinc	100	0.8	1000	8
EDB446-I	10-16 X 3/4	Y	Y	#3	Stalgard®	6000	42	-	-
EDB446-I-500	10-16 X 3/4	Y	Y	#3	Stalgard®	500	3.5	6000	42
EDB485-I	10-16 x 1	-	-	#3	Zinc	5000	45	-	-

Cat #	Description	ICC Appr.	FM Appr.	Point	Finish	Ctn Qty	Ctn Wt	Case Qty	Case Wt
-------	-------------	-----------	----------	-------	--------	---------	--------	----------	---------

EDB485-I-100	10-16 x 1	-	-	#3	Zinc	100	0.9	1000	9
EDB486-I	10-16 x 1	Y	-	#3	Stalgard®	5000	45	-	-
EDB486-I-100	10-16 x 1	Y	-	#3	Stalgard®	100	0.9	1000	9
EDB490-I-100	10-16 x 1-1/4	-	-	#3	Zinc	100	1	1000	10
EDB540-I	10-16 x 1-1/2	-	-	#3	Zinc	3000	36	-	-
EDB540-I-100	10-16 x 1-1/2	-	-	#3	Zinc	100	1.2	1000	12
EDB541-I	10-16 x 1-1/2	Y	-	#3	Stalgard®	3000	36	-	-
EDB541-I-100	10-16 x 1-1/2	Y	-	#3	Stalgard®	100	1.2	1000	12
EDB550-I-100	10-16 x 1-3/4	-	-	#3	Stalgard®	100	1.2	1000	12
EDB570-I-100	10-16 x 2	-	-	#3	Zinc	100	1.4	1000	14
EDB571-I	10-16 x 2	Y	-	#3	Stalgard®	2000	30	-	-
EDB580-I-025	10-16 x 3	-	-	#3	Zinc	25	0.45	250	4.5



**#10 DIAMETER, 5/16" HEX WASHER HEAD WITH SERRATIONS**

EDC576-I-100	10-16 x 3/4	-	-	#3	Stalgard®	100	0.7	1000	7
EFC460-I	10-16 x 3/4	-	-	#3	Zinc	6000	36	-	-

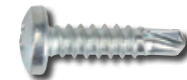

**#10 DIAMETER, #2 PHILLIPS PAN HEAD**

EDD475-I	10-16 x 3/4	-	-	#2	Stalgard®	6000	36	-	-
EDD501-I	10-16 x 1	-	-	#2	Zinc	5000	35	-	-



**#12 DIAMETER, 5/16" HEX WASHER HEAD**

EDC745-I	12-14 x 3/4	Y	-	#1	Stalgard®	5000	45	-	-
EDC745-I-500	12-14 x 3/4	Y	-	#1	Stalgard®	500	4.5	5000	45
EDB740-I	12-14 x 3/4	-	-	#3	Zinc	5000	45	-	-
EDB740-I-100	12-14 x 3/4	-	-	#3	Zinc	100	0.9	1000	9
EDB741-I	12-14 x 3/4	Y	Y	#3	Stalgard®	5000	45	-	-
EDB741-I-100	12-14 x 3/4	Y	Y	#3	Stalgard®	100	0.9	1000	9
EDB760-I	12-14 x 1	-	-	#3	Zinc	4000	44	-	-
EDB760-I-100	12-14 x 1	-	-	#3	Zinc	100	1.1	1000	11
EDB761-I	12-14 x 1	Y	-	#3	Stalgard®	4000	44	-	-
EDB761-I-100	12-14 x 1	Y	-	#3	Stalgard®	100	1.1	1000	11
EDB780-I-100	12-14 x 1-1/4	-	-	#3	Zinc	100	1.2	1000	12
EDB782-I	12-14 x 1-1/4	Y	-	#3	Stalgard®	3000	33	-	-

Screw Point Style	Uses	Product Line
Self-Drilling (#1, #2, #3, #4, #4.5, #5)	Metal connections	Drilit® / Architectural Roof Clip Fasteners Drilit® Flo-Seal® Drill Screws / Drill-Flex® / Bi-Flex® / Alumi-Flex®
Self-Drilling with Wings	Attaching wood or composite materials to metal	Drilit® Wood-to-Metal Bi-Flex® Wood-to-Metal
Self-Drilling with Pilot	Attaching wood or composite materials to light gauge metal	Drilit® Wood-to-Metal
Pierce Point	Wood/ light gauge metal applications	Architectural Roof Clip Fasteners
Type 17	Attaching light gauge metal to wood	TapFast®



Cat #	Description	ICC Appr.	FM Appr.	Point	Finish	Ctn Qty	Ctn Wt	Case Qty	Case Wt
EDB782-I-050	12-14 x 1-1/4	Y	-	#3	Stalgard®	50	0.55	500	5.5
EDB800-I	12-14 x 1-1/2	-	-	#3	Zinc	2500	35	-	-
EDB800-I-050	12-14 x 1-1/2	-	-	#3	Zinc	50	0.7	500	7
EDB801-I	12-14 x 1-1/2	Y	-	#3	Stalgard®	2500	35	-	-
EDB820-I-050	12-14 x 2	-	-	#3	Zinc	50	0.85	500	8.5
EDB821-I	12-14 x 2	Y	-	#3	Stalgard®	2000	34	-	-
EDB821-I-100	12-14 x 2	Y	-	#3	Stalgard®	100	1.7	1000	17
EDB829-I-050	12-14 x 2-1/2	-	-	#3	Zinc	50	1.1	500	11
EDB830-I	12-14 x 2-1/2	Y	-	#3	Stalgard®	1500	31.5	-	-
EDB839-I-025	12-14 x 3	-	-	#3	Zinc	25	0.65	250	6.5
EDB840-I	12-14 x 3	Y	-	#3	Stalgard®	1000	24	-	-
EDB845-I	12-14 x 4	Y	-	#3	Stalgard®	500	14	-	-



**1/4" DIAMETER, 5/16" HEX WASHER HEAD**

EDC930-I	1/4-14 x 7/8	Y	-	#1	Stalgard®	4000	44	-	-
----------	--------------	---	---	----	-----------	------	----	---	---

**1/4" DIAMETER, 5/16" HEX OVERSIZED (11/16") WASHER HEAD**

EDB947-I	1/4-14 x 1	-	-	#3	Zinc	2000	42	-	-
----------	------------	---	---	----	------	------	----	---	---

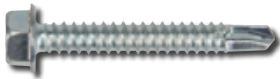

**1/4" DIAMETER, 3/8" HEX WASHER HEAD**

EDB935-I	1/4-14 x 3/4	-	-	#3	Zinc	3500	49	-	-
EDB935-I-100	1/4-14 x 3/4	-	-	#3	Zinc	100	1.4	1000	14
EDB936-I	1/4-14 x 3/4	Y	Y	#3	Stalgard®	3500	49	-	-
EDB945-I	1/4-14 x 1	-	-	#3	Zinc	3000	48	-	-
EDB945-I-050	1/4-14 x 1	-	-	#3	Zinc	50	0.8	500	8
EDB946-I	1/4-14 x 1	Y	-	#3	Stalgard®	3000	48	-	-
EDB955-I-050	1/4-14 x 1-1/4	-	-	#3	Zinc	50	0.95	500	9.5
EDB956-I	1/4-14 x 1-1/4	Y	-	#3	Stalgard®	2000	38	-	-
EDB960-I-050	1/4-14 x 1-1/2	-	-	#3	Zinc	50	1.1	500	11
EDB961-I	1/4-14 x 1-1/2	Y	-	#3	Stalgard®	2000	42	-	-
EDB965-I-050	1/4-14 x 1-3/4	-	-	#3	Zinc	50	1.3	500	13
EDB970-I	1/4-14 x 2	-	-	#3	Zinc	1500	39	-	-
EDB970-I-050	1/4-14 x 2	-	-	#3	Zinc	50	1.3	500	13
EDB971-I	1/4-14 x 2	Y	-	#3	Stalgard®	1500	45	-	-
EDB975-I-025	1/4-14 x 2-1/2	-	-	#3	Zinc	25	0.825	250	8.25
EDB976-I	1/4-14 x 2-1/2	Y	-	#3	Stalgard®	1000	30	-	-
EDB980-I-025	1/4-14 x 3	-	-	#3	Zinc	25	0.925	250	9.25
EDB981-I	1/4-14 x 3	Y	-	#3	Stalgard®	800	28	-	-
EDB983-I	1/4-14 x 4	Y	-	#3	Stalgard®	500	22	-	-



**5/16" DIAMETER, 3/8" HEX WASHER HEAD**

EDB990-I-010	5/16-18 x 1	-	-	#3	Zinc	10	0.3	100	3
EDB991-I	5/16-18 x 1	-	-	#3	Stalgard®	1000	30	-	-
EDB993-I-010	5/16-18 x 1-1/4	-	-	#3	Zinc	10	0.34	100	3.4
EDB994-I	5/16-18 x 1-1/4	-	-	#3	Stalgard®	1000	34	-	-
EDB997-I-010	5/16-18 x 1-1/2	-	-	#3	Zinc	10	0.37	100	3.7
EDB998-I	5/16-18 x 1-1/2	-	-	#3	Stalgard®	1000	37	-	-

**Drilit® Drill Screws with Bonded Sealing Washers**

*Economical fasteners for applications requiring a weather-tight seal*

This economical line of drill screws provides a weather-tight seal for protection against the elements.

**Specifications**

- Diameters: #8 to 1/4", Lengths: 3/4" to 4"
- Head Styles: Hex washer
- Drive System: Hex
- Point Types: #1 to #5
- Material: Carbon steel
- Finish: Stalgard® coating

**Features & Benefits**

- ICC ESR-3294 available on some SKUs
- EPDM washer material is UV- and heat-resistant for long-term protection against leakage
- Stalgard coating provides 1000 hours of salt spray resistance (per ASTM B117)

Cat #	Description	ICC Appr.	FM Appr.	Point	Washer O.D.	Finish	Ctn Qty	Ctn Wt	Case Qty	Case Wt
-------	-------------	-----------	----------	-------	-------------	--------	---------	--------	----------	---------

**#8 DIAMETER, 1/4" HEX WASHER HEAD**

EHL100-I-050	8-18 x 3/4	-	-	#2	1/2"	Zinc	50	0.6	500	6
--------------	------------	---	---	----	------	------	----	-----	-----	---



**#10 DIAMETER, 5/16" HEX WASHER HEAD**

EHL111-I	10-16 x 3/4	Y	Y	#3	1/2"	Stalgard®	3000	40	-	-
EHL112-I-100	10-16 x 3/4	-	-	#3	1/2"	Zinc	100	1.1	1000	11
EHL115-I-100	10-16 x 1	-	-	#3	1/2"	Zinc	100	1.3	1000	13
EHL146-I	10-16 x 1-1/2	Y	-	#3	1/2"	Stalgard®	2000	28	-	-



**#12 DIAMETER, 5/16" HEX WASHER HEAD**

EHL160-I-100	12-14 x 3/4	-	-	#3	9/16"	Zinc	100	1.1	1000	11
EHL165-I	12-14 x 3/4	Y	Y	#3	9/16"	Stalgard®	3000	33	-	-
EHL351-I	12-24 x 7/8	Y	Y	#4	9/16"	Stalgard®	2500	30	-	-
EHL180-I-100	12-14 x 1	-	-	#3	9/16"	Zinc	100	1.2	1000	12
EHL181-I	12-14 x 1	Y	-	#3	9/16"	Stalgard®	2500	32.5	-	-
EHL234-I	12-14 x 1-1/4	-	-	#3	9/16"	Zinc	200	3.2	-	-
EHL235-I	12-14 x 1-1/4	Y	-	#3	9/16"	Stalgard®	2000	28	-	-
EHL371-I	12-24 x 1-1/4	Y	-	#4.5	9/16"	Stalgard®	2500	40	-	-
EHL255-I	12-24 x 1-1/4	Y	Y	#5	9/16"	Stalgard®	2500	35	-	-
ECW725-I-050	12-24 x 1-1/4	Y	Y	#5	9/16"	Stalgard®	50	0.7	500	7
EHL276-I	12-14 x 1-1/2	Y	-	#3	9/16"	Stalgard®	2000	34	-	-
ECW745-I	12-24 x 1-1/2	Y	Y	#5	9/16"	Stalgard®	2000	28	-	-
EHL280-I	12-14 x 2	Y	-	#3	9/16"	Stalgard®	1500	30	-	-
ECW755-I	12-24 x 2	Y	Y	#5	9/16"	Stalgard®	1000	20	-	-
EHL285-I	12-14 x 2-1/2	Y	-	#3	9/16"	Stalgard®	1000	23	-	-
EHL295-I	12-14 x 3	Y	-	#3	9/16"	Stalgard®	1000	27	-	-
EHL310-I	12-14 x 4	Y	-	#3	9/16"	Stalgard®	500	16.5	-	-

**1/4" DIAMETER, 5/16" HEX WASHER HEAD**

EHK315-I	1/4-14 x 7/8	Y	-	#1	9/16"	Stalgard®	2500	32.5	-	-
----------	--------------	---	---	----	-------	-----------	------	------	---	---

Cat #	Description	ICC Appr.	FM Appr.	Point	Washer O.D.	Finish	Ctn Qty	Ctn Wt	Case Qty	Case Wt
-------	-------------	-----------	----------	-------	-------------	--------	---------	--------	----------	---------



**1/4" DIAMETER, 3/8" HEX WASHER HEAD**

EHL514-I-050	1/4-14 x 3/4	-	-	#3	5/8"	Zinc	50	0.95	500	9.5
EHL515-I	1/4-14 x 3/4	Y	-	#3	5/8"	Stalgard®	2500	42.5	-	-
EHL525-I-050	1/4-14 x 1	-	-	#3	5/8"	Zinc	50	0.9	500	9
EHL530-I	1/4-14 x 1	Y	-	#3	5/8"	Stalgard®	2000	40	-	-
EHL555-I-050	1/4-14 x 1-1/4	-	-	#3	5/8"	Zinc	50	1.15	500	11.5
EHL556-I	1/4-14 x 1-1/4	Y	-	#3	5/8"	Stalgard®	1500	33	-	-
EHL575-I-050	1/4-14 x 1-1/2	-	-	#3	5/8"	Zinc	50	1.3	500	13
EHL577-I	1/4-14 x 1-1/2	Y	-	#3	5/8"	Stalgard®	1500	36	-	-
EHL584-I-050	1/4-14 x 2	-	-	#3	5/8"	Zinc	50	1.5	500	15
EHL585-I	1/4-14 x 2	Y	-	#3	5/8"	Stalgard®	1000	29	-	-
EHL600-I	1/4-14 x 3	Y	-	#3	5/8"	Stalgard®	800	30.4	-	-
EHL610-I	1/4-14 x 4	Y	-	#3	5/8"	Stalgard®	500	24.5	-	-

To assure a weather-tight seal, fasteners must be properly installed.

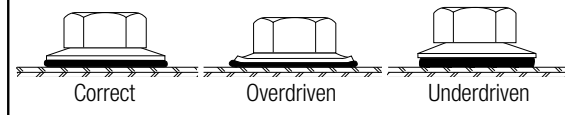

**Drilit® Flo-Seal® Drill Screws with Integral Sealing System**

For self-drilling applications requiring a weather-tight seal

Special underhead design and EPDM sealing washer combine to provide a custom, weather-tight seal

**Specifications**

- Diameters: #12"
- Lengths: 3/4" to 2"
- Head Styles: Hex washer ( 5/16" across flats)
- Drive System: Hex
- Material: Carbon steel
- Finish: Stalgard® coating

**Features & Benefits**

- EPDM washer material is UV- and heat-resistant for long-term protection against leakage
- Reliable and consistent sealing even in under-tightened, overtightened or angle driven installations
- Stalgard coating provides 1000 hours of salt spray resistance (per ASTM B117)

Cat #	Description	Point	Finish	Ctn Qty	Ctn Wt	Case Qty	Case Wt
-------	-------------	-------	--------	---------	--------	----------	---------



**#12 DIAMETER, 5/16" HEX WASHER HEAD**

EHB150-I	12-14 x 3/4	#3	Stalgard®	3000	36	-	-
EHB150-I-050	12-14 x 3/4	#3	Stalgard®	50	0.6	500	6
EHB180-I	12-14 x 1	#3	Stalgard®	2500	35	-	-
EHB235-I	12-14 x 1-1/4	#3	Stalgard®	2000	32	-	-
EHB295-I	12-14 x 1-1/2	#3	Stalgard®	2000	34	-	-
EHB310-I	12-14 x 2	#3	Stalgard®	1500	30	-	-

**Features and Benefits of the Flo-Seal Fasteners Sealing System**

- Fastener head engineered to control the flow of the special sealing washer, ensuring sealing in critical areas
- Provides reliable and consistent sealing even in under-tightened, overtightened or angle-driven installations
- Ensures long-term protection against leakage
- Compensates for different installation situations and techniques

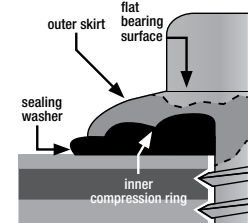

**Drill Screw with Flo-Seal System**

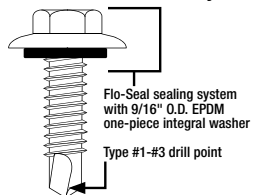

**Maximum Material Attachment**

Size	Material Attachment Max.
12-14 x 1	0.490"
12-14 x 1-1/4	0.560"
12-14 x 1-1/4	0.790"



## Drilit® Drill Screws for Wood-to-Metal Applications

For efficient fastening of wood or composite materials to steel

These self-drilling fasteners eliminate separate drilling and tapping operations for faster installation in wood-to-metal applications.

### Specifications

- Diameters: #10 to 1/4"
- Lengths: 3/4" to 4"
- Head Styles: Flat and wafer
- Drive System: Phillips
- Point Types: #2 to #4
- Material: Carbon steel
- Finishes: Gray Stalgard® coating

### Features & Benefits

- Eliminates pre-drilling of wood
- Broad selection of sizes
- Can be used with steel up to 5/16" thick
- Gray Stalgard coating provides 1000 hours of salt spray resistance; developed for use with ACQ-treated lumber with retention levels no higher than .25 PC

Cat #	Description	Point	Type Wood Thick	Drilling Capacity (min-max in steel)	Ctn Qty	Ctn Wt	Case Qty	Case Wt
-------	-------------	-------	-----------------	--------------------------------------	---------	--------	----------	---------



#### #10 DIAMETER, #2 PHILLIPS WAFER HEAD

EDM582-I	10-24 x 3/4	#3	1/4"	.036"-.187"	8000	40	-	-
EDM592-I	10-24 x 1	#3	1/2"	.036"-.187"	6000	43	-	-
EDM607-I	10-24 x 1-1/4	#3	5/8"	.036"-.187"	5000	40	-	-
EDM607-I-100	10-24 x 1-1/4	#3	5/8"	.036"-.187"	100	0.8	1000	8
EDT602-I	10-24 x 1-7/16	#3 / wings	3/4"	.036"-.187"	4000	40	-	-
EDM622-I	10-16 x 1-1/2	#3	3/4"	.036"-.187"	3500	35	-	-
EDM622-I-100	10-16 x 1-1/2	#3	3/4"	.036"-.187"	100	1	1000	10
EDM635-I	10-16 x 1-13/16	#3 / pilot	3/4"	.036"-.150"	2500	29	-	-



#### #12 DIAMETER, #3 PHILLIPS WAFER HEAD

EDT720-I	12-24 x 1-3/4	#4 /wings	3/4"	.060"-.312"	2000	29	-	-
----------	---------------	-----------	------	-------------	------	----	---	---



#### #12 DIAMETER, #3 PHILLIPS FLAT HEAD

EDT267-I	12-24 x 2-1/4	#4	1-1/4"	.312"	2000	38	-	-
EDT282-I	12-24 x 2-3/4	#4	1-5/8"	.312"	1500	35	-	-
EDJ867-I	12-14 x 3-5/8	#4	1-5/8"	.036"-.150"	1000	24	-	-



#### 1/4" DIAMETER, #3 PHILLIPS FLAT HEAD

EDT442-I	1/4 - 20 x 3	#4	2"	.312"	1000	31	-	-
EDT470-I	1/4 - 20 x 4	#4	3"	.312"	1000	42	-	-

## Drill Screws with Extended Drilling Capacity

Specially-designed drill points handle the toughest applications

This line of heavy-duty drill screws is designed for fast installation in steel applications up to 1/2" thick.

### Features & Benefits

- ICC ESR-3294 available on some SKUs

Cat #	Description	ICC Appr.	FM Appr.	Point	Finish	Qty / Carton	Wt / Carton	Qty / Case	Wt / Case
-------	-------------	-----------	----------	-------	--------	--------------	-------------	------------	-----------



#### #12 DIAMETER 5/16" HEX WASHER HEAD FOR STEEL .175" to 500" THICK

EDC801-I	12-24 x 7/8	Y	Y	#4	Stalgard®	4500	49.5	-	-
EDC816-I	12-24 x 1-1/4	Y	-	#4.5	Stalgard®	3500	45.5	-	-
ECC720-I	12-24 x 1-1/4	Y	Y	#5	Stalgard®	4000	44	-	-
ECC720-I-100	12-24 x 1-1/4	Y	Y	#5	Stalgard®	100	1.1	1000	11
EDC846-I	12-24 x 1-1/2	-	-	#4.5	Stalgard®	2500	35	-	-
ECC740-I	12-24 x 1-1/2	Y	Y	#5	Stalgard®	2500	40	-	-
ECC750-I	12-24 x 2	Y	Y	#5	Stalgard®	2000	34	-	-



#### 1/4" DIAMETER, 5/16" HEX WASHER HEAD FOR STEEL .175" to 500" THICK

ECC940-I	1/4 - 20 x 3	-	-	#5	Stalgard®	1000	36	-	-
ECC950-I	1/4 - 20 x 4	-	-	#5	Stalgard®	500	23	-	-



#### 1/4" DIAMETER, 3/8" HEX WASHER HEAD FOR STEEL .175" to 500" THICK

ECC960-I	1/4 - 20 x 5	-	-	#5	Stalgard®	500	31.5	-	-
ECC970-I	1/4 - 20 x 6	-	-	#5	Stalgard®	500	37	-	-
ECC980-I	1/4 - 20 x 8	-	-	#5	Stalgard®	150	16.05	-	-

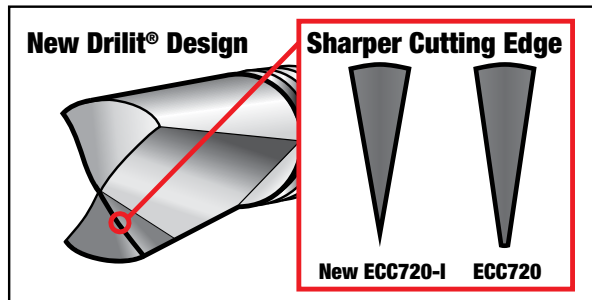

### Average Drill Time Comparison

#### Elco vs. Buildex

#12-24 x 1/14" Ty-5 Point  
3/8" Carbon Steel  
1800 RPM  
50 lb. End Load

\* Buildex is a Registered Trademark of ITW Buildex and Illinois Tool Works, Inc.

**40%  
FASTER  
DRILLING**

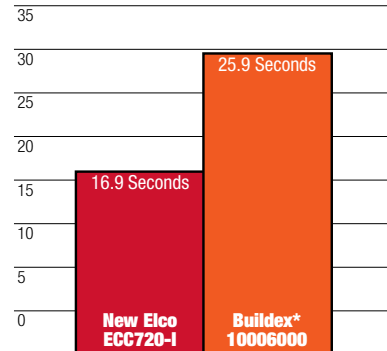

www.elcoconstruction.com

## Drill Screws Technical Information - Performance Data

### Ultimate Fastener Strength<sup>1,2,3</sup>

Description	Tension (lb)	Shear (lbs)	Maximum Torsional Strength (in.-lbs)
#6-20	1,345	815	24
#8-18	1,615	1,100	42
#10-16	2,670	1,675	61
#10-24	2,635	1,570	65
#12-14	3,210	1,785	92
#12-24	3,550	2,185	100
1/4"-14	5,020	2,305	150
1/4"-20	5,190	2,980	168
5/16"-18	8,710	4,720	438

### Ultimate Shear (Bearing) Capacity of Screw Connections, lbf<sup>1,3</sup>

Desc.	Point Type	Steel Thickness (Lapped Sheets/Bars)												
		26-26 Ga.	24-24 Ga.	22-22 Ga.	20-20 Ga.	18-18 Ga.	16-16 Ga.	14-14 Ga.	12-12 Ga.	1/8"-1/8"				
#6-20	#2	170 <sup>2</sup>	260 <sup>2</sup>	365 <sup>2</sup>	480 <sup>2</sup>	740 <sup>2</sup>	-	-	-	-	-	-	-	-
#8-18	#2	300	500	540	740	1,045	-	-	-	-	-	-	-	-
#10-16	#1	400	585	670	880	1,330	-	-	-	-	-	-	-	-
#10-16	#3	200 <sup>2</sup>	460	520	730	1,250	1,520	1,670	-	-	-	-	-	-
#10-24	#2	200 <sup>2</sup>	305 <sup>2</sup>	430 <sup>2</sup>	565 <sup>2</sup>	865 <sup>2</sup>	-	-	-	-	-	-	-	-
#12-14	#1	435	715	760	1,030	1,545	-	-	-	-	-	-	-	-
#12-14	#3	210	325 <sup>2</sup>	455 <sup>2</sup>	775	1,360	1,620	1,970	1,990	-	-	-	-	-
#12-24	#4	-	-	-	-	-	1,430	1,930	2,455	2,570	-	-	-	-
#12-24	#4.5	-	-	-	-	-	1,385	1,920	2,170	2,255	-	-	-	-
#12-24	#5	-	-	-	-	-	1,350	1,825	2,150	2,225	-	-	-	-
1/4"-14	#1	515	860	890	1,300	1,770	-	-	-	-	-	-	-	-
1/4"-14	#3	225 <sup>2</sup>	350 <sup>2</sup>	490 <sup>2</sup>	930	1,445	2,100	2,580	2,650	-	-	-	-	-
1/4"-20	#5	-	-	-	-	-	1,655	2,275	-	3,210	-	-	-	-

### Ultimate Tension Pull-Out Capacity of Screw Connections, lbf<sup>1,3</sup>

Desc.	Point Type	Thickness of Steel Not in Contact with Screw Head													
		26 Ga.	24 ga.	22 Ga.	20 Ga.	18 Ga.	16 Ga.	14 Ga.	12 Ga.	0.12	1/8"	3/16"	1/4"	5/16"	3/8"
#6-20	#2	95 <sup>2</sup>	125 <sup>2</sup>	155 <sup>2</sup>	190 <sup>2</sup>	250 <sup>2</sup>	315 <sup>2</sup>	395 <sup>2</sup>	-	-	-	-	-	-	-
#8-18	#2	120	195	265	300	490	700	960	-	-	-	-	-	-	-
#10-16	#1	150	240	315	360	565	825	1,090	-	-	-	-	-	-	-
#10-16	#2	130	205	270	300	420	550	660	1,125	-	-	-	-	-	-
#10-16	#3	130	205	270	300	420	550	660	1,125	-	-	-	-	-	-
#10-24	#2	130 <sup>2</sup>	175 <sup>2</sup>	220 <sup>2</sup>	260 <sup>2</sup>	345 <sup>2</sup>	435 <sup>2</sup>	545 <sup>2</sup>	760 <sup>2</sup>	-	-	-	-	-	-
#10-24	#3	130 <sup>2</sup>	175 <sup>2</sup>	220 <sup>2</sup>	260 <sup>2</sup>	345 <sup>2</sup>	435 <sup>2</sup>	545 <sup>2</sup>	760 <sup>2</sup>	-	-	-	-	-	-
#10-24	#3 w/wings	-	-	-	-	-	535	-	-	1,500	-	-	-	-	-
#12-14	#1	160	260	330	390	640	920	1,260	-	-	-	-	-	-	-
#12-14	#3	140	210	295	345	580	765	1,075	1,550	1,955	-	-	-	-	-
#12-24	#4 w/wings	-	-	-	-	585	-	-	-	1,605	-	2,085	-	-	-
#12-24	#4	-	-	-	310	450	495 <sup>2</sup>	620 <sup>2</sup>	865 <sup>2</sup>	990 <sup>2</sup>	1,415	3,235	3,770	-	-
#12-24	#4.5	-	-	-	310	450	495 <sup>2</sup>	620 <sup>2</sup>	865 <sup>2</sup>	990 <sup>2</sup>	1,415	3,235	3,770	-	4,125
#12-24	#5	-	-	-	310	450	495 <sup>2</sup>	620 <sup>2</sup>	865 <sup>2</sup>	990 <sup>2</sup>	1,415	3,235	3,770	-	4,125
1/4"-14	#1	225	340	430	570	800	1,165	-	-	-	-	-	-	-	-
1/4"-14	#3	150	235	300	340	700	890	1,160	1,795	2,120	-	-	-	-	-
1/4"-20	#4 w/wings	-	-	-	-	535	-	-	-	1,670	-	4,065	4,170	-	-
1/4"-20	#5	-	-	-	345 <sup>2</sup>	460 <sup>2</sup>	575 <sup>2</sup>	720 <sup>2</sup>	1,005 <sup>2</sup>	1,150 <sup>2</sup>	1,550	-	4,825	5,285	5,400
5/16"-18	#3	-	-	-	455	565	1,205	1,710	2,420	2,600	-	3,715	5,120	-	-

### Ultimate Pull-Over Capacity for Light Gauge Steel Framing with Screws<sup>2,3</sup>

Desc.	1/4" Hex Washer Head	Maximum thickness of Steel of Framing Member					
		25 Ga. Ult.	22 Ga. Ult.	20 Ga. Ult.	18 Ga. Ult.	16 Ga. Ult.	
Drill <sup>®</sup>	#6-20	445	635	765	1,015	1,270	
	#8-18	475	675	810	1,080	1,350	
	#10-16	565	805	965	1,286	1,610	
	#12-24	585	840	1,005	1,340	1,675	
	1/4"-14	585	840	1,005	1,340	1,675	
	1/4"-14	3/8" Hex Washer Head	705	1,010	1,210	1,615	2,020
	1/4"-14	3/8" Hex Oversized Washer Head	950	1,360	1,635	2,180	2,725
	1/4"-20	3/8" Hex Washer Head	840	1,200	1,440	1,920	2,400
	5/16"-18	3/8" Hex Washer Head	840	1,200	1,440	1,920	2,400
	Drill <sup>®</sup> with Bonded Sealing Washer	#8-18	605	675	810	1,080	1,350
#10-16		695	805	965	1,285	1,610	
#12-24		715	840	1,005	1,340	1,675	
1/4"-14		5/16" Hex Washer Head	715	840	1,005	1,340	1,675
1/4"-14		3/8" Hex Washer Head	705	1,010	1,210	1,615	2,020
#12-14	5/16" Flo-Seal	630	715	860	1,145	1,435	

### Drilling and Tapping Capacity (Maximum Material Thickness)\*

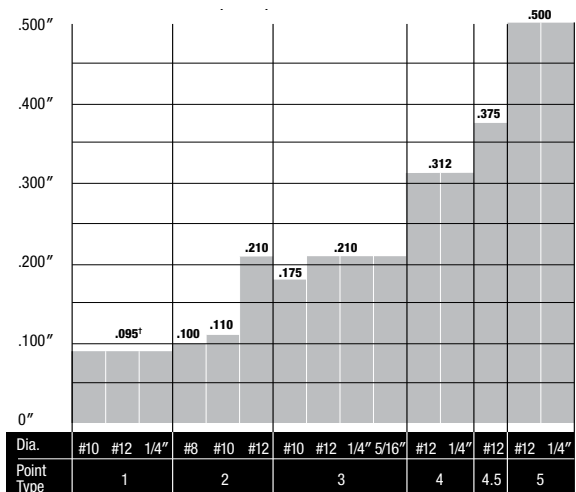

† Lapped panels: 18 ga. to 18 ga.

\* NOTE: Some drill and tap capacities may vary due to special features on some fasteners. Refer to ordering and technical information for difference in drilling and tapping capacities for any individual fastener.

1. Ultimate strengths are based on laboratory tests unless otherwise noted.
2. Ultimate strengths were calculated in accordance with AISI S100-16 based on steel with a minimum tensile strength of F<sub>y</sub> = 45 ksi.
3. Ultimate load capacities must be reduced by a minimum safety factor to determine allowable loads (ASD) or by a load resistance factor to determine strength design capacities (LRFD).



## TapFast® Fasteners

For use in metal-to-wood application

High-performance fastener designed specifically for attaching light-gauge metal panels (18 ga. max.) to wood frame structures.

### Specifications

- Size: #10, Lengths: 1" to 3"
- Head/Drive: 1/4" HWH
- Thread: Hi-lo, Point: Type 17
- Material: Carbon steel
- Finish: Stalgard® coating

### Features & Benefits

- Aluminum bonded sealing washer
- High-low thread increases performance
- Easily penetrates multiple panel thicknesses
- Stalgard coating provides 1000 hours of salt spray resistance (per ASTM B117)

Cat #	Description	Point	Finish	Ctn Qty	Ctn Wt	Case Qty	Case Wt
-------	-------------	-------	--------	---------	--------	----------	---------



### #10 DIAMETER, 1/4" HEX WASHER HEAD / ALUMINIUM BONDED SEALING WASHER

Cat #	Description	Point	Finish	Ctn Qty	Ctn Wt	Case Qty	Case Wt
EHH210-I	10-16 x 1	Type 17	Stalgard®	3000	24	-	-
EHH210-I-100	10-16 x 1	Type 17	Stalgard®	100	0.8	1000	8
EHH230-I	10-16 x 1-1/2	Type 17	Stalgard®	2500	25	-	-
EHH230-I-100	10-16 x 1-1/2	Type 17	Stalgard®	100	1	1000	10
EHH250-I	10-16 x 2	Type 17	Stalgard®	1500	18	-	-
EHH250-I-050	10-16 x 2	Type 17	Stalgard®	50	0.55	500	5.5
EHH265-I	10-16 x 2-1/2	Type 17	Stalgard®	1000	15	-	-
EHH265-I-050	10-16 x 2-1/2	Type 17	Stalgard®	50	0.75	500	7.5
EHH280-I	10-16 x 3	Type 17	Stalgard®	800	16	-	-
EHH280-I-050	10-16 x 3	Type 17	Stalgard®	50	0.85	500	8.5

## Architectural Roof Clip Fasteners

Low-profile head design for wood and steel applications

The efficiency of self-drilling fasteners and the aesthetics of an unobtrusive head are ideal for attaching metal roof clips to metal and wood.

### Specifications

- Diameters: #10 to #12", Lengths: 1" to 2"
- Head/Drive Styles: Pancake, phillips
- Material: Carbon steel; Finishes: Silver or gray Stalgard® coating

### Features & Benefits

- ICC ESR-3294 available on some SKUs
- Eliminates separate drilling and tapping operations
- Pancake head improves aesthetics, prevents panel dimpling
- Stalgard coating provides 1000 hours of salt spray resistance (per ASTM B117), Gray Stalgard is ACQ-compatible\*

Cat #	Description	ICC Approved	Point	Finish	Ctn Qty	Ctn Wt
-------	-------------	--------------	-------	--------	---------	--------



### #10 DIAMETER, #2 PHILLIPS PANCAKE HEAD

EDO450-I	10-6 x 1	Y	#3	Stalgard®	4000	36
EDO460-I	10-16 x 1-1/2	Y	#3	Stalgard®	3000	33
EDO470-I	10-16 x 2	Y	#3	Stalgard®	2000	25
ETA850-I	10-12 x 1	-	Pierce Point	Gray Stalgard®	4000	36
ETA855-I	10-12 x 1-1/2	-	Pierce Point	Gray Stalgard®	3000	33
ETA860-I	10-12 x 2	-	Pierce Point	Gray Stalgard®	2000	28



### #12 DIAMETER, #2 PHILLIPS PANCAKE HEAD

ED0735-I	12-14 x 1	-	#3	Stalgard®	4000	40
ETA870-I	12-11 x 1	-	Pierce Point	Gray Stalgard®	4000	33



MADE IN THE  
**USA**  
WITH GLOBAL MATERIALS

ICC ES ESR-3332

COLA  
(City of Los Angeles)  
Report #25095

## Dril-Flex® Structural Drill Screws

Virtually immune to delayed embrittlement failures

Dual heat treated drill screws provide the strength, ductility and resistance to embrittlement required for critical applications.

### Specifications

- Diameters: #10 to 5/16"
- Lengths: 3/4" to 4"
- Head/Drive Styles: Hex washer, phillips pan, wafer and undercut flat
- Point Types: #2, #3, #4 and #5
- Material: Alloy steel
- Heat Treat: Grade 5
- Finish: Silver Stalgard® or Stalgard SUB coating

### Features & Benefits

- Stalgard SUB coating (Hex washer product only) provides 2000 hours of salt spray resistance (per ASTM B117)
- High-hardness points and lead threads for drilling and tapping
- Lower hardness in load-bearing threads for ductility
- Virtually immune to delayed embrittlement failures

Cat #	Description	Pt.	Load-Bearing Area	Finish	Ctn Qty	Ctn Wt
-------	-------------	-----	-------------------	--------	---------	--------



**#10 Diameter, 5/16" Hex Washer Head**

EAF430	10-16 x 3/4"	#3	.380"	Stalgard SUB	6,000	48
EAF460	10-16 x 1-1/2"	#3	1.25"	Stalgard SUB	2,500	30
EAF470	10-16 x 2"	#3	1.50"	Stalgard SUB	2,000	28
EAF480	10-16 x 2-1/2"	#3	2.25"	Stalgard SUB	1,500	25

**#10 Diameter, #2 Phillips Pan Head**

EDX445	10-16 x 3/4"	#2	.380"	Stalgard	6,000	36
--------	--------------	----	-------	----------	-------	----

**#10 Diameter, #2 Phillips Wafer Head**

EBL530	10-24 x 1-1/4"	#3	.750"	Stalgard	5,000	44
--------	----------------	----	-------	----------	-------	----



**#12 Diameter, 5/16" Hex Washer Head**

EAF621*	12-14 x 7/8"	#3	.380"	Stalgard SUB	5,000	54
EAF641	12-14 x 1"	#3	.500"	Stalgard SUB	4,000	44
EAF661	12-14 x 1-1/4"	#3	.750"	Stalgard SUB	2,500	36
EAF681	12-14 x 1-1/2"	#3	1.00"	Stalgard SUB	2,500	38
EAF690	12-14 x 2"	#3	1.50"	Stalgard SUB	2,000	37
EAF715	12-14 x 3"	#2	2.35"	Stalgard SUB	1,000	27
EAF755	12-24 x 1-3/4"	#5	.800"	Stalgard SUB	2,500	45



**#12 Diameter, #3 Phillips Undercut Flat Head**

EBL215	12-14 x 1"	#3	.500"	Stalgard	4,000	36
EBL220	12-14 x 1-1/4"	#3	.750"	Stalgard SUB	3,000	29
EBL223	12-14 x 1-1/2"	#3	1.00"	Stalgard	2,500	26



**1/4" Diameter, 3/8" Hex Washer Head**

EAF816	1/4-14 x 1"	#3	.450"	Stalgard SUB	3,000	54
EAF841	1/4-14 x 1-1/2"	#3	.950"	Stalgard SUB	2,000	45
EAF876	1/4-20 x 1-1/2"	#4	.830"	Stalgard SUB	2,000	48
EAF846	1/4-14 x 2"	#3	1.45"	Stalgard SUB	1,500	41

Cat #	Description	Pt.	Load-Bearing Area	Finish	Ctn Qty	Ctn Wt
-------	-------------	-----	-------------------	--------	---------	--------

EAF886	1/4-20 x 2"	#4	1.33"	Stalgard SUB	1,500	45
EAF865	1/4-20 x 1-1/8"	#4	.500"	Stalgard SUB	2,500	51
EAF888	1/4-20 x 1-3/4"	#5	.800"	Stalgard SUB	1,000	27
EAF890	1/4-20 x 2-1/2"	#4	1.83"	Stalgard SUB	1,000	45
EAF900	1/4-20 x 3-3/8"	#4	2.70"	Stalgard SUB	500	22
EAF910	1/4-20 x 4"	#4	3.50"	Stalgard SUB	500	23



**1/4" Diameter, #3 Phillips Undercut Flat Head**

EBL330	1/4-20 x 3"	#4	2.50"	Stalgard	500	20
EBL340	1/4-20 x 4"	#4	3.50"	Stalgard	500	23



**5/16" Diameter, 3/8" Hex Washer Head**

EAF940	5/16-18 x 1-1/2"	#3	.800"	Stalgard SUB	1,000	37
EAF960	5/16-24 x 1-1/2"	#4	.800"	Stalgard SUB	1,000	40
EAF970	5/16-24 x 2"	#4	1.25"	Stalgard SUB	1,000	43

\* for aluminum applications only

**Load Bearing Area**

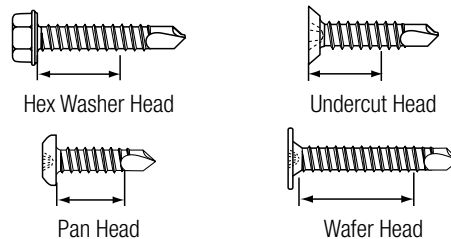

**Identification**

(hex washer head shown)



**Comparison to Stainless Steel Screws**

Galvanic Series	
Anodic End	
Metal / Alloy	EMF(v)
Magnesium	-1.60
Zinc	-1.10
Alum (5000, 6000, 7000)	-.75
Iron, Low Alloy Steels	-.70
Alum (2000)	-.60
Lead	-.55
18% Chromium Steel	-.35
Naval Brass	-.30
Brass, Bronze	-.25
Austenitic Stainless (300 Series)	-.20
Nickel	-.15
Silver	0
Gold	+15
Cathodic End	

300 series stainless steel fasteners provide high resistance to hydrogen embrittlement failures. However, stainless steel is galvanically incompatible with aluminum or steel panels. In this case, stainless steel fasteners trigger a sacrificial action, which can lead to degradation of the panel and loosening of the fastener.

A dual-hardening process allows Dril-Flex® fasteners to provide high strength and resistance to hydrogen embrittlement failures. Their Stalgard® finish provides corrosion resistance several times greater than other commonly-used finishes. If an environment is corrosive enough to significantly affect the Stalgard finish, the potential for significant degradation of the aluminum/stainless steel assembly would also exist.

**Embrittlement Tests**

Embrittlement testing of Dril-Flex screws was performed in accordance to ASTM F1624-06. Fastener lots were tested to determine their Threshold Stress Limits for both Internal Hydrogen Embrittlement and Environmental Hydrogen Embrittlement. Threshold Stress Limit is the stress level below which no time-dependent cracking will occur. Above this level, subcritical cracking that leads to time-delayed fracture or embrittlement may occur if the fastener is exposed to a hydrogen environment.

**Embrittlement Test Results**

- Dril-Flex fasteners have a hardness range of HRC 28 – 34, which is roughly equivalent to a SAE Grade 5 fastener (HRC 25 – 34).
- Dril-Flex fasteners showed resistance to the effect of hydrogen-assisted cracking when loaded to 75% of their tensile strength. This is within accepted industry guidelines for in-service loading conditions.
- Dril-Flex fasteners showed no degradation or failures in tensile strength below their ultimate tensile strength.



**MADE IN THE USA**  
WITH GLOBAL MATERIALS

### Tap-Flex™ Thread-Forming Structural Screws

*Increased thread engagement with strength and ductility*

Feature a unique thread profile to ease installation and increase performance.

#### Specifications

- Diameters: 3/8", 1/2", and 5/8"
- Head Style: Hex washer
- Threads: E-Form® five-lobe thread forming
- Material: Alloy steel, Finish: Silver Stalgard® SUB coating
- Heat Treat: Grade 5; meets ASTM A449 specifications (120 KSI strength)

#### Features and Benefits

- E-Form thread overcomes friction build-up and reduces drive torque
- Roll forms own work-hardened thread to resist loosening and provide enhanced pull-out values
- Virtually immune to delayed embrittlement failures
- Stalgard SUB coating provides 2000 hours of salt spray resistance (per ASTM B117)

Cat #	Size	Finish	Seating Torque	Drill Bit Size	Load-Bearing Length	Qty	Wt
<b>3/8" Diameter, Hex Washer Head</b>							
ESU310	3/8-16 x 1-1/2	Stalgard SUB	31 ft.lb.	11/32	1.00"	500	34
ESU320	3/8-16 x 2	Stalgard SUB	31 ft.lb.	11/32	1.49"	500	40
ESU330	3/8-16 x 2-1/2	Stalgard SUB	31 ft.lb.	11/32	1.99"	500	46
ESU340	3/8-16 x 3	Stalgard SUB	31 ft.lb.	11/32	2.49"	250	26
ESU350	3/8-16 x 4	Stalgard SUB	31 ft.lb.	11/32	3.49"	250	32
ESU360	3/8-16 x 5	Stalgard SUB	31 ft.lb.	11/32	4.49"	150	23



Cat #	Size	Finish	Seating Torque	Drill Bit Size	Load-Bearing Length	Qty	Wt
<b>1/2" Diameter, Hex Washer Head</b>							
ESU410	1/2-13 x 1-1/2	Stalgard SUB	75 ft.lb.	15/32	0.875"	250	36
ESU420	1/2-13 x 2	Stalgard SUB	75 ft.lb.	15/32	1.365"	250	41
ESU430	1/2-13 x 2-1/2	Stalgard SUB	75 ft.lb.	15/32	1.865"	250	47
ESU440	1/2-13 x 3	Stalgard SUB	75 ft.lb.	15/32	2.37"	150	32
ESU450	1/2-13 x 4	Stalgard SUB	75 ft.lb.	15/32	3.37"	100	26
ESU460	1/2-13 x 5	Stalgard SUB	75 ft.lb.	15/32	4.37"	100	30

Cat #	Size	Finish	Seating Torque	Drill Bit Size	Load-Bearing Length	Qty	Wt
<b>5/8" Diameter, Hex Washer Head</b>							
ESU510	5/8-11 x 1-1/2	Stalgard SUB	150 ft.lb.	19/32	0.800"	250	46

Cat #	Size	Finish	Seating Torque	Drill Bit Size	Load-Bearing Length	Qty	Wt
ESU520	5/8-11 x 2	Stalgard SUB	150 ft.lb.	19/32	1.24"	150	33
ESU530	5/8-11 x 2-1/2	Stalgard SUB	150 ft.lb.	19/32	1.74"	150	38
ESU540	5/8-11 x 3	Stalgard SUB	150 ft.lb.	19/32	2.24"	100	29
ESU550	5/8-11 x 4	Stalgard SUB	150 ft.lb.	19/32	3.24"	50	18
ESU560	5/8-11 x 5	Stalgard SUB	150 ft.lb.	19/32	4.24"	50	22

#### Identification



#### E-Form® Profile



### Alumi-Flex™ 302 (18-8) Stainless Steel Drill Screws

*For fastening to aluminum when corrosion and galvanic reaction are a primary concern*

Stainless steel drill screws provide strength and corrosion resistance in a variety of aluminum applications.

#### Specifications

- Diameters: #10 to 1/4"
- Lengths: 1/2" to 1-1/2"
- Head Style: Hex washer
- Drive System: Hex
- Point Types: #3 and #4
- Material: 302 stainless steel
- Finish: Stalgard® GB (Galvanic Barrier) coating

#### Features & Benefits

- Provides a very high level of corrosion resistance
- Coating allows greater galvanic compatibility in dissimilar metal applications involving aluminum
- Head marked with a "3" for easy identification

Cat #	Description	Finish	Ctn Qty	Ctn Wt
<b>#10 Diameter Hex Washer Head</b>				
EAH430-I	10-16 x 1/2"	Stalgard GB	8,000	41
EAH445-I	10-16 x 3/4"	Stalgard GB	6,000	39
EAH460-I	10-16 x 1"	Stalgard GB	5,000	45
<b>#10 Diameter, Undercut Flat Head</b>				
EBM160-I	10-16 x 3/4"	Stalgard GB	10,000	44



Cat #	Description	Finish	Ctn Qty	Ctn Wt
-------	-------------	--------	---------	--------



**#12 Diameter Hex Washer Head**

EAH630-I	12-14 x 3/4"	Stalgard GB	5,000	40
EAH650-I	12-14 x 1"	Stalgard GB	5,000	50
EAH680-I	12-14 x 1-1/2"	Stalgard GB	3,000	44



**1/4" Diameter Hex Washer Head**

EAH800-I	1/4-14 x 3/4"	Stalgard GB	3,500	51
EAH820-I	1/4-14 x 1"	Stalgard GB	3,000	48
EAH835-I	1/4-14 x 1-1/2"	Stalgard GB	2,000	41
EAH870-I	1/4-20 x 1"	Stalgard GB	2,000	35
EAH880-I	1/4-20 x 1-1/2"	Stalgard GB	2,000	42

**1/4" Diameter, Undercut Flat Head**

EBM260-I	1/4-14 x 1"	Stalgard GB	4,500	42
----------	-------------	-------------	-------	----

Note: For aluminum applications ONLY.

**Identification**

The head marking consists of the number "3" below the Elco® logo.



Hex Washer Head



Flat Head



**COLA**  
(City of Los Angeles)  
Report #25886

**Bi-Flex® 300 Series Stainless Steel Bi-Metal Self-Drilling Screws**

*Bi-metal technology provides outstanding corrosion resistance and long service life*

Bi-Flex® fasteners provide the corrosion resistance of 300 series stainless steel and the efficiency of drill screws.

**Specifications**

- Diameters: #10 to 1/4"
- Lengths: 3/4" to 8"
- Drive Systems: Hex and phillips
- Material: Hardened steel tapping threads and point fused onto an 18-8 stainless steel shank and head
- Finish: Stalgard® GB (Galvanic Barrier) coating

**Features & Benefits**

- High strength, ductility and reliability

- Virtually immune to delayed embrittlement failures
- Greater galvanic compatibility in dissimilar metal applications involving aluminum
- High in-place value over the life of application

Cat #	Dia. TPI	L Length	Drive System	Point Size	B Maximum Load-bearing Length*	Pcs per 1/4 Keg	WT per 1/4 Keg
-------	----------	----------	--------------	------------	--------------------------------	-----------------	----------------

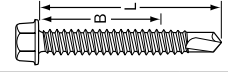

**Hex Washer Head**

EAJ100	8-18	3/4"	5/16" hex	2	0.32"	5,000	23
EAJ102	8-18	1"	5/16" hex	2	0.50"	5,000	27
EAJ110	10-16	3/4"	5/16" hex	2	0.32"	5,000	32
EAJ120	10-16	1"	5/16" hex	2	0.50"	5,000	46
EAJ140	10-16	1-1/2"	5/16" hex	2	1.10"	2,500	39
EAJ185	12-14	1"	5/16" hex	2	0.50"	3,000	31
EAJ215	12-14	1-1/2"	5/16" hex	2	1.00"	2,500	34
EAJ190	12-14	1"	5/16" hex	3	0.50"	4,000	41
EAJ200	12-14	1-1/4"	5/16" hex	3	0.750"	2,500	36
EAJ220	12-14	1-1/2"	5/16" hex	3	1.00"	2,500	34
EAJ260	12-14	2-1/2"	5/16" hex	3	2.00"	1,000	21
EAJ240	12-14	2"	5/16" hex	2	1.50"	1,500	26
EAJ320	12-24	1-1/2"	5/16" hex	5	0.60"	2,500	40
EAJ340	12-24	2"	5/16" hex	5	1.10"	2,000	35
EAJ415	1/4-14	1"	3/8" hex	2	0.50"	2,500	40
EAJ430	1/4-14	1-1/2"	3/8" hex	2	1.00"	1,000	30
EAJ445	1/4-14	2"	3/8" hex	2	1.50"	1,500	25
EAJ540	1/4-20	1"	3/8" hex	3	0.50"	2,500	40
EAJ580	1/4-20	1-1/2"	3/8" hex	3	1.00"	1,000	32
EAJ600	1/4-20	1-1/2"	3/8" hex	5	0.60"	1,000	32
EAJ610	1/4-20	2"	3/8" hex	3	1.50"	1,500	38
EAJ615	1/4-20	2"	3/8" hex	5	1.10"	1,500	38
EAJ640	1/4-20	2-1/2"	3/8" hex	3	2.00"	1,000	32
EAJ650	1/4-20	3"	3/8" hex	3	2.50"	500	18
EAJ630	1/4-20	3"	3/8" hex	5	2.10"	500	18
EAJ660	1/4-20	4"	3/8" hex	3	3.50"	500	22
EAJ670	1/4-20	4"	3/8" hex	5	3.10"	500	23
EAJ675	1/4-20	5"	3/8" hex	5	4.10"	250	16
EAJ680	1/4-20	6"	3/8" hex	5	5.10"	250	18
EAJ690C	1/4-20	8"	3/8" hex	5	7.10"	150	15

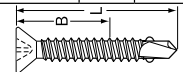

**Flat Head Reamers w/wings**

EBN140	10-16	1-1/2"	#2 phillips	3	0.800"	3,500	30
EBN345	12-24	2-13/16"	#3 phillips	5	1.710"	1,000	21
EBN645	1/4-20	2-13/16"	#3 phillips	5	1.710"	1,000	28

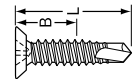

**Flat Head Undercut**

EBN200	12-14	1"	#3 phillips	2	0.500"	4,000	31
EBN220	12-14	1-1/4"	#3 phillips	2	.7500"	2,500	29
EBN240	12-14	1-1/2"	#3 phillips	2	1.00"	2,500	29
EBN630	1/4-20	3"	#3 phillips	2	2.500"	500	18
EBN640	1/4-20	4"	#3 phillips	2	3.500"	500	22

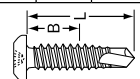

**Pan Head**

EAX100	8-18	3/4"	#2 phillips	2	0.320"	5,000	22
EAX102	8-18	1"	#2 phillips	2	0.500"	5,000	27
EAX110	10-16	3/4"	#2 phillips	2	0.320"	5,000	30
EAX120	10-16	1"	#2 phillips	2	0.500"	5,000	37



Cat #	Dia. TPI	L Length	Drive System	Point Size	B Maximum Load-bearing Length*	Pcs per 1/4 Keg	Wt per 1/4 Keg
-------	----------	----------	--------------	------------	--------------------------------	-----------------	----------------

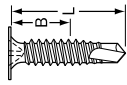

**Pancake Head**

EBN300	10-16	1"	#2 phillips	2	0.500"	4,000	29
EBN320	12-14	1"	#2 phillips	3	0.500"	4,000	40

\* The load-bearing length is the length of 300 series stainless under the hex, pan or pancake head or including the flat head. Hardened steel length (lead threads and point) should be through the connection and not in the load bearing section of the connection.

**Identification**

The head marking consists of the number "3" above the Elco® logo as shown to the right..



Flat, Pan and Pancake Head



MADE IN THE USA WITH GLOBAL MATERIALS

**Fab-Lok® Fasteners**

To maintain panel integrity in high-stress and high-vibration environments

Vibration, either from inside or outside a building, can make ordinary fasteners loosen and back out. Fab-Lok fasteners combine a slotted aluminum sleeve and fastener to provide high resistance to vibration loosening. Excellent for use with insulated panels.

**Specifications**

- Drive System: Hex
- Materials: Low carbon steel or 300 series stainless steel screw with aluminum sleeve
- Finish: Zinc

**Features & Benefits**

- Hex washer head machine screw assembled to a slotted aluminum sleeve and EPDM sealing washer
- After tightening, clamping times remain in place even if screw is removed
- Greater joint integrity with clamping force

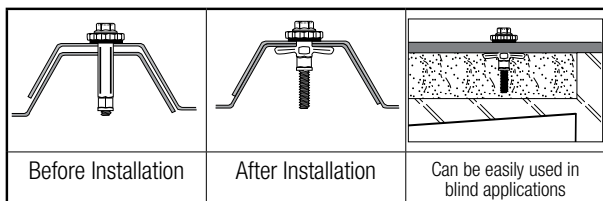

Cat #	Description	Penetrating Length	Grip Range	Ctn Qty	Ctn Wt
-------	-------------	--------------------	------------	---------	--------



**Carbon Steel**

EZJ100	FAS-10-4	1.373"	.062" – .250"	1,000	22
EZJ120	FAS-10-8	1.612"	.250" – .500"	1,000	23
EZJ140	FAS-10-12	1.807"	.500" – .750"	1,000	27

**H3 (300 Series) Stainless Steel**

EZJ210	FAC-10-4	1.373"	.062" – .250"	1,000	21
EZJ230	FAC-10-8	1.612"	.250" – .500"	1,000	25
EZJ250	FAC-10-12	1.807"	.500" – .750"	1,000	27

**Fab-Lok Drive Tools\***

EZJ900	Holding Sleeve with Socket	1			
--------	----------------------------	---	--	--	--

\*Fab-Lok fastener is inserted into a 5/16" hole (hole size is not critical) then installed with a power driver equipped with a Fab-Lok holding sleeve, with a socket designed to fit DEWALT® tools DCF622, DW267, DW268 and DW269. Max. 1000 RPM during installation.

**Identification**



Carbon Steel Screw:  
Elco Flag



Stainless Steel Screw:  
"F" Above "2"



MADE IN THE USA WITH GLOBAL MATERIALS

**ConFlex® Large Diameter Concrete Screw Anchors**

Enhanced ductility allows use in demanding exterior applications

ConFlex® masonry screws are engineered to provide high pull-out and shear values with virtual immunity to brittle failures.

**Specifications**

- Diameters: Oversized 1/4", 3/8" and 1/2"
- Material: Alloy steel
- Head Style: Hex washer head with locking serrations, flat head, TrimFit
- Thread Style: Double-lead
- Tensile Yield: 92,000 KSI min. (Grade 5); Tensile Ultimate: 120,000 KSI min. (Grade 5)

**Features & Benefits**

- Flex Technology® heat treat allows virtual immunity to brittle failures

[www.elcoconstruction.com](http://www.elcoconstruction.com)

- Locking serrations under the head provide back-out resistance
- Hardened tip ensures efficient tapping into concrete
- Head markings allow easy inspection
- Install with standard ANSI bits

Cat #	Length	Thread Length	Drive Size	Drill Bit Size	Box Qty*	Box Wt
-------	--------	---------------	------------	----------------	----------	--------



**3/8" Diameter, Hex Washer Head with Locking Serrations - Stalgard® SUB**

EMR215-050	2-1/2"	2-1/4"	9/16" hex	3/8"	50	5
EMR235-050	3"	2-1/4"	9/16" hex	3/8"	50	6
EMR255-050	4"	3-1/2"	9/16" hex	3/8"	50	7
EMR265-025	5"	3-1/2"	9/16" hex	3/8"	25	4
EMR285-025	7-1/2"	3-1/2"	9/16" hex	3/8"	25	6

**1/2" Diameter, Hex Washer Head with Locking Serrations - Stalgard® SUB**

EMR320-050	2-1/2"	2-1/4"	3/4" hex	7/16"	50	8
EMR340-050	3"	2-1/4"	3/4" hex	7/16"	50	9
EMR360-050	4"	3-1/2"	3/4" hex	7/16"	50	11
EMR370-025	5"	3-1/2"	3/4" hex	7/16"	25	7
EMR380-025	6"	3-1/2"	3/4" hex	7/16"	25	7

\* Note: Also available in bulk quantities.

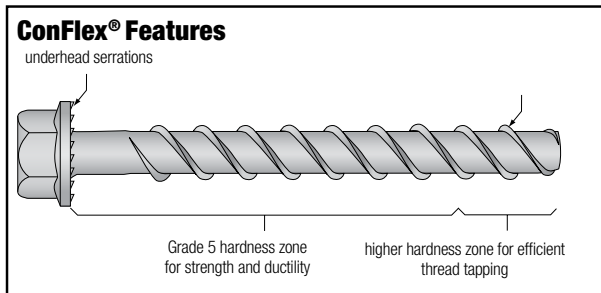

Dimensional Properties	
3/8" Diameter	1/2" Diameter
Drive system: 9/16" hex	Drive system: 3/4" hex
Washer diameter: 11/16"	Washer diameter: 1.0"
Thread O.D.: .430"	Thread O.D.: .525"
Thread root: .345"	Thread root: .405"
Unthreaded shank dia.: .360"	Unthreaded shank dia.: .426"
Head mark: Elco logo mark and length in inches	

**ConFlex® Identification**  
The head marking consists of an Elco® logo and the fastener length in inches.

**Recommended minimum embedment:**

All diameters: 2"

**Installation of 3/8" Con-Flex Screw Anchors:**

- Standard 3/8" ANSI masonry drill bit (.398" +.000"/-.010")

- Recommended functional masonry drill bit length: minimum 1" more than fastener length

**Installation of 1/2" Con-Flex Screw Anchors:**

- Standard 7/16" ANSI masonry drill bit (.468" +.000"/-.010")
- Recommended functional masonry drill bit length: minimum 1" more than fastener length



**Miami-Dade NOA**  
Notice of Acceptance  
**No. 17-1227.20**  
High Velocity  
Hurricane Zone

**#14 ConFlex®**

Grade 5 dual-hardened concrete / masonry screw

The over-sized #14 diameter ConFlex screw-anchor provides virtual immunity to embrittlement failure. Over-sized design and patented 40-45° thread profile provides enhanced anchor and connection strengths. Typical applications: Storefront/Curtain Wall, Hurricane Shutter Framing, Window Frames, Shelving and Racking, Impact Resistant Windows and Wood to Concrete or CMU.

**Features**

- Grade 5 dual-hardened heat treatment process (Flex Technology®)
- Large, oversized fastener dimensions (Thread O.D., minor diameter & unthreaded section)
- Patented 40/45° V-Notched threads
- Excellent corrosion resistance, multiple corrosion resistant finishes

**Benefits**

- Enhanced ductility
- Higher strip-out resistance in lower compression strength materials
- Stalgard SUB or Stalgard corrosion resistant finishes
- Alpha-numeric length head-marking codes ensures proper screw and anchor length have been used at inspection



### Drive & Head Styles

	HWH Hex Washer Head	TFH Phillips Trimfit Flat Head	PFH Phillips Flat Head
Drive	3/8" Hex	#3 Bit Drive	#3 Bit Drive
Washer Face Dia.	0.520"	NA	NA
Head Dia.		0.400"	0.460"
Head Height	0.240"	0.158"	0.210"
Flare	-	80°	80°

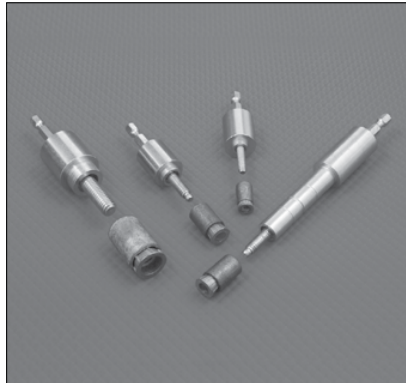

#### #14 Diameter, Hex Washer Head - Stalgard® SUB Silver (2,000 Hour)

Cat #	Length	Drive Size	Drill Bit Size	Box Qty*	Box Wt
EMR155	1-3/4"	3/8" hex	7/32"	1,000	36
EMR165	2-1/4"	3/8" hex	7/32"	1,000	30
EMR175	2-3/4"	3/8" hex	7/32"	800	25
EMR185	3-1/4"	3/8" hex	7/32"	500	23
EMR195	3-3/4"	3/8" hex	7/32"	500	21

#### #14 Phillips Flat Head - Silver Stalgard® (1,000 Hr)

EMR110	1-3/4"	#3 Phillips	7/32"	2,000	44
EMR120	2-1/4"	#3 Phillips	7/32"	1,500	35
EMR130	2-3/4"	#3 Phillips	7/32"	1,000	30
EMR140	3-1/4"	#3 Phillips	7/32"	1,000	26
EMR150	3-3/4"	#3 Phillips	7/32"	500	23

#### #14 TrimFit Flat Head - Silver Stalgard® (1,000 Hr)

EMR113	1-3/4"	#3 Phillips	7/32"	2,000	51
EMR123	2-1/4"	#3 Phillips	7/32"	1,500	40
EMR133	2-3/4"	#3 Phillips	7/32"	1,000	31
EMR143	3-1/4"	#3 Phillips	7/32"	1,000	27
EMR153	3-3/4"	#3 Phillips	7/32"	500	25

#### #14 TrimFit Flat Head - White Stalgard® (1,000 Hr)

EMR124	2-1/4"	#3 Phillips	7/32"	1,500	40
EMR134	2-3/4"	#3 Phillips	7/32"	1,000	33
EMR144	3-1/4"	#3 Phillips	7/32"	1,000	27

Note: Length measured under head for hex head anchors, total length for flat head and trim flat head anchors. See diagram above.

### Masonry Drill Bits

Drill Bit	Drill Diameter	Overall Length	Usable Bit Length	Drill Bit Shank Type
EMC100	7/32" ANSI	4-1/2"	2-3/4"	Tanged
EMC110		5-1/2"	4"	
EMC130		7"	4"	Hex SDS

### RapidSet® Tools

*The fastest, easiest and most reliable way to install machine screw anchors*

Efficient RapidSet® tools eliminate clumsy hammer and -setting processes or expensive, slow expander tools.\*

#### Specifications

- For machine screw anchor sizes #10, 1/4" and 3/8"
- Designed for use with power tools, including battery impact drivers
- MAXX model allows placement of 1/4" anchors at various depths (up to 2") below the surface

#### Features & Benefits

- Power tool does all the work – no pounding with setting tools
- Automatically sets anchor just below the surface
- Maximizes expansion of bottom portion of lead sleeve, which results in consistently high pull-out values

Cat #	For Insert-Anchor Size
-------	------------------------



#### Standard RapidSet tool

EZB790	#10-24
EZB800	1/4-20
EZB820	3/8-16

















#### RapidSet MAXX tool

EZB810	1/4-20
--------	--------

#### Repair Kits

EZB811	Repair Kit for EZB810 (Rapidset MAXX Tool)
EZB801	Repair Kit for EZB800 (Rapidset Tool for 1/4-20 Inserts)

\* Note: RapidSet tools draw the anchor's internal insert up into the anchor's outer sleeve; this installation process eliminates the need to maintain a back bearing surface (required by hammer setting tools).

													
		<b>Drillit® / Standard</b>	<b>Drillit® / Bonded Sealing Washers</b>	<b>Drillit® / Extended Drilling</b>	<b>Drillit® / Flo-Seal®</b>	<b>Drillit® / Wood-to-Metal</b>	<b>Tapfast®</b>	<b>Architectural Roof Clip Fasteners</b>	<b>Dril-Flex®</b>	<b>Tap-Flex®</b>	<b>Bi-Flex™</b>	<b>Alumi-Flex™</b>	<b>Fab-Lok®</b> <i>Requires a Fab-Lok Holding Sleeve EZJ900 to be Used with Socket</i>
	<b>DEWALT 2,500 RPM VSR VERSA-CLUTCH™ SCREWGUN</b> Amps: 6.5 No-Load Speed: 0-2500 RPM Torque: 132 in-lbs <b>DW268</b>	#6-#10	#8-#10			#10	#10	#10	#10		#8-#10	#10	✓
	<b>DEWALT 2,000 RPM VSR VERSA-CLUTCH™ SCREWGUN</b> Amps: 6.5 No-Load Speed: 0-2000 RPM Torque: 164 in-lbs <b>DW267</b>	#12 & 1/4"	#12 & 1/4"	#12 & 1/4"	#12	#12 & 1/4"		#12	#12 & 1/4"		#12 & 1/4"	#12 & 1/4"	✓
	<b>DEWALT 1,000 RPM VSR VERSA-CLUTCH™ SCREWGUN</b> Amps: 6.5 No-Load Speed: 0-1000 RPM Torque: 344 in-lbs <b>DW269</b>	5/16"							5/16"				✓
	<b>DEWALT 20V MAX* XR® VERSA-CLUTCH™ ADJUSTABLE TORQUE SCREWGUN KIT</b> No-Load Speed: 0-2000 RPM Torque: Adjustable <b>DCF622M2</b>	#6-1/4"	#8-1/4"	#12 & 1/4"	#12	#10-1/4"	#10	#10 & #12	#10-1/4"		#8-1/4"	#10-1/4"	✓
	<b>DEWALT 20V MAX* XR® 1/4 IN. 3-SPEED IMPACT DRIVER KIT</b> No-Load Speed: 0-1,000/ 2,800/ 3,250 RPM Max Torque: 1,825 in-lbs <b>DCF887M2</b>									✓			

\*For 20V MAX\* Maximum initial battery voltage measured without a workload is 20 volts. Nominal voltage is 18. Impact tools are not recommended for the installation of self drilling screws. A max 2500 RPM screw gun with torque sensing nose pieces should be used.



# DUST SOLUTIONS



# ARE YOU COMPLIANT?

The Occupational Safety and Health Administration (OSHA) rules with the intent to limit workers' exposure to respirable crystalline silica.



## TOOLS

Operate and maintain tool in accordance with manufacturer's instructions to minimize dust emissions.

- Read operator's manual provided with tool and accessories.
- To minimize dust emissions use recommended shroud or cowling and dust extractor

## ACCESSORIES AND SHROUDS

Use drill or grinder equipped with commercially available shroud or cowling with dust collection system.

- All DeWALT shrouds and dust collection systems are commercially available.

## DUST EXTRACTORS

Dust collector must provide the air flow recommended by the tool manufacturer, or greater, and have a filter with 99% or greater efficiency. Dust collector must have a cyclonic pre-separator or filter-cleaning mechanism. Cleaning/Drilling holes requires a vacuum with a HEPA filter.

- Both DWV010 and DWV012 provide the necessary airflow for drilling and hammering applications.
- Both DWV010 and DWV012 ship with dual HEPA filters, which have an efficiency of 99.97% of all particles greater than or equal to 0.3 microns.
- Both DWV010 and DWV012 have a timed automatic filter-cleaning mechanism.
- Surfacing, Tuckpointing, and Cutting with grinder requires 25 CFM per inch of wheel diameter, a filter cleaning mechanism, and 99% or greater efficiency.



## YOUR FIRST LINE OF DEFENSE.™

100 Copyright ©2017 DeWALT. The following are trademarks for one or more DeWALT power tools, accessories, anchors and concrete adhesives: The yellow and black color scheme; the "D"-shaped air intake grill; the array of pyramids on the handgrip; the kit box configuration; and the array of lozenge-shaped humps on the surface of the tool.

DeWALT's Perform & Protect™ line of Power Tools is designed to provide a high level of one or more of the following: control, dust containment, or low vibration, without sacrificing performance.

# FACTORY SERVICE

## TOOL AND EQUIPMENT REPAIR

**WE KEEP YOU WORKING.**

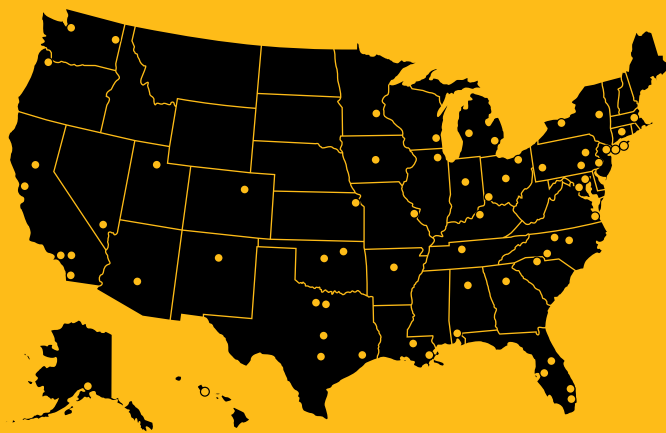

### WHY PROS TRUST DEWALT SERVICE CENTERS



#### REPAIR. REBUILD. RESTORE.

We make repair a smart option by guaranteeing the repair will not exceed the quoted price.



#### MINIMIZE DOWNTIME

Factory Service Centers are committed to providing the ultimate service advantage for your tool repair in 5 Days or Less.



#### YEAR ROUND TRADE-UP PROGRAM

Trade in a broken or functioning non-DEWALT power tool for a discount towards the purchase of a new DEWALT power tool.

- Over 30 Field Service Coordinators
- Professional technical assistance through the Factory Service Centers and Call Centers
- Over 1,800 Authorized Service Providers encompassing the industry's largest service network

### SERVICENET.DEWALT.COM

We stock the replacement parts for your DEWALT tools.

# DEWALT®

## GUARANTEED TOUGH.®

VISIT [ANCHORS.DEWALT.COM](http://ANCHORS.DEWALT.COM) FOR:



**SERVICE CENTER LOCATION**



**TOOL SERVICE LOCATION**



**ANCHOR DISTRIBUTION CENTER**

**DEWALT®**

[www.DEWALT.com](http://www.DEWALT.com)

\*Maximum initial battery voltage (measured without a workload) is 20 volts. Nominal voltage is 18.

<sup>1</sup> With 5.0Ah battery pack, driving 3/4" .102 fasteners into concrete.

Copyright ©2020 DEWALT. The following are trademarks for one or more DEWALT power tools, accessories, anchors and concrete adhesives: The yellow and black color scheme; the "D"-shaped air intake grill; the array of pyramids on the handgrip; the kit box configuration; and the array of lozenge-shaped humps on the surface of the tool.

ICDWPWRELCORG19 01/20