

SIEMENS



SIPROTEC 5

Protection, Control, Automation,
Monitoring, Power Quality – Basic

Catalog • Edition 7

SIPROTEC 5 Device Series Protection, Control, Automation, Monitoring, and Power Quality – Basic

SIPROTEC 5 – V8.4 – Catalog Edition 7

Invalid:
Edition 6

SIPROTEC 5	1
Introduction	1.1
Innovation Highlights	1.2
SIPROTEC 5 Devices and Fields of Application	2
Device Types	2.1
Device Selection Table	2.2
Application Examples	2.3
Overcurrent and Feeder Protection	2.4
Line Protection	2.5
Distance Protection	2.6
Line Differential Protection	2.7
Line Differential and Distance Protection	2.8
Circuit-Breaker Management Device	2.9
Overcurrent Protection as Backup Protection for Line Protection	2.10
Transformer Differential Protection	2.11
Motor Protection	2.12
Generator Protection	2.13
Paralleling Device	2.14
Busbar Protection	2.15
Bay Controllers	2.16
Fault Recorder	2.17
Merging Unit	2.18
SIPROTEC 5 System	3
Functional Integration	3.1
Protection	3.2
Control	3.3
Automation	3.4
Monitoring	3.5
Data Acquisition and Logging	3.6

Content

3.7	Communication
3.8	Safety and Security Concept
3.9	Test and Diagnostics
4	SIPROTEC 5 – Engineering
4.1	SIPROTEC 5 Web UI
4.2	DIGSI 5
4.3	IEC 61850 System Configurator
4.4	SIGRA
4.5	SIPROTEC DigitalTwin
4.6	SIPROTEC Dashboard
5	SIPROTEC 5 – Hardware
5.1	Hardware Modules
5.2	Conformal Coating
5.3	Modules
5.4	Integrated Interfaces
5.5	Terminals
5.6	Input/Output Modules
5.7	Plug-In Modules
5.8	Standard Variants
6	Appendix
6.1	Spare Parts and Accessories
6.2	Connection Diagrams
6.3	Assembly Dimensions
6.4	Grouping Measured Values
6.5	Technical Data
6.6	Overview Document Types
6.7	Legal Notices
7	Index



[E_CC_SIP5_GD_SS_LED, 2, --, --]



[E_CC_SIP5_PAS_Gruppe, 2, --, --]



[ph_Nesplen, 1, --, --]

Editorial

SIPROTEC has been a recognized brand leader in digital protection and bay units on the energy market for decades. The Siemens high-performance SIPROTEC devices cover the entire power spectrum and can be implemented in a wide range of fields – from power generation to transmission of very high voltages, distribution network, and industrial applications.

SIPROTEC 5 is an active component of the secure smart power system, and an important building block in the complexity of distributed energy-supply systems and networks solutions.

The SIPROTEC 5 generation of devices provides you with a modern platform of both hardware and software. This platform offers an excellent solution to the challenges associated with evolving grid structures and workflows. The quality, reliability, and proven functions of the SIPROTEC 4 device range have been preserved. Innovative approaches including holistic workflow, safety and security, and network-stability monitoring (PMU functionality) have been added.

Integrated and upgradeable functionalities for your efficient network operation:

- Various sensitive ground fault and ground-fault location methods for fast fault location
- Voltage control for transformers for cost optimization – also for parallel transformers
- PMU function for network-stability monitoring
- Adaptive adaptation of the protection parameters via IEC 61850 to increase the network load
- Protection of complex network structures, such as capacitance banks or multi-end topologies
- Process-bus applications according to IEC 61850-9-2 digitize the measured data directly at the measuring point
- IoT interface to cloud applications such as MindSphere with the standard protocol OPC UA PubSub for easy use of data from the bay, for example SIPROTEC Dashboard
- Extensive cybersecurity functionality, such as role-based access control (RBAC), logging of security-related events, signed firmware, or authenticated IEEE 802.1x network access.

With the SIPROTEC 5 generation, you are well equipped to meet the growing economic and availability requirements imposed on your power systems. The philosophy of SIPROTEC 5 is reflected in the modularity and flexibility of its hardware and software components. Perfectly tailored fit – the custom fit for your switchgear and requirements for the application and standardization of power automation.

Ingo Erkens

Smart Infrastructure
Digital Grid

The Benchmark for Protection, Automation, and Monitoring

The SIPROTEC 5 series is based on the long-term field experience of the SIPROTEC device series and has specifically been designed for the new requirements of modern power systems. For this purpose, SIPROTEC 5 is equipped with extensive functionalities and device types. With the integrated and consistent DIGSI 5 engineering tool, a solution has also been provided for increasingly complex processes, from design through to the engineering phase, up to testing and operation.

Thanks to the high degree of hardware and software modularity, the functionality of the device types can be tailored to the requested application and adjusted to the ever-changing requirements throughout the entire lifecycle.

In addition to the reliable and selective protection and the complete automation function, SIPROTEC 5 offers an extensive database for operating and monitoring modern power systems. Synchrophasors (PMU), power-quality data, and extensive equipment data are included in the functionality.

- Powerful protection functions ensure the safety of equipment and staff
- Individually configurable devices save money on the initial investment and on spare-parts storage, maintenance, extension, and adaptation of your plant
- Arc protection, transient ground-fault detection, transformer control, and process bus can easily be integrated and retro-fitted
- Purposeful and easy handling of devices and software thanks to a user-friendly design
- Increased reliability and quality of the engineering process
- High operational safety due to the consistent safety implementations
- Highest availability even under extreme environmental conditions due to the coating on the electronic modules
- Integrated switch for low-cost and redundant optical and electrical Ethernet rings
- Redundancy protocols RSTP, PRP, and HSR for maximum availability
- Efficient operating concepts due to flexible engineering of IEC 61850 Edition 2
- Comprehensive database for monitoring modern power systems, also with IoT cloud connection
- Optimal smart automation platform for your power systems based on integrated Phasor Measurement Unit (PMU) and Power Quality functions.



[SIP5_Gruppe, 2, --, --]

Figure 1.1/1 SIPROTEC 5 – Modular Hardware



[E_CC_SIP5_19Zoll_KomMod, 1, --, --]

Figure 1.1/2 SIPROTEC 5 – Modular Process Connection

Holistic Workflow

End-to-end engineering from system design to operation makes your work easier throughout the entire process.

The highlight of SIPROTEC 5 is the improved emphasis on daily ease of operation. SIPROTEC 5 provides holistic support along all the work steps, allowing for system-view management and configuration down to the details of individual devices, saving time and improving cost-effectiveness without compromising quality (Figure 1.2/1).

Holistic workflow in SIPROTEC 5 means:

- Integrated, consistent system and device engineering – from the single-line diagram of the unit all the way to device parameterization
- Simple, intuitive graphical linkage of primary and secondary equipment
- Supplied and user-defined application templates for the most frequently used applications
- IEC 61850 System Configurator independent from manufacturers, for simple system engineering
- Open-circuited interfaces for seamless integration into your process environment
- Integrated tools for testing during engineering and commissioning and for simulating operational scenarios, such as system incidents or switching operations.
- SIPROTEC DigitalTwin for virtually testing SIPROTEC 5 devices in the cloud

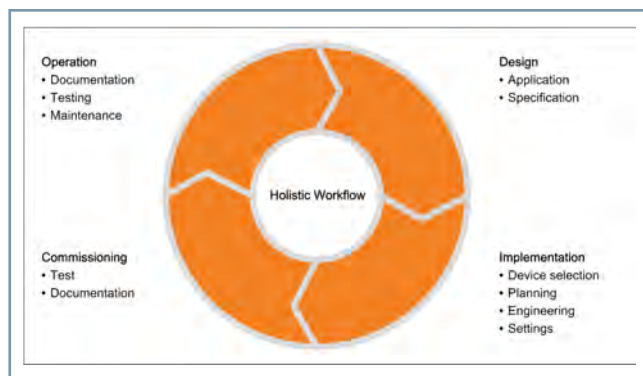

[dhw_Holistic-workflow, 1, en_US]

Figure 1.2/1 End-to-End Tools – from Design to Operation

Holistic workflow in SIPROTEC 5 means for you:

An end-to-end tool from system design to operation – even across department boundaries – saves time and ensures data security and transparency throughout the entire lifecycle of your plant.

Perfectly Tailored Fit

Individually configurable devices provide you with cost-effective solutions that match your needs precisely throughout the entire lifecycle. SIPROTEC 5 sets new standards in cost savings and availability with its innovative modular structure and flexible hardware, software, and communication. SIPROTEC 5 provides a perfectly tailored fit for your switchgear and applications that is unequaled by any other system.

Perfectly tailored fit in SIPROTEC 5 means:

- Modular system design in hardware, functionality, and communication ensures the perfect fit to your needs
- Functional integration of various applications, such as protection, control, measurement, power quality or fault recorder, voltage controller, ground-fault method
- Frequency-tracked protection functions over a wide frequency range (10 Hz to 80 Hz) and the option to assign the protection functions in a single device to different frequency tracking groups
- The same extension and communication modules for all devices in the family
- Innovative terminal technology ensures easy assembly and interchangeability at the highest possible degree of safety
- Identical functions throughout the entire system family mean fewer training requirements and increased safety.
Example: Identical automatic reclosing (AREC) for line protection devices 7SD8, 7SA8, 7SL8.

Perfectly tailored fit in SIPROTEC 5 means:

Individually configurable devices that save money on initial investment, spare-parts storage, maintenance, extension, and adaptation of your system.



[Innovationsschwerpunkte, 1, --_]

Figure 1.2/2 SIPROTEC 5 – Innovation Highlights

Designed to Communicate

The trendsetting system architecture places communication firmly under your control. Powerful, flexible, and above all, reliable communication is the prerequisite for distributed and decentralized system topologies such as Smart Grids. In the system architecture of SIPROTEC 5, we have attached immense importance to communication, and we have gone to exceptional lengths to ensure that you are ideally equipped for the communication demands of today and the future.

Designed to communicate in SIPROTEC 5 means:

- IoT interface to cloud applications such as MindSphere with the standard protocol OPC UA PubSub for easy use of data from the bay, for example SIPROTEC Dashboard
- Adaptation to the topology of your communication structure using parameters (ring, star, network, etc.)
- Scalable redundancy in hardware and software (protocols to match your requirements)
- Multiple communication channels to various higher-level systems at station and control-center level, as well as cloud applications
- Pluggable and upgradeable communication modules also for process-bus solutions according to IEC 61850-9-2

- Hardware modules decoupled from the currently used communication protocol
- 2 independent Ethernet protocols in one module
- Extensive routines for test connections, functions, and operating workflows

Designed to communicate in SIPROTEC 5 means for you: Communication as an integral component of the system architecture provides you with the flexibility and security you need in densely networked systems, today and in the future.



[SIP5_Kommunikationsschnittst, 1, ...]

Figure 1.2/3 SIPROTEC 5 Device with Extensive Communication Interfaces

Safety Inside

Multilayer safety mechanisms in all links of the system safety chain provide you with the highest possible level of safety and availability. Human safety and plant safety, as well as maximum availability, are the top priorities. As the plant landscape becomes more and more open and complex, conventional security mechanisms are no longer adequate. For this reason, a safety concept has been integrated in the SIPROTEC 5 device architecture that is designed to address and implement these multilayer aspects in a holistic approach.

Safety Inside in SIPROTEC 5 means:

- Proven functions that protect plants and personnel, which have been continuously developed over 5 generations
- Long-lasting, rugged hardware (housings, modules, plugs) and a sophisticated layout of the entire electronics for high resilience against voltage, EMC, climate, and mechanical stress
- Sophisticated self-monitoring routines identify and report device faults immediately and reliably

Comprehensive Cybersecurity

Cyberattacks on the energy infrastructure are real and are now regularly present in the media. Cybersecurity in the case of SIPROTEC 5 is therefore considered holistically in all cases. This includes the processes, personnel, and technologies.

The infrastructure used to develop the SIPROTEC 5 product family is protected in accordance with ISO/IEC 27001. Critical data, such as the software and firmware source files, are protected against unauthorized manipulation.

In addition, the following precautionary, continuous measures are in place:

- Secure development
- Security-patch management
- Antivirus and Windows patch compatibility checks
- Product hardening
- Independent security validation

The cybersecurity functions implemented in the components are state of the art and interoperable.

These include the following features:

- TLS-encrypted communication between DIGSI 5 and the SIPROTEC 5 device
- Support on the device side for role-based access control with central user management and emergency access
- Configurable read and write access restriction for DIGSI 5 and IEC 61850-MMS connections at device-port tier
- Logging of security-relevant events via syslog and in a non-erasable security buffer internal to the device
- Built-in crypto chip for secure information storage and transmission
- Device uses keys stored in the crypto chip to load only firmware signed by Siemens
- Separation of process and service communication
- Secure access with operation via the device display and Web browser

Smart Automation for Grids

Climate change and dwindling fossil fuels are forcing a total re-evaluation of the energy-supply industry, from generation to distribution and consumption. This is having fundamental effects on the structure and operation of the power systems.

Smart automation, the intelligent power automation system, is a major real-time component designed to preserve the stability of these power systems and at the same time conserve energy and reduce costs.

With SIPROTEC 5 and the unique spectrum of integrated functionality, you have the optimum smart automation platform for your smart power systems.

Smart Automation for Grids in SIPROTEC 5 means:

- Open-circuited, scalable architecture for IT integration and new functions
- Smart functions, for example for network operation, analysis of faults or power quality (power-system monitoring, power-control unit, fault location)
- Integrated automation with optimized logic blocks based on the IEC 61131-3 standard
- High-precision acquisition and processing of process values and power transmission to other components in Smart Grid
- Protection, automation, and monitoring in Smart Grid

SIPROTEC 5 devices have specifically been designed to meet the requirements of the modern grid, secure the future, and offer the necessary automation platform.

The elements that connect the 5 mentioned innovation highlights are IEC 61850 Edition 2 and its thoroughly designed, user-oriented implementation in SIPROTEC 5.

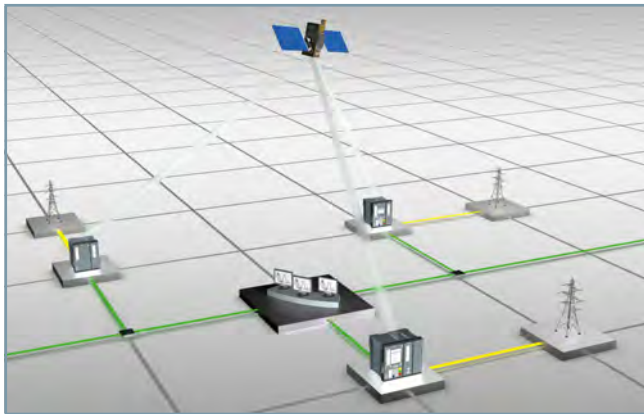

[Systemkomponente, 1, --,--]

Figure 1.2/4 SIPROTEC 5 as a System Component of the Smart Power System

IEC 61850 – Simply Usable

Siemens, the pioneer of IEC 61850, makes the full potential of this global standard easily usable for you.

The IEC 61850 standard is more than just a substation automation protocol. It comprehensively defines data types, functions, and communication in station networks. In Edition 2, the influence of the standard is extended to more domains and applications of the energy-supply industry.

Siemens was actively involved in the process of standardization from Edition 1 to Edition 2, and with the largest number of completed installations in the world, our experience as a manufacturer in the field is unsurpassed. Jointly with key customers, we designed its implementation in SIPROTEC 5, paying close attention to interoperability, flexibility, and compatibility between Editions 1 and 2.

Besides the standard protocol IEC 61850-8-2 (station bus) and IEC 61850-9-2 (process bus), SIPROTEC 5 also supports other

protocols, such as IEC 60870-5-103, IEC 60870-5-104, DNP3 (serial or TCP), or Modbus TCP.



[IEC61850 Symbol, 1, --,--]

1.2

IEC 61850 – Simply usable means:

- A stand-alone IEC 61850 System Configurator that allows IEC 61850 configuration of SIPROTEC 5, SIPROTEC 4, SIPROTEC Compact, and third-party device
- Full compatibility with Editions 1 and 2
- Open-circuited interfaces to IEC 61850 ensure system configurations and interoperability that is independent from manufacturers
- Conversion of the complexity of the IEC 61850 data model into your familiar user language
- Flexible object modeling, degrees of freedom in object addressing, and flexible communication services warrant the highest possible degree of interoperability and effective exchange and extension concepts.
- Handling optimization based on many projects and close cooperation with customers from all fields of application
- Protection settings via IEC 61850
- Using several communication modules in Edition 2

The implementation of IEC 61850 Edition 2 unleashes the full potential of this standard by optimally supporting your operational needs and simplifying handling.



IEC 61850 Certificate Level A¹

Page 1/2

Issued to:
Siemens AG, IC SG EA
Protection and Substation Control Systems
Wernerwerdamm 5
D-13623 Berlin
Germany

No. 74104438-MOC/INC 13-2336

For the server product:
SIPROTEC V5
7SL87 Differential and Distance Protection
Version 03.01

Issued by: 

The server product has not shown to be non-conforming to:
IEC 61850 Edition 2 Parts 6, 7-1, 7-2, 7-3, 7-4 and 8-1
Communication networks and systems for power utility automation

This conformance test has been performed according to IEC 61850-10 Edition 2, the UCA International Users Group Edition 2 Server Test Procedures version 1.0 with the product's protocol, modal and technical issue implementation conformance statements and the extra information for testing: "Siemens SIPROTEC 5 IEC 61850 PIXIT, PICS, TICS V3.0, C53000-G5040-C013-3" and "SIPROTEC Model Implementation Conformance Statement (MICS) According to IEC 61850, Product code 7SL87, Mapping version V03.01".

The following IEC 61850 conformance blocks have been tested with a positive result (number of relevant and executed test cases / total number of test cases):

1 Basic Exchange (22/26)	9a GOOSE Publish (10/12)
2 Data Sets (3/6)	9b GOOSE Subscribe (12/14)
2+ Data Set Definition (24/24)	12a Direct Control (11/20)
3 Substitution (3/3)	12b SBO Control (17/28)
4 Setting Group Selection (3/5)	12c Enhanced Direct Control (11/20)
5 Unbuffered Reporting (19/20)	12d Enhanced SBO Control (17/28)
6 Buffered Reporting (28/29)	13 Time Synchronization (8/7)
	14 File Transfer (5/8)
	15 Service Tracking (1/17)

This certificate includes a summary of the test results as carried out at KEMA in the Netherlands with LinUCA 61850 Client simulator 4.27.03 with test suite Ed2 3.27.01 and LinUCA 61850 Analyzer 5.27.04. This document has been issued for information purposes only, and the original paper copy of the KEMA report No. 74104438-MOC/INC 13-2337 will prevail.

The test has been carried out on one single specimen of the product as referred above and submitted to KEMA by Siemens. The manufacturer's production process has not been assessed. This attestation does not imply that KEMA has approved any product other than the specimen tested.

Amhem, June 18, 2013



M. Adriaens
Director Intelligent Networks & Communication



R. Schimmet
Certification Manager

¹ Level A - Independent test lab with certified ISO 9001 Quality System

Copyright © KEMA Nederland B.V., Amhem, the Netherlands. All rights reserved. Please note that any electronic version of this KEMA attestation is provided to KEMA's customer for convenience purposes only. It is prohibited to update or change it in any manner whatsoever, including but not limited to copying or printing. In case of a conflict between the electronic version and the original version, the original paper version issued by KEMA will prevail.

KEMA Nederland B.V.
Ulrechtseweg 310, 6812 AR Amhem, P.O.Box 9035, 6800 ET Amhem, The Netherlands
T +31 26 356 20 25 F +31 26 351 36 83 sales@kema.com www.kema.com

IEC 61850 Certificate Level A¹

Page 2/2

Applicable Test Procedures from the UCA International Users Group edition 2 Server Test Procedures version 1.0

Conformance Block	Mandatory	Conditional
1: Basic Exchange	sAss1, sAss2, sAss3, sAssN2, sAssN3, sAssN4, sAssN5, sSrv1, sSrv2, sSrv3, sSrv4, sSrv5, sSrvN1abcd, sSrvN4	sSrv6, sSrv8, sSrv11, sSrv12, sSrv13, sSrvN1e, sSrvN1f, sSrvN3
2: Data Sets	sDs1, sDs10a, sDsN1ae	
2+: Data Set Definition	sDs2, sDs3, sDs4, sDs5, sDs6, sDs7, sDs8, sDs9, sDs11, sDs12, sDs13, sDs14, sDsN1cd, sDsN2, sDsN3, sDsN4, sDsN5, sDsN6, sDsN7, sDsN8, sDsN9, sDsN10	sDsN11, sDsN12
3: Substitution	sSub1, sSub2, sSub3	
4: Setting Group Selection	sSg1, sSg3, sSgN1	
5: Unbuffered Reporting	sRp1, sRp2, sRp3, sRp4, sRp8, sRp9, sRp10, sRp11, sRp12, sRp14, sRpN1, sRpN2, sRpN3, sRpN4, sRpN8	sRp5, sRp6, sRp7, sRpN5
6: Buffered Reporting	sBr1, sBr2, sBr3, sBr4, sBr8, sBr9, sBr10, sBr11, sBr12, sBr14, sBr20, sBr21, sBr22, sBr23, sBr26, sBr27, sBr23, sBrN1, sBrN2, sBrN3, sBrN4, sBrN5, sBrN8	sBr5, sBr6, sBr7, sBr23, sBr24
9a: GOOSE publish	sGop2, sGop3, sGop4, sGop7, sGop9, sGop10, sGop11	sGop1, sGop6, sGopN1
9b: GOOSE subscribe	sGos1, sGos2, sGos3, sGos5, sGos6a, sGos7, sGosN1, sGosN2, sGosN3, sGosN4, sGosN5, sGosN6	
12a: Direct control	sCtl5, sCtl10, sCtl14, sDOms1, sDOms2	sCtl7, sCtl13, sCtl16, sCtl17, sCtl19, sCtl26
12b: SBO control	sCtl5, sCtl6, sCtl8, sCtl9, sCtl10, sCtl11, sCtl25, sSBOms1, sSBOms2, sSBOms6	sCtl4, sCtl7, sCtl16, sCtl17, sCtl19, sCtl26, sCtl27
12c: Enhanced Direct Control	sCtl5, sCtl10, sCtl14, sDOes1, sDOes2	sCtl7, sCtl13, sCtl16, sCtl17, sCtl19, sCtl26
12d: Enhanced SBO control	sCtl5, sCtl6, sCtl8, sCtl9, sCtl10, sCtl11, sCtl25, sSBOes1, sSBOes2, sSBOes6, sSBOes8	sCtl4, sCtl7, sCtl16, sCtl17, sCtl19, sCtl26
13: Time sync	sTm1, sTm2, sTmN1	sTm3, sTm4, sTm5
14: File transfer	sFt1, sFt2ab, sFt4, sFt5, sFtN1ab	
15: Service tracking		sTrk7

All configuration file and data model tests have been successfully performed for the product variants using the same communication hardware and software version: 6MD85, 6MD86, 7SA84, 7SA86, 7SA87, 7SD84, 7SD86, 7SD87, 7SJ85, 7SJ86, 7SL86 and 7VK87.

KEMA Nederland B.V.
Ulrechtseweg 310, 6812 AR Amhem, P.O.Box 9035, 6800 ET Amhem, The Netherlands
T +31 26 356 20 25 F +31 26 351 36 83 sales@kema.com www.kema.com

[IEC61850 Edition 2 Certificate Level A, 1, --,--]

Figure 1.2/5 First IEC 61850 Certificate Edition 2 Worldwide

SIPROTEC 5 Devices and Fields of Application



SIPROTEC 5 Devices and Fields of Application

Device Types

2.1

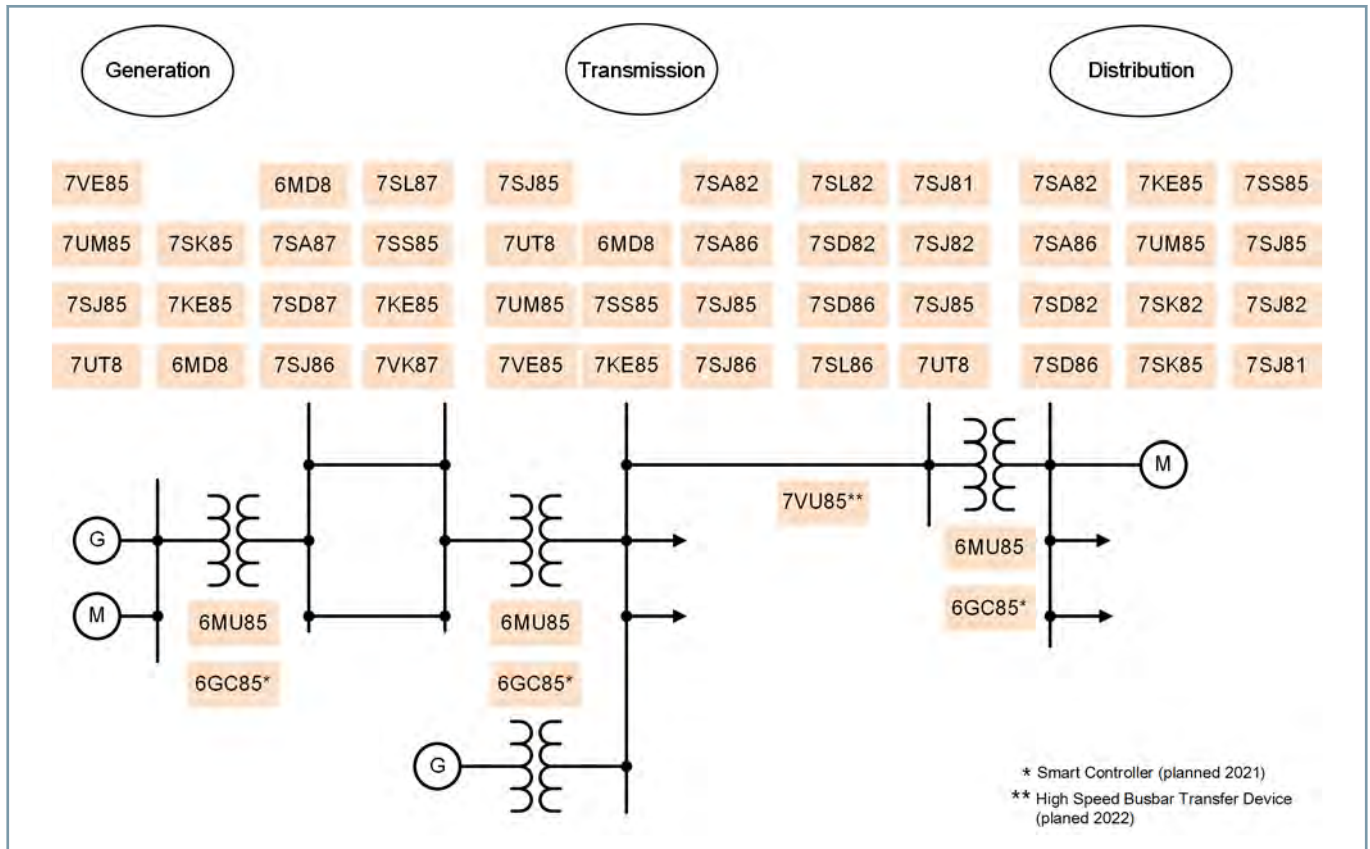

[dw_sip5_anwendung, 5, en_US]

Figure 2.1/1 Fields of Application of the SIPROTEC 5 Devices

The graphic gives an overview of the utilization of SIPROTEC 5 devices in the power system. With renewable-energy producers, in particular, there is power infeed into the grid at all voltage levels. Protected objects are busbars, overhead lines or cables, and transformers. The corresponding protection device are allocated to these objects.

Device Types

A short 5-digit code permits easy identification of the SIPROTEC 5 devices. The first digit (6 or 7) stands for digital technology. The 2 letters describe the functionality and the last 2 digits identify typical properties (Figure 2.1/2). You can

find further details in the catalog section of the related device description.

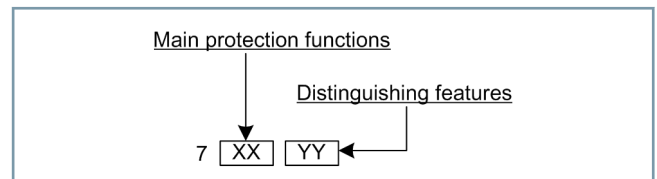

[dw_device_typ, 1, en_US]

Figure 2.1/2 Definition of the Device Types by their Designation

Main Function	Device Types
Overcurrent and Feeder Protection	
Overcurrent protection designed for the protection of feeders and lines in medium-voltage and high-voltage systems; with PMU ¹ and control	7SJ81 ² , 7SJ82, 7SJ85
Line Protection	
Distance protection for the protection of lines in medium-voltage and high-voltage systems; with a PMU ¹ and control	7SA82, 7SA86, 7SA87
Line differential protection for the selective protection of lines and cables with a single-side and multi-side infeed in medium-voltage and high-voltage systems; with a PMU ¹ and control	7SD82, 7SD86, 7SD87
Combined line differential and distance protection for the protection of lines in medium-voltage and high-voltage systems; with a PMU ¹ and control	7SL82, 7SL86, 7SL87
Switch management device for managing switches; with a PMU ¹ and control	7VK87
Overcurrent protection for lines with PMU ¹	7SJ86
Transformer Differential Protection	
Transformer differential protection for the protection of two-winding and multi-winding transformers (up to 5 sides); with a PMU ¹ , control, and monitoring	7UT82, 7UT85, 7UT86, 7UT87
Motor Protection	
Motor protection devices for the protection of motors of all sizes; with PMU ¹ and control	7SK82, 7SK85
Generator Protection	
Generator protection device for the protection of generators and power units; with PMU ¹	7UM85
Paralleling Device	
Paralleling device for the synchronization of generators (power units) with the electricity-supply system or synchronization of 2 electricity-supply systems	7VE85
Busbar Protection	
Busbar protection for busbar short circuits in medium-voltage systems, high-voltage systems, and systems for very high voltages	7SS85
Bay Controllers	
Bay controllers for control/interlocking tasks with PMU ¹ , monitoring, and protection functions ¹	6MD85, 6MD86
Merging Unit	
The merging unit is the interoperable interface between the primary and secondary equipment for process-bus solutions in accordance with IEC 61869 und IEC 61850-9-2 standards	6MU85
Fault Recorder	
Fault recorders with integrated measurement of synchrophasors (PMU) in accordance with IEEE C37.118 and power-quality measurement in accordance with IEC 61000-4-30.	7KE85

Table 2.1/1 Available Device Types in the SIPROTEC 5 System

¹ Optional

² Without PMU

SIPROTEC 5 Devices and Fields of Application

Device Selection Table

ANSI	Functions	Abbr.	6MD85	6MD86	6MD89	6MU85	7KE85	7SA82	7SA84
	Protection functions for 3-pole tripping	3-pole	■	■		■		■	■
	Protection functions for 1-pole tripping	1-pole							
	Hardware quantity structure expandable	I/O	■	■	■	■	■		
	Process Bus Client Protocol (Note: This function requires at least one dedicated ETH-BD-2FO plug-in module, with V8.0)	PB client	■	■		■	■		
	Process Bus Client Protocol 7SS85 CU (Note: This function requires a dedicated ETH-BD-2FO, with V8.40)	PB client							
	IEC61850-9-2 Merging Unit stream (Note: This function requires a dedicated ETH-BD-2FO per stream, with V8.0)	MU	■	■		■	■		
	IEC61850-9-2 Merging Unit stream 7SS85 CU (Note: Only for communication with 7SS85 CU, This function requires a dedicated ETH-BD-2FO, with V8.40)	MU	■	■		■	■		
14	Locked rotor	$I > + n <$							
21/21N	Distance protection	$Z <, V < I / \angle(V, I)$						■	■
	Automatic adjustment of the synchronization voltage when using a tap changer								
21T	Impedance protection for transformers	$Z <$						■	■
24	Overexcitation protection	V/f							
25	Synchrocheck, synchronization function	Sync	■	■	■	■		■	■
25	Synchronization function with balancing commands	Sync							
25	Synchrocheck, synchronization function with balancing commands (from V7.82)	Sync							
25	Paralleling function 1.5 channel for each sync. location (significant feature: up to 4 sync. locations)	Sync							
25	Paralleling function 1.5 channel for each sync. location (significant feature: up to 8 sync. locations)	Sync							
25	Paralleling function 2 channel for each sync. location (significant feature: up to 4 sync. locations)	Sync							
25	Paralleling function 2 channel for each sync. location (significant feature: up to 8 sync. locations)	Sync							
	Balancing commands for each sync. location								
27	Undervoltage protection: "3-phase" or "positive-sequence system V1" or "universal Vx"	$V <$				■		■	■
27	Undervoltage protection: "3-phase" or "universal Vx"	$V <$	■	■					
27	Undervoltage protection: "3-phase" or "positive-sequence system V1"	$V <$							
27R, 59R	Rate-of-voltage-change protection (from V8.30)	dV/dt	■	■		■		■	
	Undervoltage-controlled reactive power protection	$Q > / V <$						■	■
32, 37	Power protection active/reactive power	$P < >, Q < >$	■	■				■	■
32R	Reverse-power protection	$- P <$							
37	Undercurrent	$I <$						■	■
37	Power-plant disconnection protection	$- dP$							
38	Temperature supervision	$\theta >$	■	■	■	■		■	■
40	Underexcitation protection	$1/x_d$							
46	Negative-sequence overcurrent protection	$I_2 >$	■	■				■	
46	Unbalanced-load protection (thermal)	$I_2^2 t >$							
46	Negative-sequence overcurrent protection with direction	$I_2 >, \angle(V_2, I_2)$						■	■
47	Overvoltage protection, negative-sequence system	$V_2 >$						■	■
47	Overvoltage protection, negative-sequence/positive-sequence system	$V_2/V_1 >$							
47	Overvoltage protection: "negative-sequence V2" or "negative-sequence V2/positive-sequence V1"	$V_2 >; V_2/V_1 >$				■			
48	Starting-time supervision for motors	$I^2 \text{start}$							
49	Thermal overload protection	$\theta, I^2 t$	■	■	■			■	■

SIPROTEC 5 Devices and Fields of Application

Device Selection Table

	7SA86	7SA87	7SD82	7SD84	7SD86	7SD87	7SJ81	7SJ82	7SJ85	7SJ86	7SK82	7SK85	7SL82	7SL86	7SL87	7SS85	7SS85_CU	7UM85	7UT82	7UT85	7UT86	7UT87	7VE85	7VK87
	■	■	■	■	■	■	■	■	■	■	■	■	■	■	■	■	■							■
		■				■									■									■
	■	■			■	■			■	■		■		■	■	■	■				■	■	■	■
	■	■			■	■			■	■		■		■	■	■	■				■	■	■	■
																	■							
	■	■			■	■			■	■		■		■	■	■		■			■	■	■	■
	■	■			■	■			■	■		■		■	■	■					■	■	■	■
											■	■												
	■	■											■	■	■						■	■	■	■
								■	■		■	■		■	■	■		■						■
	■	■	■	■	■	■	■	■	■	■	■	■	■	■	■	■	■	■	■	■	■	■	■	■
																		■						
	■	■	■	■	■	■	■	■	■	■	■	■	■	■	■	■	■	■	■	■	■	■	■	■
	■	■	■	■	■	■	■	■	■	■	■	■	■	■	■	■	■	■	■	■	■	■	■	■
	■	■	■	■	■	■	■	■	■	■	■	■	■	■	■	■	■	■	■	■	■	■	■	■
	■	■	■	■	■	■	■	■	■	■	■	■	■	■	■	■	■	■	■	■	■	■	■	■
	■	■	■	■	■	■	■	■	■	■	■	■	■	■	■	■	■	■	■	■	■	■	■	■
	■	■	■	■	■	■	■	■	■	■	■	■	■	■	■	■	■	■	■	■	■	■	■	■
								■			■	■						■						
											■	■						■						
	■	■	■	■	■	■	■	■	■	■	■	■	■	■	■	■	■	■	■	■	■	■	■	■

2.2

SIPROTEC 5 Devices and Fields of Application

Device Selection Table

ANSI	Functions	Abbr.	6MD85	6MD86	6MD89	6MU85	7KE85	7SA82	7SA84
49	Thermal overload protection, user-defined characteristic	θ, I^2t							
49	Thermal overload protection for RLC filter elements of a capacitor bank	θ, I^2t							
49H	Hot spot calculation	θ_h, I^2t							
49R	Thermal overload rotor protection (motor)	θ_R							
49F	Field-winding overload protection	$IF^2 t$							
49S CG	Stator overload protection with cold-gas consideration	θ, I^2t							
49R CG	Rotor overload protection with cold-gas consideration	θ, IR^2t							
50/51 TD	Overcurrent protection, phases	$I>$	■	■	■	■		■	■
	Instantaneous tripping at switch onto fault	SOTF	■	■		■		■	■
50HS	Instantaneous high-current tripping	$I>>>$	■	■				■	■
50/51 TD	Overcurrent protection with positive-sequence current I_1 (from V7.9)	$I_1>$						■	
50N/ 51N TD	Overcurrent protection, ground	$IN>$	■	■	■	■		■	■
50N/ 51N TD	Overcurrent protection, 1-phase	$IN>$						■	■
50Ns/ 51Ns	Sensitive ground-current detection for systems with resonant or isolated neutral systems incl. a) $3I_0>$, b) admittance $Y_0>$, c) $3I_0\text{-harm}>$ (from V7.8)	$INs>$						■	■
50Ns/ 51Ns	Sensitive ground-current detection for systems with resonant or isolated neutral systems incl. a) $3I_0>$, b) admittance $Y_0>$	$INs>$							
50Ns/ 51Ns	Sensitive ground-current protection for systems with resonant or isolated neutral systems	$INs>$							
	Ground-fault detection via pulse pattern detection; Note: this stage additionally requires the function 50Ns/51Ns or 67Ns "Sensitive ground-fault detection for systems with resonant or isolated neutral"	$IN\text{-pulse}$						■	■
	Intermittent ground-fault protection	$lie>$						■	■
50/51 TD	Overcurrent protection for RLC filter elements of a capacitor bank	$I>$							
50GN	Shaft-current protection	$INs>$							
50/27	Inadvertent energization protection	$I>, V<\text{reset}$							
50N DC, 27,59F DC	Direct-current/ direct-voltage protection	$IDC<<, VDC <>$							
50	Startup overcurrent protection	$I\text{-Start } >$							
50BF	Circuit-breaker failure protection, 3-pole	CBFP			■	■		■	■
50BF	Circuit-breaker failure protection, 1-/3-pole	CBFP		■		■			
50BF	Inherent circuit-breaker failure protection	CBFP							
50EF	End-fault protection				■				
50EF	End-fault protection (Note: Only useable for distributed busbar protection with 7SS85 CU with V8.40)		■	■		■	■		
50RS	Circuit-breaker restrike protection	CBRS				■		■	■
50L	Load-jam protection	$I>L$							
51V	Overcurrent protection, voltage dependent	$t=f(I,V)$	■	■				■	■
59, 59N	Overvoltage protection: "3-phase" or "zero-sequence system V_0 " or "universal V_x "	$V>$				■		■	■
59, 59N	Overvoltage protection: "3-phase" or "zero-sequence system V_0 "	$V>$							
59	Overvoltage protection: "3-phase" or "positive-sequence system V_1 " or "universal V_x "	$V>$	■	■					
59C	Peak overvoltage protection, 3-phase, for capacitors	$V> \text{cap.}$							
59N, 67Ns	Stator ground-fault protection (non-directional, directional)	$V_0>, \angle(V_0,I_0)$							
27TH, 59TH, 59THD	Stator ground-fault protection with 3rd harmonic	$V_{03.H<}, V_{03.H>; \Delta V_{03.H}$							
59N IT	Turn-to-turn fault protection	$V_0>$							

SIPROTEC 5 Devices and Fields of Application

Device Selection Table

7SA86	7SA87	7SD82	7SD84	7SD86	7SD87	7SJ81	7SJ82	7SJ85	7SJ86	7SK82	7SK85	7SL82	7SL86	7SL87	7SS85	7SS85_CU	7UM85	7UT82	7UT85	7UT86	7UT87	7VE85	7VK87
							■	■		■	■						■	■	■	■	■		
																	■	■	■	■	■		
										■	■						■	■	■	■	■		
																	■	■	■	■	■		
																	■	■	■	■	■		
	■	■	■	■	■	■	■	■	■	■	■	■	■	■	■		■	■	■	■	■	■	■
	■	■	■	■	■	■	■	■	■	■	■	■	■	■	■		■	■	■	■	■	■	■
	■	■	■	■	■	■	■	■	■	■	■	■	■	■	■		■	■	■	■	■	■	■
	■	■	■	■	■	■	■	■	■	■	■	■	■	■	■		■	■	■	■	■	■	■
						■																	
																	■						
	■	■	■	■	■		■	■	■	■	■	■	■	■					■	■	■		
	■	■	■	■	■	■	■	■	■	■	■	■	■	■			■	■	■	■	■		
							■	■															
	■	■	■	■	■		■	■	■	■	■	■	■	■									
	■	■	■	■	■		■	■	■	■	■	■	■	■									
	■	■	■	■	■	■	■	■	■	■	■	■	■	■									
	■	■	■	■	■		■	■	■	■	■	■	■	■									
	■	■	■	■	■		■	■	■	■	■	■	■	■	■								
						■																	
							■	■															
																	■						
																	■						
																	■						

2.2

SIPROTEC 5 Devices and Fields of Application

Device Selection Table

ANSI	Functions	Abbr.	6MD85	6MD86	6MD89	6MU85	7KE85	7SA82	7SA84
60C	Current-unbalance protection for capacitor banks	Iunbal>							
60	Voltage-comparison supervision	ΔU>						■	■
64S	Stator ground-fault protection 100 % (20Hz)	RSG<							
64F, frated	Rotor ground-fault protection (IRgnd<, fn)	IRG>							
64F, frated	Rotor ground-fault protection (Rgnd<, fn)	RRG<							
64F (1-3Hz)	Rotor ground-fault protection (1 - 3 Hz)	RRG<							
66	Restart inhibit for motors	I²t							
67	Directional overcurrent protection, phases	I>, <(V,I)	■	■		■		■	■
67N	Directional overcurrent protection, ground	IN>, <(V,I)	■	■		■			
67N	Directional overcurrent protection for ground faults in grounded systems	IN>, <(V,I)						■	■
67Ns	Dir. sensitive ground-fault detection for systems with resonant or isolated neutral incl. a) 3I0>, b) V0>, c) Cos-φ/SinPhi, d) Transient ground-fault fct., e) Phi(V,I), f) admittance							■	■
	Directional stage with a harmonic; Note: this stage additionally requires the function "67Ns Dir. sensitive ground-fault detection for systems with resonant or isolated neutral"	<(V0h,I0h)						■	
	Directional intermittent ground-fault protection	lie dir>						■	■
68	Power-swing blocking	ΔZ/Δt						■	■
74TC	Trip-circuit supervision	TCS	■	■	■	■		■	■
78	Out-of-step protection	ΔZ/Δt						■	■
74CC	Closed-circuit supervision (from V7.9)	CCS	■	■		■		■	
79	Automatic reclosing, 1-/3-pole	AR		■		■			
79	Automatic reclosing, 3-pole	AR			■	■		■	■
SAD	Secondary Arc Detection (SAD) during 1-pole AR-cycles (from V8.30); Note: SAD additionally requires the function points for "Automatic reclosing, 1-/3-pole"	SAD							
81	Frequency protection: "f>" or "f<" or "df/dt"	f<>; df/dt<>	■	■				■	■
81 AF	Abnormal frequency protection	fBand							
81U	Underfrequency load-shedding	f<(UFLS)	■	■				■	■
	Vector-jump protection	Δφ>						■	■
85/21	Teleprotection for distance protection							■	■
85/27	Weak or no infeed: echo and tripping	WI						■	■
85/67N	Teleprotection for directional ground fault protection							■	■
87B	Busbar differential protection	ΔI							
87B	Busbar differential protection for 7UM85 (from V8.01)	ΔI							
87B	Bus coupler differential protection	ΔI							
	Bay								
	Cross stabilization								
86	Lockout		■	■	■	■		■	■
87T	Transformer differential protection	ΔI							
87T	Differential protection for special transformers	ΔI							
87T Node	Differential protection (Node protection for auto transformer)	ΔI Node							
87T	Transformer differential protection for phase angle regulating transformer (single core)	ΔI							
87T	Differential protection for phase-angle regulating transformer (two core)	ΔI							
87N T	Restricted ground-fault protection	ΔIN						■	■
87M	Motor differential protection	ΔI							
87G	Generator differential protection	ΔI							
87C	Differential protection, capacitor bank	ΔI							

2.2

SIPROTEC 5 Devices and Fields of Application

Device Selection Table

ANSI	Functions	Abbr.	6MD85	6MD86	6MD89	6MU85	7KE85	7SA82	7SA84
87V	Voltage differential protection, capacitor bank	ΔV							
87L	Line differential protection for 2 line ends	ΔI							
87L	Differential protection for lines with 2 ends for 7UT8 (communication with 7SD82,85,86, 7SL86,87)	ΔI							
87L	Differential protection for lines with 3 to 6 ends (dependent on significant properties)	ΔI							
87L/ 87T	Option for line differential protection including power transformer	ΔI							
	Option for line differential protection charging-current compensation	ΔI							
	Broken-wire detection for differential protection								
87 STUB	Stub-fault differential protection (for breaker-and-a-half scheme)								
90V	Automatic voltage controller for two-winding transformer		■	■		■		■	■
90V	Automatic voltage controller for two-winding transformer with parallel operation		■	■		■		■	
	Number of two-winding transformers with parallel operation (Note: only together with the function "Automatic voltage controller for two-winding transformer with parallel operation")		■	■		■		■	
90V	Automatic voltage controller for three-winding transformer		■	■		■			■
90V	Automatic voltage controller for grid coupling transformer		■	■		■			■
FL	Fault locator, single-sided	FL-one						■	■
FL	Fault locator plus (from V7.9)	FL plus						■	
PMU	Synchrophasor measurement	PMU	■	■		■	■	■	■
AFD	Arc-protection (only with plug-in module ARC-CD-3FO)		■	■		■		■	■
	Measured values - standard		■	■	■	■	■	■	■
	Measured values - extended: Min, Max, Avg		■	■	■	■	■	■	■
	Switching statistic counters		■	■	■	■		■	■
	PQ-Basic measured values: THD (Total Harmonic Distortion) and harmonics (from V8.01) THD voltage aggregation values (from V8.40)		■	■		■		■	
	PQ-Basic measured values: Voltage unbalance (from V8.40)		■	■		■		■	
	PQ-Basic measured values: Voltage variations - voltage dips, swells and interruptions (from V8.40)		■	■		■		■	
	PQ-Basic measured values: TDD - Total Demand Distortion (from V8.40)		■	■		■		■	
	CFC (Standard, control)		■	■	■	■	■	■	■
	CFC arithmetic		■	■	■	■	■	■	■
	Circuit-breaker wear monitoring	$\Sigma I_x, I^2t, 2P$	■	■		■	■	■	■
	CFC Switching sequences								
	Switching sequences function		■	■	■	■		■	■
	Inrush current detection		■	■		■		■	■
	External trip initiation		■	■	■	■		■	■
	Control		■	■	■	■		■	■
PoW	Point-on-wave switching (from V7.90)	PoW		■		■			
	Circuit-breaker		■	■	■	■	■	■	■
	1 Circuit-breaker object (Qty. not extendable)								
	Circuit-breaker paralleling								
	Disconnecter/Grounding switch		■	■	■	■		■	■
	3 Disconnecter/Gnd. switch objects (Qty. not extendable)								
	Fault recording of analog and binary signals		■	■	■	■	■	■	■
	Monitoring and supervision		■	■	■	■	■	■	■

2.2

SIPROTEC 5 Devices and Fields of Application

Device Selection Table

ANSI	Functions	Abbr.	6MD85	6MD86	6MD89	6MU85	7KE85	7SA82	7SA84
	Protection interface, serial		■	■	■	■		■	■
	Protection functions for 2-pole tripping	2-pole			■				
FSR	Fast-scan recorder	FSR					■		
SSR	Slow-scan recorder	SSR					■		
CR	Continuous recorder	CR					■		
TR	Trend recorder	TR					■		
PQR	Power Quality recordings (functionalities)	PQR					■		
	Splitter for harmonics and interharmonics (from V8.01)						■		
	Sequence of events recorder	SOE					■		
ExTrFct	Extended trigger functions	ExTrFct					■		
	Region France: Overload protection for lines 'PSL-PSC'							■	■
	Region France: Overcurrent protection 'MAXI-L'							■	■
	Region France: Power-system decoupling protection 'PDA'							■	■
	Region France: Overload protection for transformers							■	■
	Frequency-tracking groups (from V7.8)		■	■	■	■	■	■	■
	Transformer side 7UT85								
	Cyber Security: Role-Based Access Control (from V7.8)		■	■	■	■	■	■	■
	Temperature acquisition via communication protocol		■	■		■	■	■	
	Transformer side 7UT86								
	Transformer side 7UT87								
	Cyber Security: IEEE 802.1X based network authentication (from V8.3)		■	■		■	■	■	
	Transformer side 7UM85								

2.2

SIPROTEC 5 Devices and Fields of Application

Application Examples – Medium Voltage

Medium-Voltage Application for all Network Types

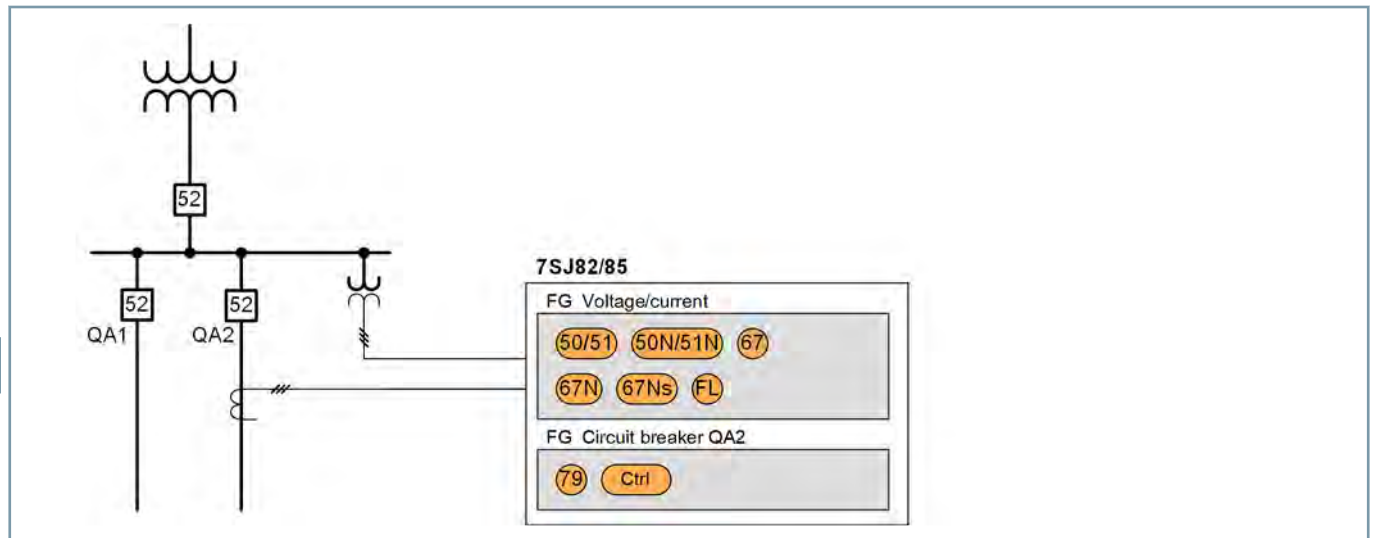
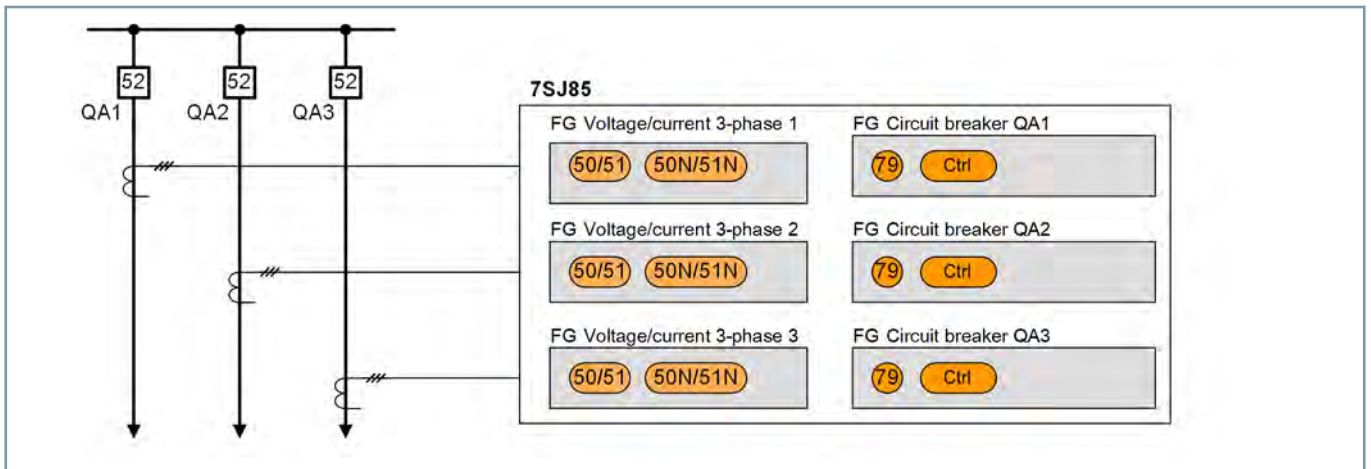

Figure 2.3/1 Medium-Voltage Application for all Network Types

Properties

- Reliable detection of transient and stationary ground faults
- Cost savings thanks to integrated transient ground-fault function
- Directional and non-directional protection and control functions available
- Recording and transmission of PMU parameters possible

Protection and Control of Several Feeders with one Device



[dw_Mittelspg-03, 3, en_US]

Figure 2.3/2 Protection and Control of Several Feeders with one Device

Properties

- Reduced investment with one device for several feeders
- Easy parameterization
- Shorter commissioning times
- Cost reduction due to protection of up to 9 feeders with a single device

SIPROTEC 5 Devices and Fields of Application

Application Examples – Medium Voltage

Fast Fault Clearing in Lines with Infeed at Both Ends (Closed Ring Feeders)

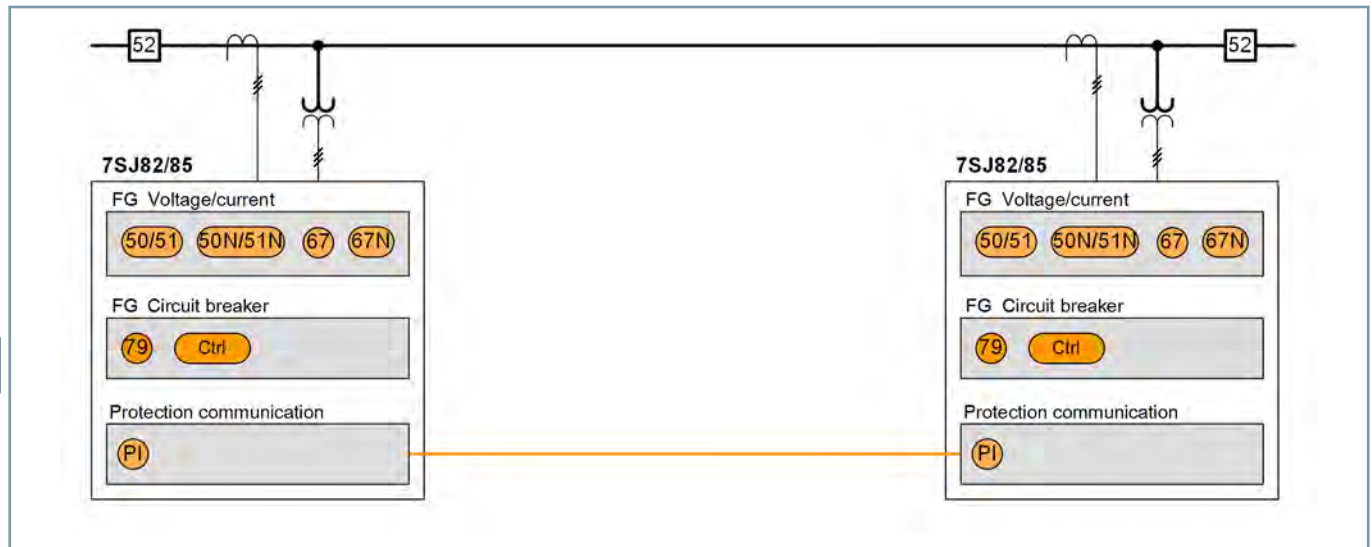

[dw_Mittelspg-02, 3, en_US]

Figure 2.3/3 Fast Fault Clearing in Lines with Infeed at 2 Ends

Properties

- Directional definite-time overcurrent protection/inverse-time overcurrent protection without grading times
- Fast fault clearing
- Cost-effective due to integrated protection interface
- Monitored data exchange
- Adaptable to various communication infrastructures

Central Control of Multiple Feeders and Dedicated Protection

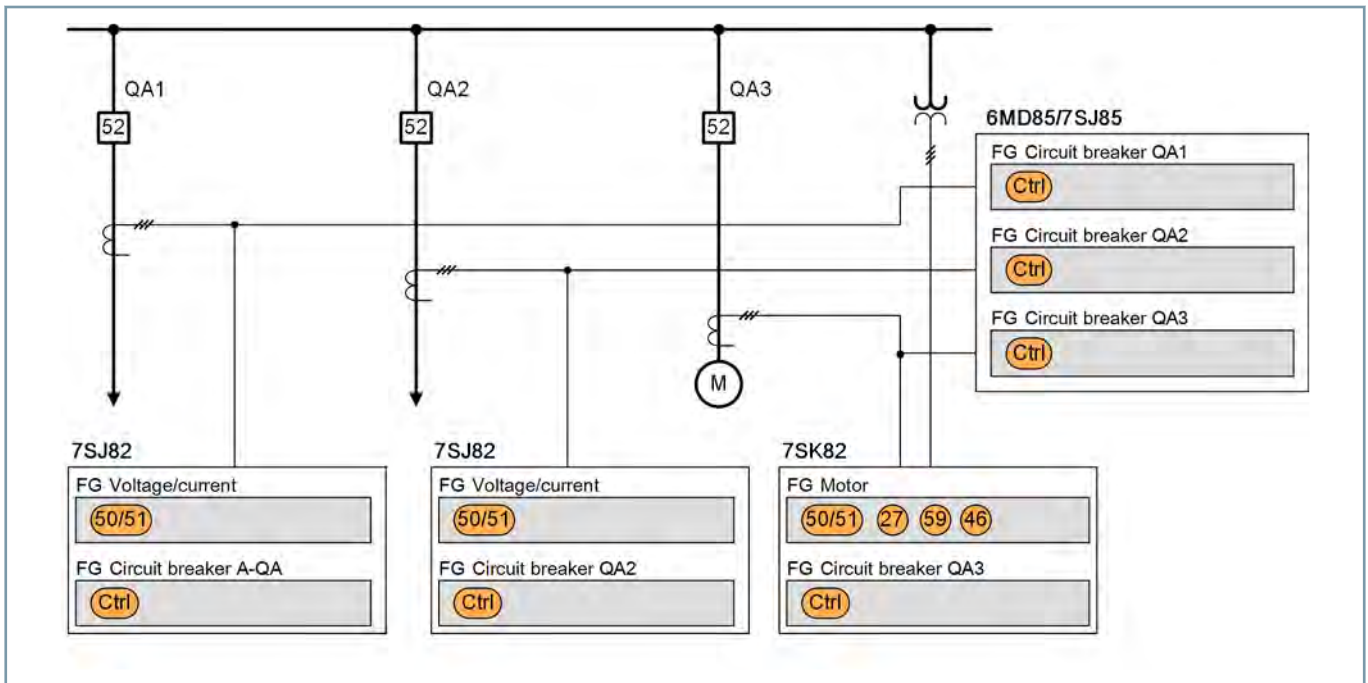

[dw_zentrale-Steuerung, 3, en_US]

Figure 2.3/4 Central Control of Multiple Feeders and Dedicated Protection

Properties

- Protection per bay
- Central control for several feeders
- High availability, as backup protection functions can be activated in the electronic control unit

SIPROTEC 5 Devices and Fields of Application

Application Examples – Motor Protection

Induction Motor: Protection and Control

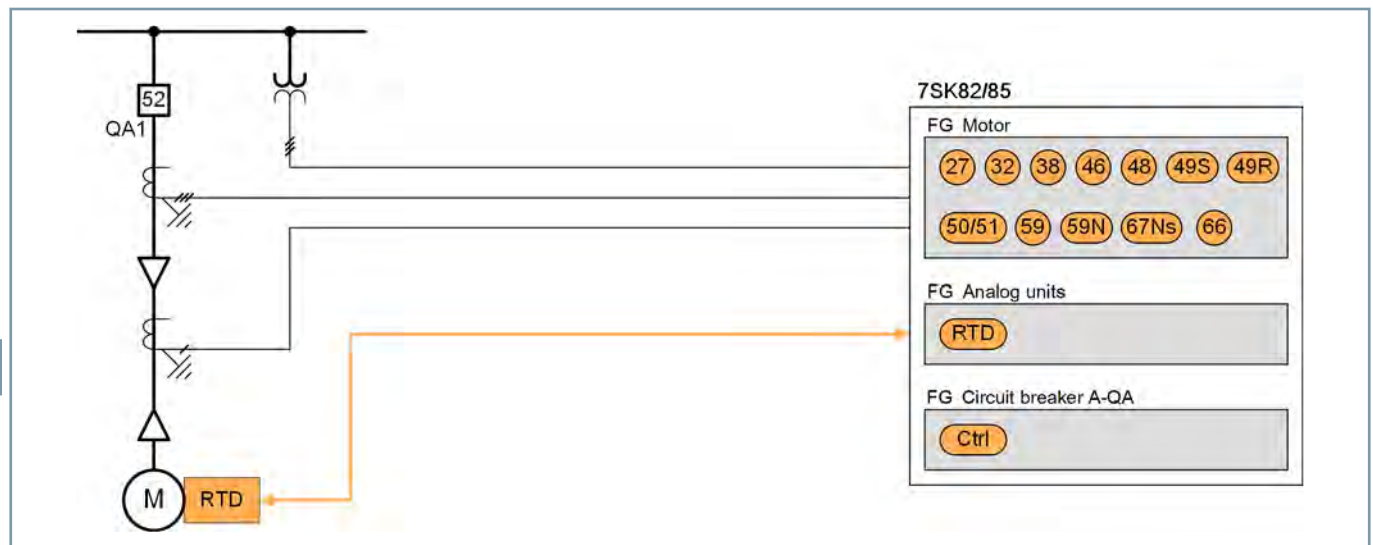
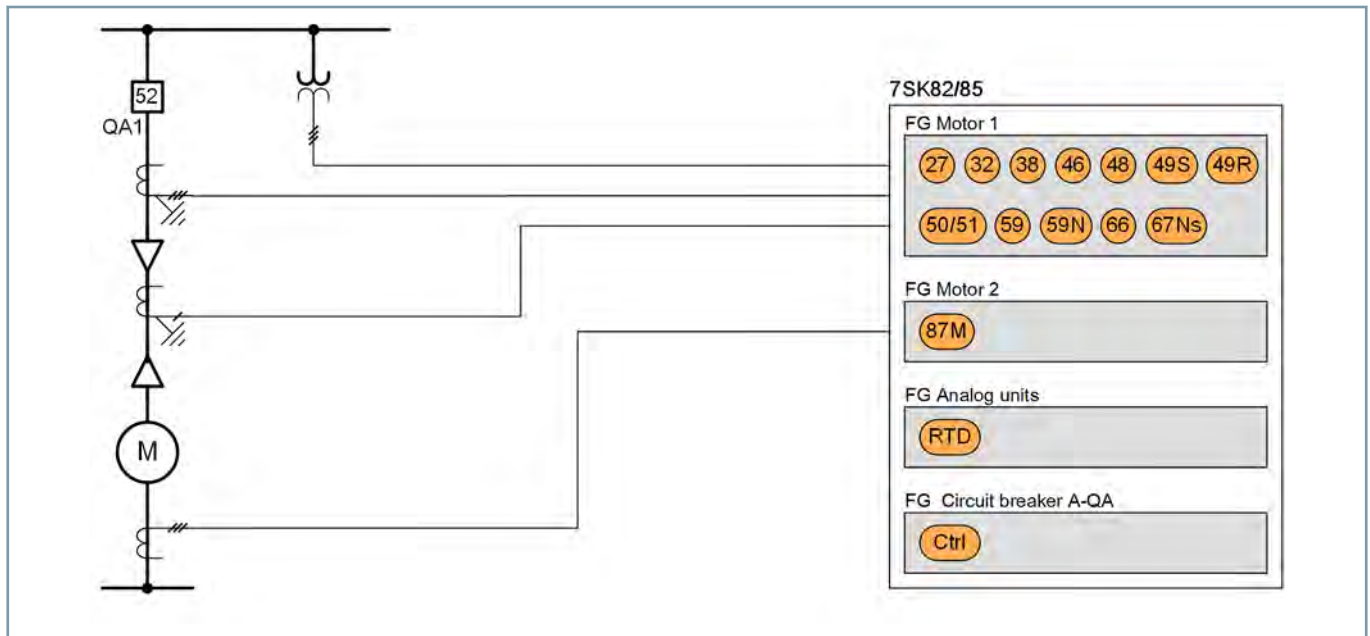

Figure 2.3/5 Induction Motor: Protection and Control

Properties

- Reduced investment due to protection and control in one device
- Thermal motor protection functions for safe monitoring of the motor
- Thermal motor protection functions with direct connection of temperature sensors

Motor Protection with Differential Protection



[dw_Motor-03, 3, en_US]

Figure 2.3/6 Motor Protection with Differential Protection

Properties

- Independent differential protection functions
- Differential protection function provides high responsivity and short tripping time
- Separate detection and monitoring of the current transformers

SIPROTEC 5 Devices and Fields of Application

Application Examples – Motor Protection

Motor Protection and Easier Differential Protection

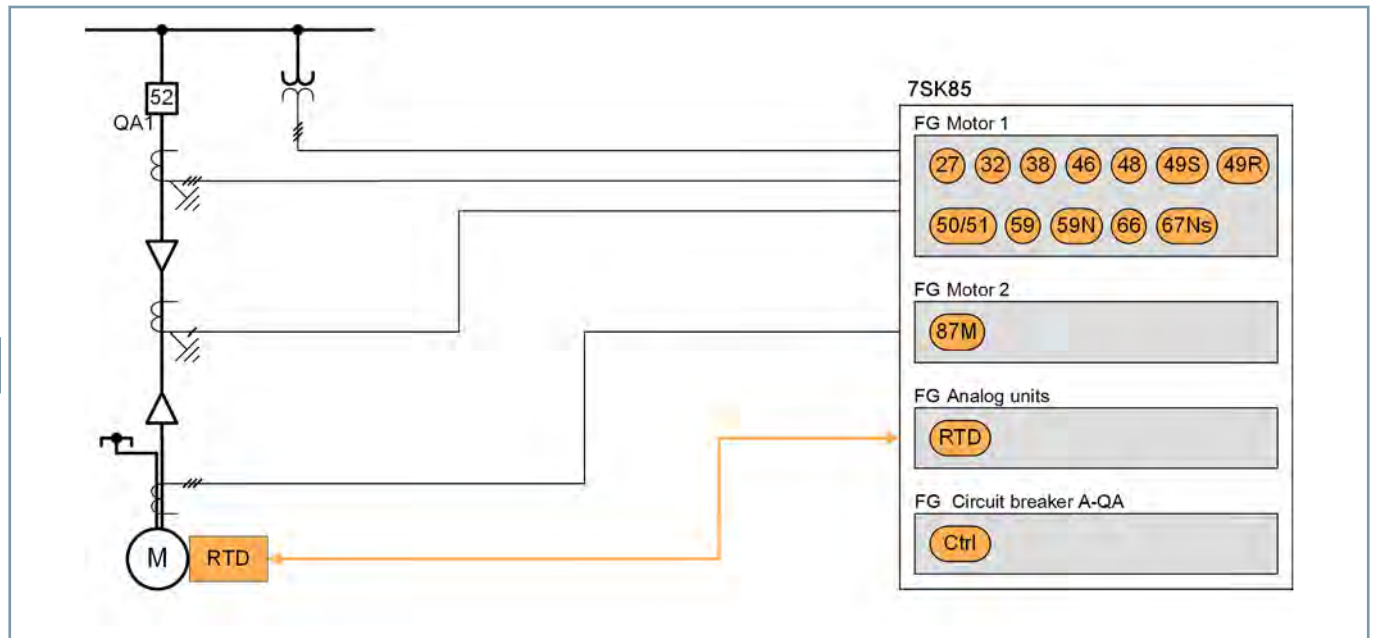

[dw_Motor-02, 4, en_US]

Figure 2.3/7 Protection and Control of Several Feeders with one Device

Properties

- Differential protection function provides high responsivity and short tripping time
- Cost reduction due to integration of the differential protection function in a separate function group

Differential Motor Protection with Korndörfer Starter

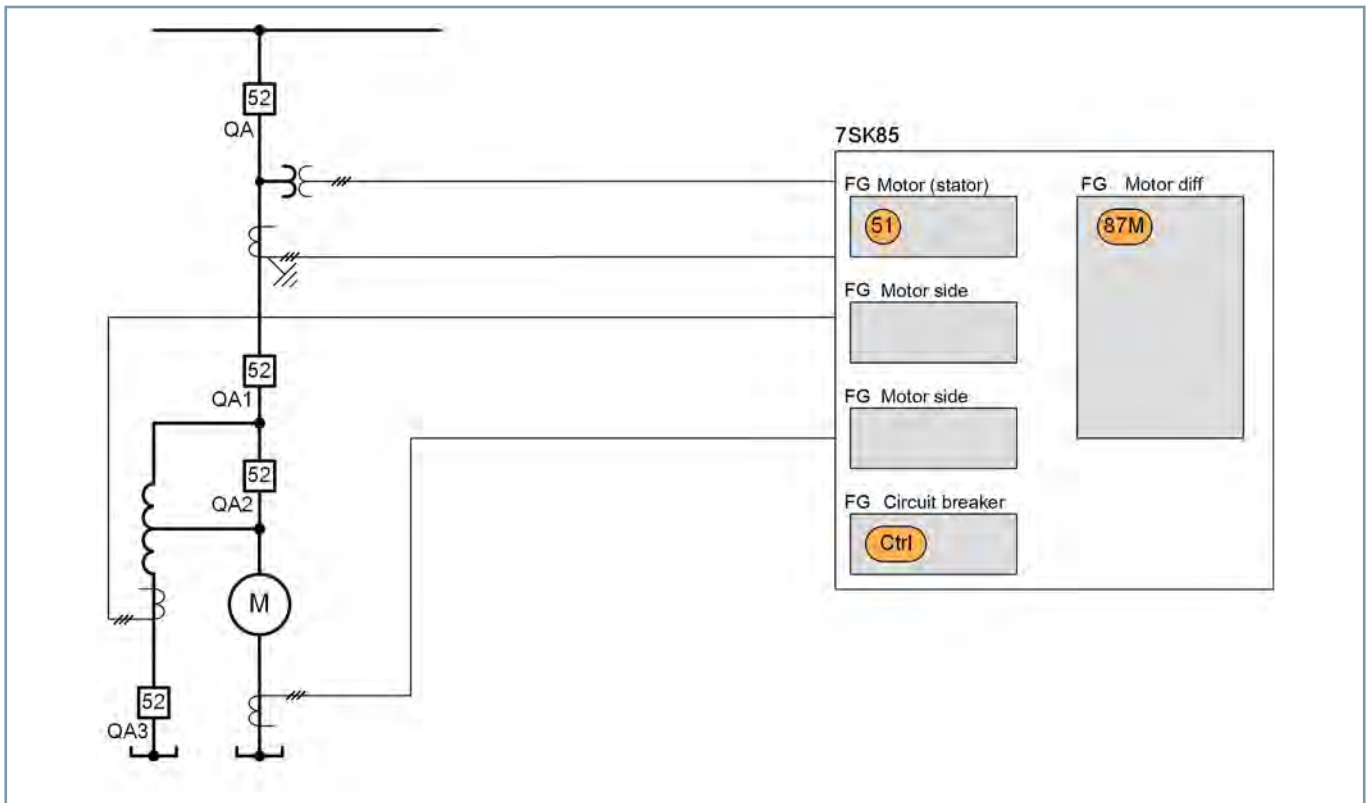

[dw_Motordiff-mit-starter, 4, en_US]

Figure 2.3/8 Differential Motor Protection with Korndörfer Starter

Properties

- Capturing, monitoring, and controlling all circuit breakers
- Differential protection function also available during startup

SIPROTEC 5 Devices and Fields of Application

Application Examples – Transformer Protection

Two-Winding Transformer

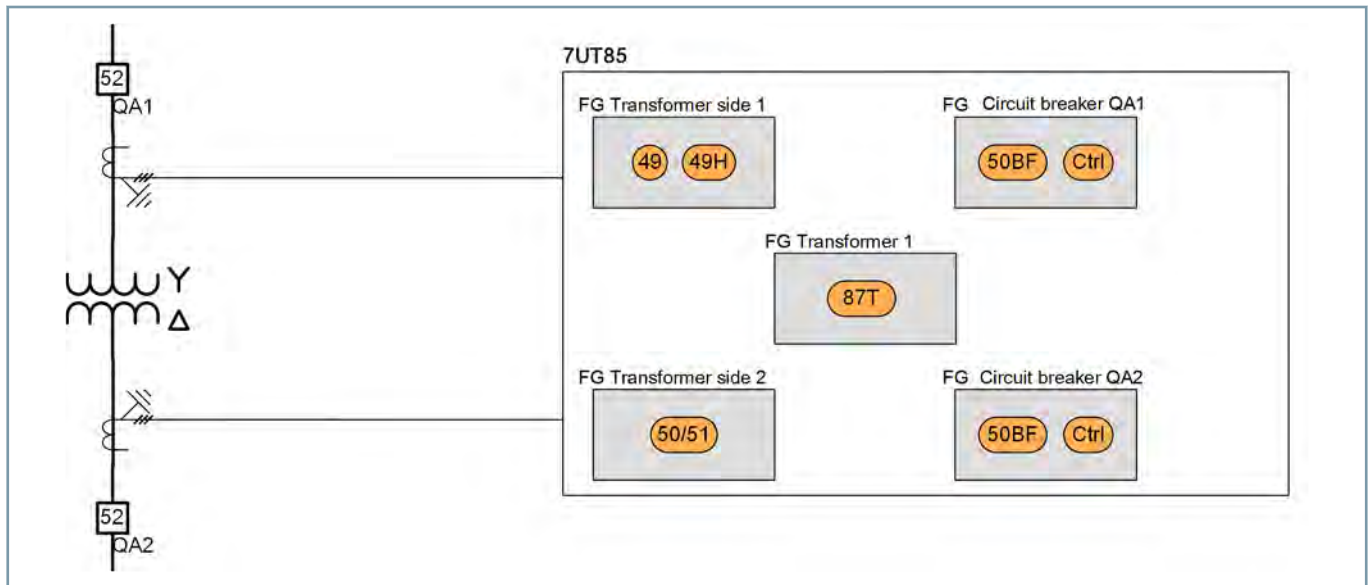

[dw_Trafo1, 4, en_US]

Figure 2.3/9 Two-Winding Transformer

Properties

- Clear assignment of the functions to the primary element
- Reduced investment
- Easy parameterization
- Reduced wiring and shortened commissioning

Two-Winding Transformer with 2 Infeeds (for Example Dual Circuit-Breaker System)

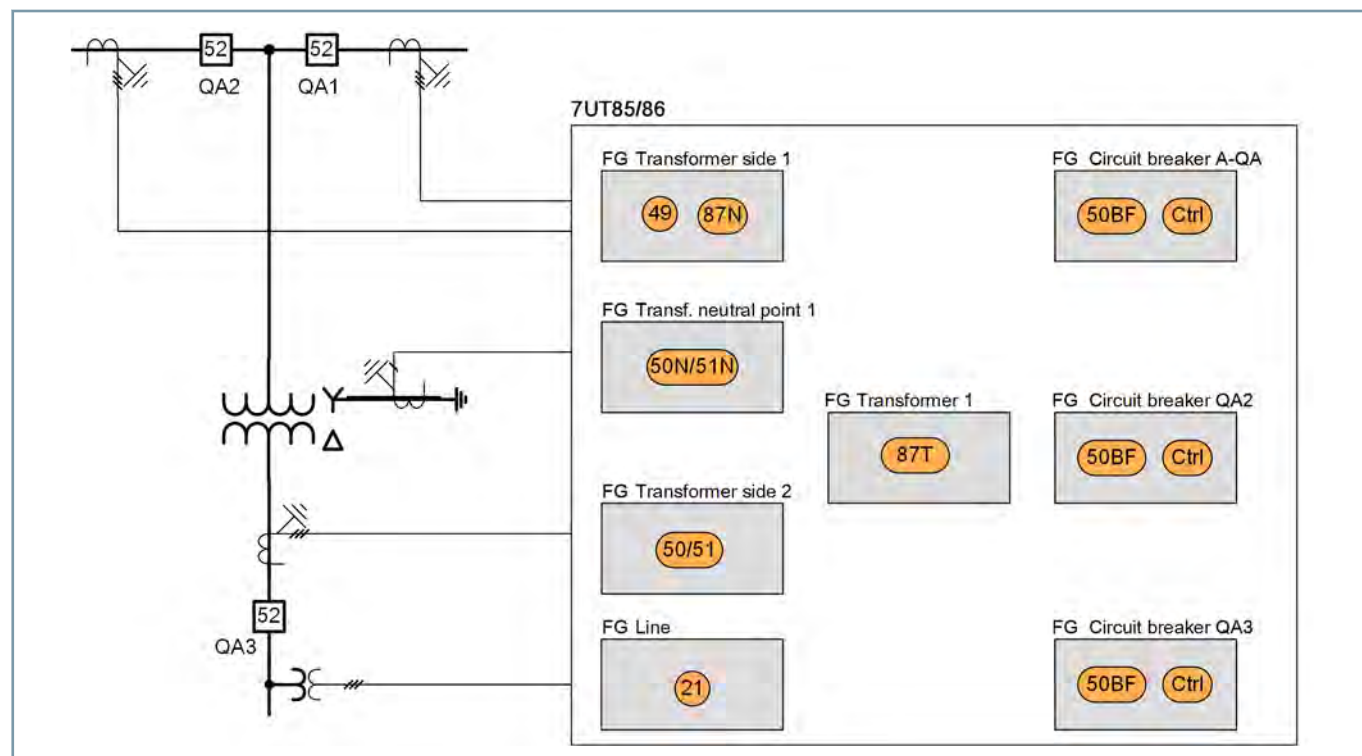

[dw_Trafo2, 4, en_US]

Figure 2.3/10 Two-Winding Transformer with 2 Infeeds (for example Dual Circuit-Breaker System)

Properties

- Separate capturing, monitoring, and controlling of all circuit breakers
- High responsivity for 1-pole restricted ground-fault protection
- Cost reduction due to 87T and 87T N in one device

SIPROTEC 5 Devices and Fields of Application

Application Examples – Transformer Protection

Auto-Transformer Bank

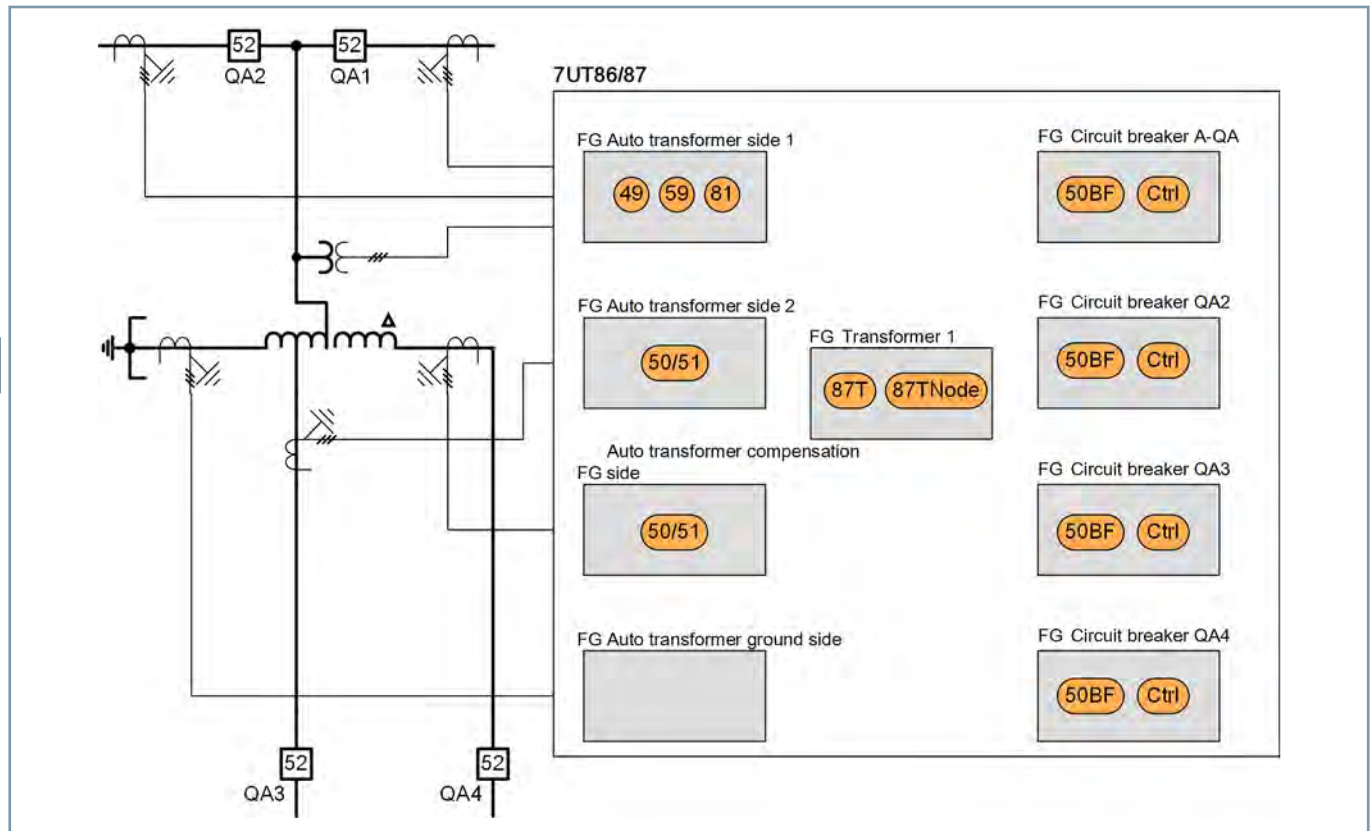

[dw_Trafo3, 3, en_US]

Figure 2.3/11 Auto-Transformer Bank

- Reduced investment due to integration of the differential and nodal-point protection function in one device (87 and 87 Node)
- High sensitivity for 1-pole restricted ground-fault protection

Protection and Backup Protection Solution for Three-Winding Transformers

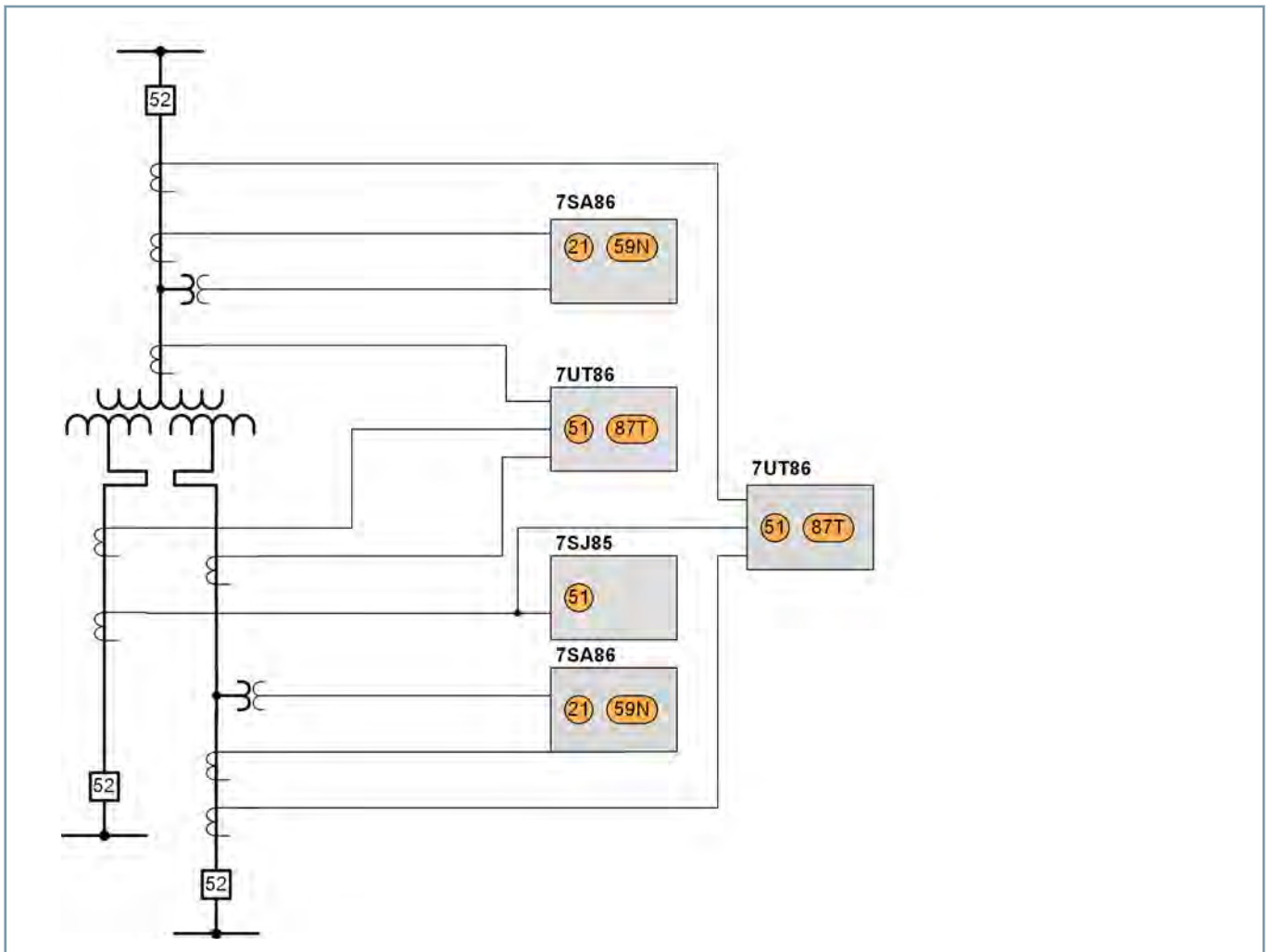

[dw_Trafo4, 2, en_US]

Figure 2.3/12 Protection and Backup Protection Solution for Three-Winding Transformers

Properties

- Free design options for the protection and backup-protection concept
- Consultation of the line protection devices
- Increased availability
- It can be implemented in the merging units as a process-bus solution with backup-protection functions

SIPROTEC 5 Devices and Fields of Application

Application Examples – Transformer Protection

Three-End Line Differential Protection with Transformer in the Protection Range (87T)

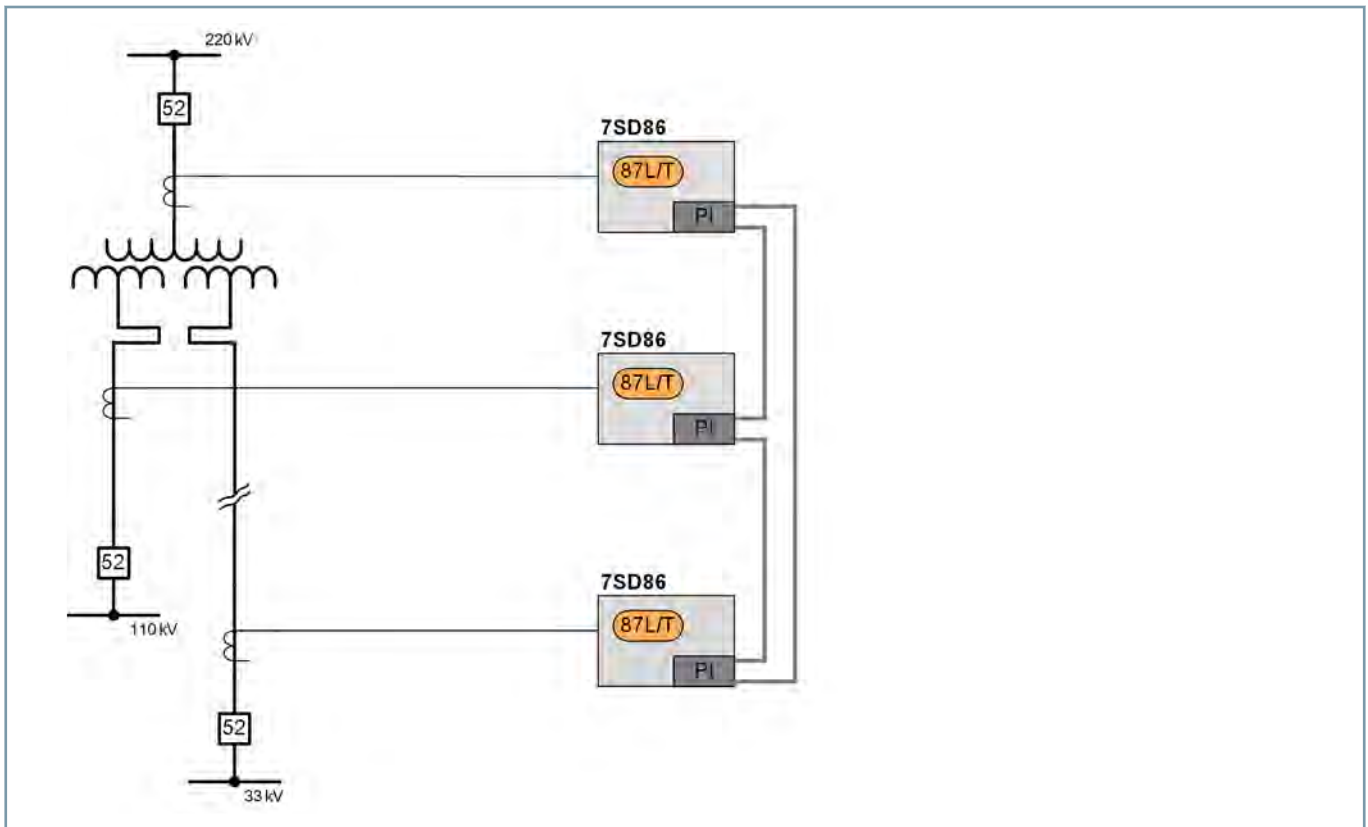

[dw_Trafo5, 2, en_US]

Figure 2.3/13 Three-End Line Differential Protection with Transformer in the Protection Range (87T)

Properties

- Protection of a transformer far from the switchgear due to line differential protection
- Transformer differential protection with widely spaced current transformers
- Integrated adaptation to vector groups and different current transformer ratios
- Cost and space reduction due to integration of the transformer protection function in the line protection device

Three-Winding Transformer with Differential Protection 87T and Distance Protection 21

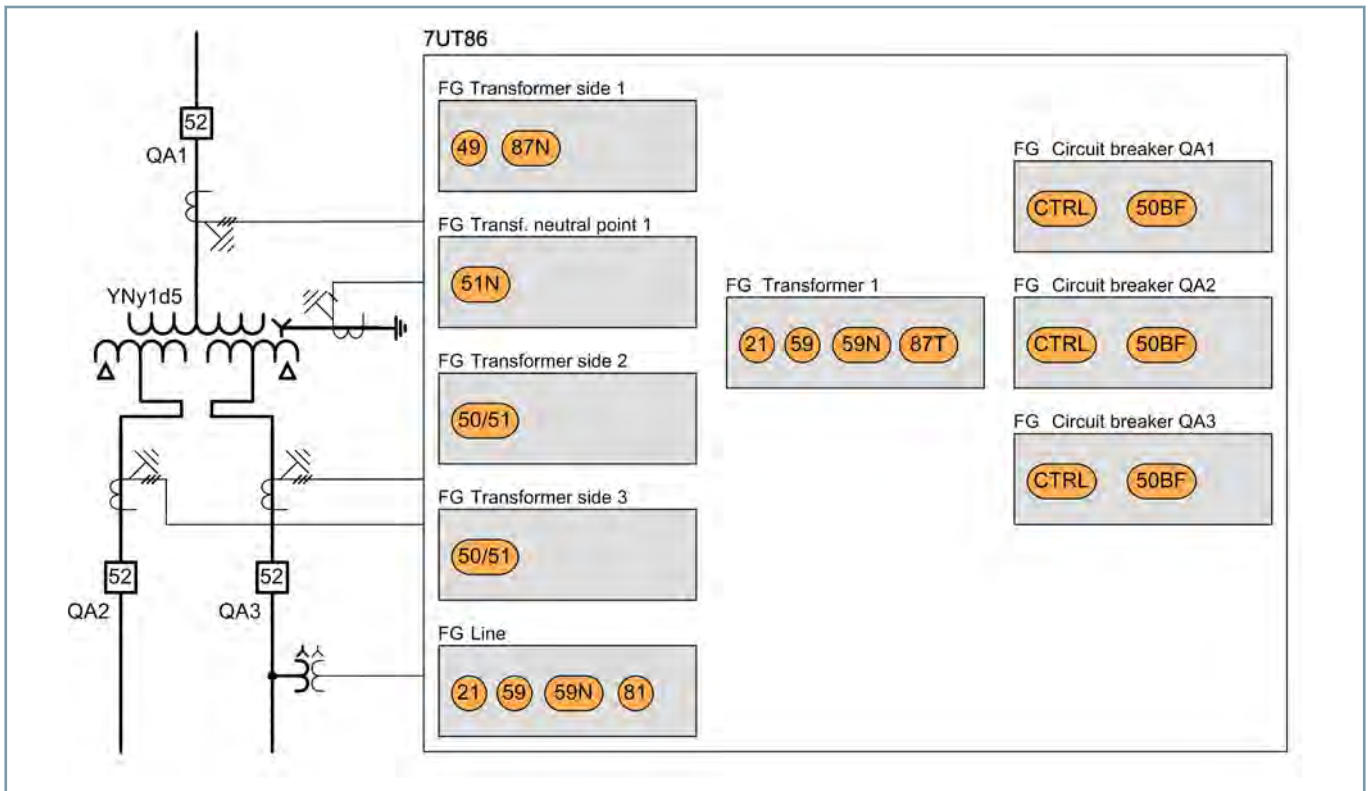

[dw_kat-three-wind_7ut86, 3, en_US]

Figure 2.3/14 Three-Winding Transformer with Differential Protection 87T and Distance Protection 21

Properties

- Integrated backup protection function for the power system
- Easy engineering
- Increased flexibility for different plant versions

SIPROTEC 5 Devices and Fields of Application

Application Examples – Generator Protection

Unit Connection of a Small-Power Generator

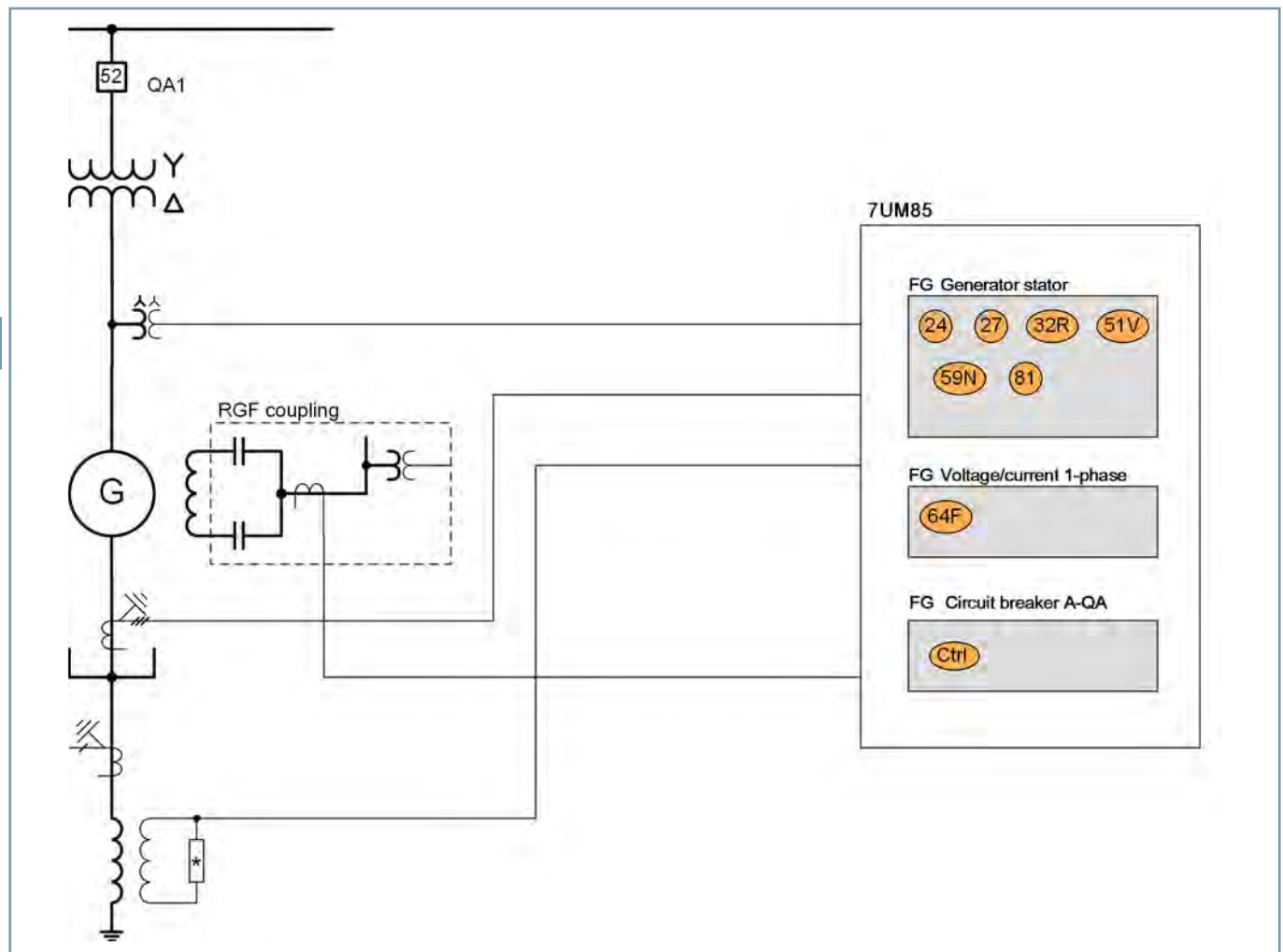

[dw_appl-01_simplified, 3, en_US]

Figure 2.3/15 Unit Connection of a Small-Power Generator

Properties

- All functions in a device keep investments low.
- Basic hardware (1/3 x 19")
- Preconfigured with the **Generator basis** application template

Unit Connection of a Medium-Power Generator

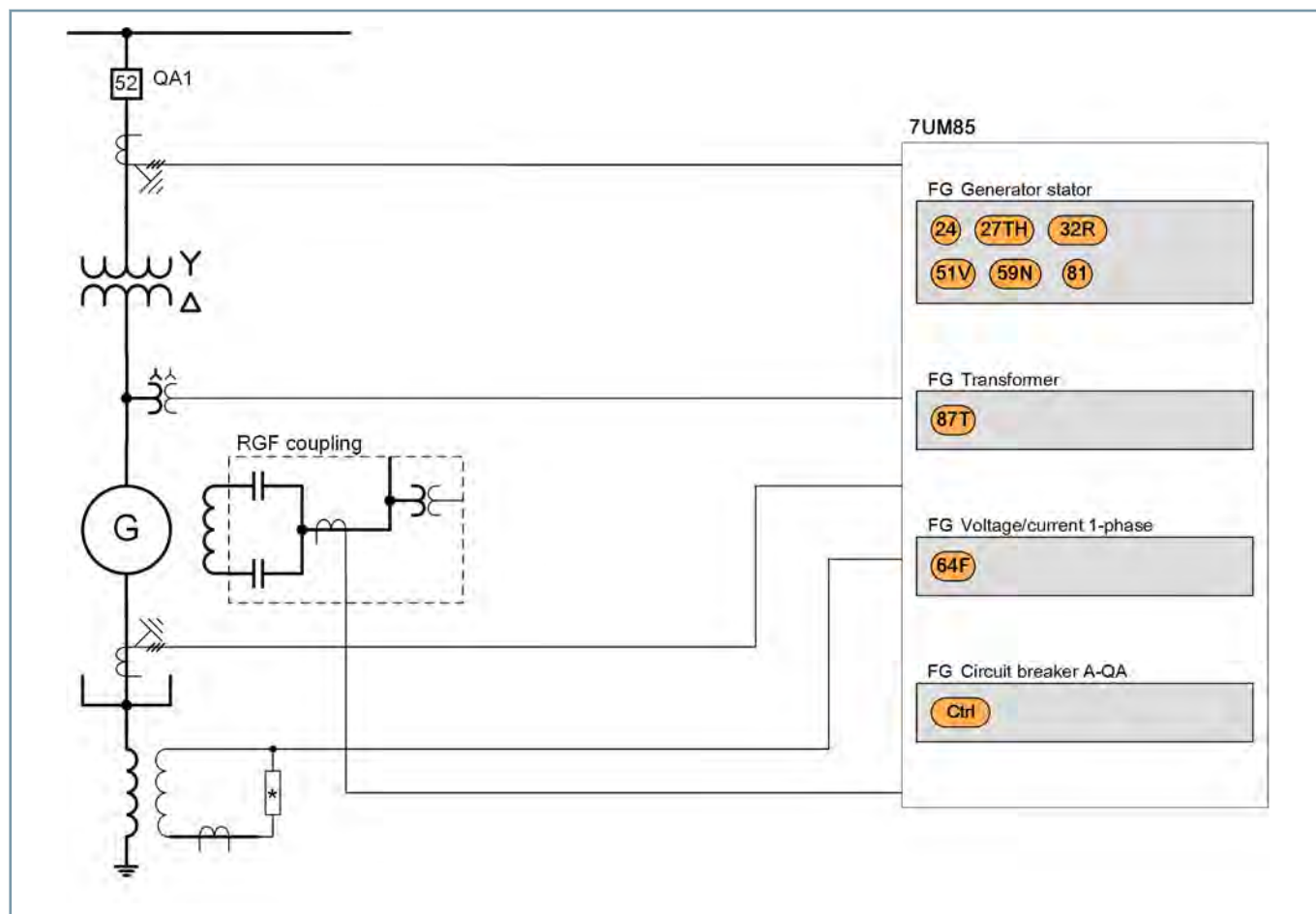

[dw_simplified_appl-03, 3, en_US]

Figure 2.3/16 Unit Connection of a Medium-Power Generator

Properties

- All functions in a device keep investments low.
- Basic hardware (1/2 x 19")
- Preconfigured with the **Generator unit connection basis** application template
- Stator ground-fault protection protects 100 % of the stator winding by evaluating the residual voltage via the fundamental component and the 3rd harmonic (59N, 27TH)
- Differential protection via generator and generator transformer with function 87T

SIPROTEC 5 Devices and Fields of Application

Application Examples – Generator Protection

Unit Connection of a Generator of Medium to High Power

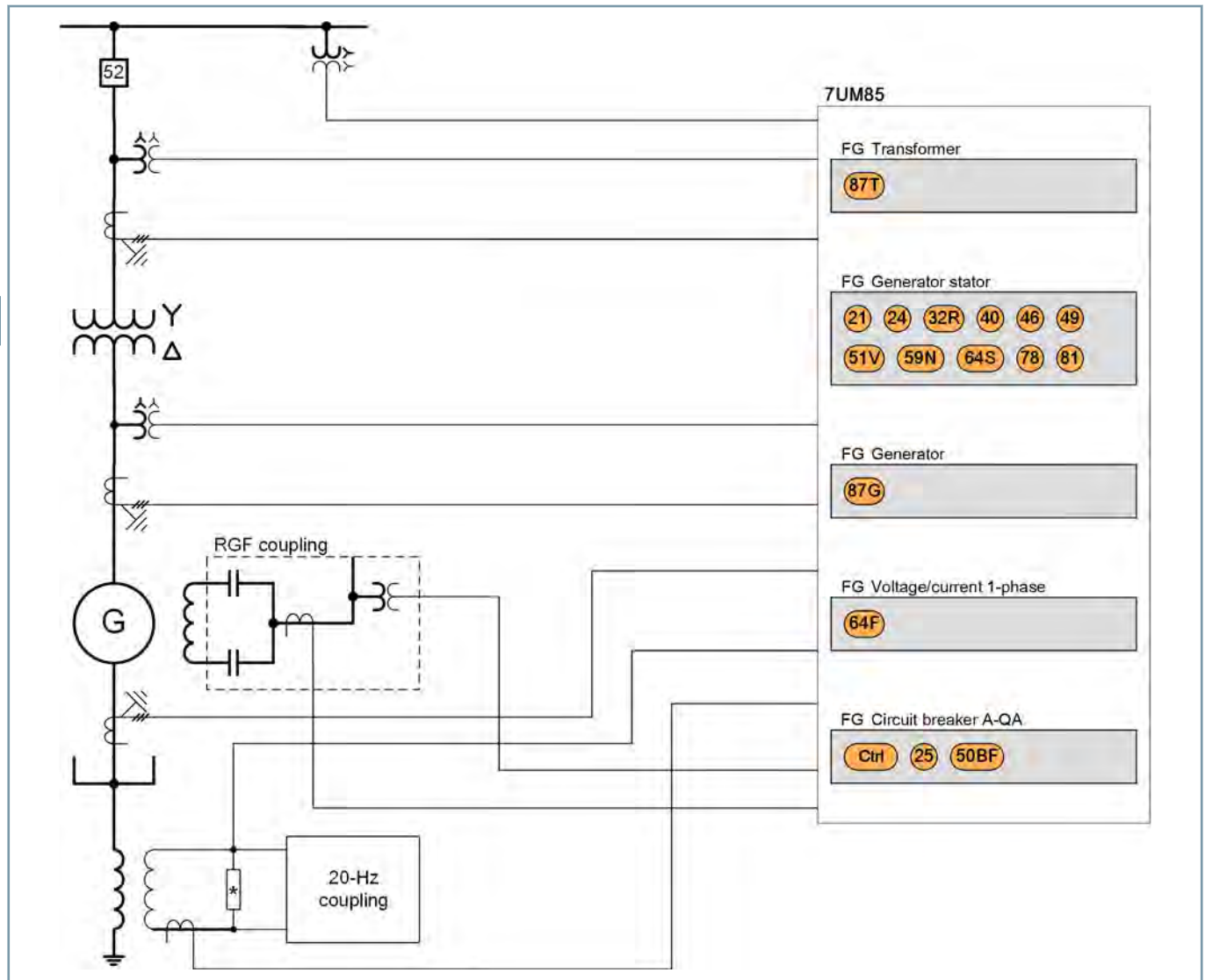

[dw_simplified_appl-04, 2, en_US]

Figure 2.3/17 Unit Connection of a Generator of Medium to High Power

Properties

- All functions in a device keep investments low.
- Minimum hardware (2/3 x 19")
- Preconfigured with the **Enhanced generator unit connection** application template
- Stand-alone differential protection for generator (87G) and generator transformer (87T)
- Real 100 % stator ground-fault protection by coupling a 20-Hz voltage
- Stator ground-fault protection possible at plant standstill
- Synchrocheck release by the device during manual synchronization
- Redundancy by device doubling

Unit Connection of a Generator with Auxiliary Transformer

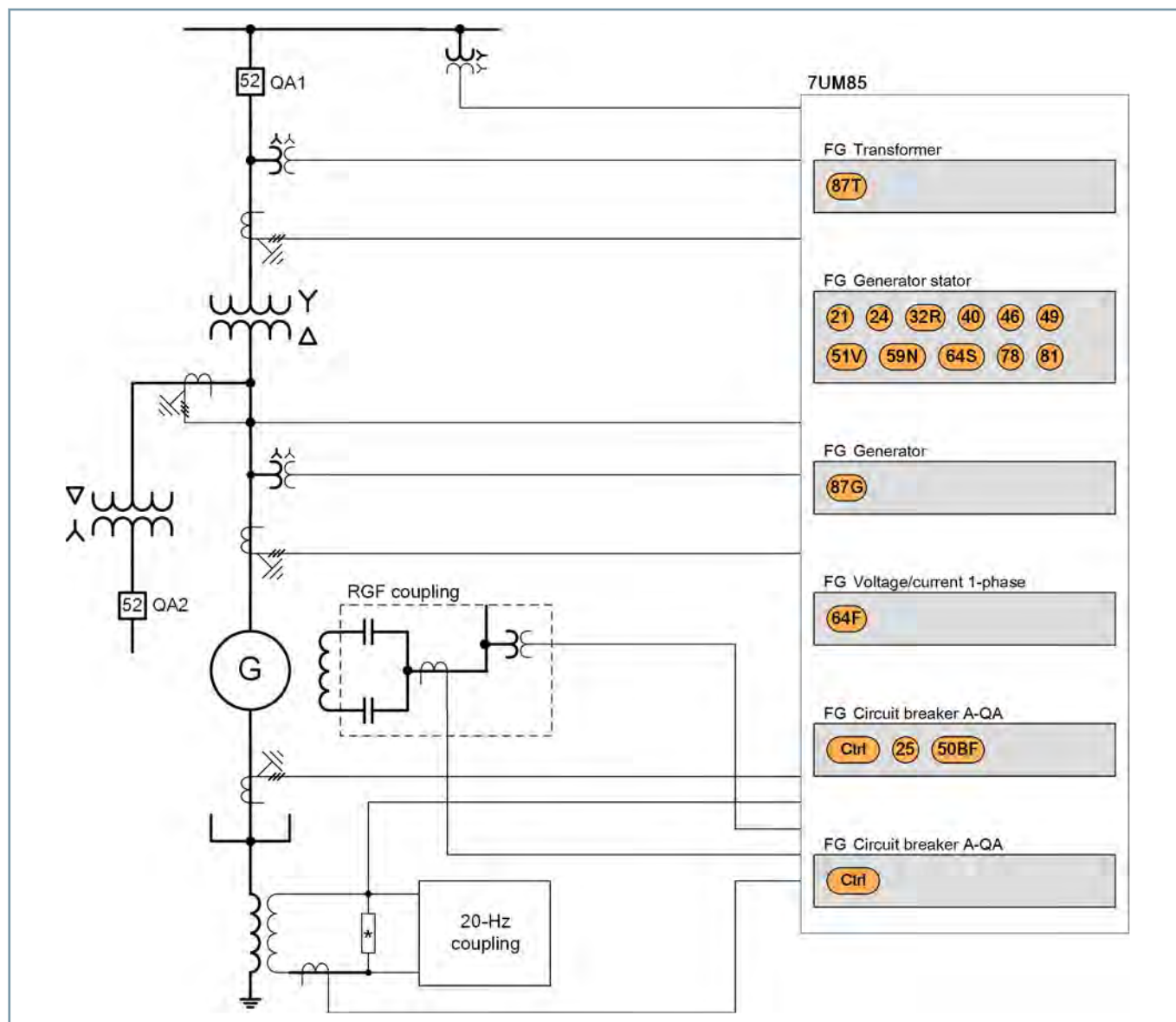

[dw_simplified_appl-04_2_3_en_US]

Figure 2.3/18 Unit Connection of a Generator with Auxiliary Transformer

Properties

- All functions in a device keep investments low.
- Minimum hardware (2/3 x 19")
- Modification of the **Enhanced generator unit connection** application template
- Stand-alone differential protection via generator (87G) and generator transformer (87T)
- Implementation of the transformer differential protection as teed-feeder differential protection
- Real 100 % stator ground-fault protection for coupling a 20-Hz voltage
- Stator ground-fault protection possible at standstill

- Synchrocheck release by the device during manual synchronization
- Redundancy by device doubling

SIPROTEC 5 Devices and Fields of Application

Application Examples – Generator Protection

Busbar Connection of a Generator

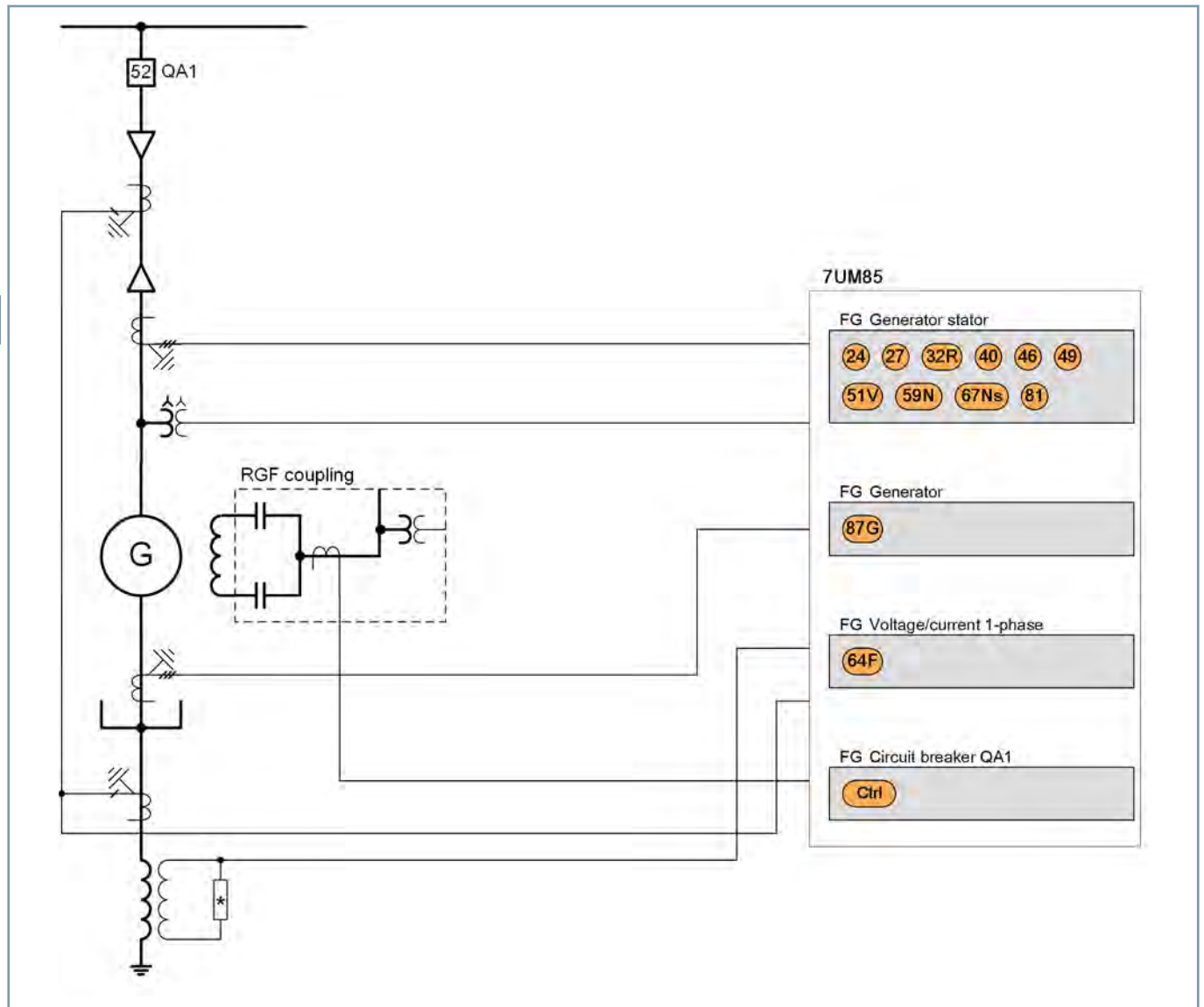

[dw_simplified_appl-02_2_3_en_US]

Figure 2.3/19 Busbar Connection of a Generator

Properties

- All functions in a device keep investments low.
- Basic hardware (1/2 x 19")
- Preconfigured with the **Generator busbar connection** application template
- Stand-alone differential protection for the generator (87G)
- Directional stator ground-fault protection (67Ns)
- Redundancy by device doubling

Protection of a High-Power Generator

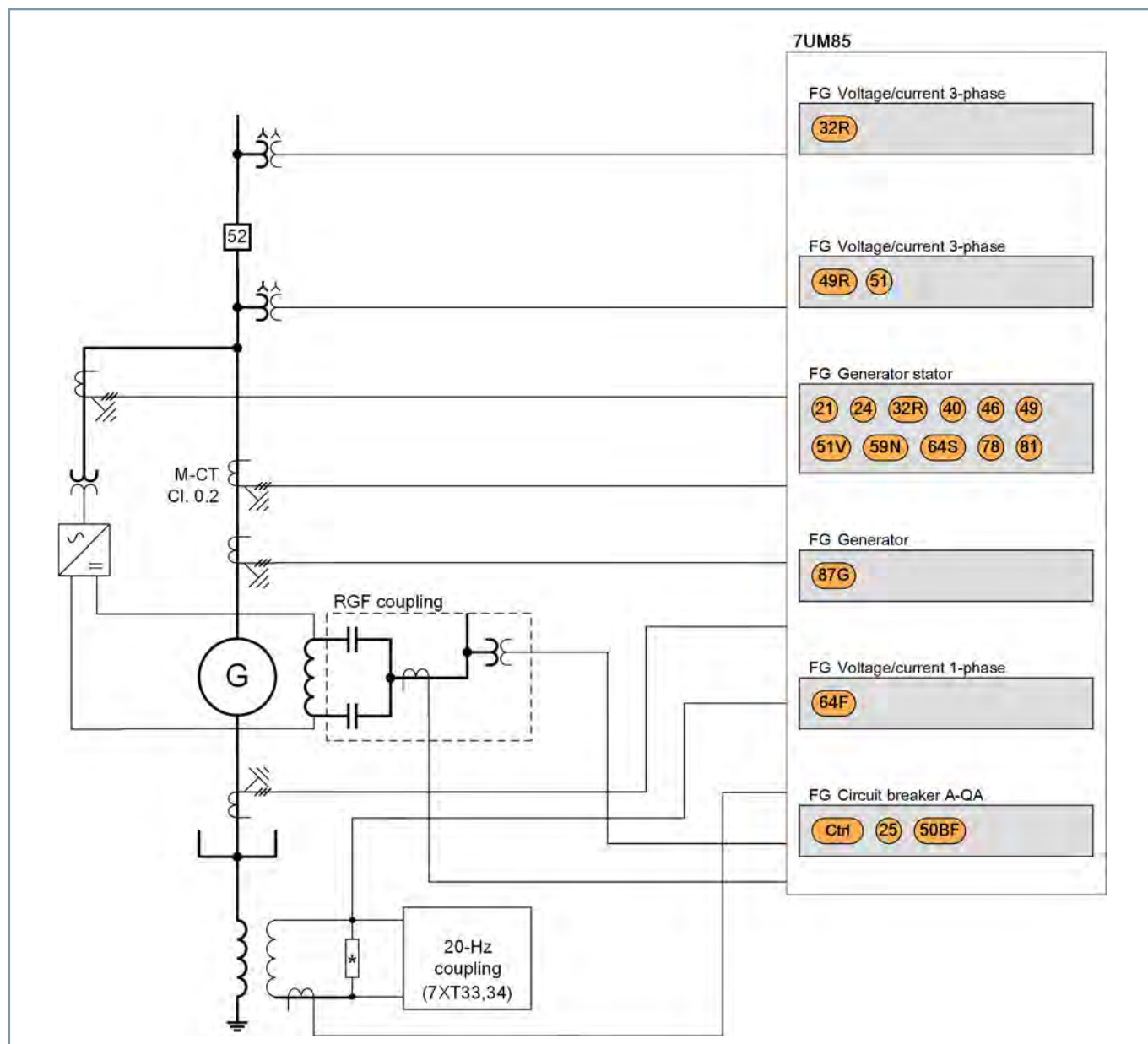

[dw_simplified_appl-04_3_3_en_US]

Figure 2.3/20 Protection of a High-Power Generator

Properties

- The delivery includes the generator, excitation, and generator protection of a plant in unit connection for a steam turbine
- All functions in a device keep investments low.
- Minimum hardware (2/3 x 19")
- Modification of the **Enhanced generator unit connection** application template
- Sensitive reverse-power protection by connection to a separate instrument transformer
- Separate protection for the exciting transformer

- Synchrocheck release by the device during manual synchronization
- Redundancy by device doubling

SIPROTEC 5 Devices and Fields of Application

Application Examples – Line Protection

Separate Protection and Control

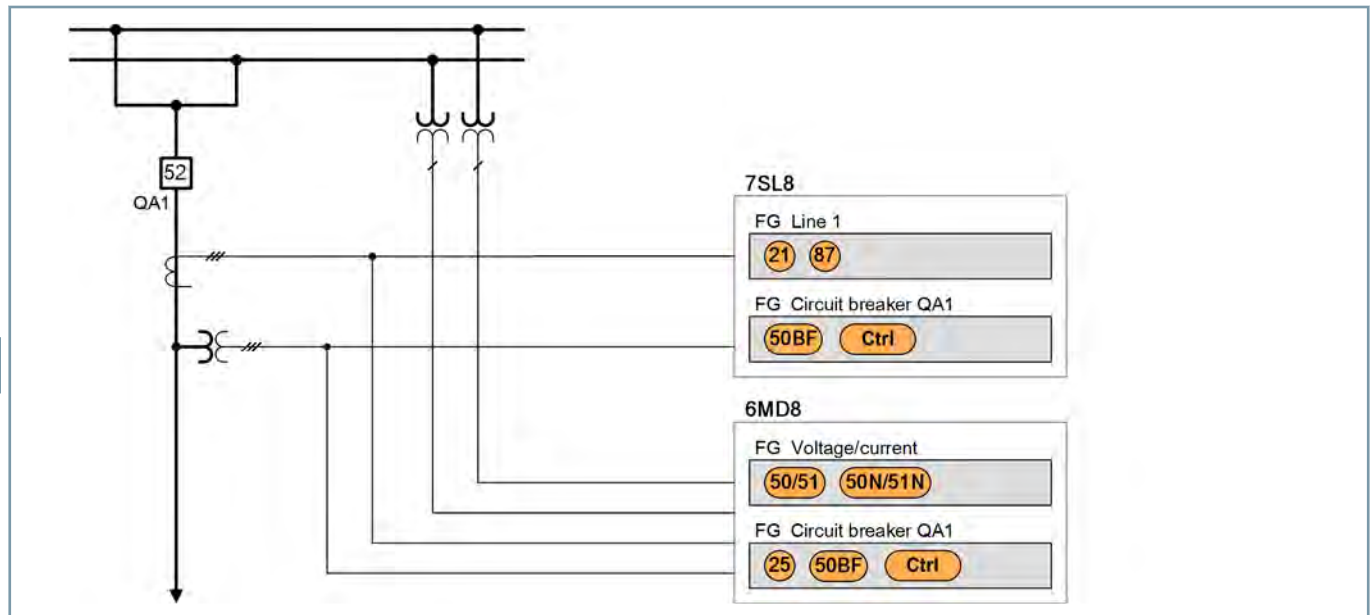

[dw_LS-getrennt, 2, en_US]

Figure 2.3/21 Separate Protection and Control

Properties

- Clear assignment of protection and control in separate devices
- Less external components due to acquisition and selection of the bus voltage in the device
- High security due to backup protection functions in the bay controller SIPROTEC 6MD8
- High availability due to emergency control in the protection device SIPROTEC 7SL8

Cost-Effective Protection and Device Redundancy

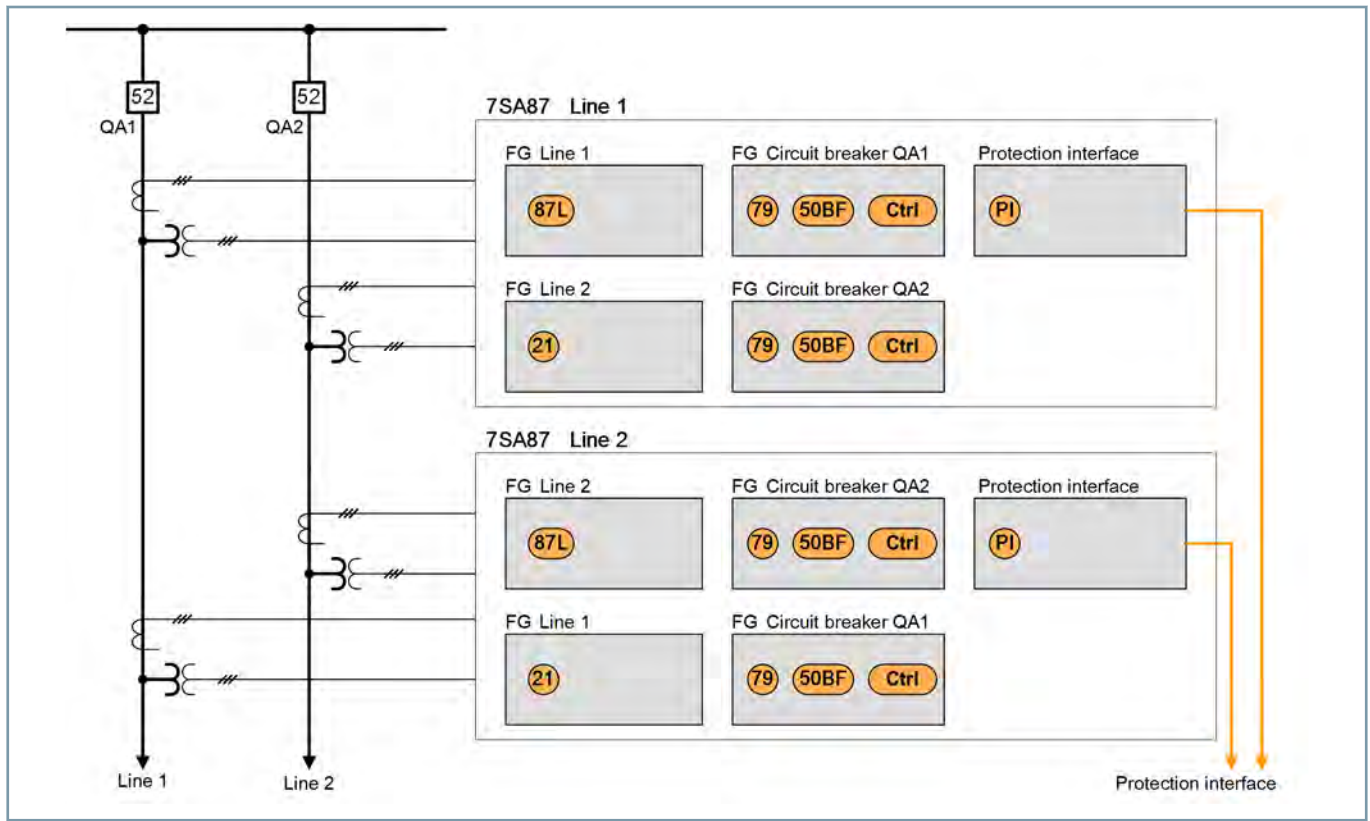

[dw_LS-guenstige-variante, 2, en_US]

Figure 2.3/22 Cost-Effective Protection and Device Redundancy

Properties

- High availability due to protection and device redundancy
- Cost effective, as only 2 devices needed for 2 lines
- Safe due to parallel processing of the protection functions in the devices

SIPROTEC 5 Devices and Fields of Application

Application Examples – Line Protection

Distance Protection of 2 Parallel Lines with a Device

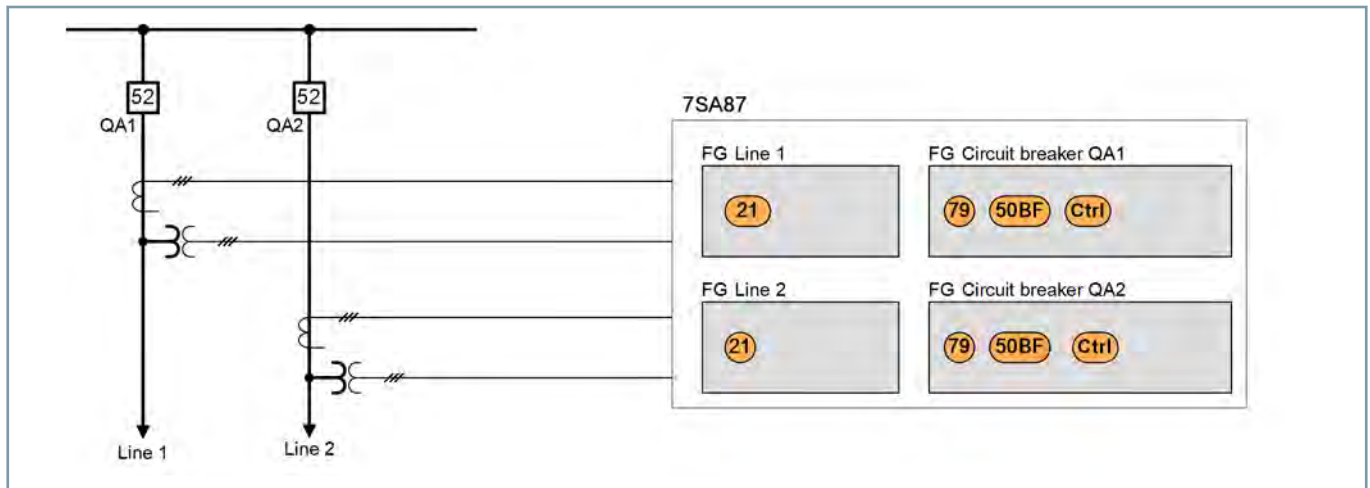

[dw_L5-parallel, 4, en_US]

Figure 2.3/23 Distance Protection of 2 Parallel Lines with a Device

Properties

- Cost-effective due to the protection of both lines in one device
- Stable due to consideration of the influences of the parallel line for the distance-protection function

Self-Repairing Multi-End Configurations

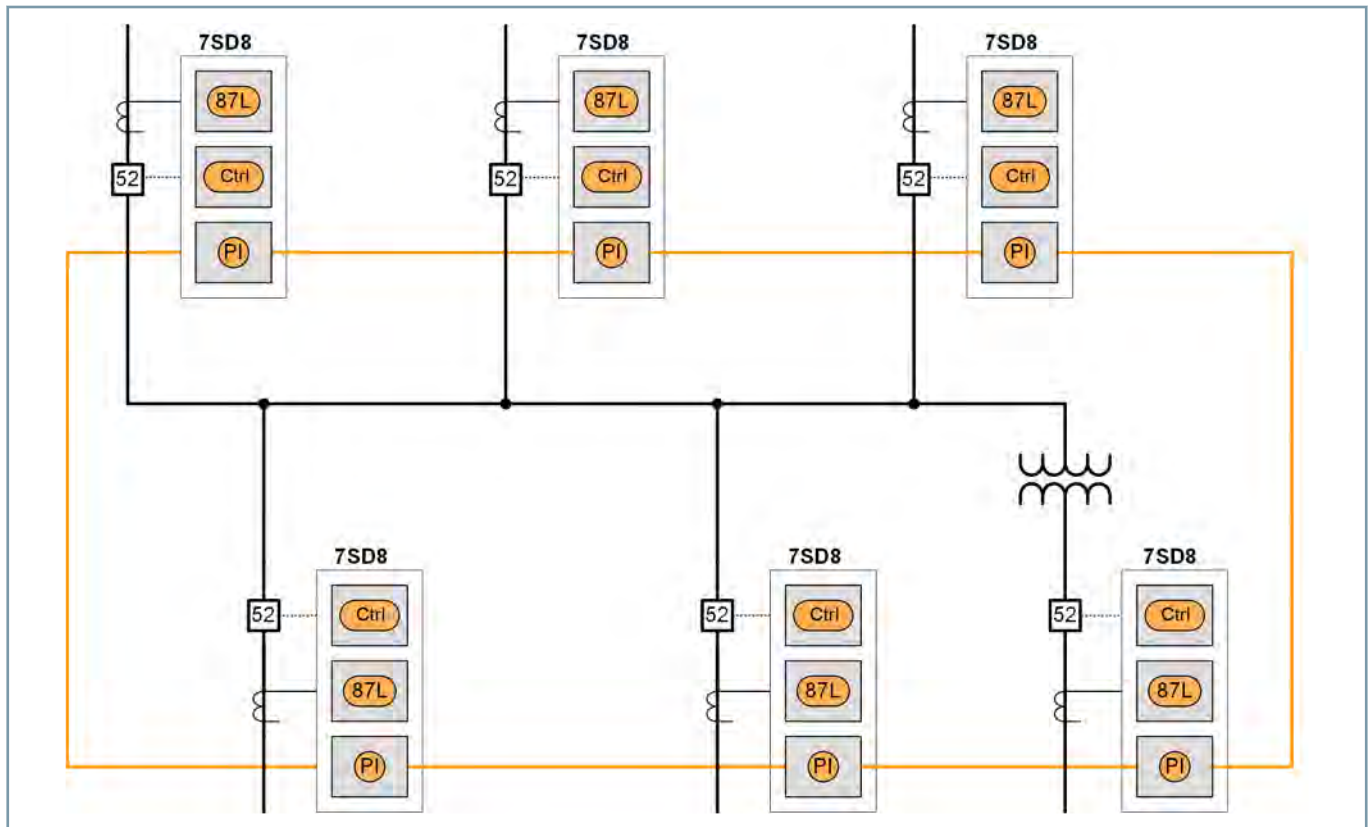

[dw_Diff-Schutz-Ringschaltung, 2, en_US]

Figure 2.3/24 Self-Repairing Multi-End Configurations

Properties

- Flexible communication of the protection interface
- Direct connection via optical fiber
- Two-wire (via communication converter)
- Communication networks on Synchronous Digital Hierarchy (SDH) and Multiprotocol Label Switching (MPLS) basis (optical or electrical)
- Cost effective as existing IT infrastructure can be used
- Change from the SDH to the MPLS power system possible without parameterization of the devices
- Redundant communication possible
- Interoperability of the protection interface of SIPROTEC 5 and SIPROTEC 4 devices allow simple migration and expansion solutions

SIPROTEC 5 Devices and Fields of Application

Application Examples – Line Protection

Impedance Protection for the Low-Voltage Side of a Transformer

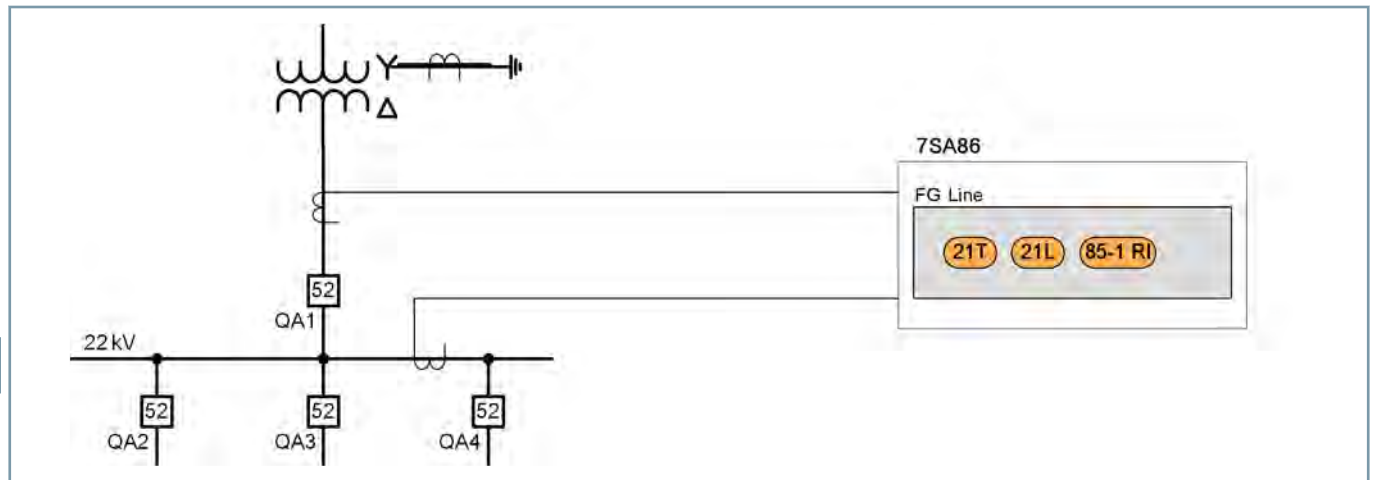

[dw_z-prot-transf-lv-side_7sa86_090115, 2, en_US]

Figure 2.3/25 Impedance Protection

Properties

- Effective backup protection with zones that reach into the transformer
- A 2nd impedance protection device can be used in the same function group to protect the busbar at the low-voltage side with reverse interlocking (85-21 RI).
- Provides the imperative backup protection for the medium-voltage feeders with highly sensitive defect detection and stability under a heavy load.

Applications with Double Circuit Breaker

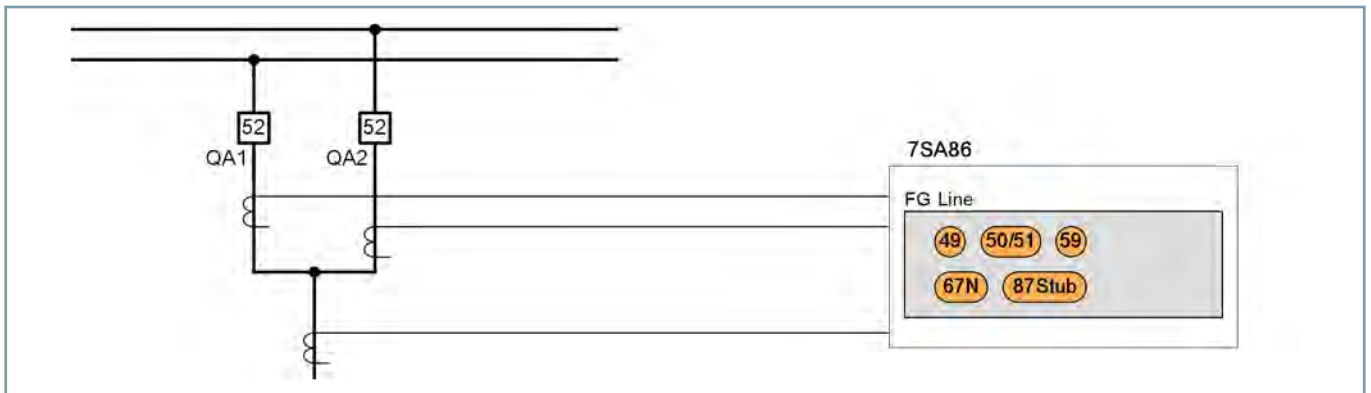

Figure 2.3/26 Applications with Double Circuit Breaker

Properties

- Separate measurement of the current-transformer current from both circuit breakers allows end-fault protection
- Separate measurement of the current-transformer currents improves stability in the case of external errors and strong current flow from one busbar to the other when both circuit breakers are closed.

SIPROTEC 5 Devices and Fields of Application

Application Examples – Breaker-and-a-Half

Modular and Decentralized Protection and Control Solution

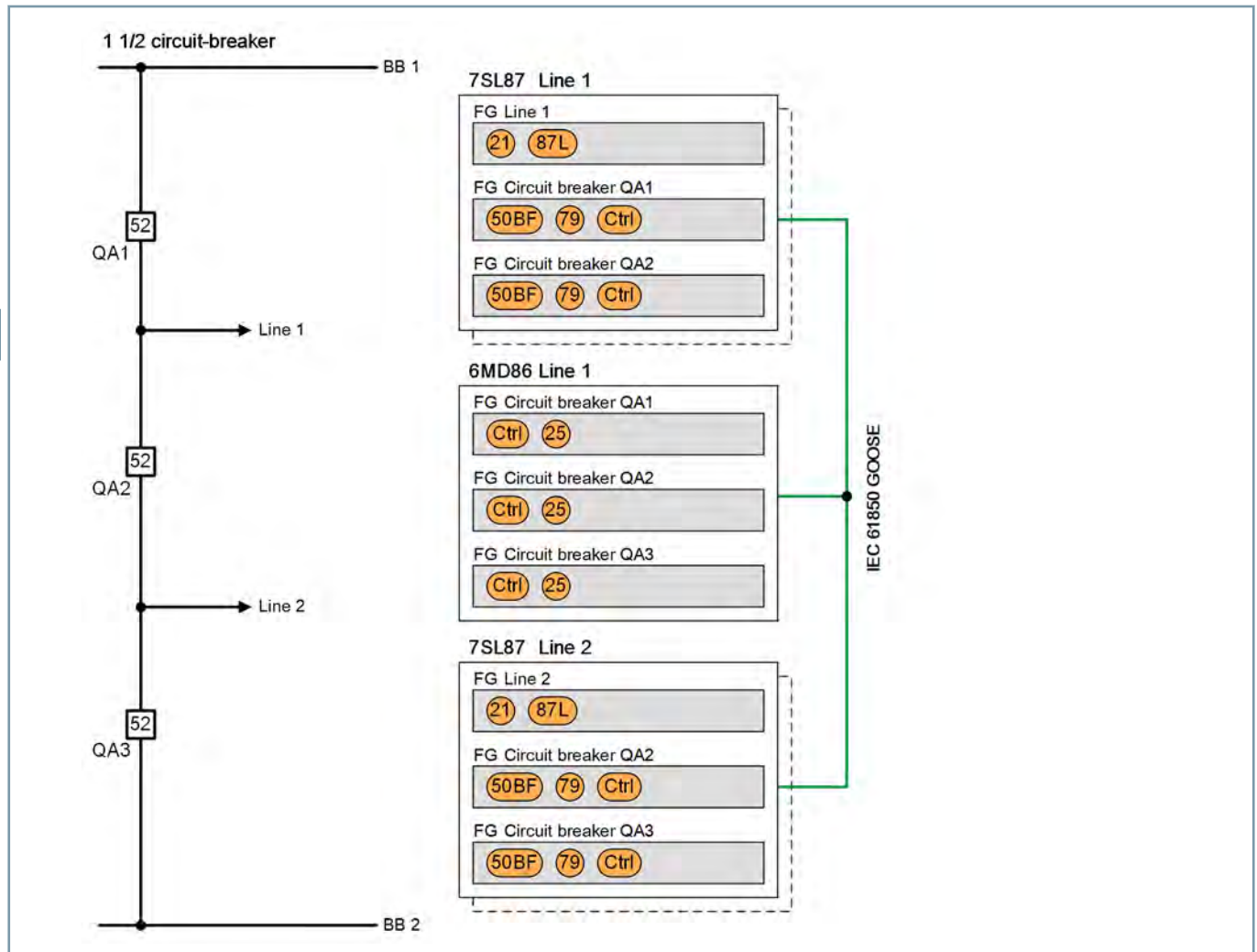

[dw_ein-einhalb-LS, 2, en_US]

Figure 2.3/27 Modular and Decentralized Protection and Control Solution

Properties

- Clearly arranged due to the clear assignment of protection and control
- Highly available due to protection redundancy
- Simple and secure central control of the entire switching unit
- Safe due to emergency control for each line in the protection device
- Reduced wiring effort due to integrated voltage selection
- System-wide exchange via IEC 61850:
 - Isolated data exchange
 - Reduced wiring effort
 - Easy expandability

Low-Cost Device and Protection Redundancy in Breaker-and-a-Half Arrangements

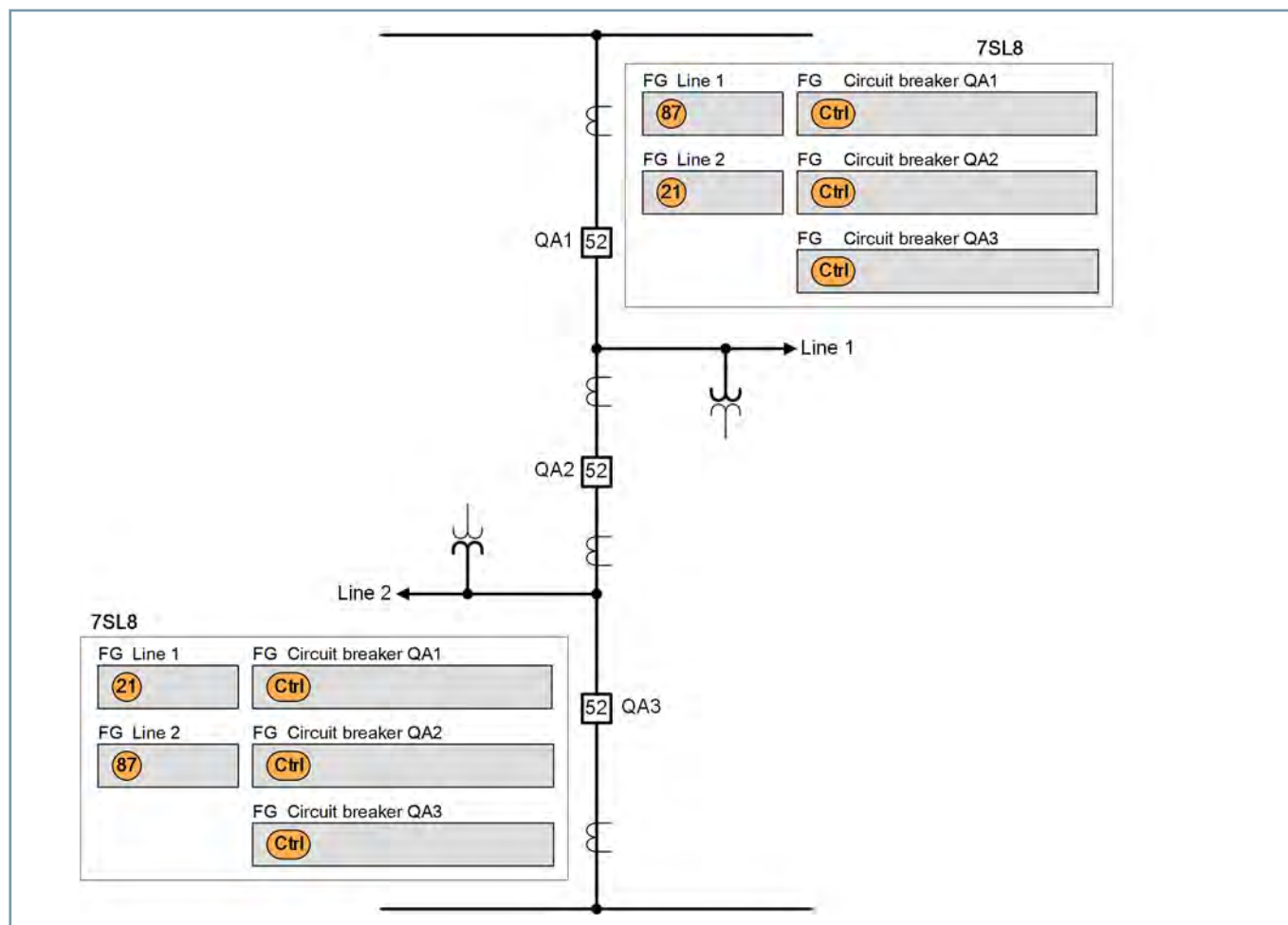

[dw_kostenguenstige-geraete, 3, en_US]

Figure 2.3/28 Low-Cost Device and Protection Redundancy in Breaker-and-a-Half Arrangements

Properties

- Unambiguous allocation of the main protection function (line differential protection 87) to a line in a device
- The distance-protection function (21) is implemented in the protection device of the other line by a 2nd Line function group.
- High availability and safety by device and protection redundancy
- Low costs due to protection and controlling of a complete diameter with only 2 devices

SIPROTEC 5 Devices and Fields of Application

Application Examples – Point-On-Wave Switching (PoW)

Point-on-Wave Switching (PoW)

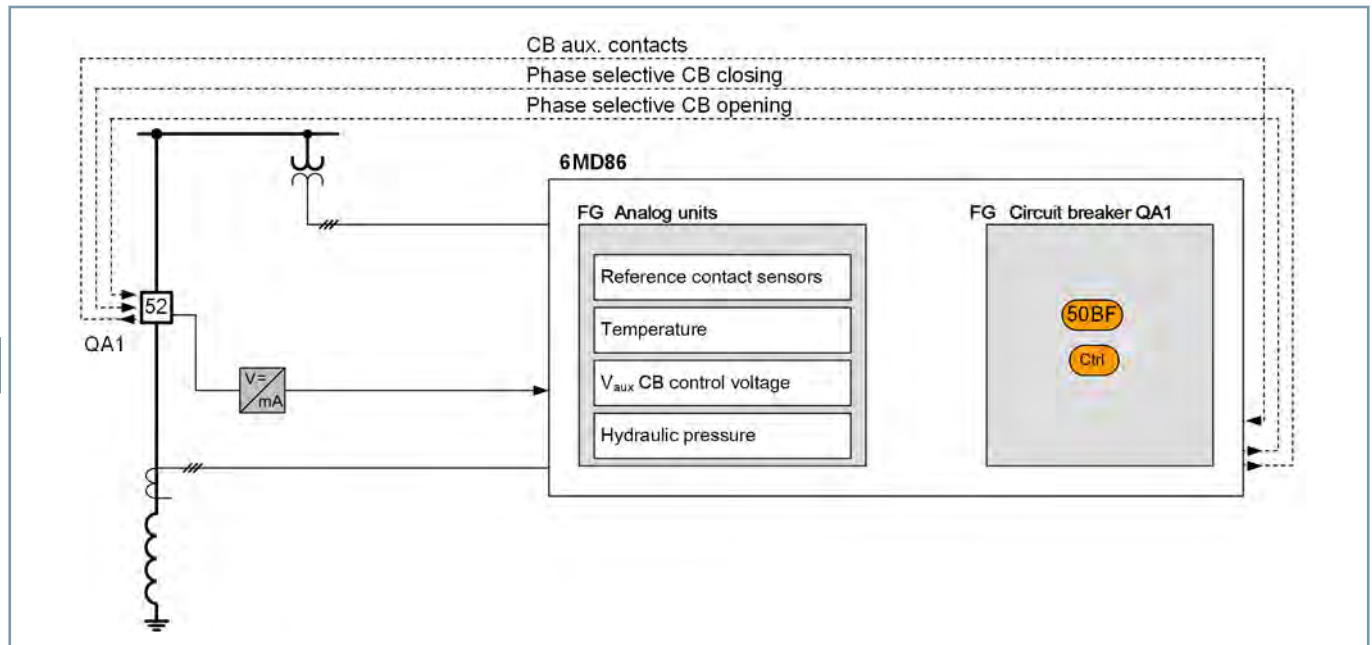

[dw_Appl_point-on-wave-switching_simple, 1, en_US]

Figure 2.3/29 Application Example: Point-on-Wave Switching on/off

Properties:

- 1-pole point-on-wave switching on and off
- Minimizing electro-dynamic and dielectric loads on equipment (overvoltages and inrush surge currents)
- Cost-effective integration of the function into SIPROTEC 5 protection devices and substation controllers

Protection of a Capacitor Bank in H-Bridge Connection

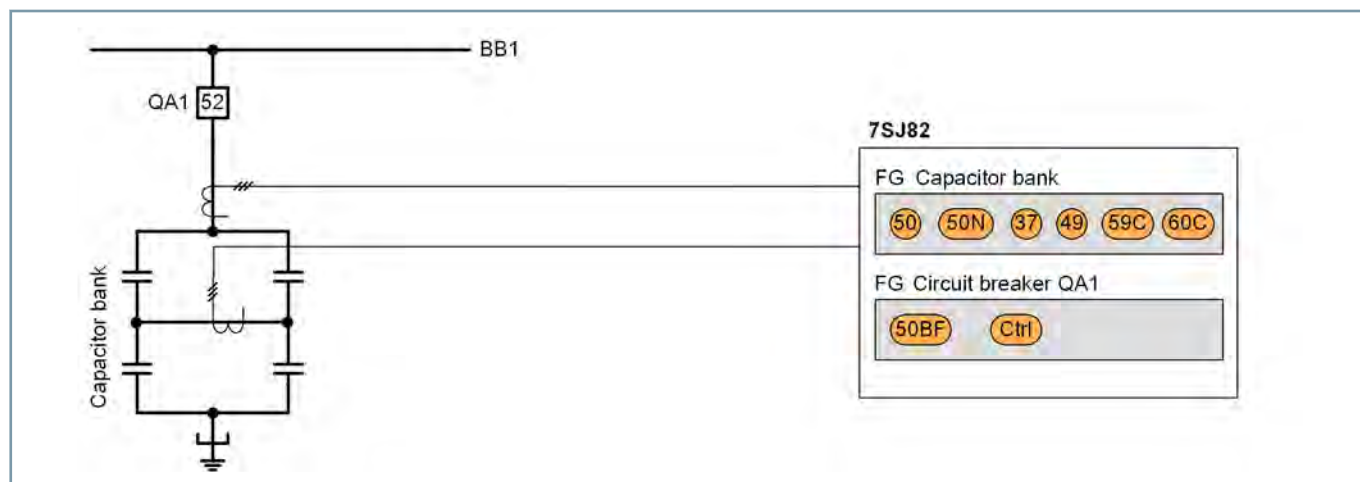

[dw_CapBank_SLE vereinfacht, 2, en_US]

Figure 2.3/30 Protection of a Capacitor Bank in H-Bridge Connection

Properties

- Precise fit due to own function group and application-specific protection function, such as peak overvoltage protection (ANSI 59C) and current-unbalance protection for capacitor banks (ANSI 60C)
- Low costs due to the integration of all necessary functions in one device

SIPROTEC 5 Devices and Fields of Application

Application Examples – Capacitor Banks

Protection of an MSCDN Capacitor Bank (MSCDN = Mechanically Switched Circuit Breaker with Damping Network)

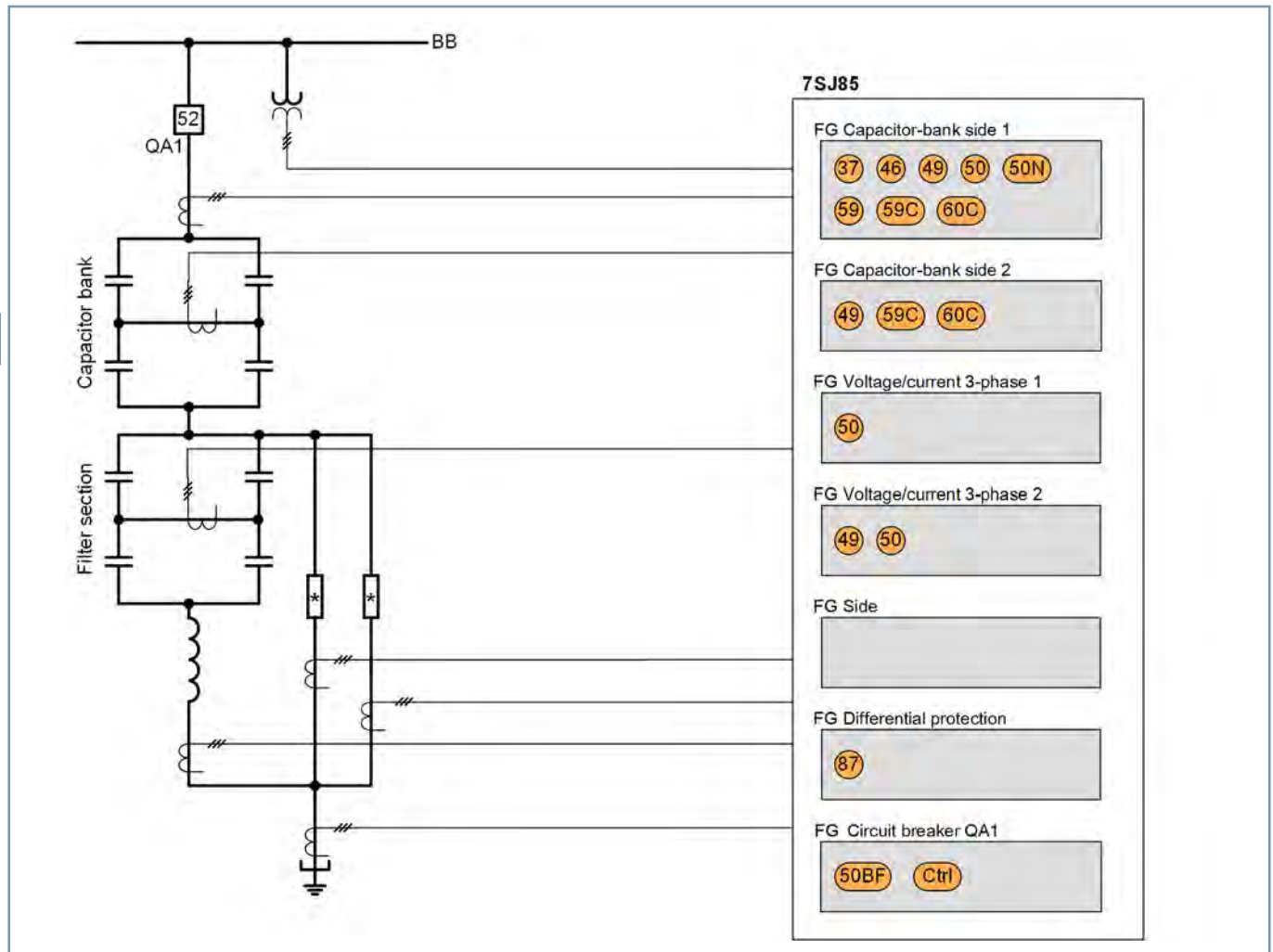
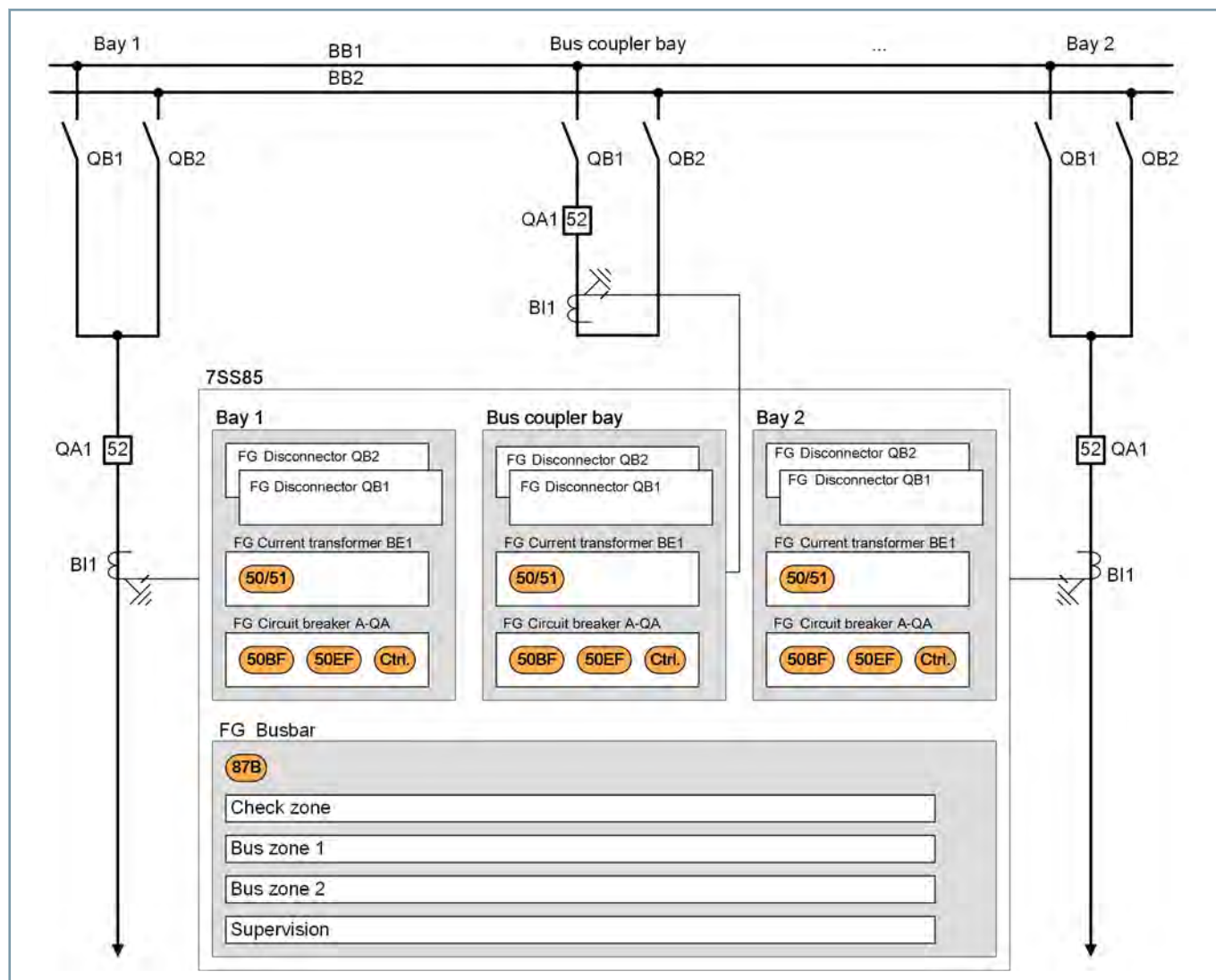

Figure 2.3/31 Protection of an MSCDN Capacitor Bank

Properties

- Optimum protection of complex banks and filter circuits with flexible hardware and a flexible function design
- Low costs due to the integration of all necessary functions in one device for up to nine 3-phase current measuring points
- Generation of current sum and current difference at the current interface of the protection function group **3-phase V/I**
- Detection of current and voltage signals up to the 50th harmonic with a high accuracy for protection and operational measured values.

Central Protection of a Double Busbar with Bus Coupler



[dw_Verbindungen-Feld-Koppl, 3, en_US]

Figure 2.3/32 Central Protection of a Double Busbar with Bus Coupler

Properties

- Central busbar protection
- Summary of all primary components of a bay in the central station bay
- 1 device for up to 20 measuring points
- Flexible adaptation to the topology (up to 6 busbar sections and 6 busbar couplers are configurable)
- Integrated disconnector image
- Comfortable graphical project engineering with DIGSI 5

SIPROTEC 5 Devices and Fields of Application

Application Examples – Busbar Protection

Project Engineering for a Quadruple Busbar in the Distributed Solution

2.3

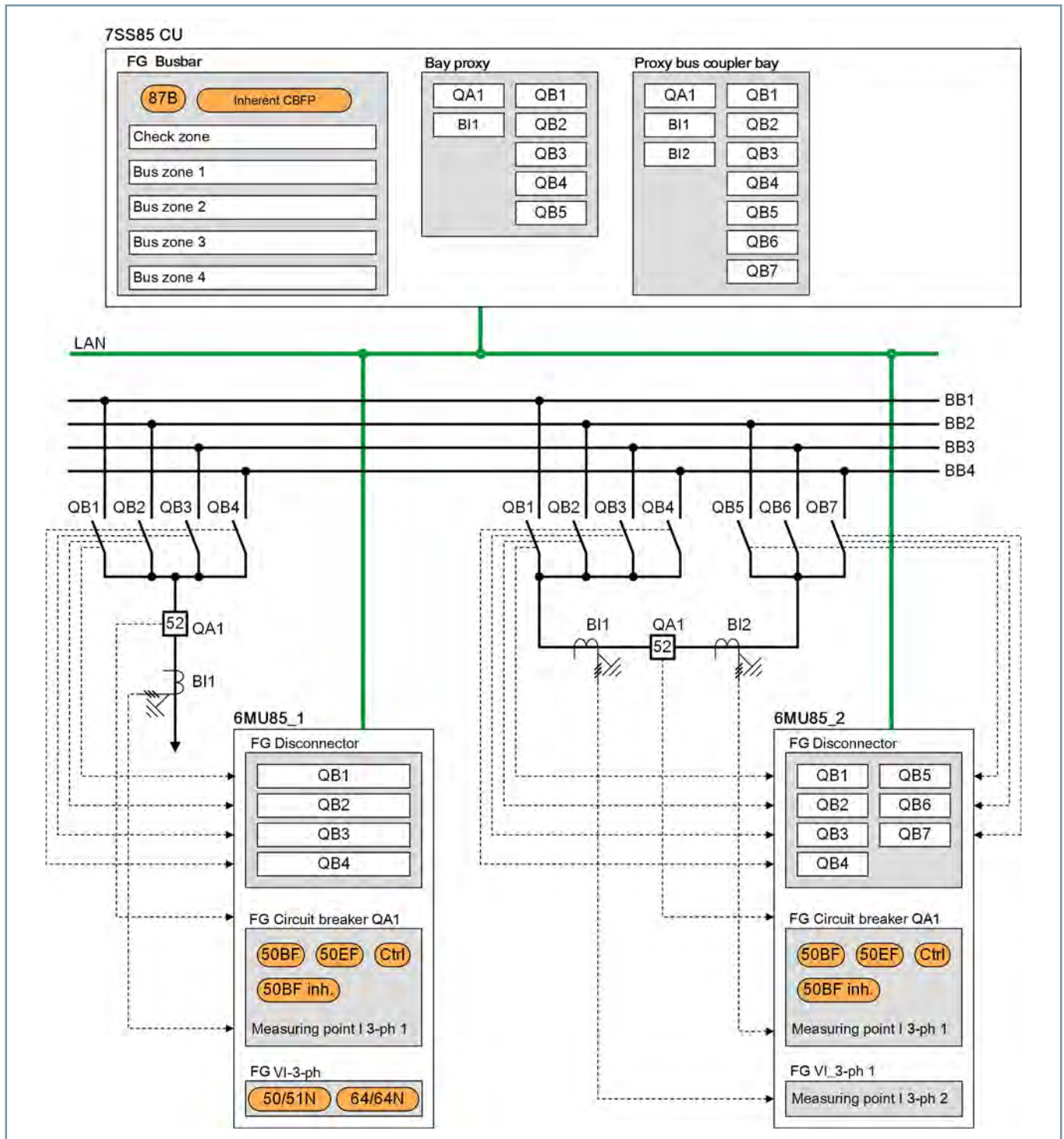

[dw_4x5S-Anlagen_Verbindungen-Feld-Koppl, 1, en_US]

Properties

- Decentralized process-data acquisition using:
 - SIPROTEC Merging Unit
- Every modular SIPROTEC 5 device
- Simple extension of existing SIPROTEC 5 plants using distributed busbar protection
- Engineering using DIGSI 5 and automated routing in the IEC 61850 system configurator

Process-Bus Application in Line Differential Protection

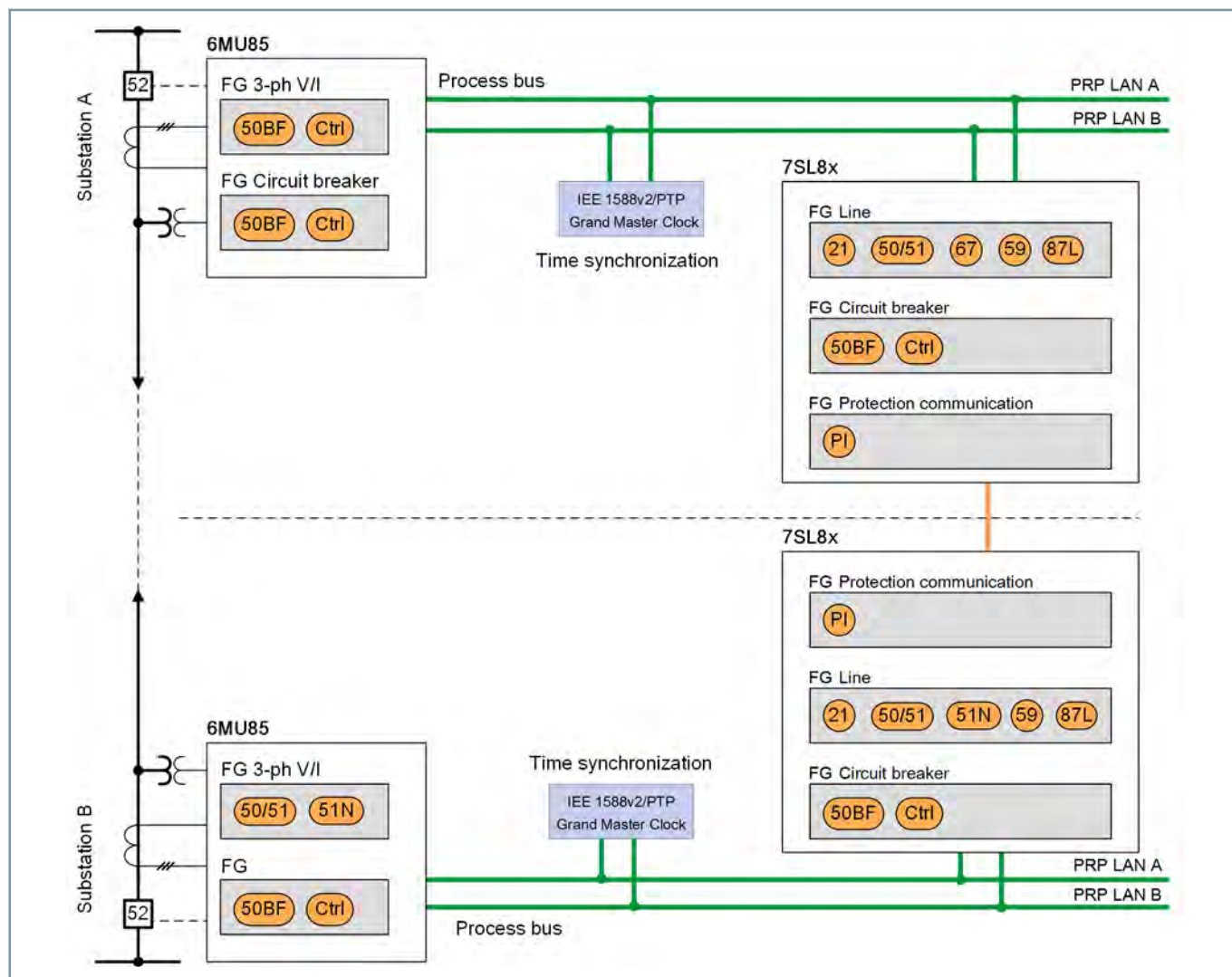

[dw_appl-exampl_line-diff-prot, 2, en_US]

Figure 2.3/33 Process-Bus Application in Line Differential Protection

Properties

- Process-bus solution for line differential protection with digital protection interface
- Increased safety due to process-oriented connection of the conventional current and voltage transformers to merging units
- Interoperable process bus according to the protocols IEC 61850-9-2 and PRP

SIPROTEC 5 Devices and Fields of Application

Application Examples – Process Bus

Process_Bus Application in Line Differential Protection with SIPROTEC 5

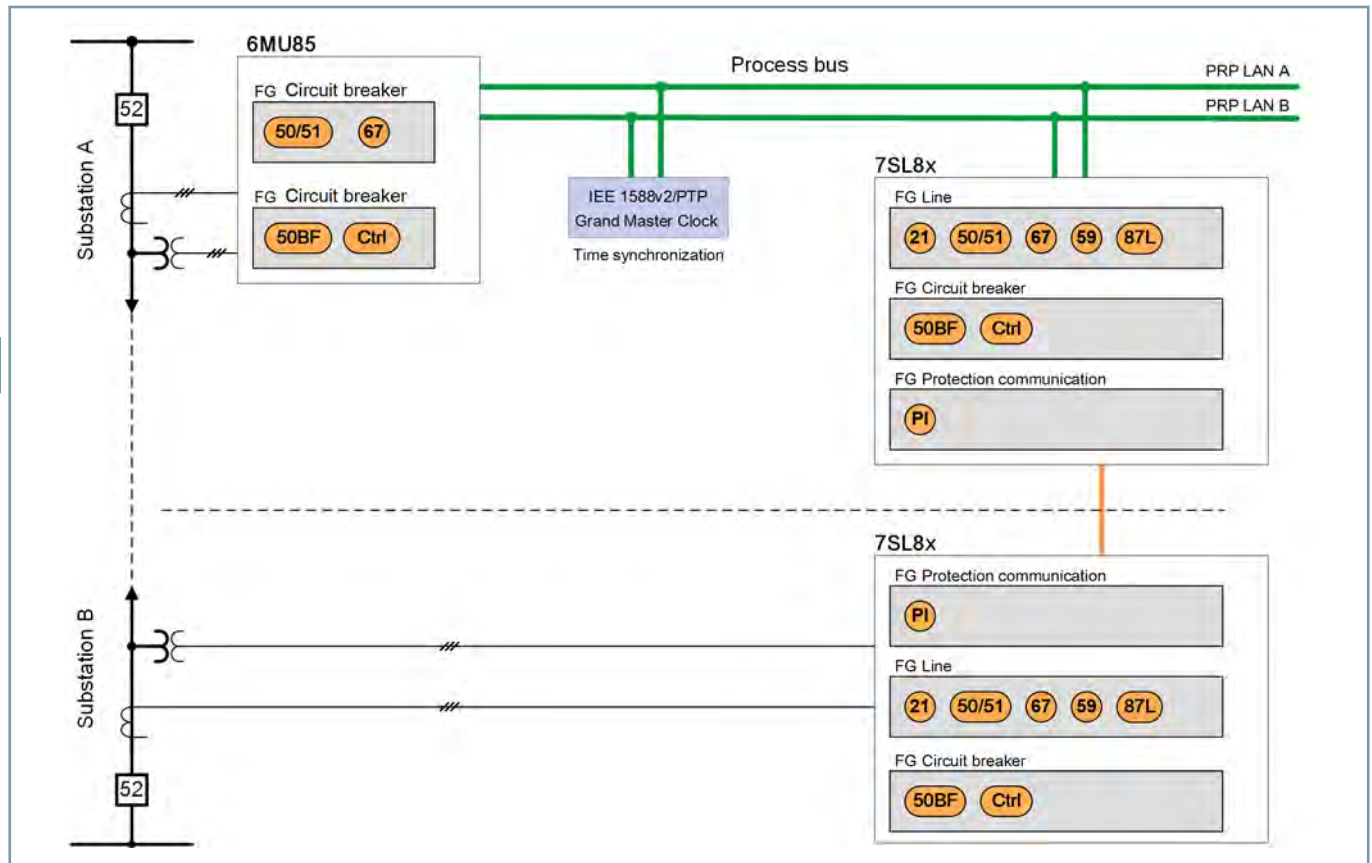
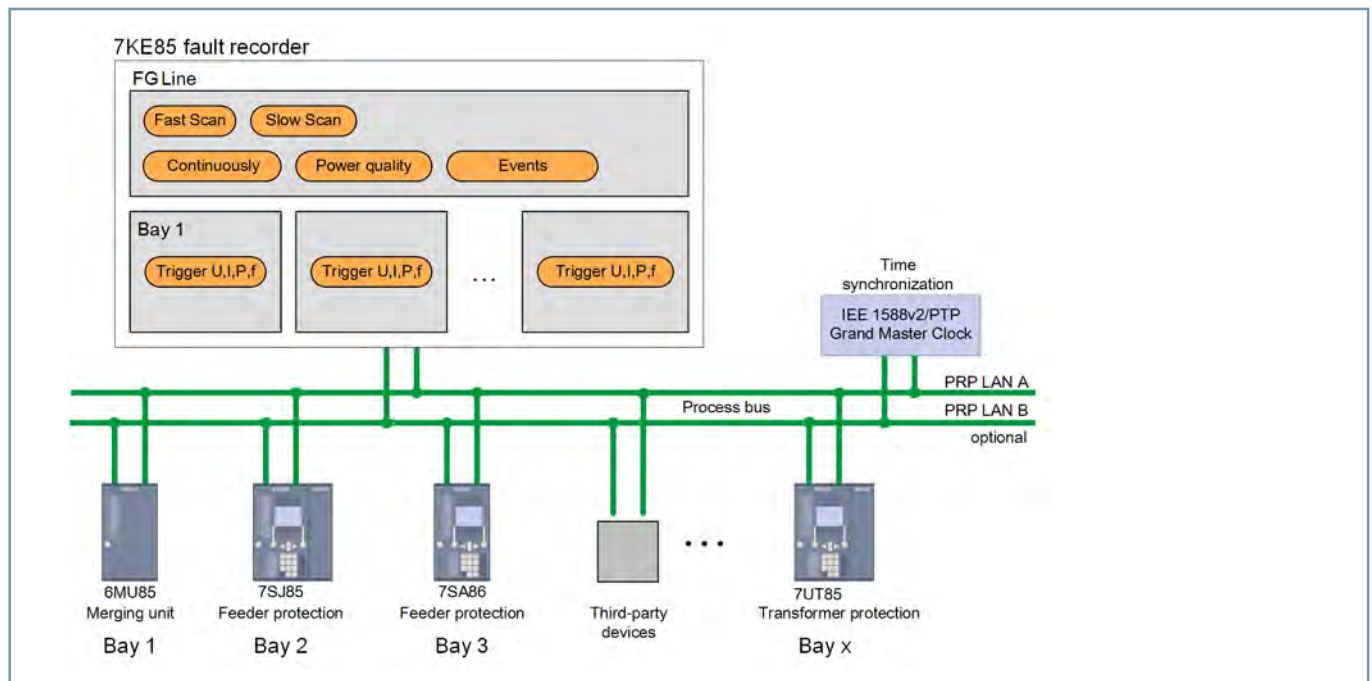

Figure 2.3/34 Process-Bus Application in Line Differential Protection with SIPROTEC 5

Properties

- Line differential protection with a digital protection interface
- A mixed solution from the process bus and conventional connection allows simple migration by gradually converting systems
- Increased safety due to process-oriented connection of the current and voltage transformers to merging units
- Interoperable process bus according to the protocols IEC 61850-9-2 and PRP

Decentralized Fault Recorder



[dw_decentr-fault-recorder, 1, en_US]

Figure 2.3/35 Decentralized Fault Recorder

Properties

- Interoperable fault-recorder solution based on the process bus according to IEC 61850-9-2
- Decentralized process-data acquisition with:
 - SIPROTEC Merging Unit
 - Merging units from third-party manufacturers
- Simple extension of existing SIPROTEC 5 plants using centralized fault recorder
- Engineering using standard IEC 61850 configuration tools and DIGSI 5

SIPROTEC 5 Devices and Fields of Application

Application Examples – Process Bus

Centralized Protection using IEC 61850-Compatible Decentralized Process Connection

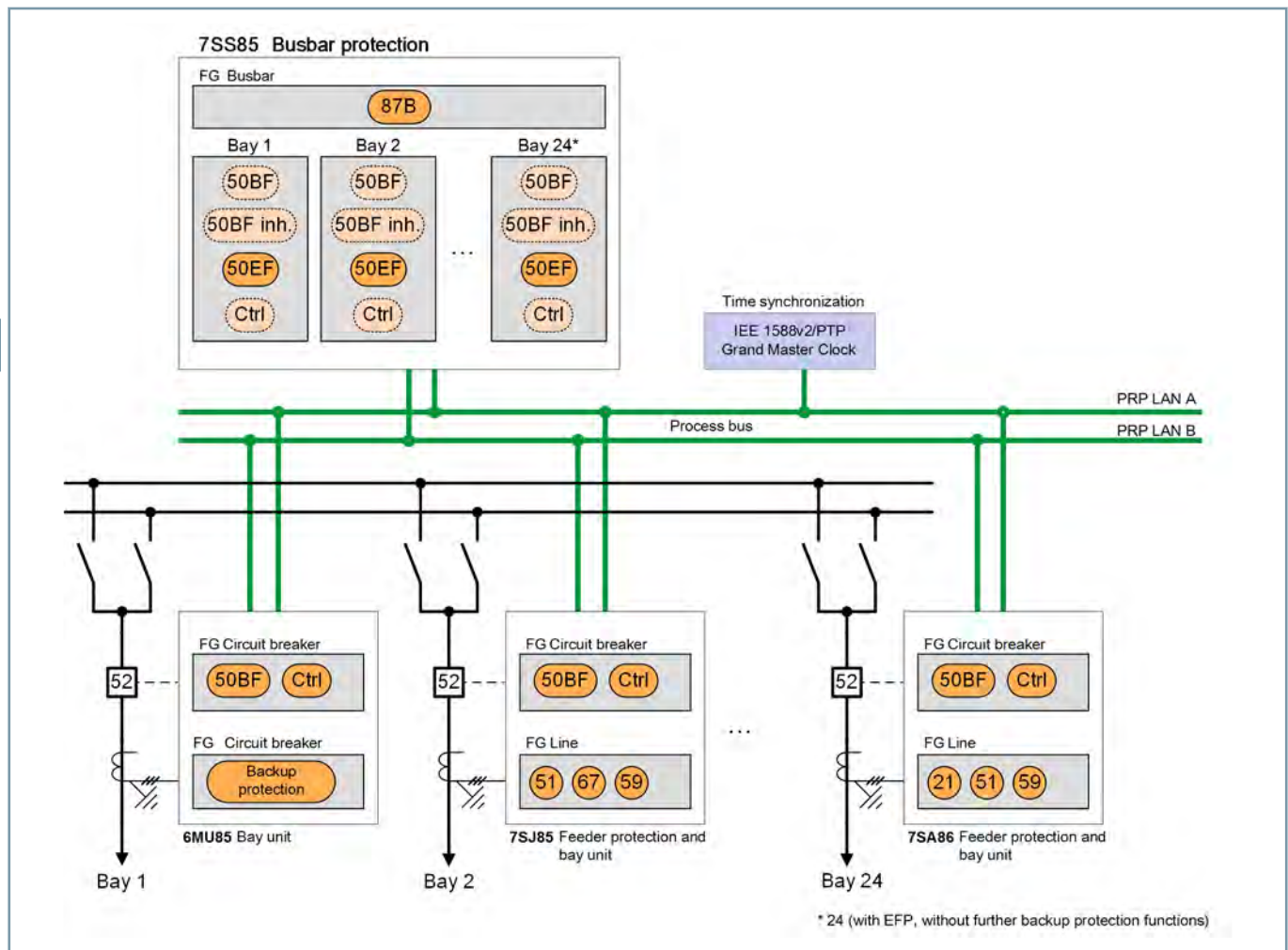

[dw_decentr-busbar, 2, en_US]

Figure 2.3/36 Centralized Protection using IEC 61850-Compatible Decentralized Process Connection

Properties

- Interoperable busbar-protection solution based on the process bus according to IEC 61850-9-2
- Decentralized process-data acquisition using:
 - SIPROTEC Merging Unit
 - Every modular SIPROTEC 5 device
 - Merging units from third-party manufacturers
- Simple extension of existing SIPROTEC 5 plants using distributed busbar protection
- Engineering using standard IEC 61850 configuration tools and DIGSI 5

Central Protection for Small Stations

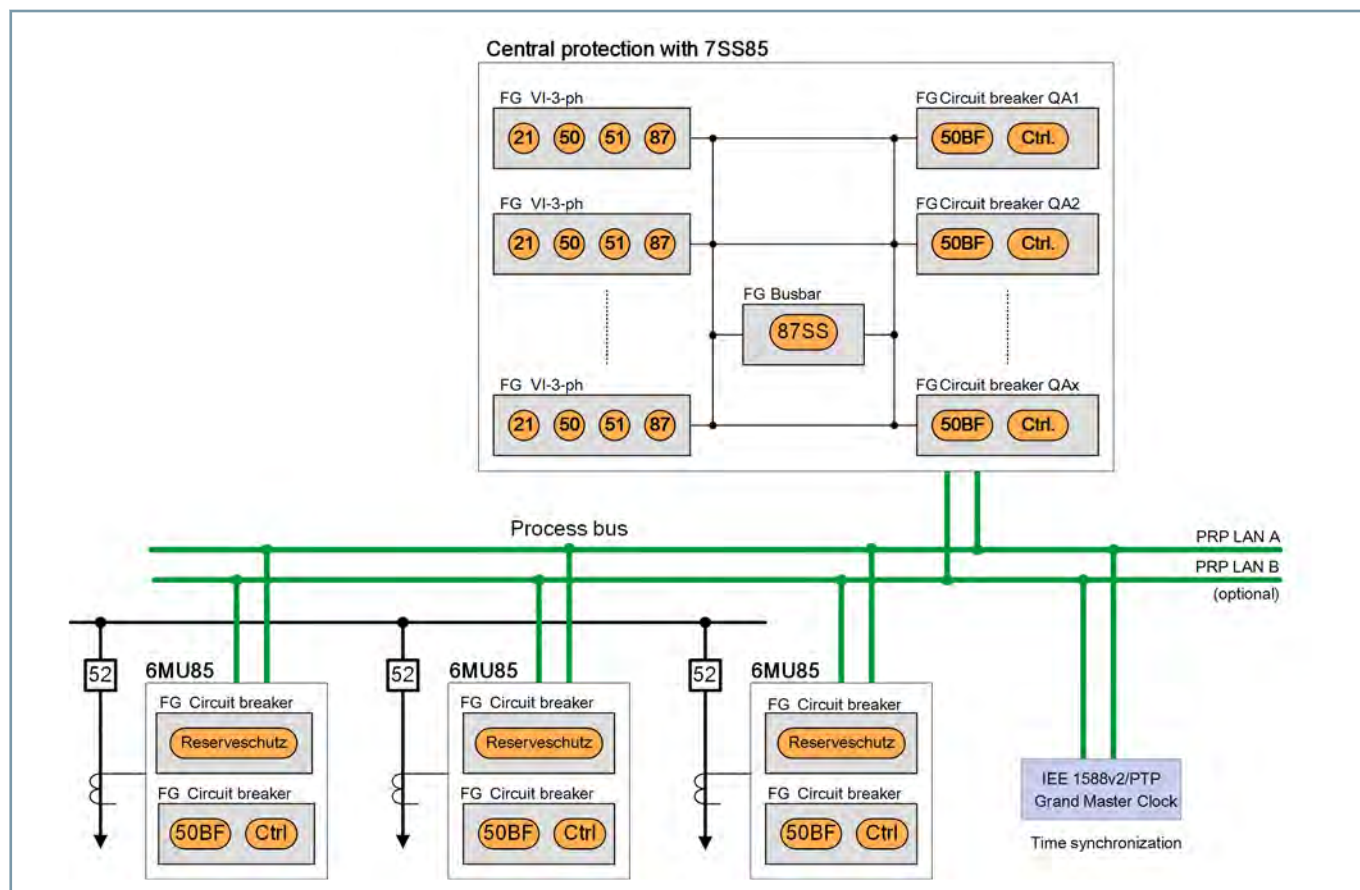

[dw_appl-exampl_micro-central-prot_with_7ss85, 1, en_US]

Figure 2.3/37 Central Protection for Small Stations

Properties

- Busbar protection
- Central impedance protection (21) for the feeders
- Reduced wiring effort by decentralized data acquisition using the merging units 6MU85
- Increased safety due to process-oriented connection of the conventional current and voltage transformers to merging units
- Redundancy due to backup protection in the merging units
- Easy to expand due to the interoperable process bus according to the protocols IEC 61850-9-2 and PRP

SIPROTEC 5 Devices and Fields of Application

Application Examples – Process Bus

Central Protection for a Small Station with a Transformer

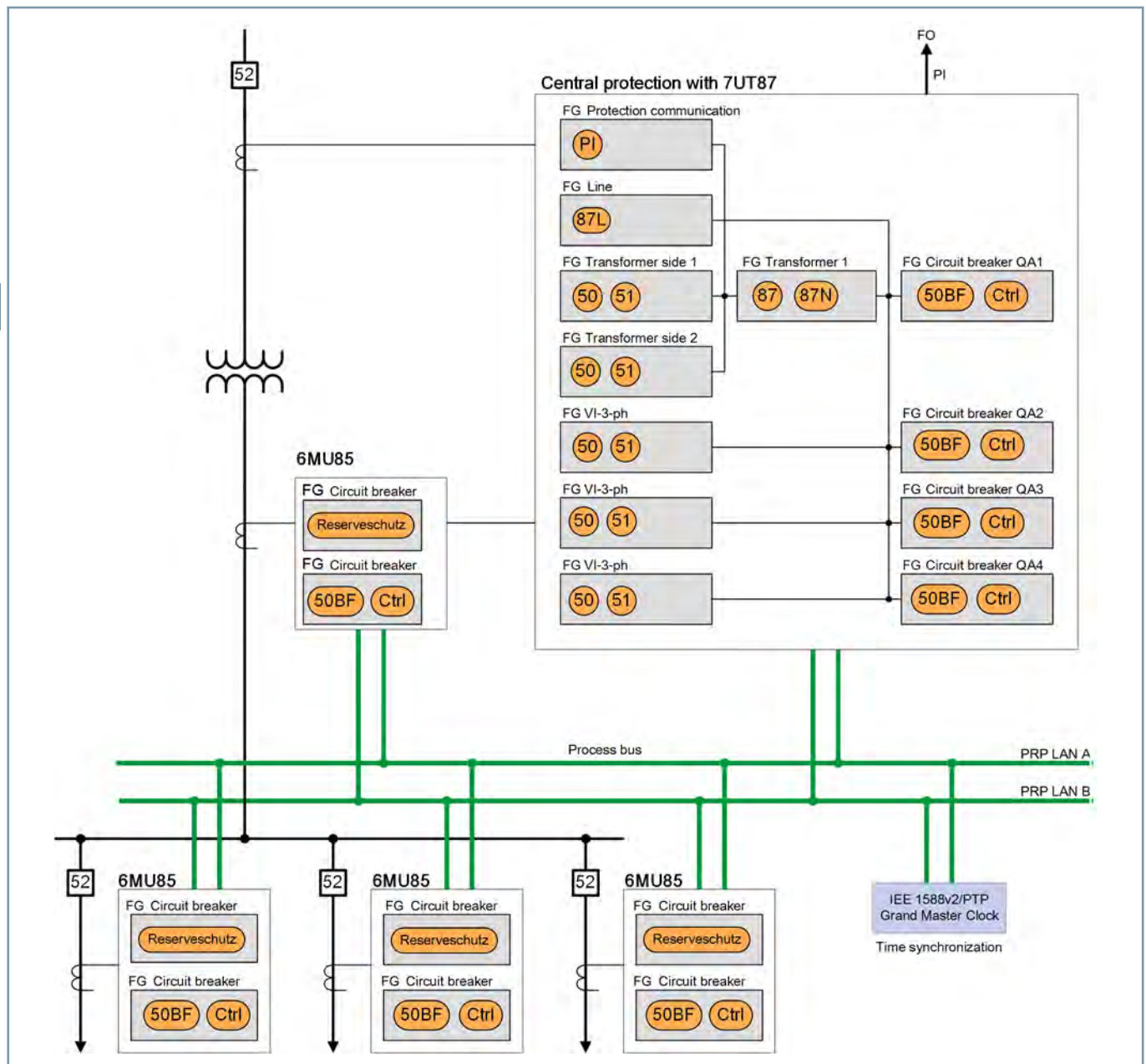

[dw_appl-exempl_micro-central-prot, 2, en_US]

Figure 2.3/38 Central Protection for a Small Station with a Transformer

Properties

- Feeder, transformer, and line protection in a single SIPROTEC 5 protection device for the complete station
- Reduced wiring effort by decentralized data acquisition using the merging units 6MU85
- Measured-value acquisition and circuit-breaker control via the process bus
- Redundancy due to backup protection in the merging units
- Easy to expand due to the interoperable process bus according to the protocols IEC 61850-9-2 and PRP

SIPROTEC 5 Devices and Fields of Application

Application Examples – Power-System Monitoring and PMU

Power-System Monitoring and PMU

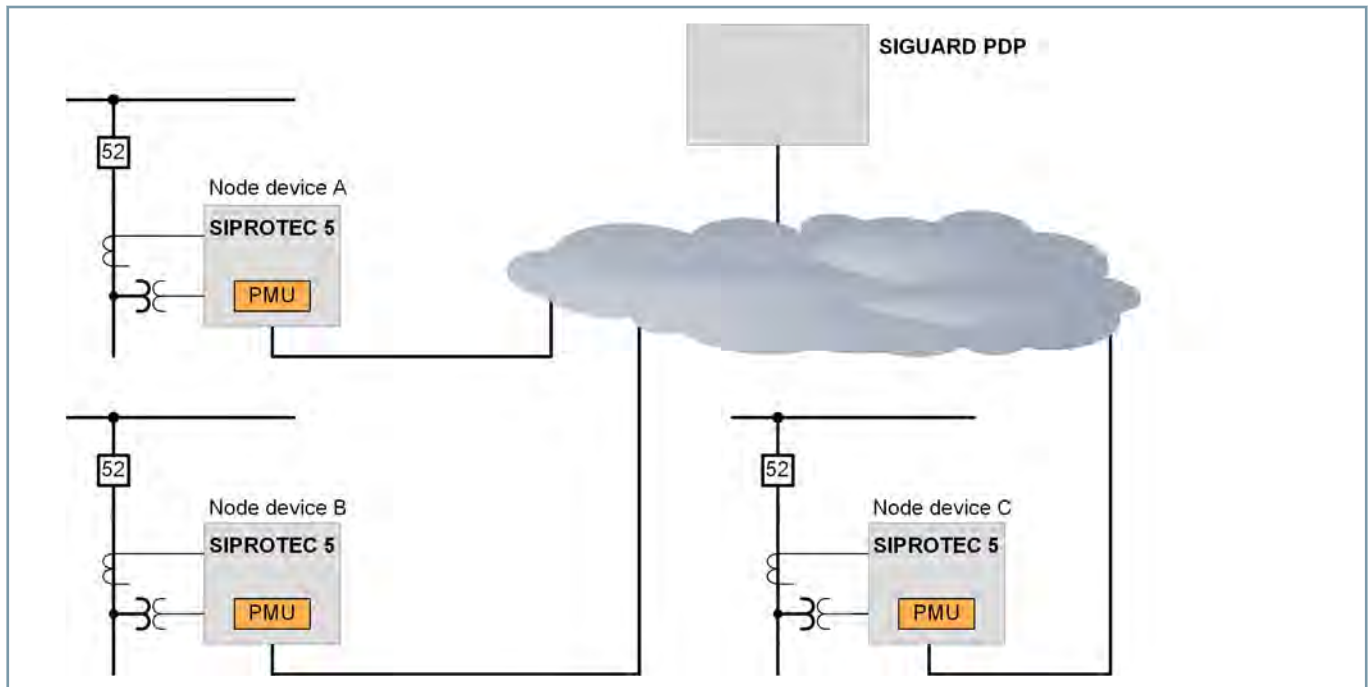

[dw_netzmonitor-mit-pmu, 2, en_US]

Figure 2.3/39 Principle of the Distributed Phasor Measurement

Properties

- Every SIPROTEC 5 device can be equipped or retrofitted with the PMU function.
- Online and offline evaluation of PMU data in the monitoring system SIGUARD PDP

SIPROTEC 5 Devices and Fields of Application

Application Examples – Power-System Monitoring and PMU

2.3

SIPROTEC 5 Devices and Fields of Application

Overcurrent and Feeder Protection



2.4

SIPROTEC 5 Devices and Fields of Application

Overcurrent and Feeder Protection

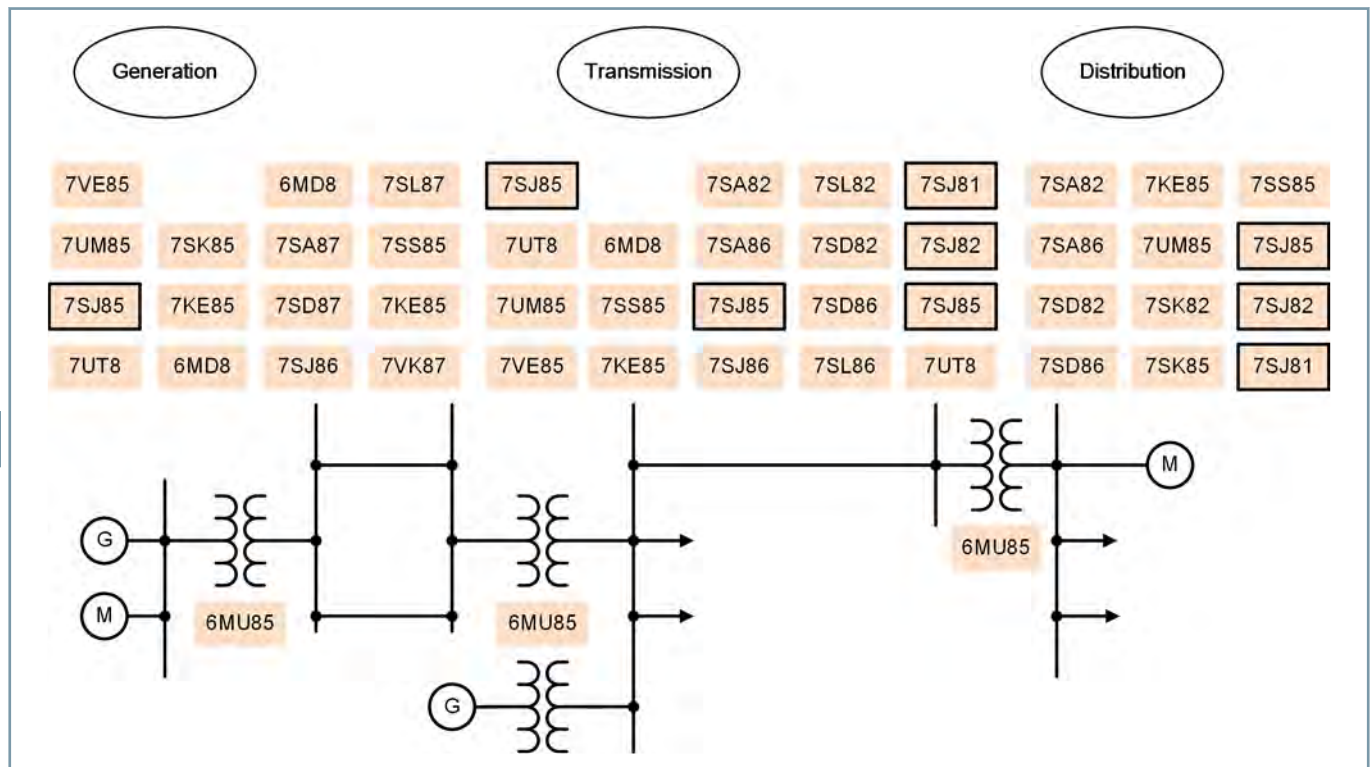

[dw_7SJ_anwendung, 4, en_US]

Figure 2.4/1 Fields of Application of the SIPROTEC 5 Devices

SIPROTEC 7SJ81, 7SJ82, 7SJ85

The main protection functions of the SIPROTEC 7SJ81/82/85 devices are based on the overcurrent-protection principle. Although they primarily protect feeders and lines in the distribution system, they can also be used in a high-voltage power system without any problems. The hardware quantity structure can be extended flexibly and permits several feeders to be protected with one device. Due to the large number of available functions and the great flexibility, the device is suitable for a multitude of additional protection and monitoring applications. Specifically for usage as backup and emergency protection for line protection, we recommend using the SIPROTEC 7SJ86 device. The large number of automatic functions allows the device to be used in all fields of energy supply.

The devices contain all important auxiliary functions that are necessary for safe network operation today. This includes func-

tions for protection, control, measurement, and monitoring. The large number of communication interfaces and communication protocols satisfies the requirements of communication-based selective protection as well as automated operation.

Commissioning and maintenance work can be completed safely, quickly, and thus cost-effectively with high-performance test functions. Their modular surface mounting allows SIPROTEC 5 devices to be always adapted flexibly to the individual requirements.

Distinguishing features

The 3 device models differ in the configurability of their hardware quantity structure.

Essential Differentiating Characteristics	
7SJ81	Different hardware quantity structures for binary inputs and outputs are available in the 1/3 base module, 1 plug-in module position; 12 LEDs; no function keys; no PMU or voltage controller
7SJ82	Different hardware quantity structures for binary inputs and outputs are available in the 1/3 base module. Adding 1/6 expansion modules is not possible
7SJ85	Flexible configuration of the hardware quantity structure for analog inputs, binary inputs and outputs, measuring transducers, and communications due to expandability by 1/6 expansion modules

Description

The SIPROTEC 7SJ81 has been designed for a cost-effective and compact protection of feeders and lines in medium-voltage systems. With its flexibility and the powerful DIGSI 5 engineering tool, the SIPROTEC 5 device offers future-oriented solutions for protection, control, automation, monitoring, and Power Quality – Basic.

Main function	Feeder and overcurrent protection
Inputs and outputs	4 current transformers, 11 binary inputs, 9 binary outputs
	4 current transformers, 18 binary inputs, 14 binary outputs
	4 current transformers, 4 voltage transformers, 11 binary inputs, 9 binary outputs
	4 current transformers, 4 voltage transformers, 16 binary inputs, 11 binary outputs
Hardware flexibility	Different hardware quantity structures for binary inputs and outputs are available in the 1/3 base module. 1 plug-in module position, available with large or small display
Housing width	1/3 × 19 inches

Benefits

- Compact and low-cost overcurrent protection
- Safety due to powerful protection functions
- Purposeful and easy handling of devices and software thanks to a user-friendly design
- Cybersecurity according to NERC CIP and BDEW Whitepaper requirements (for example, logging security-related events and alarms)
- Highest availability even under extreme environmental conditions by standard coating of the modules
- Full compatibility between IEC 61850 Editions 1, 2.0, and 2.1

Functions

DIGSI 5 permits all functions to be configured and combined as required and as per the functional scope that has been ordered.

- Directional and non-directional overcurrent protection with additional functions
- Detection of ground faults of any type in isolated or arc-suppression-coil-ground power systems using the following functions: $3I_0>$, $VO>$, transient ground-fault function, $\cos \phi$, $\sin \phi$, dir. detection of intermittent ground faults, harmonic detection, and admittance measurement
- Detection of intermittent ground faults with automatic blocking of statically measuring functions to avoid message and fault-record flooding
- Arc protection (note the resulting communication restrictions)
- Overvoltage and undervoltage protection
- Frequency protection and frequency change protection for load shedding applications
- Power protection, configurable as active or reactive power protection



[SIP5_GD_W3, 2, --]

Figure 2.4/2 SIPROTEC 7SJ81

- Directional reactive power undervoltage protection (QU protection)
- Control with switchgear interlocking protection
- Synchrocheck
- Circuit-breaker failure protection
- Detection of current and voltage signals up to the 50th harmonic with high accuracy for selected protection functions and operational measured values
- PQ – Basic: Voltage unbalance; voltage changes: overvoltage, dip, interruption; TDD, THD, and harmonics
- Graphical logic editor to create powerful automation functions in the device
- Single-line representation in small or large display
- Fixed integrated electrical Ethernet RJ45 interface for DIGSI 5 and IEC 61850 (reporting and GOOSE)
- Serial protection communication via optical fibers, two-wire connections, and communication networks (IEEE C37.94 and others), including automatic switchover between ring and chain topology
- 1 optional plug-in module for either a) communication protocol or b) for arc protection
- Redundant and simple communication protocols according to IEC 61850, IEC 60870-5-103, IEC 60870-5-104, Modbus TCP, DNP3 serial and TCP, PROFINET IO
- Reliable data transmission via PRP and HSR redundancy protocols
- Extensive cybersecurity functionality, such as role-based access control (RBAC), logging of security-related events, signed firmware, or authenticated IEEE 802.1X network access
- Simple, fast, and secure access to the device via a standard Web browser to display all information and diagnostic data, vector diagrams, single-line and device display pages

SIPROTEC 5 Devices and Fields of Application

Overcurrent and Feeder Protection – SIPROTEC 7SJ81

- Time synchronization using IEEE 1588
- Standard fault recording (buffer for a max. record time of approx. 40 sec. at 2 kHz)
- Auxiliary functions for simple tests and commissioning

Applications

- Detection and selective 3-pole tripping of short circuits in electrical equipment of star networks, lines with infeed at one or two ends, parallel lines and open-circuited or closed ring systems of all voltage levels
- Detection of ground faults in isolated or arc-suppression-coil-ground power systems in star, ring, or meshed arrangement
- Backup protection for differential protection devices of all kind for lines, transformers, generators, motors, and busbars
- Universal power protection
- Simple load shedding applications
- Detection and recording of power-quality data in the medium-voltage and subordinate low-voltage power system

2.4

Application Templates

Application templates are available in DIGSI 5 for standard applications. They contain basic configurations and default settings.

The following application templates are available:

- Non-directional definite-time overcurrent protection/inverse-time overcurrent protection (4*I)
- Non-directional definite-time overcurrent protection/inverse-time overcurrent protection (4*I, 4*V)

Application Example

Protection and Control on a Single Busbar

The following application example (Figure 2.4/3) shows the functional scope and the basic configuration of a SIPROTEC 7SJ81 device for busbar protection and control.

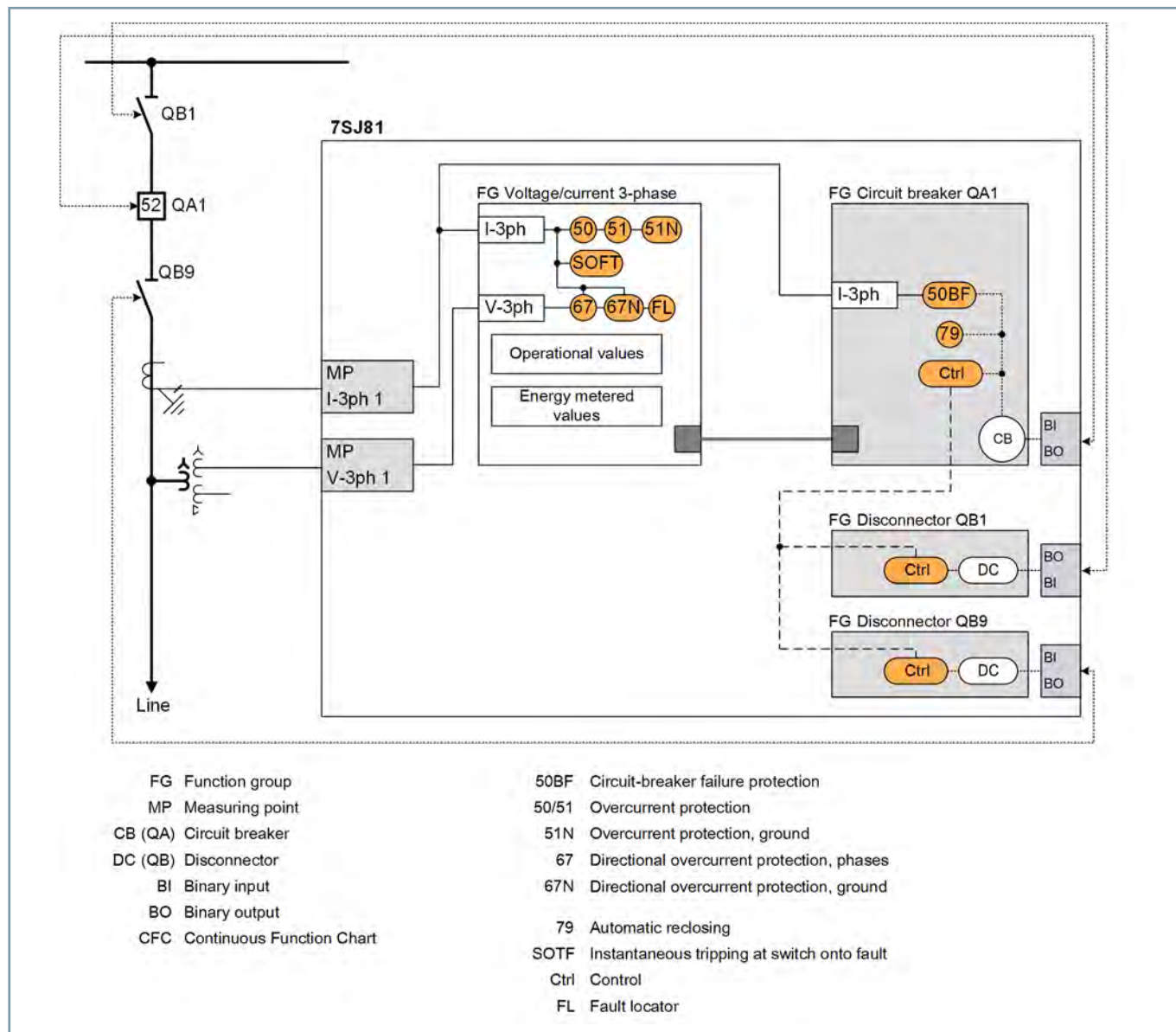

[dw_7SJ81_mit EinfachSS, 1, en_US]

Figure 2.4/3 Application Example: Overcurrent Protection 7SJ81 on a Busbar

SIPROTEC 5 Devices and Fields of Application

Overcurrent and Feeder Protection – SIPROTEC 7SJ81

ANSI	Function	Abbr.	Available	Application Templates	
				1	2
	Protection functions for 3-pole tripping	3-pole	■	■	■
25	Synchrocheck, synchronization function	Sync	■		
27	Undervoltage protection: "3-phase" or "positive-sequence system V1"	V<	■		
27R, 59R	Voltage change protection (starting with V8.30)	dV/dt	■		
	Undervoltage-controlled reactive power protection	Q>N<	■		
32, 37	Power protection active/reactive power	P<>, Q<>	■		
37	Undercurrent	I<	■		
38	Temperature supervision	θ>	■		
46	Negative-sequence system overcurrent protection	I2>	■		
47	Overvoltage protection, negative-sequence system	V2>	■		
49	Thermal overload protection	θ, I²t	■		
50/51 TD	Overcurrent protection, phases	I>	■	■	■
	Instantaneous tripping at switch onto fault	SOTF	■		
50HS	Instantaneous high-current tripping	I>>>	■		
50N/ 51N TD	Overcurrent protection, ground	IN>	■	■	■
50N/ 51N TD	Overcurrent protection, 1-phase	IN>	■		
50 Ns/ 51Ns	Sensitive ground-fault detection for grounded arc suppression coils and isolated power systems including a) 3I0> b) admittance Y0>	INs>	■		
	Intermittent ground-fault protection	IIE>	■		
50BF	Circuit-breaker failure protection, 3-pole	CBFP	■		
59, 59N	Overvoltage protection: "3-phase" or "zero-sequence system V0" or "positive-sequence system V1"	V>	■		
67	Directional overcurrent protection, phases	I>, ∠(V, I)	■		
67N	Directional overcurrent protection, ground	IN>, ∠(V, I)	■		
67 Ns	Sensitive ground-fault detection for grounded arc suppression coils and isolated power systems including a) 3I0> b) V0>, c) cos/sine Phi, d) transient ground fault, e) Phi(V, I), f) admittance		■		
	Directional Intermittent Ground-Fault Protection	IIEdir>	■		
74TC	Trip-circuit supervision		■		
79	Automatic reclosing, 3-pole	AREC	■		
81	Frequency protection: "f"> or "f"< or "df/dt"	f<>; df/dt<>	■		
	Vector-jump protection	Δφ>	■		
86	Lockout		■	■	■
FL	Fault Locator, single-side	FL-one	■		
AFD	Arc protection (only with plug-in module ARC-CD-3FO)		■		
	Measured values, standard		■	■	■
	Switching statistics counter		■		
	PQ – Basic measured values: THD (Total Harmonic Distortion) and harmonic component (starting with V8.01) and THD voltage average values (starting with V8.40)		■		
	PQ – Basic measured values: Voltage unbalance (starting with V8.40)		■		
	PQ – Basic measured values: Voltage changes – monitoring of voltage dips, overvoltages and voltage interruptions (starting with V8.40)		■		

2.4

SIPROTEC 5 Devices and Fields of Application

Overcurrent and Feeder Protection – SIPROTEC 7SJ81

ANSI	Function	Abbr.	Available	Application Templates	
				1	2
	PQ – Basic measured values: TDD - Total Demand Distortion (starting with V8.40)		■		
	CFC (standard, control)		■	■	■
	CFC arithmetic		■		
	Circuit-breaker wear monitoring	$\Sigma I_x, I^2t, 2P$	■		
	Switching sequence function		■		
	Inrush-current detection		■	■	■
	External trip initiation		■		
	Control		■	■	■
	1 circuit breaker object (number cannot be expanded)		■		
	3 disconnect/grounding conductor objects (number cannot be expanded)		■		
	Fault recording of analog and binary signals		■	■	■
	Monitoring		■	■	■
	Cyber security: Role-Based Access Control (from V7.8)		■		
	Temperature recording via communication protocol		■		
	Cyber security: Authenticated network access using IEEE 802.1X (starting from V8.3)		■		
Function point class:				0	0
The configuration and function point class for your application can be determined in the SIPROTEC 5 order configurator at www.siemens.com/siprotec .					

2.4

Table 2.4/1 SIPROTEC 7SJ81 - Functions, Application Templates

- (1) Non-directional definite-time overcurrent protection/inverse-time overcurrent protection (4*I)
- (2) Non-directional definite-time overcurrent protection/inverse-time overcurrent protection (4*I, 4*V)

SIPROTEC 5 Devices and Fields of Application

Overcurrent and Feeder Protection – SIPROTEC 7SJ81

Standard Variants for SIPROTEC 7SJ81		
AI1	1/3, 11 BI, 9 BO, 4 I	
	Housing width 1/3 x 19" 11 binary inputs 9 binary outputs (1 life contact, 8 standard) 4 current-transformer inputs Contains the following modules: base module with PS101 and IO101	
AI2	1/3, 18 BI, 14 BO, 4 I	
	Housing width 1/3 x 19" 16 binary inputs 11 binary outputs (1 life contact, 10 standard) 4 current-transformer inputs Contains the following modules: base module with IO101, PS101, IO112	
AI3	1/3, 11 BI, 9 BO, 4 I, 4V	
	Housing width 1/3 x 19" 11 binary inputs 9 binary outputs (1 life contact, 8 standard) 4 current-transformer inputs 4 voltage-transformer inputs Contains the following modules: base module with IO102 and PS101	
AI4	1/3, 16 BI, 11 BO, 4 I, 4 V	
	Housing width 1/3 x 19" 10 binary inputs 14 binary outputs (1 life contact, 13 standard) 4 current-transformer inputs 4 voltage-transformer inputs Contains the following modules: base module with IO102, PS101, and IO113	

Table 2.4/2 Standard Variants for SIPROTEC 7SJ81

You can find the technical data of the devices in the manual www.siemens.com/siprotec.

Description

The SIPROTEC 7SJ82 overcurrent protection has been designed specifically for a cost-effective and compact protection of feeders and lines in medium-voltage and high-voltage systems. With its flexibility and the high-performance DIGSI 5 engineering tool, the SIPROTEC 7SJ82 device offers future-oriented solutions for protection, control, automation, monitoring, and Power Quality – Basic.

Main function	Feeder and overcurrent protection for all voltage levels
Inputs and outputs	4 current transformers, 4 voltage transformers (optional), 11 or 23 binary inputs, 9 or 16 binary outputs, or 8 current transformers, 7 binary inputs, 7 binary outputs
Hardware flexibility	Different hardware quantity structures for binary inputs and outputs are available in the 1/3 base module. Adding 1/6 expansion modules is not possible; available with large or small display.
Housing width	1/3 × 19 inches

Benefits

- Compact and low-cost overcurrent protection
- Safety due to high-performance protection functions
- Purposeful and easy handling of devices and software thanks to a user-friendly design
- Cybersecurity according to NERC CIP and BDEW Whitepaper requirements (for example, logging security-related events and alarms)
- Highest availability even under extreme environmental conditions by standard coating of the modules
- Full compatibility between IEC 61850 Editions 1, 2.0, and 2.1

Functions

DIGSI 5 permits all functions to be configured and combined as required and as per the functional scope that has been ordered.

- Directional and non-directional overcurrent protection with additional functions
- Optimized tripping times due to directional comparison and protection communication
- Detection of ground faults of any type in compensated or isolated electrical power systems using the following functions: $3I_0>$, $V_0>$, transient ground-fault function, $\cos \varphi$, $\sin \varphi$, dir. detection of intermittent ground faults, harmonic detection, and admittance measurement
- Ground-fault detection using the pulse-detection method
- Detection of intermittent ground faults with automatic blocking of statically measuring functions to avoid message and fault-record flooding
- Fault locator plus for accurate fault location with inhomogeneous line sections and targeted automatic overhead-line section reclosing (AREC)
- Arc protection



[SIP5_7xx82_GD_W3, 2, --, --]

Figure 2.4/4 SIPROTEC 7SJ82

- Overvoltage and undervoltage protection
- Frequency protection and frequency-change protection for load-shedding applications
- Automatic frequency relief for underfrequency load shedding, taking changed infeed conditions due to decentralized power generation into consideration
- Power protection, configurable as active or reactive-power protection
- Protection functions for capacitor banks, such as overcurrent, overload, current-unbalance, peak overvoltage, or differential protection
- Directional reactive-power undervoltage protection (QU protection)
- Control, synchrocheck, and switchgear interlocking protection, circuit-breaker failure protection
- Circuit-breaker failure protection
- Circuit-breaker reignition monitoring
- Graphical logic editor to create high-performance automation functions in the device
- Detection of current and voltage signals up to the 50th harmonic with high accuracy for selected protection functions (such as peak overvoltage protection for capacitors) and operational measured values
- PQ – Basic: Voltage unbalance; voltage changes: overvoltage, dip, interruption; TDD, THD, and harmonics
- Single-line representation in the small or large display
- Fixed integrated electrical Ethernet RJ45 interface for DIGSI 5 and IEC 61850 (reporting and GOOSE)
- 2 optional, pluggable communication modules, usable for different and redundant protocols (IEC 61850, IEC 60870-5-103, IEC 60870-5-104, Modbus TCP, DNP3 serial and TCP, PROFINET IO)

SIPROTEC 5 Devices and Fields of Application

Overcurrent and Feeder Protection – SIPROTEC 7SJ82

2.4

- Serial protection communication via optical fibers, two-wire connections, and communication networks (IEEE C37.94 and others), including automatic switchover between ring and chain topology
- Reliable data transmission via PRP and HSR redundancy protocols
- Extensive cybersecurity functionality, such as role-based access control (RBAC), logging of security-related events, signed firmware, or authenticated IEEE 802.1X network access
- Simple, fast, and secure access to the device via a standard Web browser to display all information and diagnostic data, vector diagrams, single-line and device display pages
- Whitepaper Phasor Measurement Unit (PMU) for synchrophasor measured values and IEEE C37.118 protocol
- Time synchronization using IEEE 1588
- Control of power transformers
- High-performance fault recording (buffer for a max. record time of 80 s at 8 kHz or 320 s at 2 kHz)
- Auxiliary functions for simple tests and commissioning

Applications

- Detection and selective 3-pole tripping of short circuits in electrical equipment of star networks, lines with infeed at 1 or 2 ends, parallel lines, and open-circuited or closed ring systems of all voltage levels
- Detection of ground faults in isolated or arc-suppression-coil-ground systems in star, ring, or meshed arrangement
- Backup protection for differential protection devices of all kind for lines, transformers, generators, motors, and busbars
- Protection and monitoring of simple capacitor banks
- Phasor Measurement Unit (PMU)
- Reverse-power protection
- Load shedding applications
- Automatic switchover
- Regulation or control of power transformers (two-winding transformers)
- Detection and recording of power-quality data in the medium-voltage and subordinate low-voltage power system

Application Templates

DIGSI 5 provides application templates for standard applications. They include basic configurations and default settings.

The following application templates are available:

Non-directional definite-time overcurrent protection/inverse-time overcurrent protection

- Overcurrent protection (non-directional) for phases and ground
- Transformer inrush-current detection

Directional definite-time overcurrent protection/inverse-time overcurrent protection – grounded power system

- Overcurrent protection (directional and non-directional) for phases and ground
- Transformer inrush-current detection
- Measuring-voltage failure detection

Directional definite-time overcurrent protection/inverse-time overcurrent protection – arc-suppression-coil-ground systems/isolated systems

- Overcurrent protection (directional and non-directional) for phases
- Directional sensitive ground-fault detection for static ground faults
- Directional sensitive ground-fault detection for transient and static ground faults
- Transformer inrush-current detection
- Measuring-voltage failure detection

Capacitor bank. H-bridge

- Overcurrent protection for phases and ground
- Capacitor-bank phase unbalance protection
- Peak overvoltage protection
- Overload protection
- Undercurrent protection

Application Example

Directional Comparison Protection via Protection Interfaces for Power Line with an Infeed at Both Ends

With the direction determination of the directional overcurrent protection, you can implement directional comparison protection for power line with an infeed at both ends (Figure 2.4/5). Directional comparison protection is used for the selective isolation of a faulty line section (for example, subsections of closed

rings). Sections are isolated quickly, that is, they do not suffer the disadvantage of long grading times. This technique requires that directional information can be exchanged between the individual protection stations. This information exchange can, for example, be implemented via a protection interface. Alternatives for the protection interface are IEC 61850 GOOSE or exchange via pilot wires for signal transmission, with an auxiliary-voltage loop.

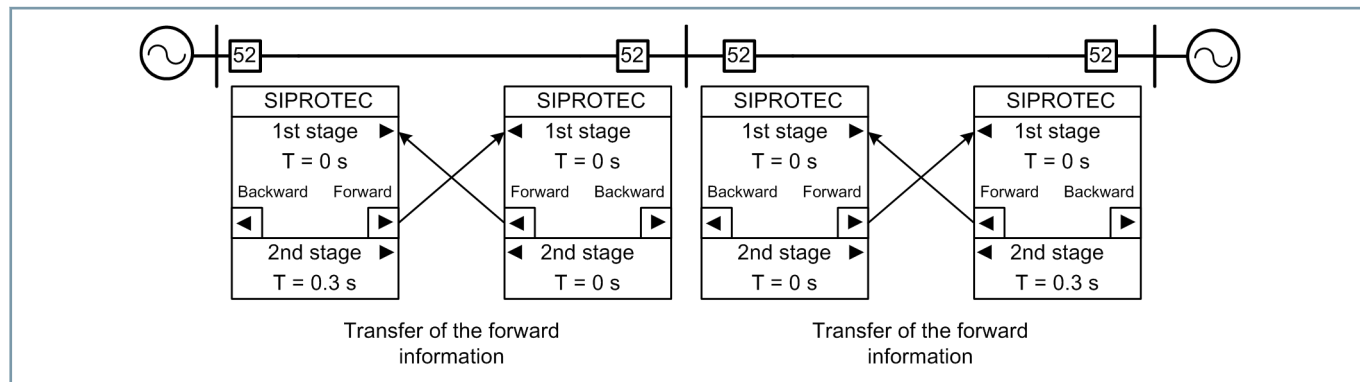

[dw_DwDOCP07, 1, en_US]

Figure 2.4/5 Principle of Directional Comparison Protection for Power Line with Infeed at 2 Ends

The following application example (Figure 2.4/6) shows the functional scope and the basic configuration of a SIPROTEC 7SJ82 device for this application. The **Directional definite-time overcurrent protection/inverse-time overcurrent protection – grounded power system** application template is used as the basis. In addition, the device must be equipped with a communication module for protection commu-

nication. The protection communication function group is created automatically when the module is configured. The **Communication mapping** DIGSI editor is used to determine the information that must be transmitted to the opposite end and received from the opposite end. The received information can directly be combined with the binary input signals of the directional overcurrent protection. No additional logic with a CFC chart is necessary.

SIPROTEC 5 Devices and Fields of Application

Overcurrent and Feeder Protection – SIPROTEC 7SJ82

2.4

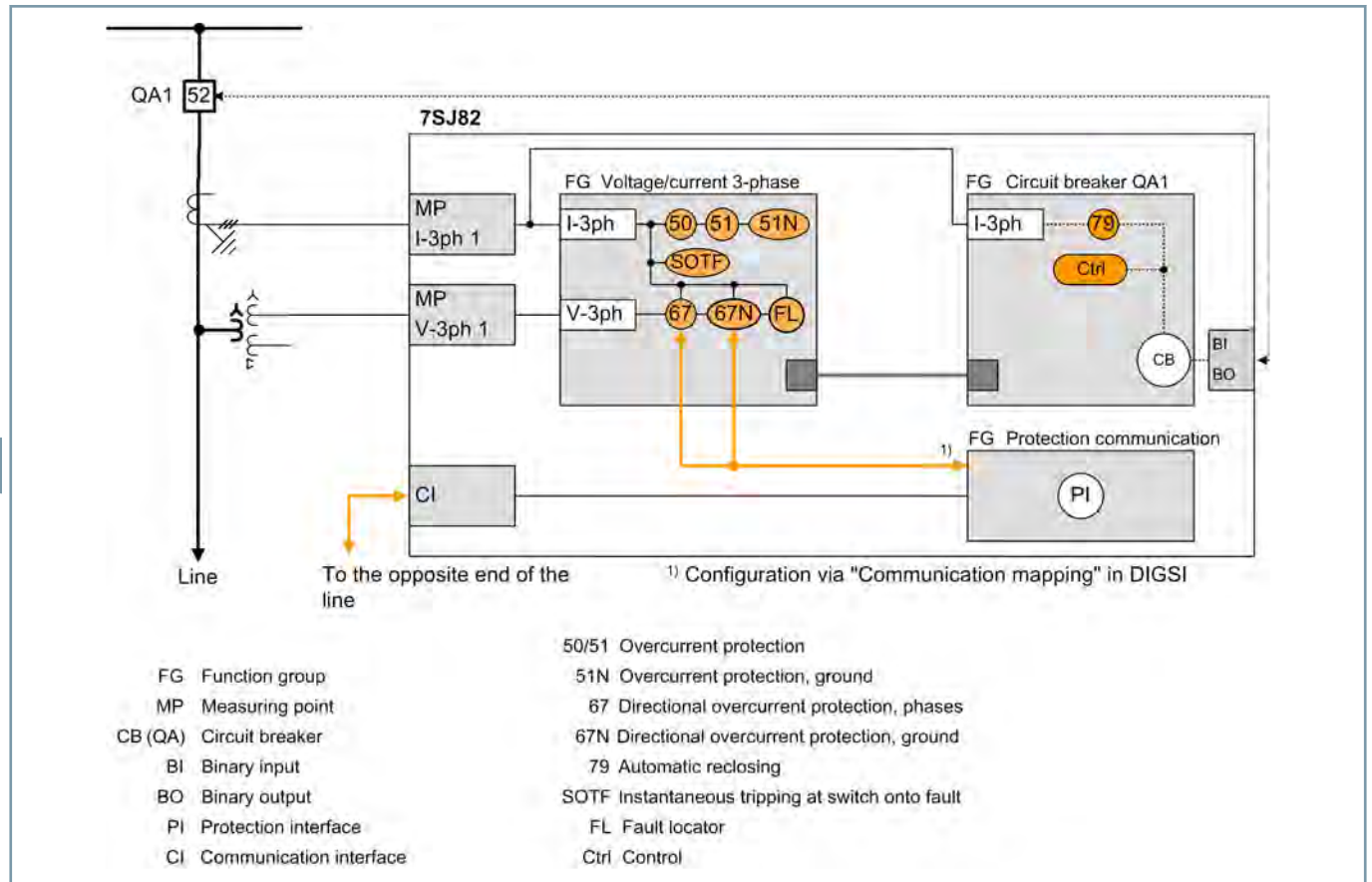

[dw_7SJ82_mit WirkKom, 3, en_US]

Figure 2.4/6 Application Example: Directional Comparison Protection for Power Line with Infeed at 2 Ends and Protection Communication

SIPROTEC 5 Devices and Fields of Application

Overcurrent and Feeder Protection – SIPROTEC 7SJ82

ANSI	Function	Abbr.	Available	Application Templates				
				1	2	3	4	5
	Protection functions for 3-pole tripping	3-pole	■	■	■	■	■	■
24	Overexcitation protection	V/f	■					
25	Synchrocheck, synchronization function	Sync	■					
25	Synchrocheck, synchronization function with adjusting commands (from V7.82)	Sync	■					
27	Undervoltage protection: "3-phase" or "positive-sequence system V1" or "universal Vx"	V<	■					
27R, 59R	Voltage change protection (starting with V8.30)	dV/dt	■					
	Undervoltage-controlled reactive power protection	Q>/V<	■					
32, 37	Power protection active/reactive power	P<>, Q<>	■					
32R	Reverse-power protection	- P<	■					
37	Undercurrent	I<	■					■
38	Temperature supervision	θ>	■					
46	Negative-sequence system overcurrent protection	I2>	■					■
46	Unbalanced-load protection (thermal)	I2² t>	■					
46	Negative-sequence system and overcurrent protection with direction	I2>, ∠(V2, I2)	■					
47	Overvoltage protection: "Negative-sequence system V2" or "negative-sequence system V1/positive-sequence system V1"	V2>; V2/V1>	■					
49	Thermal overload protection	θ, I²t	■					■
49	Thermal overload protection, user-defined characteristic curve	θ, I²t	■					
49	Overload protection for RLC filter circuit elements of a capacitor bank	θ, I²t	■					
50/51 TD	Overcurrent protection, phases	I>	■	■	■	■	■	■
	Instantaneous tripping at switch onto fault	SOTF	■					
50HS	Instantaneous high-current tripping	I>>>	■					
50/51 TD	Overcurrent protection with positive-sequence current I1 (from V7.9)	I1>	■					
50N/ 51N TD	Overcurrent protection, ground	IN>	■	■	■	■		■
50N/ 51N TD	Overcurrent protection, 1-phase	IN>	■					
50 Ns/ 51Ns	Sensitive ground-fault detection for grounded arc suppression coils and isolated power systems including a) 3I0> b) admittance Y0>, c) 3I0-harm> (from V7.8)	INs>	■					
	Sensitive ground-fault detection via pulse detection; hint: this stage also requires the function 50Ns/51Ns or 67Ns "sensitive ground-fault detection for grounded arc suppression coils and isolated power systems"	IN pulse	■					
	Intermittent ground-fault protection	IIE>	■					
50/51 TD	Overcurrent protection for RLC filter circuit elements of a capacitor bank	I>	■					
50BF	Circuit-breaker failure protection, 3-pole	CBFP	■					
50RS	Circuit breaker restrike monitoring	CBRM	■					
51V	Voltage-controlled overcurrent protection	t=f(I, V)	■					
59, 59N	Overvoltage protection: "3-phase" or "zero-sequence system V0" or "positive-sequence system V1" or "universal Vx"	V>	■					
59C	Peak overvoltage protection, 3-phase, for capacitors	V> cap.	■					■
60C	Current-unbalance protection for capacitor banks	Iunbal>	■					■
60	Voltage-comparison supervision	ΔV>	■					

SIPROTEC 5 Devices and Fields of Application

Overcurrent and Feeder Protection – SIPROTEC 7SJ82

ANSI	Function	Abbr.	Available	Application Templates				
				1	2	3	4	5
67	Directional overcurrent protection, phases	I>, <(V, I)	■			■	■	
67N	Directional overcurrent protection, ground	IN>, <(V, I)	■			■		
67 Ns	Sensitive ground-fault detection for grounded arc suppression coils and isolated power systems including a) 3I0> b) V0>, c) cos/sine Phi, d) transient ground fault, e) Phi(V, I), f) admittance		■				■	
	Directional tripping stage with one harmonic; hint: this stage also requires the function "67Ns sensitive ground-fault detection for grounded arc suppression coils and isolated power systems"	<(V0h,I0h)	■					
	Directional Intermittent Ground-Fault Protection	IIEdir>	■					
74TC	Trip-circuit supervision		■					
74CC	Single circuit monitoring (from V7.9)		■					
79	Automatic reclosing, 3-pole	AREC	■					
81	Frequency protection: "f>" or "f<" or "df/dt"	f<>; df/dt<>	■					
81U	Underfrequency load shedding	f<(ULS)	■					
	Vector-jump protection	Δφ>	■					
86	Lockout		■	■	■	■	■	■
87N T	Restricted ground-fault protection	ΔIN	■					
87C	Differential protection for capacitor banks	ΔI	■					
90 V	Voltage controller for two-winding transformer		■					
90 V	Voltage controller for two-winding transformer with parallel control		■					
	Number of two-winding transformers with parallel control (hint: only together with the function "voltage controller for two-winding transformer with parallel control")		■					
FL	Fault Locator, single-side	FL-one	■					
FL	Fault Locator Plus (from V7.9)	FL plus	■					
PMU	Synchrophasor measurement	PMU	■					
AFD	Arc protection (only with plug-in module ARC-CD-3FO)		■					
	Measured values, standard		■	■	■	■	■	■
	Measured values, extended: Min, max, average		■					
	Switching statistics counter		■					
	PQ – Basic measured values: THD (Total Harmonic Distortion) and harmonic component (starting with V8.01) and THD voltage average values (starting with V8.40)		■					
	PQ – Basic measured values: Voltage unbalance (starting with V8.40)		■					
	PQ – Basic measured values: Voltage changes – monitoring of voltage dips, overvoltages and voltage interruptions (starting with V8.40)		■					
	PQ – Basic measured values: TDD - Total Demand Distortion (starting with V8.40)		■					
	CFC (standard, control)		■	■	■	■	■	■
	CFC arithmetic		■					
	Circuit-breaker wear monitoring	ΣIx, I²t, 2P	■					
	Switching sequence function		■					
	Inrush-current detection		■	■	■	■	■	
	External trip initiation		■					
	Control		■	■	■	■	■	■
	Circuit breaker		■	■	■	■	■	■

2.4

SIPROTEC 5 Devices and Fields of Application

Overcurrent and Feeder Protection – SIPROTEC 7SJ82

ANSI	Function	Abbr.	Available	Application Templates				
				1	2	3	4	5
	Disconnect/grounding conductor		■	■	■	■	■	
	Fault recording of analog and binary signals		■	■	■	■	■	■
	Monitoring		■	■	■	■	■	■
	Protection interface, serial		■					
	Frequency group tracking (from V7.8)		■					
	Cyber security: Role-Based Access Control (from V7.8)		■					
	Temperature recording via communication protocol		■					
	Cyber security: Authenticated network access using IEEE 802.1X (starting from V8.3)		■					
Function point class:				0	0	30	50	100
The configuration and function point class for your application can be determined in the SIPROTEC 5 order configurator at www.siemens.com/siprotec .								

2.4

Table 2.4/3 SIPROTEC 7SJ82 – Functions, Application Templates

- (1) Non-directional definite-time overcurrent protection/inverse-time overcurrent protection (4*I)
- (2) Non-directional definite-time overcurrent protection/inverse-time overcurrent protection (4*I, 4*V)
- (3) Directional definite-time overcurrent protection/inverse-time overcurrent protection – grounded power system
- (4) Directional definite-time overcurrent protection/inverse-time overcurrent protection - grounded arc suppression coils/isolated power systems
- (5) Capacitor bank: H-bridge

SIPROTEC 5 Devices and Fields of Application

Overcurrent and Feeder Protection – SIPROTEC 7SJ82

2.4

Standard Variants for SIPROTEC 7SJ82		
V1	1/3, 11 BI, 9 BO, 4 I	
	Housing width 1/3 x 19" 11 binary inputs 9 binary outputs (1 life contact, 8 standard) 4 current-transformer inputs Contains the following modules: base module with PS101 and IO101	
V2	1/3, 23 BI, 16 BO, 4 I	
	Housing width 1/3 x 19" 23 binary inputs 16 binary outputs (1 life contact, 15 standard) 4 current-transformer inputs Contains the following modules: base module with PS101, IO101, and IO110	
V3	1/3, 11 BI, 9 BO, 4 I, 4 V	
	Housing width 1/3 x 19" 11 binary inputs 9 binary outputs (1 life contact, 8 standard) 4 current-transformer inputs 4 voltage-transformer inputs Contains the following modules: base module with PS101 and IO102	
V4	1/3, 23 BI, 16 BO, 4 I, 4 V	
	Housing width 1/3 x 19" 23 binary inputs 16 binary outputs (1 life contact, 15 standard) 4 current-transformer inputs 4 voltage-transformer inputs Contains the following modules: base module with PS101, IO102, and IO110.	
V5	1/3, 7 BI, 7 BO, 8 I	
	Housing width 1/3 x 19" 7 binary inputs 7 binary outputs (1 life contact, 6 standard) 8 current-transformer inputs Contains the following modules: base module with PS101 and IO103	

Table 2.4/4 Standard Variants for SIPROTEC 7SJ82

You can find the technical data of the devices in the manual www.siemens.com/siprotec.

SIPROTEC 5 Devices and Fields of Application

Overcurrent and Feeder Protection – SIPROTEC 7SJ85

Description

The SIPROTEC 7SJ85 overcurrent protection has been designed specifically for the protection of feeders and lines. With its modular structure, flexibility, and the high-performance DIGSI 5 engineering tool, the SIPROTEC 7SJ85 device offers future-oriented solutions for protection, control, automation, monitoring, and Power Quality – Basic.

Main function	Feeder and overcurrent protection for all voltage levels
Inputs and outputs	5 predefined standard variants with 4 current transformers, 4 voltage transformers, 11 to 59 binary inputs, 9 to 33 binary outputs
Hardware flexibility	Flexibly adjustable and expandable I/O quantity structure within the scope of the modular SIPROTEC 5 system; 1/6 expansion modules can be added, available with large or small display, or without display
Housing width	1/3 × 19 inches to 2/1 × 19 inches

Benefits

- Safety due to high-performance protection functions
- Purposeful and easy handling of devices and software thanks to a user-friendly design
- Cybersecurity in accordance with NERC CIP and BDEW White-paper requirements
- Highest availability even under extreme environmental conditions by standard coating of the modules
- Full compatibility between IEC 61850 Editions 1, 2.0, and 2.1

Functions

DIGSI 5 permits all functions to be configured and combined as required and as per the functional scope that has been ordered.

- Directional and non-directional overcurrent protection with additional functions
- Protection of up to 9 feeders with up to 40 analog inputs
- Optimized tripping times due to directional comparison and protection communication
- Detection of ground faults of any type in compensated or isolated electrical power systems using the following functions: 3I0>, V0>, transient ground-fault function, $\cos \varphi$, $\sin \varphi$, dir. detection of intermittent ground faults, harmonic detection, and admittance measurement
- Ground fault detection using the pulse detection method
- Detection of intermittent ground faults with automatic blocking of statically measuring functions to avoid message and fault-record flooding
- Fault locator plus for accurate fault location with inhomogeneous line sections and targeted automatic overhead-line section reclosing (AREC)
- Arc protection
- Overvoltage and undervoltage protection
- Power protection, configurable as active or reactive-power protection



[SIP5_GD_SS_W3, 2, --, --]

Figure 2.4/7 SIPROTEC 5 Device with Expansion Module

- Frequency protection and frequency-change protection for load-shedding applications
- Automatic frequency relief for underfrequency load shedding, taking changed infeed conditions due to decentralized power generation into consideration
- Protection functions for capacitor banks, such as overcurrent, overload, current-unbalance, peak overvoltage, or differential protection
- Directional reactive-power undervoltage protection (QU protection)
- Detection of current and voltage signals up to the 50th harmonic with high accuracy for selected protection functions (such as peak overvoltage protection for capacitors) and operational measured values
- PQ – Basic: Voltage unbalance; voltage changes: overvoltage, dip, interruption; TDD, THD, and harmonics
- Point-on-wave switching
- Control, synchrocheck, and switchgear interlocking protection
- Circuit-breaker failure protection
- Circuit-breaker reignition monitoring
- Graphical logic editor to create high-performance automation functions in the device
- Single-line representation in the small or large display
- Fixed integrated electrical Ethernet RJ45 interface for DIGSI 5 and IEC 61850 (reporting and GOOSE)
- 2 slots for optional communication modules, usable for different and redundant protocols (IEC 61850-8-1, IEC 61850-9-2 Client, IEC 60870-5-103, IEC 60870-5-104, Modbus TCP, DNP3 serial and TCP, PROFINET IO, PROFINET IO S2 redundancy)
- Virtual network partitioning (IEEE 802.1Q - VLAN)

SIPROTEC 5 Devices and Fields of Application

Overcurrent and Feeder Protection – SIPROTEC 7SJ85

2.4

- Serial protection communication via optical fibers, two-wire connections, and communication networks (IEEE C37.94 and others), including automatic switchover between ring and chain topology
- Reliable data transmission via PRP and HSR redundancy protocols
- Extensive cybersecurity functionality, such as role-based access control (RBAC), logging of security-related events, signed firmware, or authenticated IEEE 802.1X network access.
- Simple, fast, and secure access to the device via a standard Web browser to display all information and diagnostic data, vector diagrams, single-line and device display pages
- Phasor measurement unit (PMU) for synchrophasor measured values and IEEE C37.118 protocol
- Time synchronization using IEEE 1588
- Control of power transformers
- High-performance fault recording (buffer for a max. record time of 80 s at 8 kHz or 320 s at 2 kHz)
- Auxiliary functions for simple tests and commissioning

Applications

- Detection and selective 3-pole tripping of short circuits in electrical equipment of star networks, lines with infeed at 1 or 2 ends, parallel lines, and open-circuited or closed ring systems of all voltage levels up to AC 400 V
- Backup protection for differential protection devices of all kind for lines, transformers, generators, motors, and busbars
- Protection and monitoring of capacitor banks
- Phasor Measurement Unit (PMU)
- Reverse-power protection
- Load shedding applications
- Automatic switchover
- Regulation or control of power transformers (two-winding transformers, three-winding transformers, grid coupling transformers)
- Detection and recording of power-quality data in the medium-voltage and subordinate low-voltage power system

Application Templates

DIGSI 5 provides application templates for standard applications. They include basic configurations and default settings.

The following application templates are available:

Non-directional definite-time overcurrent protection/inverse-time overcurrent protection

- Overcurrent protection (non-directional) for phases and ground
- transformer inrush-current detection

Directional definite-time overcurrent protection/inverse-time overcurrent protection – grounded power system

- Overcurrent protection (directional and non-directional) for phases and ground
- transformer inrush-current detection
- Measuring-voltage failure detection

Directional definite-time overcurrent protection/inverse-time overcurrent protection – arc-suppression-coil-ground systems/isolated systems

- Overcurrent protection (directional and non-directional) for phases
- Directional sensitive ground-fault detection for static ground faults
- Directional sensitive ground-fault detection for transient and static ground faults
- Transformer inrush-current detection
- Measuring-voltage failure detection

Capacitor bank H-bridge + 1 x RLC

- Overcurrent protection for phases and ground
- Capacitor-bank phase unbalance protection
- Peak overvoltage protection
- Overload protection
- Undercurrent protection

MSCDN capacitor bank

- Overcurrent protection for phases and ground
- Capacitor-bank phase unbalance protection
- Differential protection for capacitor
- Peak overvoltage protection
- Overload protection
- Undercurrent protection

Application Examples

Directional Comparison Protection via Protection Interfaces for Power Line with an Infeed at Both Ends

With the direction determination of the directional overcurrent protection, you can implement directional comparison protection for power line with an infeed at both ends (Figure 2.4/8). Directional comparison protection is used for the selective isolation of a faulty line section (for example, subsections of closed

rings). Sections are isolated quickly, that is, they do not suffer the disadvantage of long grading times. This technique requires that directional information can be exchanged between the individual protection stations. This information exchange can, for example, be implemented via a protection interface. Alternatives for the protection interface are IEC 61850 GOOSE or exchange via pilot wires for signal transmission, with an auxiliary-voltage loop.

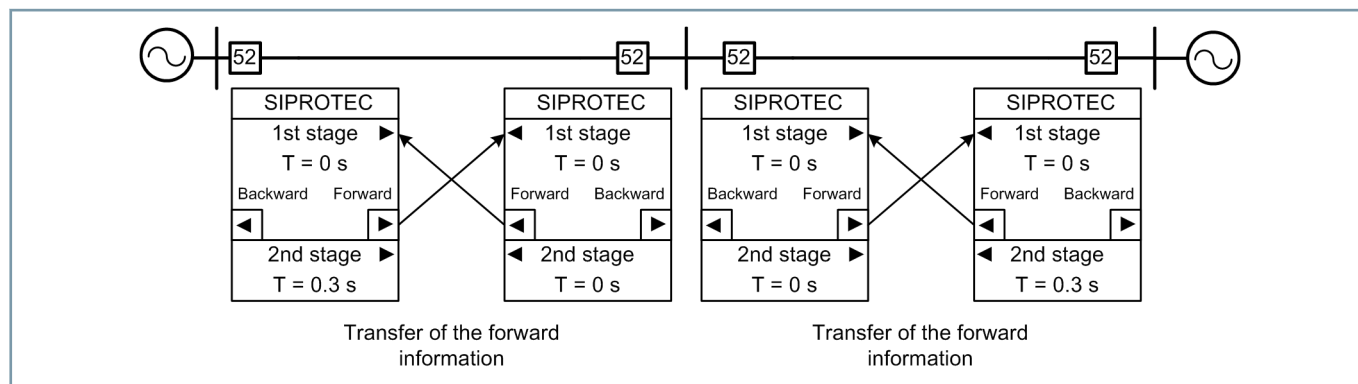

[dw_DwDOCP07, 1, en_US]

Figure 2.4/8 Application Example: Principle of Directional Comparison Protection for Power Line with an Infeed at Both Ends

The application example for SIPROTEC 7SJ82 (Figure 2.4/6) shows the functional scope and the basic configuration for this application.

Protection and Control at a Double Busbar

In the Figure 2.4/9, a double-busbar feeder is protected and additionally controlled by a SIPROTEC 7SJ85 device. This example is based on the application template **Directional definite-time overcurrent protection/inverse-time overcurrent protection – grounded power system**. In addition to the appli-

cation template, the functions Circuit-breaker failure protection, Automatic reclosing, and Synchrocheck in the circuit-breaker function group are required and configured. These functions can easily be added via **drag and drop** from the DIGSI 5 function library. Operational measured values and energy metered values are calculated in the **Voltage-current 3ph** function group. They are available for the output on the display, the transmission to the substation automation technology, and the processing in the CFC. A switching sequence stored in the CFC that is activated via a function key starts an automatically running busbar switchover process.

SIPROTEC 5 Devices and Fields of Application

Overcurrent and Feeder Protection – SIPROTEC 7SJ85

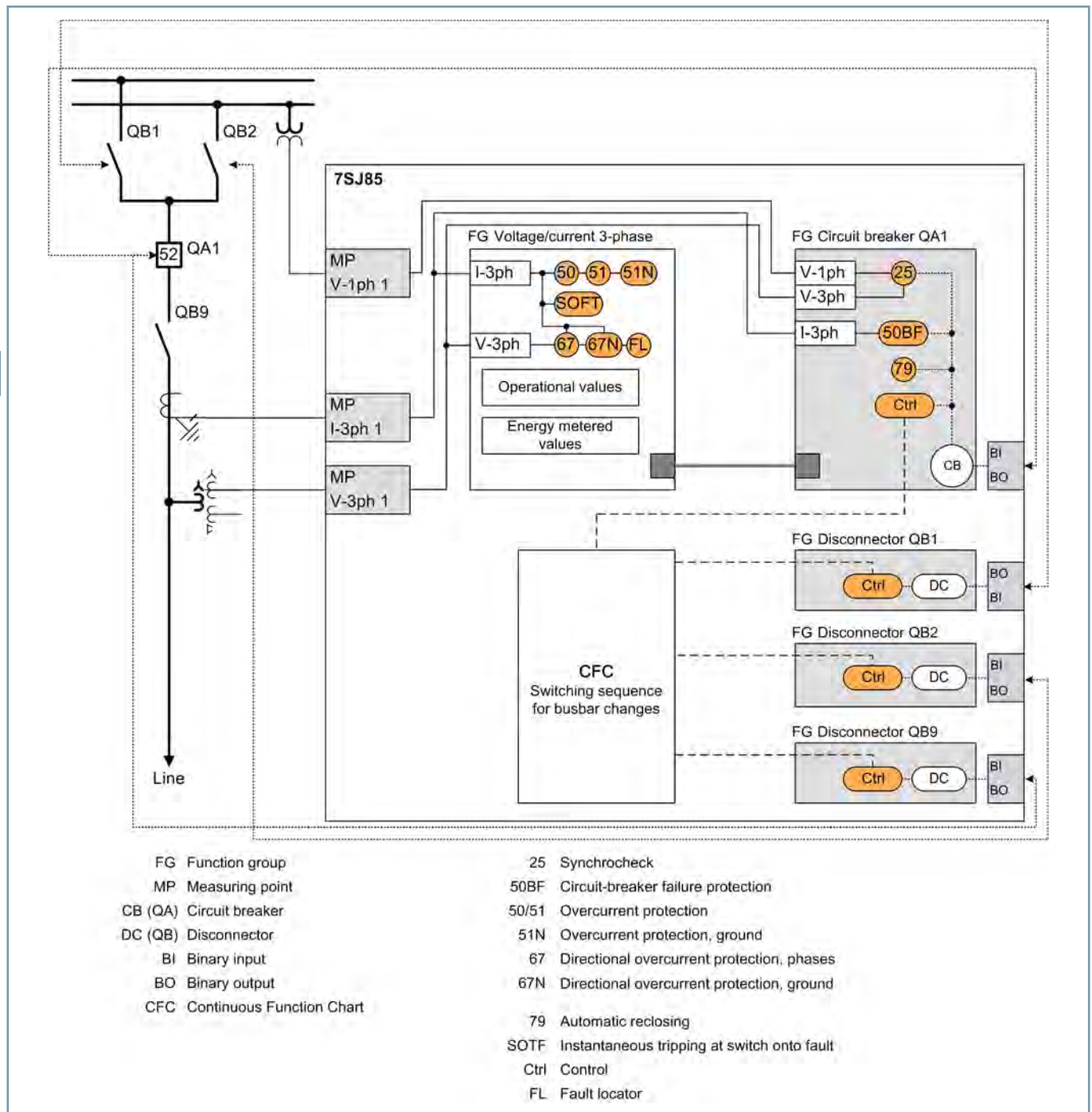

[dw_7SJ85_mit DoppelSS, 2, en_US]

Figure 2.4/9 Application Example: Overcurrent Protection 7SJ85 at a Double-Busbar Feeder

Protection of a Capacitor Bank

Figure 2.4/10 shows the protection of an H-bridge capacitor bank. For this application, the device provides special functions for the protection of capacitor banks. Thanks to the modular structure and performance of SIPROTEC 5, the complete application can be protected with one single device.

Properties:

- Short-circuit protection (ANSI 50, 50N) for phase and ground faults
- Peak overvoltage protection (ANSI 59C) to protect the dielectric medium of the bank against dangerous peak overvoltage, in particular caused by the harmonic components with consideration up to the 50th harmonic component. The peak

SIPROTEC 5 Devices and Fields of Application

Overcurrent and Feeder Protection – SIPROTEC 7SJ85

voltage is calculated from the current by calculating the integral.

- Overload protection (ANSI 49) to protect the bank against thermal overload
- Highly sensitive current-unbalance protection (ANSI 60C) to detect the failure of individual capacitor elements as monitoring and protection function; manual and automatic adjustment in the bay. The automatic adjustment permits dynamic unbalances (caused by temperature influence, for example) to be considered.

- Undercurrent protection (ANSI 37) to trip the local circuit breaker when the infeed is disconnected providing protection against hazardous voltage at the non-discharged bank, for example, in phase opposition
- Circuit-breaker failure protection (ANSI 50BF)

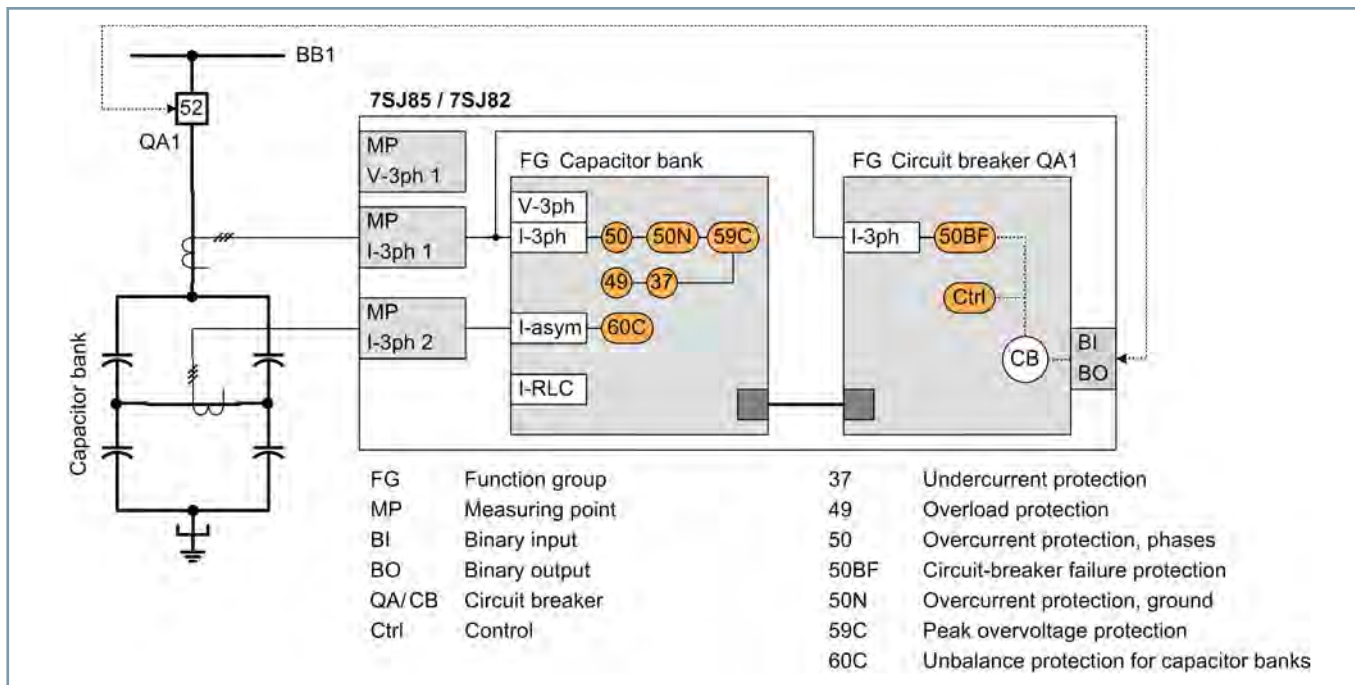

[dw_CapBank_SLE_Normal, 1, en_US]

Figure 2.4/10 Application Example: Protection of an H-Bridge Capacitor Bank

SIPROTEC 5 Devices and Fields of Application

Overcurrent and Feeder Protection – SIPROTEC 7SJ85

2.4

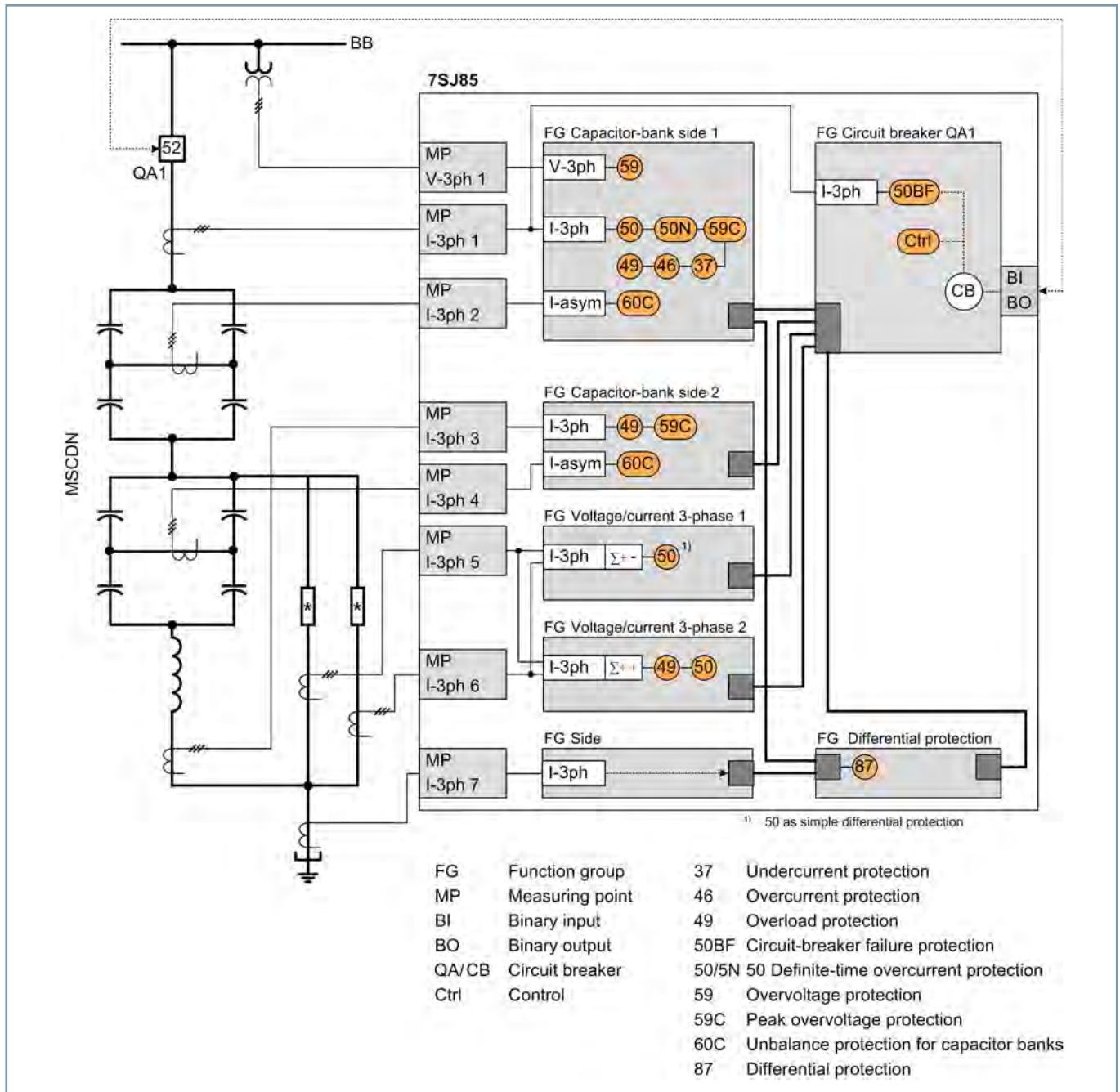

[dw_CapBank_MSCDN, 1, en_US]

Figure 2.4/11 Application Example: MSCDN Capacitor Bank

Protection of an MSCDN Capacitor Bank (MSCDN = Mechanically Switched Circuit Breaker with Damping Network)

In [Figure 2.4/11](#), the SIPROTEC 7SJ85 device protects the capacitor bank in H-bridge connection as well as the associated damping network. Thanks to the modular structure and performance of SIPROTEC 5, the complete application can be protected with a single device.

Properties:

- Acquisition of up to nine 3-phase current measuring points
- Short-circuit protection (ANSI 50, 50N) for phase and ground faults

SIPROTEC 5 Devices and Fields of Application

Overcurrent and Feeder Protection – SIPROTEC 7SJ85

- Peak overvoltage protection (ANSI 59C) to protect the dielectric medium of the bank against dangerous peak overvoltage, in particular caused by the harmonic components, with consideration up to the 50th harmonic component. The peak voltage is calculated from the current by calculating the integral.
- Overload protection (ANSI 49) to protect the bank against thermal overload
- Highly sensitive current-unbalance protection (ANSI 60C) to detect the failure of individual capacitor elements as monitoring and protection function; manual and automatic adjustment in the bay. The automatic adjustment permits dynamic unbalances (caused by temperature influence, for example) to be considered.
- Differential protection (87C) over the entire capacitor bank to protect against short circuits inside the entire installation
- Overload and overcurrent protection via the 2 resistors and a simple differential protection to detect a failure of one of the 2 resistors. For this purpose, current sum and current difference are determined with the current measuring points in the R branches, at the inputs of the V/I 3-phase function groups.
- Undercurrent protection (ANSI 37) to trip the local circuit breaker when the infeed is disconnected, providing protection against hazardous voltage at the non-discharged bank, for example, in phase opposition
- Circuit-breaker failure protection (ANSI 50BF)

SIPROTEC 5 Devices and Fields of Application

Overcurrent and Feeder Protection – SIPROTEC 7SJ85

ANSI	Function	Abbr.	Available	Application Templates				
				1	2	3	4	5
	Protection functions for 3-pole tripping	3-pole	■	■	■	■	■	■
	Expandable hardware quantity structure	I/O	■	■	■	■	■	■
	Process bus client protocol (hint: PB client requires a separate ETH-BD-2FO plug-in module, from V8.0)	PB client	■					
	IEC61850-9-2 Merging Unit Stream (hint: Each stream requires a separate ETH-BD-2FO plug-in module, from V8.0)	MU	■					
	IEC61850-9-2 Merging Unit Stream 7SS85 CU (hint: Only for communication with a 7SS85 CU. A separate ETH-BD-2FO plug-in module is required starting with V8.40)	MU	■					
24	Overexcitation protection	V/f	■					
25	Synchrocheck, synchronization function	Sync	■					
25	Synchrocheck, synchronization function with adjusting commands (from V7.82)	Sync	■					
27	Undervoltage protection: "3-phase" or "positive-sequence system V1" or "universal Vx"	V<	■					
27R, 59R	Voltage change protection (starting with V8.30)	dV/dt	■					
	Undervoltage-controlled reactive power protection	Q>/V<	■					
32, 37	Power protection active/reactive power	P<>, Q<>	■					
32R	Reverse-power protection	- P<	■					
37	Undercurrent	I<	■				■	■
38	Temperature supervision	θ>	■					
46	Negative-sequence system overcurrent protection	I2>	■				■	■
46	Unbalanced-load protection (thermal)	I2² t>	■					
46	Negative-sequence system and overcurrent protection with direction	I2>, ∠(V2, I2)	■					
47	Overvoltage protection, negative-sequence system	V2>	■					
49	Thermal overload protection	θ, I²t	■				■	■
49	Thermal overload protection, user-defined characteristic curve	θ, I²t	■					
49	Overload protection for RLC filter circuit elements of a capacitor bank	θ, I²t	■				■	
50/51 TD	Overcurrent protection, phases	I>	■	■	■	■	■	■
	Instantaneous tripping at switch onto fault	SOTF	■					
50HS	Instantaneous high-current tripping	I>>>	■					
50/51 TD	Overcurrent protection with positive-sequence current I1 (from V7.9)	I1>	■					
50N/ 51N TD	Overcurrent protection, ground	IN>	■	■	■		■	■
50N/ 51N TD	Overcurrent protection, 1-phase	IN>	■					
50 Ns/ 51Ns	Sensitive ground-fault detection for grounded arc suppression coils and isolated power systems including a) 3I0> b) admittance Y0>, c) 3I0-harm> (from V7.8)	INs>	■					
	Sensitive ground-fault detection via pulse detection; hint: this stage also requires the function 50Ns/51Ns or 67Ns "sensitive ground-fault detection for grounded arc suppression coils and isolated power systems"	IN pulse	■					
	Intermittent ground-fault protection	IIE>	■					
50/51 TD	Overcurrent protection for RLC filter circuit elements of a capacitor bank	I>	■					

2.4

SIPROTEC 5 Devices and Fields of Application

Overcurrent and Feeder Protection – SIPROTEC 7SJ85

ANSI	Function	Abbr.	Available	Application Templates				
				1	2	3	4	5
50BF	Circuit-breaker failure protection, 3-pole	CBFP	■					■
50EF	End-fault protection (hint: For use only in decentralized busbar protection with a 7SS85 CU starting with V8.40)		■					
50RS	Circuit breaker restrrike monitoring	CBRM	■					
51V	Voltage-controlled overcurrent protection	t=f(I, V)	■					
59, 59N	Overvoltage protection: "3-phase" or "zero-sequence system V0" or "positive-sequence system V1" or "universal Vx"	V>	■					■
59C	Peak overvoltage protection, 3-phase, for capacitors	V> cap.	■				■	■
60C	Current-unbalance protection for capacitor banks	Iunbal>	■				■	■
60	Voltage-comparison supervision	ΔV>	■					
67	Directional overcurrent protection, phases	I>, <(V, I)	■		■	■		
67N	Directional overcurrent protection, ground	IN>, <(V, I)	■		■			
67 Ns	Sensitive ground-fault detection for grounded arc suppression coils and isolated power systems including a) 3I0> b) V0>, c) cos/sine Phi, d) transient ground fault, e) Phi(V, I), f) admittance		■			■		
	Directional tripping stage with one harmonic; hint: this stage also requires the function "67Ns sensitive ground-fault detection for grounded arc suppression coils and isolated power systems"	<(V0h, I0h)	■					
	Directional Intermittent Ground-Fault Protection	IIEdir>	■					
74TC	Trip-circuit supervision		■					
74CC	Single circuit monitoring (from V7.9)		■					
79	Automatic reclosing, 3-pole	AREC	■					
81	Frequency protection: "f>" or "f<" or "df/dt"	f<>; df/dt<>	■					
81U	Underfrequency load shedding	f<(ULS)	■					
	Vector-jump protection	Δφ>	■					
86	Lockout		■	■	■	■	■	■
87N T	Restricted ground-fault protection	ΔIN	■					
87C	Differential protection for capacitor banks	ΔI	■					■
87V	Voltage differential protection for capacitor banks	ΔV	■					
90 V	Voltage controller for two-winding transformer		■					
90 V	Voltage controller for two-winding transformer with parallel control		■					
	Number of two-winding transformers with parallel control (hint: only together with the function "voltage controller for two-winding transformer with parallel control")		■					
90 V	Voltage controller for three-winding transformer		■					
90 V	Voltage controller for grid coupling transformer		■					
FL	Fault Locator, single-side	FL-one	■					
FL	Fault Locator Plus (from V7.9)	FL plus	■					
PMU	Synchrophasor measurement	PMU	■					
AFD	Arc protection (only with plug-in module ARC-CD-3FO)		■					
	Measured values, standard		■	■	■	■	■	■
	Measured values, extended: Min, max, average		■					
	Switching statistics counter		■					
	PQ – Basic measured values: THD (Total Harmonic Distortion) and harmonic component (starting with V8.01) and THD voltage average values (starting with V8.40)		■					

SIPROTEC 5 Devices and Fields of Application

Overcurrent and Feeder Protection – SIPROTEC 7SJ85

ANSI	Function	Abbr.	Available	Application Templates				
				1	2	3	4	5
	PQ – Basic measured values: Voltage unbalance (starting with V8.40)		■					
	PQ – Basic measured values: Voltage changes – monitoring of voltage dips, overvoltages and voltage interruptions (starting with V8.40)		■					
	PQ – Basic measured values: TDD - Total Demand Distortion (starting with V8.40)		■					
	CFC (standard, control)		■	■	■	■	■	■
	CFC arithmetic		■					
	Circuit-breaker wear monitoring	$\Sigma I_x, I^2t, 2P$	■					
	Switching sequence function		■					
	Inrush-current detection		■	■	■	■		
	External trip initiation		■					
	Control		■	■	■	■	■	■
PoW	Point-on-wave switching (starting with V7.90)	PoW	■					
	Circuit breaker		■	■	■	■	■	■
	Disconnectors/grounding conductor		■	■	■	■	■	■
	Fault recording of analog and binary signals		■	■	■	■	■	■
	Monitoring		■	■	■	■	■	■
	Protection interface, serial		■					
	Frequency group tracking (from V7.8)		■					
	Cyber security: Role-Based Access Control (from V7.8)		■					
	Temperature recording via communication protocol		■					
	Cyber security: Authenticated network access using IEEE 802.1X (starting from V8.3)		■					
Function point class:				0	30	50	100	300
The configuration and function point class for your application can be determined in the SIPROTEC 5 order configurator at www.siemens.com/siprotec .								

Table 2.4/5 SIPROTEC 7SJ85 – Functions, Application Templates

- (1) Non-directional definite-time overcurrent protection/inverse-time overcurrent protection (4*1, 4*V)
- (2) Directional definite-time overcurrent protection/inverse-time overcurrent protection – grounded power system
- (3) Directional definite-time overcurrent protection/inverse-time overcurrent protection - grounded arc suppression coils/isolated power systems
- (4) Capacitor bank: H-bridge + 1*RLC
- (5) Capacitor bank: MSCDN

SIPROTEC 5 Devices and Fields of Application

Overcurrent and Feeder Protection – SIPROTEC 7SJ85

2.4





Standard Variants for SIPROTEC 7SJ85		
S1	1/3, 11 BI, 9 BO, 4 I, 4 V Housing width 1/3 x 19" 11 binary inputs 9 binary outputs (1 life contact, 2 standard, 6 fast) 4 current-transformer inputs 4 voltage-transformer inputs Contains the following modules: base module with PS201 and IO202	
S2	1/2, 17 BI, 16 BO, 4 I, 4 V Housing width 1/2 x 19" 17 binary inputs 16 binary outputs (1 life contact, 9 standard, 6 fast) 4 current-transformer inputs 4 voltage-transformer inputs Contains the following modules: base module with PS201 and IO202 Expansion modules IO206	
S3	1/2, 27 BI, 17 BO, 4 I, 4 V Housing width 1/2 x 19" 27 binary inputs 17 binary outputs (1 life contact, 10 standard, 6 fast) 4 current-transformer inputs 4 voltage-transformer inputs Contains the following modules: base module with PS201 and IO202 Expansion modules IO207	
S4	2/3, 43 BI, 25 BO, 4 I, 4 V Housing width 2/3 x 19" 43 binary inputs 25 binary outputs (1 life contact, 18 standard, 6 fast) 4 current-transformer inputs 4 voltage-transformer inputs Contains the following modules: base module with PS201 and IO202 Expansion modules 2x IO207	
S5	5/6, 59 BI, 33 BO, 4 I, 4 V Housing width 5/6 x 19" 59 binary inputs 33 binary outputs (1 life contact, 26 standard, 6 fast) 4 current-transformer inputs 4 voltage-transformer inputs Contains the following modules: base module with PS201 and IO202 Expansion modules 3x IO207	

Table 2.4/6 Standard Variants for SIPROTEC 7SJ85

You can find the technical data of the devices in the manual
www.siemens.com/siprotec.

SIPROTEC 5 Devices and Fields of Application

Line Protection

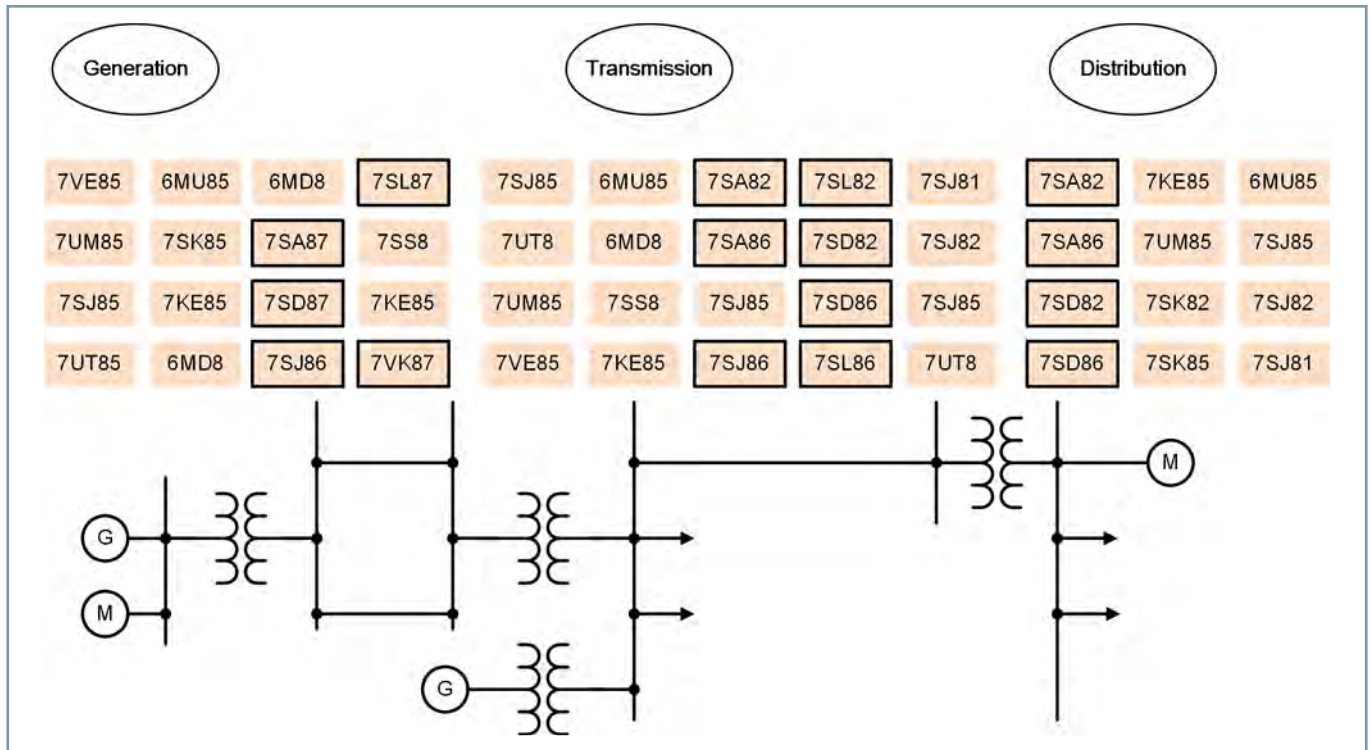

[dw_LineProt_anwendung, 3, en_US]

Figure 2.5/1 Fields of Application of the SIPROTEC 5 Devices

SIPROTEC 7SA8, 7SD8, 7SL8, 7VK8, 7SJ86

SIPROTEC 5 line protection devices protect overhead lines and cables on all voltage levels with highest possible selectivity. The large number of available protection and automatic functions allows their utilization in all line protection sections. The devices contain all important auxiliary functions that are necessary for safe network operation today. This includes control, measurement, and monitoring functions. The large number of communication interfaces and communication protocols satisfies the requirements of communication-based selective protection and of automated operation. Commissioning and maintenance work can be completed safely, quickly, and thus cost-effectively with high-performance test functions. Their modular surface mounting permits SIPROTEC 5 line protection devices to be always adapted flexibly to the individual requirements.

Distinguishing features

The device types are defined by their main-protection functions and by essential differentiating characteristics. For devices with

flexible configurability of the hardware quantity structure, you can select various standard variants when ordering. Expandability through expansion modules allows for individual adaptation to specific applications such as more analog channels for breaker-and-a-half layouts, or more binary contacts (see [Table 2.5/4](#) and [Table 2.5/5](#)).

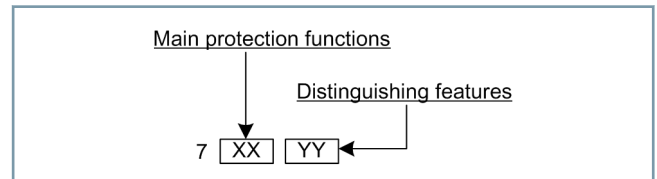

[dw_device_typ, 1, en_US]

Figure 2.5/2 Definition of the Device Types by their Designation

7	XX	YY	
Main protection			
7	SA		Distance protection
7	SD		Differential protection
7	SL		Distance and differential protection
7	SJ		Overcurrent protection
7	VK		Circuit-breaker management
Essential Differentiating Characteristics			
7		82	<ul style="list-style-type: none"> Exclusively 3-pole tripping 2 hardware variants available
7		86	<ul style="list-style-type: none"> Exclusively 3-pole tripping Hardware quantity structure flexibly configurable
7		87	<ul style="list-style-type: none"> 1-pole and 3-pole tripping Hardware quantity structure flexibly configurable

Table 2.5/1 Differentiating Characteristics of the Line Protection Devices

Type Identification	7SA82	7SA86	7SA87	7SD82	7SD86	7SD87	7SL82	7SL86	7SL87	7VK87	7SJ86
Distance protection	■	■	■				■	■	■		
Differential protection				■	■	■	■	■	■		
Overcurrent protection for lines	■	■	■	■	■	■	■	■	■		■
Circuit-breaker management										■	
3-pole trip command	■	■		■	■		■	■			■
1-/3-pole trip command			■			■			■	■	
Point-on-wave switching			■			■			■	■	
Flexibly configurable hardware		■	■		■	■		■	■	■	■

Table 2.5/2 Essential Differentiating Characteristics of the Main Protection Types

SIPROTEC 5 Devices and Fields of Application

Line Protection – Compatibility

Compatibility between SIPROTEC 5 Line Protection and SIPROTEC 4 Line Protection

Introducing the firmware version V7.90 in the SIPROTEC 5 line protection means that now, for the first time, mixed configurations comprising line protection devices from the SIPROTEC 5 series and the old SIPROTEC 4 series can be operated.

A distinction can be drawn between 2 use cases:

- Replacing individual devices of an existing topology
- Expanding an existing SIPROTEC 4 topology by one or more SIPROTEC 5 devices

Use case 1: Replacing individual devices of an existing topology (retrofitting existing systems with SIPROTEC 5 technology)

The differential protection of the remaining differential-protection topology remains in operation due to functionally logging off the device to be replaced from the topology. Now, the device that has been logged off or the complete switchgear can be upgraded to SIPROTEC 5. The complete topology is now protected in mixed operation after activating the parameterized SIPROTEC 5 line protection device.

The switchgears can be gradually replaced as a result, while maintaining the differential protection. As a result, down times and protection interruptions are reduced to a minimum.

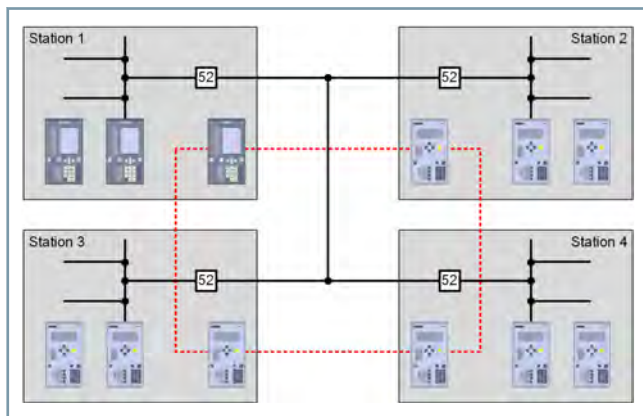

[dw_interoper_SIP4-and-SIP5_example_step-by-step_conversion_systems, 1, en_US]

Figure 2.5/3 Replacing Individual Devices of an Existing Topology

Use case 2: Expanding existing SIPROTEC 4 topologies by SIPROTEC 5 devices

If an existing topology is intended to be expanded by one or more ends (up to a max. of 6), then this can be carried out with SIPROTEC 5 devices from V7.90 upwards. This ensures that switchgear design and engineering is focused on the future.

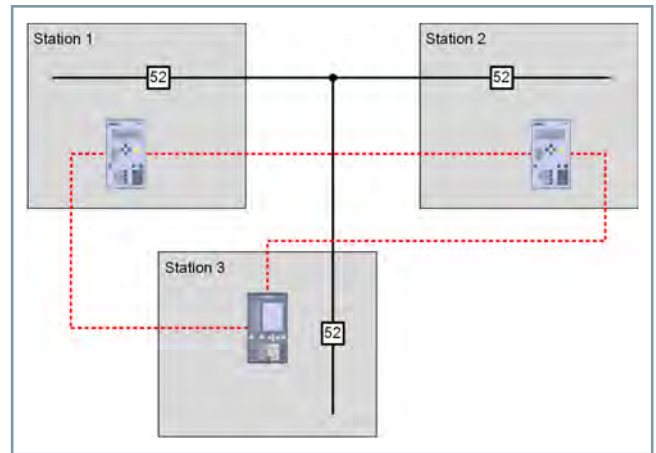

[dw_interoper_SIP4-and-SIP5_example_integr_single-feeder, 1, en_US]

Figure 2.5/4 Expanding Existing SIPROTEC 4 Topologies by SIPROTEC 5 Devices.

Device Type	HW	FW
7SA522	/FF	4.70 ¹⁾
7SA6	/EE	4.70 ¹⁾
7SD52/53	/EE	4.70
7SD610	/DD	4.70

Table 2.5/3 Hardware Releases and Firmware Versions on the SIPROTEC 4 Side

(1) Older versions are also feasible in theory, but they have not been tested by Siemens.

Protection-Interface Modules

The existing communication converters can remain on the SIPROTEC 4 side for establishing the communication link. Adaptation can be carried out on the new SIPROTEC 5 line side in each case.

All of the communication modules that are currently available are supported on the SIPROTEC 4 side. Either the USART-AD-1FO or USART-AE-2FO FO5 module is required on the SIPROTEC 5 side. FO5 modules can be connected directly to the SIPROTEC 5 devices using optical fiber in this case.

FO30 modules are also going to be supported for direct connection to communication networks in accordance with IEEE C37.94 standard in one of the upcoming releases.

Appropriate repeaters must be used on the SIPROTEC 5 side to connect the FO17, FO18, and FO19 long-distance modules.

SIPROTEC 5 Devices and Fields of Application

Line Protection – Standard Variants





Standard Variant for SIPROTEC 7SA82, 7SD82, 7SL82	
Type 1	1/3, 11 BI, 9 BO, 4 I, 4 V
	Housing width 1/3 x 19" 11 binary inputs 9 binary outputs (1 life contact, 8 standard) 4 current transformers 4 voltage transformers Contains the following modules: base module with PS101 and IO102
Type 2	1/3, 23 BI, 16 BO, 4 I, 4 V
	Housing width 1/3 x 19" 23 binary inputs 16 binary outputs (1 life contact, 15 standard) 4 current transformers 4 voltage transformers Contains the following modules: base module with PS101, IO101, and IO110

2.5

Table 2.5/4 Standard Variants for SIPROTEC 7Sx82 S Line Protection Devices

SIPROTEC 5 Devices and Fields of Application

Line Protection – Standard Variants

Standard Variants for SIPROTEC 7SA86, 7SD86, 7SL86, 7SA87, 7SD87, 7SL87, 7VK87		
Type 1	1/3, 7 BI, 14 BO, 16 LED, 4 I, 4 V	
	Housing width 1/3 × 19" 7 binary inputs 14 binary outputs (1 life contact, 5 standard, 8 fast) 16 LEDs 4 current transformers 4 voltage transformers Contains the following modules: base module with PS201 and IO208	
Type 2	1/3, 11 BI, 9 BO, 16 LED, 4 I, 4 V	
	Housing width 1/3 × 19" 11 binary inputs 9 binary outputs (1 life contact, 2 standard, 6 fast) 16 LEDs 4 current transformers 4 voltage transformers Contains the following modules: base module with PS201 and IO202	
Type 3	1/2, 13 BI, 21 BO, 16 LED, 4 I, 4 V	
	Housing width 1/2 × 19" 13 binary inputs 21 binary outputs (1 life contact, 12 standard, 8 fast) 16 LEDs 4 current transformers 4 voltage transformers Contains the following modules: base module with PS201 and IO208 Expansion module IO206	
Type 4	1/2, 19 BI, 30 BO, 16 LED, 4 I, 4 V	
	Housing width 1/2 × 19" 19 binary inputs 30 binary outputs (1 life contact, 21 standard, 8 fast) 16 LEDs 4 current transformers 4 voltage transformers Contains the following modules: base module with PS201 and IO208 Expansion module IO205	
Type 6	1/2, 15 BI, 18 BO (4 HS), 16 LED, 4 I, 4 V	
	Housing width 1/2 × 19" 15 binary inputs 18 binary outputs (1 life contact, 5 standard, 8 fast, 4 high-speed) 16 LEDs 4 current transformers 4 voltage transformers Contains the following modules: base module with PS201 and IO208 Expansion module IO209	

2.5

SIPROTEC 5 Devices and Fields of Application

Line Protection – Standard Variants

Type 7	1/2, 15 BI, 20 BO, 16 LED, 8 I, 8 V Housing width 1/2 × 19" 15 binary inputs 20 binary outputs (1 life contact, 5 standard, 14 fast) 16 LEDs 8 current transformers 8 voltage transformers Contains the following modules: base module with PS201 and IO208 Expansion module IO202	
Type 8	2/3, 31 BI, 46 BO, 16 LED, 4 I, 4 V Housing width 2/3 × 19" 31 binary inputs 46 binary outputs (1 life contact, 37 standard, 8 fast) 16 LEDs 4 current transformers 4 voltage transformers Contains the following modules: base module with PS201 and IO208 Expansion modules IO205, IO205	
Type 10	2/3, 27 BI, 34 BO (4 HS), 16 LED, 4 I, 4 V Housing width 2/3 × 19" 27 binary inputs 34 binary outputs (1 life contact, 21 standard, 8 fast, 4 high-speed) 16 LEDs 4 current transformers 4 voltage transformers Contains the following modules: base module with PS201 and IO208 Expansion modules IO205, IO209	
Type 11	2/3, 27 BI, 36 BO, 16 LED, 8 I, 8 V Housing width 2/3 × 19" 27 binary inputs 36 binary outputs (1 life contact, 21 standard, 14 fast) 16 LEDs 8 current transformers 8 voltage transformers Contains the following modules: base module with PS201 and IO208 Expansion modules IO202, IO205	
Type 12	5/6, 27 BI, 33 BO (8 HS), 16 LED, 8 I, 8 V Housing width 5/6 × 19", 27 binary inputs 33 binary outputs (1 life contact, 8 standard, 16 fast, 8 high-speed) 16 LEDs 8 current transformers 8 voltage transformers Contains the following modules: base module with PS201 and IO208 Expansion modules IO208, IO209, IO209	

Table 2.5/5 Standard Variants for Line Protection Devices 7SA86, 7SD86, 7SL86, 7SA87, 7SD87, 7SL87, 7VK87

SIPROTEC 5 Devices and Fields of Application

Line Protection – Standard Variants

Standard Variants for SIPROTEC 7SJ86		
Type 1	1/3, 11 BI, 9 BO, 16 LED, 4 I, 4 V	
	Housing width 1/3 × 19" 11 binary inputs 9 binary outputs (1 life contact, 2 standard, 6 fast) 16 LEDs 4 current transformers 4 voltage transformers Contains the following modules: base module with PS201 and IO202	
Type 2	1/2, 17 BI, 16 BO, 16 LED, 4 I, 4 V	
	Housing width 1/2 × 19" 17 binary inputs 16 binary outputs (1 life contact, 9 standard, 6 fast) 16 LEDs 4 current transformers 4 voltage transformers Contains the following modules: base module with PS201 and IO202 Expansion modules IO206	
Type 3	1/2, 23 BI, 25 BO, 16 LED, 4 I, 4 V	
	Housing width 1/2 × 19" 23 binary inputs 25 binary outputs (1 life contact, 18 standard, 6 fast) 16 LEDs 4 current transformers 4 voltage transformers Contains the following modules: base module with PS201 and IO202 Expansion modules IO205	

Table 2.5/6 Standard Variants for SIPROTEC 7SJ86 Line Protection Devices

You can find the technical data in the manual
www.siemens.com/siprotec.

Description

The SIPROTEC 7SA82 distance protection has been designed particularly for the cost-optimized and compact protection of lines in medium-voltage and high-voltage systems. With its flexibility and the high-performance DIGSI 5 engineering tool, the SIPROTEC 7SA82 device offers future-oriented solutions for protection, control, automation, monitoring, and Power Quality – Basic.

Main function	Distance protection for medium-voltage and high-voltage applications Interoperability of SIPROTEC 4 and SIPROTEC 5 line protection devices
Tripping	3-pole, minimum tripping time: 19 ms
Inputs and outputs	4 current transformers, 4 voltage transformers, 11 or 23 binary inputs, 9 or 16 binary outputs
Hardware flexibility	Different hardware quantity structures for binary inputs and outputs are available in the 1/3 base module. Adding 1/6 expansion modules is not possible; available with large or small display.
Housing width	1/3 x 19 inches

Benefits

- Compact and low-cost distance protection
- Safety due to high-performance protection functions
- Purposeful and easy handling of devices and software thanks to a user-friendly design
- Cybersecurity in accordance with NERC CIP and BDEW White-paper requirements
- Highest availability even under extreme environmental conditions by standard coating of the modules
- Full compatibility between IEC 61850 Editions 1, 2.0, and 2.1
- High investment security and low operating costs due to future-oriented system solutions

Functions

DIGSI 5 permits all functions to be configured and combined as required and as per the functional scope that has been ordered.

- Minimum tripping time: 19 ms
- 6 independent measuring loops (6-system distance protection)
- Several distance-protection functions can be selected: Classic, reactance method (RMD), impedance protection for transformers
- Directional backup protection and various additional functions
- Detection of ground faults of any type in compensated or isolated electrical power systems using the following functions: $3I_0>$, $V_0>$, transient ground fault, $\cos \varphi$, $\sin \varphi$, dir. detection of intermittent ground faults, harmonic detection, and admittance measurement
- Ground-fault detection using the pulse-detection method
- Adaptive power-swing blocking



[SIP5_GD_W3, 2, --]

Figure 2.6/1 SIPROTEC 7SA82

- Detection of current-transformer saturation for fast tripping with high accuracy
- Fault locator Plus for accurate fault location with inhomogeneous line sections and targeted automatic overhead line section reclosing (AREC)
- Arc protection
- Automatic frequency relief for underfrequency load shedding, taking changed infeed conditions due to decentralized power generation into consideration
- Power protection, configurable as active or reactive-power protection
- Directional reactive-power undervoltage protection (QU protection)
- Detection of current and voltage signals up to the 50th harmonic with high accuracy for selected protection functions (such as thermal overload protection) and operational measured values
- PQ – Basic: Voltage unbalance; voltage changes: overvoltage, dip, interruption; TDD, THD, and harmonics
- Ground fault detection using the pulse detection method
- Control, synchrocheck, and switchgear interlocking protection
- Graphical logic editor to create high-performance automation functions in the device
- Single-line representation in the small or large display
- Fixed integrated electrical Ethernet RJ45 interface for DIGSI 5 and IEC 61850 (reporting and GOOSE)
- 2 optional, pluggable communication modules, usable for different and redundant protocols (IEC 61850, IEC 60870-5-103, IEC 60870-5-104, Modbus TCP, DNP3 serial and TCP, PROFINET IO)

SIPROTEC 5 Devices and Fields of Application

Distance Protection – SIPROTEC 7SA82

- Serial protection communication via optical fibers, two-wire connections, and communication networks (IEEE C37.94, and others), including automatic switchover between ring and chain topology
- Reliable data transmission via PRP and HSR redundancy protocols
- Extensive cybersecurity functionality, such as role-based access control (RBAC), logging of security-related events, signed firmware, or authenticated IEEE 802.1X network access.
- Simple, fast, and secure access to the device via a standard Web browser to display all information and diagnostic data, vector diagrams, single-line and device display pages
- Phasor Measurement Unit (PMU) for synchrophasor measured values and IEEE C37.118 protocol
- Time synchronization using IEEE 1588
- High-performance fault recording (buffer for a max. record time of 80 s at 8 kHz or 320 s at 2 kHz)
- Auxiliary functions for simple tests and commissioning

Applications

- Detection and selective 3-pole tripping of short circuits in electrical equipment of star networks, lines with infeed at one or 2 ends, parallel lines, and open-circuited or closed ring systems of all voltage levels
- Detection of ground faults in isolated or arc-suppression-coil-ground systems in star, ring, or meshed arrangement

- Serial protection communication with SIPROTEC 5 and SIPROTEC 4 devices over different distances and physical media, such as optical fiber, two-wire connections, and communication networks
- Backup protection for differential protection devices of all kind for lines, transformers, generators, motors, and busbars
- Phasor Measurement Unit (PMU)
- Detection and recording of power-quality data in the medium-voltage and subordinate low-voltage power system

Application Templates

DIGSI 5 provides application templates for standard applications. They include basic configurations and default settings.

The following application templates are available:

- Basic
- Distance protection for resonant/isolated grounded power systems, with automatic reclosing
- Distance protection with reactance method for overhead lines in grounded electrical power systems

Application Example

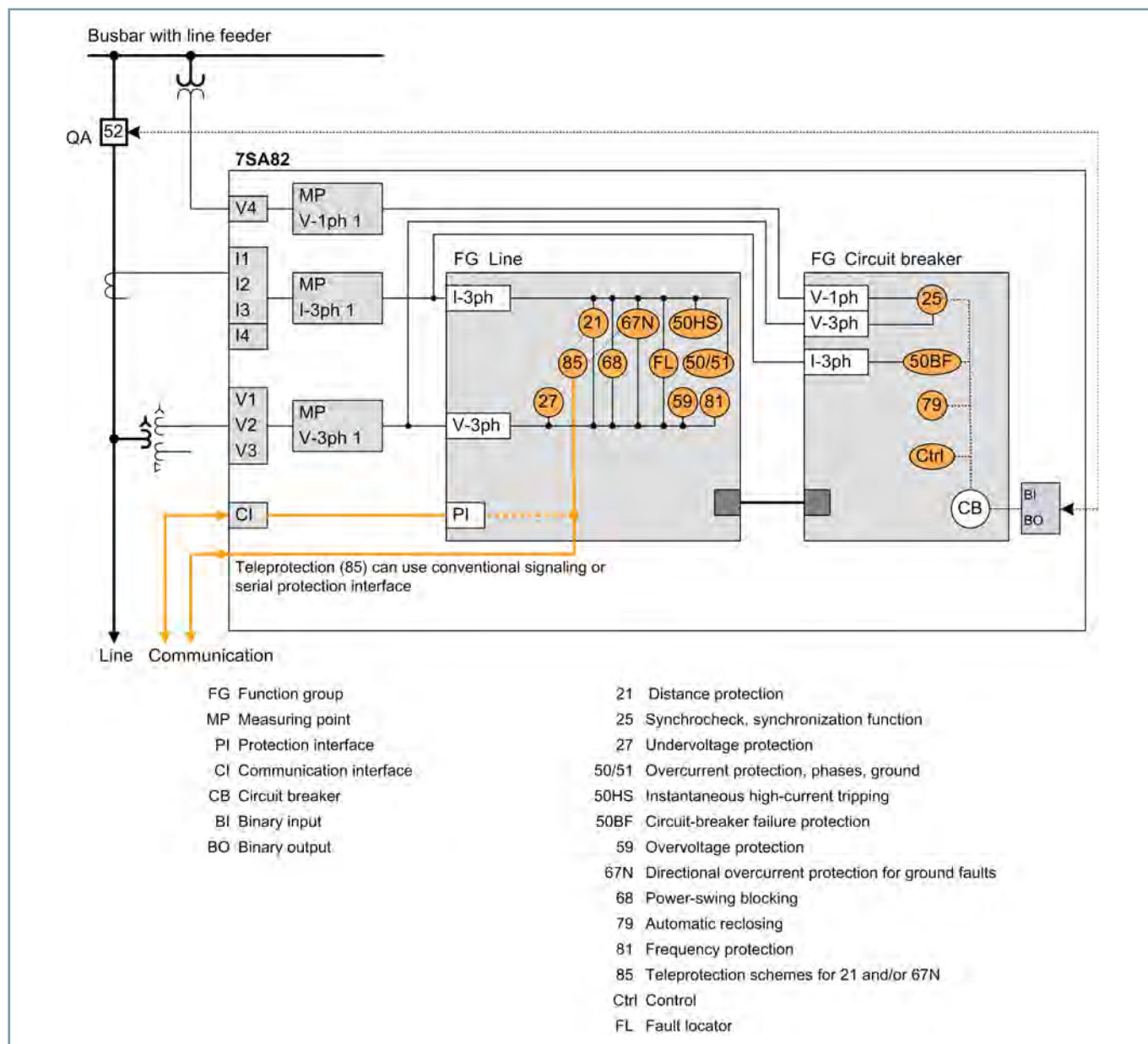

[dw_7SA82_Ltg, 1, en_US]

Figure 2.6/2 Application Example: Distance Protection for Overhead Line

SIPROTEC 5 Devices and Fields of Application

Distance Protection – SIPROTEC 7SA82

ANSI	Function	Abbr.	Available	Application Templates		
				1	2	3
	Protection functions for 3-pole tripping	3-pole	■	■	■	■
21/21N	Distance Protection	$Z<, V< /I> / \angle(V, I)$	■	■	■	■
21T	Impedance protection for transformers	$Z<$	■			
25	Synchrocheck, synchronization function	Sync	■			■
27	Undervoltage protection: "3-phase" or "positive-sequence system V1" or "universal Vx"	$V<$	■			
27R, 59R	Voltage change protection (starting with V8.30)	dV/dt	■			
	Undervoltage-controlled reactive power protection	$Q>/V<$	■			
32, 37	Power protection active/reactive power	$P<>, Q<>$	■			
37	Undercurrent	$I<$	■			
38	Temperature supervision	$\theta>$	■			
46	Negative-sequence system overcurrent protection	$I2>$	■			
46	Negative-sequence system and overcurrent protection with direction	$I2>, \angle(V2, I2)$	■			
47	Overvoltage protection, negative-sequence system	$V2>$	■			
49	Thermal overload protection	θ, I^2t	■		■	■
50/51 TD	Overcurrent protection, phases	$I>$	■	■	■	■
	Instantaneous tripping at switch onto fault	SOTF	■			
50HS	Instantaneous high-current tripping	$I>>>$	■	■	■	■
50/51 TD	Overcurrent protection with positive-sequence current I1 (from V7.9)	$I1>$	■			
50N/ 51N TD	Overcurrent protection, ground	$IN>$	■	■	■	■
50N/ 51N TD	Overcurrent protection, 1-phase	$IN>$	■			
50 Ns/ 51Ns	Sensitive ground-fault detection for grounded arc suppression coils and isolated power systems including a) $3I0>$ b) admittance $Y0>$, c) $3I0$ -harm $>$ (from V7.8)	$INs>$	■			
	Sensitive ground-fault detection via pulse detection; hint: this stage also requires the function 50Ns/51Ns or 67Ns "sensitive ground-fault detection for grounded arc suppression coils and isolated power systems"	IN pulse	■			
	Intermittent ground-fault protection	$IIE>$	■			
50BF	Circuit-breaker failure protection, 3-pole	CBFP	■		■	■
50RS	Circuit breaker restrike monitoring	CBRM	■			
51V	Voltage-controlled overcurrent protection	$t=f(I, V)$	■			
59, 59N	Overvoltage protection: "3-phase" or "zero-sequence system V0" or "positive-sequence system V1" or "universal Vx"	$V>$	■			
60	Voltage-comparison supervision	$\Delta V>$	■			
67	Directional overcurrent protection, phases	$I>, \angle(V, I)$	■			
67N	Directional ground-fault protection in grounded power systems	$IN>, \angle(V, I)$	■			■
67 Ns	Sensitive ground-fault detection for grounded arc suppression coils and isolated power systems including a) $3I0>$ b) $V0>$, c) $\cos/\sin \Phi$, d) transient ground fault, e) $\Phi(V, I)$, f) admittance		■		■	
	Directional tripping stage with one harmonic; hint: this stage also requires the function "67Ns sensitive ground-fault detection for grounded arc suppression coils and isolated power systems"	$\angle(V0h, I0h)$	■			
	Directional Intermittent Ground-Fault Protection	$IIEdir>$	■			
68	Power-swing blocking	$\Delta Z/\Delta t$	■			■

SIPROTEC 5 Devices and Fields of Application

Distance Protection – SIPROTEC 7SA82

ANSI	Function	Abbr.	Available	Application Templates		
				1	2	3
74TC	Trip-circuit supervision		■			
78	Out-of-step protection	$\Delta Z/\Delta t$	■			
74CC	Single circuit monitoring (from V7.9)		■			
79	Automatic reclosing, 3-pole	AREC	■		■	■
81	Frequency protection: "f>" or "f<" or "df/dt"	f<>; df/dt<>	■			
81U	Underfrequency load shedding	f<(ULS)	■			
	Vector-jump protection	$\Delta\varphi>$	■			
85/21	Teleprotection scheme for distance protection		■	■	■	■
85/27	Weak or no infeed: Echo and tripping		■	■	■	■
85/67N	Teleprotection scheme for directional ground-fault protection		■	■	■	■
86	Lockout		■			
87N T	Restricted ground-fault protection	ΔI_N	■			
90 V	Voltage controller for two-winding transformer		■			
90 V	Voltage controller for two-winding transformer with parallel control		■			
	Number of two-winding transformers with parallel control (hint: only together with the function "voltage controller for two-winding transformer with parallel control")		■			
FL	Fault Locator, single-side	FL-one	■	■	■	■
FL	Fault Locator Plus (from V7.9)	FL plus	■			
PMU	Synchrophasor measurement	PMU	■			
AFD	Arc protection (only with plug-in module ARC-CD-3FO)		■			
	Measured values, standard		■	■	■	■
	Measured values, extended: Min, max, average		■			
	Switching statistics counter		■	■	■	■
	PQ – Basic measured values: THD (Total Harmonic Distortion) and harmonic component (starting with V8.01) and THD voltage average values (starting with V8.40)		■			
	PQ – Basic measured values: Voltage unbalance (starting with V8.40)		■			
	PQ – Basic measured values: Voltage changes – monitoring of voltage dips, overvoltages and voltage interruptions (starting with V8.40)		■			
	PQ – Basic measured values: TDD - Total Demand Distortion (starting with V8.40)		■			
	CFC (standard, control)		■	■	■	■
	CFC arithmetic		■			
	Circuit-breaker wear monitoring	$\Sigma I_x, I^2t, 2P$	■			
	Switching sequence function		■			
	Inrush-current detection		■			
	External trip initiation		■	■	■	■
	Control		■	■	■	■
	Circuit breaker		■	■	■	■
	Disconnectors/grounding conductor		■			
	Fault recording of analog and binary signals		■	■	■	■
	Monitoring		■	■	■	■
	Protection interface, serial		■	■	■	■
	Region, France: Overload protection for 'PSL-PSC' lines		■			
	Region, France: 'MAXI-L' overcurrent protection		■			

2.6

SIPROTEC 5 Devices and Fields of Application

Distance Protection – SIPROTEC 7SA82

ANSI	Function	Abbr.	Available	Application Templates		
				1	2	3
	Region, France: 'PDA' system decoupling protection		■			
	Region, France: Overload protection for transformers		■			
	Frequency group tracking (from V7.8)		■			
	Cyber security: Role-Based Access Control (from V7.8)		■			
	Temperature recording via communication protocol		■			
	Cyber security: Authenticated network access using IEEE 802.1X (starting from V8.3)		■			
Function point class:				0	100	200
The configuration and function point class for your application can be determined in the SIPROTEC 5 order configurator at www.siemens.com/siprotec .						

Table 2.6/1 SIPROTEC 7SA82 – Functions, Application Templates

- (1) Basic
- (2) DIS Res./Isol. Power systems, with AREC
- (3) DIS RMD Overhead Line, grounded power systems

2.6

Description

The SIPROTEC 7SA86 distance protection has been designed specifically for the protection of lines. With its modular structure, flexibility and the high-performance DIGSI 5 engineering tool, the SIPROTEC 7SA86 device offers future-oriented solutions for protection, control, automation, monitoring, and Power Quality – Basic.

Main function	Distance protection Interoperability of SIPROTEC 4 and SIPROTEC 5 line protection devices
Tripping	3-pole, minimum tripping time: 9 ms
Inputs and outputs	12 predefined standard variants with 4/4 or 8/8 current transformers/voltage transformers, 5 to 31 binary inputs, 8 to 46 binary outputs
Hardware quantity structure	Flexibly adjustable I/O quantity structure within the scope of the SIPROTEC 5 modular system
Housing width	1/3 × 19 inches to 2/1 × 19 inches

Benefits

- Safety due to high-performance protection functions
- Purposeful and easy handling of devices and software thanks to a user-friendly design
- Cybersecurity in accordance with NERC CIP and BDEW White-paper requirements
- Highest availability even under extreme environmental conditions by standard coating of the modules
- Full compatibility between IEC 61850 Editions 1, 2.0, and 2.1

Functions

DIGSI 5 permits all functions to be configured and combined as required and as per the functional scope that has been ordered.

- Minimum tripping time: 9 ms
- 6 independent measuring loops (6-system distance protection)
- Several distance-protection functions can be selected: Classic, reactance method (RMD), impedance protection for transformers
- Directional backup protection and various additional functions
- Detection of ground faults of any type in compensated or isolated electrical power systems using the following functions: 3I0>, V0>, transient ground fault, cos φ, sin φ, dir. detection of intermittent ground faults, harmonic detection, and admittance measurement
- Ground-fault detection using the pulse-detection method
- Adaptive power-swing blocking, out-of-step protection
- Detection of current-transformer saturation for fast tripping with high accuracy
- Fault locator plus for accurate fault location with inhomogeneous line sections and targeted automatic overhead line section reclosing (AREC)
- Arc protection



[SIP5_GD_SS_W3, 2, --, --]

Figure 2.6/3 SIPROTEC 5 Device with Expansion Module

- Automatic frequency relief for underfrequency load shedding, taking changed infeed conditions due to decentralized power generation into consideration
- Power protection, configurable as active or reactive-power protection
- Directional reactive-power undervoltage protection (QU protection)
- Detection of current and voltage signals up to the 50th harmonic with high accuracy for selected protection functions (such as thermal overload protection) and operational measured values
- PQ – Basic: Voltage unbalance; voltage changes: overvoltage, dip, interruption; TDD, THD, and harmonics
- 3-pole automatic reclosing function
- Control, synchrocheck, and switchgear interlocking protection
- Graphical logic editor to create high-performance automation functions in the device
- Single-line representation in the small or large display
- Fixed integrated electrical Ethernet RJ45 interface for DIGSI 5 and IEC 61850 (reporting and GOOSE)
- Up to 4 optional, pluggable communication modules, usable for different and redundant protocols (IEC 61850-8-1, IEC 61850-9-2 Client, IEC 60870-5-103, IEC 60870-5-104, Modbus TCP, DNP3 serial and TCP, PROFINET IO, PROFINET IO S2 redundancy)
- Virtual network partitioning (IEEE 802.1Q - VLAN)
- Serial protection communication via optical fibers, two-wire connections, and communication networks (IEEE C37.94 and others), including automatic switchover between ring feeder and chain topology
- Reliable data transmission via PRP and HSR redundancy protocols

SIPROTEC 5 Devices and Fields of Application

Distance Protection – SIPROTEC 7SA86

- Extensive cybersecurity functionality, such as role-based access control (RBAC), logging of security-related events, signed firmware, or authenticated IEEE 802.1X network access.
- Simple, fast, and secure access to the device via a standard Web browser to display all information and diagnostic data, vector diagrams, single-line and device display pages
- Phasor Measurement Unit (PMU) for synchrophasor measured values and IEEE C37.118 protocol
- Time synchronization using IEEE 1588
- High-performance fault recording (buffer for a max. record time of 80 s at 8 kHz or 320 s at 2 kHz)
- Auxiliary functions for simple tests and commissioning
- Flexibly adjustable I/O quantity structure within the scope of the SIPROTEC 5 modular system

Applications

- Detection and selective 3-pole tripping of short circuits in electrical equipment of star networks, lines with infeed at one or 2 ends, parallel lines, and open-circuited or closed ring systems of all voltage levels
- Detection of ground faults in isolated or arc-suppression-coil-ground systems in star, ring, or meshed arrangement
- Serial protection communication with SIPROTEC 5 and SIPROTEC 4 devices over different distances and physical media, such as optical fiber, two-wire connections, and communication networks

- Backup protection for differential protection devices of all kind for lines, transformers, generators, motors, and busbars
- Phasor Measurement Unit (PMU)
- Detection and recording of power-quality data in the medium-voltage and subordinate low-voltage power system

Application Templates

DIGSI 5 provides application templates for standard applications. They include basic configurations and default settings.

The following application templates are available:

- Basic
- Distance protection for resonant/isolated-grounded power systems, with automatic reclosing
- Distance protection with reactance method for overhead lines in grounded electrical power systems
- Distance protection with reactance method for overhead lines in grounded electrical power systems and applications with breaker-and-a-half layout
- Distance protection with MHO distance zone characteristic for overhead lines in grounded electrical power systems and applications with breaker-and-a-half layout

Application Examples

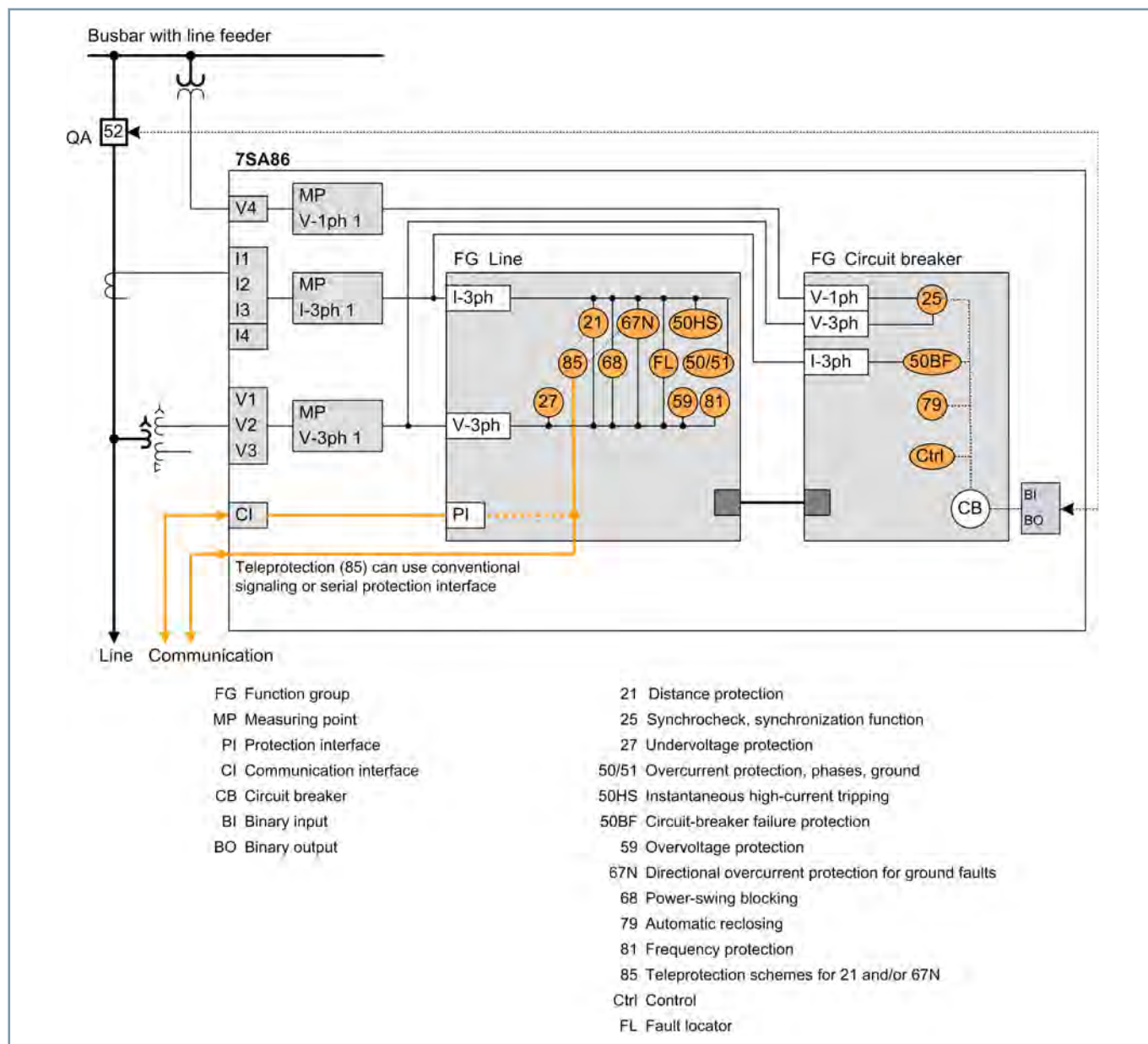

[dw_7SA86_Ltg, 1, en_US]

Figure 2.6/4 Application Example: Distance Protection for Overhead Line

SIPROTEC 5 Devices and Fields of Application

Distance Protection – SIPROTEC 7SA86

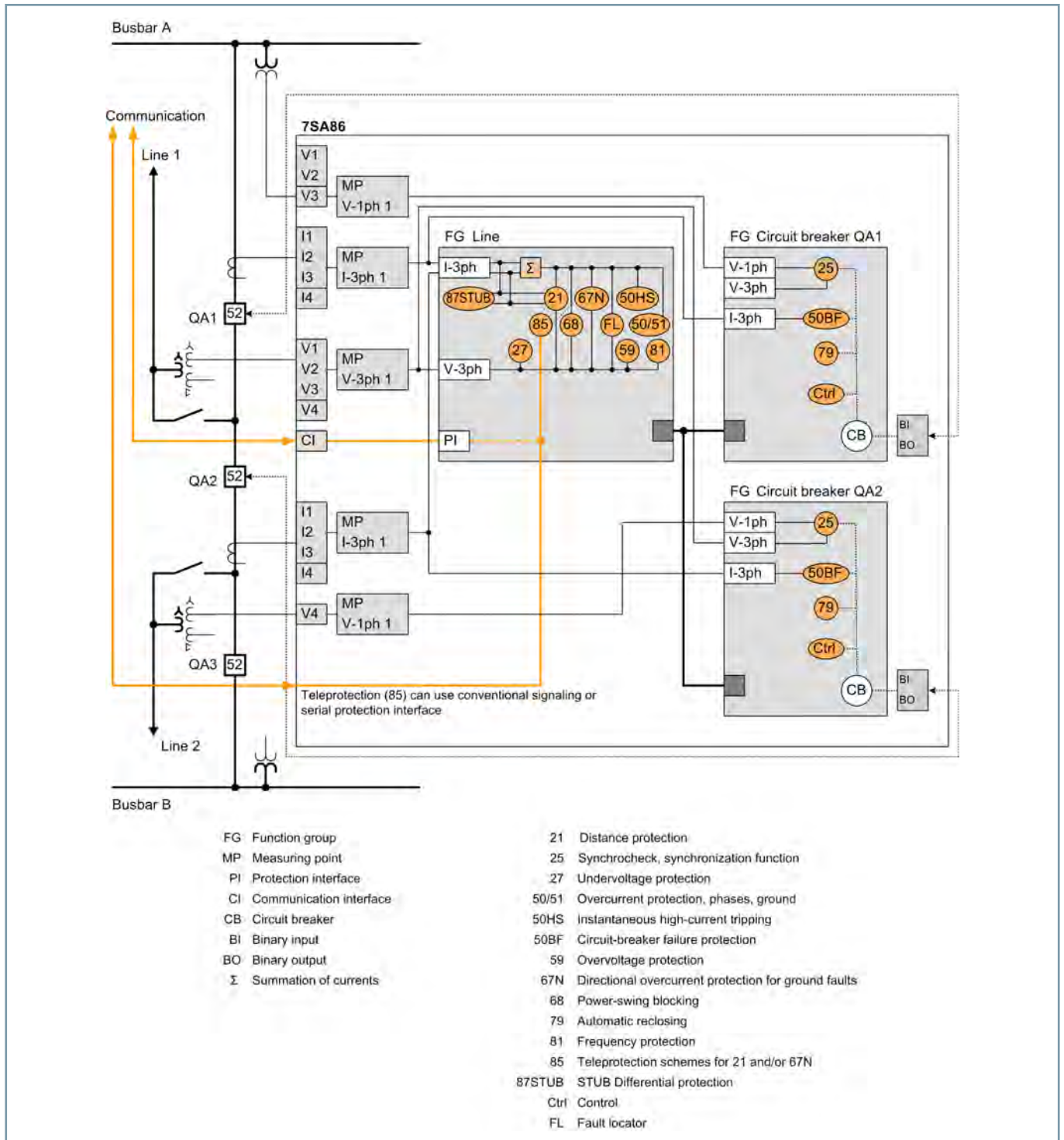

Figure 2.6/5 Application Example: Distance Protection for Overhead Line with Breaker-and-a-Half Layout

SIPROTEC 5 Devices and Fields of Application

Distance Protection – SIPROTEC 7SA86

ANSI	Function	Abbr.	Available	Application Templates				
				1	2	3	4	5
	Protection functions for 3-pole tripping	3-pole	■	■	■	■	■	■
	Expandable hardware quantity structure	I/O	■	■	■	■	■	■
	Process bus client protocol (hint: PB client requires a separate ETH-BD-2FO plug-in module, from V8.0)	PB client	■					
	IEC61850-9-2 Merging Unit Stream (hint: Each stream requires a separate ETH-BD-2FO plug-in module, from V8.0)	MU	■					
	IEC61850-9-2 Merging Unit Stream 7SS85 CU (hint: Only for communication with a 7SS85 CU. A separate ETH-BD-2FO plug-in module is required starting with V8.40)	MU	■					
21/21N	Distance Protection	$Z<, V< I>/\angle(V, I)$	■	■	■	■	■	■
21T	Impedance protection for transformers	$Z<$	■					
25	Synchrocheck, synchronization function	Sync	■			■	■	■
27	Undervoltage protection: "3-phase" or "positive-sequence system V1" or "universal Vx"	$V<$	■					
27R, 59R	Voltage change protection (starting with V8.30)	dV/dt	■					
	Undervoltage-controlled reactive power protection	$Q>/V<$	■					
32, 37	Power protection active/reactive power	$P<>, Q<>$	■					
37	Undercurrent	$I<$	■					
38	Temperature supervision	$\theta>$	■					
46	Negative-sequence system overcurrent protection	$I2>$	■					
46	Negative-sequence system and overcurrent protection with direction	$I2>, \angle(V2, I2)$	■					
47	Overvoltage protection, negative-sequence system	$V2>$	■					
49	Thermal overload protection	θ, I^2t	■		■	■	■	■
50/51 TD	Overcurrent protection, phases	$I>$	■	■	■	■	■	■
	Instantaneous tripping at switch onto fault	SOTF	■					
50HS	Instantaneous high-current tripping	$I>>>$	■	■	■	■	■	■
50/51 TD	Overcurrent protection with positive-sequence current I1 (from V7.9)	$I1>$	■					
50N/ 51N TD	Overcurrent protection, ground	$IN>$	■	■	■	■	■	■
50N/ 51N TD	Overcurrent protection, 1-phase	$IN>$	■					
50 Ns/ 51Ns	Sensitive ground-fault detection for grounded arc suppression coils and isolated power systems including a) 3I0> b) admittance Y0>, c) 3I0-harm> (from V7.8)	$INs>$	■					
	Sensitive ground-fault detection via pulse detection; hint: this stage also requires the function 50Ns/51Ns or 67Ns "sensitive ground-fault detection for grounded arc suppression coils and isolated power systems"	IN pulse	■					
	Intermittent ground-fault protection	$IIE>$	■					
50BF	Circuit-breaker failure protection, 3-pole	CBFP	■		■	■	■	■
50EF	End-fault protection (hint: For use only in decentralized busbar protection with a 7SS85 CU starting with V8.40)		■					
50RS	Circuit breaker restrike monitoring	CBRM	■					
51V	Voltage-controlled overcurrent protection	$t=f(I, V)$	■					
59, 59N	Overvoltage protection: "3-phase" or "zero-sequence system V0" or "positive-sequence system V1" or "universal Vx"	$V>$	■					
60	Voltage-comparison supervision	$\Delta V>$	■					

SIPROTEC 5 Devices and Fields of Application

Distance Protection – SIPROTEC 7SA86

ANSI	Function	Abbr.	Available	Application Templates				
				1	2	3	4	5
67	Directional overcurrent protection, phases	$I>, \angle(V, I)$	■					
67N	Directional ground-fault protection in grounded power systems	$IN>, \angle(V, I)$	■			■	■	■
67 Ns	Sensitive ground-fault detection for grounded arc suppression coils and isolated power systems including a) $3I0>$ b) $V0>$, c) $\cos/\sin \Phi$, d) transient ground fault, e) $\Phi(V, I)$, f) admittance		■		■			
	Directional tripping stage with one harmonic; hint: this stage also requires the function "67Ns sensitive ground-fault detection for grounded arc suppression coils and isolated power systems"	$\angle(V0h, I0h)$	■					
	Directional Intermittent Ground-Fault Protection	$IIEdir>$	■					
68	Power-swing blocking	$\Delta Z/\Delta t$	■			■	■	■
74TC	Trip-circuit supervision		■					
78	Out-of-step protection	$\Delta Z/\Delta t$	■					
74CC	Single circuit monitoring (from V7.9)		■					
79	Automatic reclosing, 3-pole	AREC	■		■	■	■	■
81	Frequency protection: "f>" or "f<" or "df/dt"	$f<>; df/dt<>$	■					
81U	Underfrequency load shedding	$f<(ULS)$	■					
	Vector-jump protection	$\Delta\varphi>$	■					
85/21	Teleprotection scheme for distance protection		■	■	■	■	■	■
85/27	Weak or no infeed: Echo and tripping		■	■	■	■	■	■
85/67N	Teleprotection scheme for directional ground-fault protection		■	■	■	■	■	■
86	Lockout		■					
87N T	Restricted ground-fault protection	ΔIN	■					
87 STUB	Stub fault differential protection (for breaker-and-a-half layouts)		■				■	■
90 V	Voltage controller for two-winding transformer		■					
90 V	Voltage controller for two-winding transformer with parallel control		■					
	Number of two-winding transformers with parallel control (hint: only together with the function "voltage controller for two-winding transformer with parallel control")		■					
90 V	Voltage controller for three-winding transformer		■					
90 V	Voltage controller for grid coupling transformer		■					
FL	Fault Locator, single-side	FL-one	■	■	■	■	■	■
FL	Fault Locator Plus (from V7.9)	FL plus	■					
PMU	Synchrophasor measurement	PMU	■					
AFD	Arc protection (only with plug-in module ARC-CD-3FO)		■					
	Measured values, standard		■	■	■	■	■	■
	Measured values, extended: Min, max, average		■					
	Switching statistics counter		■	■	■	■	■	■
	PQ – Basic measured values: THD (Total Harmonic Distortion) and harmonic component (starting with V8.01) and THD voltage average values (starting with V8.40)		■					
	PQ – Basic measured values: Voltage unbalance (starting with V8.40)		■					
	PQ – Basic measured values: Voltage changes – monitoring of voltage dips, overvoltages and voltage interruptions (starting with V8.40)		■					
	PQ – Basic measured values: TDD - Total Demand Distortion (starting with V8.40)		■					

2.6

SIPROTEC 5 Devices and Fields of Application

Distance Protection – SIPROTEC 7SA86

ANSI	Function	Abbr.	Available	Application Templates				
				1	2	3	4	5
	CFC (standard, control)		■	■	■	■	■	■
	CFC arithmetic		■					
	Circuit-breaker wear monitoring	$\Sigma I_x, I^2t, 2P$	■					
	Switching sequence function		■					
	Inrush-current detection		■					
	External trip initiation		■	■	■	■	■	■
	Control		■	■	■	■	■	■
	Circuit breaker		■	■	■		■	■
	Disconnectors/grounding conductor		■				■	■
	Fault recording of analog and binary signals		■	■	■	■	■	■
	Monitoring		■	■	■	■	■	■
	Protection interface, serial		■	■	■	■	■	■
	Region, France: Overload protection for 'PSL-PSC' lines		■					
	Region, France: 'MAXI-L' overcurrent protection		■					
	Region, France: 'PDA' system decoupling protection		■					
	Region, France: Overload protection for transformers		■					
	Frequency group tracking (from V7.8)		■					
	Cyber security: Role-Based Access Control (from V7.8)		■					
	Temperature recording via communication protocol		■					
	Cyber security: Authenticated network access using IEEE 802.1X (starting from V8.3)		■					
Function point class:				0	100	200	350	350
The configuration and function point class for your application can be determined in the SIPROTEC 5 order configurator at www.siemens.com/siprotec .								

2.6

Table 2.6/2 SIPROTEC 7SA86 – Functions, Application Templates

- (1) Basic
- (2) DIS Res./Isol. Power systems, with AREC
- (3) DIS RMD Overhead Line, grounded power systems
- (4) DIS RMD Overhead Line, grounded power systems, 1.5 CB
- (5) DIS MHO, overhead line, grounded power systems, 1.5 CB

SIPROTEC 5 Devices and Fields of Application

Distance Protection – SIPROTEC 7SA87

Description

The SIPROTEC 7SA87 distance protection has been designed specifically for the protection of lines. With its modular structure, flexibility and the high-performance DIGSI 5 engineering tool, the SIPROTEC 7SA87 device offers future-oriented solutions for protection, control, automation, monitoring, and Power Quality – Basic.

Main function	Distance protection Interoperability of SIPROTEC 4 and SIPROTEC 5 line protection devices
Tripping	1-pole and 3-pole, minimum tripping time: 9 ms
Inputs and outputs	12 predefined standard variants with 4/4 or 8/8 current transformers/voltage transformers, 5 to 31 binary inputs, 8 to 46 binary outputs
Hardware flexibility	Flexibly adjustable I/O quantity structure within the scope of the SIPROTEC 5 modular system
Housing width	1/3 × 19 inches to 2/1 × 19 inches



[SIP5_GD_SS_W3, 2, --, --]

Figure 2.6/6 SIPROTEC 5 Device with Expansion Module

2.6

Benefits

- Safety due to high-performance protection functions
- Purposeful and easy handling of devices and software thanks to a user-friendly design
- Cybersecurity in accordance with NERC CIP and BDEW White-paper requirements
- Highest availability even under extreme environmental conditions by standard coating of the modules
- Full compatibility between IEC 61850 Editions 1, 2.0, and 2.1

Functions

DIGSI 5 permits all functions to be configured and combined as required and as per the functional scope that has been ordered.

- Minimum tripping time: 9 ms
- 6 independent measuring loops (6-system distance protection)
- Several distance-protection functions can be selected: Classic, reactance method (RMD), impedance protection for transformers
- Directional backup protection and various additional functions
- Detection of ground faults of any type in compensated or isolated electrical power systems using the following functions: 3I0>, V0>, transient ground fault, cos φ, sin φ, dir. detection of intermittent ground faults, harmonic detection, and admittance measurement
- Ground-fault detection using the pulse-detection method
- Adaptive power-swing blocking, out-of-step protection
- Detection of current-transformer saturation for fast tripping with high accuracy
- Fault locator plus for accurate fault location with inhomogeneous line sections and targeted automatic overhead-line section reclosing (AREC)
- Arc protection

- Automatic frequency relief for underfrequency load shedding, taking changed infeed conditions due to decentralized power generation into consideration
- Power protection, configurable as active or reactive-power protection
- Directional reactive-power undervoltage protection (QU protection)
- Detection of current and voltage signals up to the 50th harmonic with high accuracy for selected protection functions (such as thermal overload protection) and operational measured values
- PQ – Basic: Voltage unbalance; voltage changes: overvoltage, dip, interruption; TDD, THD, and harmonics
- 1-pole automatic reclosing function with secondary arc detection (SAD)
- Control, synchrocheck, and switchgear interlocking protection
- Graphical logic editor to create high-performance automation functions in the device
- Single-line representation in the small or large display
- Point-on-wave switching
- Fixed integrated electrical Ethernet RJ45 interface for DIGSI 5 and IEC 61850 (reporting and GOOSE)
- Up to 4 optional, pluggable communication modules, usable for different and redundant protocols (IEC 61850-8-1, IEC 61850-9-2 Client, IEC 60870-5-103, IEC 60870-5-104, Modbus TCP, DNP3 serial and TCP, PROFINET IO, PROFINET IO S2 redundancy)
- Virtual network partitioning (IEEE 802.1Q - VLAN)
- Serial protection communication via optical fibers, two-wire connections, and communication networks (IEEE C37.94 and others), including automatic switchover between ring and chain topology.

- Reliable data transmission via PRP and HSR redundancy protocols
- Extensive cybersecurity functionality, such as role-based access control (RBAC), logging of security-related events, signed firmware, or authenticated IEEE 802.1X network access.
- Simple, fast, and secure access to the device via a standard Web browser to display all information and diagnostic data, vector diagrams, single-line and device display pages
- Phasor Measurement Unit (PMU) for synchrophasor measured values and IEEE C37.118 protocol
- Time synchronization using IEEE 1588
- High-performance fault recording (buffer for a max. record time of 80 s at 8 kHz or 320 s at 2 kHz)
- Auxiliary functions for simple tests and commissioning
- Flexibly adjustable I/O quantity structure within the scope of the SIPROTEC 5 modular system

Applications

- Detection and selective 1-pole and 3-pole tripping of short circuits in electrical equipment of star networks, lines with infeed at one or 2 ends, parallel lines, and open-circuited or closed ring systems of all voltage levels
- Detection of ground faults in isolated or arc-suppression-coil-ground systems in star, ring, or meshed arrangement

- Serial protection communication with SIPROTEC 5 and SIPROTEC 4 devices over different distances and physical media, such as optical fiber, two-wire connections, and communication networks
- Backup protection for differential protection devices of all kind for lines, transformers, generators, motors, and busbars
- Phasor Measurement Unit (PMU)
- Detection and recording of power-quality data in the medium-voltage and subordinate low-voltage power system

Application Templates

DIGSI 5 provides application templates for standard applications. They include basic configurations and default settings.

The following application templates are available:

- Distance protection basis
- Distance protection with reactance method for overhead lines in grounded electrical power systems
- Distance protection with reactance method for overhead lines in grounded electrical power systems and applications with breaker-and-a-half layout

SIPROTEC 5 Devices and Fields of Application

Distance Protection – SIPROTEC 7SA87

Application Examples

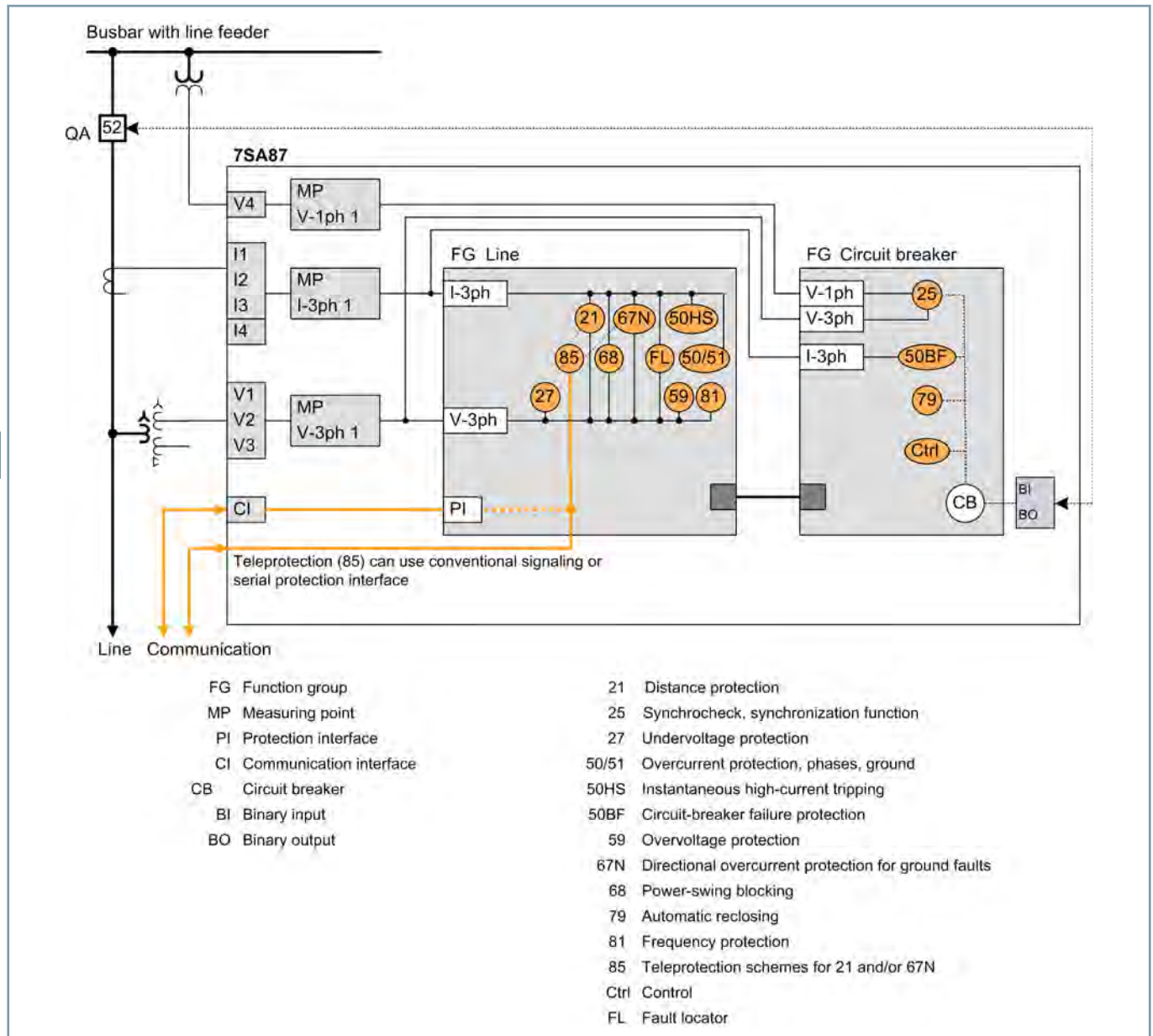

[dw_7SA87_Ltg, 1, en_US]

Figure 2.6/7 Application Example: Distance Protection for Overhead Line

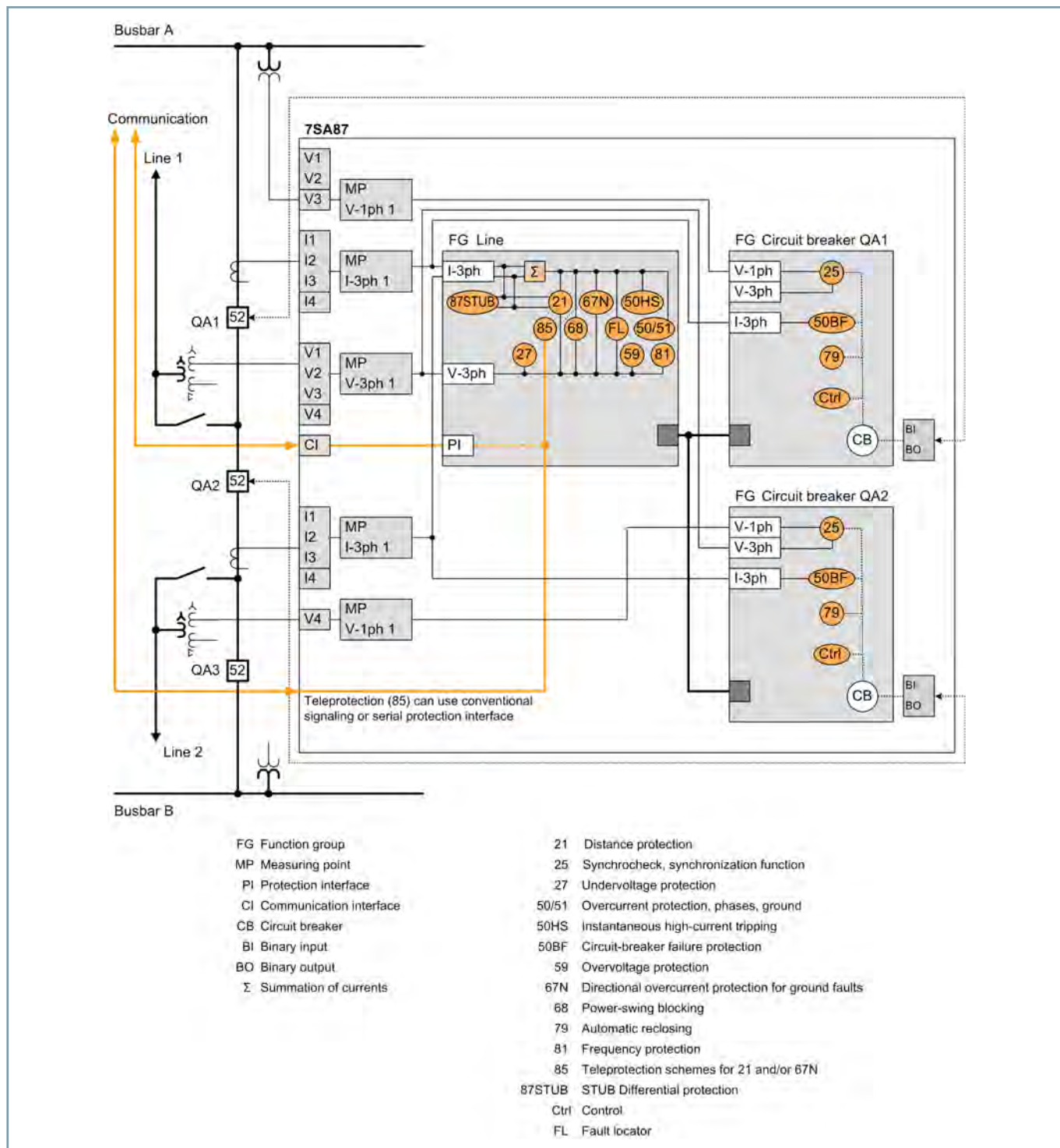

Figure 2.6/8 Application Example: Distance Protection for Overhead Line with Breaker-and-a-Half Layout

SIPROTEC 5 Devices and Fields of Application

Distance Protection – SIPROTEC 7SA87

ANSI	Function	Abbr.	Available	Application Templates		
				1	2	3
	Protection functions for 3-pole tripping	3-pole	■	■	■	■
	Protection functions for 1-pole tripping	1-pole	■	■	■	■
	Expandable hardware quantity structure	I/O	■	■	■	■
	Process bus client protocol (hint: PB client requires a separate ETH-BD-2FO plug-in module, from V8.0)	PB client	■			
	IEC61850-9-2 Merging Unit Stream (hint: Each stream requires a separate ETH-BD-2FO plug-in module, from V8.0)	MU	■			
	IEC61850-9-2 Merging Unit Stream 7SS85 CU (hint: Only for communication with a 7SS85 CU. A separate ETH-BD-2FO plug-in module is required starting with V8.40)	MU	■			
21/21N	Distance Protection	$Z<, V< I> / \angle(V, I)$	■	■	■	■
21T	Impedance protection for transformers	Z<	■			
25	Synchrocheck, synchronization function	Sync	■		■	■
27	Undervoltage protection: "3-phase" or "positive-sequence system V1" or "universal Vx"	V<	■			
27R, 59R	Voltage change protection (starting with V8.30)	dV/dt	■			
	Undervoltage-controlled reactive power protection	$Q> / V<$	■			
32, 37	Power protection active/reactive power	$P<>, Q<>$	■			
37	Undercurrent	I<	■			
38	Temperature supervision	$\theta>$	■			
46	Negative-sequence system and overcurrent protection with direction	$I2>, \angle(V2, I2)$	■			
47	Overvoltage protection, negative-sequence system	V2>	■			
49	Thermal overload protection	θ, I^2t	■		■	■
50/51 TD	Overcurrent protection, phases	I>	■	■	■	■
	Instantaneous tripping at switch onto fault	SOTF	■			
50HS	Instantaneous high-current tripping	$I>>>$	■	■	■	■
50/51 TD	Overcurrent protection with positive-sequence current I1 (from V7.9)	I1>	■			
50N/ 51N TD	Overcurrent protection, ground	IN>	■	■	■	■
50N/ 51N TD	Overcurrent protection, 1-phase	IN>	■			
50 Ns/ 51Ns	Sensitive ground-fault detection for grounded arc suppression coils and isolated power systems including a) 3I0> b) admittance Y0>, c) 3I0-harm> (from V7.8)	INs>	■			
	Sensitive ground-fault detection via pulse detection; hint: this stage also requires the function 50Ns/51Ns or 67Ns "sensitive ground-fault detection for grounded arc suppression coils and isolated power systems"	IN pulse	■			
	Intermittent ground-fault protection	IIE>	■			
50BF	Circuit-breaker failure protection 1-pole/3-pole	CBFP	■		■	■
50EF	End-fault protection (hint: For use only in decentralized busbar protection with a 7SS85 CU starting with V8.40)		■			
50RS	Circuit breaker restrike monitoring	CBRM	■			
51V	Voltage-controlled overcurrent protection	$t=f(I, V)$	■			
59, 59N	Overvoltage protection: "3-phase" or "zero-sequence system V0" or "positive-sequence system V1" or "universal Vx"	V>	■			
60	Voltage-comparison supervision	$\Delta V>$	■			

2.6

SIPROTEC 5 Devices and Fields of Application

Distance Protection – SIPROTEC 7SA87

ANSI	Function	Abbr.	Available	Application Templates		
				1	2	3
67	Directional overcurrent protection, phases	$I>, \angle(V, I)$	■			
67N	Directional ground-fault protection in grounded power systems	$IN>, \angle(V, I)$	■		■	■
67 Ns	Sensitive ground-fault detection for grounded arc suppression coils and isolated power systems including a) $3I0>$ b) $V0>$, c) $\cos/\sin\Phi$, d) transient ground fault, e) $\Phi(V, I)$, f) admittance		■			
	Directional tripping stage with one harmonic; hint: this stage also requires the function "67Ns sensitive ground-fault detection for grounded arc suppression coils and isolated power systems"	$\angle(V0h, I0h)$	■			
	Directional Intermittent Ground-Fault Protection	$IIEdir>$	■			
68	Power-swing blocking	$\Delta Z/\Delta t$	■		■	■
74TC	Trip-circuit supervision		■			
78	Out-of-step protection	$\Delta Z/\Delta t$	■			
79	Automatic reclosing, 1-pole/3-pole	AREC	■		■	■
SAD	Secondary arc detection (SAD) in 1-pole automatic reclosing cycles starting with V8.30; note: SAD also requires the function points for "79 automatic reclosing, pole/3-pole"	SAD	■			
81	Frequency protection: "f>" or "f<" or "df/dt"	$f<>; df/dt<>$	■			
81U	Underfrequency load shedding	$f<(ULS)$	■			
	Vector-jump protection	$\Delta\varphi>$	■			
85/21	Teleprotection scheme for distance protection		■	■	■	■
85/27	Weak or no infeed: Echo and tripping		■	■	■	■
85/67N	Teleprotection scheme for directional ground-fault protection		■	■	■	■
86	Lockout		■			
87N T	Restricted ground-fault protection	ΔIN	■			
87 STUB	Stub fault differential protection (for breaker-and-a-half layouts)		■			■
90 V	Voltage controller for two-winding transformer		■			
90 V	Voltage controller for two-winding transformer with parallel control		■			
	Number of two-winding transformers with parallel control (hint: only together with the function "voltage controller for two-winding transformer with parallel control")		■			
90 V	Voltage controller for three-winding transformer		■			
90 V	Voltage controller for grid coupling transformer		■			
FL	Fault Locator, single-side	FL-one	■	■	■	■
FL	Fault Locator Plus (from V7.9)	FL plus	■			
PMU	Synchrophasor measurement	PMU	■			
AFD	Arc protection (only with plug-in module ARC-CD-3FO)		■			
	Measured values, standard		■	■	■	■
	Measured values, extended: Min, max, average		■			
	Switching statistics counter		■	■	■	■
	PQ – Basic measured values: THD (Total Harmonic Distortion) and harmonic component (starting with V8.01) and THD voltage average values (starting with V8.40)		■			
	PQ – Basic measured values: Voltage unbalance (starting with V8.40)		■			

2.6

SIPROTEC 5 Devices and Fields of Application

Distance Protection – SIPROTEC 7SA87

ANSI	Function	Abbr.	Available	Application Templates		
				1	2	3
	PQ – Basic measured values: Voltage changes – monitoring of voltage dips, overvoltages and voltage interruptions (starting with V8.40)		■			
	PQ – Basic measured values: TDD - Total Demand Distortion (starting with V8.40)		■			
	CFC (standard, control)		■	■	■	■
	CFC arithmetic		■			
	Circuit-breaker wear monitoring	$\Sigma I_x, I^2t, 2P$	■			
	Switching sequence function		■			
	Inrush-current detection		■			
	External trip initiation		■	■	■	■
	Control		■	■	■	■
PoW	Point-on-wave switching (starting with V7.90)	PoW	■			
	Circuit breaker		■	■	■	■
	Disconnecter/grounding conductor		■			■
	Fault recording of analog and binary signals		■	■	■	■
	Monitoring		■	■	■	■
	Protection interface, serial		■	■	■	■
	Region, France: Overload protection for 'PSL-PSC' lines		■			
	Region, France: 'MAXI-L' overcurrent protection		■			
	Region, France: 'PDA' system decoupling protection		■			
	Region, France: Overload protection for transformers		■			
	Frequency group tracking (from V7.8)		■			
	Cyber security: Role-Based Access Control (from V7.8)		■			
	Temperature recording via communication protocol		■			
	Cyber security: Authenticated network access using IEEE 802.1X (starting from V8.3)		■			
Function point class:				0	225	400
The configuration and function point class for your application can be determined in the SIPROTEC 5 order configurator at www.siemens.com/siprotec .						

Table 2.6/3 SIPROTEC 7SA87 – Functions, Application Templates

- (1) Basic
- (2) DIS RMD Overhead Line, grounded power systems
- (3) DIS RMD Overhead Line, grounded power systems, 1.5 CB

SIPROTEC 5 Devices and Fields of Application

Line Differential Protection – SIPROTEC 7SD82

Description

The SIPROTEC 7SD82 line differential protection has been designed particularly for the cost-optimized and compact protection of lines in medium-voltage and high-voltage systems. With its flexibility and the high-performance DIGSI 5 engineering tool, the SIPROTEC 7SD82 device offers future-oriented solutions for protection, control, automation, monitoring, and Power Quality – Basic.

Main function	Differential protection for medium-voltage and high-voltage applications Interoperability of SIPROTEC 4 and SIPROTEC 5 line protection devices
Tripping	3-pole, minimum tripping time: 19 ms
Inputs and outputs	4 current transformers, 4 voltage transformers, 11 or 23 binary inputs, 9 or 16 binary outputs
Hardware flexibility	2 different quantity structures for binary inputs and outputs are available in the 1/3 base module. Adding 1/6 expansion modules is not possible; housing width available with large or small display.
Housing width	1/3 × 19 inches

Benefits

- Compact and low-cost line differential protection
- Safety due to high-performance protection functions
- Purposeful and easy handling of devices and software thanks to a user-friendly design
- Cybersecurity in accordance with NERC CIP and BDEW White-paper requirements
- Highest availability even under extreme environmental conditions by standard coating of the modules
- Full compatibility between IEC 61850 Editions 1, 2.0, and 2.1

Functions

DIGSI 5 permits all functions to be configured and combined as required and as per the functional scope that has been ordered.

- Minimum tripping time: 19 ms
- Main protection function is differential protection with adaptive algorithm for maximum sensitivity and stability even with the most different transformer errors, current-transformer saturation, and capacitive charging currents
- Directional backup protection and various additional functions
- Detection of ground faults of any type in compensated or isolated electrical power systems using the following functions: 3I0>, V0>, transient ground fault, cos φ, sin φ, dir. detection of intermittent ground faults, harmonic detection, and admittance measurement
- Ground fault detection using the pulse detection method
- Detection of current-transformer saturation
- Fault locator plus for accurate fault location with inhomogeneous line sections and targeted automatic overhead-line section reclosing (AREC)
- Arc protection



[SIP5_GD_W3, 2, --]

Figure 2.7/1 SIPROTEC 7SD82 Line Differential Protection Device

- Automatic frequency relief for underfrequency load shedding, taking changed infeed conditions due to decentralized power generation into consideration
- Power protection, configurable as active or reactive-power protection
- Directional reactive-power undervoltage protection (QU protection)
- Detection of current and voltage signals up to the 50th harmonic with high accuracy for selected protection functions (such as thermal overload protection) and operational measured values
- PQ – Basic: Voltage unbalance; voltage changes: overvoltage, dip, interruption; TDD, THD, and harmonics
- Control, synchrocheck, and switchgear interlocking protection
- Graphical logic editor to create high-performance automation functions in the device
- Single-line representation in the small or large display
- Fixed integrated electrical Ethernet RJ45 interface for DIGSI 5 and IEC 61850 (reporting and GOOSE)
- 2 optional pluggable communication modules, usable for different and redundant protocols (IEC 61850, IEC 60870-5-103, IEC 60870-5-104, Modbus TCP, DNP3 serial and TCP, PROFINET IO)
- Serial protection communication via optical fibers, two-wire connections, and communication networks (IEEE C37.94 and others), including automatic switchover between ring and chain topology.
- Reliable data transmission via PRP and HSR redundancy protocols
- Extensive cybersecurity functionality, such as role-based access control (RBAC), logging of security-related events, signed firmware, or authenticated IEEE 802.1X network access.

SIPROTEC 5 Devices and Fields of Application

Line Differential Protection – SIPROTEC 7SD82

- Simple, fast, and secure access to the device via a standard Web browser to display all information and diagnostic data, vector diagrams, single-line and device display pages
- Phasor Measurement Unit (PMU) for synchrophasor measured values and IEEE C37.118 protocol
- Time synchronization using IEEE 1588
- High-performance fault recording (buffer for a max. record time of 80 s at 8 kHz or 320 s at 2 kHz)
- Auxiliary functions for simple tests and commissioning

Applications

- Line protection for all voltage levels with 3-pole tripping
- Phase-selective protection of overhead lines and cables with single-ended and multi-ended infeed of all lengths with up to 6 line ends
- Transformers and compensating coils in the protection zone

- Detection of ground faults in isolated or arc-suppression-coil-ground power systems in star, ring, or meshed arrangement
- Serial protection communication with SIPROTEC 5 and SIPROTEC 4 devices over different distances and physical media, such as optical fiber, two-wire connections, and communication networks
- Phasor Measurement Unit (PMU)
- Detection and recording of power-quality data in the medium-voltage and subordinate low-voltage power system

Application Templates

DIGSI 5 provides application templates for standard applications. They include all basic configurations and default settings.

The following application templates are available:

- Differential protection basis
- Differential protection for overhead line

Application Example

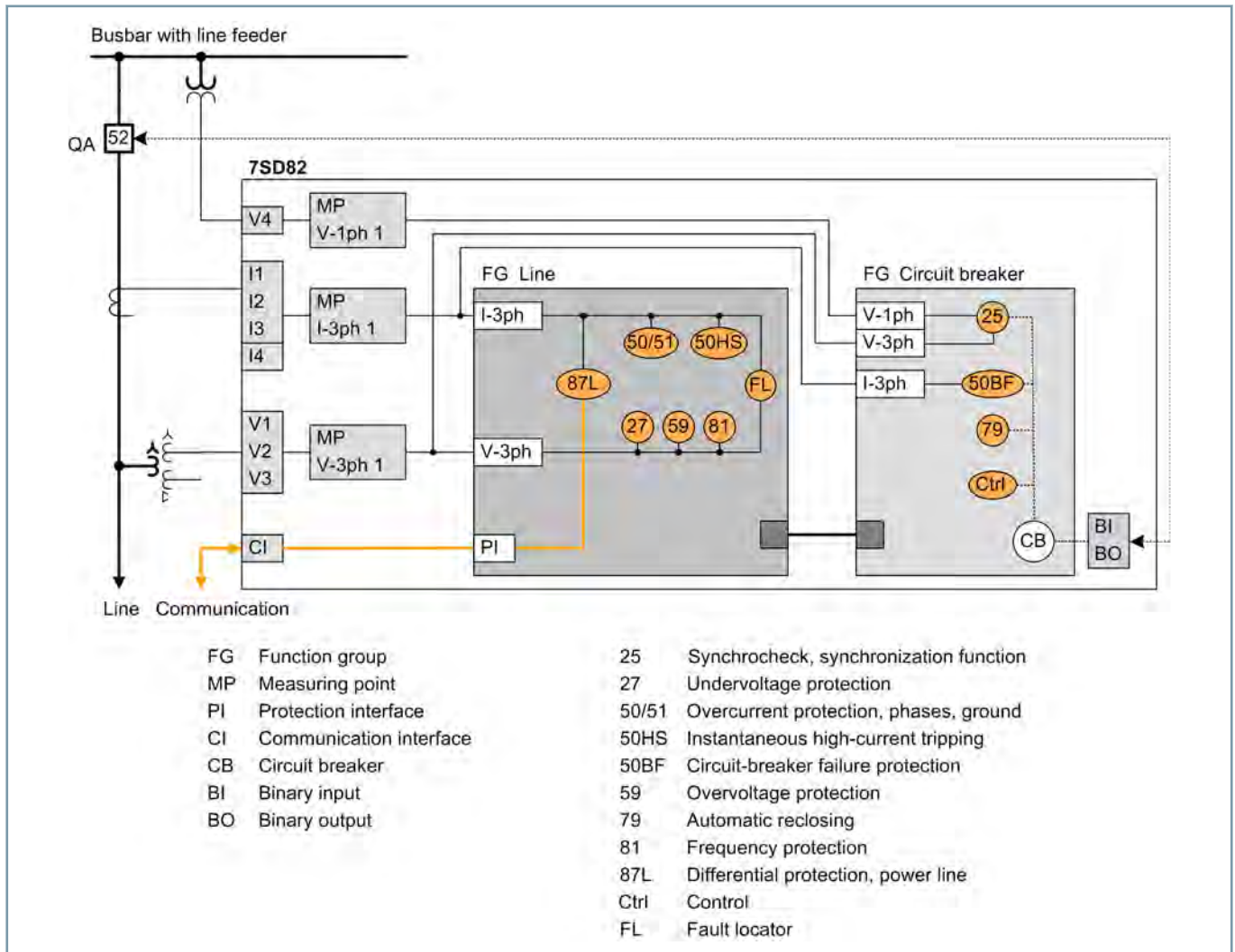

[dw_7SD82_Ltg, 1, en_US]

Figure 2.7/2 Application Example: Line Differential Protection for Overhead Line

SIPROTEC 5 Devices and Fields of Application

Line Differential Protection – SIPROTEC 7SD82

ANSI	Function	Abbr.	Available	Application Templates	
				1	2
	Protection functions for 3-pole tripping	3-pole	■	■	■
25	Synchrocheck, synchronization function	Sync	■		■
27	Undervoltage protection: "3-phase" or "positive-sequence system V1" or "universal Vx"	V<	■		
27R, 59R	Voltage change protection (starting with V8.30)	dV/dt	■		
	Undervoltage-controlled reactive power protection	Q>N<	■		
32, 37	Power protection active/reactive power	P<>, Q<>	■		
37	Undercurrent	I<	■		
38	Temperature supervision	θ>	■		
46	Negative-sequence system overcurrent protection	I2>	■		
46	Negative-sequence system and overcurrent protection with direction	I2>, ∠(V2, I2)	■		
47	Overvoltage protection, negative-sequence system	V2>	■		
49	Thermal overload protection	θ, I²t	■		■
50/51 TD	Overcurrent protection, phases	I>	■	■	■
	Instantaneous tripping at switch onto fault	SOTF	■		
50HS	Instantaneous high-current tripping	I>>>	■	■	■
50/51 TD	Overcurrent protection with positive-sequence current I1 (from V7.9)	I1>	■		
50N/ 51N TD	Overcurrent protection, ground	IN>	■	■	■
50N/ 51N TD	Overcurrent protection, 1-phase	IN>	■		
50 Ns/ 51Ns	Sensitive ground-fault detection for grounded arc suppression coils and isolated power systems including a) 3I0> b) admittance Y0>, c) 3I0-harm> (from V7.8)	INs>	■		
	Sensitive ground-fault detection via pulse detection; hint: this stage also requires the function 50Ns/51Ns or 67Ns "sensitive ground-fault detection for grounded arc suppression coils and isolated power systems"	IN pulse	■		
	Intermittent ground-fault protection	IIE>	■		
50BF	Circuit-breaker failure protection, 3-pole	CBFP	■		■
50RS	Circuit breaker restrike monitoring	CBRM	■		
51V	Voltage-controlled overcurrent protection	t=f(I, V)	■		
59, 59N	Overvoltage protection: "3-phase" or "zero-sequence system V0" or "positive-sequence system V1" or "universal Vx"	V>	■		
60	Voltage-comparison supervision	ΔV>	■		
67	Directional overcurrent protection, phases	I>, ∠(V, I)	■		
67N	Directional ground-fault protection in grounded power systems	IN>, ∠(V, I)	■		
67 Ns	Sensitive ground-fault detection for grounded arc suppression coils and isolated power systems including a) 3I0> b) V0>, c) cos/sine Phi, d) transient ground fault, e) Phi(V, I), f) admittance		■		
	Directional tripping stage with one harmonic; hint: this stage also requires the function "67Ns sensitive ground-fault detection for grounded arc suppression coils and isolated power systems"	∠(V0h, I0h)	■		
	Directional Intermittent Ground-Fault Protection	IIEdir>	■		
74TC	Trip-circuit supervision		■		
74CC	Single circuit monitoring (from V7.9)		■		
79	Automatic reclosing, 3-pole	AREC	■		■
81	Frequency protection: "f>" or "f<" or "df/dt"	f<>; df/dt<>	■		

SIPROTEC 5 Devices and Fields of Application

Line Differential Protection – SIPROTEC 7SD82

ANSI	Function	Abbr.	Available	Application Templates	
				1	2
81U	Underfrequency load shedding	f<(ULS)	■		
	Vector-jump protection	$\Delta\varphi$ >	■		
86	Lockout		■		
87N T	Restricted ground-fault protection	ΔI_N	■		
87L	Line differential protection for 2 line ends	ΔI	■	■	■
87L	Line differential protection for 3 to 6 line ends (dependent on significant properties)	ΔI	■	■	■
87L/ 87T	Option for line differential protection with Transformer in the Protection Range	ΔI	■		
	Option for line differential protection with charging-current compensation	ΔI	■		
	Broken-wire detection for differential protection		■		
90 V	Voltage controller for two-winding transformer		■		
90 V	Voltage controller for two-winding transformer with parallel control		■		
	Number of two-winding transformers with parallel control (hint: only together with the function "voltage controller for two-winding transformer with parallel control")		■		
FL	Fault Locator, single-side	FL-one	■	■	■
FL	Fault Locator Plus (from V7.9)	FL plus	■		
PMU	Synchrophasor measurement	PMU	■		
AFD	Arc protection (only with plug-in module ARC-CD-3FO)		■		
	Measured values, standard		■	■	■
	Measured values, extended: Min, max, average		■		
	Switching statistics counter		■	■	■
	PQ – Basic measured values: THD (Total Harmonic Distortion) and harmonic component (starting with V8.01) and THD voltage average values (starting with V8.40)		■		
	PQ – Basic measured values: Voltage unbalance (starting with V8.40)		■		
	PQ – Basic measured values: Voltage changes – monitoring of voltage dips, overvoltages and voltage interruptions (starting with V8.40)		■		
	PQ – Basic measured values: TDD - Total Demand Distortion (starting with V8.40)		■		
	CFC (standard, control)		■	■	■
	CFC arithmetic		■		
	Circuit-breaker wear monitoring	$\Sigma I_x, I^2t, 2P$	■		
	Switching sequence function		■		
	Inrush-current detection		■		
	External trip initiation		■	■	■
	Control		■	■	■
	Circuit breaker		■	■	■
	Disconnectors/grounding conductor		■		
	Fault recording of analog and binary signals		■	■	■
	Monitoring		■	■	■
	Protection interface, serial		■	■	■
	Region, France: Overload protection for 'PSL-PSC' lines		■		
	Region, France: 'MAXI-L' overcurrent protection		■		
	Region, France: 'PDA' system decoupling protection		■		

2.7

SIPROTEC 5 Devices and Fields of Application

Line Differential Protection – SIPROTEC 7SD82

ANSI	Function	Abbr.	Available	Application Templates	
				1	2
	Region, France: Overload protection for transformers		■		
	Frequency group tracking (from V7.8)		■		
	Cyber security: Role-Based Access Control (from V7.8)		■		
	Temperature recording via communication protocol		■		
	Cyber security: Authenticated network access using IEEE 802.1X (starting from V8.3)		■		
Function point class:				0	150
The configuration and function point class for your application can be determined in the SIPROTEC 5 order configurator at www.siemens.com/siprotec .					

Table 2.7/1 SIPROTEC 7SD82 – Functions, Application Templates

- (1) Basic
- (2) DIFF Overhead Line

SIPROTEC 5 Devices and Fields of Application

Line Differential Protection – SIPROTEC 7SD86

Description

The SIPROTEC 7SD86 line differential protection has been designed specifically for the protection of lines. With its modular structure, flexibility and the high-performance DIGSI 5 engineering tool, the SIPROTEC 7SD86 device offers future-oriented solutions for protection, control, automation, monitoring, and Power Quality – Basic.

Main function	Differential protection Interoperability of SIPROTEC 4 and SIPROTEC 5 line protection devices
Tripping	3-pole, minimum tripping time: 9 ms
Inputs and outputs	12 predefined standard variants with 4/4 or 8/8 current transformers/voltage transformers, 5 to 31 binary inputs, 8 to 46 binary outputs
Hardware flexibility	Flexibly adjustable I/O quantity structure within the scope of the SIPROTEC 5 modular system
Housing width	1/3 × 19 inches to 2/1 × 19 inches

Benefits

- Safety due to high-performance protection functions
- Purposeful and easy handling of devices and software thanks to a user-friendly design
- Cybersecurity in accordance with NERC CIP and BDEW Whitepaper requirements
- Highest availability even under extreme environmental conditions by standard coating of the modules

Functions

DIGSI 5 permits all functions to be configured and combined as required and as per the functional scope that has been ordered.

- Minimum tripping time: 9 ms
- Main protection function is differential protection with adaptive algorithm for maximum sensitivity and stability even with the most different transformer errors, current-transformer saturation, and capacitive charging currents
- Directional backup protection and various additional functions
- Detection of ground faults of any type in compensated or isolated electrical power systems using the following functions: 3I0>, V0>, transient ground fault, $\cos \varphi$, $\sin \varphi$, dir. detection of intermittent ground faults, harmonic detection, and admittance measurement
- Ground-fault detection using the pulse detection method
- Detection of current-transformer saturation
- Fault locator plus for accurate fault location with inhomogeneous line sections and targeted automatic overhead-line section reclosing (AREC)
- Arc protection
- Automatic frequency relief for underfrequency load shedding, taking changed infeed conditions due to decentralized power generation into consideration
- Power protection, configurable as active or reactive-power protection



[SIP5_GD_SS_W3, 2, --, --]

Figure 2.7/3 SIPROTEC 5 Device with Expansion Module

- Directional reactive-power undervoltage protection (QU protection)
- Detection of current and voltage signals up to the 50th harmonic with high accuracy for selected protection functions (such as thermal overload protection) and operational measured values
PQ – Basic: Voltage unbalance; voltage changes: overvoltage, dip, interruption; TDD, THD, and harmonics
- 3-pole automatic reclosing function
- Control, synchrocheck, and switchgear interlocking protection
- Graphical logic editor to create high-performance automation functions in the device
- Single-line representation in the small or large display
- Fixed integrated electrical Ethernet RJ45 interface for DIGSI 5 and IEC 61850 (reporting and GOOSE)
- Up to 4 optional, pluggable communication modules, usable for different and redundant protocols (IEC 61850-8-1, IEC 61850-9-2 Client, IEC 60870-5-103, IEC 60870-5-104, Modbus TCP, DNP3 serial and TCP, PROFINET IO, PROFINET IO S2 redundancy)
- Virtual network partitioning (IEEE 802.1Q - VLAN)
- Serial protection communication via optical fibers, two-wire connections, and communication networks (IEEE C37.94 and others), including automatic switchover between ring and chain topology.
- Reliable data transmission via PRP and HSR redundancy protocols
- Extensive cybersecurity functionality, such as role-based access control (RBAC), logging of security-related events, signed firmware, or authenticated IEEE 802.1X network access
- Simple, fast, and secure access to the device via a standard Web browser to display all information and diagnostic data, vector diagrams, single-line and device display pages

SIPROTEC 5 Devices and Fields of Application

Line Differential Protection – SIPROTEC 7SD86

- Phasor Measurement Unit (PMU) for synchrophasor measured values and IEEE C37.118 protocol
- Time synchronization using IEEE 1588
- High-performance fault recording (buffer for a max. record time of 80 s at 8 kHz or 320 s at 2 kHz)
- Auxiliary functions for simple tests and commissioning
- Flexibly adjustable I/O quantity structure

Applications

- Line protection for all voltage levels with 3-pole tripping
- Phase-selective protection of overhead lines and cables with single-ended and multi-ended infeed of all lengths with up to 6 line ends
- Also used in switchgear with breaker-and-a-half layout
- Transformers and compensating coils in the protection zone
- Detection of ground faults in isolated or arc-suppression-coil-ground power systems in star, ring, or meshed arrangement
- Serial protection communication with SIPROTEC 5 and SIPROTEC 4 devices over different distances and physical media, such as optical fiber, two-wire connections, and communication networks

- Phasor Measurement Unit (PMU)
- Detection and recording of power-quality data in the medium-voltage and subordinate low-voltage power system

Application Templates

DIGSI 5 provides application templates for standard applications. They include all basic configurations and default settings.

The following application templates are available:

- Differential protection basis
- Differential protection for overhead line
- Differential protection for overhead line with transformer in the protection range
- Differential protection for overhead line, for applications with breaker-and-a-half layout

SIPROTEC 5 Devices and Fields of Application

Line Differential Protection – SIPROTEC 7SD86

Application Examples

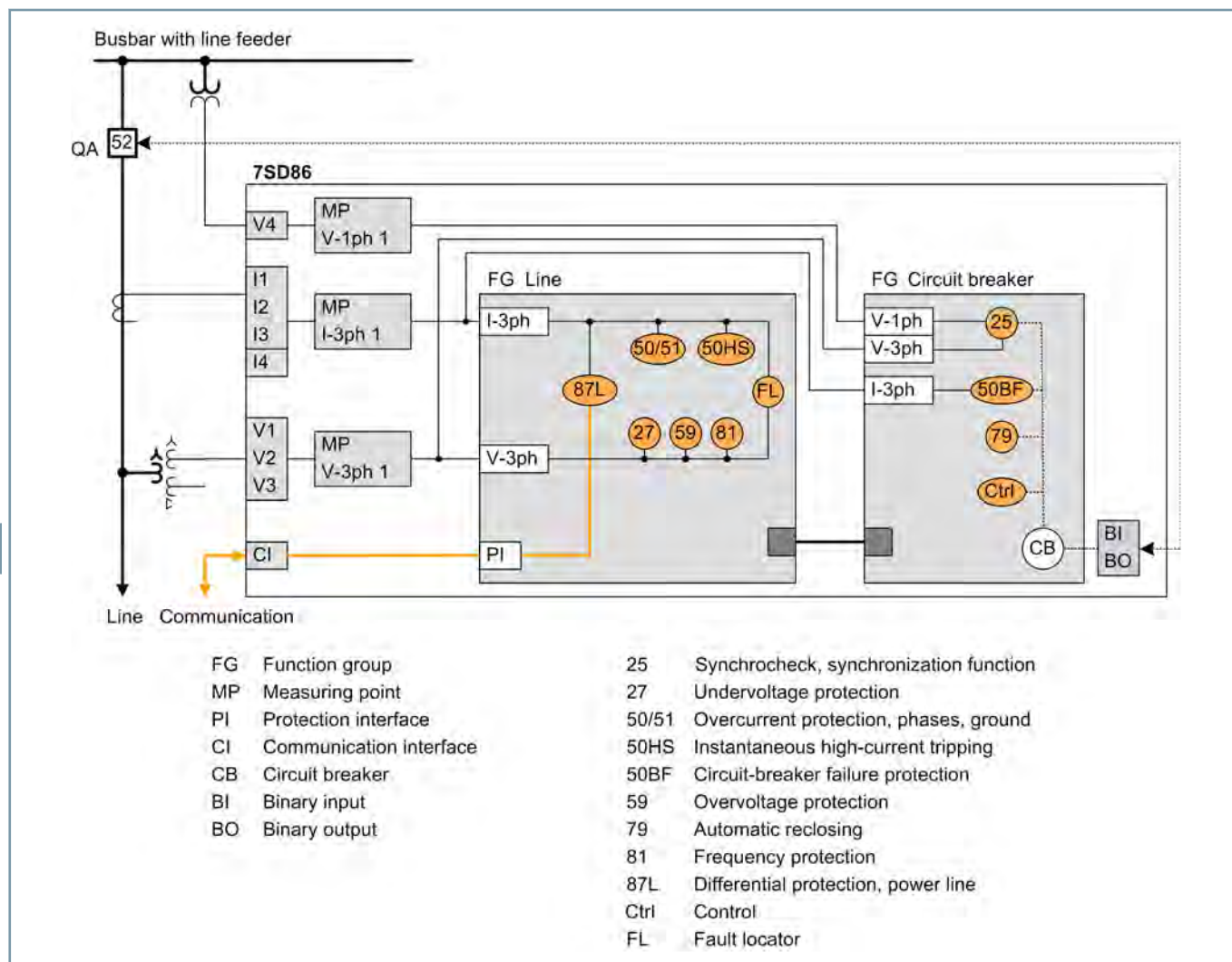

[dw_7SD86_Ltg, 1, en_US]

Figure 2.7/4 Application Example: Line Differential Protection for Overhead Line

SIPROTEC 5 Devices and Fields of Application

Line Differential Protection – SIPROTEC 7SD86

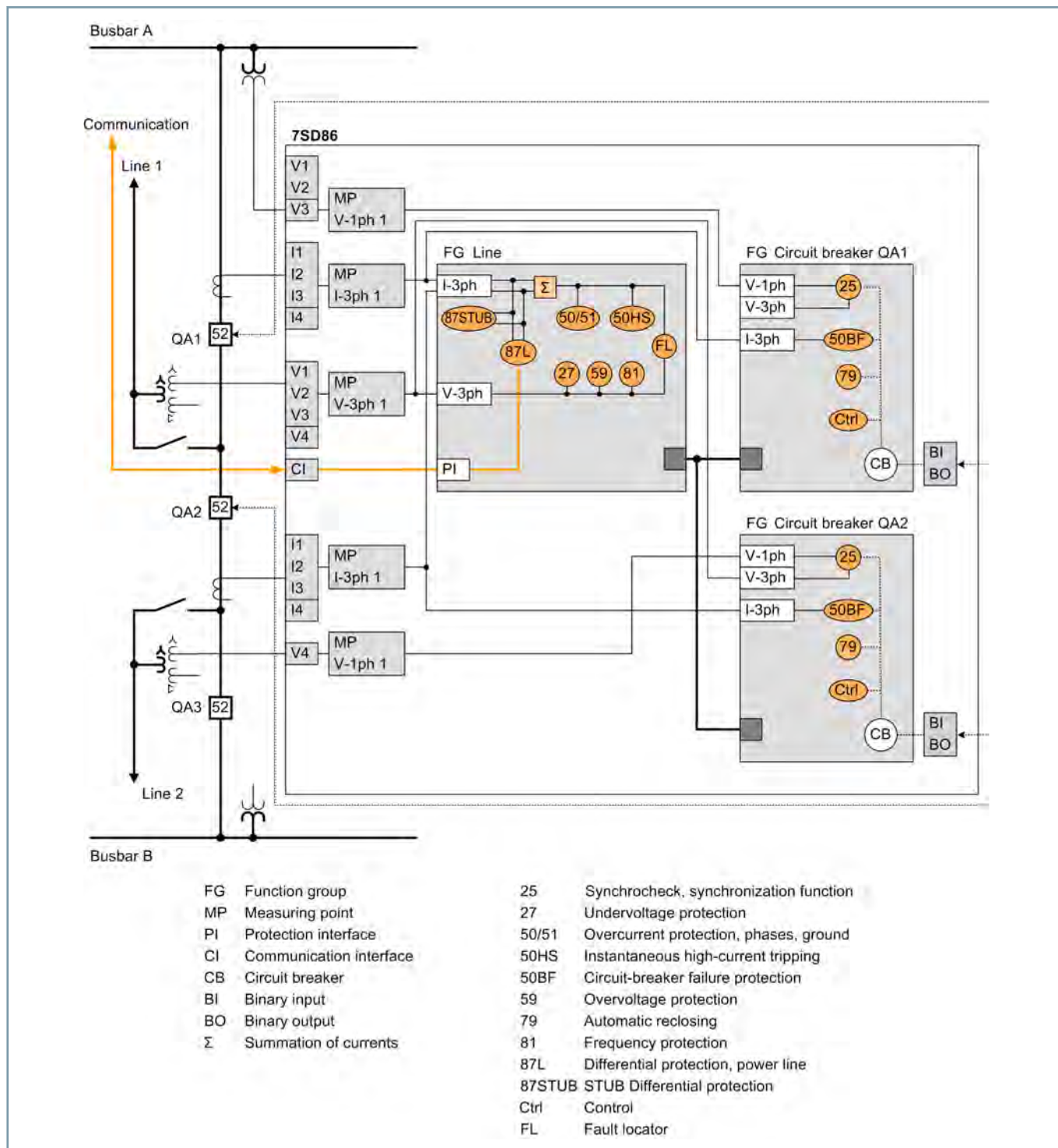

[dw_7SD86_1-5LS, 1, en_US]

Figure 2.7/5 Application Example: Line Differential Protection for Overhead Line with Breaker-and-a-Half Layout

2.7

SIPROTEC 5 Devices and Fields of Application

Line Differential Protection – SIPROTEC 7SD86

ANSI	Function	Abbr.	Available	Application Templates			
				1	2	3	4
	Protection functions for 3-pole tripping	3-pole	■	■	■	■	■
	Expandable hardware quantity structure	I/O	■	■	■	■	■
	Process bus client protocol (hint: PB client requires a separate ETH-BD-2FO plug-in module, from V8.0)	PB client	■				
	IEC61850-9-2 Merging Unit Stream (hint: Each stream requires a separate ETH-BD-2FO plug-in module, from V8.0)	MU	■				
	IEC61850-9-2 Merging Unit Stream 7SS85 CU (hint: Only for communication with a 7SS85 CU. A separate ETH-BD-2FO plug-in module is required starting with V8.40)	MU	■				
25	Synchrocheck, synchronization function	Sync	■		■	■	■
27	Undervoltage protection: "3-phase" or "positive-sequence system V1" or "universal Vx"	V<	■				
27R, 59R	Voltage change protection (starting with V8.30)	dV/dt	■				
	Undervoltage-controlled reactive power protection	Q>/V<	■				
32, 37	Power protection active/reactive power	P<>, Q<>	■				
37	Undercurrent	I<	■				
38	Temperature supervision	θ>	■				
46	Negative-sequence system and overcurrent protection with direction	I2>, ∠(V2, I2)	■				
47	Overvoltage protection, negative-sequence system	V2>	■				
49	Thermal overload protection	θ, I²t	■		■	■	■
50/51 TD	Overcurrent protection, phases	I>	■	■	■	■	■
	Instantaneous tripping at switch onto fault	SOTF	■				
50HS	Instantaneous high-current tripping	I>>>	■	■	■	■	■
50/51 TD	Overcurrent protection with positive-sequence current I1 (from V7.9)	I1>	■				
50N/ 51N TD	Overcurrent protection, ground	IN>	■	■	■	■	■
50N/ 51N TD	Overcurrent protection, 1-phase	IN>	■				
50 Ns/ 51Ns	Sensitive ground-fault detection for grounded arc suppression coils and isolated power systems including a) 3I0> b) admittance Y0>, c) 3I0-harm> (from V7.8)	INs>	■				
	Sensitive ground-fault detection via pulse detection; hint: this stage also requires the function 50Ns/51Ns or 67Ns "sensitive ground-fault detection for grounded arc suppression coils and isolated power systems"	IN pulse	■				
	Intermittent ground-fault protection	IIE>	■				
50BF	Circuit-breaker failure protection, 3-pole	CBFP	■		■	■	■
50EF	End-fault protection (hint: For use only in decentralized busbar protection with a 7SS85 CU starting with V8.40)		■				
50RS	Circuit breaker restrike monitoring	CBRM	■				
51V	Voltage-controlled overcurrent protection	t=f(I, V)	■				
59, 59N	Overvoltage protection: "3-phase" or "zero-sequence system V0" or "positive-sequence system V1" or "universal Vx"	V>	■				
60	Voltage-comparison supervision	ΔV>	■				
67	Directional overcurrent protection, phases	I>, ∠(V, I)	■				
67N	Directional ground-fault protection in grounded power systems	IN>, ∠(V, I)	■				

2.7

SIPROTEC 5 Devices and Fields of Application

Line Differential Protection – SIPROTEC 7SD86

ANSI	Function	Abbr.	Available	Application Templates			
				1	2	3	4
67 Ns	Sensitive ground-fault detection for grounded arc suppression coils and isolated power systems including a) $3I_0 >$, b) $V_0 >$, c) $\cos/\sin \Phi$, d) transient ground fault, e) $\Phi(V, I)$, f) admittance		■				
	Directional tripping stage with one harmonic; hint: this stage also requires the function "67Ns sensitive ground-fault detection for grounded arc suppression coils and isolated power systems"	$\angle(V_0h, I_0h)$	■				
	Directional Intermittent Ground-Fault Protection	IIEdir>	■				
74TC	Trip-circuit supervision		■				
74CC	Single circuit monitoring (from V7.9)		■				
79	Automatic reclosing, 3-pole	AREC	■		■	■	■
81	Frequency protection: "f>" or "f<" or "df/dt"	f<>; df/dt<>	■				
81U	Underfrequency load shedding	f<(ULS)	■				
	Vector-jump protection	$\Delta\varphi >$	■				
86	Lockout		■				
87N T	Restricted ground-fault protection	ΔI_N	■				
87L	Line differential protection for 2 line ends	ΔI	■	■	■	■	■
87L	Line differential protection for 3 to 6 line ends (dependent on significant properties)	ΔI	■	■	■	■	■
87L/ 87T	Option for line differential protection with Transformer in the Protection Range	ΔI	■			■	
	Option for line differential protection with charging-current compensation	ΔI	■				
	Broken-wire detection for differential protection		■				
87 STUB	Stub fault differential protection (for breaker-and-a-half layouts)		■				■
90 V	Voltage controller for two-winding transformer		■				
90 V	Voltage controller for two-winding transformer with parallel control		■				
	Number of two-winding transformers with parallel control (hint: only together with the function "voltage controller for two-winding transformer with parallel control")		■				
90 V	Voltage controller for three-winding transformer		■				
90 V	Voltage controller for grid coupling transformer		■				
FL	Fault Locator, single-side	FL-one	■	■	■	■	■
FL	Fault Locator Plus (from V7.9)	FL plus	■				
PMU	Synchrophasor measurement	PMU	■				
AFD	Arc protection (only with plug-in module ARC-CD-3FO)		■				
	Measured values, standard		■	■	■	■	■
	Measured values, extended: Min, max, average		■				
	Switching statistics counter		■	■	■	■	■
	PQ – Basic measured values: THD (Total Harmonic Distortion) and harmonic component (starting with V8.01) and THD voltage average values (starting with V8.40)		■				
	PQ – Basic measured values: Voltage unbalance (starting with V8.40)		■				
	PQ – Basic measured values: Voltage changes – monitoring of voltage dips, overvoltages and voltage interruptions (starting with V8.40)		■				
	PQ – Basic measured values: TDD - Total Demand Distortion (starting with V8.40)		■				
	CFC (standard, control)		■	■	■	■	■

2.7

SIPROTEC 5 Devices and Fields of Application

Line Differential Protection – SIPROTEC 7SD86

ANSI	Function	Abbr.	Available	Application Templates			
				1	2	3	4
	CFC arithmetic		■				
	Circuit-breaker wear monitoring	$\Sigma I_x, I^2t, 2P$	■				
	Switching sequence function		■				
	Inrush-current detection		■				
	External trip initiation		■	■	■	■	■
	Control		■	■	■	■	■
	Circuit breaker		■	■	■	■	■
	Disconnectors/grounding conductor		■				■
	Fault recording of analog and binary signals		■	■	■	■	■
	Monitoring		■	■	■	■	■
	Protection interface, serial		■	■	■	■	■
	Region, France: Overload protection for 'PSL-PSC' lines		■				
	Region, France: 'MAXI-L' overcurrent protection		■				
	Region, France: 'PDA' system decoupling protection		■				
	Region, France: Overload protection for transformers		■				
	Frequency group tracking (from V7.8)		■				
	Cyber security: Role-Based Access Control (from V7.8)		■				
	Temperature recording via communication protocol		■				
	Cyber security: Authenticated network access using IEEE 802.1X (starting from V8.3)		■				
Function point class:				0	150	250	300
The configuration and function point class for your application can be determined in the SIPROTEC 5 order configurator at www.siemens.com/siprotec .							

Table 2.7/2 SIPROTEC 7SD86 – Functions, Application Templates

- (1) Basic
- (2) DIFF Overhead Line
- (3) DIFF Overhead Line with Transformer
- (4) DIFF Overhead Line, breaker-and-a-half layout

SIPROTEC 5 Devices and Fields of Application

Line Differential Protection – SIPROTEC 7SD87

Description

The SIPROTEC 7SD87 differential protection device is suitable for the selective protection of overhead lines and cables with single-ended and multi-ended infeed of all lengths with up to 6 ends. Transformers and compensating coils in the protection range are also possible. With its modular structure, flexibility and the high-performance DIGSI 5 engineering tool, the SIPROTEC 7SD87 device offers future-oriented solutions for protection, control, automation, monitoring, and Power Quality – Basic.

Main function	Differential protection Interoperability of SIPROTEC 4 and SIPROTEC 5 line protection devices
Tripping	1-pole and 3-pole, minimum tripping time: 9 ms
Inputs and outputs	12 predefined standard variants with 4/4 or 8/8 current transformers/voltage transformers, 5 to 31 binary inputs, 8 to 46 binary outputs
Hardware flexibility	Flexibly adjustable I/O quantity structure within the scope of the SIPROTEC 5 modular system
Housing width	1/3 × 19 inches to 2/1 × 19 inches

Benefits

- Safety due to high-performance protection functions
- Purposeful and easy handling of devices and software thanks to a user-friendly design
- Cybersecurity in accordance with NERC CIP and BDEW White-paper requirements
- Highest availability even under extreme environmental conditions by standard coating of the modules

Functions

DIGSI 5 permits all functions to be configured and combined as required and as per the functional scope that has been ordered.

- Minimum tripping time: 9 ms
- Main protection function is differential protection with adaptive algorithm for maximum sensitivity and stability even with the most different transformer errors, current-transformer saturation, and capacitive charging currents
- Directional backup protection and various additional functions
- Detection of ground faults of any type in compensated or isolated electrical power systems using the following functions: 3I0>, V0>, transient ground fault, cos φ, sin φ, dir. detection of intermittent ground faults, harmonic detection, and admittance measurement
- Ground-fault detection using the pulse detection method
- Detection of current-transformer saturation
- Fault locator plus for accurate fault location with inhomogeneous line sections and targeted automatic overhead-line section reclosing (AREC)
- Arc protection
- Automatic frequency relief for underfrequency load shedding, taking changed infeed conditions due to decentralized power generation into consideration



[SIP5_GD_SS_W3, 2, --, --]

Figure 2.7/6 SIPROTEC 5 Device with Expansion Module

- Power protection, configurable as active or reactive-power protection
- Directional reactive-power undervoltage protection (QU protection)
- Detection of current and voltage signals up to the 50th harmonic with high accuracy for selected protection functions (such as thermal overload protection) and operational measured values
- PQ – Basic: Voltage unbalance; voltage changes: overvoltage, dip, interruption; TDD, THD, and harmonics
- 1-pole automatic reclosing function with secondary arc detection (SAD)
- Point-on-wave switching
- Control, synchrocheck, and switchgear interlocking protection
- Graphical logic editor to create high-performance automation functions in the device
- Single-line representation in the small or large display
- Fixed integrated electrical Ethernet RJ45 interface for DIGSI 5 and IEC 61850 (reporting and GOOSE)
- Up to 4 optional, pluggable communication modules, usable for different and redundant protocols (IEC 61850-8-1, IEC 61850-9-2 Client, IEC 60870-5-103, IEC 60870-5-104, Modbus TCP, DNP3 serial and TCP, PROFINET IO, PROFINET IO S2 redundancy)
- Virtual network partitioning (IEEE 802.1Q - VLAN)
- Serial protection communication via optical fibers, two-wire connections, and communication networks (IEEE C37.94 and others), including automatic switchover between ring and chain topology.
- Reliable data transmission via PRP and HSR redundancy protocols

2.7

SIPROTEC 5 Devices and Fields of Application

Line Differential Protection – SIPROTEC 7SD87

- Extensive cybersecurity functionality, such as role-based access control (RBAC), logging of security-related events, signed firmware, or authenticated IEEE 802.1X network access
- Simple, fast, and secure access to the device via a standard Web browser to display all information and diagnostic data, vector diagrams, single-line and device display pages
- Phasor Measurement Unit (PMU) for synchrophasor measured values and IEEE C37.118 protocol
- Time synchronization using IEEE 1588
- High-performance fault recording (buffer for a max. record time of 80 s at 8 kHz or 320 s at 2 kHz)
- Auxiliary functions for simple tests and commissioning
- Flexibly adjustable I/O quantity structure within the scope of the SIPROTEC 5 modular system

Applications

- Line protection for all voltage levels with 1-pole and 3-pole tripping
- Phase-selective protection of overhead lines and cables with single-ended and multi-ended infeed of all lengths with up to 6 line ends

- Also used in switchgear with breaker-and-a-half layout
- Transformers and compensating coils in the protection zone
- Detection of ground faults in isolated or arc-suppression-coil-ground power systems in star, ring, or meshed arrangement
- Serial protection communication with SIPROTEC 5 and SIPROTEC 4 devices over different distances and physical media, such as optical fiber, two-wire connections, and communication networks
- Phasor Measurement Unit (PMU)
- Detection and recording of power-quality data in the medium-voltage and subordinate low-voltage power system

Application Templates

DIGSI 5 provides application templates for standard applications. They include all basic configurations and default settings.

The following application templates are available:

- Differential protection basis
- Differential protection for overhead line
- Differential protection for overhead line, for applications with breaker-and-a-half layout

Application Examples

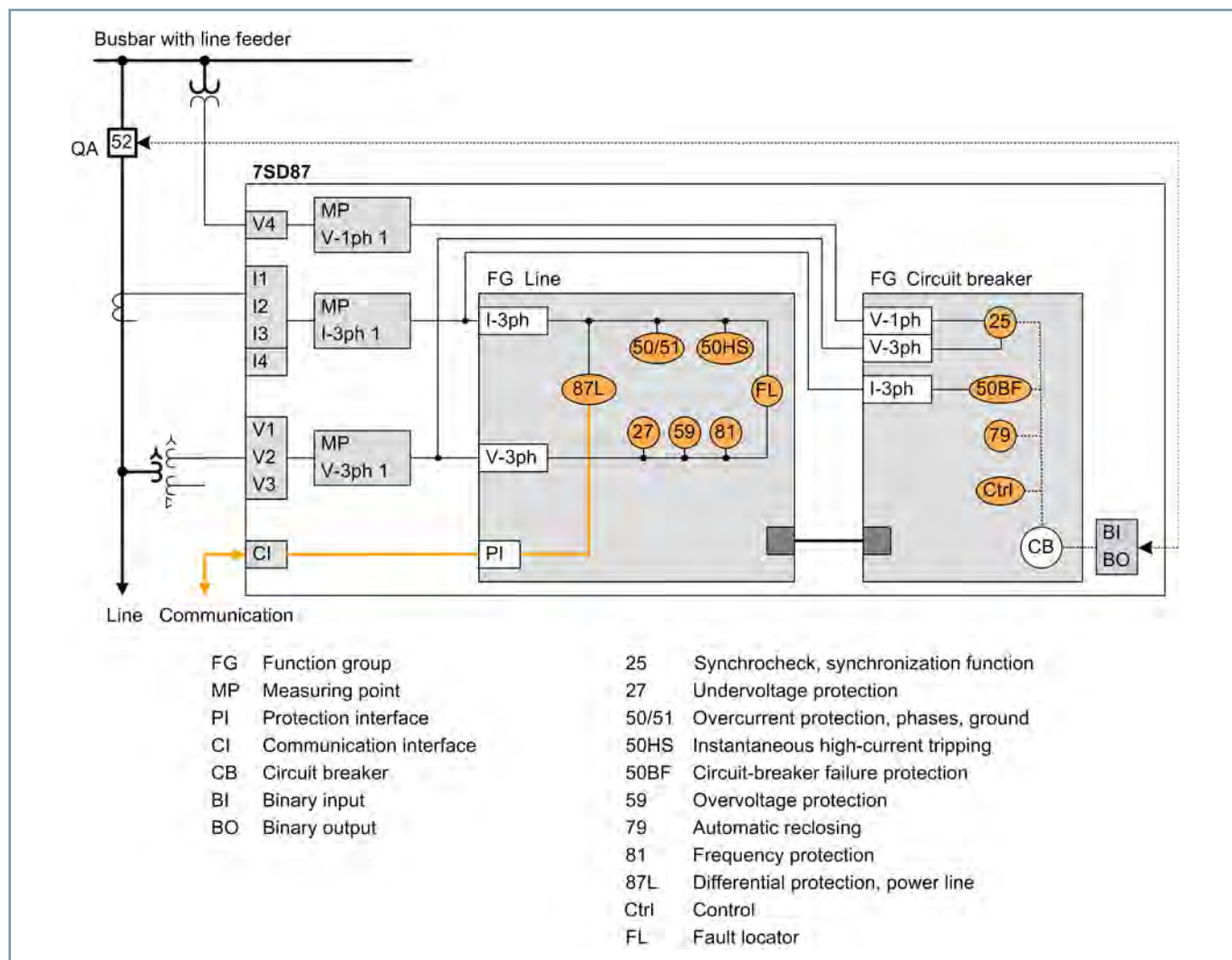

[dw_7SD87_Ltg, 1, en_US]

Figure 2.7/7 Application Example: Line Differential Protection for Overhead Line

2.7

SIPROTEC 5 Devices and Fields of Application

Line Differential Protection – SIPROTEC 7SD87

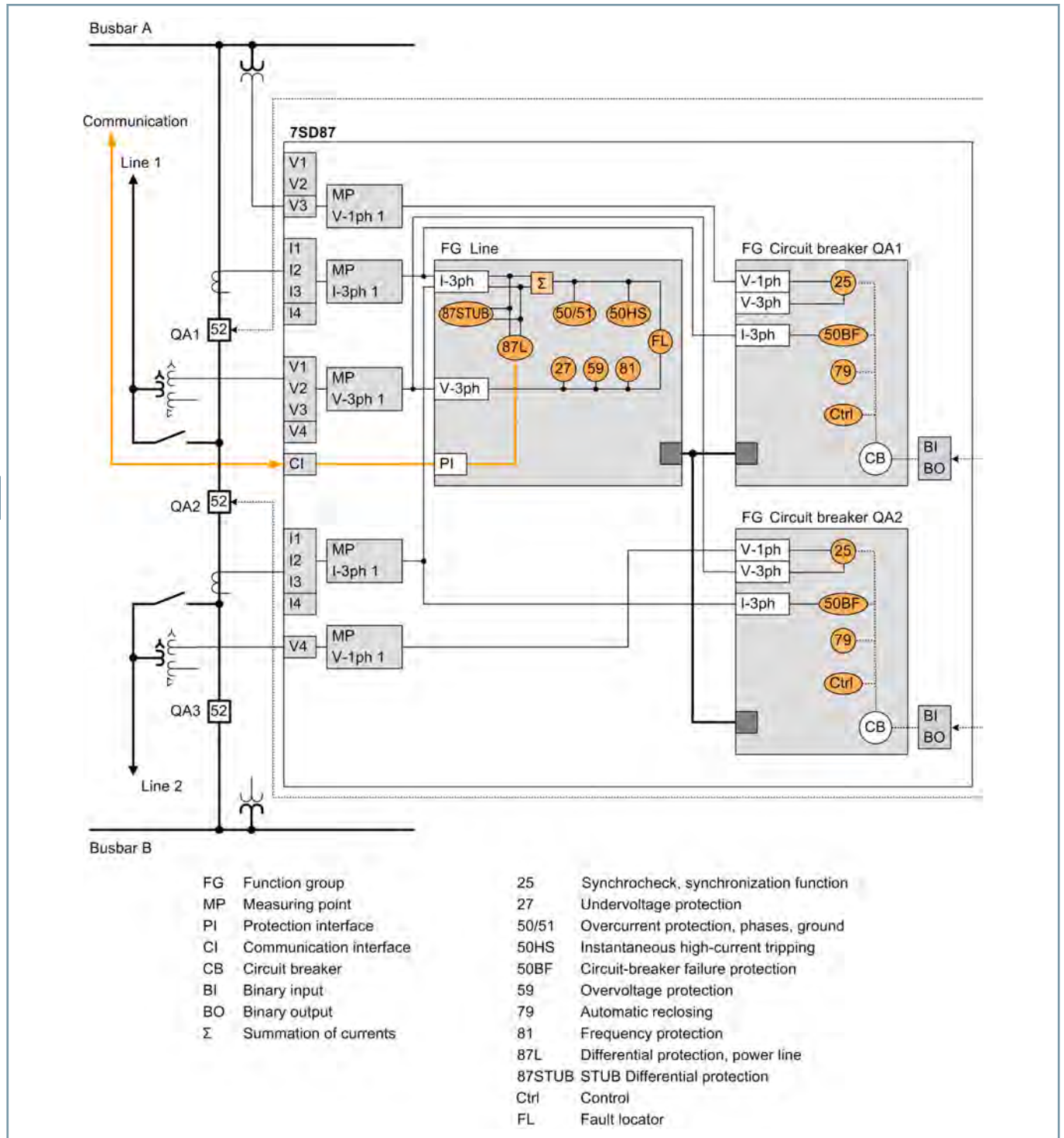

Figure 2.7/8 Application Example: Line Differential Protection for Overhead Line with Breaker-and-a-Half Layout

SIPROTEC 5 Devices and Fields of Application

Line Differential Protection – SIPROTEC 7SD87

ANSI	Function	Abbr.	Available	Application Templates		
				1	2	3
	Protection functions for 3-pole tripping	3-pole	■	■	■	■
	Protection functions for 1-pole tripping	1-pole	■	■	■	■
	Expandable hardware quantity structure	I/O	■	■	■	■
	Process bus client protocol (hint: PB client requires a separate ETH-BD-2FO plug-in module, from V8.0)	PB client	■			
	IEC61850-9-2 Merging Unit Stream (hint: Each stream requires a separate ETH-BD-2FO plug-in module, from V8.0)	MU	■			
	IEC61850-9-2 Merging Unit Stream 7SS85 CU (hint: Only for communication with a 7SS85 CU. A separate ETH-BD-2FO plug-in module is required starting with V8.40)	MU	■			
25	Synchrocheck, synchronization function	Sync	■		■	■
27	Undervoltage protection: "3-phase" or "positive-sequence system V1" or "universal Vx"	V<	■			
27R, 59R	Voltage change protection (starting with V8.30)	dV/dt	■			
	Undervoltage-controlled reactive power protection	Q>I<	■			
32, 37	Power protection active/reactive power	P<>, Q<>	■			
37	Undercurrent	I<	■			
38	Temperature supervision	θ>	■			
46	Negative-sequence system overcurrent protection	I2>	■			
46	Negative-sequence system and overcurrent protection with direction	I2>, ∠(V2, I2)	■			
47	Overvoltage protection, negative-sequence system	V2>	■			
49	Thermal overload protection	θ, I²t	■		■	■
50/51 TD	Overcurrent protection, phases	I>	■	■	■	■
	Instantaneous tripping at switch onto fault	SOTF	■			
50HS	Instantaneous high-current tripping	I>>>	■	■	■	■
50/51 TD	Overcurrent protection with positive-sequence current I1 (from V7.9)	I1>	■			
50N/ 51N TD	Overcurrent protection, ground	IN>	■	■	■	■
50N/ 51N TD	Overcurrent protection, 1-phase	IN>	■			
50 Ns/ 51Ns	Sensitive ground-fault detection for grounded arc suppression coils and isolated power systems including a) 3I0> b) admittance Y0>, c) 3I0-harm> (from V7.8)	INs>	■			
	Sensitive ground-fault detection via pulse detection; hint: this stage also requires the function 50Ns/51Ns or 67Ns "sensitive ground-fault detection for grounded arc suppression coils and isolated power systems"	IN pulse	■			
	Intermittent ground-fault protection	IIE>	■			
50BF	Circuit-breaker failure protection 1-pole/3-pole	CBFP	■		■	■
50EF	End-fault protection (hint: For use only in decentralized busbar protection with a 7SS85 CU starting with V8.40)		■			
50RS	Circuit breaker restrike monitoring	CBRM	■			
51V	Voltage-controlled overcurrent protection	t=f(I, V)	■			
59, 59N	Overvoltage protection: "3-phase" or "zero-sequence system V0" or "positive-sequence system V1" or "universal Vx"	V>	■			
60	Voltage-comparison supervision	ΔV>	■			
67	Directional overcurrent protection, phases	I>, ∠(V, I)	■			

2.7

SIPROTEC 5 Devices and Fields of Application

Line Differential Protection – SIPROTEC 7SD87

ANSI	Function	Abbr.	Available	Application Templates		
				1	2	3
67N	Directional ground-fault protection in grounded power systems	IN>, ∠(V, I)	■			
67 Ns	Sensitive ground-fault detection for grounded arc suppression coils and isolated power systems including a) 3I0> b) V0>, c) cos/sine Phi, d) transient ground fault, e) Phi(V, I), f) admittance		■			
	Directional tripping stage with one harmonic; hint: this stage also requires the function "67Ns sensitive ground-fault detection for grounded arc suppression coils and isolated power systems"	∠(V0h, I0h)	■			
	Directional Intermittent Ground-Fault Protection	IIEdir>	■			
74TC	Trip-circuit supervision		■			
79	Automatic reclosing, 1-pole/3-pole	AREC	■		■	■
SAD	Secondary arc detection (SAD) in 1-pole automatic reclosing cycles starting with V8.30; note: SAD also requires the function points for "79 automatic reclosing, pole/3-pole"	SAD	■			
81	Frequency protection: "f>" or "f<" or "df/dt"	f<>; df/dt<>	■			
81U	Underfrequency load shedding	f<(ULS)	■			
	Vector-jump protection	Δφ>	■			
86	Lockout		■		■	■
87N T	Restricted ground-fault protection	ΔIN	■			
87L	Line differential protection for 2 line ends	ΔI	■	■	■	■
87L	Line differential protection for 3 to 6 line ends (dependent on significant properties)	ΔI	■	■	■	■
87L/ 87T	Option for line differential protection with Transformer in the Protection Range	ΔI	■			
	Option for line differential protection with charging-current compensation	ΔI	■			
	Broken-wire detection for differential protection		■			
87 STUB	Stub fault differential protection (for breaker-and-a-half layouts)		■			■
90 V	Voltage controller for two-winding transformer		■			
90 V	Voltage controller for two-winding transformer with parallel control		■			
	Number of two-winding transformers with parallel control (hint: only together with the function "voltage controller for two-winding transformer with parallel control")		■			
90 V	Voltage controller for three-winding transformer		■			
90 V	Voltage controller for grid coupling transformer		■			
FL	Fault Locator, single-side	FL-one	■	■	■	■
FL	Fault Locator Plus (from V7.9)	FL plus	■			
PMU	Synchrophasor measurement	PMU	■			
AFD	Arc protection (only with plug-in module ARC-CD-3FO)		■			
	Measured values, standard		■	■	■	■
	Measured values, extended: Min, max, average		■			
	Switching statistics counter		■	■	■	■
	PQ – Basic measured values: THD (Total Harmonic Distortion) and harmonic component (starting with V8.01) and THD voltage average values (starting with V8.40)		■			
	PQ – Basic measured values: Voltage unbalance (starting with V8.40)		■			

2.7

SIPROTEC 5 Devices and Fields of Application

Line Differential Protection – SIPROTEC 7SD87

ANSI	Function	Abbr.	Available	Application Templates		
				1	2	3
	PQ – Basic measured values: Voltage changes – monitoring of voltage dips, overvoltages and voltage interruptions (starting with V8.40)		■			
	PQ – Basic measured values: TDD - Total Demand Distortion (starting with V8.40)		■			
	CFC (standard, control)		■	■	■	■
	CFC arithmetic		■			
	Circuit-breaker wear monitoring	$\Sigma I_x, I^2t, 2P$	■			
	Switching sequence function		■			
	Inrush-current detection		■	■	■	■
	External trip initiation		■	■	■	■
	Control		■	■	■	■
PoW	Point-on-wave switching (starting with V7.90)	PoW	■			
	Circuit breaker		■	■	■	■
	Disconnectors/grounding conductor		■			■
	Fault recording of analog and binary signals		■	■	■	■
	Monitoring		■	■	■	■
	Protection interface, serial		■	■	■	■
	Region, France: Overload protection for 'PSL-PSC' lines		■			
	Region, France: 'MAXI-L' overcurrent protection		■			
	Region, France: 'PDA' system decoupling protection		■			
	Region, France: Overload protection for transformers		■			
	Frequency group tracking (from V7.8)		■			
	Cyber security: Role-Based Access Control (from V7.8)		■			
	Temperature recording via communication protocol		■			
	Cyber security: Authenticated network access using IEEE 802.1X (starting from V8.3)		■			
Function point class:				0	150	325
The configuration and function point class for your application can be determined in the SIPROTEC 5 order configurator at www.siemens.com/siprotec .						

2.7

Table 2.7/3 SIPROTEC 7SD87 – Functions, Application Templates

- (1) Basic
- (2) DIFF Overhead Line
- (3) DIFF Overhead Line, breaker-and-a-half layout

SIPROTEC 5 Devices and Fields of Application

Line Differential and Distance Protection – SIPROTEC 7SL82

Description

The combined SIPROTEC 7SL82 line differential and distance protection has been designed particularly for the cost-optimized and compact protection of lines in medium-voltage and high-voltage systems. With its flexibility and the high-performance DIGSI 5 engineering tool, SIPROTEC 7SL82 offers future-oriented solutions for protection, control, automation, monitoring, and Power Quality – Basic.

Main function	Differential protection and distance protection for medium-voltage and high-voltage applications Interoperability of SIPROTEC 4 and SIPROTEC 5 line protection devices
Tripping	3-pole, minimum tripping time: 19 ms
Inputs and outputs	4 current transformers, 4 voltage transformers, 11 or 23 binary inputs, 9 or 16 binary outputs
Hardware flexibility	Different hardware quantity structures for binary inputs and outputs are available in the 1/3 base module. Adding 1/6 expansion modules is not possible; available with large or small display.
Housing width	1/3 × 19 inches



[SIP5_GD_W3, 2, --]

Figure 2.8/1 SIPROTEC 5 Device

2.8

Benefits

- Compact and low-cost line differential and distance protection
- Safety due to high-performance protection functions
- Purposeful and easy handling of devices and software thanks to a user-friendly design
- Cybersecurity in accordance with NERC CIP and BDEW White-paper requirements
- Highest availability even under extreme environmental conditions by standard coating of the modules
- Full compatibility between IEC 61850 Editions 1, 2.0, and 2.1

Functions

DIGSI 5 permits all functions to be configured and combined as required and as per the functional scope that has been ordered.

- Minimum tripping time: 19 ms
- Main protection function is differential protection with adaptive algorithm for maximum sensitivity and stability even with the most different transformer errors, current-transformer saturation, and capacitive charging currents
- Several distance-protection functions selectable as backup protection or secondary main protection: Classic, reactance method (RMD), impedance protection for transformers
- Directional backup protection and various additional functions
- Detection of ground faults of any type in compensated or isolated electrical power systems using the following functions: 3I0>, V0>, transient ground fault, cos φ, sin φ, dir. detection of intermittent ground faults, harmonic detection, and admittance measurement
- Ground-fault detection using the pulse detection method
- Detection of current-transformer saturation for fast tripping with high accuracy

- Adaptive power-swing blocking
- Fault locator plus for accurate fault location with inhomogeneous line sections and targeted automatic overhead-line section reclosing (AREC)
- Arc protection
- Automatic frequency relief for underfrequency load shedding, taking changed infeed conditions due to decentralized power generation into consideration
- Directional reactive-power undervoltage protection (QU protection)
- Detection of current and voltage signals up to the 50th harmonic with high accuracy for selected protection functions (such as thermal overload protection) and operational measured values
- PQ – Basic: Voltage unbalance; voltage changes: overvoltage, dip, interruption; TDD, THD, and harmonics
- Control, synchrocheck, and switchgear interlocking protection
- Graphical logic editor to create high-performance automation functions in the device
- Single-line representation in the small or large display
- Fixed integrated electrical Ethernet RJ45 interface for DIGSI 5 and IEC 61850 (reporting and GOOSE)
- 2 optional pluggable communication modules, usable for different and redundant protocols (IEC 61850, IEC 60870-5-103, IEC 60870-5-104, Modbus TCP, DNP3 serial and TCP, PROFINET IO)
- Serial protection communication via optical fibers, two-wire connections, and communication networks (IEEE C37.94 and others), including automatic switchover between ring and chain topology.
- Reliable data transmission via PRP and HSR redundancy protocols

SIPROTEC 5 Devices and Fields of Application

Line Differential and Distance Protection – SIPROTEC 7SL82

- Extensive cybersecurity functionality, such as role-based access control (RBAC), logging of security-related events, signed firmware, or authenticated IEEE 802.1X network access
- Simple, fast, and secure access to the device via a standard Web browser to display all information and diagnostic data, vector diagrams, single-line and device display pages
- Phasor Measurement Unit (PMU) for synchrophasor measured values and IEEE C37.118 protocol
- Time synchronization using IEEE 1588
- High-performance fault recording (buffer for a max. record time of 80 s at 8 kHz or 320 s at 2 kHz)
- Auxiliary functions for simple tests and commissioning

Applications

- Line protection for all voltage levels with 3-pole tripping
- Phase-selective protection of overhead lines and cables with single-ended and multi-ended infeed of all lengths with up to 6 line ends
- Transformers and compensating coils in the protection zone
- Detection of ground faults in isolated or arc-suppression-coil-ground power systems in star, ring, or meshed arrangement
- Serial protection communication with SIPROTEC 5 and SIPROTEC 4 devices over different distances and physical media, such as optical fiber, two-wire connections, and communication networks
- Phasor Measurement Unit (PMU)
- Detection and recording of power-quality data in the medium-voltage and subordinate low-voltage power system

Application Templates

DIGSI 5 provides application templates for standard applications. They include all basic configurations and default settings.

The following application templates are available:

- Basic differential and distance protection
- Differential and distance protection for overhead line in grounded power systems

SIPROTEC 5 Devices and Fields of Application

Line Differential and Distance Protection – SIPROTEC 7SL82

Application Example

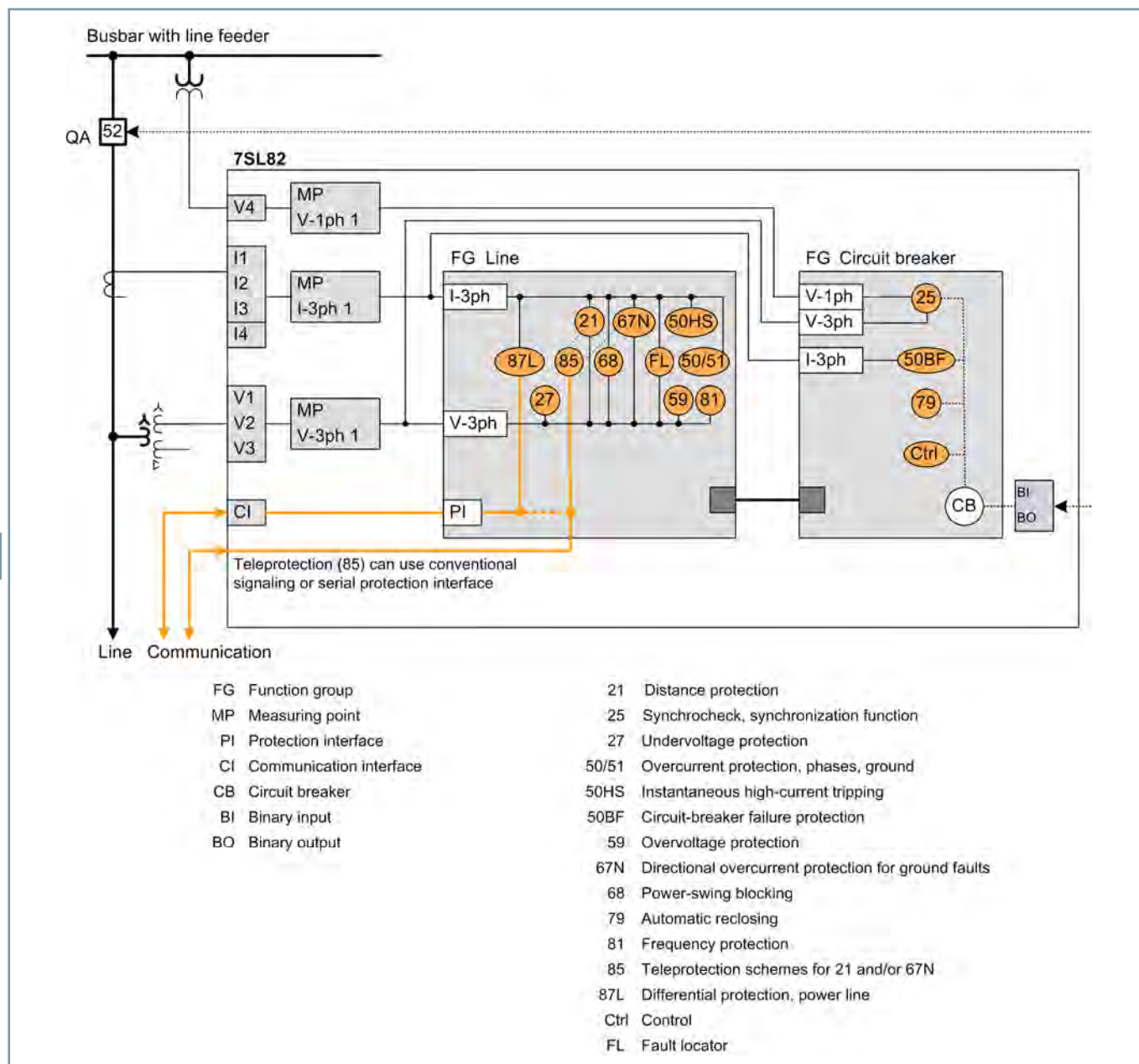

[dw_7SL82_Ltg_1_en_US]

Figure 2.8/2 Application Example: Combined Line Differential and Distance Protection for Overhead Line

SIPROTEC 5 Devices and Fields of Application

Line Differential and Distance Protection – SIPROTEC 7SL82

ANSI	Function	Abbr.	Available	Application Templates	
				1	2
	Protection functions for 3-pole tripping	3-pole	■	■	■
21/21N	Distance Protection	$Z<, V< I>/\angle(V, I)$	■	■	■
21T	Impedance protection for transformers	$Z<$	■		
25	Synchrocheck, synchronization function	Sync	■		■
27	Undervoltage protection: "3-phase" or "positive-sequence system V1" or "universal Vx"	$V<$	■		
27R, 59R	Voltage change protection (starting with V8.30)	dV/dt	■		
	Undervoltage-controlled reactive power protection	$Q>/V<$	■		
32, 37	Power protection active/reactive power	$P<>, Q<>$	■		
37	Undercurrent	$I<$	■		
38	Temperature supervision	$\theta>$	■		
46	Negative-sequence system overcurrent protection	$I2>$	■		
46	Negative-sequence system and overcurrent protection with direction	$I2>, \angle(V2, I2)$	■		
47	Overvoltage protection, negative-sequence system	$V2>$	■		
49	Thermal overload protection	θ, I^2t	■		■
50/51 TD	Overcurrent protection, phases	$I>$	■	■	■
	Instantaneous tripping at switch onto fault	SOTF	■		
50HS	Instantaneous high-current tripping	$I>>>$	■	■	■
50/51 TD	Overcurrent protection with positive-sequence current I1 (from V7.9)	$I1>$	■		
50N/ 51N TD	Overcurrent protection, ground	$IN>$	■	■	■
50N/ 51N TD	Overcurrent protection, 1-phase	$IN>$	■		
50 Ns/ 51Ns	Sensitive ground-fault detection for grounded arc suppression coils and isolated power systems including a) 3I0> b) admittance Y0>, c) 3I0-harm> (from V7.8)	$INs>$	■		
	Sensitive ground-fault detection via pulse detection; hint: this stage also requires the function 50Ns/51Ns or 67Ns "sensitive ground-fault detection for grounded arc suppression coils and isolated power systems"	IN pulse	■		
	Intermittent ground-fault protection	$IIE>$	■		
50BF	Circuit-breaker failure protection, 3-pole	CBFP	■		■
50RS	Circuit breaker restrike monitoring	CBRM	■		
51V	Voltage-controlled overcurrent protection	$t=f(I, V)$	■		
59, 59N	Overvoltage protection: "3-phase" or "zero-sequence system V0" or "positive-sequence system V1" or "universal Vx"	$V>$	■		
60	Voltage-comparison supervision	$\Delta V>$	■		
67	Directional overcurrent protection, phases	$I>, \angle(V, I)$	■		
67N	Directional ground-fault protection in grounded power systems	$IN>, \angle(V, I)$	■		■
67 Ns	Sensitive ground-fault detection for grounded arc suppression coils and isolated power systems including a) 3I0> b) V0>, c) cos/sine Phi, d) transient ground fault, e) Phi(V, I), f) admittance		■		
	Directional tripping stage with one harmonic; hint: this stage also requires the function "67Ns sensitive ground-fault detection for grounded arc suppression coils and isolated power systems"	$\angle(V0h, I0h)$	■		
	Directional Intermittent Ground-Fault Protection	$IIEdir>$	■		
68	Power-swing blocking	$\Delta Z/\Delta t$	■		■

SIPROTEC 5 Devices and Fields of Application

Line Differential and Distance Protection – SIPROTEC 7SL82

ANSI	Function	Abbr.	Available	Application Templates	
				1	2
74TC	Trip-circuit supervision		■		
78	Out-of-step protection	$\Delta Z/\Delta t$	■		
74CC	Single circuit monitoring (from V7.9)		■		
79	Automatic reclosing, 3-pole	AREC	■		■
81	Frequency protection: "f>" or "f<" or "df/dt"	f<>; df/dt<>	■		
81U	Underfrequency load shedding	f<(ULS)	■		
	Vector-jump protection	$\Delta\phi$ >	■		
85/21	Teleprotection scheme for distance protection		■	■	■
85/27	Weak or no infeed: Echo and tripping		■	■	■
85/67N	Teleprotection scheme for directional ground-fault protection		■	■	■
86	Lockout		■		
87N T	Restricted ground-fault protection	ΔI_N	■		
87L	Line differential protection for 2 line ends	ΔI	■	■	■
87L	Line differential protection for 3 to 6 line ends (dependent on significant properties)	ΔI	■	■	■
87L/ 87T	Option for line differential protection with Transformer in the Protection Range	ΔI	■		
	Option for line differential protection with charging-current compensation	ΔI	■		
	Broken-wire detection for differential protection		■		
90 V	Voltage controller for two-winding transformer		■		
FL	Fault Locator, single-side	FL-one	■	■	■
FL	Fault Locator Plus (from V7.9)	FL plus	■		
PMU	Synchrophasor measurement	PMU	■		
AFD	Arc protection (only with plug-in module ARC-CD-3FO)		■		
	Measured values, standard		■	■	■
	Measured values, extended: Min, max, average		■		
	Switching statistics counter		■	■	■
	PQ – Basic measured values: THD (Total Harmonic Distortion) and harmonic component (starting with V8.01) and THD voltage average values (starting with V8.40)		■		
	PQ – Basic measured values: Voltage unbalance (starting with V8.40)		■		
	PQ – Basic measured values: Voltage changes – monitoring of voltage dips, overvoltages and voltage interruptions (starting with V8.40)		■		
	PQ – Basic measured values: TDD - Total Demand Distortion (starting with V8.40)		■		
	CFC (standard, control)		■	■	■
	CFC arithmetic		■		
	Circuit-breaker wear monitoring	$\Sigma I_x, I^2t, 2P$	■		
	Switching sequence function		■		
	Inrush-current detection		■		
	External trip initiation		■	■	■
	Control		■	■	■
	Circuit breaker		■	■	■
	Disconnectors/grounding conductor		■		
	Fault recording of analog and binary signals		■	■	■
	Monitoring		■	■	■
	Protection interface, serial		■	■	■

2.8

SIPROTEC 5 Devices and Fields of Application

Line Differential and Distance Protection – SIPROTEC 7SL82

ANSI	Function	Abbr.	Available	Application Templates	
				1	2
	Region, France: Overload protection for 'PSL-PSC' lines		■		
	Region, France: 'MAXI-L' overcurrent protection		■		
	Region, France: 'PDA' system decoupling protection		■		
	Region, France: Overload protection for transformers		■		
	Frequency group tracking (from V7.8)		■		
	Cyber security: Role-Based Access Control (from V7.8)		■		
	Temperature recording via communication protocol		■		
	Cyber security: Authenticated network access using IEEE 802.1X (starting from V8.3)		■		
Function point class:				0	200
The configuration and function point class for your application can be determined in the SIPROTEC 5 order configurator at www.siemens.com/siprotec .					

Table 2.8/1 SIPROTEC 7SL82 – Functions, Application Templates

- (1) Basic
- (2) DIFF/DIS RMD Overhead Line, grounded power systems

SIPROTEC 5 Devices and Fields of Application

Line Differential and Distance Protection – SIPROTEC 7SL86

Description

The combined SIPROTEC 7SL86 line differential and distance protection has been designed specifically for the protection of lines. With its modular structure, flexibility and the high-performance DIGSI 5 engineering tool, the SIPROTEC 7SL86 device offers future-oriented solutions for protection, control, automation, monitoring, and Power Quality – Basic.

Main function	Differential and distance protection Interoperability of SIPROTEC 4 and SIPROTEC 5 line protection devices
Tripping	3-pole, minimum tripping time: 9 ms
Inputs and outputs	12 predefined standard variants with 4/4 or 8/8 current transformers/voltage transformers, 5 to 31 binary inputs, 8 to 46 binary outputs
Hardware flexibility	Flexibly adjustable I/O quantity structure within the scope of the SIPROTEC 5 modular system
Housing width	1/3 × 19 inches to 2/1 × 19 inches

Benefits

- Safety due to high-performance protection functions
- Purposeful and easy handling of devices and software thanks to a user-friendly design
- Cybersecurity in accordance with NERC CIP and BDEW White-paper requirements
- Highest availability even under extreme environmental conditions by standard coating of the modules

Functions

DIGSI 5 permits all functions to be configured and combined as required and as per the functional scope that has been ordered.

- Minimum tripping time: 9 ms
- Main protection function is differential protection with adaptive algorithm for maximum sensitivity and stability even with the most different transformer errors, current-transformer saturation, and capacitive charging currents
- Several distance-protection functions selectable as backup protection or secondary main protection: Classic, reactance method (RMD), impedance protection for transformers
- Directional backup protection and various additional functions
- Adaptive power-swing blocking, out-of-step protection
- Detection of ground faults of any type in compensated or isolated electrical power systems using the following functions: 3I0>, V0>, transient ground fault, cos φ, sin φ, dir. detection of intermittent ground faults, harmonic detection, and admittance measurement
- Ground-fault detection using the pulse detection method
- Detection of current-transformer saturation for fast tripping with high accuracy
- Fault locator plus for accurate fault location with inhomogeneous line sections and targeted automatic overhead-line section reclosing (AREC)
- Arc protection



[SIP5_GD_SS_W3, 2, --, --]

Figure 2.8/3 SIPROTEC 5 Device with Expansion Module

- Automatic frequency relief for underfrequency load shedding, taking changed infeed conditions due to decentralized power generation into consideration
- Directional reactive-power undervoltage protection (QU protection)
- Detection of current and voltage signals up to the 50th harmonic with high accuracy for selected protection functions (such as thermal overload protection) and operational measured values
- PQ – Basic: Voltage unbalance; voltage changes: overvoltage, dip, interruption; TDD, THD, and harmonics
- 3-pole automatic reclosing function
- Control, synchrocheck, and switchgear interlocking protection
- Graphical logic editor to create high-performance automation functions in the device
- Single-line representation in the small or large display
- Fixed integrated electrical Ethernet RJ45 interface for DIGSI 5 and IEC 61850 (reporting and GOOSE)
- Up to 4 optional, pluggable communication modules, usable for different and redundant protocols (IEC 61850-8-1, IEC 61850-9-2 Client, IEC 60870-5-103, IEC 60870-5-104, Modbus TCP, DNP3 serial and TCP, PROFINET IO, PROFINET IO S2 redundancy)
- Virtual network partitioning (IEEE 802.1Q - VLAN)
- Serial protection communication via optical fibers, two-wire connections, and communication networks (IEEE C37.94 and others), including automatic switchover between ring and chain topology.
- Reliable data transmission via PRP and HSR redundancy protocols

SIPROTEC 5 Devices and Fields of Application

Line Differential and Distance Protection – SIPROTEC 7SL86

- Extensive cybersecurity functionality, such as role-based access control (RBAC), logging of security-related events, signed firmware, or authenticated IEEE 802.1X network access.
- Simple, fast, and secure access to the device via a standard Web browser to display all information and diagnostic data, vector diagrams, single-line and device display pages
- Phasor Measurement Unit (PMU) for synchrophasor measured values and IEEE C37.118 protocol
- Time synchronization using IEEE 1588
- High-performance fault recording (buffer for a max. record time of 80 s at 8 kHz or 320 s at 2 kHz)
- Auxiliary functions for simple tests and commissioning
- Flexibly adjustable I/O quantity structure within the scope of the SIPROTEC 5 modular system

Applications

- Line protection for all voltage levels with 3-pole tripping
 - Phase-selective protection of overhead lines and cables with single-ended and multi-ended infeed of all lengths with up to 6 line ends
 - Also used in switchgear with breaker-and-a-half layout
- Transformers and compensating coils in the protection zone
 - Detection of ground faults in isolated or arc-suppression-coil-ground power systems in star, ring, or meshed arrangement
 - Serial protection communication with SIPROTEC 5 and SIPROTEC 4 devices over different distances and physical media, such as optical fiber, two-wire connections, and communication networks
 - Phasor Measurement Unit (PMU)
 - Detection and recording of power-quality data in the medium-voltage and subordinate low-voltage power system

Application Templates

DIGSI 5 provides application templates for standard applications. They include all basic configurations and default settings.

The following application templates are available:

- Basic
- Differential protection and distance protection with reactance method for overhead lines in grounded electrical power systems
- Differential protection and distance protection with reactance method for overhead lines in grounded electrical power systems and applications with breaker-and-a-half layout

2.8

SIPROTEC 5 Devices and Fields of Application

Line Differential and Distance Protection – SIPROTEC 7SL86

Application Examples

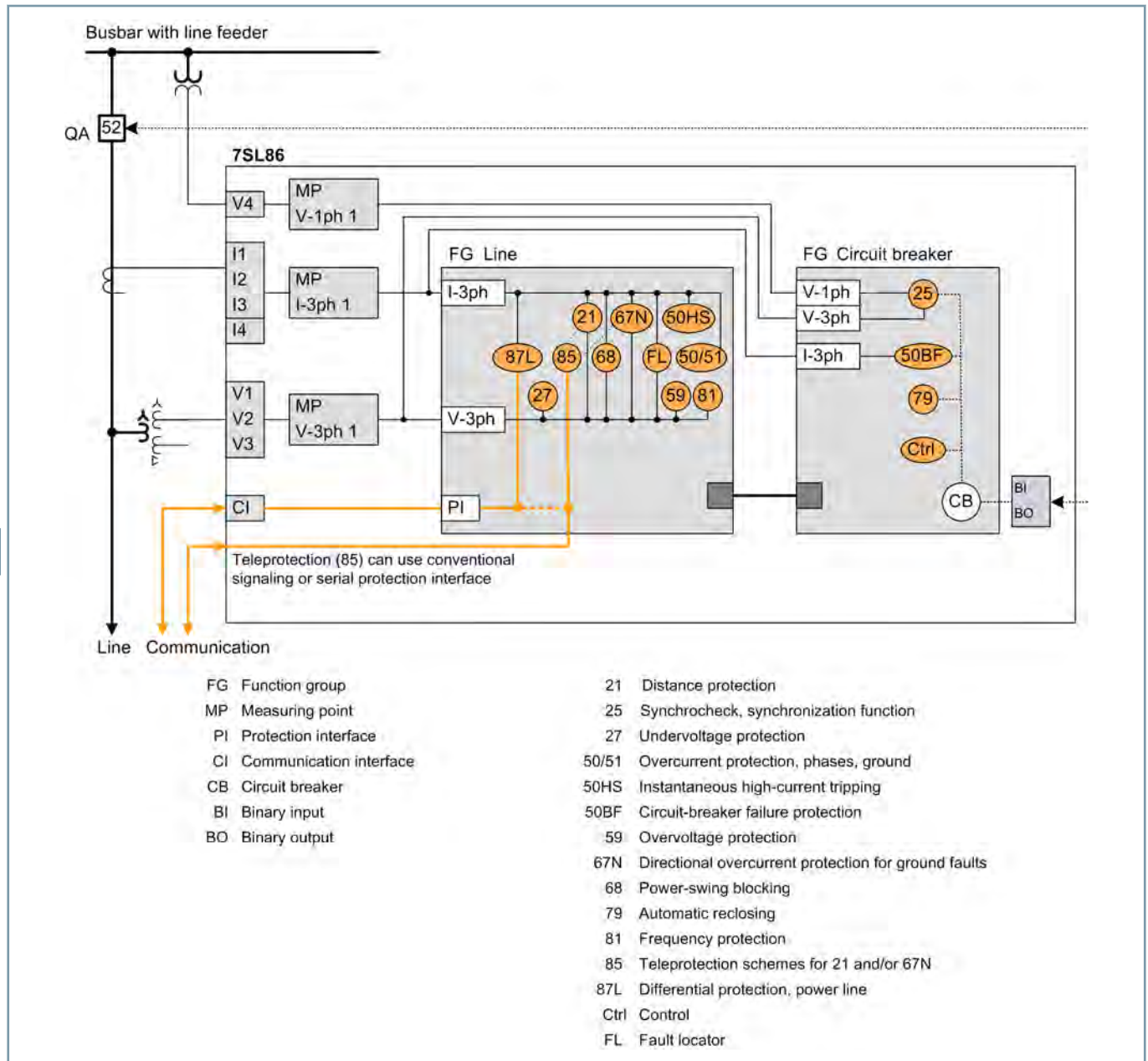
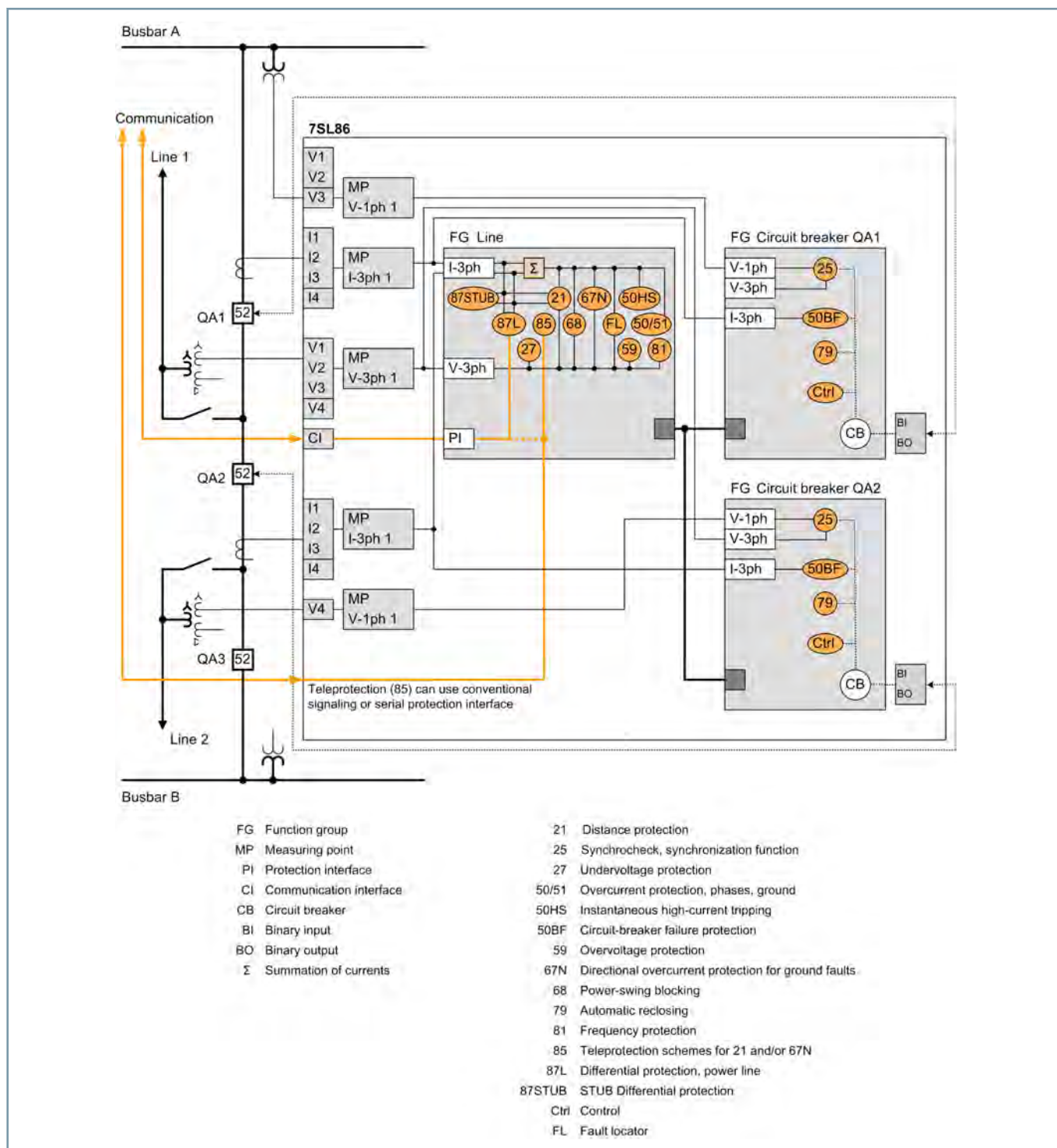

Figure 2.8/4 Application Example: Combined Line Differential and Distance Protection for Overhead Line

SIPROTEC 5 Devices and Fields of Application

Line Differential and Distance Protection – SIPROTEC 7SL86



[dw_7SL86_1-5LS, 1, en_US]

Figure 2.8/5 Application Example: Combined Line Differential and Distance Protection for Overhead Line with Breaker-and-a-Half Layout

SIPROTEC 5 Devices and Fields of Application

Line Differential and Distance Protection – SIPROTEC 7SL86

ANSI	Function	Abbr.	Available	Application Templates		
				1	2	3
	Protection functions for 3-pole tripping	3-pole	■	■	■	■
	Expandable hardware quantity structure	I/O	■	■	■	■
	Process bus client protocol (hint: PB client requires a separate ETH-BD-2FO plug-in module, from V8.0)	PB client	■			
	IEC61850-9-2 Merging Unit Stream (hint: Each stream requires a separate ETH-BD-2FO plug-in module, from V8.0)	MU	■			
	IEC61850-9-2 Merging Unit Stream 7SS85 CU (hint: Only for communication with a 7SS85 CU. A separate ETH-BD-2FO plug-in module is required starting with V8.40)	MU	■			
21/21N	Distance Protection	$Z<, V< /I> /Z(V, I)$	■	■	■	■
21T	Impedance protection for transformers	$Z<$	■			
25	Synchrocheck, synchronization function	Sync	■		■	■
27	Undervoltage protection: "3-phase" or "positive-sequence system V1" or "universal Vx"	$V<$	■			
27R, 59R	Voltage change protection (starting with V8.30)	dV/dt	■			
	Undervoltage-controlled reactive power protection	$Q>/V<$	■			
32, 37	Power protection active/reactive power	$P<>, Q<>$	■			
37	Undercurrent	$I<$	■			
38	Temperature supervision	$\theta>$	■			
46	Negative-sequence system overcurrent protection	$I2>$	■			
46	Negative-sequence system and overcurrent protection with direction	$I2>, \angle(V2, I2)$	■			
47	Overvoltage protection, negative-sequence system	$V2>$	■			
49	Thermal overload protection	θ, I^2t	■		■	■
50/51 TD	Overcurrent protection, phases	$I>$	■	■	■	■
	Instantaneous tripping at switch onto fault	SOTF	■			
50HS	Instantaneous high-current tripping	$I>>>$	■	■	■	■
50/51 TD	Overcurrent protection with positive-sequence current I1 (from V7.9)	$I1>$	■			
50N/ 51N TD	Overcurrent protection, ground	$IN>$	■	■	■	■
50N/ 51N TD	Overcurrent protection, 1-phase	$IN>$	■			
50 Ns/ 51Ns	Sensitive ground-fault detection for grounded arc suppression coils and isolated power systems including a) $3I0>$ b) admittance $Y0>$, c) $3I0$ -harm> (from V7.8)	$INs>$	■			
	Sensitive ground-fault detection via pulse detection; hint: this stage also requires the function 50Ns/51Ns or 67Ns "sensitive ground-fault detection for grounded arc suppression coils and isolated power systems"	IN pulse	■			
	Intermittent ground-fault protection	$IIE>$	■			
50BF	Circuit-breaker failure protection, 3-pole	CBFP	■		■	■
50EF	End-fault protection (hint: For use only in decentralized busbar protection with a 7SS85 CU starting with V8.40)		■			
50RS	Circuit breaker restrike monitoring	CBRM	■			
51V	Voltage-controlled overcurrent protection	$t=f(I, V)$	■			
59, 59N	Overvoltage protection: "3-phase" or "zero-sequence system V0" or "positive-sequence system V1" or "universal Vx"	$V>$	■		■	■
60	Voltage-comparison supervision	$\Delta V>$	■			

SIPROTEC 5 Devices and Fields of Application

Line Differential and Distance Protection – SIPROTEC 7SL86

ANSI	Function	Abbr.	Available	Application Templates		
				1	2	3
67	Directional overcurrent protection, phases	$I>, \angle(V, I)$	■			
67N	Directional ground-fault protection in grounded power systems	$IN>, \angle(V, I)$	■		■	■
67 Ns	Sensitive ground-fault detection for grounded arc suppression coils and isolated power systems including a) $3I0>$ b) $V0>$, c) $\cos/\sin \Phi$, d) transient ground fault, e) $\Phi(V, I)$, f) admittance		■			
	Directional tripping stage with one harmonic; hint: this stage also requires the function "67Ns sensitive ground-fault detection for grounded arc suppression coils and isolated power systems"	$\angle(V0h, I0h)$	■			
	Directional Intermittent Ground-Fault Protection	$IIEdir>$	■			
68	Power-swing blocking	$\Delta Z/\Delta t$	■		■	■
74TC	Trip-circuit supervision		■			
78	Out-of-step protection	$\Delta Z/\Delta t$	■			
74CC	Single circuit monitoring (from V7.9)		■			
79	Automatic reclosing, 3-pole	AREC	■		■	■
81	Frequency protection: "f>" or "f<" or "df/dt"	$f<>; df/dt<>$	■			
81U	Underfrequency load shedding	$f<(ULS)$	■			
	Vector-jump protection	$\Delta\varphi>$	■			
85/21	Teleprotection scheme for distance protection		■	■	■	■
85/27	Weak or no infeed: Echo and tripping		■	■	■	■
85/67N	Teleprotection scheme for directional ground-fault protection		■	■	■	■
86	Lockout		■			
87N T	Restricted ground-fault protection	ΔIN	■			
87L	Line differential protection for 2 line ends	ΔI	■	■	■	■
87L	Line differential protection for 3 to 6 line ends (dependent on significant properties)	ΔI	■	■	■	■
87L/ 87T	Option for line differential protection with Transformer in the Protection Range	ΔI	■			
	Option for line differential protection with charging-current compensation	ΔI	■			
	Broken-wire detection for differential protection		■			
87 STUB	Stub fault differential protection (for breaker-and-a-half layouts)		■			■
90 V	Voltage controller for two-winding transformer		■			
90 V	Voltage controller for three-winding transformer		■			
90 V	Voltage controller for grid coupling transformer		■			
FL	Fault Locator, single-side	FL-one	■	■	■	■
FL	Fault Locator Plus (from V7.9)	FL plus	■			
PMU	Synchrophasor measurement	PMU	■			
AFD	Arc protection (only with plug-in module ARC-CD-3FO)		■			
	Measured values, standard		■	■	■	■
	Measured values, extended: Min, max, average		■			
	Switching statistics counter		■	■	■	■
	PQ – Basic measured values: THD (Total Harmonic Distortion) and harmonic component (starting with V8.01) and THD voltage average values (starting with V8.40)		■			
	PQ – Basic measured values: Voltage unbalance (starting with V8.40)		■			

2.8

SIPROTEC 5 Devices and Fields of Application

Line Differential and Distance Protection – SIPROTEC 7SL86

ANSI	Function	Abbr.	Available	Application Templates		
				1	2	3
	PQ – Basic measured values: Voltage changes – monitoring of voltage dips, overvoltages and voltage interruptions (starting with V8.40)		■			
	PQ – Basic measured values: TDD - Total Demand Distortion (starting with V8.40)		■			
	CFC (standard, control)		■	■	■	■
	CFC arithmetic		■			
	Circuit-breaker wear monitoring	$\Sigma I_x, I^2t, 2P$	■			
	Switching sequence function		■			
	Inrush-current detection		■			
	External trip initiation		■	■	■	■
	Control		■	■	■	■
	Circuit breaker		■	■	■	■
	Disconnecter/grounding conductor		■			■
	Fault recording of analog and binary signals		■	■	■	■
	Monitoring		■	■	■	■
	Protection interface, serial		■	■	■	■
	Region, France: Overload protection for 'PSL-PSC' lines		■			
	Region, France: 'MAXI-L' overcurrent protection		■			
	Region, France: 'PDA' system decoupling protection		■			
	Region, France: Overload protection for transformers		■			
	Frequency group tracking (from V7.8)		■			
	Cyber security: Role-Based Access Control (from V7.8)		■			
	Temperature recording via communication protocol		■			
	Cyber security: Authenticated network access using IEEE 802.1X (starting from V8.3)		■			
Function point class:				0	200	350
The configuration and function point class for your application can be determined in the SIPROTEC 5 order configurator at www.siemens.com/siprotec .						

2.8

Table 2.8/2 SIPROTEC 7SL86 – Functions, Application Templates

- (1) Basic
- (2) DIFF/DIS RMD Overhead Line, grounded power systems
- (3) DIFF/DIS RMD Overhead Line, grounded power systems, 1.5 CB

SIPROTEC 5 Devices and Fields of Application

Line Differential and Distance Protection – SIPROTEC 7SL87

Description

The combined SIPROTEC 7SL87 differential and distance protection has specifically been designed for the protection of lines. With its modular structure, flexibility and the powerful DIGSI 5 engineering tool, the SIPROTEC 7SL87 device offers future-oriented solutions for protection, control, automation, monitoring, and Power Quality – Basic.

Main function	Differential and distance protection Interoperability of SIPROTEC 4 and SIPROTEC 5 line protection devices
Tripping	1-pole and 3-pole, minimum tripping time: 9 ms
Inputs and outputs	12 predefined standard variants with 4/4 or 8/8 current transformers/voltage transformers, 5 to 31 binary inputs, 8 to 46 binary outputs
Hardware flexibility	Flexibly adjustable I/O quantity structure within the scope of the SIPROTEC 5 modular system
Housing width	1/3 × 19 inches to 2/1 × 19 inches

Benefits

- Safety due to powerful protection functions
- Purposeful and easy handling of devices and software thanks to a user-friendly design
- Cybersecurity in accordance with NERC CIP and BDEW Whitepaper requirements
- Highest availability even under extreme environmental conditions by standard coating of the modules

Functions

DIGSI 5 permits all functions to be configured and combined as required and as per the functional scope that has been ordered.

- Minimum tripping time: 9 ms
- Main protection function is differential protection with adaptive algorithm for maximum sensitivity and stability even with the most different transformer errors, current-transformer saturation, and capacitive charging currents
- Several distance-protection functions selectable as backup protection or secondary main protection: Classic, reactance method (RMD), impedance protection for transformers
- Directional backup protection and various additional functions
- Adaptive power-swing blocking, out-of-step protection
- Detection of ground faults of any type in compensated or isolated electrical power systems using the following functions: $3I_0>$, $V_0>$, transient ground fault, $\cos \varphi$, $\sin \varphi$, harmonic, dir. detection of intermittent ground faults, harmonic detection, and admittance measurement
- Ground-fault detection using the pulse detection method
- Detection of current-transformer saturation for fast tripping with high accuracy
- Fault locator plus for accurate fault location with inhomogeneous line sections and targeted automatic overhead-line section reclosing (AREC)
- Arc protection



[SIP5_GD_SS_W3, 2, --, --]

Figure 2.8/6 SIPROTEC 5 Device with Expansion Module

- Automatic frequency relief for underfrequency load shedding, taking changed infeed conditions due to decentralized power generation into consideration
- Directional reactive power undervoltage protection (QU protection)
- Detection of current and voltage signals up to the 50th harmonic with high accuracy for selected protection functions (such as thermal overload protection) and operational measured values
- PQ – Basic: Voltage unbalance; voltage changes: overvoltage, dip, interruption; TDD, THD, and harmonics
- 1-pole automatic reclosing function with secondary arc detection (SAD)
- Point-on-wave switching
- Control, synchrocheck, and switchgear interlocking protection
- Graphical logic editor to create powerful automation functions in the device
- Single-line representation in the small or large display
- Fixed integrated electrical Ethernet RJ45 interface for DIGSI 5 and IEC 61850 (reporting and GOOSE)
- Up to 4 optional, pluggable communication modules, usable for different and redundant protocols (IEC 61850-8-1, IEC 61850-9-2 Client, IEC 60870-5-103, IEC 60870-5-104, Modbus TCP, DNP3 serial and TCP, PROFINET IO, PROFINET IO S2 redundancy)
- Virtual network partitioning (IEEE 802.1Q - VLAN)
- Serial protection communication via optical fibers, two-wire connections, and communication networks (IEEE C37.94 and others), including automatic switchover between ring and chain topology.
- Reliable data transmission via PRP and HSR redundancy protocols

SIPROTEC 5 Devices and Fields of Application

Line Differential and Distance Protection – SIPROTEC 7SL87

- Extensive cybersecurity functionality, such as role-based access control (RBAC), logging of security-related events, signed firmware, or authenticated IEEE 802.1X network access.
- Simple, fast, and secure access to the device via a standard Web browser to display all information and diagnostic data, vector diagrams, single-line and device display pages
- Phasor Measurement Unit (PMU) for synchrophasor measured values and IEEE C37.118 protocol
- Time synchronization using IEEE 1588
- Powerful fault recording (buffer for a max. record time of 80 s at 8 kHz or 320 s at 2 kHz)
- Auxiliary functions for simple tests and commissioning
- Flexibly adjustable I/O quantity structure within the scope of the SIPROTEC 5 modular system

Applications

- Line protection for all voltage levels with 1-pole and 3-pole tripping
- Phase-selective protection of overhead lines and cables with single-ended and multi-ended infeed of all lengths with up to 6 line ends
- Also used in switchgear with breaker-and-a-half layout

- Transformers and compensating coils in the protection zone
- Detection of ground faults in isolated or arc-suppression-coil-ground power systems in star, ring, or meshed arrangement
- Serial protection communication with SIPROTEC 5 and SIPROTEC 4 devices over different distances and physical media, such as optical fiber, two-wire connections, and communication networks
- Phasor Measurement Unit (PMU)
- Detection and recording of power-quality data in the medium-voltage and subordinate low-voltage power system

Application Templates

DIGSI 5 provides application templates for standard applications. They include all basic configurations and default settings.

The following application templates are available:

- Basic differential and distance protection
- Differential protection and distance protection with reactance method for overhead lines in grounded electrical power systems
- Differential protection and distance protection with reactance method for overhead lines in grounded electrical power systems and applications with breaker-and-a-half layout

SIPROTEC 5 Devices and Fields of Application

Line Differential and Distance Protection – SIPROTEC 7SL87

Application Examples

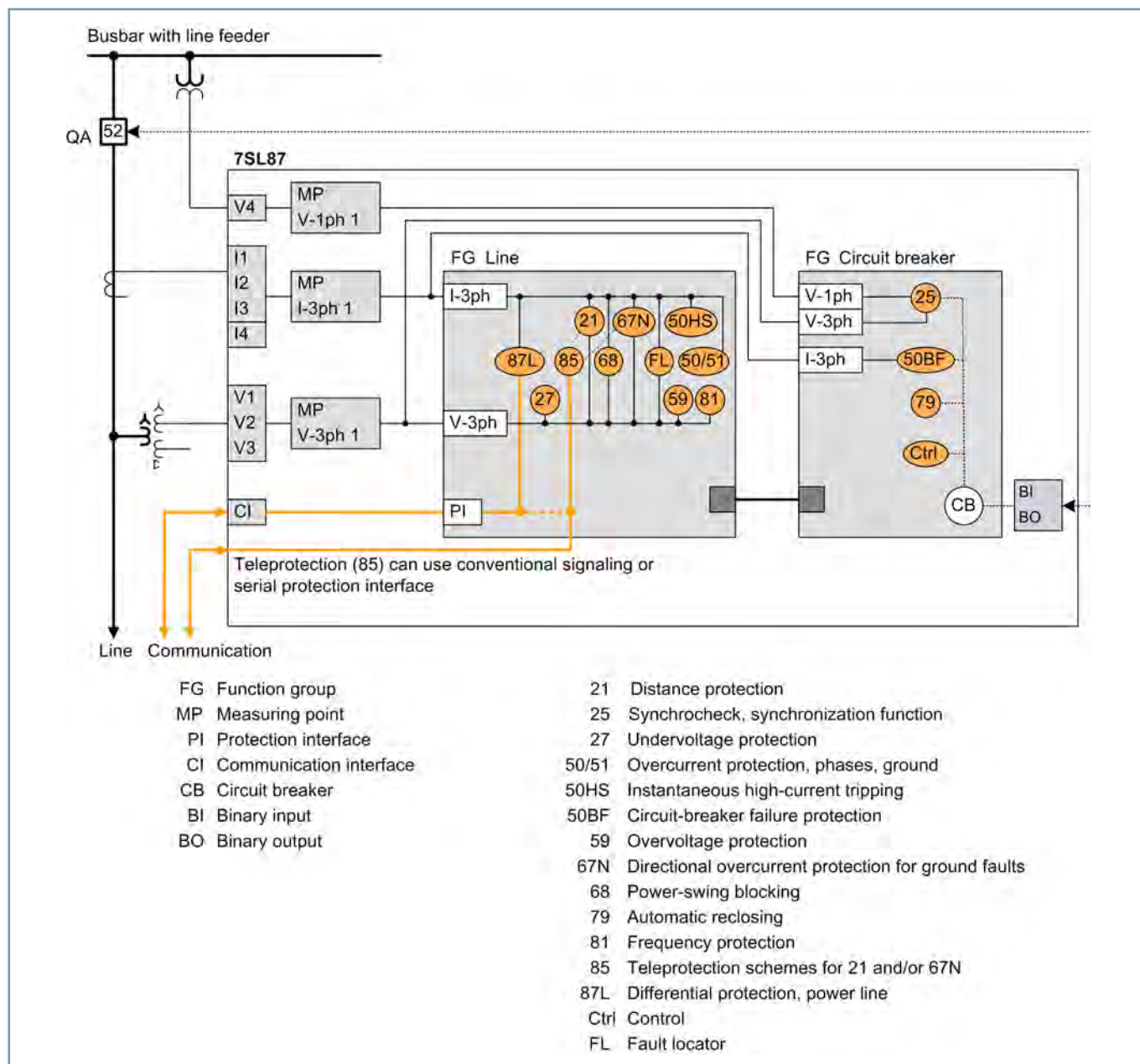

[dw_7SL87_Ltg, 1, en_US]

Figure 2.8/7 Application Example: Combined Line Differential and Distance Protection for Overhead Line

SIPROTEC 5 Devices and Fields of Application

Line Differential and Distance Protection – SIPROTEC 7SL87

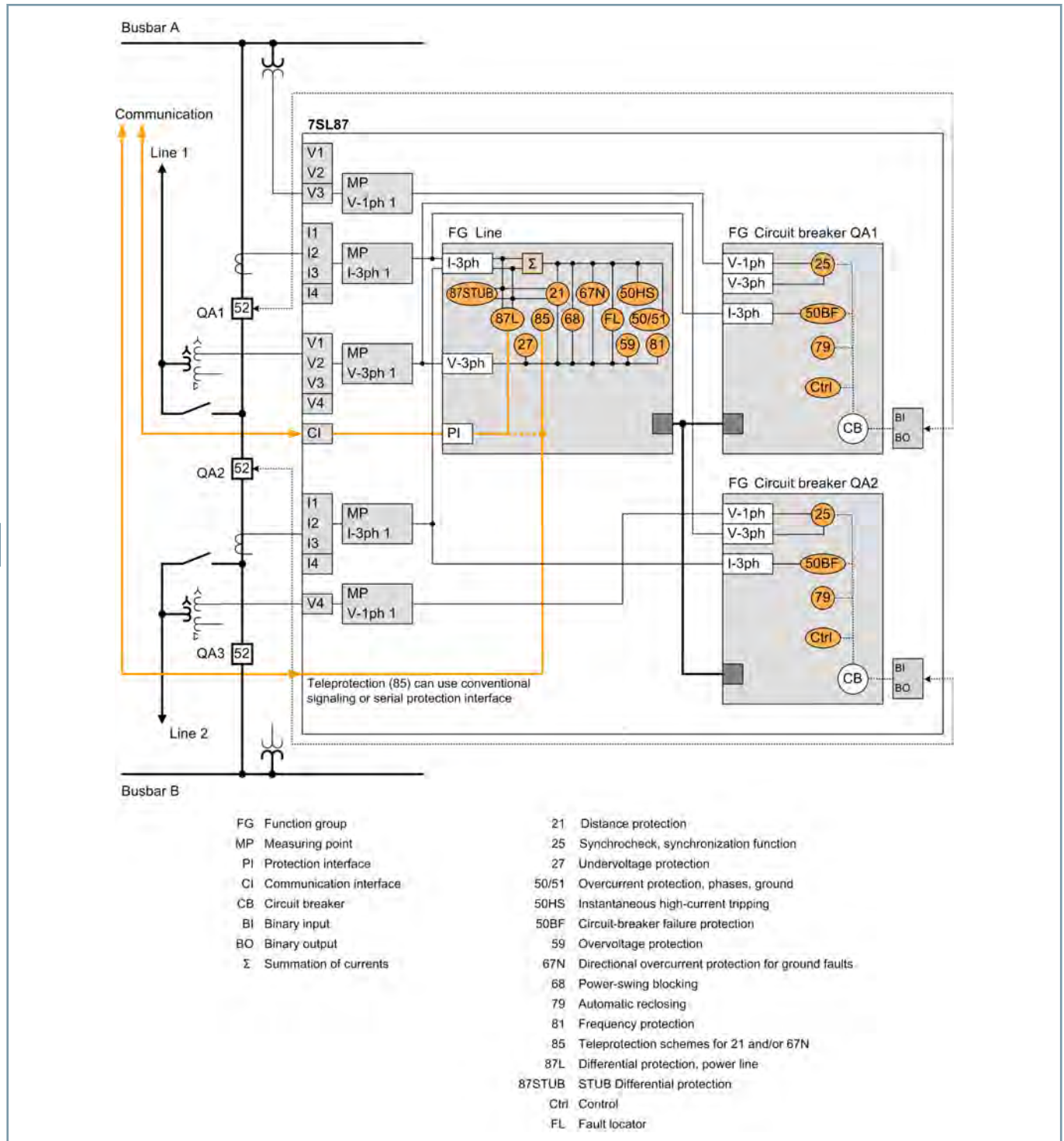

Figure 2.8/8 Application Example: Combined Line Differential and Distance Protection for Overhead Line with Breaker-and-a-Half Layout

SIPROTEC 5 Devices and Fields of Application

Line Differential and Distance Protection – SIPROTEC 7SL87

ANSI	Function	Abbr.	Available	Application Templates		
				1	2	3
	Protection functions for 3-pole tripping	3-pole	■	■	■	■
	Protection functions for 1-pole tripping	1-pole	■	■	■	■
	Expandable hardware quantity structure	I/O	■	■	■	■
	Process bus client protocol (hint: PB client requires a separate ETH-BD-2FO plug-in module, from V8.0)	PB client	■			
	IEC61850-9-2 Merging Unit Stream (hint: Each stream requires a separate ETH-BD-2FO plug-in module, from V8.0)	MU	■			
	IEC61850-9-2 Merging Unit Stream 7SS85 CU (hint: Only for communication with a 7SS85 CU. A separate ETH-BD-2FO plug-in module is required starting with V8.40)	MU	■			
21/21N	Distance Protection	Z<, V< I> Z(V, I)	■	■	■	■
21T	Impedance protection for transformers	Z<	■			
25	Synchrocheck, synchronization function	Sync	■		■	■
27	Undervoltage protection: "3-phase" or "positive-sequence system V1" or "universal Vx"	V<	■			
27R, 59R	Voltage change protection (starting with V8.30)	dV/dt	■			
	Undervoltage-controlled reactive power protection	Q>V<	■			
32, 37	Power protection active/reactive power	P<>, Q<>	■			
37	Undercurrent	I<	■			
38	Temperature supervision	θ>	■			
46	Negative-sequence system overcurrent protection	I2>	■			
46	Negative-sequence system and overcurrent protection with direction	I2>, ∠(V2, I2)	■			
47	Overvoltage protection, negative-sequence system	V2>	■			
49	Thermal overload protection	θ, I²t	■		■	■
50/51 TD	Overcurrent protection, phases	I>	■	■	■	■
	Instantaneous tripping at switch onto fault	SOTF	■			
50HS	Instantaneous high-current tripping	I>>>	■	■	■	■
50/51 TD	Overcurrent protection with positive-sequence current I1 (from V7.9)	I1>	■			
50N/ 51N TD	Overcurrent protection, ground	IN>	■	■	■	■
50N/ 51N TD	Overcurrent protection, 1-phase	IN>	■			
50 Ns/ 51Ns	Sensitive ground-fault detection for grounded arc suppression coils and isolated power systems including a) 3I0> b) admittance Y0>, c) 3I0-harm> (from V7.8)	INs>	■			
	Sensitive ground-fault detection via pulse detection; hint: this stage also requires the function 50Ns/51Ns or 67Ns "sensitive ground-fault detection for grounded arc suppression coils and isolated power systems"	IN pulse	■			
	Intermittent ground-fault protection	IIE>	■			
50BF	Circuit-breaker failure protection 1-pole/3-pole	CBFP	■		■	■
50EF	End-fault protection (hint: For use only in decentralized busbar protection with a 7SS85 CU starting with V8.40)		■			
50RS	Circuit breaker restrike monitoring	CBRM	■			
51V	Voltage-controlled overcurrent protection	t=f(I, V)	■			
59, 59N	Overvoltage protection: "3-phase" or "zero-sequence system V0" or "positive-sequence system V1" or "universal Vx"	V>	■			

SIPROTEC 5 Devices and Fields of Application

Line Differential and Distance Protection – SIPROTEC 7SL87

ANSI	Function	Abbr.	Available	Application Templates		
				1	2	3
60	Voltage-comparison supervision	$\Delta V >$	■			
67	Directional overcurrent protection, phases	$I >, \angle(V, I)$	■			
67N	Directional ground-fault protection in grounded power systems	$IN >, \angle(V, I)$	■		■	■
67 Ns	Sensitive ground-fault detection for grounded arc suppression coils and isolated power systems including a) $3I0 >$ b) $V0 >$, c) cos/sine Phi, d) transient ground fault, e) $\Phi(V, I)$, f) admittance		■			
	Directional tripping stage with one harmonic; hint: this stage also requires the function "67Ns sensitive ground-fault detection for grounded arc suppression coils and isolated power systems"	$\angle(V0h, I0h)$	■			
	Directional Intermittent Ground-Fault Protection	$IIEdir >$	■			
68	Power-swing blocking	$\Delta Z/\Delta t$	■		■	■
74TC	Trip-circuit supervision		■			
78	Out-of-step protection	$\Delta Z/\Delta t$	■			
79	Automatic reclosing, 1-pole/3-pole	AREC	■		■	■
SAD	Secondary arc detection (SAD) in 1-pole automatic reclosing cycles starting with V8.30; note: SAD also requires the function points for "79 automatic reclosing, pole/3-pole"	SAD	■			
81	Frequency protection: "f>" or "f<" or "df/dt"	$f <>; df/dt <>$	■			
81U	Underfrequency load shedding	$f <(ULS)$	■			
	Vector-jump protection	$\Delta \varphi >$	■			
85/21	Teleprotection scheme for distance protection		■	■	■	■
85/27	Weak or no infeed: Echo and tripping		■	■	■	■
85/67N	Teleprotection scheme for directional ground-fault protection		■	■	■	■
86	Lockout		■			
87N T	Restricted ground-fault protection	ΔIN	■			
87L	Line differential protection for 2 line ends	ΔI	■	■	■	■
87L	Line differential protection for 3 to 6 line ends (dependent on significant properties)	ΔI	■	■	■	■
87L/ 87T	Option for line differential protection with Transformer in the Protection Range	ΔI	■			
	Option for line differential protection with charging-current compensation	ΔI	■			
	Broken-wire detection for differential protection		■			
87 STUB	Stub fault differential protection (for breaker-and-a-half layouts)		■			■
90 V	Voltage controller for two-winding transformer		■			
90 V	Voltage controller for three-winding transformer		■			
90 V	Voltage controller for grid coupling transformer		■			
FL	Fault Locator, single-side	FL-one	■	■	■	■
FL	Fault Locator Plus (from V7.9)	FL plus	■			
PMU	Synchrophasor measurement	PMU	■			
AFD	Arc protection (only with plug-in module ARC-CD-3FO)		■			
	Measured values, standard		■	■	■	■
	Measured values, extended: Min, max, average		■			
	Switching statistics counter		■	■	■	■
	PQ – Basic measured values: THD (Total Harmonic Distortion) and harmonic component (starting with V8.01) and THD voltage average values (starting with V8.40)		■			

2.8

SIPROTEC 5 Devices and Fields of Application

Line Differential and Distance Protection – SIPROTEC 7SL87

ANSI	Function	Abbr.	Available	Application Templates		
				1	2	3
	PQ – Basic measured values: Voltage unbalance (starting with V8.40)		■			
	PQ – Basic measured values: Voltage changes – monitoring of voltage dips, overvoltages and voltage interruptions (starting with V8.40)		■			
	PQ – Basic measured values: TDD - Total Demand Distortion (starting with V8.40)		■			
	CFC (standard, control)		■	■	■	■
	CFC arithmetic		■			
	Circuit-breaker wear monitoring	ΣIx, I ² t, 2P	■			
	Switching sequence function		■			
	Inrush-current detection		■			
	External trip initiation		■	■	■	■
	Control		■	■	■	■
PoW	Point-on-wave switching (starting with V7.90)	PoW	■			
	Circuit breaker		■	■	■	■
	Disconnectors/grounding conductor		■			■
	Fault recording of analog and binary signals		■	■	■	■
	Monitoring		■	■	■	■
	Protection interface, serial		■	■	■	■
	Region, France: Overload protection for 'PSL-PSC' lines		■			
	Region, France: 'MAXI-L' overcurrent protection		■			
	Region, France: 'PDA' system decoupling protection		■			
	Region, France: Overload protection for transformers		■			
	Frequency group tracking (from V7.8)		■			
	Cyber security: Role-Based Access Control (from V7.8)		■			
	Temperature recording via communication protocol		■			
	Cyber security: Authenticated network access using IEEE 802.1X (starting from V8.3)		■			
Function point class:				0	225	400
The configuration and function point class for your application can be determined in the SIPROTEC 5 order configurator at www.siemens.com/siprotec .						

2.8

Table 2.8/3 SIPROTEC 7SL87 – Functions, Application Templates

- (1) Basic
- (2) DIFF/DIS RMD Overhead Line, grounded power systems
- (3) DIFF/DIS RMD Overhead Line, grounded power systems, 1.5 CB

SIPROTEC 5 Devices and Fields of Application

Circuit-Breaker Management Device – SIPROTEC 7VK87

Description

The circuit-breaker management device SIPROTEC 7VK87 has specifically been designed for circuit-breaker management. With its modular structure, flexibility and the high-performance DIGSI 5 engineering tool, the SIPROTEC 7VK87 device offers future-oriented solutions for protection, control, automation, monitoring, and Power Quality – Basic.

Main function	Automatic reclosing function, synchrocheck, circuit-breaker failure protection
Tripping	1-pole and 3-pole or 3-pole
Inputs and outputs	12 predefined standard variants with 4/4 or 8/8 current transformers/voltage transformers, 5 to 31 binary inputs, 8 to 46 binary outputs
Hardware flexibility	Flexibly adjustable I/O quantity structure within the scope of the SIPROTEC 5 modular system
Housing width	1/3 × 19 inches to 2/1 × 19 inches

Benefits

- Safe and reliable automation and control of your systems
- Purposeful and easy handling of devices and software thanks to a user-friendly design
- Cybersecurity in accordance with NERC CIP and BDEW White-paper requirements
- Highest availability even under extreme environmental conditions by standard coating of the modules

Functions

DIGSI 5 permits all functions to be configured and combined as required and as per the functional scope that has been ordered.

- 1-pole automatic reclosing function with secondary arc detection (SAD)
- Circuit-breaker failure protection for 1-pole and 3-pole tripping
- Point-on-wave switching
- Control, synchrocheck, and switchgear interlocking protection
- Voltage controller for transformers
- Fault locator plus for accurate fault location with inhomogeneous line sections and targeted automatic overhead-line section reclosing (AREC)
- Arc protection
- Voltage protection
- Graphical logic editor to create high-performance automation functions in the device
- Single-line representation in the small or large display
- Fixed integrated electrical Ethernet RJ45 interface for DIGSI 5 and IEC 61850 (reporting and GOOSE)
- Up to 4 optional, pluggable communication modules, usable for different and redundant protocols (IEC 61850-8-1, IEC 61850-9-2 Client, IEC 60870-5-103, IEC 60870-5-104, Modbus TCP, DNP3 serial and TCP, PROFINET IO, PROFINET IO S2 redundancy)
- Virtual network partitioning (IEEE 802.1Q - VLAN)



[SIP5_GD_SS_W3, 2, --, --]

Figure 2.9/1 SIPROTEC 5 Device with Expansion Module

- Serial protection communication via optical fibers, two-wire connections, and communication networks (IEEE C37.94 and others), including automatic switchover between ring and chain topology.
- PQ – Basic: Voltage unbalance; voltage changes: overvoltage, dip, interruption; TDD, THD, and harmonics
- Reliable data transmission via PRP and HSR redundancy protocols
- Extensive cybersecurity functionality, such as role-based access control (RBAC), logging of security-related events, signed firmware, or authenticated IEEE 802.1X network access
- Simple, fast, and secure access to the device via a standard Web browser to display all information and diagnostic data, vector diagrams, single-line and device display pages
- Phasor Measurement Unit (PMU) for synchrophasor measured values and IEEE C37.118 protocol
- Time synchronization using IEEE 1588
- High-performance fault recording (buffer for a max. record time of 80 s at 8 kHz or 320 s at 2 kHz)
- Auxiliary functions for simple tests and commissioning
- Flexibly adjustable I/O quantity structure within the scope of the SIPROTEC 5 modular system

Applications

- Automatic reclosing after 1/3-pole tripping
- Synchrocheck before reclosing
- Circuit-breaker failure protection
- Also used in switchgear with breaker-and-a-half layout
- Backup overcurrent and voltage protection

SIPROTEC 5 Devices and Fields of Application

Circuit-Breaker Management Device – SIPROTEC 7VK87

- Serial protection communication with SIPROTEC 5 and SIPROTEC 4 devices over different distances and physical media, such as optical fiber, two-wire connections, and communication networks
- Phasor Measurement Unit (PMU)
- Detection and recording of power-quality data in the medium-voltage and subordinate low-voltage power system

Application Template

DIGSI 5 provides application templates for standard applications. They include all basic configurations and default settings.

For SIPROTEC 7VK87, the following application template exists:

- Basic Circuit-breaker management device

Application Example

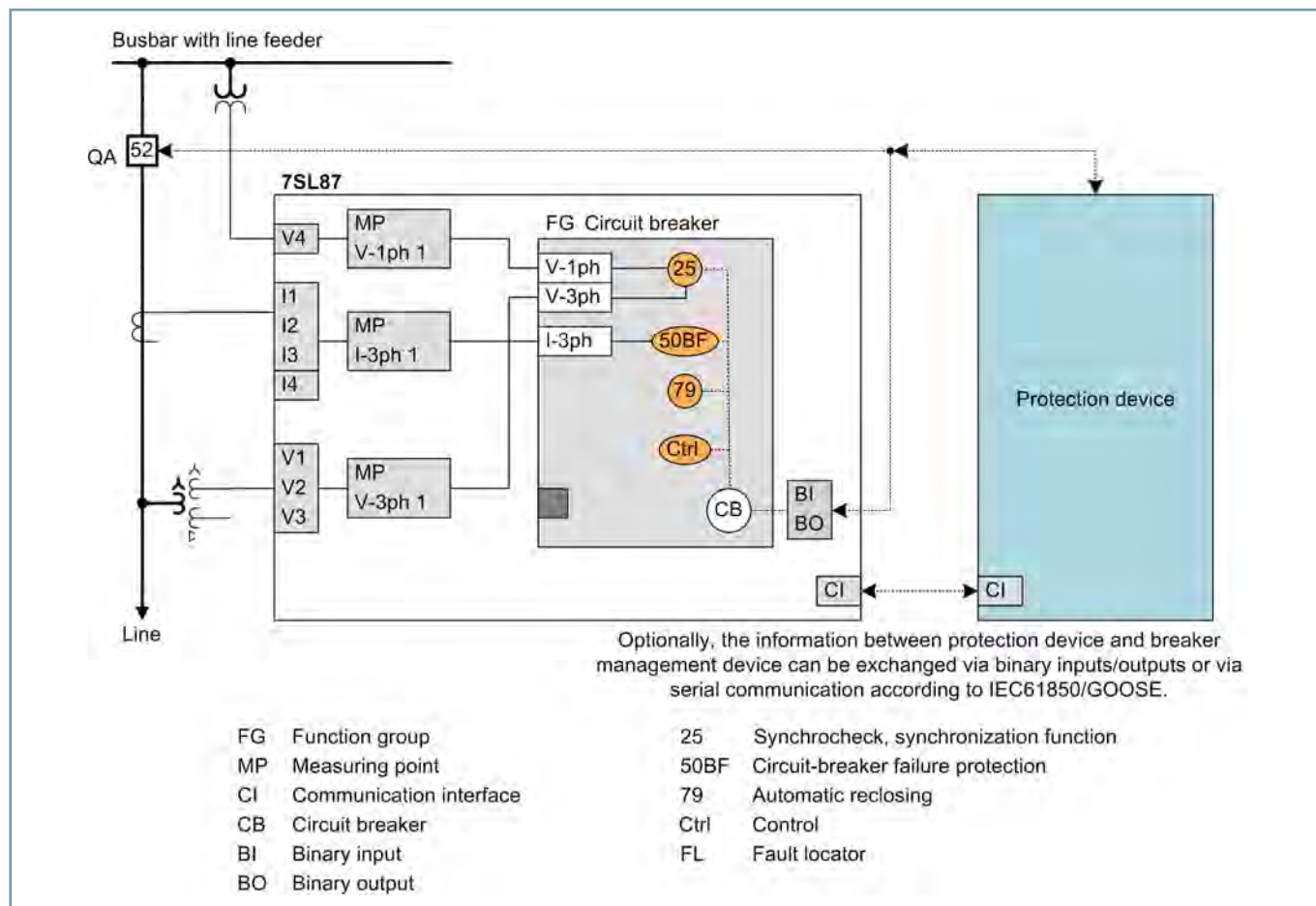

[dw_7VK87_Ltg, 1, en_US]

Figure 2.9/2 Application Example: Circuit-Breaker Failure Protection

SIPROTEC 5 Devices and Fields of Application

Circuit-Breaker Management Device – SIPROTEC 7VK87

ANSI	Function	Abbr.	Available	Application Templates	
					1
	Protection functions for 3-pole tripping	3-pole	■		■
	Protection functions for 1-pole tripping	1-pole	■		■
	Expandable hardware quantity structure	I/O	■		■
	Process bus client protocol (hint: PB client requires a separate ETH-BD-2FO plug-in module, from V8.0)	PB client	■		
	IEC61850-9-2 Merging Unit Stream (hint: Each stream requires a separate ETH-BD-2FO plug-in module, from V8.0)	MU	■		
	IEC61850-9-2 Merging Unit Stream 7SS85 CU (hint: Only for communication with a 7SS85 CU. A separate ETH-BD-2FO plug-in module is required starting with V8.40)	MU	■		
25	Synchrocheck, synchronization function	Sync	■		■
27	Undervoltage protection: "3-phase" or "positive-sequence system V1" or "universal Vx"	V<	■		
27R, 59R	Voltage change protection (starting with V8.30)	dV/dt	■		
32, 37	Power protection active/reactive power	P<>, Q<>	■		
37	Undercurrent	I<	■		
38	Temperature supervision	θ>	■		
46	Negative-sequence system overcurrent protection	I2>	■		
46	Negative-sequence system and overcurrent protection with direction	I2>, ∠(V2, I2)	■		
47	Overvoltage protection, negative-sequence system	V2>	■		
50/51 TD	Overcurrent protection, phases	I>	■		
	Instantaneous tripping at switch onto fault	SOTF	■		
50HS	Instantaneous high-current tripping	I>>>	■		
50/51 TD	Overcurrent protection with positive-sequence current I1 (from V7.9)	I1>	■		
50N/ 51N TD	Overcurrent protection, ground	IN>	■		
50N/ 51N TD	Overcurrent protection, 1-phase	IN>	■		
50BF	Circuit-breaker failure protection 1-pole/3-pole	CBFP	■		■
50EF	End-fault protection (hint: For use only in decentralized busbar protection with a 7SS85 CU starting with V8.40)		■		
50RS	Circuit breaker restrike monitoring	CBRM	■		
59, 59N	Overvoltage protection: "3-phase" or "zero-sequence system V0" or "positive-sequence system V1" or "universal Vx"	V>	■		
60	Voltage-comparison supervision	ΔV>	■		
67	Directional overcurrent protection, phases	I>, ∠(V, I)	■		
67N	Directional ground-fault protection in grounded power systems	IN>, ∠(V, I)	■		
74TC	Trip-circuit supervision		■		
79	Automatic reclosing, 1-pole/3-pole	AREC	■		■
SAD	Secondary arc detection (SAD) in 1-pole automatic reclosing cycles starting with V8.30; note: SAD also requires the function points for "79 automatic reclosing, pole/3-pole"	SAD	■		
81	Frequency protection: "f>" or "f<" or "df/dt"	f<>; df/dt<>	■		
81U	Underfrequency load shedding	f<(ULS)	■		
	Vector-jump protection	Δφ>	■		
86	Lockout		■		
87N T	Restricted ground-fault protection	ΔIN	■		

SIPROTEC 5 Devices and Fields of Application

Circuit-Breaker Management Device – SIPROTEC 7VK87

ANSI	Function	Abbr.	Available	Application Templates
				1
90 V	Voltage controller for two-winding transformer		■	
90 V	Voltage controller for two-winding transformer with parallel control		■	
	Number of two-winding transformers with parallel control (hint: only together with the function "voltage controller for two-winding transformer with parallel control")		■	
90 V	Voltage controller for three-winding transformer		■	
90 V	Voltage controller for grid coupling transformer		■	
FL	Fault Locator, single-side	FL-one	■	
PMU	Synchrophasor measurement	PMU	■	
AFD	Arc protection (only with plug-in module ARC-CD-3FO)		■	
	Measured values, standard		■	■
	Measured values, extended: Min, max, average		■	
	Switching statistics counter		■	■
	PQ – Basic measured values: THD (Total Harmonic Distortion) and harmonic component (starting with V8.01) and THD voltage average values (starting with V8.40)		■	
	PQ – Basic measured values: Voltage unbalance (starting with V8.40)		■	
	PQ – Basic measured values: Voltage changes – monitoring of voltage dips, overvoltages and voltage interruptions (starting with V8.40)		■	
	PQ – Basic measured values: TDD - Total Demand Distortion (starting with V8.40)		■	
	CFC (standard, control)		■	■
	CFC arithmetic		■	
	Circuit-breaker wear monitoring	$\Sigma I_x, I^2t, 2P$	■	
	Switching sequence function		■	
	Inrush-current detection		■	
	External trip initiation		■	■
	Control		■	■
PoW	Point-on-wave switching (starting with V7.90)	PoW	■	
	Circuit breaker		■	■
	Disconnectors/grounding conductor		■	■
	Fault recording of analog and binary signals		■	■
	Monitoring		■	■
	Protection interface, serial		■	
	Region, France: Overload protection for 'PSL-PSC' lines		■	
	Region, France: 'MAXI-L' overcurrent protection		■	
	Region, France: 'PDA' system decoupling protection		■	
	Region, France: Overload protection for transformers		■	
	Frequency group tracking (from V7.8)		■	
	Cyber security: Role-Based Access Control (from V7.8)		■	
	Temperature recording via communication protocol		■	
	Cyber security: Authenticated network access using IEEE 802.1X (starting from V8.3)		■	

SIPROTEC 5 Devices and Fields of Application

Circuit-Breaker Management Device – SIPROTEC 7VK87

ANSI	Function	Abbr.	Available	Application Templates
				1
	Function point class:			0
The configuration and function point class for your application can be determined in the SIPROTEC 5 order configurator at www.siemens.com/siprotec .				

Table 2.9/1 SIPROTEC 7VK87 – Functions, Application Templates

(1) Basic (AREC, Sync., Circuit-breaker failure protection)

SIPROTEC 5 Devices and Fields of Application

Overcurrent Protection as Backup Protection for Line Protection – SIPROTEC 7SJ86

Description

The SIPROTEC 7SJ86 overcurrent protection has specifically been designed as backup or emergency protection for the line protection devices. With its modular structure, flexibility and the high-performance DIGSI 5 engineering tool, the SIPROTEC 7SJ86 device offers future-oriented solutions for protection, control, automation, monitoring, and Power Quality – Basic.

Main function	Overcurrent protection (definite-time overcurrent protection/inverse-time overcurrent protection)
Tripping	3-pole
Inputs and outputs	3 predefined standard variants with 4/4 current transformers/voltage transformers, 11 to 23 binary inputs, 9 to 25 binary outputs
Hardware flexibility	Flexibly adjustable and expandable I/O quantity structure within the scope of the SIPROTEC 5 modular system.
Housing width	1/3 × 19 inches to 2/1 × 19 inches

Benefits

- Safety due to high-performance protection functions
- Purposeful and easy handling of devices and software thanks to a user-friendly design
- Highest availability even under extreme environmental conditions by standard coating of the modules
- Cybersecurity in accordance with NERC CIP and BDEW White-paper requirements

Functions

DIGSI 5 permits all functions to be configured and combined as required and as per the functional scope that has been ordered.

- Overcurrent protection as backup / emergency line protection for all voltage levels with 3-pole tripping
- Optimized tripping times due to directional comparison and protection communication
- Detection of ground faults of any type in compensated or isolated electrical power systems using the following functions: 3I0>, V0>, transient ground fault, $\cos \varphi$, $\sin \varphi$, dir. detection of intermittent ground faults, harmonic detection, and admittance measurement
- Ground-fault detection using the pulse-detection method
- Fault locator plus for accurate fault location with inhomogeneous line sections and targeted automatic overhead-line section reclosing (AREC)
- Arc protection
- Automatic frequency relief for underfrequency load shedding, taking changed infeed conditions due to decentralized power generation into consideration
- Overvoltage and undervoltage protection
- Frequency protection and frequency-change protection for load-shedding applications
- Power protection, configurable as active or reactive-power protection



[SIP5_GD_SS_W3, 2, --, --]

Figure 2.10/1 SIPROTEC 5 Device with Expansion Module

- Directional reactive-power undervoltage protection (QU protection)
- Detection of current and voltage signals up to the 50th harmonic with high accuracy for selected protection functions (such as thermal overload protection) and operational measured values
- PQ – Basic: Voltage unbalance; voltage changes: overvoltage, dip, interruption; TDD, THD, and harmonics
- Control, synchrocheck, and switchgear interlocking protection
- Circuit-breaker failure protection
- Circuit-breaker reignition monitoring
- Graphical logic editor to create high-performance automation functions in the device
- Single-line representation in the small or large display
- Fixed integrated electrical Ethernet RJ45 interface for DIGSI 5 and IEC 61850 (reporting and GOOSE)
- 4 optional, pluggable communication modules, usable for different and redundant protocols (IEC 61850-8-1, IEC 61850-9-2 Client, IEC 60870-5-103, IEC 60870-5-104, Modbus TCP, DNP3 serial and TCP, PROFINET IO, PROFINET IO S2 redundancy)
- Virtual network partitioning (IEEE 802.1Q - VLAN)
- Serial protection communication via optical fibers, two-wire connections, and communication networks (IEEE C37.94 and others), including automatic switchover between ring and chain topology
- Reliable data transmission via PRP and HSR redundancy protocols
- Extensive cybersecurity functionality, such as role-based access control (RBAC), logging of security-related events, signed firmware, or authenticated IEEE 802.1X network access

2.10

SIPROTEC 5 Devices and Fields of Application

Overcurrent Protection as Backup Protection for Line Protection – SIPROTEC 7SJ86

- Simple, fast, and secure access to the device via a standard Web browser to display all information and diagnostic data, vector diagrams, single-line and device display pages
- Phasor Measurement Unit (PMU) for synchrophasor measured values and IEEE C37.118 protocol
- Time synchronization using IEEE 1588
- High-performance fault recording (buffer for a max. record time of 80 s at 8 kHz or 320 s at 2 kHz)
- Auxiliary functions for simple tests and commissioning
- Flexibly adjustable I/O quantity structure within the scope of the SIPROTEC 5 modular system

Applications

- Backup and emergency protection for line protection
- Detection and selective 3-pole tripping of short circuits in electrical equipment of star networks, lines with infeed at 1 or 2 ends, parallel lines and open-circuited or closed ring systems of all voltage levels
- Used in switchgear with breaker-and-a-half layout configuration
- Detection of ground faults in isolated or arc-suppression-coil-ground systems in star, ring, or meshed arrangement
- Serial protection communication with SIPROTEC 5 and SIPROTEC 4 devices over different distances and physical media, such as optical fiber, two-wire connections, and communication networks

- Backup protection for differential protection devices of all kind for lines, transformers, generators, motors, and busbars
- Phasor Measurement Unit (PMU)
- Reverse-power protection
- Detection and recording of power-quality data in the medium-voltage and subordinate low-voltage power system

Application Templates

DIGSI 5 provides application templates for standard applications. They include all basic configurations and default settings.

The following application templates are available:

- SIPROTEC 7SJ86 Non-directional overcurrent protection
- SIPROTEC 7SJ86 Directional overcurrent protection

Application Example

Figure 2.10/2 shows an application example for directional protection of an overhead line. The functional scope is based on the application template **Directional overcurrent protection**. The functions **Instantaneous high-current tripping**, **Fault locator**, and **Automatic reclosing** from the DIGSI 5 library are also used.

SIPROTEC 5 Devices and Fields of Application

Overcurrent Protection as Backup Protection for Line Protection – SIPROTEC 7SJ86

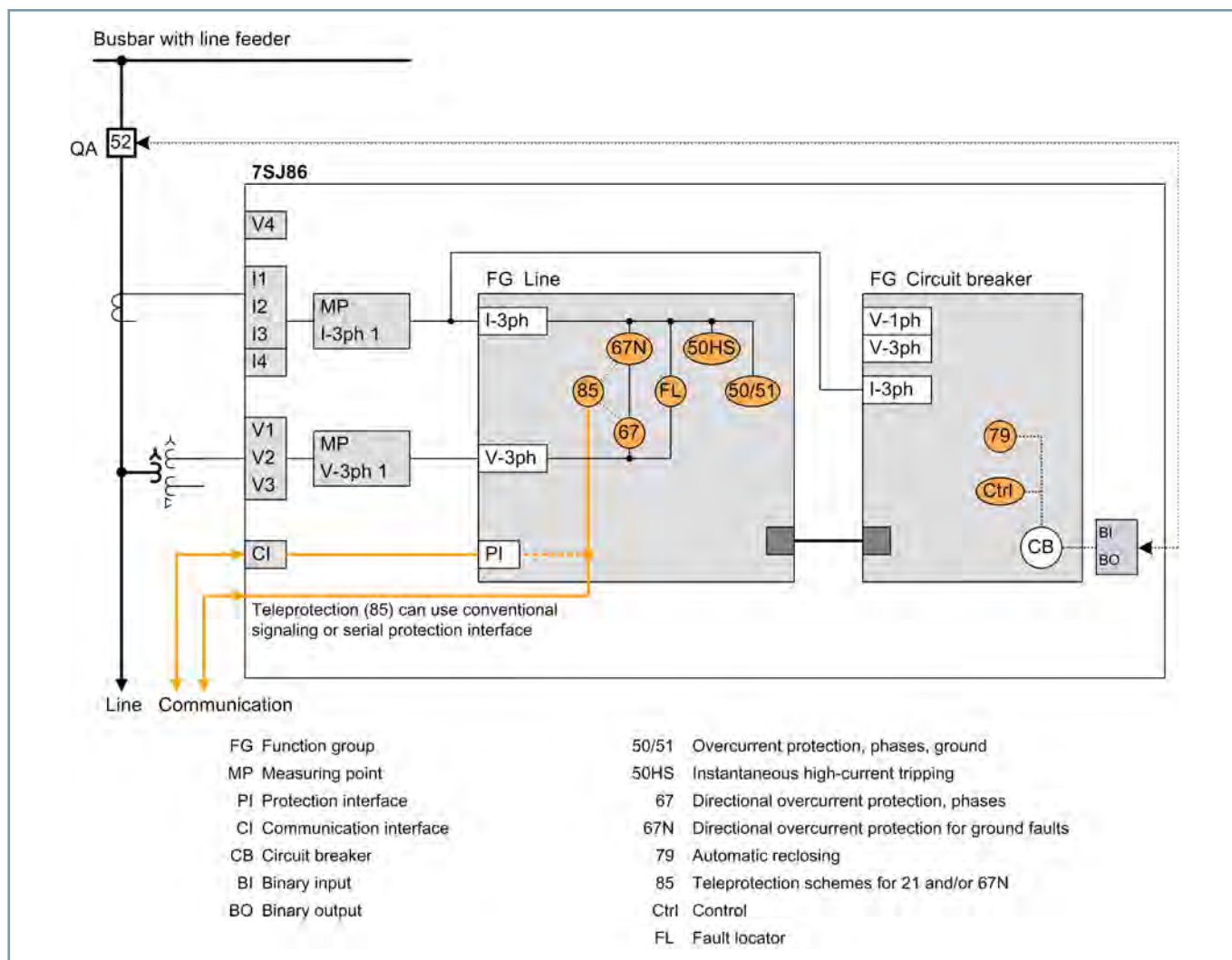

[dw_7SJ86_Ltg_2_en_US]

Figure 2.10/2 Application Example: Directional Overcurrent Protection for Overhead Line

SIPROTEC 5 Devices and Fields of Application

Overcurrent Protection as Backup Protection for Line Protection – SIPROTEC 7SJ86

ANSI	Function	Abbr.	Available	Application Templates	
				1	2
	Protection functions for 3-pole tripping	3-pole	■	■	■
	Expandable hardware quantity structure	I/O	■	■	■
	Process bus client protocol (hint: PB client requires a separate ETH-BD-2FO plug-in module, from V8.0)	PB client	■		
	IEC61850-9-2 Merging Unit Stream (hint: Each stream requires a separate ETH-BD-2FO plug-in module, from V8.0)	MU	■		
	IEC61850-9-2 Merging Unit Stream 7SS85 CU (hint: Only for communication with a 7SS85 CU. A separate ETH-BD-2FO plug-in module is required starting with V8.40)	MU	■		
25	Synchrocheck, synchronization function	Sync	■		
27	Undervoltage protection: "3-phase" or "positive-sequence system V1" or "universal Vx"	V<	■		
27R, 59R	Voltage change protection (starting with V8.30)	dV/dt	■		
	Undervoltage-controlled reactive power protection	Q>/V<	■		
32, 37	Power protection active/reactive power	P<>, Q<>	■		
37	Undercurrent	I<	■		
38	Temperature supervision	θ>	■		
46	Negative-sequence system overcurrent protection	I2>	■		
46	Negative-sequence system and overcurrent protection with direction	I2>, ∠(V2, I2)	■		
47	Overvoltage protection, negative-sequence system	V2>	■		
49	Thermal overload protection	θ, I²t	■		
50/51 TD	Overcurrent protection, phases	I>	■	■	■
	Instantaneous tripping at switch onto fault	SOTF	■		
50HS	Instantaneous high-current tripping	I>>>	■		
50/51 TD	Overcurrent protection with positive-sequence current I1 (from V7.9)	I1>	■		
50N/ 51N TD	Overcurrent protection, ground	IN>	■	■	■
50N/ 51N TD	Overcurrent protection, 1-phase	IN>	■		
50 Ns/ 51Ns	Sensitive ground-fault detection for grounded arc suppression coils and isolated power systems including a) 3I0> b) admittance Y0>, c) 3I0-harm> (from V7.8)	INs>	■		
	Sensitive ground-fault detection via pulse detection; hint: this stage also requires the function 50Ns/51Ns or 67Ns "sensitive ground-fault detection for grounded arc suppression coils and isolated power systems"	IN pulse	■		
	Intermittent ground-fault protection	IIE>	■		
50BF	Circuit-breaker failure protection, 3-pole	CBFP	■		
50EF	End-fault protection (hint: For use only in decentralized busbar protection with a 7SS85 CU starting with V8.40)		■		
50RS	Circuit breaker restrike monitoring	CBRM	■		
51V	Voltage-controlled overcurrent protection	t=f(I, V)	■		
59, 59N	Overvoltage protection: "3-phase" or "zero-sequence system V0" or "positive-sequence system V1" or "universal Vx"	V>	■		
60	Voltage-comparison supervision	ΔV>	■		
67	Directional overcurrent protection, phases	I>, ∠(V, I)	■		■
67N	Directional ground-fault protection in grounded power systems	IN>, ∠(V, I)	■		■

2.10

SIPROTEC 5 Devices and Fields of Application

Overcurrent Protection as Backup Protection for Line Protection – SIPROTEC 7SJ86

ANSI	Function	Abbr.	Available	Application Templates	
				1	2
67 Ns	Sensitive ground-fault detection for grounded arc suppression coils and isolated power systems including a) $3I_0 >$, b) $V_0 >$, c) $\cos/\sin \Phi$, d) transient ground fault, e) $\Phi(V, I)$, f) admittance		■		
	Directional tripping stage with one harmonic; hint: this stage also requires the function "67Ns sensitive ground-fault detection for grounded arc suppression coils and isolated power systems"	$\angle(V_0h, I_0h)$	■		
	Directional Intermittent Ground-Fault Protection	$IIEdir >$	■		
74TC	Trip-circuit supervision		■		
74CC	Single circuit monitoring (from V7.9)		■		
79	Automatic reclosing, 3-pole	AREC	■		
81	Frequency protection: "f" or "f" or "df/dt"	$f < >$; $df/dt < >$	■		
81U	Underfrequency load shedding	$f < (ULS)$	■		
	Vector-jump protection	$\Delta\varphi >$	■		
85/67N	Teleprotection scheme for directional ground-fault protection		■		
86	Lockout		■		■
87N T	Restricted ground-fault protection	ΔI_N	■		
90 V	Voltage controller for two-winding transformer		■		
90 V	Voltage controller for three-winding transformer		■		
90 V	Voltage controller for grid coupling transformer		■		
FL	Fault Locator, single-side	FL-one	■		
FL	Fault Locator Plus (from V7.9)	FL plus	■		
PMU	Synchrophasor measurement	PMU	■		
AFD	Arc protection (only with plug-in module ARC-CD-3FO)		■		
	Measured values, standard		■	■	■
	Measured values, extended: Min, max, average		■		
	Switching statistics counter		■	■	
	PQ – Basic measured values: THD (Total Harmonic Distortion) and harmonic component (starting with V8.01) and THD voltage average values (starting with V8.40)		■		
	PQ – Basic measured values: Voltage unbalance (starting with V8.40)		■		
	PQ – Basic measured values: Voltage changes – monitoring of voltage dips, overvoltages and voltage interruptions (starting with V8.40)		■		
	PQ – Basic measured values: TDD - Total Demand Distortion (starting with V8.40)		■		
	CFC (standard, control)		■	■	■
	CFC arithmetic		■		
	Circuit-breaker wear monitoring	$\Sigma I_x, I^2t, 2P$	■		
	Switching sequence function		■		
	Inrush-current detection		■	■	■
	External trip initiation		■		
	Control		■	■	■
	Circuit breaker		■	■	■
	Disconnect/grounding conductor		■		■
	Fault recording of analog and binary signals		■	■	■
	Monitoring		■	■	■
	Protection interface, serial		■	■	
	Region, France: Overload protection for 'PSL-PSC' lines		■		

2.10

SIPROTEC 5 Devices and Fields of Application

Overcurrent Protection as Backup Protection for Line Protection – SIPROTEC 7SJ86

ANSI	Function	Abbr.	Available	Application Templates	
				1	2
	Region, France: 'MAXI-L' overcurrent protection		■		
	Region, France: 'PDA' system decoupling protection		■		
	Region, France: Overload protection for transformers		■		
	Frequency group tracking (from V7.8)		■		
	Cyber security: Role-Based Access Control (from V7.8)		■		
	Temperature recording via communication protocol		■		
	Cyber security: Authenticated network access using IEEE 802.1X (starting from V8.3)		■		
Function point class:				0	50
The configuration and function point class for your application can be determined in the SIPROTEC 5 order configurator at www.siemens.com/siprotec .					

Table 2.10/1 SIPROTEC 7SJ86 – Functions, Application Templates

- (1) Non-directional definite-time overcurrent protection/inverse-time overcurrent protection (4*1, 4*V)
- (2) Directional definite-time overcurrent protection/inverse-time overcurrent protection – grounded power system

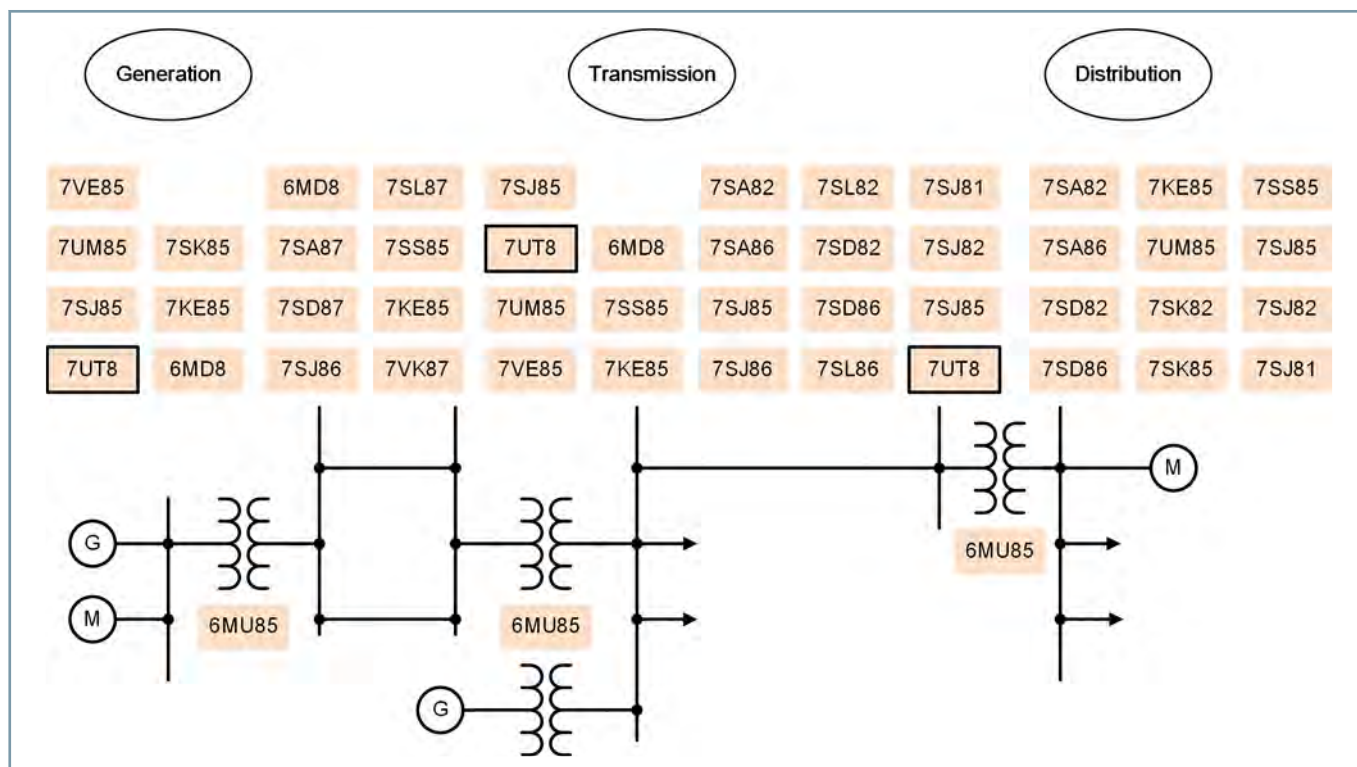

[dw_7UT_anwendung, 4, en_US]

Figure 2.11/1 Fields of Application of the SIPROTEC 5 Devices

SIPROTEC 7UT82, 7UT85, 7UT86, 7UT87

SIPROTEC 5 transformer differential protection devices are multi-functional devices whose main protection functions are based on the differential protection principle. They protect different types of transformer variants, such as two-winding, three-winding, and multi-winding transformers with different numbers of measuring points and, besides standard power transformers, also auto transformers.

The devices can be used at all voltage levels. The large number of protection and automatic functions allows the usage in all sections of electric power supply. The devices contain all important auxiliary functions that are necessary for safe network operation today. This includes control, measurement, and monitoring functions. The large number of communication interfaces and communication protocols satisfies the requirements of communication-based selective protection and of automated operation.

Commissioning and maintenance work can be completed safely, quickly, and thus cost-effectively with high-performance test

functions. Their modular surface mounting allows SIPROTEC 5 transformer differential protection devices always to be adapted flexibly to the requirements.

When ordering, you can select the devices from various standard variants. Additional expansion modules allow you to adapt the device to your specific applications (see Tables of the Standard Variants).

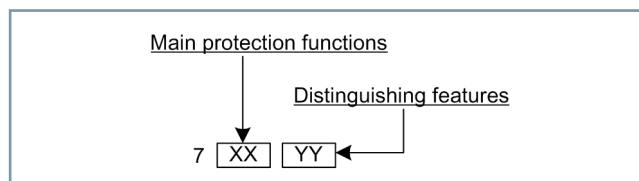

[dw_device_typ, 1, en_US]

Figure 2.11/2 Definition of the Device Types by their Designation

SIPROTEC 5 Devices and Fields of Application

Transformer Differential Protection

Device		Number of Measuring Points			
		I-3ph	I-1ph	V-3ph	V-1ph
7TU82	Two-winding transformer (2 sides and a maximum of 2 measuring points)	2	2	-	-
7TU85	Two-winding transformer (2 sides and a maximum of 5 measuring points; expandable to 3 sides)	5	3	3	2
7TU86	Three-winding transformer (3 sides and a maximum of 6 measuring points; expandable to 4 sides)	6	4	4	3
7TU87	Multi-winding transformer (5 sides and a maximum of 9 measuring points)	9	5	5	3

Table 2.11/1 Essential Differentiating Characteristics

Description

The SIPROTEC 7UT82 transformer differential protection has been designed specifically for the protection of two-winding transformers. It is the main protection for the transformer and contains many other protection and monitoring functions. The additional protection functions can also be used as backup protection for subsequent protected objects (such as short cables and lines, reactance coil (shunt reactors)). The modular expandability of the hardware supports you in this process. With its modular structure, flexibility, and the high-performance DIGSI 5 engineering tool, SIPROTEC 7UT82 offers future-oriented solutions for protection, control, automation, monitoring, and Power Quality – Basic.

Main function	1 differential protection function (standard or auto transformer) with additional stabilization; up to 2 restricted ground-fault protection functions
Usable measuring points	2 x 3-phase current measuring points, 2 x 1-phase current measuring points
Inputs and outputs	1 predefined standard variant with 8 current transformers, 7 binary inputs, 7 binary outputs
Hardware flexibility	The 1/3 base module is available with the IO103 module; it is not possible to add 1/6 expansion modules, available with large and small display
Housing width	1/3 x 19 inches

Benefits

- Compact and low-cost transformer differential protection
- Safety due to high-performance protection functions
- Purposeful and easy handling of devices and software thanks to a user-friendly design
- Cybersecurity in accordance with NERC CIP and BDEW White-paper requirements
- Highest availability even under extreme environmental conditions by standard coating of the modules
- Full compatibility between IEC 61850 Editions 1, 2.0, and 2.1

Functions

DIGSI 5 permits all functions to be configured and combined as required and as per the functional scope that has been ordered.

- Transformer differential protection for two-winding transformers with versatile, additional protection functions
- Transformer differential protection for phase-angle regulating transformers of the single-core transformer type
- Universal usability of the permissible measuring points
- Applicable from average up to extra-high voltage
- Protection of standard power transformers, auto transformers, short lines, cables, shunt reactor and motors
- Increased sensitivity with ground faults near the neutral point through a separate restricted ground-fault protection
- Flexible adaptation to the transformer vector group
- Controlling closing and overexcitation processes



[ph_SIPROTEC 7UT82, 3, --]

Figure 2.11/3 SIPROTEC 7UT82 Transformer Differential Protection (1/3 Device = Standard Variant W1)

- Safe behavior in case of current-transformer saturation with different degrees of saturation
- Adaptive adaptation of the operate curve to the transformer tap position
- Arc protection
- Graphical logic editor to create high-performance automation functions in the device
- Single line representation in the small or large display
- Fixed integrated electrical Ethernet RJ45 interface for DIGSI 5 and IEC 61850 (reporting and GOOSE)
- Up to 2 optional pluggable communication modules, usable for different and redundant protocols (IEC 61850, IEC 60870-5-103, IEC 60870-5-104, Modbus TCP, DNP3 serial and TCP, PROFINET IO)
- Serial protection communication via optical fibers, two-wire connections, and communication networks (IEEE C37.94 and others), including automatic switchover between ring and chain topology
- PQ – Basic: Voltage unbalance; voltage changes: overvoltage, dip, interruption; TDD, THD, and harmonics
- Reliable data transmission via PRP and HSR redundancy protocols
- Extensive cybersecurity functionality, such as role-based access control (RBAC), logging of security-related events, signed firmware, or authenticated IEEE 802.1X network access
- Simple, fast, and secure access to the device via a standard Web browser to display all information and diagnostic data, vector diagrams, single-line and device display pages
- Time synchronization using IEEE 1588

SIPROTEC 5 Devices and Fields of Application

Transformer Differential Protection – SIPROTEC 7UT82

- High-performance fault recording (buffer for a max. record time of 80 s at 8 kHz or 320 s at 2 kHz)
- Auxiliary functions for simple tests and commissioning

Applications

- Protection of special transformers (phase shifters, FACTS and converter transformers, electric arc furnace transformers, HVDC transformers)
- As backup protection for motor and generator differential protection applications
- For the protection of short cables and lines

Application templates are available in DIGSI 5 for standard applications. These include basic configurations and default settings that you can use straight away, or as a template for adjustments depending on the application. The available measuring points make varied applications possible. Before ordering a device, please configure the application with DIGSI 5. The table **Function overview** shows the functional scope of the device. Use the [configurator](#) to determine the necessary function points.

Application Templates

The following application templates are available for the device 7UT82 in the DIGSI 5 function library:

- Two-winding transformer base (Diff. protection)
- Two-winding transformer with restricted ground-fault protection (Diff. protection, CBFP, REF)
- Motor (DIFF protection)

Application Examples

The following examples show the typical structure of an application template, the measuring points used, the function groups used, their internal circuiting, and the predefined functions.

Two-winding transformer basis

- Differential protection
- Overload protection, backup protection for the downstream power system

Two-winding transformer with restricted ground-fault protection (REF) [Figure 2.11/5](#)

- Differential protection
- Restricted ground-fault protection on the neutral side
- Overload protection, backup protection for the downstream power system
- Circuit-breaker failure protection

SIPROTEC 5 Devices and Fields of Application

Transformer Differential Protection – SIPROTEC 7UT82

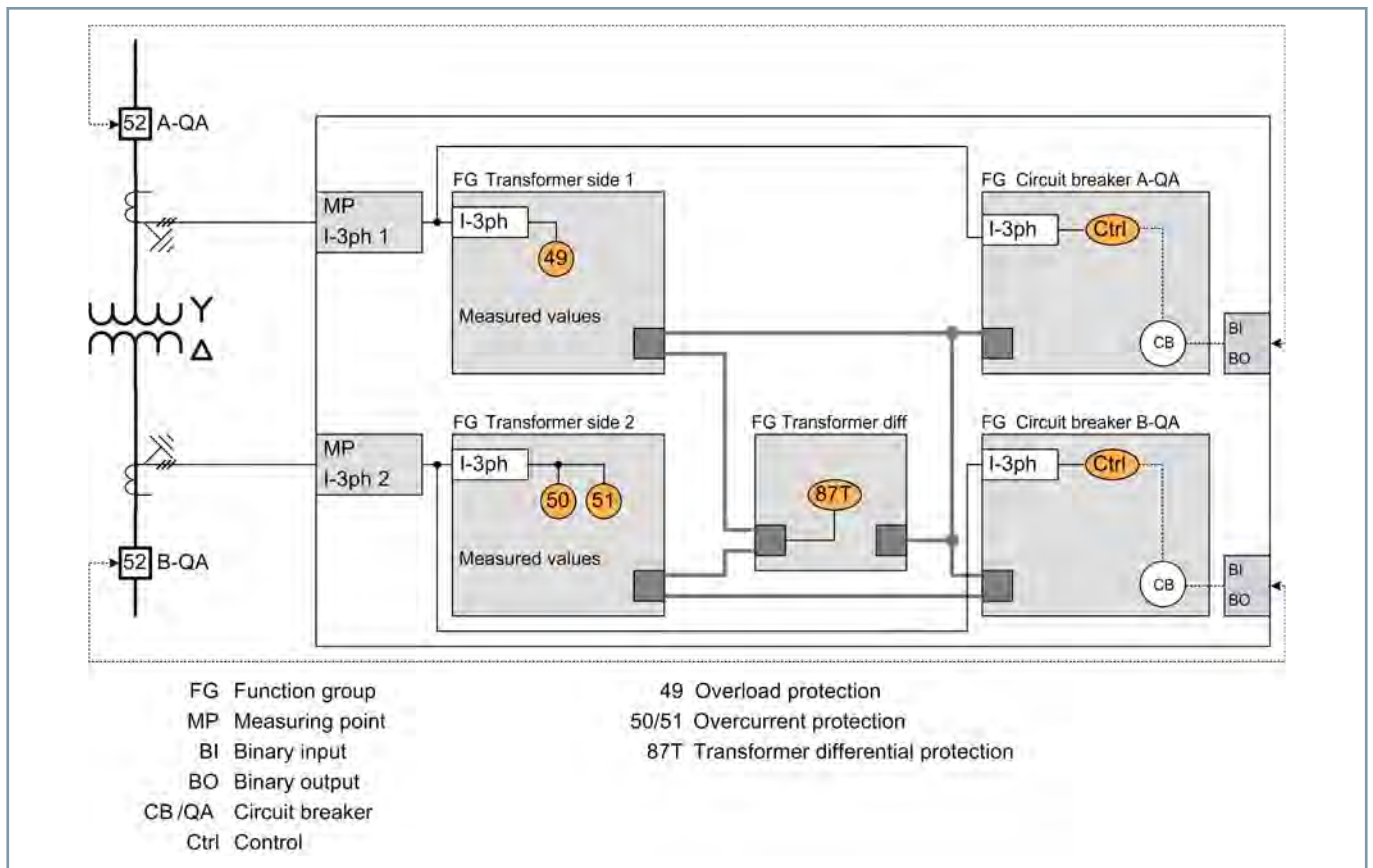

[dw_two-winding-temp_01_2_en_US]

Figure 2.11/4 Application Example: Protection of a Two-Winding Transformer

SIPROTEC 5 Devices and Fields of Application

Transformer Differential Protection – SIPROTEC 7UT82

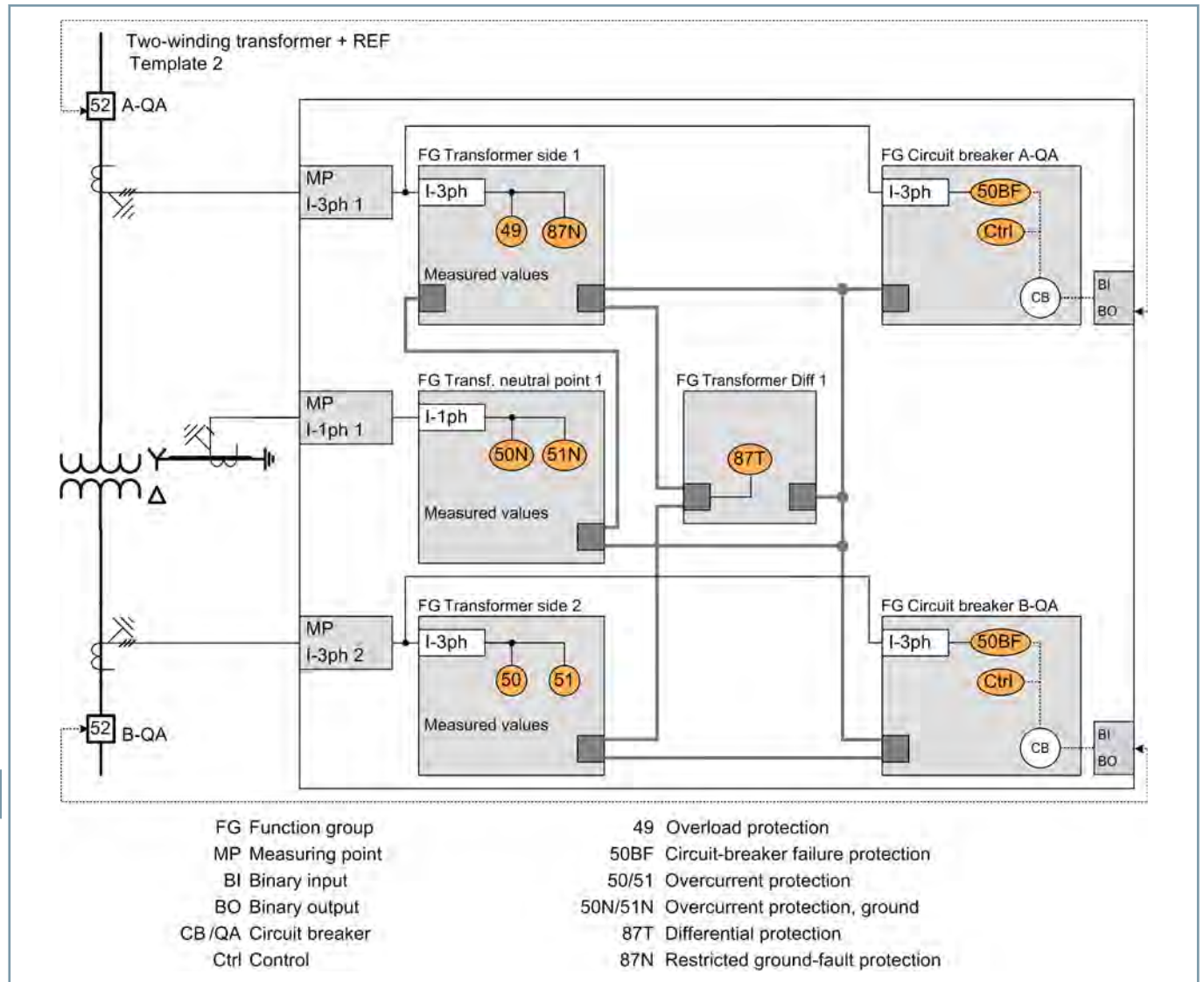

[dw_two-winding-temp_02, 3, en_US]

Figure 2.11/5 Application Example: Protection of a Two-Winding Transformer with Restricted Ground-Fault Protection

SIPROTEC 5 Devices and Fields of Application

Transformer Differential Protection – SIPROTEC 7UT82

ANSI	Function	Abbr.	Available	Application Templates		
				1	2	3
37	Undercurrent	I<	■			
38	Temperature supervision	θ>	■			
46	Negative-sequence system overcurrent protection	I2>	■			
46	Unbalanced-load protection (thermal)	I2 ² t>	■			
49	Thermal overload protection	θ, I ² t	■	■	■	■
49	Thermal overload protection, user-defined characteristic curve	θ, I ² t	■			
49H	Hotspot calculation	θh, I ² t	■			
50/51 TD	Overcurrent protection, phases	I>	■	■	■	■
	Instantaneous tripping at switch onto fault	SOTF	■			
50HS	Instantaneous high-current tripping	I>>>	■			
50/51 TD	Overcurrent protection with positive-sequence current I1 (from V7.9)	I1>	■			
50N/ 51N TD	Overcurrent protection, ground	IN>	■		■	
50N/ 51N TD	Overcurrent protection, 1-phase	IN>	■			
50 Ns/ 51Ns	Sensitive ground-fault detection for grounded arc suppression coils and isolated power systems including a) 3I0> b) admittance Y0>, c) 3I0-harm> (from V7.8)	INs>	■			
	Intermittent ground-fault protection	IIE>	■			
50BF	Circuit-breaker failure protection, 3-pole	CBFP	■		■	
50RS	Circuit breaker restrike monitoring	CBRM	■			
74TC	Trip-circuit supervision		■	■	■	■
74CC	Single circuit monitoring (from V7.9)		■			
86	Lockout		■	■	■	■
87T	Transformer Differential Protection	ΔI	■	■	■	
87T Node	Differential protection (nodal point protection for auto transformer)	ΔI nodes	■			
87T	Differential protection for phase-angle regulating transformers (single core)	ΔI	■			
87N T	Restricted ground-fault protection	ΔIN	■		■	
87M	Differential motor protection	ΔI	■			■
87G	Generator differential protection	ΔI	■			
AFD	Arc protection (only with plug-in module ARC-CD-3FO)		■			
	Measured values, standard		■	■	■	■
	Measured values, extended: Min, max, average		■			
	Switching statistics counter		■	■	■	■
	PQ – Basic measured values: THD (Total Harmonic Distortion) and harmonic component (starting with V8.01) and THD voltage average values (starting with V8.40)		■			
	PQ – Basic measured values: Voltage unbalance (starting with V8.40)		■			
	PQ – Basic measured values: Voltage changes – monitoring of voltage dips, overvoltages and voltage interruptions (starting with V8.40)		■			
	PQ – Basic measured values: TDD - Total Demand Distortion (starting with V8.40)		■			
	CFC (standard, control)		■	■	■	■
	CFC arithmetic		■			
	Circuit-breaker wear monitoring	ΣIx, I ² t, 2P	■			
	Switching sequence function		■			
	Inrush-current detection		■	■	■	■
	External trip initiation		■			

SIPROTEC 5 Devices and Fields of Application

Transformer Differential Protection – SIPROTEC 7UT82

ANSI	Function	Abbr.	Available	Application Templates		
				1	2	3
	Control		■	■	■	■
	Circuit breaker		■	■	■	■
	Disconnect/grounding conductor		■			
	Fault recording of analog and binary signals		■	■	■	■
	Monitoring		■	■	■	■
	Protection interface, serial		■			
	Frequency group tracking (from V7.8)		■			
	Cyber security: Role-Based Access Control (from V7.8)		■			
	Temperature recording via communication protocol		■			
	Cyber security: Authenticated network access using IEEE 802.1X (starting from V8.3)		■			
Function point class:				0	30	0
The configuration and function point class for your application can be determined in the SIPROTEC 5 order configurator at www.siemens.com/siprotec .						

Table 2.11/2 SIPROTEC 7UT82 – Functions, Application Templates

- (1) 2-Winding Transformer Base (DIFF protection)
- (2) 2-Winding Transformer (DIFF protection, SVS, REF)
- (3) Motor (DIFF protection)

Standard Variant for SIPROTEC 7UT82	
W1	1/3, 7 BI, 7 BO, 8 I Housing width 1/3 x 19" 7 binary inputs 7 binary outputs (1 life contact, 6 standard) 8 current transformers Contains the following modules: Base module with PS101 and IO103



Table 2.11/3 Standard Variants for Transformer Differential Protection Devices

You can find the technical data of the devices in the manual www.siemens.com/siprotec.

SIPROTEC 5 Devices and Fields of Application

Transformer Differential Protection – SIPROTEC 7UT85

Description

The SIPROTEC 7UT85 transformer differential protection device has been designed specifically for the protection of two-winding transformers (2 sides). It is the main protection for the transformer and contains many other protection and monitoring functions. The additional protection functions can also be used as backup protection for subsequent protected objects (such as short cables and lines, reactance coil (shunt reactors)).

With its modular structure, flexibility, and the high-performance DIGSI 5 engineering tool, SIPROTEC 7UT85 offers future-oriented solutions for protection, control, automation, monitoring, and Power Quality – Basic.

Main function	1 differential protection function (standard or auto transformer) with additional stabilization; up to 2 restricted ground-fault protection functions Interoperability of SIPROTEC 4 and SIPROTEC 5 line protection devices when using the line differential protection function in the 7UT85, 86, 87
Usable measuring points	5 x 3-phase current measuring points, 3 x 1-phase current measuring points, 3 x 3-phase voltage measuring points; expandable to 3 sides
Inputs and outputs	2 predefined standard variants with 8 current transformers, 7 to 19 binary inputs, 7 to 23 binary outputs
Hardware flexibility	Flexibly adjustable and expandable I/O quantity structure within the scope of the SIPROTEC 5 modular system.
Housing width	1/3 x 19 inches to 2/1 x 19 inches

Benefits

- Safety due to high-performance protection functions
- Purposeful and easy handling of devices and software thanks to a user-friendly design
- Highest availability even under extreme environmental conditions by standard coating of the modules
- Cybersecurity in accordance with NERC CIP and BDEW White-paper requirements
- Full compatibility between IEC 61850 Editions 1, 2.0, and 2.1

Functions

With the Disconnection of measuring points function, you can disconnect the I-3ph measuring point from a protection function group. If the measuring point has been disconnected, you can perform any work without influencing the work of the protection functions that have been assigned to the measuring point. After disconnection of the measuring point, the differential protection, for example, stops taking the measured values of this measuring point into account for calculating the differential current.

DIGSI 5 permits all functions to be configured and combined as required and as per the functional scope that has been ordered.



[SIP5_GD_SS_W3, 2, --, --]

Figure 2.11/6 SIPROTEC 7UT85 Transformer Differential Protection (1/2 Device = Standard Variant P1)

- Transformer differential protection for two-winding transformers with versatile, additional protection functions; expandable to 3 windings
- Transformer differential protection for phase-angle regulating transformers of the single-core type and special transformers
- Universal usability of the permissible measuring points
- Applicable from average up to extra-high voltage
- Protection of standard power transformers, auto transformers, short lines, cables, shunt reactor, and motors
- Typical properties of a transformer differential protection such as flexible adaptation to the transformer vector group, control of inrush and overexcitation processes, safe behavior in case of current-transformer saturation with different degrees of saturation
- Adaptive adaptation of the operate curve to the transformer tap position
- Increased sensitivity with ground faults near the neutral point through a separate restricted ground-fault protection
- Point-on-wave switching
- Additional current and voltage inputs can be added for standard protection functions, such as overcurrent, voltage, frequency protection, etc.
- Fault locator plus for accurate fault location with inhomogeneous line sections and targeted automatic overhead-line section reclosing (AREC)
- Arc protection
- Voltage-controller function ANSI 90V for two-winding transformers, three-winding transformers, and grid coupling transformers with parallel control (master/follower, circulating reactive current minimization)

SIPROTEC 5 Devices and Fields of Application

Transformer Differential Protection – SIPROTEC 7UT85

2.11

- Dynamic voltage control (DSR) for adaptation of the voltage set point value using a characteristic curve that depends on the power direction with a large infeed of renewable energies.
- Graphical logic editor to create high-performance automation functions in the device
- Up to 4 pluggable communication modules, usable for different and redundant protocols (IEC 61850-8-1, IEC 61850-9-2 Client, IEC 60870-5-103, IEC 60870-5-104, Modbus TCP, DNP3 serial and TCP, PROFINET IO, PROFINET IO S2 redundancy)
- Virtual network partitioning (IEEE 802.1Q - VLAN)
- Reliable data transmission via PRP and HSR redundancy protocols
- Extensive cybersecurity functionality, such as role-based access control (RBAC), logging of security-related events, signed firmware, or authenticated IEEE 802.1X network access
- Simple, fast, and secure access to the device via a standard Web browser to display all information and diagnostic data, vector diagrams, single-line and device display pages
- Serial protection communication via optical fibers, two-wire connections, and communication networks (IEEE C37.94 and others), including automatic switchover between ring and chain topology
- PQ – Basic: Voltage unbalance; voltage changes: overvoltage, dip, interruption; TDD, THD, and harmonics
- Detecting operational measured variables and protection-function measured values to evaluate the systems, to support commissioning, and to analyze faults
- Frequency tracked protection functions over a wide frequency range (10 Hz to 90 Hz) and the option to assign the protection functions in a single device to different frequency tracking groups.
- Phasor Measurement Unit (PMU) for synchrophasor measured values and IEEE C37.118 protocol
- High-performance fault recording (buffer for a max. record time of 80 s at 8 kHz or 320 s at 2 kHz)
- Auxiliary functions for simple tests and commissioning
- Flexibly adjustable I/O quantity structure within the scope of the SIPROTEC 5 modular system

Applications

- Protection of special transformers (phase shifters, FACTS and converter transformers, electric arc furnace transformers, HVDC transformers)
- As backup protection for motor and generator differential protection applications
- For the protection of short cables and lines

- Voltage control for two-winding and three-winding transformers with parallel control
- As additional line protection function such as distance and line differential protection

Application templates are available in DIGSI 5 for standard applications. These include basic configurations and default settings that you can use straight away, or as a template for adjustments depending on the application. The available measuring points make varied applications possible. Before ordering a device, please configure the application with DIGSI 5. The table **Function overview** shows the functional scope of the device. Use the [configurator](#) to determine the necessary function points.

Application Templates

The following application templates are available for the device 7UT85 in the DIGSI 5 function library:

- Two-winding-transformer base (Diff. protection)
- Two-winding transformer with restricted ground-fault protection (Diff. protection, CBFP, REF)
- Two-winding transformer 1.5 CB (DIFF protection, CBFP, REF)
- Two-winding-transformer (Diff. protection, voltage controller)
- Motor (DIFF. protection, CBFP)

Application Examples

The following examples show the typical structure of an application template, the measuring points used, the function groups used, their internal circuiting, and the predefined functions.

Two-winding transformer basis ([Figure 2.11/7](#))

- Differential protection
- Overload protection, backup protection for the downstream power system

Two-winding transformer with restricted ground-fault protection (REF) ([Figure 2.11/8](#))

- Differential protection
- Restricted ground-fault protection on the neutral side
- Overload protection, backup protection for the downstream power system
- Circuit-breaker failure protection

Two-winding transformer in breaker-and-a-half layout ([Figure 2.11/9](#))

- Differential protection
- Restricted ground-fault protection on the neutral side
- Overload protection, backup protection for the downstream power system
- Circuit-breaker failure protection

SIPROTEC 5 Devices and Fields of Application

Transformer Differential Protection – SIPROTEC 7UT85

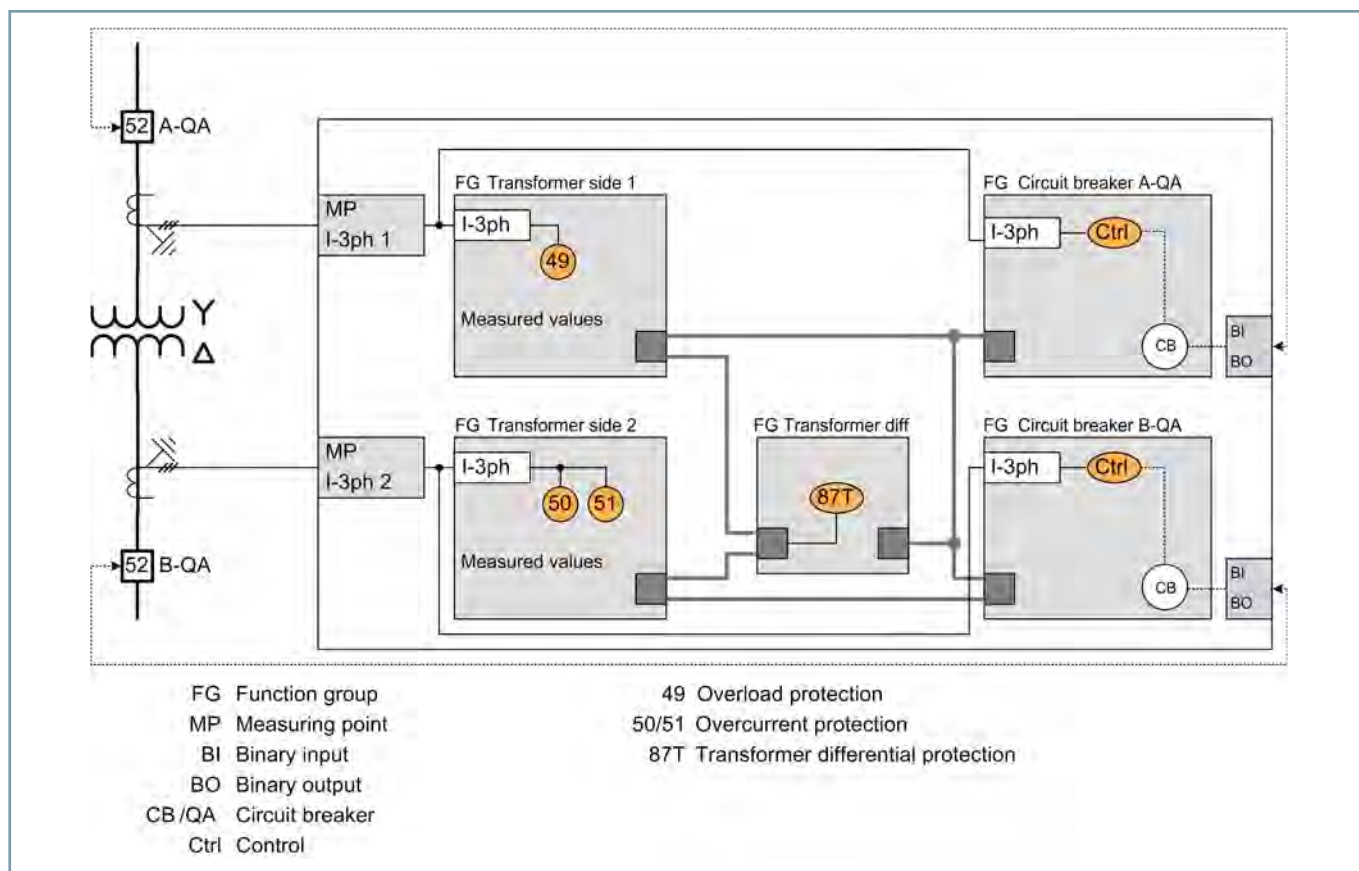

[dw_two-winding-temp_01_2_en_US]

Figure 2.11/7 Application Example: Protection of a Two-Winding Transformer

SIPROTEC 5 Devices and Fields of Application

Transformer Differential Protection – SIPROTEC 7UT85

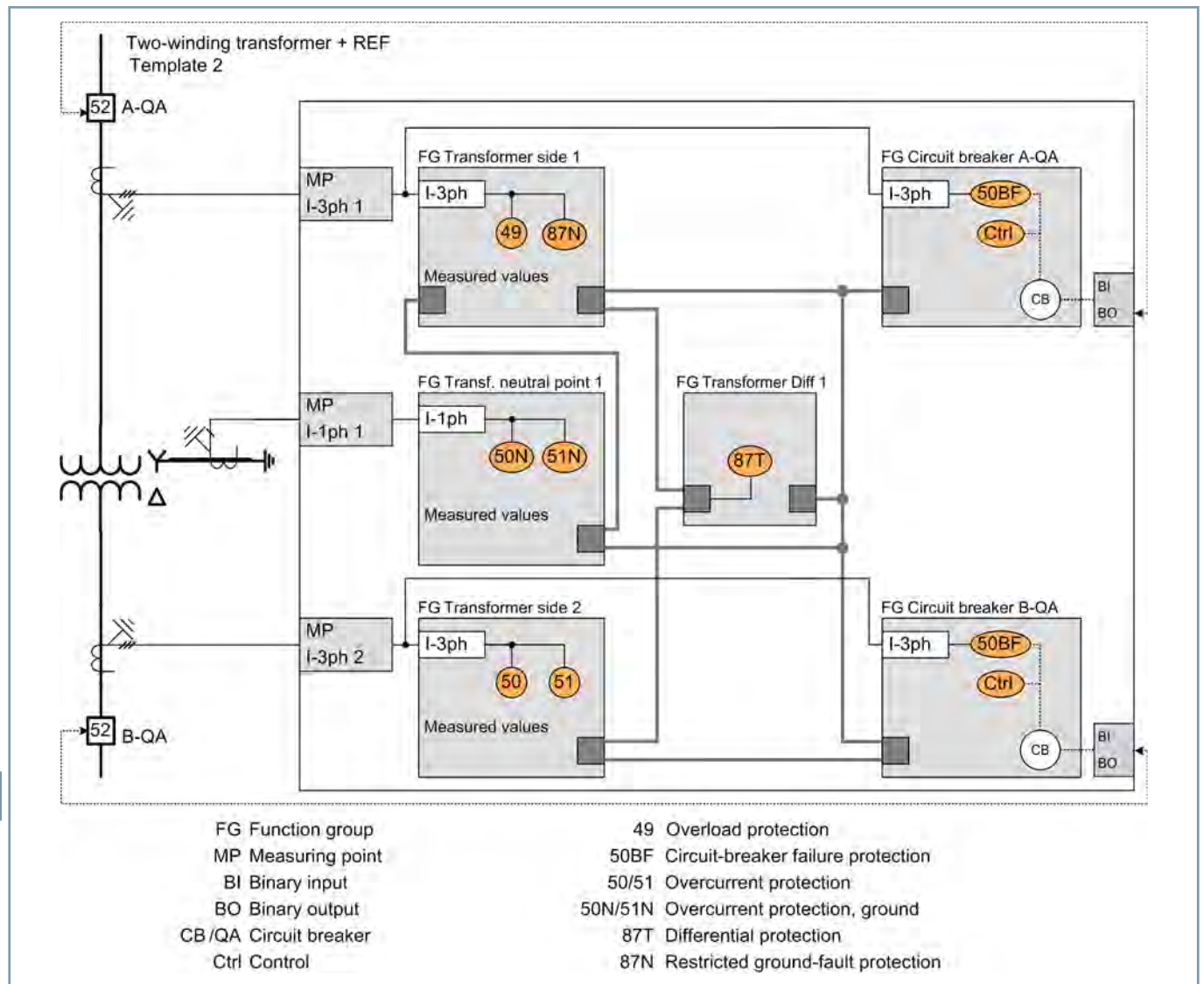

[dw_two-winding-temp_02, 3, en_US]

Figure 2.11/8 Application Example: Protection of a Two-Winding Transformer with Restricted Ground-Fault Protection

SIPROTEC 5 Devices and Fields of Application

Transformer Differential Protection – SIPROTEC 7UT85

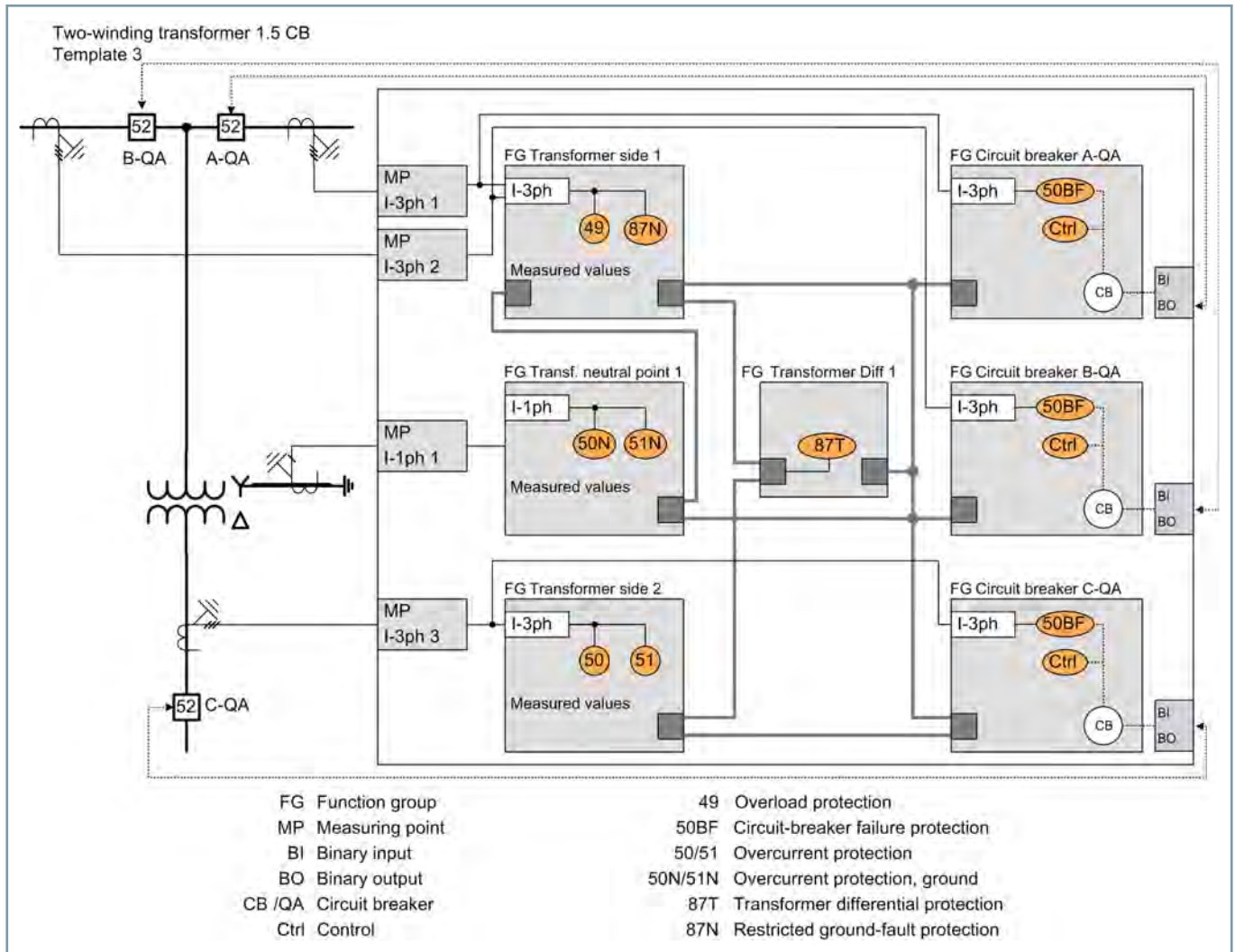

[dw_two-winding-temp_03_3_en_US]

Figure 2.11/9 Application Example: Protection of a Two-Winding Transformer in Breaker-and-a-Half Layout

SIPROTEC 5 Devices and Fields of Application

Transformer Differential Protection – SIPROTEC 7UT85

ANSI	Function	Abbr.	Available	Application Templates				
				1	2	3	4	5
	Expandable hardware quantity structure	I/O	■					
	Process bus client protocol (hint: PB client requires a separate ETH-BD-2FO plug-in module, from V8.0)	PB client	■					
	IEC61850-9-2 Merging Unit Stream (hint: Each stream requires a separate ETH-BD-2FO plug-in module, from V8.0)	MU	■					
	IEC61850-9-2 Merging Unit Stream 7SS85 CU (hint: Only for communication with a 7SS85 CU. A separate ETH-BD-2FO plug-in module is required starting with V8.40)	MU	■					
21/21N	Distance Protection	Z<, V< I> <(V, I)	■					
21T	Impedance protection for transformers	Z<	■					
24	Overexcitation protection	V/f	■					
25	Synchrocheck, synchronization function	Sync	■					
27	Undervoltage protection: "3-phase" or "positive-sequence system V1" or "universal Vx"	V<	■					■
27R, 59R	Voltage change protection (starting with V8.30)	dV/dt	■					
	Undervoltage-controlled reactive power protection	Q>/V<	■					
32, 37	Power protection active/reactive power	P<>, Q<>	■					
32R	Reverse-power protection	- P<	■					
37	Undercurrent	I<	■					
37	Power-plant disconnection protection	-dP	■					
38	Temperature supervision	θ>	■					
46	Negative-sequence system overcurrent protection	I2>	■					■
46	Unbalanced-load protection (thermal)	I2² t>	■					
47	Overvoltage protection, negative-sequence system	V2>	■					
47	Overvoltage protection, negative-sequence system/positive-sequence system	V2/V1>	■					
49	Thermal overload protection	θ, I²t	■	■	■	■	■	■
49	Thermal overload protection, user-defined characteristic curve	θ, I²t	■					
49H	Hotspot calculation	θh, I²t	■					
50/51 TD	Overcurrent protection, phases	I>	■	■	■	■	■	■
	Instantaneous tripping at switch onto fault	SOTF	■					
50HS	Instantaneous high-current tripping	I>>>	■					
50/51 TD	Overcurrent protection with positive-sequence current I1 (from V7.9)	I1>	■					
50N/ 51N TD	Overcurrent protection, ground	IN>	■		■			
50N/ 51N TD	Overcurrent protection, 1-phase	IN>	■			■		
50 Ns/ 51Ns	Sensitive ground-fault detection for grounded arc suppression coils and isolated power systems including a) 3I0> b) admittance Y0>, c) 3I0-harm> (from V7.8)	INs>	■					
	Sensitive ground-fault detection via pulse detection; hint: this stage also requires the function 50Ns/51Ns or 67Ns "sensitive ground-fault detection for grounded arc suppression coils and isolated power systems"	IN pulse	■					
	Intermittent ground-fault protection	IIE>	■					
50BF	Circuit-breaker failure protection, 3-pole	CBFP	■		■	■	■	■

2.11

SIPROTEC 5 Devices and Fields of Application

Transformer Differential Protection – SIPROTEC 7UT85

ANSI	Function	Abbr.	Available	Application Templates				
				1	2	3	4	5
50EF	End-fault protection (hint: For use only in decentralized busbar protection with a 7SS85 CU starting with V8.40)		■					
50RS	Circuit breaker restrike monitoring	CBRM	■					
51V	Voltage-controlled overcurrent protection	$t=f(I, V)$	■					
59, 59N	Overvoltage protection: "3-phase" or "zero-sequence system V0" or "positive-sequence system V1" or "universal Vx"	V>	■				■	■
59	Overvoltage protection: "3-phase" or "positive-sequence system V1" or "universal Vx"	V>	■					
60	Voltage-comparison supervision	$\Delta V>$	■					
67	Directional overcurrent protection, phases	$I>, \angle(V, I)$	■					
67N	Directional overcurrent protection, ground	$IN>, \angle(V, I)$	■					■
67N	Directional ground-fault protection in grounded power systems	$IN>, \angle(V, I)$	■					
67 Ns	Sensitive ground-fault detection for grounded arc suppression coils and isolated power systems including a) $3I0>$ b) $V0>$, c) $\cos/\sin \Phi$, d) transient ground fault, e) $\Phi(V, I)$, f) admittance		■					
	Directional tripping stage with one harmonic; hint: this stage also requires the function "67Ns sensitive ground-fault detection for grounded arc suppression coils and isolated power systems"	$\angle(V0h, I0h)$	■					
	Directional Intermittent Ground-Fault Protection	$IIEdir>$	■					
68	Power-swing blocking	$\Delta Z/\Delta t$	■					
74TC	Trip-circuit supervision		■	■	■	■	■	
74CC	Single circuit monitoring (from V7.9)		■					
79	Automatic reclosing, 3-pole	AREC	■					
81	Frequency protection: "f>" or "f<" or "df/dt"	$f<>; df/dt<>$	■					■
81 AF	Abnormal frequency protection	fBand	■					
81U	Underfrequency load shedding	$f<(ULS)$	■					
	Vector-jump protection	$\Delta \varphi>$	■					
85/21	Teleprotection scheme for distance protection		■					
85/27	Weak or no infeed: Echo and tripping		■					
85/67N	Teleprotection scheme for directional ground-fault protection		■					
86	Lockout		■	■	■	■	■	
87T	Transformer Differential Protection	ΔI	■	■	■	■	■	
87T	Differential protection for special transformers	ΔI	■					
87T Node	Differential protection (nodal point protection for auto transformer)	ΔI nodes	■					
87T	Differential protection for phase-angle regulating transformers (single core)	ΔI	■					
87N T	Restricted ground-fault protection	ΔIN	■		■	■		
87M	Differential motor protection	ΔI	■					■
87G	Generator differential protection	ΔI	■					
87L	Line differential protection for 2 line ends for 7UT8 (communication with 7SD82, 85, 86, 7SL86, 87)	ΔI	■					
	Option for line differential protection with charging-current compensation	ΔI	■					
87 STUB	Stub fault differential protection (for breaker-and-a-half layouts)		■					
90 V	Voltage controller for two-winding transformer		■				■	
90 V	Voltage controller for two-winding transformer with parallel control		■					

SIPROTEC 5 Devices and Fields of Application

Transformer Differential Protection – SIPROTEC 7UT85

ANSI	Function	Abbr.	Available	Application Templates				
				1	2	3	4	5
	Number of two-winding transformers with parallel control (hint: only together with the function "voltage controller for two-winding transformer with parallel control")		■					
90 V	Voltage controller for three-winding transformer		■					
90 V	Voltage controller for grid coupling transformer		■					
FL	Fault Locator, single-side	FL-one	■					
FL	Fault Locator Plus (from V7.9)	FL plus	■					
PMU	Synchrophasor measurement	PMU	■					
AFD	Arc protection (only with plug-in module ARC-CD-3FO)		■					
	Measured values, standard		■	■	■	■	■	■
	Measured values, extended: Min, max, average		■					
	Switching statistics counter		■	■	■		■	
	PQ – Basic measured values: THD (Total Harmonic Distortion) and harmonic component (starting with V8.01) and THD voltage average values (starting with V8.40)		■					
	PQ – Basic measured values: Voltage unbalance (starting with V8.40)		■					
	PQ – Basic measured values: Voltage changes – monitoring of voltage dips, overvoltages and voltage interruptions (starting with V8.40)		■					
	PQ – Basic measured values: TDD - Total Demand Distortion (starting with V8.40)		■					
	CFC (standard, control)		■	■	■	■	■	■
	CFC arithmetic		■					
	Circuit-breaker wear monitoring	$\Sigma I_x, I^2t, 2P$	■					
	Switching sequence function		■					
	Inrush-current detection		■	■	■	■	■	
	External trip initiation		■			■		
	Control		■	■	■	■	■	■
PoW	Point-on-wave switching (starting with V7.90)	PoW	■					
	Circuit breaker		■	■	■	■	■	■
	Disconnect/grounding conductor		■					
	Fault recording of analog and binary signals		■	■	■	■	■	■
	Monitoring		■	■	■	■	■	■
	Protection interface, serial		■					
	Frequency group tracking (from V7.8)		■					
	Transformer side 7UT85		■					
	Cyber security: Role-Based Access Control (from V7.8)		■					
	Temperature recording via communication protocol		■					
	Cyber security: Authenticated network access using IEEE 802.1X (starting from V8.3)		■					
Function point class:				0	30	30	175	50
The configuration and function point class for your application can be determined in the SIPROTEC 5 order configurator at www.siemens.com/siprotec .								

Table 2.11/4 SIPROTEC 7UT85 – Functions, Application Templates

- (1) 2-Winding Transformer Base (DIFF protection)
- (2) 2-Winding Transformer (DIFF protection, SVS, REF)
- (3) 2-Winding Transformer 1.5 CB (DIFF protection, SVS, REF)

SIPROTEC 5 Devices and Fields of Application

Transformer Differential Protection – SIPROTEC 7UT85

- (4) 2-Winding Transformer (DIFF. Protection, Voltage Controller)
- (5) Motor (DIFF protection, CBFP, voltage protection)

SIPROTEC 5 Devices and Fields of Application

Transformer Differential Protection – SIPROTEC 7UT85



Standard Variants for SIPROTEC 7UT85		
O1	1/3, 7 BI, 7 BO, 8 I	
	Housing width 1/3 x 19" 7 binary inputs 7 binary outputs (1 life contact, 2 standard, 4 fast) 8 current transformers Contains the following modules: Base module with PS201 and IO203	
O2	1/2, 19 BI, 23 BO, 8 I	
	Housing width 1/2 x 19" 19 binary inputs, 23 binary outputs (1 life contact, 18 standard, 4 fast) 8 current transformers Contains the following modules: Base module with PS201 and IO203 Expansion module IO205	

Table 2.11/5 Standard Variants for Transformer Differential Protection Devices

You can find the technical data in the manual
www.siemens.com/siprotec.

SIPROTEC 5 Devices and Fields of Application

Transformer Differential Protection – SIPROTEC 7UT86

Description

The SIPROTEC 7UT86 transformer differential protection has been designed specifically for the protection of three-winding transformers (3 sides). It is the main protection for the transformer and contains many other protection and monitoring functions. The additional protection functions can also be used as backup protection for subsequent protected objects (such as short cables and lines, reactance coil (shunt reactors)). The modular expandability of the hardware also supports you in this process. The device supports all SIPROTEC 5 system characteristics. With its modular structure, flexibility, and the high-performance DIGSI 5 engineering tool, SIPROTEC 7UT86 offers future-oriented solutions for protection, control, automation, monitoring, and Power Quality – Basic.

Main function	1 differential protection function (standard) with additional stabilization; up to 3 restricted ground-fault protection functions For auto transformer applications, 2 differential protection functions can be processed in an auto transformer function group. Interoperability of SIPROTEC 4 and SIPROTEC 5 line protection devices when using the line differential protection function in the 7UT85, 86, 87
Usable measuring points	7 x 3-phase current measuring points, 7 x 1-phase current measuring points, 7 x 3-phase and 7 x 1-phase voltage measuring points; expandable to 4 sides
Inputs and outputs	2 predefined standard variants with 12 current transformers, 4 voltage transformers, 11 to 23 binary inputs, 18 to 34 binary outputs
Hardware flexibility	Flexibly adjustable and expandable I/O quantity structure within the scope of the SIPROTEC 5 modular system.
Housing width	1/2 x 19 inches to 2/1 x 19 inches

Benefits

- Safety due to high-performance protection functions
- Purposeful and easy handling of devices and software thanks to a user-friendly design
- Highest availability even under extreme environmental conditions by standard coating of the modules
- Cybersecurity in accordance with NERC CIP and BDEW Whitepaper requirements
- Full compatibility between IEC 61850 Editions 1, 2.0, and 2.1

Functions

DIGSI 5 permits all functions to be configured and combined as required and as per the functional scope that has been ordered.

- Transformer differential protection for three-winding transformers with versatile, additional protection functions; expandable to 4 sides
- Transformer differential protection for phase-angle regulating transformers of the single-core type and special transformers
- Universal usability of the permissible measuring points
- Applicable from average up to extra-high voltage



[SIP5_GD_SS_W3, 2, --, --]

Figure 2.11/10 SIPROTEC 7UT86 Transformer Differential Protection (1/2 Device = Standard Variant P1)

- Protection of standard power transformers, auto transformers, short lines, cables, shunt reactor, and motors
- Typical properties of a transformer differential protection such as flexible adaptation to the transformer vector group, control of inrush, and overexcitation processes, safe behavior in case of current-transformer saturation with different degrees of saturation
- Adaptive adaptation of the operate curve to the transformer tap position
- Increased sensitivity with ground faults near the neutral point through a separate restricted ground-fault protection
- Point-on-wave switching
- Additional current and voltage inputs can be added for standard protection functions, such as overcurrent, voltage, frequency, protection etc.
- Dynamic voltage control (DSR) for adaptation of the voltage set point value using a characteristic curve that depends on the power direction with a large infeed of renewable energies.
- Graphical logic editor to create high-performance automation functions in the device
- Fault locator plus for accurate fault location with inhomogeneous line sections and targeted automatic overhead-line section reclosing (AREC)
- Arc protection
- Voltage-controller function ANSI 90V for two-winding transformers, three-winding transformers, and grid coupling transformers with parallel control (master/follower, circulating reactive current minimization)

2.11

SIPROTEC 5 Devices and Fields of Application

Transformer Differential Protection – SIPROTEC 7UT86

- Up to 4 pluggable communication modules, usable for different and redundant protocols (IEC 61850-8-1, IEC 61850-9-2 Client, IEC 60870-5-103, IEC 60870-5-104, Modbus TCP, DNP3 serial and TCP, PROFINET IO, PROFINET IO S2 redundancy)
- Virtual network partitioning (IEEE 802.1Q - VLAN)
- Reliable data transmission via PRP and HSR redundancy protocols
- Extensive cybersecurity functionality, such as role-based access control (RBAC), logging of security-related events, signed firmware, or authenticated IEEE 802.1X network access
- Simple, fast, and secure access to the device via a standard Web browser to display all information and diagnostic data, vector diagrams, single-line and device display pages
- Secure serial protection communication, also over great distances and all available physical media (optical fiber, two-wire connections, and communication networks)
- PQ – Basic: Voltage unbalance; voltage changes: overvoltage, dip, interruptions; TDD, THD, and harmonics
- Detecting operational measured variables and protection-function measured values to evaluate the systems, to support commissioning, and to analyze faults
- Frequency tracked protection functions over a wide frequency range (10 Hz to 90 Hz) and the option to assign the protection functions in a single device to different **frequency tracking groups**.
- Phasor Measurement Unit (PMU) for synchrophasor measured values and IEEE C37.118 protocol
- High-performance fault recording (buffer for a max. record time of 80 s at 8 kHz or 320 s at 2 kHz)
- Auxiliary functions for simple tests and commissioning
- Flexibly adjustable I/O quantity structure within the scope of the SIPROTEC 5 modular system

Applications

- Protection of special transformers (phase shifters, FACTS and converter transformers, electric arc furnace transformers, HVDC transformers)
- As backup protection for motor and generator differential protection applications
- For the protection of short cables and lines
- Voltage control for two-winding and three-winding transformers with parallel control
- As additional line protection function such as distance and line differential protection

Application templates are available in DIGSI 5 for standard applications. These include basic configurations and default settings that you can use straight away, or as a template for adjustments depending on the application. The available measuring points

make varied applications possible. Before ordering a device, please configure the application with DIGSI 5. The table **Function overview** shows the functional scope of the device. Use the [configurator](#) to determine the necessary function points.

Application Templates

Besides the application templates for SIPROTEC 7UT85, the following application templates are also available:

- Three-winding transformer base (DIFF protection)
- Three-winding transformer 1.5 CB (DIFF. protection, CBFP, REF)
- Three-winding transformer (DIFF. protection, CBFP, REF, DIS)
- Auto transformer (DIFF. protection, CBFP, REF)
- Auto transformer 1.5 CB (2 DIFF. protection, CBFP, voltage protection, frequency protection)

Application Examples

The following examples show the typical structure of an application template, the measuring points used, the function groups used, their internal circuiting, and the predefined functions.

Three-winding transformer basis

- Differential protection

Auto transformer with stabilizing winding

- Differential protection for the complete transformer (auto transformer winding + stabilizing winding)
- Restricted ground-fault protection (neutral point + maximum side current)
- Overload protection, backup protection for the downstream power system
- Circuit-breaker failure protection

Three-winding transformer in breaker-and-a-half layout

- Differential protection
- Restricted ground-fault protection on the neutral side
- Ground-current protection on the neutral side as backup protection for the electrical power system
- Overload protection
- Circuit-breaker failure protection
- Frequency and voltage protection on the neutral side

[Figure 2.11/11](#) shows the template for the protection of a three-winding transformer in a breaker-and-a-half layout. You can recognize the 3 required function groups for the transformer side, the integration of the restricted ground-fault protection, the internal circuiting, and selected functions. In addition, a voltage transformer is available on the upper-voltage side. Here, for example, voltage and frequency limits can be monitored. The required protection settings are made as required by the system.

SIPROTEC 5 Devices and Fields of Application

Transformer Differential Protection – SIPROTEC 7UT86

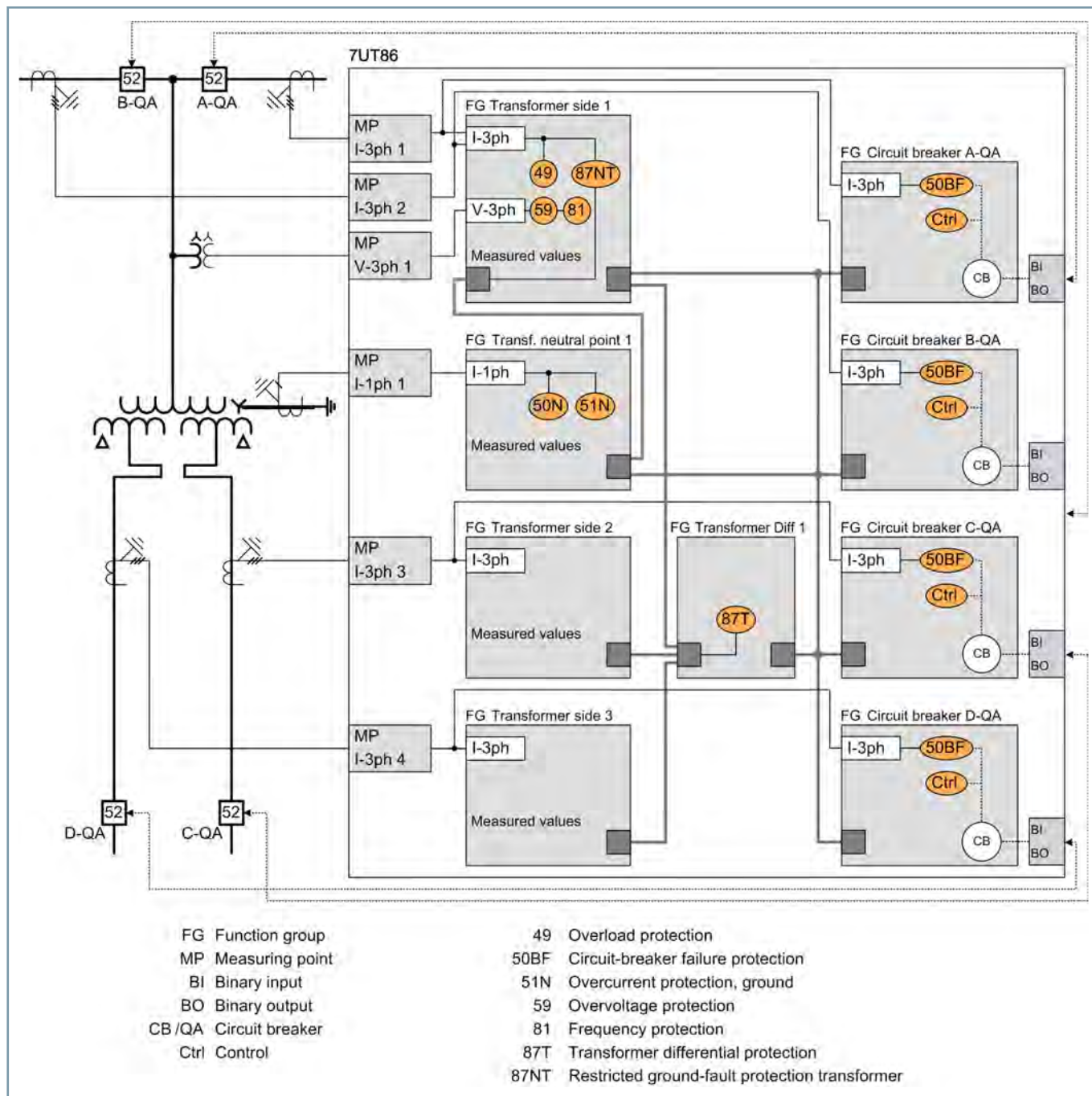

[dw_Kat-three-wind, 2, en_US]

Figure 2.11/11 Application Example: Protection of a Three-Winding Transformer in Breaker-and-a-Half Layout

SIPROTEC 5 Devices and Fields of Application

Transformer Differential Protection – SIPROTEC 7UT86

ANSI	Function	Abbr.	Available	Application Templates										
				1	2	3	4	5	6	7	8	9		
	Expandable hardware quantity structure	I/O	■											
	Process bus client protocol (hint: PB client requires a separate ETH-BD-2FO plug-in module, from V8.0)	PB client	■											
	IEC61850-9-2 Merging Unit Stream (hint: Each stream requires a separate ETH-BD-2FO plug-in module, from V8.0)	MU	■											
	IEC61850-9-2 Merging Unit Stream 7SS85 CU (hint: Only for communication with a 7SS85 CU. A separate ETH-BD-2FO plug-in module is required starting with V8.40)	MU	■											
21/21N	Distance Protection	Z<, V< /I> /∠(V, I)	■			■								
21T	Impedance protection for transformers	Z<	■											
24	Overexcitation protection	V/f	■											
25	Synchrocheck, synchronization function	Sync	■											
27	Undervoltage protection: "3-phase" or "positive-sequence system V1" or "universal Vx"	V<	■											
27R, 59R	Voltage change protection (starting with V8.30)	dV/dt	■											
	Undervoltage-controlled reactive power protection	Q>/V<	■											
32, 37	Power protection active/reactive power	P<>, Q<>	■											
32R	Reverse-power protection	- P<	■											
37	Undercurrent	I<	■											
37	Power-plant disconnection protection	-dP	■											
38	Temperature supervision	θ>	■											
46	Negative-sequence system overcurrent protection	I2>	■											
46	Unbalanced-load protection (thermal)	I2² t>	■											
47	Overvoltage protection, negative-sequence system	V2>	■											
47	Overvoltage protection, negative-sequence system/positive-sequence system	V2/V1>	■											
49	Thermal overload protection	θ, I²t	■		■	■	■	■	■			■	■	
49	Thermal overload protection, user-defined characteristic curve	θ, I²t	■											
49H	Hotspot calculation	θh, I²t	■											
50/51 TD	Overcurrent protection, phases	I>	■		■	■	■	■	■	■	■	■	■	■
	Instantaneous tripping at switch onto fault	SOTF	■											
50HS	Instantaneous high-current tripping	I>>>	■											
50/51 TD	Overcurrent protection with positive-sequence current I1 (from V7.9)	I1>	■											
50N/ 51N TD	Overcurrent protection, ground	IN>	■									■		
50N/ 51N TD	Overcurrent protection, 1-phase	IN>	■		■	■	■						■	
50 Ns/ 51Ns	Sensitive ground-fault detection for grounded arc suppression coils and isolated power systems including a) 3I0> b) admittance Y0>, c) 3I0-harm> (from V7.8)	INs>	■											
	Sensitive ground-fault detection via pulse detection; hint: this stage also requires the function 50Ns/51Ns or 67Ns "sensitive ground-fault detection for grounded arc suppression coils and isolated power systems"	IN pulse	■											
	Intermittent ground-fault protection	IIE>	■											
50BF	Circuit-breaker failure protection, 3-pole	CBFP	■		■	■	■	■				■	■	■

2.11

SIPROTEC 5 Devices and Fields of Application

Transformer Differential Protection – SIPROTEC 7UT86

ANSI	Function	Abbr.	Available	Application Templates										
				1	2	3	4	5	6	7	8	9		
50EF	End-fault protection (hint: For use only in decentralized busbar protection with a 7SS85 CU starting with V8.40)		■											
50RS	Circuit breaker restrike monitoring	CBRM	■											
51V	Voltage-controlled overcurrent protection	$t=f(I, V)$	■											
59, 59N	Overvoltage protection: "3-phase" or "zero-sequence system V0" or "positive-sequence system V1" or "universal Vx"	V>	■		■	■		■						■
59	Overvoltage protection: "3-phase" or "positive-sequence system V1" or "universal Vx"	V>	■											
60	Voltage-comparison supervision	$\Delta V>$	■											
67	Directional overcurrent protection, phases	$I>, \angle(V, I)$	■											
67N	Directional overcurrent protection, ground	$IN>, \angle(V, I)$	■											
67N	Directional ground-fault protection in grounded power systems	$IN>, \angle(V, I)$	■											
67 Ns	Sensitive ground-fault detection for grounded arc suppression coils and isolated power systems including a) $3I0>$ b) $V0>$, c) $\cos/\sin \Phi$, d) transient ground fault, e) $\Phi(V, I)$, f) admittance		■											
	Directional tripping stage with one harmonic; hint: this stage also requires the function "67Ns sensitive ground-fault detection for grounded arc suppression coils and isolated power systems"	$\angle(V0h, I0h)$	■											
	Directional Intermittent Ground-Fault Protection	$IIEdir>$	■											
68	Power-swing blocking	$\Delta Z/\Delta t$	■											
74TC	Trip-circuit supervision		■	■	■	■	■	■	■	■	■	■	■	■
74CC	Single circuit monitoring (from V7.9)		■											
79	Automatic reclosing, 3-pole	AREC	■											
81	Frequency protection: "f>" or "f<" or "df/dt"	$f<>; df/dt<>$	■		■	■		■						
81 AF	Abnormal frequency protection	fBand	■											
81U	Underfrequency load shedding	$f<(ULS)$	■											
	Vector-jump protection	$\Delta\varphi>$	■											
85/21	Teleprotection scheme for distance protection		■											
85/27	Weak or no infeed: Echo and tripping		■											
85/67N	Teleprotection scheme for directional ground-fault protection		■											
86	Lockout		■	■	■	■	■	■	■	■	■	■	■	■
87T	Transformer Differential Protection	ΔI	■	■	■	■	■	■	■	■	■	■	■	■
87T	Differential protection for special transformers	ΔI	■											
87T Node	Differential protection (nodal point protection for auto transformer)	ΔI nodes	■					■						
87T	Differential protection for phase-angle regulating transformers (single core)	ΔI	■											
87N T	Restricted ground-fault protection	ΔIN	■		■	■	■				■	■		
87M	Differential motor protection	ΔI	■											
87G	Generator differential protection	ΔI	■											
87L	Line differential protection for 2 line ends for 7UT8 (communication with 7SD82, 85, 86, 7SL86, 87)	ΔI	■											
	Option for line differential protection with charging-current compensation	ΔI	■											
87 STUB	Stub fault differential protection (for breaker-and-a-half layouts)		■											
90 V	Voltage controller for two-winding transformer		■											■
90 V	Voltage controller for two-winding transformer with parallel control		■											

SIPROTEC 5 Devices and Fields of Application

Transformer Differential Protection – SIPROTEC 7UT86

ANSI	Function	Abbr.	Available	Application Templates										
				1	2	3	4	5	6	7	8	9		
	Number of two-winding transformers with parallel control (hint: only together with the function "voltage controller for two-winding transformer with parallel control")		■											
90 V	Voltage controller for three-winding transformer		■											
90 V	Voltage controller for grid coupling transformer		■											
FL	Fault Locator, single-side	FL-one	■											
FL	Fault Locator Plus (from V7.9)	FL plus	■											
PMU	Synchrophasor measurement	PMU	■											
AFD	Arc protection (only with plug-in module ARC-CD-3FO)		■											
	Measured values, standard		■	■	■	■	■	■	■	■	■	■	■	■
	Measured values, extended: Min, max, average		■											
	Switching statistics counter		■											■
	PQ – Basic measured values: THD (Total Harmonic Distortion) and harmonic component (starting with V8.01) and THD voltage average values (starting with V8.40)		■											
	PQ – Basic measured values: Voltage unbalance (starting with V8.40)		■											
	PQ – Basic measured values: Voltage changes – monitoring of voltage dips, overvoltages and voltage interruptions (starting with V8.40)		■											
	PQ – Basic measured values: TDD - Total Demand Distortion (starting with V8.40)		■											
	CFC (standard, control)		■	■	■	■	■	■	■	■	■	■	■	■
	CFC arithmetic		■											
	Circuit-breaker wear monitoring	$\Sigma I_x, I^2t, 2P$	■											
	Switching sequence function		■											
	Inrush-current detection		■		■	■	■	■	■	■	■	■	■	■
	External trip initiation		■								■	■		
	Control		■	■	■	■	■	■	■	■	■	■	■	■
PoW	Point-on-wave switching (starting with V7.90)	PoW	■											
	Circuit breaker		■	■	■	■	■	■	■	■	■	■	■	■
	Disconnecter/grounding conductor		■											
	Fault recording of analog and binary signals		■	■	■	■	■	■	■	■	■	■	■	■
	Monitoring		■	■	■	■	■	■	■	■	■	■	■	■
	Protection interface, serial		■											
	Frequency group tracking (from V7.8)		■											
	Cyber security: Role-Based Access Control (from V7.8)		■											
	Temperature recording via communication protocol		■											
	Transformer side 7UT86		■											
	Cyber security: Authenticated network access using IEEE 802.1X (starting from V8.3)		■											
Function point class:				0	50	150	30	30	0	30	30	175		

Table 2.11/6 SIPROTEC 7UT86 – Functions, Application Templates

- (1) 3-winding transformer Base (DIFF protection)
- (2) 3-winding transformer 1.5 CB (DIFF protection, SVS, REF)
- (3) 3-winding transformer (DIFF protection, SVS, REF, DIS)

SIPROTEC 5 Devices and Fields of Application

Transformer Differential Protection – SIPROTEC 7UT86

- (4) Auto transformer (DIFF protection, SVS, REF)
- (5) Auto transformer, 1.5 CB (2 DIFF protection, SVS, voltage protection, frequency protection)
- (6) 2-Winding Transformer Base (DIFF protection)
- (7) 2-Winding Transformer (DIFF protection, SVS, REF)
- (8) 2-Winding Transformer 1.5 CB (DIFF protection, SVS, REF)
- (9) 2-Winding Transformer (DIFF. Protection, Voltage Controller)

SIPROTEC 5 Devices and Fields of Application

Transformer Differential Protection – SIPROTEC 7UT86



Standard Variants for SIPROTEC 7UT86		
P1	1/2, 11 BI, 18 BO, 12 I, 4 V Housing width 1/2 × 19" 11 binary inputs 18 binary outputs (1 life contact, 5 standard, 12 fast) 12 current transformers 4 voltage transformers Contains the following modules: Base module with PS201 and IO203, expansion module IO208	
P2	2/3, 23 BI, 34 BO, 12 I, 4 V Housing width 2/3 × 19" 23 binary inputs 34 binary outputs (1 life contact, 21 standard, 12 fast) 12 current transformers 4 voltage transformers Contains the following modules: Base module with PS201 and IO203 Expansion modules IO208, IO205	

Table 2.11/7 Standard Variants for Transformer Differential Protection Devices

You can find the technical data in the manual
www.siemens.com/siprotec.

Description

The SIPROTEC 7UT87 transformer differential protection has been designed specifically for the protection of multi-winding transformers (up to 5 sides). Furthermore, it is to be used where numerous measuring points (up to 11 3-phase current measuring points) are required. Another application is simultaneous protection of 2 parallel transformers (additional fast backup protection). The SIPROTEC 7UT87 is the main protection for the transformer and contains many other protection and monitoring functions. The additional protection functions can also be used as backup protection for subsequent protected objects (such as short cables and lines, reactance coil (shunt reactors)). With its modular structure, flexibility, and the high-performance DIGSI 5 engineering tool, SIPROTEC 7UT87 offers future-oriented solutions for protection, control, automation, monitoring, and Power Quality – Basic.

Main function	Up to 3 differential protection functions with additional stabilization (in different transformer function groups); up to 5 restricted ground-fault protection functions. For auto transformer applications, 2 differential protection functions can be processed in an Auto transformer function group. Interoperability of SIPROTEC 4 and SIPROTEC 5 line protection devices when using the line differential protection function in the 7UT85, 86, 87
Usable measuring points	11 x 3-phase current measuring points, 11 x 1-phase current measuring points, 11 x 3-phase and 11 x 1-phase voltage measuring points
Inputs and outputs	2 predefined standard variants with 20 current transformers, 4 voltage transformers, 15 to 27 binary inputs, 22 to 38 binary outputs
Hardware flexibility	Flexibly adjustable and expandable I/O quantity structure within the scope of the SIPROTEC 5 modular system.
Housing width	2/3 x 19 inches to 2/1 x 19 inches

Benefits

- Safe and reliable automation and control of your systems
- Purposeful and easy handling of devices and software thanks to a user-friendly design
- Cybersecurity in accordance with NERC CIP and BDEW White-paper requirements
- Highest availability even under extreme environmental conditions by standard coating of the modules
- Full compatibility between IEC 61850 Editions 1, 2.0, and 2.1

Functions

DIGSI 5 permits all functions to be configured and combined as required and as per the functional scope that has been ordered. In SIPROTEC 7UT87, 2 transformer function groups can be used.



[SIP5_GD_SS_LED_W3, 2, --, --]

Figure 2.11/12 SIPROTEC 7UT87 Transformer Differential Protection (2/3 Device = Standard Variant Q1)

- Transformer differential protection for multi-winding transformers with versatile, additional protection functions (multi-winding transformers are typical in power-converter applications (such as HVDC))
- Transformer differential protection for phase-angle regulating transformers of the single-core and 2-core types, and special transformers
- Transformer-protection applications with up to 11 3-phase current measuring points
- Simultaneous differential protection for 3 parallel transformers (such as 3 two-winding transformers)
- Universal usability of the permissible measuring points
- Applicable from average up to extra-high voltage
- Protection of standard power transformers, auto transformers, short lines, cables, shunt reactor, and motors
- Typical properties of a transformer differential protection such as flexible adaptation to the transformer vector group, control of inrush and overexcitation processes, safe behavior in case of current-transformer saturation with different degrees of saturation
- Fault locator plus for accurate fault location with inhomogeneous line sections and targeted automatic overhead-line section reclosing (AREC)
- Arc protection
- Voltage-controller function ANSI 90V for two-winding transformers, three-winding transformers, and grid coupling transformers with parallel control (master/follower, circulating reactive current minimization)
- Adaptive adaptation of the operate curve to the transformer tap position
- Increased sensitivity with ground faults near the neutral point through a separate restricted ground-fault protection
- Point-on-wave switching

SIPROTEC 5 Devices and Fields of Application

Transformer Differential Protection – SIPROTEC 7UT87

- Additional current and voltage inputs can be added for standard protection functions, such as overcurrent, voltage, frequency, protection etc.
- Dynamic voltage control (DSR) for adaptation of the voltage set point value using a characteristic curve that depends on the power direction with a large infeed of renewable energies.
- Graphical logic editor to create high-performance automation functions in the device
- Up to 4 pluggable communication modules, usable for different and redundant protocols (IEC 61850-8-1, IEC 61850-9-2 Client, IEC 60870-5-103, IEC 60870-5-104, Modbus TCP, DNP3 serial and TCP, PROFINET IO, PROFINET IO S2 redundancy)
- Virtual network partitioning (IEEE 802.1Q - VLAN)
- Reliable data transmission via PRP and HSR redundancy protocols
- Extensive cybersecurity functionality, such as role-based access control (RBAC), logging of security-related events, signed firmware, or authenticated IEEE 802.1X network access
- Simple, fast, and secure access to the device via a standard Web browser to display all information and diagnostic data, vector diagrams, single-line and device display pages
- Secure serial protection communication, also over great distances and all available physical media (optical fiber, two-wire connections, and communication networks)
- PQ – Basic: Voltage unbalance; voltage changes: overvoltage, dip, interruptions; TDD, THD, and harmonics
- Detecting operational measured variables and protection-function measured values for the evaluation of the system, to support commissioning, and to analyze faults
- Frequency tracked protection functions over a wide frequency range (10 Hz to 90 Hz) and the option to assign the protection functions in a single device to different **frequency tracking groups**.
- Phasor Measurement Unit (PMU) for synchrophasor measured values and IEEE C37.118 protocol

- High-performance fault recording (buffer for a max. record time of 80 s at 8 kHz or 320 s at 2 kHz)
- Auxiliary functions for simple tests and commissioning
- Flexibly adjustable I/O quantity structure within the scope of the SIPROTEC 5 modular system

Applications

- Protection of special transformers (phase shifters, FACTS and converter transformers, electric arc furnace transformers, HVDC transformers)
- As backup protection for motor and generator differential protection applications
- For the protection of short cables and lines
- Voltage control for two-winding and three-winding transformers with parallel control
- As additional line protection function such as distance and line differential protection

Application Templates

Application templates are available in DIGSI 5 for the applications of the device 7UT87. The application templates contain the basic configurations, required functions, and default settings. All application templates, which were described for the devices 7UT82, 7UT85, and 7UT86, can be implemented in 7UT87.

Application Examples

- Auto transformer with stabilizing winding in a breaker-and-a-half layout ([Figure 2.11/13](#))
- Possible application of SIPROTEC 7UT87 in a power plant (up to 7 3-phase current measuring points) ([Figure 2.11/14](#))
- Protection of 2 parallel transformers with one SIPROTEC 7UT87 ([Figure 2.11/15](#))
- Protection of an inverter transformer ([Figure 2.11/16](#))

SIPROTEC 5 Devices and Fields of Application

Transformer Differential Protection – SIPROTEC 7UT87

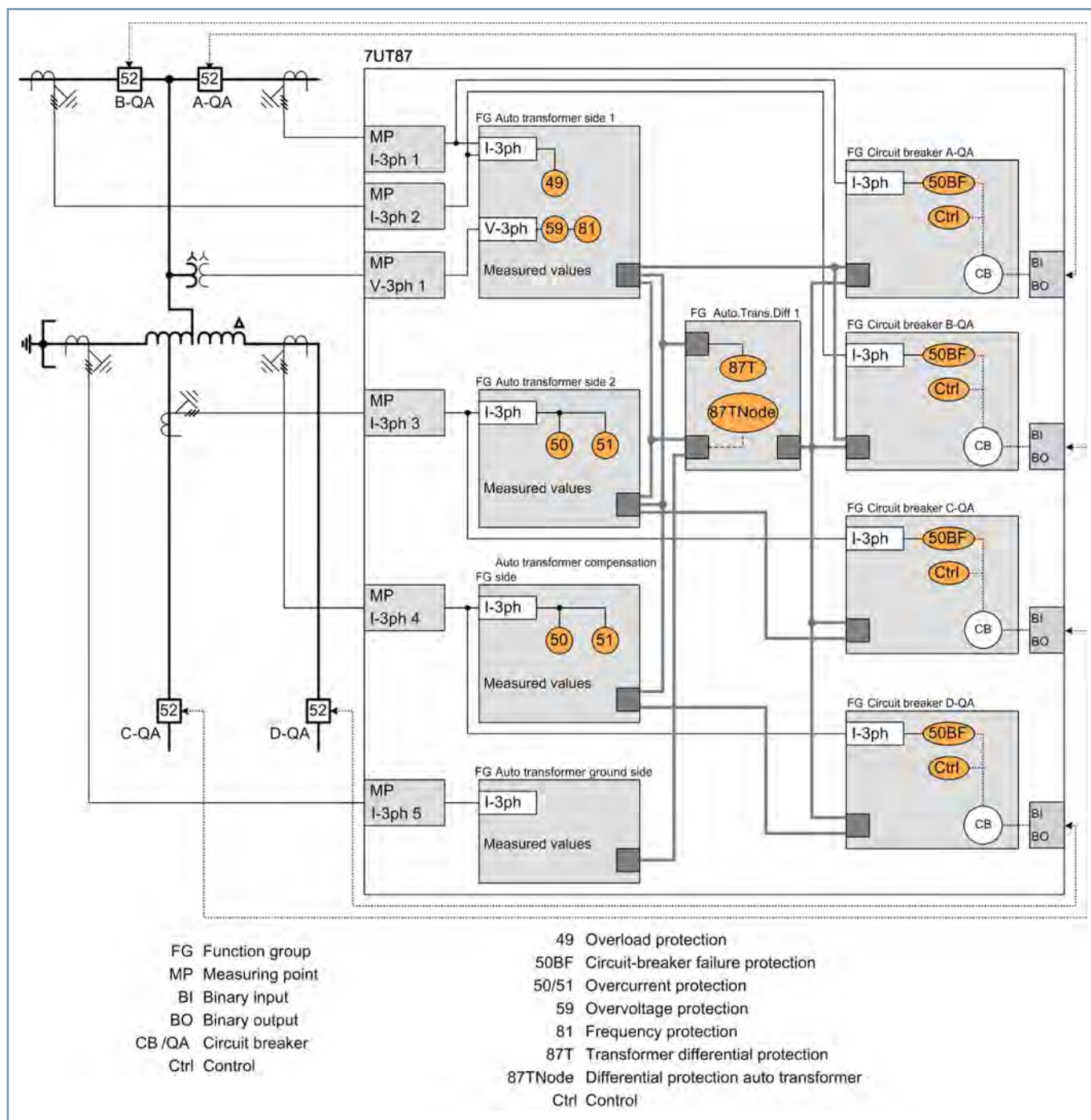

2.11

Figure 2.11/13 Application Example: Protection of an Auto Transformer with Stabilizing Winding in Breaker-and-a-Half Layout

the [Figure 2.11/13](#) shows the template for the protection of an auto transformer that is connected to a breaker-and-a-half layout. The special feature of this application is that the current on the neutral-point side is directly recorded per phase. A separate nodal-point differential protection via the auto winding reliably records ground faults and turn-to-turn faults. The classic differential protection is assigned over the entire transformer (auto and stabilizing winding). Both functions run in the Auto

transformer function group. This type of execution gives you a redundant differential protection with supplementing responsibility. A separate restricted ground-fault protection is not required. In addition, a voltage transformer is available on the upper-voltage side. Here, for example, voltage and frequency limits can be monitored. The required protection settings are made as required by the system.

SIPROTEC 5 Devices and Fields of Application

Transformer Differential Protection – SIPROTEC 7UT87

Since the SIPROTEC 7UT87 is intended to be used for special applications, you must create your own application template as a function of the application. Save this template with the device. To ease your work, you can use an available template and modify it as required. The following examples may help you:

Example 1:

This example requires a large number of 3-phase current measuring points for a complex application in the power-plant area. [Figure 2.11/14](#) shows a possible configuration.

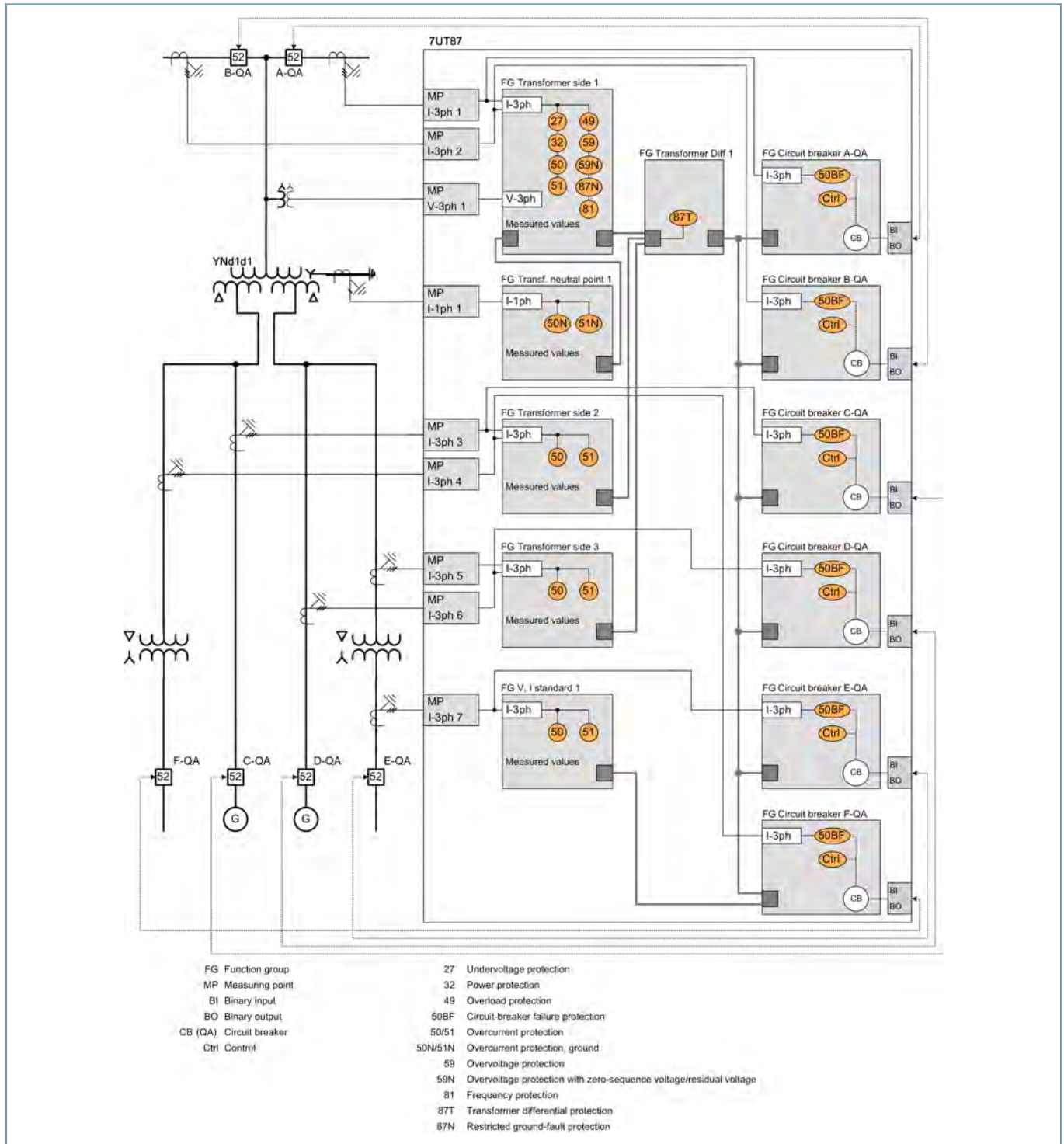

[dw_7-messstellen, 2, en_US]

Figure 2.11/14 Possible Application of SIPROTEC 7UT87 in a Power Plant (up to Seven 3-Phase Current Measuring Points)

SIPROTEC 5 Devices and Fields of Application

Transformer Differential Protection – SIPROTEC 7UT87

Example 2:

Another example (Figure 2.11/15) is a powerful functional redundancy with parallel transformers. The differential protection function is doubled. 1 protection device is used for each transformer. 2 differential protection functions run in each

protection device. The 2nd differential protection function is the backup protection for the parallel transformer. For example, start with an application template of the two-winding transformer and duplicate it. An alternative cost-optimized variant is the use of one device to protect both transformers.

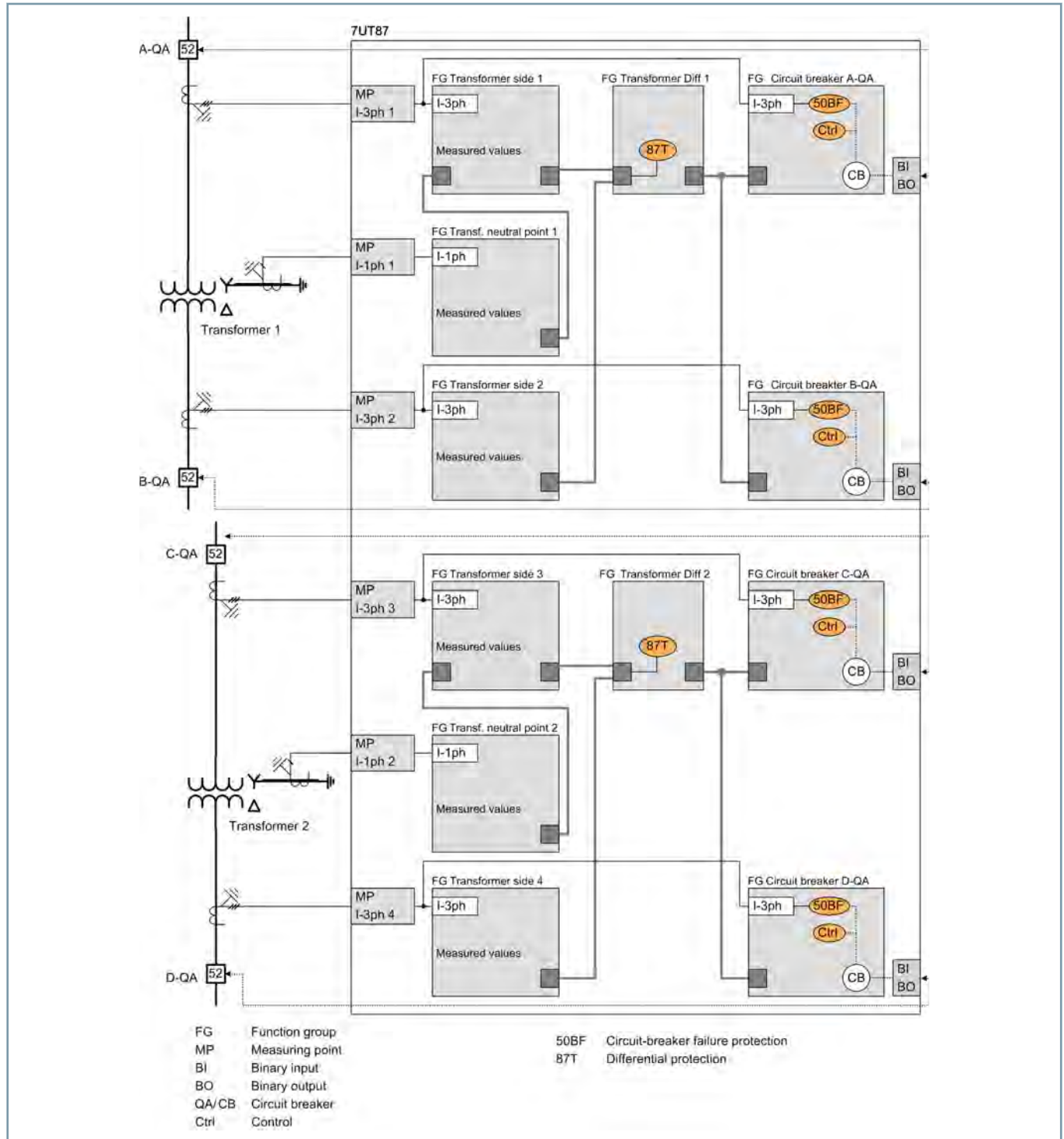

[dw_two-transformer, 2, en_US]

Figure 2.11/15 Protection of Two Parallel Transformers with One SIPROTEC 7UT87

SIPROTEC 5 Devices and Fields of Application

Transformer Differential Protection – SIPROTEC 7UT87

Example 3:

The last example (Figure 2.11/16) shows the protection of an inverter transformer. 4 sides and 6 measuring points are required here.

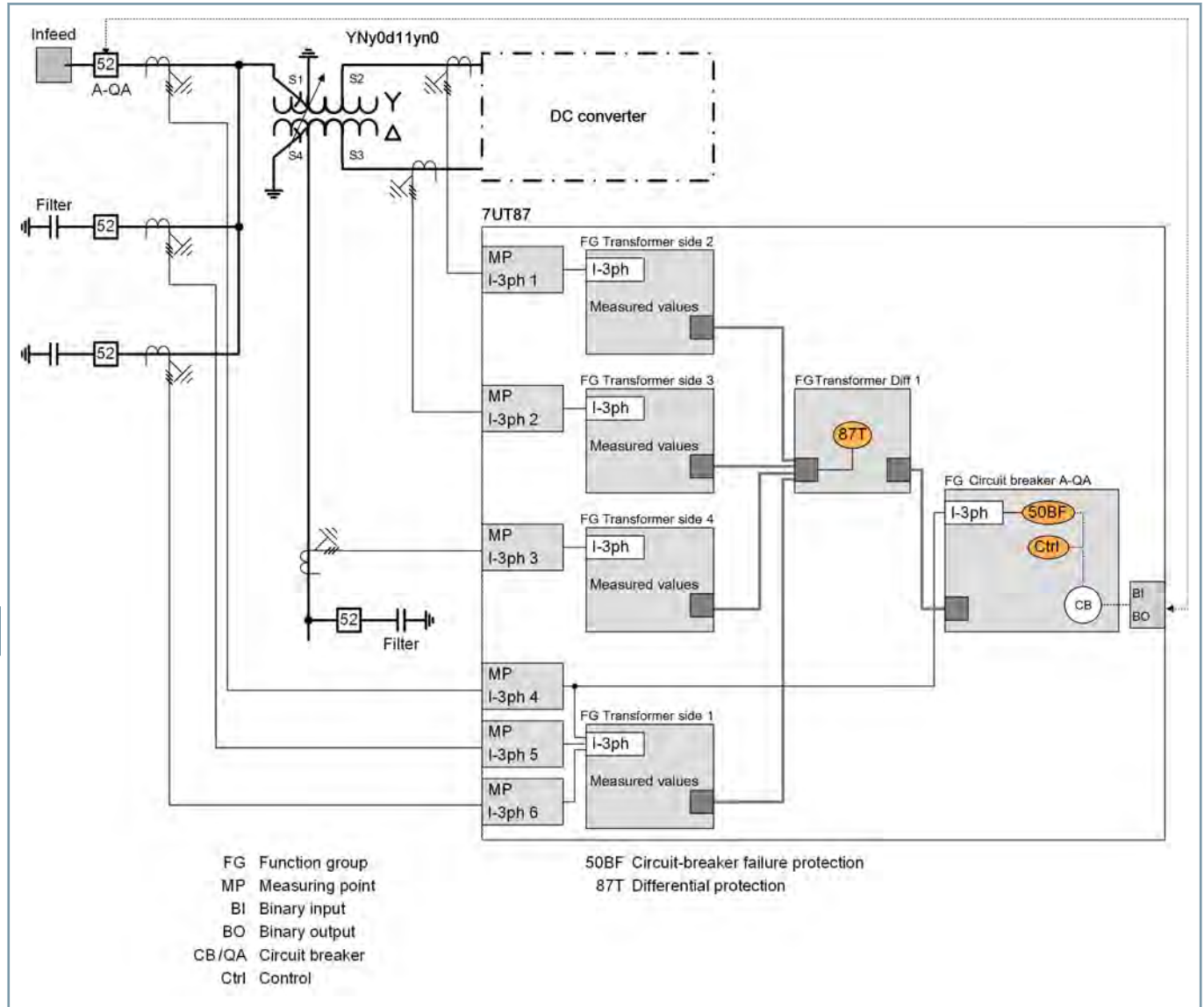

[dw_umrichter-transf, 3, en_US]

Figure 2.11/16 Protection of an Inverter Transformer

SIPROTEC 5 Devices and Fields of Application

Transformer Differential Protection – SIPROTEC 7UT87

ANSI	Function	Abbr.	Available	Application Templates										
				1	2	3	4	5	6	7	8	9		
	Expandable hardware quantity structure	I/O	■											
	Process bus client protocol (hint: PB client requires a separate ETH-BD-2FO plug-in module, from V8.0)	PB client	■											
	IEC61850-9-2 Merging Unit Stream (hint: Each stream requires a separate ETH-BD-2FO plug-in module, from V8.0)	MU	■											
	IEC61850-9-2 Merging Unit Stream 7SS85 CU (hint: Only for communication with a 7SS85 CU. A separate ETH-BD-2FO plug-in module is required starting with V8.40)	MU	■											
21/21N	Distance Protection	Z<, V< /I> /Z(V, I)	■									■		
21T	Impedance protection for transformers	Z<	■											
24	Overexcitation protection	V/f	■											
25	Synchrocheck, synchronization function	Sync	■											
27	Undervoltage protection: "3-phase" or "positive-sequence system V1" or "universal Vx"	V<	■											
27R, 59R	Voltage change protection (starting with V8.30)	dV/dt	■											
	Undervoltage-controlled reactive power protection	Q>/V<	■											
32, 37	Power protection active/reactive power	P<>, Q<>	■											
32R	Reverse-power protection	- P<	■											
37	Undercurrent	I<	■											
37	Power-plant disconnection protection	-dP	■											
38	Temperature supervision	θ>	■											
46	Negative-sequence system overcurrent protection	I2>	■											
46	Unbalanced-load protection (thermal)	I2² t>	■											
47	Overvoltage protection, negative-sequence system	V2>	■											
47	Overvoltage protection, negative-sequence system/positive-sequence system	V2/V1>	■											
49	Thermal overload protection	θ, I²t	■	■	■	■	■			■	■	■	■	■
49	Thermal overload protection, user-defined characteristic curve	θ, I²t	■											
49H	Hotspot calculation	θh, I²t	■											
50/51 TD	Overcurrent protection, phases	I>	■	■	■	■	■			■	■	■	■	■
	Instantaneous tripping at switch onto fault	SOTF	■											
50HS	Instantaneous high-current tripping	I>>>	■											
50/51 TD	Overcurrent protection with positive-sequence current I1 (from V7.9)	I1>	■											
50N/ 51N TD	Overcurrent protection, ground	IN>	■		■									
50N/ 51N TD	Overcurrent protection, 1-phase	IN>	■			■				■	■	■		
50 Ns/ 51Ns	Sensitive ground-fault detection for grounded arc suppression coils and isolated power systems including a) 3I0> b) admittance Y0>, c) 3I0-harm> (from V7.8)	INs>	■											
	Sensitive ground-fault detection via pulse detection; hint: this stage also requires the function 50Ns/51Ns or 67Ns "sensitive ground-fault detection for grounded arc suppression coils and isolated power systems"	IN pulse	■											
	Intermittent ground-fault protection	IIE>	■											
50BF	Circuit-breaker failure protection, 3-pole	CBFP	■		■	■	■			■	■	■	■	■

2.11

SIPROTEC 5 Devices and Fields of Application

Transformer Differential Protection – SIPROTEC 7UT87

ANSI	Function	Abbr.	Available	Application Templates										
				1	2	3	4	5	6	7	8	9		
50EF	End-fault protection (hint: For use only in decentralized busbar protection with a 7SS85 CU starting with V8.40)		■											
50RS	Circuit breaker restrike monitoring	CBRM	■											
51V	Voltage-controlled overcurrent protection	$t=f(I, V)$	■											
59, 59N	Overvoltage protection: "3-phase" or "zero-sequence system V0" or "positive-sequence system V1" or "universal Vx"	V>	■				■		■	■				■
59	Overvoltage protection: "3-phase" or "positive-sequence system V1" or "universal Vx"	V>	■											
60	Voltage-comparison supervision	$\Delta V>$	■											
67	Directional overcurrent protection, phases	$I>, \angle(V, I)$	■											
67N	Directional overcurrent protection, ground	$IN>, \angle(V, I)$	■											
67N	Directional ground-fault protection in grounded power systems	$IN>, \angle(V, I)$	■											
67 Ns	Sensitive ground-fault detection for grounded arc suppression coils and isolated power systems including a) $3I0>$ b) $V0>$, c) $\cos/\sin \Phi$, d) transient ground fault, e) $\Phi(V, I)$, f) admittance		■											
	Directional tripping stage with one harmonic; hint: this stage also requires the function "67Ns sensitive ground-fault detection for grounded arc suppression coils and isolated power systems"	$\angle(V0h, I0h)$	■											
	Directional Intermittent Ground-Fault Protection	$IIEdir>$	■											
68	Power-swing blocking	$\Delta Z/\Delta t$	■											
74TC	Trip-circuit supervision		■	■	■	■	■	■	■	■	■	■	■	■
74CC	Single circuit monitoring (from V7.9)		■											
79	Automatic reclosing, 3-pole	AREC	■											
81	Frequency protection: "f>" or "f<" or "df/dt"	$f<>; df/dt<>$	■						■	■				■
81 AF	Abnormal frequency protection	fBand	■											
81U	Underfrequency load shedding	$f<(ULS)$	■											
	Vector-jump protection	$\Delta \varphi>$	■											
85/21	Teleprotection scheme for distance protection		■											
85/27	Weak or no infeed: Echo and tripping		■											
85/67N	Teleprotection scheme for directional ground-fault protection		■											
86	Lockout		■	■	■	■	■	■	■	■	■	■	■	■
87T	Transformer Differential Protection	ΔI	■	■	■	■	■	■	■	■	■	■	■	■
87T	Differential protection for special transformers	ΔI	■											
87T Node	Differential protection (nodal point protection for auto transformer)	ΔI nodes	■											■
87T	Differential protection for phase-angle regulating transformers (single core)	ΔI	■											
87T	Differential protection for phase-angle regulating transformers (two core)	ΔI	■											
87N T	Restricted ground-fault protection	ΔIN	■		■	■			■	■	■			
87M	Differential motor protection	ΔI	■											
87G	Generator differential protection	ΔI	■											
87L	Line differential protection for 2 line ends for 7UT8 (communication with 7SD82, 85, 86, 7SL86, 87)	ΔI	■											
	Option for line differential protection with charging-current compensation	ΔI	■											
87 STUB	Stub fault differential protection (for breaker-and-a-half layouts)		■											
90 V	Voltage controller for two-winding transformer		■				■							

2.11

SIPROTEC 5 Devices and Fields of Application

Transformer Differential Protection – SIPROTEC 7UT87

ANSI	Function	Abbr.	Available	Application Templates									
				1	2	3	4	5	6	7	8	9	
90 V	Voltage controller for two-winding transformer with parallel control		■										
	Number of two-winding transformers with parallel control (hint: only together with the function "voltage controller for two-winding transformer with parallel control")		■										
90 V	Voltage controller for three-winding transformer		■										
90 V	Voltage controller for grid coupling transformer		■										
FL	Fault Locator, single-side	FL-one	■										
FL	Fault Locator Plus (from V7.9)	FL plus	■										
PMU	Synchrophasor measurement	PMU	■										
AFD	Arc protection (only with plug-in module ARC-CD-3FO)		■										
	Measured values, standard		■	■	■	■	■	■	■	■	■	■	■
	Measured values, extended: Min, max, average		■										
	Switching statistics counter		■				■						
	PQ – Basic measured values: THD (Total Harmonic Distortion) and harmonic component (starting with V8.01) and THD voltage average values (starting with V8.40)		■										
	PQ – Basic measured values: Voltage unbalance (starting with V8.40)		■										
	PQ – Basic measured values: Voltage changes – monitoring of voltage dips, overvoltages and voltage interruptions (starting with V8.40)		■										
	PQ – Basic measured values: TDD - Total Demand Distortion (starting with V8.40)		■										
	CFC (standard, control)		■	■	■	■	■	■	■	■	■	■	■
	CFC arithmetic		■										
	Circuit-breaker wear monitoring	$\Sigma I_x, I^2t, 2P$	■										
	Switching sequence function		■										
	Inrush-current detection		■	■	■	■	■		■	■	■	■	■
	External trip initiation		■		■	■							
	Control		■	■	■	■	■	■	■	■	■	■	■
PoW	Point-on-wave switching (starting with V7.90)	PoW	■										
	Circuit breaker		■	■	■	■	■	■	■	■	■	■	■
	Disconnectors/grounding conductor		■										
	Fault recording of analog and binary signals		■	■	■	■	■	■	■	■	■	■	■
	Monitoring		■	■	■	■	■	■	■	■	■	■	■
	Protection interface, serial		■										
	Frequency group tracking (from V7.8)		■										
	Cyber security: Role-Based Access Control (from V7.8)		■										
	Temperature recording via communication protocol		■										
	Transformer side 7UT87		■										
	Cyber security: Authenticated network access using IEEE 802.1X (starting from V8.3)		■										
Function point class:				0	30	30	175	0	50	150	30	30	

2.11

Table 2.11/8 SIPROTEC 7UT87 – Functions, Application Templates

- (1) 2-Winding Transformer Base (DIFF protection)
- (2) 2-Winding Transformer (DIFF protection, SVS, REF)

SIPROTEC 5 Devices and Fields of Application

Transformer Differential Protection – SIPROTEC 7UT87

- (3) 2-Winding Transformer 1.5 CB (DIFF protection, SVS, REF)
- (4) 2-Winding Transformer (DIFF. Protection, Voltage Controller)
- (5) 3-winding transformer Base (DIFF protection)
- (6) 3-winding transformer 1.5 CB (DIFF protection, SVS, REF)
- (7) 3-winding transformer (DIFF protection, SVS, REF, DIS)
- (8) Auto transformer (DIFF protection, SVS, REF)
- (9) Auto transformer, 1.5 CB (2 DIFF protection, SVS, voltage protection, frequency protection)

SIPROTEC 5 Devices and Fields of Application

Transformer Differential Protection – SIPROTEC 7UT87



Standard Variants for SIPROTEC 7UT87		
Q1	2/3, 15 BI, 22 BO, 20 I, 4 V	
	Housing width 2/3 × 19", 15 binary inputs, 22 binary outputs (1 life contact, 5 standard, 16 fast) 20 current transformers 4 voltage transformers Contains the following modules: Base module with PS201 and IO203 Expansion modules IO208 and IO203.	
Q2	5/6, 27 BI, 38 BO, 20 I, 4 V	
	Housing width 5/6 × 19", 27 binary inputs, 38 binary outputs (1 life contact, 21 standard, 16 fast) 20 current transformers 4 voltage transformers Contains the following modules: Base module with PS201 and IO203 Expansion modules IO208, IO203, and IO205.	

Table 2.11/9 Standard Variants for Transformer Differential Protection Devices

You can find the technical data in the manual
www.siemens.com/siprotec.

SIPROTEC 5 Devices and Fields of Application

Motor Protection

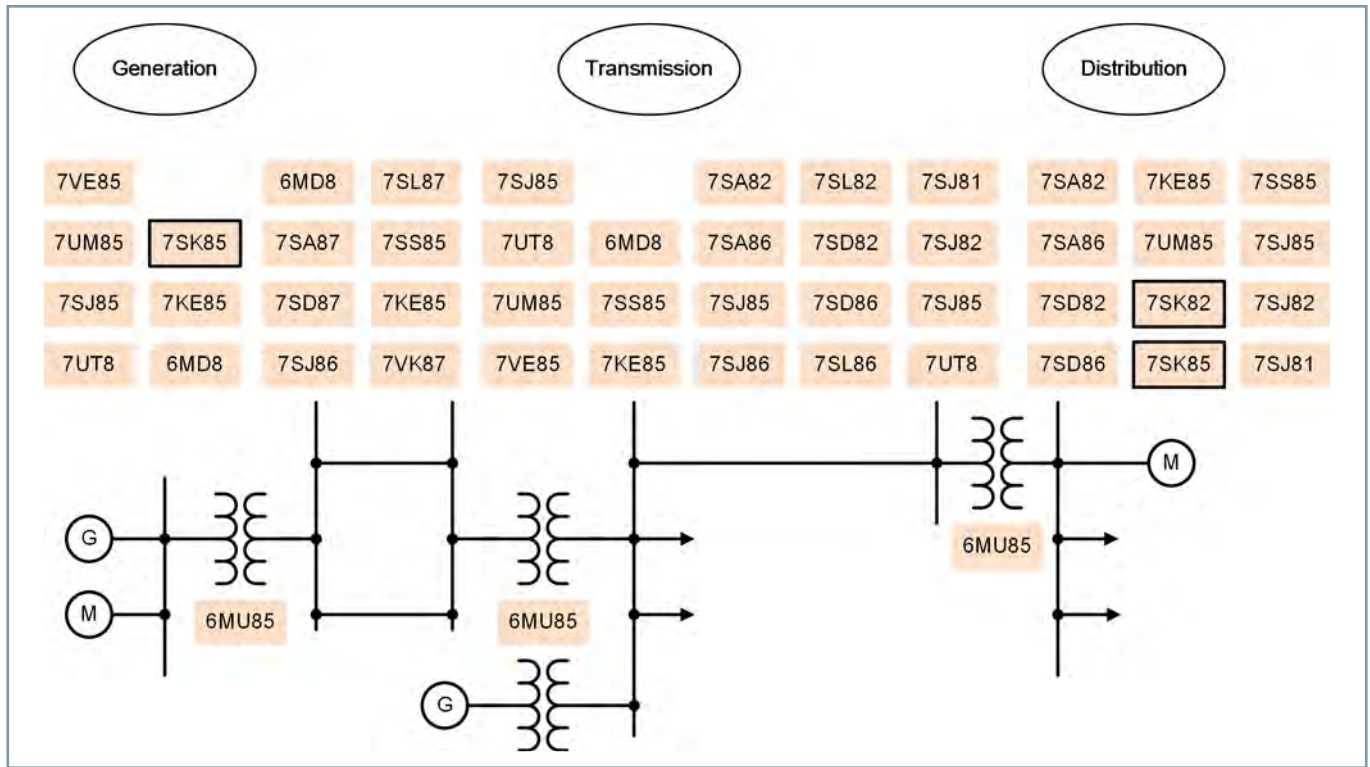

[dw_7SK_anwendung, 4, en_US]

Figure 2.12/1 Fields of Application of the SIPROTEC 5 Devices

SIPROTEC 7SK82, 7SK85

SIPROTEC 5 motor protection devices have been designed specifically for the protection of asynchronous motors of small and medium power.

The devices contain all important auxiliary functions that are necessary for safe network operation today. This includes functions for protection, control, measurement, and monitoring. The large number of communication interfaces and communication protocols satisfies the requirements of communication-based selective protection, as well as automated operation.

Commissioning and maintenance work can be completed safely, quickly, and thus cost-effectively with high-performance test functions. Their modular surface mounting allows SIPROTEC 5 devices to be always adapted flexibly to the individual requirements.

Distinguishing features

The difference between the 2 device models SIPROTEC 7SK82 and SIPROTEC 7SK85 is in the configurability of their hardware quantity structure.

Essential Differentiating Characteristics	
7SK82	Different hardware quantity structures for binary inputs and outputs are available in the 1/3 base module
7SK85	Flexible configuration of the hardware quantity structure for analog inputs, binary inputs and outputs, measuring transducers, and communications due to expandability with 1/6 expansion modules

Description

The SIPROTEC 7SK82 motor protection has been designed specifically for a cost-optimized and compact utilization of small-sized to medium-sized motors. With its flexibility and the high-performance DIGSI 5 engineering tool, SIPROTEC 7SK82 offers future-oriented solutions for protection, control, automation, monitoring, and Power Quality – Basic.

For motors in explosive environments, the SIPROTEC 7SK82 is also available with EN 60079-14 or VDE (Verband der Elektrotechnik, Elektronik und Informationstechnik) 0165, Part 1 (ATEX) certification.

Main function	Motor protection for small-sized to medium-sized motors (100 kW to 2 MW)
Inputs and outputs	4 current transformers, 4 voltage transformers (optional), 11 or 23 binary inputs, 9 or 16 binary outputs, 12 RTD inputs (optional)
Hardware flexibility	Different hardware quantity structures for binary inputs and outputs are available in the 1/3 base module. Adding 1/6 expansion modules is not possible; available with large or small display.
Housing width	1/3 × 19 inches

Benefits

- Compact and low-cost motor protection
- Safety due to high-performance protection functions
- Purposeful and easy handling of devices and software thanks to a user-friendly design
- Cybersecurity in accordance with NERC CIP and BDEW White-paper requirements
- Highest availability even under extreme environmental conditions by standard coating of the modules
- Full compatibility between IEC 61850 Editions 1, 2.0, and 2.1

Functions

DIGSI 5 permits all functions to be configured and combined as required and as per the functional scope that has been ordered.

- Motor protection functions: Starting time supervision, thermal overload protection for stator and rotor, restart inhibit, unbalanced-load protection, load-jam protection
- Stator and storage-temperature monitoring via temperature sensors with optional temperature inputs or with external RTD unit.
- Sensitive ground-fault protection (non-directional, directional) to detect stator ground faults
- Directional and non-directional overcurrent protection (short-circuit protection) with additional functions
- Detection of ground faults of any type in compensated or isolated electrical power systems using the following functions: $3I_0>$, $V_0>$, transient ground fault, $\cos \phi$, $\sin \phi$, dir. detection of intermittent ground faults, harmonic detection, and admittance measurement
- Ground-fault detection using the pulse-detection method
- Overvoltage and undervoltage protection



[SIP5_GD_W3, 2, --, --]

Figure 2.12/2 SIPROTEC 7SK82 Motor Protection

- Arc protection
- Power protection, configurable as active or reactive-power protection
- Detection of current and voltage signals up to the 50th harmonic with high accuracy for selected protection functions (such as thermal overload protection) and operational measured values
- PQ – Basic: Voltage unbalance; voltage changes: overvoltage, dip, interruptions; TDD, THD, and harmonics
- Control, synchrocheck, and switchgear interlocking protection
- Graphical logic editor to create high-performance automation functions in the device
- Single-line representation in the small or large display
- Fixed integrated electrical Ethernet RJ45 interface for DIGSI 5 and IEC 61850 (reporting and GOOSE)
- 2 optional pluggable communication modules, usable for different and redundant protocols (IEC 61850, IEC 60870-5-103, IEC 60870-5-104, Modbus TCP, DNP3 serial and TCP, PROFINET IO)
- Reliable data transmission via PRP and HSR redundancy protocols
- Certification for use in environments at risk of explosion (EN 60079-14 or VDE 0165, Part 1, ATEX)
- Extensive cybersecurity functionality, such as role-based access control (RBAC), logging of security-related events, signed firmware, or authenticated IEEE 802.1X network access.
- Simple, fast, and secure access to the device via a standard Web browser to display all information and diagnostic data, vector diagrams, single-line and device display pages
- Secure serial protection communication, also over great distances and all available physical media (optical fiber, two-wire connections, and communication networks)

SIPROTEC 5 Devices and Fields of Application

Motor Protection – SIPROTEC 7SK82

- Detecting operational measured variables and protection-function measured values to evaluate of the systems, to support commissioning, and to analyze faults
- Integrated RTD inputs (optional) for thermal motor monitoring
- Phasor Measurement Unit (PMU) for synchrophasor measured values and IEEE C37.118 protocol
- High-performance fault recording (buffer for a max. record time of 80 s at 8 kHz or 320 s at 2 kHz)
- Auxiliary functions for simple tests and commissioning

Applications

- Protection against thermal overload of the stator from overcurrent, cooling problems, or pollution
- Protection against thermal overload of the rotor during startup due to frequent startups, excessively long startups, or blocked rotor
- Monitoring for voltage unbalance or phase outage
- Monitoring the thermal state and the storage temperatures with temperature measurement
- Detection of idling drives of pumps and compressors, for example
- Detection of ground faults in the motor
- Protection against motor short circuits
- Protection against instability due to undervoltage
- Detection and recording of power-quality data in the medium-voltage and subordinate low-voltage power system

Application Templates

DIGSI 5 provides application templates for standard applications. They include basic configurations and default settings.

The following application templates are available:

- Current measurement
 - Thermal overload protection for stator and rotor
 - Starting time supervision
 - Restart inhibit
 - Unbalanced-load protection (thermal)
 - Temperature supervision

- Load-jam protection
- Overcurrent protection (non-directional) for phases and ground
- Transformer inrush-current detection
- Current and voltage measurement
 - Thermal overload protection for stator and rotor
 - Starting time supervision
 - Restart inhibit
 - Unbalanced-load protection (thermal)
 - Temperature supervision
 - Load-jam protection
 - Overcurrent protection (non-directional) for phases and ground
 - Transformer inrush-current detection
 - Directional sensitive ground-fault detection for isolated or grounded power systems and for detection of stator ground faults
 - Overvoltage protection with zero-sequence system V0
 - Undervoltage protection with positive-sequence system V1
 - Measuring-voltage failure detection

Application Example

SIPROTEC 7SK82 – Protection of a medium-power Motor

The motor protection functions and the overcurrent protection of the SIPROTEC 7SK82 protect an asynchronous motor of medium power (up to approximately 2 MW) against thermal and mechanical overload and short circuits. The directional sensitive ground-fault detection and the overvoltage protection with zero-sequence voltage V0 detect stator ground faults in the motor. Integrated temperature measuring inputs allow the thermal state of the motor and the storage temperatures to be captured and monitored. The temperature sensors (for example PT100) are connected directly to the integrated RTD measuring inputs.

[Figure 2.12/3](#) shows the functional scope and the basic configuration of a SIPROTEC 7SK82 for this application. It is based on the application template "Current and voltage measurement". In addition, the device must be equipped with a plug-in module for communication with the RTD unit.

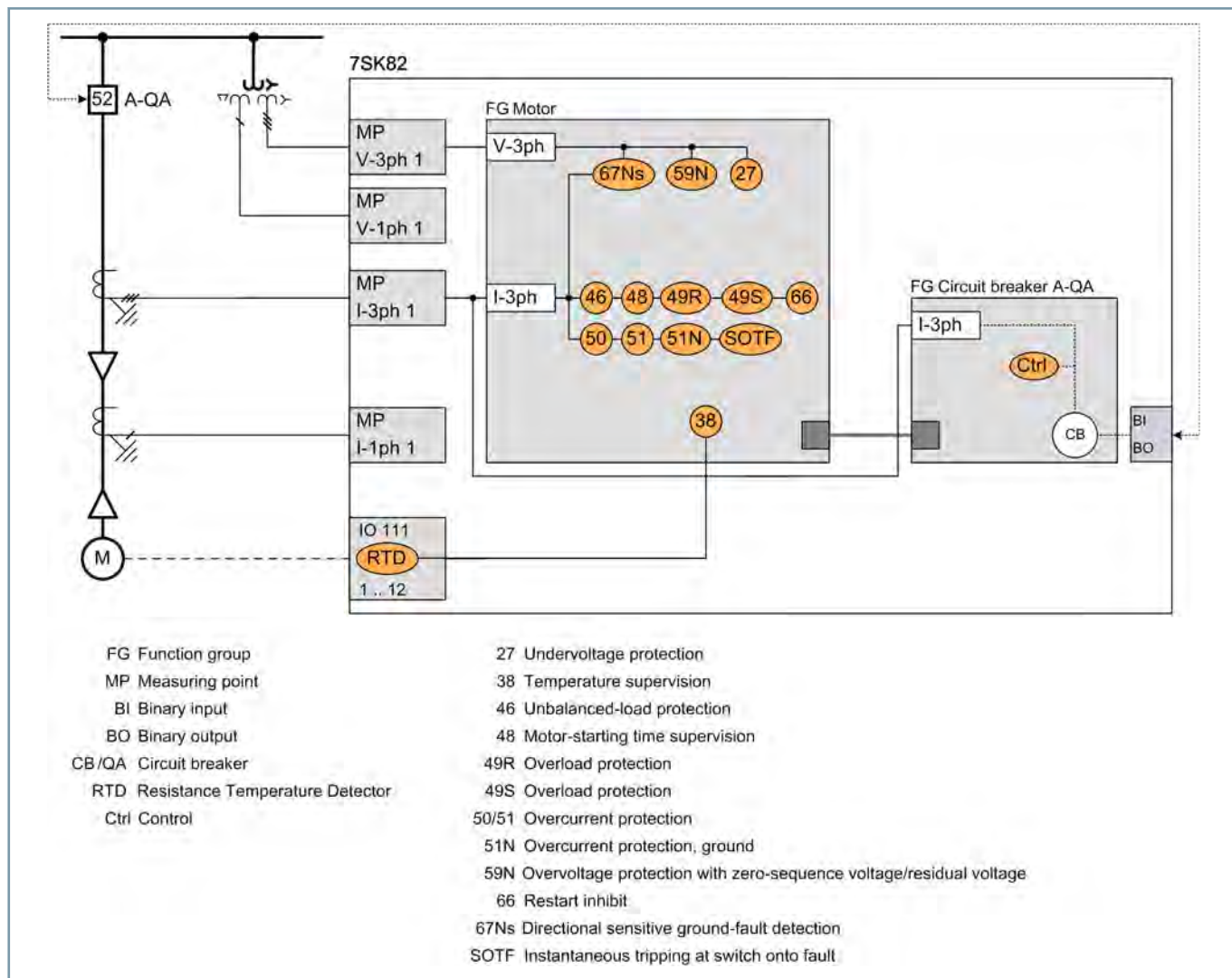

[dw_motor-protection-7SK82, 2, en_US]

Figure 2.12/3 Protection of a Medium-Power Motor

SIPROTEC 5 Devices and Fields of Application

Motor Protection – SIPROTEC 7SK82

ANSI	Function	Abbr.	Available	Application Templates	
				1	2
	Protection functions for 3-pole tripping	3-pole	■	■	
14	Locked rotor	$I > + n <$	■	■	■
24	Overexcitation protection	V/f	■		
25	Synchrocheck, synchronization function	Sync	■		
27	Undervoltage protection: "3-phase" or "positive-sequence system V1" or "universal Vx"	$V <$	■		■
27R, 59R	Voltage change protection (starting with V8.30)	dV/dt	■		
	Undervoltage-controlled reactive power protection	$Q > / V <$	■		
32, 37	Power protection active/reactive power	$P < >, Q < >$	■		
32R	Reverse-power protection	$- P <$	■		
37	Undercurrent	$I <$	■		
38	Temperature supervision	$\theta >$	■	■	■
46	Negative-sequence system overcurrent protection	$I2 >$	■		
46	Unbalanced-load protection (thermal)	$I2^2 t >$	■	■	■
46	Negative-sequence system and overcurrent protection with direction	$I2 >, \angle(V2, I2)$	■		
47	Overvoltage protection, negative-sequence system	$V2 >$	■		
47	Overvoltage protection: "Negative-sequence system V2" or "negative-sequence system V1/positive-sequence system V1"	$V2 >; V2/V1 >$	■		
48	Starting time monitoring for motors	$I^2 \text{start}$	■	■	■
49	Thermal overload protection	$\theta, I^2 t$	■	■	■
49	Thermal overload protection, user-defined characteristic curve	$\theta, I^2 t$	■		
49R	Thermal overload protection, rotor (motor)	θR	■	■	■
50/51 TD	Overcurrent protection, phases	$I >$	■	■	■
	Instantaneous tripping at switch onto fault	SOTF	■		
50HS	Instantaneous high-current tripping	$I >>>$	■		
50/51 TD	Overcurrent protection with positive-sequence current I1 (from V7.9)	$I1 >$	■		
50N/ 51N TD	Overcurrent protection, ground	$IN >$	■	■	■
50N/ 51N TD	Overcurrent protection, 1-phase	$IN >$	■		
50 Ns/ 51Ns	Sensitive ground-fault detection for grounded arc suppression coils and isolated power systems (including a) $3I0 >$ b) admittance $Y0 >$, c) $3I0\text{-harm} >$ (from V7.8)	$INs >$	■		
	Sensitive ground-fault detection via pulse detection; hint: this stage also requires the function 50Ns/51Ns or 67Ns "sensitive ground-fault detection for grounded arc suppression coils and isolated power systems"	IN pulse	■		
	Intermittent ground-fault protection	$IIE >$	■		
50BF	Circuit-breaker failure protection, 3-pole	CBFP	■		
50RS	Circuit breaker restrike monitoring	CBRM	■		
50L	Load-jam protection	$I > L$	■	■	■
51V	Voltage-controlled overcurrent protection	$t = f(I, V)$	■		
59, 59N	Overvoltage protection: "3-phase" or "zero-sequence system V0" or "positive-sequence system V1" or "universal Vx"	$V >$	■		
60	Voltage-comparison supervision	$\Delta V >$	■		
66	Restart inhibit for motors	$I^2 t$	■	■	■
67	Directional overcurrent protection, phases	$I >, \angle(V, I)$	■		
67N	Directional overcurrent protection, ground	$IN >, \angle(V, I)$	■		

SIPROTEC 5 Devices and Fields of Application

Motor Protection – SIPROTEC 7SK82

ANSI	Function	Abbr.	Available	Application Templates	
				1	2
67 Ns	Sensitive ground-fault detection for grounded arc suppression coils and isolated power systems including a) $3I_0$, b) V_0 , c) $\cos/\sin \Phi$, d) transient ground fault, e) $\Phi(V, I)$, f) admittance		■		■
	Directional tripping stage with one harmonic; hint: this stage also requires the function "67Ns sensitive ground-fault detection for grounded arc suppression coils and isolated power systems"	$\angle(V_0h, I_0h)$	■		
	Directional Intermittent Ground-Fault Protection	IIEdir>	■		
74TC	Trip-circuit supervision		■		
74CC	Single circuit monitoring (from V7.9)		■		
79	Automatic reclosing, 3-pole	AREC	■		
81	Frequency protection: "f>" or "f<" or "df/dt"	f<>; df/dt<>	■		
81U	Underfrequency load shedding	f<(ULS)	■		
	Vector-jump protection	$\Delta\varphi$ >	■		
86	Lockout		■	■	■
87N T	Restricted ground-fault protection	ΔI_N	■		
90 V	Voltage controller for two-winding transformer		■		
90 V	Voltage controller for two-winding transformer with parallel control		■		
	Number of two-winding transformers with parallel control (hint: only together with the function "voltage controller for two-winding transformer with parallel control")		■		
FL	Fault Locator, single-side	FL-one	■		
PMU	Synchrophasor measurement	PMU	■		
AFD	Arc protection (only with plug-in module ARC-CD-3FO)		■		
	Measured values, standard		■	■	■
	Measured values, extended: Min, max, average		■		
	Switching statistics counter		■		
	PQ – Basic measured values: THD (Total Harmonic Distortion) and harmonic component (starting with V8.01) and THD voltage average values (starting with V8.40)		■		
	PQ – Basic measured values: Voltage unbalance (starting with V8.40)		■		
	PQ – Basic measured values: Voltage changes – monitoring of voltage dips, overvoltages and voltage interruptions (starting with V8.40)		■		
	PQ – Basic measured values: TDD - Total Demand Distortion (starting with V8.40)		■		
	CFC (standard, control)		■	■	■
	CFC arithmetic		■		
	Circuit-breaker wear monitoring	$\Sigma I_x, I^2t, 2P$	■		
	Switching sequence function		■		
	Inrush-current detection		■	■	■
	External trip initiation		■		
	Control		■	■	■
	Circuit breaker		■	■	■
	Disconnectors/grounding conductor		■		
	Fault recording of analog and binary signals		■	■	■
	Monitoring		■	■	■
	Protection interface, serial		■		
	Frequency group tracking (from V7.8)		■		

2.12

SIPROTEC 5 Devices and Fields of Application

Motor Protection – SIPROTEC 7SK82







ANSI	Function	Abbr.	Available	Application Templates	
				1	2
	Cyber security: Role-Based Access Control (from V7.8)		■		
	Temperature recording via communication protocol		■		
	Cyber security: Authenticated network access using IEEE 802.1X (starting from V8.3)		■		
Function point class:				0	40
The configuration and function point class for your application can be determined in the SIPROTEC 5 order configurator at www.siemens.com/siprotec .					

Table 2.12/1 SIPROTEC 7SK82 – Functions, Application Templates

- (1) Current measurement
- (2) Current and voltage measurement

SIPROTEC 5 Devices and Fields of Application

Motor Protection – SIPROTEC 7SK82

Standard Variants for SIPROTEC 7SK82		
T1	1/3, 11 BI, 9 BO, 4 I Housing width 1/3 x 19", 11 binary inputs 9 binary outputs (1 life contact, 8 standard) 4 current transformers Contains the following modules: base module with PS101 and IO101	
T2	1/3, 23 BI, 16 BO, 4 I Housing width 1/3 x 19", 23 binary inputs 16 binary outputs (1 life contact, 15 standard) 4 current transformers Contains the following modules: base module with PS101, IO101, and IO110	
T3	1/3, 11 BI, 9 BO, 2 I, 12 RTDs Housing width 1/3 x 19" 11 binary inputs 9 binary outputs (1 life contact, 8 standard) 4 current transformers 12 temperature inputs Contains the following modules: base module with PS101, IO101, and IO111	
T4	1/3, 11 BI, 9 BO, 4 I, 4 V Housing width 1/3 x 19" 11 binary inputs 9 binary outputs (1 life contact, 8 standard) 4 current transformers 4 voltage transformers Contains the following modules: base module with PS101 and IO102	
T5	1/3, 23 BI, 16 BO, 4 I, 4 V Housing width 1/3 x 19" 23 binary inputs 16 binary outputs (1 life contact, 15 standard) 4 current transformers 4 voltage transformers Contains the following modules: base module with PS101, IO102, and IO110	
T6	1/3, 11 BI, 9 BO, 4 I, 4 V, 12 RTDs Housing width 1/3 x 19" 11 binary inputs 9 binary outputs (1 life contact, 8 standard) 4 current transformers 4 voltage transformers 12 temperature inputs Contains the following modules: base module with PS101, IO102, and IO111	

2.12

Table 2.12/2 Standard Variants for SIPROTEC 7SK82 Motor Protection Devices

You can find the technical data in the manual
www.siemens.com/siprotec

SIPROTEC 5 Devices and Fields of Application

Motor Protection – SIPROTEC 7SK85

Description

The SIPROTEC 7SK85 motor protection device is designed for the protection of motors of all sizes. With its modular structure, flexibility and the high-performance DIGSI 5 engineering tool, SIPROTEC 7SK85 offers future-oriented solutions for protection, control, automation, monitoring, and Power Quality – Basic.

For motors in explosive environments, the SIPROTEC 7SK85 is also available with EN 60079-14 or VDE 0165, Part 1, ATEX (Verband der Elektrotechnik, Elektronik und Informationstechnik) certification.

Main function	Motor protection for motors of all sizes
Inputs and outputs	3 predefined standard variants with 4 current transformers, 4 voltage transformers, 11 to 27 binary inputs, 9 to 17 binary outputs
Hardware flexibility	Flexibly adjustable and expandable I/O quantity structure within the scope of the modular SIPROTEC 5 system. 1/6 expansion modules can be added, available with large or small display, or without display
Housing width	1/3 × 19 inches to 2/1 × 19 inches

Benefits

- Safety due to high-performance protection functions
- Purposeful and easy handling of devices and software thanks to a user-friendly design
- Cybersecurity in accordance with NERC CIP and BDEW Whitepaper requirements
- Highest availability even under extreme environmental conditions by standard coating of the modules
- Full compatibility between IEC 61850 Editions 1, 2.0, and 2.1

Functions

DIGSI 5 permits all functions to be configured and combined as required and as per the functional scope that has been ordered.

- Motor protection functions: Starting time supervision, thermal overload protection for stator and rotor, restart inhibit, unbalanced-load protection, load-jam protection
- Stator and storage-temperature monitoring via temperature sensors with external RTD unit.
- Differential motor protection as fast short-circuit protection for motors of high power
- Sensitive ground-fault protection (non-directional, directional) to detect stator ground faults
- Directional and non-directional overcurrent protection (short-circuit protection) with additional functions
- Detection of ground faults of any type in compensated or isolated electrical power systems using the following functions: 3I0>, V0>, transient ground fault, cos φ, sin φ, harmonic, dir. detection of intermittent ground faults and admittance
- Ground-fault detection using the pulse-detection method
- Overvoltage and undervoltage protection
- Arc protection



[SIP5_GD_SS_W3, 2, --, --]

Figure 2.12/4 SIPROTEC 5 Device with Expansion Module

- Power protection, configurable as active or reactive-power protection
- Detection of current and voltage signals up to the 50th harmonic with high accuracy for selected protection functions (such as thermal overload protection) and operational measured values
- PQ – Basic: Voltage unbalance; voltage changes: overvoltage, dip, open circuit; TDD, THD, and harmonics
- Control, synchrocheck, and switchgear interlocking protection
- Graphical logic editor to create high-performance automation functions in the device
- Fixed integrated electrical Ethernet RJ45 interface for DIGSI 5 and IEC 61850 (reporting and GOOSE)
- Up to 4 pluggable communication modules, usable for different and redundant protocols (IEC 61850-8-1, IEC 61850-9-2 Client, IEC 60870-5-103, IEC 60870-5-104, Modbus TCP, DNP3 serial and TCP, PROFINET IO, PROFINET IO S2 redundancy)
- Virtual network partitioning (IEEE 802.1Q - VLAN)
- Reliable data transmission via PRP and HSR redundancy protocols
- Certification for use in environments at risk of explosion (EN 60079-14 or VDE 0165, Part 1, ATEX)
- Extensive cybersecurity functionality, such as role-based access control (RBAC), logging of security-related events, signed firmware, or authenticated IEEE 802.1X network access.
- Simple, fast, and secure access to the device via a standard Web browser to display all information and diagnostic data, vector diagrams, single-line and device display pages
- Secure serial protection communication, also over great distances and all available physical media (optical fiber, two-wire connections, and communication networks)

- Detecting operational measured variables and protection-function measured values to evaluate the systems, to support commissioning, and to analyze faults
- Synchrophasor measured values with the IEEE C37.118 protocol integrated (PMU)
- High-performance fault recording (buffer for a max. record time of 80 s at 8 kHz or 320 s at 2 kHz)
- Auxiliary functions for simple tests and commissioning
- Flexibly adjustable I/O quantity structure within the scope of the SIPROTEC 5 modular system

Applications

- Protection against thermal overload of the stator from over-current, cooling problems, or pollution
- Protection against thermal overload of the rotor during startup due to: Frequent startups, excessively long startups, or blocked rotor
- Monitoring for voltage unbalance or phase outage
- Monitoring the thermal state and the storage temperatures with temperature measurement
- Detection of idling drives of pumps and compressors, for example
- Detection of ground faults in the motor
- Protection against motor short circuits
- Protection against instability due to undervoltage
- Detection and recording of power-quality data in the medium-voltage and subordinate low-voltage power system

Application Templates

DIGSI 5 provides application templates for standard applications. They include basic configurations and default settings.

The following application templates are available:

- Current measurement
 - Thermal overload protection for stator and rotor
 - Starting time supervision
 - Restart inhibit
 - Unbalanced-load protection (thermal)
 - Temperature supervision
 - Load-jam protection
 - Overcurrent protection (non-directional) for phases and ground
 - Transformer inrush-current detection
- Current and voltage measurement
 - Thermal overload protection for stator and rotor
 - Starting time supervision
 - Restart inhibit

- Unbalanced-load protection (thermal)
- Temperature supervision
- Load-jam protection
- Overcurrent protection (non-directional) for phases and ground
- Transformer inrush-current detection
- Directional sensitive ground-fault detection for isolated or grounded power systems and for detection of stator ground faults
- Overvoltage protection with zero-sequence system V0
- Undervoltage protection with positive-sequence system V1
- Measuring-voltage failure detection
- Motor differential protection, current and voltage measurement
 - Motor differential protection
 - Thermal overload protection for stator and rotor
 - Starting time supervision
 - Restart inhibit
 - Unbalanced-load protection (thermal)
 - Temperature supervision
 - Load-jam protection
 - Overcurrent protection (non-directional) for phases and ground
 - Transformer inrush-current detection
 - Directional sensitive ground-fault detection for isolated or grounded power systems and for detection of stator ground faults
 - Overvoltage protection with zero-sequence system V0
 - Undervoltage protection with positive-sequence system V1
 - Measuring-voltage failure detection

Application Example

SIPROTEC 7SK85 – Protection of a medium-power motor

The motor protection functions and the overcurrent protection of the SIPROTEC 7SK85 protect an asynchronous motor of medium power (up to approximately 2 MW) against thermal and mechanical overload and short circuits. The directional sensitive ground-fault detection and the overvoltage protection with zero-sequence voltage V0 detect stator ground faults in the motor. An external RTD unit captures and monitors the thermal state of the motor and the storage temperatures. The RTD unit is connected to the device via Ethernet or serial communication.

[Figure 2.12/5](#) shows the functional scope and the basic configuration of a SIPROTEC 7SK85 for this application. It is based on the application template "Current and voltage measurement". In addition, the device must be equipped with a plug-in module for communication with the RTD unit.

SIPROTEC 5 Devices and Fields of Application

Motor Protection – SIPROTEC 7SK85

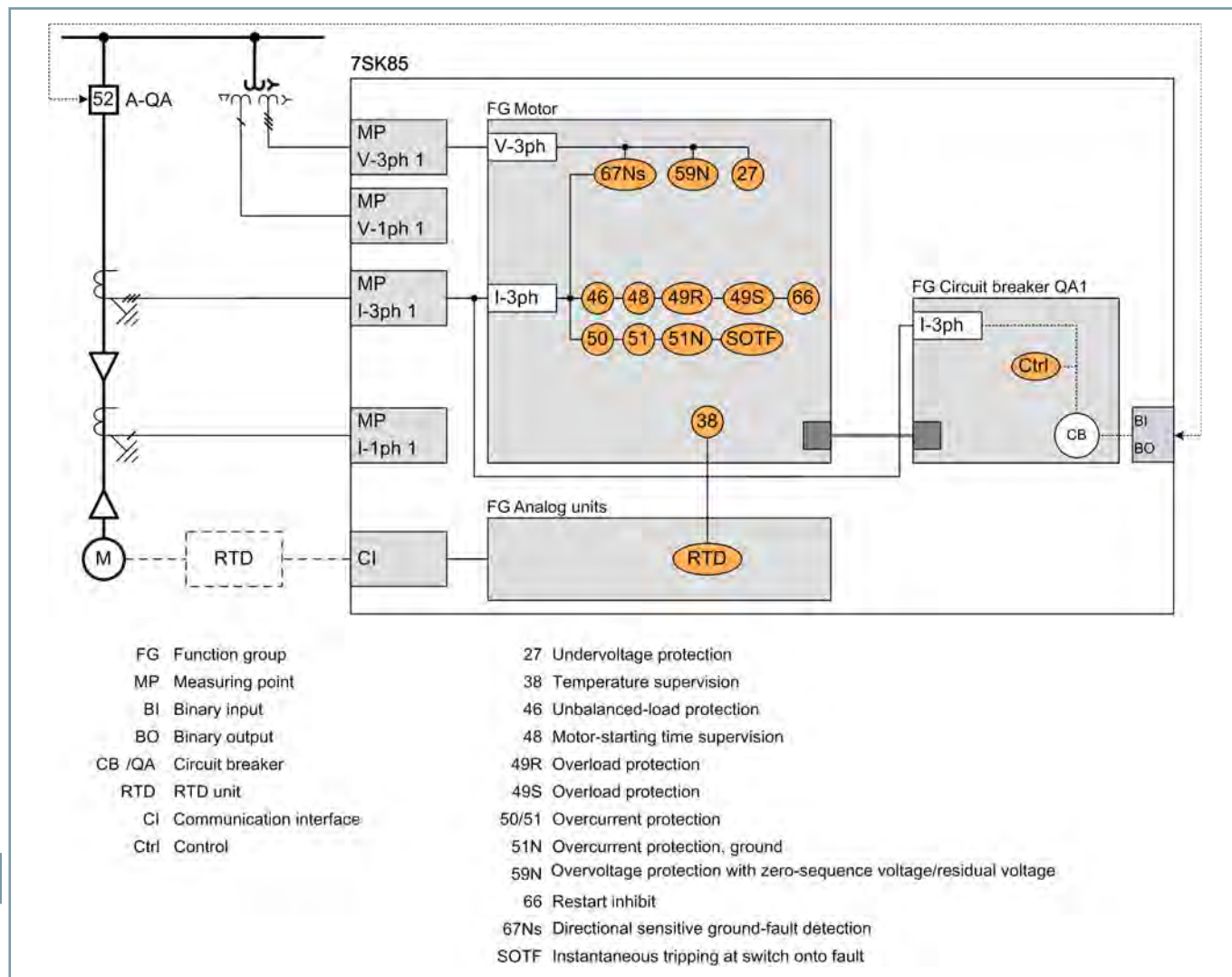

[Motorschutz-7SK85, 1, en_US]

Figure 2.12/5 Protection of a Medium-Power Motor

SIPROTEC 5 Devices and Fields of Application

Motor Protection – SIPROTEC 7SK85

ANSI	Function	Abbr.	Available	Application Templates		
				1	2	3
	Protection functions for 3-pole tripping	3-pole	■	■	■	■
	Expandable hardware quantity structure	I/O	■	■	■	■
	Process bus client protocol (hint: PB client requires a separate ETH-BD-2FO plug-in module, from V8.0)	PB client	■			
	IEC61850-9-2 Merging Unit Stream (hint: Each stream requires a separate ETH-BD-2FO plug-in module, from V8.0)	MU	■			
	IEC61850-9-2 Merging Unit Stream 7SS85 CU (hint: Only for communication with a 7SS85 CU. A separate ETH-BD-2FO plug-in module is required starting with V8.40)	MU	■			
14	Locked rotor	$I > + n <$	■	■	■	■
24	Overexcitation protection	V/f	■			
25	Synchrocheck, synchronization function	Sync	■			
27	Undervoltage protection: "3-phase" or "positive-sequence system V1" or "universal Vx"	$V <$	■		■	■
27R, 59R	Voltage change protection (starting with V8.30)	dV/dt	■			
	Undervoltage-controlled reactive power protection	$Q > / V <$	■			
32, 37	Power protection active/reactive power	$P < >, Q < >$	■			
32R	Reverse-power protection	$- P <$	■			
37	Undercurrent	$I <$	■			
38	Temperature supervision	$\theta >$	■	■	■	■
46	Negative-sequence system overcurrent protection	$I2 >$	■			
46	Unbalanced-load protection (thermal)	$I2^2 t >$	■	■	■	■
46	Negative-sequence system and overcurrent protection with direction	$I2 >, \angle(V2, I2)$	■			
47	Overvoltage protection, negative-sequence system	$V2 >$	■			
47	Overvoltage protection: "Negative-sequence system V2" or "negative-sequence system V1/positive-sequence system V1"	$V2 >; V2/V1 >$	■			
48	Starting time monitoring for motors	$I^2 start$	■	■	■	■
49	Thermal overload protection	$\theta, I^2 t$	■	■	■	■
49	Thermal overload protection, user-defined characteristic curve	$\theta, I^2 t$	■			
49R	Thermal overload protection, rotor (motor)	θR	■	■	■	■
50/51 TD	Overcurrent protection, phases	$I >$	■	■	■	■
	Instantaneous tripping at switch onto fault	SOTF	■			
50HS	Instantaneous high-current tripping	$I >>>$	■			
50/51 TD	Overcurrent protection with positive-sequence current I1 (from V7.9)	$I1 >$	■			
50N/ 51N TD	Overcurrent protection, ground	$IN >$	■	■	■	■
50N/ 51N TD	Overcurrent protection, 1-phase	$IN >$	■			
50 Ns/ 51Ns	Sensitive ground-fault detection for grounded arc suppression coils and isolated power systems including a) 3I0> b) admittance Y0>, c) 3I0-harm> (from V7.8)	$INs >$	■			
	Sensitive ground-fault detection via pulse detection; hint: this stage also requires the function 50Ns/51Ns or 67Ns "sensitive ground-fault detection for grounded arc suppression coils and isolated power systems"	IN pulse	■			
	Intermittent ground-fault protection	$IIE >$	■			
50BF	Circuit-breaker failure protection, 3-pole	CBFP	■			

2.12

SIPROTEC 5 Devices and Fields of Application

Motor Protection – SIPROTEC 7SK85

ANSI	Function	Abbr.	Available	Application Templates		
				1	2	3
50EF	End-fault protection (hint: For use only in decentralized busbar protection with a 7SS85 CU starting with V8.40)		■			
50RS	Circuit breaker restrike monitoring	CBRM	■			
50L	Load-jam protection	I>L	■	■	■	■
51V	Voltage-controlled overcurrent protection	t=f(I, V)	■			
59, 59N	Overvoltage protection: "3-phase" or "zero-sequence system V0" or "positive-sequence system V1" or "universal Vx"	V>	■			
60	Voltage-comparison supervision	ΔV>	■			
66	Restart inhibit for motors	I²t	■	■	■	■
67	Directional overcurrent protection, phases	I>, ∠(V, I)	■			
67N	Directional overcurrent protection, ground	IN>, ∠(V, I)	■			
67 Ns	Sensitive ground-fault detection for grounded arc suppression coils and isolated power systems including a) 3I0> b) V0>, c) cos/sine Phi, d) transient ground fault, e) Phi(V, I), f) admittance		■		■	■
	Directional tripping stage with one harmonic; hint: this stage also requires the function "67Ns sensitive ground-fault detection for grounded arc suppression coils and isolated power systems"	∠(V0h, I0h)	■			
	Directional Intermittent Ground-Fault Protection	IIEdir>	■			
74TC	Trip-circuit supervision		■			
74CC	Single circuit monitoring (from V7.9)		■			
79	Automatic reclosing, 3-pole	AREC	■			
81	Frequency protection: "f>" or "f<" or "df/dt"	f<>; df/dt<>	■			
81U	Underfrequency load shedding	f<(ULS)	■			
	Vector-jump protection	Δφ>	■			
86	Lockout		■	■	■	■
87N T	Restricted ground-fault protection	ΔIN	■			
87M	Differential motor protection	ΔI	■			■
90 V	Voltage controller for two-winding transformer		■			
90 V	Voltage controller for two-winding transformer with parallel control		■			
	Number of two-winding transformers with parallel control (hint: only together with the function "voltage controller for two-winding transformer with parallel control")		■			
90 V	Voltage controller for three-winding transformer		■			
90 V	Voltage controller for grid coupling transformer		■			
FL	Fault Locator, single-side	FL-one	■			
PMU	Synchrophasor measurement	PMU	■			
AFD	Arc protection (only with plug-in module ARC-CD-3FO)		■			
	Measured values, standard		■	■	■	■
	Measured values, extended: Min, max, average		■			
	Switching statistics counter		■			
	PQ – Basic measured values: THD (Total Harmonic Distortion) and harmonic component (starting with V8.01) and THD voltage average values (starting with V8.40)		■			
	PQ – Basic measured values: Voltage unbalance (starting with V8.40)		■			
	PQ – Basic measured values: Voltage changes – monitoring of voltage dips, overvoltages and voltage interruptions (starting with V8.40)		■			

SIPROTEC 5 Devices and Fields of Application

Motor Protection – SIPROTEC 7SK85

ANSI	Function	Abbr.	Available	Application Templates		
				1	2	3
	PQ – Basic measured values: TDD - Total Demand Distortion (starting with V8.40)		■			
	CFC (standard, control)		■	■	■	■
	CFC arithmetic		■			
	Circuit-breaker wear monitoring	$\Sigma I_x, I^2t, 2P$	■			
	Switching sequence function		■			
	Inrush-current detection		■	■	■	■
	External trip initiation		■			
	Control		■	■	■	■
	Circuit breaker		■	■	■	■
	Disconnectors/grounding conductor		■			
	Fault recording of analog and binary signals		■	■	■	■
	Monitoring		■	■	■	■
	Protection interface, serial		■			
	Frequency group tracking (from V7.8)		■			
	Cyber security: Role-Based Access Control (from V7.8)		■			
	Temperature recording via communication protocol		■			
	Cyber security: Authenticated network access using IEEE 802.1X (starting from V8.3)		■			
Function point class:				0	40	100
The configuration and function point class for your application can be determined in the SIPROTEC 5 order configurator at www.siemens.com/siprotec .						

Table 2.12/3 SIPROTEC 7SK85 – Functions, Application Templates

- (1) Current measurement
- (2) Current and voltage measurement
- (3) Differential protection with current and voltage measurement

SIPROTEC 5 Devices and Fields of Application

Motor Protection – SIPROTEC 7SK85



Standard Variants for SIPROTEC 7SK85		
R1	1/3, 11 BI, 9 BO, 4 I, 4 V	
	Housing width 1/3 x 19", 11 binary inputs, 9 binary outputs (1 life contact, 2 standard, 6 fast) 4 current transformers 4 voltage transformers Contains the following modules: base module with PS201 and IO202	
R2	1/2, 17 BI, 16 BO, 4 I, 4 V	
	Housing width 1/2 x 19", 17 binary inputs, 16 binary outputs (1 life contact, 9 standard, 6 fast) 4 current transformers 4 voltage transformers Contains the following modules: base module with PS201 and IO202, expansion module IO206	
R3	1/2, 27 BI, 17 BO, 4 I, 4 V	
	Housing width 1/2 x 19", 27 binary inputs, 17 binary outputs (1 life contact, 10 standard, 6 fast) 4 current transformers 4 voltage transformers Contains the following modules: base module with PS201 and IO202, expansion module IO207	

Table 2.12/4 Standard Variants for SIPROTEC 7SK85 Motor Protection Devices

You can find the technical data in the manual

www.siemens.com/siprotec

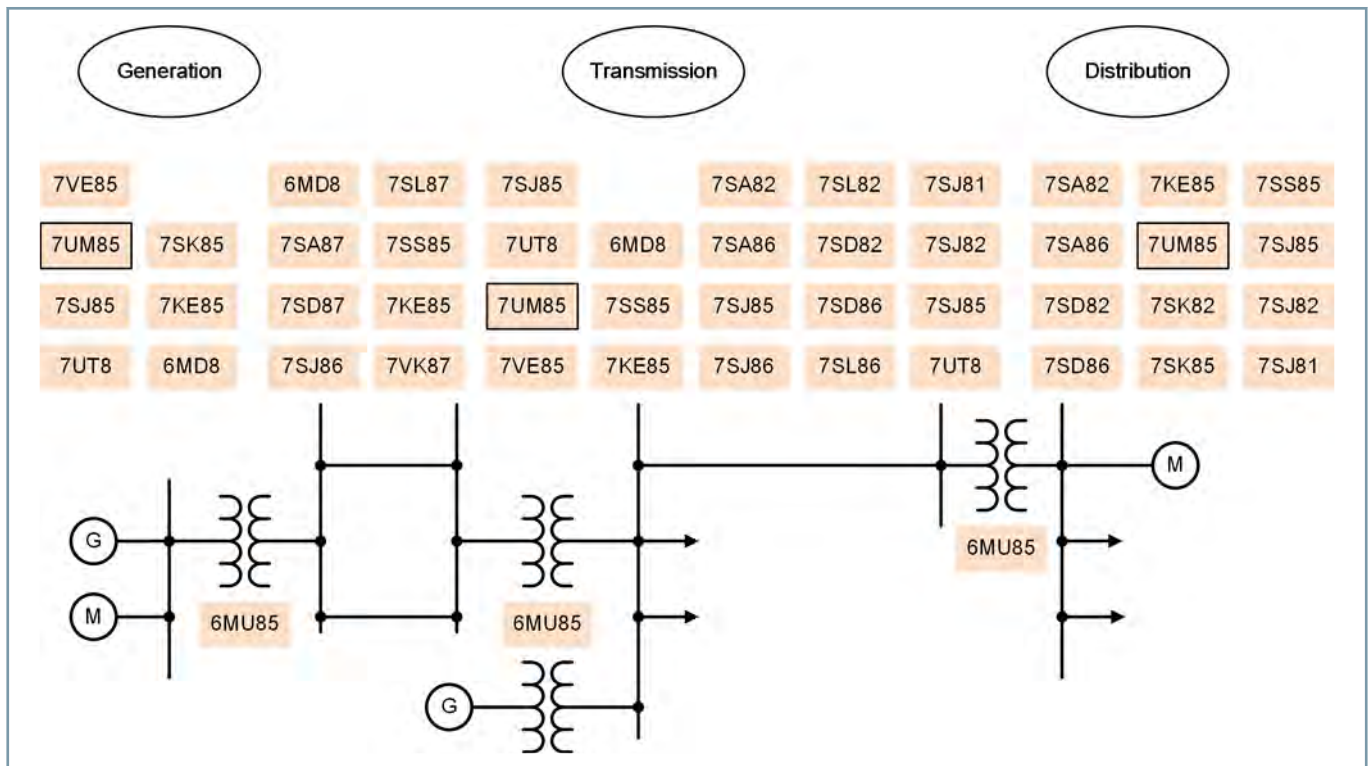

[dw_7UM8_anwendung, 3, en_US]

Figure 2.13/1 Fields of Application of the SIPROTEC 5 Devices

SIPROTEC 7UM85

The main protection functions of the SIPROTEC 5 7UM85 generator protection devices are based on typical generator protection functions (stator and rotor ground-fault protection, reverse-power protection, unbalanced-load protection, differential protection, underexcitation protection, and many others). They protect generators and power units in bus and unit connection. The protection functions are implemented in such a way that they satisfy the requirements of different power-plant versions. These can be conventional run-of-river power plants or pumped-storage hydropower plants with phase-rotation reversal in pump operation. Besides standard unit-type power plants (different raw-material sources), complete protection is also possible for nuclear power plants and for power plants that are started with a starting-frequency converter (for example, gas turbine power plants). The scalability of the devices regarding to hardware design and functionality opens a wide field of applications. By selecting hardware and functionality as required, you can thus cover the entire power range of the machines (starting at approximately 1 MVA) at low costs. The devices are also perfectly suited for industrial applications. The large number of protection and automatic functions allows the device to be used in all fields of power generation.

The devices contain all important auxiliary functions that are necessary for safe network operation today. This includes control, measurement, and monitoring functions. The large number of communication interfaces and communication protocols satisfies the requirements of communication-based selective protection and of automated operation.

Commissioning and maintenance work can be completed safely, quickly, and thus cost-effectively with high-performance test functions. Their modular surface mounting allows SIPROTEC 5 devices to be always adapted flexibly to the individual requirements.

Distinguishing features

The SIPROTEC 7UM85 devices are characterized by their specialized hardware scalability and functionality. Using the configurator, you can create the hardware configuration (number of V, I measuring points, binary inputs and outputs, communication interfaces, etc.) as required by the application. Using the DIGSI 5 engineering tool, you can download the required functions from the library into the 7UM85 device. The usable functional scope is limited by the ordered function points. You can order additional points without any problems.

When ordering, you can select the devices from various standard variants. Additional expansion modules allow the device to be adapted to your specific applications (see [Table 2.13/2](#)).

Significant Features

7UM85	Flexible configuration of the hardware quantity structure for analog inputs, binary inputs and outputs, measuring transducers, and communication due to expandability with 1/6 expansion modules
-------	--

SIPROTEC 5 Devices and Fields of Application

Generator Protection – SIPROTEC 7UM85

Description

The generator protection device SIPROTEC 7UM85 has been designed specifically for the protection of generators and power units. It contains all necessary main protection functions and a large number of other protection and monitoring functions. With its modular structure, flexibility, and the high-performance DIGSI 5 engineering tool, SIPROTEC 7UM85 offers future-oriented solutions for protection, control, automation, monitoring, and Power Quality – Basic.

For motors in explosive environments, the SIPROTEC 7UM85 is also available with EN 60079-14 or VDE 0165, Part 1, ATEX (Verband der Elektrotechnik, Elektronik und Informationstechnik) certification.

Main function	Typical generator protection functions
Inputs and outputs	5 predefined standard variants with up to 16 current transformers and 8 voltage transformers, 7 to 15 binary inputs, 9 to 20 binary outputs 4 fast measuring transducer inputs (10 V or 20 mA)
Hardware flexibility	Flexibly adjustable and expandable I/O quantity structure within the scope of the modular SIPROTEC 5 system; 1/6 expansion modules can be added, available with large or small display, or without display
Housing width	1/3 × 19 inches to 2 × 19 inches

Benefits

- Safe and reliable automation and control of your systems
- Purposeful and easy handling of devices and software thanks to a user-friendly design
- Cybersecurity in accordance with NERC CIP and BDEW Whitepaper requirements
- Highest availability even under extreme environmental conditions by standard coating of the populated printed circuit boards

Functions

DIGSI 5 permits all functions to be configured and combined as required and as per the functional scope that has been ordered.

- Short-circuit protection (overcurrent protection, impedance protection, differential protection)
- Stator ground-fault protection (90 % non-directional or directional, 100 % with 3rd harmonic, real 100 % protection with 20-Hz voltage interference)
- Rotor ground-fault protection with different measuring methods (ground-current or ground-resistance monitoring)
- High-precision reverse-power protection and universal power protection
- Underexcitation and overexcitation protection
- Unbalanced-load protection
- Overload protection and temperature supervision via external RTD unit (with PT 100, for example)
- Out-of-step protection



[SIP5_GD_SS_LED_W3, 2, --, --]

Figure 2.13/2 SIPROTEC 7UM85 Generator Protection (Width: 1/3 × 19" to 2 × 19")

- Rotor and stator overload protection with cold-gas consideration (coolant temperature)
- Power-plant disconnection protection
- Shaft-current protection (in particular with hydropower applications)
- Universal overvoltage and undervoltage protection with different measuring methods
- Overfrequency and underfrequency protection, frequency change protection, and supervision of duration time in frequency bands as turbine protection (protection against abnormal frequencies)
- Protection functions for network decoupling (voltage and frequency protection, directional reactive-power undervoltage protection (QU protection), and vector-jump protection)
- Inadvertent energization protection to detect incorrect activation of the circuit breaker
- Circuit-breaker failure protection (CBFP)
- Circuit-breaker reignition monitoring
- Single-channel parallel connection function (synchronization) with adjustment commands for speed (frequency) and voltage
- Graphical logic editor to create high-performance automation functions in the device
- Fixed integrated electrical Ethernet RJ45 interface for DIGSI 5 and IEC 61850 (reporting and GOOSE)
- Optional, pluggable communication modules, usable for different and redundant protocols (IEC 61850-8-1, IEC 61850-9-2 Client, IEC 60870-5-103, IEC 60870-5-104, Modbus TCP, DNP3 serial and TCP, PROFINET IO, PROFINET IO S2 redundancy)
- Virtual network partitioning (IEEE 802.1Q - VLAN)

- Secure serial protection communication, also over great distances and all available physical media (optical fiber, two-wire connections, and communication networks)
- PQ – Basic: Voltage unbalance; voltage changes: overvoltage, dip, interruption; TDD, THD, and harmonics
- Reliable data transmission via PRP and HSR redundancy protocols
- Certification for use in environments at risk of explosion (EN 60079-14 or VDE 0165, Part 1, ATEX)
- Extensive cybersecurity functionality, such as role-based access control (RBAC), logging of security-related events, signed firmware, or authenticated IEEE 802.1X network access.
- Simple, fast, and secure access to the device via a standard Web browser to display all information and diagnostic data, vector diagrams, single-line and device display pages
- Phasor Measurement Unit (PMU) for synchrophasor measured values and IEEE C37.118 protocol
- Time synchronization using IEEE 1588
- Detecting operational measured variables and protection-function measured values to evaluate the system, to support commissioning, and to analyze faults
- Frequency tracked protection functions over a wide frequency range (10 Hz to 80 Hz) and the option to assign the protection functions in a single device to different **frequency tracking groups**.
- High-performance fault recording (buffer for a max. record time of 80 s at 8 kHz or 320 s at 2 kHz)
- Auxiliary functions for simple tests and commissioning
- Flexibly adjustable I/O quantity structure within the scope of the SIPROTEC 5 modular system

Applications

- Protection of generators in busbar connection of different power, with directional stator ground-fault protection.
- Protection of generators in unit connection of different power (using the 100 % stator ground fault (20 Hz) with larger generators)
- Protection of power units with one device per protection group. In the generator transformer variant, the 7UM85 implements both generator and transformer protection.
- In more complex power units (unit connection with generator circuit breaker and several auxiliary transformers), additional SIPROTEC 5 devices are used, for example, 7UT8x, 7SJ82, or 7SJ85 and 7SA, SD, SL86, at the upper-voltage side of the generator transformer.
- Using motor and generator protection functions (for example, underexcitation protection) to protect synchronous motors
- Detection and recording of power-quality data in the medium-voltage and subordinate low-voltage power system

Application Templates

DIGSI 5 provides application templates for standard applications. They include basic configurations and default settings.

The following application templates are available:

- Generator basis
 - Basic protection functions (overcurrent protection, stator ground-fault protection, reverse-power protection, overexcitation protection, voltage protection, frequency protection, and unbalanced-load protection),
 - Rotor ground-fault protection (ground-current measurement)
- Generator bus connection basis
 - Basic protection functions
 - Generator differential protection
 - Underexcitation protection
- Generator unit connection basis
 - Basic protection functions
 - Transformer differential protection as overall protection (transformer + generator)
 - Underexcitation protection
 - 100 % stator ground-fault protection with 3rd harmonic
- Enhanced generator unit connection
 - Basic protection functions
 - Transformer differential protection
 - Generator differential protection
 - Underexcitation protection
 - Out-of-step protection
 - 100 % stator ground-fault protection with 20-Hz coupling
 - Synchronization function (without adjusting commands)
 - Circuit-breaker failure protection

SIPROTEC 5 Devices and Fields of Application

Generator Protection – SIPROTEC 7UM85

Application Examples

SIPROTEC 7UM85 – Generator Protection in Bus Connection

([Figure 2.13/3](#)) is based on the application template **Generator busbar connection, basis** and shows the single-line diagram, the connection to the 7UM85, and the logic structure in the device. The ground current for the stator ground-fault protection is generated via a neutral-point transformer. Sensitive ground-fault detection must be implemented via a different connection to the ground-current transformer (same transformation ratio). The rotor ground-fault protection is implemented as a power-frequency coupling and is based on the rotor ground-current measurement. 7XR61 + 3PP1336 must be provided as accessories. A base module and an expansion module (such as standard variant AA2 + IO201) are required as minimum device hardware.

The figure also shows the internal functional structure of the device. The measuring points are connected with the function groups. The function groups are also interconnected. Functions are routed to function groups and interconnected automatically. The **FG Generator stator** is the main function group. The differential protection requires additional function groups. The rotor ground-fault protection runs in the **FG VI 1ph**. The circuit-breaker function group controls the entire interaction with the circuit breaker. Additional functions, such as activating quick stop and actuating de-excitation, are activated via a direct routing of the tripping signal to the relay contacts. Alternatively, you may use additional circuit breaker FGs. All connections are preset in the application template. 100 function points are required for the application template. To use additional functions, the number of function points may need to be increased.

SIPROTEC 5 Devices and Fields of Application

Generator Protection – SIPROTEC 7UM85

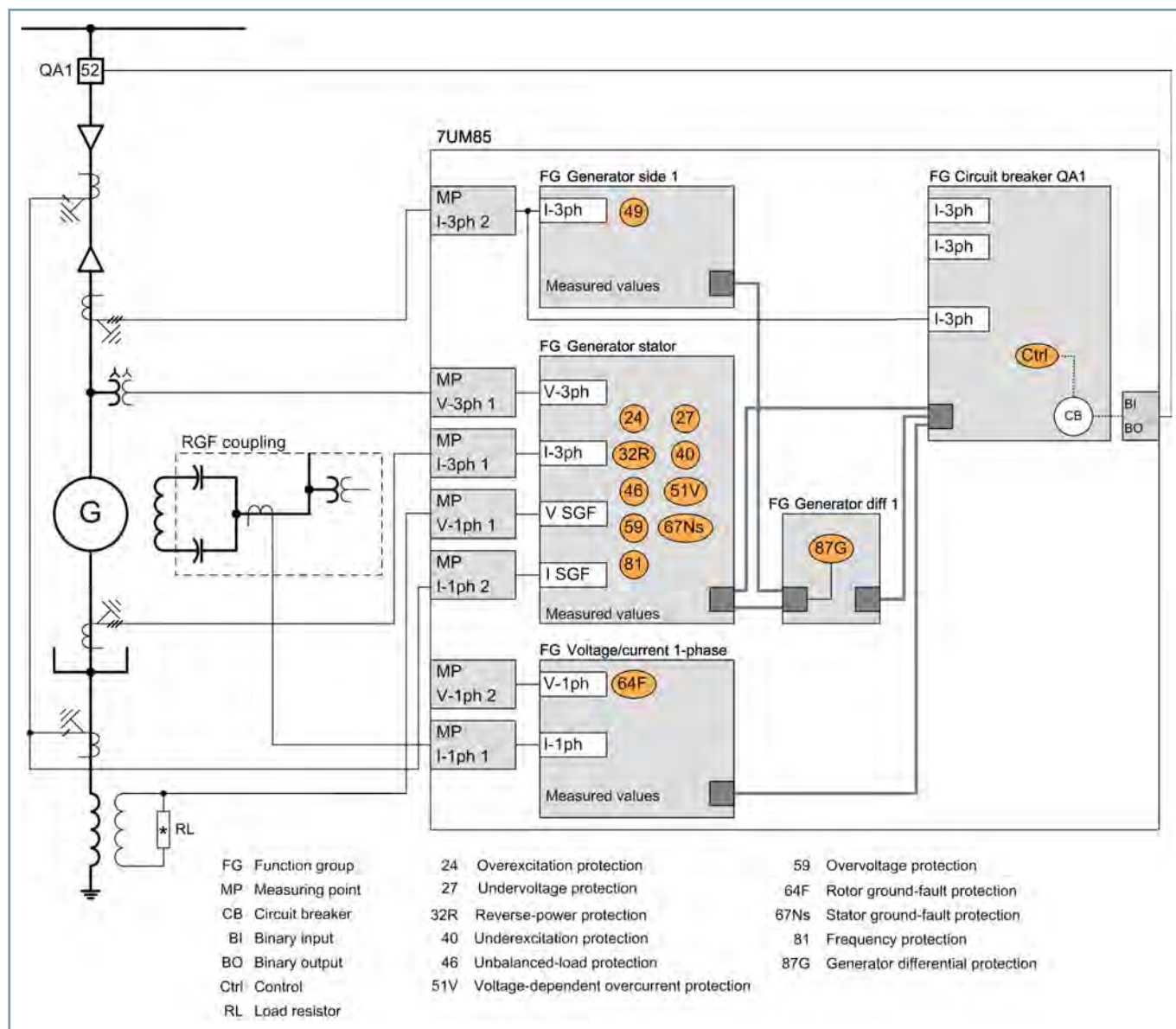

[dw_appl-02_legend_2_en_US]

Figure 2.13/3 Generator Protection in a Bus Connection (Application Template: Generator Bus Connection Basis)

2.13

SIPROTEC 5 Devices and Fields of Application

Generator Protection – SIPROTEC 7UM85

SIPROTEC 7UM85 – Generator Protection in Unit Connection

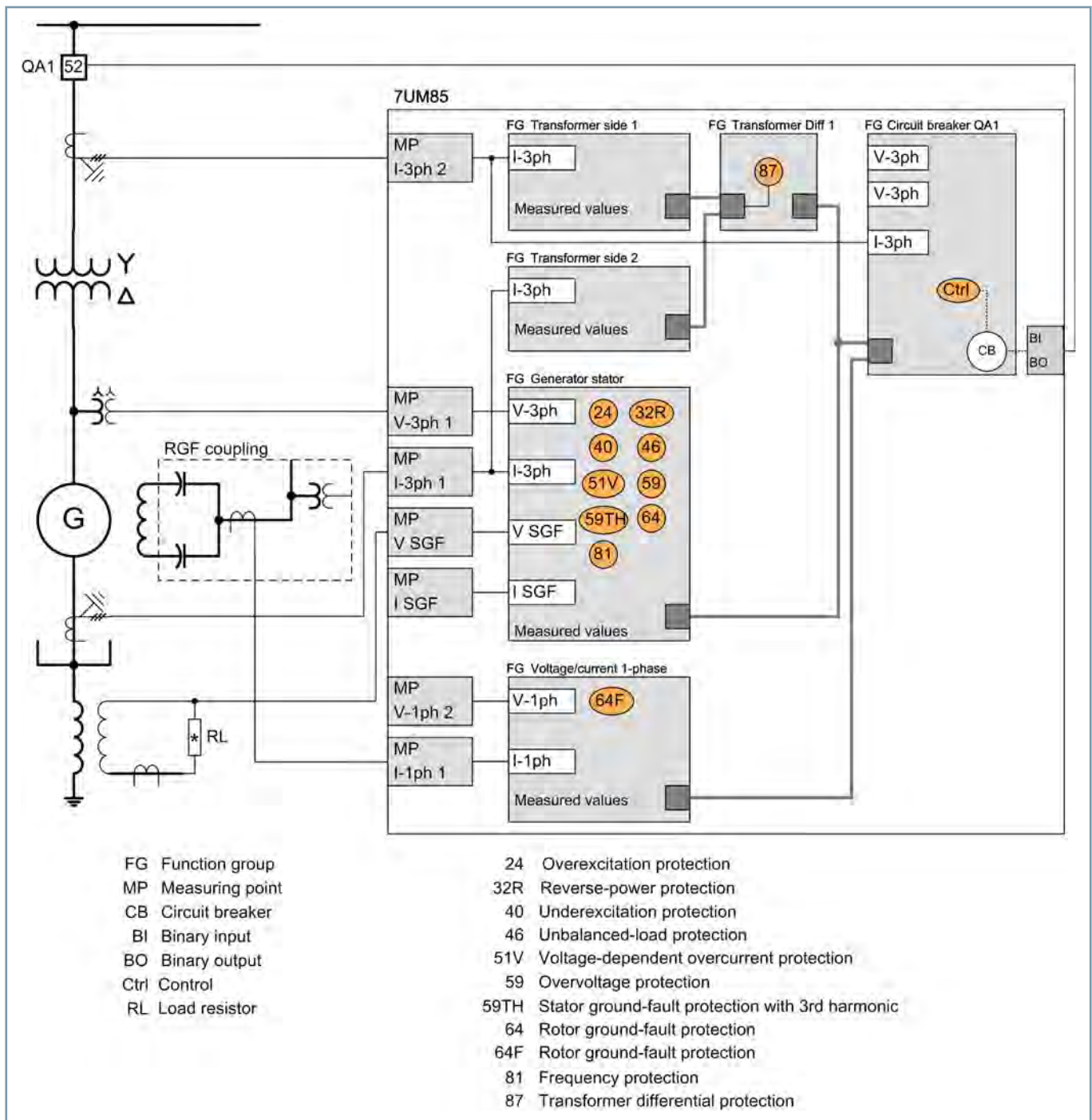

[dw_appl-03_legend, 2, en_US]

Figure 2.13/4 Generator Protection in Unit Connection (Application Template: Generator Unit Connection Basis)

Figure 2.13/4 shows the typical implementation of a plant for small to medium-sized generators (1 MVA to 50 MVA, for example) in unit connection. The generator feeds power into the power system via the generator step-up transformer. The figure shows the single-line diagram, the connection to

the 7UM85, and the logic structure in the device. The protection range of the 90 % stator ground-fault protection is guaranteed by the neutral-point transformer with load resistor. The rotor ground-fault protection is implemented as a power-frequency coupling and is based on the rotor ground current measure-

ment. A 7XR61 + 3PP1336 must be provided as accessory. A base module and an expansion module (such as standard variant AA2 + IO201) are required as minimum device hardware. The example also shows the internal functional structure of the device. It is almost identical to the busbar version. The differential protection was changed. It is to protect the generator and the transformer. The transformer differential protection must therefore be used with the associated function groups.

All connections are preset in the application template. 125 function points are required for the application template. To use additional functions, the number of function points may need to be increased.

SIPROTEC 7UM85 – Protection of a Power Unit

[Figure 2.13/5](#) shows a more complex version of a plant for medium-sized to large generators (for example, 20 MVA to 200 MVA) in unit connection. The auxiliary system is supplied via a separate infeed. This example is intended to demonstrate the performance of the system. An extension for plants with an auxiliary transformer is possible. If necessary, an additional transformer differential protection can be provided. The maximum number of differential protection functions is limited to 3. The example also shows the single-line diagram, the connection to the 7UM85, and the logic structure in the device.

The protection range of the 90 % stator ground-fault protection is guaranteed by the neutral-point transformer with load resistor. The 100 % stator ground fault with 20-Hz infeed is provided, in order to warrant 100 % protection range. This requires the accessories 7XT33 and 7XT34 and a miniature current transformer. The rotor ground-fault protection is implemented as a power-frequency coupling and is based on a resistance measurement. A 7XR61 + 3PP1336 must be provided as accessory. 1 base module and 2 expansion modules (such as standard variant AA3 + an additional IO201) are required as minimum device hardware. [Figure 2.13/5](#) also shows the internal functional structure of the device. To locate the faulty piece of equipment more rapidly, stand-alone differential protection is provided for the generator and for the transformer. This affects the function-group size and circuiting. In addition, the circuit-breaker failure protection and the synchronization function are provided in the **FG Circuit breaker**. A 1-channel parallel connection function (synchronization) with adjustment commands for speed (frequency) and voltage is available. The synchronization function can be used to release manual synchronization.

All connections are preset in the application template. 350 function points are required for the application template. To use additional functions, the number of function points may need to be increased.

SIPROTEC 5 Devices and Fields of Application

Generator Protection – SIPROTEC 7UM85

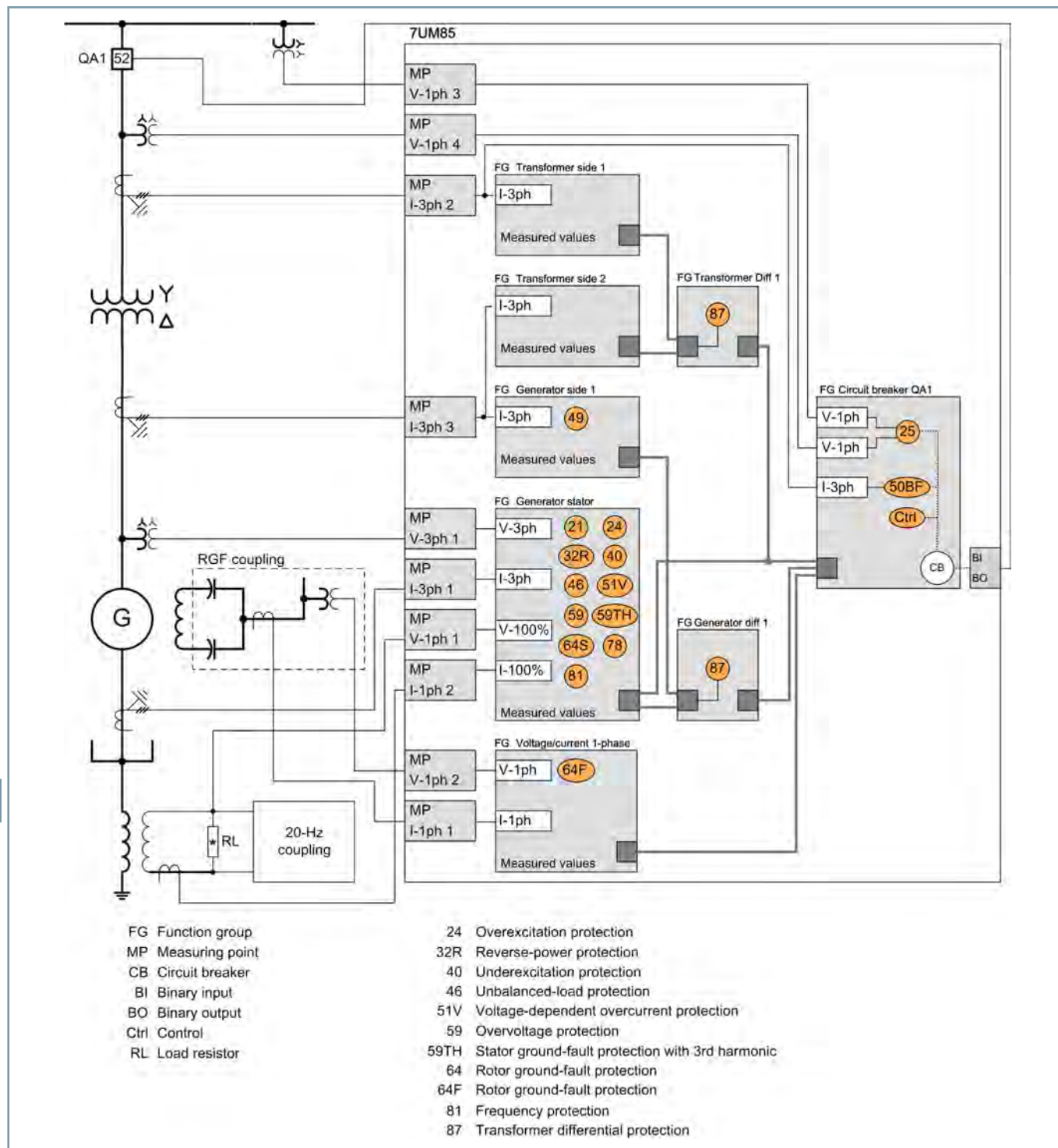

[dw_app1_04_legend_1_en_US]

Figure 2.13/5 Protection of a Power Unit (Application Template: Enhanced Generator Unit Connection)

SIPROTEC 5 Devices and Fields of Application

Generator Protection – SIPROTEC 7UM85

ANSI	Function	Abbr.	Available	Application Templates				
				1	2	3	4	5
	Expandable hardware quantity structure	I/O	■					
	Process bus client protocol (hint: PB client requires a separate ETH-BD-2FO plug-in module, from V8.0)	PB client	■					
	IEC61850-9-2 Merging Unit Stream (hint: Each stream requires a separate ETH-BD-2FO plug-in module, from V8.0)	MU	■					
21T	Impedance protection for transformers	Z<	■				■	■
24	Overexcitation protection	V/f	■	■	■	■	■	■
25	Synchrocheck, synchronization function	Sync	■				■	
25	Synchronization function with adjusting commands	Sync	■					
27	Undervoltage protection: "3-phase" or "positive-sequence system V1" or "universal Vx"	V<	■	■	■			
27	Undervoltage protection: "3-phase" or "universal Vx"	V<	■					
27R, 59R	Voltage change protection (starting with V8.30)	dV/dt	■					
	Undervoltage-controlled reactive power protection	Q>/V<	■					
32, 37	Power protection active/reactive power	P<>, Q<>	■					
32R	Reverse-power protection	- P<	■	■	■	■	■	■
37	Undercurrent	I<	■					
37	Power-plant disconnection protection	-dP	■					
38	Temperature supervision	θ>	■					
40	Underexcitation protection	1/xd	■		■	■	■	■
46	Negative-sequence system overcurrent protection	I2>	■					
46	Unbalanced-load protection (thermal)	I2² t>	■	■	■	■	■	■
46	Negative-sequence system and overcurrent protection with direction	I2>, ∠(V2, I2)	■					
47	Overvoltage protection, negative-sequence system	V2>	■					
47	Overvoltage protection, negative-sequence system/positive-sequence system	V2/V1>	■					
48	Starting time monitoring for motors	I²start	■					
49	Thermal overload protection	θ, I²t	■		■	■	■	■
49	Thermal overload protection, user-defined characteristic curve	θ, I²t	■					
49H	Hotspot calculation	θh, I²t	■					
49R	Thermal overload protection, rotor (motor)	θR	■					
49F	Field-winding overload protection	IL² t	■					
49S CG	Stator overload protection with cold gas consideration	θ, I²t	■					
49R CG	Field-winding overload protection with cold gas consideration	θ, IL²t	■					
50/51 TD	Overcurrent protection, phases	I>	■					
	Instantaneous tripping at switch onto fault	SOTF	■					
50HS	Instantaneous high-current tripping	I>>>	■					
50/51 TD	Overcurrent protection with positive-sequence current I1 (from V7.9)	I1>	■					
50N/ 51N TD	Overcurrent protection, ground	IN>	■					
50N/ 51N TD	Overcurrent protection, 1-phase	IN>	■					

2.13

SIPROTEC 5 Devices and Fields of Application

Generator Protection – SIPROTEC 7UM85

ANSI	Function	Abbr.	Available	Application Templates				
				1	2	3	4	5
50 Ns/ 51Ns	Sensitive ground-fault detection for grounded arc suppression coils and isolated power systems including a) 3I0> b) admittance Y0>, c) 3I0-harm> (from V7.8)	INs>	■					
50 Ns/ 51Ns	Sensitive ground-current protection for power systems with resonant or isolated neutral	INs>	■					
	Intermittent ground-fault protection	IIE>	■					
50GN	Shaft-current protection	INs>	■					
50/27	Inadvertent energization protection (to halted generator)	I>, V< dropout	■					
50N DC, 27.59F DC	Direct current/direct-voltage protection	IDC<>, VDC <>	■					■
50	Startup overcurrent protection	I-Anf>	■					
50BF	Circuit-breaker failure protection, 3-pole	CBFP	■				■	■
50RS	Circuit breaker restrike monitoring	CBRM	■					
50L	Load-jam protection	I>L	■					
51V	Voltage-controlled overcurrent protection	t=f(I, V)	■	■	■	■	■	■
59, 59N	Overvoltage protection: "3-phase" or "zero-sequence system V0" or "positive-sequence system V1" or "universal Vx"	V>	■	■	■	■	■	■
59N, 67Ns	Stator ground-fault protection (non-directional, directional)	V0>, ∠(V0, I0)	■	■	■	■	■	■
27TH, 59TH, 59 THD	Stator ground-fault protection with 3rd harmonic	V03.H<, V03.H>; ΔV03.H	■		■			
59N IT	Turn-to-turn Fault Protection	V0>	■					
60	Voltage-comparison supervision	ΔV>	■					
64S	100 % stator ground-fault protection (20 Hz)	RSE<	■				■	■
64F, frated	Rotor ground-fault protection (IRE>, fn)	IRE>	■	■	■	■		
64F, frated	Rotor ground-fault protection (RE<, fn)	IRE<	■				■	
64F (1-3Hz)	Rotor ground-fault protection (1 - 3 Hz)	IRE<	■					■
66	Restart inhibit for motors	I²t	■					
67	Directional overcurrent protection, phases	I>, ∠(V, I)	■					
67N	Directional overcurrent protection, ground	IN>, ∠(V, I)	■					
67N	Directional ground-fault protection in grounded power systems	IN>, ∠(V, I)	■					
67 Ns	Sensitive ground-fault detection for grounded arc suppression coils and isolated power systems including a) 3I0> b) V0>, c) cos/sine Phi, d) transient ground fault, e) Phi(V, I), f) admittance		■					
	Directional tripping stage with one harmonic; hint: this stage also requires the function "67Ns sensitive ground-fault detection for grounded arc suppression coils and isolated power systems"	∠(V0h,I0h)	■					
	Directional Intermittent Ground-Fault Protection	IIEdir>	■					
68	Power-swing blocking	ΔZ/Δt	■					
74TC	Trip-circuit supervision		■	■	■	■	■	
78	Out-of-step protection	ΔZ/Δt	■				■	■
74CC	Single circuit monitoring (from V7.9)		■					
81	Frequency protection: "f>" or "f<" or "df/dt"	f<>; df/dt<>	■	■	■	■	■	■
81 AF	Abnormal frequency protection	fBand	■					
81U	Underfrequency load shedding	f<(ULS)	■					
	Vector-jump protection	Δφ>	■					
87B	Busbar differential protection for the 7UM85 (starting with V8.01)	ΔI	■					

2.13

SIPROTEC 5 Devices and Fields of Application

Generator Protection – SIPROTEC 7UM85

ANSI	Function	Abbr.	Available	Application Templates				
				1	2	3	4	5
	Bay		■					
86	Lockout		■	■	■	■	■	■
87T	Transformer Differential Protection	ΔI	■			■	■	
87N T	Restricted ground-fault protection	ΔI_N	■					
87M	Differential motor protection	ΔI	■					
87G	Generator differential protection	ΔI	■		■		■	■
PMU	Synchrophasor measurement	PMU	■					
AFD	Arc protection (only with plug-in module ARC-CD-3FO)		■					
	Measured values, standard		■	■	■	■	■	■
	Measured values, extended: Min, max, average		■					
	Switching statistics counter		■	■	■	■	■	■
	PQ – Basic measured values: THD (Total Harmonic Distortion) and harmonic component (starting with V8.01) and THD voltage average values (starting with V8.40)		■					
	PQ – Basic measured values: Voltage unbalance (starting with V8.40)		■					
	PQ – Basic measured values: Voltage changes – monitoring of voltage dips, overvoltages and voltage interruptions (starting with V8.40)		■					
	PQ – Basic measured values: TDD - Total Demand Distortion (starting with V8.40)		■					
	CFC (standard, control)		■	■	■	■	■	■
	CFC arithmetic		■					
	Circuit-breaker wear monitoring	$\Sigma I_x, I^2t, 2P$	■					
	Switching sequence function		■					
	Inrush-current detection		■					
	External trip initiation		■					
	Control		■	■	■	■	■	■
PoW	Point-on-wave switching (starting with V7.90)	PoW	■					
	Circuit breaker		■	■	■	■	■	■
	Disconnectors/grounding conductor		■					
	Fault recording of analog and binary signals		■	■	■	■	■	■
	Monitoring		■	■	■	■	■	■
	Protection interface, serial		■					
	Frequency group tracking (from V7.8)		■					
	Cyber security: Role-Based Access Control (from V7.8)		■					
	Temperature recording via communication protocol		■					
	Cyber security: Authenticated network access using IEEE 802.1X (starting from V8.3)		■					
	Transformer side 7UM85		■					
Function point class:				0	100	125	350	275
The configuration and function point class for your application can be determined in the SIPROTEC 5 order configurator at www.siemens.com/siprotec .								

2.13

Table 2.13/1 SIPROTEC 7UM85 – Functions, Application Templates

- (1) Generator basis
- (2) Generator bus connection
- (3) Generator unit connection basis
- (4) Enhanced generator unit connection
- (5) Large generator

SIPROTEC 5 Devices and Fields of Application

Generator Protection – SIPROTEC 7UM85





Standard Variants for SIPROTEC 7UM85		
AA1	1/3, 11 BI, 9 BO, 4 V, 4 I, Housing width 1/3 x 19" 11 binary inputs 9 binary outputs (1 life contact, 2 standard, 6 fast) 4 voltage-transformer inputs 3 current-transformer inputs 1 sensitive ground-current input Contains the following modules: base module with PS201 and IO202	
AA2	1/3, 7 BI, 14 BO, 4 V, 4 I, Housing width 1/2 x 19" 7 binary inputs 14 binary outputs (1 life contact, 5 standard, 8 fast) 4 voltage-transformer inputs 3 current-transformer inputs 1 sensitive ground-current input Contains the following modules: base module with PS201 and IO208	
AA3	1/2, 15 BI, 20 BO, 8 V, 8 I, Housing width 1/2 x 19" 15 binary inputs 20 binary outputs (1 life contact, 7 standard, 12 fast), 8 voltage-transformer inputs 6 current-transformer inputs 2 sensitive ground-current inputs Contains the following modules: base module with PS201 and IO208 Expansion module IO202	
AA4	1/2, 11 BI, 16 BO, 7 V, 8 I, 4 MU Housing width 1/2 x 19" 11 binary inputs 16 binary outputs (1 life contact, 5 standard, 10 fast), 7 voltage-transformer inputs 6 current-transformer inputs 2 sensitive ground-current inputs 4 fast measuring-transducer inputs (alternatively 20 mA, 10 V) Contains the following modules: base module with PS201 and IO202 Expansion module IO210	
AA5	2/3, 15 BI, 20 BO, 7 V, 16 I, 4 MU Housing width 1/2 x 19" 15 binary inputs 20 binary outputs (1 life contact, 5 standard, 14 fast) 7 voltage-transformer inputs 14 current-transformer inputs 2 sensitive ground-current inputs 4 fast measuring-transducer inputs (alternatively 20 mA, 10 V) Contains the following modules: base module with PS201 and IO202 Expansion modules IO210 and IO203	

Table 2.13/2 Standard Variants for SIPROTEC 7UM85

You can find the technical data in the manual
www.siemens.com/siprotec.

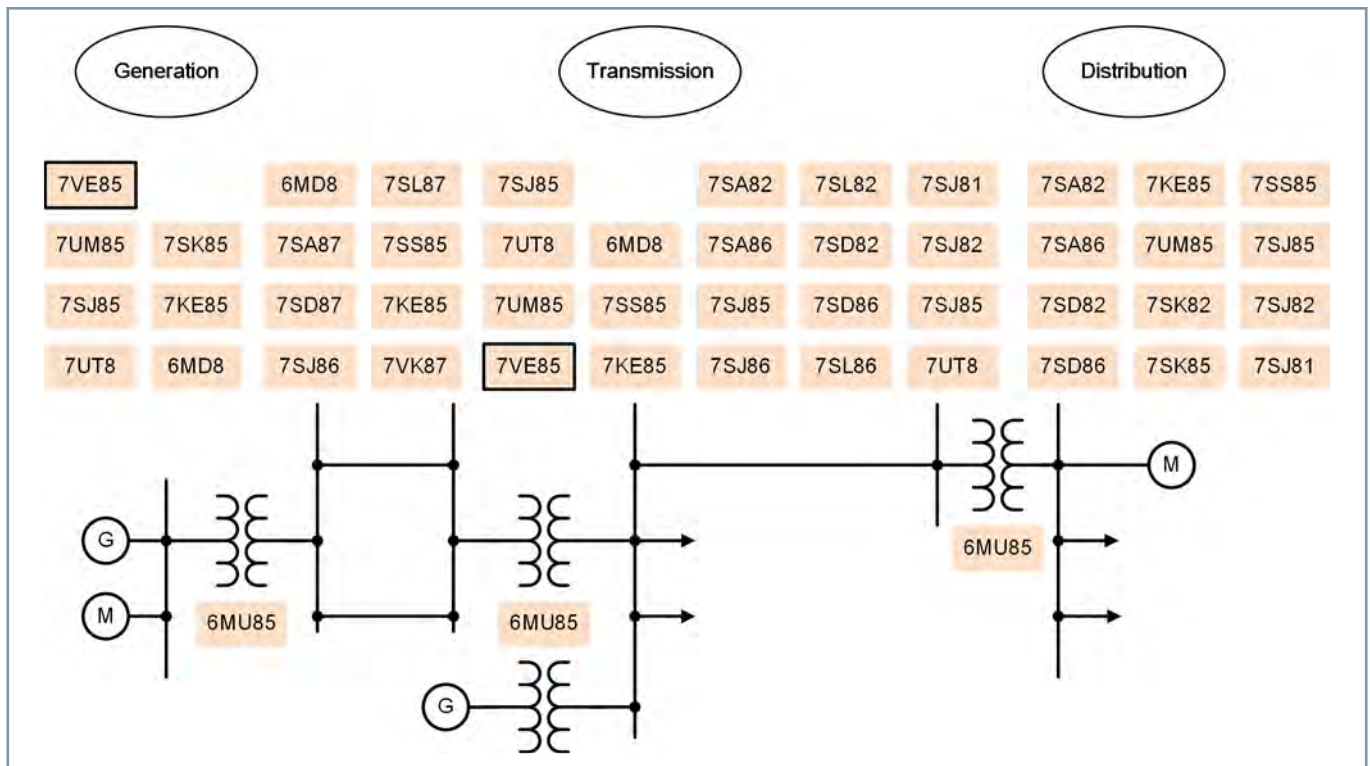

[dw_7VE85_anwendung, 2, en_US]

Figure 2.14/1 Fields of Application of the SIPROTEC 5 Devices

SIPROTEC 7VE85

In their main functions, the SIPROTEC 5 paralleling devices 7VE85 are based on the 1.5-channel and 2-channel synchronization paralleling.

The devices contain all important auxiliary functions that are necessary for safe network operation today. This includes functions for protection, control, measurement, and monitoring. The large number of communication interfaces and communication protocols satisfies the requirements of communication-based selective protection and of automated operation.

Commissioning and maintenance work can be completed safely, quickly, and thus cost-effectively with high-performance test functions. Their modular surface mounting allows SIPROTEC 5 devices to be always adapted flexibly to the individual requirements.

Distinguishing features

SIPROTEC 7VE85 device are characterized by their specialized hardware scalability and functionality. Using the configurator, you can create the hardware configuration (number of V, I measuring points, binary inputs and outputs, communication interfaces, etc.) as required by the application. Using the DIGSI 5 engineering tool, you can download the required functions from the library into the 7VE85 device. The usable functional scope is limited by the ordered function points. You may order additional points without any problems.

When ordering, you can select the devices from 2 different standard variants. Additional expansion modules allow the device to be adapted to your specific application (see Standard Variants [Table 2.14/2](#)).

The SIPROTEC 7VE85 differs due to the selection of the significant functions. The significant function L can be selected for up to 4 synchronizing points and the significant function M can be selected for up to 8 synchronizing points.

Significant Features

7VE85	Flexible configuration of the hardware quantity structure for analog inputs, binary inputs and outputs, measuring transducers, and communication due to expandability with 1/6 expansion modules
-------	--

SIPROTEC 5 Devices and Fields of Application

Paralleling Device – SIPROTEC 7VE85

Description

The paralleling device SIPROTEC 7VE85 is specifically designed for the synchronization of generators (power units) with the power grid or synchronization of 2 electricity-supply systems.

The 1.5-channel and 2-channel paralleling function is the main function of the SIPROTEC 7VE85. To achieve a high level of security and reliability, the software works with various monitoring functions. In addition, the most important hardware components are duplicated. 2 different measuring algorithms are used in accordance with the multi-channel redundancy. This avoids overfunction due to systematic errors. At the same time, the different methods of measurement are applied and processed independently of each other with different memory areas. The high level of reliability and flexible options to adapt to the equipment requirements allow a wide variety of applications.

Main function	1.5-channel and 2-channel paralleling function
Inputs and outputs	2 predefined standard variants with up to 8 current transformers, 8 voltage transformers, 7 to 15 binary inputs, 14 to 20 binary outputs
Hardware flexibility	Flexibly adjustable and expandable I/O quantity structure within the scope of the modular SIPROTEC 5 system; 1/6 expansion modules can be added, available with large or small display, or without display
Housing width	1/3 × 19 inches to 2 × 19 inches

The SIPROTEC 7VE85 recognizes the operating conditions automatically and reacts in accordance with the settings. In the **Switching synchronous electrical power systems** operating mode, the frequency difference is measured with a high level of accuracy. If the frequency difference is almost 0 for a long time, this is referred to as a synchronous electrical power system for which a wider switching angle can be permitted.

If asynchronous conditions occur, such as when synchronizing the generators, the speed is automatically adjusted to the power frequency and the generator voltage is adjusted to the voltage in an electrical power system. It is then switched in the synchronization point, considering the circuit-breaker closing time.

The 1.5-channel parallel switching function (synchronization function and synchrocheck) is provided for use in small to medium-sized generators and in electrical power systems. This function is more secure than a 1-channel paralleling device and can also be used for synchrocheck applications. For larger generators and electrical power systems with high safety requirements, the 2-channel parallel switching function is recommended. In this example, 2 distinctly independent methods of measurement decide on the switching conditions.

Furthermore, SIPROTEC 7VE85 offers additional current, frequency, power, and voltage protection functions and many other control and monitoring functions. As a result, the paralleling device offers synchronization and protection functions in a single device. With its modular structure, flexibility, and the high-performance DIGSI 5 engineering tool, the SIPROTEC 7VE85 device offers future-oriented solutions for protection, control, automation, monitoring, and power quality.



[SIP5_GD_SS_LED_W3, 2, --, --]

Figure 2.14/2 SIPROTEC 7VE85 (Width: 1/3 × 19" to 2 × 19")

The following modes of operation are covered:

- Switching synchronous/asynchronous electrical power systems
- Switching to de-energized line or dead busbar
- Synchrocheck function
- Adjusting commands for voltage and frequency (speed)

Benefits

- Safe and reliable synchronization of generators and electricity-supply systems by multichannel redundancy
- Purposeful and easy handling of devices and software thanks to a user-friendly design
- Cost savings as no external switchover of synchronization and voltage measuring points is required
- Cybersecurity in accordance with NERC CIP and BDEW White-paper requirements
- Highest availability even under extreme environmental conditions by standard coating of the modules

Functions

DIGSI 5 permits all functions to be configured and combined as required and as per the functional scope that has been ordered.

- Stabilization function for the output of adaptive frequency control pulses
- Synchrocheck function for manual synchronization
- Analog output of operational measured values
- Commissioning aids (measurement of the circuit-breaker closing time, sample synchronization)
- Functionality for protection and network decoupling tasks
- Undervoltage protection (ANSI 27)
- Overvoltage protection (ANSI 59)
- Voltage differential protection (ANSI 60)

- Overcurrent protection (ANSI 50/51)
- Vector jump
- Overfrequency (ANSI 81)
- Underfrequency (ANSI 81)
- Rate-of-frequency-change protection (ANSI 81R)
- Instantaneous high-current tripping (ANSI 50HS)
- Instantaneous tripping at switch upon error
- Power protection active/reactive power (ANSI 32/37)
- Power-plant disconnection (ANSI 37)
- Circuit-breaker failure protection (ANSI 50BF)
- PQ – Basic: Voltage unbalance; voltage changes: overvoltage, dip, interruption; TDD, THD, and harmonics
- Circuit-breaker reignition monitoring (RBRF)
- Extensive cybersecurity functionality, such as role-based access control (RBAC), logging of security-related events, signed firmware, or authenticated IEEE 802.1X network access.
- Simple, fast, and secure access to the device via a standard Web browser to display all information and diagnostic data, vector diagrams, single-line and device display pages
- Optional, pluggable communication modules, usable for different and redundant protocols (IEC 61850-8-1, IEC 61850-9-2 Client, IEC 60870-5-103, IEC 60870-5-104, Modbus TCP, DNP3 serial and TCP, PROFINET IO, PROFINET IO S2 redundancy)
- Virtual network partitioning (IEEE 802.1Q - VLAN)

Applications

- Synchronization of generators (power units) with the electricity-supply system under consideration of the vector group of transformers and transformer tap
- Synchronization of 2 electricity-supply systems

Application Examples

Application Template: Paralleling only Synchrocheck 4 V, 4 I

[Figure 2.14/3](#) shows an extract of the 1st basic application template for the device 7VE85 without function points. The application template is suitable for applications in generator systems or network-coupling tasks with 1 synchronization location. The synchrocheck function is used in the **Circuit-breaker** function group and is realized in a 1-channel design. Therefore, no additional inverse voltage needs to be connected to the device.

This application can realize the following operations:

- Synchrocheck for systems and the manual synchronization
The maximum number of synchronization locations is 8.
- Paralleling switching for systems
- Visualization of the system conditions through a graphic display and the local control

- Operation of up to 8 synchronizing points without external switchover
- Detection and recording of power-quality data in the medium-voltage and subordinate low-voltage power system

Application Templates

Application templates are available in **DIGSI 5** for the applications of the device **7VE85**. The application templates contain the basic configurations, required functions, and default settings.

The following application templates are available for the device **7VE85** in the **DIGSI 5** function library:

- Paralleling only synchrocheck 4 V, 4 I
- Paralleling basic 1.5 channels with balancing commands 4 V, 4 I
- Paralleling basic 2 channels with balancing commands 4 V, 4 I
- Paralleling extended 2 channels with balancing commands 8 V, 8 I
- Paralleling 2 channels for 1 synchronization location with voltage selection and balancing commands 12 V, 4 I
- Paralleling extended 2 channels for 2 synchronization locations with balancing commands 8 V, 8 I

This application is a cost-efficient solution with the base module connecting with 2-phase isolated voltage transformers on both sides.

Extra protection functions for this application are available. Due to the flexibility of the SIPROTEC 5 hardware, you can use the current inputs:

- To supervise the open-pole threshold
- To operate immediately with the **Instantaneous high-current tripping** function when switching onto an existing fault

The default functions in this application template are without function points. If you want to add extra functions into this application template, the corresponding number of function points is required.

SIPROTEC 5 Devices and Fields of Application

Paralleling Device – SIPROTEC 7VE85

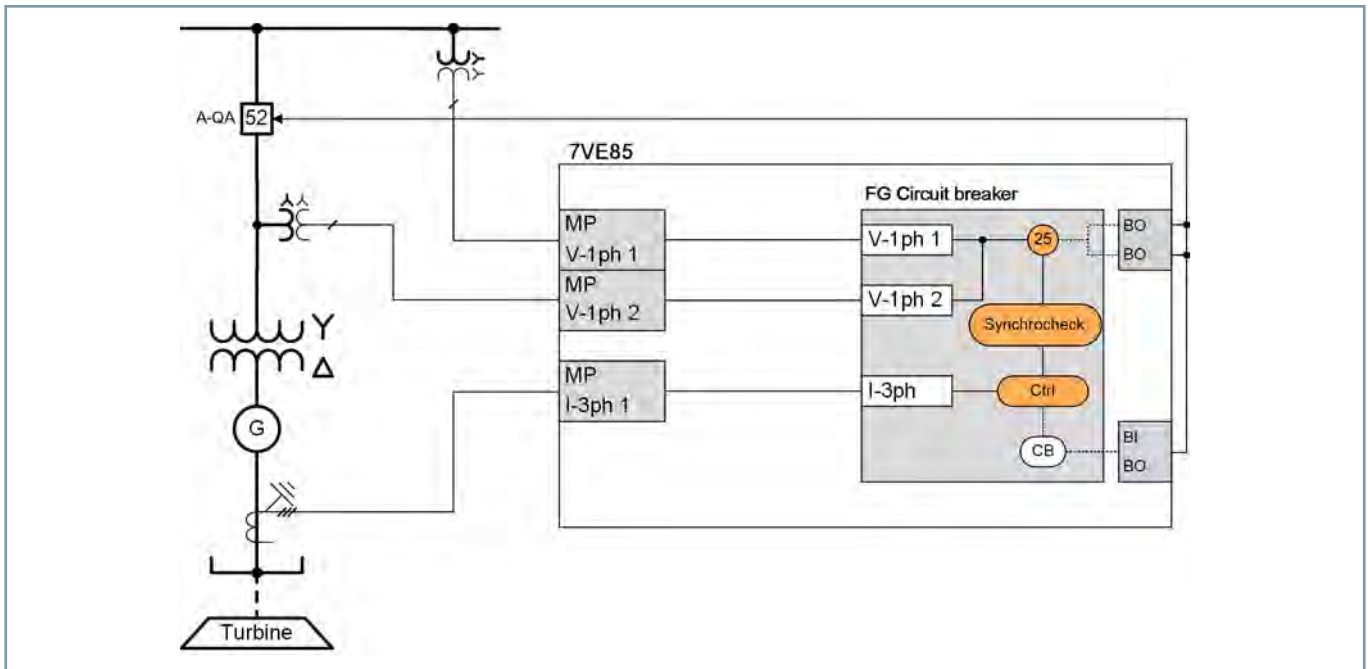

[dw_7VE85-Appl_parall-only synchrocheck, 2, en_US]

Figure 2.14/3 Application Template: Paralleling only Synchrocheck 4 V, 4 I

Application Template: Paralleling Basic 1.5 Channels with Balancing Commands 4 V, 4 I

Figure 2.14/4 shows an extract of the 2nd basic application template for the device 7VE85. The application template is suitable for applications in small to medium generator systems in unit connection with one synchronization location.

This application can realize the following operations:

- Synchrocheck for systems and the manual synchronization
The maximum number of synchronization locations is 8.
- Paralleling switching for systems
- System disconnection and automatic resynchronization
- Visualization of the system conditions through a graphic display and the local control

This application is a cost-efficient solution with the base module connecting with 2-phase isolated voltage transformers on both sides.

Extra protection functions for this application are available. Due to the flexibility of the SIPROTEC 5 hardware, you can use the current inputs:

- To supervise the open-pole threshold
- To operate immediately with the **Instantaneous high-current tripping** function when switching onto an existing fault

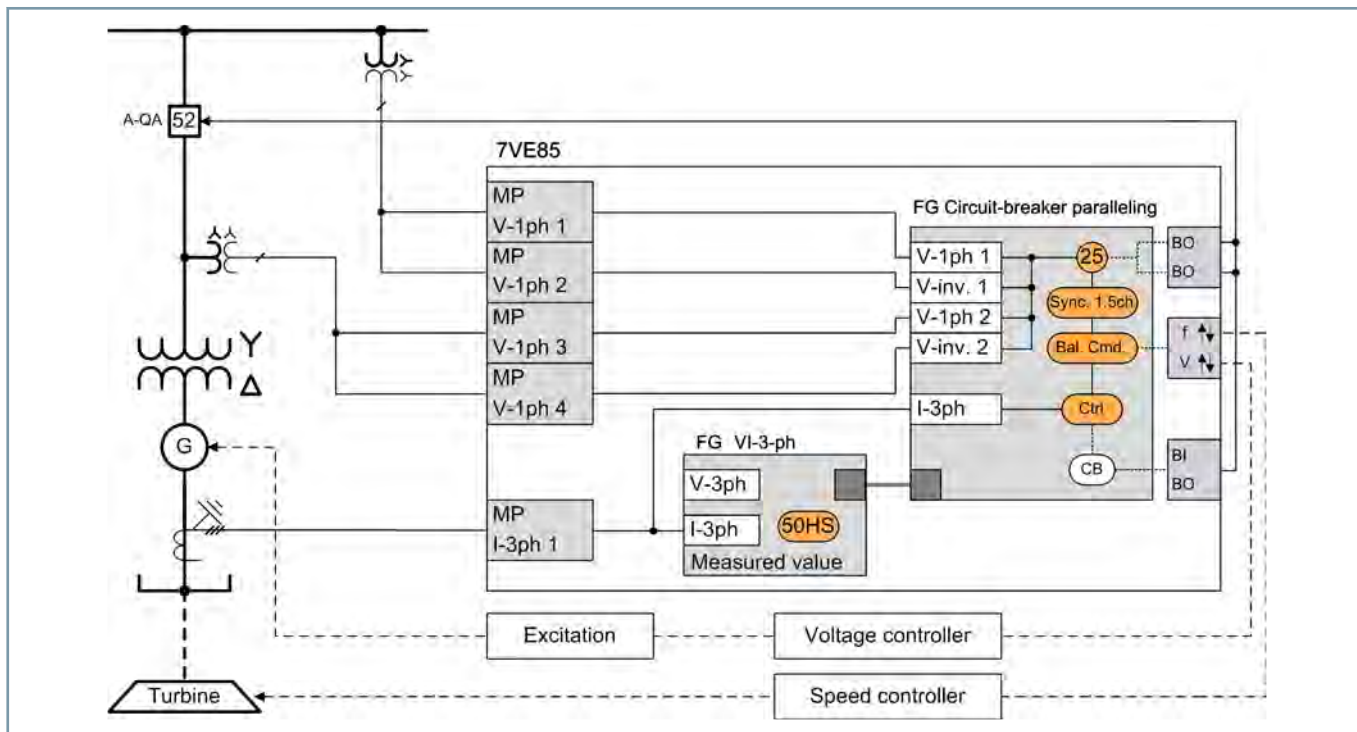

[dw_7VE85-Appl_parall-basic-1.5ch_with_balancing, 1, en_US]

Figure 2.14/4 Application Template: Paralleling Basic 1.5 Channels with Balancing Commands 4 V, 4 I

Application Template: Paralleling Basic 2 Channels with Balancing Commands 4 V, 4 I

Figure 2.14/5 shows an extract of the 3rd basic application template for the device 7VE85. The application template is suitable for applications in medium to large generator systems in unit connection with one synchronization location.

This application can realize the following operations with the increased safety requirements via a 2-channel feature:

- Paralleling switching for high-voltage and extra-high voltage systems
- Automatic synchronization of generators with large power
- Operation of several synchronization locations by a device
The maximum number of synchronization locations is 8.
- Visualization of the system conditions through a graphic display and the local control

This application is a cost-efficient solution with the basic hardware connecting with 2-phase isolated voltage transformers on both sides. This connection can fully ensure the 2-channel redundancy of the **Paralleling** function.

Extra protection functions for this application are available. Due to the flexibility of the SIPROTEC 5 hardware, you can use the current inputs:

- To supervise the open-pole threshold
- To operate immediately with the **Instantaneous high-current tripping** function when switching onto an existing fault

SIPROTEC 5 Devices and Fields of Application

Paralleling Device – SIPROTEC 7VE85

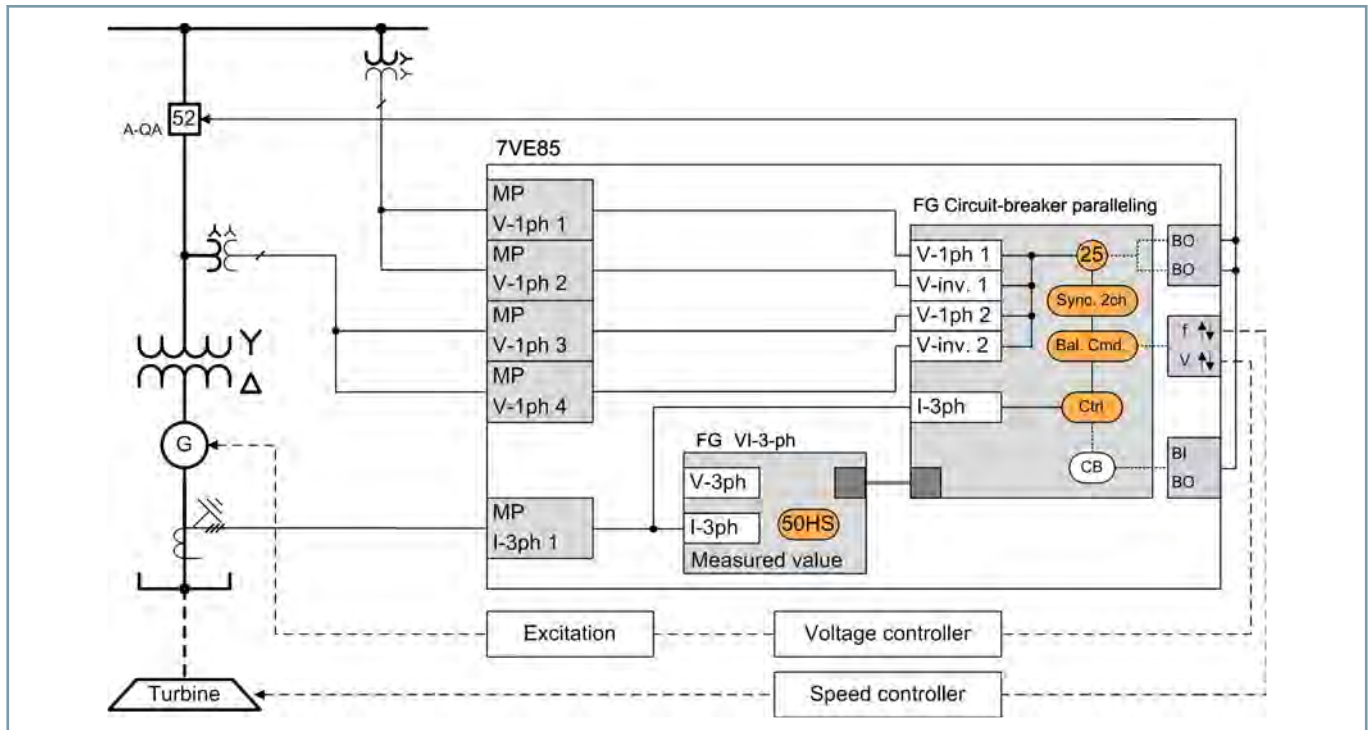

[dw_7VE85-Appl_parall-basic-2ch_with_balancing, 1, en_US]

Figure 2.14/5 Application Template: Paralleling Basic 2 Channels with Balancing Commands 4 V, 4 I

Application Template: Paralleling Extended 2 Channels with Balancing Commands 8 V, 8 I

Figure 2.14/6 shows an extract of the 4th application template for the device 7VE85 with an expansion module IO202. The application template is suitable for applications in medium to large generator systems in unit connection with one synchronization location.

This application can realize the following operations with the increased safety requirements via a 2-channel feature:

- Paralleling switching for high-voltage and extra-high voltage systems
- Automatic synchronization of generators with large power
- Operation of several synchronization locations by a device. The maximum number of synchronization locations is 8.
- Visualization of the system conditions through a graphic display and the local control

The base module and the expansion module can connect with the V-connected voltage transformers. On the basis of electricity, the connection with V-connected voltage transformers has no difference from the connection with the 3 star-connected voltage transformers for the **Paralleling** function. This connection can fully ensure the 2-channel redundancy of the **Paralleling** function.

Extra protection functions for this application are available. Due to the flexibility of the SIPROTEC 5 hardware, you can use the current inputs:

- To supervise the open-pole threshold
- To operate immediately with the **Instantaneous high-current tripping** function when switching onto an existing fault

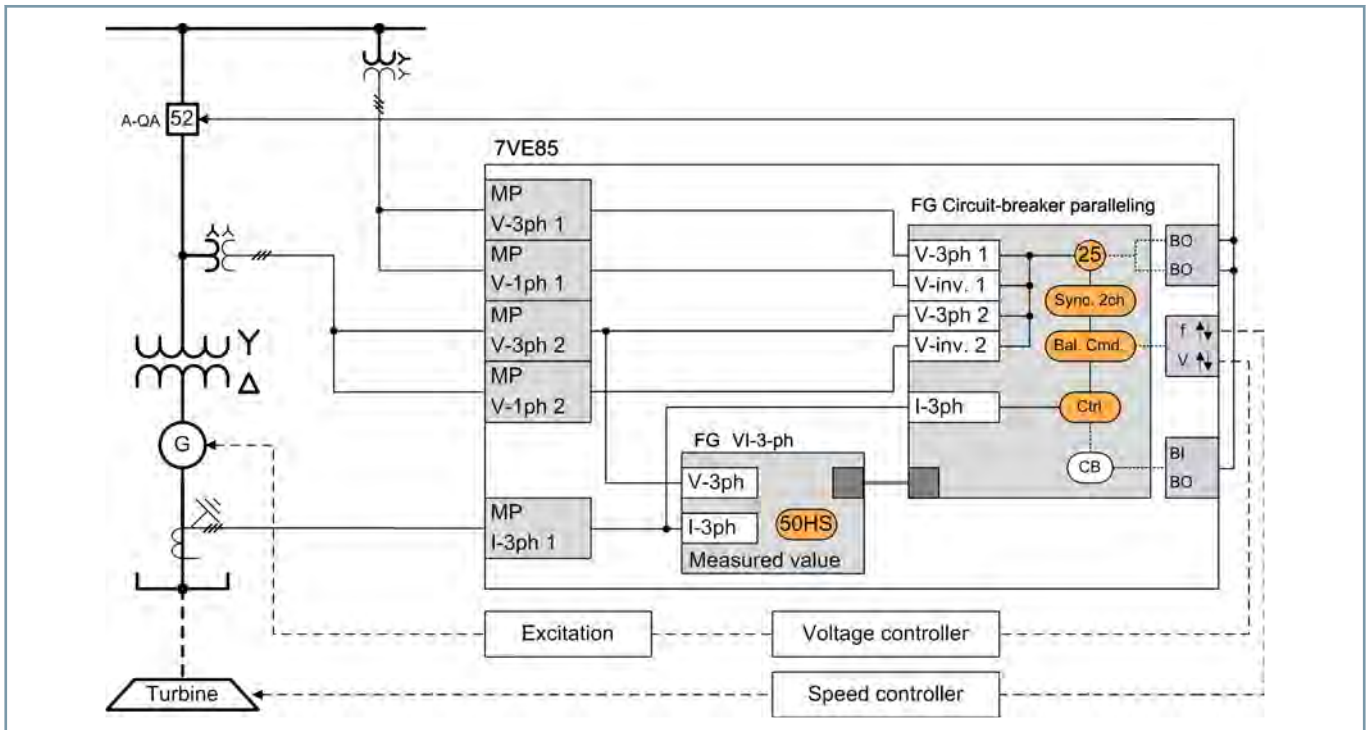

[dw_7VE85-Appl_ext-2channel_with_adjusting-comm, 1, en_US]

Figure 2.14/6 Application Template: Paralleling Extended 2 Channels with Balancing Commands 8 V, 8 I

Application Template: Paralleling Extended 2 Channels for 2 Synchronization Locations with Balancing Commands 8 V, 8 I

Figure 2.14/7 shows an extract of the 6th application template for the device 7VE85 with an expansion module IO202. The application template is suitable for applications in medium to large generator systems in unit connection with 2 synchronization locations (generator circuit breaker and high-voltage circuit breaker).

This application can realize the following operations with the increased safety requirements via a 2-channel feature:

- Paralleling switching for high-voltage and extra-high voltage systems
- Automatic synchronization of generators with large power
- Operation of several synchronization locations by a device
The maximum number of synchronization locations is 8.
- Visualization of the system conditions through a graphic display and the local control

This application is a cost-efficient solution with the base module and an expansion module IO202 connecting separately with two 2-phase isolated voltage transformers on the generator circuit breaker synchronization location and the high-voltage circuit-breaker synchronization location. This connection can fully ensure the 2-channel redundancy of the **Paralleling** function.

Extra protection functions for this application are available. Due to the flexibility of the SIPROTEC 5 hardware, you can use the current inputs:

- To supervise the open-pole threshold
- To operate immediately with the **Instantaneous high-current tripping** function when switching onto an existing fault

SIPROTEC 5 Devices and Fields of Application

Paralleling Device – SIPROTEC 7VE85

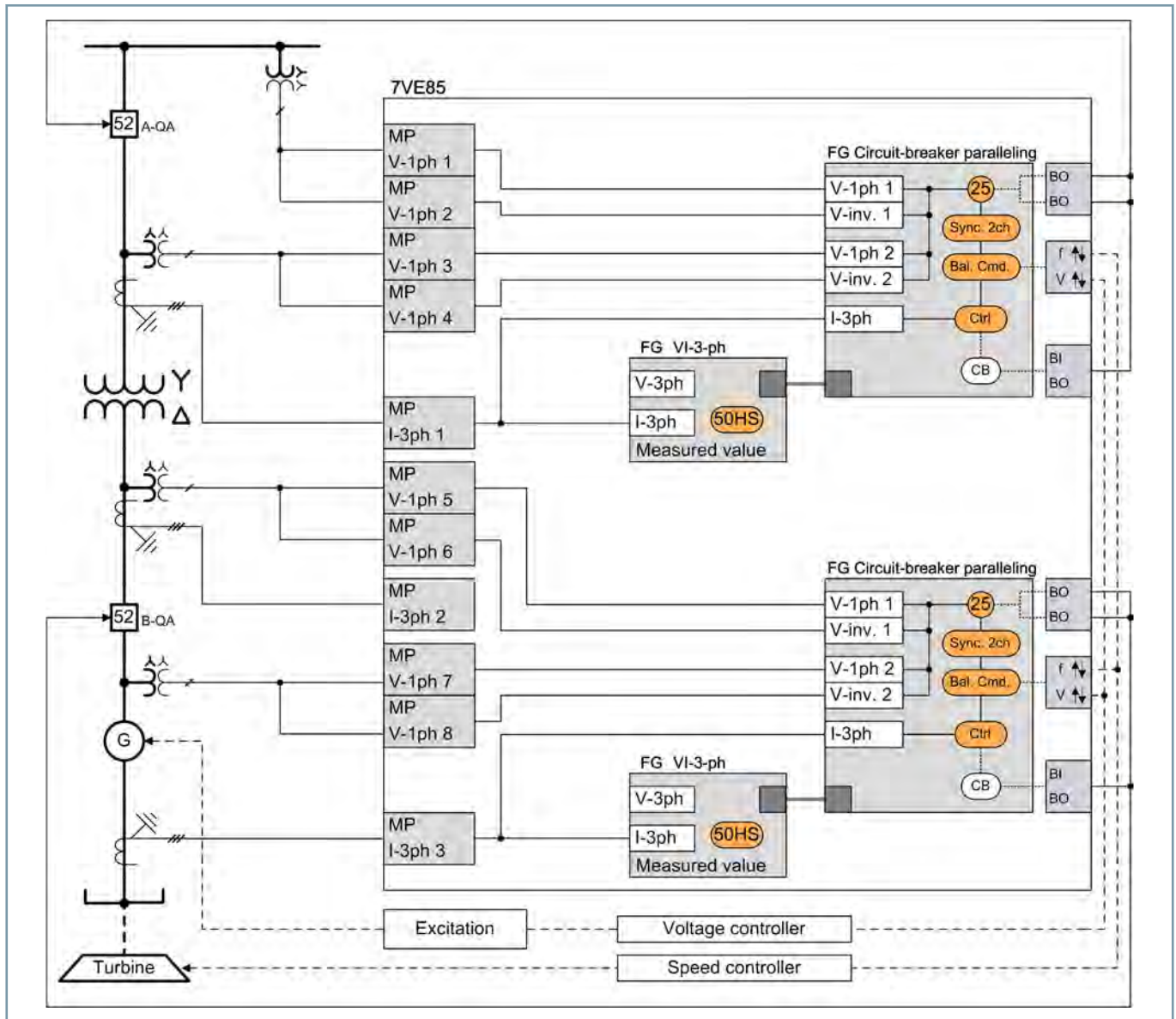

[dw_7VE85-2channel_for_2synch_with_adjusting-com, 1, en_US]

Figure 2.14/7 Application Template: Paralleling Extended 2 Channels for 2 Synchronization Locations with Balancing Commands 8 V, 8 I

Application Template: Paralleling 2 Channels for 1 Synchronization Location with Voltage Selection and Balancing Commands 12 V, 4 I

Figure 2.14/10 shows an extract of the 5th application template for the device 7VE85 with an expansion module IO211. The application template is suitable for applications in medium to large generator systems in unit connection with 1 synchronization location in a double busbar connection.

The synchronization voltage V_{sync1} is selectable via binary inputs. Therefore, the function block **Voltage measuring-point selection for paralleling** is needed to select the correct synchronization voltage (busbar voltage) depending on the switch positions of the disconnectors.

The function block **Voltage measuring-point selection for paralleling** is used to switch the synchronization voltages and their inverse voltages of the routed voltage measuring points. No additional equipment is needed. This solution reduces the wiring and commissioning effort.

In order to check the currently used busbar voltage on the operation panel, special display pages are introduced in this template:

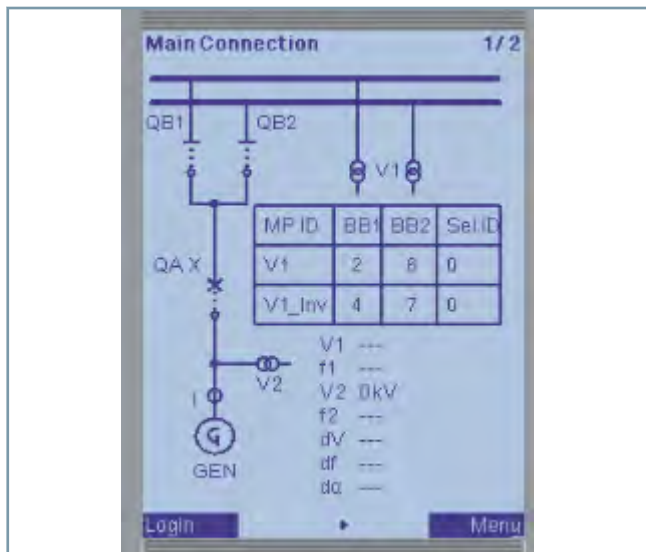

[sc_display pages for VMP_01, 1, en_US]

Figure 2.14/8 Display Page 1 on the Large Screen for the Voltage Selection and the Synchronization Functional Values

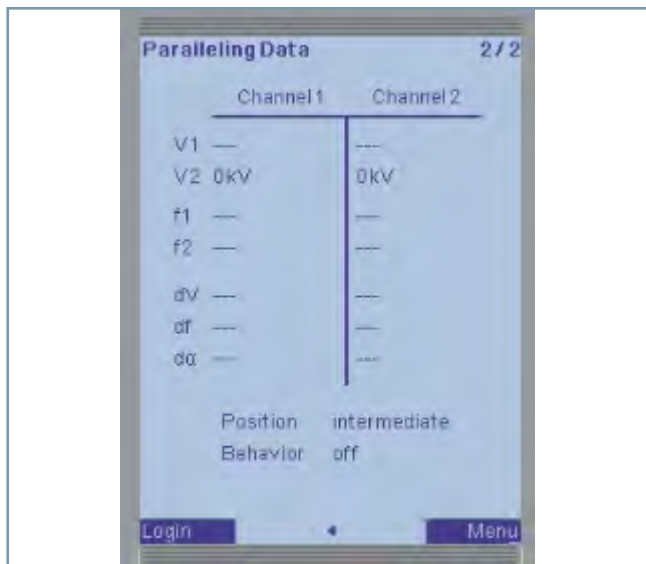

[sc_display pages for VMP_02, 1, en_US]

Figure 2.14/9 Display Page 2 on the Large Screen for the Voltage Selection and the Synchronization Functional Values

This application can realize the following operations with the increased safety requirements via a 2-channel feature:

- Paralleling switching for high-voltage and extra-high voltage systems
- Automatic synchronization of generators with large power
- Operation of several synchronization locations by a device
The maximum number of synchronization locations is 8.
- Visualization of the system conditions through a graphic display and the local control
- Voltage selection via binary input (disconnecter auxiliary contacts)

The base module and the expansion module can connect with the V-connected voltage transformers. On the basis of electricity, the connection with V-connected voltage transformers has no difference from the connection with the 3 star-connected voltage transformers for the **Paralleling** function. This connection can fully ensure the 2-channel redundancy of the **Paralleling** function.

Extra protection functions for this application are available. Due to the flexibility of the SIPROTEC 5 hardware, you can use the current inputs:

- To supervise the open-pole threshold
- To operate immediately with the **Instantaneous high-current tripping** function when switching onto an existing fault

SIPROTEC 5 Devices and Fields of Application

Paralleling Device – SIPROTEC 7VE85

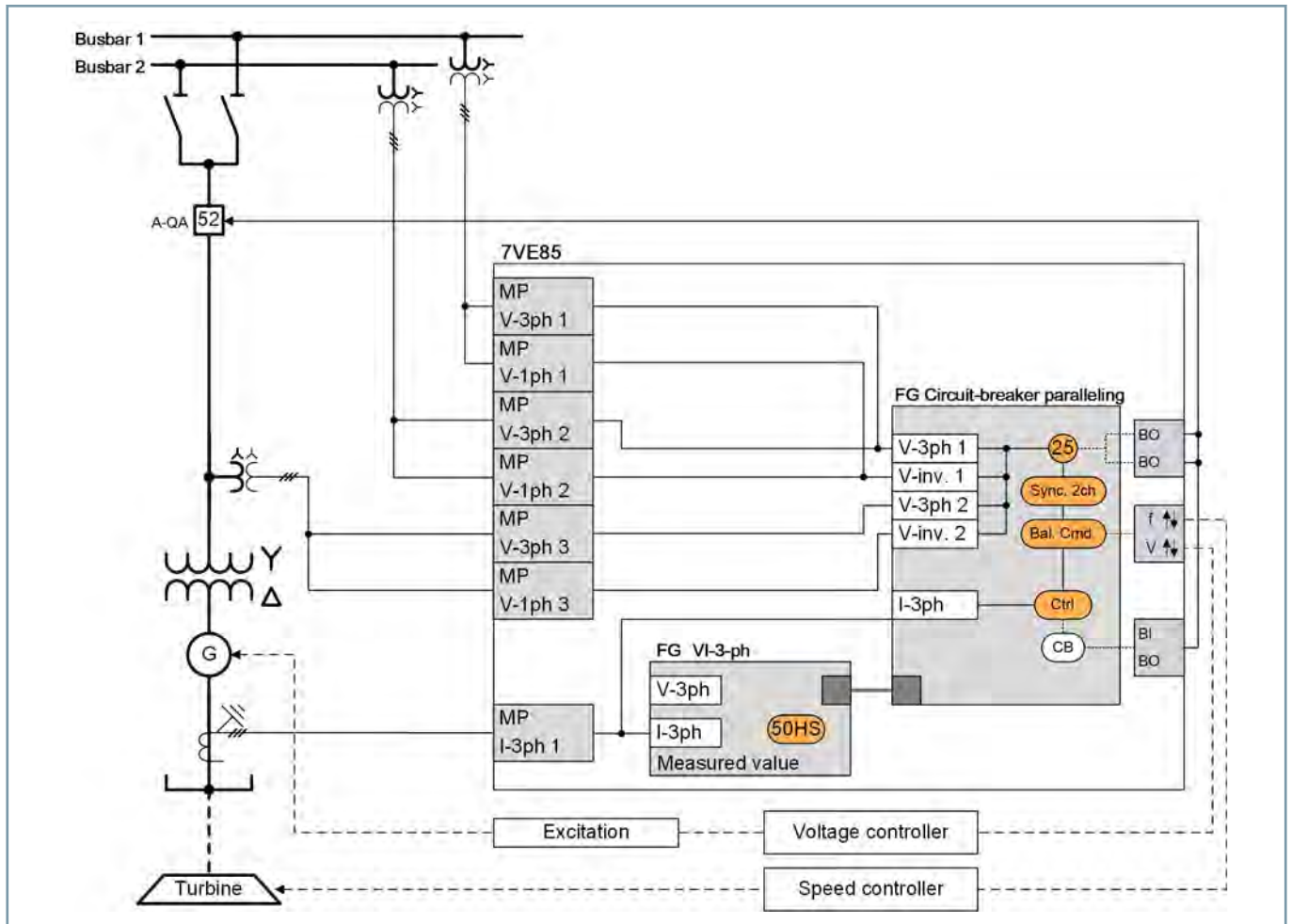

[dw_7VE85-Appl_parall_2ch_VMP_2, en_US]

Figure 2.14/10 Application Template: Paralleling 2 Channels for 1 Synchronization Location with Voltage Selection and Balancing Commands 12 V, 4 I

SIPROTEC 5 Devices and Fields of Application

Paralleling Device – SIPROTEC 7VE85

ANSI	Function	Abbr.	Available	Application Templates					
				1	2	3	4	5	6
	Expandable hardware quantity structure	I/O	■						
	Process bus client protocol (hint: PB client requires a separate ETH-BD-2FO plug-in module, from V8.0)	PB client	■						
	IEC61850-9-2 Merging Unit Stream (hint: Each stream requires a separate ETH-BD-2FO plug-in module, from V8.0)	MU	■						
	IEC61850-9-2 Merging Unit Stream 7SS85 CU (hint: Only for communication with a 7SS85 CU. A separate ETH-BD-2FO plug-in module is required starting with V8.40)	MU	■						
	Automatic matching of the synchronization voltage when using a tap changer		■						
25	Synchrocheck, synchronization function	Sync	■	■					
25	Synchronization function 1.5-channel per synchronizing location (Significant Property: up to 4 synchronizing locations)	Sync	■		■				
25	Synchronization function 1.5-channel per synchronizing location (Significant Property: up to 8 synchronizing locations)	Sync	■						
25	Synchronization function 2-channel per synchronization location (Significant Property: up to 4 synchronizing locations)	Sync	■			■	■	■	■
25	Synchronization function 2-channel per synchronization location (Significant Property: up to 8 synchronizing locations)	Sync	■						
	Adjusting commands per synchronization location		■		■	■	■	■	■
27	Undervoltage protection: "3-phase" or "positive-sequence system V1" or "universal Vx"	V<	■						
27	Undervoltage protection: "3-phase" or "universal Vx"	V<	■						
27R, 59R	Voltage change protection (starting with V8.30)	dV/dt	■						
32, 37	Power protection active/reactive power	P<>, Q<>	■						
37	Power-plant disconnection protection	-dP	■						
50/51 TD	Overcurrent protection, phases	I>	■						
	Instantaneous tripping at switch onto fault	SOTF	■						
50HS	Instantaneous high-current tripping	I>>>	■		■	■	■	■	■
50N/ 51N TD	Overcurrent protection, ground	IN>	■						
50BF	Circuit-breaker failure protection, 3-pole	CBFP	■						
50EF	End-fault protection (hint: For use only in decentralized busbar protection with a 7SS85 CU starting with V8.40)		■						
50RS	Circuit breaker restrike monitoring	CBRM	■						
59	Overvoltage protection: "3-phase" or "positive-sequence system V1" or "universal Vx"	V>	■						
60	Voltage-comparison supervision	ΔV>	■						
74CC	Single circuit monitoring (from V7.9)		■						
81	Frequency protection: "f>" or "f<" or "df/dt"	f<>; df/dt<>	■						
	Vector-jump protection	Δφ>	■						
PMU	Synchrophasor measurement	PMU	■						
AFD	Arc protection (only with plug-in module ARC-CD-3FO)		■						
	Measured values, standard		■						
	Measured values, extended: Min, max, average		■						
	Switching statistics counter		■						

SIPROTEC 5 Devices and Fields of Application

Paralleling Device – SIPROTEC 7VE85

ANSI	Function	Abbr.	Available	Application Templates					
				1	2	3	4	5	6
	PQ – Basic measured values: THD (Total Harmonic Distortion) and harmonic component (starting with V8.01) and THD voltage average values (starting with V8.40)		■						
	PQ – Basic measured values: Voltage unbalance (starting with V8.40)		■						
	PQ – Basic measured values: Voltage changes – monitoring of voltage dips, overvoltages and voltage interruptions (starting with V8.40)		■						
	PQ – Basic measured values: TDD - Total Demand Distortion (starting with V8.40)		■						
	CFC (standard, control)		■						
	CFC arithmetic		■						
	Circuit-breaker wear monitoring	ΣIx, I ² t, 2P	■						
	Switching sequence function		■						
	Inrush-current detection		■						
	External trip initiation		■						
	Control		■						
	Circuit breaker		■						
	Circuit-breaker paralleling		■						
	Disconnectors/grounding conductor		■						
	Fault recording of analog and binary signals		■						
	Monitoring		■						
	Protection interface, serial		■						
	Frequency group tracking (from V7.8)		■						
	Cyber security: Role-Based Access Control (from V7.8)		■						
	Temperature recording via communication protocol		■						
	Cyber security: Authenticated network access using IEEE 802.1X (starting from V8.3)		■						
Function point class:				0	125	225	225	425	225
The configuration and function point class for your application can be determined in the SIPROTEC 5 order configurator at www.siemens.com/siprotec .									

2.14

Table 2.14/1 SIPROTEC 7VE85 - Functions, Application Templates

- (1) Parallel switching only for Synchrocheck 4V 4I (base device)
- (2) Parallel switching 1.5-channel with 1 synchronizing location and adjusting commands 4V 4I (base device)
- (3) Parallel switching 2-channel with 1 synchronizing location and adjusting commands 4V 4I (base device)
- (4) Parallel switching 2-channel with 1 synchronizing location and adjusting commands 8V 8I (base device + extension)
- (5) Parallel switching 2-channel with 2 synchronizing locations and adjusting commands 8V 8I (base device + extension)
- (6) Parallel switching 2-channel with 1 synchronizing location, voltage selection and adjusting commands 12V 12I

SIPROTEC 5 Devices and Fields of Application

Paralleling Device – SIPROTEC 7VE85

Standard Variants for SIPROTEC 7VE85	
AF1	<p>1/3, 7 BI, 14 BO, 4 V, 4 I,</p> <p>Housing width 1/3 x 19"</p> <p>7 binary inputs</p> <p>14 binary outputs (1 life contact, 2 standard, 11 fast)</p> <p>4 voltage-transformer inputs</p> <p>3 current-transformer inputs</p> <p>1 sensitive ground-current input</p> <p>Contains the following modules: base module with PS201 and IO208</p>
AF2	<p>1/2, 15 BI, 20 BO, 8 V, 8 I,</p> <p>Housing width 1/2 x 19"</p> <p>15 binary inputs</p> <p>20 binary outputs (1 life contact, 2 standard, 17 fast)</p> <p>8 voltage-transformer inputs</p> <p>6 current-transformer inputs</p> <p>2 sensitive ground-current inputs</p> <p>Contains the following modules: base module with PS201 and IO208</p> <p>Expansion module IO202</p>

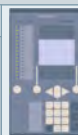

Table 2.14/2 Standard Variants for SIPROTEC 7VE85

You can find the technical data in the manual

www.siemens.com/siprotec.

SIPROTEC 5 Devices and Fields of Application

Busbar Protection

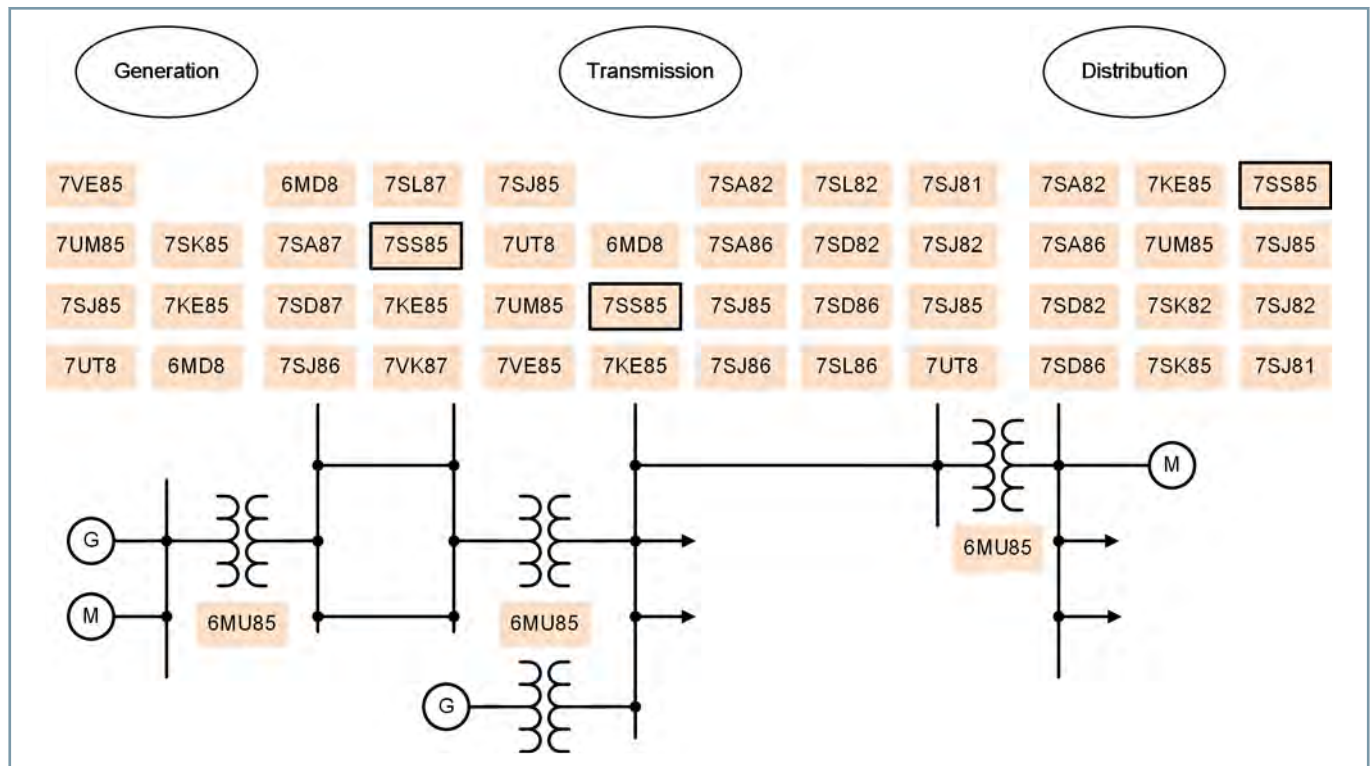

[dw_7SS85_anwendung, 4, en_US]

Figure 2.15/1 Fields of Application of the SIPROTEC 5 Devices

SIPROTEC 7SS85

The SIPROTEC 7SS85 busbar protection has been designed with the highest selectivity possible for a large variety of different busbars and all voltage levels. Additional protection and control functions extend the field of application to a complete station protection.

SIPROTEC 7SS85

The SIPROTEC 7SS85 busbar protection is a selective, safe, and fast protection against busbar short circuits in medium-voltage systems, high-voltage systems, and systems for very high voltage. The proven, fast, and reliable algorithms from the SIPROTEC 7SS52 in conjunction with the flexible, scalable, open, and user-friendly SIPROTEC 5 platform set the new bar for the SIPROTEC 7SS85 busbar protection.

The SIPROTEC 7SS85 is the right solution for interoperable, compatible busbar protection as per IEC 61850, a cost-effective extension of your electrical power system with busbar protection or as the replacement for the SIPROTEC 7SS52.

ONE platform, ONE device, ONE configuration tool for all applications, voltage levels, and busbar-protection systems. The new SIPROTEC 7SS85 offers various options for the busbar-protection architecture: Centralized, distributed or – for the 1st time in the history of busbar protection – a hybrid busbar-protection system where process information can be connected directly as well as measured by distributed bay devices.

The selection of the device base functionalities (significant features) and the modular hardware structure allow optimum adaptation of the SIPROTEC 7SS85 to a large variety of system configurations and functional requirements up to a complete station protection.

Benefits

- Fast and secure – Proven and reliable algorithms since 1989
- Cyber Secure – Compliant with NERC CIP and BDEW white paper requirements
- Robust – Highest availability even under extreme environmental conditions
- Consistent – One platform, one device, one configuration tool
- User-friendly – Configuration by the user during the entire service life
- Clear – Fully graphical engineering and online plant visualization with DIGSI 5
- Flexibility – Centralized, decentralized or combined (hybrid) architecture
- Universal – SIPROTEC 5 protection devices and merging units as a bay unit
- Powerful – Busbar protection device as centralized feeder protection
- Economical – Extension of power-system protection with busbar protection
- Interoperable – Compatible with merging units according to IEC 61850 Rev. 2.1



[SIP5_GD_SS_LED_LED_W3, 2, --, -]

Figure 2.15/2 SIPROTEC 7SS85 – Centralized Busbar Protection

The performance and flexibility of the SIPROTEC 7SS85 allow the implementation of the most varied, customer-specific secondary-equipment concepts and solutions, such as:

- IEC 61850 compatible and interoperable distributed busbar protection
- Cost-efficient extension of power-system protection using busbar protection
- Replacement solution for the proven SIPROTEC 7SS52 in the electrical power system

Functions

Characteristic Key Values of SIPROTEC 7SS85

- Phase-selective measurement and display
- Selective tripping of faulty bus zones
- Disconnecter-independent check zone as additional tripping criterion
- Shortest tripping times to ensure network stability and minimize damage to the system:
 - Centralized busbar protection: 3 ms/7 ms (relay type HS/type F)
 - Distributed busbar protection: 8 ms/12 ms (relay type HS/type F)
- Highest stability in case of external faults, even in case of transformer saturation, through stabilization with flowing currents
- Operate curve with freely adjustable characteristic curve sections
- Additional operate curve with increased sensitivity for low-current errors, for example in resistance-grounded power systems
- Fast recognition of internal or external errors requires only 2 ms of saturation-free time of the current transformers

SIPROTEC 5 Devices and Fields of Application

Busbar Protection – SIPROTEC 7SS85

- Using closed iron core or linearized current transformers in a plant is possible
- Adaptation of different current transformer ratios per parameterization
- Straight-forward dimensioning of current transformers and stabilization factor
- 3 interacting methods of measurement allow minimum tripping times after busbar faults and ensure maximum stability in case of large short-circuit currents
- The integrated circuit-breaker failure protection (CBFP) detects circuit-breaker faults in case of a busbar short circuit and provides a trip signal for the circuit breaker at the line end. The adjacent busbar trips if a circuit breaker in the bus coupler fails.
- Expensive monitoring of current-transformer circuits, measured-value acquisition and processing, and trip circuits to avoid overfunction and underfunction of the protection and effort reduction for routine testing.
- Various control possibilities, such as bay out of order, acquisition blocking from disconnectors and circuit breakers, blocking of protection zones, or circuit-breaker failure protection make the adaptation to operationally-caused special states of your plant easier.
- 1/3-pole or 3-pole circuit-breaker failure protection using the integrated disconnector image for tripping all circuit breakers of the busbar section affected
- End-fault protection for the protection of the section between circuit breaker and current transformer for feeders and bus couplers
- Direct tripping of protection zones through external signals
- Release of the tripping of a protection zone through additional external signals
- Release of tripping through additional, external phase-selective signals
- Cross stabilization as additional tripping release in 3-pole enclosed gas-insulated switchgear
- Bus coupler differential protection for fault clearing in couplers with 2 current transformers
- With distributed busbar protection, any feeder protection function can also be implemented using any modular SIPROTEC 5 device as the bay device.
- Extensive cybersecurity functionality, such as role-based access control (RBAC), logging of security-related events, signed firmware, or authenticated IEEE 802.1X network access

Applications

The SIPROTEC 7SS85 busbar protection is the solution for the following plant layouts:

- Single busbars up to quintuple busbars with or without a transfer busbar
- Breaker-and-a-half layout
- Dual circuit breaker systems and one or 2 current transformer(s) per feeder
- Truck-type switchgear
- Systems with combined busbars (alternatively main/transfer busbar)
- H-bridge arrangement with bus coupler or disconnection
- Ring busbars

SIPROTEC 5 Devices and Fields of Application

Busbar Protection – SIPROTEC 7SS85

	Central Protection	Central Protection with IEC 61850 Compatible Distributed Process Connection	Distributed Protection
Significant features	9, A, B, C, D, E		F, G, H, J, K
Centralized process connection	yes	yes	no
Distributed process connection	no	yes	yes
Hybrid: central and distributed process connection	no	yes	no
Number of bars (max.)	3	3	6
3-phase current measuring points (max.)	20	20 / 24 (with EFP, without further backup protection function in 7SS85)	45
3-phase voltage measuring points	4	4 central and in the Merging Units	In the bay units
Number of busbar sections (max.)	6	6	20
Number couplers (max.)	6	6	20
Number reserve busbar (without measuring function) (max.)	3	3	12
Interoperable measured-value acquisition	yes (1/5A)	yes (IEC 61850-9-2, IEC 61869)	yes (IEC 61850-9-2, IEC 61869, 4000 Hz, 1 ASDU)
Backup protection function	20 x CBFP, 20 x EFP, 20 x definite-time overcurrent protection, 10 x Z<(transformer), 10 x overcurrent protection dir., 10 x V>, 10 x V<	24 x CBFP, 24 x EFP, 24 x definite-time overcurrent protection, 10 x Z<(transformer), 10 x overcurrent protection dir., 10 x V>, 10 x V< plus all protection functions of the individual merging unit	all protection functions of the individual bay unit
Bay Units			
Merging Units SIPROTEC 6MU85	no	yes	yes
SIPROTEC 5 protection device (modular)	no	yes	yes
Interoperable Merging Units according to IEC 61850 Rev. 2.1 (third-party devices)	no	yes	no
Engineering of the protection functionality			
DIGSI 5	yes	yes	yes
IEC 61850 system configurator	-	yes	yes/automated routing according to single-line editor

Table 2.15/1 Selection Table of the Matching Significant Features

2.15

Short description	Significant Features Centralized Protection					
	9	A	B	C	D	E
Main function	Busbar differential protection					Only Circuit-breaker failure protection
Busbar sections	1	2	2	6	6	6
Disconnecter image	No	No	Yes	No	Yes	Yes
Measuring points centralized, 3-phase (maximum)	20	20	20	20	20	20
or...						
Measuring points distributed, 3-phase (maximum)	24	24	24	24	24	24
Bays (maximum)	26	26	26	26	26	26
Bays (included in the basic scope) ³	3	4	4	6	6	6
Recommended standard hardware variant centralized	V1	V2	V2	V3	V3	V3

³ For further bays, you need function points.

SIPROTEC 5 Devices and Fields of Application

Busbar Protection – SIPROTEC 7SS85

Significant Features Centralized Protection						
Included measuring points 3-phase centralized	3	4	4	6	6	6
Related standard hardware variant distributed	V4	V4	V4	V4	V4	V4

Table 2.15/2 Significant Features Centralized Protection

Significant Features Distributed Protection					
Short description	F	G	J	K	H
Main function	Busbar differential protection				Only Circuit-breaker failure protection
Busbar sections	6	20	6	20	20
Disconnecter image	No	No	Yes	Yes	Yes
Measuring points distributed, 3-phase (maximum)	45	45	45	45	45
Related standard hardware variant	V4	V4	V4	V4	V4

Table 2.15/3 Significant Features Distributed Protection

The significant properties E and H *only circuit-breaker failure protection* are a special feature. Here, the main protection function is the Circuit-breaker failure protection. The device permits the implementation of an independent, complete backup protection for a circuit-breaker failure in the station.

Configuration and Parameterization

The busbar protection is configured and engineered graphically using the primary topology of your plant. That is where you add the SIPROTEC 7SS85 and other devices. Use drag and drop to add the required functions from the DIGSI 5 library to the devices. Then, connect the primary elements of the single-line diagram (busbars, current transformers, disconnectors, circuit breakers) to the function blocks of the devices. The primary topology is now connected to the secondary equipment. This ensures a flexible adaptation to changes and extensions over the entire lifecycle of the plant. You adapt the protection to the various operating states and requirements by means of parameterization.

Online visualization for commissioning, operation, and analysis of important information occurs in the same single-line diagram. The switch positions are shown in addition to the measured values of the feeders and the protection ranges. Additionally, you get information about special operating states, for example in the case of *Bay out of service* or reduced selectivity of protection, for example, with a direct busbar coupler via disconnector switches (busbar shunt by disconnectors).

Disconnecter Image

With the integrated SIPROTEC 7SS85 disconnector image, the bay currents are assigned dynamically to the protection zones based on the disconnector-switch position. In case of a failure, selective tripping of the feeders and bus couplers involved takes place by way of the disconnector image. This ensures the availability of the healthy system part for network operation.

SIPROTEC 7SS85 in general has a check zone that is independent of the disconnector. This ensures system stability, even in case of an incorrect assignment of the currents.

This function is characterized by the following product features:

- Processing of up to 20 or 24 current measuring points and 6 busbar sections in the centralized SIPROTEC 7SS85
- Processing of up to 45 current measuring points and 20 busbar sections in the distributed busbar protection
- Disconnector runtime and position monitoring
- Due to the program assignment Disconnector NOT off = Disconnector on, calibrated disconnector auxiliary contacts are not necessary.
- Storage of the disconnector-switch positions in case of an auxiliary-voltage failure
- Convenient graphical project engineering using DIGSI 5
- Dynamic graphical visualization using DIGSI 5 in online mode

Application Examples

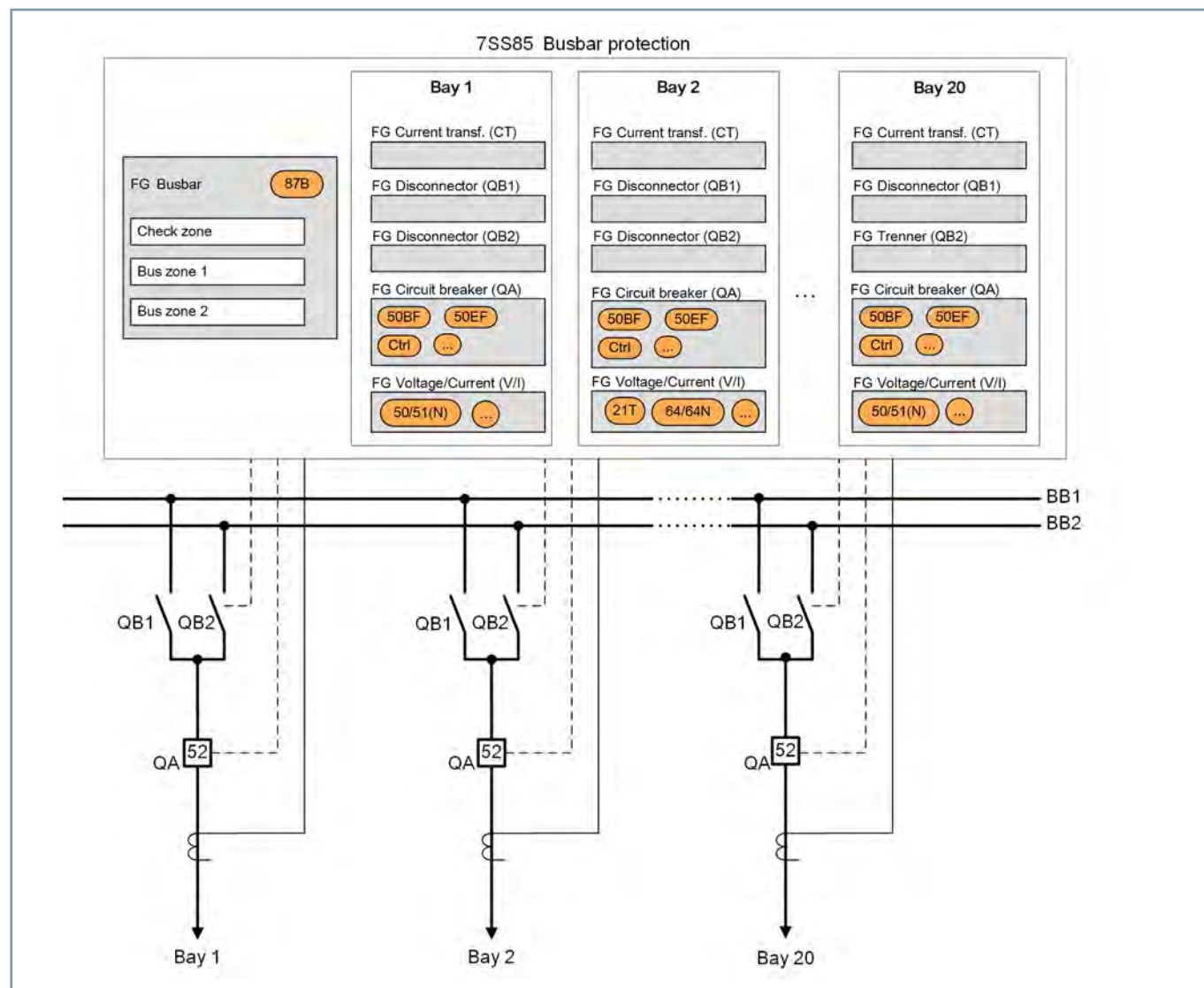

[dw_01_config_cent-busbar, 1, en_US]

Figure 2.15/3 Centralized Busbar Protection

SIPROTEC 5 Devices and Fields of Application

Busbar Protection – SIPROTEC 7SS85

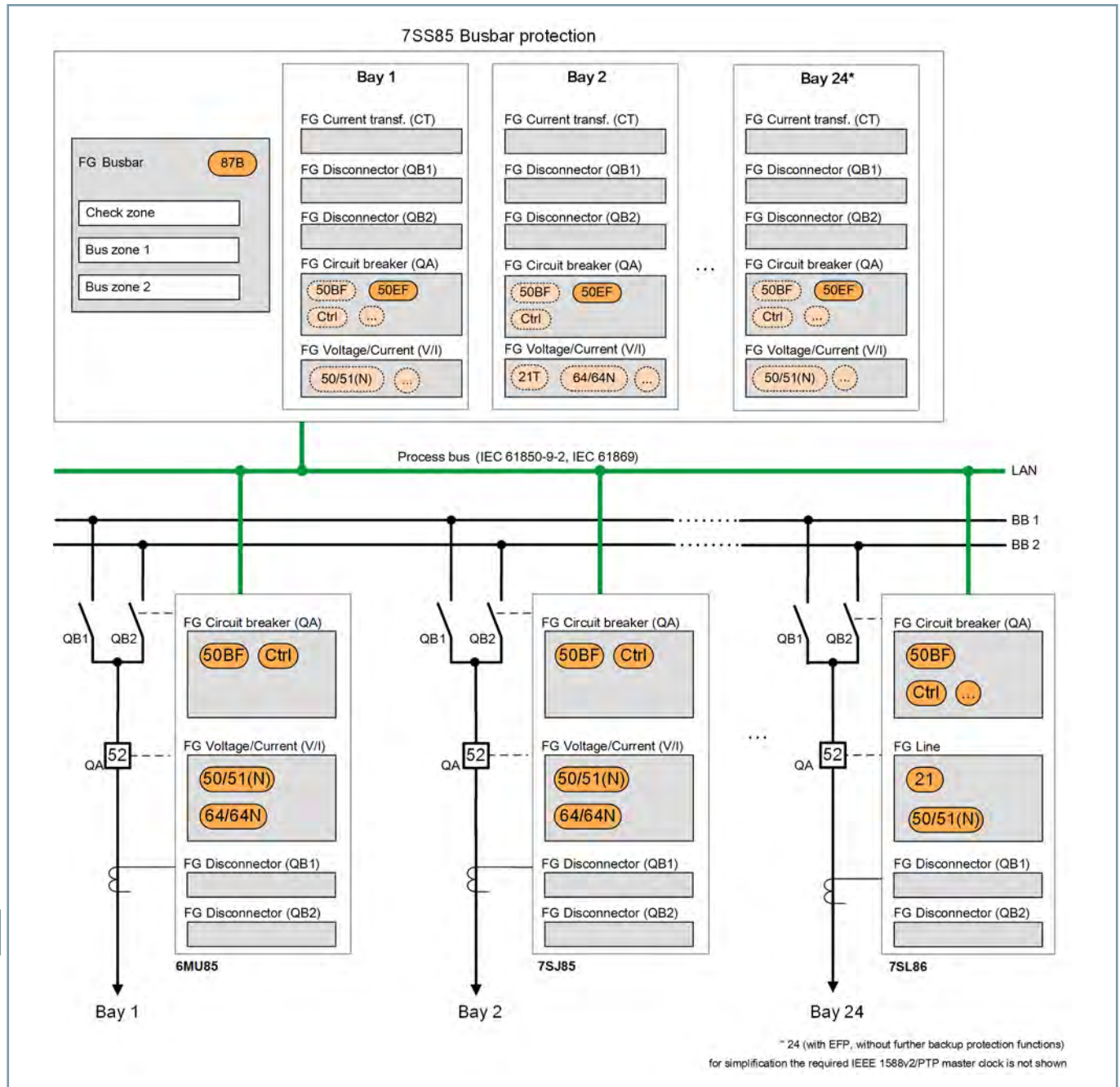

[dw_02_config_decentr-busbar_IEC61850_1_en_US]

Figure 2.15/4 Centralized Busbar Protection using IEC 61850 Compatible Distributed Process Connection

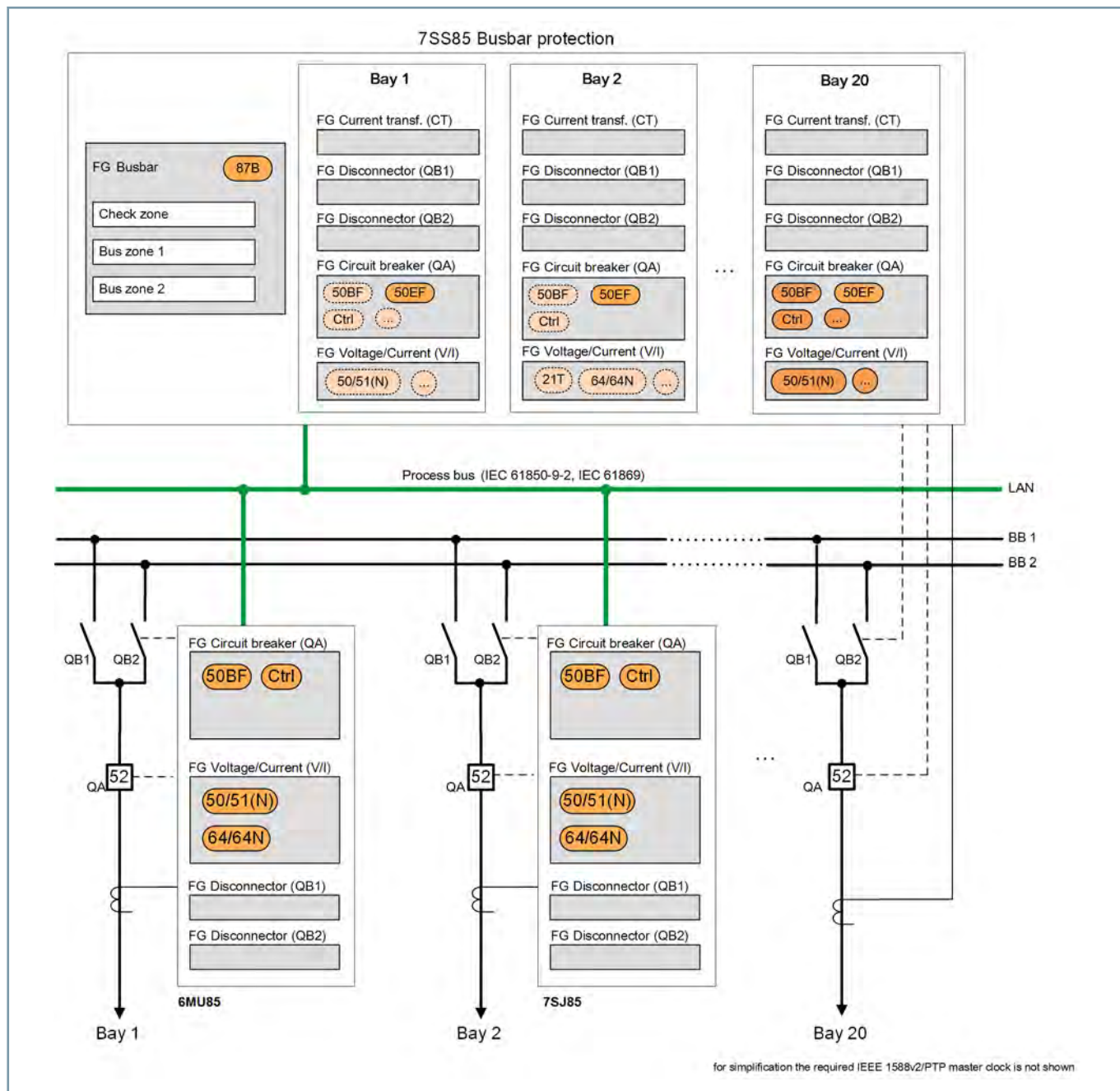

[dw_03_config_decentr-busbar_hybrid, 1, en_US]

Figure 2.15/5 Centralized Busbar Protection using Hybrid Process Connection

2.15

SIPROTEC 5 Devices and Fields of Application

Busbar Protection – SIPROTEC 7SS85

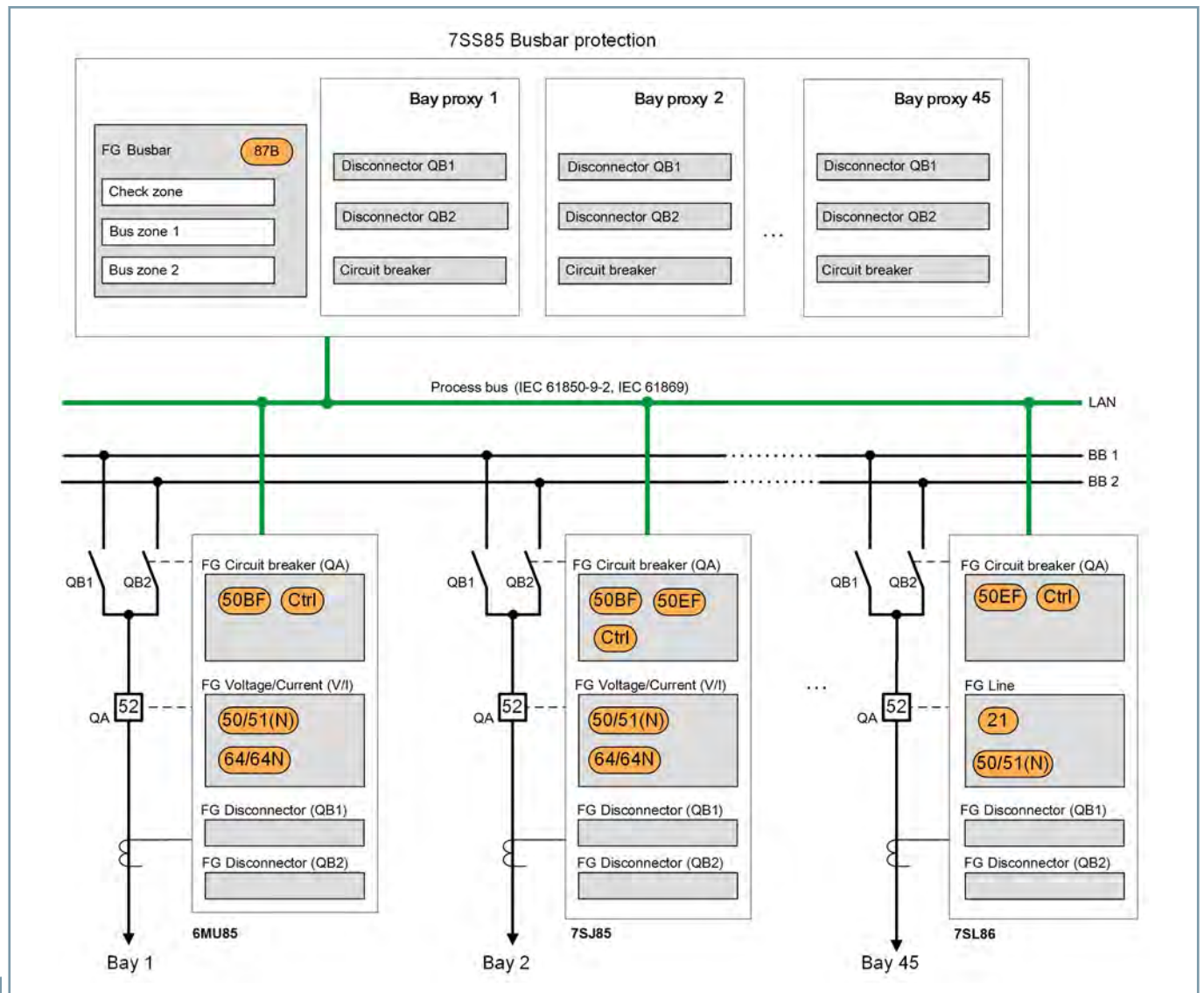

2.15

[dw_04_config_decentr-busbar, 1, en_US]

Figure 2.15/6 Distributed Busbar Protection

SIPROTEC 5 Devices and Fields of Application

Busbar Protection – SIPROTEC 7SS85

ANSI	Function	Abbr.	Available	Application Templates
				1
	Protection functions for 3-pole tripping	3-pole	■	
	Protection functions for 1-pole tripping	1-pole	■	
	Expandable hardware quantity structure	I/O	■	
	Process bus client protocol (hint: PB client requires a separate ETH-BD-2FO plug-in module, from V8.0)	PB client	■	
	IEC61850-9-2 Merging Unit Stream (hint: Each stream requires a separate ETH-BD-2FO plug-in module, from V8.0)	MU	■	
21T	Impedance protection for transformers	Z<	■	
27	Undervoltage protection: "3-phase" or "positive-sequence system V1" or "universal Vx"	V<	■	
38	Temperature supervision	θ>	■	
47	Overvoltage protection, negative-sequence system	V2>	■	
50/51 TD	Overcurrent protection, phases	I>	■	
50N/ 51N TD	Overcurrent protection, ground	IN>	■	
50BF	Circuit-breaker failure protection, 3-pole	CBFP	■	
50BF	Circuit-breaker failure protection 1-pole/3-pole	CBFP	■	
50BF	Inherent circuit-breaker failure protection	CBFP	■	
50EF	End-Fault Protection		■	
59, 59N	Overvoltage protection: "3-phase" or "zero-sequence system V0" or "positive-sequence system V1" or "universal Vx"	V>	■	
67	Directional overcurrent protection, phases	I>, <(V, I)	■	
67N	Directional overcurrent protection, ground	IN>, <(V, I)	■	
74TC	Trip-circuit supervision		■	
81	Frequency protection: "f>" or "f<" or "df/dt"	f<>; df/dt<>	■	
87B	Busbar differential protection	ΔI	■	
87B	Bus coupler differential protection	ΔI	■	
	Bay		■	
	Cross Stabilization		■	
86	Lockout		■	
	Broken-wire detection for differential protection		■	
87 STUB	Stub fault differential protection (for breaker-and-a-half layouts)		■	
PMU	Synchrophasor measurement	PMU	■	
AFD	Arc protection (only with plug-in module ARC-CD-3FO)		■	
	Measured values, standard		■	
	Measured values, extended: Min, max, average		■	
	Switching statistics counter		■	
	PQ – Basic measured values: THD (Total Harmonic Distortion) and harmonic component (starting with V8.01) and THD voltage average values (starting with V8.40)		■	
	PQ – Basic measured values: Voltage unbalance (starting with V8.40)		■	
	PQ – Basic measured values: Voltage changes – monitoring of voltage dips, overvoltages and voltage interruptions (starting with V8.40)		■	
	PQ – Basic measured values: TDD - Total Demand Distortion (starting with V8.40)		■	
	CFC (standard, control)		■	
	CFC arithmetic		■	

SIPROTEC 5 Devices and Fields of Application

Busbar Protection – SIPROTEC 7SS85

ANSI	Function	Abbr.	Available	Application Templates
				1
	Circuit-breaker wear monitoring	$\Sigma I_x, I^2t, 2P$	■	
	Switching sequence function		■	
	Inrush-current detection		■	
	External trip initiation		■	
	Control		■	
	Circuit breaker		■	
	Disconnectors/grounding conductor		■	
	Fault recording of analog and binary signals		■	
	Monitoring		■	
	Protection interface, serial		■	
	Cyber security: Role-Based Access Control (from V7.8)		■	
	Temperature recording via communication protocol		■	
	Cyber security: Authenticated network access using IEEE 802.1X (starting from V8.3)		■	
Function point class:				0
The configuration and function point class for your application can be determined in the SIPROTEC 5 order configurator at www.siemens.com/siprotec .				

Table 2.15/4 SIPROTEC 7SS85 – Functions, Application Templates

(1) Standard busbar

SIPROTEC 5 Devices and Fields of Application

Busbar Protection – SIPROTEC 7SS85

Standard Variants for SIPROTEC 7SS85		
V1	1/2, 15 BI, 13 BO, 12 I	
	Housing width 1/2 x 19" 15 binary inputs 13 binary outputs (1 life contact, 2 standard, 10 fast), 12 current transformers Contains the following modules: Base module with PS201 and IO203 Expansion module IO201	
V2	1/2, 11 BI, 11 BO, 16 I	
	Housing width 1/2 x 19" 11 binary inputs 11 binary outputs (1 life contact, 2 standard, 8 fast) 16 current transformers Contains the following modules: base module with PS201 and IO203 Expansion module IO203	
V3	2/3, 15 BI, 15 BO, 24 I	
	Housing width 2/3 x 19" 15 binary inputs 15 binary outputs (1 life contact, 2 standard, 12 fast) 24 current transformers Contains the following modules: base module with PS201 and IO203 2 expansion modules IO203	
V4	1/3, 19 BI, 11 BO	
	Housing width 1/3 x 19" 15 binary inputs 11 binary outputs (1 life contact, 10 standard, 0 fast) 0 current transformers 1 communication module ETH_BD_2FO	

Table 2.15/5 Standard Variants for SIPROTEC 7SS85

You can find the technical data in the manual
www.siemens.com/siprotec.

2.15

Standard Variant for SIPROTEC 6MU85		
AJ1	1/3, 11 BI, 9 BO, 4 I	
	Housing width 1/3 11 binary inputs 9 binary outputs (1 life contact, 2 standard, 6 fast) 4 current transformers Contains the following modules: base module with PS201 and IO201 1 communication module ETH-BD-2FO	

Table 2.15/6 Standard Variant for Decentralized Busbar Protection SIPROTEC 6MU85

SIPROTEC 5 Devices and Fields of Application

Bay Controllers

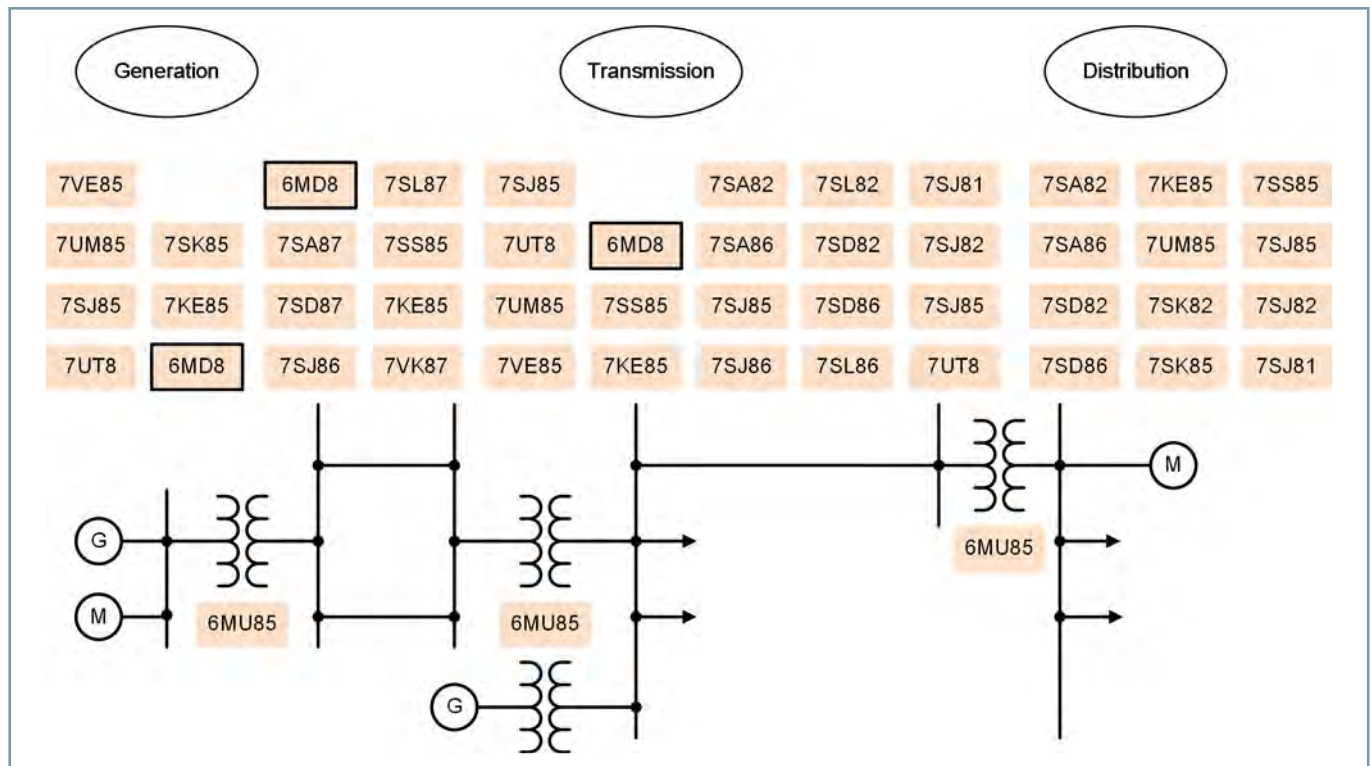

[dw_6md_anwendung, 4, en_US]

Figure 2.16/1 Fields of Application of the SIPROTEC 5 Devices

SIPROTEC 6MD85, 6MD86

SIPROTEC 5 Bay Controllers control and monitor plants of all voltage levels. The large number of automatic functions allows the device to be used in all fields of energy supply.

The devices contain all important auxiliary functions that are necessary for safe network operation today. This includes functions for protection, control, measurement, and monitoring. The large number of communication interfaces and communication protocols satisfies the requirements of communication-based selective protection and of automated operation.

2.16 Commissioning and maintenance work can be completed safely, quickly, and thus cost-effectively with high-performance test functions. Their modular surface mounting permits SIPROTEC 5 bay controllers to always be adapted flexibly to the individual requirements.

Overview of the SIPROTEC 6MD85 and 6MD86 devices

The SIPROTEC 5 bay controllers are based on the flexible and powerful SIPROTEC 5 modular system. When ordering, you can select from among various standard variants. The expandability through expansion modules allows individual adaptation to specific applications.

Sets of devices

The bay controllers are differentiated into the SIPROTEC 6MD85 and SIPROTEC 6MD86 product groups.

Although the SIPROTEC 6MD85 devices are tailored for applications in distribution systems, they can also be used in high-voltage and extra-high voltage applications.

The SIPROTEC 6MD86 devices are designed for applications in the power transmission system. They can be used with a maximum variety of auxiliary functions. Both device types can be configured flexibly in your hardware variant.

Essential Differentiating Characteristics	6MD85	6MD86
Circuit-breaker failure protection	–	Optional
Automatic reclosing	–	Optional
Point-on-Wave Switching (PoW)	–	Optional
Switching sequences	Optional	■
CFC arithmetic	Optional	■
Measured-value processing	Optional	■
Number of switching devices greater than 4	Optional	■
Synchrocheck	Optional	■

Table 2.16/1 Essential Differentiating Characteristics

Common points:

- Configuration of a large number of protection functions
- Modular expansion of the quantity structure
- Optionally usable as Phasor Measurement Unit (PMU)
- High-performance automation with CFC

Description

The SIPROTEC 6MD85 bay controller is a general-purpose control and automation device with protection function. It is designed for use in all voltage levels from distribution to transmission. As part of the SIPROTEC 5 family, it enables a wealth of protection functions from the SIPROTEC library. The modular hardware permits integration of the IOs depending on the application. Adapt the hardware exactly to your requirements and rely on future-oriented solutions for protection, control, automation, monitoring, and Power Quality – Basic.

Main function	Bay controller for medium and high to extra-high voltage switchgear with integrated operation and comprehensive protection functions. Powerful automation, simple configuration with DIGSI 5
Inputs and outputs	5 predefined standard variants with 4 current transformers, 4 voltage transformers, 11 to 75 binary inputs, 9 to 41 binary outputs
Hardware flexibility	Flexibly adjustable and expandable I/O quantity structure within the scope of the SIPROTEC 5 modular system. If high requirements are placed on the quantity structure, the device can be extended in the 2nd row. For example, 240 (and more) binary inputs are possible with the IO230.
Housing width	1/3 × 19 inches to 2/1 × 19 inches

Benefits

- Safe and reliable automation and control of your plants
- Purposeful and simple operation of the devices and software thanks to user-friendly design
- Cybersecurity to NERC CIP and BDEW Whitepaper requirements
- Highest availability even under extreme environmental conditions by standard coating of the populated printed circuit boards

Functions

DIGSI 5 permits all functions to be configured and combined as required and as per the functional scope that has been ordered.

- Integrated bay controller with versatile protection function from medium to extra-high voltage
- Control of switching devices
- Synchrocheck and switchgear interlocking protection
- Fixed integrated electrical Ethernet RJ45 interface for DIGSI 5 and IEC 61850 (reporting and GOOSE)
- Up to 4 pluggable communication modules, usable for different and redundant protocols (IEC 61850-8-1, IEC 61850-9-2 Client, IEC 60870-5-103, IEC 60870-5-104, Modbus TCP, DNP3 serial and TCP, PROFINET IO, PROFINET IO S2 redundancy)
- Virtual network partitioning (IEEE 802.1Q - VLAN)
- Reliable data transmission via PRP and HSR redundancy protocols
- Arc protection



[SIP5_GD_SS_W3, 2, --, --]

Figure 2.16/2 Bay Controller SIPROTEC 6MD85 (1/3 Device with 1/6 Expansion Module with Key Switch Operation Panel)

- Extensive cybersecurity functionality, such as role-based access control (RBAC), logging of security-related events, signed firmware, or authenticated IEEE 802.1X network access
- Simple, fast, and secure access to the device via a standard Web browser to display all information and diagnostic data, vector diagrams, single-line and device display pages
- Graphical logic editor to create powerful automation functions in the device
- Optional overcurrent protection for all voltage levels with 3-pole tripping
- Also used in switchgear with breaker-and-a-half layout
- Selective protection of overhead lines and cables with single-ended and multi-ended feeders using protection communication
- Overcurrent protection also configurable as emergency function
- Secure serial protection communication, also over great distances and all available physical media (optical fiber, two-wire connections and communication networks)
- PQ – Basic: Voltage unbalance; voltage changes: overvoltage, dip, interruptions; TDD, THD, and harmonics
- Detecting operational measured variables and protection function measured values to evaluate the plant state, to support commissioning, and to analyze faults
- Synchrophasor measured values with the IEEE C37.118 protocol integrated (PMU)
- Powerful fault recording (buffer for a max. record time of 80 sec. at 8 kHz and 320 sec. at 2 kHz)
- Auxiliary functions for simple tests and commissioning
- Flexibly adjustable I/O quantity structure within the scope of the SIPROTEC 5 modular system.

SIPROTEC 5 Devices and Fields of Application

Bay Controllers – SIPROTEC 6MD85

Applications

The SIPROTEC 6MD85 bay controller is a general-purpose control and automation device with a protection function based on the SIPROTEC 5 system. The standard variants of the SIPROTEC 6MD85 device are delivered with instrument transformers. Furthermore, protection-class current transformers are also possible in SIPROTEC 6MD85 devices, thus allowing protection functions to be used. Due to its high flexibility, the device is suitable as selective protection equipment for overhead lines and cables with single-ended and multi-ended infeeds when protection communication is used. The device supports all SIPROTEC 5 system characteristics as well as detection and recording of power-quality data in the medium-voltage and subordinate low-voltage power system.

Application Templates

DIGSI 5 provides application templates for standard applications. They include basic configurations and default settings.

The following application templates are available:

- *SIPROTEC 6MD85 Standard*
 - Double busbar feeder with switchgear interlocking protection
- *SIPROTEC 6MD85 Not preconfigured*
- *SIPROTEC 6MD85 Extended control*
 - In addition to the SIPROTEC 6MD85 Standard application template, this template also includes the CFC building blocks for switching sequences and arithmetic.
 - Switching sequence for automatic busbar switchover is preconfigured (triggered by function key)

Application Example

Double Busbar with Switching Sequences

Figure 2.16/3 shows a simple typical application with a SIPROTEC 6MD85 on a double busbar. The **FG Circuit breaker** function group includes the synchrocheck. The disconnectors are also controlled by 1 function group each. Operational meas-

ured values and energy metered values are calculated in the **FG VI-3-ph** function group. They are available for output on the display, transfer to the substation automation technology, and processing in the CFC. A switching sequence stored in the CFC that is activated via a function key starts an automatic busbar switchover process.

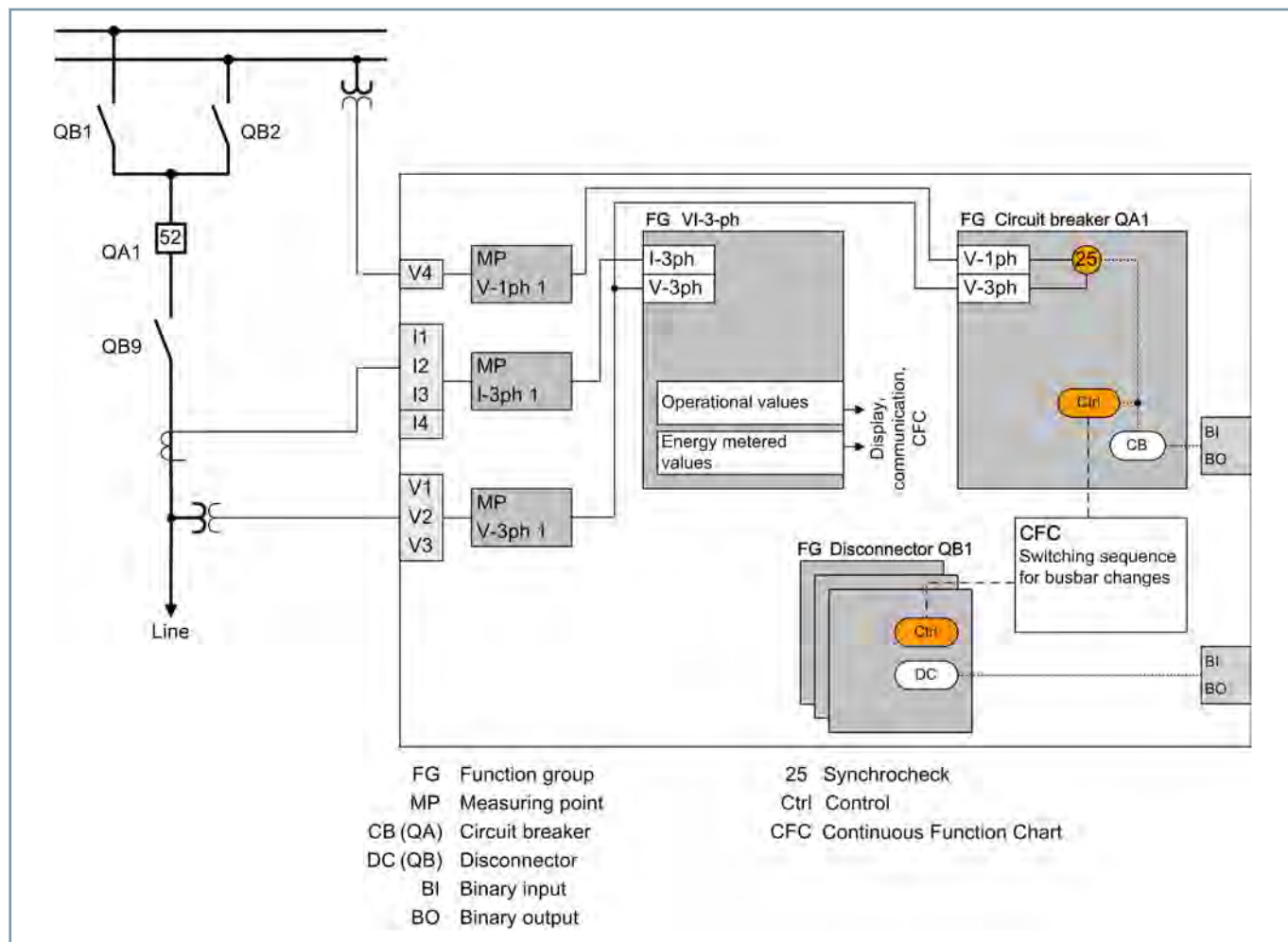

[dw_6MD8-Bsp-Application-1, 2, en_US]

Figure 2.16/3 SIPROTEC 6MD85 Bay Controller for Double Busbars with Switching Sequence for Busbar Switchover

SIPROTEC 5 Devices and Fields of Application

Bay Controllers – SIPROTEC 6MD85

ANSI	Function	Abbr.	Available	Application Templates		
				1	2	3
	Protection functions for 3-pole tripping	3-pole	■	■	■	■
	Expandable hardware quantity structure	I/O	■	■	■	■
	Process bus client protocol (hint: PB client requires a separate ETH-BD-2FO plug-in module, from V8.0)	PB client	■			
	IEC61850-9-2 Merging Unit Stream (hint: Each stream requires a separate ETH-BD-2FO plug-in module, from V8.0)	MU	■			
	IEC61850-9-2 Merging Unit Stream 7SS85 CU (hint: Only for communication with a 7SS85 CU. A separate ETH-BD-2FO plug-in module is required starting with V8.40)	MU	■			
25	Synchrocheck, synchronization function	Sync	■			
27	Undervoltage protection: "3-phase" or "universal Vx"	V<	■			
27R, 59R	Voltage change protection (starting with V8.30)	dV/dt	■			
32, 37	Power protection active/reactive power	P<>, Q<>	■			
38	Temperature supervision	θ>	■			
46	Negative-sequence system overcurrent protection	I2>	■			
49	Thermal overload protection	θ, I²t	■			
50/51 TD	Overcurrent protection, phases	I>	■			
	Instantaneous tripping at switch onto fault	SOTF	■			
50HS	Instantaneous high-current tripping	I>>>	■			
50N/ 51N TD	Overcurrent protection, ground	IN>	■			
50EF	End-fault protection (hint: For use only in decentralized busbar protection with a 7SS85 CU starting with V8.40)		■			
51V	Voltage-controlled overcurrent protection	t=f(I, V)	■			
59	Overvoltage protection: "3-phase" or "positive-sequence system V1" or "universal Vx"	V>	■			
67	Directional overcurrent protection, phases	I>, ∠(V, I)	■			
67N	Directional overcurrent protection, ground	IN>, ∠(V, I)	■			
74TC	Trip-circuit supervision		■			
74CC	Single circuit monitoring (from V7.9)		■			
81	Frequency protection: "f>" or "f<" or "df/dt"	f<>; df/dt<>	■			
81U	Underfrequency load shedding	f<(ULS)	■			
86	Lockout		■			
90 V	Voltage controller for two-winding transformer		■			
90 V	Voltage controller for two-winding transformer with parallel control		■			
	Number of two-winding transformers with parallel control (hint: only together with the function "voltage controller for two-winding transformer with parallel control")		■			
90 V	Voltage controller for three-winding transformer		■			
90 V	Voltage controller for grid coupling transformer		■			
PMU	Synchrophasor measurement	PMU	■			
AFD	Arc protection (only with plug-in module ARC-CD-3FO)		■			
	Measured values, standard		■	■		■
	Measured values, extended: Min, max, average		■			■
	Switching statistics counter		■	■		■

2.16

SIPROTEC 5 Devices and Fields of Application

Bay Controllers – SIPROTEC 6MD85

ANSI	Function	Abbr.	Available	Application Templates		
				1	2	3
	PQ – Basic measured values: THD (Total Harmonic Distortion) and harmonic component (starting with V8.01) and THD voltage average values (starting with V8.40)		■			
	PQ – Basic measured values: Voltage unbalance (starting with V8.40)		■			
	PQ – Basic measured values: Voltage changes – monitoring of voltage dips, overvoltages and voltage interruptions (starting with V8.40)		■			
	PQ – Basic measured values: TDD - Total Demand Distortion (starting with V8.40)		■			
	CFC (standard, control)		■	■		■
	CFC arithmetic		■			
	Circuit-breaker wear monitoring	$\Sigma Ix, I^2t, 2P$	■			
	Switching sequence function		■			■
	Inrush-current detection		■			
	External trip initiation		■			
	Control		■	■		■
	Circuit breaker		■	■		■
	Disconnectors/grounding conductor		■	■		■
	Fault recording of analog and binary signals		■	■		■
	Monitoring		■	■		■
	Protection interface, serial		■			
	Frequency group tracking (from V7.8)		■			
	Cyber security: Role-Based Access Control (from V7.8)		■			
	Temperature recording via communication protocol		■			
	Cyber security: Authenticated network access using IEEE 802.1X (starting from V8.3)		■			
Function point class:				0	0	20
The configuration and function point class for your application can be determined in the SIPROTEC 5 order configurator at www.siemens.com/siprotec .						

Table 2.16/2 SIPROTEC 6MD85 – Functions, Application Templates

- (1) Standard
- (2) Not preconfigured
- (3) Control expanded

SIPROTEC 5 Devices and Fields of Application

Bay Controllers – SIPROTEC 6MD85

Standard Variants for SIPROTEC 6MD85		
J1	1/3, 11 BI, 9 BO, 4 I, 4 V Housing width 1/3 x 19" 11 binary inputs 9 binary outputs (1 life contact, 2 standard, 6 fast) 4 sensitive current-transformer inputs 4 voltage-transformer inputs Contains the following modules: base module with PS201 and IO202	
J2	1/2, 27 BI, 17 BO, 4 I, 4 V Housing width 1/2 x 19" 27 binary inputs 17 binary outputs (1 life contact, 10 standard, 6 fast) 4 sensitive current-transformer inputs 4 voltage-transformer inputs Contains the following modules: base module with PS201 and IO202 Expansion module IO207	
J4	2/3, 43 BI, 25 BO, 4 I, 4 V Housing width 2/3 x 19" 43 binary inputs 25 binary outputs (1 life contact, 18 standard, 6 fast) 4 sensitive current-transformer inputs 4 voltage-transformer inputs Contains the following modules: base module with PS201 and IO202 Expansion modules 2 x IO207	
J5	5/6, 59 BI, 33 BO, 4 I, 4 V Housing width 2/3 x 19" 59 binary inputs 33 binary outputs (1 life contact, 26 standard, 6 fast) 4 sensitive current-transformer inputs 4 voltage-transformer inputs Contains the following modules: base module with PS201 and IO202 Expansion modules 3 x IO207	
J7	1/1, 75 BI, 41 BO, 4 I, 4 V Housing width 1/1 x 19" 75 binary inputs 41 binary outputs (1 life contact, 34 standard, 6 fast) 4 sensitive current-transformer inputs 4 voltage-transformer inputs Contains the following modules: base module with PS201 and IO202 Expansion modules 4 x IO207	

2.16

Table 2.16/3 Standard Variants for Bay Controllers SIPROTEC 6MD85

You can find the technical data of the devices in the manual
www.siemens.com/siprotec

Description

The SIPROTEC 6MD86 bay controller is a general-purpose control and automation device with protection function. It is designed for use in all voltage levels from distribution to transmission. As part of the SIPROTEC 5 family, it enables a wealth of protection functions from the SIPROTEC library. The modular hardware permits integration of the I/Os depending on the application. Adapt the hardware precisely to your requirements and rely on the future-oriented solutions for protection, control, automation, monitoring, and Power Quality – Basic.

Main function	Bay controller for medium and high to extra-high voltage switchgear with integrated operation and comprehensive protection functions; performance automation, simple configuration with DIGSI 5
Inputs and outputs	7 predefined standard variants with 8 current transformers, 8 voltage transformers, 11 to 75 binary inputs, 9 to 41 binary outputs
Hardware flexibility	Flexibly adjustable and expandable I/O quantity structure within the scope of the SIPROTEC 5 modular system. If high requirements are placed on the quantity structure, the device can be extended in the 2nd row. For example, 240 (and more) binary inputs are possible with the IO230 (see Hardware section).
Housing width	1/3 × 19 inches to 2/1 × 19 inches

Benefits

- Safe and reliable automation and control of your plants
- Purposeful and simple operation of the devices and software thanks to user-friendly design
- Cybersecurity in accordance with NERC CIP and BDEW White-paper requirements
- Highest availability even under extreme environmental conditions by standard coating of the populated printed circuit boards

Functions

DIGSI 5 permits all functions to be configured and combined as required and as per the functional scope that has been ordered.

- Integrated bay controller with versatile protection function from medium to extra-high voltage
- Control of switching devices
- Point-on-wave switching
- Synchrocheck, switchgear interlocking protection and switch-related protection functions, such as circuit-breaker failure protection and automatic reclosing
- Fixed integrated electrical Ethernet RJ45 interface for DIGSI 5 and IEC 61850 (reporting and GOOSE)
- Up to 4 pluggable communication modules, usable for different and redundant protocols (IEC 61850-8-1, IEC 61850-9-2 Client, IEC 60870-5-103, IEC 60870-5-104, Modbus TCP, DNP3 serial and TCP, PROFINET IO, PROFINET IO S2 redundancy)
- Virtual network partitioning (IEEE 802.1Q - VLAN)



[SIP5_GD_SS_W3, 2, --, --]

Figure 2.16/4 SIPROTEC 6MD86 (1/3 Device with 1/6 Expansion Module with Key Switch Operation Panel)

- Reliable data transmission via PRP and HSR redundancy protocols
- Extensive cybersecurity functionality, such as role-based access control (RBAC), logging of security-related events, signed firmware, or authenticated IEEE 802.1X network access
- Simple, fast, and secure access to the device via a standard Web browser to display all information and diagnostic data, vector diagrams, single-line and device display pages
- Arc protection
- Graphical logic editor to create powerful automation functions in the device
- Optional overcurrent protection with 3-pole tripping
- Also used in switchgear with breaker-and-a-half layout
- Overcurrent protection also configurable as emergency function
- Secure serial protection communication, also over great distances and all available physical media (optical fiber, two-wire connections and communication networks)
- PQ – Basic: Voltage unbalance; voltage changes: overvoltage, dip, interruption; TDD, THD, and harmonics
- Capturing operational measured variables and protection function measured values to evaluate the plant state, to support commissioning, and to analyze faults
- Synchrophasor measured values with the IEEE C37.118 protocol integrated (PMU)
- Powerful fault recording (buffer for a max. record time of 80 sec. at 8 kHz and 320 sec. at 2 kHz)
- Point-on-wave switching (PoW)
- Auxiliary functions for simple tests and commissioning
- Flexibly adjustable I/O quantity structure within the scope of the SIPROTEC 5 modular system

SIPROTEC 5 Devices and Fields of Application

Bay Controllers – SIPROTEC 6MD86

Applications

The SIPROTEC 6MD86 bay controller is a general-purpose control and automation device with a protection function on the basis of the SIPROTEC 5 system. The standard variants of the SIPROTEC 6MD86 device are delivered with instrument transformers. Furthermore, protection-class current transformers are also possible in SIPROTEC 6MD86 devices, allowing protection functions to be used. Due to its high flexibility, the device is suitable as selective protection equipment for overhead lines and cables with single-ended and multi-ended infeeds when protection communication is used. The device supports all SIPROTEC 5 system characteristics as well as detection and recording of power-quality data in the medium-voltage and subordinate low-voltage power system.

Application Templates

The following application templates are available:

- SIPROTEC 6MD86 standard double busbar
 - Double busbar feeder with switchgear interlocking protection
 - Synchrocheck for circuit breaker
 - Switching sequence for automatic busbar switchover preconfigured (triggered by function key)
- SIPROTEC 6MD86 breaker-and-a-half type 1
 - Control of a breaker-and-a-half layout (3 circuit breakers, 14 disconnectors)
 - Synchrocheck for the 3 circuit breakers with dynamic measuring-point switchover
- SIPROTEC 6MD86 breaker-and-a-half type 2
 - Control of a part of a breaker-and-a-half layout
 - Supports concepts with multiple bay controllers per bay
 - Circuit-breaker failure protection and automatic reclosing

SIPROTEC 6MD86 point-on-wave switching

- Controlled switching (Point-on-Wave (PoW)) for precise activation of the 3 individual phases of a switch to minimize the load placed on the equipment.

Application Examples

Double Busbar with Protection Functions

In [Figure 2.16/5](#) the double busbar feeder is controlled and also protected by a 6MD86. For this purpose, circuit-breaker failure protection and the automatic reclosing are activated in the **Circuit breaker** function group. The **VI 3ph** function group

includes the protection functions overvoltage protection, frequency protection, and power protection. In contrast to [Figure 2.16/3](#), it is therefore connected to the circuit breaker so that the resulting trip signals have a destination. Such linkages can be created quickly and flexibly in the DIGSI 5 Editor **Function-group connections** ([Figure 2.16/6](#)).

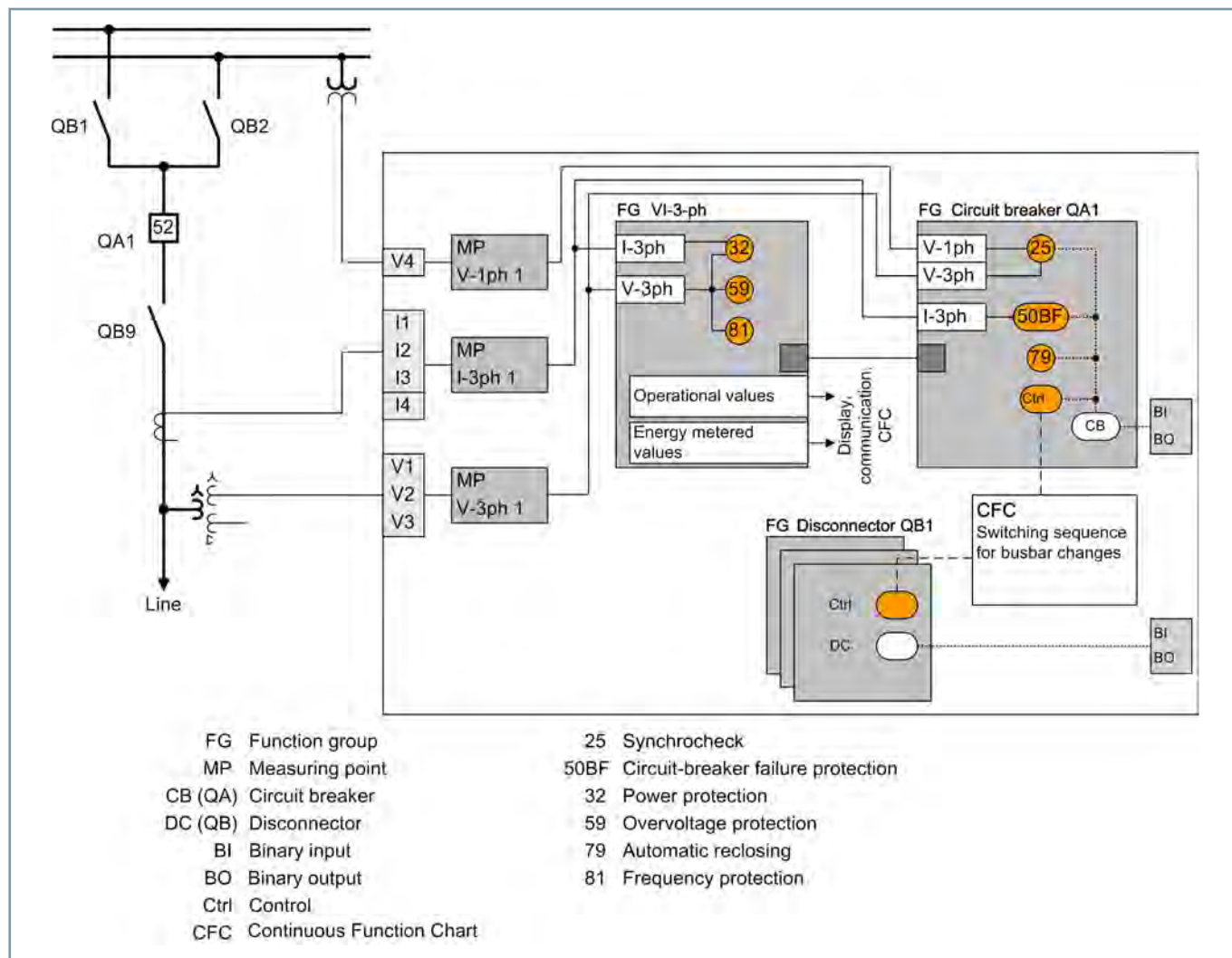

[dw_6MD8-Bsp-Application-2_3_en_US]

Figure 2.16/5 Bay Controller 6MD86 for Double Busbar with Protection Functions

SIPROTEC 5 Devices and Fields of Application

Bay Controllers – SIPROTEC 6MD86

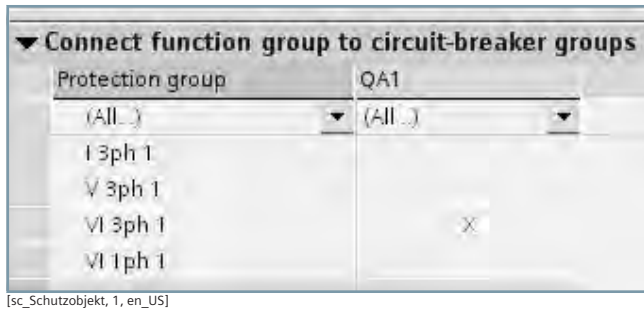
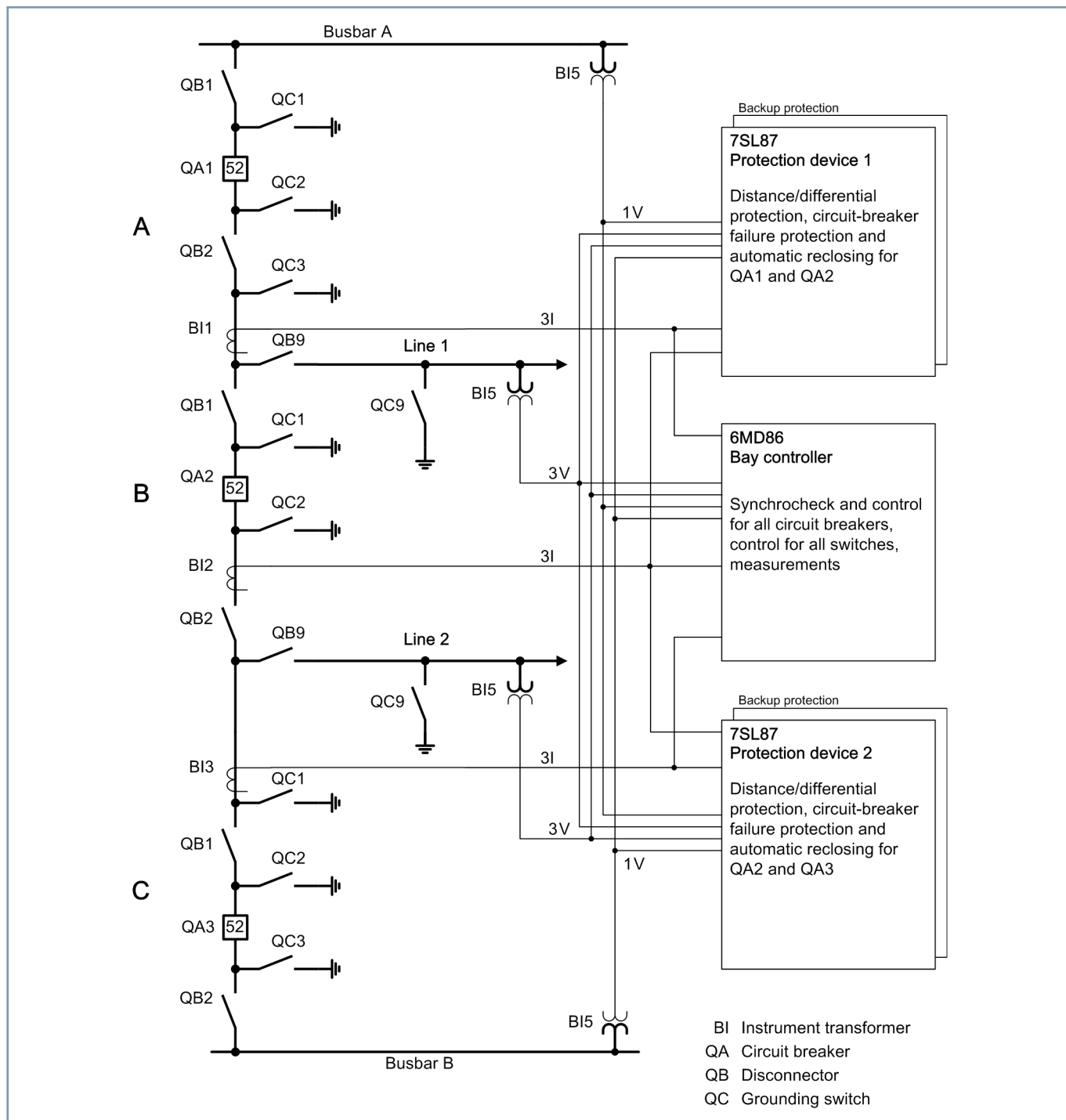

Figure 2.16/6 Assignment of the Function Group with Protection Functions to the Switch (Protected Object)

Breaker-and-a-Half Scheme with Protection and Systems Control

[Figure 2.16/7](#) shows a breaker-and-a-half scheme with protection and systems control. The protection is achieved by 2 SIPROTEC 7SL87 line protection devices which also assume circuit-breaker failure protection and the automatic reclosing of the 3 circuit breakers. The control of all switches and the synchrocheck of the circuit breakers is assumed by the SIPROTEC 6MD86 bay controller. [Figure 2.16/8](#) provides an insight view of the functions of the SIPROTEC 6MD86.



[dw_1-5_CB-Feldleit., 2, en_US]

Figure 2.16/7 Breaker-and-a-Half Layout with a Bay Controller and 2 Line Protection Devices (Overview)

Figure 2.16/8 shows the principle of the dynamic switchover of the voltage measurements for the synchrocheck functions of the 3 circuit breakers in the SIPROTEC 6MD86 bay controller. Each synchrocheck function (ANSI number 25) requires both voltages V_{sync1} and V_{sync2} (feeder voltage and reference voltage). With the middle QA2 circuit breaker, there are 2 possi-

bilities for each of the 2 voltages depending on the position of the disconnector and circuit breaker. For the 2 outer QA1 and QA3 circuit breakers, there is 1 possibility for a voltage (that is, the neighboring busbar), while the other voltage is connected by means of 1 of 3 possibilities (likewise depending on the switch position).

SIPROTEC 5 Devices and Fields of Application

Bay Controllers – SIPROTEC 6MD86

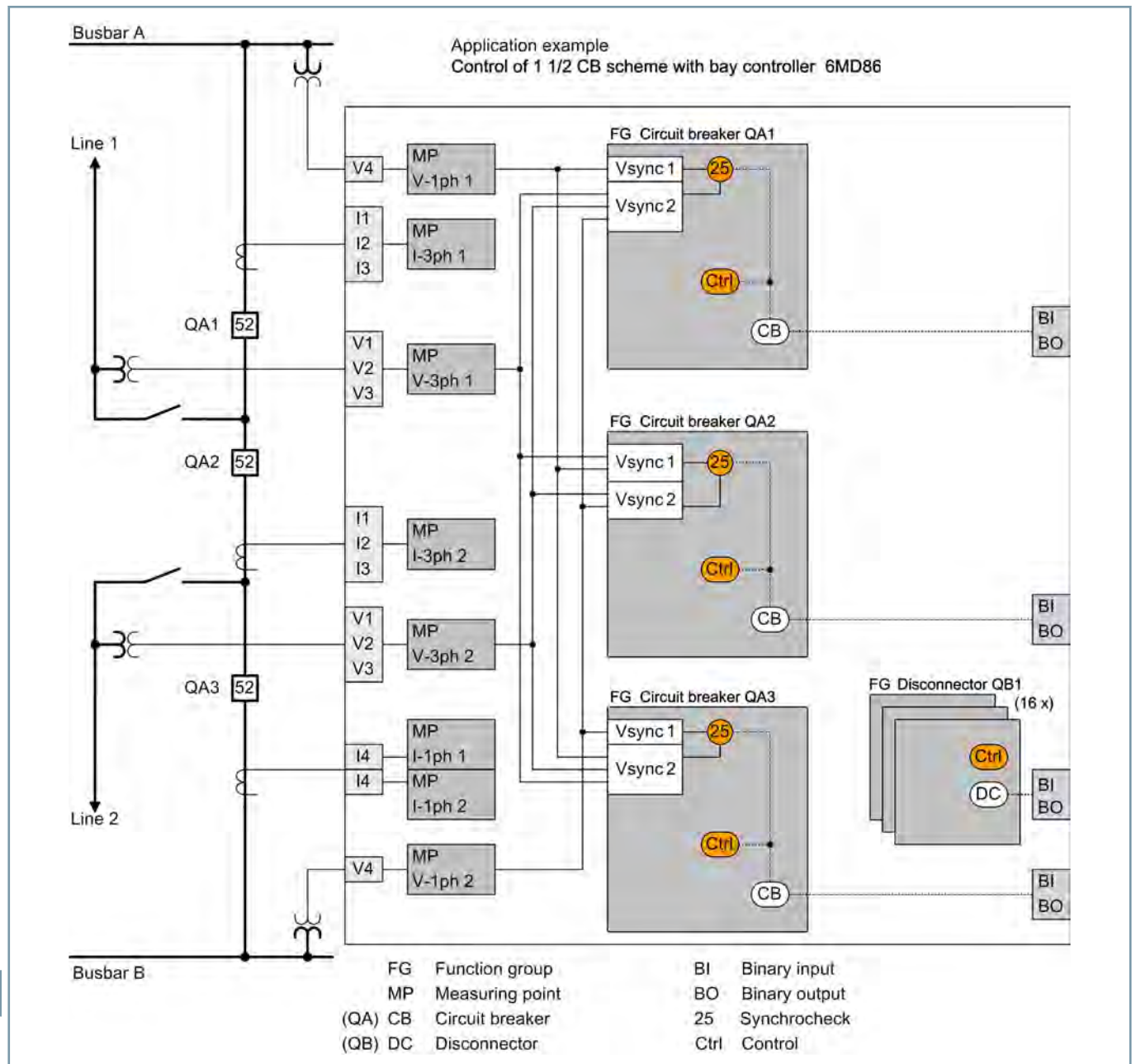

[dw_6MD8-Bsp-Application-3, 1, en_US]

Figure 2.16/8 Breaker-and-a-Half Layout with 1 Bay Controller and 2 Line Protection Devices (Detail for Bay Controller)

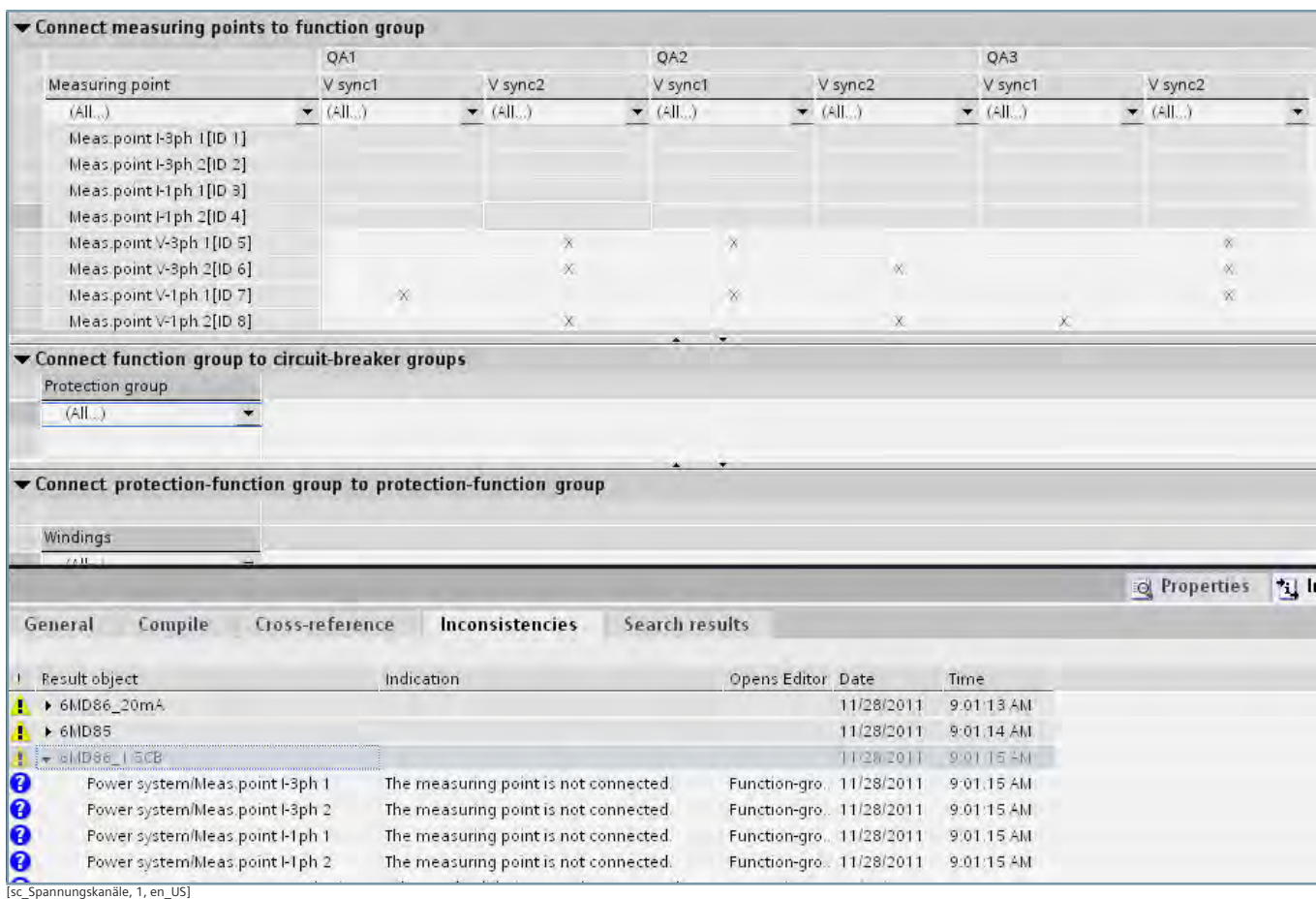

Figure 2.16/9 Routing of the Possible Voltage Terminals to the 3 Circuit-Breaker Function Groups

Figure 2.16/9 shows the routing in the **Function Group Connections** editor. All voltages which are considered as a feeder or reference voltage for the synchrocheck are assigned to the Vsync1 or Vsync2 inputs.

The ID number of the measured values is used to select the voltages which are currently operationally attached in a CFC chart (Figure 2.16/10).

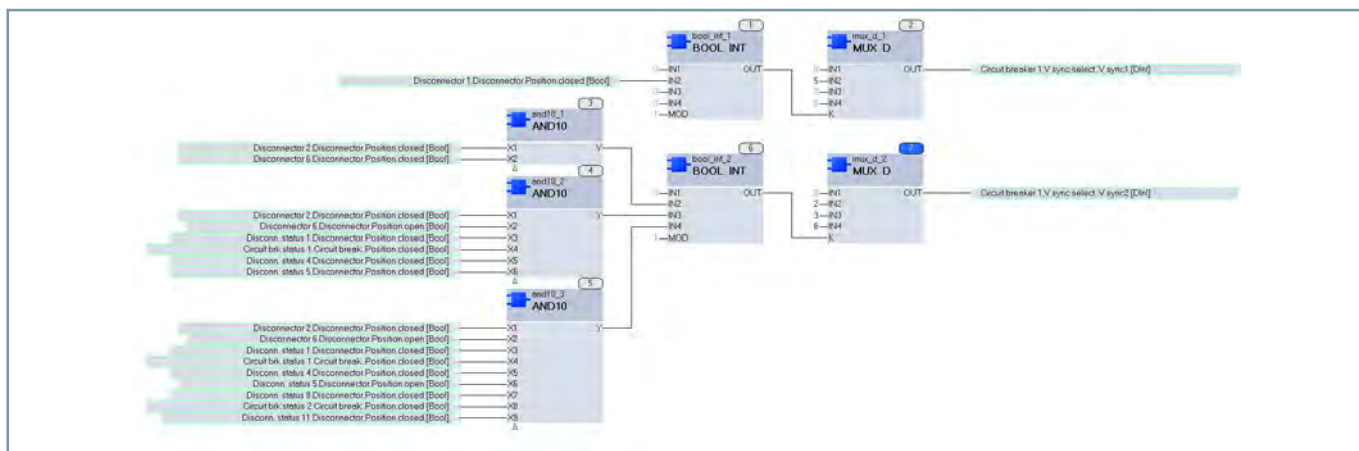

Figure 2.16/10 CFC Chart to Select the Synchrocheck Reference Voltages

SIPROTEC 5 Devices and Fields of Application

Bay Controllers – SIPROTEC 6MD86

Use as a Phasor Measurement Unit

At selected stations of the transmission system, a measurement of current and voltage for absolute value and phase is carried out using PMUs. Due to the high-precision time synchronization (via GPS), the measured values from different substations that are far away from each other are compared, and conclusions about the system state and dynamic events, such as power fluctuations, are drawn from the phase angles and dynamic curves.

If you select the **Phasor Measurement Unit** option, the devices determine current and voltage phasors, add high-precision time stamps, and send these together with other measured values (frequency, rate of change of frequency) to an evaluation station via the communication protocol IEEE C37.118, see [Figure 2.16/12](#). With the aid of the synchrophasor and a suitable analysis program (for example, SIGUARD PDP), it is possible to detect power swings and trip alarms automatically which are sent to the network control center, for example.

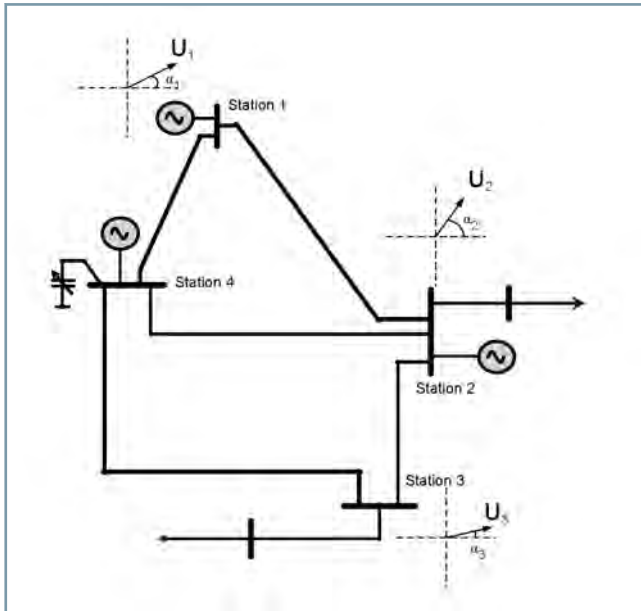

[Zeigermessung (PMU), 1, --, --]

Figure 2.16/11 Principle of the Distributed Phasor Measurement

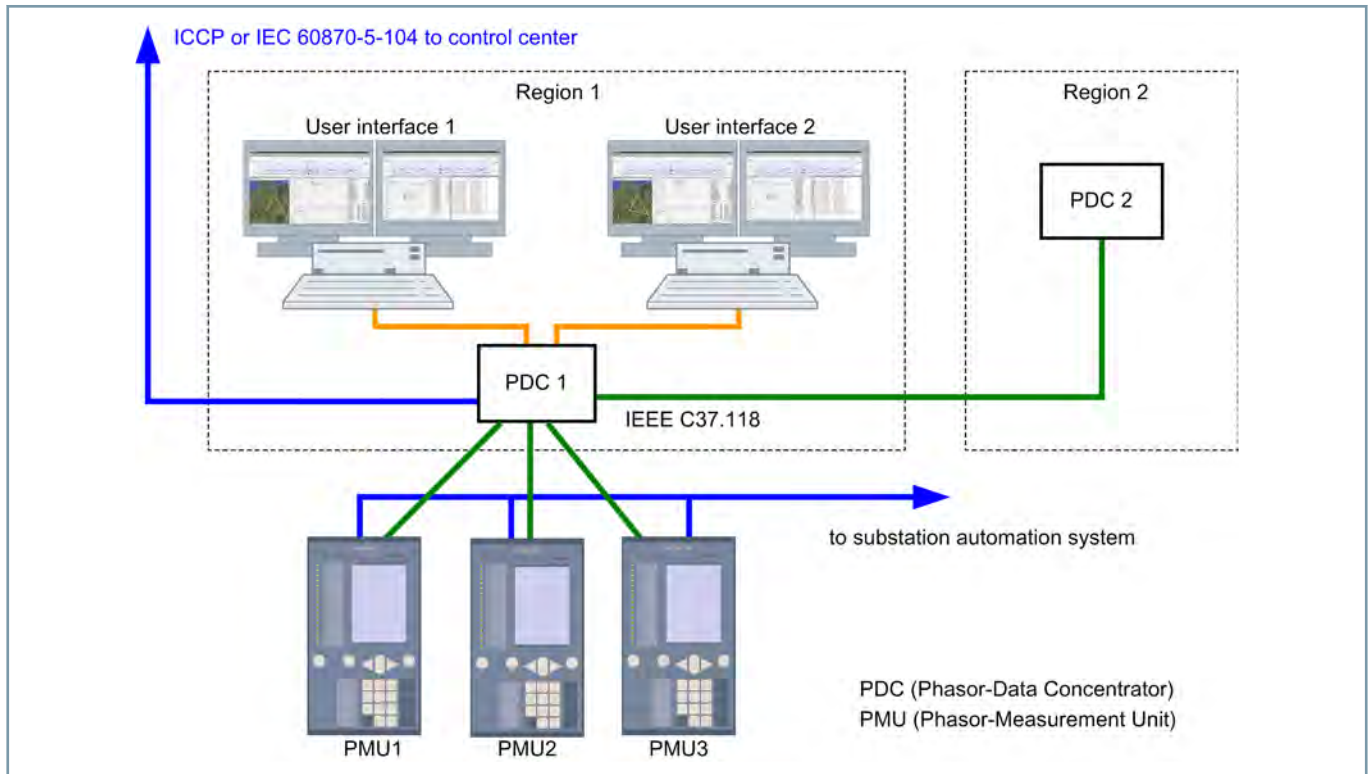

[dw_struct_WAM, 1, en_US]

Figure 2.16/12 Connecting 3 Phasor Measurement Units with 2 Phasor Data Concentrators (PDCs) SIGUARD PDP

When the PMU function is used, a **FG PMU** function group is created in the device. This function group calculates the phasor and analog values, add time stamps, and transmits the data to

the selected Ethernet interface via the protocol IEEE C37.118. There, they can be received, saved, and processed by one or more clients. Up to 3 IP addresses from clients can be assigned in the device.

SIPROTEC 5 Devices and Fields of Application

Bay Controllers – SIPROTEC 6MD86

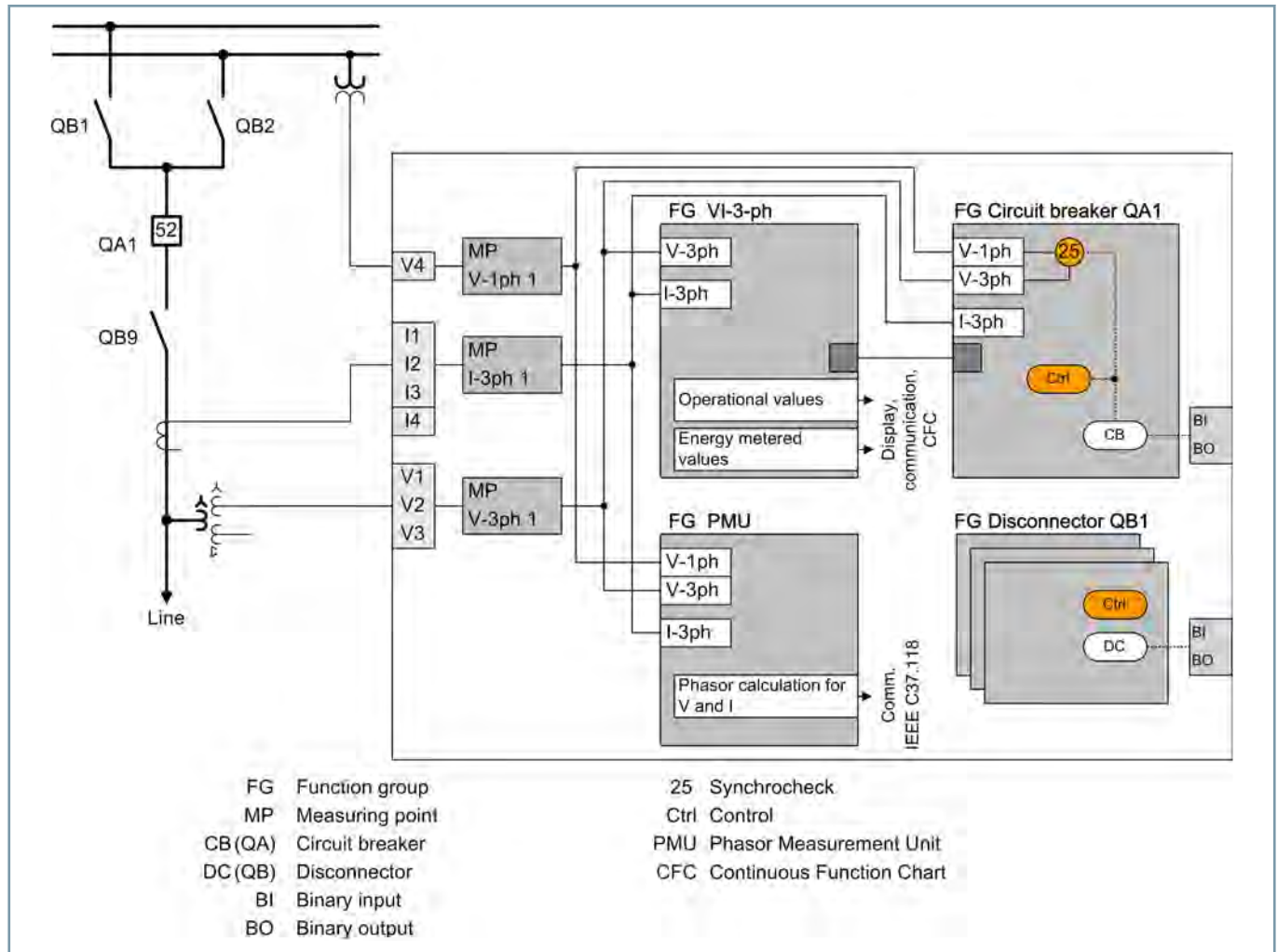

Figure 2.16/13 Application Example: Double Busbar with SIPROTEC 6MD86 Used as a Bay Controller and Phasor Measurement Unit (PMU)

SIPROTEC 5 Devices and Fields of Application

Bay Controllers – SIPROTEC 6MD86

ANSI	Function	Abbr.	Available	Application Templates				
				1	2	3	4	5
	Protection functions for 3-pole tripping	3-pole	■	■	■	■	■	
	Expandable hardware quantity structure	I/O	■	■	■	■	■	■
	Process bus client protocol (hint: PB client requires a separate ETH-BD-2FO plug-in module, from V8.0)	PB client	■					
	IEC61850-9-2 Merging Unit Stream (hint: Each stream requires a separate ETH-BD-2FO plug-in module, from V8.0)	MU	■					
	IEC61850-9-2 Merging Unit Stream 7SS85 CU (hint: Only for communication with a 7SS85 CU. A separate ETH-BD-2FO plug-in module is required starting with V8.40)	MU	■					
25	Synchrocheck, synchronization function	Sync	■		■	■	■	
27	Undervoltage protection: "3-phase" or "universal Vx"	V<	■					
27R, 59R	Voltage change protection (starting with V8.30)	dV/dt	■					
32, 37	Power protection active/reactive power	P<>, Q<>	■					
38	Temperature supervision	θ>	■					
46	Negative-sequence system overcurrent protection	I2>	■					
49	Thermal overload protection	θ, I²t	■					
50/51 TD	Overcurrent protection, phases	I>	■		■	■	■	
	Instantaneous tripping at switch onto fault	SOTF	■					
50HS	Instantaneous high-current tripping	I>>>	■					
50N/ 51N TD	Overcurrent protection, ground	IN>	■					
50BF	Circuit-breaker failure protection 1-pole/3-pole	CBFP	■				■	
50EF	End-fault protection (hint: For use only in decentralized busbar protection with a 7SS85 CU starting with V8.40)		■					
51V	Voltage-controlled overcurrent protection	t=f(I, V)	■					
59	Overvoltage protection: "3-phase" or "positive-sequence system V1" or "universal Vx"	V>	■					
67	Directional overcurrent protection, phases	I>, ∠(V, I)	■					
67N	Directional overcurrent protection, ground	IN>, ∠(V, I)	■					
74TC	Trip-circuit supervision		■					
74CC	Single circuit monitoring (from V7.9)		■					
79	Automatic reclosing, 1-pole/3-pole	AREC	■				■	
81	Frequency protection: "f>" or "f<" or "df/dt"	f<>; df/dt<>	■					
81U	Underfrequency load shedding	f<(ULS)	■					
86	Lockout		■					
90 V	Voltage controller for two-winding transformer		■					
90 V	Voltage controller for two-winding transformer with parallel control		■					
	Number of two-winding transformers with parallel control (hint: only together with the function "voltage controller for two-winding transformer with parallel control")		■					
90 V	Voltage controller for three-winding transformer		■					
90 V	Voltage controller for grid coupling transformer		■					
PMU	Synchrophasor measurement	PMU	■					
AFD	Arc protection (only with plug-in module ARC-CD-3FO)		■					
	Measured values, standard		■		■	■	■	
	Measured values, extended: Min, max, average		■					
	Switching statistics counter		■		■	■	■	

SIPROTEC 5 Devices and Fields of Application

Bay Controllers – SIPROTEC 6MD86

ANSI	Function	Abbr.	Available	Application Templates				
				1	2	3	4	5
	PQ – Basic measured values: THD (Total Harmonic Distortion) and harmonic component (starting with V8.01) and THD voltage average values (starting with V8.40)		■					
	PQ – Basic measured values: Voltage unbalance (starting with V8.40)		■					
	PQ – Basic measured values: Voltage changes – monitoring of voltage dips, overvoltages and voltage interruptions (starting with V8.40)		■					
	PQ – Basic measured values: TDD - Total Demand Distortion (starting with V8.40)		■					
	CFC (standard, control)		■		■	■	■	
	CFC arithmetic		■		■	■	■	
	Circuit-breaker wear monitoring	$\Sigma I_x, I^2t, 2P$	■					
	Switching sequence function		■			■		
	Inrush-current detection		■					
	External trip initiation		■					
	Control		■		■	■	■	■
PoW	Point-on-wave switching (starting with V7.90)	PoW	■					■
	Circuit breaker		■		■	■	■	■
	Disconnectors/grounding conductor		■		■	■	■	
	Fault recording of analog and binary signals		■		■	■	■	
	Monitoring		■		■	■	■	
	Protection interface, serial		■					
	Frequency group tracking (from V7.8)		■					
	Cyber security: Role-Based Access Control (from V7.8)		■					
	Temperature recording via communication protocol		■					
	Cyber security: Authenticated network access using IEEE 802.1X (starting from V8.3)		■					
Function point class:				0	0	0	75	200
The configuration and function point class for your application can be determined in the SIPROTEC 5 order configurator at www.siemens.com/siprotec .								

Table 2.16/4 SIPROTEC 6MD86 – Functions, Application Templates

- (1) Not preconfigured
- (2) Breaker-and-a-half type 1
- (3) Double busbar
- (4) Breaker-and-a-half type 2
- (5) Point-on-wave switching

2.16

SIPROTEC 5 Devices and Fields of Application

Bay Controllers – SIPROTEC 6MD86

Standard Variants for SIPROTEC 6MD86		
The standard variants of the 6MD86 also include an Ethernet communication module, a large display, and key switch (starting with type K2)		
K1	1/3, 11 BI, 9BO, 4 I, 4 V Housing width 1/3 x 19" 1 electrical Ethernet module ETH-BA-2EL 11 binary inputs 9 binary outputs (1 life contact, 2 standard, 6 fast) 4 sensitive current-transformer inputs 4 voltage-transformer inputs Contains the following modules: base module with PS201 and IO202	
K2	1/2, 27 BI, 17 BO, 4 I, 4 V Housing width 1/2 x 19" 1 electrical Ethernet module ETH-BA-2EL 27 binary inputs 17 binary outputs (1 life contact, 10 standard, 6 fast) 4 sensitive current-transformer inputs 4 voltage-transformer inputs Contains the following modules: base module with PS201 and IO202 Expansion module IO207	
K4	2/3, 43 BI, 25 BO, 4 I, 4 V Housing width 2/3 x 19" 1 electrical Ethernet module ETH-BA-2EL 43 binary inputs 25 binary outputs (1 life contact, 18 standard, 6 fast) 4 sensitive current-transformer inputs 4 voltage-transformer inputs Contains the following modules: base module with PS201 and IO202 Expansion modules 2 x IO207	
K5	5/6, 59 BI, 33 BO, 4 I, 4 V Housing width 5/6 x 19" 1 electrical Ethernet module ETH-BA-2EL 59 binary inputs 33 binary outputs (1 life contact, 26 standard, 6 fast) 4 sensitive current-transformer inputs, 4 voltage-transformer inputs Contains the following modules: base module with PS201 and IO202 Expansion modules 3 x IO207	
K7	1/1, 75 BI, 41 BO, 4 I, 4 V Housing width 1/1 x 19" 1 electrical Ethernet module ETH-BA-2EL 75 binary inputs 41 binary outputs (1 life contact, 34 standard, 6 fast) 4 sensitive current-transformer inputs 4 voltage-transformer inputs Contains the following modules: base module with PS201 and IO202 Expansion modules 4 x IO207	

SIPROTEC 5 Devices and Fields of Application

Bay Controllers – SIPROTEC 6MD86



<p>K8</p>	<p>1/1, 67 BI, 39 BO, 8 I, 8 V</p> <p>Housing width 1/1 x 19"</p> <p>1 electrical Ethernet module ETH-BA-2EL</p> <p>67 binary inputs</p> <p>39 binary outputs (1 life contact, 26 standard, 12 fast)</p> <p>8 sensitive current-transformer inputs</p> <p>8 voltage-transformer inputs</p> <p>Contains the following modules: base module with PS201 and IO202</p> <p>Expansion modules IO202, 3 x IO207</p>	
<p>K9</p>	<p>5/6, 35BI, 17BO(8HS), 4I, 4V, 8 MT-F</p> <p>Housing width 5/6 x 19"</p> <p>35 binary inputs</p> <p>17 binary outputs (1 life contact, 2 standard, 6 fast, 8 high-speed relays with semiconductor acceleration)</p> <p>4 current transformers (protection)</p> <p>4 voltage transformers</p> <p>8 fast measuring-transducer inputs for current (20 mA) or voltage (10 V)</p>	

Table 2.16/5 Standard Variants for Bay Controllers SIPROTEC 6MD86

You can find the technical data of the devices in the manual www.siemens.com/siprotec

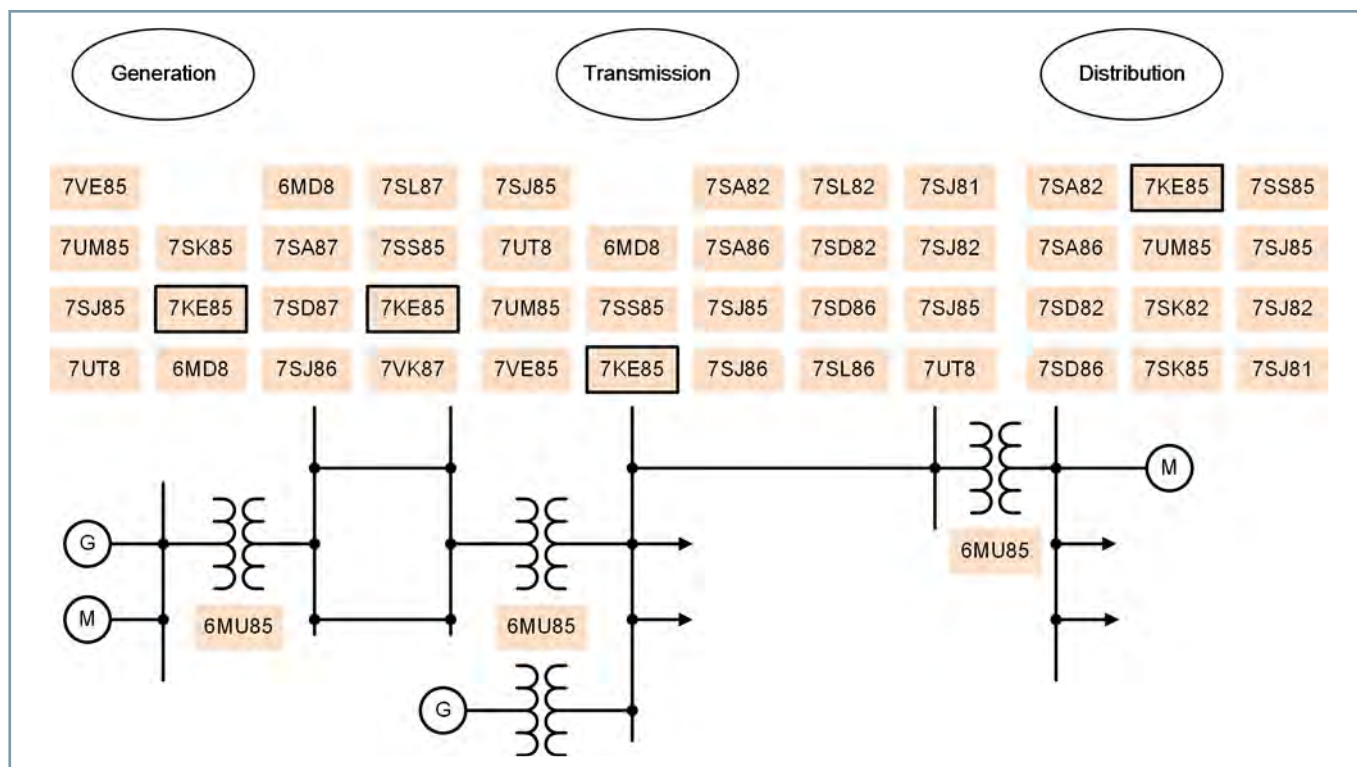

[dw_7KE85_anwendung_3_en_US]

Figure 2.17/1 Fields of Application of the SIPROTEC 5 Devices

SIPROTEC 7KE85

SIPROTEC fault recorders are a component of the SIPROTEC 5 modular system and support all SIPROTEC 5 system properties. They can be used individually as well as universally within the scope of system solutions.

The SIPROTEC 7KE85 fault recorder is designed to suit present and future requirements in a changing energy market. High-performance and reliable monitoring combined with flexible engineering and communication features provide the basis for maximum supply reliability.

Commissioning and maintenance work can be completed safely, quickly, and thus cost-effectively with high-performance test functions. Due to their modular surface mounting, SIPROTEC 5 fault recorders can always be flexibly adapted to specific requirements.

The SIPROTEC 7KE85 fault recorder has the following additional functionalities compared to the SIPROTEC 5 protection devices and bay controllers:

- Sampling configurable from 1 kHz to 16 kHz
- Mass storage of 16 GB
- All recorders can run parallel
- Individually triggered recorders
- Continuous recorders
- Separate activation of the recorders
- Freely configurable memory for each recorder
- Additional quality information supplements the records
- Power Quality recordings

- Recording of GOOSE messages in a continuous recorder
- Sequence-of-events recorder functionality
- Freely configurable channel names, LEDs, binary inputs and outputs
- Freely configurable channel-name sequence
- LCD display on the device available as an option

Distinguishing features

The SIPROTEC 7KE85 fault recorder can be configured with different basic functions.

Basic functions	
Fault recorder	Comprehensive flexible, event-triggered, and continuous recording options
PMU	Synchrophasor measurement (PMU) according to IEEE C37.118-2011
Power Quality recordings	Continuous measurement of events and failures in the electrical distribution system to IEC 61000-4-30
SOE	Message printer functionality or sequence-of-events recorder

SIPROTEC 5 Devices and Fields of Application

Fault Recorder – SIPROTEC 7KE85

Description

Powerful Fault Recorder with integrated measurement of synchrophasors (PMU) in accordance with IEEE C37.118 and power-quality measurement in accordance with IEC 61000-4-30. Due to the great flexibility of trigger functions, the SIPROTEC 7KE85 is ideally suited for monitoring the entire energy value added chain, from generation to distribution. The high-performance automation and flexible configuration with DIGSI 5 complements the range of functions.

Main function	Fault recorder
Inputs and outputs	4 predefined standard variants with up to 40 analog channels, 43 binary inputs, 33 binary outputs
Hardware flexibility	Flexibly adjustable and expandable I/O quantity structure within the scope of the SIPROTEC 5 modular system.
Housing width	1/3 to 1/1 x 19 inches

Benefits

- Clearly organized documentation and focused analysis of power-system processes and failures
- Purposeful and easy handling of devices and software thanks to a user-friendly design
- Increased reliability and quality of the engineering process
- Full compatibility between IEC 61850 Editions 1, 2.0, and 2.1
- Cyber security in accordance with NERC CIP and BDEW White-paper requirements
- Siemens supports the interface in accordance with IEC 61850-9-2 for process-bus solutions
- Highest availability even under extreme environmental conditions by standard coating of the modules

Functions

DIGSI 5 permits all functions to be configured and combined as required and as per the functional scope that has been ordered.

- Up to 40 analog channels
- Fast-scan recorder
- Up to 2 slow-scan recorders
- Up to 5 continuous recorders and 2 trend recorders
- Power Quality recordings in accordance with IEC 61000-4-30
- Sequence-of-events recorder for continuous recording of binary status changes and IEC 61850 GOOSE messages
- Usable as Phasor Measurement Unit (PMU) in accordance with IEEE C37.118 protocol
- Transmission of the records and triggering via IEC 61850 GOOSE messages
- Variable sampling frequencies parameterizable between 1 kHz and 16 kHz
- Distribution of the mass storage of 16 GB to the various recorders by the user as desired



[ph_SIPROTEC 7KE85, 1, --, -]

Figure 2.17/2 SIPROTEC 7KE85 Device with Expansion Module

- Intelligent monitoring routines of the storage medium ensure a high level of availability and completeness for the archived data
- Data compression without loss
- Time synchronization via the Precision Time Protocol (PTP) IEEE 1588, IRIG-B, DCF77, and SNTP
- Routing of the measured values to the individual recorders as desired
- Combination of the measuring groups for the power calculation as desired
- Quality attributes for representing the instantaneous signal quality in the time-signal view
- The Trigger functions of a function block are fundamental component value, RMS value, zero-sequence system power, positive-sequence system power, negative-sequence system power, frequency power, Σ active power, Σ reactive power and Σ apparent power
- Level trigger and gradient trigger for every trigger function
- Flexible cross trigger and system trigger, manual trigger
- Creation of independent trigger functions with the graphic automation editor CFC (continuous function chart)
- Trigger functions via a combination of single-point indications, double-point indications, analog values, binary signals, Boolean signals, and GOOSE messages, including for triggering on individual harmonics or the THD
- Consistent monitoring concept
- Auxiliary functions for simple tests and commissioning
- Special test mode for commissioning
- Fixed integrated electrical Ethernet RJ45 interface for DIGSI 5 and IEC 61850 (reporting and GOOSE)
- Data transmission via IEC 61850 of fault recordings in accordance with COMTRADE 2013, 1999 standard and continuous recording in accordance with IEEE Std 1159.3-2003

- Reliable data transmission via PRP and HSR redundancy protocols
- Extensive cybersecurity functionality, such as role-based access control (RBAC), logging of security-related events, signed firmware, or authenticated IEEE 802.1x network access.
- Simple, fast, and secure access to the device via a standard Web browser to display all information and diagnostic data, vector diagrams, single-line and device display pages
- Up to 4 pluggable communication modules, usable for different and redundant protocols (IEC 61850-8-1, IEC 61850-9-2 Client, IEC 60870-5-103, IEC 60870-5-104, Modbus TCP, DNP3 serial and TCP, PROFINET IO, PROFINET IO S2 redundancy)
- Virtual network partitioning (IEEE 802.1Q - VLAN)
- Intelligent terminal technology enables prewiring and an easy device replacement

Applications

The fault recorder is for use in medium-voltage systems, high-voltage systems, and systems for very high voltage and in power plants with comprehensive trigger and recording functions. With the SIPROTEC 7KE85 fault recorder, you receive a clearly organized and event-related evaluation and documentation of your power-system processes. You are thereby able to analyze failures in a targeted manner and optimize your power system.

Typical processes to be monitored and documented:

- System incidents, such as critical load cases or short circuits
- Failures of the supply quality
- Dynamic behavior of generators
- Closing and breaking operations of transformers (saturation response)
- Power fluctuations and power-swing cycles
- Test runs during commissioning

Application Templates

DIGSI 5 provides application templates for standard applications. They include basic configurations and default settings.

The following application templates are available:

Fault recorder 4 V/4 I/11 BI

- Application templates related to the monitoring of a total of 8 current/voltage transformers

Fault recorder 8 V/11 BI

- Application templates related to the monitoring of a total of 8 voltage transformers

Fault recorder 8 V/8 I/19 BI

- Application templates related to the monitoring of a total of 16 current/voltage transformers

Fault recorder 20 V/20 I/43 BI

- Application templates related to the monitoring of a total of 40 current/voltage transformers

SIPROTEC 5 Devices and Fields of Application

Fault Recorder – SIPROTEC 7KE85

Application Examples

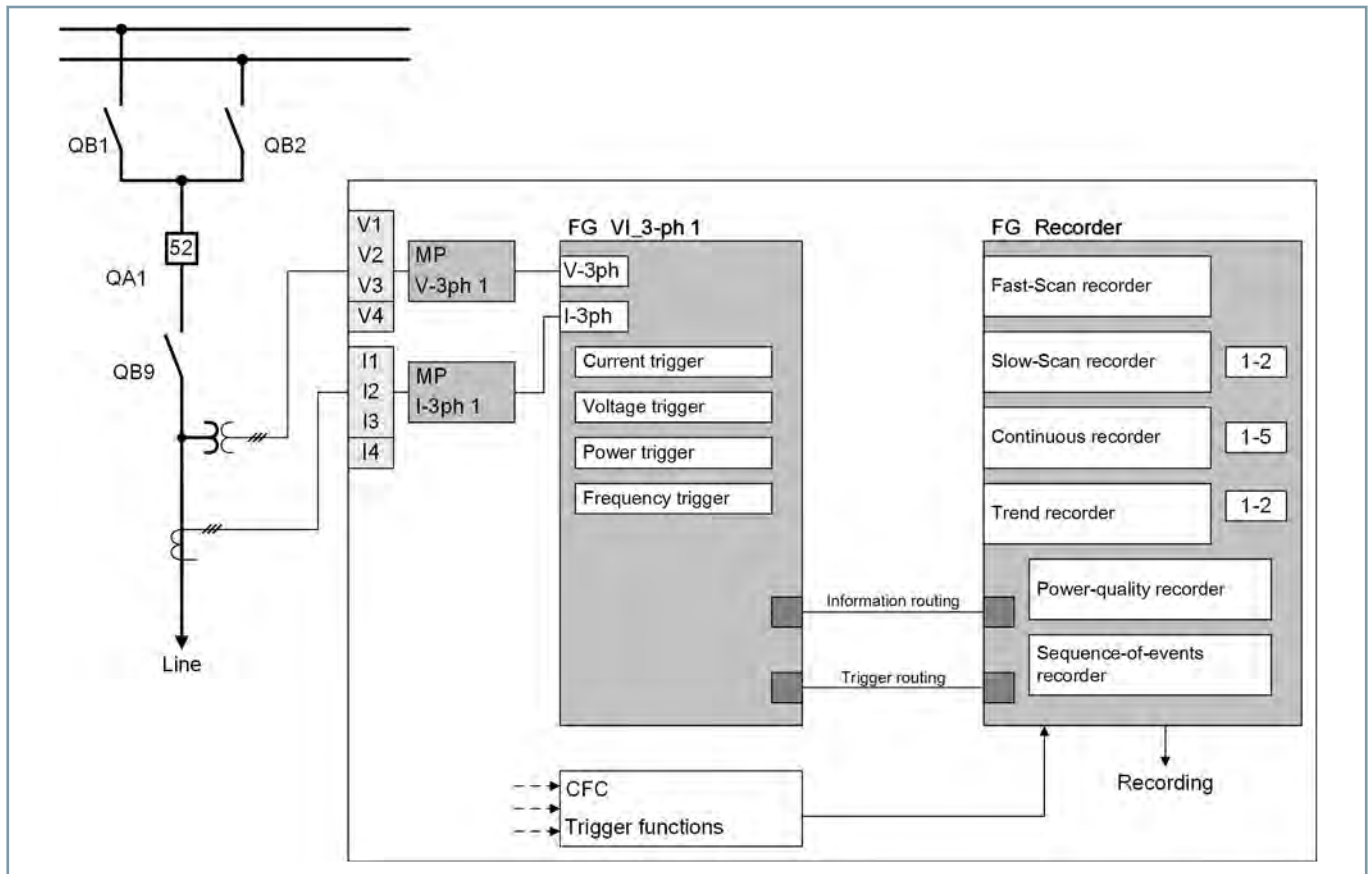

[dwanwsto-031212-01.tif, 3, en_US]

Figure 2.17/3 Fault Recorder SIPROTEC 7KE85 for Monitoring a Feeder

Fault Recorder for Monitoring Feeders

Figure 2.17/3 and Figure 2.17/4 show simple application examples with a SIPROTEC 7KE85, which is connected for monitoring feeders. In these examples, the various triggers are provided via function group **FG VI_3-phase** and are available to the function

group **FG Recorder** and, thus, to the event-triggered recorders. In parallel, individually generated trigger functions (combination of GOOSE messages, single-point/double-point indications, binary signals, etc.) can start a recorder via the CFC and thus generate a fault record.

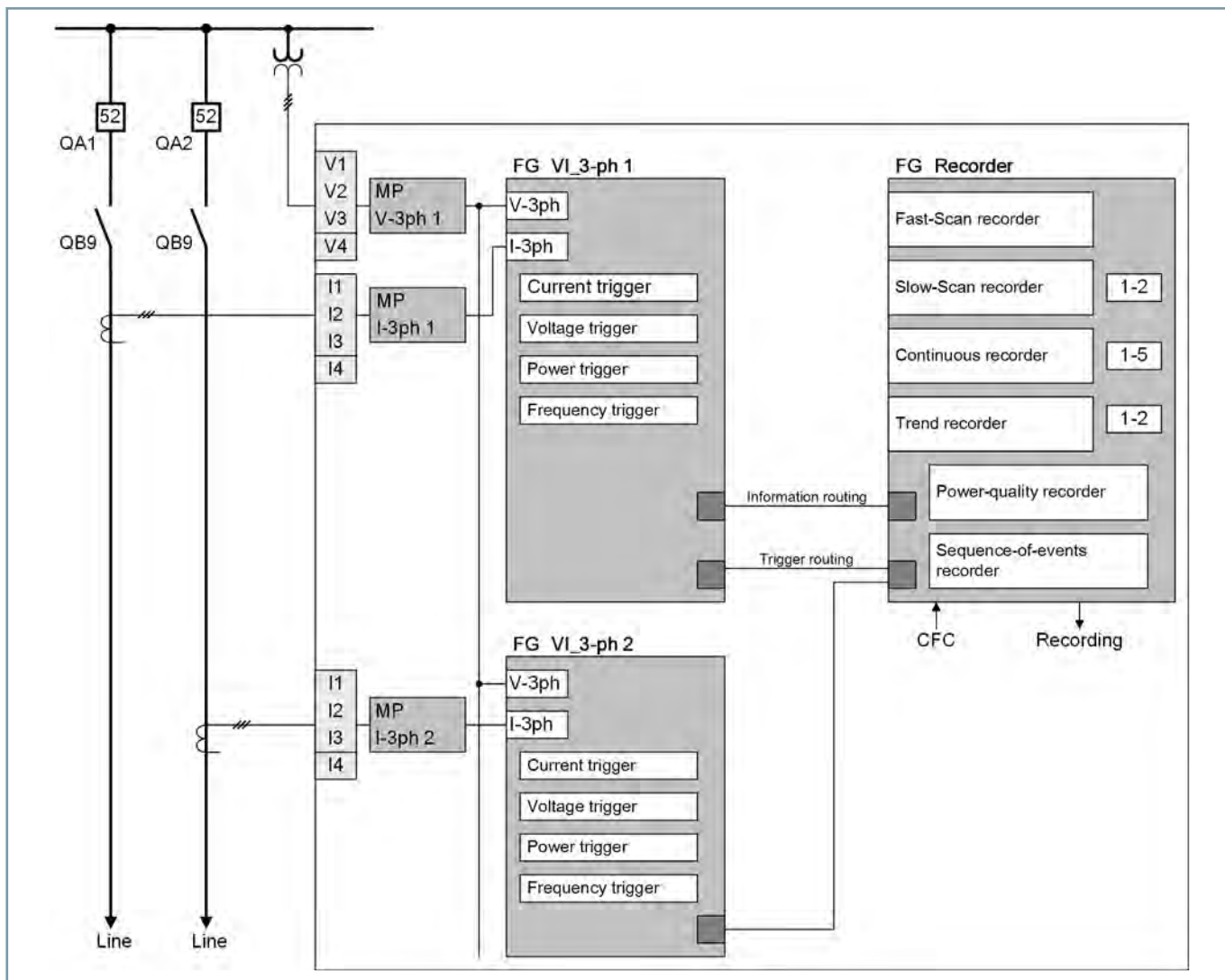

[dwrefee-031212-01.tif, 3, en_US]

Figure 2.17/4 Application Example: Fault Recorder for Several Feeders

SIPROTEC 5 Devices and Fields of Application

Fault Recorder – SIPROTEC 7KE85

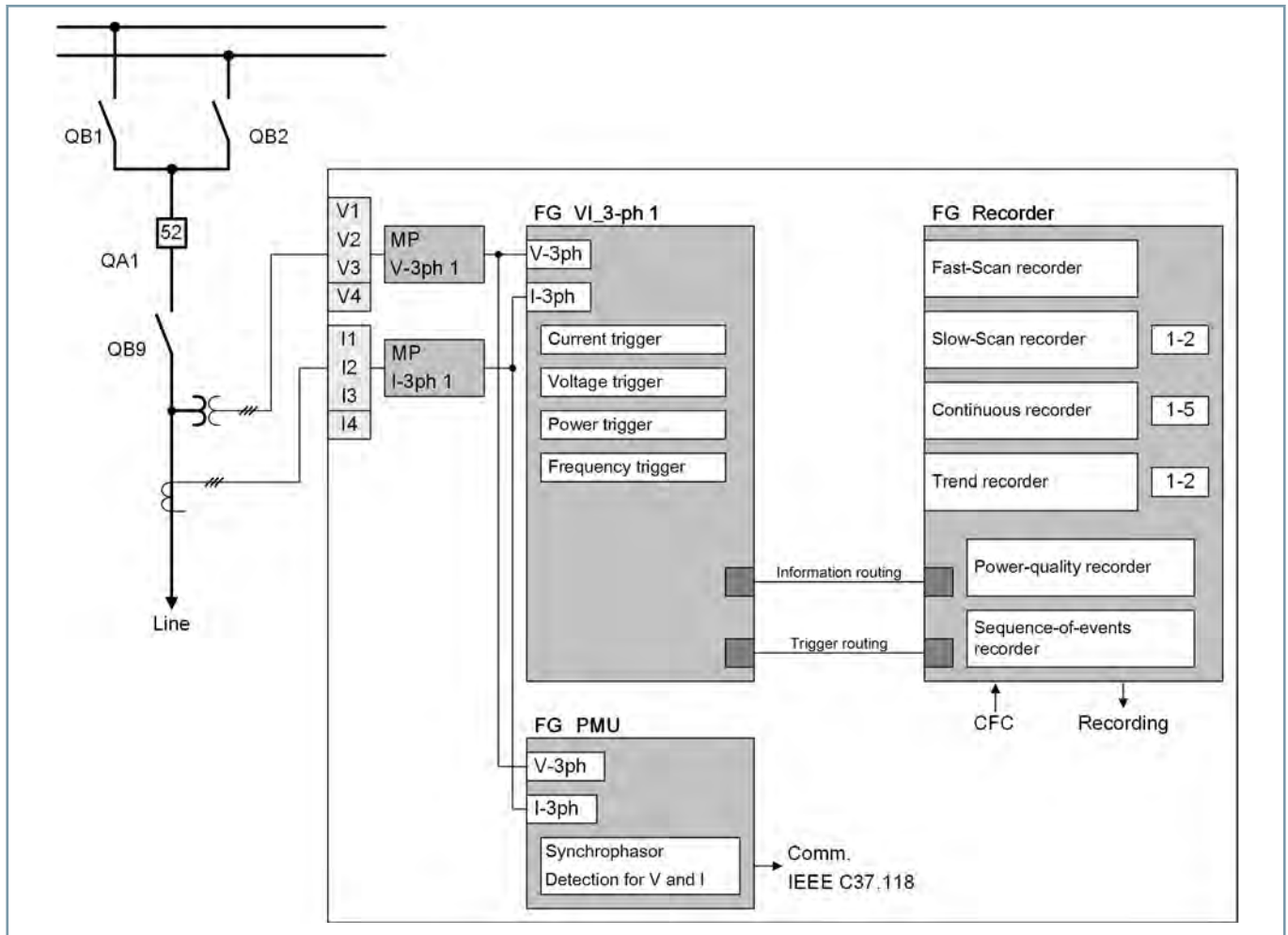

[dwrecpmu-031212-01.tif, 2, en_US]

Figure 2.17/5 Double Busbar with SIPROTEC 7KE85 Used as a Fault Recorder and Phasor Measurement Unit (PMU)

Fault Recorder with PMU

When the PMU function is used, a “FG PMU” function group is created in the device, see [Figure 2.17/5](#). This function group calculates the phasor and analog values, performs time stamping and transmits the data to the selected Ethernet interface via the protocol IEEE C37.118. There, they can be received, saved, and processed by one or more clients. Up to 3 IP addresses from clients can be assigned in the device.

Use as a Phasor Measurement Unit

At selected stations of the transmission system, a measurement of current and voltage for absolute value and phase is carried out using PMUs. Due to the high-precision time synchronization (via GPS), the measured values from different substations that are far away from each other are compared, and conclusions about the system state and dynamic events, such as power fluctuations, are drawn from the phase angles and dynamic curves.

2.17

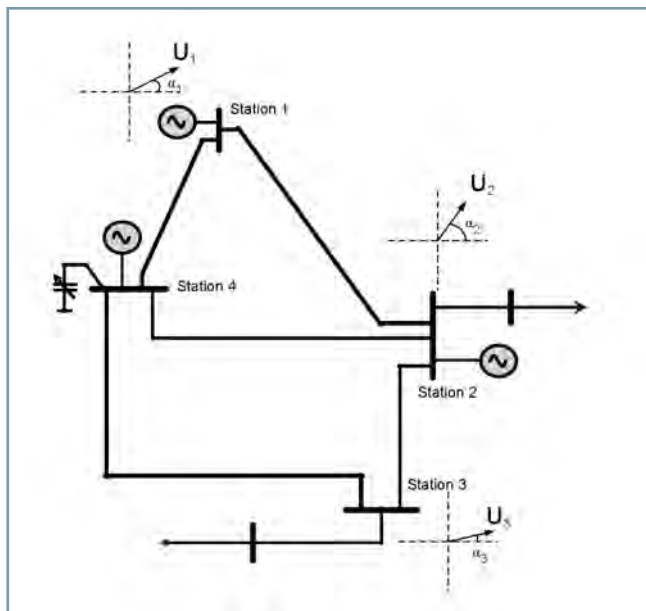

[Zeigermessung (PMU), 1, --, --]

Figure 2.17/6 Principle of the Distributed Phasor Measurement

If you select the **Phasor Measurement Unit** option, the devices determine current and voltage phasors, add high-precision time stamps, and send these together with other measured values (frequency, rate of change of frequency) to an evaluation station via the communication protocol IEEE C37.118, see [Figure 2.16/12](#). With the aid of the synchrophasor and a suitable analysis program (for example, SIGUARD PDP), it is possible to detect power swings and trip alarms automatically which are sent to the network control center, for example.

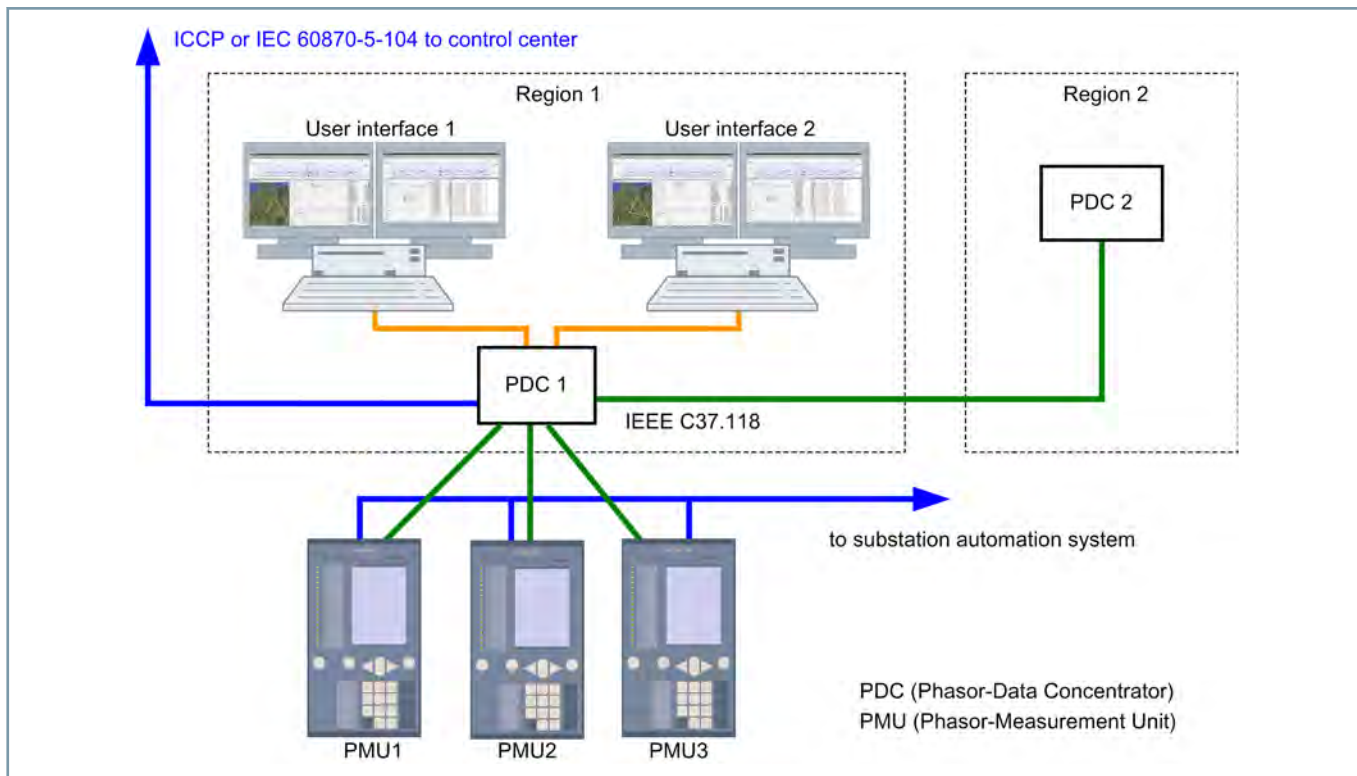

[dw_struct_WAM, 1, en_US]

Figure 2.17/7 Connecting 3 Phasor Measurement Units with 2 Phasor Data Concentrators (PDCs) SIGUARD PDP

When the PMU function is used, a **FG PMU** function group is created in the device. This function group calculates the phasor and analog values, add time stamps, and transmits the data to the selected Ethernet interface via the protocol IEEE C37.118.

There, they can be received, saved, and processed by one or more clients. Up to 3 IP addresses from clients can be assigned in the device.

SIPROTEC 5 Devices and Fields of Application

Fault Recorder – SIPROTEC 7KE85

Recorder

Fast-scan recorder

Transient processes, short circuits, or ground faults and also the behavior of protection devices can be analyzed with the fast-scan recorder. Transient processes can be tripped, for example, by switching operations. The fast-scan recorder can record the history of the sampled values of all analog inputs, internally calculated measured values, and binary signals when an error occurs for over 90 s with a pre-trigger time of 3 s. The sampling rate can be set from 20 to 320 sampled values per cycle. This corresponds to a sampling frequency of 1 kHz to 16 kHz.

Binary changes are recorded at a resolution of 1 ms. The input signals are analyzed according to the specified trigger conditions and recorded if the limiting values are violated. This recorded fault record includes the pre-trigger time, the trigger point, and the fault recording. In addition, the cause that trips the trigger is saved. The trigger limiting values and record times can easily be set with DIGSI 5.

Slow-scan recorder

The function principal is similar to that of the fast-scan recorder, but the values are calculated every 10 ms and averaged over a configurable interval. The averaging time can be configured from a rated period up to 3000 rated periods. The averaged values are stored by the slow-scan recorder as a recording in the mass storage. Binary changes are recorded, in a similar way to the fast-scan recorder, with a resolution of 1 ms.

Slow-scan recorders are therefore well-suited for detecting, for example, the load conditions before, during, and after a failure and, thus, also power-swing cycles.

The slow-scan recorder can record the history of sampled values from all analog inputs, internally calculated measured values,

and binary signals when an error occurs for over 90 minutes with a pre-trigger time of 90 s. Here, too, the input signals are analyzed according to the specified trigger conditions and recorded if the limiting values are violated. These fault records include the pre-trigger time, the trigger point, and the fault recording. In addition, the cause that trips the trigger is saved. The user sets trigger values and record times in DIGSI 5 for this purpose. Furthermore, up to 2 independent instances of the slow-scan recorder can be created.

Continuous recorder

The SIPROTEC 7KE85 has up to 5 continuous recorders. They are used for data acquisition of analog parameters and internally calculated measured values over longer time frames. This makes it possible to perform an exact long-term analysis of the system behavior.

An average value is formed over an adjustable time range and stored in memory for each recorded quantity of the continuous recorder. Each of these recorders can be activated separately. The user can set the available storage capacity in the ring archive specifically for each recorder.

Trend recorder

The SIPROTEC 7KE85 has up to 2 trend recorders that are used for long-term recording and monitoring of the process of voltage change within parameterizable tolerance ranges. The flicker measurement can be determined and stored in the trend recorder. The trend recorder can also be used as sequence-of-events recorder. The sequence-of-events or status change of binary signals, GOOSE messages, or messages (SPS) for example is stored in chronological sequence in the recorder. The user can set the available storage capacity in the ring archive specifically for each recorder.

2.17

	Common Data Class (IEC 61850)	Pre-Trigger Time (Max.)	Seal-in Time (Max.)	Sampling/Resolution	Posting Time
Fast-scan recorder	SMV/MV	3 s	90 s	1 kHz to 16 kHz	–
	SPS	3 s	90 s	1 ms	–
Slow-scan recorder	MV	90 s	5400 s	MVs every 10 ms	1 period to 3000 periods
	SPS	90 s	5400 s	1 ms	–
Continuous recorder	MV	–	–	MVs every 10 ms	1 s to 900 s
Trend recorder	SPS	–	–	–	–
	MV	–	–	–	–

SMV = Sample Measured Values
SPS = Single Point Status
MV = Measured Values

Table 2.17/1 Overview of the Recorders

Trigger Functions

The event-triggered recorders (fast-scan and slow-scan) have a large number of analog and binary triggers that enable the user to record the particular system problem exactly and avoid unnecessary recordings. The input signals are thus queried corresponding to the trigger conditions and start the fault

recording. In the SIPROTEC 7KE85, all triggers can also be assigned multiple times to the various recorders.

Analog trigger

The analog triggers are essentially subdivided into level triggers and gradient triggers. Level triggers monitor measurands for conformity to the configured limiting values (min/max). As soon

as the measurand exceeds or falls below the respective limiting value, the trigger is tripped. Gradient triggers respond to the level change over time.

Each analog trigger can be configured as primary, secondary, or percentage value. A distinction is made here between frequency, voltage, current, and power triggers. With current and voltage as trigger variables, it is possible to select between fundamental, RMS, or symmetric components.

Binary trigger

A binary trigger starts a recording via the logical status change of a binary signal. Along with the manual trigger, which can be

tripped via the device keypad, DIGSI 5, or any IEC 61850 client (for example, SICAM PAS/PQS), the triggering can occur via binary input (external trigger) or IEC 61850 GOOSE messages via the communication network. The logic triggers are implemented via the powerful graphical logic editor (CFC). In this case, the free combination of all available analog values (absolute values or phases), binary signals, Boolean signals, GOOSE messages, single-point and double-point indications is possible via Boolean or arithmetic operations.

As a user, you can thus set the trigger conditions appropriate for your problem and start the recording.

SIPROTEC 5 Devices and Fields of Application

Fault Recorder – SIPROTEC 7KE85

ANSI	Function	Abbr.	Available	Application Templates			
				1	2	3	4
	Expandable hardware quantity structure	I/O	■	■	■	■	■
	Process bus client protocol (hint: PB client requires a separate ETH-BD-2FO plug-in module, from V8.0)	PB client	■				
	IEC61850-9-2 Merging Unit Stream (hint: Each stream requires a separate ETH-BD-2FO plug-in module, from V8.0)	MU	■				
	IEC61850-9-2 Merging Unit Stream 7SS85 CU (hint: Only for communication with a 7SS85 CU. A separate ETH-BD-2FO plug-in module is required starting with V8.40)	MU	■				
50EF	End-fault protection (hint: For use only in decentralized busbar protection with a 7SS85 CU starting with V8.40)		■				
PMU	Synchrophasor measurement	PMU	■				
	Measured values, standard		■	■	■	■	■
	Measured values, extended: Min, max, average		■	■	■	■	■
	CFC (standard, control)		■	■	■	■	■
	CFC arithmetic		■				
	Circuit-breaker wear monitoring	$\Sigma I_x, I^2t, 2P$	■				
	Circuit breaker		■				
	Fault recording of analog and binary signals		■	■	■	■	■
	Monitoring		■	■	■	■	■
FSR	Fast-scan recorder	FSR	■	■	■	■	■
SSR	Slow-scan recorder	SSR	■	■	■	■	■
Change request	Continuous recorder	Change request	■	■	■	■	■
TR	Trend recorder	TR	■				
PQR	Power Quality recordings (functions)	PQR	■				
	Split bar for harmonic and interharmonic components (starting with V8.01)		■				
	Sequence-of-events recorder	SOE	■	■	■	■	■
ExTrFct	Expanded trigger functions	ExTrFkt	■	■	■	■	■
	Frequency group tracking (from V7.8)		■				
	Cyber security: Role-Based Access Control (from V7.8)		■				
	Temperature recording via communication protocol		■				
	Cyber security: Authenticated network access using IEEE 802.1X (starting from V8.3)		■				
	Function point class:			0	0	0	0

2.17

The configuration and function point class for your application can be determined in the SIPROTEC 5 order configurator at www.siemens.com/siprotec.





Table 2.17/2 SIPROTEC 7KE85 – Functions, Application Templates

- (1) Fault recorder 4 V / 4 I / 11 BI
- (2) Fault recorder 8 V / 11 BI
- (3) Fault recorder 8 V / 8 I / 19 BI
- (4) Fault recorder 20 V / 20 I / 43 BI

Hints on **ANSI PQR**: 150 function points per measuring point /
One measuring point = 4 V and 4 I

SIPROTEC 5 Devices and Fields of Application

Fault Recorder – SIPROTEC 7KE85

Standard Variants for SIPROTEC 7KE85		
N1	1/3 x 19", 4 V, 4 I, 11 BI, 9 BO	
	Housing width 1/3 x 19" 4 voltage-transformer inputs 4 current-transformer inputs 11 binary inputs 9 binary outputs (1 life contact, 2 standard, 6 fast) Contains the following modules: base module with PS201 and IO202	
N2	1/3 x 19", 8 V, 11 BI, 3 BO	
	Housing width 1/3 x 19", 8 voltage-transformer inputs, 11 binary inputs, 3 binary outputs (1 life contact, 2 standard) Contains the following modules: base module with PS201 and IO211	
N5	1/2 x 19", 8 V, 8 I, 19 BI, 15 BO	
	Housing width 1/2 x 19" 8 voltage-transformer inputs 8 current-transformer inputs 19 binary inputs 15 binary outputs (1 life contact, 2 standard, 12 fast) Contains the following modules: base module with PS201 and IO202 Expansion modules IO202	
N6	1 x 19", 20 V, 20 I, 43 BI, 33 BO	
	Housing width 1/1 x 19" 20 voltage-transformer inputs 20 current-transformer inputs 43 binary inputs 33 binary outputs (1 life contact, 2 standard, 30 fast) Contains the following modules: base module with PS201 and IO202 Expansion modules IO202	

You can find the technical data of the device in the manual:

www.siemens.com/siprotec

SIPROTEC 5 Devices and Fields of Application

Merging Unit – SIPROTEC 6MU85

Description

The new merging unit SIPROTEC 6MU85 has been universally designed based on the flexible SIPROTEC 5 system for conventional and non-conventional instrument transformers (LPIT) and enables all primary data to be digitized close to the process. SIPROTEC 5 process-bus solutions enable a wide range of implementation options and migration concepts for new and existing systems.

Main function	Merging Unit, Circuit-breaker and disconnecter-switch functions, Backup protection functions, Additional functions
Communication	Up to 4 sampled measured value streams according to IEC 61850-9-2LE or IEC 61850-9-2/IEC 61869 flexible streams
Hardware flexibility	Flexibly adjustable and expandable I/O quantity structure within the scope of the modular SIPROTEC 5 system; 1/6 expansion modules can be added
Housing width	1/3 × 19 inches to 2/1 × 19 inches
Standard	Coated modules

Benefits

- Can be adjusted to a wide range of current transformer, voltage transformer, and low-power instrument transformer (LPIT) sensors ⁴
- The number of binary inputs and outputs can be scaled.
- It can be expanded by a second row.
- Direct **High-speed** circuit-breaker tripping < 1 ms
- Additional data acquisition (temperature, pressure, tap-changer setting, ...)
- Cybersecurity in accordance with NERC CIP and BDEW White-paper requirements
- Highest availability even under extreme environmental conditions by standard coating of the modules

Functions

Merging Unit

- 1 or 2 sampled measured value streams per ETH-BD-2FO Ethernet module
 - Up to 32 analog values in every combination of current and voltage measured values or
 - 4 x current, 4 x voltage (IEC 61850-9-2LE)
- Up to 4 ETH-BD-2FO modules possible
- Reliable and redundant data transmission via PRP
- Compliant with IEC 61869-9, IEC 61869-13
- IEC 61850-8-1 GOOSE, MMS, and Merging Unit protocol on the same Ethernet module
- Measured value and date/time synchronization via IEEE 1588v2/PTP



[SIP5_OD_o.LED_W3, 2, --, --]

Figure 2.18/1 Merging Unit SIPROTEC 6MU85

- Redundant power supply
- Expanded temperature ranges (-40 °C to 70 °C)

Circuit-breaker and disconnecter-switch functions

- Control system with switchgear interlocking
- Circuit-breaker failure protection (50BF)
- Circuit-breaker wear monitoring
- Switching statistics
- Point-on-wave switching (PoW)
- Trip-circuit supervision (74TC)
- Automatic reclosing (79)
- Synchrocheck (25)

Backup protection functions

- Non-directional overcurrent protection (50/51, 50N/51N)
- Directional overcurrent protection (67/67N)
- Overvoltage and undervoltage protection (27/59)

Additional protection functions

- Phasor Measurement Unit (PMU) for synchrophasor measured values and IEEE C37.118 protocol
- Arc protection
- Utility functions for simple commissioning and tests
- Temperature acquisition using a TR1200 RTD unit (7XV5662-6AD10 or 7XV5662-8AD10)
- 4-mA to 20-mA measuring input for a wide range of analog process values, for example, pressure, tap-changer setting
- PQ – Basic: Voltage unbalance; voltage changes: overvoltage, dip, interruptions; TDD, THD, and harmonics

⁴ In preparation

Communication

- Pluggable communication modules, usable for different and redundant protocols (IEC 61850-8-1, IEC 61850-9-2 Merging Unit, IEC 60870-5-103, IEC 60870-5-104, Modbus TCP, DNP3 serial and TCP, PROFINET IO, PROFINET IO S2 redundancy)
- Serial protection communication via optical fibers, two-wire connections, and communication networks (IEEE C37.94 and others), including automatic switchover between ring and chain topology.
- Extensive cybersecurity functionality, such as role-based access control (RBAC), logging of security-related events, signed firmware, or authenticated IEEE 802.1X network access
- Simple, fast, and secure access to the device via a standard Web browser to display all information and diagnostic data, vector diagrams, single-line and device display pages
- Virtual network partitioning (IEEE 802.1Q - VLAN)

Applications

Merging Unit for

- Analog measured values and digital inputs and outputs
- Centralized merging unit for transformer process-data acquisition
- Centralized protection
- Bay units for decentralized busbar protection
- Process-bus fault recorder
- Centralized synchrocheck
- Detection and recording of power-quality data in the medium-voltage and subordinate low-voltage power system

SIPROTEC 5 Devices and Fields of Application

Merging Unit – SIPROTEC 6MU85

Application Templates

Application templates are available in **DIGSI 5** for applications of device 6MU85. The application templates contain the basic configurations, required functions, and default settings.

The following application templates are available for the merging unit 6MU85 in the **DIGSI 5** function library:

- Basic application template 6MU85 Merging Unit
- Application template 6MU85 Merging Unit – 4I

- Application template 6MU85 Merging Unit – 4I, 4U
- Appl. template 6MU85 Merging Unit – 4I, 4U, overcurrent protection
- Application template 6MU85 Merging Unit – 8I

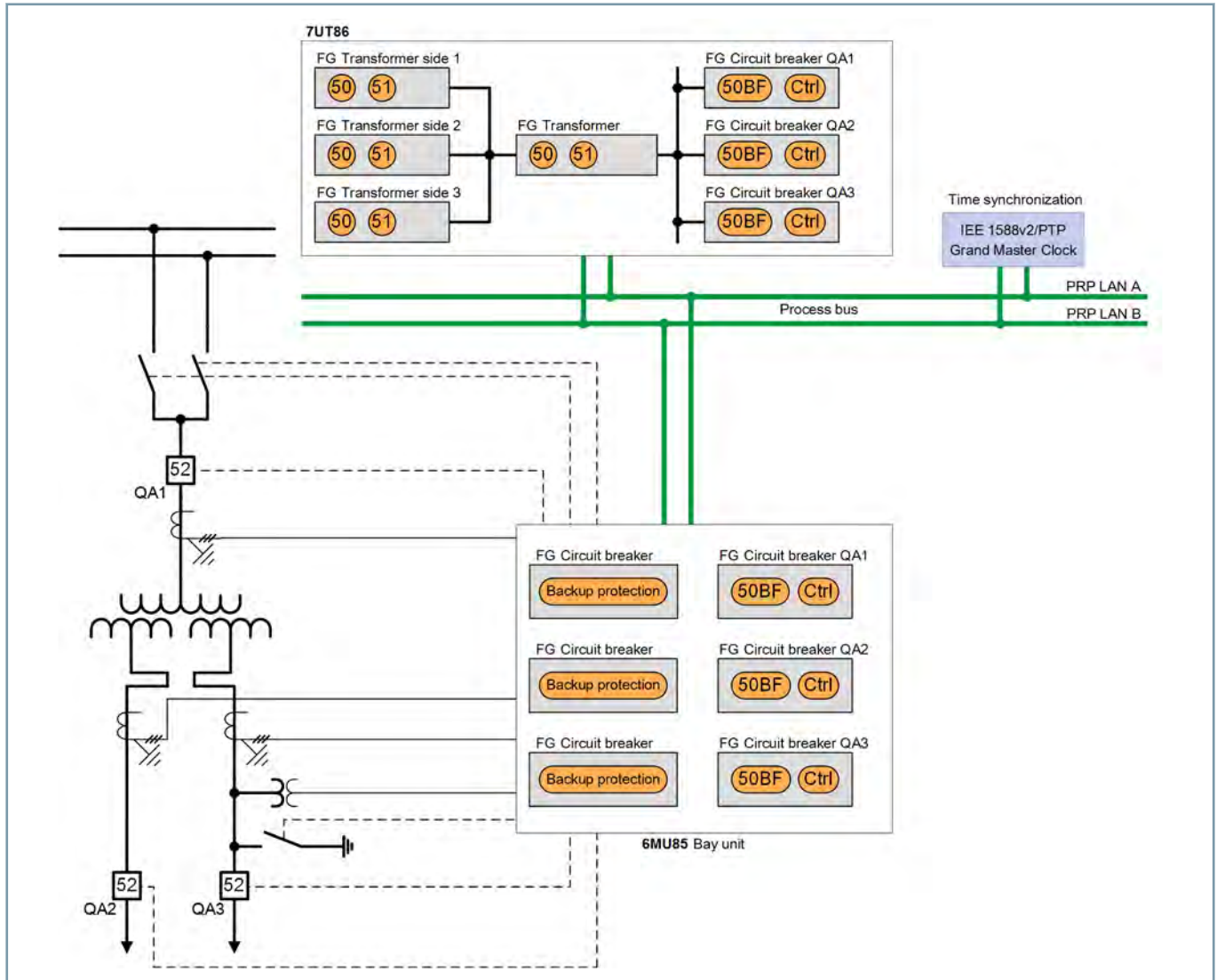

[dw_cent-trans-prot_with_one_merging_6MU85, 1, en_US]

Figure 2.18/2 Centralized Transformer Protection with a 6MU85 Merging Unit

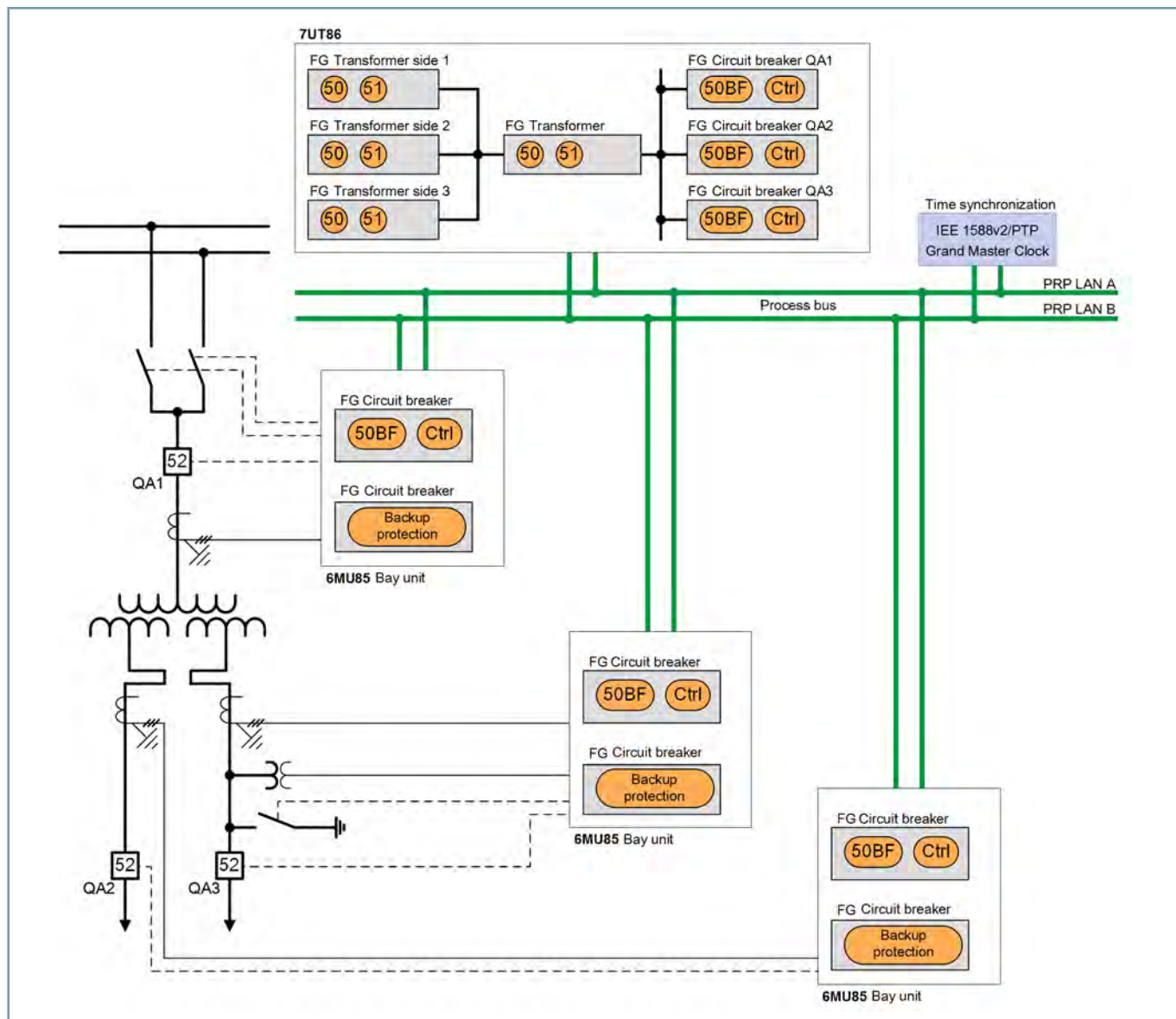

[dw_cent-trans-prot_with_3-merging_6MU85, 1, en_US]

Figure 2.18/3 Centralized Transformer Protection with 3 6MU85 Merging Units

SIPROTEC 5 Devices and Fields of Application

Merging Unit – SIPROTEC 6MU85

ANSI	Function	Abbr.	Available	Application Templates	
				1	
	Protection functions for 3-pole tripping	3-pole	■		■
	Expandable hardware quantity structure	I/O	■		■
	Process bus client protocol (hint: PB client requires a separate ETH-BD-2FO plug-in module, from V8.0)	PB client	■		
	IEC61850-9-2 Merging Unit Stream (hint: Each stream requires a separate ETH-BD-2FO plug-in module, from V8.0)	MU	■		■
	IEC61850-9-2 Merging Unit Stream 7SS85 CU (hint: Only for communication with a 7SS85 CU. A separate ETH-BD-2FO plug-in module is required starting with V8.40)	MU	■		
25	Synchrocheck, synchronization function	Sync	■		
27	Undervoltage protection: "3-phase" or "positive-sequence system V1" or "universal Vx"	V<	■		
27R, 59R	Voltage change protection (starting with V8.30)	dV/dt	■		
38	Temperature supervision	θ>	■		
47	Overvoltage protection: "Negative-sequence system V2" or "negative-sequence system V1/positive-sequence system V1"	V2>; V2/V1>	■		
50/51 TD	Overcurrent protection, phases	I>	■		
	Instantaneous tripping at switch onto fault	SOTF	■		
50N/ 51N TD	Overcurrent protection, ground	IN>	■		
50BF	Circuit-breaker failure protection, 3-pole	CBFP	■		
50BF	Circuit-breaker failure protection 1-pole/3-pole	CBFP	■		
50EF	End-fault protection (hint: For use only in decentralized busbar protection with a 7SS85 CU starting with V8.40)		■		
50RS	Circuit breaker restrike monitoring	CBRM	■		
59, 59N	Overvoltage protection: "3-phase" or "zero-sequence system V0" or "positive-sequence system V1" or "universal Vx"	V>	■		
67	Directional overcurrent protection, phases	I>, ∠(V, I)	■		
67N	Directional overcurrent protection, ground	IN>, ∠(V, I)	■		
74TC	Trip-circuit supervision		■		
74CC	Single circuit monitoring (from V7.9)		■		
79	Automatic reclosing, 1-pole/3-pole	AREC	■		
79	Automatic reclosing, 3-pole	AREC	■		
86	Lockout		■		■
90 V	Voltage controller for two-winding transformer		■		
90 V	Voltage controller for two-winding transformer with parallel control		■		
	Number of two-winding transformers with parallel control (hint: only together with the function "voltage controller for two-winding transformer with parallel control")		■		
90 V	Voltage controller for three-winding transformer		■		
90 V	Voltage controller for grid coupling transformer		■		
PMU	Synchrophasor measurement	PMU	■		
AFD	Arc protection (only with plug-in module ARC-CD-3FO)		■		
	Measured values, standard		■		■
	Measured values, extended: Min, max, average		■		
	Switching statistics counter		■		

SIPROTEC 5 Devices and Fields of Application

Merging Unit – SIPROTEC 6MU85



ANSI	Function	Abbr.	Available	Application Templates
				1
	PQ – Basic measured values: THD (Total Harmonic Distortion) and harmonic component (starting with V8.01) and THD voltage average values (starting with V8.40)		■	
	PQ – Basic measured values: Voltage unbalance (starting with V8.40)		■	
	PQ – Basic measured values: Voltage changes – monitoring of voltage dips, overvoltages and voltage interruptions (starting with V8.40)		■	
	PQ – Basic measured values: TDD - Total Demand Distortion (starting with V8.40)		■	
	CFC (standard, control)		■	■
	CFC arithmetic		■	
	Circuit-breaker wear monitoring	$\Sigma I_x, I^2t, 2P$	■	
	Switching sequence function		■	
	Inrush-current detection		■	
	External trip initiation		■	
	Control		■	■
PoW	Point-on-wave switching (starting with V7.90)	PoW	■	
	Circuit breaker		■	■
	Disconnectors/grounding conductor		■	
	Fault recording of analog and binary signals		■	■
	Monitoring		■	■
	Protection interface, serial		■	
	Frequency group tracking (from V7.8)		■	
	Cyber security: Role-Based Access Control (from V7.8)		■	
	Temperature recording via communication protocol		■	
	Cyber security: Authenticated network access using IEEE 802.1X (starting from V8.3)		■	
Function point class:				0
The configuration and function point class for your application can be determined in the SIPROTEC 5 order configurator at www.siemens.com/siprotec .				

Table 2.18/1 SIPROTEC 6MU85 – Functions, Application Templates

(1) Merging Unit

SIPROTEC 5 Devices and Fields of Application

Merging Unit – SIPROTEC 6MU85

Standard Variants for SIPROTEC 6MU85		
AJ1	1/3 x 19", 4 I, 11 BI, 9 BO	
	Housing width 1/3 x 19" no display 4 current-transformer inputs 11 binary inputs 9 binary outputs (1 life contact, 2 standard, 6 fast) Contains the modules: base module with PS201 and IO201 Communication module ETH-BD-2FO	
AJ2	1/3 x 19", 4 V, 4 I, 11 BI, 9 BO	
	Housing width 1/3 x 19" no display 4 voltage-transformer inputs 4 current-transformer inputs 11 binary inputs 9 binary outputs (1 life contact, 2 standard, 6 fast) Contains the modules: base module with PS201 and IO202 Communication module ETH-BD-2FO	
AJ3	1/3 x 19", 8 I, 7 BI, 7 BO	
	Housing width 1/3 x 19" no display 8 current-transformer inputs 7 binary inputs 7 binary outputs (1 life contact, 2 standard, 4 fast) Contains the modules: base module with PS201 and IO203 Communication module ETH-BD-2FO	



SIPROTEC 5 System

Functional Integration

Due to the modular design of the hardware and software, as well as the functional integration, SIPROTEC 5 devices are suited for all tasks in the energy sector.

The SIPROTEC 5 devices include:

- Protection
- Control and automation
- Supervision and monitoring
- Data acquisition and logging
- Communication and cyber security
- Test and diagnostics

Due to the modular design of the hardware and software and the high-performance engineering tool DIGSI 5, SIPROTEC 5 is ideally suitable for protection, automation, measurement, and monitoring tasks for the operation and monitoring of modern power systems.

The devices are not only protection and electronic control units; their performance enables them to assure functional integration of desired depth. For example, they can also perform monitoring, synchrophasor measurement (phasor measurement), powerful fault recording, a wide range of measuring functions, and much more, in parallel, and they have been designed to facilitate future extensions.

SIPROTEC 5 provides extensive, precise data acquisition and data logging on bay level for these functions. In connection with its communication flexibility, this expands the field of application and opens up a wide variety of possibilities in meeting requirements for present and future power systems. With SIPROTEC 5, you are on the safe side for your application. The following figure shows the possible functional expansion of a SIPROTEC 5 device.

Faster results with application templates

A common function library provides all protection, automation, monitoring, and auxiliary functions for the SIPROTEC 5 line protection devices. The same functions are the same for all devices. Once established, configurations can be transmitted from device to device. This results in substantially reduced engineering effort.

DIGSI 5 provides predefined application templates for every device type. These contain basic configurations, required functions, and default settings. In addition, you can save a device as a master template in a user-defined library and reuse it as a template for your typical applications. This saves time and money. Saving user-defined application templates is possible.

Figure 3.1/2 shows an example of a transformer in a system configuration in which the functions in the application template are combined into function groups (FGs). The function groups correspond to the primary components (protected object, transformer side 1, transformer side 2, neutral point, transformer; circuit breaker switching devices) thereby simplifying the direct reference to the actual system. For example, if your switchgear includes 2 circuit breakers, this is also represented by 2 "Circuit breaker" function groups.

3.1

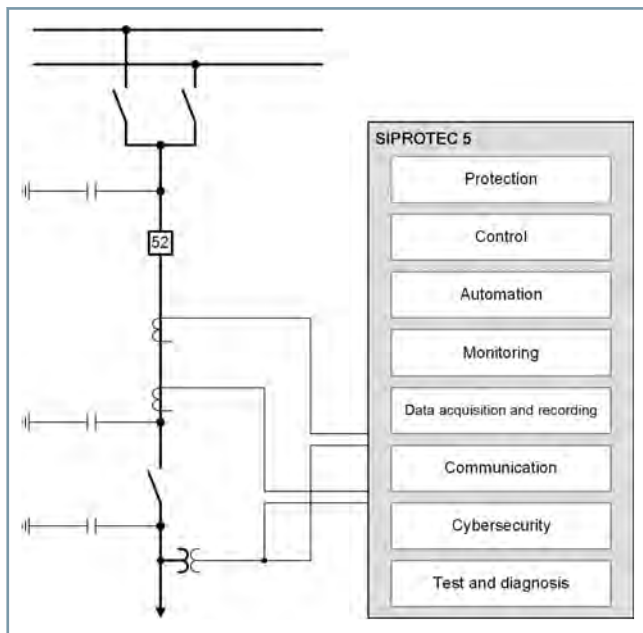

[dw_funktionale-Integration, 4, en_US]

Figure 3.1/1 Possible Functional Expansion of SIPROTEC 5 Devices

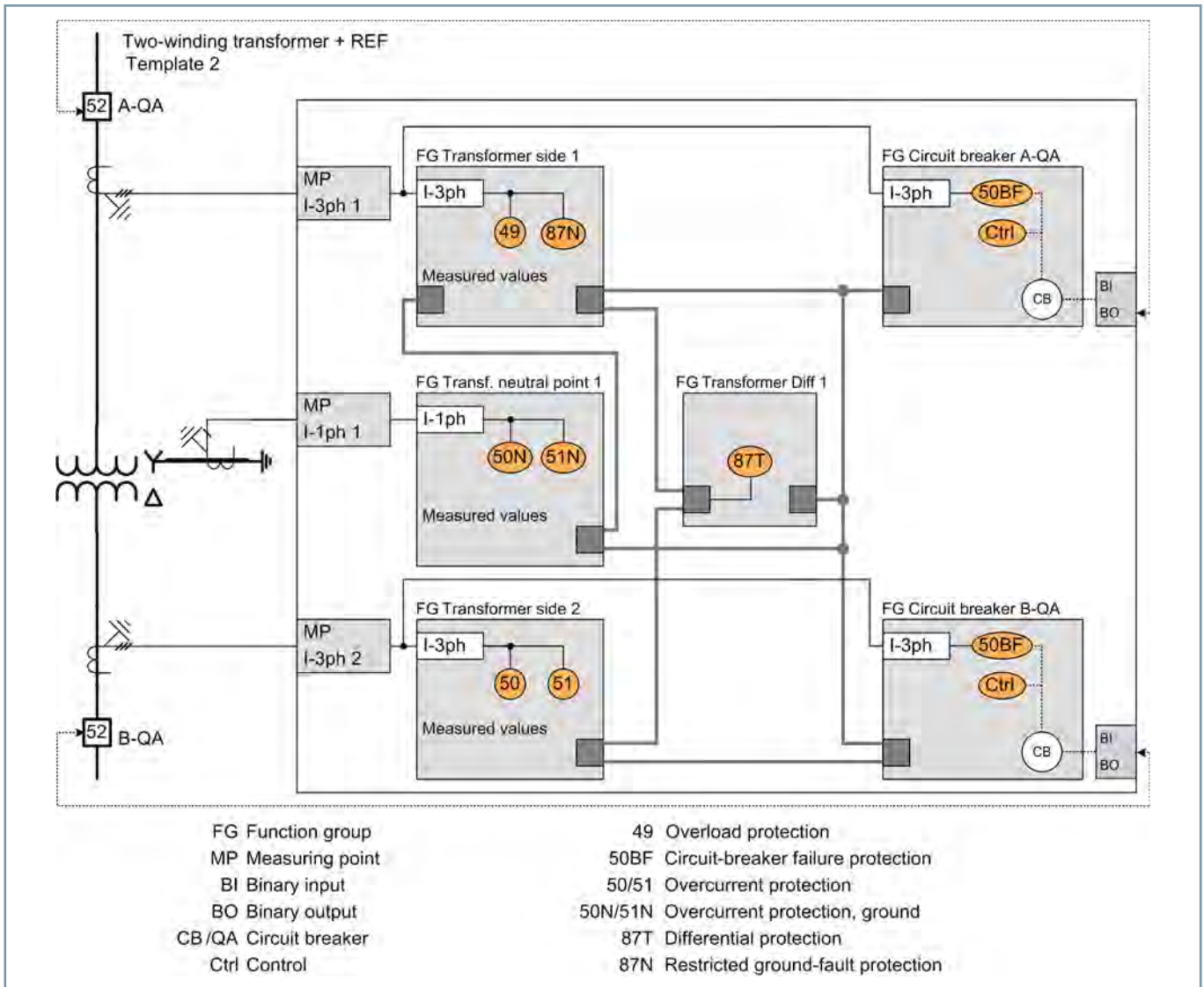

[dw_two-winding-temp_02, 3, en_US]

Figure 3.1/2 Transformer Protection

Instrument and Protection-Class Current Transformers

The flexibility of the SIPROTEC 5 family enables even greater functional integration and parallel processing of a wide range of functions. The modular hardware enables an application-specific device configuration. If you also want to use the Synchrophasor measurement function, that is, the high-precision acquisition of current and voltage phasors and the variables derived from them such as power and frequency, this function can be assigned to the measuring input. Another possible application is monitoring power quality characteristic key values.

Figure 3.1/3 shows the connection to an instrument transformer and protection-class current transformer for a feeder. The necessary protection functions are assigned to the protection-class current transformer and the measuring functions are assigned to the instrument transformer according to the application.

The high-precision measured values and status information provided by the SIPROTEC 5 devices can be transmitted to automation systems such as a SICAM substation automation tech-

nology and power systems control or central analysis systems (for example, SIGUARD PDP) via the high-performance communication system. In particular, the control and monitoring of intelligent power systems require information from power generators (conventional or renewable energy) and from consumers (line feeders). The required information may be measured values, switching states, or messages from protection and monitoring functions. In addition to performing local protection, control, and monitoring tasks, the SIPROTEC 5 devices are an excellent data source. The flexible communication among the devices enables them to be combined in various communication topologies. In this context, the widely used Ethernet-based communications standard IEC 61850 offers many advantages.

SIPROTEC 5 System

Functional Integration

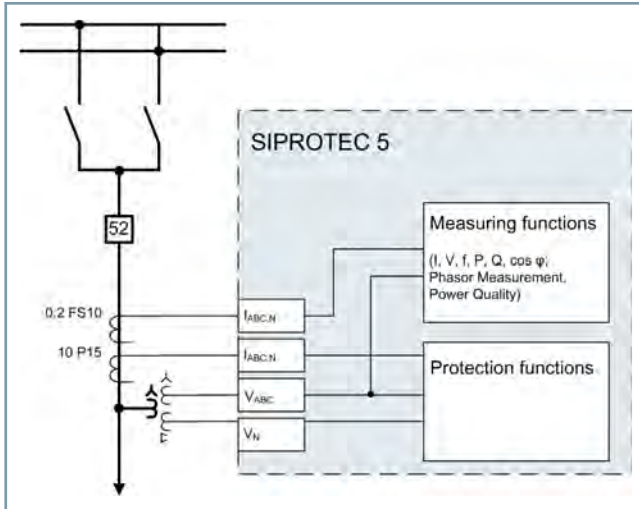

[dw_Anschl_Feldgeraete, 1, en_US]

Figure 3.1/3 Connection of Bay Units to Instrument Transformers and Protection-Class Current Transformers

The modular, flexible structure of the hardware and software ensures perfectly customized solutions for all your requirements in the power system.

With SIPROTEC 5, you have flexibility throughout the entire product lifecycle and your investment is thus protected.

Protection

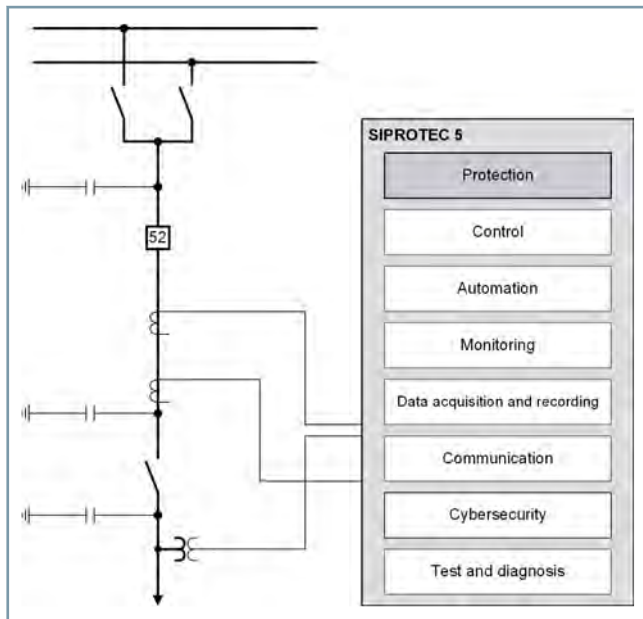

[dw_schutz, 4, en_US]

Figure 3.2/1 SIPROTEC 5 – Functional Integration – Protection

SIPROTEC 5 provides all the necessary protection functions to address reliability and security of power systems and their components. System configurations in multiple busbars and breaker-and-a-half layouts are both supported. The functions are based on decades of experience in using systems, including suggestions from the Siemens customers.

The modular, functional structure of SIPROTEC 5 allows exceptional flexibility and a perfect adaptation of the protection functionality to the conditions of the system and is still capable of further changes in the future.

The available device functions are described in the following sections.

The Distance Protection Function (ANSI 21, 21N) – Classical Method

SIPROTEC 5 provides a 6-system distance protection featuring algorithms that have been proven in previously supplied SIPROTEC protection devices. This method of measurement is referred to as the "classical method".

By parallel calculation and monitoring of all 6 impedance loops, a high degree of responsivity and selectivity is achieved for all types of faults. All methods of neutral-point treatment (arc-suppression-coil-ground system, isolated, solidly or low-impedance grounded) are reliably handled. Depending on the respective device type, 1-pole and 3-pole tripping are possible. The distance protection is suitable for cables and overhead lines with or without series compensation.

The device offers quadrilateral characteristics as well as MHO zone characteristics. The characteristics can be used separately for phase and ground faults.

Thus, high-impedance ground faults can, for instance, be covered with the polygonal zone characteristics and phase faults with the MHO characteristic. The evaluation of quadrature voltages and the use of a voltage memory make optimal direction determination possible.

Polygonal zone characteristics

The polygonal zone characteristic permits separate setting of the reactance X and the resistance R . The resistance portion R can be set separately for errors with or without ground involvement. This characteristic is therefore best suited for detecting high-impedance errors. Applications with a reactance radius per zone depending on the ground fault can be covered as well by simply using additional distance zones. Each distance zone can be set separately to operate for ground faults only, for phase faults only, or for all fault types.

The distance zones can be set forward, backward, or non-directional (*Figure 3.2/2*).

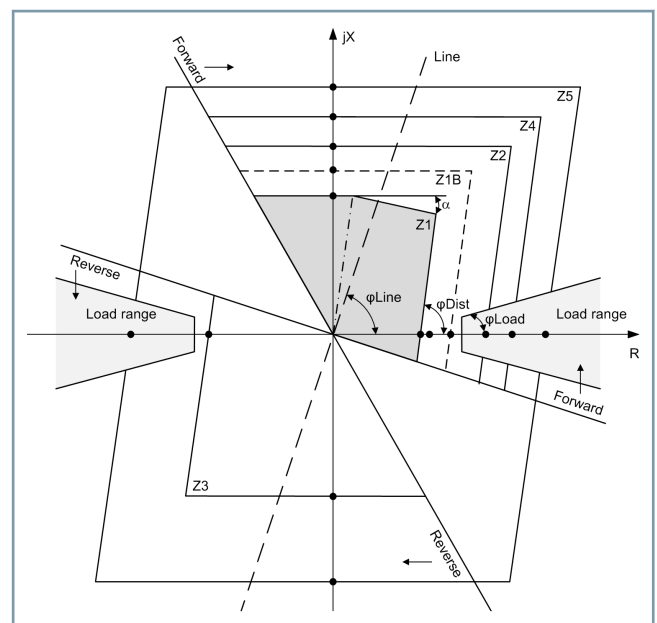

[Dw_polygonale-zone, 1, en_US]

Figure 3.2/2 Polygonal Zone Characteristics with the Example of 4 Zones

MHO zone characteristics

With the MHO zone characteristics, the MHO circle expansion guarantees safe and selective protection behavior for all types of faults. The circle expands to the source impedance but never more than the selected impedance radius. *Figure 3.2/3* shows the characteristics for a forward fault.

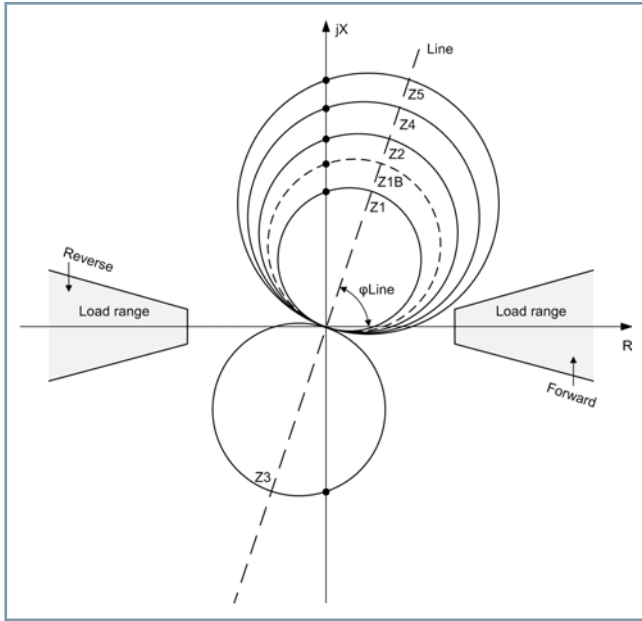

[Dw_MHO-zone, 1, en_US]

Figure 3.2/3 MHO Zone Characteristics, for Example, with 6 Zones

Selectable number of distance zones

The number of distance zones can be adapted freely according to the application requirements. For functions that use a dependent zone, for example the permissive overreach transfer trip scheme, all parameterized zones from the distance protection are available (the usage of the zone in the distance protection itself is not affected by this). Each distance zone has its own timer, separately dedicated to 1-phase and multi-phase errors. Thus, the new flexibility of the SIPROTEC 5 device family allows optimal adaptation to each application. The distance protection will always provide the exact number of required distance zones.

Load zone

In order to guarantee reliable differentiation between load operation and short circuit – especially on long lines under large loads –, an adjustable load range is used. Impedances within this load range do not result in unwanted tripping in the distance zones.

4 pickup methods

The following pickup methods can be used optionally:

- Overcurrent pickup $I >>>$
- Voltage-dependent overcurrent pickup V/I
- Voltage-dependent and phase-angle-dependent overcurrent pickup $V/I \varphi$
- Impedance pickup $Z <$

Absolute phase selectivity

The distance-protection function incorporates a well-proven, highly sophisticated phase-selection algorithm. The pickup of healthy phases due to the negative effect of the short-circuit currents and voltages in other phases is reliably eliminated. This phase-selection algorithm makes appropriate trip decisions and

ensures correct distance measurement in a wide field of application.

Arrangements for breaker-and-a-half layout

When the cores of the 2 current transformers are connected in parallel, the resulting measured current will be the sum of the 2 currents flowing in the current transformers. This summation current corresponds to the current flowing into the feeder and is therefore used for the power protection functions and other functions. This method is commonly used. SIPROTEC 5 devices provide sufficient measuring inputs to connect 2 or several sets of CTs separately to the device. In this case, the summation is carried out in software internally. The distance-protection function detects possible saturation of only 1 of the current transformers and can thus prevent unwanted pickup in case of an external error with high current flowing. Through the separately measured currents, separate circuit-breaker failure protection functions can be activated for both switches. Moreover, the separately measured currents allow a complete differential protection for the "end zone" between the current transformers if the feeder is switched off (see STUB differential protection, ANSI 87-STUB).

Parallel-line compensation

Wrong distance-protection measurements due to the effect of parallel lines can be compensated by detecting the parallel-line ground current. Parallel-line compensation can be used for distance protection as well as for fault location.

Load compensation

The distance-protection function provides options to compensate the load influence on the radius measurement.

Elimination of disturbance variables

Digital filters render the classic distance-protection function immune to disturbance variables contained in the measured values. In particular, the influence of DC components, capacitive voltage transformers, and frequency changes is considerably reduced. A special method of measurement is used in order to assure selectivity of protection during current-transformer saturation.

Measuring-voltage failure detection

Tripping the distance protection is blocked automatically in the event of a measuring-voltage outage, thus preventing unwanted tripping. Distance protection is blocked if 1 of the voltage monitoring functions or the auxiliary contact of the voltage-transformer circuit breaker picks up. In this case, the EMERGENCY definite-time overcurrent protection can be activated.

Distance Protection with the Reactance Method (RMD) (ANSI 21, 21N)

Under extreme conditions, load currents and high fault resistances can influence the selectivity. The distance protection with the reactance method (RMD) function reduces the unfavorable influence of high fault resistances at high loads.

Load compensation is a part of the principle

If the electrical power system shows inhomogeneities, for example, different impedance angles of the infeeds, this can

also affect the radius of the distance protection. The reactance method compensates this influence via adjustable compensation angles.

The distance-protection function with the reactance method (RMD):

- Works in power systems with a grounded neutral point
- Is a selective short-circuit protection for lines and cables supplied from one or more ends in radial, looped, or meshed power systems
- Is used as a backup protection for busbars, transformers, and other lines
- Is suitable for use at all voltage levels

The distance-protection function with the reactance method (RMD) can be used additionally or as an alternative for the distance-protection function with the classical method.

Polygonal zone characteristics

The polygonal zone characteristic permits separate setting for the reactance X and the fault resistance R_F . Each distance zone can be configured separately to operate for ground faults only, for phase faults only or for all fault types. All distance zones can be set forward, backward, or non-directional.

The RMD function calculates up to 7 impedance loops A-gnd, B-gnd, C-gnd, A-B, B-C, C-A, and A-B-C. The pickup method is the impedance pickup $Z<$. The evaluation of healthy voltages, the use of a voltage memory, and the evaluation of delta values and symmetric components allow the optimal direction determination.

MHO zone characteristics

With the MHO zone characteristics, the MHO circle expansion guarantees safe and selective protection behavior. The circle expands to the source impedance but never more than the selected impedance radius. As an alternative to the quadrilateral zone characteristics, the RMD function for phase errors with MHO zone characteristics can be used if there are requirements for the compatibility with existing distance-protection systems.

Selectable number of distance zones

The number of distance zones can be adapted freely according to the application requirements.

Load zone

In order to guarantee reliable differentiation between load operation and short circuit – especially on long lines under large loads –, an adjustable load range is used. Impedances within this load range do not result in unwanted tripping in the distance zones.

Absolute phase selectivity

The distance-protection function with reactance method (RMD) includes a highly sophisticated algorithm for the adaptive loop selection. Different loop-selection criteria are processed in parallel. The loop-selection criteria work with jump detection, delta-value detection, symmetric components, and current, voltage and impedance permissive overreach transfer trips. The pickup of healthy phases due to the negative influence of short-circuit currents and voltages in other phases is thus reliably eliminated. This adaptive loop-selection algorithm takes appropriate

trip decisions and ensures correct distance measurement in a wide field of application.

Arrangements for breaker-and-a-half layout

The function RMD is just as suitable as the classical distance-protection function for breaker-and-a-half layouts.

Parallel-line compensation

The RMD function can compensate the influences on the distance measurements resulting from parallel lines by detection of the parallel-line ground current.

Elimination of disturbance variables

Digital filters make the RMD function insensitive to disturbance variables in the measured values. In particular, the influence of DC components, capacitive voltage transformers, and frequency changes is considerably reduced. A special method of measurement is used in order to assure selectivity of protection during current-transformer saturation.

Measuring-Voltage Failure Detection

The measuring-voltage failure blocks the distance-protection tripping automatically and thus prevents unwanted tripping. The pickup of one of the voltage monitoring functions or of the auxiliary contact of the voltage-transformer circuit breaker blocks the RMD function and can activate the EMERGENCY definite-time overcurrent protection.

Impedance Protection for Transformers (ANSI 21T)

SIPROTEC 5 offers a 6-system impedance protection with up to 4 impedance zones, especially for the use as backup protection on power transformers.

The function

- Protects transformers as backup protection for transformer differential protection
- Is used as backup protection for the generator transformer and the generator in power units
- Functions as backup protection in the event of reverse power flow to faults in the upstream electrical power system beyond a transformer

Depending on the application, the loop selection can be controlled. In active grounded power systems, all 6 measuring loops work independently of each other. The general release is performed via the minimum current criterion. In non-active grounded power systems (for example, generator protection), the measuring-loop selection is controlled by an overcurrent pickup with undervoltage stability.

By using the frequency-tracked sampled values, the impedance is measured over a broad frequency range. This is advantageous for island networks or power units, for example, for startup operations.

Polygonal zone characteristics

The polygonal zone characteristic permits separate setting of the reactance X and the resistance R for phase-to-ground and phase-to-phase loops. The quadrilateral characteristic is a rectangle in the impedance plane. Within the function, a maximum of 4 impedance zones can be operated simultane-

ously They can be set forward, backward, or non-directional. Each impedance zone has its own timer.

Direction determination

The direction is determined with saved prefault voltages or with negative-sequence variables.

Measuring-voltage failure detection

The quadrilateral operate curve permits separate setting of the reactance X and the resistance R for phase-to-ground and phase-to-phase loops. The quadrilateral characteristic is a rectangle in the impedance plane. Within the function, a maximum of 4 impedance zones can be operated simultaneously They can be set forward, backward, or non-directional. Each impedance zone has its own timer.

Overexcitation Protection (ANSI 24)

The overexcitation protection is used for detecting high induction values in generators and transformers. It protects the equipment from excessive thermal loads.

The induction is recorded indirectly by the evaluation of the V/Hz ratio. Overvoltage leads to excessive magnetizing currents, while underfrequency leads to higher losses when resetting the magnetization.

There is a danger of overexcitation if the power system is disconnected and the voltage and frequency control function in the remaining system does not react quickly or the power unbalance is excessive.

Within this function, the following maximum number of stages can be operated simultaneously: 1 dependent stage with user-defined characteristics and 2 independent stages.

Synchrocheck, Synchronization Function (ANSI 25)

When 2 subsystems or a live equipment are connected to the power system, the systems must be synchronous with one another at the moment of connection. The synchronization function monitors this requirement.

The synchronization function can be used for synchronous power systems (galvanically coupled, no frequency difference) as well as for asynchronous power systems (galvanically separated, frequency difference present).

It has 3 operating modes:

- Synchrocheck (monitoring of voltage difference, frequency difference, and phase-angle difference)
- Switching of synchronous power systems (control of equality of frequency, voltage difference, and phase-angle difference and continuity over a time frame)
- Switching of asynchronous power systems (voltage and frequency difference, connection to the synchronization point considering the circuit-breaker closing time).

Evaluation of the frequency difference causes the function to switch automatically between the synchronous and asynchronous power system functions. The synchrocheck function can be used for pure monitoring.

The relative parameters for synchronization are derived from voltage transformers (arranged to the left and right on the

circuit breaker). Depending on the available number of voltage-transformer inputs, 1 or 2 synchronizing points (circuit breakers) can be processed.

Several functions can be used per device. For these functions, up to 2 parameter sets (stages) can be used for the synchrocheck and up to 6 parameter sets (stages) for the synchronization function. This enables the device to always react to different power system or plant conditions with the correct synchronization parameters.

Adjusting Commands for the Automatic Synchronization (ANSI 25)

The synchronization function ensures a synchronous switching of the generator circuit breaker. Automatic synchronization is possible via the output of the adjusting commands to the speed or voltage controller. If the synchronization conditions are not met, the function automatically issues adjusting signals. Depending on the operating state, these are commands (step up/down) to voltage or speed controllers (frequency controllers). The adjusting signals are proportional to the voltage or frequency difference. This means that with a greater voltage or frequency difference, longer adjusting commands are issued. The gradient is adjustable. Between the adjusting commands, there is a wait during a set dead time to settle the status change. A quick adaptation of the generator voltage or frequency to the target conditions is achieved with this method. If frequency equality is established during the synchronization of generators with the power system (stationary synchrophasor), then a kick pulse ensures a status change.

If a voltage adaptation via the tap changer is desired, a defined control pulse is issued.

Monitoring of the induction (V/f value) ensures that the continuously permissible limiting value of $V/f = 1.1$ is not exceeded when the adjusting commands are issued (for example, "increase" voltage, "reduce speed").

Undervoltage Protection (ANSI 27)

The undervoltage protection monitors the permissible voltage range or protects equipment from subsequent damage due to undervoltage. It can be used in the power system for decoupling or load-shedding tasks.

Various undervoltage protection functions are available. By default, 2 stages are preconfigured. Up to 3 identical stages are possible. The undervoltage protection functions can be blocked by means of a current criterion.

The following functions are available:

- Undervoltage protection with 3-phase voltage
 - Optionally, measurement of phase-to-phase voltages or phase-to-ground voltages
 - Methods of measurement: optionally, measurement of the fundamental component or of the RMS value (true RMS value).
- Undervoltage protection with positive-sequence voltage
 - 2-phase short circuits or ground faults lead to an unbalanced voltage collapse. In comparison to phase-related measuring systems, such events have no noticeable impact on the positive-sequence voltage. Therefore, this function particularly suitable for the assessment of stability problems.
 - Methods of Measurement: Calculation of positive-sequence voltage from the measured phase-to-ground voltages.
- Undervoltage protection with any voltage
 - Detection of any 1-phase undervoltage for special applications
 - Methods of Measurement: optionally, measurement of the fundamental component or of the RMS value (true RMS value).
- Rate-of-voltage change protection dV/dt
 - Detects system states that are not secure caused by an unbalance between generated and consumed active power
 - Can be used as a criterion for load-shedding applications

Reactive-Power Undervoltage Protection (QU Protection)

The reactive-power undervoltage protection (QU protection) represents a system protection for power-system disconnection. To avoid a voltage collapse in energy systems, the energy producing side, for example a generator, should be provided with voltage and frequency protection devices. An undervoltage-controlled reactive power direction protection (QU protection) is required at the power-system interconnection point. The QU protection detects critical power-system situations and ensures that the power-generation system is disconnected from the power system. It also ensures that reconnection only takes place if the network conditions are stable. The criteria for this are parameterizable and can be found in the document [Technical directive for generating plants on the medium-voltage power system \(BDEW, June 2008\)](#) and in the "FNN requirement specification reactive power direction undervoltage protection (FNN, Feb 2010)".

Power Protection (ANSI 32, 37)

The power protection works on a 3-phase basis and detects exceedance or underrunning of the set active-power or reactive-power thresholds ([Figure 3.2/4](#)). Predefined power limits are monitored and corresponding warning indications are issued. The power direction can be determined by measuring the angle of the active power. Thus, for example, reverse energization in the power systems or at electric machines can be detected. Machines in idle state (motors, generators) are detected and can be shut down via a message.

The power protection can be integrated into any automation solution, for example, to monitor very specific power limits (further logical processing in CFC).

The power protection function comes with a factory-set stage each for the active power and the reactive power. A maximum of 4 active-power stages and 4 reactive-power stages can be operated simultaneously in the function. The stages have an identical structure.

You can define thresholds for exceedance or underrunning of the power lines. The combination of the different stages via CFC result in various applications.

Application Examples

- Detection of negative active power. In this case, the reverse-power protection can be applied using the CFC to link power protection outputs to the "direct tripping" function.
- Detection of capacitive reactive power. If overvoltage is detected due to long lines under no-load conditions, it is possible to select the lines where capacitive reactive power is measured.

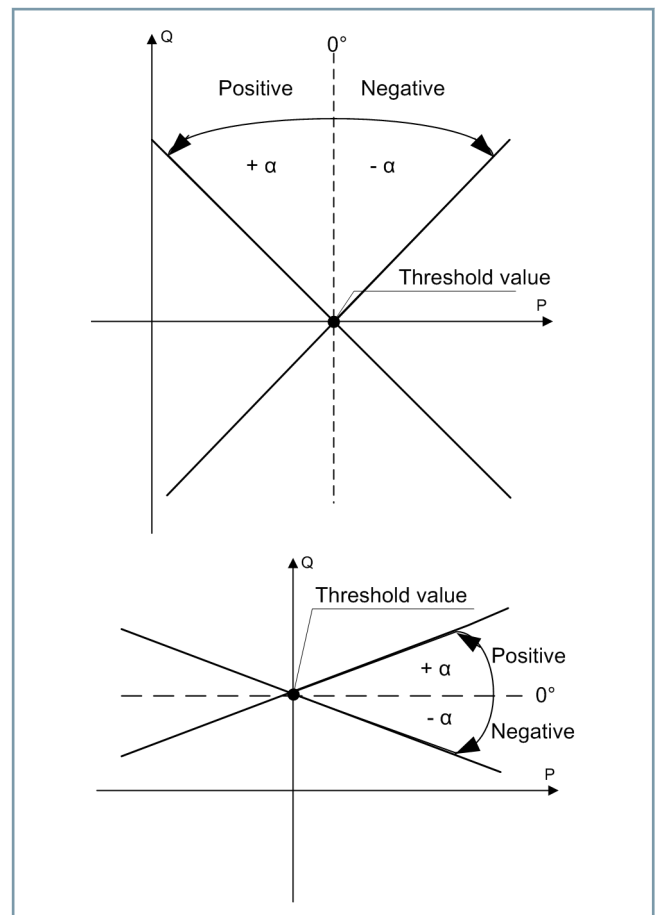

[dw_Wirk_Blind_KL, 1, en_US]

Figure 3.2/4 Active-Power Characteristic Curve and Reactive-Power Characteristic Curve

SIPROTEC 5 System

Protection – Functions

Reverse-Power Protection (ANSI 32R)

The reverse-power protection is used in generators and power units. If the **mechanical** energy (for example, steam supply at the turbine) fails, the generator obtains the driving energy from the power system. In this operating state, the turbine can be damaged, which is prevented by tripping of the reverse-power protection. In order to react quicker if there is a steam outage, the position of the quick-stop valve is coupled additionally via binary input. It is used to switch between 2 time delays of the trip command. Furthermore, the function is used for operational disconnection (sequential circuit) of generators.

For other applications, the universal power protection (ANSI 32, 37) is recommended.

The reverse-power protection works on a 3-phase basis and monitors the absorbed active power (negative threshold value). By evaluating the positive-sequence system power and selecting a long measuring window, the function is insensitive to disturbance variables and very precise (minimum setting threshold: $-0.3\% P/S_{rated}$). The measuring accuracy is substantially affected by the angle error. Because the SIPROTEC 5 devices are compensated, the primary transformers affect the measuring accuracy. The function can correct the angle error: You can find the angle error in the test report of the transformer or it can be measured using the primary system. The problem with the angle error is bypassed if high-precision instrument transformers are used as primary transformers (class 0.2 or 0.1). For this purpose, the reverse-power protection should be assigned to an independent measuring module.

Power-Plant Disconnection (ANSI 32 dP/dt; 27, 50)

3-phase close-up faults result in electrical and mechanical stresses on the turbo-generator unit. The determining criterion for the magnitude of the mechanical stress to be expected on a turbo-generator unit is the negative active-power jump ΔP , because torque and active power are proportional to each other. The sudden force release results in an acceleration of the rotor. At the same time, the phase situation and amplitude of the synchronous generated voltage changes. These changes occur on a delayed basis corresponding to the inertia constant of the machine and the magnitude of the active-power change. The longer this state persists, the more critical the stress on the generator becomes when there is a sudden voltage recovery. It is then possible to compare the effects of the subsequent operation more or less to a **missynchronization**. If the power system protection does not trip the high-current short circuits close to the power plant within the defined quick-operating time, the stress mentioned in the preceding sections can occur.

The power-plant disconnection function intervenes in this case and opens the main switch on the upper-voltage side. After fault clearing, the block can be resynchronized with the paralleling device.

The protection function evaluates the negative active-power jump of the positive-sequence system power. This is derived from the 3-phase voltage and current measured values. After an admissible time delay (to be specified by the turbo-generator unit manufacturer), the trip command is issued. Overcurrent and undervoltage pickups act as additional restraining quanti-

ties. Additionally, the generator must be operated before with a minimum active power and fall below an active power threshold.

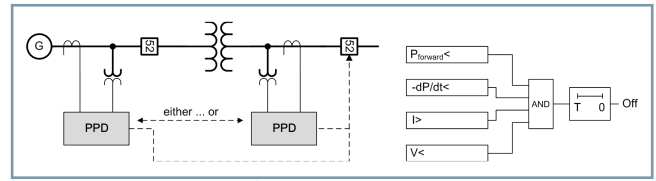

[dw_7UM8_kraftwerkseinkuppl, 1, en_US]

Figure 3.2/5 Setup of the Function and Principal Logic

Undercurrent Protection (ANSI 37)

Undercurrent protection detects the falling edge or decreasing current flow. This may be due to switching operations, for example, from a higher-level circuit breaker, or by decreasing loads, for example, pumps running empty.

In both situations, it may be necessary to open the local circuit breaker in order to prevent consequential damage. The undercurrent protection handles this task.

The function consists of an undercurrent stage with a current-independent time delay. A maximum of 2 stages can be operated in parallel.

Optionally, the auxiliary contacts of the local circuit breaker are evaluated in order to prevent overfunction.

Temperature Supervision (ANSI 38)

The temperatures (for example winding or oil temperatures) are recorded via an external temperature-supervision device. Typical sensors are Pt 100, Ni 100, and Ni 120. The temperatures are transmitted via serial or Ethernet interfaces for protection and monitored in the temperature-supervision function to ensure that they do not exceed set limiting values. There are 2 threshold values per temperature measuring point. The function is designed so that the temperatures from up to 12 measuring points can be processed. The integrated broken-wire detection sends an alarm indication depending on the measuring point.

Underexcitation Protection (ANSI 40)

The generator capability diagram describes the stability limits. In the per-unit view, it can be transformed easily into an admittance diagram by changing the axis labels. The underexcitation protection monitors the stability limits and prevents damage in the generator by out-of-step conditions (asynchronous operation) as a result of problems with the excitation or voltage control during underexcited operation.

The protection function offers 3 characteristics for monitoring the static as well as dynamic stability. A quick protection reaction is achieved via binary trip initiation if there is an excitation outage and short-time tripping is enabled. Alternatively, the excitation voltage can be measured by a measuring transducer and the release signal for falling below the threshold value can be evaluated. The characteristic-curve lines enable an optimal adaptation of the generator protection diagram (see [Figure](#)

3.2/6). The setting values can be read directly from the per-unit view of the diagram.

The admittance is calculated from the positive-sequence variables of the 3-phase currents and voltages. This guarantees correct behavior of the protection function even under unbalanced power system conditions. If the voltage deviates from the rated voltage, the admittance calculation provides the advantage that the characteristics run in the same direction as the generator capability diagram shifts.

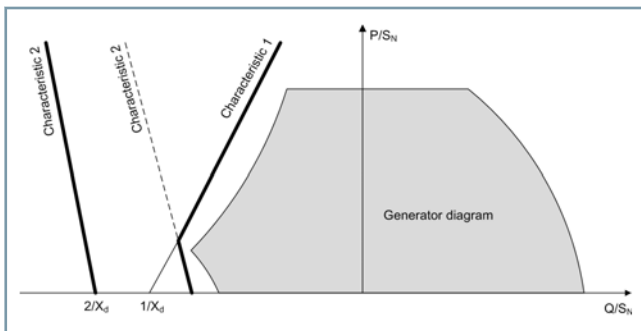

[dw_charac-underexcitation-protection, 1, en_US]

Figure 3.2/6 Characteristic of the Underexcitation Protection

Unbalanced-Load Protection (ANSI 46)

Asymmetrical current loading of the 3 windings of a generator result in heat buildup in the rotor because of the developing reverse field. The protection detects an asymmetrical loading of 3-phase current machines. It operates on the basis of symmetric components. The protection function evaluates the negative-sequence current and prevents thermal overloading of the rotor of electric machines (generators, motors). The thermal behavior is modeled using the integral method.

The following equation forms the basis of the protection function.

$$K = \left(\frac{I_2}{I_{N,M}} \right)^2 * t$$

[fo_Schieflastschutz, 1, en_US]

With

K	Constant of the machine (5 s to 40 s)
I_2	Negative-sequence current
$I_{N,M}$	Rated current of the machine

An inverse-time characteristic curve results as the operate curve. Small unbalanced load currents result in longer tripping times. To prevent overfunction in case of large unbalanced load currents (for example, with asymmetrical short circuits), large negative-sequence currents (approx. $10 \cdot I$ permissible) are limited. In addition, the continuous additional unbalanced load is monitored, and if the threshold is exceeded, an alarm indication is issued after a time delay.

Negative-Sequence System Overcurrent Protection (ANSI 46)

The protection function determines the negative-sequence current from the phase currents. It can be related to the rated object current or to the positive-sequence current (advantageous for conductor break monitoring).

The negative-sequence system overcurrent protection can be used with the transformer as a responsive backup protection on the supply side for detecting low-current 1-pole and 2-pole errors. Also low-voltage side, 1-phase errors can be detected here, which create no zero-sequence system in the current on the upper-voltage side (for example, in vector group Dyn).

With the negative-sequence overcurrent protection system, various monitoring and protection tasks can be realized:

- Detection of 1-pole or 2-pole short circuits in the power system with a higher responsivity than in classic overcurrent protection (setting under rated object current).
- Detection of phase-conductor interruptions in the primary system and in the current-transformer secondary circuits
- Location of short circuits or reversals in the connections to the current transformers
- Indication of unbalanced states in the energy system
- Protection of electrical machines following unbalanced loads that are caused by unbalanced voltages or conductor interruptions (for example, through a defective fuse)

The function comes factory-set with 1 stage. A maximum of 6 stages can be operated simultaneously. If the device is equipped with the inrush-current detection function, the stages can be stabilized against tripping due to transformer inrush currents.

Overcurrent Protection, Negative-Sequence System with Direction (ANSI 46, 67)

The function overcurrent protection, negative-sequence system with direction serves as the backup short-circuit protection for unbalanced faults.

With the negative-sequence system, various monitoring and protection tasks can be realized:

- Detection of 1-pole or 2-pole short circuits in the power system with a higher responsivity than in classic overcurrent protection.
- Detection of phase conductor interruptions in the primary system and in the current-transformer secondary circuits
- Location of short circuits or reversals in the connections to the current transformers
- Indication of unbalanced states in the energy system
- Protection of electrical machines following unbalanced loads that are caused by unbalanced voltages or conductor interruptions (for example, through a defective fuse)

The function comes factory-set with 1 stage. A maximum of 6 stages can be operated simultaneously. If the device is equipped with the inrush-current detection function, the stages can be stabilized against tripping due to transformer inrush currents.

Overvoltage Protection Functions (ANSI 59, 47, 59N)

Overvoltages occur in long lines with little or no load, for example. The overvoltage protection monitors the permissible voltage range, protects equipment from subsequent damage through overvoltages, and serves to decouple systems (for example wind-energy infeeds).

Various overvoltage protection functions are available. By default, 2 stages are configured. Up to 3 identical stages are possible.

The following functions are available:

Overvoltage protection with 3-phase voltage (ANSI 59)

- Optionally, measurement of phase-to-phase voltages or phase-to-ground voltages
- Measuring methods: optionally, measurement of the fundamental component or of the RMS value (true RMS value).

Overvoltage protection with positive-sequence voltage (ANSI 59)

- Detecting symmetrical, stationary overvoltages with positive-sequence voltage
- Method of measurement: Calculation of positive-sequence voltage from the measured phase-to-ground voltages.

Overvoltage protection with positive-sequence voltage and compounding in line protection (ANSI 59)

- Capacitive line impedances can lead to stationary overvoltages at the opposite end of the line (Ferranti effect).
- Method of measurement: The positive-sequence system of the voltage is calculated at the other end of the line by means of the local, measured voltages and current using the equivalent circuit of the line.

Overvoltage protection with negative-sequence voltage (ANSI 47)

- Monitoring the power system and electric machines for voltage unbalance
- Method of measurement: Calculation of negative-sequence voltage from the measured phase-to-ground voltages

Overvoltage protection with zero-sequence system/residual voltage (ANSI 59N/64)

- Detection of ground faults in isolated or arc-suppression-coil-ground systems, as well as in electric equipment (for example machines)
- Detection of the faulty phase (optional)
- Method of measurement: Measurement of the residual voltage directly at the broken-delta winding or calculation of the zero-sequence voltage from the phase-to-ground voltages
- Measuring methods: Optionally, measurement of the fundamental component (standard or with especially strong attenuation of harmonics and transients) or of the RMS value

Overvoltage protection with any voltage (ANSI 59)

- Detection of any 1-phase overvoltage for special applications
- Measuring methods: optionally, measurement of the fundamental component or of the RMS value (true RMS value)

Starting Time Supervision (ANSI 48)

The starting time supervision protects the motor from too long startup procedures. In particular, rotor-critical high-voltage motors can quickly be heated above their limiting temperature when multiple starting attempts occur in a short period of time. If the durations of these starting attempts are prolonged for example by excessive voltage surges during motor switching, by excessive load torque, or by blocked rotor conditions, a trip signal will be initiated by the protection device. [Figure 3.2/7](#) shows the thermal characteristic curve of the function. Different maximum starting times can be taken into account for starting with the motor cold or hot.

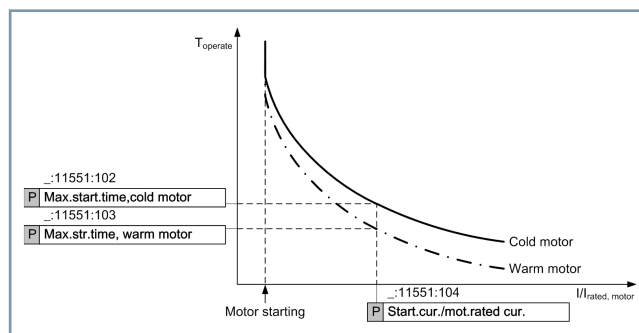

[dwttherms-200712-03.tif, 1, en_US]

Figure 3.2/7 Thermal Characteristic Curve of the Starting Time Monitoring

Hotspot Calculation (ANSI 49H)

The hotspot calculation function protects the transformer windings from thermal destruction at higher operating currents.

The hotspot calculation considers IEC 60076-7 and IEEE C57.91 standards and calculates 3 relevant variables for the protection function:

- Hotspot temperature
- Relative aging
- Load margin until warning/alarm indication.

These parameters can be used to generate an alarm. The hotspot temperature can also initiate a tripping. The calculation of the hotspot temperature depends on the upper transformer oil temperature, the cooling method, the power factor, the transformer dimension, the oil and winding time constant, and a few other factors according to IEC 60076-7 and IEEE C57.91.

The upper oil temperature is measured using temperature measuring points. In this case, up to 12 temperature measuring points can be transmitted to the protection device via a temperature coupling. One of these measuring points can be selected for the calculation of the hotspot temperature in the oil.

The customer can set the additional factors needed such as type of cooling and transformer dimension in the function. The relative aging is recorded cyclically and added up to make a total aging.

Stator Overload Protection (ANSI 49S)

The function of the thermal stator overload protection protects the motor from thermal overload by monitoring the thermal state of the stator.

The thermal stator overload protection calculates the overtemperature from the measured phase current according to a thermal single-body model. The RMS value is determined for each phase from the highly sampled current measured values (8 kHz). Due to the wide frequency operating range, all parameters that lead to heating are taken into account.

Stages

A current and thermal alarm stage is provided for the thermal overload protection to initiate an alarm before tripping. The tripping time characteristics are exponential functions according to IEC 60255-8. The preload is considered in the tripping times for overloads.

Startup Overcurrent Protection (ANSI 50)

Gas turbines are powered up via starting-frequency converters. The startup overcurrent protection detects short circuits in the low frequency range (from about 2 Hz to 3 Hz) and is designed as a definite-time overcurrent protection. The pickup value is set below the rated current. The function is only active during startup (blocking by open circuit breaker of the starting-frequency converter). At frequencies higher than 10 Hz, the sampling-frequency tracking activates and then the other short-circuit functions are active.

Circuit-Breaker Failure Protection (ANSI 50BF)

The circuit-breaker failure protection consists of 2 stages and provides phase and ground backup protection if the main circuit breaker fails to clear a power-system incident. If the fault current is not interrupted after a time delay has expired, a retrip command or the busbar trip command will be generated. The correct circuit-breaker operation is monitored via current measurement and via circuit-breaker position contacts. The current detection logic is phase-segregated and can therefore also be used in 1-pole tripping schemes.

The circuit-breaker failure protection can be initiated by all integrated protection functions as well as by external devices via binary input signals or by serial communication via GOOSE messages in IEC 61850 systems. To increase operational reliability, an external start can be applied with 2 binary inputs in parallel. Various delays may take place for 1-pole and 3-pole starting.

For applications with 2 current transformers per feeder, for example, breaker-and-a-half, ring-bus or double circuit breaker applications, the device can be configured with 2 independent circuit-breaker failure protection functions.

External Trip Initiations

Any signals from external protection and monitoring devices can be coupled in via binary inputs or serial communication. These signals can then be included in message and trigger processing or used to start a fault record. The trip initiation acts like a protection function. The trip command may be delayed. 1-pole

tripping is available if the device and switch are capable of 1-pole disconnection. Thus the integration of mechanical protection equipment (for example, pressure or oil-level monitors or Buchholz protection) as well as protection devices working in parallel is possible with no problems. Depending on the application, you can select the required number of trip initiations.

Instantaneous High-Current Tripping (ANSI 50HS)

When switching on a faulty line, immediate tripping is possible. In the case of high fault currents, this overcurrent protection with instantaneous tripping leads to a very fast tripping when switching onto faults.

The function comes factory-set with 1 stage. A maximum of 2 stages can be operated simultaneously within the function. The stages have an identical structure. Actual closure detection takes place in the switch-position recognition. It activates directly in case of manual closure or is automatically determined from the measured values (current, voltage) or by means of the circuit-breaker auxiliary contacts.

When used in the transformer, the current stage must be set above the maximum short-circuit current or inrush current flowing through.

End-Fault Protection (ANSI 50EF)

Without particular measures, the installation site of the current transformer defines the measuring range of the differential protection. If the circuit breaker is open, the section between the current transformer and the circuit breaker can be optimally protected by the end-fault protection. A recognized current in the case of open circuit breaker indicates a fault in the affected section. Through corresponding tripping of the surrounding circuit breakers, the fault can be cleared.

Together with the busbar protection, the reaction to a fault is dependent on the installation site of the current transformer. In case of busbar-side current transformers, the immediate and selective tripping of the busbar section occurs. In case of line-side current transformers, the end-fault protection can, through a transmission device, cause the tripping of the circuit breaker on the opposite end.

Circuit-Breaker Restrike Protection (ANSI 50RS)

The circuit-breaker restrike protection function monitors the circuit breaker for arc reignition, which may be triggered by overvoltage at the circuit-breaker poles after disconnection of the capacitor bank, for example. The function generates an auxiliary trip signal in the event of a circuit-breaker reignition.

Instantaneous Tripping at Switch-onto Fault (SOTF)

This function is available for applications in which overcurrent protection (50HS) is not sufficient or not used. It enables instantaneous tripping even with low fault currents. The function has no measuring function of its own. It is linked on the input side with the pickup (measurement) of another protection function, for example, the stage of an overcurrent protection, and then trips with switching to a short circuit. Typically, such protection stages are configured that themselves trip with a delay. Actual closure detection takes place in the switch-position recognition.

Load-Jam Protection (ANSI 50L)

The load-jam protection function serves to protect the motor during sudden rotor blocking. Damage to drives, bearings, and other mechanic motor components can be avoided and reduced by means of quick motor shutdown.

The rotor blocking results in a current jump in the phases. The current jump is detected by the function as a recognition characteristic.

The thermal overload protection can also pick up as soon as the configured threshold values of the thermal replica are exceeded. The load-jam protection, however, is able to detect a blocked rotor more quickly, thus reducing possible damage to the motor and powered equipment.

Overcurrent Protection, Phases and Ground (ANSI 50/51, 50N/51N)

The overcurrent protection functions for phases and ground detect short circuits on electric equipment. The non-directional overcurrent protection is suitable as main protection for single-side infeed radial power systems or open ring systems. As a backup or emergency overcurrent protection, it can be used additionally to the main protection, for example, on lines or transformers. With transformers, the preferred application is the backup protection for downstream parts of the electrical power system.

2 definite-time overcurrent protection stages and an inverse-time overcurrent protection stage are preconfigured. Additional definite-time overcurrent protection stages, and 1 stage with a user-defined characteristic curve can be configured within this function.

All the usual characteristic curves according to IEC and ANSI/IEEE are available for the inverse-time overcurrent protection stages, see for example [Figure 3.2/8](#).

Apart from the characteristic, the stages of the overcurrent protection are structured identically.

- They can be blocked individually via binary input or by other functions (for example, inrush-current detection, automatic reclosing, cold-load pickup detection)
- Each stage can be stabilized against over-responding because of transformer inrush currents
- Each stage can be operated as an alarm stage (no operate indication)
- You can select either the measurement of the fundamental component and the measurement of the RMS value for the method of measurement
- The ground function evaluates the calculated zero-sequence current (3I0) or the measured ground current
- Dropout delays can be set individually.

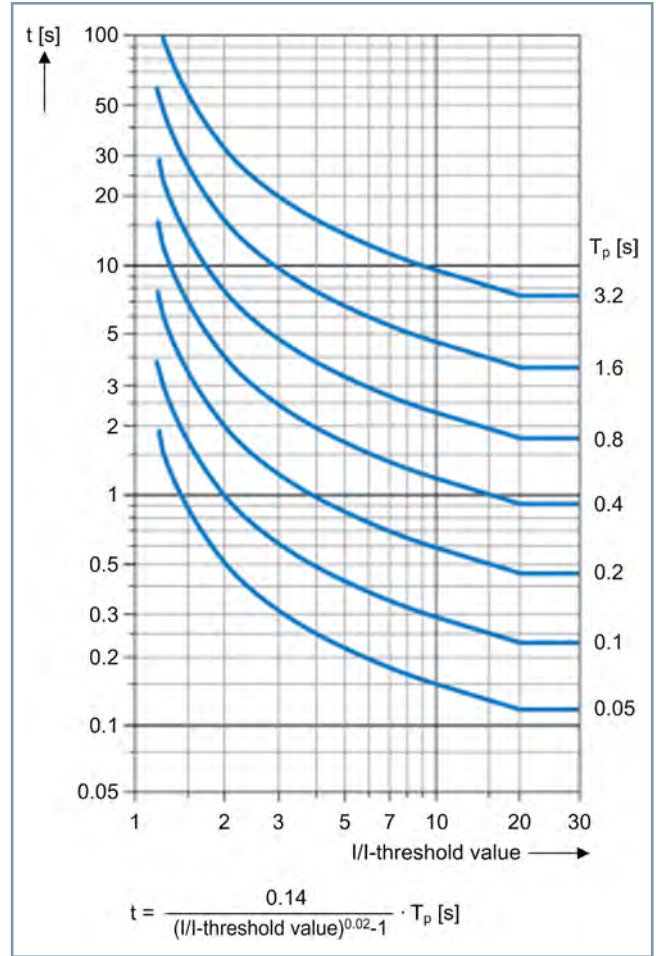

[dw_IEC-kennlinie, 1, en_US]

Figure 3.2/8 IEC Characteristic Curves of the "Normal Inverse" Type

Overcurrent Protection, 1-Phase (ANSI 50N/51N)

With transformers, the preferred application is the backup protection for the parts of the electrical power system connected to the grounded star winding. The neutral-point current of the transformer is thus processed directly. Alternatively, the function can also be used as high-impedance restricted ground-fault protection.

Tank leakage protection for insulated transformers is another application.

The modular design and scope of the protection function are identical to the overcurrent protection ground function (ANSI 50N/51N).

Sensitive Ground-Current Protection (ANSI 50Ns/51Ns)

The sensitive ground-current protection function detects ground-fault currents in isolated and arc-suppression-coil-grounded systems. It can also be used for special applications where a highly sensitive current measurement is required. Responses of protection devices and trippings can be saved in the separate ground-fault log.

Intermittent Ground-Fault Protection

Intermittent (reigniting) faults occur due to insulation weaknesses in cables or due to the ingress of water into cable joints. The faults will eventually go off by themselves or expand to permanent short-circuits. During intermittent operation, neutral-point resistors can be thermally overloaded in the case of low-impedance grounded power systems. The normal ground-fault protection cannot reliably detect and switch off the current pulses that are sometimes very brief.

The necessary selectivity of protection in the case of intermittent ground faults is achieved by adding up the single pulses over time and tripping after a reached (adjustable) total time. The pickup threshold $I_{IE} >$ evaluates RMS values in relation to a system period.

Transformer Inrush-Current Detection

When the device is used on a power transformer, large magnetizing inrush currents will flow when the transformer is switched on. These inrush currents may be several times the rated transformer current, and, depending on the transformer size and type of construction, may last from several tens of milliseconds to several seconds. The inrush-current detection function detects a transformer switch-on process and generates a blocking signal for protection functions that are affected in undesirable ways when transformers are switched on. This enables a sensitive setting of these protection functions.

In order to record the switch-on processes securely, the function uses the **Harmonic Analysis** method of measurement and the **CWA method** (current wave shape analysis). Both methods work in parallel and link the results through logical OR. This means that a **1-out-of-2 decision** is made which increases the availability of the electrical plant.

Inadvertent Energization Protection (ANSI 50/27)

Accidental switching of the circuit breaker can cause damage to generators that are stationary or already started but not yet excited or synchronized. The protection function has the task of limiting harm. The voltage defined by the power system allows the generator to start with a great amount of slip as an asynchronous machine. As a consequence, unacceptably high currents are induced in the rotor. A logic consisting of sensitive current measurement for each phase, instrument transformers, time control, and blocking starting at a minimum voltage, causes an immediate trip command. If the fuse-failure monitor responds, this function is inactive.

Shaft-Current Protection (ANSI 50GN)

The protection function is required in particular for hydro generators. Because of design constraints, hydro generators have relatively long shafts. Due to different causes, such as friction, magnetic fields of the generators, and others, a voltage can develop through the shaft, which then acts as a voltage source. This induced voltage of approximately 10 V to 30 V depends on load, plant, and machine. If the oil film on a bearing of the shaft is too thin, this can result in electric breakdown. Due to the low impedance (shaft, bearing, and grounding), greater currents can flow that would result in the destruction of the bearing. Experi-

ence shows that currents greater than 1 A are critical for the bearing. Because different bearings can be affected, the current flowing in the shaft is detected by a special core balance current transformer.

The shaft-current protection processes this current and trips when there is a threshold-value violation. In addition to the fundamental component, the 3rd harmonic and the current mixture (1st and 3rd harmonics) are evaluated. The measurand and the threshold value are set during commissioning. A high degree of measuring accuracy (minimum secondary threshold is 0.3 mA) is achieved by the selected measurement technology.

Voltage-Controlled Overcurrent Protection (ANSI 51V)

Short circuit and backup protection are also integrated here. It is used where power system protection operates with current-dependent protection equipment.

There are 3 different forms of the function (stage types):

- Controlled
- Voltage-dependent
- Undervoltage stability

The current function can be controlled via an evaluation of the machine voltage. The **controlled** variant triggers the sensitively set current stage. In the **voltage-dependent** variant, the current pickup value drops in a linear relationship with dropping voltage. The fuse-failure monitor prevents overfunction.

IEC and ANSI characteristics are supported, see [Table 3.2/1](#).

Supported inverse-time characteristic curves		
Characteristic curve	ANSI/IEEE	IEEE/IEC 60255-3
Inverse	•	•
Moderately inverse	•	
Very inverse	•	•
Extremely inverse	•	•
Fully inverse	•	

Table 3.2/1 IEC and ANSI Characteristic

For generator protection applications, the function **undervoltage stability** is frequently used. If the exciting transformer is connected directly to the generator lead and a short circuit occurs, the excitation voltage drops. As a result, the synchronous generated voltage and with it the short-circuit current are reduced and can drop below the pickup value. With the undervoltage stability feature, the pickup is maintained. If an external error is cleared according to protective grading, the voltage recovery results in the dropout of the pickup maintenance. If the voltage fails due to an error in the voltage-transformer circuit, this does not result in an overfunction. A pickup additionally causes an overcurrent.

Arc Protection

The arc protection function detects arcs in switchgear via optical sensors. Thus, the resulting arcs can be detected reliably and quickly. The protection device can trip correspondingly quickly and without time delays.

SIPROTEC 5 System

Protection – Functions

Detection of arcs takes place either optically only or optionally using an additional current criterion in order to prevent an over-function.

The arc protection function uses a self-monitoring circuit. This circuit monitors the optical arc sensors and the fiber-optic cables.

Peak Overvoltage Protection for Capacitors (ANSI 59C)

The dielectric medium of a capacitor is stressed by the applied peak voltage. Hence excessively high peak voltages may lead to destruction of the dielectric medium. IEC and IEEE standards define how long capacitors should withstand which overvoltages.

The function calculates the peak voltage in a phase-segregated way from the fundamental component and superimposed harmonics. Integration of the phase currents then yields the peak voltage.

The function offers different stage types with regard to the time delay:

- Stage with inverse-time characteristic according to IEC and IEEE standards
- Stage with user-defined characteristic curve
- Stage with independent characteristic curve

A maximum of 4 stages with independent characteristic curve can be applied in parallel.

Turn-to-Turn Fault Protection (ANSI 59N (IT))

The turn-to-turn fault protection is used to detect short circuits between the turns within a winding (phase) of the generator. In this case, relatively high ring currents flow in the short-circuited turns and result in damage to the winding and stator. The protection function is distinguished by high responsivity. The residual voltage across the broken-delta winding is detected via three 2-pole isolated voltage transformers. In order to be insensitive to ground faults, the isolated voltage-transformer neutral point must be connected via a high-voltage cable to the generator neutral point. The voltage-transformer neutral point must not be grounded; otherwise, the generator neutral point would also be grounded and every ground fault would result in a 1-pole ground fault. In case of a turn-to-turn, the result would be a drop in voltage in the affected phase. This ultimately leads to a residual voltage that is detected across the broken-delta winding. The responsivity is limited more by the winding unbalance and less by the protection device. The protection function processes the voltage across the broken-delta winding and determines the fundamental component. The selected filter design suppresses the effect of higher frequency oscillations and eliminates the disruptive influence of the 3rd harmonic. In this way, the required measuring responsivity is achieved.

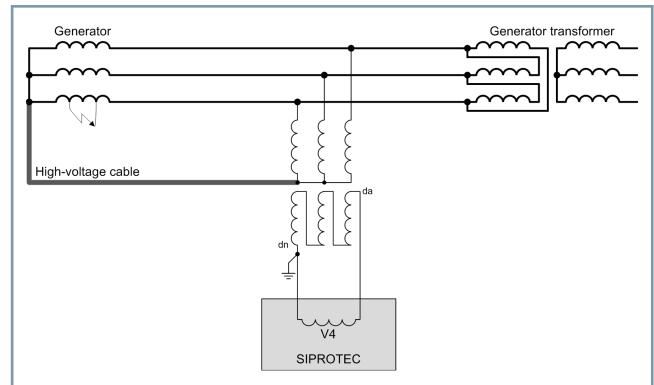

[dw_7um85-Ausf-bsp, 1, en_US]

Figure 3.2/9 Implementation Example

Direct-Voltage/Direct-Current Protection (ANSI 59N(DC), 50N(DC))

Hydro generators or gas turbines are started via starting-frequency converters. A ground fault in the intermediate circuit of the starting-frequency converter results in the direct-voltage shift and thus a direct current. Because zero point or grounding transformers have a lower ohmic resistance than the voltage transformers, most of the direct current flows through them. There is therefore a danger of destruction from thermal overload. The direct current is detected via a shunt converter (measuring transducer or special transformer). Depending on the variant of the measuring transducer, currents or voltages are fed to the SIPROTEC 7UM85.

The measuring algorithm filters out the DC component and takes the threshold-value decision. The protection function is active starting at 0 Hz. If a voltage is transmitted by the measuring transducer for the protection device, the connection must be designed in an interference-immune and short manner. Transmission as a 4-mA to 20-mA signal brings advantages because applied currents are insensitive to disturbances and at the same time broken-wire detection is possible.

The function can also be used for special applications. Therefore, for the quantity present at the input, the RMS value can be evaluated over a broad frequency range.

90 % Stator Ground-Fault Protection (ANSI 59N, 67Ns)

With generators that operate on an isolated basis, a ground fault is expressed by the occurrence of a residual voltage. In a unit connection, the residual voltage is a selective protection criterion. If generator and busbar (bus connection) are directly connected to each other, the direction of the flowing ground current must also be evaluated for a selective sensitive ground-fault detection. The protection function measures the residual voltage either at the generator neutral point via a voltage transformer or neutral-point transformer at the derivation via the broken-delta winding of a voltage transformer or grounding transformer. Alternatively, the residual voltage (zero-sequence voltage) can also be calculated from the phase-to-ground voltages. 85 % to 95 % of the stator winding of a generator can be protected depending on the selected load resistor.

For the ground-current measurement, a sensitive ground-current input is used. It should be connected to a core balance

current transformer. The direction of the error is determined from residual voltage and ground current. The vector can easily be adapted to the plant conditions. Effective generator protection in bus connection is realized in this way. During startup, the residual-voltage measurement must also be activated because in some cases, the ground-current source (connected power system or loading device on the busbar) is absent. The stator ground-fault protection function is realized in such a way that it has different stage types. These are to be loaded in the devices depending on the application (block or bus connection).

Stage types:

- Residual-voltage measurement (evaluation of the zero-sequence voltage) $V_0>$
- Directional 3I0 stage with φ (V_0 , 3I0) measurement (freely adjustable direction straight line)
- Non-directional 3I0 stage

Stator Ground-Fault Protection with 3rd Harmonic (ANSI 27TH/59TH, 59THD)

Due to design constraints, a generator can produce a 3rd harmonic voltage that forms a zero-sequence system. It is detectable via a broken-delta winding on the generator lead or via a voltage transformer or neutral-point transformer on the generator neutral point. The voltage amplitude depends on the machine and operation.

A ground fault near the neutral point results in the voltage shift of the 3rd harmonic voltage (drop within the neutral point and increase on the derivation). In combination with the 90 % stator ground-fault protection ($V_0>$), 100 % of the stator winding can be protected.

The protection function is designed in such a way that different methods of measurement can be selected for different applications are possible.

- A 3rd harmonic undervoltage protection at the generator neutral point
- A 3rd harmonic overvoltage protection at the generator lead.
- A 3rd harmonic differential voltage protection (with measurements of the neutral point and the derivation)

A typical application is the 3rd harmonic undervoltage protection at the generator neutral point. The protection function can only be used with a unit connection.

To avoid overfunctions, a release is issued if a minimum active power is exceeded and the generator voltage is within the permissible voltage range.

The final protection setting can only be made through a primary testing of the generator. If the magnitude of the 3rd harmonic is too small, the protection function cannot be used.

100 % Stator Ground-Fault Protection with 20-Hz Coupling (ANSI 64S)

The coupling of a 20-Hz voltage has proven to be a safe and reliable method for detecting errors in the neutral point or in the near of generator neutral point in unit connection. In contrast to the 3rd harmonic criterion, it depends on the generator properties and the operating mode. Moreover, a measurement during

plant standstill is possible. The protection function is designed in such a way that it detects ground faults in the entire generator (true 100 %) as well as in all electrically connected plant components.

The protection function detects the coupled 20-Hz voltage and the flowing 20-Hz current. The interfering quantities, for example, the stator capacitances, are eliminated and the ohmic fault resistance is determined using a mathematical model. This ensures, on the one hand, a high responsivity and, on the other hand, the use of generators having ground capacitances, for example, in hydropower plants.

Angle errors or contact resistances through the grounding transformer or neutral-point transformer are detected during commissioning and corrected in the algorithm. The protection function has a warning and tripping stage. In addition, there is a measuring-circuit supervision and the detection of an outage of the 20-Hz generator. Furthermore, the protection function has an independent frequency measurement function and in plants that are started via frequency converter (for example, gas turbines), the protection function can control the function in such a way that an overfunction is prevented.

Independent of the ground-resistance calculation, the backup protection function additionally evaluates the magnitude of the current RMS value.

If a parallel load resistor (grounding transformer with load resistor on the undervoltage side of the generator transformer) is also present in plants with generator switches, this is automatically corrected. The control is done via a binary input that receives its signal from the circuit-breaker auxiliary contact.

Current-Unbalance Protection for Capacitor Banks (ANSI 60C)

Capacitor banks are often implemented in so-called H-bridge configurations (see [Figure 3.2/10](#)). In a variant of this kind, the outage of a single C-element generates an unbalance in the bank and subsequently leads to a low unbalance current via the cross-connection.

The function measures the unbalanced current in the cross-connection in a phase-segregated manner. The overcurrent-protection stage is activated when a threshold value is exceeded, and is triggered after a time delay. The counter stage generates an alarm or a tripping when a certain number of defective C-elements has been detected.

In order to detect even the smallest unbalance currents – as a result of a defective C-element –, operational unbalances, which also cause unbalance currents must be compensated. The function allows both static and dynamic compensation. The latter must be used if dynamic environmental influences such as temperature fluctuations already generate relevant operational unbalances.

In addition, the measured unbalance can optionally be normalized using the current of the capacitor bank in order to ensure a constant responsivity even with different power.

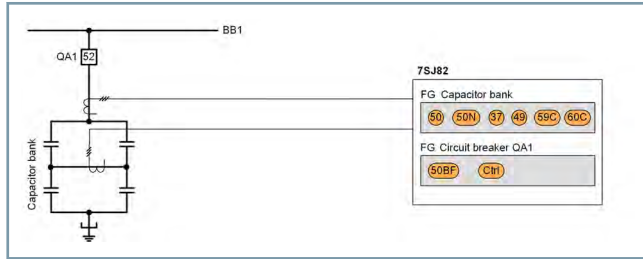

[dw_CapBank_SLE_vereinfacht, 2, en_US]

Figure 3.2/10 Protection of an H-Bridge Capacitor Bank

Measuring-Voltage Failure Detection (ANSI 60FL)

This function monitors the voltage-transformer secondary circuits:

- For non-connected transformers
- For pick up of the voltage-transformer circuit breaker (in the event of short circuits in the secondary circuit)
- For broken conductor in one or more measuring loops.

All these events cause a voltage of 0 in the voltage-transformer secondary circuits. This can lead to failures of the protection functions.

The following protection functions are automatically blocked in the case of a measuring-voltage failure:

- Distance protection
- Directional negative-sequence protection
- Ground-fault protection for high-impedance faults in grounded systems.

Rotor Ground-Fault Protection (ANSI 64F)

The protection function detects ground faults in the rotor (including rotor circuit). High-impedance faults are already signaled by a warning stage. The operational crew can respond accordingly (for example at the slip rings). When there is a low-impedance ground fault, tripping occurs and the machine is halted. Thus, the critical case of a 2nd ground fault that is a turn-to-turn fault of the rotor winding is prevented. The turn-to-turn fault can produce magnetic unbalances that result in a destruction of the machine due to the extreme mechanical forces.

Depending on the application, you can select from 3 different implementations.

Rotor ground-current measurement $I_r >, fn$

In this method, a power-frequency voltage (50 Hz, 60 Hz) is fed into the rotor circuit via a coupling device (7XR61 + 3PP1336). Through the protection function, the current threshold is monitored via a sensitive current input. 2 current stages can be set (warning, tripping). In addition, the rotor circuit is monitored for interruption by an undercurrent stage.

Rotor resistance measurement $R_r <, fn$

In this method, a power-frequency voltage (50 Hz, 60 Hz) is also fed into the rotor circuit via a coupling device (7XR61 + 3PP1336). In addition to the current measurement via the sensitive current input, the coupled voltage is also evalu-

ated. The rotor ground resistance is calculated using a mathematical model. This procedure eliminates the interfering influence of the rotor ground capacitance and increases the responsiveness. In the case of interference-free excitation voltage, fault resistances of up to 30 kΩ can be detected. The function has a two-stage design (warning and tripping stages). In addition, the rotor circuit is monitored for interruption by an undercurrent stage.

Rotor resistance measurement $R_r <, 1 \text{ Hz to } 3 \text{ Hz}$

In this method, a low-frequency, square-wave voltage (typically, 1 Hz to 3 Hz) is coupled into the rotor circuit through an injection unit (7XT71) and resistor device (7XR6004). With this method, the interfering influence of the rotor ground capacitance is eliminated and a good signal-to-noise ratio is achieved for the harmonic components (for example, 6th harmonic) of the excitation machine. A high responsiveness in the measurement is possible. Fault resistances of up to 80 kΩ can be detected. The rotor ground circuit is monitored for continuity by evaluation of the current during polarity reversal.

Due to the high responsiveness, this function is recommended for larger generators.

The function requires a hardware configuration of the SIPROTEC 7UM85 with an IO210.

Restart Inhibit (ANSI 66)

The restart inhibit prevents restarting of the motor if the permissible temperature limit would be exceeded as a result.

In normal operation, and also under increased load conditions, the rotor temperature of a motor is far below the permissible temperature limit. The high starting currents required during motor startup increase the risk of the rotor being damaged by overheating instead of the stator. This is related to the short thermal constant of the rotor. To prevent the circuit breaker being tripped by several attempts to start the motor, the motor must be prevented from restarting if it is obvious that the temperature limit of the rotor would be exceeded during the start attempt (Figure 3.2/11).

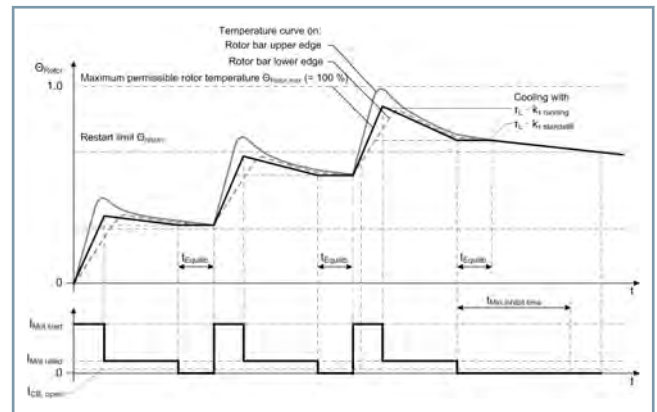

[Dw_PrReLo_02, 1, en_US]

Figure 3.2/11 Temperature Curve of the Rotor and Repeated Attempts to Start the Motor

Directional Overcurrent Protection, Phases and Ground (ANSI 67, 67N)

The directional overcurrent protection functions for phases and ground detect short circuits on electric equipment. The directional overcurrent protection allows the application of devices also in systems where selectivity of protection depends on knowing both the magnitude of the fault current and the direction of energy flow to the fault location. This is the case with parallel lines fed from one side, in lines fed from 2 sides, or in lines connected in rings.

2 definite-time overcurrent protection stages and an inverse-time overcurrent protection stage are preconfigured. Additional definite-time overcurrent protection stages and 1 stage with a user-defined characteristic curve can be configured within this function.

For the inverse-time overcurrent protection stages, all usual characteristic curves according to IEC and ANSI/IEEE are available.

Figure 3.2/12 shows the free configurability of the directivity of the ground function. The characteristic can be rotated for the phase function.

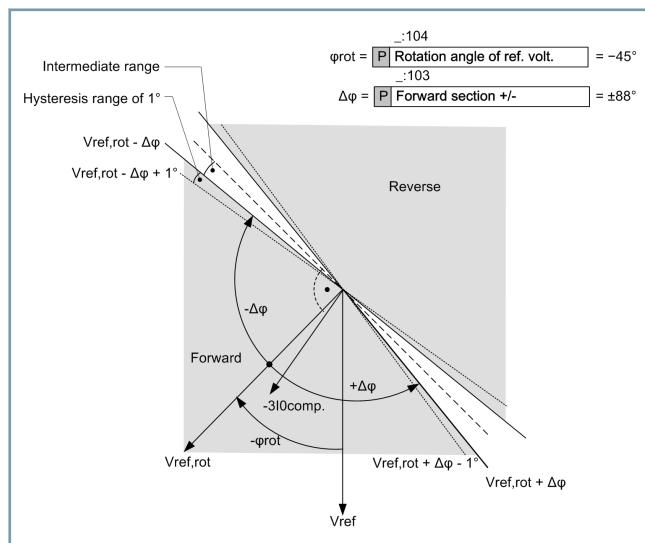

[dw_DwDirRot, 1, en_US]

Figure 3.2/12 Directivity of the Ground Function

Apart from the characteristics, the stages are structured identically.

- Blocking options for the stage: in the event of measuring-voltage failure, via binary input signal or by means of other functions (automatic reclosing, cold-load pickup detection).
- Each stage can be stabilized against over-responding because of transformer inrush currents
- The directional mode can be set for each stage.
- The stage can optionally be used for directional comparison protection. Hence both a release procedure and a blocking method can be implemented.
- Each stage can be operated as an alarm stage (no operate indication)

- You can select either the measurement of the fundamental component or the measurement of the RMS value for the method of measurement.
- The ground function evaluates the calculated zero-sequence current (3I₀) or the measured ground current
- Logarithmic-inverse characteristics are also available for the ground stages.

Directional Ground-Fault Protection with Phase Selector for High-Impedance Ground Faults (ANSI 67G, 50G, 51G)

In grounded systems, line-protection responsivity may not be sufficient to detect high-impedance ground faults. The line protection device therefore offers different protection levels for this type of fault.

Multiple stages

The ground-fault overcurrent protection can be used with 6 definite-time stages (DT) and 1 inverse-time stage (IDMTL).

The following inverse-time characteristics are provided:

- Inverse acc. to IEC 60255-3
- ANSI/IEEE inverse
- Logarithmic-inverse
- V₀ inverse
- S₀ inverse

Appropriate direction decision modes

The direction decision can be determined by the zero-sequence current I_0 and the zero-sequence voltage V_0 or by the negative sequence components V_2 and I_2 . Using negative-sequence components can be advantageous in cases where the zero-sequence voltage tends to be very low due to unfavorable zero-sequence impedances.

In addition or as an alternative to the direction determination with zero-sequence voltage, the ground current of a grounded power transformer may also be used. Dual polarization applications can therefore be fulfilled. Alternatively, the direction can be determined by the evaluation of zero-sequence system power. Each stage can be set in forward or reverse direction, or both directions (non-directional).

High responsivity and stability

The SIPROTEC 5 devices can be provided with a sensitive neutral (residual) current transformer input. This feature provides a measuring range for the ground current (fault current) from 5 mA to 100 A with a rated current of 1 A and from 5 mA to 500 A with a rated current of 5 A. Thus, the ground fault overcurrent protection can be applied with extreme sensitivity.

The function is equipped with special digital filter algorithms, thereby eliminating higher harmonics. This feature is particularly important for low ground-fault currents which usually have a high content of 3rd and 5th harmonics.

Dynamic setting change

A dynamic setting change of pickup threshold and runtime settings can be activated depending on the status of the auto-

SIPROTEC 5 System

Protection – Functions

matic reclosing function. An instantaneous switch onto fault is active for each stage.

Phase selector

The ground-fault protection is suitable for 3-pole and, optionally, for 1-pole tripping by means of a sophisticated phase selector. It may be blocked during the dead time of 1-pole auto-reclosing cycles or during pickup of a main protection function.

Directional Sensitive Ground-Fault Detection (ANSI 67Ns, ANSI 51Ns, 59N)

The directional sensitive ground-fault detection function detects ground faults in isolated and arc-suppression-coil-ground systems. Various function stages are available for this purpose that can also be used in parallel. Thus, the working method of the function can be perfectly adapted to the conditions of the power system, the user philosophy, and different manifestations of the error:

Overvoltage protection stage with zero-sequence system residual voltage

The zero-sequence voltage (residual voltage) is evaluated in relation to threshold-value violation. In addition, the faulty phase can be determined when the phase-to-ground voltages are connected.

Directional ground-current stage with direction determination using $\cos \varphi$ and $\sin \varphi$ measurement

This is the "classical" watt-metric ($\cos \varphi$, in the arc-suppression-coil-ground system) or var-metric ($\sin \varphi$, in the isolated power system) method of measurement for the direction determination of static ground faults. For direction determination, the current component which is perpendicular to the set direction-characteristic curve (= axis of symmetry) is decisive ($3I_{0,dir}$), see [Figure 3.2/13](#). The stage can be adapted to the power-system conditions by a corresponding setting (position of the direction-characteristic curve). Therefore, highly sensitive and precise measurements are possible.

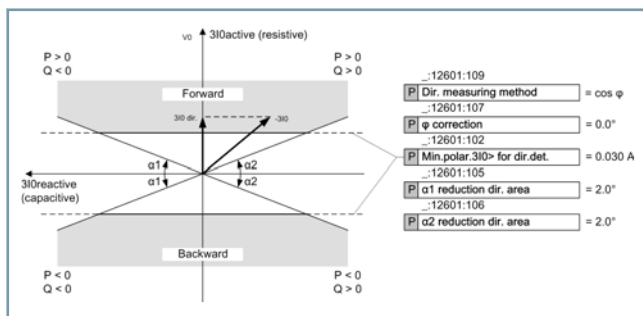

[dwcosp1-171012-01.tif, 3, en_US]

Figure 3.2/13 Direction Determination with $\cos \varphi$ Measurement

Directional sensitive ground-fault detection via harmonics

The function is used for fault localization in stationary ground faults, particularly in connection with restriction circuits in circuited medium-voltage rings. It is based on a continuous measurement with direction determination. This is determined by means of the phasors of the 3rd, 5th, or 7th harmonic of the

zero-sequence voltage V_0 and of the zero-sequence current $3I_0$ ([Figure 3.2/14](#)).

The advantages of this method are the simple difference between "faulty" and "healthy" in the directional areas and the reliable directional result independent of the measuring tolerances.

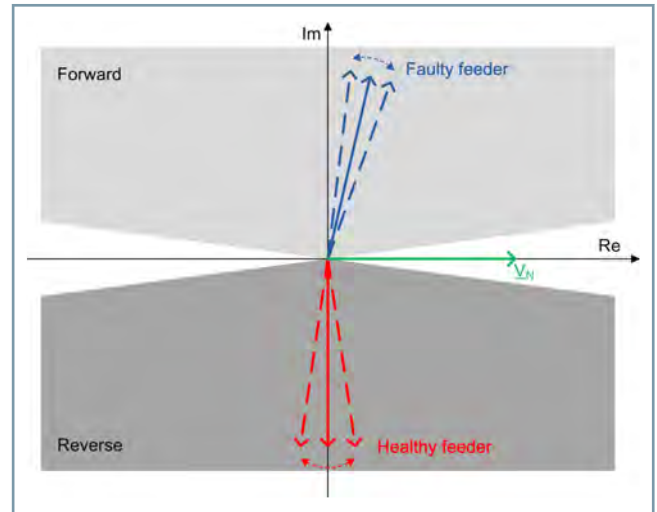

[dw_dir-sens-gnd-fault-detect_harm, 1, en_US]

Figure 3.2/14 Sensitive Ground-Fault Detection via Harmonics

Directional ground-current stage with direction determination using φ (V, I) measurement

This method can be applied as an alternative to the $\cos \varphi$ or $\sin \varphi$ method if this is desired because of user philosophy. The direction is determined by determining the phase angle between the angle-error compensated ground current and the rotated zero-sequence voltage V_0 . To take different system conditions and applications into account, the reference voltage can be rotated via an adjustable angle. This moves the vector of the rotated reference voltage close to the vector of the ground current $3I_{0,com}$. Consequently, the result of direction determination is as reliable as possible (see also [Figure 3.2/12](#)).

Sensitive ground-fault detection via pulse-pattern detection

The pulse-pattern detection function is used when a pulsating ground-fault current is generated for fault localization by connecting and disconnecting a capacitor arranged in parallel to the arc-suppression coil. The function then detects a faulty feeder using the pulse pattern during a stationary ground fault in overcompensated systems.

Transient ground-fault method

This transient method operates only during the first 1 to 2 periods after fault inception. It determines the direction via the evaluation of the active energy of the transient process. It is especially appropriate if direction information is required for errors that expire again very quickly (after 0.5 to a few periods). Thus, parallel use to the stage with $\cos \varphi$ measurement or harmonic methods is appropriate.

This method can also be operated in meshed power systems. It is also especially well-suited for closed rings because circulating

zero-sequence currents are eliminated. Due to additional logic, the function can also optionally clear a static error.

Non-directional ground-current stage

If necessary, a simple, non-directional ground-current stage can be configured.

Stabilization in the event of intermittent ground faults (starting with V8.0)

Stabilization in the event of intermittent ground faults

Functions for the detection of stationary ground faults (for example, $\cos\phi$ function) can react adversely in the event of intermittent ground faults: Message and fault-record flooding is possible. This can be effectively avoided by automatic blocking of these functions in the event of intermittent ground faults.

Power-Swing Blocking (ANSI 68)

Dynamic transient incidents, for instance short-circuits, load fluctuations, automatic reclosing, or switching operations can lead to power swings in the power system. During power swings, large currents along with small voltages can cause unwanted tripping of distance protection. The power-swing blocking function avoids uncontrolled tripping of the distance protections. Power swings can be detected under symmetric load conditions as well as during 1-pole autoreclosing cycles (Figure 3.2/15).

No settings required

The function requires no settings as an optimal functioning is always obtained by automatic adaptation. During a power-swing blocking situation, all swing properties are constantly supervised. A subsequent system incident is reliably detected and results in a phase-segregated reset of the distance-protection blocking by the power-swing blocking.

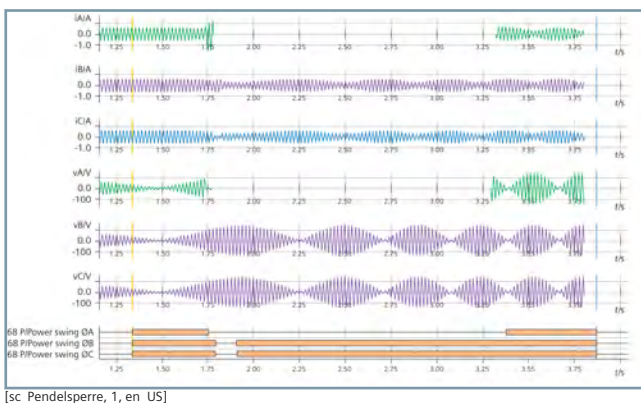

Figure 3.2/15 Power-Swing Blocking During 1-Pole Tripping

Trip-Circuit Supervision (ANSI 74TC)

The circuit-breaker coil and its feed lines are monitored via 2 binary inputs. If the trip circuit is interrupted, and alarm indication is generated.

Out-of-Sep Protection (ANSI 78)

In electric power transmission systems, electrical stability is always required. If system conditions arise that threaten the

stability, measures must be taken to avoid an escalation. These measures can be realized, for example, with an out-of-step protection. The out-of-step protection function is available as individual protection function or can be integrated into more complex systems for supervision and load control, for example system integrity protection systems (SIPS).

The out-of-step protection function constantly evaluates the impedance course of the positive-sequence impedance. The characteristic curve is defined by impedance zones in the R-X plane. Accumulators are incremented depending on the point at which the impedance course enters or exits the associated impedance zone. Tripping or signaling occurs when the set accumulator limits are reached. The out-of-step protection provides up to 4 independent impedance zones which can be adjusted and tilted according to the requirements of the loss of stability in the power system (see Figure 3.2/16).

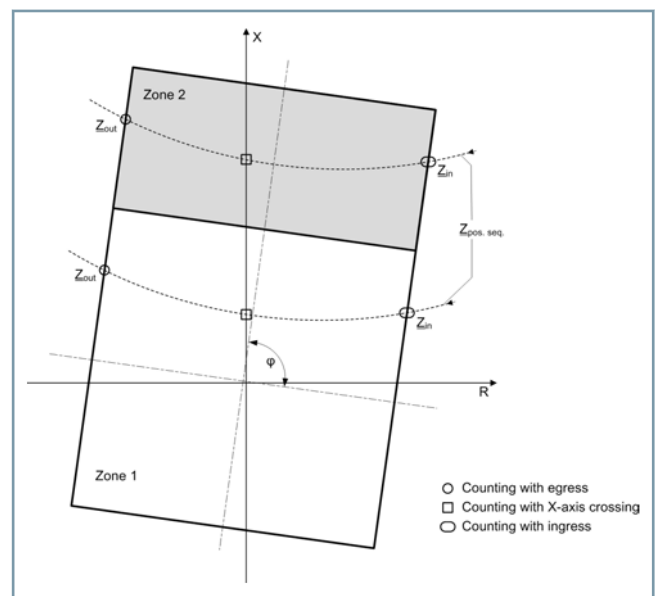

[dw_impedance_zone, 1, en_US]

Figure 3.2/16 Impedance Zones for Out-of-Step Protection

Automatic Reclosing (ANSI 79)

About 85 % of the arc faults on overhead lines are extinguished automatically after being tripped by the protection function. The overhead line can therefore be put back into operation. Reclosure is performed by an automatic reclosing function (AR). Each protection function can be configured to start or block the automatic reclosing function.

Basic features and operating modes

- Tripping-controlled start with or without action time
- Pickup-controlled start with or without action time
- 3-pole automatic reclosing for all types of faults; different dead times are available depending on the type of fault
- Multiple-shot automatic reclosing
- Cooperation with external devices via binary inputs and outputs or via serial communication with GOOSE message in IEC 61850 systems

- Control of the integrated automatic reclosing function by an external protection
- Cooperation with the internal or external synchrocheck
- Monitoring of the circuit-breaker auxiliary contacts
- Dynamic change of the settings of the overcurrent protection functions depending on the automatic reclosing status

2 automatic reclosing functions

For applications with 2 circuit breakers per feeder, for example, 1 1/2 circuit breaker, ring bus, or double circuit-breaker applications, the devices can be configured to operate with 2 independent automatic reclosing functions.

1-pole automatic reclosing

In electricity-supply systems with grounded system neutral points where the circuit-breaker poles can be operated individually, a 1-pole automatic reclosing is usually initiated for 1-phase short circuits.

The 1-pole automatic reclosing functionality is available in SIPROTEC 5 devices with 1-pole tripping capability.

The following operating modes are provided in addition to the features mentioned in the preceding sections:

- 1-pole automatic reclosing for 1-pole short circuits, no reclosing for multiphase short circuits
- 1-pole automatic reclosing for 1-phase short circuits and for 2-phase short circuits without "touching ground", no reclosing for multiphase short circuits
- 1-pole automatic reclosing for 1-pole fault and 3-pole automatic reclosing for multiphase short circuits
- 1-pole automatic reclosing for 1-phase short circuits and for 2-phase short circuits without "touching ground" and 3-pole automatic reclosing for other faults
- Appropriate behavior in the event of evolving faults
- 3-pole coupling (positive 3-pole tripping) in case of circuit-breaker pole discrepancy

Voltage-dependent supplementary functions

The integration of automatic reclosing in the feeder protection allows evaluation of the line-side voltages.

A number of voltage-dependent supplementary functions are thus available:

- **Dead-line check**
By means of a dead-line check, reclosure is triggered only when the line is de-energized (prevention of asynchronous pickup), if no synchrocheck can be used
- **ASP**
The adaptive dead time is used only if automatic reclosing at the opposite end was successful (reduction of stress on equipment).
- **RDT**
Reduced dead time is used together with the automatic reclosing function where no teleprotection scheme is used: When faults within the overreach zone, but outside the protected line, are switched off for short-time interruption, the RDT function decides on the basis of the measured of the reverse polarity voltage from the opposite end which has not tripped whether to reduce the dead time.

Frequency Protection (ANSI 81)

Frequency deviations are caused by an unbalance between generated and the consumed active power. This is caused by, for example, load shedding, network disconnections, increased need for active power, generator failures, or faulty functioning of the load-frequency control. The frequency protection detects frequency deviations in the power system or in electric machines.

It monitors the frequency band and outputs alarm indications. In case of critical power frequency, entire power units can be isolated or networks can be decoupled. To ensure network stability, load shedding can be initiated.

Different frequency-measuring elements with high accuracy and short pickup times are available. Tripping by frequency-measuring elements can be triggered either at the local circuit breaker or at the opposite end by automatic remote tripping.

The following measuring elements are available:

- **Overfrequency protection (ANSI 81O)**
Two-stage designs can be increased up to 3 stages. All stages are of identical design.
- **Underfrequency protection (ANSI 81U)**
Three-stage design (default), can be increased up to 5 stages. All stages are of identical design.

Each frequency-measuring element provides 2 different methods of measurement:

- **Angle difference method:** Angle change of the voltage phasor over a time interval
- **Filter method of measurement:** Evaluation of instantaneous voltage values with special filters

The DIGSI 5 library provides the corresponding protection function for every method of measurement.

Rate-of-Frequency Change Protection (ANSI 81R)

With the rate-of-frequency change protection, frequency changes can be detected quickly. The function can prevent system states that are not secure, caused by an unbalance

between the generated and the consumed active power. For this purpose, it is integrated into power-system decoupling and load-shedding measures.

The function offers 2 stage types:

- df/dt rising
- df/dt falling

A maximum of 5 stages of each stage type can be applied in the function.

Either the measuring accuracy or the pickup time can be optimized for the specific application by defining the measuring-window length.

The function is automatically blocked in the event of undervoltages, in order to rule out imprecise or incorrect measurements.

Teleprotection Scheme for Distance Protection (ANSI 85/21)

A teleprotection scheme is available for fast fault clearing of up to 100 % of the line length.

For conventional signal transmission, the required send and receive signals can be distributed freely to binary inputs and outputs. The signals can also be transmitted via the protection interface, a system-wide feature of the SIPROTEC 5 product family. Transmission via GOOSE messages with IEC 61850 system interfaces is provided as well, if the available communication structures in the switchgear fulfill the requirements in accordance with IEC 61850-90-1.

The following teleprotection schemes are available for the distance protection:

- Distance protection with underreaching (permissive underreach transfer trip)
 - Grading-time reduction with overreaching zone (transfer tripping via expanded measuring range)
 - Grading-time reduction with pickup (intertripping via pickup)
 - Intertripping scheme (intertripping underreach protection)
- Distance protection with underreaching (permissive overreach transfer trip)
 - Overreaching zone (permissive overreach transfer trip scheme)
 - Directional comparison with directional pickup
- Unblocking method
 - Each scheme in permissive mode can be extended with an unblocking logic
- Blocking method
- Reverse interlocking
- Bus-section protection

The send and receive signals are available as general signals or as phase-segregated signals. The phase-segregated signals are advantageous as they warrant reliable 1-pole disconnection, especially if 1-phase short circuits occur on different power lines. The protection schemes with automatic remote tripping are suitable also for power lines with more than 2-ended lines, for example teed-feeder lines. Up to 6-ended configurations are possible.

Transient blocking (current reversal monitoring) is provided for all release and blocking methods in order to suppress interference signals during tripping of parallel lines.

Weak or no Infeed: Echo and Tripping (ANSI 85/27)

To prevent delayed tripping of the distance-protection function and of the ground-fault directional comparison scheme during situations with weak or no infeed, an echo function is provided. If no fault detector is picked up at the weak-infeed end of the line, the signal received here is returned as echo to allow accelerated tripping at the strong-infeed end of the line. It is also possible to initiate phase-segregated tripping at the weak-infeed end. A phase-segregated 1-pole or 3-pole tripping is issued if a send signal is received and if the measured voltage drops correspondingly. This function is available for all permissive underreach and overreach schemes. As an option, the weak-infeed logic can be equipped according to a French specification.

Teleprotection for Directional Ground-Fault Protection (ANSI 85/67N)

For fast fault clearing of up to 100 % of the line length, the directional ground-fault protection can be expanded with a teleprotection scheme.

The following schemes are available:

- Directional comparison
- Blocking
- Deblocking

The send and receive signals are available as general signals or as phase-selective signals in combination with the phase selector of the directional ground-fault protection. For conventional signal transmission, the send and receive signals can be assigned freely to binary inputs and outputs. The signals can certainly be transmitted via the serial protection interface, a SIPROTEC 5-wide system feature. Transmission via GOOSE messages with IEC 61850 system interfaces is provided as well, if the available communication structures in the switchgear fulfill the requirements in accordance with IEC 61850-90-1.

The **transient blocking** function can be activated in order to suppress the interference signals during tripping of parallel lines. Communication of the teleprotection functions for distance protection and ground-fault protection can use the same signaling channel or separate and redundant channels.

Line Differential Protection (ANSI 87L, 87T)

Line differential protection is a selective short-circuit protection for overhead lines, cables, and busbars with single-side and multi-side infeed in radial, looped, or meshed power systems. It can be used at all voltage levels. The line differential protection works strictly phase-segregated and allows instantaneous tripping of 1-phase or 3-phase short circuits at up to 6 line ends. Depending on the device variant, 1-pole/3-pole (7SD87/7SL87) or only 3-pole tripping (7SD82/7SD86/7SL82/7SL86) is possible. The devices in a differential-protection topology communicate with each other via protection interfaces (protection communication). The flexible use of available communication media saves investment in communication infrastructure and guarantees the protection of lines of all lengths.

SIPROTEC 5 System

Protection – Functions

SIPROTEC 5 line differential protection devices can also be used in configurations with SIPROTEC 4 line protection devices. This ensures that individual SIPROTEC 4 devices of an existing topology can be easily replaced or an existing SIPROTEC 4 topology can be expanded by one or more SIPROTEC 5 devices.

Adaptive measurement

An adaptive measurement method ensures a maximum of responsivity to detect internal faults under all conditions. To guarantee highest stability, any measurement or communication errors are taken into account (see [Figure 3.2/17](#)).

Simple settings and supervision functions shorten time of engineering and commissioning:

- A sensitive measurement stage ($I_{diff}>$) detects high-impedance errors. Special algorithms ensure high stability even with high-level DC-components in the short-circuit current. The tripping time of this stage is about 30 ms when standard output contacts are used.
- A high-current differential stage ($I_{diff}>>$) offers high-speed fault clearance with very short tripping times when high-speed contacts are used.
- No external matching transformers are needed by taking different current-transformer ratios into consideration.
- With the setting of current-transformer error data, the differential protection device calculates the restraint current automatically and sets its permissible responsivity. Thus, the user does not need to parameterize the protection characteristics. Only $I_{diff}>$ (sensitive stage) and $I_{diff}>>$ (high-current differential stage) must be set according to the charging current of the line/cable.
- Enhanced communication features guarantee stability and accuracy even under disturbed or interrupted connections on all kinds of transmission media, like optical fibers, control lines, telephone cables, or communication networks.
- Monitoring and display of differential currents and restraint currents during normal operation
- High stability during external short circuits, even with different current-transformer saturation levels.
- When long lines or cables get switched on, large transient charging-current peaks occur. To avoid higher settings and less sensitivity of the $I_{diff}>>$ differential current stage, the pickup threshold of the $I_{diff}>$ stage may be increased for a settable time interval. This offers higher responsivity under normal load conditions.

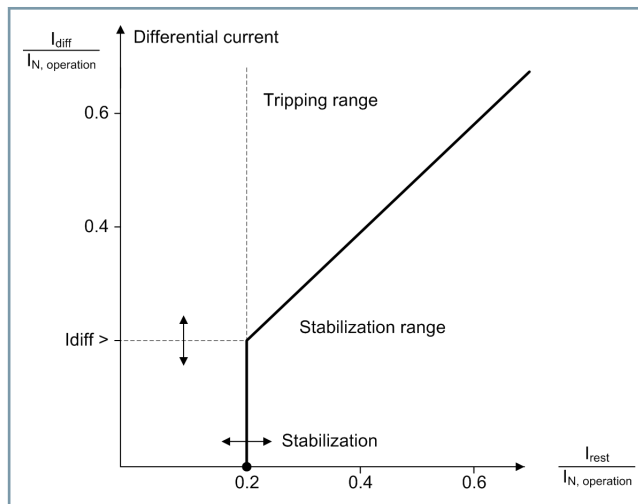

[dw_ausl_seChar, 1, en_US]

Figure 3.2/17 Operate Curves

Charging-current compensation

Particularly with long cables and very long extra-high voltage lines, ground capacitances can cause considerable, permanently flowing capacitive load currents. These must be taken into account by the tripping threshold of the sensitive differential protection stage because they generate a differential current.

- The charging-current compensation serves to improve the sensitivity so that protection with maximum sensitivity is possible even at high charging currents.
- The charging-current compensation requires that local voltage transformers are connected.
- The principle of distributed compensation guarantees maximum availability, since with local measuring-voltage failures of a device, the remaining devices continue to warrant their part of the compensation.

Transformer in the protection range

Apart from normal lines, the line differential protection can also protect lines with a transformer in unit connection. The current transformers delimit the protection range selectively.

- A separate transformer protection device can therefore be omitted, since the line differential protection acts as transformer protection with measuring points that may lie far away from one another.
- With few additional transformer parameters, for example, rated apparent power, primary voltages, vector groups, and any neutral-point groundings of the respective windings, no external matching transformers are necessary.
- The responsivity of differential protection can be further increased by detecting the ground currents of grounded neutral-point windings.
- The inrush-current detection function stabilizes the differential protection against tripping due to transformer inrush currents. This can occur in a phase-segregated or in a 3-phase way by means of the crossblock function.

Breaker-and-a-half layouts

The differential protection can be integrated easily into the breaker-and-a-half layout. With the corresponding hardware extension (see standard variants), two 3-phase current inputs per device are configurable. Thus, topologies of up to 12 measuring points with 6 devices can be configured. The protection of a STUB-BUS can be assumed by the separate STUB differential protection.

Enhanced communications features

The line differential protection uses the protection interfaces in the **Differential protection** configuration (Type 1, see Protection communication). Different communication modules and external converters allow the interfacing and use of all available communication media.

- The direct data transmission via fiberglass cables is immune to electromagnetic disturbances and offers the highest transmission rate to achieve the shortest tripping times.
- External communication converters enable communication via existing control cables, telephone lines, or communication networks.

The data required for the differential calculations are exchanged cyclically in full-duplex mode in the form of synchronous, serial telegrams between the protection devices.

Comprehensive supervision functions ensure stability in operation in any communication environment:

- Telegrams are secured with CRC checksums to detect transmission errors immediately. The differential protection processes only valid telegrams.
- Supervision of all communication routes between the device without the need for additional equipment
- Unambiguous identification of each unit is ensured by the assignment of settable communication addresses for each unit within a differential-protection topology.
- Detection of telegrams reflected back to the sending device in the communication network
- Detection of time-delay changes in communication networks
- Dynamic compensation of runtimes in the differential measurement and supervision of the maximum permissible signal-transit time
- Indication of disturbed communication links. Counters of faulty telegrams are available as operational measured values.
- Switched communication networks can lead to unbalance in the runtimes in receive and transmit directions. The resulting differential current is taken into account by the adaptive measuring techniques of the differential protection.
- With a high-precision 1-s pulse from a GPS receiver, the device can be synchronized with an absolute time at each line end. In this way, time delays in the receive and transmit path can be measured exactly. Thus, the differential protection can also be used in communication networks with a maximum of sensitivity even under massive runtime unbalance conditions.

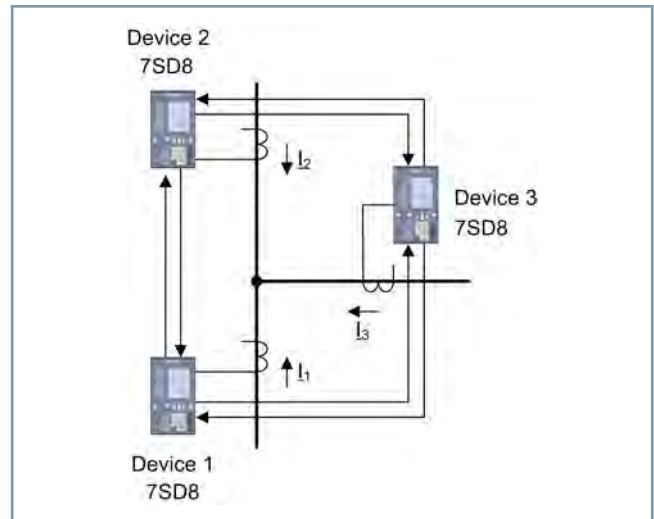

[dw_ring, 2, en_US]

Figure 3.2/18 Differential Protection in Ring Topologies

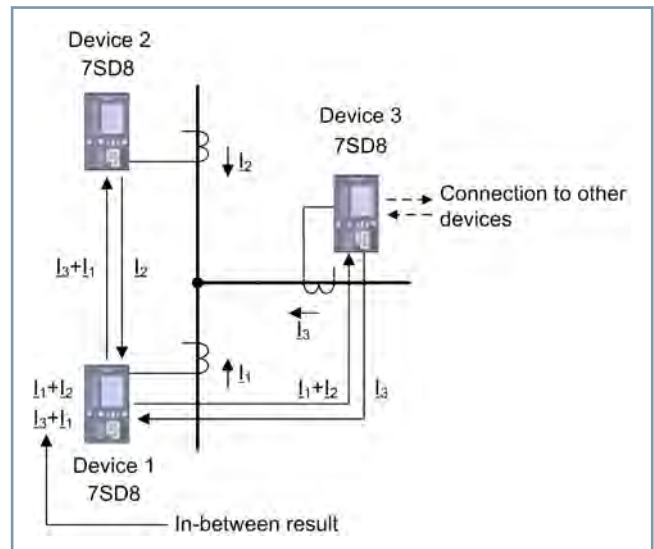

[dw_Ketten, 2, en_US]

Figure 3.2/19 Differential Protection in Chain Topologies

Phase-segregated circuit-breaker intertripping and remote trip/indications

- Normally, the differential current is calculated for each line end at the same time. This leads to fast and uniform tripping times. Under weak infeed conditions, especially when the differential protection function is combined with an overcurrent pickup, a phase-segregated circuit-breaker intertripping offers a tripping of all line ends. Therefore high-speed transfer-trip signals get transmitted to the other line ends. These transfer-trip signals can also be initiated by an external device via binary inputs. Therefore, they can be used to indicate, for example, a direction decision of the backup distance protection.
- The protection interfaces can exchange freely configurable, binary input and output signals and measured values with each other (see protection communication).

Communication topologies/modes of function

Differential protection devices may be arranged in a ring or chain topology. A test mode offers advantages during commissioning and service operations.

- In a ring topology, the system tolerates the outage of a data connection. The ring topology is converted within 20 ms into a chain topology, so that the differential protection function continues to work without interruption.
- When a chain topology is specified by the communication infrastructure, cost-effective relays with only one protection interface can be used at both chain ends.
- For important 2-end lines, a hot standby transmission is possible by a redundant communication link to ensure high availability. When the main connection is interrupted, the communication switches over from the main path to the secondary path.
- For service or maintenance reasons, individual differential protection devices within multi-end topologies can be removed from the differential-protection topology using a binary input. Switch positions and load currents get checked before such a "logout" takes effect. The remaining devices can continue to operate in this reduced topology.
- The whole configuration can be shifted into a differential-protection test mode. All functions and indications continue to be available, but the circuit breakers do not trip. In this way, the local relay can be tested with disconnection or inter-tripping of the other relays.

STUB Differential Protection (ANSI 87 STUB)

Stub differential protection is a fully fledged line differential protection, but without communication between the line ends. It is used with a teed feeder or a 1 1/2 circuit breaker layout, when a feeder of the line section can no longer be protected selectively by opening the disconnecter (for example, distance protection).

The tub differential protection is activated by the feedback of the disconnecter-switch position. The SIPROTEC 5 line protection device must be equipped with two 3-phase current inputs in its hardware for this. Regarding the structure and the setting parameters, the Stub differential protection corresponds to the line differential protection (ANSI 87L) in all regards, with the exception of protection communication. It guarantees the selective protection of the remaining line section and fast tripping times up to 10 ms.

Transformer Differential Protection (ANSI 87T)

The transformer differential protection is a selective short-circuit protection for power transformers of different designs (standard transformers as well as auto transformers) and different switching types. The number of protectable windings (sides) and the number of usable measuring points depends on the device type (see the variants mentioned in the preceding sections).

In the protection function, the following properties become important:

- Error-current stabilized operate curve with freely adjustable characteristic-curve sections in accordance with [Figure 3.2/20](#)
- Integrated adaptation to the transformer ratio with consideration of different current-transformer rated currents (primary as well as secondary)
- Flexible adaptation to the different transformer switching groups.
- Adaptive adaptation of the operate curve by recording the transformer tap position.
- Additional consideration of the neutral-point currents with grounded winding and hence one-third increase in responsibility.
- Redundant stabilization procedure (2nd harmonic + wave shape analysis) in order to a sensitivity rising by a third at the transformer
- Further stabilization options by evaluating the 3rd or 5th harmonics in the differential current. The 5th harmonic is well suited to reliably detect a stationary overexcitation of the transformer and hence to avoid an overfunction.
- Additional stabilization procedure against external errors with current-transformer saturation. The 1st procedure reacts to high-current errors and monitors the history of the differential current (time-limited occurrence of a differential current from the additional stabilization area, see [Figure 3.2/20](#)). A shift to an internal error is reliably detected. The 2nd procedure works for low-current errors. The DC component in the short-circuit current and the remanence of the current transformer can lead to phase-angle rotations in the secondary current. If jumps in the restraint current occur and if DC components are simultaneously detected in the differential current, an elevation of the operate curve is carried out on a time-limited basis.
- If asynchronous motors are connected to transformers, distorted transmission of the starting current may result in differential currents. Due to a startup detection (jump within the restraint current and DC component evaluation), the operate curve is raised.
- High-current internal errors are detected reliably and quickly by the high-current stage Idiff-fast (see [Figure 3.2/21](#)). In order to prevent an overfunction by quadrature-axis current components (for example, use in breaker-and-a-half layouts), the instantaneous values from the differential and restraint currents are evaluated. In a few milliseconds, interior and exterior errors are reliably differentiated.

For the protection of auto transformers, the protection function has been adapted to the special conditions of the auto transformer. The pure nodal-point protection can be used as additional sensitive protection for the auto winding. The nodal point protection works in parallel to the classic differential protection. With auto-transformer banks, this ensures high sensitivity to ground faults and turn-to-turn faults. [Figure 3.2/22](#) shows the underlying concept.

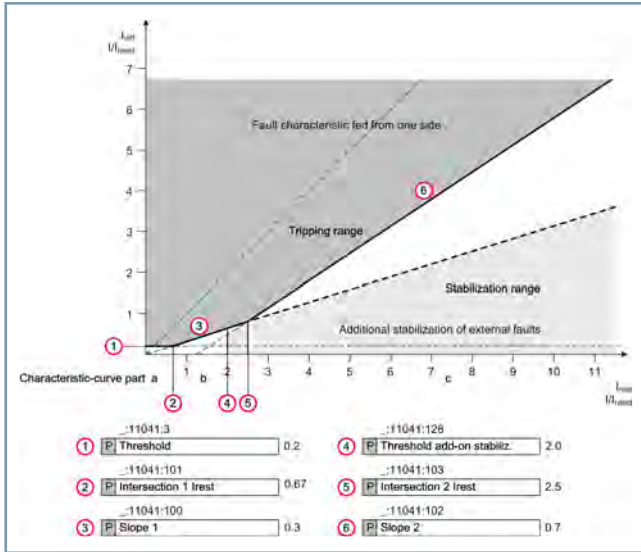

[dwdifaus-030912-01.tif, 2, en_US]

Figure 3.2/20 Error-Current Stabilized Operate Curve of the Function I_{diff}

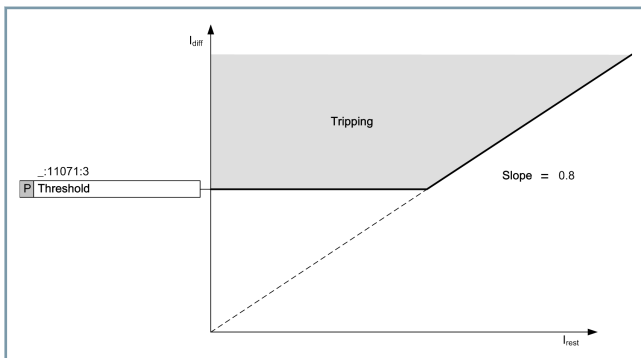

[dwidfast-300114-01.tif, 1, en_US]

Figure 3.2/21 Characteristic Curve of the Function I_{diff} -Fast

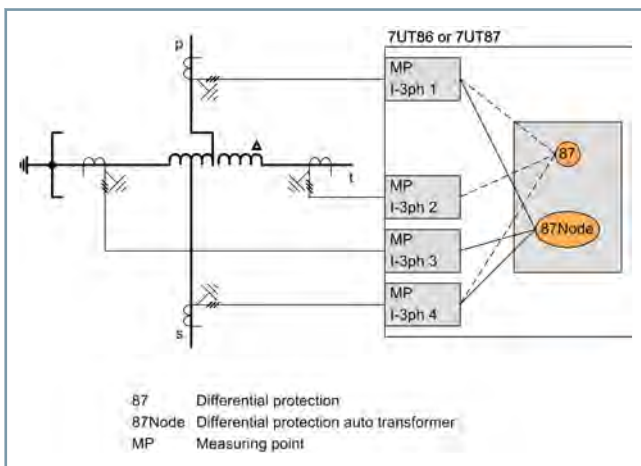

[dw_spartrafobank, 1, en_US]

Figure 3.2/22 Protection of an Auto-Transformer Bank by 2 Differential Protection Functions in one Device

Differential Protection for Phase-Angle Regulating Transformers (ANSI 87T)

The Differential protection for phase-angle regulating transformers (PAR) function supplements the existing Transformer differential protection function (ANSI 87T).

Phase-angle regulating transformers are used to control the reactive-power flow and active-power flow in high-voltage power systems. The objective is to achieve voltage stability and uniform load dispatching in parallel transmission lines, and to prevent unbalanced current in the meshes of the transmission systems. The main function of the phase-angle regulating transformer is to alter the effective phase displacement between the input and output voltage of a transmission line. This function controls the amount of current that can be transmitted by a single line. In order to apply an introduced voltage boost to influence the active-power flow, phase-angle regulating transformers are integrated into the electrical power system in series. This situation arises, for example, if an increase in the transmission capacity is required due to the installation of an additional line. By using selective control of the angle between the current and the voltage in a line, both lines can be used up to their projected load limit. The control of the power flow or the energy flow direction at the tie-point of 2 electrical power systems is another typical application.

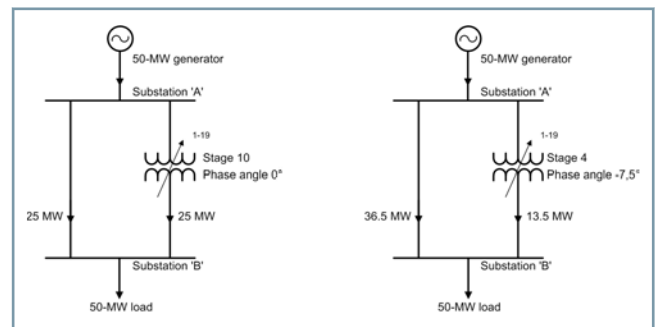

[dw_PST_DIFF_01, 1, en_US]

Figure 3.2/23 Power Distribution between 2 Lines when Using Different Phase-Angle Values

3 function blocks are available for the adaptation of the differential protection to the various types of phase-angle regulating transformers:

- Single-core PSTs are phase-angle regulating transformers with a max. phase shift of 60°.
- Two-Core PSTs are transformers with quadrature regulation, with a phase shift of 90°.
- Special transformers are transformers with a fixed circuiting of the windings. This will result in a vector-group number that is not an integer value (for example, SG 0.25 = 7.5°). They can be used, for instance, as inverter transformers.

The transformer differential protection automatically considers the resulting absolute-value and angle changes. Therefore, the changes do not need to be taken into consideration in the pickup-characteristic settings for the differential protection. The switch makes it possible to change between negative and positive no-load phase displacement even under full load. In this

SIPROTEC 5 System

Protection – Functions

case, blocking of the I-DIFF stage of the differential protection is adjustable.

Restricted Ground-Fault Protection (on the Transformer) (ANSI 87N T)

The longitudinal differential protection can detect ground faults close to the neutral point of a grounded star winding only to a limited extent. The restricted ground-fault protection assists you with this. The neutral-point current and the calculated zero-sequence current of the phase currents are evaluated according to [Figure 3.2/24](#) and [Figure 3.2/25](#). Overfunction in response to external ground faults is prevented by stabilizing measures. In addition to the differential and restraint currents, based on the zero-sequence variables, the phase angles of the zero-sequence currents are monitored between each other. The tripping variable is the zero-sequence current in the neutral point.

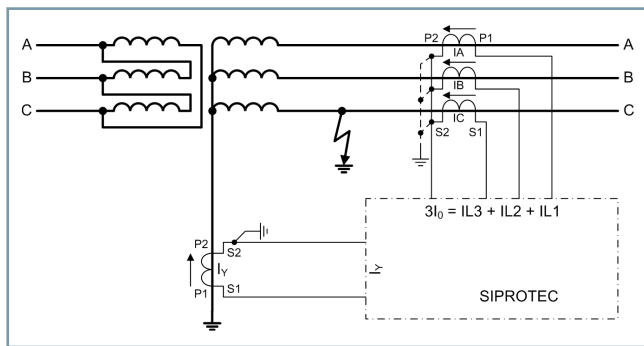

[dwgrdpri-170712-01.tif, 2, en_US]

Figure 3.2/24 Restricted Ground-Fault Protection Basic Principle

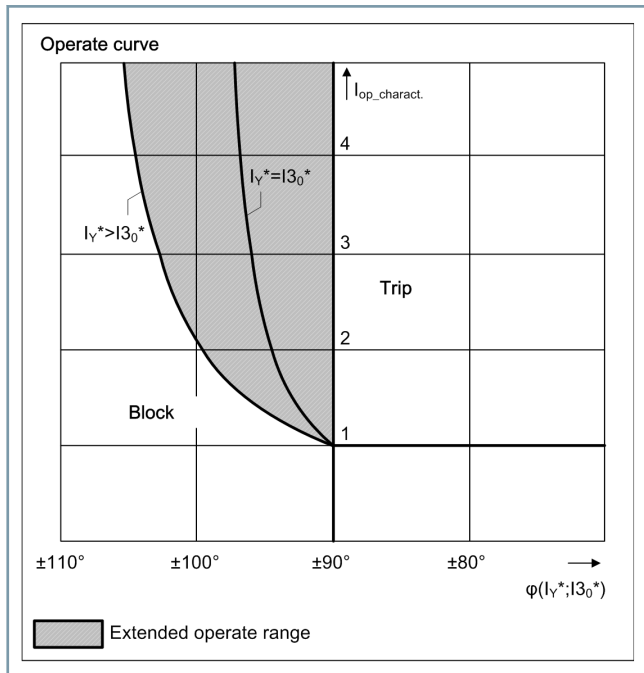

[dwausken-170712-01.tif, 2, en_US]

Figure 3.2/25 Operate Curve

For use in auto transformers, an additional measure was adopted in order to prevent a failure in response to external ground faults. The protection function independently determines the side of the auto winding that is necessary for reliable operation of the protection function. A measuring point is selected that results in the greatest restraint current (see also [Figure 3.2/26](#)).

This method is also used if multiple 3-phase current measuring points are present on the neutral side, such as in breaker-and-a-half layouts (see [Figure 3.2/24](#) and [Figure 3.2/25](#)).

In the differential protection devices, other protection functions are available that can be used as supplemental protection and monitoring functions and backup protection for the upstream and downstream power system. It is also possible to monitor limiting values.

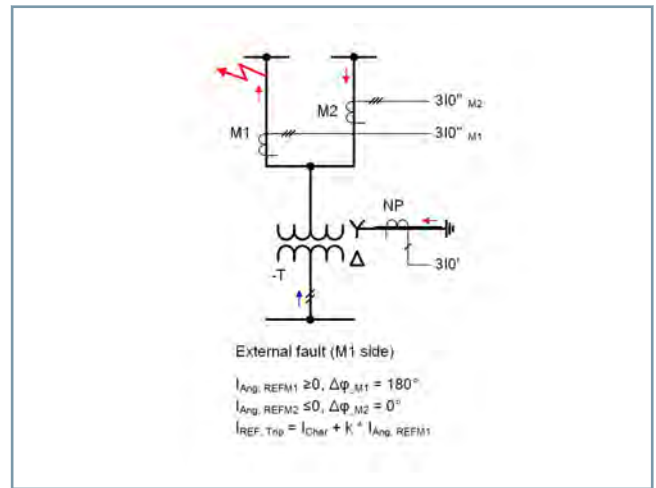

[dw_fault_M1 side, 2, en_US]

Figure 3.2/26 Measuring-Point Selection for Multiple Infeeds on the Neutral Side

Motor Differential Protection (ANSI 87M)

The Differential motor protection

- Detects ground faults and multiphase short circuits in motors
- Detects short circuits during the operation of motors on power systems with a grounded neutral point
- Is stable during startup processes with current-transformer saturation through intelligent saturation recognition methods
- Triggers safely in case of internal high-current faults through an additional high-current stage

and is based on a comparison of currents (Kirchhoff's current law). The basic principle is that the currents add up to zero in the protected object when it is in the undisturbed operating state. If a current difference occurs, this is a sure sign of a fault within the protected object.

The calculation of the difference is determined through the current direction definition. The direction of current is defined as positive to the protected object. The current difference results from the vector addition of the currents.

In the protection function, the following properties become important:

- Error-current stabilized operate curve with freely adjustable characteristic curve sections in accordance with [Figure 3.2/21](#)
- Additional stabilization procedure against external errors with current-transformer saturation. The 1st procedure reacts to high-current errors and monitors the history of the differential current (time-limited occurrence of a differential current from the additional stabilization area, see [Figure 3.2/21](#)). A shift to an internal error is reliably detected. The 2nd procedure works for low-current errors. Due to the DC component in the short-circuit current and remanence of the current transformer, phase angle rotations in the secondary current can result. If jumps in the restraint current occur and if DC components are simultaneously detected in the differential current, an elevation of the operate curve is carried out on a time limited basis.
- In the case of asynchronous motors, distorted transmission of the starting current may result in differential currents. Due to a startup detection (jump within the restraint current and DC component evaluation), the operate curve is raised.
- High-current internal errors are reliably and quickly detected by the high-current stage Idiff-fast (see [Figure 3.2/20](#)). In order to prevent an overfunction by quadrature-axis current components (for example, use in breaker-and-a-half layouts), the instantaneous values from the differential and restraint currents are evaluated. In a few milliseconds, interior and exterior errors are reliably differentiated.

Generator Differential Protection (ANSI 87G)

The generator differential protection is a selective short-circuit protection for different generator variants. It processes the currents from the 3-phase neutral-point transformers and feeder-side current transformers (see [Figure 3.2/27](#)).

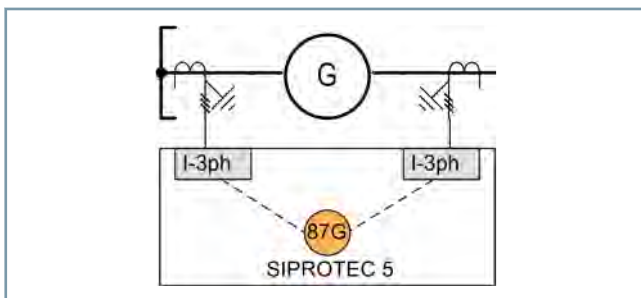

[dw_anschaltung, 1, en_US]

Figure 3.2/27 Generator Differential Protection Connection

In the protection function, the following properties become important:

- Error-current stabilized operate curve with freely adjustable characteristic curve sections in accordance with [Figure 3.2/20](#)
- Automatic correction of a current-transformer mismatch

- Additional stabilization procedure against external errors with current-transformer saturation. The 1st procedure reacts to high-current errors and monitors the history of the differential current (time-limited occurrence of a differential current from the additional stabilization area, see [Figure 3.2/20](#)). A shift to an internal error is reliably detected. The 2nd procedure works for low-current errors. Due to the DC component in the short-circuit current and remanence of the current transformer, phase angle rotations in the secondary current can result. If jumps in the restraint current occur and if DC components are simultaneously detected in the differential current, an elevation of the operate curve is carried out on a time limited basis.
- Jump monitoring in the restraint current (typically during startup operations for motors) can also be used to prevent overfunction in response to external errors. If a jump is detected, the operate curve is raised on a time-limited basis.
- High-current internal errors are reliably and quickly detected by the high-current stage Idiff-fast (see [Figure 3.2/21](#)). In order to prevent an overfunction, the instantaneous values from the differential and restraint currents are evaluated. In a few milliseconds, interior and exterior errors are reliably differentiated.

Busbar Differential Protection (ANSI 87B)

The busbar differential protection is a selective, safe, and fast protection against busbar short circuits in medium-voltage systems, high-voltage systems, and systems for very high voltage with a large variety of busbar configurations.

The protection is suitable for switchgear with closed iron core or linearized current transformers.

Its short tripping time is particularly advantageous in cases of high-output short circuits or when network stability is threatened.

The modular hardware system allows for the optimum adaptation of the system configuration protection.

In the protection function, the following properties become important:

- Phase-segregated measurement and display
- Selective tripping of faulty busbar sections
- Additional disconnector-independent check zone as additional tripping criterion
- Shortest operate times (<10 ms)
- Highest stability in case of external faults, even in case of transformer saturation, through stabilization with flowing currents
- Operate curve with freely adjustable characteristic curve sections according to [Figure 3.2/20](#)
- Additional, activatable sensitive operate curve for low-current faults, for example in resistance-grounded networks in accordance with [Figure 3.2/21](#)

- Low requirements of the saturation-free time of the current transformers through fast detection of internal or external faults within 2ms
- 3 interacting methods of measurement allow minimum tripping times after busbar faults and ensure maximum stability in case of large short-circuit currents.

The integrated circuit-breaker failure protection recognizes circuit-breaker faults in case of busbar short-circuits and provides a trip signal for the circuit breaker at the line end. The adjacent busbar trips if a coupler circuit breaker fails.

Capacitor Bank Differential Protection (ANSI 87C)

The Capacitor bank differential protection

- Detects ground faults and multiphase short circuits in motors on capacitor banks
- Detects ground faults during the operation of capacitors using mains with a grounded neutral point
- Uses the necessary stabilization procedures during switching operations
- Triggers safely and very fast in the case of internal high-current faults through an additional high-current stage.

Voltage Differential Protection for Capacitor Banks (ANSI 87V)

The voltage differential protection function is used to detect C-element errors within a capacitor bank. It can be used if a voltage tap is present within the capacitor installation. The function calculates in a phase-segregated manner the differential voltage between the voltage advance multiplied by an adjustment factor and the busbar voltage.

Fault Locator (FL)

Single ended fault locator

The integrated fault locator calculates the fault impedance and the fault distance. The result is displayed in ohms, miles, kilome-

ters, or in percent of the line length. The influence of parallel lines and of load currents can also be compensated.

Double-end fault locator

Due to load current, there is phase-angle displacement between the voltages of both line ends. This angle and possible differences in the source impedance angle cause the angle displacement between the currents at both ends. The angle displacement of the currents affects the voltage drop at a possible fault resistance (RF). The single ended measurement cannot compensate for this.

As an option for a line with 2 ends, a fault locator function with measurement at both ends of the line is available. The full connectivity model is considered. Thanks to this feature, measuring accuracy on long lines under high load conditions and high fault resistances is considerably increased.

Phasor Measurement Unit (PMU)

Phasor Measurement Units (PMUs) make a valuable contribution to the dynamic monitoring of transient processes in energy-supply systems. On the one hand, the advantage over standard RMS values is that the phasor values of current and voltage are transmitted. On the other hand, each measured value includes the exact time stamp and therefore should be assigned within the transmission path in which it originates independent of the time delay. The phasors and analog values are transmitted by the PMU with a configurable repetition rate (reporting rate). Due to the high-precision time synchronization (via GPS), the measured values from different substations that are far away from each other are compared, and conclusions about the system state and dynamic events, such as power fluctuations, are drawn from the phase angles and dynamic curves.

The PMU function transmits its data via an integrated Ethernet module using the standardized protocol IEEE C37.118. The evaluation can be done with a Wide Area Monitoring System ([Figure 3.2/28](#)) for example SIGUARD PDP (Phasor Data Processor).

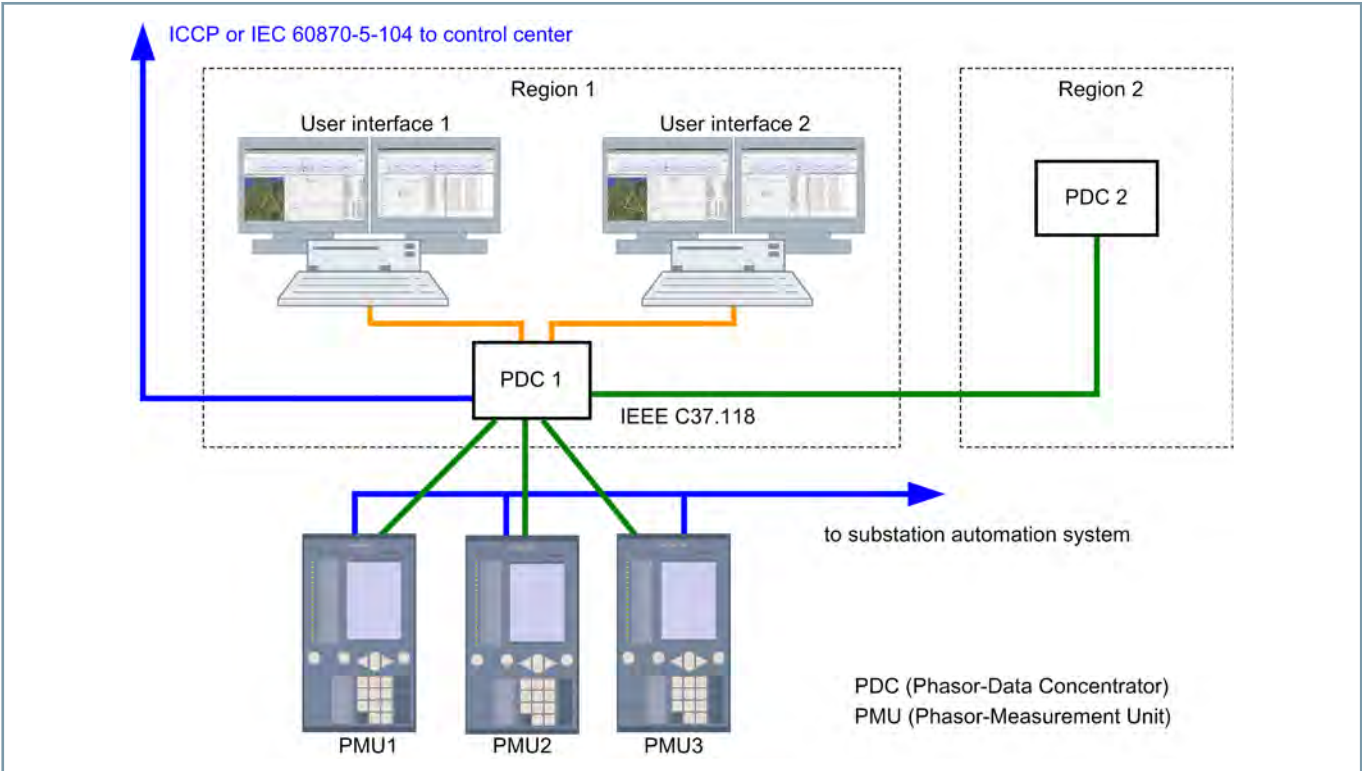

[dw_struct_WAM, 1, en_US]

Figure 3.2/28 Use of SIPROTEC 5 Devices as Phasor Measurement Units on a SIGUARD PDP Evaluation System

SIPROTEC 5 System

Control

Control

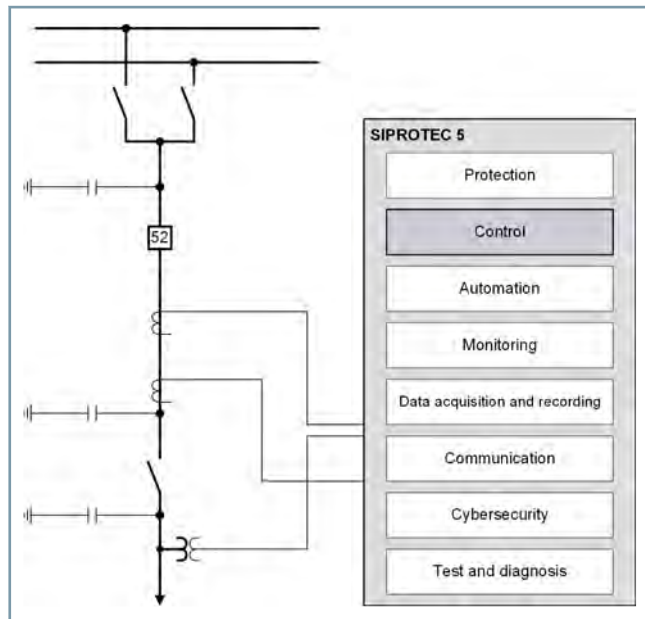

[dw_steuerung, 4, en_US]

Figure 3.3/1 SIPROTEC 5 – Functional Integration – Control

SIPROTEC 5 includes all bay level control and supervision functions that are required for efficient operation of the switchgear.

The large, freely configurable graphics display for control diagrams is available for convenient local control. Frequent operating actions, such as starting switching sequences or displaying the indication list, can be called up via one of the 9 function keys. The required security is guaranteed by the key switches for local/remote and interlocked/unlocked switch-over.

The application templates supplied provide the full functionality that you need for your application. Protection and control functions access the same logical elements. From the perspective of switching devices, protection and control are treated with equal priority.

The modular, scalable hardware can be adapted to the system conditions. You can easily put together the desired hardware quantity structure. For example, a single SIPROTEC 5 device can be used to control and monitor an entire breaker-and-a-half diameter.

A new level of quality in control is achieved with the application of the communication standard IEC 61850. For example, binary information from the bay can be processed very elegantly and data (such as for interlocking across multiple fields) can be

exchanged between the devices. Cross communications via GOOSE enable efficient solutions, since here, the wiring is replaced with data telegrams.

All devices already have up to 4 switching objects (switches, disconnectors, or grounding conductors) via the base control package. Optionally, additional switching objects and switching sequence blocks (CFC switching sequences) can be activated.

Transformer Voltage Controller (ANSI 90V)

The transformer voltage controller functionality (ANSI 90V) is used to control power transformers (two-winding transformers, three-winding transformers, interconnecting transformers) and auto transformers using a motor-operated tap changer. In addition, the voltage control can be used for two-winding transformers connected in parallel.

This function is designed to control the following:

- For two-winding transformers: the voltage on the secondary circuit of the power transformer
- For three-winding transformers: the voltage of the secondary winding 1 or winding 2
- For grid coupling transformers: voltage of winding 1 or winding 2, selectively depending on the power direction

The function provides automatic voltage control within a specified voltage range on the secondary side of the transformers or, as an alternative, at a remote load point (Z compensation or R/X compensation) in the network. In order to compensate for the voltage variations in the power system, use the LDC-Z procedure (Z compensation). For voltage drops on the line, use the LDC-X and R procedure (R/X compensation).

The control principle is based on the fact that a higher or lower command to the tap changer, depending on the voltage change (ΔV) per stage, causes a voltage increase or decrease.

The voltage control operates on a tap-for-tap basis and compares the measured actual voltage (V_{act}) with the specified target voltage (V_{set}). If the difference is greater than the set bandwidth (B), a higher or lower command is sent to the tap changer once the set time delay (T1) has elapsed.

The voltage controller function also monitors the currents on the upper voltage side and the low voltage side to block the controller during impermissible operating states (overcurrent/undercurrent/overvoltage/undervoltage, reverse power).

The voltage controller function can also be used for parallel control of up to 8 two-winding transformers in different groups. You can carry out parallel control based on the Master-Follower method or using circulating reactive current minimization method.

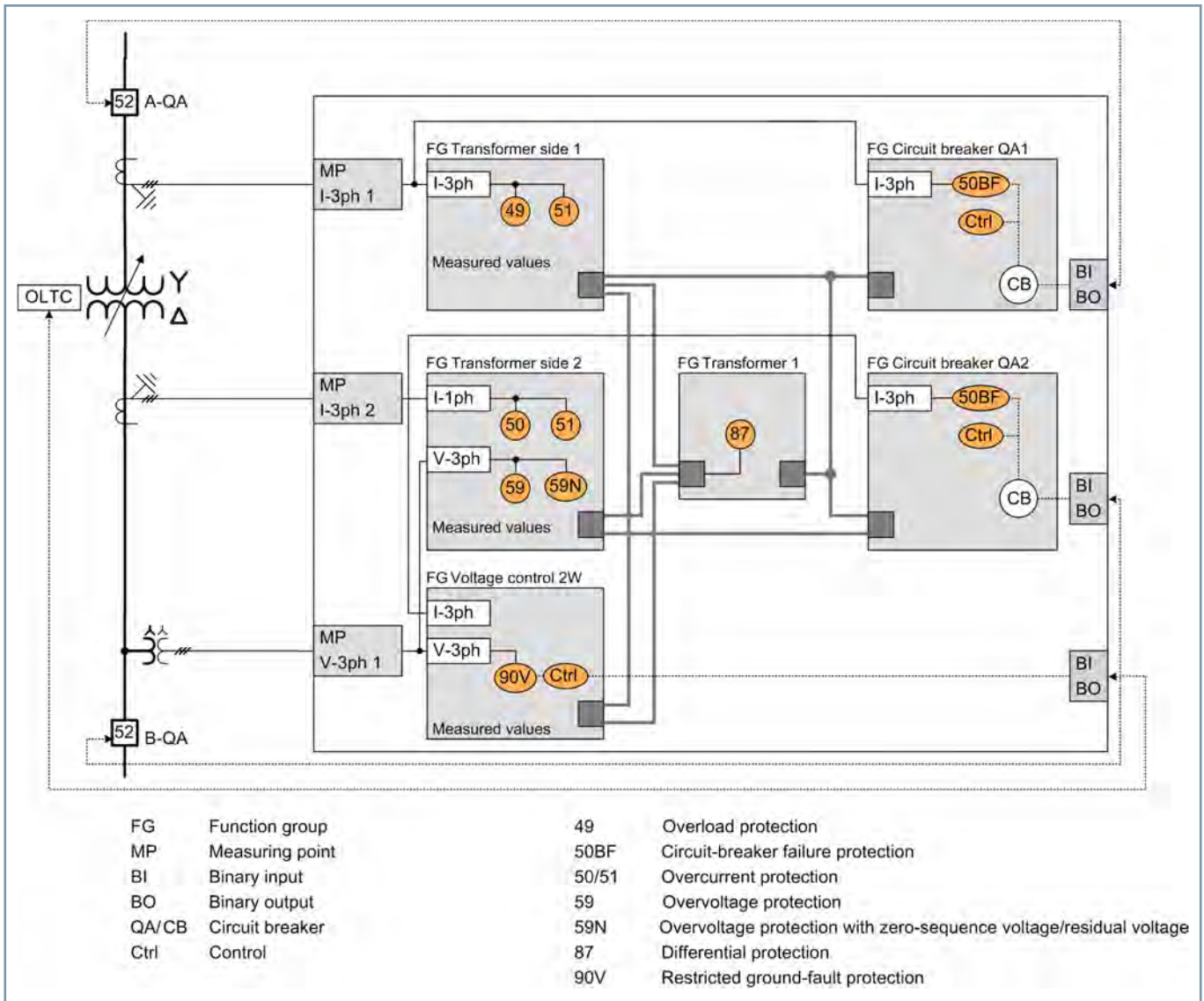

[dw_two-winding-appl-voltage, 1, en_US]

Figure 3.3/2 Application Example: SIPROTEC 7UT85 with Differential Protection and Voltage Controller

SIPROTEC 5 System

Control – Point-On-Wave Switching (PoW)

Point-on-Wave Switching (PoW)

Point-on-wave and phase-segregated switching is a new function in the modular SIPROTEC 5 device range and can be added to any device from the DIGSI function library.

Point-on-wave switching can be used in various ways:

- Stand-alone device for point-on-wave switching: type 6MD86
- Bay-control and point-on-wave switching in a single device: type 6MD86
- Protection, control, and point-on-wave switching in a single device: for example, 7SJ85 (protection of capacitor banks)

Switch applications for point-on-wave switching:

- Common-mode reactor
- Capacitors
- Transformers
- Simple power lines and cables (no compensation lines)

Point-on-wave and phase-segregated circuit-breaker switching minimizes electrodynamic and dielectric loads on equipment (overvoltages and inrush surge currents).

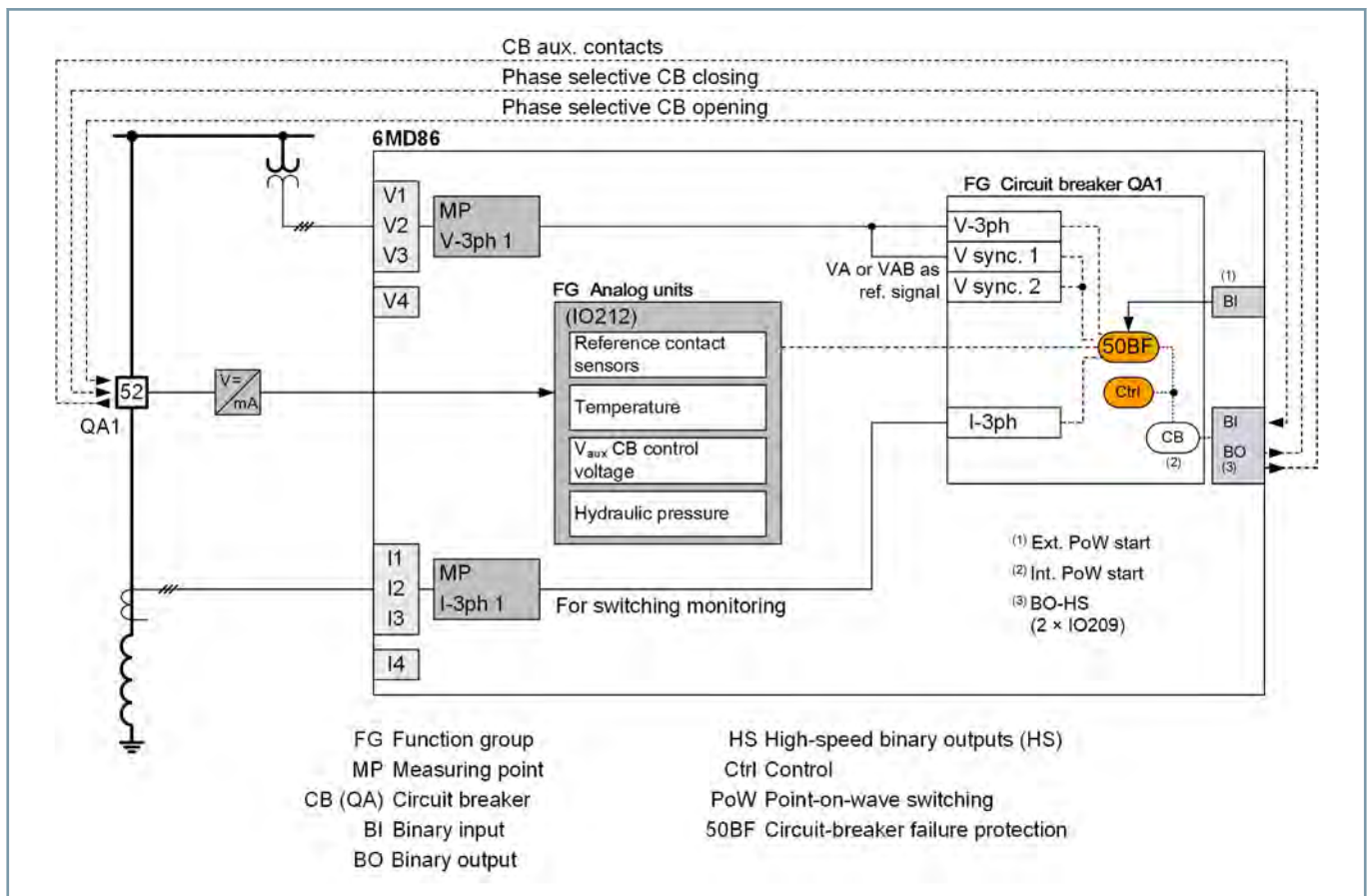

[dw_Appl_point-on-wave-switching, 1, en_US]

Figure 3.3/3 Application Example: Point-on-Wave on and off Switching for a Reactance Coil

Properties:

- A reactance coil is switched off using point-on-wave switching to prevent overvoltages and arc reignitions.
- A reactance coil is switched on using point-on-wave switching to prevent inrush currents.
- Switching accuracy on the device contact < 50 μ by using solid-state outputs (IO209)

- Receiving and compensating for process and environment influences - via 0-mA to 20-mA inputs (IO212), which influence the switching time: Recording the control voltage of the closing and trip circuit, the temperature, and the hydraulic pressure, if required.
- Recording reference contacts for Siemens circuit breakers (IO212) for high-precision detection of circuit-breaker pole mechanical contact and disconnection.

- Recording the circuit-breaker auxiliary contacts for non-Siemens circuit breakers via normal binary inputs for accurate detection of circuit-breaker pole mechanical contact and disconnection.
- The function is cost-effectively integrated into a protection or electronic control unit. This ensures that the use of 2 physical devices, a) for controlled switching and b) for bay device functionality, can be avoided.

Module	Connections	Use
IO202	4 x I, 4 x V: Current and voltage measurement	<ul style="list-style-type: none"> • As a reference voltage • For switching monitoring/recording
2 x IO209	With 8 x high-speed contacts for switching accuracy < 50 μ	<ul style="list-style-type: none"> • For supervised circuit-breaker opening and closing
IO212	With 8 x quick measuring-transducer inputs (0 mA to 20 mA)	<ul style="list-style-type: none"> • 3 inputs as a Siemens circuit-breaker reference contact • 2 inputs for circuit-breaker opening and closing (control voltage) • 1 input for temperature measurement
Optional	1 plug-in module with 4 additional standard measuring-transducer inputs	<ul style="list-style-type: none"> • 3 inputs for hydraulic circuit-breaker pressure
Hints:		
<ul style="list-style-type: none"> • All measuring-transducer inputs are passive and require an external DC 24-V power supply. • The circuit-breaker control voltage must be converted into 4 mA to 20 mA externally. 		

Table 3.3/1 Device Specification for Point-on-Wave Switching

SIPROTEC 5 System

Automation

Automation

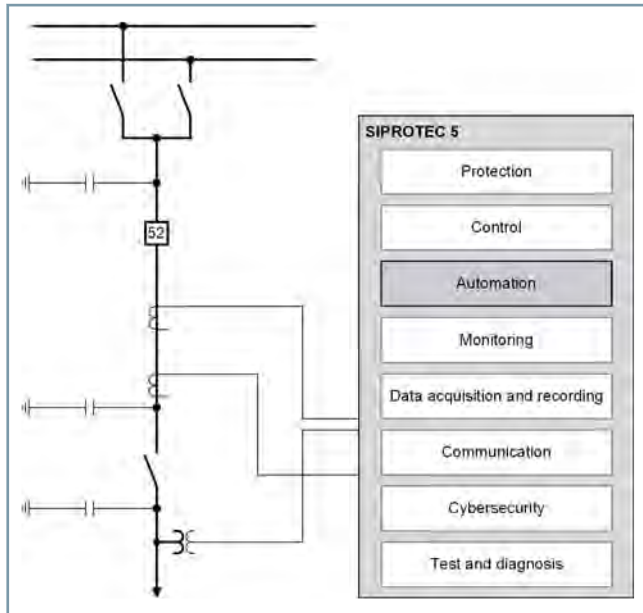

[dw_automation, 4, en_US]

Figure 3.4/1 SIPROTEC 5 – Functional Integration – Automation

The integrated CFC (Continuous Function Chart) graphical automation editor enables you to create logic diagrams clearly and simply. DIGSI 5 supports this with powerful logic blocks based on the standard IEC 61131-3. All devices already have a powerful base automation package. This makes it easy to provide specific functions for automation of a switchgear.

Various stages of expansion for the CFC function charts are available for the realization of your solutions:

- Function chart (CFC) basic
- Function chart (CFC) arithmetic

With the basic function chart (CFC) package, you can link all internal digital information graphically, such as internal protection signals or operating states, directly to the logic blocks and process them in real time. With the arithmetic function chart (CFC) package, you can also link measured values or monitor them regarding to limiting values.

Examples of automation applications are:

- Interlocking checks
- Switching sequences
- Message derivations or the tripping of switching operations
- Messages or alarms by linking available information
- Load shedding in a feeder
- Administration of decentralized energy infeeds
- System switchovers depending on the network status
- Automatic grid separations in the event of grid stability problems

Of course, SIPROTEC 5 provides a substation automation system, such as SICAM PAS/PQS, with all necessary information, thus ensuring consistent, integrated, and efficient solutions for further automation.

Using macros makes it possible to reuse CFC subplans simply and clearly, in the device, project, or in other projects. CFC online monitoring makes it possible to track and check the sequence of the plans in the device. Corrections can therefore be made in a fast and efficient way.

Monitoring

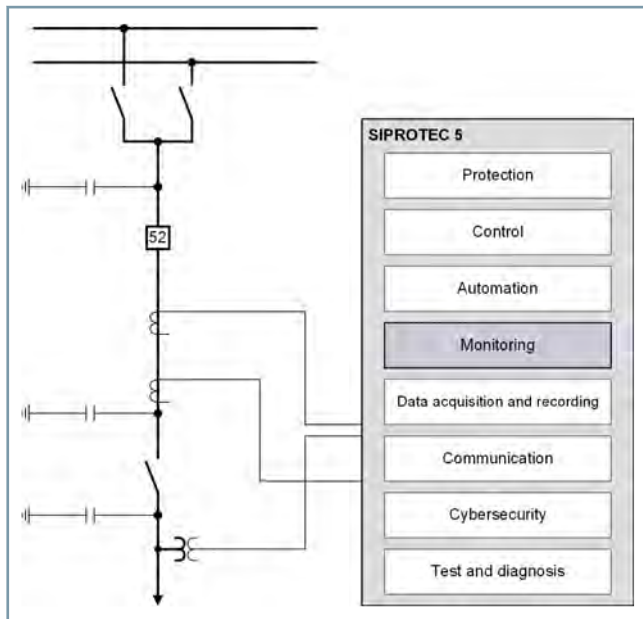

[dw_Monitoring, 4, en_US]

Figure 3.5/1 SIPROTEC 5 – Functional Integration – Monitoring

SIPROTEC 5 devices can take on a wide variety of monitoring tasks.

These can be divided into the following groups:

- Self monitoring
- Monitoring power-system stability
- Monitoring of equipment (condition monitoring)
- Monitoring power quality

Self-Monitoring

SIPROTEC 5 devices are equipped with many monitoring procedures. These procedures detect faults, internal as well as external, in secondary circuits, store them in logs, and report them. This information is used to record the device fault and helps to determine the cause of the error in order to take appropriate corrective actions.

Monitoring power-system stability

Grid Monitoring combines all of the monitoring systems that are necessary to assure power-system stability during normal operation. SIPROTEC 5 provides all necessary functionalities, such as fault recorders, continuous recorders, fault locators, and synchrophasor measurement (Phasor Measurement Units, PMU) for Grid Monitoring. This functionality allows to monitor power system limit violations (for example, stability monitoring via load-angle control) and to trigger the appropriate responses actively. This data in the network control systems can also be used as input variables for online power-flow calculation and enable a significantly faster response in case of status changes in the power system.

Monitoring of equipment (condition monitoring)

Condition monitoring is an important tool in asset management and operational support from which both the environment and the company can benefit. Equipment that typically requires monitoring includes for example: circuit breakers, transformers, and gas compartments in gas-insulated switchgear (GIS).

The measuring-transducer inputs (0 mA to 20 mA) enable connection to various sensors and monitoring of non-electrical variables, such as gas pressure, gas density, and temperature. Thus, SIPROTEC 5 enables a wide range of monitoring tasks to be carried out.

SIPROTEC 5 provides the process interfaces, buffers, recorders, and automation functions necessary for monitoring equipment:

- Process values are stored together with a time stamp in the operational log
- The circuit-breaker statistics provide essential data for condition-based maintenance of switchgear
- Process variables (for example, pressure, SF6 loss, speed, and temperature) are monitored for limit violations via measuring transducers connected to the sensors.
- Using external 20 mA or temperature measurement devices that are connected serially or by Ethernet, other measured values can be captured and processed.

Monitoring power quality

Besides availability, the ultimate consumers demand also a high quality concerning the electrical energy (power quality). This is dependent on process management and the responsibility of the power utilities and consumers among other factors. The increasing use of power electronic components (for example, nonlinear motor drives, renewable infeeds) can have loading effects on power quality. Switching operations in the electrical power system can result in brief voltage dips. An inadequate power quality can lead to interruptions of supply, damages, production outages, and high follow-up costs. Consequently, a reliable measurement of the appropriate power quality features becomes more and more important.

Starting with V8.40, SIPROTEC 5 offers platform-wide⁵ basic detection and recording of some power-quality data with PQ Basic:

- Voltage changes (overvoltage, dips, interruption) and voltage unbalance according to IEC 61000-4-30 Class S
- Harmonic voltages and currents up to the 20th harmonic, THD and TDD

Many applications do not require detections according to the most stringent PQ standards. PQ-Basic offers a cost-effective, simple solution without having to install and operate additional power-quality devices. In this way, you can quickly get an overview of your PQ status for the entire power system since all the installed SIPROTEC 5 devices can simply be upgraded via a firmware update without having to install additional hardware. You can then, for example, perceive trends and be warned if the power quality has reached problematic limits at sensitive points. This can be used to detect weak points early so that corrective measures can be taken.

⁵ without 7KE85 because, in this case, an extended detection of PQ measured values has been implemented.

SIPROTEC 5 System

Monitoring

If a detection and evaluation of the power-system quantities is necessary as per the entire scope of grid codes, such as the EN 50160 standard, SIPROTEC 5 provides appropriate power-quality recorders such as the SIPROTEC 7KE85. A SICAM PQS system provides centralized data archiving and an elegant evaluation of the weekly reports as per, for example, EN 50160, among others.

Power Quality – Basic (PQ-Basic)

Voltage Unbalance

In a 3-phase power system, the voltages are normally balanced, as well as the connected loads. In some cases, however, the balanced conditions can be disturbed due to various influences.

Voltage unbalances can be caused by various factors:

- Unbalanced load, for example, caused by different consumers in the individual phases
- Phase failure, for example, due to a tripped 1-phase fuse or a broken conductor
- Faults in the primary system, for example, at the transformer

The function **Voltage unbalance**:

- Detects the voltage-unbalance conditions in the distribution and industrial power systems.
- Monitors the voltage-unbalance conditions.

In the function **Voltage unbalance**, the following stage types are available:

- **V2/V1**: ratio of the negative-sequence voltage to the positive-sequence voltage
- **V0/V1**: ratio of the zero-sequence voltage to the positive-sequence voltage

All the measured values are displayed under **Power quality basic > Voltage unbalance** of a specific function group in the HMI.

The specific function group in which the function **Voltage unbalance** is instantiated must be connected to the 3-phase voltage measuring point.

The values are recorded according to the standard for voltage quality IEC 61000-4-30 class S.

Voltage Variation

The function **Voltage variation** is used for measuring and monitoring short-duration variations of the voltage in distribution and industrial power systems. The power-quality events such as voltage dips, swells, and interruptions in 3-phase systems are detected.

This measuring function provides the RMS value of the voltage for the minimum value in the event of a voltage dip, the lowest residual voltage in the event of an interruption or the highest swell, as well as the duration of the event.

All events can be logged in operational or user-defined logs. They can enable the fault recorder via binary warning indications, and write their values as tracks.

The values are recorded according to the standard for voltage quality IEC 61000-4-30 class S.

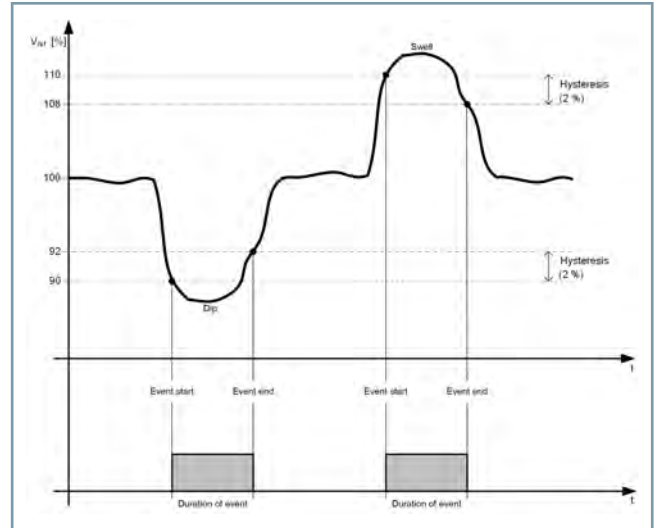

[dw_PQ_VoltVar_event_duration, 1, en_US]

Figure 3.5/2 Duration of a Voltage Dip or Overvoltage Event

THD and Harmonics

At the connection point to the public power system, the allowed total harmonic distortion (THD) is limited according to the power-quality related standards. The function **THD and harmonics** can be used to monitor the THD value.

The function **THD and harmonics** serves for the calculation of the following values:

- THD values of the 3-phase currents and 3-phase voltages
- Aggregated THD values of the 3-phase voltages
If the aggregated THD value exceeds the threshold, a warning is generated.
- 2nd to 20th harmonics of the 3-phase currents and 3-phase voltages

The calculated THD values and harmonics are displayed under **Power quality basic > THD and harmonics** of a specific function group in the HMI or via the DIGSI Online-Editor. If routed, the calculated THD values and harmonics are available in the communication protocols and in the fault record. Abnormal values can be logged in the operational or user-defined log if routed.

Total Demand Distortion

At the connection point to the public power system, the allowed total demand distortion (TDD) is limited according to the power-quality related standards. The function **Total demand distortion** can be used to monitor the TDD value.

The function **Total demand distortion** serves for calculating the following values of the 3-phase currents:

- 3-s TDD value
- TDD value within an interval
If the TDD value **TDD intv1** exceeds the threshold value, a warning is generated.

The TDD values are displayed under **Power quality basic > TDD** of a specific function group in the HMI or via the DIGSI Online-Editor. If routed, the TDD values are available in the communica-

tion protocols and the fault records. Abnormal values can be logged in the operational log or user-defined logs.

General Properties, Power Quality – Basic:

Values of the 3 phases (phases-selectively) can

- be viewed on the device display as well as remotely using DIGSI 5 and even used with CFC
- be transmitted using the protocols supported by SIPROTEC 5 (typically, as per IEC 61850) for additional use or for documentation
- optionally be recorded in the fault record; started via CFC (it is possible to configure one binary input to an external start condition of the fault recorder).
- All events and anomalous PQ data can be logged in operational logs or user-defined logs with a time stamp and they can be displayed on the HMI and in the DIGSI 5 information list. The data is stored in non-volatile memories (and are not lost in case of a power failure). You can also export data to a file with DIGSI.
- If limiting values are exceeded, warning signals can be generated.
- Statistical values such as meters and previous maximum values can be reset via the HMI, BI, or remotely via DIGSI or via the protocol (resetting via the protocol should be done using the CFC and a user-defined signal)
- PQ-Basic is a SIPROTEC 5 platform-wide feature and can thus be used for all devices (except for the 7KE). Older firmware versions can simply be upgraded, a hardware change is not necessary.

SIPROTEC 5 System

Data Acquisition and Logging

Data Acquisition and Logging

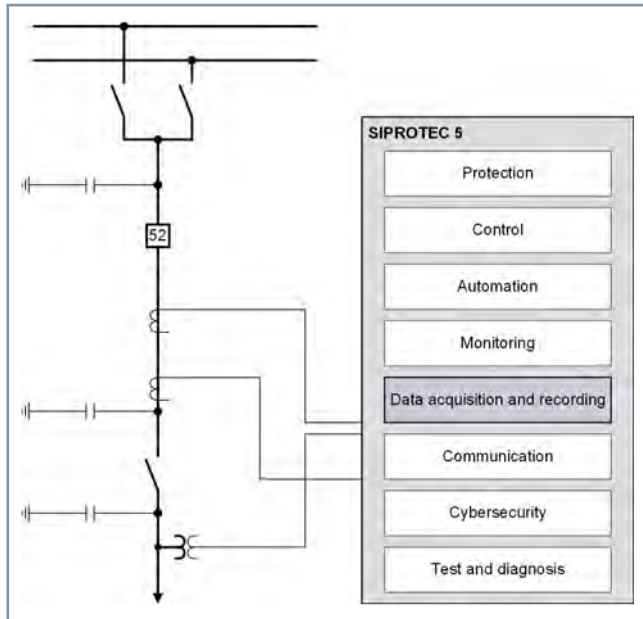

[dw_data, 4, en_US]

Figure 3.6/1 SIPROTEC 5 – Functional Integration – Data Acquisition and Logging

The recorded and logged bay data is comprehensive. It represents the image and history of the bay. It is also used by the functions in the SIPROTEC 5 device for monitoring, substation automation, and multibay automation tasks. Thus, they represent the basis both for the functions available today and for future applications.

Measurement and PMU

A large number of measured values are derived from the analog input variables, which supply a current image of the process.

Depending on the device type, the following basic measured values are available:

- Operational measured values
- Fundamental phasor and symmetrical components
- Protection-specific measured values, such as differential and restraint current for differential protection
- Mean values
- Minimum values and maximum values
- Energy measured values
- Statistical values
- Limiting values

Besides the basic measured values, synchrophasor measured values can also be activated in the devices (application as PMU, Phase Measurement Unit)

Synchrophasor measured values support a range of applications for monitoring grid stability. For this purpose, SIPROTEC 5 devices acquire the necessary PMU data. These high-precision, time-stamped phasors indicate power frequency and the change in the power frequency. They can be transmitted to

central analysis systems via the high-performance communication systems.

Measured values are displayed as primary and secondary values and as reference values. These values are also available for other applications, for example, transmission to the systems control or automation tasks.

Up to 40 analog inputs can be supplied for each device. Up to 80 analog inputs are supported in the busbar protection SIPROTEC 7SS85.

The analog inputs of the SIPROTEC 5 devices can be selected with a corresponding accuracy class and dynamic range suitable for connection to both protections and measurement cores. The innovative current-terminal technology enables these to be simply adapted later on-site if needed. All analog inputs are factory-calibrated and thereby ensure maximum accuracy.

The following accuracies are typical:

- $V, I \leq 0.1\%$ at f_{rated}
- $V, I \leq 0.3\%$ in the expanded frequency range ($f_{rated} - 10\text{Hz}, f_{rated} + 10\text{Hz}$)
- $P \leq 0.3\%$ at f_{rated}
- $P \leq 0.5\%$ in the expanded frequency range ($f_{rated} - 10\text{Hz}, f_{rated} + 10\text{Hz}$)
- $Q \leq 1.0\%$ at f_{rated}
- $Q \leq 1.5\%$ in the expanded frequency range ($f_{rated} - 10\text{Hz}, f_{rated} + 10\text{Hz}$)

Separate measuring transducers (analog inputs) are therefore unnecessary. The high-precision measured data enables extended energy management and makes commissioning much easier.

SIPROTEC 5 thus provides the following measured values for analysis and further processing:

- The basic measured values with high dynamic range and high accuracy (protection-class current transformer)
- The basic measured values with very high accuracy (instrument transformer)
- Synchrophasor measured values with high-precision time stamping for subsequent tasks such as grid stability monitoring.
- Detection of current and voltage signals up to the 50th harmonic with a high accuracy for selected protection functions (for example thermal overload protection, peak over-voltage protection for capacitors) and operational measured values.

Recorder

In SIPROTEC 5, recorders are able to record large volumes of data. They feature a large number of analog and binary inputs, and a high sampling frequency. An extremely wide range of records can be converted, either continuously or via various trigger criteria.

Besides storing the data on internal mass storage, a transmission to central analysis systems is possible. Consequently, you are able to monitor systems regarding typical characteristics.

Fault Recorder

The fault recording in protection devices and bay controllers stores analog and binary data during a fault event, for example, in case of short circuits or ground faults, and preserves the records, including high-precision time stamps for subsequent analysis. Calculated measurands such as power or frequency can also be incorporated into the fault recording function. Analysis takes place after the data is read out from the device by DIGSI using SIGRA. Recorded data is archived to prevent data loss in the case of supply voltage failure. Analog and binary signal traces to be recorded are freely configurable, and pre-trigger and post-trigger record duration can be programmed within a very wide range. SIPROTEC 5 fault recording provides long recording times with outstanding accuracy.

Features of the fault recorders:

- Recording of all analog channels
 - Sampling frequencies from 1 kHz to 8 kHz
 - High recording capacity for individual records of 20 s for 24 channels at an 8 kHz sampling frequency
 - Storage capacity for up to 128 fault records
 - The recording duration for all records is limited by the available storage capacity of the device, and depends on the number of configured channels and sampling frequency.
- Example
- Line protection with 8 analog channels (4 I, 4 V),
 - Sampling frequency 1 kHz, 6 measured-value channels, and 20 binary channels: resulting recording capacity of the device about 890 s!
- Up to 100 freely configurable binary tracks and 50 additional measured-value tracks
 - **Due to the high number of up to 120 measured values, a different record duration results for SIPROTEC 7SS85.**
 - **The SIPROTEC 7KE85 fault recorder has yet more properties:**
 - Expanded trigger criteria: Gradient trigger ($\Delta M/\Delta t$), binary trigger, network trigger, GOOSE trigger, trigger on harmonics via CFC, etc.
 - Higher sampling frequency of 16 kHz for up to 40 analog channels
 - Substantially longer record duration due to the additionally installed mass storage.

You can find the descriptions for the fast-scan, slow-scan, and continuous recorder as well as for the trigger functions in the chapter "SIPROTEC 7KE85 fault recorder".

Time synchronization

To be able to compare the measured values and recordings of the devices at different locations to each other, a very exact time synchronization of all devices is necessary. Thus, the time synchronization is an important property and must be done with a high degree of accuracy. In particular, the use of the Phasor Measurement Unit (PMU) function and the applications with the process bus require a precise time stamping, [Figure 3.6/2](#).

The time synchronization can be done using 1 or 2 timers. Depending on the time source, an accuracy from 1 ms to 1 μ s is

achieved. Events are logged with a date and time with 1-ms resolution.

The time synchronization is optionally realized via:

- DCF77 signal
- IRIG-B signal
- SNTP protocol
- Substation automation protocol (for example, IEC 60870-5-103, IEC 61850)
- IEEE 1588 protocol (accuracy: 1 μ s)
- Seconds pulse (for special high-precision applications)
- DIGSI 5 protocol (not cyclical)
- Timing master of a protection communication
- Internal time with integrated quartz crystal

Time synchronization in the device has a battery-buffered. Thus, the internal clock continues to run with the quartz accuracy of the device even in case of an auxiliary-voltage failure.

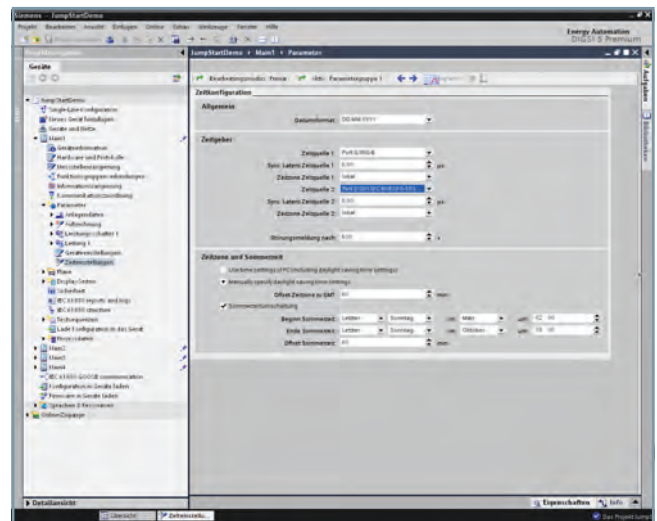

[Time_settings, 1, --, --]

Figure 3.6/2 Time Settings in DIGSI 5

GPS time signal receiver for IRIG-B, DCF77

The recommended GPS receiver from Meinberg ([Figure 3.6/3](#)) synchronizes the internal time of all connected protection devices. The internal clock of the protection devices are updated using the respective telegram (IRIG-B, DCF77). Optical fiber can also be used to transmit time signals (telegrams or second intervals) without interference even over larger distances and in electromagnetically polluted environments. SIPROTEC 5 devices generally support redundant time synchronization. The time information can be provided by 2 external timers. One timer functions as the primary time source. If it fails, a switchover to the second (secondary) timer is performed.

SIPROTEC 5 System

Data Acquisition and Logging

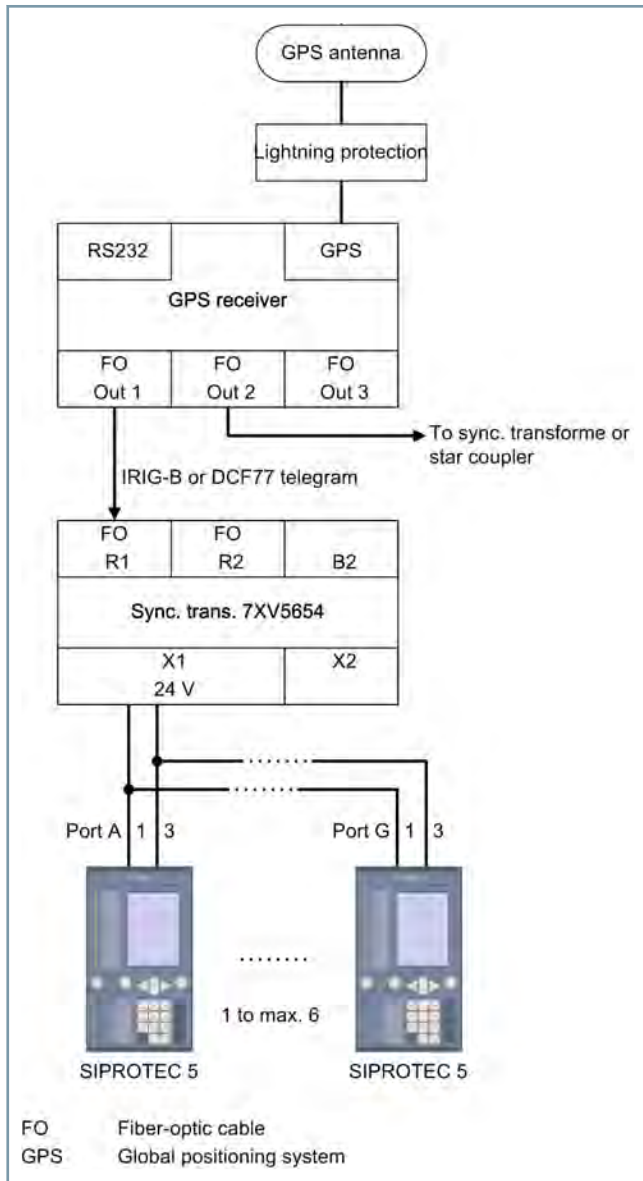

[dw_7KE85_GPS, 2, en_US]

Figure 3.6/3 SIPROTEC 5 Device with IRIG-B or DCF77 Time Synchronization

Event-log buffer

Event-log buffers mark important events with a time stamp (accurate to 1 ms) for subsequent analysis.

The long recording length is achieved with large event-log buffers and separate logs for different event categories. The events to be logged are freely configurable and provide improved manageability. Configuration of user-specific event-log buffers for cyclical or event-driven recording is also supported.

Convenient, complete analysis

Event-log buffers of different categories enable easier, targeted analysis. Changes to parameters and configuration data are recorded.

Maintainability

Hardware and software are constantly monitored and irregularities are detected immediately. In this way, extremely high levels of security, reliability, and availability are achieved at the same time. Important information about essential maintenance activities (for example, battery supervision), hardware defects detected by internal monitoring, or compatibility problems are recorded separately in the device-diagnosis log. All entries include specific instructions. The following table provides an overview of the typical logs.

The log entries and fault records are retained even in case of an auxiliary-voltage and battery-voltage failure.

Type of Log	Number of Messages	Property
Operational log	2000 messages	Cyclical logging of operational indications (for example, control processes)
Fault log	1000 messages per fault	Event-driven recording of faults. A maximum of 128 faults can be stored. A maximum of 1000 messages can be recorded for each fault.
User-specific buffer	200 messages	Option of cyclical or event-driven recording of user-defined signals
Ground-fault log	100 messages per ground fault	Event-driven recording of ground faults. A maximum of 10 ground faults can be stored. A maximum of 100 messages can be recorded for each ground fault.
Parameterization history log (cannot be deleted)	200 messages	Logging of all parameter changes and configuration downloads
Communication log	500 messages	Logging the status of all configured communication links (such as disturbances that arise, testing and diagnostic operation, and communication loads)
Security log (cannot be deleted)	500 messages	Logging the successful and unsuccessful attempts to access restricted areas of the device
Device-diagnosis log	500 messages	Logging and display of specific instructions in case of necessary maintenance (for example, battery supervision), detected hardware defects, or compatibility problems

Table 3.6/1 Overview of Typical Logs

SIPROTEC 5 devices are equipped with high-performance, pluggable communication interfaces and thus support optimal migration concepts in system modernizations. These interfaces are integrated or extendable via plug-in modules to offer a high degree of flexibility. The concept of plug-in modules and loadable protocols enables exchangeability and retrofitting.

Communication

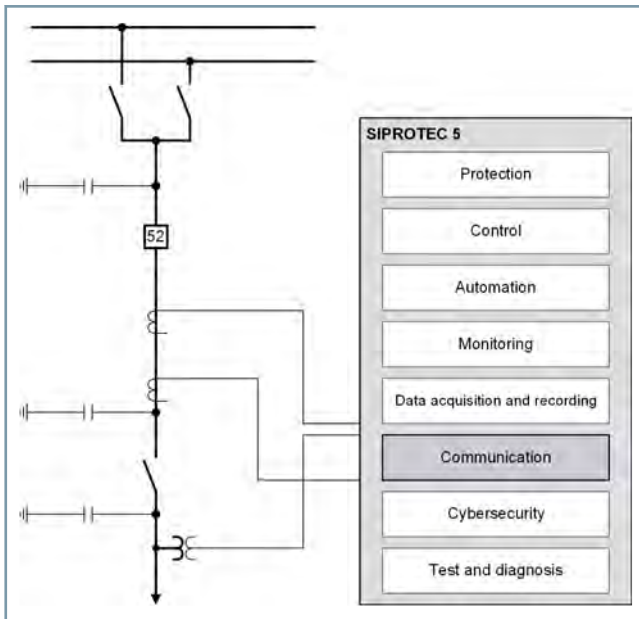

[dw_Communication, 4, en_US]

Figure 3.7/1 SIPROTEC 5 – Functional Integration – Communication

SIPROTEC 5 devices are equipped with high-performance communication interfaces. These are integrated interfaces or interfaces that are extendable with plug-in modules to provide a high level of security and flexibility. Various communication modules are available.

Particular importance was given to the realization of full communication redundancy:

- Several serial and Ethernet-based communication interfaces
- A large number of serial and Ethernet-based protocols (for example, IEC 60870-5-103, DNP3 serial and TCP, Modbus TCP, IEC 60870-5-104, PROFINET, and IEC 61850 Edition 1, 2.0, and 2.1)
- IoT interface via the OPC UA PubSub protocol for integration in cloud systems such as MindSphere
- Full availability of the communication ring when the switchgear is enabled for servicing operations by means of separate auxiliary power supply of the communication module CB202
- Ethernet redundancy protocols PRP and HSR, in particular for process bus and high-availability station communication
- A large number of plug-in modules with various communication protocols.

Plug-In Module Position of the Device

The base module can be extended via module slots E and F. All available modules can be installed there. The expansion module CB202 is designed for 3 additional plug-in modules if the 2 slots in the base module are not sufficient. Any additional plug-in modules can be installed in slots N and P. Analog expansion modules can be plugged into slot M. This slot does not support serial or Ethernet modules.

Serial Plug-In Modules

Serial electrical plug-in modules are used for asynchronous serial protocols, for example IEC 60870-5-103, DNP3. Optical 820-nm/1300-nm and 1550-nm modules can also be configured as a protection interface for the point-to-point connection.

Serial electrical RS485 module

This module has either 1 (USART-AB-1EL) or 2 (USART-AC-2EL) RS485 interfaces. The use of RJ45 sockets allows for the assembly of an economical serial RS485 bus with patch cables, which are simply looped through. This saves wiring time and cable costs. [Figure 3.7/2](#) shows an electrical serial module with 2 interfaces on which 2 independent serial protocol applications are executed.

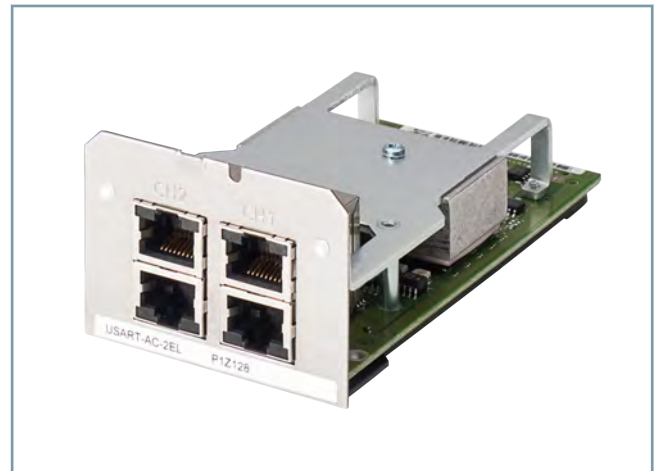

[E_CC_USART-AC-2EL_SRGB, 1, --]

Figure 3.7/2 Serial Electrical Double Module (USART-AC-2EL)

Serial optical 820-nm module

This module exists with 1 (USART-AD-1FO) or 2 (USART-AE-2FO) optical 820-nm interfaces ([Figure 3.7/3](#)), with which distances of 1.5 km to 2 km can be bridged via 62.5/125 μm multimode optical fibers. The optical connection is made via ST connectors. Apart from serial protocols, the synchronous serial protection interface can be operated on the module and enables optical direct connections via multimode optical fibers. 2 devices can thus either exchange data, for example of the differential protection via a short direct connection, or they can be connected through communication networks via a 7XV5662 converter. Additionally, the module can be connected directly with an optical multiplexer input in accordance with standard IEEE C37.94.

SIPROTEC 5 System

Communication – Plug-In Modules

3.7

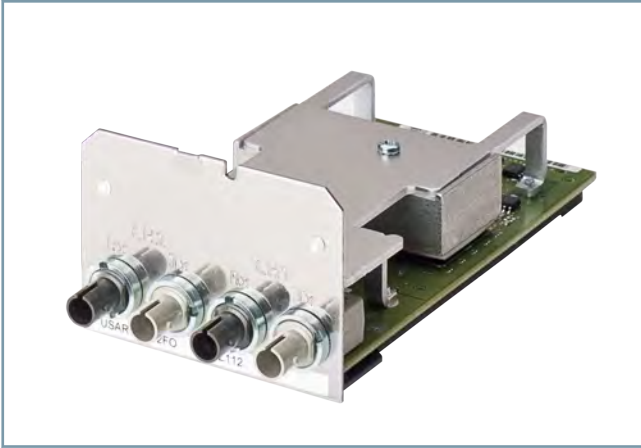

[E_CC_USART-AE-2FO_sRGB, 1, --]

Figure 3.7/3 Serial Optical 820-nm Double Module (USART-AE-2FO)

Serial optical 1300-nm/1550-nm modules for unidirectional data exchange

Long-distance modules are used for synchronous serial data exchange of protection communication via multimode or single-mode optical fibers. They are available with 1 or 2 interfaces (Table 3.7/1). The optical connection is made via duplex LC plugs.

Optical Wavelength	Module Designation with 1 or 2 Interfaces	Application
1300 nm	USART-AF-1LDFO, USART-AU-2LDFO	Max. 24 km via 2 single-mode optical fibers or max. 4 km via 2 multimode optical fibers
1300 nm	USART-AG-1LDFO, USART-AV-2LDFO	Max. 60 km via singlemode optical fiber
1550 nm	USART-AK-1LDFO, USART-AY-2LDFO	100 km via singlemode optical fiber

Table 3.7/1 Distance Modules for Different Distances for Point-to-Point Connections with 2 Fibers

Serial optical 1300-nm/1550-nm modules for bidirectional data exchange

Special modules enable bidirectional data exchange via one optical fiber. This saves one fiber per data connection on fiber-optic lines, without functional limitations in comparison with connections with 2 fibers. These modules transmit at 1300 nm or 1550 nm, but must be used in pairs (see Table 3.7/2 and Figure 3.7/4). The optical connection is made via LC simplex plugs.

Optical Wavelength	Module Designation with 1 or 2 Interfaces	Application
1300 nm	USART-AH-1LDFO <->	Max. 40 km via one single-mode optical fiber (with integrated fiber-optic multiplexer)
1550 nm	USART-AJ-1LDFO	
	USART-AX-2LDFO <->	
	USART-AY-2LDFO	

Table 3.7/2 WAN Modules for Point-to-Point Connections with One Fiber

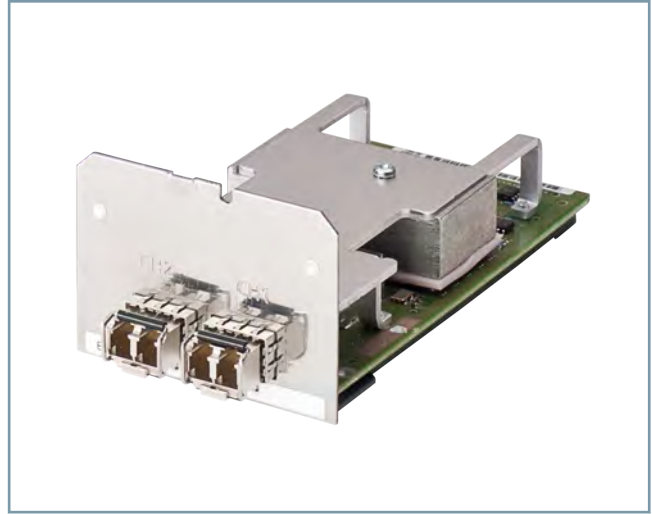

[E_CC_USART-BB-2FO-2LDFO_sRGB, 1, --]

Figure 3.7/4 Serial, Optical Double Module for Wide-Range Connections via Optical Fibers (for Module Designation, see Tables "Long-distance Modules")

Plug-In Modules for Ethernet

Ethernet modules are used for Ethernet-based protocol applications, for example, IEC 61850, IEC 60870-5-104, DNP3 TCP, PROFINET, time synchronization via SNTP, network management via SNMP, DIGSI 5 via TCP etc. Several applications can run in parallel, whereby unused applications can be switched off for security reasons.

Electrical Ethernet module

The ETH-BO-2EL module (Figure 3.7/5) has 2 RJ45 interfaces (Figure 3.7/5). It can be configured with or without an integrated switch. The maximum electrically permitted distance via CAT 5 patch cables is 20 m.

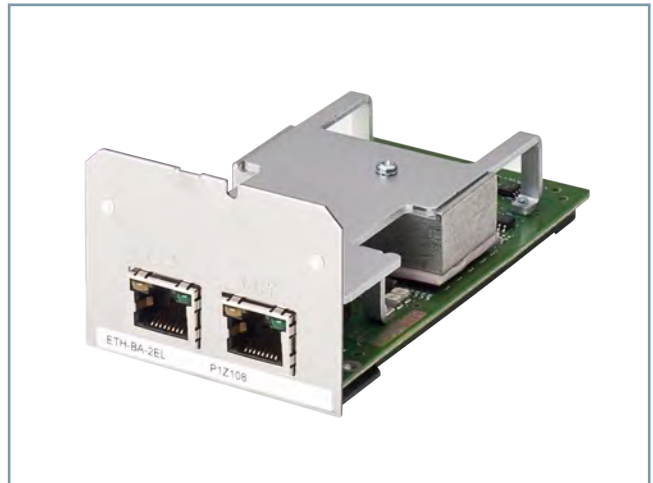

[E_CC_ETH-BA-2EL_sRGB, 1, --]

Figure 3.7/5 Electrical Ethernet Module (ETH-BO-2EL)

Optical Ethernet module

The ETH-BB-2FO module ([Figure 3.7/6](#)) has 2 optical duplex LC 1300-nm interfaces ([Figure 3.7/6](#)). It can be configured with or without an integrated switch. The maximum optically permitted distance via 50/125 μm or 62.5/125 μm multimode optical fibers is 2 km. The optical transmission and receiving level is measured in the module and can be displayed with DIGSI 5.

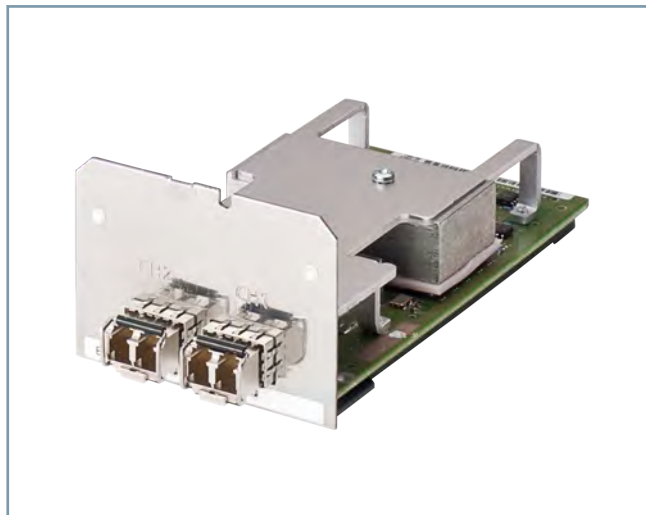

[E_CC_ETH-BB-2FO_sRGB, 1, --, --]

Figure 3.7/6 Optical Ethernet Module (ETH-BB-2FO)

Optical Ethernet Module for the Process Bus

The ETH-BD-2FO module ([Figure 3.7/7](#)) has 2 optical duplex LC 1300 nm interfaces (multimode). It can be configured with or without an integrated switch. The maximum optically permitted distance via 50/125 μm or 62.5/125 μm multimode optical fibers is 2 km. In addition, the module has a pluggable connection for SFP. Using this, the physical communication medium can also be an electrical interface with RJ45 or a 9/125 μm fiber-optic interface with a range of 24 km.

The optical transmission and receiving level is measured in the module and can be displayed with DIGSI 5.

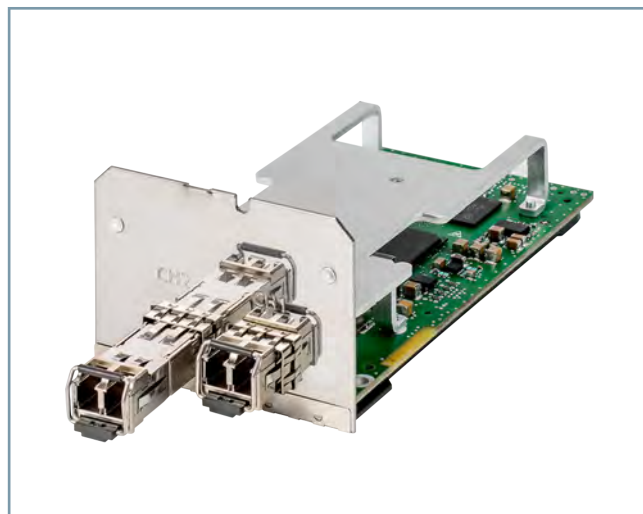

[E_CC_ETH-BD-2FO_sRGB, 1, --, --]

Figure 3.7/7 Optical Ethernet Module (ETH-BD-2FO)

SIPROTEC 5 System

Communication – Plug-In Modules

3.7

Plug-In Modules for the Communication

Port or Plug-In Module	Front Interface	Port G: Time Synchronization	Port J: Integrated Ethernet	Module Type: USART-AB-1EL	Module Type: USART-AC-2EL	Module Type: Plug-In Module USART-AD-1FO	Module Type: USART-AE-2FO	Module Type: ETH-BA-2EL	Module Type: ETH-BB-2FO	Module Type: ETH-BD-2FO ⁶
Physical Connection										
USB	■									
9-pin D-sub socket		■								
1 x electrical Ethernet 10/100 Mbit/s, RJ45			■							
1 x electrical serial RS485, RJ45				■						
2 x electrical serial RS485, RJ45					■					
1 x optical serial, 820 nm, ST connector, 2 km via 62.5/125 µm multimode optical fiber						■				
2 x optical serial, 820 nm, ST connector, 2 km via 62.5/125 µm multimode optical fiber							■			
2 x electrical Ethernet 10/100 Mbit/s, RJ45, 20 m								■		■ ⁷
2 x optical Ethernet 100 Mbit/s, 1300 nm, LC connector, 24 km via 9/125 µm singlemode optical fiber										■ ⁷
2 x optical Ethernet 100 Mbit/s, 1300 nm, LC connector, 2 km via 50/125 µm or 62.5/125 µm multimode optical fiber									■	■
Applications										
DIGSI 5 protocol	■		■					■	■	■
IRIG-B, DCF77, PPS		■								
IEC 61850-8-1 server (including GOOSE, reporting to 6 clients)			■					■	■	■
IEC 61850-9-2 Merging Unit										■
IEC 61850-9-2 Process-Bus Client										■
IEC 60870-5-103				■	■	■	■			
IEC 60870-5-104								■	■	■
DNP3 serial				■	■	■	■			
DNP3 TCP								■	■	
Modbus TCP								■	■	
Synchrophasor (IEEE C37.118 - PMU)								■	■	■
Protection interface (Sync. HDLC, IEEE C37.94) *						■	■			
PROFINET IO								■	■	■ ⁸
SUP Serial (Slave Unit Protocol) for connecting external temperature- or 20-mA measuring devices				■	■	■				
SUP Ethernet SUP (Slave Unit Protocol) for connecting external temperature- or 20-mA measuring devices			■					■	■	
Diagnostic homepage			■					■	■	■
Additional Ethernet protocols and services										
DHCP, DCP (automatic IP configuration)			■					■	■	■
Line Mode								■	■	■
PRP (Ethernet ring redundancy)								■	■	■
HSR (Ethernet ring redundancy) ⁹								■	■	■

⁶ For modular devices only (not for 7ST85 and 6MD89)

⁷ For the **2 x electrical Ethernet and 2 x optical Ethernet over 24 km** function, separate SFPs are necessary. These can be ordered as accessories.

⁸ PROFINET IO is available in the ETH-BD-2FO module with S2 redundancy and SOE functionality for V8.30 and higher.

⁹ HSR is available in the ETH-BD-2FO module for V8.30 and higher, without supporting the IEEE 1588v2 transparent clock.

Port or Plug-In Module	Front Interface	Port G: Time Synchronization	Port J: Integrated Ethernet	Module Type: USART-AB-1EL	Module Type: USART-AC-2EL	Module Type: USART-AD-1FO	Module Type: USART-AE-2FO	Module Type: ETH-BA-2EL	Module Type: ETH-BB-2FO	Module Type: ETH-BD-2FO ⁶
RSTP (Ethernet ring redundancy)								■	■	■
SNTP (time synchronization via Ethernet)			■					■	■	■
SNMP V3 (network management protocol)								■	■	■ ¹⁰
IEEE 1588v2 (PTP protocol via Ethernet – ms accuracy)								■	■	
IEEE 1588v2 (PTP protocol via Ethernet – μs accuracy) ¹¹										■
IEEE 802.1q (VLAN)										■

Table 3.7/3 Communication Applications and Plug-In Modules



NOTE

The USART and ETH plug-in module types can be used in slots E and F in the base module as well as in slots N and P in the CB202 expansion module. They are not intended for use in slot M in the CB202 expansion module.

* Additional plug-in modules for protection interface: see next table

⁶ For modular devices only (not for 7ST85 and 6MD89)

¹⁰ Available for V8.30 and higher

¹¹ With optional RJ45, the SFP accuracy is 1 ms.

SIPROTEC 5 System

Communication – Plug-In Modules

3.7

Plug-In Modules for the Communication

Plug-In Module	USART-AB-1EL	USART-AC-2EL	USART-AD-1FO	USART-AE-2FO	ETH-BA-2EL	ETH-BB-2FO	ETH-BD-2FO ¹²	USART-AF-1LDFO	USART-AW-2LDFO	USART-AG-1LDFO	USART-AU-2LDFO	USART-AK-1LDFO	USART-AV-2LDFO	USART-AH-1LDFO ¹³	USART-AJ-1LDFO ¹⁴	USART-AX-2LDFO ¹⁵	USART-AY-2LDFO ¹⁶	ANAI-CA-4EL	ARC-CD-3FO
	Physical Connection																		
1 x electrical serial RS485, RJ45	■																		
2 x electrical serial RS485, RJ45		■																	
1 x optical serial, 820 nm, ST connector, 2 km via 62.5/125 µm multimode optical fiber			■																
2 x optical serial, 820 nm, ST connector, 2 km via 62.5/125 µm multimode optical fiber				■															
2 x electrical Ethernet 100 Mbit/s, RJ45, 20 m					■		■												
2 x optical Ethernet 100 Mbit/s, 1300 nm, LC connector, 24 km via 9/125 µm singlemode optical fiber							■												
2 x optical Ethernet 100 Mbit/s, 1300 nm, LC connector, 2 km via 50/125 µm or 62.5/125 µm multimode optical fiber						■	■												
1 x optical serial, 1300 nm, LC connector, 24 km via 9/125 µm singlemode optical fiber or 4 km via 62.5/125 µm multimode optical fiber								■											
2 x optical serial, 1300 nm, LC connector, 24 km via 9/125 µm singlemode optical fiber or 4 km via 62.5/125 µm multimode optical fiber									■										
1 x optical serial, 1300 nm, LC connector, 60 km via 9/125 µm singlemode optical fiber										■									
2 x optical serial, 1300 nm, LC connector, 60 km via 9/125 µm singlemode optical fiber											■								
1 x optical serial, 1550 nm, LC connector, 100 km via 9/125 µm singlemode optical fiber												■							
2 x optical serial, 1550 nm, LC connector, 100 km via 9/125 µm singlemode optical fiber													■						
1 x optical serial, bidirectional via 1 common optical fiber, 1300 nm/1550 nm (Tx/Rx), 2 x LC simplex plug, 40 km via 9/125 µm singlemode optical fiber ¹³														■					
1 x optical serial, bidirectional via 1 common optical fiber, 1550 nm/1300 nm (Tx/Rx), LC simplex plug, 40 km via 9/125 µm singlemode optical fiber ¹⁴															■				
2 x optical serial, bidirectional via 1 common optical fiber, 1300 nm/1550 nm (Tx/Rx), 2 x LC simplex plug, 40 km via 9/125 µm singlemode optical fiber ¹⁵																■			
2 x optical serial, bidirectional via 1 common optical fiber, 1550 nm/1300 nm (Tx/Rx), 2 x LC simplex plug, 40 km via 9/125 µm singlemode optical fiber ¹⁶																	■		
8-pin screw-type terminal spring																		■	

¹² For modular devices only (not for 7ST85 and 6MD89)

¹³ USART-AH-1LDFO only in connection with USART-AJ-1LDFO or USART-AY-2LDFO

¹⁴ USART-AJ-1LDFO only in connection with USART-AH-1LDFO or USART-AX-2LDFO

¹⁵ USART-AX-2LDFO only in connection with USART-AJ-1LDFO or USART-AY-2LDFO

¹⁶ USART-AY-2LDFO only in connection with USART-AH-1LDFO or USART-AX-2LDFO

¹⁷ For the 2 x electrical Ethernet and 2 x optical Ethernet over 24 km function, separate SFPs are necessary. These can be ordered as accessories.

Plug-In Module	USART-AB-1EL	USART-AC-2EL	USART-AD-1FO	USART-AE-2FO	ETH-BA-2EL	ETH-BB-2FO	ETH-BD-2FO ¹²	USART-AF-1LDFO	USART-AW-2LDFO	USART-AG-1LDFO	USART-AU-2LDFO	USART-AK-1LDFO	USART-AV-2LDFO	USART-AH-1LDFO ¹³	USART-AJ-1LDFO ¹⁴	USART-AX-2LDFO ¹⁵	USART-AY-2LDFO ¹⁶	ANAI-CA-4EL	ARC-CD-3FO
3 x optical (for point sensor)																			■
Application																			
DIGSI 5 protocol					■	■	■												
IEC 61850-8-1 server					■	■	■												
You can find more information (whether GOOSE or MMS reporting) in the Communication protocols manual, chapter IEC 61850.																			
IEC 61850-9-2 Merging Unit							■												
IEC 61850-9-2 Process-Bus Client							■												
IEC 60870-5-103	■	■	■	■															
IEC 60870-5-104					■	■	■												
DNP3 serial	■	■	■	■															
DNP3 TCP					■	■													
Modbus TCP					■	■													
Synchrophasor (IEEE C37.118 - PMU)					■	■	■												
Protection interface (Sync. HDLC)			■	■				■	■	■	■	■	■	■	■	■	■		
Protection interface (IEEE C37.94)			■	■															
PROFINET IO					■	■	■ ¹ 8												
SUP Serial (Slave Unit Protocol) for connecting external temperature- or 20-mA measuring devices	■	■	■	■															
SUP Ethernet (Slave Unit Protocol) for connecting external temperature or 20-mA measuring devices					■	■													
Diagnosis: Ethernet module homepage (http)					■	■	■												
Measuring transducer, 4 inputs, DC ±20 mA																		■	
Arc protection																			■
Additional Ethernet protocols and services																			
DHCP, DCP (automatic IP configuration)					■	■	■												
Line Mode					■	■	■												
PRP (Ethernet ring redundancy)					■	■	■												
HSR (Ethernet ring redundancy) ¹⁹					■	■	■												
RSTP (Ethernet ring redundancy)					■	■	■												
SNTP (time synchronization via Ethernet)					■	■	■												
SNMP V3 (network management protocol)					■	■	■												
IEEE 1588v2 (PTP protocol via Ethernet – ms accuracy)					■	■													

¹² For modular devices only (not for 7ST85 and 6MD89)

¹³ USART-AH-1LDFO only in connection with USART-AJ-1LDFO or USART-AY-2LDFO

¹⁴ USART-AJ-1LDFO only in connection with USART-AH-1LDFO or USART-AX-2LDFO

¹⁵ USART-AX-2LDFO only in connection with USART-AJ-1LDFO or USART-AY-2LDFO

¹⁶ USART-AY-2LDFO only in connection with USART-AH-1LDFO or USART-AX-2LDFO

¹⁸ PROFINET IO is available in the ETH-BD-2FO module with S2 redundancy and SOE functionality for V8.30 and higher.

¹⁹ HSR is available in the ETH-BD-2FO module for V8.30 and higher, without supporting the IEEE 1588v2 transparent clock.

²⁰ Available for V8.30 and higher

SIPROTEC 5 System

Communication – Plug-In Modules

3.7

Plug-In Module	USART-AB-1EL	USART-AC-2EL	USART-AD-1FO	USART-AE-2FO	ETH-BA-2EL	ETH-BB-2FO	ETH-BD-2FO ¹²	USART-AF-1LDFO	USART-AW-2LDFO	USART-AG-1LDFO	USART-AU-2LDFO	USART-AK-1LDFO	USART-AV-2LDFO	USART-AH-1LDFO ¹³	USART-AJ-1LDFO ¹⁴	USART-AX-2LDFO ¹⁵	USART-AY-2LDFO ¹⁶	ANAI-CA-4EL	ARC-CD-3FO
IEEE 1588v2 (PTP protocol via Ethernet – μ s accuracy) ²¹							■												
IEEE 802.1q (VLAN)							■												

Table 3.7/4 Plug-In Modules for Applications with the Protection Interface and for Other Applications



NOTE

The USART and ETH plug-in module types can be used in slots E and F in the base module as well as in slots N and P in the CB202 expansion module. They are not intended for use in slot M in the CB202 expansion module.

The plug-in modules of types ANAI and ARC can be used in both slots in the base module (ports E and F), as well as in all slots in the expansion module CB202 (ports M, N, and P).

¹² For modular devices only (not for 7ST85 and 6MD89)
¹³ USART-AH-1LDFO only in connection with USART-AJ-1LDFO or USART-AY-2LDFO
¹⁴ USART-AJ-1LDFO only in connection with USART-AH-1LDFO or USART-AX-2LDFO
¹⁵ USART-AX-2LDFO only in connection with USART-AJ-1LDFO or USART-AY-2LDFO
¹⁶ USART-AY-2LDFO only in connection with USART-AH-1LDFO or USART-AX-2LDFO
²¹ SFP accuracy is 1 ms with optional RJ45

Protocols

Plug-in modules are delivered without a protocol application. According to the tables [Table 3.7/3](#) and [Table 3.7/4](#), a module can be initialized via DIGSI 5 with a protocol application. Every interface is assigned the desired application via DIGSI 5. Assignments can be removed and reconfigured. This enables a high degree of flexibility when configuring the modules.

DIGSI 5 Protocol

The DIGSI 5 protocol works with TCP services, which can be routed via IP networks. Worldwide remote access to devices via secure connections is an integral component of the communication concept. The protocol is available on the USB interface and all Ethernet interfaces. Optionally, DIGSI 5 can also be operated via its own Ethernet module if substation controller functions and access for operation and maintenance are to be kept strictly separate.

IEC 61850-8-1 Client-Server Communication

Integrated Ethernet interface (Port J)

Besides DIGSI 5, this interface supports 6 client-server associations with reporting function and GOOSE messages, as well as the SUP protocol. Messages, measured values, and fault records can be read from an IEC 61850 client. Parameters in the device can be changed via the client and the time of the device can be set via an SNMP server.

Ethernet plug-in module

Messages, measured and metered values can be transmitted via the client-server communication in static and dynamic reports to a maximum of 6 clients (substation controllers). Dynamic reports are created and read by the client without resetting the parameters of the device. The static reports are created via the IEC 61850 system configurator and are permanently saved in the device as indication lists. Fault records can also be retrieved in binary COMTRADE format. Extensive control functions are available from the client, such as for the safe switching of a circuit breaker. The setting parameters of the device can be read and also changed via the IEC 61850 protocol. The devices can be integrated in interoperable, intelligent Smart Grids without difficulty. Changing the device parameter settings during operation is possible through substation-controller equipment in order to adapt selected setting parameters to the operating conditions. Redundant solutions can be realized with 2 Ethernet modules.

IEC 61850-8-1 GOOSE

GOOSE has been established as a worldwide standard for cross communication between devices in order to transmit messages and measured values between devices. In addition to GOOSE between devices within switchgear, GOOSE is also supported between devices in different switchgears. The exchanged infor-

mation is described in data terms via standard-conforming SCL files, which were defined in Edition 2 of IEC 61850. The exchange itself occurs via high-performance IP network connections or Ethernet network connections. This data exchange can also be realized via an Ethernet module used exclusively for this purpose.

GOOSE messages can be used to exchange time-critical information that must be transmitted in a few milliseconds. In this case, GOOSE connections replace transmission via contacts and binary inputs; for protection signals, transmission times under 10 ms are required, and under 20 ms for switch positions and interlockings. Measured and metered values are transmitted in less than 100 ms. GOOSE applications are generated in the system configurator for this purpose. This data is exchanged by the devices in a high-performance manner via GOOSE messages.

Receivers of GOOSE messages can constantly monitor the receipt of indications and measured values for an outage of the connection. The state of missing indications is automatically updated at the receiver in order to attain a secure state. This allows a constant, high-quality monitoring of GOOSE communication to be realized. GOOSE messages transmitted during the test mode of a device are ignored by the receivers if these are in normal operation. A test of a device can be performed without disconnection from the communication network.

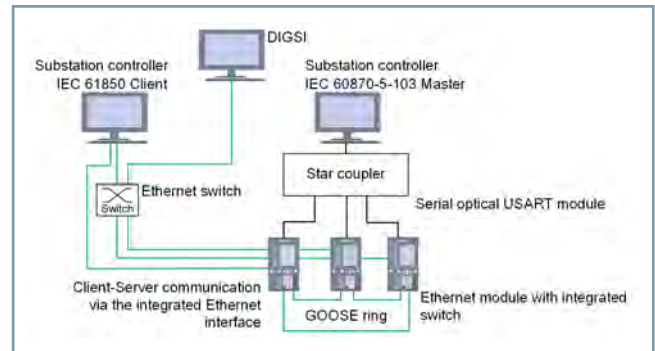

[dw_SIP5-0046, 3, en_US]

Figure 3.7/8 Separate Client-Server and GOOSE Communication via IEC 61850 with Another Serial Connection to an IEC 60870-5-103 Master

IEC 61850-9-2 Process Bus

For process bus solutions, the current and voltage is recorded in the merging unit. It is an interoperable interface between the primary and secondary equipment in accordance with IEC 61869 and IEC 61850-9-2 standards.

The measured values are digitized and converted into standardized, Ethernet-based measured value telegrams (SMV) with a selectable sampling rate, transmitted to the protection devices (process-bus clients) via optical Ethernet connections, and are processed by protection algorithms there.

Sampling Rate	Number of ASDUs per Frame	Notes
4000 Hz	1	Compatible to IEC 61850-9-2 LE for 50-Hz electrical power systems
4800 HZ	1	Compatible to IEC 61850-9-2 LE for 60-Hz electrical power systems

SIPROTEC 5 System

Communication – Protocols

3.7

Sampling Rate	Number of ASDUs per Frame	Notes
4800 HZ	2	Preferred sampling rate in compliance with IEC 61869-9 for general measurement and protection functions, irrespective of the power frequency
12 800 HZ	8	Compatible to IEC 61850-9-2 LE for 50-Hz electrical power systems
14 400 HZ	6	Preferred sampling rate in compliance with IEC 61869-9 for Power Quality and fault recording, irrespective of the power frequency
15 360 HZ	8	Compatible to IEC 61850-9-2 LE for 60-Hz electrical power systems

Table 3.7/5 Selectable Sampling Rates in Accordance with IEC 61869

A prerequisite for using the process bus is a high-precision time synchronization to allow the measured-value samples from the individual merging units to be processed at the same time base in the protection device (process-bus client). The SIPROTEC 6MU85 merging units as well as all other modular SIPROTEC 5 protection devices support time synchronization for this purpose via IEEE 1588v2/PTP, PPS²², or IRIG-B²², as well as the PRP and HSR²² redundancy processes (IEC 62439).

The integrated Web server and full support of IEC 61850-8-1 GOOSE and MMS enable process-bus technologies to be fully integrated into station automation systems of complete digital switchgears.



[Sip5_Prozessbusloesung_front, 2, --, --]

Figure 3.7/9 Process-Bus Solution according to IEC 61850-9-2: SIPROTEC 5 Device with Merging Units SIPROTEC 6MU85

Supporting IEC 61850 Edition 2.1

SIPROTEC 5 supports IEC 61850 Edition 2.1 from version 8. This standard edition introduces a common reference to

IEC 61869-9, which governs interoperability of protection functionality when using a process bus (IEC 61850-7-4 and IEC 61850-9-2).

If previous editions are used (IEC 61850 Edition 2.0), compatibility between the merging unit and process-bus client, and thereby a proper protection function cannot be fully guaranteed.

Availability, even if global time synchronization is missing

The merging units and process-bus clients must be synchronized with one another in process-bus systems. IEC 61850 Edition 2.1 makes changes to the information on sampled measured value time synchronization available. The option of specifying the grandmaster ID (GmID) for the IEEE 1588 time source can also be added. The merging-unit functionality and the process-bus client support entering and using the GmID to reduce dependency on a satellite signal during time synchronization. Uninterrupted protection-device operation is achieved by comparing the GmIDs of the streams and those of the protection device. As long as the GmIDs are identical, the protection remains active, irrespective of whether the IEEE 1588 time source has been synchronized globally or locally.

Merging Unit

The SIPROTEC 6MU85 merging unit has been universally designed based on the flexible SIPROTEC 5 system for conventional and non-conventional instrument transformers (LPIT)²³. Wiring expenditure and the risk of open current transformer circuits can be kept to a minimum by digitizing all primary data close to the process.

²²

²³ In preparation

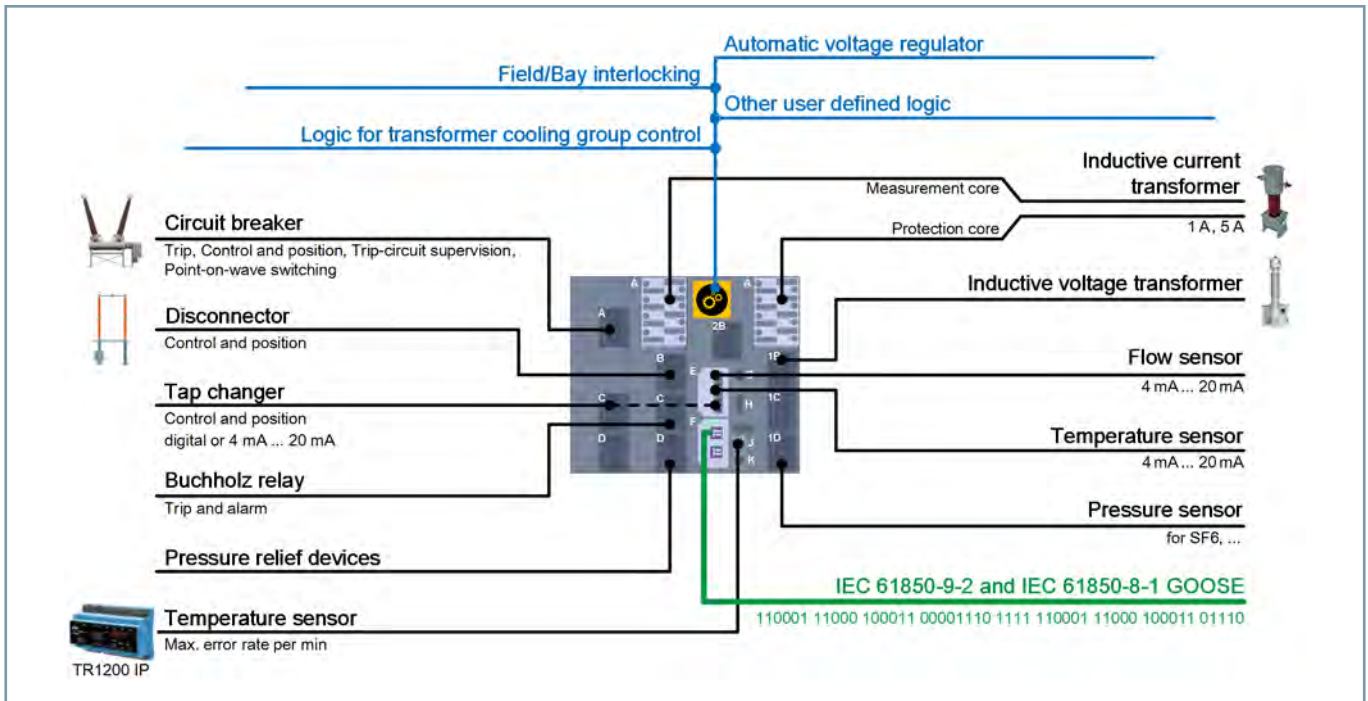

[dw_6MU85_Digital_all_prim-data_close_process, 1, en_US]

Figure 3.7/10 Digitizing All Primary Data

The modularity and flexibility of the SIPROTEC 5 system enables a wide range of solutions and migration concepts for new and existing systems. For instance, this means that backup protection functions or double power supplies can be used in the merging units, and a wide range of redundancy concepts can be implemented. In addition to recording the current and voltage measured values, the merging unit can also activate switch contacts and record virtually all signals and information of a bay close to the process, and provide them to the substation automation technology.

The merging-unit functionality can be scaled by using various ETH-BD-2FO plug-in modules and the SIPROTEC 5 expansion modules, which in turn increases the number of streams to be sent or allows the quantity structure of binary inputs, binary outputs, voltage-transformer and current-transformer inputs to be adjusted to the application. IEC 61850-9-2 LE as well as flexible streams according to IEC 61869-9 can be used.

Merging-Unit Functionality		
Stream type	IEC 61850-9-2 LE	IEC 61869-9
Analog channels per stream	8 (fix ²⁴)	Max 32 ²⁵
Streams per ETH-BD-2FO	2 ²⁶	

Merging-Unit Functionality	
Max. ETH-BD-2FO to be used for merging-unit functionality	4
Analog channels per device	Max. 40

Table 3.7/6 Merging-Unit Functionality

Process-bus client

Every modular SIPROTEC 5 protection device with the ETH-BD-2FO plug-in module can be used as a process-bus client. The fact that these plug-in modules can be easily retrofitted also ensures that existing SIPROTEC 5 devices can be incorporated into process-bus solutions.

Using several ETH-BD-2FO plug-in modules per device ensures that the network traffic can be distributed to several process-bus networks, which means that up to 80 measured-value channels (sampled measured values) can be physically split up among different networks, received and processed for each SIPROTEC 5 device.

Process-Bus Client Functionality		
Stream type	IEC 61850-9-2 LE	IEC 61869-9
Streams per ETH-BD-2FO	16	

²⁴ IEC 61850-9-2 LE defines 4 currents and 4 voltages (IA, IB, IC, IN, VA, VB, VC, VN)

²⁵ IEC 61869-9 limits the max. analog values per data stream to 24, this must be considered in interoperability scenarios

²⁶ With V8.30

SIPROTEC 5 System

Communication – Protocols

3.7

Process-Bus Client Functionality		
Analog channels per stream	8 (fix ²⁷)	Max 32 ²⁸
Analog channels per ETH-BD-2FO	64 ²⁹	
Max. ETH-BD-2FO to be used for the PB client functionality	3	
Analog channels per device	40 (80 for 7SS85)	

Table 3.7/7 Process-Bus Client Functionality

Sampled measured value (LSVS) reception is supervised in the same way as GOOSE (LGOS) in accordance with IEC 61850, and the errors are reported accordingly. This is carried out via additional information on the status of the sampled measured values and GOOSE signals alongside the elements that are required by the standard. This ensures supervised and effective operation of a process-bus system and simple troubleshooting and diagnostics during commissioning.

Parallel operation of a conventional and digital (process bus) instrument-transformer connection

A simple protection for a feeder can be used to test the process bus. Modular expansion is possible for modern protection devices such as the SIPROTEC 5 range. For example, an existing SIPROTEC 7SJ85 overcurrent protection device can be extended by process-bus inputs. This enables cost-effective piloting. Another major advantage of modern protection devices is their ability to protect more than one protected object effectively. For example, the SIPROTEC 7SJ85 allows up to 9 feeders to be protected with one device. These 2 properties and the fact that the overcurrent protection requires only the currents from one merging unit permit effective parallel operation here.

If a system with less than 7 feeders is protected in one device, this device still has free capacities. This permits parallel operation of process bus and conventional connection. For this purpose, an ETH-BD-2FO plug-in module is added to the device and the current from a feeder is additionally measured in a merging unit. The measured current of the merging unit is then connected to the protection device via the process bus. This gives the protection device twice the measured current values. On the one hand, it measures the values itself, and on the other hand, it receives the current values via the process bus. The protection function is doubly instantiated. The protection device protects the same feeder conventionally and via the process bus. This permits direct comparison between the process bus and the direct measurement.

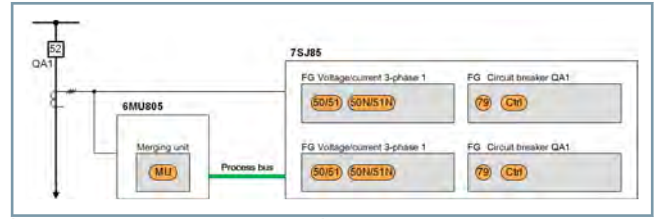

[dw_prozessbus_eines_wdl_7sj85_200115, 3, en_US]

Figure 3.7/11 Parallel Operation of Conventional and Digital (Process Bus) Connection to an Instrument Transformer

Mixed operation with a process bus and measured values that have been directly recorded

For economic reasons, it may be necessary to not just record the measured values via the process bus, but also to do so directly using the current and voltage transformers, which are directly connected to the protection device, particularly in the context of line or transformer differential protection. A mixed operation like this is controlled by a SIPROTEC process-bus client by buffering the measured values that have been directly recorded and synchronizing them with the measured values that have been received from the process bus.

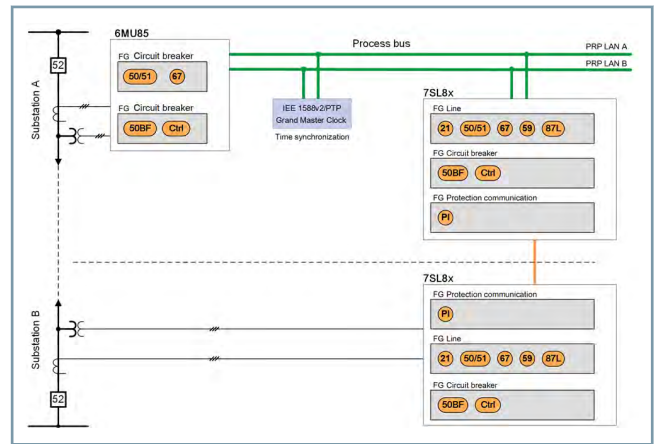

[dw_line-diff-prot_SIP5-config, 1, en_US]

Figure 3.7/12 Line Differential Protection in Mixed Operation

²⁷ IEC 61850-9-2 LE defines 4 currents and 4 voltages (IA, IB, IC, IN, VA, VB, VC, VN)

²⁸ IEC 61869-9 limits the max. analog values per data stream to 24, this must be considered in interoperability scenarios

²⁹ Theoretical limit, the analog-channel limit of the device defines the real limit

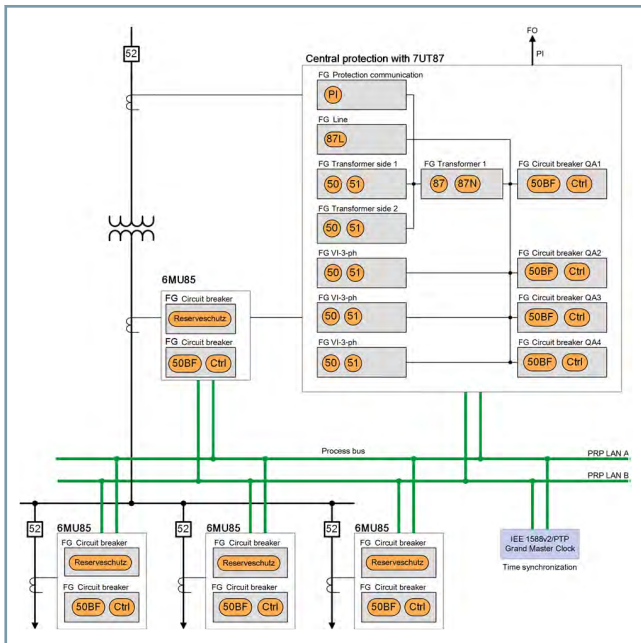

[dw_appl-exampl_micro-central-prot, 2, en_US]

Figure 3.7/13 Transformer Differential Protection in Mixed Operation

to indications, measured values, and fault records, metered values, and customer-specific defined indications of systems control are also available in protocol extensions. Control commands for switching devices can also be transmitted via the protocol. Setting values in the device can also be read or changed via the generic services of the protocol. Information about the device can be routed to the protocol interface by the user with DIGSI 5. Information types and function numbers can be freely configured here. This enables adaptation to existing solutions and the interchangeability of devices without changes in the systems control. This is an important contribution to investment security.

IEC 60870-5-104

The station and network control protocol IEC 60870-5-104 is supported via the electrical and optical Ethernet module. Besides the transmission of messages (single-point and double-point indications), measured values, metered values to 1 master or 2 (redundant) masters, 3 masters (controlling stations) which are sent the same information are also possible. Furthermore, IEC 60870-5-104 data transmission is supported and fault records can be read from the device in the COMTRADE format. In command direction, secure switching of switching objects is possible via the protocol. Time synchronization can take place via the IEC 60870-5-104 master or via SNTP via the network, redundant time servers being supported.

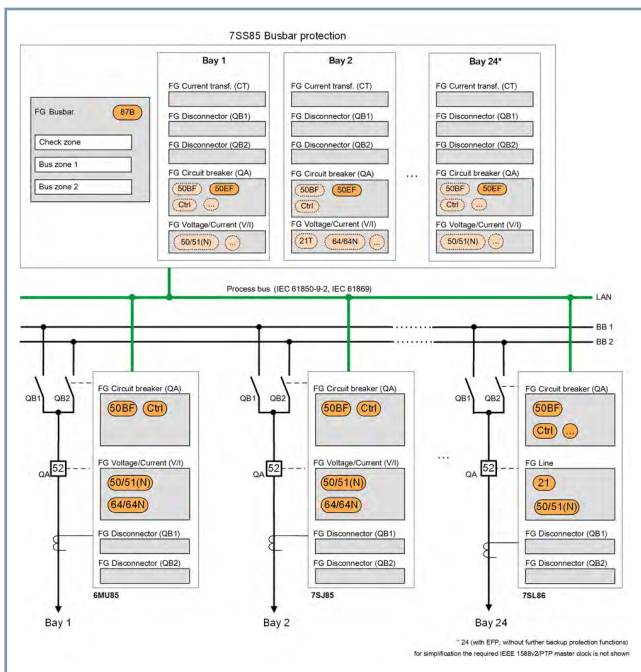

[dw_02_config_decentr-busbar_IEC61850, 1, en_US]

Figure 3.7/14 Distributed Busbar Protection

IEC 60870-5-103

The serial protocol is transmitted via RS485 or an optical 820-nm interface. The compatible IEC 60870-5-103 protocol specifically extended for Siemens is supported. The implementation is compatible with existing solutions, for example with SIPROTEC 4 devices, which will enable a trouble-free exchange and extension of devices even in the very long term. In addition

SUP – Slave Unit Protocol

This Siemens-specific protocol is used to read external 20-mA devices (SICAM AI-Unit 7XV5674) or temperature measuring devices (RTD unit 7XV5662-_AD10) in series or via Ethernet. These devices are available as accessories for extension of SIPROTEC 5 devices with analog interfaces. The measured values of these devices can be further processed in the SIPROTEC 5 device or are used for protection functions such as overload protection or transformer hotspot calculation.

Serial DNP3 or DNP3 TCP

DNP3 is supported as a serial protocol via RS485 or an optical 820-nm interface and as an Ethernet-based TCP variant via the electrical or optical Ethernet module. A redundant optical or electrical ring can be implemented simply by means of the switch integrated in the Ethernet module. Information about a device and the fault records of the device can be routed and transmitted using the DNP3 protocol. Switching commands can be executed in control direction. DNP3 TCP can support up to 2 masters (Figure 3.7/15).

Redundant connection to 2 serial substation controllers can be established via 2 modules or 1 serial double module. With Ethernet, for a redundant connection, 2 Ethernet modules that can work independently from one another via 1 or 2 networks are to be provided. Settings values in the device cannot be read or changed via the protocol.

For DNP3, the network topologies shown in Figure 3.7/29 to Figure 3.7/33 can also be used for Ethernet-based or serial communication.

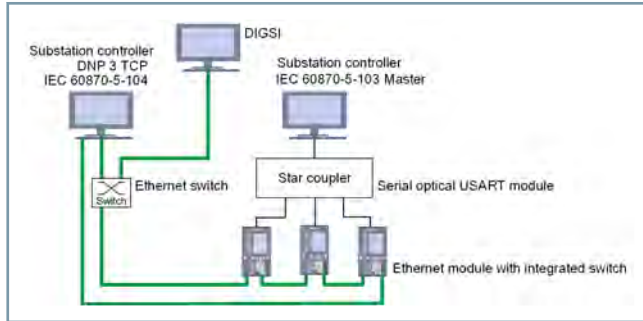

[dw_SIP5-0057, 3, en_US]

Figure 3.7/15 DNP3 TCP/IEC 60870-5-104 Communication with Further Serial Connection with an IEC 60870-5-103 Master

Modbus TCP

The Modbus TCP communication protocol is supported via the electrical and optical Ethernet module. Modbus TCP and Modbus RTU are very similar to one another. However, Modbus TCP uses TCP/IP packets for data transmission.

Modbus TCP can be used to transmit messages (single-point and double-point indications), measured values, metered values to 1 or 2 (redundant) masters. In command direction, switching of switching objects is possible via the protocol.

Time synchronization can take place via SNTP or IEEE 1588 via the network, redundant time servers being supported.

PROFINET IO

PROFINET IO is an Ethernet-based communication protocol that can be used in all areas of communication automation.

The data exchange of PROFINET IO follows the Provider/Consumer model. A configured PROFINET IO system has the same look and feel as in PROFIBUS.

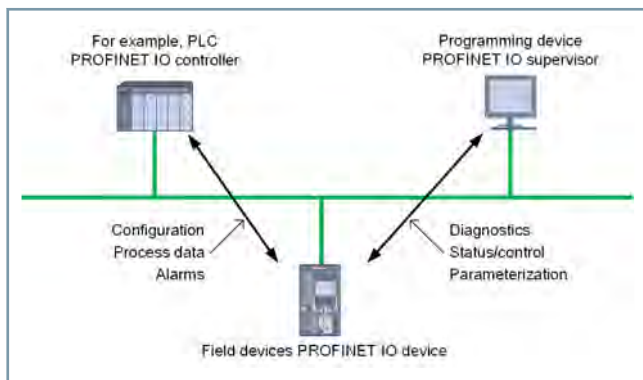

[dw_COM_PRO_IO, 2, en_US]

Figure 3.7/16 Communication Paths for PROFINET IO

The following device classes are defined for PROFINET IO:

- PROFINET IO controller**
 A PROFINET IO controller is typically the programmable logic controller (PLC) on which the automation program runs. The PROFINET IO controller provides output data to the configured IO devices in its role as provider and is the consumer of input data of IO devices.
- PROFINET IO supervisor**
 A PROFINET IO supervisor can be a Programming Device (PD), a personal computer (PC), or a human-machine interface (HMI). It serves for commissioning or diagnostic purposes and corresponds to a class-2 master in PROFIBUS.
- PROFINET IO device**
 A PROFINET IO device is a distributed IO field device that is connected to one or more IO controllers via PROFINET IO. It is comparable to the function of a slave in PROFIBUS. The PROFINET IO device is the provider of input data and the consumer of output data. The SIPROTEC 5 device works as the IO device.

System-level redundancy (S2) can only be achieved with the new ETH-BD-2FO module with additional support of transmission of sequence of events to the IO controller.

PROFINET IO S2 Redundancy and SOE (Sequence of Events)

The ETH-BD-2FO system redundancy supports the redundancy on the system level for the PROFINET IO protocol. System redundancy is the redundancy of the IO controller or of the communication interface of the input/output device. *Figure 3.7/17* shows an example in which 1 input/output device is connected to 2 different IO controllers. The input/output device maintains the active communication with one of the IO controllers as the primary controller and with the other as the standby controller.

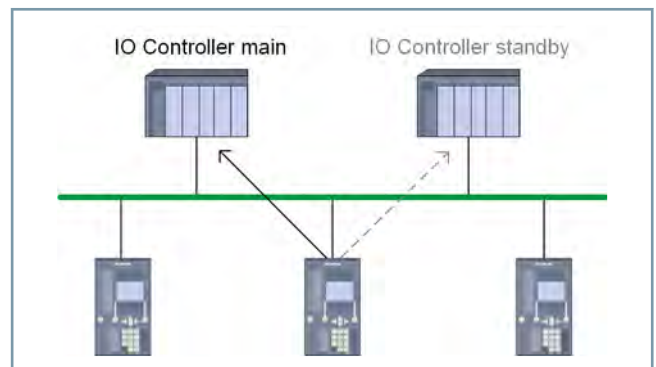

[dw_Profinet-IO-S2-redundancy, 1, en_US]

Figure 3.7/17 Connection of an Input/Output Device to 2 Different IO Controllers

The PROFINET IO S2 redundancy is only available with the ETH-BD-2FO module that can also be equipped with electrical RJ45 SFPs.

The ETH-BD-2FO module also supports SOE functionality in which the digital signals can be queried from the input/output device (SIPROTEC 5) and can be relayed to the IO controller with accurate time stamps and a FIFO buffer having a capacity of 500 signals.

VLAN according to IEEE 802.1q

VLAN according to IEEE 802.1q is the standard in which various applications on the same physical Ethernet network can be disconnected or isolated. This improves the security, availability and performance in the network and, at the same time, ensures cost efficiency.

In a VLAN-capable network, you mark the Ethernet frames that belong to the different application domains so that the other switches or receivers either transmit a package with the desired priority or discard the package due to security policy.

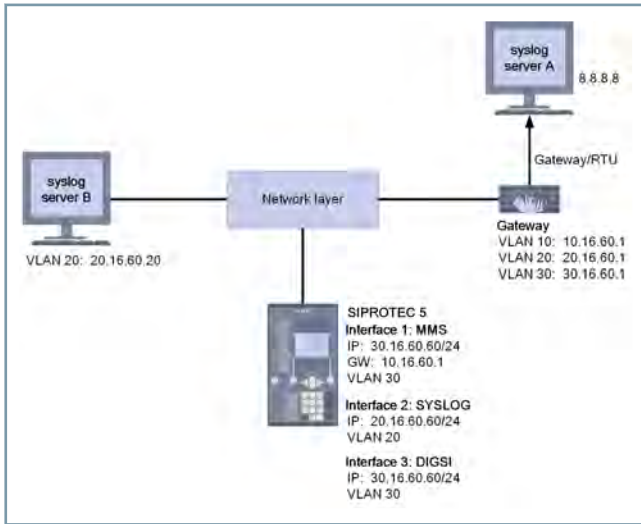

[dw_SIP5_IEEE802-1q_VLAN, 1, en_US]

Figure 3.7/18 1 Physical Medium for 3 Applications

The SIPROTEC 5 family supports VLAN only with ETH-BD-2FO modules. As shown in the example figure above, the SIPROTEC 5 device uses only one single physical medium for 3 different applications with 3 different IP interfaces. The switches control the telegrams to be transmitted in accordance with their setting. Devices can only receive those telegrams for which they are configured.

IEEE C37.118 (Synchrophasor)

SIPROTEC 5 devices optionally calculate synchrophasors and work as a Phasor Measurement Unit (PMU). These measured values, which are synchronized across large geographic areas with high precision, allow for assessment of power system stability. These values are transmitted via an Ethernet network with the IEEE C37.118 protocol to a data concentrator. The transmission occurs via an optical or electrical Ethernet module (Figure 3.7/19)

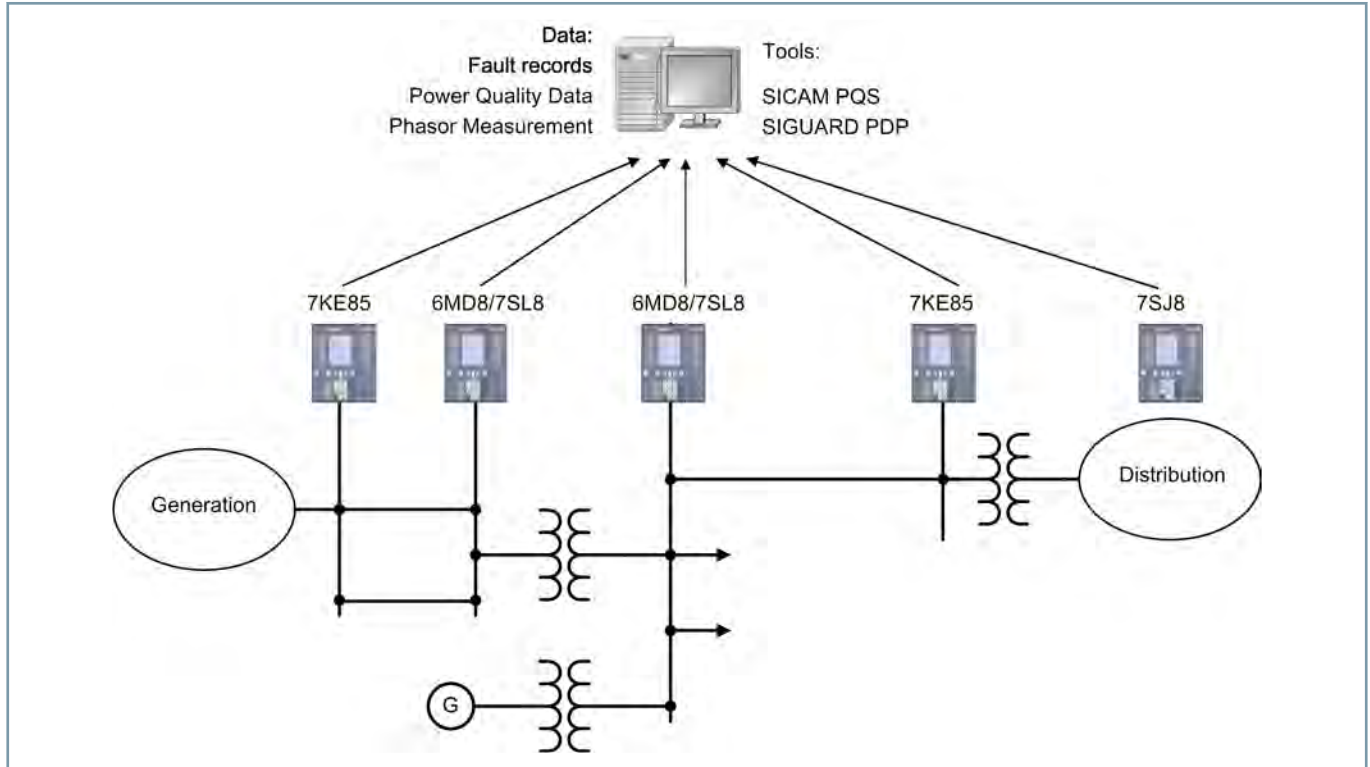

[dw_central.vsd, 1, en_US]

Figure 3.7/19 Central Evaluation of Fault Records and Phasors

Further Ethernet-based Protocols and Services

Besides the actual protocol application, these services can run in parallel on an Ethernet module. They can be switched on and off by the user with DIGSI 5.

Ethernet redundancy with RSTP, PRP, HSR

The electrical and optical Ethernet module supports the building of redundant ring structures in Ethernet with the redundancy protocol (RSTP, HSR). With HSR, an uninterrupted ring redundancy is achieved with up to 50 devices in the ring. PRP can be used to communicate without interruption via parallel networks. These procedures can be activated by means of parameters. They are independent of the substation automation protocol or the selected additional services.

Time Synchronization with SNTP Protocol

The device can poll the absolute time from 1 or 2 time servers via an SNTP server. In redundant operation, both servers are read and the time of the 1st server is used for setting the device clock with an accuracy of 1 ms. If this server fails, the time is synchronized by the 2nd server. In addition to Ethernet modules, SNTP can also be used via the integrated Ethernet interface (Port J).

Time Synchronization Using IEEE 1588

The IEEE 1588 protocol is available for greater time-synchronization accuracy via Ethernet³⁰. A high accuracy of 1 μs is required to synchronize measured values for process-bus applications, PMU data synchronization, and to stabilize unbalanced protection communications³¹ for line differential protection applications. It can be activated on electrical or optical Ethernet modules. A prerequisite is that the power-system components (for example switches) also support the protocol and special IEEE 1588 time servers are available in the network. With IEEE 1588, a runtime measurement for the time-synchronous telegrams in the Ethernet network is carried out so that the terminal devices (for example SIPROTEC 5) receive time information corrected by the runtime, which is more precise than with SNTP. Both the Power Utility Profile (IEC 61850-9-3) and the Power Profile³² IEEE C37.238 are supported with the devices working as ordinary slave clock (terminal device) in the network.

For the high-precision time synchronization via Ethernet IEEE 1588, the ETH-BD-2FO Ethernet module and a suitable router, for example, from Ruggedcom, are used.

Optical PPS (Pulse Per Second) Reception

SIPROTEC 5 devices can be synchronized using an optical PPS (pulse per second) with the 820 nm serial plug-in modules

³⁰ Use with the HSR and RSTP protocols in preparation

³¹ Planned with V8.50

³² With V8.30

(USART-AD-1FO and USART-AE-2FO). This allows existing merging units to be replaced with SIPROTEC 5-based modern merging units or existing process-bus plants based on a PPS synchronization of the merging units to be extended. As a result, it is not necessary to also install IEEE 1588v2/PTP-capable network devices and station clocks. The existing PPS infrastructure remains in use.

Furthermore, the optical PPS, as an alternative to the electrical PPS using interface G of the SIPROTEC 5 device, can be used to stabilize unbalanced protection communication.

Network Monitoring with SNMP

The device can be integrated in network monitoring or power-management systems via the SNMP protocol V3. Extensive monitoring variables, for example the state of the Ethernet interfaces, their data throughput etc. can be made known to the monitoring system via MIB (Management Information Base) files. These variables are described in data-specific terms in MIB files and can be cyclically read out and monitored by the monitoring system. No values can be changed in the device via SNMP. It serves exclusively as a diagnosis interface.

Transmission of Data via the Protection Communication

The protection interface and protection topology enable data exchange between devices via synchronous serial point-to-point connections from 64 kbit/s to 2 Mbit/s. These connections can be directly via optical fiber or via other communication media such as via dedicated lines in communication networks.

A protection topology consists of 2 to 6 devices, which form point-to-point operative connections via communication links [Figure 3.7/20](#), and operative connections can have different bandwidths within a topology. A certain amount of binary information and measured values can be transmitted bi-directionally between the devices depending on the bandwidth. The connection with the lowest bandwidth establishes this quantity. The user can route the information with DIGSI 5.

This information has the following tasks:

- Topology data and values are exchanged for monitoring and testing the connection.
- Protection data, for example, differential protection data or directional comparison data of the distance protection, is transmitted.
- The devices can be synchronized in time via the connection, whereby a device of the protection topology assumes the role of the timing master.
- The link is continuously monitored for data faults and outages, and the runtime of the data is measured.

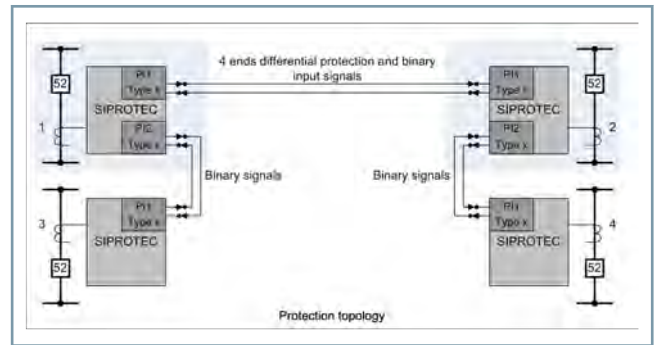

[dw_wirkkom-diff-BI, 1, en_US]

Figure 3.7/20 Protection Communication of the Differential Protection and Transmission of Binary Signals

Operative connections integrated in the device have previously been used for differential protection ([Figure 3.7/20](#)) and for the teleprotection for the distance protection. In addition to these protection applications, you can configure operative connections in all devices for SIPROTEC 5. At the same time, any binary information and measured values can be transmitted between the devices. Even connections with low bandwidth, such as 64 kbit/s, can be used for this. Operative connections that mainly serve for the power transmission of data for differential protection are designated as type 1 links and are used in the SIPROTEC 7SD8 and 7SL8 devices. Connections for the transmission of any data that can be configured in the other devices (for example, SIPROTEC 7SA8, 7SJ8) are of type 2. The protection interfaces must be of the same type on both sides.

The figures [Figure 3.7/21](#) to [Figure 3.7/27](#) show possible communication variants for establishing protection communications.

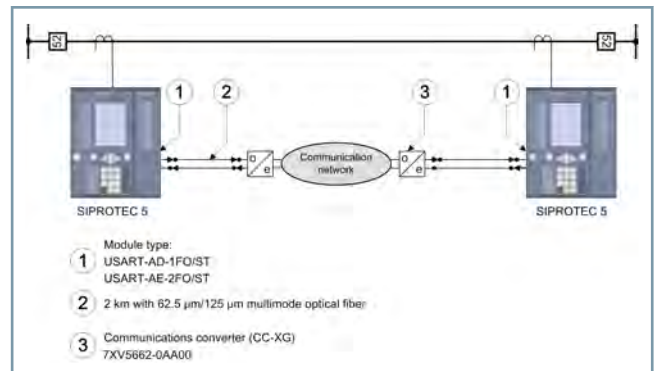

[dw_Wirkkom-IEEE-interface-lwi-anschl, 2, en_US]

Figure 3.7/21 Protection Communication via a Communication Network with X21 or G703.1 (64 kbit/s / G703.6 (2 Mbit) Interface

SIPROTEC 5 System

Communication – Protocols

3.7

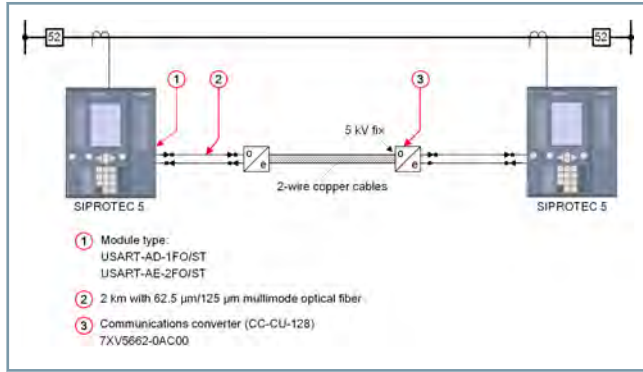

[dw_Wirkkom-Kupferverbindung, 3, en_US]

Figure 3.7/22 Protection Communication via a Copper Connection

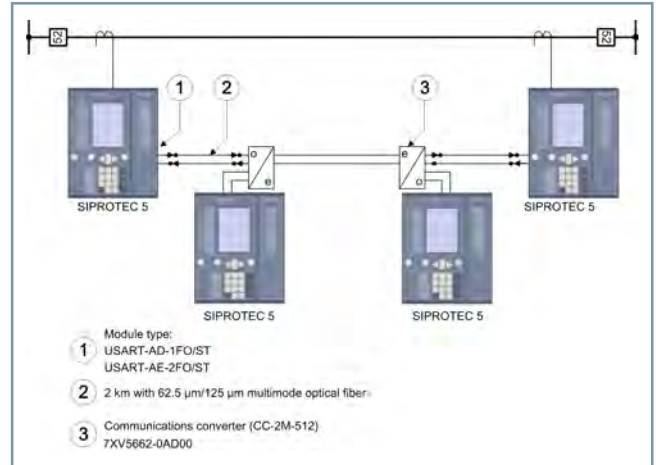

[dw_Wirkkom-Singlemodefaser-Repeater.vsd, 2, en_US]

Figure 3.7/25 Protection Communication via Singlemode Optical Fiber and Repeater

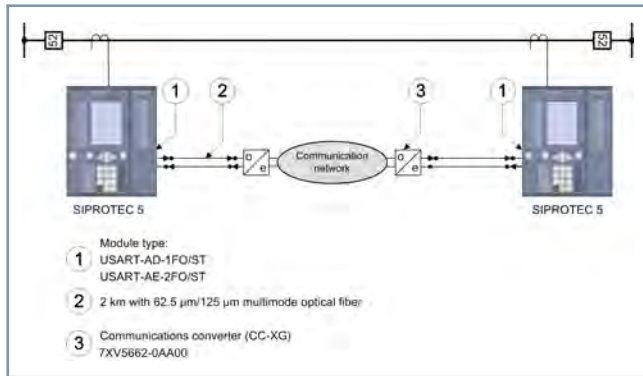

[dw_Wirkkom-IEEE-interface-lwl-anschl, 2, en_US]

Figure 3.7/23 Protection Communication via an IEEE C37.94 (2 Mbit/s) Interface – Direct Fiber-Optic Connection to a Multiplexer

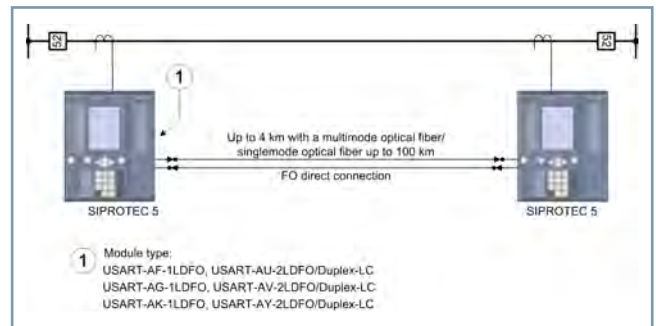

[dw_Wirkkom-direkt-lwl-verb.vsd, 2, en_US]

Figure 3.7/26 Protection Communication via Direct Fiber-Optic Connections

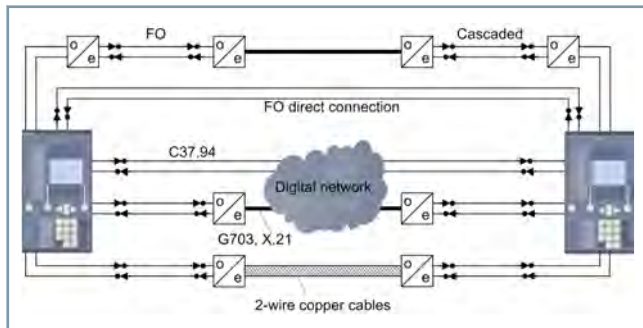

[dw_multimediale_Schutzdatenkommunikation, 1, en_US]

Figure 3.7/24 Multimedia Protection Communication

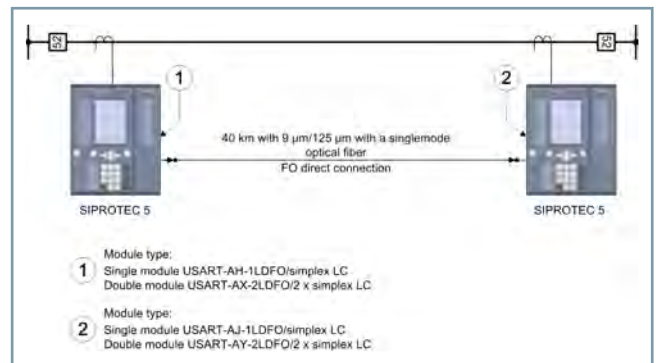

[dw_Wirkkom-Singlemodefaser.vsd, 2, en_US]

Figure 3.7/27 Protection Communication via a Singlemode Optical Fiber

Figure 3.7/28 shows the interfacing to multiprotocol label switching (MPLS) IP networks via router line cards with VPN tunnel and jitter buffer, as well as with the interfaces C37.94 (optical fiber module) and E1 (G703.6) via an external converter.

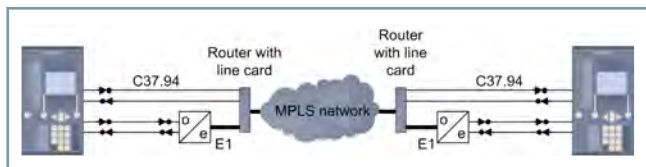

[dw_MPLS_Schutzdatenkommunikation, 1, en_US]

Figure 3.7/28 Protection Communication via IP-MPLS Networks

Compatibility between SIPROTEC 5 Line Protection and SIPROTEC 4 Line Protection

Introducing the firmware version V7.90 in the SIPROTEC 5 line protection means that now, for the first time, mixed configurations comprising line protection devices from the SIPROTEC 5 series and the old SIPROTEC 4 series can be operated.

See [Compatibility between SIPROTEC 5 Line Protection and SIPROTEC 4 Line Protection, Page 94](#) in the Line Protection section.

Ethernet Redundancy – Network Topologies

Regardless of the selected protocol (IEC 61850, DNP3 TCP), the electrical and optical Ethernet modules support different network topologies.

If such a module works without an integrated switch that can be switched off via DIGSI 5, it is connected to external switches individually or redundantly. In the case of a double connection, only one interface processes the protocol applications (for example, IEC 61850). The 2nd interface works in hot standby and the connection to the switch is monitored. In the case of an outage of interface 1, a switch is made to interface 2 within just a few milliseconds ([Figure 3.7/29](#)).

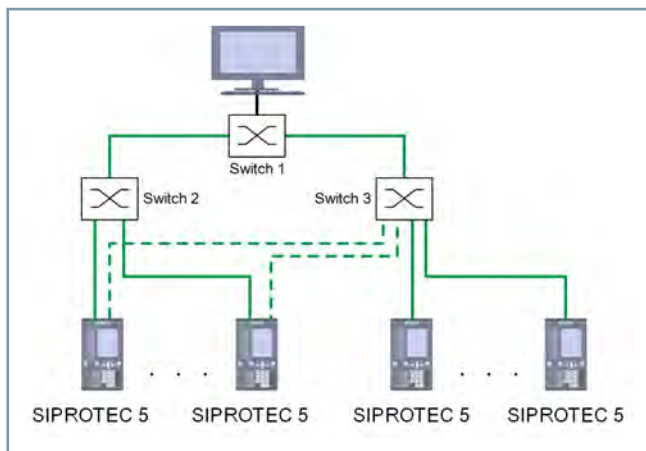

[dw_SIP5-0031, 4, en_US]

Figure 3.7/29 Single or Redundant Connection to External Switches

The Ethernet module can be plugged into the device one or more times. This allows the same or different protocol applications to be executed multiple times. For IEC 61850, several networks are possible, for example, one for client-server communication to the systems control and a second for the GOOSE connections between the devices that can potentially be assigned to the process ([Figure 3.7/30](#)). Through the client-server architecture of IEC 61850, a server (device) can simulta-

neously send reports to a maximum of 6 clients. The doubling of the interfaces on the Ethernet module enables the operation of redundant network structures, for example, optical rings or the redundant connection to 2 switches.

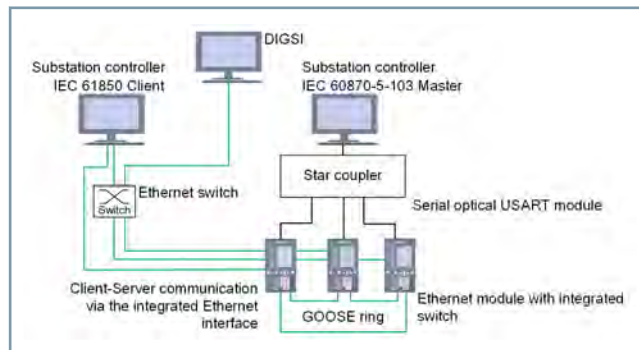

[dw_SIP5-0046, 3, en_US]

Figure 3.7/30 Separate Client-Server and GOOSE Communication via IEC 61850 with Another Serial Connection to an IEC 60870-5-103 Master

Redundancy in a Ring Using RSTP (Rapid Spanning Tree Protocol)

With an integrated switch, electrical or optical rings with a maximum of 40 devices can be established (RSTP) ([Figure 3.7/31](#)). Both interfaces of the module transmit and receive simultaneously. Mixed operation with SIPROTEC 4 devices is possible in the ring with up to 30 devices. A special ring redundancy process, based on RSTP, ensures short recovery times in case of a failure of a device, so that the protocol applications continue running nearly interruption-free. This configuration is also independent of the protocol application that runs on the Ethernet module.

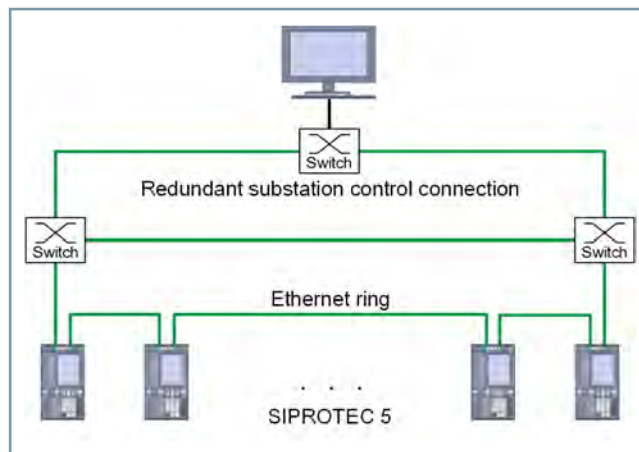

[dw_SIP5-0032, 3, en_US]

Figure 3.7/31 Ring Operation with Integrated Switch and Ring Redundancy

Seamless Redundancy with PRP and HSR

New technologies decisively shorten the time for the reconfiguration of communication networks in the event of interruptions.

SIPROTEC 5 System

Communication – Protocols

3.7

These technologies include:

- PRP = Parallel Redundancy Protocol
- HSR = High Available Seamless Ring Redundancy

Both systems operate according to the same principle and conform to the standard IEC 62439-3.

The same information (Ethernet telegram) is thus transmitted via 2 different information routes. The receiver uses the 1st telegram that arrives and discards the 2nd. If the 1st telegram does not arrive, the 2nd one is still available and is used. This mechanism is based on the Ethernet stack, which assigns the same MAC address to the 2 telegrams.

- The PRP protocol uses 2 physically separated networks to transmit the 2 identical telegrams. Although this doubles the effort and cost for the network equipment, the PRP protocol provides greater availability of the Ethernet system compared to the HSR protocol.
- HSR operates according to the same principle, but the 2 identical telegrams are distributed in 2 directions on one Ethernet ring. The cost for the Ethernet network infrastructure is less, but HSR handles N-1 errors – however, evolving faults result in a communication failure in parts of the HSR ring.

The procedures can be activated via setting parameters and do not have any other parameters. They are therefore easy to set up. The number of network users is limited in both procedures to a maximum of 512.

HSR and PRP can be combined using so-called RedBoxes (redundancy boxes).

This cost-efficient solution according to IEC 62439-3 can be designed in the following manner:

- 2 switches in the control center
- 2 switches in the bay
- 2 RedBoxes (RB) per HSR ring
- Up to 50 devices per HSR ring
- Easy extension using 2 additional PRP switches

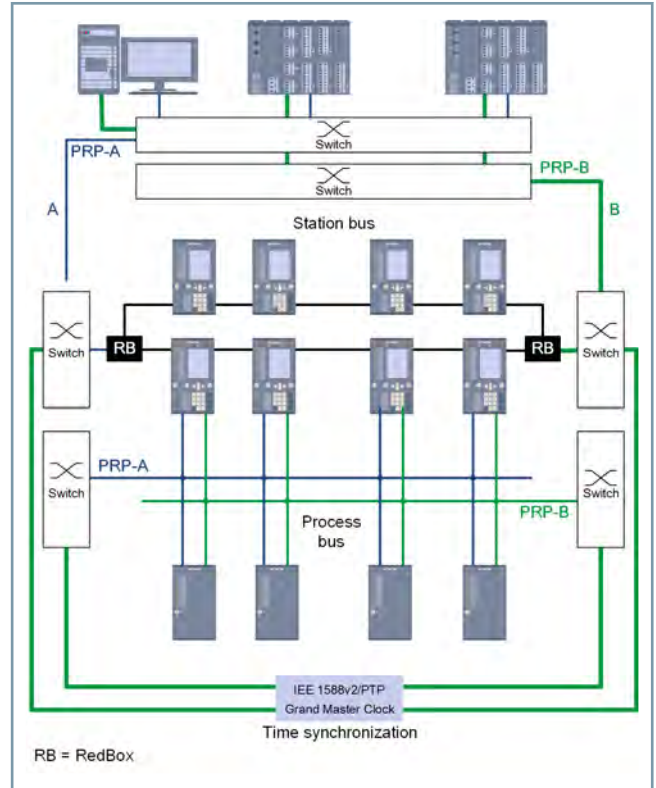

[dw_stossfreie-n-1-struktur, 3, en_US]

Figure 3.7/32 Economical Seamless n-1 Structure with 1 Time Source

Serial Redundancy

Redundant connection to 2 substation controllers, for example, SICAM PAS, is possible via 2 independent, serial plug-in modules or a serial double module. For example, the serial protocol IEC 60870-5-103 or the serial protocol DNP3 can run on the modules. Mixed operation is also possible. Figure 3.7/33 shows a serial optical network that connects each of the serial protocol interfaces of the device to a master. The transmission occurs interference-free via optical fibers. For the IEC 60870-5-103 protocol, special redundancy processes are supported in the device. Thus, a primary master can be set that is preferred over the 2nd master in the control direction. The current process image is transmitted to both masters.

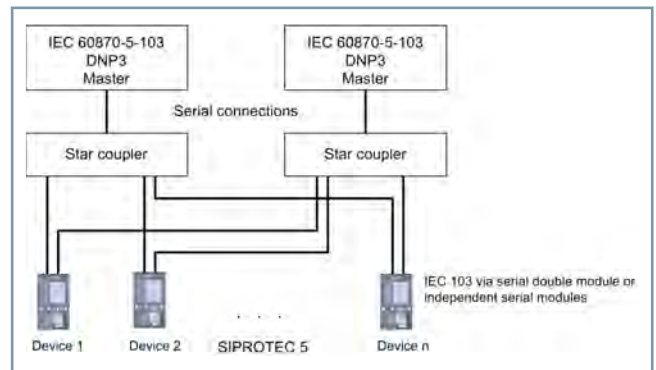

[dw_SIP5-0033, 2, en_US]

Figure 3.7/33 Redundant Optical Connection of Devices to IEC 60870-5-103 or DNP3 Master (for example, SICAM PAS)

SIPROTEC 5 System

Communication – Protocols

3.7

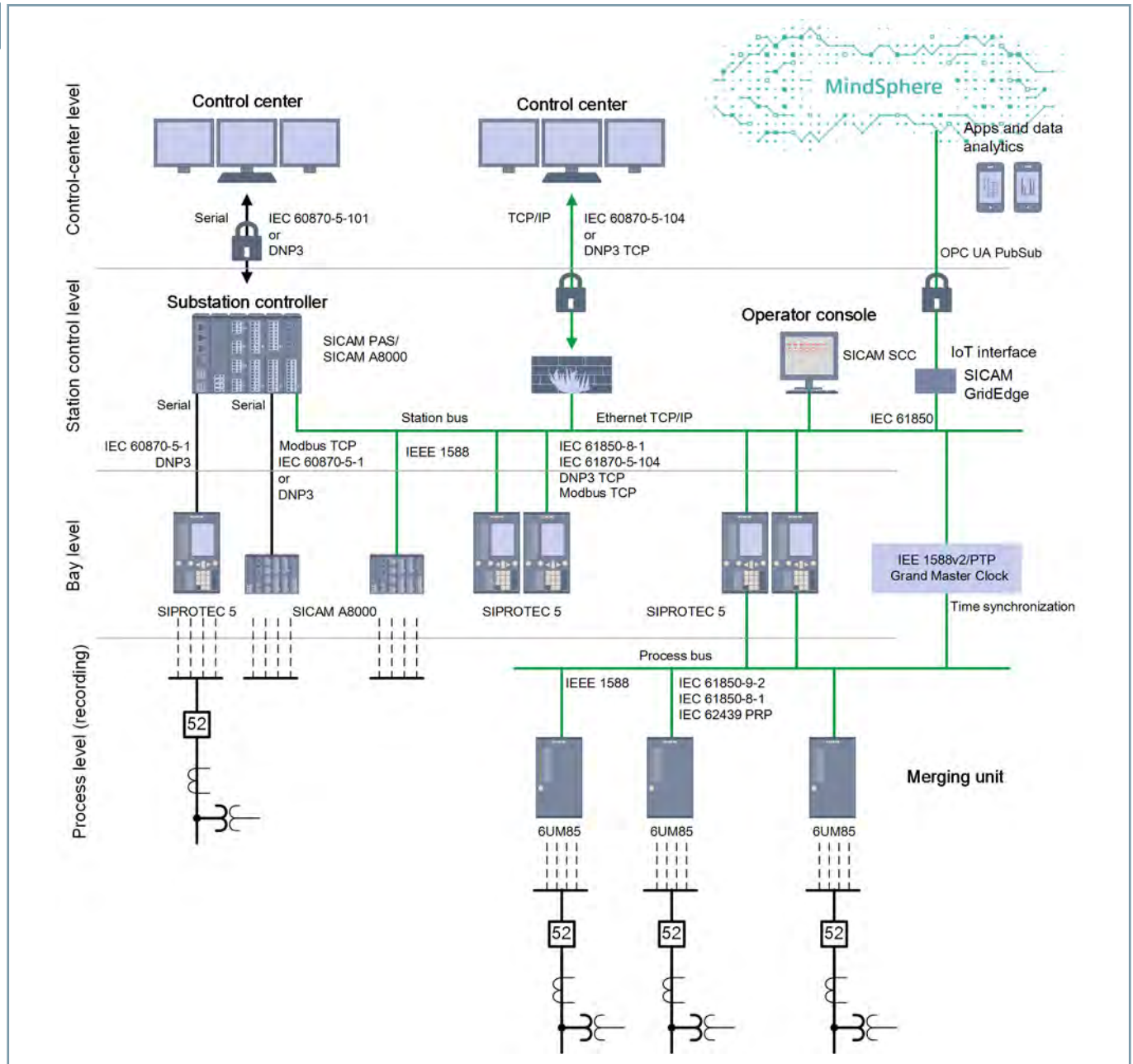

[dw_example protection_substation_com, 3, en_US]

Figure 3.7/35 Communication Protocols in the Substation Automation Technology and in Network Control Systems

Design to communicate

- Adaptation to the topology of your communication structure using settings (ring, star, or network)
- Scalable redundancy in hardware and software (protocols to match your requirements)
- Pluggable and upgradeable communication modules
- Extensive routines for testing connections, functions, and operating workflows

Safety for personnel and equipment are first priority, but availability is also critically important. As the plant landscape becomes more open and complex, conventional security mechanisms are no longer adequate.

For this reason, a security concept has been implemented in the SIPROTEC 5 device architecture that is designed to address the multidimensional aspects of security in a holistic approach.

Multilayer safety mechanisms in all links of the system security chain provide you with the highest possible level of safety and availability.

Safety and cybersecurity includes:

- Security concept in device design
- Information security against IT attacks (IT threats from outside)

- Crossover wiring of internal analog/digital transformers allows to monitor the analog inputs of the device effectively and to block potentially threatened functions early, in a similar manner to differential protection if a current channel fails.
- Storage of calibration data in the analog acquisition modules allows completely safe exchange or extensions within the module unit.
- Fully pluggable terminals and plug-in modules mean that a wiring test is no longer necessary when devices or modules are replaced.
- Now that the current transformer is integrated in the terminal block (Safety CT-Plug), open secondary current circuits cannot occur anymore during replacement of a device or a module. When the terminal is pulled out, the transformer is always opened on the safe, secondary circuit.
- The device does not need to be opened to adjust binary-input thresholds or to adapt to the rated current of the transformer (1 A, 5 A). The device does not need to be opened to replace the battery or to change the plug-in modules.

Safety

Multilayer safety mechanisms

Safety comprises all aspects of protection for personnel and primary equipment installations. The devices and DIGSI 5 support this from the functional point of view. Cybersecurity ensure secure operations in networks. The manufacturer can support the user with these measures. The responsibility to implement a comprehensive cybersecurity concept lies with the operator of the system. The concept must consider all system components regarding to all technical aspects of cybersecurity.

Safety in the hardware design

- The device system consisting of configured hardware building blocks, each with its own cooling system, reduces thermal load, prolongs service life, and allows error-free operation in a wide ambient temperature range.
- High availability is achieved with the auxiliary power supply concept. Central wide-range supply ensures the provision of a common voltage to all components. Individually required voltage levels are created in the modules concerned. Thus, the possible outage of a local voltage level causes only one module to failure, not the entire device. This selective outage is reported.

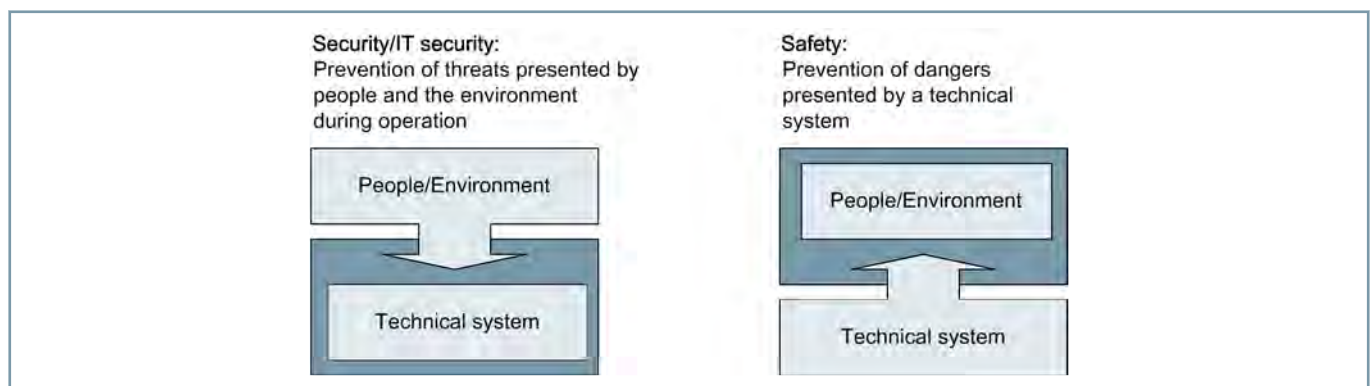

[dw_safety-security, 1, en_US]

Figure 3.8/1 Differentiation of Safety/Security

Monitoring functions

Comprehensive monitoring functions ensure secure operation by fast detection of irregularities and automatic initiation of appropriate measures to avert incorrect responses. Depending on the severity of the irregularity detected, a warning may be issued, the functions concerned be blocked, or the entire device may be isolated by disconnecting the life contact. In all cases, the device-diagnosis log shows the cause and issues an appropriate instruction.

Hardware monitoring

All hardware in the device is continuously monitored.

This includes, for example, the CPU, the auxiliary voltage, the battery status, the internal clock, the storage modules, the analog inputs, the bus connections, the expansion and communication modules.

Monitoring the analog inputs

As a data source for the protection functions, monitoring of the analog inputs is assured in multiple stages. Some monitoring functions are primarily dedicated to the commissioning (incorrect or missing connections) and only generate a warning indication.

These include:

- Current and voltage balance
- Current and voltage sum
- Phase-rotation supervision

Other monitoring functions detect outages during operation and initiate blocking of the affected functions rapidly:

- Measuring-voltage failure detection (loss of voltage)
- Fast current-sum supervision and broken-wire detection for the power circuits.

In addition, the proper working method of all analog/digital transformers is assured by a plausibility check at the sampling level.

Trip-circuit supervision (ANSI 74TC)

The circuit-breaker coil and its lines are monitored via 2 binary inputs. If the trip circuit is interrupted, and alarm indication is generated.

Communication links

Telegrams are monitored for correct transmission. Faults are reported via warning messages. Data associated with protection and control is transmitted via protection interfaces and IEC 61850 GOOSE messages. The transmitted information is also monitored constantly on the receiving side.

Monitoring of protection interfaces

- 32-bit CRC checksum monitoring compliant with CCITT/ITU for detecting corrupted telegrams
- Invalid telegrams are flagged and not used by the protection system
- Sporadic interference is ignored, persistent interference triggers blocking of the affected protection (differential protection) and control functions.
- Propagation times are measured and taken into account for purposes of differential protection and protection communication.
- The topology of the protected area is monitored. Outages in the communication links lead to an automatic trigger switching to other communication paths (ring to chain operation or hot standby), or to blocking the entire protected area. The same applies if an outage of a device in the topology is detected.

Monitoring of IEC 61850 GOOSE messages

- Cyclic redundancy check checksum monitoring, sequence number monitoring and repetition time monitoring, for detecting wrong or missing telegrams
- Applications detect corrupt GOOSE messages or GOOSE messages transmitted under test conditions and switch to safe operating mode.

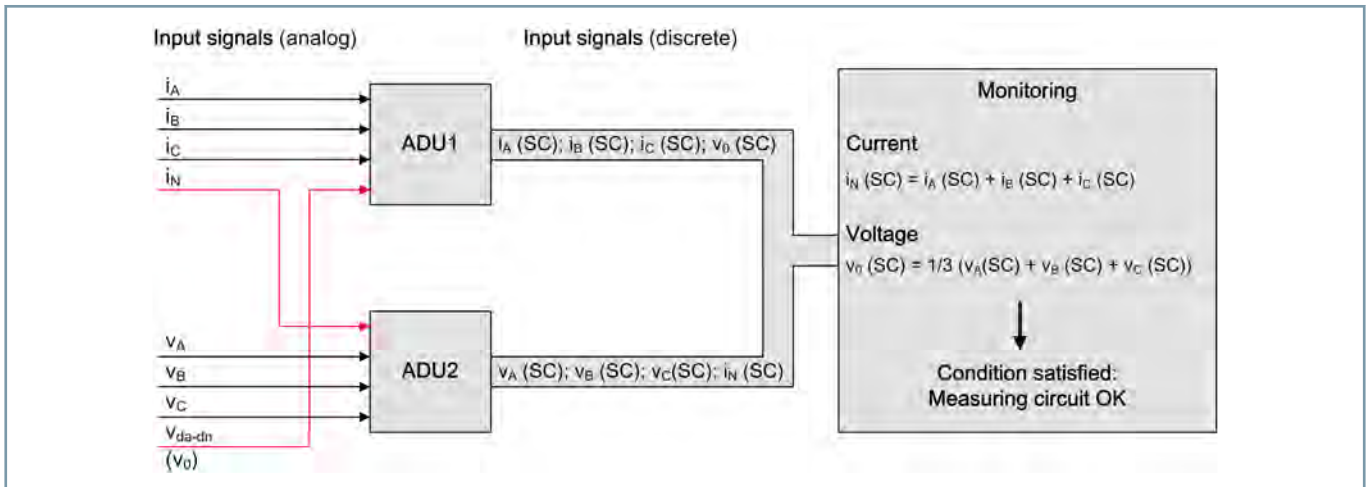

Figure 3.8/2 Monitoring of Analog Input Circuits for Malfunctions during Analog-Digital Conversion

Load Management

The free configurability of protection functions and function charts (CFC) allows them to be adapted to different applications. During engineering with DIGSI 5, the integrated load model calculates the resulting device load. This ensures that only viable configurations can be loaded into the device.

Consistent Administration of Device Modes

Test modes and the health state of information are forwarded and handled uniformly and consistently throughout the entire system. Analysis functions consider the modes and warrant secure operation. This is particularly critical when data related to protection and control is transmitted via protection interfaces and IEC 61850 GOOSE messages. But it applies equally for signal processing in the function charts (CFC).

Cybersecurity

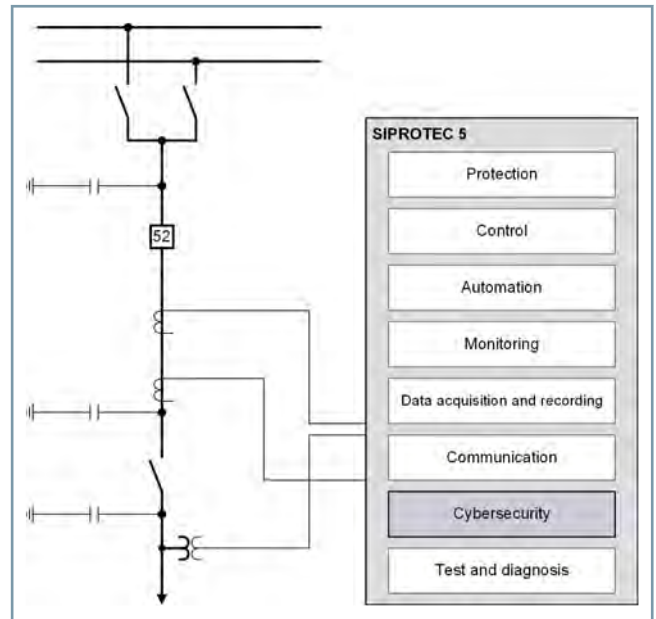

Figure 3.8/3 SIPROTEC 5 – Functional Integration – Cybersecurity

With the increasing integration of bay devices in Ethernet-based communication networks, communication must be secured against internal disturbances and attacks from outside. Standards and directives such as IEC 62443, IEC 62351, NERC CIP (North American Electric Reliability Corporation – Critical Infrastructure Protection), and the BDEW Whitepaper (Requirements for Secure Control and Telecommunications Systems of the Bundesverband der Energie- und Wasserwirtschaft e.V) contain requirements for the secure operation of devices in the critical communications infrastructure, and are addressed to at both manufacturers and operators.

Cybersecurity must be incorporated into the design of devices right from the start. This has been carried out systematically in

the case of SIPROTEC 5. Measures in the hardware ensure that key material for protecting the communication and datasets of a device is stored in absolute security. Communication stacks that are hardened against cyberattacks, a multistage role-based access concept in operation, and logging of events relevant to cybersecurity provide the operator with a high degree of cybersecurity when the devices are integrated in the network of the operator.

By default only the connection of DIGSI 5 is enabled in the device. All other Ethernet services and their ports are deactivated by default in the device and can be enabled with DIGSI 5. If, for example, only the ring redundancy protocol RSTP is used, then you as the user enable this with DIGSI 5 (Figure 3.8/5). The secure standard configuration provides no open interfaces to a potential attacker and only services that are really in use are activated in a network.

Cybersecurity at communication level

Secure authentication takes place between the device and the communication partner (for example DIGSI 5, Web monitor or cloud). This prevents an unauthorized program accessing the devices and reading or writing data there. Through this transmission protocol secured by Transport Layer Security (TLS), the integrity and confidentiality of the transmitted data are ensured. This prevents manipulation and unauthorized access of the data. TLS security is the basis for future communication routes and certificate management, both across stations (for example IEC 61850-MMS) and in the direction of cloud systems (for example, IoT connectivity to MindSphere).

More operational security (safety) by means of confirmation ID

If Role-Based Access Control (or RBAC) is not activated, confirmation ID entering the confirmation ID is required for safety-critical actions (safety), such as changing parameters, in order to obtain write access to the device. These confirmation IDs can be configured by the user and may be different for different fields of application.

Establishing connection after password verification

Optionally, if RBAC is not activated, a connection password can be set up on the device. Remote access via the Ethernet does not take place until the user enters the predefined password. The user has read and write access to the device only after the connection has been established. This connection password conforms to the cybersecurity requirements for assigning passwords defined in NERC CIP. It has 8 to 30 characters and must include upper-case and lower-case letters, digits, and special characters. Through this secure transmission protocol, the integrity and confidentiality of the transmitted data are ensured. This prevents manipulation and unauthorized access of the data.

Establishing of the connection after central authentication and authorization of the user

As a new option, the device supports role-based access control (RBAC). With this option, the device can authenticate and authorize the users by means of centrally managed login data and user accounts. Authentication means that the device checks with the central user management system whether the user name and password combination entered by the user is valid. After successful authentication, the device tests the permitted

roles of the user (authorization). Depending on the role assigned to the user, he can only perform authorized operations on the device.

The main advantages of this option for power utilities are:

- Central maintenance of user accounts and roles in RADIUS/ Microsoft Active Directory Server
- Protection against unauthorized access to the device via DIGSI 5, Web browser, and on-site operation thanks to built-in RADIUS authentication and authorization option
- Support for standard roles and rights according to standards and directives such as IEC 62351-8, IEEE 1686, and BDEW Whitepaper
- Emergency-access options in the case of a RADIUS server connection outage

Logging of events relevant to cybersecurity

Events relevant to cybersecurity, such as login attempts or device restarts, are recorded and optionally transmitted to a central server via the standardized Syslog UDP protocol. The device-internal log entries are secured to prevent deletion and protected against anonymous access with the RBAC option. The events can additionally be transmitted to the substation automation unit and archived there.

Integrity assurance of firmware and cybersecurity settings

SIPROTEC 5 device-firmware files are digitally signed. In this way, corruption from outside by viruses or trojans, for example by manipulated firmware files, is reliably prevented. In addition, the cybersecurity settings of a device configured with DIGSI 5 are stored in an encrypted way and thus protected against manipulation and disclosure.

Secure standard configuration

By default, only the connection of DIGSI 5 is enabled in the device. All other Ethernet services and their ports are deactivated by default in the device and can be enabled with DIGSI 5. If, for example, only the ring redundancy protocol RSTP is used, then you as the user enable this with DIGSI 5 (Figure 3.8/5). The secure standard configuration provides no open interfaces to a potential attacker and only services that are really in use are activated in a network.

It is generally not desirable to have to enter login data, connection passwords, or confirmation IDs during the configuration and testing phase. During operation, however, the focus is on the reading of data. Complete access protection can be deactivated in the device until commissioning has been completed and can then be activated again for operation.

Differentiation of the various network accesses

In SIPROTEC 5, the IP attack interface of the SIPROTEC 5 devices can be reduced effectively.

- Setting the IP-based access per device port (mainboard RJ45, slot F/E/P/N)
- Setting options: Full access, read access, or no access
- Adjustable for DIGSI 5 engineering, IEC 61850-MMS process communication, or Web monitor access

These settings function independently of RBAC.

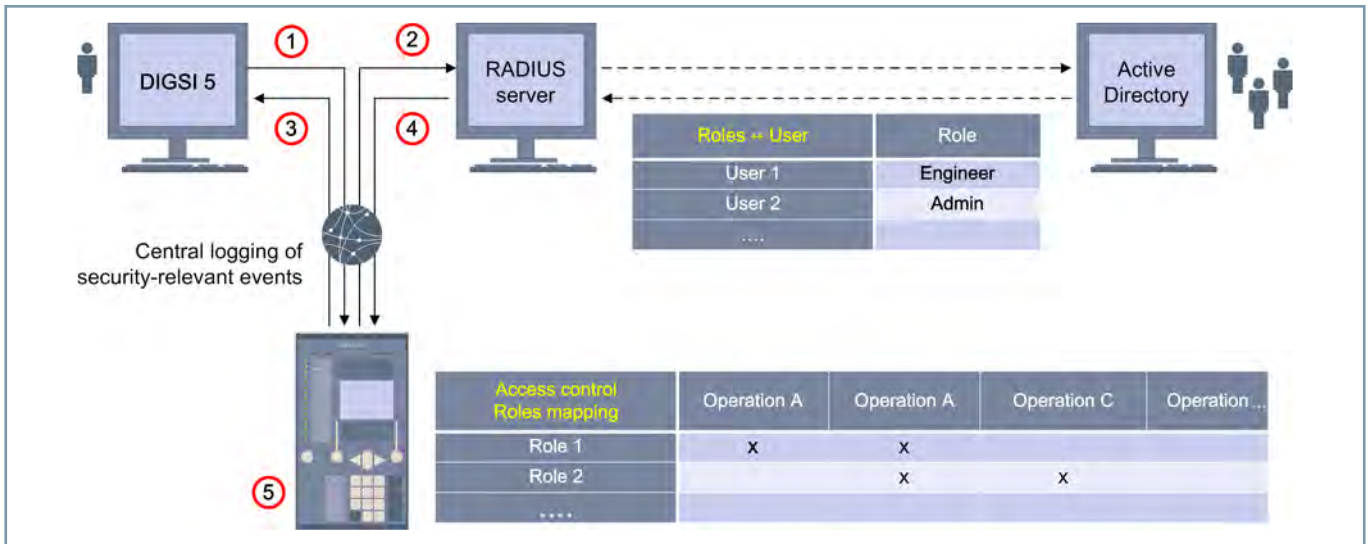

[dw_cyber-security_syslog_protocol, 1, en_US]

Figure 3.8/4 Role-Based Access Control (RBAC) with Central User Management

- (1) User requests device access (with user name & password)
- (2) Authentication request via RADIUS
- (3) Authentication & authorization (role) by RADIUS
- (4) Success/rejection response from device to user
- (5) Role-based user session initiated or rejected

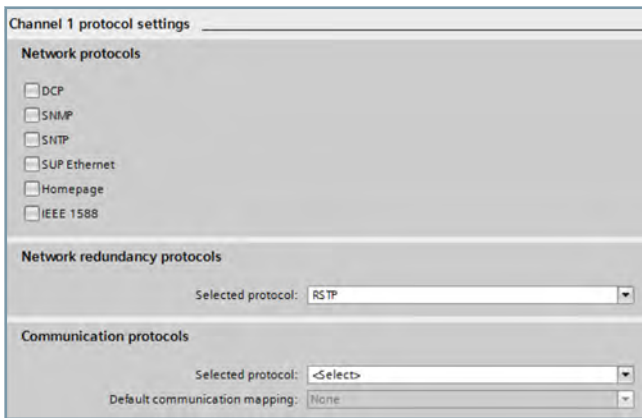

[sc_onlyRSTP_de, 1, en_US]

Figure 3.8/5 Isolatable Communication Services during Access via Ethernet Networks

optical Ethernet rings via switches. In these rings, each Ethernet-based substation automation protocol, for example, IEC 61850 or DNP3 TCP, runs together with the systems control without loss of performance. Accesses from a non-secure external network are allowed via a gateway that is responsible for safeguarding the network. The accessing party is authenticated, for example, by DIGSI 5, in the gateway and the communication is encrypted via VPN. This is fully supported by the communication services of DIGSI 5.

Product Security Blueprint

You can find valuable hints on the integration and on secure operation of devices in your network in the Product Security Blueprint and in the **Application Note – SIP5-APP-009** for SIPROTEC 5 devices. An overall security concept should be drawn up and maintained in a **Spanning Security Blueprint**. This documents typical network configurations, the services used, and their ports. Measures for updating the components that are critical for cybersecurity, password protection, and anti-virus protection are also described.

[Figure 3.8/6](#) shows a recommendation of this kind for protecting switchgear. The SIPROTEC 5 devices are integrated in

SIPROTEC 5 System

Safety and Security Concept – Cybersecurity

3.8

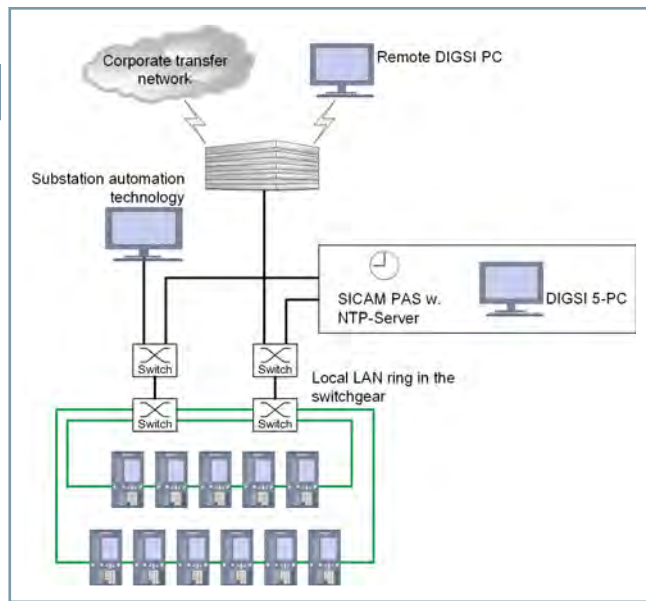

[dw_schaltanlage-mit-remote-zugriff, 3, en_US]

Figure 3.8/6 Secure Operation of Devices within a Switchgear with Remote Access from an External Network

The systems-control network and the network for remote access can also be separated entirely by selection of an independent Ethernet port for communication between the device and DIGSI 5. This falls within the scope of the philosophy of the operator. With their concept of pluggable modules, the devices also allow solutions with separate power systems. An extensive range of cybersecurity features have been integrated in SIPROTEC 5 and DIGSI 5.

Security-Patch Management (Security Updates) for SIPROTEC 5 and DIGSI 5

According to the requirements for protecting power plants, **patch management** was introduced for SIPROTEC 5 and DIGSI 5. This means that regular security updates for the software components from third-party vendors integrated into SIPROTEC 5/DIGSI 5 or used by SIPROTEC 5/DIGSI 5 are tested for compatibility with SIPROTEC 5 and DIGSI 5. A corresponding list with the last Microsoft Windows Security Updates tested and hints on the compatibility with DIGSI 5 is provided for downloading from the [Internet](#) and is updated every month.

Device Authentication Using IEEE 802.1x

IEEE 802.1x is the standard protocol that can be used to connect only to cryptographically authorized network devices as members of the IEEE 802.1x network. The standard defines 2 main roles where the terminal devices that are to be members of a network act as Supplicants and the basic network responsible for the switching procedure acts as the Authenticator.

In IEEE 802.1x-capable networks, supplicants (SIPROTEC 5 or other terminal devices) must provide their cryptographic identity which is then reported to the authenticators (normally switching devices). Then, the authenticator compares the requested login data to the centralized user directory (in this case, this is the RADIUS server) and activates or deactivates the

access to this port according to the validity of the login data of the supplicant.

If you use IEEE 802.1x in your OT network, you can individually control which devices should be part of the network and block all undesired third-party devices through the use of certificate authorities or user certificates in the SIPROTEC 5 family.

Safety and Cybersecurity means:

- Long-lasting, rugged hardware with regarding EMC immunity and resistance to weather and mechanical loads
- Sophisticated self-monitoring routines identify and report device faults immediately and reliably
- Compliant with the strict cybersecurity requirements in accordance with international cybersecurity standards and directives
- Effective and efficient role-based access control (RBAC) with central user management in the SIPROTEC 5 device
- Automatic logging of cybersecurity-critical events
- Reduction of the IP attack interface of the device

SIPROTEC 5 devices are equipped with extensive test and diagnostic functions. These are available to users in SIPROTEC 5 together with DIGSI 5, and they shorten the testing and commissioning phase significantly.

The DIGSI 5 Test Suite offers:

- Simulation of binary signals and analog sequences by integrated test equipment
- Hardware and wiring test
- Testing device functionality and protection functions
- Circuit-breaker test and automatic reclosing test functions
- Communication test including loop test
- Analysis of function charts

DIGSI 5 Test Suite

The objective of the extensive test and diagnostic functions that are provided to the user with SIPROTEC 5 together with DIGSI 5 is to shorten testing and commissioning times. All test functions are integrated in DIGSI 5. This enables engineering including the device test to be carried out with one tool. The most important functions are listed as examples here. There are also other specific test functions depending on the device type.

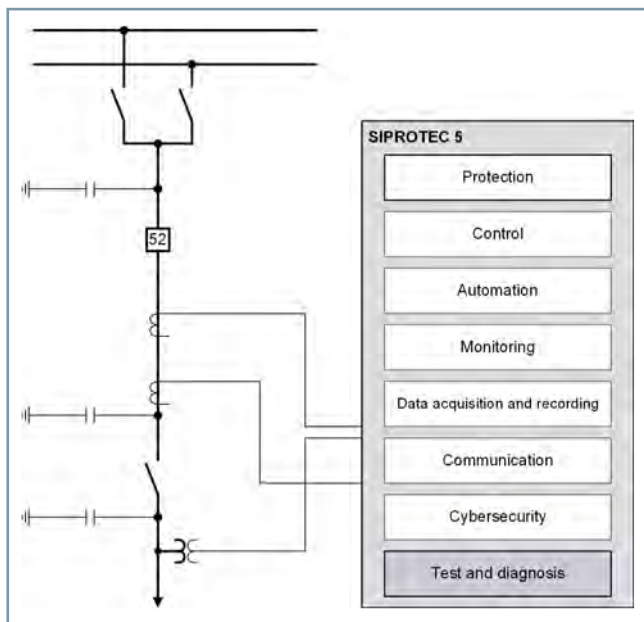

[dw_test_and_diagnosis, 3_en_US]

Figure 3.9/1 SIPROTEC 5 – Functional Integration – Test

Integrated test sequencer

The integrated test sequencer enables functions to be tested via the test sequencer integrated in the device. Normally, the device receives analog and binary signals from the process or from an external secondary test equipment. Until now, the protection functions and communication were tested with variables such as these. With SIPROTEC 5 devices, in the simulation mode, these variables can now be substituted with values supplied

from an integrated test equipment. For this, the analog and binary inputs are decoupled from the process and connected to the integrated test sequencer.

The tester uses DIGSI 5 to create a test sequence, for example, a short-circuit sequence, loads it into the device, and runs it in simulation mode. The test sequencer in DIGSI 5 is capable of combining up to 6 test items in one test sequence. When loaded into the device, this test sequence is run in real time and simulates the functions of the device like a real process at binary and analog inputs. Protection functions, control, logic functions, and communication can thus be tested in real time without secondary test equipment.

The test sequence is started manually from DIGSI 5 or controlled via a binary input. This also makes it possible to test the interaction between several devices.

Hardware and Wiring Test

In the hardware test, the state of the binary inputs can be read out by DIGSI 5 and contacts and LEDs can be switched or set through DIGSI 5 for test purposes.

The parameters measured at voltage and current inputs are represented in phasor diagrams – divided according to absolute value and phase angle (Figure 3.9/2). Thus it is easy to detect and check if the connections in the measurand wiring are inverted, as well as the vector group or the direction between current and voltage. In devices that are connected via operative connections, even analog measuring points of remote phasor ends can be represented as vectors. This makes it easy to check the stability of a differential protection.

In the wiring test, the wiring connections between devices are tested. If the devices are connected to a network via Ethernet, this test can be carried out with unprecedented ease. For this, the contact on a device is closed with the aid of DIGSI 5. This contact is connected to a binary input of one or more SIPROTEC 5 devices via a wire connection. These automatically send a report to DIGSI 5 to the effect that the binary input has been picked up by the closing operation of the contact. The tester can then log this test and check the wiring between the devices.

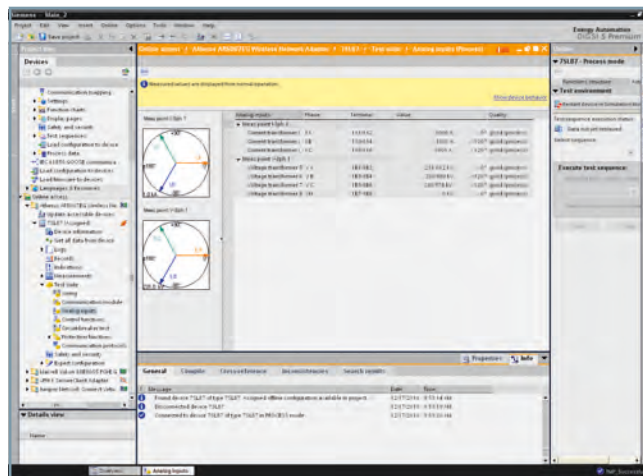

[sc_Analog_Inputs, 1_en_US]

Figure 3.9/2 Display of Analog Measuring Points in Phasor Diagrams

Testing Device Functionality and Protection Functions

The graphical representation of characteristic curves or diagrams of protection functions helps not only the engineer who parameterizes the test functions, but also the engineer who tests them (Figure 3.9/3). In this test, the operating point of a protection function is represented graphically in the diagrams, for example the calculated impedance of a distance protection in the zone diagram. Additionally, messages relating to the protection function are logged, for example pickup or tripping. This test can be carried out with signals from the process or with the test equipment integrated in the device.

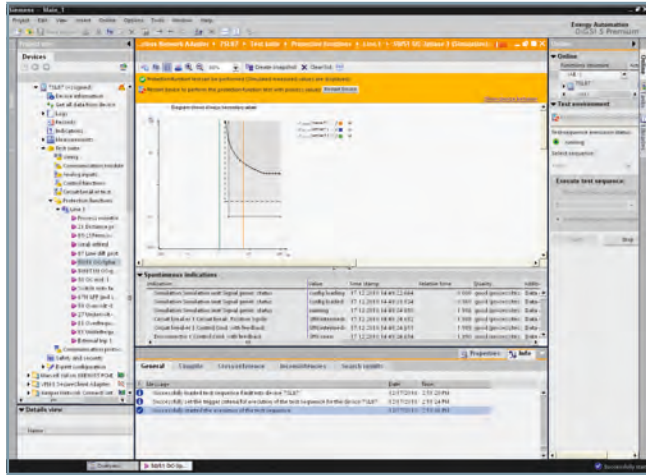

Figure 3.9/3 Test of Protection Function with Operating Point of the Protection Function in the Pickup Characteristic

Circuit-breaker testing and automatic reclosing test function

Switching sequences can be initiated via DIGSI 5 to test the automatic reclosing (AREC). However, this is only possible if remote switching via the key switch is permitted. In addition, a security prompt (confirmation ID) must be entered for switching authorization via DIGSI 5. There are additional security prompts for non-interlocked switching. This provides protection against unauthorized use or inadvertent actuation during operation.

The test logs the closing operation of the switch including the interlocking and feedback signals at the binary inputs. A circuit-breaker test can also be deactivated and activated without an interlocking check.

Communication Testing

Since communication is an integral component of the devices and they are connected either directly or via systems control, they must be thoroughly tested at commissioning and monitored continuously during operation. The integrated test tools support the user in the testing and monitoring of communication routes.

Loop test for communication links (loop test)

This test is launched by DIGSI 5 for a communication module and a selected interface if a protection communication is configured at a remote line end. It is used to detect disturbances in subsections when inspecting the physical connection of the communication paths (Figure 3.9/4). Test telegrams are sent

from the transmitting side Tx of an interface, and these are measured again at the receiving Rx interface. The user thus has the capability to insert loops at various points in the communication network and to test the connection of the loop. The number of telegrams sent, received, and corrupted is displayed continuously in DIGSI 5, so that the quality of the connection can be monitored.

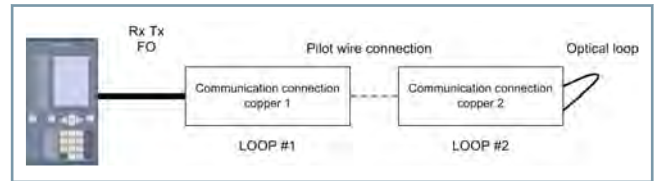

[dw_loop-test, 2, en_US]

Figure 3.9/4 Loop Test for Operative Connections (Loop Test)

Online monitoring of communication links

The data flow at communication interfaces can be monitored constantly. To do this, the number of telegrams that are sent, received, and corrupted per time unit for serial connections and Ethernet interfaces during operation is measured and displayed constantly. If faults occur, an alarm can be issued. A network management and monitoring system performs detailed monitoring of Ethernet modules via the SNMP protocol.

For operative connections, the transmission time of the signals is also monitored, and it is calculated during synchronization by means of a high-precision second pulse in the transmit and receive directions. Additionally, the communication topology is also monitored constantly there and displayed in DIGSI 5. GOOSE connections can be monitored permanently at the receiving site during operation. This means that an outage is detected within a few seconds.

Protocol test

For the protocol test, specific signal values are set and reset using DIGSI 5 (Figure 3.9/5). The test mode itself is configurable. The device sends the selected value to the client using the configured communication protocol, for example IEC 61850. In this case, a report is generated or a GOOSE message is sent automatically when this information is routed correspondingly.

The device can be used to test systems control information for all protocols (for example, IEC 61850, IEC 60870-5-103, serial DNP3, DNP3 TCP) without the effortful generation of signal states with test equipment. Signals that are transmitted across operative connections can also be tested.

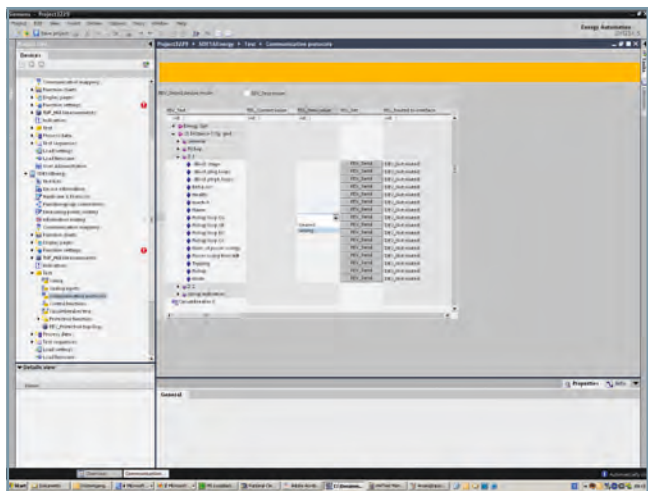

[sc_Protokolltest, 1, en_US]

Figure 3.9/5 Protocol Test for Substation Automation Technology or for GOOSE and Operative Connections

Test and Display of External Timers

If the system time of the device is set externally using 1 or 2 timers, this time can be read out in the device or with DIGSI 5. When the time protocol returns these values, it indicates which timer is setting the system time and issues a statement regarding the quality of the time source. Synchronization via external clocks can thus be monitored and displayed during operation (*Figure 3.9/6*).

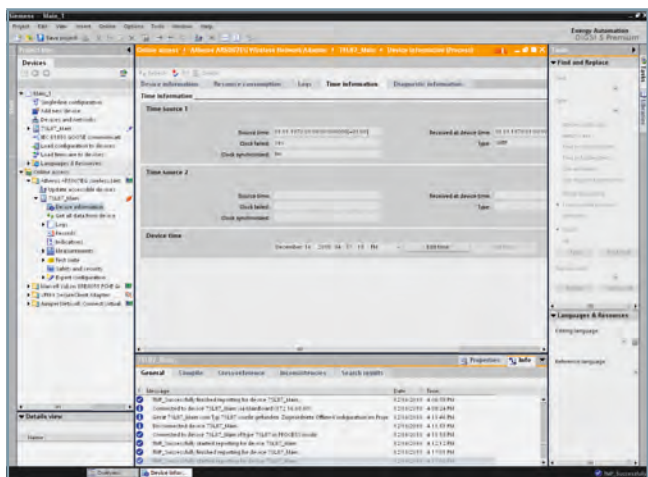

[sc_DIGSI5_TimeSynch, 1, en_US]

Figure 3.9/6 Test of External Timers

Analysis of Function Charts (CFC Debugging)

Function charts generated in the form of function charts (CFCs) can be tested offline in DIGSI 5. To this end, test sequences can be generated with the DIGSI 5 sequencer that act on logical inputs of the function chart or on the analog and binary inputs of the device. This makes it possible to test not only the function chart but also its interaction with upstream and downstream functions. During this test, the values of variables are displayed and their changes over time are logged in records that can be analyzed at a later date, for example, with SIGRA. This enables even complex temporal dependencies to be analyzed with ease.

Function charts (CFC) can thus be created offline in the office and tested without needing a device.

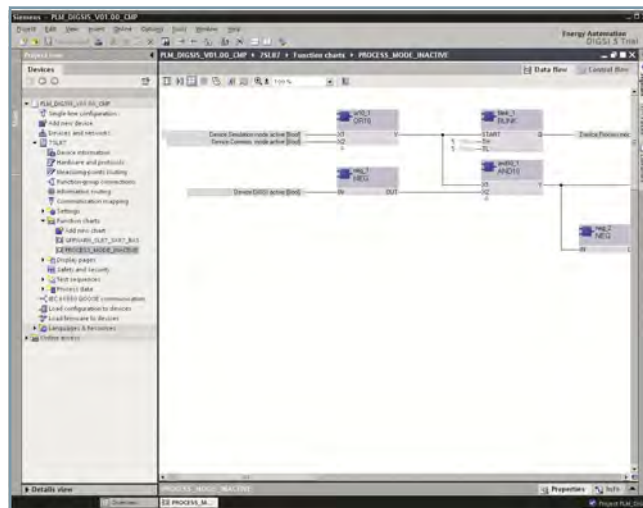

[sc_Interlocking, 1, en_US]

Figure 3.9/7 Easy Analysis of Function Charts

Using the DIGSI 5 Test Suite means:

- Considerably shorter testing and commissioning time
- Having commissioning support personnel in the adjacent substation is not absolutely necessary
- All test routines performed are documented.
- Testing using secondary test equipment is for the most part dispensable.

SIPROTEC 5 System

Test and Diagnostics

3.9



In project engineering with SIPROTEC 5, your workflow is in the center of interest – beginning with the single-line diagram of the primary system on to ordering, engineering and parameter setting all the way through to testing and commissioning. For you, this means: less errors, higher quality, and higher efficiency.

Holistic workflow means optimal, integrated support for all project phases:

- Project specification
- Device engineering
- System engineering
- Commissioning
- Operation and service

Product Selection via the Order Configurator

The *SIPROTEC 5 configurator* assists you in the selection of SIPROTEC 5 products. The configurator is a Web application that can be used with any browser. The SIPROTEC 5 configurator can be used to configure complete devices or individual components, such as communication modules or expansion modules.

At the end of the configuration process, the product code and a detailed presentation of the configuration result are provided. It clearly describes the product and also serves as the order number.

All functions from the library

The SIPROTEC 5 devices always have a basic functionality available depending on device type. You can extend these flexibly with any desired functions from the library. Additional functions are paid with your credit balance, which is reflected in function points. The function points calculator assists you in finding the correct function points value for your application. This guarantees that the selected device has the required functionality.

In the SIPROTEC 5 system, the main function is determined by the selection of the device type, while the scope of the additional functionality is determined by a single property, the function points value. This means that the functionality does not have to be fixed in detail during product selection. In the later engineering phase, any optional additional function can be selected from the device-specific function library. You must simply ensure that the function-point credit ordered for the device is not exceeded. Extra function points can simply be reordered at any time.

Clearly Presented Result Representation

The successful configuration of a device is represented on a clearly organized result page. You can also save the result as a .pdf file (see *Figure 4/1* and *Figure 4/2*). The specified product code can then be adopted directly into the information system or the ordering system or DIGSI 5 (www.siemens.com/siprotec).



[Konfiguration_1_3_en_US]

Figure 4/1 Example: Representation of a Configuration Result (Hardware Details)

SIEMENS
SIPROTEC 5
Configuration
Jan 7, 2020 1:16 PM

Functional scope: 7SA97 Distance Prot. 1/2 p.:

ANSI	Function	Abbr.	Always included	Add selected Qty.	x Value = Points	Result Qty.
	Protection functions for 3-pole tripping	3-pole	✓			✓
	Protection functions for 1-pole tripping	1-pole	✓			✓
	Hardware quantity structure expandable	I/O	✓			✓
	Process Bus Client Protocol (Note: This function requires at least one dedicated ETH-BD-2FO plug-in module, with V8.0)	PB client			x 100 =	
	IEC61850-9-2 Merging Unit stream (Note: This function requires a dedicated ETH-BD-2FO per stream, with V8.0)	MU			x 200 =	
21/21N	Distance protection	Z<, V</I>(V,I)	1x		x 95 =	1x
21T	Impedance protection for transformers	Z<			x 25 =	
25	Synchrocheck, synchronization function	Sync			x 80 =	
32, 37	Power protection active/reactive power	P<>, Q<>			x 10 =	
27	Undervoltage protection: "3-phase" or "positive-sequence system V/I" or "universal V/I"	V<			x 5 =	
	Undervoltage-controlled reactive power protection	Q>/V<			x 15 =	
37	Undercurrent	I<			x 10 =	
38	Temperature supervision	>	✓			✓
46	Negative-sequence overcurrent protection with direction	I2>, (V2,I2)			x 15 =	
47	Overvoltage protection, negative-sequence system	V2>			x 5 =	
49	Thermal overload protection	, Pt			x 10 =	
50N/51N TD	Overcurrent protection, ground	IN>	✓			✓
50/51 TD	Overcurrent protection, phases	I>	2x		x 30 =	2x
	Instantaneous tripping at switch onto fault	SOTF	✓			✓

[Konfiguration_2, 3, en_US]

Figure 4/2 Extract from the Representation of a Configuration Result (Functional Scope)

SIPROTEC 5 – Engineering

SIPROTEC 5 Web UI

Operation Using the Web UI

Apart from the use of an engineering tool such as DIGSI 5 or SICAM TOOLBOX II for configuration and maintenance, SIPROTEC 5 devices provide a Web front end that can be used with a standard Web browser. The **browser-based user interface** is a comprehensive commissioning and monitoring tool that provides an easy-to-understand display of the most important measured data. You can operate the device remotely or locally using the **browser-based user interface** and a Web browser.

4.1

The **browser-based user interface** can be used via a communication network:

- During commissioning
 - Checking and adjusting the values of a specific setting
 - Comparing the values of 2 or more devices
 - Checking a setting value against a user-defined setting to verify whether the setting value differs from the default value specified by Siemens
- During an inspection
 - Querying a value in order to adjust a test case, for example to preset the tripping current
 - Viewing all types of measured values, for example functional measured values and derived values such as the minimum/maximum and mean values
 - Displaying the deviation of the expected measured-value quality.
- While operating the device

The **browser-based user interface** is especially optimized for the protection system and provides comprehensive support during testing and commissioning from the PC or laptop computer.

All relevant device information and setting options are displayed graphically on the screen.

Application Options

You can also use the **browser-based user interface** for the following applications, for example:

- Checking and adjusting the values of a specific setting
- Comparing the values of 2 or more devices
- Checking a setting value against a user-defined setting as to whether the setting value differs from the default value specified by Siemens
- Querying a value to adjust a test case, for example, to preset the tripping current
- Viewing all types of measured values, for example functional measured values and derived values such as the minimum/maximum and mean values
- Displaying the deviation of the expected measured value quality.

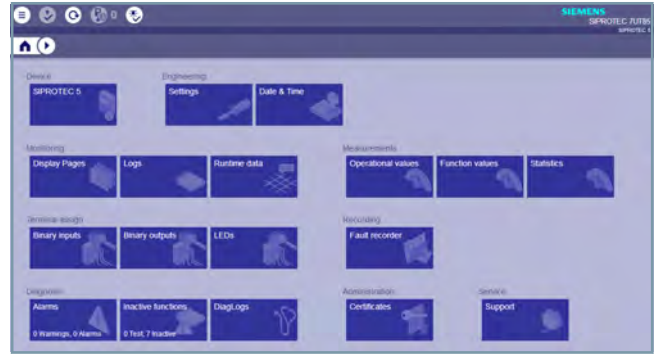

[scwebmonitor1, 5, en_US]

Figure 4.1/1 Buttons for the Browser-Based User Interface



[scwebmonitor2, 2, en_US]

Figure 4.1/2 Device Information

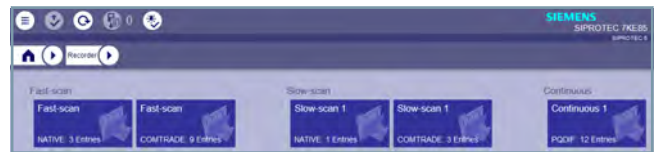

[sc_faultrec-ke, 1, en_US]

Figure 4.1/3 Additional Buttons on the 7KE85

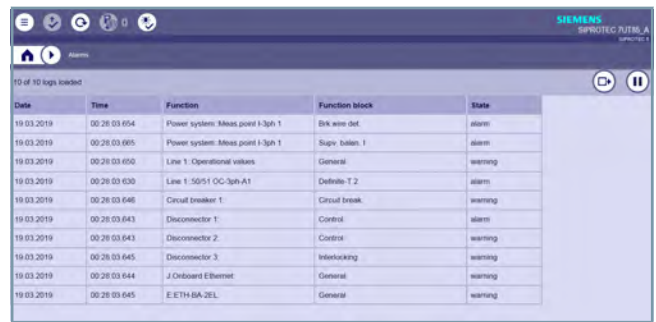

[scAlarmAndWarningList, 1, en_US]

Figure 4.1/4 Alarm List

Additional Information

For more information on **Operation with a browser-based user interface**, please refer to the latest device manual for **SIPROTEC 5 Operation – C53000-G5000-C003** under [SIOS](#).

Description

DIGSI 5 is the versatile engineering tool for parameterization, commissioning, and operating all SIPROTEC 5 devices. Its innovative user interface includes context-sensitive user instructions. Simple connection to the device via USB enables you to work with a device easily and efficiently. The full capabilities of DIGSI 5 are revealed when you connect it to a network of protection devices: Then you can work with all of the devices in a substation in one project. DIGSI 5 offers superior usability and is optimized for your work processes. Only the information you actually need to carry out your tasks is shown. This can be reduced further via expanded filter mechanisms. Consistent use of sophisticated and standardized mechanisms in the user interfaces requires less training.

Functions

Using a PC or laptop computer, you can set parameters for the devices using the interfaces and export the fault data.

DIGSI 5 is available in different variants (Compact, Standard and Premium) with various functionalities:

- Using the Single-Line Editor, you can visually define a substation and the primary equipment. Connect these elements with the protection function of your protection devices.
- The visual display of the SIPROTEC devices can be configured and edited with the Display Editor or with a graphics program. Take your single-line diagram and convert it into a display image. You can also define your own icons.
- You can configure additional functions like interlocking of the devices graphically with the function block diagrams editor (CFC).
- Using the Siemens IEC 61850 System Configurator, you can configure and set parameters for IEC 61850 stations. Using this tool, you can administer subnetworks, network users and their IP addresses and link the information of various participants.
- The DIGSI 5 test suite provides extensive test tools, which accelerate commissioning and support you with operation. One of the test functions enables you to compile and execute test sequences, to test devices without external test equipment.
- SIGRA for simple, fast and convenient analysis of fault records, such as those recorded during faults in power plants by fault recorders.

Languages: English, German, French, Italian, Portuguese, Spanish, Turkish, Czech, Polish and Russian (selectable)

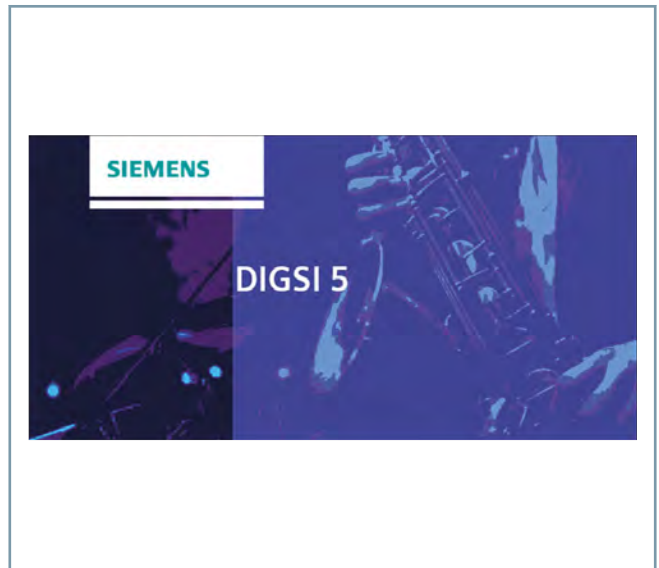

[sc_DIGSI 5_SplashScreen, 2, --, --]

4.2

DIGSI 5 is available in 3 different functional scopes:

• DIGSI 5 Compact

Software for configuration and operation of individual SIPROTEC 5 protection devices including transmission of process data from the device. Includes a graphical editor for Continuous Function Charts (CFC). Integrated test and commissioning functions, including the possibility of creating test sequences and their execution in the protection device without external test equipment. Projects may only contain a single SIPROTEC 5 protection device.

• DIGSI 5 Standard

Like DIGSI 5 Compact, but without constraint with regard to the number of supported SIPROTEC 5 devices per project, incl. IEC 61850 System Configurator. Contains additional graphical editors for single-line diagrams, device display pages and the network topology. SIGRA for professional fault-record analysis is available as an option.

• DIGSI 5 Premium with SIGRA

Same as DIGSI 5 Standard, but with enhanced functionality for IEC 61850, for example, flexible engineering and functional naming. Contains SIGRA for a professional analysis of fault records.

• DIGSI 5 for SIPROTEC 5 Compact

- For purely SIPROTEC 5 Compact projects
- Prospective scope equivalent to Premium with SIGRA

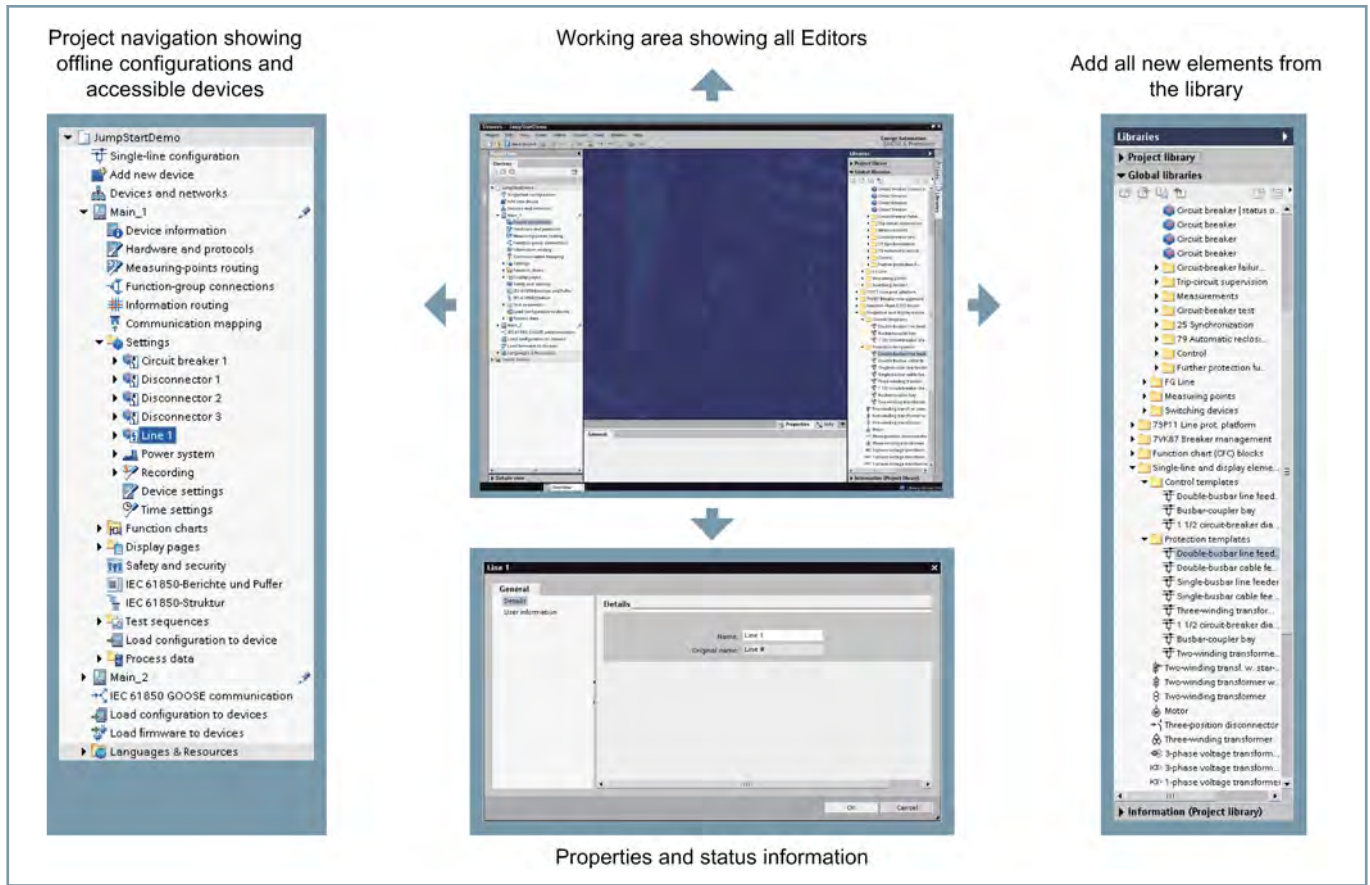

[dw_digsi-bo, 1, en_US]

Figure 4.2/1 Structure of the DIGSI 5 User Interface

Product Code

The product code calculated with the SIPROTEC 5 configurator can be adopted directly into the engineering program DIGSI 5. In this way, you create your selected devices directly in DIGSI 5. Since all device characteristics are unambiguously specified via the product code, engineering work with DIGSI 5 starts on a consistent basis without the need to reenter the device characteristics which would take much time.

From Planning to Engineering up to Testing – DIGSI 5

The engineering tool DIGSI 5 assists you in your workflow from planning to operation of your systems with SIPROTEC 5 devices. With DIGSI 5, you have full control over the engineering. The functional scope of the tool covers all tasks – from device configuration and device setting to commissioning and evaluation of fault data.

This is how a modern, efficient engineering process looks in short form:

In the rough planning, the system layout is documented using CAD. This system layout is prepared as the basis for the detail planning in the Single-Line Editor. Depending on the application, the required functionality (protection functions, control and automation scope as well as auxiliary functions) is defined and a device is selected. In the next step, the device is assigned an appropriate application template. You can use your own personally created, exactly matching application templates or

standard application templates here. Function adaptations are possible at any time after the selection of the application template. The high-performance copy functions with consistency checks allow fast project engineering. Then, you must configure the system (routings, implementation of corresponding logic into function charts (CFC)) and set the parameters.

The new program structure of DIGSI 5 is designed to support the required work steps during a project optimally. The application-oriented engineering approach guarantees that you are always aware of the workflow. DIGSI 5 makes you more productive – from design to engineering and even with installation, commissioning, and operation.

The Project View Guides You Through the Entire Workflow

In DIGSI 5, processing and maintenance of all components of IEDs and of all associated data is carried out in a project-oriented way. This means that the topology, devices, parameter values, communication settings, process data, and much more are stored in one project.

All devices are available in one central location. Just open the device in the project tree and the entire content is provided. When you begin with a device, you can edit your tasks in a simple and intuitive way.

The user interface of DIGSI 5 is divided into several sections (Figure 4.2/1). The project tree on the left displays everything

that belongs to your project, for example, devices and global settings. Double-clicking an entry opens an Editor in the main section of the window. This can be, for example, an editor for changing protection parameters, for configuring communication mappings, or for creating function charts (CFC).

In the lower section of the screen view, you can access the properties of all elements (for example, for circuit breakers or signals) quickly and conveniently. This section also contains lists with warnings and errors.

The libraries are particularly important in DIGSI 5. They are located on the right and contain everything that is used in the editors. Here, you select the required scope and insert it into your project. When configuring the hardware, you can select different hardware components, for example, a communication module. On the other hand, if you are working with function charts (CFC), you select the corresponding logical building blocks and select the required functionality while configuring the protection scope. For this purpose, you drag the elements to the position of the editor where you need them.

Visual Definition of the Primary Topology in Single Lines

The single-line diagram describes the primary topology of your system ([Figure 4.2/2](#)). For this, simply select the correct single-line template from the library. Further processing, for example, an extension, is possible without difficulty. DIGSI 5 contains a library with elements that are familiar to you from the ANSI and ISO standards.

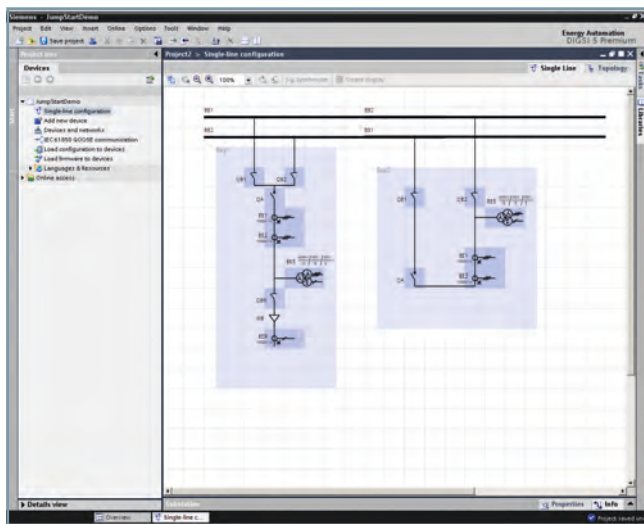

Figure 4.2/2 Graphical Definition of the Topology of a Substation in the Single-Line

From the Application to the Solution: Application Templates and Their Modification

After the topology has been defined, the next step is to add the required device. You simply use the ordering code from the configurator in DIGSI 5 and your device specification is already known. In the next step, you select the application template appropriate for your application and adapt it according to your requirements. Remove functions that are not needed and add the desired functions. The library offers you an extensive selection that you can use for this. The consistency of the device

configuration is continually checked. Finally, you can connect the application template with the primary elements of the single-line diagram (voltage and current transformers as well as circuit breakers) graphically. Thus, a topological reference is created. Setting values of the transformers (primary and secondary rated values, as well as the neutral-point formation for current transformers) can then be adopted from the single-line diagram.

If you have created a suitable device type, you can save it as your own application template and use it in other devices of the same device family. To do this, export the application template with DIGSI 5 in UAT format (User-defined Application Template).

Design of User-Defined Control Displays

With the Display Editor, you can create or change the factory-set displays, known as control displays. The editor assists you in a typical workflow. You simply decide which fields of the single-line diagram you already created are to be used for the display pages – and that is all. Of course, the displays can also be completely newly created or imported. To do this, drag a signal from the library to a dynamic element in the display and the connection is created. Besides the use of icons in accordance with the IEC and ANSI standards, you can create your own static or dynamic icons in an icon editor.

Routing and Assignment

The routing matrix is one of the most important functionalities of DIGSI 5. It is conveniently divided between 2 editors: **Information routing** and **Communication mapping**. Both views are designed in such a way that you can complete your task quickly. With pre-defined or user-defined filters, you reduce the displayed information to a minimum. As in Excel, you can select which information is to be displayed for each column ([Figure 4.2/4](#)).

In the matrix, all signals are sorted according to function and function groups. Sources and targets are displayed as columns. The scope reaches from the compressed form of representation to a detailed representation of information in which you can view and change each piece of information (routing to binary inputs and outputs, LEDs, buffers, etc.) in different columns. In this way, all information can be configured very simply.

For communication mapping, all necessary settings are already predefined for the selected protocol. You can adapt these to your needs in a fast and simple way.

With a large selection of filters and the option to open and close rows and columns, you will find it easy to display only the information you need.

Saving time is a priority with DIGSI 5. All table-based data displays provide the functionality to fill adjacent cells with a single mouse-click – in the same way you know from Excel.

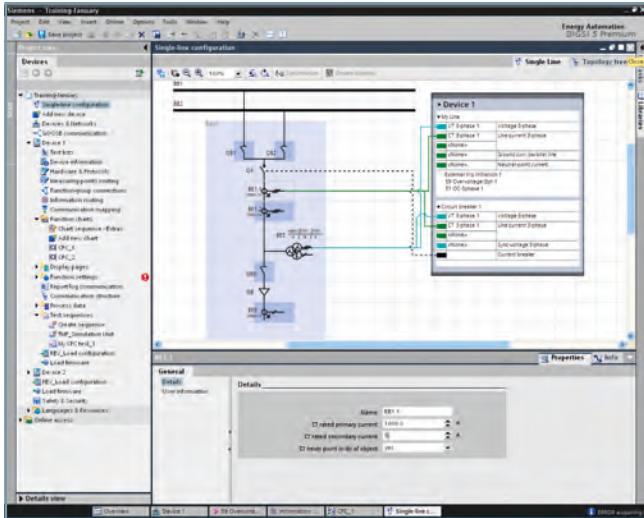

[sc_change CT ratio, 1, en_US]

Figure 4.2/3 Graphical Linkage of Primary and Secondary Equipment

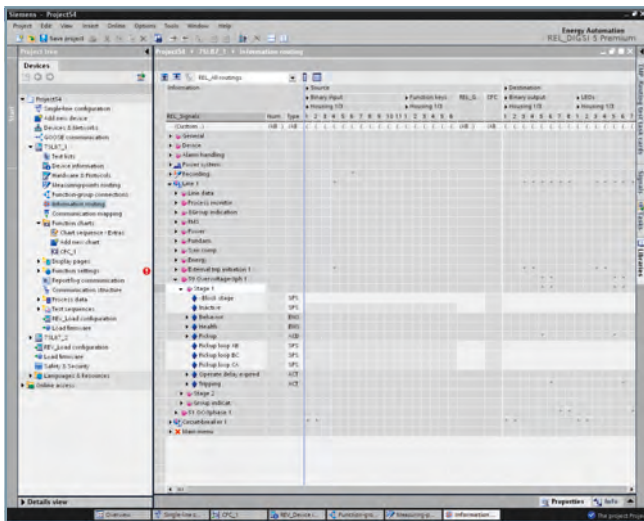

[sc_Information_routing_long, 1, en_US]

Figure 4.2/4 The Entire Flexibility of the Information Routing Editor

Automation and Switchgear Interlocking Protection

A PLC (Programmable Logic Controller) is integrated in SIPROTEC 5 devices. In this PLC, automation functions, logic for switchgear interlocking protection, and lots more can be executed. If you want to change or adapt these, use the function-chart (CFC) editor that is included as a component in DIGSI 5 Standard and Premium. Thanks to the fully graphical user interface, even users without programming knowledge can fully utilize the functional scope and thus adapt the functionality of the device (Figure 4.2/5) flexibly.

For this, an entire library is available to you with building blocks that are compatible with IEC 61131-3. This library contains simple logical operators, such as AND, but also complex functions such as timers, command chains for switching sequences, and much more.

The use of the editor is more efficient than ever before. You thus need less building blocks in order to achieve your objec-

tives. This improves the readability of the function-chart (CFC) decisively. New display modes also increase clarity. The new modes offer you a compressed view of the building blocks and connection points, so that you can see all the information you need without having to scroll through it.

Use macros (chart in chart) to reuse recurring tasks clearly and in a pre-checked manner.

Even the use of signals in a function-chart (CFC) is designed to be simpler. Drag a signal via drag and drop from the signal library to the input or output port of a building block – and you are finished. Created logic plans can be tested even without devices (offline) with DIGSI 5. This ensures the necessary quality for commissioning and saves time.

The logic sequence with DIGSI 5 can be monitored and analyzed online in the device as well.

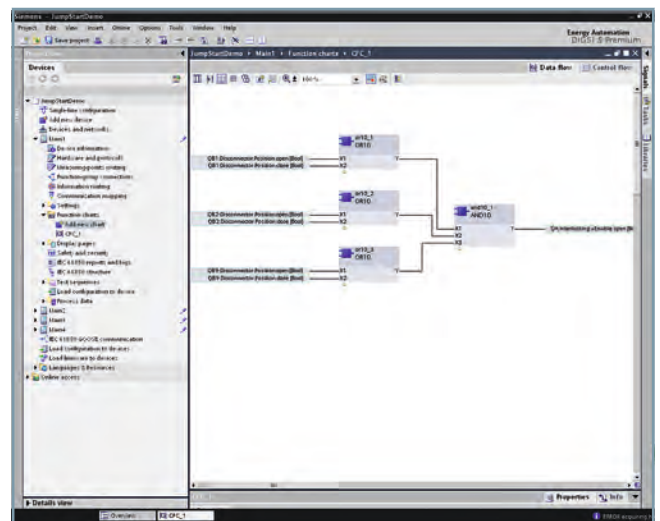

[sc_CFC, 1, en_US]

Figure 4.2/5 Simple Creation of Automations with the CFC Editor

Setting the Parameters of the Device

All parameter settings are represented in the same way. This occurs in the parameter editor, which displays all parameters of a function. Here, you can select between different views of the settings. On the one hand, there is a primary view where you can directly enter the primary setting values.

In this way, you can avoid using transformer ratios which can lead to setting errors. The same applies for the "per unit" view where setting parameters refer to object rated values. If you opt for the secondary view, the setting parameters must be converted to secondary values.

For setting special protection characteristics, the graphical representation of the characteristics is advantageous. In the parameter editor, all characteristic variants of the function are represented. In this way, you can check the effects of changes in the settings immediately in the graphic. Setting values of different settings groups can be compared in a common window in a fast and easy way, differences can be detected and compensated (Figure 4.2/6).

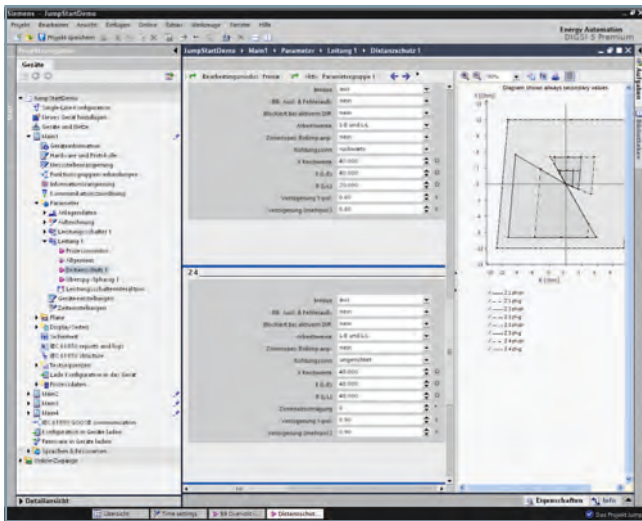

[sc_Function Settings_with_diagram, 1, en_US]

Figure 4.2/6 Easy Parameter Setting

Cooperating in Teams

Improve your engineering performance by cooperating in teams. Using extensive export and import functions, one team can define the protection parameters and work on the routing settings while others set system-interface parameters. The individual sections can be updated at any time with the new input of colleagues. For example, when the protection-parameter crew has updated its data, this data can be adopted into the project.

Comprehensive Testing Support During Commissioning and Operation

The testing and diagnostic functions support you in the commissioning phase. You can thus quickly and simply test the wiring or observe the effect that a message transmitted via the system interface has in the superordinate station. The error messages that are recorded in the relay in case of a disturbance of the protected object are listed in DIGSI 5 and can be displayed, saved, and printed for documentation purposes.

The new testing options are an innovation. Multi-level test sequences can be defined (even for phasor factors) via a sequence functionality. These are loaded into the device with DIGSI 5 and simulate the physical inputs there. These are then executed in the device via the integrated test sequencer, which simulates the analog process values. In this way, you can define and execute complex checks for testing your project engineering and logic at an early stage.

With the test and diagnostic functions, extensive test equipment is no longer necessary or its tests are reduced to a minimum. You can find processes that were developed for testing special protection principles, for example, for line differential protection, in the appropriate device manual. The function-chart (CFC) editor also offers new analysis functions. DIGSI 5 thus allows offline debugging of logic plans as well as tracing of measured values – both in the representation of the logic chart and in the representation of lists. This reduces overall testing effort during commissioning. The results of the function-chart (CFC) analysis can also be represented after completion of the test sequence,

for example, with SIGRA. Thus, even complex runtime relations can easily be analyzed.

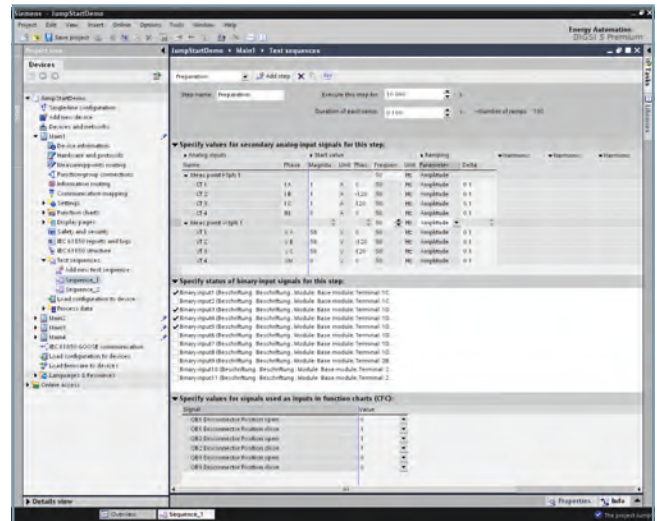

[sc_Test sequence, 1, en_US]

Figure 4.2/7 Definition of Test Sequences for Comprehensive Tests of Device Configurations

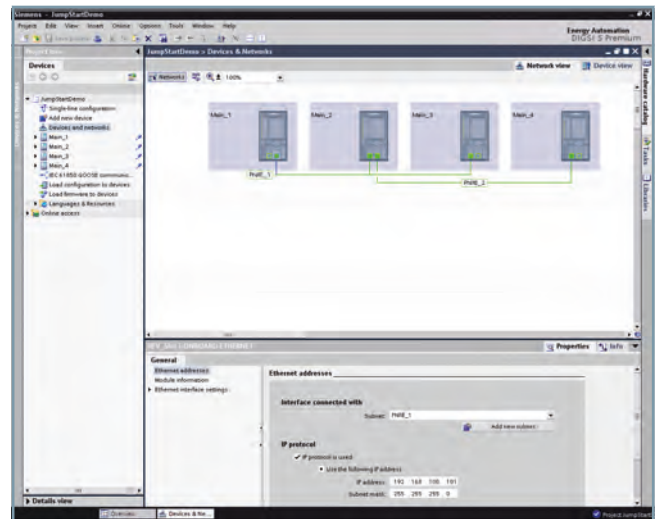

[sc_Grafische_Konfiguration, 1, en_US]

Figure 4.2/8 Graphical Configuration of Network Connections between Devices

Direct Online Access of all Accessible Devices

DIGSI 5 also assists you in your workflow if your devices engineered offline are connected to the devices in your plant in your system. In DIGSI 5, all devices accessible via communication interfaces are displayed immediately next to your offline devices. The preferred communication in networks is Ethernet. Of course, you can individually access devices via a USB interface. In order to work with a physical device, connect the online device and offline configuration via drag and drop, and you are done.

Besides transmitting the device configuration to individual devices, you can also transmit all device configurations to your devices automatically.

SIPROTEC 5 – Engineering

DIGSI 5

Besides online access, in addition to reading fault records and logs, you can also display measured values and messages. You can save snapshots of measured values and messages in archives for subsequent analysis or for documenting tests of temporary operating states or commissioning.

Openness Through Import and Export

DIGSI 5 offers a broad spectrum of exchange formats. These include the standard formats of IEC 61850 as well as the uniform data exchange format TEA-X of Siemens tools. This XML-based format is the basis for all import-export scenarios and ensures efficient workflows in the engineering process. Since data must only be entered once, engineering effort is reduced and you profit from consistent data quality at all levels of automation.

Besides efficient data exchange for the levels of power automation, the XML data format also supports easy exchange of data with other applications.

Via the import interface, you can read data from other applications into DIGSI 5. Thus, this enables external project engineering of the devices. Similarly, you can export the settings data to other applications for further processing. It is therefore easy to exchange data with other power-distribution applications: for example, network calculation, protection-data administration/evaluation, and data for the protection-function test.

4.2

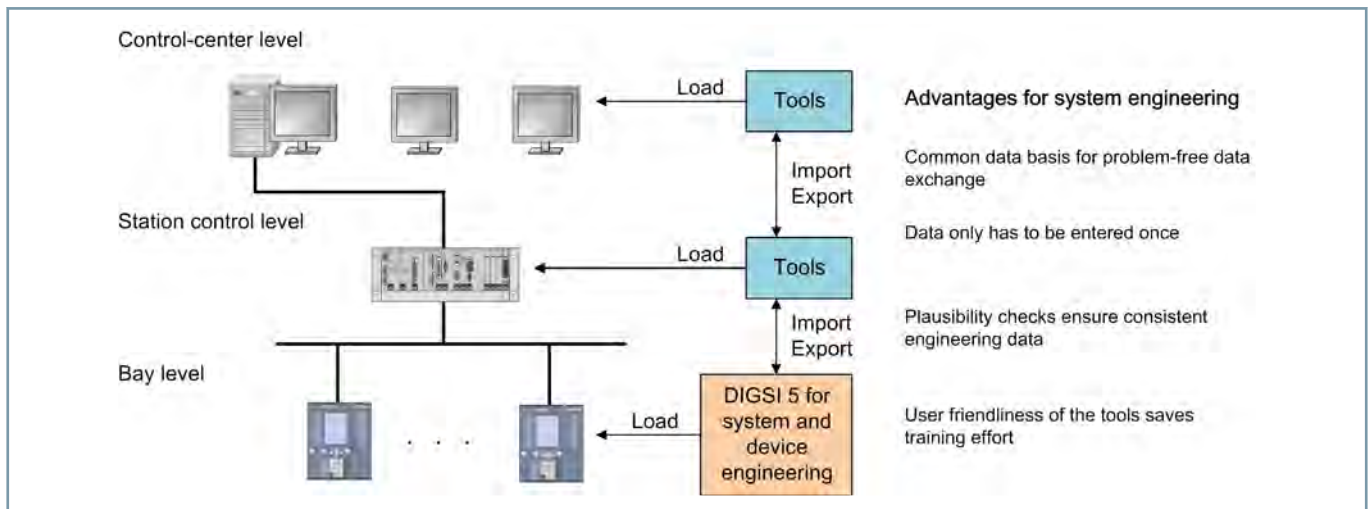

[dw_engineering_appl, 2, en_US]

Figure 4.2/9 Open Exchange Formats Allow Reuse of Data at all Tiers

Overview of Functions

	Compact	Standard	Premium
Project processing			
Maximum number of devices per project	1	Unlimited	Unlimited
Copy and paste	■	■	■
Multilingualism is supported	■	■	■
Single-line diagrams and device displays			
Single-Line Editor with ANSI - and IEC standard icons available	–	■	■
Device display editor permits creation of user-defined displays and icons	–	■	■
Setting parameters and routing			
Information routing including filtering and sorting	■	■	■
Graphical visualization of protection parameters	–	■	■
Comparison of devices (offline/offline – offline/online)	□ ³³	■	■
Continuous function charts (CFC)			
Graphic continuous function chart editor (CFC) available	■	■	■
Communication			
Assignment of communications to system interface	■	■	■
Assignment of communications to various protocols	■	■	■
Graphical network view of devices	–	■	■
Inter-device communication (via IEC 61850 System Configurator)	–	■	■
IEC 61850			
IEC 61850 Edition 2 is fully supported	–	■	■
IEC 61850 structure editor for flexible engineering and functional naming	–	–	■
Access and communication			
Via USB and Ethernet	■	■	■
Access to communication partners via system interface	■	■	■
Online			
Measured values (current values, minimum, maximum, average values) and storage in the project as snapshots	■	■	■
Messages (and storage in the project as snapshots)	■	■	■
Protocols and records	■	■	■
Display fault records	■	■	■
	COMTRADE Viewer	COMTRADE viewer ³⁴	SIGRA
Loading settings for the selected device	■	■	■
Commissioning and testing			
Creating and running multistage test sequences, no external equipment necessary	■	■	■
Test views for testing the device configuration	■	■	■
Analysis/debugging of continuous function charts (CFCs) in offline and online mode	■	■	■
Export and import			
SCL formats (IEC 61850– ICD/IID/MICS)	–	■	■
Device configurations (full and partial)	■	■	■
Single-line diagrams/topology	–	■ ³⁵	■
Display pages	–	■	■
Test object definition (RIO)	■	■	■
Documentation			
Printing and exporting project documentation	■	■	■
Creation of user-defined print formats	■	■	■
Safeguarding and security			
Authorization of access to devices with NERC CIP-compatible password	■	■	■

4.2

³³ only offline/online

³⁴ (SIGRA available as optional package)

³⁵ WMF export only

SIPROTEC 5 – Engineering

DIGSI 5

	Compact	Standard	Premium
Secure connection to the device	■	■	■
Configuration data protected from alteration	■	■	■
Confirmation IDs for safeguarding critical activities (for example, switching)	■	■	■

DIGSI 5 Order Variants

	DIGSI 5 Compact	DIGSI 5 Standard	DIGSI 5 Premium with SIGRA
Description	<ul style="list-style-type: none"> • Software for the configuration and operation of individual SIPROTEC 5 protection devices, including transmission of process data from the device. • Includes a graphical editor for Continuous Function Charts (CFC) • Integrated test and commissioning functions, including the possibility of creating test sequences and executing them in the protection device without external test equipment • Projects may only contain a single SIPROTEC 5 protection device. 	<ul style="list-style-type: none"> • Like DIGSI 5 Compact, but without constraint with regard to the number of supported SIPROTEC 5 devices per project, incl. IEC 61850 System Configurator • Contains additional graphical editors for single-line diagrams, device display pages and the network topology • SIGRA for professional fault-record analysis is available as an option 	<ul style="list-style-type: none"> • Same as DIGSI 5 Standard, but with enhanced functionality for IEC 61850, for example, flexible engineering and functional naming • Contains SIGRA for a professional analysis of fault records
Product features	All features are listed in the Overview of Functions, Page 381 table.		
Authorization	No license key necessary	Authorization required using the license key; can be used on one computer per license.	
Available interface languages	German, English, Portuguese, Spanish, Italian, French, Russian, Polish, Czech, and Turkish (selectable)		
Contained in the scope of delivery of the DVD version	<ul style="list-style-type: none"> • Program, device drivers, and online documentation on DVD-ROM • USB stick including a 30-day test license for a free test of DIGSI 5 Premium • Product information • USB cable for connecting a PC/laptop computer and all SIPROTEC 5 device types 	<ul style="list-style-type: none"> • Program, device drivers, and online documentation on DVD-ROM • USB stick with the number of licenses ordered. The program can be used on one computer per license. • Includes a 30-day test license for a free test of DIGSI 5 Premium • Product information • USB cable for connecting a PC/laptop computer and all SIPROTEC 5 device types 	<ul style="list-style-type: none"> • Program, device drivers, and online documentation on DVD-ROM • USB stick with the number of licenses ordered. The program can be used on one computer per license. • Product information • USB cable for connecting a PC/laptop computer and all SIPROTEC 5 device types
DIGSI 5 can also be ordered and delivered via online software delivery (OSD). The delivery of the DVD and USB cable is unnecessary. The program is offered for downloading. The license can be loaded online on the Automation License Manager.			

SIPROTEC 5 – Engineering

DIGSI 5

Selection and Ordering Data

Versions	Number of Licenses	Delivery Form	Order no. (Short Designation)
DIGSI 5 Compact	Unlimited		P1V178
DIGSI 5 Standard without SIGRA (with COMTRADE viewer)	1 single license	DVD/USB Download	P1V24 P1X338
	5 single licenses	DVD/USB Download	P1V48 P1X347
	10 single licenses	DVD/USB Download	P1V376 P1X356
DIGSI 5 Standard with SIGRA	1 single license	DVD/USB Download	P1V246 P1X365
	5 single licenses	DVD/USB Download	P1V31 P1X374
	10 single licenses	DVD/USB Download	P1V253 P1X383
DIGSI 5 Premium with SIGRA	1 single license	DVD/USB Download	P1V123 P1X426
	5 single licenses	DVD/USB Download	P1V185 P1X435
	10 single licenses	DVD/USB Download	P1V130 P1X444
DIGSI 5 Premium Trial (Premium full version for 30 days) ³⁶	Unlimited		P1V192
DIGSI 5 Premium Scientific (only for technical colleges)	10 single licenses	DVD/USB Download	P1V55 P1X453
DIGSI 5 Premium Sales (only for Siemens sales and distribution Dept.)	10 single licenses	DVD/USB Download	P1V62 P1X462
Upgrade from DIGSI 5 Standard to Premium	1 single license	DVD/USB Download	P1V369 P1X392
	5 single licenses	DVD/USB Download	P1V215 P1X408
	10 single licenses	DVD/USB Download	P1V383 P1X417
Upgrade from DIGSI 4 Professional to DIGSI 5 Standard	10 single licenses	DVD/USB Download	P1V86 P1X471
	10 single licenses	DVD/USB Download	P1V390 P1X480
Upgrade from DIGSI 4 Professional + IEC 61850 to DIGSI 5 Standard	10 single licenses	DVD/USB Download	P1V93 P1X499
	10 single licenses	DVD/USB Download	P1V208 P1X505
SIGRA option package for DIGSI 5 Standard ³⁶	1 single license		P1V154
	5 single licenses		P1V406
	10 single licenses		P1V161

Table 4.2/1 DIGSI 5 Selection and Ordering Data

³⁶ Physical delivery only (DVD/USB)

Description

The IEC 61850 System Configurator is the manufacturer-independent solution for the interoperable engineering of IEC 61850 products and systems. It supports all devices with IEC 61850, not just Siemens products – like SIPROTEC 5, SIPROTEC 4, SIPROTEC Compact, Reyrolle, SICAM RTUs, SICAM IO/AI/P85x/Q200 – but also devices from other Siemens divisions (such as SITRAS PRO) or from third parties.

The IEC 61850 System Configurator supports the SCL configuration files (substation configuration language) from the IEC 61850-6 through import or export of all formats (ICD/IID/CID/SCD/SSD/SED). Thus, IEC 61850 devices can be added and a complete IEC 61850 station is available for substation automation technology.

IEDs from the IEC 61850 standard of Edition 1, 2.0, or 2.1 are supported. The possible engineering therefore includes not only GOOSE communication and client-server configuration via MMS reporting, but also system topology, process bus communication with SMV (sampled measured values) and IEC 60870-5-104 addresses for the gateway to the network control center via IEC 61850-8-1.

Simple engineering thanks to customer-friendly workflows and the universal display of IEC 61850 addresses as well as customer description texts. Users with basic or expert IEC 61850 knowledge find the desired level of detail. For documentation purposes, the engineering can be displayed in the Web browser in a customer-friendly form. Harmonized interfaces of the tool, such with DIGSI 4 and DIGSI 5, reduce the engineering effort for Siemens plants even more.

Benefits

- Comprehensive – one tool for configuring all digital IEC 61850 devices
- Simple extension and adaptation of plants by using IEC 61850 Edition 1 and 2 in a project
- Customer-specific IEC 61850 structures (flexible engineering) permit the implementation of customer standards
- Easy to understand by using application-oriented signal names instead of the specific IEC 61850 language (logical nodes, etc.)

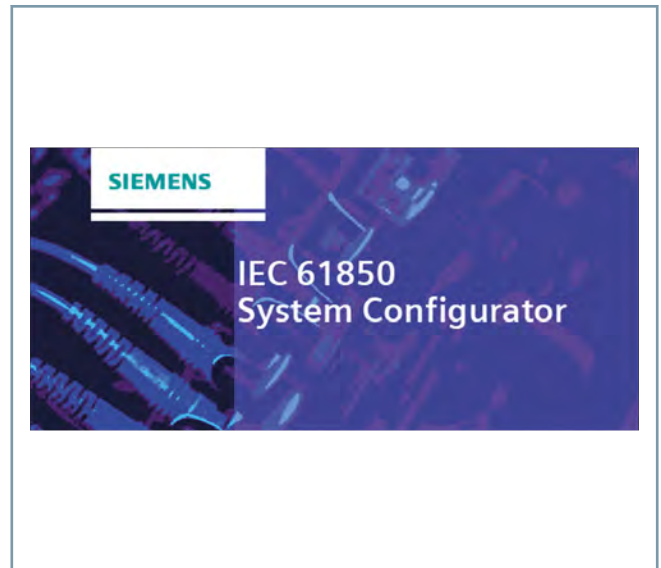

[sc_IEC 61850 SysConf, 2, --,--]

Figure 4.3/1 Splash Screen for the IEC 61850 System Configurator

- Proven by experience from worldwide standardization activities and engineering of more than 500 000 devices
- Facilitated engineering by means of integrated interfaces to DIGSI, SICAM SCC, SICAM PAS, SICAM protocol test system and IEC 6150 browser

Applications

- Interoperable engineering of IEC 61850 (MMS; GOOSE; SMV)
- Import and export of all SCL formats, such as ICD, IID, CID, SCD, SSD or SED
- Supporting of Editions 1, 2.0, and 2.1 of IEC 61850
- Engineering with IEC 61850-80-1
- Engineering independent from manufacturers

SIPROTEC 5 – Engineering

IEC 61850 System Configurator

4.3

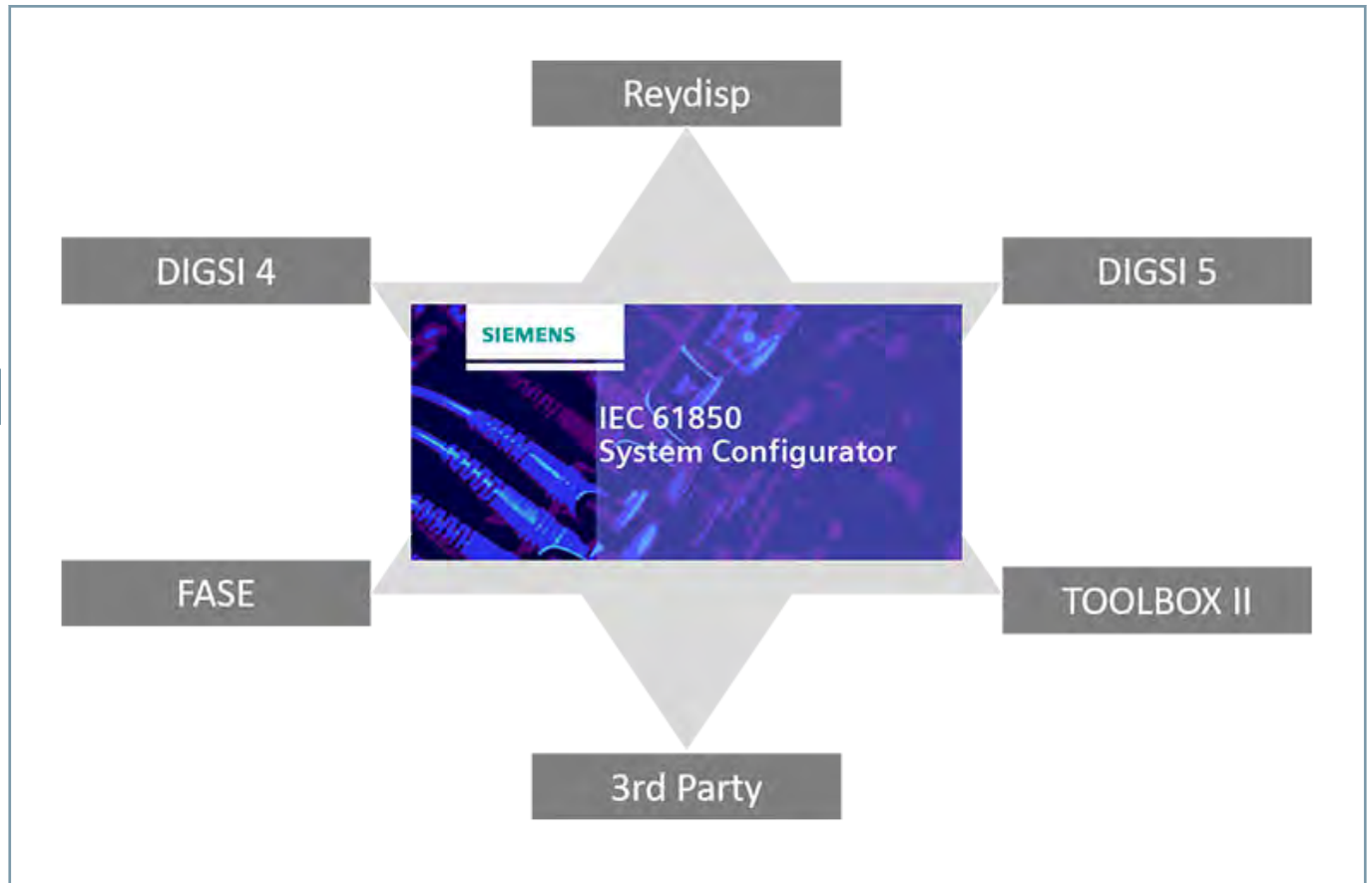

[One IEC 61850, 3, --_]

Figure 4.3/2 One IEC 61850 System Configurator for all Devices in the Station

IEC 61850 – Ethernet-Based Substation Automation Protocol

IEC 61850 is more than just a substation automation protocol. The standard comprehensively defines data types, functions, and communication in station networks. In Edition 2, the influence of the standard is extended to more sectors of the energy-supply industry. Siemens actively participated in designing the process of adapting Edition 1 to Edition 2 for the purposes of the standardization framework. Edition 2 fills in certain omissions and defines additional applications. As a global market leader with Edition 1 SIPROTEC 4 devices, Siemens has resolved the issues of interoperability, flexibility, and compatibility between Editions 1 and 2: Cooperation with Edition 1 devices is possible without difficulties.

- Converting the complexity of the IEC 61850 data model into your familiar user language
- Integrated, consistent system and device engineering (from the single line of the plant to device parameterization on the basis of the IEC 61850 data model)
- Flexible object modeling, freedom in addressing objects, and flexible communication services warrant the highest possible degree of interoperability and effective exchange and expansion concepts.
- Full compatibility and interoperability with IEC 61850 Editions 1, 2.0, and 2.1

The internal structure of SIPROTEC 5 devices conforms to IEC 61850. The result is that for the first time, an integrated, consistent system and device engineering, from the single line of the plant to device parameterization, conforming to the guiding principles of IEC 61850 is possible.

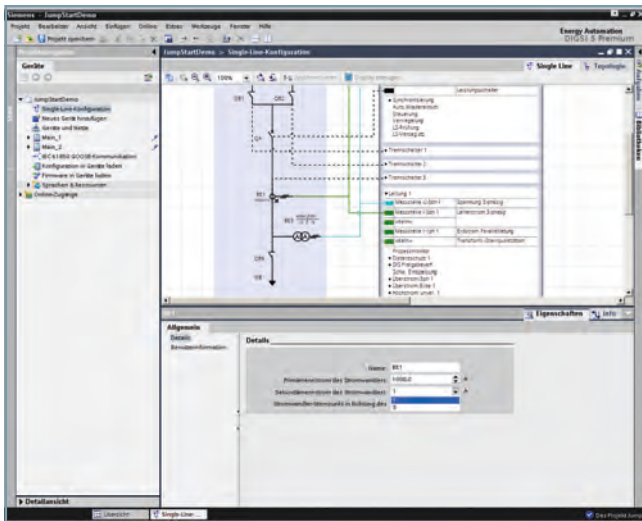

[IEC_Change_CT_ratio, 1, --, --]

Figure 4.3/3 System Specification and Configuration in DIGSI 5 – the Complexity of IEC 61850 is Transparent

DIGSI 5 with integrated IEC 61850 engineering covers the complexity of the standard with a sophisticated user interface. In standard engineering, you as the user will not be required to deal with the details of IEC 61850; you get to use your user language.

In the user language, distance protection is distance protection with zones and dependent functions, not a collection of logical nodes. Reports are message lists in which information about the systems control is configured. In the system configurator, GOOSE connections are simply configured in a table with source and target information. You work in your language, with functions and messages associated with a device. If you wish, you can view the assigned IEC 61850 objects in the IEC 61850 protocol language. This bilingualism is supported throughout the user interface by DIGSI 5 and the export files on the systems control. As the user, you can even add helpful notes to the data points you define in your language and then export them for data purposes in the ICD and SCD description.

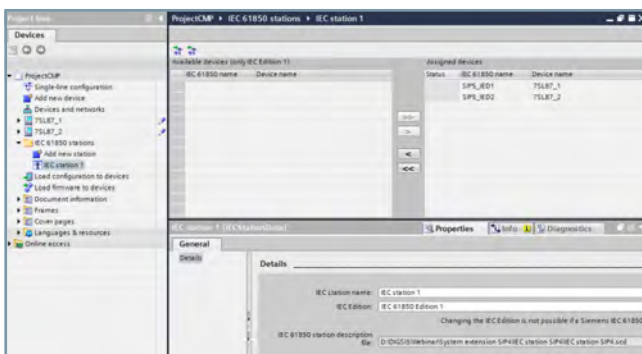

[sc_DIGSI_catalog, 1, en_US]

Figure 4.3/4 Creating an IEC 61850 Station

Flexible engineering offers IEC 61850 experts a wide range of freedom to design their own IEC 61850 structure, including with user-defined functions and objects. Flexible object modeling, freedom in addressing objects, and flexible communication serv-

ices warrant the highest possible degree of interoperability and effective exchange and expansion concepts.

The name of the logical device (IdName) is freely editable. For example, the standard-conforming name CTRL can be changed to CONTROL. Structural changes can also be made by changing the logical device (LD), so that the interface structure can be adapted flexibly to the requirements of the user. Rigid manufacturer specifications are a thing of the past. Prefix and instance (inst) of the logical node (LN) can also be edited.

The standard defines the length and rules that are checked by DIGSI 5 when they are entered.

Stages of functions of a device, which the standard maps to logical nodes (LN), can be deleted, copied, and extended with objects of the user. Messages can be added to a switching object such as the LN XCBB, for example, monitoring messages for a circuit breaker that have not been defined in the original LN. You as a user, you can route all of the information associated with a given switching object into a logical node (LN).

Logical nodes (LN) can be added from a library. These instructions can be supplemented with your own objects. You can also define and create generic nodes. For example, there are logical nodes (LN) whose functionality you as the user create for yourself through logic functions. These user-defined functions can be loaded into the device and run there. Monitoring functions can be created and expanded as required.

A high degree of flexibility in communication is offered for configuration of GOOSE messages and reports.

Addresses, dataset names, etc. can be set by you, the user.

Flexible engineering offers a high degree of design freedom on many levels, enhancing interoperability for more complete communication interchangeability. This in turn safeguards investments in model devices in accordance with IEC 61850.

With the single-line diagram, you as the user can view the topological structure of the system. DIGSI 5 has been prepared so that it can export this topological structure of a system to the SSD file conforming to the standard. This description, as an extension of the SCD file, represents the primary system for technical data purposes. In the future, the objects of the device with which processes of the primary system are controlled can be adapted flexibly to reflect the specifications of the customer. Flexible engineering is the key to bringing the system view into harmony with the IEC 61850 structure of the device.

SIPROTEC 5 – Engineering

IEC 61850 System Configurator

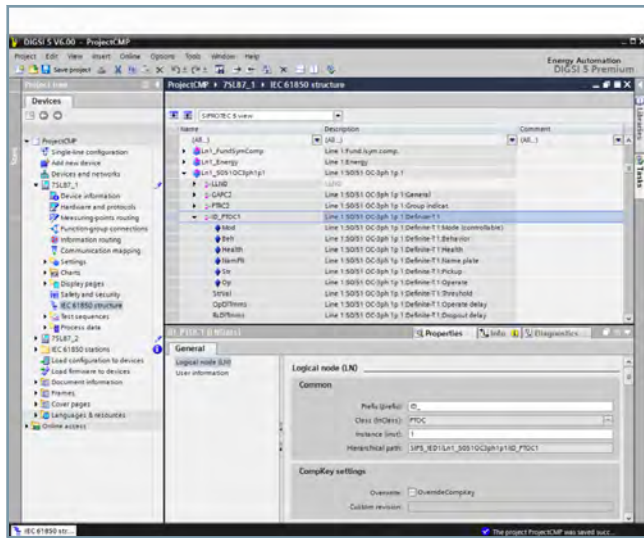

[structure_editor, 1, --,--]

Figure 4.3/5 Editor for Adapting the IEC 61850 Structure in the SIPROTEC 5 View

Description

SIGRA user program supports you in analyzing failures in your electrical power system. It graphically analyzes data recorded during the failure and calculates additional supplemental quantities such as impedances, powers or RMS values, from the supplied measured values, making evaluation of the fault record easier.

The quantities can be shown as desired in the diagrams of the following views: **time signals, phasor diagrams, locus diagrams and harmonic components** and **fault locators** and represented in the **table** view.

After a system incident, it is especially important to quickly and completely analyze the error, so that the respective measures can be derived immediately from the cause analysis. This will enable the original network status to be recovered and the down time to be reduced to an absolute minimum.

As well as the usual time signal display of the recorded measured quantity, the current version is also set up to display vector, pie and bar charts to show the harmonics and data tables. From the measured values recorded in the fault records, SIGRA calculates further values, for instance missing quantities in the 3-phase electrical power system, impedances, outputs, symmetrical components, etc. Using 2 measurement cursors, the fault current can be easily and conveniently evaluated. With the aid of SIGRA however, further fault record can also be added. The signals from another fault record (for example, from the opposite end of the line) are added to the current signal pattern using drag and drop.

SIGRA facilitates the display of signals from various fault records in one diagram as well as a fully automated synchronization of these signals on a common time base. As well as the precise determination of the individual factors of the line fault, the fault location is also of particular interest.

A precise determination of the fault location saves time which the user can use for an on-site inspection of the error. This function is also supported by SIGRA using the **offline fault location function**. SIGRA can be used for all fault records in COMTRADE file format.

The functions and advantages of SIGRA can only be optimally displayed directly on the product. Consequently, SIGRA is available as a 30-day test version.

Functions

- Evaluation of fault records
- One-sided and two-sided offline fault location
- Synchronized display of various diagram types, such as time signal display, locus diagrams, bar charts
- 6 diagram types:
 - Time-signal representation (standard)
 - Locus diagram (for example for RX)
 - Vector diagram (reading of angles)
 - Bar chart (for example for visualizing harmonics)
 - Table (with values of several signals at the same point in time)
 - Fault-location determination (display of fault location)

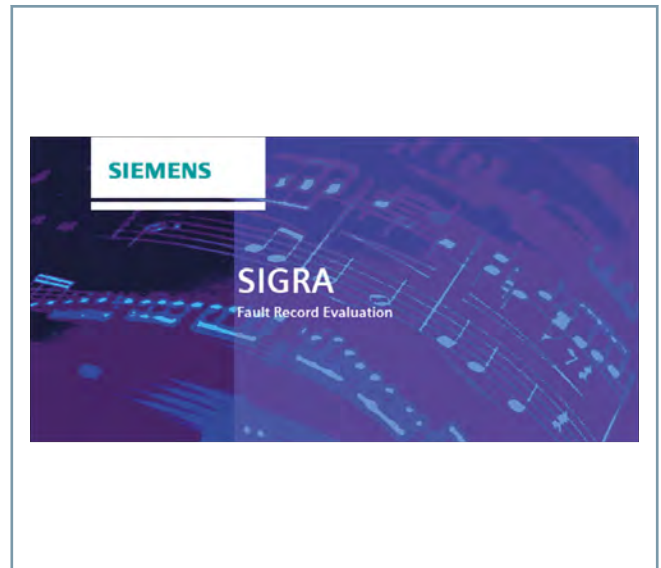

[sc_SIGRA_Splash, 1, --,--]

Figure 4.4/1 Fault-Record Analysis with SIGRA

- Calculation of additional values, such as positive-sequence impedances, RMS values, symmetrical components, phasors
- 2 measuring cursors that are synchronized in all views
- High-performance panning and zoom functions (for example, section enlargement)
- User-friendly project engineering via drag and drop
- Innovative signal routing in a clearly structured matrix
- Time-saving user profiles, which can be assigned to individual relay types or series
- Addition of further fault records and synchronization of multiple fault records with a common time base
- Simple documentation through copying of the diagrams for example, into MS Office programs
- Offline fault-location determination
- Commenting of fault records, and commenting of individual measuring points in diagrams and free placement of these comments in diagrams
- Application of mathematical operations to signals.

Hardware requirements

- Pentium 4 with 1 GHz processor or similar
- 1 GB RAM (2 GB recommended)
- Graphic display with resolution of 1024 × 768 pixels (1280 × 1024 recommended)
- 50 MB available hard disk space
- DVD ROM drive
- Keyboard and mouse

Software requirements

- MS Windows 7 Ultimate, Enterprise and Professional
- MS Windows 8.1 Enterprise
- MS Windows Server 2008 R2

SIPROTEC 5 – Engineering

SIGRA

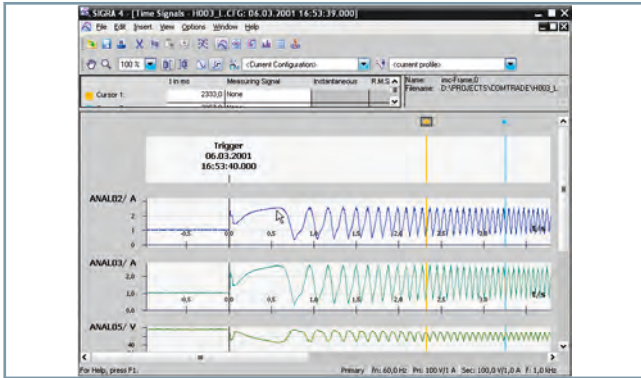

[sc_TimeSignalsDiagram, 1, en_US]

Figure 4.4/2 SIGRA Time Signals



[sc_Oberschwingung, 1, en_US]

Figure 4.4/5 SIGRA Harmonics

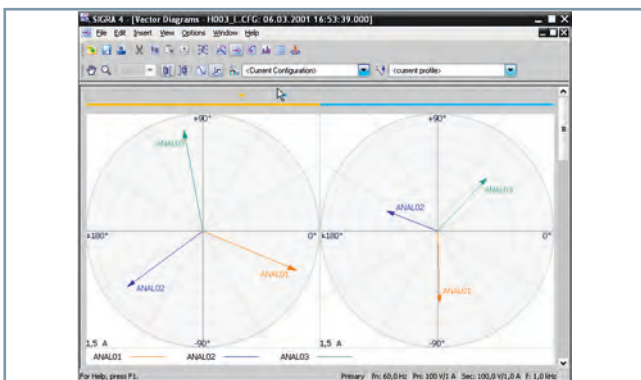

[sc_VectorDiagram, 1, en_US]

Figure 4.4/3 SIGRA Phasor Diagram

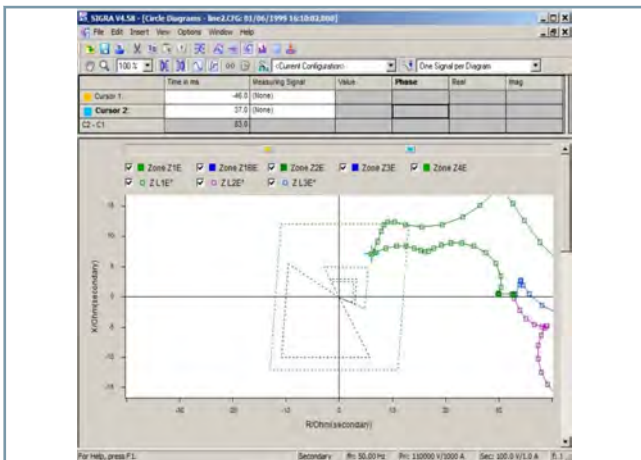

[sc_circle diagram, 1, en_US]

Figure 4.4/4 SIGRA Locus Diagrams

DIGSI 5, IEC 61850, and SIGRA support you in an optimal and holistic manner for your SIPROTEC 5 project:

- Powerful and effective analysis of fault records
- Integrated system and device engineering
- Graphical user interface simplifies and accelerates project engineering
- Application templates and function groups as images of the primary application and the primary objects, such as the line or circuit breaker, warrant a user-oriented working method and perspective
- Test and simulations tools offer optimal plausibility checks

4.4

Description

The SIPROTEC DigitalTwin is the virtual, digital twin of a real SIPROTEC 5 device, including the interfaces, functions, and algorithms.

The new, innovative, cloud-based **SIPROTEC DigitalTwin** ensures that the performance, safety, and availability of SIPROTEC 5 devices can be extensively tested as part of the power automation system - 24/7, from anywhere, and without any hardware.

3 steps to success:

- Uploading engineering data and test cases
- Simulating and testing the automation system in the cloud
- System test reports

Application Areas

- Training in device operation
- Process-data simulation
- Testing the protection functions, the automation logics, and the customer-specific applications
- Testing the functionality of the SIPROTEC 5 device inside the power automation
- Online testing with the DIGSI 5 operating program
- Integration into SICAM PAS, SICAM PQS, SICAM SCC substation automation systems
- IEC 61850 GOOSE communication between devices, for example, for interlocking systems
- Protection-data communication
- Error analysis, for example, fault-record playback

Customer Benefit

- Testing the power-automation system 24/7 without any hardware, without any additional expenditure, and regardless of location.
- Simulating and validating product properties



[sc_DigitalTwin_SplashScreen, 1, --]

4.5

- The new systems can be added more quickly due to shorter project lead times.
- Reduced OPEX with shorter downtimes ensure high availability due to improved pretesting (incl. patches)
- Efficient, scalable, practical training sessions
- Quick and realistic error analysis due to easy reproducibility of the product and system behavior

SIPROTEC 5 – Engineering

SIPROTEC DigitalTwin

SIPROTEC DigitalTwin Application Areas

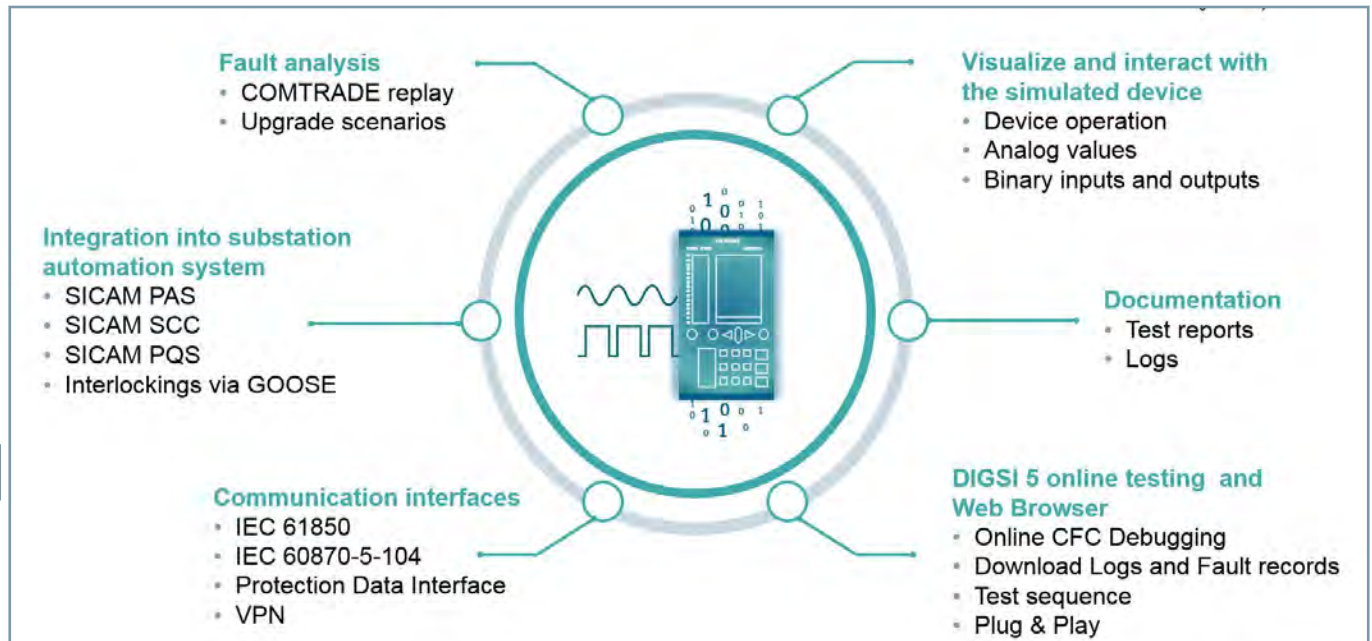

[SIPROTEC DigitalTwin_Appl, 1, en_US]

Figure 4.5/1 Application Areas

Transparency Increases Efficiency

Protection relays sit at the very heart of our power grid infrastructure. They operate silently inside substations and listen to the AC 50 Hz or AC 60 Hz heartbeat of the power lines. Once they come into action however, literally every millisecond counts to initiate switching operations to avert disaster and alert the grid operator about a specific fault situation. This is where the SIPROTEC Dashboard comes into play.

As part of our Grid Diagnostic Suite, the cloud-based SIPROTEC Dashboard application benefits from a new communication architecture. SIPROTEC 5 devices communicate not only to the substation automation level but also to the new SICAM GridEdge node, and from there to the MindSphere cloud. This way we can unlock the best of two worlds: Full data transparency on the Edge level and a grid-wide data overview in the cloud while adhering to state-of-the-art cyber security standards through the decoupling of field devices from the cloud.

Empowerment of Maintenance Crews

The SIPROTEC Dashboard empowers operational crews in their task to troubleshoot faults in the power grid. Instead of waiting for information from the control center they can now directly access key data like fault logs and fault records of a given protection relay that initiated a trip – even before going on-site. The new SIPROTEC Dashboard enables different views for all relays in the grid, including a map view, station view and device view.

Furthermore, the Dashboard offers additional insights into compact condition monitoring parameters like the switched fault current (I^2t) or temperature hotspots of transformers or switchgear – all very helpful indications for an early assessment of the situation on the ground.

One source of complexity when troubleshooting the behavior of protection relays is related to firmware versions. Are all devices on the same version? Is the latest version deployed everywhere? Through our new firmware cross-check functionality, firmware versions can be analyzed at a glance within the context of a substation or even across the entire grid.

In summary the SIPROTEC Dashboard is an innovative new offering for our SIPROTEC devices and offers insightful views on your protection fleet at a glance.

Advantages at a Glance

- Simplifies workflows for faster response times
- Increases grid availability and service quality
- Full support for SIPROTEC and Reyrolle relays as well as cross-vendor support for IEC 61850 enabled protection devices
- Compliant with industry cyber-security standards

Main Features

Monitor the status of your protection relay fleet:

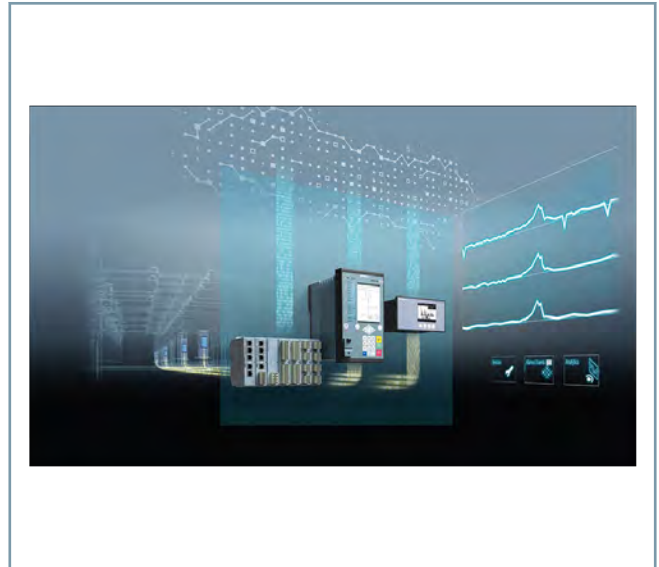

[IoT, 1, --, -]

Figure 4.6/1 Grid Diagnostic Suite

4.6

Multiple Views

- Map view, substation view, device and measurement data views
- Drill down option for each event

Fault Analysis

- Automated fault record and fault log retrieval
- Fault record visualization

Device Management

- Firmware cross-check on station and grid-level
- Settings monitoring on station and grid-level

SICAM GridEdge

- Full data transparency via direct device access
- Cross-vendor compatible for IEC 61850 enabled protection relays
- Modular extensible functionality via containerized applications
- Secure decoupling from relays to the cloud

Condition Monitoring Views

- Circuit breaker I^2t statistics
- Hotspot measurements for transformers and switchgear
- Transformer tap position statistics

SIPROTEC 5 – Engineering

SIPROTEC Dashboard

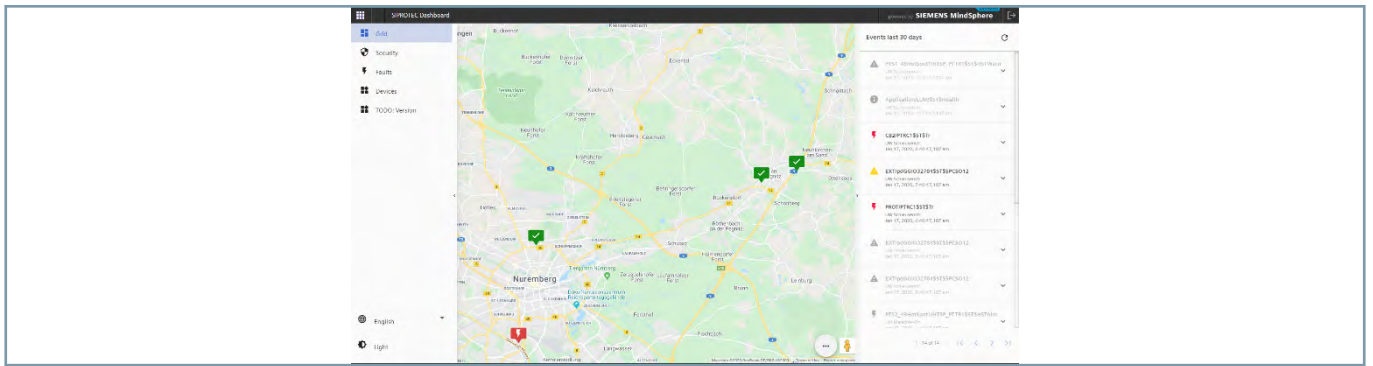

[sc_SIPROTEC_Dashboard, 1, --,]

Figure 4.6/2 IoT Architecture for Power Automation Systems



SIPROTEC 5 – Hardware

Hardware Modules

The SIPROTEC 5 Hardware building blocks offer a freely configurable device model. You have the choice: Either you use a pre-configured device with a quantity structure already tailored to your application, or you build a device yourself from the extensive SIPROTEC 5 hardware building blocks to exactly fit your application.

The flexible hardware building blocks offer you:

- Base modules and expansion modules with different input/output modules
- Various On-site Operation Panels
- A large number of modules for communication, measured value conversion and memory extension

Hardware Design – Flexible and Modular

With SIPROTEC 5, Siemens has also taken a new path with the design. Proven elements have been improved and innovative ideas have been added. When looking at the new devices, surface mounting is evident. In this way, the scope of the process data can be adapted flexibly to the requirements in the switchgear. You can select: Either you use a preconfigured device with a quantity structure already tailored to your application, or you build a device yourself from the SIPROTEC 5 hardware design to exactly fit your application. Preconfigured devices can be extended or adapted as needed.

For the SIPROTEC devices 7xx85, 7xx86 and 7xx87, you can also combine different base and expansion modules, add communication modules and select an installation variant that fits the space you have available. The SIPROTEC 7xx82 devices cannot be expanded with expansion modules.

With this modular principle, you can realize any quantity structures you desire. In this way, hardware that is tailored to the application can be selected. [Figure 5.1/1](#) shows a modular device consisting of a base module and 4 expansion modules.



[SIP5 GD_SS_LED_LED_oLED_W3, 2, --_]

Figure 5.1/1 Example of a Modular SIPROTEC 5 Device

SIPROTEC 5 – Advantages of the Modular Design

The SIPROTEC 5 modular hardware design provides the cumulative experience of Siemens in digital protection devices and bay controllers. In addition, specific innovations were realized that make the application easier for you, such as recorder and PQ functionalities.

The SIPROTEC 5 modular hardware design offers:

- Durability and reliability
 - Tailored hardware extension
 - Robust housings
 - Excellent EMC shielding in compliance with the most recent standards and IEC 61000-4
 - Expanded temperature range: -25 °C to +70 °C
 - Redundant power supply
- Modular device technique
 - Freely configurable and extendable devices
 - Large process data range (up to 40 current and voltage transformers for protection applications and up to 80 for central busbar protection; more than 200 inputs and outputs for recording applications possible)
 - Operation panel that is freely selectable for all device types (for example, large or small display, with or without key switches, detached operation panel)
 - Identical wiring of flush-mounting and surface-mounting housings
- User-friendly operation panel
 - 9 freely assignable function keys for frequently required operator control actions
 - Separate control keys for switching commands
 - Context-sensitive keys with labeling in the display
 - Complete numeric keypad for simple input of setting values and easy navigation in the menu
 - Up to 80 LEDs for signaling, 16 of which are in 2 colors
- User-friendly design
 - No opening of device necessary for installation and servicing
 - Easy battery replacement on the back of the device
 - Simple replacement of communication modules with plug-in technology
 - Electronically settable (no jumpers) threshold for binary inputs
 - Rated current (1 A/5 A) of current transformer inputs configurable electronically
 - Removable terminal blocks
 - Rewiring of terminals is possible
 - Simple replacement of current transformers, for example with sensitive ground-current transformers for network conversions
 - Increased safety, since open current-transformer circuits are no longer possible (safety CT plug)

Conformal Coating – The Highest Degree of Availability, Even Under Extreme Environmental Conditions

Conformal Coating refers to the coating of electronic modules. This coating ensures protection against extreme humidity, corrosive gases, and high levels of dust, or a combination of these. In addition, the coating offers mechanical protection against improper handling and external influences. The **Conformal coating** extends the life of your devices, particularly under extreme environmental conditions.

SIPROTEC devices offer very high availability and a long life even without the additional **Coating**. More than 2 million devices are in use worldwide. When developing our devices, we place utmost priority on adhering to the relevant product standards, demonstrated by the type testing we undertake, such as the cyclic damp and heat test in accordance with IEC 60068-2-30, injection with mixed gases, sulfur dioxide SO₂, or hydrogen sulfide H₂S.

The new coating offers you an additional level of security for SIPROTEC devices used in especially harsh environmental conditions, such as:

- H₂S gas, which occurs in certain industrial environments and can attack surface-mounted device components even at concentrations of just 10 ppm
- Prolonged exposure to silver sulfide. These can result in **silver whiskers** on the surface of surface-mounted device components.
- These negative impacts are intensified by a high level of humidity.

In extreme cases, this can result in short circuits or interruptions on the module and thus place constraints on the functionality of the device or cause its outage.

Qualified Production Process

The **Conformal coating** used on SIPROTEC modules has been developed using a high quality, tried and trusted method.

In this method, the modules are coated and then hardened automatically by a robot.

Type Test of Coated Modules

SIPROTEC protection and automation devices are tested and certified by independent and accredited test institutes.

The SIPROTEC device undergoes various test complexes as part of this.

For example, in test complex A the device is exposed first to corrosive gases and then to extreme heat and humidity. Unlike separate tests, these combinations simulate the harshest possible environmental conditions.

Test Complex A: Corrosion and Climatic Tests

- Corrosive gas SO₂, in accordance with IEC 60068-2-42
- Corrosive gas H₂S, in accordance with IEC 60068-2-43
- Mixed corrosive gases, in accordance with IEC 60068-2-60
- Corrosion test with mixed gases in accordance with ISA 71.04:2013-08, G3 (Harsh) (SIPROTEC 5)
- Humidity, thermal energy, cyclical, in accordance with IEC 60068-2-30 and LR test specification § 14



[ph_Lackierlinie für Abnahme, 1, --]

Figure 5.2/1 Qualified Coating System

Test Complex B: Climatic and Mechanical, Dynamic Tests

- Temperature: +55 °C permanent, +70 °C for 96 hours
- Rapid temperature change -40 °C <-> +85 °C in accordance with IEC 60068-2-14
- Vibration and shock stress, in accordance with IEC 60068-2-6, IEC 60255-21-1
- Damp and heat, cyclical, in accordance with IEC 60068-2-30

Test Complex C: Hygroscopic Dust

- Dust and sand, Arizona test dust, duration of 24 hours, in accordance with IEC 60068-2-68
- Damp and heat, cyclical, in accordance with IEC 60068-2-30

Test Complex D: Salt Mist

- Special, additional test for the simulation of offshore conditions
- Salt mist in accordance with IEC 60068-2-52, Kb test with increased Lloyd's Register specification parameters

SIPROTEC Devices with Conformal Coating

- SIPROTEC 5
 - 7SJ81, 7SJ82, 7SK82, 7SA82, 7SD82, 7SL82, 7UT82
 - 6MD85, 6MD86, 6MD89, 7SJ85, 7SJ86, 7SK85, 7SA86, 7SA87, 7SD86, 7SD87, 7SL86, 7SL87, 7UT85, 7UT86, 7UT87, 7VK87, 7UM85, 7KE85, 7SS85

Benefits

- Highest service life and availability of SIPROTEC devices even under extreme environmental conditions
- Increased protection against harmful environmental influences such as corrosive gases and salts
- Additional mechanical protection against dust, abrasion and insects
- Reliable prevention of "dendrite growth" between individual components

SIPROTEC 5 – Hardware

Conformal Coating

- Increased protection of modules against humidity
- Highest quality of coating using a qualified production process



[chemiefabrik-sideshot5, 1, --, --]

Figure 5.2/2 Chemical Industry



[Offshore, 1, --, --]

Figure 5.2/3 Offshore Platform

Base and Expansion Modules

A SIPROTEC 5 device consists of a base module, up to 9 expansion modules and a power supply module for the optional second row. Base and expansion modules are distinguished firstly by their width. The base module is 1/3 x 19" wide. Located on the rear panel are process connections and space for up to 2 plug-in modules. The expansion modules and the power supply for the second row are each 1/6 x 19" wide.

If you want to equip a SIPROTEC 5 device with a redundant power supply, you need the power-supply module PS204. For devices with a 2nd row, the PS203 module must be supplemented with a 2nd PS204 module.

Expansion modules can provide either additional process connections or communication connections and are available for the devices 7xx85, 7xx86, 7xx87, and 6MD8.

Figure 5.3/1 shows the rear panel of a device consisting of a base module in which the power supply, the CPU board, and an input/output CPU module are permanently installed, as well as 4 expansion modules for extending the input/output quantity structure, and communication modules. Each expansion module contains an input/output module. The components are connected by bus connector plugs and mechanical interlockings.

Such a device can be ordered pre-configured from the factory. In this context, you can select between the standard variants predefined by Siemens and the devices you have combined yourself. Every SIPROTEC 5 device can also be converted or extended according to your wishes. The modular concept absolutely ensures that the final device meets all standards, particularly with regard to EMC and environmental requirements.



[E_CC_SIP5_19Zoll_KomMod, 1, --]

Figure 5.3/1 Rear View of Base Module with 4 Expansion Modules

On-Site Operation Panel

The on-site operation panel is a separate component within the SIPROTEC 5 modular system. This allows you to combine a base or expansion module with a suitable on-site operation panel, according to your requirements. The modular system offers 3 different on-site operation panels for selection for base modules and also for expansion modules.

The following variants are available for base modules:

- With a large display, keypad and 16 two-colored LEDs
- With a small display, keypad, and 16 two-colored LEDs
- 16 two-colored LEDs



[SIPROTEC 5 Moduls, 2, --]

Figure 5.3/2 Operation Panels with (from Left) Large and Small Display, and Operation Panel without Display

SIPROTEC 5 – Hardware

Modules

The following variants are available for expansion modules:

- Without operating or control elements
- With 16 LEDs (single-colored)
- With 16 LEDs (single-colored) and key switch

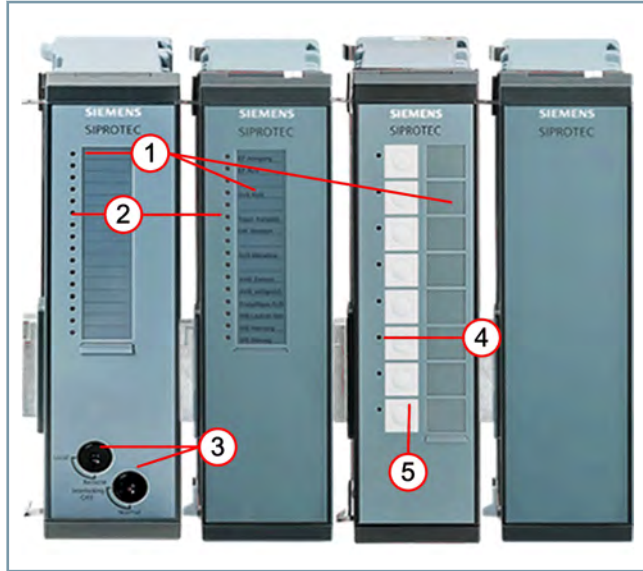

[le_4 expansion modules, 1, --_]

Figure 5.3/3 Variants of the Expansion Modules

- (1) Labeling strips
- (2) 16 monochrome LEDs
- (3) 2 key switches
- (4) 8 monochrome LEDs
- (5) 8 push-buttons

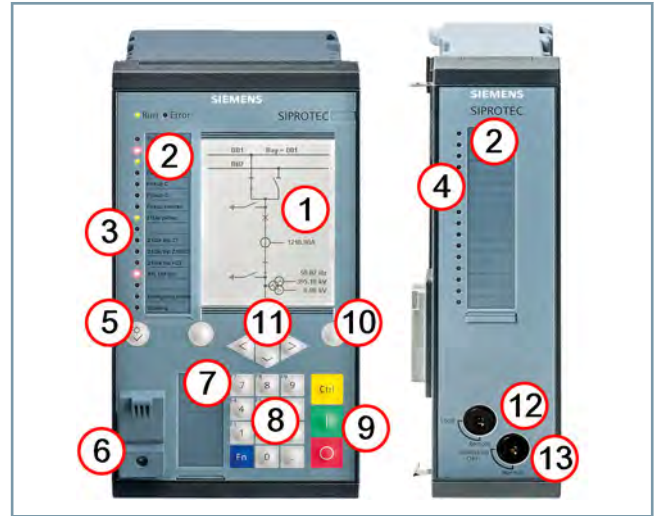

[le_operation panel, 2, --_]

Figure 5.3/4 Operation Panel SIPROTEC 5

- (1) Graphic display
- (2) Labeling field for LEDs
- (3) 16 LEDs (green or red, settable parameters)
- (4) 16 LEDs (red)
- (5) LED-Reset
- (6) USB interface
- (7) Labeling field for function keys
- (8) Numerical keys and function keys
- (9) Control/command keys
- (10) Context-sensitive keys
- (11) Navigation keys
- (12) Key switch S5 "Remote/Local"
- (13) Key switch S1 "Interlocking Off/Normal"

The SIPROTEC 5 module is flexible with regard to selection of the operation panel. You can order any device type with a large graphical display or with a smaller economical standard display. For applications without device control, an operation panel without display is also available. The operation panel with a small display provides 7 rows for measured values or menu texts and the graphical representation of, for example, a single busbar. All operation and control keys are available to the user, that is, he can also control switching devices.

Elements of the on-site operation panels

The operator elements are illustrated with the example of the on-site operation panel with a large display.

The central element is the generously sized display for text and graphics. With its high resolution, it has ample space for icons in graphical representations.

Below the display there is a 12-key block. In combination with 4 navigation keys and 2 option keys, you have everything you need to navigate conveniently and quickly through all information that is shown in the display. 2 LEDs on the upper border

of the operation panel inform you about the current device operating state.

16 additional LEDs, to the left of the keypad, ensure quick, targeted process feedback. The USB interface enables fast data transmission. It is easily accessible from the front and well protected with a plastic cover.

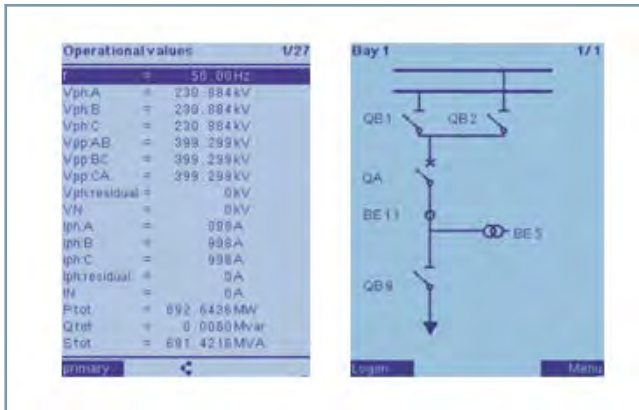

[sc_Display, 1, en_US]

Figure 5.3/5 Display Images – Measured Value and Control Display

The operation panel with large display can also show a complex control display and thus offers more room for measured values and the display of event lists. This operation panel is therefore the first choice for bay controllers, busbar protection or combined protection and electronic control units.

As a third option, an economical variant is available without keypad and display. This variant is appropriate for devices that are seldom or never used by the operational crew.

The keys O and I (red and green) for the direct control of equipment, a reset button for the LEDs, and the CTRL key for activating the system diagram complete the operation panel.

Options

You can order any SIPROTEC 5 device, regardless of its individual configuration, in 3 different installation variants:

- As a flush-mounting device
- As a surface-mounted device with integrated on-site operation panel
- As a surface-mounted device with the on-site operation panel detached.

The construction of the flush-mounting devices will be recognizable from the previous sections. We would like to briefly introduce you to the 2 other variants here.

A surface-mounted device with integrated on-site operation panel

For wall-installation, the SIPROTEC 5 devices can be ordered in the surface-mounting housing (Figure 5.3/6 and Figure 5.3/7). Thanks to a new concept, these devices have terminal diagrams that are identical to the corresponding flush-mounting devices. This is achieved by installing the devices using the principle "with the face to the wall" and then attaching the operation panels to the terminal side. With the distance frames that are used, sufficient space remains for the wiring, which can be routed away upward and downward.



[ph_surface mounting, 2, --]

Figure 5.3/6 Device in the Surface-Mounting Housing with Integrated Operation Panel for Modular Devices



[ph_Assembly frame, 2, --]

Figure 5.3/7 Device in the Surface-Mounting Housing with Integrated Operation Panel for Modular Devices (7x82)

SIPROTEC 5 – Hardware

Modules



[ph_SIP5_abgesetztes_display, 1, --]

Figure 5.3/8 Device with Detached Operation Panel

A surface-mounted device with the on-site operation panel detached

If the operation panel is to be installed detached from the device, it can be installed as a separate part and connected to the device with a 2.5 m or 5 m long connecting cable (Figure 5.3/8). In this way, the SIPROTEC 5 device can be situated, for example, in the low-voltage fixture and the operation panel can be installed precisely at the correct working height in the cabinet door. In this case, the device is fastened like a surface-mounted device to the cabinet wall. An opening must be provided in the door for the operation panel.

Hardware Properties	7SJ81	7xx82	7xx85, 86, 87, 6MD8
Hardware expandable (modular)	No	No	yes
Binary inputs	11/16/18	11/23	Flexible
Binary outputs	9/11/14	9/16	Flexible
Analog measuring-transducer inputs (20 mA)	0 to 4	0 to 8	Flexible, 0 to 12
Light sensor inputs	0 to 3	0 to 6	0 to 12
Current inputs	4	4/8	Flexible
Voltage inputs	4/0	4/0	Flexible
Housing (x 19")	1/3	1/3	1/3 to 2/1
Flush-mounting device	Yes	Yes	Yes
Surface-mounting device with integrated on-site operation panel	Yes, with assembly frame	Yes, with assembly frame	Yes
Surface-mounting device with detached on-site operation panel	No	No	Yes
Small display (rows)	8	8	8
Large display (pixels)	320x240	320x240	320x240
Function Keys	None	9	9
Key switch	No	No	Optional
LEDs	12	16	Flexible, 16 to 80
Power supply	DC 24 to 48 V and DC 60 to 250 V/AC 115 to 230 V		
Redundant power supply	No	No	Yes

Table 5.3/1 Hardware Properties

Integrated Interfaces

Integrated Interfaces

USB connections on the front side

The device can be accessed with the operating program DIGSI 5 by plugging a standard USB cable into the USB-B socket on the front side of the base module. The complete configuration and setting of the device can be carried out via this point-to-point connection.

Integrated interfaces on the rear panel of the base module

The base module offers various, permanently installed interfaces on the rear panel. For even greater flexibility, 2 slots are available for plug-in modules. For this, please observe the connection plans in the attachment.



[Rückansicht_Basis_CB202, 1, --_]

Figure 5.4/1 Rear View of the Device with Integrated Interfaces and Module Slots (left: Base Module, Right: CB202)

Integrated Ethernet interface (port J)

This electrical RJ45 interface serves to connect DIGSI 5 via a local Ethernet network. In this way, several devices can be operated from DIGSI 5 via one external switch. DIGSI 5 detects the devices even without an IP configuration on the local network and can then assign them IP addresses.

Optionally, the protocol IEC 61850 can be activated on this interface for connections with up to 6 clients. With the 7Sx82 devices and SIPROTEC 5 devices with CP300, GOOSE messages are also supported on this interface.

Time-Synchronization Interface (port G)

Via the 9-pole D-sub socket (connection compatible with SIPROTEC 4), the time in the device can be synchronized. The set clock telegram IRIG-B005 (007) of a GPS receiver can be fed with 5 V, 12 V, or 24 V levels. In addition, the Central European DCF77 format with summer and standard time changes is supported. An additional, second pulse input enables microsecond-precise synchronization of the device from a highly precise time source, for example a special GPS receiver. This

accuracy is needed for special protection and measuring tasks. In this way, devices can be precisely synchronized to the microsecond across stations. For this, Siemens provides a prefabricated complete solution with time receiver, FO converters, and appropriate connecting cables.

Connecting a detached operation panel (port H)

A detached operation panel provided together with the connecting cable can be connected to this interface. The maximum distance is 2.5 m or 5 m.

Connecting the expansion unit CB202 (port K)

The base module offers slots for 2 plug-in modules. If more plug-in modules are needed, these can be provided via a special expansion module CB202. This module is connected via port K. The expansion module is delivered with an appropriate cable and is connected with the base module via port L. The CB202 has its own wide-range power supply unit. A great advantage here is that the switch integrated in an Ethernet module can execute its data forwarding function for neighboring devices even if the power supply of the base device is switched off, provided the CB202 is still powered. Thus, an Ethernet ring is not broken when one device is in service.

Via plug-in modules, the devices can be extended with protocol interfaces and analog inputs. The devices can be ordered with assembled modules or be extended with modules retroactively. An expansion module CB202 (right photo in [Figure 5.4/1](#)) can also be assembled with plug-in modules. The modules are easy to service and can be plugged in without having to open the device. Since the modules have their own processor, the basic functions of the device, for example, the protection functions and the protocol application, are largely independent.

Modules are delivered without configured protocols or applications. One or more appropriate modules are suggested in the order configurator corresponding to the desired protocol on a module. There are serial modules with 1 or 2 electrical and optical interfaces. Different applications can run on both interfaces, for example, synchronous protection communication of a differential protection on one interface and an IEC 60870-5-103 protocol on the second interface. Electrical and optical modules for Ethernet are still available. For example, the IEC 61850 protocol as well as auxiliary services may be executed for each module.

The SIPROTEC 5 Terminals

Innovative terminals were developed for the SIPROTEC 5 family. All terminals are individually removable (Figure 5.5/1). This enables prewiring of the systems, as well as simple device replacement without costly rewiring.



[E_CC_Close_up_AB-03_sRGB, 1, --]

Figure 5.5/1 Removed Current Terminal Block

Current terminals

The 8-pole current terminal with 4 integrated current transformers is available in 3 variants:

- 4 protection-class current transformers
- 3 protection-class current transformers + 1 sensitive protection-class transformer
- 4 instrument transformers.

The terminal design provides the following advantages for the connection of currents:

- Exchange of the current transformer type also possible retroactively on-site (for example, protection-class current transformers for instrument transformer, sensitive for normal ground-current transformers in cases of network conversions)
- Additional safety during tests or device replacement since the secondary current transformer circuits always remain closed.

Voltage terminal

The voltage transformers and the binary input and output signals are connected via the 14-pole voltage terminal. The cable route away from the device enables clear terminal wiring. Jumpers precisely matching the current and voltage terminals are available for connecting to common potential (see spare parts and accessories, chapter Attachment).

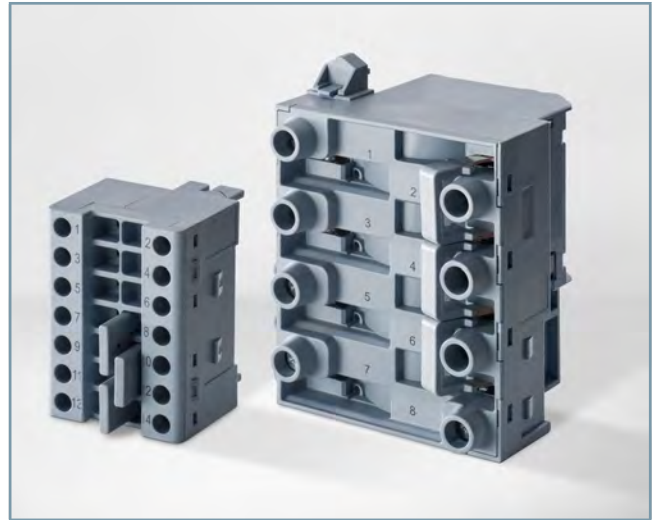

[terminal blocks, 1, --]

Figure 5.5/2 Voltage and Current Terminal Block with Jumpers

SIPROTEC 5 – Hardware

Input/Output Modules

Selection of the Input/Output Module

Which and how many process connections a base or expansion module has depends on the choice of a particular input/output module. The modular building block concept includes different input/output modules.

The IO202 input/output module (Figure 5.6/1) is used, for example, as a base measuring module. By equipping several modules with this module, you can achieve up to 40 measuring channels per SIPROTEC 5 device.

In the module, there are connections for:

- 4 voltage transformers
- 4 current transformers, optional protection-class current transformer, sensitive protection transformer, or instrument transformer
- 8 binary inputs (BI)
- 6 binary outputs (BO), designed as 4 fast speed (type F) make contacts and 2 fast speed change-over contacts.

The connections are distributed over:

- 1 x 8-pole current terminal block
- 3 x 14-pole voltage terminal blocks

Select the modules suitable for your purposes so that you can build the SIPROTEC 5 device that precisely matches your application. An overview of the modules that are available and their quantity structures can be found in Table 5.7/1.



[IO202, 1, --, --]

Figure 5.6/1 Rear View of an Expansion Module IO202

2. device row

Should the quantity structure of a device with 4 expansion modules not suffice, it can be expanded by a 2nd row. A PS203 power supply is required for this in the first mounting position of the 2nd row. The remaining 5 positions can be filled with expansion modules from the SIPROTEC 5 modules. Exception: The CB202 must always be positioned in the 1st row and can only be used once per device.

CB202 module

The CB202 module represents a special case. The CB202 provides 3 plug-in module positions for up to 2 commu-

nication modules or up to 3 measuring-transducer modules. Combinations are also possible, for example, 2 communication modules and one measuring-transducer module.

The power supply is integrated, so that the CB202 can be powered independently of the master unit. Communication with the master unit is assured via an RJ45 connector and the bus connection on the front of the module.



[CB202, 1, --, --]

Figure 5.6/2 Expansion Module CB202

Measuring Ranges of the Current Transformer Modules

The measuring range (full modulation) of the current transformers can be set to different values electronically – depending on the field of application. In all cases, you can choose between protection and instrument transformers. Due to the wide dynamic range, only protection-class current transformers should be considered for busbar protection. The possible measuring ranges according to rated current are shown in Table 5.6/1 "Measuring ranges according to rated current".

A large dynamic range is necessary for network protection applications, so that short circuit currents can be recorded without distortion. A value of $100 \times I_{\text{rated}}$ has proven optimal. For 5 W transformers, this corresponds to a transformer rated current setting of 500 A, and consequently of 100 A for 1 A transformers. For applications in generator protection, while it is true that there are very large primary currents, a dynamic range of $20 \times I_{\text{rated}}$ is still quite sufficient. Thus, a measuring range of 100 A is obtained for a setting of $I_{\text{rated}} = 5 \text{ A}$ and a measuring range of 20 A for $I_{\text{rated}} = 1 \text{ A}$.

A smaller dynamic range means that greater measuring accuracy is achieved in the rated current range. Consequently, the dynamic range for instrument transformers and sensitive protection-class current transformer input for ground fault currents is extremely limited. In this case, limited means that the input current is truncated on the analog side. Of course, the inputs in this case are protected against overdriving.

	Rated current	Measuring	Measuring
	I_{rated}	range	range
			7xx82 devices
Protection-class current transformers	5 A	500 A	250 A
	1 A	100 A	50 A
Instrument trans- formers	5 A	8 A	8 A
	1 A	1.6 A	1.6 A
Sensitive ground- current input	5 A	8 A	8 A
	1 A	1.6 A	1 A

Table 5.6/1 Measuring Ranges according to Rated Current

SIPROTEC 5 – Hardware

Plug-In Modules

Plug-In Modules

Plug-in modules are available for communication or analog inputs and arc protection. The communication modules are described in the **Communication** chapter.

Measuring-transducer module ANAI-CA-4EL

The module has four 20-mA inputs. It can be plugged into one of the slots in the PS201 or CB202. Multiple measured value modules can be used with each device (one in each available slot). The connections are created via an 8-pole screw terminal block [Figure 5.7/1](#).

The technical data for the measuring-transducer module is provided in the manual "SIPROTEC 5, Description, Hardware". An extract from the technical data can also be found in the catalog in the chapter Attachment – Technical data.



[ANAI-CA-4EL, 1, --_--]

Figure 5.7/1 Measuring-Transducer Module ANAI-CA-4EL

Arc protection module ARC-CD-3FO

Up to 3 optical point or line sensors per arc protection plug-in module ([Figure 5.7/2](#)) can be connected. This yields a maximum number of up to 15 sensors for modular SIPROTEC 5 devices.

The point sensors can be ordered with line lengths from 3 m to 35 m. Line sensors detect arcs along the entire sensor length. Lengths from 5 m to 40 m are available. Line sensors are connected via a line to the arc protection module. The power line can be ordered in lengths from 3 m to 10 m.



[ARC-CD-3FO, 1, --_--]

Figure 5.7/2 Arc Protection Module ARC-CD-3FO

Quantity Structure of the Modules for Non-Modular Devices – 7xx81 and 7xx82

Module	Description	V Input	I Input	BI (Isolated)	BI (Connected to Common Potential)	BO, Make Contact	Temperature Inputs	BO, Change-Over Contact	BO, Change-Over Contact Type F*	Fast Measuring Transducer 20 mA/10 V	BO Power Relay	Number of Slots for Plug-In Modules	Available in Base Module	Available in the Expansion Module	Power Supply Usable in Device Row	
PS101	Power supply module for all 7xx82 devices	–	–	–	3	1	–	2 ¹⁾	–	–	–	2	■	–	■	1
IO101	Base module for all 7xx82 devices that require current measurement	–	4	1	7	4	–	2	–	–	–	–	■	–	–	1
IO102	Base module for all 7xx82 devices that require current and voltage measurement	4	4	1	7	4	–	2	–	–	–	–	■	–	–	1
IO103	Base module for all 7xx82 devices that require current measurement	–	8	–	4	4	–	–	–	–	–	–	■	–	–	1
IO110	Module for additional binary input and output for all 7xx82 devices	–	–	–	12	7	–	–	–	–	–	–	■	–	–	1
IO111	Input module for all 7xx82 devices from V7.50	–	–	–	–	–	12	–	–	–	–	–	■	–	–	1

1) Of these, 1 life contact

The connection diagrams of the individual modules are included in the chapter Attachment.

Table 5.7/1 Quantity Structure of the Modules for Non-Modular Devices (7xx81 and 7xx82)

SIPROTEC 5 – Hardware

Plug-In Modules

Quantity Structure of the Modules for All Modular Devices - 7xx85, 7xx86, 7xx87, and 6MD8

Module	Description	V Input	I Input	BI (Isolated)	BI (Connected to Common Potential)	BO, Make Contact	BO, Make Contact Type F*	BO Make Contact Type HS**	BO, Change-Over Contact	BO, Change-Over Contact Type F*	Fast Measuring Transducer 20 mA/10 V	BO Power Relay	Number of Slots for Plug-In Modules	Available in Base Module	Available in Expansion Module	Power Supply	Can be used in Device Row
PS201	Power supply module for first device row	-	-	-	3	1	-	-	2 ¹⁾	-	-	-	2	■	-	■	1
PS203	Power supply module for the 2nd printed circuit board assembly row	-	-	-	-	-	-	-	-	-	-	-	-	-	■	■	2
PS204	Power supply module for redundant power supply	-	-	-	-	-	-	-	-	-	-	-	-	-	■	■	1.2
CB202	Printed circuit board assembly with 3 additional slots for modules and an independent power supply	-	-	-	-	-	-	-	-	-	-	-	3	-	■	■	1
IO201	Base module for protection applications that do not require voltage measurement	-	4	8	-	-	4	-	-	2	-	-	-	■	■	-	1.2
IO202	Base module for all devices that require current and voltage measurement	4	4	8	-	-	4	-	-	2	-	-	-	■	■	-	1.2
IO203	Printed circuit board assembly for devices that require numerous current inputs	-	8	4	-	-	4	-	-	-	-	-	-	■	■	-	1.2
IO204	This printed circuit board assembly contains 4 power relays for direct control of the operating mechanism motors of grounding conductors and disconnectors	-	-	10	-	4	-	-	-	-	-	4	-	-	■	-	1.2
IO205	For applications with binary inputs and binary outputs	-	-	12	-	16	-	-	-	-	-	-	-	-	■	-	1.2
IO206	For applications with binary inputs and binary outputs	-	-	6	-	7	-	-	-	-	-	-	-	-	■	-	1.2
IO207	Geared toward bay controllers due to the predominant number of binary inputs	-	-	16	-	8	-	-	-	-	-	-	-	-	■	-	1.2
IO208	Typical printed circuit board assembly for protective applications. In contrast to the IO202, it is equipped with more relay outputs	4	4	4	-	3	6	-	-	2	-	-	-	■	■	-	1.2
IO209	This printed circuit board assembly is used when extremely fast tripping times (4 make contacts, 0.2 ms pickup time) are required, such as in extra-high voltage protection	-	-	8	-	-	-	4	-	-	-	-	-	-	■	-	1.2
IO210	Input and output module with 4 fast measuring transducer inputs for current or voltage	4	3	7	-	-	-	-	-	-	4	-	-	-	-	-	-
IO211	This printed circuit board assembly is for devices that require numerous voltage inputs	8	-	8	-	8	-	-	-	-	-	-	-	-	■	-	1.2
IO212	Printed circuit board assembly for very fast detection of measuring transducer signals (20 mA or 10 V) with a main field of application for the recording of interference signals and monitoring	-	-	8	-	-	-	-	-	-	8	-	-	-	-	-	1.2

*Type F – fast relay with monitoring (operating time < 5 ms) / **Type HS – high-speed relay (contact with solid-state bypass) with monitoring (operating time < 0.2 ms)

1) Of these, 1 life contact / 2) 10 V voltage inputs for RC dividers with high impedance

The connection diagrams of the individual modules are included in the chapter Attachment.

Module	Description	V Input	I Input	BI (Isolated)	BI (Connected to Common Potential)	BO, Make Contact	BO, Make Contact Type F*	BO Make Contact Type HS**	BO, Change-Over Contact	BO, Change-Over Contact Type F*	Fast Measuring Transducer 20 mA/10 V	BO Power Relay	Number of Slots for Plug-In Modules	Available in Base Module	Available in Expansion Module	Power Supply	Can be used in Device Row
IO214	Typical printed circuit board assembly for protective applications. In contrast to the IO202, it has a reduced quantity structure	4	4	2	-	-	4	-	-	4	-	-	-	■	■	-	1.2
IO215	Special module for connection of special high-impedance voltage dividers via 10-V voltage inputs	4 ²⁾	4	8	-	-	4	-	-	2	-	-	-	-	■	-	1.2
IO216	Input module for special binary inputs with maximized robustness against electrical disturbances	-	-	16	-	-	-	-	-	-	-	-	-	-	■	-	1.2
IO230	Printed circuit board assembly for receiving great volumes of information, such in the bay controllers or busbar protection. The process connection is made via special terminals	-	-	-	48	-	-	-	-	-	-	-	-	-	■	-	1.2
IO231	Printed circuit board assembly for receiving and the output of great volumes of information, such in the bay controllers or busbar protection. The process connection is made via special terminals	-	-	-	24	24	-	-	-	-	-	-	-	-	■	-	1.2
IO233	Input module with special version for binary inputs.	-	-	-	48	-	-	-	-	-	-	-	-	-	-	-	-
IO240	Input module for low-power instrument transformer (LPIT) from Siemens Energy	4	4	-	-	-	-	-	-	-	-	-	-	-	-	-	-

*Type F – fast relay with monitoring (operating time < 5 ms) / **Type HS – high-speed relay (contact with solid-state bypass) with monitoring (operating time < 0.2 ms)

1) Of these, 1 life contact / 2) 10 V voltage inputs for RC dividers with high impedance

The connection diagrams of the individual modules are included in the chapter Attachment.

Table 5.7/2 Quantity Structure of the Modules for All Modular Devices (7xx85, 7xx86, 7xx87 and 6MD8)

SIPROTEC 5 – Hardware

Standard Variants

Standard Variants

To make it easier to select the correct devices, Siemens offers you pre-configured devices called standard variants. These combinations of a base module and one or more expansion modules are intended for specific applications. In this way, you can order exactly the right device with a single order number. The standard variants can also be modified easily and quickly with additional expansion modules. Thus, it is just as easy to add modules as it is to replace certain modules with others. The available standard variants are listed in the [order configurator](#).



[SIP5_GD_SS_W3, 2, --, --]

Figure 5.8/1 Standard Variant for SIPROTEC 7SL87

Figure 5.8/1 shows one possible standard variant for SIPROTEC 7SL87.

This variant describes a 2/3 x 19" wide device having the following quantity structure.

5.8

- 15 binary inputs
- 20 binary outputs
- 8 current inputs
- 8 voltage inputs.

The modules used in the device can be seen on the results page of the SIPROTEC 5 configurator (see chapter Engineering [Product Selection via the Order Configurator, Page 372](#) for more details).

In our example, the following modules are used in positions 1 to 3:

- Position 1: IO208
- Position 2: PS201
- Position 3: IO202.

The individual terminals are defined by the mounting position of the module and the terminal designations of the module (see section: Attachment – connection diagrams).

As an example, the terminals of the first 4 current inputs, which are on the IO208 at position 1, are designated as follows:

- I1: 1A1 and 1A2
- I2: 1A3 and 1A4
- I3: 1A5 and 1A6
- I4: 1A7 and 1A8.

The additional 4 current inputs are at the 3rd mounting position on the IO202 module, and are designated as follows:

- I1: 3A1 and 3A2
- I2: 3A3 and 3A4
- I3: 3A5 and 3A6
- I4: 3A7 and 3A8.

Regardless of whether you choose a standard variant or configure your devices freely – you always receive a thoroughly tested, complete device.

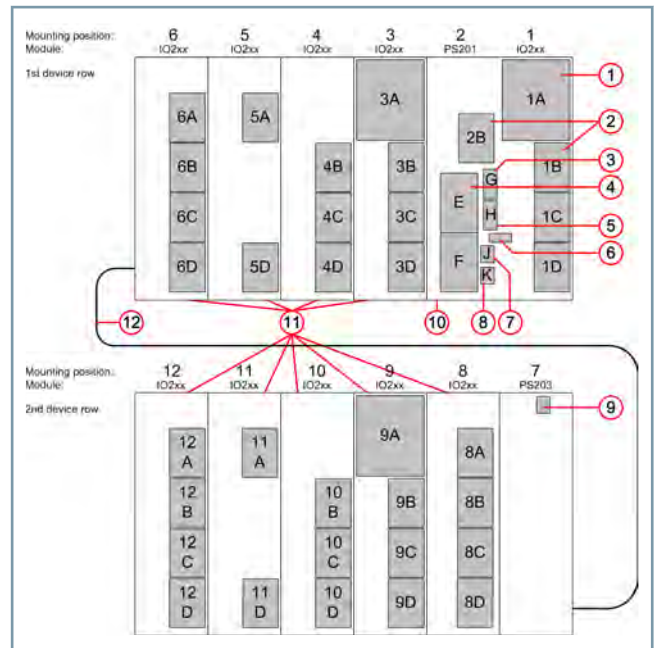

[dwbgrpos-170713-01.tif, 3, en_US]

Figure 5.8/2 Connector Designations and Counting Method

- (1) Current terminal A
- (2) Voltage terminal A, B, C, D
- (3) Connector for time synchronization G
- (4) Plug-in module E, F
- (5) Connector for detached on-site operation panel H
- (6) Battery compartment
- (7) Connector for integrated Ethernet interface J
- (8) Connector for COM link K
- (9) 2-pole terminal to connect power supply
- (10) Base module 1/3 of 19"
- (11) Expansion module 1/6 of 19"
- (12) Connecting cable between 1st and 2nd device row

Advantages of the flexible hardware module:

- With the flexible hardware module range, you conveniently configure the optimal hardware scope for your application.
- For many applications, the appropriate device specification is already pre-defined as a standard variant.
- The hardware design is appropriate for your switching cell.
- The innovative SIPROTEC 5 terminal with integrated current transformers offers increased safety in systems testing and flexibility when exchanging the transformer type.

SIPROTEC 5 – Hardware

Standard Variants



Appendix

Spare Parts and Accessories

Group	Accessories	Article per packaging unit	Order no. (short designation)
Terminal	Voltage terminal, terminal block, 14-pole	8	P1Z499
Terminal	Voltage terminal (power supply) Terminal block, 2-pole ¹	2	P1Z505
Terminal	Type A current terminal, 4 x protection ² (for modular devices)	1	P1Z512
Terminal	Type A current terminal, 3 x protection and 1 x measurement ² (for modular devices)	1	P1Z529
Terminal	Type A current terminal, 4 x measurement ² (for modular devices)	1	P1Z536
Terminal	Type B current terminal, 4 x protection ³ (for non-modular devices)	1	P1Z1869
Terminal	Type B current terminal, 3 x protection and 1 x measurement ³ (for non-modular devices)	1	P1Z1647
Terminal	2-pole cross connector for current terminal	3	P1Z543
Terminal	Terminals for IO110, IO112, IO113 ¹	2	P1Z1656
Terminal	Terminals and shielding for IO111 ^{1, 4, 5}	2	P1X240
Terminal	Terminal set for IO23x ¹ only	1	P1Z1841
Terminal	2-pole cross connector for voltage terminal	6	P1Z550
Terminal	Cover for current terminal block	1	P1Z567
Terminal	Cover for voltage terminal block	8	P1Z574
Terminal	Transport safety, current terminal	2	P1X222
Terminal	Transport safety, voltage terminal	10	P1X231
Terminal	Terminal set for direct connection to 400 V low voltage	4	P1X301
Accessories	USB covers (10 pieces each for CP 100, 200, 300)	30	P1X213
Accessories	Cable, integrated operation panel, 0.43 m	1	P1Z666
Accessories	Cable, detached operation panel, 2.50 m (for retrofitting surface-mounting housing with integrated operation panel in surface-mounting housing with detached operation panel)	1	P1Z1878
Accessories	Cable, detached operation panel, 5.00 m (for retrofitting surface-mounting housing with integrated operation panel in surface-mounting housing with detached operation panel)	1	P1Z2132
Accessories	Cable set, COM link cable	1	P1Z673
Accessories	Set of angle rails	2	P1Z1850
Accessories	Labeling strips, LEDs/function keys	10	P1Z697
Accessories	Labeling strips, push-buttons	5	P1Z2752
Accessories	Set of parts, mounting bracket 1/2	2	P1Z703
Accessories	Set of parts, mounting bracket 2/3	2	P1Z710
Accessories	Set of parts, mounting bracket 5/6	2	P1Z727
Accessories	Set of parts, mounting bracket 1/1	2	P1Z734
Accessories	Screw cover 1/3, type C11	4	P1Z901
Accessories	Screw cover 1/3, type C22	4	P1Z2512
Accessories	Screw cover 1/6, type C21	4	P1Z1281
Accessories	Cover plate for unused plug-in module positions	1	P1Z680
Accessories	Cover panel 1/6	5	
Accessories	Bus termination plate	2	P1Z1496
Accessories	Panel surface mounting assembly frame (for mounting a 7xx81 or 7xx82 device in the panel surface mounting)	1	P1X73
Accessories	SDHC memory card for 7KE85	1	P1Z2530
Accessories	Battery holder	10	P1X91
Accessories	Connecting cable for 2nd row	1	P1Z2655
Accessories	DIGSI 5 USB 2.0 cable	1	P1Z2859
Accessories	SFP RJ45, 10 units	10	P1Z3201

Group	Accessories	Article per packaging unit	Order no. (short designation)
Accessories	SFP Single-mode, 24 km, 10 units	10	P1Z3210
Sensors for arc protection	Point sensor with line length of 3 m	1	P1X19
Sensors for arc protection	Point sensor with line length of 4 m	1	P1X28
Sensors for arc protection	Point sensor with line length of 5 m	1	P1X37
Sensors for arc protection	Point sensor with line length of 7 m	1	P1X277
Sensors for arc protection	Point sensor with line length of 10 m	1	P1X46
Sensors for arc protection	Point sensor with line length of 15 m	1	P1X55
Sensors for arc protection	Point sensor with line length of 20 m	1	P1X64
Sensors for arc protection	Point sensor with line length of 35 m	1	P1X82
Sensors for arc protection	Line sensor, length 3 m	1	P1X107
Sensors for arc protection	Line sensor, length 10 m	1	P1X116
Sensors for arc protection	Line sensor, length 20 m	1	P1X125
Sensors for arc protection	Line sensor, length 30 m	1	P1X134
Sensors for arc protection	Line sensor, length 40 m	1	P1X143
Sensors for arc protection	Supply line for line sensors 3 m	1	P1X152
Sensors for arc protection	Supply line for line sensors 5 m	1	P1X161
Sensors for arc protection	Supply line for line sensors 10 m	1	P1X170

Table 6.1/1 Accessories

¹ Recommended tightening torque when screwing down the terminal on the rear plate: 0.3 Nm

² For all modular SIPROTEC 5 devices, not for non-modular devices 7xx81 and 7xx82

³ For all non-modular SIPROTEC 5 devices 7xx82 (light), starting from V07.40

⁴ The set comprises terminals and shielding for IO111 for the terminal positions M and N.

⁵ Only for non-modular devices 7xx82

Appendix

Connection Diagrams – Modular Devices

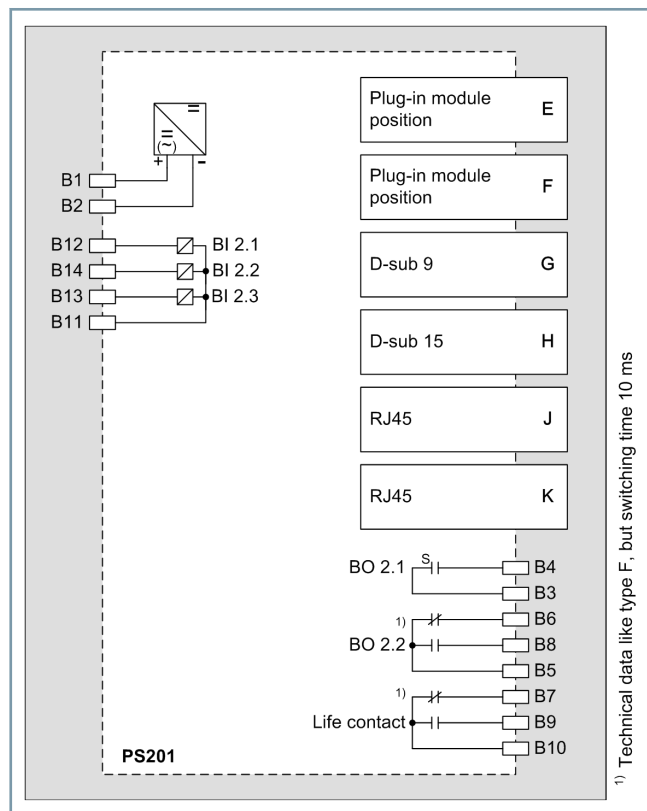

[tdps201x-270812-01.tif, 1, en_US]

Figure 6.2/1 Connection Diagram PS201

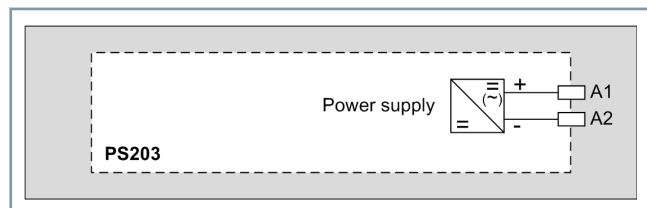

[tdps203x-030713-01.tif, 2, en_US]

Figure 6.2/2 Connection Diagram PS203

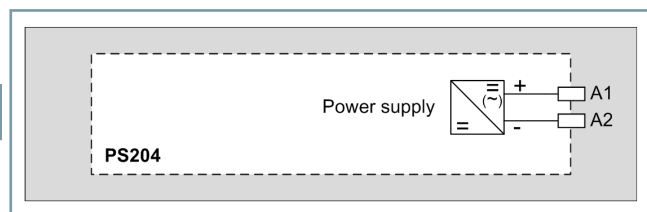

[tdps204x, 1, en_US]

Figure 6.2/3 Connection Diagram PS204

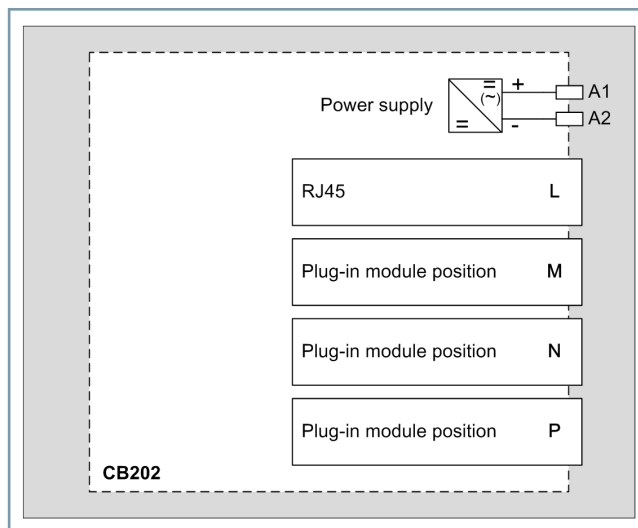

[tdcb202x-100713-01.tif, 2, en_US]

Figure 6.2/4 Connection Diagram CB202

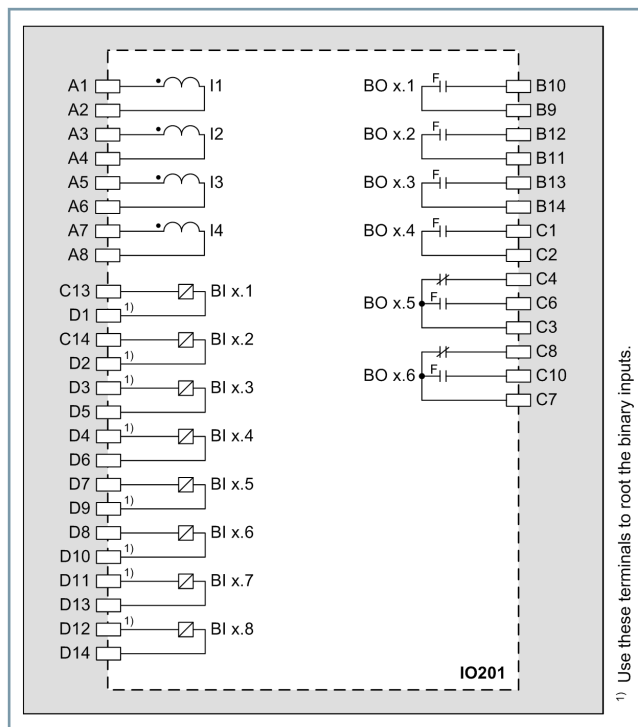

[tdio201x-290812-01.tif, 1, en_US]

Figure 6.2/5 Connection Diagram IO201

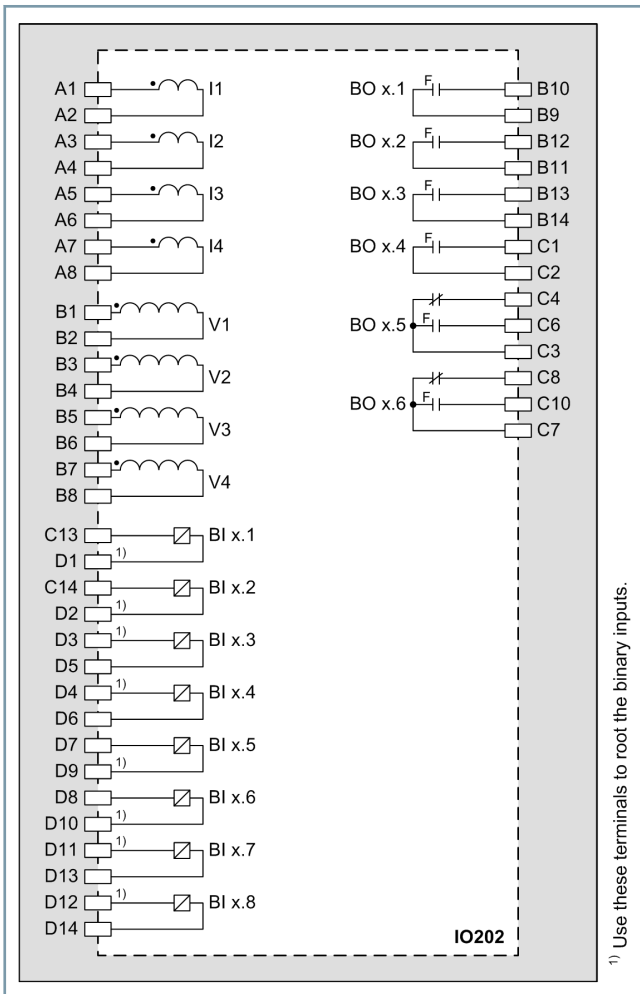

[tdio202x-240812-01.tif, 1, en_US]

Figure 6.2/6 Connection Diagram IO202

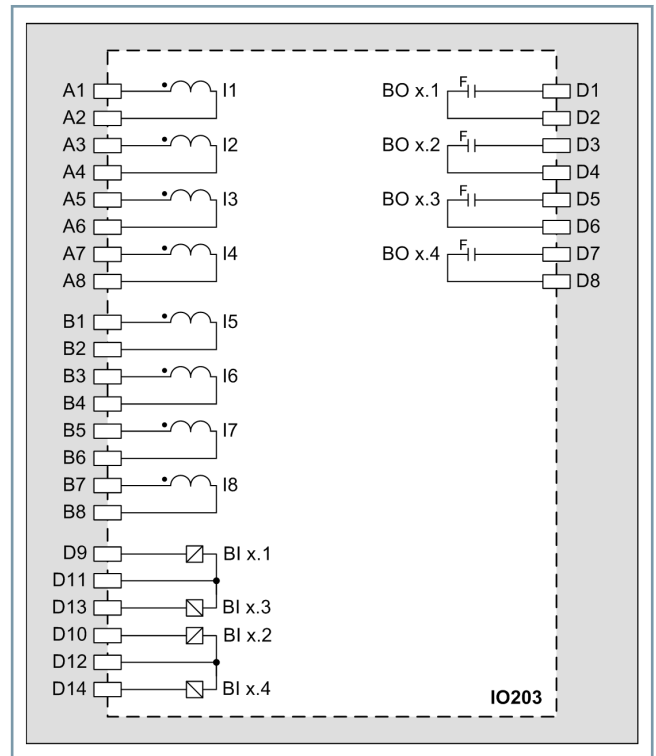

[tdio203x-110313-01.tif, 1, en_US]

Figure 6.2/7 Connection Diagram IO203

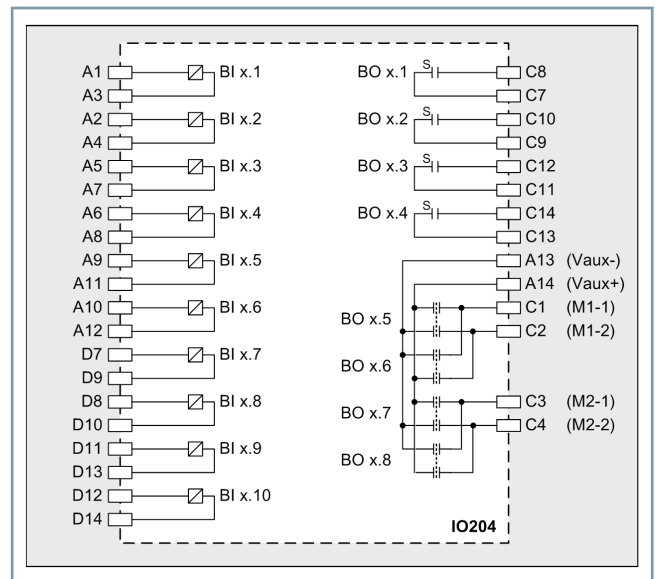

[tdio204x-201112-01.tif, 1, en_US]

Figure 6.2/8 Connection Diagram IO204

Appendix

Connection Diagrams – Modular Devices

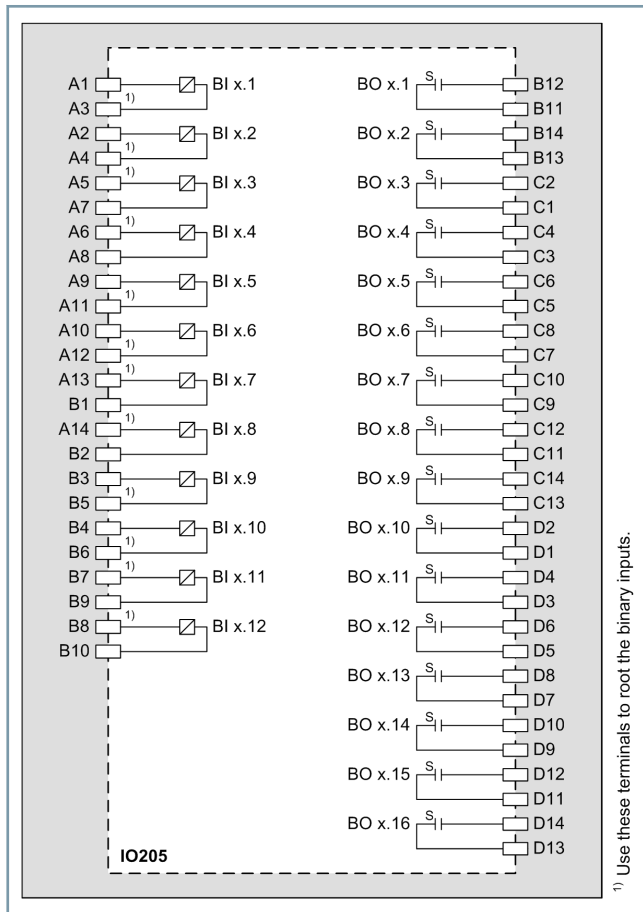

[tdio205x-240812-01.tif, 1, en_US]

Figure 6.2/9 Connection Diagram IO205

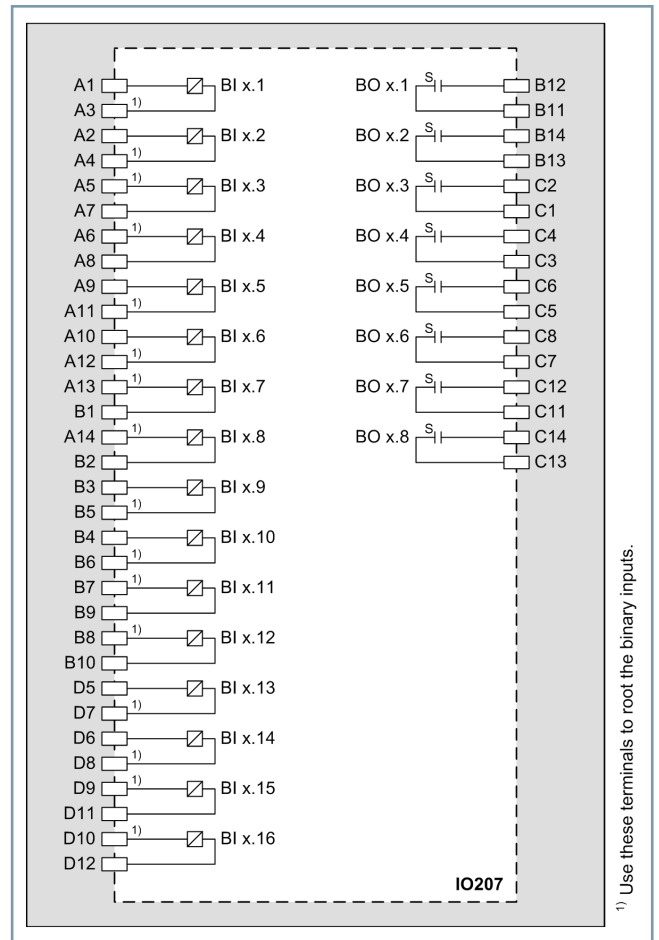

[tdio207x-300812-01.tif, 1, en_US]

Figure 6.2/11 Connection Diagram IO207

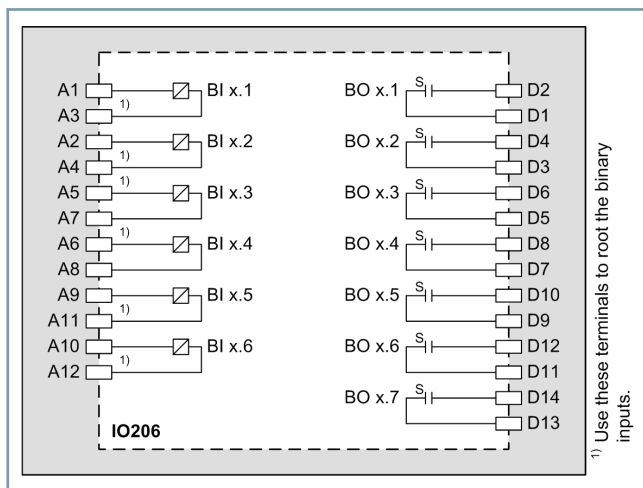

[tdio206x-050313-02.tif, 1, en_US]

Figure 6.2/10 Connection Diagram IO206

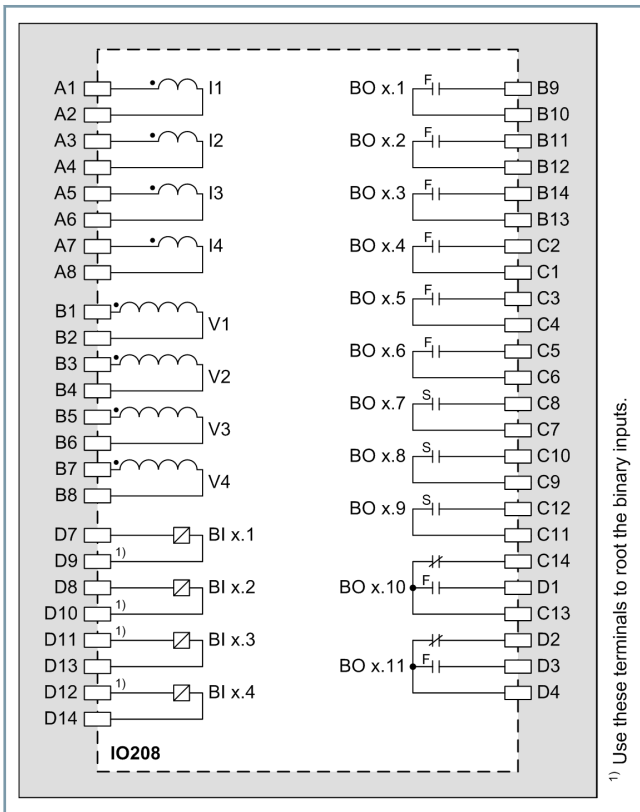

Figure 6.2/12 Connection Diagram IO208

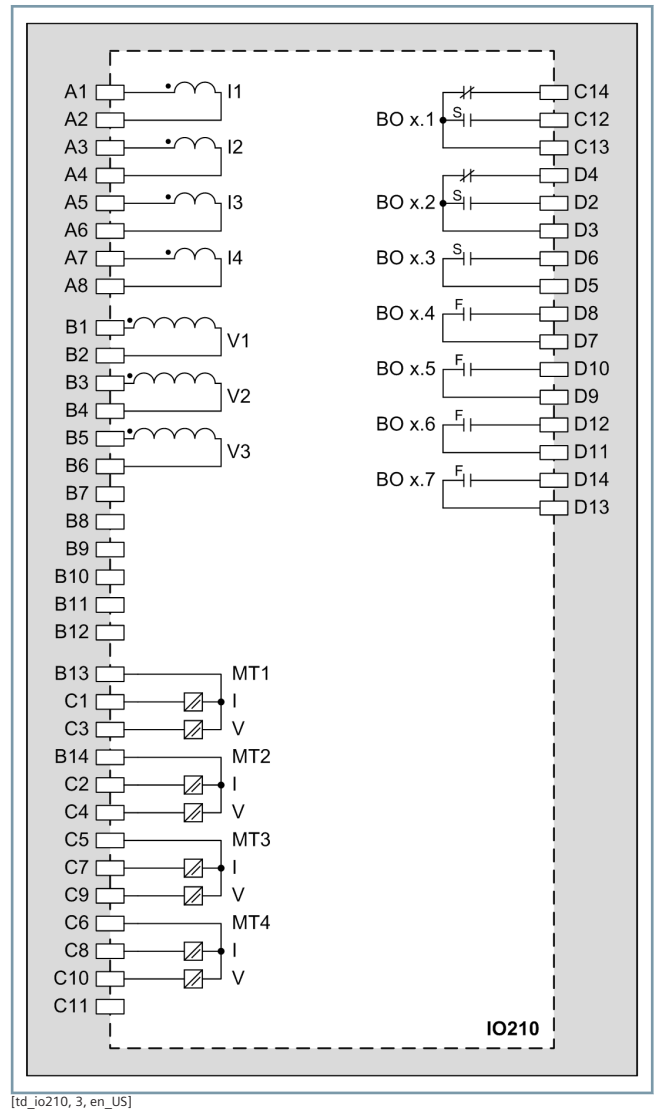

Figure 6.2/14 Connection Diagram IO210

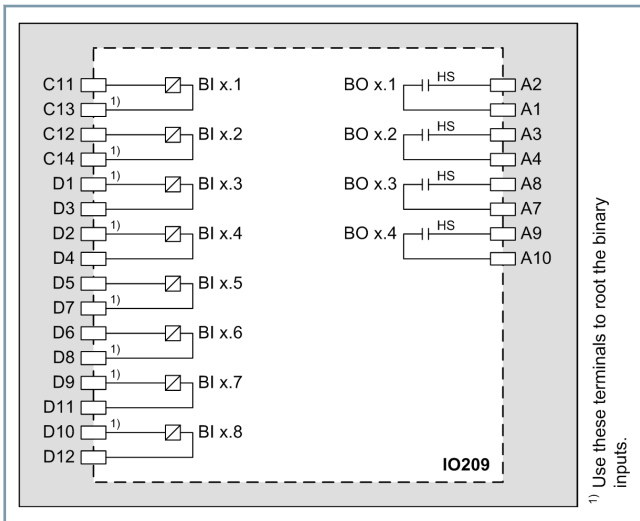
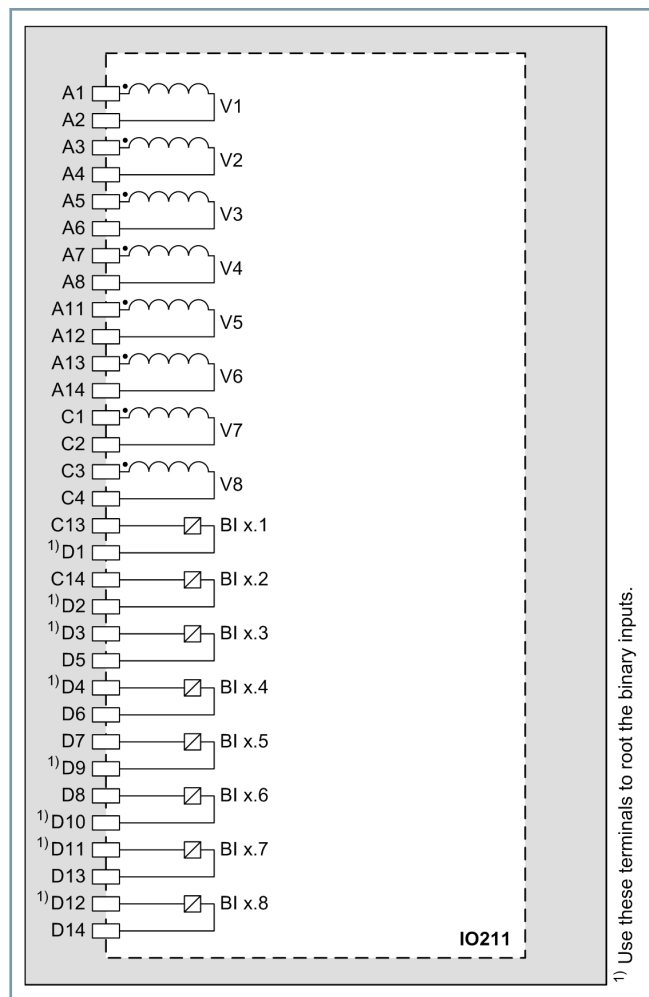

Figure 6.2/13 Connection Diagram IO209

Appendix

Connection Diagrams – Modular Devices



[tdio211x-2111112-01.tif, 1, en_US]

Figure 6.2/15 Connection Diagram IO211

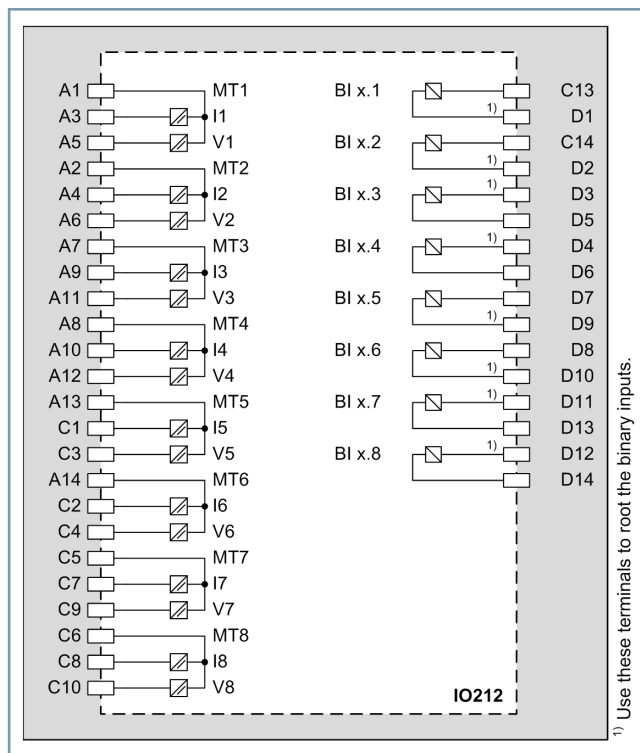

[tdio212x, 2, en_US]

Figure 6.2/16 Connection Diagram IO212

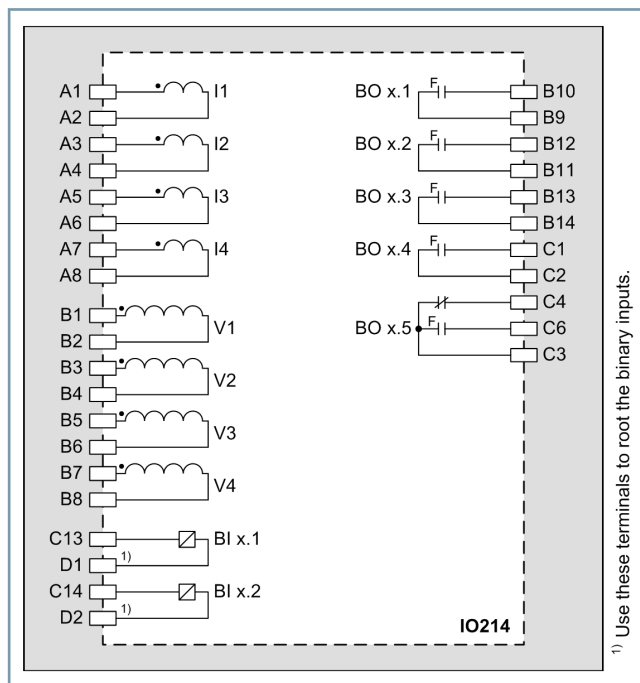

[tdio214x-270812-01.tif, 1, en_US]

Figure 6.2/17 Connection Diagram IO214

IO215

The terminal and connection diagram of the IO215 is identical to the input and output module IO202 (Figure 6.2/6) in the expansion module.

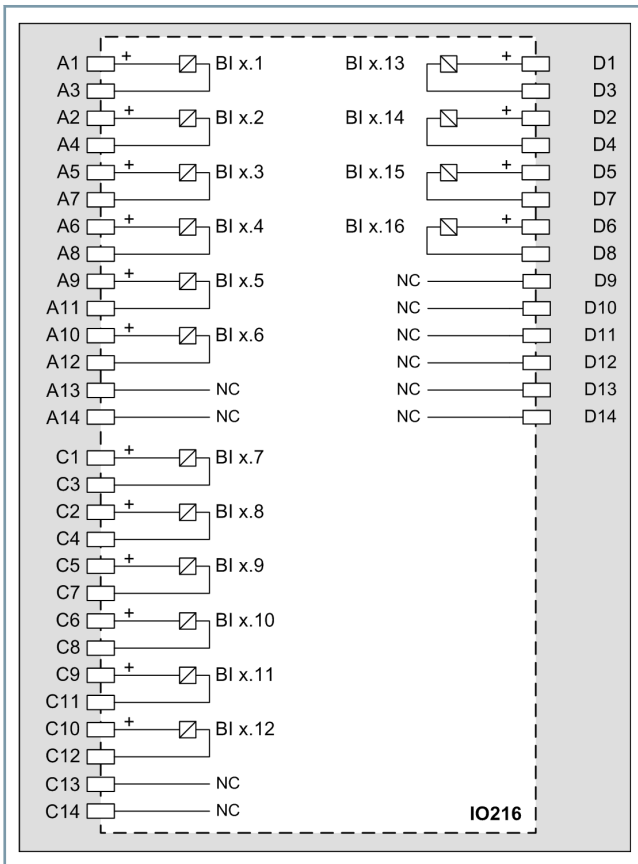

[tdio216x, 1, en_US]

Figure 6.2/18 Connection Diagram IO216

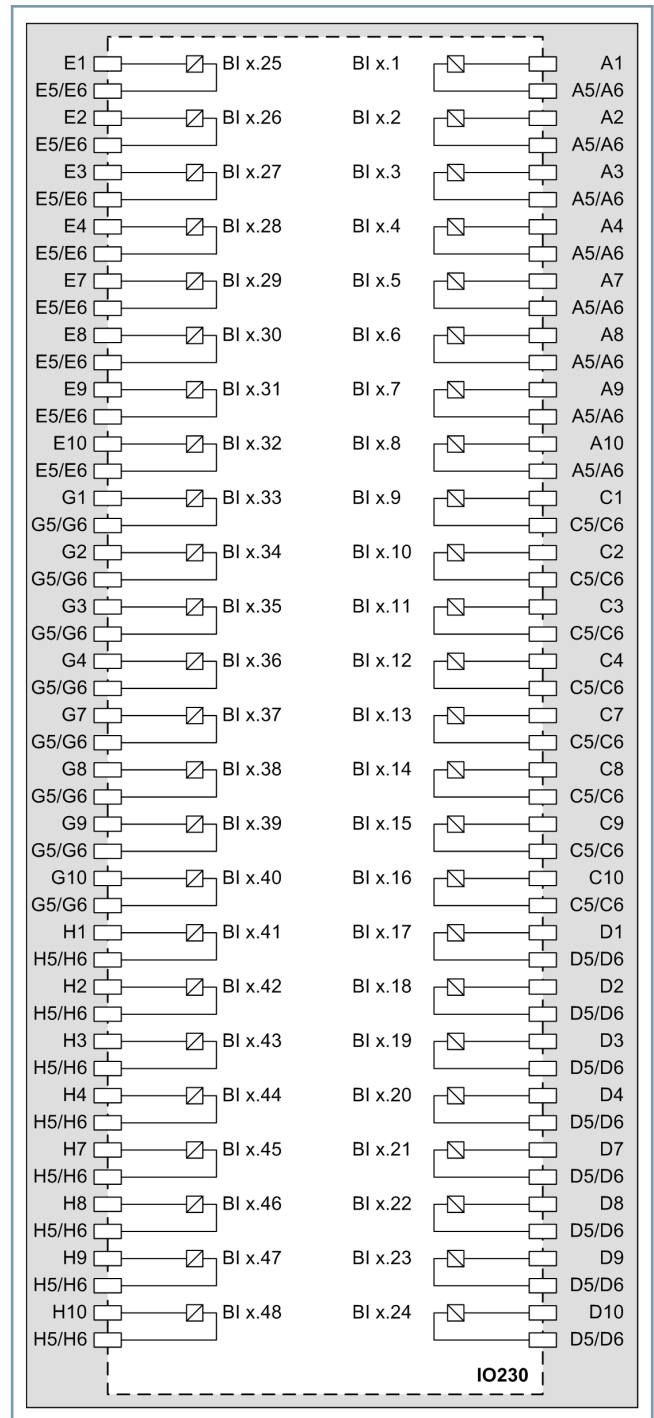

[tdio230x, 1, en_US]

Figure 6.2/19 Connection Diagram IO230

Appendix

Connection Diagrams – Modular Devices

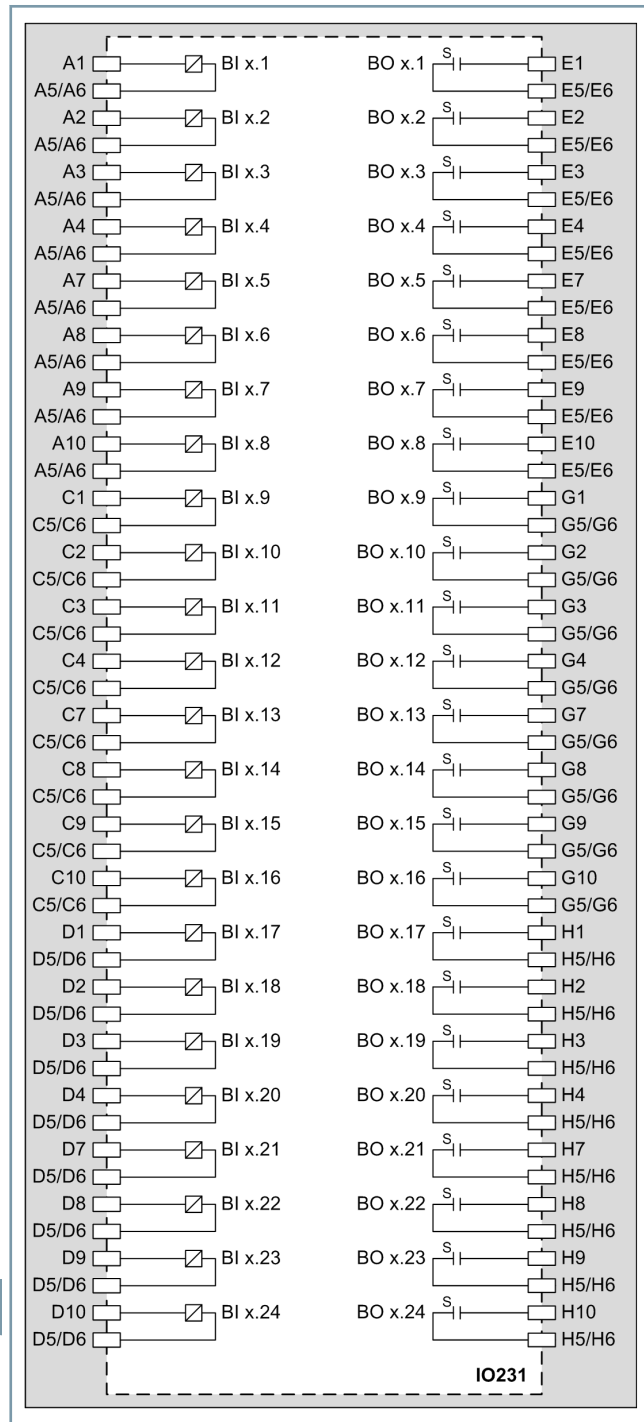

[td_tdio231x, 1, en_US]

Figure 6.2/20 Connection Diagram IO231

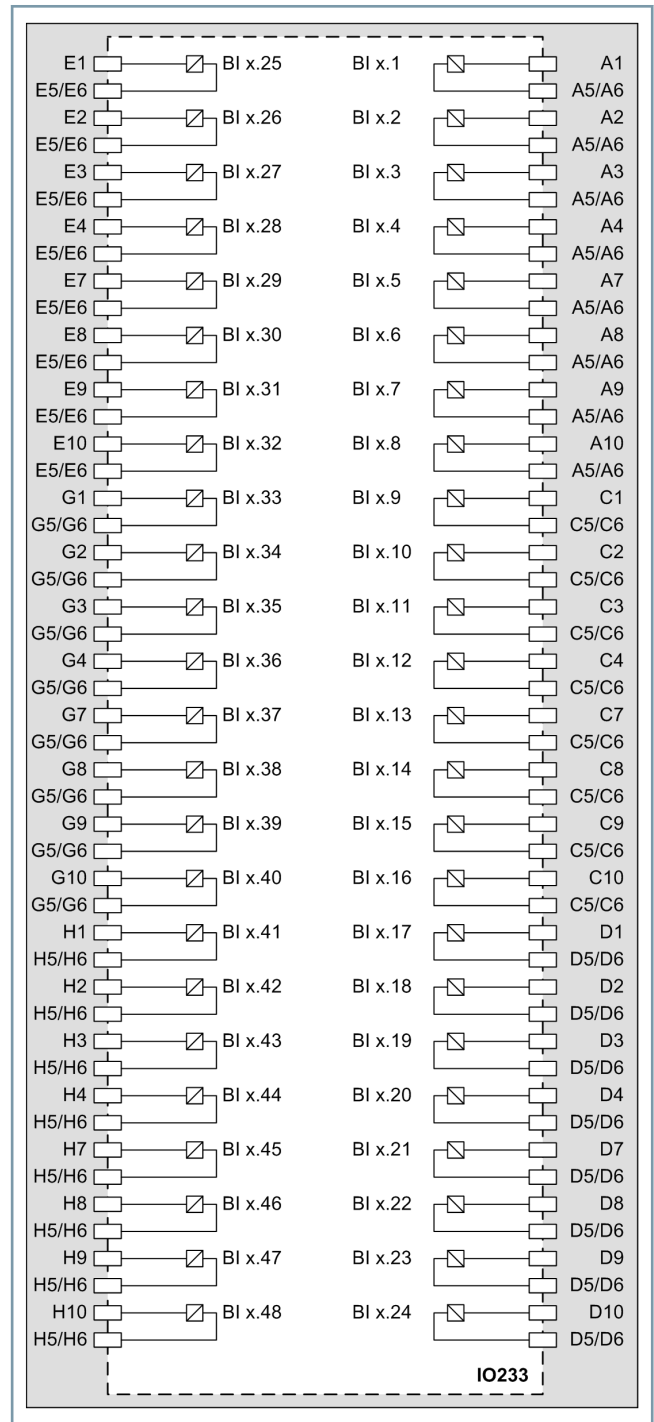

[td_io233x, 1, en_US]

Figure 6.2/21 Connection Diagram IO233

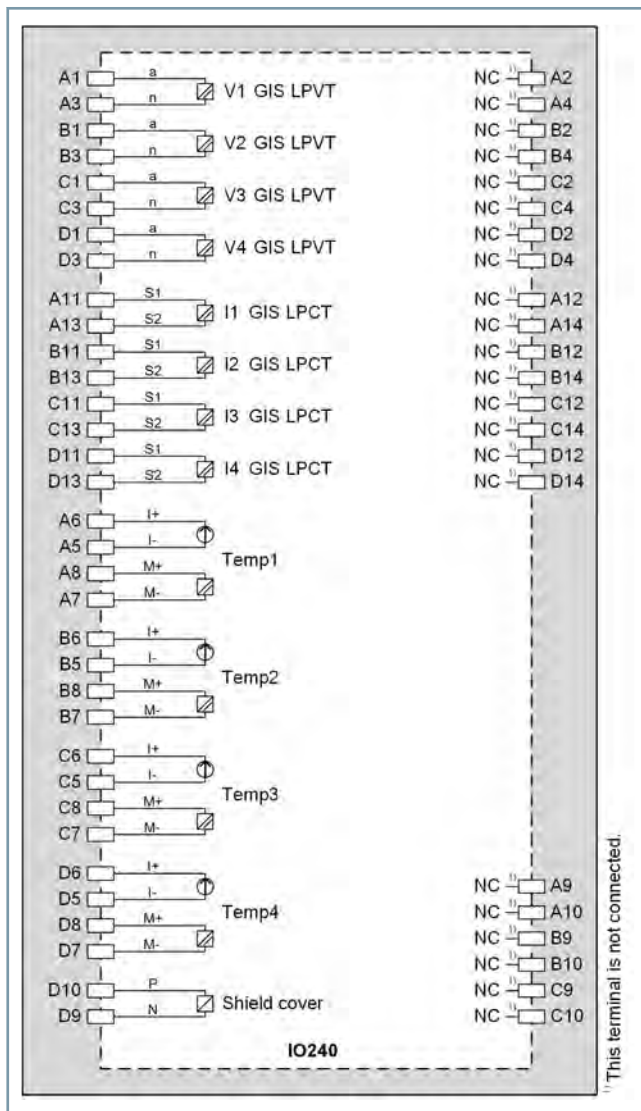

[td_io240x, 3, en_US]

Figure 6.2/22 Connection Diagram IO240

Appendix

Connection Diagrams – for Non-Modular Devices (7xx81 and 7xx82)

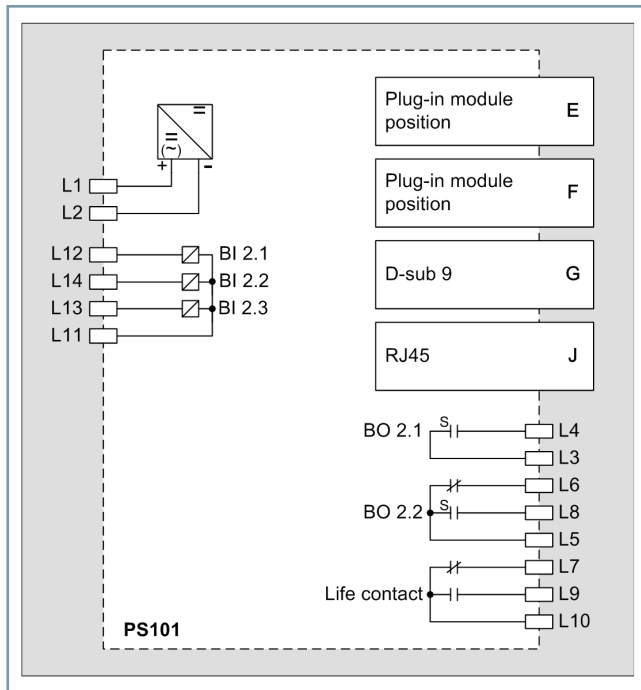

[tdps101x-210513-01.tif, 1, en_US]

Figure 6.2/23 Connection Diagram PS101

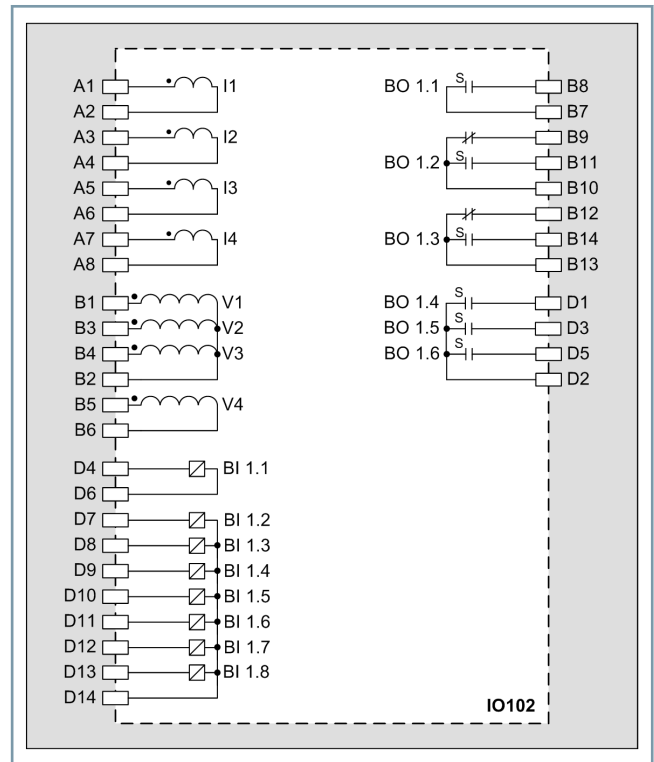

[tdio102x-220513-01.tif, 1, en_US]

Figure 6.2/25 Connection Diagram IO102

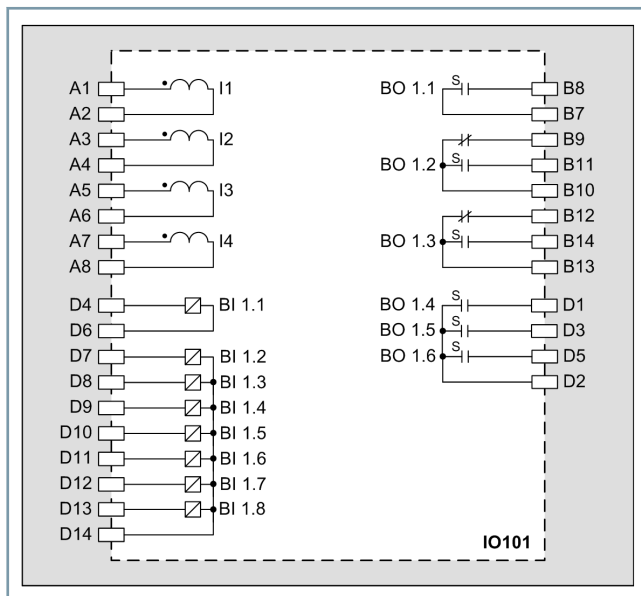

[tdio101x-220513-01.tif, 1, en_US]

Figure 6.2/24 Connection Diagram IO101

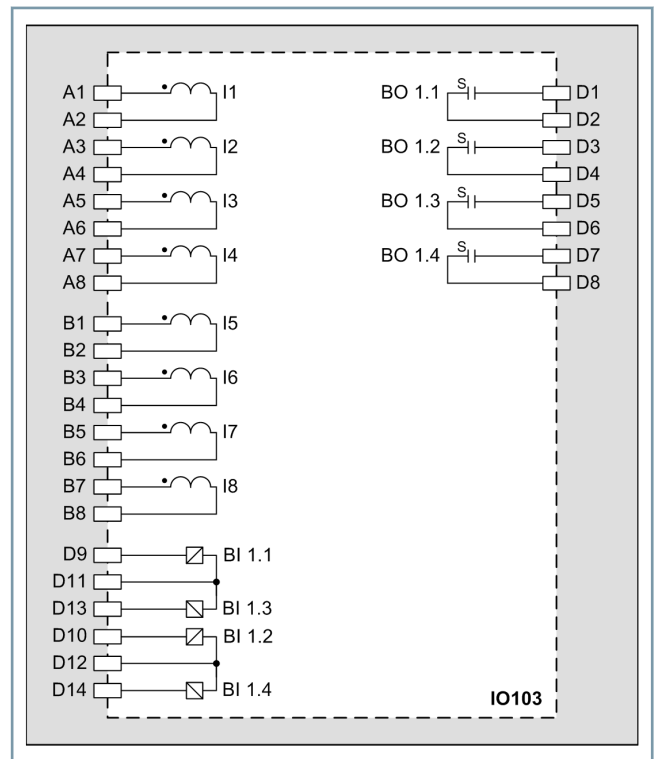

[tdio103x-01.vsd, 1, en_US]

Figure 6.2/26 Connection Diagram IO103

Connection Diagrams – for Non-Modular Devices (7xx81 and 7xx82)

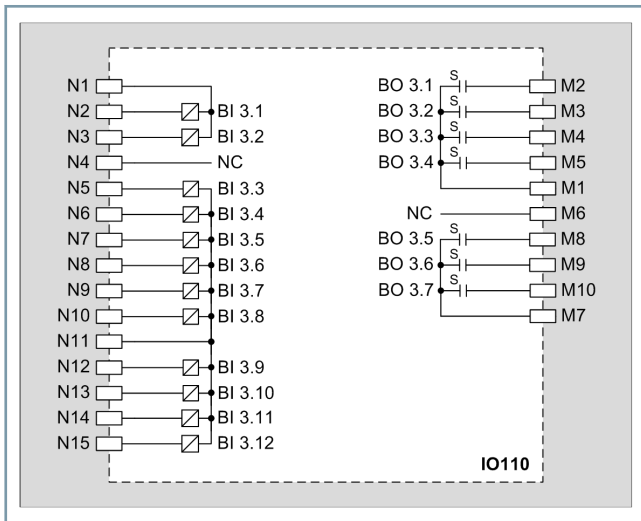

[tdio110x-220513-01.tif, 1, en_US]

Figure 6.2/27 Connection Diagram IO110

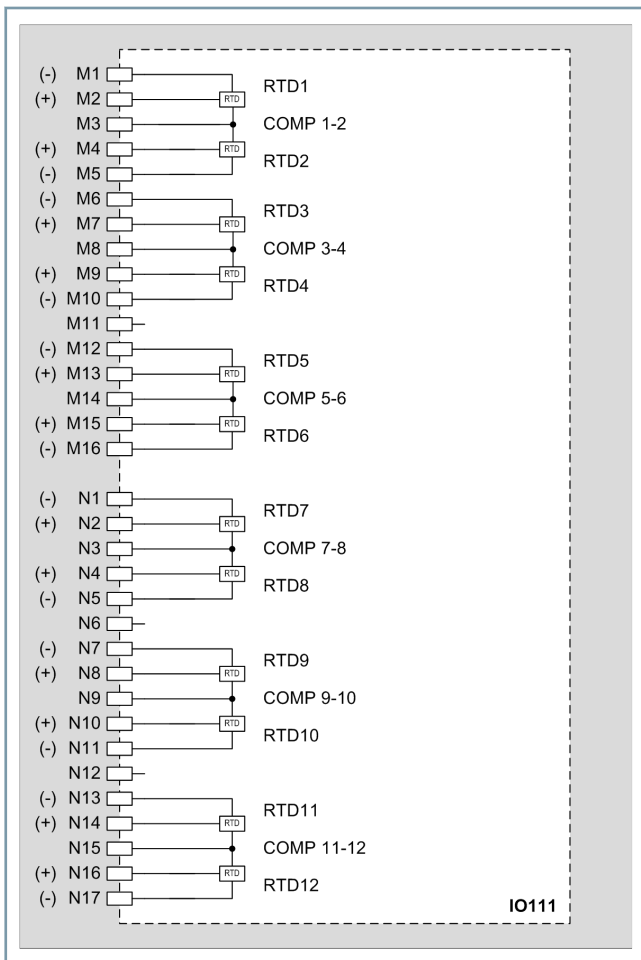

[td_io111, 1, en_US]

Figure 6.2/28 Connection Diagram IO111

Appendix

Connection Diagrams – for Non-Modular Devices (7xx81 and 7xx82)

Flush-Mounting Device

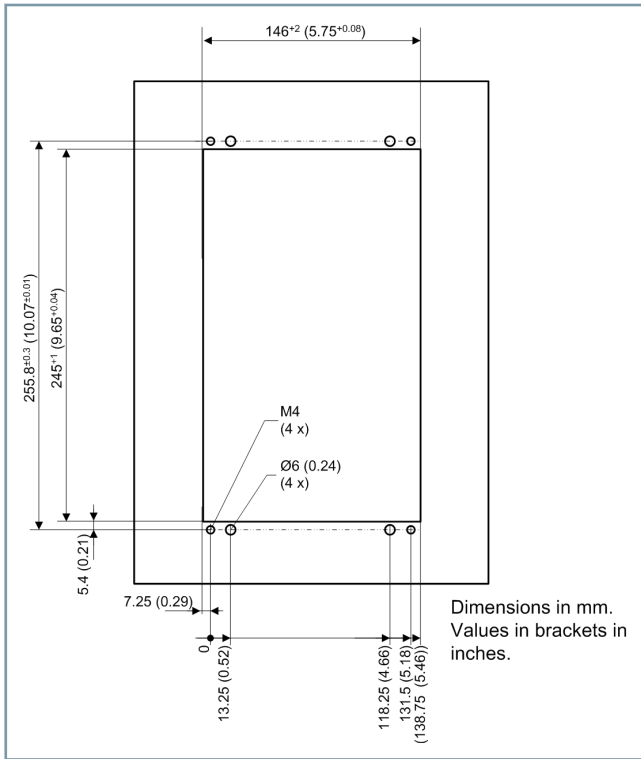

Figure 6.3/1 Cut-Out Widths and Drilling Pattern – 1/3 Device, 1st Device Row

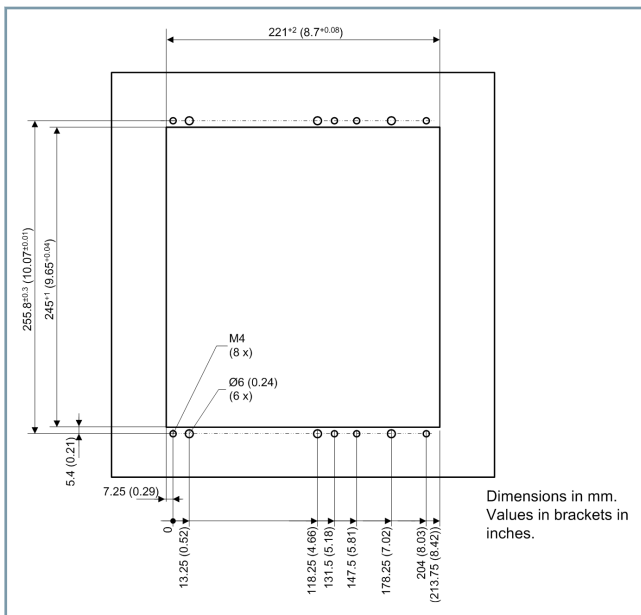

Figure 6.3/2 Cut-Out Widths and Drilling Pattern – 1/2 Device, 1st Device Row

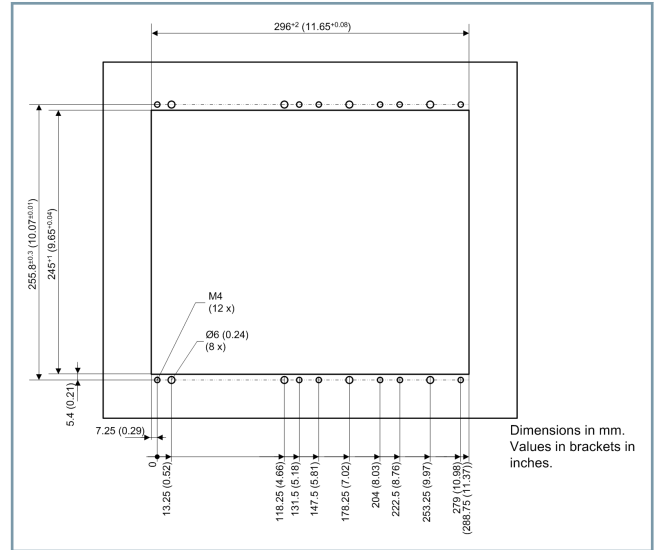

Figure 6.3/3 Cut-Out Widths and Drilling Pattern – 2/3 Device, 1st Device Row

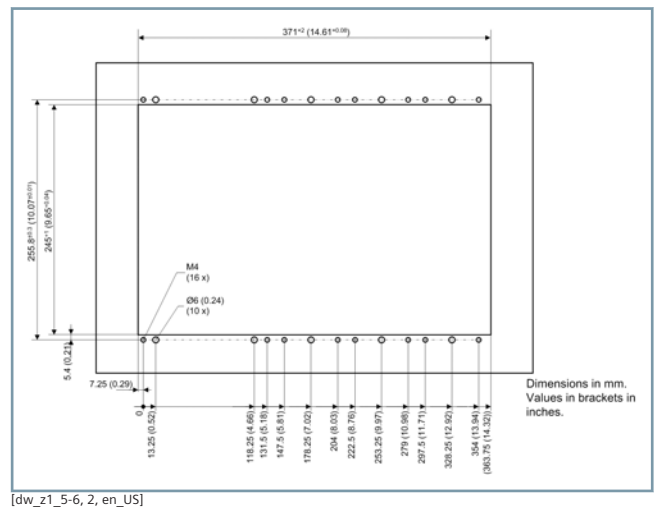
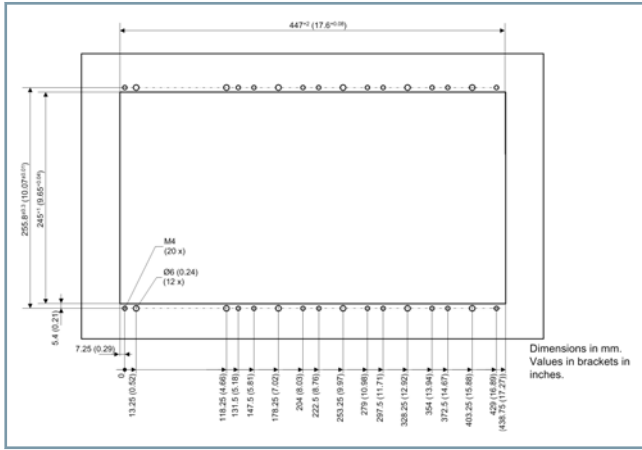

Figure 6.3/4 Cut-Out Widths and Drilling Pattern – 5/6 Device, 1st Device Row

Appendix

Assembly Dimensions



[dw_z1_1-1, 3, en_US]

Figure 6.3/5 Cut-Out Widths and Drilling Pattern – 1/1 Device, 1st Device Row

All drillings in the area of the specific device cut-out widths (see [Table 6.3/1](#)) must comply with the dimensions in the corresponding figures.

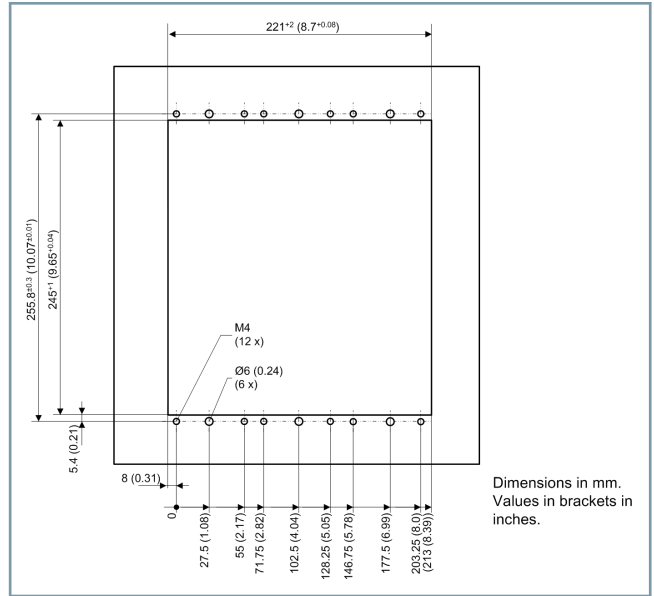

[dw_z2_3-6, 2, en_US]

Figure 6.3/7 Cut-Out Widths and Drilling Pattern – 1/2 Device, 2nd Device Row

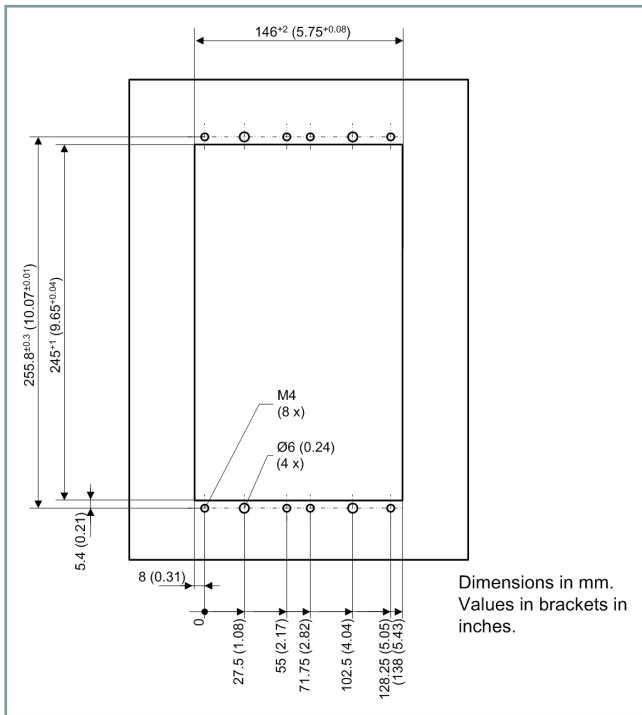

[dw_z2_2-6, 2, en_US]

Figure 6.3/6 Cut-Out Widths and Drilling Pattern – 1/3 Device, 2nd Device Row

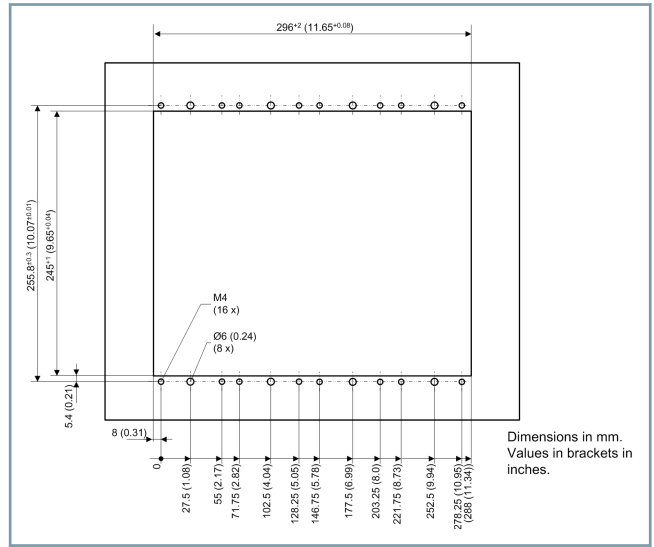

[dw_z2_4-6, 2, en_US]

Figure 6.3/8 Cut-Out Widths and Drilling Pattern – 2/3 Device, 2nd Device Row

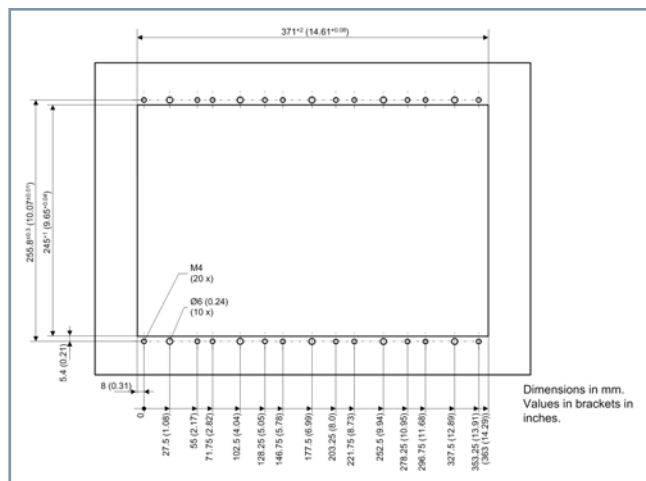

[dw_z2_5-6, 2, en_US]

Figure 6.3/9 Cut-Out Widths and Drilling Pattern – 5/6 Device, 2nd Device Row

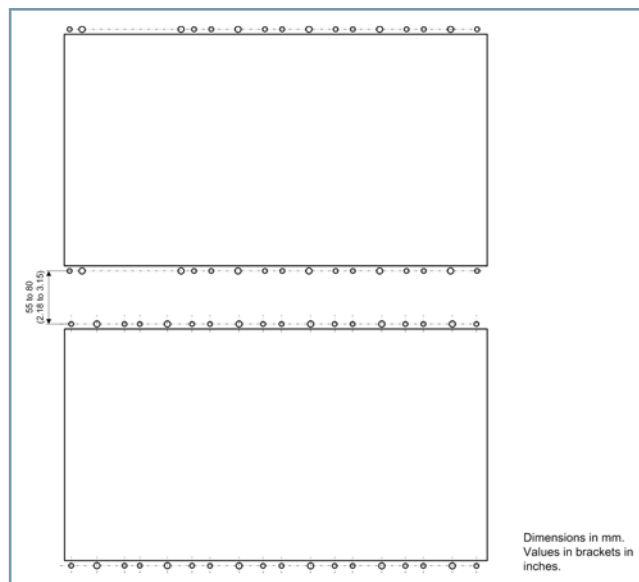

[dw_first and second device row, 1, en_US]

Figure 6.3/11 Drilling Pattern – 1/1 Devices, 1st and 2nd Device Row

Siemens recommends a drilling space of at least 55 mm (2.17 in) between the 1st and 2nd device row. Due to the connecting-cable length, the maximum space may be approx. 80 mm (3.15 in). The length of the cable is 890 mm (35.04 in) from the center of the plug to the center of the plug.

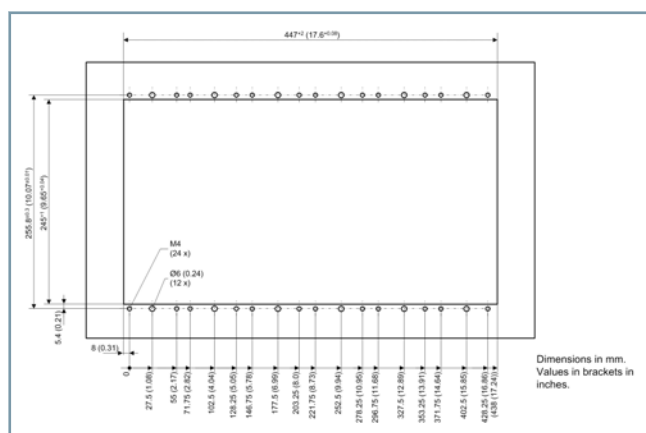

[dw_z2_6-6, 3, en_US]

Figure 6.3/10 Cut-Out Widths and Drilling Pattern – 1/1 Device, 2nd Device Row

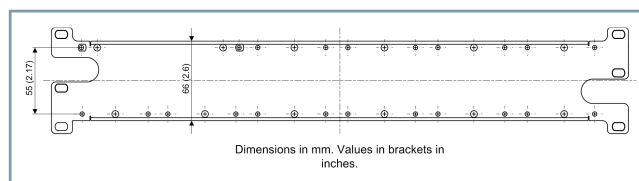

[dw_angle rail, 1, en_US]

Figure 6.3/12 Angle Rail for Connection of the 1st and 2nd Device Row

	Width of the Assembly Opening in mm (in Inches)
1/3 device (base module)	146 ⁺² mm (5.75 ^{+0.08})
1/2 device (base module with one expansion module)	221 ⁺² mm (8.7 ^{+0.08})
2/3 device (base module with 2 expansion modules)	296 ⁺² mm (11.65 ^{+0.08})
5/6 device (base module with 3 expansion modules)	371 ⁺² mm (14.61 ^{+0.08})
1/1 device (base module with 4 expansion modules)	447 ⁺² mm (17.6 ^{+0.08})

Table 6.3/1 Cut-Out Widths

	Dimension a Housing Widths in mm (in Inches) (Total Width: Housing Width + 4.6 mm (0.18 in))
1/3 device	145 (5.71)
1/2 device	220 (8.66)
2/3 device	295 (11.61)

Appendix

Assembly Dimensions

Dimension a	
Housing Widths in mm (in Inches)	
(Total Width: Housing Width + 4.6 mm (0.18 in))	
5/6 device	370 (14.57)
1/1 device	445 (17.52)

Table 6.3/2 Variable Housing Widths

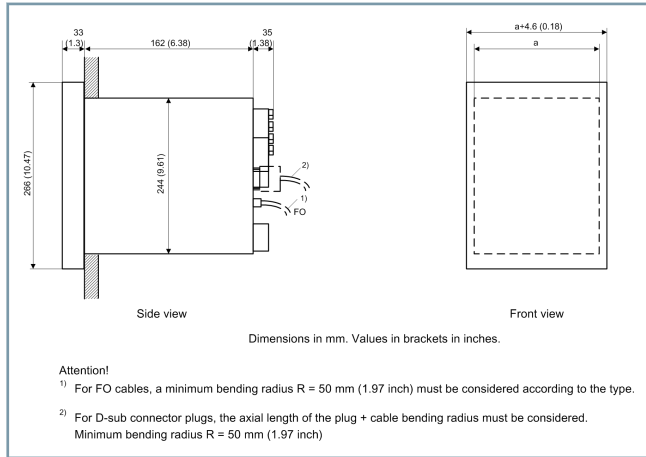

[dw_surface_mounting_in_2, en_US]

Figure 6.3/13 Flush-Mounting Devices, Dimensions from the Side and Front Views

Surface-Mounted Devices with Detached On-Site Operation Panel

You can find more information on the drilling patterns for the devices in section [Surface-Mounted Devices with Integrated On-Site Operation Panel \(Modular Device\)](#), Page 433.

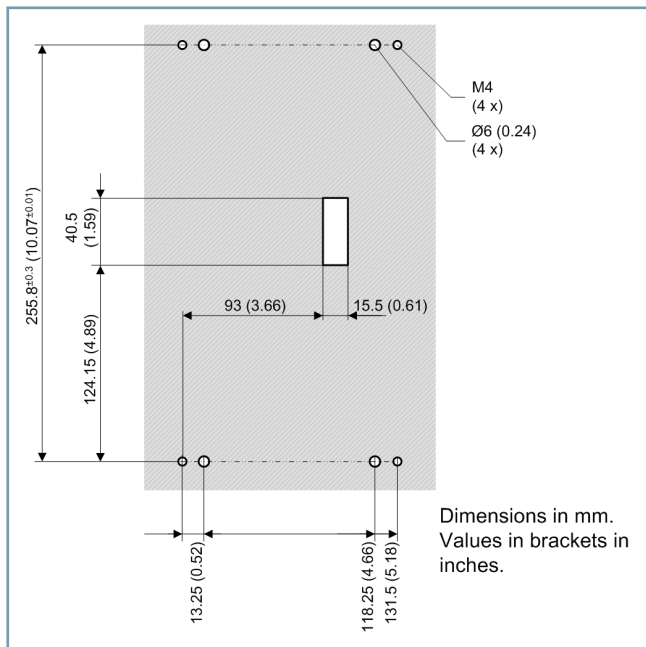

[dw_z1_osop_1-3, 1, en_US]

Figure 6.3/14 Drilling Pattern of the On-Site Operation Panel of the 1/3 Device

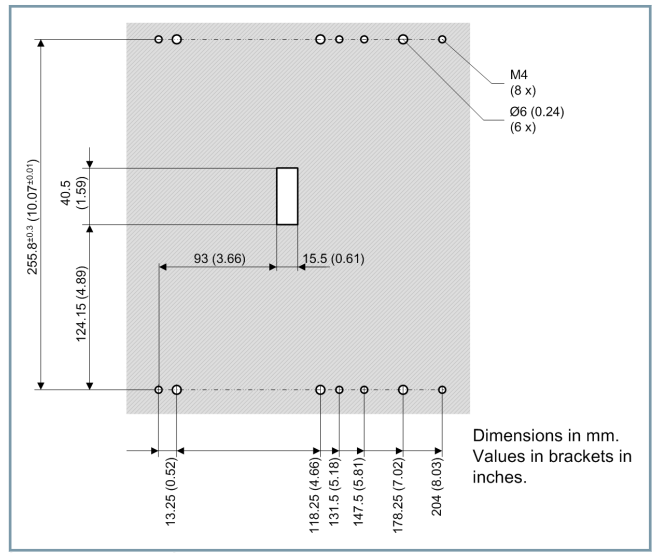

[dw_z1_osop_1-2, 1, en_US]

Figure 6.3/15 Drilling Pattern of the On-Site Operation Panel of the 1/2 Device

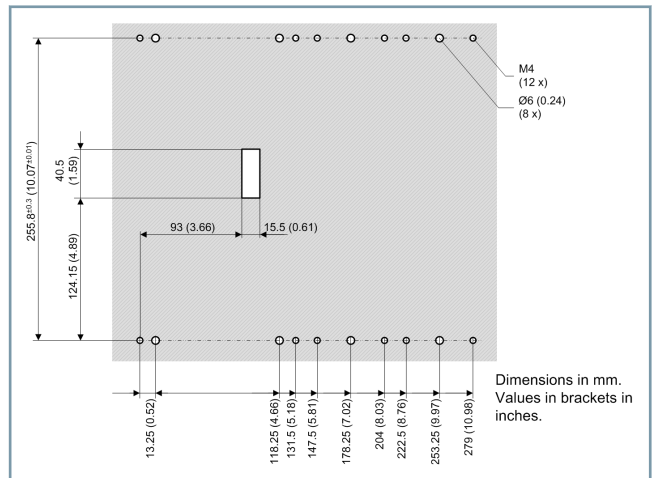

[dw_z1_osop_2-3, 1, en_US]

Figure 6.3/16 Drilling Pattern of the On-Site Operation Panel of the 2/3 Device

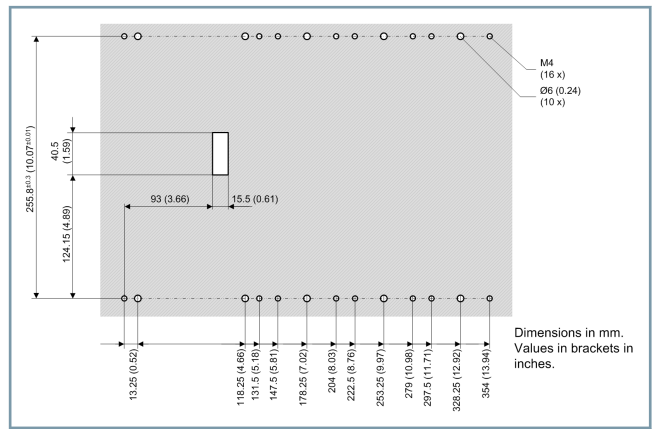

[dw_z1_osop_5-6, 1, en_US]

Figure 6.3/17 Drilling Pattern of the On-Site Operation Panel of the 5/6 Device

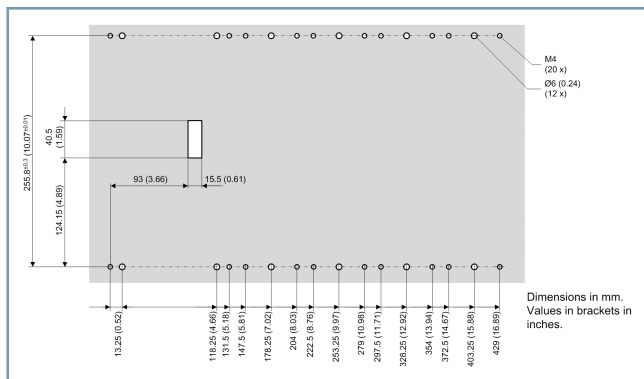

[dw_z1_osop_1-1, en_US]

Figure 6.3/18 Drilling Pattern of the On-Site Operation Panel of the 1/1 Device

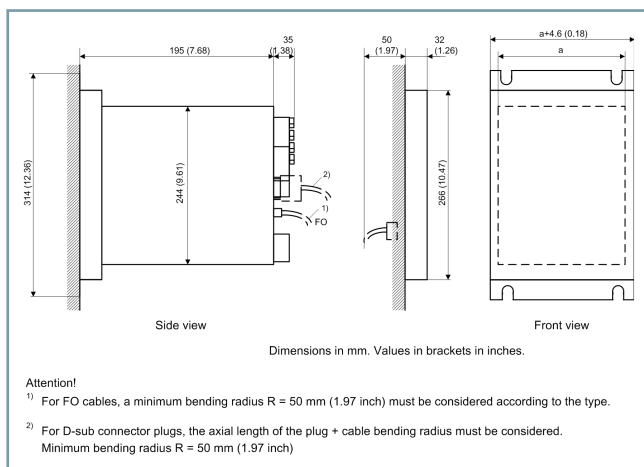

[dwsopab-070211-01.tif, 3, en_US]

Figure 6.3/19 Surface-Mounted Device with Detached On-Site Operation Panel, Dimensions in the Side and Front Views

Refer to [Table 6.3/2](#) for the variable dimension a.

The drilling patterns correspond to the figures [Figure 6.3/23](#) to [Figure 6.3/32](#).

The cable length for the detached operation panel is up to 5 m (196.85 in).



NOTE

Cables with a length of 5 m (196.85 in) are only specified for PCs and laptop computers with a USB2 connection. These cables are not specified for PCs and laptop computers with a USB3 connection.

Cables with a length of 2.5 m (98.43 in) are specified for USB2 and USB3 connections.

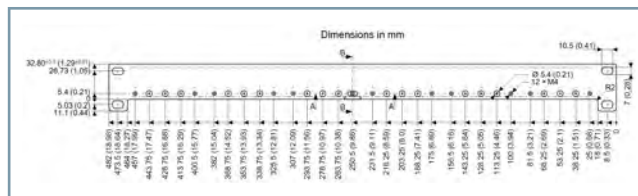

[dw_angel-bracket_without_relief-cutouts, 1, en_US]

Figure 6.3/20 Angle Rail with Assembly Dimensions

Surface-Mounted Devices with Integrated On-Site Operation Panel (Non-Modular Device)

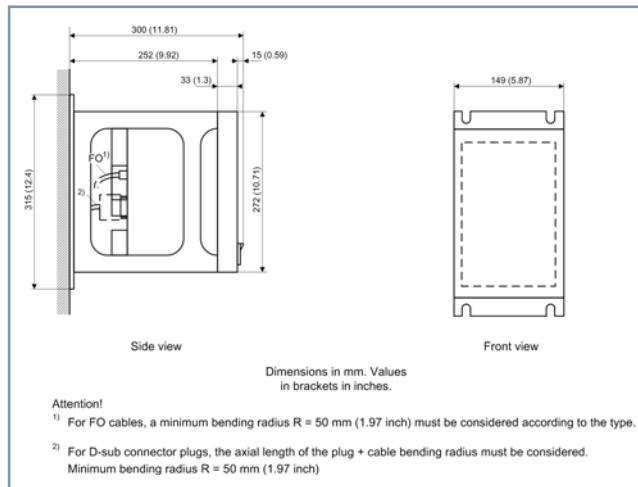

[dw_console side view.vsd, 3, en_US]

Figure 6.3/21 Non-Modular Surface-Mounted Device with Integrated On-Site Operation Panel, Dimensions from the Side and Front Views

Surface-Mounted Devices with Integrated On-Site Operation Panel (Modular Device)

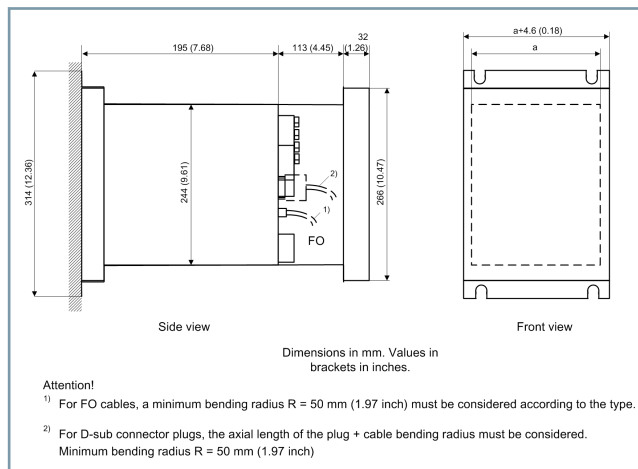

[dwsopin-070211-01.tif, 3, en_US]

Figure 6.3/22 1/3 Surface-Mounted Device with Integrated On-Site Operation Panel, Dimensions in the Side and Front Views

Appendix

Assembly Dimensions



NOTE

For surface-mounted devices, make sure that the drillings fit for a screw of the size M6.

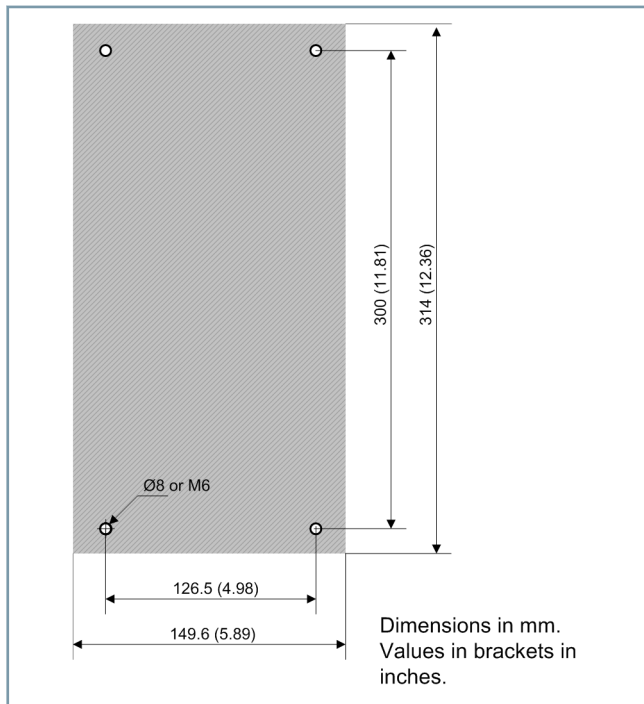

[dwbohrge-1_3_vsd, 2, en_US]

Figure 6.3/23 Drilling Pattern of a 1/3 Surface-Mounted Device – 1st Device Row

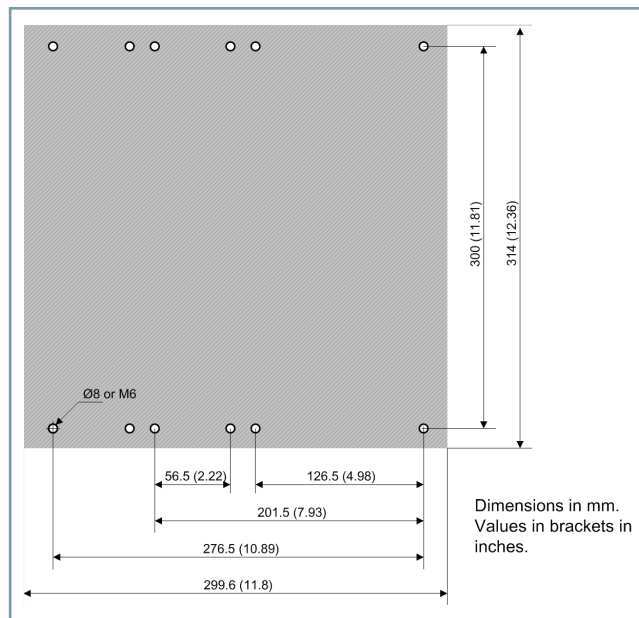

[dwbohrge-2_3_vsd, 2, en_US]

Figure 6.3/25 Drilling Pattern of a 2/3 Surface-Mounted Device – 1st Device Row

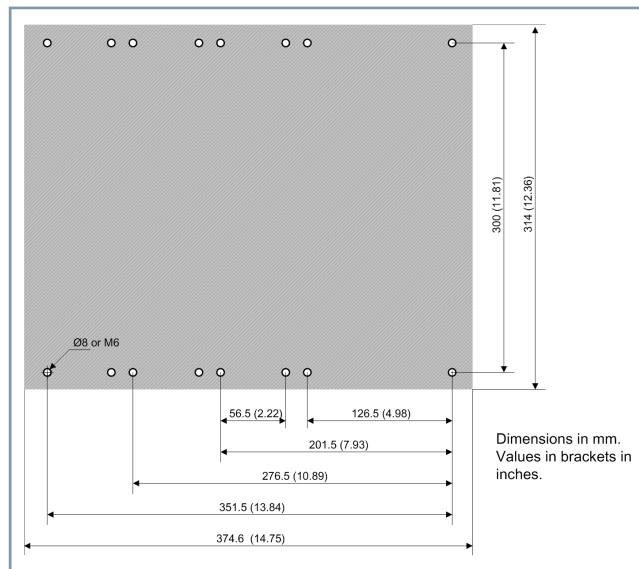

[dwbohrge-5_6_vsd, 2, en_US]

Figure 6.3/26 Drilling Pattern of a 5/6 Surface-Mounted Device – 1st Device Row

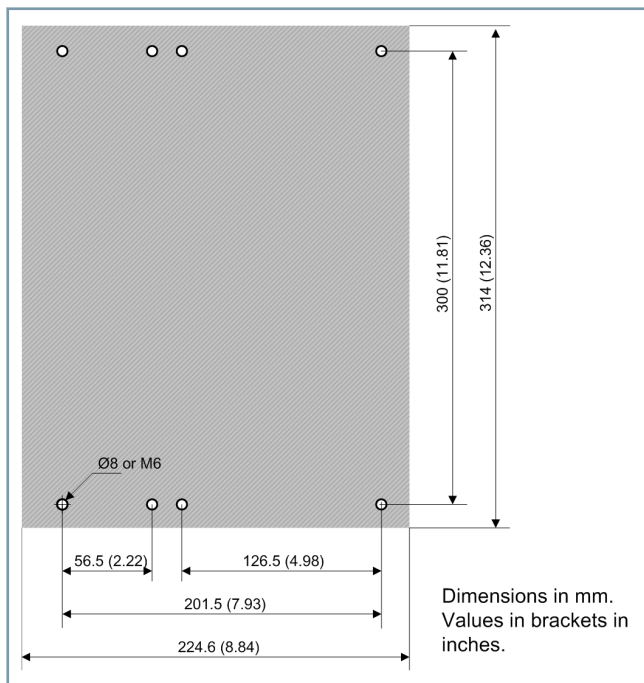

[dwbohrge-1_2_vsd, 2, en_US]

Figure 6.3/24 Drilling Pattern of a 1/2 Surface-Mounted Device – 1st Device Row

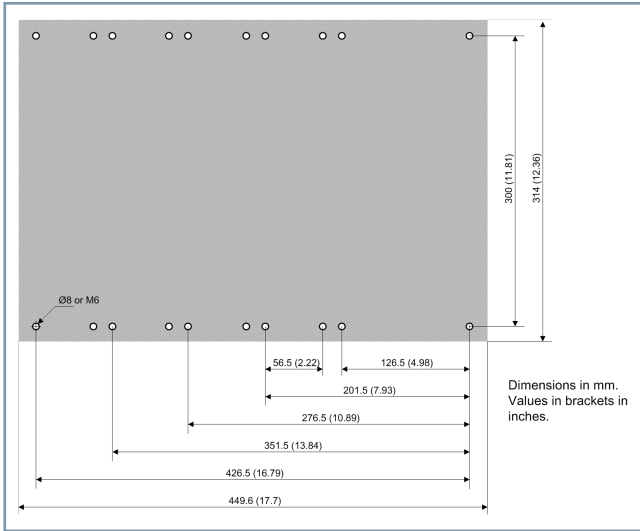

[dwbohrge-070211-01.tif, 3, en_US]

Figure 6.3/27 Drilling Pattern of a 1/1 Surface-Mounted Device – 1st Device Row

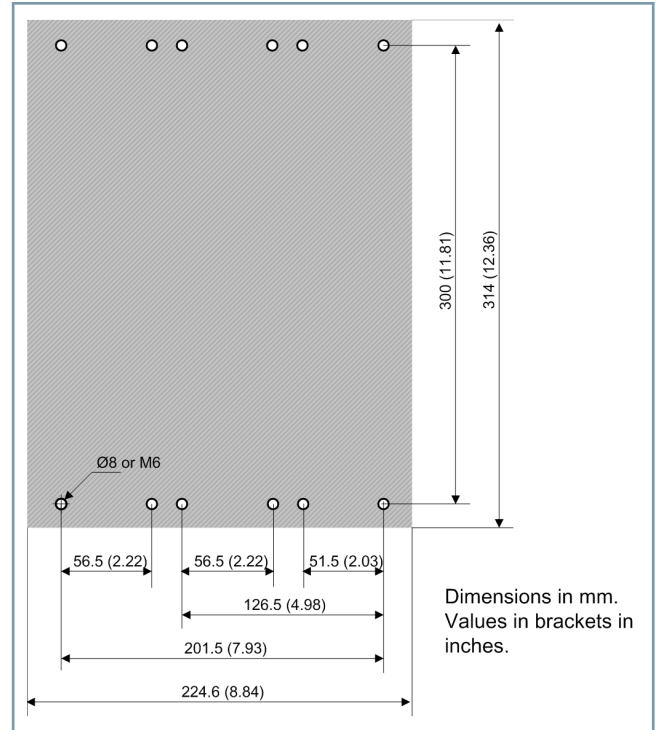

[dw_z2_bohr_1-2.vsd, 2, en_US]

Figure 6.3/29 Drilling Pattern of a 1/2 Surface-Mounted Device – 2nd Device Row

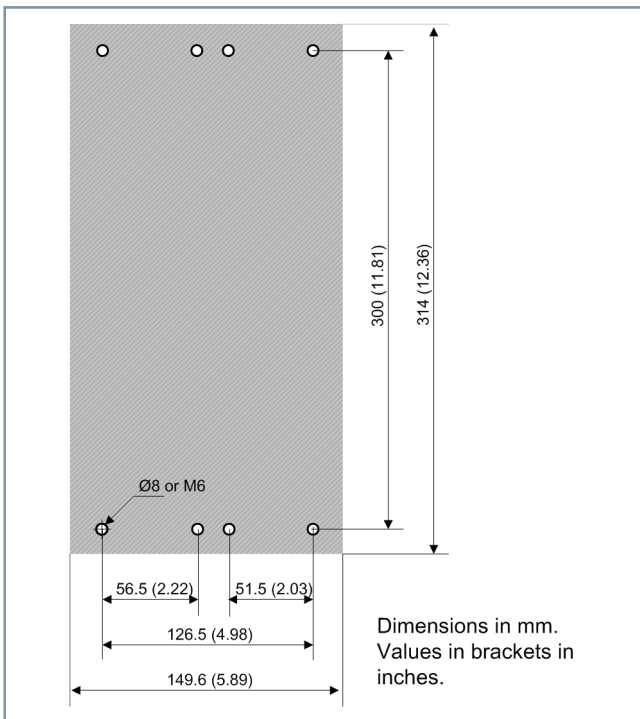

[dw_z2_bohr_1-3.vsd, 2, en_US]

Figure 6.3/28 Drilling Pattern of a 1/3 Surface-Mounted Device – 2nd Device Row

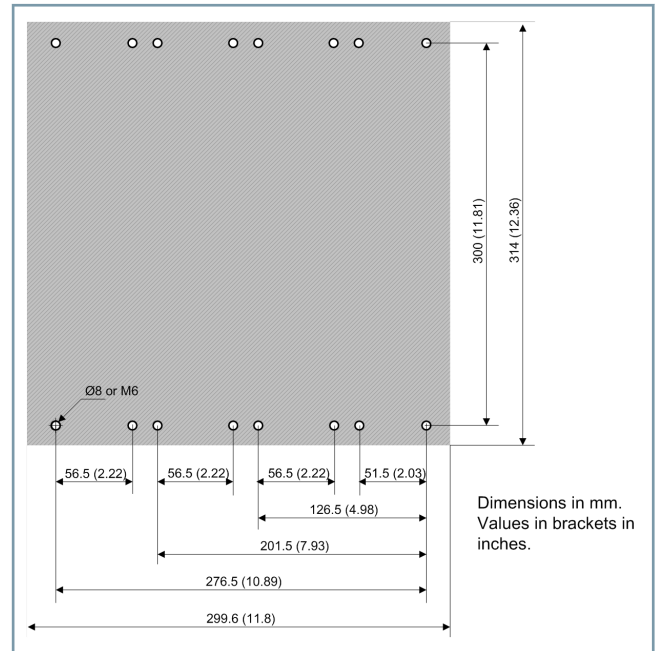

[dw_z2_bohr_2-3.vsd, 2, en_US]

Figure 6.3/30 Drilling Pattern of a 2/3 Surface-Mounted Device – 2nd Device Row

Measured Value	Description
Grouping of Base Measured Values	
Operational measured values	<p>RMS value calculation and power calculation as per the definition</p> <p>Phase currents I_A, I_B, I_C</p> <p>Ground current I_N, I_{NS} (sensitive)</p> <p>Phase-to-ground voltages V_A, V_B, V_C</p> <p>Phase-to-phase voltages V_{AB}, V_{BC}, V_{CA}</p> <p>Residual voltage V_{NG}</p> <p>Frequency f</p> <p>Power P, Q, S (3-phase and phase-specific)</p> <p>Power factor f</p>
Fundamental and symmetrical components	<p>Calculation of phasor variables with Fourier filter or according to transformation rule</p> <p>Phase currents $\underline{I}_A, \underline{I}_B, \underline{I}_C$</p> <p>Ground current $\underline{I}_N, \underline{I}_{NS}$ (sensitive)</p> <p>Phase-to-ground voltages $\underline{V}_A, \underline{V}_B, \underline{V}_C$</p> <p>Phase-to-phase voltages $\underline{V}_{AB}, \underline{V}_{BC}, \underline{V}_{CA}$</p> <p>Residual voltage \underline{V}_{NG}</p> <p>Symmetrical components $\underline{I}_0, \underline{I}_1, \underline{I}_2, \underline{V}_0, \underline{V}_1, \underline{V}_2$</p>
Protection-specific measured values	<p>Measured values that are especially calculated for individual protection functions, such as:</p> <p>Distance protection (reactances and resistances of conductor loops)</p> <p>Differential protection (differential and restraint current, charging currents per phase)</p> <p>...</p>
Energy values	<p>Metered values are determined for active and reactive energy. Restore time, restore interval and counting mode are adjustable. Restoring can also be initiated via a binary input. The following metered values are available:</p> <p>Active energy W_{p+} (release), W_{p-} (uptake)</p> <p>Reactive energy W_{q+} (release), W_{q-} (uptake)</p>
Statistical values	<p>The following statistical values are formed as follows:</p> <p>Total number of initiated trippings of the circuit breaker</p> <p>Number of initiated trippings of the circuit breaker, separated per switch pole</p> <p>Total sum of primary breaking currents</p> <p>Sum of the primary breaking currents, separated for each switch pole</p>
Grouping of Advanced Measured Values	
Mean values	<p>Mean values can be calculated on the basis of the operational measured values and the symmetrical components. The time slot for demand calculation and the output interval are parameterizable.</p>
Minimum values and maximum values	<p>The minimum/maximum values can be generated on the basis of operational measured values, symmetrical components, and selected measured values (for example, from mean values). The display of minimum and maximum values contains the time of their occurrence. The calculation is stabilized against smaller value fluctuations in currents and voltages.</p>

Appendix

Technical Data – Analog Inputs

The following is an extract from the technical data for SIPROTEC 5. You can find more information in the current manual **SIPROTEC 5 Description Hardware** under www.siemens.com/siprotec.

Voltage Input

All current, voltage, and power data are specified as RMS values.		
Rated frequency f_{rated}	50 Hz, 60 Hz 16.7 Hz (for rail devices only)	
Input and output modules	IO102, IO202, IO208, IO211, IO214	IO215
Measuring range	0 V to 200 V	0 V to 7.07 V
Burden	< 0.1 VA	< 0.01 VA
Thermal rating	230 V continuously	20 V continuously

Measuring-Transducer Inputs (via Module ANAI-CA-4EL)

Insulation class	SELV (Safety Extra Low Voltage) (according to IEC 60255-27)	
Connector type	8-pin terminal spring	
Differential current input channels	4	
Measuring range	DC -25.6 mA to +25.6 mA	
Fault	< 0.5 % of the measuring range	
Input impedance	140 Ω	
Conversion principle	Delta-sigma (16 bit)	
Permissible potential difference between channels	DC 20 V	
Galvanic separation from ground/housing	DC 700 V	
Permissible overload	DC 100 mA continuously	
Measured-value repetition	200 ms	

Inputs for Optical Sensors for Arc Protection (via Module ARC-CD-3FO)

Connector type	AVAGO AFBR-4526Z
Number of transceivers	3
Fiber type	Plastic Optical Fiber (POF) 1 mm
Receiver	
Maximum	-10 dBm \pm 2 dBm
Minimum	-40 dBm \pm 2 dBm
Spectrum	400 nm to 1100 nm
Attenuation	In the case of plastic optical fibers, you can expect a path attenuation of 0.2 dB/m. Additional attenuation comes from the plug and sensor head.
Optical budget ³⁷	Minimal 25 dB
Analog sampling rate	16 kHz
ADC type	10-bit successive approximation
Transmitter	
Type	LED

Wavelength	$\lambda = 650 \text{ nm}$
Transmitter power	Minimum 0 dBm Maximum 2 dBm
Numerical aperture	0.5 ³⁸
Signal rate connection test	1 pulse per second
Pulse duration connection test	11 μs

³⁷ All values in combination with sensors approved by Siemens.

³⁸ Numerical aperture (NA = $\sin \theta$ (launch angle))

Integrated Power Supply			
For modular devices, the following modules contain a power supply: PS201 – Power supply of the base module and of the 1st device row PS203 – Power supply of the 2nd device row PS204 – Redundant power supply CB202 – Plug-in module assembly with integrated power supply, for example, to accommodate communication modules			
Permissible voltage ranges (PS201, PS203, PS204, CB202)	DC 19 V to DC 60 V	DC 48 V to DC 300 V AC 80 V to AC 265 V, 50 Hz/60 Hz	
Auxiliary rated voltage V_H (PS201, PS203, PS204, CB202)	DC 24 V/DC 48 V	DC 60 V/DC 110 V/DC 125 V/DC 220 V/ DC 250 V or AC 100 V/AC 115 V/AC 230 V, 50 Hz/60 Hz	
Permissible voltage ranges (PS101) Only for non-modular devices	DC 19 V to DC 60 V	DC 48 V to 150 V	DC 88 V to DC 300 V AC 80 V to AC 265 V, 50 Hz/60 Hz
Auxiliary rated voltage V_H (PS101) Only for non-modular devices	DC 24 V/DC 48 V	DC 60 V/DC 110 V/ DC 125 V	DC 110 V/ DC 125 V/ DC 220 V/DC 250 V or AC 100 V/AC 115 V/ AC 230 V, 50 Hz/60 Hz
Superimposed alternating voltage, peak-to-peak, IEC 60255-11, IEC 61000-4-17	≤ 15 % of the DC auxiliary rated voltage (applies only to direct voltage)		
Inrush current	≤ 18 A		
Recommended external protection	Miniature circuit breaker 6 A, characteristic C according to IEC 60898		
Internal fuse			
–	DC 24 V to DC 48 V	DC 60 V to DC 125 V	DC 24 V to DC 48 V AC 100 V to AC 230 V
PS101 Only for non-modular devices	4 A inert, AC 250 V, DC 150 V, UL recognized SIBA type 179200 or Schurter type SPT 5x20	2 A time-lag, AC 250 V, DC 300 V, UL recognized SIBA type 179200 or Schurter type SPT 5x20	

Integrated Power Supply			
PS201, PS203, CB202 (to device version xA)	4 A inert, AC 250 V, DC 150 V, UL recognized SIBA type 179200 or Schurter type SPT 5x20	2 A time-lag, AC 250 V, DC 300 V, UL recognized SIBA type 179200 or Schurter type SPT 5x20	
PS201, PS203, PS204 (Device version xB and higher)	4 A inert, AC 250 V, DC 150 V, UL recognized SIBA type 179200 or Schurter type SPT 5x20	3.15 A time-lag, AC 250 V, DC 300 V, UL recognized SIBA type 179200 or Schurter type SPT 5x20	
Power consumption (life relay active)			
–	DC	AC 230 V/50 Hz	AC 115 V/50 Hz
1/3 module, non-modular Without plug-in modules	7 W	16 VA	12.5 VA
1/3 base module, modular Without plug-in modules	13 W	55 VA	40 VA
1/6 expansion module	3 W	6 VA	6 VA
1/6 plug-in module assembly without plug-in modules (modules CB202)	3.5 W	14 VA	7 VA
Plug-in module for base module or plug-in module assembly (for example, communication module)	< 5 W	< 6 VA	< 6 VA
Stored-energy time for auxiliary voltage outage or short circuit, modular devices IEC 61000-4-11 IEC 61000-4-29	For $V \geq$ DC 24 V \geq 50 ms For $V \geq$ DC 110 V \geq 50 ms For $V \geq$ AC 115 V \geq 50 ms		
Stored-energy time for auxiliary voltage outage or short circuit, non-modular devices IEC 61000-4-11 IEC 61000-4-29	For $V \geq$ DC 24 V \geq 20 ms For $V \geq$ DC 60 V \geq 50 ms For $V \geq$ AC 115 V \geq 200 ms		

Appendix

Technical Data – Binary Inputs

Standard Binary Input

Rated voltage range	DC 24 V to 250 V The binary inputs of SIPROTEC 5 are bipolar, with the exception of the binary inputs on the modules IO230, IO231, and IO233.	
Current consumption, excited	Approx. DC 0.6 mA to 2.5 mA (independent of the control voltage)	
Power consumption, max.	0.6 W	
Pickup time	Approx. 3 ms	
Dropout time ³⁹	Capacitive load (supply-line capacitance)	Dropout time
	< 5 nF	< 4 ms
	< 10 nF	< 6 ms
	< 50 nF	< 10 ms
Control voltage for all modules with binary inputs, except module IO233	Adapt the binary-input threshold to be set in the device to the control voltage.	
	Range 1 for 24 V, 48 V, and 60 V Control voltage	$V_{\text{low}} \leq \text{DC } 10 \text{ V}$ $V_{\text{high}} \geq \text{DC } 19 \text{ V}$
	Range 2 for 110 V and 125 V Control voltage	$V_{\text{low}} \leq \text{DC } 44 \text{ V}$ $V_{\text{high}} \geq \text{DC } 88 \text{ V}$
	Range 3 for 220 V and 250 V Control voltage	$V_{\text{low}} \leq \text{DC } 88 \text{ V}$ $V_{\text{high}} \geq \text{DC } 176 \text{ V}$
Control voltage for binary inputs of the IO233 module	Range for 125 V Control voltage	$V_{\text{low}} \leq \text{DC } 85 \text{ V}$ $V_{\text{high}} \geq \text{DC } 105 \text{ V}$
Maximum permitted voltage	DC 300 V	
The binary inputs contain interference suppression capacitors. To ensure EMC immunity, use the terminals shown in the terminal diagrams/connection diagrams to connect the binary inputs to the common potential.		

³⁹ For time-critical applications with low-active signals, consider the specified dropout times. If necessary, provide for active discharge of the binary input (for example, a resistor in parallel to the binary input or using a change-over contact).

Standard Relay (Type S)

Making capacity	Max. 1000 W (L/R = 40 ms) Max. 3600 VA (power factor ≤ 0.35, 50 Hz to 60 Hz)
Breaking capacity	Max. 30 W (L/R = 40 ms) Max. 360 VA (power factor ≤ 0.35, 50 Hz to 60 Hz)
AC and DC contact voltage	250 V
Permissible current per contact (continuous)	5 A
Permissible current per contact (switching on and holding)	30 A for 1 s (make contact)
Short-time current across closed contact	250 A for 30 ms
Total permissible current for contacts connected to common potential	5 A
Switching time OOT (Output Operating Time)	Make time: typical: 8 ms; maximum: 10 ms
Additional delay of the output medium used	Break time: typical: 2 ms; maximum: 5 ms
Max. rated data of the output contacts in accordance with UL certification	DC 24 V, 5 A, General Purpose DC 48 V, 0.8 A, General Purpose DC 240 V, 0.1 A, General Purpose AC 240 V, 5 A, General Purpose AC 120 V, 1/6 hp AC 250 V, 1/2 hp B300 R300
Interference suppression capacitors across the contacts	4.7 nF, ± 20 %, AC 250 V

Fast Relay (Type F)

Making capacity	Max. 1000 W (L/R = 40 ms) Max. 3600 VA (power factor ≤ 0.35, 50 Hz to 60 Hz)
Breaking capacity	Max. 30 W (L/R = 40 ms) Max. 360 VA (power factor ≤ 0.35, 50 Hz to 60 Hz)
AC and DC contact voltage	250 V
Permissible current per contact (continuous)	5 A
Permissible current per contact (switching on and holding)	30 A for 1 s (make contact)
Short-time current across closed contact	250 A for 30 ms
Total permissible current for contacts connected to common potential	5 A
Switching time OOT (Output Operating Time)	Make time: typical: 4 ms; maximum: 5 ms
Additional delay of the output medium used	Break time: typical: 2 ms; maximum: 5 ms

Rated data of the output contacts in accordance with UL certification	DC 24 V, 5 A, General Purpose DC 48 V, 0.8 A, General Purpose DC 240 V, 0.1 A, General Purpose AC 120 V, 5 A, General Purpose AC 250 V, 5 A, General Purpose AC 250 V, 0.5 hp B300 R300
Interference suppression capacitors across the contacts	4.7 nF, ± 20 %, AC 250 V
Supervision	2-channel activation with cyclic testing (only for make contact)

High-Speed Relay with Semiconductor Acceleration (Type HS)

Making capacity	Max. 2500 W (L/R = 40 ms) Max. 3600 VA (power factor ≤ 0.35, 50 Hz to 60 Hz)
Breaking capacity	Max. 2500 W (L/R = 40 ms) Max. 360 VA (power factor ≤ 0.35, 50 Hz to 60 Hz)
Contact voltage	AC 200 V, DC 250 V
Permissible current per contact (continuous)	5 A (according to UL certification) 10 A (no UL certification; AWG 14 / 2.5-mm ² (0.0039-in ²) copper conductors necessary)
Permissible current per contact (switching on and holding)	30 A for 1 s (make contact)
Short-time current across closed contact	250 A for 30 ms
Switching time OOT (Output Operating Time)	Make time, typical: 0.2 ms; maximum: 0.2 ms
Additional delay of the output medium used	Break time, typical: 9 ms; maximum: 9 ms
Rated data of the output contacts in accordance with UL certification	B150 Q300

Power Relay (for Direct Control of Motor Switches)

Switching power for permanent and periodic operation		
250 V/4.0 A	1000 W	In order to prevent any damage, the external protection circuit must switch off the motor in case the rotor is blocked.
220 V/4.5 A	1000 W	
110 V/5.0 A	550 W	
60 V/5.0 A	300 W	
48 V/5.0 A	240 W	
24 V/5.0 A	120 W	
Turn on switching power for 30 s, recovery time until switching on again is 15 minutes.		
For short-term switching operations, an impulse/pause ratio of 3 % must be considered.		

Appendix

Technical Data – Relay Outputs

100 V/9.0 A	1000 W	Continuous and inching operation is not permitted. In order to prevent any damage, the external protection circuit must switch off the motor in case the rotor is blocked.
60 V/10.0 A	600 W	
48 V/10.0 A	480 W	
24 V/10.0 A	240 W	
AC and DC contact voltage		250 V
Permissible continuous current per contact		5 A
Permissible current per contact (switching on and holding)		30 A for 1 s
Short-time current across closed contact		250 A for 30 ms
Total permissible current for contacts connected to common potential		5 A
Switching time OOT (Output Operating Time)		≤ 16 ms
Additional delay of the output medium used		
Rated data of the output contacts in accordance with UL certification		DC 300 V, 4.5 A – 30 s ON, 15 min OFF DC 250 V, 1 hp motor – 30 s ON, 15 min OFF DC 110 V, 3/4 hp motor – 30 s ON, 15 min OFF DC 60 V, 10 A, 1/2 hp motor – 30 s ON, 15 min OFF DC 48 V, 10 A, 1/3 hp motor – 30 s ON, 15 min OFF DC 24 V, 10 A, 1/6 hp motor – 30 s ON, 15 min OFF
Interference suppression capacitors across the contacts		4.7 nF, ± 20 %, AC 250 V
The power relays operate in interlocked mode, that is, only one relay of each switching pair picks up at a time thereby avoiding a power-supply short circuit.		

Base Module

Status	Color	Quantity
RUN	Green	1
ERROR	Red	1
Routable (adjustable with DIGSI 5) Only the defined color can be used in operation.	2-colored: red or green	16

Expansion Module

Status	Color	Quantity
Routable	Red	16 optional

Appendix

Technical Data – Communication Interfaces

User Interface, Front Side

You can find a USB connection of type B for the connection to a laptop computer or to a PC on the front side of the device. A protection cover protects this USB connection against pollution and humidity.

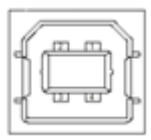
USB	User interface
Connection	USB type B
	
Insulation class	PELV (Protective Extra Low Voltage) (according to IEC 60255-27)

Time-Synchronization Interface (Port G)

The terminal for time synchronization is located on the D-sub 9 interface (position G). Time synchronization signals for DC 5 V, DC 12 V, and DC 24 V can be processed as an option.

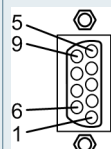
Time Synchronization	External synchronization sources, for example, DCF77 IRIG B signal
Connection	Rear D-sub 9
	
Rated signal voltages	DC 5 V, DC 12 V, or DC 24 V (optional)
Test voltage	AC 500 V at 50 Hz
Insulation class	SELV (according to IEC 60255-27)
Max. line length	10 m (0.39 in)

On-Site Operation Panel for Surface-Mounting Housing (Port H) (Available only for Modular Devices)

The terminal for the on-site operation panel of surface-mounted devices is located on the D-sub 15 interface (position H). The on-site operation panel of surface-mounted devices with integrated or detached on-site operation panel is connected to this interface.

User interface	Detached on-site operation panel
Connection	On the rear side D-sub 15
	
Insulation class	PELV (according to IEC 60255-27)

Integrated Ethernet Interface (Port J)

This terminal is used to load the device with DIGSI 5 using Ethernet. This terminal also enables IEC 61850 Ethernet communication or communication with another protocol via Ethernet, for example, for connecting an external RTD unit.

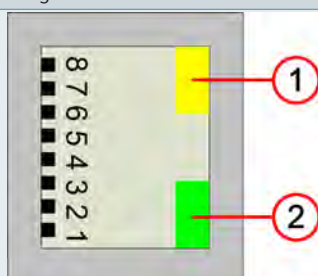
Interface	Integrated Ethernet interface
Connection	 (1) LED 1: Yellow (2) LED 2: Green
Connector type	1 x RJ45
Baud rate	100 Mbit/s
Max. line length	20 m with Ethernet patch cable CAT 6 S/FTP, F/FTP, or SF/FTP
Insulation class	SELV (acc. to IEC 60255-27)
Interface design	Corresponds to IEEE 802.3, 100Base-TX

Electrical Tests

Standards

IEC 60255 (product standard)

IEEE Std C37.90

UL 508

Additional standards are listed for the individual tests.

Voltage-Immunity and Safety Tests

Standards	IEC 60255-27
Voltage test (routine test), current measurement inputs, voltage measurement inputs, relay outputs	AC 2.5 kV 50 Hz
Voltage test (routine test), Auxiliary voltage, binary inputs	DC 3.5 kV
Voltage test (routine test), only isolated communication and time-synchronization interfaces and analog inputs (module position E, F, M, N, and P)	DC 700 V
Surge immunity test (type testing), all circuits except communication and time-synchronization interfaces and analog inputs, class III	5 kV (peak value) 1.2 μs/50 μs 0.5 J 3 positive and 3 negative impulses at intervals of 1 s
Insulation resistance	> 100 MΩ @ DC 500 V
Resistor of protective-equipotential-bonding	< 0.1 Ω @ DC 12 V, 30 A after 1 min.

EMC Immunity Tests (Type Tests, Test under Mounting Conditions)

Standards	IEC 60255-1 and -26 (product standards) EN 61000-6-2 (generic standard)
Electrostatic discharge test IEC 61000-4-2	Contact discharge: <ul style="list-style-type: none"> • Front-side modular and non-modular devices 8 kV • Rear panel modular devices 8 kV • Rear panel non-modular devices 6 kV Air discharge 15 kV Both polarities 150 pF Ri = 330 Ω
Radiated electromagnetic field immunity Frequency sweep IEC 61000-4-3	20 V/m, 80 MHz to 1 GHz 10 V/m, 1 GHz to 6 GHz 80 % AM 1 kHz

Radiated electromagnetic field immunity Spot frequencies IEC 61000-4-3	20 V/m, 80 MHz/160 MHz/380 MHz/450 MHz/900 MHz 10 V/1.85 GHz/2.15 GHz 80 % AM 1 kHz Dwell time ≥ 10 s	
Electrical fast transient/burst immunity IEC 61000-4-4	4 kV 5 ns/50 ns 5 kHz Burst length 15 ms Repetition rate 300 ms Both polarities Ri = 50 Ω Test duration ≥ 1 min	
High-energy surge voltages IEC 61000-4-5	Pulse: 1.2 μs/50 μs	
	Auxiliary voltage	Common mode: 4 kV, 12 Ω, 9 μF Differential mode: 2 kV, 2 Ω, 18 μF (device version xB and higher) Differential mode: 1 kV, 2 Ω, 18 μF (to device version xA) and non-modular devices
	Measuring inputs, binary inputs, and relay outputs	Common mode: 4 kV, 42 Ω, 0.5 μF Differential mode: 2 kV, 42 Ω, 0.5 μF or varistor
Conducted RF, amplitude-modulated IEC 61000-4-6	10 V, 150 kHz to 80 MHz, 80 % AM, 1 kHz	
Conducted RF, amplitude-modulated IEC 61000-4-6 Spot frequencies	27 MHz/68 MHz at 10 V, dwell time ≥ 10 s 80 % AM, 1 kHz	
Power frequency magnetic field immunity test IEC 61000-4-8	100 A/m (continuous) 1000 A/m for 3 s	
Pulsed magnetic field IEC 61000-4-9	1000 A/m, 8 μs/20 μs	

Appendix

Technical Data – Electrical and Mechanical Tests

Standard for Surge Withstand Capability (SWC) IEEE Std C37.90.1	2.5 kV (peak value) 1 MHz $\tau = 15 \mu\text{s}$ 400 impulses per s Test duration ≥ 10 s $R_i = 200 \Omega$ Common mode and differential mode test
Standard for Fast Transient Surge Withstand Capability IEEE Std C37.90.1 ⁴⁰	4 kV 5 ns/50 ns 5 kHz Burst length 15 ms Repetition rate 300 ms Both polarities $R_i = 50 \Omega$ Test duration 60 s Common mode and differential mode test
Standard for Withstand Capability or Relay Systems to Radiated Electromagnetic Interference from Transceivers (Keying test) IEEE Std C37.90.2	20 V/m 80 MHz to 1 GHz Pulse modulation (not valid for IO216)
Damped oscillatory wave immunity test IEC 61000-4-18	100 kHz, 1 MHz, 2.5 kV (peak value) 3 MHz, 10 MHz, 30 MHz, 2 kV (peak value) Test duration ≥ 60 s
Power-frequency disturbance variables at binary inputs IEC 61000-4-16	Zone A 150 V (differential mode) 300 V (common mode)

EMC Electromagnetic Emission Tests (Type Tests, Test under Mounting Conditions)

Standards	IEC 60255-26 (product standard) IEC 61000-6-4 (generic standard)
Conducted emission on auxiliary-voltage lines CISPR 22	150 kHz to 30 MHz limit class A
Radiated emission	CISPR 11 30 MHz to 1 000 MHz limit class A
	CISPR 22 1 GHz to 6 GHz limit class A

Loading effect in electricity-supply systems, harmonics Harmonic current emissions	Does not apply! (see EN 61000-3-2, section 7, power consumption < 75 W)
Loading effect in electricity-supply systems, voltage fluctuations Flicker	Does not apply! (see EN 61000-3-3, section 6, no significant voltage fluctuations)

Mechanical Tests

Vibration and Shock Stress in Stationary Use

Standards	IEC 60255-21 and IEC 60068
Vibration Test (sinusoidal) IEC 60255-21-1, class 2 ⁴¹ and IEC 60068-2-6	Sinusoidal 10 Hz to 60 Hz: ± 0.075 mm amplitude 60 Hz to 150 Hz: 10 m/s ² acceleration Frequency sweep 1 octave/min 20 cycles in 3 axes perpendicular to one another
Shock Test IEC 60255-21-2, class 1	Semi-sinusoidal Acceleration 50 m/s ² Duration 11 ms 3 shocks each in both directions of the 3 axes
Seismic Tests IEC 60255-21-3, class 2 and IEC 60068-3-3	Sinusoidal 3 Hz ⁴² to 35 Hz: Frequency sweep 1 octave/min 1 cycle in 3 axes perpendicular to one another 3 Hz to 8 Hz: ± 7.5 mm amplitude (horizontal axes) 3 Hz to 8 Hz: ± 3.5 mm amplitude (vertical axis) 8 Hz to 35 Hz: 20 m/s ² acceleration (horizontal axes) 8 Hz to 35 Hz: 10 m/s ² acceleration (vertical axis)

Vibration and Shock Stress During Transport

Standards	IEC 60255-21 and IEC 60068
Vibration Test (sinusoidal) IEC 60255-21-1, class 2 ⁴³ and IEC 60068-2-6	Sinusoidal 5 Hz to 8 Hz: ± 7.5 mm amplitude 8 Hz to 150 Hz: 20 m/s ² acceleration Frequency sweep 1 octave/min 20 cycles in 3 axes perpendicular to one another

⁴⁰ If a module ETH-BD-2FO is installed on a PS201 in the top slot (plug-in module position E in), the immunity for this module is currently restricted to 3.5 kV.

⁴¹ The non-modular devices in the assembly frame meet class 1.

⁴² For technical reasons, the frequency range is raised from 1 Hz to 3 Hz at the lower limit.

⁴³ The non-modular devices in the assembly frame meet class 1.

Shock Test IEC 60255-21-2, class 1 and IEC 60068-2-27	Semi-sinusoidal Acceleration 150 m/s ² Duration 11 ms 3 shocks each in both directions of the 3 axes
Continuous shock IEC 60255-21-2, class 1 and IEC 60068-2-27	Semi-sinusoidal Acceleration 100 m/s ² Duration 16 ms 1000 shocks each in both directions of the 3 axes

Appendix

Technical Data – Environmental Conditions – Approval

Temperatures

Type test, in operation (in compliance with IEC 60068-2-1 and IEC 60068-2-2, test Ad for 16 h and test Bd for 16 h)	-25 °C to +85 °C
Temporarily permissible during operation (tested for 96 h)	-25 °C to +70 °C Load conditions for the non-modular devices: With temperatures above 55 °C, no more than 50 % of the binary inputs and relay outputs per printed circuit board assembly are allowed to be continuously active. Readability of the display may be impaired below -10 °C and above +55 °C.
Recommended for uninterrupted duty (in compliance with IEC 60255-1)	-10 °C to +55 °C
Temperatures for continuous storage	-25 °C to +55 °C
Type test, transport and storage for 16 h	-40 °C to +85 °C

Heat-related limitations for the binary inputs on the IO216 input module (modular devices)		
Switching thresholds	Up to 55 °C	Up to 70 °C
220 V operating voltage	All 16 binary inputs usable for uninterrupted duty	10 binary inputs usable for uninterrupted duty

Heat-related limitations for the binary inputs on the IO230 input module (modular devices)			
Switching thresholds	Up to 40 °C	Up to 55 °C	Up to 70 °C
Range 1 for 24 V, 48 V, and 60 V operating voltage	All 48 binary inputs usable for uninterrupted duty	All 48 binary inputs usable for uninterrupted duty	All 48 binary inputs usable for uninterrupted duty
Range 2 for 110 V and 125 V operating voltage	All 48 binary inputs usable for uninterrupted duty	All 48 binary inputs usable for uninterrupted duty	36 binary inputs usable for uninterrupted duty (max. 3 in each group of 4 at the same time)
Range 3 for 220 V and 250 V operating voltage	36 binary inputs usable for uninterrupted duty (max. 3 in each group of 4 at the same time)	24 binary inputs usable for uninterrupted duty (max. 2 in each group of 4 at the same time)	12 binary inputs usable for uninterrupted duty (max. 1 in each group of 4 at the same time)

Heat-related limitations for the binary inputs on the IO231 input module (modular devices)			
Switching thresholds	Up to 40 °C	Up to 55 °C	Up to 70 °C
Range 1 for 24 V, 48 V, and 60 V operating voltage	All 24 binary inputs usable for uninterrupted duty	All 24 binary inputs usable for uninterrupted duty	All 24 binary inputs usable for uninterrupted duty
Range 2 for 110 V and 125 V operating voltage	All 24 binary inputs usable for uninterrupted duty	All 24 binary inputs usable for uninterrupted duty	18 binary inputs usable for uninterrupted duty (max. 3 in each group of 4 at the same time)
Range 3 for 220 V and 250 V operating voltage	18 binary inputs usable for uninterrupted duty (max. 3 in each group of 4 at the same time)	12 binary inputs usable for uninterrupted duty (max. 2 in each group of 4 at the same time)	6 binary inputs usable for uninterrupted duty (max. 1 in each group of 4 at the same time)

Heat-related limitations for the binary inputs on the IO233 input module (modular devices)			
Switching thresholds	Up to 40 °C	Up to 55 °C	Up to 70 °C
Range 2 for 110 V and 125 V operating voltage	All 48 binary inputs usable for uninterrupted duty	All 48 binary inputs usable for uninterrupted duty	36 binary inputs usable for uninterrupted duty (max. 3 in each group of 4 at the same time)

UL-Listed/UL-Approved

Base module and 1/3 base module	IND. CONT. EQ. 69CA
Expansion module	IND. CONT. EQ. 69CA

NOTE

At an ambient temperature of 55 °C to 70 °C, a maximum of 36 relays per row can be switched on simultaneously.

Further Documentation

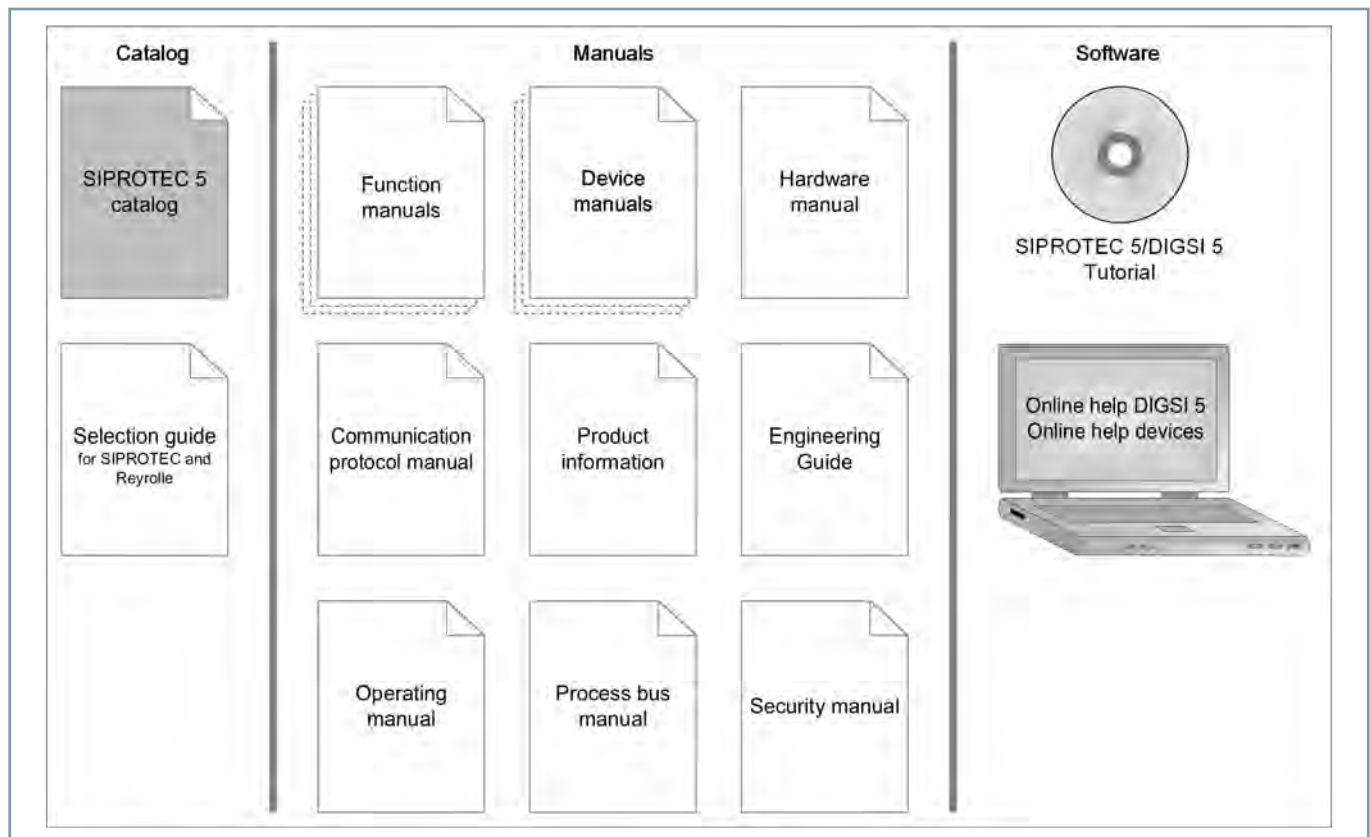

[dw_product-overview_catalog_SIP5, 1, en_US]

- **Device manuals**
Each Device manual describes the functions and applications of a specific SIPROTEC 5 device. The printed manual and the online help for the device have the same informational structure.
- **Hardware manual**
The Hardware manual describes the hardware building blocks and device combinations of the SIPROTEC 5 device family.
- **Operating manual**
The Operating manual describes the basic principles and procedures for operating and assembling the devices of the SIPROTEC 5 range.
- **Communication protocol manual**
The Communication protocol manual contains a description of the protocols for communication within the SIPROTEC 5 device family and to higher-level network control centers.
- **Security manual**
The Security manual describes the security features of the SIPROTEC 5 devices and DIGSI 5.
- **Process bus manual**
The process bus manual describes the functions and applications specific for process bus in SIPROTEC 5.
- **Product information**
The Product information includes general information about device installation, technical data, limiting values for input and output modules, and conditions when preparing for operation. This document is provided with each SIPROTEC 5 device.
- **Engineering Guide**
The Engineering Guide describes the essential steps when engineering with DIGSI 5. In addition, the Engineering Guide shows you how to load a planned configuration to a SIPROTEC 5 device and update the functionality of the SIPROTEC 5 device.
- **DIGSI 5 online help**
The DIGSI 5 online help contains a help package for DIGSI 5 and CFC.
The help package for DIGSI 5 includes a description of the basic operation of software, the DIGSI principles and editors. The help package for CFC includes an introduction to CFC programming, basic examples of working with CFC, and a reference chapter with all the CFC blocks available for the SIPROTEC 5 range.
- **SIPROTEC 5/DIGSI 5 Tutorial**
The tutorial on the DVD contains brief information about important product features, more detailed information about the individual technical areas, as well as operating sequences with tasks based on practical operation and a brief explanation.

Appendix

Overview Document Types

- SIPROTEC 5 catalog
The SIPROTEC 5 catalog describes the system features and the devices of SIPROTEC 5.
- Selection guide for SIPROTEC and Reyrolle
The selection guide offers an overview of the device series of the Siemens protection devices, and a device selection table.

Indication of Conformity



This product complies with the directive of the Council of the European Communities on harmonization of the laws of the Member States concerning electromagnetic compatibility (EMC Directive 2014/30/EU), restriction on usage of hazardous substances in electrical and electronic equipment (RoHS Directive 2011/65/EU), and electrical equipment for use within specified voltage limits (Low Voltage Directive 2014/35/EU).

This conformity has been proved by tests performed according to the Council Directive in accordance with the product standard EN 60255-26 (for EMC directive), the standard EN 50581 (for RoHS directive), and with the product standard EN 60255-27 (for Low Voltage Directive) by Siemens.

The device is designed and manufactured for application in an industrial environment.

The product conforms with the international standards of IEC 60255 and the German standard VDE 0435.

Disclaimer of Liability

Subject to changes and errors. The information given in this document only contains general descriptions and/or performance features which may not always specifically reflect those described, or which may undergo modification in the course of further development of the products. The requested performance features are binding only when they are expressly agreed upon in the concluded contract.

Document version: 07

Release status: 11.2020

Version of the product: V8.40

Copyright

Copyright © Siemens AG. All rights reserved.

The disclosure, duplication, distribution and editing of this document, or utilization and communication of the content are not permitted, unless authorized in writing. All rights, including rights created by patent grant or registration of a utility model or a design, are reserved.

Trademarks

SIPROTEC, DIGSI, SIGRA, SIGUARD, SIMEAS SAFIR, SICAM, and MindSphere are trademarks of Siemens. Any unauthorized use is prohibited.

Appendix

Legal Notices

1,2,3 ...

309, 340, 341

A

Arc protection module ARC-CD-3FO 408
 Assembly dimensions
 Flush-mounting device 429
 Surface-mounted devices variant of non-modular devices 433
 Surface-mounted devices with detached on-site operation panel 432
 Surface-mounted devices with integrated on-site operation panel 433

B

Bay Controllers 258
 Browser-based user interface 374
 Busbar protection 246
 Busbar Protection 247

C

Circuit Breaker Management Device 158
 Communication interfaces 339
 Conformal coating 397
 Cybersecurity 363

D

Device Types 12
 DIGSI 5 375
 Distance Protection 99
 Drilling pattern
 Flush-mounting device 429
 Surface-mounted devices variant of non-modular devices 433
 Surface-mounted devices with detached on-site operation panel 432
 Surface-mounted devices with integrated on-site operation panel 433

E

EMC test 445, 446
 Event-log buffer 338

F

Fault recorders 279
 Fault Recorders 280
 Function
 ANSI - 24 Overexcitation protection 304
 ANSI - 87M Motor differential protection 324
 ANSI 21, 21N - Distance protection with reactance method (RMD) 302
 ANSI 21, 21N – Distance Protection 301
 ANSI 21T - Impedance Protection for Transformers 303
 ANSI 25 - Synchrocheck 304
 ANSI 25 – Adjusting commands for autom. synchro. 304
 ANSI 27 - Undervoltage protection 304
 ANSI 27TH/59TH, 59THD - Stator ground-fault protection with 3rd harmonic 313
 ANSI 32 dP/dt; 27, 50 - Power-plant disconnection 306
 ANSI 32, 37 – Power Protection 305
 ANSI 32R – Reverse-power protection 306
 ANSI 37 - Undercurrent protection 306
 ANSI 38 - Temperature supervision 306
 ANSI 40 - Underexcitation protection 306
 ANSI 46 - Unbalanced-load protection 307
 ANSI 46, 67 - Overcurrent protection, negative-sequence system with direction 307
 ANSI 48 – Starting time supervision 308
 ANSI 49H - Hotspot calculation 308
 ANSI 49S - Stator overload protection 309
 ANSI 50 - Startup overcurrent protection 309
 ANSI 50/27 - Inadvertent energization protection 311
 ANSI 50/51, 50N/51N - Overcurrent protection, phases and ground 310
 ANSI 50BF – Circuit-breaker failure protection 309
 ANSI 50EF - End-fault protection 309
 ANSI 50GN - Shaft-current protection 311
 ANSI 50HS - Instantaneous high-current tripping 309
 ANSI 50L – Load-jam protection 310
 ANSI 50N/51N - Overcurrent protection, 1-phase 310
 ANSI 50Ns/51Ns – Sensitive ground-current protection 310
 ANSI 50RS - Circuit-breaker restrike protection 309
 ANSI 51V - Voltage-controlled overcurrent protection 311
 ANSI 59, 47, 59N - Overvoltage protection functions 308
 ANSI 59C - Peak overvoltage protection for capacitors 312
 ANSI 59N (IT) - Turn-to-turn fault protection 312
 ANSI 59N, 67Ns - 90 % Stator ground-fault protection 312
 ANSI 59N(DC), 50N(DC) - Direct-voltage/direct-current protection 312
 ANSI 60C - Current-unbalance protection for capacitor banks 313
 ANSI 60FL - Measuring-voltage failure detection 314
 ANSI 64F - Rotor ground-fault protection 314
 ANSI 64S - 100 % Stator ground-fault protection 313
 ANSI 66 - Restart inhibit 314
 ANSI 67, 67N – Directional overcurrent protection, phases/ground 315
 ANSI 67G, 50G, 51G - Directional ground-fault protection with phase selector 315
 ANSI 67Ns, ANSI 51Ns, 59N - Directional sensitive ground-fault detection 316
 ANSI 74TC – Trip-circuit supervision 317
 ANSI 78 - Out-of-step protection 317

- ANSI 79 - Automatic reclosing 317
- ANSI 81 – Frequency protection 318
- ANSI 81R - Rate-of-frequency change protection 318
- ANSI 85/21 - Teleprotection scheme for distance protection 319
- ANSI 85/27 - Weak or no infeed 319
- ANSI 85/67N – Teleprotection for directional ground-fault protection 319
- ANSI 87 STUB - STUB differential protection 322
- ANSI 87 V – Voltage differential protection for capacitor banks 326
- ANSI 87B - Busbar differential protection 325
- ANSI 87C - Capacitor bank differential protection 326
- ANSI 87G - Generator differential protection 325
- ANSI 87L, 87T - Line differential protection 319
- ANSI 87N T - Restricted ground-fault protection 324
- ANSI 87T - Differential protection for phase-angle regulating transformers 323
- ANSI 90V - Transformer voltage controller 328
- Arc Protection 311
- External trip initiations 309
- Fault locator (FL) 326
- Instantaneous tripping at switch-onto fault (SOFT) 309
- Intermittent ground-fault protection 311
- Phasor Measurement Unit (PMU) 326
- Point-on-wave switching (PoW) 330
- QU protection 305
- Reactive-power undervoltage protection (QU protection) 305

G

- Generator Protection Device 222
- Generator protection devices 221
- Grid Diagnostic Suite 393

H

- HSR = High Available Seamless Ring Redundancy 358

I

- IEC 61850 – Ethernet-based substation automation protocol 386
- IEC 61850 System Configurator 385
- IEEE 802.1x 366
- Insulation test 445
- Interfaces 404
 - Detached operation panel (port H) 404
 - Expansion unit CB202 (port K) 404
 - Integrated Ethernet interface (port J) 404
 - Time-synchronization interface (port G) 404

L

- Line Differential and Distance Protection 138
- Line Differential Protection 119
- Line protection devices 92
- Log 338

M

- Measuring-transducer module ANAI-CA-4EL 408
- Modules
 - Base and expansion modules 399
 - Hardware Properties 403
 - Modular devices 411
 - Non-modular devices - 7xx81, 7xx82 409
- Motor protection devices 206

O

- Overcurrent protection 163
- Overcurrent protection devices 66

P

- P1V 384
- P1X 384
- Paralleling Device 234
- Paralleling Devices 233
- Plug-in modules 339
 - Arc protection module ARC-CD-3FO 408
 - Electrical Ethernet module (ETH-BO-2EL) 340
 - Long-distance fiber optical modules 340
 - Measuring-transducer module ANAI-CA-4EL 408
 - Optical Ethernet module (ETH-BB-2FO) 341, 341
 - Plug-in modules for Ethernet 340
 - Serial electrical RS485 module 339
 - Serial optical 820-nm module 339
 - Serial plug-in modules 339
 - USART-AB-1EL 339
 - USART-AC-2EL 339
 - USART-AE-2FO 340
 - USART-Ax- 340
- Point-on-wave switching (PoW) 330
- Power Quality – Basic (PQ-Basic) 334
- PROFINET IO S2 redundancy 352
- Protection communication 355
- Protocols 347
 - Ethernet redundancy with RSTP, PRP, HSR 354
 - IEC 60870-5-103 351
 - IEC 60870-5-104 351
 - IEC 61850-8-1 Client-server communication 347
 - IEC 61850-8-1 GOOSE 347
 - IEC 61850-9-2 Process bus 347
 - IEEE C37.118 (Synchrophasor) 353
 - Modbus TCP 352
 - Serial DNP3 or DNP3 TCP 351

SNMP 355
SUP – Slave Unit Protocol 351
PRP = Parallel Redundancy Protocol 358

R

Recorder 336
Redundancy 359
 Seamless redundancy with PRP and HSR 357
 Serial redundancy 358

S

Safety 361
SIGRA 389
SIPROTEC 6MD85 259
SIPROTEC 6MD86 265
SIPROTEC 7KE85 280
SIPROTEC 7SA82 99
SIPROTEC 7SA86 105
SIPROTEC 7SA87 112
SIPROTEC 7SD82 119
SIPROTEC 7SD86 124
SIPROTEC 7SD87 131
SIPROTEC 7SJ81 67
SIPROTEC 7SJ82 73
SIPROTEC 7SJ85 81
SIPROTEC 7SJ86 163
SIPROTEC 7SK82 207
SIPROTEC 7SK85 214
SIPROTEC 7SL82 138
SIPROTEC 7SL86 144
SIPROTEC 7SL87 151
SIPROTEC 7SS85 247
SIPROTEC 7UM85 222
SIPROTEC 7UT82 171
SIPROTEC 7UT85 177
SIPROTEC 7UT86 187
SIPROTEC 7UT87 195
SIPROTEC 7VE85 234
SIPROTEC 7VK87 158
SIPROTEC Dashboard 393
SIPROTEC DigitalTwin 391
Standards 445
Surface-mounted device components 397

T

Terminals 405
 Current terminals 405
 Voltage terminals 405
Time synchronization 337
Time synchronization using IEEE 1588 354
Time synchronization with SNTP protocol 354
Transformer differential protection devices 169

V

VLAN 353

W

Web UI 374

Published by
Siemens AG 2020

Smart Infrastructure
Digital Grid
Automation Products
Humboldtstr. 59
90459 Nuremberg, Germany

www.siemens.com/siprotec

Customer Support Center
Our Customer Support Center provides a 24-hour service.
Siemens AG
Smart Infrastructure – Digital Grid
Customer Support Center
Tel.: +49 911 2155 4466
E-Mail: energy.automation@siemens.com

Article No. SIDG-C10059-00-7600
CA 112020_455_pdf_EN

For all products using security features of OpenSSL the following shall apply:

This product includes software developed by the OpenSSL Project for use in the OpenSSL Toolkit. (<http://www.openssl.org>)

This product includes cryptographic software written by Eric Young (ey@cryptsoft.com)

This product includes software written by Tim Hudson (tjh@cryptsoft.com)

This product includes software developed by Bodo Moeller.