

# HYDRAULIC LUBE FILTRATION

## Products Catalog



High Pressure Filters

Element Technology

Medium Pressure  
Filters

Low Pressure  
Filters

Suction Filters

Manifold Cartridge Kits & Filters

Custom Solutions



## Vision Mission Value Quality Statement:

### Vision:

We design solutions for industry and for the success of our customers by:

- Optimizing the use of technology with applications
- Using an efficient, timely customized process to fill specific customer needs
- Increasing capacity and streamlining operations
- Preserving our reputation for reliability
- Expanding globally to support our customers and stay current with new technologies
- Leveraging and sharing our knowledge to meet challenges openly
- Nurturing a creative, cooperative culture committed to the individual and to providing the best solutions for the customers

### Mission Statement:

#### Partnerships

Innovating products, processes and services to improve performance and efficiency in our industry.

#### Schroeder Industries Core | Shared Values:

##### Honesty

Day-to-Day Behaviors:

- Tell the truth at all times, in all matters
- Have open lines of communication and share timely, accurate and thorough information with internal and external customers
- Do not steal and respect each other's and the Company's property

##### Teamwork

Day-to-Day Behaviors:

- Work as a team
- Cooperate within and between departments
- Coach and mentor; listen and share knowledge, experience and ideas
- Treat others with respect and consideration in all circumstances
- Invest in the development and growth of all team members
- Keep our work areas safe and clean

##### Leadership

Day-to-Day Behaviors:

- Recognize that we are empowered to act as leaders and participate in the decision making process
- Take responsibility for and have pride in our work
- Set goals and celebrate the efforts and accomplishments of our teammates
- Value our greater community and take leadership roles in our neighborhoods and for the environment

##### Ingenuity | Innovation

Day-to-Day Behaviors:

- Value innovative thinking and the generation and implementation of new ideas to solve customer (internal & external) problems
- Be flexible and adapt to new ideas and different ways of doing things
- Utilize available resources for new designs and innovations

### Quality Policy:

Continuous improvement in our business to ensure a quality product, shipped on time, without compromise.

### Limitations of Liability

The information contained in the catalog (including, but not limited to, specifications, configurations, drawings, photographs, dimensions and packaging) is for descriptive purposes only. Any description of the products contained in this catalog is for the sole purpose of identifying the products and shall not be deemed a warranty that the products shall conform to such description. No representation or warranty is made concerning the information contained in this catalog as to the accuracy or completeness of such information. Schroeder Industries LLC reserves the right to make changes to the products included in this catalog without notice. A copy of our warranty terms and other conditions of sale are available upon request. A placed order constitutes acceptance of Schroeder's terms and conditions.

Failure, improper selection or improper use of the products and/or systems described herein or related items can cause death, personal injury and property damage.

This catalog and other documentation from Schroeder Industries provides product information for consideration by users possessing technical expertise.

It is important that the user analyze all aspects of the specific application and review the current product information in the current catalog. Due to the variety of operating conditions and applications for these products, the user is solely responsible for making the final product selection and assuring that all performance, safety and warning requirements of the application are met.

The products described herein, including without limitation, product features, specifications, design, availability and pricing are subject to change at any time without notice.



Leetsdale Facility

# Contents at a Glance

<b>Detailed Contents: Hydraulic &amp; Lube Filters</b> . . . . .	4
Filter Housing: Flow vs. Operating Pressure . . . . .	6
Note to the Reader . . . . .	7
Corporate Overview . . . . .	8
Capabilities . . . . .	9
Products . . . . .	10
<b>Section 1: Principles of Filtration</b> . . . . .	11
Contamination Control Fundamentals . . . . .	12
Element Technical Data Fundamentals . . . . .	16
Element Media Selection Considerations . . . . .	20
7 Steps to Selecting a Filter . . . . .	23
Filter Selection Considerations . . . . .	24
Ordering Information . . . . .	27
<b>Section 2: Element Technology</b> . . . . .	29
Excellement® Z-Media® Elements (Synthetic) . . . . .	30
Element Case Weight . . . . .	33
GeoSeal® Selection Guide . . . . .	34
Private Labeled Elements . . . . .	35
Anti-Stat Pleat Elements (Synthetic) . . . . .	36
DirtCatcher® Elements . . . . .	36
BestFit® High Performance Replacement Elements . . . . .	37
CoreCentric® Coreless Element . . . . .	38
Melt-Blown and Spun Bonded Filter Elements . . . . .	38
E Media Elements (Cellulose) . . . . .	39
M Media Elements (Reusable Metal) . . . . .	40
F-Pack Media Elements . . . . .	40
W Media Elements (Water Removal) . . . . .	41
Aqua-Excellement™ High Efficiency Media (Water Removal) . . . . .	41
<b>Section 3: High Pressure Filters (1500 - 6500 psi)</b> . . . . .	43
Selection Guide . . . . .	44
Top-Ported High Pressure Filters . . . . .	45
Base-Ported High Pressure Filters . . . . .	97
Hydrostatic (Bidirectional) Flow Filters . . . . .	117
In-Line Filters . . . . .	125
Servo Protection (Sandwich) Filters . . . . .	131
Manifold Mount Filter Kit . . . . .	143
Cartridge Elements for use in Manifold Applications . . . . .	147
<b>Section 4: Medium Pressure Filters (up to 1500 psi)</b> . . . . .	149
Selection Guide . . . . .	150
Top-Ported Medium Pressure Filters . . . . .	151
Base-Ported Medium Pressure Filters . . . . .	169
<b>Section 5: Low Pressure Filters (up to 500 psi)</b> . . . . .	209
Selection Guide . . . . .	210
Top-Ported Low Pressure Filters . . . . .	211
Tank-Mounted Low Pressure Filters . . . . .	239
Special Feature Tank-Mounted Low Pressure Filters . . . . .	297
Severe Duty Tank-Mounted Filters . . . . .	305
Accessories For Tank-Mounted Filters . . . . .	309
Spin-On Low Pressure Filters . . . . .	311
<b>Section 6: Suction Filters</b> . . . . .	323
Selection Guide . . . . .	324
Tank-Mounted Suction Filter . . . . .	325
In-Line Magnetic Suction Separators . . . . .	329
Tank-Mounted Magnetic Suction Separator . . . . .	331
Magnetic Inserts for Filters . . . . .	332
<b>Appendices</b> . . . . .	333
Appendix A: Filter Dirt Alarm® Selection . . . . .	333
Appendix B: Viscosity Charts . . . . .	340
<b>Glossary</b> . . . . .	341

# Detailed Contents: Hydraulic & Lube Filters

		Pressure psi (bar)	Flow gpm (L/min)	Page
SECTION 3: High Pressure Filters (1500 - 6500 psi)	<b>Top-Ported High Pressure Filters</b>			
	NF30	3000 (210)	20 (75)	45
	NFS30	3000 (210)	20 (75)	49
	YF30	3000 (210)	25 (100)	53
	CFX30	3000 (210)	30 (115)	57
	PLD	3000 (210)	100 (380)	61
	DF40	4000 (275)	30 (115)	65
	CF40	4000 (275)	45 (170)	65
	PF40	4000 (275)	50 (190)	69
	RFS50	5000 (345)	30 (115)	73
	RF60	6000 (415)	30 (115)	77
	CF60	6000 (415)	50 (190)	81
	CTF60	6000 (415)	75 (284)	85
	VF60	6000 (415)	70 (265)	89
	LW60	6000 (415)	300 (1135)	93
	<b>Base-Ported High Pressure Filters</b>			
	KF30	3000 (210)	100/150 (380/570)	97
	KF50	5000 (345)	100/150 (380/570)	97
	TF50	5000 (345)	40 (150)	101
	KC50	5000 (345)	100/150 (380/570)	105
	MKF50	5000 (345)	200 (760)	109
	MKC50	5000 (345)	200 (760)	109
	KC65	6500 (450)	100 (380)	113
	MKC65	6000 (413)	300 (1136)	117
	<b>Hydrostatic (Bidirectional) Flow High Pressure Filters</b>			
	HS60	6000 (415)	100 (380)	121
	MHS60	6000 (415)	100 (380)	121
	KFH50 (Base-Ported)	5000 (345)	70 (265)	125
	<b>In-Line Filters</b>			
	LC60	6000 (415)	8 (30)	129
	LC35	3500 (241)	15 (57)	131
	LC50	5000 (345)	9 (35)	133
<b>Servo Protection (Sandwich) Filters DO7, DO3, Moog, Parker &amp; Vickers</b>				
NOF30-05	3000 (210)	12 (45)	135	
NOF50-760	5000 (345)	15 (57)	139	
FOF60-03	6000 (415)	12 (45)	143	
<b>Manifold Mount Filter Kits (Bowls &amp; Installation Drawings)</b>				
NMF30	3000 (210)	20 (75)	147	
RMF60	6000 (415)	30 (115)	149	
<b>Cartridge Elements for use in Manifold Applications</b>				
14-CRZX10	3000 (210)	6 (23)	151	
20-CRZX10	3000 (210)	12 (45)	152	

SECTION 4: Medium Pressure Filters (up to 1500 psi)	<b>Top-Ported Medium Pressure Return Line Filters</b>			
	GH	725 (50)	35 (130)	155
	RLT	1000 (69)	70 (265)	161
	KF5	500 (35)	100 (380)	165
	SRLT	1400 (100)	25 (100)	169
	<b>Base-Ported Medium Pressure Filters</b>			
	K9	900 (60)	100 (380)	173
	2K9	900 (60)	100 (380)	177
	3K9	900 (60)	100 (380)	177
	QF5	500 (35)	300 (1135)	181
	3QF5	500 (35)	300 (1135)	197
	QF5i	500 (35)	120 (454)	185
	3QF5	500 (35)	300 (1135)	189
	QFD5	500 (35)	350 (1325)	193
	QF15	1500 (100)	450 (1700)	197
	QLF15	1500 (100)	500 (1900)	201
	SSQLF15	1500 (100)	500 (1900)	205



# Detailed Contents (cont.)

		Pressure psi (bar)	Flow gpm (L/min)	Page	
SECTION 5: Low Pressure Filters (up to 500 psi)	<b>Top-Ported Low Pressure Filters</b>				
	IRF	100 (7)	100 (380)	211	
	TF1	300 (20)	30 (120)	215	
	KF3	300 (20)	100 (380)	219	
	KL3	300 (20)	120 (455)	223	
	LF1-2"	300 (20)	120 (455)	227	
	MLF1	300 (20)	200 (760)	231	
	RLD	350 (24)	100 (380)	235	
	<b>Tank-Mounted (In-Tank/Tank Top) Low Pressure Filters</b>				
	GRTB	100 (7)	100 (380)	239	
	MTA	100 (7)	15 (55)	243	
	MTB	100 (7)	35 (135)	247	
	ZT	100 (7)	40 (150)	251	
	KFT	100 (7)	100 (380)	255	
	RT	100 (7)	100 (380)	259	
	RTI	100 (7)	120 (455)	263	
	LRT	100 (7)	150 (570)	267	
	ART	145 (10)	225 (850)	271	
	BRT	145 (10)	160 (600)	275	
	TRT	145 (10)	634 (2400)	281	
	BFT	100 (7)	300 (1135)	289	
	QT	100 (7)	450 (1700)	293	
	<b>Special Feature Tank-Mounted Low Pressure Filters</b>				
	Internal	KTK	100 (7)	100 (380)	297
	Internal	LTK	100 (7)	150 (570)	301
	<b>Severe Duty Tank-Mounted Filters</b>				
		MRT	900 (62)	150 (570)	305
<b>Spin-On Low Pressure Filters</b>					
	PAF1	100 (7)	20 (75)	311	
	MAF1	100 (7)	50 (190)	315	
	MF2	150 (10)	60 (230)	319	

SECTION 6: Suction Filters	<b>Tank-Mounted Suction Filter</b>				
		ST	Suction	20 (75)	325
	<b>In-Line Magnetic Suction Separators</b>				
		TF-SKB	Suction	12.5 (47)	329
		KF3-SKB	Suction	35 (130)	330
<b>Tank-Mounted Magnetic Suction Separator</b>					
	BFT-SKB	Suction	75 (285)	331	



# Note to the Reader

The aim of our catalog is to provide the information and guidance you'll need to make informed and appropriate choices for your filtration needs.

Illustrated and easy to understand, Section 1 is now widely used as a training tool by many companies, including original equipment manufacturers for whom Schroeder provides value-added products. The revised Section 1 continues to serve as an effective "primer" on contamination control fundamentals. In this section, we also provide filtration information and guidance for selecting the optimal filter and element media for your application.

Section 1 also explains recent changes in industry standards regarding how fluid cleanliness is defined and measured. Recent technological advancements in the measurement of microscopic particles, coupled with the establishment of a new standard test dust for calibration purposes, necessitated these changes. Although the new standards may seem confusing at first, they enable more accurate sizing of dirt particles and reduce variability in output among different automatic particle counters. The end result is more reliable data for the user.

In Section 2, you'll find extensive technical data on Schroeder's Excellement® Z-Media®, which combines high efficiency, low pressure drop and exceptional dirt holding capacity. Schroeder's design engineers have also given special attention to developing more environmentally friendly products, such as CoreCentric® elements, which contain no metal and can be crushed, shredded or burned.

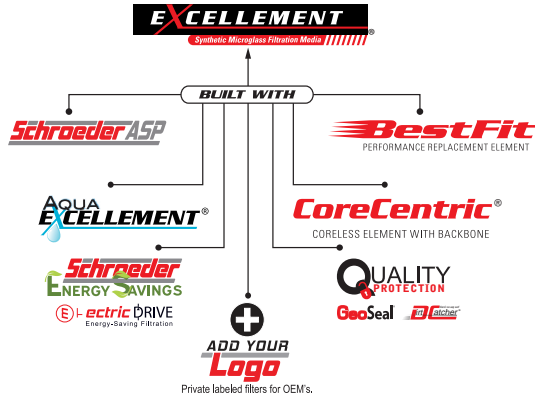

Sections 3 through 6 describe the types of contamination control products and accessories we offer. Whether your hydraulic system requires pressure filters, tank-mounted filters, return-line filters, or some combination of these, this updated catalog will help you find the right Schroeder filter to do the job. Of course, every filter comes with a Schroeder original element, available in a wide variety of media and micron ratings.

Dirt Alarm®, BestFit®, Excellement®, DirtCatcher® and CoreCentric® are registered trademarks of Schroeder Industries.

Schroeder's web site, [www.schroederindustries.com](http://www.schroederindustries.com), is filled with helpful resources.

Replacing filter elements is simpler than ever before with our Online Cross-Reference Guide to BestFit® replacement elements. With this user-friendly guide you can match 41,000 filter elements from 150 other manufacturers with appropriate BestFit® replacements. Click the BestFit® link on our home page or go to the direct link at [www.schroederindustries.info](http://www.schroederindustries.info).

Visit Us Online...



# Corporate Overview



Schroeder Industries, an ISO 9001:2015 certified company, focuses on developing filtration and fluid service products for our customers in the fluid power industry and is proud of our proven track record of providing quality products over the last 75 years. The designs you see in this catalog are the result of thousands of hours of field testing and laboratory research...and decades of experience.

Schroeder was one of the first companies to demonstrate the need for, and benefits of, hydraulic filtration. We pioneered the development of micronic filtration, helping to set performance standards in industrial fluid power systems. As a result, Schroeder is now a leader in filtration and fluid conditioning—and the proof of our expertise lies in our broad mix of unsurpassed products. Our mission statement reflects our continuing commitment to excellence:

## Partnerships

**Innovating products, solutions, processes and services to improve performance and efficiency in industry.**

We design solutions for industry and for the success of our customers by:

- Optimizing the use of technology with applications
- Using an efficient, timely customization process to fill specific customer needs
- Increasing manufacturing capacity and streamlining operations
- Preserving our reputation for reliability
- Expanding globally to support our customers and stay current with new technologies
- Leveraging and sharing our knowledge to meet challenges openly
- Nurturing a creative, cooperative culture committed to the individual and to providing the best solutions for our customers

Our goal is to be your filtration partner. Our expertise in filtration technology, our superior filter and element manufacturing capabilities, and our dedication to customer service and product support are the reasons we're considered experts in Advanced Fluid Conditioning Solutions®.

We are committed to providing the best available filter products to meet necessary cleanliness levels at a competitive price. As a cost-effective quality producer, we can work with your purchasing department to supply contamination control technology or develop long-range pricing programs that can improve your company's bottom line.

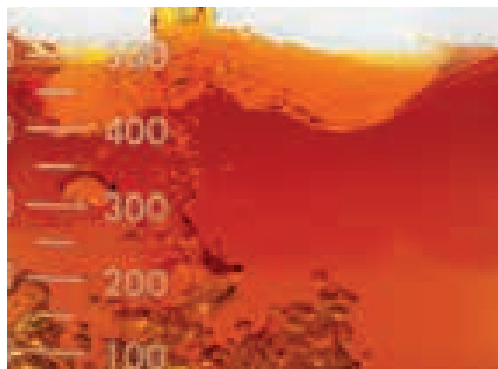

# Capabilities

Schroeder Industries has in place a strategically located international distribution network, supported by our professional and experienced sales and marketing team. Distributor personnel are trained in the important aspects of filter application by Schroeder in training sessions held at our factory and around the globe. The effectiveness of our product and service support is multiplied by utilizing Schroeder's extensive distributor network. All Schroeder Industries distributors meet very strict criteria to enhance our ability to serve the needs of our valued customers.

Schroeder's distributor network includes over 100 distributor locations throughout Europe, the United Kingdom, South Africa, Australia, Asia, North America and South America, so that customers worldwide can rely on Schroeder's exceptional support.

Schroeder Industries' corporate headquarters are located in Leetsdale, PA (USA) with an additional manufacturing facility in Cumberland, MD (USA). Filter housings and diagnostic and specialty products are manufactured at our Pittsburgh plant, while filter elements are manufactured in our Cumberland plant. Both facilities have the skilled workforce and the capacity to meet our customers' needs. Schroeder's research and development center as well as our contamination control laboratory are located at our corporate headquarters.

Schroeder's products, technical expertise, commitment to research and development, and ongoing improvements in manufacturing enable us to provide products and services that improve performance and efficiency in many major industries, including:



AGRICULTURE



AUTOMOTIVE MANUFACTURING



BULK FUEL FILTRATION



CHEMICAL PROCESSING



CONSTRUCTION



INDUSTRIAL



MACHINE TOOL



MARINE



MINING TECHNOLOGY



MOBILE VEHICLES



OFFSHORE



POWER GENERATION



PULP & PAPER



RAILROAD



STEEL MAKING



WASTE WATER TREATMENT

## Product Distribution

## Manufacturing and Testing

## Markets Served





# Products

## Engineering Laboratory

Schroeder Industries' products are continually tested using the latest ISO and NFPA test procedures in our engineering lab. Our dynamic test stands are in constant operation, subjecting our filter housings to cyclic pressure to verify their rated fatigue and burst pressures per NFPA Standard T2.6.1. Statistically sampled elements are tested to ensure fabrication integrity in the manufacturing process. They are also tested for efficiency and dirt-holding capacity in a multi-pass test stand, equipped with in-line particle counting capabilities, which are calibrated to ISO standards.

Extensive testing is conducted to ensure compatibility with various hydraulic fluids, including the newest fire-resistant fluids, per ISO 2943 Standard. Flow fatigue tests are run to evaluate the structural strength of elements, per ISO 3724 Standard.

### Design and Testing Standards of Schroeder Filter Housings

Description	Standard
Burst Pressure Test	NFPA/T-2.6.1
Fatigue Testing	NFPA/T-2.6.1
Pressure/Life Rating of a Spin-On Filter	NFPA/T-3.10.17
Pressure Drop vs. Flow	ISO 3968

### Design and Testing Standards of Schroeder High Efficiency Elements

Description	Standard
Element Collapse (Burst)	ISO 2941
Fabrication Integrity	ISO 2942
Material Compatibility	ISO 2943
End Load	ISO 3723
Element Flow Fatigue	ISO 3724
Pressure Drop vs. Flow	ISO 3968
Multi-Pass	ISO 16889

## An Open Invitation

We invite you to present us with any specific filtration challenge you may experience. Schroeder will design and make filters to meet your specific requirements. To find out more, and/or obtain a quote, call us to speak with a sales representative or technical specialist. They can help determine the optimal filtration strategy for a given system. While the quantity of any product manufactured to fit a customer's needs will determine the economic feasibility of a particular project, in many cases, we can offer modified products in relatively small quantities at competitive prices and short lead times.

Over the years, Schroeder design engineers have encountered virtually every type of hydraulic system. We are proud of our continuing success in providing "value-added products" for our customers, that is, making or modifying our products to meet their specific needs. When customers order products from Schroeder, they are assured of a reliable source of supply, consistent and prompt service, and direct support. Pre and post-technical service is provided to ensure customer satisfaction.

So if you're faced with a filtration dilemma, call us.  
Schroeder Industries: Advanced Fluid Conditioning Solutions®.



Section 1:

# PRINCIPLES OF FILTRATION

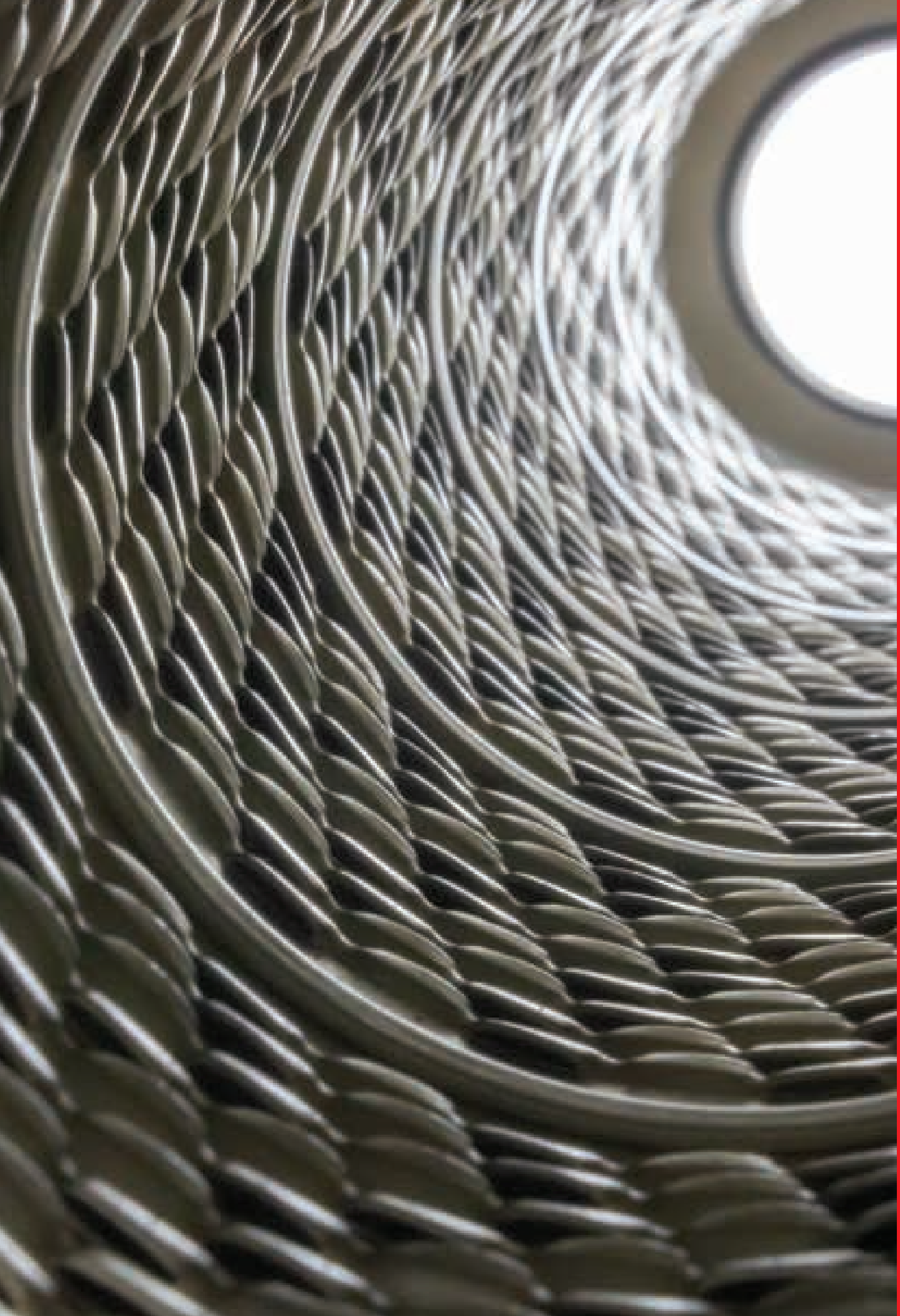

# Contamination Control Fundamentals

## Why Filter?

**Over 70% of all hydraulic system failures are caused by contaminants in the fluid.** Even when no immediate failures occur, high contamination levels can sharply decrease operating efficiency.

Contamination is defined as any substance which is foreign to a fluid system and damaging to its performance. Contamination can exist as a gas, liquid or solid. Solid contamination, generally referred to as particulate contamination, comes in all sizes and shapes and is normally abrasive.

High contaminant levels accelerate component wear and decrease service life. Worn components, in turn, contribute to inefficient system operation, seizure of parts, higher fluid temperatures, leakage, and loss of control. All of these phenomena are the result of direct mechanical action between the contaminants and the system components. Contamination can also act as a catalyst to accelerate oxidation of the fluid and spur the chemical breakdown of its constituents.

Filtering a system's fluid can remove many of these contaminants and extend the life of system components.

## How a System Gets Contaminated

Contaminants come from two basic sources: they either enter the system from outside (ingestion) or are generated from within (ingression). New systems often have contaminants left behind from manufacturing and assembly operations. Unless they are filtered as they enter the circuit, both the original fluid and make-up fluid are likely to contain more contaminants than the system can tolerate. Most systems ingest contaminants through such components as inefficient air breathers and worn cylinder rod seals during normal operation. Airborne contaminants are likely to gain admittance during routine servicing or maintenance. Also, friction and heat can produce internally generated contamination.

**Figure 1. Typical Examples of Wear Due to Contamination**



Vanes for Vane Pump

Relief Valve Piston

Vane Pump Cam Ring

## Size of Solid Contaminants

The size of solid particle contaminants is commonly measured in micrometers,  $\mu\text{m}$ , (usually referred to as microns,  $\mu$ ). A micron is a unit of length equal to one millionth of a meter or about .00004 inch. Particles that are less than 40  $\mu$  cannot be detected by the human eye.

Substance	Microns	Inches
Grain of table salt	100 $\mu$	.0039"
Human hair	70 $\mu$	.0027"
Talcum powder	10 $\mu$	.00039"
Bacteria (average)	2 $\mu$	.000078"

Figure 2 shows the sizes of some common substances. To gain some perspective, consider the diameters of the following substances:

A *micron rating* identifies the size of particles that a particular filtration media will remove. For instance, Schroeder Z10 filter media is rated at  $\beta_{10} \geq 1000$ , meaning that it can remove particles of 10  $\mu$  and greater at 99.9% efficiency.

**Figure 2. Sizes of Known Particles in Inches and Microns**

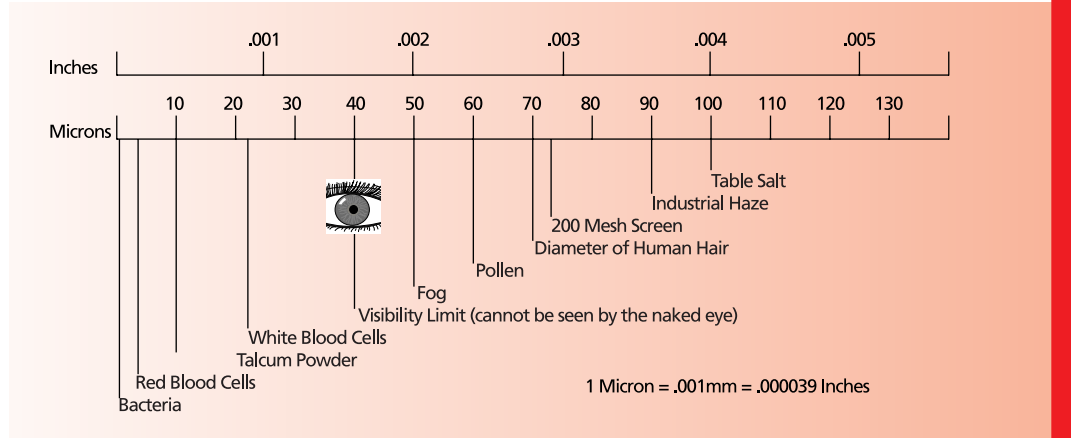

In hydraulic fluid power systems, power is transmitted and contained through a liquid under pressure within an enclosed circuit. These fluids all contain a certain amount of solid particle contaminants. The amount of particulate contaminants present in a hydraulic or lubrication system's fluid is commonly referred to as its cleanliness level.

## How Contaminants are Measured and Reported

ISO 4406:1999 provides guidelines for defining the level of contamination present in a fluid sample in terms of an ISO rating. It uses three scale numbers, representing the number of particles greater than or equal to 4  $\mu(c)$ , 6  $\mu(c)$ , and 14  $\mu(c)$  in size per 1 mL of sample fluid.

Figure 3 shows the graph used to plot particle counts per ISO 4406:1999.

## ISO Scale Numbers—ISO 4406:1999

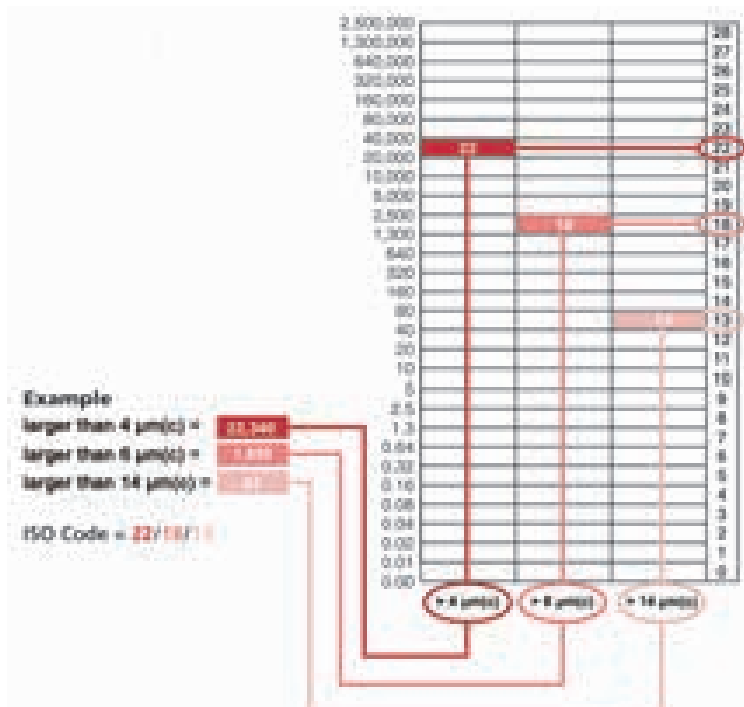

- Reproducibility below scale number 8 is affected by the actual number of particles counted in the fluid sample. Raw counts should be more than 20 particles. If this is not possible, then refer to bullet below.
- When the raw data in one of the size ranges results in a particle count of fewer than 20 particles, the scale number for that size range shall be labeled with the symbol  $\geq$ .

EXAMPLE: A code of 14/12/ $\geq$ 7 signifies that there are more than 80 and up to and including 160 particles equal to or larger than 4  $\mu(c)$  per mL and more than 20 and up to and including 40 particles equal to or larger than 6  $\mu(c)$  per mL. The third part of the code,  $\geq$ 7 indicates that there are more than 20 and up to and including 1.3 particles equal to or larger than 14  $\mu(c)$  per mL. The  $\geq$  symbol indicates that less than 20 particles were counted, which lowers statistical confidence. Because of this lower confidence, the 14  $\mu(c)$  part of the code could actually be higher than 7, thus the presence of the  $\geq$  symbol.

## Cleanliness Levels—ISO 4406:1999

The following example shown in Figure 4 illustrates the cleanliness level, or ISO rating, of a typical petroleum-based fluid sample using the ISO Code 4406:1999 rating system.

The fluid sample contains a certain amount of solid particle contaminants, in various shapes and sizes.

Since the number of 4 μ(c) particles falls between 2500 and 5000, the first ISO range number is 19 using Table 1. The number of 6 μ(c) particles falls between 160 and 320 particles, so the second ISO range number is 15. The number of 14 μ(c) particles falls between 10 and 20, making the third range number 11. Therefore, the cleanliness level for the fluid sample shown in Figure 4 per ISO 4406:1999 is 19/15/≥11.

**Figure 4. Determining the ISO Rating of a Fluid Using ISO 4406:1999**

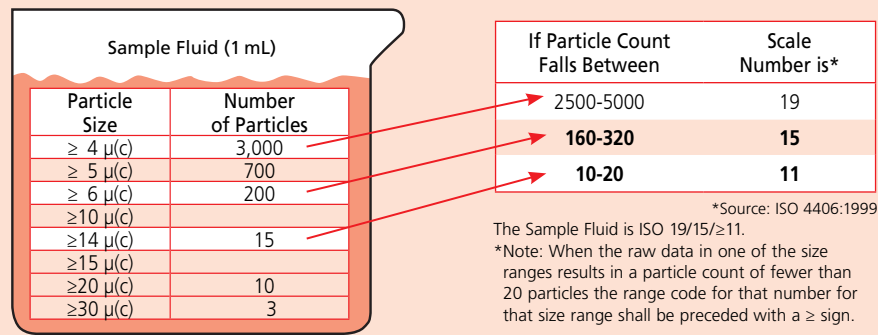

## Required Cleanliness Levels

The pressure of a hydraulic system provides the starting point for determining the cleanliness level required for efficient operation. Table 2 provides guidelines for recommended cleanliness levels based on pressure. In general, Schroeder defines pressure as follows:

Low pressure: 0-500 psi (0-35 bar)  
 Medium pressure: 500-2999 psi (35-206 bar)  
 High pressure: 3000 psi (206 bar) and above

A second consideration is the type of components present in the hydraulic system. The amount of contamination that any given component can tolerate is a function of many factors, such as clearance between moving parts, frequency and speed of operation, operating pressure, and materials of construction. Tolerances for contamination range from that of low pressure gear pumps, which normally will give satisfactory performance with cleanliness levels typically found in new fluid (ISO 19/17/14), to the more stringent requirements for servo-control valves, which need oil that is eight times cleaner (ISO 16/14/11).

Today, many fluid power component manufacturers are providing cleanliness level (ISO code) recommendations for their components. They are often listed in the manufacturer's component product catalog or can be obtained by contacting the manufacturer directly. Their recommendations may be expressed in desired filter element ratings or in system cleanliness levels (ISO codes or other codes). Some typically recommended cleanliness levels for components are provided in Table 3.

This table is based on data shown in various hydraulic component manufacturer's catalogs. Contact Schroeder for recommendations for your specific system needs.

**Table 2. Cleanliness Level Guidelines Based on Pressure**

System Type	Recommended Cleanliness Levels (ISO Code)
Low pressure – manual control (0 - 500 psi)	20/18/15 or better
Low to medium pressure – electrohydraulic controls	19/17/14 or better
High pressure – servo controlled	16/14/11 or better

**Table 3. Recommended Cleanliness Levels (ISO Codes) for Fluid Power Components**

Components	Cleanliness Levels (ISO Code) 4 μ(c)/6 μ(c)/14 μ(c)
Hydraulic Servo Valves	15/13/11
Hydraulic Proportional Valves	16/14/12
Hydraulic Variable Piston Pump	16/14/12
Hydraulic Fixed Piston Pump	17/15/12
Hydraulic Variable Vane Pump	17/15/12
Hydraulic Fixed Vane Pump	18/16/13
Hydraulic Fixed Gear Pump	18/16/13
Ball Bearings	15/13/11
Roller Bearings	16/14/12
Journal Bearings (>400 rpm)	17/15/13
Journal Bearings (<400 rpm)	18/16/14
Gearboxes	18/16/13
Hydrostatic Transmissions	16/14/11
Pumps	16/14/12



**Table 4. Cleanliness Class Comparisons**

ISO 4409:1999	SAE AS 4059:E	NAS 1638-01/196	MIL-STD 1246A 1967	ACFTD Gravimetric Level-mg/L
24				
23/20/18		12		
22/19/17	12	11		
21/18/16	11	10		
20/17/15	10	9	300	
19/16/14	9	8		
18/15/13	8	7	200	1
17/14/12	7	6		
16/13/11	6	5		
15/12/10	5	4		0.1
14/11/9	4	3	100	
13/10/8	3	2		
12/9/7	2	1		0.01
11/8/6	1	0		
10/7/5	0	00		
8/7/4	00		50	
5/3/01			25	
2/0/0			5	

**Required Cleanliness Levels**

*(continued)*

For your convenience, Table 4 provides a cross reference showing the approximate correlation between several different scales or levels used in the marketplace to quantify contamination. The table shows the code levels used for military standards 1638 and 1246A, as well as the SAE AS4059 standard.

## What does ISO Code Cleanlines mean to YOUR Hydraulic System?

For Example if your Hydraulic system ran at 33 GPM, 8 hours a day, for 200 days a year at the above ISO codes, the corresponding amounts of contaminants would flow through each component in a given year. You can easily see what lowering your ISO code can do to the Total Cost of Ownership of your equipment.

# Element Technical Data Fundamentals

## Performance Specifications/ Filtration Ratings

Schroeder filter elements meet a wide variety of requirements in today's workplace, from the simplest to the most sophisticated fluid power systems. Established industry standards enable users to select the optimal filter element for any application.

When evaluating the performance of hydraulic filter elements, the most important parameters to consider are:

- (a) efficiency
- (b) beta stability
- (c) dirt holding capacity
- (d) pressure drop vs. flow

(a) *Efficiency*, or filtration ratio, expressed by "Beta" ( $\beta$ ) relates to how well an element removes contamination from fluid. Higher efficiency translates to cleaner oil, better protection of system components, less down time for repair, and lower maintenance costs.

(b) *Beta stability* is defined as an element's ability to maintain its expected efficiency as differential pressure across the element increases. Differential pressure will increase as contamination is trapped, or with an increase in fluid viscosity (cold start). Beta stability is important because it relates to how well an element will perform in service over time. When the element is loaded with contamination, or when it is subjected to cold starts, will it perform as well as it did when new?

(c) *Dirt holding capacity (DHC)* is the amount of contamination that an element can trap before it reaches a predetermined "terminal" differential pressure. Dirt holding capacity is related to element life. Since elements with higher DHC need changed less frequently, DHC has a direct impact on the overall cost of operation. When selecting filter elements, it is beneficial to compare DHC of elements with similar particle removal efficiency.

(d) *Pressure Drop vs. Flow* is simply a measure of resistance to fluid flow in a system. It is important to consider the initial pressure drop ( $\Delta p$ ) across the filter element (and housing). Ideally, a filter element should be sized so that the initial pressure drop across the clean element (plus the filter housing drop) is less than half the bypass valve setting in the filter housing.

When selecting a filter element for your system, be sure to consider all four of these performance criteria. If an element is strong in three areas, but weak in another, it may not be the right choice. At every level of filtration, Schroeder's Excellement® Z-Media® elements offer the best combination of high efficiency, high beta stability, high dirt holding capacity, and low pressure drop.

## The Multi-pass Test

Filter element efficiency ratings, beta stability, and capacities are determined by conducting a multi-pass test under controlled laboratory conditions. This is a standard industry test with procedure published by the International Standards Organization (ISO 16889). The multi-pass test yields reproducible test data for appraising the filtration performance of a filter element including its particle removal efficiency. These test results enable the user to: (1) compare the quality and specifications offered by various filter element suppliers and (2) select the proper filter element to obtain the optimal contamination control level for any particular system.

Hydraulic fluid (Mil-H-5606) is circulated through a system containing the filter element to be tested. Additional fluid contaminated with ISO MTD Test Dust is introduced upstream of the element being tested. Fluid samples are then extracted upstream and downstream of the test element.

Dirt holding capacity is defined as the total grams of ISO MTD Test Dust added to the system to bring the test filter element to terminal pressure drop.

Figure 5. Multi-Pass Test Schematic

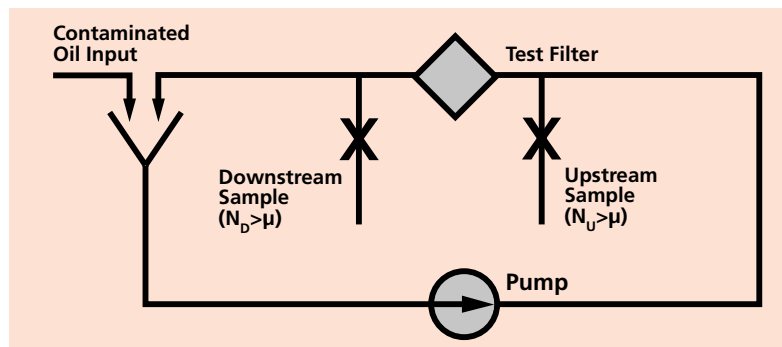

The filtration ratio (more commonly referred to as the Beta ratio) is, in fact, a measure of the particle capture efficiency of a filter element.

Per ISO 16889 
$$\beta_{x(c)} = \frac{\text{number of particles upstream @ } x(c) \text{ microns}}{\text{number of particles downstream @ } x(c) \text{ microns}}$$

where  $x(c)$  is a specified particle size.

$$\text{Example: } \beta_{10} = \frac{400}{100} = 4$$

This particle capture efficiency can also be expressed as a percent by subtracting the number 1 from the Beta (in this case 4) and multiplying it by 100:

$$\text{Efficiency}_{10} = \frac{(4 - 1)}{4} \times 100 = 75\%$$

The example is read as "Beta ten is equal to four, where 400 particles, 10 microns and larger, were counted upstream of the test filter (before) and 100 particles, 10 microns and larger, were counted downstream of the test filter (after)."

The filter element tested was 75% efficient in removing particles 10 microns and larger.

## Efficiency / Filtration Ratio (Beta)

To calculate a filter element's percent efficiency, subtract 1 from the Beta, divide that answer by the Beta, then multiply by 100.

### Example

Step 1:	$\beta_{10(c)} > +1000$
Step 2:	$1000 - 1 = 999$
Step 3:	$999 \div 1000 = .999\%$
Step 4:	$.999 \times 100 = 99.9\%$

## Efficiency

According to ISO 16889, each filter manufacturer can test a given filter element at a variety of flow rates and terminal pressure drop ratings that fit the application, system configuration and filter element size. Results may vary depending on the configuration of the filter element tested and the test conditions.

Currently, there is no accepted ISO, ANSI, or NFPA standard regarding absolute ratings. Some filter manufacturers use  $\beta_{x(c)} \geq 75$  (98.7% efficiency) for their absolute rating. Others use  $\beta_{x(c)} \geq 100$  (99.0% efficiency),  $\beta_{x(c)} \geq 200$  (99.5% efficiency), or  $\beta_{x(c)} \geq 1000$  (99.9% efficiency). Performance of Schroeder elements is shown in the Element Performance Chart for each filter housing in Sections 3 through 8 at a number of filtration ratios to allow the user to evaluate our performance against that of our competitors.

## Filtration Ratio

## Beta Stability

*Beta stability* is defined as an element's ability to maintain its expected efficiency as differential pressure across the element increases. Differential pressure will increase as contamination is trapped, or with an increase in fluid viscosity. An element's beta stability is displayed in the Filtration Ratio (Beta) vs. Differential Pressure curve from a typical multi-pass test report per ISO 16889. Good beta stability is demonstrated by consistent or improving efficiency as differential pressure builds across the element. Conversely, decreasing efficiency as pressure builds is a sign of poor stability. Poor beta stability is an indication of a filter element's structural deficiency. It is a sign of potential problems in a "real world" situation. Contamination, "cold starts", and flow surges can all create high differential pressure across an element that may cause efficiency to decrease if it is not structurally sound. In cases of "cold starts" and flow surges, the media structure in elements with poor stability can become permanently damaged in milliseconds. The result is lower efficiency and decreased system protection without warning to the operator. High beta stability results when an element is well-built with quality, durable materials. Strength of filter media and reinforcement layers, impervious seaming, proper end cap adhesion, and a rigidly supported structure all play a part in an element's beta stability. Excellement® media structure typically maintains beta stability over 100 psi.

**Example of poor beta stability – efficiency declines as differential pressure increases.**

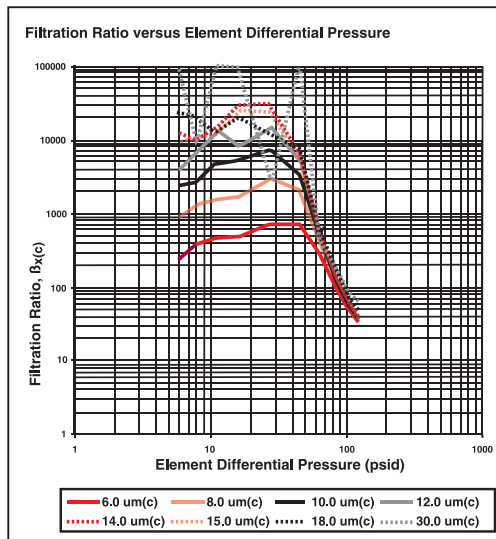

**Example of Excellement® beta stability – efficiency does not decline as differential pressure increases.**

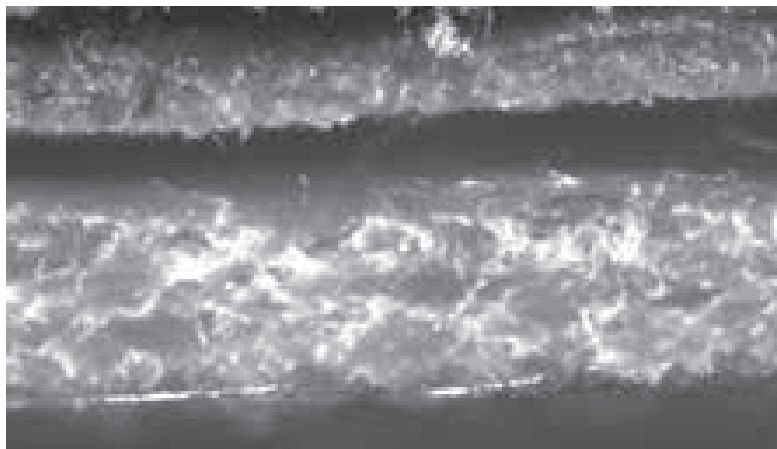
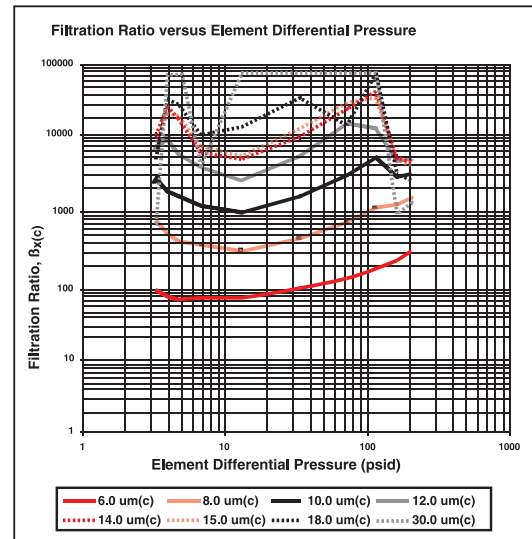

**Microscopic Photo - 50x magnification**

**Top: competitor's media      Bottom: Schroeder Excellement® Z-Media®**  
**Thin, weak media cannot withstand differential pressure as well as Z-Media®.**

This photo shows a comparison of our competitor's filtering layer media versus our Schroeder Excellement® Z-Media®. Schroeder Z-Media® offers better depth filtration to withstand a higher differential pressure and entrap more contaminant / particles.

Dirt holding capacity (DHC) is the amount of contaminant (expressed in grams) the element will retain before it goes into bypass. All other factors being equal, an element's DHC generally indicates how long the element will operate until it needs to be replaced. The element's life span is directly related to the cost of operating the filter.

Dirt holding capacity, sometimes referred to as "retained capacity," is a very important and often overlooked factor in selecting the right element for the application. The dirt holding capacity of an element is measured in grams of ISO medium test dust contaminant as determined from the multi-pass test (ISO 16889). When selecting filter elements, it is beneficial to compare the dirt holding capacities of elements with similar particle removal efficiencies.

## Dirt Holding Capacity

When sizing a filter, it is important to consider the initial differential pressure ( $\Delta P$ ) across the element and the housing. Elements offering a lower pressure drop at a high Beta efficiency are better than elements with a high  $\Delta P$  at the same efficiency. At every level of filtration, Schroeder's Excellement® Z-Media® elements offer the best combination of high efficiency, high stability, high dirt holding capacity, and low pressure drop. The pressure drop of an element is determined by testing according to ISO 3968.

## Pressure Drop

The collapse (crush) rating of a filter (determined by ISO 2941/ANSI B93.25) represents the differential pressure across the element that causes it to collapse. The collapse rating of a filter element installed in a filter housing, with a bypass valve, should be at least two times greater than the full flow bypass valve pressure drop. The collapse rating for filter elements used in filter housings with no bypass valve should be at least the same as the setting of the system relief valve upstream of the high-crush element. When a high collapse element becomes clogged with contamination all functions downstream of the filter will become inoperative.

## Collapse Rating



# Element Media Selection Considerations

## The Right Media for the Right Application = Job Matched Filtration

### Filtration Application Guidelines

Selecting the proper Schroeder media for your application is easy if you follow these simple guidelines.

**Step 1.** Remember that the key to cost effective contamination control is to maintain the system's cleanliness at the tolerance level of the system's most sensitive component. So, the first step is to identify the most sensitive component.

**Step 2.** Determine the desired cleanliness level (ISO Code) for that component by referring to Figure 3 on page 13 or by contacting the component manufacturer directly.

**Step 3.** Identify the Schroeder filter medium referencing Table 6 that will meet or exceed the desired cleanliness level.

**Step 4.** Remember to regularly check the effectiveness of the selected media through the use of contamination monitoring equipment.

**Table 6. Schroeder Element Media Recommendations**

Desired Cleanliness Levels (ISO Code)	Schroeder Media
20/18/15-19/17/14	Z25
19/17/14-18/16/13	Z10
18/16/13-15/13/10	Z5
15/13/10-14/12/9	Z3
14/12/9-13/11/8	Z1

### Effect of Ingression

Filter element life varies with the dirt holding capacity of the element and the amount of dirt introduced into the circuit. The rate of this ingression in combination with the desired cleanliness level should be considered when selecting the media to be used for a particular application. Table 7 provides recommendations accordingly.

The amount of dirt introduced can vary from day to day and hour to hour, generally making it difficult to predict when an element will become fully loaded. This is why we recommend specifying a Dirt Alarm®.

Schroeder-designed Dirt Alarms® provide a vital measure of protection for your system by indicating when the filter element needs to be changed or cleaned. Schroeder filters are available with visual, electrical and electrical-visual combination Dirt Alarms®. These indicators may also be purchased as separate items. For more information on Dirt Alarms®, see Appendix A.

**Table 7. Recommended Schroeder Media to Achieve Desired Cleanliness Levels Based on Ingression Level**

Desired Cleanliness Levels (ISO Code)	Ingression Rate	Schroeder Element Medium
20/18/15	High	Z25
19/17/14	Low	Z25
19/17/14	High	Z10
18/16/13	Low	Z10
18/16/13	High	Z5
15/13/10	Low	Z5
15/13/10	High	Z3
14/12/9	Low	Z3
14/12/9	High	Z1
13/12/9	Low	Z1

To obtain the desired cleanliness level (ISO Code) using the suggested Schroeder filter medium, it is recommended that a minimum of one-third of the total fluid volume in the system pass through the filter per minute. If fluid is filtered at a higher flow rate, better results may be achieved. If only a lesser flow rate can be filtered, a more efficient media will be required.

Systems operating in a clean environment, with efficient air-breather filters and effective cylinder rod wiper seals, may achieve the desired results at a lower turnover rate. Systems operating in a severe environment or under minimal maintenance conditions should have a higher turnover. Turnover must be considered when selecting the location of the system's filter(s).

Since the pressure drop versus flow data contained in our filter catalog is for fluids with a viscosity of 150 SUS (32.0 cSt), and a specific gravity of .86, we are often asked how to size a filter with a viscosity other than 150 SUS (32.0 cSt) or a specific gravity other than .86. In those instances where the viscosity or specific gravity is significantly higher, it may be necessary to use a larger element. To make this determination, we need to calculate the life of the element, using the following equation:

$$EL = RC - (H + E)$$

Where:

EL = Element Life (expressed in psi)

H = Housing pressure drop

RC = Relief valve cracking pressure

E = Element pressure drop

1. The housing pressure drop can be read directly from the graph. This value is not affected by viscosity or the number of elements in the housing, since housing flow is turbulent.
2. The element pressure drop is directly proportional to viscosity, since element flow is laminar.

Schroeder's "rule of thumb" for element life, as calculated from the above equation, is to work towards a differential pressure drop that is no more than half (50%) of the bypass setting.

The interval between element change outs can be extended by increasing the total filter element area. Many Schroeder filters can be furnished with one, two, or three elements or with larger elements. By selecting a filter with additional element area, the time between servicing can be extended for little additional cost.

Schroeder filters have been used successfully to filter a variety of fire resistant fluids for over five decades. Filtering these fluids requires careful attention to filter selection and application. Your fluid supplier should be the final source of information when using these fluids. The supplier should be consulted for recommendations regarding limits of operating conditions, material and seal compatibility, and other requirements peculiar to the fluid being used within the conditions specified by the fluid supplier.

### High Water Content Fluids

High water content fluids consist primarily of two types: water and soluble mineral base oil, and water with soluble synthetic oil. The oil proportion is usually 5%, but may vary from as low as 2% to as high as 10%.

Standard Schroeder Z1, Z3, Z5, Z10, and Z25 elements are compatible with both types of high water content fluids. Filter sizing should be the same as with 150 SUS (32 cSt) mineral based hydraulic oil. Z1 and Z3 elements may be used; however, element change outs will be more frequent. Some special factors that need to be considered in the selection process include the following:

- All aluminum in the filter housing should be anodized. This can be accomplished by using the "W" adder as shown in the filter model number selection chart.
- When using 95/5 fluids, check with fluid supplier for compatibility with aluminum.
- Buna N or Viton® seals are recommended.
- The high specific gravity and low vapor pressure of these fluids create a potential for severe cavitation problems. Suction filters or strainers should not be used. The Schroeder Magnetic Separator (SKB), page 327, with its low pressure drop, is recommended for pump protection from ferrous or large particles.

### Invert Emulsions

Invert emulsions consist of a mixture of petroleum based oil and water. Typical proportions are 60% oil to 40% water. Standard Schroeder filters with Z10 and Z25 media elements are satisfactory for use with these fluids. Filters should be sized conservatively for invert emulsions. These fluids are non-Newtonian—their viscosity is a function of shear. We recommend up to twice the normal element area be used as space and other conditions permit.

## Amount of Fluid Filtered

## Sizing a Filter Element

## Fluid Compatibility: Fire Resistant Fluids

## Fluid Compatibility: Fire Resistant Fluids (cont.)

Some special factors that need to be considered in the selection process include the following:

- Potential exists for cavitation problems with invert emulsions similar to high water based fluids. SKB suction separators are recommended for pump protection from ferrous or large particles.
- Buna N or Viton® seals are recommended.

### Water Glycols

Water glycols consist of a mixture of water, glycol, and various additives. Schroeder Z3, Z5, Z10 and Z25 elements are satisfactory for use with these fluids. Some special factors that need to be considered in the selection process include the following:

- All aluminum in the filter should be anodized. This can be accomplished by using the "W" option as shown in the filter model number selection chart.
- Potential exists for cavitation problems with water glycols similar to high water based fluids. SKB suction separators are recommended for pump protection from ferrous or large particles.
- Buna N or Viton® seals are recommended.

### Phosphate Esters

Phosphate esters are classified as synthetic fluids. All Schroeder filters and elements can be used with most of these fluids. Sizing should be the same as with mineral based oils of similar viscosity. Some special factors that need to be considered in the selection process include the following:

- For phosphate esters, specify EPR seals (designated by "H" seal option) for all elements. As a general rule, all Z-Media® (synthetic) is compatible and 10 and 25 μ only E media (cellulose) with phosphate esters.
- For Skydrol®, only 3, 5, 10, and 25 μ Z-Media® (synthetic) should be used, and "H.5" should be designated as the seal option. The "H.5" seal designation calls for EPR seals and stainless steel wire mesh in element construction.

### Pressure Drop Correction for Specific Gravity

Pressure drop curves shown in this catalog are predicated on the use of petroleum based fluid with a specific gravity of 0.86. The various fire resistant fluids discussed in this section have a specific gravity higher than 0.86, which affects pressure drop. Use the following formula to compute the correct pressure drop for the higher specific gravity:

$$\text{Corrected pressure drop} = \frac{\text{Fluid specific gravity}}{0.86} \times \text{Catalog pressure drop}$$

Viton® is a registered trademark of DuPont Dow Elastomers.

Skydrol® is a registered trademark of Solutia Inc.

# 7 Steps to Selecting a Filter

In the new era, systems are getting smaller and more compact, causing flow rates in hydraulic reservoirs to decrease, as well as a tighter space for overall reservoir components.

Without a properly sized filter and element in your machine's reservoir, operators can experience occurrences such as: foaming, cavitation, shortened fluid lifespan, poor response time from hydraulic valves, increase in replacement filter elements, and more valve and pump repairs.

In this section, we will walk you through our **7 Steps for Choosing the Correct Filtration**.

**Example Parameters:** A piston pump and servo system with 20 gpm (76 L/min) pump flow, 30 gpm (144 L/min) return flow, 4000 psi (275 bar) system pressure, and a total system volume of 60 gallons (227 liters), with a non-pressurized reservoir. The fluid is 150 SUS.

## Seven Steps to Selecting a Filter



### Step 1: "Operating Pressures"

Determine the operating pressure of the system you are looking to apply filtration to.



### Step 2: "Flow Rate"

Look at all of the characteristics of the fluid that is needing the filtration, including the flow rate.



### Step 3: "MVP Components"

Determine what component is the most critical to your operation.



### Step 4: "ISO Level"

Reference our chart on page 13 to determine the recommended ISO level of your MVP component (determined in Step 3). This will help you select what media type will help you achieve your cleanliness goal.



### Step 5: "Fluid Type"

Ask yourself "what type of fluid is being filtered?" and "what is my main contamination type?" (Reference contamination types on page 16).



### Step 6: "Temperature"

Determine the highest and lowest temperatures of your operating fluid.



### Step 7: "Piecing It All Together"

Based on the previous steps, you can now take the information learned, calculate overall system differential pressure, and determine the right choice for filtration.

By following these simple steps, we can guarantee you will see cleaner fluid. In addition, all major hydraulic components should be working to expectation, last longer, and ultimately save you and your company money.

# Filter Selection Considerations

## Filter Location

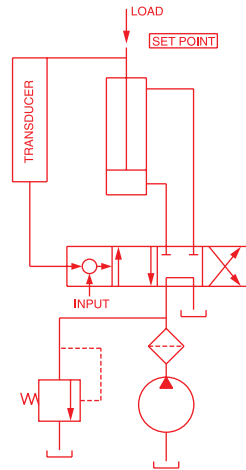

Figure 6(a). Pressure Filtration Circuit

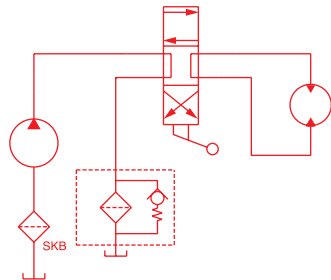

Figure 6(b). Return Line Filtration Circuit

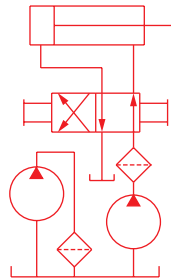

Figure 6(c). Re-circulating Filtration Circuit

**Pressure filtration:** Pressure filters usually produce the lowest system contamination levels to assure clean fluid for sensitive high-pressure components and provide protection of downstream components in the event of catastrophic failures. Systems with high intermittent return line flows may need only be sized to match the output of the pump, where the return line may require a much larger filter for the higher intermittent flows. See Figure 6(a).

**Return line filtration:** Return line filters are often considered when initial cost is a major concern. A special concern in applying return line filters is sizing for flow. Large rod cylinders and other components can cause return line flows to be much greater than pump output. Return lines can have substantial pressure surges, which need to be taken into consideration when selecting filters and their locations. See Figure 6(b).

**Re-circulating filtration:** While usually not recommended as a system's primary filtration (due to the high cost of obtaining adequate flow rates) re-circulating, or off-line, filtration is often used to supplement on-line filters when adequate turnover cannot be obtained with the latter. It is also often an ideal location in which to use a water removal filter. Off-line re-circulating filters normally do not provide adequate turnover flow rates to handle the high contamination loading occasioned by component failures and/or inefficient maintenance practices. See Figure 6(c).

**Suction filtration:** Micronic suction filters are not recommended for open-loop circuits. The cavitation these filters can cause significantly outweighs any advantage obtained by attempting to clean the fluid in this part of the system. SKB magnetic suction separators are recommended, as they will protect the pump from large and ferrous particles, without the risks of cavitation.

**Breather filtration:** Efficient filter breathers are required for effective contamination control on non-pressurized reservoirs and should complement the liquid filtration component.

**Multiple filtration:** For systems incorporating large total fluid volumes, it may be necessary to employ filters in more than one location. Multiple pressure filters, pressure and return line filters, and recirculating filters are examples of multiple filtration applications.

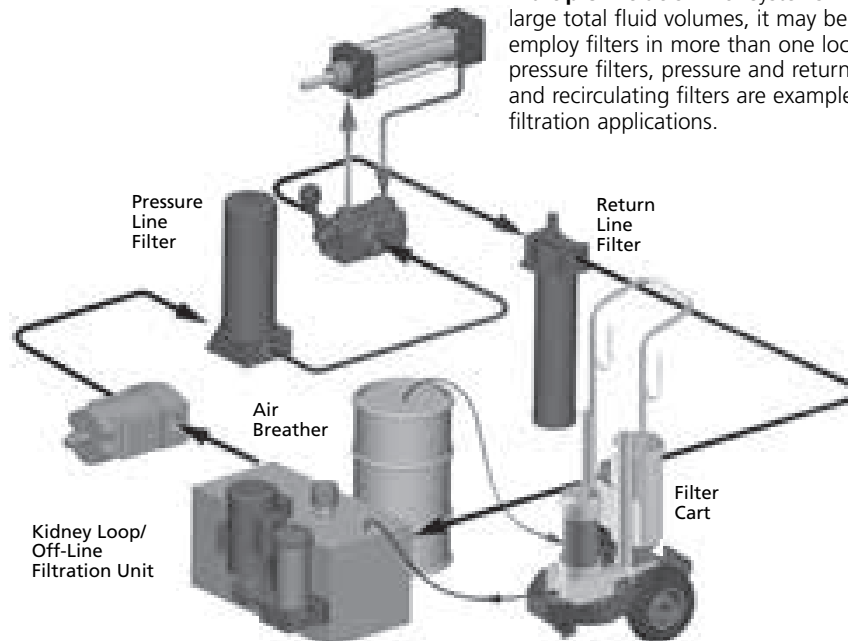



Parameters: A piston pump and servo system with 20 gpm (76 L/min) pump flow, 30 gpm (114 L/min) return flow, 4000 psi (275 bar) system pressure, and total system volume of 60 gallons (227 liters), with a non-pressurized reservoir.

**Step 1 example.** The servo valve is the system's most sensitive component. Referring to Figures 2 and 3 (page 13), you can see that a cleanliness level (ISO Code) of 16/14/11 or better is recommended for a high pressure system containing a servo valve.

**Step 2 example.** Table 8 recommends the Schroeder Z5 element media or finer to achieve a cleanliness level of 16/14/11.

**Step 3 example.** A combination of a pressure filter upstream of the servo valve and a return line filter would provide cost effective contamination control for servo systems.

**Step 4 example.** Filter model DF40, shown on page 65, is selected as the appropriate pressure filter because of its 30 gpm and 4000 psi capacities. A look at the Element Selection Chart for the DF40 located on page 67 verifies that the CZ5 element will handle 20 gpm, and the appropriate model number is DF40-1CZ5.

The ZT in-tank return line filter is selected for the 30 gpm return flow and the Z5 media. As shown in the model selection chart for the ZT on page 266, the proper model number to meet the specifications is ZT-8ZZ5.

**Step 5 example.** Using our Accessories Catalog; L-4329, select the ABF-3/10-S breather/strainer.

**Step 6 example.** Implement the appropriate manufacturing, assembly and maintenance contamination control procedures.

**Step 7 example.** Check start-up and ongoing system cleanliness (ISO Codes). Schroeder offers oil sampling kits that can be forwarded to a lab for particle counting and determination of cleanliness levels.

**Table 8. Schroeder Element Media Recommendations**

Desired Cleanliness Levels (ISO Code)	Schroeder Media
20/18/15-19/17/14	Z25
19/17/14-18/16/13	Z10
18/16/13-15/13/10	Z5
15/13/10-14/12/9	Z3
14/12/9-13/11/8	Z1

## Rated Fatigue Pressure

The application of individual filters should take fatigue ratings into consideration when there are flow or pressure variations creating pressure peaks and shock loads.

Typical hydraulic systems that use highly repetitive operations include plastic injection molding machines, die-cast machines, and forging and stamping press systems. In these and other similar applications, rated fatigue pressure should be considered when selecting a filter.

It has been common practice in the fluid power industry to establish component ratings for maximum operating pressure based on the minimum yield pressure, which is usually one third of the minimum yield pressure for higher-pressure components and one fourth of the minimum yield pressure for lower-pressure components. This rating method has proved satisfactory for many years, but it does not directly address the subject of fatigue.

The National Fluid Power Association has introduced a method (NFPA T2.6.1) for verifying the fatigue pressure rating of the pressure-containing envelope of a metal fluid power component. In this method, components are cycled from 0 to test pressure for 1 million cycles (10 million cycles is optional). The rated fatigue pressure (RFP) is verified by testing. We establish the desired RFP from design, then we calculate the cycle testing pressure (CTP), and then conduct tests at CTP per 1,000,000 cycles.

The T2.6.1 Pressure Rating document is available from the National Fluid Power Association, 3333 N. Mayfair Road, Milwaukee, WI 53222-3219.

**Table 9. Fatigue Pressure Ratings**

Model	Rated Fatigue Pressure psi (bar)	Model	Rated Fatigue Pressure psi (bar)
NF30/NFS30	2400 (165)	LW60	5800 (400)
YF30	1800 (125)	ZT	90 (6)
DF40/CF40	1800 (125)	RT/LRT	90 (6)
PF40	2500 (173)	QT/IRF	100 (7)
LC50	5000 (350)	KF3	290 (20)
CFX30	1800 (125)	KL3	300 (20)
RF60	3500 (240)	TF1	270 (19)
CF60	4000 (276)	LF1/MLF1	250 (17)
VF60	3300 (230)	RLD	350 (24)
KF30	2500 (170)	RLT	750 (52)
TF50	3500 (240)	GH	725 (50)
KF50/KC50	3500 (240)	GHHF	725 (50)
KFH50	3500 (240)	SRLT	750 (52)
MKF50	3500 (240)	KF8/QF5/3QF5	500 (35)
KC65	5500 (380)	K9/2K9/3K9	750 (52)
NOF50-760	4000 (275)	QF15/QLF15/SSQLF15	800 (55)
FOF60/PF40	4000 (275)	HS60	6000 (415)
CTF60	6000 (415)		

Contact Factory For: RF550, FOF30, NOF30-05, MTA, MTB, KT, BFT, PAF1, MAF1, MF2, RTI, KTK, LTK, QF5 and QFD5 Fatigue Ratings. All water service and GeoSeal® models match their standard model for Rated Fatigue Pressure.

## Manifold Mounting

In some filtration applications, it is advantageous to have the inlet and outlet ports mount directly onto a block without any hydraulic hose in between. Schroeder offers several such manifold-mounted filter models, including NFS30, YF30, PF40, LC50 DF40, RF550, KF30, TF50, KF50, KC50, and KFH50. Drawings for these porting options are labelled "Optional Subplate Porting" and are included on respective catalog pages.

## No-Element Indicator

The No-Element Indicator is a unique, patented signaling device designed to alert the user if no filter element is present in the housing. This virtually eliminates any possible confusion on the part of the user that the filter contains an element and is functioning in a normal manner.

The tamper proof system utilizes a patented internal valve design. If the element is not installed in the housing, the valve restricts flow, causing a high pressure drop. The high pressure drop, in turn, causes the Schroeder Dirt Alarm® to indicate that the element is not installed in the housing.

The only way to deactivate the indicator is to install the element in the housing.

This feature is available in the following filter models: RT, TF1, KF3, CF40, DF40, CF60, TF50, KF30, KF50, KC50, KC65, and MKF50 that are equipped with a Schroeder Dirt Alarm®. No-element indicator is not available when the indicator is placed in the cap in base-ported filters.

# Ordering Information

For each filter that is shown in Sections 3, 4, 5, and 6 there is a Model Number Selection Chart. This chart lists all the configurations and accessories available for that specific filter.

Model numbers for all Schroeder filters are formulated by listing the appropriate codes, from left to right, according to the designated boxes shown in the chart. The letter or letter/number combination identifies the basic filter series. For instance, as shown in Figure 7, KF30-3KZ3-P-D5 designates a KF30 high-pressure, base-ported filter with three synthetic 3 µ elements, Buna N seals, 1½" NPTF porting, and a visual cartridge Dirt Alarm®.

**Figure 7. Model Number Selection**

## How to Build a Valid Model Number for a Schroeder KF30:

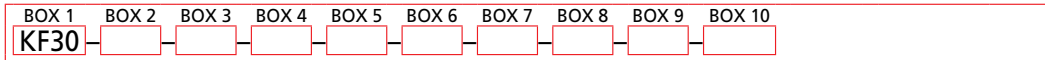

**Example:** NOTE: Only boxes 8 and 10 may contain more than one option

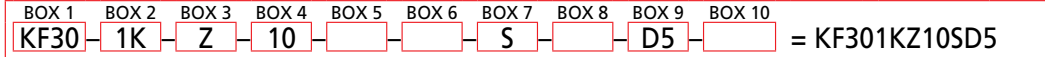

Filter Series	Number & Size of Elements	Media Type	Seal Material	Magnet Option
<b>KF30</b> <b>KFN30</b> (Non-bypassing: requires ZX high collapse elements) <b>GKF30</b> (GeoSeal®) <b>KF50</b> <b>KFN50</b> (Non-bypassing: requires ZX high collapse elements) <b>GKF50</b> (GeoSeal®)	1 = K, KK, 27K 2 = K 3 = K  <b>GeoSeal® Options</b> 1 = KG, KKG, 27KKG 2 = KG 3 = KG	Omit = E Media (Cellulose) AS = Anti-Stat Media (synthetic) Z = Excellement® Z-Media® (synthetic) ZW = Aqua-Excellement® ZW Media ZX = Excellement® Z-Media® (High Collapse centertube) W = W Media (water removal) M = Media (reusable metal mesh) N size only	Omit = Buna N V = Viton® H = EPR H.5 = Skydrol® compatibility	Omit = None M = Magnet inserts (not available w/ indicator in cap)
	<b>Micron Rating</b> 1 = 1 Micron (Z, ZW, ZX media) 3 = 3 Micron (AS, E, Z, ZW, ZX media) 5 = 5 Micron (AS, Z, ZW, ZX media) 10 = 10 Micron (AS, E, M, Z, ZW, ZX media) 25 = 25 Micron (E, M, Z, ZW, ZX media) 60 = 60 Micron (M media) 150 = 150 Micron (M media) 260 = 260 Micron (M media)	<b>BOX 4</b> <b>Dirt Alarm® Options</b> Omit = None D = Pointer D5 = Visual pop-up Visual D5C = D5 in cap D9 = All stainless D5 Visual with Thermal Lockout D8 = Visual w/ thermal lockout D8C = D8 in cap Electrical MS5 = Electrical w/ 12 in. 18 gauge 4-conductor cable MS5LC = Low current MS5 MS10 = Electrical w/ DIN connector (male end only) MS10LC = Low current MS10 MS11 = Electrical w/ 12 ft. 4-conductor wire MS12 = Electrical w/ 5 pin Brad Harrison connector (male end only) MS12LC = Low current MS12 MS16 = Electrical w/ weather-packed sealed connector MS16LC = Low current MS16 MS17LC = Electrical w/ 4 pin Brad Harrison male connector Electrical with Thermal Lockout MS5T = MS5 (see above) w/ thermal lockout MS5LCT = Low current MS5T MS10T = MS10 (see above) w/ thermal lockout MS10LCT = Low current MS10T MS12T = MS12 (see above) w/ thermal lockout MS12LCT = Low current MS12T MS16T = MS16 (see above) w/ thermal lockout MS16LCT = Low current MS16T MS17LCT = Low current MS17T Electrical Visual MS = Cam operated switch w/ ½" conduit female connection MS13DC = Supplied w/ threaded connector & light MS14DC = Supplied w/ 5 pin Brad Harrison connector & light (male end) Electrical Visual MS13DCT = MS13 (see above), direct current, w/ thermal lockout MS13DCLCT = Low current MS13DCT MS14DCT = MS14 (see above), direct current, w/ thermal lockout MS14DCLCT = Low current MS14DCT	<b>BOX 5</b> <b>Porting</b> P = 1 ½" NPTF P32 = 2" NPTF S = SAE-24 F = 1 ½" SAE 4-bolt flange Code 61 F32 = 2" SAE 4-bolt flange Code 61(KF30) *KF30 Only O = Subplate B24 = ISO 228 G-1 ½"	<b>BOX 6</b> <b>Options</b> Omit = None X = Blocked bypass 50 = 50 psi bypass setting L = Two ¼" NPTF inlet & outlet female test ports U = Series 1215 7/8 UNF Schroeder Check Test Point installed in cap (upstream) UU = Series 1215 7/8 UNF Schroeder Check Test Point installed in block (upstream and downstream)
	<b>BOX 7</b> <b>Additional Options</b> Omit = None N = No-Element Indicator (not available w/ KFN30/KFN50/GKF30/GKF50 or housings w/ indicator in cap) G509 = Dirt Alarm and drain opposite standard G588 = Electric Switch and drain opposite standard	<b>BOX 8</b> <b>Additional Options</b> Omit = None N = No-Element Indicator (not available w/ KFN30/KFN50/GKF30/GKF50 or housings w/ indicator in cap) G509 = Dirt Alarm and drain opposite standard G588 = Electric Switch and drain opposite standard		

## Model Number Selection

### NOTES:

- Box 2.** Number of elements must equal 1 when using KK or 27K elements. Replacement element part numbers are identical to contents of Boxes 2, 3, 4 and 5. Double and triple stacking of K-size elements can be replaced by single KK and 27K elements, respectively. ZW media not available in 27K length.
- Box 5.** H.5 seal designation includes the following: EPR seals, stainless steel wire mesh on elements, and light oil coating on housing exterior. Viton® is a registered trademark of DuPont Dow Elastomers. Skydrol® is a registered trademark of Solutia Inc.
- Box 7.** For options F & F32, bolt depth .75" (19 mm).  
  
For option O, O-rings included; hardware not included.
- Box 8.** X and 50 options are not available with KFN30.
- Box 9.** Standard indicator setting for non-bypassing model is 50 psi unless otherwise specified.
- Box 10.** Options N, G509 and G588 are not available with KFN30. N option should be used in conjunction with dirt alarm.

## Element Selection Chart for Flow Requirements

For each filter shown in the catalog, there is an element selection chart to determine the correct element to be used for a particular flow requirement (see Figure 8 for an example). The chart uses a petroleum-based hydraulic fluid with 150 SUS viscosity.

The process involves the following: Determine the working pressure of the system (3000 psi in this example) and the maximum flow (75 gpm). Then select the media (Z-Media®), and the micron filtration (3 μ). For example, the filter selected, following the above steps, is a KF30-2KZ3-P-D5. If the system pressure is 5000 psi and all other parameters are the same, then the model number would be KF50-2KZ3-P-D5.

Figure 8. KF30 Housing and Element Selection Chart for Flow Requirement

Pressure	Element		Element selections are predicated on the use of 150 SUS (32 cSt) petroleum based fluid and a 40 psi (2.8 bar) bypass valve.						
	Series	Part No.	1K3	2K3	3K3	See MFK50			
To 3000 psi (210 bar)	E Media	K3	1K3	2K3	3K3	See MFK50			
		K10	1K10	2K10	3K10	3K10	See MFK50		
		K25	1K25			2K25			
	Z Media	KZ1	1KZ1	2KZ1		3KZ1			
		KZ3	1KZ3		2KZ3	3KZ3			
		KZ5	1KZ5			2KZ5	3KZ5		
		KZ10	1KZ10			2KZ10	3K10		
		KZ25	2KZ25			2KZ25			
	Flow	gpm	0	25	50	75	100	125	150
		(L/min)	0	100	200	300	400	500	600

Shown above are the elements most commonly used in this housing.   requires 2" porting (P32)

Element pressure drop information in this publication is based on the viscosity (150 SUS or 32 cSt) and specific gravity (0.86) of the most commonly used hydraulic oils.

If the viscosity or specific gravity of the fluid you are designing for is different from these, use the following formulas to obtain the correct ΔP values.

$$\text{Corrected element } \Delta P = \Delta P \text{ from curve} \times \frac{\text{SUS viscosity}}{150} \times \frac{\text{specific gravity}}{0.86}$$

OR

$$\text{Corrected element } \Delta P = \Delta P \text{ from curve} \times \frac{\text{cST viscosity}}{32} \times \frac{\text{specific gravity}}{0.86}$$

## Correcting for Viscosity and Specific Gravity

# FILTER ELEMENTS



# Schroeder Element Media

## Z-Media® Elements (Synthetic)



**Schroeder**  
ORIGINAL ELEMENTS

### EXCELLEMENT

Synthetic Microglass Filtration Media

The special class of micro-glass and other fibers used in Z-Media® are manufactured with utmost precision, to specific thicknesses and densities, and bonded with select resins to create material with extra fine passages. No other filter media can provide the benefits of Schroeder's Excellement® Z-Media®: maximum dirt-holding capacity, superior particle capture, excellent beta stability, minimum pressure drop, high flow rate and low operating cost.

The typical multiple layer construction (shown in Figure 9) has evolved from comprehensive laboratory testing to provide extended element life and system protection. Each successive layer performs a distinct and necessary function. The outermost layer is designed to maintain element integrity. Beyond this layer is a spun bonded scrim, offering coarse filtration and protection for the filtering layers within. Multiple sheets of fine filtering media follow, providing intricate passageways for the entrapment of dirt particles. Together, the various layers of filter media provide the ideal combination for peak filtration performance.

**Figure 9. Cutaway of Excellement® Z-Media®**

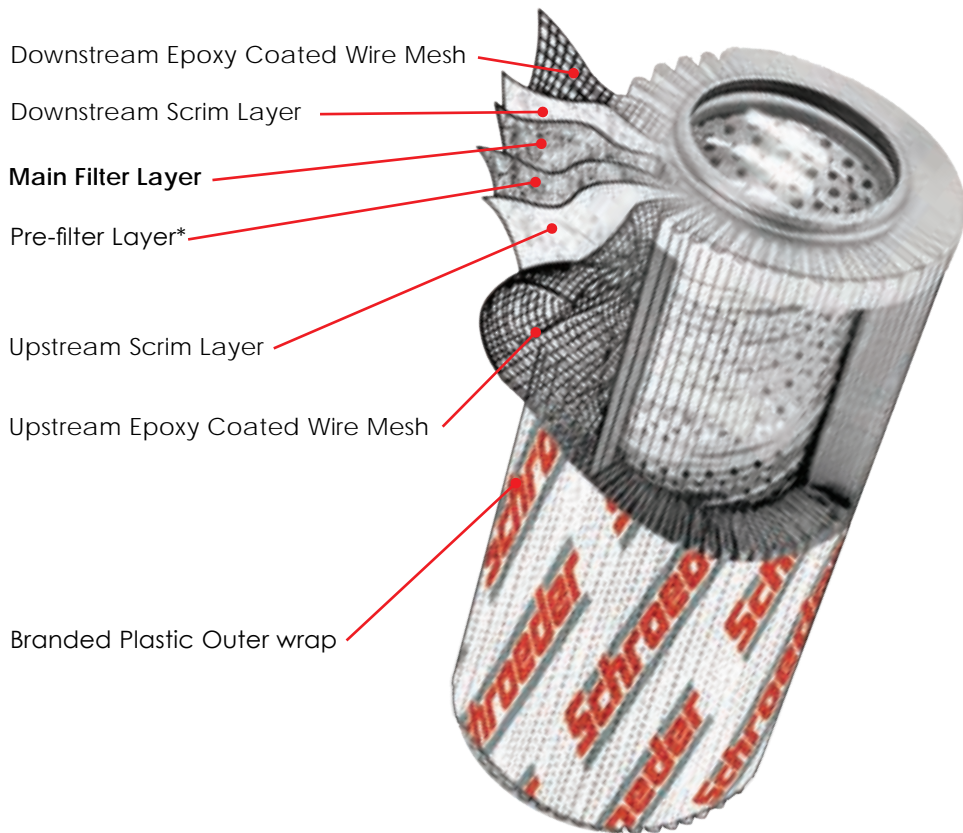

Schroeder's complete line of quality filtration elements—including Schroeder's original element designs, BestFit® replacement elements, CoreCentric® coreless elements and DirtCatcher®—are manufactured with Excellement® Z-Media®.

The better efficiencies, excellent stability, lower pressure drops, and higher dirt holding capacities provided by Excellement® Z-Media® mean cleaner oil, longer element life, and less downtime. They outlast, outperform, and excel in every measurable benchmark.

The Excellement® Z-Media® series of filter elements have been designed, tested, and proven to be the best performing elements available on the market today.



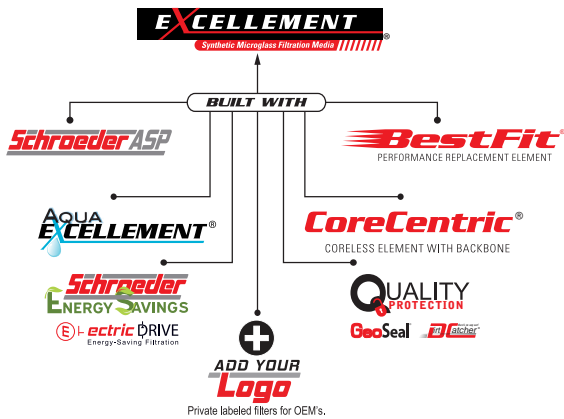

- **Better flow characteristics:**  
Lower pressure drop and improved flow stability
- **Improved efficiency:**  
Cleans oil in less time and improved reliability
- **Higher dirt holding capacity:**  
Longer element life, lower maintenance costs (labor) and decreased inventory costs (parts)
- **Multi-layer construction:**  
Each layer performs a distinct function
- **Beta stability:**  
Excellement® Z-Media® maintains efficiency as differential pressure increases

## Features and Benefits

Schroeder Z-Media® elements are tested under cyclic flow conditions to verify flow fatigue characteristics. Extra strength and rigidity are engineered into every one of these filter elements through the use of epoxy-coated steel wire mesh and additional support layers. (ZX Series high crush strength capabilities are available for 3000 psi applications.)

A wide range of Schroeder Z-Media® elements enable you to achieve the desired cleanliness level for your system. Developed through comprehensive laboratory testing and field performance studies, these elements have been proven effective. Shown in Table 10 are cleanliness levels that can be achieved using Z-Media® filter elements in various applications.

**Table 10. Typical Field Application Results**

Application	Cleanliness* Level
Railroad Maintenance-of-Way Equipment	ISO 19/17/14
Power Generation Turbine Skid	ISO 17/15/13
Timber Harvesting Equipment	ISO 17/15/12
Plastic Injection Molding Machine	ISO 17/15/12
Paper Mill Lube System	ISO 16/14/11
Aircraft Test Stand	ISO 15/13/10
Hydraulic Production Test Stand	ISO 13/11/8

\*Higher or lower levels can be obtained by selecting coarser or finer Schroeder Z-Media®, respectively.

## Excellement® Elements Have Improved Filtration Ratios

Table 11 shows the ISO 16889 filtration ratios (Betas) for Schroeder Z-Media® elements Z1, Z3, Z5, Z10 and Z25. Figure 10 depicts the information in Table 11 graphically and provides corresponding % efficiencies. The numbers contained in the tables are simply specific data points from the plots for the respective media shown. The filtration ratio (Beta) is shown on the left side and the equivalent particle capture efficiency (%) is shown on the right for particle sizes shown across the bottom. The filtration ratio (in Table 13) indicates the particle size at which the filtration ratio for the element is greater than a given number.

**Table 11. Z-Media® Filtration Ratios**

Element Media	Filtration Ratio Per ISO 16889			
	$\beta_x(c) \geq 75$ (98.7%)	$\beta_x(c) \geq 100$ (99%)	$\beta_x(c) \geq 200$ (99.5%)	$\beta_x(c) \geq 1000$ (99.9%)
Z1	<4.0	<4.0	<4.0	4.2
Z3	<4.0	<4.0	<4.0	4.8
Z5	<4.0	4.2	4.8	6.3
Z10	6.8	7.1	8.0	10.0
Z25	16.3	17.1	19.0	24.0

Schroeder offers a line of high crush media elements with a collapse rating of 3000 psid for use in its non-bypass version of filter housings, which include the: NFN30, DFN40, CFN40, RFN60, CFN60, TFN50, KFN30, KFN50, KCN50, MKFN50, KCN65, FOF30, FOF60 and NOF30.

## Series ZX High Collapse Elements (Synthetic)



**Schroeder**  
ORIGINAL ELEMENTS

**Excellement  
Elements Have  
High Dirt  
Holding  
Capacities**



Dirt holding capacity (DHC), simply stated, is the amount of solid contamination that an element can hold before the filter housing reaches its terminal bypass setting. The higher the dirt holding capacity, the longer the element will last. This translates to fewer element purchases, less frequent equipment shutdowns, decreased maintenance time, and reduced inventory. In short, it means money saved.

**Figures 11(a) - 11(e). DHC Comparison for Z-Media® Elements and Competition**

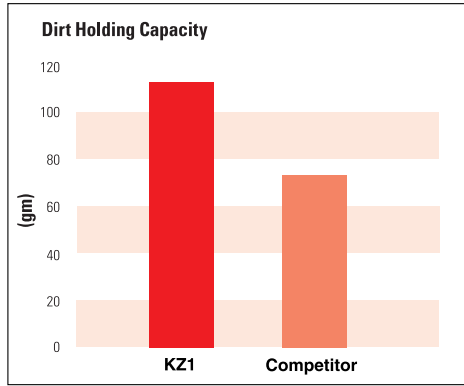

11(a)

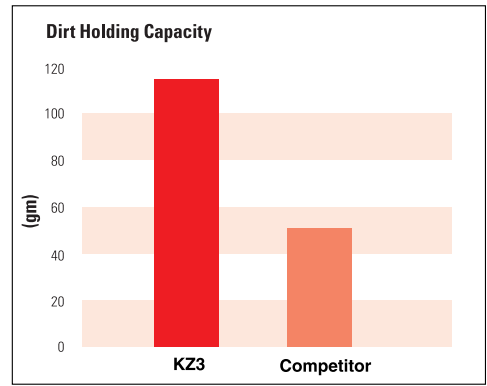

11(b)

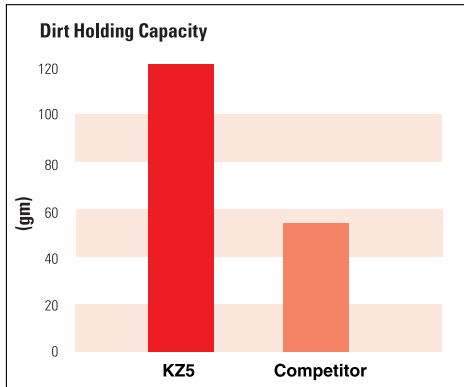

11(c)

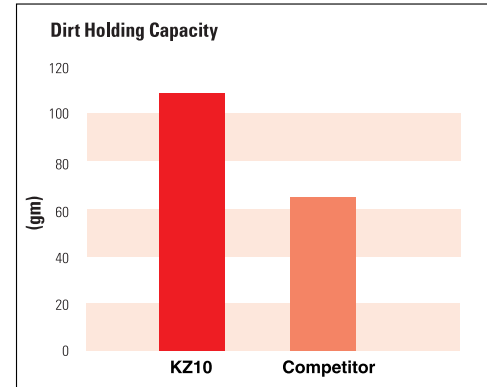

11(d)

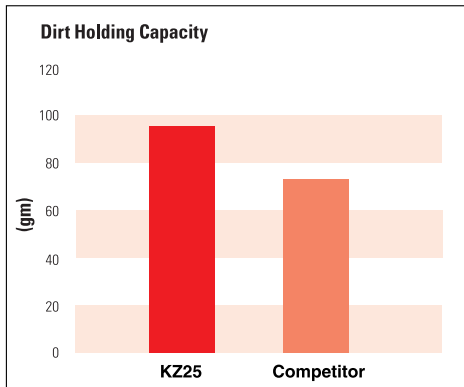

11(e)

**Table 12. Typical Dirt-Holding Capacities for Z-Media® Element (in grams)**

Type Medium	Element Size (Diameter x Length)				
	2" x 6" 6R	3" x 8" 8T	4" x 9" K	5" x 18" BB	6" x 39" Q
Z1	15	51	112	268	1485
Z3	15	52	115	275	1525
Z5	16	59	119	301	1536
Z10	14	55	108	272	1432
Z25	15	56	93	246	1299

The data shown represents the cumulative results of multi-pass tests in accordance with ISO 16889. Tests are conducted on a regular basis at Schroeder's own laboratory and at approved independent facilities.



A monetary value can be calculated for a filter element by considering its dirt holding capacity and efficiency in combination with its cost. To make this determination, first find out how much you're spending to clean your fluid to a desirable cleanliness level. Then figure out how much contamination (in grams) that the element is actually retaining. These two numbers will make it possible to calculate the grams of dirt per dollar spent. It's one thing to clean the oil, but it's another to clean the oil and simultaneously provide maximum element life. With Excellement® Z-Media®, you don't need to sacrifice element life to achieve high efficiency.

We are confident that the high efficiencies, exceptional dirt holding capacities, and low pressure drops—combined with Schroeder's competitive prices—make elements made with Excellement® Z-Media® the best value in the market today.

**Cost Per Gram  
Analysis/  
Excellement®  
Efficiency**

**Figure 12. Grams of Dirt Retained per Dollar Spent**

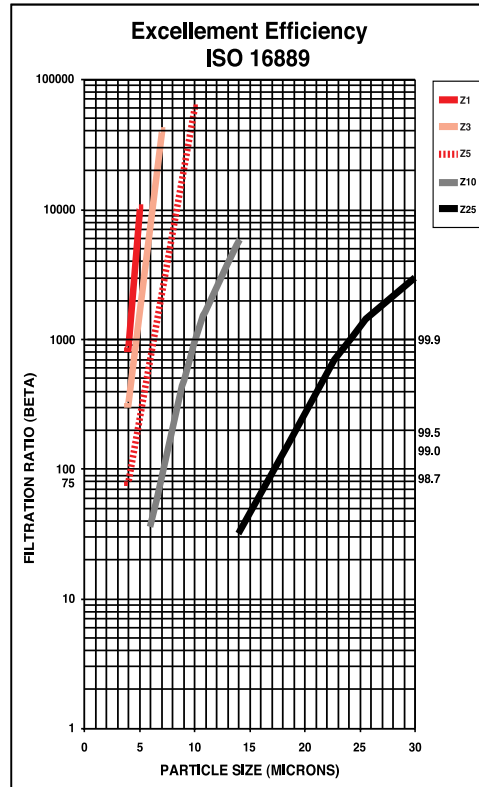
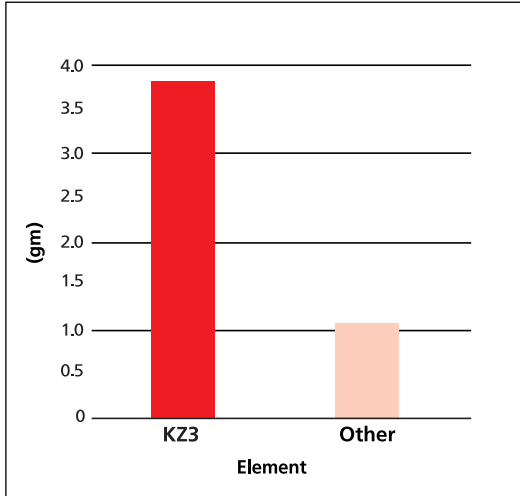

**Figure 10. Z-Media® Excellement® Efficiency**

## Element Case Weights

In proportion to the high volume of filter elements we make and ship, one of the most frequently asked questions our order desk receives involves the weights of various cases of elements. In an effort to include this information in this edition of the catalog, we made the assumption that the various micron ratings within a media type weigh the same; i.e., a KZ1 weighs approximately the same as a KZ25.

The following table represents our findings given the above assumption.

	Case Lot	Weight (lb.)		Case Lot	Weight (lb.)		Case Lot	Weight (lb.)			
A	paper	12	7	K	paper	12	17	8Z	paper	12	12
AZ	synthetic (Z)	12	8	KZ	synthetic (Z)	12	22	8ZZ	synthetic (Z)	12	13
BB	paper	6	29	KW	Water Removal	12	18	9V	synthetic (Z)	12	14
BBZ	synthetic (Z)	6	29	KK	paper	6	18	14V	synthetic (Z)	6	10
C	paper	12	7	KKZ	synthetic (Z)	6	20	14C	synthetic (Z)	6	11
CZ	synthetic (Z)	12	8	27K	paper	6	20	18L	synthetic (Z)	6	20
CC	paper	12	11	M	paper	12	33	39Q	paper	1	17
CCZ	synthetic (Z)	12	15	N	paper	12	4	39QPML	synthetic (Z)	1	18
FZX3	synthetic (Z)	12	3	NZ	synthetic (Z)	12	7	39QCL	synthetic (Z)	1	11
FZX10	synthetic (Z)	12	3	NN	paper	12	6	16Q	paper	1	8
6G	synthetic (Z)	12	8	NNZ	synthetic (Z)	12	9	16QPML	synthetic (Z)	1	15
9G	synthetic (Z)	12	13	6R	synthetic (Z)	12	10	16QCL	synthetic (Z)	1	3

# GeoSeal®

U.S. Patent D658740

Far too often, customers make purchasing decisions based solely on price, only to be extremely disappointed with the poor quality delivered by low cost imitations. To make the matter worse, the customer often points an accusing finger at the filter housing manufacturer for poor performance, rather than the inadequate element they used as a replacement for the original Schroeder element.

GeoSeal® is a patented offering from Schroeder that provides a unique way for OEM's to retain replacement element business and to keep a filter's performance at the level that it was supplied. The idea is brilliantly simple: the critical sealing arrangement between a filter housing and its replacement element takes on a shape other than the standard circular arrangement. Specifically, the element grommet & mating bushing are given a new geometric shape. Figures 1 & 2 show the initial configuration being used.



Figure 1. Filter element with GeoSeal grommet.



Figure 2. Filter housing (cut-away) with GeoSeal bushing.

## Availability

Currently, the GeoSeal® design is available on the K-size element and in the following Schroeder filter series: KF30, KF50, KC50, KC65, MKF50, K9, 2K9, 3K9, KF3, KL3, MLF1, KF5, RT, ZT, and LRT.

## How To Order

To order the filter housing and element incorporated with the GeoSeal® design:

- "G" is added to the front of the housing model code (KF30, KF50, KC50, KC65, MKF50, KF3, KL3, MLF1, KF5, K9, 2K9, 3K9, RT, ZT, and LRT).
- "BG" is added to the element model code for RT (one end of the element has the GeoSeal®; the other end has an integrated bypass valve)

## GeoSeal® Filters Selection Guide

	Pressure psi (bar)	Flow gpm (L/min)	Element Length/Size	Page	
GeoSeal® Filters	<b>High Pressure GeoSeal® Filters</b>				
	GKF30 GeoSeal®	3000 (210)	100/150 (380/570)	KG, KKG, 27KG	97
	GKF50 GeoSeal®	5000 (345)	100/150 (380/570)	KG, KKG, 27KG	97
	GKC50 GeoSeal®	5000 (345)	100/150 (380/570)	KG, KKG, 27KG	105
	GMKF50 GeoSeal®	5000 (345)	200 (760)	KG, KKG, 27KG	109
	GKC65 GeoSeal®	6500 (450)	100 (380)	KG, KKG, 27KG	113
	<b>Medium Pressure GeoSeal® Filters</b>				
	GKF5 GeoSeal®	500 (35)	100 (380)	KG	161
	GK9 GeoSeal®	900 (60)	100 (380)	KG, KKG, 27KG	169
	G2K9 GeoSeal®	900 (60)	100 (380)	KG, KKG, 27KG	173
	G3K9 GeoSeal®	900 (60)	100 (380)	KG, KKG, 27KG	173
	<b>Low Pressure GeoSeal® Filters</b>				
	GKF3 GeoSeal®	300 (20)	100 (380)	KG, KKG, 27KG	219
	GKL3 GeoSeal®	300 (20)	120 (455)	KG, KKG, 27KG, 18LG	223
	GMLF1 GeoSeal®	300 (20)	200 (760)	KG	231
GZT GeoSeal®	100 (7)	40 (150)	8GTZ	251	
GRT GeoSeal®	100 (7)	100 (380)	KBG, KKBG, 27KBG	259	
GLRT GeoSeal®	100 (7)	150 (570)	18LG	267	

# Private Labeled Elements

Schroeder offers a full line of branding solutions for air breathers, spin-ons, and replacement elements. Using the Element Private Label Form (L-2993), OEMs can obtain Schroeder elements with their very own custom logo (for Spin-on elements and air breathers, reference L-2994 on our website). Furnishing elements with custom branding enables OEMs to capture their aftermarket element business. Custom labeled products also protect against the use of unauthorized elements, thus reducing the potential of field warranty issues. Additionally, private branded products are proprietary and will not be shared with others without written consent from the OEM.

## Steps for Establishing an Outer Wrap/End Cap Markings

1. Elements can be private labeled by marking the end caps, adding a private labeled plastic outerwrap, or both.
2. Customer name and part number will be etched on to one of the end caps with Schroeder date codes unless otherwise specified.
  - a. Logos can be laser etched onto the end cap if space allows on the desired element (a .DXF file of the logo is required).
3. When requesting a plastic outer wrap, the customer must supply all artwork in a vector file format (.AI or .EPS).
4. Once the artwork is received, a RIP file (used to print the wrap) will be created and a sample swatch will be provided for customer approval (average lead time is approximately 2 weeks).
5. The sample printed polyester swatch will be sent to the customer for approval. The sample swatch can be temporarily wrapped around a SBF-9600-8 element, but this must be requested.
6. Once the customer has approved the sample, element part numbers (specific to element size) can be established and structured. Cost, delivery and required minimum quantity may depend on element size and private labeling style.



## Packaging Capabilities

Schroeder has the ability to brand both individual and master cartons as requested. We can apply the customer name, part number, logo (black and white - .jpg file), and other customer texts. Bar coding and customer pre-printed boxes can also be requested (set up fees and minimum order quantities are required for customer pre-printed boxes).

## Extra Aftermarket Retention Advantages:

Incorporating a private labeling program has shown that upwards of 60% of aftermarket element business is retained. Instituting of a private branding program also protects against the use of inferior and/or unqualified replacement element substitutions.

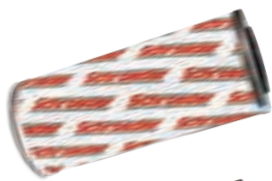

**1. Schroeder Branding**  
Expected Retention Rate:

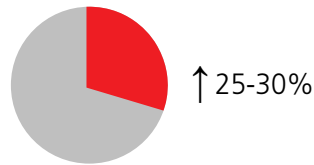

**2. OEM Branding**  
Expected Retention Rate:

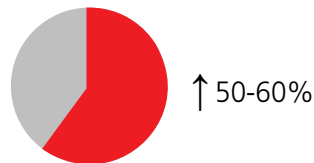

**3. OEM Branding with Aftermarket Protection**  
- Exclusive to OEM  
Expected Retention Rate:

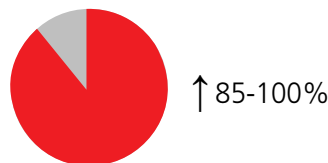

## Anti-Static Pleat Elements



## Schroeder ASP

During the production of hydraulic oils, “additive packages” are introduced into the base oils to give the fluids certain characteristics they need for the demanding conditions of today’s systems. The additives improve viscosity, reduce friction, prevent wear, and allow the fluid to tolerate high temperatures without oxidation. Some oils are produced with toxic aromatics and heavy metals, with a high electrical conductivity, but because of their toxicity and potential threat to the environment, they no longer comply with current, international environmental standards. Other groups of oils are produced with the appropriate, approved additive packages, often labeled as highly refined or synthetic. They contain no toxins or carcinogens, and are free of heavy metals, but due to their metal-free nature, they have a lower electrical conductivity rating. Low electrical conductivity means that any charges that are generated through the oil flow may not be dissipated quick enough, thus causing sparking. Ultimately, this can cause explosions in the reservoir or damages in vital hydraulic components, such as valves and filters.

The sparks can also interfere with or damage expensive electronic components, and form oil-ageing deposits, such as varnish. Varnish then settles on the oily surfaces of the vital components and has a detrimental effect on how well your machine functions. Potential consequences of varnish also includes seized valve spools, overheated solenoids, and extremely short filter element service life.

The Anti-Static Pleat Media (ASP®) element was developed to greatly reduce or eliminate electrostatic discharging problems that can occur during filtration of hydraulic and lube fluids. By combining proven Excellement® media and ASP® technology, it is now possible to offer both high filtration efficiency and electrical conductivity.

### Other key areas that can contribute to Electrostatic Discharge:

- Filter Media – media layer construction can influence high voltage charge
- Hydraulic Fluids – group II and III have low conductivity
- Temperature – higher voltage charge will generally exist with lower temperature

## DirtCatcher® Elements



## DirtCatcher®

Patent # 7384547

DirtCatcher® elements from Schroeder offer a superior alternative to inside-out filtration. The patented outer shell prevents contaminants from falling back into the system during element changes while still providing the excellent dirt retention of Excellement® media. DirtCatcher® elements are currently available in single and double length K, BB, and 18L size elements, and feature Excellement® media within.

Currently, DirtCatcher® elements can be purchased separately or as part of our RT, KF3, KF8, BFT, and LRT filter assemblies.

The DirtCatcher® solution provides peace of mind to those concerned with dirt escaping from elements during the removal process while delivering all the advantages of Schroeder original (outside-in flow) elements:

- Better Pressure Drop
- Greater Surface Area
- Better Pleat Stability

This design is only available from Schroeder. It goes without saying that DirtCatcher’s unique design also allows OEM’s to retain 100% of after-market business.

# BestFit®

Schroeder Industries manufactures over 2000 BestFit® performance replacement elements. In addition, Schroeder Industries produces all of the technical data to support the sale of these products. The BestFit® family consists of standard cartridge and spin-on replacements, CoreCentric® coreless elements, high collapse elements, and the melt-blown and spun-bonded process filtration elements. Most importantly, we offer the easiest way to determine the Schroeder equivalent of more than 42,000 competitive elements using the Schroeder online element search, accessible through our web site at [www.schroederindustries.info](http://www.schroederindustries.info).

Simply clicking on “BestFit® Element Cross Reference” on the Schroeder Industries home page ([www.schroederindustries.com](http://www.schroederindustries.com)) allows you to match filter elements by entering either the manufacturer’s name or part number.

There are two ways to search on the Schroeder BestFit® cross reference page. The first way is to type a competitor element part number in the search bar. When searching by competitor part number, the search will activate as soon as three characters are entered (no spaces or symbols). The second way is to use the two drop down menus to find the competitor and part number you are trying to cross. When a cross has been located, the results table includes the corresponding BestFit® replacement element, dimensions (inside diameter, outside diameter and length), element style (e.g., cartridge or spin-on), media type (metal mesh, water removal, synthetic glass, or paper) and performance specifications, including beta ratios and dirt holding capacity. Also, a link to the left of the results table links to a generalized element drawing with all of the desired information on it. If there is an element that cannot be crossed, Schroeder Industries can work with you in finding a replacement solution to your element problem!

Schroeder BestFit® Elements include the following series:

QCLZ (8314 replacement)	SBF-0160R	SBF-0660R	SBF-170B	SBF-7500	SBF-9021	SBF-MF-100
QPML (8310 replacement)	SBF-0161D	SBF-0661D	SBF-2000	SBF-7507	SBF-9100	SBF-PXX
SBF-0030D	SBF-0240D	SBF-0850R	SBF-2544	SBF-8200	SBF-9400	SBF-PXW
SBF-0030R	SBF-0240R	SBF-0950R	SBF-2600R	SBF-8300	SBF-9600	SBF-RP83
SBF-0031D	SBF-0241D	SBF-1000	SBF-270	SBF-8400	SBF-9601	SBF-TXX
SBF-0060D	SBF-0280D	SBF-1001	SBF-270B	SBF-8500	SBF-9604	SBF-TXW
SBF-0060R	SBF-0281D	SBF-1002	SBF-370	SBF-8700	SBF-9650	SBF-UE210
SBF-0661D	SBF-0330D	SBF-1010	SBF-370B	SBF-8800	SBF-9651	SBF-UE219
SBF-0110D	SBF-0330R	SBF-1050	SBF-6000	SBF-8900	SBF-9800	SBF-UE310
SBF-0110R	SBF-0331D	SBF-1051	SBF-6400	SBF-8914	SBF-9801	SBF-UE319
SBF-0111D	SBF-0500R	SBF-1300R	SBF-6500	SBF-937	SBF-9901	SBF-UE610
SBF-0160D	SBF-0660D	SBF-170	SBF-7400	SBF-9020	SBF-BPE-7509	SBF-UE619

Schroeder BestFit® element model codes are determined by replicating the element model code it is replacing. An example of a breakdown of the model code is shown below:

Schroeder BestFit® Model Code: **SBF-9600-13Z10V**

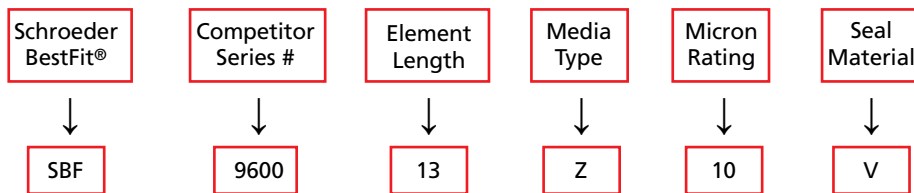

BestFit®  
High Performance  
Replacement  
Elements

**Schroeder**  
ORIGINAL ELEMENTS

## CoreCentric® Coreless Element



**Schroeder**  
ORIGINAL ELEMENTS

## CoreCentric®

CORELESS ELEMENT WITH BACKBONE

The CoreCentric® Coreless element is an environmentally friendly, all plastic element (no metal parts) that can be crushed, shredded or burned. These alternative methods of disposal will not only greatly reduce solid waste volumes, but also reduce disposal costs simultaneously.

CoreCentric® Coreless elements are designed to ensure optimum performance and ease of service. Built with Excellement® Z-Media®, CoreCentric® Coreless elements (QCL) fit in all Pall 8304 and 8314 housings and are available in the 8", 13", 16", and 39" lengths. Note: To ensure fast delivery, CoreCentric® elements are available with Viton® seals only.

CoreCentric® elements are designed with an integral patent design, cylindrical center core that provides column strength, added structural stability, and easy element removal. This core eliminates both the sticking and vertical sagging problems that can occur when using other manufacturer's coreless designs.

Schroeder's CoreCentric® elements are the only coreless element designed with backbone. We call it the "CORE ON CORE" element design.

## Melt-Blown and Spun-Bonded Filter Elements For Process and Cutting Fluid Applications



Used in process and cutting fluid applications, melt-blown and spun-bonded elements are manufactured with either polypropylene or nylon filter media. Element fibers are blown onto and thermally bonded to a central support core with increasing fiber density towards the core, creating depth filtration. All layers are interlinked to offer maximum support while ensuring high void volume. The thermal bonding process minimizes media migration, providing consistent and reliable performance. They excel in dirt holding capacity and have low pressure drops. They also offer wide chemical compatibility, as well as being structurally sound and able to withstand high flow rates.

Melt-blown and spun-bonded elements fit most industrial housings incorporating the double open ended sealing arrangement, as well as standard polypropylene, PVC, and polycarbonate housings. In addition, these elements are available with end caps for most plug-in style O-ring fittings, making them ideally suited to more critical applications requiring the assurance of these double seals.

They have a wide range of applications including:

- Machine tool coolants
- Roll mill coolants
- EDM fluids
- Quench oils
- Parts washing solvents
- Electrophoretic paints
- Etching solutions
- Plating solutions
- Light oils
- Fuels
- High water containing fluids

For technical information on process filtration solutions, request catalog #L-2728.

The use of Schroeder's GREEN, Electric Drive (E-Drive) Media filtration technology guarantees safe and reliable equipment operation, all-while conserving the use of energy.

Part of Schroeder's Energy Saver initiative, filter elements made using the all-new E-Drive Media are characterized by an unusually low pressure drop, making them suitable for low energy requirements compared to conventional hydraulic elements under the same ambient conditions.

E-Drive Media is the clear choice for use in electric hydraulic drive motor-pump units. Use it for conserving energy bills and wherever high viscosity fluids are employed – especially at low temperatures that produce a cold start behavior.

**Schroeder's E-Drive Energy Saving Features:**

- Low resistance of flow to reduce the  $\Delta P$  across the element.
- Constructed of multi-layered, synthetic fiber material with support.
- Great for cold start conditions where a low pressure drop is required.

**Technical Specs:**

- Element Collapse Rating: 145 psid (10 bar).
- Temperature Range: -22°F to 212°F (-30°C to 100°C).
- Flow Direction: Outside to Inside.

E-Drive Media is currently rated for 8, 10, & 15  $\mu\text{m}$  filtration..

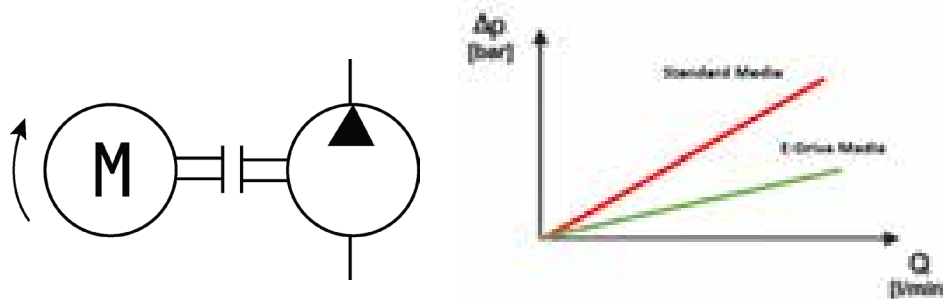

## E Media Elements (Cellulose)



Recognized as one of the industry's most cost effective media available in the marketplace, Schroeder E media is an excellent choice for a wide variety of hydraulic system applications.

The E3 media is a specially designed mixture of cellulose and micro-glass, which provides both high dirt holding capacity and high particle capture efficiency, resulting in one of the industry's most cost effective cellulose media. Schroeder E10 media, used in the popular K10 element, is a standard for numerous industries, enabling continuous, trouble-free system operation.

**Please note: The "E" identification for the media is not shown in the element model number. For example, our standard K3 and K10 elements are constructed with E media.**

Table 14 shows the filtration ratios for Schroeder E media elements, while Figure 18 depicts this information graphically and provides corresponding % efficiencies for both the E3 and E10 media.

**Table 14. E Media Efficiency Ratings per ISO 4572 without Antistatic Additive**

Element Media	Filtration Ratios (Beta)						
	$\beta_x \geq 75$ (98.7%)	$\beta_x \geq 100$ (99%)	$\beta_x \geq 200$ (99.5%)	$\beta_3$	$\beta_5$	$\beta_{10}$	$\beta_{20}$
E3	6.8	7.5	10.0	28	48	200	>1000
E10	15.5	16.2	18.0	—	1.3	10	400

The cost effectiveness of E media becomes even more apparent when dirt holding capacity is considered (see Table 15). The dollars spent per gram of dirt retained with an E media element makes it an excellent choice for many contamination control programs.

**Table 15. Typical Dirt Holding Capacities for E Media Elements (ACFTD capacity in grams)**

Element Size	Media	
	E3	E10
N	8	7
NN	12	10
C	14	12
CC	30	25
A	16	13
K	54	44
9C	30	25
BB	162	132
18L	108	88
M	50	37
8Z	39	32
8T	39	32
P	—	37
9V	32	26
14V	51	41
6R	9	8

The data shown represents the cumulative results of E media multi-pass tests. Tests are conducted on a regular basis at Schroeder's own laboratory and at approved independent facilities. Tests are conducted without antistatic additive.

**Figure 16. E Media Element Efficiencies Per ISO 4572**

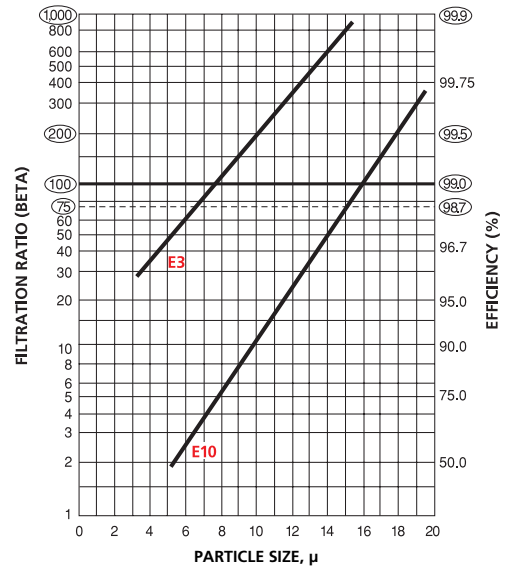

The data shown represents the cumulative results of E media multi-pass tests. Tests are conducted on a regular basis at Schroeder's own laboratory and at approved independent facilities. Tests are conducted without antistatic additive.



Schroeder offers a line of metal reusable elements to meet specific application needs. These rugged elements are constructed of high-strength woven stainless steel wire mesh. The wire mesh and center tube are epoxy-bonded to the end caps.

The element design incorporates shallow pleats which provide an efficient flow pattern with optimum pressure drop. In addition, the shallow pleat construction simplifies the cleaning process. These elements may be cleaned using a liquid solution (either Kleenite or Oakite) or by ultrasonics. Request Schroeder's #L-2094 Data Sheet for details regarding recommended cleaning procedures.

Schroeder metal elements are available in a variety of sizes for 10, 25, 60, 150, and 260  $\mu$  filtration and are shown in Table 16. The size and type of wire mesh used for each micron rating are shown in Table 17.

## M Media Elements (Reusable Metal)



**Figure 17. Typical Pressure Drop Performance Data for Schroeder Series M Media Elements**

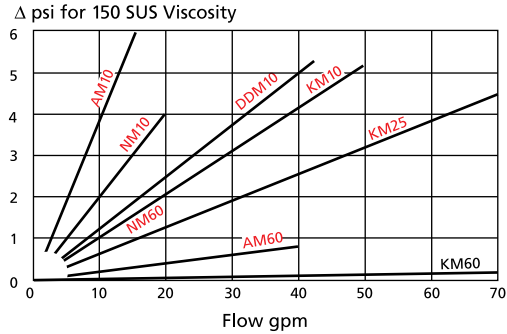

**Table 17. Micron Ratings and Wire Mesh**

10 $\mu$	200 x 1400 twilled Dutch weave
25 $\mu$	165 x 1400 twilled Dutch weave
60 $\mu$	50 x 250 plain Dutch weave
150 $\mu$	100 x 100 square Dutch weave
260 $\mu$	60 x 60 square Dutch weave

Today's demand for the use of fire-resistant fluids that assure safe and dependable operation in an electrohydraulic control system (EHC) demand peak performing media. The change-over to Schroeder "F" Pack media from a traditional, high performance, synthetic media results in lower, clean pressure drop and higher efficiency. Most importantly, the change eliminates cast-off, or shedding of synthetic fibers, which can result in servo valve failure.

### Construction

- Total stainless steel, sintered depth style media
- Pleated media
- Sintered construction prevents shedding of media
- Outside/in flow

### Performance

- Extremely efficient:  $\beta_3=1000$  and  $\beta_{10}=1000$
- Excellent choice for use with phosphate esters and Fyrquel® fluids
- Operating temperature -20°F to 350°F with use of Viton® seals
- Element collapse rating 3000 psid for use at high differential pressures

## F-Pack Media



## W Media Elements (Water Removal)



Water can cause a host of contamination problems in hydraulic and lubrication systems. It can exist in a system in a dissolved state or in a free state. In a dissolved state, the fluid is holding the water. In a free state, the water is above the specific saturation point of the fluid, and thus cannot dissolve or hold more water. A mild discoloration of the fluid generally indicates that a free water condition exists in the system.

Schroeder's uniquely designed water removal elements employ a quick-acting water-absorbent polymer, capable of holding over 400 times its own weight in water. These elements are ideal for in-line use, re-circulating filter systems, or in portable filtration carts.

Water retention is positive, even under high pressure, so there is no downstream unloading. However, water retention capacity is dependent on the type of fluid and additives present in a system, its viscosity and its flow rate. As a result, retention capacity may be diminished by some additives present in the system, by a high viscosity, or a high flow rate.

Table 18 shows water holding capacity and Table 19 shows the pressure drops for select W media elements. (On net page)

For best results, flow rates through a single KW element should be 10 gpm (38 L/min) or less.

## Aqua-Excellement™ High Efficiency Particulate Water Removal Media



Schroeder offers Aqua-Excellement™ filter elements, which excel at removing both water and solid particulates from petroleum-based fluids. The filtering media incorporated into Aqua-Excellement™ elements is referred to as ZW and includes layers of Schroeder's high efficiency Excellement® Z-Media® for capturing particulate contaminations in combination with water removal capabilities. The high efficiencies, outstanding beta stabilities, and excellent dirt holding capacities that Excellement® customers have become accustomed to are present in the new ZW media. Paired together, these two types of media make a winning combination and are highly effective at filtering out water and solids simultaneously.

Aqua-Excellement™ elements are currently available in multiple sizes for both cartridge and spin on style. Equipped, with ZW media, Schroeder MFS/AMS series carts can be effectively utilized for on-site flushing applications for cleaning stagnant large volume reservoirs. When used on a kidney loop system installed on power units, the ZW media allows for smaller kidney loop system and lower dimensional clearance and weight. Other applications include mobile filtration systems and bulk transfer systems.

## Schroeder Kidney Loop Systems and Mobile Filtration Carts *can utilize the KZW cartridge elements*



## ZW Spin-On Elements



NOTE: When using any K-size housing do not exceed 14 gpm

Shown below is a breakdown of the layers of the new K-size ZW cartridge element.

- Epoxy-coated steel wire fabric provides maximum support and rigidity.
- Two layers of Z-Media provide maximum efficiency and dirt-holding capacity with minimal pressure drop
- Water removal media
- Spun-bonded scrim provides downstream media support and increased stability
- Epoxy-coated steel wire fabric provides maximum support and rigidity.

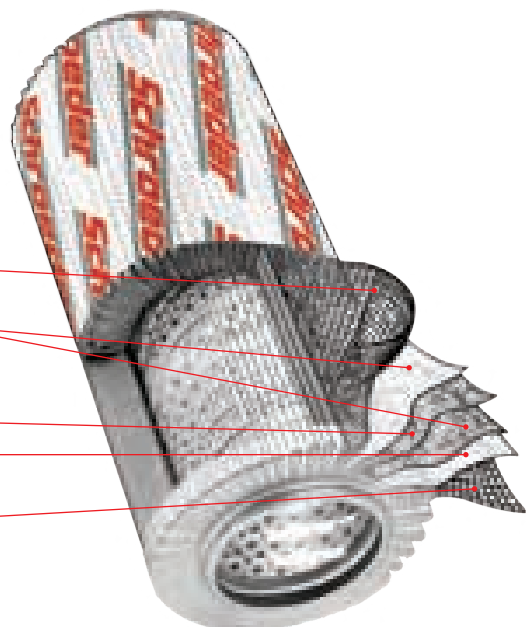

Total water injection flow rate: 2.0 ml/min.

**Table 18. Water Holding Capacity**

Element Model No.	Flow gpm (L/min)	Capacity	
		mL	ounces
KW	20 (75)	150	5
KW	16 (60)	200	7
KW	10 (38)	320	11
KW	2 (7.5)	500	17
6RW	20 (75)	31	1
6RW	2 (7.5)	104	4
8TW	20 (75)	93	3
8TW	2 (7.5)	311	11
9VW	20 (75)	81	3
9VW	2 (7.5)	270	9
14VW	20 (75)	130	4.4
14VW	2 (7.5)	435	14.7
16QW	60 (225)	480	16
16QW	10 (38)	1350	45
39QW	140 (530)	1100	37
39QW	22 (83)	3100	105
MW	14 (53)	100	3.5
MW	1.5 (6)	350	12

**Table 19. Pressure Drop**

Element Model No.	Flow gpm (L/min)	ΔP psi (bar)
KW	20 (75)	2.5 (0.17)
14VW	20 (75)	2.5 (0.17)
16QW	65 (246)	2.5 (0.17)
39QW	150 (570)	2.5 (0.17)

**Table 20. Maximum Recommended Flow Rate**

Element Model No.	Maximum Recommended Flow Rate	
	gpm	L/min
KW	20	75.7
6RW	4	16
8TW	12	47
9VW	11	41
14VW	20	75
16QW	60	225
39QW	140	530
MW	16	6

**Table 21. KZW Cartridge Element Dirt and Water Holding Capacities**

Element Part Number	DHC (g)	Water Removal Capacity		Filtration Ratios (Beta)		
		2.5 gpm	10 gpm	β <sub>x</sub> ≥ 200	β <sub>x</sub> ≥ 1000	ΔP Factor
KZW1	61	197 mL/ 6.66 oz	134 mL/ 4.53 oz	<4.0	<4.0	0.43
KZW3/KKZW3	64/128			4.0	4.8	0.32
KZW5/KKZW5	63/126			5.1	6.4	0.28
KZW10/KKZW10	57/114			6.9	8.6	0.23
KZW25/KKZW25	79/158			15.4	18.5	0.14



**Aqua-Excellement™  
High Efficiency  
Particulate Water  
Removal Media**

**Table 22. ZW Spin-On Element Dirt and Water Holding Capacities**

Element Part Number	DHC (g)	Water Removal Capacity		Filtration Ratios (Beta)	
		2.5 gpm	10 gpm	β <sub>x</sub> ≥ 200	β <sub>x</sub> ≥ 1000
10MZW10	53	185 mL/ 6.3 oz	126 mL/ 4.3 oz	6.9	8.6



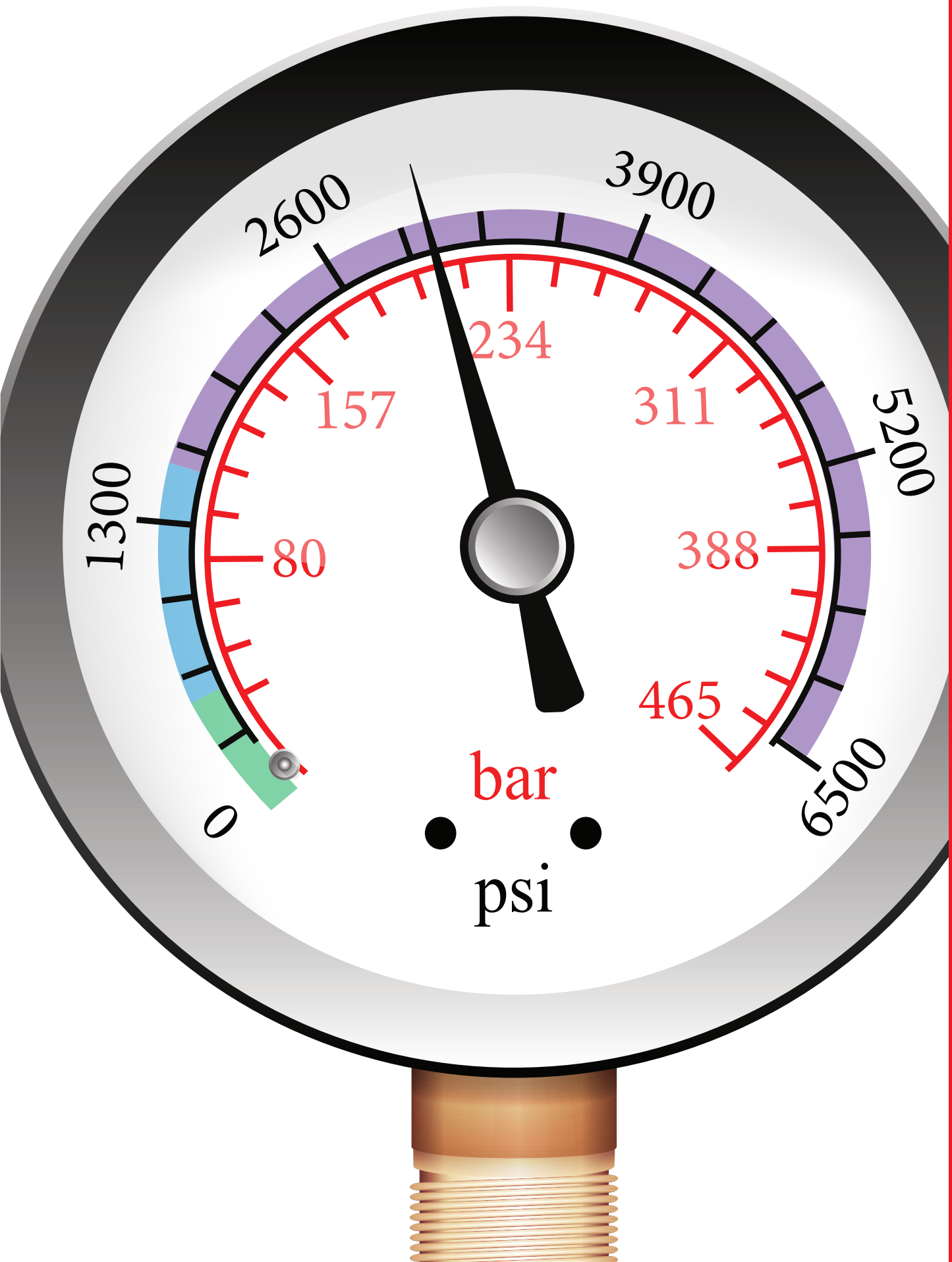

Section 3:  
above 1500 psi

# HIGH PRESSURE FILTERS

# Section 3

# High Pressure Filters Selection Guide

	Pressure psi (bar)	Flow gpm (L/min)	Element Length/Size	Page
<b>Top-Ported High Pressure Filters</b>				
NF30	3000 (210)	20 (75)	N, NN	45
NFS30	3000 (210)	20 (75)	N, NN	49
YF30	3000 (210)	25 (100)	4Y, 8Y	53
CFX30	3000 (210)	30 (115)	CC, DD	57
PLD	3000 (210)	100 (380)	DV	61
CF40	4000 (275)	45 (170)	C, CC	65
DF40	4000 (275)	30 (113)	C, CC	65
PF40	4000 (275)	50 (190)	5H, 9H	69
RFS50	5000 (345)	30 (115)	8R	73
RF60	6000 (415)	30 (115)	8R	77
CF60	6000 (415)	50 (190)	CC	81
CTF60	6000 (415)	75 (284)	5CT, 8CT, 14CT	85
VF60	6000 (415)	70 (265)	9V	89
LW60	6000 (415)	300 (1135)	39ZP	93
<b>Base-Ported High Pressure Filters</b>				
KF30	3000 (210)	100/150 (380/570)	K, KK, 27K	97
KF50	5000 (345)	100/150 (380/570)	K, KK, 27K	97
TF50	5000 (345)	40 (150)	A, CC	101
KC50	5000 (345)	100/150 (380/570)	K, KK, 27K	105
MKF50	5000 (345)	200 (760)	K, KK, 27K	109
MKC50	5000 (345)	200 (760)	K, KK, 27K	109
KC65	6500 (450)	100 (380)	K, KK, 27K	113
MKC65	6000 (413)	300 (1136)	K, KK, 27K	117
<b>Hydrostatic (Bidirectional) Flow High Pressure Filters</b>				
HS60	6000 (415)	100 (380)	13HZ	121
MHS60	6000 (415)	100 (380)	13HZ	121
KFH50 (Base-Ported)	5000 (345)	70 (265)	K, KK, 27K	125
<b>In-Line Filters</b>				
LC60	6000 (415)	8 (30)	SSD	129
LC35	3500 (241)	15 (57)	BS	131
LC50	5000 (345)	9 (35)	5H	133
<b>Servo Protection (Sandwich) Filters DO7, DO3, Moog, Parker &amp; Vickers</b>				
NOF30-05	3000 (210)	12 (45)	NN	135
NOF50-760	5000 (345)	15 (57)	SV	139
FOF60-03	6000 (415)	12 (45)	F	143
<b>Manifold Mount Filter Kits (Bowls &amp; Installation Drawings)</b>				
NMF30	3000 (210)	20 (75)	NN	147
RMF60	6000 (415)	30 (115)	8R	149
<b>Cartridge Elements for use in Manifold Applications</b>				
14-CRZX10	3000 (210)	6 (23)	—	151
20-CRZX10	3000 (210)	12 (45)	—	152

High Pressure Filters (1500 - 6500 psi)

# Top-Ported Pressure Filter

# NF30



### Features and Benefits

- Top-ported pressure filter
- All aluminum assembly
- Available with non-bypass option with high collapse element
- Offered in pipe, SAE straight thread and ISO 228 porting
- Same day shipment model available

**20 gpm**  
**75 L/min**  
**3000 psi**  
**210 bar**

**NF30**

NFS30

YF30

CFX30

PLD

CF40

DF40

PF40

RFS50

RF60

CF60

CTF60

VF60

LW60

KF30

KF50

TF50

KC50

MKF50

MKC50

KC65

MKC65

HS60

MHS60

KFH50

LC60

LC35

LC50

Model No. of filter in photograph is NF301NZ10SD5.

Flow Rating:	Up to 20 gpm (75 L/min) for 150 SUS (32 cSt) fluids
Max. Operating Pressure:	3000 psi (210 bar)
Min. Yield Pressure:	10,000 psi (690 bar), per NFPA T2.6.1
Rated Fatigue Pressure:	2400 psi (165 bar), per NFPA T2.6.1
Temp. Range:	-20°F to 225°F (-29°C to 107°C)
Bypass Setting:	Cracking: 40 psi (2.8 bar) Full Flow: 85 psi (5.9 bar) Non-bypassing model has a blocked bypass.
Porting Head:	Aluminum
Element Case:	Aluminum
Weight of NF30-1N:	3.4 lbs. (1.5 kg)
Weight of NF30-1NN:	4.4 lbs. (2.0 kg)
Element Change Clearance:	4.50" (115 mm)

### Filter Housing Specifications

Type Fluid	Appropriate Schroeder Media
Petroleum Based Fluids	All E Media (cellulose), Z-Media® and ASP® Media (synthetic)
High Water Content	All Z-Media® and ASP® media (synthetic)
Invert Emulsions	10 and 25 μ Z-Media® and 10 μ ASP® media (synthetic)
Water Glycols	3, 5, 10 and 25 μ Z-Media® and 3, 5 and 10 μ ASP® Media (synthetic)

### Fluid Compatibility

NOF30-05

NOF-50-760

FOF60-03

NMF30

RMF60

14-CRZX10

20-CRZX10

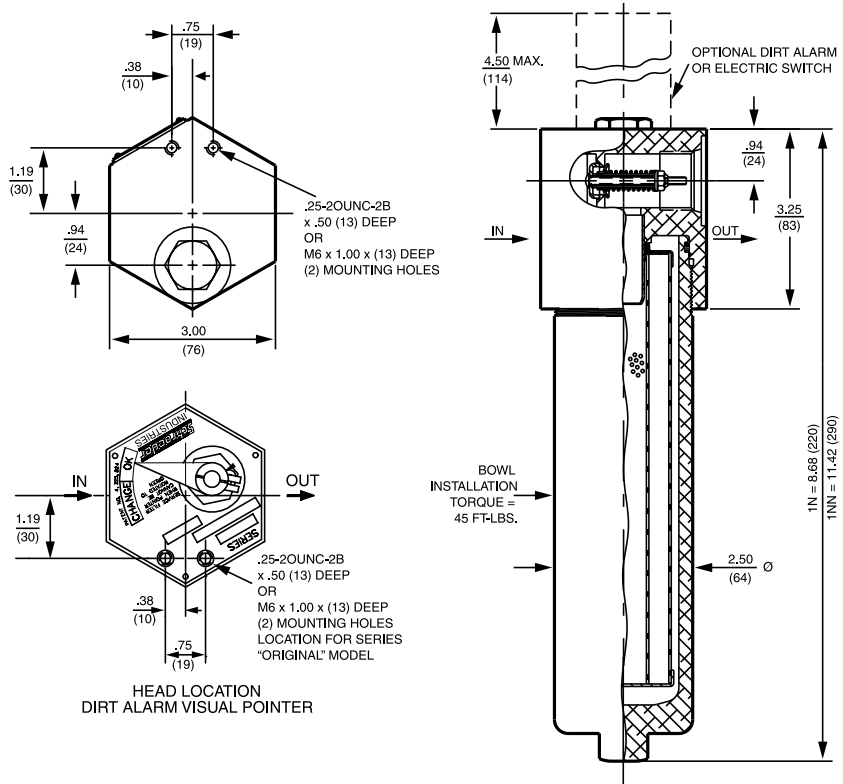

Metric dimensions in ( ).  
 Dimensions shown are inches (millimeters) for general information and overall envelope size only.  
 For complete dimensions please contact Schroeder Industries to request a certified print.

## Element Performance Information & Dirt Holding Capacity

Element	Filtration Ratio Per ISO 4572/NFPA T3.10.8.8 Using automated particle counter (APC) calibrated per ISO 4402			Filtration Ratio per ISO 16889 Using APC calibrated per ISO 11171	
	$\beta_x \geq 75$	$\beta_x \geq 100$	$\beta_x \geq 200$	$\beta_x(c) \geq 200$	$\beta_x(c) \geq 1000$
	NZ1/NNZ1	<1.0	<1.0	<1.0	<4.0
NZ3/NNZ3	<1.0	<1.0	<2.0	<4.0	4.8
NZ5/NNZ5	2.5	3.0	4.0	4.8	6.3
NZ10/NNZ10	7.4	8.2	10.0	8.0	10.0
NZ25/NNZ25	18.0	20.0	22.5	19.0	24.0
NNZX3	<1.0	<1.0	<2.0	4.7	5.8
NNZX10	7.4	8.2	10.0	8.0	9.8

### Dirt Holding Capacity

Element	DHC (gm)	Element	DHC (gm)
NZ1	12	NNZ3	16
NZ3	12	NNZ5	18
NZ5	12	NNZ10	15
NZ10	11	NNZ25	15
NZ25	11	NNZX3	11*
NNZ1	15	NNZX10	13*

\* Based on 100 psi terminal pressure

Element Collapse Rating: 150 psid (10 bar) for standard elements  
 3000 psid (210 bar) for high collapse (ZX) versions

Flow Direction: Outside In

Element Nominal Dimensions: N: 1.75" (45 mm) O.D. x 5.25" (135 mm) long  
 NN: 1.75" (45 mm) O.D. x 8.0" (200 mm) long



### $\Delta P_{\text{housing}}$

NF30  $\Delta P_{\text{housing}}$  for fluids with sp gr (specific gravity) = 0.86:

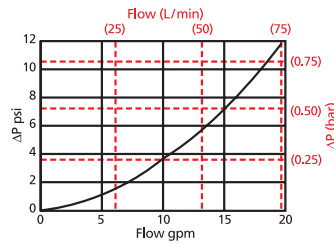

### $\Delta P_{\text{element}}$

1NZ

Element Pressure Drop versus Flow Rate at 32 cSt (150 SUS)

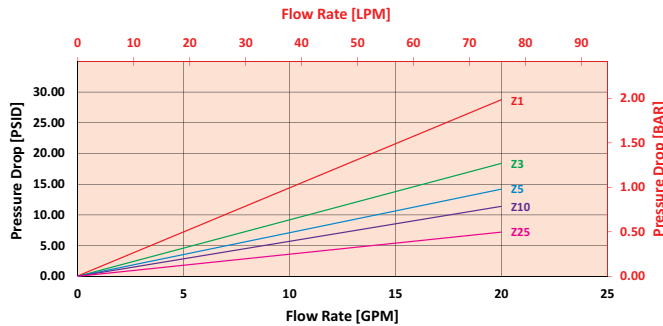

1NNZ

Element Pressure Drop versus Flow Rate at 32 cSt (150 SUS)

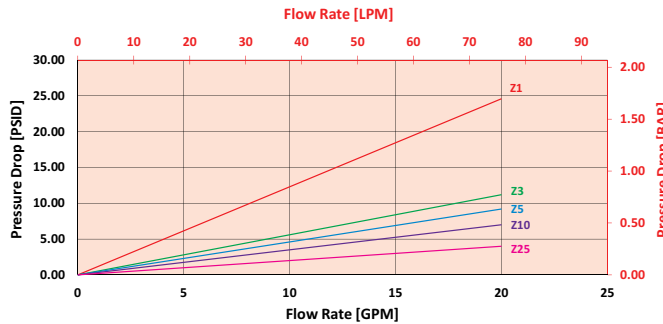

$$\Delta P_{\text{filter}} = \Delta P_{\text{housing}} + (\Delta P_{\text{element}} * V_f)$$

#### Exercise:

Determine  $\Delta P_{\text{filter}}$  at 15 gpm (57 L/min) for NF301NZ10SD5 using 160 SUS (34 cSt) fluid.

Use the housing pressure curve to determine  $\Delta P_{\text{housing}}$  at 15 gpm. In this case,  $\Delta P_{\text{housing}}$  is 7 psi (.48 bar) according to the graph for an NF30 housing.

Use the element pressure curve to determine  $\Delta P_{\text{element}}$  at 15 gpm. In this case,  $\Delta P_{\text{element}}$  is 8 psi (.55 bar) according to the graph for an NZ10 element.

Because the viscosity in this sample is 160 SUS (34 cSt), we determine the Viscosity Factor ( $V_f$ ) by dividing the **Operating Fluid Viscosity** with the **Standard Viscosity** of 150 SUS (32 cSt). To best determine your Operating Fluid Viscosity, please reference the chart in Appendix D.

Finally, the overall filter pressure differential,  $\Delta P_{\text{filter}}$ , is calculated by adding  $\Delta P_{\text{housing}}$  with the true element pressure differential, ( $\Delta P_{\text{element}} * V_f$ ). The  $\Delta P_{\text{element}}$  from the graph has to be multiplied by the viscosity factor to get the true pressure differential across the element.

#### Solution:

$$\Delta P_{\text{housing}} = 7 \text{ psi [0.48 bar]} \quad | \quad \Delta P_{\text{element}} = 8 \text{ psi [0.55 bar]}$$

$$V_f = 160 \text{ SUS (34 cSt)} / 150 \text{ SUS (32 cSt)} = 1.1$$

$$\Delta P_{\text{filter}} = 7 \text{ psi} + (8 \text{ psi} * 1.1) = 15.8 \text{ psi}$$

OR

$$\Delta P_{\text{filter}} = .48 \text{ bar} + (.55 \text{ bar} * 1.1) = 1.1 \text{ bar}$$

## Pressure Drop Information Based on Flow Rate and Viscosity

Note:  
If your element is not graphed, use the following equation:  
 $\Delta P_{\text{element}} = \text{Flow Rate} \times \Delta P_f$  Plug this variable into the overall pressure drop equation.

Ele.	$\Delta P$
N3	1.10
N10	0.17
N25	0.10
NAS3	0.92
NAS5	0.71
NAS10	0.57

## Filter Model Number Selection

BOX 1	BOX 2	BOX 3	BOX 4	BOX 5	BOX 6	BOX 7	BOX 8	BOX 9
NF30								

BOX 1	BOX 2	BOX 3	BOX 4	BOX 5	BOX 6	BOX 7	BOX 8	BOX 9
NF30	1N	Z	10		S		D5	

= NF301NZ10SD5

BOX 1	BOX 2	BOX 3
<b>Filter Series</b>	<b>Number &amp; Size of Elements</b>	<b>Media Type</b>
NF30 NFN30 <small>(Non-bypassing: requires ZX high collapse elements)</small>	1 N = Single Length NN = Double Length	Omit = E Media (Cellulose) Z = Excellement® Z-Media® (synthetic) AS = Anti-Stat Media (synthetic) ZX = Excellement® Z-Media® (high collapse center tube) M = Media (reusable metal mesh) N size only

BOX 4	BOX 5	BOX 6	BOX 7
<b>Micron Rating</b>	<b>Seal Material</b>	<b>Porting</b>	<b>Options</b>
1 = 1 Micron (Z, ZX media) 3 = 3 Micron (AS,E, Z, ZX media) 5 = 5 Micron (AS, Z, ZX media) 10 = 10 Micron (AS,E,M, Z, ZX media) 25 = 25 Micron (E, Z, ZX media) 60 = 60 Micron (M media)	Omit = Buna N V = Viton® W = Buna N, <i>Anodized Aluminum parts</i>	B = ISO228 G-¾" P = ¾" NPTF S = SAE-12	Omit = None X = Blocked bypass (N/A with NFN30)

BOX 8	
Dirt Alarm® Options	
	Omit = None
Visual	D = Pointer D5 = Visual pop-up
Visual with Thermal Lockout	D8 = Visual w/ thermal lockout
Electrical	MS5 = Electrical w/ 12 in. 18 gauge 4-conductor cable MS5LC = Low current MS5 MS10 = Electrical w/ DIN connector (male end only) MS10LC = Low current MS10 MS11 = Electrical w/ 12 ft. 4-conductor wire MS12 = Electrical w/ 5 pin Brad Harrison connector (male end only) MS12LC = Low current MS12 MS16 = Electrical w/ weather-packed sealed connector MS16LC = Low current MS16 MS17LC = Electrical w/ 4 pin Brad Harrison male connector
Electrical with Thermal Lockout	MS5T = MS5 (see above) w/ thermal lockout MS5LCT = Low current MS5T MS10T = MS10 (see above) w/ thermal lockout MS10LCT = Low current MS10T MS12T = MS12 (see above) w/ thermal lockout MS12LCT = Low current MS12T MS16T = MS16 (see above) w/ thermal lockout MS16LCT = Low current MS16T MS17LCT = Low current MS17T
Electrical Visual	MS13DC = Supplied w/ threaded connector & light MS14DC = Supplied w/ 5 pin Brad Harrison connector & light (male end)
Electrical Visual with Thermal Lockout	MS13DCT = MS13 (see above), direct current, w/ thermal lockout MS13DCLCT = Low current MS13DCT MS14DCT = MS14 (see above), direct current, w/ thermal lockout MS14DCLCT = Low current MS14DCT

BOX 9
Additional Options
Omit = None G792 = 7/16" -20 UNF drain on housing

**NOTES:**

Box 2. Replacement element part numbers are identical to contents of Boxes 2, 3, 4 and 5.

Box 5. E media (cellulose) elements are only available with Buna N seals. For options V and W, all aluminum parts are anodized. Viton® is a registered trademark of DuPont Dow Elastomers.

# Manifold Mounted Pressure Filter

# NFS30



### Features and Benefits

- Manifold mounted pressure filter
- Offered in square head conventional subplate porting
- Direct mounting to inlet port on customer's manifold

Model No. of filter in photograph is NFS301NZ3OD5.

**20 gpm**  
**75 L/min**  
**3000 psi**  
**210 bar**

NF30

**NFS30**

YF30

CFX30

PLD

CF40

DF40

PF40

RFS50

RF60

CF60

CTF60

VF60

LW60

KF30

KF50

TF50

KC50

MKF50

MKC50

KC65

MKC65

HS60

MHS60

KFH50

LC60

LC35

LC50

Flow Rating:	Up to 20 gpm (75 L/min) for 150 SUS (32 cSt) fluids
Max. Operating Pressure:	3000 psi (210 bar)
Min. Yield Pressure:	10,000 psi (690 bar), per NFPA T2.6.1
Rated Fatigue Pressure:	2400 psi (165 bar), per NFPA T2.6.1
Temp. Range:	-20°F to 225°F (-29°C to 107°C)
Bypass Setting:	Cracking: 40 psi (2.8 bar) Full Flow: 85 psi (5.9 bar)
Porting Head:	Aluminum
Element Case:	Aluminum
Weight of NFS30-1N:	3.6 lbs. (1.6 kg)
Weight of NFS30-1NN:	4.3 lbs. (2.0 kg)
Element Change Clearance:	4.50" (115 mm)

### Filter Housing Specifications

Type Fluid	Appropriate Schroeder Media
Petroleum Based Fluids	All E Media (cellulose), Z-Media® and ASP® Media (synthetic)
High Water Content	All Z-Media® and ASP® media (synthetic)
Invert Emulsions	10 and 25 µ Z-Media® and 10 µ ASP® media (synthetic)
Water Glycols	3, 5, 10 and 25 µ Z-Media® and 3, 5 and 10 µ ASP® Media (synthetic)

### Fluid Compatibility

NOF30-05

NOF-50-760

FOF60-03

NMF30

RMF60

14-CRZX10

20-CRZX10

### NFS30 WITH "O" PORT CONFIGURATION

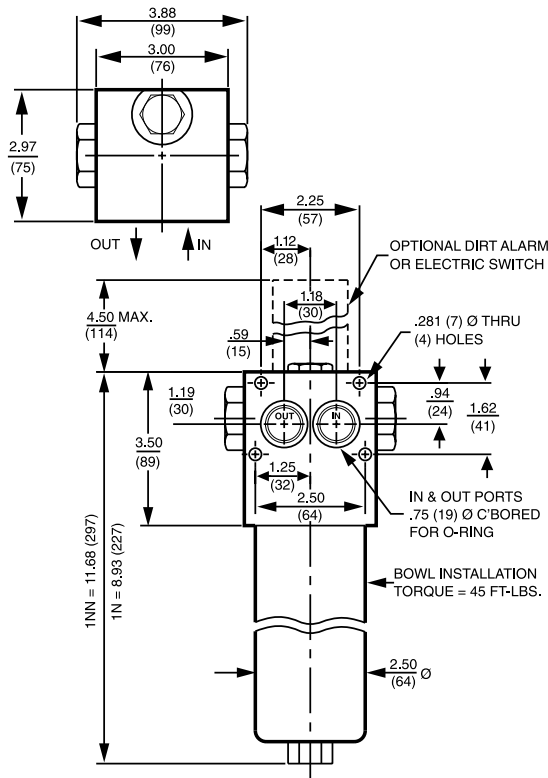

### NFS30 WITH PO, SO, FO PORT CONFIGURATION

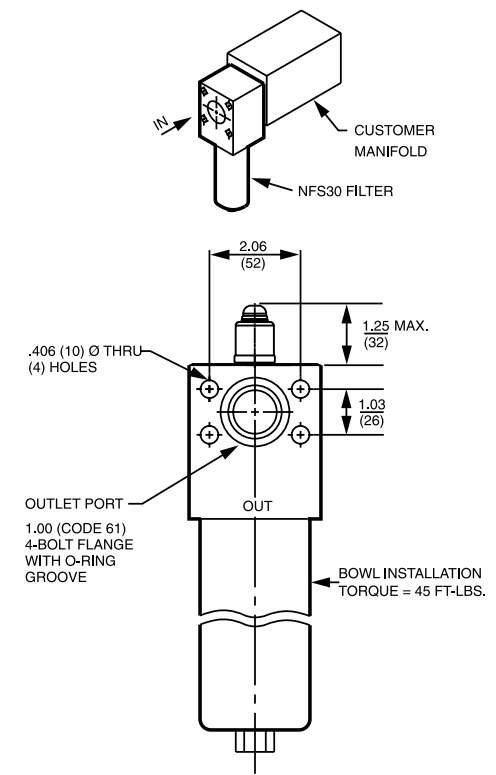

Metric dimensions in ( ).

Dimensions shown are inches (millimeters) for general information and overall envelope size only. For complete dimensions please contact Schroeder Industries to request a certified print.

## Element Performance Information & Dirt Holding Capacity

Element	Filtration Ratio Per ISO 4572/NFPA T3.10.8.8			Filtration Ratio per ISO 16889	
	Using automated particle counter (APC) calibrated per ISO 4402			Using APC calibrated per ISO 11171	
	$\beta_x \geq 75$	$\beta_x \geq 100$	$\beta_x \geq 200$	$\beta_x(c) \geq 200$	$\beta_x(c) \geq 1000$
NZ1/NNZ1	<1.0	<1.0	<1.0	<4.0	4.2
NZ3/NNZ3	<1.0	<1.0	<2.0	<4.0	4.8
NZ5/NNZ5	2.5	3.0	4.0	4.8	6.3
NZ10/NNZ10	7.4	8.2	10.0	8.0	10.0
NZ25/NNZ25	18.0	20.0	22.5	19.0	24.0

Element	DHC (gm)	Element	DHC (gm)
NZ1	12	NNZ1	15
NZ3	12	NNZ3	16
NZ5	12	NNZ5	18
NZ10	11	NNZ10	15
NZ25	11	NNZ25	15

Element Collapse Rating: 150 psid (10 bar) for standard elements  
3000 psid (210 bar) for high collapse (ZX) versions

Flow Direction: Outside In

Element Nominal Dimensions: N: 1.75" (45 mm) O.D. x 5.25" (135 mm) long  
NN: 1.75" (45 mm) O.D. x 8.0" (200 mm) long

$\Delta P_{\text{housing}}$

NFS30  $\Delta P_{\text{housing}}$  for fluids with sp gr (specific gravity) = 0.86:

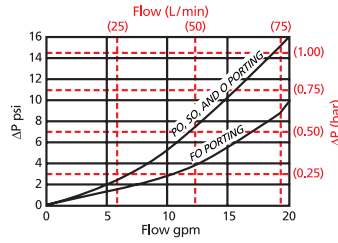

$\Delta P_{\text{element}}$

NZ

Element Pressure Drop versus Flow Rate at 32 cSt (150 SUS)

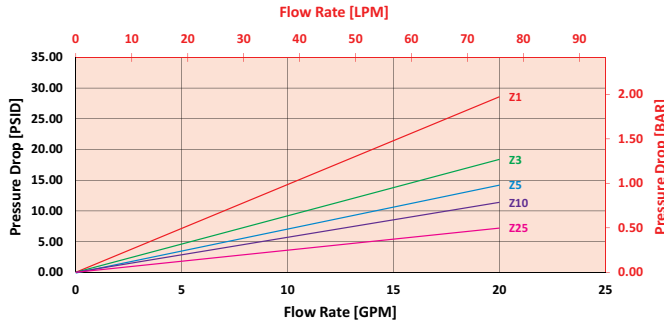

NNZ

Element Pressure Drop versus Flow Rate at 32 cSt (150 SUS)

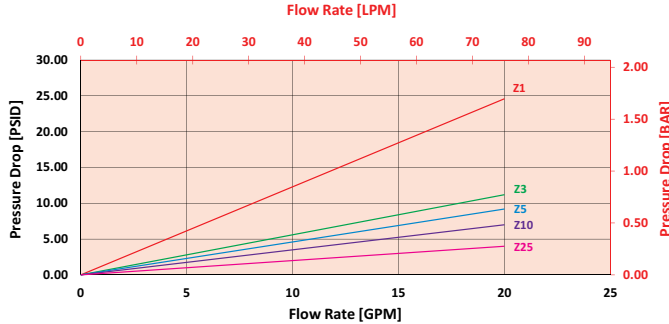

$$\Delta P_{\text{filter}} = \Delta P_{\text{housing}} + (\Delta P_{\text{element}} * V_f)$$

### Exercise:

Determine  $\Delta P_{\text{filter}}$  at 15 gpm (57 L/min) for NFS301NZ10S0 using 175 SUS (37.2 cSt) fluid.

Use the housing pressure curve to determine  $\Delta P_{\text{housing}}$  at 15 gpm. In this case,  $\Delta P_{\text{housing}}$  is 10 psi (.69 bar) on the graph for the NFS30 housing.

Use the element pressure curve to determine  $\Delta P_{\text{element}}$  at 15 gpm. In this case,  $\Delta P_{\text{element}}$  is 8 psi (.55 bar) according to the graph for the NZ10 element.

Because the viscosity in this sample is 175 SUS (37.2 cSt), we determine the **Viscosity Factor ( $V_f$ )** by dividing the **Operating Fluid Viscosity** with the **Standard Viscosity** of 150 SUS (32 cSt). To best determine your Operating Fluid Viscosity, please reference the chart in Appendix D.

Finally, the overall filter pressure differential,  $\Delta P_{\text{filter}}$ , is calculated by adding  $\Delta P_{\text{housing}}$  with the true element pressure differential,  $(\Delta P_{\text{element}} * V_f)$ . The  $\Delta P_{\text{element}}$  from the graph has to be multiplied by the viscosity factor to get the true pressure differential across the element.

### Solution:

$$\Delta P_{\text{housing}} = 10 \text{ psi } [.69 \text{ bar}] \quad | \quad \Delta P_{\text{element}} = 8 \text{ psi } [.55 \text{ bar}]$$

$$V_f = 175 \text{ SUS } (37.2 \text{ cSt}) / 150 \text{ SUS } (32 \text{ cSt}) = 1.2$$

$$\Delta P_{\text{filter}} = 10 \text{ psi} + (8 \text{ psi} * 1.2) = 19.6 \text{ psi}$$

OR

$$\Delta P_{\text{filter}} = .69 \text{ bar} + (.55 \text{ bar} * 1.2) = 1.35 \text{ bar}$$

**Pressure Drop Information Based on Flow Rate and Viscosity**

Note:  
If your element is not graphed, use the following equation:  
 $\Delta P_{\text{element}} = \text{Flow Rate} \times \Delta P_f$  Plug this variable into the overall pressure drop equation.

Ele.	$\Delta P$	Ele.	$\Delta P$
N3	1.10	NN3	0.77
N10	0.17	NN10	0.13
N25	0.10	NN25	0.07
NAS3	0.92	NNAS3	0.56
NAS5	0.71	NNAS5	0.46
NAS10	0.57	NNAS10	0.35

## Filter Model Number Selection

BOX 1	BOX 2	BOX 3	BOX 4	BOX 5	BOX 6	BOX 7	BOX 8
NFS30							

BOX 1	BOX 2	BOX 3	BOX 4	BOX 5	BOX 6	BOX 7	BOX 8	
NFS30	1N	Z	10		SO		D	= NFS301NZ10SOD

BOX 1	BOX 2	BOX 3
<b>Filter Series</b>	<b>Number &amp; Size of Elements</b>	<b>Media Type</b>
NFS30	1 N = Single Length NN = Double Length	Omit = E Media (Cellulose) Z = Excellement® Z-Media® (synthetic) AS = Anti-Stat Media (synthetic) ZX = Excellement® Z-Media® (high collapse center tube) M = Media (reusable metal mesh) N size only
NFSN30 <small>(Non-bypassing: requires ZX high collapse elements)</small>		

BOX 4	BOX 5	BOX 6	BOX 7
<b>Micron Rating</b>	<b>Seal Material</b>	<b>Porting</b>	<b>Options</b>
1 = 1 Micron (Z, ZX media) 3 = 3 Micron (AS, E, Z, ZX media) 5 = 5 Micron (AS, Z, ZX media) 10 = 10 Micron (AS, E, M, Z, ZX media) 25 = 25 Micron (E, Z, ZX media) 60 = 60 Micron (M media)	Omit = Buna N V = Viton® W = Buna N, <i>Anodized Aluminum parts</i>	SO = SAE-12 PO = 3/4" NPTF FO = 1" SAE 4-bolt flange Code 61 O = Manifold	Omit = None X = Blocked bypass (N/A with NFSN30)

BOX 8	
Dirt Alarm® Options	
	Omit = None
Visual	D = Pointer D5 = Visual pop-up
Visual with Thermal Lockout	D8 = Visual w/ thermal lockout
Electrical	MS5 = Electrical w/ 12 in. 18 gauge 4-conductor cable MS5LC = Low current MS5 MS10 = Electrical w/ DIN connector (male end only) MS10LC = Low current MS10 MS11 = Electrical w/ 12 ft. 4-conductor wire MS12 = Electrical w/ 5 pin Brad Harrison connector (male end only) MS12LC = Low current MS12 MS16 = Electrical w/ weather-packed sealed connector MS16LC = Low current MS16 MS17LC = Electrical w/ 4 pin Brad Harrison male connector
Electrical with Thermal Lockout	MS5T = MS5 (see above) w/ thermal lockout MS5LCT = Low current MS5T MS10T = MS10 (see above) w/ thermal lockout MS10LCT = Low current MS10T MS12T = MS12 (see above) w/ thermal lockout MS12LCT = Low current MS12T MS16T = MS16 (see above) w/ thermal lockout MS16LCT = Low current MS16T MS17LCT = Low current MS17T
Electrical Visual	MS13 = Supplied w/ threaded connector & light MS14 = Supplied w/ 5 pin Brad Harrison connector & light (male end)
Electrical Visual with Thermal Lockout	MS13DCT = MS13 (see above), direct current, w/ thermal lockout MS13DCLCT = Low current MS13DCT MS14DCT = MS14 (see above), direct current, w/ thermal lockout MS14DCLCT = Low current MS14DCT

### NOTES:

Box 2. Replacement element part numbers are identical to contents of Boxes 2, 3, 4 and 5.

Box 5. E media (cellulose) elements are only available with Buna N seals. For options V and W, all aluminum parts are anodized. Viton® is a registered trademark of DuPont Dow Elastomers.

Box 6. For option O, O-rings included; fastening hardware not included.

Box 8. For options SO, PO and FO, available dirt alarm is D only.

# Top-Ported Pressure Filter

# YF30



## Features and Benefits

- Top-ported pressure filter
- All aluminum assembly
- Meets HF2 automotive standards
- Offered in straight thread porting
- Optional drain plug in bowl for easy servicing
- Available with non-bypass option

25 gpm  
**100 L/min**  
 3000 psi  
**210 bar**

NF30

NFS30

**YF30**

CFX30

PLD

CF40

DF40

PF40

RFS50

RF60

CF60

CTF60

VF60

LW60

KF30

KF50

TF50

KC50

MKF50

MKC50

KC65

MKC65

HS60

MHS60

KFH50

LC60

LC35

LC50

Model No. of filter in photograph is YF308YZ10SD5.

Flow Rating:	Up to 25 gpm (100 L/min) for 150 SUS (32 cSt) fluids
Max. Operating Pressure:	3000 psi (210 bar)
Min. Yield Pressure:	10,000 psi (690 bar), per NFPA T2.6.1
Rated Fatigue Pressure:	1800 psi (124 bar), per NFPA T2.6.1-2005
Temp. Range:	-20°F to 225°F (-29°C to 107°C)
Bypass Setting:	Cracking: 50 psi (3.4 bar) Non-bypassing model has a blocked bypass.
Porting Head:	Aluminum
Element Case:	Aluminum
Weight of YF30-4Y:	3.75 lbs. (1.70 kg)
Weight of YF30-8Y:	4.25 lbs. (1.93 kg)
Element Change Clearance:	4.50" (115 mm)

## Filter Housing Specifications

Type Fluid	Appropriate Schroeder Media
Petroleum Based Fluids	All E Media (cellulose) and Z-Media® (synthetic)
High Water Content	All Z-Media® (synthetic)
Invert Emulsions	10 and 25 μ Z-Media® (synthetic)
Water Glycols	3, 5, 10 and 25 μ Z-Media® (synthetic)

## Fluid Compatibility

NOF30-05

NOF-50-760

FOF60-03

NMF30

RMF60

14-CRZX10

20-CRZX10

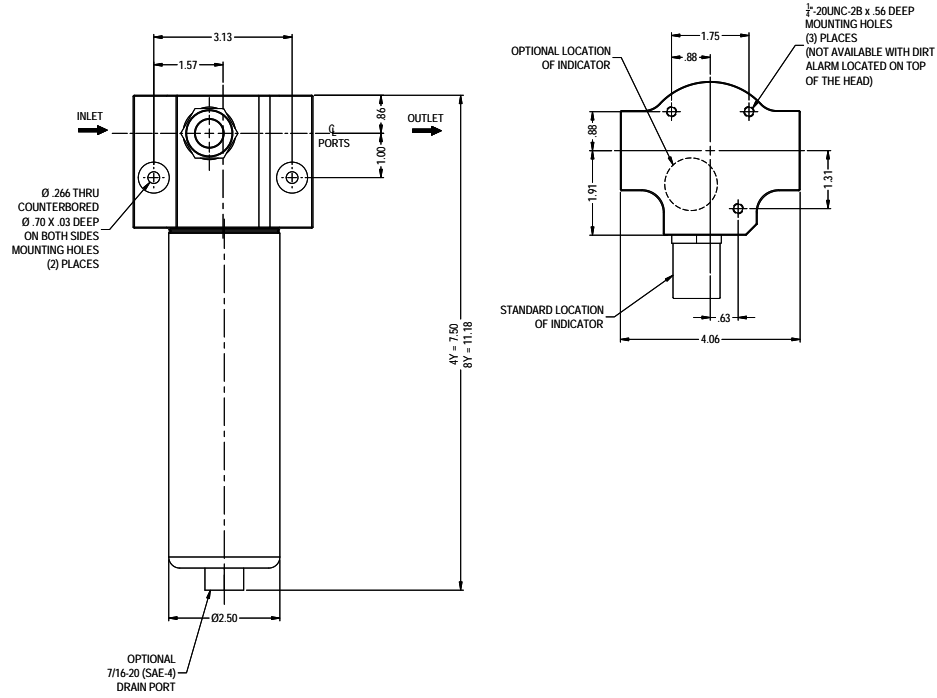

NOTES:  
1.) BOWL INSTALLATION TORQUE = 45 FT.LBS.

Metric dimensions in ( ).  
Dimensions shown are inches (millimeters) for general information and overall envelope size only.  
For complete dimensions please contact Schroeder Industries to request a certified print.

Element	Filtration Ratio Per ISO 4572/NFPA T3.10.8.8 Using automated particle counter (APC) calibrated per ISO 4402			Filtration Ratio per ISO 16889 Using APC calibrated per ISO 11171	
	$\beta_x \geq 75$	$\beta_x \geq 100$	$\beta_x \geq 200$	$\beta_x(c) \geq 200$	$\beta_x(c) \geq 1000$
4YZ1/8YZ1	<1.0	<1.0	<1.0	<4.0	4.2
4YZ3/8YZ3	<1.0	<1.0	<2.0	<4.0	4.8
4YZ5/8YZ5	2.5	3.0	4.0	4.8	6.3
4YZ10/8YZ10	7.4	8.2	10.0	8.0	10.0
4YZ25/8YZ25	18.0	20.0	22.5	19.0	24.0
4YZX5/8YZX5	2.5	3.0	4.0	5.6	7.2
4YZX10/8YZX10	7.4	8.2	10.0	8.0	9.8

Element	DHC (gm)	Element	DHC (gm)
4YZ1	6.3	8YZ1	12.1
4YZ3	5.1	8YZ3	9.9
4YZ5	6.4	8YZ5	12.4
4YZ10	5.4	8YZ10	10.5
4YZ25	4.9	8YZ25	9.4
4YZX5	4.3	8YZX5	8.9
4YZX10	4.3	8YZX10	8.9

Element Collapse Rating: 150 psid (10 bar) for standard elements  
3000 psid (210 bar) for high collapse (ZX) versions

Flow Direction: Outside In

Element Nominal Dimensions: 4Y: 1.77" (45 mm) O.D. x 4.50" (114 mm) long  
8Y: 1.77" (45 mm) O.D. x 8.21" (209 mm) long



# Top-Ported Pressure Filter

# YF30

$\Delta P_{\text{housing}}$

YF30  $\Delta P_{\text{housing}}$  for fluids with sp gr (specific gravity) = 0.86:

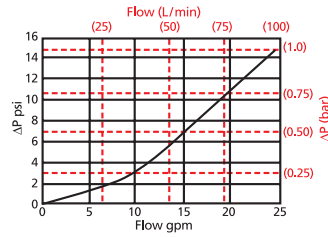

$\Delta P_{\text{element}}$

4YZ

Element Pressure Drop versus Flow Rate at 32 cSt (150 SUS)

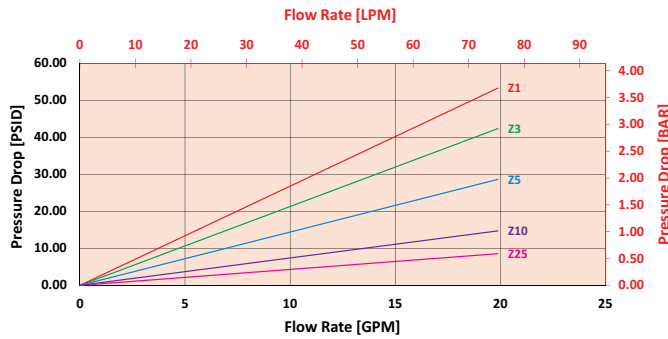

8YZ

Element Pressure Drop versus Flow Rate at 32 cSt (150 SUS)

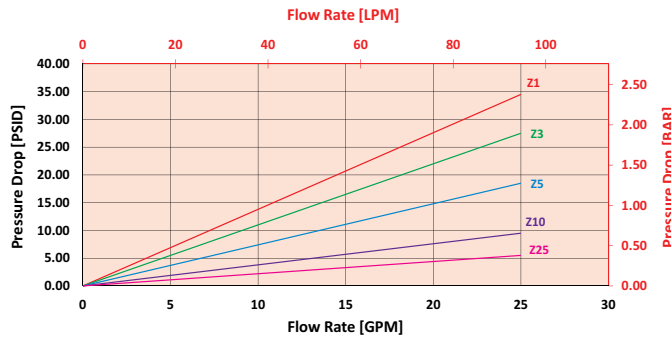

$$\Delta P_{\text{filter}} = \Delta P_{\text{housing}} + (\Delta P_{\text{element}} * V_f)$$

### Exercise:

Determine  $\Delta P_{\text{filter}}$  at 10 gpm (37.9 L/min) for YF304YZ10WSDRD5 using 200 SUS (42.6 cSt) fluid.

Use the housing pressure curve to determine  $\Delta P_{\text{housing}}$  at 10 gpm. In this case,  $\Delta P_{\text{housing}}$  is 3 psi (.21 bar) on the graph for the YF30 housing.

Use the element pressure curve to determine  $\Delta P_{\text{element}}$  at 10 gpm. In this case,  $\Delta P_{\text{element}}$  is 8 psi (.55 bar) according to the graph for the 4YZ10 element.

Because the viscosity in this sample is 200 SUS (42.6 cSt), we determine the **Viscosity Factor** ( $V_f$ ) by dividing the **Operating Fluid Viscosity** with the **Standard Viscosity** of 150 SUS (32 cSt). To best determine your Operating Fluid Viscosity, please reference the chart in Appendix D.

Finally, the overall filter pressure differential,  $\Delta P_{\text{filter}}$ , is calculated by adding  $\Delta P_{\text{housing}}$  with the true element pressure differential, ( $\Delta P_{\text{element}} * V_f$ ). The  $\Delta P_{\text{element}}$  from the graph has to be multiplied by the viscosity factor to get the true pressure differential across the element.

### Solution:

$$\Delta P_{\text{housing}} = 3 \text{ psi } [.21 \text{ bar}] \quad | \quad \Delta P_{\text{element}} = 8 \text{ psi } [.55 \text{ bar}]$$

$$V_f = 200 \text{ SUS } (42.6 \text{ cSt}) / 150 \text{ SUS } (32 \text{ cSt}) = 1.3$$

$$\Delta P_{\text{filter}} = 3 \text{ psi } + (8 \text{ psi } * 1.3) = 13.4 \text{ psi}$$

OR

$$\Delta P_{\text{filter}} = .21 \text{ bar } + (.55 \text{ bar } * 1.3) = .93 \text{ bar}$$

**Pressure Drop Information Based on Flow Rate and Viscosity**

Note:

If your element is not graphed, use the following equation:  
 $\Delta P_{\text{element}} = \text{Flow Rate} \times \Delta P_f$  Plug this variable into the overall pressure drop equation.

Ele.	$\Delta P$	Ele.	$\Delta P$
4YZX5	1.65	8YZX5	0.92
4YZX10	0.09	8YZX10	0.63

## Filter Model Number Selection

### How to Build a Valid Model Number for a Schroeder YF30:

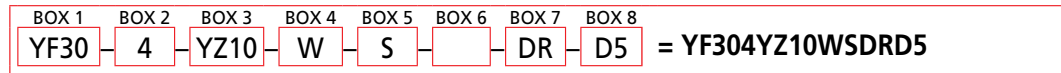
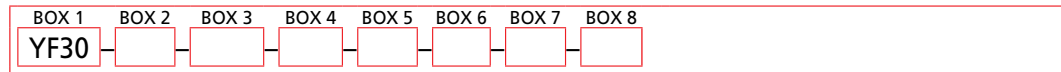

BOX 1	BOX 2	BOX 3	BOX 4	BOX 5
<b>Filter Series</b>	<b>Element Length (in)</b>	<b>Element Size and Media</b>	<b>Seal Material</b>	<b>Inlet Port</b>
YF30	4 8	YZ1 = Y size 1 μ Excellement® Z-Media® (synthetic) YZ3 = Y size 3 μ Excellement® Z-Media® (synthetic) YZ5 = Y size 5 μ Excellement® Z-Media® (synthetic) YZ10 = Y size 10 μ Excellement® Z-Media® (synthetic) YZ25 = Y size 25 μ Excellement® Z-Media® (synthetic) YZX5 = Y size 5 μ Excellement® Z-Media® (high collapse center tube) YZX10 = Y size 10 μ Excellement® Z-Media® (high collapse center tube)	Omit = Buna N V = Viton® W = Buna N, <i>Anodized Aluminum parts</i>	S = SAE-12 O = Subplate (contact factory)
YFN30 (Non-bypassing; requires ZX high collapse elements)				

BOX 6	BOX 7	BOX 8
<b>Dirt Alarm® Location</b>	<b>Optional Bowl Drain</b>	<b>Dirt Alarm® Options</b>
Omit = Side of filter head T = Top of filter head	Omit = No drain DR = Drain	Omit = None
		Visual D5 = Visual pop-up
		Visual with Thermal Lockout D8 = Visual w/ thermal lockout
		Electrical MS5 = Electrical w/ 12 in. 18 gauge 4-conductor cable MS5LC = Low current MS5 MS10 = Electrical w/ DIN connector (male end only) MS10LC = Low current MS10 MS11 = Electrical w/ 12 ft. 4-conductor wire MS12 = Electrical w/ 5 pin Brad Harrison connector (male end only) MS12LC = Low current MS12 MS16 = Electrical w/ weather-packed sealed connector MS16LC = Low current MS16 MS17LC = Electrical w/ 4 pin Brad Harrison male connector
		Electrical with Thermal Lockout MS5T = MS5 (see above) w/ thermal lockout MS5LCT = Low current MS5T MS10T = MS10 (see above) w/ thermal lockout MS10LCT = Low current MS10T MS12T = MS12 (see above) w/ thermal lockout MS12LCT = Low current MS12T MS16T = MS16 (see above) w/ thermal lockout MS16LCT = Low current MS16T MS17LCT = Low current MS17T
		Electrical Visual MS13DC = Supplied w/ threaded connector & light MS14DC = Supplied w/ 5 pin Brad Harrison connector & light (male end)
		Electrical Visual with Thermal Lockout MS13DCT = MS13 (see above), direct current, w/ thermal lockout MS13DCLCT = Low current MS13DCT MS14DCT = MS14 (see above), direct current, w/ thermal lockout MS14DCLCT = Low current MS14DCT

#### NOTES:

Box 2. Replacement element part numbers are combination of Boxes 2,3, and 4. Example 4YZ10V

Box 4. For options V and W, all aluminum parts are anodized. Viton® is a registered trademark of DuPont Dow Elastomers.

Box 8. Standard indicator setting for non-bypassing model is 50 psi unless otherwise specified.

# Non-Bypassing Pressure Filter

# CFX30



## Features and Benefits

- Top-ported non-bypassing pressure filter
- Unique valve eliminates need for high collapse elements, valve begins to close off flow at 50 psi: Differential Pressure and fully closes off flow by 80 psi: DP. This ensures that no un-filtered flow is allowed down stream to critical components.
- Offered in pipe, SAE straight thread and ISO 228 porting
- Integral inlet and outlet female test points option available

**30 gpm**  
**115 L/min**  
**3000 psi**  
**210 bar**

NF30

NFS30

YF30

**CFX30**

PLD

CF40

DF40

PF40

RFS50

RF60

CF60

CTF60

VF60

LW60

KF30

KF50

TF50

KC50

MKF50

MKC50

KC65

MKC65

HS60

MHS60

KFH50

LC60

LC35

LC50

NOF30-05

NOF50-760

FOF60-03

NMF30

RMF60

14-CRZX10

20-CRZX10

Model No. of filter in photograph is CFX301CC10SD5.

Flow Rating:	Up to 30 gpm (115 L/min) for 150 SUS (32 cSt) fluids
Max. Operating Pressure:	3000 psi (210 bar)
Min. Yield Pressure:	12,000 psi (828 bar), per NFPA T2.6.1
Rated Fatigue Pressure:	1800 psi (125 bar), per NFPA T2.6.1-2005
Temp. Range:	-20°F to 225°F (-29°C to 107°C)
Bypass Setting:	Non-Bypassing
Porting Head:	Aluminum
Element Case:	Steel
Weight of CFX30-1CC:	19.5 lbs. (8.9 kg)
Element Change Clearance:	4.00" (100 mm)

## Filter Housing Specifications

Type Fluid	Appropriate Schroeder Media
Petroleum Based Fluids	All E Media (cellulose), Z-Media® and ASP® Media (synthetic)
High Water Content	All Z-Media® and ASP® media (synthetic)
Invert Emulsions	10 and 25 μ Z-Media® and 10 μ ASP® media (synthetic)
Water Glycols	3, 5, 10 and 25 μ Z-Media® and 3, 5 and 10 μ ASP® Media (synthetic)
Phosphate Esters	All Z-Media® and ASP® media (synthetic) with H (EPR) seal designation
Skydrol®	3, 5, 10 and 25 μ Z-Media® (synthetic) with H.5 seal designation (EPR seals and stainless steel wire mesh in element, and light oil coating on housing exterior)

## Fluid Compatibility

Schroeder's CFX30 series is a non-bypassing filter that incorporates the use of a unique pressure drop limiting valve that maintains the differential pressure across the element below the element's collapse pressure rating. As the element accumulates dirt, the pressure drop increases across the element and, therefore, across the spool of the valve. At 50 psi, the spool begins to move, restricting flow as needed to prevent the pressure drop from increasing further and compromising element integrity. This design allows the CFX30 filters to safely use the lower cost standard elements, eliminating the need for expensive high-crush replacement elements.

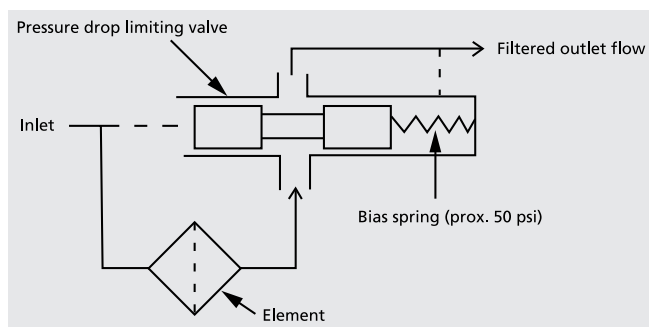

**Unique Non-Bypassing Filtration:**  
 A Better Way That Does Not Require High Crush Elements

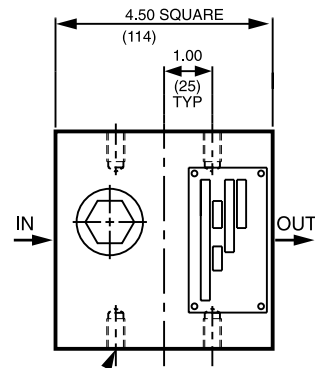

.38-16UNC-2B  
x .62 (16) DEEP  
OR  
M10 x 1.5 x (16) DEEP  
(4) MOUNTING HOLES

NOTE: FOR ALL CFX INSTALLATIONS, AN UPSTREAM  
RELIEF VALVE SET FOR 3000 PSI OR LESS  
IS REQUIRED TO PROTECT THE SYSTEM  
AND FILTER

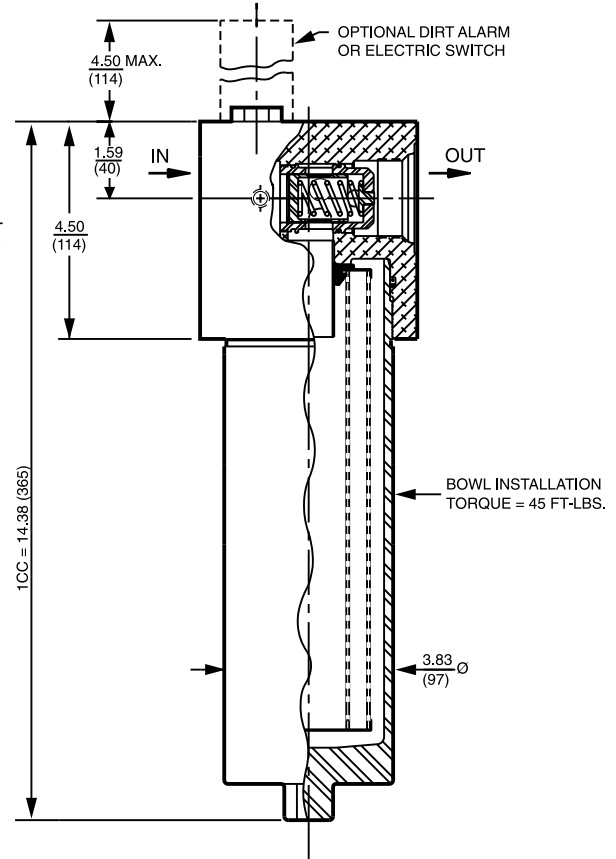

Metric dimensions in ( ).

Dimensions shown are inches (millimeters) for general information and overall envelope size only.  
For complete dimensions please contact Schroeder Industries to request a certified print.

## Element Performance Information & Dirt Holding Capacity

Element	Filtration Ratio Per ISO 4572/NFPA T3.10.8.8			Filtration Ratio per ISO 16889	
	Using automated particle counter (APC) calibrated per ISO 4402			Using APC calibrated per ISO 11171	
	$\beta_x \geq 75$	$\beta_x \geq 100$	$\beta_x \geq 200$	$\beta_x(c) \geq 200$	$\beta_x(c) \geq 1000$
CCZ1	<1.0	<1.0	<1.0	<4.0	4.2
CCZ3	<1.0	<1.0	<2.0	<4.0	4.8
CCZ5	2.5	3.0	4.0	4.8	6.3
CCZ10	7.4	8.2	10.0	8.0	10.0
CCZ25	18.0	20.0	22.5	19.0	24.0

Element	DHC (gm)
CCZ1	57
CCZ3	58
CCZ5	63
CCZ10	62
CCZ25	63

Element Collapse Rating: 150 psid (10 bar) for standard elements

Flow Direction: Outside In

Element Nominal CC: 3.0" (75 mm) O.D. x 9.5" (240 mm) long  
Dimensions:

$\Delta P_{\text{housing}}$

CFX30  $\Delta P_{\text{housing}}$  for fluids with sp gr (specific gravity) = 0.86:

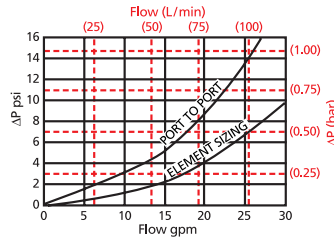

$\Delta P_{\text{element}}$

CCZ

Element Pressure Drop versus Flow Rate at 32 cSt (150 SUS)

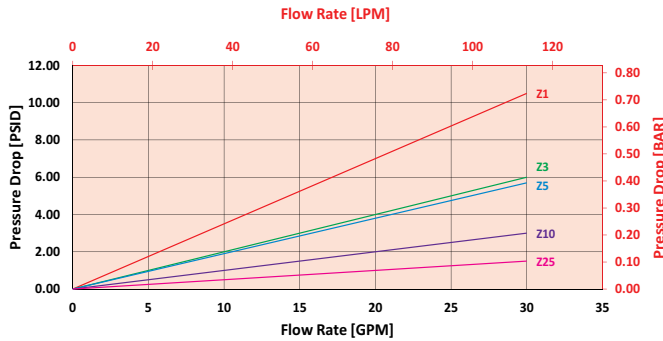

$$\Delta P_{\text{filter}} = \Delta P_{\text{housing}} + (\Delta P_{\text{element}} * V_f)$$

### Exercise:

Determine  $\Delta P_{\text{filter}}$  at 15 gpm (57 L/min) for CFX301CZ5SD5 using 100 SUS (21.3 cSt) fluid.

Use the housing pressure curve to determine  $\Delta P_{\text{housing}}$  at 15 gpm. In this case,  $\Delta P_{\text{housing}}$  is 5 psi (.34 bar) on the graph for the CFX30 housing.

Use the element pressure curve to determine  $\Delta P_{\text{element}}$  at 15 gpm. In this case,  $\Delta P_{\text{element}}$  is 3 psi (.21 bar) according to the graph for the CZ5 element.

Because the viscosity in this sample is 100 SUS (21.3 cSt), we determine the **Viscosity Factor ( $V_f$ )** by dividing the **Operating Fluid Viscosity** with the **Standard Viscosity** of 150 SUS (32 cSt). To best determine your Operating Fluid Viscosity, please reference the chart in Appendix D.

Finally, the overall filter pressure differential,  $\Delta P_{\text{filter}}$ , is calculated by adding  $\Delta P_{\text{housing}}$  with the true element pressure differential,  $(\Delta P_{\text{element}} * V_f)$ . The  $\Delta P_{\text{element}}$  from the graph has to be multiplied by the viscosity factor to get the true pressure differential across the element.

### Solution:

$$\Delta P_{\text{housing}} = 5 \text{ psi } [.34 \text{ bar}] \quad | \quad \Delta P_{\text{element}} = 3 \text{ psi } [.21 \text{ bar}]$$

$$V_f = 100 \text{ SUS } (21.3 \text{ cSt}) / 150 \text{ SUS } (32 \text{ cSt}) = .67$$

$$\Delta P_{\text{filter}} = .34 \text{ psi} + (.21 \text{ psi} * .67) = .48 \text{ psi}$$

OR

$$\Delta P_{\text{filter}} = .34 \text{ bar} + (.21 \text{ bar} * .67) = .48 \text{ bar}$$

## Pressure Drop Information Based on Flow Rate and Viscosity

Note:  
If your element is not graphed, use the following equation:  
 $\Delta P_{\text{element}} = \text{Flow Rate} \times \Delta P_f$  Plug this variable into the overall pressure drop equation.

Ele.	$\Delta P$
CC3	0.22
CC10	0.13
CC25	0.03
CAS3/CCAS3	0.20
CAS5/CCAS5	0.19
CAS10/CCAS10	0.35

## Filter Model Number Selection

### How to Build a Valid Model Number for a Schroeder CFX30:

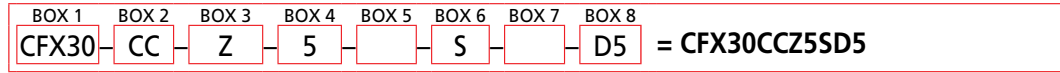
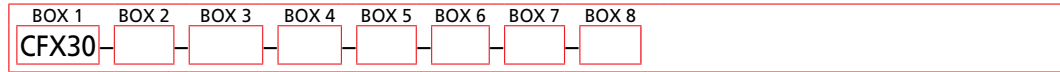

BOX 1	BOX 2	BOX 3
<b>Filter Series</b>	<b>Number &amp; Size of Elements</b>	<b>Media Type</b>
CFX30	1 C = Single Length CC = Double Length	Omit = E Media (cellulose) Z = Excellement® Z-Media® (synthetic) AS = Anti-Stat Media (synthetic) M = Media (reusable metal mesh)

BOX 4	BOX 5	BOX 6
<b>Micron Rating</b>	<b>Seal Material</b>	<b>Porting</b>
1 = 1 Micron (Z-Media®) 3 = 3 Micron (E, Z, AS Media) 5 = 5 Micron (Z, AS Media) 10 = 10 Micron (E, M, Z, AS Media) 25 = 25 Micron (E & Z-Media®)	Omit = Buna N V = Viton® W = Buna N, Anodized Aluminum parts H = EPR H.5 = Skydrol® compatibility	S = SAE-20 P = 1¼" NPTF B = ISO 228 G-1¼"

BOX 7	BOX 8
<b>Options</b>	<b>Dirt Alarm® Options</b>
Omit = None L = Two ¼" NPTF inlet and outlet female test ports U = Schroeder Check 7/16"-20 UNF Test Point installation in cap (upstream)	Omit = None Visual D5 = Visual pop-up Visual with Thermal Lockout D8 = Visual w/ thermal lockout
	Electrical MS5 = Electrical w/ 12 in. 18 gauge 4-conductor cable MS5LC = Low current MS5 MS10 = Electrical w/ DIN connector (male end only) MS10LC = Low current MS10 MS11 = Electrical w/ 12 ft. 4-conductor wire MS12 = Electrical w/ 5 pin Brad Harrison connector (male end only) MS12LC = Low current MS12 MS16 = Electrical w/ weather-packed sealed connector MS16LC = Low current MS16 MS17LC = Electrical w/ 4 pin Brad Harrison male connector
	Electrical with Thermal Lockout MS5T = MS5 (see above) w/ thermal lockout MS5LCT = Low current MS5T MS10T = MS10 (see above) w/ thermal lockout MS10LCT = Low current MS10T MS12T = MS12 (see above) w/ thermal lockout MS12LCT = Low current MS12T MS16T = MS16 (see above) w/ thermal lockout MS16LCT = Low current MS16T MS17LCT = Low current MS17T
	Electrical Visual MS13DC = Supplied w/ threaded connector & light MS14DC = Supplied w/ 5 pin Brad Harrison connector & light (male end)
	Electrical Visual with Thermal Lockout MS13DCLCT = MS13 (see above), direct current, w/ thermal lockout MS14DCLCT = MS14 (see above), direct current, w/ thermal lockout
	Visual with Thermal Lockout MS13DCLCT = Low current MS13DCLCT MS14DCLCT = Low current MS14DCLCT

#### NOTES:

Box 2. Replacement element part numbers are identical to contents of Boxes 2, 3, 4 and 5. E media (cellulose) elements are only available with Buna N seals.

Box 5. For options H, V, W, and H.5, all aluminum parts are anodized. H.5 seal designation includes the following: EPR seals, stainless steel wire mesh on elements, and light oil coating on housing exterior. Viton® is a registered trademark of DuPont Dow Elastomers. Skydrol® is a registered trademark of Solutia Inc.

Box 6. B porting option supplied with metric mounting holes.

# High Pressure Filter

**PLD**



## Features and Benefits

- Durable carbon steel construction
- Filter housings are designed to withstand pressure surges as well as high static pressure loads
- Screw-in bowl allows the filter element to be easily removed for replacement or cleaning
- Standard model supplied with drain plugs
- Standard Viton® seal on filter housing
- Filter contains an integrated equalization valve
- Pressure is equalized between filters by raising the change-over lever prior to switching it to the relevant filter side

**100 gpm**  
**380 L/min**  
**3000 psi**  
**210 bar**

NF30

NFS30

YF30

CFX30

**PLD**

CF40

DF40

PF40

RFS50

RF60

CF60

CTF60

VF60

LW60

KF30

KF50

TF50

KC50

MKF50

MKC50

KC65

MKC65

HS60

MHS60

KFH50

LC60

LC35

LC50

Model No. of filter in photograph is PLD10DVZ3VF24.

Flow Rating:	Up to 100 gpm (380 L/min) for 150 SUS (32 cSt) fluids
Max. Operating Pressure:	3000 psi (207 bar)
Min. Yield Pressure:	10,600 psi (730 bar)
Rated Fatigue Pressure:	3000 psi (207 bar)
Temp. Range:	-22°F to 250°F (-30°C to 121°C)
Bypass Setting:	102 psi (7 bar)
Porting Head:	Ductile Iron
Element Case:	Steel
Weight of PLD-10DV:	97 lbs. (43.9 kg)
Weight of PLD-16DV:	100 lbs. (45.3 kg)
Element Change Clearance:	10DV: 3.5" (89 mm) 16DV: 3.5" (89 mm)

## Filter Housing Specifications

Type Fluid	Appropriate Schroeder Media
Petroleum Based Fluids	All Z-Media® (synthetic)
Invert Emulsions	10 and 25 μ Z-Media® (synthetic)
Water Glycols	3, 5, 10 and 25 μ Z-Media® (synthetic)

## Fluid Compatibility

NOF30-05

NOF-50-760

FOF60-03

NMF30

RMF60

14-CRZX10

20-CRZX10

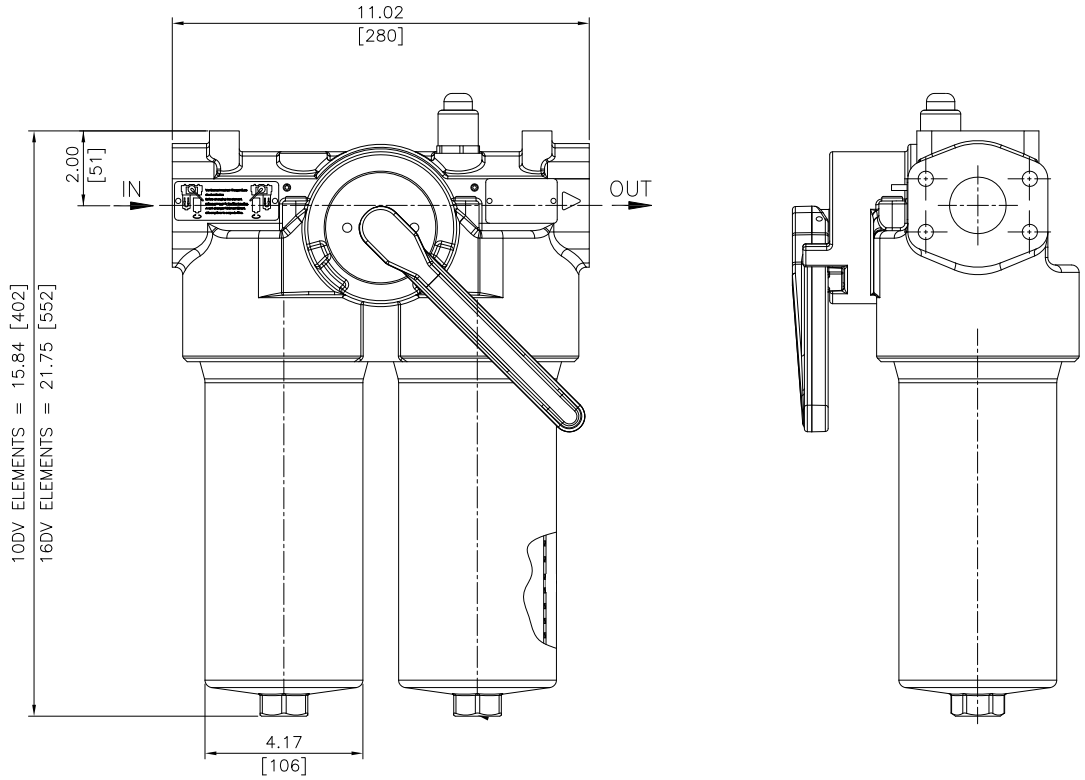

Metric dimensions in ( ).  
 Dimensions shown are inches (millimeters) for general information and overall envelope size only.  
 For complete dimensions please contact Schroeder Industries to request a certified print.

### Element Performance Information & Dirt Holding Capacity

Element	Filtration Ratio Per ISO 4572/NFPA T3.10.8.8 Using automated particle counter (APC) calibrated per ISO 4402			Filtration Ratio per ISO 16889 Using APC calibrated per ISO 11171	
	$\beta_x \geq 75$	$\beta_x \geq 100$	$\beta_x \geq 200$	$\beta_x(c) \geq 200$	$\beta_x(c) \geq 1000$
10/16DVZ1	<1.0	<1.0	<1.0	<4.0	4.2
10/16DVZ3	<1.0	<1.0	<2.0	<4.0	4.8
10/16DVZ5	2.5	3.0	4.0	4.8	6.3
10/16DVZ10	7.4	8.2	10.0	8.0	10.0
10/16DVZ25	18.0	20.0	22.5	19.0	24.0

Element	DHC (gm)	Element	DHC (gm)
10DVZ1	57	16DVZ1	110
10DVZ3	59	16DVZ3	114
10DVZ5	64	16DVZ5	124
10DVZ10	62	16DVZ10	112
10DVZ25	63	16DVZ25	102

Element Collapse Rating: 290 psid (20 bar)  
 Flow Direction: Outside In  
 Element Nominal Dimensions: 3.0" (75 mm) O.D. x 14.5" (370 mm) long



### $\Delta P_{\text{housing}}$

PLD  $\Delta P_{\text{housing}}$  for fluids with sp gr (specific gravity) = 0.86:

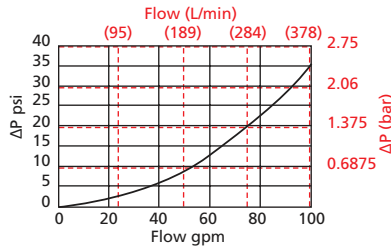

### $\Delta P_{\text{element}}$

10DVZ

Element Pressure Drop versus Flow Rate at 32 cSt (150 SUS)

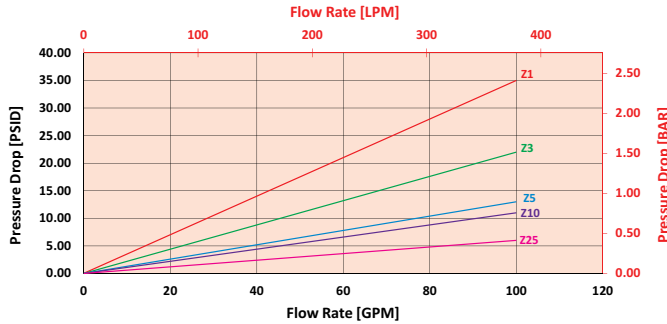

16DVZ

Element Pressure Drop versus Flow Rate at 32 cSt (150 SUS)

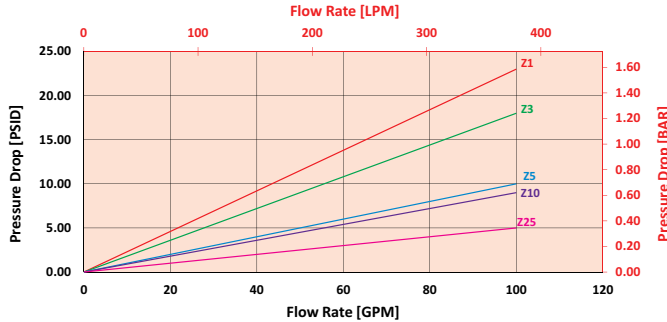

$$\Delta P_{\text{filter}} = \Delta P_{\text{housing}} + (\Delta P_{\text{element}} * V_f)$$

### Exercise:

Determine  $\Delta P_{\text{filter}}$  at 50 gpm (189 L/min) for PLD10DVZ1VF24VM using 200 SUS (42.6 cSt) fluid.

Use the housing pressure curve to determine  $\Delta P_{\text{housing}}$  at 50 gpm. In this case,  $\Delta P_{\text{housing}}$  is 8 psi (.55 bar) on the graph for the PLD housing.

Use the element pressure curve to determine  $\Delta P_{\text{element}}$  at 50 gpm. In this case,  $\Delta P_{\text{element}}$  is 17.5 psi (1.2 bar) according to the graph for the 10DVZ1 element.

Because the viscosity in this sample is 200 SUS (42.6 cSt), we determine the **Viscosity Factor ( $V_f$ )** by dividing the **Operating Fluid Viscosity** with the **Standard Viscosity** of 150 SUS (32 cSt). To best determine your Operating Fluid Viscosity, please reference the chart in Appendix D.

Finally, the overall filter pressure differential,  $\Delta P_{\text{filter}}$ , is calculated by adding  $\Delta P_{\text{housing}}$  with the true element pressure differential, ( $\Delta P_{\text{element}} * V_f$ ). The  $\Delta P_{\text{element}}$  from the graph has to be multiplied by the viscosity factor to get the true pressure differential across the element.

### Solution:

$$\Delta P_{\text{housing}} = 8 \text{ psi } [.55 \text{ bar}] \quad | \quad \Delta P_{\text{element}} = 17.5 \text{ psi } [1.2 \text{ bar}]$$

$$V_f = 200 \text{ SUS } (42.6 \text{ cSt}) / 150 \text{ SUS } (32 \text{ cSt}) = 1.3$$

$$\Delta P_{\text{filter}} = 8 \text{ psi } + (17.5 \text{ psi } * 1.3) = 30.8 \text{ psi}$$

OR

$$\Delta P_{\text{filter}} = .55 \text{ bar } + (1.2 \text{ bar } * 1.3) = 2.1 \text{ bar}$$

## Pressure Drop Information Based on Flow Rate and Viscosity

Note:

If your element is not graphed, use the following equation:  
 $\Delta P_{\text{element}} = \text{Flow Rate} \times \Delta P_f$   
 Plug this variable into the overall pressure drop equation.

Ele.	$\Delta P$	Ele.	$\Delta P$	Ele.	$\Delta P$
K3	0.25	KZW25	0.14	2KZW10	0.12
K10	0.09	2K3	0.12	2KZW25	0.07
K25	0.02	2K10	0.05	3K3	0.08
KAS3	0.10	2K25	0.01	3K10	0.03
KAS5	0.08	2KAS3	0.05	3K25	0.01
KAS10	0.05	2KAS5	0.04	3KAS3	0.03
KZX10	0.22	2KAS10	0.03	3KAS5	0.02
KZW1	0.43	2KZX10	0.11	3KAS10	0.02
KZW3	0.32	2KZW1	-	3KZX10	0.07
KZW5	0.28	2KZW3	0.16		
KZW10	0.23	2KZW5	0.14		

## Filter Model Number Selection

### How to Build a Valid Model Number for a Schroeder PLD:

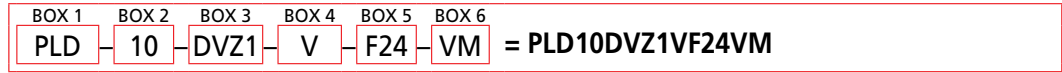

BOX 1	BOX 2	BOX 3	BOX 4
<b>Filter Series</b>	<b>Length of Elements (in)</b>	<b>Element Size and Media</b>	<b>Seal Material</b>
PLD	10 16	DVZ1 = DV size 1 μ synthetic media DVZ3 = DV size 3 μ synthetic media DVZ5 = DV size 5 μ synthetic media DVZ10 = DV size 10 μ synthetic media DVZ25 = DV size 25 μ synthetic media	Omit = Buna N V = Viton®

BOX 5
<b>Porting</b>
F24 = 1½" SAE 4-bolt flange Code 61 S24 = SAE-24 (1½")

BOX 6
<b>Dirt Alarm® Options</b>
Omit = None Visual VM = Visual pop-up w/manual rest Electrical DW = AC/DC 3-wire (NO or NC)



VM = Manual Reset

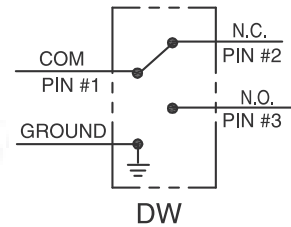

DW = AC/DC 3-wire  
(NO or NC)

#### NOTES:

Box 2. Replacement element part numbers are a combination of Boxes 2, 3 and 4.  
Example: 16DVZ10

Box 4. Filter housings are supplied with standard Viton seals. Seal designation in Box 4 applies to element only. Viton is a registered trademark of DuPont Dow Elastomers.

# Top-Ported Pressure Filter

# CF40/DF40



### Features and Benefits

- Top-ported pressure filter
- Available with non-bypass option with high collapse element
- Offered in pipe, SAE straight thread and ISO 228 porting
- Integral inlet and outlet female test points option available
- No-Element indicator option available

Up to  
**45 gpm**  
**170 L/min**  
**4000 psi**  
**275 bar**

- NF30
- NFS30
- YF30
- CFX30
- PLD
- CF40**
- DF40**
- PF40
- RFS50
- RF60
- CF60
- CTF60
- VF60
- LW60
- KF30
- KF50
- TF50
- KC50
- MKF50
- MKC50
- KC65
- MKC65
- HS60
- MHS60
- KFH50
- LC60
- LC35
- LC50
- NOF30-05
- NOF-50-760
- FOF60-03
- NMF30
- RMF60
- 14-CRZX10
- 20-CRZX10

Model No. of filters in photograph are CF401CC10SD5 and DF401CCZ10PD5.

Flow Rating:	CF40 - 45 gpm (170 L/min) for 150 SUS (32 cSt) fluids DF40 - 30 gpm (113 L/min) for 150 SUS (32 cSt) fluids
Max. Operating Pressure:	4000 psi (275 bar)
Min. Yield Pressure:	12,000 psi (828 bar), per NFPA T2.6.1
Rated Fatigue Pressure:	1800 psi (125 bar), per NFPA T2.6.1-2005
Temp. Range:	-20°F to 225°F (-29°C to 107°C)
Bypass Setting:	Cracking: 40 psi (2.8 bar) Full Flow: 72 psi (5.0 bar) Non-bypassing model has a blocked bypass.
Porting Head:	Aluminum
Element Case:	Steel
Weight of CF40/DF40-1C:	14.0 lbs. (6.4 kg)
Weight of CF40/DF40-1CC:	19.5 lbs. (8.9 kg)
Element Change Clearance:	4.00" (100 mm) for C elements 8.75" (219 mm) for CC elements

### Filter Housing Specifications

Type Fluid	Appropriate Schroeder Media
Petroleum Based Fluids	All E Media (cellulose), Z-Media® and ASP® Media (synthetic)
High Water Content	All Z-Media® and ASP® Media (synthetic)
Invert Emulsions	10 and 25 µ Z-Media® (synthetic), 10 µ ASP® Media (synthetic)
Water Glycols	3, 5, 10 and 25 µ Z-Media® (synthetic), and all ASP® Media (synthetic)
Phosphate Esters	All Z-Media® and ASP® Media (synthetic) with H (EPR) seal designation
Skydrol®	3, 5, 10 and 25 µ Z-Media (synthetic) and all ASP Media (synthetic) with H.5 seal designation (EPR seals and stainless steel wire mesh in element, and light oil coating on housing exterior)

### Fluid Compatibility

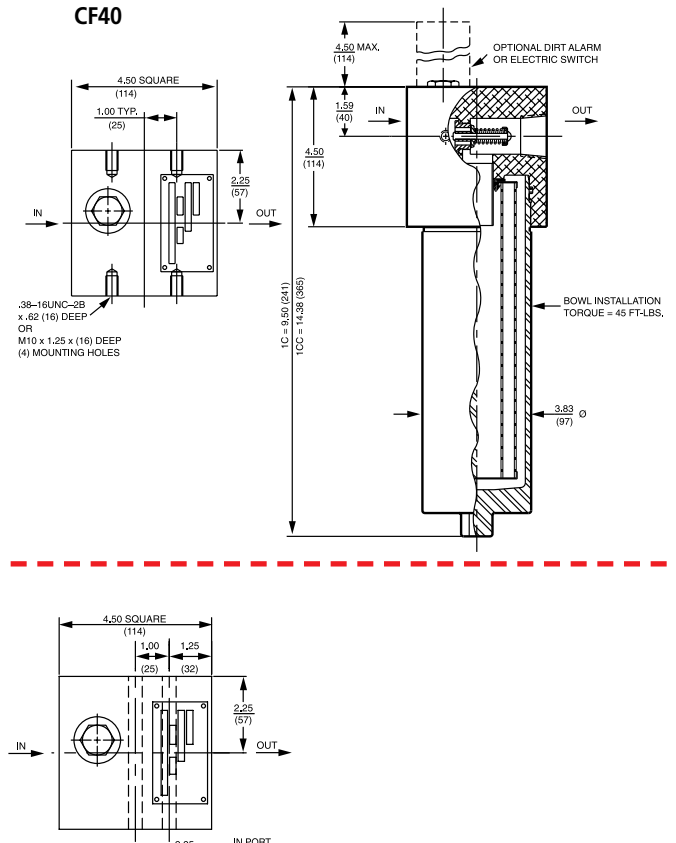
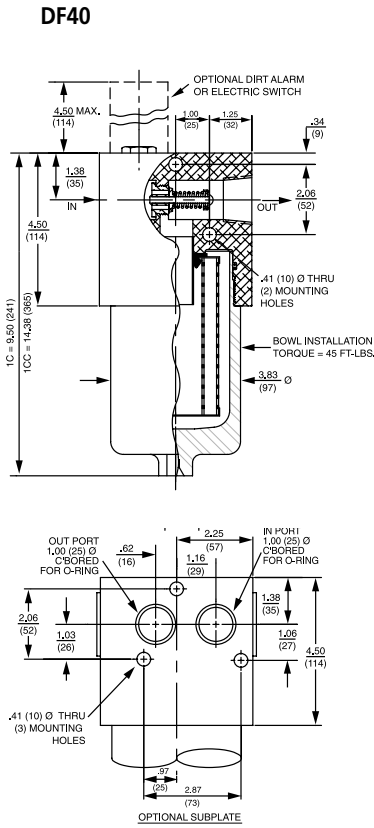

Metric dimensions in ( ).

Dimensions shown are inches (millimeters) for general information and overall envelope size only. For complete dimensions please contact Schroeder Industries to request a certified print.

## Element Performance Information & Dirt Holding Capacity

Element	Filtration Ratio Per ISO 4572/NFPA T3.10.8.8 Using automated particle counter (APC) calibrated per ISO 4402			Filtration Ratio per ISO 16889 Using APC calibrated per ISO 11171	
	$\beta_x \geq 75$	$\beta_x \geq 100$	$\beta_x \geq 200$	$\beta_x(c) \geq 200$	$\beta_x(c) \geq 1000$
CZ1/CCZ1	<1.0	<1.0	<1.0	<4.0	4.2
CZ3/CCZ3	<1.0	<1.0	<2.0	<4.0	4.8
CZ5/CCZ5	2.5	3.0	4.0	4.8	6.3
CZ10/CCZ10	7.4	8.2	10.0	8.0	10.0
CCZ25/CCZ25	18.0	20.0	22.5	19.0	24.0
CCZX3	<1.0	<1.0	<2.0	4.7	5.8
CCZX10	7.4	8.2	10.0	8.0	9.8

Element	DHC (gm)	Element	DHC (gm)
CZ1	25	CCZ1	57
CZ3	26	CCZ3	58
CZ5	30	CCZ5	63
CZ10	28	CCZ10	62
CZ25	28	CCZ25	63
		CCZX3	26*
		CCZX10	28*

Element Collapse Rating: 150 psid (10 bar) for standard elements  
3000 psid (210 bar) for high collapse (ZX) versions

Flow Direction: Outside In

Element Nominal Dimensions: C: 3.0" (75 mm) O.D. x 4.75" (120 mm) long  
CC: 3.0" (75 mm) O.D. x 9.5" (240 mm) long

\* Based on 100 psi terminal pressure

## $\Delta P_{\text{housing}}$

CF40/DF40  $\Delta P_{\text{housing}}$  for fluids with sp gr (specific gravity) = 0.86:

CF40- 1-1/4" Porting

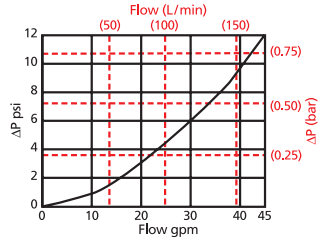

DF40- 1" Porting

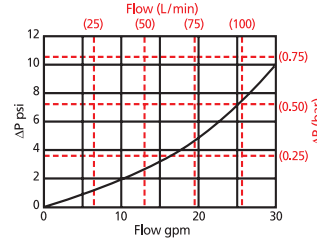

## $\Delta P_{\text{element}}$

CZ

Element Pressure Drop versus Flow Rate at 32 cSt (150 SUS)

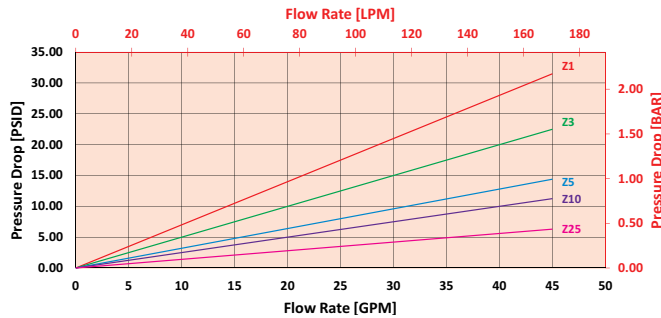

CCZ

Element Pressure Drop versus Flow Rate at 32 cSt (150 SUS)

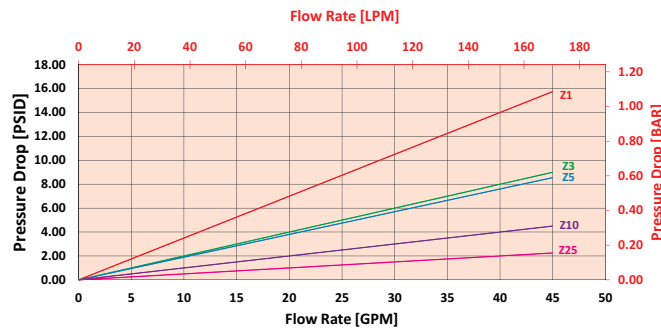

$$\Delta P_{\text{filter}} = \Delta P_{\text{housing}} + (\Delta P_{\text{element}} * V_f)$$

### Exercise:

Determine  $\Delta P_{\text{filter}}$  at 25 gpm (94.6 L/min) for CF401CZ10SD5 using 200 SUS (42.6 cSt) fluid.

Use the housing pressure curve to determine  $\Delta P_{\text{housing}}$  at 25 gpm. In this case,  $\Delta P_{\text{housing}}$  is 4.5 psi (.31 bar) on the graph for the CF40 housing.

Use the element pressure curve to determine  $\Delta P_{\text{element}}$  at 25 gpm. In this case,  $\Delta P_{\text{element}}$  is 6 psi (.42 bar) according to the graph for the CZ10 element.

Because the viscosity in this sample is 200 SUS (42.6 cSt), we determine the **Viscosity Factor ( $V_f$ )** by dividing the **Operating Fluid Viscosity** with the **Standard Viscosity** of 150 SUS (32 cSt). To best determine your Operating Fluid Viscosity, please reference the chart in Appendix D.

Finally, the overall filter pressure differential,  $\Delta P_{\text{filter}}$ , is calculated by adding  $\Delta P_{\text{housing}}$  with the true element pressure differential,  $(\Delta P_{\text{element}} * V_f)$ . The  $\Delta P_{\text{element}}$  from the graph has to be multiplied by the viscosity factor to get the true pressure differential across the element.

### Solution:

$$\Delta P_{\text{housing}} = 4.5 \text{ psi } [.31 \text{ bar}] \quad | \quad \Delta P_{\text{element}} = 6 \text{ psi } [.42 \text{ bar}]$$

$$V_f = 200 \text{ SUS } (42.6 \text{ cSt}) / 150 \text{ SUS } (32 \text{ cSt}) = 1.3$$

$$\Delta P_{\text{filter}} = 4.5 \text{ psi } + (6 \text{ psi } * 1.3) = 12.3 \text{ psi}$$

OR

$$\Delta P_{\text{filter}} = .31 \text{ bar } + (.42 \text{ bar } * 1.3) = .86 \text{ bar}$$

## Pressure Drop Information Based on Flow Rate and Viscosity

Note:  
If your element is not graphed, use the following equation:  
 $\Delta P_{\text{element}} = \text{Flow Rate} \times \Delta P_f$ . Plug this variable into the overall pressure drop equation.

Ele.	$\Delta P$	Ele.	$\Delta P$
C3	0.50	CC3	0.22
C10	0.19	CC10	0.13
C25	0.09	CC25	0.03
CAS3	0.50	CCAS3	0.20
CAS5	0.32	CCAS5	0.19
CAS10	0.25	CCAS10	0.10
		CCZX3	0.29
		CCZX10	0.26

## Filter Model Number Selection

### How to Build a Valid Model Number for a Schroeder CF40:

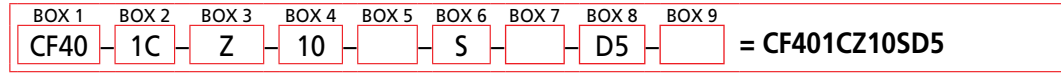
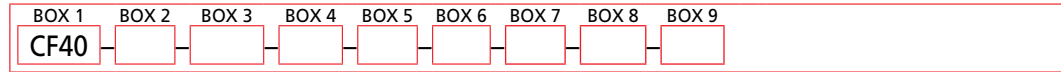

Filter Series	Number and Size of Elements	Media Type	Seal Material	Porting
CF40	1 C CC	Omit = E Media(Cellulose) Z = Excellement® Z-Media® (synthetic) ZX = Excellement® Z-Media® (high collapse center tube) AS = Anti-Stat Media (synthetic) M = Media (reusable metal mesh) D size only		S = SAE-20" P = 1 1/4" NPTF B = ISO 228 G-1 1/4"
CFN40 (Non-bypassing; requires ZX high collapse elements)				
DF40				
DFN40 (Non-bypassing; requires ZX high collapse elements)				
	<b>Micron Rating</b>			
	1 = 1 Micron (Z, ZX media) 3 = 3 Micron (AS, E, Z, ZX media) 5 = 5 Micron (AS, Z, ZX media) 10 = 10 Micron (AS, E, M, Z, ZX media) 25 = 25 Micron (E & Z media®)			
			<b>Seal Material</b>	
			Omit = Buna N V = Viton® W = Buna N, Anodized Aluminum parts H = EPR H.5 = Skydrol® compatibility	
				<b>Porting</b>
				O = Manifold mounting S = SAE-16 P = 1" NPTF B = ISO 228 G-1

Options	Dirt Alarm® Options
Omit = None X = Blocked bypass 25 = 25 psi bypass setting 30 = 30 psi bypass setting 50 = 50 psi bypass setting 60 = 60 psi bypass setting 75 = 75 psi bypass setting L = Two 1/4" NPTF inlet and outlet female test ports	Omit = None D = Pointer D5 = Visual pop-up D8 = Visual w/ thermal lockout
	Visual with Thermal Lockout MS5 = Electrical w/ 12 in. 18 gauge 4-conductor cable MS5LC = Low current MS5 MS10 = Electrical w/ DIN connector (male end only) MS10LC = Low current MS10 MS11 = Electrical w/ 12 ft. 4-conductor wire MS12 = Electrical w/ 5 pin Brad Harrison connector (male end only) MS12LC = Low current MS12 MS16 = Electrical w/ weather-packed sealed connector MS16LC = Low current MS16 MS17LC = Electrical w/ 4 pin Brad Harrison male connector
	Electrical MS5T = MS5 (see above) w/ thermal lockout MS5LCT = Low current MS5T MS10T = MS10 (see above) w/ thermal lockout MS10LCT = Low current MS10T MS12T = MS12 (see above) w/ thermal lockout MS12LCT = Low current MS12T MS16T = MS16 (see above) w/ thermal lockout MS16LCT = Low current MS16T MS17LCT = Low current MS17T
	Electrical with Thermal Lockout MS = Cam operated switch w/ 1/2" conduit female connection MS13DC = Supplied w/ threaded connector & light MS14DC = Supplied w/ 5 pin Brad Harrison connector & light (male end)
	Electrical Visual MS13DCT = MS13 (see above), direct current, w/ thermal lockout MS13DCLCT = Low current MS13DCT MS14DCT = MS14 (see above), direct current, w/ thermal lockout MS14DCLCT = Low current MS14DCT

Additional Options
Omit = None N = No-Element Indicator (CF40 or DF40)

- NOTES:
- Box 2. Replacement element part numbers are identical to contents of Boxes 2, 3, 4 and 5.
  - Box 5. For options H, V, W, and H.5, all aluminum parts are anodized. H.5 seal designation includes the following: EPR seals, stainless steel wire mesh on elements, and light oil coating on housing exterior. Viton® is a registered trademark of DuPont Dow Elastomers. Skydrol® is a registered trademark of Solutia Inc.
  - Box 6. B porting option supplied with metric mounting holes.
  - Box 7. Options X and 50 are not available with CFN40 or DFN40.
  - Box 8. Standard indicator setting for non-bypassing model is 50 psi unless otherwise noted.
  - Box 9. N option is not available with CFN40 or DFN40. N option should be used in conjunction with dirt alarm.

# Top-Ported Pressure Filter

## PF40



### Features and Benefits

- Top-ported pressure filter
- All steel housing offers unparalleled fatigue rating
- Available with non-bypass option with high collapse element
- Two bowl lengths provide optimal sizing for the application
- Offered in conventional sub-plate, SAE straight thread, and ISO 228 porting

**50 gpm**  
**190 L/min**  
**4000 psi**  
**275 bar**

Model No. of filter in photograph is PF409HZ10S.

- NF30
- NFS30
- YF30
- CFX30
- PLD
- CF40
- DF40
- PF40**
- RFS50
- RF60
- CF60
- CTF60
- VF60
- LW60
- KF30
- KF50
- TF50
- KC50
- MKF50
- MKC50
- KC65
- MKC65
- HS60
- MHS60
- KFH50
- LC60
- LC35
- LC50
- NOF30-05
- NOF-50-760
- FOF60-03
- NMF30
- RMF60
- 14-CRZX10
- 20-CRZX10

Flow Rating:	Up to 50 gpm (190 L/min) for 150 SUS (32 cSt) fluids
Max. Operating Pressure:	4000 psi (275 bar)
Min. Yield Pressure:	12,000 psi (828 bar), per NFPA T2.6.1
Rated Fatigue Pressure:	2500 psi (173 bar), per NFPA T2.6.1-R1-2005
Temp. Range:	-20°F to 225°F (-29°C to 107°C)
Bypass Setting:	Cracking: 40 psi (2.8 bar) Full Flow: 75 psi (5.2 bar)
Porting Head:	Steel
Element Case:	Steel
Weight of PF40-5H:	21.8 lbs. (9.9 kg)
Weight of PF40-9H:	25.5 lbs. (11.6 kg)
Element Change Clearance:	3.25" (83 mm)

### Filter Housing Specifications

Type Fluid	Appropriate Schroeder Media
Petroleum Based Fluids	All E Media (cellulose) and Z-Media® (synthetic)
High Water Content	All Z-Media® (synthetic)
Invert Emulsions	10 and 25 μ Z-Media® (synthetic)
Water Glycols	3, 5, 10 and 25 μ Z-Media® (synthetic)
Phosphate Esters	All Z-Media® (synthetic) with H (EPR) seal designation

### Fluid Compatibility

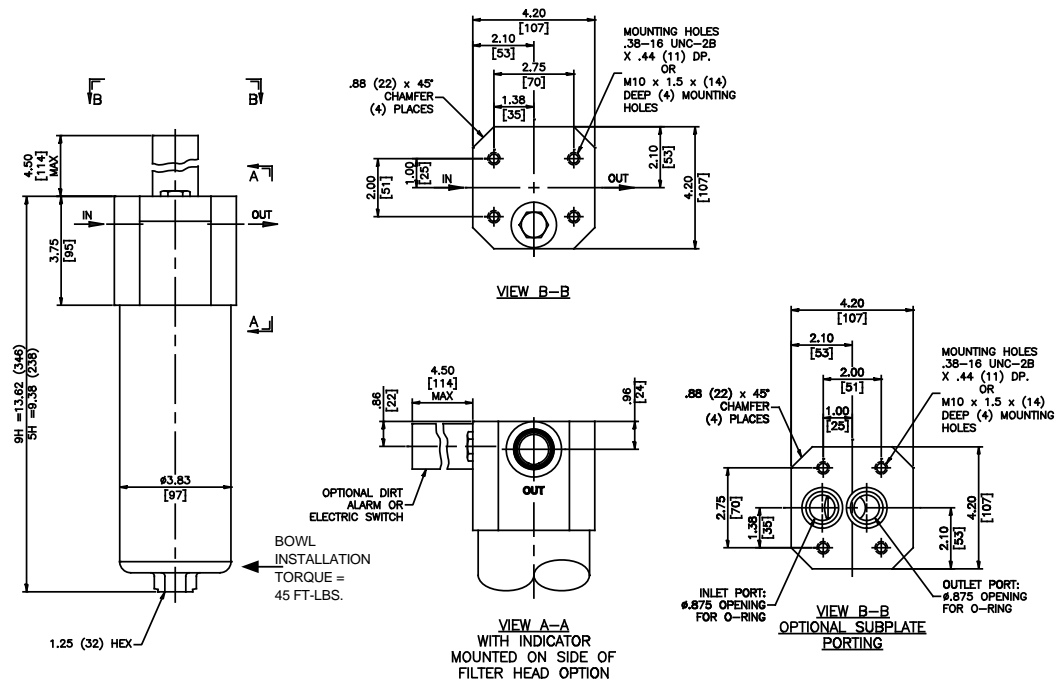

Metric dimensions in ( ).  
 Dimensions shown are inches (millimeters) for general information and overall envelope size only.  
 For complete dimensions please contact Schroeder Industries to request a certified print.

## Element Performance Information & Dirt Holding Capacity

Element	Filtration Ratio Per ISO 4572/NFPA T3.10.8.8 Using automated particle counter (APC) calibrated per ISO 4402			Filtration Ratio per ISO 16889 Using APC calibrated per ISO 11171	
	$\beta_x \geq 75$	$\beta_x \geq 100$	$\beta_x \geq 200$	$\beta_x(c) \geq 200$	$\beta_x(c) \geq 1000$
5HZ1/9HZ1	<1.0	<1.0	<1.0	<4.0	4.2
5HZ3/9HZ3	<1.0	<1.0	<2.0	<1.0	4.8
5HZ5/9HZ5	2.5	3.0	4.0	4.8	6.3
5HZ10/9HZ10	7.4	8.2	10.0	8.0	10.0
5HZ25/9HZ25	18.0	20.0	22.5	19.0	24.0
5HZX1/9HZX1	<1.0	<1.0	<1.0	<4.0	4.2
5HZX3/9HZX3	<1.0	<1.0	<2.0	<1.0	4.8
5HZX5/9HZX5	2.5	3.0	4.0	4.8	6.3
5HZX10/9HZX10	7.4	8.2	10.0	8.0	10.0
5HZX25/9HZX25	18.0	20.0	22.5	19.0	24.0

Element	DHC (gm)	Element	DHC (gm)	Element	DHC (gm)	Element	DHC (gm)
5HZ1	26	9HZ1	51	5HZX1	14	9HZX1	29
5HZ3	28	9HZ3	42	5HZX3	14	9HZX3	29
5HZ5	39	9HZ5	59	5HZX5	15	9HZX5	31
5HZ10	31	9HZ10	47	5HZX10	15	9HZX10	31
5HZ25	32	9HZ25	48	5HZX25	16	9HZX25	33

Element Collapse Rating: 150 psid (10 bar) for standard elements  
 3000 psid (210 bar) for high collapse elements

Flow Direction: Outside In

Element Nominal Dimensions: 5H: 2.5" (100 mm) O.D. x 5.36" (136 mm) long  
 9H: 2.5" (100 mm) O.D. x 9.63" (244 mm) long



$\Delta P_{\text{housing}}$

PF40  $\Delta P_{\text{housing}}$  for fluids with sp gr (specific gravity) = 0.86:

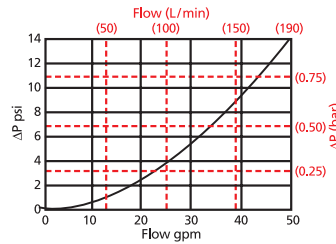

$\Delta P_{\text{element}}$

5HZ

Element Pressure Drop versus Flow Rate at 32 cSt (150 SUS)

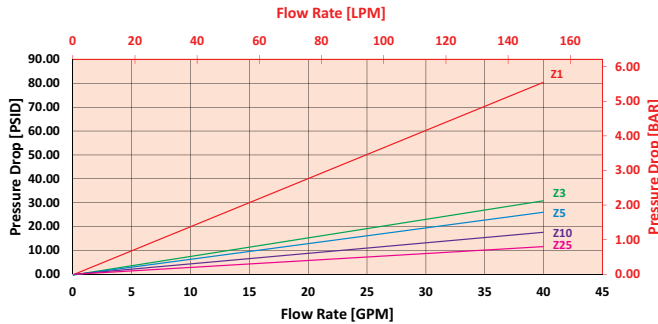

9HZ

Element Pressure Drop versus Flow Rate at 32 cSt (150 SUS)

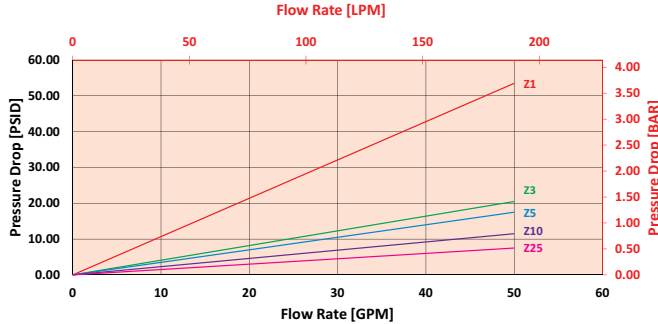

$$\Delta P_{\text{filter}} = \Delta P_{\text{housing}} + (\Delta P_{\text{element}} * V_f)$$

**Exercise:**

Determine  $\Delta P_{\text{filter}}$  at 20 gpm (75.7 L/min) for PF405HZ3SD5S using 160 SUS (34 cSt) fluid.

Use the housing pressure curve to determine  $\Delta P_{\text{housing}}$  at 20 gpm. In this case,  $\Delta P_{\text{housing}}$  is 2.5 psi (.17 bar) on the graph for the PF40 housing.

Use the element pressure curve to determine  $\Delta P_{\text{element}}$  at 20 gpm. In this case,  $\Delta P_{\text{element}}$  is 15 psi (1 bar) according to the graph for the 5HZ3 element.

Because the viscosity in this sample is 160 SUS (34 cSt), we determine the **Viscosity Factor ( $V_f$ )** by dividing the **Operating Fluid Viscosity** with the **Standard Viscosity** of 150 SUS (32 cSt). To best determine your Operating Fluid Viscosity, please reference the chart in Appendix D.

Finally, the overall filter pressure differential,  $\Delta P_{\text{filter}}$ , is calculated by adding  $\Delta P_{\text{housing}}$  with the true element pressure differential,  $(\Delta P_{\text{element}} * V_f)$ . The  $\Delta P_{\text{element}}$  from the graph has to be multiplied by the viscosity factor to get the true pressure differential across the element.

**Solution:**

$\Delta P_{\text{housing}} = 2.5 \text{ psi } [.17 \text{ bar}] \mid \Delta P_{\text{element}} = 15 \text{ psi } [1 \text{ bar}]$

$V_f = 160 \text{ SUS } (34 \text{ cSt}) / 150 \text{ SUS } (32 \text{ cSt}) = 1.1$

$\Delta P_{\text{filter}} = 2.5 \text{ psi} + (15 \text{ psi} * 1.1) = 19 \text{ psi}$

**OR**

$\Delta P_{\text{filter}} = .17 \text{ bar} + (1 \text{ bar} * 1.1) = 1.3 \text{ bar}$

**Pressure Drop Information Based on Flow Rate and Viscosity**

Note:  
If your element is not graphed, use the following equation:  
 $\Delta P_{\text{element}} = \text{Flow Rate} \times \Delta P_f$  Plug this variable into the overall pressure drop equation.

Ele.	$\Delta P$
5HZX3	1.17
5HZX10	0.50
5HZX25	0.27
9HZX3	0.62
9HZX10	0.26
9HZX25	0.14

## Filter Model Number Selection

### How to Build a Valid Model Number for a Schroeder PF40:

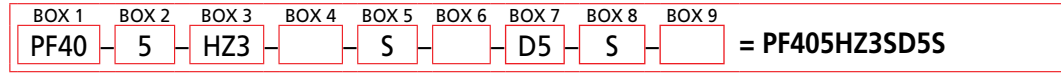
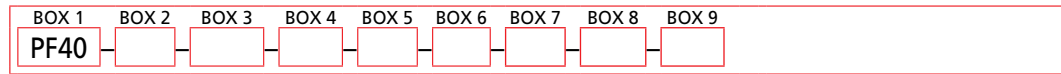

BOX 1	BOX 2	BOX 3
<b>Filter Series</b>	<b>Element Length (in)</b>	<b>Element Part Number</b>
PF40	5	HZ1 = H size 1 μ Excellement® Z-Media® (synthetic) HZ3 = H size 3 μ Excellement® Z-Media® (synthetic) HZ5 = H size 5 μ Excellement® Z-Media® (synthetic) HZ10 = H size 10 μ Excellement® Z-Media® (synthetic) HZ25 = H size 25 μ Excellement® Z-Media® (synthetic) HZX3 = H size 3 μ Excellement® Z-Media® (high collapse center tube) HZX10 = H size 10 μ Excellement® Z-Media® (high collapse center tube) HZX25 = H size 25 μ Excellement® Z-Media® (high collapse center tube)
PFN40 (Non-bypassing: requires ZX high collapse elements)	9	

BOX 4	BOX 5	BOX 6
<b>Seal Material</b>	<b>Porting</b>	<b>Options</b>
Omit = Buna N  H = EPR  V = Viton®  H.5 = Skydrol® compatibility	O = Manifold  S = SAE-16  B = ISO 228 G-1"	Omit = None  L = Two ¼" NPTF inlet & outlet female test ports U = Schroeder Check 7/16"-20 UNF test point installation in head (upstream)

BOX 7	BOX 8
<b>Dirt Alarm® Options</b>	<b>Dirt Alarm® Location</b>
Omit = None Visual D5 = Visual pop-up Visual with Thermal Lockout D8 = Visual w/ thermal lockout	Omit = Top mounted S = Side mounted

BOX 9
<b>Bowl Drain Options</b>
Omit = None DR = Drain 7/16"-20

#### NOTES:

Box 2. Replacement element part numbers are a combination of Boxes 2, 3 and 4. Example: 5HZ10V

Box 4. For options H, V, and H.5, all aluminum parts are anodized. H.5 seal designation includes the following: EPR seals, stainless steel wire mesh on elements, and light oil coating on housing exterior. Viton® is a registered trademark of DuPont Dow Elastomers. Skydrol® is a registered trademark of Solutia Inc.

Box 5. B porting option supplied with metric mounting holes.

Box 7. Standard indicator setting for non-bypassing model is 50 psi unless otherwise noted.

# Manifold Mounted Pressure Filter

# RFS50



### Features and Benefits

- Manifold mounted high pressure filter
- Offered in square head conventional subplate porting
- Direct mounting to customer's manifold
- Standard drain plug in bowl for easy servicing
- Various dirt alarm options available

Model No. of filter in photograph is RFS508R100.

**30 gpm**  
**115 L/min**  
**5000 psi**  
**345 bar**

- NF30
- NFS30
- YF30
- CFX30
- PLD
- CF40
- DF40
- PF40
- RFS50**
- RF60
- CF60
- CTF60
- VF60
- LW60
- KF30
- KF50
- TF50
- KC50

Flow Rating:	Up to 30 gpm (115 L/min) for 150 SUS (32 cSt) fluids
Max. Operating Pressure:	5000 psi (345 bar)
Min. Yield Pressure:	15,500 psi (1070 bar), per NFPA T2.6.1
Rated Fatigue Pressure:	Contact Factory
Temp. Range:	-20°F to 225°F (-29°C to 107°C)
Bypass Setting:	Cracking: 40 psi (2.8 bar) Full Flow: 56 psi (3.9 bar)
Porting Head:	Steel
Element Case:	Steel
Weight of RFS50-8R:	16.50 lbs. (7.5 kg)
Element Change Clearance:	3.0" (75 mm)

### Filter Housing Specifications

- MKF50
- MKC50
- KC65
- MKC65
- HS60
- MHS60
- KFH50
- LC60
- LC35
- LC50

Type Fluid	Appropriate Schroeder Media
Petroleum Based Fluids	All E Media (cellulose) and Z-Media® (synthetic)
High Water Content	All Z-Media® (synthetic)
Invert Emulsions	10 and 25 μ Z-Media® (synthetic)
Water Glycols	3, 5, 10 and 25 μ Z-Media® (synthetic)
Phosphate Esters	All Z-Media® (synthetic) with H (EPR) seal designation
Skydrol®	3, 5, 10 and 25 μ Z-Media® (synthetic) with H.5 seal designation (EPR seals and stainless steel wire mesh in element, and light oil coating on housing exterior)

### Fluid Compatibility

- NOF30-05
- NOF-50-760
- FOF60-03
- NMF30
- RMF60
- 14-CRZX10
- 20-CRZX10

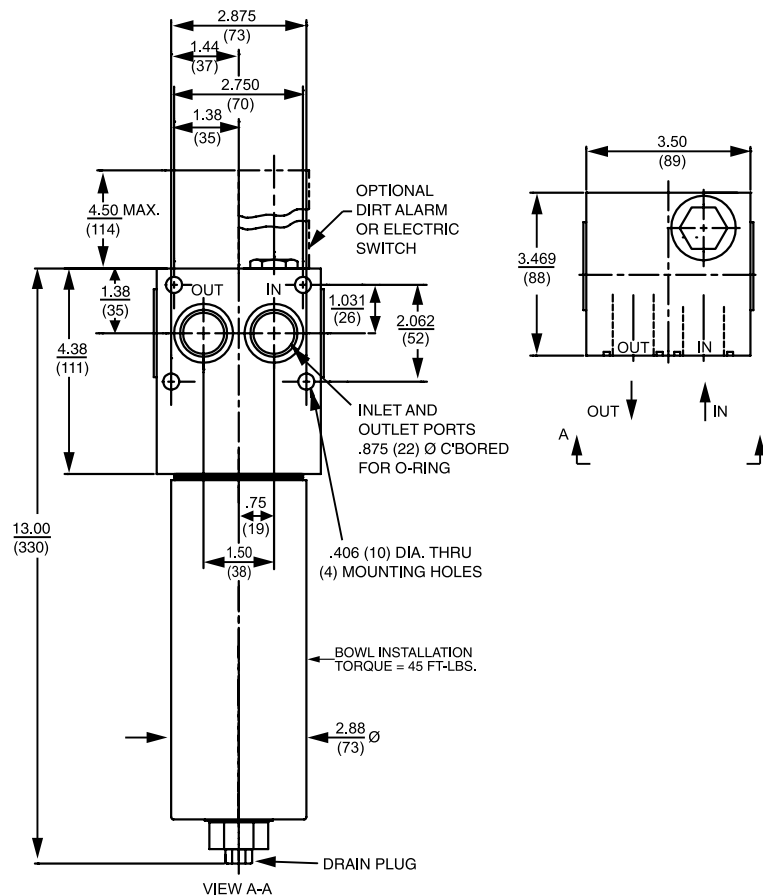

Metric dimensions in ( ).  
 Dimensions shown are inches (millimeters) for general information and overall envelope size only.  
 For complete dimensions please contact Schroeder Industries to request a certified print.

## Element Performance Information & Dirt Holding Capacity

Element	Filtration Ratio Per ISO 4572/NFPA T3.10.8.8 Using automated particle counter (APC) calibrated per ISO 4402			Filtration Ratio per ISO 16889 Using APC calibrated per ISO 11171	
	$\beta_x \geq 75$	$\beta_x \geq 100$	$\beta_x \geq 200$	$\beta_x(\cdot) \geq 200$	$\beta_x(\cdot) \geq 1000$
8RZ1	<1.0	<1.0	<1.0	<4.0	4.2
8RZ3	<1.0	<1.0	<2.0	<4.0	4.8
8RZ5	2.5	3.0	4.0	4.8	6.3
8RZ10	7.4	8.2	10.0	8.0	10.0
8RZ25	18.0	20.0	22.5	19.0	24.0

Element	DHC (gm)
8RZ1	33
8RZ3	26
8RZ5	51
8RZ10	29
8RZ25	30

Element Collapse Rating: 150 psid (10 bar) for standard elements  
 Flow Direction: Outside In  
 Element Nominal Dimensions: 2.18" (55 mm) O.D. x 8.15" (206 mm) long

## $\Delta P_{\text{housing}}$

RFS50  $\Delta P_{\text{housing}}$  for fluids with sp gr (specific gravity) = 0.86:

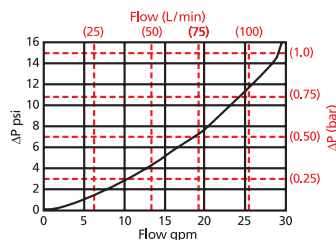

## $\Delta P_{\text{element}}$

8RZ

Element Pressure Drop versus Flow Rate at 32 cSt (150 SUS)

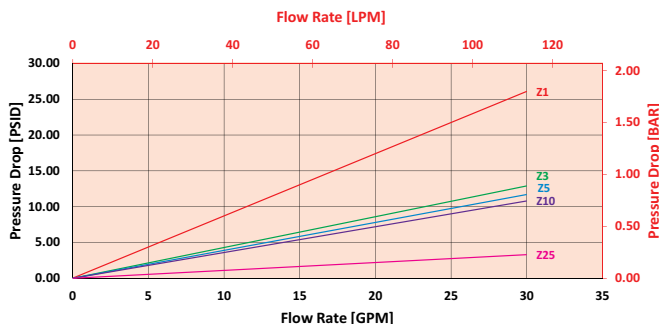

## Pressure Drop Information Based on Flow Rate and Viscosity

$$\Delta P_{\text{filter}} = \Delta P_{\text{housing}} + (\Delta P_{\text{element}} * V_f)$$

### Exercise:

Determine  $\Delta P_{\text{filter}}$  at 15 gpm (57 L/min) for RFS508RZ10VOD5 using 200 SUS (42.6 cSt) fluid.

Use the housing pressure curve to determine  $\Delta P_{\text{housing}}$  at 15 gpm. In this case,  $\Delta P_{\text{housing}}$  is 5 psi (.34 bar) on the graph for the RFS50 housing.

Use the element pressure curve to determine  $\Delta P_{\text{element}}$  at 15 gpm. In this case,  $\Delta P_{\text{element}}$  is 5 psi (.34 bar) according to the graph for the 8RZ10 element.

Because the viscosity in this sample is 200 SUS (42.6 cSt), we determine the **Viscosity Factor ( $V_f$ )** by dividing the **Operating Fluid Viscosity** with the **Standard Viscosity** of 150 SUS (32 cSt). To best determine your Operating Fluid Viscosity, please reference the chart in Appendix D.

Finally, the overall filter pressure differential,  $\Delta P_{\text{filter}}$ , is calculated by adding  $\Delta P_{\text{housing}}$  with the true element pressure differential, ( $\Delta P_{\text{element}} * V_f$ ). The  $\Delta P_{\text{element}}$  from the graph has to be multiplied by the viscosity factor to get the true pressure differential across the element.

### Solution:

$$\Delta P_{\text{housing}} = 5 \text{ psi } [.34 \text{ bar}] \quad | \quad \Delta P_{\text{element}} = 5 \text{ psi } [.34 \text{ bar}]$$

$$V_f = 200 \text{ SUS } (42.6 \text{ cSt}) / 150 \text{ SUS } (32 \text{ cSt}) = 1.3$$

$$\Delta P_{\text{filter}} = 5 \text{ psi } + (5 \text{ psi } * 1.3) = 11.5 \text{ psi}$$

OR

$$\Delta P_{\text{filter}} = .34 \text{ bar } + (.34 \text{ bar } * 1.3) = .78 \text{ bar}$$

Note:

If your element is not graphed, use the following equation:  
 $\Delta P_{\text{element}} = \text{Flow Rate} \times \Delta P_f$  Plug this variable into the overall pressure drop equation.

Ele.	$\Delta P$
8R3	0.35
8R10	0.30

## Filter Model Number Selection

### How to Build a Valid Model Number for a Schroeder RFS50:

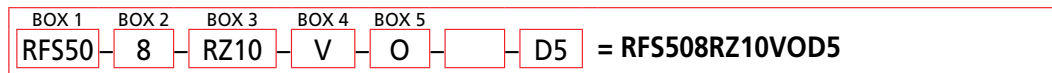
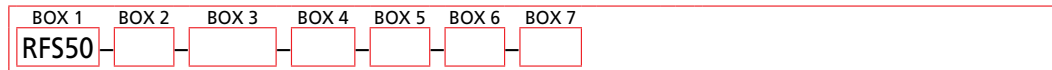

BOX 1	BOX 2	BOX 3
<b>Filter Series</b>	<b>Element Length (in)</b>	<b>Element Size and Media</b>
RFS50	8	R3 = R size 3 μ E media (cellulose) R10 = R size 10 μ E media (cellulose) RZ1 = R size 1 μ Excellement® Z-Media® (synthetic) RZ3 = R size 3 μ Excellement® Z-Media® (synthetic) RZ5 = R size 5 μ Excellement® Z-Media® (synthetic) RZ10 = R size 10 μ Excellement® Z-Media® (synthetic) RZ25 = R size 25 μ Excellement® Z-Media® (synthetic)

BOX 4	BOX 5	BOX 6
<b>Seal Material</b>	<b>Inlet Port</b>	<b>Options</b>
Omit = Buna N H = EPR V = Viton®	O = Manifold mounting	Omit = None X = Blocked bypass 50 = 50 psi bypass setting L = Two ¼" NPTF inlet and outlet female test ports U = Schroeder Check 7/16"-20 UNF Test Point installation in head (upstream)

BOX 7	
Dirt Alarm® Options	
	Omit = None
Visual	D5 = Visual pop-up
Visual with Thermal Lockout	D8 = Visual w/ thermal lockout
Electrical	MS5 = Electrical w/ 12 in. 18 gauge 4-conductor cable MS5LC = Low current MS5 MS10 = Electrical w/ DIN connector (male end only) MS10LC = Low current MS10 MS11 = Electrical w/ 12 ft. 4-conductor wire MS12 = Electrical w/ 5 pin Brad Harrison connector (male end only) MS12LC = Low current MS12 MS16 = Electrical w/ weather-packed sealed connector MS16LC = Low current MS16 MS17LC = Electrical w/ 4 pin Brad Harrison male connector
Electrical with Thermal Lockout	MS5T = MS5 (see above) w/ thermal lockout MS5LCT = Low current MS5T MS10T = MS10 (see above) w/ thermal lockout MS10LCT = Low current MS10T MS12T = MS12 (see above) w/ thermal lockout MS12LCT = Low current MS12T MS16T = MS16 (see above) w/ thermal lockout MS16LCT = Low current MS16T MS17LCT = Low current MS17T
Electrical Visual	MS13DC = Supplied w/ threaded connector & light MS14DC = Supplied w/ 5 pin Brad Harrison connector & light (male end)
Electrical Visual with Thermal Lockout	MS13DCT = MS13 (see above), direct current, w/ thermal lockout MS13DCLCT = Low current MS13DCT MS14DCT = MS14 (see above), direct current, w/ thermal lockout MS14DCLCT = Low current MS14DCT

#### NOTES:

Box 2. Replacement element part numbers are a combination of Boxes 2, 3, and 4.

Box 3. Example: 8RZ1V synthetic media elements are only available with Viton seals.

Box 4. Viton® is a registered trademark of DuPont Dow Elastomers.

Box 5. For option O, O-rings included, fastening hardware not included.

# Top-Ported Pressure Filter

## RF60



### Features and Benefits

- Top-ported high pressure filter
- Offered in pipe, SAE straight thread, flanged and ISO 228 porting
- Available with non-bypass option with high collapse element
- Various dirt alarm options available

**30 gpm**  
**115 L/min**  
**6000 psi**  
**415 bar**

NF30  
 NFS30  
 YF30  
 CFX30  
 PLD  
 CF40  
 DF40  
 PF40  
 RFS50  
**RF60**  
 CF60  
 CTF60  
 VF60  
 LW60  
 KF30  
 KF50  
 TF50  
 KC50

Model No. of filter in photograph is RF608R10P.

Flow Rating:	Up to 30 gpm (115 L/min) for 150 SUS (32 cSt) fluids
Max. Operating Pressure:	6000 psi (415 bar)
Min. Yield Pressure:	18,000 psi (1241 bar), per NFPA T2.6.1
Rated Fatigue Pressure:	2300 psi (159 bar), per NFPA T2.6.1-2005
Temp. Range:	-20°F to 225°F (-29°C to 107°C)
Bypass Setting:	Cracking: 40 psi (2.8 bar) Full Flow: 56 psi (3.9 bar) Non-bypassing model has a blocked bypass.
Porting Head:	Steel
Element Case:	Steel
Weight of RF60-8R:	15.75 lbs. (7.2 kg)
Element Change Clearance:	3.0" (75 mm)

### Filter Housing Specifications

MKF50  
 MKC50  
 KC65  
 MKC65  
 HS60  
 MHS60  
 KFH50  
 LC60  
 LC35  
 LC50

Type Fluid	Appropriate Schroeder Media
Petroleum Based Fluids	All E-Media (cellulose) and Z-Media® (synthetic)
High Water Content	All Z-Media® (synthetic)
Invert Emulsions	10 and 25 μ Z-Media® (synthetic)
Water Glycols	3, 5, 10 and 25 μ Z-Media® (synthetic)
Phosphate Esters	All Z-Media® (synthetic) with H (EPR) seal designation
Skydrol®	3, 5, 10 and 25 μ Z-Media® (synthetic) with H.5 seal designation (EPR seals and stainless steel wire mesh in element, and light oil coating on housing exterior)

### Fluid Compatibility

NOF30-05  
 NOF-50-760  
 FOF60-03  
 NMF30  
 RMF60  
 14-CRZX10  
 20-CRZX10

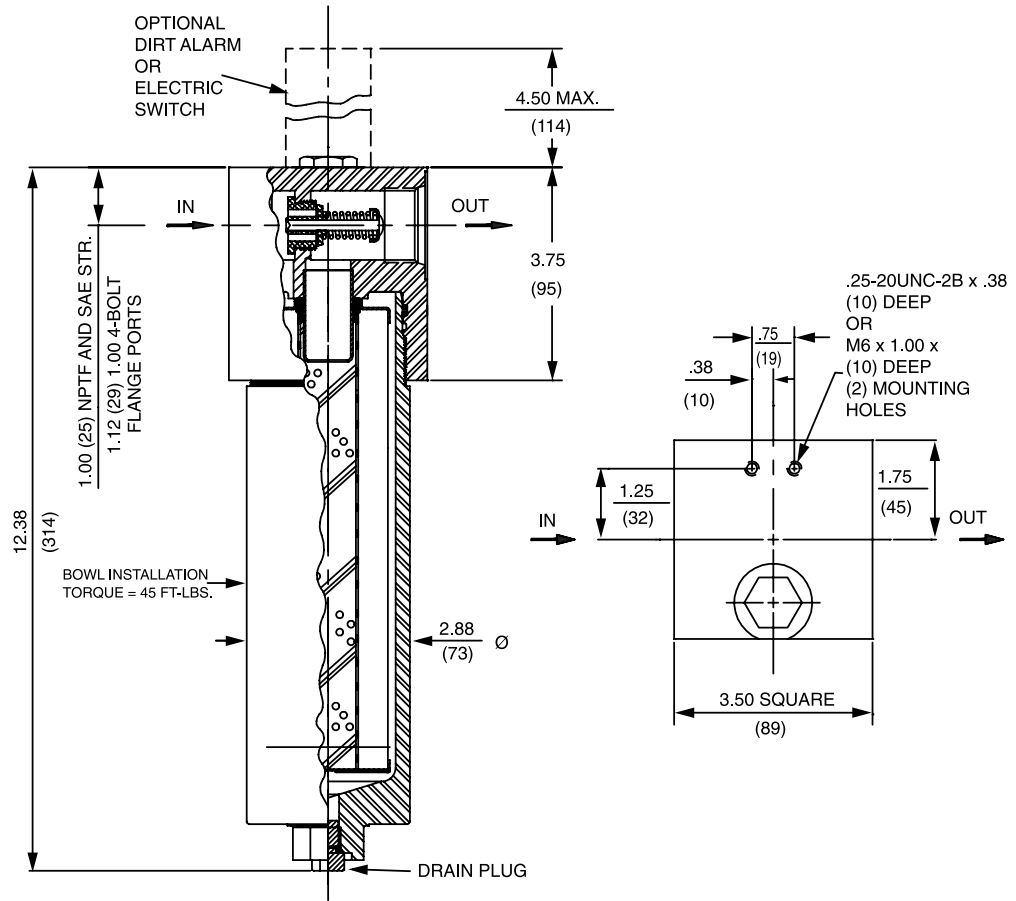

Metric dimensions in ( ).  
 Dimensions shown are inches (millimeters) for general information and overall envelope size only.  
 For complete dimensions please contact Schroeder Industries to request a certified print.

## Element Performance Information & Dirt Holding Capacity

Element	Filtration Ratio Per ISO 4572/NFPA T3.10.8.8 Using automated particle counter (APC) calibrated per ISO 4402			Filtration Ratio per ISO 16889 Using APC calibrated per ISO 11171	
	$\beta_x \geq 75$	$\beta_x \geq 100$	$\beta_x \geq 200$	$\beta_x(\alpha) \geq 200$	$\beta_x(\alpha) \geq 1000$
8RZ1	<1.0	<1.0	<1.0	<4.0	4.2
8RZ3	<1.0	<1.0	<2.0	<4.0	4.8
8RZ5	2.5	3.0	4.0	4.8	6.3
8RZ10	7.4	8.2	10.0	8.0	10.0
8RZ25	18.0	20.0	22.5	19.0	24.0
8RZX3	<1.0	<1.0	<2.0	4.7	5.8
8RZX10	7.4	8.2	10.0	8.0	9.8

Element	DHC (gm)
8RZ1	33
8RZ3	26
8RZ5	51
8RZ10	29
8RZ25	30
8RZX3	C/F
8RZX10	C/F

Element Collapse Rating: 150 psid (10 bar) for standard elements  
 3000 psid (210 bar) for high collapse (ZX) versions

Flow Direction: Outside In

Element Nominal Dimensions: 2.18" (55 mm) O.D. x 8.15" (206 mm) long



$\Delta P_{\text{housing}}$

RF60  $\Delta P_{\text{housing}}$  for fluids with sp gr (specific gravity) = 0.86:

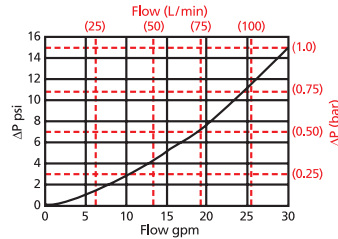

$\Delta P_{\text{element}}$

8RZ

Element Pressure Drop versus Flow Rate at 32 cSt (150 SUS)

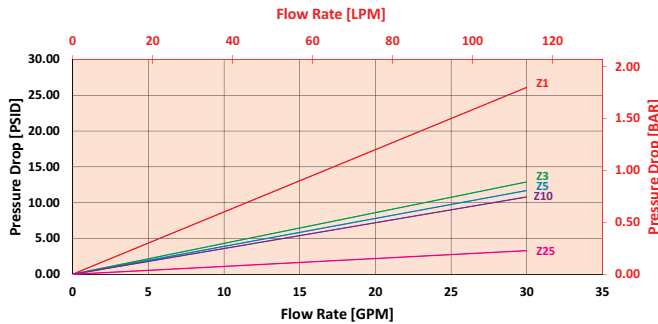

**Pressure Drop Information Based on Flow Rate and Viscosity**

$$\Delta P_{\text{filter}} = \Delta P_{\text{housing}} + (\Delta P_{\text{element}} * V_f)$$

**Exercise:**

Determine  $\Delta P_{\text{filter}}$  at 15 gpm (57 L/min) for RF608RZ10VPD5 using 100 SUS (21.3 cSt) fluid.

Use the housing pressure curve to determine  $\Delta P_{\text{housing}}$  at 15 gpm. In this case,  $\Delta P_{\text{housing}}$  is 5 psi (.34 bar) on the graph for the RF60 housing.

Use the element pressure curve to determine  $\Delta P_{\text{element}}$  at 15 gpm. In this case,  $\Delta P_{\text{element}}$  is 5 psi (.34 bar) according to the graph for the 8RZ10 element.

Because the viscosity in this sample is 100 SUS (21.3 cSt), we determine the **Viscosity Factor ( $V_f$ )** by dividing the **Operating Fluid Viscosity** with the **Standard Viscosity** of 150 SUS (32 cSt). To best determine your Operating Fluid Viscosity, please reference the chart in Appendix D.

Finally, the overall filter pressure differential,  $\Delta P_{\text{filter}}$ , is calculated by adding  $\Delta P_{\text{housing}}$  with the true element pressure differential,  $(\Delta P_{\text{element}} * V_f)$ . The  $\Delta P_{\text{element}}$  from the graph has to be multiplied by the viscosity factor to get the true pressure differential across the element.

**Solution:**

$\Delta P_{\text{housing}} = 5 \text{ psi } [.34 \text{ bar}] \mid \Delta P_{\text{element}} = 5 \text{ psi } [.34 \text{ bar}]$

$V_f = 100 \text{ SUS } (21.3 \text{ cSt}) / 150 \text{ SUS } (32 \text{ cSt}) = .67$

$\Delta P_{\text{filter}} = 5 \text{ psi} + (5 \text{ psi} * .67) = 8.3 \text{ psi}$

**OR**

$\Delta P_{\text{filter}} = .34 \text{ bar} + (.34 \text{ bar} * .67) = .57 \text{ bar}$

Note:  
If your element is not graphed, use the following equation:  
 $\Delta P_{\text{element}} = \text{Flow Rate} \times \Delta P_f$ . Plug this variable into the overall pressure drop equation.

Ele.	$\Delta P$
8R3	0.35
8R10	0.30
8RZX3	C/F
8RZX10	C/F

## Filter Model Number Selection

### How to Build a Valid Model Number for a Schroeder RF60:

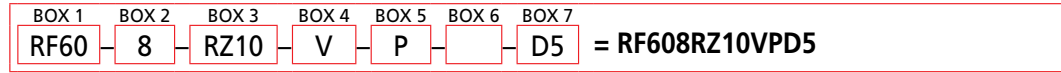
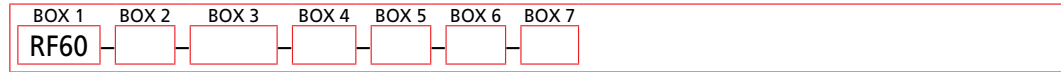

BOX 1	BOX 2	BOX 3	BOX 4
<b>Filter Series</b> RF60  RFN60 <small>(Non-bypassing: requires ZX high collapse elements)</small>	<b>Element Length (in)</b> 8	<b>Element Size and Media</b> R3 = R size 3 μ E media (cellulose) R10 = R size 10 μ E media (cellulose) RZ1 = R size 1 μ Excellement® Z-Media® (synthetic) RZ3 = R size 3 μ Excellement® Z-Media® (synthetic) RZ5 = R size 5 μ Excellement® Z-Media® (synthetic) RZ10 = R size 10 μ Excellement® Z-Media® (synthetic) RZ25 = R size 25 μ Excellement® Z-Media® (synthetic) RZX3 = R size 3 μ Excellement® Z-Media® (high collapse center tube) RZX10 = R size 10 μ Excellement® Z-Media® (high collapse center tube)	<b>Seal Material</b> Omit = Buna N H = EPR V = Viton®

BOX 5	BOX 7
<b>Inlet Port</b> P = 1" NPTF S = SAE-16 F = 1" SAE 4-bolt flange Code 62 B = ISO 228 G-1"	<b>Dirt Alarm® Options</b> Omit = None Visual D5 = Visual pop-up Visual with Thermal Lockout D8 = Visual w/ thermal lockout Electrical MS5 = Electrical w/ 12 in. 18 gauge 4-conductor cable MS5LC = Low current MS5 MS10 = Electrical w/ DIN connector (male end only) MS10LC = Low current MS10 MS11 = Electrical w/ 12 ft. 4-conductor wire MS12 = Electrical w/ 5 pin Brad Harrison connector (male end only) MS12LC = Low current MS12 MS16 = Electrical w/ weather-packed sealed connector MS16LC = Low current MS16 MS17LC = Electrical w/ 4 pin Brad Harrison male connector Electrical with Thermal Lockout MS5T = MS5 (see above) w/ thermal lockout MS5LCT = Low current MS5T MS10T = MS10 (see above) w/ thermal lockout MS10LCT = Low current MS10T MS12T = MS12 (see above) w/ thermal lockout MS12LCT = Low current MS12T MS16T = MS16 (see above) w/ thermal lockout MS16LCT = Low current MS16T MS17LCT = Low current MS17T Electrical Visual MS13DC = Supplied w/ threaded connector & light MS14DC = Supplied w/ 5 pin Brad Harrison connector & light (male end) Electrical Visual with Thermal Lockout MS13DCT = MS13 (see above), direct current, w/ thermal lockout MS13DCLCT = Low current MS13DCT MS14DCT = MS14 (see above), direct current, w/ thermal lockout MS14DCLCT = Low current MS14DCT
<b>Options</b> Omit = None X = Blocked bypass 50 = 50 psi bypass setting L = Two ¼" NPTF inlet and outlet female test ports U = Schroeder Check 7/16"-20 UNF Test Point installation in head (upstream)	

**NOTES:**

Box 2. Replacement element part numbers are a combination of Boxes 2, 3 and 4. Example: 8RZ1V synthetic media elements are only available with Viton seals.

Box 4. Viton® is a registered trademark of DuPont Dow Elastomers.

Box 5. B porting option supplied with metric mounting holes.

Box 6. Options X and 50 are not available with RFN60.

Box 7. Standard indicator setting for non-bypassing model is 50 psi unless otherwise noted.

# Top-Ported Pressure Filter

## CF60



### Features and Benefits

- Top-ported high pressure filter
- Available with non-bypass option with high collapse element
- Offered in pipe, SAE straight thread, flange and ISO 228 porting
- No-Element indicator option available

**50 gpm**  
**190 L/min**  
**6000 psi**  
**415 bar**

NF30

NFS30

YF30

CFX30

PLD

CF40

DF40

PF40

RFS50

RF60

**CF60**

CTF60

VF60

LW60

KF30

KF50

TF50

KC50

MKF50

MKC50

KC65

MKC65

HS60

MHS60

KFH50

LC60

LC35

LC50

### Filter Housing Specifications

Flow Rating:	Up to 50 gpm (190 L/min) for 150 SUS (32 cSt) fluids
Max. Operating Pressure:	6000 psi (415 bar)
Min. Yield Pressure:	15,500 psi (1070 bar), per NFPA T2.6.1
Rated Fatigue Pressure:	4000 psi (276 bar), per NFPA T2.6.1-R1-2005
Temp. Range:	-20°F to 225°F (-29°C to 107°C)
Bypass Setting:	Cracking: 40 psi (2.8 bar) Full Flow: 75 psi (5.2 bar) Non-bypassing model has a blocked bypass.
Porting Head:	Ductile Iron
Element Case:	Steel
Weight of CF60-9C:	24.0 lbs. (10.9 kg)
Element Change Clearance:	4.0" (103 mm)

### Fluid Compatibility

Type Fluid	Appropriate Schroeder Media
Petroleum Based Fluids	All E-Media (cellulose), Z-Media® and ASP® Media (synthetic)
High Water Content	All Z-Media® and ASP® Media (synthetic)
Invert Emulsions	10 and 25 µ Z-Media® (synthetic) and 10 µ ASP® Media (synthetic)
Water Glycols	3, 5, 10 and 25 µ Z-Media® and all ASP® Media (synthetic)
Phosphate Esters	All Z-Media® and ASP® Media (synthetic) with H (EPR) seal designation
Skydrol®	3, 5, 10 and 25 µ Z-Media® and all ASP® Media (synthetic) with H.5 seal designation (EPR seals and stainless steel wire mesh in element, and light oil coating on housing exterior)

NOF30-05

NOF-50-760

FOF60-03

NMF30

RMF60

14-CRZX10

20-CRZX10

Model No. of filter in photograph is CF601CCZ3SD5.

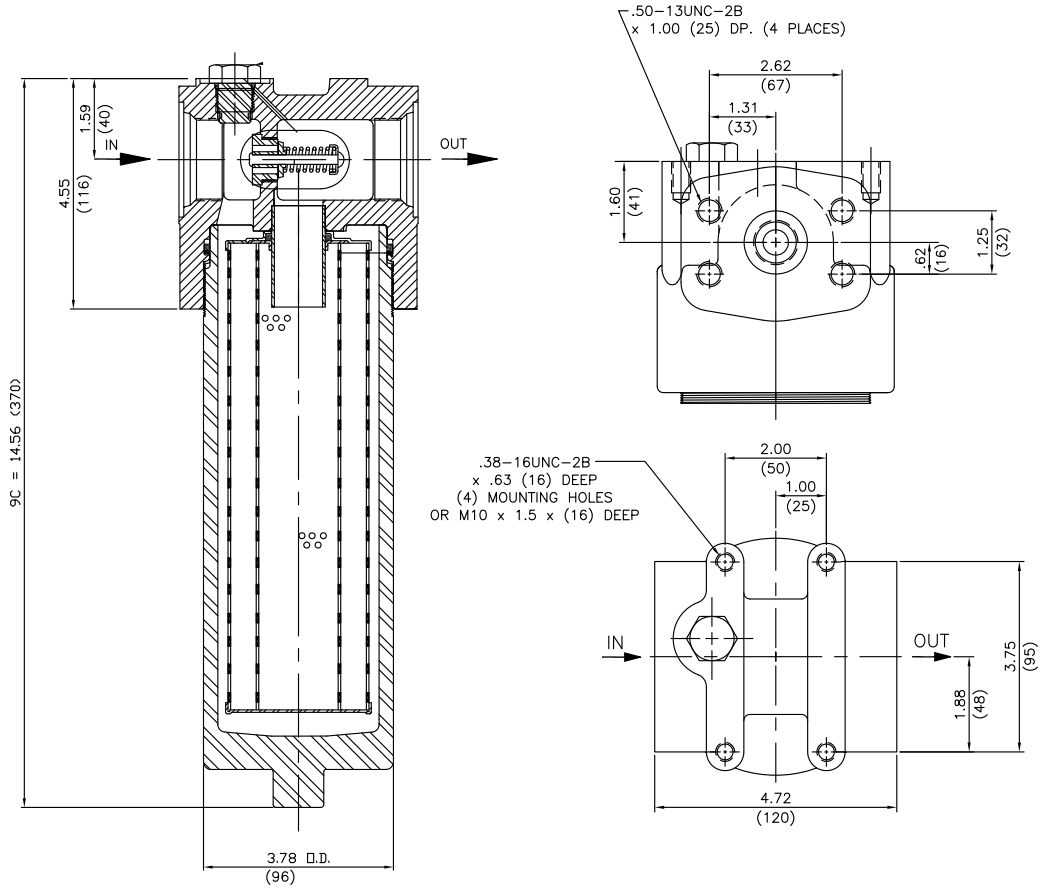

Metric dimensions in ( ).  
 Dimensions shown are inches (millimeters) for general information and overall envelope size only.  
 For complete dimensions please contact Schroeder Industries to request a certified print.

## Element Performance Information & Dirt Holding Capacity

Element	Filtration Ratio Per ISO 4572/NFPA T3.10.8.8 Using automated particle counter (APC) calibrated per ISO 4402			Filtration Ratio per ISO 16889 Using APC calibrated per ISO 11171	
	$\beta_x \geq 75$	$\beta_x \geq 100$	$\beta_x \geq 200$	$\beta_x(c) \geq 200$	$\beta_x(c) \geq 1000$
CCZ1	<1.0	<1.0	<1.0	<4.0	4.2
CCZ3	<1.0	<1.0	<2.0	<4.0	4.8
CCZ5	2.5	3.0	4.0	4.8	6.3
CCZ10	7.4	8.2	10.0	8.0	10.0
CCZ25	18.0	20.0	22.5	19.0	24.0
CCZX3	<1.0	<1.0	<2.0	4.7	5.8

Element	DHC (gm)
CCZ1	57
CCZ3	58
CCZ5	63
CCZ10	62
CCZ25	63
CCZX3	26*

Element Collapse Rating: 150 psid (10 bar) for standard elements  
 3000 psid (210 bar) for high collapse (ZX) versions

Flow Direction: Outside In

Element Nominal Dimensions: CC: 3.0" (75 mm) O.D. x 9.5" (240 mm) long

### $\Delta P_{\text{housing}}$

CF60  $\Delta P_{\text{housing}}$  for fluids with sp gr (specific gravity) = 0.86:

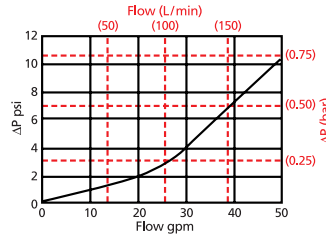

### $\Delta P_{\text{element}}$

CCZ

Element Pressure Drop versus Flow Rate at 32 cSt (150 SUS)

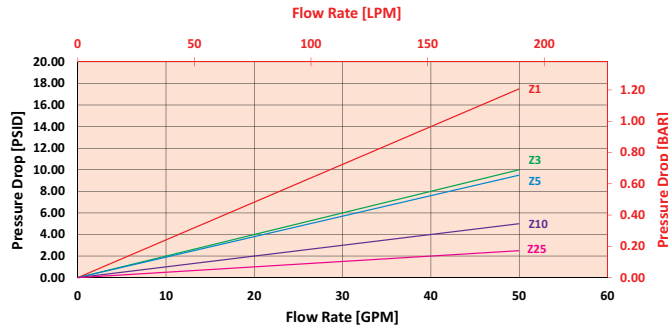

## Pressure Drop Information Based on Flow Rate and Viscosity

$$\Delta P_{\text{filter}} = \Delta P_{\text{housing}} + (\Delta P_{\text{element}} * V_f)$$

### Exercise:

Determine  $\Delta P_{\text{filter}}$  at 30 gpm (113.6 L/min) for CF601CCZ10SD5 using 175 SUS (37.2 cSt) fluid.

Use the housing pressure curve to determine  $\Delta P_{\text{housing}}$  at 30 gpm. In this case,  $\Delta P_{\text{housing}}$  is 4 psi (.28 bar) on the graph for the CF60 housing.

Use the element pressure curve to determine  $\Delta P_{\text{element}}$  at 30 gpm. In this case,  $\Delta P_{\text{element}}$  is 3 psi (.21 bar) according to the graph for the CCZ10 element.

Because the viscosity in this sample is 175 SUS (37.2 cSt), we determine the **Viscosity Factor ( $V_f$ )** by dividing the **Operating Fluid Viscosity** with the **Standard Viscosity** of 150 SUS (32 cSt). To best determine your Operating Fluid Viscosity, please reference the chart in Appendix D.

Finally, the overall filter pressure differential,  $\Delta P_{\text{filter}}$ , is calculated by adding  $\Delta P_{\text{housing}}$  with the true element pressure differential, ( $\Delta P_{\text{element}} * V_f$ ). The  $\Delta P_{\text{element}}$  from the graph has to be multiplied by the viscosity factor to get the true pressure differential across the element.

### Solution:

$$\Delta P_{\text{housing}} = 4 \text{ psi } [.28 \text{ bar}] \quad | \quad \Delta P_{\text{element}} = 3 \text{ psi } [.21 \text{ bar}]$$

$$V_f = 175 \text{ SUS } (37.2 \text{ cSt}) / 150 \text{ SUS } (32 \text{ cSt}) = 1.2$$

$$\Delta P_{\text{filter}} = 4 \text{ psi } + (3 \text{ psi } * 1.2) = 7.6 \text{ psi}$$

OR

$$\Delta P_{\text{filter}} = .28 \text{ bar } + (.21 \text{ bar } * 1.2) = .53 \text{ bar}$$

Note:  
If your element is not graphed, use the following equation:  
 $\Delta P_{\text{element}} = \text{Flow Rate} \times \Delta P_f$  Plug this variable into the overall pressure drop equation.

Ele.	$\Delta P$
CC3	0.22
CC10	0.13
CC25	0.03
CCAS3	0.20
CCAS5	0.19
CCAS10	0.10
CCZX3	0.29
CCZX10	0.26

## Filter Model Number Selection

### How to Build a Valid Model Number for a Schroeder CF60:

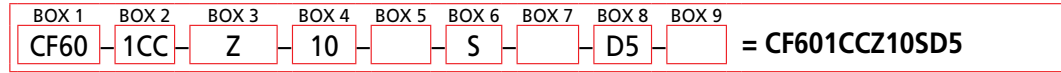
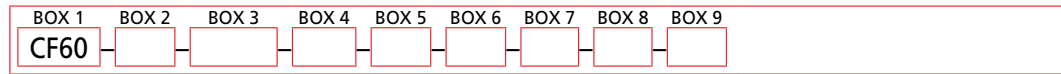

BOX 1	BOX 2	BOX 3
<b>Filter Series</b>	<b>Number and Size of Elements</b>	<b>Media Type</b>
CF60	1CC	Omit = E Media (cellulose)
CFN60 <small>(Non-bypassing: requires ZX high collapse elements)</small>		Z = Excellement® Z-Media® (synthetic)
		ZX = Excellement® Z-Media® (high collapse center tube)
		AS = Anti-Stat Media (synthetic)

BOX 4	
Micron Rating	
1	= 1 Micron (Z media)
3	= 3 Micron (AS, E, Z and ZX media)
5	= 5 Micron (AS, Z, and ZX media)
10	= 10 Micron (AS, E, Z, and ZX media)
25	= 25 Micron (E, Z and ZX media)

BOX 5
Seal Material
Omit = Buna N
V = Viton®
H = EPR
H.5 = Skydrol® compatibility

BOX 6
Porting
S = SAE-20
P = 1¼" NPTF
F = 1¼" SAE 4-bolt flange code 62
B = ISO 228 G-1¼"

BOX 7
Options
Omit = None
25 = 25 psi bypass setting
30 = 30 psi bypass setting
50 = 50 psi bypass setting
60 = 60 psi bypass setting
75 = 75 psi bypass setting

BOX 8	
Dirt Alarm® Options	
Omit = None	
Visual	D5 = Visual pop-up
Visual with Thermal Lockout	D8 = Visual w/ thermal lockout
Electrical	MS5 = Electrical w/ 12 in. 18 gauge 4-conductor cable
	MS5LC = Low current MS5
	MS10 = Electrical w/ DIN connector (male end only)
	MS10LC = Low current MS10
	MS11 = Electrical w/ 12 ft. 4-conductor wire
	MS12 = Electrical w/ 5 pin Brad Harrison connector (male end only)
	MS12LC = Low current MS12
Electrical with Thermal Lockout	MS16 = Electrical w/ weather-packed sealed connector
	MS16LC = Low current MS16
	MS17LC = Electrical w/ 4 pin Brad Harrison male connector
	MS5T = MS5 (see above) w/ thermal lockout
	MS5LCT = Low current MS5T
	MS10T = MS10 (see above) w/ thermal lockout
	MS10LCT = Low current MS10T
Electrical Visual with Thermal Lockout	MS12T = MS12 (see above) w/ thermal lockout
	MS12LCT = Low current MS12T
	MS16T = MS16 (see above) w/ thermal lockout
	MS16LCT = Low current MS16T
	MS17LCT = Low current MS17T
	MS13 = Supplied w/ threaded connector & light
	MS14 = Supplied w/ 5 pin Brad Harrison connector & light (male end)
Electrical Visual with Thermal Lockout	MS13DCT = MS13 (see above), direct current, w/ thermal lockout
	MS13DCLCT = Low current MS13DCT
	MS14DCT = MS14 (see above), direct current, w/ thermal lockout
MS14DCLCT = Low current MS14DCT	

#### NOTES:

Box 2. Replacement element part numbers are identical to contents of Boxes 2, 3, 4 and 5. E media (cellulose) elements are only available with Buna N seals.

Box 5. H.5 seal designation includes the following: EPR seals, stainless steel wire mesh on elements, and light oil coating on housing exterior. Viton® is a registered trademark of DuPont Dow Elastomers. Skydrol® is a registered trademark of Solutia Inc.

Box 6. B porting option supplied with metric mounting holes.

Box 8. Standard indicator setting for non-bypassing model is 50 psi unless otherwise specified.

# Top-Ported Pressure Filter

# CTF60



### Features and Benefits

- Top-ported high pressure filter
- High cyclic fatigue performance (6000 psi)
- Available with non-bypass option with high collapse element
- Offered in pipe, SAE straight thread, flange and ISO 228 porting
- Thread on bowl with optional drain plug for easy element service

**75 gpm**  
**284 L/min**  
**6000 psi**  
**415 bar**

NF30

NFS30

YF30

CFX30

PLD

CF40

DF40

PF40

RFS50

RF60

CF60

**CTF60**

VF60

LW60

KF30

KF50

TF50

KC50

MKF50

MKC50

KC65

MKC65

HS60

MHS60

KFH50

LC60

LC35

LC50

### Filter Housing Specifications

Flow Rating:	Up to 75 gpm (284 L/min) for 150 SUS (32 cSt) fluids
Max. Operating Pressure:	6000 psi (415 bar)
Min. Yield Pressure:	18,000 psi (1241 bar), per NFPA T2.6.1
Rated Fatigue Pressure:	6000 psi (415 bar), per NFPA T2.6.1-R1-2005 (only with F20 4-bolt flange porting)
Temp. Range:	-20°F to 225°F (-29°C to 107°C)
Bypass Setting:	Cracking: 50 psi (3.4 bar) Full Flow: 83 psi (5.7 bar) Non-bypassing model has a blocked bypass.
Porting Head:	Ductile Iron
Element Case:	Steel
Weight of CTF60-5CT:	25 lbs. (11.4 kg)
CTF60-8CT:	29 lbs. (13.2 kg)
CTF60-14CT:	38 lbs. (17.3 kg)
Element Change Clearance:	4.0" (103 mm)

### Fluid Compatibility

Type Fluid	Appropriate Schroeder Media
High Water Content	All Z-Media® (synthetic)
Invert Emulsions	10 and 25 μ Z-Media® (synthetic)
Water Glycols	3, 5, 10 and 25 μ Z-Media® (synthetic)
Phosphate Esters	All Z-Media® (synthetic) with H (EPR) seal designation

NOF30-05

NOF-50-760

FOF60-03

NMF30

RMF60

14-CRZX10

20-CRZX10

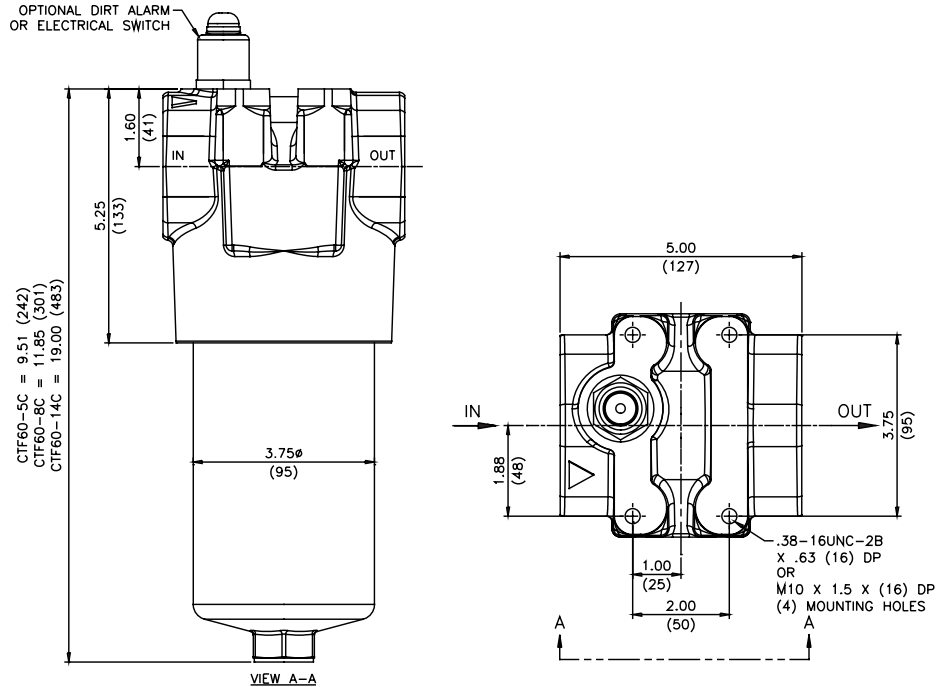

Metric dimensions in ( ).  
 Dimensions shown are inches (millimeters) for general information and overall envelope size only.  
 For complete dimensions please contact Schroeder Industries to request a certified print.

## Element Performance Information & Dirt Holding Capacity

Element	Filtration Ratio Per ISO 4572/NFPA T3.10.8.8 Using automated particle counter (APC) calibrated per ISO 4402			Filtration Ratio per ISO 16889 Using APC calibrated per ISO 11171	
	$\beta_x \geq 75$	$\beta_x \geq 100$	$\beta_x \geq 200$	$\beta_x(d) \geq 200$	$\beta_x(d) \geq 1000$
CTZ1/CTZX1	<1.0	<1.0	<1.0	<4.0	4.2
CTZ3/CTZX3	<1.0	<1.0	<2.0	<4.0	4.8
CTZ5/CTZX5	2.5	3.0	4.0	4.8	6.3
CTZ10/CTZX10	7.4	8.2	10.0	8.0	10.0
CTZ25/CTZX25	18.0	20.0	22.5	19.0	24.0

Element	DHC (gm)	Element	DHC (gm)	Element	DHC (gm)
5CTZ1	19	8CTZ1	31	14CTZ1	66
5CTZ3	16	8CTZ3	27	14CTZ3	57
5CTZ5	18	8CTZ5	30	14CTZ5	64
5CTZ10	21	8CTZ10	34	14CTZ10	72
5CTZ25	17	8CTZ25	28	14CTZ25	60
5CTZX1	14	8CTZX1	24	14CTZX1	53
5CTZX3	11	8CTZX3	18	14CTZX3	41
5CTZX5	10	8CTZX5	17	14CTZX5	38
5CTZX10	12	8CTZX10	20	14CTZX10	44
5CTZX25	11	8CTZX25	18	14CTZX25	39

Element Collapse Rating: 150 psid (10 bar) for standard elements  
 Flow Direction: 3000 psid (210 bar) for high collapse (ZX) versions  
 Outside In

Element Nominal Dimensions: 5CT : 2.64" (67 mm) O.D. x 4.88" (124 mm) long  
 8CT : 2.64" (67 mm) O.D. x 7.25" (184 mm) long  
 14CT : 2.64" (67 mm) O.D. x 14.38" (365 mm) long



## $\Delta P_{\text{housing}}$

CTF60  $\Delta P_{\text{housing}}$  for fluids with sp gr (specific gravity) = 0.86:

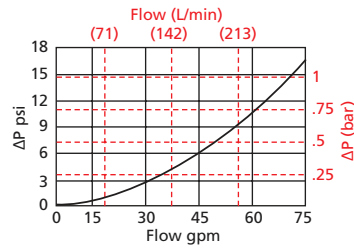

## $\Delta P_{\text{element}}$

8CTZ

Element Pressure Drop versus Flow Rate at 32 cSt (150 SUS)

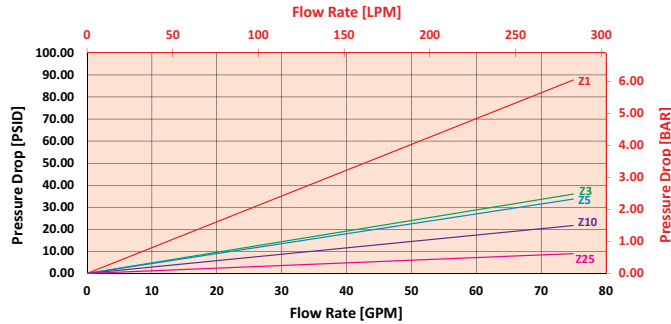

14CTZ

Element Pressure Drop versus Flow Rate at 32 cSt (150 SUS)

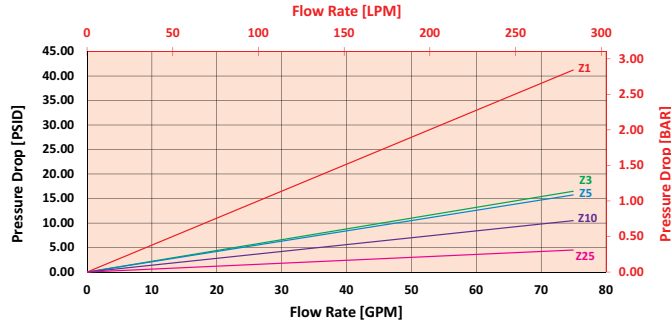

$$\Delta P_{\text{filter}} = \Delta P_{\text{housing}} + (\Delta P_{\text{element}} * V_f)$$

### Exercise:

Determine  $\Delta P_{\text{filter}}$  at 50 gpm (189 L/min) for CTF608CTZ5S20D9 using 200 SUS (42.6 cSt) fluid.

Use the housing pressure curve to determine  $\Delta P_{\text{housing}}$  at 50 gpm. In this case,  $\Delta P_{\text{housing}}$  is 7 psi (.48 bar) on the graph for the CTF60 housing.

Use the element pressure curve to determine  $\Delta P_{\text{element}}$  at 50 gpm. In this case,  $\Delta P_{\text{element}}$  is 22 psi (1.5 bar) according to the graph for the 8CTZ5 element.

Because the viscosity in this sample is 200 SUS (42.6 cSt), we determine the **Viscosity Factor ( $V_f$ )** by dividing the **Operating Fluid Viscosity** with the **Standard Viscosity** of 150 SUS (32 cSt). To best determine your Operating Fluid Viscosity, please reference the chart in Appendix D.

Finally, the overall filter pressure differential,  $\Delta P_{\text{filter}}$ , is calculated by adding  $\Delta P_{\text{housing}}$  with the true element pressure differential, ( $\Delta P_{\text{element}} * V_f$ ). The  $\Delta P_{\text{element}}$  from the graph has to be multiplied by the viscosity factor to get the true pressure differential across the element.

### Solution:

$$\Delta P_{\text{housing}} = 7 \text{ psi } [.48 \text{ bar}] \quad | \quad \Delta P_{\text{element}} = 22 \text{ psi } [1.5 \text{ bar}]$$

$$V_f = 200 \text{ SUS } (42.6 \text{ cSt}) / 150 \text{ SUS } (32 \text{ cSt}) = 1.3$$

$$\Delta P_{\text{filter}} = 7 \text{ psi } + (22 \text{ psi } * 1.3) = 35.6 \text{ psi}$$

OR

$$\Delta P_{\text{filter}} = .48 \text{ bar } + (1.5 \text{ bar } * 1.3) = 2.4 \text{ bar}$$

## Pressure Drop Information Based on Flow Rate and Viscosity

Note:  
If your element is not graphed, use the following equation:  
 $\Delta P_{\text{element}} = \text{Flow Rate} \times \Delta P_f$  Plug this variable into the overall pressure drop equation.

Ele.	$\Delta P$	Ele.	$\Delta P$	Ele.	$\Delta P$
5CTZ1	1.87	5CTZX1	1.64	8CTZX1	1.00
5CTZ3	0.77	5CTZX3	0.96	8CTZX3	0.59
5CTZ5	0.72	5CTZX5	0.68	8CTZX5	0.41
5CTZ10	0.46	5CTZX10	0.46	8CTZX10	0.28
5CTZ25	0.19	5CTZX25	0.25	8CTZX25	0.15
14CTZX1	0.46	14CTZX3	0.27	14CTZX5	0.19
14CTZX10	0.13	14CTZX25	0.07		

## Filter Model Number Selection

### How to Build a Valid Model Number for a Schroeder CTF60:

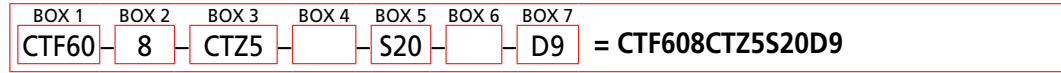
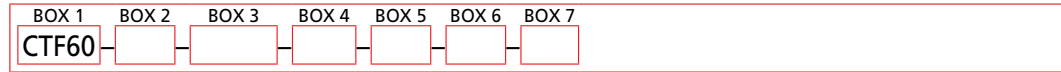

BOX 1	BOX 2	BOX 3	BOX 4
<b>Filter Series</b>	<b>Element Length (in.)</b>	<b>Element Part Number</b>	
CTF60	5	CTZ1 = 1 μ Excellement® Z-Media® (synthetic)	<b>Seal Material</b>
CTFN60 (Non-bypassing; requires ZX high collapse elements)	8	CTZ3 = 3 μ Excellement® Z-Media® (synthetic)	
	14	CTZ5 = 5 μ Excellement® Z-Media® (synthetic)	Omit = Buna N
		CTZ10 = 10 μ Excellement® Z-Media® (synthetic)	V = Viton®
		CTZ25 = 25 μ Excellement® Z-Media® (synthetic)	H = EPR
		CTZX1 = 1 μ Excellement® Z-Media® (high collapse center tube)	
		CTZX3 = 3 μ Excellement® Z-Media® (high collapse center tube)	
		CTZX5 = 5 μ Excellement® Z-Media® (high collapse center tube)	
		CTZX10 = 10 μ Excellement® Z-Media® (high collapse center tube)	
		CTZX25 = 25 μ Excellement® Z-Media® (high collapse center tube)	

BOX 5
Inlet Port
P20 = 1¼" NPTF
S20 = SAE-20
F20 = 1¼" SAE 4-bolt flange Code 62
B20 = ISO 228 G-1¼"

BOX 7	
Dirt Alarm® Options	
Omit = None	
Visual D9 = Visual pop-up	
Electrical	MS5SS = Electrical w/ 12 in. 18 gauge 4-conductor cable
	MS5SSL = Low current MS5
	MS10SS = Electrical w/ DIN connector (male end only)
	MS10SSL = Low current MS10
	MS11SS = Electrical w/ 12 ft. 4-conductor wire
	MS12SS = Electrical w/ 5 pin Brad Harrison connector (male end only)
	MS12SSL = Low current MS12
Electrical with Thermal Lockout	MS16SS = Electrical w/ weather-packed sealed connector
	MS16SSL = Low current MS16
	MS17SSL = Electrical w/ 4 pin Brad Harrison male connector
	MS5SST = MS5 (see above) w/ thermal lockout
	MS5SSLCT = Low current MS5T
	MS10SST = MS10 (see above) w/ thermal lockout
	MS10SSLCT = Low current MS10T
Electrical Visual	MS12SST = MS12 (see above) w/ thermal lockout
	MS12SSLCT = Low current MS12T
	MS16SST = MS16 (see above) w/ thermal lockout
	MS16SSLCT = Low current MS16T
	MS17SSLCT = Low current MS17T
	MS13DC = Supplied w/ threaded connector & light
	MS14DC = Supplied w/ 5 pin Brad Harrison connector & light (male end)
Electrical Visual with Thermal Lockout	MS13SSDCT = MS13 (see above), direct current, w/ thermal lockout
	MS13SSDCLCT = Low current MS13DCT
	MS14SSDCT = MS14 (see above), direct current, w/ thermal lockout
	MS14SSDCLCT = Low current MS14DCT

BOX 6
Options
Omit = None
UU = Series 1215 7/16" UNF Schroeder Check Test Points installed in the filter head (upstream & downstream)
DR = Drain on bowl
30 = 30 psi bypass setting
40 = 40 psi bypass setting

#### NOTES:

- Box 2. Replacement element part numbers are identical to contents of Boxes 2, 3 and 4.
- Box 4. Viton® is a registered trademark of DuPont Dow Elastomers.
- Box 5. B porting option supplied with metric mounting holes.
- Box 7. All Dirt Alarm® Indicators must be Stainless Steel. Standard indicator setting is 50 psi. For replacement indicators, contact the factory.

# Top-Ported Pressure Filter

## VF60



### Features and Benefits

- Top-ported high pressure filter
- Threaded bowl for easy element servicing
- Offered in pipe, SAE straight thread and ISO 228 porting
- Various dirt alarm options available

**70 gpm**  
**265 L/min**  
**6000 psi**  
**415 bar**

- NF30
- NFS30
- YF30
- CFX30
- PLD
- CF40
- DF40
- PF40
- RFS50
- RF60
- CF60
- CTF60
- VF60**
- LW60
- KF30
- KF50
- TF50
- KC50
- MKF50
- MKC50
- KC65
- MKC65
- HS60
- MHS60
- KFH50
- LC60
- LC35
- LC50
- NOF30-05
- NOF-50-760
- FOF60-03
- NMF30
- RMF60
- 14-CRZX10
- 20-CRZX10

Model No. of filter in photograph is VF609VZ10SD5.

Flow Rating:	Up to 70 gpm (265 L/min) for 150 SUS (32 cSt) fluids
Max. Operating Pressure:	6000 psi (415 bar)
Min. Yield Pressure:	15,500 psi (1070 bar), per NFPA T2.6.1
Rated Fatigue Pressure:	3300 psi (230 bar), per NFPA T2.6.1-R1-2005
Temp. Range:	-20°F to 225°F (-29°C to 107°C)
Bypass Setting:	Cracking: 50 psi (3.5 bar) Full Flow: 65 psi (4.5 bar)
Porting Head:	Ductile Iron
Element Case:	Steel
Weight of VF60-9V:	24.0 lbs. (10.9 kg)
Element Change Clearance:	4.0" (103 mm)

### Filter Housing Specifications

Type Fluid	Appropriate Schroeder Media
Petroleum Based Fluids	All E-Media (cellulose) and Z-Media® (synthetic)
High Water Content	All Z-Media® (synthetic)
Invert Emulsions	10 and 25 μ Z-Media® (synthetic)
Water Glycols	3, 5, 10 and 25 μ Z-Media® (synthetic)
Phosphate Esters	All Z-Media® (synthetic) with H (EPR) seal designation
Skydrol®	3, 5, 10 and 25 μ Z-Media® (synthetic) with H.5 seal designation (EPR seals and stainless steel wire mesh in element, and light oil coating on housing exterior)

### Fluid Compatibility

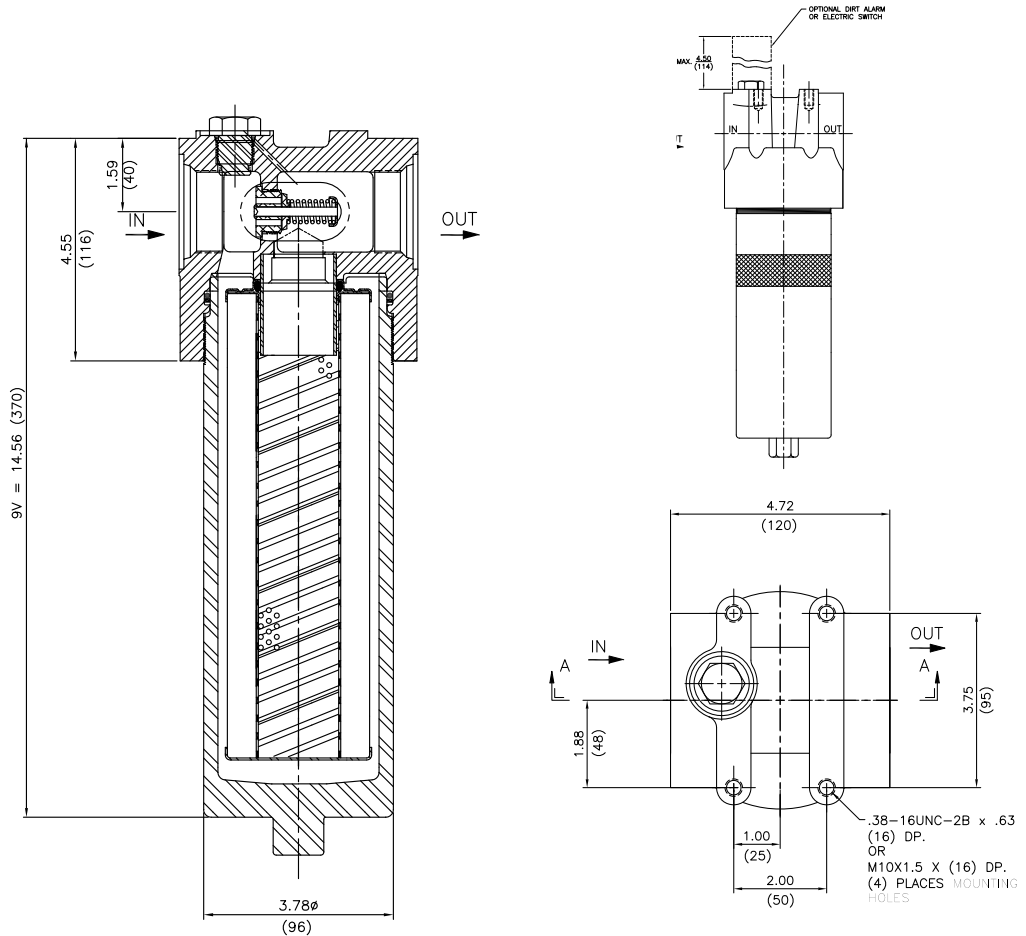

Metric dimensions in ( ).  
 Dimensions shown are inches (millimeters) for general information and overall envelope size only.  
 For complete dimensions please contact Schroeder Industries to request a certified print.

### Element Performance Information & Dirt Holding Capacity

Element	Filtration Ratio Per ISO 4572/NFPA T3.10.8.8 Using automated particle counter (APC) calibrated per ISO 4402			Filtration Ratio per ISO 16889 Using APC calibrated per ISO 11171	
	$\beta_x \geq 75$	$\beta_x \geq 100$	$\beta_x \geq 200$	$\beta_x(\alpha) \geq 200$	$\beta_x(\alpha) \geq 1000$
9VZ1	<1.0	<1.0	<1.0	<4.0	4.2
9VZ3	<1.0	<1.0	<2.0	<4.0	4.8
9VZ5	2.5	3.0	4.0	4.8	6.3
9VZ10	7.4	8.2	10.0	8.0	10.0
9VZ25	18.0	20.0	22.5	19.0	24.0

Element	DHC (gm)
9VZ1	55
9VZ3	57
9VZ5	62
9VZ10	60
9VZ25	61

Element Collapse Rating: 150 psid (10 bar) for standard elements  
 Flow Direction: Outside In  
 Element Nominal Dimensions: 9V: 2.9" (75 mm) O.D. x 9.5" (240 mm) long

### $\Delta P_{\text{housing}}$

VF60  $\Delta P_{\text{housing}}$  for fluids with sp gr (specific gravity) = 0.86:

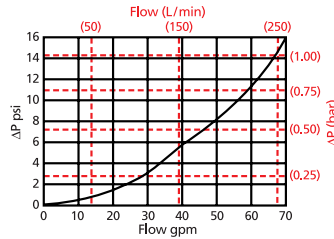

### $\Delta P_{\text{element}}$

9VZ

Element Pressure Drop versus Flow Rate at 32 cSt (150 SUS)

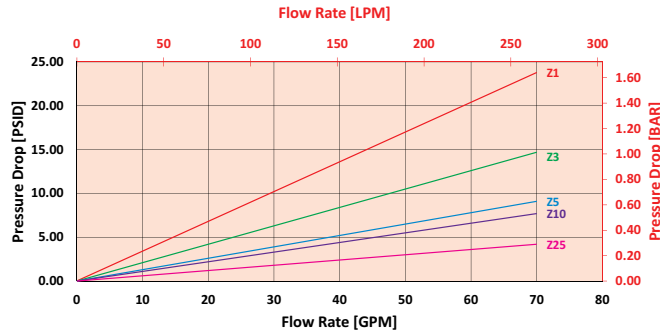

## Pressure Drop Information Based on Flow Rate and Viscosity

$$\Delta P_{\text{filter}} = \Delta P_{\text{housing}} + (\Delta P_{\text{element}} * V_f)$$

### Exercise:

Determine  $\Delta P_{\text{filter}}$  at 40 gpm (151 L/min) for VF609VZ15 using 120 SUS (25.5 cSt) fluid.

Use the housing pressure curve to determine  $\Delta P_{\text{housing}}$  at 40 gpm. In this case,  $\Delta P_{\text{housing}}$  is 6 psi (.42 bar) on the graph for the VF60 housing.

Use the element pressure curve to determine  $\Delta P_{\text{element}}$  at 40 gpm. In this case,  $\Delta P_{\text{element}}$  is 13 psi (.90 bar) according to the graph for the 9VZ1 element.

Because the viscosity in this sample is 120 SUS (25.5 cSt), we determine the **Viscosity Factor ( $V_f$ )** by dividing the **Operating Fluid Viscosity** with the **Standard Viscosity** of 150 SUS (32 cSt). To best determine your Operating Fluid Viscosity, please reference the chart in Appendix D.

Finally, the overall filter pressure differential,  $\Delta P_{\text{filter}}$ , is calculated by adding  $\Delta P_{\text{housing}}$  with the true element pressure differential, ( $\Delta P_{\text{element}} * V_f$ ). The  $\Delta P_{\text{element}}$  from the graph has to be multiplied by the viscosity factor to get the true pressure differential across the element.

### Solution:

$$\Delta P_{\text{housing}} = 6 \text{ psi } [.42 \text{ bar}] \quad | \quad \Delta P_{\text{element}} = 13 \text{ psi } [.90 \text{ bar}]$$

$$V_f = 120 \text{ SUS } (25.5 \text{ cSt}) / 150 \text{ SUS } (32 \text{ cSt}) = .80$$

$$\Delta P_{\text{filter}} = 6 \text{ psi } + (13 \text{ psi } * .80) = 16.4 \text{ psi}$$

OR

$$\Delta P_{\text{filter}} = .42 \text{ bar } + (.90 \text{ bar } * .80) = 1.14 \text{ bar}$$

Note:

If your element is not graphed, use the following equation:  
 $\Delta P_{\text{element}} = \text{Flow Rate} \times \Delta P_f$  Plug this variable into the overall pressure drop equation.

Ele.	$\Delta P$
9V3	0.32
9V10	0.24

## Filter Model Number Selection

### How to Build a Valid Model Number for a Schroeder VF60:

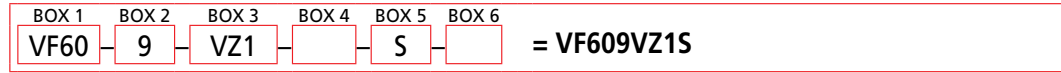

BOX 1	BOX 2	BOX 3	BOX 4
<b>Filter Series</b>	<b>Element Length (in)</b>	<b>Element Size and Media</b>	<b>Seal Material</b>
VF60	9	V3 = V size 3 μ E media (cellulose) V10 = V size 10 μ E media (cellulose) VZ1 = V size 1 μ Excellement® Z-Media® (synthetic) VZ3 = V size 3 μ Excellement® Z-Media® (synthetic) VZ5 = V size 5 μ Excellement® Z-Media® (synthetic) VZ10 = V size 10 μ Excellement® Z-Media® (synthetic) VZ25 = V size 25 μ Excellement® Z-Media® (synthetic) VM150 = V size 150 μ M media (reusable metal)	Omit = Buna N V = Viton® H = EPR

BOX 5	BOX 6
<b>Inlet Port</b>	<b>Dirt Alarm® Options</b>
P = 1¼" NPTF S = SAE-20 B = ISO 228 G-1¼"	Omit = None Visual D5 = Visual pop-up Visual with Thermal Lockout D8 = Visual w/ thermal lockout Electrical MS5 = Electrical w/ 12 in. 18 gauge 4-conductor cable MS5LC = Low current MS5 MS10 = Electrical w/ DIN connector (male end only) MS10LC = Low current MS10 MS11 = Electrical w/ 12 ft. 4-conductor wire MS12 = Electrical w/ 5 pin Brad Harrison connector (male end only) MS12LC = Low current MS12 MS16 = Electrical w/ weather-packed sealed connector MS16LC = Low current MS16 MS17LC = Electrical w/ 4 pin Brad Harrison male connector Electrical with Thermal Lockout MS5T = MS5 (see above) w/ thermal lockout MS5LCT = Low current MS5T MS10T = MS10 (see above) w/ thermal lockout MS10LCT = Low current MS10T MS12T = MS12 (see above) w/ thermal lockout MS12LCT = Low current MS12T MS16T = MS16 (see above) w/ thermal lockout MS16LCT = Low current MS16T MS17LCT = Low current MS17T Electrical Visual MS13DC = Supplied w/ threaded connector & light MS14DC = Supplied w/ 5 pin Brad Harrison connector & light (male end) Electrical Visual with Thermal Lockout MS13DCT = MS13 (see above), direct current, w/ thermal lockout MS13DCLCT = Low current MS13DCT MS14DCT = MS14 (see above), direct current, w/ thermal lockout MS14DCLCT = Low current MS14DCT

**NOTES:**

Box 2. Replacement element part numbers are a combination of Boxes 2, 3, and 4.

Box 2. Example: 9VZ1V synthetic media elements are only available with Viton seals.

Box 4. Viton® is a registered trademark of DuPont Dow Elastomers.

Box 5. B porting option supplied with metric mounting holes.

# High-Flow, High Pressure Filter

# LW60

## Features and Benefits

- Horizontal alignment allows straight-through flow, maximizing efficiency and minimizing pressure drop
- Proprietary synthetic media designed specifically for the mining industry. Excellement-MD™ provides level of filtration not achievable using alternative wire mesh elements because of their lack of absolute ratings
- Two-inch BSPP ports are easily adaptable to Super Stecko fittings commonly used underground
- Stainless steel bypass valve that ensures smooth integration with 95/5 fluid
- Non-bypassing version available with high crush (4500 psid) cleanable metal mesh (25 micron) element



Model No. of filter in photograph is LW6039ZPZ5VB32DPG.

**300 gpm**  
**1135 L/min**  
**6000 psi**  
**415 bar**

- NF30
- NFS30
- YF30
- CFX30
- PLD
- CF40
- DF40
- PF40
- RFS50
- RF60
- CF60
- CTF60
- VF60
- LW60**

Flow Rating:	Up to 300 gpm (1135 L/min) for use with 95/5 fluids
Max. Operating Pressure:	6000 psi (414 bar)
Min. Yield Pressure:	18,000 psi (1240 bar), per NFPA T2.6.1
Rated Fatigue Pressure:	4500 psi (310 bar), per NFPA T2.6.1
Temp. Range:	-20°F to 225°F (-29°C to 107°C)
Bypass Setting:	Cracking: 50 psi (3.4 bar) LWN60 non-bypassing model available with high crush element
Porting Cap:	Steel
Housing:	Steel
Weight:	550 lb. (250 kg)
Element Change Clearance:	34.0" (864 mm)

## Filter Housing Specifications

- KF30
- KF50
- TF50
- KC50
- MKF50
- MKC50
- KC65
- MKC65
- HS60
- MHS60
- KFH50
- LC60
- LC35
- LC50

## Type Fluid Appropriate Schroeder Media

95/5 fluids Specifically designed for use with 95/5 fluids applications

## Fluid Compatibility

- NOF30-05
- NOF-50-760
- FOF60-03
- NMF30
- RMF60
- 14-CRZX10
- 20-CRZX10

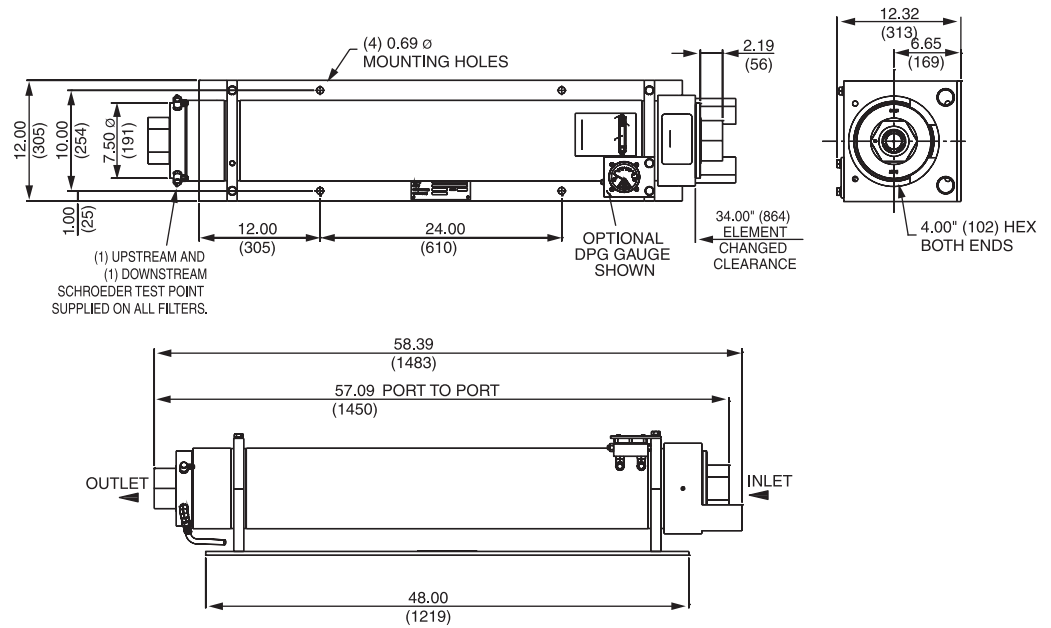

Metric dimensions in ( ).  
 Dimensions shown are inches (millimeters) for general information and overall envelope size only.  
 For complete dimensions please contact Schroeder Industries to request a certified print.

## Element Performance Information & Dirt Holding Capacity

Filtration Ratio per ISO 16889 Using APC calibrated per ISO 11171	
Element	$\beta_{x(\phi)} \geq 1000$
39ZPZ3V	5.1
39ZPZ5V	6.1
39ZPZ10V	12.1
39ZPZ25V	17.7

Element	DHC (gm)
39ZPZ3V	449
39ZPZ5V	359
39ZPZ10V	429
39ZPZ25V	284

Element Collapse Rating: 150 psid (10 bar)  
 Flow Direction: Outside In  
 Element Nominal Dimensions: 5.0" (127 mm) O.D. x 38.0" (965 mm) long



## $\Delta P_{\text{housing}}$

LW60  $\Delta P_{\text{housing}}$  for fluids with sp gr (specific gravity) = 0.86:

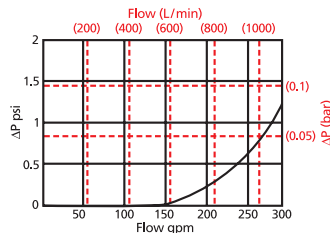

## $\Delta P_{\text{element}}$

39ZPZ

Element Pressure Drop versus Flow Rate at 32 cSt (150 SUS)

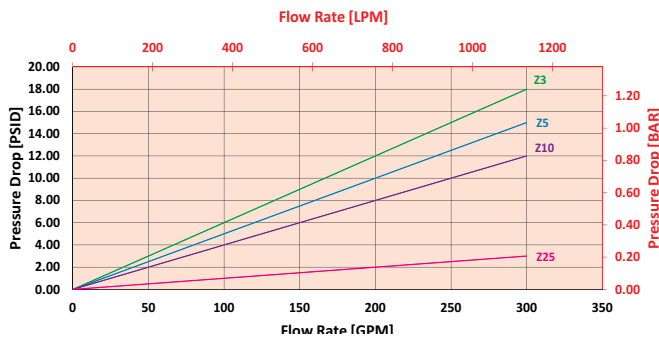

Pressure Drop Information Based on Flow Rate and Viscosity

$$\Delta P_{\text{filter}} = \Delta P_{\text{housing}} + (\Delta P_{\text{element}} * V_f)$$

### Exercise:

Determine  $\Delta P_{\text{filter}}$  at 200 gpm (757 L/min) for LW6039ZPZ3VB32DPG using 75 SUS (16 cSt) fluid.

Use the housing pressure curve to determine  $\Delta P_{\text{housing}}$  at 200 gpm. In this case,  $\Delta P_{\text{housing}}$  is .25 psi (.02 bar) on the graph for the LW60 housing.

Use the element pressure curve to determine  $\Delta P_{\text{element}}$  at 200 gpm. In this case,  $\Delta P_{\text{element}}$  is 12 psi (.83 bar) according to the graph for the 39ZPZ3 element.

Because the viscosity in this sample is 75 SUS (16 cSt), we determine the **Viscosity Factor ( $V_f$ )** by dividing the **Operating Fluid Viscosity** with the **Standard Viscosity** of 150 SUS (32 cSt). To best determine your Operating Fluid Viscosity, please reference the chart in Appendix D.

Finally, the overall filter pressure differential,  $\Delta P_{\text{filter}}$ , is calculated by adding  $\Delta P_{\text{housing}}$  with the true element pressure differential,  $(\Delta P_{\text{element}} * V_f)$ . The  $\Delta P_{\text{element}}$  from the graph has to be multiplied by the viscosity factor to get the true pressure differential across the element.

### Solution:

$$\Delta P_{\text{housing}} = .25 \text{ psi } [.02 \text{ bar}] \quad | \quad \Delta P_{\text{element}} = 12 \text{ psi } [.83 \text{ bar}]$$

$$V_f = 75 \text{ SUS (16 cSt)} / 150 \text{ SUS (32 cSt)} = .50$$

$$\Delta P_{\text{filter}} = .25 \text{ psi} + (12 \text{ psi} * .50) = 6.25 \text{ psi}$$

OR

$$\Delta P_{\text{filter}} = .02 \text{ bar} + (.83 \text{ bar} * .50) = .44 \text{ bar}$$

## Filter Model Number Selection

### How to Build a Valid Model Number for a Schroeder LW60:

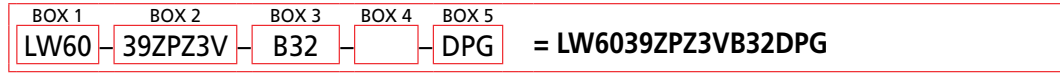

BOX 1	BOX 2	BOX 3
<b>Filter Series</b>	<b>Element Part Number</b>	<b>Porting</b>
LW60	39ZPZ3V = 3 µm Excellement® Z-Media® (synthetic) 39ZPZ5V = 5 µm Excellement® Z-Media® (synthetic) 39ZPZ10V = 10 µm Excellement® Z-Media® (synthetic) 39ZPZ25V = 25 µm Excellement® Z-Media® (synthetic)	B32 = ISO 228 G-2" (2-11 BSPP)

BOX 4	BOX 5
<b>Bypass Settings</b>	<b>Dirt Alarm® Options</b>
Omit = 50 psi cracking 30 = 30 psi cracking	DPG = Differential pressure gauge

### How to Build a Valid Model Number for a Schroeder LWN60:

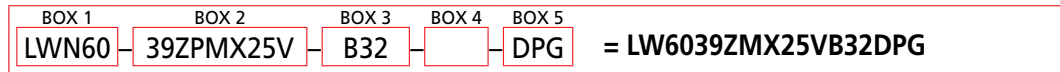
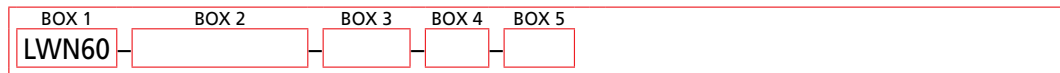

BOX 1	BOX 2	BOX 3
<b>Filter Series</b>	<b>Element Part Number</b>	<b>Porting</b>
LWN60 <small>(Non-bypassing: requires MX high collapse elements)</small>	39ZPMX25V = 25 µm Excellement® Z-Media® (high collapse center tube)	B32 = ISO 228 G-2" (2-11 BSPP)

BOX 4	BOX 5
<b>Bypass Settings</b>	<b>Dirt Alarm® Options</b>
Omit = Blocked	DPG = Differential pressure gauge

# Base-Ported Pressure Filter

# KF30/KF50



## Features and Benefits

- Base-ported pressure filter
- Can be installed in vertical or horizontal position
- Meets HF4 automotive standard
- Element changeout from top minimizes oil spillage
- Offered in pipe, SAE straight thread, flanged and ISO 228 porting
- No-Element indicator option available
- Available with non-bypass option with high collapse element
- Integral inlet and outlet female test points option available
- Offered in conventional subplate porting
- Same day shipment model available
- Double and triple stacking of K-size elements can be replaced by single KK or 27K-size elements
- Available with quality-protected GeoSeal® Elements (GKF30/GKF50)

**100/150 gpm** <sup>NF30</sup>  
**380/570 L/min** <sup>NF30</sup>

**KF30- 3000 psi** <sup>YF30</sup>  
**210 bar** <sup>CFX30</sup>

**KF50- 5000 psi** <sup>PLD</sup>  
**345 bar** <sup>CF40</sup>

<sup>DF40</sup>  
<sup>PF40</sup>  
<sup>RFS50</sup>  
<sup>RF60</sup>  
<sup>CF60</sup>  
<sup>CTF60</sup>  
<sup>VF60</sup>  
<sup>LW60</sup>

Model No. of filter in photograph is KF30/KF501K10SD.

Flow Rating:	Up to 100 gpm (380 L/min) for 150 SUS (32 cSt) fluids With 2" porting only, up to 150 gpm (570 L/min) for 150 SUS (32 cSt) fluids
Max. Operating Pressure:	KF30- 3000 psi (210 bar) KF50- 5000 psi (345 bar)
Min. Yield Pressure:	KF30- 12,000 psi (830 bar), per NFPA T2.6.1 KF50- 15,000 psi (1025 bar), per NFPA T2.6.1
Rated Fatigue Pressure:	KF30- 2500 psi (170 bar), per NFPA T2.6.1-2005 KF50- 3500 psi (240 bar), per NFPA T2.6.1-2005
Temp. Range:	-20°F to 225°F (-29°C to 107°C)
Bypass Setting:	Cracking: 40 psi (2.8 bar) Full Flow: 61 psi (4.2 bar) Non-bypassing model has a blocked bypass.
Porting Base & Cap:	Ductile Iron
Element Case:	Steel
Weight of KF30-1K:	48 lbs. (22 kg)
Weight of KF30-2K:	65 lbs. (30 kg)
Weight of KF30-3K:	81 lbs. (37 kg)
Weight of KF50-1K:	59.7 lbs. (27.1 kg)
Weight of KF50-2K:	80.7 lbs. (36.6 kg)
Weight of KF50-3K:	102.0 lbs. (46.3 kg)
Element Change Clearance:	8.50" (215 mm) for 1K; 17.50" (445 mm) for KK; 26.5" (673 mm) for 27K

## Filter Housing Specifications

**KF30**  
**KF50**  
<sup>TF50</sup>  
<sup>KC50</sup>  
<sup>MKF50</sup>  
<sup>MKC50</sup>  
<sup>KC65</sup>  
<sup>MKC65</sup>  
<sup>HS60</sup>  
<sup>MHS60</sup>  
<sup>KFH50</sup>  
<sup>LC60</sup>  
<sup>LC35</sup>  
<sup>LC50</sup>

Type Fluid	Appropriate Schroeder Media
Petroleum Based Fluids	All E media (cellulose), Z-Media® and ASP® Media (synthetic)
High Water Content	All Z-Media® and ASP® Media (synthetic)
Invert Emulsions	10 and 25 µ Z-Media® (synthetic), 10 µ ASP® Media
Water Glycols	3, 5, 10 and 25 µ Z-Media® (synthetic) and all ASP® Media
Phosphate Esters	All Z-Media® and ASP® Media (synthetic) with H (EPR) seal designation and 3 and 10 µ E media (cellulose) with H (EPR) seal designation
Skydrol®	3, 5, 10 and 25 µ Z-Media® (synthetic) and all ASP® Media (synthetic) with H.5 seal designation (EPR seals and stainless steel wire mesh in element, and light oil coating on housing exterior)

## Fluid Compatibility

<sup>NOF30-05</sup>  
<sup>NOF-50-760</sup>  
<sup>FOF60-03</sup>  
<sup>NMF30</sup>  
<sup>RMF60</sup>  
<sup>14-CRZX10</sup>  
<sup>20-CRZX10</sup>

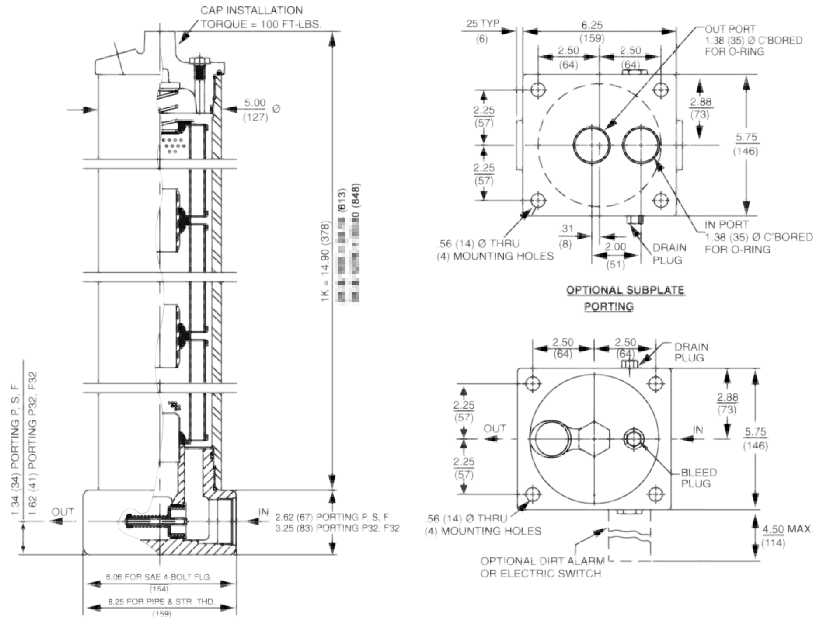

Metric dimensions in ( ).  
 Dimensions shown are inches (millimeters) for general information and overall envelope size only.  
 For complete dimensions please contact Schroeder Industries to request a certified print.

## Element Performance Information & Dirt Holding Capacity

Element	Filtration Ratio Per ISO 4572/NFPA T3.10.8.8 Using automated particle counter (APC) calibrated per ISO 4402			Filtration Ratio per ISO 16889 Using APC calibrated per ISO 11171	
	$\beta_x \geq 75$	$\beta_x \geq 100$	$\beta_x \geq 200$	$\beta_x(c) \geq 200$	$\beta_x(c) \geq 1000$
KZ1/KKZ1/27KZ1	<1.0	<1.0	<1.0	<4.0	4.2
KZ3/KKZ3/27KZ3	<1.0	<1.0	<2.0	<4.0	4.8
KZ5/KKZ5/27KZ5	2.5	3.0	4.0	4.8	6.3
KZ10/KKZ10/27KZ10	7.4	8.2	10.0	8.0	10.0
KZ25/KKZ25/27KZ25	18.0	20.0	22.5	19.0	24.0
KZW1	N/A	N/A	N/A	<4.0	<4.0
KZW3/KKZW3	N/A	N/A	N/A	4.0	4.8
KZW5/KKZW5	N/A	N/A	N/A	5.1	6.4
KZW10/KKZW10	N/A	N/A	N/A	6.9	8.6
KZW25/KKZW25	N/A	N/A	N/A	15.4	18.5
KZX3/KKZX3/27KZX3	<1.0	<1.0	<2.0	4.7	5.8
KZX10/KKZX10/27KZX10	7.4	8.2	10.0	8.0	9.8

Element	DHC (gm)	Element	DHC (gm)	Element	DHC (gm)	Element	DHC (gm)	Element	DHC (gm)
KZ1	112	KKZ1	224	27KZ1	336	KZW1	61		
KZ3	115	KKZ3	230	27KZ3	345	KZW3	64	KKZW3	128
KZ5	119	KKZ5	238	27KZ5	357	KZW5	63	KKZW5	126
KZ10	108	KKZ10	216	27KZ10	324	KZW10	57	KKZW10	114
KZ25	93	KKZ25	186	27KZ25	279	KZW25	79	KKZW25	158
KZX3	81*	KKZX3	163*	27KZX3	249*				
KZX10	90*	KKZX10	182*	27KZX10	279*				

\* Based on 100 psi terminal pressure

Element Collapse Rating: 150 psid (10 bar) for standard elements  
 3000 psid (210 bar) for high collapse (ZX) versions

Flow Direction: Outside In

Element Nominal Dimensions: K: 3.9" (99 mm) O.D. x 9.0" (230 mm) long  
 KK: 3.9" (99 mm) O.D. x 18.0" (460 mm) long  
 27K: 3.9" (99 mm) O.D. x 27.0" (690 mm) long

# Base-Ported Pressure Filter

# KF30/KF50

$\Delta P_{\text{housing}}$

KF30/KF50  $\Delta P_{\text{housing}}$  for fluids with sp gr (specific gravity) = 0.86:

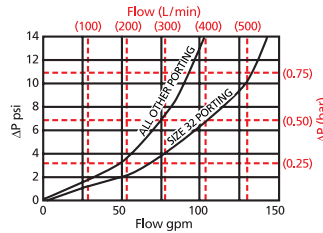

$\Delta P_{\text{element}}$

KZ/KGZ Element Pressure Drop versus Flow Rate at 32 cSt (150 SUS)

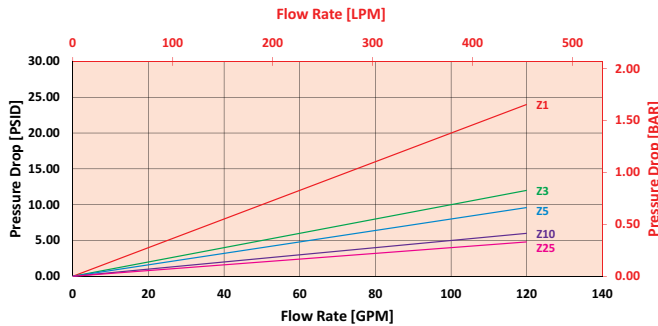

KKZ/KKGZ

Element Pressure Drop versus Flow Rate at 32 cSt (150 SUS)

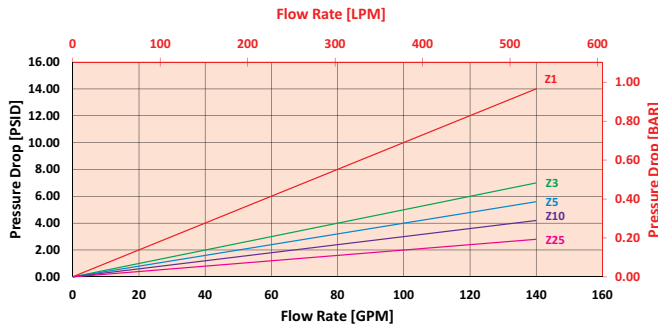

$$\Delta P_{\text{filter}} = \Delta P_{\text{housing}} + (\Delta P_{\text{element}} * V_f)$$

### Exercise:

Determine  $\Delta P_{\text{filter}}$  at 50 gpm (189.5 L/min) for KF301KZ10SD5 using 160 SUS (34 cSt) fluid.

Use the housing pressure curve to determine  $\Delta P_{\text{housing}}$  at 50 gpm. In this case,  $\Delta P_{\text{housing}}$  is 3 psi (.21 bar) on the graph for the KF30 housing.

Use the element pressure curve to determine  $\Delta P_{\text{element}}$  at 50 gpm. In this case,  $\Delta P_{\text{element}}$  is 2.5 psi (.17 bar) according to the graph for the KZ10 element.

Because the viscosity in this sample is 160 SUS (34 cSt), we determine the **Viscosity Factor ( $V_f$ )** by dividing the **Operating Fluid Viscosity** with the **Standard Viscosity** of 150 SUS (32 cSt). To best determine your Operating Fluid Viscosity, please reference the chart in Appendix D.

Finally, the overall filter pressure differential,  $\Delta P_{\text{filter}}$ , is calculated by adding  $\Delta P_{\text{housing}}$  with the true element pressure differential, ( $\Delta P_{\text{element}} * V_f$ ). The  $\Delta P_{\text{element}}$  from the graph has to be multiplied by the viscosity factor to get the true pressure differential across the element.

### Solution:

$$\Delta P_{\text{housing}} = 3 \text{ psi } [.21 \text{ bar}] \quad | \quad \Delta P_{\text{element}} = 2.5 \text{ psi } [.17 \text{ bar}]$$

$$V_f = 160 \text{ SUS (34 cSt)} / 150 \text{ SUS (32 cSt)} = 1.1$$

$$\Delta P_{\text{filter}} = 3 \text{ psi} + (2.5 \text{ psi} * 1.1) = 5.8 \text{ psi}$$

OR

$$\Delta P_{\text{filter}} = .21 \text{ bar} + (.17 \text{ bar} * 1.1) = .40 \text{ bar}$$

## Pressure Drop Information Based on Flow Rate and Viscosity

Note:

If your element is not graphed, use the following equation:

$\Delta P_{\text{element}} = \text{Flow Rate} \times \Delta P_f$  Plug this variable into the overall pressure drop equation.

Ele.	$\Delta P$	Ele.	$\Delta P$	Ele.	$\Delta P$
K3	0.25	2K3/ KK3	0.12	3KZ1/ 27KZ1	0.05
K10	0.09	2K10/ KK10	0.05	3KZ3/ 27KZ3	0.03
K25	0.02	2K25/ KK25	0.01	3KZ5/ 27KZ5	0.02
KAS3	0.10	2KAS3/ KKAS3	0.05	3KZ10/ 27KZ10	0.02
KAS5	0.08	2KAS5/ KKAS5	0.04	3KZ25/ 27KZ25	0.01
KAS10	0.05	2KAS10/ KKAS10	0.03	3K3	0.08
KZX10	0.22	2KZX10/ KKZX10	0.11	3K10	0.03
KZW1	0.43	2KZW1	-	3K25	0.01
KZW3	0.32	2KZW3/ KKZW3	0.16	3KAS3/ 27KAS3	0.03
KZW5	0.28	2KZW5/ KKZW5	0.14	3KAS5/ 27KAS5	0.02
KZW10	0.23	2KZW10/ KKZW10	0.12	3KAS10/ 27KAS10	0.02
KZW25	0.14	2KZW25/ KKZW25	0.07	3KAS25/ 27KAS25	0.07

## Filter Model Number Selection

Highlighted product eligible for **QuickDelivery**

### How to Build a Valid Model Number for a Schroeder KF30:

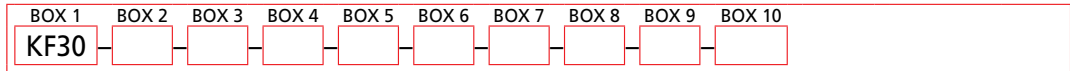

**Example:** NOTE: Only boxes 8 and 10 may contain more than one option

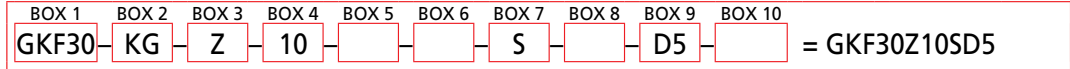

Filter Series	Number & Size of Elements	Media Type
<b>KF30</b> <b>KFN30</b> (Non-bypassing: requires ZX high collapse elements)	1 = K, KK, 27K 2 = K 3 = K  <b>GeoSeal® Options</b> 1 = KG, KKG, 27KKG	Omit = E Media (Cellulose) AS = Anti-Stat Media (synthetic) Z = Excellement® Z-Media® (synthetic) ZW = Aqua-Excellement® ZW Media ZX = Excellement® Z-Media® (High Collapse centertube) W = W Media (water removal) M = Media (reusable metal mesh) N size only
<b>GKF30</b> (GeoSeal®)	2 = KG 3 = KG	
<b>KF50</b> <b>KFN50</b> (Non-bypassing: requires ZX high collapse elements)		
<b>GKF50</b> (GeoSeal®)		

#### NOTES:

**Box 2.** Number of elements must equal 1 when using KK or 27K elements. Replacement element part numbers are identical to contents of Boxes 2, 3, 4 and 5. Double and triple stacking of K-size elements can be replaced by single KK and 27K elements, respectively. ZW media not available in 27K length. For standard elements, a plastic connector SAP P/N: 7630900(LF-1997) is used to connect two or three K elements. For high collapse, a steel connector is required SAP P/N: 7608360 (LF-3255C).

**Box 5.** H.5 seal designation includes the following: EPR seals, stainless steel wire mesh on elements, and light oil coating on housing exterior. Viton® is a registered trademark of DuPont Dow Elastomers. Skydrol® is a registered trademark of Solutia Inc.

**Box 7.** For options F & F32, bolt depth .75" (19 mm).  
For option O, O-rings included; hardware not included.

**Box 8.** X and 50 options are not available with KFN30 or KFN50.

**Box 9.** Standard indicator setting for non-bypassing model is 50 psi unless otherwise specified.

**Box 10.** Options N, are not available with KFN30, KFN50. N option should be used in conjunction with dirt alarm.

BOX 1	BOX 2	BOX 3	BOX 4	BOX 5	BOX 6	BOX 7	BOX 8	BOX 9	BOX 10
<b>Filter Series</b>	<b>Number &amp; Size of Elements</b>	<b>Media Type</b>	<b>Micron Rating</b>	<b>Seal Material</b>	<b>Magnet Option</b>	<b>Porting</b>			
<b>Options</b>								<b>Dirt Alarm® Options</b>	<b>Additional Options</b>
Omit = None X = Blocked bypass 50 = 50 psi bypass setting L = Two ¼" NPTF inlet & outlet female test ports U = Series 1215 ⅝ UNF Schroeder Check Test Point installed in cap (upstream) UU = Series 1215 ⅝ UNF Schroeder Check Test Point installed in block (upstream and downstream)			1 = 1 Micron (Z, ZW, ZX media) 3 = 3 Micron (AS, E, Z, ZW, ZX media) 5 = 5 Micron (AS, Z, ZW, ZX media) 10 = 10 Micron (AS, E, M, Z, ZW, ZX media) 25 = 25 Micron (E, M, Z, ZW, ZX media) 60 = 60 Micron (M media) 150 = 150 Micron (M media) 260 = 260 Micron (M media)	Omit = Buna N V = Viton® H = EPR H.5 = Skydrol® compatibility	Omit = None M = Magnet inserts (not available w/ indicator in cap)	P = 1 ½" NPTF P32 = 2" NPTF S = SAE-24 F = 1 ½" SAE 4-bolt flange (KF30 Code 61) (KF50 Code 62) F32 = 2" SAE 4-bolt flange Code 61(KF30) *KF30 Only O = Subplate B24 = ISO 228 G-1 ½"		Omit = None D = Pointer D5 = Visual pop-up D5C = D5 in cap D9 = All stainless D5 D8 = Visual w/ thermal lockout D8C = D8 in cap	Omit = None N = No-Element Indicator (not available w/ KFN30/KFN50/GKF30/GKF50 or housings w/ indicator in cap) C = Electrical indicator in cap vs. in base standard G509 = Dirt Alarm and drain opposite standard G588 = Electric Switch and drain opposite standard
								MS5 = Electrical w/ 12 in. 18 gauge 4-conductor cable MS5LC = Low current MS5 MS10 = Electrical w/ DIN connector (male end only) MS10LC = Low current MS10 MS11 = Electrical w/ 12 ft. 4-conductor wire MS12 = Electrical w/ 5 pin Brad Harrison connector (male end only) MS12LC = Low current MS12 MS16 = Electrical w/ weather-packed sealed connector MS16LC = Low current MS16 MS17LC = Electrical w/ 4 pin Brad Harrison male connector MS5T = MS5 (see above) w/ thermal lockout MS5LCT = Low current MS5T MS10T = MS10 (see above) w/ thermal lockout MS10LCT = Low current MS10T MS12T = MS12 (see above) w/ thermal lockout MS12LCT = Low current MS12T MS16T = MS16 (see above) w/ thermal lockout MS16LCT = Low current MS16T MS17LCT = Low current MS17T MS = Cam operated switch w/ ½" conduit female connection MS13DC = Supplied w/ threaded connector & light MS14DC = Supplied w/ 5 pin Brad Harrison connector & light (male end) MS13DCT = MS13 (see above), direct current, w/ thermal lockout MS13DCLCT = Low current MS13DCT MS14DCT = MS14 (see above), direct current, w/ thermal lockout MS14DCLCT = Low current MS14DCT	

# Base-Ported Pressure Filter

# TF50

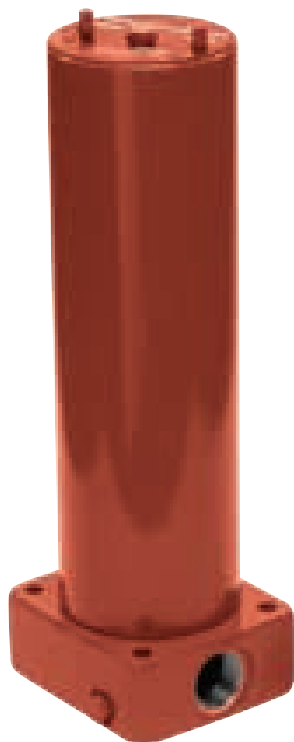

## Features and Benefits

- Base-ported pressure filter
- Can be installed in vertical or horizontal position
- Element changeout from top minimizes oil spillage
- Offered in pipe, SAE straight thread, flanged and ISO 228 porting
- Available with non-bypass option with high collapse element
- Integral inlet and outlet female test points option available
- Offered in conventional subplate porting

Model No. of filter in photograph is TF502A10P.

**40 gpm**  
**150 L/min**  
**5000 psi**  
**345 bar**

NF30  
NFS30  
YF30  
CFX30  
PLD  
CF40  
DF40  
PF40  
RFS50  
RF60  
CF60  
CTF60  
VF60  
LW60  
KF30  
KF50

**TF50**

KC50

MKF50

MKC50

KC65

MKC65

HS60

MHS60

KFH50

LC60

LC35

LC50

## Filter Housing Specifications

Flow Rating:	Up to 40 gpm (150 L/min) for 150 SUS (32 cSt) fluids
Max. Operating Pressure:	5000 psi (345 bar)
Min. Yield Pressure:	15,000 psi (1035 bar), per NFPA T2.6.1
Rated Fatigue Pressure:	3500 psi (240 bar), per NFPA T2.6.1-2005
Temp. Range:	-20°F to 225°F (-29°C to 107°C)
Bypass Setting:	Cracking: 40 psi (2.8 bar) Full Flow: 69 psi (4.8 bar) Non-bypassing model has a blocked bypass.
Porting Base:	Ductile Iron
Element Case & Cap:	Steel
Weight of TF50-1A:	24.4 lbs. (11.1 kg)
Weight of TF50-2A:	29.8 lbs. (13.5 kg)
Element Change Clearance:	8.50" (215 mm)

## Fluid Compatibility

Type Fluid	Appropriate Schroeder Media
Petroleum Based Fluids	All E media (cellulose) and Z-Media® (synthetic)
High Water Content	All Z-Media® (synthetic)
Invert Emulsions	10 and 25 μ Z-Media® (synthetic)
Water Glycols	3, 5, 10 and 25 μ Z-Media® (synthetic)
Phosphate Esters	All Z-Media® (synthetic) with H (EPR) seal designation
Skydrol®	3, 5, 10 and 25 μ Z-Media® (synthetic) with H.5 seal designation (EPR seals and stainless steel wire mesh in element, and light oil coating on housing exterior)

NOF30-05

NOF-50-760

FOF60-03

NMF30

RMF60

14-CRZX10

20-CRZX10

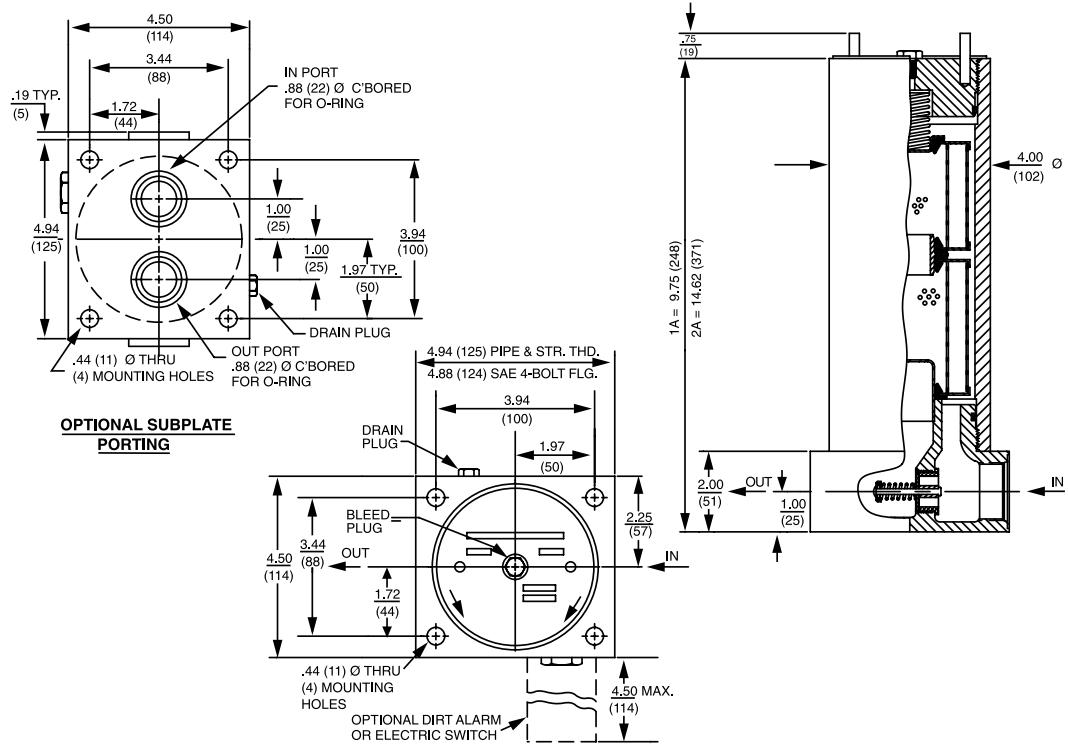

Metric dimensions in ( ).  
 Dimensions shown are inches (millimeters) for general information and overall envelope size only.  
 For complete dimensions please contact Schroeder Industries to request a certified print.

## Element Performance Information & Dirt Holding Capacity

Element	Filtration Ratio Per ISO 4572/NFPA T3.10.8.8 Using automated particle counter (APC) calibrated per ISO 4402			Filtration Ratio per ISO 16889 Using APC calibrated per ISO 11171	
	$\beta_x \geq 75$	$\beta_x \geq 100$	$\beta_x \geq 200$	$\beta_x(c) \geq 200$	$\beta_x(c) \geq 1000$
AZ1	<1.0	<1.0	<1.0	<4.0	4.2
AZ3	<1.0	<1.0	<2.0	<4.0	4.8
AZ5	2.5	3.0	4.0	4.8	6.3
AZ10	7.4	8.2	10.0	8.0	10.0
AZ25	18.0	20.0	22.5	19.0	24.0
CCZX3	<1.0	<1.0	<2.0	4.7	5.8
CCZX10	7.4	8.2	10.0	8.0	10.0

Element	DHC (gm)
AZ1	25
AZ3	26
AZ5	30
AZ10	28
AZ25	28
CCZX3	26*
CCZX10	28*

Element Collapse Rating: 150 psid (10 bar) for standard elements  
 3000 psid (210 bar) for high collapse (ZX) versions

Flow Direction: Outside In \* Based on 100 psi terminal pressure

Element Nominal Dimensions: A: 3.0" (75 mm) O.D. x 4.5" (115 mm) long  
 CC: 3.0" (75 mm) O.D. x 9.5" (240 mm) long



$\Delta P_{\text{housing}}$

TF50  $\Delta P_{\text{housing}}$  for fluids with sp gr (specific gravity) = 0.86:

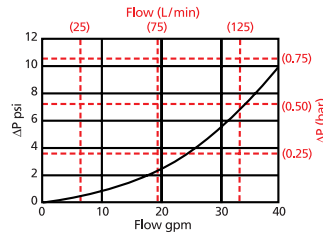

$\Delta P_{\text{element}}$

1AZ

Element Pressure Drop versus Flow Rate at 32 cSt (150 SUS)

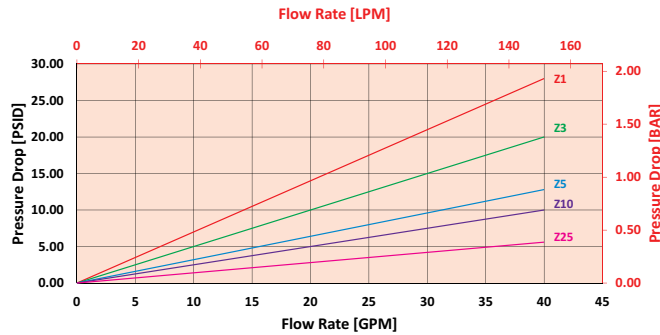

2AZ

Element Pressure Drop versus Flow Rate at 32 cSt (150 SUS)

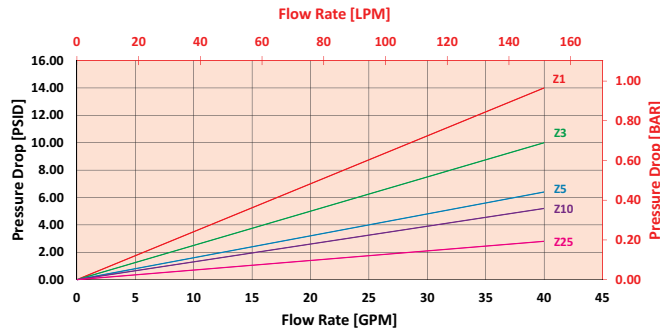

$$\Delta P_{\text{filter}} = \Delta P_{\text{housing}} + (\Delta P_{\text{element}} * V_f)$$

**Exercise:**

Determine  $\Delta P_{\text{filter}}$  at 15 gpm (57 L/min) for TF501AZ10SD5 using 175 SUS (37.2 cSt) fluid.

Use the housing pressure curve to determine  $\Delta P_{\text{housing}}$  at 15 gpm. In this case,  $\Delta P_{\text{housing}}$  is 1.8 psi (.12 bar) on the graph for the TF50 housing.

Use the element pressure curve to determine  $\Delta P_{\text{element}}$  at 15 gpm. In this case,  $\Delta P_{\text{element}}$  is 3.8 psi (.26 bar) according to the graph for the AZ10 element.

Because the viscosity in this sample is 175 SUS (37.2 cSt), we determine the **Viscosity Factor ( $V_f$ )** by dividing the **Operating Fluid Viscosity** with the **Standard Viscosity** of 150 SUS (32 cSt). To best determine your Operating Fluid Viscosity, please reference the chart in Appendix D.

Finally, the overall filter pressure differential,  $\Delta P_{\text{filter}}$ , is calculated by adding  $\Delta P_{\text{housing}}$  with the true element pressure differential,  $(\Delta P_{\text{element}} * V_f)$ . The  $\Delta P_{\text{element}}$  from the graph has to be multiplied by the viscosity factor to get the true pressure differential across the element.

**Solution:**

$\Delta P_{\text{housing}} = 1.8 \text{ psi } [.12 \text{ bar}] \mid \Delta P_{\text{element}} = 3.8 \text{ psi } [.26 \text{ bar}]$

$V_f = 175 \text{ SUS } (37.2 \text{ cSt}) / 150 \text{ SUS } (32 \text{ cSt}) = 1.2$

$\Delta P_{\text{filter}} = 1.8 \text{ psi} + (3.8 \text{ psi} * 1.2) = 6.4 \text{ psi}$

**OR**

$\Delta P_{\text{filter}} = .12 \text{ bar} + (.26 \text{ bar} * 1.2) = .43 \text{ bar}$

**Pressure Drop Information Based on Flow Rate and Viscosity**

Note:  
If your element is not graphed, use the following equation:  
 $\Delta P_{\text{element}} = \text{Flow Rate} \times \Delta P_f$ . Plug this variable into the overall pressure drop equation.

Ele.	$\Delta P$	Ele.	$\Delta P$
A3	0.53	AA3	0.16
A10	0.36	AA10	0.18
A25	0.05	AA25	0.03
CCZX3	0.29		
CCZX10	0.26		

## Filter Model Number Selection

### How to Build a Valid Model Number for a Schroeder TF50:

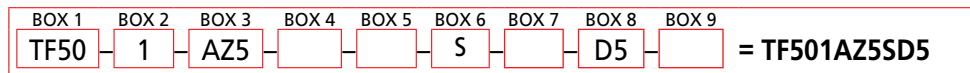
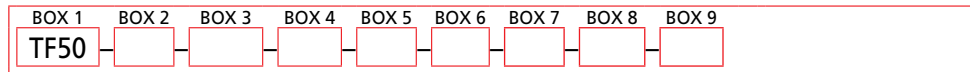

BOX 1	BOX 2	BOX 3
<b>Filter Series</b>	<b>Number</b>	<b>Media Type</b>
TF50	1	AZ1 = 1 µm Excellement® Z-Media® (synthetic)
TFN50 (Non-bypassing: requires ZX high collapse elements)	2 (AZ elements only)	AZ3 = 3 µm Excellement® Z-Media® (synthetic)
		AZ5 = 5 µm Excellement® Z-Media® (synthetic)
		AZ10 = 10 µm Excellement® Z-Media® (synthetic)
		AZ25 = 25 µm Excellement® Z-Media® (synthetic)
		CCZX1 = 1 µm Excellement® Z-Media® (high collapse center tube)
		CCZX3 = 3 µm Excellement® Z-Media® (high collapse center tube)
		CCZX10 = 10 µm Excellement® Z-Media® (high collapse center tube)

BOX 4	BOX 5	BOX 6
<b>Seal Material</b>	<b>Magnet option</b>	<b>Porting</b>
Omit = Buna N V = Viton® H = EPR H.5 = Skydrol® compatibility	Omit = None M = Magnet inserts (not available w/ indicator in cap or TFN50)	P = 1" NPTF S = SAE-16 F = 1" SAE 4-bolt flange Code 61 O = Subplate B = ISO 228 G-1*

BOX 7
<b>Options</b>
Omit = None
X = Blocked bypass
25 = 25 psi bypass setting
30 = 30 psi bypass setting
50 = 50 psi bypass setting
60 = 60 psi bypass setting
75 = 75 psi bypass setting
L = Two 1/4" NPTF inlet and outlet female test ports
U = Series 1215 7/16 UNF Schroeder Check Test Point installation in cap (upstream)
UU = Series 1215 7/16 UNF Schroeder Check Test Point installation in block (upstream and downstream)

BOX 9
<b>Additional Options</b>
Omit = None
N = No-Element indicator (not available with TFN50)
G509 = Dirt alarm and drain opposite standard
G588 = Electrical switch and drain opposite standard

BOX 8	
<b>Dirt Alarm® Options</b>	
None	Omit = None
Visual	D = Pointer
	D5 = Visual pop-up
	D5C = D5 in cap D9 = All stainless D5
Visual with Thermal Lockout	D8 = Visual w/ thermal lockout
	D8C = D8 in cap
Electrical	MS5 = Electrical w/ 12 in. 18 gauge 4-conductor cable
	MS5LC = Low current MS5
	MS10 = Electrical w/ DIN connector (male end only)
	MS10LC = Low current MS10
	MS11 = Electrical w/ 12 ft. 4-conductor wire
	MS12 = Electrical w/ 5 pin Brad Harrison connector (male end only)
	MS12LC = Low current MS12
	MS16 = Electrical w/ weather-packed sealed connector
	MS16LC = Low current MS16
	MS17LC = Electrical w/ 4 pin Brad Harrison male connector
	MS5T = MS5 (see above) w/ thermal lockout
Electrical with Thermal Lockout	MS5LCT = Low current MS5T
	MS10T = MS10 (see above) w/ thermal lockout
	MS10LCT = Low current MS10T
	MS12T = MS12 (see above) w/ thermal lockout
	MS12LCT = Low current MS12T
	MS16T = MS16 (see above) w/ thermal lockout
	MS16LCT = Low current MS16T
MS17LCT = Low current MS17T	
Electrical Visual	MS = Cam operated switch w/ 1/2" conduit female connection
	MS13 = Supplied w/ threaded connector & light
	MS14 = Supplied w/ 5 pin Brad Harrison connector & light (male end)
Electrical Visual with Thermal Lockout	MS13DCT = MS13 (see above), direct current, w/ thermal lockout
	MS13DCLCT = Low current MS13DCT
	MS14DCT = MS14 (see above), direct current, w/ thermal lockout
	MS14DCLCT = Low current MS14DCT

# Base-Ported Pressure Filter

# KC50



## Features and Benefits

- Base-ported pressure filter
- Patented dirt-tolerant cap design
- Can be installed in vertical or horizontal position
- Meets HF4 automotive standard
- Element changeout from top minimizes oil spillage
- Offered in pipe, SAE straight thread, flanged and ISO 228 porting
- No-Element indicator option available
- Available with non-bypass option with high collapse element
- Integral inlet and outlet female test points option available
- Offered in conventional subplate porting
- Double and triple stacking of K-size elements can be replaced by single KK or 27K-size elements
- Available with quality-protected GeoSeal® Elements (GKC50)

**100/150 gpm** NF30  
**380/570 L/min** NFS30  
**5000 psi** YF30  
**345 bar** CFX30

PLD

CF40

DF40

PF40

RFS50

RF60

CF60

CTF60

VF60

LW60

KF30

KF50

TF50

## Filter Housing Specifications

**KC50**

MKF50

MKC50

KC65

MKC65

HS60

MHS60

KFH50

LC60

LC35

LC50

## Fluid Compatibility

NOF30-05

NOF-50-760

FOF60-03

NMF30

RMF60

14-CRZX10

20-CRZX10

Model No. of filter in photograph is KC501KZ10PD.

Flow Rating:	Up to 100 gpm (380 L/min) for 150 SUS (32 cSt) fluids With 2" porting only, up to 150 gpm (570 L/min) for 150 SUS (32 cSt) fluids
Max. Operating Pressure:	5000 psi (345 bar)
Min. Yield Pressure:	15,000 psi (1035 bar), per NFPA T2.6.1
Rated Fatigue Pressure:	3500 psi (240 bar), per NFPA T2.6.1-2005
Temp. Range:	-20°F to 225°F (-29°C to 107°C)
Bypass Setting:	Cracking: 40 psi (2.8 bar) Optional Cracking: 50 psi (3.5 bar) Full Flow: 61 psi (4.2 bar) Non-bypassing model has a blocked bypass.
Porting Base & Cap:	Ductile Iron
Element Case:	Steel
Weight of KF30-1K:	66.8 lbs. (30.3 kg)
Weight of KF30-2K:	87.8 lbs. (39.8 kg)
Weight of KF30-3K:	109.6 lbs. (49.7 kg)
Element Change Clearance:	8.50" (215 mm) for 1K; 17.50" (445 mm) for KK; 26.5" (673 mm) for 27K

Type Fluid	Appropriate Schroeder Media
Petroleum Based Fluids	All E-Media (cellulose) and Z-Media® and ASP® Media (synthetic)
High Water Content	All Z-Media® and ASP® Media (synthetic)
Invert Emulsions	10 and 25 µ Z-Media® (synthetic), 10 µ ASP® Media (synthetic)
Water Glycols	3, 5, 10 and 25 µ Z-Media® (synthetic), and all ASP® Media
Phosphate Esters	All Z-Media® and ASP® Media (synthetic) with H (EPR) seal designation and 3 and 10 µ E media (cellulose) with H (EPR) seal designation
Skydrol®	3, 5, 10 and 25 µ Z-Media® (synthetic), and all ASP® Media (synthetic) with H.5 seal designation (EPR seals and stainless steel wire mesh in element, and light oil coating on housing exterior)

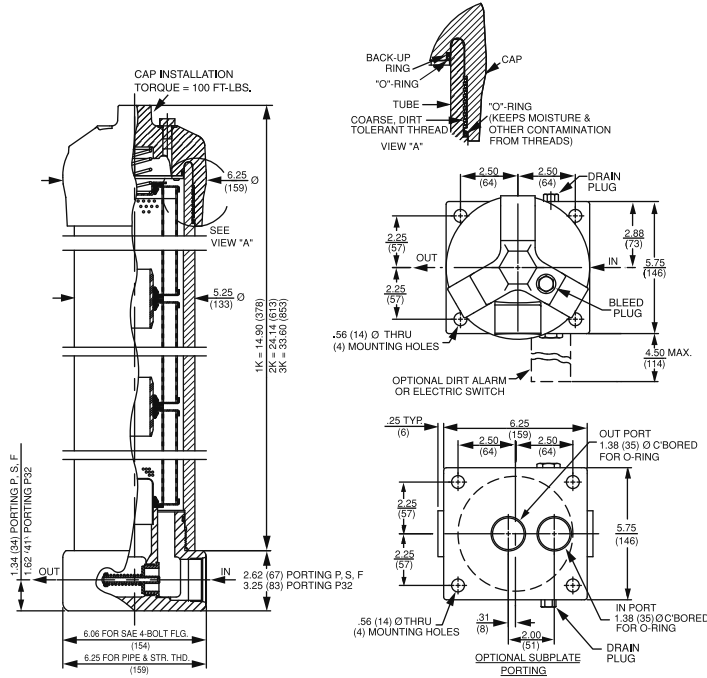

Metric dimensions in ( ).  
 Dimensions shown are inches (millimeters) for general information and overall envelope size only.  
 For complete dimensions please contact Schroeder Industries to request a certified print.

## Element Performance Information & Dirt Holding Capacity

Element	Filtration Ratio Per ISO 4572/NFPA T3.10.8.8 Using automated particle counter (APC) calibrated per ISO 4402			Filtration Ratio per ISO 16889 Using APC calibrated per ISO 11171	
	$\beta_x \geq 75$	$\beta_x \geq 100$	$\beta_x \geq 200$	$\beta_x(c) \geq 200$	$\beta_x(c) \geq 1000$
KZ1/KKZ1/27KZ1	<1.0	<1.0	<1.0	<4.0	4.2
KZ3/KKZ3/27KZ3	<1.0	<1.0	<2.0	<4.0	4.8
KZ5/KKZ5/27KZ5	2.5	3.0	4.0	4.8	6.3
KZ10/KKZ10/27KZ10	7.4	8.2	10.0	8.0	10.0
KZ25/KKZ25/27KZ25	18.0	20.0	22.5	19.0	24.0
KZW1	N/A	N/A	N/A	<4.0	<4.0
KZW3/KKZW3	N/A	N/A	N/A	4.0	4.8
KZW5/KKZW5	N/A	N/A	N/A	5.1	6.4
KZW10/KKZW10	N/A	N/A	N/A	6.9	8.6
KZW25/KKZW25	N/A	N/A	N/A	15.4	18.5
KZX3/KKZX3/27KZX3	<1.0	<1.0	<2.0	4.7	5.8
KZX10/KKZX10/27KZX10	7.4	8.2	10.0	8.0	9.8

Element	DHC (gm)	Element	DHC (gm)	Element	DHC (gm)	Element	DHC (gm)	Element	DHC (gm)
KZ1	112	KKZ1	224	27KZ1	336	KZW1	61	KKZW3	128
KZ3	115	KKZ3	230	27KZ3	345	KZW3	64	KKZW5	126
KZ5	119	KKZ5	238	27KZ5	357	KZW5	63	KKZW10	114
KZ10	108	KKZ10	216	27KZ10	324	KZW10	57	KKZW25	158
KZ25	93	KKZ25	186	27KZ25	279	KZW25	79		
KZX3	81*	KKZX3	163*	27KZX3	249*				
KZX10	90*	KKZX10	182*	27KZX10	279*				

\* Based on 100 psi terminal pressure

Element Collapse Rating: 150 psid (10 bar) for standard elements  
 3000 psid (210 bar) for high collapse (ZX) versions

Flow Direction: Outside In

Element Nominal Dimensions: K: 3.9" (99 mm) O.D. x 9.0" (230 mm) long  
 KK: 3.9" (99 mm) O.D. x 18.0" (460 mm) long  
 27K: 3.9" (99 mm) O.D. x 27.0" (690 mm) long

# Base-Ported Pressure Filter

# KC50

$\Delta P_{\text{housing}}$

KC50  $\Delta P_{\text{housing}}$  for fluids with sp gr (specific gravity) = 0.86:

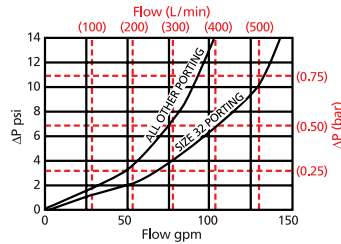

$\Delta P_{\text{element}}$

KZ/KGZ

Element Pressure Drop versus Flow Rate at 32 cSt (150 SUS)

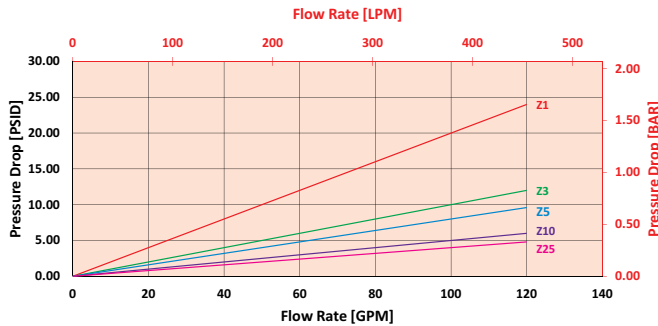

2KZ/KKGZ

Element Pressure Drop versus Flow Rate at 32 cSt (150 SUS)

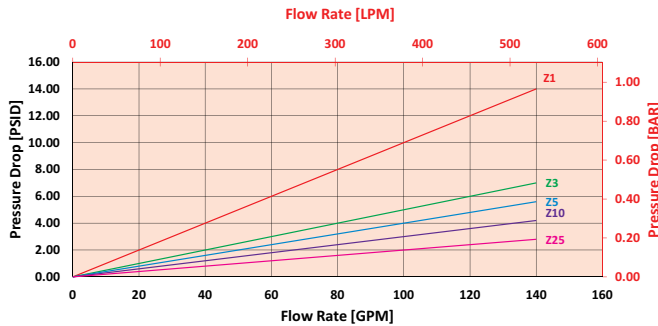

$$\Delta P_{\text{filter}} = \Delta P_{\text{housing}} + (\Delta P_{\text{element}} * V_f)$$

### Exercise:

Determine  $\Delta P_{\text{filter}}$  at 50 gpm (189.5 L/min) for KC501KZ10SD5 using 160 SUS (34 cSt) fluid.

Use the housing pressure curve to determine  $\Delta P_{\text{housing}}$  at 50 gpm. In this case,  $\Delta P_{\text{housing}}$  is 3 psi (.21 bar) on the graph for the KC50 housing.

Use the element pressure curve to determine  $\Delta P_{\text{element}}$  at 50 gpm. In this case,  $\Delta P_{\text{element}}$  is 2.5 psi (.17 bar) according to the graph for the KZ10 element.

Because the viscosity in this sample is 160 SUS (34 cSt), we determine the **Viscosity Factor ( $V_f$ )** by dividing the **Operating Fluid Viscosity** with the **Standard Viscosity** of 150 SUS (32 cSt). To best determine your Operating Fluid Viscosity, please reference the chart in Appendix D.

Finally, the overall filter pressure differential,  $\Delta P_{\text{filter}}$ , is calculated by adding  $\Delta P_{\text{housing}}$  with the true element pressure differential, ( $\Delta P_{\text{element}} * V_f$ ). The  $\Delta P_{\text{element}}$  from the graph has to be multiplied by the viscosity factor to get the true pressure differential across the element.

### Solution:

$$\Delta P_{\text{housing}} = 3 \text{ psi } [.21 \text{ bar}] \quad | \quad \Delta P_{\text{element}} = 2.5 \text{ psi } [.17 \text{ bar}]$$

$$V_f = 160 \text{ SUS } (34 \text{ cSt}) / 150 \text{ SUS } (32 \text{ cSt}) = 1.1$$

$$\Delta P_{\text{filter}} = 3 \text{ psi } + (2.5 \text{ psi } * 1.1) = 5.8 \text{ psi}$$

OR

$$\Delta P_{\text{filter}} = .21 \text{ bar } + (.17 \text{ bar } * 1.1) = .40 \text{ bar}$$

## Pressure Drop Information Based on Flow Rate and Viscosity

Note:

If your element is not graphed, use the following equation:

$\Delta P_{\text{element}} = \text{Flow Rate} \times \Delta P_f$  Plug this variable into the overall pressure drop equation.

Ele.	$\Delta P$	Ele.	$\Delta P$	Ele.	$\Delta P$
K3	0.25	2K3/ KK3	0.12	3KZ1/ 27KZ1	0.05
K10	0.09	2K10/ KK10	0.05	3KZ3/ 27KZ3	0.03
K25	0.02	2K25/ KK25	0.01	3KZ5/ 27KZ5	0.02
KAS3	0.10	2KAS3/ KKAS3	0.05	3KZ10/ 27KZ10	0.02
KAS5	0.08	2KAS5/ KKAS5	0.04	3KZ25/ 27KZ25	0.01
KAS10	0.05	2KAS10/ KKAS10	0.03	3K3	0.08
KZX10	0.22	2KZX10/ KKZX10	0.11	3K10	0.03
KZW1	0.43	2KZW1	-	3K25	0.01
KZW3	0.32	2KZW3/ KKZW3	0.16	3KAS3/ 27KAS3	0.03
KZW5	0.28	2KZW5/ KKZW5	0.14	3KAS5/ 27KAS5	0.02
KZW10	0.23	2KZW10/ KKZW10	0.12	3KAS10/ 27KAS10	0.02
KZW25	0.14	2KZW25/ KKZW25	0.07	3KAS25/ 27KAS25	0.07

## Filter Model Number Selection

### How to Build a Valid Model Number for a Schroeder KC50:

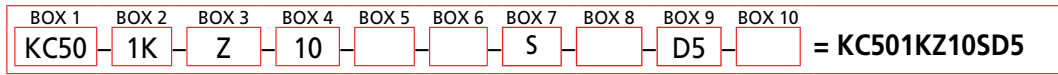
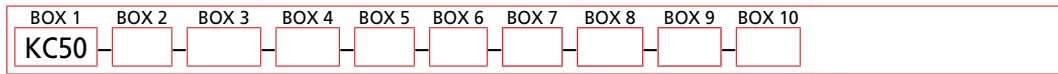

BOX 1	BOX 2	BOX 3
<b>Filter Series</b>	<b>Number &amp; Size of Elements</b>	<b>Media Type</b>
KC50	1 K, KK, 27K	Omit = E Media (Cellulose) (KC50 only)
KCN50 (Non-bypassing: requires ZX high collapse elements)	2 K	AS = Anti-Stat Media (synthetic)
	3 K	Z = Excellence® Z-Media® (synthetic)
	<b>GeoSeal® Options</b>	ZX = Excellence® Z-Media® (High Collapse centertube) (KCN50 Only)
	1 KG, KKG, 27KG	ZW = Aqua-Excellence ZW Media (KC50 Only)
	2 KG	W = W Media (water removal)
	3 KG	M = Media (reusable metal mesh) (KC50 & KCN50 Only)
GKC50 (GeoSeal®)		
WKC50 (Water)		

#### NOTES:

**Box 2.** Number of elements must equal 1 when using KK or 27K elements. Replacement element part numbers are identical to contents of Boxes 2, 3, 4 and 5. Double and triple stacking of K-size elements can be replaced by single KK and 27K elements, respectively. ZW media not available in 27K length. For standard elements, a plastic connector SAP P/N: 7630900 (LF-1997) is used to connect two or three K elements. For high collapse, a steel connector is required SAP P/N: 7608360 (LF-3255C).

**Box 5.** H.5 seal designation includes the following: EPR seals, stainless steel wire mesh on elements, and light oil coating on housing exterior. Viton® is a registered trademark of DuPont Dow Elastomers. Skydrol® is a registered trademark of Solutia Inc.

**Box 7.** For option F, bolt depth .75" (19 mm). For option O, O-rings included; hardware not included.

**Box 8.** X and 50 options are not available with KCN50.

**Box 9.** Standard indicator setting for non-bypassing model is 50 psi unless otherwise specified.

**Box 10.** Option N, are not available with KCN50/ GKC50. N option should be used in conjunction with dirt alarm.

BOX 4	BOX 5	BOX 6	BOX 7
<b>Micron Rating</b>	<b>Seal Material</b>	<b>Magnet Option</b>	<b>Porting</b>
1 = 1 Micron (Z, ZW, ZX media)	Omit = Buna N	Omit = None	P = 1 1/2" NPTF
3 = 3 Micron (AS,E, Z, ZW, ZX media)	V = Viton®	M = Magnet inserts (not available w/ indicator in cap)	P32 = 2" NPTF
5 = 5 Micron (AS, Z, ZW, ZX media)	H = EPR		S = SAE-24
10 = 10 Micron (AS,E,M, Z, ZW, ZX media)	H.5 = Skydrol® compatibility		F = 1 1/2" SAE 4-bolt flange Code 62
25 = 25 Micron (E,M, Z, ZW, ZX media)			O = Subplate
60 = 60 Micron (M media)			B24 = ISO 228 G-1 1/2"
150 = 150 Micron (M media)			
260 = 260 Micron (M media)			

BOX 8	BOX 9	BOX 10
<b>Options</b>	<b>Dirt Alarm® Options</b>	<b>Additional Options</b>
Omit = None	None	Omit = None
X = Blocked bypass	Omit = None	N = No-Element Indicator (not available w/ KCN50 or GKC50 housings w/ indicator in cap)
50 = 50 psi bypass setting	D = Pointer	G509 = Dirt Alarm and drain opposite standard
L = Two 1/2" NPTF inlet & outlet female test ports	D5 = Visual pop-up	G588 = Electric Switch and drain opposite standard
U = Series 1215 7/16 UNF Schroeder Check Test Point installed in cap (upstream)	D5C = D5 in cap	
UU = Series 1215 7/16 UNF Schroeder Check Test Point installed in block (upstream and downstream)	D9 = All stainless D5	
	D8 = Visual w/ thermal lockout	
	D8C = D8 in cap	
	MS5 = Electrical w/ 12 in. 18 gauge 4-conductor cable	
	MS5LC = Low current MS5	
	MS10 = Electrical w/ DIN connector (male end only)	
	MS10LC = Low current MS10	
	MS11 = Electrical w/ 12 ft. 4-conductor wire	
	MS12 = Electrical w/ 5 pin Brad Harrison connector (male end only)	
	MS12LC = Low current MS12	
	MS16 = Electrical w/ weather-packed sealed connector	
	MS16LC = Low current MS16	
	MS17LC = Electrical w/ 4 pin Brad Harrison male connector	
	MS5T = MS5 (see above) w/ thermal lockout	
	MS5LCT = Low current MS5T	
	MS10T = MS10 (see above) w/ thermal lockout	
	MS10LCT = Low current MS10T	
	MS12T = MS12 (see above) w/ thermal lockout	
	MS12LCT = Low current MS12T	
	MS16T = MS16 (see above) w/ thermal lockout	
	MS16LCT = Low current MS16T	
	MS17LCT = Low current MS17T	
	MS = Cam operated switch w/ 1/2" conduit female connection	
	MS13DC = Supplied w/ threaded connector & light	
	MS14DC = Supplied w/ 5 pin Brad Harrison connector & light (male end)	
	MS13DCT = MS13 (see above), direct current, w/ thermal lockout	
	MS13DCLCT = Low current MS13DCT	
	MS14DCT = MS14 (see above), direct current, w/ thermal lockout	
	MS14DCLCT = Low current MS14DCT	

# Base-Ported Pressure Filter

## MKF50/ MKC50



### Features and Benefits

- Base-ported high pressure dual filter manifold mounted
  - Meets HF4 automotive standard
  - Element changeout from top minimizes oil spillage
  - Offered in pipe porting (contact factory for other porting options)
  - No-Element indicator option available
  - Available with non-bypass option with high collapse element
  - Integral inlet and outlet female test points option available
  - Double and triple stacking of K-size elements can be replaced by single KK or 27K-size elements
- G** Available with quality-protected GeoSeal® Elements (GMKF50)

**200 gpm**  
**760 L/min**  
**5000 psi**  
**345 bar**

NF30  
NFS30  
YF30  
CFX30  
PLD  
CF40  
DF40  
PF40  
RFS50  
RF60  
CF60  
CTF60  
VF60  
LW60  
KF30  
KF50

Model No. of filter in photograph are MKF504K10PD5 and MKC504K10PD5.

Flow Rating:	Up to 200 gpm (760 L/min) for 150 SUS (32 cSt) fluids
Max. Operating Pressure:	5000 psi (345 bar)
Min. Yield Pressure:	15,000 psi (1035 bar), per NFPA T2.6.1
Rated Fatigue Pressure:	3500 psi (240 bar), per NFPA T2.6.1-2005
Temp. Range:	-20°F to 225°F (-29°C to 107°C)
Bypass Setting:	Cracking: 40 psi (2.8 bar) Optional Cracking: 50 psi (3.5 bar) Full Flow: 61 psi (4.2 bar) Non-bypassing model has a blocked bypass.
Porting Base & Cap:	Ductile Iron
Element Case:	Steel
Weight of MKF50-2K:	214.0 lbs. (97.3 kg)
Weight of MKF50-4K:	243.0 lbs. (110.2 kg)
Weight of MKF50-6K:	284.4 lbs. (129.0 kg)
Weight of MKC50-2K:	216.0 lbs. (98.0 kg)
Weight of MKC50-4K:	245.0 lbs. (111.1 kg)
Weight of MKC50-6K:	286.4 lbs. (129.9 kg)
Element Change Clearance:	8.50" (215 mm) for 1K; 17.50" (445 mm) for KK; 26.5" (673 mm) for 27K

### Filter Housing Specifications

**MKF50**  
**MKC50**  
KC65  
MKC65  
HS60  
MHS60  
KFH50  
LC60  
LC35  
LC50

Type Fluid	Appropriate Schroeder Media
Petroleum Based Fluids	All E-Media (cellulose) and Z-Media® and ASP® Media (synthetic)
High Water Content	All Z-Media® and ASP® Media (synthetic)
Invert Emulsions	10 and 25 µ Z-Media® (synthetic), 10 µ ASP® Media (synthetic)
Water Glycols	3, 5, 10 and 25 µ Z-Media® (synthetic), and all ASP® Media
Phosphate Esters	All Z-Media® and ASP® Media (synthetic) with H (EPR) seal designation and 3 and 10 µ E media (cellulose) with H (EPR) seal designation
Skydrol®	3, 5, 10 and 25 µ Z-Media® (synthetic), and all ASP® Media (synthetic) with H.5 seal designation (EPR seals and stainless steel wire mesh in element, and light oil coating on housing exterior)

### Fluid Compatibility

NOF30-05  
NOF-50-760  
FOF60-03  
NMF30  
RMF60  
14-CRZX10  
20-CRZX10



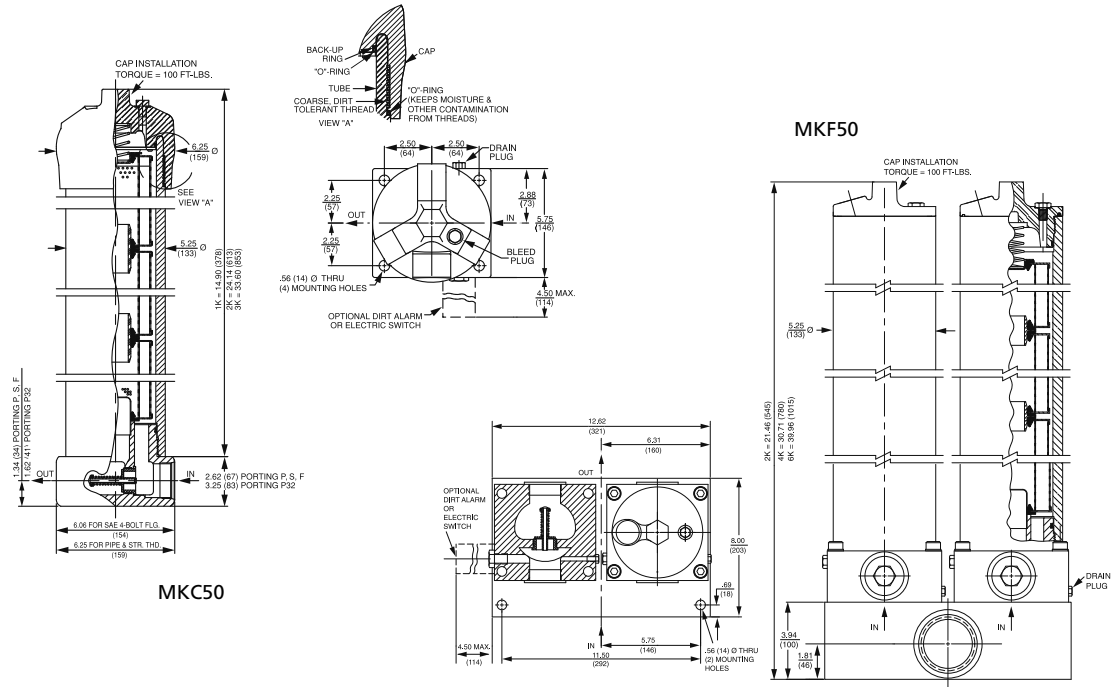

Metric dimensions in ( ).  
Dimensions shown are inches (millimeters) for general information and overall envelope size only.  
For complete dimensions please contact Schroeder Industries to request a certified print.

### Element Performance Information & Dirt Holding Capacity

Element	Filtration Ratio Per ISO 4572/NFPA T3.10.8.8 Using automated particle counter (APC) calibrated per ISO 4402			Filtration Ratio per ISO 16889 Using APC calibrated per ISO 11171	
	$\beta_x \geq 75$	$\beta_x \geq 100$	$\beta_x \geq 200$	$\beta_x(c) \geq 200$	$\beta_x(c) \geq 1000$
KZ1/KKZ1/27KZ1	<1.0	<1.0	<1.0	<4.0	4.2
KZ3/KKZ3/27KZ3	<1.0	<1.0	<2.0	<4.0	4.8
KZ5/KKZ5/27KZ5	2.5	3.0	4.0	4.8	6.3
KZ10/KKZ10/27KZ10	7.4	8.2	10.0	8.0	10.0
KZ25/KKZ25/27KZ25	18.0	20.0	22.5	19.0	24.0
KZW1	N/A	N/A	N/A	<4.0	<4.0
KZW3/KKZW3	N/A	N/A	N/A	4.0	4.8
KZW5/KKZW5	N/A	N/A	N/A	5.1	6.4
KZW10/KKZW10	N/A	N/A	N/A	6.9	8.6
KZW25/KKZW25	N/A	N/A	N/A	15.4	18.5
KZX3/KKZX3/27KZX3	<1.0	<1.0	<2.0	4.7	5.8
KZX10/KKZX10/27KZX10	7.4	8.2	10.0	8.0	9.8

Element	DHC (gm)	Element	DHC (gm)	Element	DHC (gm)	Element	DHC (gm)	Element	DHC (gm)
KZ1	112	KKZ1	224	27KZ1	336	KZW1	61		
KZ3	115	KKZ3	230	27KZ3	345	KZW3	64	KKZW3	128
KZ5	119	KKZ5	238	27KZ5	357	KZW5	63	KKZW5	126
KZ10	108	KKZ10	216	27KZ10	324	KZW10	57	KKZW10	114
KZ25	93	KKZ25	186	27KZ25	279	KZW25	79	KKZW25	158
KZX3	81*	KKZX3	163*	27KZX3	249*				
KZX10	90*	KKZX10	182*	27KZX10	279*				

\* Based on 100 psi terminal pressure

Element Collapse Rating: 150 psid (10 bar) for standard elements  
3000 psid (210 bar) for high collapse (ZX) versions

Flow Direction: Outside In

Element Nominal Dimensions: K: 3.9" (99 mm) O.D. x 9.0" (230 mm) long  
KK: 3.9" (99 mm) O.D. x 18.0" (460 mm) long  
27K: 3.9" (99 mm) O.D. x 27.0" (690 mm) long



# Base-Ported Pressure Filter

# MKF50/ MKC50

**Pressure Drop Information Based on Flow Rate and Viscosity**

$\Delta P_{\text{housing}}$

MKF50/MKC50  $\Delta P_{\text{housing}}$  for fluids with sp gr (specific gravity) = 0.86:

95-5 @ 40C

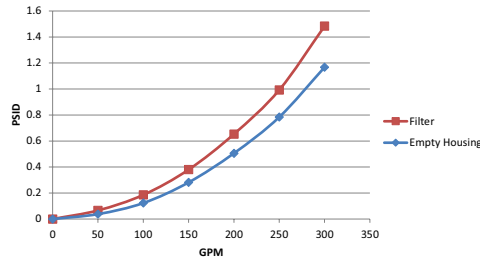
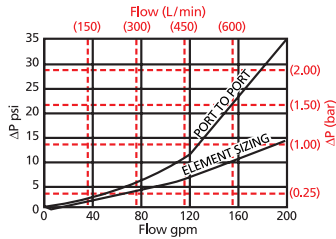

$\Delta P_{\text{element}}$

4KZ/2KZ

Element Pressure Drop versus Flow Rate at 32 cSt (150 SUS)

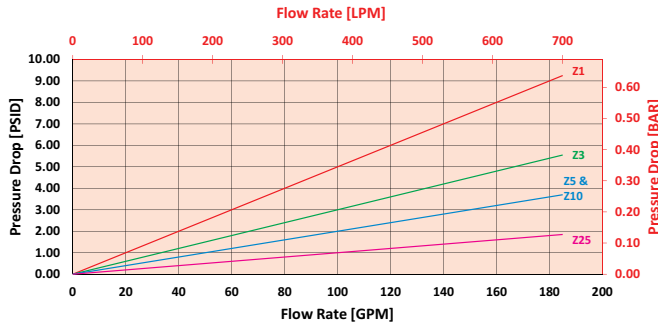

6KZ/2-27KZ

Element Pressure Drop versus Flow Rate at 32 cSt (150 SUS)

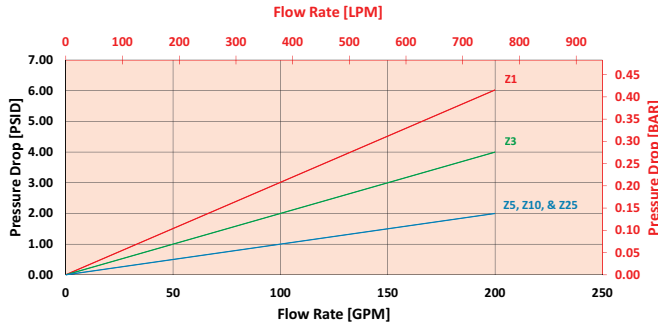

$$\Delta P_{\text{filter}} = \Delta P_{\text{housing}} + (\Delta P_{\text{element}} * V_f)$$

**Exercise:**

Determine  $\Delta P_{\text{filter}}$  at 100 gpm (379 L/min) for MKF504KZ10PD5 using 160 SUS (34 cSt) fluid.

Use the housing pressure curve to determine  $\Delta P_{\text{housing}}$  at 100 gpm. In this case,  $\Delta P_{\text{housing}}$  is 8 psi (.55 bar) on the graph for the MKF50 housing.

Use the element pressure curve to determine  $\Delta P_{\text{element}}$  at 100 gpm. In this case,  $\Delta P_{\text{element}}$  is 2 psi (.14 bar) according to the graph for the KZ10 element.

Because the viscosity in this sample is 160 SUS (34 cSt), we determine the **Viscosity Factor ( $V_f$ )** by dividing the **Operating Fluid Viscosity** with the **Standard Viscosity** of 150 SUS (32 cSt). To best determine your Operating Fluid Viscosity, please reference the chart in Appendix D.

Finally, the overall filter pressure differential,  $\Delta P_{\text{filter}}$ , is calculated by adding  $\Delta P_{\text{housing}}$  with the true element pressure differential,  $(\Delta P_{\text{element}} * V_f)$ . The  $\Delta P_{\text{element}}$  from the graph has to be multiplied by the viscosity factor to get the true pressure differential across the element.

**Solution:**

$\Delta P_{\text{housing}} = 8 \text{ psi } [.55 \text{ bar}] \mid \Delta P_{\text{element}} = 2 \text{ psi } [.14 \text{ bar}]$

$V_f = 160 \text{ SUS } (34 \text{ cSt}) / 150 \text{ SUS } (32 \text{ cSt}) = 1.1$

$\Delta P_{\text{filter}} = 8 \text{ psi } + (2 \text{ psi } * 1.1) = 10.2 \text{ psi}$

**OR**

$\Delta P_{\text{filter}} = .55 \text{ bar } + (.14 \text{ bar } * 1.1) = .70 \text{ bar}$

Note:

If your element is not graphed, use the following equation:  
 $\Delta P_{\text{element}} = \text{Flow Rate} \times \Delta P_f$  Plug this variable into the overall pressure drop equation.

Ele.	$\Delta P$	Ele.	$\Delta P$	Ele.	$\Delta P$
2KZ1	0.10	2K3	0.12	4K3/ KK3	0.06
2KZ3	0.05	2K10	0.05	4K10/ KK10	0.02
2KZ5	0.04	2K25	0.01	4K25/ KK25	0.01
2KZ10	0.03	2KAS3	0.05	4KAS3/ KKAS3	0.03
2KZ25	0.02	2KAS5	0.04	4KAS5/ KKAS5	0.02
KZW1	0.43	2KAS10	0.03	4KAS10/ KKAS10	0.02
KZW3	0.32	2KZX10	0.11	4KZX10	0.06
KZX5	0.28	2KZW3	0.16	6KAS3/ 27KAS3	0.02
KZW10	0.23	2KZW5	0.14	6KAS5/ 27KAS5	0.01
KZW25	0.14	2KZW10	0.12	6KAS10/ 27KAS10	0.01
		2KZW25	0.07	6KZX10	0.04

## Filter Model Number Selection

### How to Build a Valid Model Number for a Schroeder MFK50:

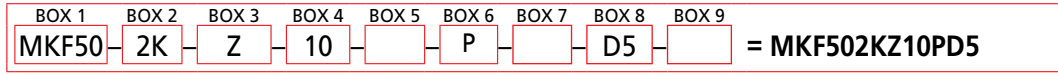
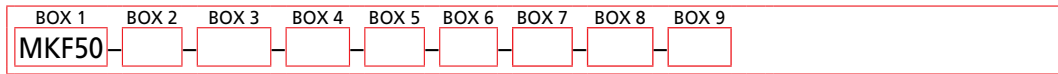

BOX 1	BOX 2	BOX 3
<b>Filter Series</b>	<b>Number &amp; Size of Elements</b>	<b>Media Type</b>
MKF50	2 K, KK, 27K	Omit = E Media (Cellulose) (MKF50 only)
MKFN50 (Non-bypassing: requires ZX high collapse elements)	4 K	AS = Anti-Stat Media (synthetic)
GMKF50 (GeoSeal®)	6 K	Z = Excellement® Z-Media® (synthetic)
MKC50	<b>GeoSeal® Options</b>	ZX = Excellement® Z-Media® (High Collapse centertube) (MKFN50 Only)
MKCN50 (Non-bypassing: requires ZX high collapse elements)	2 KG, KKG, 27KG	ZW = Aqua-Excellement ZW Media (MKF50 Only)
WKC50 (Water)	4 KG	W = W Media (water removal)
	6 KG	M = Media (reusable metal mesh) (MKF50 & MKFN50 Only)

BOX 4	BOX 5	BOX 6	BOX 7
<b>Micron Rating</b>	<b>Seal Material</b>	<b>Porting Option</b>	<b>Porting</b>
1 = 1 Micron (DZ, Z, ZW, ZX media)	Omit = Buna N	P = 2½" NPTF	Omit = None
3 = 3 Micron (AS,DZ, E, Z, ZW, ZX media)	V = Viton®		X = Blocked bypass
5 = 5 Micron (AS, DZ, Z, ZW, ZX media)	H = EPR		50 = EPR
10 = 10 Micron (AS, DZ, E, M, Z, ZW, ZX media)	H.5 = Skydrol® compatibility		L = Two ¼" NPTF inlet and outlet female test ports
25 = 25 Micron (E, DZ, M, Z, ZW, ZX media)			U = Series 1215 7/16 UNF Schroeder Check Test Point installed in cap (upstream)
60 = 60 Micron (M media)			
150 = 150 Micron (M media)			
260 = 260 Micron (M media)			

BOX 8	
Dirt Alarm® Options	
None	Omit = None
Visual	D = Pointer
	D5 = Visual pop-up
	D5C = D5 in cap
Visual with Thermal Lockout	D9 = All stainless D5
	D8 = Visual w/ thermal lockout
	D8C = D8 in cap
Electrical	MS5 = Electrical w/ 12 in. 18 gauge 4-conductor cable
	MS5LC = Low current MS5
	MS10 = Electrical w/ DIN connector (male end only)
	MS10LC = Low current MS10
	MS11 = Electrical w/ 12 ft. 4-conductor wire
	MS12 = Electrical w/ 5 pin Brad Harrison connector (male end only)
	MS12LC = Low current MS12
	MS16 = Electrical w/ weather-packed sealed connector
	MS16LC = Low current MS16
	MS17LC = Electrical w/ 4 pin Brad Harrison male connector
	MS5T = MS5 (see above) w/ thermal lockout
	MS5LCT = Low current MS5T
	MS10T = MS10 (see above) w/ thermal lockout
MS10LCT = Low current MS10T	
MS12T = MS12 (see above) w/ thermal lockout	
MS12LCT = Low current MS12T	
MS16T = MS16 (see above) w/ thermal lockout	
MS16LCT = Low current MS16T	
MS17LCT = Low current MS17T	
Electrical Visual	MS = Cam operated switch w/ ½" conduit female connection
	MS13 = Supplied w/ threaded connector & light
	MS14 = Supplied w/ 5 pin Brad Harrison connector & light (male end)
Electrical	MS13DCT = MS13 (see above), direct current, w/ thermal lockout
Visual with Thermal Lockout	MS13DCLCT = Low current MS13DCT
	MS14DCT = MS14 (see above), direct current, w/ thermal lockout
	MS14DCLCT = Low current MS14DCT

BOX 9
Additional Options
Omit = None
N = No-Element Indicator (not available w/ MKFN30/ MKCN50 or housings w/ indicator in cap)

#### NOTES:

- Box 2.** Number of elements must equal 2 when using KK or 27K elements. Replacement element part numbers are identical to contents of Boxes 2, 3, 4 and 5. Double and triple stacking of K-size elements can be replaced by single KK and 27K elements, respectively. ZW media not available in 27K length. For standard elements, a plastic connector SAP P/N: 7630900 (LF-1997) is used to connect two or three K elements. For high collapse, a steel connector is required SAP P/N: 7608360 (LF-3255C).
- Box 5.** H.5 seal designation includes the following: EPR seals, stainless steel wire mesh on elements, and light oil coating on housing exterior. Viton® is a registered trademark of DuPont Dow Elastomers. Skydrol® is a registered trademark of Solutia Inc.
- Box 7.** 50 option is not available with MKFN50.
- Box 8.** Standard indicator setting for non-bypassing model is 50 psi unless otherwise specified.
- Box 9.** N option should be used in conjunction with dirt alarm.

# Base-Ported Pressure Filter

# KC65



## Features and Benefits

- Base-ported high pressure filter
- Patented dirt-tolerant cap design
- Can be installed in vertical or horizontal position
- Meets HF4 automotive standard
- Element changeout from top minimizes oil spillage
- Offered in flanged porting
- No-Element indicator option available
- Available with non-bypass option with high collapse element
- Integral inlet and outlet female test points option available
- Double and triple stacking of K-size element can be replaced by single KK or 27K-size element
- G** Available with quality-protected GeoSeal® Elements (GKC65)

**100 gpm**  
**380 L/min**  
**6500 psi**  
**450 bar**

NF30  
NFS30  
YF30  
CFX30  
PLD  
CF40  
DF40  
PF40  
RFS50  
RF60  
CF60  
CTF60  
VF60  
LW60  
KF30  
KF50  
TF50  
KC50  
MKF50  
MKC50  
**KC65**  
MKC65  
HS60  
MHS60  
KFH50  
LC60  
LC35  
LC50  
NOF30-05  
NOF-50-760  
FOF60-03  
NMF30  
RMF60  
14-CRZX10  
20-CRZX10

Model No. of filter in photograph is KC651K10FD9.

Flow Rating:	Up to 100 gpm (380 L/min) for 150 SUS (32 cSt) fluids
Max. Operating Pressure:	6500 psi (450 bar)
Min. Yield Pressure:	19,500 psi (1345 bar), per NFPA T2.6.1
Rated Fatigue Pressure:	5000 psi (345 bar), per NFPA T2.6.1-2005
Temp. Range:	-20°F to 225°F (-29°C to 107°C)
Bypass Setting:	Cracking: 40 psi (2.8 bar) Full Flow: 75 psi (5.2 bar) Non-bypassing model has a blocked bypass.
Porting Base & Cap:	Ductile Iron
Element Case:	Steel
Weight of KC65-1K:	80 lbs. (36.3 kg)
Weight of KC65-2K:	102 lbs. (46.3 kg)
Weight of KC65-3K:	124 lbs. (56.3 kg)
Element Change Clearance:	8.50" (215 mm) for 1K; 17.50" (445 mm) for KK; 26.5" (673 mm) for 27K

## Filter Housing Specifications

Type Fluid	Appropriate Schroeder Media
Petroleum Based Fluids	All E media (cellulose) and Z-Media® (synthetic)
High Water Content	All Z-Media® and ASP® Media (synthetic)
Invert Emulsions	10 and 25 μ Z-Media® (synthetic), 10 μ ASP® Media (synthetic)
Water Glycols	3, 5, 10 and 25 μ Z-Media® (synthetic) and all ASP® Media (synthetic)
Phosphate Esters	All Z-Media® and ASP® Media (synthetic) with H (EPR) seal designation and 3 and 10 μ E media (cellulose) with H (EPR) seal designation
Skydrol®	3, 5, 10 and 25 μ Z-Media® (synthetic) and ASP® Media (synthetic) with H.5 seal designation (EPR seals and stainless steel wire mesh in element, and light oil coating on housing exterior)

## Fluid Compatibility

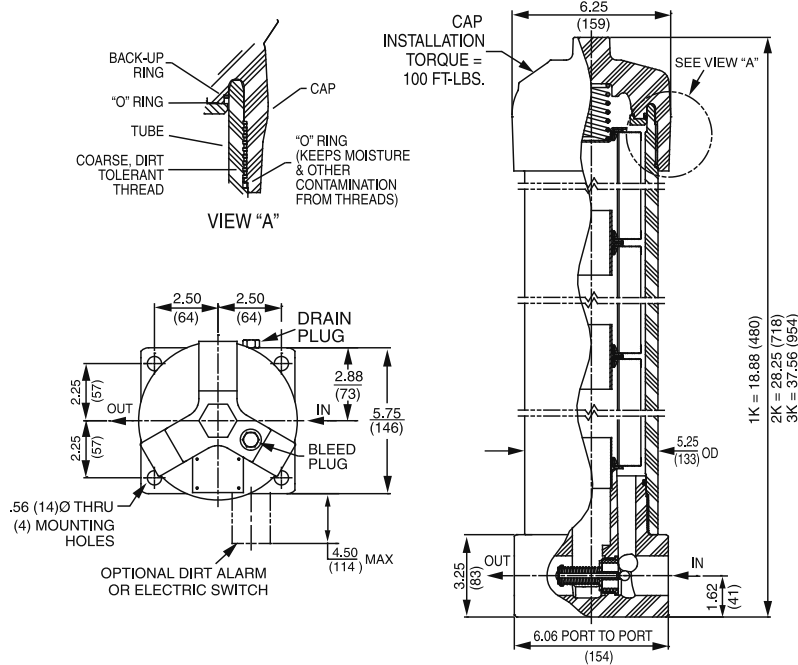

Metric dimensions in ( ).  
 Dimensions shown are inches (millimeters) for general information and overall envelope size only.  
 For complete dimensions please contact Schroeder Industries to request a certified print.

## Element Performance Information & Dirt Holding Capacity

Element	Filtration Ratio Per ISO 4572/ NFPA T3.10.8.8 Using automated particle counter (APC) calibrated per ISO 4402			Filtration Ratio per ISO 16889 Using APC calibrated per ISO 11171	
	$\beta_x \geq 75$	$\beta_x \geq 100$	$\beta_x \geq 200$	$\beta_x(c) \geq 200$	$\beta_x(c) \geq 1000$
KZ1/KKZ1/27KZ1	<1.0	<1.0	<1.0	<4.0	4.2
KZ3/KKZ3/27KZ3	<1.0	<1.0	<2.0	<4.0	4.8
KZ5/KKZ5/27KZ5	2.5	3.0	4.0	4.8	6.3
KZ10/KKZ10/27KZ10	7.4	8.2	10.0	8.0	10.0
KZ25/KKZ25/27KZ25	18.0	20.0	22.5	19.0	24.0
KZW1	N/A	N/A	N/A	<4.0	<4.0
KZW3/KKZW3	N/A	N/A	N/A	4.0	4.8
KZW5/KKZW5	N/A	N/A	N/A	5.1	6.4
KZW10/KKZW10	N/A	N/A	N/A	6.9	8.6
KZW25/KKZW25	N/A	N/A	N/A	15.4	18.5
KZX3/KKZX3/27KZX3	<1.0	<1.0	<2.0	4.7	5.8
KZX10/KKZX10/27KZX10	7.4	8.2	10.0	8.0	9.8

Element	DHC (gm)	Element	DHC (gm)	Element	DHC (gm)	Element	DHC (gm)	Element	DHC (gm)
KZ1	112	KKZ1	224	27KZ1	336	KZW1	61		
KZ3	115	KKZ3	230	27KZ3	345	KZW3	64	KKZW3	128
KZ5	119	KKZ5	238	27KZ5	357	KZW5	63	KKZW5	126
KZ10	108	KKZ10	216	27KZ10	324	KZW10	57	KKZW10	114
KZ25	93	KKZ25	186	27KZ25	279	KZW25	79	KKZW25	158
KZX3	81*	KKZX3	163*	27KZX3	249*				
KZX10	90*	KKZX10	182*	27KZX10	279*				

\* Based on 100 psi terminal pressure

Element Collapse Rating: 150 psid (10 bar) for standard elements  
 3000 psid (210 bar) for high collapse (ZX) versions

Flow Direction: Outside In

Element Nominal Dimensions: K: 3.9" (99 mm) O.D. x 9.0" (230 mm) long  
 KK: 3.9" (99 mm) O.D. x 18.0" (460 mm) long  
 27K: 3.9" (99 mm) O.D. x 27.0" (690 mm) long

$\Delta P_{\text{housing}}$

KC65  $\Delta P_{\text{housing}}$  for fluids with sp gr (specific gravity) = 0.86:

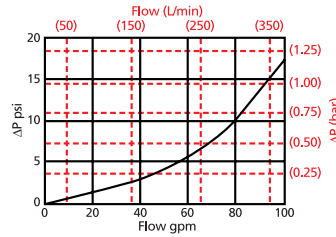

$\Delta P_{\text{element}}$

KZ/KGZ

Element Pressure Drop versus Flow Rate at 32 cSt (150 SUS)

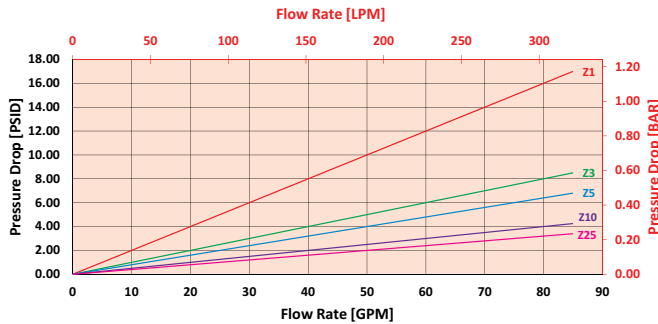

2KZ/KKZ

Element Pressure Drop versus Flow Rate at 32 cSt (150 SUS)

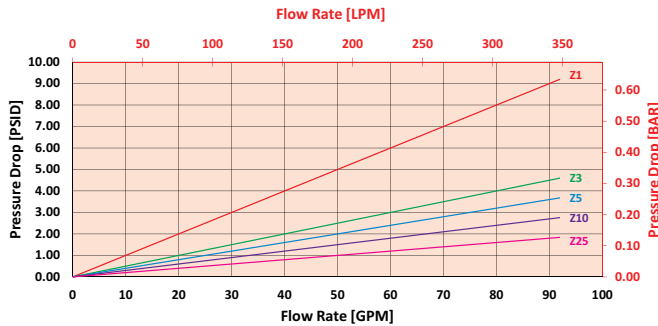

$$\Delta P_{\text{filter}} = \Delta P_{\text{housing}} + (\Delta P_{\text{element}} * V_f)$$

### Exercise:

Determine  $\Delta P_{\text{filter}}$  at 50 gpm (189.5 L/min) for KC651KZ10FD9 using 160 SUS (34 cSt) fluid.

Use the housing pressure curve to determine  $\Delta P_{\text{housing}}$  at 50 gpm. In this case,  $\Delta P_{\text{housing}}$  is 4 psi (.27 bar) on the graph for the KC65 housing.

Use the element pressure curve to determine  $\Delta P_{\text{element}}$  at 50 gpm. In this case,  $\Delta P_{\text{element}}$  is 2.5 psi (.17 bar) according to the graph for the KZ10 element.

Because the viscosity in this sample is 160 SUS (34 cSt), we determine the **Viscosity Factor ( $V_f$ )** by dividing the **Operating Fluid Viscosity** with the **Standard Viscosity** of 150 SUS (32 cSt). To best determine your Operating Fluid Viscosity, please reference the chart in Appendix D.

Finally, the overall filter pressure differential,  $\Delta P_{\text{filter}}$ , is calculated by adding  $\Delta P_{\text{housing}}$  with the true element pressure differential, ( $\Delta P_{\text{element}} * V_f$ ). The  $\Delta P_{\text{element}}$  from the graph has to be multiplied by the viscosity factor to get the true pressure differential across the element.

### Solution:

$$\Delta P_{\text{housing}} = 4 \text{ psi } [.27 \text{ bar}] \quad | \quad \Delta P_{\text{element}} = 2.5 \text{ psi } [.17 \text{ bar}]$$

$$V_f = 160 \text{ SUS } (34 \text{ cSt}) / 150 \text{ SUS } (32 \text{ cSt}) = 1.1$$

$$\Delta P_{\text{filter}} = 4 \text{ psi } + (2.5 \text{ psi } * 1.1) = 6.8 \text{ psi}$$

OR

$$\Delta P_{\text{filter}} = .27 \text{ bar } + (.17 \text{ bar } * 1.1) = .46 \text{ bar}$$

## Pressure Drop Information Based on Flow Rate and Viscosity

Note:

If your element is not graphed, use the following equation:

$\Delta P_{\text{element}} = \text{Flow Rate} \times \Delta P_f$  Plug this variable into the overall pressure drop equation.

Ele.	$\Delta P$	Ele.	$\Delta P$	Ele.	$\Delta P$
K3	0.25	2K3/ KK3	0.12	3KZ1/ 27KZ1	0.05
K10	0.09	2K10/ KK10	0.05	3KZ3/ 27KZ3	0.03
K25	0.02	2K25/ KK25	0.01	3KZ5/ 27KZ5	0.02
KAS3	0.10	2KAS3/ KAS3	0.05	3KZ10/ 27KZ10	0.02
KAS5	0.08	2KAS5/ KAS5	0.04	3KZ25/ 27KZ25	0.01
KAS10	0.05	2KAS10/ KAS10	0.03	3K3	0.08
KZX10	0.22	2KZX10/ KKZX10	0.11	3K10	0.03
KZW1	0.43	2KZW1	-	3K25	0.01
KZW3	0.32	2KZW3/ KKZX3	0.16	3KAS3/ 27KAS3	0.03
KZW5	0.28	2KZW5/ KKZX5	0.14	3KAS5/ 27KAS5	0.02
KZW10	0.23	2KZW10/ KKZX10	0.12	3KAS10/ 27KAS10	0.02
KZW25	0.14	2KZW25/ KKZX25	0.07	3KZX10/ 27KZX10	0.07

## Filter Model Number Selection

### How to Build a Valid Model Number for a Schroeder KC65:

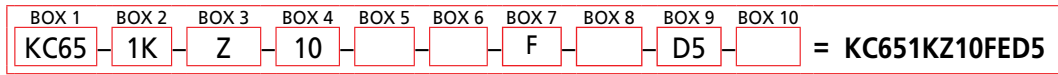
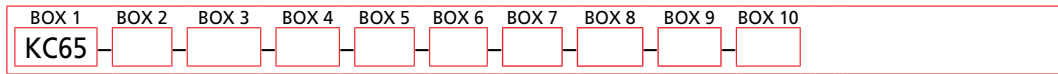

BOX 1	BOX 2	BOX 3
<b>Filter Series</b>	<b>Number &amp; Size of Elements</b>	<b>Media Type</b>
KC65	1 K, KK, 27K	Omit = E Media (Cellulose)
KCN65 (Non-bypassing: requires ZX high collapse elements)	2 K	AS = Anti-Stat Media (synthetic)
GKC65 (GeoSeal®)	<b>GeoSeal® Options</b>	Z = Excellement® Z-Media® (synthetic)
	1 KG, KKG, 27KG	ZX = Excellement® Z-Media® (High Collapse centertube) (KCN65 Only)
	2 KG	ZW = Aqua-Excellement ZW Media (KC65 Only)
	3 KG	W = W Media (water removal)
		M = Media (reusable metal mesh) (KC65 & KCN65 Only)

#### NOTES:

**Box 2.** Number of elements must equal 1 when using KK or 27K elements. Replacement element part numbers are identical to contents of Boxes 2, 3, 4 and 5. Double and triple stacking of K-size elements can be replaced by single KK and 27K elements, respectively. ZW media not available in 27K length. For standard elements, a plastic connector SAP P/N: 7630900 (LF-1997) is used to connect two or three K elements. For high collapse, a steel connector is required SAP P/N: 7608360 (LF-3255C).

**Box 5.** H.5 seal designation includes the following: EPR seals, stainless steel wire mesh on elements, and light oil coating on housing exterior. Viton® is a registered trademark of DuPont Dow Elastomers. Skydrol® is a registered trademark of Solutia Inc.

**Box 7.** For option F, bolt depth 1.12" (30 mm).

**Box 8.** X and 50 options are not available with KCN65.

**Box 9.** Standard indicator setting for non-bypassing model is 50 psi unless otherwise specified.

**Box 10.** Option N is not available with KCN65. N option should be used in conjunction with dirt alarm.

BOX 4	BOX 5	BOX 6	BOX 7
<b>Micron Rating</b>	<b>Seal Material</b>	<b>Magnet Option</b>	<b>Porting</b>
1 = 1 Micron (Z, ZW, ZX media)	Omit = Buna N	Omit = None	F = 1 1/2" SAE 4-bolt flange Code 6Z
3 = 3 Micron (AS, E, Z, ZW, ZX media)	V = Viton®	M = Magnet inserts (not available w/ indicator in cap)	
5 = 5 Micron (AS, Z, ZW, ZX media)	H = EPR		
10 = 10 Micron (AS, E, M, Z, ZW, ZX media)	H.5 = Skydrol® compatibility		
25 = 25 Micron (E, M, Z, ZW, ZX media)			
60 = 60 Micron (M media)			
150 = 150 Micron (M media)			
260 = 260 Micron (M media)			

BOX 8	BOX 9	BOX 10
<b>Options</b>	<b>Dirt Alarm® Options</b>	<b>Additional Options</b>
Omit = None	None Omit = None	Omit = None
X = Blocked bypass	Visual D9 = All stainless D5	N = No-Element Indicator (not available w/ KFN65 or housings w/ indicator in cap)
50 = 50 psi bypass setting	MS55S = Electrical w/ 12 in. 18 gauge 4-conductor cable	G509 = Dirt Alarm and drain opposite standard
L = Two 1/4" NPTF inlet & outlet female test ports	MS55SLC = Low current MS5	
U = Series 1215 7/16 UNF Schroeder Check Test Point installed in cap (upstream)	MS10SS = Electrical w/ DIN connector (male end only)	
UU = Series 1215 7/16 UNF Schroeder Check Test Point installed in block (upstream and downstream)	MS10SSLC = Low current MS10	
	MS11SS = Electrical w/ 12 ft. 4-conductor wire	
	MS12SS = Electrical w/ 5 pin Brad Harrison connector (male end only)	
	MS12SSLC = Low current MS12	
	MS16SS = Electrical w/ weather-packed sealed connector	
	MS16SSLC = Low current MS16	
	MS17SSLC = Electrical w/ 4 pin Brad Harrison male connector	
	MS5T = MS5 (see above) w/ thermal lockout	
	MS5LCT = Low current MS5T	
	MS10T = MS10 (see above) w/ thermal lockout	
	MS10LCT = Low current MS10T	
	MS12T = MS12 (see above) w/ thermal lockout	
	MS12LCT = Low current MS12T	
	MS16T = MS16 (see above) w/ thermal lockout	
	MS16LCT = Low current MS16T	
	MS17LCT = Low current MS17T	
	MS = Cam operated switch w/ 1/2" conduit female connection	
	MS13DC = Supplied w/ threaded connector & light	
	MS14DC = Supplied w/ 5 pin Brad Harrison connector & light (male end)	
	MS13DCT = MS13 (see above), direct current, w/ thermal lockout	
	MS13DCLCT = Low current MS13DCT	
	MS14DCT = MS14 (see above), direct current, w/ thermal lockout	
	MS14DCLCT = Low current MS14DCT	

# Base-Ported Pressure Filter

# MKC65

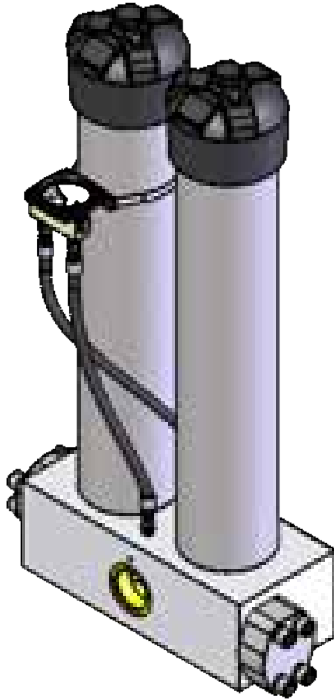

## Features and Benefits

- Base-ported high pressure dual filter manifold mounted
- Meets HF4 automotive standard
- Element changeout from top minimizes oil spillage
- Offered in pipe porting (contact factory for other porting options)
- No-Element indicator option available
- Available with non-bypass option with high collapse element
- Integral inlet and outlet female test points option available
- Double and triple stacking of K-size elements can be replaced by single KK or 27K-size elements

**200 gpm** NF30  
**760 L/min** NFS30  
**300 gpm\*** YF30  
**1,136 L/min\*** CFX30  
**6000 psi** PLD  
**413 bar** CF40

DF40

PF40

RFS50

RF60

CF60

CTF60

VF60

LW60

KF30

KF50

TF50

KC50

MKF50

MKC50

KC65

**MKC65**

HS60

MHS60

KFH50

LC60

LC35

LC50

## Filter Housing Specifications

Flow Rating:	Up to 200 gpm (760 L/min) for 150 SUS (32 cSt) fluids Up to 300 gpm (1,136 L/min) for Water/Oil Emulsions
Max. Operating Pressure:	6000 psi (413 bar)
Min. Yield Pressure:	18,000 psi (1240 bar), per NFPA T2.6.1
Rated Fatigue Pressure:	4500 psi (310 bar), per NFPA T2.6.1-2005
Temp. Range:	-20°F to 225°F (-29°C to 107°C)
Bypass Setting:	Cracking: 40 psi (2.8 bar) Optional Cracking: 50 psi (3.5 bar) Full Flow: 61 psi (4.2 bar) Non-bypassing model has a blocked bypass.
Porting Base & Cap:	Ductile Iron
Element Case:	Steel
Weight of MKC65-2K:	216.0 lbs. (98.0 kg)
Weight of MKC65-4K:	245.0 lbs. (111.1 kg)
Weight of MKC65-6K:	286.4 lbs. (129.9 kg)
Element Change Clearance:	8.50" (215 mm) for 1K; 17.50" (445 mm) for KK; 26.5" (673 mm) for 27K

## Fluid Compatibility

Type Fluid	Appropriate Schroeder Media
Petroleum Based Fluids	All E-Media (cellulose) and Z-Media® and ASP® Media (synthetic)
High Water Content	All Z-Media® and ASP® Media (synthetic)
Invert Emulsions	10 and 25 µ Z-Media® (synthetic), 10 µ ASP® Media (synthetic)
Water Glycols	3, 5, 10 and 25 µ Z-Media® (synthetic), and all ASP® Media
Phosphate Esters	All Z-Media® and ASP® Media (synthetic) with H (EPR) seal designation and 3 and 10 µ E media (cellulose) with H (EPR) seal designation
Skydrol®	3, 5, 10 and 25 µ Z-Media® (synthetic), and all ASP® Media (synthetic) with H.5 seal designation (EPR seals and stainless steel wire mesh in element, and light oil coating on housing exterior)

NOF30-05

NOF-50-760

FOF60-03

NMF30

RMF60

14-CRZX10

20-CRZX10

Model No. of filter in photograph is MKC654K10BD5.

\*Rated for Water/Oil Emulsions



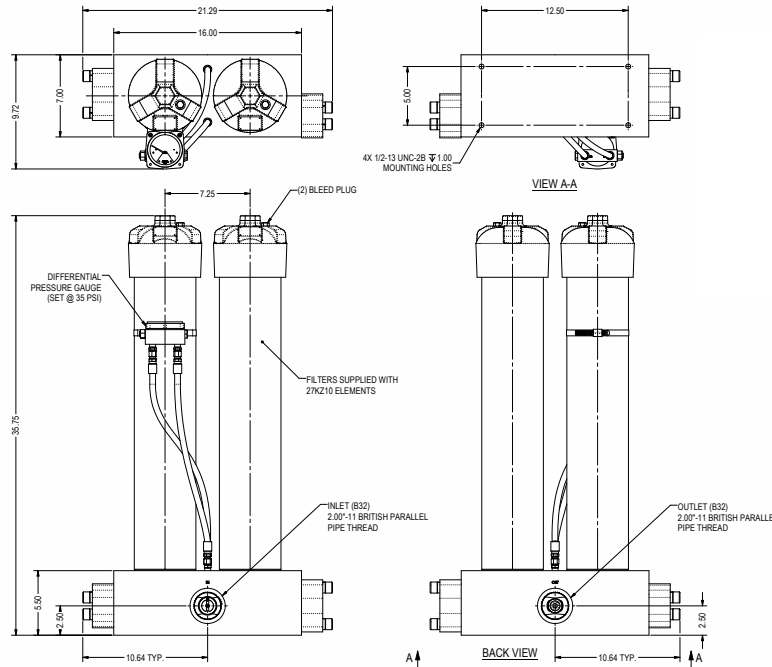

Metric dimensions in ( ).  
 Dimensions shown are inches (millimeters) for general information and overall envelope size only.  
 For complete dimensions please contact Schroeder Industries to request a certified print.

## Element Performance Information & Dirt Holding Capacity

Element	Filtration Ratio Per ISO 4572/NFPA T3.10.8.8 Using automated particle counter (APC) calibrated per ISO 4402			Filtration Ratio per ISO 16889 Using APC calibrated per ISO 11171	
	$\beta_x \geq 75$	$\beta_x \geq 100$	$\beta_x \geq 200$	$\beta_x(c) \geq 200$	$\beta_x(c) \geq 1000$
KZ1/KKZ1/27KZ1	<1.0	<1.0	<1.0	<4.0	4.2
KZ3/KKZ3/27KZ3	<1.0	<1.0	<2.0	<4.0	4.8
KZ5/KKZ5/27KZ5	2.5	3.0	4.0	4.8	6.3
KZ10/KKZ10/27KZ10	7.4	8.2	10.0	8.0	10.0
KZ25/KKZ25/27KZ25	18.0	20.0	22.5	19.0	24.0
KZW1	N/A	N/A	N/A	<4.0	<4.0
KZW3/KKZW3	N/A	N/A	N/A	4.0	4.8
KZW5/KKZW5	N/A	N/A	N/A	5.1	6.4
KZW10/KKZW10	N/A	N/A	N/A	6.9	8.6
KZW25/KKZW25	N/A	N/A	N/A	15.4	18.5
KZX3/KKZX3/27KZX3	<1.0	<1.0	<2.0	4.7	5.8
KZX10/KKZX10/27KZX10	7.4	8.2	10.0	8.0	9.8

Element	DHC (gm)	Element	DHC (gm)	Element	DHC (gm)	Element	DHC (gm)	Element	DHC (gm)
KZ1	112	KKZ1	224	27KZ1	336	KZW1	61		
KZ3	115	KKZ3	230	27KZ3	345	KZW3	64	KKZW3	128
KZ5	119	KKZ5	238	27KZ5	357	KZW5	63	KKZW5	126
KZ10	108	KKZ10	216	27KZ10	324	KZW10	57	KKZW10	114
KZ25	93	KKZ25	186	27KZ25	279	KZW25	79	KKZW25	158
KZX3	81*	KKZX3	163*	27KZX3	249*				
KZX10	90*	KKZX10	182*	27KZX10	279*				

\* Based on 100 psi terminal pressure

Element Collapse Rating: 150 psid (10 bar) for standard elements  
 3000 psid (210 bar) for high collapse (ZX) versions

Flow Direction: Outside In

Element Nominal Dimensions: K: 3.9" (99 mm) O.D. x 9.0" (230 mm) long  
 KK: 3.9" (99 mm) O.D. x 18.0" (460 mm) long  
 27K: 3.9" (99 mm) O.D. x 27.0" (690 mm) long



## $\Delta P_{\text{housing}}$

MKC65  $\Delta P_{\text{housing}}$  for fluids with sp gr (specific gravity) = 0.86:

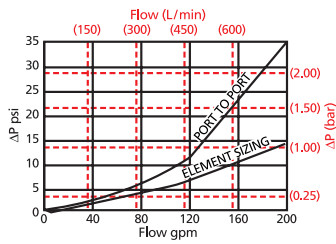

## 98-2 Water/Oil Emulsion A 40C

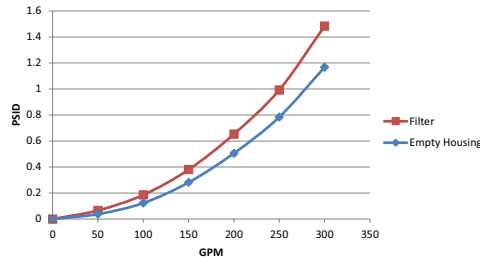

## $\Delta P_{\text{element}}$

4KZ/2KZ Element Pressure Drop versus Flow Rate at 32 cSt (150 SUS)

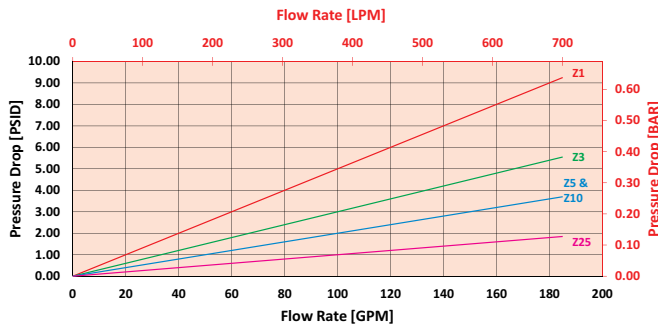

6KZ/2-27KZ Element Pressure Drop versus Flow Rate at 32 cSt (150 SUS)

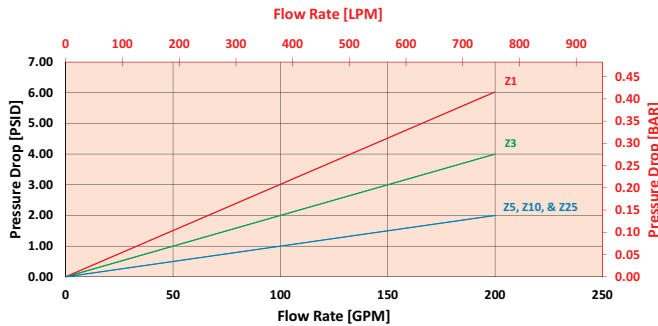

$$\Delta P_{\text{filter}} = \Delta P_{\text{housing}} + (\Delta P_{\text{element}} * V_f)$$

### Exercise:

Determine  $\Delta P_{\text{filter}}$  at 100 gpm (379 L/min) for MKC654KZ10PD5 using 160 SUS (34 cSt) fluid.

Use the housing pressure curve to determine  $\Delta P_{\text{housing}}$  at 100 gpm. In this case,  $\Delta P_{\text{housing}}$  is 8 psi (.55 bar) on the graph for the MKC65 housing.

Use the element pressure curve to determine  $\Delta P_{\text{element}}$  at 100 gpm. In this case,  $\Delta P_{\text{element}}$  is 2 psi (.14 bar) according to the graph for the KZ10 element.

Because the viscosity in this sample is 160 SUS (34 cSt), we determine the **Viscosity Factor ( $V_f$ )** by dividing the **Operating Fluid Viscosity** with the **Standard Viscosity** of 150 SUS (32 cSt). To best determine your Operating Fluid Viscosity, please reference the chart in Appendix D.

Finally, the overall filter pressure differential,  $\Delta P_{\text{filter}}$ , is calculated by adding  $\Delta P_{\text{housing}}$  with the true element pressure differential,  $(\Delta P_{\text{element}} * V_f)$ . The  $\Delta P_{\text{element}}$  from the graph has to be multiplied by the viscosity factor to get the true pressure differential across the element.

### Solution:

$$\Delta P_{\text{housing}} = 8 \text{ psi } [.55 \text{ bar}] \quad | \quad \Delta P_{\text{element}} = 2 \text{ psi } [.14 \text{ bar}]$$

$$V_f = 160 \text{ SUS } (34 \text{ cSt}) / 150 \text{ SUS } (32 \text{ cSt}) = 1.1$$

$$\Delta P_{\text{filter}} = 8 \text{ psi } + (2 \text{ psi } * 1.1) = 10.2 \text{ psi}$$

OR

$$\Delta P_{\text{filter}} = .55 \text{ bar } + (.14 \text{ bar } * 1.1) = .70 \text{ bar}$$

## Pressure Drop Information Based on Flow Rate and Viscosity

Note:

If your element is not graphed, use the following equation:  
 $\Delta P_{\text{element}} = \text{Flow Rate} \times \Delta P_f$  Plug this variable into the overall pressure drop equation.

Ele.	$\Delta P$	Ele.	$\Delta P$	Ele.	$\Delta P$
2KZ1	0.10	2K3	0.12	4K3/ KK3	0.06
2KZ3	0.05	2K10	0.05	4K10/ KK10	0.02
2KZ5	0.04	2K25	0.01	4K25/ KK25	0.01
2KZ10	0.03	2KAS3	0.05	4KAS3/ KKAS3	0.03
2KZ25	0.02	2KAS5	0.04	4KAS5/ KKAS5	0.02
KZW1	0.43	2KAS10	0.03	4KAS10/ KKAS10	0.02
KZW3	0.32	2KZX10	0.11	4KZX10	0.06
KZX5	0.28	2KZW3	0.16	6KAS3/ 27KAS3	0.02
KZW10	0.23	2KZW5	0.14	6KAS5/ 27KAS5	0.01
KZW25	0.14	2KZW10	0.12	6KAS10/ 27KAS10	0.01
		2KZW25	0.07	6KZX10	0.04

## Filter Model Number Selection

### How to Build a Valid Model Number for a Schroeder MKC65:

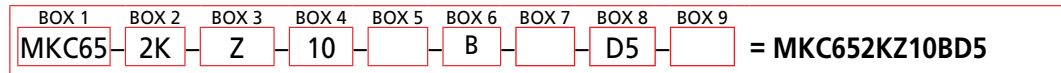
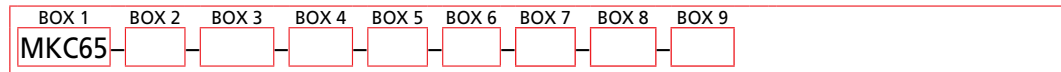

BOX 1	BOX 2	BOX 3
<b>Filter Series</b>	<b>Number &amp; Size of Elements</b>	<b>Media Type</b>
MKC65	2 K, KK, 27K 4 K 6 K <b>GeoSeal® Options</b> 2 KG, KKG, 27KG 4 KG 6 KG	Omit = E Media (Cellulose) AS = Anti-Stat Media (synthetic) Z = Excellement® Z-Media® (synthetic) ZX = Excellement® Z-Media® (High Collapse centertube) ZW = Aqua-Excellement ZW Media W = W Media (water removal) M = Media (reusable metal mesh)

BOX 4	BOX 5	BOX 6	BOX 7
<b>Micron Rating</b>	<b>Seal Material</b>	<b>Porting Option</b>	<b>Porting</b>
1 = 1 Micron (DZ, Z, ZW, ZX media) 3 = 3 Micron (AS, DZ, E, Z, ZW, ZX media) 5 = 5 Micron (AS, DZ, Z, ZW, ZX media) 10 = 10 Micron (AS, DZ, E, M, Z, ZW, ZX media) 25 = 25 Micron (E, DZ, M, Z, ZW, ZX media) 60 = 60 Micron (M media) 150 = 150 Micron (M media) 260 = 260 Micron (M media)	Omit = Buna N V = Viton® H = EPR H.5 = Skydrol® compatibility	B = 2" BSPP	Omit = None X = Blocked bypass 50 = EPR = Two ¼" NPTF inlet and outlet female test ports L = Series 1215 ⅜ UNF Schroeder Check Test Point installed in cap (upstream)

BOX 8	
Dirt Alarm® Options	
None	Omit = None
Visual	D = Pointer
	D5 = Visual pop-up
	D5C = D5 in cap
Visual with Thermal Lockout	D9 = All stainless D5
	DPG = Differential pressure gauge
	D8 = Visual w/ thermal lockout
Electrical	D8C = D8 in cap
	MS5 = Electrical w/ 12 in. 18 gauge 4-conductor cable
	MS5LC = Low current MS5
	MS10 = Electrical w/ DIN connector (male end only)
	MS10LC = Low current MS10
	MS11 = Electrical w/ 12 ft. 4-conductor wire
	MS12 = Electrical w/ 5 pin Brad Harrison connector (male end only)
	MS12LC = Low current MS12
	MS16 = Electrical w/ weather-packed sealed connector
	MS16LC = Low current MS16
Electrical with Thermal Lockout	MS17LC = Electrical w/ 4 pin Brad Harrison male connector
	MS5T = MS5 (see above) w/ thermal lockout
	MS5LCT = Low current MS5T
	MS10T = MS10 (see above) w/ thermal lockout
	MS10LCT = Low current MS10T
	MS12T = MS12 (see above) w/ thermal lockout
	MS12LCT = Low current MS12T
	MS16T = MS16 (see above) w/ thermal lockout
	MS16LCT = Low current MS16T
	MS17LCT = Low current MS17T
Electrical Visual	MS = Cam operated switch w/ ½" conduit female connection
	MS13 = Supplied w/ threaded connector & light
	MS14 = Supplied w/ 5 pin Brad Harrison connector & light (male end)
Electrical Visual with Thermal Lockout	MS13DCT = MS13 (see above), direct current, w/ thermal lockout
	MS13DCLCT = Low current MS13DCT
Electrical Visual with Thermal Lockout	MS14DCT = MS14 (see above), direct current, w/ thermal lockout
	MS14DCLCT = Low current MS14DCT

BOX 9
Additional Options
Omit = None
N = No-Element Indicator

#### NOTES:

- Box 2.** Number of elements must equal 2 when using KK or 27K elements. Replacement element part numbers are identical to contents of Boxes 2, 3, 4 and 5. Double and triple stacking of K-size elements can be replaced by single KK and 27K elements, respectively. ZW media not available in 27K length. For standard elements, a plastic connector SAP P/N: 7630900 (LF-1997) is used to connect two or three K elements. For high collapse, a steel connector is required SAP P/N: 7608360 (LF-3255C).
- Box 5.** H.5 seal designation includes the following: EPR seals, stainless steel wire mesh on elements, and light oil coating on housing exterior. Viton® is a registered trademark of DuPont Dow Elastomers. Skydrol® is a registered trademark of Solutia Inc.
- Box 8.** Standard indicator setting for non-bypassing model is 50 psi unless otherwise specified.
- Box 9.** N option should be used in conjunction with dirt alarm.

# Top-Ported Pressure Filter

**HS60/  
MHS60**



## Features and Benefits

- Full flow reverse flow check valve diverts flow past the element in hydrostatic applications
- Top-ported design capable of handling 100 gpm flow
- Offered in SAE straight thread and flange porting
- Thread on bowl with drain plug for easy element service
- 6000 psi cyclic
- Certified for Offshore Standard DNVGL-OS-D101 "Marine and Machinery Systems and Equipment"
- Contact factory for higher flow applications

**120 gpm**  
**450 L/min**  
**6000 psi**  
**415 bar**

NF30  
NFS30  
YF30  
CFX30  
PLD  
CF40  
DF40  
PF40  
RFS50  
RF60  
CF60  
CTF60  
VF60  
LW60  
KF30  
KF50  
TF50  
KC50  
MKF50  
MKC50  
KC65  
MKC65  
**HS60**  
**MHS60**  
KFH50  
LC60  
LC35  
LC50  
NOF30-05  
NOF-50-760  
FOF60-03  
NMF30  
RMF60  
14-CRZX10  
20-CRZX10

Model No. of filters in photograph are HS6013HZ3F24 and MHS6013HZ3F24.

Flow Rating:	Up to 100 gpm (380 L/min)
Max. Operating Pressure:	6000 psi (415 bar) only for flange ported models
Min. Yield Pressure:	Contact factory
Rated Fatigue Pressure:	6000 psi (415 bar) (only with 4-bolt flange porting)
Temp. Range:	-20°F to 225°F (-29°C to 107°C)
Bypass Setting:	Cracking: 87 psi (5.9 bar)
Porting Head:	Ductile Iron
Element Case:	Steel
Weight of HS60-13H:	75 lbs. (34.2 kg)
Weight of MHS60:	160 lbs. (72.6 kg)
Element Change Clearance:	4.0" (103 mm)

## Filter Housing Specifications

Type Fluid	Appropriate Schroeder Media
High Water Content	All Z-Media® (synthetic)
Invert Emulsions	10 and 25 µ Z-Media® (synthetic)
Water Glycols	3, 5, 10 and 25 µ Z-Media® (synthetic)
Phosphate Esters	All Z-Media® (synthetic) with H (EPR) seal designation

## Fluid Compatibility

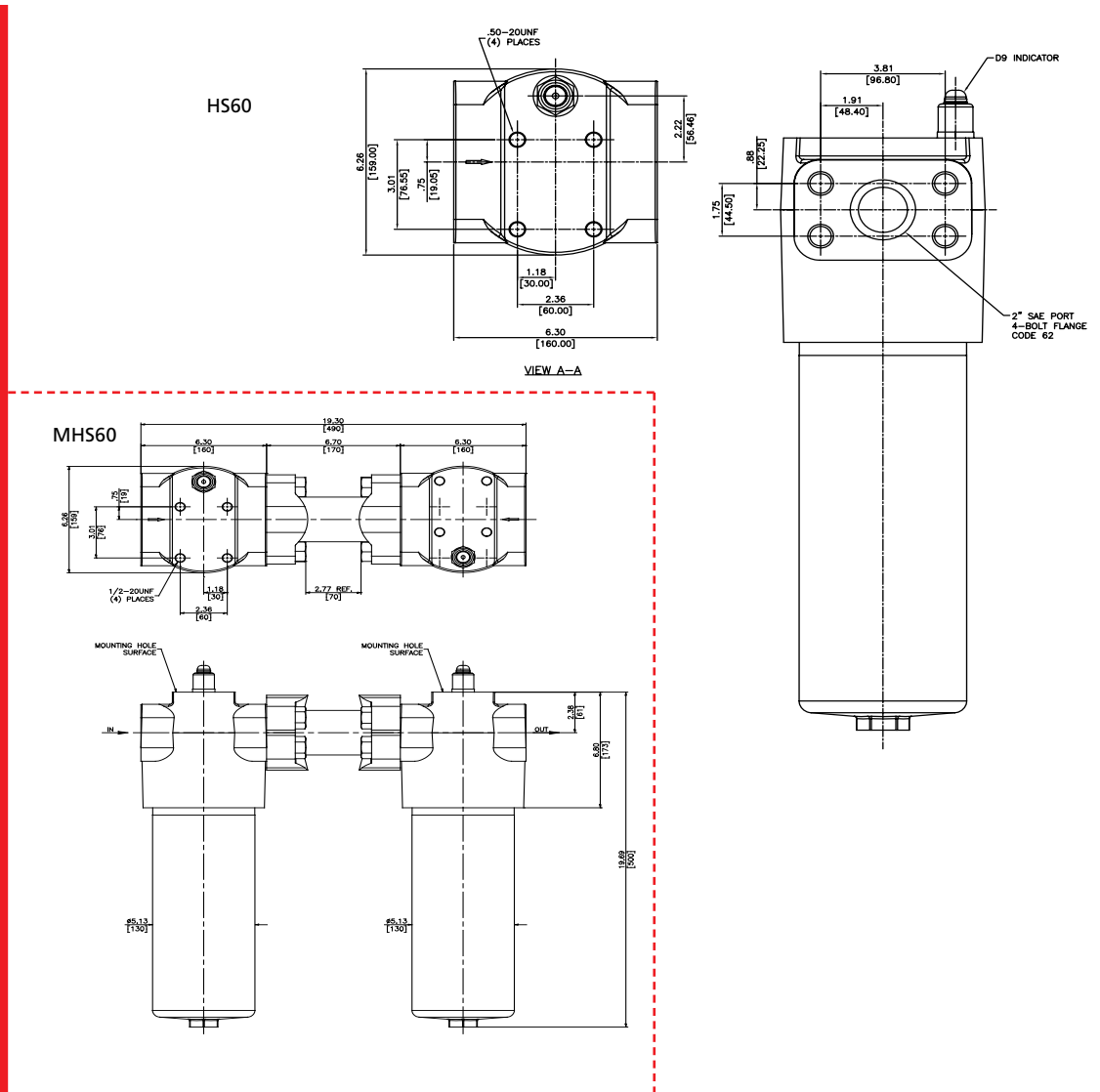

Metric dimensions in ( ).  
 Dimensions shown are inches (millimeters) for general information and overall envelope size only.  
 For complete dimensions please contact Schroeder Industries to request a certified print.

### Element Performance Information & Dirt Holding Capacity

Element	Filtration Ratio Per ISO 4572/NFPA T3.10.8.8 Using automated particle counter (APC) calibrated per ISO 4402			Filtration Ratio per ISO 16889 Using APC calibrated per ISO 11171	
	$\beta_x \geq 75$	$\beta_x \geq 100$	$\beta_x \geq 200$	$\beta_{x(c)} \geq 200$	$\beta_{x(c)} \geq 1000$
13HZ3/13HZX3	<1.0	<1.0	<2.0	<4.0	4.8
13HZ5/13HZX5	2.5	3.0	4.0	4.8	6.3
13HZ10/13HZX10	7.4	8.2	10.0	8.0	10.0
13HZ25/13HZX25	18.0	20.0	22.5	19.0	24.0

Element	DHC (gm)	Element	DHC (gm)
13HZ3	100.7	13HZX3	75.7
13HZ5	113.2	13HZX5	74.1
13HZ10	119.7	13HZX10	81.4
13HZ25	123.5	13HZX25	92.9

Element Collapse Rating: 290 psi (20 bar) for standard elements  
 3045 psi (210 bar) for high collapse (ZX) versions

Flow Direction: Outside In

Element Nominal Dimensions: 13HZ : 3.5" (90 mm) O.D. x 13" (325 mm) long

# Top-Ported Pressure Filter

## HS60/ MHS60

$\Delta P_{\text{housing}}$

HS60/MHS60  $\Delta P_{\text{housing}}$  for fluids with sp gr (specific gravity) = 0.86:

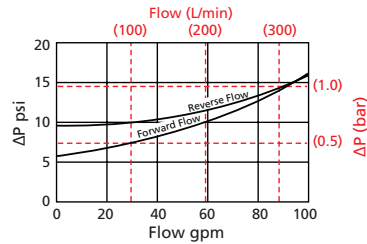

$\Delta P_{\text{element}}$

13HZ

Element Pressure Drop versus Flow Rate at 32 cSt (150 SUS)

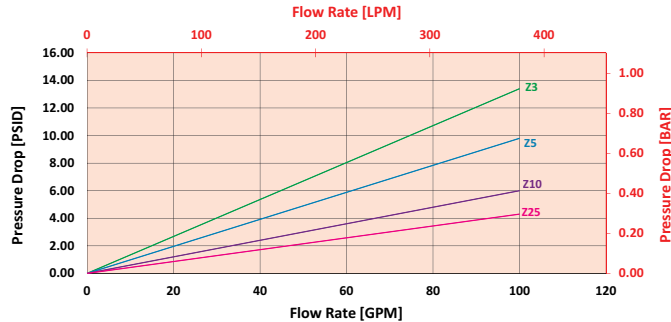

Pressure  
Drop  
Information  
Based on  
Flow Rate  
and Viscosity

$$\Delta P_{\text{filter}} = \Delta P_{\text{housing}} + (\Delta P_{\text{element}} * V_f)$$

### Exercise:

Determine  $\Delta P_{\text{filter}}$  at 30 gpm (113.7 L/min) for HS6013HZ10S24D13 using 160 SUS (34 cSt) fluid.

Use the housing pressure curve to determine  $\Delta P_{\text{housing}}$  at 30 gpm. In this case,  $\Delta P_{\text{housing}}$  is 7 psi (.48 bar) on the graph for the HS60 housing.

Use the element pressure curve to determine  $\Delta P_{\text{element}}$  at 30 gpm. In this case,  $\Delta P_{\text{element}}$  is 2 psi (.14 bar) according to the graph for the 13HZ10 element.

Because the viscosity in this sample is 160 SUS (34 cSt), we determine the **Viscosity Factor ( $V_f$ )** by dividing the **Operating Fluid Viscosity** with the **Standard Viscosity** of 150 SUS (32 cSt). To best determine your Operating Fluid Viscosity, please reference the chart in Appendix D.

Finally, the overall filter pressure differential,  $\Delta P_{\text{filter}}$ , is calculated by adding  $\Delta P_{\text{housing}}$  with the true element pressure differential, ( $\Delta P_{\text{element}} * V_f$ ). The  $\Delta P_{\text{element}}$  from the graph has to be multiplied by the viscosity factor to get the true pressure differential across the element.

### Solution:

$$\Delta P_{\text{housing}} = 7 \text{ psi } [.48 \text{ bar}] \quad | \quad \Delta P_{\text{element}} = 2 \text{ psi } [.14 \text{ bar}]$$

$$V_f = 160 \text{ SUS } (34 \text{ cSt}) / 150 \text{ SUS } (32 \text{ cSt}) = 1.1$$

$$\Delta P_{\text{filter}} = 7 \text{ psi } + (2 \text{ psi } * 1.1) = 9.2 \text{ psi}$$

OR

$$\Delta P_{\text{filter}} = .48 \text{ bar } + (.14 \text{ bar } * 1.1) = .63 \text{ bar}$$

Note:

If your element is not graphed, use the following equation:

$\Delta P_{\text{element}} = \text{Flow Rate} \times \Delta P_f$ . Plug this variable into the overall pressure drop equation.

Ele.	$\Delta P$
13HZX3	0.176
13HZX5	0.104
13HZX10	0.054
13HZX25	0.048

## Filter Model Number Selection

### How to Build a Valid Model Number for a Schroeder HS60:

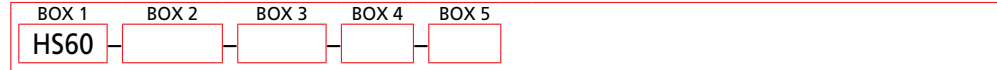

Example: NOTE: One option per box

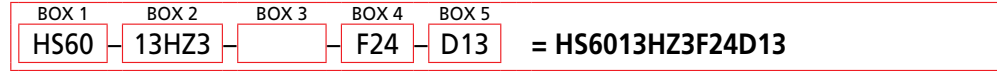

BOX 1	BOX 2	BOX 3
<b>Filter Series</b>  <b>HS60</b>  <b>HSN60</b> <small>(Non-bypassing: requires ZX high collapse elements)</small>  <b>MHS60</b>  <b>MHSN60</b> <small>(Non-bypassing: requires ZX high collapse elements)</small>	<b>Element Part Number</b>  13HZ3 = 3 µm Excellement® Z-Media® (synthetic) 13HZ5 = 5 µm Excellement® Z-Media® (synthetic) 13HZ10 = 10 µm Excellement® Z-Media® (synthetic) 13HZ25 = 25 µm Excellement® Z-Media® (synthetic) 13HZX3 = 3 µm Excellement® Z-Media® (high collapse center tube) 13HZX5 = 5 µm Excellement® Z-Media® (high collapse center tube) 13HZX10 = 10 µm Excellement® Z-Media® (high collapse center tube) 13HZX25 = 25 µm Excellement® Z-Media® (high collapse center tube)	<b>Seal Material</b>  Omit = Buna N V = Viton® H = EPR

BOX 4	BOX 5																													
<b>Porting Options</b>  S24 = SAE-24  F24 = 1½" SAE 4-bolt flange Code 62  F32 = 2" SAE 4-bolt flange Code 62	<b>Dirt Alarm® Options</b>																													
	<table border="1"> <tr> <td>None</td> <td>Omit = None</td> </tr> <tr> <td>Visual</td> <td>D13 = Visual pop-up</td> </tr> </table>	None	Omit = None	Visual	D13 = Visual pop-up																									
None	Omit = None																													
Visual	D13 = Visual pop-up																													
	<table border="1"> <tr> <td rowspan="10">Electrical</td> <td>MS5SS = Electrical w/ 12 in. 18 gauge 4-conductor cable</td> </tr> <tr> <td>MS5SSLC = Low current MS5</td> </tr> <tr> <td>MS10SS = Electrical w/ DIN connector (male end only)</td> </tr> <tr> <td>MS10SSLC = Low current MS10</td> </tr> <tr> <td>MS11SS = Electrical w/ 12 ft. 4-conductor wire</td> </tr> <tr> <td>MS12SS = Electrical w/ 5 pin Brad Harrison connector (male end only)</td> </tr> <tr> <td>MS12SSLC = Low current MS12</td> </tr> <tr> <td>MS16SS = Electrical w/ weather-packed sealed connector</td> </tr> <tr> <td>MS16SSLC = Low current MS16</td> </tr> <tr> <td>MS17SSLC = Electrical w/ 4 pin Brad Harrison male connector</td> </tr> <tr> <td rowspan="7">Electrical with Thermal Lockout</td> <td>MS5SST = MS5 (see above) w/ thermal lockout</td> </tr> <tr> <td>MS5SSLC = Low current MS5T</td> </tr> <tr> <td>MS10SST = MS10 (see above) w/ thermal lockout</td> </tr> <tr> <td>MS10SSLC = Low current MS10T</td> </tr> <tr> <td>MS12SST = MS12 (see above) w/ thermal lockout</td> </tr> <tr> <td>MS12SSLC = Low current MS12T</td> </tr> <tr> <td>MS16SST = MS16 (see above) w/ thermal lockout</td> </tr> <tr> <td>MS16SSLC = Low current MS16T</td> </tr> <tr> <td rowspan="2">Electrical Visual</td> <td>MS13SS = Supplied w/ threaded connector &amp; light</td> </tr> <tr> <td>MS14SS = Supplied w/ 5 pin Brad Harrison connector &amp; light (male end)</td> </tr> <tr> <td rowspan="3">Electrical Visual with Thermal Lockout</td> <td>MS13SSDCT = MS13 (see above), direct current, w/ thermal lockout</td> </tr> <tr> <td>MS13SSDCLCT = Low current MS13DCT</td> </tr> <tr> <td>MS14SSDCT = MS14 (see above), direct current, w/ thermal lockout</td> </tr> <tr> <td></td> <td>MS14SSDCLCT = Low current MS14DCT</td> </tr> </table>	Electrical	MS5SS = Electrical w/ 12 in. 18 gauge 4-conductor cable	MS5SSLC = Low current MS5	MS10SS = Electrical w/ DIN connector (male end only)	MS10SSLC = Low current MS10	MS11SS = Electrical w/ 12 ft. 4-conductor wire	MS12SS = Electrical w/ 5 pin Brad Harrison connector (male end only)	MS12SSLC = Low current MS12	MS16SS = Electrical w/ weather-packed sealed connector	MS16SSLC = Low current MS16	MS17SSLC = Electrical w/ 4 pin Brad Harrison male connector	Electrical with Thermal Lockout	MS5SST = MS5 (see above) w/ thermal lockout	MS5SSLC = Low current MS5T	MS10SST = MS10 (see above) w/ thermal lockout	MS10SSLC = Low current MS10T	MS12SST = MS12 (see above) w/ thermal lockout	MS12SSLC = Low current MS12T	MS16SST = MS16 (see above) w/ thermal lockout	MS16SSLC = Low current MS16T	Electrical Visual	MS13SS = Supplied w/ threaded connector & light	MS14SS = Supplied w/ 5 pin Brad Harrison connector & light (male end)	Electrical Visual with Thermal Lockout	MS13SSDCT = MS13 (see above), direct current, w/ thermal lockout	MS13SSDCLCT = Low current MS13DCT	MS14SSDCT = MS14 (see above), direct current, w/ thermal lockout		MS14SSDCLCT = Low current MS14DCT
Electrical	MS5SS = Electrical w/ 12 in. 18 gauge 4-conductor cable																													
	MS5SSLC = Low current MS5																													
	MS10SS = Electrical w/ DIN connector (male end only)																													
	MS10SSLC = Low current MS10																													
	MS11SS = Electrical w/ 12 ft. 4-conductor wire																													
	MS12SS = Electrical w/ 5 pin Brad Harrison connector (male end only)																													
	MS12SSLC = Low current MS12																													
	MS16SS = Electrical w/ weather-packed sealed connector																													
	MS16SSLC = Low current MS16																													
	MS17SSLC = Electrical w/ 4 pin Brad Harrison male connector																													
Electrical with Thermal Lockout	MS5SST = MS5 (see above) w/ thermal lockout																													
	MS5SSLC = Low current MS5T																													
	MS10SST = MS10 (see above) w/ thermal lockout																													
	MS10SSLC = Low current MS10T																													
	MS12SST = MS12 (see above) w/ thermal lockout																													
	MS12SSLC = Low current MS12T																													
	MS16SST = MS16 (see above) w/ thermal lockout																													
MS16SSLC = Low current MS16T																														
Electrical Visual	MS13SS = Supplied w/ threaded connector & light																													
	MS14SS = Supplied w/ 5 pin Brad Harrison connector & light (male end)																													
Electrical Visual with Thermal Lockout	MS13SSDCT = MS13 (see above), direct current, w/ thermal lockout																													
	MS13SSDCLCT = Low current MS13DCT																													
	MS14SSDCT = MS14 (see above), direct current, w/ thermal lockout																													
	MS14SSDCLCT = Low current MS14DCT																													

#### NOTES:

- Box 2. Replacement element part numbers are identical to contents of Boxes 2 and 3.
- Box 3. Viton® is a registered trademark of DuPont Dow Elastomers.
- Box 5. All Dirt Alarm® Indicators must be Stainless Steel. Standard indicator setting is 75 psi. For replacement indicators, contact the factory.

# Hydrostatic Base-Ported Filter

# KFH50



## Features and Benefits

- Base-ported Hydrostatic high pressure filter
- Hydrostatic transmission filter for reversing loop systems
- Filters in the "in to out" direction, bypasses in reverse direction
- Element changeout from top minimizes oil spillage
- Offered in pipe, SAE straight thread, flanged and ISO 228 porting
- Integral inlet and outlet female test points option available
- Offered in conventional subplate porting
- Completion of application questionnaire a requirement L-2549 (contact factory)
- Double and triple stacking of K-size elements can be replaced by single KK or 27K-size elements

**70 gpm**  
**265 L/min**  
**5000 psi**  
**345 bar**

- NF30
- NFS30
- YF30
- CFX30
- PLD
- CF40
- DF40
- PF40
- RFS50
- RF60
- CF60
- CTF60
- VF60
- LW60
- KF30
- KF50
- TF50
- KC50
- MKF50
- MKC50
- KC65
- MKC65
- HS60
- MHS60
- KFH50**
- LC60
- LC35
- LC50
- NOF30-05
- NOF-50-760
- FOF60-03
- NMF30
- RMF60
- 14-CRZX10
- 20-CRZX10

Model No. of filter in photograph is KFH501K10SD5.

Flow Rating:	Up to 70 gpm (265 L/min) for 150 SUS (32 cSt) fluids
Max. Operating Pressure:	5000 psi (345 bar)
Min. Yield Pressure:	15,000 psi (1035 bar), per NFPA T2.6.1
Rated Fatigue Pressure:	3500 psi (240 bar), per NFPA T2.6.1-2005
Temp. Range:	-20°F to 225°F (-29°C to 107°C)
Bypass Setting:	Cracking: 40 psi (2.8 bar) Full Flow: 61 psi (4.2 bar)
Porting Base & Cap:	Ductile Iron
Element Case:	Steel
Weight of KFH50-1K:	60.0 lbs. (27.2 kg)
Weight of KFH50-2K:	80.3 lbs. (36.4 kg)
Weight of KFH50-3K:	100.5 lbs. (45.6 kg)
Element Change Clearance:	8.50" (215 mm) for 1K; 17.50" (445 mm) for KK; 26.5" (673 mm) for 27K

## Filter Housing Specifications

Type Fluid	Appropriate Schroeder Media
Petroleum Based Fluids	All E media (cellulose), Z-Media® and ASP® Media (synthetic)
High Water Content	All Z-Media® (synthetic)
Invert Emulsions	10 and 25 µ Z-Media® (synthetic)
Water Glycols	3, 5, 10 and 25 µ Z-Media® (synthetic)
Phosphate Esters	All Z-Media® (synthetic) with H (EPR) seal designation and 3 and 10 µ E media (cellulose) with H (EPR) seal designation
Skydrol®	3, 5, 10 and 25 µ Z-Media® (synthetic) with H.5 seal designation (EPR seals and stainless steel wire mesh in element, and light oil coating on housing exterior)

## Fluid Compatibility

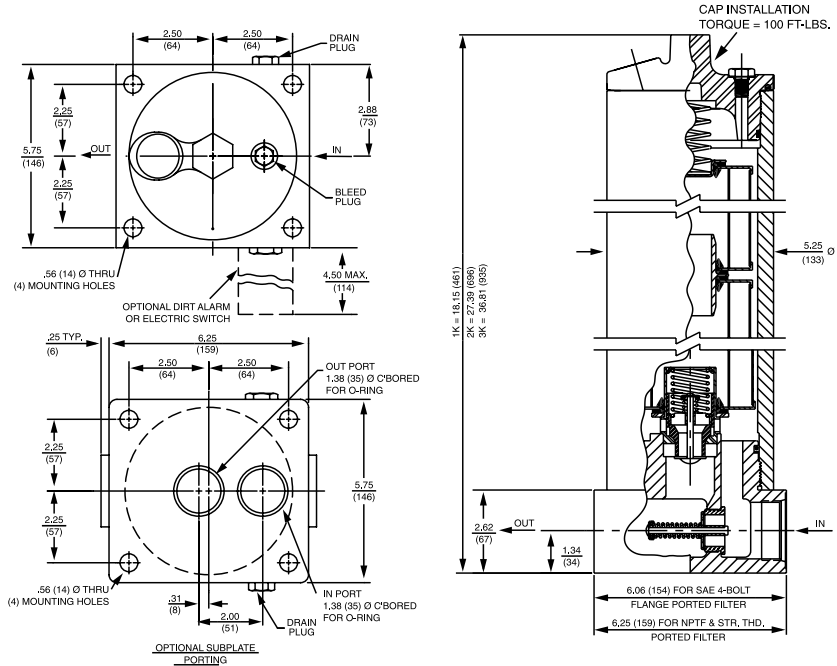

Metric dimensions in ( ).  
 Dimensions shown are inches (millimeters) for general information and overall envelope size only.  
 For complete dimensions please contact Schroeder Industries to request a certified print.

## Element Performance Information & Dirt Holding Capacity

Element	Filtration Ratio Per ISO 4572/NFPA T3.10.8.8 Using automated particle counter (APC) calibrated per ISO 4402			Filtration Ratio per ISO 16889 Using APC calibrated per ISO 11171	
	$\beta_x \geq 75$	$\beta_x \geq 100$	$\beta_x \geq 200$	$\beta_x(c) \geq 200$	$\beta_x(c) \geq 1000$
KZ1/KKZ1/27KZ1	<1.0	<1.0	<1.0	<4.0	4.2
KZ3/KKZ3/27KZ3	<1.0	<1.0	<2.0	<4.0	4.8
KZ5/KKZ5/27KZ5	2.5	3.0	4.0	4.8	6.3
KZ10/KKZ10/27KZ10	7.4	8.2	10.0	8.0	10.0
KZ25/KKZ25/27KZ25	18.0	20.0	22.5	19.0	24.0
KZW1	N/A	N/A	N/A	<4.0	<4.0
KZW3/KKZW3	N/A	N/A	N/A	4.0	4.8
KZW5/KKZW5	N/A	N/A	N/A	5.1	6.4
KZW10/KKZW10	N/A	N/A	N/A	6.9	8.6
KZW25/KKZW25	N/A	N/A	N/A	15.4	18.5
KZX3/KKZX3/27KZX3	<1.0	<1.0	<2.0	4.7	5.8
KZX10/KKZX10/27KZX10	7.4	8.2	10.0	8.0	9.8

Element	DHC (gm)	Element	DHC (gm)	Element	DHC (gm)	Element	DHC (gm)	Element	DHC (gm)
KZ1	112	KKZ1	224	27KZ1	336	KZW1	61		
KZ3	115	KKZ3	230	27KZ3	345	KZW3	64	KKZW3	128
KZ5	119	KKZ5	238	27KZ5	357	KZW5	63	KKZW5	126
KZ10	108	KKZ10	216	27KZ10	324	KZW10	57	KKZW10	114
KZ25	93	KKZ25	186	27KZ25	279	KZW25	79	KKZW25	158
KZX3	81*	KKZX3	163*	27KZX3	249*				
KZX10	90*	KKZX10	182*	27KZX10	279*				

\* Based on 100 psi terminal pressure

Element Collapse Rating: 150 psid (10 bar) for standard elements  
 3000 psid (210 bar) for high collapse (ZX) versions

Flow Direction: Outside In

Element Nominal Dimensions: K: 3.9" (99 mm) O.D. x 9.0" (230 mm) long  
 KK: 3.9" (99 mm) O.D. x 18.0" (460 mm) long  
 27K: 3.9" (99 mm) O.D. x 27.0" (690 mm) long



# Hydrostatic Base-Ported Filter

# KFH50

$\Delta P_{\text{housing}}$

KFH50  $\Delta P_{\text{housing}}$  for fluids with sp gr (specific gravity) = 0.86:

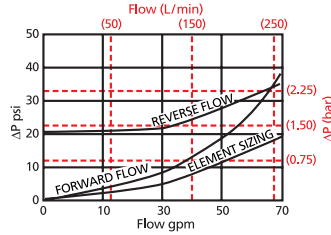

$\Delta P_{\text{element}}$

KZ

Element Pressure Drop versus Flow Rate at 32 cSt (150 SUS)

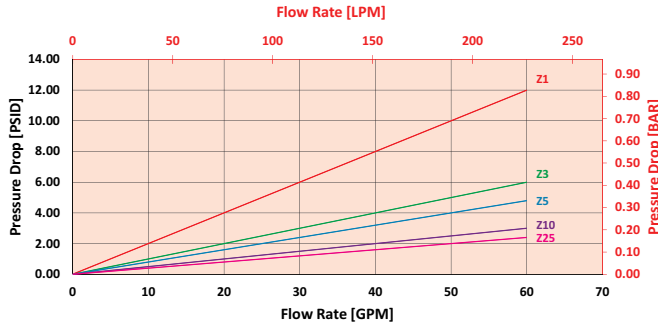

2KZ/KKZ

Element Pressure Drop versus Flow Rate at 32 cSt (150 SUS)

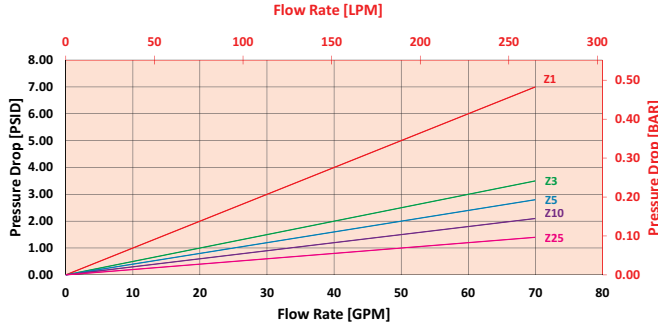

$$\Delta P_{\text{filter}} = \Delta P_{\text{housing}} + (\Delta P_{\text{element}} * V_f)$$

### Exercise:

Determine  $\Delta P_{\text{filter}}$  at 30 gpm (113.7 L/min) for KFH501KZ10SD5 using 160 SUS (34 cSt) fluid.

Use the housing pressure curve to determine  $\Delta P_{\text{housing}}$  at 30 gpm. In this case,  $\Delta P_{\text{housing}}$  is 9 psi (.62 bar) on the graph for the KFH50 housing.

Use the element pressure curve to determine  $\Delta P_{\text{element}}$  at 30 gpm. In this case,  $\Delta P_{\text{element}}$  is 1.5 psi (.10 bar) according to the graph for the KZ10 element.

Because the viscosity in this sample is 160 SUS (34 cSt), we determine the **Viscosity Factor ( $V_f$ )** by dividing the **Operating Fluid Viscosity** with the **Standard Viscosity** of 150 SUS (32 cSt). To best determine your Operating Fluid Viscosity, please reference the chart in Appendix D.

Finally, the overall filter pressure differential,  $\Delta P_{\text{filter}}$ , is calculated by adding  $\Delta P_{\text{housing}}$  with the true element pressure differential, ( $\Delta P_{\text{element}} * V_f$ ). The  $\Delta P_{\text{element}}$  from the graph has to be multiplied by the viscosity factor to get the true pressure differential across the element.

### Solution:

$$\Delta P_{\text{housing}} = 9 \text{ psi } [.62 \text{ bar}] \quad | \quad \Delta P_{\text{element}} = 1.5 \text{ psi } [.10 \text{ bar}]$$

$$V_f = 160 \text{ SUS } (34 \text{ cSt}) / 150 \text{ SUS } (32 \text{ cSt}) = 1.1$$

$$\Delta P_{\text{filter}} = 9 \text{ psi } + (1.5 \text{ psi } * 1.1) = 10.7 \text{ psi}$$

OR

$$\Delta P_{\text{filter}} = .62 \text{ bar } + (.10 \text{ bar } * 1.1) = .73 \text{ bar}$$

## Pressure Drop Information Based on Flow Rate and Viscosity

Note:

If your element is not graphed, use the following equation:

$\Delta P_{\text{element}} = \text{Flow Rate} \times \Delta P_f$  Plug this variable into the overall pressure drop equation.

Ele.	$\Delta P$	Ele.	$\Delta P$	Ele.	$\Delta P$
K3	0.25	2K3/ KK3	0.12	3KZ1/ 27KZ1	0.05
K10	0.09	2K10/ KK10	0.05	3KZ3/ 27KZ3	0.03
K25	0.02	2K25/ KK25	0.01	3KZ5/ 27KZ5	0.02
KAS3	0.10	2KAS3/ KAS3	0.05	3KZ10/ 27KZ10	0.02
KAS5	0.08	2KAS5/ KAS5	0.04	3KZ25/ 27KZ25	0.01
KAS10	0.05	2KAS10/ KAS10	0.03	3K3	0.08
KZX10	0.22	2KZX10/ KKZX10	0.11	3K10	0.03
KZW1	0.43	2KZW1	-	3K25	0.01
KZW3	0.32	2KZW3/ KKZW3	0.16	3KAS3/ 27KAS3	0.03
KZW5	0.28	2KZW5/ KKZW5	0.14	3KAS5/ 27KAS5	0.02
KZW10	0.23	2KZW10/ KKZW10	0.12	3KAS10/ 27KAS10	0.02
KZW25	0.14	2KZW25/ KKZW25	0.07	3KAS25/ 27KAS25	0.07

## Filter Model Number Selection

### How to Build a Valid Model Number for a Schroeder KFH50:

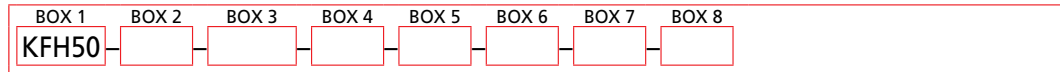

**Example:** NOTE: Only box 6 may contain more than one option

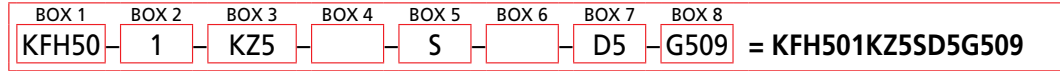

Filter Series	Number of Elements	Element Part Number			Seal Material	
KFH50	1	K	KK	27K	Omit = Buna N V = Viton® H = EPR H.5 = Skydrol® compatibility	
	2	Length	Length	Length		
	3					
			K3	KK3		27K3 = 3 μ E media (cellulose)
			K10	KK10		27K10 = 10 μ E media (cellulose)
			K25			= 25 μ E media (cellulose)
			KZ1	KKZ1		27KZ1 = 1 μ Excellement® Z-Media® (synthetic)
			KZ3	KKZ3		27KZ3 = 3 μ Excellement® Z-Media® (synthetic)
			KZ5	KKZ5		27KZ5 = 5 μ Excellement® Z-Media® (synthetic)
			KZ10	KKZ10		27KZ10 = 10 μ Excellement® Z-Media® (synthetic)
			KZ25	KKZ25		27KZ25 = 25 μ Excellement® Z-Media® (synthetic)
			KZW1			= 1 μ Aqua-Excellement™ ZW media
			KZW3	KKZW3		= 3 μ Aqua-Excellement™ ZW media
		KZW5	KKZW5	= 5 μ Aqua-Excellement™ ZW media		
		KZW10	KKZW10	= 10 μ Aqua-Excellement™ ZW media		
		KZW25	KKZW25	= 25 μ Aqua-Excellement™ ZW media		
		KW	KKW	27KW = W media (water removal)		
		KM10		= K size 10 μ M media (reusable metal)		
		KM25		= K size 25 μ M media (reusable metal)		
		KM60		= K size 60 μ M media (reusable metal)		
		KM150		= K size 150 μ M media (reusable metal)		
		KM260		= K size 260 μ M media (reusable metal)		

**BOX 6**

Options
Omit = None
L = Two ¼" NPTF inlet and outlet female test ports
U = Series 1215 7/16 UNF Schroeder Check Test Point installation in cap (upstream)
UU = Series 1215 7/16 UNF Schroeder Check Test Point installation in block (upstream and downstream)

**BOX 7**

Dirt Alarm® Options	
None	Omit = None
Visual	D = Pointer D5 = Visual pop-up D5C = D5 in cap D9 = All stainless D5
Visual with Thermal Lockout	D8 = Visual w/ thermal lockout D8C = D8 in cap
Electrical	MS5 = Electrical w/ 12 in. 18 gauge 4-conductor cable MS5LC = Low current MS5 MS10 = Electrical w/ DIN connector (male end only) MS10LC = Low current MS10 MS11 = Electrical w/ 12 ft. 4-conductor wire MS12 = Electrical w/ 5 pin Brad Harrison connector (male end only) MS12LC = Low current MS12 MS16 = Electrical w/ weather-packed sealed connector MS16LC = Low current MS16 MS17LC = Electrical w/ 4 pin Brad Harrison male connector
Electrical with Thermal Lockout	MS5T = MS5 (see above) w/ thermal lockout MS5LCT = Low current MS5T MS10T = MS10 (see above) w/ thermal lockout MS10LCT = Low current MS10T MS12T = MS12 (see above) w/ thermal lockout MS12LCT = Low current MS12T MS16T = MS16 (see above) w/ thermal lockout MS16LCT = Low current MS16T MS17LCT = Low current MS17T
Electrical Visual	MS = Cam operated switch w/ ½" conduit female connection MS13DC = Supplied w/ threaded connector & light MS14DC = Supplied w/ 5 pin Brad Harrison connector & light (male end)
Electrical Visual with Thermal Lockout	MS13DCT = MS13 (see above), direct current, w/ thermal lockout MS13DCLCT = Low current MS13DCT MS14DCT = MS14 (see above), direct current, w/ thermal lockout MS14DCLCT = Low current MS14DCT

**BOX 8**

Additional Options
Omit = None
G509 = Dirt alarm and drain opposite standard

**NOTES:**

**Box 2.** Number of elements must equal 1 when using KK or 27K elements.

**Box 3.** Replacement element part numbers are identical to contents of Boxes 3 and 4. Double and triple stacking of K-size elements can be replaced by single KK and 27K elements, respectively. ZW media not available in 27K length.

**Box 4.** H.5 seal designation includes the following: EPR seals, stainless steel wire mesh on elements, and light oil coating on housing exterior. Viton® is a registered trademark of DuPont Dow Elastomers. Skydrol® is a registered trademark of Solutia Inc.

**Box 5.** For option F, bolt depth .75" (19 mm). For option O, O-rings included; hardware not included.



### Features and Benefits (LC60)

- Compact design allows for in-line installation.
- Small profile allows filter to be mounted in tight areas.
- Quick and easy cartridge element change outs.
- Durable, compact design.
- Uses 10 micron stainless steel wire mesh filtration.
- Perfect for pilot pressure circuits and pressure compensated pump protection.

**8 gpm**  
**30 L/min**  
**6000 psi**  
**415 bar**

NF30  
 NFS30  
 YF30  
 CFX30  
 PLD  
 CF40  
 DF40  
 PF40  
 RFS50  
 RF60  
 CF60

Model No. of filter in photograph is LC601SSD10S.

Flow Rating:	Up to 8 gpm (30 L/min) for 150 SUS (32 cSt) fluids
Max. Operating Pressure:	6000 psi (414 bar)
Min. Yield Pressure:	18000 psi (1241 bar), per NFPA T2.6.1
Rated Fatigue Pressure:	6000 psi (414 bar), per NFPA T2.6.1
Temp. Range:	-20°F to 225°F (-29°C to 107°C)
Porting Head:	Steel
Element Case:	Steel
Weight:	0.93 lbs. (0.42 kg)
Element Change Clearance:	2.50" (63.5 mm)
Type Fluid	Appropriate Schroeder Media
Petroleum Based Fluids	All Stainless Steel Wire Mesh
Invert Emulsions	10 μ Stainless Steel Wire Mesh
Water Glycols	10 μ Stainless Steel Wire Mesh

### Filter Housing Specifications

CTF60  
 VF60  
 LW60  
 KF30  
 KF50  
 TF50

### Fluid Compatibility

KC50  
 MKF50  
 MKC50  
 KC65  
 MKC65  
 HS60  
 MHS60  
 KFH50

**LC60**

LC35  
 LC50  
 NOF30-05  
 NOF50-760  
 FOF60-03  
 NMF30  
 RMF60  
 14-CRZX10  
 20-CRZX10

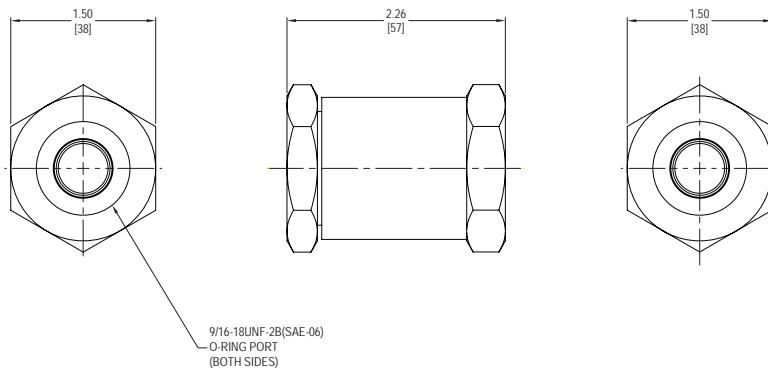

Metric dimensions in ( ).  
 Dimensions shown are inches (millimeters) for general information and overall envelope size only.  
 For complete dimensions please contact Schroeder Industries to request a certified print.

### Element Performance Information & Dirt Holding Capacity

Element	Filtration Ratio Per ISO 4572/NFPA T3.10.8.8 Using automated particle counter (APC) calibrated per ISO 4402			Filtration Ratio per ISO 16889 Using APC calibrated per ISO 11171	
	$\beta_x \geq 75$	$\beta_x \geq 100$	$\beta_x \geq 200$	$\beta_x(c) \geq 200$	$\beta_x(c) \geq 1000$

**\*Please contact manufacture for more details\***

### Pressure Drop Information Based on Flow Rate and Viscosity

$\Delta P_{\text{housing}}$

LC60  $\Delta P_{\text{housing}}$  for fluids with sp gr (specific gravity) = 0.86:

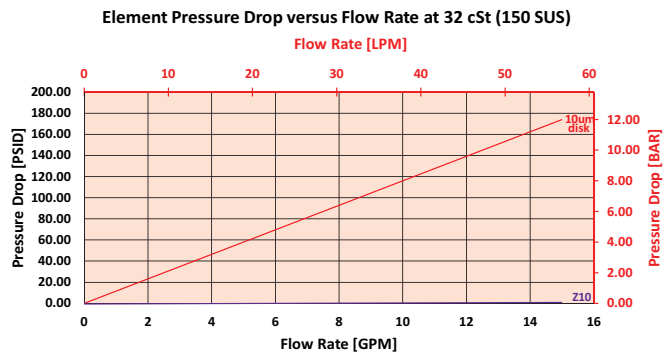

### Filter Model Number Selection

**How to Build a Valid Model Number for a Schroeder LC60:**

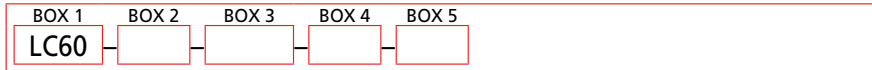

Example:

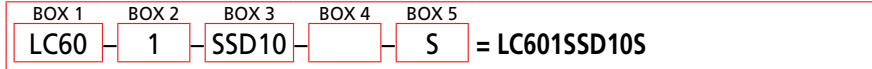

BOX 1 <b>Filter Series</b> LC60	BOX 2 <b>Number of Elements</b> 1	BOX 3 <b>Element Part Number</b> SSD10 = 10 μ Stainless Steel Wire Mesh
BOX 4 <b>Seal Material</b> Omit = Buna N	BOX 5 <b>Porting</b> S = SAE-6	



### Features and Benefits (LC35)

- Compact design allows for in-line installation.
- Small profile allows filter to be mounted in tight areas.
- Quick and easy cartridge element change outs.
- Durable, compact design.
- Uses 10 or 40 micron Sintered Bronze filtration.
- Perfect for pilot pressure circuits and pressure compensated pump protection.

**15 gpm**  
**57 L/min**  
**3500 psi**  
**241 bar**

NF30

NFS30

YF30

CFX30

PLD

CF40

DF40

PF40

RFS50

RF60

CF60

CTF60

VF60

LW60

KF30

KF50

TF50

KC50

MKF50

MKC50

KC65

MKC65

HS60

MHS60

KFH50

LC60

**LC35**

LC50

NOF30-05

NOF-50-760

FOF60-03

NMF30

RMF60

14-CRZX10

20-CRZX10

Model No. of filter in photograph is LC351B5105.

Flow Rating:	Up to 15 gpm (57 L/min) for 150 SUS (32 cSt) fluids
Max. Operating Pressure:	3500 psi (241 bar)
Min. Yield Pressure:	10500 psi (724 bar), per NFPA T2.6.1
Rated Fatigue Pressure:	2200 psi (152 bar), per NFPA T2.6.1
Temp. Range:	-20°F to 225°F (-29°C to 107°C)
Porting Head:	Steel
Element Case:	Steel
Weight:	1.32 lbs. (0.60 kg)
Element Change Clearance:	3.25" (82.6 mm)
Type Fluid	Appropriate Schroeder Media
Petroleum Based Fluids	All Sintered Bronze
Invert Emulsions	10 and 40 μ Sintered Bronze
Water Glycols	10 and 40 μ Sintered Bronze

### Filter Housing Specifications

### Fluid Compatibility

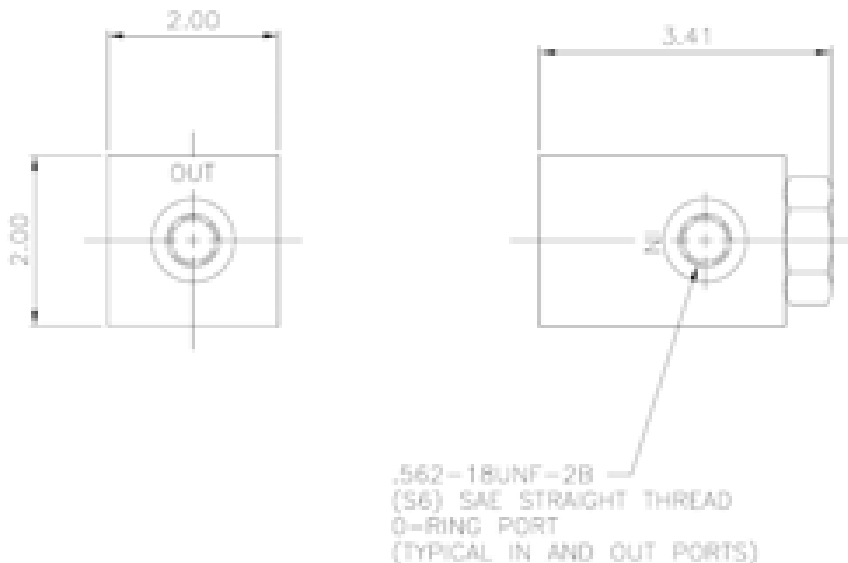

Metric dimensions in ( ).  
Dimensions shown are inches (millimeters) for general information and overall envelope size only.  
For complete dimensions please contact Schroeder Industries to request a certified print.

### Element Performance Information & Dirt Holding Capacity

Element	Filtration Ratio Per ISO 4572/NFPA T3.10.8.8 Using automated particle counter (APC) calibrated per ISO 4402			Filtration Ratio per ISO 16889 Using APC calibrated per ISO 11171	
	$\beta_x \geq 75$	$\beta_x \geq 100$	$\beta_x \geq 200$	$\beta_{x(c)} \geq 200$	$\beta_{x(c)} \geq 1000$

**\*Please contact manufacturer for more details\***

### Pressure Drop Information Based on Flow Rate and Viscosity

$\Delta P_{\text{housing}}$

LC35  $\Delta P_{\text{housing}}$  for fluids with sp gr (specific gravity) = 0.86:

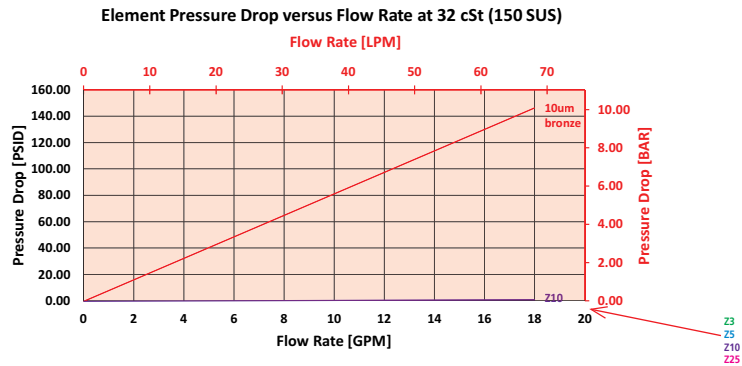

### Filter Model Number Selection

#### How to Build a Valid Model Number for a Schroeder LC35:

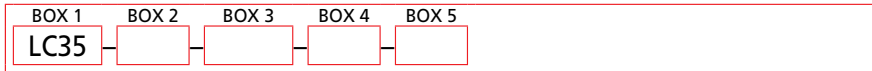

Example:

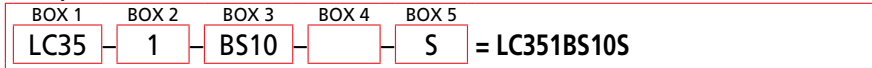

BOX 1	BOX 2	BOX 3	BOX 4
<b>Filter Series</b>	<b>Number of Elements</b>	<b>Element Part Number</b>	<b>Seal Material</b>
LC35	1	BS10 = 10 $\mu$ Sintered Bronze BS40 = 40 $\mu$ Sintered Bronze	Omit = Buna N
BOX 5			
<b>Porting</b>			
S = SAE-6			

# In-Line Filter

# LC50



### Features and Benefits

- Compact design allows for in-line installation on hose reels
- High quality synthetic ZX-Media high collapse elements ensure all fluid is filtered
- Available with SAE or NPT threading
- Convenient 2 1/4" Hex for easy service

Model No. of filter in photograph is LC501LZX105.

Flow Rating:	Up to 9 gpm (35 L/min) for 150 SUS (32 cSt) fluids
Max. Operating Pressure:	5000 psi (350 bar)
Min. Yield Pressure:	15,000 psi (1050 bar)
Rated Fatigue Pressure:	5000 psi (350 bar), per NFPA T2.6.1-R1-2005
Temp. Range:	-20°F to 225°F (-29°C to 107°C)
Body and Cap:	Steel
Element Case:	Steel
Weight of LC50:	3.63 lbs. (1.65 kg)
Element Change Clearance:	3.25" (83 mm)

Type Fluid	Appropriate Schroeder Media
Petroleum Based Fluids	All Z-Media® (synthetic)
High Water Content	All Z-Media® (synthetic)
Invert Emulsions	10 and 25 μ Z-Media® (synthetic)
Water Glycols	10 and 25 μ Z-Media® (synthetic)

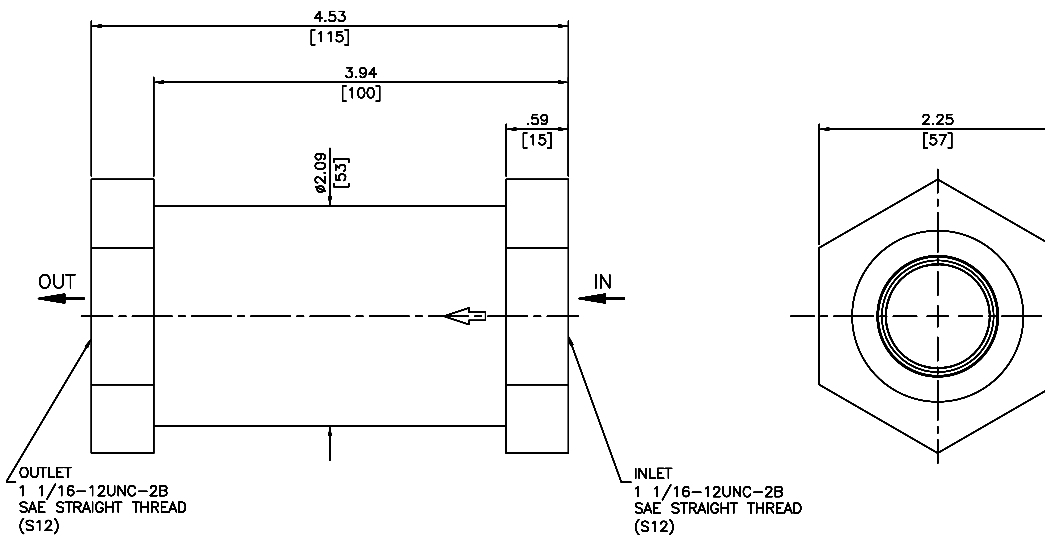

Metric dimensions in ( ).  
 Dimensions shown are inches (millimeters) for general information and overall envelope size only.  
 For complete dimensions please contact Schroeder Industries to request a certified print.

**9 gpm**  
**35 L/min**  
**5000 psi**  
**345 bar**

### Filter Housing Specifications

### Fluid Compatibility

- NF30
- NFS30
- YF30
- CFX30
- PLD
- CF40
- DF40
- PF40
- RFS50
- RF60
- CF60
- CTF60
- VF60
- LW60
- KF30
- KF50
- TF50
- KC50
- MKF50
- MKC50
- KC65
- MKC65
- HS60
- MHS60
- KFH50
- LC60
- LC35
- LC50**
- NOF30-05
- NOF-50-760
- FOF60-03
- NMF30
- RMF60
- 14-CRZX10
- 20-CRZX10

### Element Performance Information & Dirt Holding Capacity

Element	Filtration Ratio per ISO 16889 Using APC calibrated per ISO 11171		
	$\beta_{x(c)} \geq 200$	$\beta_{x(c)} \geq 1000$	
LZX3	<4.0	4.8	
LZX10	8.0	10.0	
LZX25	19.0	24.0	

  

Element	DHC (gm)	Element	DHC (gm)
LZX3	1.1	LZX25	1.0
LZX10	1.0	LZX40	0.9

### Pressure Drop Information Based on Flow Rate and Viscosity

Element Collapse Rating: 3000 psi (207 bar)  
 Flow Direction: Outside In  
 Element Nominal Dimensions: 1.4" (43 mm) O.D. x 1.7" (35 mm) long

$\Delta P_{\text{housing}}$   
 LC50  $\Delta P_{\text{housing}}$  for fluids with sp gr (specific gravity) = 0.86:

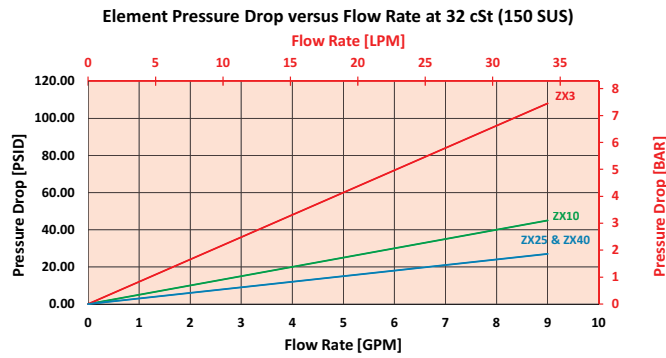

### Filter Model Number Selection

#### How to Build a Valid Model Number for a Schroeder LC50:

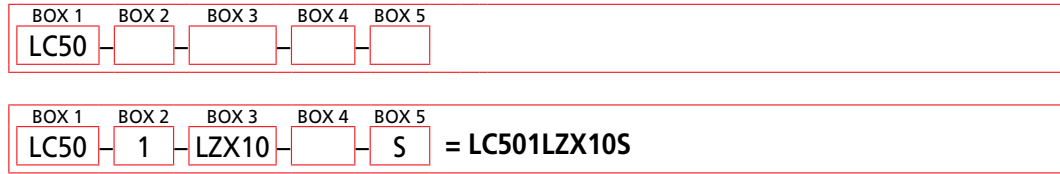

BOX 1	BOX 2	BOX 3	BOX 4
<b>Filter Series</b>	<b>Number of Elements</b>	<b>Element Part Number</b>	<b>Seal Material</b>
LC50 (non-bypassing only)	1	LZX3 = 3 $\mu$ Excellement® Z-Media® (high collapse center tube) LZX10 = 10 $\mu$ Excellement® Z-Media® (high collapse center tube) LZX25 = 25 $\mu$ Excellement® Z-Media® (high collapse center tube) LZX40 = 40 $\mu$ Excellement® Z-Media® (high collapse center tube)	Omit = Buna N V = Viton®
<b>BOX 5</b>	<b>Porting</b>		
S = SAE-12 P = 3/4" NPT			



# High-Pressure Sandwich Filter

# NOF30-05



### Features and Benefits

- Sandwich filter configured for D05 subplate
- Withstands high pressure surges, high static pressure loads
- 3000 psi collapse elements

**12 gpm**  
**45 L/min**  
**3000 psi**  
**210 bar**

NF30  
NFS30  
YF30  
CFX30  
PLD  
CF40  
DF40  
PF40  
RFS50  
RF60  
CF60  
CTF60  
VF60  
LW60  
KF30  
KF50  
TF50  
KC50

Model No. of filter in photograph is NOF301NNZX305D5.

Flow Rating:	Up to 12 gpm (45 L/min) for 150 SUS (32 cSt) fluids
Max. Operating Pressure:	3000 psi (210 bar)
Min. Yield Pressure:	10,000 psi (690 bar), per NFPA T2.6.1
Rated Fatigue Pressure:	Contact Factory
Temp. Range:	-20°F to 225°F (-29°C to 107°C)
Bypass Setting:	High collapse elements are standard
Porting Base & Cap:	Aluminum
Element Case:	Aluminum
Weight of NOF30-1NN:	6.6 lbs. (3.0 kg)
Element Change Clearance:	4.50" (115 mm)

### Filter Housing Specifications

MKF50  
MKC50  
KC65  
MKC65  
HS60  
MHS60  
KFH50  
LC60  
LC35  
LC50

Type Fluid	Appropriate Schroeder Media
Petroleum Based Fluids	All Z-Media® (synthetic)
High Water Content	3, 10 and 25 μ Z-Media® (synthetic)
Invert Emulsions	10 and 25 μ Z-Media® (synthetic)
Water Glycols	3, 10 and 25 μ Z-Media® (synthetic)

### Fluid Compatibility

**NOF30-05**  
NOF-50-760  
FOF60-03  
NMF30  
RMF60  
14-CRZX10  
20-CRZX10

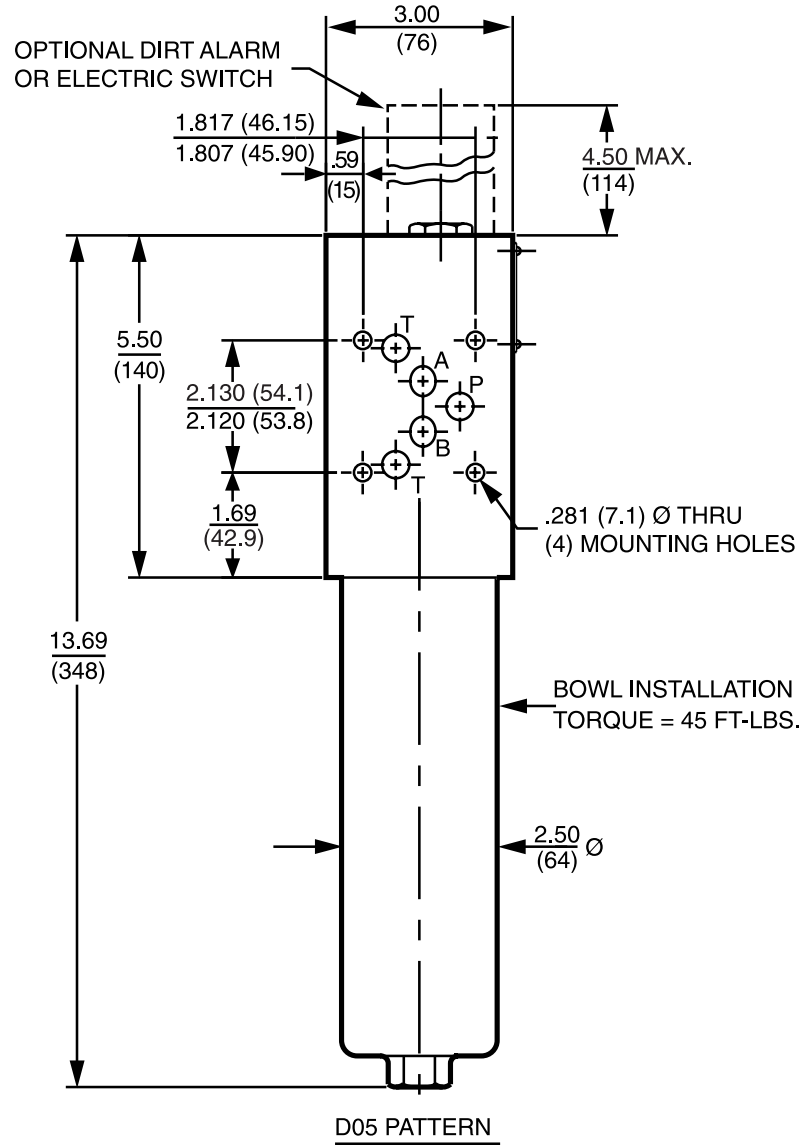

Metric dimensions in ( ).  
 Dimensions shown are inches (millimeters) for general information and overall envelope size only.  
 For complete dimensions please contact Schroeder Industries to request a certified print.

**Element Performance Information & Dirt Holding Capacity**

Element	Filtration Ratio Per ISO 4572/NFPA T3.10.8.8 Using automated particle counter (APC) calibrated per ISO 4402			Filtration Ratio per ISO 16889 Using APC calibrated per ISO 11171	
	$\beta_x \geq 75$	$\beta_x \geq 100$	$\beta_x \geq 200$	$\beta_x(\alpha) \geq 200$	$\beta_x(\alpha) \geq 1000$
NNZX3	<1.0	<1.0	<2.0	4.7	5.8
NNZX10	7.4	8.2	10.0	8.0	9.8

Element	DHC (gm)
NNZX3	11*
NNZX10	13*

Element Collapse Rating: 3000 psid (210 bar) for high collapse (ZX) versions \*Based on 100 psi terminal pressure  
 Flow Direction: Outside In  
 Element Nominal Dimensions: 1.75" (45 mm) O.D. x 8.00" (200 mm) long

$\Delta P_{\text{housing}}$

NOF30-05  $\Delta P_{\text{housing}}$  for fluids with sp gr (specific gravity) = 0.86:

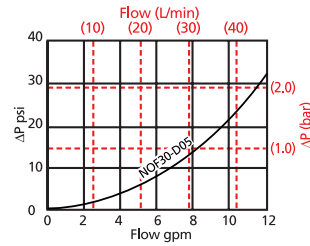

$\Delta P_{\text{element}}$

1NNZX

Element Pressure Drop versus Flow Rate at 32 cSt (150 SUS)

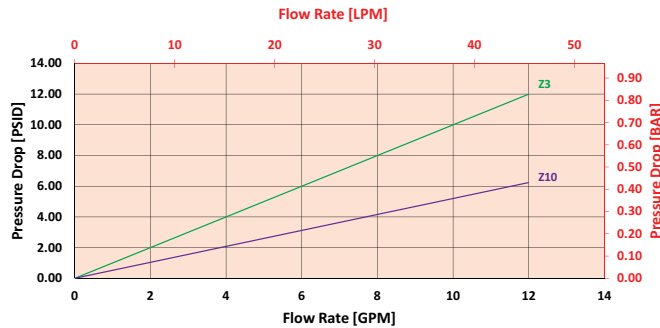

Pressure Drop Information Based on Flow Rate and Viscosity

$$\Delta P_{\text{filter}} = \Delta P_{\text{housing}} + (\Delta P_{\text{element}} * V_f)$$

**Exercise:**

Determine  $\Delta P_{\text{filter}}$  at 5 gpm (19 L/min) for NOF301NNZX1005D5 using 160 SUS (34 cSt) fluid.

Use the housing pressure curve to determine  $\Delta P_{\text{housing}}$  at 5 gpm. In this case,  $\Delta P_{\text{housing}}$  is 5 psi (.34 bar) on the graph for the NOF30 housing.

Use the element pressure curve to determine  $\Delta P_{\text{element}}$  at 5 gpm. In this case,  $\Delta P_{\text{element}}$  is 3 psi (.21 bar) according to the graph for the NNZX10 element.

Because the viscosity in this sample is 160 SUS (34 cSt), we determine the **Viscosity Factor ( $V_f$ )** by dividing the **Operating Fluid Viscosity** with the **Standard Viscosity** of 150 SUS (32 cSt). To best determine your Operating Fluid Viscosity, please reference the chart in Appendix D.

Finally, the overall filter pressure differential,  $\Delta P_{\text{filter}}$ , is calculated by adding  $\Delta P_{\text{housing}}$  with the true element pressure differential, ( $\Delta P_{\text{element}} * V_f$ ). The  $\Delta P_{\text{element}}$  from the graph has to be multiplied by the viscosity factor to get the true pressure differential across the element.

**Solution:**

$\Delta P_{\text{housing}} = 5 \text{ psi } [.34 \text{ bar}] \mid \Delta P_{\text{element}} = 3 \text{ psi } [.21 \text{ bar}]$

$V_f = 160 \text{ SUS } (34 \text{ cSt}) / 150 \text{ SUS } (32 \text{ cSt}) = 1.1$

$\Delta P_{\text{filter}} = 5 \text{ psi } + (3 \text{ psi } * 1.1) = 8.3 \text{ psi}$

**OR**

$\Delta P_{\text{filter}} = .34 \text{ bar } + (.21 \text{ bar } * 1.1) = .57 \text{ bar}$

## Filter Model Number Selection

### How to Build a Valid Model Number for a Schroeder NOF30-05:

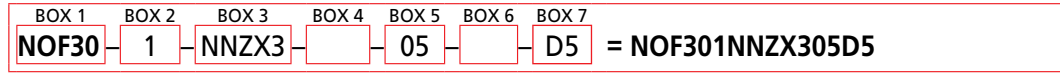
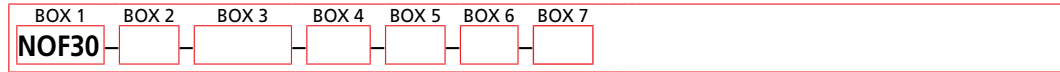

BOX 1	BOX 2	BOX 3	BOX 4	BOX 5
<b>Filter Series</b>	<b>Number &amp; Size of Elements</b>	<b>Element Part Number</b>	<b>Seal Material</b>	<b>Porting</b>
NOF30	1	NNZX3 = NN size 3 μ high collapse media NNZX10 = NN size 10 μ high collapse media NNZX25 = NN size 25 μ high collapse media	Omit = Buna N V = Viton® W = Buna N	05 = D05 subplate pattern

BOX 6	BOX 7
Options	Dirt Alarm® Options
Omit = None	None      Omit = None Visual      D5 = Visual pop-up Visual with Thermal Lockout      D8 = Visual w/ thermal lockout
	Electrical MS5 = Electrical w/ 12 in. 18 gauge 4-conductor cable MS5LC = Low current MS5 MS10 = Electrical w/ DIN connector (male end only) MS10LC = Low current MS10 MS11 = Electrical w/ 12 ft. 4-conductor wire MS12 = Electrical w/ 5 pin Brad Harrison connector (male end only) MS12LC = Low current MS12 MS16 = Electrical w/ weather-packed sealed connector MS16LC = Low current MS16 MS17LC = Electrical w/ 4 pin Brad Harrison male connector
	Electrical with Thermal Lockout MS5T = MS5 (see above) w/ thermal lockout MS5LCT = Low current MS5T MS10T = MS10 (see above) w/ thermal lockout MS10LCT = Low current MS10T MS12T = MS12 (see above) w/ thermal lockout MS12LCT = Low current MS12T MS16T = MS16 (see above) w/ thermal lockout MS16LCT = Low current MS16T MS17LCT = Low current MS17T
	MS13DC = Supplied w/ threaded connector & light MS14DC = Supplied w/ 5 pin Brad Harrison connector & light (male end) Electrical Visual with Thermal Lockout MS13DCT = MS13 (see above), direct current, w/ thermal lockout MS13DCLCT = Low current MS13DCT MS14DCT = MS14 (see above), direct current, w/ thermal lockout MS14DCLCT = Low current MS14DCT

#### NOTES:

Box 3. Replacement element part numbers are identical to contents of Boxes 3 and 4.

Box 4. For options V and W, all aluminum parts are anodized. Viton® is a registered trademark of DuPont Dow Elastomers.

# High-Pressure Servo Sandwich Filter

# NOF50



## Features and Benefits

- Localized protection at the servo helps to eliminate downtime and protect critical applications from contamination-related servo valve failures
- Sandwich style 4-bolt design – no additional lines to connect
- Designed to protect these commonly installed servo valves: Moog 761 & 62, Vickers SM4-20 and Parker BD15
- High collapse elements, rated to 3000 psi (210 bar)
- Easily applied to new and existing systems
- All steel construction

**15 gpm**  
**57 L/min**  
**5000 psi**  
**345 bar**

Model No. of filter in photograph is NOF501SVZX3760.

Flow Rating:	Up to 15 gpm (57 L/min) for 150 SUS (32 cSt) fluids
Max. Operating Pressure:	5000 psi (345 bar)
Min. Yield Pressure:	15,000 psi (1034 bar), per NFPA T2.6.1
Rated Fatigue Pressure:	4000 psi (276 bar) per NFPA T2-6.1 R2-2005
Temp. Range:	-20°F to 225°F (-29°C to 107°C)
Non-Bypass Model:	Standard with high collapse elements
Porting Head:	Steel
Element Case:	Steel
Weight of NOF50-1SV:	17 lb. (7.7 kg)
Element Change Clearance:	4.50" (115 mm)

## Filter Housing Specifications

Type Fluid	Appropriate Schroeder Media
Petroleum Based Fluids	All Z-Media® (synthetic)
High Water Content	3, 10 and 25 μ Z-Media® (synthetic)
Invert Emulsions	10 and 25 μ Z-Media® (synthetic)
Water Glycols	3, 10 and 25 μ Z-Media® (synthetic)

## Fluid Compatibility

**NOF-50-760**

- NF30
- NFS30
- YF30
- CFX30
- PLD
- CF40
- DF40
- PF40
- RFS50
- RF60
- CF60
- CTF60
- VF60
- LW60
- KF30
- KF50
- TF50
- KC50
- MKF50
- MKC50
- KC65
- MKC65
- HS60
- MHS60
- KFH50
- LC60
- LC35
- LC50
- NOF30-05
- FOF60-03
- NMF30
- RMF60
- 14-CRZX10
- 20-CRZX10

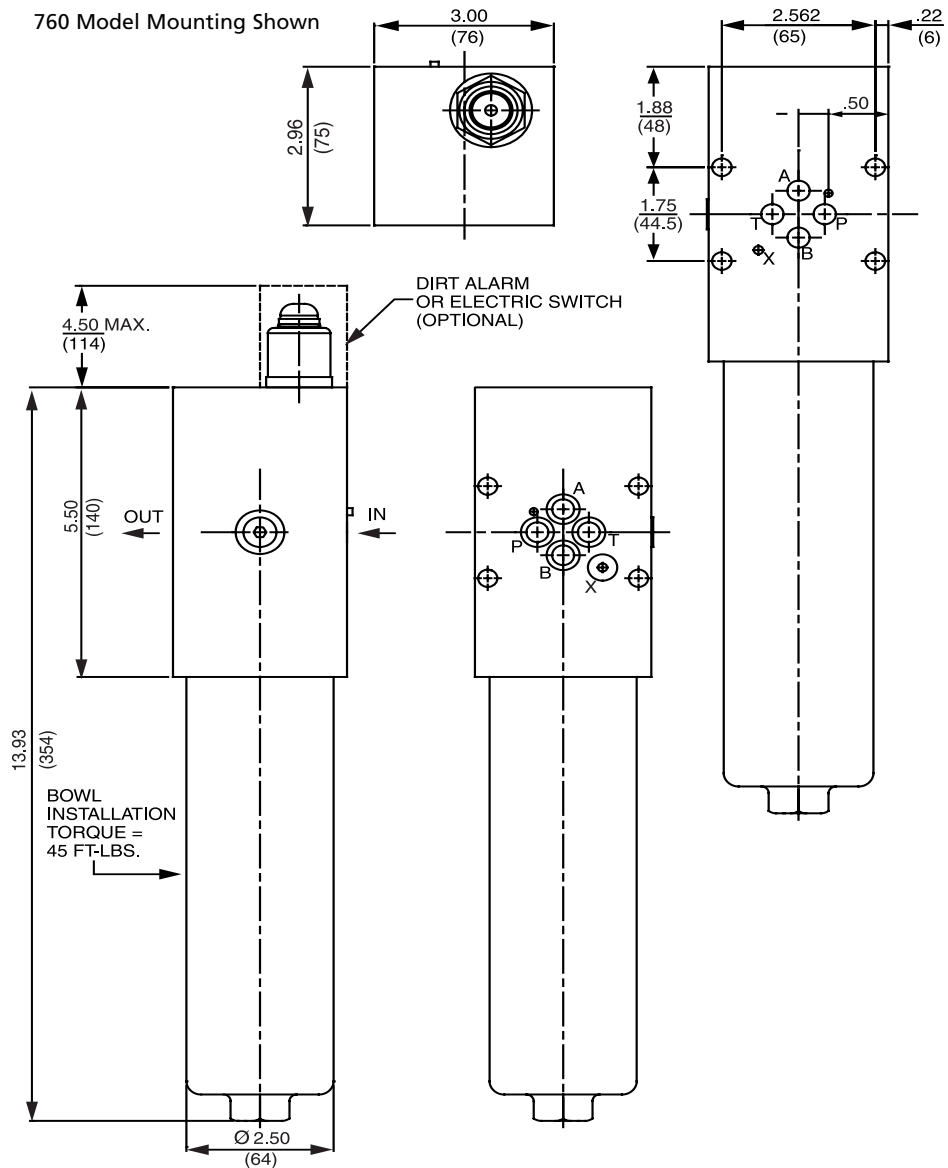

Metric dimensions in ( ).  
 Dimensions shown are inches (millimeters) for general information and overall envelope size only.  
 For complete dimensions please contact Schroeder Industries to request a certified print.

## Element Performance Information & Dirt Holding Capacity

Element	Filtration Ratio Per ISO 4572/NFPA T3.10.8.8 Using automated particle counter (APC) calibrated per ISO 4402			Filtration Ratio per ISO 16889 Using APC calibrated per ISO 11171	
	$\beta_x \geq 75$	$\beta_x \geq 100$	$\beta_x \geq 200$	$\beta_{x(c)} \geq 200$	$\beta_{x(c)} \geq 1000$
SVZX3	<1.0	<1.0	<2.0	4.7	5.8
SVZX10	7.4	8.2	10.0	8.0	9.7

Element	DHC (gm)
SVZX3	11*
SVZX10	13*

Element Collapse Rating: 3000 psid (210 bar) for high collapse (ZX) versions  
 Flow Direction: Outside In  
 Element Nominal Dimensions: 1.75" (45 mm) O.D. x 8.0" (200 mm) long

\*Based on 100 psi terminal pressure

$\Delta P_{\text{housing}}$

NOF50  $\Delta P_{\text{housing}}$  for fluids with sp gr (specific gravity) = 0.86:

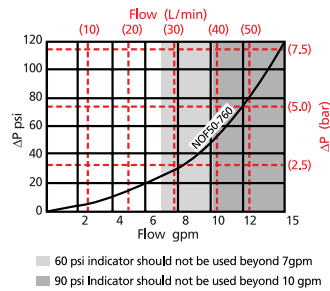

$\Delta P_{\text{element}}$

1SVZX

Element Pressure Drop versus Flow Rate at 32 cSt (150 SUS)

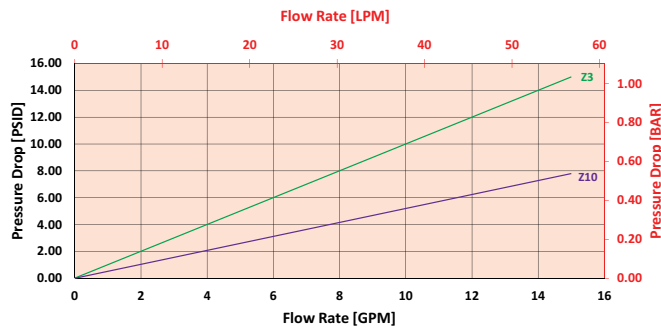

Pressure Drop Information Based on Flow Rate and Viscosity

$$\Delta P_{\text{filter}} = \Delta P_{\text{housing}} + (\Delta P_{\text{element}} * V_f)$$

### Exercise:

Determine  $\Delta P_{\text{filter}}$  at 5 gpm (19 L/min) for NOF501SVZX10760D5 using 160 SUS (34 cSt) fluid.

Use the housing pressure curve to determine  $\Delta P_{\text{housing}}$  at 5 gpm. In this case,  $\Delta P_{\text{housing}}$  is 15 psi (1 bar) on the graph for the NOF30 housing.

Use the element pressure curve to determine  $\Delta P_{\text{element}}$  at 5 gpm. In this case,  $\Delta P_{\text{element}}$  is 3 psi (.21 bar) according to the graph for the SVZX10 element.

Because the viscosity in this sample is 160 SUS (34 cSt), we determine the **Viscosity Factor ( $V_f$ )** by dividing the **Operating Fluid Viscosity** with the **Standard Viscosity** of 150 SUS (32 cSt). To best determine your Operating Fluid Viscosity, please reference the chart in Appendix D.

Finally, the overall filter pressure differential,  $\Delta P_{\text{filter}}$ , is calculated by adding  $\Delta P_{\text{housing}}$  with the true element pressure differential, ( $\Delta P_{\text{element}} * V_f$ ). The  $\Delta P_{\text{element}}$  from the graph has to be multiplied by the viscosity factor to get the true pressure differential across the element.

### Solution:

$$\Delta P_{\text{housing}} = 15 \text{ psi [1 bar]} \quad | \quad \Delta P_{\text{element}} = 3 \text{ psi [.21 bar]}$$

$$V_f = 160 \text{ SUS (34 cSt)} / 150 \text{ SUS (32 cSt)} = 1.1$$

$$\Delta P_{\text{filter}} = 15 \text{ psi} + (3 \text{ psi} * 1.1) = 18.3 \text{ psi}$$

OR

$$\Delta P_{\text{filter}} = 1 \text{ bar} + (.21 \text{ bar} * 1.1) = 1.2 \text{ bar}$$

## Filter Model Number Selection

### How to Build a Valid Model Number for a Schroeder NOF50:

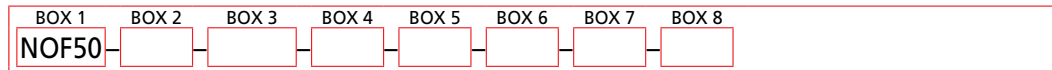

Example: NOTE: One option per box

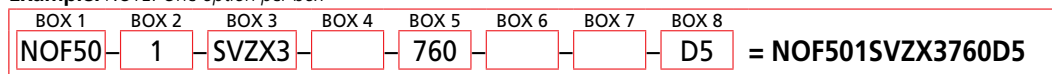

BOX 1	BOX 2	BOX 3	BOX 4	BOX 5
<b>Filter Series</b>	<b>Number of Elements</b>	<b>Element Part Number</b>	<b>Seal Material</b>	<b>Porting</b>
NOF50	1	SVZX3 = S size 3 μ high collapse media SVZX10 = S size 10 μ high collapse media SVZX25 = S size 25 μ high collapse media	Omit = Buna N V = Viton®	760 = Moog servo configuration 761 = Moog servo configuration

BOX 6	BOX 7
<b>Options</b>	<b>Optional Test Point</b>
Omit = 60 psid 90 = 90 psid	Omit = None U = Series 1215 7/16"-20 UNF Schroeder Check Test Point installation

BOX 8	
Dirt Alarm® Options	
None	Omit = None
Visual	D5 = Visual pop-up
Visual with Thermal Lockout	D8 = Visual w/ thermal lockout
Electrical	MS5 = Electrical w/ 12 in. 18 gauge 4-conductor cable MS5LC = Low current MS MS10 = Electrical w/ DIN connector (male end only) MS10LC = Low current MS10 MS11 = Electrical w/ 12 ft. 4-conductor wire MS12 = Electrical w/ 5 pin Brad Harrison connector (male end only) MS12LC = Low current MS12 MS16 = Electrical w/ weather-packed sealed connector MS16LC = Low current MS16 MS17LC = Electrical w/ 4 pin Brad Harrison male connector
Electrical with Thermal Lockout	MS5T = MS5 (see above) w/ thermal lockout MS5LCT = Low current MS5T MS10T = MS10 (see above) w/ thermal lockout MS10LCT = Low current MS10T MS12T = MS12 (see above) w/ thermal lockout MS12LCT = Low current MS12T MS16T = MS16 (see above) w/ thermal lockout MS16LCT = Low current MS16T MS17LCT = Low current MS17T
Electrical Visual	MS13 = Supplied w/ threaded connector & light MS14 = Supplied w/ 5 pin Brad Harrison connector & light (male end)
Electrical Visual with Thermal Lockout	MS13DCT = MS13 (see above), direct current, w/ thermal lockout MS13DCLCT = Low current MS13DCT MS14DCT = MS14 (see above), direct current, w/ thermal lockout MS14DCLCT = Low current MS14DCT

#### NOTES:

Box 3. Replacement element part numbers are identical to contents of Boxes 3 and 4.

Box 4. Viton® is a registered trademark of DuPont Dow Elastomers.

Box 6. Please note indicator flow limitations on pressure drop graph, previous page.



# High-Pressure Sandwich Filter

# FOF60-30



## Features and Benefits

- Sandwich filter configured for D03 subplate pattern
- Withstands high pressure surges, high static pressure loads
- 3000 psi collapse elements

**12 gpm**  
**45 L/min**  
**6000 psi**  
**415 bar**

NF30  
 NFS30  
 YF30  
 CFX30  
 PLD  
 CF40  
 DF40  
 PF40  
 RFS50  
 RF60  
 CF60  
 CTF60  
 VF60  
 LW60  
 KF30  
 KF50  
 TF50  
 KC50

Model No. of filter in photograph is FOF601FZX303BD5.

Flow Rating:	Up to 12 gpm (45 L/min) for 150 SUS (32 cSt) fluids
Max. Operating Pressure:	6000 psi (415 bar)
Min. Yield Pressure:	26,000 psi (1790 bar), per NFPA T2.6.1
Rated Fatigue Pressure:	4000 psi (275 bar), per NFPA T2.6.1
Temp. Range:	-20°F to 225°F (-29°C to 107°C)
Non-Bypass Model:	Available with high collapse elements
Porting Head:	Steel
Element Case:	Steel
Weight:	7.3 lbs. (3.3 kg)
Element Change Clearance:	4.50" (115 mm)

## Filter Housing Specifications

MKF50  
 MKC50  
 KC65  
 MKC65  
 HS60  
 MHS60  
 KFH50  
 LC60  
 LC35  
 LC50

Type Fluid	Appropriate Schroeder Media
Petroleum Based Fluids	All Z-Media® (synthetic)
High Water Content	3 and 10 μ Z-Media® (synthetic)

## Fluid Compatibility

NOF30-05  
 NOF-50-760  
**FOF60-03**  
 NMF30  
 RMF60  
 14-CRZX10  
 20-CRZX10



$\Delta P_{\text{housing}}$

FOF60-03  $\Delta P_{\text{housing}}$  for fluids with sp gr (specific gravity) = 0.86:

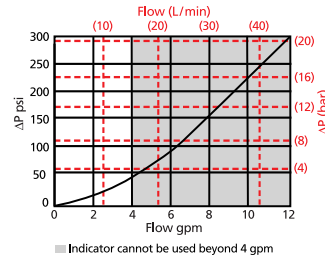

$\Delta P_{\text{element}}$

FXZ

Element Pressure Drop versus Flow Rate at 32 cSt (150 SUS)

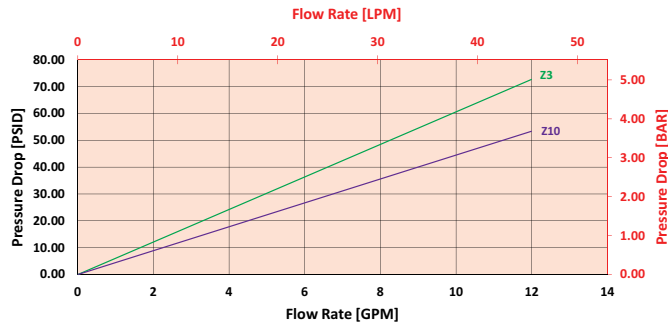

Pressure Drop Information Based on Flow Rate and Viscosity

$$\Delta P_{\text{filter}} = \Delta P_{\text{housing}} + (\Delta P_{\text{element}} * V_f)$$

**Exercise:**

Determine  $\Delta P_{\text{filter}}$  at 5 gpm (19 L/min) for FOF601FZX1003BD5 using 160 SUS (34 cSt) fluid.

Use the housing pressure curve to determine  $\Delta P_{\text{housing}}$  at 5 gpm. In this case,  $\Delta P_{\text{housing}}$  is 60 psi (4.1 bar) on the graph for the FOF60 housing.

Use the element pressure curve to determine  $\Delta P_{\text{element}}$  at 5 gpm. In this case,  $\Delta P_{\text{element}}$  is 22 psi (1.5 bar) according to the graph for the FZX10 element.

Because the viscosity in this sample is 160 SUS (34 cSt), we determine the **Viscosity Factor ( $V_f$ )** by dividing the **Operating Fluid Viscosity** with the **Standard Viscosity** of 150 SUS (32 cSt). To best determine your Operating Fluid Viscosity, please reference the chart in Appendix D.

Finally, the overall filter pressure differential,  $\Delta P_{\text{filter}}$ , is calculated by adding  $\Delta P_{\text{housing}}$  with the true element pressure differential,  $(\Delta P_{\text{element}} * V_f)$ . The  $\Delta P_{\text{element}}$  from the graph has to be multiplied by the viscosity factor to get the true pressure differential across the element.

**Solution:**

$\Delta P_{\text{housing}} = 60 \text{ psi [4.1 bar]} \mid \Delta P_{\text{element}} = 22 \text{ psi [1.5 bar]}$

$V_f = 160 \text{ SUS (34 cSt)} / 150 \text{ SUS (32 cSt)} = 1.1$

$\Delta P_{\text{filter}} = 60 \text{ psi} + (22 \text{ psi} * 1.1) = 64.2 \text{ psi}$

**OR**

$\Delta P_{\text{filter}} = 4.1 \text{ bar} + (1.5 \text{ bar} * 1.1) = 5.8 \text{ bar}$

## Filter Model Number Selection

### How to Build a Valid Model Number for a Schroeder FOF60-03:

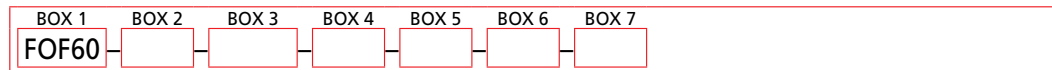

Example: NOTE: One option per box

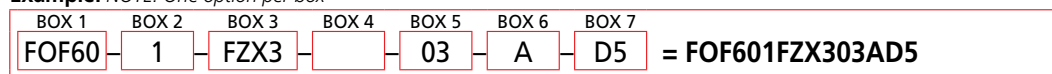

BOX 1	BOX 2	BOX 3	BOX 4	BOX 5
<b>Filter Series</b>	<b>Number of Elements</b>	<b>Element Part Number</b>	<b>Seal Material</b>	<b>Porting</b>
FOF60	1	FZX3 = F size 3 μ high collapse media FZX10 = F size 10 μ high collapse media	Omit = Buna N V = Viton®	03 = D03 subplate pattern

BOX 6	BOX 7
<b>Filter Bowl Location</b>	<b>Dirt Alarm® Options</b>
A = Bowl adjacent to Port "A"	None      Omit = None
B = Bowl adjacent to Port "B"	Visual      D5 = Visual pop-up
(Refer to drawing on page 140.)	Visual with Thermal Lockout      D8 = Visual w/ thermal lockout
	Electrical
	MS5 = Electrical w/ 12 in. 18 gauge 4-conductor cable
	MS5LC = Low current MS
	MS10 = Electrical w/ DIN connector (male end only)
	MS10LC = Low current MS10
	MS11 = Electrical w/ 12 ft. 4-conductor wire
	MS12 = Electrical w/ 5 pin Brad Harrison connector (male end only)
	MS12LC = Low current MS12
	MS16 = Electrical w/ weather-packed sealed connector
	MS16LC = Low current MS16
	MS17LC = Electrical w/ 4 pin Brad Harrison male connector
	Electrical with Thermal Lockout
	MS5T = MS5 (see above) w/ thermal lockout
	MS5LCT = Low current MS5T
	MS10T = MS10 (see above) w/ thermal lockout
	MS10LCT = Low current MS10T
	MS12T = MS12 (see above) w/ thermal lockout
	MS12LCT = Low current MS12T
	MS16T = MS16 (see above) w/ thermal lockout
	MS16LCT = Low current MS16T
	MS17LCT = Low current MS17T
	Electrical Visual
	MS13 = Supplied w/ threaded connector & light
	MS14 = Supplied w/ 5 pin Brad Harrison connector & light (male end)
	Electrical Visual with Thermal Lockout
	MS13DCT = MS13 (see above), direct current, w/ thermal lockout
	MS13DCLCT = Low current MS13DCT
	MS14DCT = MS14 (see above), direct current, w/ thermal lockout
	MS14DCLCT = Low current MS14DCT

#### NOTES:

Box 3. Replacement element part numbers are identical to contents of Boxes 3 and 4.

Box 4. Viton® is a registered trademark of DuPont Dow Elastomers.

Box 7. Dirt Alarm® cannot be used beyond 4 gpm. Filters ordered without a Dirt Alarm do not include a machined indicator port. Therefore, one cannot be added at a later date.

# Manifold Filter Kit

# NMF30

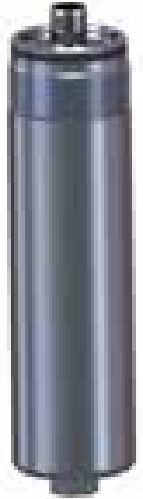

### Features and Benefits

- Allows for effective filtration in customer's manifold

**20 gpm**  
**75 L/min**  
**3000 psi**  
**210 bar**

NF30  
NFS30  
YF30  
CFX30  
PLD  
CF40  
DF40  
PF40  
RFS50  
RF60  
CF60

Model No. of filter in photograph is NMF301NNZX10.

Flow Rating:	Up to 20 gpm (75 L/min) for 150 SUS (32 cSt) fluids
Max. Operating Pressure:	3000 psi (210 bar)*
Min. Yield Pressure:	10,000 psi (690 bar)*, per NFPA T2.6.1
Rated Fatigue Pressure:	2400 psi (185 bar)*, per NFPA T2.6.1
Temp. Range:	-20°F to 225°F (-29°C to 107°C)
Element Case:	Aluminum
Element Change Clearance:	4.50" (115 mm)

### Filter Housing Specifications

CTF60  
VF60  
LW60  
KF30  
KF50

\*Only with manifold material properties equivalent to aluminum 6061-T651.

Type Fluid
Petroleum Based Fluids
High Water Content

### Fluid Compatibility

TF50  
KC50  
MKF50

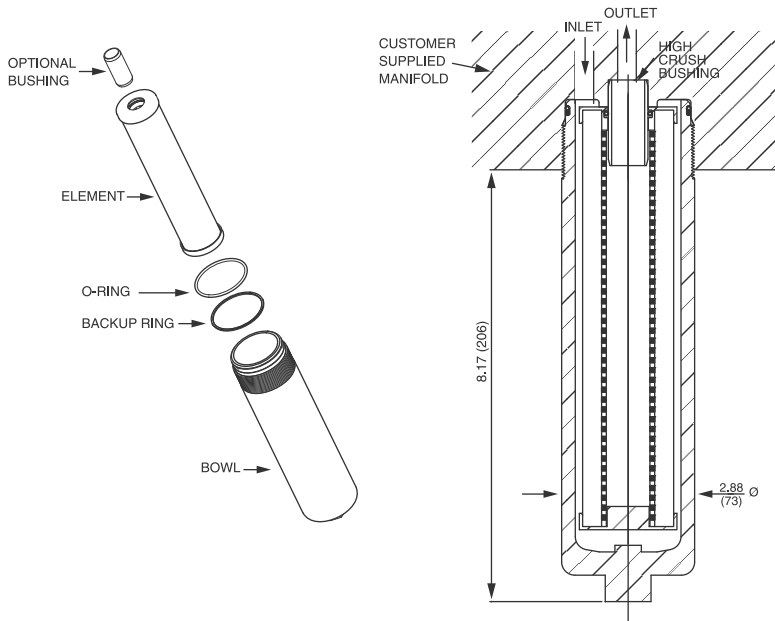

MKC50  
KC65  
MKC65  
HS60  
MHS60  
KFH50  
LC60  
LC35  
LC50  
NOF30-05  
NOF-50-760  
FOF60-03

### NMF30

RMF60  
14-CRZX10  
20-CRZX10

Metric dimensions in ( ).  
Dimensions shown are inches (millimeters) for general information and overall envelope size only.  
For complete dimensions please contact Schroeder Industries to request a certified print.

## Element Performance Information & Dirt Holding Capacity

Element	Filtration Ratio Per ISO 4572/NFPA T3.10.8.8 Using automated particle counter (APC) calibrated per ISO 4402			Filtration Ratio per ISO 16889 Using APC calibrated per ISO 11171		Dirt Holding Capacity gm
	$\beta_x \geq 75$	$\beta_x \geq 100$	$\beta_x \geq 200$	$\beta_x(\epsilon) \geq 200$	$\beta_x(\epsilon) \geq 1000$	
NNZX3	<1.0	<1.0	<2.0	4.7	5.8	11*
NNZX10	7.4	8.2	10.0	8.0	9.8	13*

Element	DHC (gm)
NNZX3	11*
NNZX10	13*

Element Collapse Rating: 3000 psid (210 bar)

Flow Direction: Outside In

Element Nominal Dimensions: 1.75" (45 mm) O.D. x 8.00" (200 mm) long

## Filter Model Number Selection

### How to Build a Valid Model Number for a Schroeder NMF30:

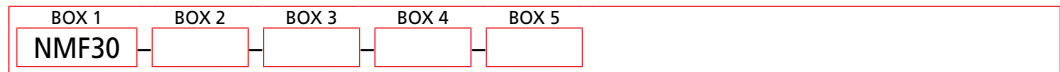

**Example:** NOTE: One option per box

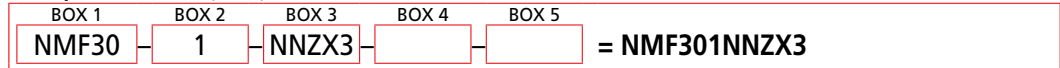

BOX 1	BOX 2	BOX 3	BOX 4	BOX 5
<b>Filter Series</b>	<b>Number of Elements</b>	<b>Element Part Number</b>	<b>Seal Material</b>	<b>Bushing</b>
NMF30	1	NNZX3 = NN size 3 $\mu$ high collapse media NNZX10 = NN size 10 $\mu$ high collapse media NNZX25 = NN size 25 $\mu$ high collapse media	Omit = Buna N V = Viton® W = Buna N	Omit = Included N = Not included

#### NOTES:

Box 3. Replacement element part numbers are identical to contents of Boxes 3 and 4.

Box 4. For options V and W, all aluminum parts are anodized. Viton® is a registered trademark of DuPont Dow Elastomers.

# Manifold Filter Kit

# RMF60



## Features and Benefits

- Allows for effective filtration in customer's manifold

**30 gpm**  
**115 L/min**  
**6000 psi**  
**415 bar**

NF30  
 NFS30  
 YF30  
 CFX30  
 PLD  
 CF40  
 DF40  
 PF40  
 RFS50  
 RF60  
 CF60

Model No. of filter in photograph is RMF608RZX10.

Flow Rating:	Up to 30 gpm (115 L/min) for 150 SUS (32 cSt) fluids
Max. Operating Pressure:	6000 psi (415 bar)*
Min. Yield Pressure:	18,000 psi (1240 bar)*
Rated Fatigue Pressure:	2300 psi (159 bar)*
Temp. Range:	-20°F to 225°F (-29°C to 107°C)
Element Case:	Steel
Element Change Clearance:	3.0" (75 mm)

## Filter Housing Specifications

CTF60  
 VF60  
 LW60  
 KF30  
 KF50  
 TF50

\*Only with manifold material properties equivalent to AISI 1018 C.R.S.

Type Fluid	Petroleum Based Fluids High Water Content
------------	--

## Fluid Compatibility

KC50  
 MKF50  
 MKC50  
 KC65  
 MKC65  
 HS60  
 MHS60  
 KFH50  
 LC60  
 LC35  
 LC50

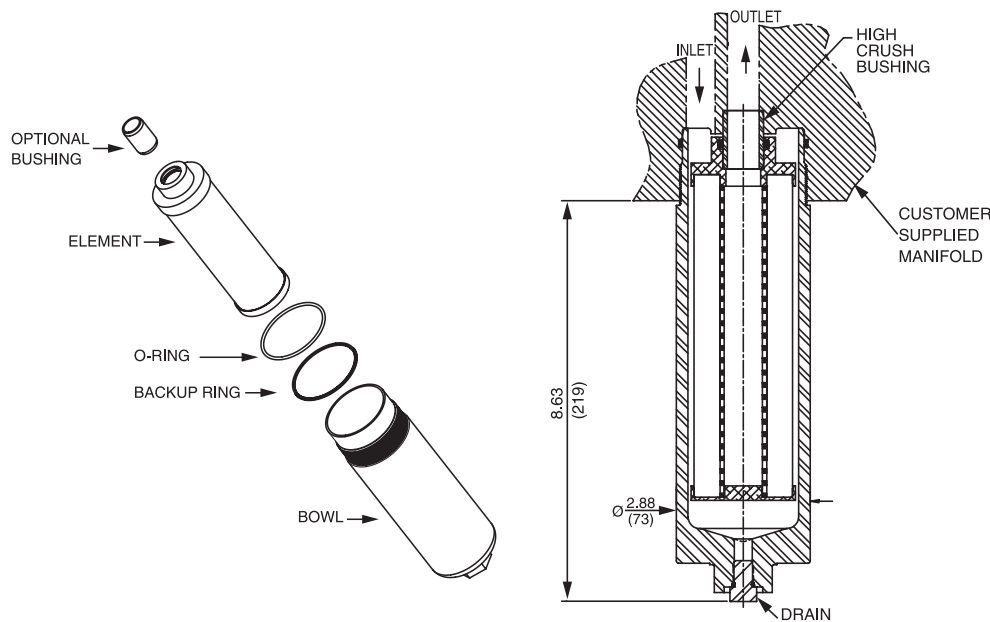

NOF30-05  
 NOF-50-760  
 FOF60-03  
 NMF30

## RMF60

14-CRZX10  
 20-CRZX10

Metric dimensions in ( ).  
 Dimensions shown are inches (millimeters) for general information and overall envelope size only.  
 For complete dimensions please contact Schroeder Industries to request a certified print.

## Element Performance Information & Dirt Holding Capacity

Element	Filtration Ratio Per ISO 4572/NFPA T3.10.8.8 Using automated particle counter (APC) calibrated per ISO 4402			Filtration Ratio per ISO 16889 Using APC calibrated per ISO 11171	
	$\beta_x \geq 75$	$\beta_x \geq 100$	$\beta_x \geq 200$	$\beta_x(c) \geq 200$	$\beta_x(c) \geq 1000$
NNZX3	<1.0	<1.0	<2.0	4.7	5.8
NNZX10	7.4	8.2	10.0	8.0	9.8

Element	DHC (gm)

Element Collapse Rating: 3000 psid (210 bar)  
 Flow Direction: Outside In  
 Element Nominal Dimensions: 2.18" (55mm) O.D. x 8.15" (206 mm) long

## Filter Model Number Selection

### How to Build a Valid Model Number for a Schroeder RMF60:

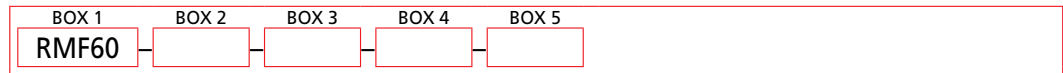

Example: NOTE: One option per box

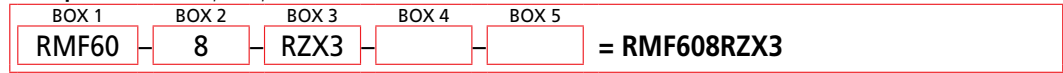

BOX 1	BOX 2	BOX 3	BOX 4	BOX 5
<b>Filter Series</b>	<b>Element Length</b>	<b>Element Size and Media</b>	<b>Seal Material</b>	<b>Bushing</b>
RMF60	8	RZX3 = E size 3 $\mu$ Excellement® Z-Media® (high collapse center tube) RZX10 = E size 10 $\mu$ Excellement® Z-Media® (high collapse center tube) RZX25 = E size 25 $\mu$ Excellement® Z-Media® (high collapse center tube)	Omit = Buna N V = Viton® H = EPR	Omit = Included N = Not included

#### NOTES:

Box 2: Replacement element part numbers are a combination of Boxes 2, 3, and 4. Example: 8RZX3V

Box 4: Viton® is a registered trademark of DuPont Dow Elastomers.



# Cartridge Element

# 14-CRZX10

## Features and Benefits (14-CRZX10)

- Cartridge filters are designed to be mounted directly in the manifold
- Withstands high pressure surges—3000 psi (210 bar) collapse rating

**6 gpm**  
**23 L/min**  
**3000 psi**  
**210 bar**

NF30  
NFS30  
YF30  
CFX30  
PLD

## Filter Housing Specifications

CF40  
DF40  
PF40

## Fluid Compatibility

RFS50  
RF60

## Element Performance Information & Dirt Holding Capacity

CF60  
CTF60  
VF60  
LW60  
KF30  
KF50  
TF50  
KC50

MKF50  
MKC50  
KC65

MKC65  
HS60  
MHS60

KFH50  
LC60  
LC35

LC50  
NOF30-05  
NOF-50-760

FOF60-03  
NMF30  
RMF60

**14-CRZX10**

20-CRZX10

Max. Operating Pressure:	3000 psi (210 bar)
Temp. Range:	-20°F to 225°F (-29°C to 107°C)
Element Change Clearance:	14-CRZX10: 4.50" (115 mm)

Type Fluid	Appropriate Schroeder Media
Petroleum Based Fluids	All Z-Media® (synthetic)
High Water Content	3 and 10 μ Z-Media® (synthetic)

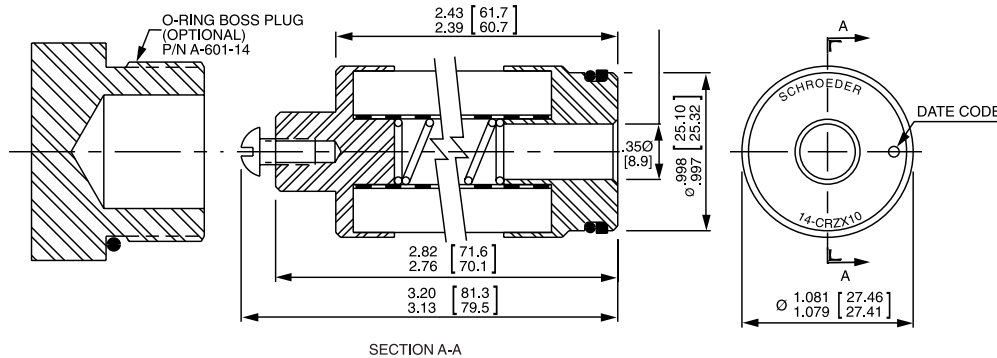

Metric dimensions in ( ).  
Dimensions shown are inches (millimeters) for general information and overall envelope size only.  
For complete dimensions please contact Schroeder Industries to request a certified print.

Element	Filtration Ratio Per ISO 4572/NFPA T3.10.8.8 Using automated particle counter (APC) calibrated per ISO 4402			Filtration Ratio per ISO 16889 Using APC calibrated per ISO 11171	
	$\beta_x \geq 75$	$\beta_x \geq 100$	$\beta_x \geq 200$	$\beta_x(\epsilon) \geq 200$	$\beta_x(\epsilon) \geq 1000$
ZX10	7.4	8.2	10.0	8.0	9.8

Contact factory for other media options.

Element	DHC (gm)
---------	----------

Element Collapse Rating: 3000 psid (210 bar) for high collapse (ZX) versions

Flow Direction: Outside In

Element Nominal Dimensions:

## How to Build a Valid Model Number for a Schroeder 14-CRZX10:



Example: NOTE: One option per box

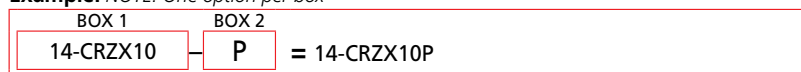

BOX 1 Filter Series	BOX 2 Number of Elements
14-CRZX10	Omit = No Plug P = Plug

NOTES:

Box 2: Replacement element part numbers are a combination of Boxes 2, 3, and 4. Example: 8RZX3V

Box 4: Viton® is a registered trademark of DuPont Dow Elastomers.

**12 gpm**  
**45 L/min**  
**3000 psi**  
**210 bar**

### Features and Benefits (20-CRZX10)

- Cartridge filters are designed to be mounted directly in the manifold
- Withstands high pressure surges—3000 psi (210 bar) collapse rating

### Filter Housing Specifications

Max. Operating Pressure:	3000 psi (210 bar)
Temp. Range:	-20°F to 225°F (-29°C to 107°C)
Element Change Clearance:	20-CRZX10: 3.50" (90 mm)

### Fluid Compatibility

Type Fluid	Appropriate Schroeder Media
Petroleum Based Fluids	All Z-Media® (synthetic)
High Water Content	3 and 10 μ Z-Media® (synthetic)

### Element Performance Information & Dirt Holding Capacity

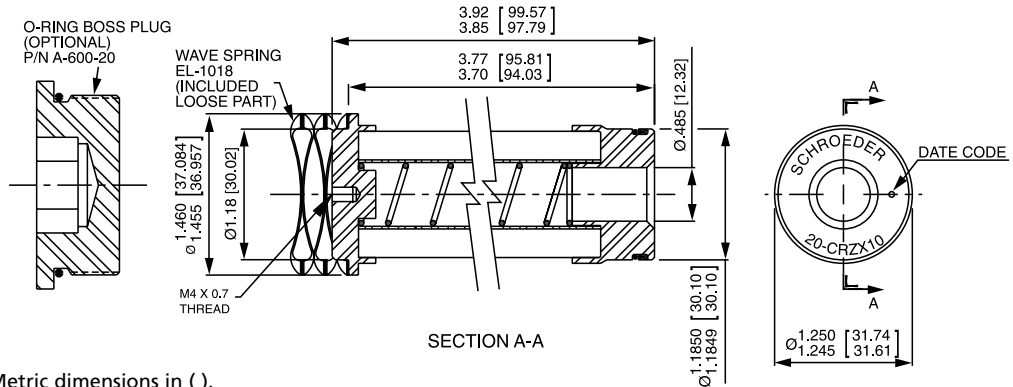

Metric dimensions in ( ).  
 Dimensions shown are inches (millimeters) for general information and overall envelope size only.  
 For complete dimensions please contact Schroeder Industries to request a certified print.

### Element Performance Information & Dirt Holding Capacity

Element	Filtration Ratio Per ISO 4572/NFPA T3.10.8.8 Using automated particle counter (APC) calibrated per ISO 4402			Filtration Ratio per ISO 16889 Using APC calibrated per ISO 11171	
	$\beta_x \geq 75$	$\beta_x \geq 100$	$\beta_x \geq 200$	$\beta_x(c) \geq 200$	$\beta_x(c) \geq 1000$
ZX10	7.4	8.2	10.0	8.0	9.8

Contact factory for other media options.

Element DHC (gm)

--	--

Element Collapse Rating: 3000 psid (210 bar) for high collapse (ZX) versions

Flow Direction: Outside In

\*Based on 100 psi terminal pressure

Element Nominal Dimensions:

### Filter Model Number Selection

#### How to Build a Valid Model Number for a Schroeder 20-CRZX10:



Example: NOTE: One option per box

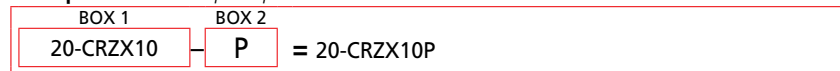

NOTES:

Box 2: Replacement element part numbers are a combination of Boxes 2, 3, and 4. Example: 8RZX3V

Box 4: Viton® is a registered trademark of DuPont Dow Elastomers.

BOX 1	BOX 2
Filter Series	Number of Elements
20-CRZX10	Omit = No Plug P = Plug

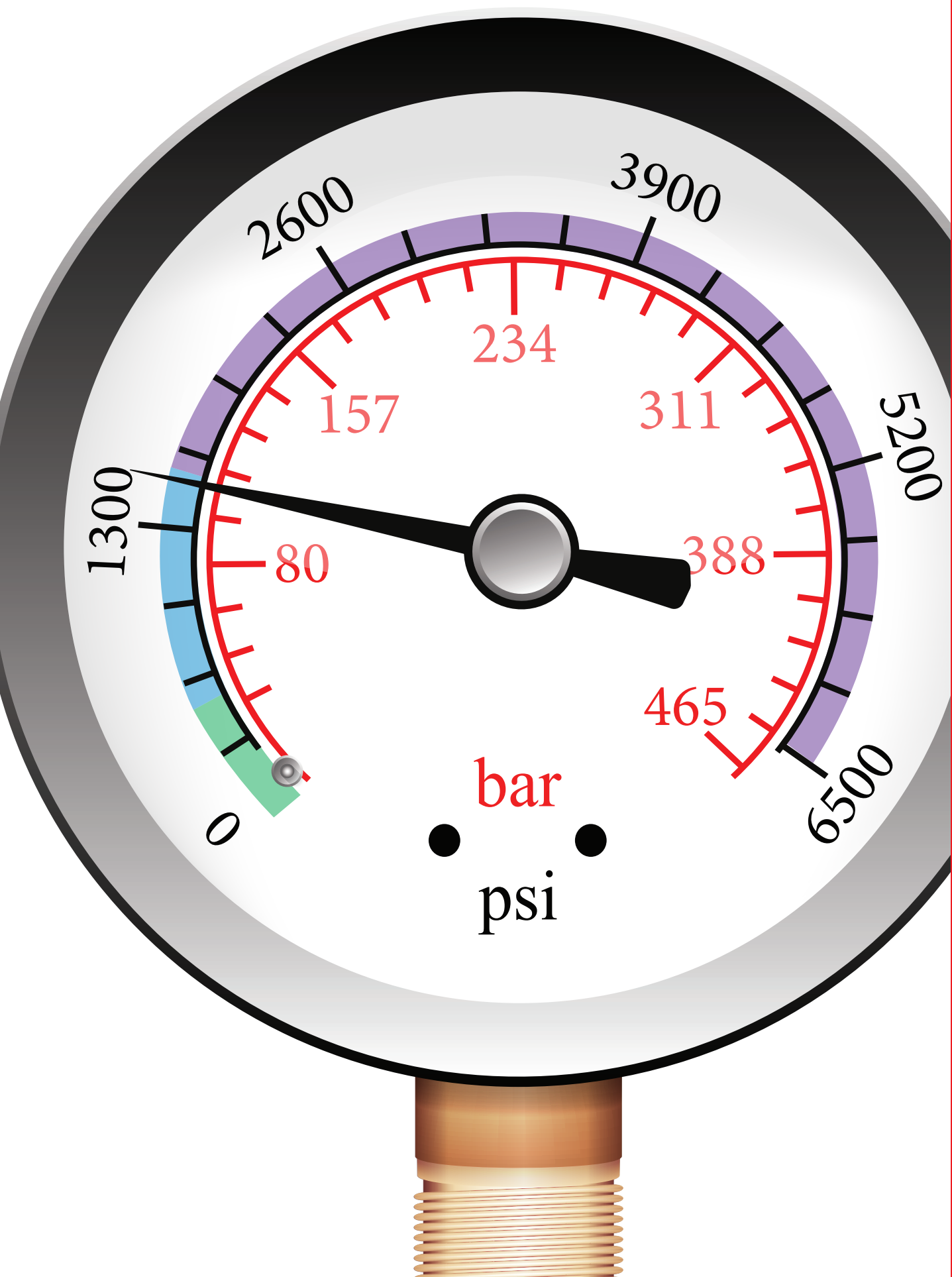

Section 4:  
up to 1500 psi

# MEDIUM PRESSURE FILTERS

# Section 4

# Medium Pressure Filters Selection Guide

		Pressure psi (bar)	Flow gpm (L/min)	Element Length/Size	Page
Medium Pressure Filters (up to 1500 psi)	<b>Top-Ported Medium Pressure Return Line Filters</b>				
	GH	725 (50)	35 (130)	6G, 9G	155
	RLT	1000 (69)	70 (265)	9V, 14V	161
	KF5	500 (35)	100 (380)	K	165
	SRLT	1400 (100)	25 (100)	6R	169
	<b>Base-Ported Medium Pressure Filters</b>				
	K9	900 (60)	100 (380)	K, KK, 27K	173
	2K9	900 (60)	100 (380)	K, KK, 27K	177
	3K9	900 (60)	100 (380)	K, KK, 27K	177
	QF5	500 (35)	300 (1135)	16Q, 16QCLQF, 16QPML, 39Q, 39QCLQF, 39QPML	181
	QF5i	500 (35)	120 (454)	16QCLQF, 39QCLQF	185
	3QF5	500 (35)	300 (1135)	16Q, 16QCLQF, 16QPML, 39Q, 39QCLQF, 39QPML	189
	QFD5	500 (35)	350 (1325)	16Q, 16QCLQF, 16QPML, 39Q, 39QCLQF, 39QPML	193
	QF15	1500 (100)	450 (1700)	16Q, 16QCLQF, 16QPML, 39Q, 39QCLQF, 39QPML	197
QLF15	1500 (100)	500 (1900)	16Q, 16QCLQF, 16QPML, 39Q, 39QCLQF, 39QPML	201	
SSQLF15	1500 (100)	500 (1900)	16Q, 16QPML, 39Q, 39QPML	205	

# HydraSPIN Filter Series

**GH**



## Features and Benefits

- Variety of differential indicator port options (visual and electrical indicators)
- Leak proof bar indicator, rugged visual indicator with protective aluminum shield is standard
- Proprietary bowl to element seal - minimizes potential leakage point by use of one seal on element
- Cartridge style element (non spin-on) that is proprietary and patented with integrated bypass valve features
- Wide variety of media grades that can be application specific
- Light weight bowl design with replaceable element minimizes landfill waste
- Mounting interchangeability with competitor's filter head
- The inherent capability to pre-print the perforated outer element wrap provides a branding solution that helps to capture after-market replacement element sales
- Same day shipment model available (GH6 & GH9)

Part of Schroeder Industries Energy Savings Initiative

**35-112 gpm** **GH**  
**130-425 L/min** **RLT**  
**500-725 psi**  
**35-50 bar** **KF5**

**SRLT**

**K9**

**2K9**

**3K9**

**QF5**

**QF5i**

**3QF5**

**QFD5**

**QF15**

**QLF15**

**SSQLF15**

Model No. of filters in photograph are GH6, GH9, GH11, and GH14.

	GH6	GH9	GH11	GH14
<b>Flow Rating:</b> (150 SUS (32 cSt) fluids)	Up to 35 gpm (130 L/min)	Up to 35 gpm (130 L/min)	Up to 87 gpm (325 L/min)	Up to 112 gpm (425 L/min)
<b>Max. Operating Pressure:</b>	725 psi (50 bar)	725 psi (50 bar)	500 psi (35 bar)	500 psi (35 bar)
<b>Min. Yield Pressure:</b>	2600 psi (179 bar)	2600 psi (179 bar)	2700 psi (186 bar)	2700 psi (186 bar)
<b>Rated Fatigue Pressure:</b>	725 psi (50 bar)	725 psi (50 bar)	500 psi (35 bar)	500 psi (35 bar)
<b>Temp. Range:</b>	-20°F to 225°F (-29°C to 107°C)	-20°F to 225°F (-29°C to 107°C)	-22°F to 212°F (-30°C to 100°C)	-22°F to 212°F (-30°C to 100°C)
<b>Bypass Setting:</b>	25 psi (1.7 bar) standard 50 psi (3.5 bar) optional Non-Bypassing	25 psi (1.7 bar) standard 50 psi (3.5 bar) optional Non-Bypassing	43 psi (3 bar) standard 87 psi (6 bar) optional Non-Bypassing	43 psi (3 bar) standard 87 psi (6 bar) optional Non-Bypassing
<b>Porting Head:</b>	Cast Aluminum	Cast Aluminum	Cast Aluminum	Cast Aluminum
<b>Element Case:</b>	Aluminum	Aluminum	Aluminum	Aluminum
<b>Weight:</b>	3.2 lbs (1.4 kg)	3.8 lbs (1.7 kg)	8.0 lbs (3.6 kg)	10.0 lbs (4.5 kg)
<b>Element Change Clearance:</b>	2" (50 mm)	2" (50 mm)	7.4" (187 mm)	7.4" (187 mm)

## Filter Housing Specifications

Type Fluid	Appropriate Schroeder Media
Petroleum Based Fluids	All media (synthetic) and H media (Hydraspin)

## Fluid Compatibility

## Dimensions (GH6 & GH9)

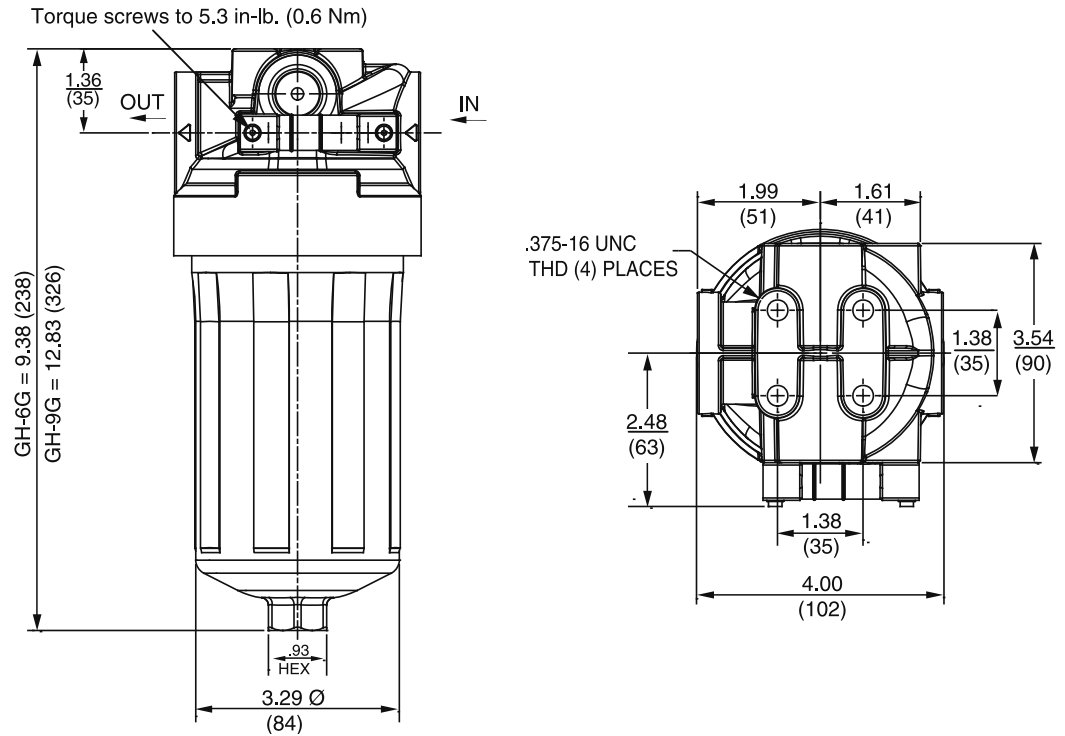

Metric dimensions in ( ).

## Element Performance Information & Dirt Holding Capacity

Media Type	Element	Filtration Ratio Per ISO 4572/NFPA T3.10.8.8 Using automated particle counter (APC) calibrated per ISO 4402			Filtration Ratio per ISO 16889 Using APC calibrated per ISO 11171	
		$\beta_x \geq 75$	$\beta_x \geq 100$	$\beta_x \geq 200$	$\beta_x(c) \geq 200$	$\beta_x(c) \geq 1000$
Resin Impregnated Cellulose Media	6G3/9G3	6.8	7.5	10.0	N/A	N/A
	6G10/9G10	15.5	16.2	18.0	N/A	N/A
Traditional Excellement® Z-Media®	6GZ3 / 9GZ3	<1.0	<1.0	<2.0	<4.0	4.8
	6GZ5 / 9GZ5	2.5	3.0	4.0	4.8	6.3
	6GZ10 / 9GZ10	7.4	8.2	10.0	8.0	10.0
	6GZ25 / 9GZ25	18.0	20.0	22.5	19.0	24.0
Hydraspin H Media, designed to specifically reduce filter pressure drop	6GH10/ 9GH10	N/A	N/A	N/A	10.6	13.0

Media Type	Element	DHC (gm)
Resin Impregnated Cellulose Media	6G3/9G3	18/30
	6G10/9G10	15/25
Traditional Excellement® Z-Media®	6GZ3 / 9GZ3	30/51
	6GZ5 / 9GZ5	24.5/42
	6GZ10 / 9GZ10	31/49
	6GZ25 / 9GZ25	34/58
Hydraspin H Media, designed to specifically reduce filter pressure drop	6GH10/9GH10	12/20

Element Collapse Rating: 250 psid (17.2 bar) for standard and non-bypassing elements

Flow Direction: Outside In

Element Nominal 6G: 3.25" (82 mm) O.D. x 5.7" (144 mm) long

Dimensions: 9G: 3.25" (82 mm) O.D. x 9.0" (229 mm) long

## Dimensions (GH11 & GH14)

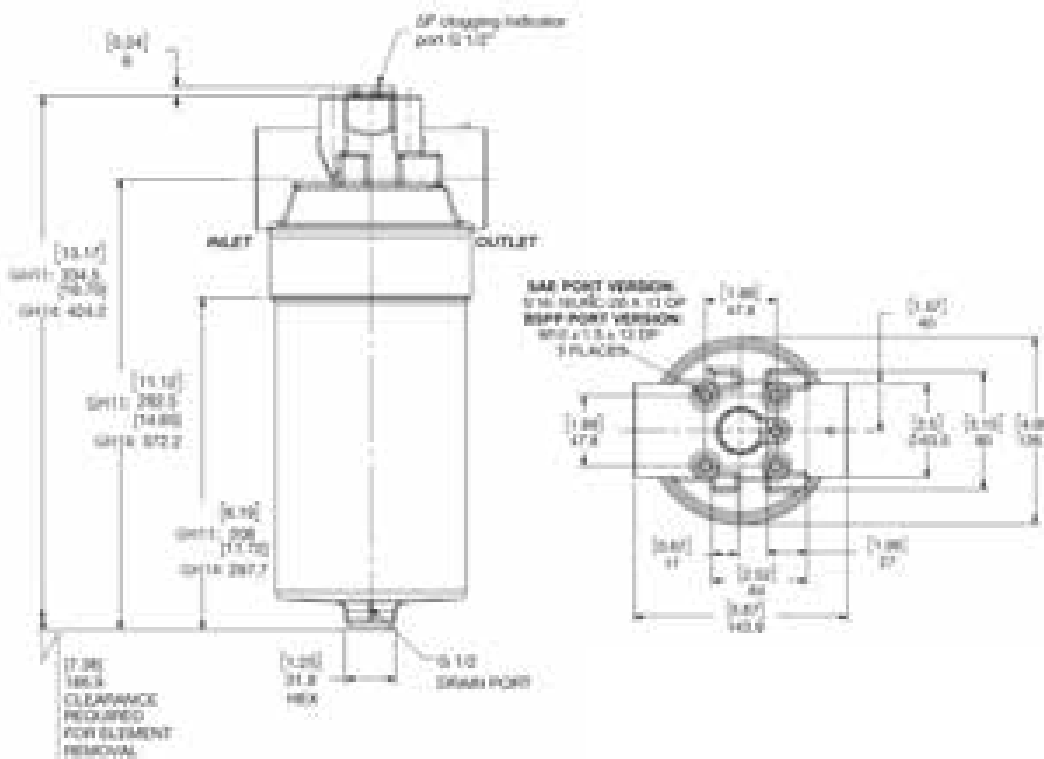

Metric dimensions in ( ).

Media Type	Element	Filtration Ratio Per ISO 4572/NFPA T3.10.8.8 Using automated particle counter (APC) calibrated per ISO 4402			Filtration Ratio per ISO 16889 Using APC calibrated per ISO 11171	
		$\beta_x \geq 75$	$\beta_x \geq 100$	$\beta_x \geq 200$	$\beta_x(c) \geq 200$	$\beta_x(c) \geq 1000$
Traditional Excellement® Z-Media®	11GZ3/14GZ3 11GZ5/14GZ5 11GZ10/14GZ10 11GZ25/14GZ25	Consult Factory			Consult Factory	

Media Type	Element	DHC (gm)
Traditional Excellement® Z-Media®	11GZ3/14GZ3 11GZ5/14GZ5 11GZ10/14GZ10 11GZ25/14GZ25	Contact Factory

Element Collapse Rating: 290 psid (17.2 bar) for standard and non-bypassing elements

Flow Direction: Outside In

Element Nominal 11G: 3.25" (82 mm) O.D. x 5.7" (144 mm) long

Dimensions: 14G: 3.25" (82 mm) O.D. x 9.0" (229 mm) long

## Element Performance Information & Dirt Holding Capacity

**Pressure Drop Information (GH6 & GH9)**  
Based on Flow Rate and Viscosity

$\Delta P_{\text{housing}}$

GH  $\Delta P_{\text{housing}}$  for fluids with sp gr (specific gravity) = 0.86:

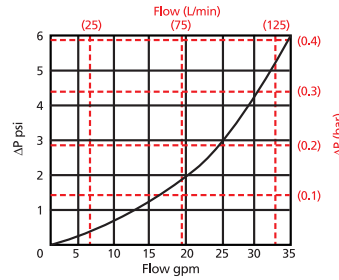

$\Delta P_{\text{element}}$

6GZ

Element Pressure Drop versus Flow Rate at 32 cSt (150 SUS)

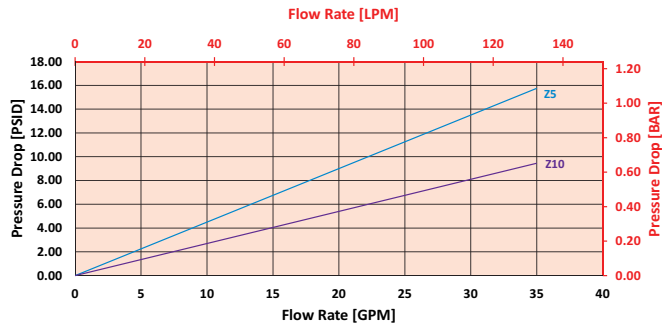

9GZ

Element Pressure Drop versus Flow Rate at 32 cSt (150 SUS)

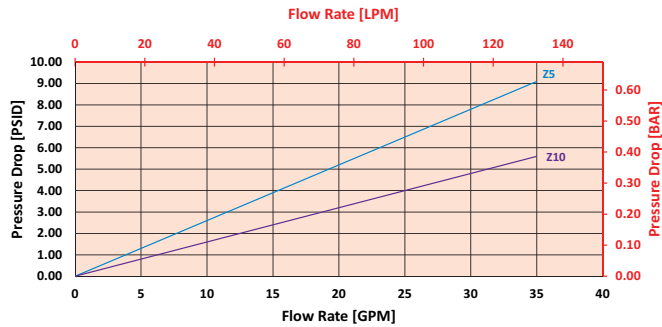

$$\Delta P_{\text{filter}} = \Delta P_{\text{housing}} + (\Delta P_{\text{element}} * \mathbf{V}_f)$$

**Exercise:**

Determine  $\Delta P_{\text{filter}}$  at 15 gpm (57 L/min) for GH6GZ10S12L using 160 SUS (34 cSt) fluid.

Use the housing pressure curve to determine  $\Delta P_{\text{housing}}$  at 15 gpm. In this case,  $\Delta P_{\text{housing}}$  is 1.5 psi (0.10 bar) on the graph for the GH housing.

Use the element pressure curve to determine  $\Delta P_{\text{element}}$  at 15 gpm. In this case,  $\Delta P_{\text{element}}$  is 4 psi (0.27 bar) according to the graph for the 6GZ10 element.

Because the viscosity in this sample is 160 SUS (34 cSt), we determine the **Viscosity Factor ( $\mathbf{V}_f$ )** by dividing the **Operating Fluid Viscosity** with the **Standard Viscosity** of 150 SUS (32 cSt). To best determine your Operating Fluid Viscosity, please reference the chart in Appendix D.

Finally, the overall filter pressure differential,  $\Delta P_{\text{filter}}$ , is calculated by adding  $\Delta P_{\text{housing}}$  with the true element pressure differential,  $(\Delta P_{\text{element}} * \mathbf{V}_f)$ . The  $\Delta P_{\text{element}}$  from the graph has to be multiplied by the viscosity factor to get the true pressure differential across the element.

**Solution:**

$\Delta P_{\text{housing}} = 1.5 \text{ psi [0.10 bar]} \mid \Delta P_{\text{element}} = 4 \text{ psi [0.27 bar]}$

$\mathbf{V}_f = 160 \text{ SUS (34 cSt)} / 150 \text{ SUS (32 cSt)} = 1.1$

$\Delta P_{\text{filter}} = 1.5 \text{ psi} + (4 \text{ psi} * 1.1) = 5.9 \text{ psi}$

**OR**

$\Delta P_{\text{filter}} = 0.10 \text{ bar} + (0.27 \text{ bar} * 1.1) = 0.40 \text{ bar}$

Note:

If your element is not graphed, you can obtain your  $\Delta P_{\text{element}}$  by multiplying the flow rate by the following:  $\Delta P_{\text{element}} \text{ Factors} * \mathbf{V}_f$  (Visc. Factor)

$\Delta P_{\text{element}} \text{ Factors @ 150 SUS (32 cSt)}$

Ele.	$\Delta P$	Ele.	$\Delta P$
6G3	0.60	9G3	0.35
6G10	0.40	9G10	0.24
6G25	0.08	9G25	0.05
6GH10	C/F	9GH10	C/F
6GZ3	0.60	9GZ3	0.35
6GZ25	C/F	9GZ25	C/F



$\Delta P_{\text{housing}}$

GH  $\Delta P_{\text{housing}}$  for fluids with sp gr (specific gravity) = 0.86:

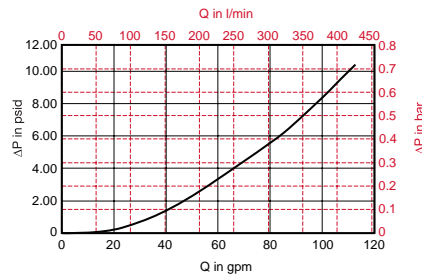

$\Delta P_{\text{element}}$

11GZ

Element Pressure Drop versus Flow Rate at 32 cSt (150 SUS)

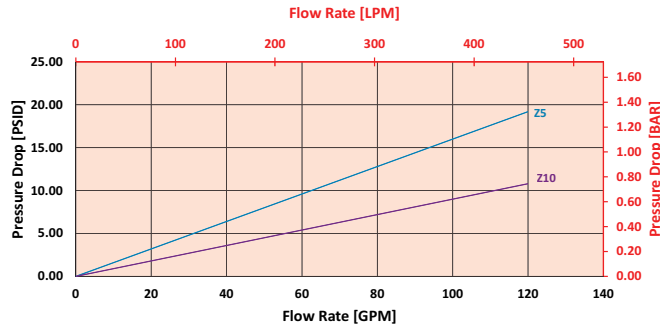

14GZ

Element Pressure Drop versus Flow Rate at 32 cSt (150 SUS)

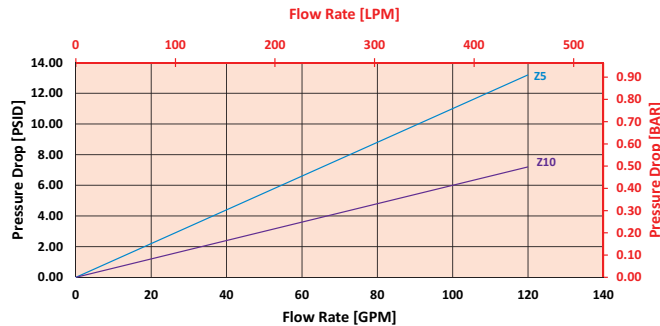

$$\Delta P_{\text{filter}} = \Delta P_{\text{housing}} + (\Delta P_{\text{element}} * \mathbf{V}_f)$$

### Exercise:

Determine  $\Delta P_{\text{filter}}$  at 60 gpm (227.4 L/min) for GH11GZ10S24VA using 160 SUS (34 cSt) fluid.

Use the housing pressure curve to determine  $\Delta P_{\text{housing}}$  at 60 gpm. In this case,  $\Delta P_{\text{housing}}$  is 3 psi (0.21 bar) on the graph for the GH housing.

Use the element pressure curve to determine  $\Delta P_{\text{element}}$  at 60 gpm. In this case,  $\Delta P_{\text{element}}$  is 5 psi (0.34 bar) according to the graph for the 11GZ10 element.

Because the viscosity in this sample is 160 SUS (34 cSt), we determine the **Viscosity Factor ( $\mathbf{V}_f$ )** by dividing the **Operating Fluid Viscosity** with the **Standard Viscosity** of 150 SUS (32 cSt). To best determine your Operating Fluid Viscosity, please reference the chart in Appendix D.

Finally, the overall filter pressure differential,  $\Delta P_{\text{filter}}$ , is calculated by adding  $\Delta P_{\text{housing}}$  with the true element pressure differential, ( $\Delta P_{\text{element}} * \mathbf{V}_f$ ). The  $\Delta P_{\text{element}}$  from the graph has to be multiplied by the viscosity factor to get the true pressure differential across the element.

### Solution:

$$\Delta P_{\text{housing}} = 3 \text{ psi [0.21 bar]} \quad | \quad \Delta P_{\text{element}} = 5 \text{ psi [0.34 bar]}$$

$$\mathbf{V}_f = 160 \text{ SUS (34 cSt)} / 150 \text{ SUS (32 cSt)} = 1.1$$

$$\Delta P_{\text{filter}} = 3 \text{ psi} + (5 \text{ psi} * 1.1) = 8.5 \text{ psi}$$

OR

$$\Delta P_{\text{filter}} = 0.21 \text{ bar} + (0.34 \text{ bar} * 1.1) = 0.58 \text{ bar}$$

**Pressure Drop Information (GH11 & GH14)**  
Based on Flow Rate and Viscosity

Note:  
If your element is not graphed, you can obtain your  $\Delta P_{\text{element}}$  by multiplying the flow rate by the following:  $\Delta P_{\text{element}} \text{ Factors} \times \mathbf{V}_f$  (Visc. Factor)  
 $\Delta P_{\text{element}} \text{ Factors @ 150 SUS (32 cSt)}$

Ele.	$\Delta P$
11GZ3	0.21
11GZ25	0.06
14GZ3	0.14
14GZ25	0.04

## Filter Model Number Selection (GH6 & GH9)

Highlighted product eligible for **QuickDelivery**

### How to Build a Valid Model Number for a Schroeder GH6/GH9:

BOX 1	BOX 2	BOX 3	BOX 4	BOX 5	BOX 6	BOX 7
GH						

Example: NOTE: One option per box

BOX 1	BOX 2	BOX 3	BOX 4	BOX 5	BOX 6	BOX 7
GH	6	GZ10			S16	L

= GH6GZ10S16L

BOX 1	BOX 2	BOX 3	BOX 4
Filter Series	Element Length (in)	Element Part Number	Bypass Setting
GH	6 9	G3 = 3 μ E media (cellulose) G10 = 10 μ E media (cellulose) G25 = 25 μ E media (cellulose)  GZ3 = 3 μ Excellement® Z-Media® (synthetic) GZ5 = 5 μ Excellement® Z-Media® (synthetic) GZ10 = 10 μ Excellement® Z-Media® (synthetic) GZ25 = 25 μ Excellement® Z-Media® (synthetic) GH10 = 10 μ Excellement® Hydraspin media	Omit = 25 psid 50 = 50 psid N = Non-bypassing

BOX 5	BOX 6	BOX 7
Element Seal Material	Inlet Port	Dirt Alarm® Options
Omit = Buna N	S12 = SAE-12 S16 = SAE-16 B12 = ISO 228 G-3/4" B16 = ISO 228 G-1"	Omit = None  Visual: <ul style="list-style-type: none"> <li>L = Bar indicator, left side std</li> <li>R = Bar indicator, right side std</li> <li>B = Bar indicators, left and right side</li> <li>VA = Visual pop-up w/auto reset</li> <li>VM = Visual pop-up w/manual reset</li> </ul> Omit = None M = Drilled, tapped, plugged Electrical: <ul style="list-style-type: none"> <li>DTC = DC 2 wire, normally closed (NC)</li> <li>DTO = DC 2 wire, normally open (NO)</li> <li>DW = AC/DC 3-wire (NO or NC)</li> </ul>

## Filter Model Number Selection (GH11 & GH14)

### How to Build a Valid Model Number for a Schroeder GH11/GH14:

BOX 1	BOX 2	BOX 3	BOX 4	BOX 5	BOX 6	BOX 7
GH						

Example: NOTE: One option per box

BOX 1	BOX 2	BOX 3	BOX 4	BOX 5	BOX 6	BOX 7
GH	11	GZ10	87		S24	VA

= GH11GZ1087S24VA

BOX 1	BOX 2	BOX 3	BOX 4
Filter Series	Element Length (in)	Element Part Number	Bypass Setting
GH	11 14	GZ3 = 3 μ Excellement® Z-Media® (synthetic) GZ5 = 5 μ Excellement® Z-Media® (synthetic) GZ10 = 10 μ Excellement® Z-Media® (synthetic) GZ25 = 25 μ Excellement® Z-Media® (synthetic)	Omit = 47 psid 87 = 87 psid N = Non-bypassing

BOX 5	BOX 6	BOX 7
Element Seal Material	Inlet Port	Dirt Alarm® Options
Omit = Buna N  V = Viton	B24 = ISO 228 G-1½" S24 = SAE 24 Straight Thread Ports	Omit = None  Visual: <ul style="list-style-type: none"> <li>VA = Visual pop-up w/auto reset</li> <li>VM = Visual pop-up w/manual reset</li> <li>VF = Visual analog</li> </ul> Electrical: <ul style="list-style-type: none"> <li>EC = Electrical switch - SPDT</li> <li>ED = Electrical switch and LED light - SPDT</li> </ul>

**NOTES:**

Box 2. Replacement element part numbers are a combination of Boxes 2, 3 and 4. Replacement elements contain bypass. For 50 psid setting or non-bypassing version, element part number includes suffix. Examples: 11GZ1050, 14GZ10N.

Box 7. VA and VM indicators are available with 50 psid bypass element only.

# Medium Pressure Filter

**RLT**



### Features and Benefits

- Durable, compact design
- Quick and easy cartridge element changeouts
- Available in 9" and 14" element lengths
- Lightweight at 8 pounds
- Offered in pipe, SAE straight thread, flange and ISO 228 porting
- Available with NPTF inlet and outlet female test ports
- Various Dirt Alarm® options
- Same day shipment model available

**70 gpm**  
**265 L/min**  
**1000 psi**  
**69 bar**

GH

**RLT**

KF5

SRLT

K9

2K9

3K9

QF5

QF5i

3QF5

QFD5

QF15

QLF15

SSQLF15

Model No. of filter in photograph is RLT9VZ10P20D5.

<b>Flow Rating:</b>	Up to 70 gpm (265 L/min) for 150 SUS (32 cSt) fluids for P20, S20, & B20 porting Up to 50 gpm (190 L/min) for 150 SUS (32 cSt) fluids for P16, S16, F16, F20 & B16 porting
<b>Max. Operating Pressure:</b>	1000 psi (69 bar)
<b>Min. Yield Pressure:</b>	4200 psi (290 bar), per NFPA T2.6.1
<b>Rated Fatigue Pressure:</b>	415 psi (29 bar), per NFPA T2.6.1-R1-2005
<b>Temp. Range:</b>	-20°F to 225°F (-29°C to 107°C)
<b>Bypass Setting:</b>	Cracking: 40 psi (2.8 bar) for all porting Full Flow: 57 psi (3.9 bar) for P20 & S20 porting Full Flow: 75 psi (5.2 bar) for P16, S16, F16 & F20 porting
<b>Porting Head:</b>	Aluminum
<b>Element Case:</b>	Aluminum
<b>Weight of RLT-9V:</b>	6.7 lbs. (3.0 kg)
<b>Weight of RLT-14V:</b>	8.0 lbs. (3.6 kg)
<b>Element Change Clearance:</b>	9V & 14V: 2.75" (70 mm)

### Filter Housing Specifications

Type Fluid	Appropriate Schroeder Media
Petroleum Based Fluids	All E media (cellulose) and Z-Media® (synthetic)
High Water Content	All Z-Media® (synthetic)
Invert Emulsions	10 and 25 μ Z-Media® (synthetic)
Water Glycols	3, 5, 10 and 25 μ Z-Media® (synthetic)
Phosphate Esters	All Z-Media® (synthetic) with H (EPR) seal designation
Skydrol®	3, 5, 10 and 25 μ Z-Media® (synthetic) with H.5 seal designation (EPR seals and stainless steel wire mesh in element, and light oil coating on housing exterior)

### Fluid Compatibility

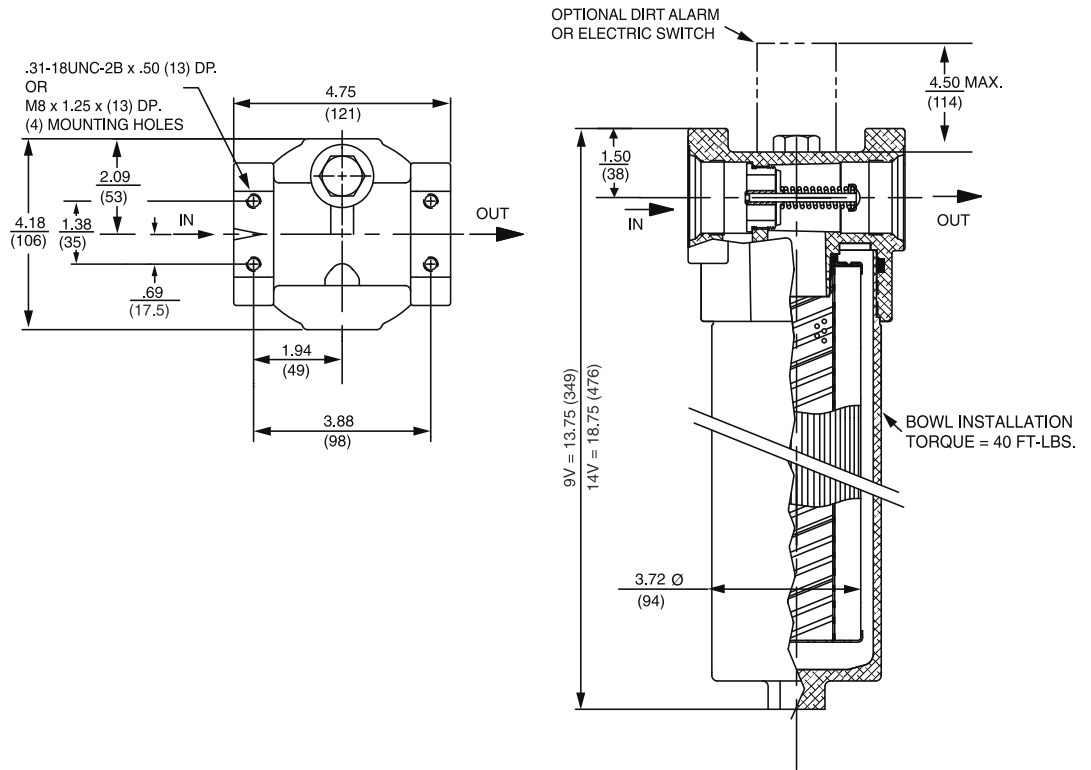

Metric dimensions in ( ).  
 Dimensions shown are inches (millimeters) for general information and overall envelope size only.  
 For complete dimensions please contact Schroeder Industries to request a certified print.

## Element Performance Information & Dirt Holding Capacity

Element	Filtration Ratio Per ISO 4572/NFPA T3.10.8.8 Using automated particle counter (APC) calibrated per ISO 4402			Filtration Ratio per ISO 16889 Using APC calibrated per ISO 11171	
	$\beta_x \geq 75$	$\beta_x \geq 100$	$\beta_x \geq 200$	$\beta_x(c) \geq 200$	$\beta_x(c) \geq 1000$
9VZ1/14VZ1	<1.0	<1.0	<1.0	<4.0	4.2
9VZ3/14VZ3	<1.0	<1.0	<2.0	<4.0	4.8
9VZ5/14VZ5	2.5	3.0	4.0	4.8	6.3
9VZ10/14VZ10	7.4	8.2	10.0	8.0	10.0
9VZ25/14VZ25	18.0	20.0	22.5	19.0	24.0

Element	DHC (gm)	Element	DHC (gm)
9VZ1	55	14VZ1	102
9VZ3	57	14VZ3	105
9VZ5	62	14VZ5	115
9VZ10	52	14VZ10	104
9VZ25	48	14VZ25	94

Element Collapse Rating: 150 psid (10 bar)  
 500 psid (34.5 bar) for hydrostatic high collapse (9V5Z and 14V5Z) version

Flow Direction: Outside In

Element Nominal Dimensions: 9V: 3.0" (75 mm) O.D. x 9.5" (240 mm) long  
 14V: 3.0" (75 mm) O.D. x 14.5" (370 mm) long

$\Delta P_{\text{housing}}$

RLT  $\Delta P_{\text{housing}}$  for fluids with sp gr (specific gravity) = 0.86:

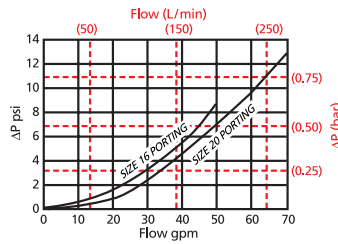

**Pressure Drop Information Based on Flow Rate and Viscosity**

$\Delta P_{\text{element}}$

9VZ

Element Pressure Drop versus Flow Rate at 32 cSt (150 SUS)

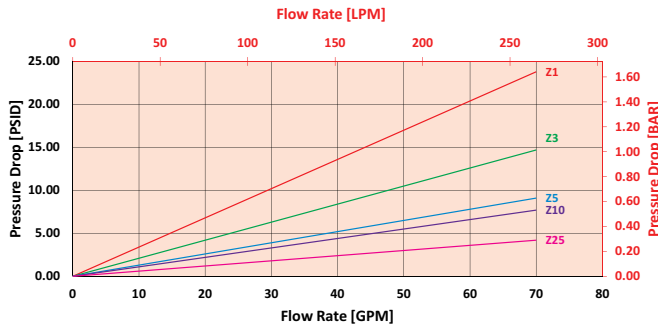

14VZ

Element Pressure Drop versus Flow Rate at 32 cSt (150 SUS)

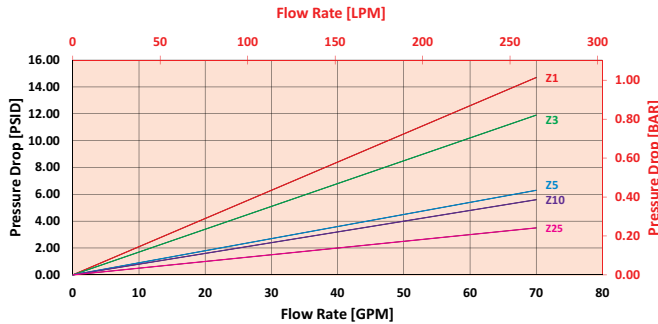

$$\Delta P_{\text{filter}} = \Delta P_{\text{housing}} + (\Delta P_{\text{element}} * \mathbf{V}_f)$$

**Exercise:**

Determine  $\Delta P_{\text{filter}}$  at 40 gpm (151.6 L/min) for RLT9VZ10S20D5 using 175 SUS (37.2 cSt) fluid.

Use the housing pressure curve to determine  $\Delta P_{\text{housing}}$  at 40 gpm. In this case,  $\Delta P_{\text{housing}}$  is 4.5 psi (.31 bar) on the graph for the RLT housing.

Use the element pressure curve to determine  $\Delta P_{\text{element}}$  at 40 gpm. In this case,  $\Delta P_{\text{element}}$  is 6 psi (.415 bar) according to the graph for the 9VZ10 element.

Because the viscosity in this sample is 175 SUS (37.2 cSt), we determine the **Viscosity Factor ( $\mathbf{V}_f$ )** by dividing the **Operating Fluid Viscosity** with the **Standard Viscosity** of 150 SUS (32 cSt). To best determine your Operating Fluid Viscosity, please reference the chart in Appendix D.

Finally, the overall filter pressure differential,  $\Delta P_{\text{filter}}$ , is calculated by adding  $\Delta P_{\text{housing}}$  with the true element pressure differential,  $(\Delta P_{\text{element}} * \mathbf{V}_f)$ . The  $\Delta P_{\text{element}}$  from the graph has to be multiplied by the viscosity factor to get the true pressure differential across the element.

**Solution:**

$\Delta P_{\text{housing}} = 4.5 \text{ psi } [.31 \text{ bar}] \mid \Delta P_{\text{element}} = 6 \text{ psi } [.415 \text{ bar}]$

$\mathbf{V}_f = 175 \text{ SUS } (37.2 \text{ cSt}) / 150 \text{ SUS } (32 \text{ cSt}) = 1.2$

$\Delta P_{\text{filter}} = 4.5 \text{ psi } + (6 \text{ psi } * 1.2) = 11.7 \text{ psi}$

**OR**

$\Delta P_{\text{filter}} = .31 \text{ bar } + (.415 \text{ bar } * 1.2) = .808 \text{ bar}$

Note:

If your element is not graphed, use the following equation:

$\Delta P_{\text{element}} = \text{Flow Rate} \times \Delta P_f$  Plug this variable into the overall pressure drop equation.

Ele.	$\Delta P$	Ele.	$\Delta P$
9V3	0.32	14V3	0.19
9V10	0.24	14V10	0.15

## Filter Model Number Selection

Highlighted product eligible for **QuickDelivery**

### How to Build a Valid Model Number for a Schroeder RLT:

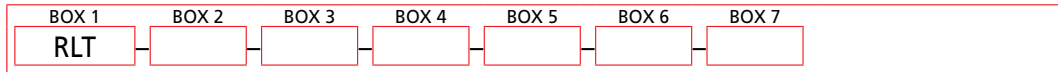

**Example:** NOTE: One option per box

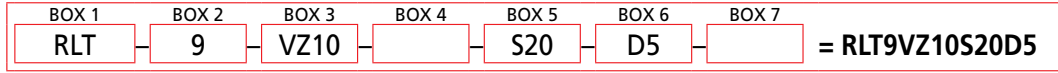

BOX 1	BOX 2	BOX 3	BOX 4
<b>Filter Series</b>	<b>Element Length (in)</b>	<b>Element Size and Media</b>	
RLT	9	VZ1 = V size 1 μ Excellement® Z-Media® (synthetic) VZ3 = V size 3 μ Excellement® Z-Media® (synthetic) VZ5 = V size 5 μ Excellement® Z-Media® (synthetic) VZ10 = V size 10 μ Excellement® Z-Media® (synthetic) VZ25 = V size 25 μ Excellement® Z-Media® (synthetic) VW = V size W media (water removal) V5Z3 = V size 3 μ Excellement® media, 500 psid collapse V5Z5 = V size 5 μ Excellement® media, 500 psid collapse V5Z10 = V size 10 μ Excellement® media, 500 psid collapse V5Z25 = V size 25 μ Excellement® media, 500 psid collapse	
RLTN <small>(Non-bypassing: requires V5Z high collapse elements)</small>	14	<b>Water Service Element Options</b> VM60 = V size 60 μ M media (reusable metal) VM150 = V size 150 μ M media ( reusable metal) VM260 = V size 260 μ M media (reusable metal)	
WRLT <small>(Water)</small>			
		<b>Seal Material</b>	
		Omit = Buna N H = EPR V = Viton® H.5 = Skydrol® Compatibility	

BOX 5	BOX 6	BOX 7
<b>Porting Options</b>	<b>Dirt Alarm® Options</b>	<b>Additional Options</b>
P16 = 1" NPTF P20 = 1¼" NPTF S16 = SAE-16 S20 = SAE-20 F20 = 1¼" SAE 4-bolt flange Code 61 B16 = ISO 228 G-1" B20 = ISO 228 G-1¼"	None      Omit = None Visual      D5 = Visual pop-up D8 = Visual w/ thermal lockout Electrical      MS5 = Electrical w/ 12 in. 18 gauge 4-conductor cable MS5LC = Low current MS5 MS10 = Electrical w/ DIN connector (male end only) MS10LC = Low current MS10 MS11 = Electrical w/ 12 ft. 4-conductor wire MS12 = Electrical w/ 5 pin Brad Harrison connector (male end only) MS12LC = Low current MS12 MS16 = Electrical w/ weather-packed sealed connector MS16LC = Low current MS16 MS17LC = Electrical w/ 4 pin Brad Harrison male connector Electrical      MS5T = MS5 (see above) w/ thermal lockout MS5LCT = Low current MS5T MS10T = MS10 (see above) w/ thermal lockout MS10LCT = Low current MS10T MS12T = MS12 (see above) w/ thermal lockout MS12LCT = Low current MS12T MS16T = MS16 (see above) w/ thermal lockout MS16LCT = Low current MS16T MS17LCT = Low current MS17T Electrical      MS13 = Supplied w/ threaded connector & light Visual            MS14 = Supplied w/ 5 pin Brad Harrison connector & light (male end) Electrical      MS13DCT = MS13 (see above), direct current, w/ thermal lockout Visual            MS13DCLCT = Low current MS13DCT with                MS14DCT = MS14 (see above), direct current, w/ thermal lockout Thermal            MS14DCLCT = Low current MS14DCT Lockout	Omit = None L = Two ¼" NPTF inlet and outlet female test ports

**NOTES:**

- Box 2. Replacement element part numbers are a combination of Boxes 2, 3, and 4. Example: 9VZ10V
- Box 3. E media elements are only available with Buna N seals. V5Z10 and V5Z25 are only available with RLTN 9".
- Box 4. For options H, V, and H.5, all aluminum parts are anodized. H.5 seal designation includes the following: EPR seals, stainless steel wire mesh on elements, and light oil coating on housing exterior. Viton® is a registered trademark of DuPont Dow Elastomers. Skydrol® is a registered trademark of Solutia Inc.
- Box 5. B porting supplied with metric mounting holes.

# Medium Pressure Filter

## KF5



Model No. of filter in photograph is KF51KZ10SD5.

### Features and Benefits

- Meets HF4 automotive standard
- Offered in pipe, SAE straight thread, flange and ISO 228 porting
- Available with NPTF inlet and outlet female test ports
- KFN5 non-bypass version with high collapse elements also available
- Various Dirt Alarm® options
- Allows consolidation of inventoried replacement elements by using K-size elements
- Also available with DirtCatcher® elements (KD & KKD)
- **G** Available with quality-protected GeoSeal® Elements (GKF5)

**100 gpm**  
**380 L/min**  
**500 psi**  
**35 bar**

GH

RLT

**KF5**

SRLT

K9

2K9

3K9

QF5

QF5i

3QF5

QFD5

QF15

QLF15

SSQLF15

Flow Rating:	Up to 100 gpm (380 L/min) for 150 SUS (32 cSt) fluids
Max. Operating Pressure:	500 psi (35 bar)
Min. Yield Pressure:	1500 psi (100 bar) , per NFPA T2.6.1
Rated Fatigue Pressure:	300 psi (35 bar), per NFPA T2.6.1-2005
Temp. Range:	-20°F to 225°F (-29°C to 107°C)
Bypass Setting:	Cracking: 40 psi (2.8 bar) Full Flow: 61 psi (4.2 bar)
Porting Head:	Grey Cast Iron
Element Case:	Steel
Weight of KF5-1K:	23.2 lbs. (10.5 kg)
Element Change Clearance:	2.0" (51 mm)

### Filter Housing Specifications

Type Fluid	Appropriate Schroeder Media
Petroleum Based Fluids	All E media (cellulose), Z-Media® and ASP® media (synthetic)
High Water Content	All Z-Media® (synthetic), 3, 5 and 10 µ ASP® media (synthetic)
Invert Emulsions	10 and 25 µ Z-Media® (synthetic), 10 µ ASP® media (synthetic)
Water Glycols	3, 5, 10 and 25 µ Z-Media® (synthetic), 3, 5 and 10 µ ASP® media (synthetic)
Phosphate Esters	All Z-Media® (synthetic) with H (EPR) seal designation and 3 and 10 µ E media (cellulose) with H (EPR) seal designation, 3, 5 and 10 µ ASP® media (synthetic)
Skydrol®	3, 5, 10 and 25 µ Z-Media® (synthetic) with H.5 seal designation (EPR seals & stainless steel wire mesh in element, and light oil coating on housing exterior), 3, 5 and 10 µ ASP® media (synthetic)

### Fluid Compatibility

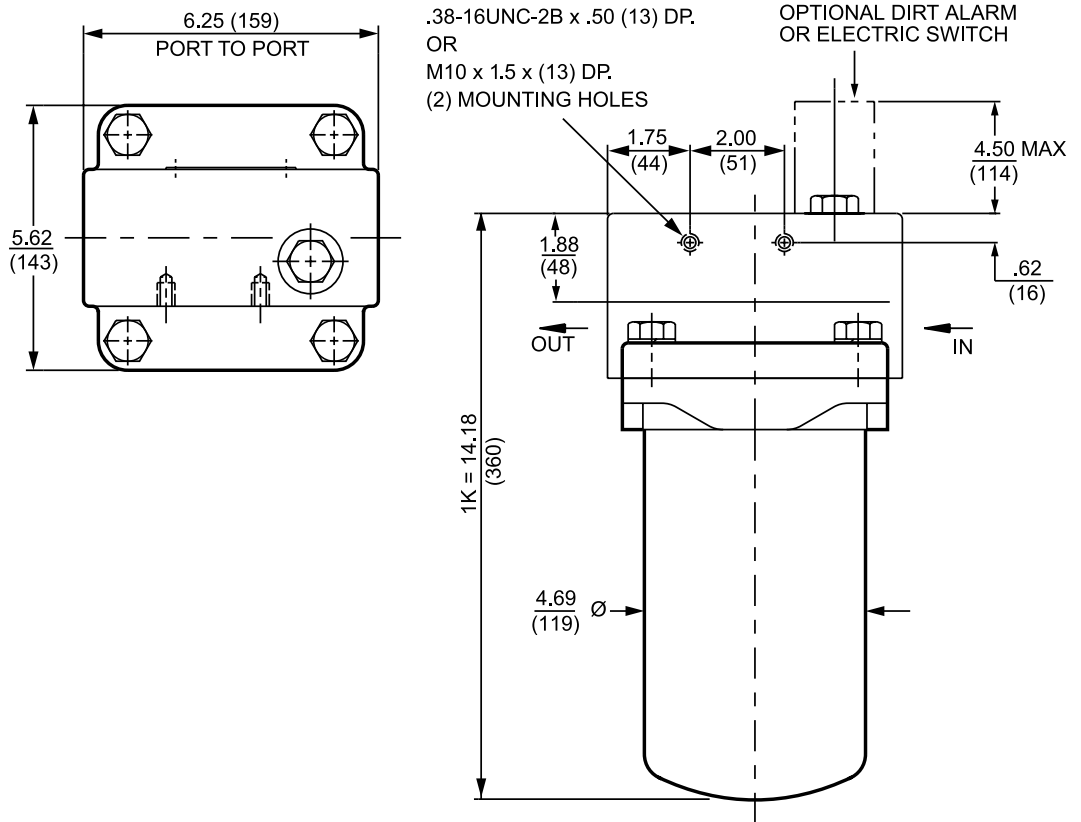

Metric dimensions in ( ).  
 Dimensions shown are inches (millimeters) for general information and overall envelope size only.  
 For complete dimensions please contact Schroeder Industries to request a certified print.

## Element Performance Information & Dirt Holding Capacity

Element	Filtration Ratio Per ISO 4572/NFPA T3.10.8.8 Using automated particle counter (APC) calibrated per ISO 4402			Filtration Ratio per ISO 16889 Using APC calibrated per ISO 11171	
	$\beta_x \geq 75$	$\beta_x \geq 100$	$\beta_x \geq 200$	$\beta_x(c) \geq 200$	$\beta_x(c) \geq 1000$
KZ1	<1.0	<1.0	<1.0	<4.0	4.2
KZ3	<1.0	<1.0	<2.0	<4.0	4.8
KZ5	2.5	3.0	4.0	4.8	6.3
KZ10	7.4	8.2	10.0	8.0	10.0
KZ25	18.0	20.0	22.5	19.0	24.0
KZW1	N/A	N/A	N/A	<4.0	<4.0
KZW3	N/A	N/A	N/A	4.0	4.8
KZW5	N/A	N/A	N/A	5.1	6.4
KZW10	N/A	N/A	N/A	6.9	8.6
KZW25	N/A	N/A	N/A	15.4	18.5

Element	DHC (gm)	Element	DHC (gm)	Element	DHC (gm)
KZ1	112	KZW1	61	KDZ1	89
KZ3/KAS3	115	KZW3	64	KDZ3	71
KZ5/KAS5	119	KZW5	63	KDZ5	100
KZ10/KAS10	108	KZW10	67	KDZ10	80
KZ25	93	KZW25	79	KDZ25	81

Element Collapse Rating: 150 psid (10 bar) for standard elements  
 Flow Direction: Outside In  
 Element Nominal Dimensions: 3.9" (99 mm) O.D. x 9.0" (230 mm) long



# Medium Pressure Filter

# KF5

$\Delta P_{\text{housing}}$

KF5  $\Delta P_{\text{housing}}$  for fluids with sp gr (specific gravity) = 0.86:

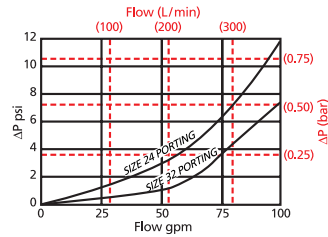

$\Delta P_{\text{element}}$

KZ

Element Pressure Drop versus Flow Rate at 32 cSt (150 SUS)

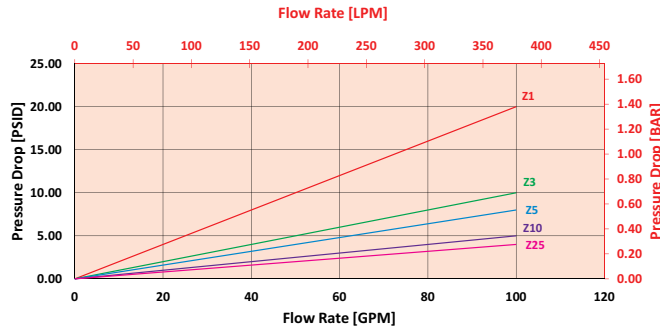

## Pressure Drop Information Based on Flow Rate and Viscosity

$$\Delta P_{\text{filter}} = \Delta P_{\text{housing}} + (\Delta P_{\text{element}} * \mathbf{V}_f)$$

### Exercise:

Determine  $\Delta P_{\text{filter}}$  at 50 gpm (189.5 L/min) for KF51KZ10S24D5 using 200 SUS (42.6 cSt) fluid.

Use the housing pressure curve to determine  $\Delta P_{\text{housing}}$  at 50 gpm. In this case,  $\Delta P_{\text{housing}}$  is 3 psi (.21 bar) on the graph for the KF5 housing.

Use the element pressure curve to determine  $\Delta P_{\text{element}}$  at 50 gpm. In this case,  $\Delta P_{\text{element}}$  is 2 psi (.14 bar) according to the graph for the KZ10 element.

Because the viscosity in this sample is 200 SUS (42.6 cSt), we determine the **Viscosity Factor ( $\mathbf{V}_f$ )** by dividing the **Operating Fluid Viscosity** with the **Standard Viscosity** of 150 SUS (32 cSt). To best determine your Operating Fluid Viscosity, please reference the chart in Appendix D.

Finally, the overall filter pressure differential,  $\Delta P_{\text{filter}}$ , is calculated by adding  $\Delta P_{\text{housing}}$  with the true element pressure differential,  $(\Delta P_{\text{element}} * \mathbf{V}_f)$ . The  $\Delta P_{\text{element}}$  from the graph has to be multiplied by the viscosity factor to get the true pressure differential across the element.

### Solution:

$$\Delta P_{\text{housing}} = 3 \text{ psi } [.21 \text{ bar}] \quad | \quad \Delta P_{\text{element}} = 2 \text{ psi } [.14 \text{ bar}]$$

$$\mathbf{V}_f = 200 \text{ SUS } (42.6 \text{ cSt}) / 150 \text{ SUS } (32 \text{ cSt}) = 1.3$$

$$\Delta P_{\text{filter}} = 3 \text{ psi } + (2 \text{ psi } * 1.3) = 5.6 \text{ psi}$$

OR

$$\Delta P_{\text{filter}} = .21 \text{ bar } + (.14 \text{ bar } * 1.3) = .40 \text{ bar}$$

Note:  
If your element is not graphed, use the following equation:  
 $\Delta P_{\text{element}} = \text{Flow Rate} \times \Delta P_f$  Plug this variable into the overall pressure drop equation.

Ele.	$\Delta P$
K3	0.25
K10	0.09
K25	0.02
KAS3	0.10
KAS5	0.08
KAS10	0.05
KDZ1	0.24
KDZ3	0.12
KDZ5	0.10
KDZ10	0.06
KDZ25	0.04
KZW1	0.43
KZW3	0.32
KZW5	0.28
KZW10	0.23
KZW25	0.14

## Filter Model Number Selection

### How to Build a Valid Model Number for a Schroeder KF5:

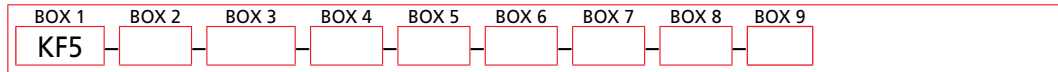

**Example:** NOTE: One option per box

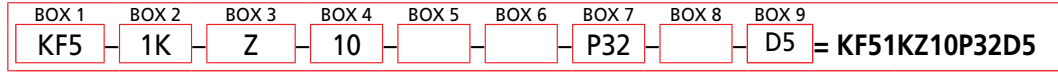

BOX 1	BOX 2	BOX 3	BOX 4
<b>Filter Series</b>	<b>Number &amp; Size of Elements</b>	<b>Media Type</b>	<b>Micron Rating</b>
KF5	1 K GeoSeal® Options 1 KG	Omit = E media (Cellulose) AS = Anti-Static Pleated media Z = Excellement® Z-Media® (Synthetic) ZW = Aqua-Excellement® ZW media ZX = Excellement® Z-Media® (High Collapse Centertube) W = Water Removal media M = M media (Reusable Metal) MXX = M media (reusable metal mesh; high collapse centertube) DZ = DirtCatcher® Excellement® Z-Media®	1 = 1 μ (Z, ZW, ZX and DZ media) 3 = 3 μ (E, AS, Z, ZW, ZX and DZ media) 5 = 5 μ (AS, Z, ZW, ZX and DZ media) 10 = 10 μ (E, AS, Z, ZW, ZX, M and DZ media) 25 = 25 μ (E, Z, ZW, ZX, M, MXX and DZ media) 60 = 60 μ (M media)

BOX 5	BOX 6	BOX 7
<b>Seal Material</b>	<b>Magnetic Option</b>	<b>Porting Options</b>
Omit = Buna N H = EPR V = Viton® H.5 = Skydrol® Compatibility	Omit = None M = Magnet Inserts	P24 = 1½" NPTF P32 = 2" NPTF S24 = SAE-24 S32 = SAE-32 F24 = 1½" SAE split 4-bolt flange Code 61 B24 = ISO 228 G-1½"

BOX 8	BOX 9
<b>Test Port Options</b>	<b>Dirt Alarm® Options</b>
Omit = None L = Two ¼" NPTF inlet and outlet female test ports	Omit = None Visual D = Pointer D5 = Visual pop-up Visual with Thermal Lockout D8 = Visual w/ thermal lockout Electrical MS5 = Electrical w/ 12 in. 18 gauge 4-conductor cable MS5LC = Low current MS5 MS10 = Electrical w/ DIN connector (male end only) MS10LC = Low current MS10 MS11 = Electrical w/ 12 ft. 4-conductor wire MS12 = Electrical w/ 5 pin Brad Harrison connector (male end only) MS12LC = Low current MS12 MS16 = Electrical w/ weather-packed sealed connector MS16LC = Low current MS16 MS17LC = Electrical w/ 4 pin Brad Harrison male connector Electrical with Thermal Lockout MS5T = MS5 (see above) w/ thermal lockout MS5LCT = Low current MS5T MS10T = MS10 (see above) w/ thermal lockout MS10LCT = Low current MS10T MS12T = MS12 (see above) w/ thermal lockout MS12LCT = Low current MS12T MS16T = MS16 (see above) w/ thermal lockout MS16LCT = Low current MS16T MS17LCT = Low current MS17T Electrical Visual MS = Cam operated switch w/ ½" conduit female connection MS13 = Supplied w/ threaded connector & light MS14 = Supplied w/ 5 pin Brad Harrison connector & light (male end) Electrical Visual with Thermal Lockout MS13DCT = MS13 (see above), direct current, w/ thermal lockout MS13DCLCT = Low current MS13DCT MS14DCT = MS14 (see above), direct current, w/ thermal lockout MS14DCLCT = Low current MS14DCT

**NOTES:**

Box 2. Replacement element part numbers are a combination of Boxes 2, 3, 4 and 5.  
Example: KZ10V  
High collapse media only available with KFN5.

Box 5. For options H, V, and H.5, all aluminum parts are anodized.  
H.5 seal designation includes the following: EPR seals, stainless steel wire mesh on elements, and light oil coating on housing exterior.  
Viton® is a registered trademark of DuPont Dow Elastomers.  
Skydrol® is a registered trademark of Solutia Inc.

Box 7. B porting supplied with metric mounting holes.

# Medium Pressure Filter

# SRLT



### Features and Benefits

- Smaller, compact version of the RLT
- Quick and easy cartridge element changeouts
- Lightweight at 3 pounds
- Offered in pipe, SAE straight thread and ISO 228 porting
- Available with NPTF inlet and outlet female test ports
- Various Dirt Alarm® options
- Same day shipment model available

**25 gpm**  
**100 L/min**  
**1400 psi**  
**100 bar**

GH

RLT

KF5

**SRLT**

K9

2K9

3K9

QF5

QF5i

3QF5

QFD5

QF15

QLF15

SSQLF15

Model No. of filter in photograph is SRLT6RZ10S12D5.

Flow Rating:	Up to 25 gpm (100 L/min) for 150 SUS (32 cSt) fluids
Max. Operating Pressure:	1400 psi (100 bar)
Min. Yield Pressure:	4000 psi (276 bar), per NFPA T2.6.1
Rated Fatigue Pressure:	750 psi (52 bar) per NFPA T2.6.1-R1-2005
Temp. Range:	-20°F to 225°F (-29°C to 107°C)
Bypass Setting:	Cracking: 40 psi (2.8 bar) Full Flow: 55 psi (3.8 bar)
Porting Head:	Aluminum
Element Case:	Aluminum
Weight of SRLT-6R:	3.0 lbs. (1.4 kg)
Weight of SRLT-12R:	4.5 lbs. (2 kg)
Element Change Clearance:	2.75" (70 mm)

### Filter Housing Specifications

Type Fluid	Appropriate Schroeder Media
Petroleum Based Fluids	All E media (cellulose) and Z-Media® (synthetic)
High Water Content	All Z-Media® (synthetic)
Invert Emulsions	10 and 25 µ Z-Media® (synthetic)
Water Glycols	3, 5, 10 and 25 µ Z-Media® (synthetic)
Phosphate Esters	All Z-Media® (synthetic) with H (EPR) seal designation
Skydrol®	3, 5, 10 and 25 µ Z-Media® (synthetic) with H.5 seal designation (EPR seals and stainless steel wire mesh in element, and light oil coating on housing exterior)

### Fluid Compatibility

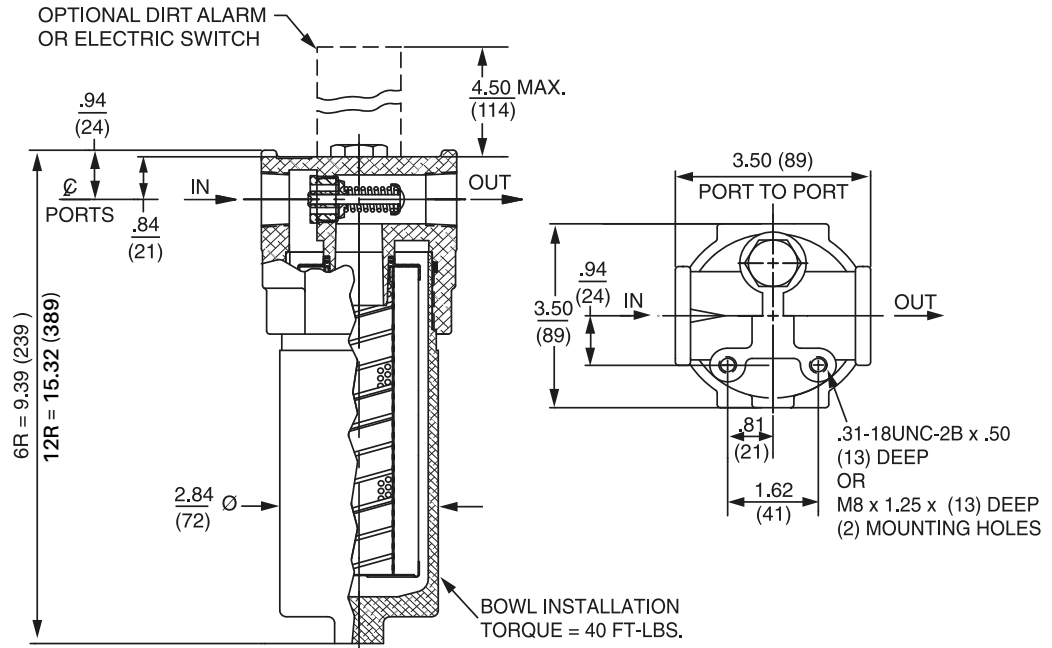

Metric dimensions in ( ).  
 Dimensions shown are inches (millimeters) for general information and overall envelope size only.  
 For complete dimensions please contact Schroeder Industries to request a certified print.

## Element Performance Information & Dirt Holding Capacity

Element	Filtration Ratio Per ISO 4572/NFPA T3.10.8.8 Using automated particle counter (APC) calibrated per ISO 4402			Filtration Ratio per ISO 16889 Using APC calibrated per ISO 11171	
	$\beta_x \geq 75$	$\beta_x \geq 100$	$\beta_x \geq 200$	$\beta_x(c) \geq 200$	$\beta_x(c) \geq 1000$
6RZ1	<1.0	<1.0	<1.0	<4.0	4.2
6RZ3	<1.0	<1.0	<2.0	<4.0	4.8
6RZ5	2.5	3.0	4.0	4.8	6.3
6RZ10	7.4	8.2	10.0	8.0	10.0
6RZ25	18.0	20.0	22.5	19.0	24.0

Element	DHC (gm)	Element	DHC (gm)
6RZ1	15	12RZ1	30
6RZ3	15	12RZ3	30
6RZ5	17	12RZ5	34
6RZ10	14	12RZ10	28
6RZ25	25	12RZ25	50

Element Collapse Rating: 150 psid (10 bar)  
 Flow Direction: Outside In  
 Element Nominal Dimensions: 2.0" (50 mm) O.D. x 6.0" (150 mm) long

$\Delta P_{\text{housing}}$

SRLT  $\Delta P_{\text{housing}}$  for fluids with sp gr (specific gravity) = 0.86:

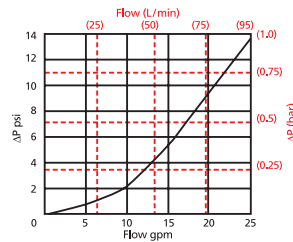

$\Delta P_{\text{element}}$

6RZ

Element Pressure Drop versus Flow Rate at 32 cSt (150 SUS)

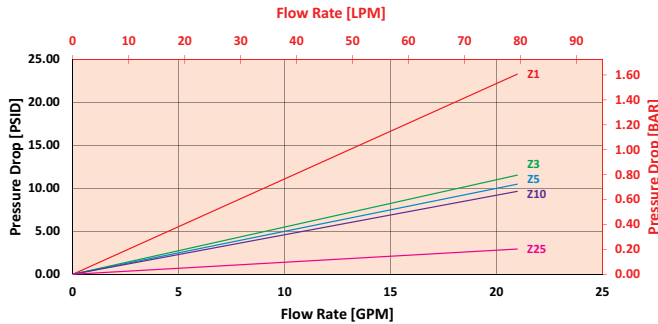

12RZ

Element Pressure Drop versus Flow Rate at 32 cSt (150 SUS)

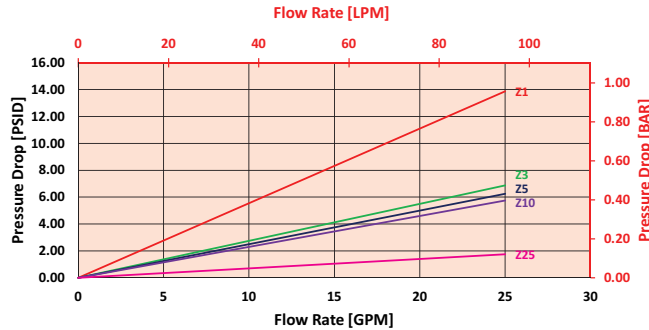

$$\Delta P_{\text{filter}} = \Delta P_{\text{housing}} + (\Delta P_{\text{element}} * \mathbf{V}_f)$$

### Exercise:

Determine  $\Delta P_{\text{filter}}$  at 15 gpm (57 L/min) for SRLT6RZ10S12D5 using 100 SUS (21.3 cSt) fluid.

Use the housing pressure curve to determine  $\Delta P_{\text{housing}}$  at 15 gpm. In this case,  $\Delta P_{\text{housing}}$  is 5 psi (.34 bar) on the graph for the SRLT housing.

Use the element pressure curve to determine  $\Delta P_{\text{element}}$  at 15 gpm. In this case,  $\Delta P_{\text{element}}$  is 7 psi (.48 bar) according to the graph for the 6RZ10 element.

Because the viscosity in this sample is 100 SUS (21.3 cSt), we determine the **Viscosity Factor ( $\mathbf{V}_f$ )** by dividing the **Operating Fluid Viscosity** with the **Standard Viscosity** of 150 SUS (32 cSt). To best determine your Operating Fluid Viscosity, please reference the chart in Appendix D.

Finally, the overall filter pressure differential,  $\Delta P_{\text{filter}}$ , is calculated by adding  $\Delta P_{\text{housing}}$  with the true element pressure differential,  $(\Delta P_{\text{element}} * \mathbf{V}_f)$ . The  $\Delta P_{\text{element}}$  from the graph has to be multiplied by the viscosity factor to get the true pressure differential across the element.

### Solution:

$$\Delta P_{\text{housing}} = 5 \text{ psi } [.34 \text{ bar}] \quad | \quad \Delta P_{\text{element}} = 7 \text{ psi } [.48 \text{ bar}]$$

$$\mathbf{V}_f = 100 \text{ SUS } (21.3 \text{ cSt}) / 150 \text{ SUS } (32 \text{ cSt}) = .67$$

$$\Delta P_{\text{filter}} = 5 \text{ psi } + (7 \text{ psi } * .67) = 9.7 \text{ psi}$$

OR

$$\Delta P_{\text{filter}} = .34 \text{ bar } + (.48 \text{ bar } * .67) = .66 \text{ bar}$$

**Pressure Drop Information Based on Flow Rate and Viscosity**

Note:

If your element is not graphed, use the following equation:  
 $\Delta P_{\text{element}} = \text{Flow Rate} \times \Delta P_f$  Plug this variable into the overall pressure drop equation.

Ele.	$\Delta P$
6R3	0.45
6R10	0.38

## Filter Model Number Selection

Highlighted product eligible for **QuickDelivery**

### How to Build a Valid Model Number for a Schroeder SRLT:

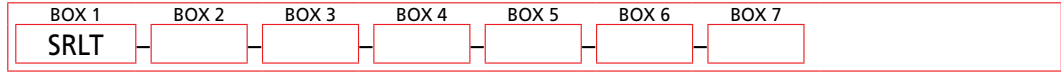

**Example:** NOTE: One option per box

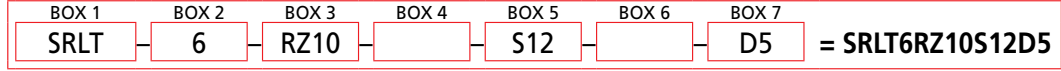

Filter Series	Length of Element (in)	Element Size and Media
SRLT (requires RZ elements only)	6	RZ1 = R size 1 μ Excellement® Z-Media® (synthetic) RZ3 = R size 3 μ Excellement® Z-Media® (synthetic) RZ5 = R size 5 μ Excellement® Z-Media® (synthetic) RZ10 = R size 10 μ Excellement® Z-Media® (synthetic) RZ25 = R size 25 μ Excellement® Z-Media® (synthetic) RW = R size W media (water removal) R5Z1 = R size 1 μ Excellement® Z-Media® 500 psid collapse R5Z3 = R size 3 μ Excellement® Z-Media® 500 psid collapse R5Z5 = R size 5 μ Excellement® Z-Media® 500 psid collapse R5Z10 = R size 10 μ Excellement® Z-Media® 500 psid collapse R5Z25 = R size 25 μ Excellement® Z-Media® 500 psid collapse
SRLTN (Non-bypassing requires R5Z elements only)	12	

Seal Material
Omit = Buna N
H = EPR
V = Viton®
H.5 = Skydrol® Compatibility

Porting
P12 = 3/4" NPTF
S12 = SAE-12
B12 = ISO 228 G-3/4"

Additional Options
Omit = 40 psi bypass setting
L = Two 1/8" NPTF inlet and outlet female test ports
30 = 30 psi bypass setting
50 = 50 psi bypass setting
60 = 60 psi bypass setting

Dirt Alarm® Options	
Omit = None	
Visual	D5 = Visual pop-up
Visual with Thermal Lockout	D8 = Visual w/ thermal lockout
Electrical	MS5 = Electrical w/ 12 in. 18 gauge 4-conductor cable
	MS5LC = Low current MS5
	MS10 = Electrical w/ DIN connector (male end only)
	MS10LC = Low current MS10
	MS11 = Electrical w/ 12 ft. 4-conductor wire
	MS12 = Electrical w/ 5 pin Brad Harrison connector (male end only)
	MS12LC = Low current MS12
	MS16 = Electrical w/ weather packed sealed connector
	MS16LC = Low current MS16
	MS17LC = Electrical w/ 4 pin Brad Harrison male connector
Electrical with Thermal Lockout	MS5T = MS5 (see above) w/ thermal lockout
	MS5LCT = Low current MS5T
	MS10T = MS10 (see above) w/ thermal lockout
	MS10LCT = Low current MS10T
	MS12T = MS12 (see above) w/ thermal lockout
	MS12LCT = Low current MS12T
	MS16T = MS16 (see above) w/ thermal lockout
	MS16LCT = Low current MS16T
	MS17LCT = Low current MS17T
	MS13 = Supplied w/ threaded connector & light
Electrical Visual with Thermal Lockout	MS14 = Supplied w/ 5 pin Brad Harrison connector & light (male end)
	MS13DCT = MS13 (see above), direct current, w/ thermal lockout
	MS13DCLCT = Low current MS13DCT
	MS14DCT = MS14 (see above), direct current, w/ thermal lockout
MS14DCLCT = Low current MS14DCT	

**NOTES:**

- Box 2. Replacement element part numbers are a combination of Boxes 2, 3, and 4. Example: 6R3V
- Box 3. E media elements are only available with Buna N seals.
- Box 4. For options H, V, and H.5, all aluminum parts are anodized. H.5 seal designation includes the following: EPR seals, stainless steel wire mesh on elements, and light oil coating on housing exterior. Viton® is a registered trademark of DuPont Dow Elastomers. Skydrol® is a registered trademark of Solutia Inc.
- Box 5. B porting option supplied with metric mounting holes.

# Medium Pressure Filter

# K9



## Features and Benefits (K9)

- Extremely versatile multiple inlet and outlet ports; can be used alone or in series with another K9
- Top loading for easy access for element change-out
- Allows consolidation of inventoried replacement elements by using K-size elements
- Multiple inlet and outlet porting options reduce the need for additional adaptors on installation
- Can be fitted with test ports for oil sampling
- Small profile allows filter to be mounted in tight areas
- Various Dirt Alarm<sup>®</sup> options
- Meets HF4 automotive standard

 Part of Schroeder Industries Energy Savings Initiative

**100 gpm**  
**380 L/min**  
**900 psi**  
**60 bar**

GH

RLT

KF5

SRLT

**K9**

2K9

3K9

QF5

QF5i

3QF5

QFD5

QF15

QLF15

SSQLF15

Model No. of filter in photograph is K91KZ5BP20NP20ND5C.

Flow Rating:	Up to 100 gpm (380 L/min) for 150 SUS (32 cSt) fluids
Max. Operating Pressure:	900 psi (60 bar)
Min. Yield Pressure:	3200 psi (220 bar), per NFPA T2.6.1
Rated Fatigue Pressure:	750 psi (52 bar) per NFPA T2.6.1-R1-2005
Temp. Range:	-20°F to 225°F (-29°C to 107°C)
Bypass Setting:	Cracking: 40 psi (2.8 bar) Full Flow: 80 psi (5.5 bar)
Porting Head & Cap:	Cast Aluminum
Element Case:	Steel
Weight of K9-1K:	19 lbs. (8.6 kg)
Weight of K9-2K:	30 lbs. (13.6 kg)
Weight of K9-3K:	41 lbs. (18.6 kg)
Element Change Clearance:	8.50" (215 mm) for 1K; 17.50" (445 mm) for KK; 26.5" (673 mm) for 27K

## Filter Housing Specifications

Type Fluid	Appropriate Schroeder Media
Petroleum Based Fluids	All E media (cellulose), Z-Media <sup>®</sup> and ASP <sup>®</sup> media (synthetic)
High Water Content	All Z-Media <sup>®</sup> (synthetic), 3, 5 and 10 μ ASP <sup>®</sup> media (synthetic)
Invert Emulsions	10 and 25 μ Z-Media <sup>®</sup> (synthetic), 10 μ ASP <sup>®</sup> media (synthetic)
Water Glycols	3, 5, 10 and 25 μ Z-Media <sup>®</sup> (synthetic), 3, 5 and 10 μ ASP <sup>®</sup> media (synthetic)
Phosphate Esters	All Z-Media <sup>®</sup> (synthetic) with H (EPR) seal designation and 3 and 10 μ E media (cellulose) with H (EPR) seal designation, 3, 5 and 10 μ ASP <sup>®</sup> media (synthetic)
Skydrol <sup>®</sup>	3, 5, 10 and 25 μ Z-Media <sup>®</sup> (synthetic) with H.5 seal designation (EPR seals and stainless steel wire mesh in element, and light oil coating on housing exterior), 3, 5 and 10 μ ASP <sup>®</sup> Media (synthetic)

## Fluid Compatibility

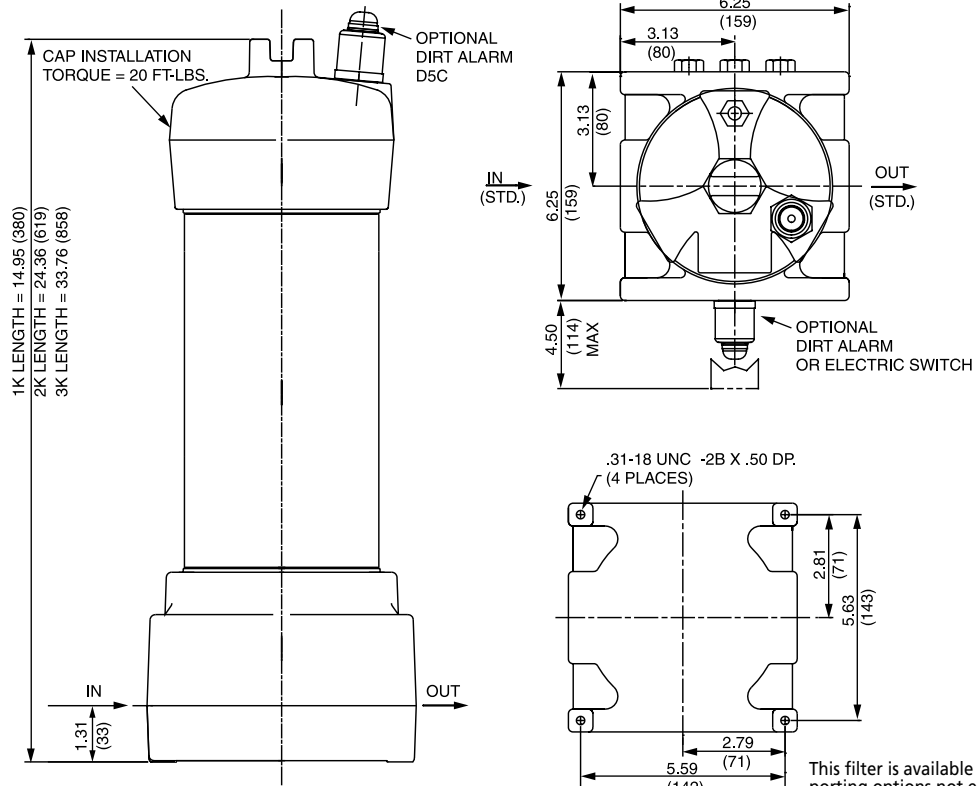

Metric dimensions in ( ).  
 Dimensions shown are inches (millimeters) for general information and overall envelope size only.  
 For complete dimensions please contact Schroeder Industries to request a certified print.

## Element Performance Information & Dirt Holding Capacity

Element	Filtration Ratio Per ISO 4572/NFPA T3.10.8.8 Using automated particle counter (APC) calibrated per ISO 4402			Filtration Ratio per ISO 16889 Using APC calibrated per ISO 11171	
	$\beta_x \geq 75$	$\beta_x \geq 100$	$\beta_x \geq 200$	$\beta_x(c) \geq 200$	$\beta_x(c) \geq 1000$
KZ1/KKZ1/27KZ1	<1.0	<1.0	<1.0	<4.0	4.2
KZ3/KAS3/KKZ3	<1.0	<1.0	<2.0	<4.0	4.8
KZ5/KAS5/KKZ5	2.5	3.0	4.0	4.8	6.3
KZ10/KAS10/KKZ10	7.4	8.2	10.0	8.0	10.0
KZ25/KKZ25/27KZ25	18.0	20.0	22.5	19.0	24.0
KZW1	N/A	N/A	N/A	<4.0	<4.0
KZW3/KKZW3	N/A	N/A	N/A	4.0	4.8
KZW5/KKZW5	N/A	N/A	N/A	5.1	6.4
KZW10/KKZW10	N/A	N/A	N/A	6.9	8.6
KZW25/KKZW25	N/A	N/A	N/A	15.4	18.5

### Dirt Holding Capacity

Element	DHC (gm)	Element	DHC (gm)	Element	DHC (gm)	Element	DHC (gm)	Element	DHC (gm)
KZ1	112	KKZ1	224	27KZ1	336	KZW1	61		
KZ3	115	KKZ3	230	27KZ3	345	KZW3	64	KKZW3	128
KZ5	119	KKZ5	238	27KZ5	357	KZW5	63	KKZW5	126
KZ10	108	KKZ10	216	27KZ10	324	KZW10	57	KKZW10	114
KZ25	93	KKZ25	186	27KZ25	279	KZW25	79	KKZW25	158

Element Collapse Rating: 150 psid (10 bar) for standard elements

Flow Direction: Outside In

Element Nominal Dimensions: K: 3.9" (99 mm) O.D. x 9.0" (230 mm) long  
 KK: 3.9" (99 mm) O.D. x 18.0" (460 mm) long  
 27K: 3.9" (99 mm) O.D. x 27.0" (690 mm) long



# Medium Pressure Filter

# K9

$\Delta P_{\text{housing}}$

K9  $\Delta P_{\text{housing}}$  for fluids with sp gr (specific gravity) = 0.86:

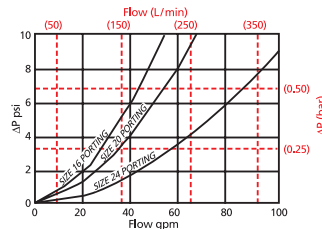

$\Delta P_{\text{element}}$

KZ

Element Pressure Drop versus Flow Rate at 32 cSt (150 SUS)

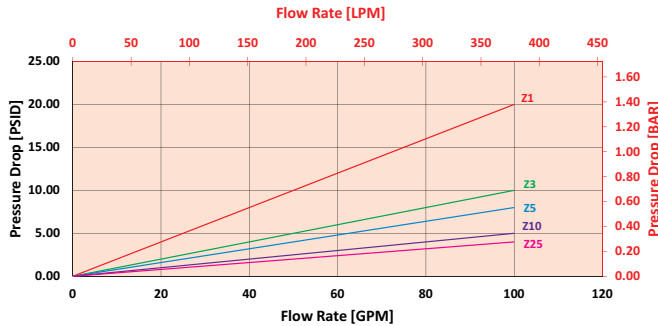

2KZ/KKZ

Element Pressure Drop versus Flow Rate at 32 cSt (150 SUS)

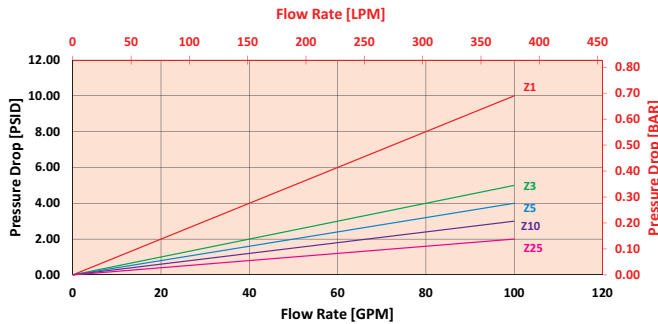

$$\Delta P_{\text{filter}} = \Delta P_{\text{housing}} + (\Delta P_{\text{element}} * \mathbf{V}_f)$$

### Exercise:

Determine  $\Delta P_{\text{filter}}$  at 50 gpm (189.5 L/min) for K91KZ10BP16NP16ND5 using 160 SUS (34 cSt) fluid.

Use the housing pressure curve to determine  $\Delta P_{\text{housing}}$  at 50 gpm. In this case,  $\Delta P_{\text{housing}}$  is 8 psi (.55 bar) on the graph for the K9 housing.

Use the element pressure curve to determine  $\Delta P_{\text{element}}$  at 50 gpm. In this case,  $\Delta P_{\text{element}}$  is 2 psi (.14 bar) according to the graph for the KZ10 element.

Because the viscosity in this sample is 160 SUS (34 cSt), we determine the **Viscosity Factor ( $\mathbf{V}_f$ )** by dividing the **Operating Fluid Viscosity** with the **Standard Viscosity** of 150 SUS (32 cSt). To best determine your Operating Fluid Viscosity, please reference the chart in Appendix D.

Finally, the overall filter pressure differential,  $\Delta P_{\text{filter}}$ , is calculated by adding  $\Delta P_{\text{housing}}$  with the true element pressure differential,  $(\Delta P_{\text{element}} * \mathbf{V}_f)$ . The  $\Delta P_{\text{element}}$  from the graph has to be multiplied by the viscosity factor to get the true pressure differential across the element.

### Solution:

$$\Delta P_{\text{housing}} = 8 \text{ psi } [.55 \text{ bar}] \quad | \quad \Delta P_{\text{element}} = 2 \text{ psi } [.14 \text{ bar}]$$

$$\mathbf{V}_f = 160 \text{ SUS (34 cSt)} / 150 \text{ SUS (32 cSt)} = 1.1$$

$$\Delta P_{\text{filter}} = 8 \text{ psi} + (2 \text{ psi} * 1.1) = 10.2 \text{ psi}$$

OR

$$\Delta P_{\text{filter}} = .55 \text{ bar} + (.14 \text{ bar} * 1.1) = .70 \text{ bar}$$

## Pressure Drop Information Based on Flow Rate and Viscosity

Note:

If your element is not graphed, use the following equation:  
 $\Delta P_{\text{element}} = \text{Flow Rate} \times \Delta P_f$  Plug this variable into the overall pressure drop equation.

Ele.	$\Delta P$	Ele.	$\Delta P$	Ele.	$\Delta P$
K3	0.25	2K3/ KK3	0.12	3KZ1/ 27KZ1	0.05
K10	0.09	2K10/ KK10	0.05	3KZ3/ 27KZ3	0.03
K25	0.02	2K25/ KK25	0.01	3KZ5/ 27KZ5	0.02
KAS3	0.10	2KAS3/ KKAS3	0.05	3KZ10/ 27KZ10	0.02
KAS5	0.08	2KAS5/ KKAS5	0.04	3KZ25/ 27KZ25	0.01
KAS10	0.05	2KAS10/ KKAS10	0.03	3K3	0.08
KZX10	0.22	2KZX10/ KKZX10	0.11	3K10	0.03
KZW1	0.43	2KZW1	-	3K25	0.01
KZW3	0.32	2KZW3/ KKZW3	0.16	3KAS3/ 27KAS3	0.03
KZW5	0.28	2KZW5/ KKZW5	0.14	3KAS5/ 27KAS5	0.02
KZW10	0.23	2KZW10/ KKZW10	0.12	3KAS10/ 27KAS10	0.02
KZW25	0.14	2KZW25/ KKZW25	0.07	3KZ10/ 27KZ10	0.07

## Filter Model Number Selection

### How to Build a Valid Model Number for a Schroeder K9:

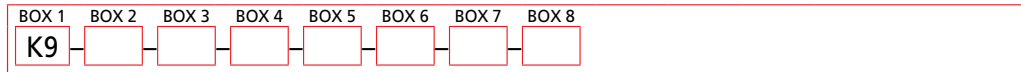

**Example:** NOTE: One option per box

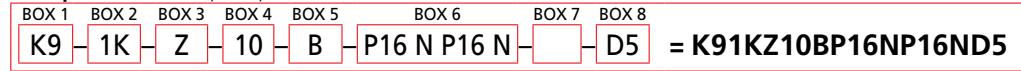

BOX 1	BOX 2	BOX 3	BOX 4	BOX 5
<b>Filter Series</b> K9	<b>Number &amp; Size of Elements</b> 1 K, KK, 27K 2 K 3 K	<b>Media Type</b> Omit = E-media (cellulose) Z = Excellement® Z-Media® AS = Anti-Stat Pleat media (synthetic) ZW = Aqua-Excellement® ZW media ZX = Excellement® Z-Media® (high collapse centertube) W = W media (water removal) M = media (reusable metal mesh)	<b>Micron Rating</b> 1 = 1 μ Z, ZW, ZX media 3 = 3 μ AS, E, Z, ZW, ZX media 5 = 5 μ AS, Z, ZW, ZX media 10 = 10 μ AS, E, M, Z, ZW, ZX media 25 = 25 μ E, M, Z, ZW, ZX media 60 = 60 μ M media 150 = 150 μ M media 260 = 260 μ M media	<b>Seal Material</b> B = Buna N V = Viton® H = EPR H.5 = Skydrol® Compatibility

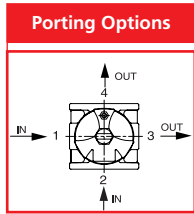

BOX 6 Specification of all 4 ports is required				BOX 7
Porting				Options
Port 1 (standard) N = None P16 = 1" NPTF P20 = 1 1/4" NPTF P24 = 1 1/2" NPTF S16 = SAE-16 S20 = SAE-20 S24 = SAE-24 B16 = ISO 228 G-1" B20 = ISO 228 G-1 1/4" B24 = ISO 228 G-1 1/2"	Port 2 N = None P16 = 1" NPTF P20 = 1 1/4" NPTF P24 = 1 1/2" NPTF F16 = 1" SAE 4-bolt flange Code 61 F20 = 1 1/4" SAE 4-bolt flange Code 61 F24 = 1 1/2" SAE 4-bolt flange Code 61 S16 = SAE-16 S20 = SAE-20 S24 = SAE-24 B16 = ISO 228 G-1" B20 = ISO 228 G-1 1/4" B24 = ISO 228 G-1 1/2"	Port 3 N = None P16 = 1" NPTF P20 = 1 1/4" NPTF P24 = 1 1/2" NPTF S16 = SAE-16 S20 = SAE-20 S24 = SAE-24 B16 = ISO 228 G-1" B20 = ISO 228 G-1 1/4" B24 = ISO 228 G-1 1/2"	Port 4 N = None P16 = 1" NPTF P20 = 1 1/4" NPTF P24 = 1 1/2" NPTF F16 = 1" SAE 4-bolt flange Code 61 F20 = 1 1/4" SAE 4-bolt flange Code 61 F24 = 1 1/2" SAE 4-bolt flange Code 61 S16 = SAE-16 S20 = SAE-20 S24 = SAE-24 B16 = ISO 228 G-1" B20 = ISO 228 G-1 1/4" B24 = ISO 228 G-1 1/2"	Omit=None X=Blocked bypass U= Test point in cap (upstream) UU= Test points in block (upstream and downstream) 10= 10 psi bypass setting 20= 20 psi bypass setting 25= 25 psi bypass setting 30= 30 psi bypass setting 40= 40 psi bypass setting 60= 60 psi bypass setting 75= 75 psi bypass setting

BOX 8	
Dirt Alarm® Options	
	Omit = None
Visual	D5 = Visual pop-up D5C = D5 in cap
Visual with Thermal Lockout	D8 = Visual w/ thermal lockout D8C = D8 in cap
Electrical	MS5 = Electrical w/ 12 in. 18 gauge 4-conductor cable MS5LC = Low current MS5 MS10 = Electrical w/ DIN connector (male end only) MS10LC = Low current MS10 MS11 = Electrical w/ 12 ft. 4-conductor wire MS12 = Electrical w/ 5 pin Brad Harrison connector (male end only) MS12LC = Low current MS12 MS16 = Electrical w/ weather-packed sealed connector MS16LC = Low current MS16 MS17LC = Electrical w/ 4 pin Brad Harrison male connector
Electrical with Thermal Lockout	MS5T = MS5 (see above) w/ thermal lockout MS5LCT = Low current MS5T MS10T = MS10 (see above) w/ thermal lockout MS10LCT = Low current MS10T MS12T = MS12 (see above) w/ thermal lockout MS12LCT = Low current MS12T MS16T = MS16 (see above) w/ thermal lockout MS16LCT = Low current MS16T MS17LCT = Low current MS17T
Electrical Visual	MS13 = Supplied w/ threaded connector & light MS14 = Supplied w/ 5 pin Brad Harrison connector & light (male end)
Electrical Visual with Thermal Lockout	MS13DCT = MS13 (see above), direct current, w/ thermal lockout MS13DCLCT = Low current MS13DCT MS14DCT = MS14 (see above), direct current, w/ thermal lockout MS14DCLCT = Low current MS14DCT

**NOTES:**

**Box 2.** Double and triple stacking of K-size elements can be replaced by KK and 27K elements, respectively. Number of elements must equal 1 when using KK or 27K elements. Replacement element part numbers are identical to contents of Boxes 2, 3, 4, and 5. ZW media not available in 27K length.

**Box 5.** For options H, V, and H.5, all aluminum parts are anodized. H.5 seal designation includes the following: EPR seals, stainless steel wire mesh on elements, and light oil coating on housing exterior. Viton® is a registered trademark of DuPont Dow Elastomers. Skydrol® is a registered trademark of Solutia Inc.

**Box 8.** If location 1 is used as inlet port, dirt alarm will occupy location 2. If location 2 is used as inlet port, dirt alarm will occupy location 1. If dual inlet ports are specified, the only dirt alarm option is pop-up indicator in cap (D5C).

# Single Pass Filter Kit

# 2K9/3K9



## Features and Benefits

- Two or three patented-pending K9 filters supplied in series as a single filter assembly providing in-line single pass particulate and water filtration
- Meets HF4 automotive standard
- 900 psi rating covers almost all transfer line pressure specs including air driven transfer systems
- Top loading for easy access for element change out
- Allows consolidation of inventoried elements by using K-size elements
- Can be fitted with test points for oil sampling

**100 gpm**  
**380 L/min**  
**900 psi**  
**60 bar**

GH

RLT

KF5

SRLT

K9

**2K9**

**3K9**

QF5

QF5i

3QF5

QFD5

QF15

QLF15

SSQLF15

Model No. of filters in photograph are 3K9127EDBBP20P20UUD5C and Custom 2K9.

Flow Rating:	Up to 100 gpm (380 L/min) for 150 SUS (32 cSt) fluids
Max. Operating Pressure:	900 psi (60 bar)
Min. Yield Pressure:	3200 psi (220 bar), per NFPA T2.6.1
Rated Fatigue Pressure:	750 psi (52 bar) per NFPA T2.6.1-R1-2005
Temp. Range:	-20°F to 225°F (-29°C to 107°C)
Bypass Setting:	Cracking: 40 psi (2.8 bar) each filter housing
Porting Base & Cap:	Cast Aluminum
Element Case:	Steel
Element Change Clearance:	8.50" (215 mm) for 1K; 17.5" (445 mm) for KK; 26.5" (673 mm) for 27K

## Filter Housing Specifications

Type Fluid	Appropriate Schroeder Media
Petroleum Based Fluids	All Z-Media® and ASP® media (synthetic)
High Water Content	All Z-Media® and ASP® media (synthetic)
Invert Emulsions	10 and 25 µ Z-Media® and 10 µ ASP® media (synthetic)
Water Glycols	3, 5, 10 and 25 µ Z-Media®, 3, 5 and 10 µ ASP® media (synthetic)
Phosphate Esters	All Z-Media® (synthetic) with H (EPR) seal designation and 3 and 10 µ E media (cellulose) with H (EPR) seal designation
Skydrol®	3, 5, 10 and 25 µ Z-Media® (synthetic) with H.5 seal designation (EPR seals and stainless steel wire mesh in element, and light oil coating on housing exterior), 3, 5 and 10 µ ASP® Media (synthetic)

## Fluid Compatibility

**2K9**

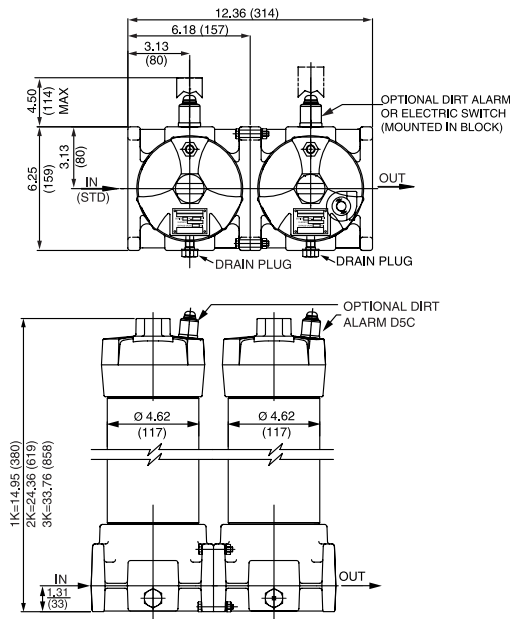

**3K9**

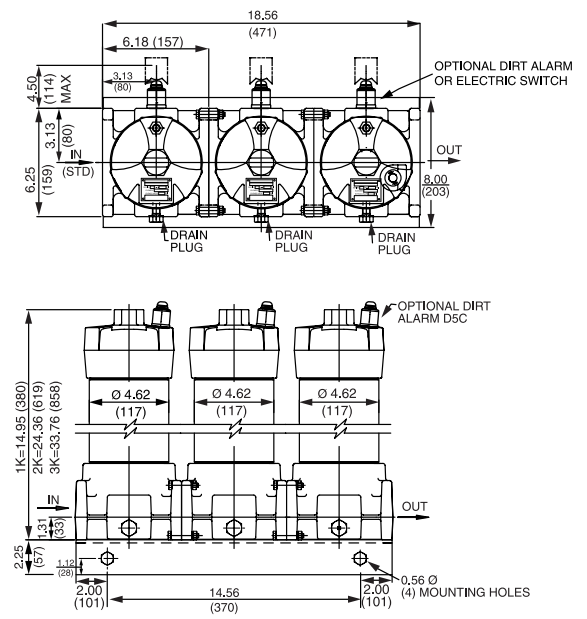

Metric dimensions in ( ).

Dimensions shown are inches (millimeters) for general information and overall envelope size only. For complete dimensions please contact Schroeder Industries to request a certified print.

## Element Performance Information & Dirt Holding Capacity

Element	Filtration Ratio Per ISO 4572/NFPA T3.10.8.8 Using automated particle counter (APC) calibrated per ISO 4402			Filtration Ratio per ISO 16889 Using APC calibrated per ISO 11171	
	$\beta_x \geq 75$	$\beta_x \geq 100$	$\beta_x \geq 200$	$\beta_x(c) \geq 200$	$\beta_x(c) \geq 1000$
KZ1/KKZ1/27KZ1	<1.0	<1.0	<1.0	<4.0	4.2
KZ3/KKZ3/27KZ3	<1.0	<1.0	<2.0	<4.0	4.8
KZ5/KKZ5/27KZ5	2.5	3.0	4.0	4.8	6.3
KZ10/KKZ10/27KZ10	7.4	8.2	10.0	8.0	10.0
KZ25/KKZ25/27KZ25	18.0	20.0	22.5	19.0	24.0
KZW1	N/A	N/A	N/A	<4.0	<4.0
KZW3/KKZW3	N/A	N/A	N/A	4.0	4.8
KZW5/KKZW5	N/A	N/A	N/A	5.1	6.4
KZW10/KKZW10	N/A	N/A	N/A	6.9	8.6
KZW25/KKZW25	N/A	N/A	N/A	15.4	18.5

Element	DHC (gm)	Element	DHC (gm)	Element	DHC (gm)	Element	DHC (gm)	Element	DHC (gm)
KZ1	112	KKZ1	224	27KZ1	336	KZW1	61		
KZ3	115	KKZ3/	230	27KZ3	345	KZW3	64	KKZW3	128
KZ5	119	KKZ5	238	27KZ5	357	KZW5	63	KKZW5	126
KZ10	108	KKZ10	216	27KZ10	324	KZW10	57	KKZW10	114
KZ25	93	KKZ25	186	27KZ25	279	KZW25	79	KKZW25	158

Element Collapse Rating: 150 psid (10 bar) for standard elements

Flow Direction: Outside In

Element Nominal Dimensions: K: 3.9" (99 mm) O.D. x 9.0" (230 mm) long  
 KK: 3.9" (99 mm) O.D. x 18.0" (460 mm) long  
 27K: 3.9" (99 mm) O.D. x 27.0" (690 mm) long

## $\Delta P_{\text{housing}}$

2K9/3K9  $\Delta P_{\text{housing}}$  for fluids with sp gr (specific gravity) = 0.86:

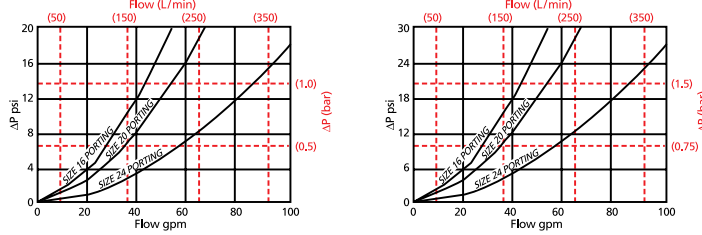

## $\Delta P_{\text{element}}$

KZ

Element Pressure Drop versus Flow Rate at 32 cSt (150 SUS)

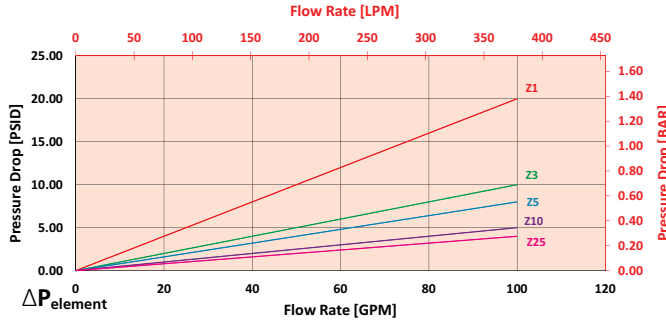

## $\Delta P_{\text{element}}$

2KZ

Element Pressure Drop versus Flow Rate at 32 cSt (150 SUS)

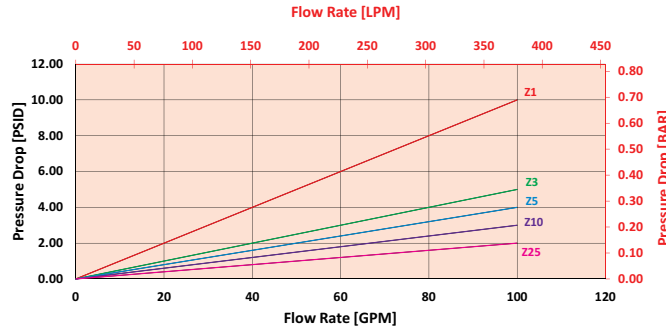

$$\Delta P_{\text{filter}} = \Delta P_{\text{housing}} + (\Delta P_{\text{element}} * \mathbf{V}_f)$$

### Exercise:

Determine  $\Delta P_{\text{filter}}$  at 50 gpm (189.5 L/min) for 2K9109DBBP16P16D5 using 160 SUS (34 cSt) fluid.

Use the housing pressure curve to determine  $\Delta P_{\text{housing}}$  at 50 gpm. In this case,  $\Delta P_{\text{housing}}$  is 16 psi (1.1 bar) on the graph for the 2K9 housing.

Use the element pressure curve to determine  $\Delta P_{\text{element}}$  at 50 gpm for the first element. In this case,  $\Delta P_{\text{element}}$  is 2 psi (.14 bar) according to the graph for the KZ10 element.

Use the element pressure curve to determine  $\Delta P_{\text{element}^2}$  at 50 gpm for the first element. In this case,  $\Delta P_{\text{element}}$  is 5 psi (.34 bar) according to the graph for the KZ3 element.

Because the viscosity in this sample is 160 SUS (34 cSt), we determine the **Viscosity Factor ( $\mathbf{V}_f$ )** by dividing the **Operating Fluid Viscosity** with the **Standard Viscosity** of 150 SUS (32 cSt). To best determine your Operating Fluid Viscosity, please reference the chart in Appendix D.

Finally, the overall filter pressure differential,  $\Delta P_{\text{filter}}$ , is calculated by adding  $\Delta P_{\text{housing}}$  with the true element pressure differential,  $(\Delta P_{\text{element}} * \mathbf{V}_f)$ . The  $\Delta P_{\text{element}}$  from the graph has to be multiplied by the viscosity factor to get the true pressure differential across the element.

### Solution:

$$\Delta P_{\text{housing}} = 16 \text{ psi [1.1 bar]} \mid \Delta P_{\text{element}^1} = 2 \text{ psi [.14 bar]} \mid \Delta P_{\text{element}^2} = 5 \text{ psi [.34 bar]}$$

$$\mathbf{V}_f = 160 \text{ SUS (34 cSt)} / 150 \text{ SUS (32 cSt)} = 1.1$$

$$\Delta P_{\text{filter}} = 16 \text{ psi} + (2 \text{ psi} * 1.1) + (5 \text{ psi} * 1.1) = 23.7 \text{ psi}$$

OR

$$\Delta P_{\text{filter}} = 1.1 \text{ bar} + (.14 \text{ bar} * 1.1) + (.34 * 1.1) = 1.6 \text{ bar}$$

## Pressure Drop Information Based on Flow Rate and Viscosity

Note:  
If your element is not graphed, use the following equation:  
 $\Delta P_{\text{element}} = \text{Flow Rate} \times \Delta P_f$ . Plug this variable into the overall pressure drop equation.

Ele.	$\Delta P$	Ele.	$\Delta P$	Ele.	$\Delta P$
K3	0.25	2K3/ KK3	0.12	3KZ1/ 27KZ1	0.05
K10	0.09	2K10/ KK10	0.05	3KZ3/ 27KZ3	0.03
K25	0.02	2K25/ KK25	0.01	3KZ5/ 27KZ5	0.02
KAS3	0.10	2KAS3/ KKAS3	0.05	3KZ10/ 27KZ10	0.02
KAS5	0.08	2KAS5/ KKAS5	0.04	3KZ25/ 27KZ25	0.01
KAS10	0.05	2KAS10/ KKAS10	0.03	3K3	0.08
KZX10	0.22	2KZX10/ KKZX10	0.11	3K10	0.03
KZW1	0.43	2KZW1	-	3K25	0.01
KZW3	0.32	2KZW3/ KKZW3	0.16	3KAS3/ 27KAS3	0.03
KZW5	0.28	2KZW5/ KKZW5	0.14	3KAS5/ 27KAS5	0.02
KZW10	0.23	2KZW10/ KKZW10	0.12	3KAS10/ 27KAS10	0.02
KZW25	0.14	2KZW25/ KKZW25	0.07	3KZ10/ 27KZ10	0.07

## Filter Model Number Selection

### How to Build a Valid Model Number for a Schroeder 2K9:

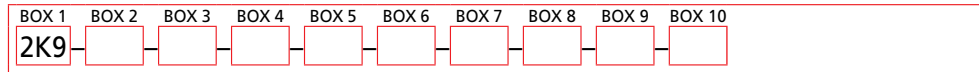

Example: NOTE: One option per box

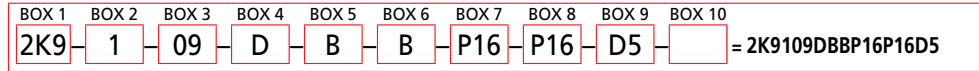

Filter	Number of Elements	Length of Elements	First Housing Element Micron Rating	Second Housing Element Micron Rating	Third Housing
2K9	1	09 = K-Size Element	A = 1 μ Z-Media® B = 3 μ Z-Media® C = 5 μ Z-Media®	A = 1 μ Z-Media® B = 3 μ Z-Media® C = 5 μ Z-Media®	A = 1 μ Z-Media® B = 3 μ Z-Media® C = 5 μ Z-Media® D = 10 μ Z-Media® E = 25 μ Z-Media® F = W media (water removal) G = 1 μ ZW-media H = 3 μ ZW-media J = 5 μ ZW-media K = 10 μ ZW-media L = 25 μ ZW-media M = 3 μ AS-media N = 5 μ AS-media O = 10 μ AS-media
3K9	3	18 = KK Size Element 27 = 27K Size Element	D = 10 μ Z-Media® E = 25 μ Z-Media® F = W Water Removal G = 1 μ ZW-media H = 3 μ ZW-media J = 5 μ ZW-media K = 10 μ ZW-media L = 25 μ ZW-media M = 3 μ AS-media N = 5 μ AS-media O = 10 μ AS-media	D = 10 μ Z-Media® E = 25 μ Z-Media® F = W Water Removal G = 1 μ ZW-media H = 3 μ ZW-media J = 5 μ ZW-media K = 10 μ ZW-media L = 25 μ ZW-media M = 3 μ AS-media N = 5 μ AS-media O = 10 μ AS-media	

BOX 7	BOX 8	BOX 9
<b>Seal Material</b>	<b>"In" Porting</b>	<b>"Out" Porting</b>
B = Buna N V = Viton® H = EPR H.5 = Skydrol® Compatible	P16 = 1" NPTF P20 = 1 1/4" NPTF P24 = 1 1/2" NPTF  B16 = ISO 228 G-1" B20 = ISO 228 G-1 1/4" B24 = ISO 228 G-1 1/2"  F16 = 1" SAE 4-bolt flange Code 61 F20 = 1 1/4" SAE 4-bolt flange Code 61 F24 = 1 1/2" SAE 4-bolt flange Code 61  S16 = SAE-16 S20 = SAE-20 S24 = SAE-24	P16 = 1" NPTF P20 = 1 1/4" NPTF P24 = 1 1/2" NPTF  B16 = ISO 228 G-1" B20 = ISO 228 G-1 1/4" B24 = ISO 228 G-1 1/2"  F16 = 1" SAE 4-bolt flange Code 61 F20 = 1 1/4" SAE 4-bolt flange Code 61 F24 = 1 1/2" SAE 4-bolt flange Code 61  S16 = SAE-16 S20 = SAE-20 S24 = SAE-24

BOX 10		BOX 11
<b>Dirt Alarm® Options</b>		<b>Options</b>
	Omit = None	Omit = None
Visual	D5 = Visual pop-up D5C = D5 in cap	U = Test point in cap (upstream)
Visual with Thermal Lockout	D8 = Visual w/ thermal lockout D8C = D8 in cap	UU = Test points in block (upstream and downstream)
Electrical	MS5 = Electrical w/ 12 in. 18 gauge 4-conductor cable MS5LC = Low current MS5 MS10 = Electrical w/ DIN connector (male end only) MS10LC = Low current MS10 MS11 = Electrical w/ 12 ft. 4-conductor wire MS12 = Electrical w/ 5 pin Brad Harrison connector (male end only) MS12LC = Low current MS12 MS16 = Electrical w/ weather-packed sealed connector MS16LC = Low current MS16 MS17LC = Electrical w/ 4 pin Brad Harrison male connector	
Electrical with Thermal Lockout	MS5T = MS5 (see above) w/ thermal lockout MS5LCT = Low current MS5T MS10T = MS10 (see above) w/ thermal lockout MS10LCT = Low current MS10T MS12T = MS12 (see above) w/ thermal lockout MS12LCT = Low current MS12T MS16T = MS16 (see above) w/ thermal lockout MS16LCT = Low current MS16T MS17LCT = Low current MS17T	
Electrical Visual	MS13 = Supplied w/ threaded connector & light MS14 = Supplied w/ 5 pin Brad Harrison connector & light (male end)	
Electrical Visual with Thermal Lockout	MS13DCT = MS13 (see above), direct current, w/ thermal lockout MS13DCLCT = Low current MS13DCT MS14DCT = MS14 (see above), direct current, w/ thermal lockout MS14DCLCT = Low current MS14DCT	

**NOTES:**

Box 2. Double and triple stacking of K-size elements can be replaced by KK and 27K elements, respectively. Number of elements must equal 1 when using KK or 27K elements. ZW media not available in 27K length.

Box 4 & 5. Replacement element part numbers are identical to K9 replacement parts. Please reference page 184.

Box 6. For options H, V, and H.5, all aluminum parts are anodized. H.5 seal designation includes the following: EPR seals, stainless steel wire mesh on elements, and light oil coating on housing exterior. Viton® is a registered trademark of DuPont Dow Elastomers. Skydrol® is a registered trademark of Solutia Inc.

Box 10. Option UU not available in combination with indicator in block.



### Features and Benefits

- Element changeout from the top minimizes oil spillage
- Available with optional core assembly to accommodate coreless elements
- Offered with standard Q, QPML deep-pleated and QCLQF coreless elements in 16" and 39" lengths with standard Viton® seals
- Offered in pipe, SAE straight thread, and flange porting
- Optional inlet and outlet test points
- WQF5 model for water service also available
- Various Dirt Alarm® options

**300 gpm**  
**1135 L/min**  
**500 psi**  
**35 bar**

Model No. of filter in photograph is QF539QZ10P32.

Flow Rating:	Up to 300 gpm (1135 L/min) for 150 SUS (32 cSt) fluids
Max. Operating Pressure:	500 psi (35 bar)
Min. Yield Pressure:	2500 psi (172 bar), per NFPA T2.6.1-R1-2005
Rated Fatigue Pressure:	Contact Factory
Temp. Range:	-20°F to 225°F (-29°C to 107°C)
Bypass Setting:	Cracking: 30 psi (2.1 bar) Full Flow: 55 psi (3.8 bar)
Porting Base:	Cast Aluminum
Element Case:	Steel
Cap:	Ductile Iron
Weight of QF516:	85 lbs. (39 kg)
Weight of QF539:	120 lbs. (55 kg)
Element Change Clearance:	16Q 12.0" (205 mm) 39Q 33.8" (859 mm)

### Filter Housing Specifications

Type Fluid	Appropriate Schroeder Media
Petroleum Based Fluids	All Z-Media® and ASP® media (synthetic)
High Water Content	All Z-Media® and ASP® media (synthetic)
Invert Emulsions	10 and 25 µ Z-Media® and 10 µ ASP® media (synthetic)
Water Glycols	3, 5, 10 and 25 µ Z-Media® and all ASP® Media (synthetic)
Phosphate Esters	All Z-Media® (synthetic) with H (EPR) seal designation and all ASP® media (synthetic)
Skydrol®	3, 5, 10 and 25 µ Z-Media® (synthetic) with H.5 seal designation (EPR seals and stainless steel wire mesh in element, and light oil coating on housing exterior) and all ASP® media (synthetic)

### Fluid Compatibility

- GH
- RLT
- KF5
- SRLT
- K9
- 2K9
- 3K9
- QF5**
- QF5i
- 3QF5
- QFD5
- QF15
- QLF15
- SSQLF15



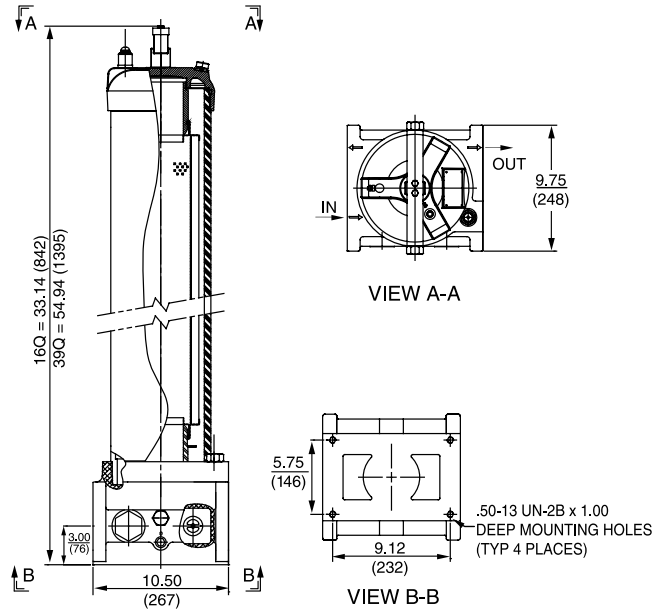

Metric dimensions in ( ).  
 Dimensions shown are inches (millimeters) for general information and overall envelope size only.  
 For complete dimensions please contact Schroeder Industries to request a certified print.

## Element Performance Information & Dirt Holding Capacity

Element	Filtration Ratio Per ISO 4572/NFPA T3.10.8.8 Using automated particle counter (APC) calibrated per ISO 4402			Filtration Ratio per ISO 16889 Using APC calibrated per ISO 11171		
	$\beta_x \geq 75$	$\beta_x \geq 100$	$\beta_x \geq 200$	$\beta_x(c) \geq 200$	$\beta_x(c) \geq 1000$	
16Q	Z1/CLQFZ1/PMLZ1	<1.0	<1.0	<1.0	<4.0	4.2
	Z3/CLQFZ3/PMLZ3	<1.0	<1.0	<2.0	<4.0	4.8
	Z5/CLQFZ5/PMLZ5	2.5	3.0	4.0	4.8	6.3
	Z10/CLQFZ10/PMLZ10	7.4	8.2	10.0	8.0	10.0
	Z25/CLQFZ25/PMLZ25	18.0	20.0	22.5	19.0	24.0
39Q	Z1/CLQFZ1/PMLZ1	<1.0	<1.0	<1.0	<4.0	4.2
	Z3/CLQFZ3/PMLZ3	<1.0	<1.0	<2.0	<4.0	4.8
	Z5/CLQFZ5/PMLZ5	2.5	3.0	4.0	4.8	6.3
	Z10/CLQFZ10/PMLZ10	7.4	8.2	10.0	8.0	10.0

Element	DHC (gm)	Element	DHC (gm)	Element	DHC (gm)	
16Q	Z1	276	CLQFZ1	307	PMLZ1	307
	Z3	283	CLQFZ3	315	PMLZ3	315
	Z5	351	CLQFZ5	364	PMLZ5	364
	Z10	280	CLQFZ10	306	PMLZ10	330
	Z25	254	CLQFZ25	278	PMLZ25	299
39Q	Z1	974	CLQFZ1	1259	PMLZ1	1485
	Z3	1001	CLQFZ3	1293	PMLZ3	1525
	Z5	954	CLQFZ5	1302	PMLZ5	1235
	Z10	940	CLQFZ10	1214	PMLZ10	1432
	Z25	853	CLQFZ25	1102	PMLZ25	1299

Element Collapse Rating: Q and QPML: 150 psid (10 bar), QCLQF: 100 psid (7 bar)

Flow Direction: Outside In

Element Nominal Dimensions: 16Q: 6.0" (150 mm) O.D. x 16.85" (430 mm) long  
 16QCLQF: 6.0" (150 mm) O.D. x 18.21" (463 mm) long  
 16QPML: 6.0" (150 mm) O.D. x 16.00" (405 mm) long  
 39QCLQF: 6.0" (150 mm) O.D. x 40.01" (1016 mm) long  
 39QPML: 6.0" (150 mm) O.D. x 37.80" (960 mm) long



### $\Delta P_{\text{housing}}$

QF5  $\Delta P_{\text{housing}}$  for fluids with sp gr (specific gravity) = 0.86:

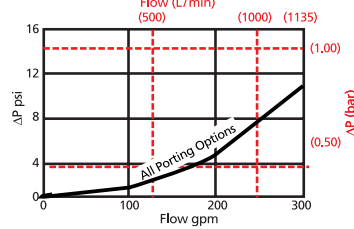

### $\Delta P_{\text{element}}$

16QCLQFZ Element Pressure Drop versus Flow Rate at 32 cSt (150 SUS)

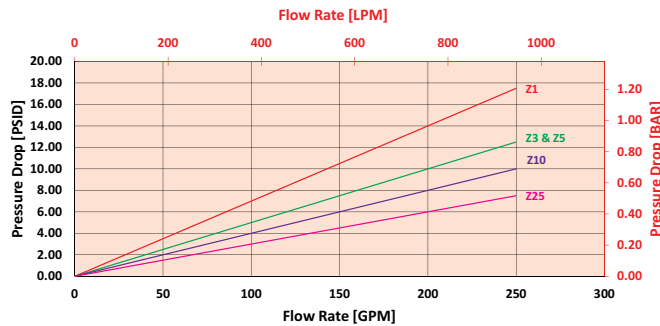

39QCLQFZ Element Pressure Drop versus Flow Rate at 32 cSt (150 SUS)

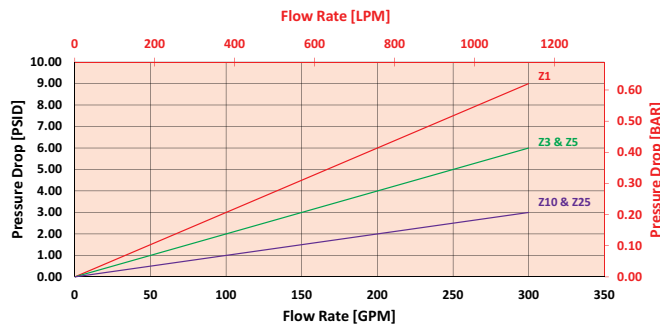

$$\Delta P_{\text{filter}} = \Delta P_{\text{housing}} + (\Delta P_{\text{element}} * \mathbf{V}_f)$$

#### Exercise:

Determine  $\Delta P_{\text{filter}}$  at 100 gpm (379 L/min) for QF539QZ3P32UDPG using 160 SUS (34 cSt) fluid.

Use the housing pressure curve to determine  $\Delta P_{\text{housing}}$  at 100 gpm. In this case,  $\Delta P_{\text{housing}}$  is 2 psi (.14 bar) on the graph for the QF5 housing.

Use the element pressure curve to determine  $\Delta P_{\text{element}}$  at 100 gpm. In this case,  $\Delta P_{\text{element}}$  is 1 psi (.07 bar) according to the graph for the 39QZ3 element.

Because the viscosity in this sample is 160 SUS (34 cSt), we determine the **Viscosity Factor ( $\mathbf{V}_f$ )** by dividing the **Operating Fluid Viscosity** with the **Standard Viscosity** of 150 SUS (32 cSt). To best determine your Operating Fluid Viscosity, please reference the chart in Appendix D.

Finally, the overall filter pressure differential,  $\Delta P_{\text{filter}}$ , is calculated by adding  $\Delta P_{\text{housing}}$  with the true element pressure differential,  $(\Delta P_{\text{element}} * \mathbf{V}_f)$ . The  $\Delta P_{\text{element}}$  from the graph has to be multiplied by the viscosity factor to get the true pressure differential across the element.

#### Solution:

$$\Delta P_{\text{housing}} = 2 \text{ psi } [.14 \text{ bar}] \quad | \quad \Delta P_{\text{element}} = 1 \text{ psi } [.07 \text{ bar}]$$

$$\mathbf{V}_f = 160 \text{ SUS (34 cSt)} / 150 \text{ SUS (32 cSt)} = 1.1$$

$$\Delta P_{\text{filter}} = 2 \text{ psi} + (1 \text{ psi} * 1.1) = 3.1 \text{ psi}$$

OR

$$\Delta P_{\text{filter}} = .14 \text{ bar} + (.07 \text{ bar} * 1.1) = .22 \text{ bar}$$

## Pressure Drop Information Based on Flow Rate and Viscosity

Note:

If your element is not graphed, use the following equation:  
 $\Delta P_{\text{element}} = \text{Flow Rate} \times \Delta P_f$  Plug this variable into the overall pressure drop equation.

Ele.	$\Delta P$	Ele.	$\Delta P$	Ele.	$\Delta P$
16QAS3V	0.04	16QPMLZ1	0.08	39QZ1	0.03
16QAS5V	0.04	16QPMLZ3	0.05	39QZ3	0.01
16QAS10V	0.03	16QPMLZ5	0.05	39QZ5	0.01
16QPMLAS3V	0.05	16QPMLZ10	0.04	39QZ10	0.01
16QPMLAS5V	0.05	16QPMLZ25	0.02	39QZ25	0.01
16QPMLAS10V	0.04	39QAS3V	0.01	39QPMLZ1	0.03
16QZ1	0.09	39QAS5V	0.01	39QPMLZ3	0.02
16QZ3	0.04	39QAS10V	0.01	39QPMLZ5	0.02
16QZ5	0.04	39QPMLAS3V	0.02	39QPMLZ10	0.01
16QZ10	0.03	39QPMLAS5V	0.02	39QPMLZ25	0.01
16QZ25	0.01	39QPMLAS10V	0.01		

## Filter Model Number Selection

### How to Build a Valid Model Number for a Schroeder QF5:

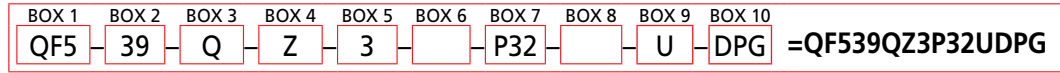
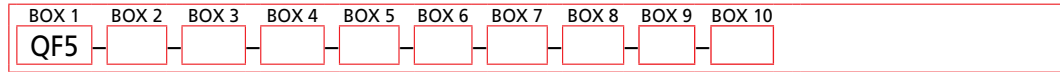

BOX 1	BOX 2	BOX 3	BOX 4	BOX 5
<b>Filter Series</b>	<b>Element Length (in)</b>	<b>Element Style</b>	<b>Media Type</b>	<b>Micron Rating</b>
QF5	16	Q	Z = Excellement® Z-Media® (synthetic)	1 = 1 µ Z-Media®
WQF5 (Water)	39	QCLQF	AS = Anti-Stat Pleat media (synthetic)	3 = 3 µ AS and Z-Media®
		QPML	W = W Media (water removal)	5 = 5 µ AS and Z-Media®
			<b>Water System Element Options</b>	10 = 10 µ AS and Z-Media®
			QM25 = Q size 25 µ M media (resuable metal)	25 = 25 µ Z-Media®
			QM60 = Q size 60 µ M media (resuable metal)	
			QM150 = Q size 150 µ M media (resuable metal)	

**BOX 6**

**Housing Seal Material**

Omit = Buna N  
 H = EPR  
 V = Viton®

**BOX 7**

**Porting**

P32 = 2" NPTF    F32 = 2" SAE 4-bolt flange Code 61  
 P40 = 2½" NPTF  
 P48 = 3" NPTF    F40 = 2½" SAE 4-bolt flange Code 61  
 F48 = 3" SAE 4-bolt flange Code 61  
 S32 = SAE-32

**BOX 8**

**Bypass Setting**

Omit = 30 psi cracking  
 50 = 50 psi cracking  
 X = Blocked bypass

**BOX 9**

**Options**

U = Test point in cap (upstream)  
 UU = Test points in block (upstream and downstream)

**BOX 10**

**Dirt Alarm® Options**

None    Omit = None

Visual    DPG = Standard differential pressure gauge  
           D5 = Visual pop-up  
           D5C = D5 in cap  
           D5R = D5 mounted opposite standard location

Visual with Thermal Lockout    D8 = Visual w/ thermal lockout  
   D8C = D8 in cap  
   D8R = D8 mounted opposite standard location

Electrical    MS5 = Electrical w/ 12 in. 18 gauge 4-conductor cable  
                   MS5LC = Low current MS5  
                   MS10 = Electrical w/ DIN connector (male end only)  
                   MS10LC = Low current MS10  
                   MS11 = Electrical w/ 12 ft. 4-conductor wire  
                   MS12 = Electrical w/ 5 pin Brad Harrison connector (male end only)  
                   MS12LC = Low current MS12  
                   MS16 = Electrical w/ weather-packed sealed connector  
                   MS16LC = Low current MS16  
                   MS17LC = Electrical w/ 4 pin Brad Harrison male connector

Electrical with Thermal Lockout    MS5T = MS5 (see above) w/ thermal lockout  
   MS5LCT = Low current MS5T  
   MS10T = MS10 (see above) w/ thermal lockout  
   MS10LCT = Low current MS10T  
   MS12T = MS12 (see above) w/ thermal lockout  
   MS12LCT = Low current MS12T  
   MS16T = MS16 (see above) w/ thermal lockout  
   MS16LCT = Low current MS16T  
   MS17LCT = Low current MS17T

Electrical Visual    MS13 = Supplied w/ threaded connector & light  
                                   MS14 = Supplied w/ 5 pin Brad Harrison connector & light (male end)

Electrical Visual with Thermal Lockout    MS13DCT = MS13 (see above), direct current, w/ thermal lockout  
   MS13DCLCT = Low current MS13DCT  
   MS14DCT = MS14 (see above), direct current, w/ thermal lockout  
   MS14DCLCT = Low current MS14DCT

- NOTES:**
- Box 2. Replacement element part numbers are a combination of Boxes 2, 3, 4 and 5 plus the letter V.  
 Example: 39QZ10V
  - Box 3. QCLQF are CoreCentric® coreless elements – housing includes rigid metal core. QPML are deep-pleated elements with more media and higher dirt holding capacity.
  - Box 4. For option W, Box 3 must equal Q.
  - Box 6. All elements for this filter are supplied with Viton® seals. Seal designation in Box 6 applies to housing only. Viton® is a registered trademark of DuPont Dow Elastomers.

# Cold Start Protection Inside-Out Flow Filter

# QF5i



## Features and Benefits (QF5i)

- Magnetic filtration protection while filter is in cold start bypass
- Coreless QCL element with inside-out flow for eco-friendly easy disposal
- Efficient means to remove both ferromagnetic and non-ferromagnetic parts from the fluid
- Designed for inside-out flow
- Depending on the filter length, a magnetic rod can be threaded into the element top cap sealing plug
- Element changeout from the top minimizes oil spillage
- Offered in pipe, SAE straight thread, and flange porting
- Optional inlet and outlet test points
- Various Dirt Alarm® options

**120 gpm**  
**454 L/min**  
**500 psi**  
**35 bar**

GH

RLT

KF5

SRLT

K9

2K9

3K9

QF5

**QF5i**

3QF5

QFD5

QF15

QLF15

SSQLF15

Model No. of filter in photograph is QF5i16QCLIZ10F3260M.

Flow Rating:	Up to 120 gpm (454 L/min) for 150 SUS (32 cSt) fluids
Max. Operating Pressure:	500 psi (35 bar)
Min. Yield Pressure:	2500 psi (172 bar), per NFPA T2.6.1-R1-2005
Rated Fatigue Pressure:	Contact Factory
Temp. Range:	-20°F to 225°F (-29°C to 107°C)
Bypass Setting:	Cracking: 60 psi (4.1 bar) Full Flow: 95 psi (6.6 bar)
Porting Base:	Cast Aluminum
Element Case:	Steel
Cap:	Ductile Iron
Weight of QF5i16:	85 lbs. (39 kg)
Weight of QF5i39:	120 lbs. (55 kg)
Element Change Clearance:	16QCLI 16.0" (407 mm) 39QCLI 39.0" (991 mm)

## Filter Housing Specifications

Type Fluid	Appropriate Schroeder Media
Petroleum Based Fluids	All Z-Media® and ASP® media (synthetic)
High Water Content	All Z-Media® and ASP® media (synthetic)
Invert Emulsions	10 and 25 µ Z-Media® and 10 µ ASP® media (synthetic)
Water Glycols	3, 5, 10 and 25 µ Z-Media® and all ASP® Media (synthetic)

## Fluid Compatibility

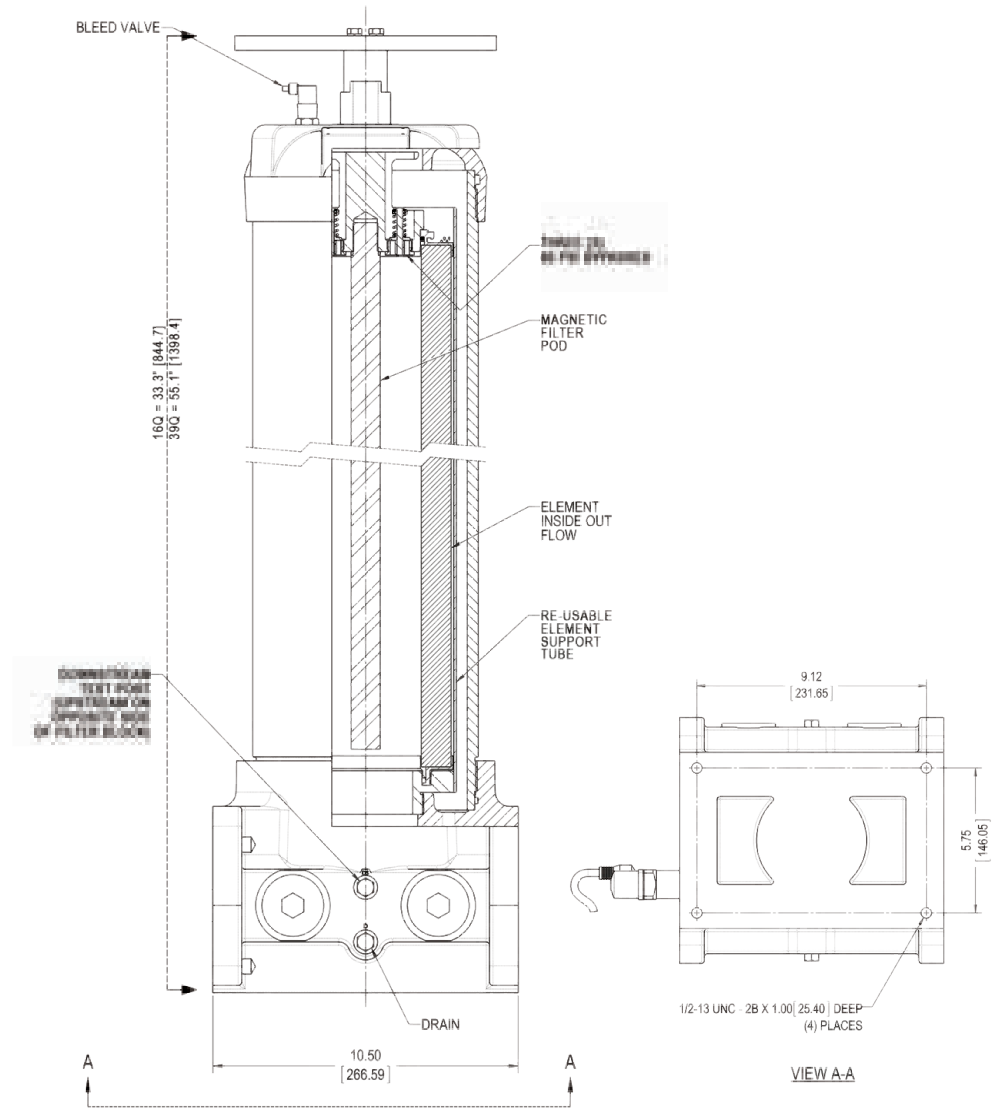

Metric dimensions in ( ).

## Element Performance Information & Dirt Holding Capacity

Element	Filtration Ratio Per ISO 4572/NFPA T3.10.8.8 Using automated particle counter (APC) calibrated per ISO 4402			Filtration Ratio per ISO 16889 Using APC calibrated per ISO 11171		Dirt Holding Capacity		
	$\beta_x \geq 75$	$\beta_x \geq 100$	$\beta_x \geq 200$	$\beta_x(c) \geq 200$	$\beta_x(c) \geq 1000$	Element	DHC (gm)	
16Q	CLIZ1	<1.0	<1.0	<1.0	<4.0	4.2	CLIZ1	307
	CLIZ3	<1.0	<1.0	<2.0	<4.0	4.8	CLIZ3	315
	CLIZ5	2.5	3.0	4.0	4.8	6.3	CLIZ5	364
	CLIZ10	7.4	8.2	10.0	8.0	10.0	CLIZ10	306
	CLIZ25	18.0	20.0	22.5	19.0	24.0	CLIZ25	278
39Q	CLIZ1	<1.0	<1.0	<1.0	<4.0	4.2	CLIZ1	1259
	CLIZ3	<1.0	<1.0	<2.0	<4.0	4.8	CLIZ3	1293
	CLIZ5	2.5	3.0	4.0	4.8	6.3	CLIZ5	1302
	CLIZ10	7.4	8.2	10.0	8.0	10.0	CLIZ10	1214
	CLIZ25	18.0	20.0	22.5	19.0	24.0	CLIZ25	1102

**Flow Direction:** Inside-Out

**Element Nominal Dimensions:** 16QCLI: 6.0" (150 mm) O.D. x 17.81" (452 mm) long  
 39QCLI: 6.0" (150 mm) O.D. x 39.63" (1007 mm) long

$\Delta P_{\text{housing}}$

QF5i  $\Delta P_{\text{housing}}$  for fluids with sp gr (specific gravity) = 0.86:

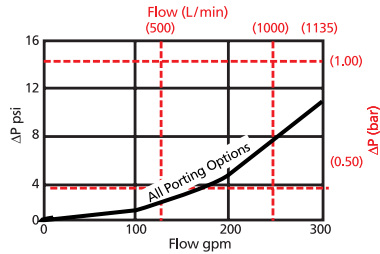

$\Delta P_{\text{element}}$

16QCLIZ

Element Pressure Drop versus Flow Rate at 32 cSt (150 SUS)

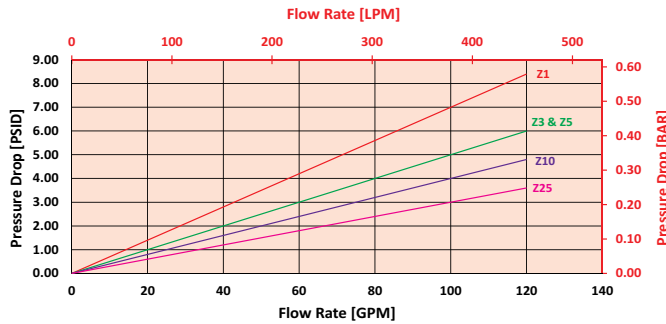

39QCLIZ

Element Pressure Drop versus Flow Rate at 32 cSt (150 SUS)

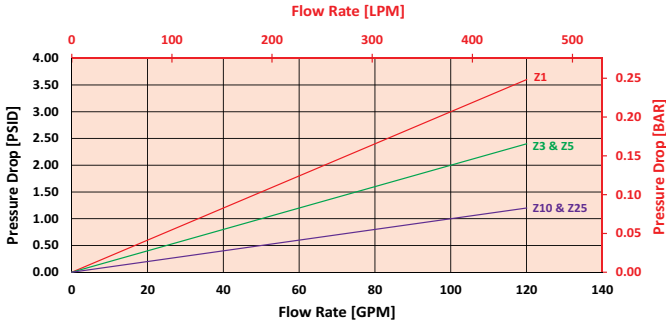

$$\Delta P_{\text{filter}} = \Delta P_{\text{housing}} + (\Delta P_{\text{element}} * \mathbf{V}_f)$$

### Exercise:

Determine  $\Delta P_{\text{filter}}$  at 120 gpm (455 L/min) for QF5i16QCLIZ3P32 using 200 SUS (44 cSt) fluid.

Use the housing pressure curve to determine  $\Delta P_{\text{housing}}$  at 120 gpm. In this case,  $\Delta P_{\text{housing}}$  is 3 psi (.21 bar) on the graph for the QF5i housing.

Use the element pressure curve to determine  $\Delta P_{\text{element}}$  at 120 gpm. In this case,  $\Delta P_{\text{element}}$  is 6 psi (.415 bar) according to the graph for the 16QCLIZ3 element.

Because the viscosity in this sample is 200 SUS (44 cSt), we determine the **Viscosity Factor ( $\mathbf{V}_f$ )** by dividing the **Operating Fluid Viscosity** with the **Standard Viscosity** of 150 SUS (32 cSt). To best determine your Operating Fluid Viscosity, please reference the chart in Appendix D.

Finally, the overall filter pressure differential,  $\Delta P_{\text{filter}}$ , is calculated by adding  $\Delta P_{\text{housing}}$  with the true element pressure differential,  $(\Delta P_{\text{element}} * \mathbf{V}_f)$ . The  $\Delta P_{\text{element}}$  from the graph has to be multiplied by the viscosity factor to get the true pressure differential across the element.

### Solution:

$$\Delta P_{\text{housing}} = 3 \text{ psi } [.21 \text{ bar}] \quad | \quad \Delta P_{\text{element}} = 6 \text{ psi } [.415 \text{ bar}]$$

$$\mathbf{V}_f = 200 \text{ SUS } (42.4 \text{ cSt}) / 150 \text{ SUS } (32 \text{ cSt}) = 1.333$$

$$\Delta P_{\text{filter}} = 3 \text{ psi } + (6 \text{ psi } * 1.333) = 11 \text{ psi}$$

OR

$$\Delta P_{\text{filter}} = .21 \text{ bar } + (.415 \text{ bar } * 1.333) = .76 \text{ bar}$$

Pressure Drop Information Based on Flow Rate and Viscosity

## Filter Model Number Selection

### How to Build a Valid Model Number for a Schroeder QF5i:

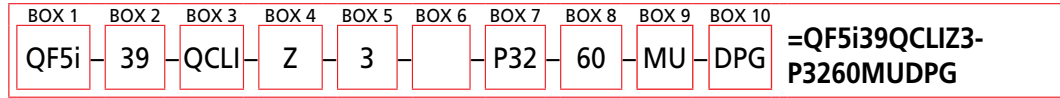
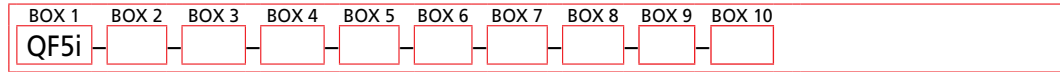

BOX 1	BOX 2	BOX 3	BOX 4	BOX 5
<b>Filter Series</b>	<b>Element Length (in)</b>	<b>Element Style</b>	<b>Media Type</b>	<b>Micron Rating</b>
QF5i	16 39	QCLI	Z = Excellement® Z-Media® (synthetic)	1 = 1 µm Z-Media® 3 = 3 µm Z-Media® 5 = 5 µm Z-Media® 10 = 10 µm Z-Media® 25 = 25 µm Z-Media®

BOX 6	BOX 7	BOX 8	BOX 9
<b>Housing Seal Material</b>	<b>Porting</b>	<b>Bypass Setting</b>	<b>Options</b>
Omit = Buna N V = Viton®	P32 = 2" NPTF    F32 = 2" SAE 4-bolt flange Code 61  P40 = 2½" NPTF    F40 = 2½" SAE 4-bolt flange Code 61 P48 = 3" NPTF  S32 = SAE-32    F48 = 3" SAE 4-bolt flange Code 61	60 = 60 psi cracking	Omit = No Magnet  M = Magnetic Filter Rod  Omit = No Test point  U = Test point in cap (upstream)  UU = Test points in block (upstream and downstream)

Dirt Alarm® Options	
	Omit = None
Visual	DPG = Standard differential pressure gauge D5 = Visual pop-up
Visual with Thermal Lockout	D8 = Visual w/ thermal lockout
Electrical	MS5 = Electrical w/ 12 in. 18 gauge 4-conductor cable MS5LC = Low current MS5 MS10 = Electrical w/ DIN connector (male end only) MS10LC = Low current MS10 MS11 = Electrical w/ 12 ft. 4-conductor wire MS12 = Electrical w/ 5 pin Brad Harrison connector (male end only) MS12LC = Low current MS12 MS16 = Electrical w/ weather-packed sealed connector MS16LC = Low current MS16 MS17LC = Electrical w/ 4 pin Brad Harrison male connector
Electrical with Thermal Lockout	MS5T = MS5 (see above) w/ thermal lockout MS5LCT = Low current MS5T MS10T = MS10 (see above) w/ thermal lockout MS10LCT = Low current MS10T MS12T = MS12 (see above) w/ thermal lockout MS12LCT = Low current MS12T MS16T = MS16 (see above) w/ thermal lockout MS16LCT = Low current MS16T MS17LCT = Low current MS17T
Electrical Visual	MS13 = Supplied w/ threaded connector & light MS14 = Supplied w/ 5 pin Brad Harrison connector & light (male end)
Electrical Visual with Thermal Lockout	MS13DCT = MS13 (see above), direct current, w/ thermal lockout MS13DCLCT = Low current MS13DCT MS14DCT = MS14 (see above), direct current, w/ thermal lockout MS14DCLCT = Low current MS14DCT

**NOTES:**

Box 2. Replacement element part numbers are a combination of Boxes 2, 3, 4 and 5 plus the letter V.  
*Example: 16QCLIZ10V*

Box 6. All elements for this filter are supplied with Viton® seals. Seal designation in Box 6 applies to housing only. Viton® is a registered trademark of DuPont Dow Elastomers.



### Features and Benefits

- Element changeout from the top minimizes oil spillage
- Available with optional core assembly to accommodate coreless elements
- Offered with standard Q, QPML deep-pleated and QCLQF coreless elements in 16" and 39" lengths with standard Viton® seals
- Offered in pipe, SAE straight thread, and flange porting
- Optional inlet and outlet test points
- Various Dirt Alarm® options

Model No. of filter in photograph is 3QF539QEDBP40P40.

**300 gpm**  
**1135 L/min**  
**500 psi**  
**35 bar**

GH  
 RL7  
 KF5  
 SRLT  
 K9  
 2K9  
 3K9  
 QF5  
 QF5i

**3QF5**

QFD5

QF15

QLF15

SSQLF15

Flow Rating:	Up to 300 gpm (1135 L/min) for 150 SUS (32 cSt) fluids
Max. Operating Pressure:	500 psi (35 bar)
Min. Yield Pressure:	2500 psi (172 bar), per NFPA T2.6.1-R1-2005
Rated Fatigue Pressure:	Contact Factory
Temp. Range:	-20°F to 225°F (-29°C to 107°C)
Bypass Setting:	Cracking: 30 psi (2.1 bar) Full Flow: 55 psi (3.8 bar)
Porting Base:	Cast Aluminum
Element Case:	Steel
Cap:	Ductile Iron
Weight of 3QF539:	655 lbs. (298 kg)
Element Change Clearance:	33.8" (859 mm)

### Filter Housing Specifications

Type Fluid	Appropriate Schroeder Media
Petroleum Based Fluids	All Z-Media® and ASP® media (synthetic)
High Water Content	All Z-Media® and ASP® media (synthetic)
Invert Emulsions	10 and 25 µ Z-Media® and 10 µ ASP® media (synthetic)
Water Glycols	3, 5, 10 and 25 µ Z-Media® and all ASP® Media (synthetic)
Phosphate Esters	All Z-Media® (synthetic) with H (EPR) seal designation and all ASP® media (synthetic)
Skydrol®	3, 5, 10 and 25 µ Z-Media® (synthetic) with H.5 seal designation (EPR seals and stainless steel wire mesh in element, and light oil coating on housing exterior) and all ASP® media (synthetic)

### Fluid Compatibility

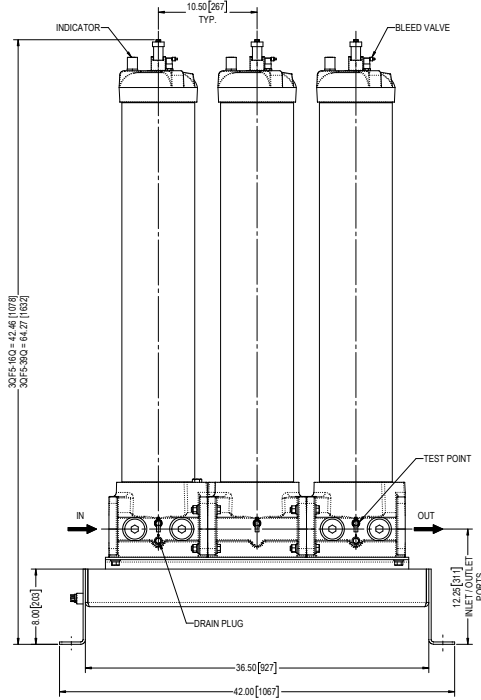
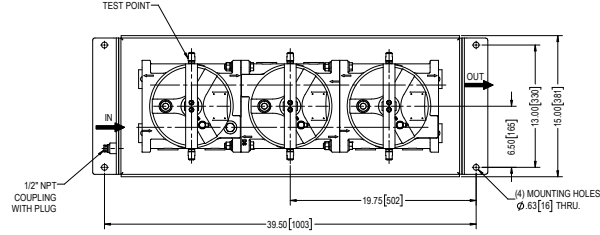

Metric dimensions in ( ).  
 Dimensions shown are inches (millimeters) for general information and overall envelope size only.  
 For complete dimensions please contact Schroeder Industries to request a certified print.

## Element Performance Information & Dirt Holding Capacity

Element	Filtration Ratio Per ISO 4572/NFPA T3.10.8.8 Using automated particle counter (APC) calibrated per ISO 4402			Filtration Ratio per ISO 16889 Using APC calibrated per ISO 11171	
	$\beta_x \geq 75$	$\beta_x \geq 100$	$\beta_x \geq 200$	$\beta_x(c) \geq 200$	$\beta_x(c) \geq 1000$
39Q Z1/CLQFZ1/PMLZ1	<1.0	<1.0	<1.0	<4.0	4.2
Z3/CLQFZ3/PMLZ3	<1.0	<1.0	<2.0	<4.0	4.8
Z5/CLQFZ5/PMLZ5	2.5	3.0	4.0	4.8	6.3
Z10/CLQFZ10/PMLZ10	7.4	8.2	10.0	8.0	10.0
Z25/CLQFZ25/PMLZ25	18.0	20.0	22.5	19.0	24.0

Element	DHC (gm)	Element	DHC (gm)	Element	DHC (gm)
39Q Z1	974	CLQFZ1	1259	PMLZ1	1485
Z3	1001	CLQFZ3	1293	PMLZ3	1525
Z5	954	CLQFZ5	1302	PMLZ5	1235
Z10	940	CLQFZ10	1214	PMLZ10	1432
Z25	853	CLQFZ25	1102	PMLZ25	1299

Element Collapse Rating: Q and QPML: 150 psid (10 bar), QCLQF: 100 psid (7 bar)

Flow Direction: Outside In

Element Nominal Dimensions: 39Q: 6.0" (150 mm) O.D. x 38.70" (985 mm) long  
 39QCLQF: 6.0" (150 mm) O.D. x 40.01" (1016 mm) long  
 39QPML: 6.0" (150 mm) O.D. x 37.80" (960 mm) long



$\Delta P_{\text{housing}}$

3QF5  $\Delta P_{\text{housing}}$  for fluids with sp gr (specific gravity) = 0.86:

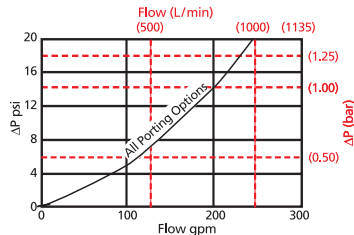

$\Delta P_{\text{element}}$

16QCLQF Element Pressure Drop versus Flow Rate at 32 cSt (150 SUS)

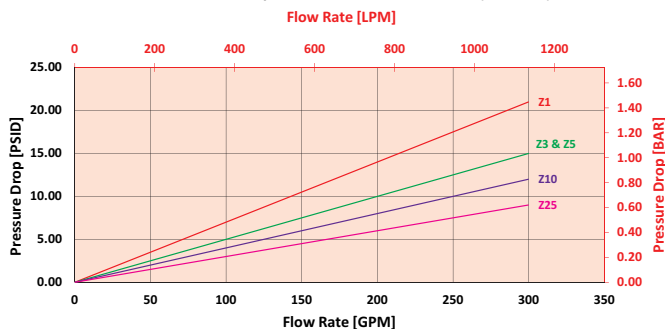

39QCLQF Element Pressure Drop versus Flow Rate at 32 cSt (150 SUS)

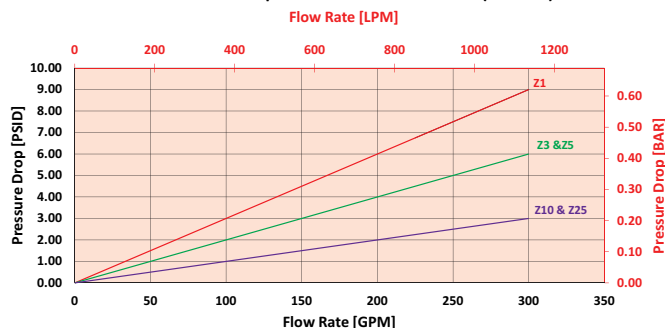

$$\Delta P_{\text{filter}} = \Delta P_{\text{housing}} + (\Delta P_{\text{element}} * \mathbf{V}_f)$$

**Exercise:**

Determine  $\Delta P_{\text{filter}}$  at 100 gpm (379 L/min) for 3QF539QEDBVP32P3250DPG using 160 SUS (34 cSt) fluid.

Use the housing pressure curve to determine  $\Delta P_{\text{housing}}$  at 100 gpm. In this case,  $\Delta P_{\text{housing}}$  is 5.5 psi (.39 bar) on the graph for the 3QF5 housing.

Use the element pressure curve to determine  $\Delta P_{\text{element}}$  at 100 gpm for the first element. In this case,  $\Delta P_{\text{element}}$  is 1 psi (.07 bar) according to the graph for the 39QZ25 element.

Use the element pressure curve to determine  $\Delta P_{\text{element}^2}$  at 100 gpm for the first element. In this case,  $\Delta P_{\text{element}}$  is 1 psi (.07 bar) according to the graph for the 39QZ10 element.

Use the element pressure curve to determine  $\Delta P_{\text{element}^3}$  at 100 gpm for the first element. In this case,  $\Delta P_{\text{element}}$  is 1 psi (.07 bar) according to the graph for the 39QZ3 element.

Because the viscosity in this sample is 160 SUS (34 cSt), we determine the **Viscosity Factor ( $\mathbf{V}_f$ )** by dividing the **Operating Fluid Viscosity** with the **Standard Viscosity** of 150 SUS (32 cSt). To best determine your Operating Fluid Viscosity, please reference the chart in Appendix D.

Finally, the overall filter pressure differential,  $\Delta P_{\text{filter}}$ , is calculated by adding  $\Delta P_{\text{housing}}$  with the true element pressure differential,  $(\Delta P_{\text{element}} * \mathbf{V}_f)$ . The  $\Delta P_{\text{element}}$  from the graph has to be multiplied by the viscosity factor to get the true pressure differential across the element.

**Solution:**

$$\Delta P_{\text{housing}} = 5.5 \text{ psi } [.39 \text{ bar}] \mid \Delta P_{\text{element}^1} = 1 \text{ psi } [.07 \text{ bar}] \mid \Delta P_{\text{element}^2} = 1 \text{ psi } [.07 \text{ bar}] \mid \Delta P_{\text{element}^3} = 1 \text{ psi } [.07 \text{ bar}]$$

$$\mathbf{V}_f = 160 \text{ SUS (34 cSt)} / 150 \text{ SUS (32 cSt)} = 1.1$$

$$\Delta P_{\text{filter}} = 5.5 \text{ psi} + (1 \text{ psi} * 1.1) + (1 \text{ psi} * 1.1) + (1 \text{ psi} * 1.1) = 8.8 \text{ psi}$$

OR

$$\Delta P_{\text{filter}} = .39 \text{ bar} + (.07 \text{ bar} * 1.1) + (.07 \text{ bar} * 1.1) + (.07 \text{ bar} * 1.1) = .62 \text{ bar}$$

## Pressure Drop Information Based on Flow Rate and Viscosity

Note:

If your element is not graphed, use the following equation:  
 $\Delta P_{\text{element}} = \text{Flow Rate} \times \Delta P_f$  Plug this variable into the overall pressure drop equation.

Ele.	$\Delta P$	Ele.	$\Delta P$	Ele.	$\Delta P$
16QAS3V	0.04	16QPMLZ1	0.08	39QZ1	0.03
16QAS5V	0.04	16QPMLZ3	0.05	39QZ3	0.01
16QAS10V	0.03	16QPMLZ5	0.05	39QZ5	0.01
16QPMLAS3V	0.05	16QPMLZ10	0.04	39QZ10	0.01
16QPMLASSV	0.05	16QPMLZ25	0.02	39QZ25	0.01
16QPMLAS10V	0.04	39QAS3V	0.01	39QPMLZ1	0.03
16QZ1	0.09	39QAS5V	0.01	39QPMLZ3	0.02
16QZ3	0.04	39QAS10V	0.01	39QPMLZ5	0.02
16QZ5	0.04	39QPMLAS3V	0.02	39QPMLZ10	0.01
16QZ10	0.03	39QPMLAS5V	0.02	39QPMLZ25	0.01
16QZ25	0.01	39QPMLAS10V	0.01		

## Filter Model Number Selection

### How to Build a Valid Model Number for a Schroeder 3QF5:

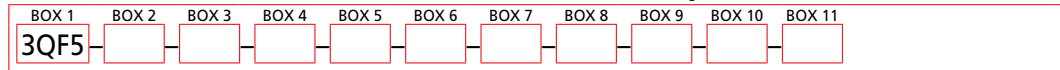

Example: NOTE: One option per box

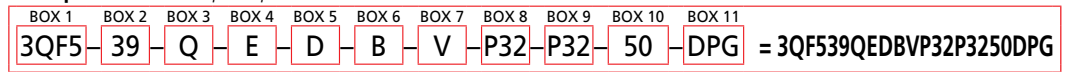

BOX 1	BOX 2	BOX 3	BOX 4	BOX 5	BOX 6
<b>Filter Series</b>	<b>Element Length (in)</b>	<b>Element Style</b>	<b>First Housing Element Media</b>	<b>Second Housing Element Media</b>	<b>Third Housing Element Media</b>
3QF5	16 39	Q QCLQF QPML	A = Z1 B = Z3 C = Z5 D = Z10 E = Z25 F = W G = AS3 H = AS5 J = AS10	A = Z1 B = Z3 C = Z5 D = Z10 E = Z25 F = W G = AS3 H = AS5 J = AS10	A = Z1 B = Z3 C = Z5 D = Z10 E = Z25 F = W G = AS3 H = AS5 J = AS10

**BOX 7**

**Housing Seal Material**

Omit = Buna N  
H = EPR  
V = Viton®

BOX 8	BOX 9	BOX 10
<b>"IN" Porting</b>	<b>"OUT" Porting</b>	<b>Bypass Setting</b>
P32 = 2" NPTF P40 = 2½" NPTF P48 = 3" NPTF S32 = SAE-32 F32 = 2" SAE 4-bolt flange Code 61 F40 = 2½" SAE 4-bolt flange Code 61 F48 = 3" SAE 4-bolt flange Code 61	P32 = 2" NPTF P40 = 2½" NPTF P48 = 3" NPTF S32 = SAE-32 F32 = 2" SAE 4-bolt flange Code 61 F40 = 2½" SAE 4-bolt flange Code 61 F48 = 3" SAE 4-bolt flange Code 61	Omit = 30 psi cracking 50 = 50 psi cracking X = Blocked bypass

**BOX 11**

**Dirt Alarm® Options**

None	Omit = None
Visual	DPG = Standard differential pressure gauge D5 = Visual pop-up D5C = D5 in cap D5R = D5 mounted opposite standard location
Visual with Thermal Lockout	D8 = Visual w/ thermal lockout D8C = D8 in cap D8R = D8 mounted opposite standard location
Electrical	MS5 = Electrical w/ 12 in. 18 gauge 4-conductor cable MS5LC = Low current MS5 MS10 = Electrical w/ DIN connector (male end only) MS10LC = Low current MS10 MS11 = Electrical w/ 12 ft. 4-conductor wire MS12 = Electrical w/ 5 pin Brad Harrison connector (male end only) MS12LC = Low current MS12 MS16 = Electrical w/ weather-packed sealed connector MS16LC = Low current MS16 MS17LC = Electrical w/ 4 pin Brad Harrison male connector
Electrical with Thermal Lockout	MS5T = MS5 (see above) w/ thermal lockout MS5LCT = Low current MS5T MS10T = MS10 (see above) w/ thermal lockout MS10LCT = Low current MS10T MS12T = MS12 (see above) w/ thermal lockout MS12LCT = Low current MS12T MS16T = MS16 (see above) w/ thermal lockout MS16LCT = Low current MS16T MS17LCT = Low current MS17T
Electrical Visual	MS13 = Supplied w/ threaded connector & light MS14 = Supplied w/ 5 pin Brad Harrison connector & light (male end)
Electrical Visual with Thermal Lockout	MS13DCT = MS13 (see above), direct current, w/ thermal lockout MS13DCLCT = Low current MS13DCT MS14DCT = MS14 (see above), direct current, w/ thermal lockout MS14DCLCT = Low current MS14DCT

**NOTES:**

Box 2. Replacement element part numbers are a combination of Boxes 2, 3, and 4, plus the letter V.  
Example: 39QZ10V

Box 3. QCLQF are CoreCentric® coreless elements – housing includes rigid metal core. QPML are deep-pleated elements with more media and higher dirt holding capacity.

Box 4. For option F, Box 3 must equal Q.

Box 7. All elements for this filter are supplied with Viton® seals. Seal designation in Box 5 applies to housing only. Viton® is a registered trademark of DuPont Dow Elastomers.

# In-Line Filter

# QFD5



## Features and Benefits

- Duplex filter design
- Approved for API 5L use
- Element changeout from the top minimizes oil spillage
- Available with optional core assembly to accommodate coreless elements
- Offered with standard Q, QPML deep-pleated and QCLQF coreless elements in 16" and 39" lengths with Viton® seals as the standard
- Offered in 2" and 3" SAE J518 4-bolt flange Code 61 and ANSI 300# flange porting
- Integral inlet and outlet test points are standard on all models
- Various Dirt Alarm® options
- Also available in 4, 6 or 8 housing modular designs (contact factory)

**350 gpm**  
**1325 L/min**  
**500 psi**  
**35 bar**

GH

RLT

KF5

SRLT

K9

2K9

3K9

QF5

QF5i

3QF5

**QFD5**

Model No. of filter in photograph is QFD516QZ10F48DPG.

Flow Rating:	Up to 175 gpm (675 L/min) for 2"; 350 gpm (1325 L/min) for 3" for 150 SUS (32 cSt) fluids
Max. Operating Pressure:	500 psi (35 bar)
Min. Yield Pressure:	Contact Factory
Rated Fatigue Pressure:	Contact Factory
Temp. Range:	-15°F to 200°F (-26°C to 93°C)
Bypass Setting:	Cracking: 30 psi (2.1 bar) Full Flow: 33 psi (2.3 bar) for 2"; 38 psi (2.6 bar) for 3"
Porting Base & Cap:	Ductile Iron
Element Case & Transfer Valve:	Steel
Weight of QFD5-16Q:	410.0 lbs. (186.0 kg) for 2"; 455.0 (206.0 kg) for 3"
Weight of QFD5-39Q:	562.0 lbs. (255.0 kg) for 2"; 607.0 (275.0 kg) for 3"
Element Change Clearance:	16Q 12.00" (305 mm) 39Q 33.80" (859 mm)

## Filter Housing Specifications

QF15

QLF15

SSQLF15

Type Fluid	Appropriate Schroeder Media
Petroleum Based Fluids	All E media (cellulose), Z-Media® and ASP® media (synthetic)
High Water Content	All Z-Media® and ASP® media (synthetic)
Invert Emulsions	10 and 25 µ Z-Media® and 10 µ ASP® media (synthetic)
Water Glycols	3, 5, 10 and 25 µ Z-Media® and all ASP® media (synthetic)
Phosphate Esters	All Z-Media® (synthetic) with H (EPR) seal designation and all ASP® media (synthetic)

## Fluid Compatibility

PORT SIZE	DIM A	DIM B	DIM C	DIM D	DIM E	
					16Q	39Q
2" Ports	4.00 (101.6)	8.19 (208.0)	10.75 (273.1)	4.80 (121.9)	36.50 (927)	58.31 (1481)
3" Ports	5.1 (130.2)	11.07 (281.1)	13.63 (346.1)	7.00 (177.8)	39.38 (1000)	61.19 (1559)

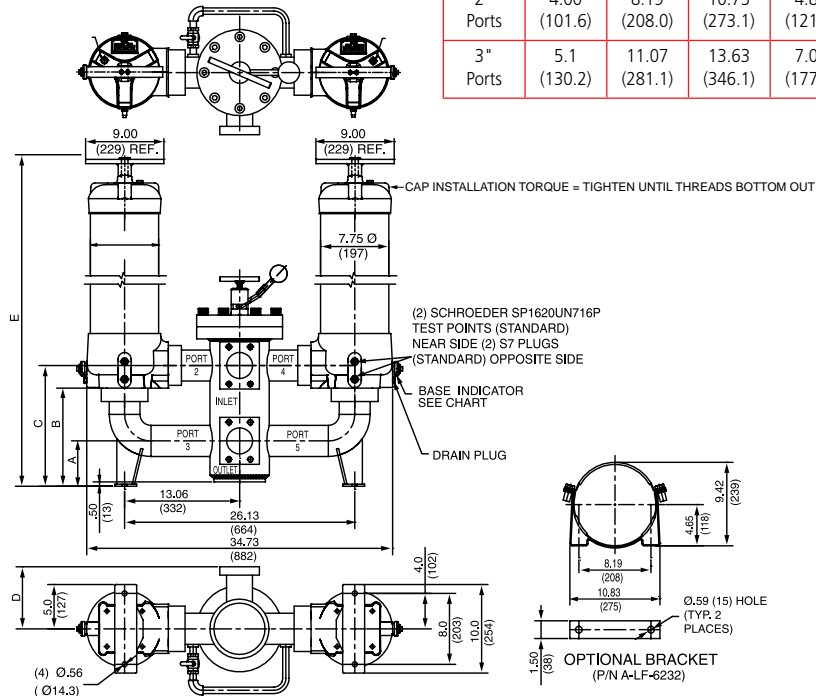

Metric dimensions in ( ).

## Element Performance Information & Dirt Holding Capacity

Element	Filtration Ratio Per ISO 4572/NFPA T3.10.8.8 Using automated particle counter (APC) calibrated per ISO 4402			Filtration Ratio per ISO 16889 Using APC calibrated per ISO 11171		
	$\beta_x \geq 75$	$\beta_x \geq 100$	$\beta_x \geq 200$	$\beta_x(c) \geq 200$	$\beta_x(c) \geq 1000$	
16Q	Z1/CLQFZ1/PMLZ1	<1.0	<1.0	<1.0	<4.0	4.2
	Z3/CLQFZ3/PMLZ3	<1.0	<1.0	<2.0	<4.0	4.8
	Z5/CLQFZ5/PMLZ5	2.5	3.0	4.0	4.8	6.3
	Z10/CLQFZ10/PMLZ10	7.4	8.2	10.0	8.0	10.0
	Z25/CLQFZ25/PMLZ25	18.0	20.0	22.5	19.0	24.0
39Q	Z1/CLQFZ1/PMLZ1	<1.0	<1.0	<1.0	<4.0	4.2
	Z3/CLQFZ3/PMLZ3	<1.0	<1.0	<2.0	<4.0	4.8
	Z5/CLQFZ5/PMLZ5	2.5	3.0	4.0	4.8	6.3
	Z10/CLQFZ10/PMLZ10	7.4	8.2	10.0	8.0	10.0
	Z25/CLQFZ25/PMLZ25	18.0	20.0	22.5	19.0	24.0

Element	DHC (gm)	Element	DHC (gm)	Element	DHC (gm)	
16Q	Z1	276	CLQFZ1	307	PMLZ1	307
	Z3	283	CLQFZ3	315	PMLZ3	315
	Z5	351	CLQFZ5	364	PMLZ5	364
	Z10	280	CLQFZ10	306	PMLZ10	330
	Z25	254	CLQFZ25	278	PMLZ25	299
39Q	Z1	974	CLQFZ1	1259	PMLZ1	1485
	Z3	1001	CLQFZ3	1293	PMLZ3	1525
	Z5	954	CLQFZ5	1302	PMLZ5	1235
	Z10	940	CLQFZ10	1214	PMLZ10	1432
	Z25	853	CLQFZ25	1102	PMLZ25	1299

Element Collapse Rating: Q and QPML: 150 psid (10 bar), QCLQF: 100 psid (7 bar)

Flow Direction: Outside In

Element Nominal Dimensions: 39Q: 6.0" (150 mm) O.D. x 38.70" (985 mm) long  
 39QCLQF: 6.0" (150 mm) O.D. x 40.01" (1016 mm) long  
 39QPML: 6.0" (150 mm) O.D. x 37.80" (960 mm) long

## $\Delta P_{\text{housing}}$

QFD5  $\Delta P_{\text{housing}}$  for fluids with sp gr (specific gravity) = 0.86:

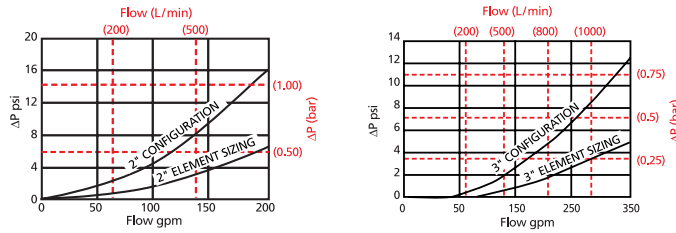

## $\Delta P_{\text{element}}$

16QCLQFZ Element Pressure Drop versus Flow Rate at 32 cSt (150 SUS)

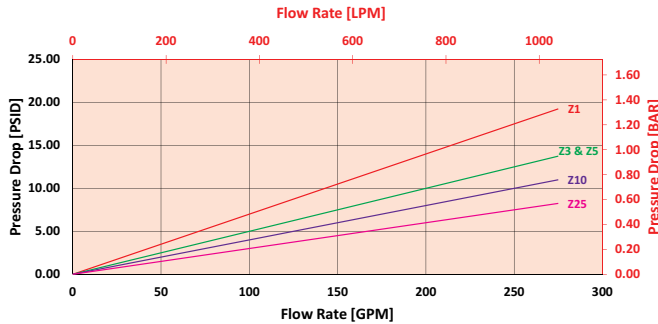

39QCLQFZ Element Pressure Drop versus Flow Rate at 32 cSt (150 SUS)

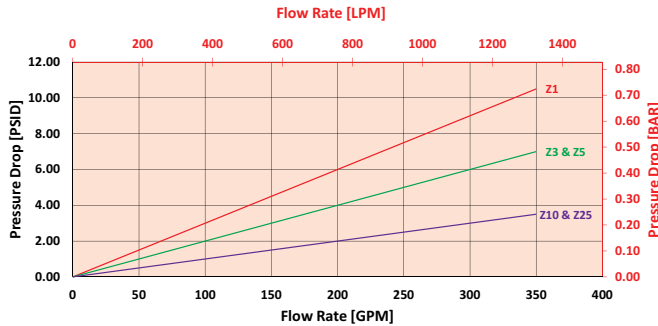

$$\Delta P_{\text{filter}} = \Delta P_{\text{housing}} + (\Delta P_{\text{element}} * \mathbf{V}_f)$$

### Exercise:

Determine  $\Delta P_{\text{filter}}$  at 200 gpm (758 L/min) for QFD516QZ3F48D5C using 100 SUS (21.3 cSt) fluid.

Use the housing pressure curve to determine  $\Delta P_{\text{housing}}$  at 200 gpm. In this case,  $\Delta P_{\text{housing}}$  is 5 psi (.34 bar) on the graph for the QFD5 housing.

Use the element pressure curve to determine  $\Delta P_{\text{element}}$  at 200 gpm. In this case,  $\Delta P_{\text{element}}$  is 7 psi (.48 bar) according to the graph for the 16QCZ3 element.

Because the viscosity in this sample is 100 SUS (21.3 cSt), we determine the **Viscosity Factor ( $\mathbf{V}_f$ )** by dividing the **Operating Fluid Viscosity** with the **Standard Viscosity** of 150 SUS (32 cSt). To best determine your Operating Fluid Viscosity, please reference the chart in Appendix D.

Finally, the overall filter pressure differential,  $\Delta P_{\text{filter}}$ , is calculated by adding  $\Delta P_{\text{housing}}$  with the true element pressure differential,  $(\Delta P_{\text{element}} * \mathbf{V}_f)$ . The  $\Delta P_{\text{element}}$  from the graph has to be multiplied by the viscosity factor to get the true pressure differential across the element.

### Solution:

$$\Delta P_{\text{housing}} = 5 \text{ psi } [.34 \text{ bar}] \quad | \quad \Delta P_{\text{element}} = 7 \text{ psi } [.48 \text{ bar}]$$

$$\mathbf{V}_f = 100 \text{ SUS } (21.3 \text{ cSt}) / 150 \text{ SUS } (32 \text{ cSt}) = .67$$

$$\Delta P_{\text{filter}} = 5 \text{ psi } + (7 \text{ psi } * .67) = 9.7 \text{ psi}$$

OR

$$\Delta P_{\text{filter}} = .34 \text{ bar } + (.48 \text{ bar } * .67) = .66 \text{ bar}$$

## Pressure Drop Information Based on Flow Rate and Viscosity

Note:

If your element is not graphed, use the following equation:  
 $\Delta P_{\text{element}} = \text{Flow Rate} \times \Delta P_f$   
 Plug this variable into the overall pressure drop equation.

Ele.	$\Delta P$	Ele.	$\Delta P$	Ele.	$\Delta P$
16QAS3V	0.04	16QPMLZ1	0.08	39QZ1	0.03
16QAS5V	0.04	16QPMLZ3	0.05	39QZ3	0.01
16QAS10V	0.03	16QPMLZ5	0.05	39QZ5	0.01
16QPML-AS3V	0.05	16QPMLZ10	0.04	39QZ10	0.01
16QPML-AS5V	0.05	16QPMLZ25	0.02	39QZ25	0.01
16QPML-AS10V	0.04	39QAS3V	0.01	39QPMLZ1	0.03
16QZ1	0.09	39QAS5V	0.01	39QPMLZ3	0.02
16QZ3	0.04	39QAS10V	0.01	39QPMLZ5	0.02
16QZ5	0.04	39QPMLAS-3V	0.02	39QPMLZ10	0.01
16QZ10	0.03	39QPMLAS-5V	0.02	39QPMLZ25	0.01
16QZ25	0.01	39QPMLAS-10V	0.01		

## Filter Model Number Selection

### How to Build a Valid Model Number for a Schroeder QF5:

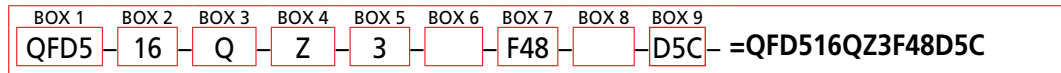
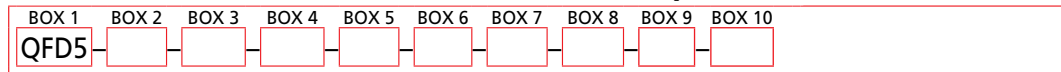

BOX 1	BOX 2	BOX 3	BOX 4	BOX 5
Filter Series	Element Length (in)	Element Style	Media Type	Micron Rating
QFD5	16 39	Q QCLQF QPML	Z = Excellement® Z-Media® (synthetic) AS = Anti-Stat Pleat media (synthetic) W = W media (water removal)	1 = 1 µm Z-Media® 3 = 3 µm Z-Media® 5 = 5 µm Z-Media® 10 = 10 µm Z-Media® 25 = 25 µm Z-Media®

BOX 6	BOX 7	BOX 8
Housing Seal Material	Porting	Bypass Setting
Omit = Buna N V = Viton®	F32 = 2" SAE 4-bolt flange Code 61 F32M = 2" SAE 4-bolt flange Code 61 FA32 = 2" ANSI 300# flange F48 = 3" SAE 4-bolt flange Code 61 F48M = 3" SAE 4-bolt flange Code 61 FA48 = 3" ANSI 300# flange	Omit = 30 psi cracking 50 = 50 psi cracking X = Blocked bypass

BOX 9	
Dirt Alarm® Options	
	Omit = None
Visual	DPG = Standard differential pressure gauge D5 = Visual pop-up D5C = D5 in cap
Visual with Thermal Lockout	D8 = Visual w/ thermal lockout D8C = D8 in cap
Electrical	MS5 = Electrical w/ 12 in. 18 gauge 4-conductor cable MS5LC = Low current MS5 MS10 = Electrical w/ DIN connector (male end only) MS10LC = Low current MS10 MS11 = Electrical w/ 12 ft. 4-conductor wire MS12 = Electrical w/ 5 pin Brad Harrison connector (male end only) MS12LC = Low current MS12 MS16 = Electrical w/ weather-packed sealed connector MS16LC = Low current MS16 MS17LC = Electrical w/ 4 pin Brad Harrison male connector
Electrical with Thermal Lockout	MS5T = MS5 (see above) w/ thermal lockout MS5LCT = Low current MS5T MS10T = MS10 (see above) w/ thermal lockout MS10LCT = Low current MS10T MS12T = MS12 (see above) w/ thermal lockout MS12LCT = Low current MS12T MS16T = MS16 (see above) w/ thermal lockout MS16LCT = Low current MS16T MS17LCT = Low current MS17T
Electrical Visual	MS13 = Supplied w/ threaded connector & light MS14 = Supplied w/ 5 pin Brad Harrison connector & light (male end)
Electrical Visual with Thermal Lockout	MS13DCT = MS13 (see above), direct current, w/ thermal lockout MS13DCLCT = Low current MS13DCT MS14DCT = MS14 (see above), direct current, w/ thermal lockout MS14DCLCT = Low current MS14DCT

#### NOTES:

Box 2. Replacement element part numbers are a combination of Boxes 2, 3, 4 and 5 plus the letter V.  
*Example: 39QZ10V*

Box 3. QCLQF are CoreCentric® coreless elements – housing includes rigid metal core. QPML are deep-pleated elements with more media and higher dirt holding capacity.

Box 4. For option W, Box 3 must equal Q.

Box 6. All elements for this filter are supplied with Viton® seals. Seal designation in Box 6 applies to housing only. Viton® is a registered trademark of DuPont Dow Elastomers.

# In-Line Filter

# QF15



## Features and Benefits

- Also available in L-ported version
- Element changeout from the top minimizes oil spillage
- Available with optional core assembly to accommodate coreless elements
- Offered with standard Q, QPML deep-pleated and QCLQF coreless elements in 16" and 39" lengths with Viton® seals as the standard
- Offered in pipe, SAE straight thread, and flange porting
- Integral inlet and outlet test points are standard on all models
- Various Dirt Alarm® options

**450 gpm**  
**1700 L/min**  
**1500 psi**  
**100 bar**

Model No. of filter in photograph is QF1516QZ10P24MS10AC.

Flow Rating:	Up to 450 gpm (1700 L/min) for 150 SUS (32 cSt) fluids
Max. Operating Pressure:	1500 psi (100 bar)
Min. Yield Pressure:	4900 psi (340 bar), per NFPA T2.6.1
Rated Fatigue Pressure:	800 psi (55 bar), per NFPA T2.6.1-R1-2005
Temp. Range:	-20°F to 225°F (-29°C to 107°C)
Bypass Setting:	Cracking: 30 psi (2.1 bar) Full Flow: 55 psi (3.8 bar)
Porting Base & Cap:	Ductile Iron
Element Case:	Steel
Weight of QF15-16Q:	139.0 lbs. (63.0 kg)
Weight of QF15-39Q:	198.0 lbs. (90.0 kg)
Element Change Clearance:	16Q 12.0" (305 mm) 39Q 33.8" (859 mm)

## Filter Housing Specifications

**QF15**

QLF15

SSQLF15

Type Fluid	Appropriate Schroeder Media
Petroleum Based Fluids	All E media (cellulose), Z-Media® and ASP® Media (synthetic)
High Water Content	All Z-Media® and ASP® media (synthetic)
Invert Emulsions	10 and 25 µ Z-Media® and 10 µ ASP® media (synthetic)
Water Glycols	3, 5, 10 and 25 µ Z-Media® and all ASP® media (synthetic)
Phosphate Esters	All Z-Media® (synthetic) with H (EPR) seal designation and all ASP® media (synthetic)

## Fluid Compatibility

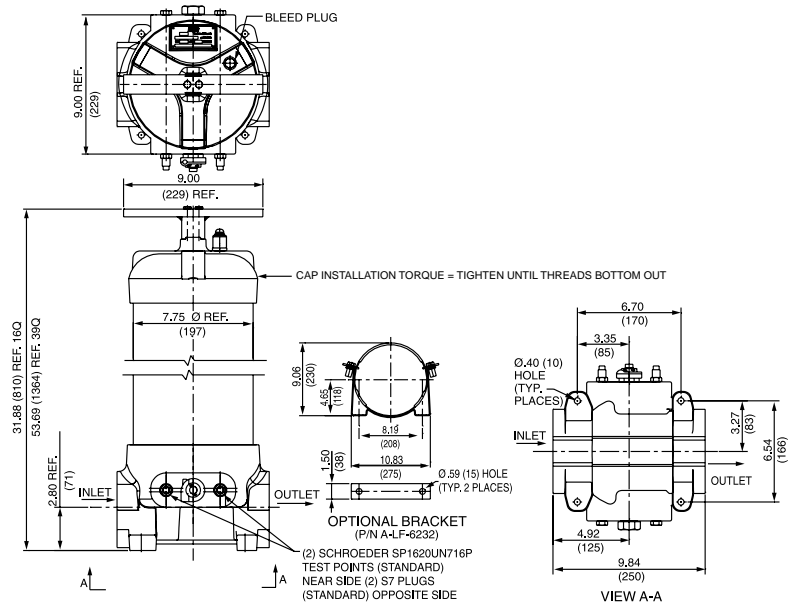

Metric dimensions in ( ).

## Element Performance Information & Dirt Holding Capacity

Element	Filtration Ratio Per ISO 4572/NFPA T3.10.8.8 Using automated particle counter (APC) calibrated per ISO 4402			Filtration Ratio per ISO 16889 Using APC calibrated per ISO 11171		
	$\beta_x \geq 75$	$\beta_x \geq 100$	$\beta_x \geq 200$	$\beta_x(c) \geq 200$	$\beta_x(c) \geq 1000$	
16Q	Z1/CLQFZ1/PMLZ1	<1.0	<1.0	<1.0	<4.0	4.2
	Z3/CLQFZ3/PMLZ3	<1.0	<1.0	<2.0	<4.0	4.8
	Z5/CLQFZ5/PMLZ5	2.5	3.0	4.0	4.8	6.3
	Z10/CLQFZ10/PMLZ10	7.4	8.2	10.0	8.0	10.0
	Z25/CLQFZ25/PMLZ25	18.0	20.0	22.5	19.0	24.0
39Q	Z1/CLQFZ1/PMLZ1	<1.0	<1.0	<1.0	<4.0	4.2
	Z3/CLQFZ3/PMLZ3	<1.0	<1.0	<2.0	<4.0	4.8
	Z5/CLQFZ5/PMLZ5	2.5	3.0	4.0	4.8	6.3
	Z10/CLQFZ10/PMLZ10	7.4	8.2	10.0	8.0	10.0
	Z25/CLQFZ25/PMLZ25	18.0	20.0	22.5	19.0	24.0

Element	DHC (gm)	Element	DHC (gm)	Element	DHC (gm)	
16Q	Z1	276	CLQFZ1	307	PMLZ1	307
	Z3/AS3V	283	CLQFZ3	315	PMLZ3/PMLAS3V	315
	Z5/AS5V	351	CLQFZ5	364	PMLZ5/PMLAS5V	364
	Z10/AS10V	280	CLQFZ10	306	PMLZ10/PMLAS10V	330
	Z25	254	CLQFZ25	278	PMLZ25	299
39Q	Z1	974	CLQFZ1	1259	PMLZ1	1485
	Z3/AS3V	1001	CLQFZ3	1293	PMLZ3/PMLAS3V	1525
	Z5/AS5V	954	CLQFZ5	1302	PMLZ5/PMLAS5V	1235
	Z10/AS10V	940	CLQFZ10	1214	PMLZ10/PMLAS10V	1432
	Z25	853	CLQFZ25	1102	PMLZ25	1299

Element Collapse Rating: Q and QPML: 150 psid (10 bar), QCLQF: 100 psid (7 bar)

Flow Direction: Outside In

Element Nominal Dimensions:

- 16Q: 6.0" (150 mm) O.D. x 16.85" (430 mm) long
- 16QCLQF: 6.0" (150 mm) O.D. x 18.21" (463 mm) long
- 16QPML: 6.0" (150 mm) O.D. x 16.00" (405 mm) long
- 39Q: 6.0" (150 mm) O.D. x 38.70" (985 mm) long
- 39QCLQF: 6.0" (150 mm) O.D. x 40.01" (1016 mm) long
- 39QPML: 6.0" (150 mm) O.D. x 37.80" (960 mm) long



$\Delta P_{\text{housing}}$

QF15  $\Delta P_{\text{housing}}$  for fluids with sp gr (specific gravity) = 0.86:

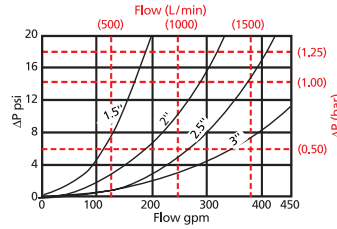

$\Delta P_{\text{element}}$

16QCLQFZ Element Pressure Drop versus Flow Rate at 32 cSt (150 SUS)

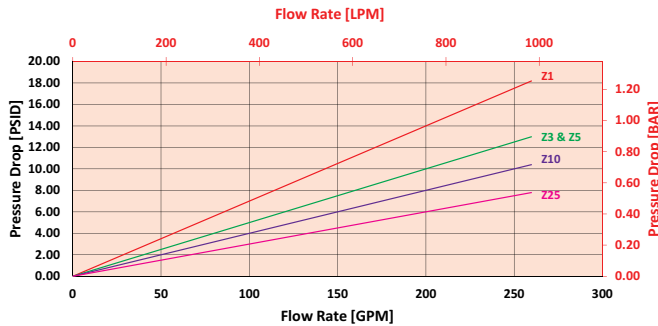

39QCLQFZ Element Pressure Drop versus Flow Rate at 32 cSt (150 SUS)

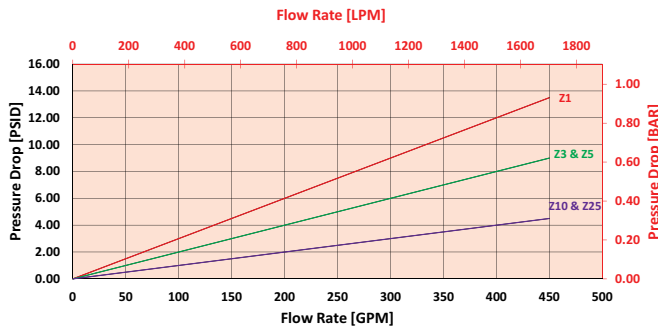

$$\Delta P_{\text{filter}} = \Delta P_{\text{housing}} + (\Delta P_{\text{element}} * \mathbf{V}_f)$$

### Exercise:

Determine  $\Delta P_{\text{filter}}$  at 200 gpm (758 L/min) for QF1516QZ3D5C using 100 SUS (21.3 cSt) fluid.

Use the housing pressure curve to determine  $\Delta P_{\text{housing}}$  at 200 gpm. In this case,  $\Delta P_{\text{housing}}$  is 2 psi (.14 bar) on the graph for the QF15 housing.

Use the element pressure curve to determine  $\Delta P_{\text{element}}$  at 200 gpm. In this case,  $\Delta P_{\text{element}}$  is 7 psi (.48 bar) according to the graph for the 16QZ3 element.

Because the viscosity in this sample is 100 SUS (21.3 cSt), we determine the **Viscosity Factor ( $\mathbf{V}_f$ )** by dividing the **Operating Fluid Viscosity** with the **Standard Viscosity** of 150 SUS (32 cSt). To best determine your Operating Fluid Viscosity, please reference the chart in Appendix D.

Finally, the overall filter pressure differential,  $\Delta P_{\text{filter}}$ , is calculated by adding  $\Delta P_{\text{housing}}$  with the true element pressure differential,  $(\Delta P_{\text{element}} * \mathbf{V}_f)$ . The  $\Delta P_{\text{element}}$  from the graph has to be multiplied by the viscosity factor to get the true pressure differential across the element.

### Solution:

$$\Delta P_{\text{housing}} = 3 \text{ psi } [.14 \text{ bar}] \quad | \quad \Delta P_{\text{element}} = 7 \text{ psi } [.48 \text{ bar}]$$

$$\mathbf{V}_f = 100 \text{ SUS } (21.3 \text{ cSt}) / 150 \text{ SUS } (32 \text{ cSt}) = .67$$

$$\Delta P_{\text{filter}} = 2 \text{ psi } + (7 \text{ psi } * .67) = 6.7 \text{ psi}$$

OR

$$\Delta P_{\text{filter}} = .14 \text{ bar } + (.48 \text{ bar } * .67) = .46 \text{ bar}$$

## Pressure Drop Information Based on Flow Rate and Viscosity

Note:

If your element is not graphed, use the following equation:  
 $\Delta P_{\text{element}} = \text{Flow Rate} \times \Delta P_f$  Plug this variable into the overall pressure drop equation.

Ele.	$\Delta P$	Ele.	$\Delta P$	Ele.	$\Delta P$
16QAS3V	0.04	16QPMLZ1	0.08	39QZ1	0.03
16QAS5V	0.04	16QPMLZ3	0.05	39QZ3	0.01
16QAS10V	0.03	16QPMLZ5	0.05	39QZ5	0.01
16QPML-AS3V	0.05	16QPMLZ10	0.04	39QZ10	0.01
16QPML-ASSV	0.05	16QPMLZ25	0.02	39QZ25	0.01
16QPML-AS10V	0.04	39QAS3V	0.01	39QPMLZ1	0.03
16QZ1	0.09	39QAS5V	0.01	39QPMLZ3	0.02
16QZ3	0.04	39QAS10V	0.01	39QPMLZ5	0.02
16QZ5	0.04	39QPMLAS-3V	0.02	39QPMLZ10	0.01
16QZ10	0.03	39QPMLAS-5V	0.02	39QPMLZ25	0.01
16QZ25	0.01	39QPMLAS-10V	0.01		

## Filter Model Number Selection

### How to Build a Valid Model Number for a Schroeder QF15:

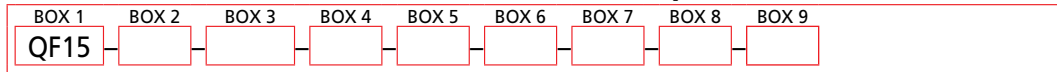

Example: NOTE: One option per box

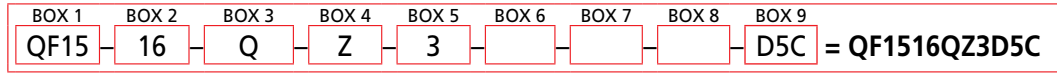

BOX 1	BOX 2	BOX 3	BOX 4	BOX 5
<b>Filter Series</b>	<b>Element Length (in)</b>	<b>Element Style</b>	<b>Media Type</b>	<b>Micron Rating</b>
QF15	16 39	Q QCLQF QPML	Z = Excellement® Z-Media® (synthetic) AS = Anti-Stat Pleat media (synthetic) W = W media (water removal)	1 = 1 µ Z-Media® 3 = 3 µ AS and Z-Media® 5 = 5 µ AS and Z-Media® 10 = 10 µ AS and Z-Media® 25 = 25 µ Z-Media®

BOX 6	BOX 7	BOX 8
<b>Housing Seal Material</b>	<b>Porting</b>	<b>Bypass Setting</b>
Omit = Buna N V = Viton®	P24 = 1½" NPTF P32 = 2" NPTF P40 = 2½" NPTF P48 = 3" NPTF  S32 = SAE-32  B24 = ISO 228 G-1½" B32 = ISO 228 G-2" B40 = ISO 228 G-2½" B48 = ISO 228 G-3"	F24 = 1½" SAE 4-bolt flange Code 61 F32 = 2" SAE 4-bolt flange Code 61 F40 = 2½" SAE 4-bolt flange Code 61 F48 = 3" SAE 4-bolt flange Code 61  F24M = 1½" SAE 4-bolt flange Code 61 F32M = 2" SAE 4-bolt flange Code 61 F40M = 2½" SAE 4-bolt flange Code 61 F48M = 3" SAE 4-bolt flange Code 61
		Omit = 30 psi cracking 15 = 15 psi cracking 40 = 40 psi cracking 50 = 50 psi cracking X = Blocked bypass

BOX 9	
Dirt Alarm® Options	
	Omit = None
Visual	DPG = Standard differential pressure gauge D5 = Visual pop-up D5C = D5 in cap D5R = D5 mounted opposite standard location
Visual with Thermal Lockout	D8 = Visual w/ thermal lockout D8C = D8 in cap D8R = D8 mounted opposite standard location
Electrical	MS5 = Electrical w/ 12 in. 18 gauge 4-conductor cable MS5LC = Low current MS5 MS10 = Electrical w/ DIN connector (male end only) MS10LC = Low current MS10 MS11 = Electrical w/ 12 ft. 4-conductor wire MS12 = Electrical w/ 5 pin Brad Harrison connector (male end only) MS12LC = Low current MS12 MS16 = Electrical w/ weather-packed sealed connector MS16LC = Low current MS16 MS17LC = Electrical w/ 4 pin Brad Harrison male connector
Electrical with Thermal Lockout	MS5T = MS5 (see above) w/ thermal lockout MS5LCT = Low current MS5T MS10T = MS10 (see above) w/ thermal lockout MS10LCT = Low current MS10T MS12T = MS12 (see above) w/ thermal lockout MS12LCT = Low current MS12T MS16T = MS16 (see above) w/ thermal lockout MS16LCT = Low current MS16T MS17LCT = Low current MS17T
Electrical Visual	MS13 = Supplied w/ threaded connector & light MS14 = Supplied w/ 5 pin Brad Harrison connector & light (male end)
Electrical Visual with Thermal Lockout	MS13DCT = MS13 (see above), direct current, w/ thermal lockout MS13DCLCT = Low current MS13DCT MS14DCT = MS14 (see above), direct current, w/ thermal lockout MS14DCLCT = Low current MS14DCT

**NOTES:**

Box 2. Replacement element part numbers are a combination of Boxes 2, 3, 4 and 5, plus the letter V.  
Example: 16QZ1V

Box 3. QCLQF are CoreCentric® coreless elements – housing includes rigid metal core. QPML are deep-pleated elements with more media and higher dirt holding capacity.

Box 4. For option W, Box 3 must equal Q.

Box 6. All elements for this filter are supplied with Viton® seals. Seal designation in Box 6 applies to housing only. Viton® is a registered trademark of DuPont Dow Elastomers.

Box 7. F24M, F32M, F40M and F48M are supplied with metric flange mounting holes.

Integral inlet and outlet test points are standard on all models.

# Base-Ported Filter

# QLF15



## Features and Benefits

- In-line version also available
- Element changeout from the top minimizes oil spillage
- Available with optional core assembly to accommodate coreless elements
- Offered with standard Q, QPML deep-pleated and QCLQF coreless elements in 16" and 39" lengths with Viton® seals as the standard
- Offered in pipe, SAE straight thread, and flange porting
- Integral inlet and outlet test points are standard on all models
- Various Dirt Alarm® options

**500 gpm**  
**1900 L/min**  
**1500 psi**  
**100 bar**

GH  
 RLTL  
 KF5  
 SRLT  
 K9  
 2K9  
 3K9  
 QF5  
 QF5i  
 3QF5

Model No. of filter in photograph is QLF1539QZ5F4850D5.

Flow Rating:	Up to 500 gpm (1900 L/min) for 150 SUS (32 cSt) fluids
Max. Operating Pressure:	1500 psi (100 bar)
Min. Yield Pressure:	4900 psi (340 bar), per NFPA T2.6.1
Rated Fatigue Pressure:	800 psi (55 bar), per NFPA T2.6.1-R1-2005
Temp. Range:	-20°F to 225°F (-29°C to 107°C)
Bypass Setting:	Cracking: 30 psi (2 bar) Full Flow: 55 psi (4 bar)
Porting Base & Cap:	Ductile Iron
Element Case:	Steel
Weight of QLF15-16Q:	121.0 lbs. (55.0 kg)
Weight of QLF15-39Q:	180.0 lbs. (82.0 kg)
Element Change Clearance:	16Q 12.00" (305 mm) 39Q 33.80" (859 mm)

## Filter Housing Specifications

QF15

**QLF15**

SSQLF15

Type Fluid	Appropriate Schroeder Media
Petroleum Based Fluids	All E media (cellulose), Z-Media® and ASP® media (synthetic)
High Water Content	All Z-Media® and ASP® media (synthetic)
Invert Emulsions	10 µ and 25 µ Z-Media® and 10 µ ASP® media (synthetic)
Water Glycols	3, 5, 10, and 25 µ Z-Media® and all ASP® media (synthetic)
Phosphate Esters	All Z-Media® with H (EPR) seal designation and all ASP® media (synthetic)

## Fluid Compatibility

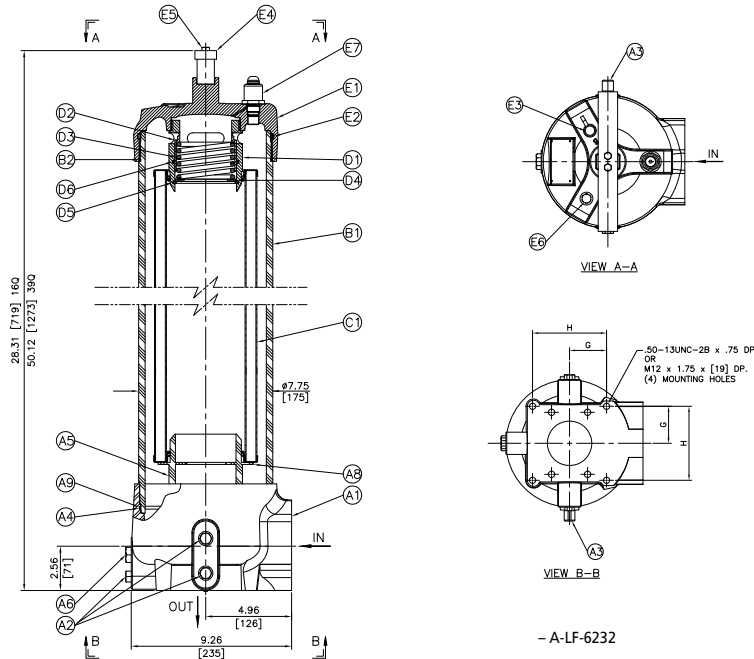

DIMENSIONAL DATA		
PORT SIZE	DIM G	DIM H
1½" (38)	2.00 (51)	4.00 (102)
2" (51)	2.00 (51)	4.00 (102)
2½" (64)	2.00 (51)	4.00 (102)
3" (76)	2.50 (63.5)	4.00 (102)

Metric dimensions in ( ).

## Element Performance Information & Dirt Holding Capacity

Element	Filtration Ratio Per ISO 4572/NFPA T3.10.8.8 Using automated particle counter (APC) calibrated per ISO 4402			Filtration Ratio per ISO 16889 Using APC calibrated per ISO 11171		
	$\beta_x \geq 75$	$\beta_x \geq 100$	$\beta_x \geq 200$	$\beta_x(c) \geq 200$	$\beta_x(c) \geq 1000$	
16Q	Z1/CLQFZ1/PMLZ1	<1.0	<1.0	<1.0	<4.0	4.2
	Z3/CLQFZ3/PMLZ3	<1.0	<1.0	<2.0	<4.0	4.8
	Z5/CLQFZ5/PMLZ5	2.5	3.0	4.0	4.8	6.3
	Z10/CLQFZ10/PMLZ10	7.4	8.2	10.0	8.0	10.0
	Z25/CLQFZ25/PMLZ25	18.0	20.0	22.5	19.0	24.0
39Q	Z1/CLQFZ1/PMLZ1	<1.0	<1.0	<1.0	<4.0	4.2
	Z3/CLQFZ3/PMLZ3	<1.0	<1.0	<2.0	<4.0	4.8
	Z5/CLQFZ5/PMLZ5	2.5	3.0	4.0	4.8	6.3
	Z10/CLQFZ10/PMLZ10	7.4	8.2	10.0	8.0	10.0
	Z25/CLQFZ25/PMLZ25	18.0	20.0	22.5	19.0	24.0

Element	DHC (gm)	Element	DHC (gm)	Element	DHC (gm)	
16Q	Z1	276	CLQFZ1	307	PMLZ1	307
	Z3	283	CLQFZ3	315	PMLZ3	315
	Z5	351	CLQFZ5	364	PMLZ5	364
	Z10	280	CLQFZ10	306	PMLZ10	330
	Z25	254	CLQFZ25	278	PMLZ25	299
39Q	Z1	974	CLQFZ1	1259	PMLZ1	1485
	Z3	1001	CLQFZ3	1293	PMLZ3	1525
	Z5	954	CLQFZ5	1302	PMLZ5	1235
	Z10	940	CLQFZ10	1214	PMLZ10	1432
	Z25	853	CLQFZ25	1102	PMLZ25	1299

Element Collapse Rating: Q and QPML: 150 psid (10 bar), QCLQF: 100 psid (7 bar)

Flow Direction: Outside In

Element Nominal Dimensions:

- 16Q: 6.0" (150 mm) O.D. x 16.85" (430 mm) long
- 16QCLQF: 6.0" (150 mm) O.D. x 18.21" (463 mm) long
- 16QPML: 6.0" (150 mm) O.D. x 16.00" (405 mm) long
- 39Q: 6.0" (150 mm) O.D. x 38.70" (985 mm) long
- 39QCLQF: 6.0" (150 mm) O.D. x 40.01" (1016 mm) long
- 39QPML: 6.0" (150 mm) O.D. x 37.80" (960 mm) long

$\Delta P_{\text{housing}}$

QLF15  $\Delta P_{\text{housing}}$  for fluids with sp gr (specific gravity) = 0.86:

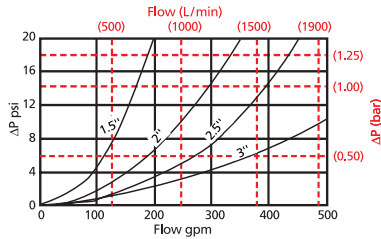

$\Delta P_{\text{element}}$

16QCLQFZ Element Pressure Drop versus Flow Rate at 32 cSt (150 SUS)

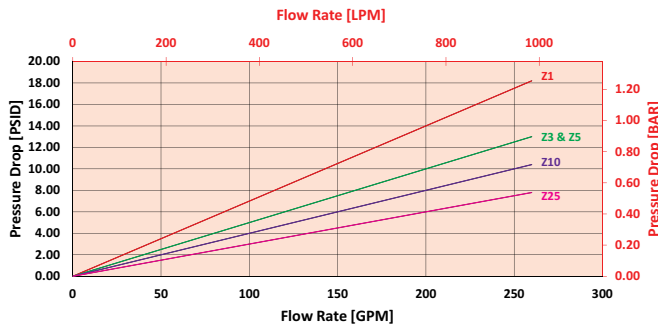

39QCLQFZ Element Pressure Drop versus Flow Rate at 32 cSt (150 SUS)

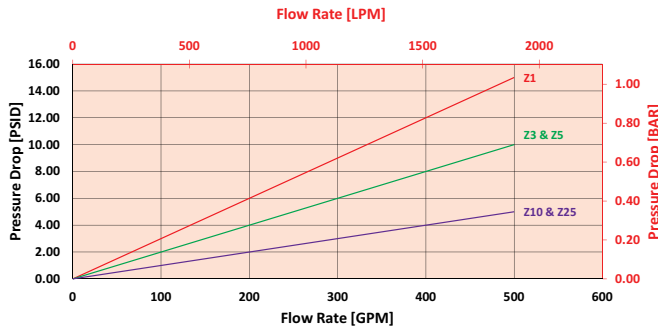

$$\Delta P_{\text{filter}} = \Delta P_{\text{housing}} + (\Delta P_{\text{element}} * \mathbf{V}_f)$$

**Exercise:**

Determine  $\Delta P_{\text{filter}}$  at 200 gpm (758 L/min) for QLF1516QZ3D5C using 100 SUS (21.3 cSt) fluid.

Use the housing pressure curve to determine  $\Delta P_{\text{housing}}$  at 200 gpm. In this case,  $\Delta P_{\text{housing}}$  is 2 psi (.14 bar) on the graph for the QLF15 housing.

Use the element pressure curve to determine  $\Delta P_{\text{element}}$  at 200 gpm. In this case,  $\Delta P_{\text{element}}$  is 7 psi (.48 bar) according to the graph for the 16QZ3 element.

Because the viscosity in this sample is 100 SUS (21.3 cSt), we determine the **Viscosity Factor ( $\mathbf{V}_f$ )** by dividing the **Operating Fluid Viscosity** with the **Standard Viscosity** of 150 SUS (32 cSt). To best determine your Operating Fluid Viscosity, please reference the chart in Appendix D.

Finally, the overall filter pressure differential,  $\Delta P_{\text{filter}}$ , is calculated by adding  $\Delta P_{\text{housing}}$  with the true element pressure differential,  $(\Delta P_{\text{element}} * \mathbf{V}_f)$ . The  $\Delta P_{\text{element}}$  from the graph has to be multiplied by the viscosity factor to get the true pressure differential across the element.

**Solution:**

$\Delta P_{\text{housing}} = 2 \text{ psi } [.14 \text{ bar}] \mid \Delta P_{\text{element}} = 7 \text{ psi } [.48 \text{ bar}]$

$\mathbf{V}_f = 100 \text{ SUS } (21.3 \text{ cSt}) / 150 \text{ SUS } (32 \text{ cSt}) = .67$

$\Delta P_{\text{filter}} = 2 \text{ psi } + (7 \text{ psi } * .67) = 6.7 \text{ psi}$

**OR**

$\Delta P_{\text{filter}} = 14 \text{ bar } + (.48 \text{ bar } * .67) = .46 \text{ bar}$

**Pressure Drop Information Based on Flow Rate and Viscosity**

Note:

If your element is not graphed, use the following equation:  
 $\Delta P_{\text{element}} = \text{Flow Rate} \times \Delta P_f$   
 Plug this variable into the overall pressure drop equation.

Ele.	$\Delta P$	Ele.	$\Delta P$	Ele.	$\Delta P$
16QAS3V	0.04	16QPMLZ1	0.08	39QZ1	0.03
16QAS5V	0.04	16QPMLZ3	0.05	39QZ3	0.01
16QAS10V	0.03	16QPMLZ5	0.05	39QZ5	0.01
16QPML-AS3V	0.05	16QPMLZ10	0.04	39QZ10	0.01
16QPML-ASSV	0.05	16QPMLZ25	0.02	39QZ25	0.01
16QPML-AS10V	0.04	39QAS3V	0.01	39QPMLZ1	0.03
16QZ1	0.09	39QAS5V	0.01	39QPMLZ3	0.02
16QZ3	0.04	39QAS10V	0.01	39QPMLZ5	0.02
16QZ5	0.04	39QPMLAS-3V	0.02	39QPMLZ10	0.01
16QZ10	0.03	39QPMLAS-5V	0.02	39QPMLZ25	0.01
16QZ25	0.01	39QPMLAS-10V	0.01		

## Filter Model Number Selection

### How to Build a Valid Model Number for a Schroeder QF15:

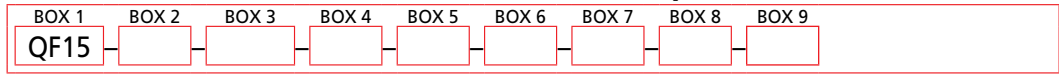

Example: NOTE: One option per box

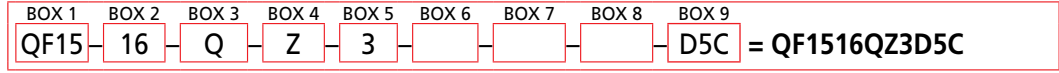

BOX 1	BOX 2	BOX 3	BOX 4	BOX 5
<b>Filter Series</b>	<b>Element Length (in)</b>	<b>Element Style</b>	<b>Media Type</b>	<b>Micron Rating</b>
QLF15	16 39	Q QCLQF	Z = Excellement® Z-Media® (synthetic) AS = Anti-Stat Pleat media (synthetic) W = W media (water removal)	1 = 1 µ Z-Media® 3 = 3 µ AS and Z-Media® 5 = 5 µ AS and Z-Media®
WQLF5 (Water)		QPML	<b>Water System Element Options</b> QM60 = Q size 60 µ M media (reusable metal) QM150 = Q size 150 µ M media (reusable metal)	10 = 10 µ AS and Z-Media® 25 = 25 µ Z-Media®

BOX 6	BOX 7	BOX 8
<b>Housing Seal Material</b>	<b>Porting</b>	<b>Bypass Setting</b>
Omit = Buna N V = Viton®	P24 = 1½" NPTF P32 = 2" NPTF P40 = 2½" NPTF P48 = 3" NPTF  S32 = SAE-32  B24 = ISO 228 G-1½" B32 = ISO 228 G-2" B40 = ISO 228 G-2½" B48 = ISO 228 G-3"	Omit = 30 psi cracking 15 = 15 psi cracking 40 = 40 psi cracking 50 = 50 psi cracking X = Blocked bypass
	F24 = 1½" SAE 4-bolt flange Code 61 F32 = 2" SAE 4-bolt flange Code 61 F40 = 2½" SAE 4-bolt flange Code 61 F48 = 3" SAE 4-bolt flange Code 61  F24M = 1½" SAE 4-bolt flange Code 61 F32M = 2" SAE 4-bolt flange Code 61 F40M = 2½" SAE 4-bolt flange Code 61 F48M = 3" SAE 4-bolt flange Code 61	

BOX 9	
Dirt Alarm® Options	
	Omit = None
Visual	DPG = Standard differential pressure gauge D5 = Visual pop-up D5C = D5 in cap
Visual with Thermal Lockout	D8 = Visual w/ thermal lockout D8C = D8 in cap
Electrical	MS5 = Electrical w/ 12 in. 18 gauge 4-conductor cable MS5LC = Low current MS5 MS10 = Electrical w/ DIN connector (male end only) MS10LC = Low current MS10 MS11 = Electrical w/ 12 ft. 4-conductor wire MS12 = Electrical w/ 5 pin Brad Harrison connector (male end only) MS12LC = Low current MS12 MS16 = Electrical w/ weather-packed sealed connector MS16LC = Low current MS16 MS17LC = Electrical w/ 4 pin Brad Harrison male connector
Electrical with Thermal Lockout	MS5T = MS5 (see above) w/ thermal lockout MS5LCT = Low current MS5T MS10T = MS10 (see above) w/ thermal lockout MS10LCT = Low current MS10T MS12T = MS12 (see above) w/ thermal lockout MS12LCT = Low current MS12T MS16T = MS16 (see above) w/ thermal lockout MS16LCT = Low current MS16T MS17LCT = Low current MS17T
Electrical Visual	MS13 = Supplied w/ threaded connector & light MS14 = Supplied w/ 5 pin Brad Harrison connector & light (male end)
Electrical Visual with Thermal Lockout	MS13DCT = MS13 (see above), direct current, w/ thermal lockout MS13DCLCT = Low current MS13DCT MS14DCT = MS14 (see above), direct current, w/ thermal lockout MS14DCLCT = Low current MS14DCT

**NOTES:**

Box 2. Replacement element part numbers are a combination of Boxes 2, 3, 4, and 5 plus the letter V.  
Example: 16QZ1V

Box 3. QCLQF are CoreCentric® coreless elements – housing includes rigid metal core. QPML are deep-pleated elements with more media and higher dirt holding capacity.

Box 4. For option W, Box 3 must equal Q.

Box 6. All elements for this filter are supplied with Viton® seals. Seal designation in Box 6 applies to housing only. Viton® is a registered trademark of DuPont Dow Elastomers.

Box 7. B24, B32 and B40 are supplied with metric mounting holes. F24M, F32M, F40M and F48M are supplied with metric flange mounting holes.

Integral inlet and outlet test points are standard on all models.

# Stainless Steel Base-Ported Filter

# SSQLF15



## Features and Benefits

- In-line version also available
- Element changeout from the top minimizes oil spillage
- Offered with standard Q and QPML deep-pleated coreless elements in 16" and 39" lengths with Viton® seals as the standard
- Offered in pipe, SAE straight thread, and flange porting
- Integral inlet and outlet test points are standard on all models
- Various Dirt Alarm® options
- All stainless steel provides compatibility with water-based fluids

**500 gpm**  
**1900 L/min**  
**1500 psi**  
**100 bar**

GH

RLT

KF5

SRLT

K9

2K9

3K9

QF5

QF5i

3QF5

QFD5

QF15

QLF15

**SSQLF15**

Model No. of filter in photograph is SSQLF1539QZ5F4850D5.

Flow Rating:	Up to 500 gpm (1900 L/min) for 150 SUS (32 cSt) fluids
Max. Operating Pressure:	1500 psi (100 bar)
Min. Yield Pressure:	4500 psi (310 bar), per NFPA T2.6.1
Rated Fatigue Pressure:	Contact Factory
Temp. Range:	-20°F to 225°F (-29°C to 107°C)
Bypass Setting:	Cracking: 30 psi (2 bar) Full Flow: 55 psi (4 bar)
Porting Base & Cap:	Stainless Steel
Element Case:	Stainless Steel
Weight of SSQLF15-16Q:	163.0 lbs. (74.0 kg)
Weight of SSQLF15-39Q:	240.0 lbs. (109.0 kg)
Element Change Clearance:	16Q 12.00" (305 mm) 39Q 33.80" (859 mm)

## Filter Housing Specifications

Type Fluid	Appropriate Schroeder Media
Petroleum Based Fluids	All E media (cellulose), Z-Media® and ASP® media (synthetic)
High Water Content	All Z-Media® and ASP® media (synthetic)
Invert Emulsions	10 and 25 µ Z-Media® and 10 µ ASP® media (synthetic)
Water Glycols	3, 5, 10 and 25 µ Z-Media® and all ASP® media (synthetic)
Phosphate Esters	All Z-Media® (synthetic) with H (EPR) seal designation and all ASP® media (synthetic)

## Fluid Compatibility

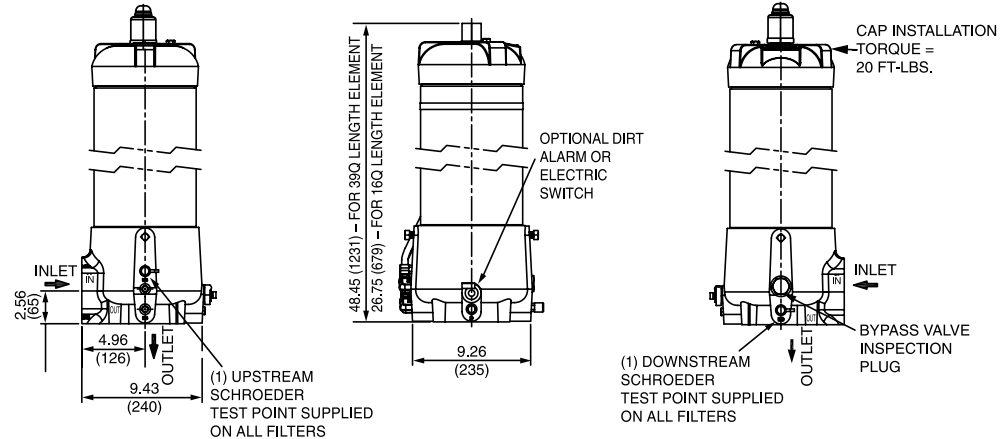

DIMENSIONAL DATA		
PORT SIZE	DIM A	DIM B
1½" (38)	2.00 (51)	4.00 (102)
2" (51)	2.00 (51)	4.00 (102)
2½" (64)	2.00 (51)	4.00 (102)
3" (76)	2.00 (51)	4.00 (102)
3" (4 bolt port only)	2.50 (64)	5.00 (127)

Metric dimensions in ( ).

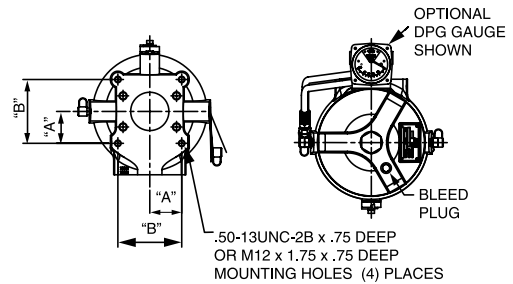

## Element Performance Information & Dirt Holding Capacity

Element	Filtration Ratio Per ISO 4572/NFPA T3.10.8.8 Using automated particle counter (APC) calibrated per ISO 4402			Filtration Ratio per ISO 16889 Using APC calibrated per ISO 11171		
	$\beta_x \geq 75$	$\beta_x \geq 100$	$\beta_x \geq 200$	$\beta_x(c) \geq 200$	$\beta_x(c) \geq 1000$	
16Q	Z1/CLQFZ1/PMLZ1	<1.0	<1.0	<1.0	<4.0	4.2
	Z3/CLQFZ3/PMLZ3	<1.0	<1.0	<2.0	<4.0	4.8
	Z5/CLQFZ5/PMLZ5	2.5	3.0	4.0	4.8	6.3
	Z10/CLQFZ10/PMLZ10	7.4	8.2	10.0	8.0	10.0
	Z25/CLQFZ25/PMLZ25	18.0	20.0	22.5	19.0	24.0
39Q	Z1/CLQFZ1/PMLZ1	<1.0	<1.0	<1.0	<4.0	4.2
	Z3/CLQFZ3/PMLZ3	<1.0	<1.0	<2.0	<4.0	4.8
	Z5/CLQFZ5/PMLZ5	2.5	3.0	4.0	4.8	6.3
	Z10/CLQFZ10/PMLZ10	7.4	8.2	10.0	8.0	10.0
	Z25/CLQFZ25/PMLZ25	18.0	20.0	22.5	19.0	24.0

Element	DHC (gm)	Element	DHC (gm)
16Q	Z1	PMLZ1	307
	Z3	PMLZ3	315
	Z5	PMLZ5	364
	Z10	PMLZ10	330
	Z25	PMLZ25	299
39Q	Z1	PMLZ1	1485
	Z3	PMLZ3	1525
	Z5	PMLZ5	1235
	Z10	PMLZ10	1432
	Z25	PMLZ25	1299

Element Collapse Rating: Q and QPML: 150 psid (10 bar)

Flow Direction: Outside In

Element Nominal Dimensions: 16Q: 6.0" (150 mm) O.D. x 16.85" (430 mm) long  
 16QPML: 6.0" (150 mm) O.D. x 16.00" (405 mm) long  
 39Q: 6.0" (150 mm) O.D. x 38.70" (985 mm) long  
 39QPML: 6.0" (150 mm) O.D. x 37.80" (960 mm) long



# Stainless Steel Base-Ported Filter

# SSQLF15

$\Delta P_{\text{housing}}$

SSQLF15  $\Delta P_{\text{housing}}$  for fluids with sp gr (specific gravity) = 0.86:

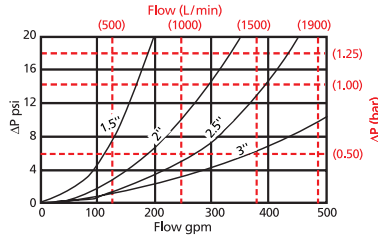

$\Delta P_{\text{element}}$

39QZ

Element Pressure Drop versus Flow Rate at 32 cSt (150 SUS)

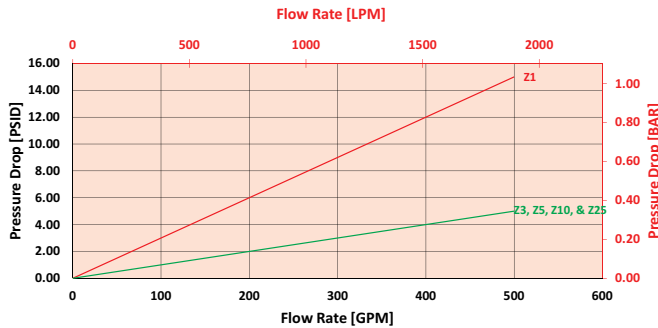

39QPMLZ

Element Pressure Drop versus Flow Rate at 32 cSt (150 SUS)

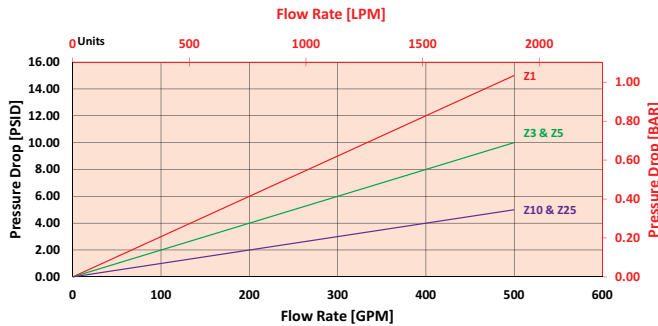

$$\Delta P_{\text{filter}} = \Delta P_{\text{housing}} + (\Delta P_{\text{element}} * \mathbf{V}_f)$$

### Exercise:

Determine  $\Delta P_{\text{filter}}$  at 200 gpm (758 L/min) for SSQLF1516QZ3P48D9C using 100 SUS (21.3 cSt) fluid.

Use the housing pressure curve to determine  $\Delta P_{\text{housing}}$  at 200 gpm. In this case,  $\Delta P_{\text{housing}}$  is 2 psi (.14 bar) on the graph for the SSQLF housing.

Use the element pressure curve to determine  $\Delta P_{\text{element}}$  at 200 gpm. In this case,  $\Delta P_{\text{element}}$  is 7 psi (.48 bar) according to the graph for the 16QZ3 element.

Because the viscosity in this sample is 100 SUS (21.3 cSt), we determine the **Viscosity Factor ( $\mathbf{V}_f$ )** by dividing the **Operating Fluid Viscosity** with the **Standard Viscosity** of 150 SUS (32 cSt). To best determine your Operating Fluid Viscosity, please reference the chart in Appendix D.

Finally, the overall filter pressure differential,  $\Delta P_{\text{filter}}$ , is calculated by adding  $\Delta P_{\text{housing}}$  with the true element pressure differential,  $(\Delta P_{\text{element}} * \mathbf{V}_f)$ . The  $\Delta P_{\text{element}}$  from the graph has to be multiplied by the viscosity factor to get the true pressure differential across the element.

### Solution:

$$\Delta P_{\text{housing}} = 2 \text{ psi } [.14 \text{ bar}] \quad | \quad \Delta P_{\text{element}} = 7 \text{ psi } [.48 \text{ bar}]$$

$$\mathbf{V}_f = 100 \text{ SUS } (21.3 \text{ cSt}) / 150 \text{ SUS } (32 \text{ cSt}) = .67$$

$$\Delta P_{\text{filter}} = 2 \text{ psi } + (7 \text{ psi } * .67) = 6.7 \text{ psi}$$

OR

$$\Delta P_{\text{filter}} = .14 \text{ bar } + (.48 \text{ bar } * .67) = .46 \text{ bar}$$

**Pressure Drop Information Based on Flow Rate and Viscosity**

Note:

If your element is not graphed, use the following equation:  
 $\Delta P_{\text{element}} = \text{Flow Rate} \times \Delta P_f$   
 Plug this variable into the overall pressure drop equation.

Ele.	$\Delta P$	Ele.	$\Delta P$
16QAS3V	0.04	16QPMLZ1	0.08
16QAS5V	0.04	16QPMLZ3	0.05
16QAS10V	0.03	16QPMLZ5	0.05
16QPMLAS3V	0.05	16QPMLZ10	0.04
16QPMLAS5V	0.05	16QPMLZ25	0.02
16QPMLAS10V	0.04	39QAS3V	0.01
16QZ1	0.09	39QAS5V	0.01
16QZ3	0.04	39QAS10V	0.01
16QZ5	0.04	39QPMLAS3V	0.02
16QZ10	0.03	39QPMLAS5V	0.02
16QZ25	0.01	39QPMLAS10V	0.01

## Filter Model Number Selection

### How to Build a Valid Model Number for a Schroeder SSQLF15:

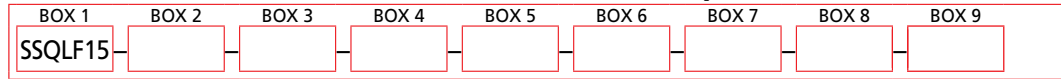

Example: NOTE: One option per box

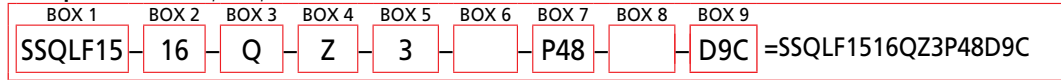

BOX 1	BOX 2	BOX 3	BOX 4
<b>Filter Series</b>	<b>Element Length (in)</b>	<b>Element Style</b>	<b>Media Type</b>
SSQLF15	16 39	Q QCLQF QPML	Z = Excellement® Z-Media® (synthetic) AS = Anti-Stat Pleat media (synthetic) M = M media (reusable metal) W = W media (water removal) 150PSV = 150 μ nominal synthetic media with plastic outer wrap

BOX 5	BOX 6	BOX 7
<b>Micron Rating</b>	<b>Housing Seal Material</b>	<b>Porting</b>
1 = 1 μ Z-Media® 3 = 3 μ AS and Z-Media® 5 = 5 μ AS and Z-Media® 10 = 10 μ AS and Z-Media® 25 = 25 μ M and Z-Media® 60 = 60 μ M media 150 = 150 μ M-media or 150 PSV W = water removal media	Omit = Buna N H = EPR V = Viton®	P24 = 1½" NPTF P32 = 2" NPTF P40 = 2½" NPTF P48 = 3" NPTF S32 = SAE-32 B24 = ISO 228 G-1½" B32 = ISO 228 G-2" B40 = ISO 228 G-2½" B48 = ISO 228 G-3"  F24 = 1½" SAE 4-bolt flange Code 61 F32 = 2" SAE 4-bolt flange Code 61 F40 = 2½" SAE 4-bolt flange Code 61 F48 = 3" SAE 4-bolt flange Code 61 F24M = 1½" SAE 4-bolt flange Code 61 F32M = 2" SAE 4-bolt flange Code 61 F40M = 2½" SAE 4-bolt flange Code 61 F48M = 3" SAE 4-bolt flange Code 61

BOX 8	BOX 9
<b>Bypass Setting</b>	<b>Dirt Alarm® Options</b>
Omit = 30 psi cracking 50 = 50 psi cracking X = Blocked bypass	Omit = None Visual DPG = Standard differential pressure gauge D9 = Visual pop-up in base (stainless steel) D9C = D9 in cap (stainless steel)

#### NOTES:

Box 2. Replacement element part numbers are a combination of Boxes 2, 3, 4 and 5 plus the letter V.  
Example: 16QZ1V

Box 4. For options W, 150PSV, M25, M60, and M150, Box 3 must equal Q.

Box 6. All elements for this filter are supplied with Viton® seals. Seal designation in Box 6 applies to housing only. Viton® is a registered trademark of DuPont Dow Elastomers.

Box 7. B24, B32 and B40 are supplied with metric mounting holes. F24M, F32M, F40M and F48M are supplied with metric flange mounting holes.

Integral inlet and outlet test points are standard on all models.

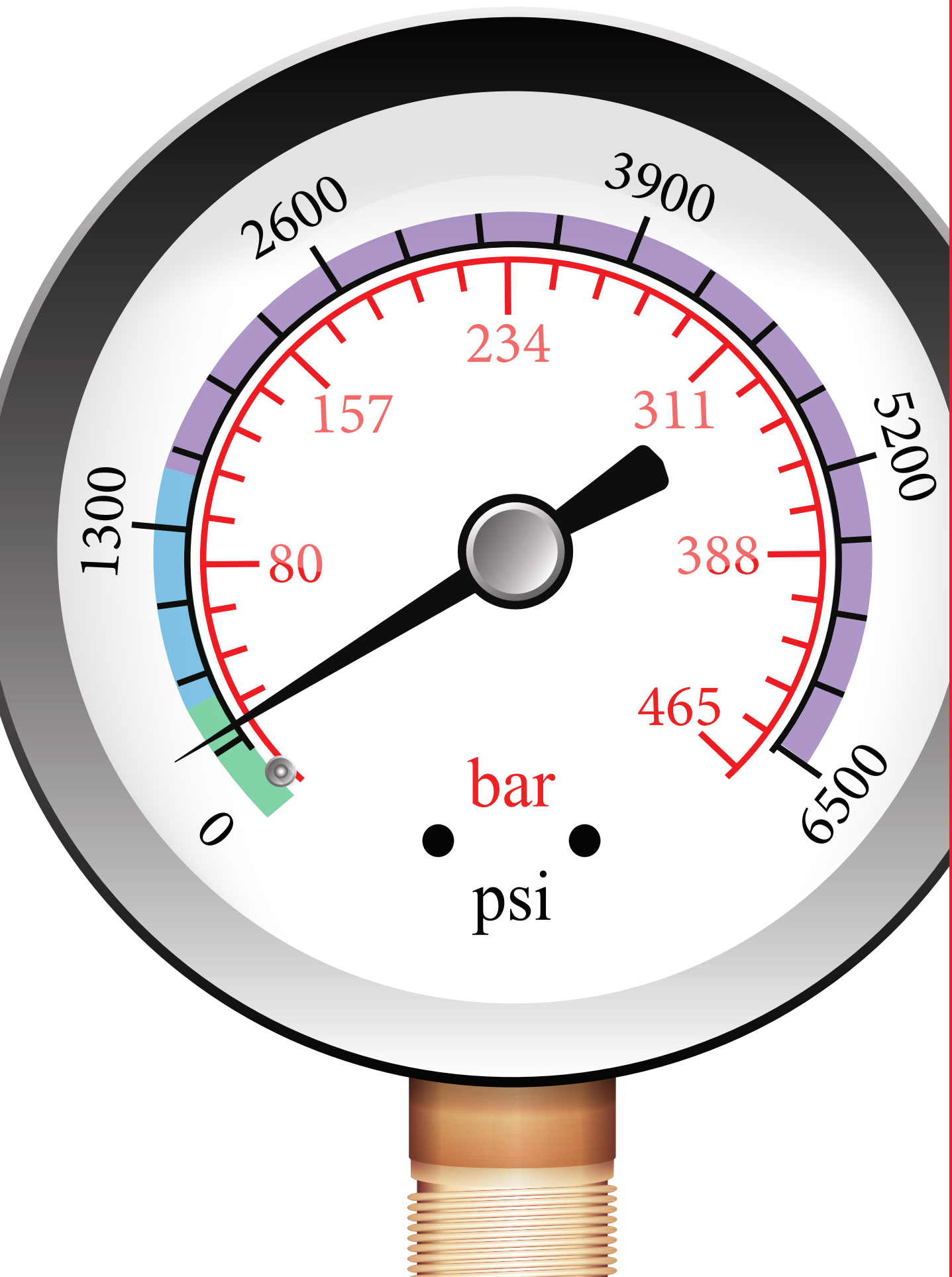

Section 5:  
up to 500 psi

# LOW PRESSURE FILTERS

# Section 5

## Low Pressure Filters Selection Guide

		Pressure psi (bar)	Flow gpm (L/ min)	Element Length/Size	Page	
Low Pressure Filters (up to 500 psi)	<b>Top-Ported Low Pressure Filters</b>					
	IRF	100 (7)	100 (380)	K, KK, KD, KKD	209	
	TF1	300 (20)	30 (120)	A	215	
	KF3	300 (20)	100 (380)	K, KK, 27K	219	
	KL3	300 (20)	120 (455)	K, KK, 27K, 18LC	223	
	LF1-2"	300 (20)	120 (455)	18LC	227	
	MLF1	300 (20)	200 (760)	K	231	
	RLD	350 (24)	100 (380)	25DN, 40D	235	
	<b>Tank-Mounted (In-Tank/Tank Top) Low Pressure Filters</b>					
	GRTB	100 (7)	100 (380)	KBG	239	
	MTA	100 (7)	15 (55)	3TA	243	
	MTB	100 (7)	35 (135)	3TB, 5TB	247	
	ZT	100 (7)	40 (150)	8Z	251	
	KFT	100 (7)	100 (380)	K, KK, KD, KKD, 27K	255	
	RT	100 (7)	100 (380)	K, KK, KD, KKD, 27K	259	
	RTI	100 (7)	120 (455)	KI, KKI, 27KI	263	
	LRT	100 (7)	150 (570)	18L, 18LD	267	
	ART	145 (10)	225 (850)	85Z1, 85Z3, 85Z5, 85Z10, 85Z25	271	
	BRT	145 (10)	160 (600)	2RBZ10/25, 3RBZ10/25, 4RBZ10/25, 6RBZ10/25	277	
	TRT	145 (10)	634 (2400)	2RTZ10/25, 3RTZ10/25, 4RTZ10/25, 6RTZ10/25	281	
	BFT	100 (7)	300 (1135)	BB	289	
	QT	100 (7)	450 (1700)	16Q, 16QPML, 39Q, 39QPML	293	
	<b>Special Feature Tank-Mounted Low Pressure Filters</b>					
	Internal	KTK	100 (7)	100 (380)	K, KK, 27K	297
	Internal	LTK	100 (7)	150 (570)	18L	301
	<b>Severe Duty Tank-Mounted</b>					
		MRT	900 (62)	150 (570)	18L	305
	<b>Spin-On Low Pressure Filters</b>					
		PAF1	100 (7)	20 (75)	6P	311
	MAF1	100 (7)	50 (190)	M, 10M	315	
	MF2	150 (10)	60 (230)	M, 10M	319	

# Inline Return Filter

# IRF



## Features and Benefits

- Low pressure top servicing in-line filter
- Meets HF4 automotive standard
- Unique side mounting flange provides reliable seal arrangement between head and bowl
- The use of K-size elements allows consolidation of inventoried replacement elements
- Single and double length options provide optimal size for specific applications
- Also available with new DirtCatcher® elements (KDZ and KKDZ)
- Various Dirt Alarm® options

**100 gpm**  
**380 L/min**  
**100 psi**  
**7 bar**

**IRF**

TF1

KF3

KL3

LF1

MLF1

RLD

GRTB

MTA

MTB

ZT

KFT

RT

RTI

LRT

ART

BRT

TRT

BFT

QT

KTK

LTK

MRT

Model No. of filter in photograph is IRF2KZ10S20Y2.

Flow Rating:	Up to 100 gpm (380 L/min) for 150 SUS (32 cSt) fluids
Max. Operating Pressure:	100 psi (7 bar)
Min. Yield Pressure:	400 psi (28 bar), per NFPA T2.6.1
Rated Fatigue Pressure:	90 psi (6 bar), per NFPA T2.6.1-2005
Temp. Range:	-20°F to 225°F (-29°C to 107°C)
Bypass Setting:	Cracking: 25 psi (1.7 bar) Full Flow: 48 psi (3.3 bar)
Porting Head:	Sand Cast Aluminum
Element Case:	Steel
Weight of IRF-1K:	13.5 lbs. (6.12 kg)
Weight of IRF-2K:	17.0 lbs. (7.71 kg)
Element Change Clearance:	8.0" (205 mm) for 1K; 17.50" (445 mm) for KK

## Filter Housing Specifications

Type Fluid	Appropriate Schroeder Media
Petroleum Based Fluids	All E media (cellulose), Z-Media® and ASP® media (synthetic)
High Water Content	All Z-Media® and ASP® media (synthetic)
Invert Emulsions	10 and 25 µ Z-Media® (synthetic), 10 µ ASP® media (synthetic)
Water Glycols	3, 5, 10 and 25 µ Z-Media® (synthetic), 3, 5, and 10 µ ASP® media (synthetic)
Phosphate Esters	All Z-Media® (synthetic) with H (EPR) seal designation and 3 and 10 µ E media (cellulose) with H (EPR) seal designation and all ASP® Media (synthetic)
Skydrol®	3, 5, 10 and 25 µ Z-Media® (synthetic) with H.5 seal designation (EPR seals and stainless steel wire mesh in element, and light oil coating on housing exterior) and all ASP® media (synthetic)

## Fluid Compatibility

## Accessories For Tank-Mounted Filters

PAF1

MAF1

MF2

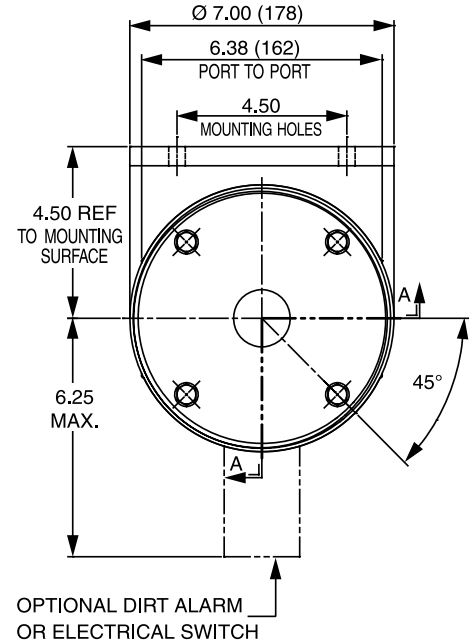
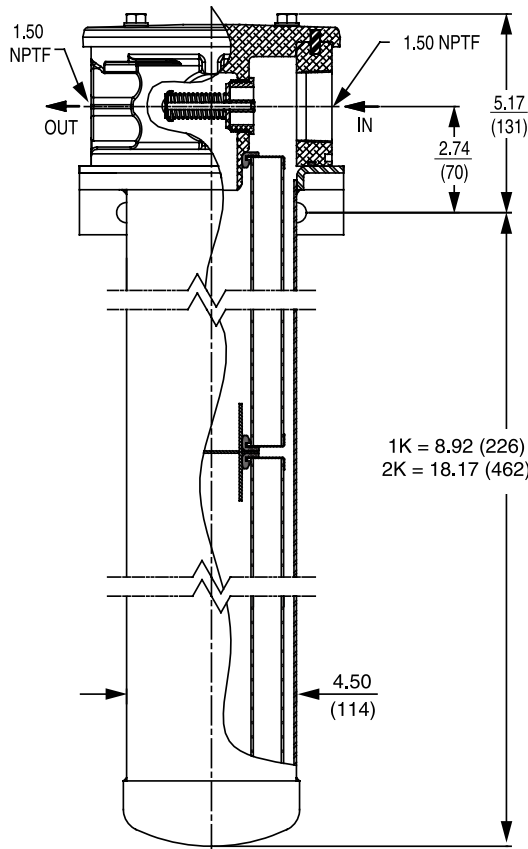

SECTION A-A

Metric dimensions in ( ).

## Element Performance Information & Dirt Holding Capacity

Element	Filtration Ratio Per ISO 4572/NFPA T3.10.8.8 Using automated particle counter (APC) calibrated per ISO 4402			Filtration Ratio per ISO 16889 Using APC calibrated per ISO 11171	
	$\beta_x \geq 75$	$\beta_x \geq 100$	$\beta_x \geq 200$	$\beta_x(c) \geq 200$	$\beta_x(c) \geq 1000$
KZ1/KKZ1/27KZ1	<1.0	<1.0	<1.0	<4.0	4.2
KZ3/KKZ3	<1.0	<1.0	<2.0	<4.0	4.8
KZ5/KKZ5	2.5	3.0	4.0	4.8	6.3
KZ10/KKZ10	7.4	8.2	10.0	8.0	10.0
KZ25/KKZ25/27KZ25	18.0	20.0	22.5	19.0	24.0
KZW1	N/A	N/A	N/A	<4.0	<4.0
KZW3/KKZW3	N/A	N/A	N/A	4.0	4.8
KZW5/KKZW5	N/A	N/A	N/A	5.1	6.4
KZW10/KKZW10	N/A	N/A	N/A	6.9	8.6
KZW25/KKZW25	N/A	N/A	N/A	15.4	18.5

Element	DHC (g)	Element	DHC (g)	Element	DHC (g)	Element	DHC (g)	Element	DHC (g)	Element	DHC (g)
KZ1	112	KKZ1	224	27KZ1	336	KDZ1	89	KKDZ1	188	KZW1	61
KZ3	115	KKZ3	230	27KZ3	345	KDZ3	71	KKDZ3	150	KZW3	64
KZ5	119	KKZ5	238	27KZ5	357	KDZ5	100	KKDZ5	210	KZW5	63
KZ10	108	KKZ10	216	27KZ10	324	KDZ10	80	KKDZ10	168	KZW10	57
KZ25	93	KKZ25	186	27KZ25	279	KDZ25	81	KKDZ25	171	KZW25	79
										KKZW3	128
										KKZW5	126
										KKZW10	114
										KKZW25	158

Element Collapse Rating: 150 psid (10 bar) for standard elements

Flow Direction: Outside In

Element Nominal Dimensions:

- K: 3.9" (99 mm) O.D. x 9.0" (230 mm) long
- KK: 3.9" (99 mm) O.D. x 18.0" (460 mm) long
- 27K: 3.9" (99 mm) O.D. x 27.0" (690 mm) long

### $\Delta P_{\text{housing}}$

IRF  $\Delta P_{\text{housing}}$  for fluids with sp gr (specific gravity) = 0.86:

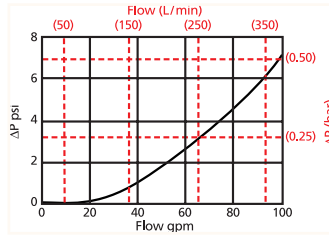

### $\Delta P_{\text{element}}$

1KZ

Element Pressure Drop versus Flow Rate at 32 cSt (150 SUS)

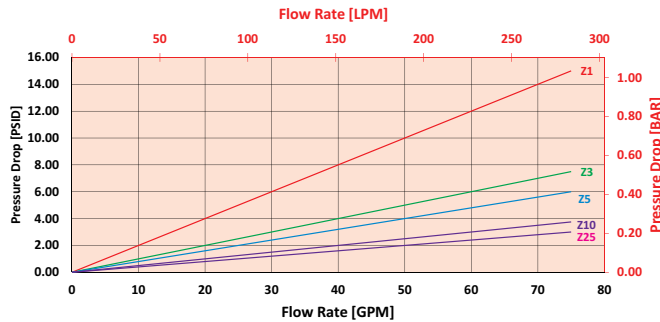

2KZ/KKZ

Element Pressure Drop versus Flow Rate at 32 cSt (150 SUS)

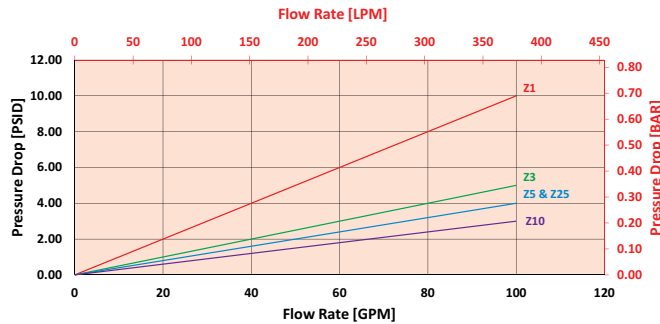

$$\Delta P_{\text{filter}} = \Delta P_{\text{housing}} + (\Delta P_{\text{element}} * \mathbf{V}_f)$$

### Exercise:

Determine  $\Delta P_{\text{filter}}$  at 70 gpm (265.3 L/min) for IRF2KZ10S20Y2 using 160 SUS (34 cSt) fluid.

Use the housing pressure curve to determine  $\Delta P_{\text{housing}}$  at 70 gpm. In this case,  $\Delta P_{\text{housing}}$  is 3.5 psi (.24 bar) on the graph for the IRF housing.

Use the element pressure curve to determine  $\Delta P_{\text{element}}$  at 70 gpm. In this case,  $\Delta P_{\text{element}}$  is 2 psi (.14 bar) according to the graph for the 2KZ10 element.

Because the viscosity in this sample is 160 SUS (24 cSt), we determine the **Viscosity Factor ( $\mathbf{V}_f$ )** by dividing the **Operating Fluid Viscosity** with the **Standard Viscosity** of 150 SUS (32 cSt). To best determine your Operating Fluid Viscosity, please reference the chart in Appendix D.

Finally, the overall filter pressure differential,  $\Delta P_{\text{filter}}$ , is calculated by adding  $\Delta P_{\text{housing}}$  with the true element pressure differential,  $(\Delta P_{\text{element}} * \mathbf{V}_f)$ . The  $\Delta P_{\text{element}}$  from the graph has to be multiplied by the viscosity factor to get the true pressure differential across the element.

### Solution:

$$\Delta P_{\text{housing}} = 3.5 \text{ psi } [.24 \text{ bar}] \quad | \quad \Delta P_{\text{element}} = 2 \text{ psi } [.14 \text{ bar}]$$

$$\mathbf{V}_f = 160 \text{ SUS (34 cSt)} / 150 \text{ SUS (32 cSt)} = 1.1$$

$$\Delta P_{\text{filter}} = 3.5 \text{ psi} + (2 \text{ psi} * 1.1) = 5.7 \text{ psi}$$

OR

$$\Delta P_{\text{filter}} = .24 \text{ bar} + (.14 \text{ bar} * 1.1) = .39 \text{ bar}$$

## Pressure Drop Information Based on Flow Rate and Viscosity

Note:  
If your element is not graphed, use the following equation:  
 $\Delta P_{\text{element}} = \text{Flow Rate} \times \Delta P_f$  Plug this variable into the overall pressure drop equation.

Ele.	$\Delta P$	Ele.	$\Delta P$
K3	0.25	2K3	0.12
K10	0.09	2K10	0.05
K25	0.02	2K25	0.01
KAS3	0.10	2KAS3	0.05
KAS5	0.08	2KAS5	0.04
KAS10	0.05	2KAS10	0.03
KDZ1	0.24	2KDZ1	0.12
KDZ3	0.12	2KDZ3	.06
KDZ5	0.10	2KDZ5	0.05
KDZ10	0.06	2KDZ10	0.03
KDZ25	0.04	2KDZ25	0.02
KZW1	0.43	2KZW1	-
KZW3	0.32	2KZW3	0.16
KZW5	0.28	2KZW5	0.14
KZW10	0.23	2KZW10	0.12
KZW25	0.14	2KZW25	0.07

## Filter Model Number Selection

### How to Build a Valid Model Number for a Schroeder IRF:

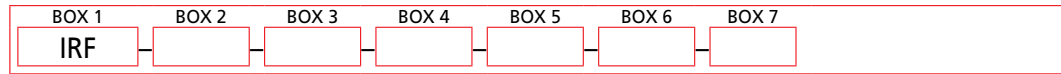

Example: NOTE: One option per box

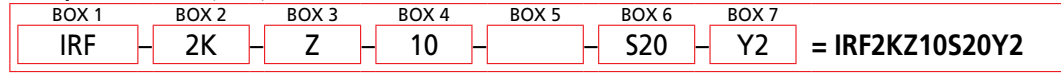

BOX 1	BOX 2	BOX 3
<b>Filter Series</b>	<b>Number and Size of Elements</b>	<b>Element Type</b>
IRF	1 = K, KK 2 = K	Omit = E media (cellulose) AS = Anti-Static Pleat Media Z = Excellement® Z-Media® (synthetic) ZW = Aqua-Excellement® ZW media W = Water Removal media M = M media (reusable metal) DZ = DirtCatcher® Excellement® Z-Media®

BOX 4	BOX 5	BOX 6
<b>Micron Rating</b>	<b>Seal Material</b>	<b>Inlet Porting</b>
1 = 1 μ (Z, ZW and DZ media) 3 = 3 μ (E, AS, Z, ZW and DZ media) 5 = 5 μ (AS, Z, ZW and DZ media) 10 = 10 μ (E, AS, Z, ZW and DZ media) 25 = 25 μ (E, AS, Z, ZW and DZ media) 60 = 60 μ (M media)	Omit = Buna N H = EPR V = Viton®	P16 = 1" NPTF P20 = 1¼" NPTF S16 = SAE-16 S20 = SAE-20 F20 = 1¼" SAE 4-bolt flange Code 61 F24 = 1½" SAE 4-bolt flange Code 61 B24 = ISO 228 G-1½"

BOX 7		
Dirt Alarm® Options		
Omit = None		
Located @ Port D (Standard)	Visual	Y2 = Back-mounted tri-color gauge
	Electrical	ES = Electrical switch ES1 = Heavy-duty electrical switch with conduit connector
Located @ Port C (Optional)	Visual	Y2R = Back-mounted gauge mounted on opposite side of standard location
	Electrical	ESR = Electrical switch mounted on opposite side of standard location ES1R = Heavy-duty electrical switch with conduit connector

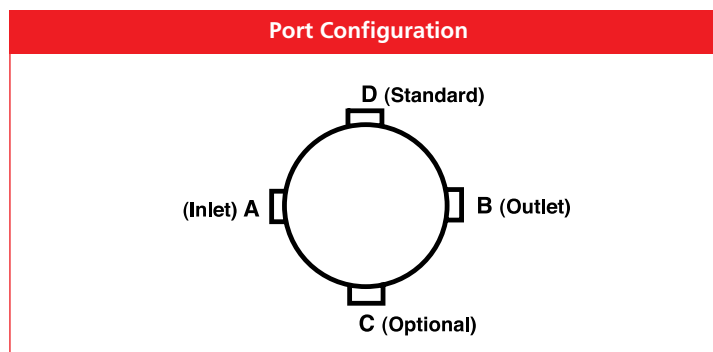

#### NOTES:

- Box 2. Number of elements must equal 1 when using KK elements.
- Box 3. Replacement element part numbers are identical to contents of Boxes 2, 3, 4, and 5. Double stacking of K-size elements can be replaced by single KK elements.
- Box 5. Viton® is a registered trademark of DuPont Dow Elastomers.



# Return Line Filter

# TF1



### Features and Benefits

- Offered in pipe, SAE straight thread, flange and ISO 228 porting
- Various Dirt Alarm® options
- Available with No-Element indicator
- Available with NPTF inlet and outlet female test ports
- Available with magnet inserts
- Available with housing drain plug

**30 gpm**  
**120 L/min**  
**300 psi**  
**20 bar**

IRF

**TF1**

KF3

KL3

LF1

MLF1

RLD

GRTB

MTA

MTB

ZT

KFT

RT

RTI

LRT

ART

BRT

TRT

BFT

QT

KTK

LTK

MRT

Accessories  
 For Tank-  
 Mounted  
 Filters

PAF1

MAF1

MF2

Model No. of filter in photograph is TF11AZ10S.

Flow Rating:	Up to 30 gpm (120 L/min) for 150 SUS (32 cSt) fluids
Max. Operating Pressure:	300 psi (20 bar)
Min. Yield Pressure:	1200 psi (80 bar), per NFPA T2.6.1
Rated Fatigue Pressure:	270 psi (19 bar), per NFPA T2.6.1-2005
Temp. Range:	-20°F to 225°F (-29°C to 107°C)
Bypass Setting:	Cracking: 30 psi (2 bar) Full Flow: 51 psi (4 bar)
Porting Head:	Cast Aluminum
Element Case:	Steel
Weight of TF1-1A:	5.1 lbs. (2.3 kg)
Weight of TF1-2A:	6.3 lbs. (2.9 kg)
Element Change Clearance:	3.50" (90 mm)

### Filter Housing Specifications

Type Fluid	Appropriate Schroeder Media
Petroleum Based Fluids	All E media (cellulose) and Z-Media® (synthetic)
High Water Content	All Z-Media® (synthetic)
Invert Emulsions	10 and 25 µ Z-Media® (synthetic)
Water Glycols	3, 5, 10 and 25 µ Z-Media® (synthetic)
Phosphate Esters	All Z-Media® (synthetic) with H (EPR) seal designation
Skydrol®	3, 5, 10 and 25 µ Z-Media® (synthetic) with H.5 seal designation (EPR seals and stainless steel wire mesh in element, and light oil coating on housing exterior)

### Fluid Compatibility

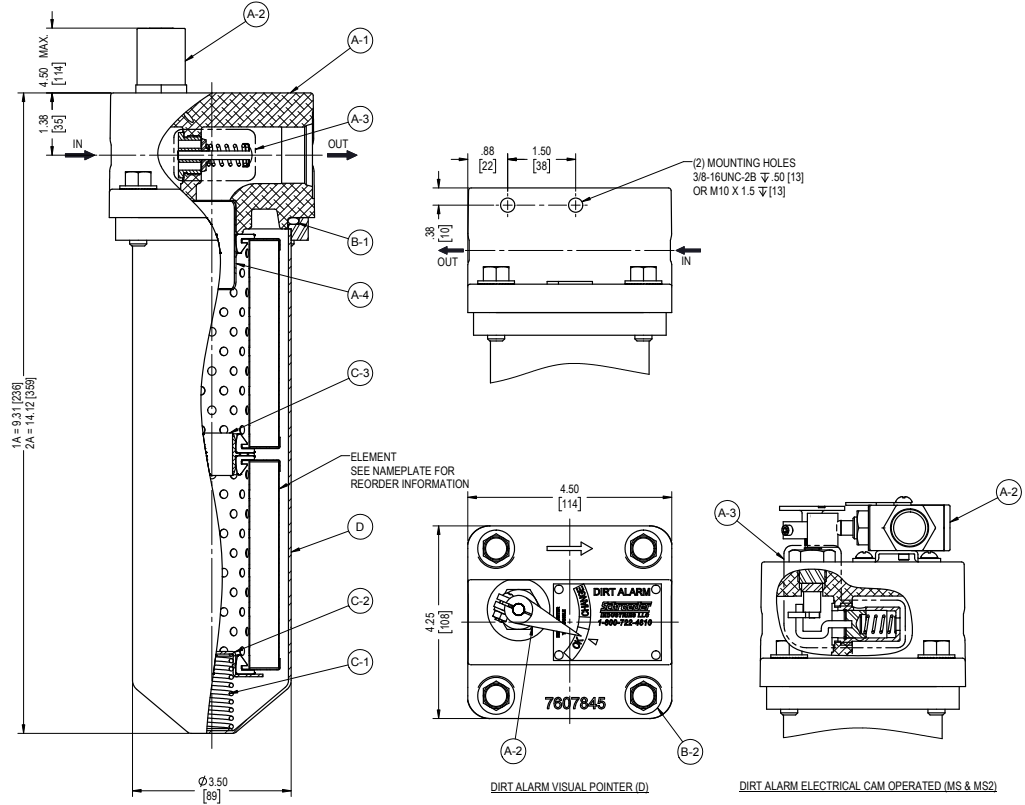

Metric dimensions in ( ).

## Element Performance Information & Dirt Holding Capacity

Element	Filtration Ratio Per ISO 4572/NFPA T3.10.8.8 Using automated particle counter (APC) calibrated per ISO 4402			Filtration Ratio per ISO 16889 Using APC calibrated per ISO 11171	
	$\beta_x \geq 75$	$\beta_x \geq 100$	$\beta_x \geq 200$	$\beta_x(c) \geq 200$	$\beta_x(c) \geq 1000$
AZ1	<1.0	<1.0	<1.0	<4.0	4.2
AZ3	<1.0	<1.0	<2.0	<4.0	4.8
AZ5	2.5	3.0	4.0	4.8	6.3
AZ10	7.4	8.2	10.0	8.0	10.0
AZ25	18.0	20.0	22.5	19.0	24.0

Element	DHC (gm)
A3	16
A10	13
AZ1	25
AZ3	26
AZ5	30
AZ10	28
AZ25	28

Element Collapse Rating: 150 psid (10 bar)

Flow Direction: Outside In

Element Nominal Dimensions: 3.0" (75 mm) O.D. x 4.5" (115 mm) long

$\Delta P_{\text{housing}}$

TF1  $\Delta P_{\text{housing}}$  for fluids with sp gr (specific gravity) = 0.86:

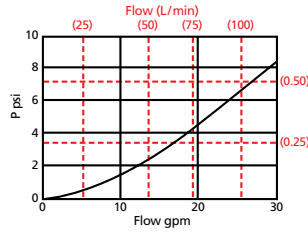

$\Delta P_{\text{element}}$

AZ

Element Pressure Drop versus Flow Rate at 32 cSt (150 SUS)

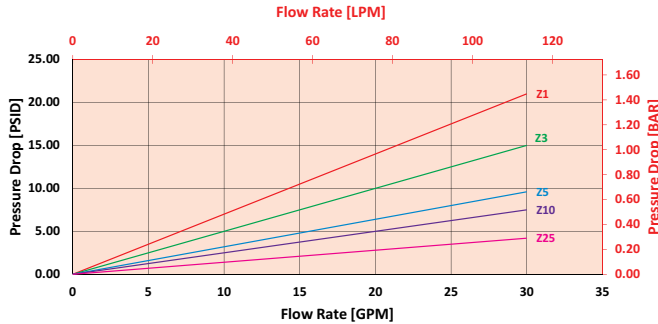

2AZ

Element Pressure Drop versus Flow Rate at 32 cSt (150 SUS)

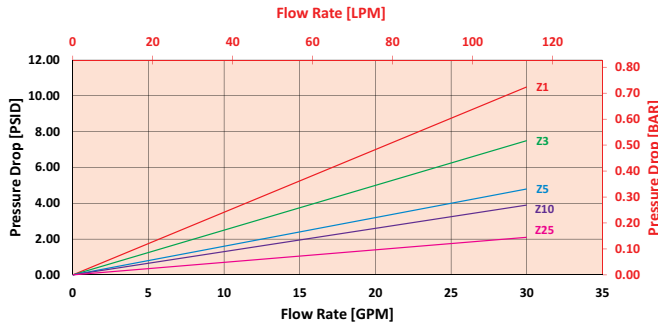

$$\Delta P_{\text{filter}} = \Delta P_{\text{housing}} + (\Delta P_{\text{element}} * \mathbf{V}_f)$$

**Exercise:**

Determine  $\Delta P_{\text{filter}}$  at 15 gpm (57 L/min) for TF11AZ3PD5 using 175 SUS (37.2 cSt) fluid.

Use the housing pressure curve to determine  $\Delta P_{\text{housing}}$  at 15 gpm. In this case,  $\Delta P_{\text{housing}}$  is 3 psi (.21 bar) on the graph for the TF1 housing.

Use the element pressure curve to determine  $\Delta P_{\text{element}}$  at 15 gpm. In this case,  $\Delta P_{\text{element}}$  is 7.5 psi (.52 bar) according to the graph for the AZ3 element.

Because the viscosity in this sample is 175 SUS (37.2 cSt), we determine the **Viscosity Factor ( $\mathbf{V}_f$ )** by dividing the **Operating Fluid Viscosity** with the **Standard Viscosity** of 150 SUS (32 cSt). To best determine your Operating Fluid Viscosity, please reference the chart in Appendix D.

Finally, the overall filter pressure differential,  $\Delta P_{\text{filter}}$ , is calculated by adding  $\Delta P_{\text{housing}}$  with the true element pressure differential,  $(\Delta P_{\text{element}} * \mathbf{V}_f)$ . The  $\Delta P_{\text{element}}$  from the graph has to be multiplied by the viscosity factor to get the true pressure differential across the element.

**Solution:**

$\Delta P_{\text{housing}} = 3 \text{ psi } [.21 \text{ bar}] \mid \Delta P_{\text{element}} = 7.5 \text{ psi } [.52 \text{ bar}]$

$\mathbf{V}_f = 175 \text{ SUS } (37.2 \text{ cSt}) / 150 \text{ SUS } (32 \text{ cSt}) = 1.2$

$\Delta P_{\text{filter}} = 3 \text{ psi } + (7.5 \text{ psi } * 1.2) = 12 \text{ psi}$

**OR**

$\Delta P_{\text{filter}} = .21 \text{ bar } + (.52 \text{ bar } * 1.2) = .83 \text{ bar}$

**Pressure Drop Information Based on Flow Rate and Viscosity**

Note:  
If your element is not graphed, use the following equation:  
 $\Delta P_{\text{element}} = \text{Flow Rate} \times \Delta P_f$  Plug this variable into the overall pressure drop equation.

Ele.	$\Delta P$	Ele.	$\Delta P$
A3	0.53	AA3	0.27
A10	0.36	AA10	0.18
A25	0.05	AA25	0.03

## Filter Model Number Selection

### How to Build a Valid Model Number for a Schroeder TF1:

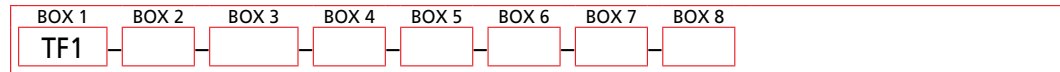

**Example:** NOTE: Only box 8 may contain more than one option

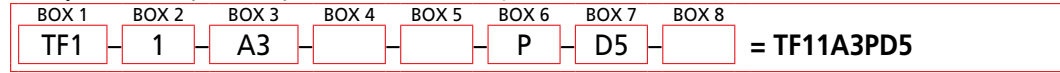

BOX 1	BOX 2	BOX 3	BOX 4	BOX 5
<b>Filter Series</b>	<b>Number of Elements</b>	<b>Element Part Number</b>	<b>Seal Material</b>	<b>Magnet Option</b>
TF1	1 2	A3 = 3 μ E media (cellulose) A10 = 10 μ E media (cellulose) A25 = 25 μ E media (cellulose) AZ1 = 1 μ Excellement® Z-Media® (synthetic) AZ3 = 3 μ Excellement® Z-Media® (synthetic) AZ5 = 5 μ Excellement® Z-Media® (synthetic) AZ10 = 10 μ Excellement® Z-Media® (synthetic) AZ25 = 25 μ Excellement® Z-Media® (synthetic) AM10 = 10 μ M media (reusable metal) AM25 = 25 μ M media (reusable metal)	Omit = Buna N H = EPR V = Viton® H.5 = Skydrol® compatibility	Omit = None M = Magnet inserts

BOX 6	BOX 7	BOX 8
<b>Porting Options</b>	<b>Dirt Alarm® Options</b>	
P = 1" NPTF S = SAE-16 B = ISO 228 G-1" 10 = 10 psi bypass setting 15 = 15 psi bypass setting 20 = 20 psi bypass setting 25 = 25 psi bypass setting 30 = 30 psi bypass setting 40 = 40 psi bypass setting 60 = 60 psi bypass setting 75 = 75 psi bypass setting	Omit = None Visual D = Pointer D5 = Visual pop-up Visual with Thermal Lockout D8 = Visual w/ thermal lockout Electrical MS5 = Electrical w/ 12 in. 18 gauge 4-conductor cable MS5LC = Low current MS5 MS10 = Electrical w/ DIN connector (male end only) MS10LC = Low current MS10 MS11 = Electrical w/ 12 ft. 4-conductor wire MS12 = Electrical w/ 5 pin Brad Harrison connector (male end only) MS12LC = Low current MS12 MS16 = Electrical w/ weather-packed sealed connector MS16LC = Low current MS16 MS17LC = Electrical w/ 4 pin Brad Harrison male connector MS5T = MS5 (see above) w/ thermal lockout MS5LCT = Low current MS5T MS10T = MS10 (see above) w/ thermal lockout MS10LCT = Low current MS10T MS12T = MS12 (see above) w/ thermal lockout MS12LCT = Low current MS12T MS16T = MS16 (see above) w/ thermal lockout MS16LCT = Low current MS16T MS17LCT = Low current MS17T MS = Cam operated switch w/ ½" conduit female connection MS13 = Supplied w/ threaded connector & light MS14 = Supplied w/ 5 pin Brad Harrison connector & light (male end) MS13DCT = MS13 (see above), direct current, w/ thermal lockout MS13DCLCT = Low current MS13DCT MS14DCT = MS14 (see above), direct current, w/ thermal lockout MS14DCLCT = Low current MS14DCT	Omit = None L = Two ¼" NPTF inlet and outlet female test ports N = No-Element indicator G440 = ½" drain on bottom of housing

**NOTES:**

Box 3. Replacement element part numbers are identical to contents of Boxes 3 and 4. E media elements are only available with Buna N seals.

Box 4. For option V, all aluminum parts are anodized. H.5 seal designation includes the following: EPR seals, stainless steel wire mesh on elements, and light oil coating on housing exterior. Viton® is a registered trademark of DuPont Dow Elastomers. Skydrol® is a registered trademark of Solutia Inc.

Box 6. B porting option supplied with metric mounting holes.

# Return Line Filter

# KF3



## Features and Benefits

- Meets HF4 automotive standard
- Offered in pipe, SAE straight thread, flange and ISO 228 porting
- Various Dirt Alarm® options
- Available with No-Element indicator
- Available with NPTF inlet and outlet female test ports
- Available with magnet inserts
- Available with housing drain plug
- Takes the standard "K" element in K, KK or 27K lengths
- Allows consolidation of inventoried replacement elements by using K-size elements
- Also available with DirtCatcher® elements (KD & KKD)
- G** Available with quality-protected GeoSeal® Elements (GKF3)

Part of the Schroeder Industries 2030 Initiative

**100 gpm**  
**380 L/min**  
**300 psi**  
**20 bar**

IRF

TF1

**KF3**

KL3

LF1

MLF1

RLD

GRTB

MTA

MTB

ZT

KFT

RT

RTI

LRT

ART

BRT

TRT

BFT

QT

KTK

LTK

MRT

Model No. of filter in photograph is KF31K10SD5.

Flow Rating:	Up to 100 gpm (380 L/min) for 150 SUS (32 cSt) fluids
Max. Operating Pressure:	300 psi (20 bar)
Min. Yield Pressure:	1000 psi (70 bar), per NFPA T2.6.1
Rated Fatigue Pressure:	290 psi (20 bar), per NFPA T2.6.1-2005
Temp. Range:	-20°F to 225°F (-29°C to 107°C)
Bypass Setting:	Cracking: 30 psi (2 bar) Full Flow: 51 psi (4 bar)
Porting Head:	Die Cast Aluminum
Element Case:	Steel
Weight of KF3-1K:	10.5 lbs. (4.8 kg)
Weight of KF3-2K:	14.2 lbs. (6.4 kg)
Weight of KF3-3K:	18.5 lbs. (8.4 kg)
Element Change Clearance:	1.50" (40 mm) for all lengths

## Filter Housing Specifications

Type Fluid	Appropriate Schroeder Media
Petroleum Based Fluids	All E media (cellulose), Z-Media® and ASP® media (synthetic)
High Water Content	All Z-Media® and ASP® Media (synthetic)
Invert Emulsions	10 and 25 µ Z-Media® (synthetic), 10 µ ASP® media (synthetic)
Water Glycols	3, 5, 10 and 25 µ Z-Media® (synthetic), 3, 5, and 10 µ ASP® Media (synthetic)
Phosphate Esters	All Z-Media® (synthetic) with H (EPR) seal designation and 3 and 10 µ E media (cellulose) with H (EPR) seal designation and all ASP® media (synthetic)
Skydrol®	3, 5, 10 and 25 µ Z-Media® (synthetic) with H.5 seal designation (EPR seals and stainless steel wire mesh in element, and light oil coating on housing exterior) and all ASP® media (synthetic)

## Fluid Compatibility

Accessories For Tank-Mounted Filters

PAF1

MAF1

MF2

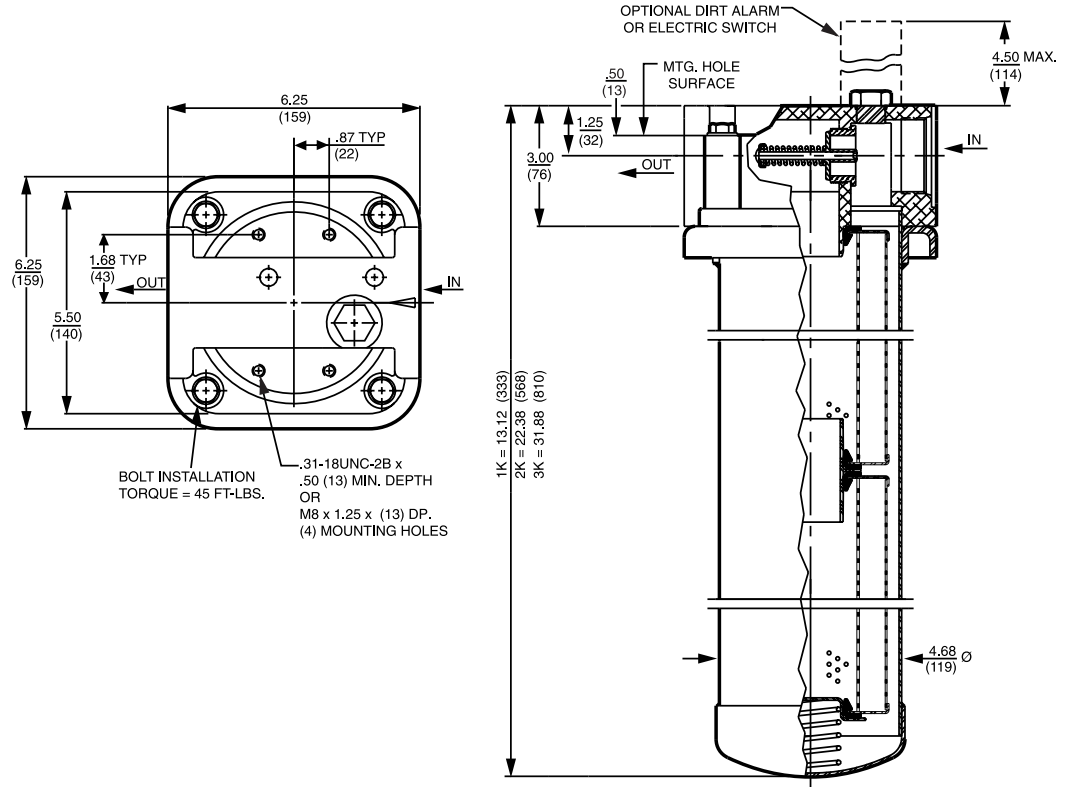

Metric dimensions in ( ).

## Element Performance Information & Dirt Holding Capacity

Element	Filtration Ratio Per ISO 4572/NFPA T3.10.8.8 Using automated particle counter (APC) calibrated per ISO 4402			Filtration Ratio per ISO 16889 Using APC calibrated per ISO 11171	
	$\beta_x \geq 75$	$\beta_x \geq 100$	$\beta_x \geq 200$	$\beta_x(c) \geq 200$	$\beta_x(c) \geq 1000$
KZ1/KKZ1/27KZ1	<1.0	<1.0	<1.0	<4.0	4.2
KZ3/KKZ3/27KZ3	<1.0	<1.0	<2.0	<4.0	4.8
KZ5/KKZ5/27KZ5	2.5	3.0	4.0	4.8	6.3
KZ10/KKZ10/27KZ10	7.4	8.2	10.0	8.0	10.0
KZ25/KKZ25/27KZ25	18.0	20.0	22.5	19.0	24.0
KZW1	N/A	N/A	N/A	<4.0	<4.0
KZW3/KKZW3	N/A	N/A	N/A	4.0	4.8
KZW5/KKZW5	N/A	N/A	N/A	5.1	6.4
KZW10/KKZW10	N/A	N/A	N/A	6.9	8.6
KZW25/KKZW25	N/A	N/A	N/A	15.4	18.5

Element	DHC (g)	Element	DHC (g)	Element	DHC (g)	Element	DHC (g)	Element	DHC (g)	Element	DHC (g)
KZ1	112	KKZ1	224	27KZ1	336	KDZ1	89	KKDZ1	188	KZW1	61
KZ3	115	KKZ3	230	27KZ3	345	KDZ3	71	KKDZ3	150	KZW3	64
KZ5	119	KKZ5	238	27KZ5	357	KDZ5	100	KKDZ5	210	KZW5	63
KZ10	108	KKZ10	216	27KZ10	324	KDZ10	80	KKDZ10	168	KZW10	57
KZ25	93	KKZ25	186	27KZ25	279	KDZ25	81	KKDZ25	171	KZW25	79
										KKZW3	128
										KKZW5	126
										KKZW10	114
										KKZW25	158

Element Collapse Rating: 150 psid (10 bar) for standard elements

Flow Direction: Outside In

Element Nominal Dimensions: K: 3.9" (99 mm) O.D. x 9.0" (230 mm) long  
 KK: 3.9" (99 mm) O.D. x 18.0" (460 mm) long  
 27K: 3.9" (99 mm) O.D. x 27.0" (690 mm) long

$\Delta P_{\text{housing}}$

KF3  $\Delta P_{\text{housing}}$  for fluids with sp gr (specific gravity) = 0.86:

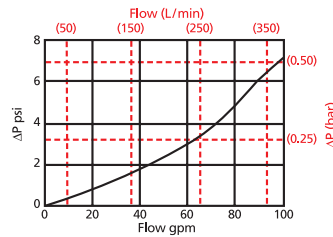

$\Delta P_{\text{element}}$

KZ

Element Pressure Drop versus Flow Rate at 32 cSt (150 SUS)

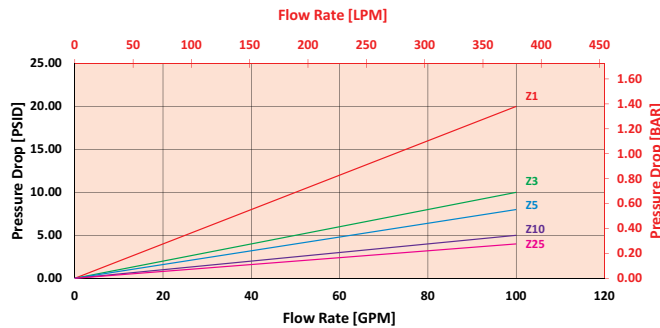

2KZ/KKZ

Element Pressure Drop versus Flow Rate at 32 cSt (150 SUS)

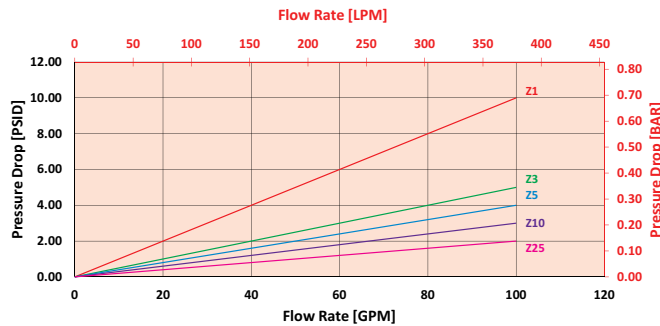

$$\Delta P_{\text{filter}} = \Delta P_{\text{housing}} + (\Delta P_{\text{element}} * \mathbf{V}_f)$$

### Exercise:

Determine  $\Delta P_{\text{filter}}$  at 70 gpm (265.3 L/min) for KF31KZ10SD5 using 160 SUS (34 cSt) fluid.

Use the housing pressure curve to determine  $\Delta P_{\text{housing}}$  at 70 gpm. In this case,  $\Delta P_{\text{housing}}$  is 4 psi (.27 bar) on the graph for the KF3 housing.

Use the element pressure curve to determine  $\Delta P_{\text{element}}$  at 70 gpm. In this case,  $\Delta P_{\text{element}}$  is 3 psi (.21 bar) according to the graph for the KZ10 element.

Because the viscosity in this sample is 160 SUS (34 cSt), we determine the **Viscosity Factor ( $\mathbf{V}_f$ )** by dividing the **Operating Fluid Viscosity** with the **Standard Viscosity** of 150 SUS (32 cSt). To best determine your Operating Fluid Viscosity, please reference the chart in Appendix D.

Finally, the overall filter pressure differential,  $\Delta P_{\text{filter}}$ , is calculated by adding  $\Delta P_{\text{housing}}$  with the true element pressure differential,  $(\Delta P_{\text{element}} * \mathbf{V}_f)$ . The  $\Delta P_{\text{element}}$  from the graph has to be multiplied by the viscosity factor to get the true pressure differential across the element.

### Solution:

$$\Delta P_{\text{housing}} = 4 \text{ psi } [.227 \text{ bar}] \quad | \quad \Delta P_{\text{element}} = 3 \text{ psi } [.21 \text{ bar}]$$

$$\mathbf{V}_f = 160 \text{ SUS (34 cSt) } / 150 \text{ SUS (32 cSt) } = 1.1$$

$$\Delta P_{\text{filter}} = 4 \text{ psi } + (3 \text{ psi } * 1.1) = 7.7 \text{ psi}$$

OR

$$\Delta P_{\text{filter}} = .27 \text{ bar } + (.21 \text{ bar } * 1.1) = .50 \text{ bar}$$

## Pressure Drop Information Based on Flow Rate and Viscosity

Note:

If your element is not graphed, use the following equation:

$\Delta P_{\text{element}} = \text{Flow Rate} \times \Delta P_f$  Plug this variable into the overall pressure drop equation.

Ele.	$\Delta P$	Ele.	$\Delta P$	Ele.	$\Delta P$
K3	0.25	2K3/ KK3	0.12	3KZ1/ 27KZ1	0.05
K10	0.09	2K10/ KK10	0.05	3KZ3/ 27KZ3	0.03
K25	0.02	2K25/ KK25	0.01	3KZ5/ 27KZ5	0.02
KAS3	0.10	2KAS3/ KKAS3	0.05	3KZ10/ 27KZ10	0.02
KAS5	0.08	2KAS5/ KKAS5	0.04	3KZ25/ 27KZ25	0.01
KAS10	0.05	2KAS10/ KKAS10	0.03	K3K	0.08
KDZ1	0.24	2KDZ1	0.12	3K10	0.03
KDZ3	0.12	2KDZ3	0.06	3K25	0.01
KDZ5	0.10	2KDZ5	0.05	3KAS3/ 27KAS3	0.03
KDZ10	0.06	2KDZ10	0.03	3KAS5/ 27KAS5	0.02
KDZ25	0.04	2KDZ25	0.02	3KAS10/ 27KAS10	0.02
KZW1	0.43	2KZW1	-		
KZW3	0.32	2KZW3/ KKZW3	0.16		
KZW5	0.28	2KZW5/ KKZW5	0.14		
KZW10	0.23	2KZW10/ KKZW10	0.12		
KZW25	0.14	2KZW25/ KKZW25	0.07		

## Filter Model Number Selection

Highlighted product eligible for **QuickDelivery**

### How to Build a Valid Model Number for a Schroeder KF3:

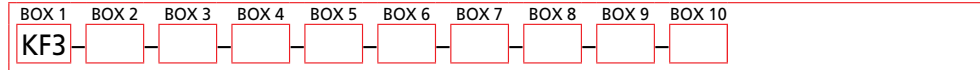

**Example:** NOTE: Only box 10 may contain more than one option

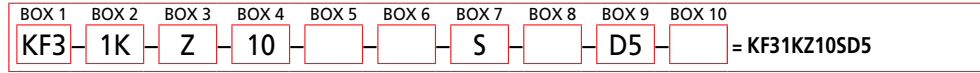

BOX 1	BOX 2	BOX 3	BOX 4
<b>Filter Series</b>	<b>Number &amp; Size of Elements</b>	<b>Media Type</b>	<b>Micron Rating</b>
KF3	1K, KK,27K	Omit = E media (cellulose)	1 = 1 μ (Z, ZW and DZ media)
GKF3 (GeoSeal®)	2K	AS = Anti-Static Pleat Media	3 = 3 μ (E, AS, Z, ZW and DZ media)
WKF3 (Water)	3K	Z = Excellement® Z-Media® (synthetic)	5 = 5 μ (AS, Z, ZW and DZ media)
	<b>GeoSeal®</b>	ZW = Aqua-Excellement® ZW media	10 = 10 μ (E, AS, Z, ZW, M and DZ media)
	1KG, KKG, 27KG	W = Water Removal media	25 = 25 μ (E, Z, ZW, M and DZ media)
	2KG	M = M Media (reusable metal)	60 = 60 μ (M media)
	3KG	DZ = DirtCatcher® Excellement® Z-Media®	
		<b>Water System Element Options</b>	
		KM10 = K size 25 μ M media (reusable metal)	
		KM25 = K size 10 μ M media (reusable metal)	
		KM60 = K size 60 μ M media (reusable metal)	
		KM150 = K size 150 μ M media (reusable metal)	
		KM260 = K size 260 μ M media (reusable metal)	
BOX 5	BOX 6	BOX 7	BOX 8
<b>Seal Material</b>	<b>Magnet Option</b>	<b>Porting</b>	<b>Bypass Setting</b>
Omit = Buna N	Omit = None	P = 1½" NPTF	Omit = 30 psi cracking
H = EPR	M = Magnet	S = SAE-24	50 = 50 psi cracking (req. for HF4)
V = Viton®		F = 1½" SAE-4-bolt flange Code 61	
H.5 = Skydrol® Compatibility		B = ISO 228 G-1½"	
W = Buna N			
BOX 9	BOX 10		
<b>Dirt Alarm® Options</b>	<b>Additional Options</b>		
Omit = None	Omit = None		
Visual D = Pointer	L = Two ¼" NPTF inlet and outlet test ports		
Visual D5 = Visual pop-up	N = No-Element indicator		
Visual with Thermal Lockout D8 = Visual w/ thermal lockout	G426 = ¾" drain on bottom of housing		
Electrical MS5 = Electrical w/ 12 in. 18 gauge 4-conductor cable	G440 = ½" drain on bottom of housing		
MS5LC = Low current MS5			
MS10 = Electrical w/ DIN connector (male end only)			
MS10LC = Low current MS10			
MS11 = Electrical w/ 12 ft. 4-conductor wire			
MS12 = Electrical w/ 5 pin Brad Harrison connector (male end only)			
MS12LC = Low current MS12			
MS16 = Electrical w/ weather-packed sealed connector			
MS16LC = Low current MS16			
MS17LC = Electrical w/ 4 pin Brad Harrison male connector			
MS5T = MS5 (see above) w/ thermal lockout			
MS5LCT = Low current MS5T			
MS10T = MS10 (see above) w/ thermal lockout			
MS10LCT = Low current MS10T			
MS12T = MS12 (see above) w/ thermal lockout			
MS12LCT = Low current MS12T			
MS16T = MS16 (see above) w/ thermal lockout			
MS16LCT = Low current MS16T			
MS17LCT = Low current MS17T			
Electrical Visual MS = Cam operated switch w/ ½" conduit female connection			
MS13 = Supplied w/ threaded connector & light			
MS14 = Supplied w/ 5 pin Brad Harrison connector & light (male end)			
Electrical Visual with Thermal Lockout MS13DCT = MS13 (see above), direct current, w/ thermal lockout			
MS13DCLCT = Low current MS13DCT			
MS14DCT = MS14 (see above), direct current, w/ thermal lockout			
MS14DCLCT = Low current MS14DCT			

**NOTES:**

- Box 2. Double and triple stacking of K-size elements can be replaced by single KK and 27K elements, respectively. Number of elements must equal 1 when using KK or 27K elements. ZW media not available in 27K.
- Box 3. Replacement element part numbers are identical to contents of Boxes 2, 3, 4, and 5.
- Box 5. For options H, W, V, and H.5, all aluminum parts are anodized. H.5 seal designation includes the following: EPR seals, stainless steel wire mesh on elements, and light oil coating on housing exterior. Viton® is a registered trademark of DuPont Dow Elastomers. Skydrol® is a registered trademark of Solutia Inc.
- Box 7. For option F, bolt thread depth .63" (16 mm). B porting option supplied with metric mounting holes.
- Box 10. Option L not available with MS Dirt Alarm



# Return Line Filter with Threaded Bowl

# KL3



## Features and Benefits

- Threaded bowl allows for easier removal and facilitates element changes
- Available with 18LC and K-size elements
- Available with 1½" and 2" porting
- Offered in pipe, SAE straight thread, ISO 228, and flange porting
- Various Dirt Alarm® options
- Available with NPTF inlet and outlet female test ports
- Available with housing drain plug
- G** Available with quality-protected GeoSeal® Elements (GKL3)

**120 gpm**  
**455 L/min**  
**300 psi**  
**20 bar**

IRF

TF1

KF3

**KL3**

LF1

MLF1

RLD

GRTB

MTA

MTB

ZT

KFT

RT

RTI

LRT

ART

BRT

TRT

BFT

QT

KTK

LTK

MRT

Model No. of filter in photograph is KL31KZ10F24.

<b>Flow Rating:</b>	Up to 100 gpm (380 L/min) for 150 SUS (32 cSt) fluids for P24, S24, F24 and B24 porting Up to 120 gpm (455 L/min) for 150 SUS (32 cSt) fluids for P32, S32 and B32 porting
<b>Max. Operating Pressure:</b>	300 psi (20 bar)
<b>Min. Yield Pressure:</b>	1000 psi (70 bar), per NFPA T2.6.1
<b>Rated Fatigue Pressure:</b>	300 psi (20 bar), per NFPA T2.6.1-2005
<b>Temp. Range:</b>	-20°F to 225°F (-29°C to 107°C)
<b>Bypass Setting:</b>	Cracking: 30 psi (2 bar) Full Flow: 68 psi (4.7 bar)
<b>Porting Head:</b>	Cast Aluminum
<b>Element Case:</b>	Steel
<b>Weight of KL3-18LC:</b>	20.00 lbs. (9.1 kg)
<b>Weight of KL3-1K:</b>	14.75 lbs. (6.7 kg)
<b>Weight of KL3-2K:</b>	18.50 lbs. (8.4 kg)
<b>Weight of KL3-3K:</b>	22.75 lbs. (10.3 kg)
<b>Element Change Clearance:</b>	2.50" (64 mm)

## Filter Housing Specifications

<b>Type Fluid</b>	Appropriate Schroeder Media
<b>Petroleum Based Fluids</b>	All E media (cellulose), Z-Media® and ASP® media (synthetic)
<b>High Water Content</b>	All Z-Media® and ASP® media (synthetic)
<b>Invert Emulsions</b>	10 and 25 µ Z-Media® (synthetic), 10 µ ASP® media (synthetic)
<b>Water Glycols</b>	3, 5, 10 and 25 µ Z-Media® (synthetic), 3, 5, and 10 µ ASP® media (synthetic)
<b>Phosphate Esters</b>	All Z-Media® with H (EPR) seal designation and all ASP® media (synthetic)

## Fluid Compatibility

Accessories  
For Tank-  
Mounted  
Filters

PAF1

MAF1

MF2

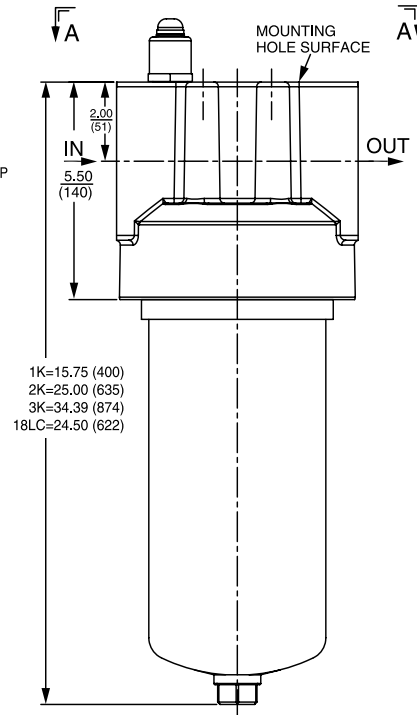
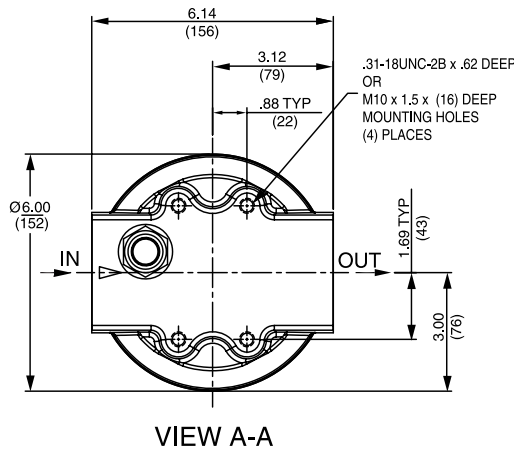

Metric dimensions in ( ).

## Element Performance Information & Dirt Holding Capacity

Element	Filtration Ratio Per ISO 4572/NFPA T3.10.8.8 Using automated particle counter (APC) calibrated per ISO 4402			Filtration Ratio per ISO 16889 Using APC calibrated per ISO 11171	
	$\beta_x \geq 75$	$\beta_x \geq 100$	$\beta_x \geq 200$	$\beta_x(c) \geq 200$	$\beta_x(c) \geq 1000$
KZ1/KKZ1/27KZ1	<1.0	<1.0	<1.0	<4.0	4.2
KZ3/KKZ3/27KZ3	<1.0	<1.0	<2.0	<4.0	4.8
KZ5/KKZ5/27KZ5	2.5	3.0	4.0	4.8	6.3
KZ10/KKZ10/27KZ10	7.4	8.2	10.0	8.0	10.0
KZ25/KKZ25/27KZ25	18.0	20.0	22.5	19.0	24.0
KZW1	N/A	N/A	N/A	<4.0	<4.0
KZW3/KKZW3	N/A	N/A	N/A	4.0	4.8
KZW5/KKZW5	N/A	N/A	N/A	5.1	6.4
KZW10/KKZW10	N/A	N/A	N/A	6.9	8.6
KZW25/KKZW25	N/A	N/A	N/A	15.4	18.5
18LCZ1	<1.0	<1.0	<1.0	<4.0	4.2
18LCZ3	<1.0	<1.0	<2.0	<4.0	4.8
18LCZ5	2.5	3.0	4.0	4.8	6.3
18LCZ10	7.4	8.2	10.0	8.0	10.0
18LCZ25	18.0	20.0	22.5	19.0	24.0

Element	DHC (g)	Element	DHC (g)	Element	DHC (g)	Element	DHC (g)	Element	DHC (g)	Element	DHC (g)
KZ1	112	KKZ1	224	27KZ1	336	KZW1	61	18LCZ1	224		
KZ3	115	KKZ3	230	27KZ3	345	KZW3	64	KKZW3	128	18LCZ3	230
KZ5	119	KKZ5	238	27KZ5	357	KZW5	63	KKZW5	126	18LCZ5	238
KZ10	108	KKZ10	216	27KZ10	324	KZW10	57	KKZW10	114	18LCZ10	216
KZ25	93	KKZ25	186	27KZ25	279	KZW25	79	KKZW25	158	18LCZ25	186

Element Collapse Rating: 150 psid (10 bar) for standard elements

Flow Direction: Outside In

Element Nominal Dimensions: K: 3.9" (99 mm) O.D. x 9.0" (230 mm) long  
 KK: 3.9" (99 mm) O.D. x 18.0" (460 mm) long  
 27K: 3.9" (99 mm) O.D. x 27.0" (690 mm) long  
 18LC: 4.0" (100 mm) O.D. x 18.5" (470 mm) long

# Return Line Filter with Threaded Bowl

# KL3

$\Delta P_{\text{housing}}$

KL3  $\Delta P_{\text{housing}}$  for fluids with sp gr (specific gravity) = 0.86:

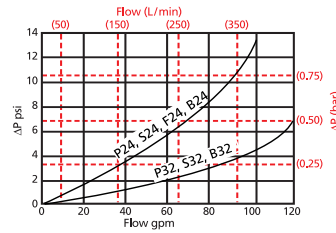

$\Delta P_{\text{element}}$

KZ

Element Pressure Drop versus Flow Rate at 32 cSt (150 SUS)

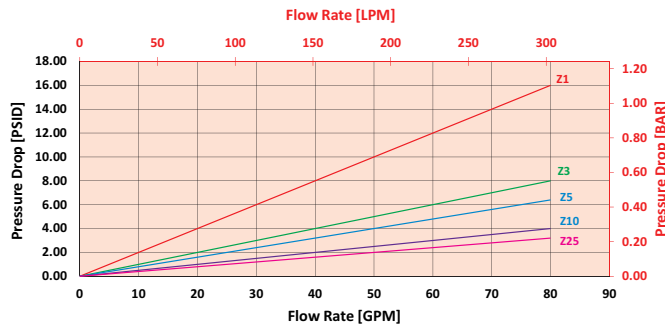

2KZ/KKZ

Element Pressure Drop versus Flow Rate at 32 cSt (150 SUS)

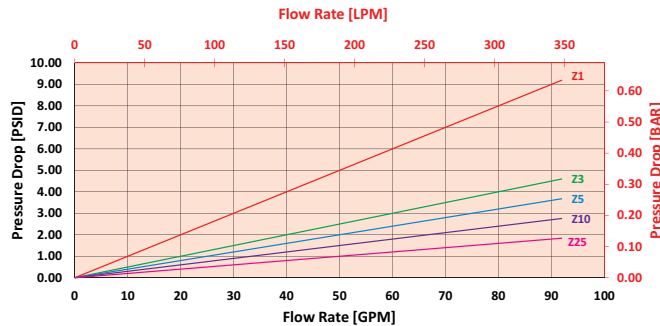

$$\Delta P_{\text{filter}} = \Delta P_{\text{housing}} + (\Delta P_{\text{element}} * \mathbf{V}_f)$$

### Exercise:

Determine  $\Delta P_{\text{filter}}$  at 70 gpm (265.3 L/min) for KL31KZ10P24D5L using 160 SUS (34 cSt) fluid.

Use the housing pressure curve to determine  $\Delta P_{\text{housing}}$  at 70 gpm. In this case,  $\Delta P_{\text{housing}}$  is 7 psi (.48 bar) on the graph for the KL3 housing.

Use the element pressure curve to determine  $\Delta P_{\text{element}}$  at 70 gpm. In this case,  $\Delta P_{\text{element}}$  is 3 psi (.21 bar) according to the graph for the KZ10 element.

Because the viscosity in this sample is 160 SUS (34 cSt), we determine the **Viscosity Factor ( $\mathbf{V}_f$ )** by dividing the **Operating Fluid Viscosity** with the **Standard Viscosity** of 150 SUS (32 cSt). To best determine your Operating Fluid Viscosity, please reference the chart in Appendix D.

Finally, the overall filter pressure differential,  $\Delta P_{\text{filter}}$ , is calculated by adding  $\Delta P_{\text{housing}}$  with the true element pressure differential,  $(\Delta P_{\text{element}} * \mathbf{V}_f)$ . The  $\Delta P_{\text{element}}$  from the graph has to be multiplied by the viscosity factor to get the true pressure differential across the element.

### Solution:

$$\Delta P_{\text{housing}} = 7 \text{ psi } [.48 \text{ bar}] \quad | \quad \Delta P_{\text{element}} = 3 \text{ psi } [.21 \text{ bar}]$$

$$\mathbf{V}_f = 160 \text{ SUS (34 cSt) } / 150 \text{ SUS (32 cSt) } = 1.1$$

$$\Delta P_{\text{filter}} = 7 \text{ psi } + (3 \text{ psi } * 1.1) = 10.7 \text{ psi}$$

OR

$$\Delta P_{\text{filter}} = .48 \text{ bar } + (.21 \text{ bar } * 1.1) = .71 \text{ bar}$$

## Pressure Drop Information Based on Flow Rate and Viscosity

Note:

If your element is not graphed, use the following equation:  
 $\Delta P_{\text{element}} = \text{Flow Rate} \times \Delta P_f$   
 Plug this variable into the overall pressure drop equation.

Ele.	$\Delta P$	Ele.	$\Delta P$	Ele.	$\Delta P$
K3	0.25	2K3/ KK3	0.12	18LC3	0.12
K10	0.09	2K10/ KK10	0.05	18L10	0.05
K25	0.02	2K25/ KK25	0.01	18LCZ1	0.10
KAS3	0.10	2KAS3/ KKAS3	0.05	18LCZ3	0.05
KAS5	0.08	2KAS5/ KKAS5	0.04	18LCZ5	0.04
KAS10	0.05	2KAS10/ KKAS10	0.03	18LCZ10	0.03
KZW1	0.43	2KZW1	-	18LCZ25	0.02
KZW3	0.32	2KZW3/ KKZW3	0.16		
KZW5	0.28	2KZW5/ KKZW5	0.14		
KZW10	0.23	2KZW10/ KKZW10	0.12		
KZW25	0.14	2KZW25/ KKZW25	0.07		

## Filter Model Number Selection

### How to Build a Valid Model Number for a Schroeder KL3:

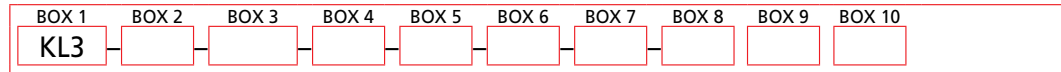

Example: Option 1 NOTE: One option per box

Option 2 NOTE: One option per box

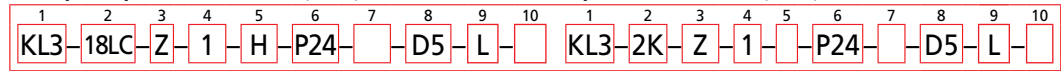

BOX 1	BOX 2	BOX 3	BOX 4
Option 1	Option 1	Option 1	Option 1
Filter Series	Size	Media Type	Micron Rating
KL3 GKL3 (GeoSeal®) WKL3 (Water)	18 LC	Omit = E media (cellulose) Z = Excellement® Z-Media® (synthetic) <b>Water System Element Option</b> KM10 = 10 µ M media (reusable metal) KM25 = 25 µ M media (reusable metal) KM60 = 60 µ M media (reusable metal) KM150 = 150 µ M media (reusable metal) KM260 = 260 µ M media (reusable metal)	1 = 1 µ (Z-Media®) 3 = 3 µ (E and Z-Media®) 5 = 5 µ (Z-Media®) 10 = 10 µ (E and Z-Media®) 25 = 25 µ (E and Z-Media®)
BOX 2	BOX 3	BOX 4	BOX 5
Option 2	Option 2	Option 2	
Number & Size of Elements	Media Type	Micron Rating	Seal Material
1K, KK, 27K 2K 3K	Omit = E media (cellulose) Z = Excellement® Z-Media® (synthetic) AS = Anti-Static Pleat Media (synthetic) ZW = Aqua-Excellement® ZW media W = Water Removal media M = M media (reusable metal) DZ = DirtCatcher® Excellement® Z-Media®	1 = 1 µ (Z, ZW and DZ media) 3 = 3 µ (E, AS, Z, ZW and DZ media) 5 = 5 µ (AS, Z, ZW and DZ media) 10 = 10 µ (E, AS, Z, ZW, M and DZ media) 25 = 25 µ (E, Z, ZW, M and DZ media) 60 = 60 µ (M media)	Omit = Buna N H = EPR V = Viton® H.5 = Skydrol® Compatibility W = Buna N
BOX 6	BOX 7		
Porting	Bypass Setting		
P24 = 1½" NPTF S24 = SAE-24 F24 = 1½" SAE 4-bolt flange Code 61 B24 = ISO 228 G-1½" P32 = 2" NPTF S32 = SAE-32 B32 = SO 228 G-2"	Omit = 30 psi cracking 50 = 50 psi cracking (req. for HF4)		
BOX 8	BOX 9	BOX 10	
Dirt Alarm® Options	Test Port Options	Bowl Drain Option	
Omit = None Visual D5 = Visual pop-up Visual with Thermal Lockout D8 = Visual w/ thermal lockout Electrical MS5 = Electrical w/ 12 in. 18 gauge 4-conductor cable MS5LC = Low current MS5 MS10 = Electrical w/ DIN connector (male end only) MS10LC = Low current MS10 MS11 = Electrical w/ 12 ft. 4-conductor wire MS12 = Electrical w/ 5 pin Brad Harrison connector (male end only) MS12LC = Low current MS12 MS16 = Electrical w/ weather-packed sealed connector MS16LC = Low current MS16 MS17LC = Electrical w/ 4 pin Brad Harrison male connector Electrical with Thermal Lockout MS5T = MS5 (see above) w/ thermal lockout MS5LCT = Low current MS5T MS10T = MS10 (see above) w/ thermal lockout MS10LCT = Low current MS10T MS12T = MS12 (see above) w/ thermal lockout MS12LCT = Low current MS12T MS16T = MS16 (see above) w/ thermal lockout MS16LCT = Low current MS16T MS17LCT = Low current MS17T Electrical Visual MS13 = Supplied w/ threaded connector & light MS14 = Supplied w/ 5 pin Brad Harrison connector & light (male end) Electrical Visual with Thermal Lockout MS13DCT = MS13 (see above), direct current, w/ thermal lockout MS13DCLCT = Low current MS13DCT MS14DCT = MS14 (see above), direct current, w/ thermal lockout MS14DCLCT = Low current MS14DCT	Omit = None L = Two ¼" NPTF inlet and outlet female test ports	Omit = None DR = ¾" drain on bottom of housing	

#### NOTES:

Box 2. Double and triple stacking of K-size elements can be replaced by single KK and 27K elements, respectively. Number of elements must equal 1 when using KK or 27K elements. Replacement element part numbers are identical to contents of Boxes 2, 3, 4, and 5. ZW media not available in 27K length. Example: 18LCZ3V

Box 5. For options H, W, V, and H.5, all aluminum parts are anodized. H.5 seal designation includes the following: EPR seals, stainless steel wire mesh on elements, and light oil coating on housing exterior. Viton® is a registered trademark of DuPont Dow Elastomers. Skydrol® is a registered trademark of Solutia Inc.

Box 6. B24 and B32 porting options supplied with metric mounting holes. 18LC elements require 2" ports for up to 120 gpm. K size elements require 1½" ports for up to 100 gpm.

# Return Line Filter with 2" Ports

**LF1**



### Features and Benefits

- Offered in pipe, SAE straight thread and ISO 228 porting
- Available in 18" element lengths only
- Various Dirt Alarm® options
- Available with NPTF inlet and outlet female test ports
- Available with 2" porting with "K" size element
- Available with housing drain plug

**120 gpm**  
**455 L/min**  
**300 psi**  
**20 bar**

IRF

TF1

KF3

KL3

**LF1**

MLF1

RLD

GRTB

MTA

MTB

ZT

KFT

RT

RTI

LRT

ART

BRT

TRT

BFT

QT

KTK

LTK

MRT

Accessories  
For Tank-  
Mounted  
Filters

PAF1

MAF1

MF2

Model No. of filter in photograph is LF118LCZ10P32D.

Flow Rating:	Up to 120 gpm (455 L/min) for 150 SUS (32 cSt) fluids
Max. Operating Pressure:	300 psi (20 bar)
Min. Yield Pressure:	1000 psi (70 bar), per NFPA T2.6.1
Rated Fatigue Pressure:	250 psi (17 bar), per NFPA T2.6.1-2005
Temp. Range:	-20°F to 225°F (-29°C to 107°C)
Bypass Setting:	Cracking: 30 psi (2.1 bar) Full Flow: 60 psi (4.1 bar)
Porting Head:	Cast Aluminum
Element Case:	Steel
Available Porting:	2" NPTF, 2½-12 SAE Straight
Weight of LF1-18LC:	17.5 lbs. (7.9 kg)
Element Change Clearance:	2.0" (55 mm)

### Filter Housing Specifications

Type Fluid	Appropriate Schroeder Media
Petroleum Based Fluids	All E media (cellulose) and Z-Media® (synthetic)
High Water Content	All Z-Media (synthetic)
Invert Emulsions	10 and 25 µ Z-Media® (synthetic)
Water Glycols	3, 5, 10 and 25 µ Z-Media® (synthetic)
Phosphate Esters	All Z-Media® (synthetic) with H (EPR) seal designation
Skydrol®	3, 5, 10 and 25 µ Z-Media® (synthetic) with H.5 seal designation (EPR seals and stainless steel wire mesh in element, and light oil coating on housing exterior)

### Fluid Compatibility

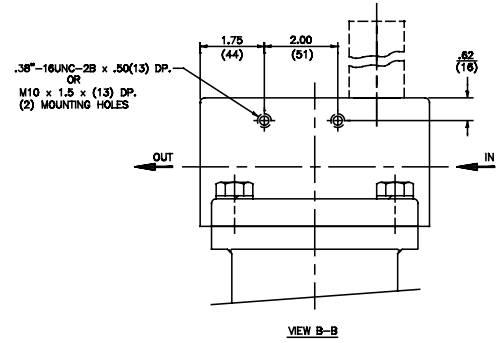
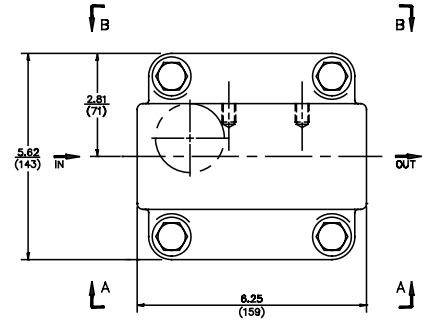
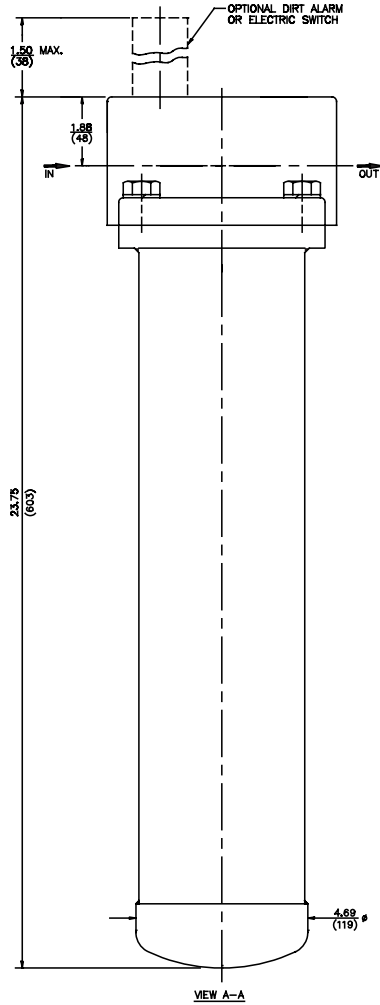

Metric dimensions in ( ).

## Element Performance Information & Dirt Holding Capacity

Element	Filtration Ratio Per ISO 4572/NFPA T3.10.8.8 Using automated particle counter (APC) calibrated per ISO 4402			Filtration Ratio per ISO 16889 Using APC calibrated per ISO 11171	
	$\beta_x \geq 75$	$\beta_x \geq 100$	$\beta_x \geq 200$	$\beta_x(c) \geq 200$	$\beta_x(c) \geq 1000$
18LCZ1	<1.0	<1.0	<1.0	<4.0	4.2
18LCZ3	<1.0	<1.0	<2.0	<4.0	4.8
18LCZ5	2.5	3.0	4.0	4.8	6.3
18LCZ10	7.4	8.2	10.0	8.0	10.0
18LCZ25	18.0	20.0	22.5	19.0	24.0

Element	DHC (gm)
18LCZ1	224
18LCZ3	230
18LCZ5	238
18LCZ10	216
18LCZ25	186

Element Collapse Rating: 150 psid (10 bar)

Flow Direction: Outside In

Element Nominal Dimensions: 4.0" (100 mm) O.D. x 18.5" (470 mm) long

$\Delta P_{\text{housing}}$

LF1-2"  $\Delta P_{\text{housing}}$  for fluids with sp gr (specific gravity) = 0.86:

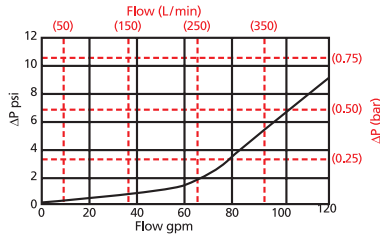

$\Delta P_{\text{element}}$

18LCZ

Element Pressure Drop versus Flow Rate at 32 cSt (150 SUS)

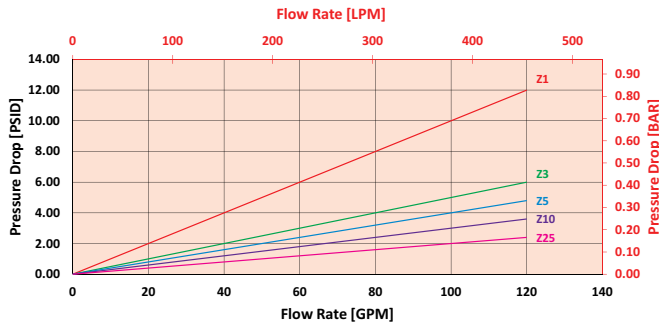

$$\Delta P_{\text{filter}} = \Delta P_{\text{housing}} + (\Delta P_{\text{element}} * \mathbf{V}_f)$$

**Exercise:**

Determine  $\Delta P_{\text{filter}}$  at 70 gpm (265.3 L/min) for LF118LCZ3P32D5 using 160 SUS (34 cSt) fluid.

Use the housing pressure curve to determine  $\Delta P_{\text{housing}}$  at 70 gpm. In this case,  $\Delta P_{\text{housing}}$  is 2 psi (.14 bar) on the graph for the LF1 housing.

Use the element pressure curve to determine  $\Delta P_{\text{element}}$  at 70 gpm. In this case,  $\Delta P_{\text{element}}$  is 3.5 psi (.24 bar) according to the graph for the 18LCZ3 element.

Because the viscosity in this sample is 160 SUS (34 cSt), we determine the **Viscosity Factor ( $\mathbf{V}_f$ )** by dividing the **Operating Fluid Viscosity** with the **Standard Viscosity** of 150 SUS (32 cSt). To best determine your Operating Fluid Viscosity, please reference the chart in Appendix D.

Finally, the overall filter pressure differential,  $\Delta P_{\text{filter}}$ , is calculated by adding  $\Delta P_{\text{housing}}$  with the true element pressure differential, ( $\Delta P_{\text{element}} * \mathbf{V}_f$ ). The  $\Delta P_{\text{element}}$  from the graph has to be multiplied by the viscosity factor to get the true pressure differential across the element.

**Solution:**

$\Delta P_{\text{housing}} = 2 \text{ psi } [.14 \text{ bar}] \mid \Delta P_{\text{element}} = 3.5 \text{ psi } [.24 \text{ bar}]$

$\mathbf{V}_f = 160 \text{ SUS (34 cSt) } / 150 \text{ SUS (32 cSt)} = 1.1$

$\Delta P_{\text{filter}} = 2 \text{ psi } + (3.5 \text{ psi } * 1.1) = 5.9 \text{ psi}$

**OR**

$\Delta P_{\text{filter}} = .14 \text{ bar } + (.24 \text{ bar } * 1.1) = .40 \text{ bar}$

## Filter Model Number Selection

### How to Build a Valid Model Number for a Schroeder LF1:

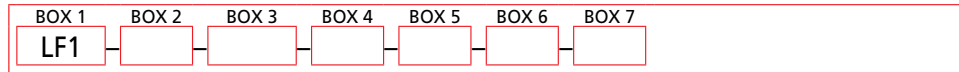

**Example:** NOTE: Only box 7 may contain more than one option

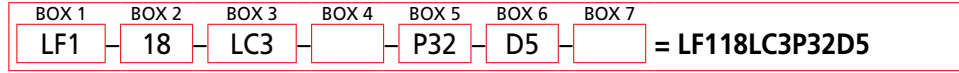

BOX 1	BOX 2	BOX 3	BOX 4
<b>Filter Series</b>	<b>Length of Element (in)</b>	<b>Element Size and Media</b>	<b>Seal Material</b>
LF1	18	LC3 = LC size 3 μ E media (cellulose) LC10 = LC size 10 μ E media (cellulose) LCZ1 = LC size 1 μ Excellement® Z-Media™ (synthetic) LCZ3 = LC size 3 μ Excellement Z-Media (synthetic) LCZ5 = LC size 5 μ Excellement Z-Media (synthetic) LCZ10 = LC size 10 μ Excellement Z-Media (synthetic) LCZ25 = LC size 25 μ Excellement Z-Media (synthetic)	Omit = Buna N H = EPR V = Viton® H.5 = Skydrol® Compatibility
WLF1 (Water)			

BOX 5	BOX 6	BOX 7
<b>Porting</b>	<b>Dirt Alarm® Options</b>	<b>Additional Options</b>
P32 = 2" NPTF	Omit = None	Omit = None
S32 = SAE-32	Visual D = Pointer	L = Two ¼" NPTF inlet and outlet female test ports
B32 = ISO 228 G-2"	D5 = Visual pop-up	G426 = ¾" drain on bottom of housing
	Visual with Thermal Lockout D8 = Visual w/ thermal lockout	G440 = ½" drain on bottom of housing
	Electrical MS5 = Electrical w/ 12 in. 18 gauge 4-conductor cable MS5LC = Low current MS5 MS10 = Electrical w/ DIN connector (male end only) MS10LC = Low current MS10 MS11 = Electrical w/ 12 ft. 4-conductor wire MS12 = Electrical w/ 5 pin Brad Harrison connector (male end only) MS12LC = Low current MS12 MS16 = Electrical w/ weather-packed sealed connector MS16LC = Low current MS16 MS17LC = Electrical w/ 4 pin Brad Harrison male connector	
	Electrical with Thermal Lockout MS5T = MS5 (see above) w/ thermal lockout MS5LCT = Low current MS5T MS10T = MS10 (see above) w/ thermal lockout MS10LCT = Low current MS10T MS12T = MS12 (see above) w/ thermal lockout MS12LCT = Low current MS12T MS16T = MS16 (see above) w/ thermal lockout MS16LCT = Low current MS16T MS17LCT = Low current MS17T	
	Electrical Visual MS = Cam operated switch w/ ½" conduit female connection MS13 = Supplied w/ threaded connector & light MS14 = Supplied w/ 5 pin Brad Harrison connector & light (male end)	
	Electrical Visual with Thermal Lockout MS13DCT = MS13 (see above), direct current, w/ thermal lockout MS13DCLCT = Low current MS13DCT MS14DCT = MS14 (see above), direct current, w/ thermal lockout MS14DCLCT = Low current MS14DCT	

**NOTES:**

Box 2. Replacement element part numbers are a combination of Boxes 2, 3, and 4. Example: 18LCZ3V

Box 4. For options H, V, and H.5, all aluminum parts are anodized. H.5 seal designation includes the following: EPR seals, stainless steel wire mesh on elements, and light oil coating on housing exterior. Viton® is a registered trademark of DuPont Dow Elastomers. Skydrol® is a registered trademark of Solutia Inc.

Box 5. B porting option supplied with metric mounting holes.



# Top-Ported Return Line Filter

# MLF1



## Features and wBenefits

- Equipped with inlet and outlet manifolds
- Meets HF4 automotive standard
- Offered in pipe and flange porting
- Available in 2, 4 or 6 element configurations
- Various Dirt Alarm® options
- Available with NPTF inlet and outlet female test ports
- Available with housing drain plugs
- **G** Available with quality-protected GeoSeal® Elements (GMLF1)

**200 gpm**  
**760 L/min**  
**300 psi**  
**20 bar**

IRF

TF1

KF3

KL3

LF1

**MLF1**

RLD

GRTB

MTA

MTB

ZT

KFT

RT

RTI

LRT

ART

BRT

TRT

BFT

QT

KTK

LTK

MRT

Accessories  
 For Tank-  
 Mounted  
 Filters

PAF1

MAF1

MF2

Model No. of filter in photograph is MLF14K10PD.

Flow Rating:	Up to 200 gpm (760 L/min) for 150 SUS (32 cSt) fluids
Max. Operating Pressure:	300 psi (20 bar)
Min. Yield Pressure:	1000 psi (70 bar), per NFPA T2.6.1
Rated Fatigue Pressure:	250 psi (17 bar), per NFPA T2.6.1-2005
Temp. Range:	-20°F to 225°F (-29°C to 107°C)
Bypass Setting:	Cracking: 25 psi (2 bar) Full Flow: 60 psi (4 bar)
Porting Head:	Anodized Cast Aluminum
Element Case:	Steel
Weight of MLF1-2K:	44.0 lbs. (20.0 kg)
Weight of MLF1-4K:	50.0 lbs. (23.0 kg)
Weight of MLF1-6K:	58.0 lbs. (26.0 kg)
Element Change Clearance:	2.0" (55 mm)

## Filter Housing Specifications

Type Fluid	Appropriate Schroeder Media
Petroleum Based Fluids	All E media (cellulose), Z-Media® and ASP® media (synthetic)
High Water Content	All Z-Media® (synthetic)
Invert Emulsions	10 and 25 µ Z-Media® (synthetic)
Water Glycols	3, 5, 10 and 25 µ Z-Media® (synthetic)
Phosphate Esters	All Z-Media® (synthetic) with H (EPR) seal designation and 3 and 10 µ E media (cellulose) with H (EPR) seal designation and all ASP® media (synthetic)
Skydrol®	3, 5, 10 and 25 µ Z-Media® (synthetic) with H.5 seal designation (EPR seals and stainless steel wire mesh in element, and light oil coating on housing exterior) and all ASP® media (synthetic).

## Fluid Compatibility

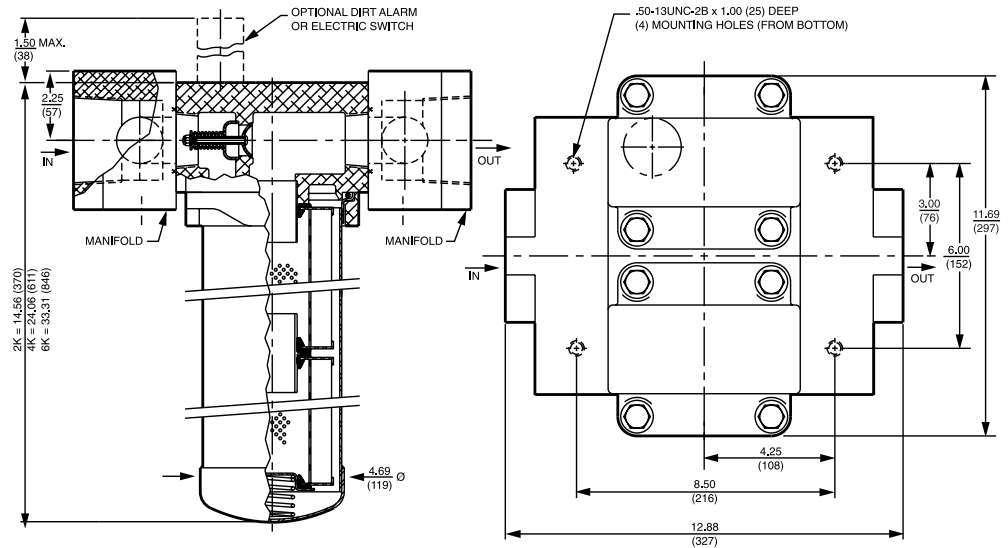

Metric dimensions in ( ).

## Element Performance Information & Dirt Holding Capacity

Element	Filtration Ratio Per ISO 4572/NFPA T3.10.8.8 Using automated particle counter (APC) calibrated per ISO 4402			Filtration Ratio per ISO 16889 Using APC calibrated per ISO 11171	
	$\beta_x \geq 75$	$\beta_x \geq 100$	$\beta_x \geq 200$	$\beta_x(c) \geq 200$	$\beta_x(c) \geq 1000$
KZ1	<1.0	<1.0	<1.0	<4.0	4.2
KZ3	<1.0	<1.0	<2.0	<4.0	4.8
KZ5	2.5	3.0	4.0	4.8	6.3
KZ10	7.4	8.2	10.0	8.0	10.0
KZ25	18.0	20.0	22.5	19.0	24.0
KZW3	N/A	N/A	N/A	<4.0	4.8
KZW5	N/A	N/A	N/A	5.1	6.4
KZW10	N/A	N/A	N/A	6.9	8.6
KZW25	N/A	N/A	N/A	15.4	18.5

Element	DHC (gm)	Element	DHC (gm)	Element	DHC (gm)	Element	DHC (gm)
2KZ1	224	4KZ1	448	6KZ1	672		
2KZ3	230	4KZ3	460	6KZ3	690	KZW3	64
2KZ5	238	4KZ5	476	6KZ5	714	KZW5	63
2KZ10	216	4KZ10	432	6KZ10	648	KZW10	67
2KZ25	186	4KZ25	372	6KZ25	558	KZW25	79

Element Collapse Rating: 150 psid (10 bar) for standard elements

Flow Direction: Outside In

Element Nominal Dimensions: K: 3.9" (99 mm) O.D. x 9.0" (230 mm) long  
 KK: 3.9" (99 mm) O.D. x 18.0" (460 mm) long  
 27K: 3.9" (99 mm) O.D. x 27.0" (690 mm) long

# Top-Ported Return Line Filter

# MLF1

$\Delta P_{\text{housing}}$

MLF1  $\Delta P_{\text{housing}}$  for fluids with sp gr (specific gravity) = 0.86:

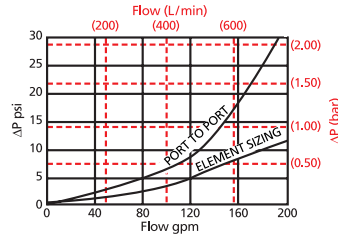

$\Delta P_{\text{element}}$

4KZ/2KKZ Element Pressure Drop versus Flow Rate at 32 cSt (150 SUS)

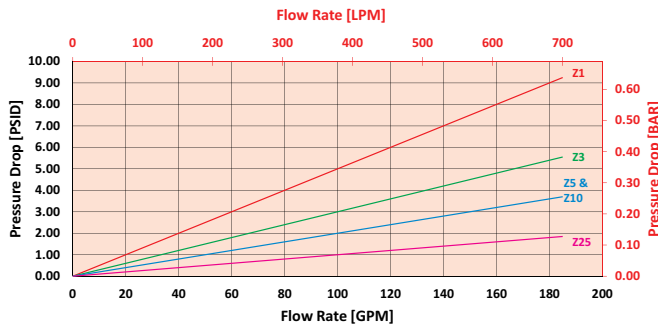

6KZ/2-27KZ Element Pressure Drop versus Flow Rate at 32 cSt (150 SUS)

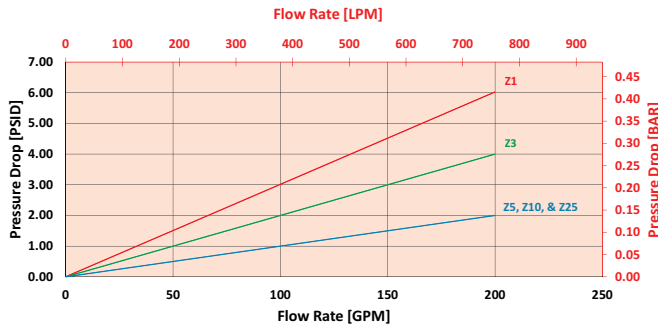

$$\Delta P_{\text{filter}} = \Delta P_{\text{housing}} + (\Delta P_{\text{element}} * \mathbf{V}_f)$$

### Exercise:

Determine  $\Delta P_{\text{filter}}$  at 150 gpm (568.5 L/min) for MLF14K10PD using 160 SUS (34 cSt) fluid.

Use the housing pressure curve to determine  $\Delta P_{\text{housing}}$  at 150 gpm. In this case,  $\Delta P_{\text{housing}}$  is 15 psi (1 bar) on the graph for the MLF1 housing.

Use the element pressure curve to determine  $\Delta P_{\text{element}}$  at 150 gpm. In this case,  $\Delta P_{\text{element}}$  is 3 psi (.21 bar) according to the graph for the KKZ10 element.

Because the viscosity in this sample is 160 SUS (34 cSt), we determine the **Viscosity Factor ( $\mathbf{V}_f$ )** by dividing the **Operating Fluid Viscosity** with the **Standard Viscosity** of 150 SUS (32 cSt). To best determine your Operating Fluid Viscosity, please reference the chart in Appendix D.

Finally, the overall filter pressure differential,  $\Delta P_{\text{filter}}$ , is calculated by adding  $\Delta P_{\text{housing}}$  with the true element pressure differential,  $(\Delta P_{\text{element}} * \mathbf{V}_f)$ . The  $\Delta P_{\text{element}}$  from the graph has to be multiplied by the viscosity factor to get the true pressure differential across the element.

### Solution:

$$\Delta P_{\text{housing}} = 15 \text{ psi [1 bar]} \quad | \quad \Delta P_{\text{element}} = 3 \text{ psi [.21 bar]}$$

$$\mathbf{V}_f = 160 \text{ SUS (34 cSt)} / 150 \text{ SUS (32 cSt)} = 1.1$$

$$\Delta P_{\text{filter}} = 15 \text{ psi} + (3 \text{ psi} * 1.1) = 18.3 \text{ psi}$$

OR

$$\Delta P_{\text{filter}} = 1 \text{ bar} + (.21 \text{ bar} * 1.1) = 1.2 \text{ bar}$$

**Pressure Drop Information**  
Based on  
Flow Rate  
and Viscosity

Note:

If your element is not graphed, use the following equation:  
 $\Delta P_{\text{element}} = \text{Flow Rate} \times \Delta P_f$ . Plug this variable into the overall pressure drop equation.

Ele.	$\Delta P$	Ele.	$\Delta P$	Ele.	$\Delta P$
2KZ1	0.10	2K3	0.12	4K3/ KK3	0.06
2KZ3	0.05	2K10	0.05	4K10/ KK10	0.02
2KZ5	0.04	2K25	0.01	4K25/ KK25	0.01
2KZ10	0.03	2KAS3	0.05	4KAS3/ KKAS3	0.03
2KZ25	0.02	2KAS5	0.04	4KAS5/ KKAS5	0.02
KZW3	0.32	2KAS10	0.03	4KAS10/ KKAS10	0.02
KZW5	0.28	2KZW3/ KKZW3	0.16	6KAS3/ 27KAS3	0.02
KZW10	0.23	2KZW5/ KKZW5	0.14	6KAS5/ 27KAS5	0.01
KZW25	0.14			6KAS10/ 27KAS10	0.01

## Filter Model Number Selection

### How to Build a Valid Model Number for a Schroeder MLF1:

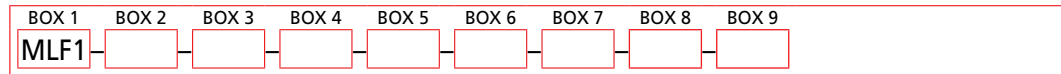

**Example:** NOTE: Only box 9 may contain more than one option

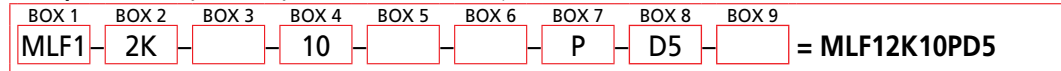

BOX 1	BOX 2	BOX 3	BOX 4
<b>Filter Series</b>	<b>Number &amp; Size of Elements</b>	<b>Media Type</b>	<b>Micron Rating</b>
MLF1	2K, KK, 27K 4 K 6 K	Omit = E media (cellulose) Z = Excellement® Z-Media® (synthetic) AS = Anti-Static Pleat Media (synthetic)  ZW = Aqua-Excellement™ ZW media  DZ = DirtCatcher® with Excellement® Z-Media® W = W media (water removal) M = M media (reusable metal mesh)	1 = 1 µ Z, ZW, and DZ media 3 = 3 µ AS, E, Z, ZW, and DZ media 5 = 5 µ AS, Z, ZW, DZ media  10 = 10 µ AS, E, M, Z, ZW, & DZ media  25 = 25 µ E, M, Z, ZW and DZ media 60 = 60 µ M media 150 = 150 µ M media
GMLF1 (GeoSeal®)	GeoSeal® 2KG, KKG, 27KG 4 KG 6 KG		

BOX 5	BOX 6	BOX 7
<b>Seal Material</b>	<b>Magnet Option</b>	<b>Porting</b>
Omit = Buna N H = EPR V = Viton® H.5 = Skydrol® Compatibility	Omit = None M = Magnet inserts	P = 2½" NPTF F = 2½" SAE 4-bolt flange Code 61

BOX 8	BOX 9
<b>Dirt Alarm® Options</b>	<b>Additional Options</b>
Omit = None	Omit = None
Visual D = Pointer D5 = Visual pop-up	L = Two ¼" NPTF inlet and outlet female test ports G426 = ¾" drain on bottom of housing G440 = ½" drain on bottom of housing
Visual with Thermal Lockout D8 = Visual w/ thermal lockout	
Electrical MS5 = Electrical w/ 12 in. 18 gauge 4-conductor cable MS5LC = Low current MS5 MS10 = Electrical w/ DIN connector (male end only) MS10LC = Low current MS10 MS11 = Electrical w/ 12 ft. 4-conductor wire MS12 = Electrical w/ 5 pin Brad Harrison connector (male end only) MS12LC = Low current MS12 MS16 = Electrical w/ weather-packed sealed connector MS16LC = Low current MS16 MS17LC = Electrical w/ 4 pin Brad Harrison male connector	
Electrical with Thermal Lockout MS5T = MS5 (see above) w/ thermal lockout MS5LCT = Low current MS5T MS10T = MS10 (see above) w/ thermal lockout MS10LCT = Low current MS10T MS12T = MS12 (see above) w/ thermal lockout MS12LCT = Low current MS12T MS16T = MS16 (see above) w/ thermal lockout MS16LCT = Low current MS16T MS17LCT = Low current MS17T	
Electrical Visual MS = Cam operated switch w/ ½" conduit female connection MS13 = Supplied w/ threaded connector & light MS14 = Supplied w/ 5 pin Brad Harrison connector & light (male end)	
Electrical Visual with Thermal Lockout MS13DCT = MS13 (see above), direct current, w/ thermal lockout MS13DCLCT = Low current MS13DCT MS14DCT = MS14 (see above), direct current, w/ thermal lockout MS14DCLCT = Low current MS14DCT	

**NOTES:**

- Box 2. Double and triple stacking of K-size elements can be replaced by KK and 27K elements, respectively. Number of elements must equal 2 when using KK or 27K elements.
- Box 3. Replacement element part numbers are identical to contents of Boxes 2, 3, 4, and 5. K25 is not available with EPR seals.
- Box 5. For options H, V, and H.5, all aluminum parts are anodized. H.5 seal designation includes the following: EPR seals, stainless steel wire mesh on elements, and light oil coating on housing exterior. Viton® is a registered trademark of DuPont Dow Elastomers. Skydrol® is a registered trademark of Solutia Inc.

# Medium Pressure Filter

# RLD



## Features and Benefits

- Lightweight duplex filter constructed of aluminum
- High chromium content aluminum alloy is water tolerant – anodization is not required for high water-based fluids (HWBF)
- Filter housings are designed to withstand pressure surges as well as high static pressure loads
- Screw-in bowl allows the filter element to be easily removed for replacement or cleaning
- Standard model supplied with drain plugs
- Standard Viton® seal on filter housing
- Filter contains an integrated equalization valve
- Pressure is equalized between filters by raising the change-over lever prior to switching it to the relevant filter side

**100 gpm**  
**380 L/min**  
**350 psi**  
**24 bar**

Model No. of filter in photograph is RLD25DNZ5S24DW.

Flow Rating:	Up to 100 gpm (380 L/min) for 150 SUS (32 cSt) fluids
Max. Operating Pressure:	350 psi (24 bar)
Min. Yield Pressure:	Contact factory
Rated Fatigue Pressure:	350 psi (24 bar)
Temp. Range:	-22°F to 250°F (-30°C to 121°C)
Bypass Setting:	Standard: 102 psi (7 bar) Optional: 43 psi (3.0 bar)
Porting Head:	Aluminum
Element Case:	Aluminum
Weight of RLD-25DN:	26 lbs. (11.8 kg)
Weight of RLD-40DN:	29 lbs. (13.0 kg)
Element Change Clearance:	25DN: 3.5" (89 mm) 40DN: 3.5" (89 mm)

## Filter Housing Specifications

Type Fluid	Appropriate Schroeder Media
Petroleum Based Fluids	All Z-Media® (synthetic)
High Water Content	All Z-Media® (synthetic)
Invert Emulsions	10 and 25 µ Z-Media® (synthetic)
Water Glycols	3, 6, 10 and 25 µ Z-Media® (synthetic)

## Fluid Compatibility

Accessories  
For Tank-  
Mounted  
Filters

IRF

TF1

KF3

KL3

LF1

MLF1

**RLD**

GRTB

MTA

MTB

ZT

KFT

RT

RTI

LRT

ART

BRT

TRT

BFT

QT

KTK

LTK

MRT

PAF1

MAF1

MF2

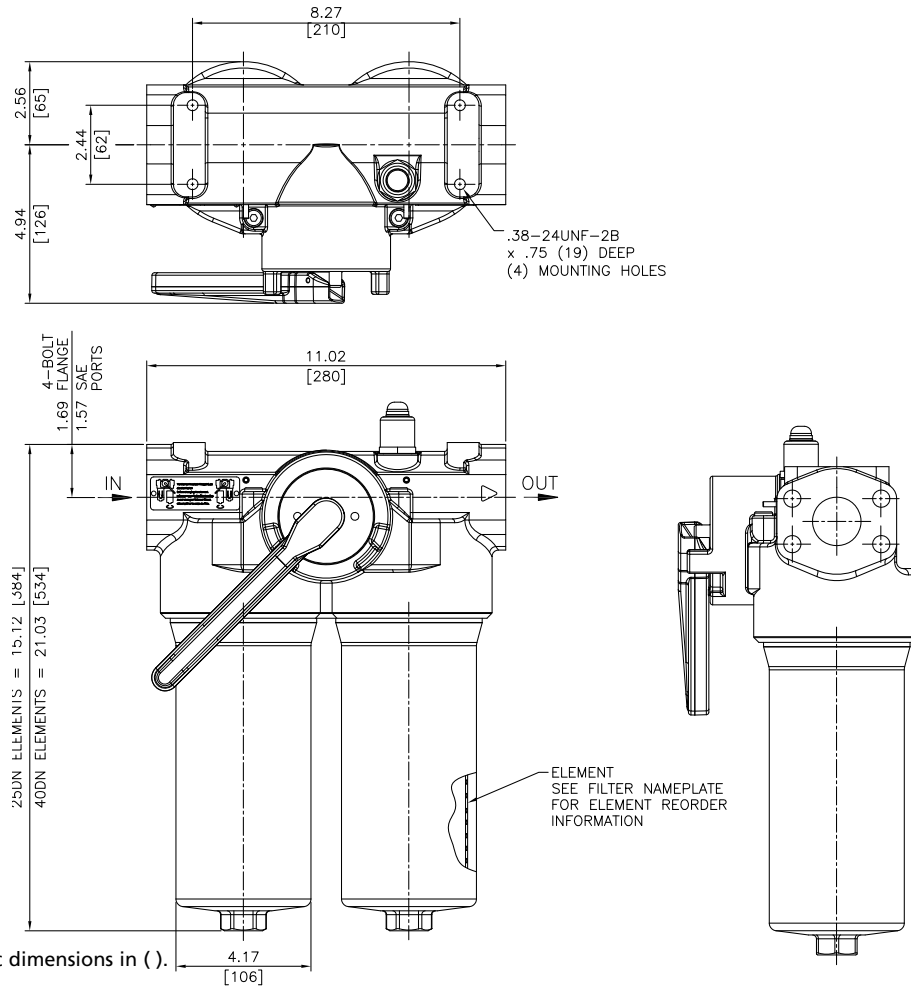

Metric dimensions in ( ).

## Element Performance Information & Dirt Holding Capacity

Element	Filtration Ratio Per ISO 4572/NFPA T3.10.8.8 Using automated particle counter (APC) calibrated per ISO 4402			Filtration Ratio per ISO 16889 Using APC calibrated per ISO 11171	
	$\beta_x \geq 75$	$\beta_x \geq 100$	$\beta_x \geq 200$	$\beta_x(\alpha) \geq 200$	$\beta_x(\alpha) \geq 1000$
25/40DNZ3	<1.0	<1.0	<2.0	<4.0	4.8
25/40DNZ6	2.5	3.0	4.0	4.8	6.3
25/40DNZ10	7.4	8.2	10.0	8.0	10.0
25/40DNZ25	18.0	20.0	22.5	19.0	24.0

Element	DHC (gm)	Element	DHC (gm)
25DNZ3	57	40DNZ3	105
25DNZ6	62	40DNZ6	115
25DNZ10	52	40DNZ10	104
25DNZ25	48	40DNZ25	94

Element Collapse Rating: 290 psid (20 bar)  
 Flow Direction: Outside In  
 Element Nominal Dimensions: 3.0" (75 mm) O.D. x 14.5" (370 mm) long

$\Delta P_{\text{housing}}$

RLD  $\Delta P_{\text{housing}}$  for fluids with sp gr (specific gravity) = 0.86:

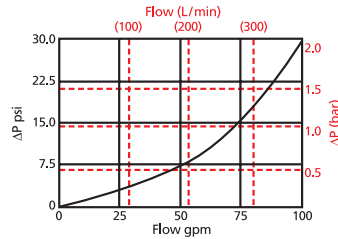

**Pressure Drop Information Based on Flow Rate and Viscosity**

$\Delta P_{\text{element}}$

25DNZ

Element Pressure Drop versus Flow Rate at 32 cSt (150 SUS)

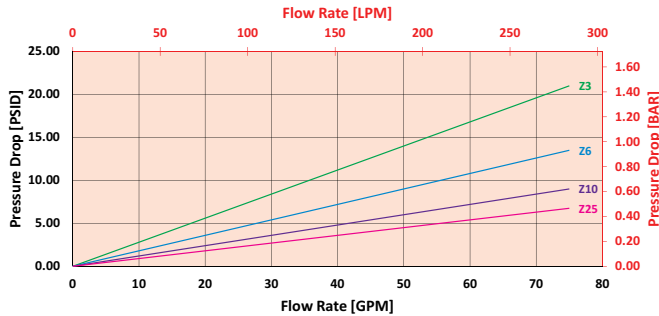

40DNZ

Element Pressure Drop versus Flow Rate at 32 cSt (150 SUS)

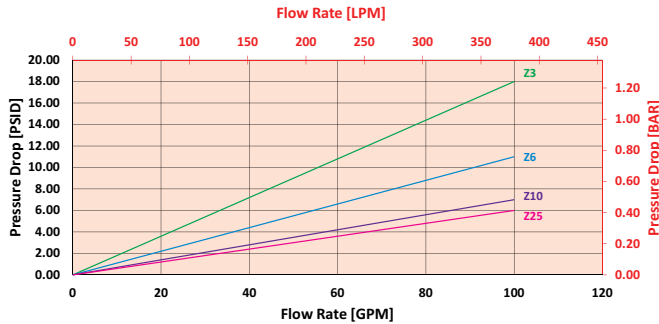

$$\Delta P_{\text{filter}} = \Delta P_{\text{housing}} + (\Delta P_{\text{element}} * \mathbf{V}_f)$$

**Exercise:**

Determine  $\Delta P_{\text{filter}}$  at 70 gpm (265.3 L/min) for RLD25DNZ5VF2440VM using 160 SUS (34 cSt) fluid.

Use the housing pressure curve to determine  $\Delta P_{\text{housing}}$  at 70 gpm. In this case,  $\Delta P_{\text{housing}}$  is 14 psi (.96 bar) on the graph for the RLD housing.

Use the element pressure curve to determine  $\Delta P_{\text{element}}$  at 70 gpm. In this case,  $\Delta P_{\text{element}}$  is 8 psi (.55 bar) according to the graph for the 25DNZ5V element.

Because the viscosity in this sample is 160 SUS (44 cSt), we determine the **Viscosity Factor ( $\mathbf{V}_f$ )** by dividing the **Operating Fluid Viscosity** with the **Standard Viscosity** of 150 SUS (32 cSt). To best determine your Operating Fluid Viscosity, please reference the chart in Appendix D.

Finally, the overall filter pressure differential,  $\Delta P_{\text{filter}}$ , is calculated by adding  $\Delta P_{\text{housing}}$  with the true element pressure differential,  $(\Delta P_{\text{element}} * \mathbf{V}_f)$ . The  $\Delta P_{\text{element}}$  from the graph has to be multiplied by the viscosity factor to get the true pressure differential across the element.

**Solution:**

$\Delta P_{\text{housing}} = 14 \text{ psi } [.96 \text{ bar}] \mid \Delta P_{\text{element}} = 8 \text{ psi } [.55 \text{ bar}]$

$\mathbf{V}_f = 160 \text{ SUS } (34 \text{ cSt}) / 150 \text{ SUS } (32 \text{ cSt}) = 1.1$

$\Delta P_{\text{filter}} = 14 \text{ psi} + (8 \text{ psi} * 1.1) = 22.8 \text{ psi}$

**OR**

$\Delta P_{\text{filter}} = .96 \text{ bar} + (.55 \text{ bar} * 1.1) = 1.6 \text{ bar}$

## Filter Model Number Selection

### How to Build a Valid Model Number for a Schroeder RLD:

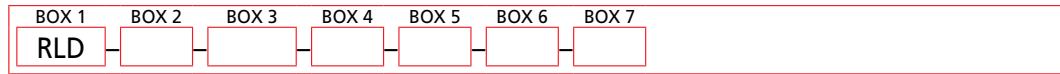

Example: NOTE: One option per box

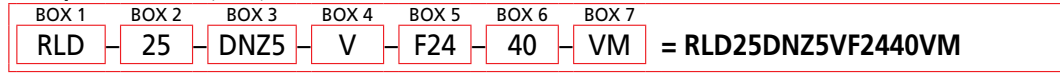

BOX 1	BOX 2	BOX 3	BOX 4
<b>Filter Series</b>	<b>Length of Elements (cm)</b>	<b>Element Size and Media</b>	<b>Element Seal Material</b>
RLD	25 40	DNZ5 = DN size 5 μ synthetic media DNZ10 = DN size 10 μ synthetic media DNZ25 = DN size 25 μ synthetic media DNM25 = DN size 25 μ M media (reusable metal) DNM50 = DN size 50 μ M media (reusable metal) DNM100 = DN size 100 μ M media (reusable metal) DNM200 = DN size 200 μ M media (reusable metal)	Omit = Buna N V = Viton®

BOX 5	BOX 6	BOX 7
<b>Porting</b>	<b>Bypass Setting</b>	<b>Dirt Alarm® Options</b>
F24 = 1½" SAE 4-bolt flange Code 61 S24 = SAE-24 (1½")	Omit = 102 psi cracking 40 = 43 psi cracking	Omit = None Visual VM = Visual pop-up w/manual reset Electrical DW = AC/DC 3-wire (NO or NC)



VM = Manual Reset

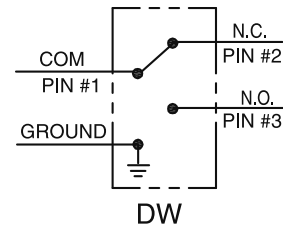

DW = AC/DC 3-wire (NO or NC)

#### NOTES:

Box 2. Replacement element part numbers are a combination of Boxes 2, 3 and 4. Example: 40DNZ10

Box 4. Filter housings are supplied with standard Viton seals. Seal designation in Box 4 applies to element only. Viton® is a registered trademark of DuPont Dow Elastomers.



# Tank-Mounted Return Line Filter

**GRTB**



## Features and Benefits

- Patented GeoSeal® Elements
- Various Dirt Alarm® options
- Cost optimized for in-tank applications
- Plastic bowl and cap lower cost and minimize weight
- UV resistant cap
- Same day shipment model available

 Part of Schroeder Industries Energy Savings Initiative

**100 gpm**  
**380 L/min**  
**100 psi**  
**7 bar**

IRF

TF1

KF3

KL3

LF1

MLF1

RLD

**GRTB**

MTA

MTB

ZT

KFT

RT

RTI

LRT

ART

BRT

TRT

BFT

QT

KTK

LTK

MRT

Model No. of filter in photograph is GRTB1KBGZ10S.

Flow Rating: Up to 100 gpm (380 L/min) for 150 SUS (32 cSt) fluids
Max. Operating Pressure: 100 psi (7 bar)
Min. Yield Pressure: 400 psi (28 bar)
Rated Fatigue Pressure: 145 psi (10 bar), Per NFPA T2.6.1-2005
Temp. Range: -20°F to 200°F (-29°C to 93°C)
Bypass Setting: Cracking: 25 psi (1.7 bar) Full Flow: 42 psi (2.9 bar)
Cap & Bowl: Nylon Porting Head: Aluminum
Weight of GRTB-1K: 5.2 lbs (2.36 kg)
Element Change Clearance: 9.5" (240 mm)

## Filter Housing Specifications

Type Fluid	Appropriate Schroeder Media
Petroleum Based Fluids	All E media (cellulose), Z-Media® and ASP® media (synthetic)
Invert Emulsions	10 and 25 µ Z-Media® and 10 µ ASP® media (synthetic)

## Fluid Compatibility

### Accessories For Tank-Mounted Filters

PAF1

MAF1

MF2

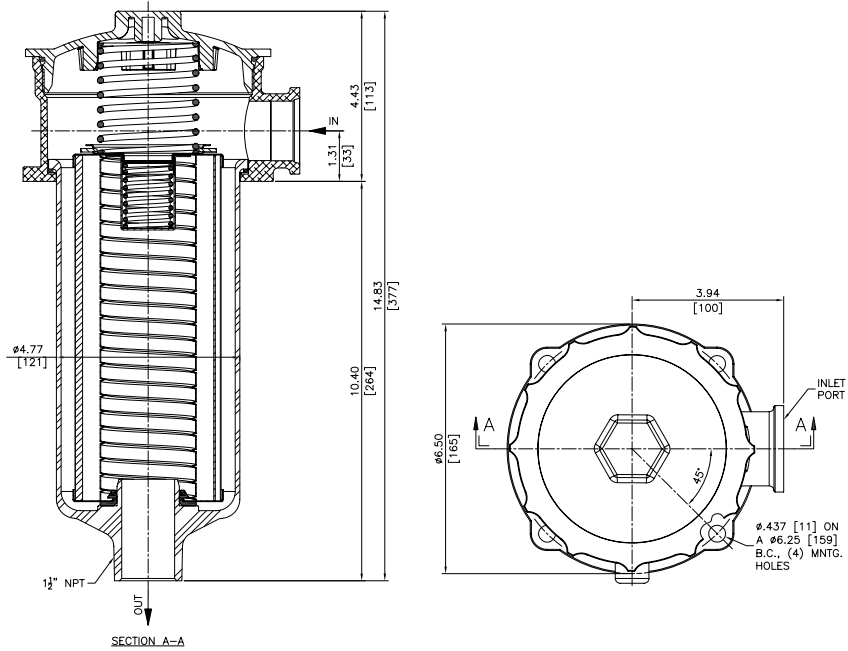

Metric dimensions in ( ).

**Element  
Performance  
Information & Dirt  
Holding Capacity**

Element	Filtration Ratio Per ISO 4572/NFPA T3.10.8.8 Using automated particle counter (APC) calibrated per ISO 4402			Filtration Ratio per ISO 16889 Using APC calibrated per ISO 11171	
	$\beta_x \geq 75$	$\beta_x \geq 100$	$\beta_x \geq 200$	$\beta_x(c) \geq 200$	$\beta_x(c) \geq 1000$
KBGZ1	<1.0	<1.0	<1.0	<4.0	4.2
KBGZ3	<1.0	<1.0	<2.0	<4.0	4.8
KBGZ5	2.5	3.0	4.0	4.8	6.3
KBGZ10	7.4	8.2	10.0	8.0	10.0
KBGZ25	18.0	20.0	22.5	19.0	24.0

Element	DHC (gm)
KBGZ1	112
KBGZ3	115
KBGZ5	119
KBGZ10	108
KBGZ25	93

Element Collapse Rating: 150 psid (10 bar) for standard elements

Flow Direction: Outside In

Element Nominal Dimensions: K: 3.9" (99 mm) O.D. x 9.0" (230 mm) long

## $\Delta P_{\text{housing}}$

GRTB  $\Delta P_{\text{housing}}$  for fluids with sp gr (specific gravity) = 0.86:

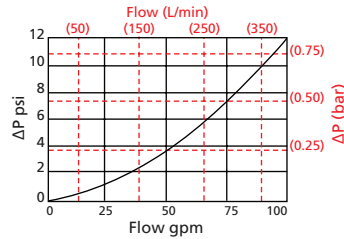

## $\Delta P_{\text{element}}$

KBGZ

Element Pressure Drop versus Flow Rate at 32 cSt (150 SUS)

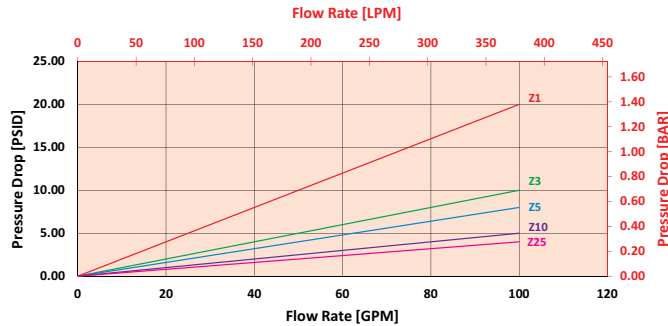

Pressure Drop Information Based on Flow Rate and Viscosity

$$\Delta P_{\text{filter}} = \Delta P_{\text{housing}} + (\Delta P_{\text{element}} * \mathbf{V}_f)$$

### Exercise:

Determine  $\Delta P_{\text{filter}}$  at 80 gpm (303.2 L/min) for GRTB1KBGZ10PY2 using 160 SUS (34 cSt) fluid.

Use the housing pressure curve to determine  $\Delta P_{\text{housing}}$  at 80 gpm. In this case,  $\Delta P_{\text{housing}}$  is 8 psi (.55 bar) on the graph for the GRTB housing.

Use the element pressure curve to determine  $\Delta P_{\text{element}}$  at 80 gpm. In this case,  $\Delta P_{\text{element}}$  is 4 psi (.27 bar) according to the graph for the KBGZ10 element.

Because the viscosity in this sample is 160 SUS (34 cSt), we determine the **Viscosity Factor ( $\mathbf{V}_f$ )** by dividing the **Operating Fluid Viscosity** with the **Standard Viscosity** of 150 SUS (32 cSt). To best determine your Operating Fluid Viscosity, please reference the chart in Appendix D.

Finally, the overall filter pressure differential,  $\Delta P_{\text{filter}}$ , is calculated by adding  $\Delta P_{\text{housing}}$  with the true element pressure differential,  $(\Delta P_{\text{element}} * \mathbf{V}_f)$ . The  $\Delta P_{\text{element}}$  from the graph has to be multiplied by the viscosity factor to get the true pressure differential across the element.

### Solution:

$$\Delta P_{\text{housing}} = 8 \text{ psi } [.55 \text{ bar}] \quad | \quad \Delta P_{\text{element}} = 4 \text{ psi } [.27 \text{ bar}]$$

$$\mathbf{V}_f = 160 \text{ SUS (34 cSt)} / 150 \text{ SUS (32 cSt)} = 1.1$$

$$\Delta P_{\text{filter}} = 8 \text{ psi} + (4 \text{ psi} * 1.1) = 12.4 \text{ psi}$$

OR

$$\Delta P_{\text{filter}} = .55 \text{ bar} + (.27 \text{ bar} * 1.1) = .85 \text{ bar}$$

## Filter Model Number Selection

Highlighted product eligible for **QuickDelivery**

### How to Build a Valid Model Number for a Schroeder GRTB:

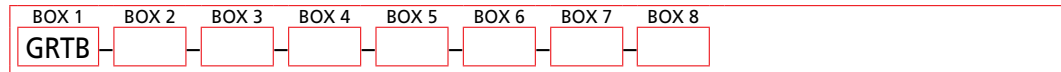

Example: NOTE: One option per box

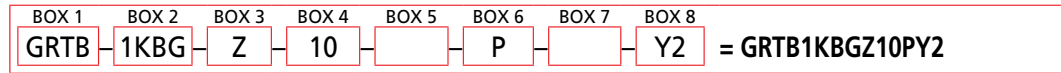

BOX 1	BOX 2	BOX 3	BOX 4
<b>Filter Series</b>	<b>Element Size</b>	<b>Media Type</b>	<b>Micron Rating</b>
GRTB	1KBG	Omit = E-Media (cellulose) Z = Excellement® Z-Media®	1 = 1 μ Z-Media® 3 = 3 μ Z-Media® 5 = 5 μ Z-Media® 10 = 10 μ E, and Z-Media® 25 = 25 μ E, and Z-Media®
BOX 5	BOX 6	BOX 7	
<b>Seals</b>	<b>Port</b>	<b>Outlet Porting Options</b>	
Omit = Buna N	P = 1.25" NPT S = SAE-20 B = ISO 228 G-1.25"	Omit = 1½" NPT male C = Check valve D = Diffuser CD = Check valve & diffuser T = 13" Tube extension	
BOX 8			
<b>Indicator</b>			
Omit = None Y2 = Back-mounted tricolor gauge ES = Electric switch ES1 = Heavy-duty electric switch with conduit connections			

# MiniMiser™ Tank-Mounted Filter

**MTA**



## Features and Benefits

- Low pressure tank-mounted filter
- Compact size minimizes space requirements
- Minimizer is cost-effective alternative to spin-on filters
- Special filter element design provides aftermarket benefits

**15 gpm**  
**55 L/min**  
**100 psi**  
**7 bar**

Model No. of filter in photograph is MTA3TAZ10P8.

- IRF
- TF1
- KF3
- KL3
- LF1
- MLF1
- RLD
- GRTB
- MTA**
- MTB
- ZT
- KFT
- RT
- RTI
- LRT
- ART
- BRT
- TRT
- BFT
- QT
- KTK
- LTK
- MRT
- PAF1
- MAF1
- MF2

Flow Rating:	Up to 15 gpm (55 L/min) for 150 SUS (32 cSt) fluids
Max. Operating Pressure:	100 psi (7 bar)
Min. Yield Pressure:	269 psi (18 bar), per NFPA T2.6.1
Rated Fatigue Pressure:	Contact factory
Temp. Range:	-20°F to 225°F (-29°C to 107°C)
Bypass Setting:	Cracking: 25 psi (2 bar) Full Flow: 48 psi (3.3 bar)
Porting Head & Cap:	Die Cast Aluminum
Element Case:	Glass Filled Nylon
Weight of MTA-3:	1.0 lbs. (0.5 kg)
Element Change Clearance:	3.0" (76 mm)

## Filter Housing Specifications

Type Fluid	Appropriate Schroeder Media
Petroleum Based Fluids	All E media (cellulose) and Z-Media® (synthetic)

## Fluid Compatibility

### Accessories For Tank-Mounted Filters

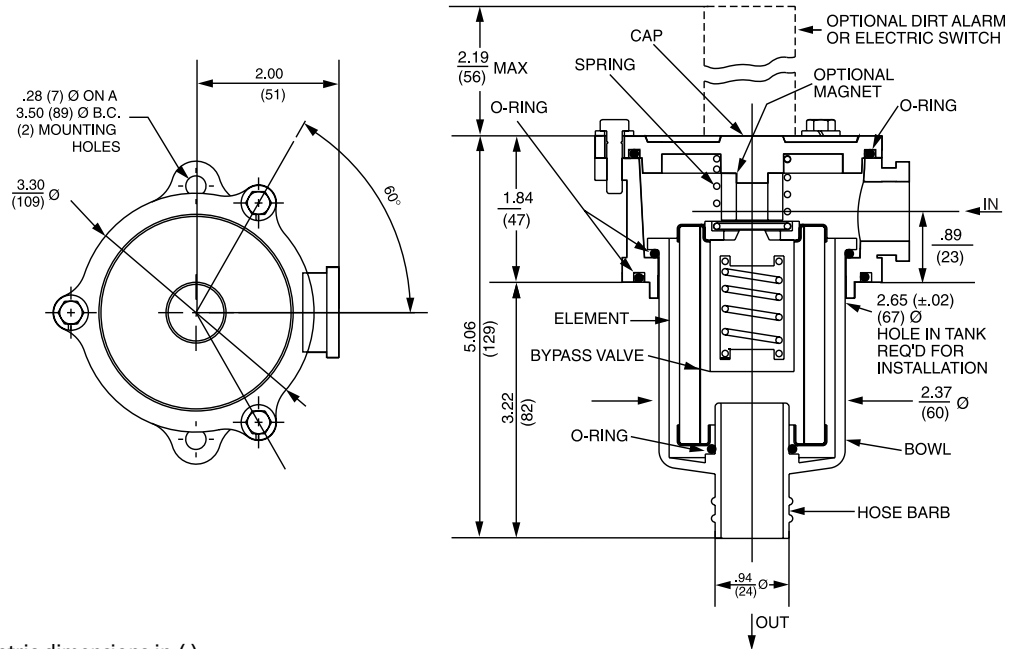

Metric dimensions in ( ).

**Element Performance Information & Dirt Holding Capacity**

Element	Filtration Ratio Per ISO 4572/NFPA T3.10.8.8 Using automated particle counter (APC) calibrated per ISO 4402			Filtration Ratio per ISO 16889 Using APC calibrated per ISO 11171	
	$\beta_x \geq 75$	$\beta_x \geq 100$	$\beta_x \geq 200$	$\beta_x(\alpha) \geq 200$	$\beta_x(\alpha) \geq 1000$
3TAZ3	<1.0	<1.0	<2.0	<4.0	4.8
3TAZ5	2.5	3.0	4.0	4.8	6.3
3TAZ10	7.4	8.2	10.0	8.0	10.0
3TAZ25	18.0	20.0	22.5	19.0	24.0

Element	DHC (gm)
3TAZ3	4
3TAZ5	6
3TAZ10	4
3TAZ25	4

Element Collapse Rating: 150 psid (10 bar)  
 Flow Direction: Outside In  
 Element Nominal Dimensions: 2.0" (51 mm) O.D. x 3.0" (76 mm) long

## $\Delta P_{\text{housing}}$

MTA  $\Delta P_{\text{housing}}$  for fluids with sp gr (specific gravity) = 0.86:

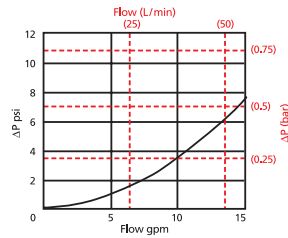

## $\Delta P_{\text{element}}$

3TAZ

Element Pressure Drop versus Flow Rate at 32 cSt (150 SUS)

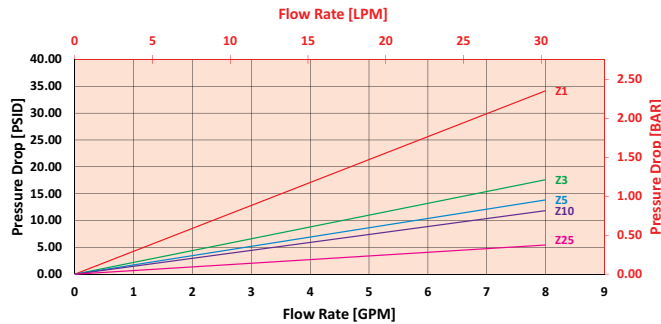

## Pressure Drop Information Based on Flow Rate and Viscosity

$$\Delta P_{\text{filter}} = \Delta P_{\text{housing}} + (\Delta P_{\text{element}} * \mathbf{V}_f)$$

### Exercise:

Determine  $\Delta P_{\text{filter}}$  at 10 gpm (37.9 L/min) for MTA3TAZ25P8Y5 using 160 SUS (34 cSt) fluid.

Use the housing pressure curve to determine  $\Delta P_{\text{housing}}$  at 10 gpm. In this case,  $\Delta P_{\text{housing}}$  is 4 psi (.27 bar) on the graph for the MTA housing.

Use the element pressure curve to determine  $\Delta P_{\text{element}}$  at 10 gpm. In this case,  $\Delta P_{\text{element}}$  is 7 psi (.48 bar) according to the graph for the 3TAZ25 element.

Because the viscosity in this sample is 160 SUS (34 cSt), we determine the **Viscosity Factor ( $\mathbf{V}_f$ )** by dividing the **Operating Fluid Viscosity** with the **Standard Viscosity** of 150 SUS (32 cSt). To best determine your Operating Fluid Viscosity, please reference the chart in Appendix D.

Finally, the overall filter pressure differential,  $\Delta P_{\text{filter}}$ , is calculated by adding  $\Delta P_{\text{housing}}$  with the true element pressure differential, ( $\Delta P_{\text{element}} * \mathbf{V}_f$ ). The  $\Delta P_{\text{element}}$  from the graph has to be multiplied by the viscosity factor to get the true pressure differential across the element.

### Solution:

$$\Delta P_{\text{housing}} = 4 \text{ psi } [.27 \text{ bar}] \quad | \quad \Delta P_{\text{element}} = 7 \text{ psi } [.48 \text{ bar}]$$

$$\mathbf{V}_f = 160 \text{ SUS (34 cSt)} / 150 \text{ SUS (32 cSt)} = 1.1$$

$$\Delta P_{\text{filter}} = 4 \text{ psi} + (7 \text{ psi} * 1.1) = 11.7 \text{ psi}$$

OR

$$\Delta P_{\text{filter}} = .27 \text{ bar} + (.48 \text{ bar} * 1.1) = .80 \text{ bar}$$

Note:

If your element is not graphed, use the following equation:

$\Delta P_{\text{element}} = \text{Flow Rate} \times \Delta P_f$  Plug this variable into the overall pressure drop equation.

Ele.	$\Delta P$
3TA10	1.40
3TA25	0.33

## Filter Model Number Selection

### How to Build a Valid Model Number for a Schroeder MTA:

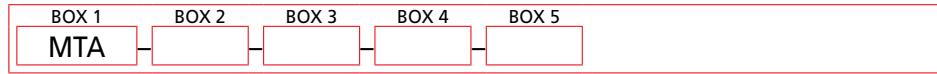

**Example:** NOTE: One option per box

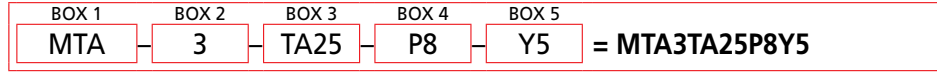

BOX 1	BOX 2	BOX 3
<b>Filter Series</b>	<b>Element Length (in)</b>	<b>Element Size and Media</b>
MTA	3	TA10 = TA size 10 μ E media (cellulose) TA25 = TA size 25 μ E media (cellulose) TAZ1 = TA size 1 μ Excellement® Z-Media® (synthetic) TAZ3 = TA size 3 μ Excellement® Z-Media® (synthetic) TAZ5 = TA size 5 μ Excellement® Z-Media® (synthetic) TAZ10 = TA size 10 μ Excellement® Z-Media® (synthetic) TAZ25 = TA size 25 μ Excellement® Z-Media® (synthetic)

BOX 4	BOX 5
<b>Porting Options</b>	<b>Dirt Alarm® Options</b>
P8 = ½" NPTF S8 = SAE-8	Omit = None Visual Y2C = Bottom-mounted gauge in cap Y5 = Back-mounted gauge in cap Electrical ESC = Electric pressure switch (2 terminals)



# MiniMiser™ Tank-Mounted Filter

# MTB



## Features and Benefits

- Low pressure tank-mounted filter
- Compact size minimizes space requirements
- Minimizer is cost-effective alternative to spin-on filters
- Special filter element design provides aftermarket benefits

**35 gpm**  
**135 L/min**  
**100 psi**  
**7 bar**

Model No. of filter in photograph is MTB5TBZ5P16.

IRF  
 TF1  
 KF3  
 KL3  
 LF1  
 MLF1  
 RLD  
 GRTB  
 MTA  
**MTB**

ZT  
 KFT  
 RT  
 RTI

Flow Rating:	Up to 25 gpm (95 L/min) for 150 SUS (32 cSt) fluids–MTB-3 Up to 35 gpm (135 L/min) for 150 SUS (32 cSt) fluids–MTB-5
Max. Operating Pressure:	100 psi (7 bar)
Min. Yield Pressure:	229 psi (15 bar), per NFPA T2.6.1
Rated Fatigue Pressure:	Contact factory
Temp. Range:	-20°F to 225°F (-29°C to 107°C)
Bypass Setting:	Cracking: 25 psi (2 bar) Full Flow: 51 psi (3.5 bar)
Porting Head & Cap:	Die Cast Aluminum
Element Case:	Glass Filled Nylon
Weight of MTB-3:	1.8 lbs. (0.8 kg)
Weight of MTB-5:	2.1 lbs. (1.0 kg)
Element Change Clearance:	3.0" (76 mm) MTB-3 5.0" (127 mm) MTB-5

## Filter Housing Specifications

LRT  
 ART  
 BRT  
 TRT  
 BFT  
 QT  
 KTK  
 LTK

Type Fluid	Appropriate Schroeder Media
Petroleum Based Fluids	All E media (cellulose) and Z-Media® (synthetic)

## Fluid Compatibility

### Accessories For Tank-Mounted Filters

MRT  
 PAF1  
 MAF1  
 MF2

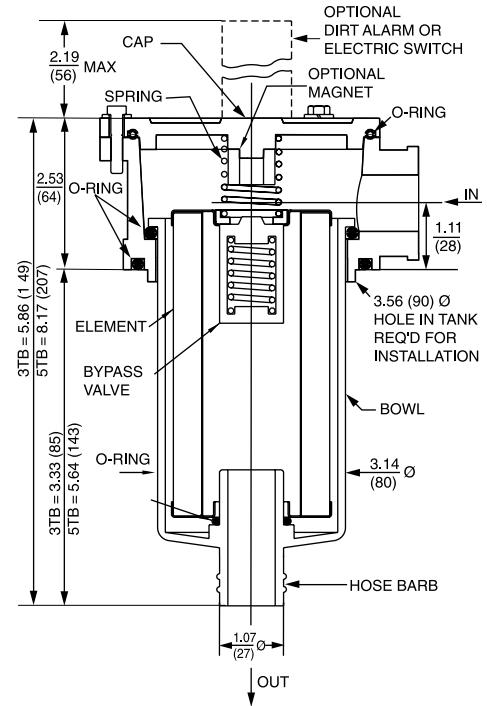
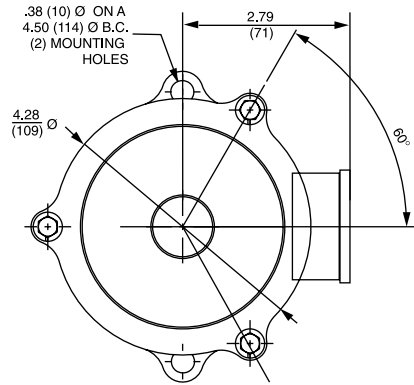

Metric dimensions in ( ).

## Element Performance Information & Dirt Holding Capacity

Element	Filtration Ratio Per ISO 4572/NFPA T3.10.8.8 Using automated particle counter (APC) calibrated per ISO 4402			Filtration Ratio per ISO 16889 Using APC calibrated per ISO 11171	
	$\beta_x \geq 75$	$\beta_x \geq 100$	$\beta_x \geq 200$	$\beta_x(c) \geq 200$	$\beta_x(c) \geq 1000$
3TBZ3	<1.0	<1.0	<2.0	<4.0	4.8
3TBZ5	2.5	3.0	4.0	4.8	6.3
3TBZ10	7.4	8.2	10.0	8.0	10.0
3TBZ25	18.0	20.0	22.5	19.0	24.0
5TBZ3	<1.0	<1.0	<2.0	4.7	5.8
5TBZ5	2.5	3.0	4.0	5.6	7.2
5TBZ10	7.4	8.2	10.0	8.0	9.8
5TBZ25	18.0	20.0	22.5	19.0	24.0

Element	DHC (gm)
3TBZ3	11
3TBZ5	12
3TBZ10	11
3TBZ25	11
5TBZ3	18
5TBZ5	21
5TBZ10	17
5TBZ25	18

Element Collapse Rating: 150 psid (10 bar)

Flow Direction: Outside In

Element Nominal Dimensions: 3TB: 3.0" (76 mm) O.D. x 3.0" (76 mm) long  
5TB: 3.0" (76 mm) O.D. x 5.0" (127 mm) long

### $\Delta P_{\text{housing}}$

MTB  $\Delta P_{\text{housing}}$  for fluids with sp gr (specific gravity) = 0.86:

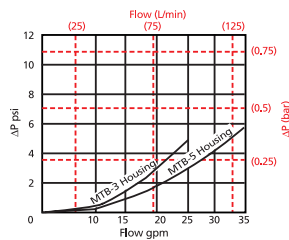

## Pressure Drop Information Based on Flow Rate and Viscosity

### $\Delta P_{\text{element}}$

3TBZ

Element Pressure Drop versus Flow Rate at 32 cSt (150 SUS)

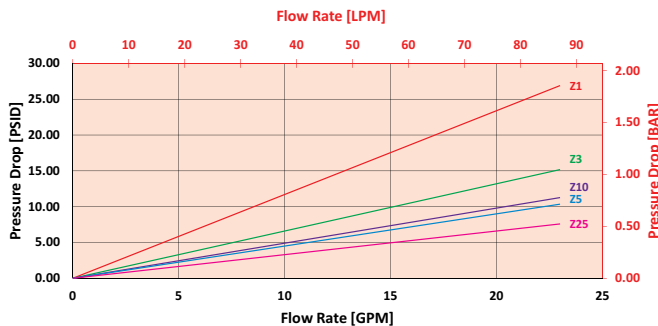

5TBZ

Element Pressure Drop versus Flow Rate at 32 cSt (150 SUS)

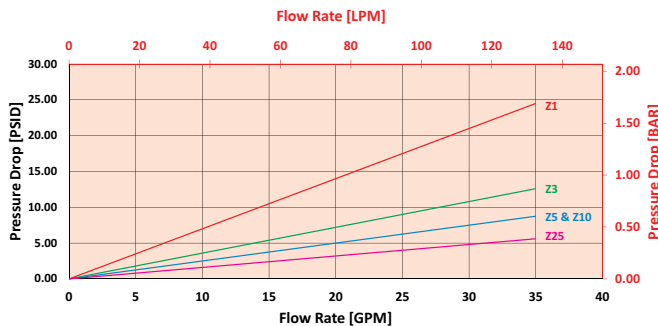

$$\Delta P_{\text{filter}} = \Delta P_{\text{housing}} + (\Delta P_{\text{element}} * \mathbf{V}_f)$$

### Exercise:

Determine  $\Delta P_{\text{filter}}$  at 10 gpm (37.9 L/min) for MTB3TBZ25P12Y5 using 160 SUS (34 cSt) fluid.

Use the housing pressure curve to determine  $\Delta P_{\text{housing}}$  at 10 gpm. In this case,  $\Delta P_{\text{housing}}$  is 1 psi (.07 bar) on the graph for the MTB housing.

Use the element pressure curve to determine  $\Delta P_{\text{element}}$  at 10 gpm. In this case,  $\Delta P_{\text{element}}$  is 3 psi (.21 bar) according to the graph for the 3TBZ25 element.

Because the viscosity in this sample is 160 SUS (34 cSt), we determine the **Viscosity Factor ( $\mathbf{V}_f$ )** by dividing the **Operating Fluid Viscosity** with the **Standard Viscosity** of 150 SUS (32 cSt). To best determine your Operating Fluid Viscosity, please reference the chart in Appendix D.

Finally, the overall filter pressure differential,  $\Delta P_{\text{filter}}$ , is calculated by adding  $\Delta P_{\text{housing}}$  with the true element pressure differential,  $(\Delta P_{\text{element}} * \mathbf{V}_f)$ . The  $\Delta P_{\text{element}}$  from the graph has to be multiplied by the viscosity factor to get the true pressure differential across the element.

### Solution:

$$\Delta P_{\text{housing}} = 1 \text{ psi } [.07 \text{ bar}] \mid \Delta P_{\text{element}} = 3 \text{ psi } [.21 \text{ bar}]$$

$$\mathbf{V}_f = 160 \text{ SUS (34 cSt)} / 150 \text{ SUS (32 cSt)} = 1.1$$

$$\Delta P_{\text{filter}} = 1 \text{ psi} + (3 \text{ psi} * 1.1) = 4.3 \text{ psi}$$

OR

$$\Delta P_{\text{filter}} = .07 \text{ bar} + (.21 \text{ bar} * 1.1) = .30 \text{ bar}$$

Note:

If your element is not graphed, use the following equation:

$\Delta P_{\text{element}} = \text{Flow Rate} \times \Delta P_f$  Plug this variable into the overall pressure drop equation.

Ele.	$\Delta P$	Ele.	$\Delta P$
3TB10	1.40	5TB10	0.40
3TB25	0.10	5TB25	0.08

## Filter Model Number Selection

### How to Build a Valid Model Number for a Schroeder MTB:

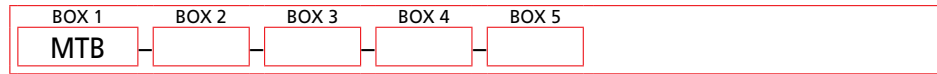

Example: NOTE: One option per box

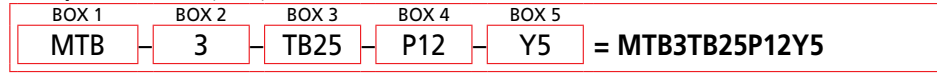

BOX 1	BOX 2	BOX 3
<b>Filter Series</b>	<b>Element Length (in)</b>	<b>Element Size and Media</b>
MTB	3	TB10 = T size 10 μ E media (cellulose)
	5	TB25 = T size 25 μ E media (cellulose)
		TBZ3 = T size 3 μ Excellement® Z-Media® (synthetic)
		TBZ5 = T size 5 μ Excellement® Z-Media® (synthetic)
		TBZ10 = T size 10 μ Excellement® Z-Media® (synthetic)
		TBZ25 = T size 25 μ Excellement® Z-Media® (synthetic)

BOX 4	BOX 5
<b>Porting Options</b>	<b>Dirt Alarm® Options</b>
P12 = ¾" NPTF	Omit = None
P16 = 1" NPTF	Visual Y2C = Bottom-mounted gauge in cap Y5 = Back-mounted gauge in cap
S12 = SAE-12	
S16 = SAE-16	Electrical ESC = Electric pressure switch (2 terminals)
B12 = ISO 228 G-¾"	
B16 = ISO 228 G-1"	

# Tank-Mounted Filter

# ZT



Model No. of filter in photograph is ZT8ZZ10PPESAB.

## Features and Benefits

- Low pressure tank-mounted filter
- Available with dual inlet porting
- Offered in pipe, SAE straight thread and ISO 228 porting
- Various Dirt Alarm® options
- Optional PAB1 breather
- Optional dipstick
- Available with quality-protected GeoSeal® Elements (GZT)
- Same day shipment model available

 Part of the Schroeder Industries 2030 Initiative

**40 gpm**  
**150 L/min**  
**100 psi**  
**7 bar**

IRF

TF1

KF3

KL3

LF1

MLF1

RLD

GRTB

MTA

MTB

**ZT**

KFT

RT

RTI

LRT

ART

BRT

TRT

BFT

QT

KTK

LTK

MRT

Accessories  
For Tank-  
Mounted  
Filters

PAF1

MAF1

MF2

Flow Rating:	Up to 40 gpm (150 L/min) for 150 SUS (32 cSt) fluids
Max. Operating Pressure:	100 psi (7 bar)
Min. Yield Pressure:	300 psi (21 bar), per NFPA T2.6.1
Rated Fatigue Pressure:	90 psi (6 bar), per NFPA T2.6.1-R1-2005
Temp. Range:	-20°F to 225°F (-29°C to 107°C)
Bypass Setting:	Cracking: 25 psi (1.7 bar) Full Flow: 39 psi (2.7 bar)
Cap & Bowl:	Nylon
Porting Head:	Aluminum
Weight of ZT-8Z:	3.3 lbs. (1.49 kg)
Element Change Clearance:	10.0" (254 mm)

## Filter Housing Specifications

Type Fluid	Appropriate Schroeder Media
Petroleum Based Fluids	All E media (cellulose) and Z-Media® (synthetic)
High Water Content	All Z-Media (synthetic)
Invert Emulsions	10 and 25 μ Z-Media® (synthetic)
Water Glycols	3, 5, 10 and 25 μ Z-Media® (synthetic)
Phosphate Esters	All Z-Media® (synthetic) with H (EPR) seal designation

## Fluid Compatibility

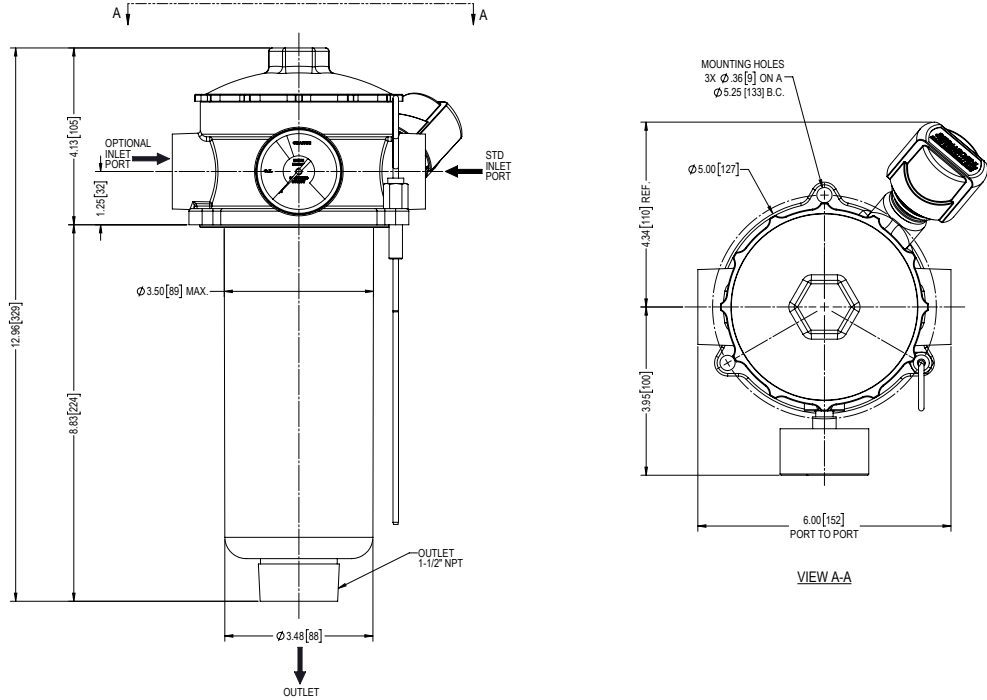

Metric dimensions in ( ).

## Element Performance Information & Dirt Holding Capacity

Element	Filtration Ratio Per ISO 4572/NFPA T3.10.8.8 Using automated particle counter (APC) calibrated per ISO 4402			Filtration Ratio wrt ISO 16889 Using APC calibrated per ISO 11171	
	$\beta_x \geq 75$	$\beta_x \geq 100$	$\beta_x \geq 200$	$\beta_x(c) \geq 200$	$\beta_x(c) \geq 1000$
8Z3	6.8	7.5	10.0	N/A	N/A
8Z10	15.5	16.2	18.0	N/A	N/A
8ZZ1	<1.0	<1.0	<1.0	<4.0	4.2
8ZZ3	<1.0	<1.0	<2.0	<4.0	4.8
8ZZ5	2.5	3.0	4.0	4.8	6.3
8ZZ10	7.4	8.2	10.0	8.0	10.0
8ZZ25	18.0	20.0	22.5	19.0	24.0

Element	DHC (gm)
8Z3	39
8Z10	32
8ZZ1	51
8ZZ3	52
8ZZ5	59
8ZZ10	55
8ZZ25	77

Element Collapse Rating: 150 psid (10 bar)  
 Flow Direction: Outside In  
 Element Nominal Dimensions: 3.2" (81 mm) O.D. x 9.25" (235 mm) long

$\Delta P_{\text{housing}}$

ZT  $\Delta P_{\text{housing}}$  for fluids with sp gr (specific gravity) = 0.86:

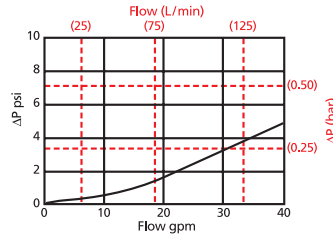

$\Delta P_{\text{element}}$

8ZZ

Element Pressure Drop versus Flow Rate at 32 cSt (150 SUS)

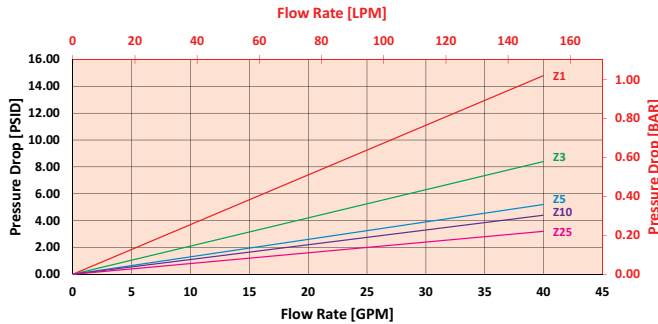

**Pressure Drop Information Based on Flow Rate and Viscosity**

$$\Delta P_{\text{filter}} = \Delta P_{\text{housing}} + (\Delta P_{\text{element}} * \mathbf{V}_f)$$

**Exercise:**

Determine  $\Delta P_{\text{filter}}$  at 30 gpm (119.7 L/min) for ZT8ZZ10SY2 using 160 SUS (34 cSt) fluid.

Use the housing pressure curve to determine  $\Delta P_{\text{housing}}$  at 30 gpm. In this case,  $\Delta P_{\text{housing}}$  is 3.5 psi (.24 bar) on the graph for the ZT housing.

Use the element pressure curve to determine  $\Delta P_{\text{element}}$  at 30 gpm. In this case,  $\Delta P_{\text{element}}$  is 3.5 psi (.24 bar) according to the graph for the 8ZZ10 element.

Because the viscosity in this sample is 160 SUS (34 cSt), we determine the **Viscosity Factor ( $\mathbf{V}_f$ )** by dividing the **Operating Fluid Viscosity** with the **Standard Viscosity** of 150 SUS (32 cSt). To best determine your Operating Fluid Viscosity, please reference the chart in Appendix D.

Finally, the overall filter pressure differential,  $\Delta P_{\text{filter}}$ , is calculated by adding  $\Delta P_{\text{housing}}$  with the true element pressure differential, ( $\Delta P_{\text{element}} * \mathbf{V}_f$ ). The  $\Delta P_{\text{element}}$  from the graph has to be multiplied by the viscosity factor to get the true pressure differential across the element.

**Solution:**

$\Delta P_{\text{housing}} = 3.5 \text{ psi } [.24 \text{ bar}] \mid \Delta P_{\text{element}} = 3.5 \text{ psi } [.24 \text{ bar}]$

$\mathbf{V}_f = 160 \text{ SUS (34 cSt)} / 150 \text{ SUS (32 cSt)} = 1.1$

$\Delta P_{\text{filter}} = 3.5 \text{ psi} + (3.5 \text{ psi} * 1.1) = 7.4 \text{ psi}$

**OR**

$\Delta P_{\text{filter}} = .24 \text{ bar} + (.24 \text{ bar} * 1.1) = .50 \text{ bar}$

Note:  
If your element is not graphed, use the following equation:  
 $\Delta P_{\text{element}} = \text{Flow Rate} \times \Delta P_f$ . Plug this variable into the overall pressure drop equation.

Ele.	$\Delta P$
8Z3	0.25
8Z10	0.09
8Z25	0.02

## Filter Model Number Selection

Highlighted product eligible for **QuickDelivery**

### How to Build a Valid Model Number for a Schroeder ZT:

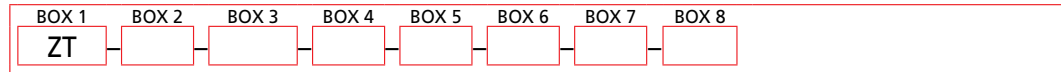

Example: NOTE: One option per box

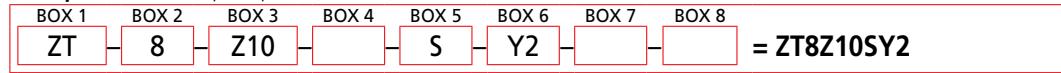

BOX 1	BOX 2	BOX 3	BOX 4
<b>Filter Series</b>	<b>Element Length (in)</b>	<b>Element Size and Media</b>	<b>Seal Material</b>
ZT	8	<p>Z3 = Z size 3 μ E media (cellulose)</p> <p>Z10 = Z size 10 μ E media (cellulose)</p> <p>Z25 = Z size 25 μ E media (cellulose)</p> <p>ZZ1 = Z size 1 μ Excellement® Z-Media® (synthetic)</p> <p>ZZ3 = Z size 3 μ Excellement® Z-Media® (synthetic)</p> <p>ZZ5 = Z size 5 μ Excellement® Z-Media® (synthetic)</p> <p>ZZ10 = Z size 10 μ Excellement® Z-Media® (synthetic)</p> <p>ZZ25 = Z size 25 μ Excellement® Z-Media® (synthetic)</p> <p><b>GeoSeal® Element Options</b></p> <p>GZ3 = Z size 3 μ E media (cellulose)</p> <p>GZ10 = Z size 10 μ E media (cellulose)</p> <p>GZ25 = Z size 25 μ E media (cellulose)</p> <p>GTZ1 = Z size 1 μ Excellement® Z-Media® (synthetic)</p> <p>GTZ3 = Z size 3 μ Excellement® Z-Media® (synthetic)</p> <p>GTZ5 = Z size 5 μ Excellement® Z-Media® (synthetic)</p> <p>GTZ10 = Z size 10 μ Excellement® Z-Media® (synthetic)</p> <p>GTZ25 = Z size 25 μ Excellement® Z-Media® (synthetic)</p>	Omit = Buna N
GZT (GeoSeal®)			H = EPR

BOX 5
<b>Inlet Porting</b>
P = 1" NPTF
PP = Dual 1" NPTF
S = SAE-16
SS = Dual SAE-16
B = ISO 228 G-1"
BB = Dual ISO 228 G-1"

BOX 6	
<b>Dirt Alarm® Options</b>	
	Omit = None
Visual	Y2 = Back-mounted tri-color gauge
	Y2C = Bottom-mounted gauge in cap
	Y5 = Back-mounted gauge in cap
Electrical	ES = Electric switch
	ES1 = Heavy-duty electric switch with conduit connection

BOX 7
<b>Outlet Porting Options</b>
Omit = 1½" NPT male
D = Diffuser
T = 13" Tube extension

BOX 8
<b>Options</b>
Omit = None
G3039 = 1.5" NPT Outlet Removed
A = Dipstick
B = Breather
AB = Dipstick & Breather
D = Diffuser
M = Mounting Gasket (Buna N)



# Tank-Mounted Filter

# KFT



## Features and Benefits

- Low pressure tank-mounted filter
- Meets HF4 automotive standard
- Multiple inlet/outlet porting options
- Top, side or bottom mounting
- Optional check valve prevents reservoir siphoning
- Can also be used in return line application (contact factory)
- Double stacking of K-size element can be replaced by single KK element
- Allows consolidation of inventoried replacement elements by using K-size elements
- Also available with DirtCatcher® elements (KD and KKD)

**100 gpm**  
**380 L/min**  
**100 psi**  
**7 bar**

Model No. of filter in photograph is KFT1K10P24P24NB

IRF  
TF1  
KF3  
KL3  
LF1  
MLF1  
RLD  
GRTB  
MTA  
MTB  
ZT  
**KFT**

Flow Rating:	Up to 100 gpm (380 L/min) for 150 SUS (32 cSt) fluids
Max. Operating Pressure:	100 psi (7 bar)
Min. Yield Pressure:	400 psi (28 bar), per NFPA T2.6.1
Rated Fatigue Pressure:	Contact Factory
Temp. Range:	-20°F to 225°F (-29°C to 107°C)
Bypass Setting:	Cracking: 25 psi (1.7 bar) Full Flow: 48 psi (3.3 bar)
Porting Head:	Steel
Porting Cap:	Die Cast Aluminum (standard); Steel (optional)
Element Case:	Steel
Weight of KFT-1K:	10.0 lbs. (4.5 kg)
Weight of KFT-2K:	13.6 lbs. (6.2 kg)
Element Change Clearance:	8.0" (205 mm) for 1K; 17.50" (445 mm) for KK; 26.5" (673 mm) for 27K

## Filter Housing Specifications

RT  
RTI  
LRT  
ART  
BRT  
TRT  
BFT  
QT  
KTK  
LTK

Type Fluid	Appropriate Schroeder Media
Petroleum Based Fluids	All E media (cellulose), Z-Media® and ASP® media (synthetic)
High Water Content	All Z-Media and ASP® media (synthetic)
Invert Emulsions	10 and 25 µ Z-Media® (synthetic), 10 µ ASP® media (synthetic)
Water Glycols	3, 5, 10 and 25 µ Z-Media® (synthetic), 3, 5 and 10 µ ASP® media (synthetic)
Phosphate Esters	All Z-Media® (synthetic) with H (EPR) seal designation, ASP® media (synthetic) and 3 and 10 µ E media (cellulose) with H (EPR) seal designation
Skydrol®	3, 5, 10 and 25 µ Z-Media® (synthetic) with H.5 seal designation, ASP® media (synthetic) (EPR seals and stainless steel wire mesh in element, and light oil coating on housing exterior)

## Fluid Compatibility

Accessories For Tank-Mounted Filters

MRT  
PAF1  
MAF1  
MF2

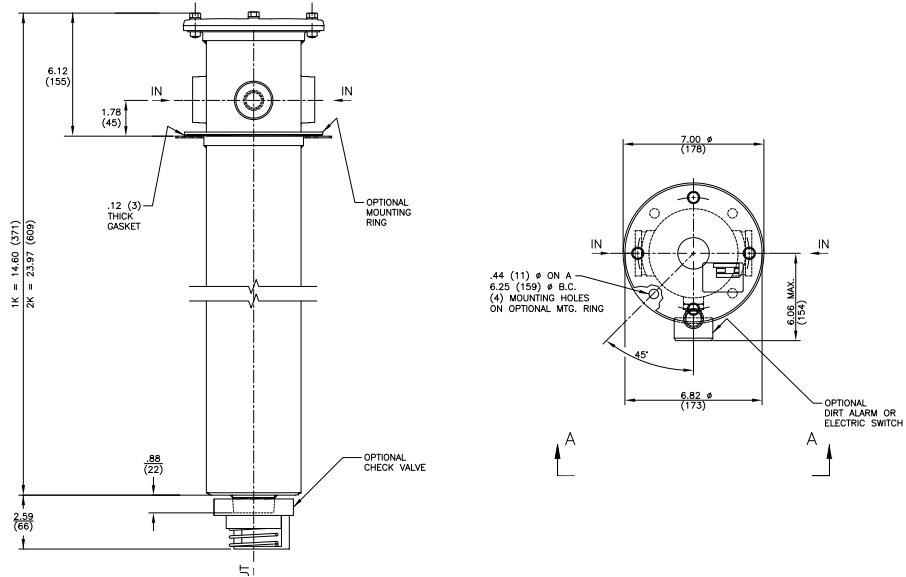

Metric dimensions in ( ).

## Element Performance Information & Dirt Holding Capacity

Element	Filtration Ratio Per ISO 4572/NFPA T3.10.8.8 Using automated particle counter (APC) calibrated per ISO 4402			Filtration Ratio per ISO 16889 Using APC calibrated per ISO 11171	
	$\beta_x \geq 75$	$\beta_x \geq 100$	$\beta_x \geq 200$	$\beta_x(c) \geq 200$	$\beta_x(c) \geq 1000$
KZ1/KKZ1	<1.0	<1.0	<1.0	<4.0	4.2
KZ3/KKZ3/KAS3/KKAS3	<1.0	<1.0	<2.0	<4.0	4.8
KZ5/KKZ5/KAS5/KKAS5	2.5	3.0	4.0	4.8	6.3
KZ10/KKZ10/KAS10/KKAS10	7.4	8.2	10.0	8.0	10.0
KZ25/KKZ25	18.0	20.0	22.5	19.0	24.0

Element	DHC (gm)	Element	DHC (gm)	Element	DHC (gm)	Element	DHC (gm)
KZ1	112	KKZ1	224	KDZ1	89	KKDZ1	188
KZ3/KAS3	115	KKZ3/KKAS3	230	KDZ3	71	KKDZ3	150
KZ5/KAS5	119	KKZ5/KKAS5	238	KDZ5	100	KKDZ5	210
KZ10/KAS10	108	KKZ10/KKAS10	216	KDZ10	80	KKDZ10	168
KZ25	93	KKZ25	186	KDZ25	81	KKDZ25	171

Element Collapse Rating: 150 psid (10 bar) for standard elements

Flow Direction: Outside In

Element Nominal Dimensions: K: 3.9" (99 mm) O.D. x 9.0" (230 mm) long  
 KK: 3.9" (99 mm) O.D. x 18.0" (460 mm) long

### $\Delta P_{\text{housing}}$

KFT  $\Delta P_{\text{housing}}$  for fluids with sp gr (specific gravity) = 0.86:

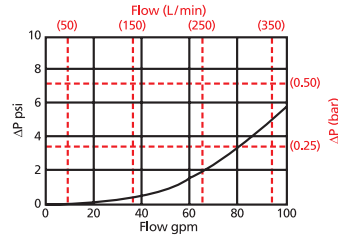

### $\Delta P_{\text{element}}$

KZ

Element Pressure Drop versus Flow Rate at 32 cSt (150 SUS)

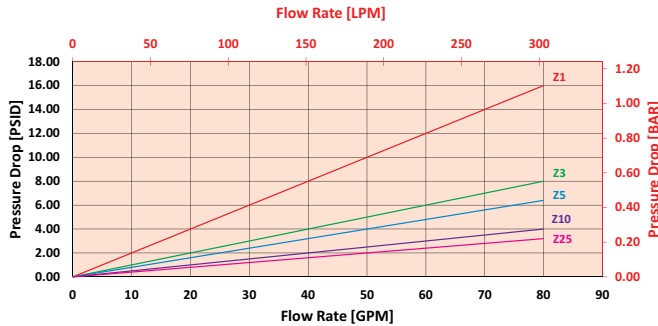

KKZ/2KZ

Element Pressure Drop versus Flow Rate at 32 cSt (150 SUS)

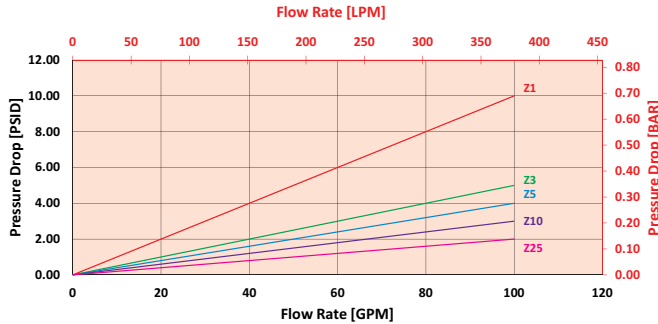

$$\Delta P_{\text{filter}} = \Delta P_{\text{housing}} + (\Delta P_{\text{element}} * \mathbf{V}_f)$$

### Exercise:

Determine  $\Delta P_{\text{filter}}$  at 80 gpm (303.2 L/min) for KFT1KZ10S24S24NY2G820 using 160 SUS (34 cSt) fluid.

Use the housing pressure curve to determine  $\Delta P_{\text{housing}}$  at 80 gpm. In this case,  $\Delta P_{\text{housing}}$  is 3.5 psi (.24 bar) on the graph for the KFT housing.

Use the element pressure curve to determine  $\Delta P_{\text{element}}$  at 80 gpm. In this case,  $\Delta P_{\text{element}}$  is 4 psi (.27 bar) according to the graph for the KZ10 element.

Because the viscosity in this sample is 200 SUS (24 cSt), we determine the **Viscosity Factor ( $\mathbf{V}_f$ )** by dividing the **Operating Fluid Viscosity** with the **Standard Viscosity** of 150 SUS (32 cSt). To best determine your Operating Fluid Viscosity, please reference the chart in Appendix D.

Finally, the overall filter pressure differential,  $\Delta P_{\text{filter}}$ , is calculated by adding  $\Delta P_{\text{housing}}$  with the true element pressure differential,  $(\Delta P_{\text{element}} * \mathbf{V}_f)$ . The  $\Delta P_{\text{element}}$  from the graph has to be multiplied by the viscosity factor to get the true pressure differential across the element.

### Solution:

$$\Delta P_{\text{housing}} = 3.5 \text{ psi } [.24 \text{ bar}] \mid \Delta P_{\text{element}} = 4 \text{ psi } [.27 \text{ bar}]$$

$$\mathbf{V}_f = 160 \text{ SUS (34 cSt)} / 150 \text{ SUS (32 cSt)} = 1.1$$

$$\Delta P_{\text{filter}} = 3.5 \text{ psi} + (4 \text{ psi} * 1.1) = 7.9 \text{ psi}$$

OR

$$\Delta P_{\text{filter}} = .24 \text{ bar} + (.27 \text{ bar} * 1.1) = .54 \text{ bar}$$

## Pressure Drop Information Based on Flow Rate and Viscosity

Note:

If your element is not graphed, use the following equation:  
 $\Delta P_{\text{element}} = \text{Flow Rate} \times \Delta P_f$   
 Plug this variable into the overall pressure drop equation.

Ele.	$\Delta P$	Ele.	$\Delta P$	Ele.	$\Delta P$
K3	0.25	2K3/ KK3	0.12	3KZ1/ 27KZ1	0.05
K10	0.09	2K10/ KK10	0.05	3KZ3/ 27KZ3	0.03
K25	0.02	2K25/ KK25	0.01	3KZ5/ 27KZ5	0.02
KAS3	0.10	2KAS3/ KKAS3	0.05	3KZ10/ 27KZ10	0.02
KAS5	0.08	2KAS5/ KKAS5	0.04	3KZ25/ 27KZ25	0.01
KAS10	0.05	2KAS10/ KKAS10	0.03	3K3	0.08
KDZ1	0.24	2KDZ1	0.12	3K10	0.03
KDZ3	0.12	2KDZ3	0.06	3K25	0.01
KDZ5	0.10	2KDZ5	0.05	3KAS3/ 27KAS3	0.03
KDZ10	0.06	2KDZ10	0.03	3KAS5/ 27KAS5	0.02
KDZ25	0.04	2KDZ25	0.02	3KAS10/ 27KAS10	0.02

## Filter Model Number Selection

### How to Build a Valid Model Number for a Schroeder KFT:

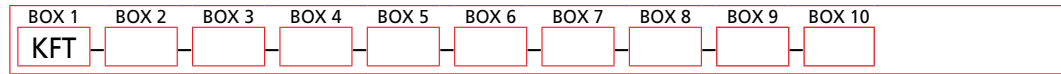

Example: NOTE: One option per box

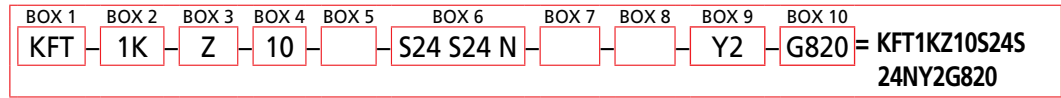

BOX 1	BOX 2	BOX 3	BOX 4
<b>Filter Series</b>	<b>Element Size and Length</b>	<b>Media Type</b>	<b>Element Part Number</b>
KFT	1 K, KK 2 K	Omit = E media (cellulose) Z = Excellement® Z-Media® (synthetic) AS = Anti-Static Pleat Media (synthetic) ZW = Aqua-Excellement™ ZW media DZ = DirtCatcher® with Excellement® Z-Media®	1 = 1 μ Z, ZW, and DZ media 3 = 3 μ AS, E, Z, ZW, and DZ media 5 = 5 μ AS, Z, ZW, and DZ media 10 = 10 μ AS, E, M, Z, ZW, and DZ media 25 = 25 μ E, M, Z, ZW, and DZ media

BOX 5	BOX 6 Specification of all 4 ports is required			
<b>Seal Material</b>	<b>Inlet Porting</b>			
Omit = Buna N H = EPR V = Viton® H.5 = Skydrol® Compatibility	<b>Port 1 (Standard)</b> N = None	<b>Port 2 (Optional)</b> N = None	<b>Port 3 (Optional)</b> N = None	<b>Port 4 (Optional)</b> N = None
	P12 = 3/4" NPTF P16 = 1" NPTF P20 = 1 1/4" NPTF P24 = 1 1/2" NPTF P32 = 2" NPTF S8 = SAE-8 S12 = SAE-12 S16 = SAE-16 S20 = SAE-20 S24 = SAE-24	P12 = 3/4" NPTF P16 = 1" NPTF P20 = 1 1/4" NPTF P24 = 1 1/2" NPTF P32 = 2" NPTF S8 = SAE-8 S12 = SAE-12 S16 = SAE-16 S20 = SAE-20 S24 = SAE-24	P8 = 1/2" NPTF P12 = 3/4" NPTF P16 = 1" NPTF P20 = 1 1/4" NPTF P24 = 1 1/2" NPTF P32 = 2" NPTF S8 = SAE-8 S12 = SAE-12 S16 = SAE-16 S20 = SAE-20 S24 = SAE-24	P2 = 1/8" NPTF P8 = 1/2" NPTF P12 = 3/4" NPTF P16 = 1" NPTF P20 = 1 1/4" NPTF P24 = 1 1/2" NPTF P32 = 2" NPTF S8 = SAE-8 S12 = SAE-12 S16 = SAE-16 S20 = SAE-20 S24 = SAE-24

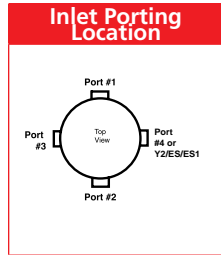

BOX 7	BOX 8	BOX 9
<b>Outlet Porting Options</b>	<b>Optional Mounting Flange</b>	<b>Dirt Alarm® Options</b>
Omit = 1 1/2" NPT male C = Check valve D = Diffuser CD = Check valve & diffuser T = 13" Tube extension A = Non-threaded outlet	Omit = None B = Flange with 4 holes BW = Flange with no holes	Omit = None Y2 = Back-mounted tri-color gauge (located in Port 4) Visual Y2C = Bottom-mounted tri-color gauge in cap Y5 = Back-mounted gauge in cap ES = Electric switch (located in port 4) Electrical ES1 = Heavy-duty electric switch with conduit connector (located in port 4)

BOX 10
<b>Additional Options</b>
Omit = None G2293 = Cork gasket G820 = Steel cap

- NOTES:
- Box 2. Number of elements must equal 1 when using KK elements.
  - Box 3. Replacement element part numbers are identical to contents of Boxes 2, 3, 4 and 5. K specifies one 9" element; KK specifies one 18" element. Example: KKZ10
  - Box 5. H.5 seal designation includes the following: EPR seals, stainless steel wire mesh on elements, and light oil coating on housing exterior. Skydrol® is a registered trademark of Solutia Inc. Viton® is a registered trademark of DuPont Dow Elastomers.
  - Box 7. See also "Accessories for Tank-Mounted Filters," page 307.
  - Box 9. YC and Y5 are not available with the G820.

# Tank-Mounted Filter

**RT**



## Features and Benefits

- Low pressure tank-mounted filter with up to 3 inlet ports
- Meets HF4 automotive standard
- Top, side or bottom mounting
- Optional check valve prevents reservoir siphoning
- RTW model allows filter to be welded to tank, instead of being bolted
- Double and triple stacking of K-size element can be replaced by single KK or 27K-size element
- Also available with new DirtCatcher® elements (KDZ and KKDZ)
- Various Dirt Alarm® options
- Allows consolidation of inventoried replacement elements by using K-size elements
- Available with quality-protected GeoSeal® Elements (GRT)
- Same day shipment model available

**100 gpm**  
**380 L/min**  
**100 psi**  
**7 bar**

Model No. of filter in photograph is RT1K10S24NP16Y2.

Flow Rating:	Up to 100 gpm (380 L/min) for 150 SUS (32 cSt) fluids
Max. Operating Pressure:	100 psi (7 bar)
Min. Yield Pressure:	400 psi (28 bar), per NFPA T2.6.1
Rated Fatigue Pressure:	90 psi (6 bar), per NFPA T2.6.1-2005
Temp. Range:	-20°F to 225°F (-29°C to 107°C)
Bypass Setting:	Cracking: 25 psi (1.7 bar) Full Flow: 48 psi (3.3 bar)
Porting Head & Cap:	Die Cast Aluminum
Element Case:	Steel
Weight of RT-1K:	11.4 lbs. (5.2 kg)
Weight of RT-2K:	14.5 lbs. (6.6 kg)
Element Change Clearance:	8.0" (205 mm) for 1K; 17.50" (445 mm) for KK; 26.5" (673 mm) for 27K

## Filter Housing Specifications

Type Fluid	Appropriate Schroeder Media
Petroleum Based Fluids	All E media (cellulose), Z-Media® and ASP® media (synthetic)
High Water Content	All Z-Media® and all ASP® media (synthetic)
Invert Emulsions	10 and 25 µ Z-Media® and 10 µ ASP® media (synthetic)
Water Glycols	3, 5, 10 and 25 µ Z-Media® and all ASP® media (synthetic)
Phosphate Esters	All Z-Media® (synthetic) with H (EPR) seal designation and 3 and 10 µ E media (cellulose) with H (EPR) seal designation and all ASP® Media (synthetic)
Skydrol®	3, 5, 10 and 25 µ Z-Media® (synthetic) with H.5 seal designation (EPR seals and stainless steel wire mesh in element, and light oil coating on housing exterior) and all ASP® media (synthetic)

## Fluid Compatibility

### Accessories For Tank-Mounted Filters

- IRF
- TF1
- KF3
- KL3
- LF1
- MLF1
- RLD
- GRTB
- MTA
- MTB
- ZT
- KFT
- RT**
- RTI
- LRT
- ART
- BRT
- TRT
- BFT
- QT
- KTK
- LTK
- MRT
- PAF1
- MAF1
- MF2

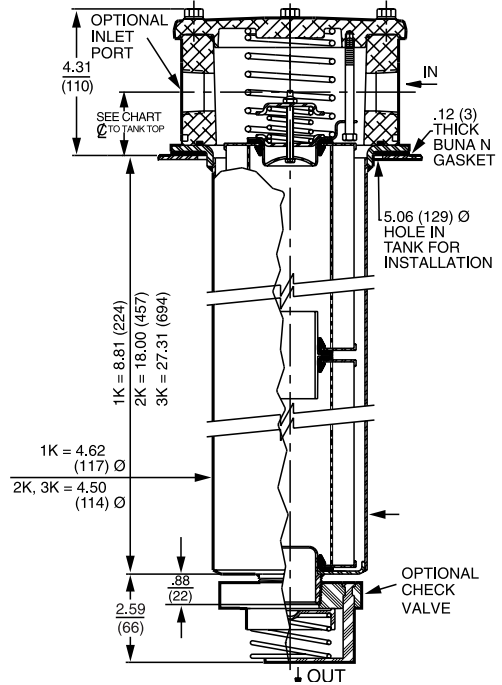
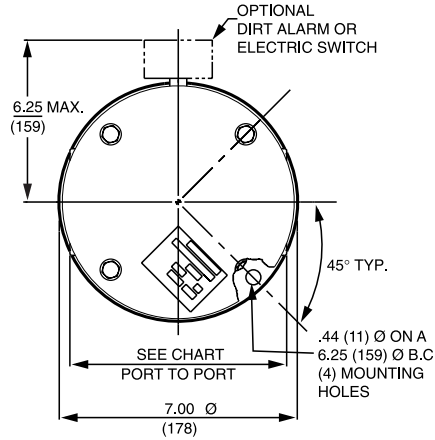

	1½" Ports 4-Bolt Flange Only	2" Ports	All Other Porting
Port to Port	7.12"	7.56" (P, S, B)	6.38"
CL to Casting Base	1.75"	1.81" (F)	1.56"
CL to Tank Top	2.06"	2.12"	1.88"

Optional mounting rings available for tank welding. See page 307, reference part numbers A-LFT-813 and A-LFT-1448.

Metric dimensions in ( ).

## Element Performance Information & Dirt Holding Capacity

Element	Filtration Ratio Per ISO 4572/NFPA T3.10.8.8 Using automated particle counter (APC) calibrated per ISO 4402			Filtration Ratio per ISO 16889 Using APC calibrated per ISO 11171	
	$\beta_x \geq 75$	$\beta_x \geq 100$	$\beta_x \geq 200$	$\beta_x(c) \geq 200$	$\beta_x(c) \geq 1000$
KZ1/KKZ1/27KZ1	<1.0	<1.0	<1.0	<4.0	4.2
KZ3/KKZ3/27KZ3	<1.0	<1.0	<2.0	<4.0	4.8
KZ5/KKZ5/27KZ5	2.5	3.0	4.0	4.8	6.3
KZ10/KKZ10/27KZ10	7.4	8.2	10.0	8.0	10.0
KZ25/KKZ25/27KZ25	18.0	20.0	22.5	19.0	24.0
KZW1	N/A	N/A	N/A	<4.0	<4.0
KZW3/KKZW3	N/A	N/A	N/A	4.0	4.8
KZW5/KKZW5	N/A	N/A	N/A	5.1	6.4
KZW10/KKZW10	N/A	N/A	N/A	6.9	8.6
KZW25/KKZW25	N/A	N/A	N/A	15.4	18.5

Element	DHC (gm)	Element	DHC (gm)	Element	DHC (gm)	Element	DHC (gm)	Element	DHC (gm)	Element	DHC (gm)
KZ1	112	KKZ1	224	27KZ1	336	KDZ1	89	KKDZ1	188	KZW1	61
KZ3	115	KKZ3	230	27KZ3	345	KDZ3	71	KKDZ3	150	KZW3	64
KZ5	119	KKZ5	238	27KZ5	357	KDZ5	100	KKDZ5	210	KKZW3	128
KZ10	108	KKZ10	216	27KZ10	324	KDZ10	80	KKDZ10	168	KZW5	63
KKZW5	126	KKZ25	186	27KZ25	279	KDZ25	81	KKDZ25	171	KKZW10	114
KKZW10	114									KKZW25	158
KKZW25	158										

Element Collapse Rating: 150 psid (10 bar) for standard elements

Flow Direction: Outside In [See RTI, page 275 for inside out flow version.](#)

Element Nominal Dimensions: K: 3.9" (99 mm) O.D. x 9.0" (230 mm) long  
 KK: 3.9" (99 mm) O.D. x 18.0" (460 mm) long  
 27K: 3.9" (99 mm) O.D. x 27.0" (690 mm) long

$\Delta P_{\text{housing}}$

RT  $\Delta P_{\text{housing}}$  for fluids with sp gr (specific gravity) = 0.86:

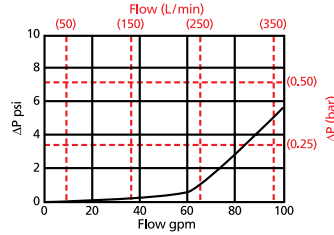

$\Delta P_{\text{element}}$

KZ

Element Pressure Drop versus Flow Rate at 32 cSt (150 SUS)

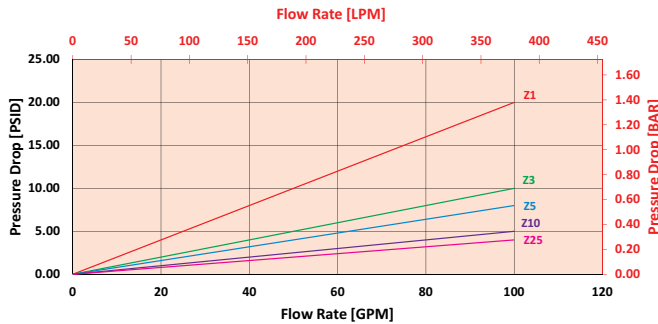

2KZ/KKZ

Element Pressure Drop versus Flow Rate at 32 cSt (150 SUS)

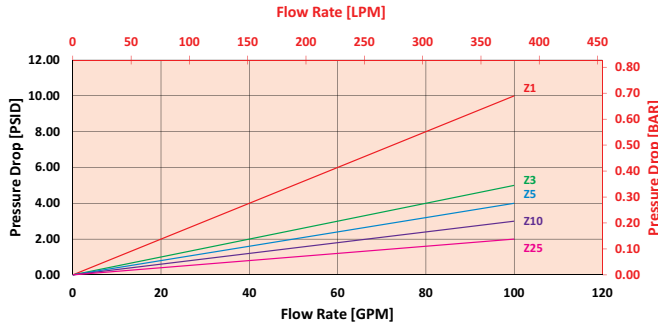

$$\Delta P_{\text{filter}} = \Delta P_{\text{housing}} + (\Delta P_{\text{element}} * \mathbf{V}_f)$$

**Exercise:**

Determine  $\Delta P_{\text{filter}}$  at 80 gpm (303.2 L/min) for RT1KZ10S24S24NY2 using 160 SUS (34 cSt) fluid.

Use the housing pressure curve to determine  $\Delta P_{\text{housing}}$  at 80 gpm. In this case,  $\Delta P_{\text{housing}}$  is 3 psi (.21 bar) on the graph for the RT housing.

Use the element pressure curve to determine  $\Delta P_{\text{element}}$  at 80 gpm. In this case,  $\Delta P_{\text{element}}$  is 4 psi (.27 bar) according to the graph for the KZ10 element.

Because the viscosity in this sample is 160 SUS (34 cSt), we determine the **Viscosity Factor ( $\mathbf{V}_f$ )** by dividing the **Operating Fluid Viscosity** with the **Standard Viscosity** of 150 SUS (32 cSt). To best determine your Operating Fluid Viscosity, please reference the chart in Appendix D.

Finally, the overall filter pressure differential,  $\Delta P_{\text{filter}}$ , is calculated by adding  $\Delta P_{\text{housing}}$  with the true element pressure differential,  $(\Delta P_{\text{element}} * \mathbf{V}_f)$ . The  $\Delta P_{\text{element}}$  from the graph has to be multiplied by the viscosity factor to get the true pressure differential across the element.

**Solution:**

$\Delta P_{\text{housing}} = 3 \text{ psi } [.21 \text{ bar}] \mid \Delta P_{\text{element}} = 4 \text{ psi } [.27 \text{ bar}]$

$\mathbf{V}_f = 160 \text{ SUS (34 cSt) } / 150 \text{ SUS (32 cSt)} = 1.1$

$\Delta P_{\text{filter}} = 3 \text{ psi } + (4 \text{ psi } * 1.1) = 7.4 \text{ psi}$

**OR**

$\Delta P_{\text{filter}} = .21 \text{ bar } + (.27 \text{ bar } * 1.1) = .51 \text{ bar}$

## Pressure Drop Information Based on Flow Rate and Viscosity

Note:  
If your element is not graphed, use the following equation:  
 $\Delta P_{\text{element}} = \text{Flow Rate} \times \Delta P_f$ . Plug this variable into the overall pressure drop equation.

Ele.	$\Delta P$	Ele.	$\Delta P$	Ele.	$\Delta P$
K3	0.25	2K3/ KK3	0.12	3KZ1/ 27KZ1	0.05
K10	0.09	2K10/ KK10	0.05	3KZ3/ 27KZ3	0.03
K25	0.02	2K25/ KK25	0.01	3KZ5/ 27KZ5	0.02
KAS3	0.10	2KAS3/ KKAS3	0.05	3KZ10/ 27KZ10	0.02
KAS5	0.08	2KAS5/ KKAS5	0.04	3KZ25/ 27KZ25	0.01
KAS10	0.05	2KAS10/ KKAS10	0.03	3K3	0.08
KDZ1	0.24	2KDZ1	0.12	3K10	0.03
KDZ3	0.12	2KDZ3	0.06	3K25	0.01
KDZ5	0.10	2KDZ5	0.05	3KAS3/ 27KAS3	0.03
KDZ10	0.06	2KDZ10	0.03	3KAS5/ 27KAS5	0.02
KDZ25	0.04	2KDZ25	0.02	3KAS10/ 27KAS10	0.02
KZW1	0.43	2KZW1	-		
KZW3	0.32	2KZW3/ KKZW3	0.16		
KZW5	0.28	2KZW5/ KKZW5	0.14		
KZW10	0.23	2KZW10/ KKZW10	0.12		
KZW25	0.14	2KZW25/ KKZW25	0.07		

## Filter Model Number Selection

Highlighted product eligible for **QuickDelivery**

### How to Build a Valid Model Number for a Schroeder RT:

BOX 1	BOX 2	BOX 3	BOX 4	BOX 5	BOX 5	BOX 6A	BOX 6B	BOX 7	BOX 8
RT									

**Example:** NOTE: Only box 9 may contain more than one option

BOX 1	BOX 2	BOX 3	BOX 4	BOX 5	BOX 6	BOX 7A	BOX 7B	BOX 8	BOX 9
RT	1K	Z	10		S24 S24 N			Y2	

= RT1KZ10S24S24Y2

BOX 1	BOX 2	BOX 3	BOX 4
<b>Filter Series</b>	<b>Element Size &amp; Length</b>	<b>Media Type</b>	<b>Element Part Number</b>
RT	1K KK, 27K	Omit = E media (cellulose)	1 = 1 μ Z, ZW, and DZ media
RTW	2K	Z = Excellement® Z-Media® (synthetic)	3 = 3 μ AS, E, Z, ZW, and DZ media
GRT	3K	AS = Anti-Static Pleat Media (synthetic)	5 = 5 μ AS, Z, ZW, and DZ media
	<b>GeoSeal®</b>	ZW = Aqua-Excellement™ ZW media	10 = 10 μ AS, E, M, Z, ZW, and DZ media
	1KBG KKBG, 27KBG	DZ = Dirtcatcher® with Excellement® Z-Media®	25 = 25 μ E, M, Z, ZW, and DZ media
	2KBG	W = W media (water removal)	60 = 60 μ M media
	3KBG	M = M media (reusable metal mesh)	

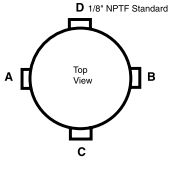
BOX 5	BOX 6
<b>Seal Material</b>	<b>Specification of all 3 ports is required</b>
Omit = Buna N	<b>Inlet Porting</b>
H = EPR	<b>Port A</b>
W = Anodized Aluminum Parts	P16 = 1" NPTF
H.5 = Skydrol® compatibility	P20 = 1¼" NPTF
	P24 = 1½" NPTF
	P32 = 2" NPTF
	S16 = SAE-16
	S20 = SAE-20
	S24 = SAE-24
	S32 = SAE-32
	F20 = 1¼" SAE 4-bolt flange Code 61
	F24 = 1½" SAE 4-bolt flange Code 61
	F32 = 2" SAE 4-bolt flange Code 61
	B24 = ISO 228 G-1½"
	<b>Flange port option only:</b>
	M = Metric SAE 4 bolt flange
	<b>Port B</b>
	N = None
	P16 = 1" NPTF
	P20 = 1¼" NPTF
	P24 = 1½" NPTF
	P32 = 2" NPTF
	S16 = SAE-16
	S20 = SAE-20
	S24 = SAE-24
	S32 = SAE-32
	F20 = 1¼" SAE 4-bolt flange Code 61
	F24 = 1½" SAE 4-bolt flange Code 61
	F32 = 2" SAE 4-bolt flange Code 61
	B24 = ISO 228 G-1½"
	<b>Port C</b>
	N = None
	P2 = ½" NPTF
	P16 = 1" NPTF
	S16 = SAE-16
	<b>Inlet Porting Location</b>
	

BOX 7A	BOX 7B
<b>Bypass Option</b>	<b>Outlet Porting Options</b>
Omit = 25 psi bypass setting	Omit = 1½" NPT male
<b>RT and RTW models only:</b>	C = Check valve
40 = 40 psi bypass setting	D = Diffuser
	T = 13" Tube ext.
	A = Non-thread outlet

BOX 8	BOX 9
<b>Dirt Alarm® Options</b>	<b>Add. Options</b>
	Omit = None
Located @ Port D	G2293 = Cork gasket
Visual	G547 = Two ½" gauge ports
Electrical	G820 = Stamped cap
ES = Electric switch	
ES3 = Electric switch with DIN connector	
ES4 = Skydrol Compatible Electric Switch	
Located in cap	
Visual	
Y2C = Bottom-mounted tri-color gauge	
Y5 = Back-mounted gauge in cap	
Located @ Port C	
Visual	
Y2R = Back-mounted gauge mounted on opposite side of standard location	
Electrical	
ESR = Electric switch mounted on opposite side of standard location	
ES1R = Heavy-duty electric switch mounted on opposite side of standard location	

#### NOTES:

- Box 1. RTW allows filter to be welded to tank instead of bolted.
- Box 2. Number of elements must equal 1 when using KK or 27K elements.
- Box 3. Replacement element part numbers are identical to contents of Boxes 2, 3, 4, and 5. Double and triple stacking of K-size elements can be replaced by single KK and 27K elements, respectively. ZW media not available in 27K length.
- Box 5. For options H, W, and H.5 all aluminum parts are anodized. H.5 seal designation includes the following: EPR seals, stainless steel wire mesh on elements, and light oil coating on housing exterior. Skydrol® is a registered trademark of Solutia Inc.
- Box 6. If using Port B, Port A & B must always be the same type and size. Example: (A) P20 (B) P20 (C) P16
- Box 7B. See also "Accessories for Tank-Mounted Filters," page 307.



# Tank-Mounted Filter (Inside Out Flow)

**RTI**

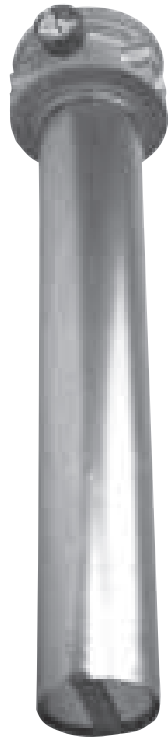

## Features and Benefits

- Tank-mounted "Inside Out" flow filter
- Up to 3 inlet ports available
- Offered in pipe, SAE straight thread and flanged porting
- Various Dirt Alarm® options

**120 gpm**  
**455 L/min**  
**100 psi**  
**7 bar**

IRF  
TF1  
KF3  
KL3  
LF1  
MLF1  
RLD  
GRTB  
MTA  
MTB  
ZT  
KFT  
RT

Model No. of filter in photograph is RTI3KZ10S24NP16Y2.

Flow Rating:	Up to 120 gpm (455 L/min) for 150 SUS (32 cSt) fluids
Max. Operating Pressure:	100 psi (7 bar)
Min. Yield Pressure:	400 psi (28 bar), per NFPA T2.6.1
Rated Fatigue Pressure:	Contact factory
Temp. Range:	-20°F to 225°F (-29°C to 107°C)
Bypass Setting:	Cracking: 25 psi (2 bar) Full Flow: 62 psi (4.3 bar)
Porting Head & Cap:	Die Cast Aluminum
Element Case:	Steel
Weight of RTI-KI:	11.4 lbs. (5.2 kg)
Weight of RTI-KKI:	14.5 lbs. (6.6 kg)
Element Change Clearance:	KI Element = 9.0 (229 mm) KKI Element = 18.0 (457 mm) 27KI Element = 27.0 (686 mm)

## Filter Housing Specifications

**RTI**  
LRT  
ART  
BRT  
TRT  
BFT  
QT  
KTK  
LTK

Type Fluid	Appropriate Schroeder Media
Petroleum Based Fluids	All E media (cellulose), Z-Media® and ASP® media (synthetic)
High Water Content	All Z-Media® and ASP® media (synthetic)
Invert Emulsions	10 and 25 µ Z-Media® and 10 µ ASP® media (synthetic)
Water Glycols	3, 5, 10 and 25 µ Z-Media® and all ASP® media (synthetic)
Phosphate Esters	All Z-Media® (synthetic) with H (EPR) seal designation and all ASP® media (synthetic)
Skydrol®	3, 5, 10 and 25 µ Z-Media® (synthetic) with H.5 seal designation (EPR seals and stainless steel wire mesh in element, and light oil coating on housing exterior) and all ASP® media (synthetic)

## Fluid Compatibility

Accessories  
For Tank-Mounted  
Filters

MRT  
PAF1  
MAF1  
MF2

# Tank-Mounted Filter (Inside Out Flow)

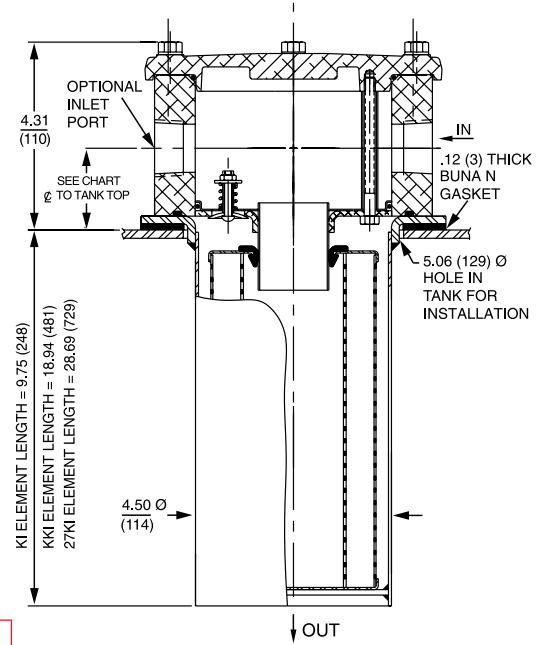
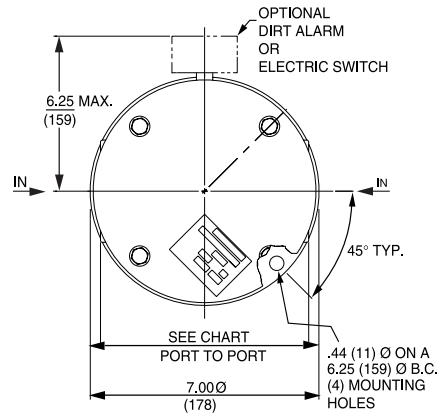

	1/4", 1/2" Standard Ports	1/2" Ports 4-Bolt Flange Only
Port to Port	6.38"	7.12"
☉ to Casting Base	1.56"	1.75"
☉ to Tank Top	1.88"	2.06"

Optional mounting rings available for tank welding. See page 307, reference part numbers A-LFT-813 and A-LFT-1448.

Metric dimensions in ( ).

## Element Performance Information & Dirt Holding Capacity

Element	Filtration Ratio Per ISO 4572/NFPA T3.10.8.8 Using automated particle counter (APC) calibrated per ISO 4402			Filtration Ratio per ISO 16889 Using APC calibrated per ISO 11171	
	$\beta_x \geq 75$	$\beta_x \geq 100$	$\beta_x \geq 200$	$\beta_x(\alpha) \geq 200$	$\beta_x(\alpha) \geq 1000$
KIZ1	<1.0	<1.0	<1.0	<4.0	4.2
KIZ3	<1.0	<1.0	<2.0	<4.0	4.8
KIZ10	<7.4	<8.2	<10.0	8.0	10.0

Element	DHC (gm)	Element	DHC (gm)	Element	DHC (gm)
KIZ1	85	KKIZ1	181	27KIZ1	276
KIZ3	88	KKIZ3	185	27KIZ3	283
KIZ10	<82	KKIZ10	174	27KIZ10	266

Element Collapse Rating: 100 psid (7 bar)

Flow Direction: Inside Out

Element Nominal Dimensions: KI: 3.9" (99 mm) O.D. x 9.0" (230 mm) long  
 KK: 3.9" (99 mm) O.D. x 18.0" (460 mm) long  
 27KI: 3.9" (99 mm) O.D. x 27.0" (690 mm) long

# Tank-Mounted Filter (Inside Out Flow)



$\Delta P_{\text{housing}}$

RTI  $\Delta P_{\text{housing}}$  for fluids with sp gr (specific gravity) = 0.86:

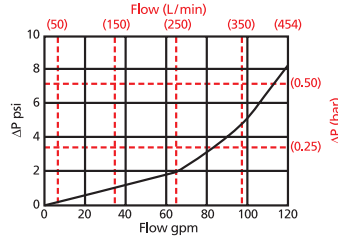

**Pressure Drop Information Based on Flow Rate and Viscosity**

$\Delta P_{\text{element}}$

KIZ

Element Pressure Drop versus Flow Rate at 32 cSt (150 SUS)

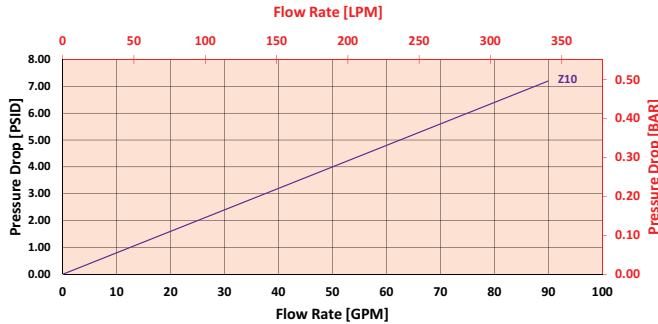

KKIZ

Element Pressure Drop versus Flow Rate at 32 cSt (150 SUS)

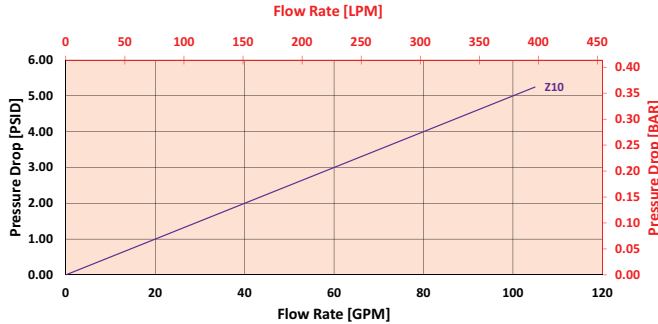

$$\Delta P_{\text{filter}} = \Delta P_{\text{housing}} + (\Delta P_{\text{element}} * \mathbf{V}_f)$$

**Exercise:**

Determine  $\Delta P_{\text{filter}}$  at 80 gpm (303.2 L/min) for RTIKIZ10S20S20NY2 using 160 SUS (34 cSt) fluid.

Use the housing pressure curve to determine  $\Delta P_{\text{housing}}$  at 80 gpm. In this case,  $\Delta P_{\text{housing}}$  is 3 psi (.21 bar) on the graph for the RTI housing.

Use the element pressure curve to determine  $\Delta P_{\text{element}}$  at 80 gpm. In this case,  $\Delta P_{\text{element}}$  is 6.5 psi (.45 bar) according to the graph for the KIZ10 element.

Because the viscosity in this sample is 160 SUS (34 cSt), we determine the **Viscosity Factor ( $\mathbf{V}_f$ )** by dividing the **Operating Fluid Viscosity** with the **Standard Viscosity** of 150 SUS (32 cSt). To best determine your Operating Fluid Viscosity, please reference the chart in Appendix D.

Finally, the overall filter pressure differential,  $\Delta P_{\text{filter}}$ , is calculated by adding  $\Delta P_{\text{housing}}$  with the true element pressure differential, ( $\Delta P_{\text{element}} * \mathbf{V}_f$ ). The  $\Delta P_{\text{element}}$  from the graph has to be multiplied by the viscosity factor to get the true pressure differential across the element.

**Solution:**

$\Delta P_{\text{housing}} = 3 \text{ psi } [.21 \text{ bar}] \mid \Delta P_{\text{element}} = 6.5 \text{ psi } [.45 \text{ bar}]$

$\mathbf{V}_f = 160 \text{ SUS (34 cSt) } / 150 \text{ SUS (32 cSt)} = 1.1$

$\Delta P_{\text{filter}} = 3 \text{ psi} + (6.5 \text{ psi} * 1.1) = 10.2 \text{ psi}$

**OR**

$\Delta P_{\text{filter}} = .21 \text{ bar} + (.45 \text{ bar} * 1.1) = .71 \text{ bar}$

Note:

If your element is not graphed, use the following equation:

$\Delta P_{\text{element}} = \text{Flow Rate} \times \Delta P_f$ . Plug this variable into the overall pressure drop equation.

Ele.	$\Delta P$
KIAS10	0.08
KKIAS10	0.05
27KIAS10/ 27KIAS10	0.04

## Filter Model Number Selection

### How to Build a Valid Model Number for a Schroeder RTI:

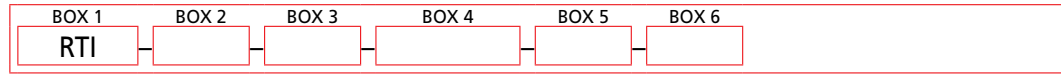

**Example:** NOTE: Only box 6 may contain more than one option

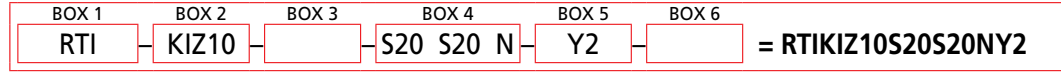

Filter Series	Element Part Number			
RTI	K Length	KK Length	27K Length	
	KIZ1	KKIZ1	27KIZ1	= 1 μ Excellement® Z-Media® and ASP® media (synthetic)
	KIZ3	KKIZ3	27KIZ3	= 3 μ Excellement® Z-Media® and ASP® media (synthetic)
	KIZ10	KKIZ10	27KIZ10	= 10 μ Excellement® Z-Media® and ASP® media (synthetic)

BOX 3

Seal Material
Omit = Buna N
H = EPR
W = Anodized Aluminum Parts
H.5 = Skydrol® Compatibility

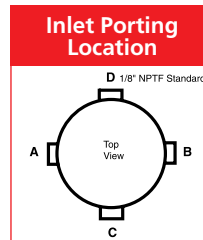

BOX 4 Specification of all 3 ports is required

Inlet Porting		
Port A	Port B	Port C
P16 = 1" NPTF	N = None	N = None
P20 = 1¼" NPTF	P16 = 1" NPTF	P2 = ⅛" NPTF
P24 = 1½" NPTF	P20 = 1¼" NPTF	P16 = 1" NPTF
S16 = SAE-16	P24 = 1½" NPTF	S16 = SAE-16
S20 = SAE-20	S16 = SAE-16	
S24 = SAE-24	S20 = SAE-20	
F20 = 1¼" SAE 4-bolt flange Code 61	S24 = SAE-24	
F24 = 1½" SAE 4-bolt flange Code 61	F20 = 1¼" SAE 4-bolt flange Code 61	
	F24 = 1½" SAE 4-bolt flange Code 61	

**NOTES:**

Box 2. Replacement element part numbers are identical to contents of Boxes 2 and 3.

Box 3. For options H, W, and H.5, all aluminum parts are anodized. H.5 seal designation includes the following: EPR seals, stainless steel wire mesh on elements, and light oil coating on housing exterior. Skydrol® is a registered trademark of Solutia Inc.

Box 4. If using Port B, Port A & B must always be the same type and size. Example: (A) P20 (B) P20 (C) P16

Box 6. See also "Accessories for Tank-Mounted Filters," page 307.

BOX 5

Dirt Alarm® Options	
Omit = None	
Located @ Port D	Visual Y2 = Back-mounted tri-color gauge
	Electrical ES = Electric switch ES1 = Heavy-duty electric switch with conduit connector
Located in cap	Visual Y2C = Bottom-mounted tri-color gauge Y5 = Back-mounted gauge in cap
	Visual Y2R = Back-mounted gauge mounted on opposite side of standard location
Located @ Port C	Electrical ES = Electric switch mounted on opposite side of standard location ES1R = Heavy-duty electric switch with conduit connector

BOX 6

Additional Options
Omit = None
G547 = Two ⅛" gauge ports
M = Metric thread for SAE 4-bolt flange mounting holes (specify after each port designation)

# Tank-Mounted Filter

# LRT



## Features and Benefits

- Low pressure tank-mounted filter
- Multiple inlet/outlet porting options
- Top, side or bottom mounting
- Optional check valve prevents reservoir siphoning
- Can also be used in return line application (contact factory)
- Visual gauge or electrical switch dirt alarms
- Offered in pipe, SAE straight thread, flanged and ISO 228 porting
- Same day shipment model available
- Also available with DirtCatcher® elements (18LD)
- **G** Available with quality-protected GeoSeal® Elements (GLRT)

**150 gpm**  
**570 L/min**  
**100 psi**  
**7 bar**

Model No. of filter in photograph is LRT18LZ10S24NP16Y2.

Flow Rating:	Up to 150 gpm (570 L/min) for 150 SUS (32 cSt) fluids
Max. Operating Pressure:	100 psi (7 bar)
Min. Yield Pressure:	400 psi (28 bar), per NFPA T2.6.1
Rated Fatigue Pressure:	90 psi (6 bar), per NFPA T2.6.1-2005
Temp. Range:	-20°F to 225°F (-29°C to 107°C)
Bypass Setting:	Cracking: 25 psi (1.7 bar) Full Flow: 34 psi (2.3 bar)
Porting Head & Cap:	Die Cast Aluminum
Element Case:	Steel
Weight of LRT-18L:	14.6 lbs. (6.6 kg)
Element Change Clearance:	17.0" (432 mm)

## Filter Housing Specifications

Type Fluid	Appropriate Schroeder Media
Petroleum Based Fluids	All E media (cellulose) and Z-Media® (synthetic)
High Water Content	All Z-Media® (synthetic)
Invert Emulsions	10 and 25 µ Z-Media® (synthetic)
Water Glycols	3, 5, 10 and 25 µ Z-Media® (synthetic)
Phosphate Esters	All Z-Media® (synthetic) with H (EPR) seal designation
Skydrol®	3, 5, 10 and 25 µ Z-Media® (synthetic) with H.5 seal designation (EPR seals and stainless steel wire mesh in element, and light oil coating on housing exterior)

## Fluid Compatibility

## Accessories For Tank-Mounted Filters

- IRF
- TF1
- KF3
- KL3
- LF1
- MLF1
- RLD
- GRTB
- MTA
- MTB
- ZT
- KFT
- RT
- RTI
- LRT**
- ART
- BRT
- TRT
- BFT
- QT
- KTK
- LTK
- MRT
- PAF1
- MAF1
- MF2

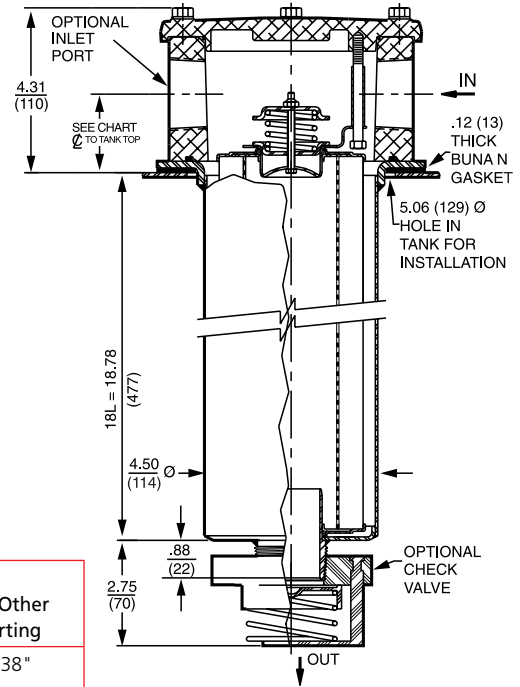
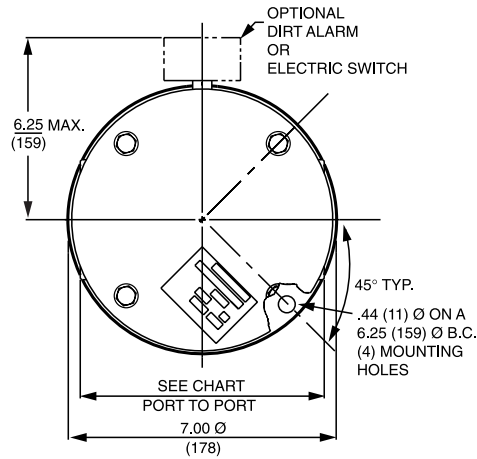

	1½" Ports 4-Bolt Flange Only	2" Ports	All Other Porting
Port to Port	7.12"	7.56" (P, S, B) 7.38" (F)	6.38"
℄ to Casting Base	1.75"	1.81"	1.56"
℄ to Tank Top	2.06"	2.12"	1.88"

Optional mounting ring available to weld to tank.

Metric dimensions in ( ).

**Element  
Performance  
Information & Dirt  
Holding Capacity**

Element	Filtration Ratio Per ISO 4572/NFPA T3.10.8.8 Using automated particle counter (APC) calibrated per ISO 4402			Filtration Ratio per ISO 16889 Using APC calibrated per ISO 11171	
	$\beta_x \geq 75$	$\beta_x \geq 100$	$\beta_x \geq 200$	$\beta_x(c) \geq 200$	$\beta_x(c) \geq 1000$
18LZ1	<1.0	<1.0	<1.0	<4.0	4.2
18LZ3	<1.0	<1.0	<2.0	<4.0	4.8
18LZ5	2.5	3.0	4.0	4.8	6.3
18LZ10	7.4	8.2	10.0	8.0	10.0
18LZ25	18.0	20.0	22.5	19.0	24.0

Element	DHC (gm)	Element	DHC (gm)
18LZ1	224	18LDZ1	194
18LZ3	230	18LDZ3	199
18LZ5	238	18LDZ5	194
18LZ10	216	18LDZ10	186
18LZ25	186	18LDZ25	169

Element Collapse Rating: 150 psid (10 bar)  
 Flow Direction: Outside In  
 Element Nominal Dimensions: 4.0" (100 mm) O.D. x 18.5" (470 mm) long

$\Delta P_{\text{housing}}$

LRT  $\Delta P_{\text{housing}}$  for fluids with sp gr (specific gravity) = 0.86:

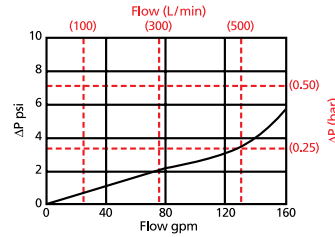

$\Delta P_{\text{element}}$

18LZ

Element Pressure Drop versus Flow Rate at 32 cSt (150 SUS)

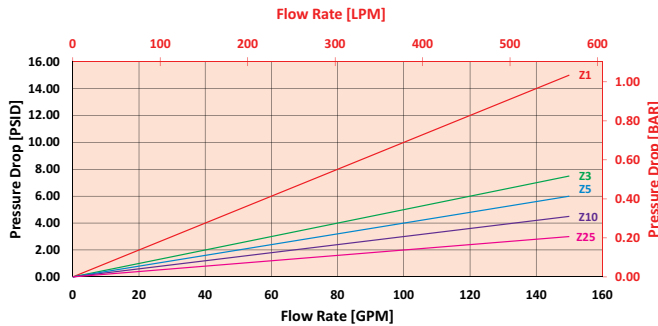

**Pressure Drop Information Based on Flow Rate and Viscosity**

$$\Delta P_{\text{filter}} = \Delta P_{\text{housing}} + (\Delta P_{\text{element}} * \mathbf{V}_f)$$

**Exercise:**

Determine  $\Delta P_{\text{filter}}$  at 120 gpm (379 L/min) for LRT18LZ10S24S24NY2 using 160 SUS (34 cSt) fluid.

Use the housing pressure curve to determine  $\Delta P_{\text{housing}}$  at 120 gpm. In this case,  $\Delta P_{\text{housing}}$  is 3 psi (.21 bar) on the graph for the LRT housing.

Use the element pressure curve to determine  $\Delta P_{\text{element}}$  at 120 gpm. In this case,  $\Delta P_{\text{element}}$  is 4 psi (.27 bar) according to the graph for the 18LZ10 element.

Because the viscosity in this sample is 160 SUS (34 cSt), we determine the **Viscosity Factor ( $\mathbf{V}_f$ )** by dividing the **Operating Fluid Viscosity** with the **Standard Viscosity** of 150 SUS (32 cSt). To best determine your Operating Fluid Viscosity, please reference the chart in Appendix D.

Finally, the overall filter pressure differential,  $\Delta P_{\text{filter}}$ , is calculated by adding  $\Delta P_{\text{housing}}$  with the true element pressure differential,  $(\Delta P_{\text{element}} * \mathbf{V}_f)$ . The  $\Delta P_{\text{element}}$  from the graph has to be multiplied by the viscosity factor to get the true pressure differential across the element.

**Solution:**

$\Delta P_{\text{housing}} = 8 \text{ psi } [.55 \text{ bar}] \mid \Delta P_{\text{element}} = 4 \text{ psi } [.27 \text{ bar}]$

$\mathbf{V}_f = 160 \text{ SUS (34 cSt)} / 150 \text{ SUS (32 cSt)} = 1.1$

$\Delta P_{\text{filter}} = 3 \text{ psi} + (4 \text{ psi} * 1.1) = 7.4 \text{ psi}$

**OR**

$\Delta P_{\text{filter}} = .21 \text{ bar} + (.27 \text{ bar} * 1.1) = .51 \text{ bar}$

Note:  
If your element is not graphed, use the following equation:  
 $\Delta P_{\text{element}} = \text{Flow Rate} \times \Delta P_f$ . Plug this variable into the overall pressure drop equation.

Ele.	ΔP
18LDZ1	0.12
18LDZ3	0.06
18LDZ5	0.05
18LDZ10	0.03
18LDZ25	0.02

## Filter Model Number Selection

Highlighted product eligible for QuickDelivery

### How to Build a Valid Model Number for a Schroeder LRT:

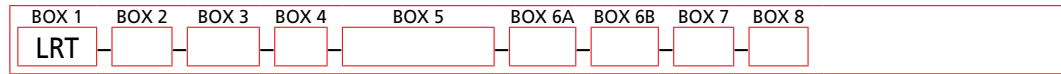

Example: NOTE: Only box 8 may contain more than one option

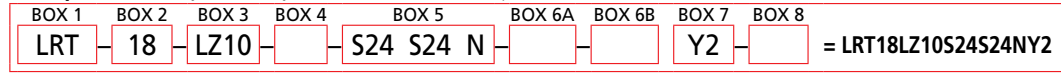

Filter Series	Element Length (in)	Element Size and Media	Seal Material
LRT	18	L3 = L size 3 μ E media (cellulose) L10 = L size 10 μ E media (cellulose) LZ1 = L size 1 μ Excellement® Z-Media® (synthetic) LZ3 = L size 3 μ Excellement® Z-Media® (synthetic) LZ5 = L size 5 μ Excellement® Z-Media® (synthetic) LZ10 = L size 10 μ Excellement® Z-Media® (synthetic) LZ25 = L size 25 μ Excellement® Z-Media® (synthetic) LDZ1 = L size DirtCatcher® 1 μ Excellement® Z-Media® LDZ3 = L size DirtCatcher® 3 μ Excellement® Z-Media® LDZ5 = L size DirtCatcher® 5 μ Excellement® Z-Media® LDZ10 = L size DirtCatcher® 10 μ Excellement® Z-Media® LDZ25 = L size DirtCatcher® 25 μ Excellement® Z-Media® GeoSeal® Element Options LGZ1 = L size 1 μ Excellement® Z-Media® (synthetic) LGZ3 = L size 3 μ Excellement® Z-Media® (synthetic) LGZ5 = L size 5 μ Excellement® Z-Media® (synthetic) LGZ10 = L size 10 μ Excellement® Z-Media® (synthetic) LGZ25 = L size 25 μ Excellement® Z-Media® (synthetic)	Omit = Buna N H = EPR = Anodized Aluminum Parts H.5 = Skydrol® compatibility
GLRT (GeoSeal®)			

### BOX 5 Specification of all 3 ports is required

Inlet Porting			Bypass Option
<b>Port A</b> P16 = 1" NPTF P20 = 1 1/4" NPTF P24 = 1 1/2" NPTF P32 = 2" NPTF S16 = SAE-16 S20 = SAE-20 S24 = SAE-24 S32 = SAE-32 F20 = 1 1/4" SAE 4-bolt flange Code 61 F24 = 1 1/2" SAE 4-bolt flange Code 61 F32 = 2" SAE 4-bolt flange Code 61 B24 = ISO 228 G-1 1/2" Flange port option only: M = Metric SAE 4 bolt flange	<b>Port B</b> N = None P16 = 1" NPTF P20 = 1 1/4" NPTF P24 = 1 1/2" NPTF P32 = 2" NPTF S16 = SAE-16 S20 = SAE-20 S24 = SAE-24 S32 = SAE-32 F20 = 1 1/4" SAE 4-bolt flange Code 61 F24 = 1 1/2" SAE 4-bolt flange Code 61 F32 = 2" SAE 4-bolt flange Code 61 B24 = ISO 228 G-1 1/2"	<b>Port C</b> N = None P2 = 1/8" NPTF P16 = 1" NPTF S16 = SAE-16 <b>Inlet Porting Location</b> 	Omit = 25 psi bypass setting 40 = 40 psi bypass setting 50 = 50 psi bypass setting
			<b>BOX 6B Outlet Porting Options</b> Omit = 2" NPT male C = Check valve D = Diffuser T = 13" Tube ext. A = Non-thread outlet

#### NOTES:

- Box 2. Replacement element part numbers are a combination of Boxes 2, 3, and 4. Example: 18LZ10
- Box 4. For options H, W, and H.5, all aluminum parts are anodized. H.5 seal designation includes the following: EPR seals, stainless steel wire mesh on elements, and light oil coating on housing exterior. Skydrol® is a registered trademark of Solutia Inc.
- Box 5. If using Port B, Port A & B must always be the same type and size. Example: (A) P20 (B) P20 (C) P16.
- Box 6. See also "Accessories for Tank-Mounted Filters," page 307.

### BOX 7

Dirt Alarm® Options	
Omit = None	
Located @ Port D	Visual Y2 = Back-mounted tri-color gauge Electrical ES = Electric switch ES1 = Heavy-duty electric switch with conduit connector
Located in cap	Visual Y2C = Bottom-mounted tri-color gauge Y5 = Back-mounted gauge in cap
Located @ Port C	Visual Y2R = Back-mounted gauge mounted on opposite side of standard location Electrical ESR = Electric switch mounted on opposite side of standard location ES1R = Heavy-duty electric switch with conduit connector

### BOX 8

Add. Options
Omit = None
G2293 = Cork gasket
G547 = Two 1/8" gauge ports
G820 = Stamped cap



# Tank-Mounted Filter

# ART



## Features and Benefits

- Compact, lightweight, low pressure tank mounted filter ideal for mobile applications
- Lightweight plastic bowl
- ART aluminum alloy is designed to be water tolerant - anodization is not required for use with water based fluids (HWCF).
- Special filter element design provides aftermarket benefits.
- Various Dirt Alarm® options

**225 gpm**  
**850 L/min**  
**145 psi**  
**10 bar**

Model No. of filter in photograph is ART85Z10F43.

- IRF
- TF1
- KF3
- KL3
- LF1
- MLF1
- RLD
- GRTB
- MTA
- MTB
- ZT
- KFT
- RT
- RTI
- LRT
- ART**
- BRT
- TRT
- BFT
- QT
- KTK
- LTK
- MRT
- PAF1
- MAF1
- MF2

## Filter Housing Specifications

Flow Rating:	Up to 225 gpm (850 L/min) for 150 SUS (32 cSt) fluids
Max. Operating Pressure:	145 psi (10 bar)
Min. Yield Pressure:	535 psi (37 bar), per NFPA T2.6.1
Rated Fatigue Pressure:	145 psi (10 bar), per NFPA T2.6.1
Temp. Range:	-20°F to 225°F (-29°C to 107°C)
Bypass Setting:	Cracking: 43 psi (3 bar) Full Flow: 69 psi (4.75 bar)
Porting Head & Cap:	Aluminum
Element Case:	Plastic
Weight of ART:	15 lbs. (7 kg)
Element Change Clearance:	16.39" (340 mm)

## Fluid Compatibility

Type Fluid	Appropriate Schroeder Media
Petroleum Based Fluids	All Z-Media® (synthetic)
High Water Content	All Z-Media® (synthetic)

## Accessories For Tank-Mounted Filters

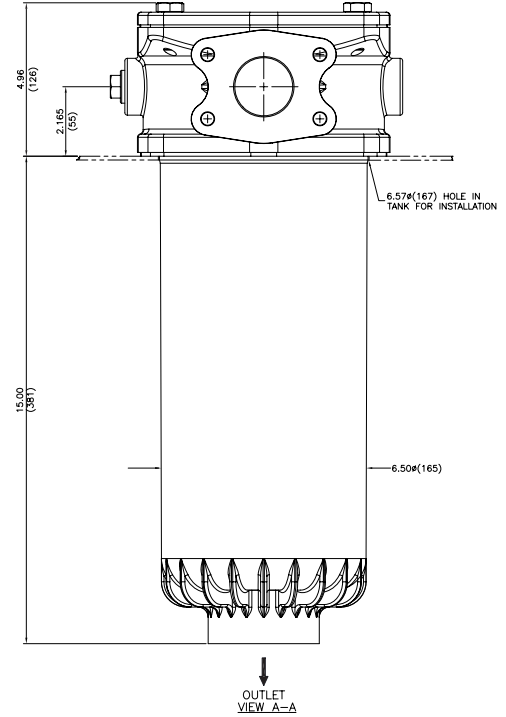
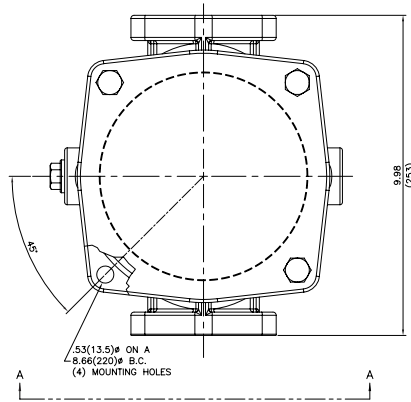

Metric dimensions in ( ).

## Element Performance Information & Dirt Holding Capacity

Element	Filtration Ratio per ISO 16889 Using APC calibrated per ISO 11171	
	$\beta_x(c) \geq 200$	$\beta_x(c) \geq 1000$
85Z1	<4.0	4.2
85Z3	<4.0	4.8
85Z5	4.8	6.3
85Z10	8.0	10.0
85Z25	19.0	24.0

Element	DHC (gm)
85Z1	185
85Z3	147
85Z5	206
85Z10	164
85Z25	167

Element Collapse Rating: 150 psid (10 bar)  
 Flow Direction: Outside In  
 Element Nominal Dimensions: 4.5" (114.3 mm) O.D. x 13.8" (350.52 mm) long

## $\Delta P_{\text{housing}}$

ART  $\Delta P_{\text{housing}}$  for fluids with sp gr (specific gravity) = 0.86:

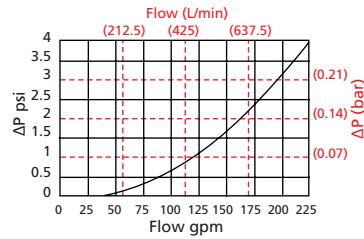

## $\Delta P_{\text{element}}$

85Z

Element Pressure Drop versus Flow Rate at 32 cSt (150 SUS)

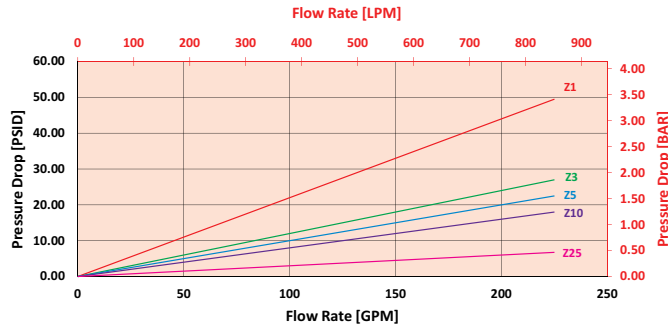

Pressure Drop Information Based on Flow Rate and Viscosity

$$\Delta P_{\text{filter}} = \Delta P_{\text{housing}} + (\Delta P_{\text{element}} * \mathbf{V}_f)$$

### Exercise:

Determine  $\Delta P_{\text{filter}}$  at 120 gpm (379 L/min) for ART85Z10F43Y2 using 160 SUS (34 cSt) fluid.

Use the housing pressure curve to determine  $\Delta P_{\text{housing}}$  at 120 gpm. In this case,  $\Delta P_{\text{housing}}$  is 1 psi (.07 bar) on the graph for the ART housing.

Use the element pressure curve to determine  $\Delta P_{\text{element}}$  at 120 gpm. In this case,  $\Delta P_{\text{element}}$  is 10 psi (.69 bar) according to the graph for the 85Z10 element.

Because the viscosity in this sample is 160 SUS (34 cSt), we determine the **Viscosity Factor ( $\mathbf{V}_f$ )** by dividing the **Operating Fluid Viscosity** with the **Standard Viscosity** of 150 SUS (32 cSt). To best determine your Operating Fluid Viscosity, please reference the chart in Appendix D.

Finally, the overall filter pressure differential,  $\Delta P_{\text{filter}}$ , is calculated by adding  $\Delta P_{\text{housing}}$  with the true element pressure differential, ( $\Delta P_{\text{element}} * \mathbf{V}_f$ ). The  $\Delta P_{\text{element}}$  from the graph has to be multiplied by the viscosity factor to get the true pressure differential across the element.

### Solution:

$$\Delta P_{\text{housing}} = 1 \text{ psi } [.07 \text{ bar}] \quad | \quad \Delta P_{\text{element}} = 10 \text{ psi } [.69 \text{ bar}]$$

$$\mathbf{V}_f = 160 \text{ SUS (34 cSt)} / 150 \text{ SUS (32 cSt)} = 1.1$$

$$\Delta P_{\text{filter}} = 1 \text{ psi} + (10 \text{ psi} * 1.1) = 12 \text{ psi}$$

OR

$$\Delta P_{\text{filter}} = .07 \text{ bar} + (.69 \text{ bar} * 1.1) = .83 \text{ bar}$$

## Filter Model Number Selection

### How to Build a Valid Model Number for a Schroeder ART:

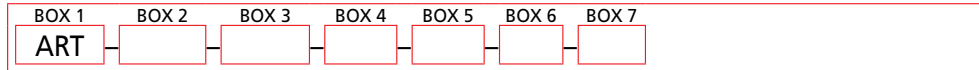

Example: NOTE: One option per box

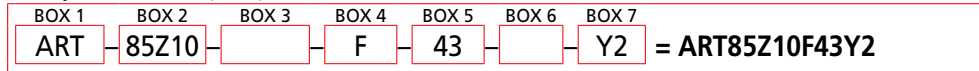

BOX 1	BOX 2	BOX 3
<b>Filter Series</b>	<b>Element Size and Media</b>	<b>Seal Material</b>
ART	85Z1 = 1 μ Excellement® Z-Media® (synthetic) 85Z3 = 3 μ Excellement® Z-Media® (synthetic) 85Z5 = 5 μ Excellement® Z-Media® (synthetic) 85Z10 = 10 μ Excellement® Z-Media® (synthetic) 85Z25 = 25 μ Excellement® Z-Media® (synthetic)	Omit = Buna N H = EPR

BOX 4	BOX 5	BOX 6
<b>Porting</b>	<b>Bypass Setting</b>	<b>Outlet Options</b>
F = 2½" SAE-40 4-bolt flange Code 61 FF = Dual 2½" SAE-40 4-bolt flange Code 61 S = SAE-32 SS = Dual SAE-32	43 = 43 psi Bypass	Omit = 2" ISO 228 G thread

BOX 7
<b>Dirt Alarm® Options</b>
Omit = None
Visual Y2 = Back-mounted tri-color gauge Y2R = Back-mounted gauge mounted on opposite side of standard location
Electrical ES = Electric switch (normally open) ESR = Electric switch mounted on opposite side of standard location ES1 = Heavy-duty electric switch with conduit connector ES1R = Heavy-duty electric switch with conduit connector mounted on opposite side of standard location ES2 = Super duty electric switch with Thermal Lockout and 2 pin Deutsche connector (DT04-2P, SPST, normally closed)

#### NOTES:

Box 2. Replacement element part numbers are identical to contents of Boxes 2 and 3.

Box 3. For option H, all aluminum parts are anodized.

# Return Line Filter

**BRT**



## Features and Benefits

- Filter is mounted in the tank and flow comes to it from a pipe connection below it or from the side
- Optimal flow conditions created by flow from beneath guaranteeing optimal air separation, even tank mixing, and long element service intervals
- Patented de-aeration windows around the housing offer superior air bubble coalescence in a 360 degree discharge
- Quality Protected Inside-Out Flow Element Design

Part of the Schroeder Industries 2030 Initiative

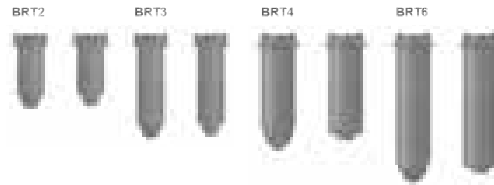

Model No. of filter in photograph is BRT6RBZ102.

**to 160 gpm**  
**to 600 L/min**  
**to 145 psi**  
**to 10 bar**

IRF  
TF1  
KF3  
KL3  
LF1  
MLF1  
RLD  
GRTB  
MTA  
MTB  
ZT  
KFT  
RT  
RTI  
LRT  
ART  
**BRT**  
TRT  
BFT  
QT  
KTK  
LTK  
MRT  
PAF1  
MAF1  
MF2

Flow Rating:	Up to 160 gpm (600 L/min) for 150 SUS (32 cSt) fluids
Max. Operating Pressure:	145 psi (10 bar)
Temp. Range:	-22°F to 248°F (-30°C to 120°C)
Bypass Setting:	Cracking: 36 psi (2.5 bar)
Filter Head & Cover:	BRT 2 - 6: Aluminum
Inlet Section:	Nylon (PA66)
Seals	Buna N
Installation:	As in-tank filter

## Filter Housing Specifications

Type Fluid	Appropriate Schroeder Media
Hydraulic Oils	Schroeder Z-Media® (synthetic)
Lubrication Oils	Schroeder Z-Media® (synthetic)
Compressor Oils	Schroeder Z-Media® (synthetic)
Biodegradable Operating Fluids	Schroeder Z-Media® (synthetic)

## Fluid Compatibility Accessories For Tank-Mounted Filters

## Dimensions BRT2 - BRT3

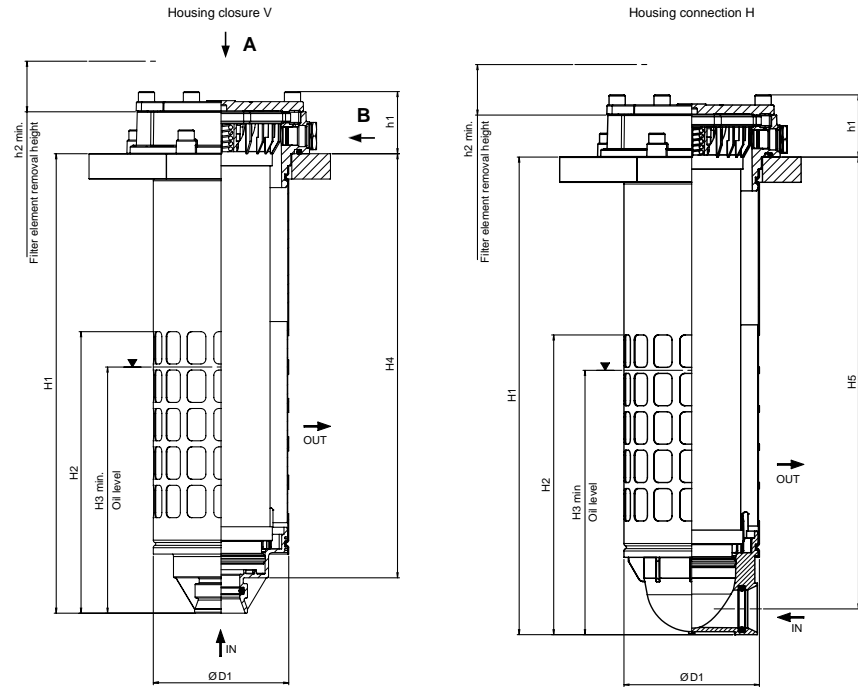
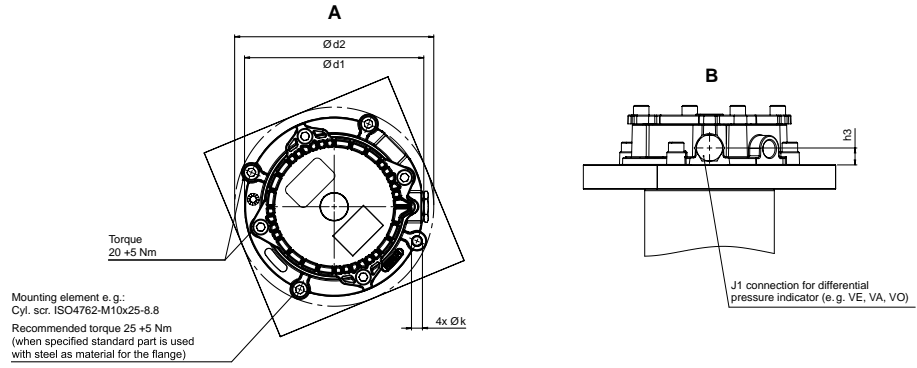

Type	Design	Connection pos.	H1	H2	H3	H4	H5	h1	h2	h3	ØD1	Ød1	Ød2	Øk	Weight [lbs]
BRT2	Diffuser with opening	H	12.7	8.68	7.32	-	11.69	2.42	11.81	0.69	5.28	7.09	7.87	0.41	7.3
	Diffuser with opening	V	11.99	7.97	6.61	10.61	-								7.1
BRT3	Diffuser with opening	H	18.6	11.67	10.31	-	17.6	17.72							8.6
	Diffuser with opening	V	17.89	10.96	9.61	16.52	-								8.8

## Element Performance Information

Element	Filtration Ratio Per ISO 4572/NFPA T3.10.8.8 Using automated particle counter (APC) calibrated per ISO 4402			Filtration Ratio per ISO 16889 Using APC calibrated per ISO 11171	
	$\beta_x \geq 75$	$\beta_x \geq 100$	$\beta_x \geq 200$	$\beta_x(c) \geq 200$	$\beta_x(c) \geq 1000$
2RBZ10	C/F	C/F	C/F	C/F	11.2
2RBZ25	C/F	C/F	C/F	C/F	16.2
3RBZ10	C/F	C/F	C/F	C/F	11.2
3RBZ25	C/F	C/F	C/F	C/F	16.2
4RBZ10	C/F	C/F	C/F	C/F	11.2
4RBZ25	C/F	C/F	C/F	C/F	16.2
6RBZ10	C/F	C/F	C/F	C/F	11.2
6RBZ25	C/F	C/F	C/F	C/F	16.2

## Dimensions BRT4 - BRT6

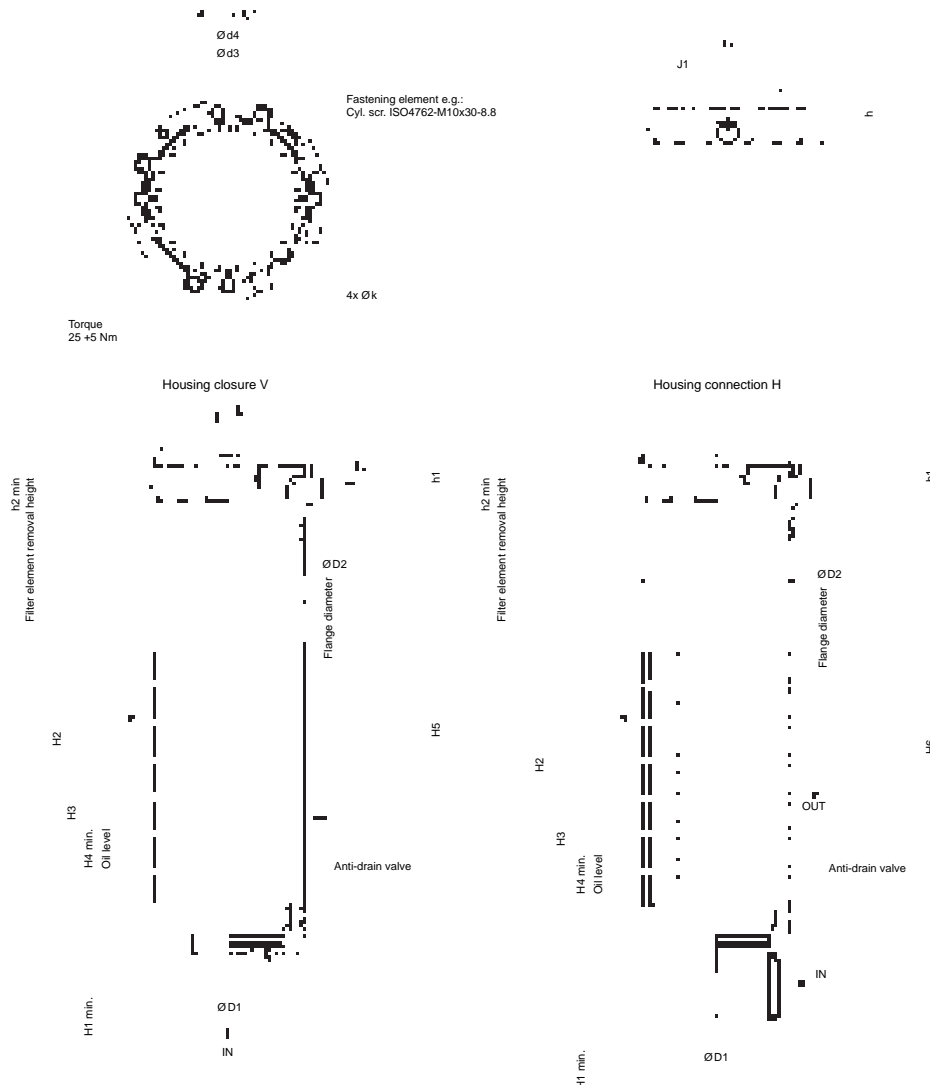

Type	Design	Connection position	H1	H2	H3	H4	H5	H6	h	h1	h2	ØD1	ØD2	Øk	Weight [lbs]
BRT4	Diffuser with opening	H	10	18.37	12.09	9.21	-	16.85	0.69	2.42	16.9	6.06	8.07	0.41	9.9
	Diffuser with opening	V		16.63	10.34	7.17	15.5	-							9.5
BRT6	Diffuser with opening	H	10	24.16	15.09	12.2	-	22.65	0.69	2.42	22.8	6.06	8.07	0.41	12.1
	Diffuser with opening	V		22.11	13.04	10.16	21.3	-							11.7

Element	DHC (g)	Element	DHC (g)
2RBZ10	70.4	4RBZ10	152.5
2RBZ25	77.8	4RBZ25	173.4
3RBZ10	114.3	6RBZ10	190.4
3RBZ25	128.3	6RBZ25	231.7

Element Burst Rating: 87 psi (6 bar) for standard elements  
Flow Direction: Inside Out

**Element  
Dirt Holding  
Capacity & Burst  
Rating**

## Dimensions BRT2 - BRT3



## Dimensions BRT4 - BRT6

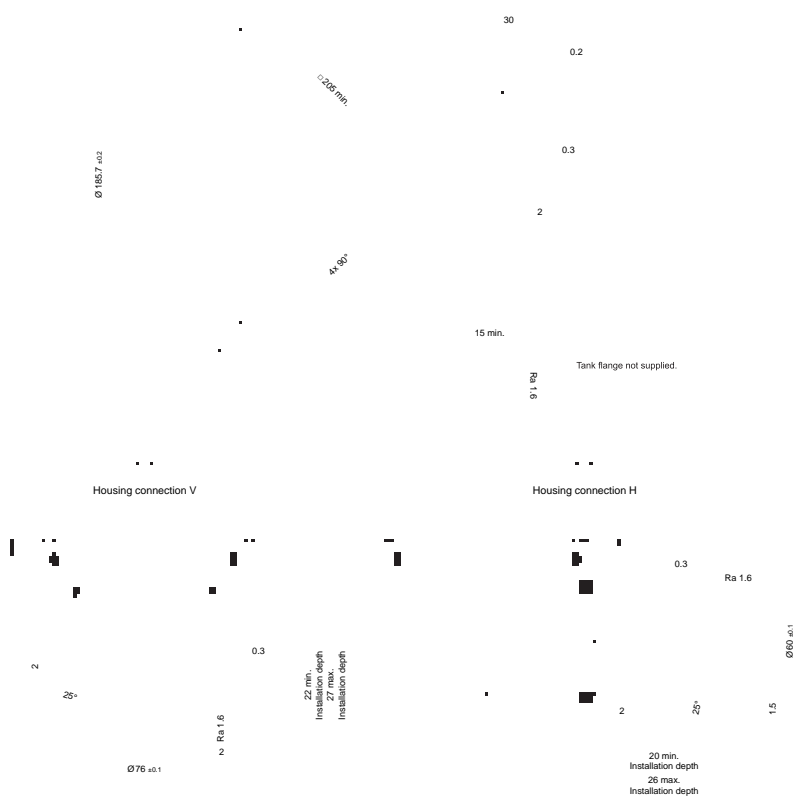



$\Delta P_{\text{element}}$   
BRT2

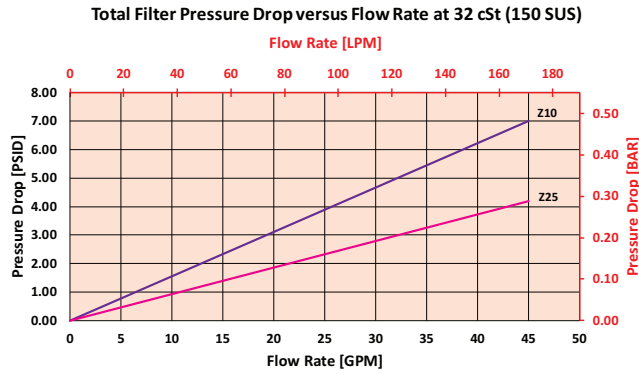

BRT3

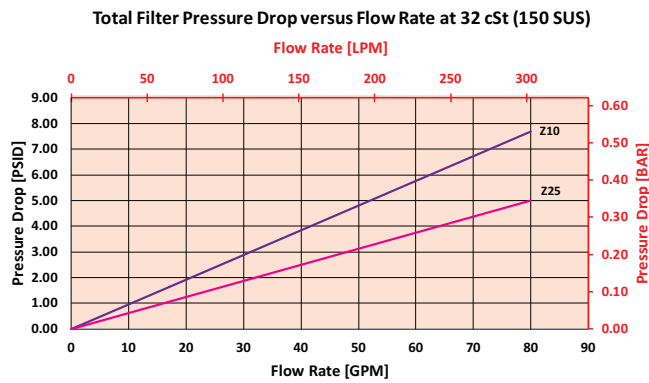

BRT4

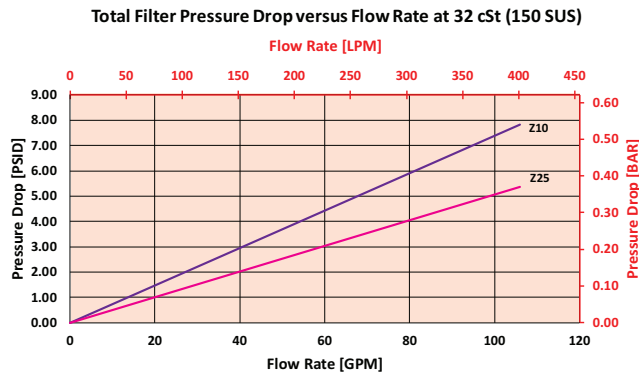

BRT6

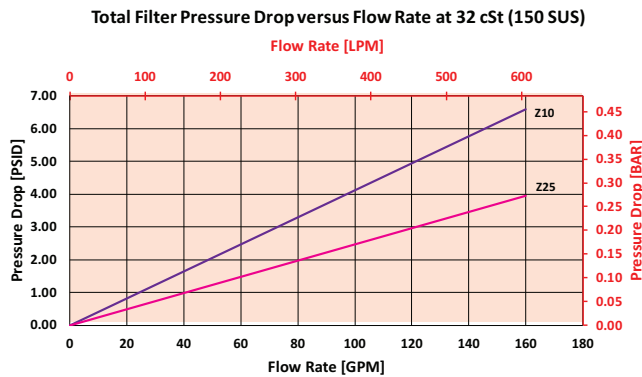

**Pressure Drop Information**  
Based on  
Flow Rate  
and Viscosity

## Filter Model Number Selection

### How to Build a Valid Model Number for a Schroeder BRT:

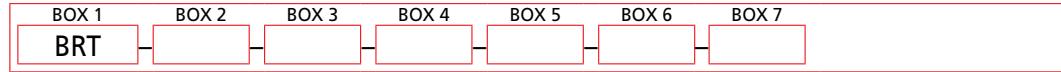

Example: NOTE: One option per box

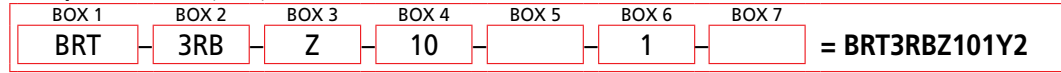

BOX 1	BOX 2	BOX 3	BOX 4
<b>Filter Series</b>	<b>Size of Element</b>	<b>Element Media Type</b>	
BRT	2RB	Z = Excellement® Z-Media® (synthetic)	
	3RB		<b>Micron Rating</b>
	4RB		10 = 10 µm
	6RB		25 = 25 µm

BOX 5	BOX 6	BOX 7
<b>Seal Material</b>	<b>Inlet Porting</b>	<b>Dirt Alarm® Options</b>
Omit = Buna N	2 = side inlet	Omit = No Indicator, sealed up w/ screw plug
V = Viton®	1 = bottom inlet	VA = visual/electrical
		VE = electrical
		VO = visual

# Return Line Filter

# TRT



### Features and Benefits

- Filter head is mounted on the tank like a standard return-line filter solution
- The protective tube can be supplied in various optional versions: 1.) as a closed tube with the outlet opening facing downwards or with a closed base and rows of operating holes at the height of the tank's oil level 2.) with an optional magnetic core connected to the filter element guaranteeing effective magnetic pre-filtration
- Patented de-aeration windows around the housing offer superior air bubble coalescence in a 360 degree discharge
- Quality Protected Element Design

 Part of Schroeder Industries' 2030 Initiative

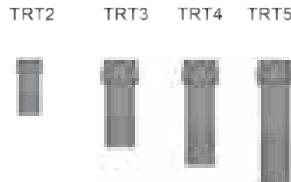

Model No. of filter in photograph is TRT5RTZ10G.

**up to 634 gpm** IRF  
**up to 2400 L/min** TF1  
**to 145 psi** KF3  
**to 10 bar** KL3

LF1

MLF1

RLD

GRTB

MTA

MTB

ZT

KFT

RT

RTI

LRT

ART

BRT

**TRT**

BFT

QT

KTK

LTK

MRT

### Filter Housing Specifications

Flow Rating:	Up to 634 gpm (2400 L/min) for 150 SUS (32 cSt) fluids
Max. Operating Pressure:	145 psi (10 bar)
Temp. Range:	-22°F to 248°F (-30°C to 120°C)
Bypass Setting:	Cracking: 36 psi (2.5 bar)
Filter Head & Cover:	Aluminum
Filter Housing:	Steel
Inlet Section:	Nylon (PA66)
Seals:	Can Drop (= Perbunan Drop)
Installation:	As in-tank filter

### Fluid Compatibility Accessories For Tank-Mounted Filters

Type Fluid	Appropriate Schroeder Media
Hydraulic Oils	Schroeder Z-Media® (synthetic)
Lubrication Oils	Schroeder Z-Media® (synthetic)
Compressor Oils	Schroeder Z-Media® (synthetic)
Biodegradable Operating Fluids	Schroeder Z-Media® (synthetic)

PAF1

MAF1

MF2

**Dimensions  
TRT2**

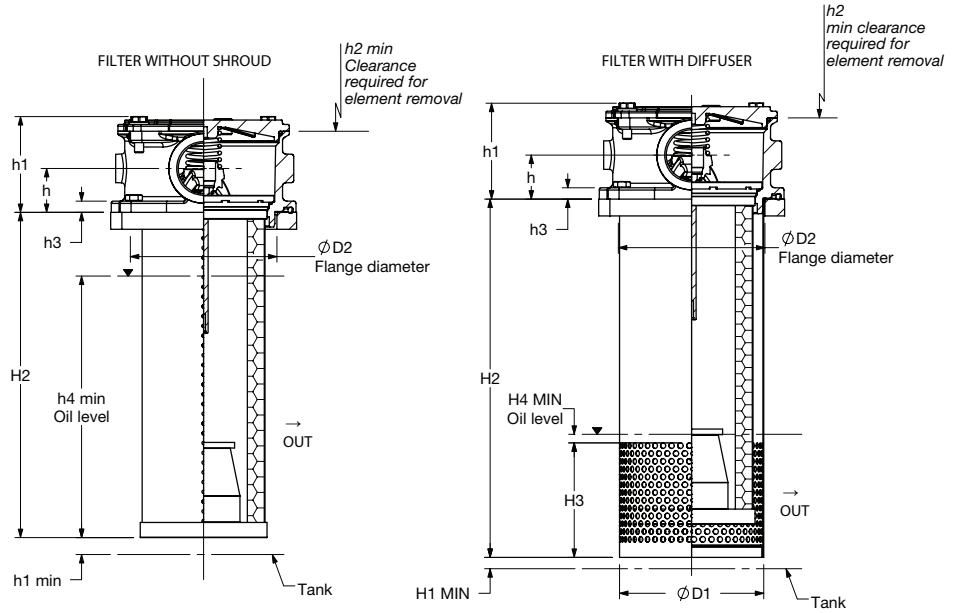

**Element  
Performance  
Information**

Element	Filtration Ratio Per ISO 4572/NFPA T3.10.8.8 Using automated particle counter (APC) calibrated per ISO 4402			Filtration Ratio per ISO 16889 Using APC calibrated per ISO 11171	
	$\beta_x \geq 75$	$\beta_x \geq 100$	$\beta_x \geq 200$	$\beta_x(c) \geq 200$	$\beta_x(c) \geq 1000$
2RTZ10	C/F	C/F	C/F	C/F	12.3
2RTZ25	C/F	C/F	C/F	C/F	16.2
3RTZ10	C/F	C/F	C/F	C/F	12.3
3RTZ25	C/F	C/F	C/F	C/F	18.6
4RTZ10	C/F	C/F	C/F	C/F	12.3
4RTZ25	C/F	C/F	C/F	C/F	18.6
5RTZ10	C/F	C/F	C/F	C/F	12.3
5RTZ25	C/F	C/F	C/F	C/F	18.6

**Element  
Dirt Holding  
Capacity & Burst  
Rating**

Element	DHC (g)	Element	DHC (g)
2RTZ10	81.0	4RTZ10	199.1
2RTZ25	89.9	4RTZ25	221.0
3RTZ10	150.5	5RTZ10	242.8
3RTZ25	167.1	5RTZ25	269.5

Element Burst Rating: 87 psi (6 bar) for standard elements  
Flow Direction: Inside Out

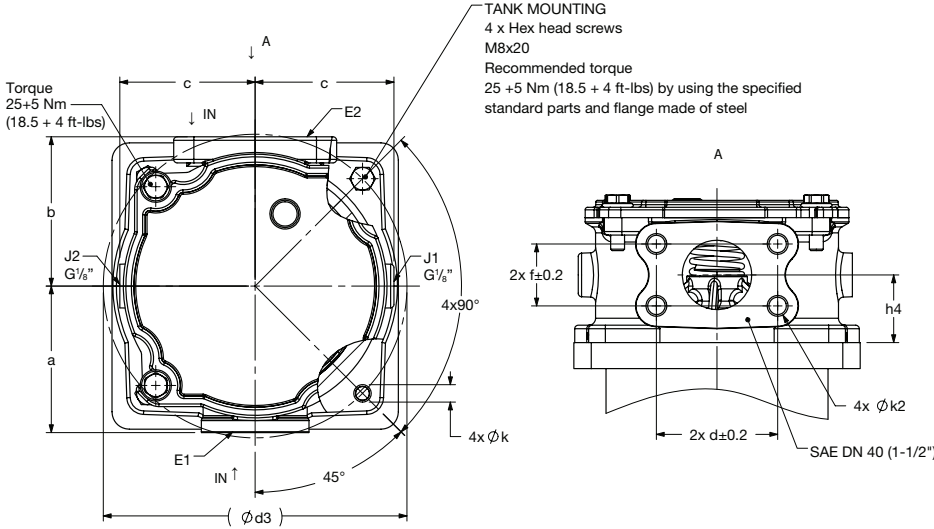

Type	Shroud Version	H1	H2	H3	H4	h	h1	h2	h3	h4	ØD1	ØD2	Ød3	a	b	c	d	f	Øk	Øk2	Wt (lbs)
TRT2	Without shroud	[0.39]	[8.58] 218	-	[6.1] 155						-										5.7
	With shroud	10			[1.97] 50																7.1
	With diffuser	[0.2]	[9.72] 247	[4.02] 102	[0.39] 10	[1.54] 39	[3.35] 85	[10.24] 260	[0.39] 10	-	[5.04] 128	[5.31] 135	[6.89] 175	[3.33] 84.5	[3.39] 86.0*	[3.15] 80*	[2.75] 69.9	[1.48] 37.5	[0.39] 10	M12	7.5
	Diffuser with opening	5		[4.96] 126											[3.33] 84.5*	[3.07] 78**					7.7

\* Non-machined port  
 \*\* Machined port

**Dimensions  
TRT3, 4, 5**

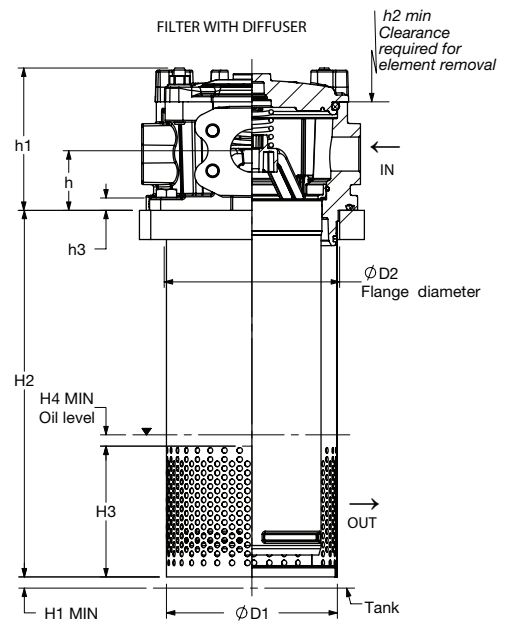
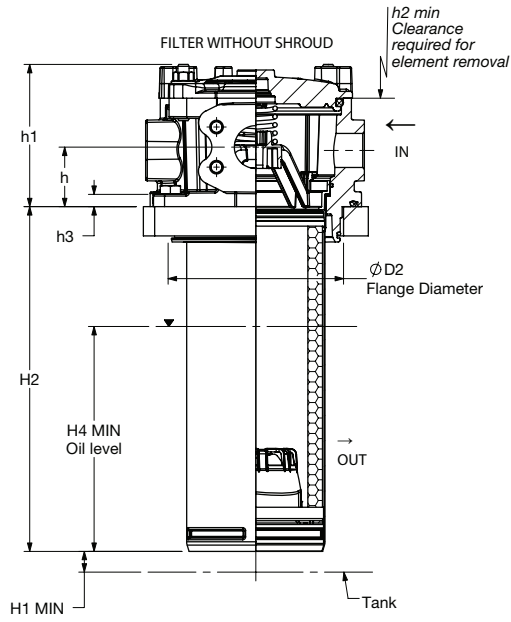

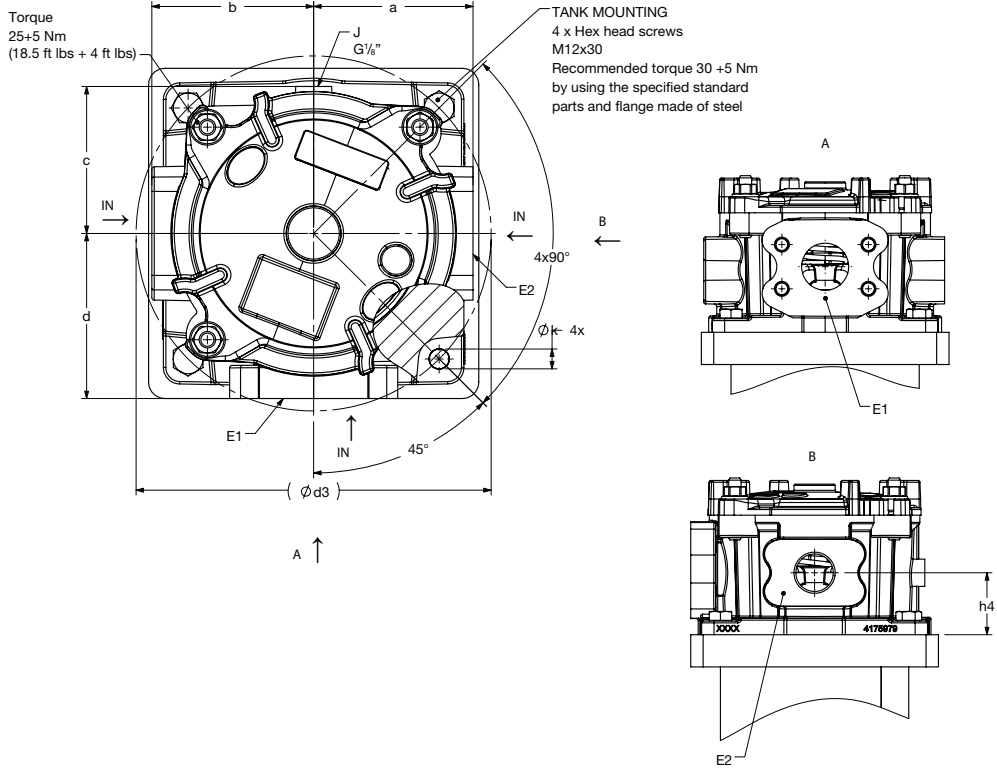

Type	Design	H1	H2	H3	H4	h	h1	h2	h3	h4	ØD1	ØD2	Ød3	a	b	c	d	Øk	Wt (lbs)
TRT3	Without shroud	[0.39]	[12.03]	-	[7.87]						-								9.3
	With shroud	10	305.5	-	[2.36]			[16.54]											10.8
	With diffuser	[0.2]	[12.83]	[4.53]	[0.39]						[5.98]								11.0
	Diffuser with opening	5	326	[6.22]	[0.39]						152								11.2
TRT4	Without shroud	[0.39]	[15.96]	-	[10.63]						-								9.9
	With shroud	10	405.5	-	[2.36]	[2.09]	[4.98]	[20.47]	[0.43]	[1.97]									11.9
	With diffuser	[0.2]	[16.77]	[4.53]	[0.39]	53	126.5	520	11	50	[5.98]	[6.14]	[8.46]	[3.85]	[3.85]	[3.58]	[3.94]	[0.49]	12.1
	Diffuser with opening	5	426	[7.68]	[0.39]						152	156	215	[3.80]	[3.80]	[3.50]	100	12.5	12.3
TRT5	Without shroud	[0.39]	[19.51]	-	[12.99]						-								11.0
	With shroud	10	495.5	-	[2.36]														13.2
	With diffuser	[0.2]	[20.31]	[4.53]	[0.39]			[24.02]			[5.98]								13.4
	Diffuser with opening	5	516	[10.63]	[0.39]						152								13.7

\* Non-machined port  
\*\* Machined port

## Dimensions TRT2

### Specifications For The Tank Flange

- 1. In the filter mounting interface, the tank flange should have a maximum flatness of 0.3 mm and maximum roughness of Ra 3.2  $\mu\text{m}$ .
- 2. In addition, the mounting interface should be free from damage and scratches.
- 3. The mounting holes of the flange must be blind, or stud bolts. Loctite must be used to mount the filter. As an alternative, the tank flange can be continuously welded from the inside.
- 4. Both the tank sheet metal and the filter mounting flange must be sufficiently robust so that neither deform when the seal is compressed during tightening.

### TRT2

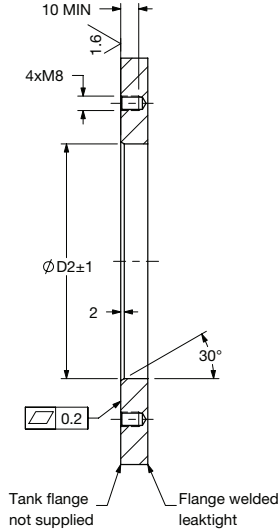
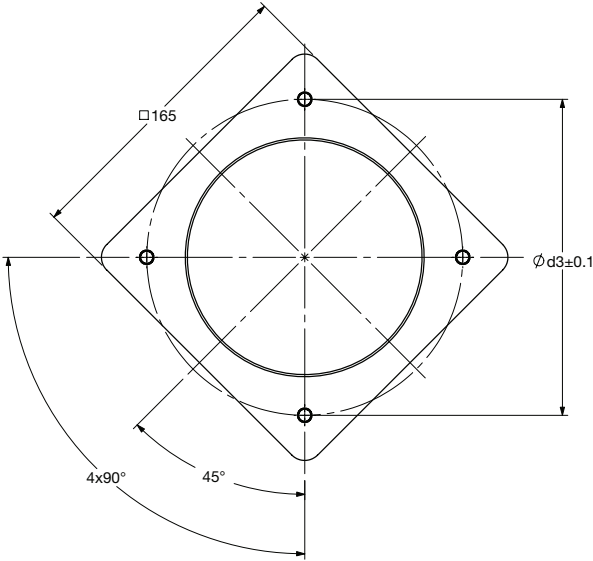

## Dimensions TRT3, 4, 5

### Dimensions TRT3, TRT4, TRT5

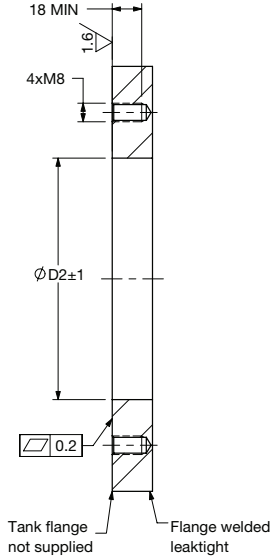
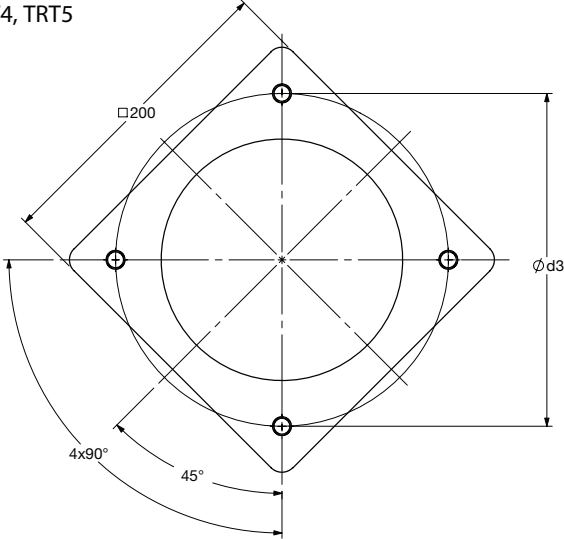



$\Delta P_{\text{element}}$   
TRT2

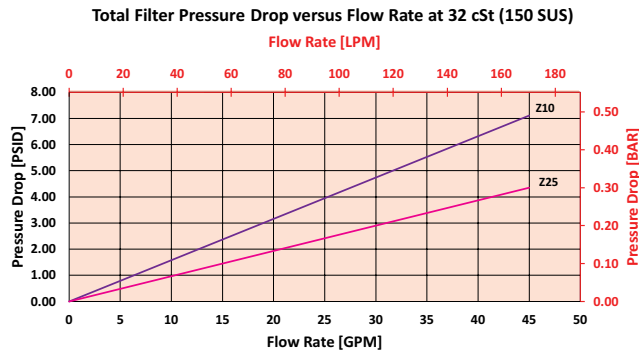

TRT3

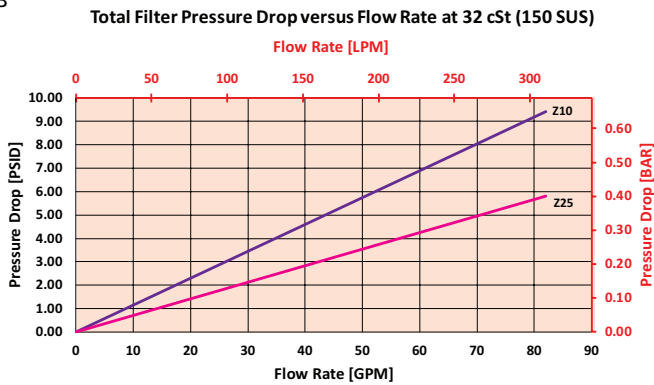

TRT4

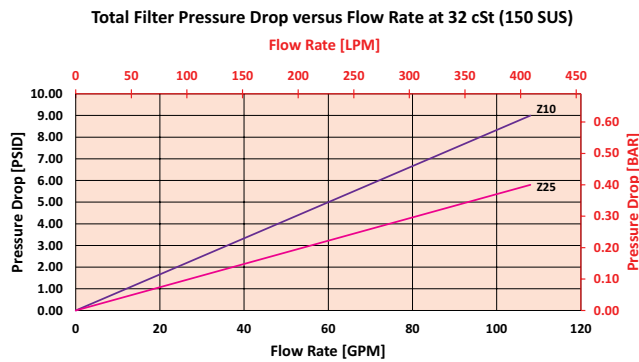

TRT5

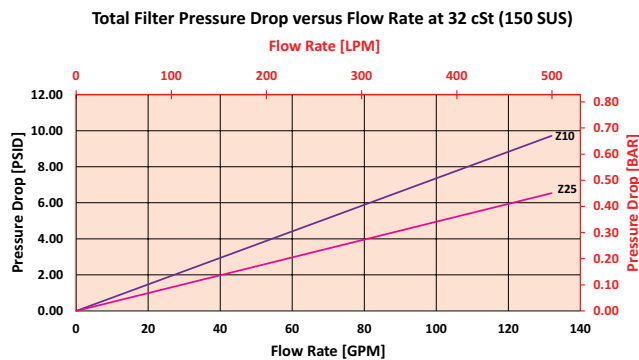

**Pressure Drop Information**  
Based on  
Flow Rate  
and Viscosity

## Filter Model Number Selection

### How to Build a Valid Model Number for a Schroeder TRT:

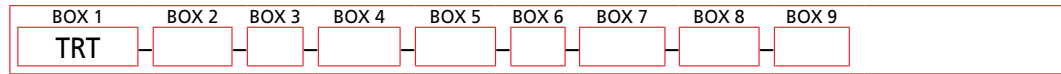

Example: NOTE: One option per box

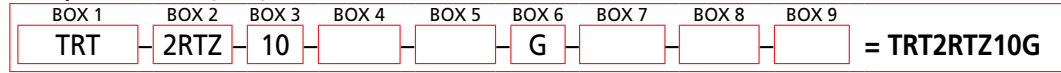

BOX 1	BOX 2	BOX 3	BOX 4
<b>Filter Series</b>	<b>Size of Element</b>	<b>Micron Rating</b>	<b>Bypass</b>
TRT	2RTZ 3RTZ 4RTZ 5RTZ	10 = 10 µm 25 = 25 µm	Omit = standard 36 psi bypass X = non bypass 12 = 12 psi bypass

BOX 5	BOX 6	BOX 7
<b>Magnet</b>	<b>Porting</b>	<b>Housing Option</b>
Omit = no magnetic core M = Magnet	G = 1 1/2" G S = 1 1/2" SAE	Omit = standard housing with diffuser X = no housing tube

BOX 8	BOX 9
<b>Seal Material</b>	<b>Dirt Alarm® Options</b>
Omit = Buna N V = Viton®	Omit = No Indicator, sealed up w/ screw plug
Clogging Indicators	VA = visual/electrical
	VE = electrical
	VO = visual

# Tank-Mounted Filter

# BFT



## Features and Benefits

- Low pressure tank-mounted filter
- Designed for high return line flows
- Dual inlet porting options available
- Top, side or bottom mounting
- Optional check valve prevents reservoir siphoning
- Special filter element design provides aftermarket benefits
- Also available with DirtCatcher® element (BBD)
- Cast iron head available

**300 gpm**  
**1135 L/min**  
**100 psi**  
**7 bar**

Model No. of filter in photograph is BFT1BBZ5F.

Flow Rating:	Up to 300 gpm (1135 L/min) for 150 SUS (32 cSt) fluids
Max. Operating Pressure:	100 psi (7 bar)
Min. Yield Pressure:	250 psi (17 bar), per NFPA T2.6.1
Rated Fatigue Pressure:	Contact factory, per NFPA T2.6.1
Temp. Range:	-20°F to 225°F (-29°C to 107°C)
Bypass Setting:	Cracking: 25 psi (1.7 bar) Full Flow: 52 psi (3.6 bar)
Porting Head & Cap:	Aluminum
Element Case:	Steel
Weight of BFT-1BB:	36.7 lbs. (16.6 kg)
Element Change Clearance:	14.75" (375 mm)

## Filter Housing Specifications

Type Fluid	Appropriate Schroeder Media
Petroleum Based Fluids	All E media (cellulose) and Z-Media® (synthetic)
High Water Content	All Z-Media® (synthetic)
Invert Emulsions	10 and 25 μ Z-Media® (synthetic)
Water Glycols	3, 5, 10 and 25 μ Z-Media® (synthetic)
Phosphate Esters	All Z-Media® (synthetic) with H (EPR) seal designation
Skydrol®	3, 5, 10 and 25 μ Z-Media® (synthetic) with H.5 seal designation (EPR seals and stainless steel wire mesh in element, and light oil coating on housing exterior)

## Fluid Compatibility

## Accessories For Tank-Mounted Filters

- IRF
- TF1
- KF3
- KL3
- LF1
- MLF1
- RLD
- GRTB
- MTA
- MTB
- ZT
- KFT
- RT
- RTI
- LRT
- ART
- BRT
- TRT
- BFT**
- QT
- KTK
- LTK
- MRT
- PAF1
- MAF1
- MF2

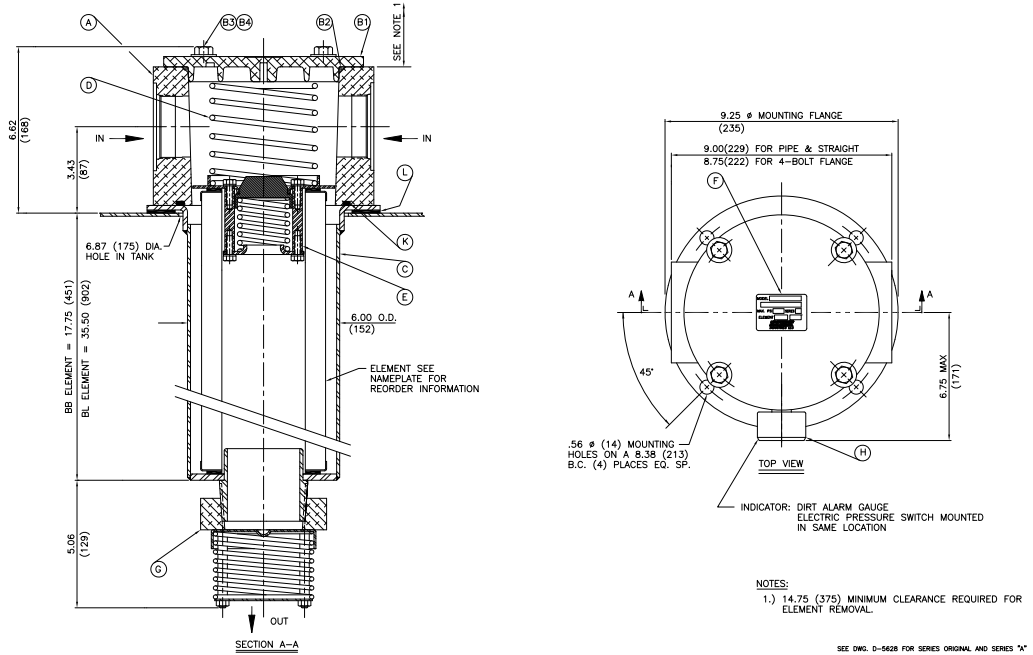

Metric dimensions in ( ).

## Element Performance Information & Dirt Holding Capacity

Element	Filtration Ratio Per ISO 4572/NFPA T3.10.8.8 Using automated particle counter (APC) calibrated per ISO 4402			Filtration Ratio per ISO 16889 Using APC calibrated per ISO 11171	
	$\beta_x \geq 75$	$\beta_x \geq 100$	$\beta_x \geq 200$	$\beta_x(c) \geq 200$	$\beta_x(c) \geq 1000$
BB/BLZ1	<1.0	<1.0	<1.0	<4.0	4.2
BB/BLZ3	<1.0	<1.0	<2.0	<4.0	4.8
BB/BLZ5	2.5	3.0	4.0	4.8	6.3
BB/BLZ10	7.4	8.2	10.0	8.0	10.0
BB/BLZ25	18.0	20.0	22.5	19.0	24.0

Element	DHC (gm)	Element	DHC (gm)	Element	DHC (gm)
BBZ1	268	BBDZ1	205	BLZ1	536
BBZ3	275	BBDZ3	163	BLZ3	550
BBZ5	301	BBDZ5	229	BLZ5	550
BBZ10	272	BBDZ10	183	BLZ10	550
BBZ25	246	BBDZ25	186	BLZ25	550

Element Collapse Rating: 150 psid (10 bar)

Flow Direction: Outside In

Element Nominal Dimensions: BB: 5.0" (125 mm) O.D. x 18.0" (460 mm) long  
BL: 5.0" (125 mm) O.D. x 36.0" (920 mm) long

$\Delta P_{\text{housing}}$

BFT  $\Delta P_{\text{housing}}$  for fluids with sp gr (specific gravity) = 0.86:

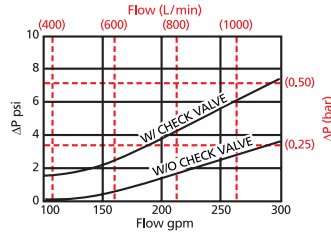

**Pressure Drop Information Based on Flow Rate and Viscosity**

$\Delta P_{\text{element}}$

BBZ

Element Pressure Drop versus Flow Rate at 32 cSt (150 SUS)

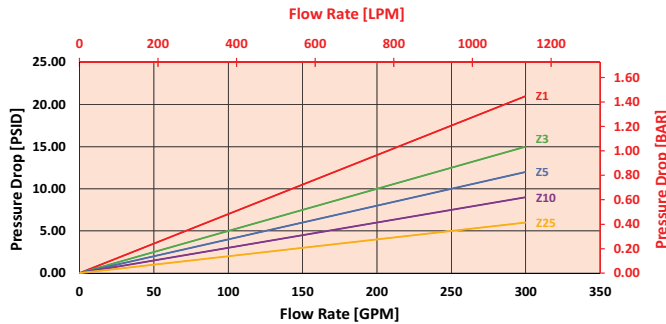

BLZ

Element Pressure Drop versus Flow Rate at 32 cSt (150 SUS)

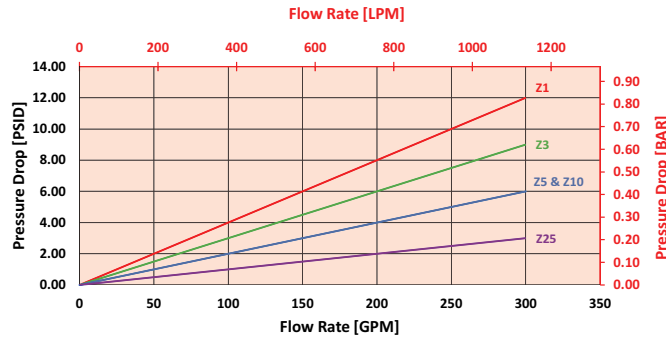

$$\Delta P_{\text{filter}} = \Delta P_{\text{housing}} + (\Delta P_{\text{element}} * \mathbf{V}_f)$$

**Exercise:**

Determine  $\Delta P_{\text{filter}}$  at 200 gpm (758 L/min) for BFT1BBZ10PY2 using 160 SUS (34 cSt) fluid.

Use the housing pressure curve to determine  $\Delta P_{\text{housing}}$  at 200 gpm. In this case,  $\Delta P_{\text{housing}}$  is 1.5 psi (.10 bar) on the graph for the BFT housing.

Use the element pressure curve to determine  $\Delta P_{\text{element}}$  at 200 gpm. In this case,  $\Delta P_{\text{element}}$  is 6 psi (.41 bar) according to the graph for the BBZ10 element.

Because the viscosity in this sample is 160 SUS (34 cSt), we determine the **Viscosity Factor ( $\mathbf{V}_f$ )** by dividing the **Operating Fluid Viscosity** with the **Standard Viscosity** of 150 SUS (32 cSt). To best determine your Operating Fluid Viscosity, please reference the chart in Appendix D.

Finally, the overall filter pressure differential,  $\Delta P_{\text{filter}}$ , is calculated by adding  $\Delta P_{\text{housing}}$  with the true element pressure differential,  $(\Delta P_{\text{element}} * \mathbf{V}_f)$ . The  $\Delta P_{\text{element}}$  from the graph has to be multiplied by the viscosity factor to get the true pressure differential across the element.

**Solution:**

$\Delta P_{\text{housing}} = 1.5 \text{ psi } [.10 \text{ bar}] \mid \Delta P_{\text{element}} = 6 \text{ psi } [.41 \text{ bar}]$

$\mathbf{V}_f = 160 \text{ SUS } (34 \text{ cSt}) / 150 \text{ SUS } (32 \text{ cSt}) = 1.1$

$\Delta P_{\text{filter}} = 1.5 \text{ psi} + (6 \text{ psi} * 1.1) = 8.1 \text{ psi}$

**OR**

$\Delta P_{\text{filter}} = .10 \text{ bar} + (.41 \text{ bar} * 1.1) = .55 \text{ bar}$

Note:  
If your element is not graphed, use the following equation:  
 $\Delta P_{\text{element}} = \text{Flow Rate} \times \Delta P_f$  Plug this variable into the overall pressure drop equation.

Ele.	$\Delta P$	Ele.	$\Delta P$
BB10	0.03	BL10	0.01
BB25	0.01	BL25	0.01
BBDZ1	0.08	BLDZ1	0.16
BBDZ3	0.06	BLDZ3	0.12
BBDZ5	0.05	BLDZ5	0.10
BBDZ10	0.04	BLDZ10	0.08
BBDZ25	0.02	BLDZ25	0.04

## Filter Model Number Selection

### How to Build a Valid Model Number for a Schroeder KF3:

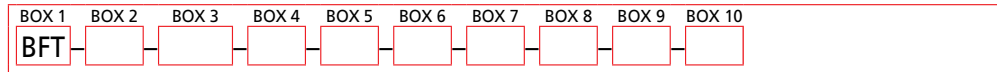

**Example:** NOTE: Only box 10 may contain more than one option

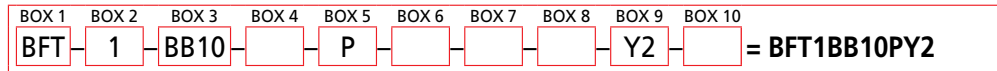

BOX 1	BOX 2	BOX 3		BOX 4
Filter Series	Number of Elements	Element Size and Media		Seal Material
BFT	1	BB Length	BL Length	Omit = Buna N H = EPR = Anodized W Aluminum Parts H.5 = Skydrol® compatibility
		BB3	= 3 μ E media (cellulose)	
		BB10	= 10 μ E media (cellulose)	
		BB25	= 25 μ E media (cellulose)	
		BBZ1	BLZ1 = 1 μ Excellement® Z-Media® (synthetic)	
		BBZ3	BLZ3 = 3 μ Excellement® Z-Media® (synthetic)	
		BBZ5	BLZ5 = 5 μ Excellement® Z-Media® (synthetic)	
		BBZ10	BLZ10 = 10 μ Excellement® Z-Media® (synthetic)	
		BBZ25	BLZ25 = 25 μ Excellement® Z-Media® (synthetic)	
		BBDZ1	= BB size DirtCatcher® 1 μ Excellement® Z-Media®	
		BBDZ3	= BB size DirtCatcher® 3 μ Excellement® Z-Media®	
		BBDZ5	= BB size DirtCatcher® 5 μ Excellement® Z-Media®	
		BBDZ10	= BB size DirtCatcher® 10 μ Excellement® Z-Media®	
		BBDZ25	= BB size DirtCatcher® 25 μ Excellement® Z-Media®	

BOX 5
Porting
P = 2½" NPTF
PP = Dual 2½" NPTF
S = SAE-32
SS = Dual SAE-32
F = 2½" SAE 4-bolt flange Code 61
FF = Dual 2½" SAE 4-bolt flange Code 61

BOX 6
Bypass Setting
Omit = 25 psi cracking
40 = 40 psi cracking

BOX 7
Outlet Porting
Omit = 3" NPT male
T = 13" Tube extension

BOX 8
Optional Check Valve
Omit = None
C = Check valve

BOX 9	
Dirt Alarm® Options	
Omit = None	
Visual	Y2 = Back-mounted tri-color gauge Y2R = Back-mounted gauge mounted on opposite side of standard location
Electrical	ES = Electric switch ESR = Electric switch mounted on opposite side of standard location ES1 = Heavy-duty electric switch with conduit connector ES1R = Heavy-duty electric switch with conduit connector mounted on opposite side of standard location

BOX 10
Additional Options
Omit = None
G547 = Two ½" gauge ports
G1476 = Three-terminal electric switch
M = Metric thread for SAE 4-bolt flange mounting holes (specify after each port designation)
40 = 40 psi bypass setting

**NOTES:**

Box 3. Replacement element part numbers are identical to contents of Boxes 3 and 4. E media elements are only available with Buna N seals.

Box 4. For options H, W, and H.5 all aluminum parts are anodized. H.5 seal designation includes the following: EPR seals, stainless steel wire mesh on elements, and light oil coating on housing exterior. Skydrol® is a registered trademark of Solutia Inc.

Box 8. See also "Accessories for Tank-Mounted Filters," page 307.

# Tank-Mounted Filter

# QT



## Features and Benefits

- Low pressure tank-mounted filter
- Designed for high return line flows
- Tank-mounted unit saves space, reduces plumbing
- Cap handles provide for easy element changeout
- Offered with standard Q, QW, and QPML deep-pleated elements in 16" and 39" lengths with Viton® seals as the standard seal option

**450 gpm**  
**1700 L/min**  
**100 psi**  
**7 bar**

Model No. of filter in photograph is QT39QZ10P48D5C.

Flow Rating:	Up to 450 gpm (1700 L/min) for 150 SUS (32 cSt) fluids
Max. Operating Pressure:	100 psi (7 bar)
Min. Yield Pressure:	300 psi (21 bar), per NFPA T2.6.1
Rated Fatigue Pressure:	100 psi (7 bar), per NFPA T2.6.1-R1-2005
Temp. Range:	-20°F to 225°F (-29°C to 107°C)
Bypass Setting:	Cracking: 30 psi (2.1 bar) Full Flow: 55 psi (3.8 bar)
Porting Head:	Steel
Element Case:	Steel
Min. Weight of QT-16Q:	100.0 lbs. (46 kg)
Min. Weight of QT-39Q:	158.0 lbs. (72 kg)
Element Change Clearance:	16Q 12.0" (305 mm) 39Q 33.8" (859 mm)

## Filter Housing Specifications

Type Fluid	Appropriate Schroeder Media
Petroleum Based Fluids	All E media (cellulose), Z-Media® and ASP® media (synthetic)
High Water Content	All Z-Media® and ASP® media (synthetic)
Invert Emulsions	10 and 25 μ Z-Media® and 10 μ ASP® media (synthetic)
Water Glycols	3, 5, 10 and 25 μ Z-Media® and all ASP® media (synthetic)
Phosphate Esters	All Z-Media® (synthetic) with H (EPR) seal designation and all ASP® media (synthetic)

## Fluid Compatibility

### Accessories For Tank-Mounted Filters

- IRF
- TF1
- KF3
- KL3
- LF1
- MLF1
- RLD
- GRTB
- MTA
- MTB
- ZT
- KFT
- RT
- RTI
- LRT
- ART
- BRT
- TRT
- BFT
- QT**
- KTK
- LTK
- MRT
- PAF1
- MAF1
- MF2

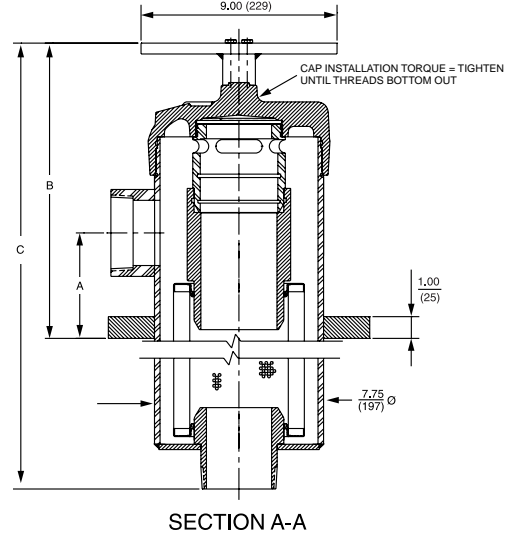
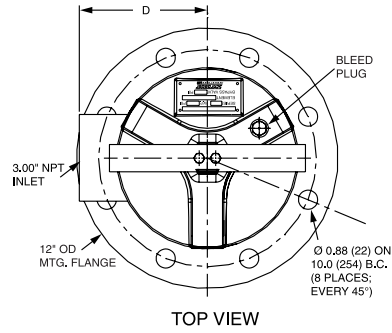

INLET PORT SIZE*	DIMENSIONS			
	A	B	C	D
3"	4.85	14.62	16Q: 30.43 (773)	5.88
	(123)	(371)	39Q: 52.25 (1327)	(149)
4"	5.75	16.12	16Q: 30.43 (773)	6.13
	(146)	(409)	39Q: 52.25 (1327)	(156)

\*Outlet port is always 3".

Metric dimensions in ( ).

Element Performance Information & Dirt Holding Capacity

Element	Filtration Ratio Per ISO 4572/NFPA T3.10.8.8 Using automated particle counter (APC) calibrated per ISO 4402			Filtration Ratio per ISO 16889 Using APC calibrated per ISO 11171		
	$\beta_x \geq 75$	$\beta_x \geq 100$	$\beta_x \geq 200$	$\beta_x(c) \geq 200$	$\beta_x(c) \geq 1000$	
16Q	Z1/PMLZ1	<1.0	<1.0	<1.0	<4.0	4.2
	Z3/PMLZ3	<1.0	<1.0	<2.0	<4.0	4.8
	Z5/PMLZ5	2.5	3.0	4.0	4.8	6.3
	Z10/PMLZ10	7.4	8.2	10.0	8.0	10.0
	Z25/PMLZ25	18.0	20.0	22.5	19.0	24.0
39Q	Z1/PMLZ1	<1.0	<1.0	<1.0	<4.0	4.2
	Z3/PMLZ3	<1.0	<1.0	<2.0	<4.0	4.8
	Z5/PMLZ5	2.5	3.0	4.0	4.8	6.3
	Z10/PMLZ10	7.4	8.2	10.0	8.0	10.0
	Z25/PMLZ25	18.0	20.0	22.5	19.0	24.0

Element	DHC (gm)	Element	DHC (gm)
16Q	Z1	PMLZ1	307
	Z3	PMLZ3	315
	Z5	PMLZ5	364
	Z10	PMLZ10	330
	Z25	PMLZ25	299
39Q	Z1	PMLZ1	1485
	Z3	PMLZ3	1525
	Z5	PMLZ5	1235
	Z10	PMLZ10	1432
	Z25	PMLZ25	1299

Element Collapse Rating: Q and QPML: 150 psid (10 bar)

Flow Direction: Outside In

Element Nominal Dimensions: 16Q: 6.0" (150 mm) O.D. x 16.85" (430 mm) long  
 16QPML: 6.0" (150 mm) O.D. x 16.00" (405 mm) long  
 39Q: 6.0" (150 mm) O.D. x 38.70" (985 mm) long  
 39QPML: 6.0" (150 mm) O.D. x 37.80" (960 mm) long



### $\Delta P_{\text{housing}}$

QT  $\Delta P_{\text{housing}}$  for fluids with sp gr (specific gravity) = 0.86:

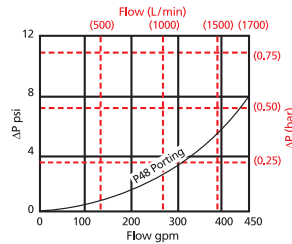

### $\Delta P_{\text{element}}$

39QZ Element Pressure Drop versus Flow Rate at 32 cSt (150 SUS)

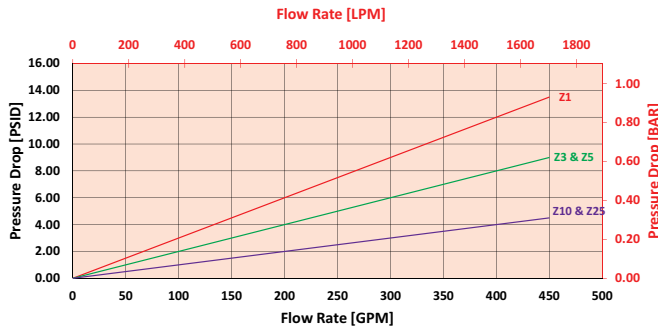

39QFMLZ Element Pressure Drop versus Flow Rate at 32 cSt (150 SUS)

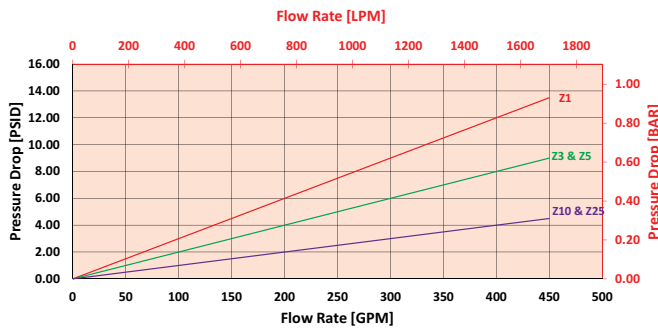

$$\Delta P_{\text{filter}} = \Delta P_{\text{housing}} + (\Delta P_{\text{element}} * \mathbf{V}_f)$$

### Exercise:

Determine  $\Delta P_{\text{filter}}$  at 200 gpm (758 L/min) for QT16QZ3P48D5C using 160 SUS (34 cSt) fluid.

Use the housing pressure curve to determine  $\Delta P_{\text{housing}}$  at 200 gpm. In this case,  $\Delta P_{\text{housing}}$  is 2 psi (.14 bar) on the graph for the QT housing.

Use the element pressure curve to determine  $\Delta P_{\text{element}}$  at 200 gpm. In this case,  $\Delta P_{\text{element}}$  is 8 psi (.55 bar) according to the graph for the 16QZ3 element.

Because the viscosity in this sample is 160 SUS (34 cSt), we determine the **Viscosity Factor ( $\mathbf{V}_f$ )** by dividing the **Operating Fluid Viscosity** with the **Standard Viscosity** of 150 SUS (32 cSt). To best determine your Operating Fluid Viscosity, please reference the chart in Appendix D.

Finally, the overall filter pressure differential,  $\Delta P_{\text{filter}}$ , is calculated by adding  $\Delta P_{\text{housing}}$  with the true element pressure differential, ( $\Delta P_{\text{element}} * \mathbf{V}_f$ ). The  $\Delta P_{\text{element}}$  from the graph has to be multiplied by the viscosity factor to get the true pressure differential across the element.

### Solution:

$$\Delta P_{\text{housing}} = 2 \text{ psi } [.14 \text{ bar}] \quad | \quad \Delta P_{\text{element}} = 8 \text{ psi } [.55 \text{ bar}]$$

$$\mathbf{V}_f = 160 \text{ SUS (34 cSt)} / 150 \text{ SUS (32 cSt)} = 1.1$$

$$\Delta P_{\text{filter}} = 2 \text{ psi} + (8 \text{ psi} * 1.1) = 10.8 \text{ psi}$$

OR

$$\Delta P_{\text{filter}} = .14 \text{ bar} + (.55 \text{ bar} * 1.1) = .75 \text{ bar}$$

## Pressure Drop Information Based on Flow Rate and Viscosity

Note:

If your element is not graphed, use the following equation:  
 $\Delta P_{\text{element}} = \text{Flow Rate} \times \Delta P_f$  Plug this variable into the overall pressure drop equation.

Ele.	$\Delta P$	Ele.	$\Delta P$
16QAS3V	0.04	16QPMLZ1	0.08
16QAS5V	0.04	16QPMLZ3	0.05
16QAS10V	0.03	16QPMLZ5	0.05
16QPMLAS3V	0.05	16QPMLZ10	0.04
16QPMLASSV	0.05	16QPMLZ25	0.02
16QPMLAS10V	0.04	39QAS3V	0.01
16QZ1	0.09	39QAS5V	0.01
16QZ3	0.04	39QAS10V	0.01
16QZ5	0.04	39QPMLAS3V	0.02
16QZ10	0.03	39QPMLASSV	0.02
16QZ25	0.01	39QPMLAS10V	0.01

## Filter Model Number Selection

### How to Build a Valid Model Number for a Schroeder QT:

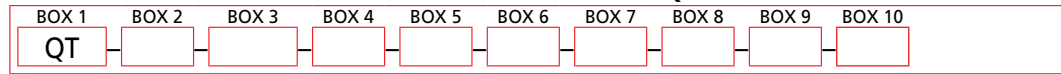

**Example:** NOTE: One option per box

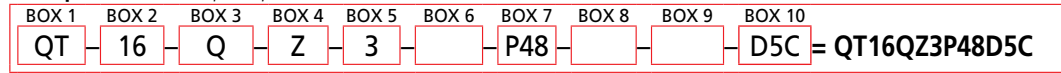

BOX 1	BOX 2	BOX 3	BOX 4	BOX 5	BOX 6
<b>Filter Series</b>	<b>Element Length (in)</b>	<b>Element Style</b>	<b>Media Type</b>	<b>Micron Rating</b>	<b>Housing Seal Material</b>
QT	16 39	Q QCLQF QPML	Z = Excellerent® Z-Media® (synthetic) W = W media (water removal) AS = Anti-Static Pleat Media (synthetic)	1 = 1 μ Z-Media® 3 = 3 μ AS and Z-Media® 5 = 5 μ AS and Z-Media® 10 = 10 μ AS and Z-Media® 25 = 25 μ Z-Media®	Omit = Buna N H = EPR V = Viton®

**BOX 7**

Inlet Porting
P48 = 3" NPTF P64 = 4" NPTF

**BOX 8**

Bypass Setting
Omit = 30 psi cracking 15 = 15 psi cracking 40 = 40 psi cracking 50 = 50 psi cracking X = Blocked bypass

**BOX 9**

Outlet Porting
Omit = 3" NPT Male C = Check valve D = Diffuser CD = Check valve and diffuser

**BOX 10**

Dirt Alarm® Options	
	Omit = None
Visual	D5C = Visual pop-up in cap
Visual with Thermal Lockout	D8C = Visual w/ thermal lockout in cap
Electrical	MS5C = Electrical w/ 12 in. 18 gauge 4-conductor cable in cap MS5LCC = Low current MS5 in cap MS10C = Electrical w/ DIN connector (male end only) in cap MS10LCC = Low current MS10 in cap MS11C = Electrical w/ 12 ft. 4-conductor wire in cap MS12C = Electrical w/ 5 pin Brad Harrison connector (male end only) in cap MS12LCC = Low current MS12 in cap MS16C = Electrical w/ weather-packed sealed connector in cap MS16LCC = Low current MS16 in cap MS17LCC = Electrical w/ 4 pin Brad Harrison male connector in cap
Electrical with Thermal Lockout	MS5T = MS5 (see above) w/ thermal lockout in cap MS5LCT = Low current MS5T in cap MS10TC = MS10 (see above) w/ thermal lockout in cap MS10LCTC = Low current MS10T in cap MS12TC = MS12 (see above) w/ thermal lockout MS12LCTC = Low current MS12T in cap MS16TC = MS16 (see above) w/ thermal lockout in cap MS16LCTC = Low current MS16T in cap MS17LCTC = Low current MS17T in cap
Electrical Visual	MS13C = Supplied w/ threaded connector & light in cap MS14C = Supplied w/ 5 pin Brad Harrison connector & light (male end) in cap
Electrical Visual with Thermal Lockout	MS13DCTC = MS13 (see above), direct current, w/ thermal lockout in cap MS13DCLCTC = Low current MS13DCT in cap MS14DCTC = MS14 (see above), direct current, w/ thermal lockout in cap MS14DCLCTC = Low current MS14DCT in cap

**NOTES:**

- Box 2. Replacement element part numbers are a combination of Boxes 2, 3, 4 and 5, plus the letter V. Example: 16QZ1V
- Box 3. QCLQF element are not available in ASP® media.
- Box 4. E media elements are also available for the QT filter housing. Contact factory for more information.
- Box 4. For Option W, Box 3 must equal Q.
- Box 6. Viton® is a registered trademark of DuPont Dow Elastomers. All elements for this filter are supplied with Viton® seals. Seal designation in Box 6 applies to housing only.

# Tank-Mounted Filter Kit

# KTK



## Features and Benefits

- Special tank-mounted filter kit
- Includes: cap assembly, weld ring assembly, element and bushing
- Available with standard K, KK or 27K-size elements
- Bypass valve in cap assembly

**100 gpm**  
**380 L/min**  
**100 psi**  
**7 bar**

Model No. of filter in photograph is KTKKKZ10.

Flow Rating:	Up to 100 gpm (380 L/min) for 150 SUS (32 cSt) fluids
Max. Operating Pressure:	100 psi (7 bar) exclusive of tank design
Min. Yield Pressure:	Contact factory
Rated Fatigue Pressure:	Contact factory
Temp. Range:	-20°F to 225°F (-29°C to 107°C)
Bypass Setting:	Cracking: 25 psi (1.7 bar) Full Flow: 40 psi (2.8 bar)
Porting Cap:	Die Cast Aluminum
Weld Ring:	Steel
Element Change Clearance:	8.0" (205 mm) for K; 17.50" (445 mm) for KK; 26.5" (673 mm) for 27K

## Filter Housing Specifications

Type Fluid	Appropriate Schroeder Media
Petroleum Based Fluids	All E media (cellulose), Z-Media® and ASP® media (synthetic)
High Water Content	All Z-Media® and all ASP® media (synthetic)
Invert Emulsions	10 and 25 µ Z-Media® and 10 µ ASP® media (synthetic)
Water Glycols	3, 5, 10 and 25 µ Z-Media® and all ASP® media (synthetic)
Phosphate Esters	All Z-Media® (synthetic) with H (EPR) seal designation and 3 and 10 µ E media (cellulose) with H (EPR) seal designation and ASP® media (synthetic)
Skydrol®	3, 5, 10 and 25 µ Z-Media® (synthetic) with H.5 seal designation (EPR seals and stainless steel wire mesh in element, and light oil coating on housing exterior) and all ASP® media (synthetic)

## Fluid Compatibility

## Accessories For Tank-Mounted Filters

- IRF
- TF1
- KF3
- KL3
- LF1
- MLF1
- RLD
- GRTB
- MTA
- MTB
- ZT
- KFT
- RT
- RTI
- LRT
- ART
- BRT
- TRT
- BFT
- QT
- KTK**
- LTK
- MRT
- PAF1
- MAF1
- MF2

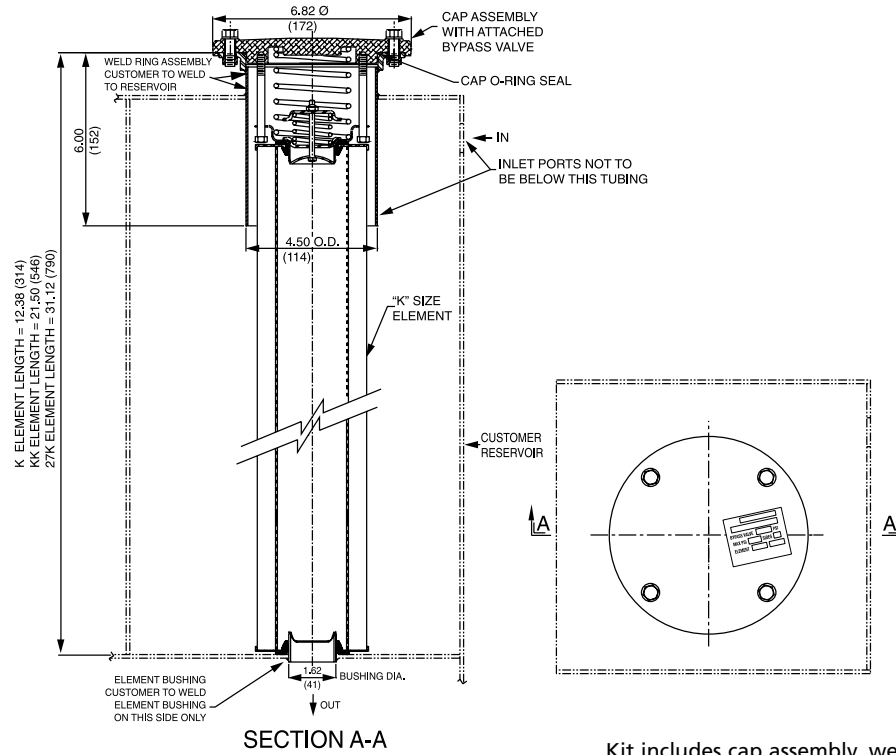

Metric dimensions in ( ).

Kit includes cap assembly, weld ring assembly, element, and bushing.

## Element Performance Information & Dirt Holding Capacity

Element	Filtration Ratio Per ISO 4572/NFPA T3.10.8.8 Using automated particle counter (APC) calibrated per ISO 4402			Filtration Ratio per ISO 16889 Using APC calibrated per ISO 11171	
	$\beta_x \geq 75$	$\beta_x \geq 100$	$\beta_x \geq 200$	$\beta_x(c) \geq 200$	$\beta_x(c) \geq 1000$
KZ1	<1.0	<1.0	<1.0	<4.0	4.2
KZ3	<1.0	<1.0	<2.0	<4.0	4.8
KZ5	2.5	3.0	4.0	4.8	6.3
KZ10	7.4	8.2	10.0	8.0	10.0
KZ25	18.0	20.0	22.5	19.0	24.0
KZW1	N/A	N/A	N/A	<4.0	<4.0
KZW3/KKZW3	N/A	N/A	N/A	4.0	4.8
KZW5/KKZW5	N/A	N/A	N/A	5.1	6.4
KZW10/KKZW10	N/A	N/A	N/A	6.9	8.6
KZW25/KKZW25	N/A	N/A	N/A	15.4	18.5

Element	DHC (gm)	Element	DHC (gm)	Element	DHC (gm)	Element	DHC (gm)	Element	DHC (gm)
KZ1	112	KKZ1	224	27KZ1	336	KZW1	61		
KZ3	115	KKZ3	230	27KZ3	345	KZW3	64	KKZW3	128
KZ5	119	KKZ5	238	27KZ5	357	KZW5	63	KKZW5	126
KZ10	108	KKZ10	216	27KZ10	324	KZW10	57	KKZW10	114
KZ25	93	KKZ25	186	27KZ25	279	KZW25	79	KKZW25	158

Element Collapse Rating: 150 psid (10 bar) for standard elements

Flow Direction: Outside In

Element Nominal Dimensions: 3.9" (99 mm) O.D. x 9.0" (230 mm) long

## Pressure Drop Information Based on Flow Rate and Viscosity

\*KTK Dirty Box Pressure Drop is Customer Tank Design Dependant. Please account for this when designing system.

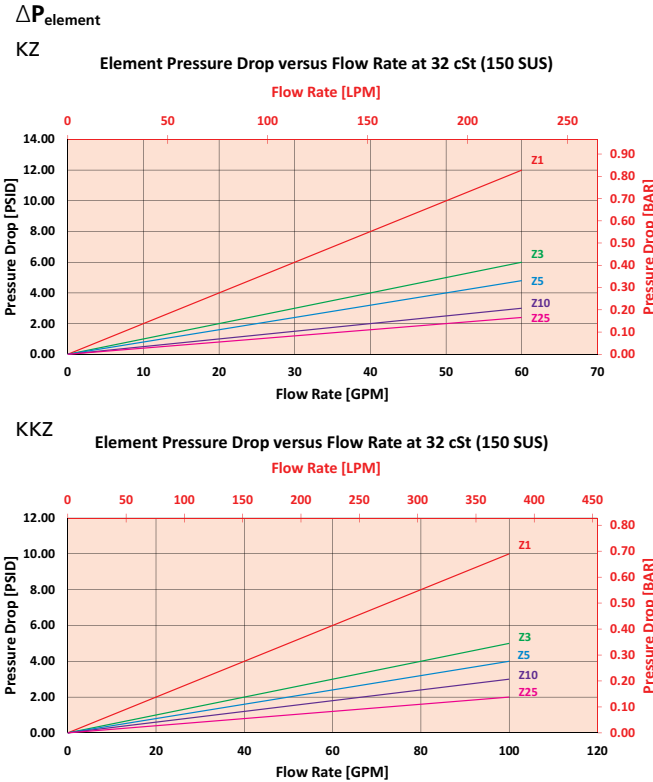

$$\Delta P_{\text{filter}} = \Delta P_{\text{housing}} + (\Delta P_{\text{element}} * \mathbf{V}_f)$$

### Exercise:

Determine  $\Delta P_{\text{filter}}$  at 80 gpm (303.2 L/min) for KTKKZ3 using 160 SUS (34 cSt) fluid.

Use the element pressure curve to determine  $\Delta P_{\text{element}}$  at 80 gpm. In this case,  $\Delta P_{\text{element}}$  is 8 psi (.55 bar) according to the graph for the KZ3 element.

Because the viscosity in this sample is 160 SUS (34 cSt), we determine the **Viscosity Factor ( $\mathbf{V}_f$ )** by dividing the **Operating Fluid Viscosity** with the **Standard Viscosity** of 150 SUS (32 cSt). To best determine your Operating Fluid Viscosity, please reference the chart in Appendix D.

Finally, the overall filter pressure differential,  $\Delta P_{\text{filter}}$ , is calculated by adding  $\Delta P_{\text{housing}}$  with the true element pressure differential,  $(\Delta P_{\text{element}} * \mathbf{V}_f)$ . The  $\Delta P_{\text{element}}$  from the graph has to be multiplied by the viscosity factor to get the true pressure differential across the element.

### Solution:

$$\Delta P_{\text{element}} = 8 \text{ psi } [.55 \text{ bar}]$$

$$\mathbf{V}_f = 160 \text{ SUS } (34 \text{ cSt}) / 150 \text{ SUS } (32 \text{ cSt}) = 1.1$$

$$\Delta P_{\text{filter}} = (8 \text{ psi} * 1.1) = 8.8 \text{ psi}$$

OR

$$\Delta P_{\text{filter}} = (.55 \text{ bar} * 1.1) = .61 \text{ bar}$$

Note:

If your element is not graphed, use the following equation:  
 $\Delta P_{\text{element}} = \text{Flow Rate} \times \Delta P_f$  Plug this variable into the overall pressure drop equation.

Ele.	$\Delta P$	Ele.	$\Delta P$	Ele.	$\Delta P$
K3	0.25	2K3/ KK3	0.12	3KZ1/ 27KZ1	0.05
K10	0.09	2K10/ KK10	0.05	3KZ3/ 27KZ3	0.03
K25	0.02	2K25/ KK25	0.01	3KZ5/ 27KZ5	0.02
KAS3	0.10	2KAS3/ KKAS3	0.05	3KZ10/ 27KZ10	0.02
KAS5	0.08	2KAS5/ KKAS5	0.04	3KZ25/ 27KZ25	0.01
KAS10	0.05	2KAS10/ KKAS10	0.03	3K3	0.08
KZW1	0.43	2KZW1	-	3K10	0.03
KZW3	0.32	2KZW3/ KKZW3	0.16	3K25	0.01
KZW5	0.28	2KZW5/ KKZW5	0.14	3KAS3/ 27KAS3	0.03
KZW10	0.23	2KZW10/ KKZW10	0.12	3KAS5/ 27KAS5	0.02
KZW25	0.14	2KZW25/ KKZW25	0.07	3KAS10/ 27KAS10	0.02

## Filter Model Number Selection

### How to Build a Valid Model Number for a Schroeder KTK:

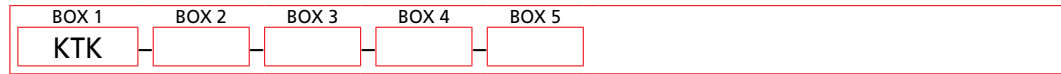

**Example:** NOTE: One option per box

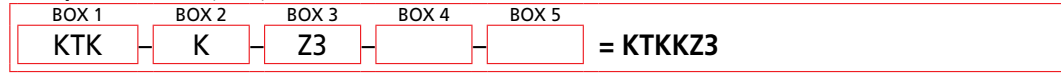

BOX 1	BOX 2	BOX 3
<b>Filter Series</b>	<b>Element Length</b>	<b>Element Part Number</b>
KTK	K KK 27K	3 = 3 μ E media (cellulose) 10 = 10 μ E media (cellulose) 25 = 25 μ E media (cellulose) Z1 = 1 μ Excellement® Z-Media® (synthetic) Z3/AS3 = 3 μ Excellement® Z-Media® (synthetic) Z5/AS5 = 5 μ Excellement® Z-Media® (synthetic) Z10/AS10 = 10 μ Excellement® Z-Media® (synthetic) Z25 = 25 μ Excellement® Z-Media® (synthetic) ZW1 = 1 μ Aqua-Excellement™ ZW media ZW3 = 3 μ Aqua-Excellement™ ZW media ZW5 = 5 μ Aqua-Excellement™ ZW media ZW10 = 10 μ Aqua-Excellement™ ZW media ZW25 = 25 μ Aqua-Excellement™ ZW media ZW1 = 1 μ Aqua-Excellement™ ZW media ZW3 = 3 μ Aqua-Excellement™ ZW media ZW5 = 5 μ Aqua-Excellement™ ZW media ZW10 = 10 μ Aqua-Excellement™ ZW media ZW25 = 25 μ Aqua-Excellement™ ZW media

BOX 4	BOX 5
<b>Seal Material</b>	<b>Dirt Alarm® Options</b>
Omit = Buna N H = EPR W = Buna N H.5 = Skydrol® Compatibility	Omit = None Visual Y2C = Bottom-mounted gauge in cap

#### NOTES:

Box 3. Replacement element part numbers are identical to contents of Boxes 2, 3, and 4.

Box 4. For options H and W, cap is anodized. H.5 seal designation includes the following: EPR seals, stainless steel wire mesh on elements, and light oil coating on housing exterior. Skydrol® is a registered trademark of Solutia Inc.

# Tank-Mounted Filter Kit

**LTK**



## Features and Benefits

- Special tank-mounted filter kit
- Includes: cap assembly, weld ring assembly, element and bushing
- Available with standard 18L sized element
- Bypass valve in cap assembly

**150 gpm**  
**570 L/min**  
**100 psi**  
**7 bar**

Model No. of filter in photograph is LTK18LZ3.

Flow Rating:	Up to 150 gpm (570 L/min) for 150 SUS (32 cSt) fluids
Max. Operating Pressure:	100 psi (7 bar) exclusive of tank design
Min. Yield Pressure:	Contact factory
Rated Fatigue Pressure:	Contact factory
Temp. Range:	-20°F to 225°F (-29°C to 107°C)
Bypass Setting:	Cracking: 25 psi (1.7 bar) Full Flow: 47 psi (3.2 bar)
Porting Cap:	Die Cast Aluminum
Weld Ring:	Steel
Element Change Clearance:	17.0" (435 mm)

## Filter Housing Specifications

Type Fluid	Appropriate Schroeder Media
Petroleum Based Fluids	All E media (cellulose) and Z-Media® (synthetic)
High Water Content	All Z-Media® (synthetic)
Invert Emulsions	10 and 25 μ Z-Media® (synthetic)
Water Glycols	3, 5, 10 and 25 μ Z-Media® (synthetic)
Phosphate Esters	All Z-Media® (synthetic) with H (EPR) seal designation and 3 and 10 μ E media (cellulose) with H (EPR) seal designation
Skydrol®	3, 5, 10 and 25 μ Z-Media® (synthetic) with H.5 seal designation (EPR seals and stainless steel wire mesh in element, and light oil coating on housing exterior)

## Fluid Compatibility

### Accessories For Tank-Mounted Filters

- IRF
- TF1
- KF3
- KL3
- LF1
- MLF1
- RLD
- GRTB
- MTA
- MTB
- ZT
- KFT
- RT
- RTI
- LRT
- ART
- BRT
- TRT
- BFT
- QT
- KTK
- LTK**
- MRT
- PAF1
- MAF1
- MF2

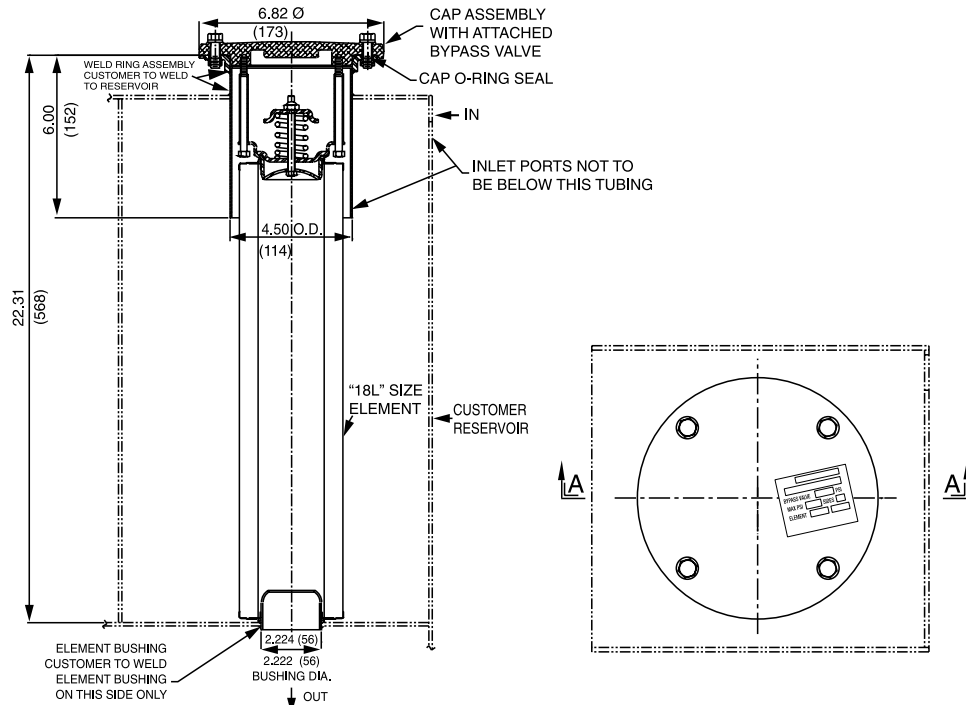

Metric dimensions in ( ). SECTION A-A

## Element Performance Information & Dirt Holding Capacity

Element	Filtration Ratio Per ISO 4572/NFPA T3.10.8.8 Using automated particle counter (APC) calibrated per ISO 4402			Filtration Ratio per ISO 16889 Using APC calibrated per ISO 11171	
	$\beta_x \geq 75$	$\beta_x \geq 100$	$\beta_x \geq 200$	$\beta_x(c) \geq 200$	$\beta_x(c) \geq 1000$
18LZ1	<1.0	<1.0	<1.0	<4.0	4.2
18LZ3	<1.0	<1.0	<2.0	<4.0	4.8
18LZ5	2.5	3.0	4.0	4.8	6.3
18LZ10	7.4	8.2	10.0	8.0	10.0
18LZ25	18.0	20.0	22.5	19.0	24.0

Element	DHC (gm)
18LZ1	224
18LZ3	230
18LZ5	238
18LZ10	216
18LZ25	186

Element Collapse Rating: 150 psid (10 bar)  
 Flow Direction: Outside In  
 Element Nominal Dimensions: 4.0" (100 mm) O.D. x 18.5" (470 mm) long



\*LTK Dirty Box Pressure Drop is Customer Tank Design Dependant. Please account for this when designing system.

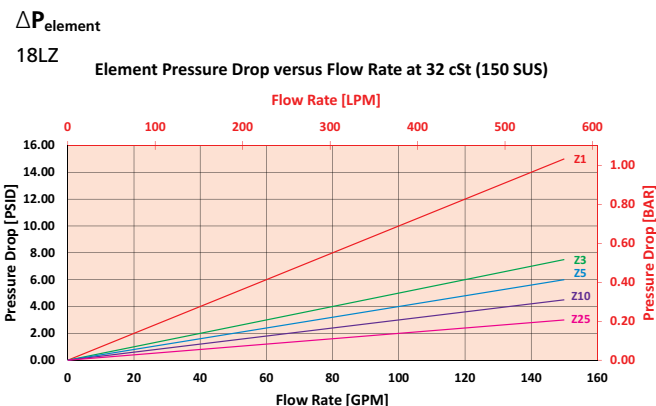

$$\Delta P_{\text{filter}} = \Delta P_{\text{housing}} + (\Delta P_{\text{element}} * \mathbf{V}_f)$$

**Exercise:**

Determine  $\Delta P_{\text{filter}}$  at 80 gpm (303.2 L/min) for LTK18LKZ3 using 160 SUS (34 cSt) fluid.

Use the element pressure curve to determine  $\Delta P_{\text{element}}$  at 80 gpm. In this case,  $\Delta P_{\text{element}}$  is 4 psi (.27 bar) according to the graph for the 18LZ3 element.

Because the viscosity in this sample is 160 SUS (34 cSt), we determine the **Viscosity Factor ( $\mathbf{V}_f$ )** by dividing the **Operating Fluid Viscosity** with the **Standard Viscosity** of 150 SUS (32 cSt). To best determine your Operating Fluid Viscosity, please reference the chart in Appendix D.

Finally, the overall filter pressure differential,  $\Delta P_{\text{filter}}$ , is calculated by adding  $\Delta P_{\text{housing}}$  with the true element pressure differential, ( $\Delta P_{\text{element}} * \mathbf{V}_f$ ). The  $\Delta P_{\text{element}}$  from the graph has to be multiplied by the viscosity factor to get the true pressure differential across the element.

**Solution:**

$$\Delta P_{\text{element}} = 4 \text{ psi } [.27 \text{ bar}]$$

$$\mathbf{V}_f = 160 \text{ SUS (34 cSt) } / 150 \text{ SUS (32 cSt) } = 1.1$$

$$\Delta P_{\text{filter}} = (4 \text{ psi } * 1.1) = 4.4 \text{ psi}$$

**OR**

$$\Delta P_{\text{filter}} = (.27 \text{ bar } * 1.1) = .30 \text{ bar}$$

**Filter Model Number Selection**

**How to Build a Valid Model Number for a Schroeder LTK:**

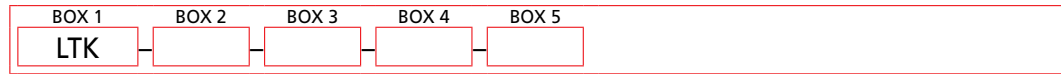

**Example:** NOTE: One option per box

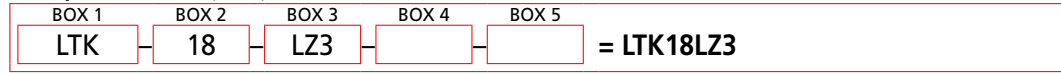

BOX 1	BOX 2	BOX 3	BOX 4
Filter Series	Length of Element (in)	Element Size and Media	Seal Material
LTK	18	L3 = L size 3 $\mu$ E media (cellulose) L10 = L size 10 $\mu$ E media (cellulose) L25 = L size 25 $\mu$ E media (cellulose) LZ1 = L size 1 $\mu$ Excellement® Z-Media® (synthetic) LZ3 = L size 3 $\mu$ Excellement® Z-Media® (synthetic) LZ5 = L size 5 $\mu$ Excellement® Z-Media® (synthetic) LZ10 = L size 10 $\mu$ Excellement® Z-Media® (synthetic) LZ25 = L size 25 $\mu$ Excellement® Z-Media® (synthetic)	Omit = Buna N H = EPR W = Buna N H.5 = Skydrol® Compatibility

BOX 5	
Dirt Alarm® Options	
Omit	= None
Visual	Y2C = Bottom-mounted gauge in cap

**NOTES:**

Box 2. Replacement element part numbers are a combination of Boxes 2, 3, and 4.  
 Example: 18LZ3H

Box 4. For options H and W, cap is anodized.  
 H.5 seal designation includes the following:  
 EPR seals, stainless steel wire mesh on elements, and light oil coating on housing exterior.  
 Skydrol® is a registered trademark of Solutia Inc.

# Medium Pressure In-Tank Filter

## MRT



### Features and Benefits

- Medium pressure tank mounted filter ideal for applications with high pressure surge in the return line
- Two possible inlet porting locations
- Various Dirt Alarm® options available
- Also available with DirtCatcher® element
- Optional sampling fitting available upon request

**150 gpm**  
**570 L/min**  
**900 psi**  
**62 bar**

IRF  
 TF1  
 KF3  
 KL3  
 LF1  
 MLF1  
 RLD  
 GRTB  
 MTA  
 MTB  
 ZT  
 KFT

Model No. of filter in photograph is MRT18LZ10S24S24D5.

Flow Rating:	Up to 150 gpm (570 L/min) for 150 SUS (32 cSt) fluids
Max. Operating Pressure:	900 psi (62 bar)
Min. Yield Pressure:	2700 psi (186 bar), per NFPA T2.6.1
Rated Fatigue Pressure:	750 psi (52 bar), per NFPA T2.6.1-2005
Temp. Range:	-20°F to 225°F (-29°C to 107°C)
Bypass Setting:	Cracking: 40 psi (2.8 bar)
Porting Head & Cap:	Cast Aluminum (Anodized)
Element Case:	Steel
Weight of MRT:	36.0 lbs. (16.4 kg)
Element Change Clearance:	17.0" (432 mm)

### Filter Housing Specifications

RT  
 RTI  
 LRT  
 ART  
 BRT  
 TRT  
 BFT  
 QT  
 KTK  
 LTK

Type Fluid	Appropriate Schroeder Media
Petroleum Based Fluids	All E media (cellulose) and Z-Media® (synthetic)
High Water Content	All Z-Media® (synthetic)
Invert Emulsions	10 and 25 µ Z-Media® (synthetic)
Water Glycols	3, 5, 10 and 25 µ Z-Media® (synthetic)

### Fluid Compatibility

#### MRT

### Accessories For Tank-Mounted Filters

PAF1  
 MAF1  
 MF2

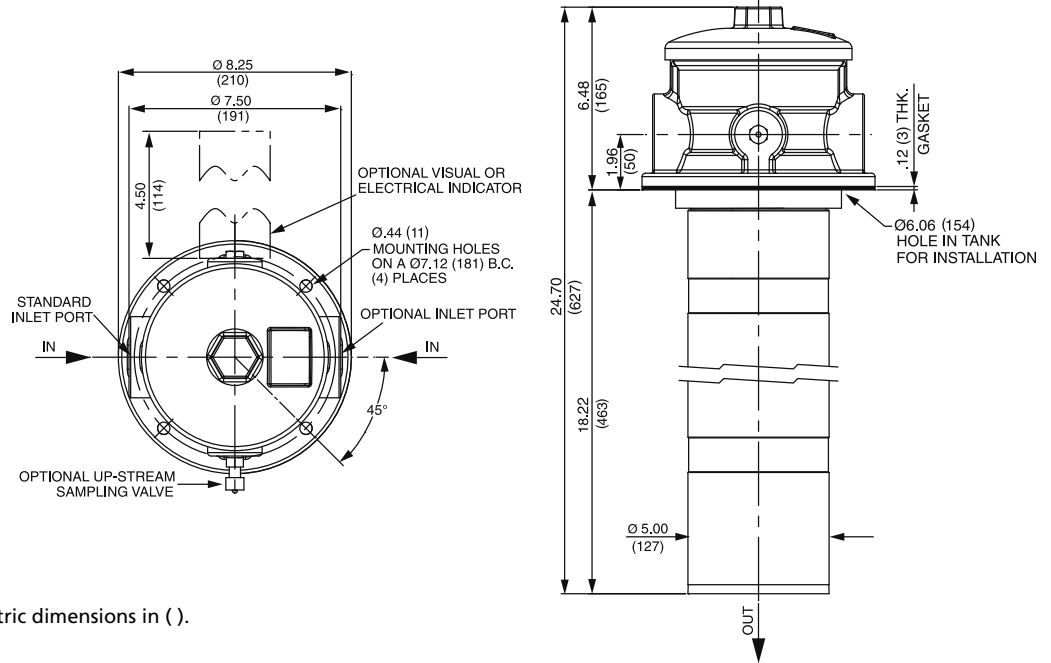

Metric dimensions in ( ).

**Element Performance Information & Dirt Holding Capacity**

Element	Filtration Ratio Per ISO 4572/NFPA T3.10.8.8 Using automated particle counter (APC) calibrated per ISO 4402			Filtration Ratio per ISO 16889 Using APC calibrated per ISO 11171	
	$\beta_x \geq 75$	$\beta_x \geq 100$	$\beta_x \geq 200$	$\beta_x(c) \geq 200$	$\beta_x(c) \geq 1000$
18LZ1	<1.0	<1.0	<1.0	<4.0	4.2
18LZ3	<1.0	<1.0	<2.0	<4.7	5.8
18LZ5	2.5	3.0	4.0	6.5	7.5
18LZ10	7.4	8.2	10.0	10.0	12.7
18LZ25	18.0	20.0	22.5	19.0	24.0
18LDZ1	<1.0	<1.0	<1.0	<4.0	4.2
18LDZ3	<1.0	<1.0	<2.0	<4.7	5.8
18LDZ5	2.5	3.0	4.0	6.5	7.5
18LDZ10	7.4	8.2	10.0	10.0	12.7
18LDZ25	18.0	20.0	22.5	19.0	24.0

Element	DHC (gm)	Element	DHC (gm)
18LZ1	224	18LDZ1	194
18LZ3	230	18LDZ3	199
18LZ5	238	18LDZ5	149
18LZ10	216	18LDZ10	186
18LZ25	186	18LDZ25	169

Element Collapse Rating: 150 psid (10 bar)

Flow Direction: Outside In

Element Nominal Dimensions: 4.0" (100 mm) O.D. x 18.5" (470 mm) long

### $\Delta P_{\text{housing}}$

MRT  $\Delta P_{\text{housing}}$  for fluids with sp gr (specific gravity) = 0.86:

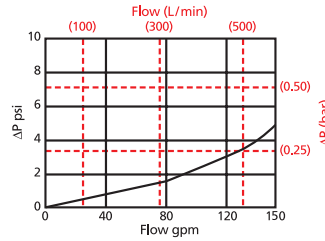

### $\Delta P_{\text{element}}$

18LZ Element Pressure Drop versus Flow Rate at 32 cSt (150 SUS)

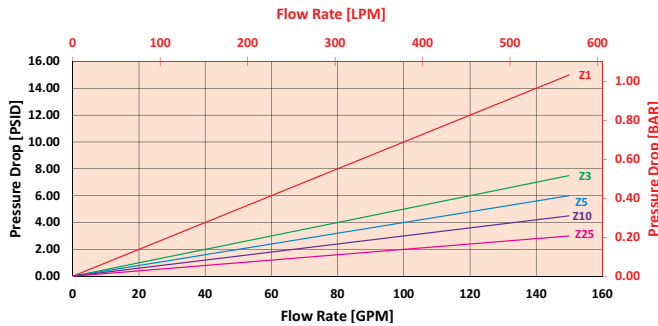

18LDZ Element Pressure Drop versus Flow Rate at 32 cSt (150 SUS)

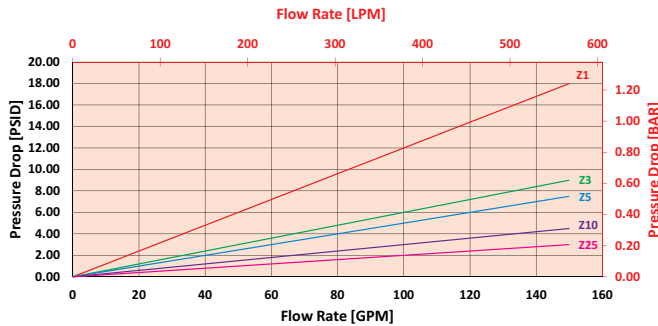

$$\Delta P_{\text{filter}} = \Delta P_{\text{housing}} + (\Delta P_{\text{element}} * \mathbf{V}_f)$$

### Exercise:

Determine  $\Delta P_{\text{filter}}$  at 80 gpm (303.2 L/min) for MRT18LZ10S24S24 using 160 SUS (34 cSt) fluid.

Use the housing pressure curve to determine  $\Delta P_{\text{housing}}$  at 80 gpm. In this case,  $\Delta P_{\text{housing}}$  is 1.5 psi (.10 bar) on the graph for the MRT housing.

Use the element pressure curve to determine  $\Delta P_{\text{element}}$  at 80 gpm. In this case,  $\Delta P_{\text{element}}$  is 2.5 psi (.17 bar) according to the graph for the 18LZ10 element.

Because the viscosity in this sample is 160 SUS (34 cSt), we determine the **Viscosity Factor ( $\mathbf{V}_f$ )** by dividing the **Operating Fluid Viscosity** with the **Standard Viscosity** of 150 SUS (32 cSt). To best determine your Operating Fluid Viscosity, please reference the chart in Appendix D.

Finally, the overall filter pressure differential,  $\Delta P_{\text{filter}}$ , is calculated by adding  $\Delta P_{\text{housing}}$  with the true element pressure differential, ( $\Delta P_{\text{element}} * \mathbf{V}_f$ ). The  $\Delta P_{\text{element}}$  from the graph has to be multiplied by the viscosity factor to get the true pressure differential across the element.

### Solution:

$$\Delta P_{\text{housing}} = 1.5 \text{ psi } [.10 \text{ bar}] \quad | \quad \Delta P_{\text{element}} = 2.5 \text{ psi } [.17 \text{ bar}]$$

$$\mathbf{V}_f = 160 \text{ SUS (34 cSt)} / 150 \text{ SUS (32 cSt)} = 1.1$$

$$\Delta P_{\text{filter}} = 1.5 \text{ psi} + (2.5 \text{ psi} * 1.1) = 4.3 \text{ psi}$$

OR

$$\Delta P_{\text{filter}} = .10 \text{ bar} + (.17 \text{ bar} * 1.1) = .29 \text{ bar}$$

Pressure Drop Information Based on Flow Rate and Viscosity

## Filter Model Number Selection

### How to Build a Valid Model Number for a Schroeder MRT:

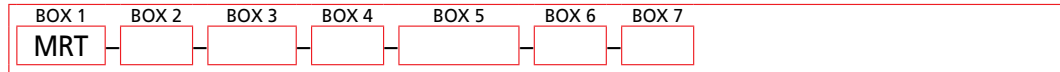

Example: NOTE: One option per box

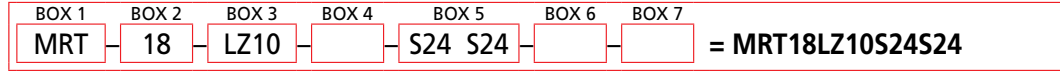

BOX 1	BOX 2	BOX 3	BOX 4
<b>Filter Series</b>	<b>Element Length (in)</b>	<b>Element Size and Media</b>	<b>Seal Material</b>
MRT	18	L3 = L size 3 µ E media (cellulose) L10 = L size 10 µ E media (cellulose) LZ1 = L size 1 µ Excellement® Z-Media® (synthetic) LZ3 = L size 3 µ Excellement® Z-Media® (synthetic) LZ5 = L size 5 µ Excellement® Z-Media® (synthetic) LZ10 = L size 10 µ Excellement® Z-Media® (synthetic) LZ25 = L size 25 µ Excellement® Z-Media® (synthetic) LDZ1 = L size DirtCatcher® 1 µ Excellement® Z-Media® LDZ3 = L size DirtCatcher® 3 µ Excellement® Z-Media® LDZ5 = L size DirtCatcher® 5 µ Excellement® Z-Media® LDZ10 = L size DirtCatcher® 10 µ Excellement® Z-Media® LDZ25 = L size DirtCatcher® 25 µ Excellement® Z-Media®	Omit = Buna N

BOX 5  
Specification of both ports is required

Inlet Porting		Inlet Porting Location
<b>Port A</b> S = S24 N = None	<b>Port B</b> S = S24 N = None	

Indicator

Top View

Sampling Valve (Optional)

BOX 6

Dirt Alarm® Options	
	Omit = None
Visual	D5 = Visual pop-up
Visual with Thermal Lockout	D8 = Visual w/ thermal lockout
Electrical	MS5 = Electrical w/ 12 in. 18 gauge 4-conductor cable MS5LC = Low current MS5 MS10 = Electrical w/ DIN connector (male end only) MS10LC = Low current MS10 MS11 = Electrical w/ 12 ft. 4-conductor wire MS12 = Electrical w/ 5 pin Brad Harrison connector (male end only) MS12LC = Low current MS12 MS16 = Electrical w/ weather-packed sealed connector MS16LC = Low current MS16 MS17LC = Electrical w/ 4 pin Brad Harrison male connector
Electrical with Thermal Lockout	MS5T = MS5 (see above) w/ thermal lockout MS5LCT = Low current MS5T MS10T = MS10 (see above) w/ thermal lockout MS10LCT = Low current MS10T MS12T = MS12 (see above) w/ thermal lockout MS12LCT = Low current MS12T MS16T = MS16 (see above) w/ thermal lockout MS16LCT = Low current MS16T MS17LCT = Low current MS17T
Electrical Visual	MS13 = Supplied w/ threaded connector & light MS14 = Supplied w/ 5 pin Brad Harrison connector & light (male end)
Electrical Visual with Thermal Lockout	MS13DCT = MS13 (see above), direct current, w/ thermal lockout MS13DCLCT = Low current MS13DCT MS14DCT = MS14 (see above), direct current, w/ thermal lockout MS14DCLCT = Low current MS14DC

BOX 7

Options
Omit = No sampling valve
SV = Up stream sampling valve

#### NOTES:

Box 2. Replacement element part numbers are a combination of Boxes 2, 3, and 4.  
Example: 18L3

# Accessories for Tank-Mounted Filters

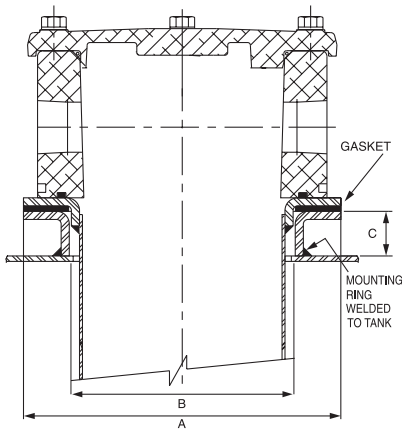

The mounting ring is welded directly to the hydraulic reservoir. The filter is then mounted to the mounting ring with bolts converting the filter to a "weld in" design. The mounting ring eliminates the need to drill and tap the hydraulic reservoir.

Model Number	Part Number	A	B	C
ST, RT, RTI, LRT	A-LFT-813	7.00 (178)	5.00 (127)	1.00 (25)
ST, RT, RTI, LRT High Version	A-LFT-1448	7.00 (178)	5.00 (127)	1.50 (38)
ZT	A-LFT-1295	6.25 (159)	3.62 (92)	.88 (22)

**Mounting Ring for ST, ZT, RT, RTI and LRT Models**

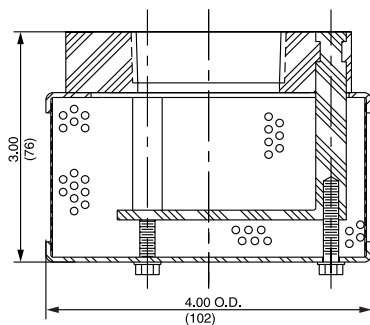

The diffuser option (designated as D for outlet porting option in model number) is threaded to the bushing on the filter bowl below the outlet opening to help decrease turbulent flow in the hydraulic reservoir.

No other outlet port options are available if the diffuser is used.

Model Number	Part Number	NPTF
RT, KFT	A-LFT-1506	1½"
LRT	A-LFT-1507	2"

**Diffuser for KFT, RT and LRT Models**

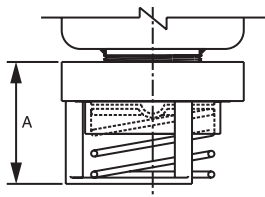

The check valve option (designated as C for outlet porting option in model number) makes it possible to service the filter without draining the oil from the reservoir when the filter is mounted below the oil level. It also prevents reservoir siphoning when system components are serviced.

The check valve can also be used on other reservoir return flow lines, where components upstream of the check valve can be serviced without the loss of reservoir oil. The spring setting is .75-1.00 psi cracking. Order by part number shown in chart.

No other outlet port options are available if the check valve is used.

Model Number	Part Number	NPTF	A
ST, KFT, RT	A-LFT-158Q-1	1½"	2.34 (59)
LRT	A-LFT-880	2"	2.34 (59)
BFT	A-BFT-103	3"	4.50 (114)

**Check Valve for ST, KFT, RT, LRT and BFT Models**

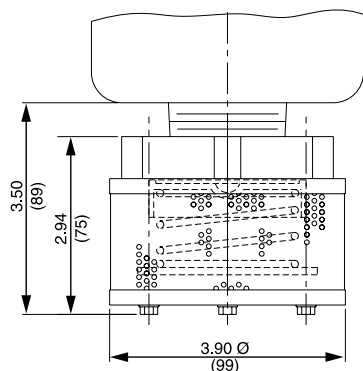

The diffuser/check valve option (designated as CD for outlet porting option in model number) is threaded on to the outlet port and combines the advantages of both separate options in one assembly.

Available as a separate item with 1½" NPT female threads, order part number A-LFT-1208.

No other outlet port options are available if the check valve/diffuser is used.

**Check Valve Diffuser Combination for KFT and RT Models**

**Accessories For Tank-Mounted Filters**

- IRF
- TF1
- KF3
- KL3
- LF1
- MLF1
- RLD
- GRTB
- MTA
- MTB
- ZT
- KFT
- RT
- RTI
- LRT
- ART
- BRT
- TRT
- BFT
- QT
- KTK
- LTK
- MRT
- PAF1
- MAF1
- MF2

# Accessories for Tank-Mounted Filters

## Tube Adapter Outlet Port for KFT, RT, LRT and BFT Models

The tube adapter outlet port option (designated as T for outlet porting option in model number) provides the means to direct flow to the bottom of the hydraulic reservoir. Other tube lengths are available for quantity purchases. Contact your Schroeder distributor for details.

Model Number	Dimension A (O.D.) in. (mm)
RT	1.62 (41)
LRT	2.25 (57)
BFT	3.50 (89)

Note: No other outlet port options are available if the tube adapter is used.

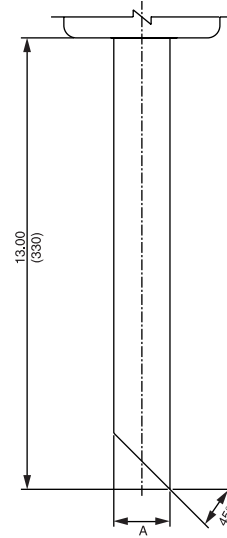

## Threaded Outlet Port for ZT, KFT, RT, LRT and BFT Models

The threaded male outlet port is standard on the KFT, RT, LRT and BFT models, and is available as an option on the ZT filter by designating OP for the outlet porting options in the model number.

- RT is furnished with 1 1/2" NPT Male (standard)
- LRT is furnished with 2" NPT Male (standard)
- KFT is furnished with 1 1/2" NPT Male (standard)
- BFT is furnished with 3" NPT Male (standard)
- ZT is furnished with 1 1/2" NPT Male (optional)



# Spin-On Filter

# PAF1



### Features and Benefits

- Spin-On with full ported die cast aluminum head for minimal pressure drop
- Offered in pipe and SAE straight thread porting
- Spin-On thread = 1.00-12UNF-2B
- Visual gauge or electrical switch dirt alarms
- Small profile for use in limited space
- Same day shipment model available

**20 gpm**  
**75 L/min**  
**100 psi**  
**7 bar**

Model No. of filter in photograph is PAF16PZ10P.

- IRF
- TF1
- KF3
- KL3
- LF1
- MLF1
- RLD
- GRTB
- MTA
- MTB
- ZT
- KFT
- RT
- RTI
- LRT
- ART
- BRT
- TRT
- BFT
- QT
- KTK
- LTK
- MRT
- MAF1
- MF2

Flow Rating:	Up to 20 gpm (75 L/min) for 150 SUS (32 cSt) fluids
Max. Operating Pressure:	100 psi (7 bar)
Min. Yield Pressure:	150 psi (10 bar), per NFPA T2.6.1
Rated Fatigue Pressure:	Contact factory
Temp. Range:	-20°F to 225°F (-29°C to 107°C)
Bypass Setting:	Cracking: 30 psi (2 bar) Full Flow: 36 psi (2 bar)
Porting Head & Cap:	Die Cast Aluminum
Element Case:	Steel
Weight of PAF1-6P:	1.8 lbs. (0.8 kg)
Element Change Clearance:	2.50" (65 mm)

### Filter Housing Specifications

Type Fluid	Appropriate Schroeder Media
Petroleum Based Fluids	All E media (cellulose) and Z-Media® (synthetic)
High Water Content	3 and 10 μ Z-Media® (synthetic)
Invert Emulsions	10 μ Z-Media® (synthetic)
Water Glycols	3 and 10 μ Z-Media® (synthetic)

### Fluid Compatibility

Accessories  
For Tank-  
Mounted  
Filters

**PAF1**

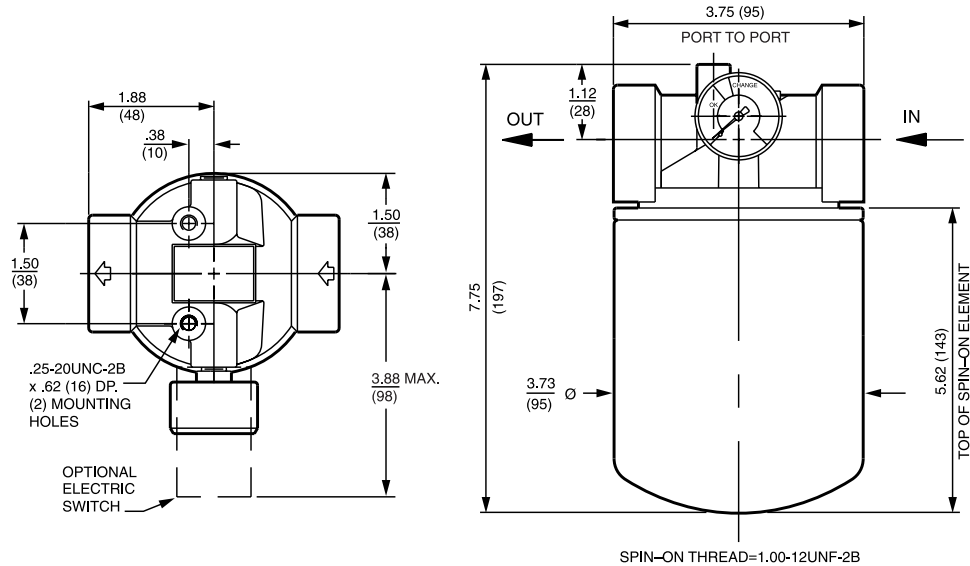

Installation instructions included on element.

Metric dimensions in ( ).

## Element Performance Information & Dirt Holding Capacity

Element	Filtration Ratio Per ISO 4572/NFPA T3.10.8.8 Using automated particle counter (APC) calibrated per ISO 4402			Filtration Ratio per ISO 16889 Using APC calibrated per ISO 11171	
	$\beta_x \geq 75$	$\beta_x \geq 100$	$\beta_x \geq 200$	$\beta_x(c) \geq 200$	$\beta_x(c) \geq 1000$
P10	15.5	16.2	18.0	N/A	N/A
PZ10	7.4	8.2	10.0	8.0	10.0
PZ25	18.0	20.0	22.5	19.0	24.0

Element	DHC (gm)	Element	DHC (gm)
P10	37	PZ25	23.0
PZ10	16.8		

Element Collapse Rating: 100 psid (7 bar)  
 Flow Direction: Outside In  
 Element Nominal Dimensions: 3.75" (95 mm) O.D. x 5.5" (140 mm) long

$\Delta P_{\text{housing}}$

PAF1  $\Delta P_{\text{housing}}$  for fluids with sp gr (specific gravity) = 0.86:

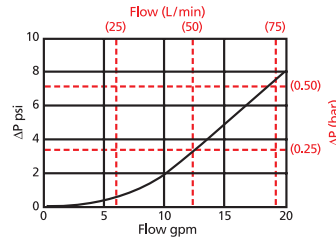

$\Delta P_{\text{element}}$

PZ

Element Pressure Drop versus Flow Rate at 32 cSt (150 SUS)

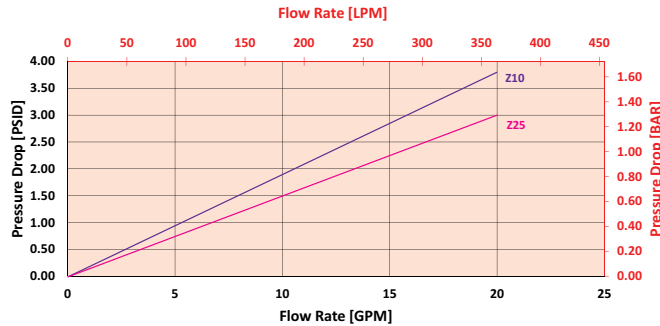

**Pressure Drop Information Based on Flow Rate and Viscosity**

$$\Delta P_{\text{filter}} = \Delta P_{\text{housing}} + (\Delta P_{\text{element}} * \mathbf{V}_f)$$

**Exercise:**

Determine  $\Delta P_{\text{filter}}$  at 10 gpm (37.9 L/min) for PAF16PZ25PY2 using 160 SUS (34 cSt) fluid.

Use the housing pressure curve to determine  $\Delta P_{\text{housing}}$  at 10 gpm. In this case,  $\Delta P_{\text{housing}}$  is 2 psi (.14 bar) on the graph for the PAF1 housing.

Use the element pressure curve to determine  $\Delta P_{\text{element}}$  at 10 gpm. In this case,  $\Delta P_{\text{element}}$  is 1.5 psi (.10 bar) according to the graph for the PZ25 element.

Because the viscosity in this sample is 160 SUS (34 cSt), we determine the **Viscosity Factor ( $\mathbf{V}_f$ )** by dividing the **Operating Fluid Viscosity** with the **Standard Viscosity** of 150 SUS (32 cSt). To best determine your Operating Fluid Viscosity, please reference the chart in Appendix D.

Finally, the overall filter pressure differential,  $\Delta P_{\text{filter}}$ , is calculated by adding  $\Delta P_{\text{housing}}$  with the true element pressure differential,  $(\Delta P_{\text{element}} * \mathbf{V}_f)$ . The  $\Delta P_{\text{element}}$  from the graph has to be multiplied by the viscosity factor to get the true pressure differential across the element.

**Solution:**

$\Delta P_{\text{housing}} = 2 \text{ psi } [.14 \text{ bar}] \mid \Delta P_{\text{element}} = 1.5 \text{ psi } [.10 \text{ bar}]$

$\mathbf{V}_f = 160 \text{ SUS } (34 \text{ cSt}) / 150 \text{ SUS } (32 \text{ cSt}) = 1.1$

$\Delta P_{\text{filter}} = 2 \text{ psi } + (1.5 \text{ psi } * 1.1) = 3.7 \text{ psi}$

**OR**

$\Delta P_{\text{filter}} = 14 \text{ bar } + (.10 \text{ bar } * 1.1) = .25 \text{ bar}$

Note:

If your element is not graphed, use the following equation:  
 $\Delta P_{\text{element}} = \text{Flow Rate} \times \Delta P_f$  Plug this variable into the overall pressure drop equation.

Ele.	$\Delta P$
P10	0.17

## Filter Model Number Selection

Highlighted product eligible for **QuickDelivery**

### How to Build a Valid Model Number for a Schroeder PAF1:

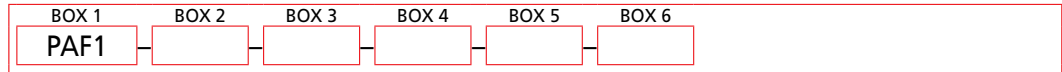

Example: NOTE: One option per box

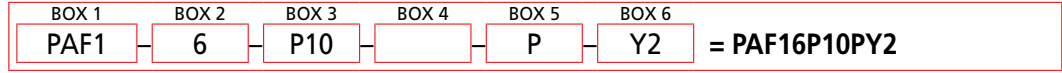

BOX 1	BOX 2	BOX 3	BOX 4
<b>Filter Series</b>	<b>Element Length (in)</b>	<b>Element Size and Media</b>	
PAF1	6	P10 = P size 10 μ E media (cellulose) PZ10 = P size 10 μ Excellement® Z-Media® (synthetic) PZ25 = P size 25 μ Excellement® Z-Media® (synthetic)	
		<b>Seal Material</b>	
		Omit = Buna N	

BOX 5	BOX 6
<b>Inlet Porting</b>	<b>Dirt Alarm® Options</b>
P = ¾" NPTF	Omit = None
S = SAE-12	Visual Y2 = Back-mounted tri-color gauge
	Electrical ES = Electric switch

NOTE:

Box 2. Replacement element part numbers are a combination of Boxes 3 and 4.  
Example: P10



### Features and Benefits

- Spin-On with full ported die cast aluminum head for minimal pressure drop
- Offered in pipe, SAE straight thread and ISO 228 porting
- Spin-On thread = 1.50-16UN-2B
- Visual gauge or electrical switch dirt alarms
- Small profile for use in limited space
- Available in 7" and 10" element lengths
- Available with NPTF inlet and outlet female test ports

**50 gpm**  
**190 L/min**  
**100 psi**  
**7 bar**

Model No. of filter in photograph is MAF17M10S.

IRF  
 TF1  
 KF3  
 KL3  
 LF1  
 MLF1  
 RLD  
 GRTB  
 MTA  
 MTB  
 ZT  
 KFT

RT  
 RTI

Flow Rating:	Up to 50 gpm (190 L/min) for 150 SUS (32 cSt) fluids
Max. Operating Pressure:	100 psi (7 bar)
Min. Yield Pressure:	200 psi (10 bar), per NFPA T2.6.1
Rated Fatigue Pressure:	Contact factory
Temp. Range:	-20°F to 225°F (-29°C to 107°C)
Bypass Setting:	Cracking: 30 psi (2 bar) Full Flow: 48 psi (3 bar)
Porting Head & Cap:	Die Cast Aluminum
Element Case:	Steel
Weight of MAF1-7M:	4.2 lbs. (1.9 kg)
Weight of MAF1-10M:	5.0 lbs. (2.3 kg)
Element Change Clearance:	2.50" (65 mm)

### Filter Housing Specifications

LRT  
 ART  
 BRT  
 TRT  
 BFT  
 QT

KTK  
 LTK

MRT

Type Fluid	Appropriate Schroeder Media
Petroleum Based Fluids	All E media (cellulose) and Z-Media® (synthetic)
High Water Content	3 and 10 μ Z-Media® (synthetic)
Invert Emulsions	10 μ Z-Media® (synthetic)
Water Glycols	3 and 10 μ Z-Media® (synthetic)

### Fluid Compatibility

Accessories  
 For Tank-  
 Mounted  
 Filters

PAF1

**MAF1**

MF2

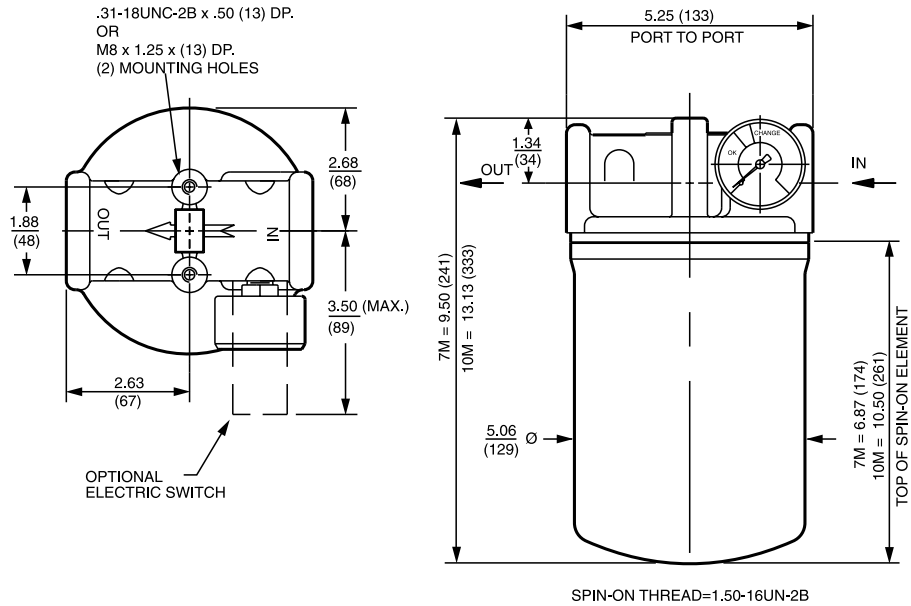

Installation instructions included on element.

Metric dimensions in ( ).

## Element Performance Information & Dirt Holding Capacity

Element	Filtration Ratio Per ISO 4572/NFPA T3.10.8.8 Using automated particle counter (APC) calibrated per ISO 4402			Filtration Ratio per ISO 16889 Using APC calibrated per ISO 11171	
	$\beta_x \geq 75$	$\beta_x \geq 100$	$\beta_x \geq 200$	$\beta_x(\epsilon) \geq 200$	$\beta_x(\epsilon) \geq 1000$
7MZ3/10MZ3	<1.0	<1.0	<2.0	<4.0	4.8
7MZ10/10MZ10	7.4	8.2	10.0	8.0	10.0
10MZW10	N/A	N/A	N/A	6.9	8.6

Element	DHC (gm)	Element	DHC (gm)
7MZ3	105		
7MZ10	104	10MZW10	53

Element Collapse Rating: 100 psid (7 bar)  
 Flow Direction: Outside In  
 Element Nominal Dimensions: 7M: 5.0" (125 mm) O.D. x 7.0" (180 mm) long  
 10M: 5.0" (125 mm) O.D. x 10.5" (261 mm) long

## $\Delta P_{\text{housing}}$

MAF1  $\Delta P_{\text{housing}}$  for fluids with sp gr (specific gravity) = 0.86:

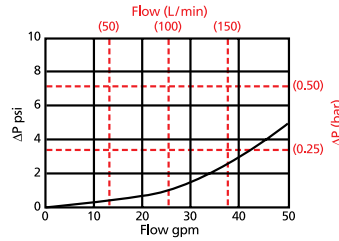

## Pressure Drop Information Based on Flow Rate and Viscosity

## $\Delta P_{\text{element}}$

7MZ

Element Pressure Drop versus Flow Rate at 32 cSt (150 SUS)

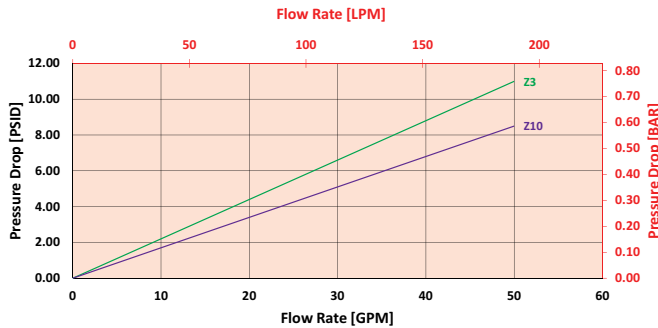

10MZ

Element Pressure Drop versus Flow Rate at 32 cSt (150 SUS)

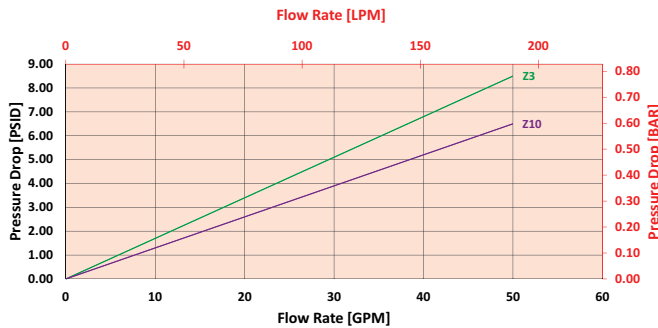

$$\Delta P_{\text{filter}} = \Delta P_{\text{housing}} + (\Delta P_{\text{element}} * \mathbf{V}_f)$$

### Exercise:

Determine  $\Delta P_{\text{filter}}$  at 40 gpm (151.6 L/min) for MAF17MZ10PY2 using 160 SUS (34 cSt) fluid.

Use the housing pressure curve to determine  $\Delta P_{\text{housing}}$  at 40 gpm. In this case,  $\Delta P_{\text{housing}}$  is 3 psi (.21 bar) on the graph for the MAF1 housing.

Use the element pressure curve to determine  $\Delta P_{\text{element}}$  at 40 gpm. In this case,  $\Delta P_{\text{element}}$  is 7 psi (.48 bar) according to the graph for the 7MZ10 element.

Because the viscosity in this sample is 160 SUS (34 cSt), we determine the **Viscosity Factor ( $\mathbf{V}_f$ )** by dividing the **Operating Fluid Viscosity** with the **Standard Viscosity** of 150 SUS (32 cSt). To best determine your Operating Fluid Viscosity, please reference the chart in Appendix D.

Finally, the overall filter pressure differential,  $\Delta P_{\text{filter}}$ , is calculated by adding  $\Delta P_{\text{housing}}$  with the true element pressure differential, ( $\Delta P_{\text{element}} * \mathbf{V}_f$ ). The  $\Delta P_{\text{element}}$  from the graph has to be multiplied by the viscosity factor to get the true pressure differential across the element.

### Solution:

$$\Delta P_{\text{housing}} = 3 \text{ psi } [.21 \text{ bar}] \quad | \quad \Delta P_{\text{element}} = 7 \text{ psi } [.48 \text{ bar}]$$

$$\mathbf{V}_f = 160 \text{ SUS (34 cSt)} / 150 \text{ SUS (32 cSt)} = 1.1$$

$$\Delta P_{\text{filter}} = 3 \text{ psi} + (7 \text{ psi} * 1.1) = 10.7 \text{ psi}$$

OR

$$\Delta P_{\text{filter}} = .21 \text{ bar} + (.48 \text{ bar} * 1.1) = .74 \text{ bar}$$

Note:

If your element is not graphed, use the following equation:  
 $\Delta P_{\text{element}} = \text{Flow Rate} \times \Delta P_f$  Plug this variable into the overall pressure drop equation.

Ele.	$\Delta P$
7M3	0.23
7M10	0.14

## Filter Model Number Selection

### How to Build a Valid Model Number for a Schroeder MAF1:

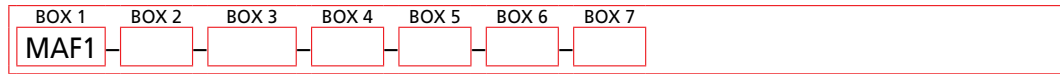

Example: NOTE: One option per box

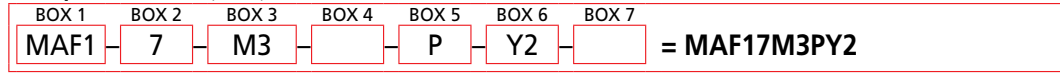

BOX 1	BOX 2	BOX 3	BOX 4
<b>Filter Series</b>	<b>Element Length (in)</b>	<b>Element Size and Media</b>	<b>Seal Material</b>
MAF1	7 10	M3 = M size 3 μ E media (cellulose) M10 = M size 10 μ E media (cellulose) MZ3 = M size 3 μ Excellement® Z-Media® (synthetic) MZ10 = M size 10 μ Excellement® Z-Media® (synthetic) MZW10 = M size 10 μ Aqua-Excellement™ ZW media MW = M size W media (water removal)	Omit = Buna N V = Viton®

BOX 5	BOX 6	BOX 7
<b>Porting Options</b>	<b>Dirt Alarm® Options</b>	<b>Additional Options</b>
P = 1¼" NPTF S = SAE-20 B = ISO 228 G-1¼"	Omit = None Visual Y2 = Back-mounted tri-color gauge Electrical ES = Electric switch	Omit = None L = Two ½" NPTF inlet and outlet female test ports

#### NOTES:

Box 2. Replacement element part numbers are a combination of Boxes 2, 3, and 4. Replacement element part numbers for 7" length begin with M. Replacement element part numbers for 10" length begin with 10M. Examples: M3V; 10MZ3V 10" only available with MZ3 and MZ10.

Box 3. ZW media only available for 10" element.

Box 4. For option V, all aluminum parts are anodized. Viton® is a registered trademark of DuPont Dow Elastomers.

Box 5. B porting option supplied with metric mounting holes.



# Spin-On Filter

# MF2



### Features and Benefits

- Spin-On with full ported cast iron head for minimal pressure drop
- Offered in pipe, SAE straight thread and ISO 228 porting
- Spin-On thread = 1.50-16UN-2B
- Various Dirt Alarm® options
- Available in 7" and 10" element lengths

**60 gpm**  
**230 L/min**  
**150 psi**  
**10 bar**

- IRF
- TF1
- KF3
- KL3
- LF1
- MLF1
- RLD
- GRTB
- MTA
- MTB
- ZT
- KFT
- RT

Model No. of filter in photograph is MF27M10SD5.

Flow Rating:	Up to 60 gpm (230 L/min) for 150 SUS (32 cSt) fluids
Max. Operating Pressure:	150 psi (10 bar)
Min. Yield Pressure:	250 psi (17 bar), per NFPA T2.6.1
Rated Fatigue Pressure:	Contact factory
Temp. Range:	-20°F to 225°F (-29°C to 107°C)
Bypass Setting:	Cracking: 30 psi (2 bar) Full Flow: 48 psi (3 bar)
Porting Head:	Cast Iron
Element Case:	Steel
Weight of MF2-7M:	8.6 lbs. (3.9 kg)
Element Change Clearance:	1.50" (40 mm)

### Filter Housing Specifications

- RTI
- LRT
- ART
- BRT
- TRT
- BFT
- QT
- KTK
- LTK

Type Fluid	Appropriate Schroeder Media
Petroleum Based Fluids	All E media (cellulose) and Z-Media® (synthetic)
High Water Content	3 and 10 μ Z-Media® (synthetic)
Invert Emulsions	10 μ Z-Media® (synthetic)
Water Glycols	3 and 10 μ Z-Media® (synthetic)

### Fluid Compatibility

### Accessories For Tank-Mounted Filters

- MRT
- PAF1
- MAF1

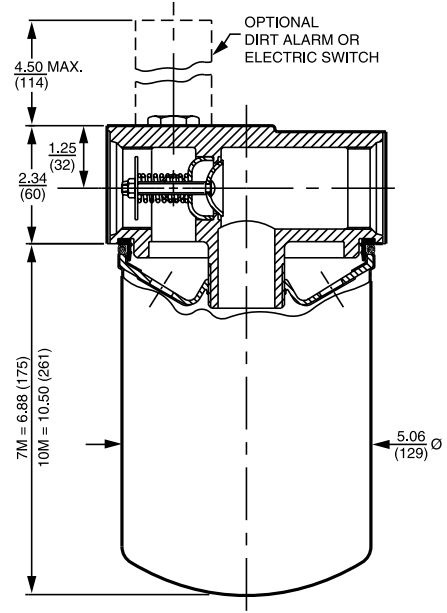
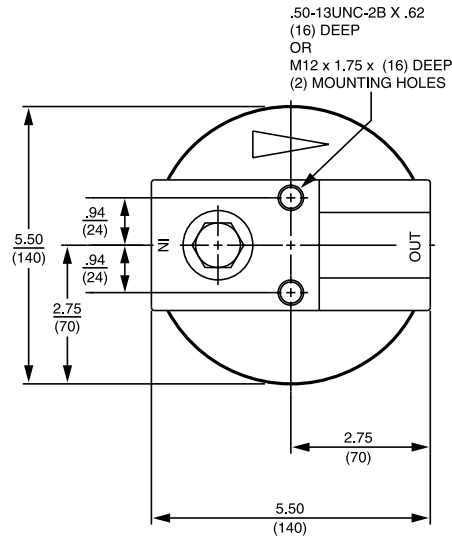

SPIN-ON THREAD=1.50-16UN-2B

Installation instructions included on element.

Metric dimensions in ( ).

## Element Performance Information & Dirt Holding Capacity

Element	Filtration Ratio Per ISO 4572/NFPA T3.10.8.8 Using automated particle counter (APC) calibrated per ISO 4402			Filtration Ratio per ISO 16889 Using APC calibrated per ISO 11171	
	$\beta_x \geq 75$	$\beta_x \geq 100$	$\beta_x \geq 200$	$\beta_x(c) \geq 200$	$\beta_x(c) \geq 1000$
7MZ3/10MZ3	<1.0	<1.0	<2.0	<4.0	4.8
7MZ10/10MZ10	7.4	8.2	10.0	8.0	10.0
10MZW10	N/A	N/A	N/A	6.9	8.6

Element	DHC (gm)	Element	DHC (gm)
7MZ3	105	10MZW10	53
7MZ10	104		

Element Collapse Rating: 100 psid (7 bar)  
 Flow Direction: Outside In  
 Element Nominal Dimensions: 7M: 5.0" (125 mm) O.D. x 7.0" (180 mm) long  
 10M: 5.0" (125 mm) O.D. x 10.5" (261 mm) long

$\Delta P_{\text{housing}}$

MF2  $\Delta P_{\text{housing}}$  for fluids with sp gr (specific gravity) = 0.86:

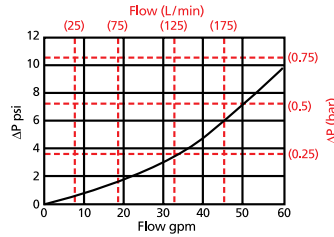

$\Delta P_{\text{element}}$

7MZ

Element Pressure Drop versus Flow Rate at 32 cSt (150 SUS)

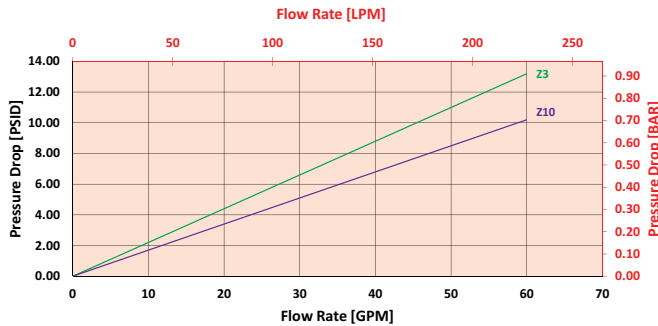

## Pressure Drop Information Based on Flow Rate and Viscosity

$$\Delta P_{\text{filter}} = \Delta P_{\text{housing}} + (\Delta P_{\text{element}} * \mathbf{V}_f)$$

### Exercise:

Determine  $\Delta P_{\text{filter}}$  at 40 gpm (151.6 L/min) for MF27MZ10PD5 using 160 SUS (34 cSt) fluid.

Use the housing pressure curve to determine  $\Delta P_{\text{housing}}$  at 40 gpm. In this case,  $\Delta P_{\text{housing}}$  is 5 psi (.34 bar) on the graph for the MF2 housing.

Use the element pressure curve to determine  $\Delta P_{\text{element}}$  at 40 gpm. In this case,  $\Delta P_{\text{element}}$  is 7 psi (.48 bar) according to the graph for the 7M210 element.

Because the viscosity in this sample is 160 SUS (34 cSt), we determine the **Viscosity Factor ( $\mathbf{V}_f$ )** by dividing the **Operating Fluid Viscosity** with the **Standard Viscosity** of 150 SUS (32 cSt). To best determine your Operating Fluid Viscosity, please reference the chart in Appendix D.

Finally, the overall filter pressure differential,  $\Delta P_{\text{filter}}$ , is calculated by adding  $\Delta P_{\text{housing}}$  with the true element pressure differential, ( $\Delta P_{\text{element}} * \mathbf{V}_f$ ). The  $\Delta P_{\text{element}}$  from the graph has to be multiplied by the viscosity factor to get the true pressure differential across the element.

### Solution:

$$\Delta P_{\text{housing}} = 5 \text{ psi } [.34 \text{ bar}] \quad | \quad \Delta P_{\text{element}} = 7 \text{ psi } [.48 \text{ bar}]$$

$$\mathbf{V}_f = 160 \text{ SUS (34 cSt)} / 150 \text{ SUS (32 cSt)} = 1.1$$

$$\Delta P_{\text{filter}} = 5 \text{ psi} + (7 \text{ psi} * 1.1) = 12.7 \text{ psi}$$

OR

$$\Delta P_{\text{filter}} = .34 \text{ bar} + (.48 \text{ bar} * 1.1) = .87 \text{ bar}$$

Note:

If your element is not graphed, use the following equation:

$\Delta P_{\text{element}} = \text{Flow Rate} \times \Delta P_f$  Plug this variable into the overall pressure drop equation.

Ele.	$\Delta P$
7M3	0.23
7M10	0.14

## Filter Model Number Selection

### How to Build a Valid Model Number for a Schroeder MF2:

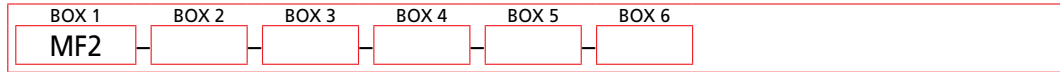

Example: Option 1 *NOTE: One option per box*

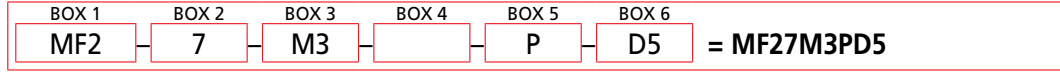

BOX 1	BOX 2	BOX 3	BOX 4	BOX 5
<b>Filter Series</b>	<b>Element Length (in)</b>	<b>Element Size and Media</b>	<b>Seal Material</b>	<b>Porting Options</b>
MF2	7 10	M3 = M size 3 μ E media (cellulose) M10 = M size 10 μ E media (cellulose) MZ3 = M size 3 μ Excellement® Z-Media® (synthetic) MZ10 = M size 10 μ Excellement® Z-Media® (synthetic) MW10 = M size 10 μ Aqua-Excellement™ ZW media MW = M size W media (water removal)	Omit = Buna N V = Viton®	P = 1¼" NPTF S = SAE-20 B = ISO 228 G-1¼"

BOX 6	
Dirt Alarm® Options	
	Omit = None
Visual	D5 = Visual pop-up
Visual with Thermal Lockout	D8 = Visual w/ thermal lockout
Electrical	MS5 = Electrical w/ 12 in. 18 gauge 4-conductor cable MS5LC = Low current MS5 MS10 = Electrical w/ DIN connector (male end only) MS10LC = Low current MS10 MS11 = Electrical w/ 12 ft. 4-conductor wire MS12 = Electrical w/ 5 pin Brad Harrison connector (male end only) MS12LC = Low current MS12 MS16 = Electrical w/ weather-packed sealed connector MS16LC = Low current MS16 MS17LC = Electrical w/ 4 pin Brad Harrison male connector
Electrical with Thermal Lockout	MS5T = MS5 (see above) w/ thermal lockout MS5LCT = Low current MS5T MS10T = MS10 (see above) w/ thermal lockout MS10LCT = Low current MS10T MS12T = MS12 (see above) w/ thermal lockout MS12LCT = Low current MS12T MS16T = MS16 (see above) w/ thermal lockout MS16LCT = Low current MS16T MS17LCT = Low current MS17T
Electrical Visual	MS13 = Supplied w/ threaded connector & light MS14 = Supplied w/ 5 pin Brad Harrison connector & light (male end)
Electrical Visual with Thermal Lockout	MS13DCT = MS13 (see above), direct current, w/ thermal lockout MS13DCLCT = Low current MS13DCT MS14DCT = MS14 (see above), direct current, w/ thermal lockout MS14DCLCT = Low current MS14DCT

**NOTES:**

Box 2. Replacement element part numbers are a combination of Boxes 2, 3, and 4. Replacement element part numbers for 7" length begin with M. Replacement element part numbers for 10" length begin with 10M.  
 Example: M3; 10MZ3  
 10" only available with MZ3 and MZ10.

Box 3. ZW media only available for 10" element.

Box 4. Viton® is a registered trademark of DuPont Dow Elastomers.

Box 5. B porting option supplied with metric mounting holes.

Section 6:

# SUCTION FILTERS



# Section 6

## Suction Filters Selection Guide

		Pressure psi (bar)	Flow gpm (L/min)	Element Length/Size	Page
<b>Suction Filters</b>	<b>Tank-Mounted Suction Filter</b>				
	ST	NA	20 (75)	K, KT	323
	<b>In-Line Magnetic Suction Separators</b>				
	TF-SKB	NA	12.5 (47)	SKB	329
	KF3-SKB	NA	35 (130)	SKB	330
	<b>Tank-Mounted Magnetic Suction Separator</b>				
BFT-SKB	NA	75 (285)	SKB	331	

# Tank-Mounted Suction Filter

**ST**



## Features and Benefits

- Tank-mounted suction filter for hydrostatic suction service
- Optional check valve prevents reservoir siphoning
- Easy Element changeout
- Inlet filter protects pump, reduces start-up failures

**20 gpm**  
**75 L/min**

**ST**

TF-SKB

KF3-SKB

BFT-SKB

Model No. of filter in photograph is ST1K105Y.

Flow Rating:	Up to 20 gpm (75 L/min) for 150 SUS (32 cSt) fluids
Max. Operating Pressure:	Suction Filter
Min. Yield Pressure:	Not Applicable
Rated Fatigue Pressure:	Not Applicable
Temp. Range:	-20°F to 225°F (-29°C to 107°C)
Bypass Setting:	Non-bypassing
Porting Head:	Die Cast Aluminum
Cap:	Steel
Element Case:	Steel
Weight of ST-1K:	11.1 lbs. (5.0 kg)
Weight of ST-2K:	14.7 lbs. (6.7 kg)
Element Change Clearance:	7.25" (185 mm) for 1K; 17.50" (445 mm) for KK

## Filter Housing Specifications

Type Fluid	Appropriate Schroeder Media
Petroleum Based Fluids	All E media (cellulose) and Z-Media® (synthetic)
High Water Content	10 μ Z-Media® (synthetic)
Invert Emulsions	10 μ Z-Media® (synthetic)
Water Glycols	10 μ Z-Media® (synthetic)
Phosphate Esters	10 μ Z-Media® (synthetic) with H (EPR) seal designation and 10 μ E media (cellulose) with H (EPR) seal designation
Skydrol®	10 μ Z-Media (synthetic) with H.5 seal designation (EPR seals and stainless steel wire mesh in element, and light oil coating on housing exterior)

## Fluid Compatibility

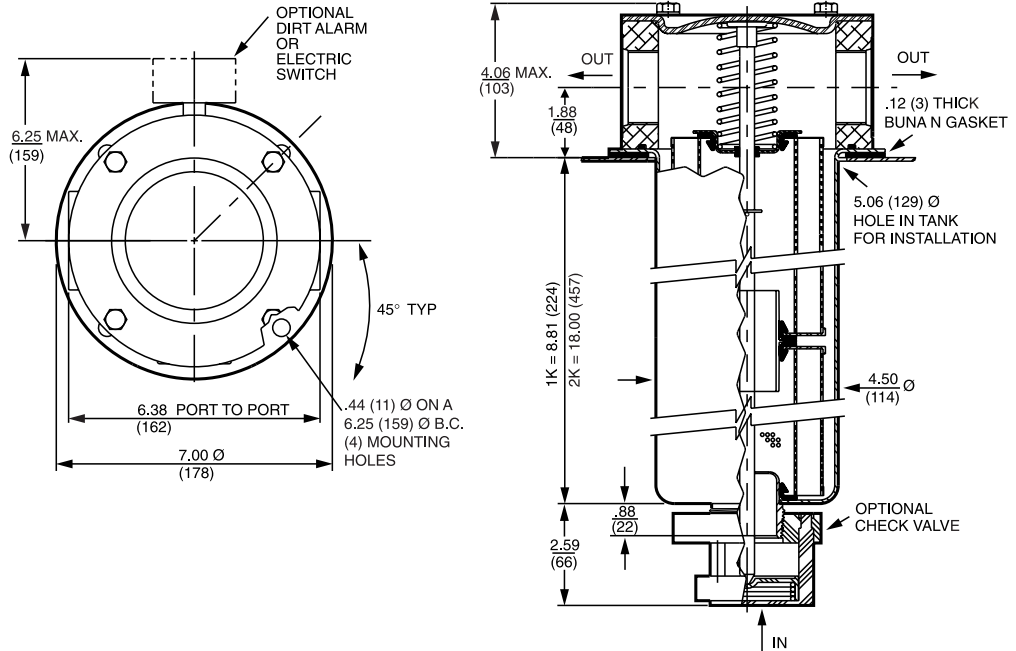

Metric dimensions in ( ).

## Element Performance Information & Dirt Holding Capacity

Element	Filtration Ratio Per ISO 4572/NFPA T3.10.8.8 Using automated particle counter (APC) calibrated per ISO 4402			Filtration Ratio per ISO 16889 Using APC calibrated per ISO 11171	
	$\beta_x \geq 75$	$\beta_x \geq 100$	$\beta_x \geq 200$	$\beta_x(c) \geq 200$	$\beta_x(c) \geq 1000$
KTZ10	7.4	8.0	10.0	8.0	10.0

Element	DHC (gm)
KTZ10	56

Element Collapse Rating: 150 psid (10 bar)

Flow Direction: Inside Out

Element Nominal Dimensions: 3.9" (99 mm) O.D. x 9.0" (230 mm) long



# Tank-Mounted Suction Filter

# ST

$\Delta P_{\text{housing}}$

ST  $\Delta P_{\text{housing}}$  for fluids with sp gr (specific gravity) = 0.86:

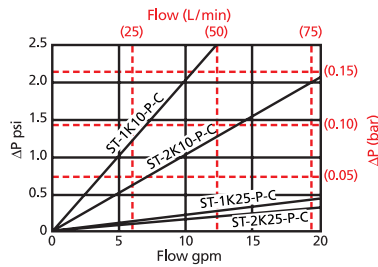

$\Delta P_{\text{element}}$

KTZ

Element Pressure Drop versus Flow Rate at 32 cSt (150 SUS)

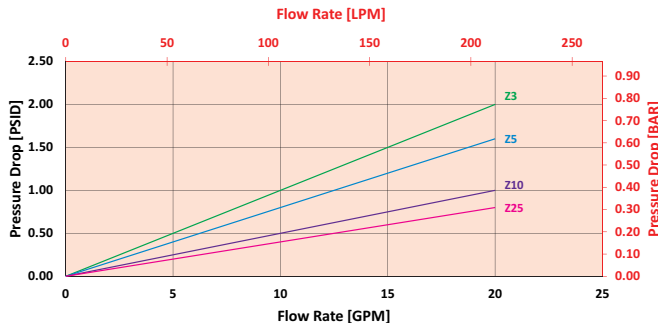

2KTZ

Element Pressure Drop versus Flow Rate at 32 cSt (150 SUS)

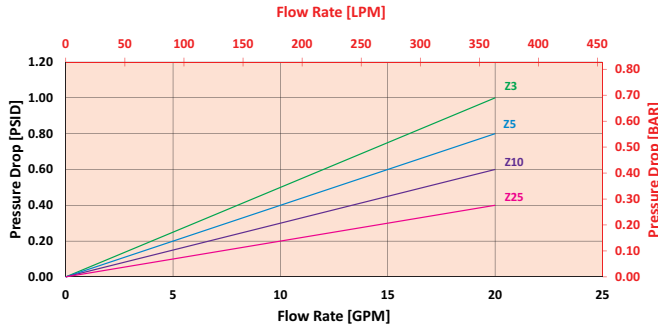

$$\Delta P_{\text{filter}} = \Delta P_{\text{housing}} + (\Delta P_{\text{element}} * v_f)$$

**Exercise:**

Determine  $\Delta P_{\text{filter}}$  at 15 gpm (57 L/min) for ST1KTZ10PY using 160 SUS (34 cSt) fluid.

Use the element pressure curve to determine  $\Delta P_{\text{housing}}$  at 15 gpm. In this case,  $\Delta P_{\text{housing}}$  is 1.5 psi (.10 bar) according to the graph for the ST element.

Use the element pressure curve to determine  $\Delta P_{\text{element}}$  at 15 gpm. In this case,  $\Delta P_{\text{element}}$  is .75 psi (.05 bar) according to the graph for the KZT10 element.

Because the viscosity in this sample is 160 SUS (34 cSt), we determine the **Viscosity Factor ( $v_f$ )** by dividing the **Operating Fluid Viscosity** with the **Standard Viscosity** of 150 SUS (32 cSt). To best determine your Operating Fluid Viscosity, please reference the chart in Appendix D.

Finally, the overall filter pressure differential,  $\Delta P_{\text{filter}}$ , is calculated by adding  $\Delta P_{\text{housing}}$  with the true element pressure differential, ( $\Delta P_{\text{element}} * v_f$ ). The  $\Delta P_{\text{element}}$  from the graph has to be multiplied by the viscosity factor to get the true pressure differential across the element.

**Solution:**

$\Delta P_{\text{housing}} = 1.5 \text{ psi } [.75 \text{ bar}] \mid \Delta P_{\text{element}} = .75 \text{ psi } [.05 \text{ bar}]$

$v_f = 160 \text{ SUS (34 cSt) } / 150 \text{ SUS (32 cSt) } = 1.07$

$\Delta P_{\text{filter}} = 1.5 \text{ psi } + (.75 \text{ psi } * 1.07) = 2.3 \text{ psi}$

**OR**

$\Delta P_{\text{filter}} = .10 \text{ bar } + (0.05 \text{ bar } * 1.07) = 0.15 \text{ bar}$

**Pressure Drop Information**  
Based on Flow Rate and Viscosity

ST

TF-SKB

KF3-SKB

BFT-SKB

Note:

If your element is not graphed, use the following equation:  
 $\Delta P_{\text{element}} = \text{Flow Rate} \times \Delta P_f$ . Plug this variable into the overall pressure drop equation.

Ele.	$\Delta P$	Ele.	$\Delta P$	Ele.	$\Delta P$
K3	0.25	KZW25	0.14	2KZW10	0.12
K10	0.09	2K3	0.12	2KZW25	0.07
K25	0.02	2K10	0.05	3K3	0.08
KAS3	0.10	2K25	0.01	3K10	0.03
KAS5	0.08	2KAS3	0.05	3K25	0.01
KAS10	0.05	2KAS5	0.04	3KAS3	0.03
KZX10	0.22	2KAS10	0.03	3KAS5	0.02
KZW1	0.43	2KZX10	0.11	3KAS10	0.02
KZW3	0.32	2KZW1	-	3KZX10	0.07
KZW5	0.28	2KZW3	0.16		
KZW10	0.23	2KZW5	0.14		

## Filter Model Number Selection

### How to Build a Valid Model Number for a Schroeder ST:

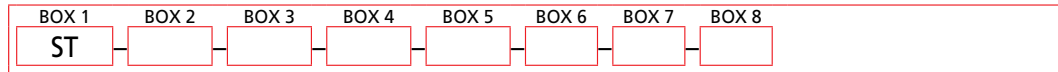

**Example:** NOTE: Only box 8 may contain more than one option

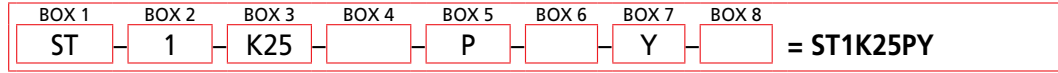

BOX 1	BOX 2	BOX 3	BOX 4
<b>Filter Series</b>	<b>Number of Elements</b>	<b>Element Part Number</b>	<b>Seal Material</b>
ST	1 2	K10 = K size 10 μ E media (cellulose) K25 = K size 25 μ E media (cellulose) KTZ3 = K size 3 μ Excellement® Z-Media® (synthetic) inside-out flow KTZ5 = K size 5 μ Excellement® Z-Media® (synthetic) inside-out flow KTZ10 = K size 10 μ Excellement® Z-Media® (synthetic) inside-out flow KTZ25 = K size 25 μ Excellement® Z-Media® (synthetic) inside-out flow	Omit = Buna N H = EPR W = Buna N H.5 = Skydrol® compatibility
BOX 5	BOX 6	BOX 7	BOX 8
<b>Outlet Port</b>	<b>Optional Check Valve</b>	<b>Dirt Alarm® Options</b>	<b>Additional Options</b>
P = 1½" NPTF PP = Dual 1½" NPTF S = SAE 24 SS = Dual SAE 24 B = ISO 228 G-1½" BB = ISO 228 G-1½"	Omit = None C = Check Valve	Omit = None Visual    Y = Vacuum gauge YR = Vacuum gauge mounted on opposite side of standard location Electrical VS = Electrical Vacuum Switch VSR = Electrical Vacuum Switch mounted on opposite side of standard location VSR1 = Heavy-Duty Vacuum Switch	Omit = None G2293 = Cork Gasket G547 = Two ⅛" gauge ports

**NOTES:**

Box 3. Replacement element part numbers are identical to contents of Boxes 3 and 4.

Box 4. For options H and W, all aluminum parts are anodized.  
 H.5 seal designation includes the following: EPR seals, stainless steel wire mesh on elements, and light oil coating on housing exterior.  
 Skydrol® is a registered trademark of Solutia Inc.

Box 6. See also "Accessories for Tank-Mounted Filters," page 299.

# In-Line Magnetic Suction Separators

# TF-SKB

ST

TF-SKB

KF3-SKB

BFT-SKB

## Features and Benefits

- Protects components downstream by capturing potentially harmful ferrous particles

## Specifications

Flow Rating: 12.5 gpm (47 L/min)

Element Replacement Part Number: SKB-1

Element Change Clearance: 2.5" (65 mm)

Weight of TF-SKB: 5.8 lbs (2.6 kg)

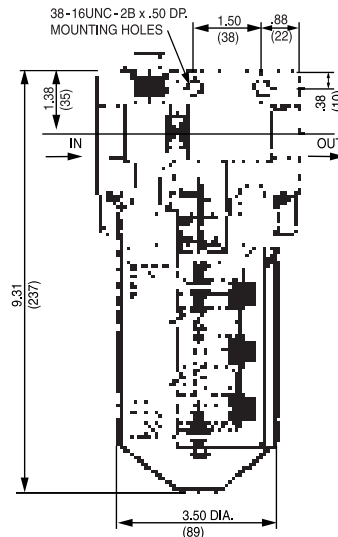

Metric dimensions in ( ).

## How to Build a Valid Model Number for a Schroeder TF-SKB:



**Example:** NOTE: One option per box

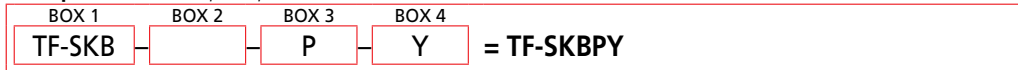

BOX 1	BOX 2	BOX 3	BOX 4
<b>Filter Series</b>	<b>Seal Material</b>	<b>Porting</b>	<b>Dirt Alarm® Options</b>
TF-SKB	Omit = Buna N	P = 1" NPTF	Omit = None Visual Y = Vacuum gauge Electrical VS = Electrical Vacuum Switch VS1 = Heavy-Duty Vacuum Switch

## Filter Model Number Selection

NOTE:  
Box 1. Element replacement part number: SKB-1.

## Features and Benefits

- Protects components downstream by capturing potentially harmful ferrous particles

## Specifications

Flow Rating:	35 gpm (130 L/min)
Element Replacement Part Number:	A-LF-1789
Element Change Clearance:	1.5" (40 mm)
Weight of KF3-SKB:	11.5 lbs (5.2 kg)

Metric dimensions in ( ).

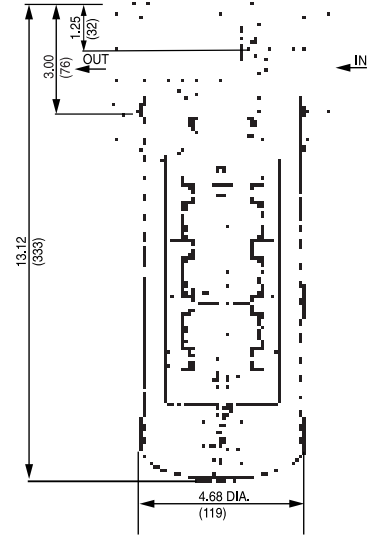

## Filter Model Number Selection

### How to Build a Valid Model Number for a Schroeder KF3-SKB:



Example: NOTE: One option per box

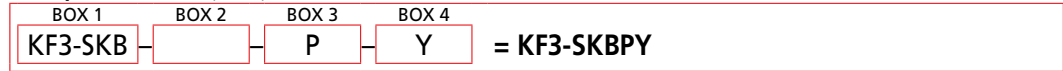

BOX 1	BOX 2	BOX 3	BOX 4
<b>Filter Series</b>	<b>Seal Material</b>	<b>Porting</b>	<b>Dirt Alarm® Options</b>
KF3-SKB	Omit = Buna N	P = 1/2" NPTF	Omit = None Visual Y = Vacuum gauge Electrical VS = Electrical Vacuum Switch VS1 = Heavy-Duty Vacuum Switch

NOTE:  
Box 1. Element replacement part number: A-LF-1789.

# Tank-Mounted Magnetic Suction Separators

**BFT-SKB**

## Features and Benefits

- Protects components downstream by capturing potentially harmful ferrous particles

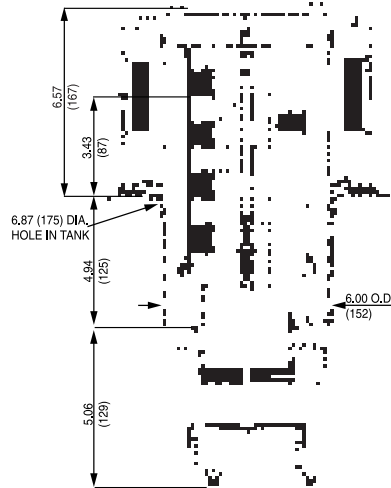

Metric dimensions in ( ).

ST

TF-SKB

**KF3-SKB**

**BFT-SKB**

## Specifications

Flow Rating: 75 gpm (285 L/min)

Element Replacement with check valve: A-SKB-3-76  
Part Number: without check valve: SKB-3

Element Change Clearance: 13.5" (345 mm)

Weight of BFT-SKB: 32.0 lbs (14.5 kg)

## How to Build a Valid Model Number for a Schroeder BFT-SKB::

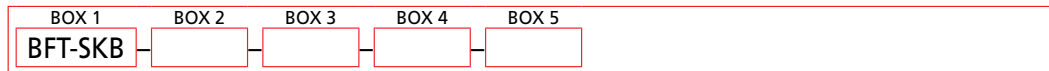

Example: NOTE: One option per box

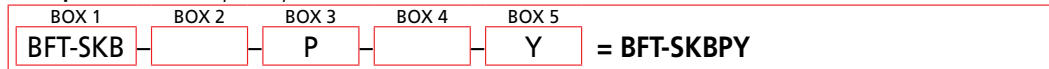

BOX 1	BOX 2	BOX 3	Box 4
<b>Filter Series</b>	<b>Seal Material</b>	<b>Porting</b>	<b>Other Options</b>
BFT-SKB	Omit = Buna N	P = 2½" NPTF PP = Dual 2½" NPTF F = 2½" SAE 4-bolt flange Code 61 FF = Dual 2½" SAE 4-bolt flange Code 61	Omit = None C = Check Valve

BOX 5	
Dirt Alarm® Options	
	Omit = None
Visual	Y = Vacuum gauge YR = Vacuum gauge mounted on opposite side of standard location
Electrical	VS = Electrical Vacuum Switch VSR = Electrical Vacuum Switch on opposite side of standard location VS1 = Heavy-Duty Vacuum Switch

## Filter Model Number Selection

NOTE:

Box 1. See specifications on previous page for element replacement part numbers.

# Magnet Inserts for Filters

## Magnet Inserts for Filters

KF30, KF50, KC50, KC65 and TF50 are available with magnet inserts to trap ferrous material that passes through the filter element.

These inserts are removed with the element each time service is performed and cleaned before being reinserted with new elements.

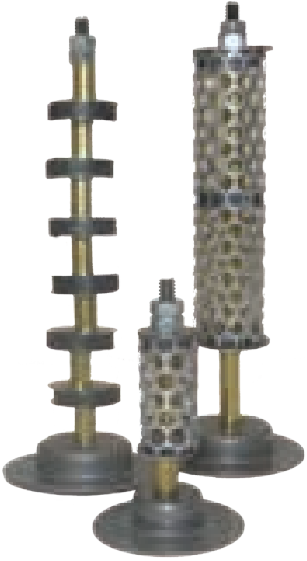

Replacements are available by ordering parts:

	Single Element	Double Element	Triple Element
KF30, KF50, KC50, KC65, KF3, LF1, MLF1	A-LF-1592	A-LF-1593	A-LF-1594
TF50	A-TF-301-1	A-TF-302-1	

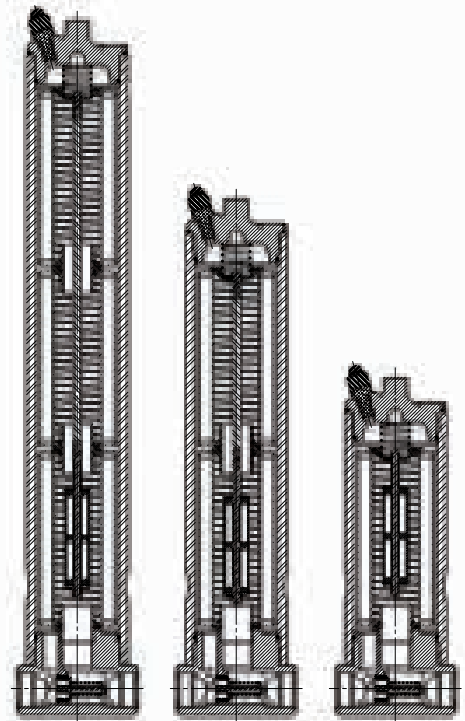
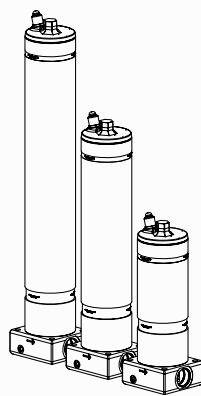
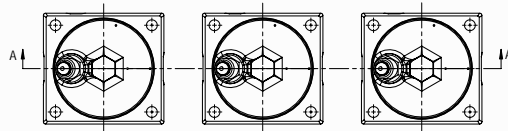

Visual indicators provide an economical way to know at a glance when a filter element needs to be replaced. A variety of styles are available, ranging from gauges to mechanical pointers and pop-up cartridges.

Schroeder pointers use a tricolor disk to indicate the element condition. The pointer will reach the red section just before bypassing occurs.

In the case of a mechanical magnetic cartridge, a highly visible orange disk springs, or “pops up”, at the pre-defined setting. Once activated, the orange signal continues to indicate a bypass or clogged condition, even following equipment shutdown, until it is manually reset. The pop-up indicator is interchangeable with other cartridge style indicators (electrical and electrical visual) available from Schroeder. A high pressure (>6000 psi working pressure) of the pop-up indicator is available and is noted below.



**D**—Tricolor Pointer Dirt Alarm®  
P/N 7619323 for plastic pointer only.  
For internal linkage and name plate, contact factory.



**D5**—Red Pop Up Visual Indicator  
**D5S\***—D5 with Protective Shroud  
\*To order Protective Shroud only, use SAP #7642053  
**D5C**—Same as D5 but mounted in cap  
**D5R**—Same as D5 but mounted on opposite side of standard location  
**D9**—Stainless Steel version of D5  
**D9C**—Stainless Steel version of D5 mounted in cap



**Y**—Vacuum Gauge mounted in porting head  
P/N 7631068  
**YR**—Same as Y but mounted on opposite side of standard location P/N 7631068

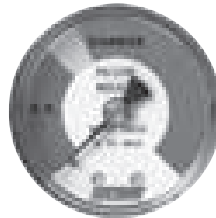

**Y2**—Back mounted 1/8" NPT Tricolor Glycerin-filled Gauge (0-60 psi) P/N 7627463 (0-100 psi) P/N 7631048  
**Y2R**—Same as Y2 but mounted on opposite side of standard location P/N 7627463  
**Y2C**—Bottom mounted 1/8" NPT Tricolor Gauge (0-60 psi) located in cap P/N 7626647  
**Y5**—Same as Y2 but located in cap P/N 7627463



**LF-4209 (G2213): 0 - 30 psid; P/N 7626589**



**DPG**—Standard Differential Pressure Gauge  
P/N 7628635 or 7626554

The thermal lockout feature prevents activation of the indicator below temperatures of 90°F (32°C). This is a welcome feature in mobile applications where fluid temperatures may be well below 90°F at equipment start-up, and will prevent the indicator from showing a premature need to change the element.



**D8**—Orange Pop Up Visual Indicator with Thermal Lock-out  
**D8C**—Same as D8 but mounted in cap  
**D8R**—Same as D8 but mounted on opposite side of standard location

## Visual

## Visual with Thermal Lockout

## Electrical Visual

In addition to providing an electrical signal to provide a desired action, Schroeder electrical visual indicators also provide a visual indication of when an element needs to be changed. In the case of the MS and MS2 switches, the visual indicator is a color-coded disk, whereas the MS13 and MS14 dirt alarms provide a light.

MS—Cam operated electrical switch P/N 7627458 for switch only.

For cam, color-coded disk, and mounting bracket, order P/N 7604908.

For internal linkage, contact factory.

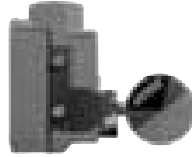

Code	Type of Contact	Electrical Rating	Connection
MS	SPDT	15 Amps @ 125/250 vac, 0.5 Amp @ 125 VDC	½" conduit, female

## Electrical

The electrical indicators (MS Series) provide an electrical signal for activating various electric alarm systems or complete machine shutdown. These cartridge-style indicators are available on most Schroeder pressure, return line, and medium pressure filters and can be used for working pressures up to 6000 psi (415 bar) and cyclic conditions up to 4000 psi (276 bar).

- The design is modular; all electrical indicators consist of an MS10 indicator with the corresponding mating connector added to convert the MS10 to a MS5, MS11 etc.
- The standard micro switch for high current indicators is good for both AC and DC use. A separate micro switch with "gold" contacts is used for low current applications. This means that specification of AC or DC is no longer required (except for MS13 and MS14) in the indicator code or part number.
- Housings of all electrical indicators are made of aluminum.
- The indicator model tag includes the electrical wiring diagram.
- All of our indicators, with the exception of MS16, have a "ground" terminal.
- We are now able to offer the thermal lockout option to high current indicators.
- All indicators can be installed in a filter cap as the wiring harness can be disconnected at the "DIN" connector in order to remove the filter cap.
- All MS indicators have achieved the NEMA4X and IP65 ratings.

Information on these indicators, including drawing, circuit diagram, and photograph is provided on the following pages.

A different set of electrical pressure switches is available for Schroeder tank-mounted filters, along with heavy duty versions.

Schroeder suction filters (ST and models that house the SKB magnetic suction strainer) can be equipped with a vacuum switch.

VS—Vacuum Switch (1/8" NPT, normally open)  
P/N 7601947

VSR—Same as VS but mounted on opposite side of standard location P/N 7601947

ES—Standard electrical pressure switch (1/8" NPT, normally open) for tank-mounted filters  
P/N 7601943 (40 psi bypass)

ESC—Electrical pressure switch (MTA & MTB only)  
P/N 7601943

ESR—Same as ES but mounted on opposite side of standard location  
P/N 7601943

ES1—Heavy duty electrical pressure switch (1/8" NPT) with conduit connection (25psi bypass) P/N 7626636 (cracking over 25 psi) P/N 7626640 (43 psi bypass) P/N 7626640 (Black = common; Red = N.O.; Blue = N.C.)

ES1R—Same as ES1 but mounted on opposite side of standard location P/N 7626636

VS1—Heavy Duty Vacuum Switch (1/8" NPT)  
P/N 7623755, LF Pressure Switch

ES2— Super duty electric switch (1/8" NPT, normally closed) with thermal lockout P/N 7626564

ES3—Electric pressure switch (1/8" NPT) with DIN connector P/N 7626592 (Black = common; Red = N.O.; Blue = N.C.)



Code	Type of Contact	Electrical Rating	Connection
ES	SPST	8 Amps @ 12 VDC, 1 Amp @ 120 VAC 4 Amps @ 24 VDC, 0.5 Amp @ 240 VAC	Screw Terminal with Rubber Boot
ES1	SPDT	10 Amps @ 115 VAC 50mA-5A @ 24 VDC	½" Conduit, Male



## Electrical and Electrical with Thermal Lockout



**MS5  
MS5LC  
MS5T  
MS5LCT**

Supplied with 12 inch long  
18 gauge 4-conductor cable

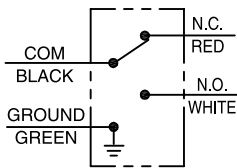

MS5/MS5LC

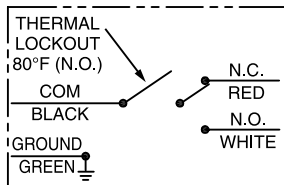

MS5T/MS5LCT

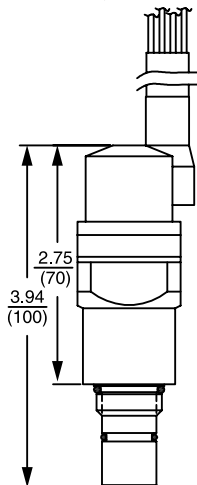
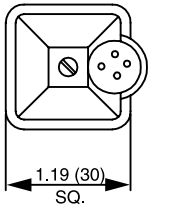

**MS10  
MS10LC  
MS10T  
MS10LCT**

Supplied with DIN connector  
(male end only)  
(conforming to DIN 43650)

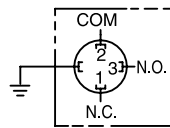

MS10/MS10LC

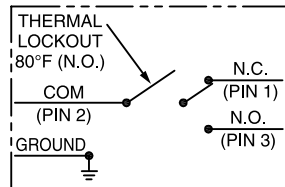

MS10T/MS10LCT

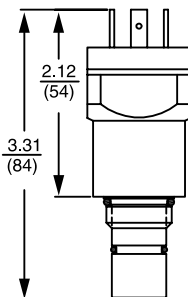
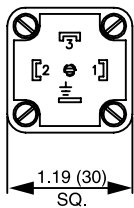

Model Codes of MSHA Version of MS10  
are MS10DCM and MS10DCCM (DC only;  
second C designates cap). For electrical  
and dimensional drawings, contact factory.



**MS11**

Supplied with 12 inch long  
18 gauge 4-conductor cable

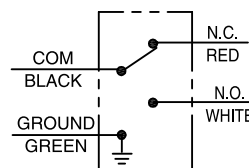

MS11

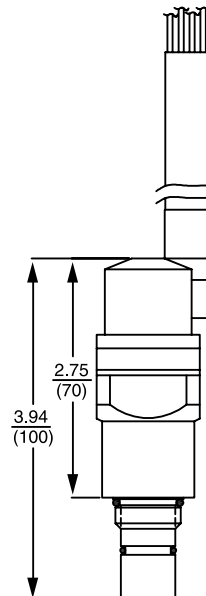
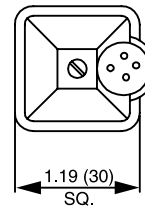

# Appendix A Filter Dirt Alarm® Selection

Electrical and  
Electrical with  
Thermal Lockout  
(cont'd.)



**MS12  
MS12LC  
MS12T  
MS12LCT**

Supplied with 5 pin  
Brad Harrison connector  
(male end only)

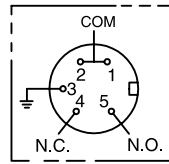

MS12/MS12LC

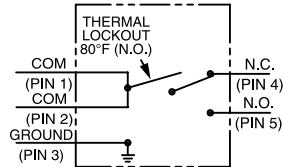

MS12T/MS12LCT

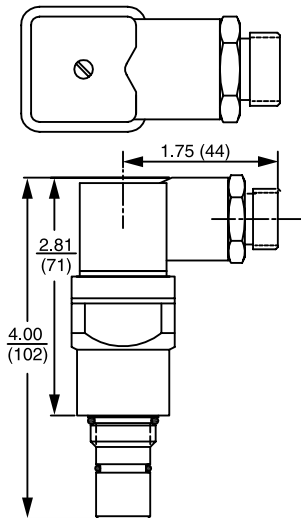

**MS16  
MS16LC  
MS16T  
MS16LCT**

Supplied with a female  
(3) contact weather-packed  
sealed connector supplied with  
DIN connector (male end only)  
(conforming to DIN 43650)

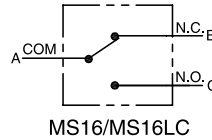

MS16/MS16LC

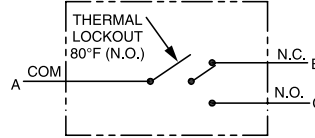

MS16T/MS16LCT

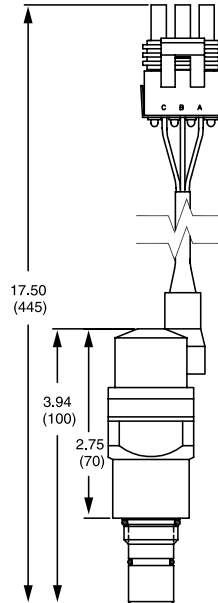

**MS17LC  
MS17LCT**

Supplied with a 4 pin  
Brad Harrison "micro" connector  
(male end only)

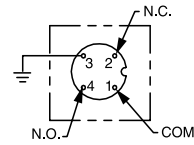

MS17LC

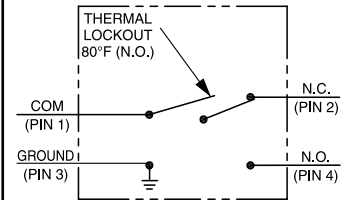

MS17LCT

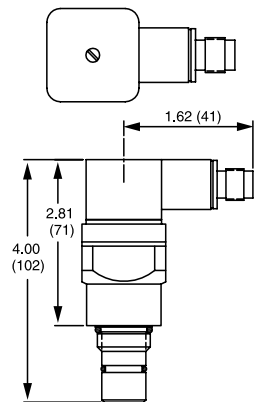

Model Codes of MSHA Version of MS12  
are MS12DCM and MS12DCCM (DC only;  
second C designates cap). For electrical and  
dimensional drawings, contact factory.



**MS17  
MS17T**

Supplied with a 4 pin M12 "micro" connector (male end only) (confirming to IEC 60947-5-2)

NORMAL OPERATING PRESSURE ELECTRICAL SCHEMATIC

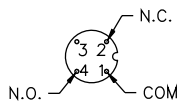

WITH THERMAL LOCKOUT

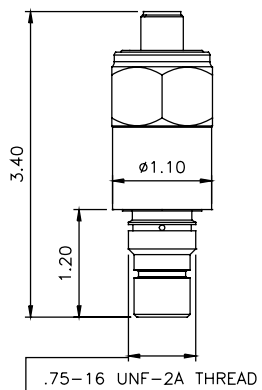
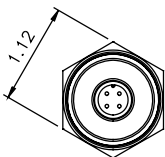
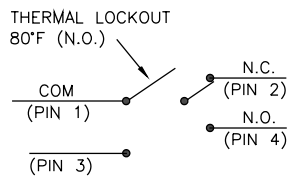

**MS18  
MS18LC  
MS18T  
MS18LCT**

Supplied with a 2 pin amp junior power timer connector (male end only) (must designate N.O. or N.C.)

NORMAL OPERATING PRESSURE ELECTRICAL SCHEMATIC

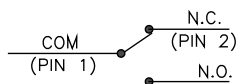

WITH THERMAL LOCKOUT

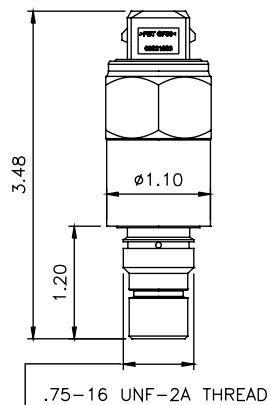
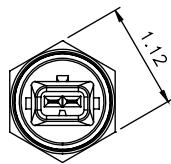
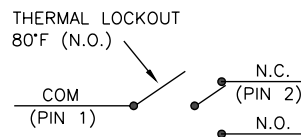

**MS19  
MS19LC  
MS19T  
MS19LCT**

Supplied with a 2 pin deutsch connector (D04-2-P, male end only) (must designate N.O. or N.C.)

NORMAL OPERATING PRESSURE ELECTRICAL SCHEMATIC

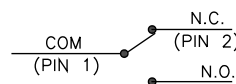

WITH THERMAL LOCKOUT

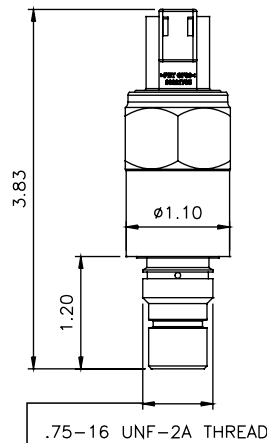
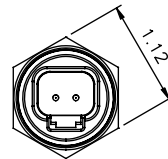
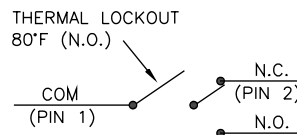

Electrical and  
Electrical with  
Thermal Lockout  
(cont'd.)

# Appendix A Filter Dirt Alarm® Selection

Electrical Visual  
and  
Electrical Visual  
with  
Thermal Lockout



**MS13DC, MS13DCLC  
MS13DCT, MS13DCLCT**

Supplied with  
threaded connector  
with light

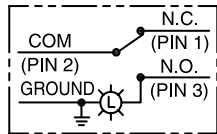
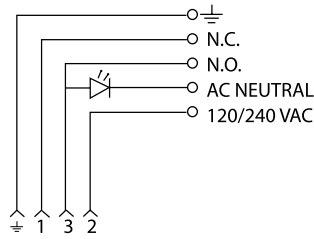

MS13DC / MS13DCLC

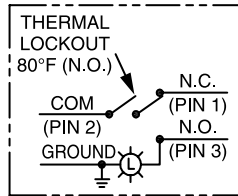

MS13DCT / MS13DCLCT

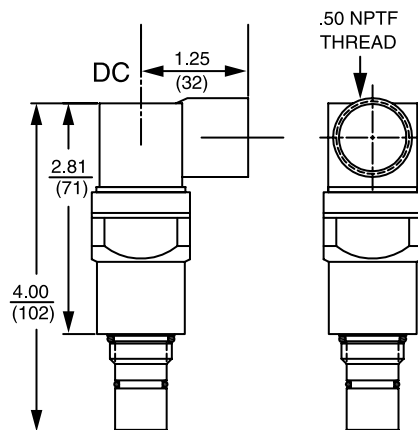
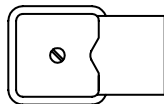

**MS14AC, MS14ACL, MS14ACLCT  
MS14DC, MS14DCLC  
MS14DCT, MS14DCLCT**

Supplied with  
5 pin  
Brad Harrison connector  
with light  
(male end only)

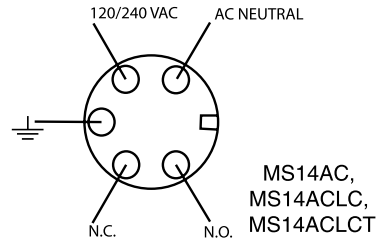

MS14AC,  
MS14ACL,  
MS14ACLCT

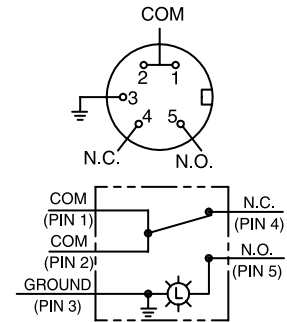

MS14DC / MS14DCLC

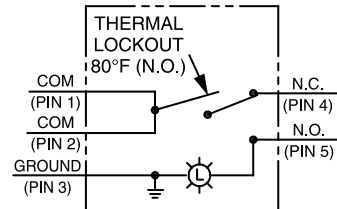

MS14DCT / MS14DCLCT

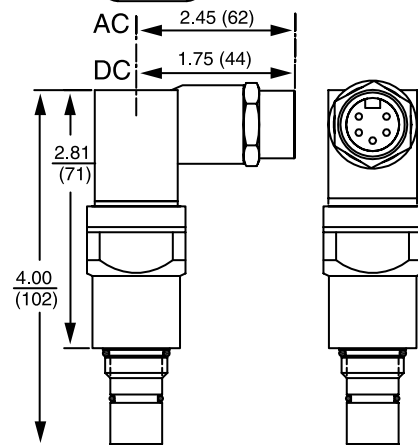
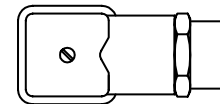

**CHART 5 Electrical Ratings: Electrical Cartridge Indicators Without Thermal Lockout**

Voltage	Voltage Volts@ Amps	Current Range (amps)	MS5	MS5LC	MS10	MS10LC	MS11	MS12	MS12LC	MS13DC	MS13DCLC	MS14DC	MS14DCLC	MS15DC	MS16	MS16LC	MS17	MS17LC	MS14AC	MS14ACL	MS18	MS18LC	MS19	MS19LC
AC	240 @ 3	0.02 to 3	✓		✓		✓	✓										✓						
AC	220 @ 0.05	0.005 to 0.05		✓		✓			✓													✓		✓
AC	120 @ 5	0.02 to 5	✓		✓		✓	✓																
AC	120 @ 0.05	0.005 to 0.05		✓		✓			✓											✓		✓		✓
AC	24 @ 0.10	0.005 to 0.010		✓		✓			✓											✓		✓		
AC	12 @ 0.25	0.005 to 0.025		✓		✓			✓											✓				
AC	120 @ 4	0.05 to 4																	✓					
AC	115 @ 0.05	0.01 to 0.05															✓				✓		✓	
DC	110 @ 0.3	0.02 to 0.3	✓		✓		✓	✓							✓		✓				✓		✓	
DC	110 @ 0.05	0.005 to 0.05		✓		✓			✓							✓		✓				✓		✓
DC	24 @ 3	0.01 to 3																			✓		✓	
DC	24 @ 2	0.02 to 2	✓		✓		✓	✓		✓		✓			✓									
DC	24 @ 1	0.01 to 1															✓							
DC	24 @ 0.20	0.0 to 0.20												✓										
DC	24 @ 0.10	0.005 to 0.10		✓		✓			✓		✓		✓			✓		✓				✓		✓
DC	12 @ 5	0.01 to 5																			✓		✓	
DC	12 @ 2	0.02 to 2	✓		✓		✓	✓		✓		✓			✓									
DC	12 @ 1	0.01 to 1															✓							
DC	12 @ 0.25	0.005 to 0.25		✓		✓			✓		✓		✓			✓		✓				✓		✓

**CHART 6 Electrical Ratings: Electrical Cartridge Indicators With Thermal Lockout\***

Voltage	Voltage Volts @ Amps	Current Range (amps)	MS5T	MS5LCT	MS10T	MS10LCT	MS12T	MS12LCT	MS13DCT	MS13DCLCT	MS14DCT	MS14DCLCT	MS16T	MS16LCT	MS17	MS17T	MS17LCT	MS14ACT	MS14ACLCT	MS18	MS18T	MS18LCT	MS19	MS19T	MS19LCT
AC	120 @ 5	0.02 to 5	✓		✓		✓																		
AC	220 @ 0.05	0.005 to 0.05		✓		✓		✓											✓			✓			✓
AC	120 @ 5	0.05 to 4																✓							
AC	115 @ 0.05	0.01 to 0.05														✓						✓		✓	
DC	24 @ 2	0.02 to 2	✓		✓		✓		✓		✓		✓			✓					✓		✓		✓
DC	24 @ 0.10	0.005 to 0.10		✓		✓		✓		✓		✓		✓			✓					✓		✓	✓
DC	12 @ 2	0.02 to 2	✓		✓		✓		✓		✓		✓			✓					✓		✓		✓
DC	12 @ 0.25	0.005 to 0.25		✓		✓		✓		✓		✓		✓			✓					✓		✓	✓

\*Thermal lockout prevents activation below 80°

Note: All indicators in Charts 4 and 5 above, meet NEMA4X and IP65 specifications.

# Appendix B Viscosity Charts

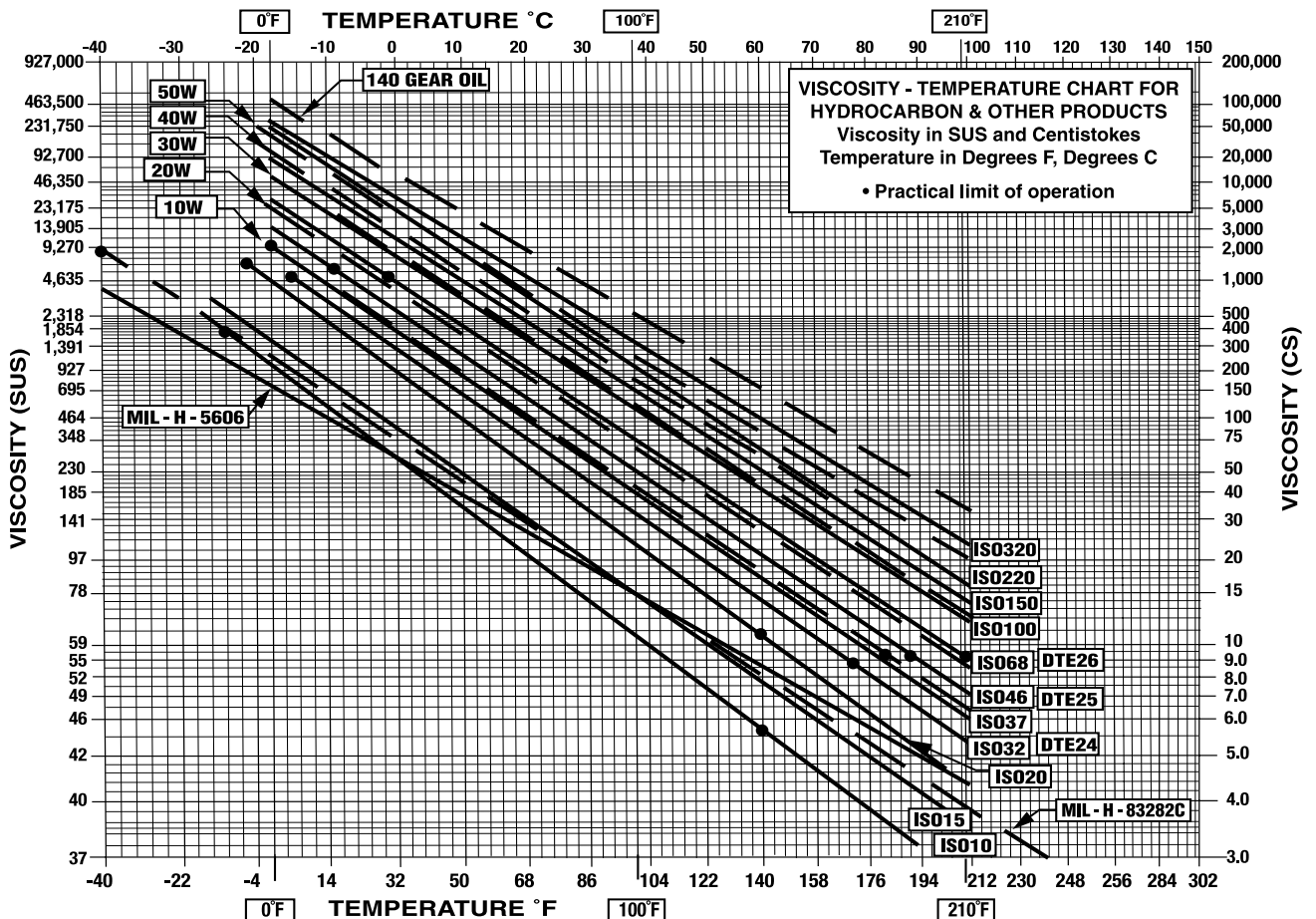
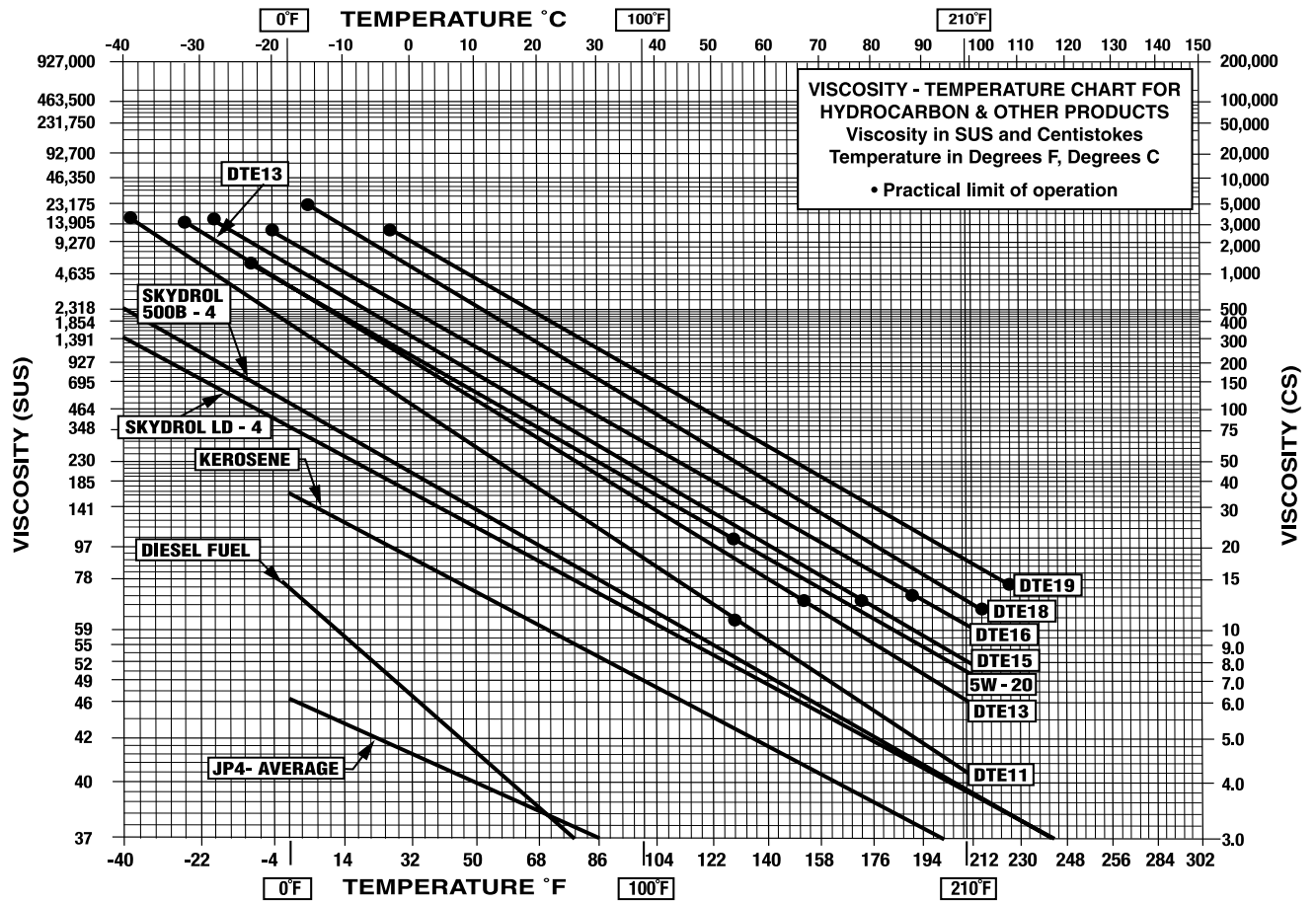

# Glossary of Standard Terms

**ABSOLUTE FILTRATION RATING:** The diameter of the largest hard spherical particle that will pass through a filter under specified test condition. This is an indication of the largest opening in the filter element. It does not indicate the largest particle that will pass through the element, since particles of greater length than diameter may pass.

**CAVITATION:** A localized condition within a liquid stream causing the rapid implosion of a gaseous bubble.

**CELSIUS:** A temperature scale. 0 Celsius (or 0 Centigrade) is the freezing point of water (32° F).

**CENTIPOISE:** A unit of absolute (dynamic) viscosity.

**CENTISTOKE:** A unit of kinematic viscosity.

**CLEANLINESS LEVEL:** The analog of contamination level.

**COLLAPSE PRESSURE:** The outside-in differential pressure that causes structural failure.

**CONTAMINATION LEVEL:** A quantitative term specifying the degree of contamination.

**CONTAMINANT:** Any material or substance which is unwanted or adversely affects the fluid power system or components, or both.

**CONTAMINANT, BUILT-IN:** Initial residual contamination in a component, fluid, or system. Typical built-in contaminants are burrs, chips, flash, dirt, dust, fiber, sand, moisture, pipe dope, weld spatter, paints and solvents, flushing solutions, incompatible fluids, and operating fluid impurities.

**DEPTH (FILTER):** A filter medium which primarily retains contaminant within tortuous passages.

**DIRT CAPACITY (DUST CAPACITY) (CONTAMINANT CAPACITY):** The weight of a specified artificial contaminant which must be added to the fluid to produce a given differential pressure across a filter at specified conditions. Used as an indication of relative service life.

**EFFICIENCY (FILTER):** The ability, expressed as a percent, of a filter to remove specified artificial contaminant at a given contaminant concentration under specified test conditions.

**ELEMENT (CARTRIDGE):** The porous device which performs the actual process of filtration.

**FLOW, LAMINAR (STREAMLINE):** A flow situation in which fluid moves in parallel lamina or layers. (See Reynold's number.)

**FLOW, TURBULENT:** A flow situation in which the fluid particles move in a random manner. (See Reynold's number.)

**FLUID:** A liquid, gas, or combination thereof.

**FLUID POWER SYSTEM:** A system that transmits and controls power through use of a pressurized fluid within an enclosed circuit.

**INDICATOR:** A device which provides external visual evidence of sensed phenomena.

**INDICATOR, BY-PASS:** An indicator which signals that an alternate flow path is being used.

**INDICATOR, DIFFERENTIAL PRESSURE:** An indicator which signals the difference in pressure between two points.

**MICROMETER (MICRON)\*:** A unit of measurement one millionth of a meter long, or approximately 0.00003937 inch expressed in English Units. \*Deprecated.

**MIGRATION:** Contaminant released downstream.

**PRESSURE, CRACKING:** The pressure at which a pressure-operated valve begins to pass fluid.

**PRESSURE, DIFFERENTIAL (PRESSURE DROP):** The difference in pressure between any two points of a system or a component.

**PRESSURE, OPERATING:** The pressure at which a system is operated.

**PRESSURE, RATED FATIGUE:** A pressure that a pressure-containing component is represented to sustain 10 million times without failure.

**RATED FLOW:** The maximum flow that the power supply system is capable of maintaining at a specific operating pressure.

**REYNOLD'S NUMBER:** A numerical ratio of the dynamic forces of mass flow to the shear stress due to viscosity. Flow usually changes from laminar to turbulent between Reynold's numbers 2,000 and 4,000.

---

## Filter CONFIGURATIONS

**Top-Ported Filter:** Also known as a T-Ported or In-Line filter. All porting, the bypass valve, and indicators are located in the head. The head is permanently attached to the plumbing and the element is accessed by removing the bowl.

**Base-Ported Filter:** All porting, the bypass valve, and indicators are located in the base. The base is permanently attached to the plumbing and the element is removed through a cap, instead of removing the entire bowl.

**Manifold Mounted Filter:** Also known as a Sub-Plate filter. Most Base-Ported filters come with a manifold mount option. In some cases, a Top-Ported filter can also have a manifold mounting option. This allows the filter to be mounted directly onto a manifold, eliminating the need for hoses and fittings.

**Cartridge Filter:** Can be inserted directly into the manifold, eliminating the need for a separate housing or plumbing. Element is removed through a plug on the manifold.

**Sandwich Filter:** Is designed to be placed in between and directly interface with a manifold and stacked valves. Eliminates the need for hoses and fittings.

**Duplex Filter:** Made up of two or more filter assemblies. A valve allows the user to switch from one chamber to another. When one element is fully loaded, fluid is redirected through the second element. The loaded element can be changed without an interruption in flow. In the center position, the valve allows the oil to flow through both filters.

## Filter CLASSIFICATIONS Types

**Low Pressure Filter\*:** Filter pressure range from 0 to 500 psi. Mostly applied in return line filtration where system pressure is at a low point.

**Medium Pressure Filter\*:** Filter pressure range from 500 to 1500 psi. Often used in hydrostatic charge pressure applications.

**High Pressure Filter\*:** Filter pressure range is 1500 psi and above. Mostly applied on the pressure side of the system where pressure is highest.

**High Pressure Hydrostatic Filter:** Used in high pressure hydrostatic closed loop systems. Allows for reverse flow through the system.

**Bypass vs. Non-Bypass:** The pressure rises as an element becomes loaded with contaminants. Standard filters are equipped with a bypass valve that redirects hydraulic fluid when the pressure drop reaches a predetermined level, so the element does not lose its structural integrity. The filter element is bypassed and fluid continues on through the system.

In non-bypass filters bypass is not optional. They are used to protect expensive components that are more sensitive to contaminants, and cannot be exposed to unfiltered fluid. The element is exposed to higher pressures, as there is no bypass. For that reason this type of filter requires a high crush element to guarantee its structural integrity.

**Air Breather:** Filters air that is drawn into a reservoir when the fluid level changes.

**Desiccant Air Breather:** In addition to filtering out particle contaminants, this breather also removes water vapor.

Schroeder Industries LLC wishes to thank both the National Fluid Power Association and Penton Publishing for the use of certain generic terms shown in this glossary. Excerpts taken from ANSI B93.2-1986/NFPA T3.10.3. 1967(R1980) and Penton Publishing's Fluid Power Handbook & Directory (2006-2007).

\*These ranges have been determined to provide a quick reference for the purpose of creating our catalog. This is currently no industry standard terminology. These ranges are subject to change.

# Other Product Line Catalogs



Filter Systems

The Filter Systems Catalog is designed to take the reader from the basic foundations of the principles of hydraulics found in the H&L catalog, to the tools required for troubleshooting and addressing the cleanliness or performance demands of any fluid system. We produce portable and permanent-mount pressure, flow and temperature evaluation instruments, oil cleanliness analysis devices, particle monitors and water-in-oil identification tools. We also produce a wide array of fluid conditioning tools — from standard in-line hydraulic filters, to sophisticated microprocessor-based instruments incorporating SMART® technology.



Fuel Filtration

The products contained in the Fuels Catalog, address issues relating to mobile and stationary equipment working in some of the toughest conditions all over the world. Schroeder's Fuel Filtration line ensures the smooth running of equipment and protects both the engine and the whole drive system from damage, which addresses both onboard and bulk tank requirements.



Process Filtration

The keystone product of Schroeder Process Filtration is the RF3 automatic self-cleaning backflush filter. This filter along with bag filters, cartridge filters and custom designed systems allows Schroeder to offer you complete solutions to your process filtration needs. Our process filters are used to remove solid contamination from fluids and protect the integrity of high grade components that depend on low viscosity water or water-based fluids and emulsions. Schroeder offers high performance filters for all industrial sectors. Improvements in operational efficiency, reduced downtime, lower maintenance costs and reduce environmental impact can all be expected.

To view the full version of our catalogs visit our website: [www.schroederindustries.com](http://www.schroederindustries.com)







## Best Filter Delivery Program

Schroeder Industries is pleased to announce the establishment of the Best Filter Delivery Program. We recognize that emergencies arise despite the best planning and forecasting efforts. To be able to offer support and service in these situations, we performed an analysis to determine our top selling filter model numbers. The result is a list of thirteen specific filter assemblies, comprising high pressure, medium pressure, return line, tank-mounted and spin-on models.

For all the models listed, guaranteed shipment is same day, provided we receive the purchase order by 1:00 pm EST. An option to specify element media other than that called for on the web page is available with a 5-day guaranteed ship date after receipt of order. No other substitutions are permitted.

At the onset of this program, a distributor/customer may be limited to a maximum quantity. This may be necessary to enable Schroeder to fulfill its guarantee of adequate inventory to all distributors alike.

The intent of this program is to provide our customers with access to the products they use most often. Therefore, as we witness shifts in filter usage, we will make changes to this list and update the corresponding web page accordingly.

We hope you and your customers find this new program useful in working through unforeseen crisis situations.

Family	Product	Specifications	Standard Part Number	Alternate Elements
High Pressure, Top-Ported	NF30	20 gpm, 3000 psi, SAE 1-1/16"-12 straight porting, cartridge dirt alarm	NF301NZ10SD5	N/A
High Pressure, Top-Ported	DF40	30 gpm, 4000 psi, SAE 1-5/16"-12 straight porting, cartridge dirt alarm	DF401CCZ3SD5	CC10, CCZ5
High Pressure, Base-Ported	GKF30	100 gpm, 3000 psi, 1 element, SAE 1-7/8"-12 straight porting, cartridge dirt alarm	GKF301KGZ10SD5	KG3, KG10, KG25, KGZ1, KGZ3, KGZ25
Low Pressure, Tank-Mounted	ZT	40 gpm, 100 psi, SAE 1-5/16"-12 straight inlet port, rear mounted tricolor visible dirt alarm	ZT8Z10SY2	N/A
Low Pressure, Tank-Mounted	GRT	100 gpm, 100 psi, 2 SAE 1.5" inlet ports, tricolor visible dirt alarm	GRT1KBGZ10S24S24NY2 (GRT-6915)	K3, K10, K25, KZ1, KZ3, KZ25
Low Pressure, Tank-Mounted	GRT	100 gpm, 100 psi, 1 SAE 1.25" straight inlet port, tricolor visible dirt alarm	GRT1KBGZ10S20NNY2 (GRT-6916)	KBG3, KBG10, BG25, KBGZ1, BGZ3, KBGZ25
Low Pressure, Tank-Mounted	LRT	150 gpm, 100 psi, 2 SAE 1.5" straight inlet ports, tricolor visible dirt alarm	LRT18LZ10S24S24NY2 (LRT-1820)	N/A
Low Pressure, Spin-On	PAF1	20 gpm, 100 psi, 3/4" NPTF porting, tricolor visible dirt alarm	PAF16PZ10PY2	N/A
Low Pressure, Top-Ported	GKF3	100 gpm, 300 psi, 1 element, SAE 1-7/8"-12 straight porting, cartridge dirt alarm	GKF31KGZ25SD5	KG3, KG10, KG25, KGZ1, KGZ3, KGZ25
Medium Pressure, Top-Ported	SRLT	25 gpm, 1400 psi, SAE 1-1/16"-12 straight porting, cartridge dirt alarm	SRLT6RZ10S12D5	6RZ3, 6RZ25
Medium Pressure, Top-Ported	RLT	70 gpm, 1000 psi, 9" element, SAE 1-5/8"-12 straight porting, cartridge dirt alarm	RLT9VZ10S20D5	9V25, 9VZ25

Hydraulic Lube Filtration

- Accessories
- Filter Systems
- Fuel Filtration
- Process Filtration

Markets Served

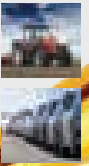

*HYDRAULIC LUBE FILTRATION*

L-2520 | 2019

**Schroeder**  
**INDUSTRIES**  
Advanced Fluid Conditioning Solutions®

DISTRIBUTED BY:



\*To access more information about Schroeder, scan the code with your app-enabled smartphone.

© Copyright 2019 Schroeder Industries. All rights reserved