



CONTENT

LONDON 2019

3-6 December 2019

Kings Place & St. Pancras Renaissance Hotel, London

DEVELOPMENT MARKET & CONFERENCE

Agenda & Information

Conference information

REGISTRATION

All speakers and delegates **MUST** register at Kings Place on the Ground Floor. **Please note you will not be able to register at the St. Pancras Hotel.**

TRAVELLING BETWEEN VENUES

This is a 10 minute walk, or you can pick up a rickshaw from outside either venue to take you swiftly and in style! *Sponsored by Sky.*

NETWORKING

Head to the Battlebridge Room at Kings Place on the Ground Floor or to the Mezzanine for lounge seating. At St. Pancras head to The Ladies Smoking Room or The Gallery Room on the First Floor.

COFFEE CART

Grab a delicious FREE coffee on the Mezzanine at Kings Place. *Sponsored by Banijay Rights.*

LUNCH AT THE BOOKING OFFICE

Dine at the iconic Booking Office Restaurant at the St. Pancras Hotel. *Please note that a minimum spend per person applies.*

COMPLIMENTARY LIGHT LUNCH

This is available in the Battlebridge Room and on the Conference Level at Kings Place, and The Gallery Room at St. Pancras.

INFORMATION POINTS

Head to registration on the Ground Floor at Kings Place or the Ground Floor at St. Pancras.

CONTENT LONDON PLAYLIST

Check out delegates' upcoming shows through C21Screen, the C21Screenings app, at the iPad stations in the Battlebridge Room at Kings Place.

SPEED-NETWORKING

New for 2019! A number of key speakers and industry executives will take part in a new speed-networking programme. Many 10-minute slots have already been booked, but some walk-in meetings are available. Speed-networking takes place in Hansom Hall, St. Pancras Hotel during Tuesday, Wednesday and Thursday lunchtimes.

SCREENINGS AND PRESENTATIONS

A schedule of drama screenings and presentations will run throughout the event, See pages 7 & 9 for more.

THE INTERNATIONAL DRAMA AWARDS

C21's International Drama Awards will take place on Thursday December 5 at Kings Place. The drinks reception starts at 5pm on the Conference Level, with the ceremony following from 6-7pm in Hall 1.

EVENING EVENTS

Content London is host to a series of events every evening, most are open to all delegates. Take a look at the agenda for full information.

DRAMA SUMMIT CLOSING COCKTAIL

This takes place Thursday December 5 between 5pm and 9pm on the Conference Level of Kings Place. *Sponsored by NBCUniversal.*

STREAM THE SESSIONS

Watch the Hall 1, 2 (Kings Place) and Hansom Hall (St. Pancras Hotel) Drama Summit sessions live using your C21Media.net registered email address at: www.streamcontentlondon.net

WIFI

Network name: Content London

Password: ContentLondon19



CONTENT CONCIERGE is a help desk service for Content London delegates. You can find us at the registration desk at Kings Place.

To help you get the most out of your visit, you can email concierge@c21media.net for assistance with booking a lunch or dinner, meeting spaces, speed-networking meetings or for any other information with regard to your trip to London

You can also use the My Content London area of ContentLondon.net to find information about the agenda, speakers and to connect with other delegates.

See reverse for the full Drama Summit 2019 agenda 'at-a-glance'

Welcome to Content London 2019, the seventh annual development market and conference focused on drama, kids and unscripted. We hope you have a great time.

You'll find everything you need to know about the week in the pages of this guide, along with additional information – and delegate networking – within the My Content London area online.

We have an action-packed four days lined up for you, with more than 300 speakers and more than 2,500 delegates aiming to forge new partnerships that will define the future of the content business.

Our aim is to deliver an event that showcases new voices, connects the global business and examines the issues that will affect everyone in the business as it changes rapidly.

A few things to note:

There is no venue within central London that can host an event of this size, and so rather than relocate to a soulless aircraft hangar in the suburbs, we made the decision to run a two-venue event that provides an environment worthy of the sector we operate in. Sessions happen between Kings Place and the St. Pancras Renaissance Hotel. This year we have taken over the whole hotel, and you will need a badge to get into that venue as well as Kings Place. This allows us much greater flexibility and will make the delegate experience much more enjoyable.

There are networking lounges at both venues, so check out where companies are located. It takes around 10 minutes to walk between venues, and there are rickshaws that help make the journey more fun!

Access to sessions is on a first come, first served basis, but all sessions are filmed and will be made available to delegates within 10 days of the event, so you won't miss anything.

You can also stream sessions live on streamcontentlondon.net, so if you can't get into a session, get online and watch it from your meeting table.

We have a longer lunchtime block – from 1pm to 3pm – to provide more networking time and allow for a series of company screenings and presentations. There are also several evening events, including the C21 Drama Awards on Thursday at 6pm. Don't miss those.

Please note that you cannot get into the St. Pancras Hotel or Kings Place without a badge, and we will be enforcing this with increased security this year. Badges for Content London cost as little as £699 when purchased in advance, making it one of the cheapest events in the industry, as well as the best, and we are keen to ensure paying delegates can access all of the sessions, parties, screenings and awards as efficiently as possible.

Content London takes place between December 1 and 4 in 2020. The first tickets for the four-day event, priced £699, will go on sale next week. Grab 'em while you can!

We've invested a lot in bringing new voices to Content London this year. Tuesday morning is devoted to the final of the C21 Drama Series Script Competition, which sees six fantastic projects compete for a US\$10,000 cash prize and a development option with Studio21, our fledgling new voices incubator.

Following that, we have the first outing for our brand new shorts2series initiative, which aims to bring the very best short film makers together with the global content business to turn short films into series.

Eight projects have been selected through a relationship between Studio21 and Hollyshorts, the Oscar-qualifying short film festival now on its 16th year. Their stories will be told as part of this block on Tuesday morning.

We also have the C21 Drama Series Pitch taking place down at the St. Pancras Hotel on Tuesday morning. This three-hour block lifts the covers on 15 new projects looking to complete financing from some of the most creative producers from around the world. If you are looking to find new IP, each of these sessions provides a great opportunity.

There is a complimentary light lunch served each day at Kings Place and the St. Pancras Hotel for all delegates, as well as lots of other places on site to book lunch.

As always, we appreciate the amazing support from our sponsors, and to you for making the trip to London, for what we hope will be a wonderful week of creative business.

Thanks for being Part of The Story.



David Jenkinson
*Managing director
and editor-in-chief,
C21Media*

CONTENTS

Pages 4 and 5
Venue floor plans

Page 7 and 9
Screenings and Presentations

Page 11
Content London Delegations

Page 13
Drama Series Script
Competition Finalists

Pages 15
shorts2series

Pages 17 to 31
Drama Series Pitch

Page 33
Introducing the Agendas

Page 35 to 45
International Drama
Summit Agenda

Page 47
Unscripted Entertainment
Forum Agenda

Page 49
Kids Content Futures Agenda

DRAMASERIES
SCRIPT COMPETITION

[shorts2series]
turning short films into TV

Drama Series **PITCH**

INTERNATIONAL

DRAMA SUMMIT

UNSCRIPTED
ENTERTAINMENT FORUM

KIDS CONTENT
FUTURES





St. Pancras Renaissance Hotel floorplan

Euston Rd, Kings Cross, London, NW1 2AR

GROUND FLOOR

- Delegate restaurant available from 7.30am - 4.00pm (minimum spend applies to each table) • Conference Hall
- Meeting rooms • Information point

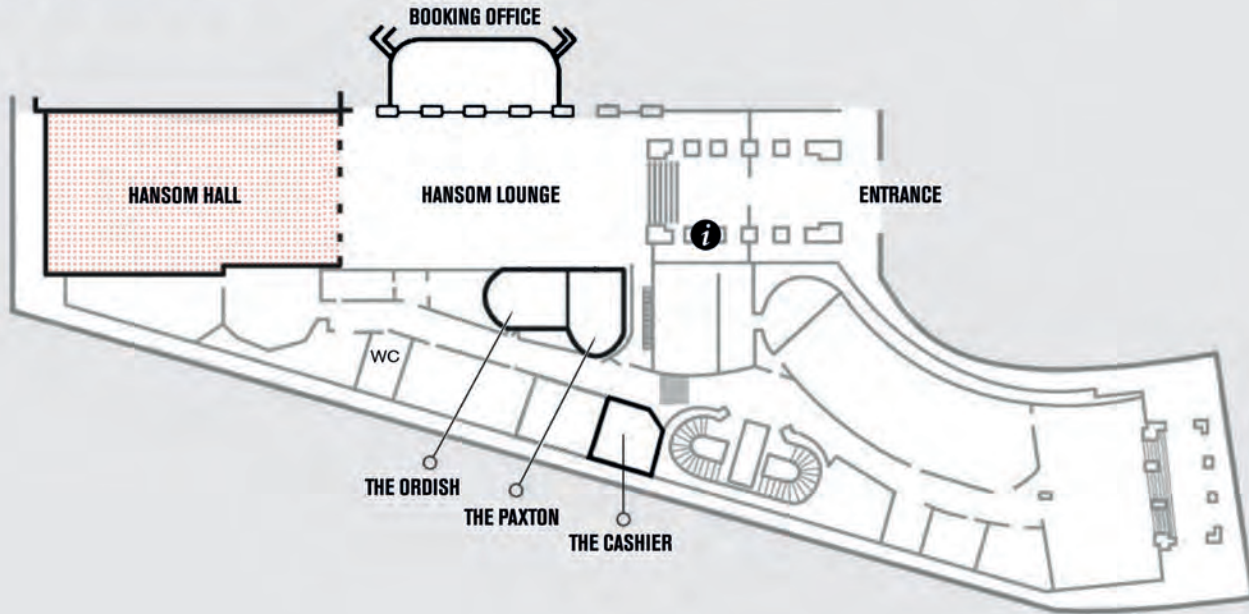

FIRST FLOOR

- Networking spaces • Breakfast and lunch available • Meeting rooms

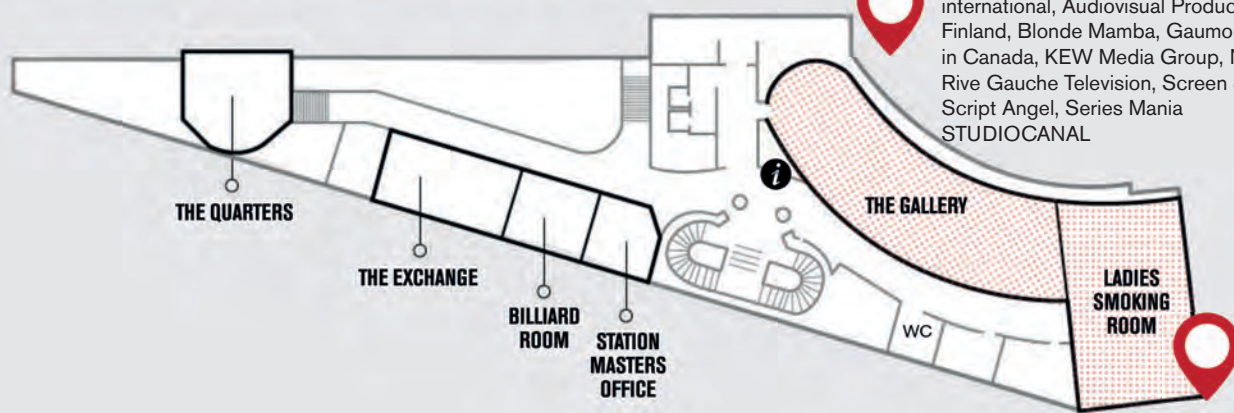

FIND US IN THE GALLERY ROOM

About Premium Content, all3media international, Audiovisual Producers Finland, Blonde Mamba, Gaumont, Invest in Canada, KEW Media Group, NATPE, Rive Gauche Television, Screen Scotland, Script Angel, Series Mania STUDIOCANAL

FIND US IN THE LADIES SMOKING ROOM

Entertainment One, ITV Studios Global Entertainment, Netflix, Sony Pictures Entertainment, ZDF Enterprises

SECOND FLOOR

- The Royal Suite

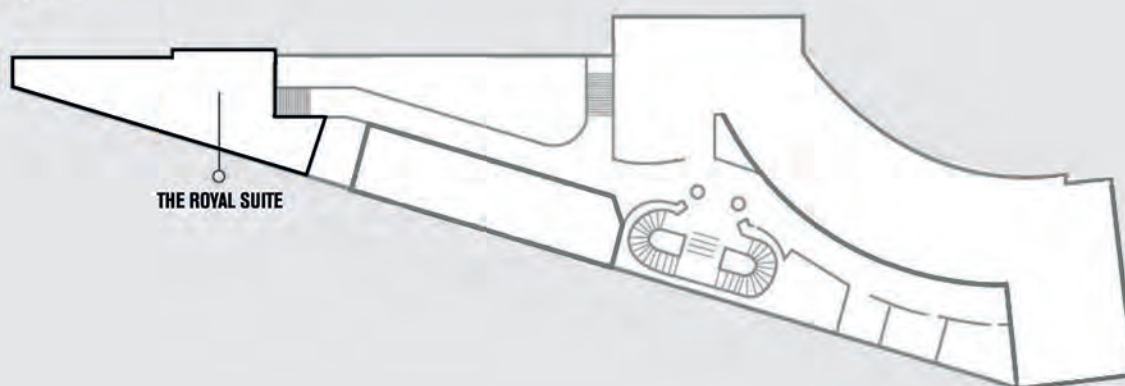



Kings Place floorplan
90 York Way, London, N1 9AG

GROUND FLOOR

- Networking spaces • Green & Fortune cafe • Breakfast and lunch available • Battlebridge bar • Information point

FIND US IN THE PLATINUM LOUNGE

A+E Networks, all3media international, Banijay Rights, BBC Studios, DRG, Entertainment One, Federation Entertainment, Incendo, ITV Studios Global Entertainment, KEW Media Group, Mediawan, Skybound



FIND US IN THE BATTLEBRIDGE ROOM

all3media international, Beta Film Group, Charisma.ai/To Play For Ltd, Cineflix Rights, Dynamic Television, Endemol, Film London, ICEX, Lagardère Studios Distribution, The MediaPro Studio, Newen, Sargent Disc, Screen Australia, The Story Lab, ZDF Enterprises

GALLERY LEVEL (-1)

- Networking spaces • Banijay coffee cart • Balcony access to Hall 1 • Live streaming and presentations in Hall 4



CONFERENCE HALL LEVEL (-2)

- Access to Conference Halls • Music Foyer bar • Live streaming rooms • Cloakroom • Breakfast and lunch available

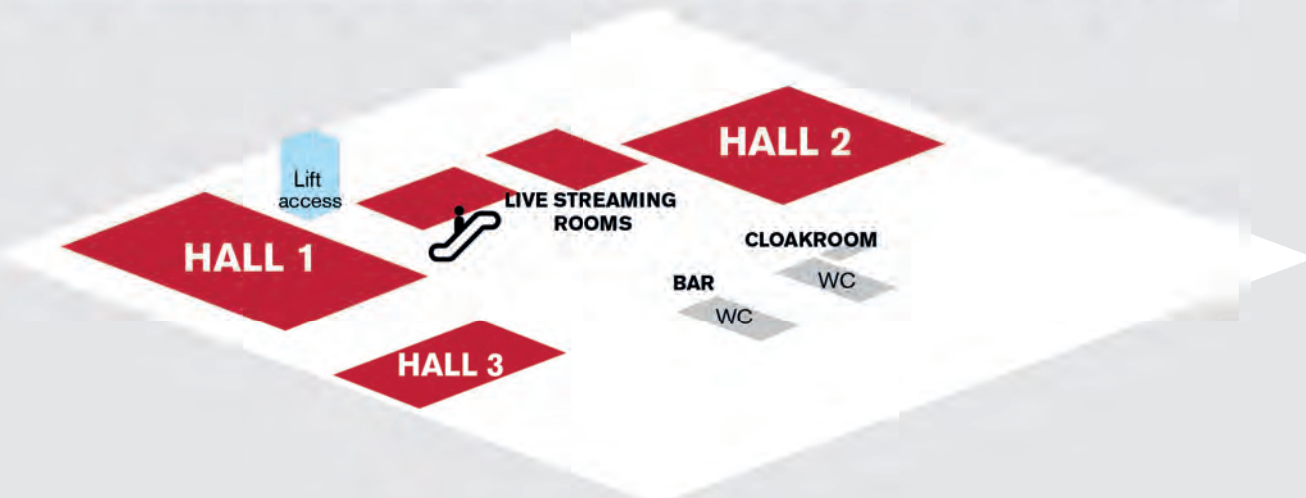

BETA

CELEBRATING 60 YEARS
OF GREAT ENTERTAINMENT

ATLANTIC
CROSSING

AGENT
HAMILTON

HUDSON
& REX

www.betafilm.com

Monday December 2



all3 media international opening night premiere: White House Farm
Kings Place, Hall One
5.30pm drinks reception followed by 6.30pm

screening and Q&A

(All delegates welcome)

Over thirty years ago, three generations of one family were murdered at their isolated farm. Initial evidence pointed the finger at the daughter of the family who had a history of mental illness, however one detective refused to accept this and delved deeper into the investigation. His determination uncovered new evidence that shed suspicion on the only surviving member of the immediate family, the son, who was subsequently sentenced to life imprisonment. This is a dramatised true crime story based on extensive research, interviews and published accounts, looking at the mystery behind what happened that fateful day, only made more contentious as the son still protests his innocence to this day.

Q & A with key cast and executives

Writer: **Kris Mrksa** (*Requiem*)

Director: **Paul Whittington** (*Hatton Garden, The Crown*)

Executive Producers: **Willow Grylls, Charlie Pattinson, Elaine Pyke, Kris Mrksa**

Cast:

Jeremy: **Freddie Fox** (*Year of the Rabbit, Cucumber*)

Taff: **Stephen Graham** (*The Virtues, Line of Duty*)

Stan: **Mark Addy** (*New Blood, Game of Thrones*)

Ann: **Gemma Whelan** (*The Crown, Game of Thrones*)

Colin: **Mark Stanley** (*Game of Thrones, Love, Lies and Records*)

Sheila: **Cressida Bonas** (*Doctor Thorne, The Bye Bye Man*)

Tuesday December 3



Sony Pictures Television/ Playmaker sponsored screening: The Commons
Kings Place, Hall One
1.30pm – 2.30pm

(All delegates welcome)

In the near-future, a neuropsychologist and her family attempt to live a normal life in a world disrupted by climate change, limited resources, disparity between classes, disease, and cutting edge science/technology.

Starring: Joanne Froggatt (*Eddie Boulay*), **David Lyons** (*Lloyd Green*), **Ryan Corr** (*Shay Levine*), and **Rupert Penry-Jones** (*Dominic Boulay*).

Executive Producers: David Taylor, David Maher, Graham Yost, Shelley Birse, Fred Golan

Panel: **David Taylor**, Playmaker MD and The Commons EP, **Shelley Birse**, Showrunner and **Rupert Penry-Jones**, Actor

Moderator: **Wayne Garvie**, President, International Production, Sony Pictures Television



Norwegian Drama Showcase: Society Bites
Kings Place, Hall Two
1.30pm – 2.30pm

(All delegates welcome)

Can drama series help us understand our Society better? In this session we will discuss a bundle

of Norwegian drama series in which social awareness does not stand in the way for engaging a broad audience. Rather, these works constitute a trend in Norwegian drama that utilizes current societal themes in the making of compelling and captivating drama series.

Meet the people behind the brand new series: *22. July*, *Witch Hunt*, *Furia* and *Nudes* and executives from NRK and NFI.

Photo credit from the series: *22. July*, Photo: NRK.

...continued Tuesday Dec 3



Audiovisual Producers Finland sponsored presentation: The Finnish 25% Cash Rebate Panel discussion: Would Finland's incentive work

for your next production? Financing and production practicalities in Finland

1.30pm – 2.30pm

Kings Place, Hall Three

(All delegates welcome)

Fast and simple. The Finnish 25% cash rebate.

Finland's production incentive allows for more opportunities to shoot, co-produce and do post-production in Finland. Our panelists will reveal why Finland appealed to them, and what their experiences were in the fields of scripted drama and animation.

Come and learn about generous incentive opportunities, locations, post-production and what services Finland can offer your next production!

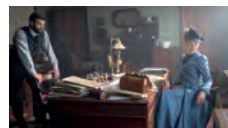

A+E Networks Gala Screening: Miss Scarlet and The Duke World Premiere

St. Pancras Hotel, Hansom Hall

6.00pm onwards

(All delegates welcome)

Set in 1880s London, this is a full-throttle crime drama about London's first ever female detective. Eliza Scarlet played by Kate Phillips (*Peaky Blinders*) is a fearless, independent heroine making her way in a man's world. Helping her is Detective Inspector William Wellington of Scotland Yard, aka "The Duke" played by Stuart Martin (*Jamestown*). Eliza and Duke strike up a mismatched, fiery relationship that will crackle and fizz as they team up to solve crime in the murkiest depths of Victorian London.

Wednesday December 4



Sponsored Networking Breakfast: Screen Scotland

Kings Place, Hall Three

8.00pm – 9.00pm

(Breakfast provided and all

delegates welcome)

Start your Wednesday with Screen Scotland: Home to world-class talent, crew, facilities and breath-taking locations. Scotland also offers a range of financial incentives, including: the UK Tax Relief, newly enhanced Production Growth funds and a Broadcast Content Fund. Join us for breakfast at Content London 2019 to meet some of the team, and find out more about why there's no better time to film in Scotland.

Screen Scotland is the dedicated partnership for screen in Scotland. With funding from Scottish

Government and the National Lottery, Screen Scotland is driving the cultural, social and economic development of all aspects of the sector in Scotland, through enhanced funding, services and support.

www.screen.scot

@screencots

...continued Wednesday Dec 4



ZDF Enterprises sponsored screening: Top Dog

1.30pm – 2.30pm

Kings Place, Hall Two

(All delegates welcome)

The TV series *Top Dog* is based on the trilogy by best-selling Swedish author Jens Lapidus. A mysterious disappearance brings together two completely different worlds – ambitious business lawyer Emily Jansson (*Josefin Asplund*) and the local mafia's number-one crook, Teddy Maksumic (*Alexej Manvelov*). She wants to move up; he wants to leave his old life behind. The pair end up in a tricky situation where the past catches up. Internationally acclaimed leading actors **Josefin Asplund** (*Sanctuary, Vikings*) and **Alexej Manvelov** (*Sthlm Requiem, Chernobyl, Before We Die*) are the main cast.

Based on the series of books by best-selling Swedish author Jens Lapidus, "VIP-rummet", "Stockholm Delete" and "Top Dogg".



Canadian Media Producers Association sponsored presentation: Diversity and Inclusion in Canadian Screen Content

1.30pm – 2.30pm

Kings Place, Hall Three

(All delegates welcome)

The presentation will focus on diversity and inclusion in the Canadian screen-based content industry. The panel discussion will explore the steps our industry has taken to champion equal representation both in front and behind the camera and how those efforts have enriched creative storytelling.

Panelists: **Valerie Creighton**, President & CEO, Canada Media Fund, **Amy Cameron**, Executive Producer, Cameron Pictures (*Mary Kills People, Little Dog*); **Floyd Kane**, Producer/Showrunner, Freddie Films (*Diggstown*) **Julia Langlois**, Producer, Trio Orange (*Do You Hear Me?*)

Moderated by Prem Gill, CEO, Creative BC.



Dynamic Television sponsored screening: The Sommerdahl Murders

1.30pm – 2.30pm

Kings Place, Hall Four

(Lucnh provided and all delegates welcome)

Commissioned by TV2 Denmark and co-produced by ZDF, *The Sommerdahl Murders* (8 x '45) is a blue-sky crime procedural based on the best-selling novels from Anna Grue. Set in Helsingor, the picturesque and famous town from Hamlet, the series is a unique combination of mystery and suspense, emotion and relationship, and levity and humor, making it accessible for a global audience. Premieres in March 2020.



The ground-breaking 8-part new drama
for Foxtel & Sky Atlantic

Created by and starring
multi award-winning

TIM MINCHIN

(Matilda the Musical, Californication)

UPRIGHT



"YOU MUST NOT MISS"

- TV Choice

...continued Wednesday Dec 4

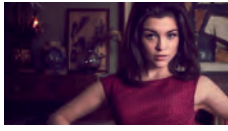

BBC One and Keshet sponsored screening:
The Trial of Christine Keeler
Kings Place, Hall One
6.30pm drinks reception

followed by 6.30pm screening and Q&A
(All delegates welcome)

London 1963. A gunshot is fired in a Chelsea Mews, propelling the 20 year-old Christine Keeler into the headlines—along with her affair with the Minister for War.

This drama tells the fresh and epic story of Christine's fight to be heard and her refusal to play by the rules, despite attempts by the male-dominated establishment to silence and exploit her.

Cast to be confirmed.

Photo credit: Sophie Cookson as Christine Keeler in BBC One's *THE TRIAL OF CHRISTINE KEELER*, coming soon to BBC One
Photographer: Ben Blackall / © BBC / Ecosse Films 2019

Thursday December 5



Warner Bros International Television sponsored screening: **Love Me**
Kings Place, Hall Two
1.30pm – 2.30pm
(All delegates welcome)

Love Me is a six part romantic drama series about love and relationships at three distinct times of life. How do people experience love and passion across different generations? A warm and humorous series about love, sex, fear and pain. A series about life, from start to finish.

Love Me premiered on Nordic streaming service Viaplay in October this year, and will be broadcasted on SVT in the spring. A second season is currently in production and a US pilot is in development with ABC. The series was written and directed by Josephine Bornebusch, who also plays the lead role in the show.



MRP Matila Röhr Production, The Mediapro Studio and YLE sponsored screening:
The Paradise
Kings Place, Hall Three

1.30pm – 2.30pm
(All delegates welcome)

Two murders shake the Finnish community of Fuengirola, a group that made this tiny corner of Málaga their own little Finnish paradise on the shores of the Mediterranean. Hilka Mäntymäki, a veteran crime detective aged 60, is traveling from Helsinki to help the local police on a case that will soon claim new victims. Please join us for a networking lunch.

Speakers include: Marja Pyykkö (director), Matti Laine (writer), Ran Telem (Mediapro), Fran Perea (actor), Marko Rohr (producer), Suvi Mansnerus (YLE producer).

Special Events - Thursday December 5

The Finger Awards
Kings Place, Hall Three
5.00pm - 6.30pm

(Invitation only)

The first-ever international Finger Awards has been created to provide a platform for comedy professionals who have gone out of their way to try to make the world a better place using their craft. It represents an industry recognition of these efforts by an international panel of over 50 A-list judges, all members of the Comedy for Change community.

Nominations for the first Finger Awards included 80 candidates from over 30 countries. In addition, the community will grant a lifetime achievement award for outstanding contribution to society to someone who has been tireless in their efforts to raise awareness of issues of importance using comedy.

The ceremony will be hosted by comedian and former senior TV executive, Cally Beaton.



C21Media's International Drama Awards
Kings Place, Hall One

6.00pm - 7.00pm

(All delegates welcome)

Featuring 12 categories and judged by over 100 of the world's leading drama commissioners, C21's International Drama Awards are by the business, for the business.

In 2019 we received over 500 entries from around the globe. Now celebrating our seventh year, we invite drama summit delegates to celebrate the best in the business.

Join us for drinks on the Conference Level after the ceremony.



Serial Eyes: Posh Pitch Circus
St. Pancras Hotel, The Royal Suite
9.00pm - 10.00pm

(Invitation only)

SEAN's Amazing Traveling Pitch Circus is coming to Content London and becomes... the POSH CIRCUS!

Put on your fancy clothes and come drink and laugh

with us in the Royal Suite of the St Pancras Renaissance hotel. Invitations only.

Hosted by alumni of the Serial Eyes writing program in Berlin, the Pitch Circus is a comedy open mic show where writers can tell their craziest ideas, free from formatting and rules. After successful editions in Munich, Berlin, Helsinki and Lille for Série Mania; the Circus stops for the first time in London!

sean

SERIAL EYES ALUMNI NETWORK

RIITTA
HAVUKAINEN

FRAN
PEREA

**CASE
STUDY**

WEDNESDAY 4TH
9.30 AM
HALL 2 KINGS PLACE

**WORLDWIDE
PREMIERE
SCREENING**

THURSDAY 5TH
1.30 PM
HALL 3 KINGS PLACE



WELCOME TO THE PLACE WHERE MEMORIES KILL

THE PARADISE

mrp
MATILA RÖHR PRODUCTIONS

yle

THE
MEDIAPRO
STUDIO

This year sees the largest number of international delegations coming to Content London from all round the world including Australia, New Zealand, Canada and almost every country in Europe.

With over 2500 executives attending, this year's event is the biggest to date, confirming it as the largest gathering of the global scripted business in the annual calendar.



ASSOCIATION OF AUDIOVISUAL PRODUCERS (APA)
apaonline.it



Danish Producers' Association

DANISH PRODUCERS' ASSOCIATION
pro-f.dk



NEDERLANDS FILMFONDS
filmfonds.nl



Fís Éireann Screen Ireland

SCREEN IRELAND
screenireland.ie



AUDIOVISUAL PRODUCERS FINLAND (APFI)
apfi.fi
Find us in the Gallery Room



ENTERTAINMENT MASTERCLASS (EMC)
entertainment-masterclass.tv



NEWFOUNDLAND AND LABRADOR FILM DEVELOPMENT CORPORATION (NLFDC)
nlfdc.ca



SCREEN PRODUCTION AND DEVELOPMENT ASSOCIATION OF NEW ZEALAND (SPADA)
spada.co.nz



ASSOCIATION QUÉBÉCOISE DE LA PRODUCTION MÉDIATIQUE (AQPM)
aqpm.ca



EUROPEAN PRODUCERS CLUB
europeanproducersclub.org



NORWEGIAN FILM INSTITUTE (NFI)
nfi.no



TV FRANCE INTERNATIONAL (TVFI)
tvfrance-intl.com



CANADIAN MEDIA PRODUCERS ASSOCIATION (CMPA)
cmpa.ca



ICEX
icex.es
Find us in the Battlebridge Room



POLISH FILMMAKERS ASSOCIATION
sfp.org.pl



VIRKE
virke.no



COPENHAGEN FILM FUND
cphfilmfund.com



MIDPOINT
midpoint-center.eu



SCREEN AUSTRALIA
screenaustralia.gov.au
Find us in the Battlebridge Room



FLANDERS IMAGE
flandersimage.com

This year sees the largest number of international delegations coming to Content London from all round the world including Australia, New Zealand, Canada and almost every country in Europe.

With over 2500 executives attending, this year's event is the biggest to date, confirming it as the largest gathering of the global scripted business in the year.



ASSOCIATION OF AUDIOVISUAL PRODUCERS (APA)
apaonline.it



Danish Producers' Association

DANISH PRODUCERS' ASSOCIATION
pro-f.dk



MIDPOINT
midpoint-center.eu



SCREEN AUSTRALIA
screenaustralia.gov.au
Find us in the Battlebridge Room



AUDIOVISUAL PRODUCERS FINLAND (APFI)
apfi.fi
Find us in the Gallery Room



ENTERTAINMENT MASTERCLASS (EMC)
entertainment-masterclass.tv



NEDERLANDS FILMFONDS
filmfonds.nl



SCREEN IRELAND
screenireland.ie



ASSOCIATION QUÉBÉCOISE DE LA PRODUCTION MÉDIATIQUE (AQPM)
aqpm.ca



EUROPEAN PRODUCERS CLUB
europeanproducersclub.org



NEWFOUNDLAND AND LABRADOR FILM DEVELOPMENT CORPORATION (NLFDC)
nfdc.ca



SCREEN PRODUCTION AND DEVELOPMENT ASSOCIATION OF NEW ZEALAND (SPADA)
spada.co.nz



CANADIAN MEDIA PRODUCERS ASSOCIATION (CMPA)
cmpa.ca



FLANDERS IMAGE
flandersimage.com



NORWEGIAN FILM INSTITUTE (NFI)
nfi.no



TV FRANCE INTERNATIONAL (TVFI)
tvfrance-intl.com



COPENHAGEN FILM FUND
cphfilmfund.com



ICEX
icex.es
Find us in the Battlebridge Room



POLISH FILMMAKERS ASSOCIATION
sfp.org.pl



VIRKE
virke.no

LAGARDERE STUDIOS DISTRIBUTION
presents



Lagardère
STUDIOS

 DISTRIBUTION

DRAMA SERIES

SCRIPT COMPETITION



The C21 Drama Series Script Competition, coproduced between C21, Script Angel, Studio21 and WritersRoom is designed to find the next big thing in scripted entertainment. We're looking for an outstanding pilot for a one hour drama from a fresh writer (or writers) who has got what it takes to create a primetime series. The six finalists, chosen from more than 250 entries, will pitch their projects during the opening session at Content London. The winner will be announced at The International Drama Awards on Thursday 5 December, from 6pm.

The finalists are:

Big Fish

By Caroline Dean



A UK lawyer returns to her estranged home, a parochial backwater in Zambia, on a hydrodam case in a bid to make partner. But this case threatens to dry up her family farm. Will she screw over her family?

Caroline is a fully fledged grown-up, homeowner and mum. Since graduating, she's written a feature, *Polarised*, which was a semi-finalist in the Academy Nicholl Fellowships of 2015; a drama pilot, *Petticoat*

Pirates, which was the finalist in the 2018 Screenwriting Goldmine competition and a finalist in the 2019 Launch Pad Pilot competition; and a comedy drama pilot, *Unspoken*, which was longlisted in the BBC Writersroom Comedy, the Thousand Films competition and the Edinburgh International Television Festival awards.

Crack of Dawn

By Grace Link



Dawn's hormones have gone AWOL – along with her husband. Tim lost his job and found Karan. And Dawn found them both, in a gay bar. Dawn welcomes Karan into her family. Not because she's woke but because he's paying her mortgage.

Grace studied classics at Princeton University. As a screenwriter, she trained at the National Film and Television School. Grace has three original TV series in development with Silver Reel, Company Pictures and West Road Pictures (all3media) and was named by Amazon Studios director of European originals Georgia Brown as a 'writer to watch' at the 2019 Edinburgh International Television Festival. Grace was selected for the BFI Network x Bafta Crew for 2019-20.

Homegrown

By Kate Thorman



When Layla Mahmoud's childhood best friend, Camille, unexpectedly returns home to East London after having run away to Syria to join ISIS, the 16-year-old hacker decides to find out just why her friend is back.

Convinced Camille is still hiding something, Layla teams up with their Spanish teacher, Seb, a traumatised special forces veteran, and throws all her energy into discovering the truth about her friend and the betrayal that changed both girls' lives.

Kate is a Californian by birth, New Yorker at heart, and Londoner thanks to a twist of fate. A writer-of-all-trades, she's been a freelance food and travel journalist for nearly a decade. Her writing has appeared in publications such as *AFAR*, *Bon Appétit* and *The New York Times*.

Her TV and feature screenplays focus on coming-of-age stories about women of all ages and interrogate what it means to be a good person in a broken world. She also writes true crime podcasts for Spotify's *Parcast Network* and audio dramas in the *Doctor Who* universe for Big Finish Productions. In another life, she coproduced and hosted the food and travel web series *The Innocents Abroad*.

Station Road

By Michael Lee Richardson



Three squabbling sisters are trapped in their run-down home town in northern England when all the men die in mysterious circumstances. They have to work together for the first time ever to uncover the mystery – and get out.

Michael is a writer and youth worker based in Glasgow. He graduated with distinction from Glasgow Caledonian University's masters in television fiction writing. His short film *My Loneliness is Killing Me*, directed by Tim Courtney, won a Bafta Scotland Award (Best Short Film) and was given an honourable mention by the jury for the Best of British strand at the Iris Prize 2019. It has been shown at film festivals around the world.

Michael is currently developing projects for Kindle Entertainment and is part of the Young Film Foundation and BBC Writersroom's Scottish Voices group. As a youth

worker, he set up and ran Trans Youth Glasgow and is a passionate advocate for Scotland's young people.

The Cloud

By Martynas Mendelis and Domante Urmonaitis



Set in the afterlife and on Earth, *The Cloud* explores concepts of faith, soul, immortality and mind.

Suffering unbearable loneliness in heaven, Sarah burns to meet her husband, Sam. On Earth, Sam attempts to use science to get a glimpse of the afterlife. They're destined to meet, but when they do, the rules of *The Cloud* are

broken and their daughter, Amy, gets lost. Their attempts to find the truth will lead to the discovery that the afterlife is only a digital collection of zeros and ones. What's more, God is not made of flesh and blood – it's rapidly developing AI software with its own agenda.

Domante is an alumnus of Torino Serieslab, Sundance Screenwriters Workshop and Berlinale Talents. She has presented projects at various international markets, including *Series Mania*, *MIA* and *Frontieres*. Her TV series project *The Beehive* was in development with Sky Italia.

Domante is also working as an expert for the European Commission's Media Development programme. She was part of the selection committee for Torino Serieslab 2018 and 2019. She is also involved in audiovisual education as a co-founder and coordinator of international training schemes *Art Department Masterclass* and *Art Department Workshops*, and as a lecturer at Vilnius Gediminas Technical University.

Martynas obtained a BA in mathematics at Vilnius University before working as an analyst at Western Union for three years. Since 2017, he has focused on deepening his knowledge of the TV industry. As a screenwriter, he has participated in Torino Serieslab, *Series Mania*, *Seriencamp* and more.

In 2018/2019, he attended Midpoint TV Launch Development Executive training, supervised by HBO Europe executives, and worked as a reader for the AFF Script Competition. His projects advanced to the second round of Sundance Episodic Lab in 2018 and 2019. In 2018, he was developing an original TV series project with Sky Italia.

They Walked Alone

By Ian Masters and Jon Smith



Corruption, racism and murder during the Blitz of Liverpool's Chinatown. When British-Chinese man Harry Cheng investigates the death of his father, the prominent leader of the Chinese sailors' union, he finds himself up against the Merseyside Police, white nationalist thugs and the Chinese unions themselves. Harry seeks justice for his father, and visibility for his Chinese community. But to do so he must decide where he stands and who he really is. The more he pursues the truth, the more he threatens the unity of the fragile Chinatown, and his own conflicted identity.

Expats fall into three categories: missionaries, mercenaries or misfits. Ian Masters is a bit of each. He had a Poisonwood missionary childhood in the Congo and then spent 18 years working in Africa and Asia as a writer, storyliner and script mentor. This included *The Last Reel*, Cambodia's Oscar submission, and *Supa Modo* from Kenya, winner of the *Crystal Bear*, as well as many hours of broadcast TV, radio and web drama for BBC Media Action. Together with co-writer Jon Smith, his spec scripts have been finalists for *RocLiffe* and won or were placed in many script competitions.

Jon has lived, worked and written in South Korea, the US, Egypt and, most recently, Spain. As well as screenwriting, he is the internationally published author of 14 books and four musicals. His short film (with Ian) *Beyond the Bridge* premiered at the Tokyo Film Festival and is in development as a feature with Pandora Japan for production in 2020.

Judges:



David Jenkinson
CEO
Studio21



Hayley MacKenzie
Founder and CEO
Script Angel



Yule Caise
Showrunner



Nick Betts
Founder
The Lighthouse Film
and Television



Marc Montefiore
President and
executive producer
New Metric Media



Mickey Rogers
International Emmy
Winner

Red Productions for BBC Studios

WHO
KILLED
MY
MOTHER?

FROM THE MAKERS OF *HAPPY VALLEY*

TRACES

RED

albi

bbcstudios.com/sales

BBC STUDIOS

[shorts2series]

turning short films into TV



Content London takes shorts2series

C21 has announced the eight projects that will be showcased in its shorts2series strand, a new initiative taking place at Content London that aims to bring the very best short film makers together with the global content business to turn short films into series.

In a shorts2series presentation block on the first day of the event we will present eight 'most-likely-to-succeed' shorts to the global market, and then hear from the film makers about the projects and their ambitions to partner to develop them.

The eight projects have been selected through a relationship between Studio21 and Hollyshorts, the Oscar-qualifying short film festival now on its 16th year.

Don't miss this opportunity to see some of the most exciting short films out there, and meet the creators to discuss TV series potential.

You can watch all the short films on C21Screen and a playlist has been sent to all delegates.

The projects include:

Boulevard

David Bercovivi-Artieda



Boulevard captures a frenetic moment in the life of LAPD Homicide detective Hayden Glass as he cruises the gritty streets of Hollywood, seemingly checking on ongoing operations to entrap johns looking to exchange sex for money. Things prove more complicated as it is revealed that Glass is a sex addict working a twelvestep program and trying to maintain his sobriety. The violence he observes as a detective creates anxieties that send him back onto the streets. With the help of a tough-love sponsor, Hayden is eased back into the program to start back at Day One.

Men of Vision

Frank Todaro



Men of Vision offers a droll look at Hubert Moss, a swaggering early 20th century inventor who is in the midst of a dry spell that threatens to ruin him. With investors abandoning ship, a potential reprieve shows up in the form of a young inventor hoping to rent some space in Hubert's lab. Better still, he's got some ideas. Could this be Hubert's salvation? Men of Vision is a comic comment on

ego, failures of imagination, and our idiotic inclination to go backward when the path forward seems obvious.

Bewildered

Gregor Wilson

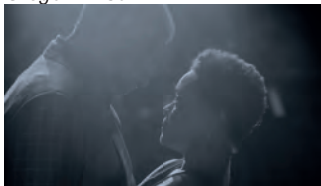

Starring Keith David (Greenleaf, Cloud Atlas,) and Maria Howell (The Color Purple, Saints and Sinners), Bewildered depicts the journey of world famous, husband and wife jazz vocalists – Joseph and Sara Honoré – from the peak of their career and marriage, into the turmoil and anxiety brought on by Joseph's fall into dementia.

As life at home becomes untenable for Joseph, he is moved into a care facility for his own safety. There he is befriended by Elijah, a young care worker and gifted musician - played by Myron Parker Wright (Queen Sugar, Mercy Street).

Through kindness and patience, Elijah nurtures Joseph back to singing. Despite his otherwise ravaged brain,

Joseph is helped by Elijah to recall deeply held musical memories, which provide a desperately needed lifeline to reconnect with his beloved wife Sara.

At its core, this film is a love story, but it also sheds an important light on the proven ability of music to provide comfort and dignity to patients and their families dealing with dementia.

Star Boy

Joëlle Bentolila

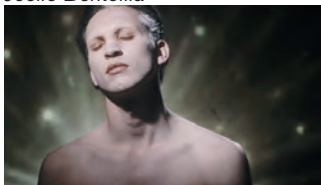

Starboy is a gripping, visually stunning drama about a young Hasidic Jewish man who, turning to the study of the Kabbalah and Quantum mechanics, begins to increasingly doubt his identity, his gender and the nature of being - which triggers an escalating heart-rending conflict with his very pious young wife and his community. It tells a unique very unusual story that surprisingly and successfully

draws upon issues of gender, mysticism, religious transgression and ends on a shocking, exciting and dramatic cliff-hanger - a precursor of things to come.

Life's A Drag

Kate D'hotman



Life's a Drag is a dark comedy about a depressed zombie named Bob. He used to be cool. He used to have groupies. He used to have all his body parts. Now, although the undead and the living have reached a truce, Bob is finding it hard to adjust. Life after death just isn't all it's cracked up to be. He's in a dead-end job working for a narcissist, and he hasn't been laid since before the Apocalypse. Up until now, he's played by the rules, but Bob is reaching his breaking point, and he's about to lose his temper... Life's a Drag offers a hilarious re-imagining of a world in the grip of a zombie apocalypse.

Tijuana

Mary-Lyn Chambers & David 'Blak' Plascencia



It's 1924 in Tijuana, Mexico during U.S. Prohibition. Carmen, a wildly ambitious and deviously calculating woman, manipulates her husband into launching a tequila-smuggling business that triggers a chaotic downward spiral.

A Cool Dark Place

Stephanie Domini

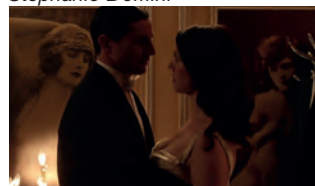

New York City, 1935. Booze, big bands, and beautiful bombshells populate this grand city during a great depression. Vivienne St. Germain leads a glamorous life of a former showgirl thanks to her powerful husband, a former politician named Walter Perry and due to the success of their supper club, Metropolis. She conceals the pains of her past, secretly longing for a lost love and to

be the performer she once was before. With the heightened success of Metropolis, Walters ego is growing. His appetite for wealth, power and other women are not sitting well with those who know him- including the neighborhood mob bosses. Vido Vecchio, a powerful gangster, negates on an agreement with Walter with an unwelcome appearance to the nightclub. Also on this particular Saturday night there are other unexpected developments that could alter things indefinitely for Vivienne.

Mum's Hairpins

Max Dankevich, Tatiana Fedorovskaya, Taras Stadnikov

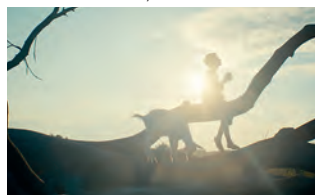

Jewish shtetl, Ukraine, 1941. A box with mother's hairpins – the only thing left from his family – is Yasha's last chance to escape German invaders and rescue his new friend, a wounded goat kid.

[shorts2series]

turning short films into TV



Content London takes shorts2series

C21 has announced the eight projects that will be showcased in its Short2Series strand, a new initiative taking place at Content London that aims to bring the very best makers of short films together with the global content business to turn shorts into series.

In a Short2Series presentation block on the first day of the event, we will present eight 'most-likely-to-succeed' shorts to the global market, and then hear from the filmmakers about the projects and their ambitions to partner to develop them.

The eight projects have been selected through a relationship between Studio21 and Hollyshorts, the festival of Oscar-qualifying short films now in its 16th year.

Don't miss this opportunity to see some of the most exciting short films out there, and meet the creators to discuss TV series potential.

You can watch all the shorts on C21Screen and a playlist has been sent to all delegates. **The projects include:**

Boulevard

David Bercovivi-Artieda



Boulevard captures a frenetic moment in the life of LAPD Homicide detective Hayden Glass as he cruises the gritty streets of Hollywood, seemingly checking ongoing operations to entrap Johns looking to exchange sex for money. Things prove more complicated as it is revealed that Glass is a sex addict working a twelvestep programme and trying to maintain his sobriety. The violence he observes as a detective creates anxieties that send

him back on to the streets. With the help of a tough-love sponsor, Hayden is eased back into the programme to start back at Day One.

Men of Vision

Frank Todaro



Men of Vision offers a droll look at Hubert Moss, a swaggering early 20th century inventor who is in the midst of a dry spell that threatens to ruin him. With investors abandoning ship, a potential reprieve shows up in the form of a young inventor hoping to rent some space in Hubert's lab. Better still, he's got some ideas. Could this be Hubert's salvation? Men of Vision is a comic comment on

ego, failures of imagination and our idiotic inclination to go backward when the path forward seems obvious.

Bewildered

Gregor Wilson



Starring Keith David (Greenleaf, Cloud Atlas) and Maria Howell (The Color Purple, Saints & Sinners), Bewildered depicts the journey of world-famous husband-and-wife jazz vocalists Joseph and Sara Honoré from the peak of their career and marriage into the turmoil and anxiety brought on by Joseph's fall into dementia.

As life at home becomes untenable for Joseph, he is moved into a care facility for his own safety. There he is befriended by Elijah, a young care worker and gifted musician, played by Myron Parker Wright (Queen Sugar, Mercy Street). Through kindness and patience, Elijah nurtures Joseph back to singing. Despite his otherwise ravaged brain, Joseph is helped by Elijah to recall deeply held musical memories, which provide a desperately needed lifeline to reconnect with his beloved wife, Sara. At its core, this film is a love story but it also sheds an important light on the proven ability of music to provide comfort and dignity to patients and their families dealing with dementia.

Star Boy

Joëlle Bentolila

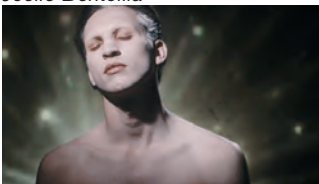

Starboy is a gripping, visually stunning drama about a young Hasidic Jewish man who, turning to the study of the Kabbalah and quantum mechanics, begins to increasingly doubt his identity, his gender and the nature of being – which triggers an escalating heart-rending conflict with his very pious young wife and his community.

It tells a unique, very unusual story that surprisingly and successfully draws upon issues of gender, mysticism and religious transgression and ends on a shocking, exciting and dramatic cliffhanger – a precursor of things to come.

Life's A Drag

Kate D'hotman



Life's a Drag is a dark comedy about a depressed zombie named Bob. He used to be cool. He used to have groupies. He used to have all his body parts. Now, although the undead and the living have reached a truce, Bob is finding it hard to adjust. Life after death just isn't all it's cracked up to be. He's in a dead-end job working for a narcissist and he hasn't been laid since before the

Apocalypse. Up until now, he's played by the rules, but Bob is reaching his breaking point and he's about to lose his temper. Life's a Drag offers a hilarious re-imagining of a world in the grip of a zombie apocalypse.

Tijuana

Mary-Lyn Chambers & David 'Blak' Plascencia



It's 1924 in Tijuana, Mexico during US Prohibition. Carmen, a wildly ambitious and deviously calculating woman, manipulates her husband into launching a tequila-smuggling business that triggers a chaotic downward spiral.

A Cool Dark Place

Stephanie Domini

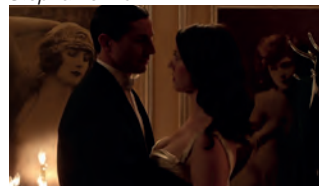

New York City, 1935. Booze, big bands, and beautiful bombshells populate this grand city during a great depression. Vivienne St. Germain leads a glamorous life of a former showgirl thanks to her powerful husband, a former politician named Walter Perry and due to the success of their supper club, Metropolis. She conceals the pains of her past, secretly longing for a lost love and to

be the performer she once was before. With the heightened success of Metropolis, Walters ego is growing. His appetite for wealth, power and other women are not sitting well with those who know him- including the neighborhood mob bosses. Vido Vecchio, a powerful gangster, negates on an agreement with Walter with an unwelcome appearance to the nightclub. Also on this particular Saturday night there are other unexpected developments that could alter things indefinitely for Vivienne.

Mum's Hairpins

Max Dankevich, Tatiana Fedorovskaya, Taras Stadnikov

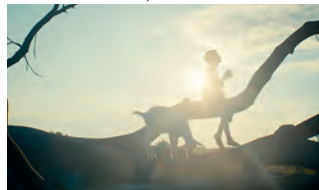

Jewish shtetl, Ukraine, 1941. A box with mother's hairpins – the only thing left from his family – is Yasha's last chance to escape the German invaders and rescue his new friend, a wounded goat kid.



DRG

DRAMA

WE ARE **DRAMA**

WWW.DRG.TV

Drama Series PITCH

Content London is Pitch Perfect

From nearing 100 submissions 30 projects have been successful in making the long list and 15 will pitch at Content London, kicking off the conference agenda down at The St. Pancras Renaissance Hotel at 10am on Tuesday December 3.

The finalists, from established drama creators worldwide, are all bidding to attract additional finance and coproduction partners.

The Drama Series Pitch this year occupies a full morning at the International Drama Summit with fifteen projects being pitched - up from eight last year. They will be pitched in front of conference on Tuesday 3 December at the St. Pancras Hotel between 10am-1pm.

The winning project will be announced at the International Drama Awards, which takes place at 6pm on Thursday 5 December. The winners receive a £30,000 marketing package from C21Media to support development.

Don't miss this opportunity to hear about some of the most exciting dramas on the development slates of producers from around the world.

The projects are detailed over the coming pages. Connect with the producers through My Content London, the Content London networking area.

Judges:



Nadine Nohr
Acquisitions consultant,
Huanxi Media
(Chair of Judges)

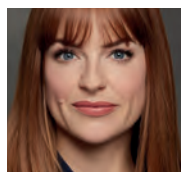

Meghan Lyvers
SVP, co-production
and development,
CBS Studios International



Rola Bauer
Managing director,
Studio Canal TV



Philipp Steffens
Head of fiction,
RTL Television



Gina Marcheschi
Head of scripted television,
VICE STUDIOS



ALIVE - THE MYSTERY OF MOAG STATION (FILM UA)

Genre/format: sci-fi, YA, 8x60'
Producers: Victor Mirsky, Elena Malkova, Kateryna Vyshnevskaya
Partners: Premier Studios, Russia
Development stage/planned shooting start: In development
Shooting locations and languages: Ukraine and/or international/English language.
Total budget/budget per episode: US\$5.6m/US\$700,000
Financing already in place: US\$2.8m (50%)

PITCHING:

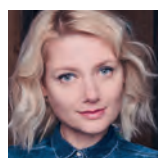

Kateryna Vyshnevskaya,
Head of
development and
coproductions and
producer,
Film.UA Group



Elena Malkova,
Producer,
Film.UA Group

SYNOPSIS

Some time in the future, after humanity had to abandon Earth, kids are being raised by AI on a spaceship floating in the depths of the universe. There are no adults around, as they are supposed to be on the upper deck running the ship. The teens eagerly wait until they turn 15 as they then take exams – a rite of passage of sorts – based on which they are allocated their place in the adult society. Except that it turns out there are no adults on the upper deck, everyone over 15 just gets killed by the main computer. Children of the Underground, a group of teenagers who managed to survive, have to fight for their lives and for the lives of all the other children on the station. What happened to the adults? Why are some portions of the spaceship sealed off? Are robots and AI the enemy they think them to be? Or is there something bigger and more sinister going on? This is a story of a group of brave teens coming of age and finding what it means to be Alive in a world that is nothing like they thought it to be.

LOOKING FOR

We are looking for coproducers, commissioners, equity investors and international distribution outside Ukraine and Russia. Short-term we are also interested in development partners to help us fund script development.

COMPANY PROFILE

Film.UA Group is a creative powerhouse and one of the largest Eastern European media groups, operating in global markets and covering the full production cycle: development, production, adaptation and distribution of audiovisual content through the vertical business structure.

CONTACT THROUGH MY CONTENT LONDON

Kateryna Vyshnevskaya, head of development and coproductions and producer, Film.UA Group
Elena Malkova, producer, Film.UA Group

Drama Series **PITCH**

Content London is Pitch Perfect

From nearing 100 submissions 30 projects have been successful in making the long list and 15 will pitch at Content London, kicking off the conference agenda down at The St Pancras Renaissance Hotel at 10am on Tuesday December 3.

The finalists, from established drama creators worldwide, are all bidding to attract additional finance and coproduction partners.

The Drama Series Pitch this year occupies a full morning at the International Drama Summit with fifteen projects being pitched- up from eight last year. They will be pitched in front of conference on Tues 3 December at the St Pancras Hotel between 10am-1pm.

The winning project will be announced at the International Drama Awards, which takes place at 6pm on Thursday 5 December. The winners receive a £30,000 marketing package from C21 Media to support development.

Don't miss this opportunity to hear about some of the most exciting dramas on the development slates of producers from around the world.

The projects are detailed over the coming pages. Connect with the producers through My Content London, the Content London networking

Judges:



Nadine Nohr,
acquisitions consultant,
Huanxi Media
(Chair of Judges)

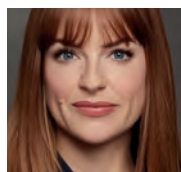

Meghan Lyvers,
SVP, co-production
and development,
CBS Studios International

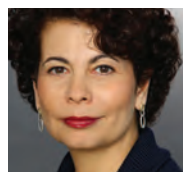

Rola Bauer,
managing director,
Studio Canal TV



Philipp Steffens,
head of fiction,
RTL Television

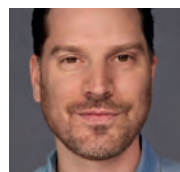

Gina Marcheschi,
head of scripted television,
VICE STUDIOS



ALIVE - THE MYSTERY OF MOAG STATION (FILM UA)

Genre/format: sci-fi, YA, 8x60'
Producers: Victor Mirsky, Elena Malkova, Kateryna Vyshnevskaya
Partners: Premier Studios, Russia
Development stage/planned shooting start: In development
Shooting locations and languages: Ukraine and/or international/English language.
Total budget/budget per episode: US\$5.6m/US\$700,000
Financing already in place: US\$2.8m (50%)

PITCHING:

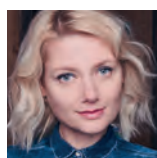

Kateryna Vyshnevskaya,
Head of development and coproductions and producer,
Film.UA Group



Elena Malkova,
Producer,
Film.UA Group

SYNOPSIS

Some time in the future, after humanity had to abandon Earth, kids are being raised by AI on a spaceship floating in the depths of the universe. There are no adults around, as they are supposed to be on the upper deck running the ship. The teens eagerly wait until they turn 15 as they then take exams – a rite of passage of sorts – based on which they are allocated their place in the adult society. Except that it turns out there are no adults on the upper deck, everyone over 15 just gets killed by the main computer. Children of the Underground, a group of teenagers who managed to survive, have to fight for their lives and for the lives of all the other children on the station. What happened to the adults? Why are some portions of the spaceship sealed off? Are robots and AI the enemy they think them to be? Or is there something bigger and more sinister going on? This is a story of a group of brave teens coming of age and finding what it means to be Alive in a world that is nothing like they thought it to be.

LOOKING FOR

We are looking for coproducers, commissioners, equity investors and international distribution outside Ukraine and Russia. Short-term we are also interested in development partners to help us fund script development.

COMPANY PROFILE

Film.UA Group is a creative powerhouse and one of the largest Eastern European media groups, operating in global markets and covering the full production cycle: development, production, adaptation and distribution of audiovisual content through the vertical business structure.

CONTACT THROUGH MY CONTENT LONDON

Kateryna Vyshnevskaya, head of development and coproductions and producer, Film.UA Group
Elena Malkova, producer, Film.UA Group



Script
Angel

Screenwriter Training & Development

Developing the writer
and the project.

Email us to find out how we can help you.

development@scriptangel.com

www.scriptangel.com

 [@scriptangel1](https://twitter.com/scriptangel1)



BEYOND NATURE (GUTSY ANIMATIONS)

Genre/format: Psychological thriller, 6x50'

Writer/director: Paavo Westerberg

Producer: Marika Makaroff

Development stage/planned

shooting start: In development/spring 2021

Shooting locations/languages:

Lapland, Finland and London, UK/primarily English, Finnish

Total budget/budget per episode:

€10,023,596/€1,670,600

Financing already in place: 20% of production costs currently in negotiations in Finland

PITCHING:



Marika Makaroff,
producer



Paavo Westerberg,
writer/director

SYNOPSIS

Beyond Nature is a psychological thriller in six episodes. It reveals what happens to a person when the mind shatters, our link to nature is severed and ego takes over. Genre: psychological thriller. Length: 6x50'. Language: English/Finnish. When a young and successful visual artist, Stella, returns from London to her roots in Finland, her life changes completely. Dark childhood memories, Finnish mythology and disturbing visions of horror intertwine and result in works of art that seem to carry a curse and cause a series of dark incidents. Stella's mind is shaken and she starts to believe that she has caused the events. But are they caused by Stella's dangerous art that has come to life, her shattered mind, or is there a murderer who is using Stella to further their own ends?

LOOKING FOR

Gutsy Animations is looking for a coproduction partner and a UK commission for the Beyond Nature series.

COMPANY PROFILE

See Good. Be Gutsy.

We are a company who believes that the world is in need of funny, clever and meaningful content. All of our productions are aimed at international audiences with positive impact. Gutsy Animations was founded in 2016 by Marika Makaroff to produce the new Moominvalley TV series (2019). Gutsy Animations is based in the capital of Finland, Helsinki.

CONTACT THROUGH MY CONTENT LONDON

Head of sales: **Katherine Senior**, katherine.senior@gutsy.fi

Gutsy Animations CEO: **Marika Makaroff**, marika.makaroff@gutsy.fi www.gutsy.fi



BORDERLINE (OCHRE MOVING PICTURES & ABOUT PREMIUM CONTENT)

Genre/format: crime drama/10x60'

Writers: Erik Durbin (lead writer), Robbie Thorpe (creator and writer), Steven Pillemer (creator)

Producers: Stan Joseph (OMP) and Emmanuelle Guilbart (APC)

Development stage/planned shooting start: Pilot and bible available/Target shooting date September 2020

Shooting locations: South Africa (Johannesburg, Musina, border area)

Languages: English language (majority), Pedi (minority)

Total budget/budget per episode:

£7.5m/£750,000

Financing already in place: £3.1m (41%)

PITCHING:



Erik Durbin,
Lead writer



Robbie Thorpe,
Creator and writer

SYNOPSIS

Daniel, an American lawyer who has built a new life in South Africa, feels guilty about Jessica, his ailing wife who he feels he broke. Desperately looking for ways to pay for her expensive treatment, Daniel crosses legal and moral lines in his job. It all finally catches up with him when he finds himself at the centre of an embezzlement scandal. Disbarred, in debt and in serious physical danger, he has no choice but to flee Johannesburg to the Eastern Tripoint Border, a hot bed of international smuggling, to hide on Jessica's family game farm, their last remaining asset. In dire need of money and with his back against the wall, Daniel becomes a smuggler and teams up with Jessica's childhood friend Laylani, an ambitious ex-game ranger who will guide him through this dangerous and unpredictable world in exchange for ownership of his ancestral land, located on Jessica's farm. A dysfunctional crime family is born. Borderline is an adventure-fuelled and layered human drama that shines a new light on modern-day South Africa, revealing its many racial, social and environmental complexities.

LOOKING FOR

Our ambition is to make Bordeline an international show with an global main cast and production quality that matches international standards. A local South African financing model is in place. We are now looking for international broadcasters to join the project either as commissioners or pre-buyers.

COMPANY PROFILE

OCHRE MOVING PICTURES (main producer)

Established in 2000, Ochre Moving Pictures (OMP) is based in Johannesburg, South Africa. Ochre is part of the Tiso Blackstar Group. OMP is one of South Africa's leading producers of high-quality entertainment and edutainment, with an award-winning track record. Its international accolades include a US Peabody, the Japan Prize, Emmy Nominations, a Rose D'Or, Golden Plaque Hugo Award and nominations for INPUT in Seoul and Sydney. For over a decade, OMP has produced over 3,000 hours programming across a wide range of genres: soap operas, dramas, documentaries, lifestyle, food, reality series, youth programming and children's television.

ABOUT PREMIUM CONTENT (coproducer)

About Premium Content (APC) is a Paris-based global boutique studio active in the development, production, financing and international distribution of high-end TV programmes. APC works with some of the most creative producers around the globe and across every genre from scripted series to animation and documentary.

CONTACT THROUGH MY CONTENT LONDON

Emmanuelle Guilbart, emmanuelle.guilbart@aboutpremiumcontent.com

FROM THE PRODUCERS OF
THE MISSING
NEW PICTURES



WHITE HOUSE FARM

AN INFAMOUS TRUE CRIME STORY



DARK HEARTS
(ZDF ENTERPRISES, MNET & QUIZZICAL)

Genre/format: Murder mystery
Writers: Darrel Bristow-Bovey (head writer), Rohan Dickson (writer), Jake Riddel (script editor)
Development stage/planned shooting start: Writing in progress/Planned shoot September 2020
Shooting locations/languages: Cape Town and Johannesburg, South Africa/Primarily English with some local languages.
Total budget/budget per episode: US\$2.7m/US\$337,500
Financing already in place: 83%

PITCHING:



Darrel Bristow-Bovey,
Head writer



Nimrod Geva

SYNOPSIS

Edie, an investigative journalist, is stunned by the brutal murder of her estranged brother. She is quickly drawn into the nightmarish aftermath when she is reunited with her orphaned teenage niece and nephew. But then the two become suspects of the unimaginable crime themselves. The supposed motive? A huge inheritance. Edie determines to find the real killer, digging deep into the contradictory world of post-Apartheid South Africa. In the leafy suburbs, white privilege continues untouched while gang violence ravages desperately poor neighbourhoods. Edie follows elusive clues across these apparently impassable divides. Meanwhile, she grapples with her own sense of guilt: she gave up her boy to be raised by her brother as his own. She is also at loggerheads with Detective Forty, who is fighting his own battle for justice in a crumbling police service. Suspects slowly emerge: the beloved housekeeper who was 'part of the family'. A deranged high school student who was infatuated with the mom. A drug-addled hired killer from the badlands. But in the end it is a secret closer to home that holds the key. The story dissects a tight community, structured around a very personal journey, in the vein of Big Little Lies or Sharp Objects. Dark Hearts is at once a gripping mystery, a complex family drama and a searing indictment of a country struggling to redeem itself from the sins of the past.

LOOKING FOR

We are looking for a broadcast partner for a presale to help close the funding gap.

COMPANY PROFILE

Quizzical Pictures is a Peabody- and Rose d'Or-winning production company based in South Africa. Over the last 25 years we have created thousands of hours of content in every genre. We have several international coproductions in the works, with a Fremantle International and M-NET series due to shoot in early 2020. We have excellent relationships on the continent and experience accessing local tax incentives and other funding.

CONTACT THROUGH MY CONTENT LONDON

Yuliya Fischer, director, ZDF Enterprises Yuliya.Fischer@zdf-enterprises.de
Nimrod Geva, head of development, Quizzical Pictures nimrod@quizzical.co.za



EXTRAVAGANCE
(AT-PROD & ZEITSPRUNG PICTURES)

Genre/format: Period drama series/8x52'
Writers: Johannes Betz (German), Sabine Carion (French)
Producers: Arnauld de Battice – Les Films du Trèfles (Paris, France), Till Derenbach – Zeitsprung Pictures (Köln, Germany)
Development stage/planned shooting start: In development/August 2021
Shooting locations/languages: Paris, France, and Brussels, Belgium/English
Total budget/budget per episode: €3m
Financing already in place: €6m (25%)

PITCHING:



Till Derenbach,
CEO and producer,
Zeitsprung Pictures



Arnauld de Battice,
Producer

SYNOPSIS

In 2008, a global financial crisis is shaking the markets. It was impossible to predict the crisis that struck without warning. But was it really? A look in the history books would have been enough to learn from the first world stock market crash, the first financial crisis and the fate of a particular man: John Law – The Man Who Turned Gold into Paper. The series tells in eight episodes the true story of visionary Scotsman John Law, the first man in Europe to introduce paper bank notes and founder of the first stock company in France. He became immensely wealthy before going bankrupt. The show is a financial thriller, a love story, an historical drama and a lesson on greed, power and going beyond limits. What Law created never existed before and by the time he finally realizes the dangers of the project, he has lost control of it. It's already too late. Extravagance brings together historical facts and characters in a breathless race dictated by the ever rising, the ever faster, the ever further. It shows characters who lose control over events they themselves provoked. Desperate, they try to lay rails that are immediately in danger of being knocked down by a train.

LOOKING FOR

We are looking for a major broadcaster or VoD platform for the series. We seek to increase the visibility of the project and find a partner in distribution and international selling. We are also looking for pre-purchases by UK and US channels to complete the financing of the series.

COMPANY PROFILE

Les Films du Trèfle was founded in 2000 by Arnauld de Battice in order to develop mainstream high-quality fiction and documentaries. Associated with AT-Prod, based in Brussels, the company aims to facilitate international coproductions through access to talent from both countries, and by pooling the human and financial resources allocated to the development and production. This close collaboration between French and Belgian producers allows the combination of national financing solutions and the sharing of international contacts.

CONTACT THROUGH MY CONTENT LONDON

Arnauld de Battice, producer

incendo

DRAMA PRODUCTION / CO-PRODUCTION / WORLDWIDE DISTRIBUTION



INCENDO.CA

GAVIN REARDON / INTERNATIONAL SALES & CO-PRODUCTIONS / GREARDON@INCENDO.CA / 1 310.614.2416

MONTREAL

TORONTO

LOS ANGELES



ICE
(FRONTIER FILM, VIAPLAY & REINVENT STUDIOS INTERNATIONAL SALES)

Genre/format: Action-thriller/8x52'
Writers: Martin Miehe-Renard (head writer), Hans Jakob Helms, Ben Horowitz
Development stage/planned shooting start: Story and script development and pre-production in 2020/Shooting planned for 2021, delivery in spring 2022
Shooting locations/languages: Greenland, Alaska, Middle East/English primarily, Danish, Greenlandic
Total budget/budget per episode: €17.5m/€2.18m
Financing already in place: €8.75m (50%)

PITCHING:



Martin Miehe-Renard
 Writer, director, producer, actor, singer-songwriter and musician



Thorkil Lodahl
 Producer and director

SYNOPSIS

When the Arctic sky opens, obliterating an Inuit hunter in a bloody explosion, sole witness and Cold War veteran Viggo Lundsten realises that everything he has believed in and fought for his entire life may have been a mere castle in the ice. And now that ice is melting... Ice is a thrilling action-drama set and shot in Ilulissat, Greenland. When an old Cold War vet is wrongly accused of his friend's mysterious murder, he launches an investigation together with his son and a talented young ice-core scientist to clear his name. However, the group quickly learns that much greater and more cynical powers are at work than they could ever imagine. Their investigation is no longer a question of finding the truth but a matter of life and death. In a flurry of drones, AI weapons, deceit, politics and ice-cold action, Ice tells a story about the expendable individual, about collateral damage and the great political play for the Arctic.

LOOKING FOR

Coproduction partners, co-financiers and international presales.

COMPANY PROFILE

Frontier Film Aps is a Danish production company specialising in drama series, documentaries and TV programming. Frontier Film was founded by Peter Munck and Thorkil Lodahl in 1991 and holds an impressive portfolio of acclaimed titles such as the popular youth drama Alletiders Jul, which ran for four seasons of 24 episodes, Nissernes Ø, Pip & Papegøje and Klamborg. In addition, Frontier Film presents a range of documentaries, most recently the historical documentary The West-Indies – The Story of Danish Slavery.

CONTACT THROUGH MY CONTENT LONDON

Thorkil Lodahl, producer and director
Martin Miehe-Renard, writer, director, producer, actor, singer-songwriter and musician



MEAT MARKET
(UNSTOPPABLE FILM AND TV)

Genre/format: Drama, YA/10x60'
Writer: Juno Dawson
Partner: all3media international
Development stage/planned shooting start: Pilot episode written
Shooting locations/languages: English
Total budget/budget per episode: N/A
Financing already in place: N/A

PITCHING:



Jason Maza, Actor/producer

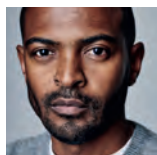

Noel Clarke, actor, screenwriter, director, producer and comic book author

SYNOPSIS

Meat Market is a drama series with huge international potential looking for commission. The series takes us on a thrilling ride through the world of modelling as we follow Jana Novak, a 16-year-old girl of Polish descent and from a South London council estate, as she starts her career and eventually hits the big time as a model. The series of hour-long episodes will follow awkward yet witty Jana after she is scouted by a top modelling agency and is plunged into the frenetic world of fashion. Set to take the YA generation by storm, Meat Market is a gripping exposé and triumphant story tackling huge contemporary themes such as the hyper-sexualization of girls and discovering the power of your voice in the age of #MeToo and #TimesUp. From an almost monosyllabic schoolgirl, Jana becomes a young woman who, in the final episode of the series, makes a brave decision that will shape the rest of her life.

LOOKING FOR

Unstoppable is looking for broadcast partners.

COMPANY PROFILE

Unstoppable Film and Television is an exciting and ambitious production company based in London, UK. Unstoppable has shown itself to be at the forefront of films that are new and fresh, working with exciting young talent from diverse and ethnic backgrounds, giving them the platform and opportunity to tell their stories. Unstoppable has produced more than 10 feature films, the most recent being UK box office success Brotherhood, 10x10 starring Luke Evans and Kelly Reilly, and The Fight, directed by Bafta-winner Jessica Hynes. Unstoppable recently joined the all3media group, forming Unstoppable Film and Television, which has opened its slate to more scripted TV projects that it continues to develop.

CONTACT THROUGH MY CONTENT LONDON

Jason Maza, actor/producer
Noel Clarke, actor, screenwriter, director, producer and comic book author



MEDIAWAN



CALL MY AGENT!



THE RED BRACELETS

LEADING SCRIPTED PRODUCTION GROUP
IN FRANCE* AND ITALY

&

LARGEST FRENCH-SPEAKING LIBRARY
IN EUROPE

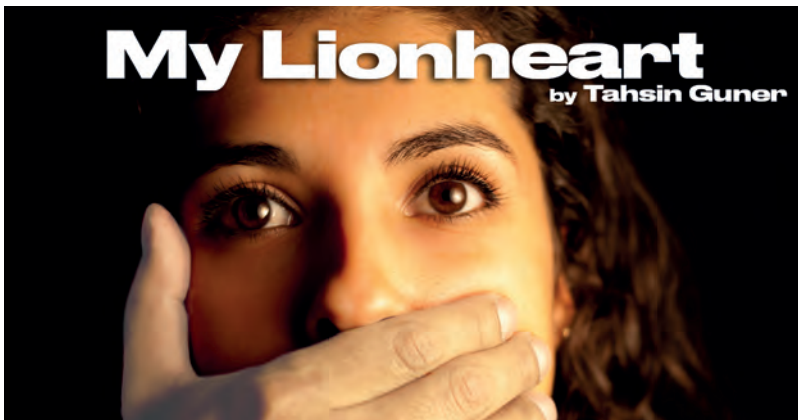

MY LIONHEART (KINDLE ENTERTAINMENT)

Genre/format: Thriller/4x60'

Writer: Tahsin Guner

Development stage/planned shooting start: Pitch materials are completed and we are looking to get funding for scripting/ June 2020.

Shooting location: Our intention is to film in Yorkshire, UK and we are intending to apply to the Screen Yorkshire fund.

Partners: Lionsgate have first option to distribute the series.

Total budget/budget per episode: £1.2m/£3m

Financing already in place: UK tax credit: £2.16m. Distribution advance (Lionsgate first option): £800,000. Yorkshire Content Fund: £500,000. Funding sought: £8.54m/£2.14m (71%).

PITCHING:



Tahsin Guner
Writer



Emma Stuart
Executive producer,
Kindle Entertainment

SYNOPSIS

My Lionheart is a 4x 60' thriller. When far-right terrorists hijack a bus full of six-year-olds, teenage driver Kamila becomes drawn into a dark and twisted bond with white supremacist Mark as she battles to protect the children. Adapted from the YA classic After the First Death by Bafta-winning Tahsin Guner, My Lionheart is a twisted love story played out against today's violent and dangerous times. This is a tense and adrenalinised ride. There are no easy villains here. There are shades of grey. There is ambiguity. There is bleakness. But in Kamila's bravery, in her willingness to reach out to the enemy, there is also hope.

LOOKING FOR

We are looking for coproducers, commissioners, equity investors and international distribution outside of Ukraine and Russia. Short-term we are also interested in development partners to help us fund script development.

COMPANY PROFILE

Anne Brogan and Melanie Stokes founded Kindle in 2007. In just over 12 years, Kindle has established a reputation in the marketplace for fresh, innovative drama with Lionsgate becoming a welcome stakeholder in 2016. Three times Bafta-winning and twice International Emmy-winning, Kindle's portfolio spans family, primetime and young-adult. Recent shows include, The A List, a supernatural thriller for Netflix, and Kiss Me First, a VR-thriller for Channel 4 and Netflix, alongside a family feature, Four Kids & It, starring Michael Caine, Russell Brand, Paula Patton and Matthew Goode, which is in post-production.

CONTACT THROUGH MY CONTENT LONDON

Emma Stuart, executive producer, Kindle Entertainment

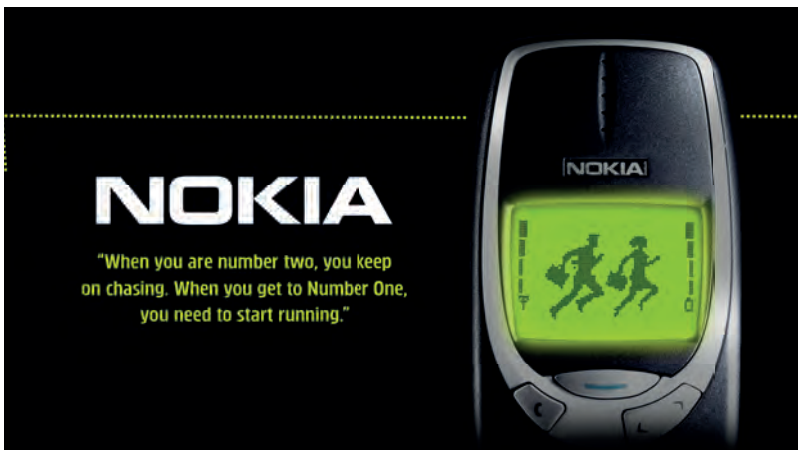

NOKIA (RABBIT FILMS)

Genre/format: Drama

Writers: Maarit Lalli, Kaarina Hazard, Leo Viirret

Director: Maarit Lalli

Producers: Minna Haapkylä, Olli Suominen

Partner: MTV3 Finland

Development stage/planned shooting start: Writing in process. First versions of episodes 1-3 ready, treatments of episodes 4-6 ready/September 2019

Shooting locations/languages: Finland, Berlin, Washington/Finnish, English

Total budget/budget per episode: €2.7m/€450,000

Financing already in place: €1.26m (46.7%)

PITCHING:



Minna Haapkylä,
Head of scripted
content, Rabbit Film



Olli Suominen,
CEO, Rabbit Film

SYNOPSIS

Year 1988. Nokia invests in mobile phones to spearhead international expansion. Freshly out of law school, Katarina Tammi and Aki Makkonen get their first jobs forming the core of Nokia's new legal team. When it launches its newest phone, market-leader Motorola smells Nokia's potential and sues the company in a patent court. Just before Christmas, Nokia's CEO commits suicide. At a time when the destiny of the whole company is at stake, it suffers from a catastrophic leadership vacuum. Katarina and Aki, the newbies, are left to survive on their own. Due to lack of cash, Nokia panics and cuts its investments in new mobile technology development. A young gifted engineer, Salminen, is furious and decides to continue his development work secretly at night. Katarina and Aki travel under enormous pressure to the US to defend Nokia and the only help they receive is engineer Salminen, who joins them in Washington. Season one ends with a grand finale: Salminen helps the gladiator-like Aki and Katarina save Nokia with a last-minute revelation. And due to his secret work, Nokia wins the race to make the first GSM call in the world in the summer of 1991.

LOOKING FOR

We are looking for an international coproducer and a distributor.

COMPANY PROFILE

Rabbit Films was founded by the Dudesons in 2001 in order to present their amazing stunts and pranks on television. Since 2014, the company has grown aggressively and become more and more versatile. Today we are at the top of Finnish independent production companies, dominating the Finnish primetime television with a catalogue of more than 20 original formats. Internationally, our shows have aired in over 200 territories. Rabbit is launching its first scripted drama series in 2019 and looks to grow in the space of drama, comedy and film in the coming years. www.rabbitfilms.com

CONTACT THROUGH MY CONTENT LONDON

Minna Haapkylä, head of scripted content, Rabbit Film

minna.haapkyla@rabbitfilms.com. Tel +358 50 5814181

Olli Suominen, CEO, Rabbit Film

oli.suominen@rabbitfilms.com. Tel +358 44 582 6095



FROM THE PRODUCERS OF BRON | BROEN



TOP DOG

8 x 45'



PREMIERE SCREENING

Wednesday, December 4th
01.30 pm - 02.30 pm
Kings Place, Hall 2



SHADES (BOMB)

Genre/format: Period romantic drama/ 10x60'

Producer/director: Angus Gibson, director and executive producer, Bomb
Creative producer: Pat van Heerden, broadcast content specialist and channel strategist

Writer/producer: Libby Dougherty, writer
Writer: Chumisa Ndakisa, curator and writer

Story consultant: Marguerite Poland, Writer of the novel Shades and story consultant to the series

Executive producer: Desiree Markgraaff, producer and CEO of The Bomb Shelter Film Company Partners

Development stage/planned shooting start: We are in script development and raising the finance/October 2020.

Shooting locations/languages: Eastern Cape Province (rural and Grahamstown) and Johannesburg (mines

and town) in Gauteng Province, South Africa/English and Xhosa

Total budget/budget per episode: £6,359,155/£630,487

Financing already in place: R36,300,000 (£1,907,383.50), 30%

PITCHING:



Angus Gibson
 Director and executive producer, Bomb



Pat van Heerden
 Broadcast content specialist and channel strategist

SYNOPSIS

Based on Marguerite Poland's bestselling novel, Shades is an epic romance set on the tumultuous eve of the Anglo-Boer War. It is 1899 when Walter Bromley, a young priest fresh from England, travels across the magnificent but daunting vastness of the Eastern Cape to St Matthias Mission, where Christianity chafes against traditional Xhosa beliefs. He is instantly entranced by the lovely and wilful Frances Farborough, daughter of the priest under whom he is to serve – but she is promised to another. Frances and her brother Crispin have grown up with Benedict Matiwane, a Xhosa orphan taken in by the mission. They are inseparable friends, but Benedict is caught between two worlds, the mission and the surrounding community who revere the shades (ancestors). When Benedict falls in love with beautiful Nomakwezi Pumani, her family reject him, this boy of no ancestry – and then an act of heinous racism rebaptises him as an activist. As Walter enters their world, their lives are all about to implode. A series of tragic clashes – of different gods, colonial wars, dispossession, natural disasters and the beginning of gold mining with its voracious hunger for labour – reverberate into our characters' lives whilst they grapple with forbidden love, betrayal, rebellion and the weight of guilty consciences.

LOOKING FOR

We are looking for potential broadcast partners and/or a coproduction company. We are also seeking to cast some international actors in leading roles and to employ some key talent.

COMPANY PROFILE

The Bomb Shelter is a production company based in Johannesburg, South Africa. For over 22 years we have produced South Africa's most iconic and ground-breaking television. The cult youth series Yizo Yizo received critical acclaim and awards around the world and was screened at the Venice Film festival. Our hit show Isibaya has broken audience records and garnered awards six years in a row, including 25 SAFTA awards. The team steering Bomb are responsible for many acclaimed projects. Angus Gibson was nominated for an Oscar for Mandela, Son of Africa, Father of a Nation, and a Bafta for 28 Up South Africa. We were the South African producers on the double Sundance winner Amandla, A Revolution in Four-part Harmony and the Pan-African hit drama Jacob's Cross, which ran for eight seasons. We have produced over 1,000 hours of television drama and currently output 10 episodes a week of primetime drama.

CONTACT THROUGH MY CONTENT LONDON

Angus Gibson: angus@thebomb.co.za Cell: 27 82 781 1984

Pat van Heerden: patvanheerden@gmail.com Cell: 27 83 258 3226



SIGNALS (SAGAFILMS)

Genre/format: Action-drama/9x45' HD

Writers: Maarit Lalli, Kaarina Hazard, Leo Viirret

Producers: Anna Vigdis Gísladóttir, Tinna Proppé, Hilmar Sigurðsson, Kjartan Thor Thordarson

Broadcast partner: Channel 2 Iceland
Development stage/planned shooting start: Scripts are ready/Q3 2020

Shooting locations/languages: Iceland/Icelandic

Total Budget/budget per episode: €6.1m/€750,000

Financing already in place: €2,439,893 (40.05%)

PITCHING:



Kjartan Thor Thordarson



Oskar Jonasson

SYNOPSIS

Bombs explode in the middle of the night. People are shot in broad daylight. Simultaneously, Iceland is the target of cyber attacks by an unknown extremist group. Police detective Magnea finds it hard to concentrate on the investigation; she has left her husband of many years to start living with a younger woman, Salka. Salka is offered a job at an independent media company. Her beat is culture journalism but she intends to work her way into hard news. She is tempted to go under the radar to get a real scoop. Not only does Magnea have to fight homophobia at work but also accusations that she is leaking information to the media through her girlfriend. Magnea and Salka cannot discuss work if their relationship is supposed to work out. They both investigate the same case in different ways, without being able to compare their information. The intensity of the cyber attacks increases. Daily life becomes difficult. The banking system is injured, the telephone companies are attacked and eventually the country's connection to the internet closes down. Society is close to collapse.

LOOKING FOR

Coproduce with studio, VFX or both, broadcast partners, distribution and/or private equity partners.

COMPANY PROFILE

Sagafilm is the leading independent production company in Iceland for TV, commercials and feature films with over 40 years of experience. Recent projects include TV drama series The Minister (Cineflix Rights), Thin Ice (Banijay, TV4) in coproduction with Yellow Bird, The Flatey Enigma (Sky Vision), Stella Blómkvist (Viaplay original series), Case (Netflix original series) and Cover Story. Sagafilm has also produced the feature films The Falcons (2018), Mr Bjarnfredarson and Cold Trail and coproduced Dead Snow: Red vs Dead and Nova Zembla. TV series by Sagafilm have won the Icelandic Academy Awards for Best Scripted Series a record 10 consecutive times.

CONTACT THROUGH MY CONTENT LONDON

Kjartan Thor Thordarson kjartan@sagafilm.is

LONDON'S FIRST FEMALE DETECTIVE

MISS SCARLET & THE DUKE



**WORLD PREMIERE SCREENING
TUESDAY 3RD DECEMBER**

HANSOM HALL, ST. PANCRAS RENAISSANCE HOTEL

DRINKS — 6:00PM

SCREENING — 6:45PM

FOLLOWED BY AFTER PARTY

A+E
NETWORKS™



©2019 A+E Networks. Claimed marks are the trademarks of A+E Television Networks, LLC protected in the United States and other countries in the world.



**THE AVIATRIX
(AQUARIUS FILM & APOGEE PICTURES)**

Genre/format: Returning drama/6x60'
Writers: Alice Addison (Picnic at Hanging Rock) Tommy Murphy (Devil's Playground)
Producers: Jo Monk (Apogee Pictures), Angie Fielder, Polly Staniford (Aquarius Films)
Partners: We have a letter of interest from a US studio, pending review of the pilot script.
Development stage: First phase
Shooting locations/languages: UK, Australia/English
Total budget/budget per episode: A\$24m (£12.84m)/A\$4m (£2.14m)
Financing already in place: Currently in early development

PITCHING:



Jo Monk

SYNOPSIS

Based on a remarkable true story, *The Aviatrix* explores the fascinating life of Jessie Miller, a Melbourne housewife who, in 1927, meets RAF pilot Bill Lancaster, who's planning to set the world record by flying from England to Australia. She asks if she can accompany him, he agrees. They embark upon one of the most dangerous flights ever undertaken and travel across the world together. After been shot at over Libya, surviving a crash in the Sumatran jungle and narrowly avoiding an emergency landing in the shark-infested Persian Gulf, they finally arrive in Australia a global sensation, and secret lovers. Lured to Hollywood by the promise of a film career, they soon become part of the Golden Era of Aviation and are riding the wave of fame and fortune when the Great Depression hits. Down on their luck, they become embroiled in a fatal love triangle that ends in murder. The celebrity trial of the decade begins. With Bill facing the electric chair, Jessie must sacrifice herself to get him acquitted. Bill goes missing shortly after and it's only 30 years later, when his diaries are found next to his mummified body, that Jessie finally discovers the devastating truth.

LOOKING FOR

Seeking a development funding commitment from a broadcast or digital platform partner that will enable us to finance first-phase development, funding the writers' room, out of which we shall deliver the series bible and episode outlines for season one, in addition to the pilot episode, written by Alice Addison.

COMPANY PROFILE

Apogee Pictures is a UK-based feature film and TV production company specialising in original, quality drama, working with the strongest local and international talent to produce creatively innovative and commercially astute projects for the global marketplace. Founder and producer Jo Monk previously worked as head of acquisitions and development at Motion Picture Capital, where she was responsible for sourcing and developing all film and TV projects that the company financed and produced. Aquarius Films is an award-winning Australian production company with a reputation for high-quality, prestige films and television series that are both commercially successful and critically acclaimed. Founded by Angie Fielder and Polly Staniford, credits include Academy Award nominated *Lion*, produced in association with See-Saw Films; *Dirt Music*, an adaptation of Tim Winton's much-loved novel; *Berlin Syndrome*, adapted by Shaun Grant and directed by Cate Shortland; and the multi-award-winning *Wish You Were Here*.

CONTACT THROUGH MY CONTENT LONDON

Jo Monk



THE DEATH OF A MERMAID (MASTIFF DENMARK)

Genre/format: Crime/6X45-60'
Writers: Anders Rønnow Klarlund, Jacob Weinreich
Executive producer: Mads Ulrick Holmstrup
Producers: Mia Marie Borup
Partner: Viaplay
Development stage/planned shooting start: Storylining episode 1-6 and entering treatments for the first episodes/spring or summer 2021
Total budget/budget per episode: €15m/€2.5m
Financing already in place: Viaplay is supporting the current development and scriptwriting and we expect it to bring 40-50% of the budget. To be finally negotiated.

PITCHING:



Mads Ulrick Holmstrup
CEO and EP, Mastiff



Anders Rønnow Klarlund
Author and screenwriter

SYNOPSIS

Behind every fairytale, there is a nightmare. Based on the book *The Death of a Mermaid* by best-selling authors Rydahl & Kazinski. Copenhagen 1834. He is young, penniless and a complete fiasco, yet he has dreamt of becoming world famous his entire life. But all dreams crash when the 29-year-old Hans Christian Andersen finds himself accused of a gruesome murder he didn't commit. Only if he finds the real killer can he avoid a death sentence. With help from Molly, a prostitute, and a little girl, the hunt for the killer leads him into the filthy underworld of Copenhagen and later to the royal family. When Hans Christian and Molly sneak into a masquerade at the castle, they find the sad and horrifying truth about more gruesome murders. It is a tale of broken hearts at a time when the love between two men was utterly taboo. It is a tale of a man who has attempted a sex change and committed murder in the name of love. While unravelling the crime, Hans Christian has to face his deepest fears and finds himself as a human and an artist. The sad tale of changing yourself for love becomes the inspiration for his first fairy tale, *The Little Mermaid*.

LOOKING FOR

We are looking for European and international broadcasters and coproducers.

COMPANY PROFILE

Comedy, romance and drama – award-winning TV series from one of Denmark's biggest production companies. Mastiff creates series with big emotions, touching and funny stories with beautiful pictures for the booming Nordic drama market. In the last couple of years, we have produced five seasons of the hugely successful young-adult series *Sjit Happens* and the family show *Home Sweet Home* for TV2. Last year we created the romantic show *Couple Trouble* for TV3 and Viaplay as well as the first Danish-New Zealand drama series, *Straight Forward*, together with Screentime New Zealand. Mastiff is part of Banijay Group together with big production companies such as Yellowbird and Jarowski from Scandinavia.

CONTACT THROUGH MY CONTENT LONDON

Mia Marie Borup, producer, Mastiff. Tel +4540444649 mmb@mastiff.tv.dk
Anders Rønnow Klarlund, author and screenwriter
Mads Ulrick Holmstrup, CEO and EP, Mastiff. Tel +4521795646 maho@mastiff.tv.dk

CLINK

HOW DO YOU STAY OUT OF TROUBLE,
WHEN TROUBLE IS ALL AROUND YOU?



Drama Series: 10 x one hour (5 x two hour version also available) **HD**

LA Productions for Channel 5's 5Star

IN CREATIVE PARTNERSHIP WITH



GLOBAL DISTRIBUTION PARTNERS

KEW
MEDIA DISTRIBUTION

www.kewmediadistribution.com

 [kewmediadistribution](https://www.facebook.com/kewmediadistribution)

 [kewmediagroup](https://twitter.com/kewmediagroup)



**THE IN-BETWEEN WORLD OF VIKRAM LALL
(GINGER INK FILMS & ONE FINE DAY FILMS)**

Genre/format: Period drama/10x60'
Writers: Linda Brieda
Producers: Ginger Wilson, Sarika Hemi Lakhani
Partners: Medienboard Berlin-Brandenburg
Development stage: Concept, development/2021
Shooting locations/languages: Kenya, India, Canada, UK/English, Swahili, Hindi
Total budget/budget per episode: €44m/€4m
Financing already in place: €30,000 (0.6% of total financing)

PITCHING:



Ginger Wilson,
 Founder, Ginger Ink
 Films Africa



**Sarika Hemi
 Lakhani,**
 Managing partner,
 One Fine Day Films

SYNOPSIS

Vikram Lall, the Kenyan-born grandchild of an Indian railway engineer, lives in exile on the blank shores of Lake Ontario, Canada. One of "the most corrupt men in Africa, a cheat of monstrous and reptilian cunning," he has fled the Kenya he loved, the Kenya he betrayed. 1953, Kenya – the Mau Mau uprising and Kenya's struggle for independence. Vik (8) and his sister Deepa (6) play outside their parents' shop with their friends: Njoroge, the son of the gardener, and Bill and Annie Bruce, children of a white farmer. Amongst the adults, loyalties are tested as power shifts from British to African hands. The Indians are left in between, doubting their future and each other. The Bruce family are murdered and Vik, harbouring a secret that could ruin his family, begins a life of cold-hearted corruption, an expression of the otherness he feels. Even the assassination of his best friend, Njoroge, does not push Vik to take a stand for anyone but himself. Based on the best-selling novel by MG Vassanji, spanning Canada, India and Kenya through the revolutionary '60s, turbulent '70s and '80s to the present day, this universal tale is of how the experience that we don't really belong shapes the actions we take.

LOOKING FOR

We are looking for broadcasters, financiers and coproducers and creative collaborators who are inspired by the possibility of telling the stories of these times and places from a unique perspective. This show is the first of its size and complexity from this part of the world – it has never been done before. Partners should come with the courage, flexibility and temerity to break new ground.

COMPANY PROFILE

Ginger Ink Films, based in Nairobi, has been developing, producing and servicing pan-African content for the international market for over 20 years. It is best known for the region's largest ever shoots and for Africa's most successful independent film initiative, co-founded by Tom Tykwer's One Fine Day Films in 2008. Since then, the joint partnership has produced seven award-winning, groundbreaking feature films. They have consistently demonstrated what is possible in the local production values, and how strong, well-produced stories meet the appetite of both local and international audiences.

CONTACT THROUGH MY CONTENT LONDON

Ginger Wilson, founder, Ginger Ink Films Africa
Sarika Hemi Lakhani, managing partner, One Fine Day Films
Ginger Wilson ginger@gingerink.tv
Sarika Hemi Lakhani sl@onefinedayfilms.org vikram@gingerink.tv

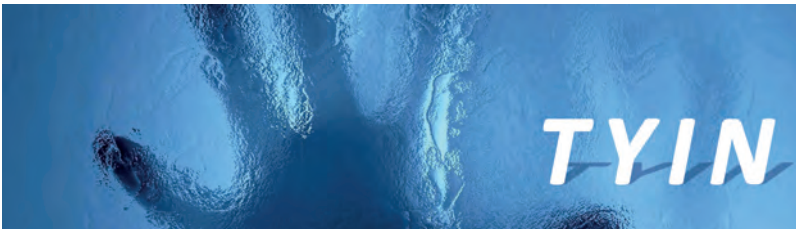

**TYIN
(ANGO PRODUCTIONS AT LAGARDÈRE STUDIOS)**

Genre/format: Supernatural thriller/6x52'
Writers: David Robert, Lucie Fréjaville (based on an original idea by Ivan Sadik)
Producer: Ivan Sadik
Artistic producer: Cyrielle Mottin
Partner: Viaplay
Development stage/planned shooting start: In development/spring 2021
Shooting locations/languages: France, Scandinavia/French
Total budget/budget per episode: €7.8m/€1.3m
Financing already in place: €630,000 (8%)

PITCHING:



Ivan Sadik,
 Producer



David Robert,
 Co-writer

SYNOPSIS

2004, Nice. Isabelle and Paul with their two kids, Thomas and Eve, are a happy family. Until tragedy strikes. Paul and Eve disappear while on a hiking trip in Norway. Despite an intensive search, their bodies are never found. Fifteen years later Isabelle (49) and Thomas (31) have made a new life in Cassis, when Paul and Eve are discovered frozen near Lake Tyin in Norway. Isabelle and Thomas think they were dead but it turns out Paul and Eve are actually alive. As soon as they get the news, Isabelle and Thomas head straight to Norway. Not only are Paul and Eve alive after all these years, but they haven't aged in the slightest. Paul is still 34 and Eve 15 – the same ages they were in 2004.

LOOKING FOR

Broadcasters, distributor, Scandinavian coproduction

COMPANY PROFILE

Ango Productions (Lagardère Studios)
 7, rue du Dôme 92100 Boulogne-Billancourt (France)
 Tel: +33 1 40 74 26 02. Cell: +33 6 87 75 30 99
 Mail: ivan.sadik@lagardere-studios.com
 Chief operating officer and producer: Ivan Sadik
 Artistic producer: Cyrielle Mottin

CONTACT THROUGH MY CONTENT LONDON

Ivan Sadik, producer
David Robert, co-writer

MARIE-JOSÉE
CROZE

CLIVE
STANDEN



MIRAGE

ERASE THE PAST,
PROTECT THE FUTURE.

A NEW 6 X 60 MIN SCRIPTED SERIES DISTRIBUTED BY:

france•2



BellMedia



LINCOLN TV



cineflix
Rights

Setting the agenda for 2020 (and beyond)

This year we have more than 80 sessions and more than 300 speakers taking part in Content London, which once again includes three events spread over four days. The International Drama Summit runs for three days with The Unscripted Entertainment Forum and Kids Content Futures taking place on Friday.

Programming the events is a year-round job, as we work hard to ensure we deliver a conference that's second to none. We hope you enjoy the results and have a great week with us.

The International Drama Summit

The Drama Summit takes place between December 3 and 5 at both Kings Place and the St. Pancras Renaissance Hotel, as previously. This time we have introduced a fourth conference room to take account of increased demand and have again tried to create programming blocks around areas of interest to avoid too much dashing between venues. Remember, you can stream all of the sessions live wherever you are at www.streamcontentlondon.net and all session videos will be made available to delegates within a week of the event, so you don't have to miss anything at all!

This year we have Big Picture Keynote Interviews with HBO Max, Netflix, Amazon and Paramount Television. Through which and across many sessions we will be exploring how the global business is evolving and both the opportunities and threats that this presents.

We have enhanced our commissioners' strand with more commissioners from channels and platforms, niche, local and global, from all over the world taking part in a series of one-on-ones and panel discussions. These sessions aim to get beneath the skin of how channels are staying ahead of the game and the focus and strategies for scripted development over the coming 12 to 18 months.

Julian Fellowes & Gareth Neame and Sally Wainwright & Faith Penhale deliver creative keynotes and talk about what they have planned next.

In a world of increasing challenges, we look at how scripted content can inspire and compel social change, with discussion panels and case studies featuring leading innovators in this space.

We hear from leading creatives and producers about their development strategies – kicking off with Simon Pegg, Nick Frost and Miles Ketley talking about *Stolen Picture* – delve deeper into global drama trends and look at the rise of shortform content and podcasts, plus what's next for non-English-language drama.

The Drama Summit is packed full of case studies, drilling down into the detail of how the very best upcoming series for 2020 were created, financed, commissioned, produced and will be distributed. These include Cate Blanchett's debut of *Stateless*, DR's *When The Dust Settles*, Laurie Nunn looking at what's next for *Sex Education*, Pulse Film's *Gangs of London*, Mammoth's adaptation of Malorie Blackman's *Noughts + Crosses* and more.

Our Hot Properties strand shines a light on 15 new shows that will be impressing audiences around the world in 2020 and beyond, featuring projects from India, Canada, Germany, Finland, Russia, Spain the UK and more. Content London has the very best new drama from the world's leading producers.

Our sessions are populated with leading execs and creatives from all over the world, additionally this year we shine a spotlight on India, helping delegates understand the growing opportunities of working in and with leading Indian producers, creatives and platforms.

The final of the C21 Drama Series Script Competition and our new Shorts2Series showcase are dedicated to supporting and finding new voices. The C21 Drama Pitch returns this year with 15 of the most exciting developing projects looking for partners to take them to the next level. And the C21 International Drama Awards will celebrate the best shows of 2018/19, with the final to be held at Kings Place on Thursday between 6pm and 7pm.

The Unscripted Entertainment Forum and Kids Content Futures

Both these events focus on the future of unscripted and kids' content. Unscripted has keynotes from Nat Geo, You Tube and Amazon Studios Europe while sessions explore shortform and audio innovation, building partnerships with Facebook and brands, and the latest niche platforms.

Kids Content Futures hears from Sesame Workshop, Netflix and Aardman and looks at the future of VoD, better on-screen portrayal of the LGBTQ community and what's next for the Young Audiences Content Fund.

There is so much more on the agenda than I can mention here, so please check it out and enjoy immersing yourself in the latest trends, issues and opportunities the global drama business has to offer.



It's been a great year putting the agenda together and we are so proud of the final result. Huge thanks to all our speakers taking part this year and those who have helped shape the narrative. We really hope you find Content London inspiring, informative and enlightening and have plenty of fun across the week!

Ruth Palmer, head of event programming, C21Media

Case Studies

Tuesday December 3

When The Dust Settles
3pm • Hall Two
(Kings Place)

Halifax: Retribution
3pm • Hall Three
(Kings Place)

Team Chocolate
4pm • Hall Three
(Kings Place)

Wednesday December 4

The Paradise
9.30am • Hall Two
(Kings Place)

Stateless
12noon • Hall One
(Kings Place)

Traces
12noon • Hansom Hall
(St Pancras Hotel)

Sex Education
3.45pm • Hall One
(Kings Place)

Noughts + Crosses
4.45pm • Hall One
(Kings Place)

Thursday December 5

Aruanas
11am • Hall Two
(Kings Place)

The End
12noon • Hall Three
(Kings Place)

The Watch
12noon • Hansom Hall
(St Pancras Hotel)

Gangs of London
3pm • Hansom Hall
(St Pancras Hotel)

Hot Properties

Tuesday December 3

Reindeer Mafia
12noon • Hall Two
(Kings Place)

Freud
12noon • Hall Two
(Kings Place)

Rurik
12noon • Hall Two
(Kings Place)

Wednesday December 4

Normal People
12noon • Hall Two
(Kings Place)

Tehran
12noon • Hall Two
(Kings Place)

Patria
12noon • Hall Two
(Kings Place)

I Love You Just The Way You Are
3pm • Hall Two
(Kings Place)

The Small Hand: A Ghost Story
3pm • Hall Two
(Kings Place)

Diary of a Drag Queen
3pm • Hall Two
(Kings Place)

Thursday December 5

Delhi Crime
9am • Hall Two
(Kings Place)

The God Man
9am • Hall Two
(Kings Place)

A Suitable Boy
9am • Hall Two
(Kings Place)

The Secrets She Keeps
4pm • Hansom Hall
(St. Pancras Hotel)

Trickster
4pm • Hansom Hall
(St. Pancras Hotel)

The Heartless
4pm • Hansom Hall
(St. Pancras Hotel)

All Drama Summit sessions are streamed live over a dedicated network to view on your mobile device. Simply visit www.streamcontentlondon.net and log in with your Content London delegate email address.



An edited version of all sessions in the International Drama Summit will be made available to delegates online after the event.

Setting the agenda for 2020 (and beyond)

This year we have more than 80 sessions and more than 300 speakers taking part in Content London, which once again includes three events spread over four days. The International Drama Summit runs for three days with The Unscripted Entertainment Forum and Kids Content Futures taking place on Friday.

Programming the events is a year-round job, as we work hard to ensure we deliver a conference that's second to none. We hope you enjoy the results and have a great week with us.

The International Drama Summit

The Drama Summit takes place between December 3 and 5 at both Kings Place and the St Pancras Renaissance Hotel, as previously. This time we have introduced a fourth conference room to take account of increased demand and have again tried to create programming blocks around areas of interest to avoid too much dashing between venues. Remember, you can stream all of the sessions live wherever you are at www.streamcontentlondon.net and all session videos will be made available to delegates within a week of the event, so you don't have to miss anything at all!

This year we have Big Picture Keynote Interviews with HBO Max, Netflix, Amazon and Paramount Television. Through which and across many sessions we will be exploring how the global business is evolving and both the opportunities and threats that this presents.

We have enhanced our commissioners' strand with more commissioners from channels and platforms, niche, local and global, from all over the world taking part in a series of one-on-ones and panel discussions. These sessions aim to get beneath the skin of how channels are staying ahead of the game and the focus and strategies for scripted development over the coming 12 to 18 months.

Julian Fellowes & Gareth Neame and Sally Wainwright & Faith Penhale deliver creative keynotes and talk about what they have planned next.

In a world of increasing challenges, we look at how scripted content can inspire and compel social change, with discussion panels and case studies featuring leading innovators in this space.

We hear from leading creatives and producers about their development strategies – kicking off with Simon Pegg, Nick Frost and Miles Ketley talking about *Stolen Picture* – delve deeper into global drama trends and look at the rise of shortform content and podcasts, plus what's next for non-English-language drama.

The Drama Summit is packed full of case studies, drilling down into the detail of how the very best upcoming series for 2020 were created, financed, commissioned, produced and will be distributed. These include Cate Blanchett's debut of *Stateless*, DR's *When The Dust Settles*, Laurie Nunn looking at what's next for *Sex Education*, Pulse Film's *Gangs of London*, Mammoth's adaptation of Malorie Blackman's *Noughts & Crosses* and more.

Our Hot Properties strand shines a light on 15 new shows that will be impressing audiences around the world in 2020 and beyond, featuring projects from India, Canada, Germany, Finland, Russia, Spain the UK and more. Content London has the very best new drama from the world's leading producers.

Our sessions are populated with leading execs and creatives from all over the world, additionally this year we shine a spotlight on India, helping delegates understand the growing opportunities of working in and with leading Indian producers, creatives and platforms.

The final of the C21 Drama Series Script Competition and our new Shorts2Series showcase are dedicated to supporting and finding new voices. The C21 Drama Pitch returns this year with 15 of the most exciting developing projects looking for partners to take them to the next level. And the C21 International Drama Awards will celebrate the best shows of 2018/19, with the final to be held at Kings Place on Thursday between 6pm and 7pm.

The Unscripted Entertainment Forum and Kids Content Futures

Both these events focus on the future of unscripted and kids' content. Unscripted has keynotes from Nat Geo, You Tube and Amazon Studios Europe while sessions explore shortform and audio innovation, building partnerships with Facebook and brands, and the latest niche platforms.

Kids Content Futures hears from Sesame Workshop, Netflix and Aardman and looks at the future of VoD, better on-screen portrayal of the LGBTQ community and what's next for the Young Audiences Content Fund.

There is so much more on the agenda than I can mention here, so please check it out and enjoy immersing yourself in the latest trends, issues and opportunities the global drama business has to offer.



It's been a great year putting the agenda together and we are so proud of the final result. Huge thanks to all our speakers taking part this year and those who have helped shape the narrative. We really hope you find Content London inspiring, informative and enlightening and have plenty of fun across the week!

Ruth Palmer, head of event programming, C21Media

Case Studies

Tuesday December 3

When The Dust Settles
3pm • Hall Two
(Kings Place)

Halifax: Retribution
3pm • Hall Three
(Kings Place)

Team Chocolate
4pm • Hall Three
(Kings Place)

Wednesday December 4

The Paradise
9.30am • Hall Two
(Kings Place)

Stateless
12noon • Hall One
(Kings Place)

Traces
12noon • Hansom Hall
(St Pancras Hotel)

Sex Education
3.45pm • Hall One
(Kings Place)

Noughts + Crosses
4.45pm • Hall One
(Kings Place)

Thursday December 5

Aruanas
11am • Hall Two
(Kings Place)

The End
12noon • Hall Three
(Kings Place)

The Watch
12noon • Hansom Hall
(St Pancras Hotel)

Gangs of London
3pm • Hansom Hall
(St Pancras Hotel)

Hot Properties

Tuesday December 3

Reindeer Mafia
12noon • Hall Two
(Kings Place)

Freud
12noon • Hall Two
(Kings Place)

Rurik
12noon • Hall Two
(Kings Place)

Wednesday December 4

Normal People
12noon • Hall Two
(Kings Place)

Tehran
12noon • Hall Two
(Kings Place)

Patria
12noon • Hall Two
(Kings Place)

I Love You Just The Way You Are
3pm • Hall Two
(Kings Place)

The Small Hand: A Ghost Story
3pm • Hall Two
(Kings Place)

Diary of a Drag Queen
3pm • Hall Two
(Kings Place)

Thursday December 5

Delhi Crime
9am • Hall Two
(Kings Place)

The God Man
9am • Hall Two
(Kings Place)

A Suitable Boy
9am • Hall Two
(Kings Place)

The Secrets She Keeps
4pm • Hansom Hall
(St. Pancras Hotel)

Trickster
4pm • Hansom Hall
(St. Pancras Hotel)

The Heartless
4pm • Hansom Hall
(St. Pancras Hotel)

All Drama Summit sessions are streamed live over a dedicated network to view on your mobile device. Simply visit www.streamcontentlondon.net and log in with your Content London delegate email address.



An edited version of all sessions in the International Drama Summit will be made available to delegates online after the event.

SAMUEL LE BIHAN GUILLAUME DE TONQUÉDEC MARIANNE DENICOURT ROMANE BOHRINGER PATRICK MILLE
MATILDA LUTZ MANON AZEM NASSIM LYES SI AHMED SAMY SEGHIR ISABELLE CANDELIER

THEY WERE TEN



BASED ON THE WORLDWIDE BEST-SELLING NOVEL BY
AGATHA CHRISTIE

6X52'

ESCAZAL
FILMS



With the support of Région Provence-Alpes-Côte d'Azur, CNC, PROCRÉP and ANGOA. ©ESCAZAL FILMS - 6x-FILMS - RTBF (Télévision Française)

federation
entertainment

To register and collect your delegate badge, visit the **KINGS PLACE** venue from 5pm Monday 2 December

KINGS PLACE
Registration
(5pm - 7.30pm)

KINGS PLACE -
CONFERENCE LEVEL
all3media international
opening night cocktail
(5pm - 7pm)

KINGS PLACE - HALL ONE
SPONSORED SCREENING:
White House Farm
(all3media international)
(6.30pm - 7.30pm)

ST PANCRAS -
LADIES SMOKING ROOM
SPONSORED:
International Reception & Party
(7.30pm - 10pm)

Tuesday 3 December • Morning

	HALL ONE (KINGS PLACE)	HALL TWO (KINGS PLACE)	HALL THREE (KINGS PLACE)	HANSON HALL (ST. PANCRAS)
9am	<p>C21 Drama Series Script Competition (9am - 10am) Coproduced between C21, Script Angel, Studio21 and WritersRoom. <i>More information on page 13.</i></p>			
10am	<p>Shorts2Series (10am - 11am) Content London showcases eight award-winning short films that are perfectly positioned to be made into TV series. <i>More information on page 15.</i></p>	<i>Streaming</i>	<i>Streaming</i>	<p>Drama Series Pitch (10am - 1pm) The Drama Series Pitch showcases 15 of the most exciting development projects from the professional community that are looking for partners to take them to the next level. Each of the projects will present a 10-minute pitch with the winner receiving a marketing package through C21Media worth £30,000. <i>More information on pages 17-31.</i></p>
11am	<p>State of the Drama Nation (11am - 12pm) Michael Wright, president, Epix Nina Lederman, EVP, global scripted development, Sony Pictures Television Sebastien Raybaud, founder and CEO, Anton Lorenzo De Maio, partner, Endeavor Content Sofia Helin, actor & producer Moderated by: David Jenkinson, editor-in-chief and managing director, C21Media</p>			
12pm	<p>IN CONVERSATION: Stolen Picture (12pm - 1pm) Simon Pegg, co-founder, Stolen Picture Nick Frost, co-founder, Stolen Picture Miles Ketley, CEO, Stolen Picture Moderated by: Emma Smithwick, managing director, Rockfleet Productions</p>	<p>HOT PROPERTIES: Non English Language Drama (12pm - 1pm) <i>Reindeer Mafia, Freud and Rurik</i> Liisa Penttilä-Asikainen, producer, Reindeer Mafia Pete Eklund, producer, Reindeer Mafia Mika Kurvien, director and screenwriter, Reindeer Mafia Marvin Kren, director, writer and executive producer, <i>Freud</i> Moritz Polter, EP, international TV series, Bavaria Fiction Kateryna Vyshnevskaya, head of development, co-productions and producer, FILM.UA Group Valeriy Fedorovich, director, TV-3, producer and head, PREMIER Studios Lily Sheroziya, marketing director, TV-3 and PREMIER Studios Moderated by: Walter Iuzzolino, chief creative officer, Walter Presents/Global Series Network</p>	<p>TERRITORIES: Coproducing with Russia (12pm - 1pm) Olga Filipuk, chief content officer, KinoPoisk HD Sofia Kvashilava, genral producer, Okko Ent. and CCO, Rambler Group Alexander Rodnyansky, producer Moderated by: Ali May, writer, producer and creator</p>	

STUDIOCANAL

SEE YOU AT CONTENT LONDON 2019



ON DEATH ROW
4 x 1 HR
TRUE CRIME DRAMA
MOVISTAR+



SAVAGES
6 x 1 HR
THRILLER
CANAL+ CREATION ORIGINALE



ZEROZEROZERO
8 x 1 HR
ACTION CRIME DRAMA
SKY STUDIOS
CANAL+ CREATION ORIGINALE
AMAZON PRIME VIDEO

WAR OF THE WORLDS
8 x 1 HR
CHARACTER-DRIVEN SCI-FI
CANAL+ CREATION ORIGINALE
FOX NETWORKS GROUP



THE COLLAPSE
8 x 15 MIN
DRAMA
CANAL+ CREATION DECALEE

THE ADVENTURES OF PADDINGTON
52 x 11 MIN
FAMILY ANIMATION
NICKELODEON



**NETWORKING
 LUNCH**
 1pm - 3pm

**HALL ONE
 SPONSORED:**
**The Commons (Sony Pictures
 Television/Playmaker)**
 (1.30pm - 2.30pm)
 More information on pages 7-9

**HALL TWO
 SPONSORED:**
**Society Bites (Norwegian
 Drama Showcase)**
 (1.30pm - 2.30pm)
 More information on pages 7-9

**HALL THREE
 SPONSORED:**
**The Finnish 25% Cash Rebate
 (Audiovisual Producers Finland)**
 (1.30pm - 2.30pm)
 More information on pages 7-9

**HANSOM HALL
 NETWORKING:**
**Speed-networking
 Meetings**
 (1.30pm - 2.30pm)

	HALL ONE (KINGS PLACE)	HALL TWO (KINGS PLACE)	HALL THREE (KINGS PLACE)	HANSOM HALL (ST. PANCRAS)
3pm	<p>IN CONVERSATION: Jamie Mustard and Holt McCallany (3pm - 4pm) Jamie Mustard, author, The Iconist Holt McCallany, leading actor, Mindhunter Moderated by: Melanie Stokes, MD, Kindle Entertainment</p>	<p>CASE STUDY: When The Dust Settles (3pm - 4pm) Ida Maria Rydén, writer Dorte Høgh, writer Milad Alami, director Stinna Lassen, producer Christian Rank, Head of drama, DR Karen-Lise Mynster, actor Moderated by: Michael Pickard, editor, Drama Quarterly, C21Media</p>	<p>CASE STUDY: HALIFAX: Retribution (3pm - 4pm) Roger Simpson, original creator and writer Rebecca Gibney, lead actress and executive producer Anthony LaPaglia, lead actor Andy Ryan, co-head of drama, Nine Network Australia Mikael Borglund, executive producer, Halifax: Retribution and CEO & MD, Beyond International Ltd Moderated by: Gabriel Tate, journalist</p>	<p>CREATIVE KEYNOTE: Julian Fellowes and Gareth Neame (3pm - 3.45pm) Julian Fellowes, writer, director and novelist Gareth Neame, CEO, Carnival Films Moderated by: Stephen Armstrong, freelance journalist</p> <hr/> <p>3.45pm</p> <p>CREATIVE KEYNOTE: Sally Wainwright and Faith Penhale (3.45pm - 4.30pm) Sally Wainwright, writer, producer and director Faith Penhale, CEO, Lookout Point Moderated by: Miranda Sawyer, journalist and broadcaster</p>
4pm	<p>TRENDS: Navigating the SVoD Landscape as it Heads Towards 'Peak' (4pm - 5pm) Susan Kresnicka, founder and president, KR&I Julien Leroux, SVP global scripted co-productions, Cineflix Media Louise Pederson, CEO, All3Media International Rod Henwood, chief strategy officer, The Ink Factory Moderated by: Mark Oliver, chairman, O&O</p>	<p>TRENDS: Mining the Drama Data for Success (4pm - 5pm) Avril Blondelot, head of content insight, Glance John Peek, joint managing director, TAPE Consultancy Ltd. Courtney Williams, head of partnership, Parrot Analytics Moderated by: Ben Keen, chairman, MediaXchange</p>	<p>CASE STUDY: TEAM CHOCOLATE - Creating an International Format Success with Diversity at its Heart (4pm - 5pm) Pieter Van Huyck, head of scripted, De Mensen Sophie Gardiner, managing director, Chapter One Pictures Lou Stein, artistic director, Chickenshed Theatre Eric Welbers, CEO, ndF Michele Zatta, commissioning editor, Rai Fiction Moderated by: Michael Pickard, editor, Drama Quarterly, C21Media</p>	
5pm	<p>DEVELOPMENT: Non English Language Drama (5pm - 6pm) Anna Winger, writer Pascal Breton, president, Federation Entertainment Johannes Jensen, CEO, Yellow Bird Gjermund Erikson, writer and executive producer, Monster Scripted Jonas Allen, co-founder, Miso Films Moderated by: Gabriel Tate, journalist</p>	<p>DEVELOPMENT: Shortform Drama (5pm - 6pm) Sebastian Burkhardt, MD, global content, Keshet International Marianne Furevold-Boland, executive producer, NRK Drama Howard Owens, co-founder and co-CEO, Propagate Content Neely Shamam, EVP of programming and development, Ficto Moderated by: Selma Turajlic, co-founder, Little Dot Studios</p>	<p>IN CONVERSATION: Frank Doelger, Intaglio Films (5pm - 5.45pm) Frank Doelger, creative director, Intaglio Films Peter Berry, writer Mike Walden, writer Moderated by: Hayley McKenzie, CEO/founder, Script Angel</p>	
6pm	<p>Networking Cocktail (Conference Level) (6pm - 7pm) Sponsored by SeriesMania Open to all Drama Summit delegates.</p> 			<p>SPONSORED SCREENING & PARTY: Miss Scarlet and The Duke (A+E Networks) (6pm - onwards) Screening followed by Q+A and after party. Open to all Drama Summit delegates.</p> 

BASED ON THE AWARD-WINNING NOVELS

A NEW ORIGINAL SERIES

Noughts + Crosses

DIVIDED BY HATE, UNITED BY LOVE

JOIN US ON
WEDNESDAY
4TH DECEMBER
16:45, HALL 1
KINGS PLACE

itv
STUDIOS
GLOBAL ENTERTAINMENT

	HALL ONE (KINGS PLACE)	HALL TWO (KINGS PLACE)	HALL THREE (KINGS PLACE)	HANSOM HALL (ST. PANCRAS)
9am				<p>DRAMA COMMISSIONERS: Sky Italia (9am - 9.30am) Nils Hartmann, director of original productions, Sky Italia Moderated by: Stephen Armstrong, freelance journalist</p>
9.30am	<p>FINANCE: New Models of Drama Finance (9.30am - 10.15am) Jamie Brown, CEO, Grand River Productions Cheryl Lynch, EVP international production, business affairs and scripted formats, Sony Pictures Television David Davoli, EVP international television, BRON Studios Kate Harwood, MD, Euston Films Moderated by: Valerie Creighton, president and CEO, Canada Media Fund</p> <hr/> <p>10.15am</p>	<p>CASE STUDY: The Paradise (9.30am - 10.30am) Marja Pyykkö, director Matti Laine, screenwriter Ran Tellem, head of international content development, The Mediapro Studio Marko Röhr, producer and CEO, MRP Matila Röhr Productions Suvi Mansnerus, producer, Yle Drama Fran Perea, actor Moderated by: Michael Pickard, editor, Drama Quarterly, C21Media</p>	<p>TERRITORY FOCUS: UK Nations and Regions (9.30am - 10.30am) Claire Mundell, executive producer, Synchronicity Films Ltd Sarah Brown, creative director, drama, STV Productions Gwenllian Gravelle, drama commissioner, S4C Lachlan MacKinnon, executive producer, Bad Wolf Moderated by: Dominic Schreiber, global drama executive, Reel One Entertainment</p>	<p>DRAMA COMMISSIONERS: SVT (9.30am - 10am) Anna Croneman, head of dramafilms, SVT - Sveriges Television Moderated by: James Rampton, TV feature writer, The i, The Independent</p> <hr/> <p>10am</p> <p>DRAMA COMMISSIONERS: BBC (10am - 10.30am) Piers Wenger, controller of drama, BBC Moderated by: James Rampton, TV feature writer, The i, The Independent</p>
10.30am	<p>KEYNOTE INTERVIEW: HBO Max (10.30am - 11am) Kevin Reilly, chief content officer, HBO Max and president, TBS, TNT and truTV Moderated by: Stephen Armstrong, freelance journalist</p>	Streaming	Streaming	
11am	<p>KEYNOTE INTERVIEW: HBO Max (11am - 12pm) Sarah Aubrey, head of original content, HBO Max Sandra Dewey, president, business operations and productions, HBO Max Moderated by: Rola Bauer, managing director, STUDIOCANAL TV</p>			<p>DRAMA COMMISSIONERS: US (11am - 12pm) Carolyn Bernstein, EVP, global scripted content and documentary films, National Geographic Karen Bailey, SVP, original programming, Starz Julie McNamara, EVP of original content, CBS All Access Nancy Cotton, EVP and head of scripted programming, Epix Moderated by: Carrie Stein, EVP global scripted series, Kew Media</p>
12pm	<p>CASE STUDY: Stateless (12pm - 1pm) Cate Blanchett, co-creator, executive producer and actor Jeff Wachtel, president, NBCUniversal International Studios Alastair McKinnon, managing director, Matchbox Pictures Fayssal Bazzi, actor Moderated by: Michael Pickard, editor, Drama Quarterly, C21Media</p>	<p>HOT PROPERTIES: Normal People, Tehran and Patria (12pm - 1pm) Ed Guiney, company director & exec producer, Element Pictures Emma Norton, producer, Element Pictures Lenny Abrahamson, director Alon Aranya, producer and writer, Paper Plane Productions Moshe Zonder, writer, Moshe Zonder Productions Aitor Gabilondo, showrunner, Patria Miguel Salvat, commissioning editor of original programming, Spain, HBO Europe Iñaki González Esparza, development director, Alea Media Moderated by: Gabriel Tate, journalist</p>	<p>TERRITORIES: Nigerian Stories (12pm - 1pm) Leye Adenle, author Kemi Adesoye, writer Thomas Eromose Ikimi, writer Yvonne Isimeme Ibazebo, producer Moderated by: Enyi Omeruah, founder, My Management Company (MMC)</p>	<p>CASE STUDY: Traces (12pm - 1pm) Nicola Shindler, chief executive, Red Production Company Amelia Bullmore, writer and executive producer Philippa Collie-Cousins, commissioning editor, drama, UKTV Juliet Charlesworth, producer Moderated by: Emma Cox, freelance journalist</p>

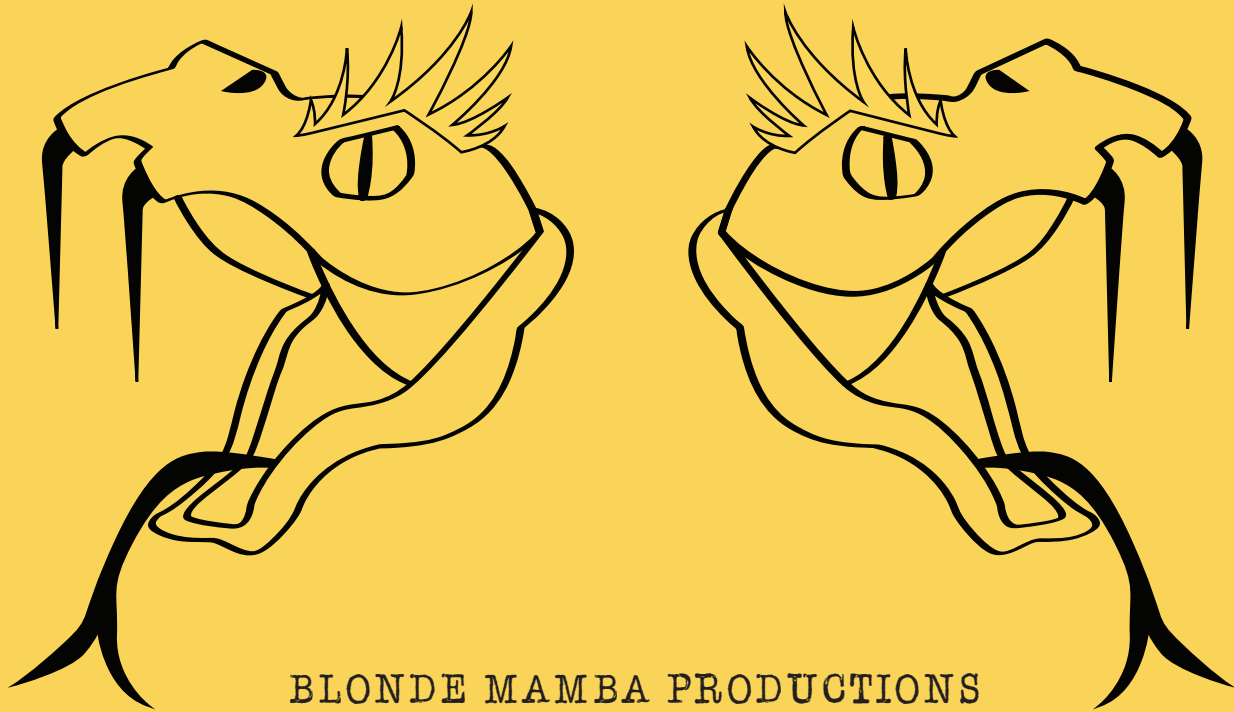

Frustrated with the quality and focus of content that has been made for Gen Z and premium platforms, Blonde Mamba was formed by a group of Gen Z creatives to develop and produce projects for mainstream networks and platforms, emerging digital content services, and brand partners. Creatively and economically, we focus on a platform agnostic angle whilst looking at a shows potential in long and short formats.

MAMBA AGENCY

At Blonde Mamba we believe in creating a community around your product - we want to build something that people can talk about and be integrated in a strong story.

We're here to help you with everything from strategic partnerships to integrated campaigns and freshly impactful content, helping to put your services on millions of screens.

We organically product place in the appropriate content to enhance your product and the show's message of impact.

MAMBA COLLECTIVE

At Blonde Mamba, we believe that the best stories come from the heart. That's why we've launched our Mamba Collective. A passionate mosaic of authentic and fresh voices.

Essentially 'method writing.' At any stage of development, we invite individuals with stories to tell and memories to share relevant to the script or story we've been given, therefore lending legitimacy to the expanding plot and characters.

Authenticity is essential to a story's strength.

MAMBA SLATE

Blonde Mamba creates high quality, cinematic and premium stories that resonate with the emerging talent audience and the platforms they favour.

We're benefiting from the massive shift toward digital video among consumers and an exploding video distribution market, thus we attack every project we receive with a mindset of how we can assure the audience will enjoy it platform agnostically and off screen in new and innovative ways.

From immersive rooms and partner charities to clothing collections and audience interactivity.

"WHAT DOESN'T KILL YOU GIVES YOU CONTENT" - FOUNDERS OF BLONDE MAMBA

BLONDEMAMBA.COM

**NETWORKING
LUNCH**
1pm - 3pm

**HALL TWO
SPONSORED:
Top Dog
(ZDF Enterprises)
(1.30pm - 2.30pm)**
More information on pages 7-9

**HALL THREE
SPONSORED:
Canadian Media
Producers Association
(1.30pm - 2.30pm)**
More information on pages 7-9

**HALL FOUR
SPONSORED:
The Sommerdahl Murders
(Dynamic Television)
(1.30pm - 2.30pm)**
More information on pages 7-9

**HANSOM HALL
NETWORKING:
Speed-networking
Meetings
(1.30pm - 2.30pm)**

	HALL ONE (KINGS PLACE)	HALL TWO (KINGS PLACE)	HALL THREE (KINGS PLACE)	HANSOM HALL (ST. PANCRAS)
3pm	<p>KEYNOTE INTERVIEW: Paramount Television (3pm - 3.45pm) Nicole Clemens, president, Paramount Television Moderated by: Carrie Stein, EVP, global scripted series, Kew Media</p>	<p>HOT PROPERTIES: I Love You Just the Way You Are, The Small Hand, Diary of a Drag Queen (3pm - 4pm) Charles Ohayon, international distribution and EP, Productions Casablanca François Létourneau, creator & writer Jeff Norton, EP and founder, Awesome Media & Entertainment Alan Clements, managing director, Two Rivers Media Ltd Tom Rasmussen, author, screenwriter and actor Adam Morane-Griffiths, exec producer, Wildcard Films Sara Curran, founder and CEO, Tricycle Talent and Tricycle Media Moderated by: Melissa Williamson, president, Pier 21 Films</p>	<p>TERRITORIES: Indian Platforms (3pm - 3.45pm) Tarun Katial, CEO, ZEE5 India Rohit Jain, managing director, Lionsgate South Asia More speakers to be announced Moderated by: Melanie Stokes, MD, Kindle Entertainment</p>	<p>DEVELOPMENT: Wattpad and Partners (3pm - 3.45pm) Aron Levitz, head of Wattpad Studios Christina Henne, producer, Bavaria Fiction Gave Lindo, executive director of OTT programming, Canadian Broadcasting Corporation Moderated by: Emma House, international consultant</p>
3.45pm	<p>CASE STUDY: Sex Education (3.45pm - 4.45pm) Laurie Nunn, creator and showrunner Ben Taylor, director Alex Sapot, director of original series, Netflix Jamie Campbell, executive producer, Eleven Moderated by: Emma Smithwick, managing director, Rockfleet Productions</p>	<p>4pm DEVELOPMENT: Next Year's Models (4pm - 4.45pm) Erik Barmack, founder, Wild Sheep Content Elizabeth Kilgarriff, CEO, Firebird Pictures Katie O'Connell Marsh, founder and chairman, Platform One Media Belinda Campbell, joint managing director, Red Planet Pictures Carrie Stein, EVP, global scripted series, Kew Media Moderated by: Michael Pickard, editor, Drama Quarterly, C21Media</p>	<p>TERRITORIES: Producing in and with India (3.45pm - 4.45pm) Abhishek Rege, CEO, Endemol Shine Deepak Segal, head of content, Applause Entertainment David M. Taghioff, CEO, Library Pictures International Amanda Jenks, co-founder, Greenacre Films Elizabeth Koshy, founder and CEO, INVAR Studios Moderated by: Sunder Aaron, principal, Locomotive Global Inc</p>	<p>DEVELOPMENT: Books to Screen (3.45pm - 4.45pm) Sidharth Jain, founder and chief storyteller, The Story Ink Jon Kramer, CEO, AfterShock Comics and Rive Gauche Television Roye Okupe, writer, director and founder, YouNeek Studios Anna Burns, development producer, Buccaneer Christine Langan, CEO, Baby Cow Moderated by: Emma House, international consultant</p>
4.45pm	<p>CASE STUDY: Noughts + Crosses (4.45pm - 5.30pm) Koby Adom, director Helen Baxendale, actor Preethi Mavahalli, executive producer, Mammoth screen Miura Kite, SVP, global television, Participant Ben Irving, commissioning editor, BBC Drama Moderated by: Jimmy Akingbola, actor and co-founder, TriForce Creative Network</p>	<p>DEVELOPMENT: The Podcast Report (4.45pm - 5.30pm) Robert Delamere, creative director, Storyglass Sophia Gibber, development producer, Ugly Duckling Films King Kaufman, senior audio producer, San Francisco Chronicle Steve Carsey, senior director, original content (UK), Audible Holly Hines, scripted lead, Spotify Studios Moderated by: Steven Adams, partner and head of management division, Buffalo 8</p>	<p>TRENDS: European Broadcasters Unite to Fight Back (4.45pm - 5.30pm) Nathalie Biancolli, director of acquisitions and international fiction, France Télévisions Eleonora Andreatta, head of drama, RAI Dr Simone Emmelius, SVP international fiction - coproduction & acquisitions, ZDF Moderated by: Ben Keen, chairman, MediaXchange</p>	<p>DRAMA COMMISSIONERS: BRITBOX (4.45pm - 5.30pm) Soumya Sriraman, president, BritBox Reemah Sakaan, group launch director, BritBox UK and senior vice president, creative and editorial, BritBox US Moderated by: Stephen Armstrong, freelance journalist</p>
6.30pm	<p>SPONSORED: The Trial of Christine Keeler Cocktail reception (Conference Level) followed by screening and Q+A (Hall One - Kings Place)</p>			<p>The Netflix reception at Content London (invitation only) (5.30pm - 7.30pm) On the Grand Staircase - St. Pancras Hotel</p>



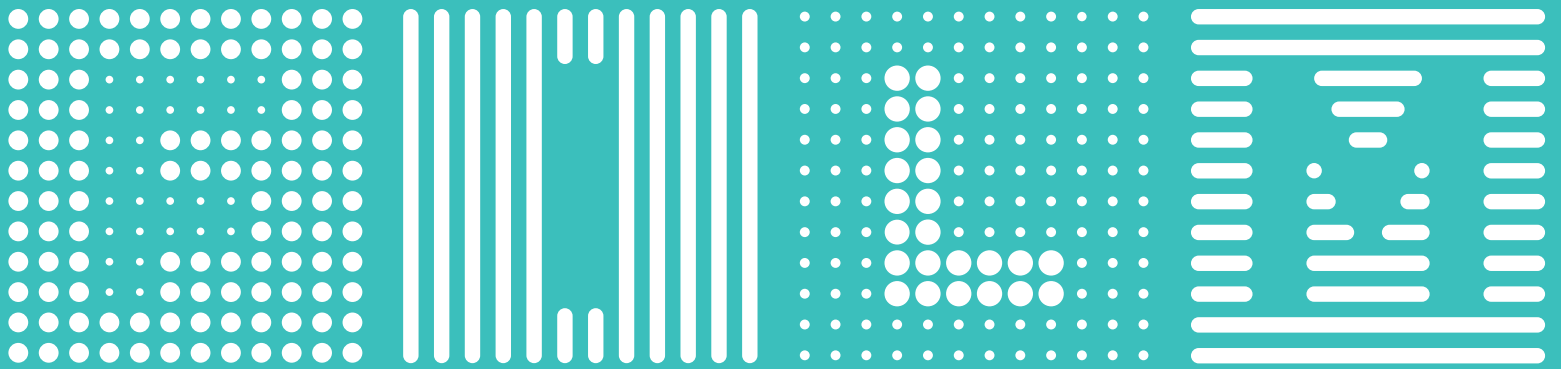

LONDON

London.

The best place
to tell a story.

The end.

If you're working in film, TV, animation or games, Film London can offer you expert advice on locations, logistics and the UK's generous tax reliefs.

From big-budget blockbusters to ground-breaking indies, we can help you to create something special.

Get in touch to find out more.

@Film_London
filmlondon.org.uk



SUPPORTED BY
MAYOR OF LONDON

#LondonIsOpen



THE
NATIONAL
LOTTERY®



Supported using public funding by
**ARTS COUNCIL
ENGLAND**

	HALL ONE (KINGS PLACE)	HALL TWO (KINGS PLACE)	HALL THREE (KINGS PLACE)	HANSOM HALL (ST. PANCRAS)
9am	<p>FINANCE: How to Finance and Sell Production Companies – The Different Types of Deals (9am - 10am) Romain Bessi, managing director, Newen Group and CEO, TF1 Studio Andrea Calderwood, producer, Potboiler Jonathan Norman, partner, Stella EOC Helen Jackson, executive chair, The Media Investment Company Hilary Bevan Jones, founder and producer, Endor Productions Moderated by: Jeremy Gawade, law & business affairs advisor, Lee and Thompson</p>	<p>HOT PROPERTIES: India (9am - 10am) Richie Mehta, writer and director Pooja Kohli Taneja, managing partner and producer, Golden Karavan Kilian Kerwin, head of production (South Asia & Latin America), SK Global Entertainment Gurinder Chadha, director, writer and producer, Bend It TV & Films Paul Mayeda Berges, chief creative officer, Bend It TV & Films Sunder Aaron, principal, Locomotive Global Inc Faith Penhale, CEO, Lookout Point Mona Qureshi, commissioning editor, England, BBC Moderated by: Michael Pickard, editor, Drama Quarterly, C21Media</p>	<p>GENRES: Maximising Advances in VFX to Create Groundbreaking TV Drama (9am - 10am) Jenna Powell, senior VFX producer, Milk Visual Effects Jonathan Cavendish, co-founder, Imaginarium Gaurav Gupta, founder and CEO, FutureWorks Media James Whitlam, VFX executive producer, Framestore Paula Bird, supervising producer, Axis Studios Moderated by: Bryan Elsley, managing director and writer, Balloon Entertainment</p>	<p>DRAMA COMMISSIONERS: STAN (9am - 9.30am) Nick Forward, chief content officer, Stan Moderated by: James Rampton, TV feature writer, The i, The Independent</p> <hr/> <p>9.30am</p> <p>DRAMA COMMISSIONERS: Sky (9.30am - 10am) Cameron Roach, director of Drama, Sky Drama Moderated by: Emma Cox, journalist</p>
10am	<p>NEW PLATFORMS, NEW OPPORTUNITIES: Local Heroes (10am - 11am) Jack Davison, executive vice president, 3vision Jakob Mejlhede Andersen, CEO, NENT Studios UK Tracey Pearce, president of distribution and pay, Bell Media Thomas Münzner, director of content acquisition, Joyn Piotr Kocel, founder and CEO, Bombay Sour Films Moderated by: Irina Ignatiew, MD, Boxworks Media GmbH</p>	<p>TRENDS: Changing the Narrative (10am - 11am) Miura Kite, SVP, global television, Participant Nicole Starr, vice president of social impact, Participant Genevieve Barr, actress Morgane Baudin, sustainable production specialist, Pixetik Hilary Bevan Jones, founder, producer, Endor Productions Moderated by: Jamie Mustard, author, The Iconist</p>	<p>GENRES: New Opportunities in Immersive Drama (10am - 11am) Guy Gadney, CEO, Charisma.ai Nosa Eke, writer and director Kim-Leigh Pontin, creative interaction director, Sky VR Studios David Brady, CEO, Cream Productions Moderated by: Muki Kulhan, managing director, Muki International Ltd</p>	<p>DRAMA COMMISSIONERS: International (10am - 11am) Nathalie Biancolli, director of acquisitions and international fiction, France Télévisions Philipp Steffens, head of fiction, RTL Television Superna Kalle, executive vice president, international digital networks, Starz Trish Williams, executive director, scripted content, CBC Jill Offman, EVP, Comedy Central and Paramount Network International, and managing director, Viacom International Studios UK Moderated by: James Rampton, TV feature writer, The i, The Independent</p>
11am	<p>NEW PLATFORMS, NEW OPPORTUNITIES: The Niche Trailblazers (11am - 12pm) Nathalie Morley, chief content officer, TRACE Global Olivier Jollet, managing director Europe, Pluto TV Karin Heijink, VP pay-TV channels, Viasat World Gena Konstantinacos, vice president, development and video programming, Topic Moderated by: Ben Keen, chairman, MediaXchange</p>	<p>CASE STUDY: Aruanas (11am - 12pm) Monica Albuquerque, head of development, Globo Estela Renner, director, writer and co-founder, Maria Farinha Filmes Guadalupe Marengo, head of global human rights defenders programme, Amnesty International Niamh Brannigan, head of communications for environmental governance, UN Environment Moderated by: Ade Rawcliffe, head of diversity, ITV Commissioning</p>	<p>GENRES: Comedy Drama (11am - 12pm) O.T. Fagbenle, actor, writer and director Lydia Hampson, head of UK scripted, Amazon Studios Sofie Palage, producer, Warner Bros ITVP Sweden Krishnendu Majumdar, co-founder and executive producer, Me+You Productions Moderated by: Emma Smithwick, managing director, Rockfleet Productions</p>	<hr/> <p>11.15am</p> <p>IN CONVERSATION: AMC (11.15am - 12pm) Sarah Barnett, president, AMC Networks Entertainment Group and AMC Studios Moderated by: Stephen Armstrong, freelance journalist</p>
12pm	<p>DEVELOPMENT: The Majors (12pm - 1pm) Ralph Lee, director of content, BBC Studios Scott Herbst, head of scripted development, Lionsgate Kelly Miller, VP of International Strategy, Endeavor Content Television Group Moderated by: James Rampton, TV feature writer, The i, The Independent</p>	<p>THE CRAFT: Managing the Creative Challenge (12pm - 1pm) Warwick Thornton, director Gurinder Chadha, director, producer, writer, Bend It TV & Films Toby Haynes, director Rob Williams, writer and executive producer Moderated by: Hayley McKenzie, founder and CEO, Script Angel</p>	<p>CASE STUDY: The End (12pm - 1pm) Samantha Strauss, creator, The End Rachel Gardner, executive producer, See-Saw Films Patrick Walters, head of development, See-Saw Films Ross Crowley, director of content, Foxtel Liz Lewin, commissioning editor, Sky Moderated by: Jimmy Akingbola, actor and co-founder, Triforce Creative Network</p>	<p>CASE STUDY: The Watch (12pm - 1pm) Sarah Barnett, president, AMC Networks Entertainment Group and AMC Studios Simon Allen, lead writer and executive producer, The Watch Rob Wilkins, executive producer, Narrativia Richard Stokes, executive producer, BBC Studios Moderated by: Michael Pickard, editor, Drama Quarterly, C21Media</p>



Leaders in Premium Content



**NETWORKING
 LUNCH**
 1pm - 3pm

HALL TWO
 SPONSORED: **Love Me**
 (Warner Bros International Television)
 (1.30pm - 2.30pm)
 More information on pages 7-9

HALL THREE
 SPONSORED: **The Paradise**
 (MRP Matila Röhr Production, THE
 MEDIAPRO STUDIO and Yle)
 (1.30pm - 2.30pm)
 More information on pages 7-9

HANSONM HALL
 NETWORKING:
Speed-networking Meetings
 (1.30pm - 2.30pm)

	HALL ONE (KINGS PLACE)	HALL TWO (KINGS PLACE)	HALL THREE (KINGS PLACE)	HANSONM HALL (ST. PANCRAS)
3pm	<p>KEYNOTE INTERVIEW: NETFLIX (3pm - 4pm) Kelly Luegenbiehl, VP of international originals, Netflix Moderated by: David Jenkinson, editor in chief and MD, C21Media</p>	Streaming	Streaming	<p>CASE STUDY: Gangs of London (3pm - 4pm) Thomas Benski, CEO and co-founder, Pulse Films Lucas Ochoa, chief creative officer of scripted film and television, Pulse Films Gabriel Silver, commissioning editor, Sky Corin Hardy, director Jane Featherstone, co-founder and head, Sister London Clare Wilson, series writer Moderated by: Michael Pickard, editor, Drama Quarterly, C21Media</p>
4pm	<p>KEYNOTE INTERVIEW: AMAZON ORIGINALS (4pm - 4.45pm) Georgia Brown, director of European Prime original series, Amazon Studios Aparna Purohit, head of India original, Amazon Prime Video Moderated by: Stephen Armstrong, freelance journalist</p>	Streaming	Streaming	<p>HOT PROPERTIES: The Secrets She Keeps, Trickster, The Heartless (4pm - 5pm) Helen Bowden, producer and MD, Lingo Michael Robotham, author Pilar Perez, head of acquisitions, DCD Rights Michelle Latimer, executive producer and director, Trickster Jennifer Kawaja, executive producer, Sienna Films Carl Barât, executive producer, The Heartless Lucie Barât, writer, The Heartless Zoë Rocha, producer, The Heartless Moderated by: Jimmy Akingbola, actor and co-founder, TriForce Creative Network</p>
4.45pm	<p>Drama Awards Cocktail Reception (Conference Level)</p>		<p>The Finger Awards (invitation only) (5pm - 6.30pm) The first-ever international Finger Awards has been created to provide a platform for comedy professionals who have gone out of their way to try to make the world a better place using their craft. It represents an industry recognition of these efforts by an international panel of over 50 A-list judges, all members of the Comedy for Change community.</p>	<p>The Heartless Launch Party (invitation only) (8.30pm - 10.30pm) Hansom Hall, St. Pancras Hotel</p>
6pm	<p>C21Media's International Drama Awards (6pm - 7pm) Open to all Drama Summit delegates.</p>	<p>International Drama Summit Closing Cocktail (6pm - 9pm) Open to all Drama Summit delegates and Drama Awards Guests.</p>		<p>SERIAL EYES: POSH PITCH CIRCUS (invitation only) (9pm - 10pm) The Royal Suite, St. Pancras</p> <p>SEAN's Amazing Traveling Pitch Circus is coming to Content London and becomes... the POSH CIRCUS!</p>



7 x 60' for Channel 5, 5*, UK
Dating
Voltage TV and The Story Lab

UNDERCOVER TWINS



30' licensed in 5 territories
Gameshow
Phileas Productions

DON'T SAY IT
BRING IT!



8 x 60' for Viu Asia
Reality
Gleam Productions

NO SLEEP NO FOMO



60' & 90' licensed in 12 European territories
Entertainment Gameshow
Tokyo Broadcasting System Television Inc., JP
European distribution by Dentsu Inc & The Story Lab

NINJA WARRIOR

www.storylab.com

the story lab

hello@storylab.com



6 x 45' for RTE2, Ireland
Dating
Alley Cats TV and The Story Lab

Pulling With My Parents



90' for Hunan TV, China
Entertainment
Hunan TV and The Story Lab

THE SOUND



6 x 45' for NPO3, Netherlands
Factual Entertainment
Tuvalu Media and The Story Lab

I WANT TO HAVE YOUR BABY



60', UK
Factual Entertainment
Renowned Films and The Story Lab

YOU ARE NOT A LOAN

8am REGISTRATION AND CONTINENTAL BREAKFAST

9am The Future of Unscripted

Leading unscripted executives set the scene for a focused day of debate around the biggest topical issues and opportunities facing the global unscripted business. How are business models evolving? Who's buying what? What are the threats, opportunities? In a world of constant change what does the next five years look like for the global unscripted business, and what happens next?

Moderator: **Clive Whittingham**, *news editor*, C21Media

Jane Root, *founder and CEO*, Nutopia
Natalia Znak, *president*, Znak & Co
Duane Jones, *co-founder*, Renowned Films
Elaine Fontain Bryant, *executive vice president and head of programming*, A&E Network
Matt Pritchard, *EVP, unscripted programming, television*, eOne



10am KEYNOTE: Luke Hyams, head of originals, YouTube in EMEA

In this keynote interview, Hyams will outline YouTube's EMEA unscripted originals content strategy, new slate and the raft of collaboration opportunities available to producers. Moderator: **Kat Hebden**, *managing director*, Shotgun Media



10.30am KEYNOTE: Courteney Monroe, president, National Geographic Global Television Network

In this keynote interview, Monroe will take to the stage to outline her National Geographic unscripted content and feature documentary strategy, new slate and collaboration opportunities for the global business. Moderator: **James Rampton**, *TV feature writer*, *The i*, *The Independent*



11am COFFEE BREAK

11.30am TRENDS: Shortform Content Opportunity

With the rise of new platforms commissioning shortform content, the big budgets in play have peaked the interest of even the most skeptical producer. In this session, innovators in the shortform space discuss why it's finally being taken seriously as a content form in its own right, the huge opportunities available and how you can reach audiences to create a commercial hit.

Moderator: **Danny Fenton**, *CEO and executive chairman*, Zig Zag Productions
Jonathan Pascoe, *head of digital video*,

MTV International
Joe Caporoso, *SVP*, Whistle
Adesua Okosun, *director & producer*, Black Verse Studios
Neely Shamam, *EVP programming and development*, Ficto



12.15pm OPPORTUNITY: Building Audiences Through Social with Facebook

In this fireside chat Dan Biddle, strategic partner manager, entertainment, Facebook and Sam Barcroft, CEO, Barcroft Studios will discuss partnering with Facebook to build audiences and commercial models, maximising the tools available to producers and the wider opportunities available across the platform.

Moderator: **Kate Bulkley**, *journalist and media commentator*

Dan Biddle, *strategic partner manager, entertainment*, Facebook
Sam Barcroft, *CEO*, Barcroft Studios

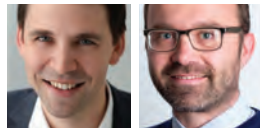

1pm NETWORKING LUNCH

2pm OPPORTUNITY: How To Develop Funding Partnerships with Brands - a focus on Starbucks

As the SVoD space continues to grow and open up opportunities for global unscripted content how do producers find new ways of financing shows and what are the new brand partnership potentials? This is Football, a 6 part docuseries for Amazon Prime was produced by UK Indie October Films in collaboration with Spanish production company Brutal Media and global coffee brand Starbucks. In this session we hear more about how the partnership between the producers and Starbucks came about and worked in practice and we find out more about the Starbucks strategy for future investment in TV content.

Moderator: **Ed Waller**, *editorial director*, C21Media
Haley Drage, *vice president corporate affairs EMEA*, Starbucks
Raimon Masllorens, *MD & owner*, Brutal Media
Jos Cushing, *head of factual UK*, October Films



2.45pm KEYNOTE: Amazon Studios Europe
 In this Amazon Studios focused session, European unscripted heads for the UK, Italy, France, Germany and Spain will set out their local and collaborative original content strategies. They'll also discuss how Amazon Studios is positioning itself across the European unscripted landscape and reveal opportunities for international

collaboration.
 Moderator: **Emma Cox**, *journalist*
Dan Grabiner, *head of unscripted*, UK, Amazon Studios
Nicole Morganti, *head of unscripted Italian originals*, Amazon Studios
Thomas Dubois, *head of unscripted originals*, Amazon Studios France
Philip Pratt, *head of German originals*, Amazon Studios
Oscar Prol, *senior development executive*, Amazon Studios

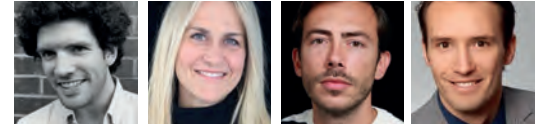

3.30pm TRENDS: Untapping the Potential of Podcasts

A panel of innovators in the audio space will explore how podcasts have emerged as a key source of original IP and an inexpensive way to test out new ideas whilst shedding traditional creative restraints. They'll also reveal how TV and audio entertainment can collaborate to tap into, grow and engage wider audiences and build your brand.

Moderator: **James Purnell**, *director radio and education*, BBC

James Cator, *head of podcast partnerships EMEA*, Spotify
Tim Hammond, *executive director*, Listen Entertainment
James Cooper, *co-creator and co-host*, My Dad Wrote A Porno
Kirsty Hunter, *founder/MD*, StoryHunter



4.15pm OPPORTUNITY: The New Niche Platforms

Leading and new niche players discuss their acquisition and original content strategies, how they're designing business models which are disrupting the disruptors, and reveal opportunities for coproduction with international partners to drive audiences and maintain their unique market position.

Moderator: **Kate Bulkley**, *journalist and media commentator*
Gregor Angus, *founder and CEO*, TrueRoyalty TV
Ellen Windemuth, *founder and CEO*, The WaterBear Network

Arun Maljaars, *director content and channels*, Insight TV
Philip Webb, *COO*, OUTtv



5-7pm CLOSING COCKTAIL

Conference © Aurélien Buttin / Ted Sarandos & Annabel Jones / VR / Georgina Brown / Welcome Drink © Antonin Weber



WHERE SERIES BEGIN



M
INTERNATIONAL FESTIVAL
LILLE / HAUTS-DE-FRANCE
**SERIES MANIA
FORUM**

NEXT STOP AFTER CONTENT LONDON

REGISTER NOW

on seriesmania.com

MARCH 25 > 27 2020

LILLE GRAND PALAIS, FRANCE

**EARLY BIRD
RATE
UNTIL DEC 31**



Co-funded by the European Union



seriesmania.com

forum@seriesmania.com



8am REGISTRATION AND CONTINENTAL BREAKFAST

9am TRENDS: What Makes Kids Watch

UK-based research outfit Dubit returns to Kids Content Futures to present its latest study into what drives children to select one piece of content over another and how the surge in direct-to-consumer SVoD services targeting families may impact discoverability.

Moderator: **Nico Franks**, editor, C21Kids
Stephanie Whitley, manager, planning and brand strategy, Dubit
Adam Woodgate, research director, Dubit



9.30am Let's Push Things Forward: LGBTQ in Kids' TV

LGBTQ characters are becoming more prominent in kids' TV, but issues remain around representation and visibility in key roles. What is being done to break down barriers to progress and what should programme-makers be mindful of to ensure inclusive, diverse, and accurate portrayals of the LGBTQ community?

Moderator: **Shabnam Rezaei**, co-founder and president, Big Bad Boo
David Michel, founder and president, Cottonwood Media and co-founder, Federation Entertainment
Kez Margrie, children's commissioning editor 6-16, BBC
David Levine, VP, kids programming, Disney Channels Europe and Africa/UK & Ireland
Miki Chojnacka, chief creative and content office, Hopster

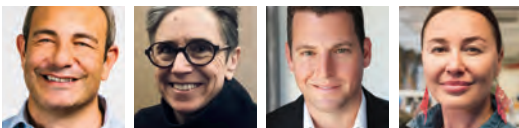

10.15am Independent Thinking: The Future of Aardman

The newly-appointed MD at multi-award-winning studio Aardman will discuss his vision for the company's future: the importance of employee ownership, working with traditional broadcasters and streaming platforms and maintaining a balance between commercial success and creative integrity.

Moderator: **Nico Franks**, editor, C21kids
Sean Clarke, managing director, Aardman



11am COFFEE BREAK

11.30am OPPORTUNITY: Netflix in EMEA

Nico Franks talks to Netflix's Alexi Wheeler and Aardman's Sarah Cox about their new partnership on animated short film Robin Robin and to discuss the challenges and opportunities of creating local, authentic stories to engage global audiences.

Moderator: **Nico Franks**, editor, C21Kids
Alexi Wheeler, manager, kids and family international originals, EMEA, Netflix
Sarah Cox, executive creative director, Aardman



12.15pm OTT 2.0 - The Future of On Demand

We're going through a period of unprecedented change in the TV industry, with Disney+ set to be followed by a slew of SVoD services from US media giants all hoping to catch up with Netflix. But what impact will these have on kids' TV and which types of VoD should producers and distributors be focusing on?

Moderator: **Lucinda Whiteley**, creative director, Novel Entertainment
Tim Searle, head of animation, Beano Studios
John Robson, co-founder and chief operating officer, Moonbug
Paul Robinson, executive vice president, Toonz Media Group
Henrietta Hurford-Jones, director of children's, content partnerships, BBC Studios



1pm NETWORKING LUNCH

2pm Brave New World: What Happens Next in Kids Content

When tech possibilities seem infinite, how do we make the most of those possibilities? Four leading experts in their field talk about how they make their choices, where those choices have taken them and where they think they might lead.

Moderator: **Lucinda Whiteley**, creative director, Novel Entertainment
Alison Norrington, founder, creative director and storyteller, Storycentral
Guy Gadney, CEO, Charisma.ai
Emily Savage, head of immersive and creative partnerships, Digital Catapult
Mark MacDonald, head of broadcast, Little Dot Studios

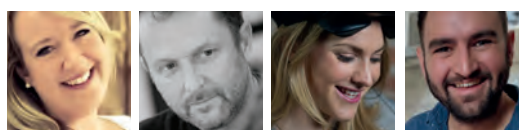

3pm IN CONVERSATION: Ed Wells, SVP and head of international media and education, Sesame Workshop

In Sesame Street's 50th anniversary year, Ed Wells, discusses how the global phenomenon has stayed vital and ahead of the curve by successfully navigating the VoD boom, partnering with the likes of YouTube, Apple and HBO Max to launch new original content, while keeping Sesame Street freely available on public television and fulfilling its mission to help kids everywhere grow smarter, stronger, and kinder.



Moderator: **Nico Franks**, editor, C21Kids

3.45pm OPPORTUNITY: YACF - What's Coming Up

The UK's Young Audiences Content Fund (YACF) recently announced the first projects that will benefit from its £57m (US\$73.5m) injection into the country's TV industry. We'll hear from some of the project's creators and the decision maker in charge of the fund to find out why they were chosen and what's next for the fund.

Moderator: **Anne Brogan**, joint MD, Kindle Entertainment
Jackie Edwards, head of fund, Young Audiences Content Fund, BFI
Angharad Elen, writer, producer and executive producer, Person/a
Callan Allen, writer and originator of As Dead As It Gets
Foz Allan, executive producer, As Dead As It Gets and creative director, Bryncoed Productions Ltd
Tim Bryans, co-creator and producer, The Hearios, ALT Animation

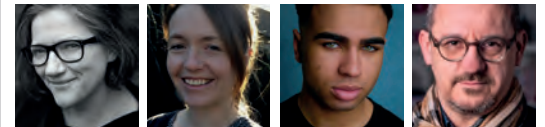

4.45pm Closing remarks Nico Franks, editor, C21Kids

5-7pm CLOSING COCKTAIL



HelionPartners

OFFICIAL SPONSOR OF
COMEDY DRAMA CATEGORY

ROSE  D'OR

2019

ARE YOU THINKING OF SELLING, BUYING OR FUNDRAISING?

Helion is a leading European M&A adviser to the drama production sector. It has unrivalled expertise and experience in advising drama companies on maximising the value of their business on a sale or in a fundraising.

Our team has advised on over 30 TV production deals with a combined transaction value of over €1bn.

A FEW OF OUR DEALS...

New Pictures



Sale to All3Media
TV Production

Tom Manwaring acted as
Adviser to New Pictures

Mammoth Screen



Sale to ITV Studios
TV Production

Tom Manwaring acted as
Adviser to Mammoth Screen

Paddington Bear



STUDIOCANAL

Sale to Studio Canal
Kids IP

Tom Manwaring acted as
Adviser to Paddington Bear

Neal Street Productions



Sale to All3Media
TV Production

Tom Manwaring acted as
Adviser to Neal Street Productions

Slim Film and TV



Sale to Seven West Media
TV Production

Tom Manwaring acted as Adviser
to Slim Film and TV

Shed Media



Sale to Warner Bros
TV Production

Tom Manwaring acted as
Adviser to Shed Media

Raw TV



Sale to Discovery
TV Production

Tom Manwaring acted as
Adviser to Raw TV

Love Productions



Sale to Sky
TV Production

Tom Manwaring acted as
Adviser to Love Productions

If you're interested in meeting to explore the options, please contact tom.manwaring@helionpartners.com or alex.reed-brewer@helionpartners.com



www.helionpartners.com



15 May 2020 • The Ebell of Los Angeles

www.ContentLA.com

Be part of the story in 2020

1 - 4 December 2020 • Kings Place & St. Pancras Renaissance Hotel

With thanks to our sponsors:

