

XpertJet

XPJ-1641SR

XPJ-1682SR



Rev.1.00

26.July.2019

MUTOH INDUSTRIES LTD

History

| Rev. | Date | Date |
|------|--------------|----------------|
| 1.00 | 26.July.2019 | ◆First version |

Reference Material

| Item | Number | Remark |
|---|----------------------|-------------------|
| Operation Manual | XPJ16xxSRE-A-01 | Language: English |
| Installation Manual (Startup Guide) | XPJ16xxSRE-Q-01 | Language: English |
| Maintenance Manual [XPJ-1641SR] | XPJ1641SRE-M-00 | Language: English |
| Maintenance Manual [XPJ-1682SR] | XPJ1682SRE-M-00 | Language: English |
| Main Firmware [XPJ-1641SR] | XPJ1641SR_V100.jfl | ver.1.00 |
| Main Firmware [XPJ-1682SR] | XPJ1682SR_V100.jfl | ver.1.01 |
| H-CONT Firmware [XPJ-1641SR/XPJ-1682SR] | new_misc_qj_V600.mfl | ver.6.00 |

1.Product Feature

1.1.Product Feature [P.4](#)

2.Road Map

2.1.VJ&XPJ Road Map [P.5](#)

3.Specifications of this product

3.1. List of Specifications [P.6](#)

4.Introduction

- 4.1. Precautions [P.9](#)
- 4.2. Name of each part [P.10](#)
- 4.3. Front Panel [P.13](#)
- 4.4. System Configurations of this product [P.15](#)
- 4.5. Warning Labels [P.16](#)
- 4.6. Instruction Precautions [P.18](#)

5.Unpacking and Initial Setup

- 5.1.Site Preparation [P.19](#)
- 5.2.Unpacking [P.20](#)
- 5.3.Assembling [P.23](#)
- 5.4. Connecting Power and Network [P.26](#)
- 5.5. Printer Initial Setup [P.28](#)
- 5.6. Test Printing [P.34](#)
- 5.7. Nozzle check and cleaning [P.39](#)
- 5.8. Setting the Printing Precision [P.40](#)
- 5.9. Advanced settings [P.52](#)

6.Ink

- 6.1.MS41 ink [P.55](#)
- 6.2.Ink System [P.56](#)
- 6.3.Sub Tank [P.58](#)
- 6.4.Error Message display (Ink) [P.59](#)

13.5. Periodic Maintenance Kit (1/1)

7. Carriage

| | |
|-------------------------------------|----------------------|
| 7.1. Carriage Assy | P.60 |
| 7.2. Changing the Head Height | P.61 |
| 7.3. Cutting media | P.61 |
| 7.4. Color Sensor | P.63 |

8. Print Head

| | |
|--|----------------------|
| 8.1. Print Head | P.65 |
| 8.2. Maintenance Parts | P.66 |
| 8.3. Replacing print head [XPJ-1641SR] | P.68 |
| 8.4. Replacing print head [XPJ-1682SR] | P.70 |

9. Printing

| | |
|------------------------------|----------------------|
| 9.1. User Type | P.72 |
| 9.2. Print Mode | P.76 |
| 9.3. Effect | P.79 |
| 9.4. Recommended Media | P.80 |

10. Advanced Operations

| | |
|---------------------------------|-----------------------|
| 10.1. Introduction | P.81 |
| 10.2. Menu 1: Setup | P.84 |
| 10.3. Menu 2: Test Print | P.96 |
| 10.4. Menu 3: Cleaning | P.97 |
| 10.5. Menu 4: Menu Option | P.98 |
| 10.6. Menu 5: System Info. | P.99 |
| 10.7. Menu 6: Sleep Mode | P.99 |
| 10.8. Menu 7: Display | P.100 |
| 10.9. Menu 8: Job Status | P.101 |

11. User Maintenance

| | |
|---|-----------------------|
| 11.1. Instruction Before Purchase | P.102 |
| 11.2. Maintenance | P.103 |
| 11.3. Checking ink and replacing ink bag | P.103 |
| 11.4. Emptying waste ink tank | P.106 |
| 11.5. Head cleaning | P.107 |
| 11.6. Cleaning of cleaning wiper | P.108 |
| 11.7. Cleaning around the capping unit | P.110 |
| 11.8. Cleaning around the print head | P.111 |
| 11.9. Cleaning around the color sensor | P.112 |
| 11.10. Inside cleaning | P.114 |
| 11.11. Replacing absorption material for the flushing box | P.115 |
| 11.12. Replacing cutter | P.117 |
| 11.13. Replacing the cleaning wiper | P.118 |
| 11.14. Moving or transporting the printer | P.120 |
| 11.15. Long-term storage | P.121 |

12. Engineer Maintenance

| | |
|---|-----------------------|
| 12.1. Removing Covers | P.125 |
| 12.2. Electric Wiring Diagram [Board] | P.134 |
| 12.3. Electric Wiring Diagram [FFC] | P.135 |
| 12.4. Lifetime replacement parts | P.137 |
| 12.5. Periodic replacement parts | P.137 |
| 12.6. Self-Diagnosis Function Mode | P.138 |

13. Maintenance Parts

| | |
|--------------------------------------|-----------------------|
| 13.1. Print Head | P.145 |
| 13.2. Board | P.146 |
| 12.3. FFC | P.148 |
| 13.4. Motor | P.149 |
| 13.5. Periodic Maintenance Kit | P.150 |

1. Product Feature

1.1. Product Feature

Product Outline

- ◆ Successor model to VJ-1624X and VJ-1638X.
- ◆ Adopted a new platform which gives flexibility to develop water-based printer, UV printer, or printer with new print head.

Product Feature

- ◆ The new cosmetic refreshes the look of VJ printer series.
- ◆ The new capacitive touch switch improves visibility and operability to light up active keys by LED.
- ◆ The new MS41 eco-solvent ink achieves cost reduction and maintains the same print quality as conventional ink.
- ◆ High-capacity ink holder with front access improves usability.
- ◆ Both operation panel and MSM remote panel support multiple languages (8 languages).
- ◆ The new spindle less roll media holder allows hassle-free media replacement.
- ◆ The main board box is located on the rear of the printer to improve operability and provide easy cable connection without blocking media path.
- ◆ The built-in color sensor achieves automatic Bi-D adjustment to reduce calibration time and variation between operators.
- ◆ Offer two lineups; the single head printer for first-time user, the dual head printer for high productivity.
- ◆ The individual head cleaning mode is available in the dual head printer to reduce ink loss.
- ◆ The print platform LED lighting improves visibility for maintenance and print inspection during printing.
- ◆ Two types of ink adapters are available; existing 2000 ml ink bag case and newly developed 1000 ml ink bag case.



2. Road Map

2.1. VJ&XPJ Road Map

VJ&XPJ series [System more than 1.6m]

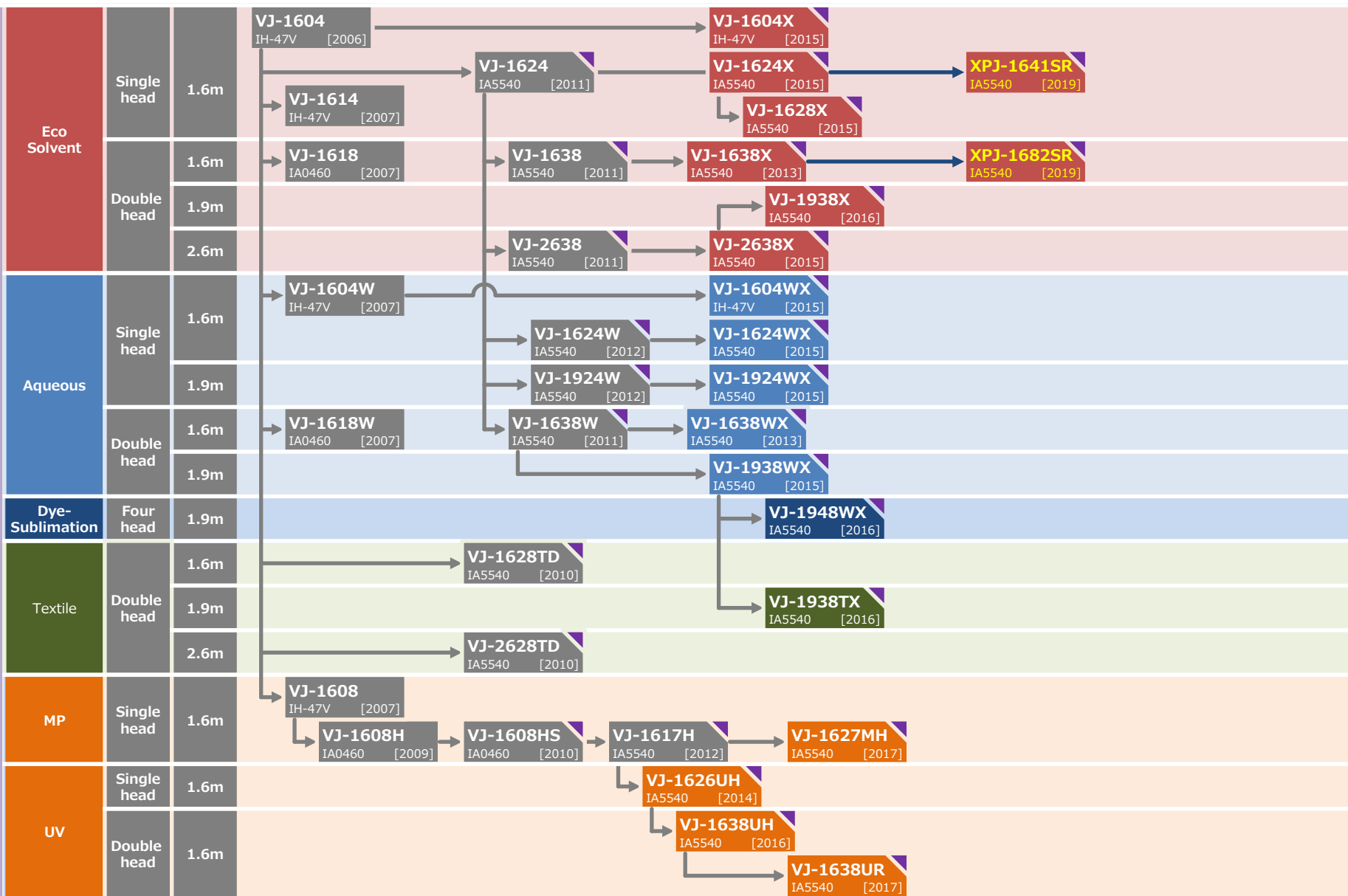

3. Specifications of this product

3.1. List of Specifications (1/3)

VJ-1624X vs XPJ-1641SR

cf. Operation Manual(Rev.01-p.161)

Specifications of this product

| item | ValueJet (VJ-1624X) | XpertJet (XPJ-1641SR) |
|----------------------------|---|---|
| Model Name | VJ-1624X (S/N: HU6U*****) | VJ-1641SR (S/N: JF6U*****) |
| Print method | On demand piezo method | |
| Drive method | Firmware servo/DC motor drive | |
| Media feed method | Multipoint pressurizing Grid roller system | |
| Media hold down system | Pressure roller down system by manual lever | |
| Conditions of usable media | <ul style="list-style-type: none"> ● Media outer diameter Φ150mm or less | |
| | <ul style="list-style-type: none"> ● Media core diameter 2inches or 3inches | |
| | <ul style="list-style-type: none"> ● Weight 30kg or less | |
| | <ul style="list-style-type: none"> ● Width 900mm ~ 1,625mm | <ul style="list-style-type: none"> ● Width 500mm ~ 1,625mm |
| | <ul style="list-style-type: none"> ● Maximum thickness 0.3mm(when the head height is set to Low) 1.3mm(when the head height is set to High) | <ul style="list-style-type: none"> ● Maximum thickness 0.3mm(when the head height is set to Low) 1.3mm(when the head height is set to Mid) 2.8mm(when the head height is set to High) |
| Maximum Printable Width | 1,615mm | |
| Maximum print length | 200m | 1,500m |
| Head height adjustment | Two-level adjustment of Low and High | Three-level adjustment of Low, Mid, and High |

VJ-1638X vs XPJ-1682SR

cf. Operation Manual(Rev.01-p.161)

Specifications of this product

| item | ValueJet (VJ-1638X) | XpertJet (XPJ-1682SR) |
|----------------------------|---|--|
| Model Name | VJ-1638X (S/N: HF6U*****) | VJ-1681SR (S/N: JE6U*****) |
| Print method | On demand piezo method | |
| Drive method | Firmware servo/DC motor drive | |
| Media feed method | Multipoint pressurizing Grid roller system | |
| Media hold down system | Pressure roller down system by manual lever | |
| Conditions of usable media | <ul style="list-style-type: none"> ● Media outer diameter Φ150mm or less | |
| | <ul style="list-style-type: none"> ● Media core diameter 2inches or 3inches | |
| | <ul style="list-style-type: none"> ● Weight 30kg or less | |
| | <ul style="list-style-type: none"> ● Width 900mm ~ 1,625mm | <ul style="list-style-type: none"> ● Width 500mm ~ 1,625mm |
| | <ul style="list-style-type: none"> ● Maximum thickness 0.3mm(when the head height is set to Low) 1.3mm(when the head height is set to Mid) 2.8mm(when the head height is set to High) | |
| Maximum Printable Width | 1,615mm | |
| Maximum print length | 200m | 1,500m |
| Head height adjustment | Three-level adjustment of Low, Mid, and High | |

3. Specifications of this product

3.1. List of Specifications (2/3)

VJ-1624X vs XPJ-1641SR

cf. Operation Manual(Rev.01-p.161)

Specifications of this product

| item | ValueJet (VJ-1624X) | XpertJet (XPJ-1641SR) |
|------------------------------------|--|--|
| Interface | Ethernet(10/100BASE-TX) | |
| Waste ink tank | 2,000ml tank is attached to the printer. Empty the tank when needed. | |
| Ink | <ul style="list-style-type: none"> ● Color 4 colors (Black, Cyan, Magenta, Yellow) | |
| | <ul style="list-style-type: none"> ● Type 220ml/440ml ink cartridge 1,000ml ink bag | <ul style="list-style-type: none"> ● Type 1,000ml ink bag (Cleaner is 300ml) |
| Environmental conditions | <ul style="list-style-type: none"> ● Printer Operation Environment Temperature 20 to 32°C, humidity 40 to 60% No condensation | |
| | <ul style="list-style-type: none"> ● Recommended Printing Environment Temperature 22 to 30°C, humidity 40 to 60% No condensation | |
| | <ul style="list-style-type: none"> ● Printer Storage Environment Storage without ink charging: up to 6 months Temperature -20 to +60°C, humidity 20 to 80% No condensation Storage with ink charging: up to 1 week Temperature -10 to +40°C, humidity 20 to 60% No condensation ※ Storage up to 4 days maximum when stored between 32°C to 40°C . | |
| Power supply specifications | <ul style="list-style-type: none"> ● MAIN Voltage: AC 100V to 120V ±10% / AC 200V to 240V ±10% Frequency: 50/ 60Hz ±1Hz | |
| | <ul style="list-style-type: none"> ● HEATER Voltage: AC 100V to 120V ±10% / AC 200V to 240V ±10% Frequency: 50/ 60Hz ±1Hz | |

VJ-1638X vs XPJ-1682SR

cf. Operation Manual(Rev.01-p.161)

Specifications of this product

| item | ValueJet (VJ-1638X) | XpertJet (XPJ-1682SR) |
|------------------------------------|--|--|
| Interface | Ethernet(10/100BASE-TX) | Gb-Ethernet (1000BASE-T) |
| Waste ink tank | 2,000ml tank is attached to the printer. Empty the tank when needed. | |
| Ink | <ul style="list-style-type: none"> ● Color 4 colors (Black, Cyan, Magenta, Yellow) 7 colors (Black, Cyan, Magenta, Yellow, Light Cyan, Light Magenta, Light Black) | |
| | <ul style="list-style-type: none"> ● Type 220ml/440ml ink cartridge 1,000ml ink bag | <ul style="list-style-type: none"> ● Type 1,000ml ink bag (Cleaner is 300ml) |
| Environmental conditions | <ul style="list-style-type: none"> ● Printer Operation Environment Temperature 20 to 32°C, humidity 40 to 60% No condensation | |
| | <ul style="list-style-type: none"> ● Recommended Printing Environment Temperature 22 to 30°C, humidity 40 to 60% No condensation | |
| | <ul style="list-style-type: none"> ● Printer Storage Environment Storage without ink charging: up to 6 months Temperature -20 to +60°C, humidity 20 to 80% No condensation Storage with ink charging: up to 1 week Temperature -10 to +40°C, humidity 20 to 60% No condensation ※ Storage up to 4 days maximum when stored between 32°C to 40°C . | |
| Power supply specifications | <ul style="list-style-type: none"> ● MAIN Voltage: AC 100V to 120V ±10% / AC 200V to 240V ±10% Frequency: 50/ 60Hz ±1Hz | |
| | <ul style="list-style-type: none"> ● HEATER Voltage: AC 100V to 120V ±10% / AC 200V to 240V ±10% Frequency: 50/ 60Hz ±1Hz | |

3. Specifications of this product

3.1. List of Specifications (3/3)

VJ-1624X vs XPJ-1641SR

cf. Operation Manual(Rev.01-p.162)

Specifications of this product

| item | ValueJet (VJ-1624X) | XpertJet (XPJ-1641SR) |
|---------------------|---|--|
| Current consumption | <ul style="list-style-type: none"> ● AC 100V to 120V MAIN: 12A or below HEATER: 12A or below | <ul style="list-style-type: none"> ● AC 100V to 120V MAIN: 9A or below HEATER: 10A or below |
| | <ul style="list-style-type: none"> ● AC 200V to 240V MAIN: 10A or below HEATER: 6.5A or below | <ul style="list-style-type: none"> ● AC 200V to 240V MAIN: 6A or below HEATER: 5A or below |
| Power consumption | <ul style="list-style-type: none"> ● Operation MAIN: 1100W or below HEATER: 1200W or below | |
| Dimensions | <ul style="list-style-type: none"> ● Height 1,261 mm | <ul style="list-style-type: none"> ● Height 1,428 mm |
| | <ul style="list-style-type: none"> ● Width 2,698mm | <ul style="list-style-type: none"> ● Width 2,750 mm |
| | <ul style="list-style-type: none"> ● Depth 885.5mm | <ul style="list-style-type: none"> ● Depth 895 mm |
| Weight | <ul style="list-style-type: none"> ● Main body 126kg | <ul style="list-style-type: none"> ● Main body 142kg |
| | <ul style="list-style-type: none"> ● Stand 34kg | <ul style="list-style-type: none"> ● Stand 32kg |

VJ-1638X vs XPJ-1682SR

cf. Operation Manual(Rev.01-p.162)

Specifications of this product

| item | ValueJet (VJ-1638X) | XpertJet (XPJ-1682SR) |
|---------------------|---|--|
| Current consumption | <ul style="list-style-type: none"> ● AC 100V to 120V MAIN: 12A or below HEATER: 12A or below | <ul style="list-style-type: none"> ● AC 100V to 120V MAIN: 9A or below HEATER: 10A or below |
| | <ul style="list-style-type: none"> ● AC 200V to 240V MAIN: 10A or below HEATER: 6.5A or below | <ul style="list-style-type: none"> ● AC 200V to 240V MAIN: 6A or below HEATER: 5A or below |
| Power consumption | <ul style="list-style-type: none"> ● Operation MAIN: 1100W or below HEATER: 1200W or below | |
| Dimensions | <ul style="list-style-type: none"> ● Height 1,261 mm | <ul style="list-style-type: none"> ● Height 1,428 mm |
| | <ul style="list-style-type: none"> ● Width 2,698mm | <ul style="list-style-type: none"> ● Width 2,750 mm |
| | <ul style="list-style-type: none"> ● Depth 885.5mm | <ul style="list-style-type: none"> ● Depth 895 mm |
| Weight | <ul style="list-style-type: none"> ● Main body 153kg | <ul style="list-style-type: none"> ● Main body 146kg |
| | <ul style="list-style-type: none"> ● Stand 34kg | <ul style="list-style-type: none"> ● Stand 32kg |

4. Introduction

4.1. Precautions (1/1)

cf. Operation Manual(Rev.01-p.20)

Introduction

Precautions

Please use this product at least once a week

- If the printer is not used for a long time, the print head nozzles can get clogged causing damage to the printer.

Please handle ink bag carefully

- Before using an ink bag, make sure to read the Safety Data Sheet (SDS).
- Do not disassemble Ink bag.
Ink may come into contact with your eyes or skin, causing irritation or allergic reaction.
- Wear protective gloves, glasses, and mask when handling ink bags.
- Avoid contact with your eyes or on your skin.
If in your eye or on your skin, immediately wash with water.
It could cause bloodshot eyes or light inflammation.
Should any anomalies occur, immediately seek medical attention.
- DO NOT drop or hit an ink bag.
Ink may leak from the bag.
- Be sure to use the ink before it expires.
The expired ink should be disposed of as industrial waste.
The empty ink bag should be put in a plastic bag and should be disposed of according to the local regulations.
- MUTOH strongly recommends to use genuine ink.
This printer is designed to bring out the best performance when using with the MUTOH genuine ink.
Non-MUTOH ink may cause print defects or damage to the printer.

Conduct periodic maintenance

This product requires regular user maintenance.

- Run a nozzle check before and after printing.
If nozzle missing is found, run a head cleaning.
- Clean the cleaning wiper and around the print head once a week.
- If you are not using the printer for an extended period*, run a head cleaning once a week.
If you may not be able to perform weekly head cleaning, perform [Longstore]
*"Extended period" means one to four weeks.
- Clean inside of your printer once a month.
- Regularly check the waste ink tank and empty the tank as needed.

Some parts need to be replaced periodically

In this product, there are some parts required to be replaced after a long-term use.

- User replaceable parts: Absorption material for the flushing box, Cutter, Cleaning wiper
- Parts required to be replaced by service personnel: Motors, Pumps, Print heads

4. Introduction

4.2. Name of each part (1/4)

cf. Operation Manual(Rev.01-p.9)

Introduction

Main components of your printer

◆ Front side

Front cover

Open this cover when loading a roll media or removing a media jam.

It is normally closed.

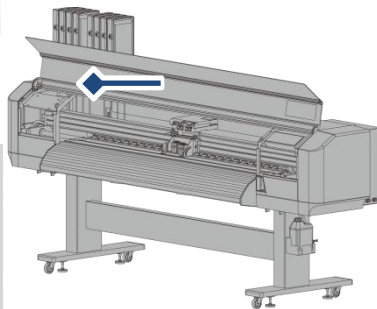
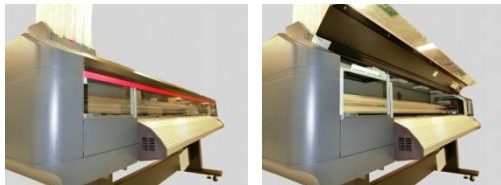

Internal LED lights

The lights allows you to inspect inside of the printer or your print during printing.

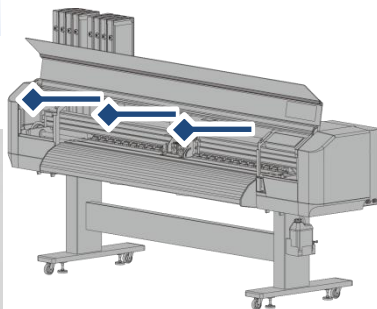

Maintenance cover L

Open this cover for cleaning.

It is normally closed.

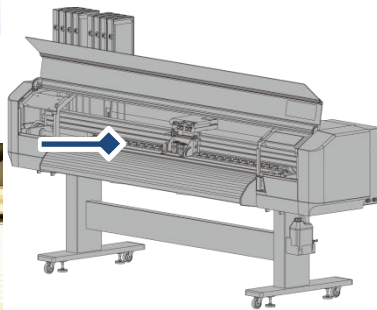

Maintenance cover R

Open this cover for cleaning or replacing consumables.

It is normally closed.

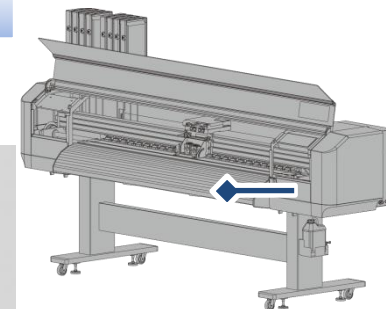

Media feed lever

Push the lever to lower the pressure rollers to keep the media flat while printing.

Pull it to release the media.

The hold down pressure can be changed between High and Normal using this lever.

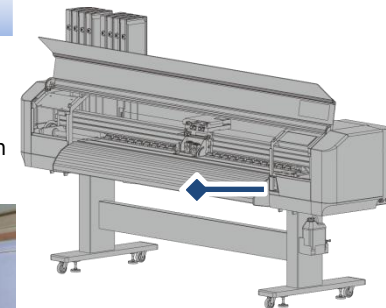

Media guide

Front media path that the heater is installed inside to dry the print.

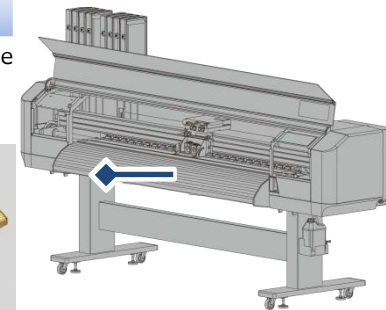

4. Introduction

4.2. Name of each part (2/4)

cf. Operation Manual(Rev.01-p.9)

Introduction

Main components of your printer

◆ Front side

Waste ink tank

Collect waste ink produced during printing and cleaning cycle.

Empty the tank as needed.

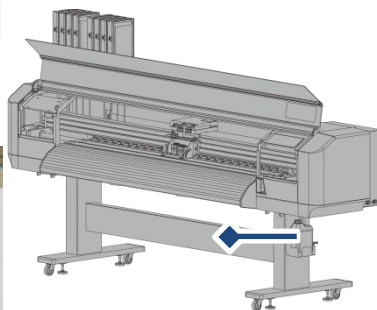

Stand

Adjuster

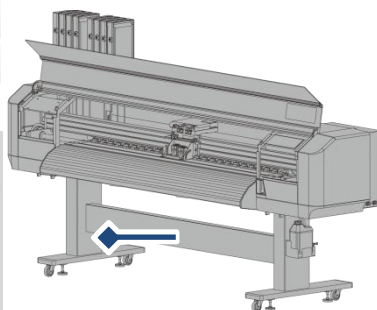

Carriage

The print head is installed on the carriage.

◆XPJ-1641SR



◆XPJ-1682SR

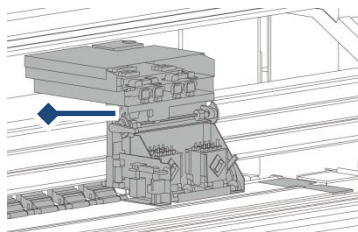

Pressure rollers

Keep the media in place to ensure proper feeding. The hold down pressure can be individually reduced or canceled by slide lock levers on the pressure rollers.

◆XPJ-1641SR



◆XPJ-1682SR

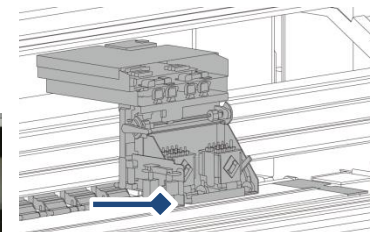
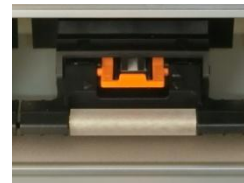

Edge holder

Place it on the edge of the media to prevent media curl while printing.

While not printing, slide them to the left and right side edges of the platen.

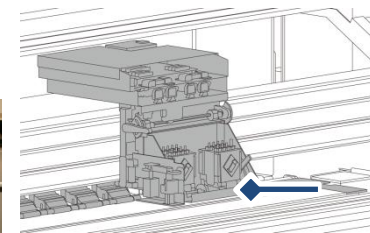

Platen

Media is printed on here.

There is an adsorption fan inside.

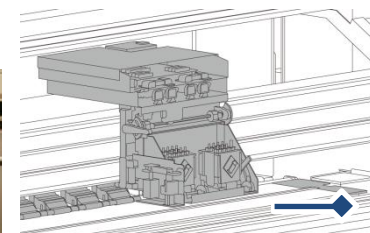

4. Introduction

4.2. Name of each part (3/4)

cf. Operation Manual(Rev.01-p.9)

Introduction

Main components of your printer

◆ Front side

Cutter

Automatically cut the media after printing.

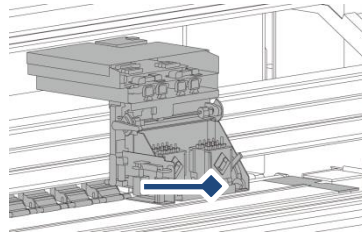

Media cut groove

Manually cut the media along the groove.

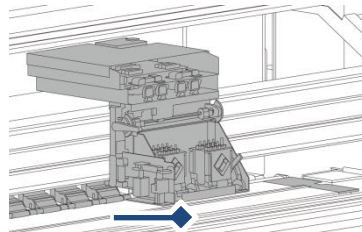

◆ Rear side

Ink slots

Insert an ink bag case into the slot.
(Illustration: XPJ-1682SR)

87654321

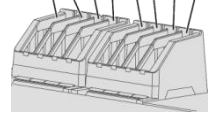

◆ XPJ-1641SR

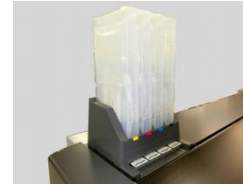

◆ XPJ-1682SR

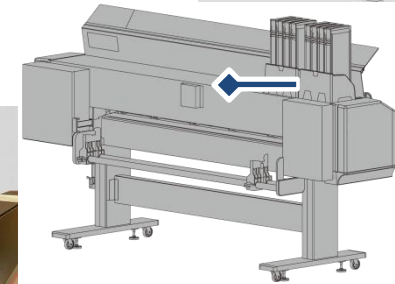
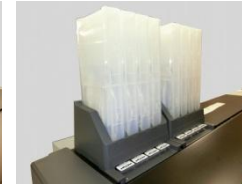

Media feed slot

Insert the front edge of the media into this slot and pass it to the front side to load it into the printer.

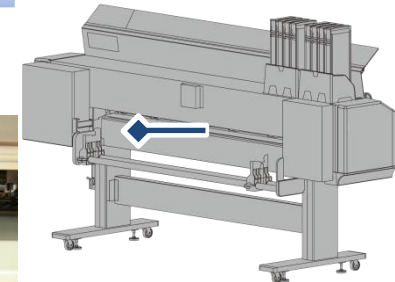

Media guide

Pass a roll media through the media guide.

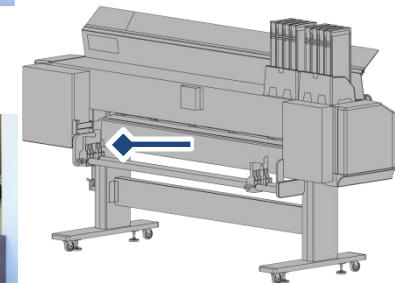

4. Introduction

4.2. Name of each part (4/4)

cf. Operation Manual(Rev.01-p.10)

Introduction

Main components of your printer

◆ Rear side

Media feed lever

Hold down or release the media.
This lever is interlocked with the media feed lever on the front side.

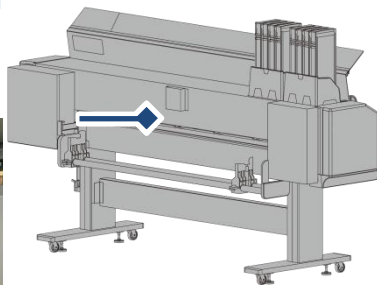

Roll media holder

Attach the media flanges to both ends of a roll media and load it onto the roll media holder.

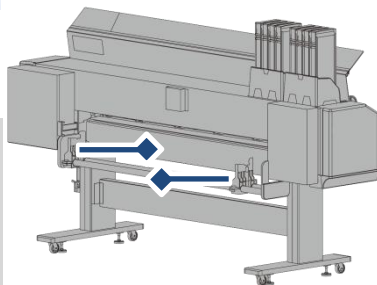
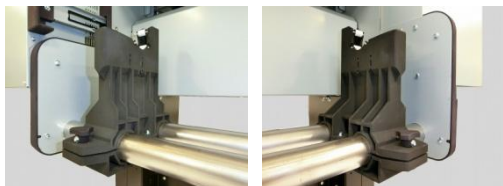

AC inlet

Network interface cable connector

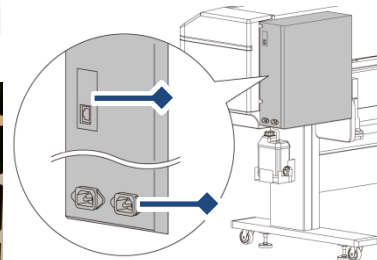

4.3. Front Panel (1/2)

cf. Operation Manual(Rev.01-p.10)

Introduction

Main components of your printer

◆ Front Panel

The printer has a touch-screen panel located on the front right of the printer. The active keys are lit up on the panel for guidance.

- Tap: Lightly touch the key with your finger, then immediately release.
- Long-touch: Keep touching the key.

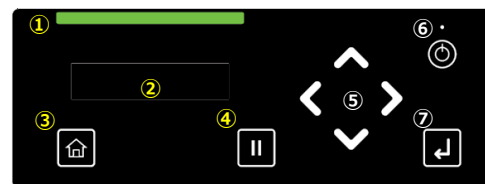

① Status Bar

Indicates the printer status by LED light.

- Working normally: Solid green
- Error/Alert state: Solid red (error) or flash red (alert)

② Display

Displays the printer status, setting menu, errors and so on.

③ [Home] Key

Access to or exit the menu.



④ [Cancel] key

- Pause the print job. While pausing, tap the key again to resume printing.
- While the printer is not printing, tap the key to cut the media.



4. Introduction

4.3. Front Panel (2/2)

cf. Operation Manual(Rev.01-p.11)

Introduction

Main components of your printer

◆ Front Panel

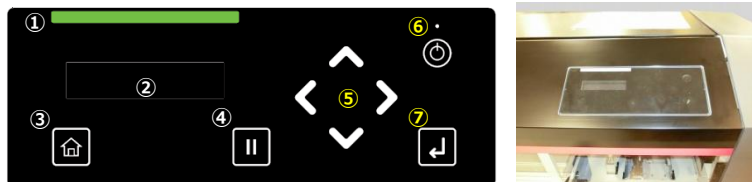

⑤ Arrow keys:

When you have entered the setup menu, the arrow keys are used to select a menu or enter a value.

- ⬆ key: Go to the previous item.
- ⬅ key: Return to the upper level menu without saving the change.
- ➡ key: Go to the sub menu.
- ⬇ key: Go to the next item.

While the printer is in standby mode, it is used to feed media, run a nozzle check, or perform head cleaning.

- ⬆ key: Feed the media backward.
Long-touch to feed it with high speed.
- ⬅ key: Tap to run a nozzle check.
- ➡ key: Tap to perform cleaning.
- ⬇ key: Feed the media forward.
Long-touch to feed it with high speed.



⑥ [Power] button

- Long press to power on the printer.
The Power LED (above the Power button) turns on with a solid white light.
- While the power is on, long press the button to power off the printer.
In the Off state, the Power LED lights off.

Note

The ⏻ symbol means “standby”.

Even the Power LED turns off, the device still consumes some power unless the power cords are disconnected.

This state is referred to as the power being “off” in this Manual.



⑦ [Enter] key

Use the Enter key to select a menu or confirm a value.

- While the printer warms up, tap the Enter key to start printing immediately before fully warming up.



4. Introduction

4.4. System Configurations of this product(1/2)

cf. Operation Manual(Rev.01-p.14)

Introduction

System configurations of this product

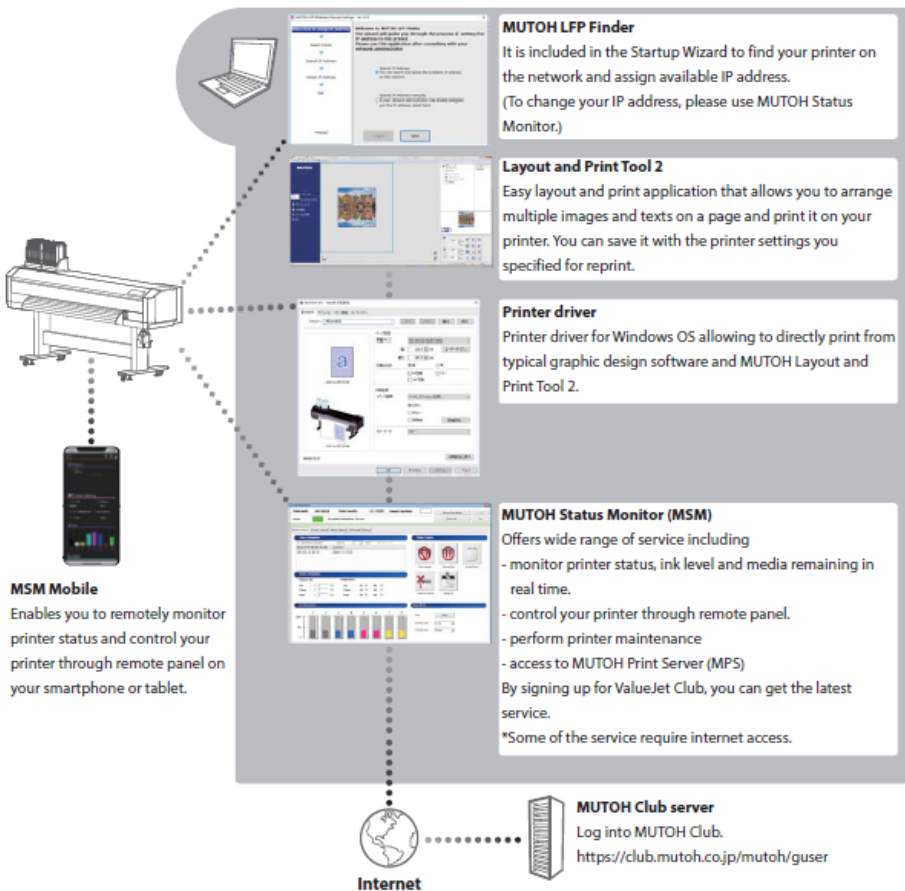

Mutoh LFP Finder

It is included in the Startup Wizard to find your printer on the network and assign available IP address.

(To change your IP address, please use MUTOH Status Monitor.)

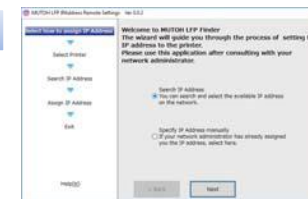

Layout and Print Tool 2

Easy layout and print application that allows you to arrange multiple images and texts on a page and print it on your printer.

You can save it with the printer settings you specified for reprint.



Printer driver

Printer driver for Windows OS allowing to directly print from typical graphic design software and MUTOH Layout and Print Tool 2.



Mutoh Status Monitor (MSM)

Offers wide range of service including
By signing up for MUTOH Club, you can get the latest service.

- monitor printer status, ink level and media remaining in real time.
- control your printer through remote panel.
- access to MUTOH Print Server (MPS)

※ Some of the service require internet access.



4. Introduction

4.4. System Configurations of this product(2/2)

cf. Operation Manual(Rev.01-p.14)

Introduction

System configurations of this product

MUTOH Club

By signing up for MUTOH Club, it offers free useful contents including

- download the latest version of application, operation manual
- download media profile
- check printer information
(printer information uploaded through MSM can be viewed)



<Print Support Software>

To get the best out of this product, use the MUTOH Print Server (MPS) function available from MUTOH

You can download the latest version of MSM from the MUTOH Club Server.
(To use MPS, specify the output port of RIP software to MPS.)

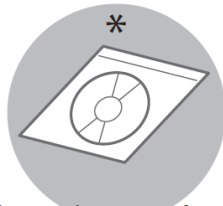

- ✓ Mutoh LFP Finder
- ✓ Printer driver
- ✓ Mutoh Status Monitor (MSM)
(Mutoh Print Server (MPS))
- ✓ Layout and Print Tool 2

□ Operation Manual CD : 1

4.5. Warning Labels (1/3)

cf. Startup Guide(Rev.01-p.44)

Safety Precautions

Warning Labels

Warning labels are applied onto the product where special attention is required. Read the messages on the labels and always follows the instructions. If the labels are peeled off or become dirty, contact your local MUTOH dealer to get new one.

Cut Hazard Label for Steel Belt

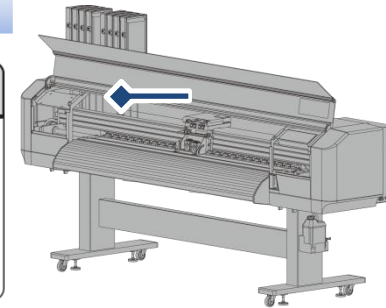

Printer Safe Handling Label

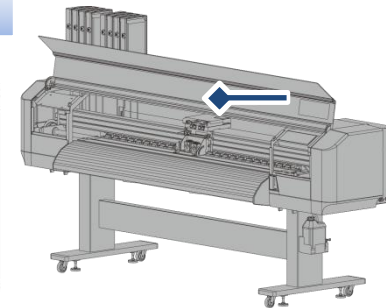

4. Introduction

4.5. Warning Labels (2/3)

Safety Precautions

Warning Labels

Cut Hazard Label for Cutter

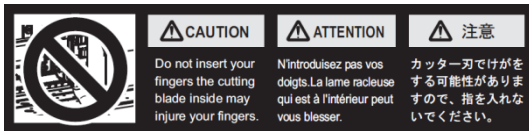

CAUTION Do not insert your fingers the cutting blade inside may injure your fingers.

ATTENTION N'introduisez pas vos doigts. La lame racleuse qui est à l'intérieur peut vous blesser.

注意 カッター刃で指を切る可能性があります。指を入れないでください。

cf. Startup Guide(Rev.01-p.44)

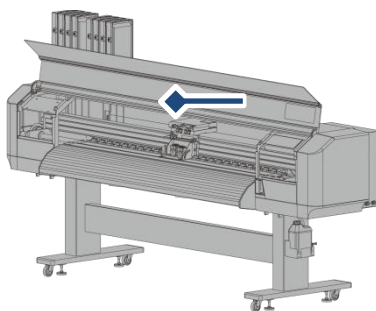

Cutter Cap Caution Label

When replacing a cutter blade, do not push the cutter cap.

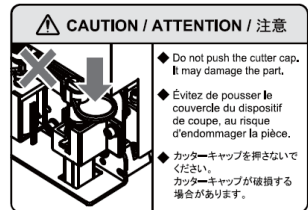

CAUTION / ATTENTION / 注意

Do not push the cutter cap. It may damage the part.

Évitez de pousser le couvercle du dispositif de coupe, au risque d'endommager la pièce.

カッターキャップを押さないでください。カッターキャップが破損する場合があります。

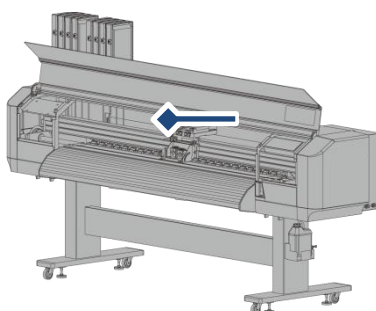

Hot Surface Caution Label

The surface may get hot and may cause burn injury. Do not touch with your hand for at least 30 minutes after turning off the printer.

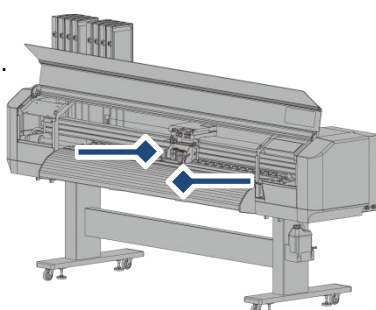

Caution Label for Waste Ink Drain Tube Handling



CAUTION / ATTENTION / 注意

Do not bend or pull the waste ink drain tube. The ink may be leaked and damages the printer.

Ne pas tirer ou plier le drain d'encre usagé; cela pourrait provoquer une fuite d'encre, et endommager l'imprimante.

廃液チューブを折り曲げたり、引っ張ったりしないで下さい。インクが漏れて製品が故障する恐れがあります。

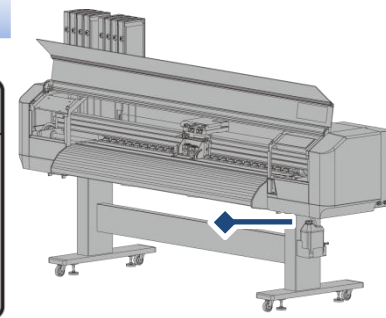

Waste Fluid Caution Label



CAUTION / ATTENTION / 注意

Emergency Measures

Measures d'urgence

注意

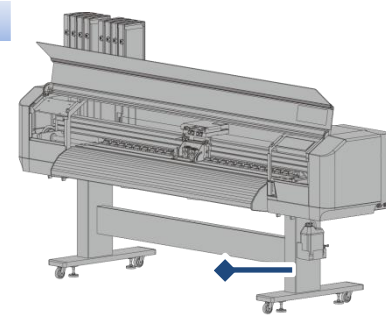

Protective equipment label

(Mask / Glasses / Gloves / Protective clothing)
Wear protective equipment when handling ink.

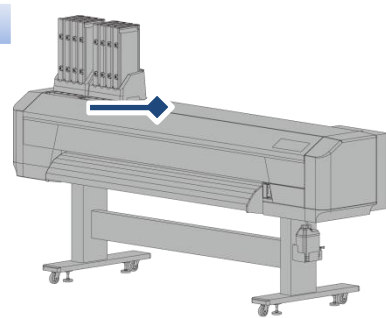

4. Introduction

4.5. Warning Labels (3/3)

cf. Startup Guide(Rev.01-p.44)

Safety Precautions

Warning Labels

Loading Position Caution Label

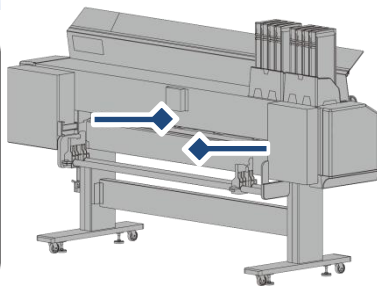
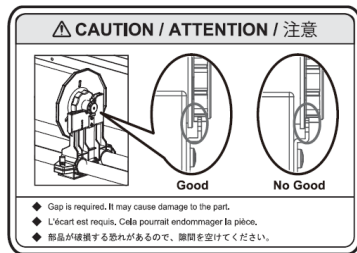

Hot Surface Caution Label

The surface may get hot and may cause burn injury. Do not touch with your hand for at least 30 minutes after turning off the printer.

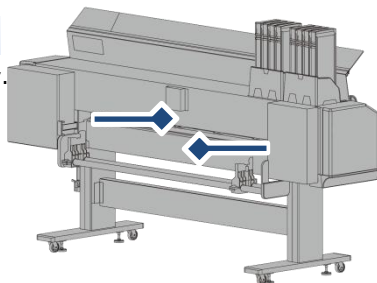

4.6. Instruction Precautions (1/1)

cf. Startup Guide(Rev.01-p.45)

Safety Precautions

Instruction Labels

The following instructions labels are applied onto the printer to ensure the proper use.

AC Inlet Label

- MAIN
- HEATER

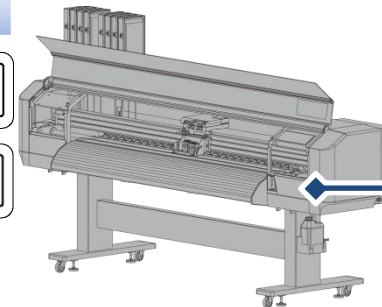

Rated nameplate

◆XPJ-1641SR

| MUTOH | | MAIN | |
|------------------------------------|------------|-----------|---------------------|
| MODEL | XPJ-1641SR | VOLTAGE | 100-120V / 200-240V |
| SERIAL NO. | ZF60XXXXXX | FREQUENCY | 50 / 60 Hz |
| 品番 | | CURRENT | 9A / 5A |
| MET | | HEATER | |
| Voltage This is input to the main. | | VOLTAGE | 100-120V / 200-240V |
| CIS (CE) mark | | FREQUENCY | 50 / 60 Hz |
| E-Test | | CURRENT | 15A / 8A |
| MAIN | | | |
| 交流電圧 | 100V | | |
| 交流電流 | 9A / 5A | | |
| 消費電力 | 1000 W | | |
| 定格電圧 | 100V | | |
| 定格電流 | 9A / 5A | | |
| 定格電力 | 1000 W | | |

This device complies with Part 15 of the FCC Rules. Operation is subject to the following two conditions:
 (1) This device may not cause harmful interference, and
 (2) This device must accept any interference received, including interference that may cause undesired operation.

CAN ICES-3(A) / NMB-3(A)

MUTOH INDUSTRIES LTD.
MUSE JAPAN

注意
 この装置は、このまま稼働します。
 この装置は有害電磁波を放射する恐れがあります。ご注意ください。
 この装置は他の電磁波を受けやすい状態になる恐れがあります。ご注意ください。

CAUTION/ATTENTION/注意

- This device has no power system. There is a risk of electric shock unless the power system are engaged during the maintenance.
- この装置は電源システムを持っていません。メンテナンス中は電源システムが稼働していない限り、感電の危険があります。
- この装置は他の電磁波を受けやすい状態になる恐れがあります。ご注意ください。

1. Apparatus has no power system.
 2. Apparatus must be engaged when maintenance.
 3. Labels on this device is suppressed from interference by microwave.
 4. Apparatus will give off radiation and radiation may give health damage if inappropriate use.

◆XPJ-1682SR

| MUTOH | | MAIN | |
|------------------------------------|------------|-----------|---------------------|
| MODEL | XPJ-1682SR | VOLTAGE | 100-120V / 200-240V |
| SERIAL NO. | ZF60XXXXXX | FREQUENCY | 50 / 60 Hz |
| 品番 | | CURRENT | 9A / 5A |
| MET | | HEATER | |
| Voltage This is input to the main. | | VOLTAGE | 100-120V / 200-240V |
| CIS (CE) mark | | FREQUENCY | 50 / 60 Hz |
| E-Test | | CURRENT | 15A / 8A |
| MAIN | | | |
| 交流電圧 | 100V | | |
| 交流電流 | 9A | | |
| 消費電力 | 1000 W | | |
| 定格電圧 | 100V | | |
| 定格電流 | 9A / 5A | | |
| 定格電力 | 1000 W | | |

This device complies with Part 15 of the FCC Rules. Operation is subject to the following two conditions:
 (1) This device may not cause harmful interference, and
 (2) This device must accept any interference received, including interference that may cause undesired operation.

CAN ICES-3(A) / NMB-3(A)

MUTOH INDUSTRIES LTD.
MUSE JAPAN

注意
 この装置は、このまま稼働します。
 この装置は有害電磁波を放射する恐れがあります。ご注意ください。
 この装置は他の電磁波を受けやすい状態になる恐れがあります。ご注意ください。

CAUTION/ATTENTION/注意

- This device has no power system. There is a risk of electric shock unless the power system are engaged during the maintenance.
- この装置は電源システムを持っていません。メンテナンス中は電源システムが稼働していない限り、感電の危険があります。
- この装置は他の電磁波を受けやすい状態になる恐れがあります。ご注意ください。

1. Apparatus has no power system.
 2. Apparatus must be engaged when maintenance.
 3. Labels on this device is suppressed from interference by microwave.
 4. Apparatus will give off radiation and radiation may give health damage if inappropriate use.

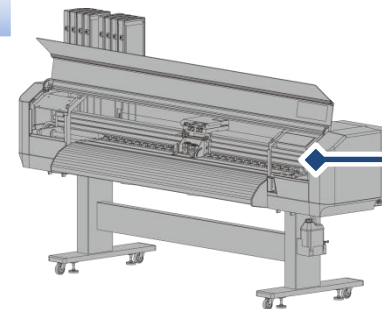

5. Unpacking and Initial Setup

5.1. Site Preparation (1/2)

cf. Startup Guide(Rev.01-p.2)

Site Preparation

Installation Location Requirements

Choose the location which satisfies the requirements below.

- The floor must be level.
- Avoid vibration from the neighboring devices.
- Low humidity and free from dust.
- Less chance of temperature and humidity changes.
- Avoid direct sunlight.
- Avoid water.
- Avoid direct air onto the printer.
- Low levels of electromagnetic waves.

⚠ CAUTION

- **Choose the floor that can safely support the weight of this product.**

The total weight of printer and stand is 280 kg.

If the floor does not have sufficient load capacity, it can lead to injury from a fall.

- **This equipment is not suitable for use in locations where children are likely to be present.**

- **Keep the work area well ventilated while operating.**

Ink odor may cause health problem such as headache, dizziness, or dull.

If you experience these symptoms, stop printer operation and move to fresh air.

Seek medical attention if vomit persists.

cf. Startup Guide(Rev.01-p.2)

Minimum Space Requirements

The following space is required for installation.

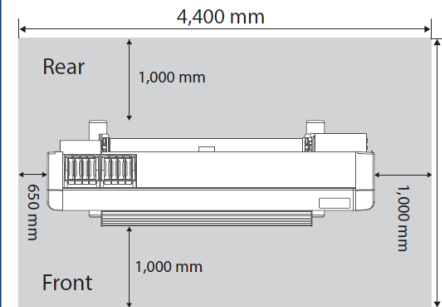

Printer Size

Width x Depth : 2,750mm x 895mm

Height : 1,611mm *1

*1 When installing ink bag cases.

The room height should be at least 1,760mm.

Power Specification

The installation site must meet the power specification and environmental requirements below.

• Printer:

Input voltage: AC 100V to 120V±10% / AC 200V to 240V±10%

Input frequency: 50 / 60Hz ±1Hz

Input load current: 9 A (AC 100V - 120V), 6 A (AC 200V - 240V)

• Heater:

Input voltage: AC 100V to 120V±10% / AC 200V to 240V±10%

Input frequency: 50 / 60Hz ±1Hz

Input load current: 10 A (AC 100V - 120V), 5 A (AC 200V - 240V)

Important!

This product has two power cords for printer and heater and requires the total load current as follows:

- XPJ-1641SR/XPJ-1682SR: 19 A (AC 100V - 120V), 11 A (AC 200V - 240V)

If the total current exceeds the maximum capacity of the wall outlet with two or more jacks, connect one of the two power plugs into another wall outlet.

5. Unpacking and Initial Setup

5.1. Site Preparation (2/2)

cf. Startup Guide(Rev.01-p.3)

Site Preparation

Environmental Requirements

- **Operating condition:**

Temperature : 20°C to 32°C
 Humidity : 40% to 60%, non condensing

- **Printing Condition:**

Temperature : 22°C to 30°C
 Humidity : 40% to 60%, non condensing

- **Change rate:**

Temperature : No more than 2°C per 1 hour
 Humidity : No more than 5% per 1 hour

- **Printer Storage Condition:**

Without ink filled: Up to 6 months
 Temperature : -20°C to 60°C
 Humidity : 20% to 80%, non condensing

With ink filled: Up to 1 week
 Temperature : -10°C to 40°C
 Humidity : 20% to 80%, non condensing
 ※.Storage up to 4 days maximum when stored between 32 °C to 40°C.

- **Ink Storage Condition:**

Black / Cyan / Magenta / Yellow/ Light Cyan / Light Magenta / Light Black (1,000ml each)
 Temperature : -20°C to 40°C
 Humidity : 5% to 85%, non condensing
 Cleaning bag (300ml)
 Temperature : -5°C to 40°C
 ※.Storage up to 6 months maximum when stored between -5°C to 5°C or 30 °C to 40°C.
 Humidity : 80% or less, non condensing

5.2. Unpacking (1/4)

cf. Startup Guide(Rev.01-p.4)

Unpacking

Unpacking Preparation

Before unpacking, read the instructions below and prepare the necessary items.

- Minimum 4 people are required for unpacking, assembling and installation.
- The items listed below are required for installation and initial setup.

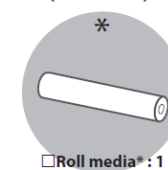
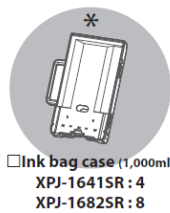
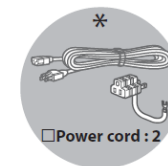
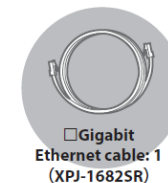
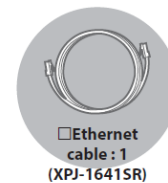
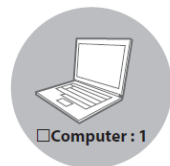

* Usable size
 Media core diameter: 2 inches or 3 inches
 Outer diameter: Φ150 mm or less
 Width: 1,000 mm to 1,625 mm
 Weight: 30 kg or less



5. Unpacking and Initial Setup

5.2. Unpacking (2/4)

cf. Startup Guide(Rev.01-p.4)

Unpacking

WARNING**Use the designated power cords.**

Failure to do so may result in electric shock or fire.

Important!**Your computer must meet the following minimum requirements:**

- **OS:** Windows 10 (64bit), Windows 8/8.1 (64bit), Windows 7 (64bit)
- **CPU:** Intel (R) Core (TM) i5 / i7
- **Memory:** 8GB minimum
- **Network:**

XPJ-1641SR: Use a network port that supports Ethernet port, Ethernet cable (Category 5 or later)

XPJ-1682SR: Use a network port that supports Gigabit Ethernet port, Gigabit Ethernet cable (Category 6 or later)

Note

Items marked with an asterisk (*) above are accessories or supplies.

cf. Startup Guide(Rev.01-p.5)

Unpacking the printer

Unpack the product.

CAUTION

- **Minimum four people are required for unpacking and moving this product.**
- **When taking out the product from the packing box, remove the plastic sheet wrapped around the product, then take out the product.**
Failure to do so may cause slip and damage to the product.
- **Keep the product level while moving it.**

[1] Open the packing box and take out the items listed below.

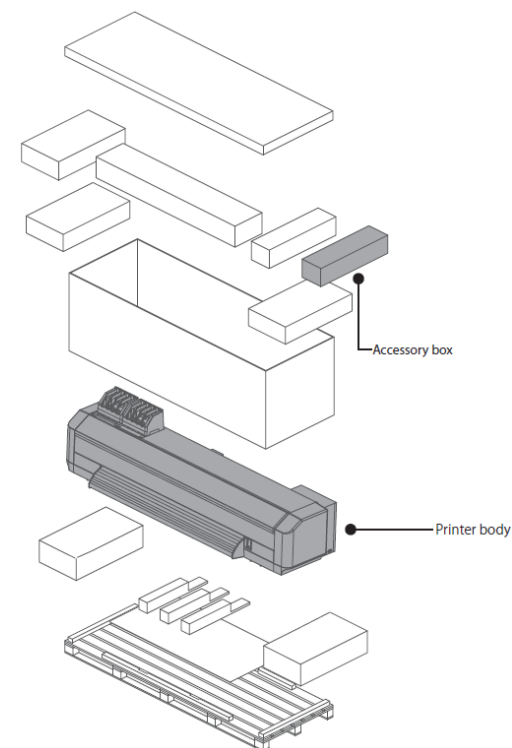

5. Unpacking and Initial Setup

5.2. Unpacking (3/4)

cf. Startup Guide(Rev.01-p.6)

Unpacking

Unpacking the printer

[2] Check that the following items are included.

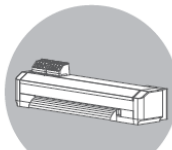

Printer : 1



Startup Guide : Japanese/English (each)

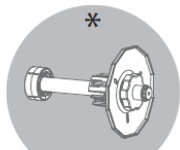

Media flange : 2



Waste ink tank : 1

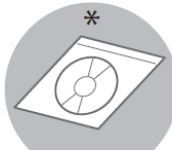

Operation Manual CD : 1



Cable tie : 1

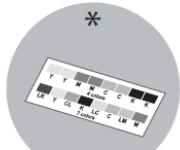

Ink slot label : 1 (XPJ-1682SR)

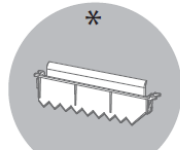

Cleaning wiper : 2

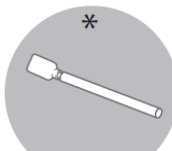

Cleaning stick : 10



Paper towel : 5

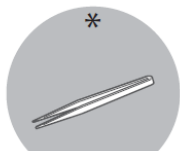

Tweezers : 1

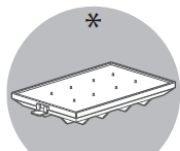

Flushing box sponge : 5

Note

Items marked with an asterisk (*) above are in the accessory box.

cf. Startup Guide(Rev.01-p.7)

Unpacking Stand

[1] Open the packing box and take out the items listed below.

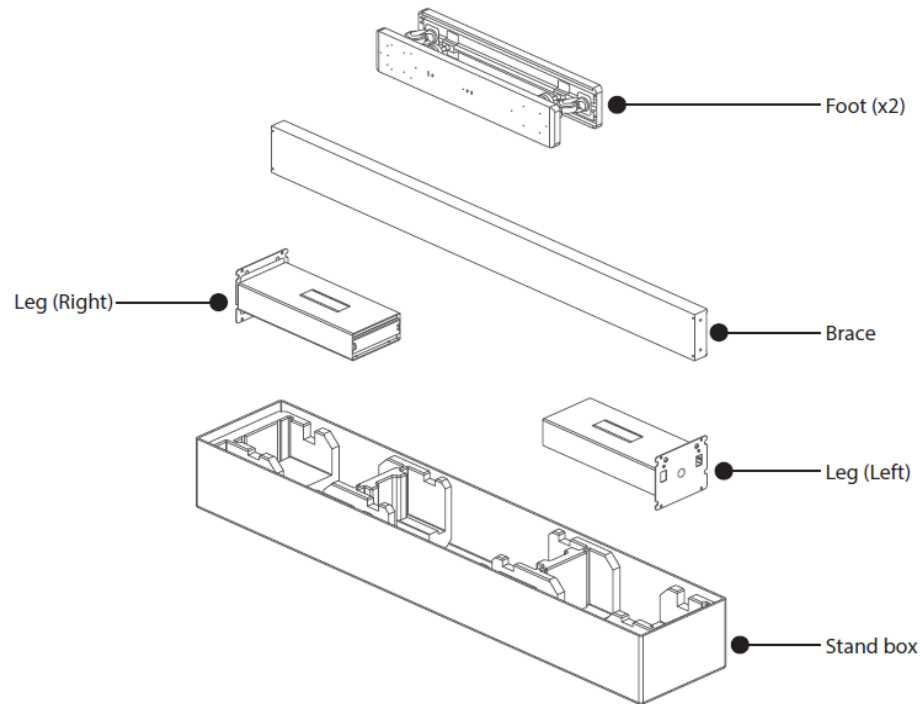

5. Unpacking and Initial Setup

5.2. Unpacking (4/4)

cf. Startup Guide(Rev.01-p.7)

Unpacking

Unpacking Stand

[2] Check that the following items are included.



□ Leg (Left): 1

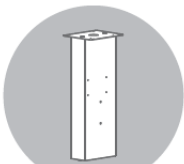

□ Leg (Right): 1

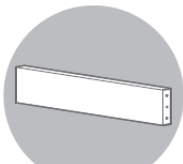

□ Brace: 1



□ Foot: 2



□ Hex head bolt: 8



□ Spring washer: 8



□ Hex wrench: 1



□ Round head screw: 12

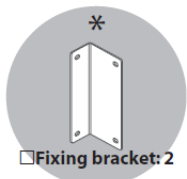

□ Fixing bracket: 2



□ Wing bolt: 8



□ Waste ink tank holder: 1

Note

Items marked with an asterisk (*) above are in the accessory box.

5.3. Assembling (1/4)

cf. Startup Guide(Rev.01-p.8)

Assembling

Assembling Stand

Follow the steps below to assemble the stand.

CAUTION

- Minimum two people are required for assembling the stand.

[1] Attach the left leg and right leg to the brace.

- Face the groove on the brace toward the rear side of the printer and attach it to both legs.
- The leg with two warning labels attached is the right leg.
- Put the spring washers on the hex head screws (4 each), then tighten the screws.

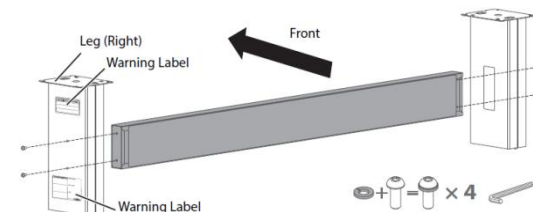

[2] Attach the foot to the leg.

- Face the screw holes on the foot toward the front side of the printer and attach it to the leg.
- Put the spring washers on the hex head screws (4 each), then tighten the screws.
- Use the round head screws (×8) to fix the fixing brackets (×2) on the brace and both legs.

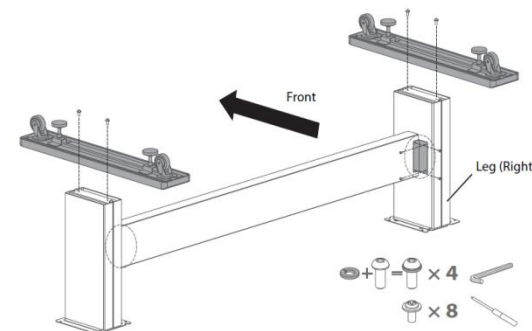

5. Unpacking and Initial Setup

5.3. Assembling (2/4)

cf. Startup Guide(Rev.01-p.9)

Assembling

Assembling Stand

[3] Use the round head screws (×4) to attach the waste ink tank holder to the right leg.

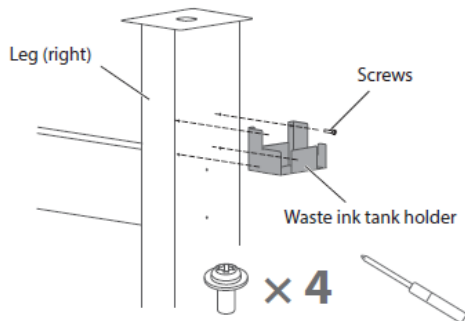

[4] Shake the stand to make sure that each part is firmly attached.

[5] Turn the leveling adjusters (×4) as shown on the left until the stand does not move.

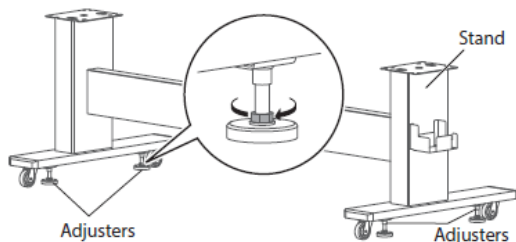

cf. Startup Guide(Rev.01-p.9)

Attaching Printer

Follow the steps below to attach the printer to the stand.

CAUTION

- Minimum four people are required for this process.
- When taking out the product from the packing box, remove the plastic sheet wrapped around the product, then take out the product.

Failure to do so may cause slip and damage to the product.

- Keep the product level while attaching.

[1] Lift the printer with at least four people and mount it on the stand.
 • Use two lifting bars to insert into the guide holes at the bottom left and right of the printer, and lift up on the stand.

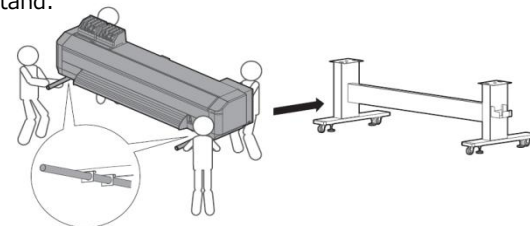

(If you do not have lifting bars) Lift the printer with at least four people and mount it on the stand.

- Use the handholds at the front bottom of the printer.

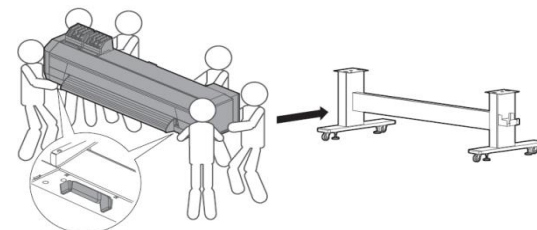

[2] Use the wing bolts (×8) and attach the printer to the stand.

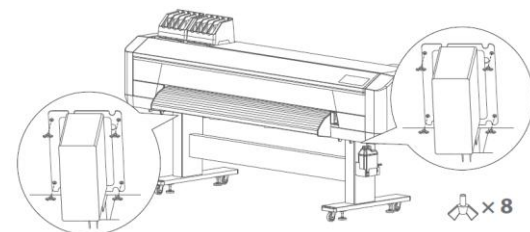

5. Unpacking and Initial Setup

5.3. Assembling (3/4)

cf. Startup Guide(Rev.01-p.10)

Assembling

Removing Packing Materials

Remove packing materials from the product.

- [1] Remove the packing tapes from all the covers.
- [2] (XPJ-1682SR only) Remove two screws each (M3 x 45) to remove two front cover locks.

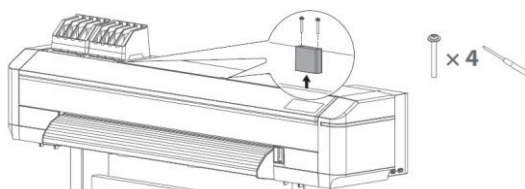

Important!

Make sure to remove two front cover locks before opening the front cover. Otherwise it will cause damage to the cover.

- [3] (XPJ-1682SR only)
 - ①: Open the front cover and remove two screws each (M4x8) to remove two front cover lock plates.
 - ②: Use the screws just removed to fasten to the mounting holes on the printer.

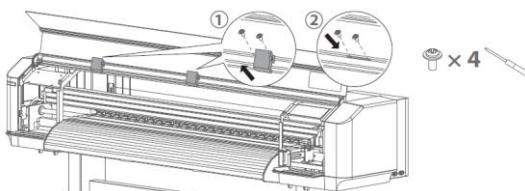

cf. Startup Guide(Rev.01-p.11)

Removing Packing Materials

- [4] Open the front cover. Remove the wing bolt to remove the shipping bracket from the carriage.

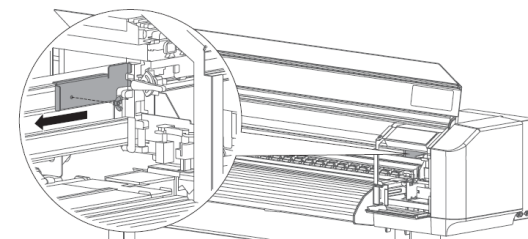

- [5] (XPJ1682SR only) Remove the tape, then remove the packing material from the bottom of the carriage.

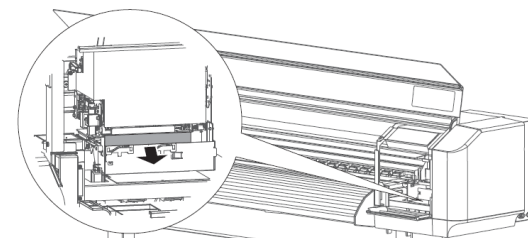

- [6] Remove the tape, and move the edge holders to the left and the right edge.

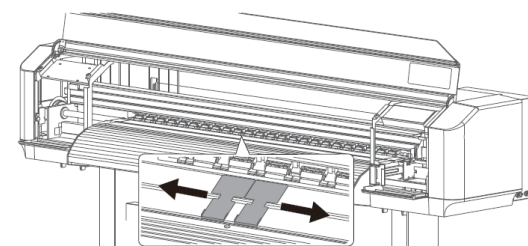

5. Unpacking and Initial Setup

5.3. Assembling (4/4)

cf. Startup Guide(Rev.01-p.12)

Assembling

Attaching Waste Ink Tank

Attach the waste ink tank to the printer.

- [1] Place the waste ink tank on the waste ink tank holder.
- [2] Use the waste ink tank tube to connect the waste ink tank to the printer.
 - Cover up the connector of the tank with the tube.
 - Connect the waste ink sensor cable to the waste ink sensor connector.

Important!

Check that the connector of the tank is fully covered with the tube.
Failure to do so may cause ink spillage.

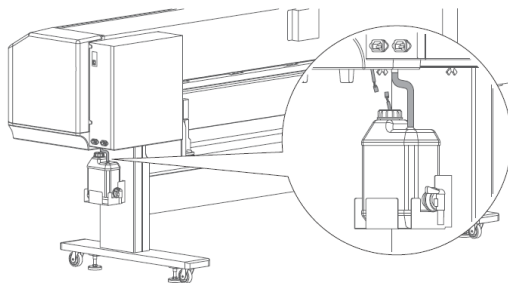

5.4. Connecting Power and Network (1/2)

cf. Startup Guide(Rev.01-p.13)

Connecting Power and Network

Connect Power Cords and Ethernet Cable

Follow the steps below to connect the power cords and Ethernet cable.

- [1] Check that the front cover is closed.

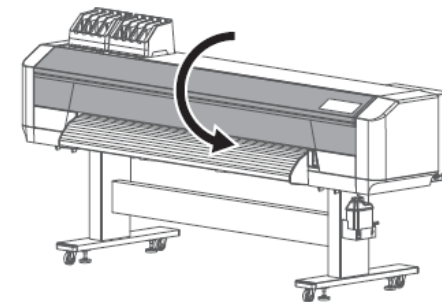

- [2] Connect two power cords and a Ethernet cable to the printer.

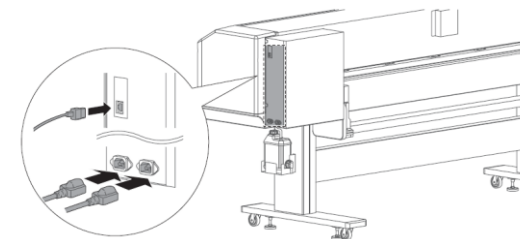

WARNING

Make sure to plug two power cords into the wall outlets with the same voltage.
Failure to do so may cause damage to the electrical circuit.

5. Unpacking and Initial Setup

5.4. Connecting Power and Network (2/2)

cf. Startup Guide(Rev.01-p.14)

Connecting Power and Network

Connect Power Cords and Ethernet Cable

[3] Insert the tip of the cable tie into the hole on the printer to attach it.

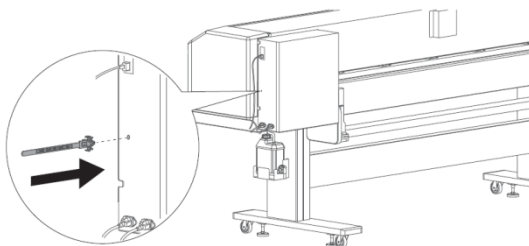

[4] Use the cable tie to secure the Ethernet cable to the printer.

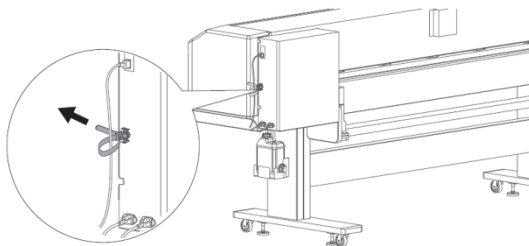

[3] Plug two power cords into the wall outlets respectively.

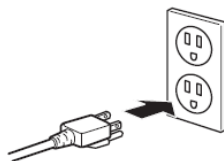

Important!

To plug into one wall outlet with two or more jacks, check that the total current does not exceed the maximum capacity of the wall outlet.

If exceeded, connect one of the two power plugs into another wall outlet.

cf. Startup Guide(Rev.01-p.14)

Connect Power Cords and Ethernet Cable

Important!

Electric shock hazard.

This printer has two power cords.

To unplug from the wall outlet, make sure to unplug both of them.



5. Unpacking and Initial Setup

5.5. Printer Initial Setup (1/7)

cf. Startup Guide(Rev.01-p.15)

Printer Initial Setup

Initial Setup Flow via Startup Wizard

Here is how to get started with your printer.

 Note

Use one of the following methods to run the initial setup.

- Follow the instructions in the Startup Wizard to set up the settings via computer.
- Follow the instructions in this Guide to set up the settings from operation panel.

Install MUTOH Status Monitor to your computer

Install MUTOH Status Monitor (MSM).

Activate the printer

Enter the activation code.

Configure the initial settings

Enter the IP address and configure the initial setup on MSM.

Perform initial ink charging

Install ink bags into the printer and perform ink charging.

Load a roll media for test printing.

Load a roll media for the nozzle check printing.

Run a nozzle check and perform cleaning

Run a nozzle check print and perform cleaning until all nozzles are clear.

Initial setup is now complete!

cf. Startup Guide(Rev.01-p.16)

Powering on - Installing MSM

To run the initial setup through the Startup Wizard on MSM, install MSM on your computer.

Then follow the Startup Wizard to run the initial setup.

 Important!

- **Make sure to install MSM stored in the supplied CD.**

- [1] Check that the front cover is closed.
- [2] Long press the Power button on the front panel.
 - The Power LED (above the Power button) lights up.
 - The printer will start mechanical initialization.

 Note

Once the Power LED lights up, release the Power button.



- [3] Use the Ethernet cable to connect the printer to your computer

- [4] Insert the supplied CD into the CD-ROM drive.

 Note

- The Startup Wizard will start up automatically.
- If the Startup wizard does not automatically start, right click the icon of CDROM drive, open the contents of CD with [Open], and double click MpTotalInst.exe.



- [5] Follow the instructions on the Startup Wizard to setup.
 - When setup is complete, carry out test printing.

 Note

- Please keep the supplied CD at hand. You will need it for reinstallation.
- If lost, you can download from MUTOH Club (user registration is required). (MUTOH Club) <https://club.mutoh.co.jp/mutoh/guser>

5. Unpacking and Initial Setup

5.5. Printer Initial Setup (2/7)

cf. Startup Guide(Rev.01-p.17)

Printer Initial Setup

Initial Setup Flow via Operation Panel

Configure the initial settings

Choose and configure the language, unit of length, temperature, and network setting from the front panel.

Activate the printer

Enter the activation code from the front panel.

Perform initial ink charging

Install ink bags into the printer and perform ink charging.

Load a roll media for test printing.

Load a roll media for the nozzle check printing.

Run a nozzle check and perform cleaning

Run a nozzle check print and perform cleaning until all nozzles are clear.

Connect the printer to your computer

Enter the IP address from the touch panel.
Install MUTOH Status Monitor (MSM) and configure the initial setup on MSM.

Initial setup is now complete!

cf. Startup Guide(Rev.01-p.18)

Step 1 Powering on - Initial settings on the front panel

Power on the printer and configure the initial settings on the front panel.

- [1] Check that the front cover is closed.
- [2] Long press the Power button on the front panel.
 - The Power LED (above the Power button) lights up.
 - The printer will start mechanical initialization.

 **Note**

Once the Power LED lights up, release the Power button.











- [3] **Language :** English Use to select the language. Tap [Enter].

Language : Japanese

- [4] **Temp :** Celsius [°C] Tap [Enter].

- [5] **Length :** mm Tap [Enter].

- [6] **IP Address :** 192. 168. 1. 253 Sets the IP address of the printer.
 -  key: Increase the number.
 -  key: Decrease the number.
 -  key: Move the cursor to the previous digit.
 -  key: Move the cursor to the next digit.
 Tap [Enter] after entering each digit.

- [7] **Subnet Mask :** 255. 255. 255. 0 Sets the subnet mask of the printer.
 -  key: Increase the number.
 -  key: Decrease the number.
 -  key: Move the cursor to the previous digit.
 -  key: Move the cursor to the next digit.
 Tap [Enter] after entering each digit.

5. Unpacking and Initial Setup

5.5. Printer Initial Setup (3/7)

cf. Startup Guide(Rev.01-p.19)

Printer Initial Setup

Step 1 Powering on - Initial settings on the front panel

- [8] **Gateway :** Sets the gateway.
 192. 168. 1. 254
- ▲ key: Increase the number
 - ▼ key: Decrease the number.
 - ◀ key: Move the cursor to the previous digit.
 - ▶ key: Move the cursor to the next digit.
- Tap [Enter] after entering each digit.

- [9] **Initializing** The printer will start mechanical initialization.

Step 2 Activation

Follow the steps below to perform activation.

Activation required

When the message on the left appears, use one of the following methods to activate the printer.

- "Activation through the front panel"
- "Activation through Internet"

Note

While "Activation required" is displayed, you can return the initial setting flow (e.g. IP Address etc.) by tapping [Home] key.

cf. Startup Guide(Rev.01-p.20)

Step 2 Activation

Activation through the front panel

- [1] **Activation required** When the message on the left appears, tap [Enter].
- [2] **0000-0000-0000-0000** Enter the 16-digit activation code.
- ▲ key: Increase the number.
 - ▼ key: Decrease the number.
 - ◀ key: Move the cursor to the previous digit.
 - ▶ key: Move the cursor to the next digit.
- Tap [Enter] after entering each digit.

Note

To obtain the activation code, please contact your local MUTOH dealer to send it by email.

- [3] **Activation Succeeded**
Reboot Printer
- When the message on the left appears, long press the Power button to power off the printer.
- When the message "Power Off" appears on the panel, release the Power button.
- Wait for a few seconds and long press the Power button to reboot the printer.

Activation through Internet

Activation required

When the message on the left appears on the front panel, follow the instructions on the Printer Activation Guide to activate the printer.

Note

To obtain the activation code and the Printer Activation Guide, access to MUTOH Club from the following URL and click "Register" to complete the user registration.

<https://club.mutoh.co.jp/mutoh/guser/>

5. Unpacking and Initial Setup

5.5. Printer Initial Setup (4/7)

cf. Startup Guide(Rev.01-p.21)

Printer Initial Setup

Step 3 Installing the cleaning wiper

Before performing the initial ink charging, the cleaning wiper must be installed on the printer.

- [1]  The message on the left appears on the front panel.

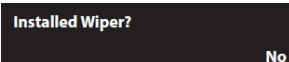

• Tap [Enter].
The message on the left appears.

- [2]  Open the front cover.

- [3]  Open the right side of the maintenance cover.

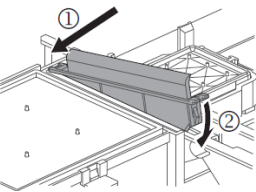
- [4]  Install the cleaning wiper as follows:
• Insert the back side of the cleaning wiper.
• Then insert the front side of the cleaning wiper until it clicks into place.

 Important!

DO NOT touch the rubber on the cleaning wiper with your bare hands.

Skin oil may cause the damage to the print head.

- [5] Close the maintenance cover.

- [6] Close the front cover.

cf. Startup Guide(Rev.01-p.21)

Step 3 Installing the cleaning wiper

- [7]  • Use  or  to choose "Installed Wiper? Yes".
• Tap [Enter].

Step 4 Initial Cleaning - Initial Ink Charging

Follow the steps below to perform initial cleaning and initial ink charging.

Items Required (XPJ-1641SR):

- Cleaning bag: ×4
- Ink bag: ×4 (Black ×1, Cyan ×1, Magenta ×1, Yellow ×1)
- Ink bag case: ×4

Items Required (XPJ-1682SR):

- Cleaning bag: ×8
- Ink bag: ×8
- 4-color setting: Black ×2, Cyan ×2, Magenta ×2, Yellow ×2
- 7-color setting: Black, Cyan, Magenta, Yellow, Light Cyan, Light Magenta, Light Black, Cleaning Bag
- Ink bag case: ×8

1. Perform initial cleaning (1/3)

- [1]  When the message on the left appears, tap [Enter].

 Note

While "Ink Charge Start -> Enter" is displayed, you can return the initial setting flow (e.g. IP Address etc.) by tapping [Home] key.

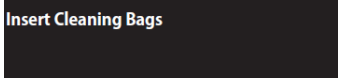
 The message on the left will appear.

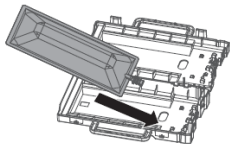
- [2]  Open the ink bag case to put the cleaning bag into the case.

5. Unpacking and Initial Setup

5.5. Printer Initial Setup (5/7)

cf. Startup Guide(Rev.01-p.22)

Printer Initial Setup

Step 4 Initial Cleaning - Initial Ink Charging

1. Perform initial cleaning (2/3)

[3]

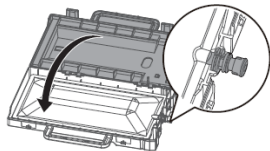

Close the case.

Important!

Make sure that the spout of cleaning bag is properly fitted into the groove in the case. If not fitted, the printer cannot correctly detect the cleaning bag.

Close the latches (x4) of the case properly.

Important!

Check that all the latches (x4) are closed. If not, it may cause cleaner spillage.

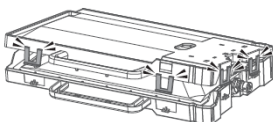

[4] Insert the ink bag cases with cleaning bags and S/C cards into each slot.

- Face the latch side towards you and insert the case into the slot.
- Make sure that they are fully inserted.

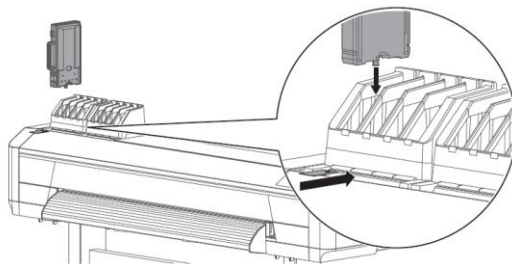

Washing Head

The printer starts filling cleaner.

Remove Bags

When the cleaner filling is complete, the message on the left will appear.

cf. Startup Guide(Rev.01-p.24)

Step 4 Initial Cleaning - Initial Ink Charging

1. Perform initial cleaning (3/3)

- [5] Remove the ink bag cases and S/C cards from the slots.
- Store the cleaning bag together with the corresponding S/C card.

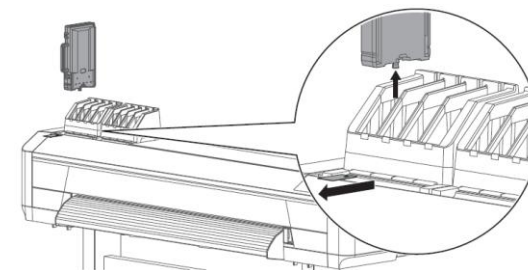

Washing Head

The printer starts discharging cleaner.

2. Perform initial ink charging (1/4)

[1] Wash Retry?

Yes

• To finish initial cleaning, use or to choose "Wash Retry? No".

• Tap [Enter].

Wash Retry?

No

Note

To perform cleaning again, choose "Wash Retry? Yes".

Insert Ink Bags

The message on the left will appear.

[2]

3 sec.

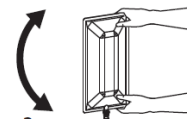

3 sec.



Prepare the new ink bag and follow the instructions below to invert it to mix the ink.

- Face the ink spout side upwards for 3 seconds.
- Invert it and count for 3 seconds.
- Repeat 3 times.

5. Unpacking and Initial Setup



5.5. Printer Initial Setup (6/7)

cf. Startup Guide(Rev.01-p.25)

Printer Initial Setup

Step 4 Initial Cleaning - Initial Ink Charging

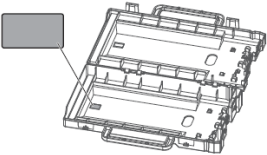
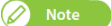
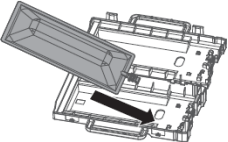
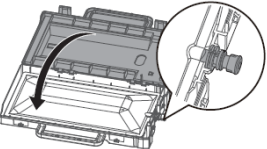
2. Perform initial ink charging (2/4)

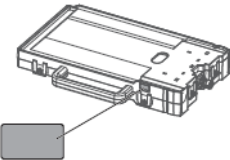
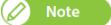
- [3]  Open an ink case and apply an ink color label onto the inside of the case.
-  **Note**
- The ink color label is supplied with the ink case.
 - The label should be applied onto the glossy surface of the case.
- [4]  Open the ink bag case to put the ink bag into the case.
- [5]  Close the case.
-  **Important!**
- Check that the spout of ink bag is properly fitted into the groove in the case.**
If not fitted, the printer cannot correctly detect the ink bag.
- Close the latches (×4) of the case properly.
-  **Important!**
- Check that all the latches (×4) are closed.**
If not, it may cause ink spillage.
- [6]  Apply an ink color label onto the outside of the case.
-  **Note**
- The label should be applied onto the glossy surface of the case.
 - Make sure to match the color of the label with the one applied onto the inside of the case.

cf. Startup Guide(Rev.01-p.26)

Step 4 Initial Cleaning - Initial Ink Charging

2. Perform initial ink charging (3/4)

- [7] (XPJ-1682SR only) Depending on the ink configuration you will use, apply an appropriate ink slot label to the recess on each ink slot.
- The label placement location and order of ink colors from left to right are shown in the illustration below.

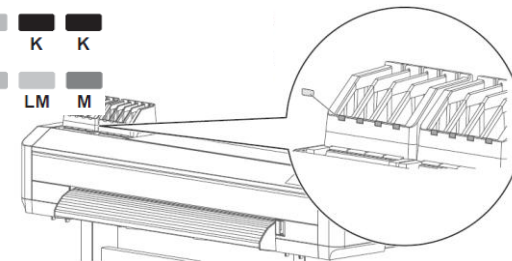
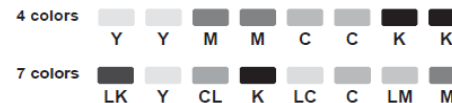

 **Important!**

- The ink slot label is supplied with the printer box.
 - Make sure to apply with the correct order of ink colors.
- [8] Insert the ink bag cases and S/C cards into each slot.
- Make sure to match the colored label on the ink slot and the colored label on the ink bag.
 - Face the latch side towards you and insert the case into the slot.
 - Make sure that they are fully inserted.

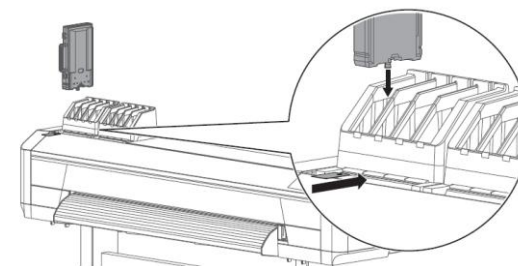

- The message on the left appears.
- The printer starts the initial ink charging.

5. Unpacking and Initial Setup

5.5. Printer Initial Setup (7/7)

cf. Startup Guide(Rev.01-p.27)

Printer Initial Setup

Step 4 Initial Cleaning - Initial Ink Charging

2. Perform initial ink charging (4/4)

⚠ CAUTION

DO NOT attempt the following actions during ink charging:

- Power off the printer.
- Disconnect the power cord.
- Open the front cover.
- Open the maintenance cover.
- Release the pressure rollers.



Once the ink has been filled, the message on the left will appear on the panel.

- The ink charging is complete.

5.6. Test Printing (1/5)

cf. Startup Guide(Rev.01-p.28)

Test printing

Load a roll media into the printer

Follow the steps below to load a media into the printer.

⚠ Important!

Depending on the size of media, two or more people are required.

Items Required:

- Roll media
- Media flange: ×2

1. Attach flanges to the media

[1] (If you are using 2-inch core roll media), remove the 3-inch adapter from the media flange.

- ①: Pull two tabs on the adapter outward, then remove it from the flange.
- ②: Pull three tabs on the adapter outward, then remove it from the flange.

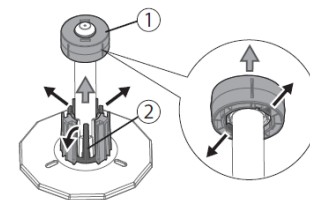

📌 Note

- If • adaptor cannot be removed, turn the handle on the flange anti-clockwise to loose (see Step 2), then remove it.
- If you are using 3-inch core roll media, skip this step.

[2] Push the media flange (×2) into the both ends of the media core.

- Before inserting, twist the handle on the flange anticlockwise to unlock it.

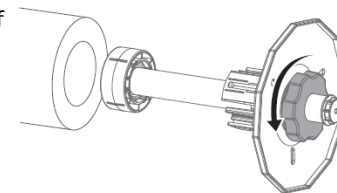

[3] Twist the handle clockwise to lock the flange.

⚠ Important!

Check that the flange is firmly locked.
If not, the media can be removed from the flanges, affecting the print quality.

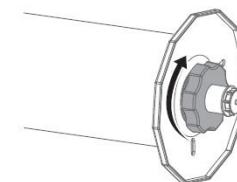

5. Unpacking and Initial Setup

5.6. Test Printing (2/5)

cf. Startup Guide(Rev.01-p.29)

Test printing

Load a roll media into the printer

2. Enable torque on media holders (1/2)

If you want to apply torque to the media holders, follow the steps below.

- [1] Twist the knob bolt on the right side of the media holder anticlockwise to loosen.

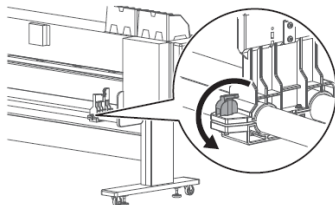

- [2] Twist the knob bolt on the left side of the media holder anticlockwise to loosen.

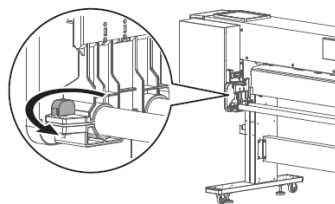

- [3] Slide both left and right media holders about 30 cm towards the center of the slider for easy access.

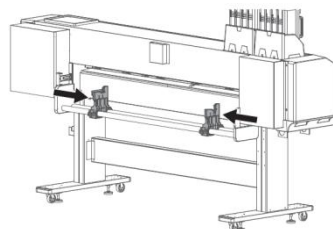

- [4] Tighten the knob bolts on both media holders.

cf. Startup Guide(Rev.01-p.30)

Load a roll media into the printer

2. Enable torque on media holders (2/2)

- [5] (When looking from the rear side of the printer) Use the screwdriver to loosen two screws securing the roller shaft guide plate to the right media holder.

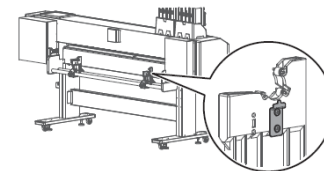

- [6] Slide up the roller shaft guide plate as far as it will go and tighten the screws.

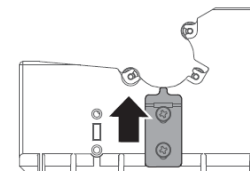

- [7] Do the same for the left media holder to slide up the roller shaft guide plate as far as it will go and tighten the screws.

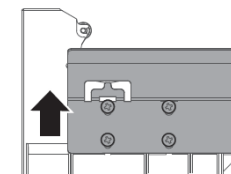

Note

The shape, number of screws, and mounting location differ between left and right guide plates.

- [8] Loosen the knob bolts and slide back both media holders to the original position.
- [9] Tighten the knob bolts.

3. Place the media onto the media holder (1/3)

- [1] Twist the knob bolt on the right side of the media holder anticlockwise to loosen.

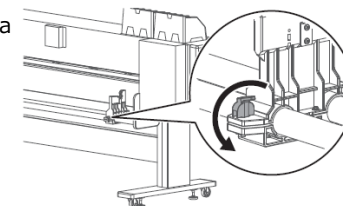

5. Unpacking and Initial Setup

5.6. Test Printing (3/5)

cf. Startup Guide(Rev.01-p.30)

Test printing

Load a roll media into the printer

3. Place the media onto the media holder (2/3)

[2] Place the roll media onto the left media holder.

Carefully and gently place it on the holder.

(If torque is enabled)

- ①: When looking from the left side, check that the protrusion on the roller shaft guide plate is fitted into between two protrusions on the flange end cap.
- ②: When looking from the rear side of the printer, check that the flange end cap is properly placed on the protrusion on the roller shaft guide plate.

Important!

Do not drop or apply excessive impact while placing the media. This will cause damage to the part.

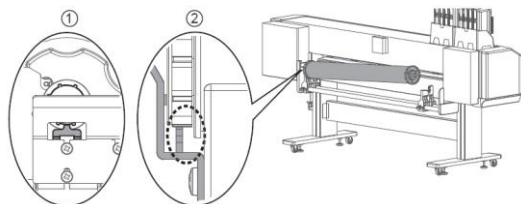

(If torque is disabled)

- Check that the stopper on the shaft is fitted into the slit as shown in the illustration (not on the media holder).

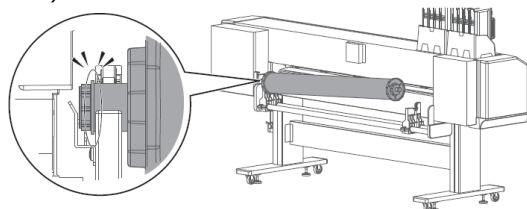

Important!

When you adjust the position of the media holder (left), do not move it more than 450 mm away from the left-hand end.

The printer will not be able to detect media.

cf. Startup Guide(Rev.01-p.31)

Load a roll media into the printer

3. Place the media onto the media holder (3/3)

[3] Slide the right side of the media holder to place the right side of the flange onto the holder.

Place the roll media onto the right media holder.

Carefully and gently place it on the holder.

(If torque is enabled)

- ①: When looking from the right side, check that the protrusion on the roller shaft guide plate is fitted into between two protrusions on the flange end cap.
- ②: When looking from the rear side of the printer, check that there is a gap between the protrusion on the roller shaft guide plate and stopper on the shaft.

Important!

- Do not drop or apply excessive impact while placing the media. This will cause damage to the part.
- If the stopper gets contact with the guide plate as "No Good" example below, it may cause damage to the part.

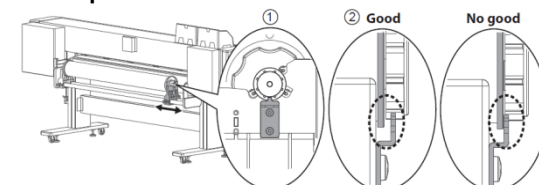

(If torque is disabled)

- Check that the stopper on the shaft is fitted into the slit as shown in the illustration (not on the media holder).

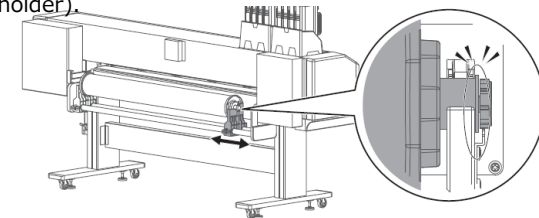

[4] Twist the knob bolt on the right side of the media holder clockwise to tighten.

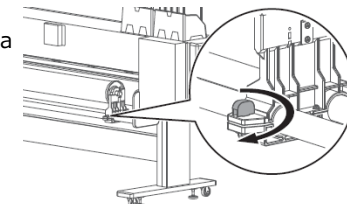

5. Unpacking and Initial Setup

5.6. Test Printing (4/5)

cf. Startup Guide(Rev.01-p.32)

Test printing

Load a roll media into the printer

4. Load the media into the printer (1/2)

- [1] Check that the printer is powered on.
- [2] From the front side of the printer, fully pull the media feed lever towards you to release the pressure rollers.

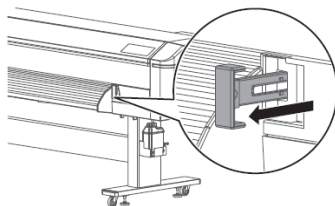

You can access to the media feed lever from the rear side of the printer.

- To release the pressure rollers, push the lever as far as it goes.

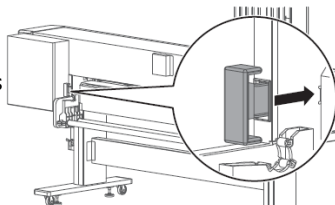

- [3] Open the front cover.

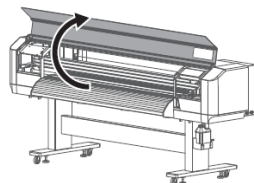

- [4] From the rear side of the printer, insert the front edge of the media into the media slot.

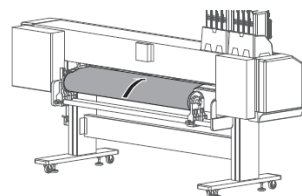

Note

Before inserting, rewind the media properly.

cf. Startup Guide(Rev.01-p.33)

Load a roll media into the printer

4. Load the media into the printer (2/2)

- [5] From the front side of the printer, pull the media for approximately 1m.

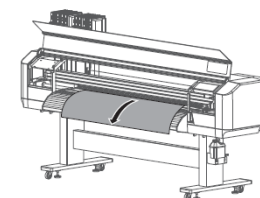

- [6] While one person holds the front edge of the media, the other person turns the flange to slightly rewind the media onto the roll to remove warp or skew.

Note

If you remove your hands from the front edge of the media while rewinding, the media can be removed from the media slot.

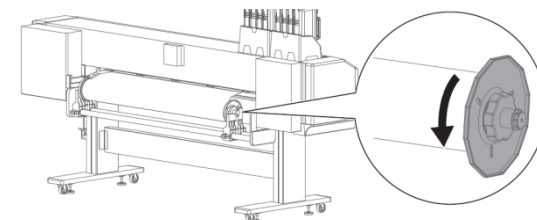

- [7] Check that the right-hand edge of the media is located at the left side of the media guide line.

If not, print quality can be affected.

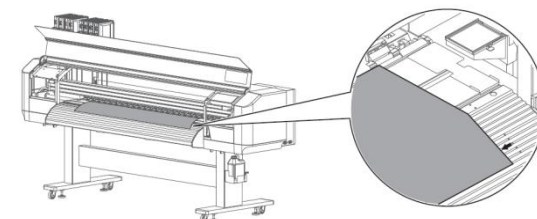

- [8] If needed, use a slide lock lever on the pressure rollers to individually cancel or reduce the pressure.

5. Unpacking and Initial Setup

5.6. Test Printing (5/5)

cf. Startup Guide(Rev.01-p.34)

Test printing

Load a roll media into the printer

5. After loading the media... (1/2)

- [1] From the front side of the printer, push the media feed lever to hold the media flat with pressure rollers.

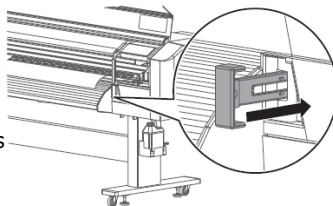

Note

Using this lever, the pressure applied to the rollers can be changed between High and Normal.

Normally push the lever until it clicks to apply normal pressure.

- [2] Check that the pressure rollers hold down the both edges of the media properly.

- If it holds as a "No Good" example, pull the media feed lever towards you as much as possible, then adjust the position of the left or right side of the media holder until the both edges of the media are held down properly

(see "Place the media onto the media holder" for more details).

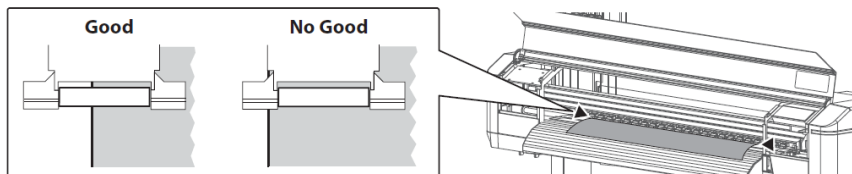

- [3] Place the edge holders on both edges of the media.

Important!

In the default setting, the printer starts printing with 5 mm margin on the sides.

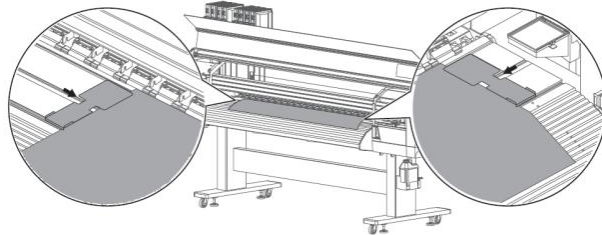

cf. Startup Guide(Rev.01-p.34)

Load a roll media into the printer

5. After loading the media... (2/2)

- [4] Tap [Home].



- [5] Tap .



- [6] Tap until the menu on the left appears.



• Tap .

- [7] Side Margin : 10 mm
(5 - 25)
- Set the side margin to 10 mm minimum.
- Use or to choose the alignment method.
 - Tap [Enter].

Note

- The side margin can be set between 5mm and 25mm.

- [8] Close the front cover.

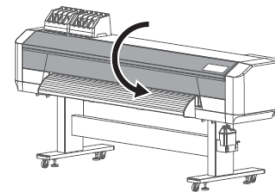

- [9] User: Type 1 OK?
- "User: Type** OK?" appears on the front panel.
- Use or to choose the correct user type and tap [Enter] to start media initialization.

End the media loading.

5. Unpacking and Initial Setup

5.7. Nozzle check and cleaning (1/1)

cf. Startup Guide(Rev.01-p.36)

Nozzle Check and Cleaning

Nozzle Check and Cleaning

Run a nozzle check print. If nozzle missing is found, perform cleaning.

1. Run a nozzle check print (1/2)

[1] Load a roll media for Nozzle check.

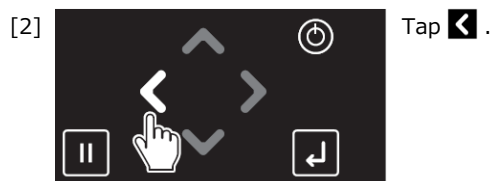

[3]  Tap [Enter].
 • The printer will print the nozzle check pattern.

[4] Look at the print.
 • If you find missing or thin lines on the print, go to "Perform cleaning"
 • If all lines are clearly printed, you can start printing.

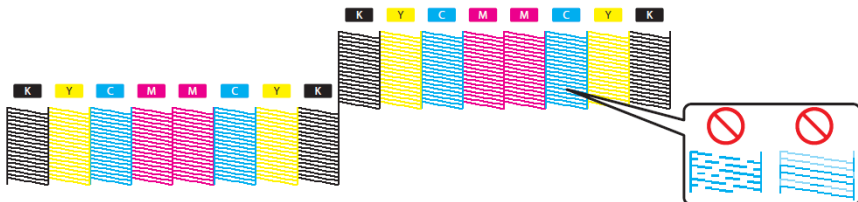

 Note

- The pattern shown above is an example when printed on XPJ-1682SR with 4-color configuration.
- Printer information (Data and time printed, serial number, firmware version) is printed next to the pattern.

cf. Startup Guide(Rev.01-p.36)

Nozzle Check and Cleaning

1. Run a nozzle check print (2/2)

 Important!

If you run a nozzle check print immediately after the initial ink charging, the following symptoms may occur:

- lines are faded.
- patterns are partially missing.

In such cases, follow the instructions on the operation manual "Menu 3: Cleaning" to perform "Little Charge"

If it does not help to solve the problem, leave the printer for one hour or more, then perform cleaning or "Little Charge" again.

2. Perform cleaning

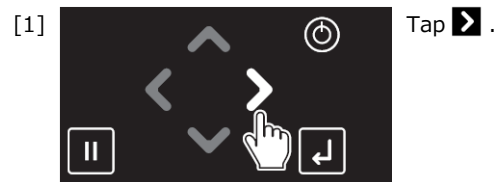

[2]  Use  or  to choose the cleaning mode.
 Tap [Enter].
 • The printer will start cleaning.

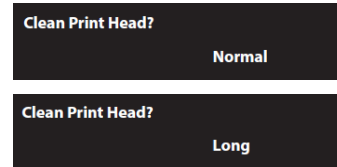

[3] Run a nozzle check print again.
 • If the problem persists, repeat normal cleaning until all nozzles are clear.

5. Unpacking and Initial Setup

5.8. Setting the Printing Precision (1/13)

cf. Operation Manual(Rev.01-p.33)

Calibrating your printer

Head alignment (XPJ-1682SR Only)

Before printing an image on your printer for the first time, follow these steps to calibrate your printer to ensure accurate print quality.

You can print out the adjustment pattern in this menu to check the misalignment of the print head, and then adjust it.

You can choose one of the following methods:

Note

- If you experience following problems, the head alignment can help to improve print quality:
 - Suffering from poor print quality in unidirectional printing mode.
 - Print quality does not improve even after performing print quality adjustment
- After you have performed head adjustment, make sure you perform print quality calibration.
 - There may be misalignment caused by head adjustment.
- If you change the print mode after performing the Standard head alignment, you need to perform the head alignment for the print mode chosen.
- Since all print modes are adjusted at once after performing Custom head adjustment, head adjustment is not required even after changing the print mode.
- When specifying a print mode for RIP software, etc, that is different from the mode set in the user type setting, perform Custom head adjustment and check all patterns (A to F), and then adjust any patterns that are misaligned beforehand.
- If print defects (like banding or grainy look) still appear on the print, try an auto calibration again, or go to "Adjust Print1/ Standard" or "Adjust Print2/ Custom" to perform calibration.
- If a roll media starts to cockle during calibration, load the media again.

cf. Operation Manual(Rev.01-p.34)

Head alignment (XPJ-1682SR Only)

Head alignment steps

[1] Turn the printer ON and load a roll media.

[2] Tap [Home].



[3] Tap until the menu on the left appears.
• Tap [Enter].



[4] Tap until the menu on the left appears.
• Tap .



[5] Use or to choose the alignment method.
• Tap [Enter].

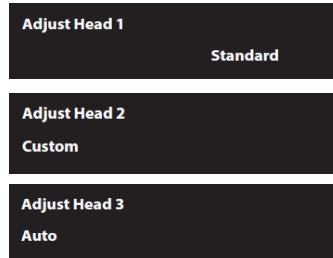

[6] The printer will print the confirmation pattern.

[7] Follow the steps below to align the two print heads.
→ "Standard or Custom Adjustment Methods"
→ "Auto Adjustment Method"

5. Unpacking and Initial Setup

5.8. Setting the Printing Precision (2/13)

cf. Operation Manual(Rev.01-p.95)

Calibrating your printer

Head alignment (XPJ-1682SR Only)

Test Print 5
Adjust Head

This menu calibrates the dot placement between two print heads installed on XPJ-1682SR.

Tap  to open the submenu.

Align the heads in the following cases:

- If the image quality does not improve after you have used the "Adjust Print" menu.
- When switching to thin media or a type of media where ink drops do not spread.

After executing this menu, be sure to perform the "Adjust Print" function.

If you don't, the image quality during bidirectional printing may drop.

Submenus

Adjust Head 1
Standard

Adjustment is performed only for the print mode set by the current User Type.

You can make the adjustments more quickly than by selecting "Fine Pattern ALL" in "Custom".

When selecting "Standard" here, you need to use the same print mode settings for the RIP (Raster Image Processor) as the print mode settings for the User Type.

Use the same settings for the resolution, pass and printing direction in the RIP print mode as in the print mode for the User Type.

Adjust Head 2
Custom

You can also adjust a print mode other than the one used for the current User Type.

You can print with an optimal image quality even if the RIP print mode is different from the print mode used for the User Type.

Adjust Head 3
Auto

Perform the automatic adjustment using the embedded color sensor.

It helps to reduce time and increase the alignment accuracy.

 Note

- If print defects (like banding or grainy look) still appear on the print, try an auto calibration again, or go to "Adjust Print1/ Standard" or "Adjust Print2/ Custom" to perform calibration.
- If a roll media starts to cockle during calibration, load the media again.

cf. Operation Manual(Rev.01-p.96)

Head alignment (XPJ-1682SR Only)

When "Adjust Head 2 Custom" is selected

Adjust Head 2
Custom

You can select the adjustment method
Tap  to open the submenu.

If the resolution, pass and the printing direction of the RIP print mode differ from the print mode for the User Type, select the fine pattern that is suitable for the RIP.

Submenus

Custom 1
Fine Pattern ALL

Adjusts all the patterns.

Custom 2
Fine Pattern A

For printing an adjust pattern selected from A to F.

⋮

Custom 7
Fine Pattern F

Standard or Custom Adjustment Methods

1. Print the Head adjustment pattern and look for a place in the pattern that has least white lines or overlapping images.
 - If you selected "Adjust Head 2: Custom", select "ALL" or "A" to "F".
 - The number printed under the pattern without alignment errors is the adjustment value.

2. Enter the adjustment value.

 Note

- Warm up the heater before printing the Adjustment pattern.
"Skip Heater Warm Up? No" is displayed on the front panel.
- You can start printing while the printer is warming up.

 **CAUTION**

While "Warming Up" is displayed, do not touch Media guide.

You could burn yourself.

5. Unpacking and Initial Setup



5.8. Setting the Printing Precision (3/13)

cf. Operation Manual(Rev.01-p.97)

Calibrating your printer

Head alignment (XPJ-1682SR Only)

Head adjustment pattern

- Press the [Enter] key to carry out printing.
For the Head adjustment pattern, the same patterns will be printed on both sides and center of the media.
- Check the print results and select the number that looks most aligned between 1 and 7.
- Pattern names such as "Pattern B: 4" are shown on the display.
- Use the / key to enter the number of the bestadjusted pattern, and press the [Enter] key.
- In the case of the picture below, enter "5", so that the display reads "Pattern B: 5".
- If you selected "Head Adj. 2: Custom" and "Fine Pattern ALL", enter the adjustment value for A to F.

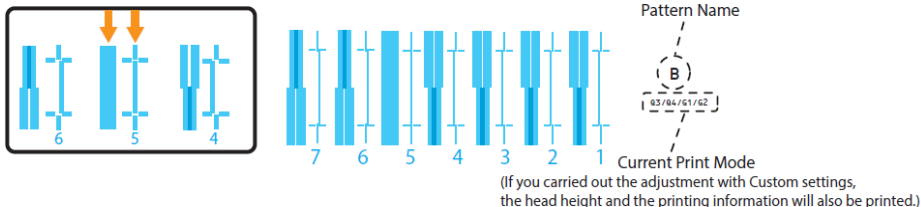

cf. Operation Manual(Rev.01-p.97)

Head alignment (XPJ-1682SR Only)

When "Adjust Head 3 Auto" is selected

Adjust Head 3
Auto

You can select the adjustment method.
Tap  to open the submenu.

Perform the automatic adjustment using the embedded color sensor.
If the resolution, pass and the printing direction of the RIP print mode differ from the print mode for the User Type, select the fine pattern that is suitable for the RIP.

Submenus

**Auto1

ALL

Perform automatic adjustment for all patterns (A to F) using the color sensor.

**Auto2

Standard

Perform automatic adjustment for the currently selected print mode using the color sensor (calibrate the same print mode as "Adjust Head1 Standard").

Auto 3

Adjust Pattern A

Choose the adjustment pattern between A and F for automatic adjustment.

⋮

Auto 8

Adjust Pattern F

5. Unpacking and Initial Setup

5.8. Setting the Printing Precision (4/13)

cf. Operation Manual(Rev.01-p.98)

Calibrating your printer

Head alignment (XPJ-1682SR Only)

Auto Adjustment Method

1. Select the adjustment pattern from "ALL", "Standard", or any specific pattern between "Adjust Pattern A" and "Adjust Pattern F".
 - The selected adjustment pattern is printed.
 - The printer scans the print using the embedded color sensor, then automatically corrects the dot placement.
2. Once successfully completed, the message "Auto Adjust Succeeded End->Enter" will appear on the panel.
 - If failed, the message "Auto Adjust Failed End -> Enter" will appear on the panel. Tap [Enter] to end the adjustment.
 - Try Auto Adjust again or perform Standard or Custom adjustment.
3. Tap [Enter] to exit the menu.

Note

- If failed in the middle of the calibration, the adjustment value for the pattern which has been successfully calibrated will be saved in the printer, but the adjustment value for the pattern which has been failed to calibrate or has not been calibrated yet will not be saved in the printer.
- Warm up the heater before printing the Adjustment pattern. "Skip Heater Warm Up? No" is displayed on the front panel.
- You can start printing while the printer is warming up.
- If print defects (like banding or grainy look) still appear on the print, try an auto calibration again, or go to "Adjust Print1/ Standard" or "Adjust Print2/ Custom" to perform calibration.
- If a roll media starts to cockle during calibration, load the media again.

CAUTION

While "Warming Up" is displayed, do not touch Media guide.

You could burn yourself.

cf. Operation Manual(Rev.01-p.35)

Print quality calibration

Before printing an image on your printer for the first time, follow these steps to calibrate your printer to ensure accurate print quality.

This menu calibrates the dot placement of bidirectional printing. Print the alignment pattern to see if dot placement is perfectly aligned.

If misaligned, enter the alignment value to correct the accuracy of dot placement.

Note

- If you are suffering from print quality defects after changing installation site or a roll media loaded on the printer, perform the print quality calibration.
- If you change the user type after performing the Standard calibration, you need to perform the print quality calibration for the print mode chosen.
- Since all print modes are adjusted at once after performing Custom adjust print, adjust print is not required even after changing the print mode.

When specifying a print mode for RIP software, etc, that is different from the mode set in the user type setting, perform Custom head adjustment and check all patterns (A to F), and then adjust any patterns that are misaligned beforehand.
- If you experience following problems, the head alignment can help to improve print quality:
 - Print quality is poor when using the uni-direction print mode.
 - Print quality does not improve by print quality calibration.
- After you have performed head adjustment, make sure you perform print quality adjustment.

There may be misalignment caused by head adjustment.

5. Unpacking and Initial Setup

5.8. Setting the Printing Precision (5/13)

cf. Operation Manual(Rev.01-p.36)

Calibrating your printer

Print quality calibration

Print quality calibration steps (1/2)

[1] Turn the printer ON and load a roll media.

[2] Tap [Home].



[3] Tap [Setup].



[4] Tap [User Type].



[5] Use or to choose the user type you want to use.
 • Tap [Enter].



[6] Tap until the menu on the left appears.
 • Tap [Right Arrow].



[7] Enter the thickness of the media.
 • Use or to specify the thickness.
 • Tap [Enter].



cf. Operation Manual(Rev.01-p.37)

Print quality calibration

Print quality calibration steps (2/2)

[8] Use or to choose the calibration method.
 • Tap [Right Arrow].

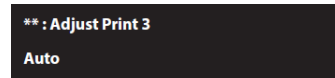
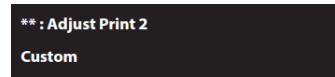
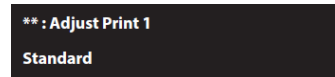

Note

- In Standard print quality adjustment and Custom print quality adjustment, the names in the available patterns are different.
- For a pre-adjustment check, select "Confirm Pattern."
 Check the printing results in "Confirm Pattern.",
 - To adjust large misalignment, select "Rough Pattern".
 - To adjust small misalignment, select "Fine Pattern".
- [9] Follow the steps below and adjust the print quality.
 → "Standard or Custom Adjustment Methods"
 → "Auto Adjustment Method"

5. Unpacking and Initial Setup

5.8. Setting the Printing Precision (6/13)

cf. Operation Manual(Rev.01-p.63)

Calibrating your printer

Print quality calibration

Type **:2
Adjust Print

Sets up when adjusting the printer for the optimum quality of image print.

Before adjusting this setting, enter the thickness of the media.

Submenus

** : Adjust Print 1
Standard

Adjusts only the print mode in the user type setting which is currently set.

** : Adjust Print 2
Custom

Adjusts the print modes other than the mode in the user type setting which is currently set.

** : Adjust Print 3
Auto

Perform an automatic calibration that the printer automatically prints and scans a pattern with the embedded color sensor to correct dot placement.

Adjust Print 1: Standard

** : Adjust Print 1
Standard

Adjusts only the print mode in the user type setting which is currently set.

- "Confirm pattern"
- "Rough adjustment pattern"
- "Fine adjustment pattern"

Submenus

** : Standard 1
Confirm Pattern

Print the test pattern for the adjustment. Check before adjusting.

** : Standard 2
Rough Pattern

Perform this to adjust large misalignment. Print Adjust pattern and enter the set value.

** : Standard 3
Fine Pattern

Perform this to adjust small misalignment. Print Adjust pattern and enter the set value.

cf. Operation Manual(Rev.01-p.64)

Print quality calibration

Adjust Print 2: Custom

** : Adjust Print 2
Custom

- Perform adjustment for all patterns (A to F).
- "Confirm pattern"
 - "Rough adjustment pattern"
 - "Fine adjustment pattern"

Submenus

** : Custom 1
Confirm Pattern

The test patterns of A to F will be printed for Adjust print. Check before adjusting.

** : Custom 2
Rough Pattern ALL

For printing all rough adjustment patterns from A to F.

** : Custom 3
Rough Pattern A

For printing an adjust pattern selected from A to F.

⋮

** : Custom 8
Rough Pattern F

** : Custom 9
Fine Pattern ALL

For printing all fine adjustment patterns from A to F.

** : Custom 10
Fine Pattern A

For printing an adjust pattern selected from A to F.

⋮

** : Custom 15
Fine Pattern F

5. Unpacking and Initial Setup

5.8. Setting the Printing Precision (7/13)

cf. Operation Manual(Rev.01-p.64)

Calibrating your printer

Print quality calibration

Adjust Print 3: Auto

**** : Adjust Print 3**
Auto Perform the automatic adjustment using the embedded color sensor.

Submenus

**** : Auto1** ALL Perform automatic adjustment for all patterns (A to F) using the color sensor.

**** : Auto2** Standard Perform automatic adjustment for the currently selected print mode using the color sensor (calibrate the same print mode as "Adjust Print 1 Standard").

**** : Auto 1** Adjust Pattern A Choose the adjustment pattern between A and F for automatic adjustment.

**** : Auto 6** Adjust Pattern F

cf. Operation Manual(Rev.01-p.65)

Print quality calibration

Adjustment patterns for each print mode (XPJ-1641SR)

| Print mode | Print mode specifications | Adjustment pattern |
|------------|------------------------------|--------------------|
| Quality 1 | 1440 x 1440 , Uni-D , 16pass | Pattern. C |
| Quality 2 | 1440 x 1440 , Bi-D , 16pass | |
| Quality 3 | 720 x 1440 , Uni-D , 8pass | Pattern. B |
| Quality 4 | 720 x 1440 , Bi-D , 8pass | |
| Graphics 1 | 720 x 720 , Uni-D , 8pass | Pattern. E |
| Graphics 2 | 720 x 720 , Bi-D , 8pass | |
| Graphics 3 | 720 x 720 L , Uni-D , 6pass | Pattern. D |
| Graphics 4 | 720 x 720 L , Bi-D , 6pass | |
| Banner 1 | 720 x 720 , Uni-D , 4pass | Pattern. A |
| Banner 2 | 720 x 720 , Bi-D , 4pass | |
| Banner 3 | 360 x 720 , Uni-D , 2pass | |
| Banner 4 | 360 x 720 , Uni-D , 2pass | |

Adjustment patterns for each print mode (XPJ-1682SR)

| Print mode | Print mode specifications | Adjustment pattern |
|------------|---------------------------------------|--------------------|
| Quality 1 | 1440 x 1440 , Uni-D , 16pass / 32pass | Pattern. C |
| Quality 2 | 1440 x 1440 , Bi-D , 16pass / 32pass | |
| Quality 3 | 720 x 1440 , Uni-D , 8pass / 16pass | Pattern. B |
| Quality 4 | 720 x 1440 , Bi-D , 8pass / 16pass | |
| Graphics 1 | 720 x 1080 , Uni-D , 6pass / 12pass | Pattern. A |
| Graphics 2 | 720 x 1080 , Bi-D , 6pass / 12pass | |
| Banner 1 | 720 x 720 , Uni-D , 4pass / 8pass | Pattern. A |
| Banner 2 | 720 x 720 , Bi-D , 4pass / 8pass | |
| Banner 3 | 360 x 720 , Uni-D , 2pass / 4pass | |
| Banner 4 | 360 x 720 , Uni-D , 2pass / 4pass | |

5. Unpacking and Initial Setup

5.8. Setting the Printing Precision (8/13)

cf. Operation Manual(Rev.01-p.66)

Calibrating your printer

Print quality calibration

Standard or Custom Adjustment Methods

1. Print a confirm pattern and check it for printing errors.
2. Print "Rough pattern" and look for a place that is properly adjusted in the printing results of print head 1.
 - If you selected "Adjust Print 2: Custom", select "ALL" or "A" to "F".
 - The number printed under the pattern without alignment errors is the adjustment value.
3. Enter the adjustment values.
4. Follow the same procedure to adjust print head 2 (XPJ-1682SR Only).
5. Print "Fine pattern" and look for a place that is properly adjusted in the printing results of print head 1.
 - If you selected "Adjust Print 2: Custom", select "ALL" or "A" to "F".
 - The number printed under the pattern without alignment errors is the adjustment value.
6. Enter the adjustment values.
7. Follow the the same procedure to adjust print head 2 (XPJ-1682SR Only).

Note

- Warm up the heater before printing the Confirm and Adjustment patterns. "Skip Heater Warm Up? No" is displayed on the front panel.
- You can start printing while the printer is warming up.

CAUTION

While "Warming Up" is displayed, do not touch Media guide. You could burn yourself.

cf. Operation Manual(Rev.01-p.67)

Print quality calibration

Confirm pattern

- Press the [Enter] key to carry out printing.
- Check the printing results. If there are shifting problems, proceed to rough adjustment pattern printing.
- In the picture below, there are misalignments.

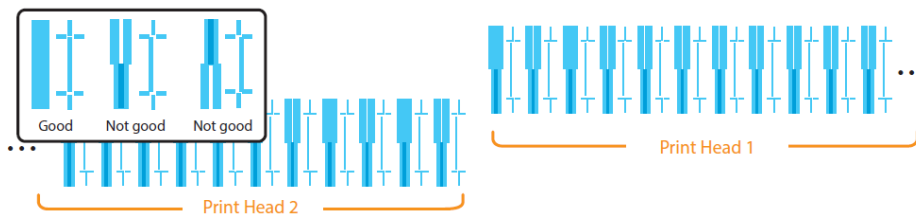

Note

Because XPJ-1682SR has 2 Print heads, 2 rows of confirmation pattern will be printed.

Rough adjustment pattern

- Tap [Enter] to carry out printing.
- For Head 1, check the print results and select the number that looks most aligned between 1 and 21.
- Pattern names such as "Pattern B1: 11" are shown on the display. Use or to enter the number of the best-adjusted pattern, and tap [Enter].
- In the case of the picture below, enter "12", so that the display reads "Pattern B1: 12". Follow the same procedure to adjust print head 2 (XPJ-1682SR Only).

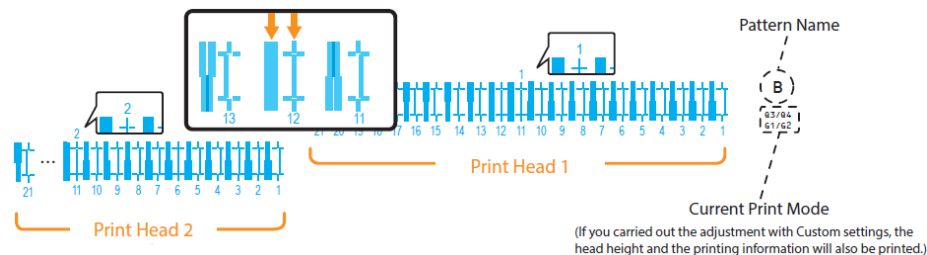

5. Unpacking and Initial Setup



5.8. Setting the Printing Precision (9/13)

cf. Operation Manual(Rev.01-p.67)

Calibrating your printer

Print quality calibration

Fine adjustment pattern

- Tap [Enter] to carry out printing.
For the Fine pattern, the same patterns will be printed repeatedly on both sides and center of the media.
- For Head 1, check the print results on both sides and center of the media and select the number that looks most aligned between 1 and 7.
- Pattern names such as "Pattern B1: 4" are shown on the display.
Use  or  to enter the number of the best-adjusted pattern, and tap [Enter].
- In the case of the picture below, enter "6", so that the display reads "Pattern B1: 6".
Follow the same procedure to adjust print head 2 (XPJ-1682SR Only).

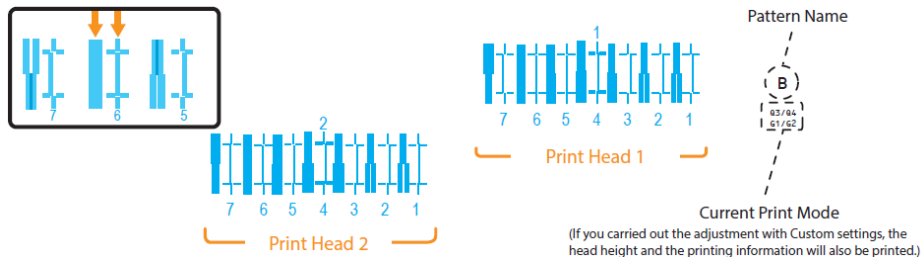

cf. Operation Manual(Rev.01-p.68)

Print quality calibration

Auto Adjustment Method

1. Select the adjustment pattern from "ALL", "Standard", or any specific pattern between "Adjust Pattern A" and "Adjust Pattern F".
 - The selected adjustment pattern is printed.
 - The printer scans the print using the embedded color sensor, then automatically corrects the dot placement.
2. Once successfully completed, the message "Auto Adjust Succeeded End->Enter" will appear on the panel.
 - If failed, the message "Auto Adjust Failed End -> Enter" will appear on the panel. Tap [Enter] to end the adjustment.
 - Try Auto Adjust again or perform Standard or Custom adjustment.
3. Tap [Enter] to exit the menu.

Note

- If failed in the middle of the calibration, the adjustment value for the pattern which has been successfully calibrated will be saved in the printer, but the adjustment value for the pattern which has been failed to calibrate or has not been calibrated yet will not be saved in the printer.
- Warm up the heater before printing the Confirm and Adjustment patterns. "Skip Heater Warm Up? No" is displayed on the front panel.
- You can start printing while the printer is warming up.
- If print defects (like banding or grainy look) still appear on the print, try an auto calibration again, or go to "Adjust Print1/ Standard" or "Adjust Print2/ Custom" to perform calibration.
- If a roll media starts to cockle during calibration, load the media again.

 CAUTION

While "Warming Up" is displayed, do not touch Media guide.
You could burn yourself.

5. Unpacking and Initial Setup

5.8. Setting the Printing Precision (10/13)

cf. Operation Manual(Rev.01-p.38)

Calibrating your printer

Media feed adjustment

This adjustment must be performed when:

- you use this product for the first time.
- you use a new type of the media.
- you have changed the holddown pressure on the pressure rollers.

Other than above cases, move to "Nozzle check and cleaning"

You will need a ruler to perform this adjustment.



Note

If the following symptom appears on your print, this adjustment may help to solve the problem.

- Image overlapping.
- Horizontal white lines on the print.

Media feed adjustment steps (1/2)

[1] Load a roll media.

[2] Tap [Home].



[3] Tap .



[4] Tap .



[5] Use or to choose the user type you want to use.
• Tap [Enter].



cf. Operation Manual(Rev.01-p.39)

Media feed adjustment

Media feed adjustment steps (2/2)

[6] Tap until the menu on the left appears.
• Tap .



[7] Use or to choose the menu.
• Tap .

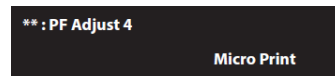

[8] Follow the steps below and adjust the print quality.

5. Unpacking and Initial Setup

5.8. Setting the Printing Precision (11/13)

cf. Operation Manual(Rev.01-p.69)

Calibrating your printer

Media feed adjustment

Type **: 3

PF Adjust

Sets up various settings on the Media feed correction. When the following defects are found in printing results, they may improve by conducting a media feed correction.

- Images are overlapping.
- There are white lines in images.

Submenus



** : PF Adjust 1

Initial Print

Performs Initial Print. Enter the "Feed Length" and tap [Enter].

** : PF Adjust 2

Initial Change

Use  or  to enter the adjustment value, and tap [Enter].

** : PF Adjust 3

Confirm Print

Performs Confirm Print. Enter the "Feed Length" and tap [Enter].



** : PF Adjust 4

Micro Print

Performs Micro adjustment Print. Enter the appropriate micro adjustment value according to the print result.

** : PF Adjust 5





Micro Change

Use  or  to enter the adjustment value, and tap [Enter].
Select whether you wish to perform confirmation print and complete the setup.

cf. Operation Manual(Rev.01-p.69)

Media feed adjustment

Steps

1. Select "PF Adjust 1: Initial Print".
 - "Feed Length: 250 mm" is displayed on the front panel.
2. After the initial adjustment printing, cut the media.
 - Measure the distance between the " + " in the initial adjustment print using a ruler.
3. Refer to Chapter 1 "Media feed adjustment steps" and select "PF Adjust 2: Initial Change" on the front panel.
4. Use  or  on the front panel and enter the measured value in Step 2.
 - Tap [Enter] to save the initial adjustment value.
5. Use  or  on the front panel to select "PF Adjust 3: Confirm Print".
 - "Feed Length: 250 mm" is displayed on the front panel.
6. After the confirmation adjustment printing, cut the media.
 - Measure the distance between the " + " in the confirmation adjustment print using a ruler. Then, confirm that the distance matches the feeding length when printing.
 - If the distance does not match the feeding length, follow the procedure from Step 1 to Step 5 and readjust.
 - If the distance matches the feeding length, proceed to Step 7.
7. Refer to Chapter 1 "Media feed adjustment steps" and select "PF Adjust 4: Micro Print" on the front panel.
 - Check the pattern and micro adjustment value. In the pattern, look for a place that has least white lines or overlapping in images.
The number printed below the adequate pattern is the micro adjustment value.
8. Enter the micro adjustment value according to the printing result in Step 7.

When you know the adjustment value (when changing the media or for similar operations)

1. Enter the adjustment value for "PF Adjust 5: Micro Change".
2. Select whether you wish to print a confirm pattern and complete the setup.

5. Unpacking and Initial Setup

5.8. Setting the Printing Precision (12/13)

cf. Operation Manual(Rev.01-p.71)

Calibrating your printer

Media feed adjustment

PF Adjust 1: Initial Print

**** : PF Adjust 1
Initial Print** Performs Initial Print. Enter the "Feed Length" and tap [Enter].

Setting values

**** : Initial Print :** 100mm ~ <250mm> ~ 500mm
Feed Length: 250 mm <> indicates the initial value.

- After the initial adjustment printing, cut the media.
- With a ruler, measure the length between " + " in the pattern.
In the example below, the measured place is shown in orange dotted lines and arrows.

Note



The length of media that is fed (feeding length) for initial adjustment printing is normally set at 250 mm.

the accuracy of the Media feed adjustment improves.

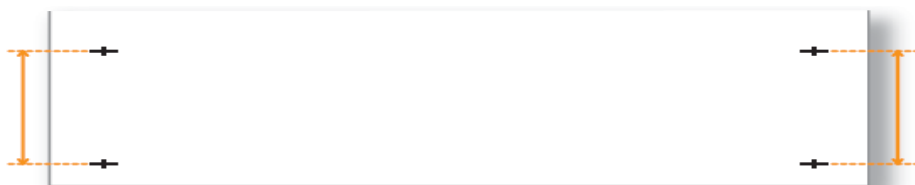
To change the feeding length, tap  or  on the front panel and change the set value.



PF Adjust 2: Initial Change

**** : PF Adjust 2
Initial Change** Use  or  to enter the adjustment value, and tap [Enter].

Setting values

**** : Initial Change :** You can set a value that is between +50 mm and -50 mm of the feed length configured in "Initial Print".
Init. : 250.0 mm / 250 mm

cf. Operation Manual(Rev.01-p.72)

Media feed adjustment

PF Adjust 3: Confirm Print

**** : PF Adjust 3
Confirm Print** Performs Confirm Print.
Enter the "Feed Length" and tap [Enter].

Setting values

**** : Initial Print :** 100mm ~ <250mm> ~ 500mm
Feed Length: 250 mm <> indicates the initial value.

- After the confirmation adjustment printing, cut the media.
- With a ruler, measure the length between " + " in the pattern.
In the example below, the measured place is shown in orange dotted lines and arrows
(the orange parts are not actually printed).
- If the measured length does not match the feeding length, re-correct with PF Adjust 1: Initial Print.
- If the measured length matches the feeding length, proceed to PF Adjust 4: Micro Print.

Note

The length of media that is fed (feeding length) for initial adjustment printing is normally set at 250 mm.

If you increase the feeding length, the accuracy of the Media feed adjustment improves.
To change the feeding length, tap  or  on the front panel and change the set value.

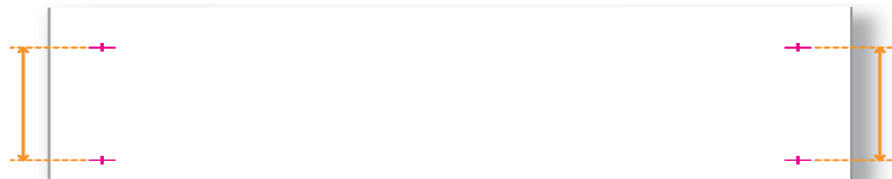

5. Unpacking and Initial Setup

5.8. Setting the Printing Precision (13/13)

cf. Operation Manual(Rev.01-p.73)

Calibrating your printer

Media feed adjustment

PF Adjust 4: Micro Print

** : PF Adjust 4

Micro Print

Performs Micro adjustment Print.
Enter the appropriate micro adjustment value according to the print result.

- Observe the pattern and verify the micro adjustment value.
In the pattern, look for a place that has least white lines or overlapping in images.
The number printed below the pattern is the micro adjustment value.
Enter the micro adjustment value according to the print result.

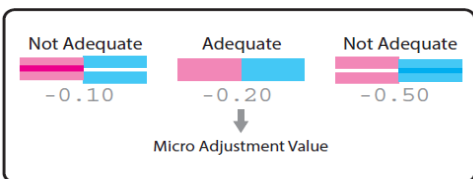

Note

Once an appropriate micro adjustment value has been saved, the value will be the baseline value from the next time to be printed in the center of the pattern.

For example, if you have entered “-0.20” and print a micro adjustment pattern, values printed below block pattern will be changed to (from left) +1.00, +0.60, +0.30, 0.00, -0.20 (baseline value), -0.30, -0.40, -0.70, -1.00, -1.40.

PF Adjust 5: Micro Change

** : PF Adjust 5

Micro Change

Use or to enter the adjustment value, and tap [Enter].

Select whether you wish to perform confirmation print and complete the setup.

Setting values

** : Micro :

(-5 -5)

0.00%

-5.00% ~ <0.00%> ~ 5.00%
<> indicates the initial value.

5.9. Advanced settings (1/3)

cf. Operation Manual(Rev.01-p.40)

Advanced settings

Changing the Head Height

If you use a roll media that warps easily or perform high-density print, the print head may contact the media while printing.

If you experience such problem, try changing the head height higher.

After you change the head height, make sure to perform the print quality calibration.



Important!

**Do not open Front cover and change the head height during printing.
Print quality cannot be guaranteed.**

[1]

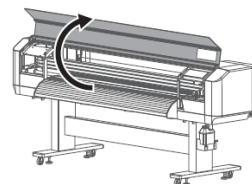

Open the front cover.

[2]

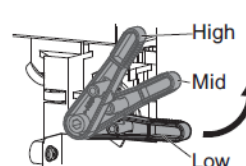

Use the head height adjustment lever (orange) to change the head height to “Mid” or “High”.

- 「High」: set the head height to High.
- 「Mid」: set the head height between Low and High.
- 「Low」: Default head height.

[3]

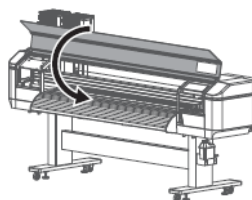

Close the front cover.

[4] Perform print quality calibration.

5. Unpacking and Initial Setup

5.9. Advanced settings (2/3)

cf. Operation Manual(Rev.01-p.41)

Advanced settings

Changing holddown pressure using media feed lever

If you want to change the holddown pressure applied across the entire width of media, use the media feed lever.

Depending on the position of the lever, you can choose the pressure between Normal and High.

- Normal : Recommended for typical roll media.
To apply normal pressure, push the lever from the front side of the printer until it clicks.
- High : Recommended for heavy weight media (such as Tarpaulin).
To apply high pressure, push it as far as it goes.

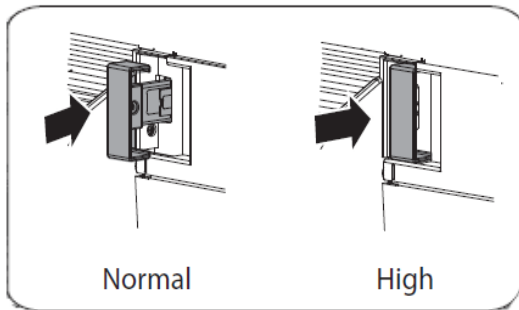
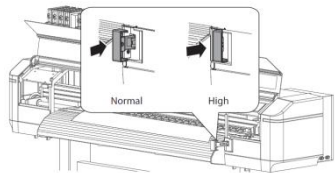

Important!

Every time after you change the holddown pressure by the media feed lever, you must perform the media feed adjustment.

cf. Operation Manual(Rev.01-p.42)

Canceling or reducing pressure rollers individually

When printing on thin media or media without stiffness, the media tends to cockle causing head strikes.

By reducing pressure or disabling the pressure rollers individually, it helps to reduce the chance of head strike.

Using the slide lock lever on the individual pressure roller, the holddown pressure can be changed between Normal, Low and Cancel.

- Normal : Recommended for typical roll media.
The factory default is set to Normal.
- Low : It reduces the holddown pressure.
- Cancel : It disables the pressure roller.

However, if the media feed lever is set to High, you can only choose between Normal and Cancel

(even you set it to Low, the holddown pressure will not be reduced).

To cancel the individual pressure rollers, release the pressure rollers by pulling the media feed lever towards you as much as possible.

| Media feed lever | Slide lock lever |
|------------------|-----------------------|
| Normal | Normal / Low / Cancel |
| Low | Normal / Cancel |

Important!

Every time after you change the holddown pressure by individual slide lock lever, you must perform the media feed adjustment.

Note

- Thin media or media without stiffness is likely to be wrinkled during printing. Wrinkles can contact the bottom side of the print head causing the media to become dirty.
- When both edges of the pressurizing rollers of media are released, it can prevent wrinkles.
- When printing on thin media or media without stiffness, wrinkles can be prevented by turning down the vacuum fan.

5. Unpacking and Initial Setup

5.9. Advanced settings (3/3)

cf. Operation Manual(Rev.01-p.42)

Advanced settings

Changing holddown pressure using media feed lever

cf. Operation Manual(Rev.01-p.43)

Changing holddown pressure using media feed lever

Steps (2/2)

Steps (1/2)

[1] Open the front cover.

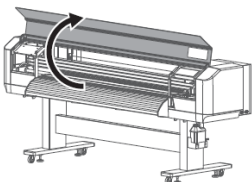

[2] (To cancel the individual pressure rollers) From the front side of the printer, pull the media feed lever towards you as much as possible to release the pressure rollers.
(To set the slide lock lever to the Low position) Set the media feed lever to the Normal position.

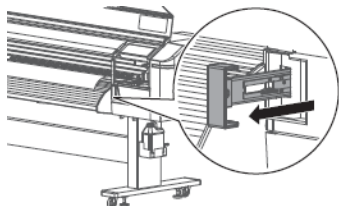

Note

• You cannot cancel the individual pressure rollers unless you release the pressure rollers by the media feed lever.

[3] Push down the tab on the slider lock lever, then slide it to the front.
• To reduce pressure, slide it to front until it clicks.
• To cancel the pressure roller, fully slide it to the front until it clicks into place.

Note

First, try to reduce or cancel the rollers on both edges of the media. If the problem persists, reduce or cancel more rollers.

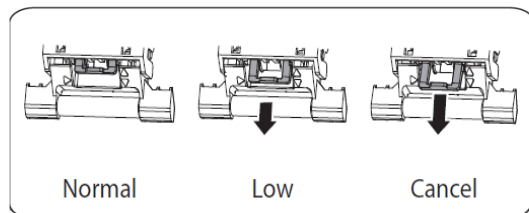
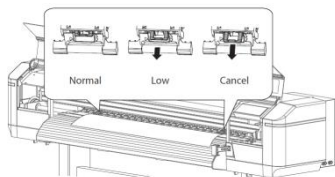

[4] (To cancel the individual pressure rollers) Push the media feed lever back to the original position to lock the pressure rollers.

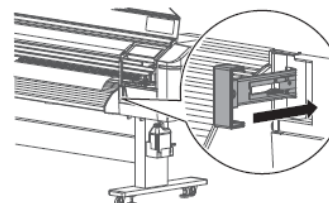

[5] Close the front cover.

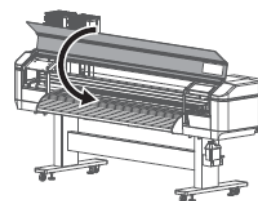

[6] Perform media feed adjustment.

6.Ink

6.1. MS41 ink (1/1)

Ink Type/ Capacity

◆ Category: MS4 ink

| Type | Ink Color | Model | Capacity | Cartridge/Bag |
|-------------|---------------|--------------|----------|---------------|
| Pigment ink | Black | MS41-BK1000* | 1000ml | Ink Bag |
| | Cyan | MS41-CY1000* | 1000ml | Ink Bag |
| | Magenta | MS41-MA1000* | 1000ml | Ink Bag |
| | Yellow | MS41-YE1000* | 1000ml | Ink Bag |
| | Light Cyan | MS41-LC1000* | 1000ml | Ink Bag |
| | Light Magenta | MS41-LM1000* | 1000ml | Ink Bag |
| | Light Black | MS41-LK1000* | 1000ml | Ink Bag |
| Cleaner | - | MS41-CL300* | 300ml | Ink Bag |

*: E (Europe) / U (other countries)

CAUTION

Optional ink cartridges are required to install ink bags or cleaning bags in the printer.
 220 ml ink cartridge and 440 ml ink cartridge are not supported



Ink Type

Eco solvent ink

Configuration

The Specified amount of ink is dispensed into an ink pouch (ink bag).

After the Product Label is applied onto the ink bag and individual box respectively, the ink bag and one piece of chip card are packed with the individual box.

Reliability and Environmental Specification

[Shelf Life]

24 months from the date manufactured

[Operating Environment]

Temperature: Same as the printer operating environment

Humidity: Same as the printer operating environment (Without condensation)

[Storage Condition]

Temperature: -20°C to 40°C (Storage under 40°C should be within one month).

※Keep the product in a cool, dark and well-ventilated area.

※Keep the product away from inflammable materials or heat source.

[Shipment Condition]

Temperature: -20°C to 50

(shipment under 40°C should be within one month, shipment under 50°C should be within 120 hours)

※If the temperature may exceed the condition above, use the refer container.)

Ink Bag Specification

“MS41” an “VJ-MS41” is not compatible because the S/C card information and the shape of ink pouch are different.

Therefore it is necessary to use the ink corresponding to the machine model to be used.

MS41: For XPJ series printers

VJ-MS41: For VJ series printers

6.Ink

6.2. Ink System (1/3)

Ink Supply System

Tube supply system from independent ink bag via sub tank.

Ink Slot Layout

The illustration below shows the ink slot layout when looking from the front of the printer.

Slot 1 is located closest to the front panel and Slot 8 (Slot 4 in the XPJ-1641SR) is located far from the panel.

◆ XPJ-1641SR (Single head, 4 slots)

| Slot.4 | Slot.3 | Slot.2 | Slot.1 |
|--------|--------|--------|--------|
| Y | M | C | K |

◆ XPJ-1682SR (Dual head, 8 slots)

◇ 4-color configuration

| Slot.8 | Slot.7 | Slot.6 | Slot.5 | Slot.4 | Slot.3 | Slot.2 | Slot.1 |
|--------|--------|--------|--------|--------|--------|--------|--------|
| Y | Y | M | M | C | C | K | K |

◇ 7-color configuration

| Slot.8 | Slot.7 | Slot.6 | Slot.5 | Slot.4 | Slot.3 | Slot.2 | Slot.1 |
|--------|--------|--------|--------|--------|--------|--------|--------|
| Lk | Y | CL | K | Lc | C | Lm | M |

Print Head Nozzle Layout

◆ XPJ-1641SR

| A row | B row | C row | D row | E row | F row | G row | H row |
|-------|-------|-------|-------|-------|-------|-------|-------|
| K | K | C | C | Y | Y | M | M |

◆ XPJ-1682SR (both print heads)

◇ 4-color configuration

| A row | B row | C row | D row | E row | F row | G row | H row |
|-------|-------|-------|-------|-------|-------|-------|-------|
| K | Y | C | M | M | C | Y | K |

◇ 7-color configuration

| A row | B row | C row | D row | E row | F row | G row | H row |
|-------|-------|-------|-------|-------|-------|-------|-------|
| M | Lk | C | CL | K | Lc | Y | Lm |

Ink channel

◆ XPJ-1641SR (Single head, 4 slots)

| Slot | Nozzle | Color |
|--------|---------------|---------|
| Slot.1 | A row / B row | Black |
| Slot.2 | C row / D row | Cyan |
| Slot.3 | G row / H row | Magenta |
| Slot.4 | E row / F row | Yellow |

◆ XPJ-1682SR (Dual head, 8 slots)

| Slot | Nozzle | Color |
|--------|--------|---------------------------------------|
| Slot.1 | A row | 4-color configuration : Black |
| | | 7-color configuration : Magenta |
| Slot.2 | H row | 4-color configuration : Black |
| | | 7-color configuration : Light Magenta |
| Slot.3 | C row | 4-color configuration : Cyan |
| | | 7-color configuration : Cyan |
| Slot.4 | F row | 4-color configuration : Cyan |
| | | 7-color configuration : Light Cyan |
| Slot.5 | E row | 4-color configuration : Magenta |
| | | 7-color configuration : Black |
| Slot.6 | D row | 4-color configuration : Magenta |
| | | 7-color configuration : Cleaner |
| Slot.7 | G row | 4-color configuration : Yellow |
| | | 7-color configuration : Yellow |
| Slot.8 | B row | 4-color configuration : Yellow |
| | | 7-color configuration : Light Black |

Sub tank

100ml individual sub tank

Waste Ink Tank

The waste ink tank (2000 ml) is attached to the printer.

Users can drain waste ink to the drain bottle from the waste ink tank valve.

The float sensor in the waste ink tank detects tank full.

⚠ CAUTION

When the waste ink tank is full, the printer will automatically stop operating.

6.Ink

6.2. Ink System (2/3)

Ink System

◆ XPJ-1641SR (Single head, 4 slots)

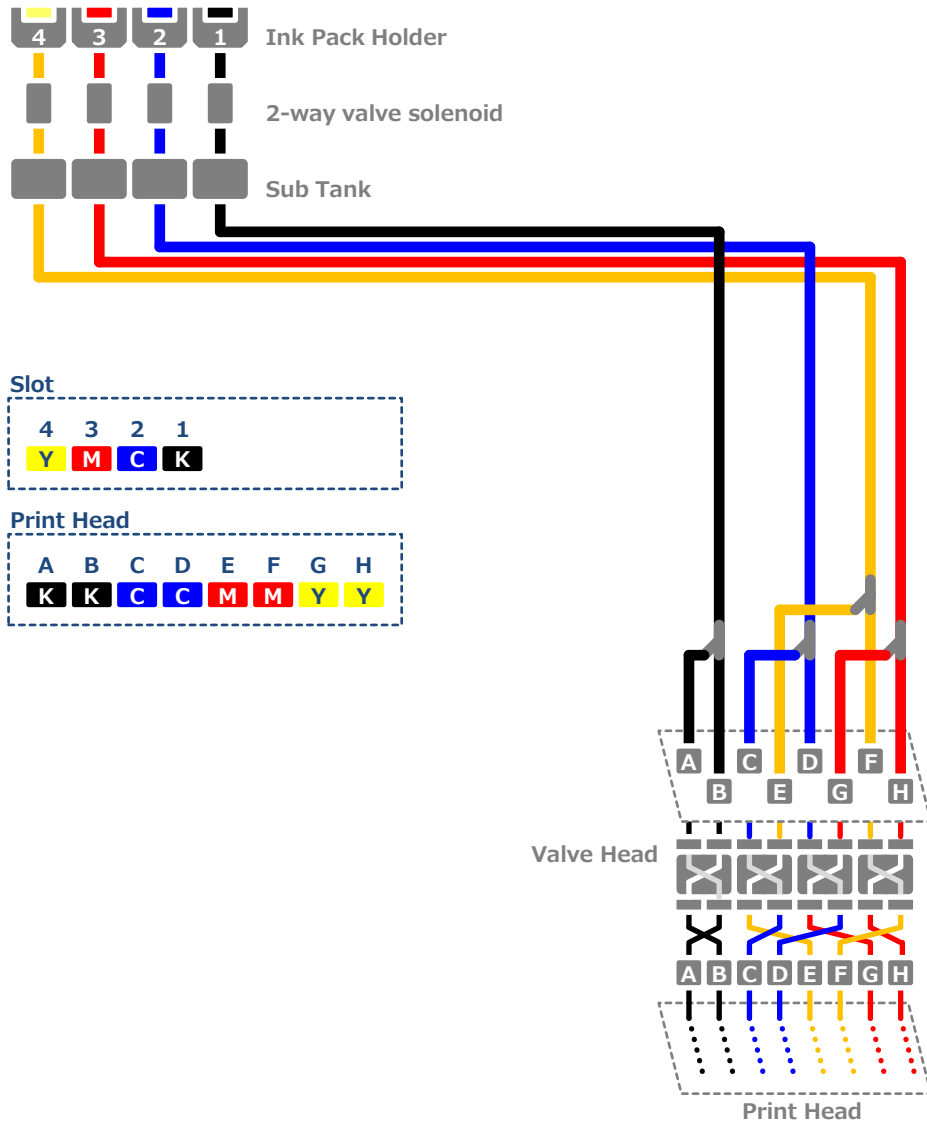

◆ XPJ-1682SR (Dual head, 8 slots) / 4-color configuration

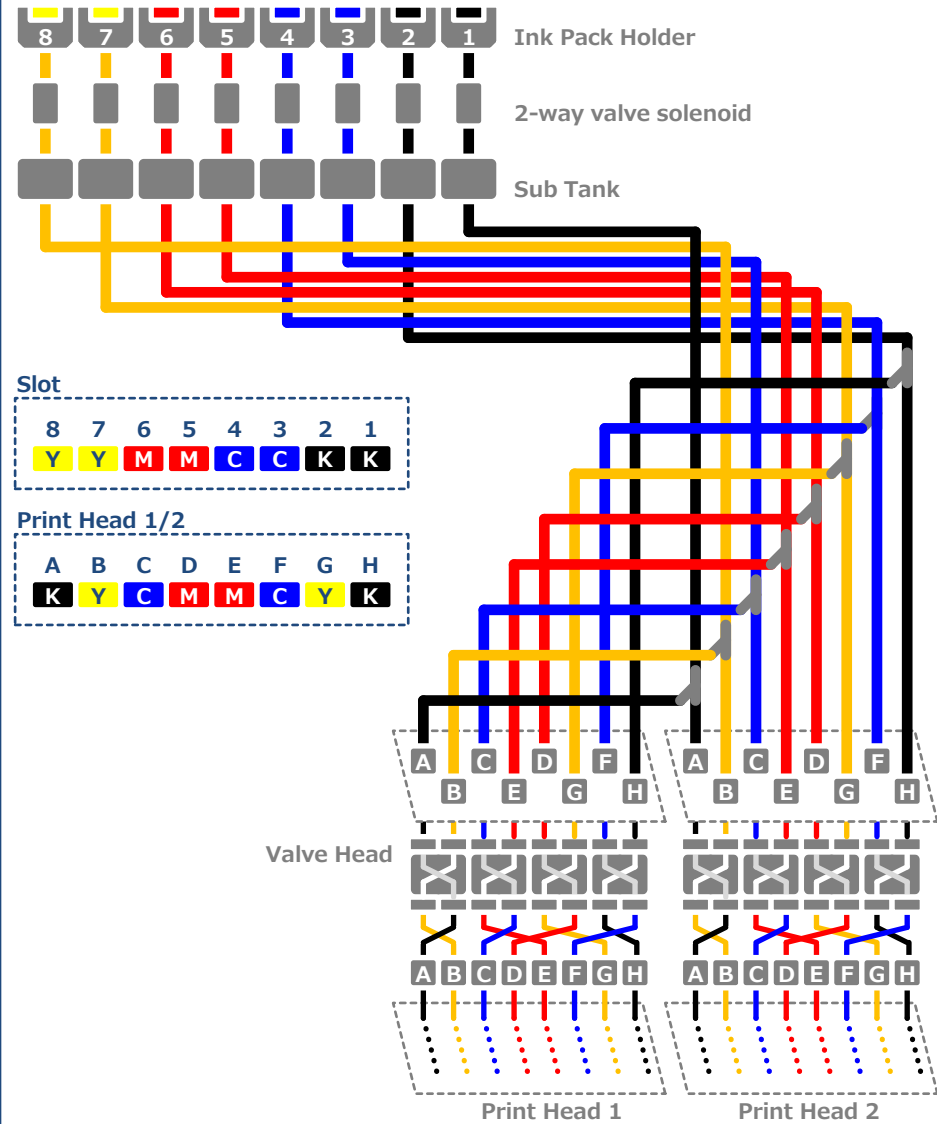

6.Ink

6.2. Ink System (3/3)

Ink System

◆ XPJ-1682SR (Dual head, 8 slots) / 7-color configuration

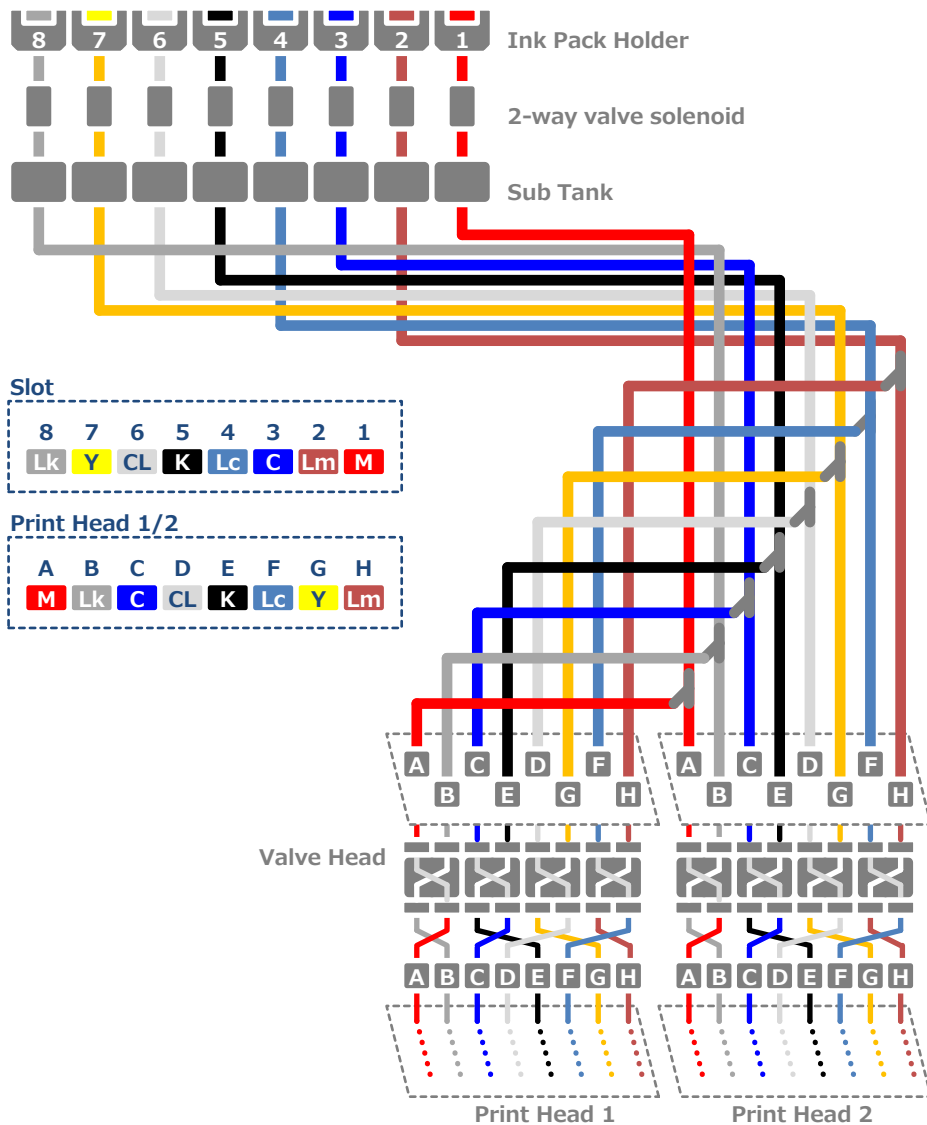

6.3. Sub tank (1/1)

Ink Type Determination

Tube supply system from independent ink bag via sub tank.

Determination System

The mechanical limit switch built inside the ink holder detects the ink/cleaner bag installation on the printer.

The smart chip can determine if the dedicated ink/cleaner is used on the printer.

Ink Level Detection

The low-level sensor and high-level sensor in the sub tank are used to detect ink level in the printer.

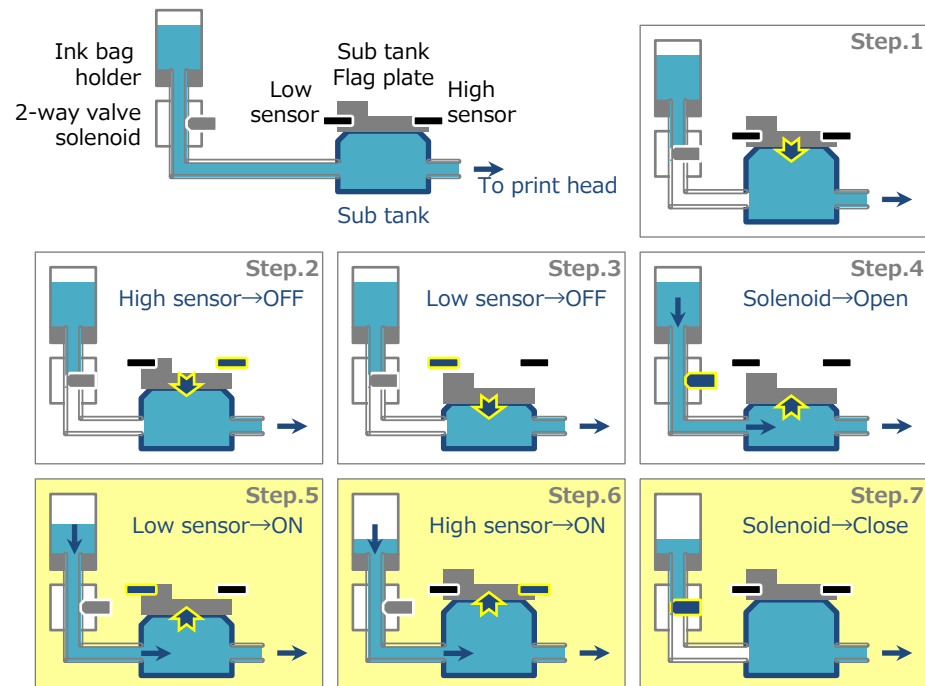

6.Ink

6.4. Error Message display (Ink) (1/1)

XPJ16xxSRJ-A-01(p.148)

XPJ16xxSRJ-A-01(p.148)

Error message display and remedies

Full Waste Ink Tank

The waste ink tank is full. (Stops operation)
Immediately empty the tank.

FullWasteInkTank

Discharged

Ink is not filled.
Perform initial ink charging.

[***] Discharged**

No Bag

Ink bag case is not inserted. (Stops operation)
Insert Ink bag case.

[***] No Bag**

Ink End

Ink has run out. (Stops operation)
Replace with a new ink bag.

[***] Ink End**

Ink End is detected when one of the following requirements is met and the printer will stop printing.

- ◆ time elapsing from low-level sensor ON to high-level sensor ON exceeds 250 seconds.
- ◆ time elapsing from low-level sensor OFF to low-level sensor ON exceeds 100 seconds.
- ◆ when it takes more than 120 seconds for the low-level sensor to turn on after the printer stops printing.
- ◆ when it takes more than 250 seconds for the high-level sensor to turn on while filling ink to the sub tank during ink charging.

No S/C Card

Ink bag case is not inserted. (Stops operation)
Insert Ink bag case.

[***] No S/C Card**

Error message display and remedies

S/C Card Near End

Slot * ink is low.
Get a replacement bag ready.

[***] S/C Ink Low**

S/C Card End

Ink has run out. (Stops operation)
Replace with a new ink bag.

[***] S/C Ink End**

When the following conditions are satisfied, judge Smart Chip card near end or Smart Chip card end and warn with panel display and sound.

- ◆ S/C card near end
 - Occurrence condition:
 - When the internal count value of ink usage (count on firmware) exceeds 900 ml
 - New printing:
 - Possible
 - Occurrence during printing:
 - Continue printing
- ◆ S/C card end
 - Occurrence condition:
 - When the internal count value of ink usage (count on firmware) exceeds 1200 ml
 - New printing:
 - Impossible
 - Occurrence during printing:
 - he printing is continued until the internal count value of ink usage after the Low-level sensor is turned OFF reaches 20 ml.
 - Print stops if it exceeds 20 ml.

7. Carriage

7.1. Carriage Assy (1/1)

◆ XPJ-1641SR

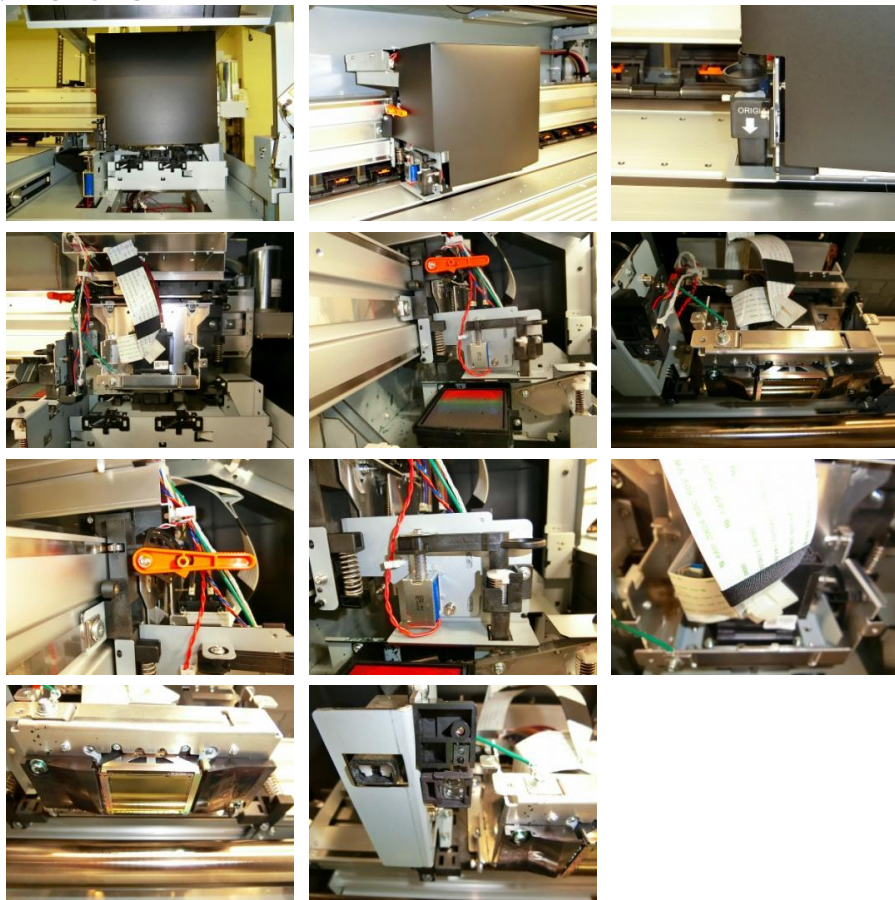

◆ XPJ-1682SR



7. Carriage

7.2. Changing the Head Height (1/1)

cf. Operation Manual(Rev.01-p.40)

Changing the Head Height

◆ XPJ-1641SR



◆ XPJ-1682SR



If you use a roll media that warps easily or perform high-density print, the print head may contact the media while printing.

If you experience such problem, try changing the head height higher.

After you change the head height, make sure to perform the print quality calibration.

Important!

**Do not open Front cover and change the head height during printing.
Print quality cannot be guaranteed.**



Use the head height adjustment lever (orange) to change the head height to "Mid" or "High".

7.3. Cutting media (1/2)

cf. Operation Manual(Rev.01-p.46)

Cutting media

◆ XPJ-1641SR

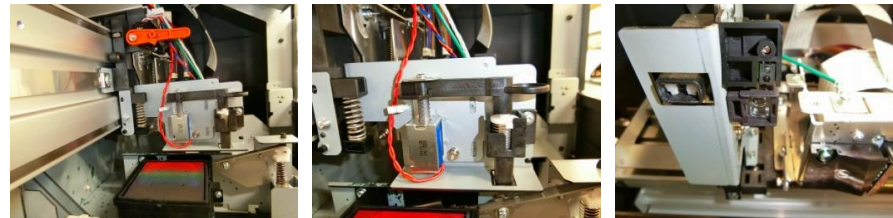

◆ XPJ-1682SR



- [1]  Check that the job has been printed.
• Tap [Cancel].

- [2]  Tap [Enter].
• The printer will advance the media for the bottom margin and will cut it.

Note

- If the front edge of a new roll media is not straight, cut it before printing.
- When the media detection is set to "Off", the printer does not cut the media automatically.
→ **"Setup 4: Media Initial"**
- When the Output mode menu is set to "Auto Cut", the printer cuts the media automatically after printing.
→ **"Setup 6: Output Mode"**
- The cutter blade is consumable parts. Replace it when needed.

7. Carriage

7.3. Cutting media (2/2)

cf. Operation Manual(Rev.01-p.78)

Setup 7: Method of Cut

Menu Setup 7 Method of Cut

Sets the media cutting operation after printing.

設定値

Method of Cut: Single Cut - 2 steps

Cut with fewer steps than "Single Cut - 3 steps".
Suitable for media with narrow width.

Method of Cut: Single Cut - 3 steps

Normal cutting method.
This is the initially set value.

Method of Cut: Double Cut - 2 steps

Set when unable to cut with "Single Cut - 2 steps".
Suitable for media with narrow width.

Method of Cut: Double Cut - 3 steps

Set when unable to cut with "Single Cut - 3 steps".

Note

- When the media detection is set to "Off", the media cannot be cut automatically.
- Some media may not be cut (cannot be cut at all or cannot be cut finely).
In such a case, set the "Output Mode menu" to "Off" and cut the media manually.

Cut Pressure menu

Method of Cut: Single Cut - 3 steps

Sets the media cutting pressure for the cutting operation.

Setting values

Cut Pressure: Low

Cut the media at low pressure.
Suitable for thin media or if the "High" pressure setting is too strong.

Cut Pressure: High

Normal cutting pressure.
This is the initially set value.

cf. Operation Manual(Rev.01-p.77)

Setup 4: Media Initial

Setup 4 Media Initial

Sets whether to detect the media width while initializing the media.

Setting values

Media Initial: Off

The media will not be detected.

Media Initial: Top&Width

Detect the media width and edge while initializing the media.

Media Initial: Width

Detect the media width while initializing the media.
This is the initially set value.

Note

When "Media Initial menu" is set to "Off", set the media width of the current media in Media Width menu.

cf. Operation Manual(Rev.01-p.78)

Setup 6: Output Mode

Setup 6 Output Mode

Sets how the media is handled after printing.

Setting values

Output Mode: Off

The Take-up Unit will not be used.
This is the initially set value.

Output Mode: Take Up

Set when using the Take-up Unit.

Output Mode: Auto Cut

Set when cutting the media automatically.

7. Carriage

7.4. Color Sensor (1/3)

◆ XPJ-1641SR

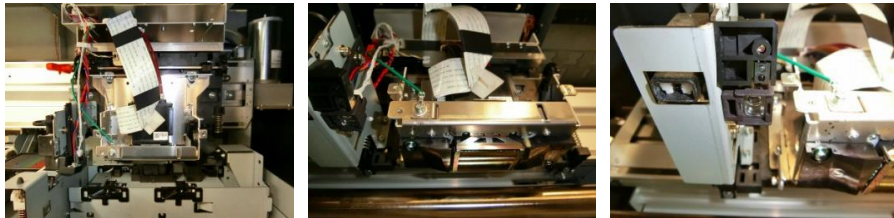

◆ XPJ-1682SR

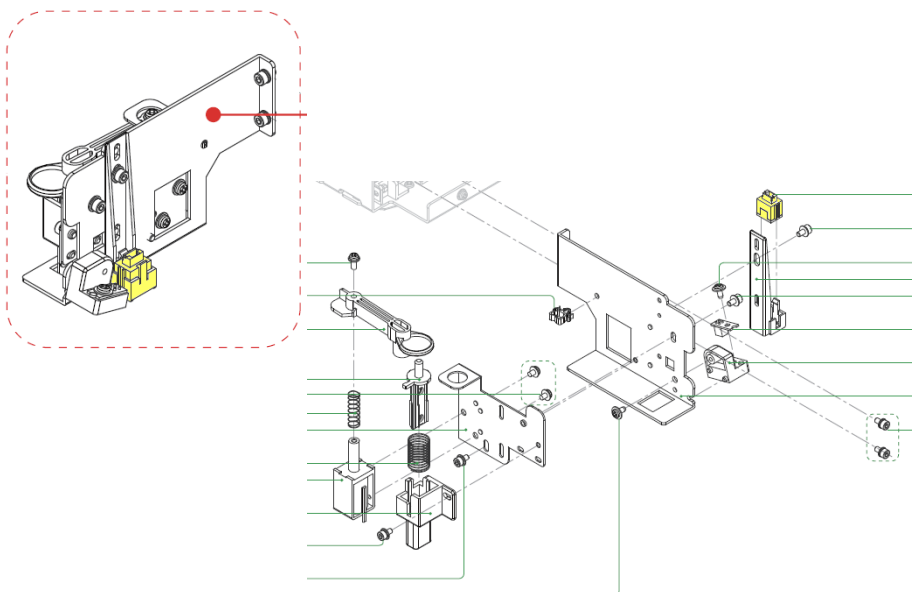

cf. Operation Manual(Rev.01-p.95)

Head alignment (XPJ-1682SR Only)

Test Print 5
Adjust Head

This menu calibrates the dot placement between two print heads installed on XPJ-1682SR.

Tap **▶** to open the submenu.

Align the heads in the following cases:

- If the image quality does not improve after you have used the "Adjust Print" menu.
- When switching to thin media or a type of media where ink drops do not spread.

After executing this menu, be sure to perform the "Adjust Print" function.

If you don't, the image quality during bidirectional printing may drop.

Submenus

Adjust Head 1

Standard

Adjustment is performed only for the print mode set by the current User Type.

You can make the adjustments more quickly than by selecting "Fine Pattern ALL" in "Custom".

When selecting "Standard" here, you need to use the same print mode settings for the RIP (Raster Image Processor) as the print mode settings for the User Type.

Use the same settings for the resolution, pass and printing direction in the RIP print mode as in the print mode for the User Type.

Adjust Head 2

Custom

You can also adjust a print mode other than the one used for the current User Type.

You can print with an optimal image quality even if the RIP print mode is different from the print mode used for the User Type.

Adjust Head 3

Auto

Perform the automatic adjustment using the embedded color sensor.

It helps to reduce time and increase the alignment accuracy.

Note

- If print defects (like banding or grainy look) still appear on the print, try an auto calibration again, or go to "Adjust Print1/ Standard" or "Adjust Print2/ Custom" to perform calibration.
- If a roll media starts to cockle during calibration, load the media again.

7. Carriage

7.4. Color Sensor (2/3)

cf. Operation Manual(Rev.01-p.97)

Head alignment (XPJ-1682SR Only)

When "Adjust Head 3 Auto" is selected

Adjust Head 3
Auto

You can select the adjustment method.
Tap  to open the submenu.

Perform the automatic adjustment using the embedded color sensor.

If the resolution, pass and the printing direction of the RIP print mode differ from the print mode for the User Type, select the fine pattern that is suitable for the RIP.

Submenus

**Auto1

ALL

Perform automatic adjustment for all patterns (A to F) using the color sensor.

**Auto2

Standard

Perform automatic adjustment for the currently selected print mode using the color sensor (calibrate the same print mode as "Adjust Head1 Standard").

Auto 3

Adjust Pattern A

⋮

Auto 8

Adjust Pattern F

Choose the adjustment pattern between A and F for automatic adjustment.

cf. Operation Manual(Rev.01-p.98)

Head alignment (XPJ-1682SR Only)

Auto Adjustment Method

1. Select the adjustment pattern from "ALL", "Standard", or any specific pattern between "Adjust Pattern A" and "Adjust Pattern F".
 - The selected adjustment pattern is printed.
 - The printer scans the print using the embedded color sensor, then automatically corrects the dot placement.
2. Once successfully completed, the message "Auto Adjust Succeeded End->Enter" will appear on the panel.
 - If failed, the message "Auto Adjust Failed End -> Enter" will appear on the panel. Tap [Enter] to end the adjustment.
 - Try Auto Adjust again or perform Standard or Custom adjustment.
3. Tap [Enter] to exit the menu.

 Note

- If failed in the middle of the calibration, the adjustment value for the pattern which has been successfully calibrated will be saved in the printer, but the adjustment value for the pattern which has been failed to calibrate or has not been calibrated yet will not be saved in the printer.
- Warm up the heater before printing the Adjustment pattern. "Skip Heater Warm Up? No" is displayed on the front panel.
- You can start printing while the printer is warming up.
- If print defects (like banding or grainy look) still appear on the print, try an auto calibration again, or go to "Adjust Print1/ Standard" or "Adjust Print2/ Custom" to perform calibration.
- If a roll media starts to cockle during calibration, load the media again.

 CAUTION

While "Warming Up" is displayed, do not touch Media guide.
You could burn yourself.

7. Carriage

7.4. Color Sensor (3/3)

cf. Operation Manual(Rev.01-p.63)

Print quality calibration

Type **: 2
Adjust Print

Sets up when adjusting the printer for the optimum quality of image print.

Before adjusting this setting, enter the thickness of the media.

Submenus

** : Adjust Print 1
Standard

Adjusts only the print mode in the user type setting which is currently set.

** : Adjust Print 2
Custom

Adjusts the print modes other than the mode in the user type setting which is currently set.

** : Adjust Print 3
Auto

Perform an automatic calibration that the printer automatically prints and scans a pattern with the embedded color sensor to correct dot placement.

cf. Operation Manual(Rev.01-p.64)

Print quality calibration

Adjust Print 3: Auto

** : Adjust Print 3
Auto

Perform the automatic adjustment using the embedded color sensor.

Submenus

** : Auto 1
ALL

Perform automatic adjustment for all patterns (A to F) using the color sensor.

** : Auto 2
Standard

Perform automatic adjustment for the currently selected print mode using the color sensor (calibrate the same print mode as "Adjust Print 1 Standard").

** : Auto 1
Adjust Pattern A

Choose the adjustment pattern between A and F for automatic adjustment.

** : Auto 6
Adjust Pattern F

cf. Operation Manual(Rev.01-p.68)

Print quality calibration

Auto Adjustment Method

1. Select the adjustment pattern from "ALL", "Standard", or any specific pattern between "Adjust Pattern A" and "Adjust Pattern F".
 - The selected adjustment pattern is printed.
 - The printer scans the print using the embedded color sensor, then automatically corrects the dot placement.
2. Once successfully completed, the message "Auto Adjust Succeeded End->Enter" will appear on the panel.
 - If failed, the message "Auto Adjust Failed End -> Enter" will appear on the panel. Tap [Enter] to end the adjustment.
 - Try Auto Adjust again or perform Standard or Custom adjustment.
3. Tap [Enter] to exit the menu.

Note

- If failed in the middle of the calibration, the adjustment value for the pattern which has been successfully calibrated will be saved in the printer, but the adjustment value for the pattern which has been failed to calibrate or has not been calibrated yet will not be saved in the printer.
- Warm up the heater before printing the Confirm and Adjustment patterns. "Skip Heater Warm Up? No" is displayed on the front panel.
- You can start printing while the printer is warming up.
- If print defects (like banding or grainy look) still appear on the print, try an auto calibration again, or go to "Adjust Print1/ Standard" or "Adjust Print2/ Custom" to perform calibration.
- If a roll media starts to cockle during calibration, load the media again.

CAUTION

While "Warming Up" is displayed, do not touch Media guide. You could burn yourself.

8. Print head

8.1. Print Head (1/2)

◆ XPJ-1641SR

- IA5540 (360dpi, 180 nozzle x 8 row) x 1 head

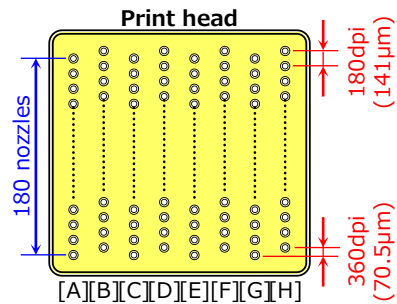

◆ XPJ-1682SR

- IA5540 (360dpi, 180 nozzle x 8 row) x 2 head
- In the dual head printer, twenty nozzles per head are overlapped between two heads so that the valid nozzles per head are 680 nozzles.

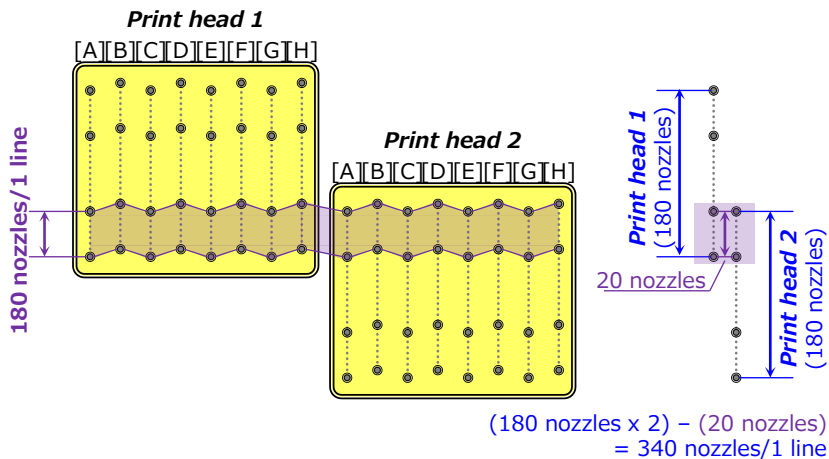

◆ XPJ-1682SR (Dual head, 8 slots)

- Print resolution
- 4-color configuration: 360dpi

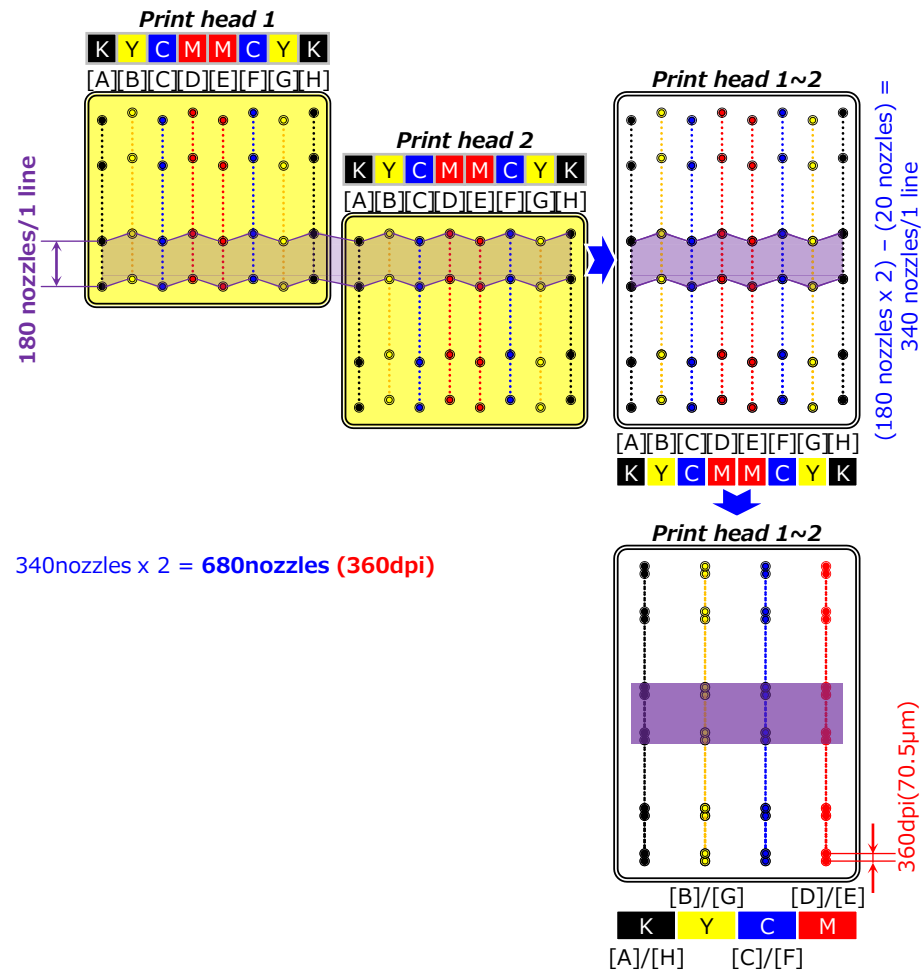

8. Print head

8.1. Print Head (2/2)

◆ XPJ-1682SR (Dual head, 8 slots)

- Print resolution
- 7-color configuration: 180dpi

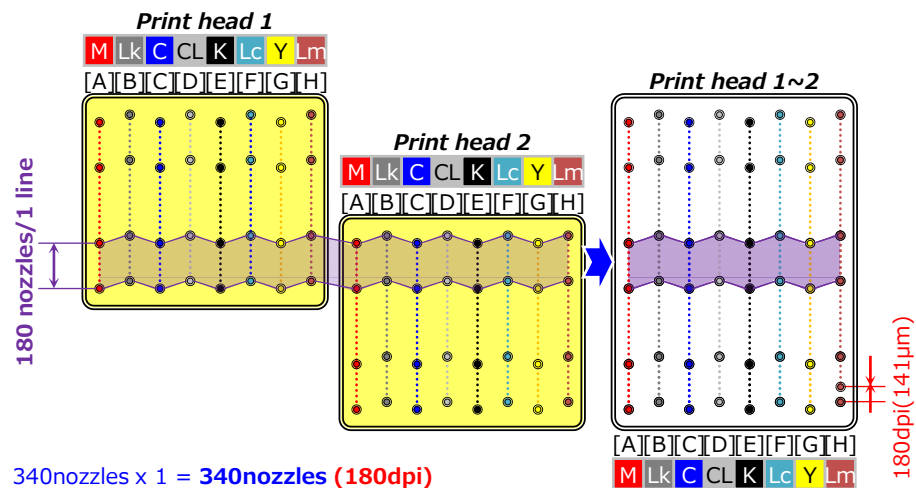

8.2. Maintenance Parts (1/1)

VJ-1624X vs XPJ-1641SR

| Item | ValueJet (VJ-1624X) | XpertJet (XPJ-1641SR) |
|------------|---------------------------------------|---|
| Print Head | DG-43988 IA5540 Head Assy | DG-49580<NEW> IA5540 Head Assy(MS41) |
| Dumper | DG-41543 Valve Head Assy | DG-49273<NEW> Valve Head Assy |
| Connector | DG-41915 Connector_Valve_Head Assy | DG-49274<NEW> Head Connector Assy |

VJ-1638X vs XPJ-1682SR

| 項目 | ValueJet (VJ-1624X) | XpertJet (XPJ-1641SR) |
|------------|---------------------------------------|--|
| Print Head | DG-43345 Print Head Assy | DG-49581<NEW> Print Head Assy(MS41) |
| Dumper | DG-41543 Valve Head Assy | DG-49273<NEW> Valve Head Assy |
| Connector | DG-41915 Connector_Valve_Head Assy | DG-49274<NEW> Head Connector Assy |

8. Print head

8.3. Replacing print head [XPJ-1641SR] (1/2)

cf. Maintenance Manual(XPJ-1641SR: Rev.00-3.8.14.)

Replacing print head [XPJ-1641SR] (1/4)

Preparation:

- Phillips Screwdriver No.2
- Round nose Pliers

Maintenance Part

- DG-49580: IA5540 Print Head Assy (MS41)

CAUTION

DO NOT use anything other than above listed Print Head Assy.
Doing so may cause critical damage to the hardware and function.

- [1] Discharge ink.



If ink remains in the path when replacing print head, occasional ink drop may destroy electric circuit of print head.

- [2] Remove CR cover.

- [3] Release carriage lock manually.

- [4] Move carriage to the middle of platen.

- [5] Release head FFC from clips on its path. (x4)

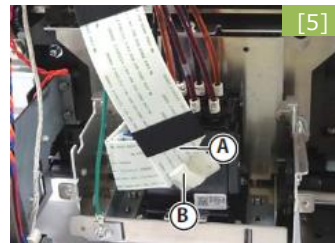
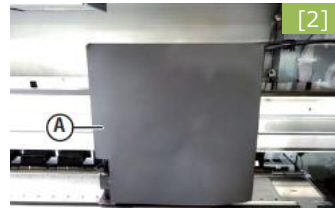
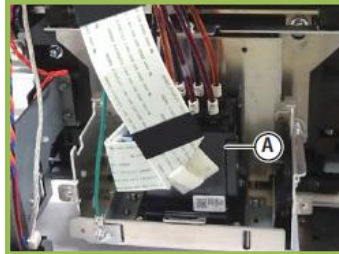

cf. Maintenance Manual(XPJ-1641SR: Rev.00-3.8.14.)

Replacing print head [XPJ-1641SR] (2/4)

- [6] Remove head connector(s).



Turn head connector by 45 degree clockwise. Pull out vertically

CAUTION

Do not turn counter-clockwise.
It may damage connector and cause ink leak.

- [7] Place head connectors in plastic bag.



To prevent environment from contamination.

- [8] Remove screw(s).

- [9] Remove print head(s).

- [10] Place print head(s) on polyknit wiper in the stainless steel tray.



Spread polyknit wiper on stainless steel tray. Pour cleansing fluid as deep as covering polyknit wiper.

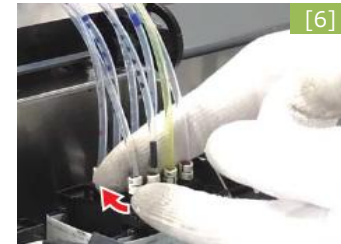

8. Print head

8.3. Replacing print head [XPJ-1641SR] (2/2)

cf. Maintenance Manual(XPJ-1641SR: Rev.00-3.8.14.)

Replacing print head [XPJ-1641SR] (3/4)

[11] Remove head cover.



Note

Lift both latches (R+L)

[12] Remove valve head.



Note

Apply pliers.



[14] To Assemble unit, reverse the removal procedure.

[15] Perform necessary adjustment.

cf. Maintenance Manual(XPJ-1641SR: Rev.00-4.2.)

Replacing print head [XPJ-1641SR] (4/4)

| Parts replaced | Order | Adjustment item | Reference |
|----------------|-------|--|-----------|
| Printer head | 1 | Head rank input (including initial ink charge) | 5.17. |
| | 2 | Head nozzle check | 5.7.6. |
| | 3 | Head slant check | 4.7. |
| | 4 | Uni-D Adjustment(Low) | 4.7. |
| | 5 | Bi-D Adjustment(Low) | 4.7. |
| | 6 | Uni-D / Bi-D Copy(Mid/High) | 4.7. |
| | 7 | Test printing | - |

8. Print head

8.4. Replacing print head [XPJ-1682SR] (1/2)

cf. Maintenance Manual(XPJ-1682SR: Rev.00-3.8.14.)

Replacing print head [XPJ-1682SR] (1/4)

Preparation:

- Hex Wrench 2.5mm
- Round nose Pliers

Maintenance Part

- DG-49581: Print Head Assy (MS41)

⚠ CAUTION

DO NOT use anything other than above listed Print Head Assy.
Doing so may cause critical damage to the hardware and function.

- [1] Discharge ink.



Note

If ink remains in the path when replacing print head, occasional ink drop may destroy electric circuit of print head.

- [2] Remove CR cover.

- [3] Release carriage lock manually.

- [4] Move carriage to the middle of platen.

- [5] Release head FFC from clips on its path. (x4)

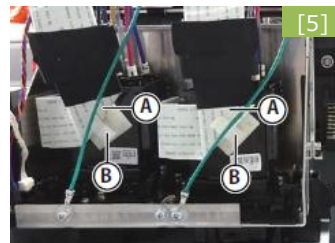

cf. Maintenance Manual(XPJ-1682SR: Rev.00-3.8.14.)

Replacing print head [XPJ-1682SR] (2/4)

- [6] Remove head connector(s).



Note

Turn head connector by 45 degree clockwise. Pull out vertically

⚠ CAUTION

Do not turn counter-clockwise.
It may damage connector and cause ink leak.

- [7] Place head connectors in plastic bag.



Note

To prevent environment from contamination.

- [8] Remove screw(s).

- [9] Remove print head(s).

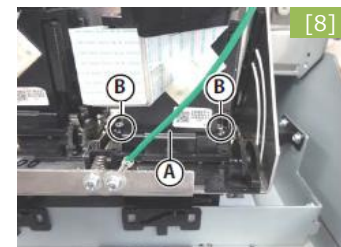
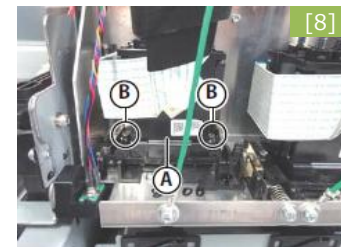
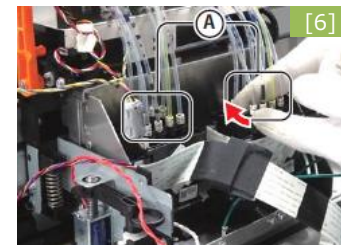

8. Print head

8.4. Replacing print head [XPJ-1682SR] (2/2)

cf. Maintenance Manual(XPJ-1682SR: Rev.00-3.8.14.)

Replacing print head [XPJ-1682SR] (3/4)

[10] Place print head(s) on polyknit wiper in the stainless steel tray.



Note

Spread polyknit wiper on stainless steel tray. Pour cleansing fluid as deep as covering polyknit wiper.



[10]

[11] Remove head cover.



Note

Lift both latches (R+L)

[12] Remove valve head.



Note

Apply pliers.



[12]

[14] To Assemble unit, reverse the removal procedure.

[15] Perform necessary adjustment.

cf. Maintenance Manual(XPJ-1682SR: Rev.00-4.2.)

Replacing print head [XPJ-1682SR] (4/4)

| Parts replaced | Order | Adjustment item | Reference |
|----------------|-------|--|-----------|
| Printer head | 1 | Head rank input (including initial ink charge) | 5.17. |
| | 2 | Head nozzle check | 5.7.6. |
| | 3 | Head slant check | 4.7. |
| | 4 | Uni-D (H_Adjust 1) Adjustment(Low) | 4.7. |
| | 5 | Uni-D (H_Adjust 2) Adjustment(Low) | 4.7. |
| | 6 | Bi-D Adjustment(Low) | 4.7. |
| | 7 | Uni-D / Bi-D Copy(Mid/High) | 4.7. |
| | 8 | Test printing | - |

9. Printing

9.1. User Type (1/5)

cf. Operation Manual(Rev.01-p.60)

Menu 1: Setup

Setup 1: User Type

Menu 1
Setup

You can have up to 15 groups of User Type, labeled "Type1" to "Type15".
When you select a User Type group ("Type") and tap [Enter], that definition group will be set for the printer. Also, a submenu will be displayed.

Setting values

User Type: Type 1
Select a "Type" number, from "Type1" to "Type15".

Submenus

Type **: 1
Print Mode

Type **: 2
Adjust Print

Type **: 3
PF Adjust

Type **: 4
Pre Heater

Type **: 5
Platen Heater

Type **: 6
Dryer

Type **: 7
Vacuum Fan

Type **: 8
Thickness

Type **: 9
Copy User Type

Important!

When you change to another User Type, all the settings that can be set via the User Type will be changed.

- The settings that can be set via the User Type include "Print Mode", "Effect" the adjustment value for "Adjust Print", "PF Adjust", the setting value for "Pre Heater", "Platen Heater", "Dryer", "Vacuum Fan" and "Thickness".

When using the printer for the first time or using a new roll media, configure a user type settings.

cf. Operation Manual(Rev.01-p.61)

Menu 1: Setup

**>1: Print Mode

Type **: 1
Print Mode

Select a print mode for the media.
· Once selected, the panel displays the effect menu.

Setting values

Mode: 1440 x 1440 16pass Uni Quality 1

High-quality print mode.

The four types of mode are available: Quality 1 to Quality 4.

Mode: 720 x 1080 6pass Uni Graphics 1

Standard print mode.

· **XPJ-1641SR:**
There are four types: Graphics 1 and Graphics 4.

Graphics 2 is the initial setting.

· **XPJ-1682SR:**
There are two types: Graphics 1 and Graphics 2.

Graphics 2 is the initial setting.

Mode: 720 x 720 4pass Uni Banner 1

High-speed print mode.

There are four types: Banner 1 to Banner 4.

9. Printing

9.1. User Type (2/5)

cf. Operation Manual(Rev.01-p.61)

Menu 1: Setup

Details of print mode (XPJ-1641SR)

| Print Mode | Resolution | Pass | Direction | Default effect settings |
|------------|-------------|--------|----------------------|-------------------------|
| Quality 1 | 1440 x 1440 | 16pass | Uni (unidirectional) | Fine&Fuzz |
| Quality 2 | 1440 x 1440 | 16pass | Bi (bidirectional) | Fine&Fuzz |
| Quality 3 | 720 x 1440 | 8pass | Uni (unidirectional) | Fine&Fuzz |
| Quality 4 | 720 x 1440 | 8pass | Bi (bidirectional) | Fine&Fuzz |
| Graphics 1 | 720 x 720 | 8pass | Uni (unidirectional) | Fine&Fuzz |
| Graphics 2 | 720 x 720 | 8pass | Bi (bidirectional) | Fine&Fuzz |
| Graphics 3 | 720 x 720 L | 8pass | Uni (unidirectional) | Fine&Fog |
| Graphics 4 | 720 x 720 L | 8pass | Bi (bidirectional) | Fine&Fog |
| Banner 1 | 720 x 720 | 4pass | Uni (unidirectional) | Fog |
| Banner 2 | 720 x 720 | 4pass | Bi (bidirectional) | Fog |
| Banner 3 | 360 x 720 | 2pass | Uni (unidirectional) | None |
| Banner 4 | 360 x 720 | 2pass | Bi (bidirectional) | None |

cf. Operation Manual(Rev.01-p.62)

Menu 1: Setup

Details of print mode (XPJ-1682SR)

| Print Mode | Resolution | Pass (4-color setting) | Pass (7-color setting) | Direction | Default effect settings |
|------------|-------------|------------------------|------------------------|----------------------|-------------------------|
| Quality 1 | 1440 x 1440 | 16pass | 32pass | Uni (unidirectional) | Fine&Fog |
| Quality 2 | 1440 x 1440 | 16pass | 32pass | Bi (bidirectional) | Fine&Fog |
| Quality 3 | 720 x 1440 | 8pass | 16pass | Uni (unidirectional) | Fine&Fog |
| Quality 4 | 720 x 1440 | 8pass | 16pass | Bi (bidirectional) | Fine&Fog |
| Graphics 1 | 720 x 1080 | 6pass | 12pass | Uni (unidirectional) | Fine&Fog |
| Graphics 2 | 720 x 1080 | 6pass | 12pass | Bi (bidirectional) | Fine&Fog |
| Banner 1 | 720 x 720 | 4pass | 8pass | Uni (unidirectional) | Fine&Fog |
| Banner 2 | 720 x 720 | 4pass | 8pass | Bi (bidirectional) | Fine&Fog |
| Banner 3 | 360 x 720 | 2pass | 4pass | Uni (unidirectional) | None |
| Banner 4 | 360 x 720 | 2pass | 4pass | Bi (bidirectional) | None |

9. Printing

9.1. User Type (3/5)

cf. Operation Manual(Rev.01-p.62)

Menu 1: Setup

**>1: Print Mode (Effect)

Mode: 1440 x 1440 Quality 1 16pass Uni



Select an effect setting.
 • Set up this menu when you want to improve print quality by adjusting the set print mode.

Setting values

| | | |
|---------------|-------------------|---|
| ** : Effect : | None | The Effect function is not used. |
| ** : Effect : | Wave | The printing joint will be the wave form. |
| ** : Effect : | Fog | The printing joint will shade off. (XPJ-1641SR Only) |
| ** : Effect : | Fine & Fuzz | The printing joint will shade off as the wave form. |
| ** : Effect : | Fine & Fog | The printing joint will shade off. |
| ** : Effect : | A - S Fine & Wave | Performs "Wave" printing using the left side of the of Print head. (XPJ-1682SR Only). |
| ** : Effect : | B - S Fine & Wave | Performs "Wave" printing using the right side of the of Print head. (XPJ-1682SR Only). |
| ** : Effect : | i-Weave EX | Edges between each pass are barely noticeable and more seamless (XPJ-1682SR Only). |

cf. Operation Manual(Rev.01-p.63)

Menu 1: Setup

**>2: Adjust Print>

Type **: 2
Adjust Print

Sets up when adjusting the printer for the optimum quality of image print.
 Before adjusting this setting, enter the thickness of the media.

Submenus

| | |
|---------------------------------|---|
| ** : Adjust Print 1 Standard | Adjusts only the print mode in the user type setting which is currently set. |
| ** : Adjust Print 2 Custom | Adjusts the print modes other than the mode in the user type setting which is currently set. |
| ** : Adjust Print 3 Auto | Perform an automatic calibration that the printer automatically prints and scans a pattern with the embedded color sensor to correct dot placement. |

9. Printing

9.1. User Type (4/5)

cf. Operation Manual(Rev.01-p.69)

Menu 1: Setup

**>3: PF Adjust

Type **: 3
PF Adjust

Sets up various settings on the Media feed correction. When the following defects are found in printing results, they may improve by conducting a media feed correction.



- Images are overlapping.
- There are white lines in images.

Submenus

** : PF Adjust 1
Initial Print

Performs Initial Print. Enter the "Feed Length" and tap [Enter].

** : PF Adjust 2
Initial Change

Use  or  to enter the adjustment value, and tap [Enter].



** : PF Adjust 3
Confirm Print

Performs Confirm Print. Enter the "Feed Length" and tap [Enter].

** : PF Adjust 4
Micro Print

Performs Micro adjustment Print. Enter the appropriate micro adjustment value according to the print result.



** : PF Adjust 5
Micro Change

Use  or  to enter the adjustment value, and tap [Enter].

Select whether you wish to perform confirmation print and complete the setup.

**>4: Pre Heater

Type **: 4
Pre Heater

Sets up Pre Heater. Use  or  to select the value, and tap [Enter].

Setting values

** : Pre Heater :
(30 - 50) 30°C



Off / <30°C> to 50°C
<> indicates the initial value.

cf. Operation Manual(Rev.01-p.74)

Menu 1: Setup

**>5: Platen Heater

Type **: 5
Platen Heater

Sets up Platen Heater. Use  or  to select the value, and tap [Enter].



Setting values

** : Platen Heater :
(30 - 50) 30°C

Off / <30°C> to 50°C
<> indicates the initial value.

**>6: Dryer

Type **: 6
Dryer

Sets up Dryer. Use  or  to select the value, and tap [Enter].



Setting values

** : Dryer :
(30 - 50) 30°C

Off / <30°C> to 50°C
<> indicates the initial value.

**>7: Vacuum Fan

Type **: 7
Vacuum Fan

Selects the vacuum level. Use  or  to select the value, and tap [Enter].
• If you are using a thin or delicate media and there is risk of it wrinkling due to the fan, set a lower value for the fan.

Setting values

** : Vacuum Fan :
High

Low / Medium / <High>
<> indicates the initial value.



9. Printing

9.1. User Type (5/5)

cf. Operation Manual(Rev.01-p.75)

Menu 1: Setup

**>8: Thickness

Type **: 8
Thickness Sets the thickness of the media you are using.
 Use  or  to select the value, and tap [Enter].

Setting values

**** : Thickness :** 80 μm to <170 μm> to 2,800 μm
 <> indicates the initial value.

170 μm

Note

- This menu is to automatically adjust print quality to a certain extent. If you want to improve print quality, manually adjust it.
- If you have adjusted the print settings, you do not need to configure the thickness of the media in this menu.

**>9: Copy User Type

Type **: 9
Copy User Type This is for copying the currently selected User Type setting into another User Type.

The items that will be copied are:

- “Print Mode”, “Effect”
- The adjustment value for “Adjust Print”, “PF Adjust”
- The setting value for “Pre Heater”, “Platen Heater”, “Dryer”, “Vacuum Fan”, and “Thickness”

Setting values

**** : UserCopy :** Here you can select the User Type to copy the settings into.

Type ** -> 1

If you select ALL, the settings will be copied into all the User Type.

**** : UserCopy :**
 Type ** -> ALL

9.2. Print Mode (1/4)

Print Mode

◆ XPJ-1641SR (Single head, 4slot)

※ Quality mode

| Print Mode | Quality 1 | Quality 2 | Quality 3 | Quality 4 |
|--|---------------------------|-------------------------|---------------------------|-------------------------|
| CR | 1440dpi (4pass) | 1440dpi (4pass) | 720dpi (2pass) | 720dpi (2pass) |
| PF | 1440dpi (4pass) | 1440dpi (4pass) | 1440dpi (4pass) | 1440dpi (4pass) |
| Total Pass | 16pass | 16pass | 8pass | 8pass |
| Print Direction | Uni-D (unidirectional) | Bi-D (bidirectional) | Uni-D (unidirectional) | Bi-D (bidirectional) |
| CR Speed | 320cps | 320cps | 320cps | 320cps |
| Dot Family in normal settings (by default) | VSD4 Variable | VSD4 Variable | VSD3 Variable | VSD3 Variable |
| Dot Family in fixed dot | VSD4 Small Dot | VSD4 Small Dot | VSD3 Small Dot | VSD3 Small Dot |
| Effect (by default) | Fine & Fuzz | Fine & Fuzz | Fine & Fuzz | Fine & Fuzz |
| Throughput Comparison | 1.93m ² /h | 3.04m ² /h | 3.92m ² /h | 6.17m ² /h |

⚠ CAUTION

The above throughput values are based on the Mutoh measurement. The accuracy of these values are not guaranteed.

Note

- Printing condition for throughput measurement.
 Data width: 1615 mm, Data length: 620 mm , Head Travel: Data
- Effect: by default

Important!

In addition to the above, custom print modes are available by PM Command.

9. Printing

9.2. Print Mode (2/4)

Print Mode

◆ XPJ-1641SR (Single head, 4slot)

※ Graphics mode

| Print Mode | Graphics 1 | Graphics 2 | Graphics 3 | Graphics 4 |
|--|---------------------------|-------------------------|---------------------------|-------------------------|
| CR | 720dpi (4pass) | 720dpi (4pass) | 720dpi L (4pass) | 720dpi L (4pass) |
| PF | 720dpi (2pass) | 720dpi (2pass) | 720dpi L (2pass) | 720dpi L (2pass) |
| Total Pass | 8pass | 8pass | 8pass | 8pass |
| Print Direction | Uni-D (unidirectional) | Bi-D (bidirectional) | Uni-D (unidirectional) | Bi-D (bidirectional) |
| CR Speed | 460cps | 460cps | 460cps | 460cps |
| Dot Family in normal settings (by default) | VSD3 Variable | VSD3 Variable | VSD1 Variable | VSD1 Variable |
| Dot Family in fixed dot | VSD3 Medium Dot | VSD3 Medium Dot | VSD1 Medium Dot | VSD1 Medium Dot |
| Effect (by default) | Fine & Fuzz | Fine & Fuzz | Fine & Fog | Fine & Fog |
| Throughput Comparison | 4.51m ² /h | 8.03m ² /h | 3.77m ² /h | 6.76m ² /h |

⚠ CAUTION

The above throughput values are based on the Mutoh measurement. The accuracy of these values are not guaranteed.

Note

- Printing condition for throughput measurement.
Data width: 1615 mm, Data length: 620 mm , Head Travel: Data
- Effect: by default

Important!

In addition to the above, custom print modes are available by PM Command.

XPJ-1641SR (Single head, 4slot)

Banner mode

| Print Mode | Banner 1 | Banner 2 | Banner 3 | Banner 4 |
|--|---------------------------|-------------------------|---------------------------|-------------------------|
| CR | 720dpi (2pass) | 720dpi (2pass) | 360dpi (1pass) | 360dpi (1pass) |
| PF | 720dpi (2pass) | 720dpi (2pass) | 720dpi (2pass) | 720dpi (2pass) |
| Total Pass | 4pass | 4pass | 2pass | 2pass |
| Print Direction | Uni-D (unidirectional) | Bi-D (bidirectional) | Uni-D (unidirectional) | Bi-D (bidirectional) |
| CR Speed | 320cps | 320cps | 320cps | 320cps |
| Dot Family in normal settings (by default) | VSD1 Variable | VSD1 Variable | VSD1 Variable | VSD1 Variable |
| Dot Family in fixed dot | VSD1 Medium Dot | VSD1 Medium Dot | VSD1 Large Dot | VSD1 Large Dot |
| Effect (by default) | Fog | Fog | None | None |
| Throughput Comparison | 9.12m ² /h | 14.05m ² /h | 19.35m ² /h | 29.25m ² /h |

⚠ CAUTION

The above throughput values are based on the Mutoh measurement. The accuracy of these values are not guaranteed.

Note

- Printing condition for throughput measurement.
Data width: 1615 mm, Data length: 620 mm , Head Travel: Data
- Effect: by default

Important!

In addition to the above, custom print modes are available by PM Command.

9. Printing

9.2. Print Mode (3/4)

Print Mode

◆ XPJ-1682SR (Double head, 8slot) / 4 color-settings

※ Quality mode

| Print Mode | Quality 1 | Quality 2 | Quality 3 | Quality 4 |
|--|---------------------------|-------------------------|---------------------------|-------------------------|
| CR | 1440dpi (4pass) | 1440dpi (4pass) | 720dpi (2pass) | 720dpi (2pass) |
| PF | 1440dpi (4pass) | 1440dpi (4pass) | 1440dpi (4pass) | 1440dpi (4pass) |
| Total Pass | 16pass | 16pass | 8pass | 8pass |
| Print Direction | Uni-D (unidirectional) | Bi-D (bidirectional) | Uni-D (unidirectional) | Bi-D (bidirectional) |
| CR Speed | 320cps | 320cps | 320cps | 320cps |
| Dot Family in normal settings (by default) | VSD4 Variable | VSD4 Variable | VSD3 Variable | VSD3 Variable |
| Dot Family in fixed dot | VSD4 Small Dot | VSD4 Small Dot | VSD3 Small Dot | VSD3 Small Dot |
| Effect (by default) | Fine & Fog | Fine & Fog | Fine & Fog | Fine & Fog |
| Throughput Comparison | 3.19m ² /h | 5.42m ² /h | 6.45m ² /h | 10.96m ² /h |

⚠ CAUTION

The above throughput values are based on the Mutoh measurement. The accuracy of these values are not guaranteed.

Note

- Printing condition for throughput measurement.
Data width: 1615 mm, Data length: 620 mm , Head Travel: Data
- Effect: by default

Important!

In addition to the above, custom print modes are available by PM Command. In some custom print modes, MPS must be required (MPS is not required in standard print modes).

XPJ-1682SR (Double head, 8slot) / 4 color-settings

Graphics mode

| Print Mode | Graphics 1 | Graphics 2 |
|--|---------------------------|-------------------------|
| CR | 720dpi (2pass) | 720dpi (2pass) |
| PF | 1080dpi (3pass) | 1080dpi (3pass) |
| Total Pass | 6pass | 6pass |
| Print Direction | Uni-D (unidirectional) | Bi-D (bidirectional) |
| CR Speed | 320cps | 320cps |
| Dot Family in normal settings (by default) | VSD3 Variable | VSD3 Variable |
| Dot Family in fixed dot | VSD3 Medium Dot | VSD3 Medium Dot |
| Effect (by default) | Fine & Fog | Fine & Fog |
| Throughput Comparison | 8.54m ² /h | 15.00m ² /h |

⚠ CAUTION

The above throughput values are based on the Mutoh measurement. The accuracy of these values are not guaranteed.

Note

- Printing condition for throughput measurement.
Data width: 1615 mm, Data length: 620 mm , Head Travel: Data
- Effect: by default

Important!

In addition to the above, custom print modes are available by PM Command. In some custom print modes, MPS must be required (MPS is not required in standard print modes).

9. Printing

9.2. Print Mode (4/4)

Print Mode

◆ XPJ-1682SR (Double head, 8slot) / 4 color-settings

※ Banner mode

| Print Mode | Banner 1 | Banner 2 | Banner 3 | Banner 4 |
|--|---------------------------|-------------------------|---------------------------|-------------------------|
| CR | 720dpi (2pass) | 720dpi (2pass) | 720dpi (2pass) | 720dpi (2pass) |
| PF | 720dpi (2pass) | 720dpi (2pass) | 360dpi (1pass) | 360dpi (1pass) |
| Total Pass | 4pass | 4pass | 2pass | 2pass |
| Print Direction | Uni-D (unidirectional) | Bi-D (bidirectional) | Uni-D (unidirectional) | Bi-D (bidirectional) |
| CR Speed | 320cps | 320cps | 320cps | 320cps |
| Dot Family in normal settings (by default) | VSD1 Variable | VSD1 Variable | VSD1 Variable | VSD1 Variable |
| Dot Family in fixed dot | VSD1 Medium Dot | VSD1 Medium Dot | VSD1 Large Dot | VSD1 Large Dot |
| Effect (by default) | Fine & Fog | Fine & Fog | None | None |
| Throughput Comparison | 12.84m ² /h | 21.00m ² /h | 31.49m ² /h | 48.21m ² /h |

⚠ CAUTION

The above throughput values are based on the Mutoh measurement. The accuracy of these values are not guaranteed.



Note

- Printing condition for throughput measurement.
Data width: 1615 mm, Data length: 620 mm, Head Travel: Data
- Effect: by default



Important!

In addition to the above, custom print modes are available by PM Command. In some custom print modes, MPS must be required (MPS is not required in standard print modes).

9.3. Effect (1/1)

Effect



- The Effect function is not used.



- The printing joint will be the wave form.



- The printing joint will shade off.



- The printing joint will shade off as the wave form.



- The printing joint will shade off.



- Performs "Wave" printing using the left side of the of Print head.



- Performs "Wave" printing using the right side of the of Print head.

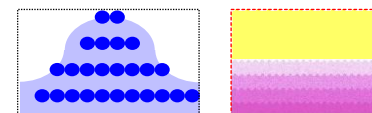
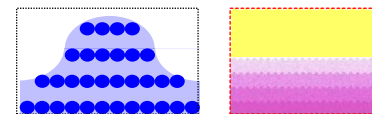
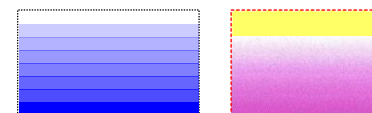
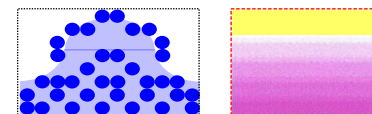
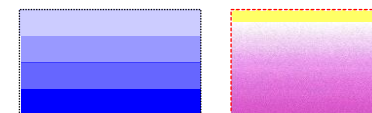
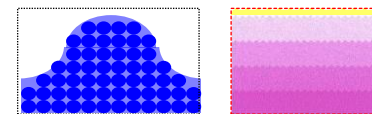
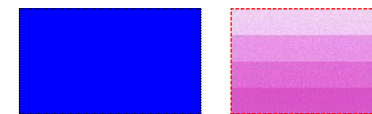

9. Printing

9.4. Recommended Media (1/1)

Recommended Media

Every sales company and distributor selects recommended media which ensures the printer performance.

Media used for internal evaluation: VJ-MF3G 1250 mm x 30 m

◆ XPJ-1641SR (Single head, 4slot)

| Quality 1 | Quality 2 | Quality 3 | Quality 4 |
|------------|------------|------------|------------|
| ● | ● | ● | ● |
| Graphics 1 | Graphics 2 | Graphics 3 | Graphics 4 |
| ● | ● | ● | ● |
| Banner 1 | Banner 2 | Banner 3 | Banner 4 |
| ▲ | ▲ | × | × |

▲:Horizontal banding or graininess is visible on some of the print patterns.

◆ XPJ-1682SR (Double head, 8slot) / 4 color-settings

| Quality 1 | Quality 2 | Quality 3 | Quality 4 |
|------------|------------|-----------|-----------|
| ● | ● | ● | ● |
| Graphics 1 | Graphics 2 | | |
| ● | ● | | |
| Banner 1 | Banner 2 | Banner 3 | Banner 4 |
| ▲ | ▲ | × | × |

▲:Horizontal banding or graininess is visible on some of the print patterns.

10. Advanced Operations

10.1. Introduction (1/3)

cf. Operation Manual(Rev.01-p.55)

Introduction

Operating the keys to use the menus

Using the panel setting menus, configure various kinds of settings for the printer.

[1] To access to the setup menu, tap [Home].

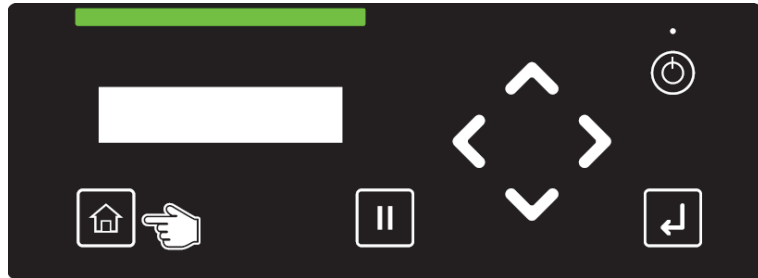

Note

You cannot access to the setup menu while printing or receiving data (the power button is flashing).

[2] Use or to go to the previous item or next item.

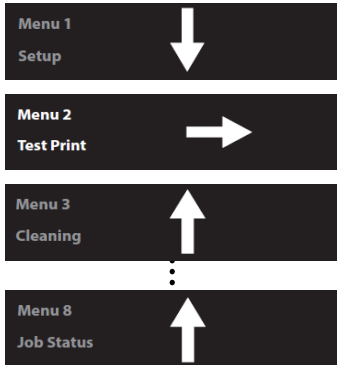

Use to go to the sub menu.



cf. Operation Manual(Rev.01-p.56)

Operating the keys to use the menus

[3] Use or to choose the option from the sub menu or enter the value.



To confirm the value or execute the selected function, tap [Enter].



Use to return to the upper level menu. (In the example on the left, the display will return to "Menu2: Test Print".)



10. Advanced Operations

10.1. Introduction (2/3)

cf. Operation Manual(Rev.01-p.56)

Introduction

Panel setup menu

Using the panel setting menus, configure various kinds of settings for the printer.

Menu 1: Setup (1/2)

Menu 1
Setup

Configure printer settings.

Submenus

| | |
|---------------------------|-----------------------------|
| Setup1 User Type | Setup 2 Spitting |
| Setup 3 Side Margin | Setup 4 Media Initial |
| Setup 5 Media Width | Setup 6 Output Mode |
| Setup 7 Method of Cut | Setup 8 Origin |
| Setup 9 Prevent Stick | Setup 10 Standby Heating |
| Setup 11 Head Travel | Setup 12 Multi Strike |
| Setup 13 Strike Wait | Setup 14 Slant Check |
| Setup 15 Auto Cleaning | Setup 16 Ink Status |
| Setup 17 Roll Length | Setup 18 Exhaust Fan |

cf. Operation Manual(Rev.01-p.57)

Panel setup menu

Menu 1: Setup (2/2)

Menu 1
Setup

Configure printer settings.

Submenus

| | |
|----------------------------|----------------------------|
| Setup 19 Longstore | Setup 20 CR Maintenance |
| Setup 21 Initialization | Setup 22 Life Times |
| Setup 23 IP Address | Setup 24 Subnet Mask |
| Setup 25 Gateway | Setup 26 Header Dump |
| Setup 27 Single Head | Setup 28 Heater Control |
| Setup 29 Start Feed | Setup 30 Alert Buzzer |
| Setup 31 LED Light | Setup 31 Temporary |

10. Advanced Operations

10.1. Introduction (3/3)

cf. Operation Manual(Rev.01-p.58)

Introduction

Panel setup menu

Using the panel setting menus, configure various kinds of settings for the printer.

Menu 2: Test Print

Menu 2
Test Print

Run a test print to check for nozzle condition, current printer settings, printer configuration, color palette, and print head alignment.

Submenus

Test Print 1

Nozzle Check

Test Print 2

Mode Print

Test Print 3

Setup List

Test Print 4

Palette

Test Print 5

Adjust Head

Menu 3: Cleaning

Menu 3
Cleaning

Perform the print head cleaning and initial ink charging.

Menu 4: Menu Option

Menu 4
Menu Option

Choose to show or hide the menus that are displayed in "Menu 1: Setup".

Menu 5: System Information

Menu 5
System Info.

Displays the version of the printer's firmware and total printed area in the printer.

cf. Operation Manual(Rev.01-p.59)

Panel setup menu

Menu 6: Sleep Mode

Menu 6
Sleep Mode

Choose the head cleaning mode and timer to be performed before entering to or while in sleep mode.

Submenus

Sleep Mode 1

Cleaning Setting

Sleep Mode 2

Start

Menu 7: Display

Menu 7
Display

Change the language, and unit of temperature and length displayed on the operation panel.

Submenus

Display 1

Language

Display 2

Temperature

Display 3

Length

Menu 8: Job Status

Menu 8
Job Status

Displays the last print job status.

10. Advanced Operations

10.2. Menu 1: Setup (1/12)

cf. Operation Manual(Rev.01-p.60)

Menu 1: Setup

Setup 1: User Type

Menu 1
Setup

You can have up to 15 groups of User Type, labeled "Type1" to "Type15".

When you select a User Type group ("Type") and tap [Enter], that definition group will be set for the printer. Also, a submenu will be displayed.

Setting values

User Type:

Type 1

Select a "Type" number, from "Type1" to "Type15".

サブメニュー

Type **: 1

Print Mode

Type **: 2

Adjust Print

Type **: 3

PF Adjust

Type **: 4

Pre Heater

Type **: 5

Platen Heater

Type **: 6

Dryer

Type **: 7

Vacuum Fan

Type **: 8

Thickness

Type **: 9

Copy User Type

Important!

When you change to another User Type, all the settings that can be set via the User Type will be changed.

- The settings that can be set via the User Type include "Print Mode", "Effect" the adjustment value for "Adjust Print", "PF Adjust", the setting value for "Pre Heater", "Platen Heater", "Dryer", "Vacuum Fan" and "Thickness".

When using the printer for the first time or using a new roll media, configure a user type settings.

cf. Operation Manual(Rev.01-p.76)

Setup 2: Spitting

Setup 2
Spitting

Sets up the spitting operation while printing.

The display will shift to setting of the pass count only if "On" is set for "Spitting".

Setting values

Spitting:

On

Perform the spitting operation on Spitting box located on the origin side for every shuttle.

This is the initially set value.

Spitting:

On Media

Perform the spitting operation on the page margins.

The printing speed will be improved since the number of time to return to Spitting box is reduced.

Spitting:

Off

Spitting operation is not performed.

Note

- Spitting is a maintenance operation for preventing clogging of the print head's nozzles.
It consumes ink.
- When Spitting is set to "Off", nozzles will become easily clogged because spitting is not performed.
In such a case, print quality cannot be guaranteed.
- When the spitting setting is "On Media", the maximum printable media width becomes 16 mm shorter.
Therefore, the side margins become the value that you have set in Side Margin menu +8 mm.

10. Advanced Operations

10.2. Menu 1: Setup (2/12)

cf. Operation Manual(Rev.01-p.76)

Menu 1: Setup

Setup 2: Spitting



Pass Count menu

Spitting:  **On**

This is for setting the interval at which the print head will carry out spitting operation.

Spitting:  **On Media**

The head will carry out spitting operation every time it completes the number of passes that you set here.

Use  or  to enter the value, and tap [Enter].

Setting values

Pass Count:  **1 cnt**

1 cnt/<2 cnt> to 999 cnt
 <> indicates the initial value.

Important!

If larger count is selected, the printing time will be faster, but it will increase the chance of nozzle clogging.

In such a case, print quality cannot be guaranteed.

<Example of spitting operation>



| Spitting setting | Pass Count setting | Operation |
|------------------|--------------------|---|
| On | 1 cnt | Perform the spitting operation on Spitting box every time Print head returns to the origin position. Spitting operation is not performed over the media. |
| On | 5 cnt | Performs the spitting operation on Spitting box on the origin side every five times Print head returns to the origin position. Spitting operation is not performed over the media. |
| On Media | 1 cnt | Performs the spitting operation on Spitting box on the origin side every time Print head returns to the origin position. Perform the spitting operation on Spitting box every time Print head returns to the origin position. |
| On Media | 5 cnt | Performs the spitting operation on Spitting box on the origin side every five times Print head returns to the origin position. Perform the spitting operation on Spitting box every time Print head returns to the origin position. |
| Off | — | Spitting is not performed on Spitting box or the media. |

cf. Operation Manual(Rev.01-p.77)

Setup 3: Side Margin

Setup 3
Side Margin

Set up the right and left margins (side margins) while printing.

Use  or  to enter the value, and tap [Enter].

Setting values

Side Margin:  **5 mm**

<5 mm> to 25 mm
 <> indicates the initial value.

Note

When the “Spitting menu” is set to “On Media”, the maximum printable media width becomes 16 mm shorter.

Therefore, the side margins become the value that you have set in Side Margin menu +8 mm.

Setup 4: Media Initial

Setup 4
Media Initial

Sets whether to detect the media width while initializing the media.

Setting values

Media Initial:  **Off**

The media will not be detected.

Media Initial:  **Top&Width**

Detect the media width and edge while initializing the media.

Media Initial:  **Width**

Detect the media width while initializing the media.
This is the initially set value.

Note

When “Media Initial menu” is set to “Off”, set the media width of the current media in Media Width menu.

10. Advanced Operations

10.2. Menu 1: Setup (3/12)

cf. Operation Manual(Rev.01-p.78)

Menu 1: Setup

Setup 5: Media Width

Setup 5
Media Width

Sets the width of the current media when the "Media Initial menu" is set to "Off".

When the "Media Initial menu" is set to "Width", the detected media width will be displayed.

Use  or  to enter the value, and tap [Enter].

Setting values

Media Width: 210 mm to <1,000 mm> to 1,625 mm
(210 - 1625) 1000 mm <> indicates the initial value.

Setup 6: Output Mode

Setup 6
Output Mode

Sets how the media is handled after printing.

Setting values

Output Mode: Off The Take-up Unit will not be used.
This is the initially set value.

Output Mode: Take Up Set when using the Take-up Unit.

Output Mode: Auto Cut Set when cutting the media automatically.

cf. Operation Manual(Rev.01-p.78)

Setup 6: Output Mode

When the "Output Mode" is set to "Take Up"

Output Mode: Take Up





When the "Output Mode" is set to "Take up", the menu is shifted to "Page Gap".

In the "Page Gap menu", you can change the margin setting between images.

Setting values

Page Gap: Normal The default margin setting between images will be applied.
This is the initially set value.

Page Gap: Narrow The margin setting between images is smaller than Normal.

After setting the Page Gap, sets the Ink drying time.
Use  or  to enter the value, and tap [Enter].

Setting values



InkDryTimer: <0 sec> to 60 min
(0 sec - 60 min) 0 sec <> indicates the initial value.

When the "Output Mode" is set to "Off" or "Auto Cut"

Output Mode: Off



Output Mode: Auto Cut

Sets the ink drying time.
Use  or  to enter the value, and tap [Enter].

Setting values

InkDryTimer: <0 sec> to 60 min
(0 sec - 60 min) 0 sec <> indicates the initial value.

10. Advanced Operations

10.2. Menu 1: Setup (4/12)

cf. Operation Manual(Rev.01-p.79)

Menu 1: Setup

Setup 7: Method of Cut

Setup 7
Method of Cut Sets the media cutting operation after printing.

Setting values

Method of Cut:
Single Cut - 2 steps
Cut with fewer steps than "Single Cut - 3 steps".
Suitable for media with narrow width.

Method of Cut:
Single Cut - 3 steps
Normal cutting method.
This is the initially set value.

Method of Cut:
Double Cut - 2 steps
Set when unable to cut with "Single Cut - 2 steps".
Suitable for media with narrow width.

Method of Cut:
Double Cut - 3 steps
Set when unable to cut with "Single Cut - 3 steps".

- Note**
- When the media detection is set to "Off", the media cannot be cut automatically.
 - Some media may not be cut (cannot be cut at all or cannot be cut finely).
In such a case, set the "Output Mode menu" to "Off" and cut the media manually.

Cut Pressure menu

Method of Cut:
Single Cut - 3 steps
Sets the media cutting pressure for the cutting operation.



Setting values

Cut Pressure:
Low
Cut the media at low pressure.
Suitable for thin media or if the "High" pressure setting is too strong.

Cut Pressure:
High
Normal cutting pressure.
This is the initially set value.

cf. Operation Manual(Rev.01-p.80)

Setup 8: Origin

Setup 8
Origin Sets the print start position (origin) on the media.
If you want to change the print start position to print an image on the blank space of the media, use this menu.

- ▲ / ▼ : Change the print start position (origin) in the PF (media feeding) direction.
- ◀ / ▶ : Change the print start position (origin) in the CR (carriage traveling) direction.
- Tap [Enter] to confirm the setting.

Setting values

Origin:
PF: -15000 CR: 1405
PF (media feeding direction):
-15,000 mm to 15,000 mm
CR (carriage traveling direction)
0 mm to 1,405 mm (maximum setting range varies by width of media being loaded).

Origin:
PF: 0 CR: 0

Confirm Position
End -> Enter
When the message on the left appears, tap [Enter] to end the origin settings.

The arrow mark on the origin label shows the current print start position in CR direction.

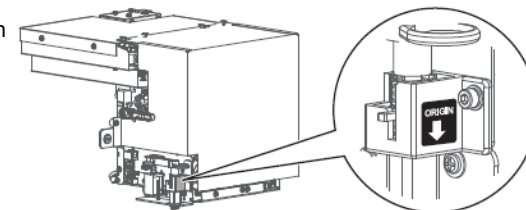

- Note**
- Depending on the set value of the side margin, the maximum set value of Y (print head transferring distance) decreases.
 - The right side margin will be the following sum depending on the setting.
Y of Origin menu + 8 mm (when the spitting is set to On Media) + Value set in Side Margin menu.

10. Advanced Operations

10.2. Menu 1: Setup (5/12)

cf. Operation Manual(Rev.01-p.81)

Menu 1: Setup

Setup 9: Prevent Stick menu

Setup 9
Prevent Stick Sets up to prevent media from sticking when printing starts.

Setting values

Prevent Stick: Off The stick-prevent operation is not performed.
This is the initially set value.

Prevent Stick: On The stick-prevent operation is performed.
Feed the media back and forth to prevent from sticking.



Note

When the "Output Mode menu" is set to "Take-up", the setting for the "Prevent Stick menu" is disabled.

Setup 10: Standby Heating

Setup 10
Standby Heating Sets the time to preheat Heater while the printer is in the standby mode.
When the preset time has passed, each Heater turns Off.
Use or to enter the value, and tap [Enter].

Setting values

Standby Heating: 10 min to <60 min>
(10 - 60) 60 min <> indicates the initial value.

cf. Operation Manual(Rev.01-p.81)

Setup 11: Head Travel

Setup 11
Head Travel Sets up the range that Print head moves while printing.

Setting values

Head Travel: Data Print head moves the range of the print data width.

Head Travel: Machine Print head moves from origin to the maximum printable media width.

Head Travel: Media Print head shifts within the media width.
This is the initially set value.

Setup 12: Multi Strike

Setup 12
Multi Strike Sets up the overwrite count per line.
Use or to enter the value, and tap [Enter].

Setting values

Multi Strike: <1 cnt> to 9 cnt
(1 - 9) 1 cnt <> indicates the initial value.

Setup 13: Strike Wait

Setup 13
Strike Wait Sets up the waiting time while overwrite printing.
Use or to enter the value, and tap [Enter].

Setting values

Strike Wait: <0.0 sec> to 5.0 sec
(0.0 - 5.0) 0.0 sec <> indicates the initial value.

10. Advanced Operations

10.2. Menu 1: Setup (6/12)

cf. Operation Manual(Rev.01-p.82)

Menu 1: Setup

Setup 14: Slant Check

Setup 14
Slant Check Sets up slanting detection during media loading.

Setting values

Media Slant: Off Slant Check is not performed.
This is the initially set value.

Media Slant: On Slant Check is performed.

Setup 15: Auto Cleaning

Setup 15
Auto Cleaning Configure the settings for the auto cleaning operation.

Submenus

Auto Cleaning 1
Standby Mode

Auto Cleaning 2
While Printing

Auto Cleaning 3
Before Print

cf. Operation Manual(Rev.01-p.83)

Setup 15: Auto Cleaning

Standby Mode menu

Auto Cleaning 1
Standby Mode Choose the auto cleaning mode and timer to be performed while in standby mode.

Submenus

Cleaning Type: Normal Off / Short / <Normal> / Long
<> indicates the initial value.

When the cleaning type is set to other than Off

Cleaning Type: Short If the cleaning type is set to Short, Normal, or Long, the display goes to the Cleaning Interval setting to set the timer for auto cleaning while in standby mode.



Setting values

Cleaning Interval: 360 min 10 min to <360 min> to 1,440 min
(10 - 1440) <> indicates the initial value.

10. Advanced Operations

10.2. Menu 1: Setup (7/12)

cf. Operation Manual(Rev.01-p.84)

Menu 1: Setup

Setup 15: Auto Cleaning

While Printing menu

Auto Cleaning 2
While Printing Choose the auto cleaning mode and timer to be performed while printing.

Submenus

Cleaning Type: Off
<Off> / Short / Normal / Long
<> indicates the initial value.

When the cleaning type is set to other than Off

Cleaning Type: Short
If the cleaning type is set to Short, Normal, or Long, the display goes to the Cleaning Interval setting to set the timer for auto cleaning while in printing.

Setting values

Cleaning Interval: 5 min
(5 - 180) 5 min <> indicates the initial value.

Before Print menu

Auto Cleaning 3
Before Print Choose the auto cleaning mode to be performed before printing.

Setting values

Before Print: Off
<Off> / Short / Normal / Long
<> indicates the initial value.

cf. Operation Manual(Rev.01-p.85)

Setup 16: Ink Status

Setup 16
Ink Status Displays the percentage of ink level in each ink bag.
The below is an example when using XPJ-1682SR.

| | |
|-------|--------------------|
| 1234: | 100 / 90 / 90 / 80 |
| 5678: | 100 / 90 / 90 / 80 |



Note
To display various information of Ink, use genuine ink and S/C cards.
If Ink bags other than genuine Ink bags are used, ink status will not be displayed correctly.

Setup 17: Roll Length

Setup 17
Roll Length Sets up the media length.

Setting values

Roll Kind: Off
Roll Length is not used.
This is the initially set value.

Roll Kind: Roll *
Sets up the media length.
The set values of the media length can be set as "Roll1" to "Roll3".

When the "Roll Kind" is set to "Roll 1", "Roll 2" or "Roll 3"

Length menu

Roll Kind: Roll 1
Sets up the media length.

Setting values

Length: 30 m
(1 - 1500) 1 m to <30 m> to 1,500 m
<> indicates the initial value.

10. Advanced Operations

10.2. Menu 1: Setup (8/12)

cf. Operation Manual(Rev.01-p.86)

Menu 1: Setup

Setup 17: Roll Length

Print stop menu

Length: (1 - 1500) 30 m

Sets whether or not to display "Roll Remain Error" and pause printing when the length of the media that is counted inside the printer becomes 0.

Setting values

Print Stop: Off

The media remaining count is not used to judge for pausing printing. Printing pauses when the rear sensor responds. **This is the initially set value.**

Print Stop: On

Even when the rear sensor does not respond, printing pauses when the media remaining count becomes 0.

Note

- Normally you can set this as "Off" as the rear sensor detects when the roll paper is finished.
- If you are using the media that does not come off the paper core easily when it is finished, printing may not be paused when the media is finished, if the "Print stop menu" is set to "Off".

If this happens, set this to "On".

Near End menu

Print Stop: On

Sets whether or not to display "Roll Near End: *m" (* is replaced with a number between 1 and 10) before the length of the media that is counted inside the printer becomes 0.

Setting values

Near End: Off

"Near end" is not displayed. **This is the initially set value.**

Near End: Remain * m

"Near end" is displayed when the remaining count for the media becomes the length you selected.

cf. Operation Manual(Rev.01-p.87)

Setup 18: Exhaust Fan

Setup 18 Exhaust Fan

Sets up Exhaust fan operation. Ventilates the inside of the printer to stabilize the parts performance. It also decreases the contamination by ink mist inside the printer. We recommend that you use Exhaust fan, especially when printing for a long time.

Setting values

Exhaust Fan: Off

Turn Off Exhaust fan.

Exhaust Fan: Low

Start Exhaust fan at Low. **This is the initially set value.**

Exhaust Fan: High

Start Exhaust fan at High.

Setup 19: Longstore

Setup 19 Longstore

Wash Print head with the cleaning fluid.

Setting values

Longstore Start -> Enter

Wash Print head with the cleaning fluid. Tap [Enter] to perform head cleaning.

Important!

Be sure to use the designated cleaning bag.

10. Advanced Operations

10.2. Menu 1: Setup (9/12)

cf. Operation Manual(Rev.01-p.87)

Menu 1: Setup

Setup 20: CR Maintenance

Setup 20
CR Maintenance

Performs maintenance. Used in the following cases.

- Cleaning and replacing of cleaning wiper
- Cleaning of print head circumference
- Replacing absorption material for the flushing box
- Replacing cutter

Submenus

CR Maintenance
End → Enter

Performs maintenance.

CR Maintenance
Start → Enter

Completes maintenance.
Perform the pumping operation (start/stop) by using .

Setup 21: Initialization

Setup 21
Initialization

Restore the printer settings to the factory default.

Submenus

Initialization:
ALL

For initializing the settings of all the menus.

Initialization:
UserType

Initializes the settings in the User Type menu.

Initialization:
Except UserType

Initializes the settings other than the ones in the User Type menu.

cf. Operation Manual(Rev.01-p.88)

Setup 22: Life Times

Setup 22
Life Times

Displays the operational life time of each part.

- The lifetime of each part is indicated by the asterisks (Maximum 5 asterisks: 100% left).
As the part deteriorates, the number of asterisks decreases one by one (20%).
- The part should be changed when all of the asterisks have disappeared and “Change” is displayed.
Contact your local MUTOH dealer to ask for replacing parts.
- After “Change” appears, “Life Times [Pump *]” or a similar message will be displayed when you are not in this menu.
You can delete this message by pressing the [Cancel] key.

The below is an example when using XPJ-1682SR.

Life Times
Head1: E*** F

Displays the service life for the print head 1.
The service life in this case is at 60%.

Life Times
Head2: E*** F

Displays the service life for the print head 2.
The service life in this case is at 60%.

Life Times
Pump1: E*** F

Displays the service life for the pump 1.
The service life in this case is at 60%.

Life Times
Pump2: E*** F

Displays the service life for the pump 2.
The service life in this case is at 60%.

Life Times
CR Motor: Change

Displays the service life for the CR motor.
The service life of the component in this case is over.
Have the component replaced.

Life Times
PF motor: E**** F

Displays the service life for the PF motor.
The service life in this case is at 80%.

10. Advanced Operations

10.2. Menu 1: Setup (10/12)





cf. Operation Manual(Rev.01-p.89)

Menu 1: Setup

Setup 23: IP Address

Setup 23 IP Address

Sets the IP address of the printer.

- Use  to increase a digit.
- Use  to decrease a digit.
- Use  to move the cursor to the previous digit.
- Use  to move the cursor to the next digit.

Tap [Enter] after entering each digit.

Setting values

IP Address: 0.0.0.0 to <192.168.1.253> to 255.255.255.255

<> indicates the initial value.







Note

Be sure to set the IP address, Subnet mask, and Gateway after consulting the network administrator.

Setup 24: Subnet Mask

Setup 24 Subnet Mask

Sets the subnet mask of the printer.

- Use  to increase a digit.
- Use  to decrease a digit.
- Use  to move the cursor to the previous digit.
- Use  to move the cursor to the next digit.

Tap [Enter] after entering each digit.

Setting values

Subnet Mask: 0.0.0.0 to <255.255.255.0> to 255.255.255.255

<> indicates the initial value.



Note





Be sure to set the IP address, Subnet mask, and Gateway after consulting the network administrator.

cf. Operation Manual(Rev.01-p.89)

Setup 25: Gateway

Setup 25 Gateway

Sets the gateway.

- Use  to increase a digit.
- Use  to decrease a digit.
- Use  to move the cursor to the previous digit.
- Use  to move the cursor to the next digit.

Tap [Enter] after entering each digit.

Setting values

Gateway: 0.0.0.0 to <192.168.1.254> to 255.255.255.255

<> indicates the initial value.



Note

Be sure to set the IP address, Subnet mask, and Gateway after consulting the network administrator.

Setup 26: Header Dump

Setup 26 Header Dump

Sets whether to print the following information when printing.

- Data header
- Data dot number (printed only when Header dump setting is "On")
- Printing date and time
- Printer serial number
- Firmware version
- Receiving time (printed only when Header dump setting is "Dump")
- Receiving size (printed only when Header dump setting is "Dump")

10. Advanced Operations

10.2. Menu 1: Setup (11/12)

cf. Operation Manual(Rev.01-p.90)

Menu 1: Setup

Setup 26: Header Dump

Setting values

| | |
|------------------------------|---|
| Header Dump: Off | Dump data is not printed. This is the initially set value. |
| Header Dump: On | Dump data is printed after the original image is printed. |
| Header Dump: Dump | Prints only dump data. "Data dot number" is not printed. |
| Header Dump: Print | Prints the last header dump. If no history is available, "No Print Data" will appear on the front panel. |

Note

- The data will be useful when contacting technical support.
- Performing printing if the printer is connected to PC, the print settings of RIP soft you are using are printed on data header.

Setup 27: Single Head (XPJ-1682SR Only)

| | |
|-------------------------|--|
| Setup 27 Single Head | Selects a print head for printing. (XPJ-1682SR Only) can still print even if some of the print heads malfunction. However, in that case the printing speed will drop. |
|-------------------------|--|

Setting values

| | |
|-------------------------------|---|
| Single Head: Off | Select this setting to use all the print heads for printing. This is the initially set value. |
| Single Head: Head 1 | Select this setting to use only print head 1 for printing. |
| Single Head: Head 2 | Select this setting to use only print head 2 for printing. |

cf. Operation Manual(Rev.01-p.91)

Setup 28: Heater Control

| | |
|----------------------------|---|
| Setup 28 Heater Control | Choose the appropriate heater mode for your media being loaded. If the media cockling is visible on the print, you can reduce it by selecting the appropriate heater mode. |
|----------------------------|---|

Setting values

| | |
|----------------------------------|--|
| Heater Control: Normal | If you are using the non-heat sensitive media, choose the Normal mode. This is the initially set value. |
| Heater Control: Fixer | If you want to reduce time to start printing and make media cockling less visible, choose the Fixer mode. |
| Heater Control: Dryer | If you are using the take-up unit and want to make media cockling less visible without reducing drying performance, choose the Dryer mode. |

Setup 29: Start Feed

| | |
|------------------------|--|
| Setup 29 Start Feed | You can change the margin setting between images. <ul style="list-style-type: none"> • Value greater than 0: The margin setting between images will be wider than when setting "0". • Value equal to 0: The default margin setting between images will be applied. • Value less than 0: The margin setting between images will be smaller than when setting "0". |
|------------------------|--|

Setting values

| | |
|----------------------------|---|
| Start Feed: (-10 - 500) | 0 mm <> indicates the initial value. |
|----------------------------|---|

Note

With take-up system: if you want to set "Start Feed" to below 0, set "Page Gap" to "Narrow".
If not, the Start Feed setting is not reflected properly.

10. Advanced Operations

10.2. Menu 1: Setup (12/12)

cf. Operation Manual(Rev.01-p.92)

Menu 1: Setup

Setup 30: Alert Buzzer

Setup 30
Alert Buzzer

Selects how to turn off the printer beep sound when an error occurs.

For unattended printing, you can select "Off" setting to avoid continuous buzzer beep.

Setting values

Alert Buzzer:

On

Press any key on the front panel to turn off beep sound.

This is the initially set value.

Alert Buzzer:

Off

After several beeps, the printer automatically turns off beep sound.

Setup 31: Internal LED Lights

Setup 31
LED Light

Selects the internal LED lights settings.

The lights help to inspect inside of the printer or your print during printing.

Setting values

LED Light:

Auto

The LED lights automatically turn on while printing, front cover open, initializing media, cutting media, specifying print start position (origin), and feeding media.

This is the initially set value.

LED Light:

On

The LED lights are always on. It will turn off while in sleep mode or when the printer is powered off.

LED Light:

Off

The LED lights are disabled.

cf. Operation Manual(Rev.01-p.92)

Setup 32: Temporary

Setup 31
Temporary

Displays the menus which have been set to hide in the "Menu4: Menu Option" temporarily.

Tap [Enter] to return to the previous menu with all set up items displayed.

10. Advanced Operations

10.3. Menu 2: Test Print (1/2)

cf. Operation Manual(Rev.01-p.93)

Menu 2: Test Print

Test Print 1: Nozzle Check

Test Print 1 Nozzle Check

Use this menu to check that the print head and print nozzles you selected can properly print without nozzle clogging and missing or too light lines.

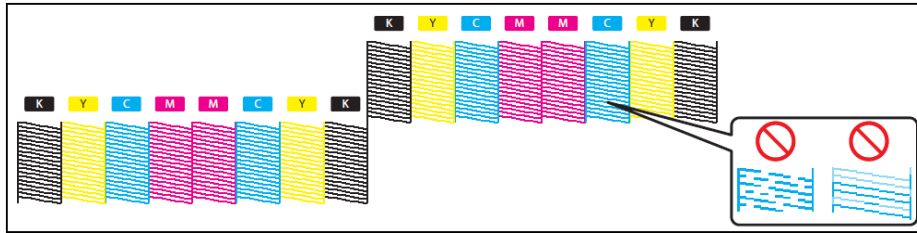

Note

- The pattern shown above is an example when printed on XPJ-1682SR with 4-color configuration.
- The printer information (date and time printed, printer's serial number, firmware version) is printed on the nozzle check pattern.

Test Print 2: Mode Print

Test Print 2 Mode Print

Mode print can be performed. Used to confirm the following printing conditions.

- Print quality
- Effect
- Setting value for Heater
- Micro adjustment value for feed correction

2019/1/01 0:00 G2(720x1080 6Pass Bi) -Fine&Fog/Pre: 30°C/Platen: 30°C/Dryer: 30°C/PF Adjust : 0.00%

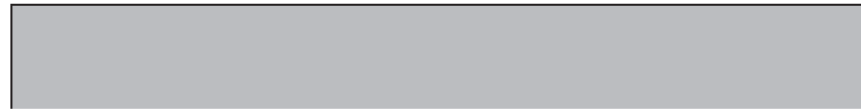

Test Print 3: Setup List

Test Print 3 Setup List

Setup list printing is performed. Use this to check the current setting contents and the User Type.

◆ Setup List

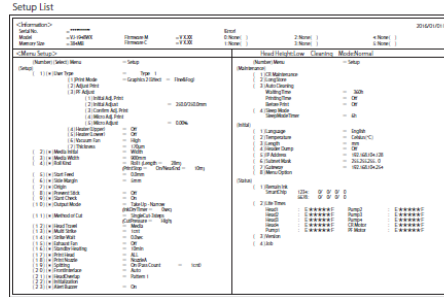

◆ User Type List

| User Type | Type1 | Type2 | Type3 | Type4 | Type5 |
|-------------------|------------|------------|------------|------------|------------|
| Print Mode | Graphics 2 | Graphics 2 | Graphics 2 | Graphics 2 | Graphics 2 |
| Print Mode Adjust | Printing | Printing | Printing | Printing | Printing |
| Header (Upper) | 2550/220mm | 2550/220mm | 2550/220mm | 2550/220mm | 2550/220mm |
| Header (Lower) | 0.00% | 0.00% | 0.00% | 0.00% | 0.00% |
| Vacuum Fan | Off | Off | Off | Off | Off |
| Thickness | High | High | High | High | High |
| | 175µm | 175µm | 175µm | 175µm | 175µm |
| User Type | Type6 | Type7 | Type8 | Type9 | Type10 |
| Print Mode | Graphics 2 | Graphics 2 | Graphics 2 | Graphics 2 | Graphics 2 |
| Print Mode Adjust | Printing | Printing | Printing | Printing | Printing |
| Header (Upper) | 2550/220mm | 2550/220mm | 2550/220mm | 2550/220mm | 2550/220mm |
| Header (Lower) | 0.00% | 0.00% | 0.00% | 0.00% | 0.00% |
| Vacuum Fan | Off | Off | Off | Off | Off |
| Thickness | High | High | High | High | High |
| | 175µm | 175µm | 175µm | 175µm | 175µm |
| User Type | Type11 | Type12 | Type13 | Type14 | Type15 |
| Print Mode | Graphics 2 | Graphics 2 | Graphics 2 | Graphics 2 | Graphics 2 |
| Print Mode Adjust | Printing | Printing | Printing | Printing | Printing |
| Header (Upper) | 2550/220mm | 2550/220mm | 2550/220mm | 2550/220mm | 2550/220mm |
| Header (Lower) | 0.00% | 0.00% | 0.00% | 0.00% | 0.00% |
| Vacuum Fan | Off | Off | Off | Off | Off |
| Thickness | High | High | High | High | High |
| | 175µm | 175µm | 175µm | 175µm | 175µm |

Test Print 4: Palette

Test Print 4 Palette

Palette print is executed for the color demonstration.

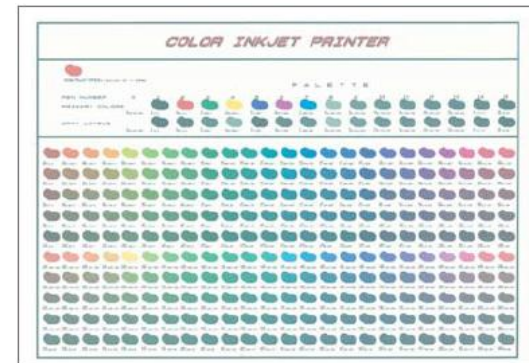

Note

When the selected print mode of the user type is Graphics 1 or Graphics 2, Palette menu is not displayed (XPJ-1682SR only).

10. Advanced Operations

10.3. Menu 2: Test Print (2/2)

cf. Operation Manual(Rev.01-p.95)

Menu 2: Test Print

Test Print 5: Adjust Head (XPJ-1682SR Only)

Test Print 5
Adjust Head

This menu calibrates the dot placement between two print heads installed on XPJ-1682SR.

Tap  to open the submenu.

Align the heads in the following cases:

- If the image quality does not improve after you have used the "Adjust Print" menu.
- When switching to thin media or a type of media where ink drops do not spread.

After executing this menu, be sure to perform the "Adjust Print" function.

If you don't, the image quality during bidirectional printing may drop.

Submenus

Adjust Head 1

Standard

Adjustment is performed only for the print mode set by the current User Type.

You can make the adjustments more quickly than by selecting "Fine Pattern ALL" in "Custom".

When selecting "Standard" here, you need to use the same print mode settings for the RIP (Raster Image Processor) as the print mode settings for the User Type.

Use the same settings for the resolution, pass and printing direction in the RIP print mode as in the print mode for the User Type.

Adjust Head 2

Custom

You can also adjust a print mode other than the one used for the current User Type.

You can print with an optimal image quality even if the RIP print mode is different from the print mode used for the User Type.

Adjust Head 3

Auto

Perform the automatic adjustment using the embedded color sensor.

It helps to reduce time and increase the alignment accuracy.



Note

- If print defects (like banding or grainy look) still appear on the print, try an auto calibration again, or go to "Adjust Print1/ Standard" or "Adjust Print2/ Custom" to perform calibration.

- If a roll media starts to cockle during calibration, load the media again.

10.4. Menu 3: Cleaning (1/2)

cf. Operation Manual(Rev.01-p.99)

Menu 3: Cleaning

Menu 3
Cleaning

(XPJ-1682SR)

Tap [Enter] to select the print heads you wish to clean. If nozzle missing is occurred in specific print head, select the print head that you want to perform cleaning.

In this way, you can reduce ink waste..

(XPJ-1641SR)

Tap [Enter] to select the cleaning mode.

The menu "Select Print Head" will not be displayed.

Setting values

Select Print Head

ALL

Select this setting to clean all the print heads. (XPJ-1682SR only)

Select Print Head

Head 1

Select this setting to clean only print head 1. (XPJ-1682SR only)

Select Print Head

Head 2

Select this setting to clean only print head 2. (XPJ-1682SR only)

10. Advanced Operations

10.4. Menu 3: Cleaning (2/2)

cf. Operation Manual(Rev.01-p.99)

Menu 3: Cleaning



Select the cleaning type.

Setting values

| | |
|---|--|
| Cleaning Type1 Short | Consumes less ink than Normal cleaning. |
| Cleaning Type2 Normal | Conduct nozzle check before and after printing, and use when nozzle missing is found. |
| Cleaning Type3 Long | Consumes more ink than Normal cleaning. When nozzle missing still occurs after Normal cleaning, conduct Long cleaning. |
| Cleaning Type4 Little Charge | Though much better cleaning results can be expected than Long cleaning, it consumes a large amount of ink. |
| Cleaning Type5 Initial Charge | Gives a rather higher cleaning effect than "LittleCharge", but also consumes rather more ink. |

Note

"InitialCharge" is available only when the Select Print Head menu is set to "ALL".

10.5. Menu 4: Menu Option (1/1)

cf. Operation Manual(Rev.01-p.100)

Menu 4 : Menu Option

You can choose whether to display the menus in "Menu 1: Setup". Choose whether you wish to display a menu by tapping [Enter].
 [*]= the item will be displayed
 []= the item will not be displayed

| | |
|-------------------------------------|---|
| Menu Option 1: User Type | [*] Displays the "User Type menu". The initial value is [*]. |
| Menu Option 2: Spitting | [*] Displays the "Spitting menu". The initial value is [*]. |
| ⋮ | |
| Menu Option 31: LED Light | [*] Displays the "LED Light menu". The initial value is [*]. |
| Menu Option 32: ALL On | If you tap [Enter], all the items in Menu Option will be marked with a [*] (displayed). |
| Menu Option 33: ALL Off | If you tap [Enter], all the items in Menu Option will be marked with a [] (not displayed). |

10. Advanced Operations

10.6. Menu 5: System Info. (1/1)

cf. Operation Manual(Rev.01-p.101)

Menu 5 : System Info.

Menu 5
System Info. Displays the versions of the firmware and total printed area.

Submenus

Version
Ver. M / C 0.00 / 0.00

Displays the versions of the firmware of the main side (M) and controller side (C).

Total Print Area
42949672m²

Displays total printed area in the printer since the purchase.
This information may be used for reference for maintenance.

10.7. Menu 6: Sleep Mode (1/2)

cf. Operation Manual(Rev.01-p.101)

Menu 6 : Sleep Mode

Menu 6
Sleep Mode Start Sleep Mode and set the head cleaning interval during Sleep Mode.

Submenus

Sleep Mode 1
Cleaning Setting

Sleep Mode 2
Start

Sleep Mode 1: Cleaning Setting

Sleep Mode 1
Cleaning Setting Set the timer to perform the head cleaning while in sleep mode.

Setting values

Cleaning Type: Short

<Short> / Normal / Long
<> indicates the initial value.
Tap [Enter] to confirm the setting and the display goes to the Cleaning Timer setting.

Cleaning Timer: 6 h

(1 - 24) 1 / 2 / 3 / 4 / 5 / <6> / 9 / 12 / 18 / 24h
<> indicates the initial value.

10. Advanced Operations

10.7. Menu 6: Sleep Mode (2/2)

cf. Operation Manual(Rev.01-p.102)

Menu 6 : Sleep Mode

Sleep Mode 2: Start

Sleep Mode 2 Start

Put the printer into sleep mode.

- Tap  .
- "Sleep Mode Start -> Enter" is displayed. Tap [Enter].
- "In Sleep Mode Wake up -> Enter" is displayed. The sleep mode will start.
- To exit the sleep mode, tap [Enter].

Important!

During Sleep Mode, even if the set amount of time has passed, print-head cleaning is not performed under the following circumstances.

- When the front cover is open.
 - When the maintenance cover is open.
 - The pressure rollers is released.
 - The waste ink tank is full.
 - The ink bag case has been removed.
 - The S/C card has been removed.
 - The inserted S/C card is not the genuine S/C card, etc.
- If one of the above conditions occurs during Head cleaning, cleaning is stopped. When the printer returns to a normal state, Head cleaning is restarted.

10.8. Menu 7: Display (1/2)

cf. Operation Manual(Rev.01-p.103)

Menu 7 : Display

Display 1: Language

Display 1 Language

Choose the language of the operation panel from the following selection.

Setting values

Language:

English

Default setting.

Language:

Dutch

Language:

Spanish

Language:

French

Language:

Italian

Language:

Portuguese

Language:

German

10. Advanced Operations

10.8. Menu 7: Display (2/2)

cf. Operation Manual(Rev.01-p.103)

Menu 7 : Display

Display 2: Temperature

Display 2
Temperature Choose the unit of the temperature displayed on the operation panel.

Setting values

Temperature: Celsius [°C] Displays the temperature in Celsius.
This is the initially set value.

Temperature: Fahrenheit [°F] Displays the temperature in Fahrenheit.

Display 3: Length

Display 3
Length Choose the unit of the length displayed on the operation panel.

Setting values

Length: mm Displays the length in millimeters (mm).
This is the initially set value.

Length: inch Displays the length in inches (inch).

10.9. Menu 8: Job Status (1/1)

cf. Operation Manual(Rev.01-p.104)

Menu 8 : Job Status

Menu 8
Job Status Various information of previous print will be displayed.

Job Status
Status: Completed Displays if the print is completed.
• When the print is completed: [Completed]
• When the print is canceled: [Canceled]

Job Status
ToDoLength: XXX.X m The total length of print data (media feeding direction) will be displayed.

Job Status
Done: XXX.X m The printed length will be displayed.

Job Status
Remain: XXX.X m The remaining length of print data will be displayed.

Note

- The values displayed in this function are just standard values, not guarantee the accuracy.
- If the print data includes no length data, all information will be displayed as "0".
- This function is to check the information of print data with the print operation is completed. For the details on data while printing, please refer to the "**Menu 7: Job Status**"

11. User Maintenance

11.1. Instruction Before Purchase (1/1)

Instruction Before Purchase

Mutoh recommends users to sign the maintenance contract.

Before the purchase of XPJ-1641SR/XPJ-1682SR, make sure that users agree to the conditions below:

- This product requires user maintenance.
- Users without maintenance contract is responsible for the periodic replacement cost.
- Users should purchase the designated consumable supplies for replacement.
- Users should bear the cost of lifetime replacement parts.
- Users must understand the following characteristics of solvent printer:
 - This product is not compatible with some of the substrates, especially it is not suitable for a roll media which cockles easily.
 - This product cannot directly print on some of the substrates.
 - The scratch resistance varies by types of media.
 - To ensure the predictable print quality, users must use a recommended media as instructed by media manufacturer.

User maintenance

The following maintenance should be performed by users.

- 吐Run a nozzle check and regular maintenance.
- Replace consumable supplies (wiper, cutter blade, and flushing pad).
- Clean the printer.

Regular maintenance

| Cycle | Maintenance | Note |
|-------------|--------------------------|---|
| Daily | N/A | - |
| Weekly | Wiper cleaning | - |
| Monthly | Clean the printer | - |
| When needed | Flushing pad replacement | When looking from the side, the ink deposits accumulated on the flushing pad is visible through the flushing box frame. |
| | Cleaning around head | When nozzle missing or ink dripping cannot recover by head cleaning. |
| | Wiper cleaning | When nozzle missing or ink dripping cannot recover by head cleaning. |

※ Users should replace a replaceable wiper every six months.

11. User Maintenance

11.2. Maintenance (1/1)

cf. Operation Manual(Rev.01-p.110)

Maintenance

To maintain the performance of this product, please conduct maintenance by yourself. The types of maintenance are shown next.

| | |
|----------------------------------|--|
| Before and after daily operation | <ul style="list-style-type: none"> • Nozzle check and cleaning |
| Based on your usage condition | <ul style="list-style-type: none"> • Head cleaning |
| | <ul style="list-style-type: none"> • Cleaning around the capping unit |
| | <ul style="list-style-type: none"> • Cleaning around the print head |
| | <ul style="list-style-type: none"> • Cleaning the color sensor |
| | <ul style="list-style-type: none"> • Replacing ink bag |
| | <ul style="list-style-type: none"> • Emptying waste ink tank |
| Weekly | <ul style="list-style-type: none"> • Replacing absorption material for the flushing box |
| | <ul style="list-style-type: none"> • Replacing Cutter |
| Weekly | <ul style="list-style-type: none"> • Cleaning of cleaning wiper |
| Monthly | <ul style="list-style-type: none"> • Inside cleaning |
| Every six months | <ul style="list-style-type: none"> • Replacing the cleaning wiper |
| When not used for a week or more | <ul style="list-style-type: none"> • Head cleaning (Once a week) |
| When not used for a long | <ul style="list-style-type: none"> • Long-term storage |

Important!

Since a service technician has to handle following cases, please contact your local MUTOH dealer.







- Error requiring restart is happening repeatedly
- The message to notify the life of print head, pump and various motors is displayed.

11.3. Checking ink and replacing ink bag (1/3)

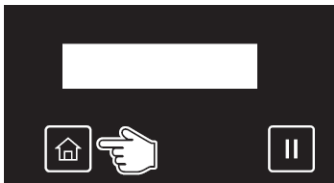
cf. Operation Manual(Rev.01-p.111)

Checking ink and replacing ink bag

Checking ink level

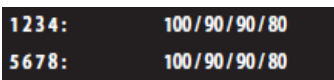
-  Tap [Home].
-  Tap .
-  Tap  until the menu on the left appears.
 - Tap .
-  The ink level is displayed from 0% to 100%.
 - The left is an example when using XPJ-1682SR.

• 4-color setting (XPJ-1641SR)

| | | | |
|----------------|---------------|------------------|-----------------|
| K Black | C Cyan | M Magenta | Y Yellow |
|----------------|---------------|------------------|-----------------|

• 4-color setting (XPJ-1682SR)

| | | | |
|-----------------------|-----------------------|----------------------|----------------------|
| 1 K1 (Black) | 2 K2 (Black) | 3 C1 (Cyan) | 4 C2 (Cyan) |
| 5 M1 (Magenta) | 6 M2 (Magenta) | 7 Y1 (Yellow) | 8 Y2 (Yellow) |

• 7-color setting (XPJ-1682SR)

| | | | |
|----------------------|-----------------------------|---------------------|---------------------------|
| 1 M (Magenta) | 2 Lm (Light Magenta) | 3 C (Cyan) | 4 Lc (Light Cyan) |
| 5 K (Black) | 6 CL (Cleaner) | 7 Y (Yellow) | 8 Lk (Light Black) |

11. User Maintenance

11.3. Checking ink and replacing ink bag (2/3)

cf. Operation Manual(Rev.01-p.112)

Checking ink and replacing ink bag

When it becomes time to replace ink bag

When the ink level becomes low, the error LED of the front panel flashes and a buzzer sounds.

[1] [4] S / C Ink Low

PG: Low

W: 1625 m

Tap [Enter].

- The buzzer stops
- In the figure to the left, the slot 4 ink bag is nearing replacement.

[2] Prepare the replacement ink bag.

Replacing ink bag

When an ink bag runs out of ink, the error message [Ink End] or [S/C Ink End] appears on the panel with blinking error LED and beep sound.

Replace an ink bag immediately.

The printer will not resume printing until the ink bag is replaced.

Important!

- **Do not replace ink bag when the printer is powered off.**
Ink level cannot be detected correctly.
- **If ink bag is moved from cold to warm place, leave it in the room temperature at least three hours.**
- **If you do not have any replacement ink bag, do not remove the empty ink bag from the printer.**

This may cause the nozzle clogs.

cf. Operation Manual(Rev.01-p.112)

Replacing ink bag

1. Removing the ink bag case

[1] [4] Ink End

Tap [Enter].

- The buzzer stops.
- In the figure to the left, the slot 4 ink bag must be replaced

[2] Remove the ink bag case and S/C card that you need to replace from each slot.

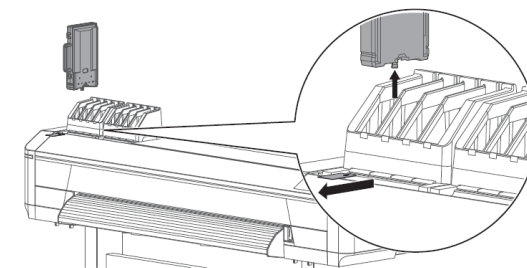

[3]

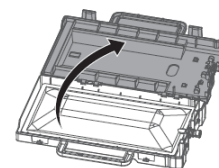

Open the ink bag case.

[4]

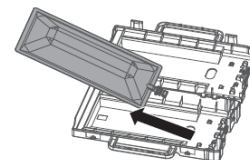

Remove the empty ink bag

Note

Place the used ink bag in a plastic bag or the like and dispose of the ink bag according to the local regulations.

11. User Maintenance

11.3. Checking ink and replacing ink bag (3/3)

cf. Operation Manual(Rev.01-p.113)

Checking ink and replacing ink bag

Replacing ink bag

2. Installing the ink bag (1/2)

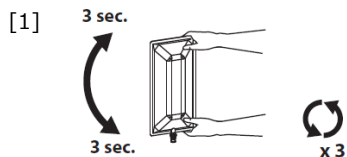

Prepare the new ink bag, and follow the instructions below to invert it to mix the ink.

- Face the ink spout side upwards for 3 seconds.
- Invert it and count for 3 seconds.
- Repeat that 3 times.

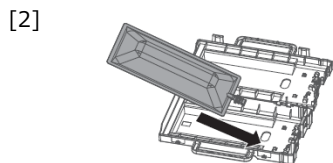

Put the ink bag into the case.

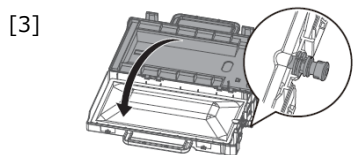

Close the ink bag case.

Important!

Make sure the spout of ink bag is properly fitted into the groove in the case.

If not fitted, the printer cannot correctly detect ink bag.

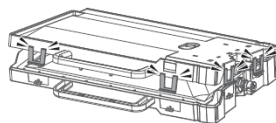

Close all the latches (×4) of the case properly.

Important!

Check that all the latches (×4) are closed. If not, it may cause ink spillage.

cf. Operation Manual(Rev.01-p.114)

Replacing ink bag

2. Installing the ink bag (2/2)

- [4] Insert the ink bag case with the new ink bag installed and new S/C card into each slot.
- Match the colors of the ink color indicating label on the printer and the label on the ink bag.
 - Face the latch side toward you and insert the case into each slot.
 - Make sure that they are fully inserted.

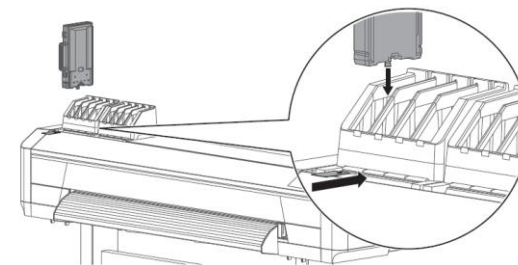

11. User Maintenance

11.4. Emptying waste ink tank (1/1)

cf. Operation Manual(Rev.01-p.115)

Emptying waste ink tank

Emptying waste ink tank

In the following cases, drain waste ink in the waste ink tank into a container to empty the tank.

- When the waste ink tank is more than half full.
- When "Full WasteInkTank" is displayed on the front panel.

Display messages

Full Waste Ink Tank

The waste ink tank is full. Empty the tank immediately.

- The printer will stop operation until you empty the waste ink tank.

1. Drain waste ink into a container (1/2)

CAUTION

Wear the protective gloves •glasses •mask and avoid contact with your eyes or skin.

Eye or skin contact may cause slight irritation or bloodshot eyes.

If in eyes or on skin, immediately flush with water.

If irritation is present, seek medical advice/attention immediately.

[1] Prepare a container to collect waste ink.



The capacity of the waste ink tank is 2,000 ml.

Make sure to prepare a container with at least 2,000 ml capacity.

[2] Cover the floor just under the waste ink tank using a paper that you do not use.

cf. Operation Manual(Rev.01-p.115)

Emptying waste ink tank

2. Drain waste ink into a container (2/2)

[3] Open the waste ink valve and drain waste ink into the container.



To avoid ink splash, move the container closer to the waste ink valve while draining waste ink.

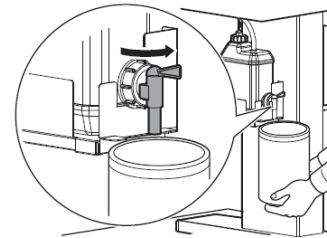

[4] Once you empty the tank, close the waste ink valve securely.

- Wipe the opening of the valve with a cloth.

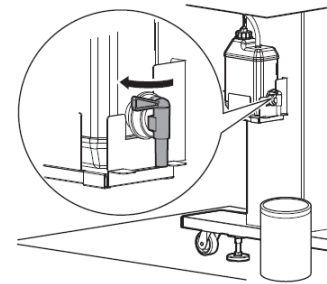

[5] Dispose of waste ink according to the local waste disposal regulations.

11. User Maintenance

11.5. Head cleaning (1/2)

cf. Operation Manual(Rev.01-p.117)

Cleaning

Head cleaning

If you find missing or thin lines on your print or nozzle check print, perform head cleaning.

Following cleaning modes are available:

| | |
|-----------------|---|
| Short cleaning | Consumes less ink than Normal cleaning. |
| Normal cleaning | If nozzle missing is found on the nozzle check print, perform Normal cleaning. |
| Long cleaning | If nozzle missing still persists after Normal cleaning, perform Long cleaning. It consumes more ink than Normal cleaning. |
| Little Charge | Little Charge gives higher cleaning than Long cleaning, but consumes large amount of ink. |
| Initial Charge | Initial Charge offers more powerful cleaning than Little Charge, but consumes large amount of ink. |

Important!

When you perform "Little Charge" or "Initial Charge",

- Do not power off the printer.
- Do not disconnect the power cords.
- Do not open the front cover and maintenance cover during cleaning.
- Do not release the pressure rollers.
- Do not remove ink bag cases and S/C cards from the printer.
- Be sure that remaining ink in the ink bag is enough to perform cleaning.

If cleaning is interrupted, it may consume more amount of ink.

cf. Operation Manual(Rev.01-p.118)

Head cleaning

1. Performing Head cleaning

[1] Tap  .

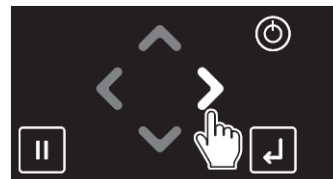

[2] Use  or  to choose the cleaning mode. Tap [Enter].
 • The printer will start cleaning.

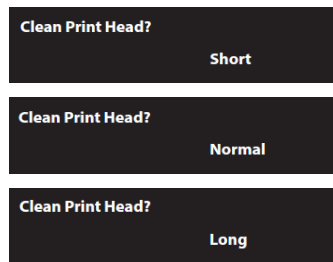

[3] Run a nozzle check.

2. Performing Nozzle check (1/2)

[1] Tap  .

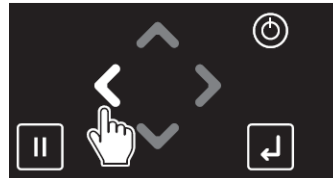

[2] Tap [Enter].
 • The printer will print the nozzle check pattern.

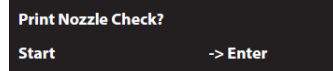

11. User Maintenance

11.5. Head cleaning (2/2)

cf. Operation Manual(Rev.01-p.119)

Cleaning

Head cleaning

2. Performing Nozzle check (2/2)

[3] Check the print result.

- If you find missing or thin lines on the print, go to **"Performing Head cleaning"**
- If all lines are clearly printed, you can start printing.

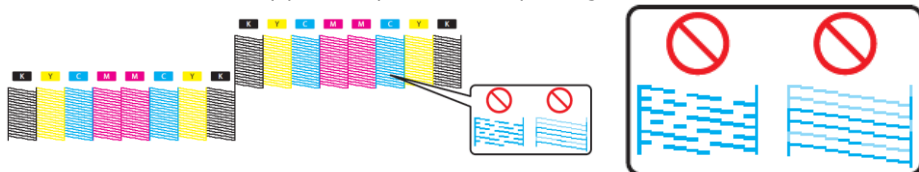

Note

- If nozzle missing persists after repeating normal cleaning several times, perform Long cleaning.
- If several Long cleaning does not help to recover nozzles, perform **"Cleaning of cleaning wiper"** or **"Cleaning around the print head"**
- nozzle missing still persists, perform Little Charge from "Menu 3 Cleaning" > "Select Print Head" > "Cleaning Type".

11.6. Cleaning of cleaning wiper (1/2)

cf. Operation Manual(Rev.01-p.120)

Cleaning

Cleaning of cleaning wiper

Cleaning period:

- Weekly
- **When print blurring and dot missing remain after head cleaning is done.**

Preparation:

- Cleaning stick

Important!

During cleaning, please note the followings.

- **If it is hard to remove the stain, perform "Short" Head cleaning, and then clean again.**
- **Use a dry cleaning stick**
A damp stick can cause damage to the print head.
- **Do not touch the tip of a cleaning stick with fingers.**
Skin oil will damage the print head.
- **Do not reuse a cleaning stick.**
Dust on the stick will damage the print head.
- **This cleaning takes about 5 minutes.**
If it takes longer, the stick will get dry causing damage to the print head.

1. Putting the printer into the CR maintenance mode (1/2)

[1] Tap [Home].



[2] Tap .



[3] Tap until the menu on the left appears.

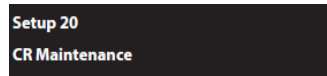

• Tap .

11. User Maintenance

11.6. Cleaning of cleaning wiper (2/2)

cf. Operation Manual(Rev.01-p.121)

Cleaning

Cleaning of cleaning wiper

1. Putting the printer into the CR maintenance mode (2/2)

- [4] **CR Maintenance**
Start → Enter
- Tap [Enter].
- The carriage will move to the left side of the printer.
 - The cleaning wiper will move upward.

- [5] **CR Maintenance**
End → Enter
- The message on the left will appear.
- The printer will start cleaning.

Note

If you tap the key while “CR Maintenance End -> Enter” is displayed, the pump is activated, sucking up the ink in the cap.

2. Cleaning the cleaning wiper (1/3)

- [1] Open the front cover.

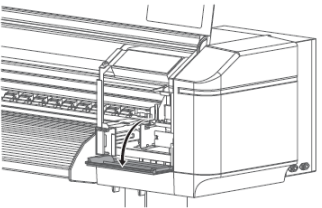
- [2]  Open the maintenance cover on the right side.

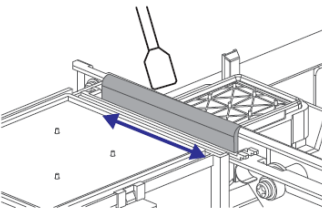
- [3]  Wipe the cleaning wiper with a cleaning stick.
- Wipe the left side of the wiper back and forth.

Important!

If it is hard to remove the stain, perform “Short” Head cleaning, and then clean again.

cf. Operation Manual(Rev.01-p.122)

Cleaning of cleaning wiper

2. Cleaning the cleaning wiper (2/3)

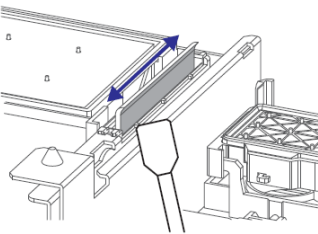
- [4]  Wipe the right side of the wiper back and forth.

- [5]  Close the maintenance cover.

- [6] Close the front cover.

- [7] **CR Maintenance**
End → Enter
- Tap [Enter].

- [8] **CR Maintenance**
Start → Enter
- Tap [Home] to end the cleaning process.

Note

Used cleaning stick should be put in a plastic bag, etc, and dispose of it in compliance with local ordinance and instructions of local authorities.

11. User Maintenance

11.7. Cleaning around the capping unit (1/1)

cf. Operation Manual(Rev.01-p.123)

Cleaning

Cleaning around the capping unit

Cleaning period:

- When print blurring and dot missing remain after head cleaning is done.

Preparation:

- Cleaning stick

Important!

During cleaning, please note the followings.

- **Use a dry cleaning stick**
A damp stick can cause damage to the print head.
- **Do not touch the tip of a cleaning stick with fingers.**
Skin oil will damage the print head.
- **Do not reuse a cleaning stick.**
Dust on the stick will damage the print head.
- **This cleaning takes about 5 minutes.**
If it takes longer, the stick will get dry causing damage to the print head.

Step (1/2)

[1] Put the printer into the CR maintenance mode.

[2] Open the front cover.

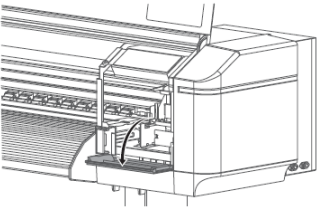
[3]  Open the maintenance cover on the right side.

cf. Operation Manual(Rev.01-p.124)

Cleaning around the capping unit

Step (2/2)

[3]

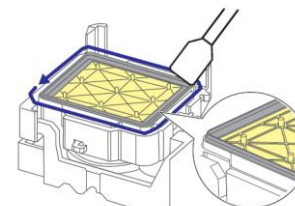

- Clean this part (grey)
- DO NOT touch the absorber (yellow)

Use the cleaning stick to clean around the rubber part of the capping unit to remove the ink deposits and dust. (Capping unit)

- XPJ-1641SR: 1
- XPJ-1682SR: 2

Important!

If it is hard to remove the stain, perform "Short" Head cleaning, and then clean again.

[5]

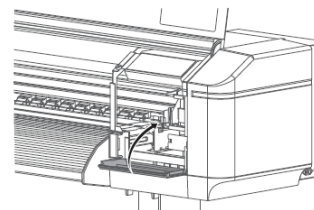

Close the maintenance cover.

[6] Close the front cover.

[7]  Tap [Enter].

[8]  Tap [Home] to end the cleaning process.

Note

cleaning stick should be put in a plastic bag, etc, and dispose of it in compliance with local ordinance and instructions of local authorities

11. User Maintenance

11.8. Cleaning around the print head (1/2)

cf. Operation Manual(Rev.01-p.125)

Cleaning

Cleaning around the print head

Cleaning period:

- When print blurring and dot missing remain after head cleaning is done.

Preparation:

- Cleaning stick

Important!

During cleaning, please note the followings.

- Use a dry cleaning stick
A damp stick can cause damage to the print head.
- Do not touch the tip of a cleaning stick with fingers.
Skin oil will damage the print head.
- Do not reuse a cleaning stick.
Dust on the stick will damage the print head.
- This cleaning takes about 5 minutes.
If it takes longer, the stick will get dry causing damage to the print head.

Step (1/3)

[1] Put the printer into the CR maintenance mode.

[2] Open the front cover.



[3]  Open the maintenance cover on the left side.

cf. Operation Manual(Rev.01-p.125)

Cleaning around the print head

Step (2/3)



[4] Use the cleaning stick to remove the ink deposits or dust on the bottom of the carriage.

-  Clean this part (grey)
-  DO NOT touch the surface of a print head (yellow)

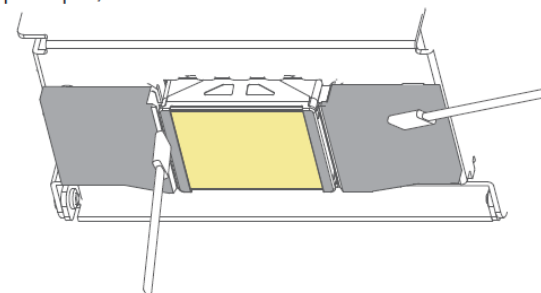
- Surface around print head (silver metal part)
- ※Clean the part between the print head and print head guide.
- Print head guide (black plastic part)



XPJ-1641SR

-  Clean this part (grey)
-  DO NOT touch the surface of a print head (yellow)

- Surface around print head (silver metal part)
- ※Clean the part between the print head and print head guide.
- Print head guide (black plastic part)

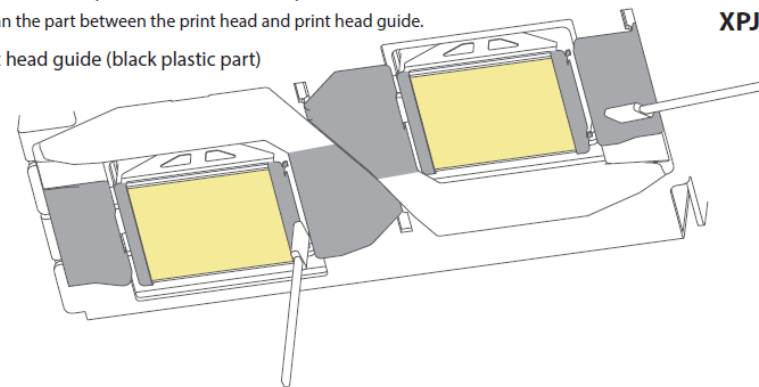

XPJ-1641SR

11. User Maintenance

11.8. Cleaning around the print head (2/2)

cf. Operation Manual(Rev.01-p.126)

Cleaning

Cleaning around the print head

Step (3/3)

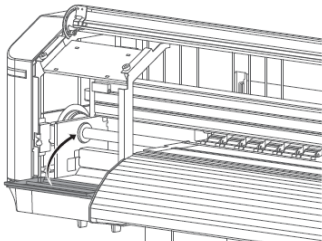
- [5]  Close the maintenance cover.

- [6] Close the front cover.

- [7]  Tap [Enter].

- [8]  Tap [Home] to end the cleaning process.

 Note

cleaning stick should be put in a plastic bag, etc, and dispose of it in compliance with local ordinance and instructions of local authorities

11.9. Cleaning around the color sensor (1/2)

cf. Operation Manual(Rev.01-p.127)

Cleaning

Cleaning the color sensor

Cleaning period:

- **If you repeatedly failed to perform an auto head alignment or auto print quality calibration .**

Preparation:

- Cleaning stick
- Ethanol (commercially available item: Use one with a concentration of 50% or higher.)

 Important!

During cleaning, please note the followings.

- **Do not push the glass on the color sensor too hard with a cleaning stick.**
This will damage the glass.
- **Do not reuse a cleaning stick.**
Dust may adhere to the color sensor causing malfunction.
- **This cleaning takes about 5 minutes.**
If it takes longer, the stick will get dry causing damage to the print head.

Step (1/3)

- [1] Put the printer into the CR maintenance mode.

- [2] Open the front cover.

- [3]  Open the maintenance cover on the left side.

11. User Maintenance

11.9. Cleaning around the color sensor (2/2)



cf. Operation Manual(Rev.01-p.127)

Cleaning



Cleaning the color sensor

Step (2/3)

[4] Using a cleaning stick slightly dampened with ethanol, gently clean the glass on the color sensor located at the bottom of the carriage to remove ink and dust.

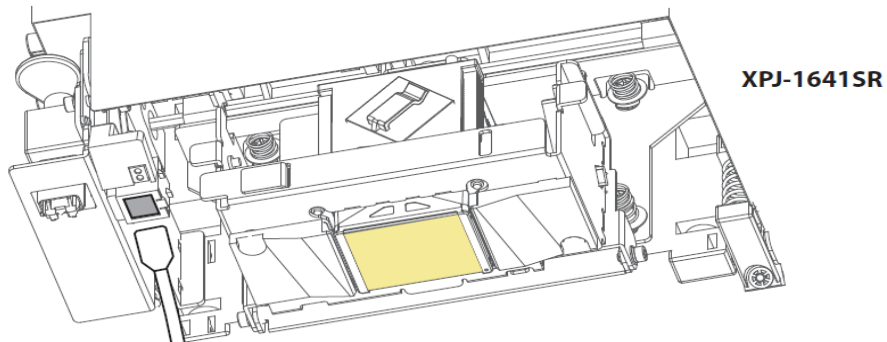
-  Clean this part (Do not push the glass too hard.)
-  DO NOT touch the surface of a print head (yellow)



-  Clean this part (Do not push the glass too hard.)
-  DO NOT touch the surface of a print head (yellow)

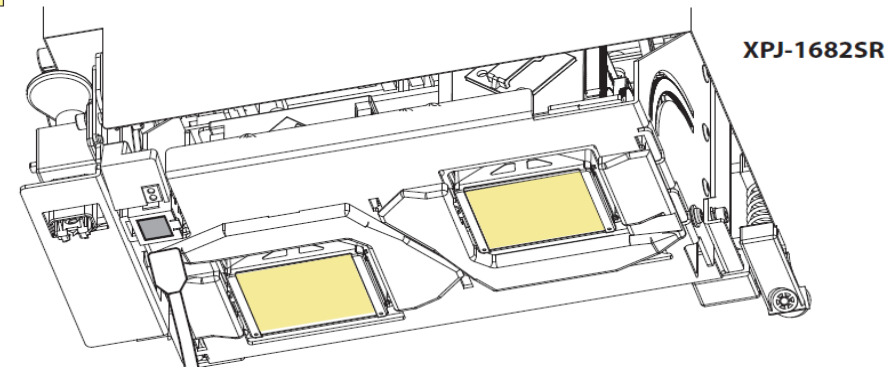

cf. Operation Manual(Rev.01-p.128)

Cleaning the color sensor

Step (3/3)

[5]  Close the maintenance cover.

[6] Close the front cover.

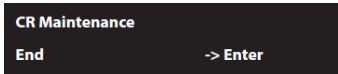
[7]  Tap [Enter].

[8]  Tap [Home] to end the cleaning process.

 Note

cleaning stick should be put in a plastic bag, etc, and dispose of it in compliance with local ordinance and instructions of local authorities

11. User Maintenance

11.10. Inside cleaning (1/1)

cf. Operation Manual(Rev.01-p.129)

Cleaning

Inside cleaning

Cleaning period:

- Monthly
- When dust or ink stains are visible

Preparation:

- Soft brush
- Paper towel or Soft cloth
- Ethanol (commercially available item: Use one with a concentration of 50% or higher.)
- Gloves

CAUTION

Unplug the power cable with the power OFF, before cleaning the inside of the printer.

Step (1/2)

- [1] Remove the media.
- [2] Make sure that the printer is turned OFF.
- [3] Open the front cover.



Immediately after turning off the power, the temperature of the heater in this product is very high.

Touch the platen or media guide and if it is too hot, allow it to cool before cleaning.

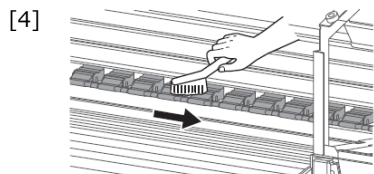

Brush off dusts on the pressure rollers with a soft brush.



Do not blow off dusts inside the product with a gas duster.

Dust can attach to moving parts, causing abnormal sound or malfunctions.

cf. Operation Manual(Rev.01-p.129)

Inside cleaning

Step (2/2)

[5]

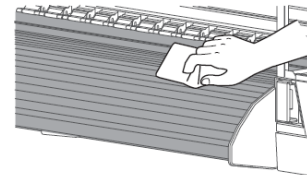

Use a soft cloth or paper towel slightly dampened with ethanol to clean off the ink on the platen, media guide and paper guide.



Wear protective gloves while cleaning.

[6] Close the front cover.

11. User Maintenance

11.11. Replacing absorption material for the flushing box (1/2)

cf. Operation Manual(Rev.01-p.130)

Replacing consumable parts

Replacing absorption material for the flushing box

The flushing box is a part that keeps receiving ink discharged from the print head. Please replace the absorption material for the flushing box periodically. If used without replacing, it can cause damage to the print head.

Replacing period:

- **Approx. every two months**
(since it differs depending on usage frequency, please check periodically)

Preparation:

- Absorption material for the flushing box
- Paper you can get dirty (paper which ink will not bleed through)

1. Checking steps (1/2)

- [1] Open the front cover.

- [2]  Open the maintenance cover on the right side.

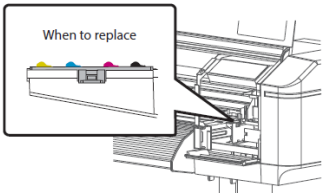
- [3]  Check the absorption material for the flushing box.
- When there are lumps of ink rise from the frame of the flushing box, it is time to replace.

cf. Operation Manual(Rev.01-p.130)

Replacing absorption material for the flushing box

1. Checking steps (2/2)

- [5]  Close the maintenance cover.

- [6] Close the front cover.

2. Replacing steps (1/3)

- [1] Put the printer into the CR maintenance mode.

- [2] Open the front cover.

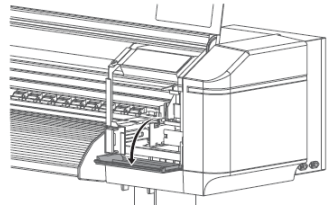
- [3]  Open the maintenance cover on the right side.

- [4] Cover the platen with the paper you can get dirty.



**Ink may drip from the absorption material for the flushing box.
We recommend covering the floor with paper as well.**

11. User Maintenance

11.11. Replacing absorption material for the flushing box (2/2)

cf. Operation Manual(Rev.01-p.131)

Replacing consumable parts

Replacing absorption material for the flushing box

2. Step (3/3)

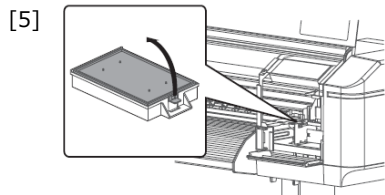

[5] Pull the tab up of the absorption material for the flushing box, and release the hook. Then remove the absorption material for the flushing box.

Important!

When removing the absorption material for the flushing box, be cautious of ink drops.

Note

Used absorption material for the flushing box should be put in a plastic bag, etc, and dispose of it in compliance with local ordinance and instructions of local authorities.

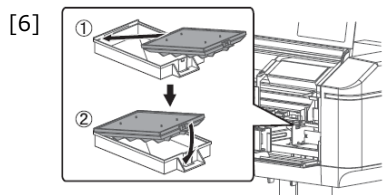

[6] Attach new absorption material for the flushing box.

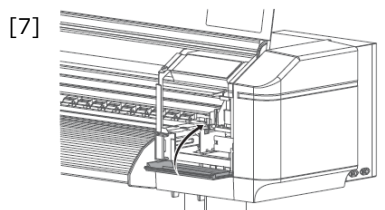

[7] Close the maintenance cover.

[8] Close the front cover.

cf. Operation Manual(Rev.01-p.132)

Replacing absorption material for the flushing box

2. Replacing steps (3/3)

[9] **CR Maintenance**
End -> Enter Tap [Enter].

[10] **CR Maintenance**
Start -> Enter Tap [Home] to end the cleaning process.

11. User Maintenance

11.12. Replacing Cutter (1/2)

cf. Operation Manual(Rev.01-p.132)

Replacing consumable parts

Replacing Cutter

Replacing period:

- When the media is not cut smoothly
- When the cut surface is feathered, etc

Preparation:

- Cutter replacement blade

⚠ CAUTION

- **Do not push the knob of cutter or release suddenly.**
Because there is a spring under the cutter, the cutter can jump out.
- **Do not touch the cutter blade.**
It may cause injury.

1. Step (1/3)

[1] Put the printer into the CR maintenance mode.

[2] Open the front cover.

[3]  Open the maintenance cover on the left side.

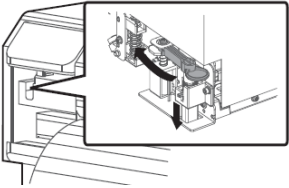
[4]  Press the cutter cap lightly, turn Cutter holder in the direction as illustrated below.



Do not push down the cutter cap.
It may damage the part.

cf. Operation Manual(Rev.01-p.133)

Replacing Cutter

1. Step (2/3)

[5]  Remove the Cutter.

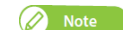

Note
Used Cutter should be put in a plastic bag, etc, and dispose of it in compliance with local ordinance and instructions of local authorities.

[6]  Attach a new cutter.

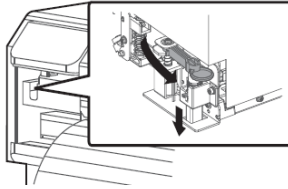
[7]  Press the cutter cap lightly, return Cutter holder to its initial position.

[5]  Close the maintenance cover.

[6] Close the front cover.

11. User Maintenance

11.12. Replacing Cutter (2/2)

cf. Operation Manual(Rev.01-p.133)

Replacing consumable parts

Replacing Cutter

1. Step (3/3)

[7]  Tap [Enter].

[8]  Tap [Home] to end the cleaning process.

11.13. Replacing the cleaning wiper (1/2)

cf. Operation Manual(Rev.01-p.134)

Replacing consumable parts

Replacing the cleaning wiper

The cleaning wiper is an essential part to make printing consistent. Please replace it periodically.

Replacing period:

- **Approx. every six months**

Preparation

- Plastic gloves, glasses, mask
- Absorption material for the flushing box
- Paper you can get dirty (paper which ink will not bleed through)

CAUTION

- **Wear the protective gloves •glasses •mask and avoid contact with your eyes or skin.**

Eye or skin contact may cause slight irritation or bloodshot eyes.

If in eyes or on skin, immediately flush with water.

If irritation is present, seek medical advice/attention immediately.

1. Step (1/3)

[1] Put the printer into the CR maintenance mode.

[2] Open the front cover.

[3]  Open the maintenance cover on the right side.

[4] Cover the platen with the paper you can get dirty.



Ink may drip from the cleaning wiper.

We recommend covering the floor with paper as well.

11. User Maintenance

11.13. Replacing the cleaning wiper (2/2)

cf. Operation Manual(Rev.01-p.135)

Replacing consumable parts

Replacing the cleaning wiper

1. Step (2/3)

[5]

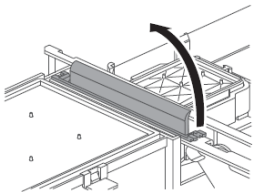

Remove the cleaning wiper.

- Lift the cleaning wiper hook and release the hook. Then, remove the cleaning wiper.

Important!

When removing the cleaning wiper, be cautious of ink drops.

Note

Used cleaning wiper should be put in a plastic bag, etc, and dispose of it in compliance with local ordinance and instructions of local authorities.

[6]

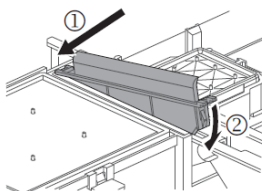

Follow the steps below to install new cleaning wiper.

- Slide the front side of the new cleaning wiper into its slot.
- Press the wiper hook down until it clicks into place.

Important!

Do NOT touch the cleaning wiper rubber with your bare hand.

If finger oil gets on the rubber, it will damage the print head.

[7]

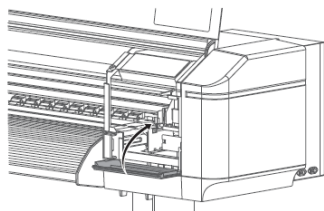

Close the maintenance cover.

[8] Close the front cover.

cf. Operation Manual(Rev.01-p.135)

Replacing the cleaning wiper

1. Step (3/3)

[9] CR Maintenance End -> Enter Tap [Enter].

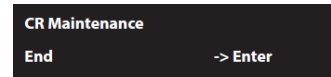

[10] CR Maintenance Start -> Enter Tap [Home] to end the cleaning process.

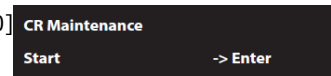

11. User Maintenance

11.14. Moving or transporting the printer (1/1)

cf. Operation Manual(Rev.01-p.136)

Moving or transporting the printer

Moving the printer

This section describes how to move the printer.



- **When moving the printer, make sure to maintain a horizontal position.**
- **Do not tilt, set against something or place this product upside down. Otherwise the ink may leak or the handling mentioned above may cause abnormality.**

1. Preparation before moving

- [1] Make sure that the printer is turned OFF.
- [2] Dispose of waste fluid.
- [3] Remove all the cables, such as Power cord set.

- [4] Loosen the four adjusters of Stand as shown in the left.

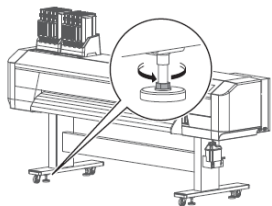

- [5] Move the printer.

2. Reinstalling

- [1] Select a suitable place for installation.
- [2] Move and install the printer to the location.
- [3] Attach Cables, such as Power cord set.
- [4] Perform Nozzle check, and then confirm that there is no clogging in Print head.
- [5] Perform print quality adjustment.

cf. Operation Manual(Rev.01-p.137)

Transporting the printer

When transporting the printer, make sure to pack it in the same condition as purchased, using protective and packing materials to protect the printer from vibration and shocks.

11. User Maintenance

11.15. Long-term storage (1/4)

cf. Operation Manual(Rev.01-p.138)

Moving or transporting the printer

Long-term storage

If not using the printer for a long time, execute [Longstore].

Preparation:

• **XPJ-1641SR**

Cleaning bag: 4

• **XPJ-1682SR**

Cleaning bag: 8

1. Step (1/5)

[1] Empty the waste ink tank.

[2] Tap [Home].



[3] Tap .



[4] Tap until the menu on the left appears.



• Tap .

[5] Tap [Enter].



Remove Bags The message on the left will appear.



cf. Operation Manual(Rev.01-p.139)

Long-term storage

1. Step (2/5)

[6] Remove all ink bag cases and S/C cards.
 • Store the ink bag together with the corresponding S/C card.

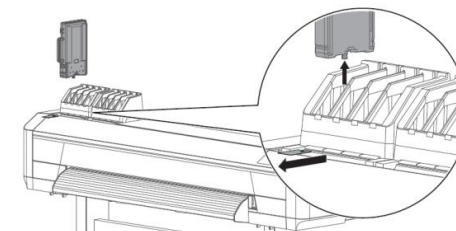

Washing Head

The message on the left will appear.
 • Ink discharging begins.

Insert Cleaning Bags

When the discharge is complete, the message to the left is displayed.

[7] Put the cleaning bag into the case.

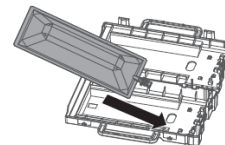

[8] Close the ink bag case.

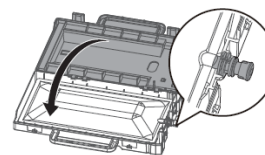

Important!

Make sure the spout of cleaning bag is properly fitted into the groove in the case. If not fitted, the printer cannot correctly detect cleaning bag.

Close all the latches (×4) of the case properly.

Important!

Check that all the latches (×4) are closed. If not, it may cause cleaner spillage.

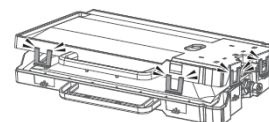

11. User Maintenance

11.15. Long-term storage (2/4)

cf. Operation Manual(Rev.01-p.140)

Moving or transporting the printer

Long-term storage

1. Step (3/5)

- [9] Insert the ink bag cases with cleaning bags and S/C cards into each slot.
- Face the latch side toward you and insert the case into each slot.
 - Make sure that they are fully inserted.

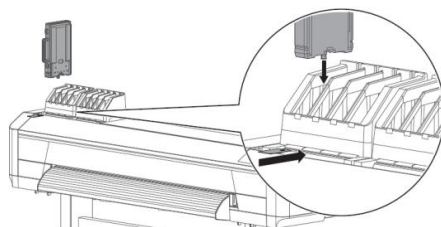

Washing Head

The message on the left will appear.

- Charging of the cleaner begins.

Remove Bags

When charging of the cleaner is complete, the message to the left is displayed.

- [10] Remove all ink bag cases and S/C cards.

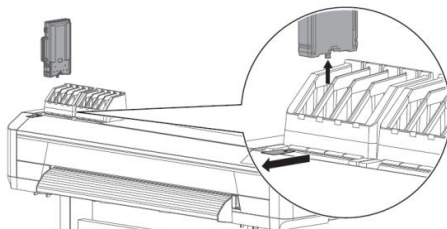

Washing Head

The message on the left will appear.

- Cleaner discharging begins.

Insert Cleaning Bags

When the discharge is complete, the message to the left is displayed.

cf. Operation Manual(Rev.01-p.141)

Long-term storage

1. Step (4/5)

- [11] Insert the ink bag cases with cleaning bags and S/C cards into each slot.
- Face the latch side toward you and insert the case into each slot.
 - Make sure that they are fully inserted.

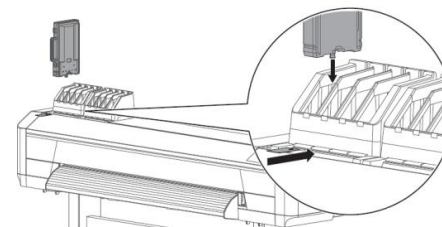

Washing Head

The message on the left will appear.

- Charging of the cleaner begins.

Remove Bags

When charging of the cleaner is complete, the message to the left is displayed.

- [12] Remove all ink bag cases and S/C cards.

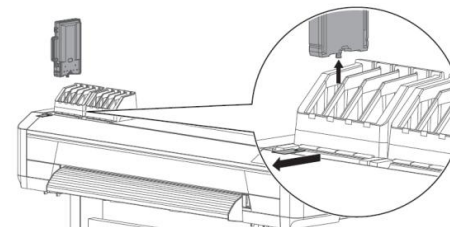

Washing Head

The message on the left will appear.

- Cleaner discharging begins.

[ALL] Discharged

When discharging is complete, the message to the left is displayed.

11. User Maintenance

11.15. Long-term storage (3/4)

cf. Operation Manual(Rev.01-p.142)

Moving or transporting the printer

Long-term storage

1. Step (5/5)

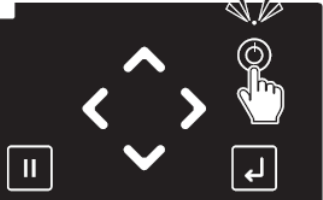
[13] 

Long press the Power button.

- This product starts its powering off operations.
- When the message “Power Off” appears on the panel, release the Power button.
- The Power LED lights off.

Performing initial charging after head cleaning

1. Step (1/4)

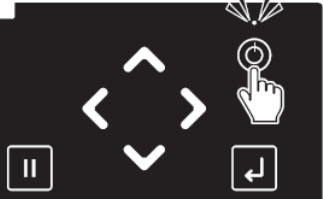
[1] 

Long press the Power button.

- The Power LED (above the Power button) lights
- This product starts its initialization operations.

Note

Once the Power LED lights up, release the Power button.

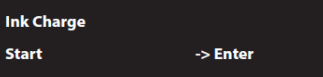
[2] 

When the message to the left is displayed, tap [Enter].

[3] 

When the message to the left is displayed, tap [Enter].

Note

If you need to perform a head cleaning and “Wash retry? No” is displayed, tap the key to change the display to “Wash retry? Yes” and tap [Enter]. After that, follow the instructions displayed on the front panel. When cleaning is complete, “Insert InkBags” is displayed. Proceed to step 4 in this section.

cf. Operation Manual(Rev.01-p.143)

Performing initial charging after head cleaning

1. Step (2/4)

 The message on the left will appear.

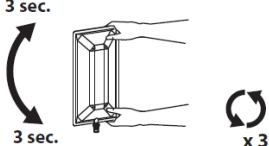
[4] 

Make sure you agitate the ink bag after you prepare it.

- Face the ink spout side upwards for 3 seconds.
- Invert it and count for 3 seconds.
- Repeat that 3 times.

Important!

Be sure to use new ink bags.
If a half-used ink bag does not have enough ink, it will run out of ink during initial ink charging and will consume more ink.

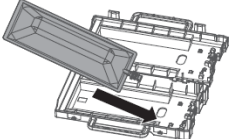
[5] 

Put the ink bag into the case.

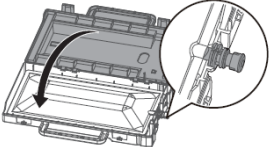
[6] 

Close the ink bag case.

Important!

Make sure the spout of ink bag is properly fitted into the groove in the case.
If not fitted, the printer cannot correctly detect ink bag.

Close all the latches (×4) of the case properly

Important!

Check that all the latches (×4) are closed.
If not, it may cause ink spillage.

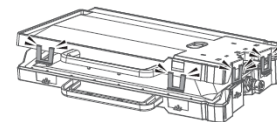

11. User Maintenance

11.15. Long-term storage (4/4)

cf. Operation Manual(Rev.01-p.143)

Moving or transporting the printer

Performing initial charging after head cleaning

1. Step (3/4)

- [9] Insert the ink bag cases and S/C cards into each slot.
- Match the colors of the ink color indicating label on the printer and the label on the ink bag.
 - Face the latch side toward you and insert the case into each slot.
 - Make sure that they are fully inserted.

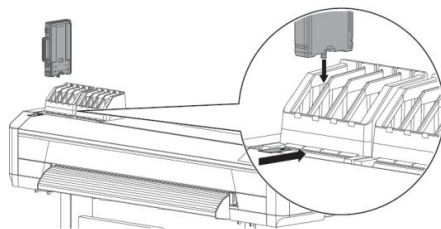

Ink Refill **%

The message on the left will appear.

- Ink charging begins.

CAUTION

During ink charging, make sure:

- Not to turn OFF the printer.
- Not to unplug the power cable of the printer.
- Not to open the front cover.
- Not to open the maintenance cover.
- Not to release the pressure rollers.

[9] Media End
PG: Low

When ink charging is complete, the message to the left is displayed.

cf. Operation Manual(Rev.01-p.144)

Performing initial charging after head cleaning

1. Step (4/4)

Important!

If the printer perform the nozzle check printing immediately after the initial ink charge is complete, the following results may occur.

- Printed lines become blurred.
 - The data is partially not printed.
- such cases, follow "Menu 3: Cleaning" and perform "Little Charge".
Then, check the print result.

If there is no improvement in the print result even after performing "Little Charge", leave the printer unused for an hour or more.

Then perform "Little Charge" again and check the print result.

12. Engineer Maintenance

12.1. Removing Covers (1/9)

cf. XPJ-1641SR Maintenance Manual(Rev.00-3.2.)

Covers - Remove / Assemble(XPJ-1641SR)

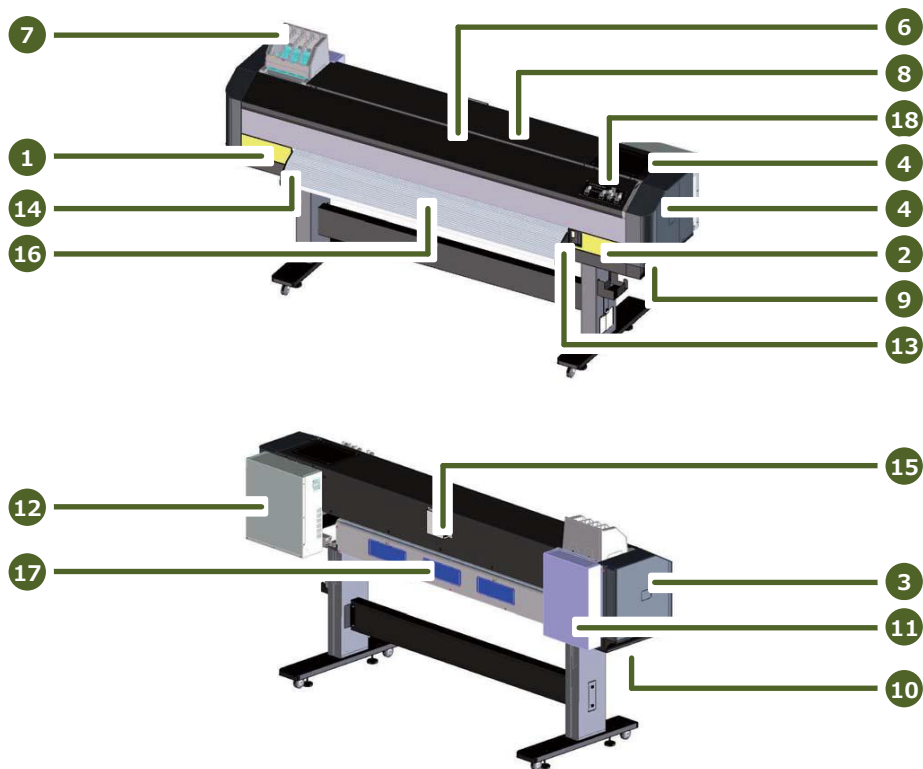

| No | Name | No | Name | No | Name |
|----|---------------------|----|---------------------|----|---------------------|
| 1 | Maintenance Cover L | 8 | Top Cover | 15 | Exhaust Fan Cover |
| 2 | Maintenance Cover R | 9 | Bottom Cover R | 16 | Paper Guide F Upper |
| 3 | Side Cover L | 10 | Bottom Cover L | 17 | Paper Guide R |
| 4 | Side Cover R | 11 | Subtank Cover | 18 | Upper Tray |
| 5 | Panel Unit | 12 | Board Box Cover | | |
| 6 | Front Cover | 13 | Paper Guide Cover R | | |
| 7 | IH Cover | 14 | Paper Guide Cover L | | |

cf. XPJ-1682SR Maintenance Manual(Rev.00-3.2.)

Covers - Remove / Assemble(XPJ-1682SR)

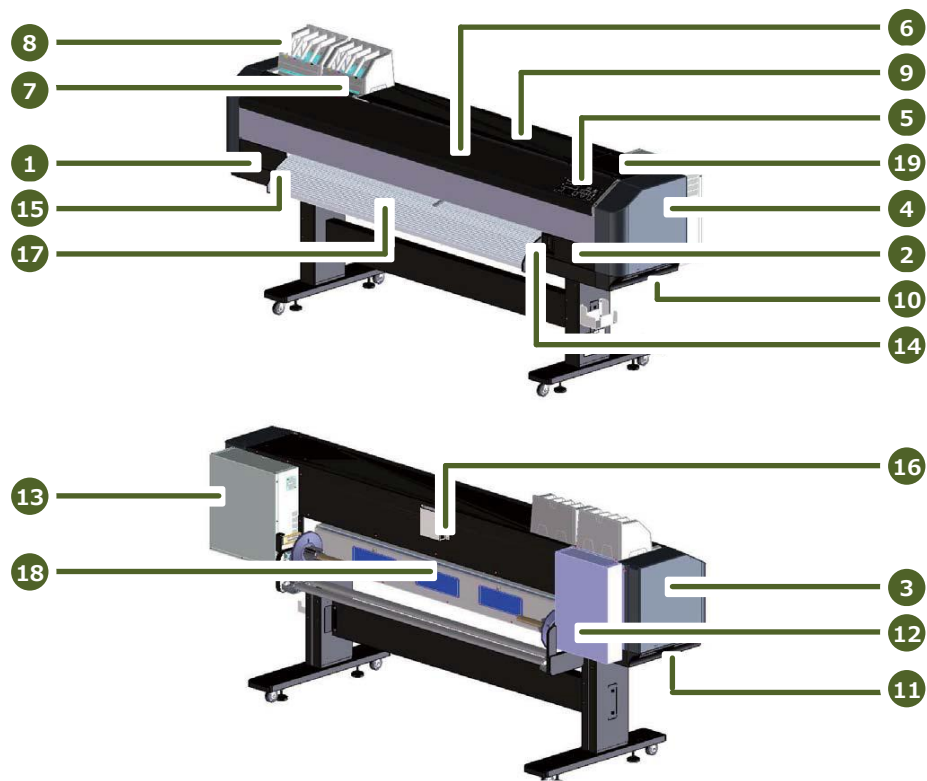

| No | Name | No | Name | No | Name |
|----|---------------------|----|---------------------|----|---------------------|
| 1 | Maintenance Cover L | 8 | IH Cover L | 15 | Paper Guide Cover L |
| 2 | Maintenance Cover R | 9 | Top Cover | 16 | Exhaust Fan Cover |
| 3 | Side Cover L | 10 | Bottom Cover R | 17 | Paper Guide F Upper |
| 4 | Side Cover R | 11 | Bottom Cover L | 18 | Paper Guide R |
| 5 | Panel Unit | 12 | Subtank Cover | 19 | Upper Tray |
| 6 | Front Cover | 13 | Board Box Cover | | |
| 7 | IH Cover R | 14 | Paper Guide Cover R | | |

12. Engineer Maintenance

12.1. Removing Covers (2/9)

cf. Maintenance Manual (XPJ-1641SR:Rev.00-3.2.1./XPJ-1682SR:Rev.00-3.2.1.)

Maintenance Cover L

Preparation:

- None

Screws:

- None

- [1] Open front cover.
- [2] Open maintenance cover L.
- [3] Move maintenance cover L to the left.
- [4] Remove maintenance cover L.
- [5] To Assemble unit, reverse the removal procedure.



cf. Maintenance Manual (XPJ-1641SR:Rev.00-3.2.2./XPJ-1682SR:Rev.00-3.2.2.)

Maintenance Cover R

Preparation:

- None

Screws:

- None

- [1] Open front cover.
- [2] Open maintenance cover R.
- [3] Move maintenance cover R to the right.
- [4] Remove maintenance cover R.
- [5] To Assemble unit, reverse the removal procedure.

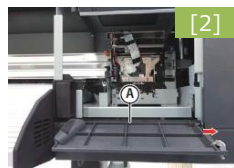

cf. Maintenance Manual (XPJ-1641SR:Rev.00-3.2.3./XPJ-1682SR:Rev.00-3.2.3.)

Side Cover L

Preparation:

- Phillips Screwdriver No.2

Screws:

- Round Head Screw with Split Washer M4x10 (x2)
- P Tight Bind Screw M4x12 (x5)

- [1] Open front cover.
- [2] Remove screw(s).
- [3] Remove side cover L.
- [4] To Assemble unit, reverse the removal procedure.

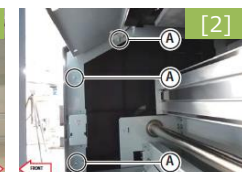

cf. Maintenance Manual (XPJ-1641SR:Rev.00-3.2.4./XPJ-1682SR:Rev.00-3.2.4.)

Side Cover R

Preparation:

- Phillips Screwdriver No.2

Screws:

- Round Head Screw with Split Washer M4x10 (x2)
- P Tight Bind Screw M4x12 (x5)

- [1] Open front cover.
- [2] Remove screw(s).
- [3] Remove side cover R.
- [4] To Assemble unit, reverse the removal procedure.

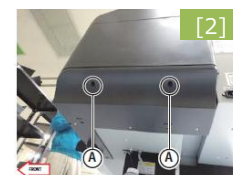
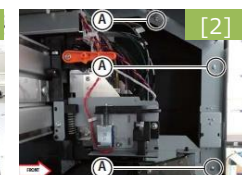

12. Engineer Maintenance

12.1. Removing Covers (3/9)

cf. Maintenance Manual (XPJ-1641SR:Rev.00-3.2.5./XPJ-1682SR:Rev.00-3.2.5.)

Panel Unit

Preparation:

- None

Screws:

- None

[1] Open front cover.

[2] Lift panel unit.



Note

- Press front latch(es) (x2).
- Lift the front portion
- Pull the unit.

- Panel Unit is fixed with 4 latches in the front stay R.

[3] Remove panel FFC.

[4] Remove panel unit.

[5] To Assemble unit, reverse the removal procedure.

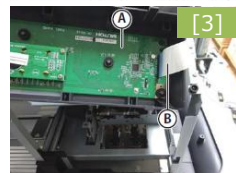
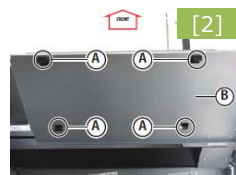
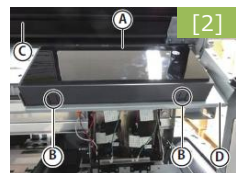

cf. Maintenance Manual (XPJ-1641SR:Rev.00-3.2.6./XPJ-1682SR:Rev.00-3.2.6.)

Front Cover (1/2)



Note

Minimum two people are required for this process.

Preparation:

- Phillips Screwdriver No.2
- Hex wrench 4mm

Screws:

- Washer M3x5 (x4)
- P Tight Bind M3x6 (x4)
- Hexagon Socket Head Bolt M4x10 (x2)

[1] Remove side cover R.

[2] Remove side cover L.

[3] Remove panel unit.

[4] Remove screw(s).

- Washer M3x5 (x4)

[5] Remove screw(s).

- P Tight Bind M3x6 (x2)

[6] Remove rotary dumper 3NL.

[7] Remove screw(s).

- P Tight Bind M3x6 (x2)

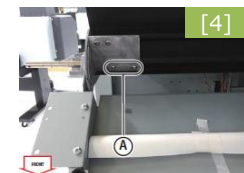

12. Engineer Maintenance

12.1. Removing Covers (4/9)

cf. Maintenance Manual (XPJ-1641SR:Rev.00-3.2.6./XPJ-1682SR:Rev.00-3.2.6.)

Front Cover (2/2)

[8] Remove rotary dumper 3NL.

[9] Remove stopper (R).

- Hexagon Socket Head Bolt M4x10 (x1)

[10] Remove stopper (L).

- Hexagon Socket Head Bolt M4x10 (x1)

[11] Remove front cover axis (L).

Note

- Open front cover by 3 centimeters.
- Do the job while another man holds the front cover.

[12] Remove front cover axis (R).

Note

- Open front cover by 3 centimeters.

[12] Remove front cover.

[13] To Assemble unit, reverse the removal procedure.



cf. Maintenance Manual (XPJ-1641SR:Rev.00-3.2.7.)

IH Cover (XPJ-1641SR)

Preparation:

- Phillips Screwdriver No.2

Screws:

- S Tight Cup M3x8 (x4)

[1] Remove S/C card(s).

[2] Remove ink cartridge(s).

[3] Remove screw(s).

[4] Remove IH Cover .

[5] To Assemble unit, reverse the removal procedure.

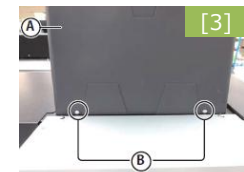

12. Engineer Maintenance

12.1. Removing Covers (5/9)

cf. Maintenance Manual (XPJ-1682SR:Rev.00-3.2.7.)

IH Cover R (XPJ-1682SR)

Preparation:

- Phillips Screwdriver No.2

Screws:

- S Tight Cup M3x8 (x4)

[1] Remove S/C card(s).

[2] Remove ink cartridge(s).

[3] Remove screw(s).

[4] Remove IH cover R.

[5] To Assemble unit, reverse the removal procedure.

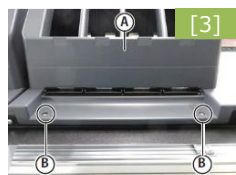
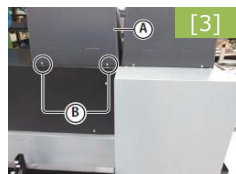
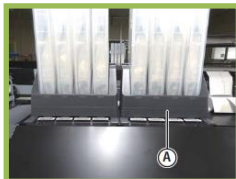

cf. Maintenance Manual (XPJ-1682SR:Rev.00-3.2.8.)

IH Cover L (XPJ-1682SR)

Preparation:

- Phillips Screwdriver No.2

Screws:

- S Tight Cup M3x8 (x4)

[1] Remove S/C card(s).

[2] Remove ink cartridge(s).

[3] Remove screw(s).

[4] Remove IH cover L.

[5] To Assemble unit, reverse the removal procedure.

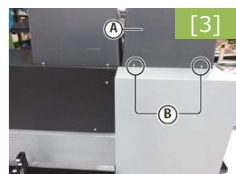
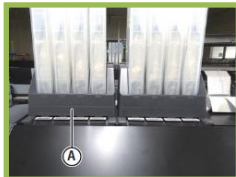

cf. Maintenance Manual (XPJ-1641SR:Rev.00-3.2.8./XPJ-1682SR:Rev.00-3.2.9.)

Top Cover (1/2)

Preparation:

- Phillips Screwdriver No.2

Screws:

- Tap Tight S M4x8 (x13)

[1] Remove side cover R.

[2] Remove side cover L.

[3] Remove panel unit.

[4] Remove front cover.

[5] Remove IH cover(s).



Note

- Removal of IH cover(s) is recommended.
- You may remove top cover while IH cover R remains.
- However, removal of top cover may scratch IH cover(s).

[6] Remove the cable.

- 排気ファンケーブルAssy

[7] Remove screw(s).



Note

- Screw(s) B (x2) fix LED Light (right).
- LED Light falls free as the screw(s) removed.
- Hold LED Light (right) while removing the screw(s).

[8] Remove LED Light.



Note

- Remove one LED Light (right) in this job sequence.

[9] Remove the cable.

- LED Light Cable 1

[10] Assemble LED Light.

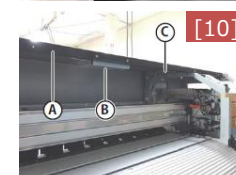
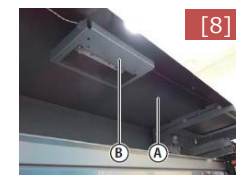
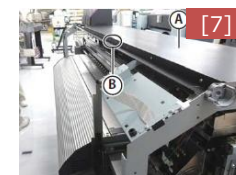
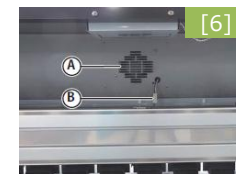

12. Engineer Maintenance

12.1. Removing Covers (6/9)

cf. Maintenance Manual (XPJ-1641SR:Rev.00-3.2.8./XPJ-1682SR:Rev.00-3.2.9.)

Top Cover (2/2)

[11] Remove screw(s).

[12] Remove top cover.



Note

Removal from the back side is recommended.

[13] To Assemble unit, reverse the removal procedure.

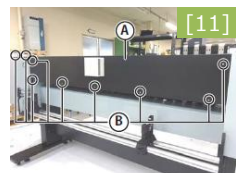
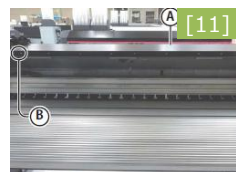
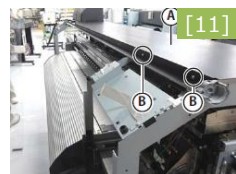

cf. Maintenance Manual (XPJ-1641SR:Rev.00-3.2.9./XPJ-1682SR:Rev.00-3.2.10.)

Bottom Cover R

Preparation:

- Phillips Screwdriver No.2

Screws:

- S Tight Cup M4x12 (x2)
- S Tight Cup M4x10 (x4)

[1] Remove maintenance cover R.

[2] Remove screw(s).

[3] Remove bottom cover R.



Note

- Bottom cover is fixed with latch(es) (x3) in the frame.

[4] To Assemble unit, reverse the removal procedure.

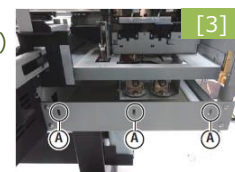
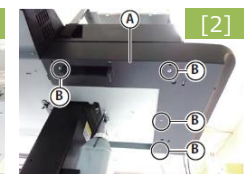

cf. Maintenance Manual (XPJ-1641SR:Rev.00-3.2.10./XPJ-1682SR:Rev.00-3.2.11.)

Bottom Cover L

Preparation:

- Phillips Screwdriver No.2

Screws:

- S Tight Cup M4x12 (x2)
- S Tight Cup M4x10 (x4)

[1] Remove maintenance cover L.

[2] Remove screw(s).

[3] Remove bottom cover L.



Note

- Bottom cover is fixed with latch(es) (x3) in the frame.

[4] To Assemble unit, reverse the removal procedure.

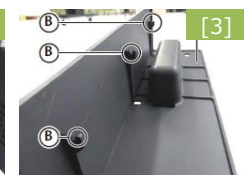
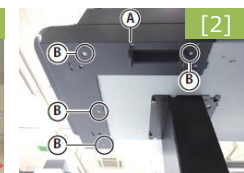

12. Engineer Maintenance

12.1. Removing Covers (7/9)

cf. Maintenance Manual (XPJ-1641SR:Rev.00-3.2.11./XPJ-1682SR:Rev.00-3.2.12.)

Subtank Cover

Preparation:

- Phillips Screwdriver No.2

Screws:

- S Tight Cup M4x6 (x9)

[1] Remove side cover L.

[2] Remove screw(s).

[3] Remove Subtank cover.



Note

- Move Subtank cover to the right.
- Pull the cover.
- Prevent interference with shaft stopper.

[4] To Assemble unit, reverse the removal procedure.

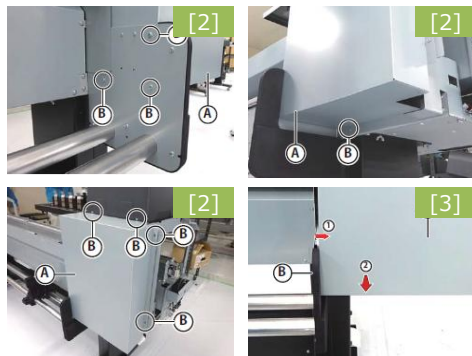

cf. Maintenance Manual (XPJ-1641SR:Rev.00-3.2.12./XPJ-1682SR:Rev.00-3.2.13.)

Board Box Cover

Preparation:

- Phillips Screwdriver No.2

Screws:

- Round Head Screw with Split Washer M3x6 (x14)

[1] Remove all the AC cables.

[2] Remove screw(s).

[3] Remove board box cover.

[4] To Assemble unit, reverse the removal procedure.

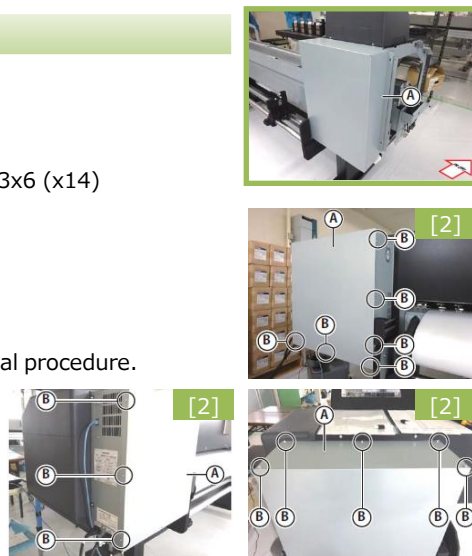

cf. Maintenance Manual (XPJ-1641SR:Rev.00-3.2.13./XPJ-1682SR:Rev.00-3.2.14.)

Paper Guide Cover R

Preparation:

- Phillips Screwdriver No.2

Screws:

- Round Head Screw with Split Washer M4x8 (x1)
- S Tight Cup M4x10 (x1)
- P Tight Bind Screw M4x10 (x3)

[1] Remove maintenance cover R.

[2] Remove bottom cover R.

[3] Open front cover.

[4] Pull pressure lever.

[5] Remove screw(s).

- Round Head Screw with Split Washer M4x8 (x1)

[6] Remove pressure lever knob.

[7] Remove screw(s).

[8] Remove Paper Guide Cover R.

[9] To Assemble unit, reverse the removal procedure.



12. Engineer Maintenance

12.1. Removing Covers (8/9)

cf. Maintenance Manual (XPJ-1641SR:Rev.00-3.2.14./XPJ-1682SR:Rev.00-3.2.15.)

Paper Guide Cover L

Preparation:

- Phillips Screwdriver No.2

Screws:

- S Tight Cup Screw M4x10 (x1)
- P Tight Bind Screw M4x10 (x2)

[1] Remove maintenance cover L.

[2] Remove bottom cover L.

[3] Open front cover.

[4] Remove screw(s).

[5] Remove Paper Guide Cover L.

[6] To Assemble unit, reverse the removal procedure.

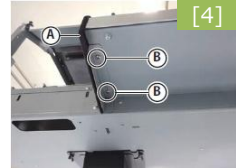
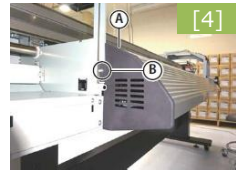

cf. Maintenance Manual (XPJ-1641SR:Rev.00-3.11.2./XPJ-1682SR:Rev.00-3.11.2.)

Paper Guide F Upper

Preparation:

- Phillips Screwdriver No.2

Screws:

- Round Head Screw with Split Washer M4x8 (x5)
- Cup Screw M3x6 (x5)

[1] Remove Paper Guide Cover R.

[2] Remove Paper Guide Cover L.

[3] Remove screw(s).

[4] Lift paper guide F upper.

[5] Remove the cable.

- After_Heater Relay Assy Connector(s)
- After_Thermistor Relay Assy Connector(s)

[6] Remove paper guide F upper.

[7] To Assemble unit, reverse the removal procedure.

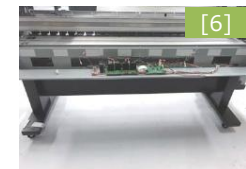
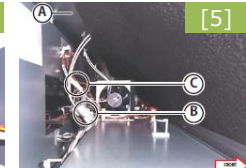
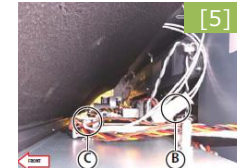
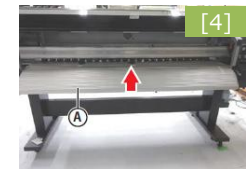

12. Engineer Maintenance

12.1. Removing Covers (9/9)

cf. Maintenance Manual (XPJ-1641SR:Rev.00-3.11.3./XPJ-1682SR:Rev.00-3.11.3.)

Paper Guide R

Preparation:

- Phillips Screwdriver No.2

Screws:

- S Tight Cup M3x6 (x12)
- Round Head Screw with Split Washer M4x8 (x10)

[1] Remove Roll Media holder(s).

[2] Remove lid(s).

- Lid (x3)
- S Tight Cup M3x6 (x12)

[3] Remove cables in the connector.

- Preheater Cable Assy(2)
- Pre_Thermistor Relay Assy(2)

[4] Remove screw(s).

[5] Remove paper guide R.

[6] To Assemble unit, reverse the removal procedure

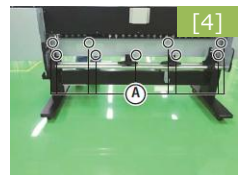
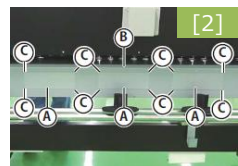

cf. Maintenance Manual (XPJ-1641SR:Rev.00-3.8.2./XPJ-1682SR:Rev.00-3.8.2.)

Manual Release of Carriage Lock

[1] Remove side cover R.

[2] Push carriage lock in the arrow direction.



cf. Maintenance Manual (XPJ-1641SR:Rev.00-3.8.3./XPJ-1682SR:Rev.00-3.8.3.)

CR Cover

Preparation:

- Phillips Screwdriver No.2

Screws:

- Round Head Screw with Split Washer M3x6 (x2)

[1] Remove side cover R.

[2] Release carriage lock manually.

[3] Remove screw(s).

[4] Remove CR cover.

[5] To Assemble unit, reverse the removal procedure.

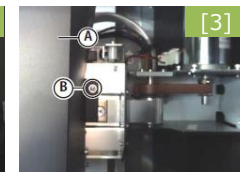
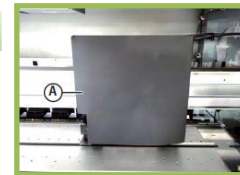

cf. Maintenance Manual (XPJ-1641SR:Rev.00-3.8.4./XPJ-1682SR:Rev.00-3.8.4.)

CR BoardCover

Preparation:

- Phillips Screwdriver No.2

Screws:

- Round Head Screw with Split Washer M3x6 (x3)

[1] Remove upper tray.

[2] Remove screw(s).

[3] Remove CR board cover.

[4] To Assemble unit, reverse the removal procedure.



12. Engineer Maintenance

12.2. Electric Wiring Diagram[Board] (1/2)

◆ XPJ-1641SR

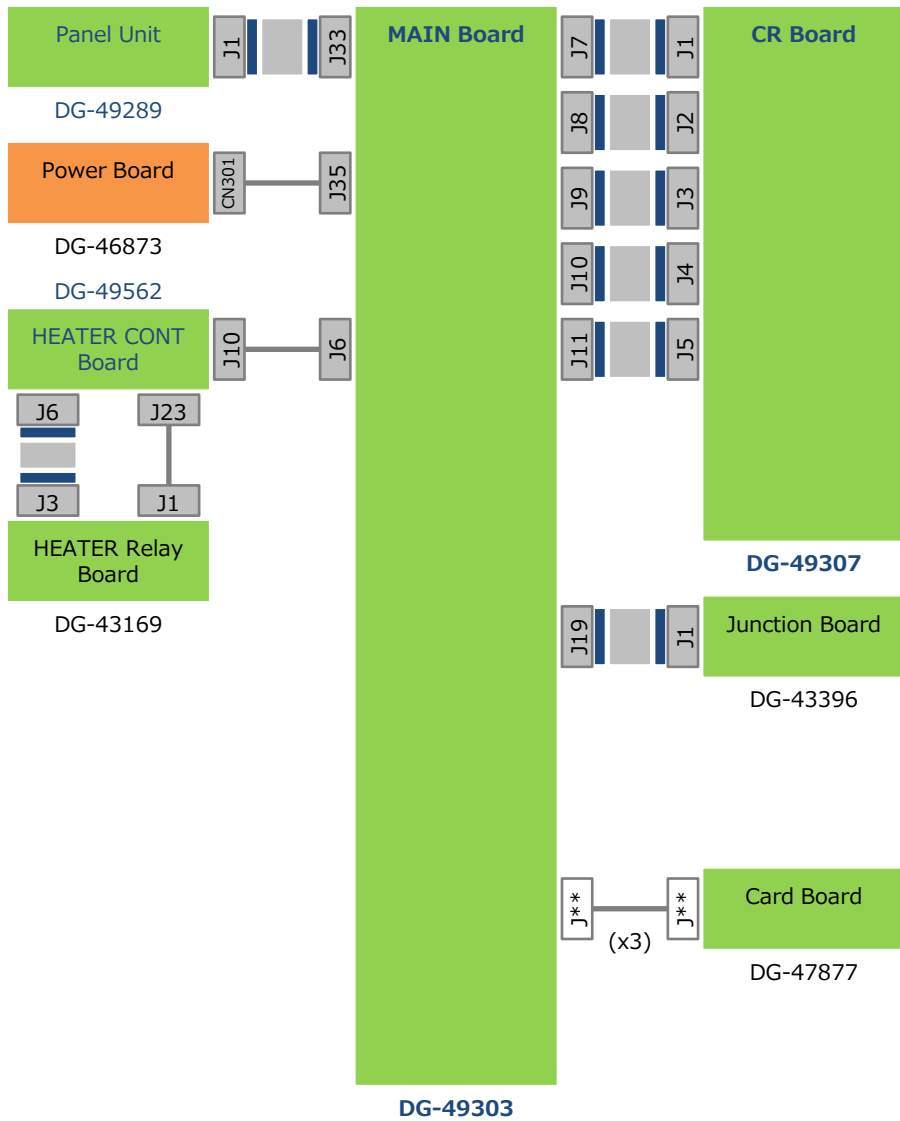

◆ XPJ-1682SR

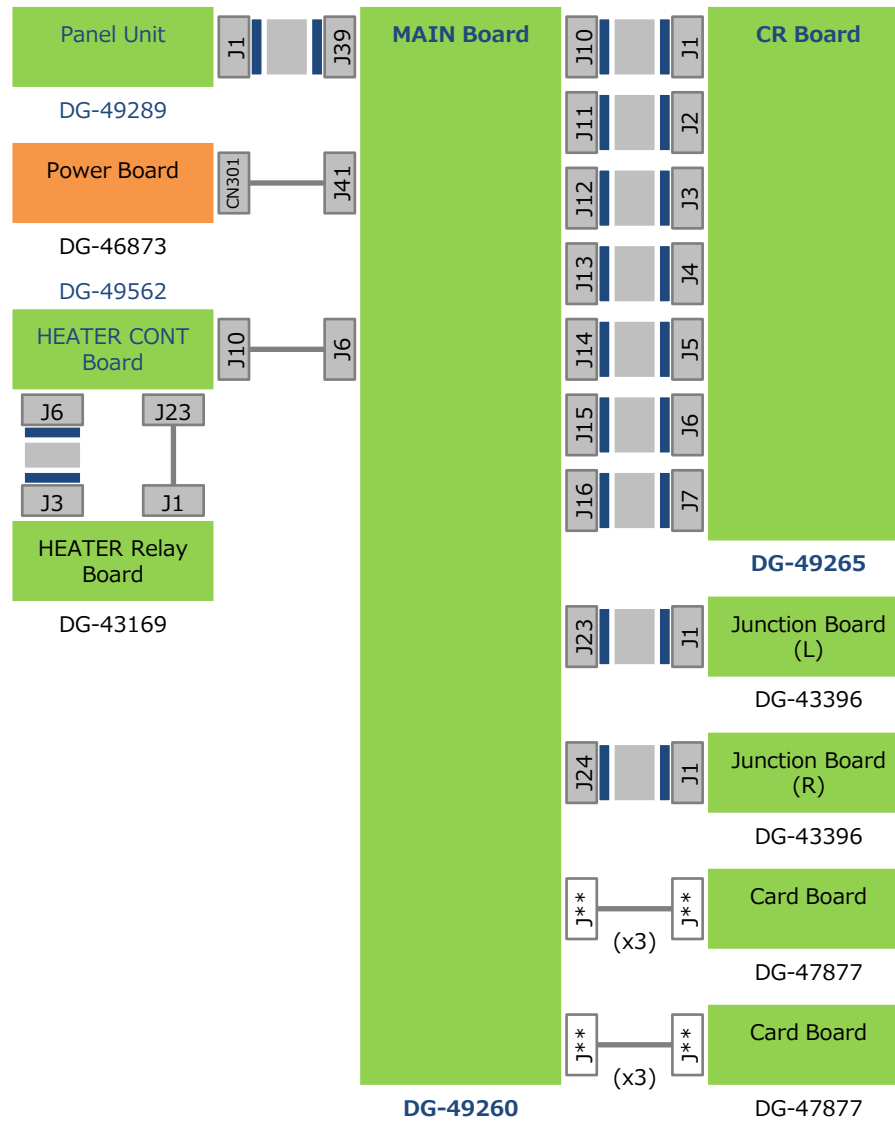

12. Engineer Maintenance

12.2. Electric Wiring Diagram[Board] (2/2)

◆ XPJ-1641SR, XPJ-1682SR

- ◇ Panel Unit [NEW]
DG-49289 :Panel Unit Assy
•REV label : [OTV*****]
- ◇ Power Board
DG-46873 :Power Board Assy
•REV label : [ZSEME05I]
- ◇ HEATER CONT Board[NEW]
DG-49562 : HEATER CONT Board Assy
•REV label : [GTV*****]
- ◇ HEATER Relay Board
DG-43169 : HEATER RELAY3 Board Assy
•REV label : [GRZ*****]
- ◇ Junction Board
DG-43396 : JUNCTION 2 Board Assy
•REV label : [GSC*****]
- ◇ Card Board
DG-47877 :Card Holder Board Assy
•REV label : [GTO*****]

◆ Only XPJ-1641SR

- ◇ MAIN Board Assy [NEW]
DG-49303 : MAIN Board Assy
•REV label : [OTT*****]
- ◇ CR Board Assy [NEW]
DG-49307 : CR Board Assy
•REV label : [OTU*****]

◆ Only XPJ-1682SR

- ◇ MAIN Board Assy [NEW]
DG-49260 : MAIN Board Assy
•REV label : [OTR*****]
- ◇ CR Board Assy [NEW]
DG-49275 : CR Board Assy
•REV label : [OTS*****]

12.3. Electric Wiring Diagram[FFC] (1/2)

◆ XPJ-1641SR, XPJ-1682SR

- ◇ Head FFC
DG-41072 :Head FFC (D)
•Cable length : 340mm
•Pin number : 29pin (Pin pitch : 1.0mm)
•Reinforcement board : Blue (Length : 10mm/10mm)
- ◇ Panel-FFC [NEW]
DG-49290 :Panel FFC Assy
•Cable length : 1,050mm
•Pin number : 28pin (Pin pitch : 1.0mm)
•Reinforcement board : Blue (Length: 10mm / 10mm)
- ◇ Junction FFC [NEW]
DG-49288 : JUNC_FFC Assy
•Cable length : 2,440mm
•Pin number : 31pin (Pin pitch : 1.0mm)
•Reinforcement board : Blue (Length : 15mm/15mm)
- ◇ Heater FFC
DG-40321 : CONTROL-RELAY間FFC1(VJ26)
•Cable length : 110mm
•Pin number : 40pin (Pin pitch : 1.0mm)
•Reinforcement board : Blue (Length : 10mm/10mm)

◆ Only XPJ-1641SR

- ◇ CR-FFC [NEW]
DG-49305 : CR-FFC Assy
•Cable length : 3,390mm
•Pin number : 31pin (Pin pitch : 1.0mm)
•Reinforcement board : Blue (Length : 15mm/15mm)

◆ XPJ-1682SR only

- ◇ CR-FFC [NEW]
DG-49268 : CR-FFC Assy
•Cable length : 3,420mm
•Pin number : 40pin (Pin pitch : 1.0mm)
•Reinforcement board : Blue (Length : 15mm/15mm)

12. Engineer Maintenance

12.3. Electric Wiring Diagram[FFC] (2/2)

◆ XPJ-1641SR



◆ XPJ-1682SR



12. Engineer Maintenance

12.4. Lifetime replacement parts (1/1)

The parts listed below should be replaced when the message to replace the part appears on the front panel.

| Parts | Lifetime | Replacement Message Cycle |
|------------|--------------------|--|
| Print Head | 6 billion dots | Not displayed |
| CR Motor | 4.37 million scans | 95% of CR motor life (4.15 million scans) |
| PF Motor | 21km | 100% of PF motor life (21,000 m) |
| Pump Unit | 294.5 hours | 95% of pump life (280 hours) |

CAUTION

If a message for replacement appears on the panel, the printer will continue to operate.

Print Head

- ◆ **Only XPJ-1641SR**
 - ◇ DG-49580 : IA5540 Head Assy(MS41)
- ◆ **Only XPJ-1682SR**
 - ◇ DG-49581 :Print Head Assy(MS41)

CR Motor

- ◆ **Only XPJ-1641SR**
 - ◇ DG-43182 :CR Motor (Direct Pulley) Assy
- ◆ **Only XPJ-1682SR**
 - ◇ DG-42456 :CR Motor(Nidec)Assy

PF Motor

- ◆ **XPJ-1641SR, XPJ-1682SR**
 - ◇ DF-49020 :PF Motor Assy

Pump Unit

- ◆ **XPJ-1641SR, XPJ-1682SR**
 - ◇ DG-43402 :DC Pump Assy

12.5. Periodic replacement parts (1/1)

The parts listed below should be replaced at the periodic maintenance (once a year).

| Parts | Replacement Cycle |
|----------|-------------------|
| Cap Unit | 12 months |
| Wiper | 12 months |

Periodic replacement parts

- ◆ **Only XPJ-1641SR**
 - ◇ DG-49312 :XPJ-1641SR Periodic Maintenance Kit
- ◆ **Only XPJ-1682SR**
 - ◇ DG-49299 :XPJ-1682SR Periodic Maintenance Kit

12. Engineer Maintenance

12.6. Self-Diagnosis Function Mode (1/7)

cf. Maintenance Manual (XPJ-1641SR:Rev.00-5.2.8./XPJ-1682SR:Rev.00-5.2.8.)

Startup to Self diagnosis mode

Startup

Step.1: While tapping **▲** · **▼** · **▶** simultaneously, tap power key.

Step.2: Do so until LED blinks.

Step.3: Release power key when LED blinks.

Step.4: Hold **▲** · **▼** · **▶** until self diagnosis mode appears.

⚠ CAUTION

Operation does not proceed unless the power key is released.

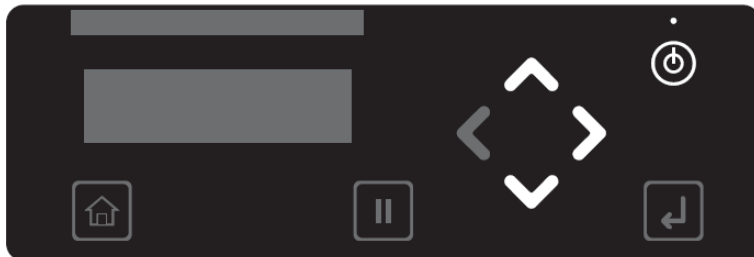

cf. Maintenance Manual (XPJ-1641SR:Rev.00-5.4./XPJ-1682SR:Rev.00-5.4.)

Check.1: Platen Adjustment

Check 1: Adj. Platen

Before performing the mechanical adjustment on the platen, use this menu to set the pre heater temperature to 47°C and the platen heater temperature to 42 °C, and warm up.

cf. Maintenance Manual (XPJ-1641SR:Rev.00-5.5./XPJ-1682SR:Rev.00-5.5.)

Check.2: Test

Check 2: Test

Submenus

| | |
|----------------------|---------------------|
| Test 1: Ram Capacity | Test 2: Version |
| Test 3: Panel | Test 4: Sensor |
| Test 5: Encoder | Test 6: Fan |
| Test 7: Record | Test 8: Head Signal |
| Test 9: Time Check | |

12. Engineer Maintenance

12.6. Self-Diagnosis Function Mode (2/7)

cf. Maintenance Manual (XPJ-1641SR:Rev.00-5.6./XPJ-1682SR:Rev.00-5.6.)

Check.3: Ink Charge

Check 3: Ink Charge

Setting values

Ink Charge 1: Normal

Ink Charge 2: Little

cf. Maintenance Manual (XPJ-1641SR:Rev.00-5.7./XPJ-1682SR:Rev.00-5.7.)

Check.4: Adjustment

Check 4: Adjustment

Submenus

Adj. 1: Rear/Edge

Adj. 2: Nozzle Check

Adj. 3: Check Skew

Adj. 4: Head Slant

Adj. 5: Uni/Bi Low

Adj. 6: Uni/Bi Copy

Adj. 7: Uni/Bi Mid

Adj. 8: Uni/Bi High

Adj. 9: Top&Bottom

Adj.10: Test Print

Adj.11: Longstore

Adj.12: Longstore 2

Adj.13: Count Clear

Adj.14: Send Pitch

cf. Maintenance Manual (XPJ-1641SR:Rev.00-5.8.)

Check.5: Cleaning (XPJ-1641SR)

Check 5: Cleaning

Setting values

Time 1: Short

Time 2: Normal

Time 3: Long

cf. Maintenance Manual (XPJ-1641SR:Rev.00-5.8.)

Check.5: Cleaning (XPJ-1682SR)

Check 5: Cleaning

Submenus

Head Select: ALL

Head Select: Head 1

Head Select: Head 2

Setting values

Time 1: Short

Time 2: Normal

Time 3: Long

12. Engineer Maintenance

12.6. Self-Diagnosis Function Mode (3/7)

cf. Maintenance Manual (XPJ-1641SR:Rev.00-5.9./XPJ-1682SR:Rev.00-5.9.)

Check.6: Test Print

Check 6: Print

Setting values

Print 1: Adjust ALL

Print 2: Parameter ALL

Print 3: Log Info.

Print 4: S/C Log Info.

Print 5: Life Info.

cf. Maintenance Manual (XPJ-1641SR:Rev.00-5.10.2./XPJ-1682SR:Rev.00-5.10.2.)

Check.7.1: Parameter- Initialization Adjustment

Param 1: Init. Adjust

Submenus

Init. 1: Uni/Bi Low

Init. 2: Uni/Bi Mid

Init. 3: Uni/Bi High

Init. 4: Mecha Param.

Init. 5: Servo

Init. 6: ParamterALL

cf. Maintenance Manual (XPJ-1641SR:Rev.00-5.10./XPJ-1682SR:Rev.00-5.10.)

Check.7: Parameter

Check 7: Parameter

This menu is to initialize or change adjustment parameters or initialize counters.

Submenus

Param 1: Init. Adjust

Param 2: Init. Counter

Param 3: Update

12. Engineer Maintenance

12.6. Self-Diagnosis Function Mode (4/7)

cf. Maintenance Manual (XPJ-1641SR:Rev.00-5.10.5.)

Check.7.2: Parameter- Initialization Counter (XPJ-1641SR)

Param 2: Init. Counter

Submenus

| | |
|-----------------------|-----------------------|
| Init. 1: CR Motor | Init. 2: PF Motor |
| Init. 3: Wiper | Init. 4: Pump |
| Init. 5: Cutter | Init. 6: Print Num. |
| Init. 7: Print Info. | Init. 8: Wiper Sol. |
| Init. 9: Cutter Sol. | Init.10: CR Lock Sol. |
| Init.11: CR Lock Pos. | Init.12: Timer |
| Init.13: Daily Log | Init.14: Counter ALL |

cf. Maintenance Manual (XPJ-1682SR:Rev.00-5.10.5.)

Check.7.2: Parameter- Initialization Counter (XPJ-1682SR)

Param 2: Init. Counter

Submenus

| | |
|-----------------------|-----------------------|
| Init. 1: CR Motor | Init. 2: PF Motor |
| Init. 3: Wiper | Init. 4: Pump1 |
| Init. 5: Pump2 | Init. 6: Cutter |
| Init. 7: Print Num. | Init. 8: Print Info. |
| Init. 9: Wiper Sol. | Init.10: Cutter Sol. |
| Init.11: CR Lock Sol. | Init.12: CR Lock Pos. |
| Init.13: Timer | Init.14: Daily Log |
| Init.15: Counter ALL | |

12. Engineer Maintenance

12.6. Self-Diagnosis Function Mode (5/7)

cf. Maintenance Manual (XPJ-1641SR:Rev.00-5.10.6.)

Check.7.3: Parameter- Parameter Update(XPJ-1641SR)

Param 3: Update

Submenus

| | |
|------------------------|-----------------------|
| Update 1: Rear/Edge | Update 2: Uni/Bi Low |
| Update 3: Uni/Bi Mid | Update 4: Uni/Bi High |
| Update 5: Mecha Param. | Update 6: Charge Flg |
| Update 7: Debug Bit | Update 8: Dot Ctrl. |
| Update 9: Heater Flg | Update10: InkType |
| Update11: NozzleCheck | Update12: Periodic CL |
| Update13: CL Type | Update14: Thickness |
| Update15: Uni/Bi Ptn | Update16: Uni/Bi Dot |
| Update17: PF Speed | Update18: CL Time |
| Update19: ResetInkBag | |

cf. Maintenance Manual (XPJ-1682SR:Rev.00-5.10.6.)

Check.7.3: Parameter- Parameter Update(XPJ-1682SR)

Param 3: Update

Submenus

| | |
|------------------------|-----------------------|
| Update 1: Rear/Edge | Update 2: Uni/Bi Low |
| Update 3: Uni/Bi Mid | Update 4: Uni/Bi High |
| Update 5: Mecha Param. | Update 6: Charge Flg |
| Update 7: Debug Bit | Update 8: Dot Ctrl. |
| Update 9: Heater Flg | Update10: InkType |
| Update11: NozzleCheck | Update12: Periodic CL |
| Update13: CL Type | Update14: Color |
| Update15: Thickness | Update16: Uni/Bi Ptn |
| Update17: Uni/Bi Dot | Update18: PF Speed |
| Update19: CL Time | Update20: ResetInkBag |

12. Engineer Maintenance

12.6. Self-Diagnosis Function Mode (6/7)

cf. Maintenance Manual (XPJ-1641SR:Rev.00-5.11./XPJ-1682SR:Rev.00-5.11.)

Check.8: Servo

Check 8: Servo

Submenus

| | |
|--------------------|---------------------|
| Servo 1: 320cps CW | Servo 2: 320cps CCW |
| Servo 3: 460cps CW | Servo 4: 460cps CCW |

cf. Maintenance Manual (XPJ-1641SR:Rev.00-5.12./XPJ-1682SR:Rev.00-5.12.)

Check.9: Endurance

Check 9: Endurance

Submenus

| | |
|-------------------|--------------------|
| Life 1: CR Motor | Life 2: PF Motor |
| Life 3: Cutter | Life 4: Pump |
| Life 5: Head Lock | Life 6: Wiper |
| Life 7: Nozzle | Life 8: Cleaning |
| Life 9: Valve | Life10: Total Life |
| Life11: Check | |

cf. Maintenance Manual (XPJ-1641SR:Rev.00-5.13./XPJ-1682SR:Rev.00-5.13.)

Check.10: Paper Feed

Check10: PaperFeed

Setting values

Feed: -/+ Cut: Enter

cf. Maintenance Manual (XPJ-1641SR:Rev.00-5.14./XPJ-1682SR:Rev.00-5.14.)

Check.11: ExControl

Check11: ExControl

Submenus

| | |
|-----------------|----------------|
| Ctrl 1: Version | Ctrl 2: Sensor |
| Ctrl 3: Heater | |

cf. Maintenance Manual (XPJ-1641SR:Rev.00-5.15./XPJ-1682SR:Rev.00-5.15.)

Check.12: Paper Initial

Check12: PaperInitial

Submenus

| | |
|--------------------|----------------|
| Init. 1: Top&Width | Init. 2: Width |
| Init. 3: Off | |

12. Engineer Maintenance

12.6. Self-Diagnosis Function Mode (7/7)

cf. Maintenance Manual (XPJ-1641SR:Rev.00-5.16./XPJ-1682SR:Rev.00-5.16.)

Check.13: Speed Mode

Check13: SpeedMode

Submenus

SpeedMode1: Normal

SpeedMode1: Low

cf. Maintenance Manual (XPJ-1641SR:Rev.00-5.10.17.)

Check.14: Head Replace (XPJ-1641SR)

Check14: HeadReplace

⌵ Setting values

ID-1/3: 17E7****

cf. Maintenance Manual (XPJ-1682SR:Rev.00-5.10.17.)

Check.14: Head Replace (XPJ-1682SR)

Check14: HeadReplace

Submenus

HeadReplace: ALL

HeadReplace: Head1

HeadReplace: Head2



⌵ Setting values

ID-1/3: 17E7****

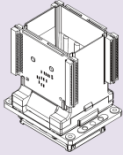
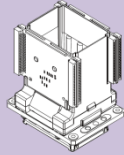
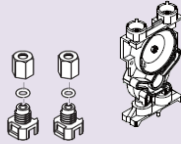
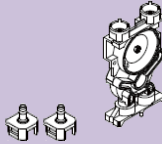

13. Maintenance Parts

13.1. Print Head (1/1)

VJ-1624X vs XPJ-1641SR

| Item | ValueJet (VJ-1624X) | XpertJet (XPJ-1641SR) |
|------------|--|--|
| Print Head | DG-43988 IA5540 Head Assy | DG-49580<NEW> IA5540 Head Assy(MS41) |
| |  |  |
| Dumper | DG-41543 Valve Head Assy | DG-49273<NEW> Valve Head Assy |
| |  |  |
| Connector | DG-41915 Connector_Valve_Head Assy | DG-49274<NEW> Head Connector Assy |
| |  |  |

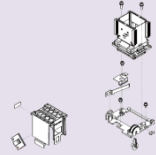
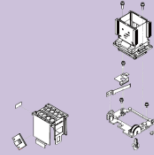
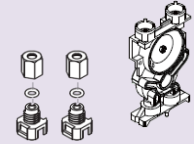
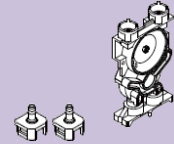
VJ-1638X vs XPJ-1682SR

| Item | ValueJet (VJ-1638X) | XpertJet (XPJ-1682SR) |
|------------|--|--|
| Print Head | DG-43345 Print Head Assy | DG-49581<NEW> Print Head Assy(MS41) |
| |  |  |
| Dumper | DG-41543 Valve Head Assy | DG-49273<NEW> Valve Head Assy |
| |  |  |
| Connector | DG-41915 Connector_Valve_Head Assy | DG-49274<NEW> Head Connector Assy |
| |  |  |

13. Maintenance Parts

13.2.Board (1/2)

VJ-1624X vs XPJ-1641SR

| Item | ValueJet (VJ-1624X) | XpertJet (XPJ-1641SR) |
|----------------------|--------------------------|----------------------------|
| MAIN Board | DG-42958 | DG-49303<NEW> |
| | MAIN Board Assy | Main Board Assy |
| | [FST*****] | [OTT*****] |
| CR Board | DG-42959 | DG-49307<NEW> |
| | CR Board Assy | CR Board Assy |
| | [ORW*****] | [OTU*****] |
| Power Board | DG-46873 | |
| | Power Supply Board Assy | |
| | [ZSEME05I] | |
| Junction Board | DG-42966 | DG-43396 |
| | JUNCTION Board Assy | Junction 2 Board |
| | [GRX*****] | [GSC*****] |
| Heater Control Board | DG-41105 | DG-49562<NEW> |
| | HEATER CONT Board 2 Assy | Heater Control Board Assy |
| | [GQE*****] | [GTV*****] |
| Heater Relay Board | DG-43169 | |
| | HEATER RELAY3 Board Assy | |
| | [GRZ*****] | |

VJ-1638X vs XPJ-1682SR

| Item | ValueJet (VJ-1638X) | XpertJet (XPJ-1682SR) |
|----------------------|--------------------------|----------------------------|
| MAIN Board | DG-44059 | DG-49260<NEW> |
| | MAIN Board (2638) Assy | Main Board Assy |
| | [FSH*****] | [OTR*****] |
| CR Board | DG-43321 | DG-49275<NEW> |
| | CR Board Assy | CR Board Assy |
| | [OSB*****] | [OTS*****] |
| Power Board | DG-46873 | |
| | Power Supply Board Assy | |
| | [ZSEME05I] | |
| Junction Board | DG-43396 | |
| | Junction 2 Board | |
| | [GSC*****] | |
| Heater Control Board | DG-41105 | DG-49562<NEW> |
| | HEATER CONT Board 2 Assy | Heater Control Board Assy |
| | [GQE*****] | [GTV*****] |
| Heater Relay Board | DG-43169 | |
| | HEATER RELAY3 Board Assy | |
| | [GRZ*****] | |

13. Maintenance Parts

13.2.Board (2/2)

VJ-1624X vs XPJ-1641SR

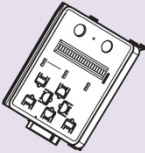
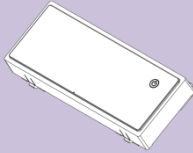
| Item | ValueJet (VJ-1624X) | XpertJet (XPJ-1641SR) |
|-------------------|---|---|
| Card Holder Board | DF-43968 | DG-49577<NEW> |
| | Ink ID Board Assy | Card Holder board Assy |
| | - | [GTX*****] |
| LED Board | - | DG-49550<NEW> |
| | - | Internal LED Board Assy |
| | - | - |
| Panel Unit | DG-42984 | DG-49289<NEW> |
| | Panel Unit Assy | Panel Unit Assy |
| |  |  |

VJ-1638X vs XPJ-1682SR

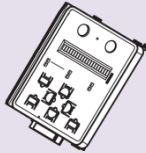
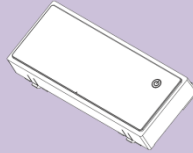
| Item | ValueJet (VJ-1638X) | XpertJet (XPJ-1682SR) |
|-------------------|---|---|
| Card Holder Board | DF-43968 | DG-49577<NEW> |
| | Ink ID Board Assy | Card Holder board Assy |
| | - | [GTX*****] |
| LED Board | - | DG-49550<NEW> |
| | - | Internal LED Board Assy |
| | - | - |
| Panel Unit | DG-42984 | DG-49289<NEW> |
| | Panel Unit Assy | Panel Unit Assy |
| |  |  |

13. Maintenance Parts

13.3.FFC (1/1)

VJ-1624X vs XPJ-1641SR

| Item | ValueJet (VJ-1624X) | XpertJet (XPJ-1641SR) |
|-----------------|-------------------------------------|-------------------------------------|
| CR-FFC | DG-42992 | DG-49305<NEW> |
| | CR_FFCAssy | CR-FFC_Assy |
| | Length: 3,690mm Pin number : 31 | Length: 3,390mm Pin number : 31 |
| Head-FFC | DG-42385 | DG-41072 |
| | Head FFC (VJ-1608H) | Head FFC(D) |
| | Length : 420mm Pin number : 29 | Length : 340mm Pin number : 29 |
| Panel-FFC | DG-42994 | DG-49290 <NEW> |
| | Panel FFC Assy | Panel FFC Assy |
| | Length : 2,450mm Pin number : 28 | Length : 1,050mm Pin number : 28 |
| Junction-FFC(1) | DG-43037 | DG-49288<NEW> |
| | JUNC_FFCAssy | JUNC_FFC Assy |
| | Length : 1,180mm Pin number : 31 | Length : 2,440mm Pin number : 31 |
| Junction-FFC(2) | - | |
| | - | |
| | - | |
| Heater FFC | DG-40321 | |
| | CNT-relay FFC1(VJ26) | |
| | Length : 110mm Pin number : 40 | |

VJ-1638X vs XPJ-1682SR

| Item | ValueJet (VJ-1638X) | XpertJet (XPJ-1682SR) |
|-----------------|-------------------------------------|-------------------------------------|
| CR-FFC | DG-43313 | DG-49268<NEW> |
| | CR-FFC_Assy | CR-FFC_Assy |
| | Length : 3,570mm Pin number : 40 | Length: 3,420mm Pin number : 40 |
| Head-FFC | DG-41072 | |
| | Head FFC(D) | |
| | Length : 340mm Pin number : 29 | |
| Panel-FFC | DG-42994 | DG-49290 <NEW> |
| | Panel FFC Assy | Panel FFC Assy |
| | Length : 2,450mm Pin number : 28 | Length : 1,050mm Pin number : 28 |
| Junction-FFC(1) | DG-43037 | DG-49288<NEW> |
| | JUNC_FFCAssy | JUNC_FFC Assy |
| | Length : 1,180mm Pin number : 31 | Length : 2,440mm Pin number : 31 |
| Junction-FFC(2) | DG-42965 | DG-49288<NEW> |
| | CR_FFCAssy | JUNC_FFC Assy |
| | Length: 3,690mm Pin number: 31 | Length: 2,440mm Pin number : 31 |
| Heater FFC | DG-40321 | |
| | CNT-relay FFC1(VJ26) | |
| | Length : 110mm Pin number : 40 | |

13. Maintenance Parts

13.4.Motor (1/1)

VJ-1624X vs XPJ-1641SR

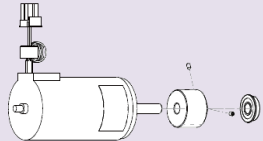
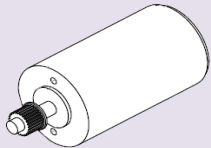
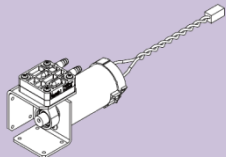
| Item | ValueJet (VJ-1624X) | XpertJet (XPJ-1641SR) |
|----------|---|--|
| CR Motor | DG-43182 CR Motor (Direct Pulley) Assy | |
| |  | |
| PF Motor | DF-49020 PF Motor Assy | |
| |  | |
| Ink Pump | - | DG-43402 |
| | - | DC Pump Assy |
| | |  |

VJ-1638X vs XPJ-1682SR

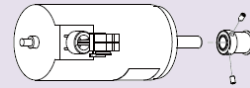
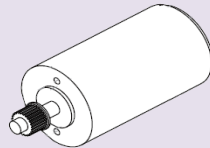
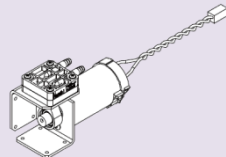
| Item | ValueJet (VJ-1638X) | XpertJet (XPJ-1682SR) |
|----------|---|--|
| CR Motor | DG-42456 CR Motor(Nidec)Assy | |
| |  | |
| PF Motor | DF-49020 PF Motor Assy | |
| |  | |
| Ink Pump | - | DG-43402 |
| | - | DC Pump Assy |
| | |  |

13. Maintenance Parts

13.5. Periodic Maintenance Kit (1/1)

VJ-1624X vs XPJ-1641SR

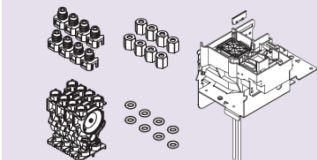
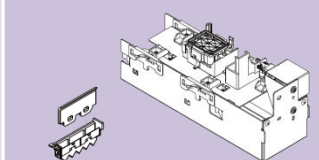
| Item | ValueJet (VJ-1624X) | XpertJet (XPJ-1641SR) |
|--------------------------|---|---|
| Periodic Maintenance Kit | DG-41555 | DG-49312<NEW> |
| | Vj1614 Periodic Maintenance Kit | XPJ-1641SR Periodic Maintenance Kit |
| |  |  |

VJ-1638X vs XPJ-1682SR

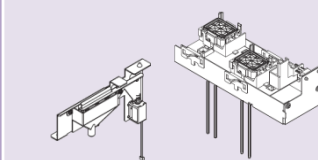
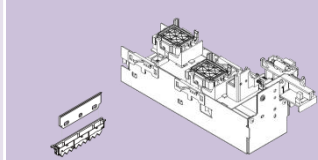
| Item | ValueJet (VJ-1638X) | XpertJet (XPJ-1682SR) |
|--------------------------|---|---|
| Periodic Maintenance Kit | DG-44062 | DG-49299<NEW> |
| | VJ2638 Regular Maintenance Kit | XPJ-1682SR Periodic Maintenance Kit |
| |  |  |