



MSA2000 Technical Cookbook

Part II introducing new MSA2000 G2

4AA2-5505ENW

Speaker name : Mo Azam
Worldwide Product Manager - StorageWorks
updated : June 2nd, 2009



Index

Item #	Section description
1	MSA2000 G2 Introduction <ul style="list-style-type: none">• Product description• What's New and Benefits• MSA2000 G2 Models
2	Product Overview (Features comparison – FC, SAS and iSCSI)
3	Performance Numbers (Comparison – FC, SAS and iSCSI)
4	MSA2000 G2 SKUs & a la carte Strategy
5	MSA2000 G2 Supported Configurations and Cable Diagrams
6	Unified LUN Presentation (ULP)
7	MSA2000G2 Management <ul style="list-style-type: none">• Improved Web Based Interface• Storage Management Utility (SMU)• Getting Started with MSA2000fc G2• Comparison between Old and New SMU• Creating Vdisk• Creating Volumes• Mapping a Volume



Introducing the new MSA2000 G2

“Twice the number of drives, twice the performance, four times the number of snapshots, and support for small form factor drives with Integrity and ProLiant servers”



HP StorageWorks 2000 G2 Modular Smart Arrays

More affordable

- More affordable interconnects allow you to easily add storage as your business grows
- Use 50% less power with small form factor (SFF) 2.5" SAS drives

Invest with confidence

- Protect your data with broad RAID support
- Upgrades and interconnect changes supported

Increased efficiency

- 33 percent more storage capacity per unit of rack space for SFF SAS drives over 3.5" drives
- Increase storage utilization with tiered storage (SAS for high performance applications and SATA for less frequently accessed data)



Flexibility and performance unmatched by ANY entry-level array product in the market

What's new

	MSA2000	New MSA2000 G2
Drives (SAS & SATA)	<ul style="list-style-type: none"> • MSA2 Large Form Factor LFF 	<ul style="list-style-type: none"> • MSA2 3.5" Large Form Factor LFF • ProLiant 2.5" Small Form Factor SFF
Max drives	<ul style="list-style-type: none"> • 48 LFF 	<ul style="list-style-type: none"> • 60 LFF • 99 SFF
Servers	<ul style="list-style-type: none"> • x86 	<ul style="list-style-type: none"> • X86 • Integrity c-class Blades
Operating Systems	<ul style="list-style-type: none"> • Windows • Linux 	<ul style="list-style-type: none"> • Windows • Linux • VMware • HP-UX (for MSA2000sa G2 Only) • Solaris
Software	<ul style="list-style-type: none"> • Snapshot (max 64 snaps) 	<ul style="list-style-type: none"> • Snapshot (max 255 snaps)
Max LUNs	<ul style="list-style-type: none"> • 256 	<ul style="list-style-type: none"> • 512







MSA2000 G2 benefits

New MSA2000 G2 features	Added Customer benefits
Support for 2.5-in. drives	Common with ProLiant: potential performance gain
Support for MSA70 enclosure	Common with ProLiant (plus legacy ROI support)
New MSA2300 high-speed controller	Faster processor, higher performance
Increased scalability & 512 LUN support	Up to 60 LFF 3.5-in drives; up to 99 SFF 2.5-in drives
HP-UX and OpenVMS support and Integrity servers	Entry-level SAN support for HP's most powerful OSes
Enhanced point-in-time copy with space-efficient snapshot	255 Snapshot capability
New DC power options	Opportunities in TELO and related industries



MSA2000 G2 family

		MSA2000G2 SFF
		MSA2000G2 LFF
	Feb. 09	MSA2000fc G2 Dual controller model shown
	June 09	MSA2000i G2 Dual controller model shown
	June 09	MSA2000sa G2 Dual controller model shown

Product overview



Technology	Features	MSA2000sa G2	MSA2000fc G2	MSA2000i G2
	Storage Controllers	Dual Active/Active hot swap (Single Controller Option available) 3 Gb SAS 4-port /Controller	Dual Active/Active hot swap (Single Controller Option available) 4 Gb FC 2-port/Controller	Dual Active/Active hot swap (Single Controller Option available) 1GbE 2-port/Controller
	Cache	1GB Standard	1GB Standard	1GB Standard
	Enclosure Form Factor	2U	2U	2U
	Max. Drives per Enclosure	12	12	12
	Drives Supported	2.5-in SAS & SATA 3.5-in SAS & SATA (Supports SAS and SATA drives in the same enclosure)	2.5-in SAS & SATA 3.5-inSAS & SATA (Supports SAS and SATA drives in the same enclosure)	2.5-in SAS & SATA 3.5-inSAS & SATA (Supports SAS and SATA drives in the same enclosure)
	Max. Storage Capacity	<ul style="list-style-type: none"> 7.2TB base capacity up to 29.2 TB using 300GB SFF SAS drives 12TB base capacity – up to 60TB using 1TB LFF SATA drives 	<ul style="list-style-type: none"> 7.2TB base capacity up to 29.2 TB using 300GB SFF SAS drives 12TB base capacity – up to 60TB using 1TB LFF SATA drives 	<ul style="list-style-type: none"> 7.2TB base capacity up to 29.2 TB using 300GB SFF SAS drives 12TB base capacity – up to 60TB using 1TB LFF SATA drives
	Power Supply& Fan	Hot swap, Redundant	Hot swap, Redundant	Hot swap, Redundant
	RAID	0, 1, 3, 5, 6, 10, 50	0, 1, 3, 5, 6, 10, 50	0, 1, 3, 5, 6, 10, 50



Product overview (cont'd)



Connectivity & Availability	Features	MSA2000sa G2	MSA2000fc G2	MSA2000i G2
	# of LUNs	511	512	512
	LUN Size	16 TB	16 TB	16 TB
	HBA's	SC08GE	Emulex and QLogic	Industry standard 1GB Ethernet
	Expansion	1+4 enclosures (LFF) 1+3 enclosures (SFF)	1+4 enclosures (LFF) 1+3 enclosures (SFF)	1+4 enclosures (LFF) 1+3 enclosures (SFF)
	Host Support	32	64	32
	Supported Drives	<ul style="list-style-type: none"> 2.5" SAS – 72,146 15K & 300GB 10K 3.5" SAS – 146GB 15K, 300GB 15K, 450GB SATA – 750GB, 1TB 	<ul style="list-style-type: none"> 2.5" SAS – 72,146 15K & 300GB 10K 3.5" SAS – 146GB 15K, 300GB 15K, 450GB SATA – 750GB, 1TB 	<ul style="list-style-type: none"> 2.5" SAS – 72 & 146 GB 15K & 300GB 10K 3.5" SAS – 146GB 15K, 300GB 15K, 450GB SATA – 750GB, 1TB
	# of Cluster Node	8-nodes (Microsoft) 8-nodes (Linux)	8-nodes (Microsoft) 16 nodes (Linux) coming	8-nodes (Microsoft) 8-nodes (Linux)



Product overview (cont'd)



Array Management and Optional Software	Features	MSA2000sa G2	MSA2000fc G2	MSA2000i G2
	OS Support	Windows 2008, Windows 2003, RH and SuSE Linux VMware, Solaris	Windows 2008, Windows 2003, RH and SuSE Linux VMware	Windows 2008, Windows 2003, RH Linux VMware
	Management Software	Out-of-band CLI & Web-based interface (WBI)	Out-of-band CLI & Web-based interface (WBI)	Out-of-band CLI & Web-based interface (WBI)
	Multipath Support	MPIO DSM	MPIO DSM	MPIO DSM
	Snapshot	Controller based snapshot and clone	Controller based snapshot and clone	Controller based snapshot and clone
	Server Support	ProLiant servers ProLiant & Integrity Blades (c-class) 3 rd Party x86	ProLiant & Integrity servers ProLiant Blades servers 3 rd Party x86	ProLiant servers ProLiant Blades servers 3 rd Party x86
	Firmware Upgrade	Non-disruptive	Non-disruptive	Non-disruptive
Value	Warranty	3.0.0	3.0.0	3.0.0



MSA2000 G1 & G2

Performance comparison

Workload	MSA2000fc	MSA2000sa	MSA2000i
	G2	G2	G2
Host Connect	4Gb Fibre Channel	3 Gb SAS	1 GbE Ethernet
MSA2000 RAID 10 Performance Results (rounded)			
Random Reads IOPs	22,800	21,800	13,600
Random Writes IOPs	15,000	14,440	14,300
Random Mix IOPs 60/40 read/write	17,800	17,700	13,400
Sequential Reads MB	1,200	1,000	270
Sequential Writes MBs	530	530	260
MSA2000 RAID 5 Performance Results (rounded)			
Random Reads IOPs	22,000	21,000	12,300
Random Writes IOPs	2,700	2,700	2,700
Random Mix IOPs 60/40 read/write	5,900	4,900	5,300
Sequential Reads MBs	1,200	1,000	270
Sequential Writes MBs	720	600	260
MSA2000 RAID 6 Performance Results (rounded)			
Random Reads IOPs	21,900	21,000	12,200
Random Writes IOPs	1,800	18,000	1,800
Random Mix IOPs 60/40 read/write	4,200	3,800	3,800
Sequential Reads MBs	1,200	1,000	270
Sequential Writes MBs	770	720	260

MSA2000 G2
SKUs & a la carte
strategy



MSA2000sa G2 Array SKUs

MSA2000sa G2 Configured Units

MSA2312sa G2 Dual Controller (LFF)	HP 2312sa G2 Dual Controller Modular Smart Array Controller (Unit ships with 2 controllers)	AJ805A
MSA2324sa G2 Dual Controller (LFF)	HP 2324sa G2 Dual Controller Modular Smart Array Controller (Unit ships with 2 controllers)	AJ807A

MSA2300sa G2 3Gb SAS Controller

MSA2300sa G2 Controller	HP 2300sa G2 Modular Smart Array Controller	AJ808A
-------------------------	---	--------



MSA2000sa G2 Package Cluster Bundle

MSA2000sa G2 – DL380G6 Package Cluster Bundle

Package Cluster Bundle	MSA2000sa G2 Package Cluster with ProLiant DL380G6 Includes: One MSA2324sa G2 DC array; Two DL380 G6 Servers Four HBAs Four cables Snapshot software 8 LTU	AP813A
------------------------	--	--------



AP813A

SKU	Description	QTY
AJ808A	MSA2300sa SAS controller	2
AJ949A	HP StorageWorks 2024 MSA SFF Chassis	1
491332-001	Proliant DL380G6	2
T5513A	HP MSA2000 Snapshot 8 Software LTU	1
488765-B21	SAS HBA	4
407337-B21	SAS Cable	4

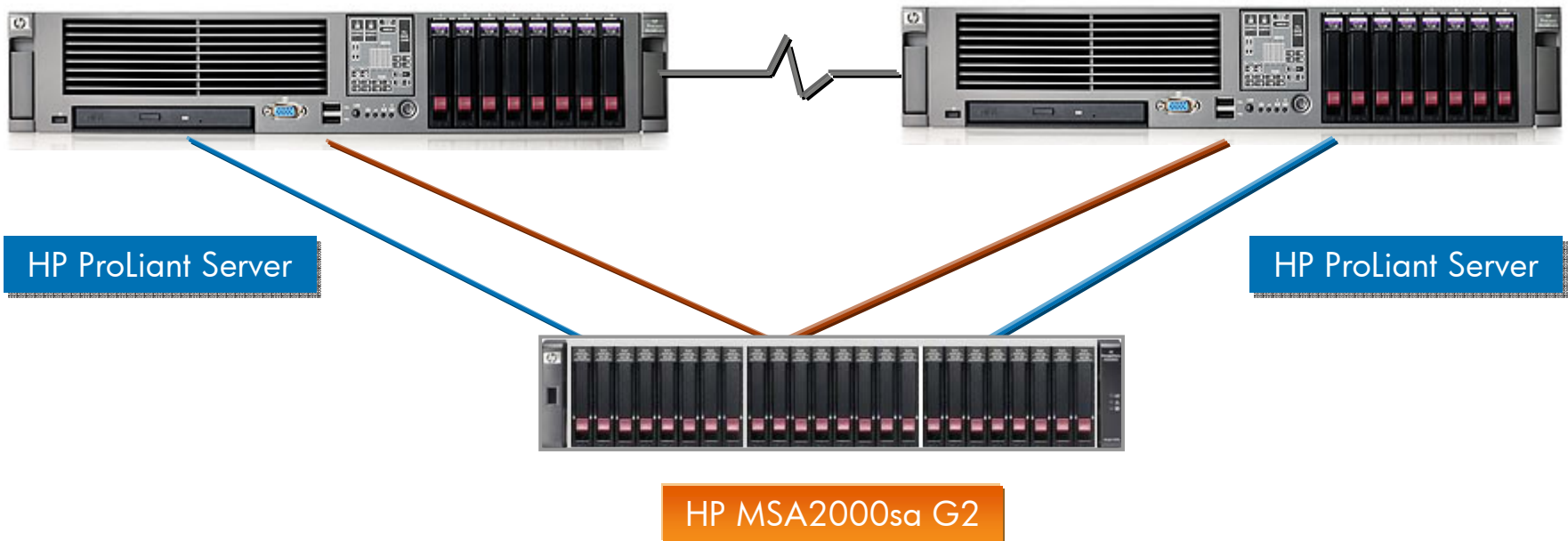

Highly available MSA2000sa G2 Cluster Solution with Redundant Paths

MSA2000i G2 Array SKUs

MSA2000i G2 Configured Units

MSA2312i G2 Dual Controller (LFF)	HP 2312i G2 Dual Controller Modular Smart Array Controller (Unit ships with 2 controllers)	AJ800A
MSA2324i G2 Dual Controller (LFF)	HP 2324i G2 Dual Controller Modular Smart Array Controller (Unit ships with 2 controllers)	AJ802A

MSA2300i G2 1Gb iSCSI Controller

MSA2300i G2 Controller	HP 2300i G2 Modular Smart Array Controller	AJ803A
------------------------	--	--------



MSA2000fc G2 Array SKUs

Controller-less CHASSIS & V2 FC Controller

AJ948A	HP StorageWorks 2012 Modular Smart Array 3.5-in Drive Bay Chassis	(LFF)
AJ949A	HP StorageWorks 2024 Modular Smart Array 2.5-in Drive Bay Chassis	(SFF)
AJ798A	HP StorageWorks 2300fc Modular Smart Array Controller	

Configured Units

AJ795A	HP StorageWorks 2312fc Dual Controller Modular Smart Array	(LFF)
AJ797A	HP StorageWorks 2324fc Dual Controller Modular Smart Array	(SFF)

SAN Starter Kits

AJ954A	HP StorageWorks 2312fc Single Controller Modular Smart Array SAN Starter Kit	(LFF)
AJ955A	HP StorageWorks 2324fc Single Controller Modular Smart Array SAN Starter Kit	(SFF)
AJ956A	HP StorageWorks 2300fc Modular Smart Array SAN Starter HA Upgrade Kit	

Controller-less CHASSIS: DC-powered

AJ950A	HP StorageWorks 2012 Modular Smart Array 3.5-in Drive Bay DC-power Chassis	(LFF)
AJ951A	HP StorageWorks 2024 Modular Smart Array 2.5-in Drive Bay DC-power Chassis	(SFF)



MSA2000 expansion JBODs SKUs

Form factor	Existing MSA2000fc & MSA70 enclosures (dual I/O enclosures required to work with dual controller array heads)	
LFF	HP StorageWorks MSA2000 Single I/O 3.5" 12 Drive Enclosure	AJ749A
LFF	HP StorageWorks MSA2000 Dual I/O 3.5" 12 Drive Enclosure	AJ750A
	HP StorageWorks MSA2000 Drive Enclosure I/O Module	AJ751A
SFF	HP StorageWorks MSA70 2.5-inch drive Single I/O JBOD	418800-B21
	HP StorageWorks MSA70 Dual Domain upgrade I/O Module	AG779A

HP StorageWorks Snapshots	
Snapshot 255 Software LTU	T5539A
Snapshot 8/256 Upgrade Software LTU	T5540A
Snapshot 64/256 Upg Software LTU	T5541A



A La Carte

the Channel's dream for fast delivery and inventory turn



- 2 Chassis – LFF & SFF



- 3 controllers: FC, SAS, iSCSI
- 1 JBOD I/O Module



- SAS & SATA Drives - Large and Small Form Factor (ProLiant!)
- MSA70 JBOD (ProLiant!)

MSA2000 G2
supported
configurations &
cabling diagrams



MSA2000 G2 supported configurations

MSA2312 Array
w/12 LFF drive bays

MSA2000 3.5-in
12 LFF Disk Enclosure

MSA2000 3.5-in
12 LFF Disk Enclosure

MSA2000 3.5-in
12 LFF Disk Enclosure

MSA2000 3.5-in
12 LFF Disk Enclosure



Max configuration with sixty Large Form Factor MSA2 drives (LFF)

- Twelve drive LFF array head with one or two MSA2300 G2 controllers
- Up to four twelve-drive MSA2000 3.5" Drive Enclosures
- 3.5" MSA2 DP SAS and/or SATA drives

MSA2324 Array
w/24 SFF drive bays

MSA70 2.5-in
25 SFF Disk Enclosure

MSA70 2.5-in
25 SFF Disk Enclosure

MSA70 2.5-in
25 SFF Disk Enclosure



Max configuration with ninety-nine Small Form Factor drives (SFF)

- Twenty-four SFF drive array head with one or two MSA2300 G2 controllers
- Up to three twenty-five drive MSA70 JBODs
- 2.5" DP ProLiant SAS and/or SATA drives

MSA2000 G2 supported configurations

MSA2324 Array
w/24 SFF drive bays

MSA2000 3.5-in
12 LFF Disk Enclosure

MSA2000 3.5-in
12 LFF Disk Enclosure

MSA2000 3.5-in
12 LFF Disk Enclosure



Max configuration with MIXED LFF and SFF drives

- Twenty-four SFF drive array head with one or two MSA2300 G2 controllers
- Up to three twelve-drive MSA2000 3.5" Drive Enclosures
- 2.5" DP ProLiant SAS and/or SATA drives
- 3.5" MSA2 DP SAS and/or SATA drives

New

MSA2324 Array
w/24 SFF drive bays

MSA70 2.5-in
25 SFF Disk Enclosure

MSA70 2.5-in
25 SFF Disk Enclosure

MSA2000 3.5-in
12 LFF Disk Enclosure

MSA2000 3.5-in
12 LFF Disk Enclosure



Max configuration with MIXED LFF and SFF drives

- Twenty-four SFF drive array head with one or two MSA2300 G2 controllers
- Up to two twenty-five drive MSA70 JBODS
- 2.5" DP ProLiant SAS and/or SATA drives
- Up to two twelve-drive MSA2000 3.5" Drive Enclosures
- 3.5" MSA2 DP SAS and/or SATA drives

Single domain

With MSA2000 JBODs

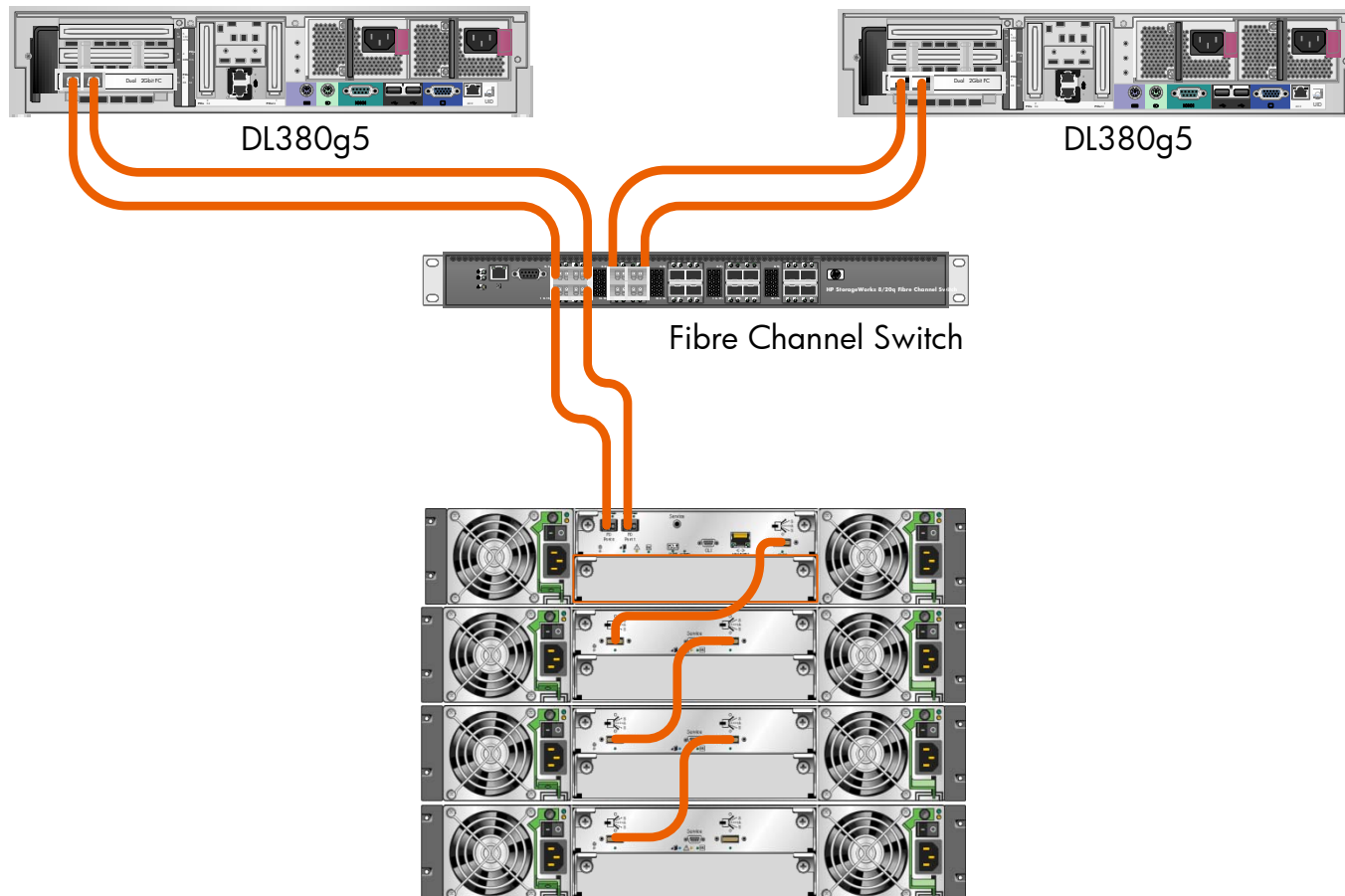

Single domain

With MSA70 JBODs

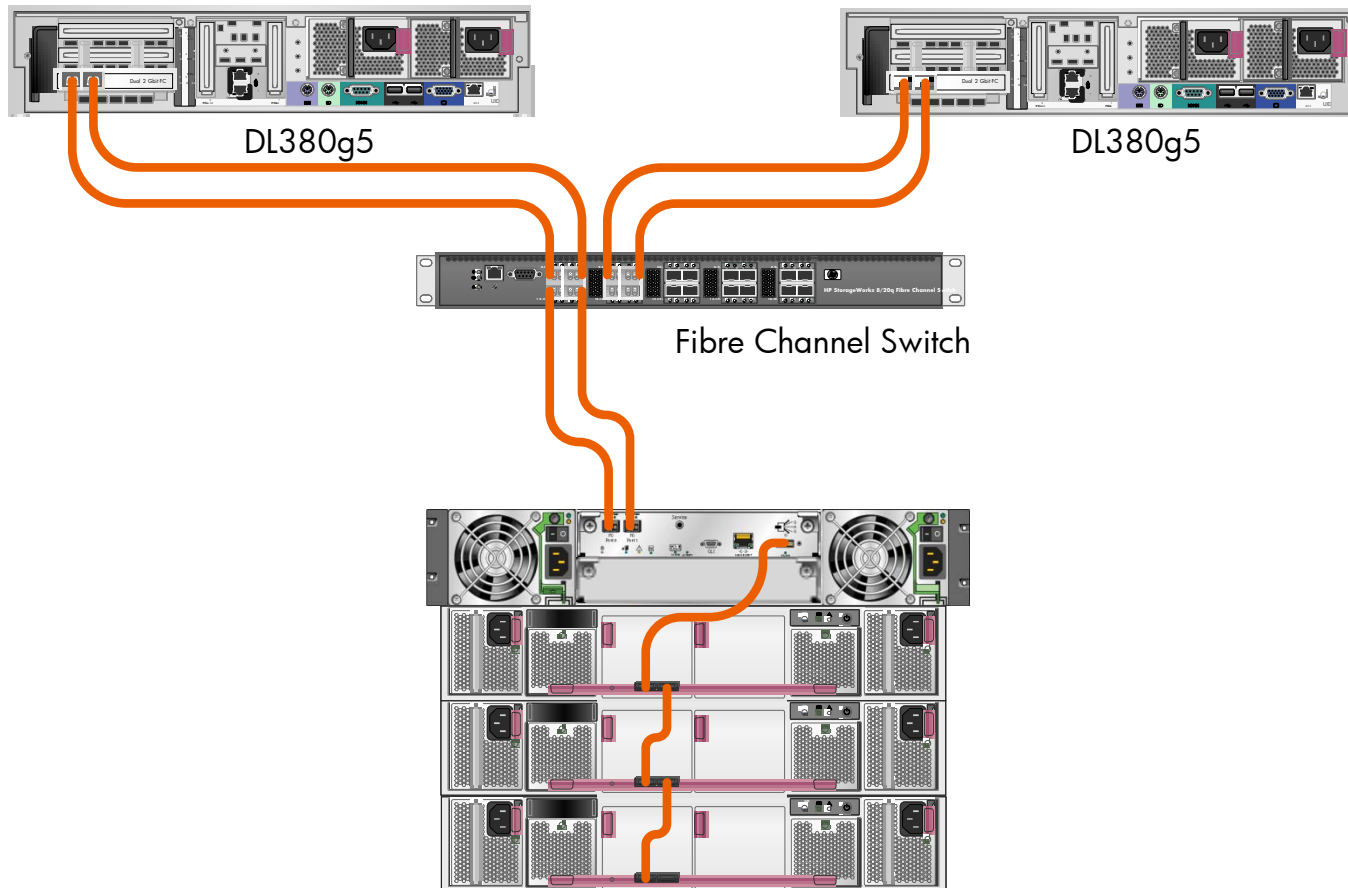

Dual domain

With MSA70 JBODs

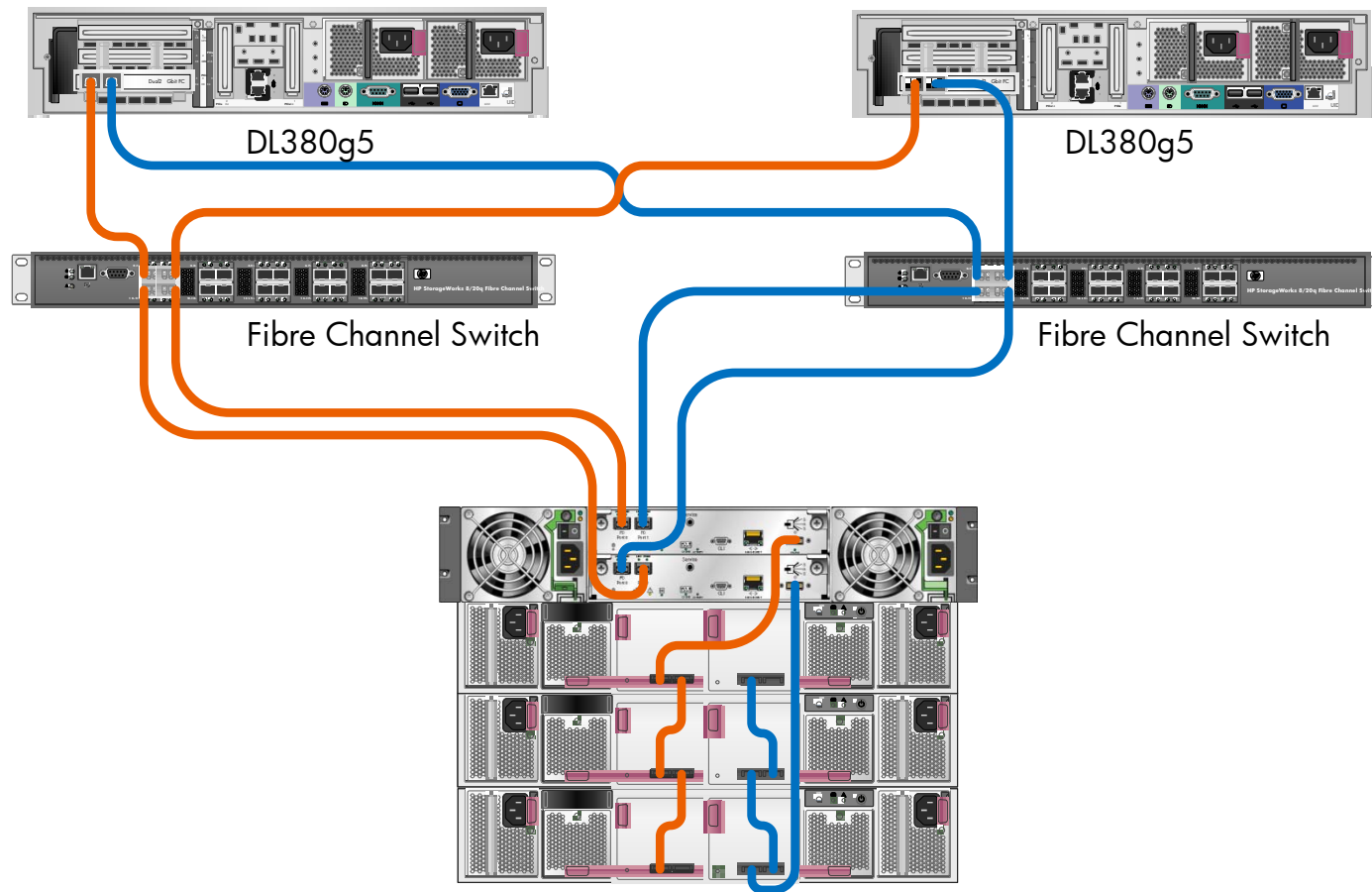

Unified LUN Presentation (ULP)



What is ULP?

- **U**nified **LUN P**resentation
- The intent of ULP is to make all LUNs in the system accessible through all ports on both Control Units
- ULP appears to the host as an active-active storage system where the host can choose any available path to access a LUN regardless of vdisk/LUN ownership
- Uses the T10 Technical Committee of INCITS* **A**symmetric **L**ogical **U**nit **A**ccess (ALUA) extensions, in SPC-3**, to negotiate portals (paths) with aware host systems. Unaware host systems see all paths as being equal



ULP basic overview

- ULP presents all LUNS to all host ports
 - Eliminates need for CU interconnect path (PBC)
 - Presents the same (single) WWNN for both CUs
- There is only one LUN name space (0-255)
 - No duplicate LUNs allowed between controllers
 - Either controller can use any unused logical unit #
- ULP recognizes which paths are “preferred”
 - The preferred path indicates which is the owning controller, per ALUA specifications
 - “Report Target Port Groups” identifies preferred path
 - Performance is slightly better on preferred path



ULP design

- Underlying concept is still vdisk ownership
- Vdisk ownership is transparent to host system
- ULP keeps the raid & disk firmware intact
 - No changes to raid and disk backend operation
- Host & cache firmware modules updated for ULP
 - Host module presents all LUNs on all ports
 - Data path routing modified at host and cache level
 - Cache mirrors write AND read operations
 - Owning controller always does I/O to disk



ULP – Write I/O processing

- Write command to controller A for LUN 1 owned by CUB:
 - The data is written to CUA cache and broadcast to CUA mirror
 - CUA acknowledges I/O completion back to host
 - Data written back to LUN 1 by CUB from CUA mirror

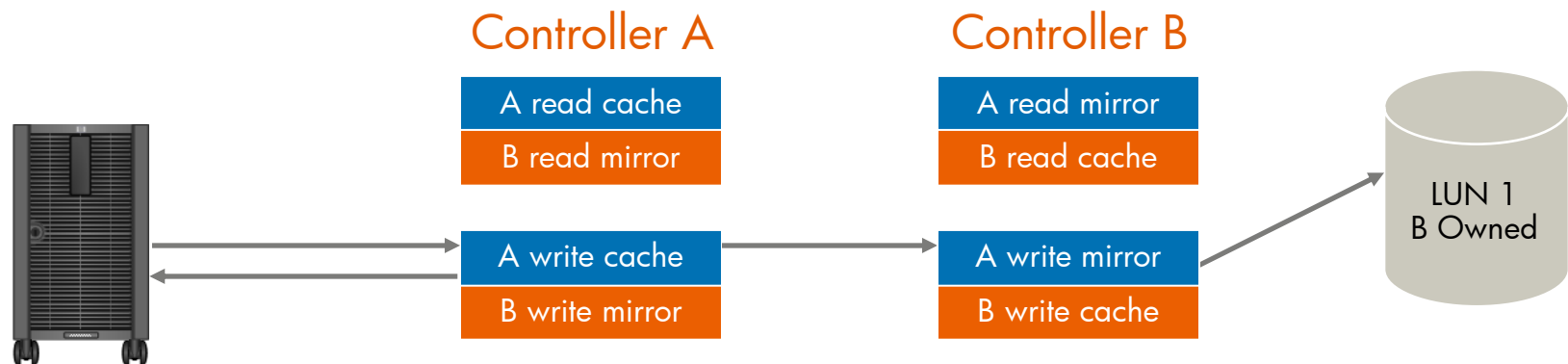

ULP – Read I/O processing

- Read command to controller A for LUN 1 owned by CUB:
 - CUA asks CUB if data is in CUB cache
 - If found, CUB tells CUA where in CUB read mirror cache it resides
 - CUA sends data to host from CUB read mirror, I/O complete
 - If not found, request is sent from CUB to disk to retrieve data
 - Disk data is placed in CUB cache and broadcast to CUB mirror
 - Read data sent to host by CUA from CUB mirror, I/O complete

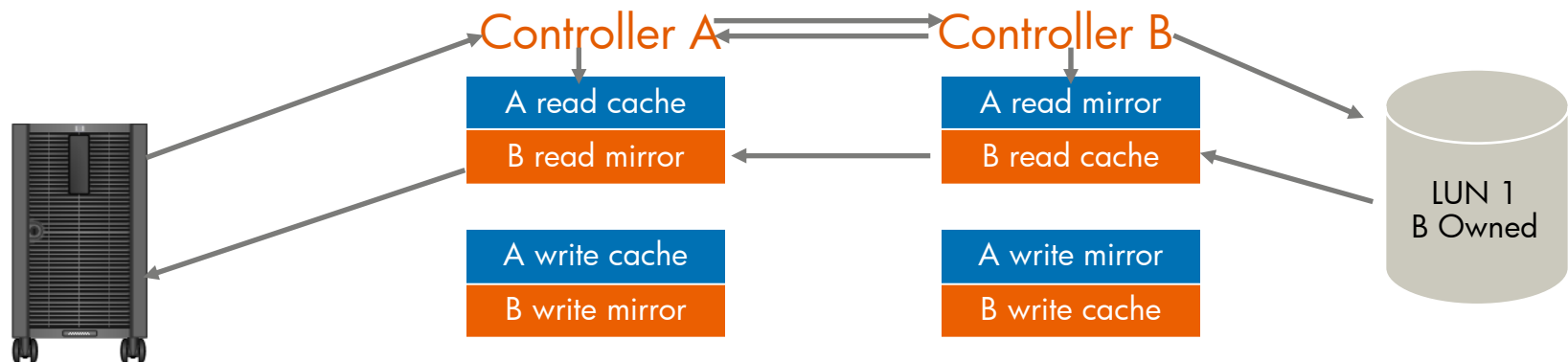

ULP – all LUNs presented to all

- LUNs 0-4 are available on all 4 host ports
- Multi-Path software sees 2 instances of LUNs
- RTPGs indicate “preferred” paths to MPIO software
- LUNs 0,2,4 preferred path is A0
- LUNs 1,3 preferred path is B0
- MPIO defaults to round robin I/O pattern, may be changed to take advantage of preferred paths

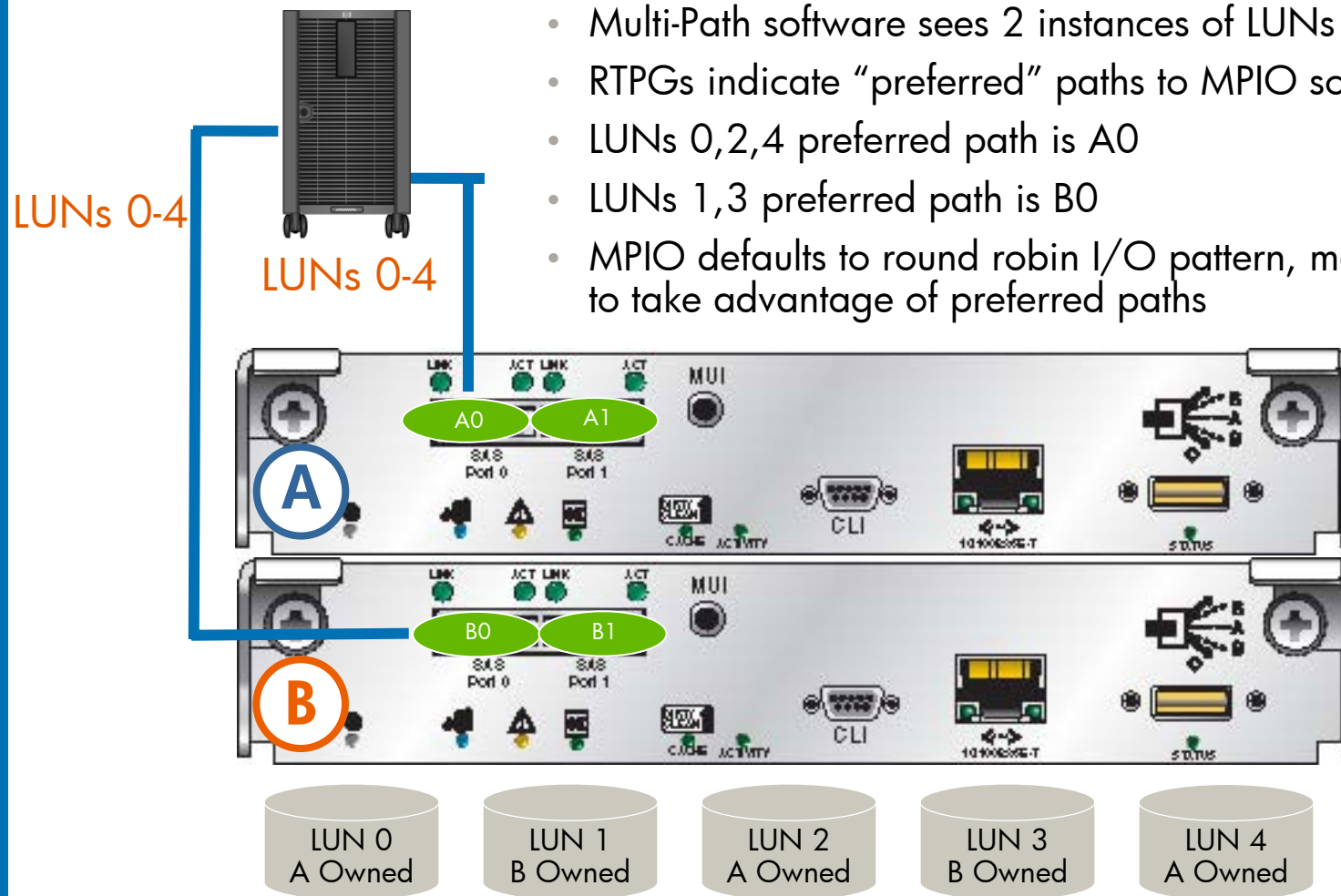

ULP – all LUNs presented: failover

- CUB fails, vdisk ownership transfers to CUA
- Same single WWN is presented
- All LUNs still presented through CUA
- MP software continues uninterrupted I/O
- Surviving controller reports all paths as preferred

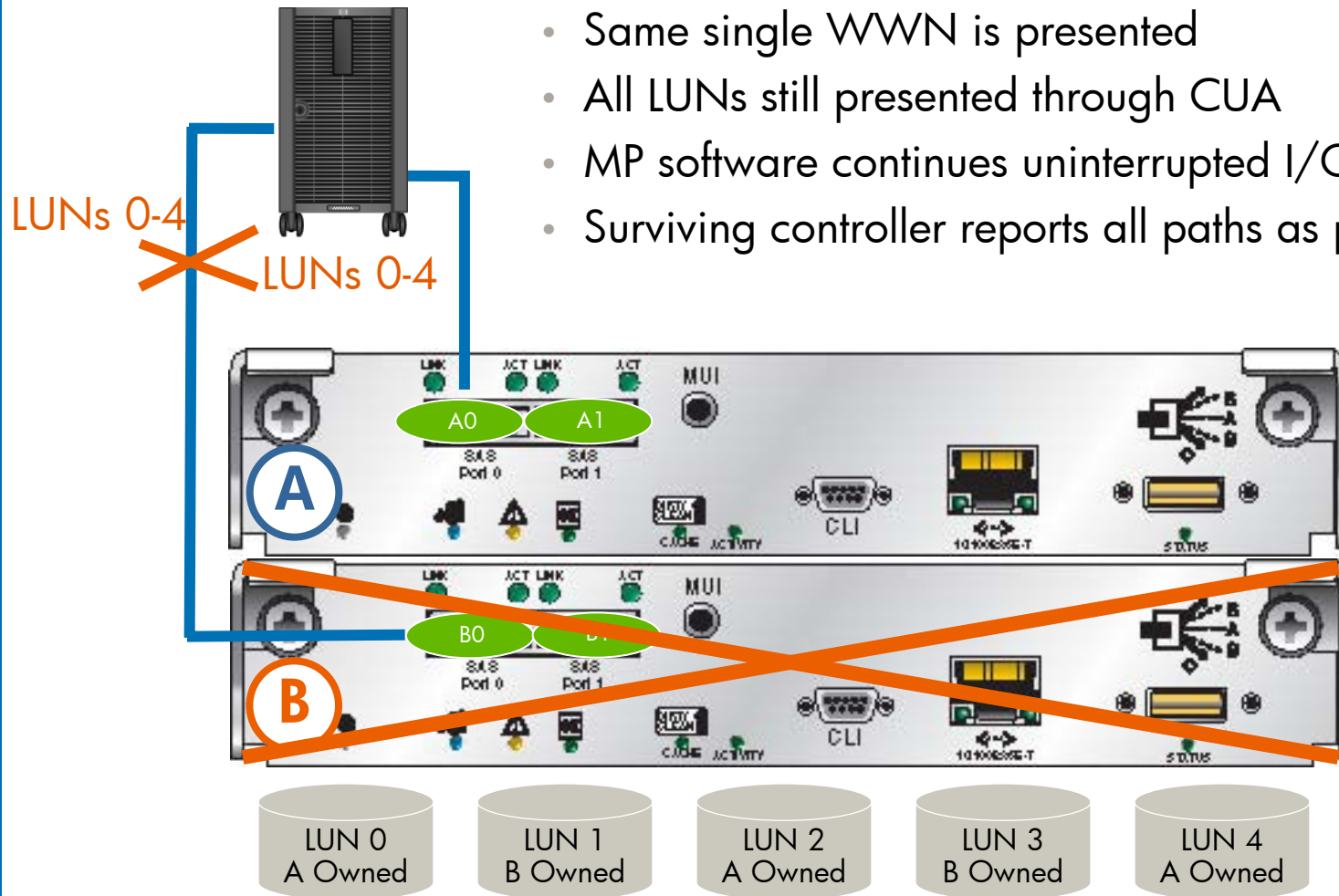

Improved Web Based Interface Storage Management Utility (SMU)

Introduction



Installation overview

- Unpack the array
- Obtain the necessary accessories and equipment
- Mount the controller and expansion trays in a rack or cabinet
- Connect the AC power to the two power modules
- Perform initial power-up
- Connect the management hosts to the controller tray
- Connect the data hosts to the controller tray
- Use WBI or the CLI to set the Ethernet IP address, netmask, and gateway address, for each controller module
- Use WBI, or the CLI, to set the array date and time; change the management password
- Set the basic array configuration parameters
- Plan and implement your storage configuration



Connecting to a terminal emulator

- Start and configure a terminal emulator, such as HyperTerminal using the following settings:
 - Terminal Emulator Display Settings
 - Terminal Emulation Mode ANSI (for color support)
 - Font Terminal
 - Translations None
 - Columns 80
 - Terminal Emulator Connection Settings
 - Connector COM1 (typically)
 - Baud rate (bits/sec) 115,200
 - Data bits 8
 - Parity None
 - Stop bits 1
 - Flow control None



Setting up the IP address

- At the prompt (#), type the following command to set the IP address for controller A
 - Set network-parameters ip <address> netmask <netmask> gateway <gateway> controller <a | b>
- Verify Ethernet connectivity by pinging the IP addresses
- Optional
- At the prompt (#), use the same command to set the IP address for controller B except b
- Type the following command to verify the new IP addresses:
 - Show network-parameters



MSA2000fc G2 Management



Management via SMU and CLI

You can now manage your MSA2000fc G2 via:

- 1) Web-based Storage Management Utility (SMU) – It is the primary interface for configuring and managing the system. A web server resides in each controller module. SMU enables you to manage the system from a web browser that is properly configured and that can access a controller module through an Ethernet
- 2) Command Line View (CLI) – The embedded CLI enables you to configure and manage the system using individual commands or command scripts through an out-of-band RS-232 or Ethernet connection

TIP: SMU uses popup windows to indicate the progress of user-requested tasks. Therefore, disable any browser features or tools that block popup windows

Comparison between old and new SMU

MSA2000fc

HP StorageWorks MSA Storage Management Utility

Username:
Password:

Please login to the HP StorageWorks MSA Storage Management Utility

System Name Uninitialized Name
System Location Uninitialized Contact

MSA2000fc G2

Storage Management Utility

User name:
Password:

Language:

Logging into HP SMU

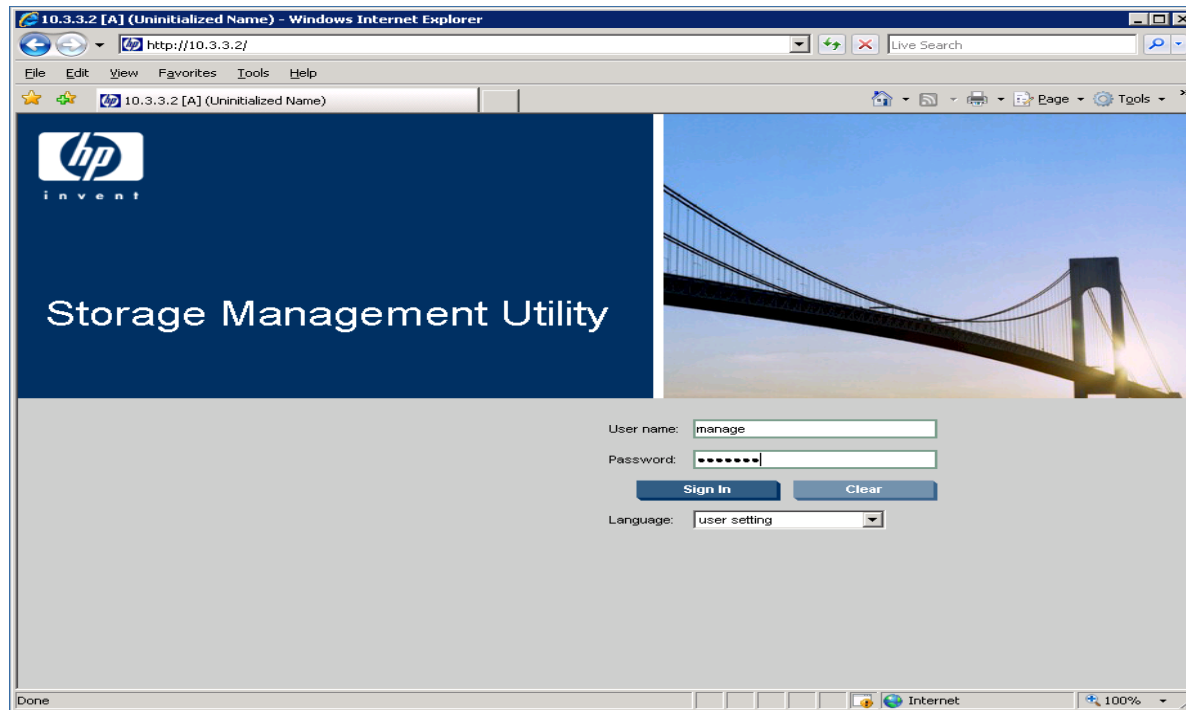

TIP

- In a web browser, type a controller module IP address in the address or location field and press Enter.
 - Type the Username: **manage**
 - Type the Password: **!manage**
- Default Login Credentials

Creating Vdisk

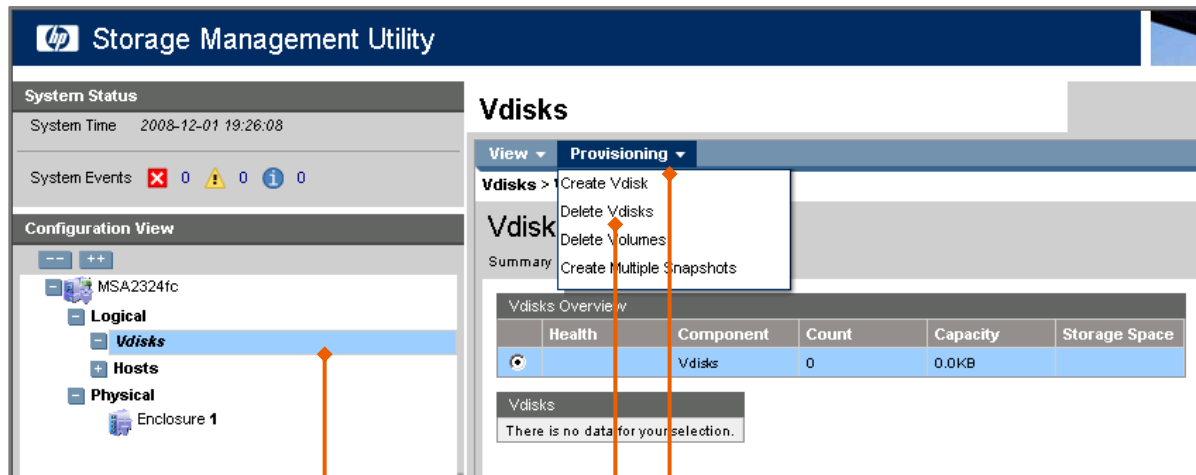

- Select Create a vdisk
- Click the "Provisioning"
- Click "Create Vdisk"
- This will bring up the "Vdisks" screen

Note – Drive Configs:

- RAID levels 3,5, 6 can contain a max of 16 disks
- RAID level 0, 50 and 10 can contain up to 32 disks

Creating Vdisk

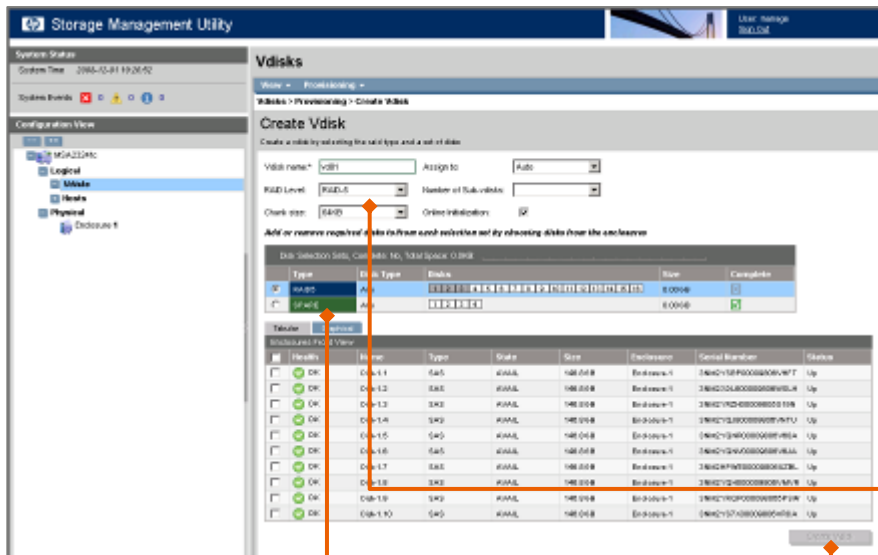

Note – Drive Configs:

- RAID levels 3, 5, 6 can contain a max of 16 disks
- RAID level 0, 50 and 10 can contain up to 32 disks

Creating Vdisk

The screenshot displays the HP Storage Management Utility interface. On the left, the 'Configuration View' shows a tree structure with 'Logical' > 'Vdisks' > 'vd01 (RAID5)' selected. An orange arrow points from this selection to the 'Vdisk Overview' panel on the right. The 'Vdisk Overview' panel shows a table with the following data:

Health	Component	Count	Capacity	Storage Space
OK	Vdisk		293.3GB	293.3GB
OK	Disks	4	293.3GB	293.3GB
	Volumes	0	0.0KB	
	Snap Pools	0	0.0KB	

Below the table is a 'Properties for vd01' section with the following details:

Property	Value
Health	OK
Health Reason	Virtual-disk is fault tolerant.
Name	vd01
Size	293.3GB
Free	293.3GB
Current Owner	A
Preferred Owner	A
Serial Number	0060ff00196000024453449000000000
RAID	RAID5
Disks	3
Spares	1
Chunk Size	64k
Created	2008-12-01 20:12:20
Minimum Disk Size	146.6GB
Status	FTOL
Current Job	Initialize (4%)

• You may now check the Vdisk properties by clicking on the newly created vdisk in the left panel



Creating volumes

The screenshot shows the HP Storage Management Utility interface. On the left is a navigation tree with 'Logical' > 'Vdisks' > 'vd01 (RAID5)' selected. The main area shows the configuration for 'vd01 (RAID5)'. A 'Provisioning' dropdown menu is open, showing options: 'Create Volume', 'Create Volume Set', 'Create Multiple Snapshots', 'Delete Volumes', and 'Expand Vdisk'. Below this is a table with columns: 'Vdisk', 'Count', 'Capacity', and 'Storage Space'. The table contains one row for 'Vdisk' with a status of 'OK', a count of 1, a capacity of 293.3GB, and a storage space of 293.3GB. Below the table is a 'Properties for vd01' section with a table of key-value pairs.

Property	Value
Health	OK
Health Reason	Virtual-disk is fault tolerant.
Name	vd01
Size	293.3GB
Free	293.3GB
Current Owner	A
Preferred Owner	A
Serial Number	00-c0#001960002446344900000000
RAID	RAID5
Disks	3
Spares	1
Chunk Size	64k
Created	2008-12-01 20:12:20
Minimum Disk Size	146.6GB
Status	FTOL
Current Job	Initialize (8%)

- Click on "Provisioning" and then on "Create Volume Set"
- Continue on next screen



Creating volumes

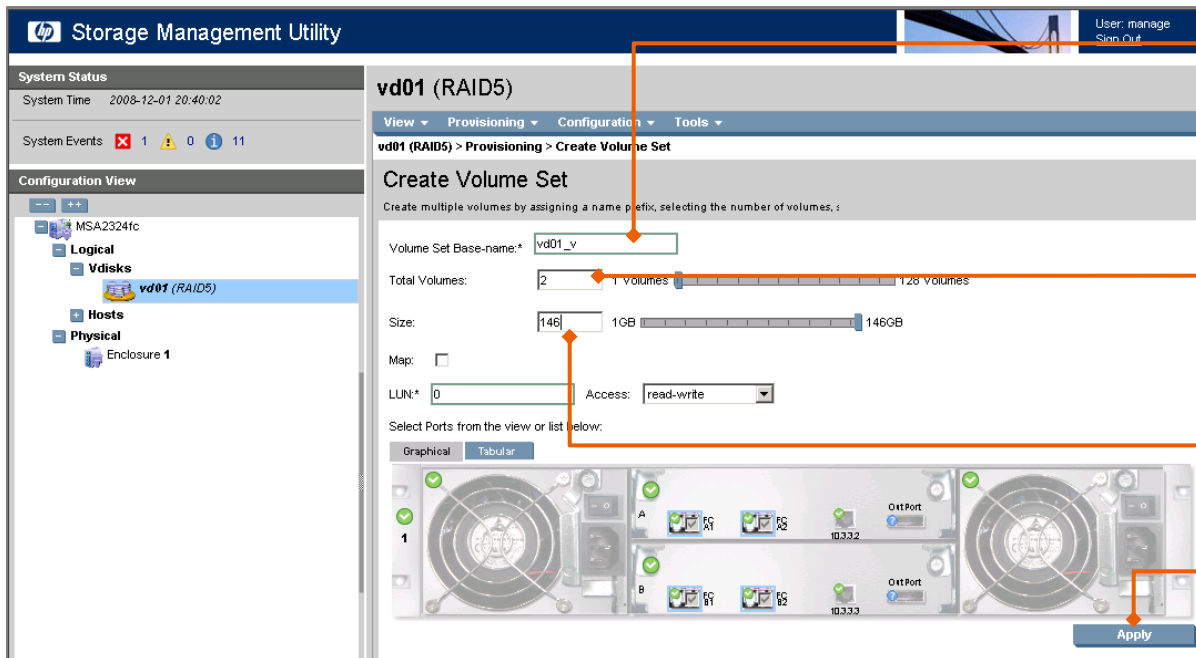

- You may want to change the “Volume Set Base-name”
- Enter the total number of volumes you want to create
- Enter the size of the volume
- Click on “Apply” to create the volumes

Creating volumes

The screenshot displays the HP Storage Management Utility interface. The main window is titled 'vd01 (RAID5)' and shows the 'Create Volume Set' configuration page. The configuration includes:

- Volume Set Base-name: vd01_v
- Total Volumes: 1 (range 1 to 126)
- Size: 1304 (range 1MB to 1304MB)
- Map:
- LUN: 0
- Access: read-write

The graphical view at the bottom shows a RAID controller with two ports, A and B, each with two SAS ports (10332 and 10333) and two Out Ports. The 'Apply' button is visible at the bottom right.

- Click on the '+' next to the Vdisk. This will expand the Vdisk and you will see your new volumes



Creating volumes

The screenshot displays the HP Storage Management Utility interface. On the left, the 'Configuration View' shows a tree structure with 'MSA2324fc' expanded to 'Logical' > 'Vdisks' > 'vd01 (RAID5)', where 'Volume vd01_v000 (145.9GB)' is selected. The main area shows the 'Volume Overview' for 'Volume vd01_v000 (145.9GB)'. It includes a table with columns 'Component', 'Count', 'Capacity', and 'Storage Space'. Below this is a 'Properties for vd01_v000' table.

Component	Count	Capacity	Storage Space
<input checked="" type="radio"/> Volume		146.0GB	<div style="width: 100%;"></div> 146.0GB
<input type="radio"/> Maps	3		
<input type="radio"/> Schedules	0		

Property	Value
Vdisk Name	vd01
Name	vd01_v000
Size	145.9GB
Preferred Owner	A
Current Owner	A
Serial Number	00:c0ff001960000b451344901000000
Cache Write Policy	write-back
Cache Optimization	standard
Read Ahead Size	Default
Type	standard
Volume Description	

- You may now check the Volume Overview by clicking on a volume in the left panel

TIPS: MSA2000 G2 allows you to expand or delete Volumes (LUNs) out of order



Mapping a volume



- Double click the icon on your desktop to launch the HP Systems Management Homepage

The screenshot shows the HP System Management Homepage for MYWSS. The page title is "System Management Homepage for MYWSS" and the system model is "ProLiant DL380G5 Storage Serv". The current user is "Administrator". The page has a navigation bar with "Home", "Settings", "Tasks", and "Logs". On the left, there are sections for "Integrated Agents", "Other Agents", "Management Processor", and "Other Software". The main content area is titled "System Status Summary" and shows "no failed/degraded items". Below this, there are several status blocks, each with a green checkmark icon. The "Storage" block is highlighted with a green border and has an orange arrow pointing to it from the "Storage" link in the "Operating System" block. The "Storage" block contains the following items: External Storage Connections, Smart Array P400 Controller in Slot, Standard IDE Controller (1), and iSCSI Initiators. The "Operating System" block contains Logical disks, Processors, Server, File System Space Used, and Memory. The "System Configuration" block contains Automatic Server Recovery, Security, Software Version Info, System Board, System Resources, and System Summary. A key at the bottom left indicates: OK (green checkmark), Degraded (yellow triangle), Failed (red triangle), and Unknown (question mark).

- Once the SMH has loaded, locate the block labeled 'STORAGE'.
- Within the block, locate and click the link labeled 'EXTERNAL STORAGE CONNECTIONS'



Mapping a volume

System Management Homepage for MYWSS

System Model: ProLiant DL380G5 Storage Server
Current User: Administrator

Home Settings Tasks Logs

Home -> Storage -> External Storage Connections

External Storage Connections

HP FC1242SR 4Gb PCI-e DC HBA	
Status:	OK
Location:	Slot 2
Serial Number:	MY50823F76
World Wide Port Name:	50014380020014A8
World Wide Node Name:	50014380020014A9
Firmware Version:	4.03.02
Option ROM Version:	1.26
Storage Systems:	None
Tape Controllers:	None

HP FC1242SR 4Gb PCI-e DC HBA	
Status:	OK
Location:	Slot 2
Serial Number:	MY50823F76
World Wide Port Name:	50014380020014AA
World Wide Node Name:	50014380020014AB
Firmware Version:	4.03.02
Option ROM Version:	1.26
Storage Systems:	None
Tape Controllers:	None

- This page shows details on the fibre channel HBA installed in the server.
- Locate and write down both of the 16 digit values next to the World Wide Port Name. This is the number displayed in the MSA2324fc LUN Mapping table.



Mapping a volume

Storage Management Utility

System Status
System Time 2008-12-02 19:19:25
System Events 1 0 32

Configuration View

MSA2324fc

- Logical
 - Vdisks
 - vd01 (RAID5)
 - Volume vd01_v000 (145.9GB)
 - Volume vd01_v001 (145.9GB)
- Hosts
 - Physical
 - Enclosure 1

Volume vd01_v000 (145.9GB)

View Provisioning Configuration Tools

Volume v...
Delete Volume
Default Mapping
Explicit Mappings
Create Snapshot
Copy Volume
Roll Back Volume
Abort Copy Volume
Delete Schedule
Schedules 0

Capacity	Storage Space
146.0GB	146.0GB

Properties for vd01_v000

Property	Value
Vdisk Name	vd01
Name	vd01_v000
Size	145.9GB
Preferred Owner	A
Current Owner	A
Serial Number	00c0ff001960000b451344901000000
Cache Write Policy	write-back
Cache Optimization	standard
Read Ahead Size	Default
Type	standard
Volume Description	

- Return to the MSA2324fc Management GUI
- Highlight the first volume
- Select on the menu 'Provisioning' then 'Explicit Mappings'

Mapping a volume

Volume vd01_v000 (145.9GB)

View Provisioning Configuration Tools

Volume vd01_v000 (145.9GB) > Provisioning > Explicit Mappings

Explicit Volume Mappings

Modify the volume mappings to specific hosts by using the default map or explicit map settings.

Select item to modify the mapping properties to a specific host:

Type	Host ID	Name	Ports	LUN	Access
<input checked="" type="radio"/> Default	50014380020014AA				not-mapped
<input type="radio"/> Default	50014380020014A8				not-mapped
<input type="radio"/> Default	50014380020012B0				not-mapped
<input type="radio"/> Default	50014380020012B2				not-mapped
<input type="radio"/> Default	21FD00051E028AFB				not-mapped

Map:

LUN*: Access:

Select Ports from the view or list below:

Graphical Tabular

Apply

- Select one of the Port WWNs
- Check the 'Map' box
- Enter a LUN ID
- Pull down the 'Access' drop down menu and select 'Read-Write'
- Click on the port that you wish to allow 'Read-Write' access on. You must also Click on each port you wish to use for host access.
- Then click on 'Apply'
- Click 'OK' on the success window

Mapping a volume

The screenshot displays the HP Storage Management Utility interface. On the left, a tree view shows the system hierarchy: MSA2324c > Logical > Vdisks > vd01 (RAID5) > Volume vd01_v000 (145.9GB). The main panel shows the configuration for Volume vd01_v000 (145.9GB), with the 'Explicit Mappings' tab selected. Below the title, there is a table of mappings for this volume.

Maps for Volume vd01_v000						
	Type	Host ID	Name	Ports	LUN	Access
<input type="radio"/>	Explicit	50014380020014A8		A1,A2,B1,B2	0	read-write
<input type="radio"/>	Explicit	50014380020014AA		A1,A2,B1,B2	0	read-write
<input type="radio"/>	Default	50014380020012B0				not-mapped
<input type="radio"/>	Default	50014380020012B2				not-mapped
<input type="radio"/>	Default	21FD00051E028AFB				not-mapped

• Notice that the mapping has changed for the port you have configured.



Useful customer links

- MSA2000sa G2 home page
 - www.hp.com/go/msa2000sa
- MSA2000i G2 home page
 - www.hp.com/go/msa2000i
- Best Practices for Optimizing the MSA2000 Whitepaper:
 - <http://h20195.www2.hp.com/V2/GetPDF.aspx/4AA2-5019ENW.pdf>
- How to Upgrade your MSA2000 from G1 to G2:
 - <http://h20195.www2.hp.com/v2/GetPDF.aspx/4AA2-5207ENW.pdf>
- Step-by-step Technical Guide to set up your SAN with MSA2000 (MSA2000 Technical Cookbook):
 - <http://h20195.www2.hp.com/V2/GetPDF.aspx/4AA2-5505ENW.pdf>
- Be a part of the conversation, and get the latest MSA related news and information at
 - <http://Twitter/MSAstorage>



Technology for better business outcomes

