

Microelectrophoresis Apparatus Mk II

Operating Manual

Manufactured by:

Rank Brothers Ltd

56 High Street, Bottisham, Cambridge CB25 9DA, England

Tel: +44 (0)1223 811369 Fax: +44 (0)1223 811441

Website: <http://www.rankbrothers.co.uk/>

Contents

1. Getting Started.....	6
1.1 Do Not	6
1.2 Do	6
1.3 Connection to your Mains Supply	6
1.4 Parts List (Standard Instrument)	7
1.5 Assembling the Instrument	7
1.5.1 Fitting the Micrometer Heads	7
1.5.2 The Handset	8
1.5.3 The Electrodes.....	8
1.5.4 The Water Pump	9
1.5.5 The Lamp.....	9
1.5.6 The Temperature Probe and Heater Element.....	9
1.5.7 The Binocular Heads	9
1.5.8 The Cells	9
2. The Controls	9
2.1 The Mains On/Off Switch	9
2.2 The Electrode Supply	9
2.3 The Handset	10
2.4 The Heater Control.....	10
2.5 The Lamp Controls	11
2.6 The Lamp Adjustments	11
2.6.1 Focusing	11
2.6.2 Beam Diameter	11
2.6.3 Lamp Filament Height Adjustment	11
2.7 The Collimator Tube Adjustments	12
2.7.1 Beam Width Adjustment.....	12
2.7.2 Beam Collimation Control	12
2.7.3 Beam Focusing Control	13
2.7.4 Beam Height Adjustment	13

2.8 The Cylindrical Cell Water Bath.....	13
2.9 The Microscope (Cylindrical Cell Set-up)	13
2.10 The Microscope (Rectangular Cell Set-up).....	13
2.11 Dark Field Condenser (Rectangular Cell Set-up)	14
2.11.1 Focusing	14
2.11.2 Beam Height Adjustment.....	14
2.11.3 Beam Horizontal Adjustment.....	14
2.12 Changing from Cylindrical Cell to Rectangular Cell Set-up.....	14
2.13 Cylindrical Cell Alignment	15
3. Calibrations	17
3.1 The Eyepiece Graticule.....	17
3.2 The Handset	17
3.3 Determination of Cell Inter-Electrode Distance.....	18
3.3.1 Determination of R.....	18
3.3.2 Determination of K.....	19
3.3.3 Determination of A	19
3.4 The Cell Stationary Levels	20
3.4.1 The Cylindrical Cell	21
3.4.2 The Rectangular Cell	21
4. Choosing the Best Configuration for your Sample.....	22
4.1 Cylindrical Cell.....	22
4.2 Rectangular Cell	23
4.3 Electrode Types.....	23
4.3.1 Platinum Electrodes	24
4.3.2 Palladium Electrodes.....	24
4.3.3 Reversible Electrodes.....	24
4.4 Four Electrode Mode	25
4.5 Constant Current or Voltage Electrode Supply	25
4.6 Temperature Stability in the Cell	25
4.6.1 Heating Effect of Illumination	25

4.6.2 Heating Effect of Current Flow.....	26
4.7 Non-Aqueous Solvents.....	27
5. Making Measurements.....	27
5.1 General.....	28
5.2 Additional Instructions with the Cylindrical Cell.....	29
5.3 Additional Instructions with the Rectangular Cell.....	29
6. Theory.....	29
6.1 Mobility.....	29
6.2 Conversion of Mobilities to Zeta (ζ) Potentials.....	29
6.3 The Significance of the Measured Zeta Potential.....	31
6.4 Calculation of Particle Charge from ζ	32
7. Appendix A: The Heater Controller.....	33
7.1 Fault Finding.....	33
7.1.1 Error EE3 Loop Break Alarm.....	33
8. Appendix B: Using the Break-out Box.....	35
9. Appendix C: Blacking Platinum Electrodes.....	36
10. Appendix D: Precharging Palladium Electrodes with Hydrogen.....	37

Warranty

We guarantee the manufacture of the instrument and parts against faults for a period of twelve months from the invoice date.

If a fault should occur within this period then we undertake to either:

- Supply free of charge replacement parts for you to fit to the instrument.
- Upon return of the item at your expense, repair or replace (at our discretion) the instrument free of charge and return it to you at our expense.

1. Getting Started

Thank you for purchasing Rank Brothers equipment. Please ensure that you have read and understood this operating manual before use. You should safely store this manual for future reference.

1.1 Do Not

- Do not plug into your local mains supply until you have checked that your local supply voltage matches that stated on the label at the rear of the instrument (adjacent to the mains inlet connector).
- Do not change the fuse or remove any covers with the mains lead connected to the unit.

1.2 Do

- Do ensure that if the moulded plug is removed from the mains lead it is disposed of safely.
- Do read and understand this manual before use.

1.3 Connection to your Mains Supply

IMPORTANT: This unit must be earthed to ensure operator safety. If the supplied mains lead does not have a moulded plug that is suitable for connection to your local supply, then cut it off. If it is necessary to remove this plug and fit a suitable one, the removed plug must be safely disposed. The removed plug would present a serious shock hazard if plugged into a suitable supply with the bare wires exposed.

The wires of the mains inlet lead are coloured as follows:

GREEN/YELLOW or GREEN	EARTH
BLUE or BLACK	NEUTRAL
BROWN or WHITE	LIVE

As the colours of the wires in the mains lead may not correspond with the coloured markings identifying the connections in your plug, proceed as follows:

- The GREEN/YELLOW or GREEN coloured wire must be connected to the terminal in the plug marked with the letter E or marked with the earth symbol or coloured GREEN or coloured GREEN/YELLOW.
- The BLUE or BLACK coloured wire must be connected to the terminal marked N or coloured BLACK.
- The BROWN or WHITE coloured wire must be connected to the terminal marked L or coloured RED.

Before connecting the unit to your mains supply ensure that your supply voltage matches that on the label at the rear of the instrument adjacent to the inlet connector.

For operator safety only the correct fuse must be used, using incorrect fuses will give reduced protection to the operator under fault conditions. Before changing a fuse, switch off the mains supply and disconnect the mains inlet lead from the instrument. The correct fuse values are as follows:

Power inlet connector (220/240 V)	F2A
Power inlet connector (110/120 V)	F3.15A
Heater circuit	F1A
Lamp supply	T630mA
Pump supply	63mA
Electrode supply	T160mA

The unit contains no user serviceable parts. Only competent personnel should remove the cover (after first switching off the power supply and disconnecting the mains inlet lead).

For any servicing or repairs, return the unit to the manufacturer with a covering letter. Please ensure the unit is carefully packaged to avoid damage during shipment.

1.4 Parts List (Standard Instrument)

Please ensure that you have received all the components (and any additional items ordered) before disposing of the packing.

Basic instrument	Handset (with voltmeter and ammeter)
2 Micrometer heads	Power lead
Binocular Head	1 pair Eyepieces (one with graticule)
Lamp unit	Dark field condenser and mount
Rectangular cell	1 pair Platinum Electrodes
Cylindrical cell	Water pump and tubing
Breakout box	Stage micrometer (to calibrate graticule)
Stopwatch	

Please notify us immediately of any shortages.

1.5 Assembling the Instrument

1.5.1 Fitting the Micrometer Heads

The two micrometer heads should first be unscrewed fully to just past the 25 mm mark on the scale. The upper and lower locking screws (Figure 1.1 and Figure 1.2) should then be slackened and the heads fitted into the holes in the mounts. The heads should be

carefully pushed fully into the mounts up to the shoulder and the locking screws tightened with the supplied key. Care should be taken to avoid over tightening the locking screws.

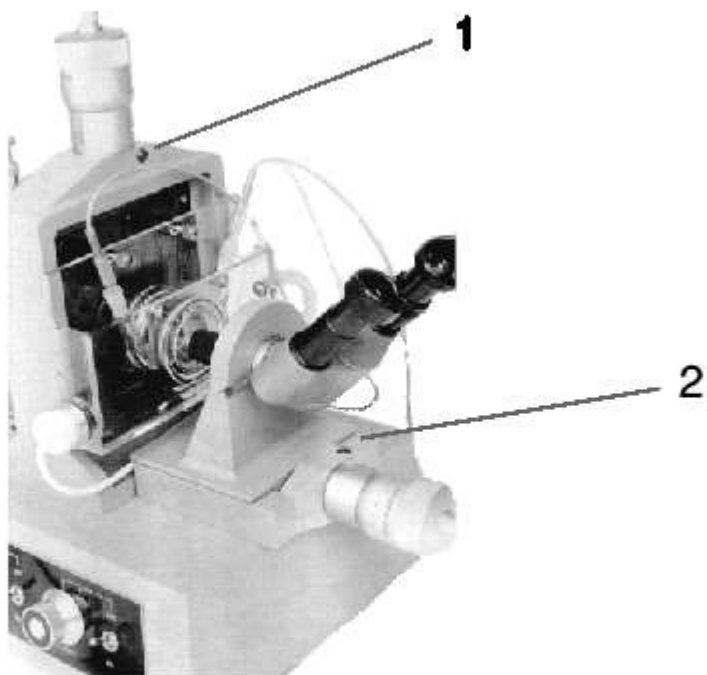

- | | |
|-----|---------------------------------------|
| 1.1 | Upper Micrometer Head Retaining Screw |
| 1.2 | Lower Micrometer Head Retaining Screw |

Figure 1 End view showing micrometer head locking screws.

1.5.2 The Handset

The handset plugs into the appropriately marked socket on the left-hand side of the front panel.

1.5.3 The Electrodes

The electrodes plug into the appropriately marked socket at the rear of the instrument. The electrodes should be placed in the nylon storage units at the rear of the upright when not in use.

1.5.4 The Water Pump

The water pump plugs into the appropriately marked socket at the rear of the instrument. The inlet to the pump is on the end of the pump housing and should be connected to the lower outlet, on whichever tank is being used, with the tubing supplied. Connect the pump outlet to the upper outlet on the same tank with the other piece of tube. Note the pump will only operate whilst the heater circuit is switched on, and may need priming when used after being emptied.

1.5.5 The Lamp

The lamp should be fitted to the black bracket (Figure 2.1) at the left hand of the instrument and should be adjusted so that the beam shines down the centre of the collimator tube (Figure 2.2) or the dark field condenser (Figure 3.4).

1.5.6 The Temperature Probe and Heater Element

Each tank has its own temperature probe and heating element. The heater element has a standard power plug and must be plugged into the appropriate socket at the rear of the instrument. The temperature probe plugs into the appropriate DIN plug at the rear of the instrument. Note do not switch on the heater circuit until the correct probe and heater element, for the tank being used, are plugged in.

1.5.7 The Binocular Heads

The eyepieces should first be fitted to the binocular head, which can then be fitted to the instrument in either the vertical or horizontal mount and locked with the appropriate locking screw (Figure 2.3).

1.5.8 The Cells

The cells should be attached to their cell holders, ensuring that they are fitted the correct way round, and that the screws are not over-tightened. It is recommended that the cells be left in their holders and fitted into the tanks when not in use.

2. The Controls

The following sections explain the controls and adjustments on the instrument.

2.1 The Mains On/Off Switch

The *Mains On/Off* switch is the master switch controlling the power to the instrument. The adjacent green indicator is illuminated when the switch is on.

2.2 The Electrode Supply

The electrode supply controls are on the left-hand side of the front panel adjacent to the handset socket.

- The *On/Off* switch controls the power to the circuit and also the power to the handset.
- The *Constant Voltage/Current* switch enables the electrode supply to either operate in constant current or constant voltage mode.
- The *Volts/Current* knob is used to adjust the supply output to a suitable value for the sample being tested.

2.3 The Handset

The handset contains an ammeter and a voltmeter display. The two displays from top to bottom (top is nearest the switch) are as follows:

- The electrode voltage in volts. Note the polarity is also shown so that with the meter showing positive the electrode with the brown lead is positive (this is with the polarity switch to the right). The switch at the top of the handset controls the electrode supply. The centre position is off, in the right position the electrodes are switched on, and in the left position the polarity is reversed.
- The electrode current in milliamps. Note this does not show polarity of the electrodes (i.e. the value is always positive).

2.4 The Heater Control

Before switching on the heater control it is essential to ensure that, whichever water bath is being used, its heating element and temperature probe are connected to the rear of the instrument. The heater control can now be switched on. The control takes a couple of seconds to self-check and should then display the temperature of the water bath in degrees Celsius. To check the set point temperature, press and hold the * button, the display will now flash the set point value. To adjust the set point press either the up or down arrow keys whilst holding down the * key until the desired set point is obtained. Note these keys repeat if held down, also although it will appear to allow a set point larger than 60 degrees, if you re-check the set point it will have corrected back to the maximum 60 degrees. This is a safety feature and must not be adjusted by the user.

The error indicator on the left of the display operates as follows:

- If the water bath is within 0.3 of a degree of the set point then the error indicator will show as a green square.
- If the temperature is between 0.3 and 1 degree above the set point then the up arrow will be green.
- If the temperature is more than 1 degree above the set point the up arrow will flash.

The down arrow shows temperatures below the set point in a similar manner.

With the Set Point adjusted to the appropriate value and the circulating pump adjusted to a steady flow, the bath should stabilise to the set temperature within 30 minutes. The

display should be accurate to within one degree, and the temperature stability should be maintained to within 0.5 degrees, although both the set point value and the stability of the ambient temperature will affect the stability.

Appendix A contains further information about fine tuning the control should it not be possible to hold the set point, and a list of fault codes.

2.5 The Lamp Controls

The *Lamp On/Off* switch is located at the right hand side of the front panel. The *Brightness* control is situated to the left of the switch. It should be turned fully anti-clockwise to minimum brightness before switching on the lamp (to extend the life of the lamp).

Note the lamp body will become hot if the lamp is used at maximum brightness. The operator should ensure that the body has a clear airflow at all times.

2.6 The Lamp Adjustments

2.6.1 Focusing

The beam can be focused using the focusing screw (Figure 3.2). Turn it anti-clockwise to loosen, slide it along the slot in the lamp body, and then tighten it clockwise when focused. To set the focus correctly, shine the lamp at a piece of white card, then shut down the iris control (Figure 3.1) to give the minimum beam diameter. Now the focusing screw can be slid along until an in-focus image of the lamp filament is seen on the card. The screw (Figure 3.2) should then be tightened to lock it in this position.

2.6.2 Beam Diameter

The diameter of the beam can be adjusted with the iris diaphragm lever (Figure 3.1) and is used to give optimum illumination to the particles once the instrument is set up. With a small beam only part of the field will be illuminated, giving a darker background. This will vary from one sample to another and will need to be adjusted by trial and error.

2.6.3 Lamp Filament Height Adjustment

The two screws (Figure 3.3) underneath the lamp body are used to adjust the height of the filament to ensure that the beam is parallel to the top of the base of the instrument. To carry out this adjustment, ensure that the lamp has been focused correctly, and then shut the iris control to give the smallest possible beam. Now measure the height of the projected filament image from the top of the base (done most easily by projecting the image onto a ruler) just in front of the lamp. Next, measure the height of the projected filament about 200 mm from the lamp. If the two measurements are not the same then adjust screws (Figure 3.3) equally until the beam is parallel with the top of the base. The height of the lamp can be adjusted by the screw in the lamp bracket (Figure 3.3). The

lamp should be aligned by eye to ensure the beam travels down the centre of the collimator tube (Figure 2.2) and gives the maximum amount of light shining on the rear face of the water bath.

2.7 The Collimator Tube Adjustments

The collimator tube has four controls and their effects are best seen with the binocular head and mount removed. To do this, loosen the locking screw (Figure 2.6) and lift the complete mount vertically off the instrument ensuring that it is placed carefully to prevent damaging either the objective or the dovetail slide.

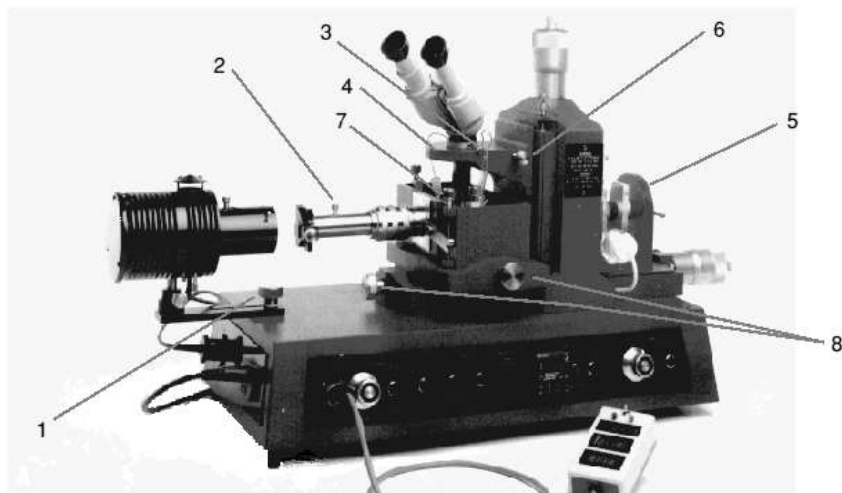

2.1 Lamp Bracket	2.5 Binocular Head Mount (Flat Cell)
2.2 Collimator Tube	2.6 Binocular Head Mount Locking Screw
2.3 Binocular Head Locking Screw	2.7 Light Beam Height Adjusting Screw
2.4 Binocular Head Mount (Cylindrical Cell)	2.8 Cell Position Adjusting Screws

Figure 2 Cylindrical cell set-up.

2.7.1 Beam Width Adjustment

On the end of the collimator tube nearest the lamp there are a pair of adjustable slits. The screw can be used to produce a thin horizontal plane of light to give better dark ground illumination to the particles. During initial set up the slits are best left wide open.

2.7.2 Beam Collimation Control

The control screw is located along the top of the collimator tube and operates in a similar manner to the lamp focusing screw. It should be adjusted to give the maximum amount of light shining on the rear of the water bath.

2.7.3 Beam Focusing Control

The control is a large knurled ring near the water bath used to adjust the focusing of the light in the water bath. With the cylindrical cell in place and water in the bath, switch on the lamp and ensure the lamp iris control is set to maximum. A beam of light should be seen in the water bath, and the focusing ring can now be adjusted so that the point of focus (crossover point) of the beam is in the centre of the cell. This gives the maximum illumination inside the cell.

2.7.4 Beam Height Adjustment

The screw (Figure 2.7) on the front of the water bath is used to adjust the height of the beam of light. When the light has been focused and the iris has been set to give a small beam of light this control will need to be adjusted, as the microscope is focused up and down through the cell, to ensure that that the field of view is always properly illuminated. Initially this can be adjusted so that the beam shines through the middle of the cell.

2.8 The Cylindrical Cell Water Bath

The water bath has two positioning screws (Figure 2.8) which are used to correctly position the cell capillary underneath the objective lens. One screw adjusts the axial position of the cell and the other the radial position relative to the microscope. This is similar to an x-y table found on conventional microscopes. Initially these may be roughly adjusted with the objective mount in place and the binocular head removed, viewing the cell capillary through the objective.

2.9 The Microscope (Cylindrical Cell Set-up)

The micrometer head on top of the instrument focuses the microscope. Before the water bath is filled, the limit screw (Figure 3.5) should be adjusted to prevent the objective lens touching the top of the cell capillary and breaking it. It should be set so that the lens focuses down to within 1mm of the top of the cell. This will prevent accidental breakage of the capillary during focusing. Remove the binocular head by loosening the locking screw (Figure 2.3), or the complete mount can be removed by loosening the locking screw (Figure 2.6).

2.10 The Microscope (Rectangular Cell Set-up)

The microscope is focused with the micrometer head on the end of the instrument. This adjustment has no stop, so be careful not to break the tank window with the objective. The micrometer head on top is now used to move the cell in a vertical plane to measure the height of the cell and to focus approximately half way up the cell whilst making measurements.

2.11 Dark Field Condenser (Rectangular Cell Set-up)

The dark field condenser has three adjustments as follows:

2.11.1 Focusing

The focusing screw (Figure 3.6) focuses the light and ensures that the crossover point of the light is in the centre of the rectangular cell.

2.11.2 Beam Height Adjustment

The stainless steel screw on top of the condenser is used to adjust the height of the condenser, and hence the height of the beam in the cell.

2.11.3 Beam Horizontal Adjustment

The nylon screw (near the stainless steel height screw) locks the condenser in its dovetail slide. With this screw slackened, it is possible to adjust the condenser sideways until the field of view is correctly illuminated.

2.12 Changing from Cylindrical Cell to Rectangular Cell Set-up

The instrument is supplied in the cylindrical cell set-up but can easily be changed to the rectangular cell set-up. Figure 2 and Figure 3 show the instrument configured for the cylindrical cell and rectangular cell set-ups respectively. The following instructions explain how to change to the rectangular cell set-up, but can easily be applied to convert back to the cylindrical cell set-up.

1. Ensure the instrument is switched off and the power lead removed.
2. Drain any water from the tank.
3. Disconnect the pump tubing from the tank water outlets.
4. Unplug the tank temperature probe and heater element.
5. Remove the binocular head from its mount (Figure 2.4) by loosening the locking screw (Figure 2.3) and lifting off.
6. Remove the binocular head mount by loosening the locking screw (Figure 2.6) and lifting off. Ensure the mount is left safely so that no damage occurs to either the slideway or the objective lens.

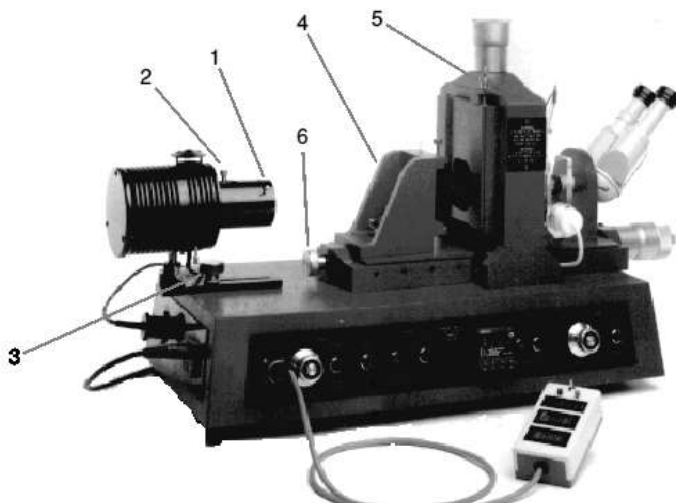

3.1 Lamp Iris Control	3.4 Dark Field Condenser and Mount
3.2 Lamp Focussing Control	3.5 Height limit stop
3.3 Lamp Height Adjusting Screw	3.6 Condenser Focussing Control

Figure 3 Rectangular cell set-up.

7. Remove the water bath and cross slide by loosening the two hexagonal screws, one at the front and one at the rear of the tank, using the key supplied.
8. Replace the tank with the dark field condenser and mount (Figure 3.4), and tighten the stainless steel thumbscrew.
9. Adjust the lamp and bracket so that the lamp is as close as possible to the condenser and the beam shines down the middle. The lamp bracket will need to be rotated through 180 degrees.
10. Connect the rectangular tank temperature probe and heater element to the appropriate sockets at the rear of the instrument.
11. Re-connect the pump tubing to the tank, with the pump inlet connected to the lower tank outlet.
12. Refill the water tank so that water covers the upper outlet and bleed the pump if required.

2.13 Cylindrical Cell Alignment

When using the cylindrical cell it is important that the centre of the viewing axis is along the diameter of the cell and not along a chord (see Figure 4).

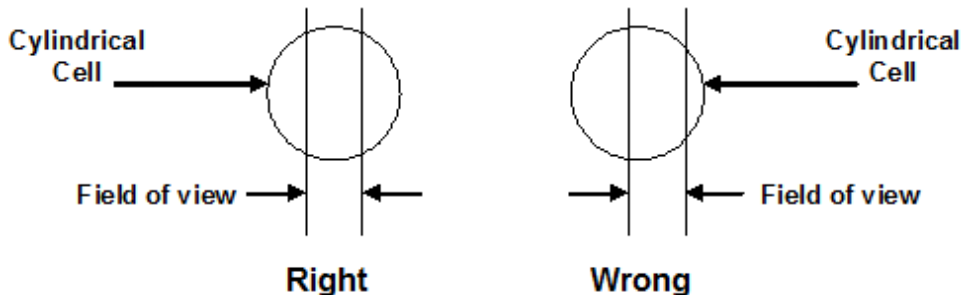

Figure 4 Positioning of the cylindrical cell.

To achieve this, follow the steps outlined below:

1. Fill the cell with a dilute sample of easily visible charged particles of about 1 micron in size, and put the electrodes into the cell.
2. Fill the water bath with water until the level is above the capillary and the top water outlet on the end of the bath is completely covered.
3. Use the height adjusting screw (Figure 2.7) to adjust the light so that it illuminates the top outside face of the capillary wall.
4. Use the cell positioning screws (Figure 2.8) to ensure that the illuminated part of the cell is directly below the objective.
5. Slowly focus down onto the cell using the top micrometer screw until part of the cell wall is in focus. Note it may be necessary to repeat steps 3 and 4 to ensure that the field of view is in the centre of the illuminated area. It is possible to recognise the cell wall by switching on the field to the electrodes. Any particles in the cell will be migrating towards the electrodes, thus by focusing upwards a point will be reached where the particles are stationary (stuck to the cell wall) and some surface imperfections in the cell wall should be seen.
6. Slowly focus upwards noting that (due to the curvature of the cell) the line of cell in focus moves sideways across the field of view.
7. Whilst continuing to focus upwards, use the cell positioning screw (Figure 2.8) to ensure that the band in focus remains in the centre of the field of view.
8. A point will be reached where focusing upwards any further causes the cell to disappear out of focus completely. Now focus downwards until the cell is just in focus.
9. The band that is now in focus should be exactly in the centre of the field of view, ensuring that you are focusing on the diameter of the cell and not on a chord. If not adjust the position using the cell positioning screw.

The microscope is now focusing along the diameter of the cell and not a chord, and is ready for further operations.

3. Calibrations

The instrument needs to have several parameters measured or calibrated before any accurate measurements can be performed.

3.1 The Eyepiece Graticule

The graticule can be calibrated using the stage micrometer supplied. Note the calibration will be different for different instrument configurations, thus the cylindrical cell set-up will be different to the rectangular cell set-up. Also the calibration will be different again, with either the rotating prism, or TV system, thus up to eight different calibrations may be required as follows:

1. Cylindrical cell
2. Rectangular cell
3. Cylindrical cell + Prism
4. Rectangular cell + Prism
5. Cylindrical cell + TV
6. Rectangular cell + TV
7. Cylindrical cell + Prism + TV
8. Rectangular cell + Prism + TV

To perform the calibration, set up the configuration required. The stage micrometer has a mount for the cylindrical cell set-up that replaces the cell in the cell holder, and can be taped to the rectangular cell holder (after removing the cell). With water in the appropriate tank, simply focus onto the graduations of the stage micrometer and use them to measure the distance apart of the grid of the eyepiece graticule.

The calibrations should remain constant providing the optical system is not altered. These calibrations will only need to be done occasionally, or after changing part of the optical system, say the TV camera.

3.2 The Handset

The voltage monitoring circuit has an input impedance of 100 megaohms and will work within specification providing the cell impedance does not approach this value (i.e. 1 microamp current at 100 volts). Both the voltage and current circuits are calibrated at 20–25 degrees Celsius. The voltage circuit has an accuracy of 1% and the current 2% in this temperature range. The voltage will maintain this accuracy from 15–30 degrees, however the current may not. For accurate determination of the cell impedance R it would be preferable to use more accurate volt and current meters in conjunction with the break-out box (see Appendix B).

3.3 Determination of Cell Inter-Electrode Distance

This procedure will be familiar to anyone who has had to find the cell constant of a conductivity cell. For a cell completely filled with a solution of electrical conductivity K with an electrical resistance between the electrodes of R and a cross-sectional area, in the viewing plane of A , then the effective inter-electrode distance l , which is not necessarily the actual inter-electrode distance, is given by:

$$l = R \cdot K \cdot A$$

A , the cross-sectional area of the cell, is the area at the point of viewing. If the cell were to have different areas at different places along its length, it would then have different effective inter-electrode distances at different points of viewing. Indeed it should be noted that the formula is not invalidated by the fact that there are sudden changes of A where the capillary is joined to the electrode chamber. The field will always be V/l where V is the applied voltage at the electrodes. In the case of a four electrode cell l will be very close to the actual distance between the inner electrodes. In the case of a two electrode cell (or when using the four electrode cell with only the outer electrodes) l will be noticeably less than the (outer) inter-electrode distance, but greater than the capillary length. A refers, of course, to the internal cross section obtained from the internal diameter.

It is thus necessary to determine R , K , and A as follows.

3.3.1 Determination of R

R can be determined either by an ac bridge operating at a minimum of 50 Hz, or by a dc method. The former method would normally be more accurate as polarisation effects of the electrodes are eliminated; however the dc method can give good results if carried out accurately. Fill the cell with a standard electrolyte of known conductivity then apply a voltage to the electrodes. Noting the voltage and the current flowing, from Ohm's law:

$$R = V/I$$

Note the voltage should be measured from the third and fourth electrodes of a four electrode cell using a very high impedance meter (>10¹² ohms), keeping the meter in circuit only long enough to take the measurement to prevent polarisation.

Using either ac or dc methods the electrolytic should be selected to give an R of a few thousand ohms.

When using the dc method the electrode supply from the instrument can be used and the voltage and current displayed on the handset taken with two electrode cells. If a more accurate voltmeter and ammeter is available the break-out box should be used

(see Appendix B). The disadvantage of the dc method is the polarisation effects of the electrodes giving an inaccurate voltage measurement.

These effects can be minimised by taking V and I measurements with the field reversed, and taking mean readings, and by switching on the field only long enough to take readings. If an accurate voltmeter is available but not an ammeter then the current can be measured from the voltage across a standard resistance inserted, in series, in the circuit.

3.3.2 Determination of K

K can be determined either by using a calibrated conductivity meter, or by accurately making up a solution of potassium chloride (KCl). The table below gives some typical values of KCl solutions at 25 °C; the calibration should thus be carried out at 25 °C, as the temperature coefficient is about 2% per degree. It should be remembered that objects of density around 1 g·cm⁻³ weighed against brass or steel weights will require a correction of about 0.1% for air buoyancy.

It is suggested that for both the cylindrical and rectangular cells a 0.1 M KCl solution be used to give a cell resistance of several thousand ohms. Lind Zwolenik and Fuoss (J. Amer. Chem. Soc. 81 (1959), 1557) give a useful interpolation equation for use where it is inconvenient to make up solutions by exact weighing:

$$A = 149.93 - 94.65c^{1/2} + 58.74c \cdot \log c + 198.4c$$

Where $\Lambda = 1000 K/c$ and c is the molar concentration taking the molecular weight of KCl as 74.557. This equation should not be used for c values much greater than 0.04 M. The relationship between molality m and molarity c for aqueous KCl at 25 °C is:

$$c / m = 0.99707 - 0.0272m$$

Concentration		Conductivity K at 25 °C ohm ⁻¹ ·cm ⁻¹
Molarity	gKCl per 1000g solution (in vacuo)	
0.01		0.001411
	0.7453	0.001409
0.10		0.01289
	7.419	0.01286
1.00		0.1117
	71.14	0.1113

3.3.3 Determination of A

For the cylindrical cell, A can be determined on the instrument using the microscope and focusing on the inside face of the cell and noting the micrometer reading, then focusing on the opposite inside face, and noting the new reading, the difference between the two

being the apparent distance. Note to eliminate possible errors due to backlash of the micrometer head, it should be rotated in the same direction, whilst making any measurements. If it is moved too far, it should be screwed half a turn in the opposite direction then screwed back to the desired position. Both the cell and the thermostatted tank should be full of water. Any correction arising from the curvature of the cell walls is negligible since the walls are less than 100 μm thick. A is then given by:

$$A = \pi d^2/4$$

Where d is the internal diameter of the capillary.

The rectangular cell should be empty and dry, although the water tank may or may not contain water; the apparent depth d is then the actual depth, no correction for refractive index being necessary. The height h of the cell can be measured using the upper micrometer to focus on the top and the bottom of the cell and noting the difference in the two readings, no correction being necessary. A is then given by:

$$A = h \times d$$

3.4 The Cell Stationary Levels

The walls of the electrophoresis cells will normally be charged in the presence of a solvent (usually negatively in water). The charge leads to the streaming of the oppositely charged solvent towards the appropriate electrode, near the cell walls. This electro-osmotic streaming velocity varies across the cell section due to the reversed flow at hydrostatic equilibrium, thus obeying Poiseuille's law. The combination of these two opposing flows leads to the situation where the solvent is stationary only in clearly defined areas of the cell section, the stationary levels. The stationary level (i.e. where the solvent is stationary) is thus the only place possible to measure the electrophoretic velocity of any particles in the sample.

Once the position of the stationary level has been calculated, the instrument should be focused onto either inside face of the appropriate cell and the micrometer reading noted. The microscope should then be moved the calculated amount to ensure that it is focusing in the stationary level. This position will need to be re-adjusted if the cell is removed for cleaning or is replaced after damage.

Note once the microscope has been focused into the stationary level the focusing should not be adjusted again during measurements. The user must wait for particles of interest to be in the field of view before carrying out measurements and not focus through the cell to find them.

The calculation of the position of the stationary levels in both the cylindrical and rectangular cells follows.

3.4.1 The Cylindrical Cell

In the cylindrical cell the stationary level is a cylindrical plane concentric with the inside face of the cell wall and at a distance s in from this wall:

$$s/d = 0.146$$

Where d is the internal diameter of the cell.

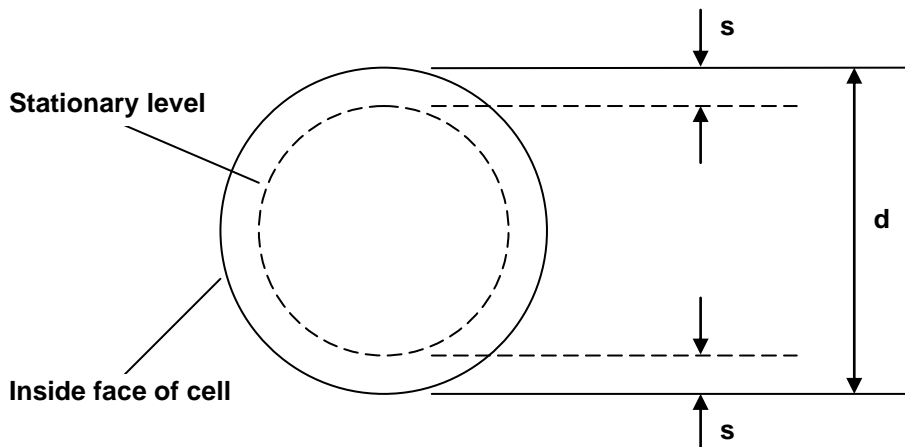

Figure 5 Stationary level in the cylindrical cell.

The internal diameter of the cell d has already been measured. No correction is needed for d , and theory shows that providing the cell wall is less than (or even a little more than) 100 microns, no correction is required for the stationary level either. Note because the stationary level is circular in the cylindrical cell and A is then the height multiplied by the depth as viewed along a diameter (see Figure 5), to be strictly correct only the particles in a line along the centre of the field of view, along the axis of movement are in the stationary level. This may be noticeable when using the rotating prism system, with particles stationary along the centre line of the field of view, but slowly moving at the outer edges of the field.

3.4.2 The Rectangular Cell

The stationary levels in the flat cell are vertical, eliminating problems with sedimenting particles. Figure 6 shows the stationary levels and the formula to calculate these positions. Also included are typical values of s/d for cells we supply, the 10 mm \times 1 mm being standard. Note no optical correction is needed when measuring s and d because the ratio s/d is valid whether the measurements are apparent or actual.

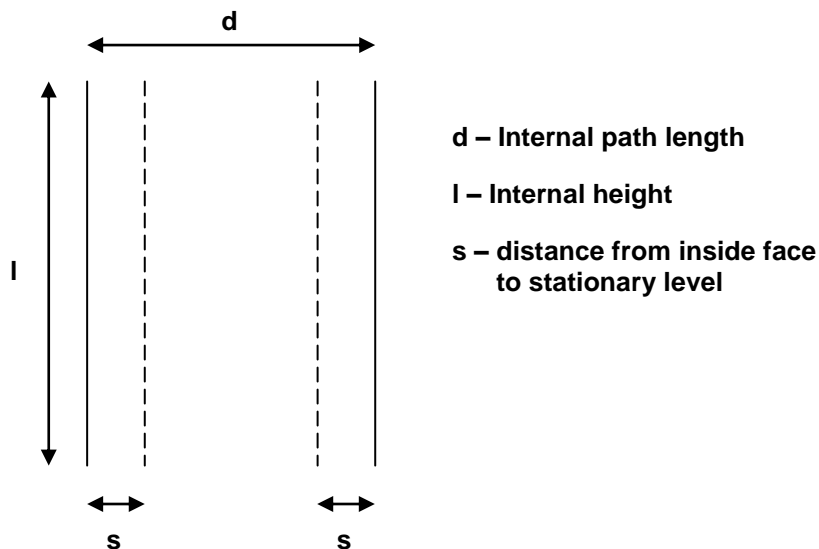

Figure 6 Stationary level in the rectangular cell.

$$\frac{s}{d} = 0.5 - \left[0.0833 + \frac{32}{\pi^5} \frac{d}{l} \right]^{1/2}$$

l/d	s/d	Example cell sizes
20	0.202	10 × 0.5 mm
10	0.194	10 × 1 mm, 5 × 0.5 mm
8	0.190	4 × 0.5 mm
5	0.177	10 × 2 mm, 5 × 1 mm

Once focused into the stationary level the upper micrometer should be adjusted so that the field of view is approximately half way up the vertical side.

4. Choosing the Best Configuration for your Sample

The instrument is supplied with both cylindrical and rectangular cells, and can be supplied with various electrode materials, and laser illumination. It is therefore important to understand the strengths and weaknesses of each item to allow the best configuration for a particular sample.

4.1 Cylindrical Cell

The cylindrical cell is nominally a 2 mm bore thin walled capillary cell with four electrodes as standard.

The advantages are:

- The cell illumination is ultra-microscopic thus very small particles can be visible and an optional 3 mW laser can be used to view particles down to 400 Å (dependent on their refractive index).
- The thin walls give good thermostating and good optical properties.
- The capillary sectional area is small, reducing the current for equivalent field strengths, thus minimising both heating effects and gassing at the electrodes.
- The third and fourth electrodes give more accurate field strength measurements (see section 4.4).

The disadvantages are that the stationary level is cylindrical, so particles denser than the electrolyte can sediment out of the field of view, and hence out of the stationary level, and settle on the bottom of the cell distorting the position of the stationary level.

4.2 Rectangular Cell

The standard rectangular cell supplied has a section of 10 mm × 1 mm and is made of silica glass.

The advantages are:

- The stationary level is vertical, so any particles sedimenting will remain both in the field of view, and also in the stationary level. The electrophoretic mobility can still be measured, as this is the horizontal component of their velocity.
- Particles sedimenting to the bottom of the cell only have a small effect on the position of the stationary level.
- The silica is an advantage in non-aqueous samples where the higher electrical resistivity is an advantage.

The disadvantages are:

- The cell is thick-walled so thermostating is not as good as the cylindrical cell.
- The larger cross-sectional area leads to higher currents at the same field strength, although we are able to supply smaller sections (e.g. 5 mm × 1 mm) to special order.
- We do not supply a four electrode system with a silica cell.

In summary it would thus be preferable to use the cylindrical cell for all aqueous samples except for large particles either falling or rising due to density differences. The flat cell is suited to either large particles or non-aqueous samples.

4.3 Electrode Types

The most commonly used electrodes for the outer electrodes are:

- Platinum (blacked).
- Palladium electrodes (partially pre-charged with hydrogen).
- Reversible electrodes (e.g. silver/silver chloride if chloride electrolytes are present).

4.3.1 Platinum Electrodes

Platinum electrodes have the advantage that they last for long periods with no treatment other than cleaning and the field strength is simply V/l where V is the applied potential (or the potential across the third and fourth electrodes in four electrode mode) and l is the effective inter-electrode distance. See Appendix C for information about 'Blacking' the electrodes. The disadvantage is the gassing at higher currents giving both polarisation effects and possible drifting due to differential pressures at the ends of the cell.

4.3.2 Palladium Electrodes

Palladium electrodes can be used to extend the upper current limit of platinum electrodes. This is achieved by partially precharging the electrodes with hydrogen; thus greatly reducing or eliminating the gassing effects. The pre-charging (see Appendix D) needs to be carried out every day, and may thus be seen as a considerable disadvantage.

It should be noted that at higher field strengths with high electrolyte concentrations Joule heating effects become the limiting factors independent of electrode type. In a cylindrical cell at $10 \text{ V}\cdot\text{cm}^{-1}$ serious difficulties will occur typically at concentrations of 0.2 M and above of typical 1:1 electrolytes. However since the heat produced per unit volume is given by:

$$E^2 K$$

Where E is the field strength and K is the conductivity of the suspending electrolyte. It can be seen that reducing the field strength has a dramatic reduction in heating effects, at the expense of accuracy of measurement of the particle velocity, which will now be lower.

4.3.3 Reversible Electrodes

Typically these would be silver/silver chloride. These electrodes avoid gassing problems however they require more maintenance and cannot be used in V/l mode (except with four electrode cells). Because of possible diffusion of electrolytes across the liquid junctions causing changes in current, and therefore the electrical length of the cell, it is necessary to note the current flowing as well and also the conductivity of the suspending electrolyte K . The field strength is then given by:

$$E = I/AK$$

Where A is the cross sectional area of the cell at the point of viewing.

4.4 Four Electrode Mode

When using a cell with additional probe electrodes fitted, several advantages occur:

- The probe electrodes are placed at the end of the cell section thus the inter-electrode length l is now very close to the actual length between these electrodes as the cell section is uniform between them.
- Providing the voltage is measured with a high impedance voltmeter (preferable $> 10^{12}$ ohms), and/or the electrodes are only connected whilst measurements are taken, then negligible polarisation of the probe electrodes will occur.
- Because polarisation is no longer a problem any outer electrodes can be used, although gassing should still be avoided to reduce mechanical effects.
- If the outer electrodes are supplied from a constant current supply then any heating effects result in a change in conductivity resulting in a change in the measured voltage with time. Steps can thus be taken to reduce these effects.

4.5 Constant Current or Voltage Electrode Supply

The instrument electrode supply is switchable to either constant voltage, or constant current. Either supply can be used for two electrode cells, but to take full advantage of four electrode cells, constant current should be used.

The advantage then is that the voltage across the probe electrodes will fall if any temperature rise in the cell occurs, caused by an increase in conductivity of the electrolyte. It would be very difficult to check the temperature by any other method.

4.6 Temperature Stability in the Cell

It is desirable to ensure that a sample is at constant temperature during measurements, to ensure maximum accuracy. Heating effects normally occur either from the illumination source, or from current flow through the cell, and lead to convection effects carrying particles in various directions, and the measurements being carried out at an incorrect, and unknown temperature. Note the temperature changes will only be observable when operating in four electrode mode.

It is clear that the cylindrical cell, being thin walled, will have better thermostating than the rectangular cell, and that it is necessary to ensure a satisfactory flow of thermostating water over either cell.

4.6.1 Heating Effect of Illumination

The dark field condenser contains a glass heat filter to remove infrared from the light source, and this is helped by passage of the beam through the thermostating water. A bath of copper sulphate solution in the beam will remove further long wavelength emissions. Reducing the brightness and switching off between measurements will all further reduce the problems. The collimator tube does not contain a heat filter, however

the better thermostating of the cylindrical cell means that the illumination rarely causes any problems.

4.6.2 Heating Effect of Current Flow

As already stated the heat generated per unit volume, in a cell, by the applied field strength E and sample conductivity K is given by E^2K . The temperature rise clearly depends on how long the field is applied, the field strength, and the efficiency of the thermostating. Any or all of the following may be used to reduce this effect to a minimum.

- Reduce the current from the electrode supply. This has a major effect on the heat produced, which is given by E^2K , where E is the field strength. The reduction of the current, and hence the field strength, will obviously lead to slower particle speeds leading to reduced measuring accuracy. These two effects thus need to be balanced one against the other.
- If possible reduce K by using lower electrolyte concentrations, although this is obviously not as effective as reducing E .
- Ensure that the electrodes are only switched on during actual measurements, and are switched off at all other times.
- Ensure the lamp brightness is as low as possible and switched off when not being used.
- Take measurements as quickly as possible, so that the electrodes and the lamp are on for the shortest time possible.

The limits below give a rough guide to the maximum field strengths for each cell, using a typical 1:1 electrolyte at 150 mM (i.e. K approximately $0.02 \text{ ohm}^{-1}\cdot\text{cm}^{-1}$):

Cylindrical cell	$E < 9 \text{ V}\cdot\text{cm}^{-1}$
Rectangular cell	$E < 3 \text{ V}\cdot\text{cm}^{-1}$

These assume the measurements are taken quickly with the field and illumination switched off between measurements. At other electrolyte concentrations the limits can be scaled from E^2K , thus halving the electrolyte concentration allows E to increase by the square root of 2 (i.e. 1.4 times).

Heating effects may lead to convection currents within the cell, visible by the particles swirling round in circular paths. The cylindrical cell is rarely prone to this problem, but it can easily occur in the rectangular cell, where constant monitoring should occur. Convection, once started, may continue for several minutes after removing the cause in the rectangular cell, although normally stops immediately in the cylindrical cell.

The temperature coefficient of the particle mobility is almost entirely that of the solution viscosity, and is virtually the same as the temperature coefficient of conductivity, thus

with constant current supply the effects of the temperature rise on the measured mobility are only modest. As a last resort it would thus be possible to note the initial probe voltage and ignore the later lowering, however, this is obviously a practise to be avoided if at all possible.

4.7 Non-Aqueous Solvents

Non-aqueous electrophoresis is frequently associated with 'low conductivity' electrophoresis, although this is not always the case.

For solvents of reasonably high dielectric constant, which support electrolytic dissociation (e.g. methanol or formaldehyde) the situation is little different from water, allowing for viscosity and density factors. Increased volatility may lead to drift due to evaporation at a poor fitting electrode and water contamination may cause further problems.

Solvents of low electrical conductivity present special problems. It is essential that current flow between the electrodes is through the sample, and not by conduction along dirty cell walls, or through the water bath. It is thus preferable to have a cell of silica (as per the standard rectangular cell), and the cell should be kept clean and dry. Water in the thermostat tank can be replaced by oil, taking care to ensure that the oil is compatible with the acrylic tank.

A more fundamental difficulty is that a very low conductivity solvent will not allow the charge on a suspended particle to come to equilibrium. This results in the electrophoretic behaviour of a particle being an accidental property of its history, rather than an equilibrium property typical of that particle. This occurs with aerosols dispersed in air. Furthermore if the electric double layer thickness is significant compared to the cell dimensions, then the stationary levels will be shifted, giving rise to erratic results.

One advantage of lower conductivity is that higher field strengths may be used. The instrument supply is only able to deliver 120 volts, thus an external supply will be required. It is important that with higher voltages care is taken to ensure operator safety. When voltages above 500 volts are used, it is necessary to ensure the particle velocity is proportional to the applied voltage, showing that valid equilibrium electrophoresis measurements are being made.

5. Making Measurements

Section 4 should be used to decide which cell/electrode combination is best for a particular sample, although some trial and error may still be necessary. The instrument should be set up for the chosen cell, all the electrical connections made and the appropriate tank filled with water.

5.1 General

Once the instrument has been set up with the appropriate cell for your sample, proceed as follows:

1. Ensure the correct water heater and temperature probe are connected, then set the desired temperature and allow the water tank temperature and the sample temperature to stabilise.
2. Dilute the sample, if possible, to suitable concentrations, using the same dispersion medium. Typically 1 μm latex would be diluted until the turbidity is just visible. If the sample is too concentrated, too many particles will be visible in the field of view giving a light background, and therefore poor contrast, typically 20–50 particles in the field of view would be adequate.
3. Fill the cell with sample and fit the electrodes ensuring no air bubbles are trapped and that the electrodes are properly seated. Rotating the electrodes slightly whilst fitting may help seating.
4. Focus into the stationary level for the particular cell.
5. Adjust the sample concentration further if necessary.
6. Adjust the illumination to give optimum results, see additional instructions for each cell type.
7. Ensure that the particles are stationary with no field applied to the electrodes. Possible causes of drift are:
 - Excessive gassing at one or both electrodes.
 - Convection currents within the cell.
 - Bad sealing of the electrodes leading to evaporation of the electrolyte, from one or both ends.
 - Air bubbles trapped in the cell during filling.
8. Apply the appropriate field to the electrodes, measuring the particle speed with the field applied in either direction, and noting the applied voltage (or probe electrode voltage in four electrode mode).
9. Take measurements of at least 10 particles with the field applied in either direction, ensuring the field is only applied whilst making measurements.
10. Empty the sample and clean out the cell. Note if the cell is removed from the instrument for cleaning, it may be necessary to check alignment and stationary level positioning before making further measurements.
11. During measurements check that no heating effects are occurring (i.e. voltage dropping on the probe electrodes, or swirling of the particles due to convection). Also ensure excessive gassing is not occurring by ensuring there is no drift with the field off between measurements. Should either occur, take the appropriate steps to reduce the effects then repeat the measurements.

5.2 Additional Instructions with the Cylindrical Cell

1. It is important to ensure that the capillary is adequately illuminated, and that the field of view is along the diameter of the cell, and not a chord.
2. Adjust the collimator and lamp controls to give a suitable dark background, ensuring the brightness is kept as low as possible.
3. Remember that because the stationary level is circular, only the particles along the centre of the field of view, along the axis of movement are in the stationary level.

5.3 Additional Instructions with the Rectangular Cell

1. The dark field condenser and lamp controls should be adjusted for optimum illumination.
2. Extra care will be needed to ensure heating effects, causing convection, are kept to a minimum, signs of heating effects should be checked for regularly during measurements.
3. The eyepiece graticule needs aligning vertically and horizontally so that only the horizontal component (i.e. the electrophoretic component) of the velocity is measured.

6. Theory

The following section covers the theory and contains formulae relevant to Zeta Potentials.

Equations in this manual are given in both rationalised and unrationalised forms. In the former, all quantities are expressed in SI units (based on m, kg, and s); this system is now much more common than the other system (based on cgs units).

6.1 Mobility

Mobility u of the particles is simply given by:

$$v = u / E$$

Where v is the particle velocity and E is the applied field strength (V/l where V is the voltage and l is the effective inter-electrode distance).

6.2 Conversion of Mobilities to Zeta (ζ) Potentials

The equation converting mobility to effective electro-kinetic potential (ζ) depends upon the value of the dimensionless quantity ka in which a is the radius of the particle (assumed spherical) and κ is the quantity:

$$\kappa^2 = \frac{e^2 \sum n z^2}{\epsilon k T} \text{ (rationalised)}$$

From the expression, given that κ is approximately 1×10^6 cm at 25 °C in water ($\epsilon / \epsilon_0 = 78$) containing 1 mM of a 1:1 electrolyte. Values of κ at other concentrations, and/or in other electrolyte types, follow by simple proportion.

If $\kappa a > 200$ it will usually be sufficiently accurate to use the Smoluchowski formula which in the (original) unrationalised form is:

$$v = \frac{\epsilon \zeta}{4\pi\eta}$$

In the rationalised form, this becomes:

$$v = \frac{\epsilon \zeta}{\eta}$$

Where ϵ is the permittivity of the suspending liquid (note the factor 4π between the rationalised and unrationalised form) and η is the viscosity.

Typical units in the older system would have been v in microns per second under 1 volt per cm (usually in the range 0 to 6), in which case for water at 25 °C, ζ in mV would be given by:

$$\zeta = 12.83v$$

If SI units are used, with v expressed in $\text{m}^2 \cdot \text{s}^{-1} \cdot \text{V}^{-1}$ then under the same conditions ζ in volts is given by:

$$\zeta = 12.83 \times 10^5 v$$

For water at 25 °C:

$$\epsilon = 78.35 \text{ (cgs unratt.) or } 6.937 \times 10^{-10} \text{ (SI rat.) and}$$

$$\eta = 8.903 \times 10^{-3} \text{ (cgs unratt.) or } 8.903 \times 10^{-4} \text{ (SI rat.)}$$

If $\kappa a < 0.1$ then the Hückel equation would be relevant. Its unrationalised form being:

$$v = \frac{\epsilon \zeta}{6\pi\eta}$$

Rationalised this becomes:

$$v = \frac{2\epsilon \zeta}{3\eta}$$

Using water as the suspending medium would mean particles being smaller than $0.01 \mu\text{m}$, and thus this formula is hardly ever used.

In the intermediate range of ka (0.1 to 200) the Henry equation can be used, if the ζ potential is small (say $< 20 \text{ mV}$), which in its rationalised form is:

$$v = \frac{2\epsilon\zeta}{3\eta} [1 + f(\kappa a)]$$

Where $f(\kappa a)$ is the correction factor taking values as follows:

κa	0	0.1	1	5	10	50	100	∞
$f(\kappa a)$	0	0.001	0.027	0.160	0.239	0.424	0.458	0.5

If the ζ potential is not small then in the range $ka = 0.1$ to 200 (and indeed at all ka) useful computations of the $u:\zeta$ relationship are those of O'Brien and White (J. Chem. Soc. Faraday II (1978), 1607) these authors also consider the effect of different electrolyte charge types.

If the particles are not spherical then, unless ka is large everywhere, there must be some doubt about the u to ζ conversion. If a large (approximately spherical) particle is an agglomerate of small spheres then the question of which radius to use is seen to arise. If $\kappa \times$ the smaller radius is large then the difficulty disappears since the Smoluchowski equation must clearly be used. If $\kappa \times$ the smaller radius is smaller than 0.1 then again it is fairly evident that the larger radius governs the effective ka .

In all of the above it has been assumed that the particle itself is rigid (i.e. of infinite viscosity). In the absence of firm evidence it seems best to treat all particles of radius $1 \mu\text{m}$ or less, as rigid and non-conducting.

6.3 The Significance of the Measured Zeta Potential

The ζ potential, if correctly calculated from the observed mobility, is best seen as the potential at the surface of the electro-kinetic unit moving through the solution. This will not be the mean wall potential, often called ψ_0 , but can be taken as the mean potential at the outer Stern plane (OSP). The OSP is seen as removed from the surface by one hydrated radius of the principal counter ion (e.g. 0.2 to 0.5 nm).

Some take ζ to refer to a plane much further removed from the surface than this, but the evidence favours the OSP hypothesis and certainly not the many nanometres sometimes proposed.

The electro-kinetic entity may include ions specifically adsorbed from the solution, this will be reflected in the value of ζ . Certainly the double layer on the solution side of ζ will be purely diffuse, so that is the relevant potential for all effects which depend on diffuse

layer effects (e.g. inter-particle repulsion), provided that a reasonable guess can be made as to the position of ζ relative to the surface.

6.4 Calculation of Particle Charge from ζ

The charge which can be calculated directly from ζ is the charge within the shear surface (which may include adsorbed ions), equal and opposite to the total net charge of the rest of the dispersion, to give overall electrical neutrality.

If the value of κa is large (> 200) then the surface may be assumed effectively planar and the charge per unit area σ within the shear surface is given, for the case of a single symmetrical z:z electrolyte, by:

$$\sigma = \frac{\kappa \epsilon 2kT}{ze} \sinh \frac{ze\zeta}{2kT}$$

Where z is taken positive in this rationalised expression.

The Gouy-Chapman expressions only have the validity of the Poisson-Boltzmann equation, from which they derive, and are therefore suspect at high electrolyte concentrations and/or high potentials. Significant error probably occurs at electrolyte concentrations above $0.1 \text{ mol}\cdot\text{dm}^{-3}$ of 1:1 electrolyte and correspondingly smaller concentrations of multi-charged electrolytes. ζ will not be high when the electrolyte concentration is high. If κa is small (< 0.1) then at low potentials ($< 25 \text{ mV}$) the Debye-Hückel equations may be used to give the total charge Q within the shear surface (σ above was per unit area) from:

$$Q = \zeta \epsilon a (1 + \kappa a) \text{ unrat.}$$

Where a is the radius of the shear surface (assumed spherical) and ϵ is the permittivity of the dispersion medium. This is the equation from which the Hückel equation connecting z and u is derived. It is based on a linearisation of exponential terms in the Poisson-Boltzmann equation and it is this that restricts the validity to low potentials. At high potentials there is no equation satisfactorily giving Q in terms of ζ at small (κa) though a very full numerical compilation exists (Loeb, Overbeek and Wiersema, 'The electric double layer around a spherical colloid particle', MIT Press, Cambridge, Mass., USA 1960) which also covers intermediate values of κa . As in the case of plane surfaces, the results depend upon the validity of the Poisson-Boltzmann equation.

7. Appendix A: The Heater Controller

The heater control supplied is a CAL 9900 and allows for precise control over a range of operating parameters. The following instructions should be read in conjunction with the manufacturers operating manual. The unit has been programmed (via parameters) to optimise the control to our instrument, and to provide certain safety features. These parameters should be adjusted with extreme care as they may affect the built-in safety facilities.

7.1 Fault Finding

Always ensure that whichever bath is being used, the heater and temperature probe for that bath are both plugged into the appropriate sockets on the rear of the base. The heater controller may detect errors in which case the display will show an EEx error number where x is listed below:

- EE1 Sensor error, either faulty or not connected.
- EE2 As EE1.
- EE3 Loop break alarm (see below).
- EE5 Unable to auto-tune within time limit.
- EE6 Overshoot during auto-tune exceeds limit.
- EE7 Unable to run auto-tune in this mode.
- EE8 Calibration error, unit needs replacing if error persists.
- EE9 Controller fault requiring repair/replacement.

Note the option numbers listed below for each function number should be suitable for both water baths, for temperatures higher than 5 °C above ambient.

7.1.1 Error EE3 Loop Break Alarm

The controller continuously monitors the water bath temperature and can usually detect heater element failure, etc. Such a failure will trigger a loop break alarm, with the display alternating between EE3 and the water temperature. In this state the controller disables output to the heater element and remains shut down until either the controller is switched off, or the up and down arrow keys are pressed simultaneously. The monitoring occurs when the heater element is either fully on, or fully off, in both cases the controller expects to see a temperature change within a given time, not enough change thus results in an EE3 error. A loop break alarm will occur if, for example, the ambient temperature is 27 °C and the set point temperature is 20 °C. Before resetting the alarm the user should investigate possible causes:

- The wrong heater element is connected.
- The wrong temperature probe is connected.
- The heater element has failed (the resistance should be between 200 and 500 ohms).

- A set point below ambient has been set.

The control has been optimised for temperatures starting at 10 °C above ambient, thus if you wish to work nearer to ambient the control may have difficulty in maintaining the set point. The controller has the ability to auto-tune its internal parameters to suit the thermal conditions and the user can carry out this auto-tune process to give better stability. Proceed as follows:

1. Ensure the desired set point temperature is set.
2. Fill water tank to the correct level with cool water (several degrees less than the set point).
3. Press the *P* button.
4. Press the * button.
5. Press the up button twice.
6. Press the *P* button.

The controller will now be in auto-tune mode, and the display will alternate between AT and the water temperature. The tuning may take up to an hour, when finished the display will either revert back to the water temperature, if tuning was successful, or will show an error code (see above) if unable to tune to the conditions. If successful, the temperature will now stabilise to the set point. Note during auto-tune the water temperature may overshoot the set point by several degrees, any temperature sensitive samples should thus be removed prior to starting.

8. Appendix B: Using the Break-out Box

The electrode break-out box has been designed so that accurate voltage and current measurements may easily be made during calibration of the cells. The unit allows the insertion of an accurate multimeter into the electrode circuit without the need to unsolder any connections. The unit should not be left connected into the system permanently during routine measurements, but should only be used during calibration measurements. The unit is very easy to use and should be connected as follows:

1. Disconnect the Microelectrophoresis Apparatus from the local power supply.
2. Unplug the electrodes from the socket at the rear of the instrument.
3. Plug the break-out box into the electrode socket.
4. Plug the electrodes into the socket on the break-out box.
5. Using the red and black leads supplied connect your multimeter to the breakout box via the red and black sockets on top of the box.

To measure voltage:

6. Set the selector switch, on top of the break-out box, to *Voltage* and set your multimeter to dc volts and the range switch to 200 volts.
7. Now reconnect the Microelectrophoresis Apparatus to your local supply and switch on the electrodes.
8. Your multimeter will now display the voltage of the electrodes.

To measure current:

9. Disconnect the Microelectrophoresis Apparatus from the local supply.
10. If necessary reconnect your multimeter (some multimeters have separate inputs for measuring voltage and current).
11. Select dc current and a range of 10 mA.
12. Set the selector switch to *Current*, on the break-out box.
13. Reconnect the Microelectrophoresis Apparatus to the local supply and switch on the electrodes.
14. Your multimeter now displays the current flowing through the electrodes.

Note the electrode voltage can reach 120 volts and thus care should be exercised to ensure all connections to the multimeter are made before switching the apparatus on.

9. Appendix C: Blacking Platinum Electrodes

To *Black* platinum electrodes, proceed as follows:

1. Clean the electrodes thoroughly in detergent then rinse in water.
2. Clean the electrodes in concentrated nitric acid then rinse in water.
3. Place the electrodes in a beaker of ~2% chloroplatinic acid containing ~0.02% lead acetate a few centimetres apart. Care should be taken to ensure the electrodes are not allowed to touch together during the blacking process.
4. The electrodes should then be connected to a variable low voltage supply (up to 20 volts) and adjusted so that a current of around 100 mA flows.
5. The polarity of each electrode should then be reversed 4 to 5 times a minute until a uniform black coat forms (after approximately five minutes).

Note the instrument electrode supply is only able to deliver a few milliamps, and is thus unsuitable.

10. Appendix D: Precharging Palladium Electrodes with Hydrogen

To precharge the electrodes proceed as follows:

1. Place the electrodes in dilute sulphuric acid adding a third electrode of say platinum.
2. Connect the platinum electrode to the positive side of a low voltage supply and the two palladium ones to the negative.
3. Adjust the supply until each palladium electrode is passing 3 mA.
4. Allow the electrolysis to continue for 30 minutes.
5. The electrodes are now ready for use.