



HUNTERS VIEW DESIGN FOR DEVELOPMENT

Hunters View Community Partners

May 29, 2008

TABLE OF CONTENTS

PART I: Overview

Chapter 1: Introduction	06
1.1 Existing Conditions	08
1.2 Historic Evolution	10
Chapter 2: Organizing Principles	12
2.1 Principles of San Francisco Neighborhood Design	13
2.2 Neighborhood Design Principles for Hunters View	14
2.3 Topography	18
2.4 Linkages	20
2.5 Transit Access	22
2.6 Site Sustainability and Green Building	23
2.7 Views	24
2.8 Program Distribution	26
2.9 Phasing	28

PART II: Development Standards

Introduction	
Chapter 3: Open Space and Streets	32
3.1 Parks	33
3.2 Restoration Areas	42
3.3 Courtyards and Common Open Spaces	43
3.4 Streets	44
3.5 Planting Guidelines for Open Spaces and Streets	51
3.6 Site Lighting, Paving and Furnishings	53
3.7 Site Sustainability	54
Chapter 4: Buildings	55
4.1 Land Use	56
4.2 Lot Coverage / Rear Yards	56
4.3 Usable Open Space	57
4.4 Building Heights	58
4.5 Massing and Bulk Controls	59
4.6 Façade Articulation	60
4.7 Setbacks / Build-to Lines	62
4.8 Side Walls and Rear Walls	63
4.9 Ground Floor Uses and Street Fronts	64
4.10 Building Entrances / Security	65
4.11 Gates and Fences	66
4.12 Parking, Parking Entrances and Curb Cuts	66
4.13 Meters, Utilities and Trash	67
4.14 Roof Design	68
4.15 Community Outreach and Culturally Appropriate Architecture	69
4.16 Green Building	69
4.17 Edge Conditions	70
Chapter 5: Appendix	72

PART I
OVERVIEW



CHAPTER 1 INTRODUCTION

There is, perhaps, no area of San Francisco more acutely in need of physical improvement and new opportunity for its residents than the public housing projects of the Hunters Point/Bayview District. Of these projects, one of the most distressed is the isolated hillside enclave known as Hunters View. It is why Mayor Gavin Newsom, the Mayor's Office of Housing, the San Francisco Housing Authority and the San Francisco Redevelopment Agency have selected Hunters View as the first project to be reconstructed under the City's HOPE SF program. This effort begins an ambitious local initiative to integrate public housing residents into the physical and social fabric of the city. The reconstruction of Hunters View is a crucial link in a series of closely related City-sponsored initiatives that will transform this long neglected quadrant of the city.



Hunters View today



Hunters View today

Much has been learned and much has been written about the problems generated by design ideas that accompanied the first generation of American public housing beginning in 1937. The HOPE VI program as it was implemented throughout the country from the mid-1990's applied many lessons learned about community building from that deeply flawed generation of projects. The most important lesson has been not to concentrate the poor in enclaves separate from and different from the cities of which they are part. This proposal for Hunters View builds upon the HOPE VI experience and carries it forward without the aid of HOPE VI funding and in ways that reflect San Francisco's unique local circumstances and opportunities.



Prior to the Hope VI program, distressed public housing was common throughout the country.



The Hope VI program replaced many distressed projects with new mixed income neighborhoods.

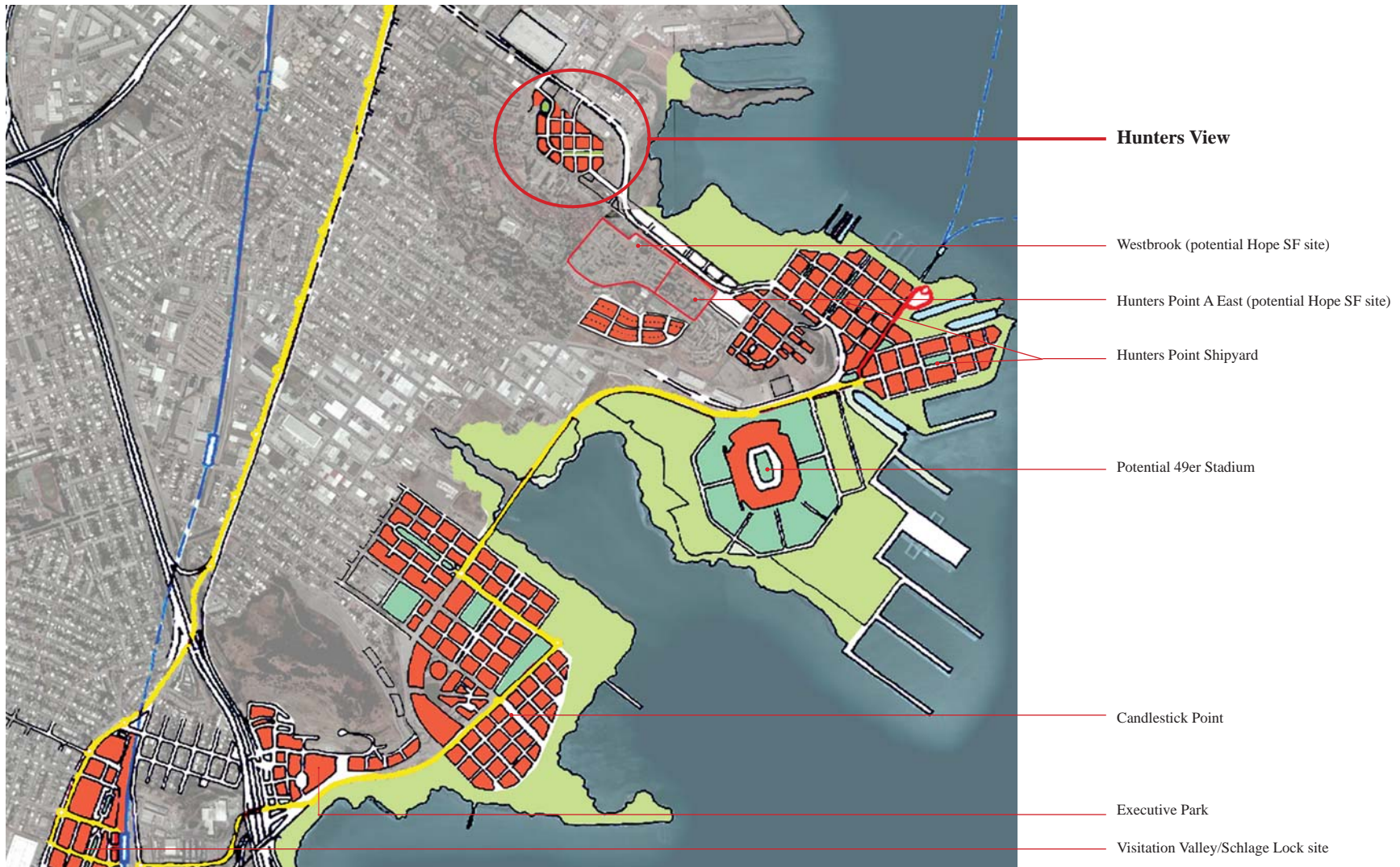

This drawing depicts a series of related projects in progress as they are proposed for 2020.

1.1 EXISTING CONDITIONS

The isolated and isolating nature of Hunters View, the grim barracks-like aspect of its buildings, and the undefined and undefended open spaces within the site constitute a vivid demonstration of design failure. There are larger economic and social conditions that have led to the problems of unemployment, drug culture and crime in Hunters View, but it is clear to any observer that physical design has contributed to and exacerbated these conditions.

The only ways into or out of Hunters View are via Middle Point Road to the north and south. Once off of Middle Point Road, even by a few feet, one quickly loses all sense of connection with the rest of the city and the larger landscape of hills and the Bay. The deteriorating buildings are scattered about the site with no apparent relationship to one another, to the streets that serve them or to the open spaces between them.

Hunters View is one of a series of isolated enclaves, built at a time when planning professionals and bureaucrats placed little value on the physical design principles that make so much of San Francisco one of the most valued, cherished and protected of all American cities.



Pictures showing existing conditions at Hunters View

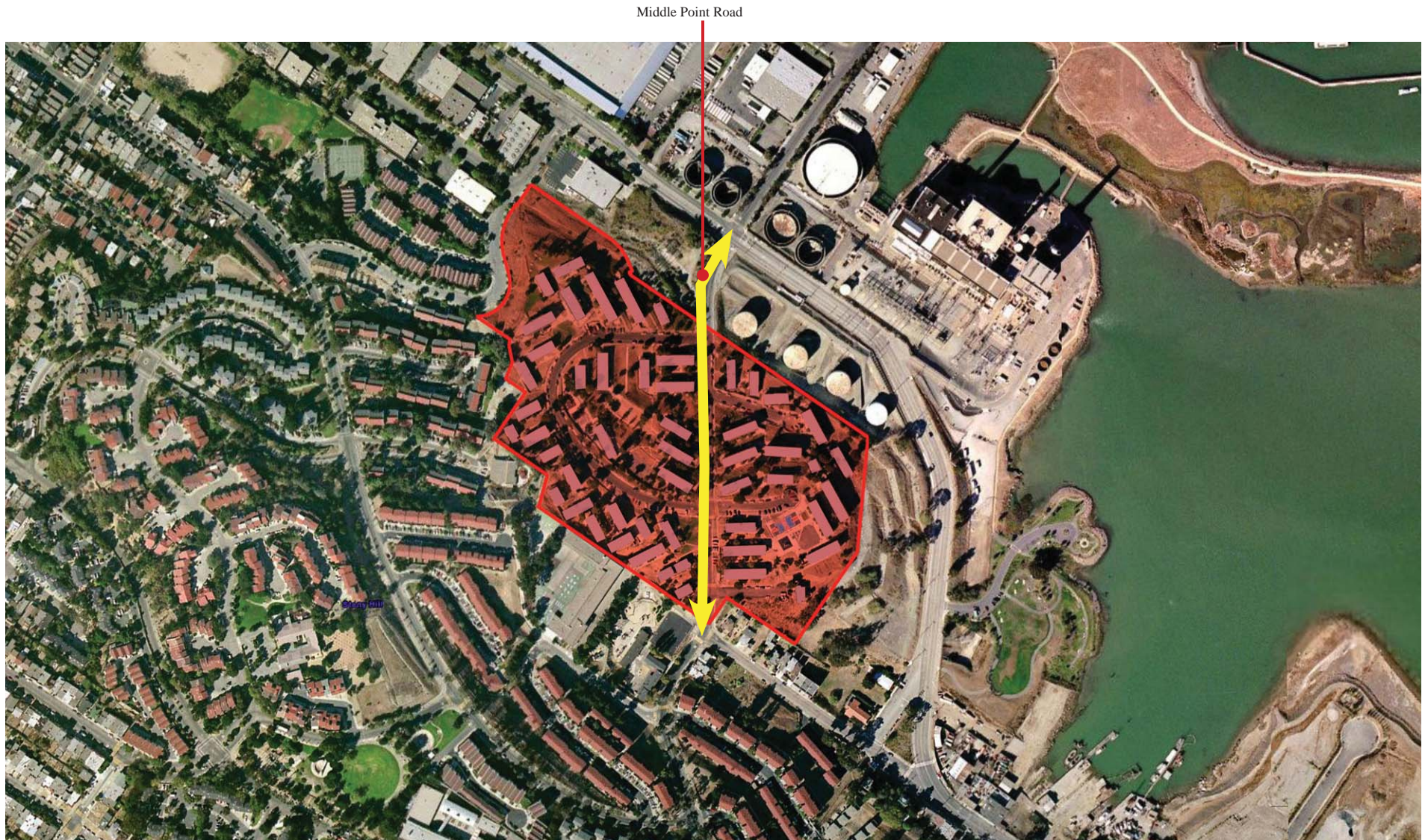

Aerial view of existing conditions

1.2 HISTORIC EVOLUTION

At the end of the nineteenth century, all of Hunters Point including Hunters View was outside of the settled and platted fabric of the city. North and west of the current Hunters View site, however, the Bayview District was being settled according to principles of neighborhood design well-established in the rest of the city. The Bayview grid of 200 ft. by 600 ft. is one of several block grids employed by different surveyors in different parts of the city to achieve similar results.

1943 is a crucial year in the story of Hunters View. In the 1930's, during the construction of the Bay and Golden Gate Bridges, Bethlehem Steel established a shipyard at Hunters Point. In 1943, this facility became the Hunters Point Naval Shipyards with rapidly constructed temporary housing for 30,000 workers extending north and west and including the Hunters View site. The layout of these urgently needed barracks with curving roads followed contours and paid no allegiance to the principles of San Francisco neighborhood design exemplified by the adjacent Bayview neighborhood.

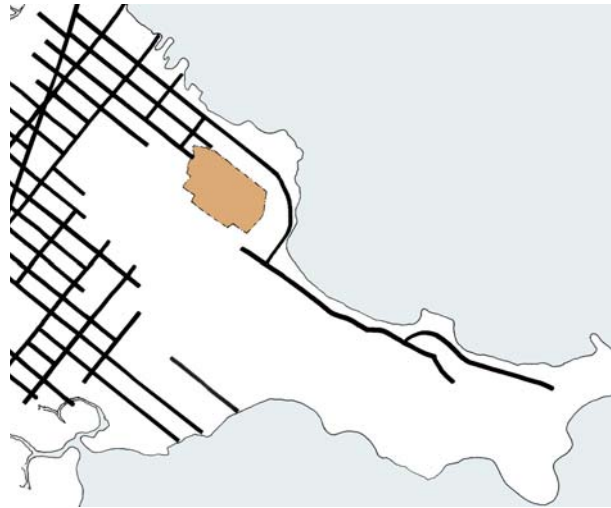

Hunters Point: 1899

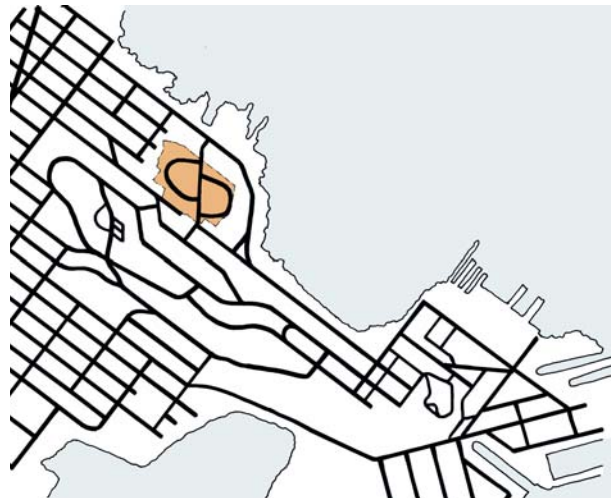

Hunters Point: 1943 Naval Shipyards Housing



Hunters Point: 1942



Hunters Point: 1944

In 1954 the San Francisco Public Housing Authority converted the shipyard barracks of Hunters View into public housing. This was done expeditiously, with the grading, road alignments and in many cases the actual foundations of the barracks buildings reused. The loop road east of Middle Point was severed into two cul-de-sacs now known as Hare and Wills Streets, further contributing to the disconnected quality of the street layout.

In the following years, all of the land west and south of Hunters View was rebuilt according to a plan authored by San Francisco architect Aaron Greene. Greene was a disciple of Frank Lloyd Wright, a representative of the Taliesin Foundation in San Francisco and a committed anti-urbanist. He believed as a matter of principle in patterns of development that were the opposite of San Francisco's historic neighborhoods – curving roads, buildings not aligned with roads, and disconnected cul-de-sacs as opposed to an interconnected grid of streets. The application of these ideas to all of the developed lands that are contiguous to Hunters View has contributed as much to the unfortunate isolation of Hunters View as the design of the project itself.



1954 onward - SF Housing Authority



As proposed

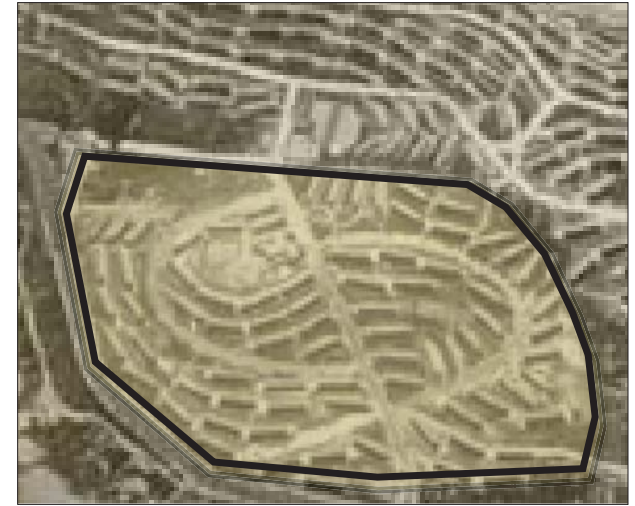

Hunters View, foreground: 1944



Hunters View - existing

CHAPTER 2

ORGANIZING PRINCIPLES

Among the ideas clearly articulated in the original federal HOPE VI guidelines are de-concentration of the poor, building practices that respect local heritage, and buildings that define and animate streets and open spaces as places of shared use. The application of these principles to Hunters Point/Bayview is in large measure the application of the very methods of town planning that created San Francisco's distinctive and enduring character in the nineteenth century. This section identifies six principles of neighborhood design that are common to virtually all of San Francisco's historic neighborhoods, but are completely absent from Hunters View as it is currently configured.

2.1 PRINCIPLES OF SAN FRANCISCO NEIGHBORHOOD DESIGN

1. Grids and Hills: San Francisco owes much of its distinctive character to the fact that its grid of streets is continuous and orthogonal, irrespective of topography. Streets do not follow the contour of the hills, except for rare anomalies.

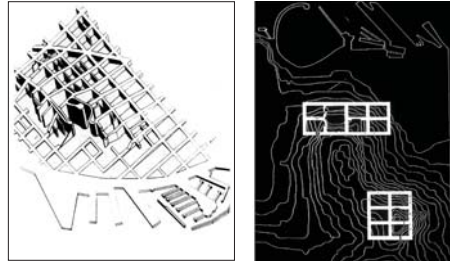

4. Narrow Parcels: A typical San Francisco lot is 25' wide along its street frontage and 100' or more deep. These narrow lots produce party wall buildings, frequently punctuated by bay windows, with buildings stepping with hills at a frequency corresponding to the lot width. This stepping of narrow, party wall buildings is common to all of San Francisco's residential neighborhoods.



2. Street Walls, Entrances and Eyes: Typically San Francisco streets are safe and congenial for pedestrians. The definition of the space of streets by continuous building frontages and the activation of streets by building entrances and orientation of rooms toward streets are fundamental factors in the safety of streets as public places.



5. Streets and Stairs as View Corridors: Typically in San Francisco, one is never far from a view corridor formed by a street right-of-way. Through these corridors one sees the Bay, the bridges, other neighborhoods and the hills of Marin and the East Bay. In most of Hunters View, by contrast, the horizon is closed by the project itself within a few hundred feet.



3. Stairs in the Grid: In many places throughout the city, the street right-of-way is too steep for an actual street. Often in these situations two segments of street are linked by public staircases in the street right-of-way. These public stairs are great amenities in the city, providing linkages, open spaces and many places of distinction and special character. Telegraph Hill, Russian Hill and Nob Hill are dotted with public stairs, each different from the others.

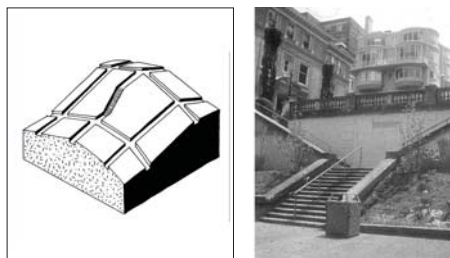

6. Hilltop Parks: One of the best features of William Eddy's 1849 plan for the Western Addition was the reservation of some of the best sites for hilltop parks tightly bounded by building frontages. Alta Plaza, Lafayette Square and Alamo Square all command spectacular views and provide models for the location and design of urban parks. Each of these parks anchors the neighborhood around it and has provided an amenity for generations of residents.



2.2A SAN FRANCISCO NEIGHBORHOOD DESIGN PRINCIPLES VIOLATED: HUNTERS VIEW TODAY

The site plan of Hunters View in its existing state reveals a systematic inversion of the six principle characteristics of neighborhood design illustrated on the preceding pages.

1. Grids and Hills: The relationship of topography and street grid so fundamental to the planning of San Francisco is ignored at Hunters View. While Middle Point Road runs straight up the hill, the other streets either wind along the contours or end in disconnected cul-de-sacs.

2. Street Walls, Entrances and Eyes: Instead of narrow buildings stepping with slopes of hills and giving them definition and providing eyes on the street, buildings at Hunters View twist in all directions along the contours.

3. Stairs in the Grid: While there are public stairs at several locations in Hunters View, stairs are not located as they are throughout the city - to continue the street grid where the land is too steep for streets.

5. Narrow Parcels: The definition of street space as safe and observed public places by the continuity of buildings along streets is completely absent in Hunters View.

4. Streets and Stairs as View Corridors: The public view corridors comprised of streets and stairs that contribute to the sense of location and connectedness throughout the city are absent in the disconnected and disorienting spaces of Hunters View.

6. Hilltop Parks: Open space in Hunters View is amorphous, undefined and indiscriminately located, unlike the tightly defined public parks on commanding hilltops elsewhere in the city.



Existing neighborhood

2.2B SAN FRANCISCO NEIGHBORHOOD DESIGN PRINCIPLES ACHIEVED: THE TRANSFORMATION OF HUNTERS VIEW

The site plan for the transformation of Hunters View shows how the six principles that define the urbanism of San Francisco can be achieved at Hunters View.

1. Grids and Hills: A new grid of streets with normal sized San Francisco blocks is created on the orientation of Middle Point Road.

2. Street Walls, Entrances and Eyes: Continuous street frontages with small buildings stepping frequently with the slopes line the streets.

3. Stairs in the Grid: There are public stairs at strategic locations on the site and suggestions for stair linkages from the site to the surroundings.

5. Narrow Parcels: Streets are lined continuously with buildings. Buildings look out on the public space of streets and activate them with frequent building entrances.

4. Streets and Stairs as View Corridors: View corridors comprised of streets, mid-block open spaces and parks link Hunters View to the city and the larger landscape. Fairfax Avenue is inflected from the grid to align with the principal view of downtown.

6. Hilltop Parks: Open space is organized into significant and well-defined parks, each in a location of commanding view.



Proposed plan for the neighborhood

2.2C RECONSTRUCTION PLAN FOR HUNTERS VIEW

The intent of the reconstruction plan for Hunters View is to transform the existing isolated enclave into a neighborhood that follows the six well-established principles discussed on the previous pages. These principles have given grace, distinctive character and enduring value to historic neighborhoods throughout San Francisco.

The organizing idea of the proposed plan is a street grid of small blocks that makes use of existing streets or street rights-of-way wherever possible. Distributed within this grid is a housing pattern that includes the affordable rental housing as a seamless component of a mixed-income neighborhood.

Because the reconstruction of Hunters View is planned without federal HOPE VI funding, a necessary feature of the plan is raising densities from the current 12 DU/Acre to over 40 DU/Acre that is more typical of a San Francisco neighborhood. The additional density accommodates a for-sale component that both establishes economic integration for Hunters View residents and provides an element of subsidy for the project.

New view corridors and physical linkage of Hunters View to its surroundings are intended to dispel completely the sense of isolation that has plagued Hunters View throughout its existence. Streetscapes and public spaces employ the lessons of civic design that one can learn as a student of San Francisco's history. The features of the proposed plan for Hunters View are discussed in detail on the pages that follow.





View of site from northeast showing proposed Promontory Park at the foot of Fairfax and the potential new linkages with the surrounding neighborhood

2.3 TOPOGRAPHY

The goal of the reconstruction of Hunters View is to eliminate the ways in which its physical design has left its residents isolated from the fabric of the city. It is San Francisco's unique combination of steep hills, spectacular vistas and dense urban development with a rarely broken regular gridiron of straight streets that gives it a special place among the cities of the world. That basic structure is enriched by characteristic patterns of architecture and block formation, and by occasional quirks and anomalies in the street pattern that address extraordinary topographic conditions.

Bringing those typical San Francisco building patterns to Hunters View is not a simple matter. It is important to note that San Francisco's characteristic development patterns were established when there were no considerations for automobile access, parking, movement of large fire trucks or handicapped access. The great challenge in reconstructing Hunters View is to capture the essential qualities of the city while meeting contemporary standards for each of those needs with which 19th-century city building did not have to contend.

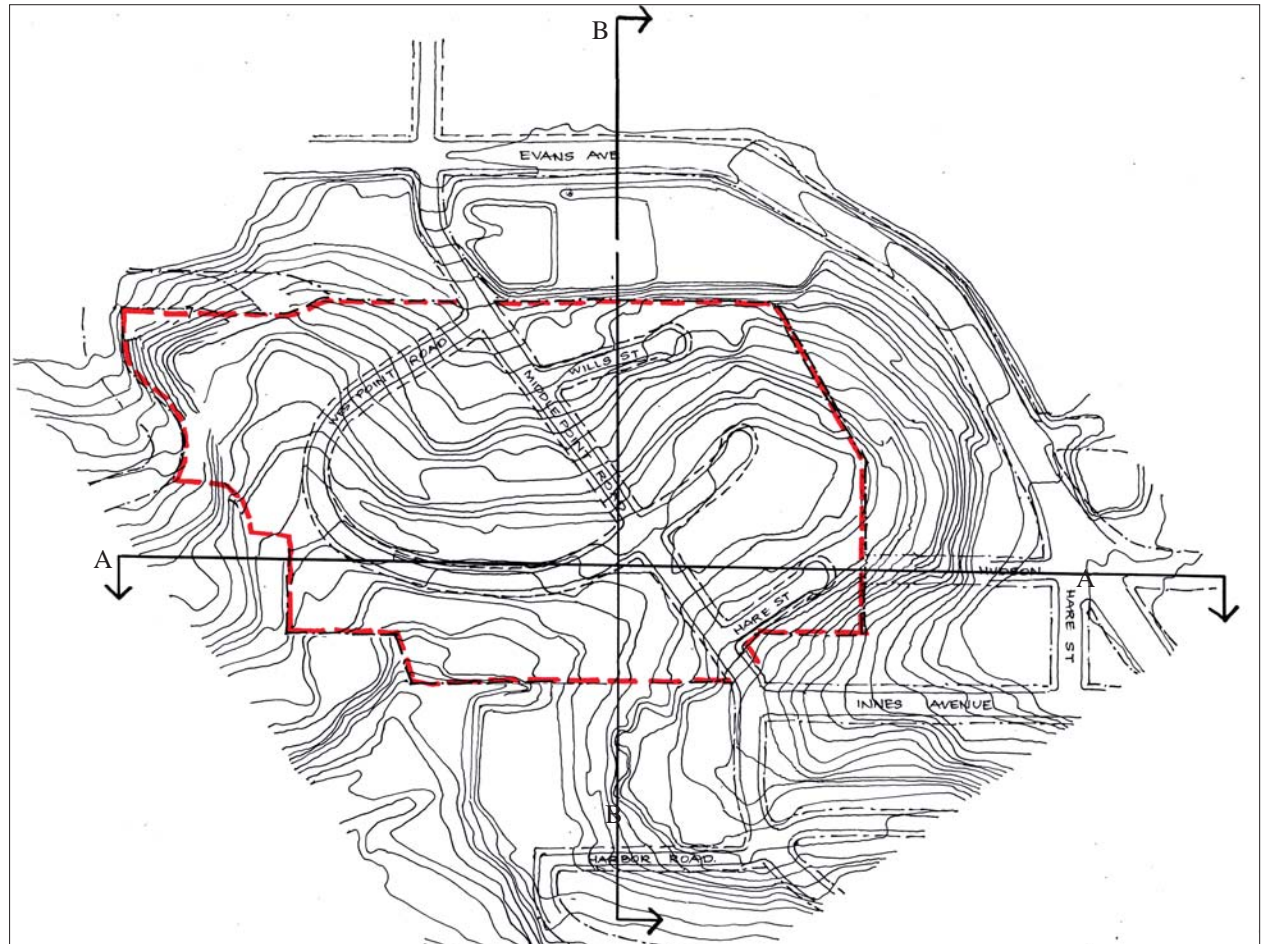

Existing plan with topography

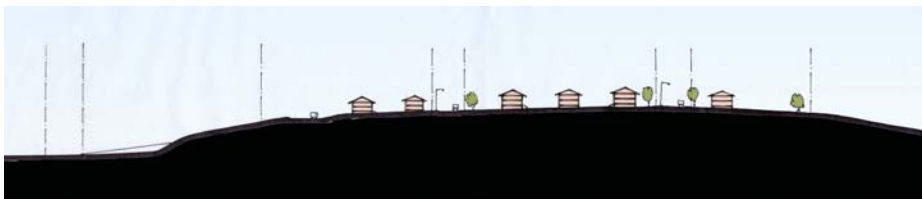

Section AA east/west



Section BB north/south

The street layout and block patterns described throughout this document are intended to bring about this synthesis of contemporary development standards and the special qualities of the city's historic neighborhoods. Because the financial resources for the reconstruction are limited, it is necessary to use existing streets and infrastructure where possible and replace or add to the existing street pattern only where necessary. The street and block pattern proposed here is the result of extensive study of the grading that will be needed and a concerted effort to make that grading as cost effective and ecologically balanced as possible.

The sections on Building Stepping in Part II: Development Controls are written specifically to address how larger scale buildings with their associated parking garages should be designed on steep blocks.

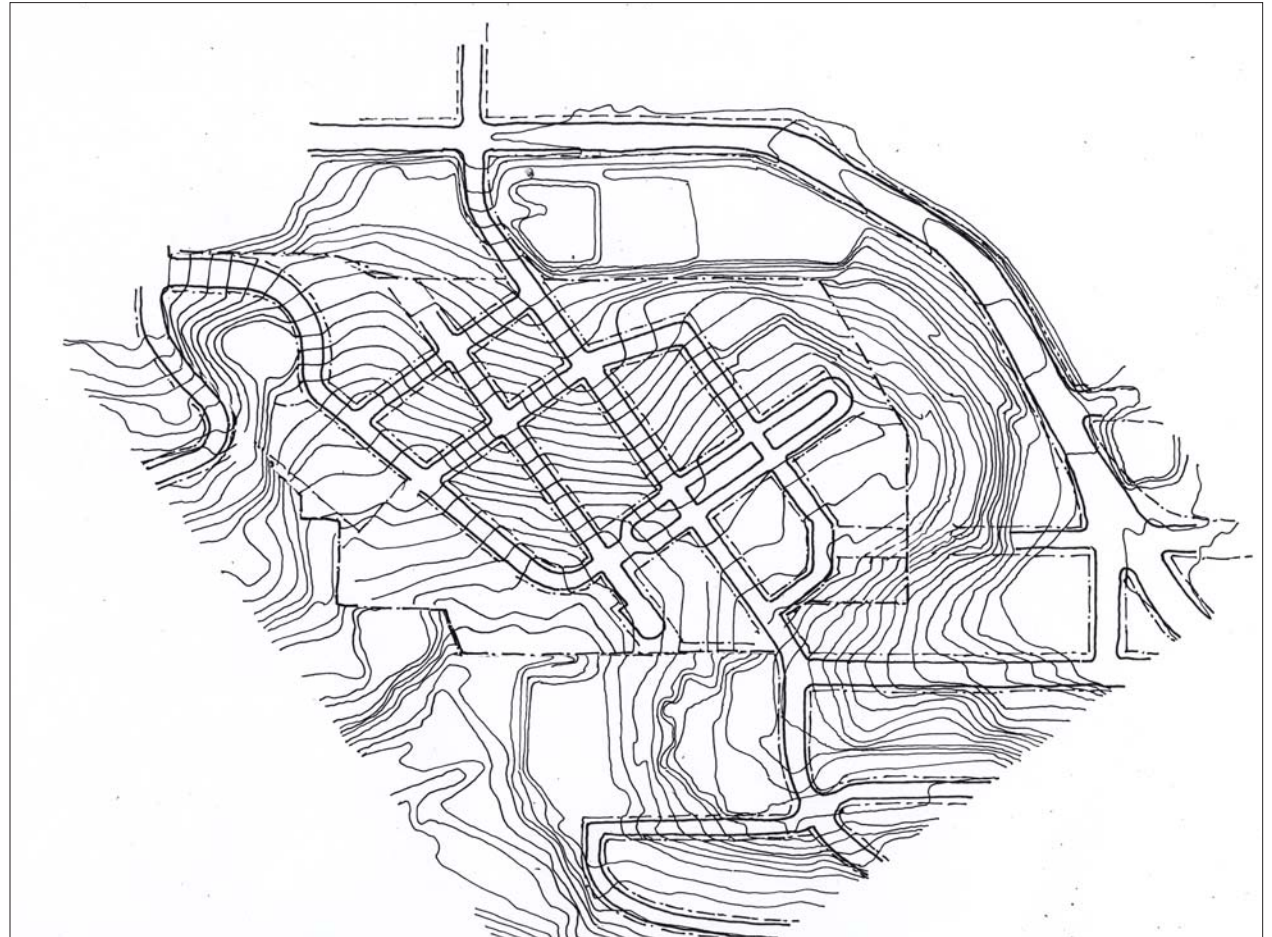

Proposed plan with topography

2.4 LINKAGES

The existing site plan of Hunters View and the design of each of the adjacent properties has left Hunters View with awkward, dangerous, and in some cases, non-existent connections to the neighborhood and essential services around it. From Hunters View to India Basin Shoreline Park and Bob's Grocery on the east, Malcolm X Academy to the southwest, the Sojourner Truth Childcare Center to the west and Bayview Plaza to the northwest, the only pedestrian linkages are a series of ad hoc, sometimes steep and treacherous paths winding through the left-over spaces behind buildings.

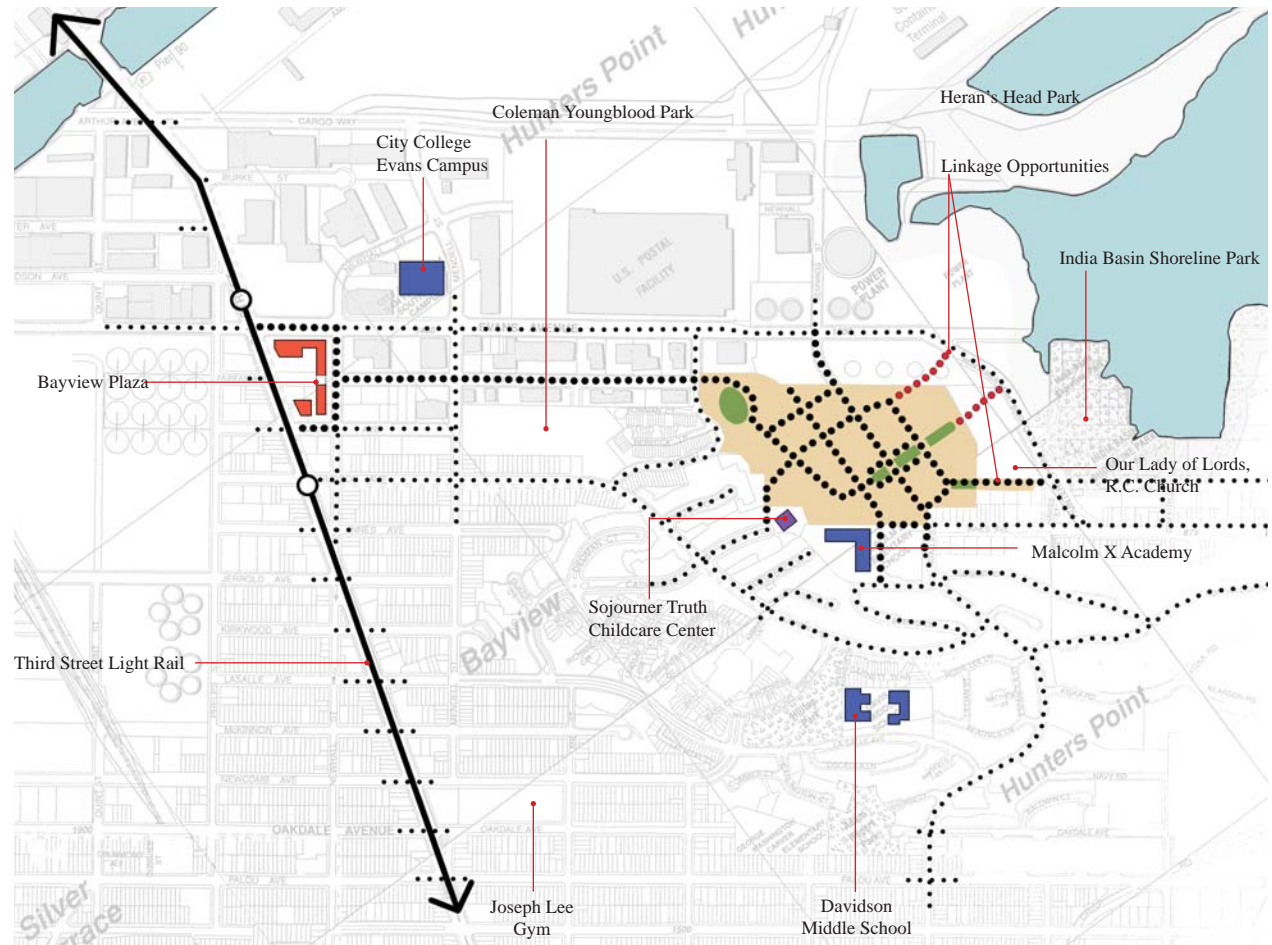

Neighborhood connections



Bayview Plaza



Malcolm X Academy



Sojourner Truth Childcare Center



Davidson Middle School



Existing connections



Proposed connections

Proposed connections



1. Fairfax Avenue to Bayview Plaza



2. Middle Point Road



3. Cashmere Street & Soujourner Truth Daycare



4. Malcolm X Academy and Harbor Way



5. Innes Avenue, 6. Hudson Avenue

2.5 TRANSIT ACCESS

The new street and block pattern will allow easier access to the local transit routes. The new 'T' light rail line has several stops on Third Street. SF Muni's #19 and #44 bus lines already serve the neighborhood with bus stops on Middle Point Road. #54 stops nearby on Hudson Avenue at Cashmere Street, a short walk from the site.

Bus line #19 connects the former Hunters Point Naval Yard with Potrero Hill and the Civic Center and runs along Innes Avenue to Middle Point Road through the site and then onto Evans Avenue to Third Street and beyond.

Bus Line #44 starts at the City College Evans Campus on Evans Avenue, travels via Fairfax Avenue and Keith Street, through the site on Middle Point Road south towards Ingalls Street and then down to Palou Avenue on its way to Balboa Park BART station and eventually to Golden Gate Park and the de Young Museum.

Bus line #54 is a local shuttle serving the SFHA sites and the 'T' Third Street Light Rail station at Palou. The existing stop on Hudson Avenue at Cashmere Street will be accessed by the new stairs from Wills Street.

In the future a new Caltrain Station is planned at Oakdale Avenue providing improved access to San Jose and the Peninsula.

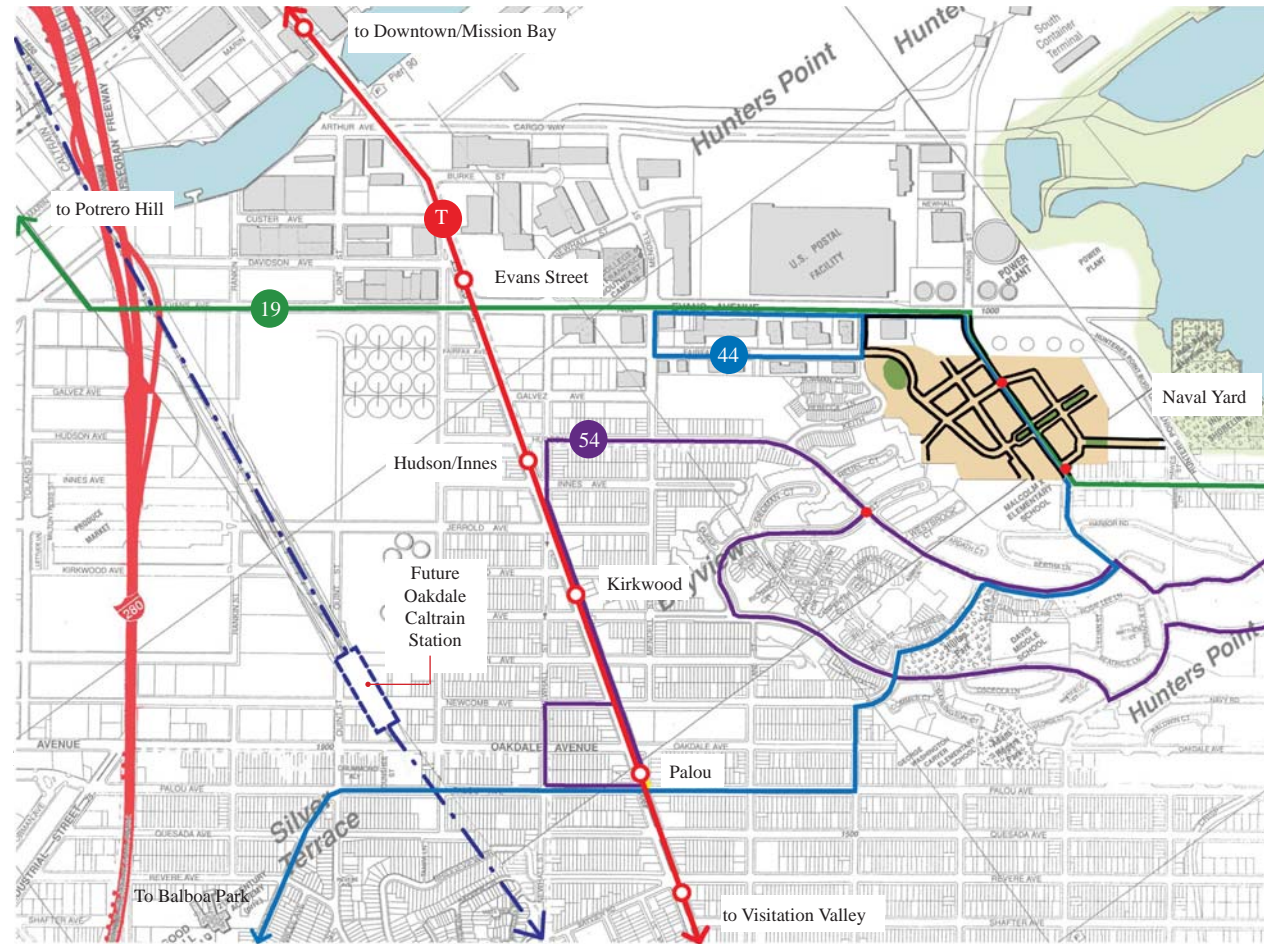

Transit map



Transit connections

2.6 SITE SUSTAINABILITY AND GREEN BUILDING

Sustainability is one of the core principles for the design of Hunters View, guiding the design of both buildings and site.

As City-funded revitalization, Hunters View presents the opportunity to realize the City's aspirations for innovative and integrated environmental design of streets, buildings and neighborhoods.

The design of Hunters View recognizes that neighborhood ecology embraces social goals as well as physical and environmental ones. The current Hunters View is unhealthy for its residents because of its declining building stock but also due to its disconnection from the city around it.

In addition to the specific provisions of the Design for Development document, three outside sets of sustainability guidelines will inform design decisions. Hunters View is a pilot project for the USGBC's LEED for Neighborhood Development (LEED-ND), and a number of development controls and design guidelines have been crafted with the LEED-ND system in mind. Individual buildings will utilize either Build It Green's Green Point Rated system, or The Enterprise Foundation's Green Communities Criteria.

The design principles articulated throughout this document support the premise that a safe, walkable mixed-income neighborhood, with its own parks, community spaces and other amenities, and with inviting connections to those in surrounding areas, is a core building block for the health of individual residents and the health of the city.

Safe streets and parks with views beyond the neighborhood encourage walking, outdoor play and recreation, and enhance the residents' connection to nature.

Energy efficient buildings and infrastructure reduce utility costs to residents and protect the environment by conserving resources, including energy, water and materials.

Careful selection of materials and building systems results in buildings that are cost effective to build, durable and practical to maintain, and result in a high-quality, healthy living environment.

Through careful design of stormwater systems and restoration areas, the neighborhood can advance the health of local and regional ecosystems.

Streets designed in conjunction with the City's forthcoming Better Streets Plan will be safe, walkable, active, attractive and accessible and support best practices in stormwater management.

2.7 VIEWS

At present the site does not take advantage of the potential views and vistas outside its current boundaries. The curving streets and building configurations close off the magnificent views of Downtown and the Bay. One of the major principles of the new street grid layout is to take advantage of these views and to orient the development in relation to the rest of the city.

The extension of Fairfax Avenue is aligned in a northwestern direction with the vista of the downtown skyline, taking advantage of the topography to offer views of the Financial District high-rises. As Fairfax Avenue turns into Park Street East and crosses Middle Point Road at right angles, it opens out to form a park (similar in scale with South Park or Precita Park on Bernal Heights). Terminating in an overlook to the Bay and the new India Basin Shoreline Park below.



Views from the site

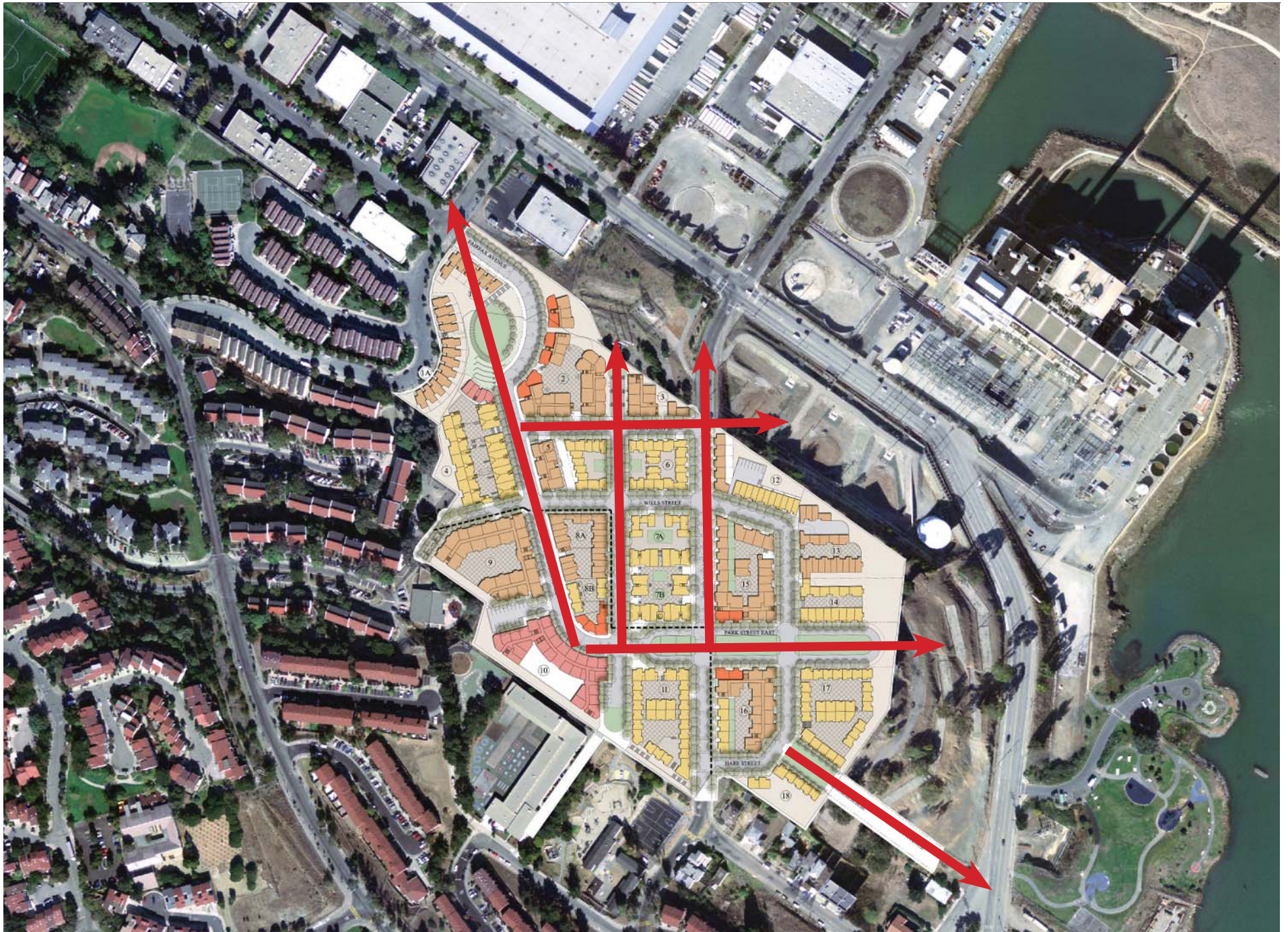

View corridors

2.8 PROGRAM DISTRIBUTION

A principle behind the design is to integrate the various constituencies that make up the community and break down the barriers that currently isolate the existing SFHA tenants from the rest of the city. There is to be no physical distinction in location between owners and renters or SF Housing Authority units from non-profit affordable housing. The plan provides a mix of incomes and unit types on every street as is found in the most historic parts of San Francisco. The small blocks provide a varied network of streets and paths and opportunities for a mix of building types and income levels.

The neighborhood includes housing for seniors as well as community serving facilities such as child care. In addition there are several sites identified for potential neighborhood retail stores.





Owners



Renters



Seniors



Community facilities and retail

2.9 PHASING

Existing:

The phasing plans for the reconstruction of Hunters View honor the desire strongly expressed by many existing residents to have the opportunity to remain on-site throughout the reconstruction process. This can be accomplished through the use of currently vacant units as temporary relocation housing and by dividing the reconstruction into three phases of roughly equal size. Vacant units in the portions of the site to be reconstructed in Phases II and III will accommodate all of the existing tenants now occupying the Phase I portion of the site.

18.4 Acres Net Site Area
267 SF Housing Authority units

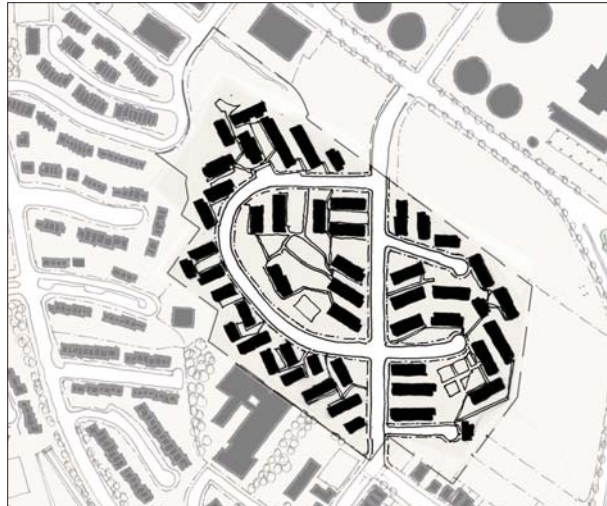

Existing

Phase I:

It is essential that the first phase of reconstruction be perceived as a new place, a fresh start that is not tainted by the stigma and history of Hunters View. It must therefore be spatially coherent, well linked to the surrounding neighborhood, well served by open space amenities, and have a principal entrance that people arrive at without going through the remaining Hunters View units or the construction projects that will replace them. For these reasons Phase I is located at the northwestern quadrant of the site and can be entered via Fairfax Avenue, linking the site to the neighborhood to the west, Bayview Plaza, and the Third Street light rail. Promontory Park serves as the heart of this segment of the new neighborhood. The buildings on Blocks 2 and 4 frame the park and the view up Fairfax, and allow active, non-residential uses such as community spaces, neighborhood retail, or the ownership sales office to face the park.

120 Rental units (approximately)
160 Ownership units (approximately)
6 Acres Net Site Area



Phase I

Phase II:

Phase II completes the reconstruction of the portion of the site that is west of Middle Point Road. It provides the main community services and childcare building in conjunction with the elderly component of the housing program. Phase II establishes new or improved linkages to Jackie Robinson Apartments and its daycare facility to the west, to Malcolm X Academy, to school buses and Muni and to the Community Youth Park to the south. Phase II has its own focal open space with the construction of the southwestern portion of Panhandle Park.

130 Rental units (approximately)
 130 Ownership units (approximately)
 4 Acres Net Site Area

*Phase II***Phase III:**

Phase III completes the reconstruction of Hunters View and sets the stage for further linkages of the site to new elements of the neighborhood to the north and east including the PG&E site and the Hudson Avenue corridor. The remaining blocks of Panhandle Park are constructed, forming the main focus of the new neighborhood.

100 Rental units (approximately)
 160 Ownership units (approximately)
 5.7 Acres Net Site Area

*Phase III*

PART II DEVELOPMENT STANDARDS

Development of the Hunters View site will be regulated by the Design for Development's Development Controls and Design Guidelines. The purpose of this Design for Development document is to set forth requirements and recommendations for platting, street design, and building design in a holistic way.

The approval of the HOPE SF Hunters View Special Use District (BOS Ord. No. XX), the text and map amendments to the Planning Code to establish the HOPE SF Hunters View 40/65X Height and Bulk District, and the Conditional Use/Planned Unit Development approval (Case No. 2007.0168CMET, CPC Motion No. XXX) will establish general densities, heights and ratios of building envelopes to non-built areas consistent with those shown herein. The Planning Code remains the controlling document for all issues not specifically addressed by those approvals or by this document.



Notwithstanding the Design for Development, Phases II and III will be reviewed by the Planning Commission as informational items to ensure quality of design and adherence to the Design for Development and the General Plan. Each subsequent phase will be subject to review by the Interagency Working Group made up of Planning and Agency staff to guide the redevelopment of Hunters View. The design of streets and open spaces may require further review by other City agencies. Approval by the San Francisco Planning Commission is required for any amendments to the Design for Development document.

CHAPTER 3

OPEN SPACE AND STREETS

Safe, active and inviting public spaces are key to the success of the new neighborhood. New parks, some publicly accessible, some shared by groups of dwellings, are linked together by tree lined streets, which in turn, connect to semi-private mews, paseos, entry courts, stoops and porches. Together these landscape and streetscape elements constitute a network designed to encourage pedestrian activity, social interaction, and outdoor play. Plantings respond to specific site conditions, such as the coastal climate and serpentine soil. In addition to elements of the landscape intended for occupancy and use, there are restoration areas and embankments that are an important part of the new neighborhood, have substantial visual and environmental impacts, and need careful attention.



3.1 PARKS

This section describes the publicly accessible parks within the master plan and sets design standards for their execution. The plan establishes the framework for two major public parks oriented toward views of downtown and the bay, one minor park, mini-parks, and connectors with amenities and uses based upon programming with residents.

Development Controls

1. The Promontory Park, Panhandle Park, Hudson Avenue Overlook and the mini-parks, although not publicly owned, shall be publicly accessible and remain open during daylight hours at a minimum.
2. All parks shall be visually and physically accessible to the public.
3. Within the constraints of the topography and through the use of retaining walls, parks shall be designed to create flat outdoor space.
4. Where large trees are shown, provide 3' of import soil to replace the serpentine soil to ensure tree health and longevity.

Design Guidelines

1. Plantings should follow the “Bay Friendly Landscaping Guidelines” in regard to native species, low water use, and invasive species.
2. Park design should consider the incorporation of stormwater management strategies to reduce runoff, such as bioswales, infiltration basins, rain gardens, permeable pavement and on-site water retention.
3. Site furnishings should be designed and/or selected to form a uniformly coherent family of elements for the entire site. Pedestrian scale lighting should balance safety and energy efficiency.
4. Bike parking should be provided at parks to encourage alternatives to auto circulation.
5. Where mini-parks occur adjacent to a specific use, such as the senior housing, the park should be programmed and designed for the use of the immediate neighbors.



3.1.1 PROMONTORY PARK

The Promontory Park is an important icon for the first phase of the new Hunters View neighborhood. Like a traditional San Francisco hilltop park, it is positioned to take advantage of impressive views; in this case, of the downtown. It is sited as the terminus of the Fairfax Avenue view corridor looking northward through the Hunters View site, and is located to encourage use by residents from the surrounding neighborhood. As the initial centerpiece of the neighborhood, it will be characterized by features typical of older San Francisco neighborhood Parks with lawn, planted terraces, large trees, walkways and monumental stairs. Because of the intention for Promontory Park to maintain clear views and provide flexible green space, programmed recreational uses, such as ball courts, will be relegated to other parks. To conform to the topography, the park will have two levels which together constitute flat, usable green open space. The upper park level will accommodate accessible parking, while the lower level connects by crosswalk to the residences across the street. Community gardens and minor architectural structures will be provided, and multiple activities will be encouraged. The sloping area to the east of the park will be designed to insure privacy and security for abutting houses.

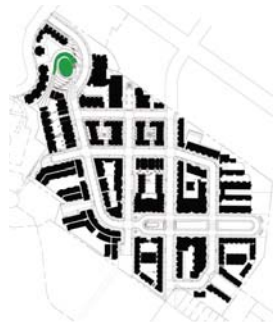

Promontory Park will provide stunning views of downtown as does Corona Heights Park



Plan and section at Promontory Park looking east toward Fairfax



View of Promontory Park looking up Fairfax to the south

3.1.2 PANHANDLE PARK

Panhandle Park will be built in conjunction with the second and third phases of construction. It will terminate Fairfax Avenue to the south and will become the symbolic heart of the new neighborhood. It is located near the highest portion of the site with views to the East Bay and India Basin Shoreline Park below. There are three sections of landscape, which together provide 0.5 acres of open space. At least 1/3 of the area will be dedicated to active recreation. Grading and retaining walls will create level outdoor space and maximize accessibility. There will also be lawn and trees, a mix of sun and shade areas, and an adjacent bus stop to serve the park.



Hayes Street Green

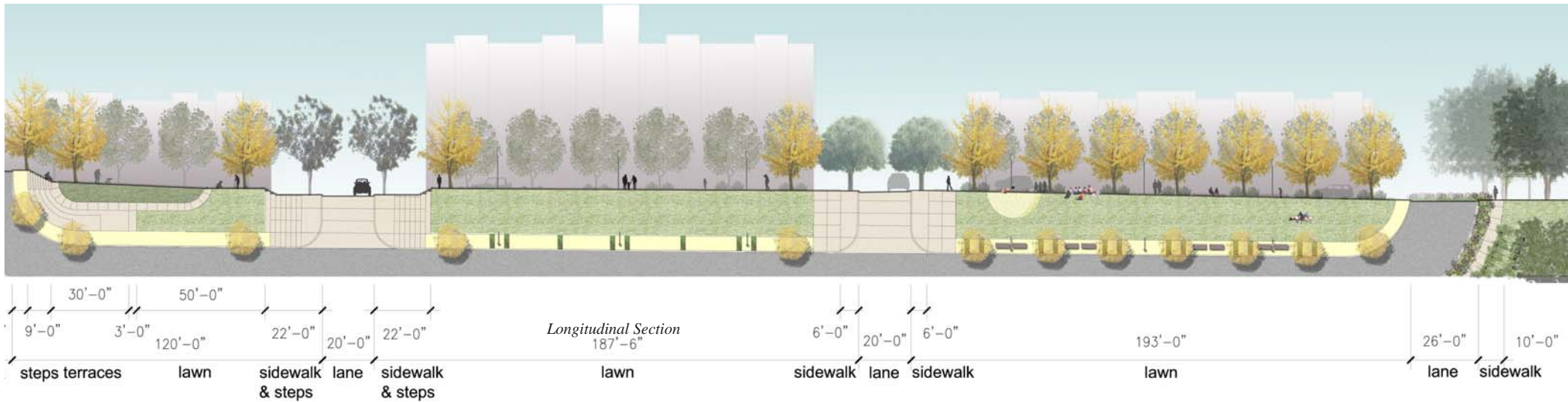



View of Panhandle Park looking west

3.1.3 HUDSON AVENUE OVERLOOK

Hudson Avenue Overlook is a secondary park with a smaller scale neighborhood character off of Hare Street with views of the Bay and India Basin Shoreline Park below. It has the potential to connect either to an extension of Hudson Avenue or to public stairs on the alignment of the Hudson right-of-way. A double row of trees framing a large, open, un-programmed lawn area for flexible use will accommodate either of these possibilities, with the trees remaining as street trees if and when the Hudson connection occurs.



Section through proposed park

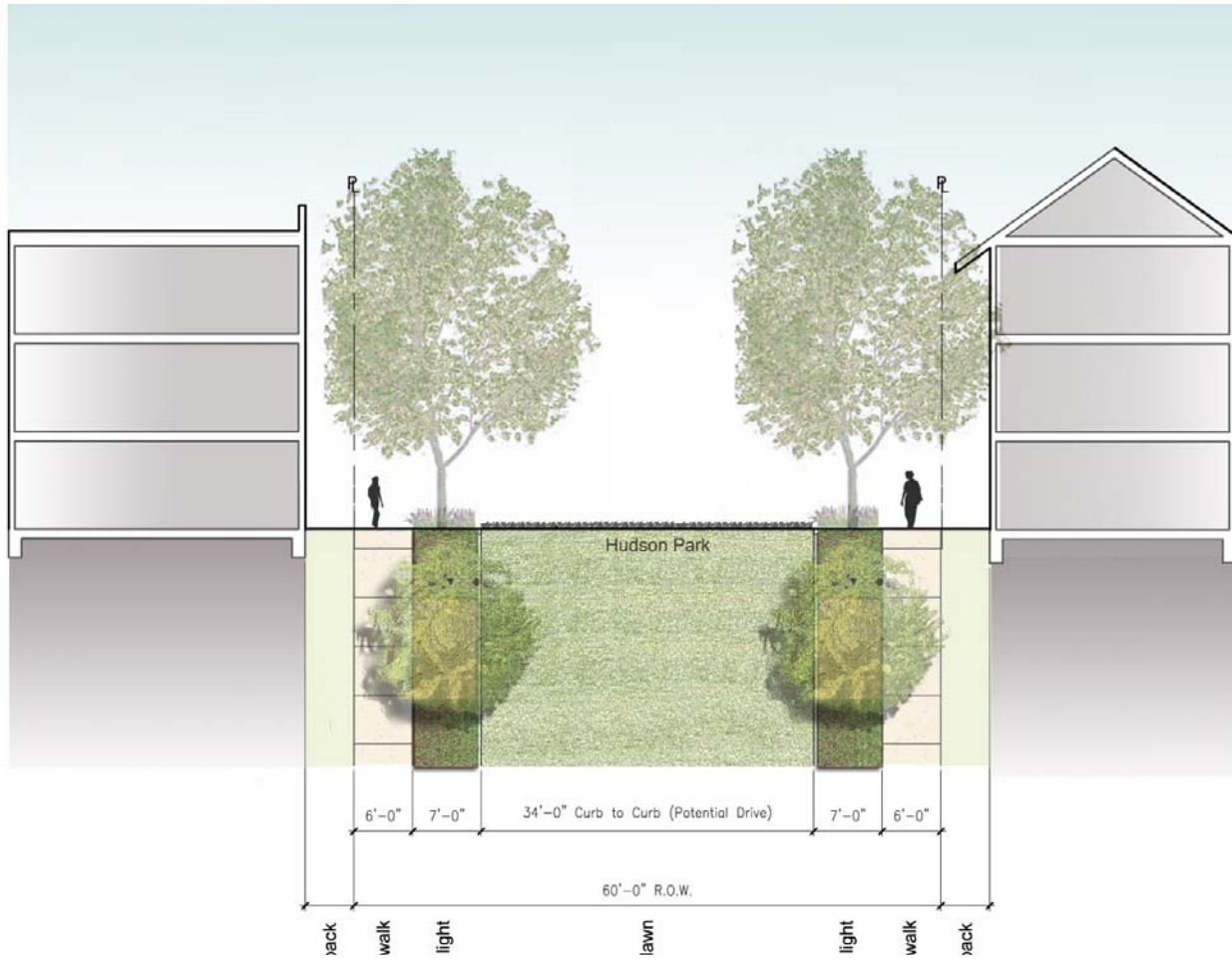

Section across proposed park

3.1.4 MINI-PARKS AND CONNECTORS

To provide small scale, safe outdoor space within short walking distance of every residence, mini-parks are placed throughout the site. Surrounding homes look onto these mini-parks to provide security and help activate these spaces. The mini-parks should be designed for intensive use with low fences and play equipment for children and landscaped seating areas for adults.

Where topography and existing cul-de-sacs prevent street connections, proposed pedestrian pathways provide safe, attractive linkages to neighborhood destinations.

Design Guidelines for Mini-Parks:

1. New Street is anchored by mini-parks at either end. The northern mini-park offers views towards Evans and the Bay.
2. The mini-park at the southern end of New Street is an especially important node. It is part of the route to Malcolm X Academy and the school bus stop on Harbor Way, to the Muni bus stop at Innes and Middle Point, and to the Community Youth Park. It is the closest park to the senior building and the proposed location for a child care center and so should be designed to be inviting to all age groups.
3. Mid-block mini-parks, such as those in the middle of blocks 5 and 6, should be visible from the street, and designed to provide young children a place to play close to home. Their semi-public character should be balanced with the need for privacy from surrounding units.



Mini-parks and connectors

Design Guidelines for Connectors:

4. The pathway along the southern edge of Block 11 connects Malcolm X Academy to the Muni bus stop at Innes and Middle Point. The homes in Block 11 should be oriented to overlook this pathway and the Community Youth Park beyond. This connector offers the opportunity to be designed in conjunction with the offsite path that parallels it along the northern edge of the Community Youth Park. These paths could be combined into a single, more generous and well-lit walkway which continues the Innes alignment as a pedestrian connection to Malcolm X School.
5. The pedestrian path at the western end of Wills Street leads to Soujourner Truth daycare, Cashmere Street, and the 54 bus line on Hudson Avenue. The housing in Block 9 and the lighting for this path way should be carefully designed for visibility and security.
6. The portion of Block 18 facing the Hudson Avenue extension presents a special opportunity to encourage future offsite linkages down to Hunters Point Boulevard and India Basin Shoreline Park. See Open Space, Hudson Avenue Overlook, page 38.

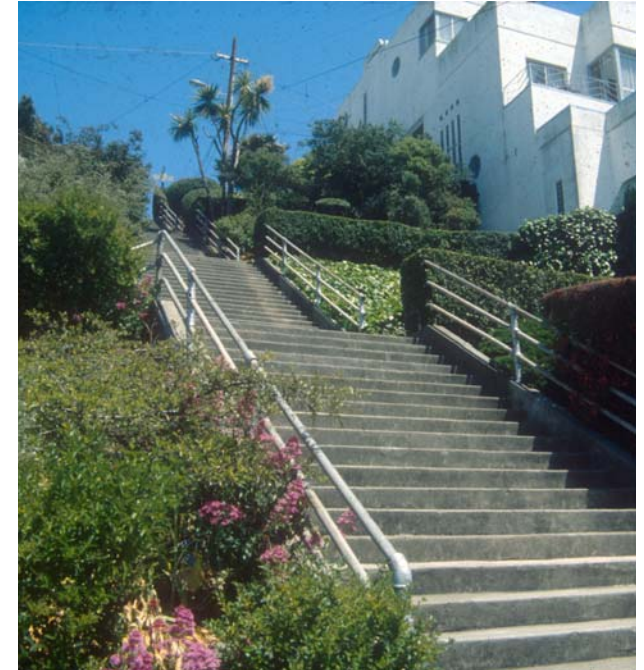
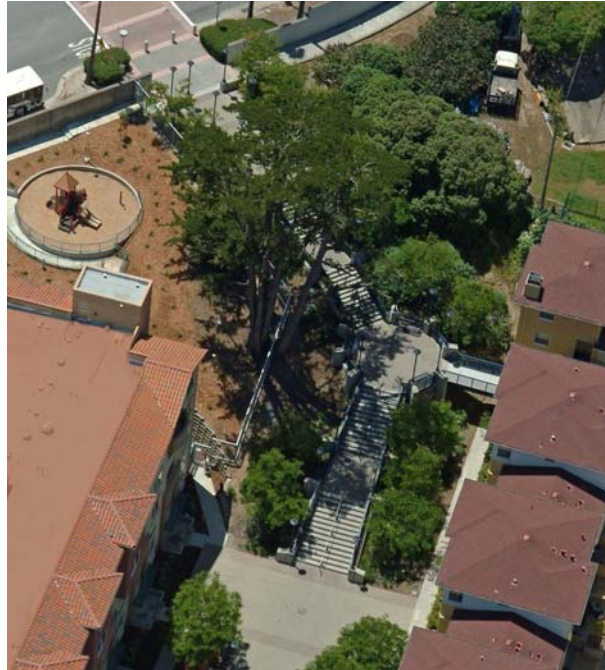

3.2 RESTORATION AREAS

Due to the widespread presence of serpentine soils, there are unique horticultural opportunities for native plant restoration at Hunters View. Embankment areas at the site perimeter may serve as a landscape buffer where limited serpentine grassland and habitat may be reestablished.

Design Guidelines

1. Restoration plantings shall be based upon site inventory, or upon a projection of plants that would likely have been present at the site prior to regrading.
2. Plants shall be contract grown from seed collected from the site prior to grading, or from seed collection from similar coastal serpentine sites and shall be planted in the first fall following regrading of portions of the site by phase.
3. Installation should be by a contractor familiar with site restoration.
4. Restoration work should include a long-term maintenance plan which includes monitoring of the site following planting.
5. Temporary irrigation should be provided for the establishment period only.
6. See Appendix for recommended species.



Potential Opportunities for Restoration Areas

3.3 COURTYARDS AND COMMON OPEN SPACES

The Hunters View neighborhood includes semi-private outdoor spaces consisting of shared mid-block courtyards, terraces, podia, roof decks, front yards and setbacks. Unlike park spaces, these spaces are intended for use by only the residents of the immediately adjacent dwelling units.

Development Controls

1. Common open spaces should have dwelling units oriented toward them around their edges and where possible entrances to dwellings facing the open space. Circulation through common open spaces is desirable.

Design Guidelines

1. Where dwelling units, particularly ground floor dwelling units, face common open spaces, there should be a landscape buffer to provide privacy between the units and space intended for common use. This buffer may be considered common open space for the purposes of Planning Code Sec. 135.
2. Front yards and setbacks should be designed and maintained as common area integral to the quality of public realm. At a minimum, each block face should have a common design, integral to the architecture of the block and sharing a common approach to fencing, gates, retaining walls and major plantings. Front yards and setbacks may also provide contained areas for residents to personalize through their own plantings.
3. Plantings and other landscape elements should be designed and configured to assure visibility through the space.
4. Security should be provided by oversight from adjacent dwellings and visibility from public streets. Security fences and gates are not prohibited, but they should be restricted to transitional spaces that are not visible from larger common spaces or public streets.
5. Where gates and fences are needed for security, they should make use of the decorative potential of the ironworker's craft.



3.4 STREETS

The streetscape design for Hunters View will reinforce the primary goal of reconnecting to the surrounding neighborhoods by creating tree-lined streets that are inviting for pedestrians and bicyclists while encouraging the use of public transit. The design will further the goals of the San Francisco Better Streets Plan*, ensuring that streets perform multiple functions such as accommodating people, stormwater management and infrastructure. Plantings will reinforce a hierarchy of major and minor streets.

Generally, all new streets should follow the right-of-way and design described below and should reflect the street type assigned to them designated in the Street Plan. The design concept of each street type is shown in the sections below. The dimensions of each element represented in the sections should serve as a guideline for the final streetscape design.

All streets are proposed to be public unless specifically indicated otherwise.

** Better Streets Plan is still in draft form at the time of this document, but implementation of the street design here should conform with the recommendations of the Better Streets Plan if it is in effect at the time of implementation of this project.*

The proposed street sections shown in the following pages are subject to review and approval from the Department of Public Works and other City agencies.



West Point Road looking east to the Bay

3.4 STREETS, CONTINUED

Development Controls

1. Trees shall be provided at a minimum of 20 feet and a maximum of 30 feet apart on streets and mews.
2. Pedestrian scaled lighting shall be energy efficient and shall be provided at the lowest light levels possible while still ensuring safety.
3. Trenches of un-compacted imported soil shall be provided as a growing medium for trees in place of the existing serpentine soil.

Design Guidelines

1. Streets should be designed to accommodate pedestrians, the movement of cars and parking needs.
2. Placement of street trees should be considered first when laying street infrastructure, including street lamps, street vaults, other street furniture, and underground infrastructure. Civil engineers, City departments, landscape architects and master plan architects need to coordinate closely to achieve this result.
3. Stormwater management should be considered in the design of sidewalk areas and permeable paving should be used when possible.
4. To reduce or minimize water consumption, trees, sidewalk plantings, and plant material should be native and drought tolerant wherever possible.
5. Streets designs should include furnishings such as seating, lighting, signage and utility enclosures that are related and compatible in design.
6. The feasibility of LED lighting should be considered.
7. Small scale, tightly spaced streetlights should be installed on the east side of Fairfax Avenue between the Promontory Park and the Panhandle Park.
8. Street trees should be a mix of evergreen and deciduous trees and should be placed as an integral component of the infrastructure. They should be as large as possible within the constraints of available soil volume and serpentine soil conditions.

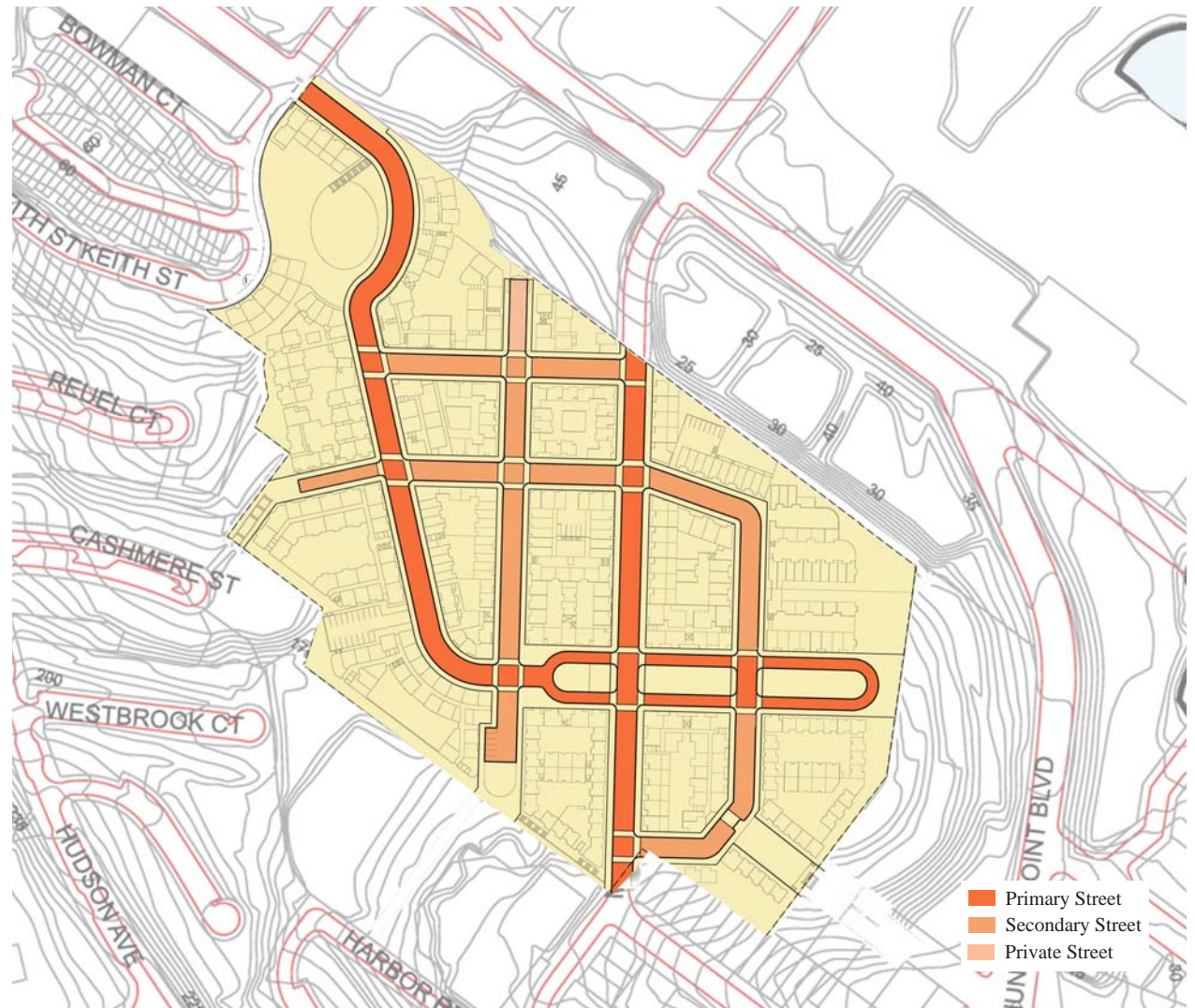

Key plan showing the street types in the proposed plan

3.4.2 FAIRFAX AVENUE (56' R.O.W.)

Fairfax Avenue extension, with a 56' right-of-way, will serve as an additional entrance to the site and the principal entrance for Phase 1. It is also the main connector between the Promontory Park and Panhandle Park. Fairfax Avenue extension will be designed in a manner that complements the Promontory Park design, reinforcing the linkage between the two major open spaces and providing adequate space for optimal tree growth.

As Fairfax Avenue ascends along the curved façade of Block 2 and wraps around the Promontory Park, the street will have a symmetrical profile with street trees on both sides to create a gateway to the Hunters View neighborhood. Once it passes the Promontory Park, a simple row of large trees will march along the west side of the street to Panhandle Park with all lighting and the majority of utilities located on the other side of the street. Lighting photometrics should be carefully studied to provide adequate street lighting with tightly spaced pedestrian scaled street lights. The asymmetry of the streetscape design will minimize utility conflicts and maximize planting space to ensure optimal tree growth.

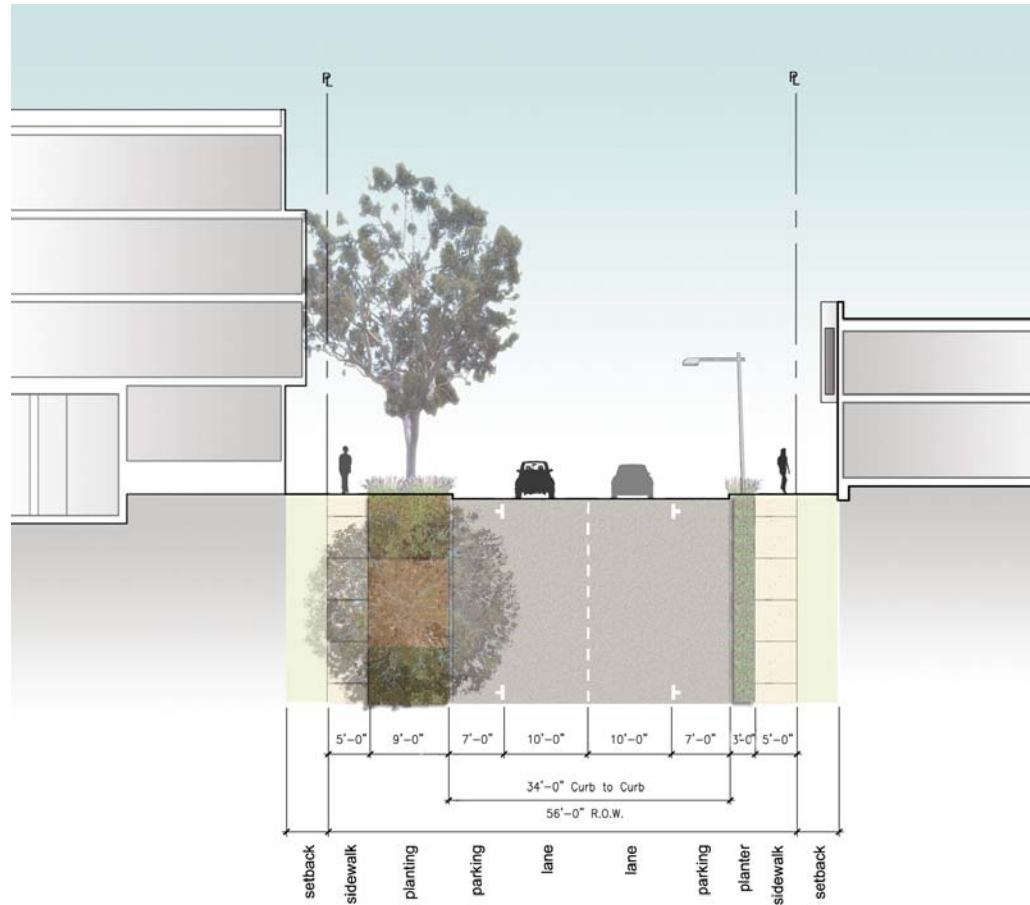

Proposed cross section

3.4.3 PARK STREET EAST (114' R.O.W.)

The intersection of Fairfax Avenue and Park Street East forms a new cross-axis with park views at either end. Park Street East forms a one-way loop around Panhandle Park. Parallel parking is provided on one side in each direction. The streetscape design of Park Street East should be closely integrated into the overall design of Panhandle Park in order to extend the sense of park space from building face to building face.

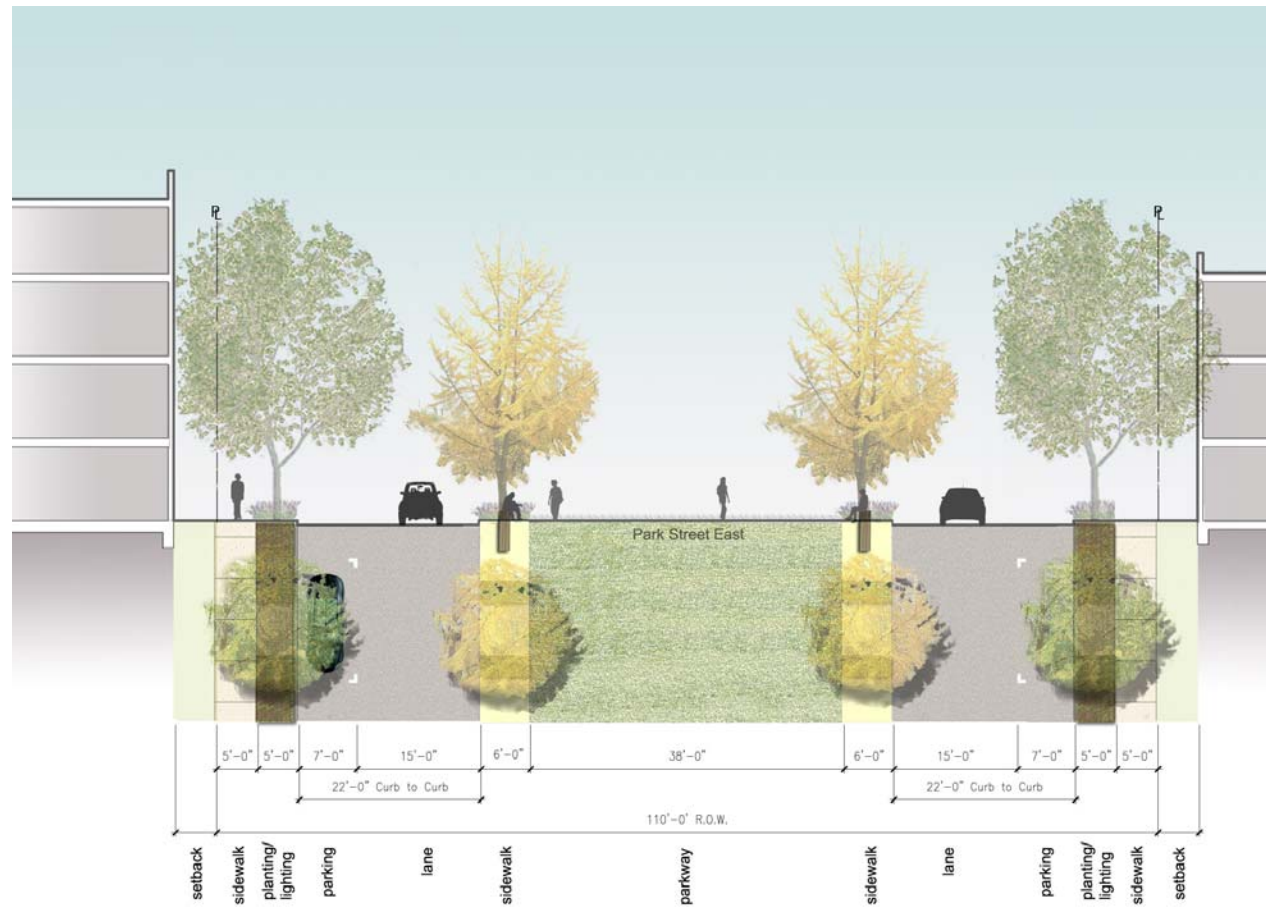

Proposed cross section

3.4.4 SECONDARY STREETS (55' R.O.W.)

Secondary streets are small neighborhood streets that feature one travel lane for cars in each direction, parallel parking, and sidewalks on both sides of the street. Trees will be planted at regular intervals with ample sidewalk space to create a pleasant pedestrian environment.

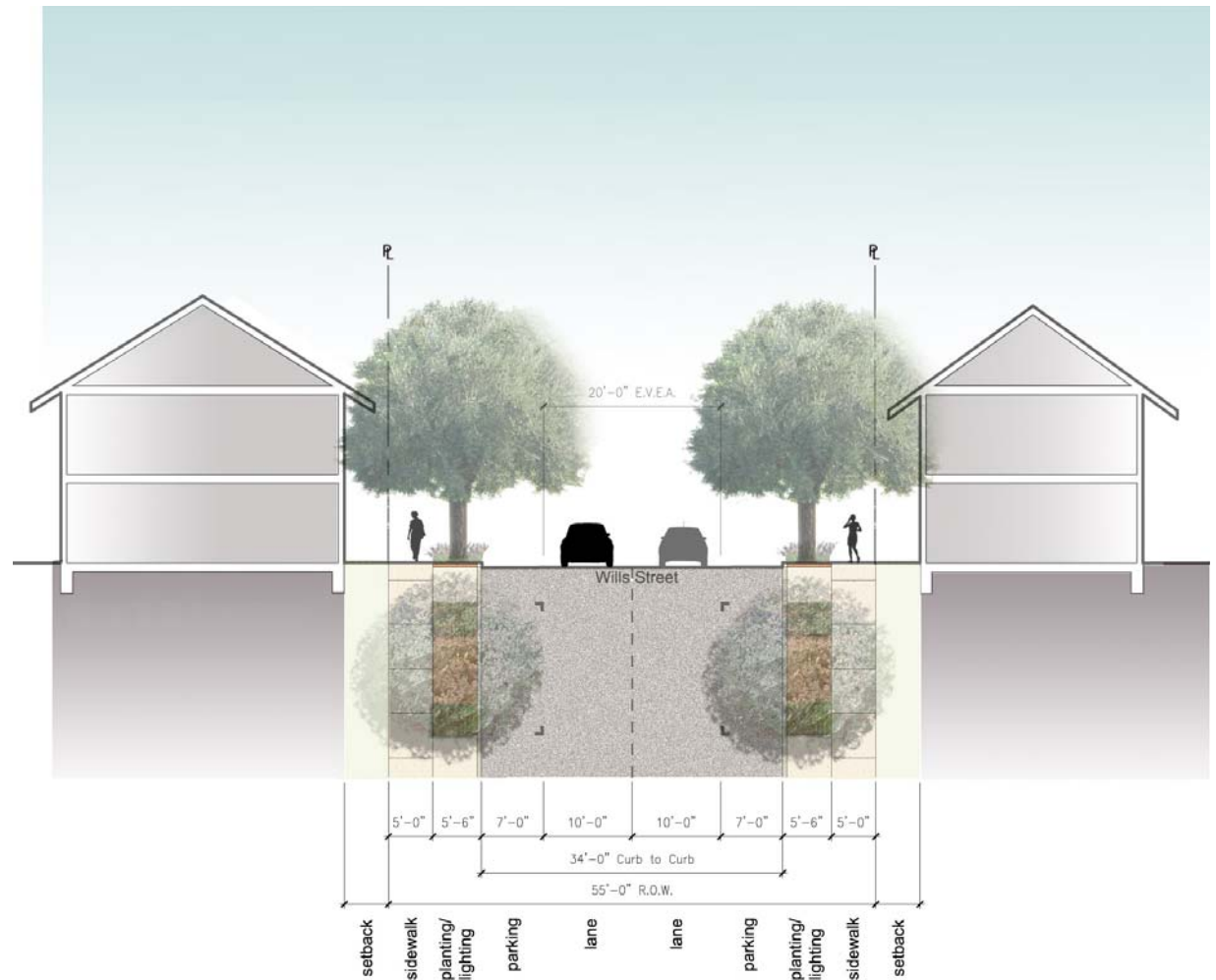
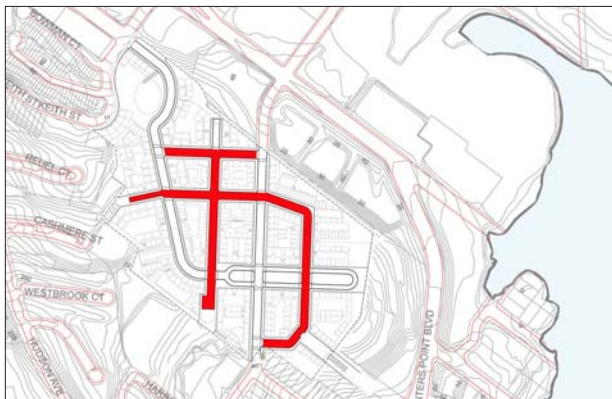

Proposed cross section

3.4.5 NEW STREET MEWS (55' R.O.W.)

The mews is a privately owned street designed to slow vehicular traffic and prioritize pedestrian flow. The mews should be wide enough to allow for access to buildings and townhouses with a minimum width of 20' for emergency vehicular access.

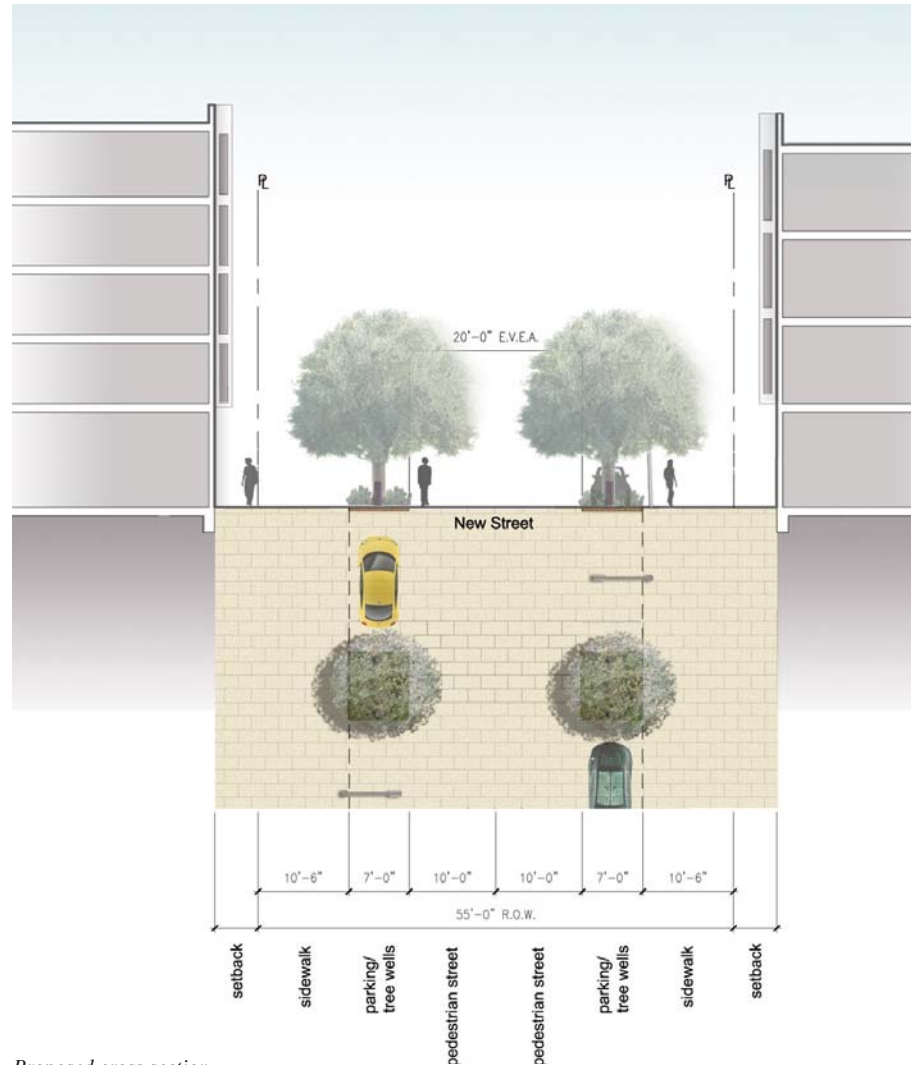
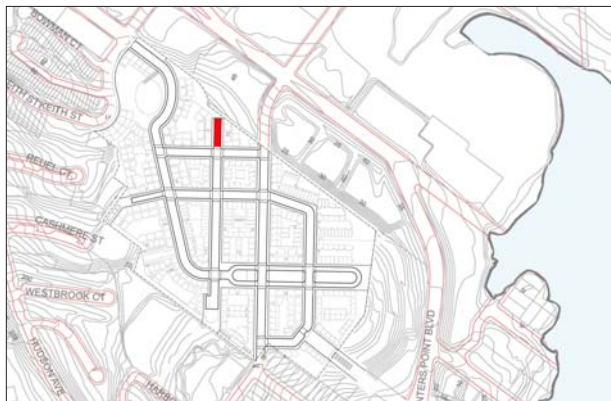

3.5 PLANTING GUIDELINES FOR OPEN SPACES AND STREETS

Plantings consist of street trees, park trees, shrubs, groundcovers and restoration plantings. Tree plantings will be a mix of evergreen and deciduous, chosen to reinforce urban design concepts, provide a continuous canopy at streets, mark site entries, provide distinct identity to streets and open spaces, provide variety and resilience to disease, and aid in stormwater management. Shrubs and groundcovers will be chosen to provide an intermediate scale of detail and texture between trees and buildings at parks, streets and residential areas. Restoration plantings will be chosen to encourage the reestablishment of a unique native plant habitat.

Design Guidelines

1. Plantings shall be selected for longevity, ease of maintenance, low water use and adaptability to serpentine soils.
2. Import soil shall be provided in sufficient volume to support anticipated future plant sizes.
3. Permanent irrigation shall be provided for intensively used areas.
4. Maintenance for restoration areas should be provided until establishment is complete.
5. Temporary irrigation should be provided where needed to establish plantings.
6. Shrub and groundcover plantings should be primarily native or climate adapted Mediterranean plantings such as those from Southern Europe, Chile, South Africa, and Australia.
7. Restoration plantings should be based upon site inventory. Seed should be collected from the site prior to grading, or should be collected for contract growing from a similar coastal serpentine site, and should be installed by a contractor familiar with restoration.



Key plan showing the proposed planting plan

3.5.1 PROPOSED TREE SPECIES

Common Name	Scientific Name	Mature Size	Water Need	Tree Character
Sydney Blue Gum	<i>Eucalyptus Saligna</i>	Large evergreen	Low	Tall and slender tree with fast growth rates
Olive	<i>Olea europea</i> 'Swan Hill'	Medium evergreen	Very low	Sculptural multi-trunk trees of Mediterranean Character
Black Acacia	<i>Acacia melanoxylon</i>	Large evergreen	Very low	Fast growing
Maidenhair	<i>Gingko biloba</i>	Medium Deciduous	Low	Urban Character with light shade and upright
Italian Stone Pine	<i>Pinus Pinea</i>	Large evergreen	Low	“Umbrella” shaped top at maturity



Sydney Blue Gum



Olive



Black Acacia



Maidenhair



Italian Stone Pine

3.6 SITE LIGHTING, PAVING AND FURNISHINGS

Street and park lighting shall be located at uniform spacing coordinated with street trees and site furnishings, and shall be scaled to pedestrians.

Site paving shall be selected to maximize site permeability, while providing a limited variety of materials, textures and finishes in order to give specific identity to streets, parks and open spaces according to their functions.

Site furnishings may include lighting, signage, seating, bike racks, fencing, retaining walls, screens, trellises, utility enclosures and other minor architectural structures. Furnishings shall be built and selected to reinforce overall design concepts throughout the neighborhood.

Design Guidelines

1. Lights should be selected for longevity and ease of maintenance, with light levels as low as possible without compromising safety.
2. Street lights and other site lighting should be designed to minimize uplighting and glare.
3. Lights and site electrical equipment should be planned with tree locations having priority over the joint trench network when feasible.
4. Lights with uniform spacing should contribute to the structure of the streets and parks.
5. LED streetlights should be used if possible, in order to take advantage of improvements in street lighting technology.
6. Concrete sidewalks should include lampblack and finishes to minimize reflection and staining.
7. Unit pavers, stone cobbles or gravel should be used at the base of tree plantings.
8. Permeable paving should be used when possible to increase site permeability.
9. Built-in and prefabricated furnishings should be of a family of elements, unified in color and form throughout the public open space.
10. Furnishings should be selected with attention to permanence and durability.



3.7 SITE SUSTAINABILITY

Best management practices should be included in all aspects of the landscape design and construction.

Development Controls

1. The landscape design shall follow the sustainability criteria of LEED-ND and Better Streets program guidelines.

Design Guidelines

1. The amount of grading, offhaul and import soil should be minimized.
2. Stormwater should be retained on site, and open spaces should provide for biofiltration and water storage when possible.
3. Permeable paving should be used where possible.
4. Low energy lighting should be used whenever possible.
5. To help reduce the urban heat island effect to the maximum extent practical, pavement areas should be minimized, alternative and light-color concrete and pavers should be used, and tree canopy over pavements should be maximized.
6. Native and low water-consuming plantings should be used to help reduce water consumption.
7. Passive landscape and streetscape area within the plan area open spaces and streets should be used for primary treatment of stormwater and should use drought-resistant plantings.

CHAPTER 4

BUILDINGS

San Francisco's neighborhoods owe much of their character to a delicate balance between the distinctiveness of individual buildings and the consistent ways in which buildings contribute to streetscapes and the definition of public spaces. The design standards which follow are conceived to replicate that delicate balance in the reconstruction of Hunters View. Stylistic variety and the distinctive imprint of different architects are encouraged by these standards, but a consistent approach to the shaping of the public realm by buildings is mandated through the series of prescriptions that follow.

In much of the city, neighborhood character derives from the presence housing of different types, scale and program. The differences in type of tenure at Hunters View provide an opportunity for this kind of variation. There will be small rowhouse buildings and larger corridor-served buildings. The neighborhood design takes advantage of these differences and has different standards for height, bulk, articulation, stepping and entrances for larger and smaller buildings.



Source: www.2020worldfair.com

4.1 LAND USE

Within Hunters View, land uses shall be restricted to those permitted by the Planning Code and the General Plan. Location of land uses shall generally adhere to the Urban Design Concept Plan as shown on this page.

Design Guidelines

1. Community facilities, such as child care or a senior center, as well as the rental management office may occupy spaces on the ground floor of Block 10.
2. Ground floor retail, community services, marketing offices and other street oriented non-residential ground floor uses may be incorporated in buildings facing Promontory Park, Panhandle Park and within 100' of the intersection of Middle Point Road and Park Street East, the entire ground floor of Block 10, and across Fairfax from Block 10.

4.2 LOT COVERAGE / REAR YARDS

Development Controls

1. Lot coverage shall not exceed 75% of each block or portion of a block devoted to a single use or housing type.
2. The unbuilt area need not be in the typical mid-block configuration described in Planning Code Sec. 134, may include setbacks and pedestrian ways, and may be provided on the first level above a parking podium.
3. Overhanging balconies and bays meeting the limitations of Planning Code Sec. 134 and this Design for Development Document may extend into the unbuilt area.



Plan showing proposed land uses*

	Proposed Rental Housing		Proposed Ground Floor Retail, Commercial or Community Space
	Proposed Ownership Housing		Proposed Park

*The Plan shown above is for illustration purpose only and may not represent the final design.

4.3 USABLE OPEN SPACE

Development Controls

1. A minimum of 80 square feet of private usable open space shall be provided for each unit. The minimum dimension for any private open space shall be 6' by 6'.
2. Common open space may be substituted for private open space at the rate of 107 square feet per unit.
3. The dimensions of common open space may be measured across areas at different elevations, provided that adjacent areas have no more than a 4' difference in elevation, and each such area is at least 6' in every horizontal dimension.
4. A portion of a unit's required usable open space need not be directly accessible to the unit as long as at least 36 square feet are directly accessible and the remainder is within 125' of the front door of the unit or the apartment building.
5. Up to 25% of the required open space for each block may be provided in the form of public open space located within 125' of the building or unit entry.

Design Guidelines

1. Private and common open space should be designed to be visible from unit living areas.
2. Private and common open space should be designed to incorporate features to detain and/or reduce runoff from rain or winter storm events.
3. Common open space at ground level should be visible from the street.
4. Common open space should be designed as usable surface area containing both landscaped and hardscaped areas.
- 5.
6. Private and common open space should reduce water usage through smart (weather based) irrigation controllers and by using drip irrigation or low flow sprinklers for all non-turf landscape, if irrigation is required.



Illustration showing common and private open spaces

4.4 BUILDING HEIGHTS

Height controls are intended to accommodate Hunters View's new density in a low-rise neighborhood of varied heights. The tallest buildings shall be allowed at the high points of the site and to frame views up Fairfax and Park Street East.

Development Controls

- Buildings above 50' in height are allowed at the following locations: Block 2A in its entirety, and the following frontages up to a depth of 85': Fairfax Avenue frontages of Blocks 9 and 10; Park Street East frontages of Blocks 7B, 11, and 15; Park Street and Hare Street frontages of Block 16 (see diagrams).
- Buildings that are taller than 40' not described above are limited to the following:
 - Anywhere within the site up to 45' in height where additional height is used to provide raised steps and stoops or raised common entries. This includes situations where such steps and stoops and front entries are wrapping partially below-grade parking podium.
 - Buildings up to 50' limited to blocks along the crest of the site, specifically Blocks 9, 10, 11 and 16, as well as the New Street frontage of Block 3 to a depth of 70'.
- Building height shall be measured at the uphill end of each segment of a building that steps laterally in relation to the street that is the basis of height measurement.

Design Guidelines

- Building heights should step with the slope of the site.
- Ground floor non-residential uses, not including parking and service spaces for trash rooms or mechanical equipment should have a minimum height of 12', and a recommended height of 15' floor to floor.



- Buildings up to 50' in height allowed
- Buildings above 50' in height allowed

4.5 MASSING AND BULK CONTROLS

The intent of the massing controls is to create a varied hill-top urban form that reflects the fine-grained scale of San Francisco's residential urban fabric. Recognition is given to the differences between walk-up buildings and corridor-access buildings. Walk-up buildings typically reflect the San Francisco pattern of narrow (25'-50') parcels, whereas corridor-access buildings typically have larger floor plans and a bigger scale on the street. Walk-up buildings also typically have more frequent entrances on the street than corridor-access buildings. Bulk controls are intended to mitigate the impact of corridor-access buildings with their larger floor plates in a neighborhood where walk-up buildings are the predominant type.

Development Controls

1. Bulk controls shall limit the maximum length and size of floor plates above 50' high in order to preserve light and air, permit views into open spaces and reduce the apparent bulk of larger buildings against the skyline. The limits shall be governed by maximum plan and diagonal dimensions stated below:
 - i. Maximum building length: 150'
 - ii. Maximum diagonal length: 240'
2. On street frontages that slope 5% or more, continuous building facades for walkups and other buildings less than 50' high shall step at intervals of 50' or less (see diagram). Notwithstanding Planning Code Sections 102.12 and 260, buildings must step along all street frontages. Furthermore, portions of buildings that are deeper than 80' from the front property line must be measured from grade below that portion of the building in stepping increments similar to those used to step along the street.

Design Guidelines

1. Regardless of whether a building reaches its maximum height, building heights should step relative to street grade.

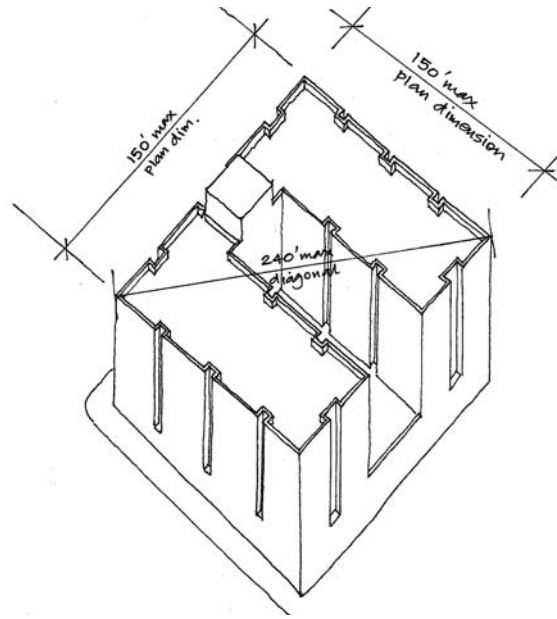

Bulk controls above 50'

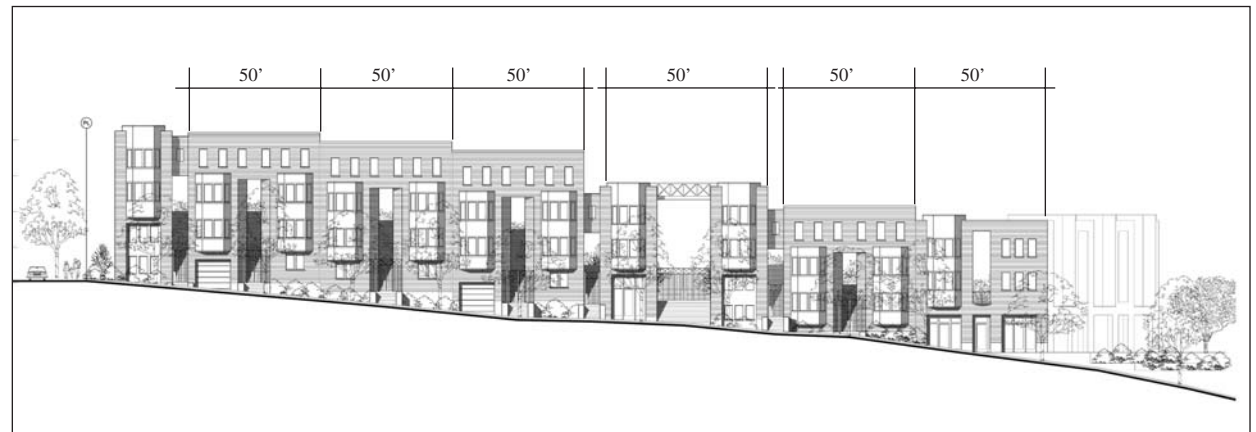

Building stepping

4.6 FAÇADE ARTICULATION

Façade articulation guidelines are intended to encourage the traditional San Francisco residential features of bay windows, cornices, recessed entrances, and stoops so that Hunters View becomes integrated into the normative pattern of the city's residential architecture.

Design Guidelines

1. Façade widths should reflect the internal plan dimensions of the individual units where possible.
2. The maximum unbroken horizontal façade for buildings less than 50' high should not exceed 35' without a recessed notch or break in the horizontal plane of the façade (see diagram).
3. Bays projecting above the roof parapet line should have wing returns perpendicular to the street, the length of which should not be less than three times the difference in height between the projecting parapet and the main parapet (see diagram).
4. Building facades should be articulated with a strong rhythm of vertical elements such as bay windows, bow fronts, recesses or other changes in plane. Pilasters with recesses between them at the lower floor or floors of buildings are appropriate means of articulating the street facades of buildings. Recesses between pilasters should be a minimum of 12" deep and have vertical proportions. See illustration.
5. Projecting details such as trellises, cornices, sunshades and awnings are encouraged in order to create visual interest and to provide weather protection.
6. Sun shades and light shelves are encouraged on east, south and west facades above ground levels to augment passive solar design and provide solar control.
7. Exposed utility connections and meters should not be visible along street fronts.
8. Dumpsters and garbage cans should be concealed in buildings or trash enclosures integrated into the design of buildings.



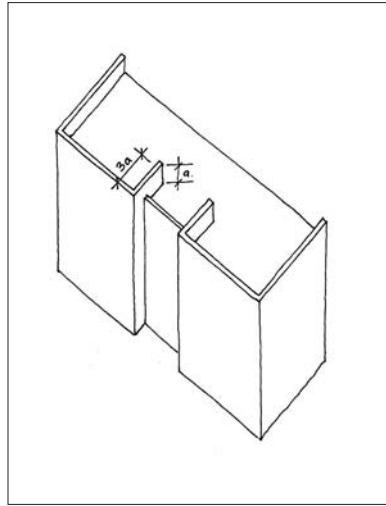

Wing wall returns on projecting bays

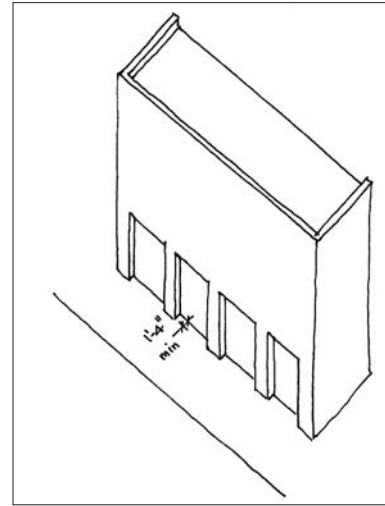

Pilasters and recessed wall plane



Sunshading elements

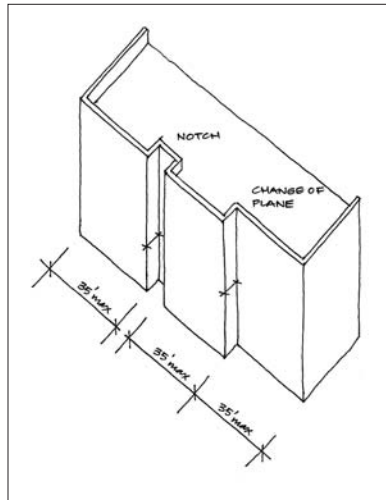

Maximum unbroken horizontal facade dimensions

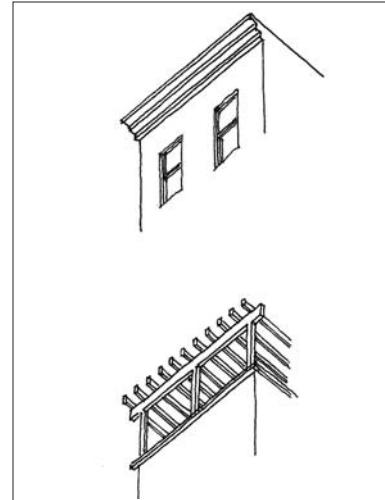

Cornices and trellises

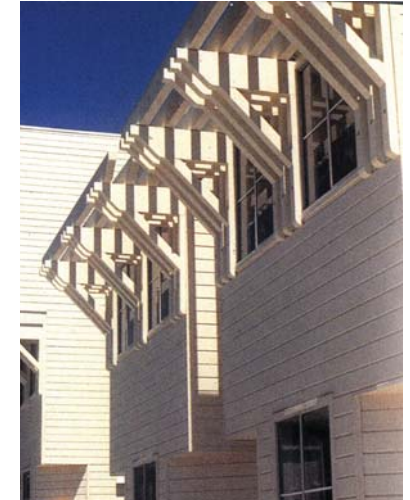

Trellises

4.7 SETBACKS/BUILD-TO LINES

Setback and build-to lines help define the street walls and create a continuous urban fabric. At Hunters View, as at most other San Francisco neighborhoods, the building facades should align with the streets and define view corridors and vistas.

Definitions:

- **Setback:** A setback is a specific dimension from the street right-of-way line that a building cannot encroach beyond, except for allowable encroachments.
- **Build-to Line:** A build-to line is a specific dimension from the street right-of-way line that encourages all the buildings on a street to form a consistent street wall that effectively defines the street as a space.
- **Allowable encroachments:** In order to promote stylistic variety, in addition to the obstructions allowed by Planning Code Sec. 136, the following encroachments are also permitted: rectangular bays up to 14' wide and 3' deep; curved or segmented bays up to 20' wide and 3' deep; sunshades of any dimension. Planning Code Sec. 136(c)(2)(G) shall not apply.

Development Controls

The accompanying diagram defines the setbacks and build-to lines for the various streets in Hunters View. Where no setback line is shown, no setback is required.

1. A minimum setback of 5' shall be required for residential uses on all streets where a setback line is marked.
2. Setbacks are not required at street frontages with an extreme slope or a shallow lot. These exceptions include: Keith Street, the 80' of West Point Road just west of Middle Point Road, the southernmost frontage of Hare Street east of Middle Point Road, and the southernmost 80' of frontage at Block 8 on both Fairfax Avenue and New Street.
3. A build-to line is set at 8' from the property line for all streets. A minimum of 75% of the building façade must be built at or in front of the build-to line. The 75% build-to requirements applies to each street frontage, or where such have frontages have been subdivided for individual



Diagram representing setbacks

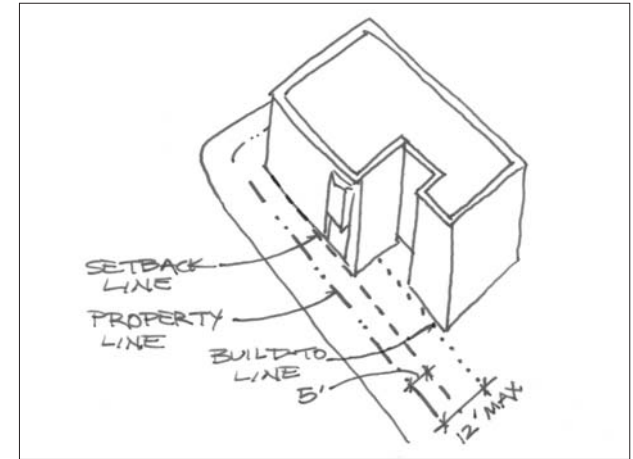

Exception to build-to line at corners

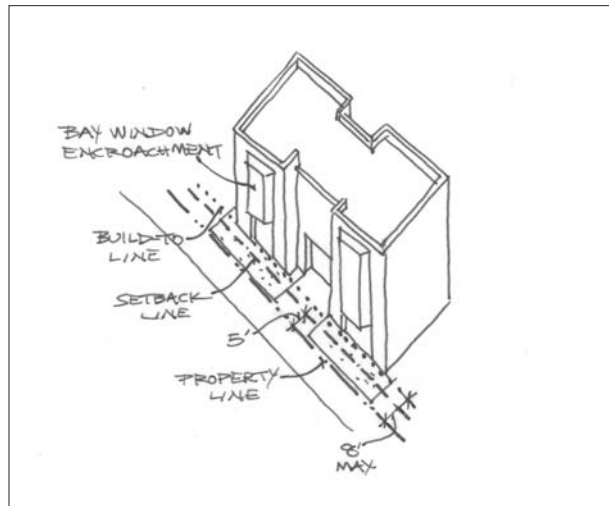

Setback and build-to line

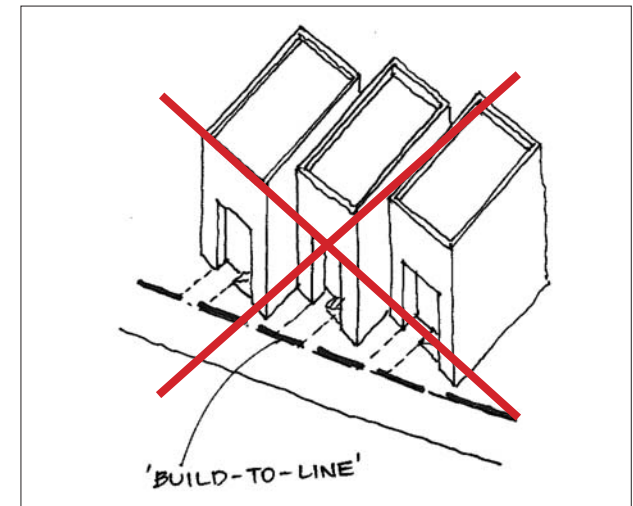

Not encouraged: Build-to line ignored

development, to each individual lot.

- The build-to line can be increased to 12' for a full block face, or an individual unit if at least 50% of the portion of building(s) within 35' of the corner(s) are built to the 5' setback line.

Design Guidelines

- Planting in setbacks should enhance the privacy of ground floor units.
- On a sloping site, setbacks can accommodate level changes and warped surfaces between the back of the sidewalk and the building entrance.
- The major planes of the building facade should be built

4.8 SIDE WALLS AND REAR WALLS

Because of Hunters View's steep hillsides and mid-block open spaces, the sides and backs of buildings are especially prominent. Since most of the site will not be subdivided into small separate parcels, the blank blind wall condition that is problematic elsewhere in the city can be avoided. Articulation of all building faces, not only those facing streets, is encouraged.

- Side walls and rear elevations refer to all visible facades not facing a public or private street or open space.

Design Guidelines

- Materials and detailing used on visible side and rear elevations shall be consistent with those on front elevations. Rear and side elevations must be designed to the same standards as the street elevations.
- Side elevations that are not on property lines shall have windows, bays and other typical façade articulations.
- Where visible side elevations longer than 30' are on property lines, provide fenestration via a Building Code variance or by pulling portions of the building back from the property line.



4.9 GROUND FLOOR USES AND STREET FRONTS

Design Guidelines

1. Blank and blind walls at street level are strongly discouraged and may be mitigated by decorative ironwork, planters or other similar design measures.
2. Transparent window materials should be used at street level to increase visibility of public spaces from the sidewalk. Dark or reflective glass is strongly discouraged.
3. Residential facades should be articulated at regular increments to express a consistent rhythm along the street using entryways, windows and other architectural features to distinguish individual units.
4. Stoops and stairs as individual unit entries are encouraged as a means of screening exposed parking podiums; however, stairs used for screening over 8' in height to an individual unit with other means of entry are discouraged, as they are unlikely to be used.
5. Non-residential ground floor uses may be distinguished from the building's upper floor uses through the use of awnings, belt courses and/or other architectural elements. Continuity of material between ground floors and the building above is desirable, except the lowest 4' to 6' along street should be constructed of durable and easily repaired material such as tile or painted concrete.

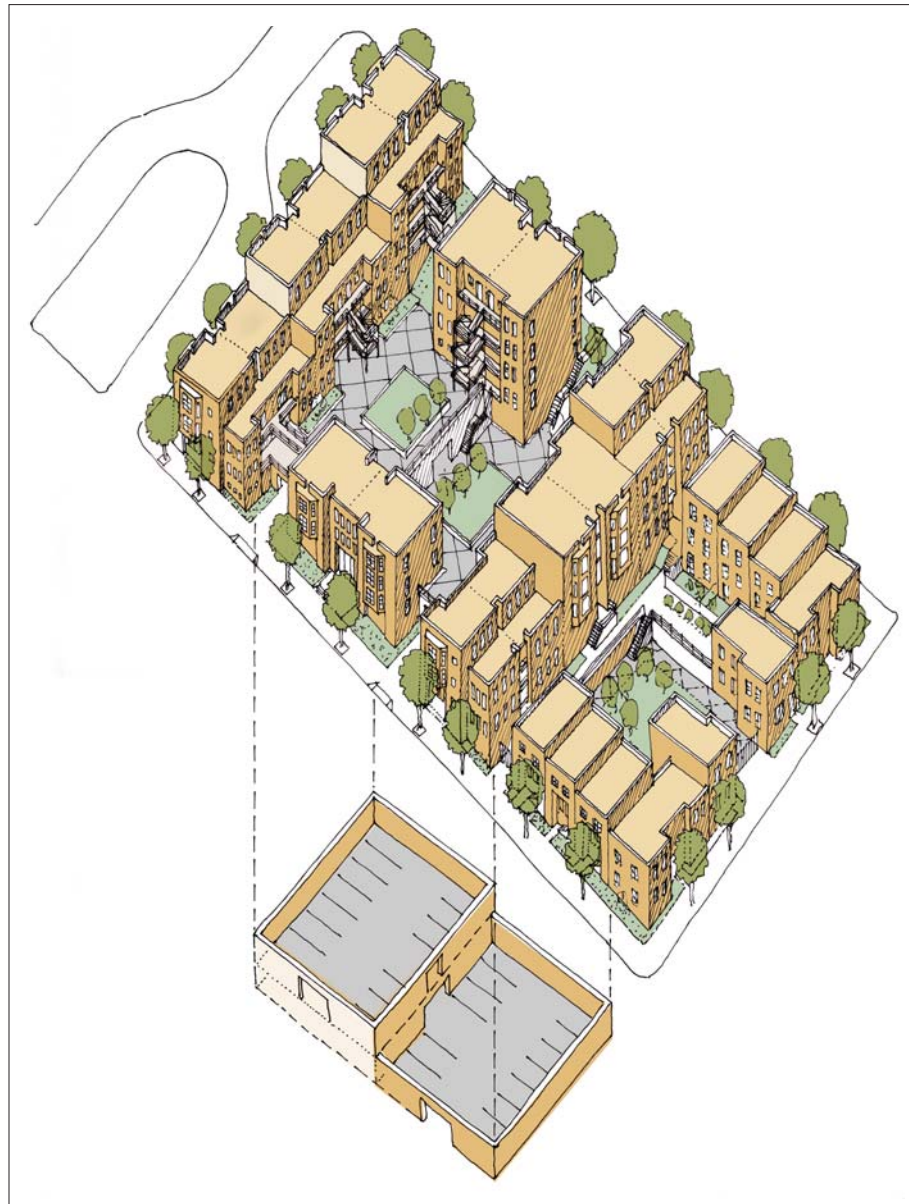

4.10 BUILDING ENTRANCES/SECURITY

Building entrances perform important roles in the overall design of the Hunters View reconstruction. Frequent entrances to small groups of units or single units and generous lobbies visible from the street help to animate streetscapes and make them safe and walkable.

In some cases the safety of entrances and circulation spaces may depend upon gates.

Development Controls

1. Street fronting townhouses shall have individual or shared entrances from the public sidewalk.
2. Stacked walk-up units shall have secured entrances from the sidewalk.
3. Entries below the level of the adjacent sidewalk are prohibited, unless adjacent to a stoop entrance to the unit directly above.
4. Security gates shall not be allowed to encroach into the setback zone and should be at or behind the principal plane of the building façade.

Design Guidelines

1. Each ground floor unit should have an individual or shared entry from the street. For multilevel units, the entrance may be at the second floor, linked to the street level by exterior stairs.
2. Where provided, stoops and stairs should have a minimum width of 48". Stoops for individual units should have a minimum width of 40".
3. Upper story units should be served by a lobby entry that opens directly onto the public right-of-way at grade level.
4. Multiple entries to interior courtyards are encouraged to provide physical and visual access.
5. Where possible, the elevation of ground floor units should be located at least 2' and ideally 3' above street level to provide privacy within those units.



Frequent building entrances along the street

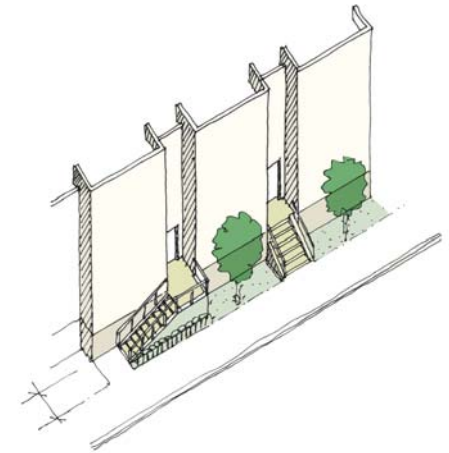

Stoop width should not be less than 40"



4.11 GATES AND FENCES

Development Controls

1. Gates are not allowed within the front setback, but may swing into the setback in their open position.
2. Fences within the front setback shall not exceed 36" in height, measured from the sidewalk.

Design Guidelines

1. The placement and design of gates should be welcoming and avoid the impression of walled enclaves.
2. Fences shall be designed to be integrated into the architecture of the building and the block.
3. Fences, planters, and other encroachments into the front setback should be designed on a block by block, not a building by building basis.
4. Gates and fences should be designed to be compatible with the architecture and the streetscape of which they are part.
5. Where metal gates and fences are used, the decorative potential of the ironworker's craft should be used to make gates and fences a positive contribution to the neighborhood.



Stacked walk-up units shall have secured entrances from the sidewalk



4.12 PARKING, PARKING ENTRANCES AND CURB CUTS

Car parking in Hunters View may occur in individual garages, congregate garages and on-street. Garage entrances and curb cuts shall be designed to minimize their impact on the safety and vibrancy of the streetscape for pedestrians.

Development Controls

1. Garage entrances accessing a street shall be no wider than 16' and are preferably 12'.
2. Parkingspaces need not meet the size and maneuverability requirements of the Planning Code.
3. Bicycle parking requirements may be met by phase rather than on a block by block basis; however, bicycle parking close to units is strongly encouraged.



Fences within the front setback shall not exceed 36" in height

Development Controls, cont'd

4. Surface parking is allowed in the mid-block only when all of the following conditions are met:

- a) The parking area is sufficiently landscaped to mitigate views of parked cars from adjacent units.
- b) The area designated for parking is not counted as required open space for the subject block.
- c) The area designated for parking is not counted as uncovered area for the purpose of calculating lot coverage for the subject block.

Design Guidelines

1. Entries to shared garages should be placed at least 10' away from lobbies and other pedestrian entries.
2. Garage entrances located on side streets, rather than principle streets, are encouraged, where topography allows.
3. Curb cuts should be kept to a minimum to allow the maximum number of on-street parking spaces and to enhance pedestrian safety.
4. Curb cuts should be positioned to permit a full on-street parking space, or spaces, between them (see diagram).

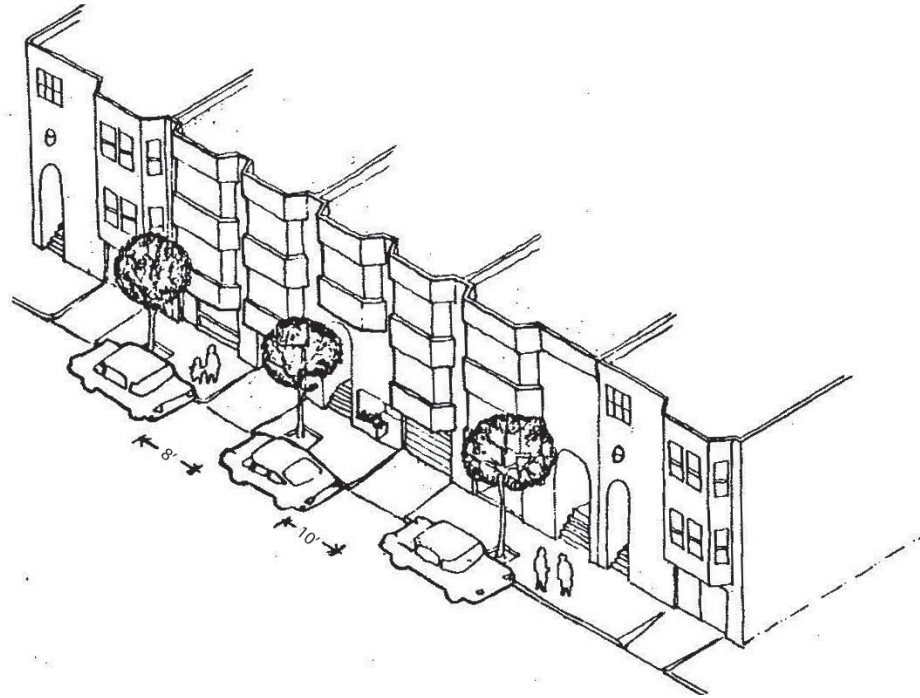
**4.13 METERS, UTILITIES AND TRASH****Development Controls**

1. Exterior meters and garbage receptacles shall not be visible from the street, and are prohibited on Middle Point Road, Fairfax Avenue, and Park Street East.

Design Guidelines

1. If meters, transformers and garbage collection are located at the building interior, exterior access points are discouraged on Middle Point Road, Fairfax Avenue, and Park Street East. Access shall be carefully located and designed in order to detract as little as possible from an active and attractive streetscape. For blocks where slope dictates the placement of these items on the above-named streets, the impact shall be mitigated through design.

4.14 ROOF DESIGN

Hunters View's hillside location ensures that the profiles of the various buildings against the skyline are an important aspect of the design of the overall development.

Development Controls

1. Mechanical equipment located on top of buildings must be screened from public view and from neighboring buildings with enclosures, parapets, landscaping or other screening.

Design Guidelines

1. Roof design should promote the deployment of renewable energy opportunities (photo-voltaics, solar thermal water heating) and energy efficiency, and be visually appealing from neighboring units.
2. Roof pitches relative to the street walls:
 - a. Mono-pitch roofs should slope towards the street and should not present end-on conditions to streets or public spaces (see diagram).
 - b. Gable roofs should be either parallel or perpendicular to the street wall.
3. Green roofs and roof designs which support the collection of stormwater run-off for detention or use within the building or for landscaping on the property are encouraged.

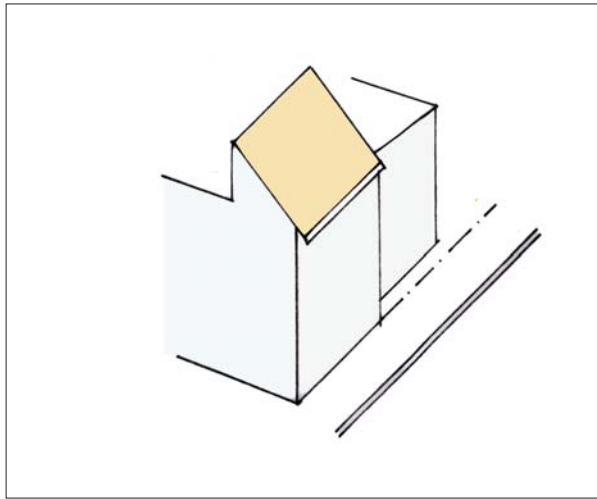

Mono pitch : acceptable

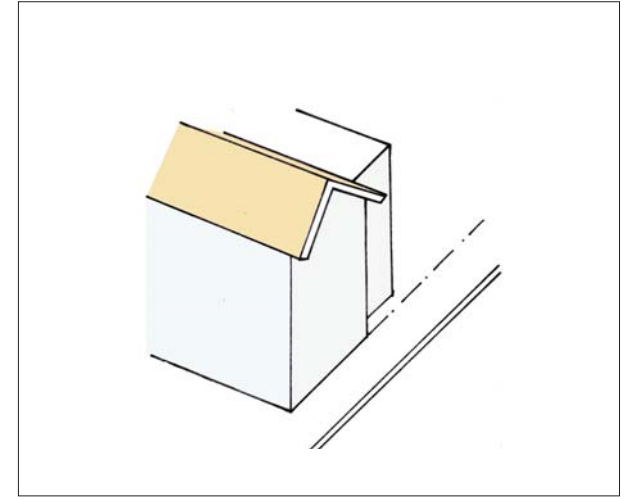

Gable-end

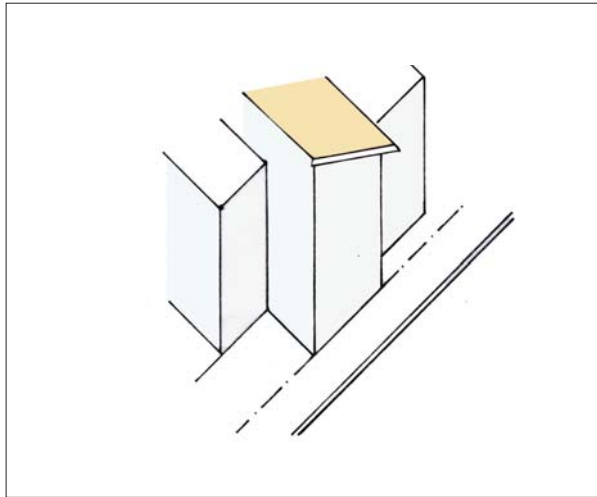

Mono-pitch : not acceptable



Green roofs

4.15 COMMUNITY OUTREACH AND CULTURALLY APPROPRIATE ARCHITECTURE

Design Guidelines

1. Design proposals should be responsive to the rich and diverse cultural heritage of the Bayview community and receive input from the residents of Hunters View, the Bayview/Hunters Point Project Area Committee members and other interested parties. Design professionals are encouraged to express the cultural heritage of the community in their work in ways that enhance the public experience of the work, emphasize the strong family and community ties of the neighborhood, and create a sense of strength, beauty and permanence.

4.16 GREEN BUILDING

Development Controls

1. All projects shall conform to one of the following green building standards:
 - Leadership in Energy and Environmental Design (LEED) green building standards as established by the United States Green Building Council (USGBC)
 - The Green Point Rated (GPR) system from Build It Green
 - Enterprise Foundation's Green Communities Criteria (GCC).



4.17 EDGE CONDITIONS

In the future, the lands to the east and north of Hunters View currently owned by PG&E are likely to be redeveloped. It is essential that the design for the reconstruction of Hunters View makes possible a graceful integration with this future development. Until the PG&E redevelopment occurs, the northern and eastern boundaries of the Hunters View site are highly visible from public streets around the site and from India Basin Shoreline Park across Innes. For both of these reasons, the north sides of Blocks 2, 3 and 12 and the east sides of Blocks 13, 14, 17 and 18 should be composed as carefully as the fronts of buildings, not treated as ad hoc, undesigned backs. Grades and the absence of perimeter streets may make it impractical to locate building entrances on these edges or fully to screen parking podia. However, other façade controls related to building articulations and stepping should apply to these edge conditions. All around the site, building designs should strive to minimize the visibility and height of exposed parking podia.

Design Guidelines

The southern edge of Block 11 adjacent to the Community Youth Park should be designed in conjunction with the City-owned adjacent parcels.

The southern edges of Blocks 9 and 10 are inaccessible. For safety the landscape design of these edges should discourage their use as pedestrian routes. The south-west side of Block 4 should be designed to provide visual surveillance and possible future connection to the landscaped area which currently straddles the Hunters View/Jackie Robinson property line. The southern edge of Block 9, however, is highly visible from the Jackie Robinson site below. Consideration should be given to screening any parking along this frontage and to using massing and building articulation so that new buildings present an attractive appearance from the adjacent property.

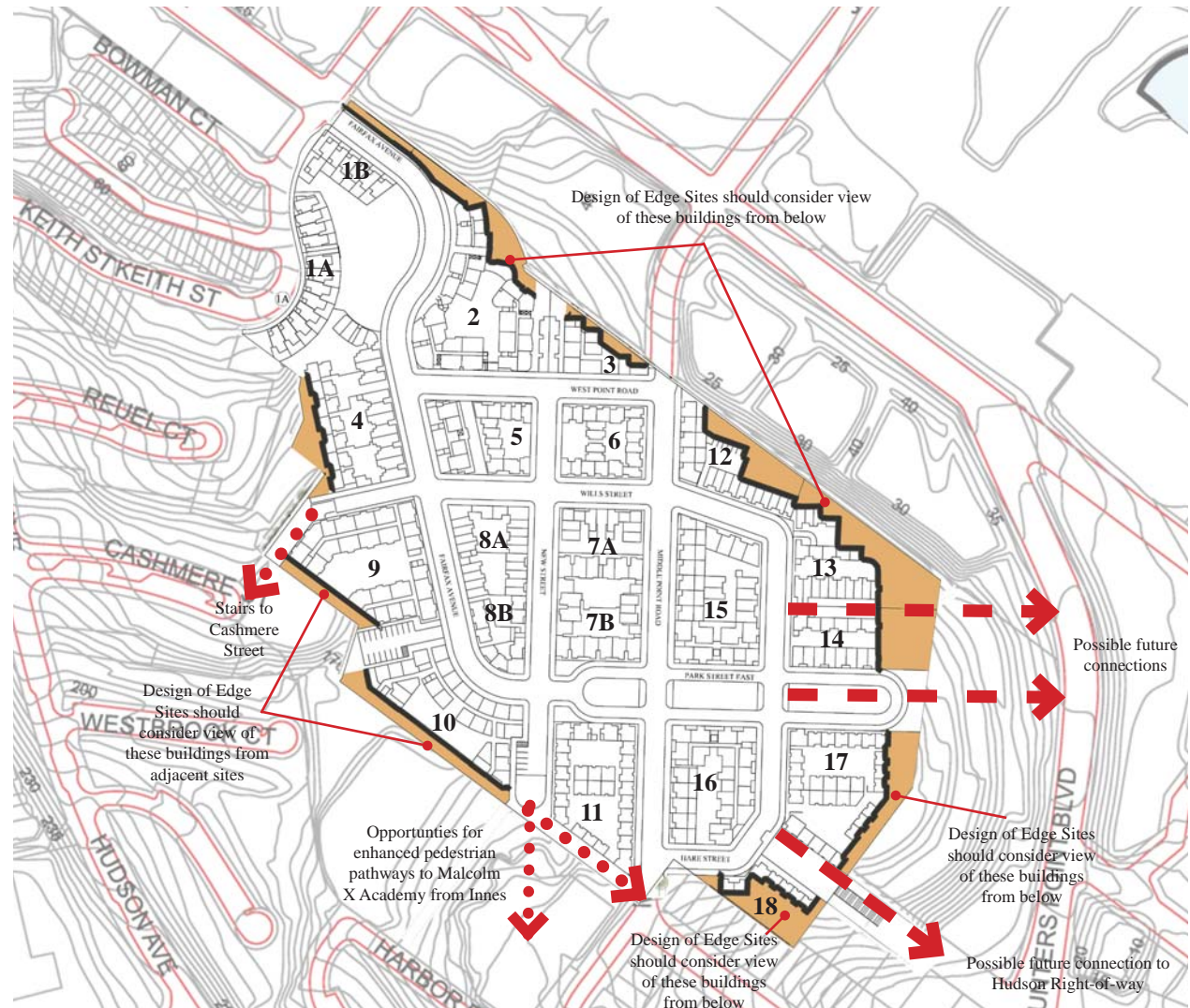



CHAPTER 5

APPENDIX

RECOMMENDED SPECIES FOR SERPENTINE GRASSLAND

Common Name	Scientific Name
Bitter Root	<i>Lewisia rediviva</i>
Blue-eyed Mary/Collinsia, Few-flowered	<i>Collinsia sparsiflora</i> var. <i>sparsiflora</i>
Brodiaea, Early Harvest ssp. coronaria	<i>Brodiaea coronaria</i> ssp. <i>coronaria</i>
Buckwheat, Naked-stemmed	<i>Eriogonum nudum</i> var. <i>auriculatum</i>
Buckwheat, Wicker/Golden	<i>Eriogonum luteolum</i> var. <i>luteolum</i>
Checkerbloom, Fringed	<i>Sidalcea diploscypha</i>
Clarkia, Ruby Chalice	<i>Clarkia rubicunda</i>
Clover, Variegated/White-tipped	<i>Trifolium variegatum</i>
Coyote-mint, ssp. villosa	<i>Monardella villosa</i> ssp. <i>villosa</i>
Cryptantha, Beaked/Flaccid	<i>Cryptantha flaccida</i>
Evax, Erect/Few-flowered	<i>Hesperavax sparsiflora</i> var. <i>sparsiflora</i>
Flax, Marin Dwarf	<i>Hesperolinon congestum</i>
Fringepod, Common/Hairy	<i>Thysanocarpus curvipes</i>
Fritillary, Fragrant	<i>Fritillaria liliacea</i>
Goldfields, California/Common	<i>Lasthenia californica</i>
Grass, Big Squirreltail	<i>Elymus multisetus</i>
Lessingia, Woolly-headed	<i>Lessingia hololeuca</i>
Linanthus, Serpentine	<i>Linanthus ambiguus</i>
Lomatium, California	<i>Lomatium californicum</i>
Lomatium, Caraway-leaved	<i>Lomatium caruifolium</i> var. <i>caruifolium</i>
Lomatium, Common/Bladder Parsnip	<i>Lomatium utriculatum</i>
Lomatium, Large-fruited	<i>Lomatium macrocarpum</i>
Lomatium, Woolly-fruited	<i>Lomatium dasycarpum</i> ssp. <i>dasycarpum</i>
Montia, Common	<i>Claytonia exigua</i> ssp. <i>exigua</i>
Morning-glory, Hill	<i>Calystegia subacaulis</i> ssp. <i>subacaulis</i>
Mouse-ears, Purple	<i>Mimulus douglasii</i>
Mustard, California	<i>Guillenia lasiophylla</i>
Onion, Scytheleaf/Sickleleaf	<i>Allium falcifolium</i>
Pentachaeta, White-rayed	<i>Pentachaeta bellidiflora</i>
Peppergrass, Shining var. nitidum	<i>Lepidium nitidum</i> var. <i>nitidum</i>
Phacelia, Divaricate	<i>Phacelia divaricata</i>
Popcornflower	<i>Plagiobothrys nothofulvus</i>
Pygmy-weed	<i>Crassula connata</i>
Sandwort, Douglas'	<i>Minuartia douglasii</i>
Sanicle, Poison	<i>Sanicula bipinnata</i>
Sun Cup, Hill	<i>Camissonia graciliflora</i>
Tarweed, Hayfield ssp. luzulifolia	<i>Hemizonia congesta</i> ssp. <i>luzulifolia</i>
Thormint, San Mateo	<i>Acanthomintha duttonii</i>
Tidy-tips	<i>Layia platyglossa</i>
Turkey Pea	<i>Sanicula tuberosa</i>
Woolly-heads/Marbles, Dwarf/Short	<i>Psilocarphus brevissimus</i> var. <i>brevissimus</i>

RECOMMENDED SPECIES FOR SERPENTINE CHAPARRAL

Most Common Name

Allseed, Four-leaved
Coyote-mint, ssp. villosa
Flax, Common/Small-flowered Dwarf
Mallow, Chaparral
Morning-glory, Western/Chaparral
Oak, Leather
Onion, Pitted
Paintbrush, Woolly Indian
Pectocarya, Little
Trisetum/Oatgrass, Nodding/Tall
Venus' Looking Glass

Scientific Name

Polycarpon tetraphyllum
Monardella villosa ssp. *villosa*
Hesperolinon micranthum
Malacothamnus fasciculatus
Calystegia purpurata ssp. *purpurata*
Quercus durata var. *durata*
Allium lacunosum var. *lacunosum*
Castilleja foliolosa
Pectocarya pusilla
Trisetum canescens
Triodanis biflora