

ValueJet 2638

Regular maintenance using Mutoh UMS or Eco-Ultra ink

Dear customer,

Each ink has its own specific drying speed and drying characteristics, which has an influence on its periodical maintenance cycle.

To maximise the life-time of all parts which are exposed to ink, it is crucial to carry out some easy but important maintenance.

The most important maintenance actions are:

- Wash away ink remainders from parts which are not (easily) accessible, avoiding that the ink dries out, possibly causing blockage.
- Regularly remove ink remainders from accessible parts.

Hereafter, tailored to each ink type, you will find simple guidelines explaining how you can maintain excellent print quality and avoid that parts wear untimely.

Overview

When using the VJ-2638 it is important to perform periodic maintenance. This will help you maintaining excellent output quality and avoid parts to wear untimely. Depending on your current ink setup, follow the required periodical maintenance scheme.

1) When using Eco ink

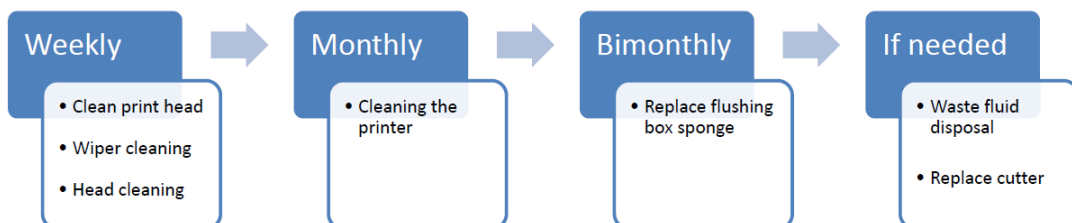

2) When using UMS ink

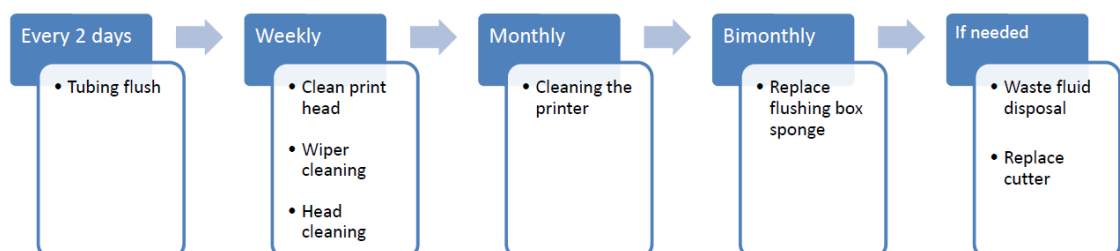

Important

- Please be aware that next to this periodical maintenance, a certified Mutoh Technician needs to perform yearly maintenance as well. Please contact your Authorised Mutoh Reseller for more information.

Important

- Please keep in mind to use the correct cleaning fluid
 - Eco Ultra cleaning
 - Used to start up new printers.
 - Used to perform periodical maintenance when printer is loaded with Eco ink
 - UMS cleaning
 - Used to perform periodical maintenance when printer is loaded with UMS ink

Items needed

Part number	Description	Quantity
PJ-GLOV	Glove	100
PP-10001	Cleaning stick	50
PP-10030	Kit Pipette 10 ml	6
VJ16STG-FB-SO3	Flushing absorbent (Eco Ultra ink)	3
VJ16STG-FB-W3	Flushing absorbent (UMS ink)	3
VJ-CB	Cutter	1
KY-14044	Polyknit wiper	30
CL-90250	Eco Ultra cleaning liquid	250 ml
RJ80UMS-100-CLN	UMS cleaning liquid	1 litre

1 Performing a tubing flush

Important

- Only needed when working with UMS ink!

(1) Cleaning frequency

Once every two days

(2) Cleaning procedures

- Use UMS cleaning liquid to perform a tubing flush when working with UMS ink.
- Step 1:** If the printer is powered ON, make sure that printing or other operations are not in progress.
- Step 2:** Display the CR Maintenance menu on the operation panel.
- Press the [Menu] key on the operation panel.
 - “Menu1: Setup>” is displayed.
 - The operation panel shifts to the Setup menu display.
 - Press [>].
 - “Set1: User Type” is displayed.
 - Press [+] or [-] to select “Set20: CR Maintenance”.
 - Press [Enter]
 - “CR Mainte.: Start” is displayed.
 - The display enters the CR Maintenance menu.
- Step 3:** Press the [Enter] key on the operation panel.
- Maintenance starts.
 - The print head moves to the left.
 - “CR Maintenance: End” is displayed on the operation panel.
- Step 4:** Press the [▼] key on the operation panel.
- The pumps start pumping
- Step 5:** Open the maintenance cover at the right side of the printer.

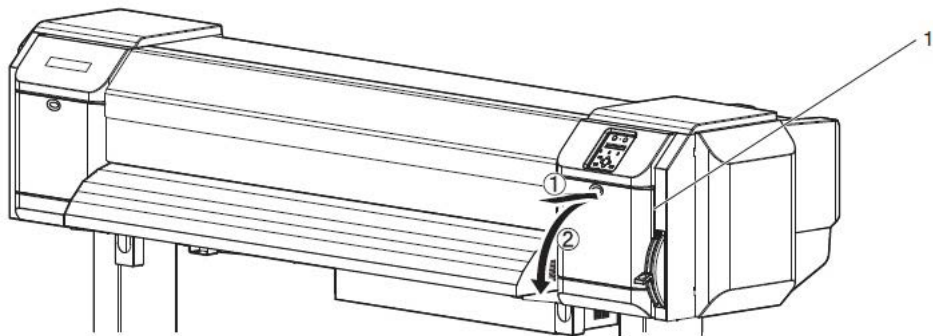

No.	Name
1	Maintenance cover

Step 6: Using a pipette filled with UMS cleaning liquid, drip about 5 ml of cleaning liquid onto each head cap unit as shown in the illustration. The cleaning liquid will be sucked into the capping unit and the connected tubing. It will remove ink remainders and prevent blocking of the tubing. Also drip some cleaning liquid onto the flushing-box sponge.

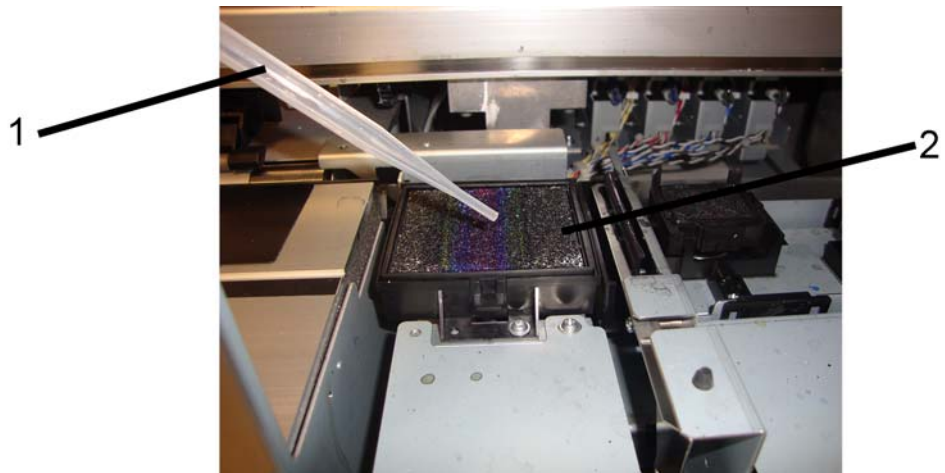

No.	Name
1	Pipette
2	Flushing-box sponge

- Also drip some cleaning liquid onto the 2 head cap units.

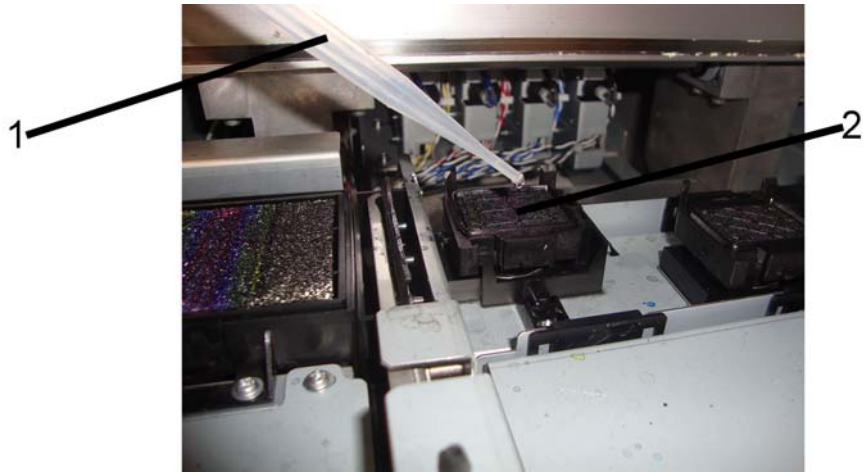

No.	Name
1	Pipette
2	Head cap unit



No.	Name
1	Pipette
2	Head cap unit

- Step 7:** Press the [▼] key once again to stop the pumps.
If you do not press [▼], pumping stops automatically after 60 seconds.
- Step 8:** Press the [ENTER] key.
- The print head returns to the capping position.
 - “CR Mainte.: Start” is displayed.
- Step 9:** Press the [Menu] key.
- The tube flush procedure is completed.

2 Cleaning around the print head

(1) Cleaning frequency

On a weekly basis, check if foreign substances (dust or ink clots that can cause missing dots or ink leakage) are attached around the print head. If it is the case, remove them as described.

(2) Cleaning procedures

Note

- Before cleaning around the print head, read this procedure thoroughly to fully understand it, and clean promptly and correctly.
- While cleaning around the print head, the print head cap is removed, therefore cleaning must be done before the print head dries. Leaving the print head at the replacement position for a long time, may result in clogging of the print head. Please limit to 15 minutes
Use the cleaning stick to clean around the print head.

Step 1: If the printer is powered ON, make sure that printing or other operations are not in progress.

Step 2: Display the CR Maintenance menu on the operation panel.

- Press the [Menu] key on the operation panel.
 - “Menu1: Setup>” is displayed.
 - The operation panel shifts to the Setup menu display.
- Press [>].
 - “Set1: UserType” is displayed on the operation panel.
- Press [+] or [-] to select “Set20: CR Maintenance”.
- Press [Enter].
 - “CR Mainte.: Start” is displayed.
 - The display enters the CR Maintenance menu.

Step 3: Press the [Enter] key on the operation panel.

- Maintenance starts.
- The print head moves to the left.
- “CR Maintenance: End” is displayed on the operation panel.

Step 4: Open the left maintenance cover.

Step 5: Move the print head manually so that you have a clear view on the print head.

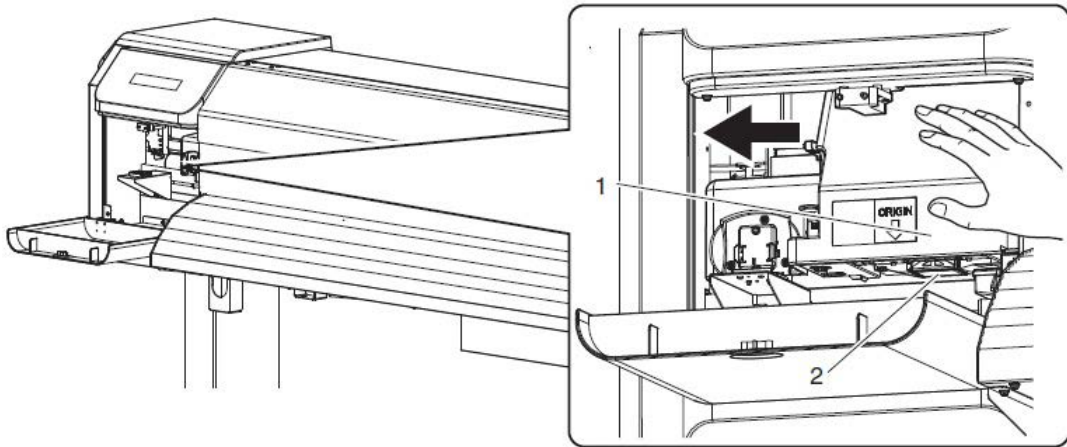

No.	Name
1	Print head section
2	Circumference of the print head

Step 6: Use a penlight, etc. to check if any foreign substances, such as dust or ink are attached to the following places.

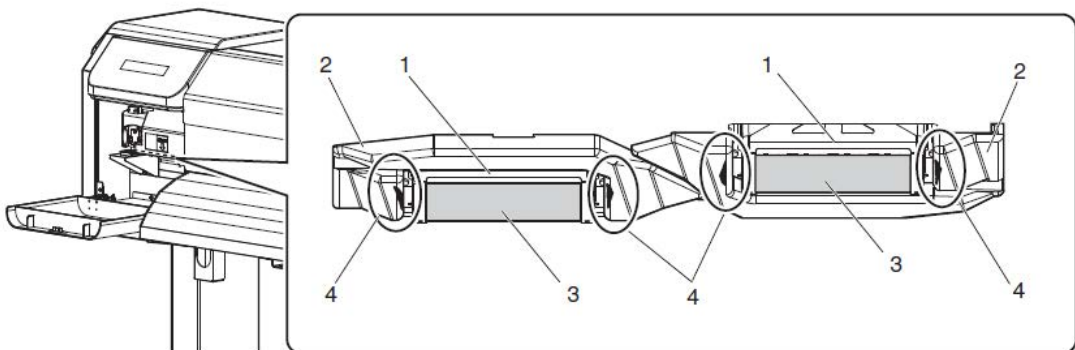

No.	Name
1	Around the print head
2	Head guide
3	Nozzles
4	Dust, ink clots, etc.

Caution

- **When cleaning around the print head,**
 - ◆ Do not touch the nozzle plate. Doing so may damage the print head.
 - ◆ Do not touch the tip of the cleaning stick. The print head may be damaged because of skin oil.
 - ◆ Never put water, etc. on the tip of the cleaning stick. Doing so may damage the print head.
 - ◆ Do not reuse the cleaning stick. The attached dust, etc may damage the print head.

Step 7: When some foreign substance such as dust or ink clot is attached, use the cleaning stick to remove it. To facilitate this action you can moisten the cleaning stick with suitable cleaning liquid.

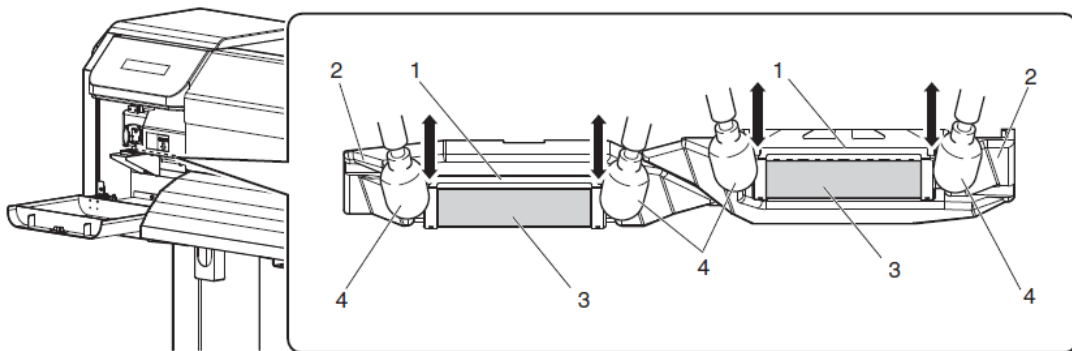

No.	Name
1	Around the print head
2	Head guide
3	Nozzle plate
4	Cleaning stick

Step 8: Close the left maintenance cover firmly to make sure it is locked.

Step 9: Press the [Enter] key on the operation panel.

- The print head returns to its original position.
- “CR Mainte.: Start” is displayed.

Step 10: Press the [Cancel] key on the operation panel.

- Cleaning around the print head is complete.

3 Cleaning the cleaning wiper

(1) Cleaning frequency

Once a week, or when blurs or lacking parts appear on printed media after head cleaning.

Important

- Please make sure the wiper is in optimal condition. If you do not clean the wiper regularly, ink residue will stick to the wiper (as shown below), which will lead to bad printing quality.

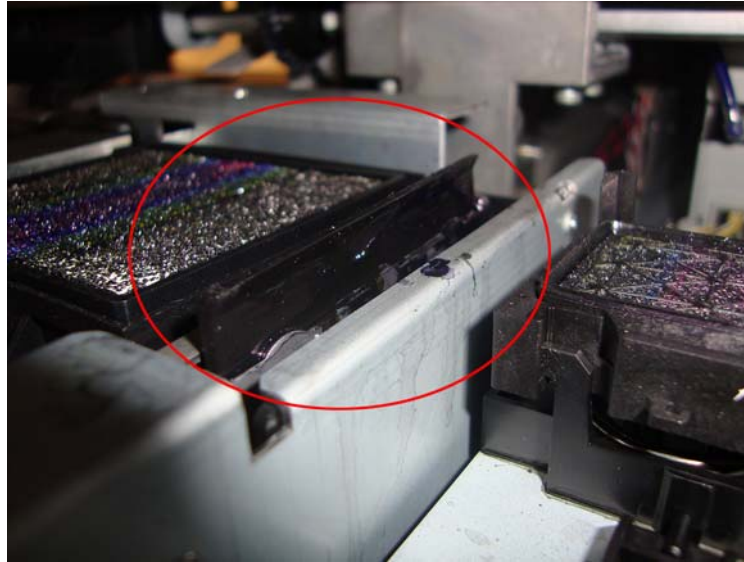

(2) Cleaning procedures

- Use the cleaning stick moistened with a suitable cleaning fluid to clean the cleaning wiper.

Step 1: If the printer is powered ON, make sure that printing or other operations are not in progress.

Step 2: Display the CR Maintenance menu on the operation panel.

- Press the [Menu] key on the operation panel.
 - “Menu1: Setup>” is displayed.
 - The operation panel shifts to the Setup menu display.
- Press [>].
 - “Set1: User Type” is displayed.
- Press [+] or [-] to select “Set20: CR Maintenance”.
- Press [Enter].
 - “CR Mainte.: Start” is displayed.
 - The display enters the CR Maintenance menu.

Step 3: Press the [Enter] key on the operation panel.

- Maintenance starts.
- The print head moves to the left.
- The cleaning wiper shifts towards the front.
- “CR Maintenance: End” is displayed on the operation panel.

Step 4: Open the maintenance cover at the right side of the printer.

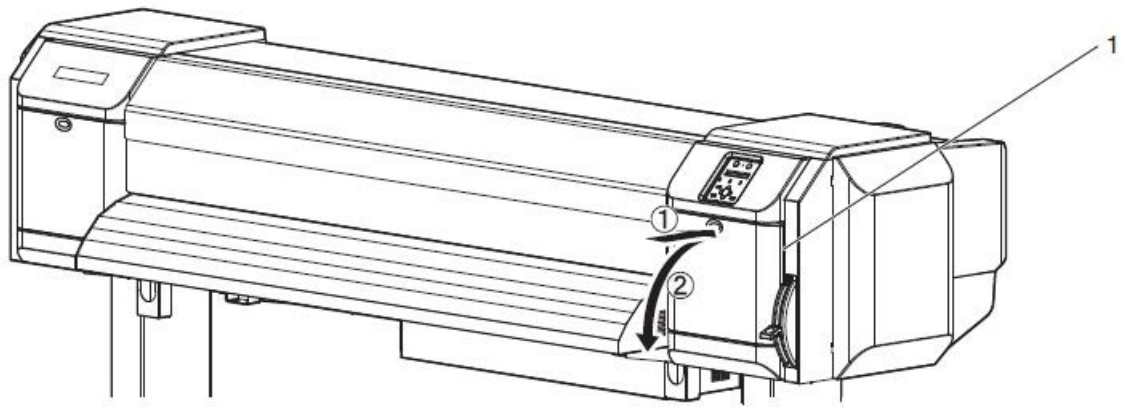

No.	Name
1	Maintenance cover

Caution

- **When cleaning the cleaning wiper**
 - ◆ Do not touch the cleaning wiper and head cap unit with your hands. Head cleaning may not be performed correctly because of skin oil.
 - ◆ Make sure to wipe the print head using the cleaning stick. A cleaning stick moistened with water may cause the print head to clog. When moistening, always use the cleaning liquid matching your ink type.
 - ◆ Do not reuse the cleaning stick. The attached dust, etc may damage the print head.

Step 5: Use a cleaning stick moistened with a suitable cleaning liquid to remove the ink and dust on the cleaning wiper.

- Front side of the cleaning wiper:
Remove the ink and dust in the horizontal direction.

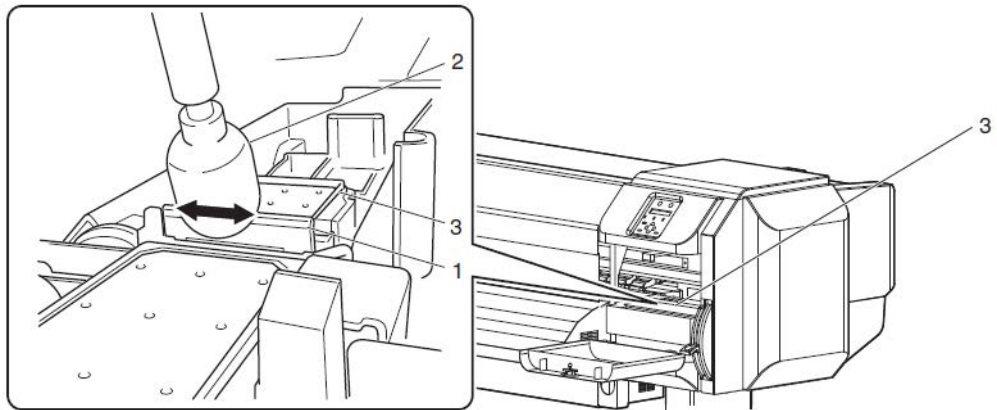

No.	Name
1	Cleaning wiper
2	Cleaning stick
3	Head cap unit

- Cleaning wiper back side:
Remove the ink and dust in the upper direction.

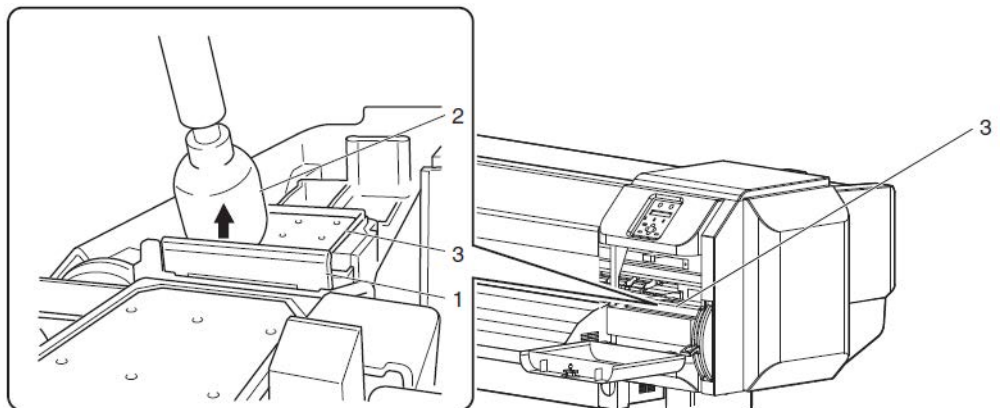

No.	Name
1	Cleaning wiper
2	Cleaning stick
3	Head cap unit

Step 6: Close the right maintenance cover.

- Close the cover firmly until it is locked.

Step 7: Press the [Enter] key on the operation panel.

- The print head returns to its original position.
- The cleaning wiper returns to the original position.
- "CR Mainte.: Start" is displayed.

Step 8: Press the [Menu] key on the operation panel.

- Cleaning the cleaning wiper is complete.

4 Head cleaning

If printed data is blurred or lacks part of it, perform a cleaning sequence as described below.

- When not using the printer for a long period (one week or more), perform head cleaning once a week.
If not performing head cleaning, the print head is clogged. Doing a head cleaning will preserve print quality.

- Remove media when cleaning.
Cleaning with media loaded may lead to contact between the print head and media.

Step 1: Check that the media loading lever is lowered.

Step 2: Press the [>] key on the operation panel to select the cleaning mode.

Step 3: Press the [Cleaning] key on the operation panel for at least two seconds.

- Start Head cleaning.
- “Cleaning **%” is displayed on the operation panel.
- If blurs or lacking parts on printed media do not disappear with one time of head cleaning, perform strong cleaning.
- If blurs or lacking parts in printed media do not disappear with several times of head cleaning, refer to the chapter “Troubleshooting” in the User’s Guide and take appropriate measures.

Important

- **Please be aware that in case your printer is loaded with UMS ink, it is necessary to perform a tubing flush after a head cleaning.**

5 Cleaning the printer

Periodic (every month) cleaning is necessary to keep the printer in good condition.

Important

- Do not insert or drop metal or flammable objects into the printer through openings such as a vent.
It could lead to an electric shock or fire.
- If foreign substances or liquids such as water entered the printer, do not use the printer as it is.
It could lead to an electric shock or fire.
Immediately turn OFF the power switch, disconnect the power plug from the electric socket, and contact your local MUTOH dealer.
- When cleaning the printer, be sure to turn OFF the power and disconnect the power plug.
- Do not use volatile solvents such as thinner, benzene, or alcohol.
These solvents could damage the paint.
- Be careful that no moisture enters the printer.
There is a possibility that the electric circuit inside the printer is short circuited.
- Do not open covers attached using screws under any circumstances.
This may cause an electric shock or a malfunction.

Cleaning the outer case

Wipe out dust and dirt attached to the outer case by using a soft cloth.

Cleaning the inside of the printer

Step 1: Open the front cover.

Step 2: Remove paper powder and dust attached to the pressure rollers using a soft brush.

- Do not blow paper powder inside the printer using tools such as an air duster.
It may cause an abnormal noise from the inside of the printer.

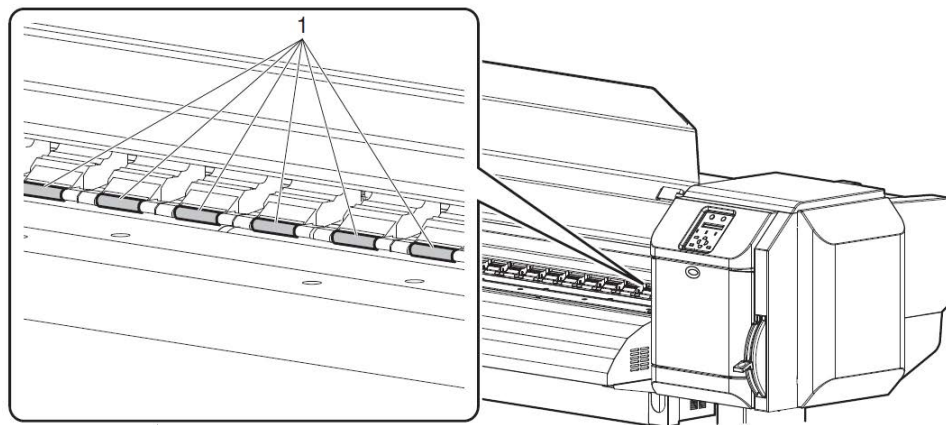

No.	Name
1	Pressure rollers

Step 3: Apply a damp and tightly squeezed soft cloth to wipe out paper powder and ink attached to the platen and media guide.

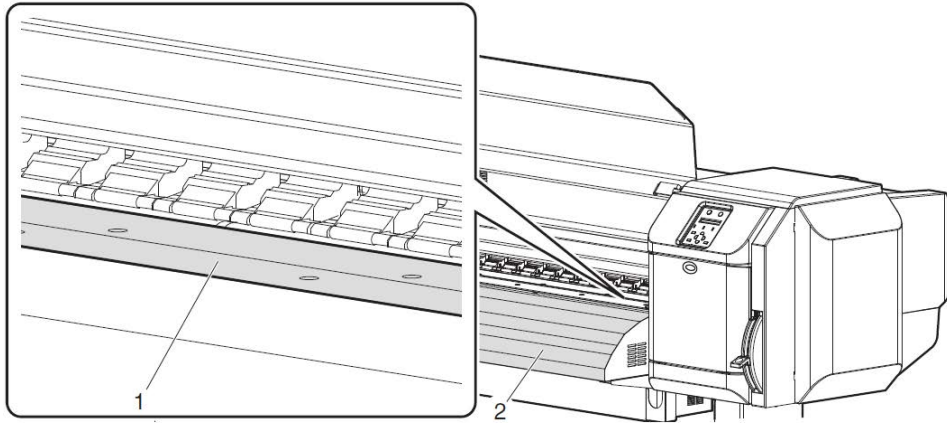

No.	Name
1	Platen
2	Media guide

Step 4: Apply a damp and tightly squeezed soft cloth to wipe off the dirt of the unpainted (silver colour) area in the centre of the grid roller

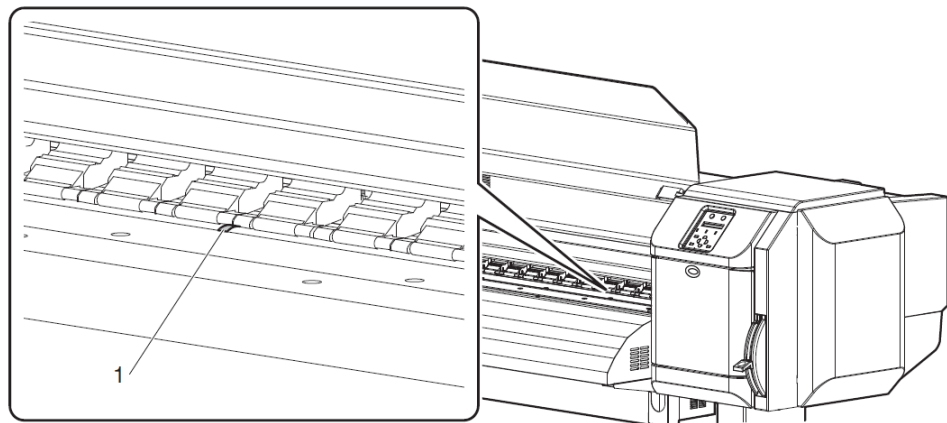

No.	Name
1	Grid roller

6 Replacing the flushing box sponge

(1) Replacement frequency

Replace the flushing-box sponge in the following situations:

- When the flushing-box sponge is deformed or saturated
- When ink is spattered on the media.
- When more than two months have passed since the last replacement.

(2) Replacing steps

Step 1: If the printer is powered ON, make sure that printing or other operations are not in progress.

Step 2: Display the CR Maintenance menu.

- Press the [Menu] key.
 - “Menu1: Setup>” is displayed.
 - The operation panel shifts to the Setup menu display.
- Press the [>] key.
 - “Set1: User Type” is displayed.
- Press the [+] key or [-] key to select “Set 20: CR Maintenance”.
- Press the [Enter] key.
 - “CR Mainte.: Start” is displayed.
 - The display enters the CR Maintenance menu.

Step 3: Press the [Enter] key.

- Maintenance starts.
- Print head moves to the left.
- “CR Mainte.: End” is displayed.

Step 4: Open the front cover.

- Replace the flushing-box sponge in a short time.
Leaving the print head at the replacement position for a long time, may result in clogging of the print head. Please limit to 15 minutes (Refer to topic 2 (2)).

Step 5: Lift the flushing-box sponge tab and unhook. Then, remove the flushing-box sponge.

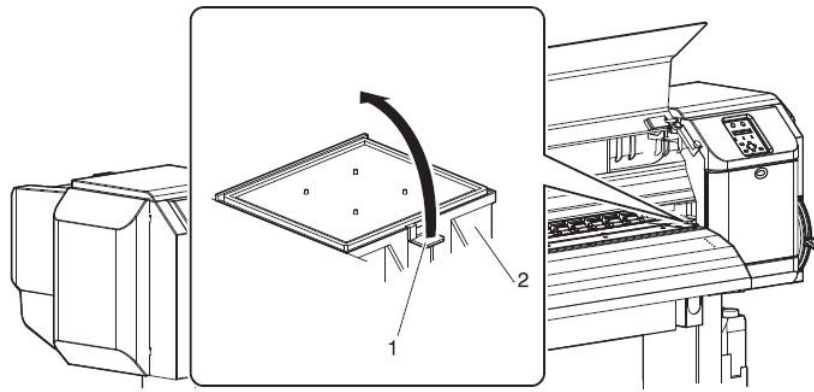

Important

- Do not spill waste fluid when replacing the flushing-box sponge. If waste fluid comes into contact with the grid roller, it may damage its surface and affect media feeding.

No.	Name
1	Flushing-box sponge tab
2	Flushing-box

Step 6: Install the new flushing-box sponge.

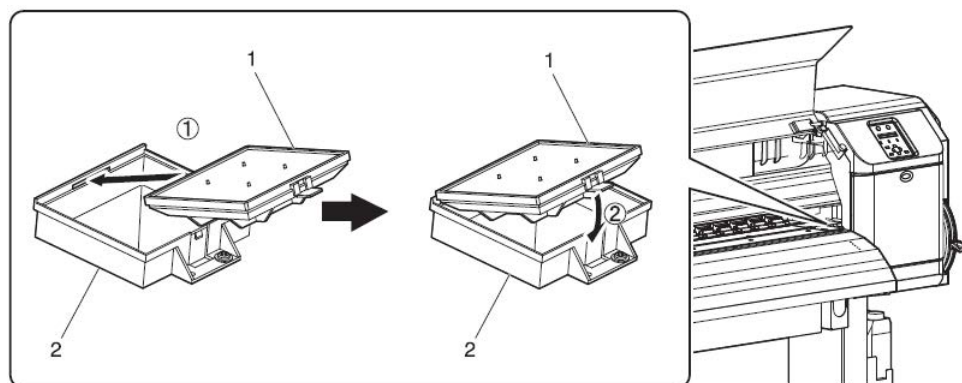

No.	Name
1	Flushing-box sponge tab
2	Flushing-box

Step 7: Close the front cover.

Step 8: 8. Press the [Enter] key.

- Print head returns to its original position.
- “CR Mainte.: Start” is displayed.

Step 9: Press the [Menu] key.

- Flushing-box sponge replacement is complete.

7 Disposal of waste fluids

(1) Disposal timing

Dispose of waste fluids in the following cases:

- When the waste fluid tank is more than half full.
- When “Waste Ink Tank Full” is displayed on the operation panel.

(2) Disposal method

Important

- **Please dispose according to local rules and regulations. For details, please verify the corresponding safety data sheet MSDS on the Mutoh website. Disposal can be found in section 13 of the SDS.**

Step 1: Please have an empty container such as a supply waste fluid bottle, to contain the waste fluid.

Step 2: Put some protective material on the floor under the waste fluid tank.

Step 3: Open the waste fluid tap, and transfer the waste fluid to the container.

- When transferring the waste fluid to the empty container, the waste fluid may spatter.
Make sure to put the container close to the waste fluid tap.

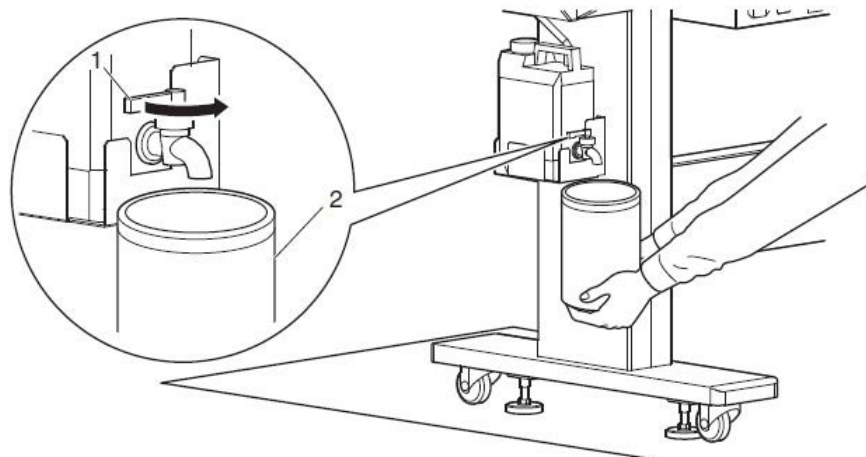

No.	Name
1	Waste fluid tap
2	Empty container

Step 4: After pouring the waste fluid to the empty container, close the waste fluid tap securely.

Step 5: Wipe the opening of the waste fluid tap with a cloth, etc.

Step 6: Dispose of the waste fluid as an industrial waste product.

Disposal of waste fluids is completed.

8 Replacing the cutter

(1) Replacement frequency

Replace the cutter when the following situation occurs:

- When the media is not cut smoothly
- When the cut surface is feathered, etc.

(2) Replacing steps

- Step 1:** If the printer is powered ON, make sure that printing or other operations are not in progress.
- Step 2:** Display the CR Maintenance menu on the operation panel.
- Press the [Menu] key on the operation panel.
 - “Menu1: Setup>” is displayed.
 - The operation panel shifts to the Setup menu display.
 - Press [>].
 - “Set1: User Type” is displayed on the operation panel.
 - Press [+] or [-] to select “Set20: CR Maintenance”.
 - Press [Enter].
 - “CR Mainte.: Start” is displayed on the operation panel.
 - The display enters the CR Maintenance menu.
- Step 3:** Press [Enter].
- Maintenance starts.
 - The print head moves to the left of the printer (cutter replacement position).
 - “CR Maintenance: End” is displayed on the operation panel.
- Step 4:** Open the maintenance cover at the left side of the printer.

Note

- **Replace the cutter in a short time.**
Leaving the print head at the cutter replacement position for a long time may result in clogging of the print head. Please limit to 15 minutes.

Step 5: Press the tab of the cutter gently, turn the cutter holder in the direction as illustrated below.

- Do not press the tab of the cutter strongly or suddenly let it go. There is a spring in the cutter holder and it may pop out.
- Do not push the cutter all the way in. The cutter blade may damage the inside of the printer.

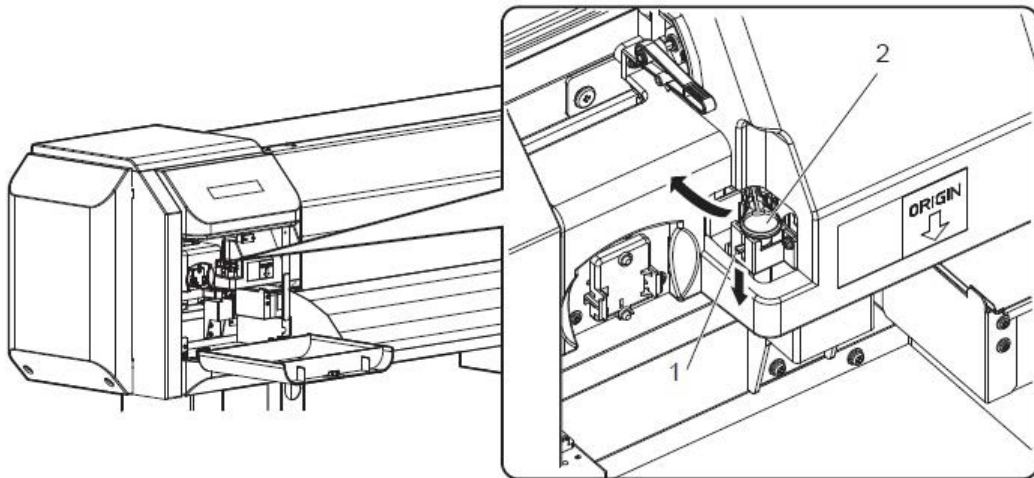

No.	Name
1	Cutter holder
2	Cutter holder lever

Step 6: Remove the cutter.

Caution

- Do not touch the blade edge. It may cause an injury.
- Do not touch the cutter blade edge with a hard substance or drop the cutter. The cutter blade may be damaged or chipped.

- Used cutter should be put in a plastic bag, etc, and disposed of in compliance with local ordinance and instructions of local authorities.

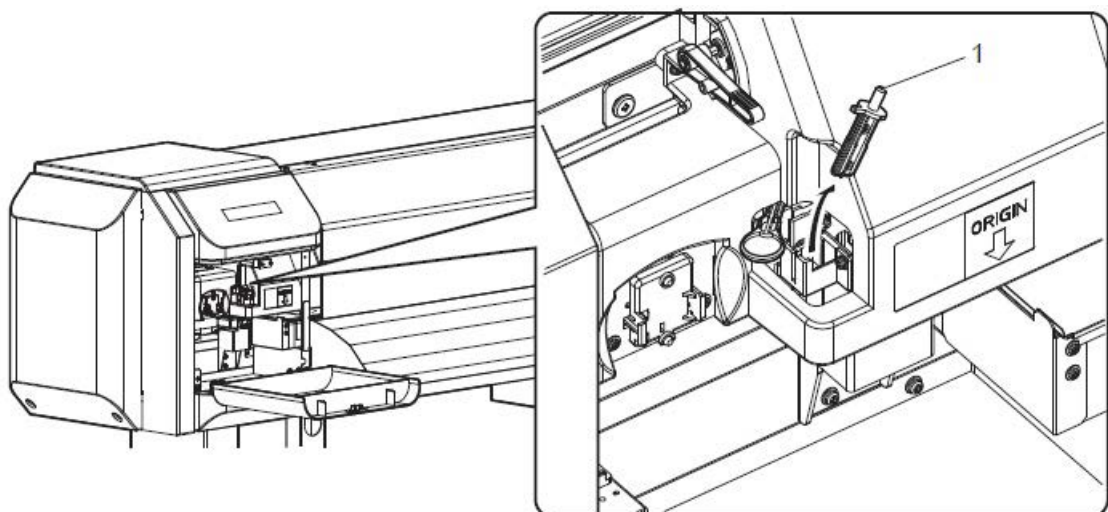

No.	Name
1	Cutting blade

Step 7: Install a new cutter.

- Make sure that the spring in the cutter holder does not fly out while installing.

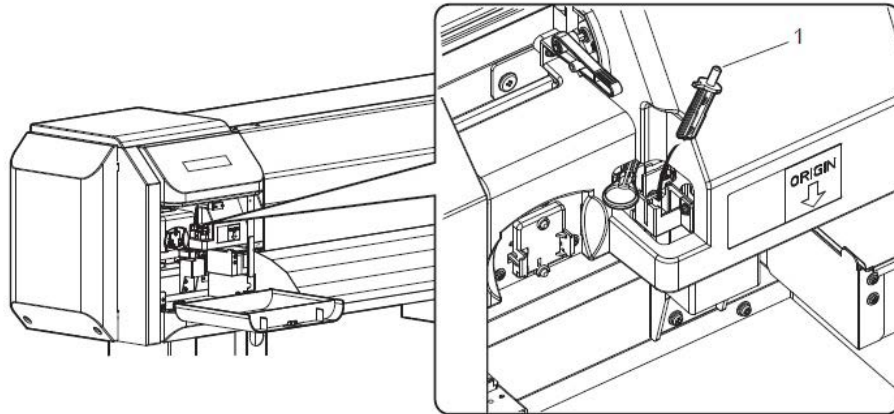

No.	Name
1	Cutting blade

Step 8: Press the tab of the cutter gently, return the cutter holder to its initial position.

- Do not press the tab of the cutter strongly or suddenly let it go. There is a spring in the cutter holder and it may pop out.
- Do not push the cutter all the way in. The cutter blade may damage the inside of the printer.
- Refer to the illustrations below and install the cutter holder correctly. If it is not installed correctly, it may cause an error. If an error occurs, check if the cutter holder is installed correctly.

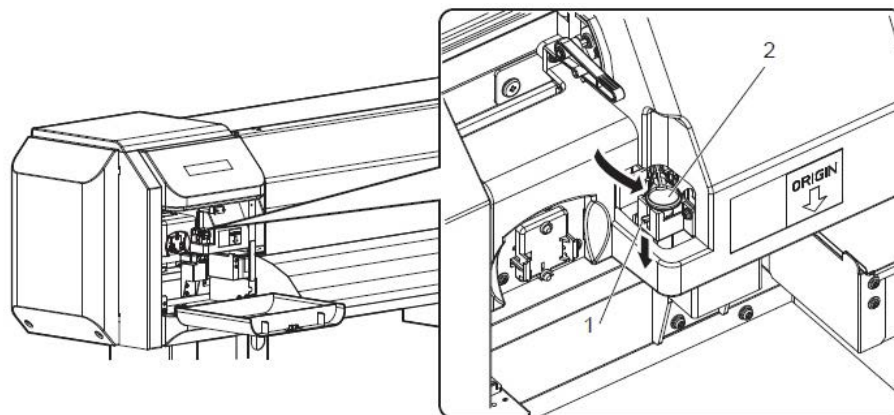

No.	Name
1	Cutter holder
2	Cutter holder lever

Step 9: Close the maintenance cover.

Step 10: Press the [Enter] key on the operation panel.

- The print head returns to its original position.
- “CR Mainte.: Start” is displayed on the operation panel.

Step 11: Press the [Menu] key on the operation panel.

- Cutter replacement is complete.

Copyright Mutoh Belgium. All rights reserved. Unauthorised copying or distribution prohibited.
Written approval required from Mutoh Belgium.