

# Oracle<sup>®</sup> MICROS Workstation 5A Setup Guide



Release 1.0  
F22801-01  
January 2020

The Oracle logo, consisting of a solid red square with the word "ORACLE" in white, uppercase, sans-serif font centered within it.

ORACLE<sup>®</sup>

Oracle MICROS Workstation 5A Setup Guide Release 1.0

F22801-01

Copyright © 2010, 2020, Oracle and/or its affiliates. All rights reserved.

This software and related documentation are provided under a license agreement containing restrictions on use and disclosure and are protected by intellectual property laws. Except as expressly permitted in your license agreement or allowed by law, you may not use, copy, reproduce, translate, broadcast, modify, license, transmit, distribute, exhibit, perform, publish, or display any part, in any form, or by any means. Reverse engineering, disassembly, or decompilation of this software, unless required by law for interoperability, is prohibited.

The information contained herein is subject to change without notice and is not warranted to be error-free. If you find any errors, please report them to us in writing.

If this software or related documentation is delivered to the U.S. Government or anyone licensing it on behalf of the U.S. Government, then the following notice is applicable:

U.S. GOVERNMENT END USERS: Oracle programs, including any operating system, integrated software, any programs installed on the hardware, and/or documentation, delivered to U.S. Government end users are "commercial computer software" pursuant to the applicable Federal Acquisition Regulation and agency-specific supplemental regulations. As such, use, duplication, disclosure, modification, and adaptation of the programs, including any operating system, integrated software, any programs installed on the hardware, and/or documentation, shall be subject to license terms and license restrictions applicable to the programs. No other rights are granted to the U.S. Government.

This software or hardware is developed for general use in a variety of information management applications. It is not developed or intended for use in any inherently dangerous applications, including applications that may create a risk of personal injury. If you use this software or hardware in dangerous applications, then you shall be responsible to take all appropriate fail-safe, backup, redundancy, and other measures to ensure its safe use. Oracle Corporation and its affiliates disclaim any liability for any damages caused by use of this software or hardware in dangerous applications.

Oracle and Java are registered trademarks of Oracle and/or its affiliates. Other names may be trademarks of their respective owners.

Intel and Intel Xeon are trademarks or registered trademarks of Intel Corporation. All SPARC trademarks are used under license and are trademarks or registered trademarks of SPARC International, Inc. AMD, Opteron, the AMD logo, and the AMD Opteron logo are trademarks or registered trademarks of Advanced Micro Devices. UNIX is a registered trademark of The Open Group.

This software or hardware and documentation may provide access to or information about content, products, and services from third parties. Oracle Corporation and its affiliates are not responsible for and expressly disclaim all warranties of any kind with respect to third-party content, products, and services unless otherwise set forth in an applicable agreement between you and Oracle. Oracle Corporation and its affiliates will not be responsible for any loss, costs, or damages incurred due to your access to or use of third-party content, products, or services, except as set forth in an applicable agreement between you and Oracle.

# Declarations

---

## Warranties

Although the best efforts are made to ensure that the information contained in this manual is complete and correct, MICROS Systems, Inc. makes no warranty of any kind with regard to this material, including but not limited to the implied warranties of marketability and fitness for a particular purpose. Information in this manual is subject to change without notice. MICROS Systems, Inc. shall not be liable for errors contained herein or for incidental or consequential damages in connection with the furnishing, performance, or use of this material.

## Trademarks

*MICROS is a registered trademark of MICROS Systems, Inc.*

*Intel, Intel Atom, Intel SpeedStep and the Intel logo are registered trademarks Intel Corporation in the U.S. and other countries.*

*Microsoft, Windows, and POSReady 2009, Embedded CE, are trademarks of Microsoft Corporation in the United States of America and in other countries.*

*Adobe, Photoshop, and FrameMaker are either registered trademarks or trademarks of Adobe Systems, Incorporated in the United States of America and/or other countries.*

*Phoenix, Phoenix Technologies, Phoenix Technologies Logo, PhoenixBIOS, Embedded BIOS, Firmbase, and StrongFrame, are either registered trademarks or trademarks of Phoenix Technologies, Ltd.*

*All other trademarks found herein are the property of their respective owners.*

# Table of Contents

## Preface

Why Read This Manual? .....	vii
Purpose .....	viii
Who Should Use This Manual? .....	viii
Bibliography .....	viii
How This Manual is Organized .....	ix
Notation Conventions .....	x
Symbols .....	x

## Chapter 1 - What Is The Workstation 5A?

The System .....	1-2
Workstation 5A .....	1-2
Casework .....	1-3
Operator LCD Panel and Touchscreen .....	1-3
Magnetic Card Reader .....	1-3
Finger Print Reader .....	1-3
Operator LED .....	1-4
Operator Power Button .....	1-4
Internal Speakers .....	1-4
Compact Flash (CF) Riser Card .....	1-4
DMA (Direct Memory Access) CF Cards .....	1-4
Recovery Button .....	1-4
Workstation 5A Options .....	1-5
Hard Disk .....	1-5
Mini-PCI Options .....	1-6
WiFi .....	1-6
Powered USB .....	1-7
Finger Print Reader .....	1-7
Workstation Mounting Options .....	1-8
The Workstation 5A Adjustable Stand .....	1-8
Power Supply Compartment .....	1-9
LCD Customer Display Options .....	1-10
Integrated LCD Customer Display .....	1-10
LCD Pole Mount Customer Display .....	1-11
Workstation 5A Adjustable Stand Pole Display .....	1-11
Protégé Customer Display System .....	1-12
Software Components .....	1-13
Phoenix Embedded BIOS /w StrongFrame Technology .....	1-13
Firmbase .....	1-13
Operating Systems .....	1-13

## Table of Contents

Workstation 5A .....	1-13
Workstation 5A Platform Software .....	1-14
Utilities .....	1-14
POS Application .....	1-14
Recovery .....	1-15
One Button Recovery .....	1-15
Windows CE .....	1-14
Windows POSReady 2009 .....	1-15
Power Management States .....	1-16
UNPLUGGED .....	1-16
NOPOWER .....	1-16
ON .....	1-16
Last Power State Retention .....	1-16
Workstation 5A Power Management State Table .....	1-17
Specifications .....	1-18
Approvals .....	1-20

## Chapter 2 - Workstation 5A BIOS

The BIOS Configuration Utility .....	2-2
Starting BIOS Configuration .....	2-2
System Summary BIOS Q1000g .....	2-3
System Summary BIOS Q1010m .....	2-4
System Summary BIOS Q2010g .....	2-4
System Summary BIOS Q2011d .....	2-5
BIOS Q2010g features .....	2-5
BIOS Q2011d features .....	2-5
BIOS Versions Q2010g/Q2011d known issues .....	2-5
Tips for Using the System Configuration Utility .....	2-6
Main .....	2-7
Phoenix System BIOS .....	2-7
Processor (CPU) .....	2-7
System Memory (RAM) .....	2-7
Real Time Clock (RTC) .....	2-7
Exit .....	2-8
Save, Restore and Exit Setup .....	2-8
Save Settings and Restart .....	2-8
Exit Setup Without Saving Changes .....	2-8
Reload WINCE Factory CMOS Defaults (Q1000g/Q1010m) .....	2-9
Reload Win32 Factory CMOS Defaults (Q1000g/Q1010m) .....	2-9
Reload WINCE Factory Default Settings (Q2010g/Q2011d) .....	2-9
Reload USB WIN32 Factory Default Settings (Q2010g/Q2011d) ..	2-9
Reload SATA WIN32 Factory Default Settings (Q2010g/Q2011d) ..	2-9

Boot .....	2-10
System Boot Configuration .....	2-10
Boot Device Prioritization - BIOS Boot Specification (BBS) .....	2-10
Windows CE Boot Configuration (All BIOS Versions) .....	2-10
Windows POSReady Boot Configuration (Q1000g and Q1010m) .....	2-11
Reload USB WIN32 Factory Default Settings (Q2010g/Q2011d) .....	2-11
Reload SATA WIN32 Factory Default Settings (Q2010g/2011d) .....	2-11
Configuring the Q1000g BIOS to boot from a SATA Disk Drive .....	2-11
IDE Drive Configuration .....	2-11
Intel ICH 8M ATA Controller Configuration .....	2-11
POST .....	2-12
PnP .....	2-13
SIO .....	2-14
Features .....	2-15
Firmware .....	2-16
Misc .....	2-17
Video .....	2-18
ODM .....	2-19
Special Configuration .....	2-20
Boot Test Image (All BIOS Versions) .....	2-20
Cash Drawer Voltage (All BIOS Versions) .....	2-20
Personality Module (All BIOS Versions) .....	2-20
WINCE Image Update (All BIOS Versions) .....	2-21
USB Port1 - USB Port4 and USB Port6 (All BIOS Versions) .....	2-21
WINCE Factory Restore (All BIOS Versions) .....	2-21
USB WIN32 Factory Restore (Q2010g and Q2011d) .....	2-21
SATA WIN32 Factory Restore (Q2010g and Q2011d) .....	2-21
Enable Password for Restore (Q2010g and Q2011d) .....	2-22
Compact Flash (Q2011d) .....	2-22
Chipset .....	2-23
AdvancedCPU .....	2-24
Upgrading the WS5A BIOS .....	2-25
Windows Embedded CE 6.0 .....	2-25
POSReady 2009 .....	2-26
Windows CE Factory Restore .....	2-27

### **Chapter 3 - What's Inside?**

Disassembling the Workstation 5A .....	3-2
System Board Components .....	3-7
WS5A System Board - Primary Components (Revisions C, D, and F) .....	3-7
WS5A System Board - Connectors (Revisions C and D) .....	3-8
WS5A System Board - Jumpers and Switches (Revisions C, D, or F) .....	3-9
WS5A System Board - Connectors (Revision F) .....	3-10
System Board - Jumper Configuration .....	3-11
J12 - Touch Screen Select .....	3-11

## Table of Contents

J20 - CMOS Reset .....	3-11
J5 - TFT Panel Mode .....	3-11
System Board Block Diagrams .....	3-12
Workstation 5A Block Diagram (CCFL Backlights/Resistive Touch ..	3-12
Workstation 5A Block Diagram (LED Backlights/Resistive Touch ..	3-13
System Board Description .....	3-14
Intel Atom N450 General Features .....	3-14
Integrated Memory Controller (ICM).....	3-14
Graphics Processing Unit (GPU) .....	3-15
Direct Media Interface .....	3-15
ICH8M General Features .....	3-16
USB 2.0 Ports .....	3-17
IDE .....	3-17
PCI Express .....	3-18
SPI (Serial Peripheral Interface) .....	3-18
PCI Bus .....	3-18
Ethernet .....	3-18
HD Audio .....	3-19
GPIO .....	3-19
LPC.....	3-19
SMBus .....	3-19
LCD/Touchscreen Assembly - Resistive Touchscreen .....	3-21
CCFL Backlight Inverter Board .....	3-22
LCD/Touchscreen Assembly - Optional Capacitive Touchscreen.....	3-23
Installing Updates and Options .....	3-24
Magnetic Stripe Reader .....	3-24
USB Hard Drive .....	3-25
DDR2 SO-DIMM .....	3-26
Installation and Removal .....	3-27
DMA Enabled CF Riser Card .....	3-28
Approved CF Enabled CF Cards .....	3-28
USB Wireless Module .....	3-29
Mini-PCI Options .....	3-29
Workstation 5A Hard Disk Kit .....	3-30
LCD Customer Display - Integrated.....	3-31
Pole LCD Customer Display .....	3-33
Protégé Customer Display System - Integrated .....	3-34
Protégé Customer Display System - Pole Mount .....	3-35
Workstation 5 Stand Pole Display .....	3-36
Reassembling the Workstation 5A .....	3-37

**Chapter 4 - Installing and Operating the Workstation 5A**

Care and Handling .....	4-2
Equipment Placement .....	4-2
Location .....	4-2
Proximity to Foreign Materials .....	4-2
Noise Induction .....	4-3
Electrostatic Discharge .....	4-3
Temperature and Humidity .....	4-3
AC Power and Data Cabling Requirements .....	4-3
Cleaning the Workstation 5ATouchscreen and Cabinet .....	4-3
LCD/Touchscreen .....	4-3
Cabinet .....	4-3
Magnetic Card Reader .....	4-3
The I/O Panel .....	4-4
Line In - Mic Out .....	4-5
IDN .....	4-5
COM5 .....	4-5
Rear Display .....	4-5
VGA .....	4-5
ANT .....	4-5
+5V/+12V/+24V Select - USB6 .....	4-6
VGA .....	4-6
OPT .....	4-6
COM1 .....	4-6
COM2 .....	4-6
USB1 - USB4 .....	4-6
10/100/1000 Ethernet .....	4-6
CF/Express Card .....	4-7
DMA Enabled CF Card .....	4-7
CF Card Cover Slot .....	4-7
How to Use the Compact Flash (CF) Card .....	4-8
Removing a CF Card .....	4-8
Disabling the CF Card .....	4-8
Installing the CF Card .....	4-9
Customer Display .....	4-9
Cash Drawer #1 - Cash Drawer #2 .....	4-9
+12V Out .....	4-9
Installation .....	4-10
Cabling for the Adjustable Stand .....	4-10
Operation .....	4-13
Operator Features .....	4-13
Turning the Workstation from NOPOWER to ON .....	4-14
Booting to Windows Embedded CE 6.0 R3 .....	4-15
Booting to POSReady 2009 .....	4-16
Turning the Workstation from ON to NOPOWER .....	4-16



## Table of Contents

Starting the Workstation for the First Time . . . . .	4-16
Using the Client Application Loader (CAL) on WINCE . . . . .	4-17
Using the Search Feature . . . . .	4-17
Configuring a Static IP Address . . . . .	4-18
CAL Keyboard Hot Keys . . . . .	4-18
Using the Windows CE Screen Saver and Backlight Utility . . . . .	4-19
Main Screen Saver . . . . .	4-19
Backlight Control . . . . .	4-20
Controlling the IO Panel USB Ports (Windows CE or POSReady) . . . . .	4-21
Using the Windows CE Input Panel . . . . .	4-21
Using the POSReady 2009 On-Screen Keyboards . . . . .	4-21
Using the Magnetic Strip Card . . . . .	4-23
Tips for using Magnetic Cards . . . . .	4-23
Calibrating the Touchscreen . . . . .	4-24
When to Calibrate the Touchscreen . . . . .	4-24
Windows Embedded CE 6.0 R3 . . . . .	4-24
Workstation 5A Recovery . . . . .	4-25
Recovery Button . . . . .	4-25
ODM Tab . . . . .	4-25
BIOS - Password and Login Requirements . . . . .	4-25
WINCE Factory Restore - Recovery Button at Splash Screen . . . . .	4-26
BIOS Q1000g (Password not Required) . . . . .	4-26
BIOS Q1010m (Login and Password Required) . . . . .	4-27
BIOS Q2010g and Q2011d (Password Required) . . . . .	4-27
POSReady Recovery CF - Recovery Button at Splash Screen . . . . .	4-28
BIOS Q1000g (Password not Required) . . . . .	4-28
BIOS Q2010g/Q2011d (Password Required) . . . . .	4-29
ODM Menu (BIOS Q1000g) . . . . .	4-30
WINCE Factory Restore . . . . .	4-30
Win32 Factory Restore . . . . .	4-30
Pre-boot Menu (BIOS Q1010m Only) . . . . .	4-31
WINCE Factory Restore . . . . .	4-31
ODM Tab (BIOS Q2010g and Q2011d) . . . . .	4-32
WINCE Factory Restore . . . . .	4-32
USB WIN32 Factory Restore . . . . .	4-32
SATA WIN32 Factory Restore . . . . .	4-33
Revision F System Board - Additional Recovery Options . . . . .	4-34
WINCE Factory Restore from the ON State . . . . .	4-34
WINCE Factory Restore from the Soft-Off (S5) State . . . . .	4-34
Starting the POSReady Recovery CF from the ON State . . . . .	4-35
Starting the POSReady Recovery CF from the Soft-Off State . . . . .	4-35
Disabling the Recovery Password in BIOS Q2010g/Q2011d . . . . .	4-36
Error: 'Image File Not Found' or Using a Custom Recovery Image . . . . .	4-36
Error: 'Recovery Detected 2 USB Hard Drives Installed' . . . . .	4-37

**Chapter 5 - Workstation 5A Diagnostics**

Basic Troubleshooting ..... 5-2  
 Workstation 5A Diagnostics ..... 5-4  
     Running the WS5A Windows CE Diagnostics Utility ..... 5-4  
         System Information Screen ..... 5-4  
         Activity Counters, Dump Sys Info, and Recovery Image Info .... 5-7  
         Testing Cash Drawers ..... 5-9  
         Controlling the IO Panel USB Ports ..... 5-10  
     Running the WS5A Diagnostics Utility (POSReady 2009) ..... 5-12  
 Wipe Compact Flash (WCF) Utility - WINCE Only ..... 5-13

**Appendix A: Equipment Dimensions**

Workstation 5A Low Profile ..... A-2  
 Workstation 5A Low Profile /w Protégé Customer Display ..... A-3  
 Workstation 5A Low Profile with Rear LCD Customer Display ..... A-4  
 Workstation 5A on Adjustable Stand /w 6” LCD Pole Display ..... A-5  
 Workstation 5A on Adjustable Stand /w Protégé Customer Display ..... A-6  
 Workstation 5A on Adjustable Stand and Protégé on 6” Pole ..... A-7  
 LCD Pole Display ..... A-8  
 Protégé Customer Display on 6” Pole ..... A-9  
 Cash Drawers ..... A-10

**Appendix B: Connector and Cable Diagrams**

IO Panel Connectors ..... B-2  
     IDN Port ..... B-2  
         IDN Driving MICROS Printers..... B-2  
         IDN - RS232 Peripheral ..... B-3  
     COM2 and 5 ..... B-3  
     RS232 Connector..... B-4  
     Cash Drawer 1 and 2 Connectors ..... B-4  
     Remote Customer Display Connector..... B-5  
 System Board Connectors ..... B-6  
     Magnetic Stripe Interface ..... B-6  
 Hook-up Cables ..... B-7  
     RS232 from the IDN Port ..... B-7  
     LCD Customer Display Cables ..... B-8  
         System Board Integrated Cable..... B-8  
         LCD Customer Display Assembly Interface Cable..... B-8  
         Remote Pole LCD Customer Display ..... B-9  
     Ethernet ..... B-10  
     Ethernet Cross-over Pinning ..... B-11  
     8-Pin to 6-Pin Hook-up RS422 Cable (300319-001) ..... B-12  
     Cash Drawer Extension Cable..... B-13

**Appendix C: FCC/DOC Statement**

**Appendix D: Oracle Linux for MICROS General Information**

## Table of Contents

# Preface



---

**NOTE**

For information about running Oracle Linux for MICROS on the Workstation 5A, refer to *Appendix D, Oracle Linux for MICROS General Information*.

---

In this preface, you'll find information about this manual. Refer to the preface if you have questions about the organization, conventions, or contents of this manual.

## ***In this section***

---

Why Read This Manual?.....	viii
How This Manual Is Organized .....	ix
Notation Conventions.....	x

---

**Preface**

Why Read This Manual?

---

## *Why Read This Manual?*

---

**Purpose**

This guide is intended for those who will be setting up, installing and operating the MICROS Workstation 5A hardware. It is not specific to a particular software application.

## *How This Manual is Organized*

This manual is divided into five Chapters, briefly discussed below.

Chapter 1 describes the Workstation 5A and each of its hardware and software components. The chapter also provides detailed product specifications.

Chapter 2 describes the current BIOS Setup Configuration Utility screens and fields, and adds new fields when a new BIOS is released. Additional background information is provided on BIOS features such as the Windows CE Platform Update, Windows CE Factory Restore and the POSReady 2009 Recovery CF.

Chapter 3 goes inside the Workstation. Topics include how to open the unit, identify and remove/replace standard and optional components. Differences between Workstation 5 and Workstation 5A are noted where possible.

Chapter 4 presents the operational aspects of the unit. This ranges from a discussion of each IO Panel connector, to using the power button and mag stripe reader, and cabling the optional Adjustable Stand.

A detailed description of each start-up screen and a discussion of how to use the Client Application Loader to connect to the application server and obtain application software. At the end of this chapter, procedures for performing a WINCE Factory Restore or using the POSReady 2009 Recovery CF can be found.

Chapter 5 provides basic troubleshooting data in the form of BIOS error messages and beep codes. An overview of the WSA Diagnostics Utility and Wipe CF Utilities is also included.

A Reference section consisting of Equipment Dimensions, Connector/Cable Diagrams, and FCC Statement can be found at the end of this document.



### **SHOCK HAZARD**

No user serviceable parts inside.  
Refer servicing to qualified personnel.

---

## *Notation Conventions*

---

### **Symbols**



#### **NOTE**

This symbol brings special attention to a related item.

---



#### **WARNING**

This symbol indicates that specific handling instructions or procedures are required to prevent damage to the hardware or loss of data.

---



#### **SHOCK HAZARD**

This symbol calls attention to a potential hazard that requires correct procedures in order to avoid personal injury.

---



#### **STATIC SENSITIVE DEVICES**

This symbol indicates that specific ESD handling procedures are required.

---

## *What is the WS5A?*

This chapter describes the Workstation 5A and optional accessories, then goes on to describe the memory, storage architecture and power management support.

Complete specifications are provided at the end of this chapter.

In addition, the differences and similarities of the Workstation 5 and Workstation 5A features, peripheral support, and connectivity are examined.

### ***In this chapter***

---

The System .....	1-2
Software Components .....	1-13
Power Management States .....	1-16
General Specifications .....	1-18
Approvals .....	1-20

---



## *The System*

The following section describes the hardware and software features of the Workstation 5A.

### **Workstation 5A**

The MICROS Workstation 5A is a diskless Windows Embedded CE 6.0 client, and is also capable of running WIN32 operating systems such as Windows Embedded POS Ready 2009. It uses the same casework, LCD and touchscreen as the original Workstation 5, but the system board, chassis and power supply are new.

The WS5A System Board is based on the Intel Atom N450, a mobile platform that improves both processor and graphics performance, while at the same time maintains the reliability of the original Workstation 5 diskless and fan-less design.

The Workstation 5A is similar in appearance to the Workstation 5 as shown in the illustration below. Figure 1-1 points out the primary external operator features of both workstations.

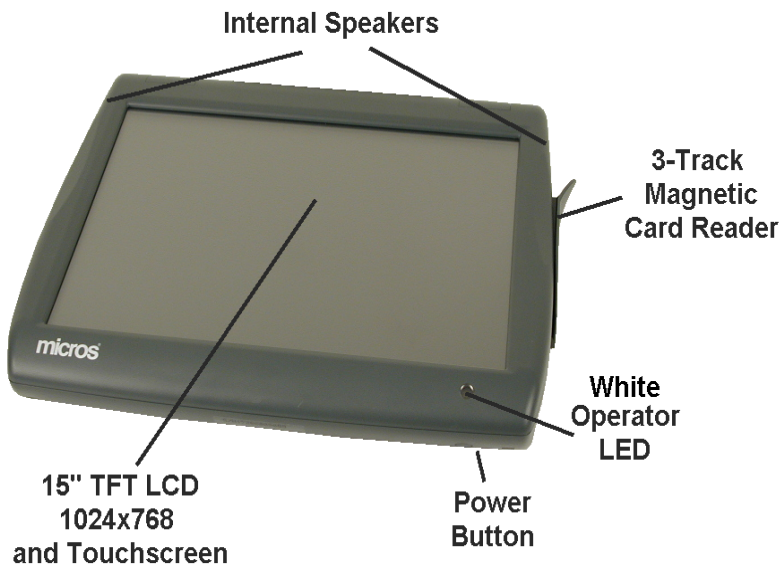

*Figure 1-1: The Workstation 5A - Operating Features*

Standard features include a 15 inch TFT LCD, internal speakers, 5-wire resistive touchscreen, and 3-Track Mag Stripe Reader.

### **Casework**

The Workstation 5A is a low profile design that consists of a base to house the chassis, system board, internal power supply, LCD Touchscreen Assembly and Mag Stripe Reader.

### **Operator LCD and Touchscreen**

The Operator LCD consists of 15" TFT LCD, runs at a fixed resolution of 1024x768 and is capable of supporting up to 262K colors. Placed over the LCD is a 5-wire resistive touchscreen. An optional capacitive touchscreen is planned.

### **Magnetic Card Reader**

The 3-Track Mag Card Reader is slim low profile design.

### **Finger Print Reader**

An optional integrated or remote fingerprint reader is available that can be mounted to the left or right side of the top cover.

### **Operator LED**

The Workstation 5A Operator LED is White to distinguish it from the Blue Operator LED of the Workstation 5. It blinks two times per second as the unit starts-up and performs the Power On Self Test (POST). After the operating system starts and loads the API, the Operator LED turns solid White.

### **Operator Power Button**

The power button is recessed and located at the lower right corner of the unit. It is used to power the workstation on or off.

### **Internal Speakers**

The Workstation 5A features audio support in both the Windows Embedded CE 6.0 and POSReady through built-in speakers. The IO panel includes a 'Line Out' jack for driving external powered speakers.

### **Compact Flash (CF) Riser Card**

Figure 1-2 shows a bottom view of the workstation featuring the I/O connectors, integral VESA 100 compatible hole centers, and CF card access slot. More information about each I/O Panel Connector can be found in Chapter 3.

### **DMA (Direct Memory Access) CF Cards**

The Workstation 5A introduced support for DMA CF cards to improve application performance and speed recovery. DMA is a method of moving large amounts of data from an IDE device such as the CF card to main memory with minimal CPU intervention. A DMA enabled CF Cards requires a DMA enabled CF Riser Card.

In a Workstation 5A with Windows Embedded CE 6.0 R3, DMA is used to move the large bit-maps used by the application from the CF card to display memory. This results in a perceived improvement in the performance of the workstation.

### **DMA Enabled CF Cards - Compatibility Issues**

DMA CF Cards and the DMA enabled CF Riser Cards required to support it may not be compatible with existing MICROS Windows CE based workstations including the WS4, WS4 LX, KWS4, and the original Workstation 5. If a DMA enabled CF card and Riser Card is installed in the these workstations, it may fail POST and not start.

On the other hand, if a CF Card without DMA support is installed in the Workstation 5A, the unit will likely function, but the performance gained from using DMA will not be realized.

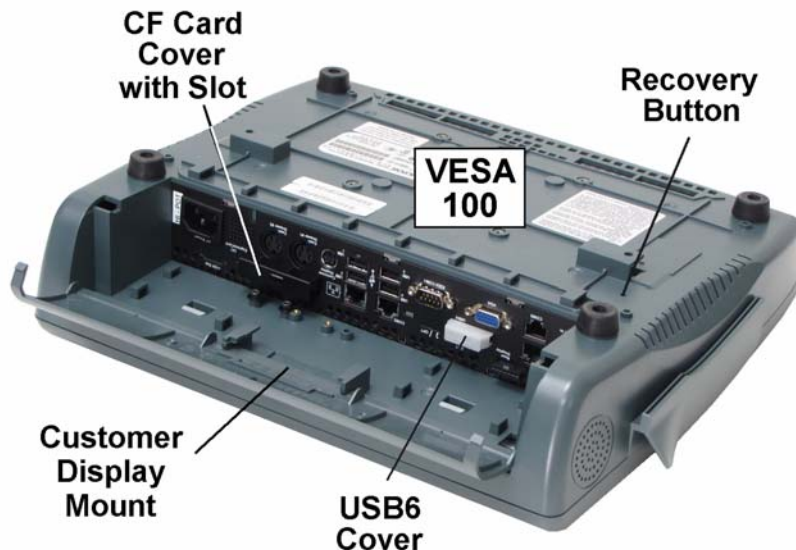

*Figure 1-2: Workstation 5A Bottom View*

The DMA enabled CF Card for Windows Embedded CE 6.0 units are secured behind the CF Card Cover, a removable bracket located on all workstations. The Windows Embedded POSReady 2009 configuration does not ship with a CF card, but the CF Daughter Card is included.

The CF Card Cover includes a slot that allows the size of the card to be determined.

### **Recovery Button**

A recessed button accessible from the bottom of the unit can be used to activate a Windows CE Factory Restore, or the optional POSReady 2009 Recovery CF.

---

## Workstation 5A Options

The following options are available for the Workstation 5A.

### **Hard Disk**

The Workstation 5A can support a single optional SATA 2.5” SSD. The drive mounts to a plate which in attaches to the rear of the LCD plate. A SATA data cable and custom power cable are provided connect the drive to the System board.

### **Mini-PCI Options**

The following options can be installed in the Mini-PCI connector.

#### ***Abocom Mini-PCI Wireless Card***

The Abocom WiFi card used on the original Workstation 5 can also be used the Workstation 5A. The kit has been modified by adding a new adhesive-backed antenna.

#### ***SparkLAN Mini-PCI Wireless Card***

The Workstation 5A will be moving to a new 802.11 a/b/g/n Mini-PCI Wireless Card from SparkLAN. The card features advanced WEP encryption, WPA, WPA2, and 802.1x for security, and drivers are available for all supported operating systems. A pair of dual-band adhesive backed antennas are included.

#### ***Mini-PCI Modem II***

The Mini-PCI Modem can only be used with POSReady 2009. The modem is not compatible with Windows Embedded CE 6.0.

## Powered USB

Powered USB, also known as Retail USB, or USB Plus Power, is an addition to the Universal Serial Bus standard that allows for higher-power devices to obtain power from the workstation instead of an external power supply.

Powered USB is a proprietary variant of USB, developed by IBM, NCR, and FCI/Berg, and not endorsed by the USB Implementers Forum (USB-IF).

The Workstation 5A implements a form of Powered USB in the following manner. See Figure 1-3, below.

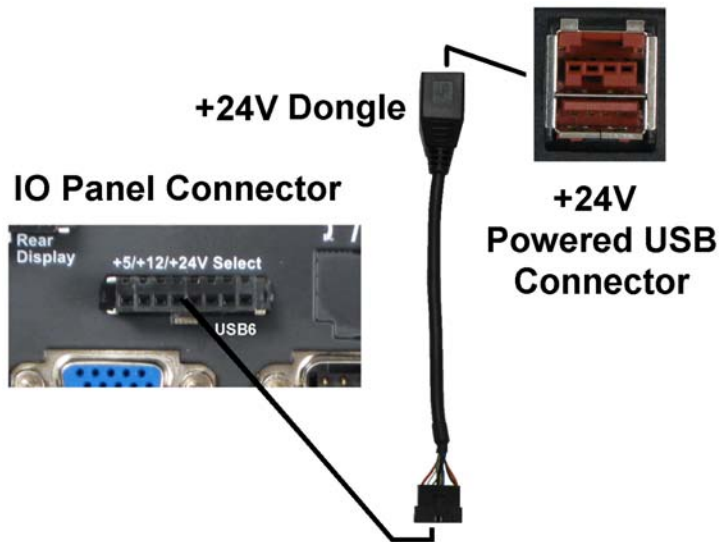

*Figure 1-3: Workstation 5A Powered USB Implementation (+12V Example)*

An internal cable carries the powered USB voltages (+5V, +12V, +24V) and USB Port 6 from system board header J14 to the IO Panel connector shown on the left of the illustration.

Separate dongles, one for each voltage, attach to the IO Panel connector and terminate in the appropriate powered USB connector. The center of the illustration shows an example of the +24V powered dongle.

Details of a +24V powered USB connector are shown on the right of the illustration. Consisting of two connectors stacked upon one another, the top half of the connector supplies the specified voltage and includes keying specific to that voltage. The lower half of the connector is a standard USB Type A receptacle that supplies +5V and USB Port 6 data.

This implementation may not be capable of providing the amount of power specified in the Powered USB Standard. The MICROS implementation provides the following power capacity. Applies to Revision C and D.

- +5V/2.2A (11W)
- +12V/1A (12W)

- +24V/0.4A (9.6W) - not capable of supporting the TM-T88 printer. Support for the TMT-88V is planned for the Revision F or later System Board.

Intelligent MICROS peripherals such as the Protégé Customer Display System are equipped with a custom interface cable that attaches directly to the USB6 IO Panel connector, bypassing the traditional Powered USB cables and connectors.

### **Finger Print Reader**

An optional finger print reader can be mounted on the left or right of the top cover.



*Figure 1-4: Optional Finger Print Reader*

---

## **Workstation Mounting Options**

All of the mounting options available for the Workstation 5 also apply to the Workstation 5A.

### **The Workstation 5A Adjustable Stand**

The Adjustable Stand converts the low profile WS5A into an adjustable display design. The stand has a weighted base for stable operation, generous cable area, printer power supply compartment and locking hinges to allow the workstation to be positioned in the range of 25° and 70°.

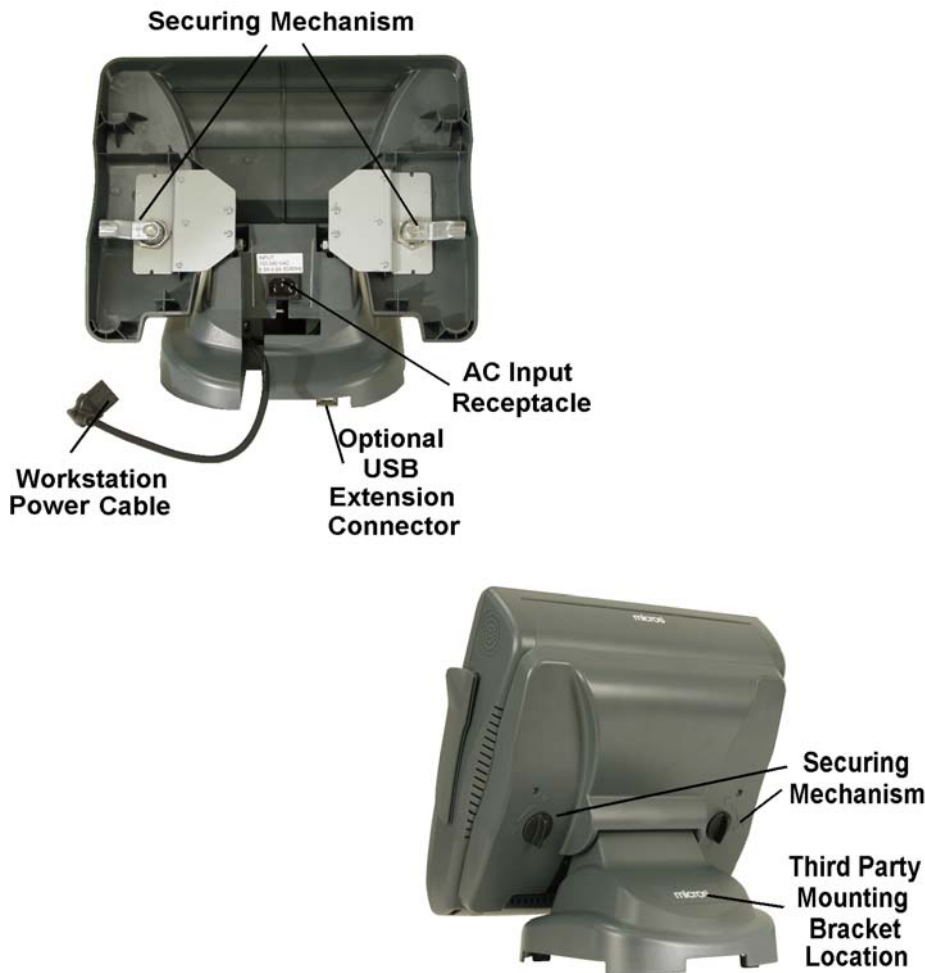
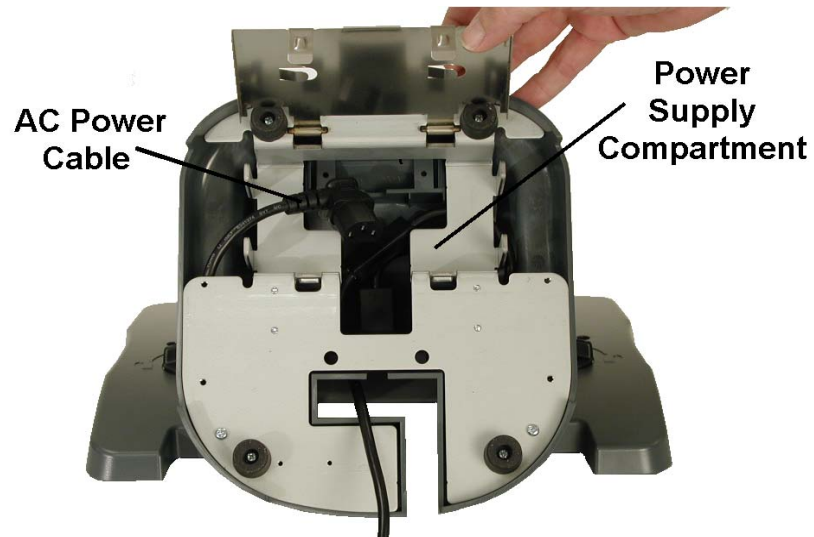

*Figure 1-5: The Workstation 5A Adjustable Stand*

The rear of the stand includes a pair of knobs that secure the workstation to the stand. The base includes a knock-out for a custom bracket that supports third party peripherals.

### ***Power Supply Compartment***

Figure 1-6, below shows a view of the stand base plate and the compartment for housing an optional Printer Power Supply. AC power is connected to a receptacle in the throat of the stand using a low profile angled connector. An internal 'Y' cable distributes power to both the workstation and printer power supply compartment.



*Figure 1-6: WS5A Adjustable Stand - Power Supply Compartment*



### **LCD Customer Display Options**

Integrated, Pole and Adjustable Stand Mounted LCD Customer Display options are available. The Workstation 5A features two customer display outputs - integrated and pole. The LCD Customer Display is based on a 240x64 monochrome STN LCD and companion controller board. The LCD Customer Display is capable of emulating the 2x20 VFD Customer Display. Part numbers and pricing can be found in the Workstation 5A PMA.

#### ***Integrated LCD Customer Display***

Figure 1-7 displays several views of the Workstation 5A Integrated LCD Customer Display.

As shown at lower right corner of the illustration, the Integrated LCD Customer Display receives power and data through a connector located on the IO Panel. No need to remove the cover to install or service the display.



*Figure 1-7: The Integrated LCD Customer Display*

### ***LCD Pole Mount Customer Display***

Figure 1-8 below, is an example of the Pole Mount LCD Customer Display. This display receives power and data from an IO panel Mini-DIN connector and can be placed on a counter surface up to four feet from the workstation. A 2x20 VFD Pole Display is also available.



*Figure 1-8: Pole Mount LCD Customer Display*

### ***Adjustable Stand Pole Display***

This version of the LCD Customer Display is mounted to the Adjustable Stand with a custom bracket and six inch pole. The base plate includes hole centers for mounting the bracket to the left, right, or rear of the workstation. This display receives power and data from an IO panel Mini-DIN connector, also used for the Pole Display.



*Figure 1-9: The Adjustable Stand Pole Mount Display*

***Protégé Customer Display System***

The MICROS Protégé Customer Display System is a customer facing 7” LCD, providing a greater level of detail than the traditional 2x20 VFD or MICROS 264x64 graphical LCD. It is available in both integrated and pole configurations and connects to the custom USB6 connector located on the IO Panel.

The Protégé is an intelligent display, featuring an ARM Processor, LCD Controller, Flash Memory, RAM and MicroSD Card. Facing the customer is a 7” 800x400 wide format TFT LCD, 4-wire resistive touchscreen, stereo speakers, and room for expansion.

The Protégé application displays full transaction details, allowing customers to confirm accuracy and improve speed of service in fast transaction environments. During idle times, the Protégé can display visual content (e.g., customized slide shows), for use as a marketing and advertising tool. See the Protégé Customer Display System Setup Guide, P/N 100016-177 for more information.



*Figure 1-10: The Protégé Customer Display System*

## *Software Components*

The WS5A is hardware platform shipped with Operating System, a collection of platform specific drivers, configuration files, BIOS and utilities. These components are pre-installed on each unit to create a foundation upon which MICROS POS applications are installed through the Client Application Utility (CAL).

### **Phoenix Embedded BIOS with StrongFrame<sup>®</sup> Technology, and Firmware<sup>®</sup> Technology**

In 2008, Phoenix Technologies purchased General Software. Embedded BIOS 2000 (EB2K) is now called the Phoenix Embedded BIOS with StrongFrame<sup>®</sup> Technology, and Firmware<sup>®</sup> Technology.

This means the custom Firmware applications originally developed for the Windows CE version of the Workstation 5 carry forward to the Workstation 5A and new applications can be added.

#### ***Firmware<sup>®</sup>***

Firmware is pre-boot operating environment that runs Portable Execution Firmware Applications. The Firmware environment runs inside the protective envelope of the System Management Mode (SMM).

The ability to execute custom firmware applications *before* the operating system allows the Windows Embedded CE 6.0 version to perform platform updates, system recovery, and BIOS updates using the Client Application Loader.

### **Operating Systems**

This section discusses the various operating systems available for each workstation.

#### ***Workstation 5A***

The Workstation 5A supports Windows Embedded CE 6.0 R3, and Windows Embedded POSReady 2009, formerly known as Windows Embedded for Point of Service (WEPOS). POSReady 2009 is derived from Windows XP Professional, and tailored for the point of service environment. Windows 7 is currently not supported.

Windows Embedded CE 6.0 R3 is a modular operating system that includes only the software components and drivers required to support the Workstation 5A and its applications. The R3 update adds features required by the Symphony application.

## **Workstation 5A Platform Software**

In addition to the Operating System, Platform Software consists of several key components developed by MICROS specifically for the workstation. Each component listed below is pre-loaded on the workstation when shipped.

- Device drivers for video, network, and sound specific to the processor and chipset platform.
- The WS5A Application Programming Interface (API), to allow application programs to access the POS hardware and ports.
- A Workstation Diagnostics Utility that uses the WS5A API to test the integrated and peripheral components of workstation.
- The MICROS Client Application Loader for WIN32 (CAL 32), an intelligent agent designed to remotely manage software installed on the workstation.

## **Utilities**

Utilities included with the Workstation 5A platform include the Client Application Loader (CAL), a Diagnostics Utility for testing the unit, and a custom screen saver/backlight utility.

## **POS Application**

The Workstation 5A is shipped with an operating system and platform software, but does not contain a POS Application.

The MICROS Client Application Loader (CAL) for Windows Embedded CE or CAL 32 for WIN32 clients connect to any MICROS application server and download the application in minutes.

Throughout this manual, the term 'POS Application' is used somewhat generically, and could in fact apply to any of the following software products listed below.

- CAL Server Version V 21 or higher
- RES - V4.8
- Symphony V1.4 MR5 and V2.1
- 9700 - V3.6 MR3
- e7 - V3.0 MR1

## *Recovery*

This section describes the recovery capabilities of both Windows Embedded CR 6.0 R3 and the supported WIN32 operating systems on the Workstation 5 and 5A.

### **Recovery Button**

One Button Recovery describes a process where the operating system image and platform files can be restored by pressing the Recovery Button shown in Figure 1-2 at specific times. Depending on the operating system, this can take two forms.

#### ***Windows CE Factory Restore***

For Windows Embedded CE 6.0 using the One Button Recovery feature initiates Windows CE Factory Restore on the USB Hard Drive. When using the Recovery Button located on the workstation a keyboard is not required. Future versions of the BIOS may require a password to initiate a Factory Restore.

WINCE Factory Restore is a Firmbase application that copies the WINCE image and platform files from a hidden recovery partition to the boot partition and \DOC partitions respectively. See Chapter 3 for a more detailed explanation.

After the files have been restored, the Wipe CF Utility is used to format the CF Card and restart the workstation.

- Windows CE Factory Restore procedures can be found in Chapter 4.

#### ***Windows POSReady 2009***

Recovery of WIN32 operating systems such as POSReady 2009 is accomplished with the optional POSReady 2009 Recovery CF. The Recovery CF is supplied with a current factory image, but a customer specific image can be substituted.

Like WINCE Factory Restore, using the Recovery Button automates recovery process without using a Keyboard. However, new BIOS Versions may require a password to start the Recovery CF.

The BIOS detects the recovery button activation and starts the WS5A from the Recovery CF, which contains a pre-boot environment and start-up scripts that determines the primary boot device (USB Hard Drive or optional SATA Disk Drive), starts Ghost and transfers the image.

When the image transfer is complete, the workstation automatically restarts and restores the boot order to the original configuration.

- Recovery CF Procedures can be found in Chapter 4.

## *Power Management States*

### **Introduction**

This section introduces the Workstation 5A power management states in all operating system configurations.

References to power management states are specified in bold capital letters, e.g., **NOPOWER**, and **ON**. See chapter 4 for more information about operating the Workstation.

### **UNPLUGGED**

- The AC power cord is not connected to a wall outlet. Also referred to in the ACPI specification as ‘mechanical off’.
- The Operator LED is Off.
- The Operator LCD is blank.

**The workstation can be safely disassembled when in this state.**

### **NOPOWER (S5 or Soft Off)**

- The AC power cable is attached, but the operating system and applications are not running. RAM contents are undefined.
- The Operator LED is Off.
- The Operator LCD is blank.

S5 is the ACPI ‘soft-off’ state where the power supply remains active, but delivering minimal power to several key circuits in order to detect a power-button press or Wake-On-Lan event.

**It is not safe to disassemble the workstation when in this state. The power supply heat sinks remain energized, presenting a shock hazard. Always remove the AC power cord from the IO Panel before disassembling the workstation.**

### **ON**

- The Operating System and POS application are operating. RAM contents are maintained.
- The Operator LED is solid White.

### **Last Power State Retention**

The WS5A retains the last power state (**ON** or **NOPOWER**) in an on-board EEPROM checked by the BIOS each time it is powered on or the AC power cable connected. In BIOS System Configuration Utility, the ‘Last Power State’ field determines how the unit behaves when AC power to the unit fails and then returns.

The default setting of ‘Last State’ means that if the unit is **ON** and AC power fails, it returns to **ON** when AC power is restored with no action required by the operator. See Chapter 3 for more information.

**WS5A Power Management State Table**

<b>Current State</b>	<b>Event Source</b>	<b>Scenario</b>	<b>New State</b>
<b>UNPLUGGED</b>	AC Power	AC Power becomes available and the last recorded state was not the <b>ON</b> state.	<b>NOPOWER</b>
<b>NOPOWER</b>	Operator	The operator presses the power button for less than 1 seconds.	<b>ON</b>
<b>NOPOWER</b>	Operator	The operator presses the power button for more than 4 seconds.	<b>ON</b>
<b>NOPOWER</b>	Server Application	A server application sends a 'Wake On LAN' command.	<b>ON</b>
<b>ON</b>	Operator	The operator presses the power button for more than 4 seconds.	<b>NOPOWER</b>
<b>ON</b>	Application	The application shuts down the workstation.	<b>NOPOWER</b>
<b>ON</b>	Server Application	A server application sends a "Wake On LAN" command.	<b>ON</b>
<b>ON</b>	Application	Restart is called by the CAL.	<b>NOPOWER</b> then <b>ON</b>
<b>NOPOWER</b>	AC Power Failure	AC Power fails and is restored	<b>NOPOWER</b>
<b>ON</b>	AC Power Failure	AC Power fails and is restored	<b>ON</b>

*Figure 1-11: WS5A Power Management States*



## *General Specifications*

The following table provides details about the Display, Network and I/O capabilities of the Workstation 5A.

<b>Specification</b>	<b>Parameters</b>
Processor and Chipset	Intel Atom N450, Single Core, 1.6GHz and Intel ICH8M I/O Controller Hub
Display	15" TFT LCD (1024x768) 262K Colors Max.
Touchscreen	EloTouchSystems Five-wire resistive, 100 thousand points-per-inch resolution rated at a screen life of over 35 million touches. Capacitive option is available.
Backlight(s)	Two CCFL backlights with three intensity settings programmable through the API.
Real Time Clock	100-year calendar with alarm features and century roll-over, includes 242 bytes of battery backed CMOS RAM.
Memory	2 SO-DIMM Sockets - Max 2 GB DDR2 667
Mag Stripe Reader	3-Track ABA compatible, operates in MAGTEK and Special modes.
Optional Customer Displays	240x64 STN graphics based LCD. Protégé 7" TFT Color Customer Display System
USB Ports	Ten USB 2.0 ports. > Five internal > Five external (Four USB type A, one optional powered USB). External USB ports can be disabled.
LAN Interface	10/100/1000 Ethernet - Modular RJ45
Serial Ports	1 DB9 RS232 Serial /w handshake 2 Modular RS232 Serial /w handshake 1 Modular IDN Serial (RS422 or RS232)
Input Voltage	Universal Input - 85 to 264VAC, 47 to 63Hz.
Input Power	24W Typical
BTU/Hour	83 Typical
Storage Temperature	-25°C (-13°F) to 80°C (176°F)
Workstation 5A Operating Temperature	0°C (32°F) to 45°C (113°F), 90% relative humidity max.
Weight	10.5 lbs. (4.7 kg) / Shipping weight 14.0 lbs. (6.35 kg)

<b>Specification</b>	<b>Parameters</b>
Case Material	PC-ABS Plastic
Physical Dimensions	See Appendix A

## *Approvals*

The WS5A meets the following safety and environmental certifications.

<b>Directive</b>	<b>Specification</b>	<b>Year</b>
Safety	EN 60950-1:2006+A11	2006
	IEC 60950-1:2005	2005
EMC:	EN 55022:2006+A1	2007
	EN 55024:1998+A1+A2	2003
	EN 61000-3-2:2006	2006
	EN 61000-3-3:2008	2008

# *Workstation 5A BIOS*

This chapter describes the Workstation 5A System Configuration Utility, highlights user settings and discusses BIOS Updates and the Windows CE Factory Restore Feature.

### ***In this chapter***

---

The BIOS System Configuration Utility .....	2-2
Main .....	2-7
Boot.....	2-10
POST.....	2-12
SIO .....	2-14
Features .....	2-15
Firmware.....	2-16
Misc .....	2-17
Video .....	2-18
ODM .....	2-19
Chipset .....	2-23
AdvancedCPU .....	2-24

---

## *The BIOS System Configuration Utility*

In 2008, Phoenix Technologies purchased General Software which provided the BIOS for the Workstation 5 and Workstation 4 LX. The General Software Embedded BIOS 2000 (EB2K) is now called the Phoenix EB(SF) Embedded BIOS with StrongFrame<sup>®</sup> Technology, and Firmbase<sup>®</sup> Technology.

The custom Firmbase applications such as Flash CE and Windows CE Factory Restore, originally developed for the Workstation 5 carry forward to the Workstation 5A.

### **Starting the BIOS System Configuration Utility**

1. Connect a USB Keyboard to one of the USB ports located on the IO panel.
2. Power-up or restart the workstation.
3. When the BIOS Splash screen shown below appears, press the [DEL] key.

#### **MICROS BIOS Version**



*Figure 2-1: Workstation 5A BIOS Splash Screen*

The MICROS BIOS Version is always displayed in the upper left hand corner of the splash screen as shown in the Figure above.

Up to four Workstation 5A BIOS Versions have been deployed. Each is detailed in the following pages.

- BIOS Version Q1000g shipped on Revision D System Boards until July 2012.
- BIOS Version Q1010m was released as part of a CE Platform update to introduce support for SparkLan Mini-PCI WiFi Card.
- BIOS Version Q2010g released as part of the Windows CE GR2.0 Platform update.

- BIOS Version Q2011d released as part of a separate BIOS upgrade to improve detection of 8GB uDOCs using a Toshiba flash chip.

When you press [Del] enter the BIOS System Configuration Utility, each displays a System Summary screen displaying the MICROS BIOS Version and build date as shown in the following pages.

### System Summary BIOS Q1000g

The BIOS Version Q1000g System Summary screen is shown below. |

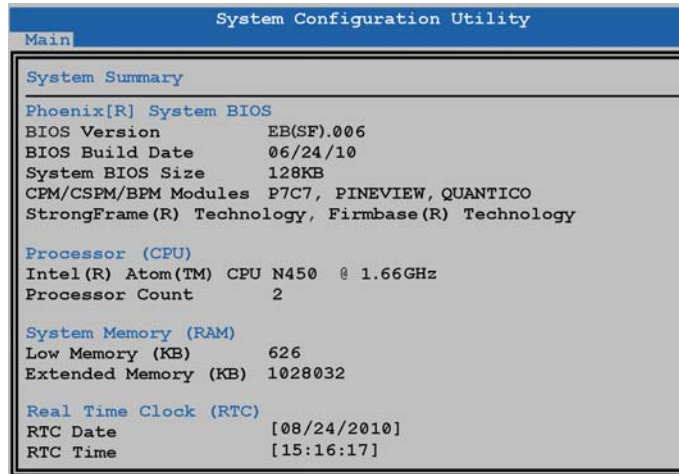

Figure 2-2: BIOS Q1000g System Configuration Utility Summary

### System Summary BIOS Q1010m

When you press delete to enter the System Configuration Utility, a Preboot Menu Appears. Press enter to proceed to the System Configuration Utility Main Screen as shown below.

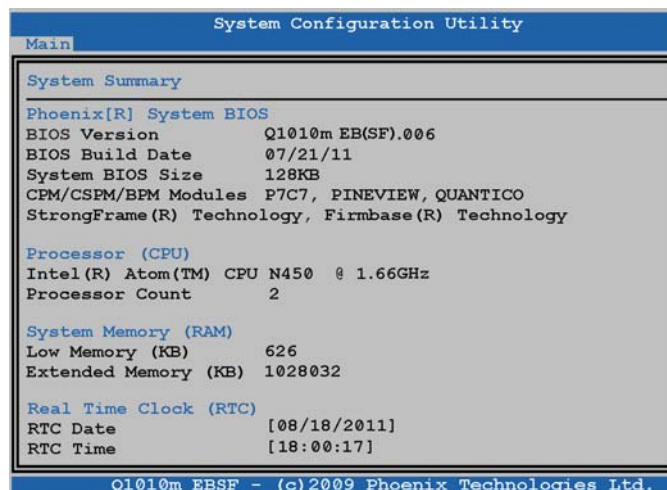
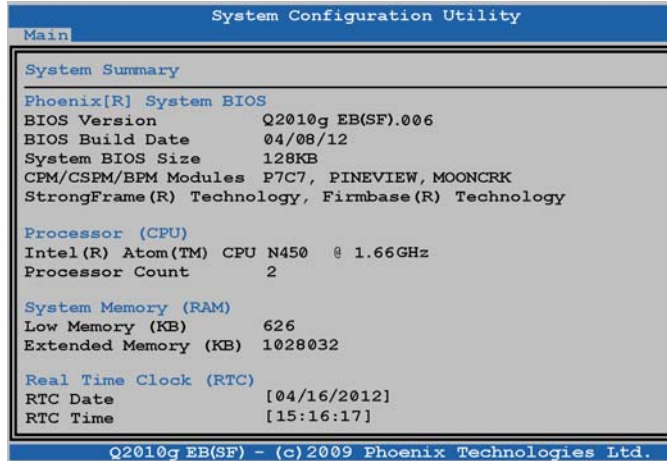

Figure 2-3: BIOS Version Q1010m System Configuration Utility Summary

### System Summary BIOS Q2010g

The BIOS Version Q2010g System Summary screen is shown below.



*Figure 2-4: BIOS Q2010g System Configuration Utility Main Screen*

### System Summary BIOS Q2011d

The BIOS Version Q2011d System Summary screen is shown below.

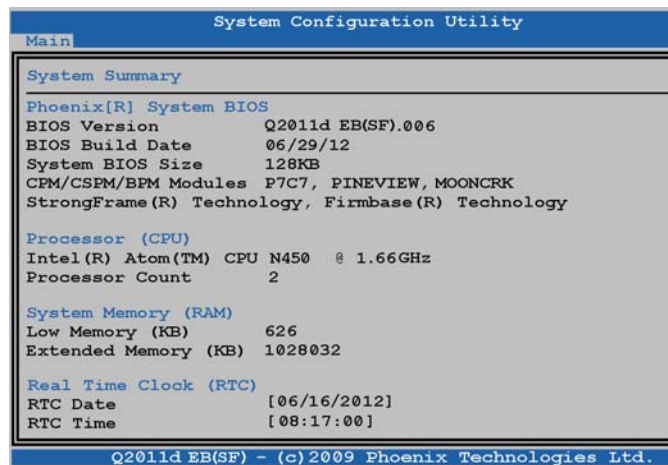

*Figure 2-5: BIOS Q2011d System Configuration Utility Main Screen*

### **BIOS Q2010g Features**

The major features of BIOS Versions Q2010g and Q2011d are highlighted below.

- The ‘Golden’ (Final) release of the Embedded BIOS with StrongFrame Technology (EBSF) BIOS.
- Merges the Pineview M (Mobile) and Pineview D (Desktop) platforms, previously a separate BIOS.
- Fully backwards compatible with the WS5A Revision D System Board.
- **By default, a password is required to start Windows Embedded CE 6.0 Factory Restore or the POS Ready Recovery CF. The password requirement can be disabled from the ODM Menu.**
- Fixes most boot issues associated with the USB Hard Disk. Symptoms include failure to boot or failure to boot every other power cycle.
- Fully supports the Protege Customer Display System.
- Support for 512MB SO-DIMMs in Windows Embedded CE 6.0 R3.
- Adds new fields to the Exit Tab: “Reload WINCE Factory Default Settings”, “Reload USB WIN32 Factory Default Settings”, and “Reload SATA WIN32 Factory Default Settings.”
- Adds new fields to the ODM Tab; ‘WINCE Factory Restore’, “USB WIN32 Factory Restore”, “SATA WIN32 Factory Restore”, and “Enable Password for Restore”.
- In addition to using the Recovery Button at the BIOS Splash screen, when combined with a Revision F System Board, offers more options for starting the recovery process. Refer to Chapter 4 for all recovery procedures.

### **BIOS Q2011d Features**

This BIOS adds the following features to the list above:

- To ensure detection of the 8G USB Hard Disk with Toshiba Flash Chip at start up, increase polling time to 5 seconds.
- Adds a new field to the ODM Tab: ‘CF Interface’ to disable the CF Interface in WIN32 applications such as POSReady 2009.

### **BIOS Versions Q2010g/Q2011d Known Issues**

- Using Intel DOS Ethernet Drivers to network boot results in ‘Stack Overflow’ errors. This issue is currently under investigation at Phoenix Technologies, Inc.
- When running a POSReady 2009 image prior to Version 2.0 from the USB Hard Disk, avoid using 2G of RAM. For example, Workstation 5A P/N 400814-104 ships with POSReady 2009, 1G of RAM and 8G USB Hard Drive.



## Workstation 5A BIOS

### The BIOS System Configuration Utility

---

Should this configuration be upgraded to 2G of RAM, the workstation may fail to start POSReady 2009, display BSODs at start-up, and or a 'Windows Failed to Start Properly Menu. In other cases, POSReady 2009 may start, but fail to properly shut down, displaying a light blue screen.

- MICROS recommends you upgrade to Version 2.0 of the POSReady 2009 image.

#### **Tips for Using the System Configuration Utility**

When using the System Configuration Utility, the general idea is to navigate to the menus containing specific configuration fields, and change those fields as required. For example, the ODM tab contains all Workstation 5A related configuration fields. To navigate, use the help text located on the right side of each menu tab. Randomly changing configuration fields when troubleshooting or testing can cause some features or the entire workstation to stop functioning.

Should this occur, try returning to the original boot defaults or see Clearing the CMOS memory in Chapter 3. When your changes are complete, navigate to the Exit menu, and select the appropriate boot defaults based on the operating system and disk media installed. When you save and exit the BIOS, all changes are stored in nonvolatile CMOS memory, and take effect on the next boot.

## *Main*

The first page that appears when you enter the System Configuration Utility is the System Summary screen. It provides information about the MICROS and Phoenix BIOS Versions, Processor type and amount of main memory, and lets you set the system RTC date and time.

### **Phoenix® System BIOS**

In 2008, Phoenix Technologies purchased General Software, the BIOS provider for the Workstation 5 and Workstation 4 LX. General Software Embedded BIOS 2000 (EB2K) is now called the Phoenix EB(SF) Embedded BIOS with StrongFrame® Technology, and Firmbase® Technology.

The MICROS BIOS Version and build date are listed on the first two lines.

### **Processor (CPU)**

The processor information is obtained directly from Model Specific Registers (MSRs).

Note the Processor Count of 2 for a single core processor such as the Intel® Atom® N450. Intel's HyperThreading Technology is used to improve the parallelization of computations performed on a PC processor. For each physical core, the operating system addresses two virtual or logical processors, and shares the workload between them when possible.

This allows a single core hyper threading processor such as the Intel® Atom® N450 to appear as two "logical" processors to the host operating system, allowing it to schedule two threads or processes simultaneously.

### **System Memory (RAM)**

The system Memory information does not report the total amount of RAM installed, but describes RAM as configured, subtracting the amount used for System Management Mode (SMM), Shadowing, Video Buffers and other uses.

This provides realistic values about how much memory is actually available to the operating system and applications.

### **Real Time Clock (RTC)**

To set or change the time and date, scroll to the RTC Date field. Use Tab or BackTab keys to navigate through the MM/DD/YYYY and HH:MM:SS fields as required. Hours are specified in military time; thus 13 is 1PM, one hour past noon. 01 is 1AM, or one hour past midnight.

When the cursor leaves the RTC fields, the change takes affect right away, unless the new values are not valid.

### *Exit*

From the Exit screen, you can save or discard any BIOS change or select the workstation Boot Defaults. Note that Versions Q2010g and Q2011d shown in the lower half of the Figure, adds WIN32 boot defaults for a USB hard drive or optional SATA disk drive.

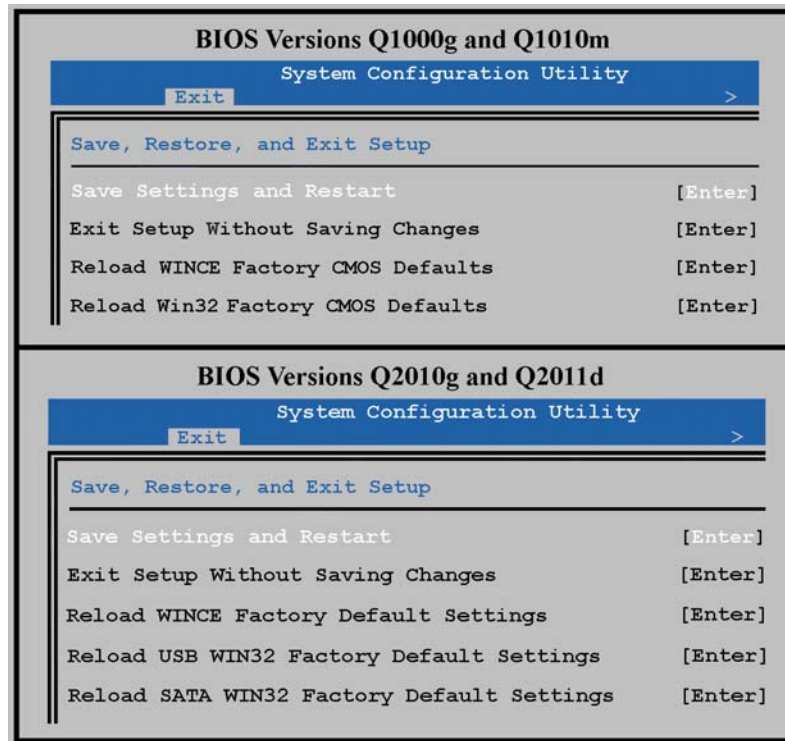

*Figure 2-6: BIOS System Configuration Utility - Exit Tab*

### **Save, Restore, and Exit Setup**

From the Exit tab, you can choose the boot configuration or save minor changes.

#### ***Save Settings and Restart***

Use this selection after making a change to a CMOS field and maintain the current boot configuration. Press [Enter] and [Y] to proceed.

#### ***Exit Setup Without Saving Changes***

Use this selection to discard any changes and exit the System Configuration Utility with the current boot defaults. [Enter] and [Y] to restart.



**NOTICE**

Selecting any of the factory defaults re-enables some fields in the ODM Tab including the IO Panel USB Ports, and the Recovery Password. In BIOS Version Q2011d, if the CF Interface is disabled, resetting defaults will re-enable it.

---

***Reload WINCE Factory CMOS Defaults (Q1000g/Q1010m)***

This selection restarts the workstation and populates the Boot Device Prioritization fields to boot from a USB Hard Drive containing Windows Embedded CE 6.0 R3. Press [Enter] and [Y] to proceed.

***Reload Win32 Factory CMOS Defaults (Q1000g/Q1010m)***

This selection restarts the workstation and populates the Boot Device Prioritization fields to boot from a USB Hard Drive containing POSReady 2009. Press [Enter] and [Y] to proceed.

***Reload WINCE Factory Default Settings (Q2010g/Q2011d)***

This selection restarts the workstation and populates the Boot Device Prioritization fields to boot from a USB Hard Drive containing Windows Embedded CE 6.0 R3. Press [Enter] and [Y] to proceed.

***Reload USB WIN32 Factory Default Settings (Q2010g/Q2011d)***

This selection restarts the workstation and populates the Boot Device Prioritization fields to boot from a USB Hard Drive containing POSReady 2009. Press [Enter] and [Y] to proceed.

***Reload SATA WIN32 Factory Default Settings (Q2010g/Q2011d)***

This selection restarts the workstation and populates the Boot Device Prioritization fields to boot from an optional SATA Disk Drive containing POSReady 2009. Press [Enter] and [Y] to proceed.

*Boot***System Boot Configuration**

This tab includes the Boot Device Prioritization order, and enables the ICH8M SATA and PATA controllers. The Figure below shows the Windows Embedded CE Configuration.

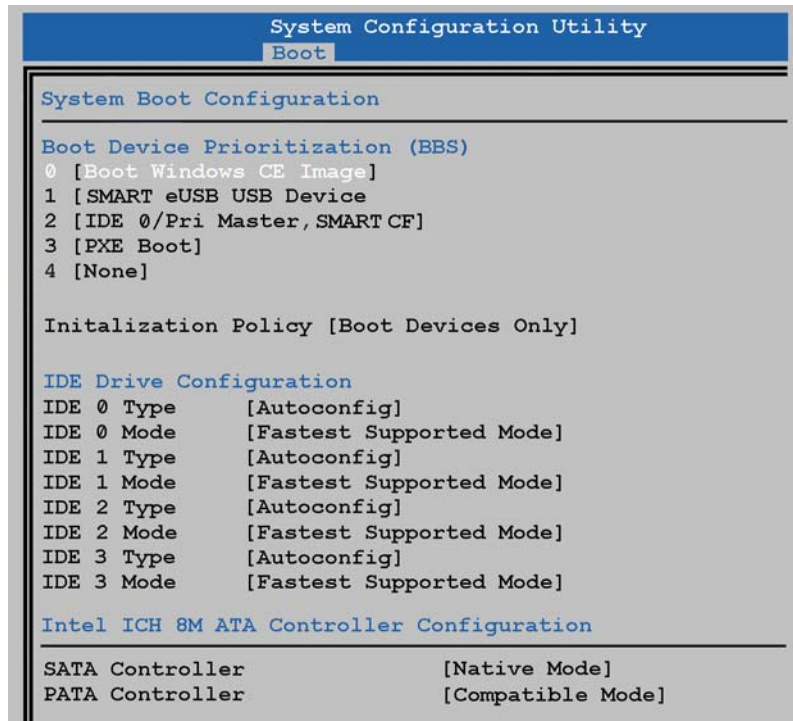

*Figure 2-7: BIOS System Configuration Utility - Boot Tab*

**Boot Device Prioritization - BIOS Boot Specification (BBS)**

This section contains the device boot order for the supported operating systems. The BBS is populated based on the Factory Default settings selected from the Exit tab. Each default is listed below. Note that BIOS Version Q2010g adds new boot defaults.

***Windows CE Boot Configuration (All BIOS Versions)***

Selecting 'Reload WINCE Factory Default Settings from the Exit tab populates the boot order as shown below.

- 0 - [Boot Windows CE Image] <- Required to Boot From NK.BIN file.
- 1 - [SMART eUSB USB Device] <- USB Hard Drive Brand/Model
- 2 - [IDE 0/Pri Master, CF 256M] <- 256M CF Card Installed
- 3 - [PXE Boot]

**Windows POSReady 2009 Boot Configuration (Q1000g and Q1010m)**

**Reload USB WIN32 Factory Default Settings (Q2010g and Q2011d)**

This selection populates the boot order for WIN32 operating systems such as POSReady 2009 when installed on a USB Hard Drive.

- 0 - [SMART eUSB USB Device] <- USB Hard Drive Brand/Model
- 1 - [IDE 0/Pri Master] CF Card Optional (not installed)
- 2 - [PXE Boot]
- 3 - [None]

**Reload SATA WIN32 Factory Default Settings (Q2010g/Q2011d)**

This selection, available in BIOS version Q2010g or later, populates the boot order to start a WIN32 OS such as POSReady 2009 from the optional SATA Solid State Drive.

- 0 - [SATA drive 0, INTEL SSDSA2M040G2GC] <- SATA Drive Brand/Model.
- 1 - [IDE 0/Pri Master] CF Card Optional (not installed)
- 2 - [PXE Boot]
- 3 - [None]

**Configuring BIOS Q1000g to boot from a SATA Disk**

To boot from a SATA disk drive, move 'SATA drive 0' to the top of the BBS as shown above. If converting a USB Hard Drive configuration to a SATA SSD, the USB Hard Drive should be removed from J8 and not included in the boot order.

When complete, proceed to the Exit menu and be sure to select the 'Save Setting and Restart.'

**IDE Drive Configuration**

The IDE 0 and IDE 1 type selection are set to [Autoconfig] to support the CF card, the only IDE device supported.

**Intel ICH 8M ATA Controller Configuration**

Enables the ICH8M SATA and PATA controllers.

## *POST*

The POST screen can be used to configure many aspects of the BIOS Power On Self Test including how the system memory is tested during start-up. Normally memory testing is held to a minimum in order to decrease boot time.

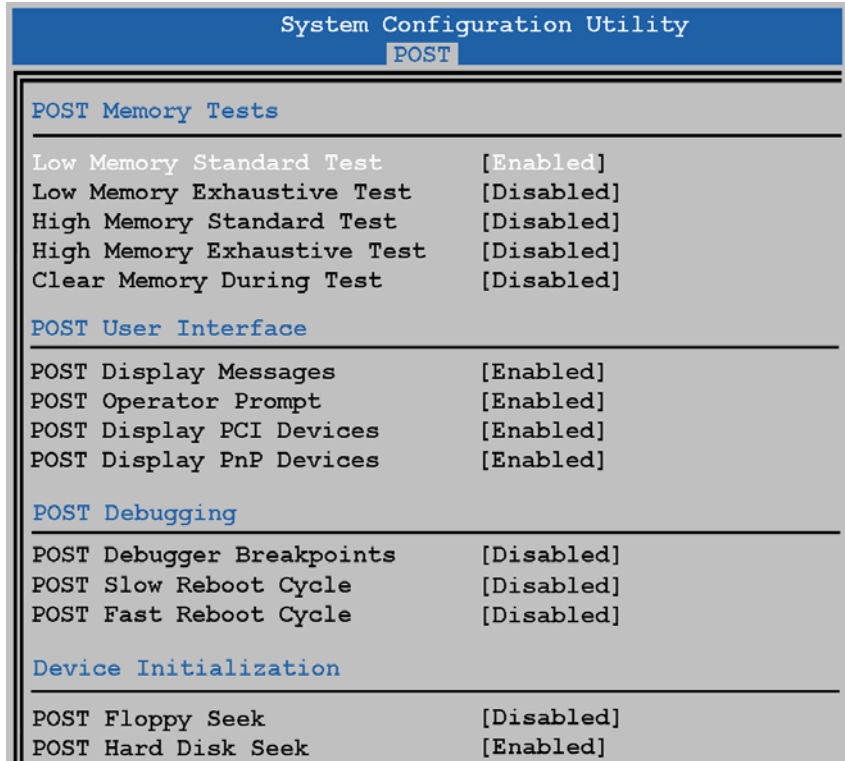

System Configuration Utility	
POST	
<b>POST Memory Tests</b>	
Low Memory Standard Test	[Enabled]
Low Memory Exhaustive Test	[Disabled]
High Memory Standard Test	[Disabled]
High Memory Exhaustive Test	[Disabled]
Clear Memory During Test	[Disabled]
<b>POST User Interface</b>	
POST Display Messages	[Enabled]
POST Operator Prompt	[Enabled]
POST Display PCI Devices	[Enabled]
POST Display PnP Devices	[Enabled]
<b>POST Debugging</b>	
POST Debugger Breakpoints	[Disabled]
POST Slow Reboot Cycle	[Disabled]
POST Fast Reboot Cycle	[Disabled]
<b>Device Initialization</b>	
POST Floppy Seek	[Disabled]
POST Hard Disk Seek	[Enabled]

*Figure 2-8: BIOS System Configuration Utility POST Selection*

## PnP

This selection enables or disables PnP support for legacy operating systems such as Windows 95, Windows 98, and Windows NT. It also allows the IRQ and DMA (Direct Memory Access) resources to be individually reserved for Plug and Play.

The Advanced Configuration and Power Interface (ACPI) replaces PnP in recent operating system such as POSReady 2009 or Windows 7.

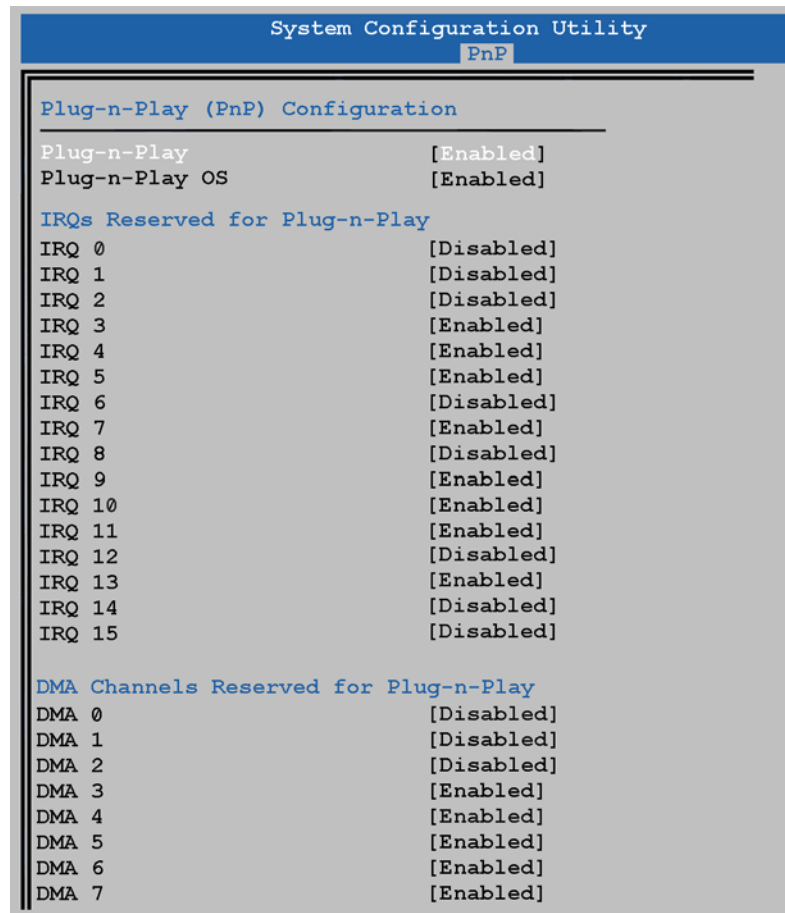

Figure 2-9: BIOS System Configuration Utility - PnP Tab

All settings are factory configured and should not be changed.



## SIO

The SIO selection displays the WS5A COM and LPT Port resources. The COM port resources are factory configured and should not be changed.

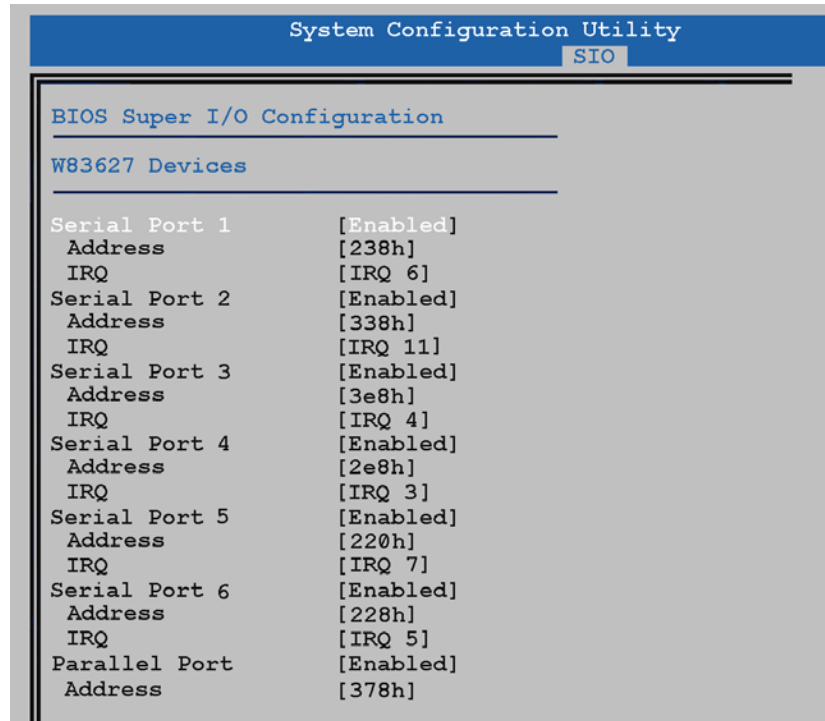

Figure 2-10: BIOS System Configuration Utility - SIO Tab

The table below describes the WS5A COM Port assignments and identifies the IO Panel Connector. The resources apply to all System Board Revisions and BIOS Versions.

PORT	I/O Addr	IRQ	SIO Port	Connector/ Function
COM1	238h	6	SIO Port A	CN2 - DB9M
COM2	338h	11	SIO Port C	CN8-2, RJ45-RS232
COM3	3E8h	4	SIO Port B	CN3/J2, Integrated/Pole Display
COM4	2E8h	3	SIO Port D	CN9-B - IDN
COM5	220h	7	SIO Port E	CN9-A, RJ45-RS232
COM6	228h	5	SIO Port F	CN13, MSR

## Features

The BIOS Features tab enables or disables features such as ACPI, APM, PnP, MP, quick boot options, and Intel VT.

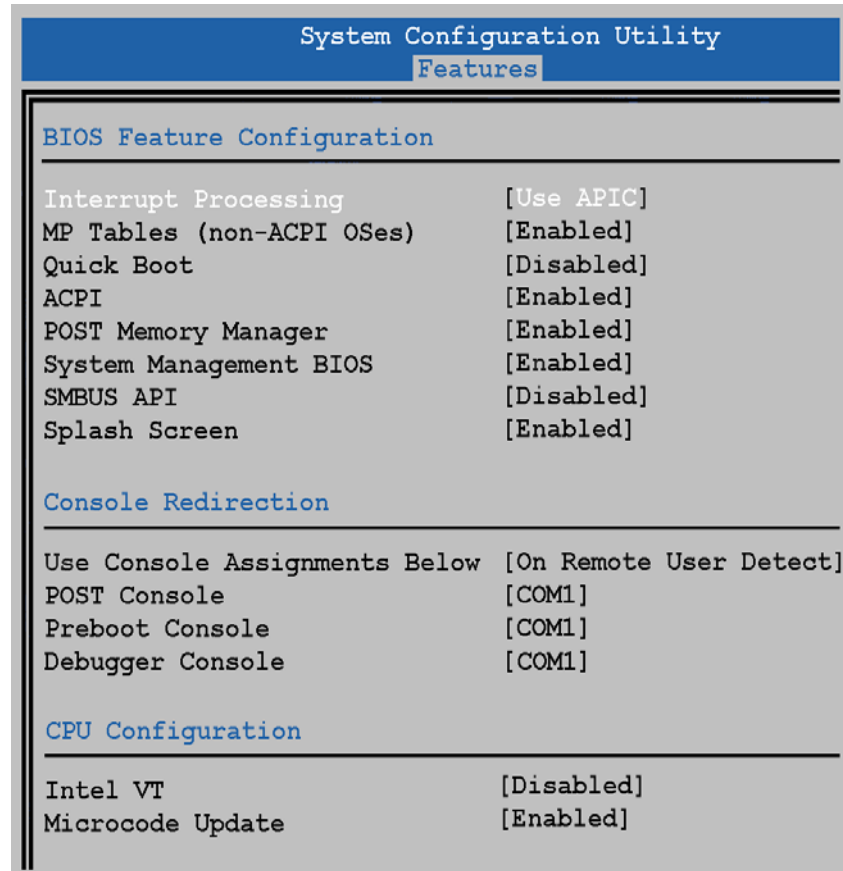
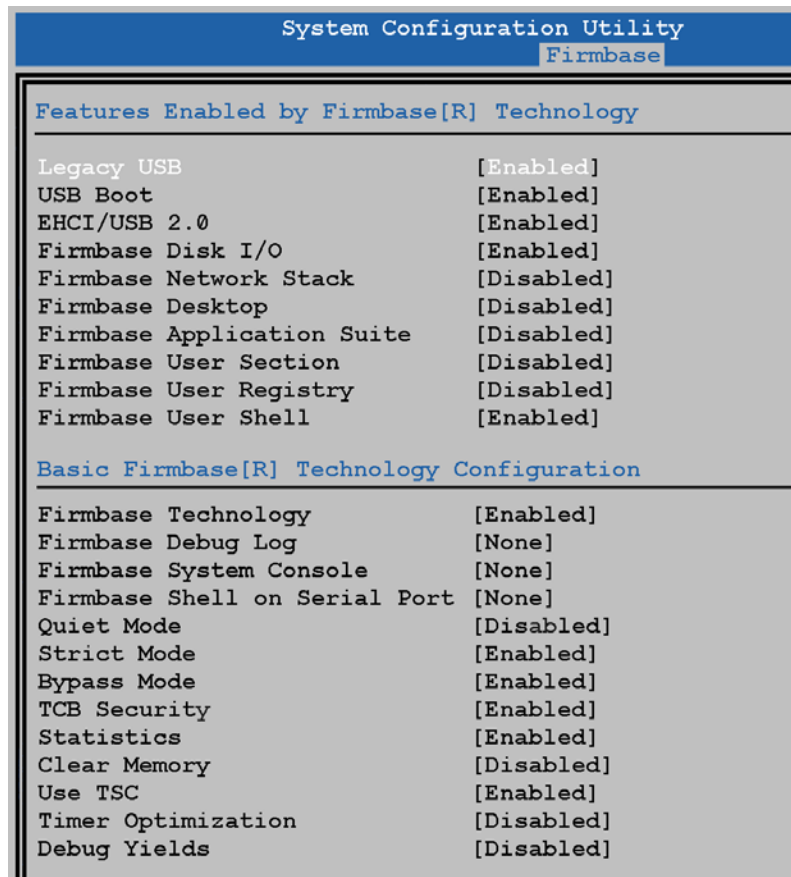

Figure 2-11: BIOS System Configuration Utility - Features Tab

## *Firmware*

The Firmware menu configures the Firmware Technology component of the BIOS. The menu consists of several parts, with the most basic user-oriented options located at the top, and the more technical parameters located in the lower sections.



*Figure 2-12: BIOS System Configuration Utility - Firmware Tab*

All Firmware fields are factory configured and should not be changed.

## Misc

This selection enables or disables the System Cache, and provides several settings to control a USB keyboard (if attached).

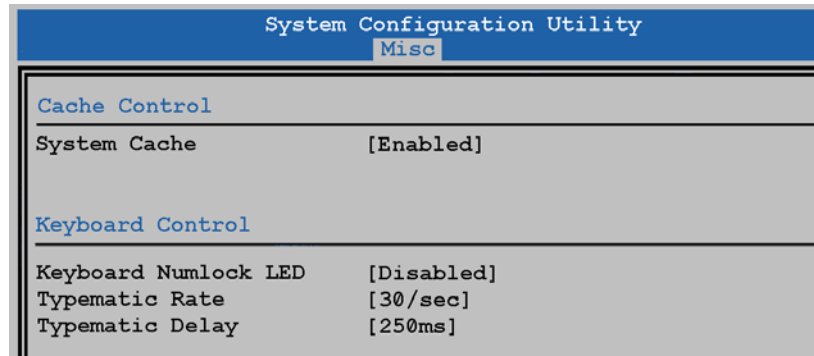

Figure 2-13: BIOS System Configuration Utility - Misc Tab

### Cache Control

We recommend that you do not change this setting.

### Keyboard Control

Several keyboard configuration settings can be found in this section.

#### **Keyboard Numlock LED**

Enables the Keyboard Numlock LED when POST initializes the keyboard.

#### **Typematic Rate**

USB typematic is automatically configured and does not use parameter.

#### **Typematic Delay**

USB typematic is automatically configured and does not use this parameter.

## *Video*

The Video tab allows some video configuration of the workstation, including selecting the default boot display device.

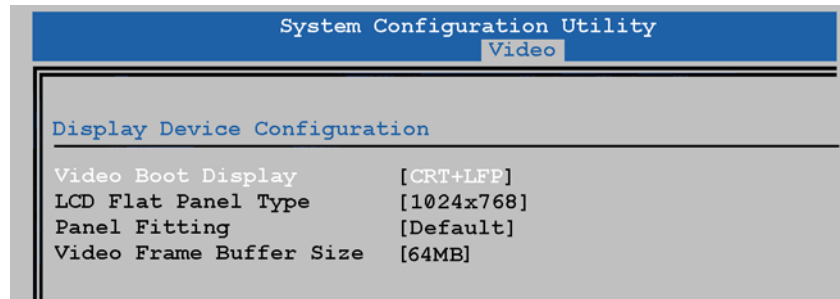

*Figure 2-14: BIOS System Configuration Utility - Video Tab*

### **Display Device Configuration**

The Display Device Configuration settings are factory configured and should not be changed.

## ODM

The Original Device Manufacturers (ODM) Special Configuration Tab contains the Workstation 5A custom fields. This includes external USB port control, Cash Drawer voltage selection, and recovery options. The ODM Tab for BIOS Version Q1000g is shown in Figure 2-15, below.

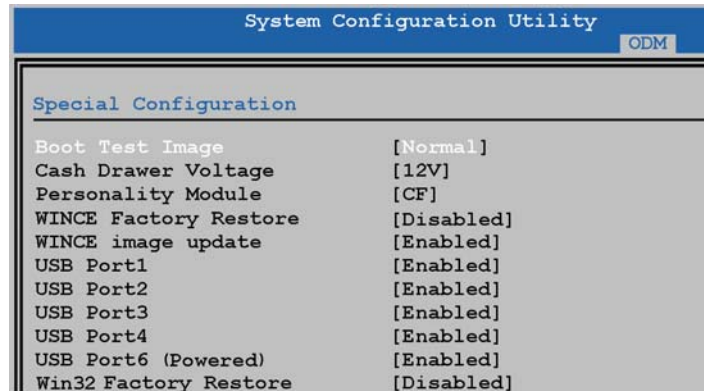

Figure 2-15: BIOS ODM Menu - Version Q1000g and Q1010m

BIOS Version Q2010g adds several new fields and by default requires a Recovery Password to start WINCE Factory Restore or a WIN32 Factory Restore from a Recovery CF.

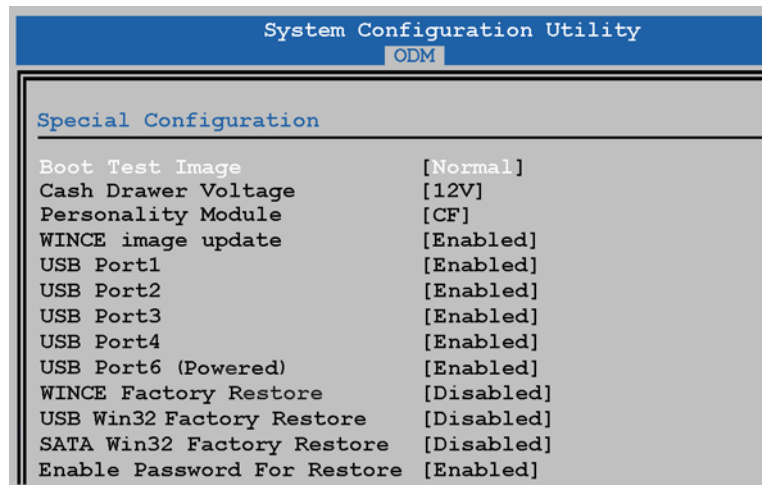

Figure 2-16: BIOS ODM Menu - Version Q2010g

BIOS Version Q2011d, shown below adds the 'Compact Flash' field.

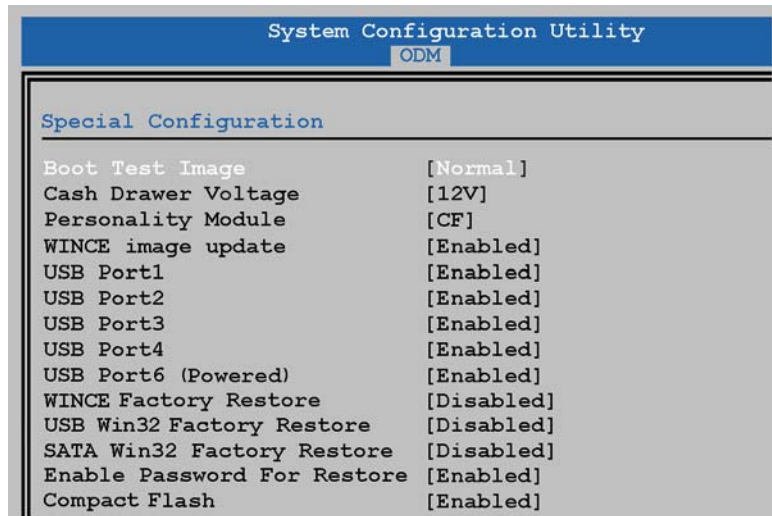

Figure 2-17: BIOS ODM Menu - Version Q2011d

## Special Configuration

Each field and the supported BIOS Versions are listed below.

### **Boot Test Image (All BIOS Versions)**

On a Windows Embedded CE 6.0 R3 Workstation 5A, the default of [Normal] causes the BIOS to boot from the USB Hard Drive installed on 2x5 header J8.

To boot from a USB thumb drive attached to the IO Panel, set this field to [Alternate], then select Save Settings and Restart. Selecting [Alternate] removes power from the USB Hard Drive header, J8 to allow the workstation to boot from a USB Thumb Drive connected to the IO panel for purposes of performing a BIOS upgrade.

### **Cash Drawer Voltage (All BIOS Versions)**

This selection determines the Cash Drawer Solenoid voltage, +12V or +24V. The default selection of +12V is compatible with all MICROS cash drawers.

### **Personality Module (All BIOS Versions)**

This field determines the location of the persistent registry, based on the Operating System configuration.

For Windows Embedded CE 6.0, this field is set to [CF].

For WIN32, this field is not valid. The registry resides with the operating system, located on either the USB Hard Drive or optional SATA Disk Drive.

### ***WINCE Image Update (All BIOS Versions)***

When set to [Enabled], each time the workstation starts, a Firmware application called FlashCE checks the CF Card for a file called NK.BIN. The file is placed on the CF card by the CAL as part of a Windows CE or platform update.

FlashCE produces the 'NK.BIN not found' message that appears just before the unit boots to Windows CE.

The FlashCE utility does not run on POSReady 2009 configurations.

### ***USB Ports 1 - 4 and USB Port 6 - (All BIOS Versions)***

USB Ports (including USB 6, the powered USB port) available at the I/O Panel can be disabled by setting the port to [Disabled], then return to the Exit Menu and select Save Settings and Restart.

IO panel USB ports can also be controlled through the Windows CE or POSReady Diagnostics Utility and do not require a reboot.



#### ***CAUTION***

If USB Port1 through USB Port 4 are disabled, a USB keyboard cannot be used to access the System Configuration Utility. IO Panel USB Port status can be changed through the WINCE or WIN32 Diagnostics Utility using the touchscreen.

---

### ***WINCE Factory Restore (All BIOS Versions)***

This field provides an alternative method of starting WINCE Factory Restore in situations when a USB keyboard is attached. To start WINCE Factory Restore, set this field to [Enabled], then return to the Exit Menu and select Save Settings and Restart. Chapter 4 contains procedures for starting WINCE Factory Restore.

### ***USB WIN32 Factory Restore (Q2010g and Q2011d)***

This field provides an alternative method of starting the optional Recovery CF. To start a Recovery CF, and restore the image to the USB Hard Drive, set this field to [Enabled], then return to the Exit Menu and select Save Settings and Restart.

See Chapter 4 to use the POSReady 2009 Recovery CF.

### ***SATA WIN32 Factory Restore (Q2010g and Q2011d)***

This field provides an alternative to using the Recovery Button to start the Recovery CF, but requires a USB Keyboard. To start the Recovery CF and restore the image to the SATA Disk Drive, set this field to [Enabled], then return to the Exit Menu and select Save Settings and Restart.



See Chapter 4 for more information about Workstation 5A Recovery options.

***Enable Password For Restore (Q2010g and Q2011d)***

This field is not available in BIOS Version Q1000g or Q1010m.

Starting with BIOS Version Q2010g, a pre-assigned password is required to start WINCE Factory Restore or use the optional POSReady 2009 CF Recovery CF.

The pre-assigned password is: *Quant1c0*

To disable the recovery password, set this field to [Disabled], Save Settings and Restart. MICROS recommends the password requirement remain enabled to prevent accidental or malicious use of WINCE Factory Restore or the CF Recovery Card.

***Compact Flash (Q2011d)***

Available in BIOS Version Q2011d or later, the Compact Flash field provides the ability to disable the IO Panel CF Slot for security purposes.

This field is intended for WIN32 configurations only. If the Compact Flash field is set to [Disabled] on a Windows Embedded CE 6.0 R3 unit, it will produce a POST error “NO CF FOUND” and fail to start.



***CAUTION***

If the Compact Flash interface is disabled on a Windows Embedded CE 6.0 workstation, the unit will fail to start and produce a POST error.

---

## Chipset

This tab displays the workstation processor temperature and contains the system power fail recovery selection.

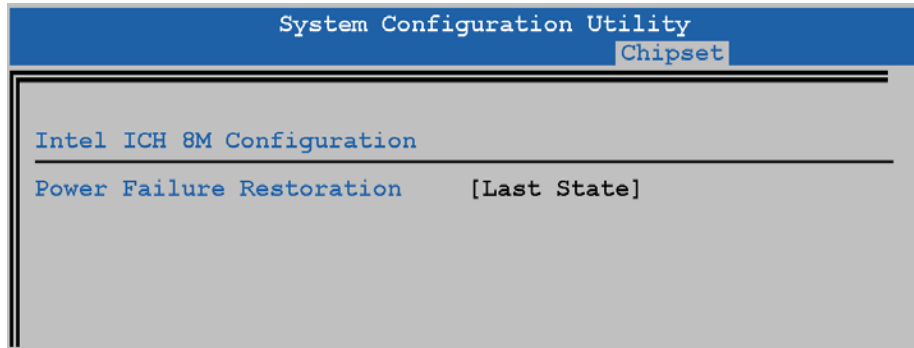

Figure 2-18: BIOS Power Failure Restoration

### Intel Pineview Information (Q1000g or Q1010m)

The read-only field displays the Pineview temperature as reported by an on-die thermal diode. This field has been removed in Q2010g or later.

### Intel ICH8M Configuration (All BIOS Versions)

The 'Power Failure Restoration' field defines how the workstation recovers from a power failure.

The default selection of [Last State] causes the workstation to return to the previous power state before AC power failed. For example, if the WS5A is **ON** and AC power fails, it will automatically restart when AC power is restored.

Conversely, if the workstation was **NOPOWER** when AC power failed, it remains **NOPOWER** when AC power returns.

If enabled, the [Power Off] selection requires the user to press the power button to restart the unit after an AC power failure.

If enabled, the [Power On] selection causes the unit to automatically power-on when the AC power cable is connected to the unit or when AC power is restored after an AC power failure.

## *AdvancedCPU*

This read-only screen displays the CPU Model, Stepping, and Microcode Version.

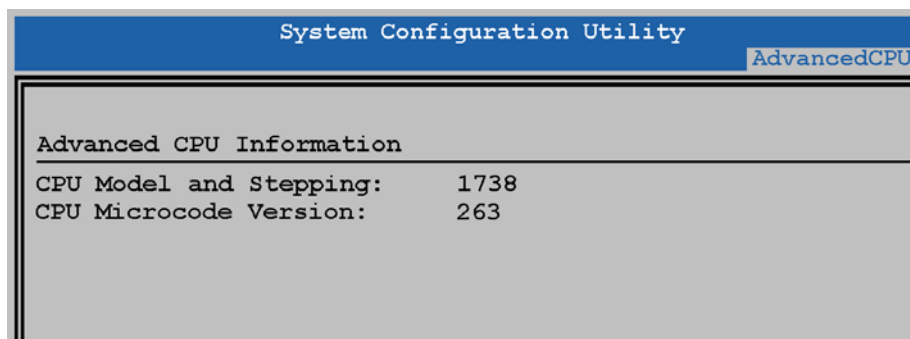

*Figure 2-19: BIOS System Configuration Utility - AdvancedCPU Tab*

## *Upgrading the BIOS*

Should it be required, this section describes how the BIOS is upgraded on Windows Embedded CE 6.0 or POSReady 2009 configurations.

### **Windows Embedded CE 6.0**

For Windows Embedded CE 6.0, a BIOS upgrade is handled by the CAL through a Platform Update. Executing the Platform Update on the server places the BIOS image and support files in the appropriate CAL server folders, which in turn distributes the files to the CF card of each workstation.

A BIOS update consists of the three files: QUNTICO.BIN, QUNTICO.LOG, and QCHKSUM.LOG. After the CAL places these files on the root of the CF card, it restarts the workstation.

When the unit restarts, Platform Update detects the QUNTICO.BIN file, performs a file size check, then generates a checksum against the binary file. The generated checksum is compared to the value stored in the QCHKSUM.LOG file. If the checksum match, the BIOS update proceeds and a message appears that a BIOS update in progress.

- If the checksum values do not match, the error messages:

‘BIOS File Chksum Failure!’

‘BIOS Not Updated’

If this error occurs, Platform Update deletes the QUNTICO.BIN file and creates a file called QBIOS\_ERR.LOG on the CF Card to indicate the BIOS binary file is corrupt.

After the BIOS update is complete, the workstation restarts. To prevent Platform Update flashing the BIOS a second time before the CAL removes the binary file, it created a file called BFLASH.LOG.

BFLASH.LOG is a text file that contains the current date in the format mm/dd/yyyy. Platform Update compares the date of the QUNTICO.BIN file with the date stored in the BFLASH.LOG file. If the dates match, the BIOS skips the update and continues with the boot process.

## **BIOS Update in Progress**

A sample of the BIOS Update screen is shown in Figure 2-20, below.

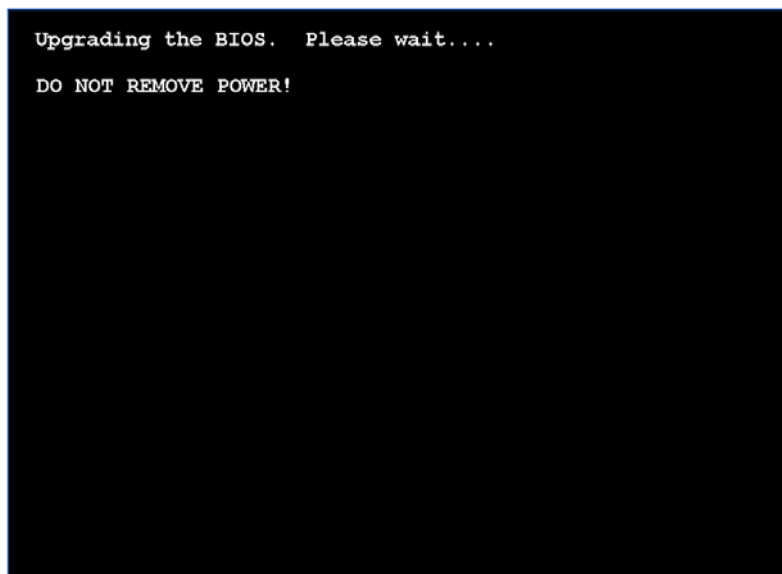

*Figure 2-20: BIOS Update in Progress - Do Not Remove Power!*



### **WARNING**

When the screen shown above is visible, pressing the power button or experiencing a sudden loss of AC Power, could result in a corrupt BIOS chip.

---

## **POSReady 2009**

Intel supplies a BIOS Flash Utility called fprog.exe to update the BIOS on WIN32 configurations of the Workstation 5A. The QUNTICO.LOG, and QCHKSUM.LOG files used by the Platform Update Utility are not required.

If a BIOS upgrade is required, it is posted in the form of a ZIP file on the Workstation 5A page of the HSG Portal. To upgrade the BIOS in this manner, a bootable USB thumb drive is required.

## Win CE Factory Restore

For Windows Embedded CE 6.0 R3, a custom pre-boot firmware application we call WINCE CE Factory Restore is available. Should the OS Image or platform files become corrupt or otherwise unusable, Factory Restore replaces all files on the USB hard drive and erases the CF card, returning the unit to the ‘out-of-box’ or factory condition. The procedure can be found in Chapter 4.

To understand how Factory Restore works, let’s examine the Windows CE USB Hard Drive partitions, as shown in Figure 2-21 below. Sizes of 256MB or 512MB may be encountered, but each contains three partitions of equal size. Two of the three partitions are hidden and not visible in ‘My Device.’

Partition 1 is a hidden boot partition, containing the OS image in a file called NK.BIN. Partition 2 is also hidden and contains the factory restore files. This includes a duplicate set of platform files, configuration files and folders, utilities, and the NK.BIN file. Partition 3 is visible and appears as ‘\DOC’ in ‘My Devices.’

Partition 1 (Hidden)	Partition 2 (Hidden)	Partition 3 (DOC)
Boot Partition NK.BIN	Factory Restore Files	Platform Files and Utilities

Figure 2-21: USB Hard Drive Partitions

Figure 2-22 illustrates how Factory Restore copies the image file and platform files to the correct partitions.

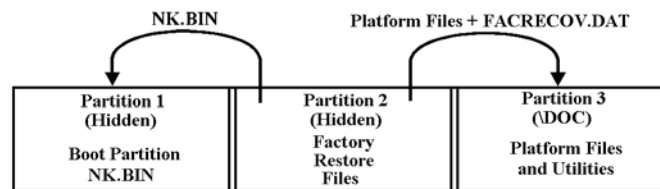

Figure 2-22: Windows CE Factory Restore Operation

The WINCE image, NK.BIN is copied from Partition 2 to Partition 1, the boot partition. The platform files and folders are copied from Partition 2 to Partition 3, the visible \DOC partition. Finally, a Wipe CF is performed to remove all files (and corruption) from the Compact Flash card.

Included with the Platform Files is a file called FACRECOV.DAT. This text file resides in the \DOC folder and contains information about the Factory Recovery feature. It can be examined from the WS5ADiagUtility System Information screen by touching the [Recovery Image Info] button. See Chapter 5 for more information.



### *What's Inside?*

This chapter describes how to open the workstation, provides a description of the system board and peripheral boards, shows how to install available options.

#### ***In this chapter***

---

Disassembling the Workstation 5A.....	3-2
System Board Components.....	3-7
System Block Diagrams.....	3-12
System Board Description .....	3-14
Installing Options.....	3-24
Reassembling the WS5A .....	3-37

---



## *Disassembling the Workstation 5A*

The following procedure describes how to disassemble the unit and access the system board and peripheral components.

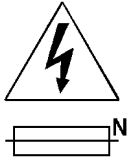

---

### **CAUTION: DOUBLE POLE/NEUTRAL FILTERING**

The Workstation 5A Power Supply contains a permanently connected fuse in the neutral line. After fuse operation, parts of the power supply remain energized and present a shock hazard as long as the AC Power Cord is connected.

Always disconnect the AC power cord before opening the unit for service or configuration.

---

1. Remove all cables from the IO Panel including the AC Power cable before disassembling the unit.
2. Place a towel or other soft cloth on your work surface to protect the touchscreen, then place the workstation face down on this surface. If an option such as the Finger Print reader is attached to the front cover, take care not to rest the unit in the casing.
  - o The cover is held in place by a pair of captive screws assessable from the underside of the unit as shown in Figure 3-1.
3. Loosen the captive screws as shown in the upper half of the Figure. Return the unit to the normal operating position. Remove the top cover from the base by lifting at the front as shown in the lower half of Figure 3-1.

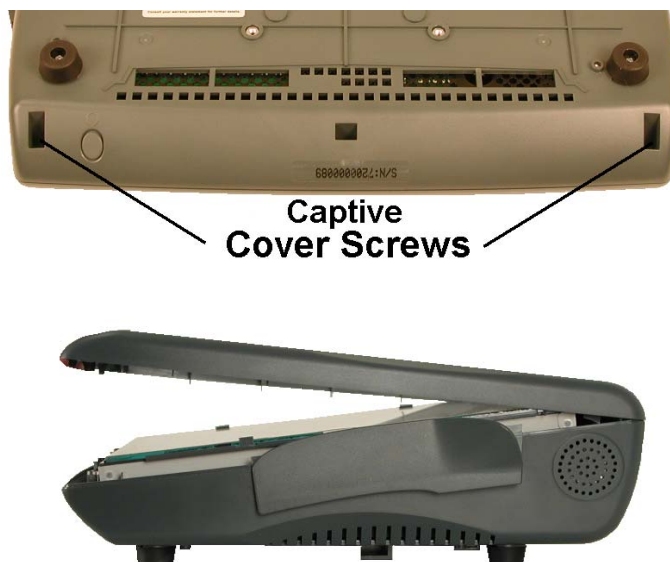

*Figure 3-1: Removing the WS5A Top Cover*

4. Remove the screw that fastens the LCD/Touchscreen assembly to the base as shown at the top of Figure 3-2.
5. Lift up the front of the LCD/Touchscreen assembly and place it to the right of the base. If you encounter resistance, check for a cable snagged under the Mini-PCI connector.

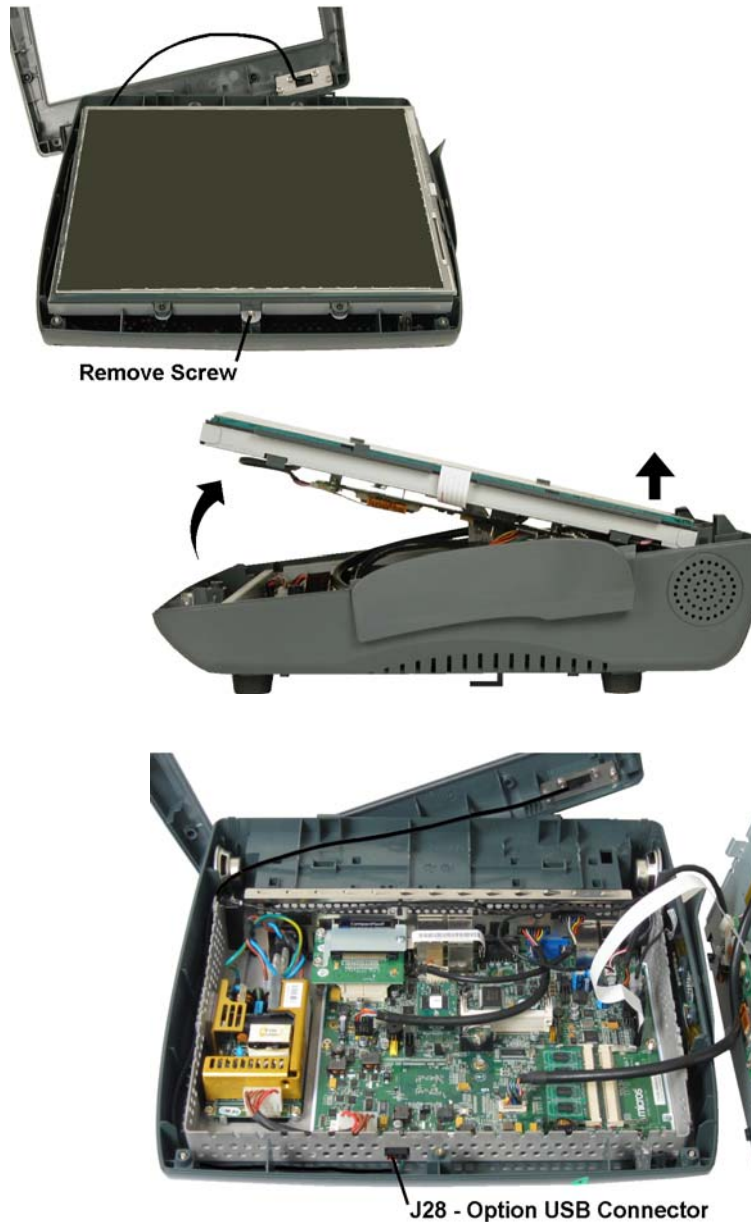

*Figure 3-2: Removing the LCD/Touchscreen Assembly*

6. If a Finger Print reader or other option is attached to the top cover, remove the interface cable from J28 located at the front of the chassis.

## What's Inside?

### Disassembling the Workstation 5A

7. If required, remove the LCD/Touchscreen cables from the WS5A System Board.
  - o The WS5A entered production with a 5-Wire Resistive Touchscreen and 15" LCD /w CCFL backlights and is shown on the left side of the Figure below. The optional capacitive touchscreen interface connectors are shown on the left.

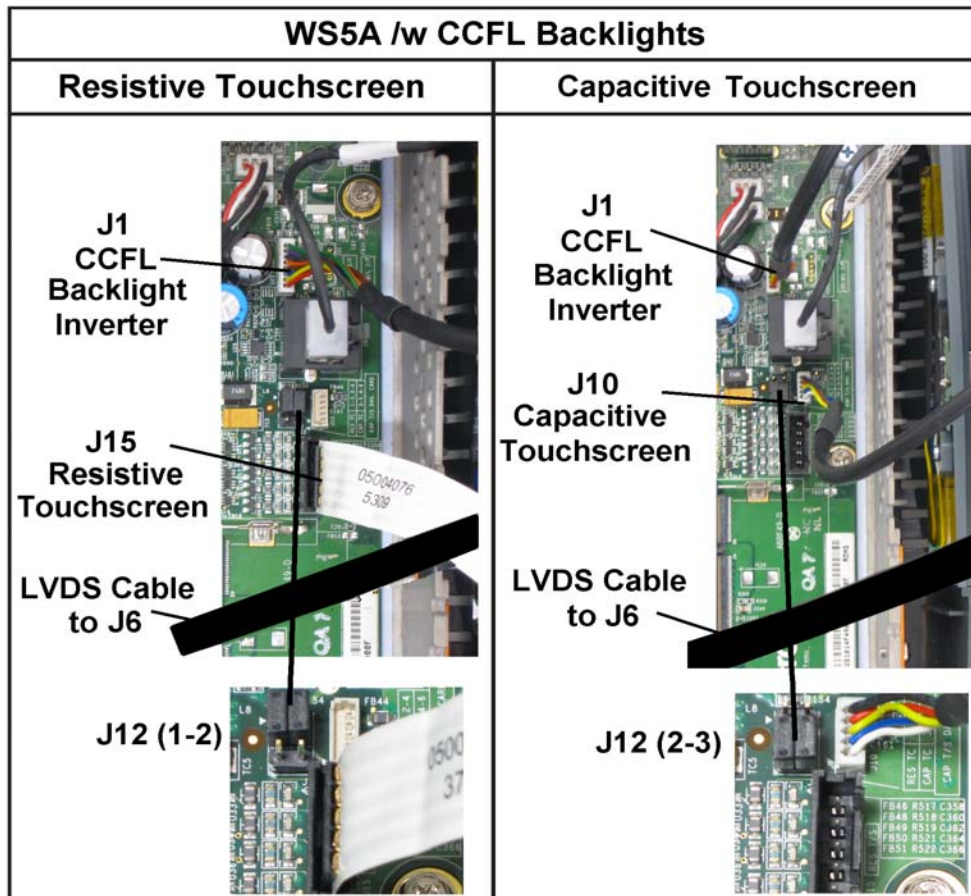

Figure 3-3: WS5A LCD/Touchscreen Connectors /w CCFL Backlights

- o The majority of Workstation 5As use a Resistive Touchscreen, the Capacitive Touchscreen is optional.
- o The LVDS connector is J6 (not shown).
- o Jumper J12, a 2x3 header selects the Resistive or Capacitive Touchscreen Interface as shown at the bottom of the illustration.

- o A small number of Workstation 5As used a 15" AUO V2 LCD with LED Backlights and Resistive Touchscreen shown in the illustration below.

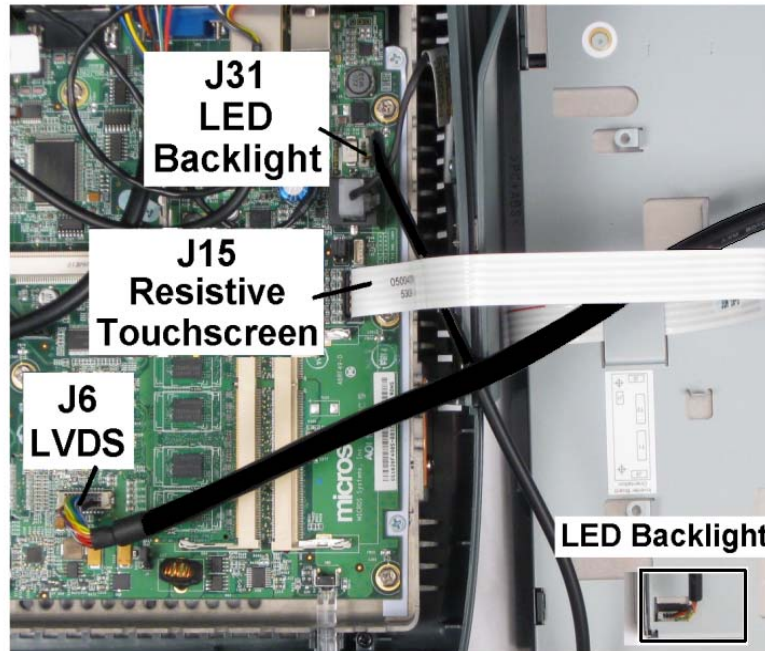

Figure 3-4: Workstation 5A with LED Backlights (AUO V2 LCD)

- o A DC-to-DC converter residing on the System Board powers the LED Backlights through connector J31. On the majority of WS5A system boards configured to drive the CCFL inverter, the DC-to-DC converter components and connector J31 are not installed.
- o The LCD panel with LED backlights (AUO V3) used on the PCWS 2015 is not compatible with Workstation 5A System Boards Revision C and D. The AUO V3 panel has a built-in DC-to-DC Converter for the LED Backlights.
- o On the Revision F System Board, J1 the backlight connector has been upgraded to support a both CCFL LCD and the AUO V3 LCD panel.

## What's Inside?

### Disassembling the Workstation 5A

With the LCD/Touchscreen removed, the upper half of Figure 3-5 below, displays the Workstation 5A base. For comparison, the original Workstation 5 is shown in the lower half of the image.

The Workstation 5A uses the same plastic base, mag card reader assembly, and speakers as the original Workstation 5. However the chassis, Intel Atom based System Boards, SO-DIMMs, DMA Enabled CF Riser Card, power supply and improved power button actuator are new to the Workstation 5A.

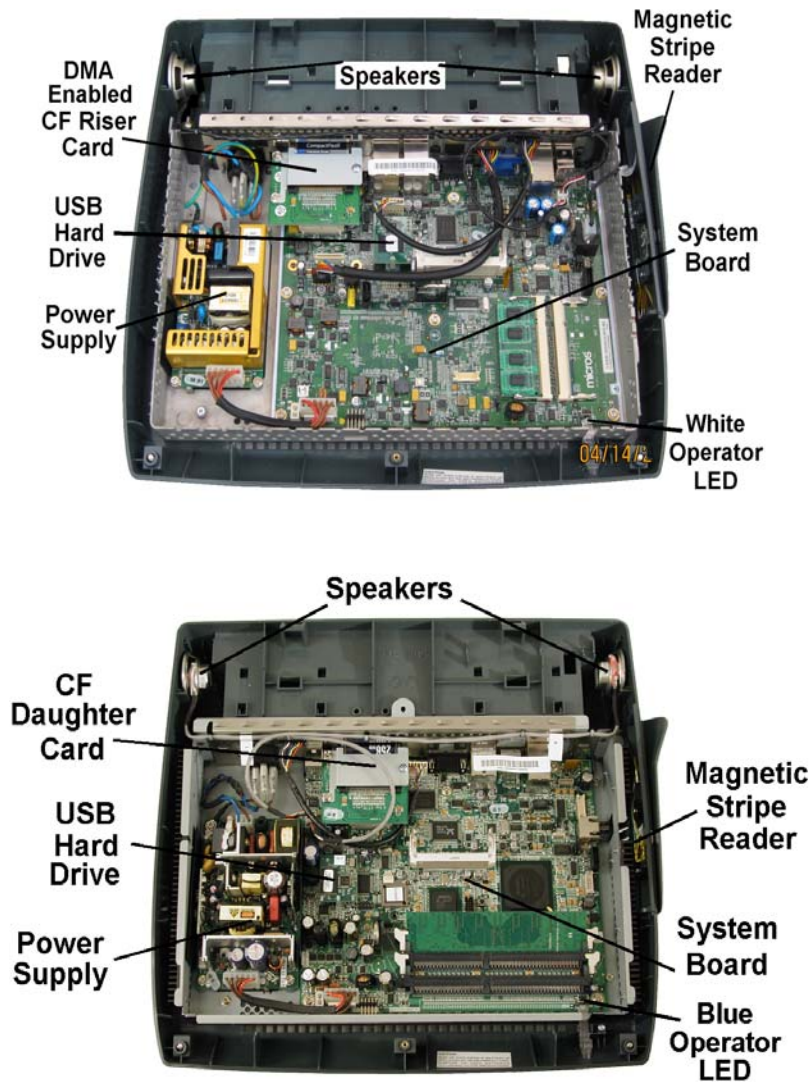

*Figure 3-5: WS5A (Top) and WS5 (Bottom) Base, System Board and Power Supply*

The Workstation 5A chassis is composed of a lightweight magnesium alloy. The CPU and ICH8M contact a copper heat sink fastened to the chassis.

## System Board Components

This section displays the WS5A System Board components, connectors and jumpers, and includes Revisions C, D, and F System Boards. The Revision E System Board did not enter production.

Revision F System Boards will appear in mid 2012.

### WS5A System Board - Primary Components (Revisions C, D, and F)

The Processor and ICH8M are mounted on the underside of the system board to contact the thermal pads and copper heat sink.

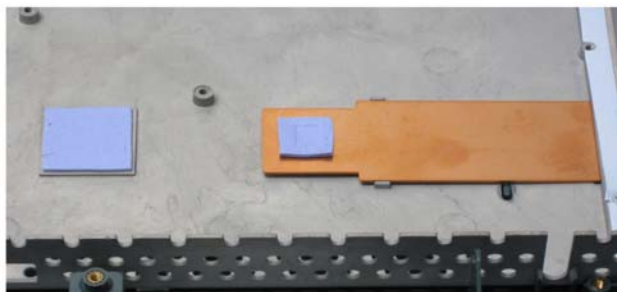
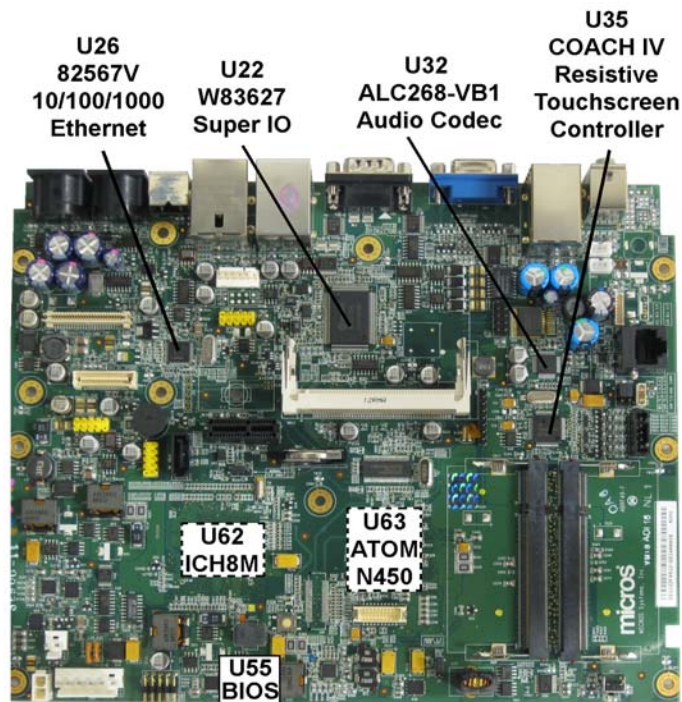

Figure 3-6: System Board Rev C, D, and F Primary Components and Heat Sink

### WS5A System Board Connectors (Revisions C, and D)

Please note that J14 is reserved for the IO Panel Powered USB Connection and is not intended for options such as the finger print reader or WiFi.

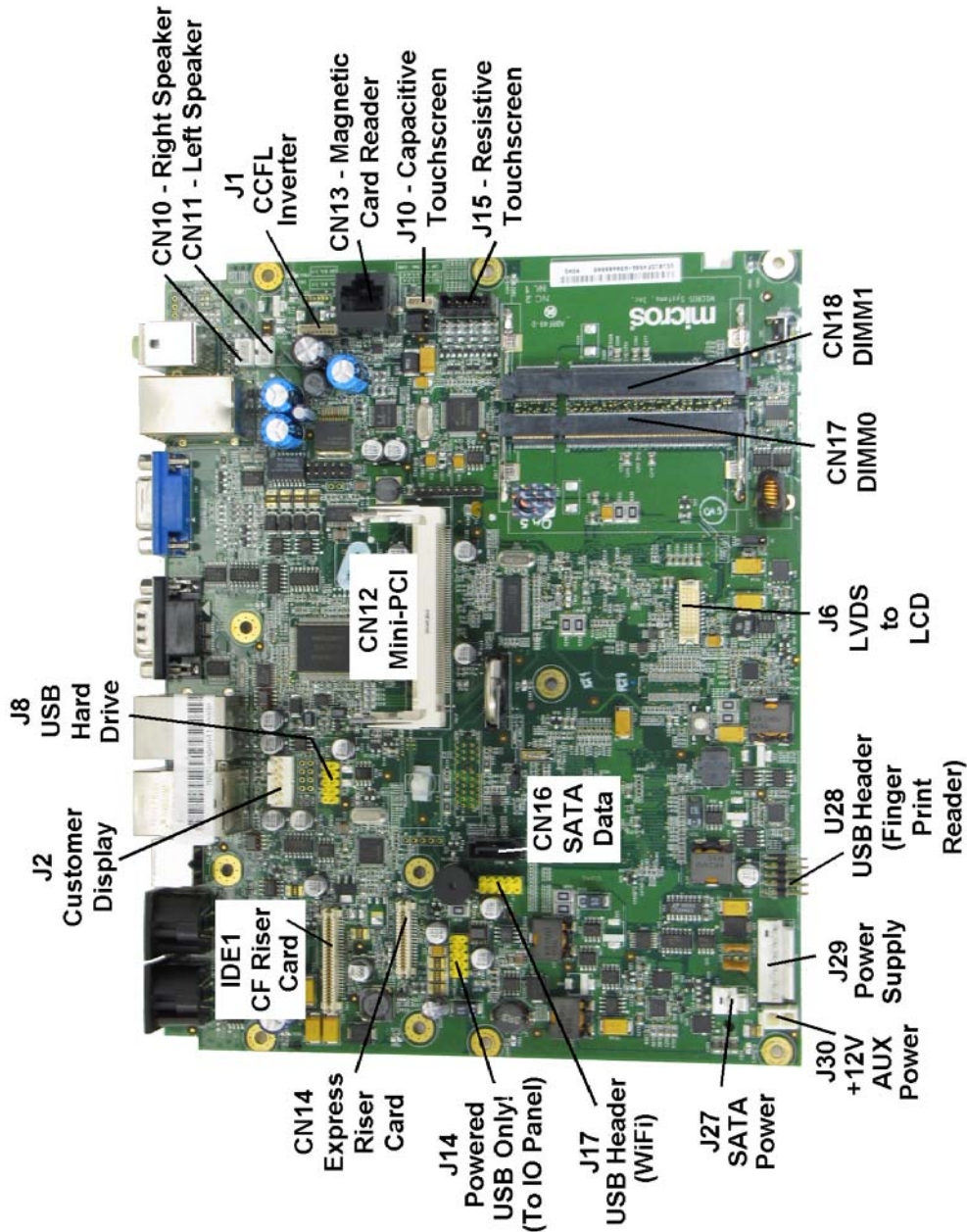

Figure 3-7: System Board Revision C or D Connectors

### WS5A System Board Jumpers and Switches (Revisions C, D and F)

The Figure below applies to all System Board Revisions. See the page 3-12 for details and a procedure for using the CMOS clear jumper.

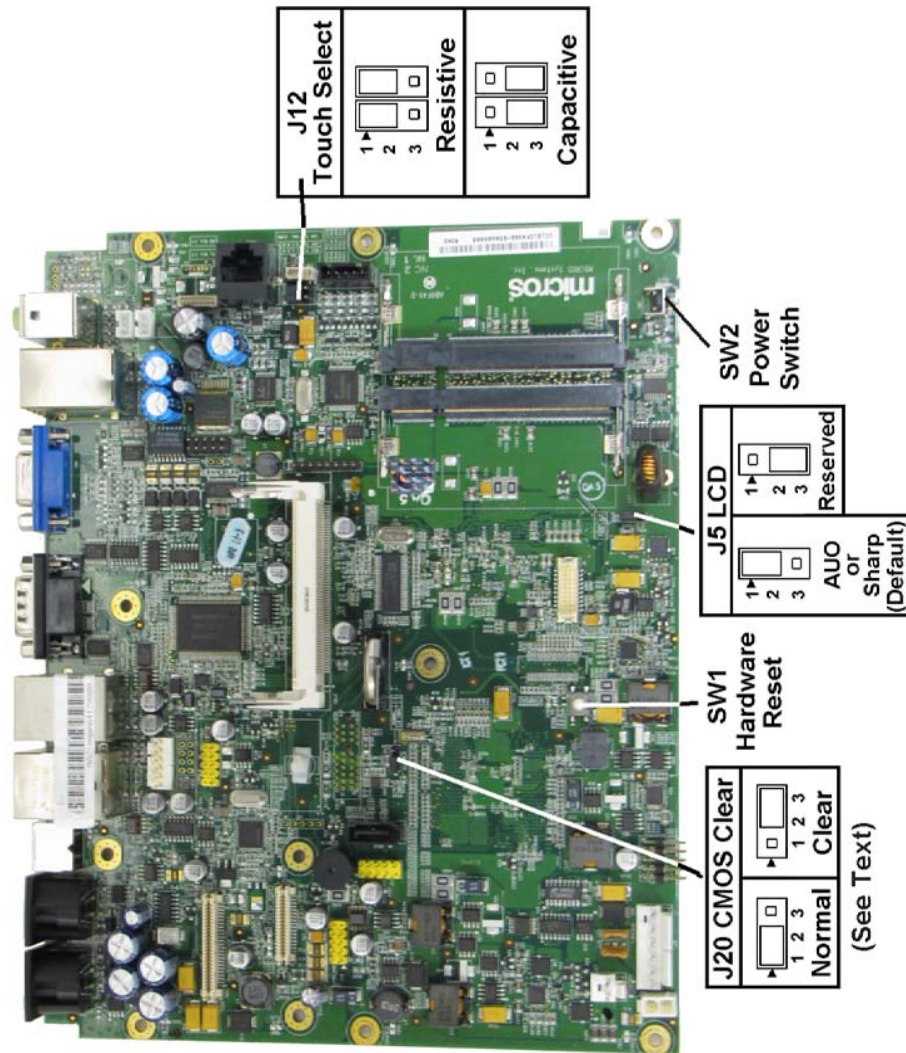

Figure 3-8: System Board Jumpers and Switches (All Revisions)



## WS5A System Board Connectors (Revision F)

The Figure below displays System Board Revision F Connectors.

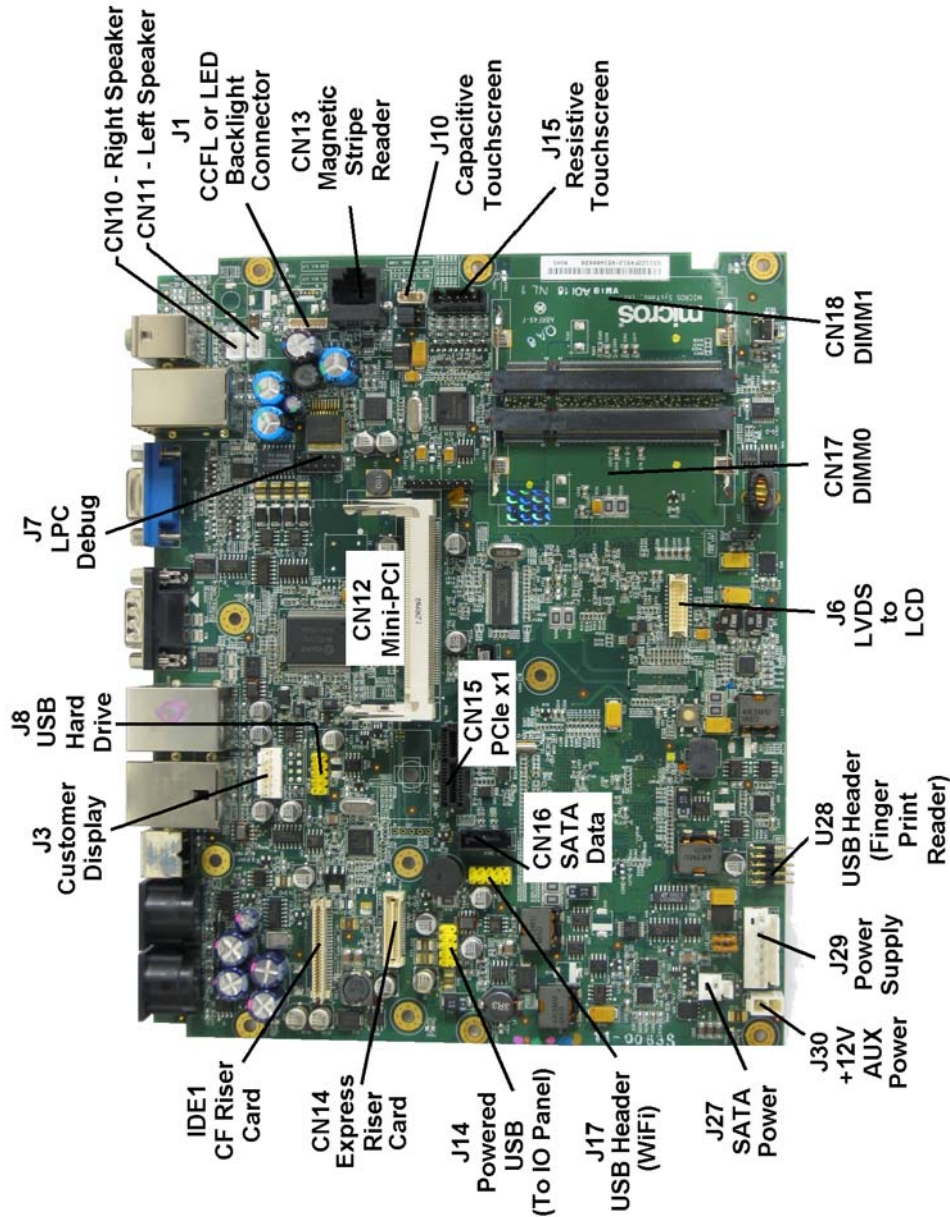

Figure 3-9: WS5A System Board Revision F Connectors

J1, the backlight connector now supports either CCFL or LED backlights. As of mid-2012, the CCFL backlight version remains in production.

---

## System Board Jumper Configuration

All revisions of the Workstation 5A System Board include the following configuration jumpers.

### J12 - Touch Screen Select

J12 is a 2x3 header consisting of two jumpers. This pair of jumpers selects between the System Board resistive touchscreen controller and the optional off-board capacitive touchscreen interface.

### J20 - CMOS Reset

J20, when used properly, clears the CMOS Memory, and re-enables the IO Panel USB Ports. After using J20 to clear CMOS, see the procedure below.

1. **Remove the AC Power Cable from the unit.** This is required to remove all standby voltages from the ICH8M circuitry.
2. Move the jumper from pins 1-2 to pins 2-3 for one second, then move the jumper back to the pins 1-2.
3. Connect a USB Keyboard and AC power cable to the workstation.
4. If the workstation does not start when the AC power cable is connected, press and release the power button. When the Blue splash screen appears, press [Del] to enter the BIOS Configuration Utility.
5. Select the 'Main' tab and scroll down to the bottom of the page to program the system time and date.
6. If required, proceed to the ODM tab and disable the IO Panel USB Ports. IO Panel USB ports can also be disabled from the WS5A Diagnostics Utility after the operating system starts. See Chapter 2 for more information about the ODM tab selections.
7. Proceed to the Exit tab and based on the BIOS Version installed, select the appropriate boot defaults as described on the Exit page of Chapter 2.

### J5 - TFT Panel Mode

J5 selects the LCD panel type. The default setting of 1-2 supports current Sharp or AUO LCD Panels. The original Workstation 5 used a Sharp LCD. The Workstation 5A uses an AUO LCD, both with CCFL Backlights.

## System Block Diagrams

### Workstation 5A Block Diagram (CCFL Backlights/Resistive Touchscreen)

Figure 3-10, shows a block diagram of the Workstation 5A, with CCFL backlights and resistive touchscreen.

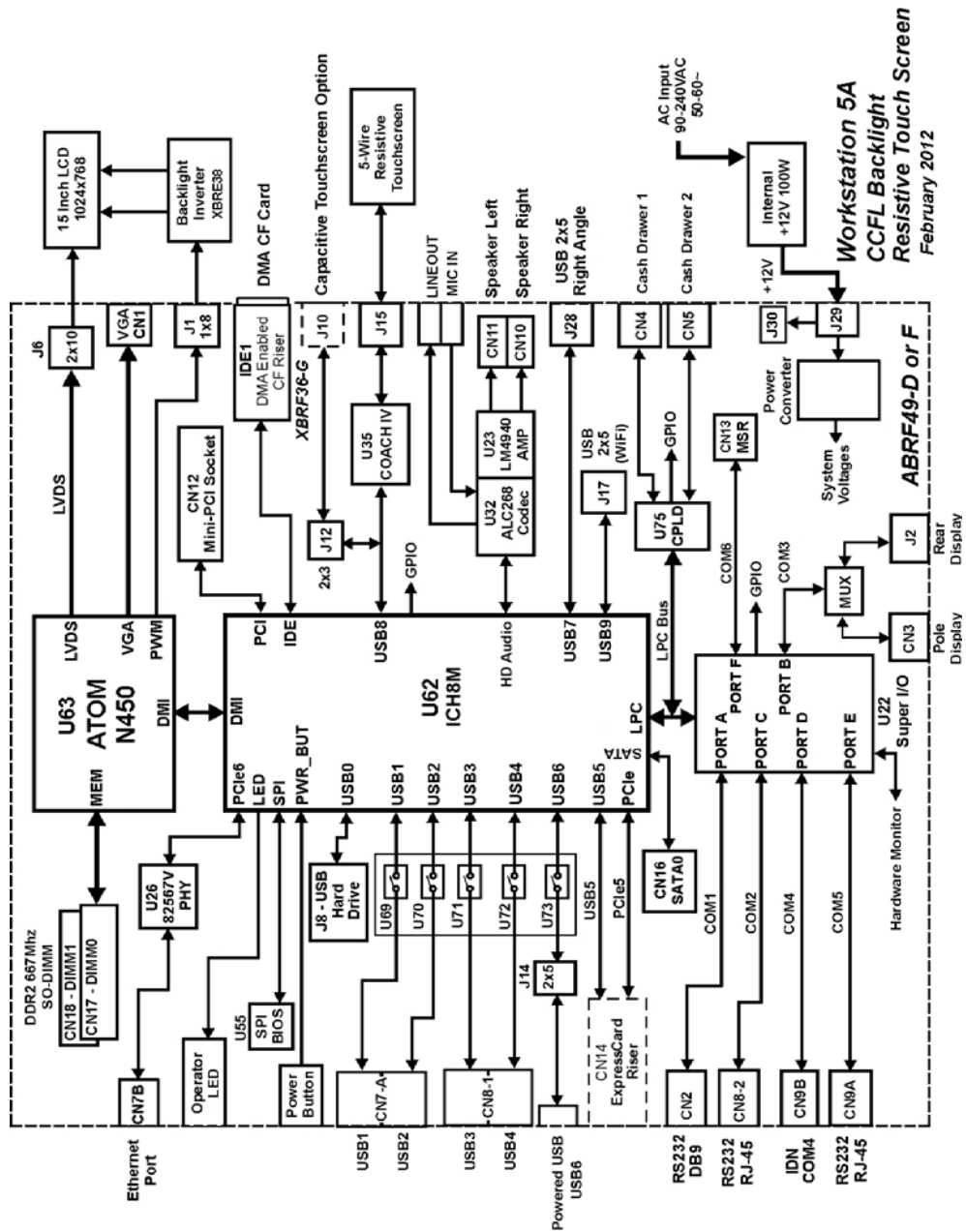

Figure 3-10: WS5A Block Diagram (CCFL Backlights and Resistive Touch Screen)

### Workstation 5A Block Diagram (LED Backlights/Resistive Touchscreen)

A small number of WS5As shipped with LED backlights and resistive touchscreen, as shown in the diagram below. This configuration uses a System Board DC-to-DC converter to drive the LED backlights.

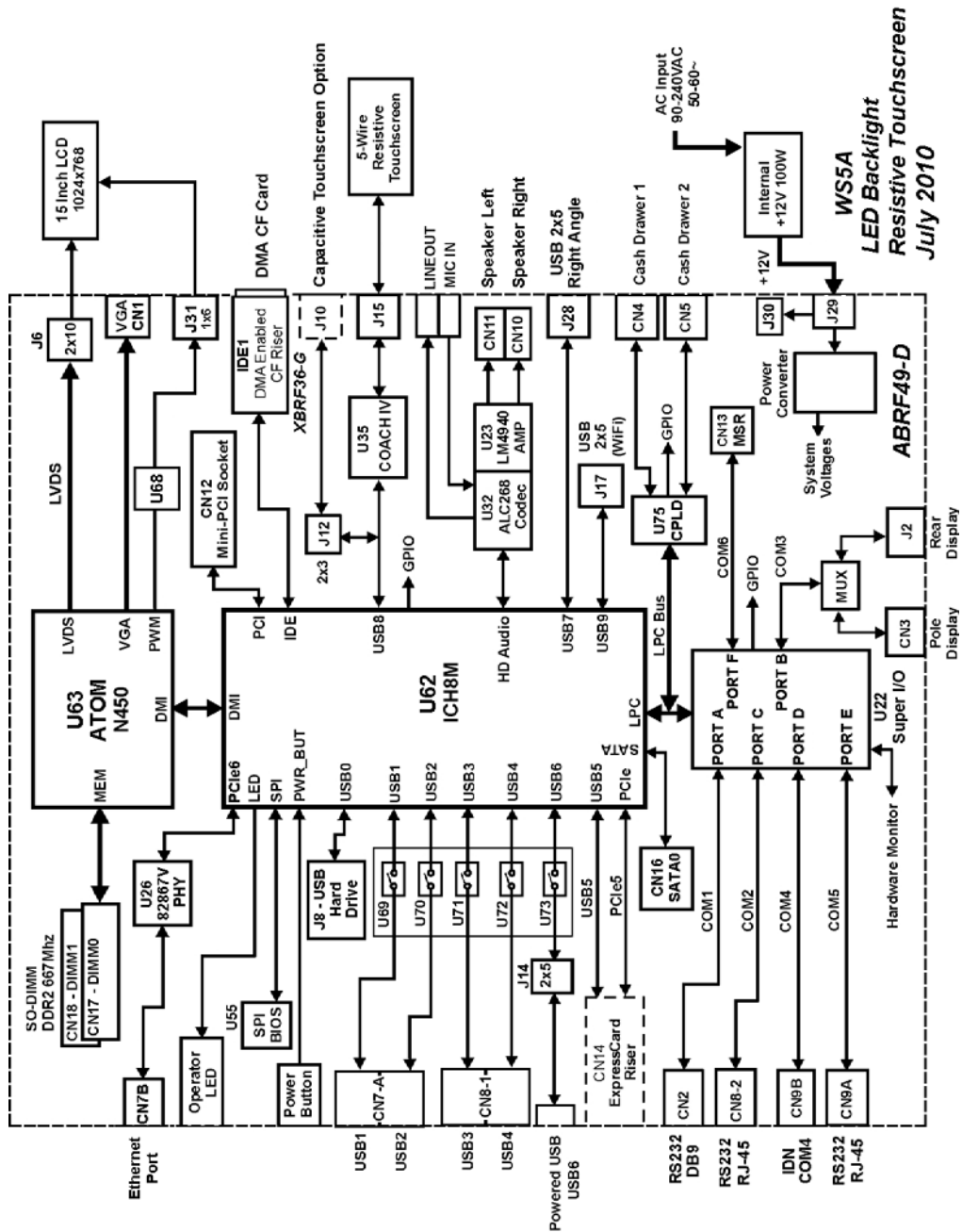

Figure 3-11: WS5A Block Diagram (LED Backlights and Resistive Touch Screen)

## *System Board Description*

The Workstation 5A System Board uses a single-core Atom N450 processor called Pineview M, part of the Intel Luna Pier platform. Luna Pier is a two-chip solution consisting of a processor core with integrated memory and graphics controller.

All versions of the WS5A System Board use the ICH8M to provide the majority of IO ports and LVDS video.

### **Intel Atom N450 General Features**

- Single Core - Speed 1.6GHz
- 32kB instruction cache, and 24 kB write back data cache.
- 512K L2 Cache
- Hyper-Threading Technology (2 threads)
- Micro-FCBGA8 package 22x22 mm
- Enhanced Intel<sup>®</sup> SpeedStep<sup>®</sup> Technology  
Intel Enhanced SpeedStep<sup>®</sup> technology monitors workstation activity and reduces power consumption when the workstation is idle. When performance is required, Intel SpeedStep<sup>®</sup> technology enables real-time switching of multiple performance modes. Changes to the core processor speeds, bus ratios, and core operating voltages all occur without resetting the system.
- Thermal Management via TM1 and TM2.

## **Interfaces**

The Pineview-M N450 integrates Memory Controller, Graphics Controller, Direct Media Interface and single or dual core CPU housed in a single die.

### **Integrated Memory Controller (ICM)**

The Integrated Memory Controller supports DDR2 protocols and a single 64-bit wide channel to access two SO-DIMMs.

Single Channel DDR2 Controller supports data transfer rates of 667 M/T.

Non-ECC, unbuffered DDR2 SO-DIMMs only.

512 Mb, 1GB, and 2GB DDR2 memory technologies supported.

The System Board includes two SO-DIMM socket supporting a maximum of 2GB which may be used for WIN32 operating systems such as POSReady 2009. The Windows Embedded CE 6.0 R3 image is limited to 512MB of RAM.

### **Graphics Processing Unit (GPU)**

The GPU is composed of engines, planes, pipes, and ports. The GPUs 3D/2D engines are fed with data through the integrated memory controller. The outputs of the engines are surfaces sent to the memory, then retrieved and processed by the processor planes. Feature highlights include:

3rd generation graphics controller refresh

Intel Dynamic Video Memory Technology

DirectX 9<sup>®</sup> compliant Pixel Shader 2.0

200 MHz render clock frequency (N450)

2 Independent Display Ports:

Single LVDS Channel to the workstation 15" LCD at 1024x768

Analog RGB display output on the IO panel supports resolutions up to 1400x1050 @ 60hz.

Intel<sup>®</sup> Clear Video Technology

MPEG2 Hardware Acceleration

The second generation Intel Atom offers improved graphics performance over previous Intel Atom platforms such as Navy Pier in three ways:

Move the graphics and memory controllers into the processor package.

Increase the system front side bus speed from 533Mhz to 667MHz.

Increase the Graphics Controller clock speed from 166Mhz to 200Mhz.

### **Direct Media Interface (DMI)**

Direct Media Interface is the chip-to-chip connection between the Processor and IO Controller Hub. This high-speed interface integrates priority based servicing allowing for concurrent traffic and true isochronous transfer capabilities.

Base functionality completely software-transparent, permitting legacy software to operate normally. Features:

- Supports two lanes in each direction

- 100MHz reference clock

- 2.5Gb/s point-to-point DMI Interface to the ICH8M

- Raw bit-rate on the data pins of 2.5Gb/s, resulting in real bandwidth per pair of 250MB/s including the 8b/10b encoding used to transmit data across this interface.

### **ICH8M General Features**

The ICH8M is part of a family of IO Controllers that encompass home, office and mobile applications. The ICH8M is targeted for low power mobile applications and is the only member of the ICH8 family that includes an IDE port.

The IDE interface is used for the CF Card in Windows Embedded CE 6.0 configurations and CF Recovery for WIN32 applications.

The ICH8M provides most IO support as shown in Figure 3-12.

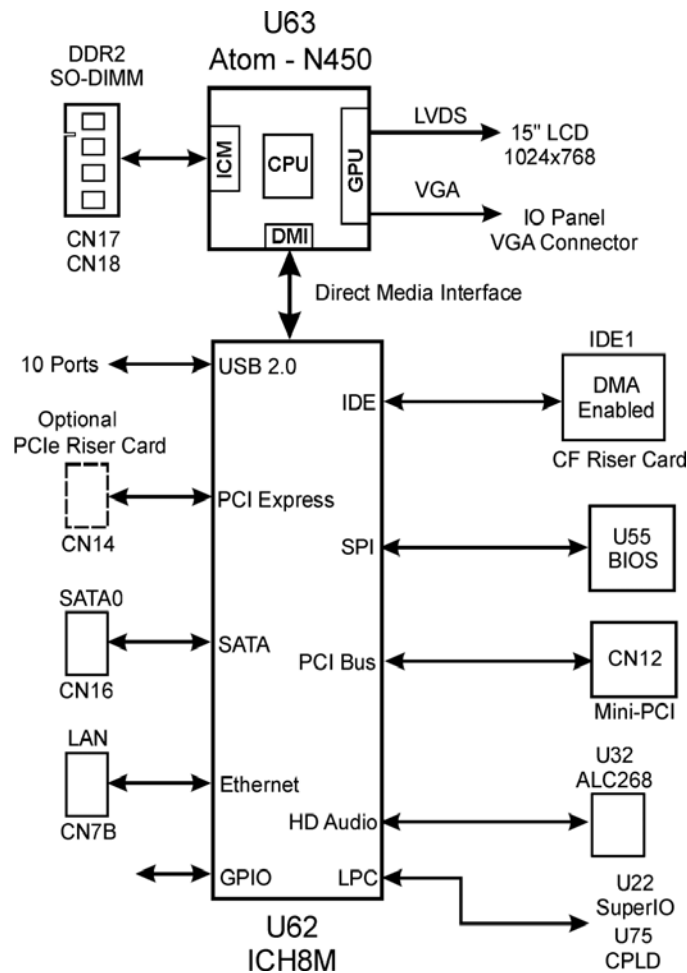

Figure 3-12: ICH8M I/O Port Summary

### USB 2.0 Ports

The ICH8M contains two Enhanced Host Controller Interface (EHCI) host controllers supporting up to ten USB 2.0 high speed ports. The ICH8M contains port-routing logic that determines whether a USB port is controlled by the UHCI (USB 1.1) controller or EHCI (USB 2.0) controller.

The WS5A System Board includes the ability to disable all external USB ports including the Powered USB Port.



### **IO Panel**

Four USB 2.0 connectors are located on the IO Panel designated USB1 through USB4. A fifth USB Port, USB6 is available through a custom connector to deliver a form of powered USB, using individual +5V, +12V, and +24V dongles.

The five USB Ports available on the IO Panel can be disabled through BIOS or WS5A Diagnostics Utility.

### **System Board**

The remaining USB ports are reserved for various IO devices within the workstation. This includes dedicated connectors for the USB Hard Drive, optional Mini-PCI WiFi Card, custom powered USB connector, and a single right-angle USB connector available for options such as the fingerprint reader.

Of the two remaining USB ports, one is dedicated to the on-board ELO COACH IV Resistive Touch screen Controller and one is routed to the PCI Express Mini Card/Express Card socket.

### ***IDE***

The ICH8M contains a single IDE channel supporting up to two ATAPI compatible devices.

The IDE interface supports PIO IDE transfers up to 16 MB/sec and Ultra ATA transfers up to 100MB/sec with full Direct Memory Access (DMA) support.

The IDE interface is routed to connector IDE1, the CF Riser Card Socket. The WS5A uses an upgraded version of the original WS4/WS4LX/KWS4/WS5 CF Riser Card that supports DMA enabled CF cards. DMA enabled CF Cards provide a boost in the graphics performance of the latest POS Applications, but may not be compatible with previous MICROS Windows CE based workstations.

The Workstation 5 and Workstation 5A Field Guide will provide more details about the DMA Enabled CF Riser Card.

### ***PCI Express***

The ICH8M supports up to 6 PCI Express Root Ports, supporting the PCI Express Base Specification, Revision 1.1.

PCI Express Ports 1-4 can be configured as one x2 ports (using ports 1 and 2) with ports 3 and 4 configured as x1 ports.

PCI Express port 5 is routed to the future optional PCI Express Riser Card socket, and PCI Express port 6 is routed to the Ethernet Controller.

### ***SPI (Serial Peripheral Interface)***

The Serial Peripheral Interface is a 4-pin interface that provides a lower cost alternative for system BIOS flash than the Firmware Hub and LPC Bus.

The ICH8M supports up to two SPI devices with speeds of up to 33Mhz.

One SPI interface is dedicated to U55, the WS5A BIOS.

### ***SATA (Serial Attached ATA)***

The ICH8M supports the Serial ATA Specification, Revision 2.5 and supports independent DMA operation on up to three ports with data transfer rates of up to 3.0 Gb/s. Each SATA channel consists of a transmit and receive pair.

The System Board includes a SATA data connector and custom power connector to support a single SATA 2 1/2" HDD or SSD. The optional kit is supplied with one SATA SSD, Mounting Plate, SATA Data Cable and custom Power Cable.

### ***PCI Bus***

The ICH8M PCI interface provides a 33 MHz, Revision 2.3 implementation. The ICH8M integrates up to four external PCI Bus masters. One PCI interface is used to support the Mini-PCI connector CN12. The Mini-PCI connector supports a WiFi card, and modem.

### ***Ethernet***

The ICH8M integrates a Gigabit Ethernet Controller that is compatible with the Intel 82867 Gigabit LAN Platform Connect Device.

The ICH8M integrated GbE controller supports multi-speed operation of 10/100/1000 Mb/s. The interface can operate in full duplex at all supported speeds or half-duplex at 10/100 Mb/s and complies with the IEEE 802.3x Flow Control Specification.

### ***HD Audio***

The ICH8M contains a High Definition Audio (HDA) controller that communicates with an external codec over the Intel High Definition Audio serial link. The HDA protocol is controller synchronous, based on a 24MHz Bit Clock sent by the ICH8M HD Audio controller.

The input and output streams, including command and PCM data, are isochronous with a 48Khz frame rate. The ICH8M implements four DMA output engines and four DMA input engines. The output DMA engines move digital data from system memory to the D-A converter in the codec. The input DMA engines move digital data from the A-D converter in the codec to system memory.

The WS5A System Board uses a Realtek ALC268-VB1 HDA Codec. The WS5A includes two internal speakers mounted to the left and right side of the base. A two watt per channel amplifier drives the speakers. In addition, the I/O panel includes Microphone Input and Line Output connectors.

### ***GPIO***

The ICH8M includes a number of General Purpose Input/Output lines that are used to implement many custom functions and actions. Typical uses include USB port control switches, and items such as +12V or +24V cash drawer voltages

### ***LPC***

The ICH8M implements an LPC interface based on the Low Pin Count Interface Specification Revision 1.1.

Several devices are connected to the LPC Bus. CPLD U75, Super IO U22, and TPM module U24. J7 is a header for a LPC compatible POST Code Reader.

### ***SMBus***

The ICH8M contains an System Management Bus (SMBus) Host interface that allows the processor to communicate with SMBus Slaves. This interface is compatible with most I2C devices. Special I2C commands are implemented.

The SMBus also implements hardware based Packet Error Checking for data robustness and the Address Resolution Protocol (ARP) to dynamically provide addresses to all SMBus devices.

System Board SM Bus devices include SMBus Repeaters U45/U65 and Temperature Monitor U47.

### LCD Touchscreen Assembly - Resistive Touchscreen

The WS5A and LCD/Touchscreen assembly carries over from the original Workstation 5. It is composed of a 15" resistive touch surface, bracket, 15" AUO LCD with CCFL Backlights, LCD Plate and Backlight Inverter Board.

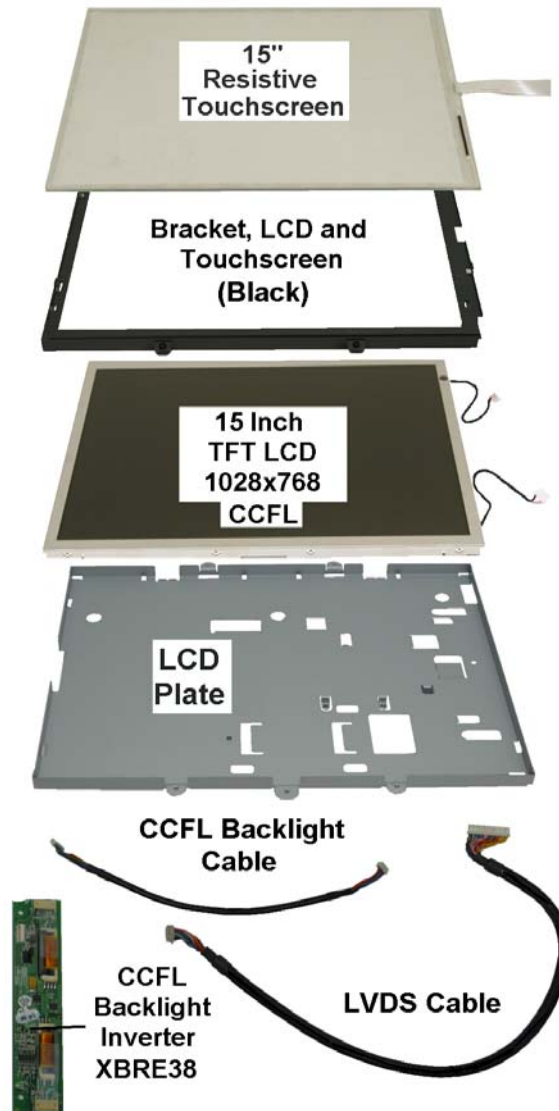

Figure 3-13: The LCD/Touchscreen Assembly /w Resistive Touchscreen

Twenty Workstation 5A were produced with LED Backlights.  
The Capacitive touchscreen option is also available.

### **CCFL Backlight Inverter Board**

The CCLF Backlight Inverter Board is mounted to the rear of the LCD Plate as shown in the Figure 3-14 below.

The inverter includes jumpers J4 and J5, used to select the LCD Panel model. The jumper settings are routed through the interface cable to GPIO ports on the system board. At start up, the WS5A WINCE API reads the GPIO to determine the type of panel installed.

Once the API determines the panel type, it references the HWInf folder and loads a panel specific INF file that contains optimum backlight values for that panel.

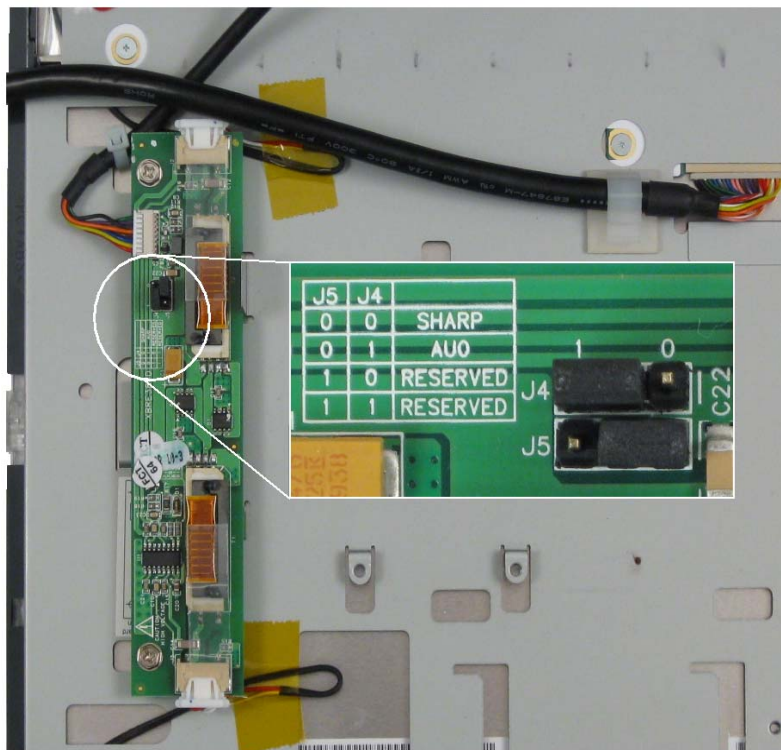

*Figure 3-14: CCFL Backlight Inverter Board and Jumper Settings*

The jumper configuration is set to support the current AUO LCD Panel with CCFL Backlights.

### LCD Touchscreen Assembly - Optional Capacitive Touchscreen

The Capacitive Touchscreen option adds the Capacitive Interface Board and Interface Cable as shown in the Figure below.

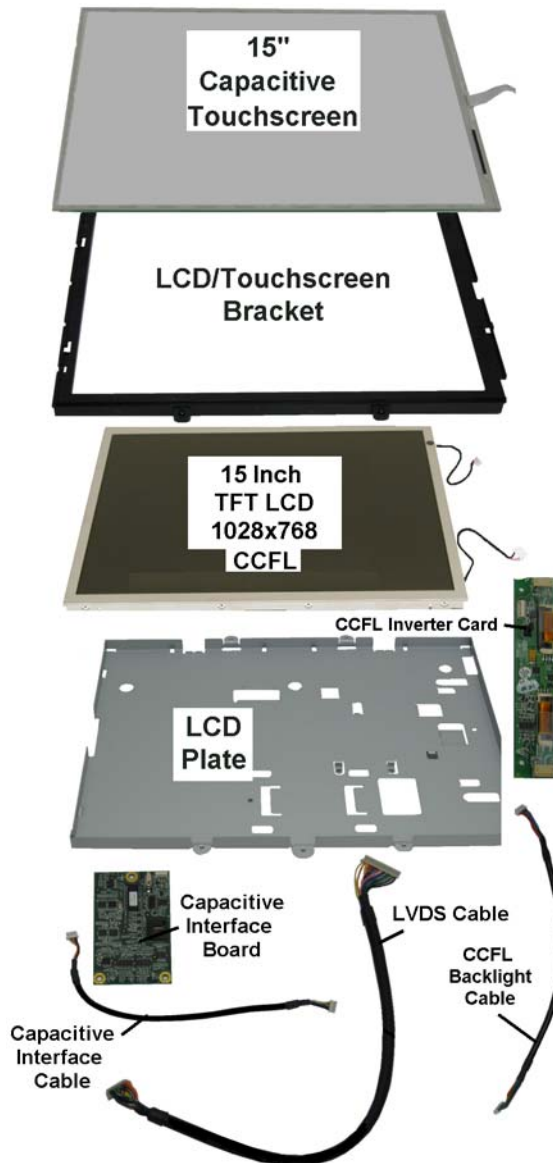

Figure 3-15: Optional Capacitive Touchscreen Components (CCFL Backlights)

## *Installing Options*

This section includes procedures for removing and replacing Workstation 5A internal components and options.

---

### **Magnetic Card Reader**

The Workstation 5A uses the same Magnetic Card Reader Assembly as the original Workstation 5. The reader head is mounted to a plastic channel located along the right side of the base.

Connector CN13, for the Mag Card Reader is shown in Figure 3-16, below.

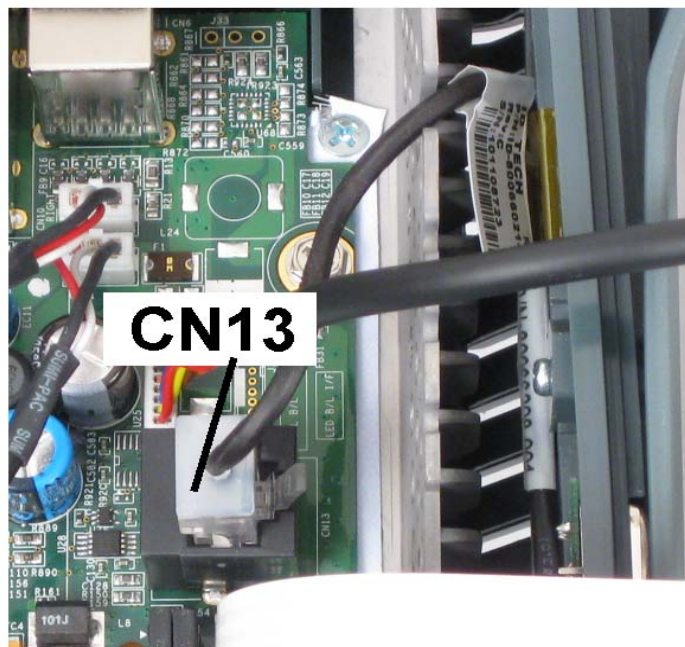

*Figure 3-16: Removing the Mag Card Reader Connector*

---

## USB Hard Drive

This procedure describes how to remove and replace the USB Hard Drive used for Windows CE and most POSReady 2009 configurations.

1. Remove the LCD/Touchscreen Assembly as previously described.
2. Refer to Figure 3-17 below. Use a pair of needle nose pliers to pinch the stand-off and remove the device.

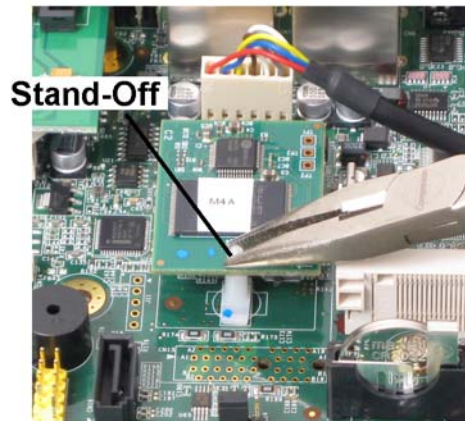

*Figure 3-17: Removing the USB Hard Drive*

## Installation

1. Figure 3-18, below points out the location of pin-9 on the dedicated USB Hard Drive header J8. Pin-9 serves as the key when installing the device. It is possible to offset the pins, which could cause a POST failure. Be sure the device is secured to the board with the stand-off clip.



*Figure 3-18: Installing the USB Hard Drive*



---

## DDR2 SO-DIMM

This section specifies the approved memory devices and describes how to remove and replace them.

The Workstation 5A System Board includes a pair of SO-DIMM sockets CN17 (DIMM0) and CN18 (DIMM1). Up to 2G of main memory is supported. For best results, memory should be composed of 2 x 1G SO-DIMMs as shown in Figure 3-20.

Avoid using 2G SO-DIMMs of any type.

### Approved SO-DIMM list

Figure 3-19, below lists DDR2 SO-DIMMs approved for use in the WS5A.

Size	MICROS P/N	Description	Source
512MB	700502-178	512MB DDR2 667	ATP XZ66L6N1HS-E-MS
512MB	700502-178	512MB DDR2 667	Unigen UG64T6400M6SU-6AA
512MB	700502-178	512MB DDR2 667	Unigen UG64T6400L8SU-6AS
512MB	700502-178	512MB DDR2 667	Transcend TS64MSQ64V6J
512MB	700502-178	512MB DDR2 667	ATP XZ66L6N1HS-F-MS
1G	700502-177	1G DDR2 667	Wintec WD2SN01Gx808-800I-PE
1G	700502-177	1G DDR2 667	Transcend TS128MSQ64V8U

*Figure 3-19: Approved SO-DIMMs for the WS5A*

Note: The Windows Embedded CE 6.0 R3 image is limited to 512MB of main memory. If more than 512MB is installed, it is not used.

### SO-DIMM Configuration

Figure 3-20 on the next page, displays the factory SO-DIMM configurations.

DIMM0	DIMM1	Total	Operating System
512MB	--	512MB	Windows Embedded CE 6.0, R3
1G	--	1G	POSReady 2009
1G	1G	2G	POSReady 2009

Figure 3-20: SO-DIMM Configuration

### Installation and Removal

To install a SO-DIMM, line up the notch in the SO-DIMM with the land in the socket and insert the device into the socket at a 30° angle. When fully inserted in the socket, press down to lock the retention clips into place. To remove an SO-DIMM, release the retention clips on each end of the SO-DIMM and the device will flip to a 30° angle.

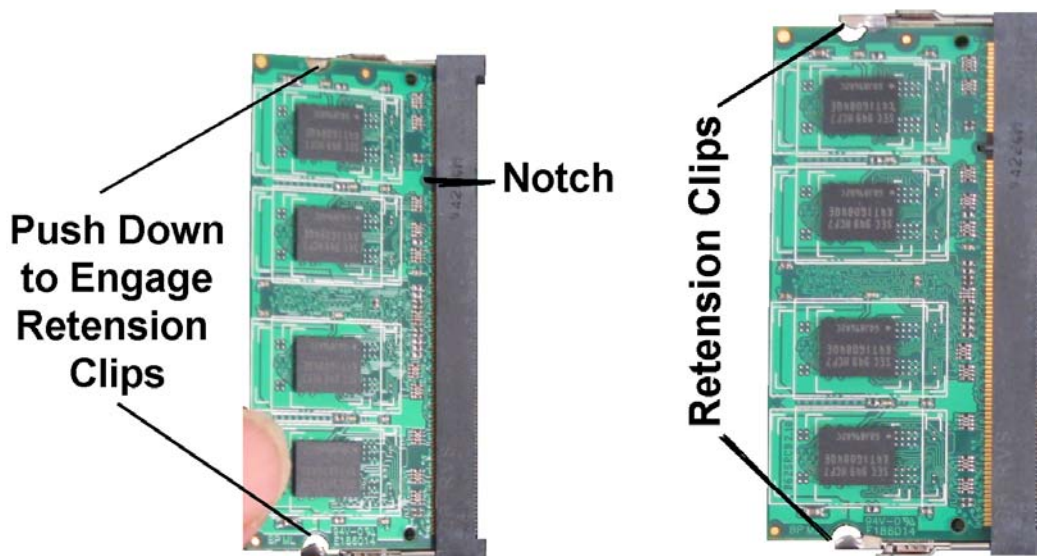

Figure 3-21: Installing or Removing a SO-DIMM (left)

### DMA Enabled CF Riser Card

The Figure below show the DMA Enabled CF card installed in the Workstation 5A. Direct Memory Access (DMA) is a method of moving large amounts of data from an IDE device such as the CF card to main memory with minimal CPU intervention.

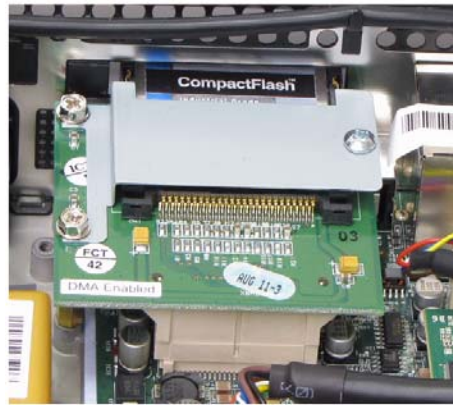

Figure 3-22: DMA Enabled CF Riser Card

#### Approved DMA Enabled CF Cards

Approved DMA Enabled CF Cards are shown in the Table below.

Size	MICROS P/N	Description
4G	700504-111	Unigen UGB30STC4000Y3 MSE
4G	700504-111	Wintec W7CF004G1DAI-H31PB-2Q2.07
4G	700504-111	Transcend TS4GCF200I (WO 432964)
4G	700504-111	Wintec W7CF004G1DAI-H41PD-04D.A5
256MB	700504-119	Wintec W7CF256M1DA I -H31PC-002.06
256MB	700504-119	Wintec W7CF256M1DAI-H31PD-002.C8
256MB	700504-119	Unigen UGB30STC0256Y5-MSE

Figure 3-23: Approved CF Cards

---

## **USB Wireless Module**

The optional USB Wireless Module is based on a Sagrad WiFi module with USB Interface. The Sagrad Wireless Module mounts to a bracket located between the power supply and IO panel.

This wireless kit can be used in both the Workstation 5 and Workstation 5A. Refer to MD0019-004 for installation instructions.

---

## **Mini-PCI Options**

Two options are available for the WS5A Mini-PCI connector.

### **Abocom Mini-PCI Wireless Card**

The Abocom WiFi card used on the original Workstation 5 can also be used the Workstation 5A. The kit has been modified by adding a new adhesive-backed antenna.

Refer to MD0013-005C for installation instructions.

### **SparkLAN Mini-PCI Wireless Card**

The Workstation 5A will be moving to a new 802.11 a/b/g/n Mini-PCI Wireless Card from SparkLAN. The card features advanced WEP encryption, WPA, WPA2, and 802.1x for security, and drivers are available for all supported operating systems. Wifi antenna type and placement are currently being evaluated.

### **Mini-PCI Modem II**

The Mini-PCI Modem can only be used with WIN32 operating systems such as POSReady 2009. The modem is not compatible with Windows Embedded CE 6.0.

Refer to MD0019-001 for installation instructions.

## Workstation 5A Hard Disk Kit

Instructions for installing the kit can be found in MD0019-003. To configure the Workstation 5A with BIOS version Q1000g to boot from a SATA disk, see below. BIOS Versions Q2010g and Q2011d support SATA drive boot options.

1. If converting a WS5A to the optional SATA SSD, be sure to remove the USB Hard Drive from J8.  
Using both a USB Hard Drive and SATA drive at the same time is not recommended because it prevents the optional POSReady 2009 Recovery CF from starting. The Recovery CF expects to recover a USB Hard Drive or optional SATA Disk. If both are present, it cannot determine which is the boot device and produces an error message.
2. Enter the System Configuration Utility (as described in Chapter 3) and select the Boot Tab.
3. In the Boot Device Prioritization (BBS) list, scroll to the first entry ('USB Hard Drive' or 'SMART eUSB USB Device') and tap the [-] key until the field displays [SATA drive 0].
4. Be sure the next device is the [IDE 0/Pri Master] selection.
  - o The Figure below displays a BBS boot order that will boot from a SATA disk drive.

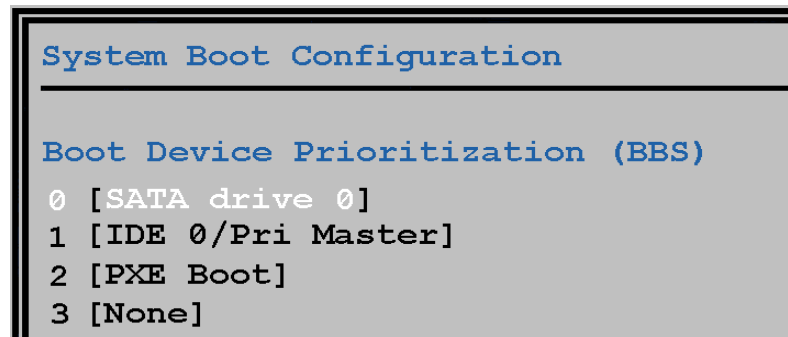

*Figure 3-24: Booting from a SATA Disk Drive*

5. When the Boot Device Prioritization list matches the Figure above, proceed to the Exit Menu and select 'Save Settings and Restart', then 'Y' to restart.
  - o Do not use the 'Reload WINCE' or 'WIN32 Factory Defaults' available in BIOS Versions Q1000g or Q1010m, it will remove the [SATA drive 0] from the list.
  - o BIOS Version Q2010g or Q2011d includes a factory default setting for the optional SATA disk drive, 'Reload SATA WIN32 Factory Default Settings'.

---

## LCD Customer Display - Integrated

This procedure describes how to attach the Rear LCD Customer Display to the Workstation 5A. The display is provided as a complete assembly, ready to install.

1. Remove the AC power cable from the unit.
2. Place a towel or soft cloth on your work surface to protect the touchscreen glass, then place the workstation face down on this surface.
3. Remove the logo plate from the rear IO door and return the door to the closed position, Figure 3-25.
  - o The logo plate can be removed by flexing the center of the IO door as shown the image below.



*Figure 3-25: Removing the I/O Door*

4. Feed the interface cable through the cut-out then insert the LCD customer display bracket until the side clips snap into place as shown in Figure 3-26.
5. Connect the interface cable to the IO panel 'Rear Display' connector as shown in Figure 3-26.
  - o *Warning: Connect the LCD Customer Display to the Remote Display connector only. Connecting the LCD Customer Display to the USB6 connector could damage the Customer Display and or USB6 port.*

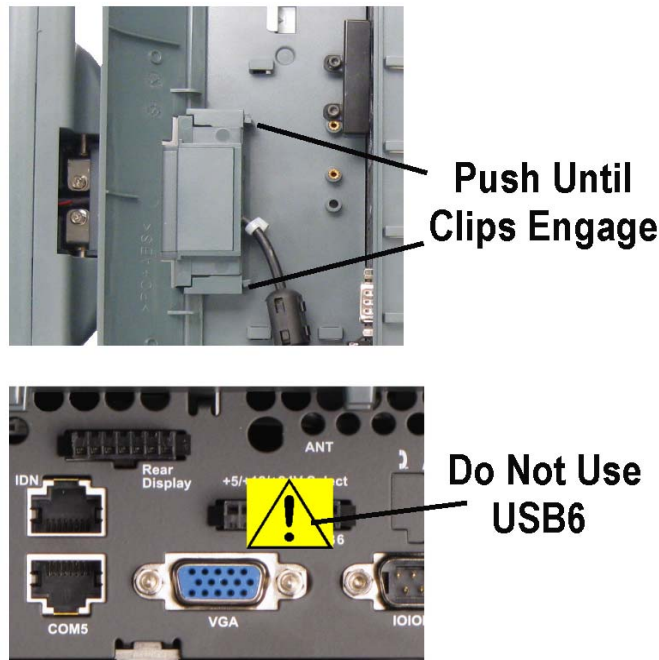

*Figure 3-26: Installing the Integrated Customer Display*

6. Return the unit to the normal operating position, connect the AC power cord and press the power button. The Integrated LCD Customer Display is automatically detected and ready for use.

#### **Testing the Integrated LCD Customer Display (WinCE)**

7. From the Windows Embedded CE Desktop, touch My Device -> DOC -> Utilities -> WS5ADiagUtility.
  - o The WS5A DiagUtility System Information Screen is displayed.
8. Touch the 'Cust Disp' tab. Press the [Send] button to send a test message to the customer display.

## LCD Customer Display - Pole Mount

This procedure describes how to install and connect the Pole LCD Customer Display to the Workstation 5A. The pole version is provided as a kit consisting of the LCD Display Assembly /w 5 ft. cable, pole, base, extension cable, and nut. The installer must provide the 8-32 x 1/2" base mounting hardware.

1. Use the base as a template to locate the mounting holes in the counter surface.
2. After mounting the pole and base to the counter surface, route the extension cable through the pole and connect it to the LCD assembly cable. Attach the LCD assembly to the pole, position the display head in the desired position and use a hex wrench to secure the display in place.

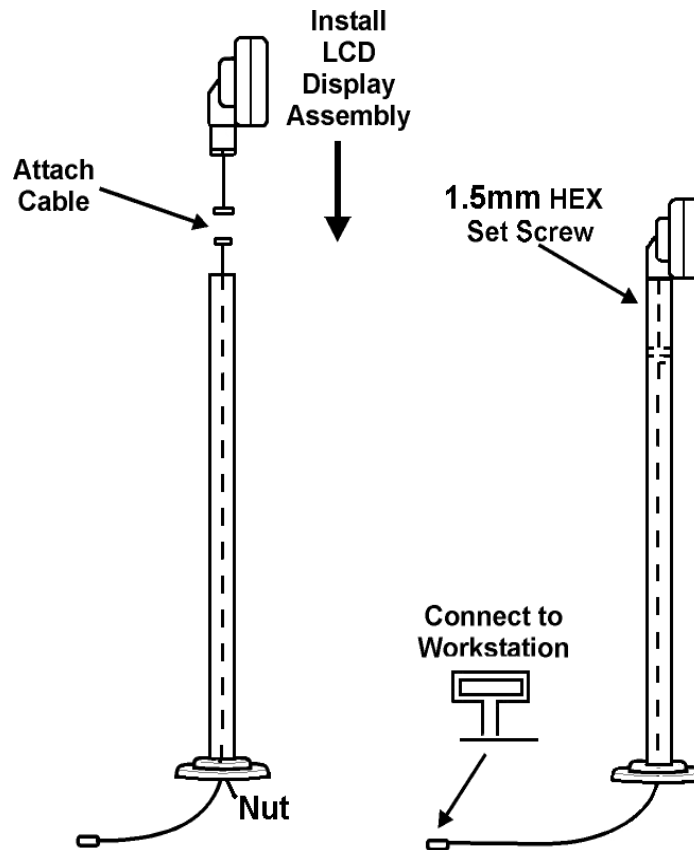

Figure 3-27: Assembling the Pole Customer Display

3. Power-off the unit and attach the keyed 4-Pin DIN connector to the port labelled "Customer Display."
4. The LCD Pole Display is automatically detected by the API at power-up.



### Protégé Customer Display System - Integrated

This procedure describes how to install the Protégé on the Workstation 5A.

1. Power Off the workstation, remove cables, then place the unit face down to access the IO panel.
2. Remove the MICROS Logo plate from the IO Door. Reinstall the door and make sure it is closed.
3. Orient the Protégé with the speakers facing towards the bottom of the workstation, then insert the bracket in the IO door cut-out. Slide the Protégé and bracket into the housing until the clips lock into place.
  - o *Warning: Connect the Protégé to the USB6 connector only. Connecting the Protégé to the Rear Display Connector could damage the Protégé.*
  - o *On later units, you may need to remove a plastic cover from the USB6 connector.*

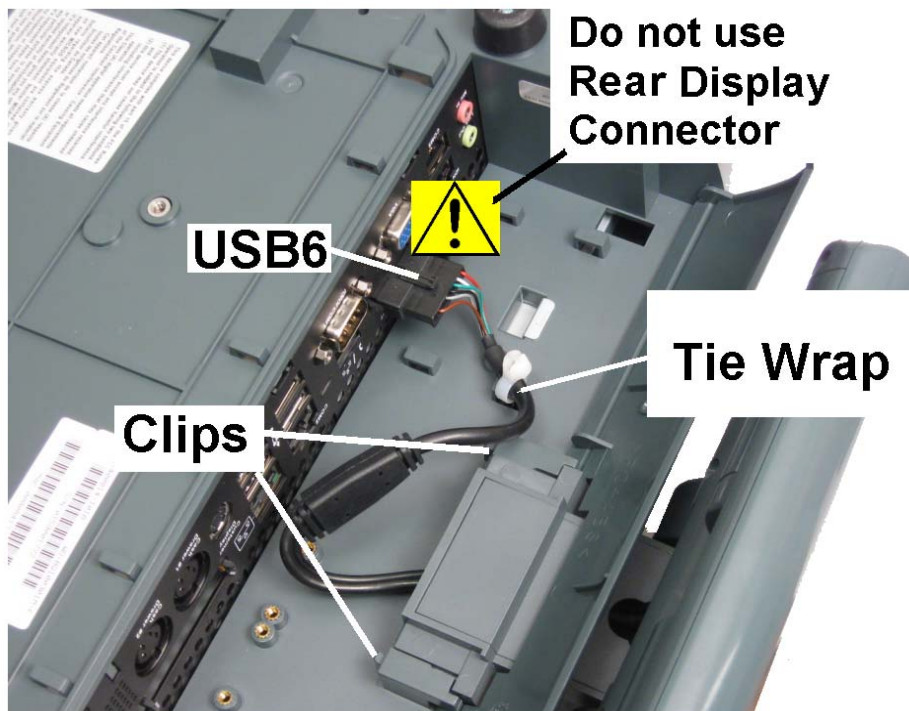

*Figure 3-28: Installing the Integrated Protégé Customer Display*

## Protégé Customer Display System - Pole Mount

The Pole Mount Protégé is shipped pre-assembled with a 19" interface cable, 6" Pole, base and nut. The Interface cable is designed for the custom powered USB interface on the IO panel called USB6.

1. Attach the base to cash drawer, or using the base of the pole as a template, attach to the counter surface. Appendix A provides details of the hole dimensions.
2. Route the Protégé Display Cable through the pole and through the stand (if used) to the IO Panel.
  - o *Warning: Do not connect the Protégé to the 'Rear Display' connector. Connecting the Protégé to the Rear Display Connector can damage the Protégé.*
3. Attach the Protégé to the pole and adjust to the desired position. Tighten the 1.5mm set screw.

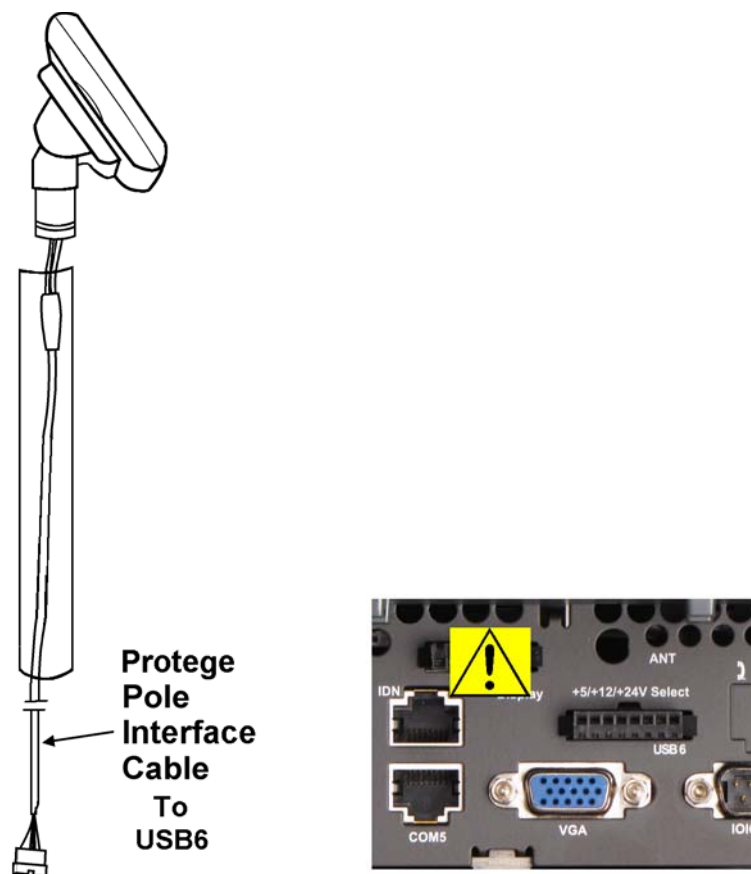

Figure 3-29: Attaching the Protégé Customer Display System to the 6" Pole

4. Connect the Protégé to the USB6 connectors on the WS5A IO Panel.

### Workstation 5 or 5A Adjustable Stand and Pole Display

The kit consists of a the LCD customer display, 6" Pole, mounting bracket and hardware.

1. Determine the location of the mounting bracket on the base plate. It can be mounted to the left, right, or rear of the base plate.
2. Attach the mounting bracket to the base plate. Be sure to use the spacers included in the kit between the base plate and bracket.
3. Refer to the numbered steps in Figure 3-30 to attach the pole to the bracket, run the interface cable, and attach the LCD to the pole.
4. Rotate the LCD to the desired position and use a 1.5mm hex wrench to tighten the set screw and lock the display in place.

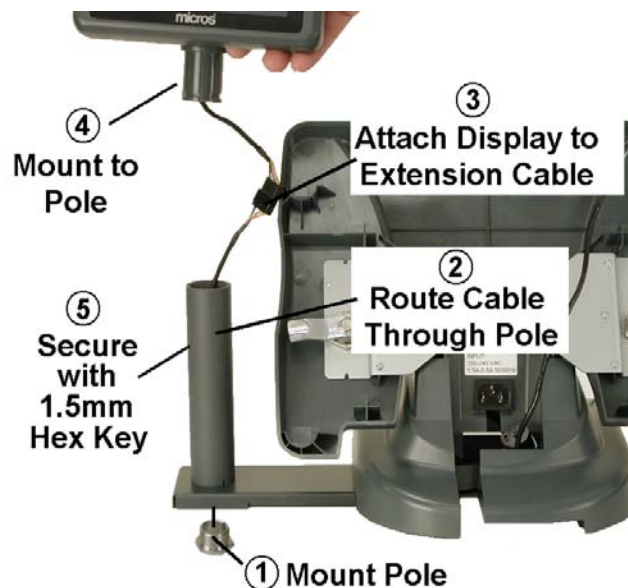

Figure 3-30: Assembling the WS5/WS5A Adjustable Stand Pole Display

5. Before placing the workstation on the Stand, connect the interface cable to Customer Display IO Connector.

### Testing the Adjustable Stand Pole Display

The LCD Pole Display is automatically detected by the API at power-up.

1. From the Windows Embedded CE 6.0 Desktop, touch My Device -> DOC -> Utilities -> WS5A Diagnostics Utility. Touch the 'Cust Disp' tab. Press the [Send] button to send a message to the LCD Customer Display.

## Reassembling the WS5A

The following procedure describes how to connect the top cover cables and reassemble the WS5A casework.

### Procedure:

1. Refer to Figure 3-31, below. If the finger print reader or other option is installed in the top cover, place it directly behind the base. Run the interface cable on either side (left side is preferred) of the chassis but make sure it stays below the chassis lip. Connect the cable to USB Option Header J28.

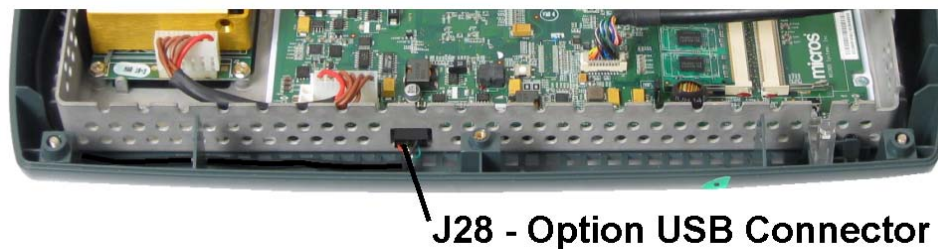

Figure 3-31: USB Option Connector J28

2. Connect the LCD/Touchscreen cables to the System Board.
  - o The Figure below shows where to connect the CCFL backlight, resistive touchscreen and LVDS cables to a Revision D or F system board.

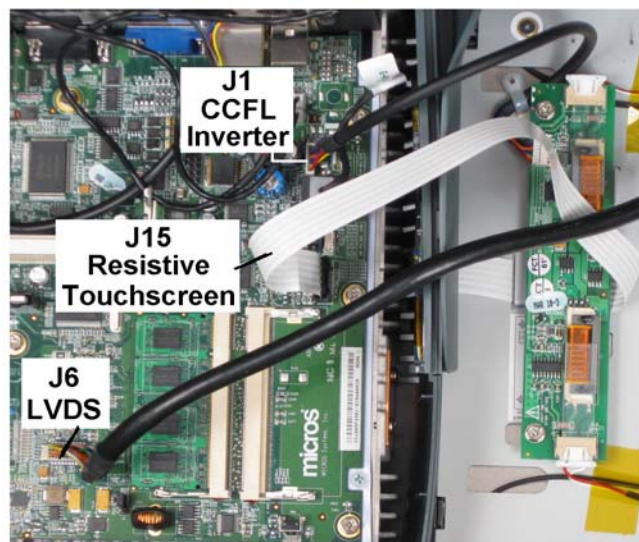
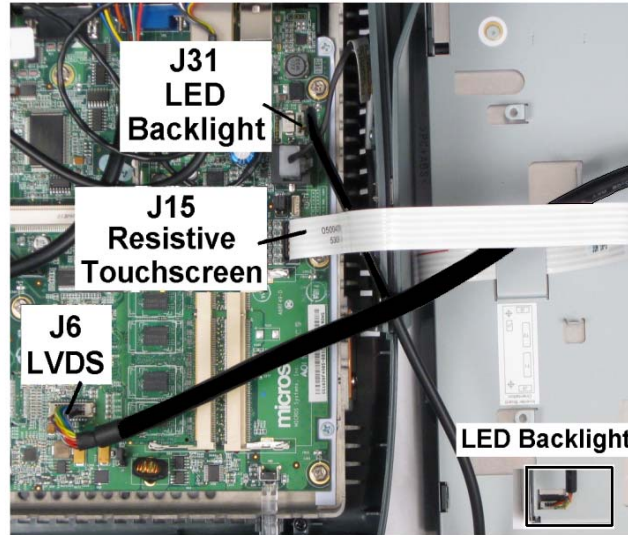

Figure 3-32: Installing LCD/Touchscreen Cables (CCFL-Resistive Touchscreen)

- o A small number of units were produced using a LED backlight LCD from AUO. The Figure below shows how to connect the LED backlights and resistive touchscreen (Revision D).



*Figure 3-33: Installing LCD/Touchscreen Cables (LED-Resistive Touchscreen)*

- o The Figure below shows how to connect the optional capacitive touchscreen interface and CCFL Inverter.
3. If an optional SATA Hard Drive is installed, connect it to the system board as shown in the Figure below.

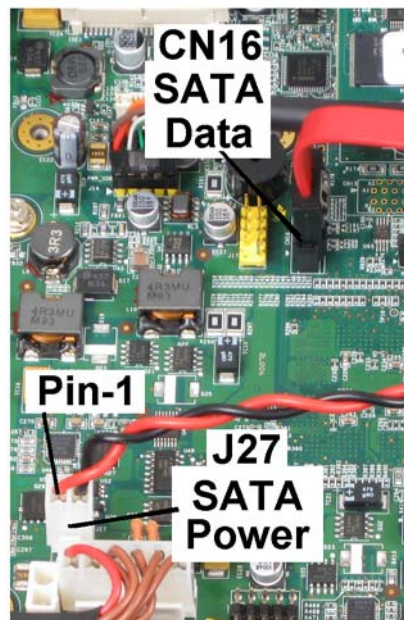

*Figure 3-34: Connecting the optional SATA Drive*

4. Install the LCD/Touchscreen Assembly in the base. The top of Figure 3-35, below shows the tabs at the rear of the assembly and the slots in the base. Insert the tabs into the base.
5. Before closing, make sure the LVDS cable is positioned as shown below and the backlight cable does not rest on the chassis lip.



*Figure 3-35: Installing the LCD/Touchscreen Assembly*

6. Install the screw that secures the LCD/Touchscreen Assembly to the base.

7. Before installing the top cover, examine the gasket to ensure it is seated in the groove. Install the cover by attaching it to the hooks at the rear of the base then rotate the front of the cover downward to snap into place.



*Figure 3-36: Installing the Top Cover*

8. Tighten the captive screws to secure the top cover.

# *Installing and Operating the Workstation 5A*

This chapter describes the environmental requirements for the workstation, describes the IO Panel, and covers the basic operational procedures.

### ***In this Chapter***

---

Care and Handling .....	4-2
The IO Panel .....	4-4
Installation .....	4-11
Operation .....	4-14

---



## *Care and Handling*

Tips for placing the unit in an environmentally sound location and instructions for cleaning the workstation cabinet are presented in this section.

---

### **Equipment Placement**

The following pages present considerations for placement of the workstation and related peripheral equipment.

#### **Location**

- Appendix A contains dimensional data for the workstation and peripheral devices. Before you decide on the space each piece of equipment will occupy, take measurements and compare them to ours.
- Locate all equipment so that it is accessible to service personnel.
- Tile is the recommended floor surface for areas surrounding the equipment. If the floor covering adjacent to the equipment is carpeted, an anti-static grade of carpeting is recommended. If the carpeting surrounding the area housing the equipment is not composed of anti-static material, the use of static discharge mats is recommended. An anti-static mat incorporates a grounding clip with a cable that can be attached to earth ground.

#### **Proximity to Foreign Materials**

Spilled liquids can cause damage to the circuits in MICROS equipment.

- Do not place equipment near food preparation areas, glass racks, or water stations.

Another source of potential hazards to the equipment are foreign objects, including paper clips, staples, and any other metallic objects.

- Safeguards should be taken to prevent the accidental dropping of such materials into the equipment.

#### **Noise Induction**

In addition to the AC Power Requirements outlined in chapter 3 of the appropriate Site Preparation Guide, other sources of electromagnetic interference must be eliminated to ensure trouble-free operation of the equipment.

- Noise radiating from AC power lines throughout the site can be absorbed by MICROS AC power and communications lines and induced into the equipment. Consequently, no exposed cable dedicated to the MICROS equipment should be run in the vicinity of any AC power lines.
- Devices that emit RF energy, such as cordless phones, and walkie-talkies should be kept at least 8 inches from the equipment or cable during operation.

### **Electrostatic Discharge (ESD)**

The occurrence of electrostatic discharge (ESD) usually takes the form of a discharge from the operator's hand to cash drawers, the workstation, the magnetic stripe card reader or other peripherals. ESD is more common in dry climates during the winter, and less common in moist climates. The workstation has excellent built-in immunity to ESD in most environments. However, tile or anti-static carpet is recommended in areas near the workstation.

### **Operating Temperature**

- The Workstation 5A operating temperature is between 0°C (32°F) and 45°C (113°F).

### **AC Power and Data Cabling Requirements**

AC Power cabling, Ethernet and MICROS IDN data cabling should be installed in accordance with the appropriate MICROS Site Preparation Guide.

### **Cleaning the Display, Cabinet, and Magnetic Stripe Reader**

Recommendations for cleaning the Cabinet, Magnetic Stripe Reader and LCD cover are described below.



#### ***SHOCK HAZARD***

Before performing preventive maintenance or cleaning the workstation, use the power button to turn the unit off.

---

#### ***LCD/Touchscreen Glass***

The Operator Display overlay can be cleaned using any common household cleaner applied with a clean cotton cloth. Always spray the cloth with the cleaner first, then use the cloth to clean the overlay.

#### ***Cabinet***

Always use a chamois or clean lint-free cloth to clean the cabinet and screen surface. Do not use chemical, alcohol, or petroleum based cleaners that are not recommended for plastics.

#### ***Magnetic Card Reader***

Depending on how much they are used, magnetic card readers may require periodic cleaning. MICROS recommends cleaning the heads as often as once a day if the reader is subjected to heavy usage.

## *The IO Panel*

Figure 4-1 displays the Workstation 5A IO Panel connectors.

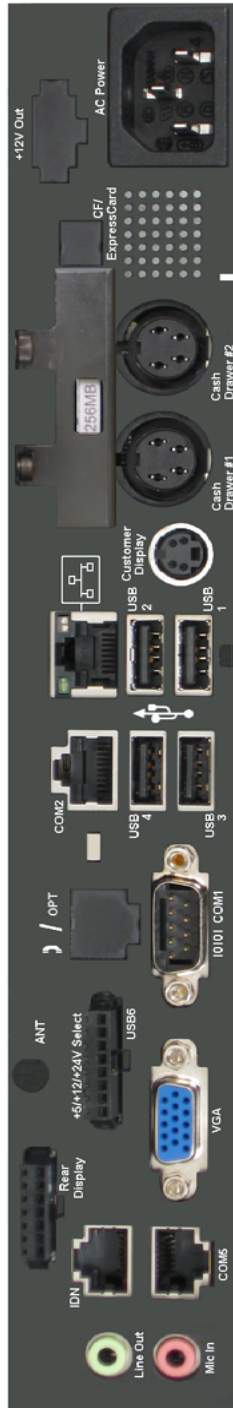

*Figure 4-1: The Workstation 5A I/O Panel*

The Workstation 5A IO Panel is similar in appearance to the original Workstation 5, but adds a DB15 VGA connector, modular COM2 port, four standard USB Ports USB1 through USB4 and one powered USB port, USB6. Working from left to right in the illustration, each connector is detailed below.

### **Line Out - Mic In**

The Green Line Out connector is an output, capable of driving external powered speakers. The internal speakers do not mute when the Line Out jack is used.

The Mic In jack allows you to connect a microphone to record sound clips in the WIN32 environment. Windows Embedded CE 6.0 configurations do not include sound recording software.

### **IDN**

The IDN port is functionally identical to the IDN Port on the Workstation 5 as well as the RS422-A and RS422-B ports on the Workstation 4/4 LX, KWS4, and KW270. It contains both an RS422 or RS232 Interface.

This port is configured through application software as a full-duplex RS422 interface to support IDN printing devices. Use cable P/Ns 300319-036 (3ft), or 300319-120 (10ft).

When used as an RS232 interface, a number peripheral devices are supported. Use cable P/N 300319-102 for RS232 devices,



#### **WARNING:**

Do not insert a 6-Pin modular plug into the 8-Pin IDN port. A 6-Pin plug can push some pins out of position where they can short to the connector shell and possibly damage the IDN and or RS232 interface components. Always use an 8-Pin modular plug when you connect IDN or RS232 peripherals to the workstation.

---

### **COM5**

COM5 is a full featured modular RS232 Interface. Use RJ45 to RS232 DB9 Adapter Cable, P/N 300319-103.

### **Rear Display**

This connector is reserved for the Integrated LCD Customer Display.

### **ANT**

This location is reserved for an external WiFi antenna. The SMA ‘cigarette’ antenna is provided in some optional WiFi kits as an alternative to using an internal antenna.

### **+5V/+12V/+24V Select - USB 6**

This is the powered USB connector. Like the other USB ports on the IO Panel, USB6 port data can be disabled through the BIOS or the Diagnostics Utility. The IO Panel connector supports three voltages, +5V, +12V and +24V along with USB6, a standard USB 2.0 compatible port. The Protege Customer Display System is supplied with a custom cable that delivers +12V and USB6 data.

Figure 4-2, below shows an example of a new cover for USB6 connector. Its purpose is to help prevent connecting a Remote Display into the USB6 connector.



*Figure 4-2: USB6 Connector Cover*

### **VGA**

WIN32 operating systems include support for dual independent display, allowing the desktop to be extended across two monitors. For workstations running Windows Embedded CE 6.0, the VGA output displays the same image that appears on the LCD, the extended desktop feature is not supported.

### **/ OPT**

This RJ45 knock out is reserved for the Mini-PCI Modem or future optional Mini-PCI Card.

### **IOIOI COM 1**

This industry standard DB9 male connector can be used for serial printer or other peripheral. The port is backed by an 16550A UART with a 16-byte receive buffer.

### **COM2**

COM2 is a full featured modular RS232 Interface. This port is similar in function to the modular COM 5 port on the Workstation 5 and PCWS 2010. Use RJ45 to RS232 DB9 Adapter Cable, P/N 300319-103.

### **USB1 - USB4**

In addition to a powered USB port, the I/O Panel includes four standard USB 2.0 compatible ports, labeled USB1 through USB4. When the unit is shipped, all USB ports are enabled.

For PCI compliance, external USB ports can be managed through the BIOS or the Workstation Diagnostics Utility.

### **10/100/1000 Ethernet**

The workstation includes a 10/100/1000 Ethernet Controller with a UTP modular connector. The modular connector features an integrated isolation transformer as well as a link status and network activity indicators. The interface is fully IEEE 802.3 compliant.

### **CF/Express Card**

This slot houses the DMA Enabled CF Daughter Card, or a future optional ExpressCard Riser.

#### ***DMA Enabled CF Card***

The Workstation 5A introduces support for DMA (Direct Memory Access) CF cards to improve application and WIN32 image recovery performance.

For Windows Embedded CE 6.0 R3 configurations, several CF card sizes will be available, including 256MB, 512MB or 4GB. The 4GB CF Card is used in some Symphony configurations. WIN32 configurations are shipped without a CF card, but the riser card is included, allowing a CF card to added for additional storage or to use the optional Recovery CF.

### ***CF Card Cover Slot***

The Figure below shows CF Card Cover and factory installed (For Windows Embedded CE 6.0) CF Card Label that allows its size to be determined at a glance. Sizes of 256MB, 512MB and 4GB are currently in the field.



*Figure 4-3: CF Cover Slot to view CF Card Size Label*

For Windows Embedded CE 6.0 R3 configurations, the CF card is blank when shipped from the factory. The CAL places the client application on the CF card, and Windows Embedded CE 6.0 places the persistent registry on this storage medium.

### ***How to use the Compact Flash (CF) Card***

If you have not used a CF card, take a moment to familiarize yourself with this device.

- For Windows Embedded CE 6.0 R3 configurations, a MICROS approved CF Card must be installed in order for the unit to start. WIN32 units ship without a CF Card installed.
- CF Cards are not plug and play devices. Do not remove or insert a CF Card when the unit is ON. Always use the power button to turn the unit off before removing or installing a CF Card.
- The CF card is a keyed device - but it is possible to force the card into the socket the wrong way and damage the CF riser card.

### **Removing a CF Card**

- Always power off the workstation before removing the CF Card.  
Figure 4-4. Use your thumbnail to catch the lip on the card and remove it from the socket.

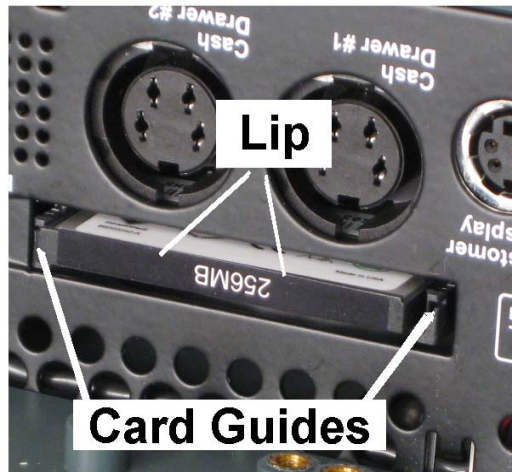

*Figure 4-4: Removing the CF Card*

### **Disabling the CF Card**

- BIOS Version Q2011d or later adds the ability to disable the CF Interface for security purposes. This is intended for WIN32 operating systems such as POSReady 2009.

Disabling the CF Card Interface when the Workstation 5A is configured for Windows Embedded CE 6.0 will cause the unit not to start, and produce a 'CF NOT FOUND' POST error.



### ***Installing the CF Card***

- Figure 4-5, displays the custom CF labels that can assist you in orienting the card when you install it.
- As you face the IO Panel, install the card with the label showing and the arrow in the upper left corner.
- Very little force is required to insert the card. Push the card into the socket until only a few millimeters are visible.



*Figure 4-5: Installing the CF Card*

### **Customer Display**

This connector supports either a stand mounted or remote pole Customer Display. See Chapter 1 for more information about optional customer displays.

### **Cash Drawer #1 - Cash Drawer #2**

This pair of connectors support standard MICROS +12V cash drawers with 4-pin DIN connectors. +24V Cash Drawers are supported through a BIOS setting.

### **+12V Out**

This knock-out is reserved for a future option.

## *Installation*

This section describes how to install the AC adapter, and discusses the recommended method of cabling the workstation.

---

### **Cabling the Adjustable Stand**

This procedure describes how to attach the workstation to the Adjustable Stand.

1. Install the optional Printer Power Supply, if required. Refer to Figure 4-6. Open the power supply compartment door and attach the AC power connector to the power supply. Close the compartment door.

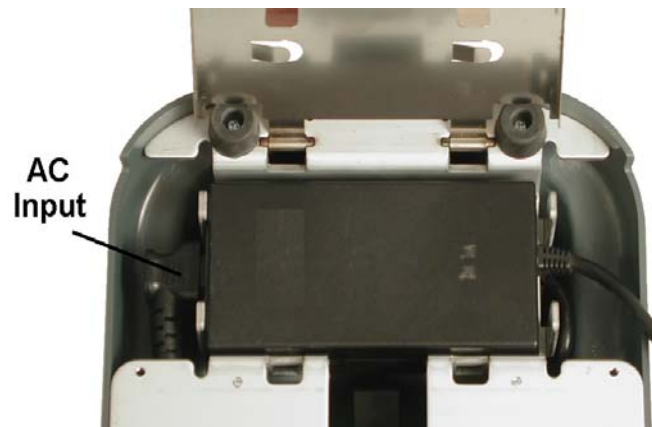

*Figure 4-6: Installing the Optional Printer Power Supply*

2. Refer to Figure 4-7, and prepare to mount the workstation on the stand.
  - Connect the AC Power Cable supplied in the Workstation 5A loose parts kit to the AC receptacle in the base of the stand. Use the longer of the two AC cables for the workstation.
  - Cable the workstation. Several cable tie points are provided in the cover, and a pair of re-usable velcro cable ties supplied with the stand can be used to bundle the cables. Figure 4-7 shows two cable ties, but these may not be needed in some situations.
  - Before placing the unit on the stand, make sure the securing latches are in the 'open position and the I/O door is closed as shown.

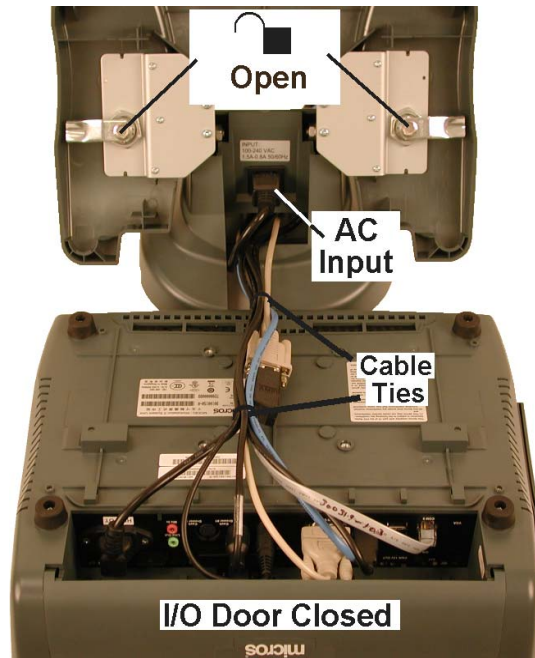

*Figure 4-7: Preparing to attach the Workstation to the optional Stand*

3. Mount the cabled workstation by placing the rubber feet into the receptacles on the adjustable stand. Figure 4-8, below.



*Figure 4-8: Placing the Workstation to the Adjustable Stand*

4. When the workstation is fully seated on the stand, turn the knobs on the rear of the stand to the 'Secured' position as shown in Figure 4-9.

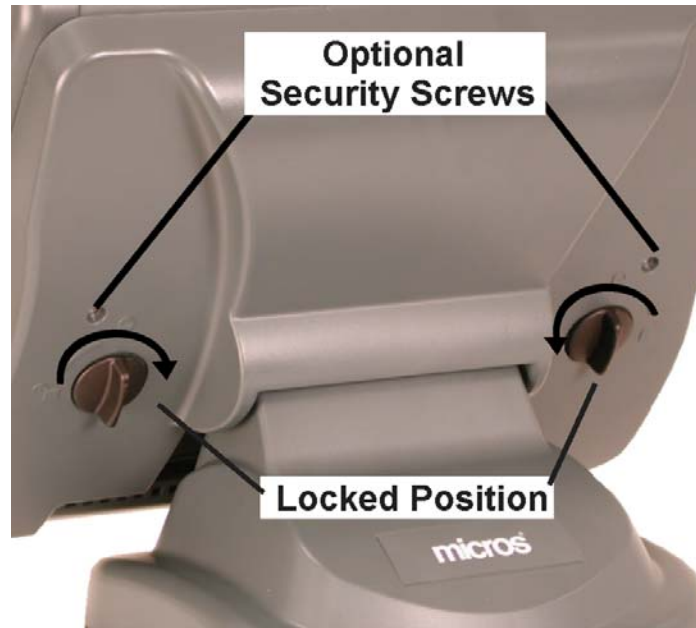

*Figure 4-9: Securing the Workstation to the Adjustable Stand*

5. For additional security, a pair of 17mm screws are provided in the Adjustable Stand loose parts kit to secure the knobs in the locked position. Make sure the knobs are in the 'Secured' position and use the hex wrench supplied in the workstation loose parts kit to install the screws.
6. Place your peripherals near the workstation and attach cables as required.
7. Connect the AC power cord to an electrical outlet installed in accordance with the appropriate site prep guide. See page 4-14 to start the workstation.

## Operation

This section presents operational procedures for the Workstation 5A including how to use the power button to transition the unit between the **NOPOWER**, and **ON** power states.

---

### Operator Features

Figure 4-10 points out the operator features of the Workstation including the Power Button, White Operator LED, Magnetic Card Reader, and the Operator Touchscreen LCD.

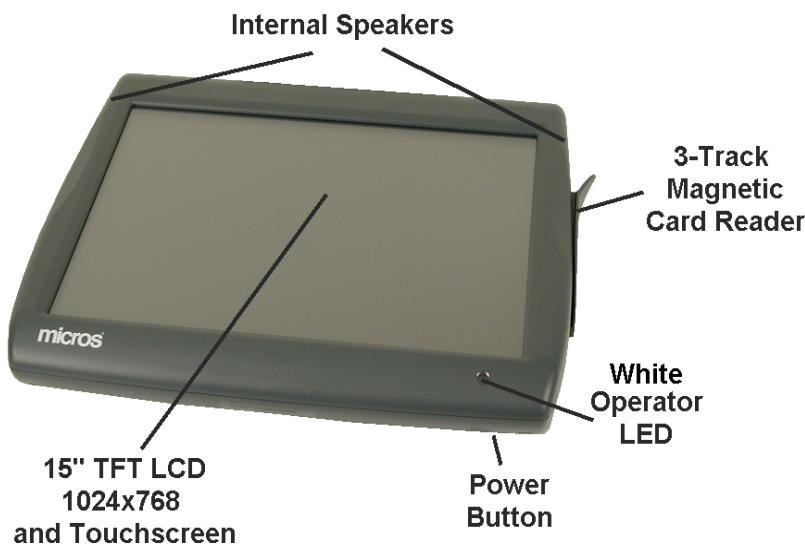

*Figure 4-10: Workstation 5A Operator Features*

#### Operator LCD and Touchscreen

The Operator LCD is a 15" Active Matrix LCD with a resolution of 1024x768. The 5-wire resistive or optional capacitive touchscreen glass is positioned over the LCD.

#### Power Switch

The power switch is used by the operator to transition the Workstation between the **NOPOWER** and **ON** states.

#### Operator LED

The White Operator LED distinguishes the Workstation 5A from the Workstation 5, with its Blue Operator LED. It blinks during start-up and turns solid White when the operating system starts.

## Turning the Workstation from NOPOWER to ON

When the workstation is NOPOWER, the Operator LCD will be blank and the Operator LED is off. See Chapter 1 for a description of the supported power management states.

1. Be sure the workstation is connected to AC power.
2. Press the power button, then release it.
  - The Operator LED starts flashing White.
  - After several seconds, the LCD displays the BIOS splash screen shown in the Figure below. The MICROS BIOS Version is displayed in the upper left corner of the screen.

As the BIOS Splash Screen displays, the unit is performing a Power On Self Test (POST) of the system board hardware. Each test is displayed as a series of icons that appear at the lower left corner of the screen.



*Figure 4-11: The BIOS Splash Screen*

- If a USB keyboard is attached to the unit, pressing the [Del] key just after the splash screen appears enters BIOS System Configuration Utility. Refer to Chapter 3 for more information.
  - If the workstation contains Windows Embedded CE 6.0, see the next page.
  - If the workstation contains a WIN32 operating system such as POSReady 2009, see page 4-16.

### ***Booting to Windows Embedded CE 6.0 R3***

As the POST completes, the splash screen clears, and a series of custom pre-boot firmware utilities start executing.

- If the Blue splash screen does not appear, or the operating system does not start, refer to Chapter 5 for troubleshooting information.

The first pre-boot utility ensures that a CF Card and USB Hard Drive are installed, since these are required components for Windows Embedded CE 6.0 R3.

Next, pre-boot Firmware applications FlashCE and Platform Update execute. Flash CE checks the CF Card for an NK.BIN file, then Platform Update checks the CF Card for the BIOS binary file.

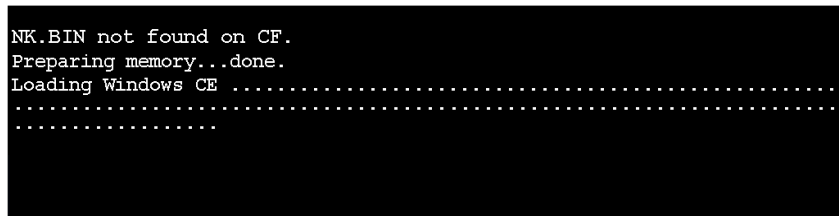

```
NK.BIN not found on CF.  
Preparing memory...done.  
Loading Windows CE .....  
.....  
.....
```

*Figure 4-12: Booting to Windows Embedded CE 6.0*

- The message ‘NK.BIN not found on CF,’ appears on the first line. This message is produced by FlashCE and is simply a statement that the upgrade file is not present.
  - If the NK.BIN file *is* present on the CF Card, the message ‘Updating the Operating System - Please Wait’ appears on the display.
  - If the BIOS Binary file is present, the message ‘Updating the BIOS, please wait.’ See chapter 3 for more information about updating the BIOS.
- The prompt ‘Loading Windows CE’ appears, followed a series of dots that move from left to right across the screen as Windows Embedded CE 6.0 starts up.
  - Each dot represents one block of data read from the NK.BIN file.
- After several seconds, the Windows Embedded CE 6.0 R3 desktop appears. The Operator LED stops blinking and turns solid white.
- If a POS Application is already installed, it starts after the desktop appears. If no application is installed, the CAL starts and presents a password screen. See the ‘Starting the Windows CE Workstation for the First Time’ section.

### ***Booting to POSReady 2009***

After the BIOS Splash Screen clears, the Windows XP start up screen and progress bar appears.

After the desktop appears, the API loads and the Operator LED stops blinking and turns solid white.

Unlike Windows Embedded CE 6.0, on new workstation, the Client Application Loader (CAL) WIN32 is not pre-installed. It can be installed by tapping the desktop icon.

---

### **Turning the Workstation from *ON* to *NOPOWER***

- For Windows Embedded CE 6.0, press and hold the power button until the Operator LED changes from solid White to OFF, then release it. This takes about 4 seconds.
- For POSReady 2009, do not hold the power button down until the workstation shuts down. Tap the power button and 'Shut Down Windows' dialog box appears. Select 'Shut Down' from the pull-down menu, and tap [OK] to shut down the unit. If the Shut Down Windows' dialog box does not appear, Tap Start -> Shut Down -> Shut Down, then [OK].

---

### **Starting the Windows CE Workstation for the First Time**

When a workstation with Windows CE is powered up for the first time, the CAL automatically starts through a registry setting and displays a password screen. Continue to the next page for more details about using the CAL on Windows Embedded CE 6.0 R3.

When a workstation with a WIN32 operating system is installed, the user must install the WIN32 CAL client.

### **Using the Client Application Loader (CAL) on Windows CE**

1. If the unit is direct from the factory, a touchscreen calibration utility will appear. See page 4-25.
2. CAL displays the password screen shown in Figure 4-13, below under the following conditions.
  - The workstation is new 'out-of-the-box', or the Wipe CF utility has been used to delete the persistent registry and or erase the CF Card.



- The CAL is started using the 'Re-Configure CAL' shortcut.

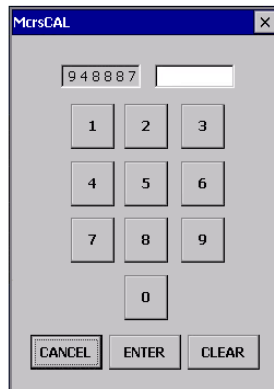

Figure 4-13: Windows CE CAL Password Entry Screen Keypad

The CAL requires a password to continue. Apply the following formula to the six-digit number that appears at the upper left box.

$$\text{Password} = \text{Digit 1} \times \text{Digit 2} + \text{Digit 4} + \text{Digit 6}$$

3. Calculate the password, enter it in the upper right field and press [Enter]. In this example, the password is 14 ( $9 \times 4 + 8 + 7 = 51$ ).
  - After the password entry is complete, the CAL client conducts a search for CAL servers.
4. Select the CAL Server. If the server is displayed, press [TAB], then use [UP]/[DOWN] to select. When the server name is complete, press [Enter] to proceed.
5. Select your Workstation 5A from the list. Double-click the entry.
  - Each workstation is pre-programmed with a workstation name, IP address, and other application related settings.
  - If the version of the CAL on your workstation is older than the version of CAL on the server, CAL will first update itself and reboot before proceeding to download the application.

The Workstation proceeds to download the application 'package' to the CF card, updates the registry and reboots when complete. After restarting, the CAL automatically starts the application.

### **Using the Search Feature**

- Type the name of the server, location, or property you are searching for or select from the list if available.
- The [Search] button finds an exact match and any characters concatenated to the match. For example, a search for 'm' will find m, m1234, m1235, mm, mmm... etc.

- The [Next] button continues processing with the current selection.

If the server name you are searching for does not appear, leave the current selection blank and press [Next] to go back to the configuration menu and run the Auto Discovery Configuration again.

6. Select the Property. If the property is displayed, press [TAB], then use [UP]/[DOWN] to select. If the property name is correct, press [Enter] to proceed.
7. Select the WS Identity. The [AVAILABLE WORKSTION LIST] button is in focus, press [Enter] to display the workstation list and search edit-text box. To configure a workstation Static IP Address, see below. Press [TAB] to focus the edit box and press [TAB] again to focus the [SEARCH] button. Pressing [TAB] a third time brings the list into focus - use the [UP]/[DOWN] keys to select, then [TAB] to the [SAVE] button and press [ENTER].

### ***Configuring a Static IP Address***

The CAL Defaults to DHCP operation. To enter a Static IP Address, [TAB] to the 'Automatic DHCP Selection' and press [SPACE] to remove the Checkbox. Press [TAB] to move to the 'IPAddr:' field and enter the Static IP Address. Press [TAB] to move to the 'NetMask' field and [TAB] again to move to the 'Gateway:' fields and enter the IP Addresses as required. When complete, press [ALT]-[S] to save and exit the WS Identity Screen.

### **CAL Keyboard Hot Keys**

The following hot keys are available from the keyboard when the CAL is running.

- [Ctrl]+[Shift]+[R] - Reconfigure CAL
- [Ctrl]+[Shift]+[D] - Run DiagUtility
- [Ctrl]+[Shift]+[L] - Run Loader CAL
- [Ctrl]+[Shift]+[E] - CMD (Open Command Window)
- [Ctrl]+[Shift]+[ESC] - Exit CAL
- [Ctrl]+[Shift]+[S] - Auto start

## Using the Windows Embedded CE Screen Saver and Backlight Utility

The Workstation 5A with Windows Embedded CE 6.0 R3 includes a custom enhanced Windows CE Screen Saver and Backlight Utility.

By default, after five minutes of inactivity, the screen saver engages and displays a Workstation 5A logo. If the unit remains inactive for an additional twenty minutes, the LCD backlights turn off. The operator LED remains solid White. Touching the screen or swiping a mag stripe card restores the LCD backlights. Instructions for modifying the default settings and using a custom logo can be found below.

### Procedure:

1. From the desktop, Touch Start -> Control Panel -> Screen Saver.
  - The Screen Saver Properties window appears. An example of this screen, with the default settings, is shown in Figure 4-14, below.

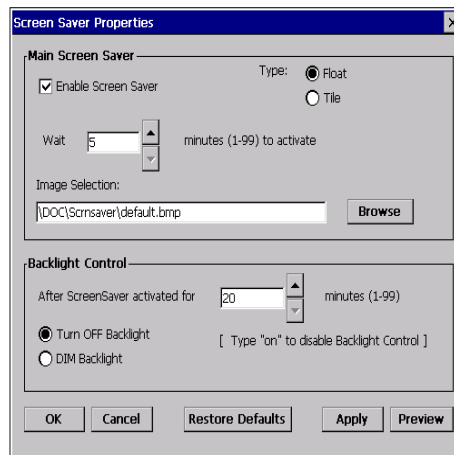

Figure 4-14: The Windows CE Screen Saver and Backlight Controls

### Main Screen Saver

- To disable the screen saver, remove the check mark from the 'Enable Screen Saver' box, touch [Apply] then [OK].
- To change the elapsed time before the screen saver engages, use the 'Wait' field up/down arrows to select the new value, touch [Apply], then [OK].
- To change the screen saver from the 'Float' mode to the 'Tile' mode, touch the 'Tile' check box, then [Apply] and [OK]. Touch the [Preview] button to see an example of the screen saver.

- To use a custom bit map, copy it to the \DOC\Scrn saver folder. To load a custom bitmap, press the [Browse] button, select the file and press [OK]. Touch [Apply], then [OK]. To view your custom bit map, touch [Preview]. Press [OK] to close the screen saver window.
- To return all screen saver and backlight utility settings to factory defaults, press the [Restore Defaults] button.

### ***Backlight Control***

This section controls the LCD CCFL backlights to extend the life of the backlight tubes. The default is to turn off the backlights twenty minutes after the screen saver engages.

- To change the backlight turn-off time, in the *After ScreenSaver activated for* field, use the up/down arrows to select the new value, then touch [Apply], and [OK].
- To prevent the backlights from turning off (not recommended) use the CE Input Panel or keyboard to type 'on' in the *After ScreenSaver activated for* field. Touch the [Apply] button, then touch [OK].
- The [Restore Defaults] button returns all screen saver/backlight utility settings to factory defaults.

### Controlling the IO Panel USB Ports (Windows CE or POSReady 2009)

The Workstation 5A System Board features the ability to individually control each IO Panel USB Port without having to restart the Workstation.

- For Windows Embedded CE 6.0, GR 1.2 or later is required.
  - For WIN32, the minimum Diagnostics Utility Version is V1.7, part of the POSReady 2009 2.0 image.
1. Start the Windows CE or WIN32 Diagnostics Utility.
  2. Tap the 'USB Port Config' tab, and password dialog box appears.

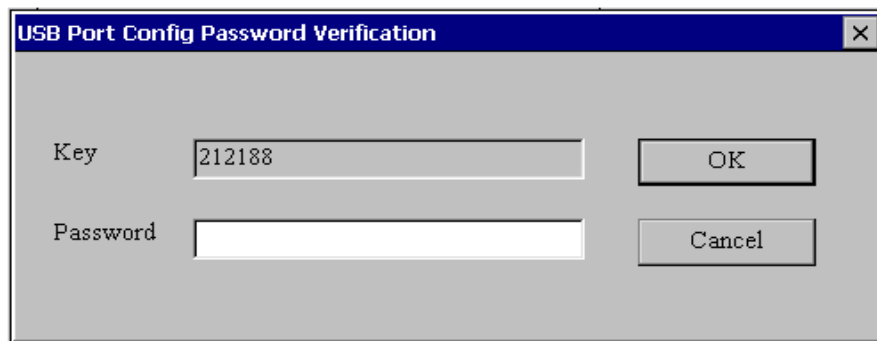

Figure 4-15: Entering a Password to access USB Port Configuration

3. Apply the formula below to the six-digit number that appears in the 'Key' field and enter the results with the on-screen keyboard as described below.

$$\text{Digit 1} \times \text{Digit 2} + \text{Digit 4} + \text{Digit 6} = \text{Password}$$

In the example above, the key field displays 212188. ( $2 \times 1 + 1 + 8 = 11$ ).

#### **Using the Windows CE Input Panel**

- To use the WinCE Input Panel, tap the keyboard or pen icon in the lower left corner of the screen and select 'LargeKB'. Tap the password entry dialog box to make sure it is active, then enter the two digit password from the Input Panel, and press the [OK] button.

#### **Using the POSReady 2009 On-Screen Keyboard**

- Tap Start -> Accessories -> Accessibility -> On-Screen Keyboard. Tap the password entry dialog box to make sure it is active, then enter the two digit password from the On-Screen Keyboard. Press [OK] to continue.

After password entry, the USB Port configuration screen appears, as shown on the next page.

The 'USB Port Config' tab contains five check-boxes, corresponding to a specific IO Panel connector label as shown in the Figure below.

The physical location of each connector is shown in the 'IO Back Panel' illustration. All USB ports are enabled when the workstation is shipped.

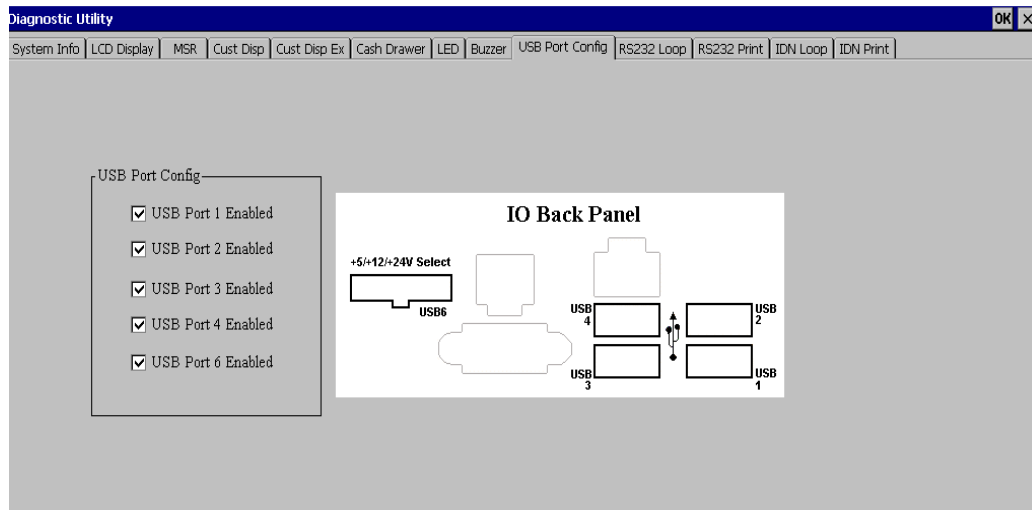

Figure 4-16: USB Port Control Tab

- To disable a USB port, touch the box to remove the check mark from the corresponding field. Or, to enable a USB Port, touch the box and the check-mark appears.
  - The change in USB port status takes affect immediately, a reboot is not required.
- When complete, exit the Diagnostics Utility.



**NOTE:**

Updating the BIOS version, or selecting WINCE and WIN32 Factory Default Settings re-enables all IO Panel USB Ports.

### **Using the Magnetic Stripe Card**

The Workstation Magnetic Stripe Reader is mounted on the right side of the top cover as shown in Figure 4-17, below. It shows how to orient the mag stripe as the card is inserted into the reader. Insert the card completely into the slot and pull it past the reader head.



*Figure 4-17: Using the Magnetic Card Reader*

#### **Tips for using Magnetic Cards**

Magnetic cards should always be kept dry, and away from magnets or sharp objects that could damage the encoded information on the card. If a mag card is damp or wet, or appears damaged in any way, DO NOT insert into the reader.

If the unit does not read the mag cards consistently, the read head may be dirty or contaminated. A cleaning card can be used to clean the reader head. This type of card has a felt strip in place of the magnetic stripe which cleans the head as it is swiped through the reader.

---

## Calibrating The Touchscreen

Calibrating the touchscreen is the process of aligning the touchscreen glass with the underlying video display.

### When to Calibrate the Touchscreen

- When installing a new workstation.
- Any time the cursor does not follow the movement of your finger, or does not reach the edges of the touchscreen.
- If the LCD panel or touchscreen glass have been replaced.
- After performing a workstation Personality Swap (Windows CE Only).

### Tips for Calibrating the Touchscreen

- Perform the calibration procedure in the position (sitting or standing) that the workstation is normally used.
- Face the Touchscreen directly. If the workstation is on a stand, adjust it to the optimum viewing angle.

### Windows Embedded CE 6.0

1. From the desktop, press Start -> Settings -> Control Panel and tap the 'EloTouch icon. Touch or click the 'Calibrate' button to proceed.
  - If you do not touch the screen within twenty seconds, the calibration utility will shut down and retain the previous calibration values.
2. To begin, touch the center of the cross-hair that appear on the screen. Continue to touch each target at the positions indicated - upper right, and lower right.
  - Make sure the cursor follows you finger at each corner of the screen. Press [Accept] to complete the procedure and exit the utility.

### POSReady 2009

Touch the desktop icon to start the touchscreen calibration.



## *Workstation 5A Recovery*

The Workstation 5A offers two methods of recovery, depending on the Operating System installed.

For Windows Embedded CE 6.0 R3 clients, WINCE Factory Restore is provided. For details about the internal operation of Factory Restore, see Chapter 3.

For WIN32, the optional POSReady 2009 Recovery CF can restore a factory or customer image to a USB Hard Drive or optional SATA Drive in minutes.

Two methods of starting a Factory Restore or the Recovery CF are available; the Recovery Button or the ODM tab in the BIOS System Configuration Utility.

### ***Recovery Button***

The Recovery Button is a recessed SPST switch accessed from the base of the workstation. It can be activated by any object less than 2mm in diameter. The location is shown below.



*Figure 4-18: Recovery Button Location*

### ***BIOS ODM Tab***

In some cases, it may not be practical to access the recovery button. The ODM Tab in the BIOS System Configuration Utility can be used to start Factory Restore or the Recovery CF. A USB Keyboard is required.

### ***BIOS - Password and Login Requirements***

Several recent BIOS releases may now prompt for a login and or password when the Recovery Button or ODM tab is used to start recovery. A list of BIOS versions and requirements can be found on the next page.

- *BIOS Version Q1000g*: Login or Password not required or supported. As of this writing, this BIOS version is installed on the majority of Workstation 5As in the field.
- *BIOS Version Q1010m*: A pre-defined log-in and password required. The Login/Password cannot be disabled or changed.
- *BIOS Versions Q2010g and Q2011d*: Requires a pre-defined password to start recovery. The password requirement can be disabled through the ODM tab.

The following pages contain detailed recovery procedures using the Recovery Button or ODM tab.

### WINCE Factory Restore - Recovery Button at Splash Screen

The Workstation 5A Recovery Button is accessed from the bottom of the unit as shown below.

1. Power off the workstation.
  - If using BIOS Version Q1010m, Q2010g or Q2011d, connect a USB Keyboard to enter the recovery password.
2. Be sure to remove all USB flash drives, sticks, or thumb drives, from the IO Panel USB Connectors.
3. Power-up the workstation using the power button.
4. Observe the LCD and press the Recovery Button when the Blue BIOS splash /w MICROS logo screen appears, shown in the Figure below.



Figure 4-19: Press the Recovery Button when the Blue Splash Screen Appears

#### **BIOS Q1000g (Password not Required)**

- The workstation restarts, displays the Blue splash screen, then: *“Factory Recovery In Progress - Please Wait...”*
- Windows CE Factory Restore takes from three to five minutes to complete, then formats the CF Card. The Workstation 5A restarts and boots to Windows CE in the out-of-box state.

***BIOS Q1010m (Login and Password Required)***

This BIOS version, distributed through a CE Platform update to support the SparkLan Mini-PCI WiFi Card, requires a pre-assigned login and recovery password to continue.

- The workstation restarts, displays the Blue Splash screen, then:
  - Prompts for a login:  
Type *M1cr0s* and press [Enter].
  - Prompts for a password:  
Type *Quant1c0* and press [Enter].
- When the login and password have been entered correctly, then:  
*“Factory Recovery In Progress - Please Wait...”*
  - Windows CE Factory Restore takes from three to five minutes to complete, then formats the CF Card. The Workstation 5A restarts and boots to Windows CE in the out-of-box state.

***BIOS Q2010g and Q2011d (Password Required)***

This BIOS version, by default, requires a pre-assigned password to continue. The password can be disabled, but is not recommended.

- The workstation restarts, displays the Blue Splash screen, then:
  - Prompts for a password to continue if the feature has not been disabled.  
Type: *Quant1c0* and press [Enter].
  - If the password is entered correctly or disabled, then:  
*“Factory Recovery In Progress - Please Wait...”*
    - Windows CE Factory Restore takes from three to five minutes to complete, then formats the CF Card. The Workstation 5A restarts and boots to Windows CE in the out-of-box state.

## POSReady Recovery CF - Recovery Button at Splash Screen

The Workstation 5A Recovery Button is accessed from the bottom of the unit as shown in Figure 4-19.

1. Power off the workstation.
  - If using BIOS Version Q2010g or Q2011d, connect a USB Keyboard to enter the recovery password (unless the password requirement is disabled).
2. Install the Recovery CF in the CF Riser Card.
  - MICROS recommends the POSReady 2009 Recovery CF remain installed in the CF Daughter Card at all times to comply with licensing requirements.
3. Be sure to remove all USB Flash Drives, Dongles, Thumb Drives or 'Sticks' connected to the IO Panel USB Ports.
4. Use the power button to start the workstation.
5. Observe the LCD and press the Recovery Button when the Blue BIOS splash /w MICROS logo screen appears, shown in the Figure below.



Figure 4-20: Press the Recovery Button when the Blue Splash Screen Appears

### **BIOS Q1000g (Password not Required)**

- The workstation restarts, and boots from the Recovery CF. A series of prompts appear, including 'Loading RAM Disk Image', followed by a 'Starting Windows Pre-boot Environment'.
- After a brief amount of time, a Command Window appears, followed by 'Loading Recovery Script...'
- If the image specified in the RECOV.DAT file is present, Ghost32 starts and transfers the image.
  - If the path and image name are not specified correctly, an error box appears, stating "Image file not found!" See page 4-36 for more information.

- When the image transfer is complete, the boot order is restored to the original configuration (optional SATA drive or USB Hard Drive), the workstation restarts.

***BIOS Q2010g/Q2011d (Password Required by Default)***

- After pressing the Recovery Button, the Blue splash screen clears and a 'password:' prompt appears.
  - Type: *Quant1c0* and press [Enter].
- If the password is disabled, or entered correctly, the workstation boots from the Recovery CF.
- The message '*Loading RAM Disk Image*' appears, followed by a '*Starting Windows Pre-boot Environment.*'
  - If an error box appears stating that "Recovery detected 2 USB hard drives installed on the system. Please remove any additional USB Flash Drives and restart recovery" See page 4-37 for more information about this error.
- After a brief time, a Command Window appears, followed by 'Loading Recovery Script...' Ghost32 starts.
  - If the image specified in RECOV.DAT is present, the transfer starts.
  - If the path and image name are not specified correctly, an error box appears, stating: "Image file not found!" You can enter the correct path and image name directly or see page 4-36.
- When the image transfer is complete, the boot order is restored to the original configuration (optional SATA SSD or USB Hard Drive connected to J8), the workstation restarts boots from the recovered image.

### **ODM Tab (BIOS Q1000g)**

The Original Device Manufacturers (ODM) Special Configuration Menu tab provides an alternate method of starting WINCE Factory Restore or CF Recovery. A USB Keyboard is required.

#### ***WINCE Factory Restore***

1. With a USB Keyboard attached, power-up the workstation with the power button.
2. When the Blue Splash Screen appears, press the [Del] key to enter the System Configuration Utility.
3. Navigate to the ODM Tab, Special Configuration Menu, select the 'WINCE Factory Restore' field to [Enabled].
4. Select the Exit tab then Save Settings and Restart, [Enter], and [Y] to restart.
  - The WS5A restarts, displays the Blue Splash Screen, then:  
*"Factory Recovery In Progress - Please Wait..."*
  - Windows CE Factory Restore takes from three to five minutes to complete, then formats the CF Card. The Workstation 5A restarts and boots to Windows CE in the 'out-of-box' condition.

#### ***Win32 Factory Restore***

The primary storage device can be the USB Hard Disk or optional SATA SSD.

1. With a USB Keyboard attached and the POSReady 2009 Recovery CF installed in the CF Daughter Card, power-up the workstation with the power button.
2. When the Blue Splash Screen appears, press the [Del] key to enter the System Configuration Utility.
3. Navigate to the ODM Special Configuration Menu, and set the 'Win32 Factory Restore' field to [Enabled].
4. Select the Exit tab then Save Settings and Restart, [Enter], and [Y] to restart the workstation.
  - The workstation restarts, and boots from the Recovery CF. A series of prompts appear, including 'Loading RAM Disk Image', followed by a 'Starting Windows Pre-boot Environment'.
  - After a brief amount of time, a Command Window appears, followed by 'Loading Recovery Script...' Ghost32 starts.
  - If the image specified in the RECOV.DAT file is present, the transfer starts.

- If the path and image name are not specified correctly, an error box appears, stating “Image file not found!” See page 4-36 for more information.
- When the image transfer is complete, the boot order is restored to start from the original USB Hard Drive, and the workstation restarts.
- If the optional SATA Disk Drive is installed, re-enter the BIOS and move ‘SATA Drive 0’ to the top of the BBS as shown below, then save and restart.
  - 0 - [SATA drive 0]
  - 1 - [IDE 0/Pri Master] CF Card
  - 2 - [PXE Boot]
  - 3 - [None]

### **Pre-Boot Menu (BIOS Q1010m Only)**

This BIOS Version moves WINCE and WIN32 Factory Restore to a Preboot Menu, shown below.

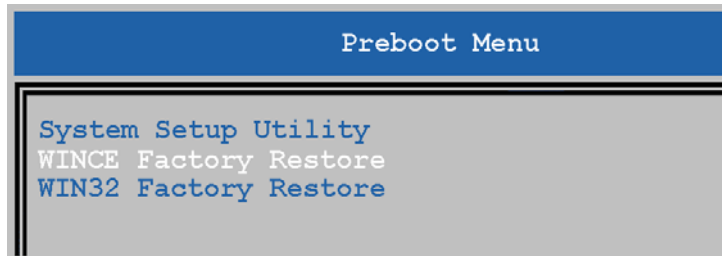

*Figure 4-21: BIOS Version Q1010m Preboot Menu*

### **WINCE Factory Restore**

1. With a USB Keyboard attached, power-up the workstation with the power button.
2. When the Blue Splash Screen appears, press the [Del] key to enter the System Configuration Utility.
  - The Preboot Menu shown above appears.
3. To start WINCE Factory Restore, select it from the Menu and press [Enter].
  - The workstation restarts, displays the Blue splash screen, then:
    - Prompts for a login:  
Type *M1cr0s* and press [Enter].
    - Prompts for a password:  
Type *Quant1c0* and press [Enter].

- When the login and password have been entered correctly, then:  
“*Factory Recovery In Progress - Please Wait...*”
  - Windows CE Factory Restore takes from three to five minutes to complete, then formats the CF Card. The Workstation 5A restarts and boots to Windows CE in the ‘out-of-box’ state.

### **ODM Tab (BIOS Q2010g and Q2011d)**

The ODM Special Configuration Menu provides an alternate method of starting WINCE Factory Restore or CF Recovery. By default, both BIOS Versions require the entry of a password to start Factory Restore or a Recovery CF.

#### ***WINCE Factory Restore***

Use this procedure to start WINCE Factory Restore from the ODM Tab.

1. With a USB Keyboard attached, power up the workstation with the Power Button.
  2. When the Blue Splash Screen appears, press the [Del] key to enter the System Configuration Utility.
  3. Navigate to the ODM Special Configuration Menu, and set the ‘Win32 Factory Restore’ field to [Enabled].
  4. Select the Exit tab then Save Settings and Restart, [Enter], and [Y] to restart the workstation.
- When the password is entered correctly or not required, then: “*Factory Recovery In Progress - Please Wait...*”
    - Windows CE Factory Restore takes from three to five minutes to complete, then formats the CF Card. The Workstation 5A restarts and boots to Windows CE in the ‘out-of-box’ condition.

#### ***USB Win32 Factory Restore***

Use this selection if the primary storage device is a USB Hard Disk.

1. With a USB Keyboard attached and the POSReady 2009 Recovery CF installed in the CF Daughter Card, power-up the workstation with the power button.
2. When the Blue Splash Screen appears, press the [Del] key to enter the System Configuration Utility.
3. Navigate to the ODM Special Configuration Menu, and set the ‘USB Win32 Factory Restore’ to [Enabled].
4. Select the Exit tab then Save Settings and Restart, [Enter], and [Y] to restart the workstation.



- The workstation restarts, and boots from the Recovery CF. A series of prompts appear, including ‘*Loading RAM Disk Image*’, followed by a ‘*Starting Windows Pre-boot Environment*’.
- After a brief time, a Command Window appears, followed by ‘*Loading Recovery Script...*’ Ghost32 starts.
- If the image specified in the RECOV.DAT file is present, the transfer starts.
  - If the path and image name are not specified correctly, an error box appears, stating “Image file not found!” See page 4-36 for more information.
- When the image transfer is complete, the boot order is restored to start from the original USB Hard Drive, and the workstation restarts.

### **SATA Win32 Factory Restore**

Use this selection if the workstation contains an optional SATA Disk Drive.

1. With a USB Keyboard attached and the POSReady 2009 Recovery CF installed in the CF Daughter Card, power-up the workstation with the power button.
2. When the Blue Splash Screen appears, press the [Del] key to enter the System Configuration Utility.
3. Navigate to the ODM Special Configuration Menu, and set the ‘SATA Win32 Factory Restore’ to [Enabled].
4. Select the Exit tab then Save Settings and Restart, [Enter], and [Y] to restart the workstation.
  - The workstation restarts, and boots from the Recovery CF. A series of prompts appear, including ‘*Loading RAM Disk Image*’, followed by a ‘*Starting Windows Pre-boot Environment*’.
  - After a brief time, a Command Window appears, followed by ‘*Loading Recovery Script...*’ Ghost32 starts.
  - If the image specified in the RECOV.DAT file is present, the transfer starts.
    - If the path and image name are not specified correctly, an error box appears, stating “Image file not found!” See page 4-36 for more information.
  - When the image transfer is complete, the workstation restarts the restores the original boot order.

## Revision F System Board - Additional Restore/Recovery Options

The recently introduced Revision F System Board combined with BIOS Versions Q2010g or later offers more recovery options; In addition to the BIOS splash screen, the Recovery Button can be used when the workstation is in the S1 (On) or S5 (Soft-Off) Power Management States.

### ***WINCE Factory Restore from the ON State***

This procedure requires the Revision F System Board and BIOS Version Q2010g or later. The ON state is defined as the BIOS System Configuration Utility, OS Desktop, or Application.

1. Connect a USB Keyboard to enter the Recovery Password.
2. Press the Recovery Button when the Workstation 5A is ON.
3. Press and Hold the Power button until the workstation powers down, then press the Power Button again to power-up.
  - The workstation starts, displays the Blue Splash screen, then requests a Password (if enabled).
4. Type *Quant1c0* and press [Enter].
  - The workstation restarts and displays the message: *Factory Restore in Progress - Please Wait.*
  - Windows CE Factory Restore takes from three to five minutes to complete, then formats the CF Card. The Workstation 5A restarts and boots to Windows CE in the 'out-of-box' state.

### ***WINCE Factory Restore from the Soft-Off (S5) State***

This procedure requires the Revision F System Board and BIOS Version Q2010g or later. The workstation is powered off, but the AC Power Cable remains connected to an AC source.

1. Connect a USB Keyboard to enter the Recovery Password.
2. Press the Recovery Button.
3. Press the Power Button to start the Workstation.
  - The workstation starts, displays the Blue Splash screen, then requests a Password (if enabled).
4. Type *Quant1c0* and press [Enter].
  - The workstation restarts and displays the message: *Factory Restore in Progress - Please Wait.*
  - Windows CE Factory Restore takes from three to five minutes to complete, then formats the CF Card. The Workstation 5A restarts and boots to Windows CE in the 'out-of-box' state.

### ***Starting the POSReady Recovery CF from the ON State***

This procedure requires the Revision F System Board and BIOS Version Q2010g or later. The ON state is defined as the BIOS System Configuration Utility, OS Desktop, or Application. The primary storage device can be a USB Hard Disk or SATA SSD.

1. With the Recovery CF installed, connect a USB Keyboard to enter the Recovery Password.
2. Press the Recovery Button when the Workstation 5A is ON.
3. Press and hold the Power Button to shut down, or from POSReady 2009, select Start -> Shutdown.
4. Press the Power Button again to start the Workstation.
  - The Workstation starts, displays the Blue Splash screen, then requests a Password (if enabled).
5. Type *QuantIc0* and press [Enter].
  - The workstation restarts, and boots from the Recovery CF. A series of prompts appear, including ‘*Loading RAM Disk Image*’, followed by a ‘*Starting Windows Pre-boot Environment*’.
  - After a brief time, a Command Window appears, followed by ‘*Loading Recovery Script...*’ Ghost32 starts.
  - If the image specified in the RECOV.DAT file is present, the transfer starts.
  - If the path and image name are not specified correctly, an error box appears, stating “Image file not found!” See page 4-36 for more information.
  - When the image transfer is complete, the workstation restarts and restores the original boot order to the primary boot device.

### ***Starting the POSReady Recovery CF from the Soft-Off State***

This procedure requires the Revision F System Board and BIOS Version Q2010g or later. The workstation is powered off, but the AC Power Cable remains connected to an AC source. The primary storage device can be a USB Hard Disk or SATA SSD.

1. Connect a USB Keyboard to enter the Recovery Password.
2. Press the Recovery Button.
3. Press the Power Button to start the Workstation.
  - The workstation starts, displays the Blue Splash screen, then requests a Password (if enabled).
4. Type *QuantIc0* and press [Enter].

- The workstation restarts, and boots from the Recovery CF. A series of prompts appear, including ‘*Loading RAM Disk Image*’, followed by a ‘*Starting Windows Pre-boot Environment*’.
  - After a brief time, a Command Window appears, followed by ‘*Loading Recovery Script...*’ Ghost32 starts.
  - If the image specified in the RECOV.DAT file is present, the transfer starts.
  - If the path and image name are not specified correctly, an error box appears, stating “Image file not found!” See page 4-36 for more information.
5. When the image transfer is complete, the workstation restarts and restores the original boot order to the primary boot device.
- The workstation restarts and displays the message: *Factory Restore in Progress - Please Wait.*

### **Disabling the Recovery Password in BIOS Q2010g/Q2011d**

To disable the recovery password in these BIOS Versions, enter the System Configuration Utility and proceed to the ODM Tab. Highlight the ‘Enable Password For Restore’ field and select [Disabled]. Select the Exit tab, then Save Settings and Restart, [Enter], then [Y] to restart the workstation. *Note: Using the WINCE, USB WIN32, or SATA WIN32 defaults re-enables this field.*

### **Error: ‘Image File Not Found’ or Using a Custom Recovery Image**

If the ‘Image File Not Found’ error appears, see below to make sure the image specified in RECOV.DAT is located on the Recovery CF.

The Recovery CF is supplied with a current MICROS WS5A POSReady 2009 image. To substitute a custom image, see the procedure below.

- Start the WS5A with the Recovery CF installed and use Windows Explorer to browse the card.
- Move or delete the factory image with the .GHO extension from the root of the CF card.
- Copy the custom image to the root directory of the Recovery CF Card.
- Use Notepad or other text editor to open the RECOV.DAT file. On the last line, replace the factory image file name with the name of your image and include the .GHO extension. For example, enter ‘YOURIMAGENAME.GHO.’
- Save the changes and exit the editor.
- Perform a test recovery to verify the image name is specified correctly. If it is not specified correctly, the error message appears stating ‘Image file not found.’

- You can enter the path, filename, and extension directly from the error box, or modify the RECOV.DAT file with the correct path and Ghost image filename. The full path is required only if the image file is not located on the root of the CF Card.

**Error: 'Recovery Detected 2 USB Hard Drives Installed on the System'**

The POSReady Recovery CF generates this error message if:

- 1) A USB Thumb or Flash Drive remains attached to the IO panel and a USB Hard Drive is attached to J8.
- 2) The WS5A contains both an optional SATA disk drive and USB Hard Drive attached to J8.

*In the first case, be sure to remove all USB Drives from the IO Panel. The POSReady 2009 Recovery CF cannot determine if a USB Flash Drive connected to the IO Panel or the USB Hard Drive connected to J8 is the boot device.*

*In the second case, when both an optional SATA disk drive and USB Hard Disk are installed, the Recovery CF cannot determine which is the boot device. One device should be removed.*

## *WS5A Diagnostics*

This chapter includes basic troubleshooting procedures for the unit and describes how to use the Diagnostics Utilities.

### ***In this chapter***

---

Basic Troubleshooting .....	5-2
Workstation 5A Diagnostics Utility .....	5-4
Wipe Compact Flash (WCF) Utility - WINCE Only .....	5-13

---

## *Basic Troubleshooting*

This section provides a brief troubleshooting guide for common problems encountered when installing or operating the Workstation 5A. Unlike the Workstation 5, the Workstation 5A BIOS does not issue a POST error if SO-DIMM is not installed or defective.

<b>Problem</b>	<b>Possible Cause</b>	<b>Solution</b>
No response to the power button. Operator LED does not blink four times per second. Operator LCD does not display blue splash screen.	No Power to WS5A  or Defective Power Supply.	Be sure AC power cable is connected to the workstation and surge protected outlet, UPS, power conditioner, or wall outlet. If unit is located on the WS5A Stand, make sure power cable is connected to base.
The unit does not start. The Operator LED blinks four times per second. The Operator LCD remains blank after 30 seconds.	Possible missing or defective SO-DIMM.  or Defective system board.	Re-seat SO-DIMM 0.  Do not use 2GB SO-DIMMs.  See Page 3-27 for approved SO-DIMM configurations.
The unit does not start. The Operator LED stays off or stays on. The Operator LCD remains blank after 30 seconds.	Possible missing or defective BIOS Chip U55 or Defective System Board	Make sure BIOS chip U55 is installed.
WINCE unit does not start. The beeper sounds four times. The LCD displays the message 'NO CF FOUND Press DEL key to enter BIOS Setup Menu'.	Power On Self Test (POST) Error. CF Card not installed, not recognized or defective.	Make sure a MICROS approved DMA enabled CF card is fully seated in a DMA enabled Riser Card Socket.
WINCE unit does not start. The Operator LCD displays the message 'No USB Hard Drive Found Press Delete key to enter BIOS Setup Menu'.	Power On Self Test (POST) Error. USB Hard Drive not installed, incorrectly installed, or defective.	Make sure USB Hard Drive is properly installed. See Chapter 3.

Problem	Possible Cause	Solution
The WS5A starts. Operator LCD displays BIOS splash screen and boots to the Operating System, but Operator LED continues to flash once per second. The POS application may report errors or not start. If the Operator LED continues to flash after the OS starts, this indicates that WS5A API did not load.	The USB Hard Drive is not, configured properly, corrupt, or defective.  or  USB Flash Drive is attached to IO Panel USB connector, and or the 'Boot Test Image' field in the BIOS ODM tab is set to 'Alternate' If the Thumb drive contains an NK.BIN file the BIOS may boot from it, but will not load platform drivers such as the API.	Replace the USB Hard Drive.  or  Remove USB Thumb Drive from IO Panel. Enter the system configuration utility, go to the Exit tab, select the correct CMOS defaults (WINCE or WIN32) and restart.
WS5A with WINCE starts and displays splash screen, but operating system does not start. Error messages such as 'Remove disk or other media. Press any key when ready, or 'Non-System disk or disk error Replace and press any key when ready.	Boot Defaults configured for WIN32.	Enter the system configuration utility, go to the Exit tab and select 'Reload WINCE Factory CMOS defaults.' Press [Enter], then [Y] to restart.
WS5A with POSReady displays splash screen, but does not start. Displays blinking cursor in the upper left corner of the LCD.	Boot Device Prioritization configured for WIndows Embedded CE 6.0.	Enter the system configuration utility, go to the Exit tab and select 'Reload WIN32 Factory CMOS defaults.' Press [Enter], then [Y] to restart.
WS5A starts and operates normally, but appears to turn-off after about 25 minutes of inactivity. The Operator LED is solid White.	The Enhanced Screen Saver and Backlight Utility automatically turns-off the backlights by default.	Touch the screen or swipe a mag stripe card through the reader to restore the screen.
WS5A does not connect to LAN.	Network Patch cable not connected.	Install appropriate patch cable between workstation and wall jack.
WS5A cannot read mag cards.	Mag card read head dirty or contaminated.  Mag card reader defective.	Use mag card cleaning kit on reader.  Replace mag stripe reader.



## *Workstation 5A Diagnostics Utility*

Windows Embedded CE 6.0 based units use the WS5A Diagnostics Utility, and POS Ready 2009 uses an updated version of the PCWS Diagnostics Utility.

The Diagnostics Utility provides a great deal of information about the platform hardware and software in addition to a set of comprehensive tests of the hardware and supported peripherals.

### **Running the Windows CE Diagnostics Utility**

For Windows Embedded CE 6.0 configurations, the utility is located in the \DOC\Utilities folder.

1. From the Desktop, touch My Device, then touch ‘DOC’
2. Touch the Utilities Folder, then select ‘WS5ADiagUtility.’

### **System Information Screen**

When the WS5A Diagnostics Utility starts, it displays the System Information Screen, as shown below.



*Figure 5-1: The WS5A System Information Screen (GR2.0)*

The System Information screen the WS5A hardware and platform software components in a central location. A brief description of each field and button follows.

***Diagnostics Version***

This field displays the WS5A Diagnostics Utility Software version. Version 1.5 is part of the GR1.5 documented in this edition.

***Workstation Model***

This field is new to WS5A Diagnostics to distinguish it from the Workstation 5.

***Hardware Revision***

This field displays the Workstation 5A System Board hardware revision. Revision D is currently shipping.

***RAM Space Available***

This field displays the amount of available RAM.

***Physical Address***

This field displays the network Media Access Control (MAC) number assigned to the system board Ethernet Controller. Each workstation will display a unique value in this field.

***DHCP Server Address***

This field displays the DHCP Server Address when the workstation operates in DHCP based network.

***IP Address (Dynamic)***

This field displays the IP Address when the workstation operates in DHCP or Static IP mode.

***Motherboard Serial***

This field displays the Workstation 5A System Board Serial Number.

***USB Flash Drive Size***

This field displays the USB Hard Drive size. For Windows Embedded CE 6.0 the device contains three partitions of roughly equal size. However, since only the \DOC partition is visible in Windows CE, this field reports about 1/3 of the total size of the device. For example, if a 256MB USB Hard Drive is installed, this field displays 80MB - roughly one third of the total size. When a 512M USB Hard Drive is installed, each partition is about 178MB.

The POS Ready 2009 configuration currently uses a 4GB USB Hard Drive with a single partition and will update to an 8GB USB Hard Drive.

***CF Size***

This field displays the total size of CF Card in bytes. Units running Windows Embedded CE 6.0 ship with a 256MB CF Card, but may switch to a 512MB CF Card. A 4GB CF Card option is also available.

***CPU Type***

This field is new to Version 1.6 of the Diagnostics Utility and reports the Processor Number, in this case, the Intel<sup>®</sup> Atom N450. Other processors may be used on future boards.

***CPU Frequency***

This field is new to Version 1.6 of the Diagnostics Utility and reports the CPU Core Frequency; the Intel<sup>®</sup> Atom N450 runs at a core frequency of 1.66GHz.

***BIOS Version***

This field displays the current MICROS BIOS Version. Note that 'Q' is Quantico - the project name for the Workstation 5A. The MICROS BIOS Version is also displayed in the upper left corner of the blue BIOS splash screen at start-up.

***CAL Version***

Displays the current Client Application Loader (CAL) Version.

***WinCE Version***

Reports Windows Embedded CE 6.0 Version Information.

***CPLD Version***

The Workstation 5A system uses a Custom Programmable Logic Device (CPLD) to add more General Purpose IO (GPIO) pins to the system. This field reports the firmware version of this device.

***MICROS Build Version***

The MICROS Build Version represents the combination of the Windows Embedded CE 6.0 image components and internal drivers. An internal driver is not accessible in the same manner as the WS5A platform drivers available on the \DOC, but are included in the image by the Windows CE Platform Builder. Should an internal driver be changed, added or removed, or a new component added or removed from the Windows CE image, a new build is generated and the MICROS 'Build Version' increments.

***UWS5A.DLL Version***

This file contains the workstation API, or Application Programming Interface. POS Applications use the API to access POS hardware such as the cash drawers, Mag Stripe Reader, and IDN Ports.

### ***LPPower.DLL Version***

This driver helps manage the power button while the operating system is running. In addition, applications such as the CAL call on this driver to force a restart of the workstation during application downloads platform or upgrades.

*When the Power Button is pressed and held for four seconds, Version 1.3 of LPPower.DLL (Part of the RC2.0) prevents the unit from entering then 'power button override' state where the unit does not respond to Wake On LAN packets.*

### ***LPBEEP.DLL Version***

This driver allows POS applications to access the system board beeper. At boot time, the BIOS controls the beeper in order to report POST codes failures should they occur.

### ***LPLED.DLL***

This driver controls the Operator LED blink rate when the operating system is running. At start-up, the LED blinks, then turns solid Blue as the operating system starts and loads this driver.

### ***LPE2PROM.DLL Version***

This driver provides access to a system board serial EEPROM that is used to store information such as the serial number reported in the System Information screen of the Diagnostics Utility.

### ***LP8543.DLL Version***

This driver appeared in GR 1.1 to support the LED backlight version of the 15" LCD.

### ***UEDCTRL.DLL Version***

This driver appears in GR1.2 or later to manage the IO panel USB ports. The 'USB Port Config' tab in the Diagnostics Utility Version 1.3 or later uses this API to control the IO Panel USB Ports. The API is available to POS applications to manage the external USB ports.

## **Activity Counters, Dump Sys Info and Recovery Image Info**

Located at the lower left side of the System Information screen are the [View Counters], [Dump Sys Info], and [Recovery Image Info] buttons. Descriptions of each button can be found below.

**[View Counters]**

The Diagnostics Utility maintains a set of counters that track the number of times an MSR swipe occurs and the number of times each cash drawer is opened. Press the [View Counters] button to view the counters. All counters are stored in the registry and lost if the CF card is wiped or formatted.

**[Dump Sys Info]**

When you press this button, a file called WS5Adump.txt is created on \CF. This text file contains all of the fields and counters reported by the System Information screen in a comma separated ASCII text format. The text file can be retrieved from the CF card and examined for troubleshooting purposes.

**[Recovery Image Info]**

Touch this button to determine the version of the factory restore files and the number of times the feature has been activated. The information is contained in file called FACRECOV.DAT, located in the \DOC folder. The Figure below shows an example of this screen. Each field is explained in more detail below.

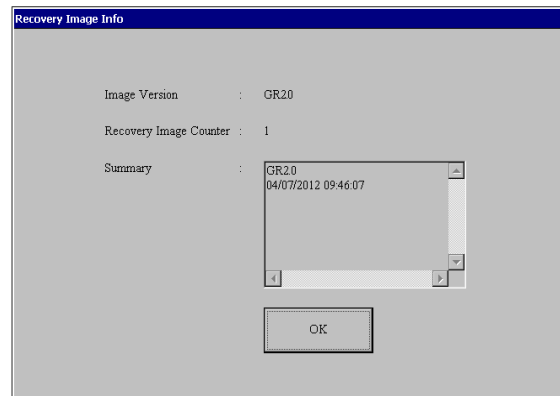

*Figure 5-2: Displaying Factory Restore Information*

The 'Image Version' field displays the version of the restore files. The restore files are contained in a hidden partition on the USB Hard Drive.

The 'Recovery Image Counter' field displays the number of times the WinCE Factory Restore feature has been used.

The 'Summary' field includes a text box that displays the version of the restore files and a date/time stamp listing each time the recovery feature is used. In this case, the WinCE Factory Restore feature has been activated one time. Note the date format is MM/DD/YYYY.

## Testing Cash Drawers

To test cash drawers, press the Cash Drawer tab. The screen displays the prompt below.

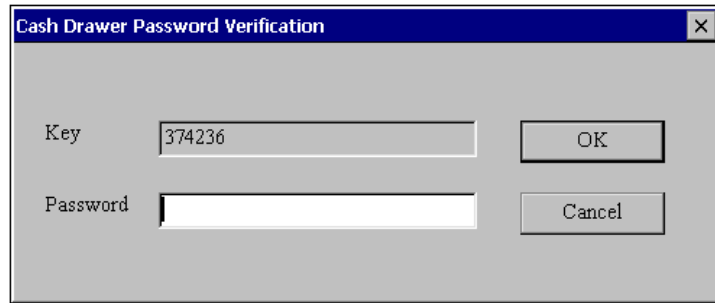

*Figure 5-3: Testing Cash Drawers*

Accessing the Cash Drawer test requires a Password. Apply the following formula to the six-digit number that appears in the 'Key' field.

$$\text{Digit 1} \times \text{Digit 2} + \text{Digit 4} + \text{Digit 6} = \text{Password}$$

For example, if the Key is 374236, the Password would equal 29. ( $3 \times 7 + 2 + 6 = 29$ ).

To enter the password using the WinCE Input Panel, tap the keyboard or pen icon in the lower left corner of the screen and select 'LargeKB'. Make sure the password entry dialog box is active, then enter the two digit password from the soft keyboard.

When the password is accepted the cash drawer test page appears.

## Controlling the IO Panel USB Ports

Disabling the WS5A IO Panel USB Ports requires Windows CE Software Platform GR1.2 or later.

1. Tap the 'USB Port Config' tab, and password dialog box appears.

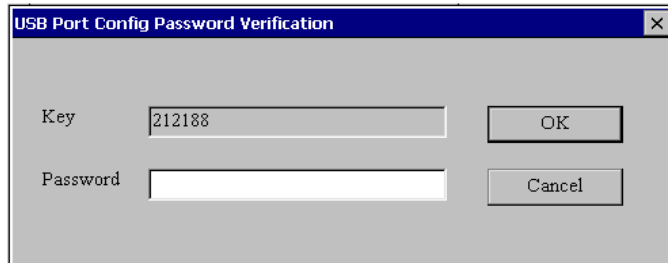

Figure 5-4: USB Port Configuration Password Entry Dialog Box

2. Apply the formula below to the six-digit number that appears in the 'Key' field.

$$\text{Digit 1} \times \text{Digit 2} + \text{Digit 4} + \text{Digit 6} = \text{Password}$$

In the example above, the key field displays 212188. ( $2 \times 1 + 1 + 8 = 11$ ).

3. To enter the password using the WinCE Input Panel, tap the keyboard or pen icon in the lower left corner of the screen and select 'LargeKB'. Tap the password field to make sure it is active, enter the calculated two-digit password from the Input Panel, and press the [OK] button.

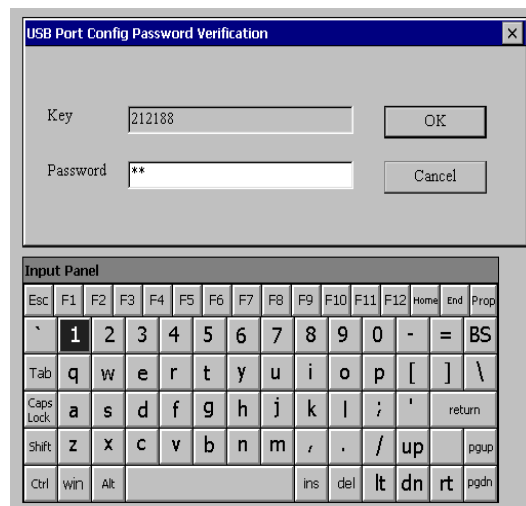

Figure 5-5: Using the Windows CE Input Panel to enter a Password

After password entry, the USB Port Configuration screen appears.

The 'USB Port Config' tab contains five check-boxes, corresponding to a specific IO Panel connector. This includes the standard Type A ports USB1 through USB4 and the optional powered USB port, USB6. The location of each connector is shown in the 'IO Back Panel' illustration.

All IO Panel USB ports are enabled when the workstation is shipped.

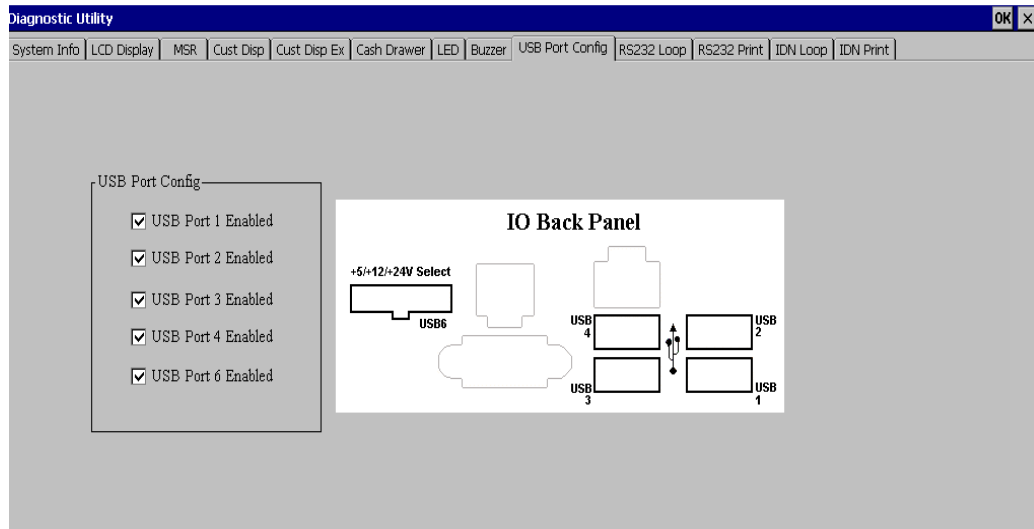

Figure 5-6: IO Panel USB Port Identification

- To disable a USB port, tap the corresponding box to remove the check box. To enable a USB Port, tap the box and the check-mark appears.
  - o The port status changes immediately, a reboot is not required.
- When complete, exit the Diagnostics Utility.



**NOTE:**

Updating the BIOS to a new version, using J20 to clear the BIOS, or Reloading the Windows CE or WIN32 Defaults re-enables all USB Ports.



## Running the WS5A Diagnostics Utility (POSReady 2009)

From the Desktop, touch the 'Diagnostics Utility' icon twice.

### System Information Screen

The Figure below displays a sample of the WIN32 version of the Diagnostics Utility, updated to Version 1.7. This version adds the processor type and speed to the System Info tab.

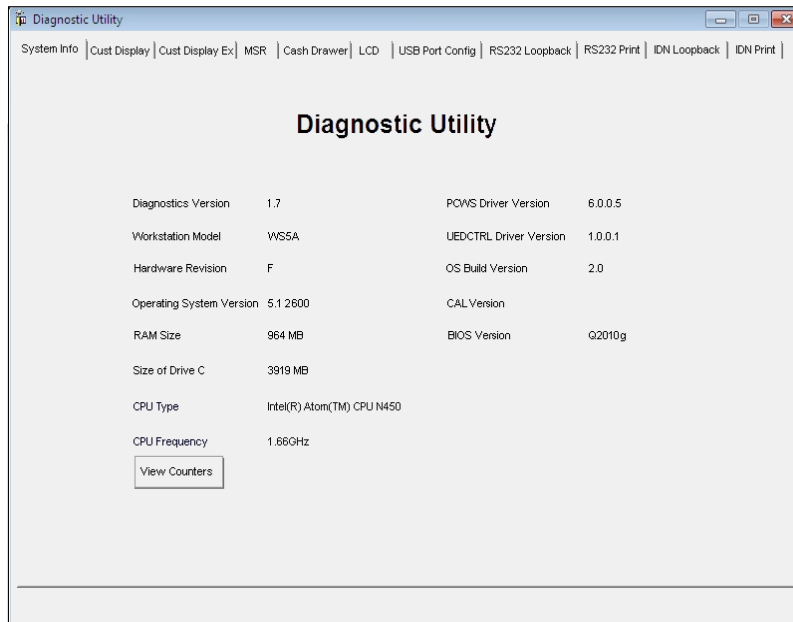

*Figure 5-7: WIN32 Diagnostics Utility System Information Screen*

The WS5A Diagnostics Utility is derived from the PCWS 2010 Utility and runs under Windows Embedded POSReady 2009.

Like the Windows CE Version, it is capable of testing all workstation point of sale interfaces. To test Cash Drawers or control the IO Panel USB Ports, use the same password formula as the Windows CE version of the Diagnostics Utility.

## *Wipe Compact Flash (WCF) Utility - WINCE Only*

In addition to the Diagnostics Utility, the \DOC\Utilities folder also contains WCF.EXE, the Wipe Compact Flash utility. Originally developed for the WS4 production line, we feel it has use as a service tool. WCF is not available for WIN32 configurations, since they do not require a CF Card.



### **CAUTION:**

However, if used in a careless or malicious manner, WCF is capable of deleting optional SAR totals and rendering a functioning workstation temporarily inoperable. WCF is not required during on-site setup and operation of the WS5A and can be removed before installation.

---

When you start WCF.EXE, it displays three options, listed below. After the selection of any option, the unit enters the **NOPOWER** mode.

- *Clear all Registry Settings?*

This selection deletes the copy of the persistent registry stored on the CF Card. It is used at the factory just prior to shipping the unit to clear any registry changes made during testing.

- *Erase Compact Flash?*

This selection removes all files from the CF card including the persistent registry folder, the POS application and SAR totals, if present.

- *Format Compact Flash?*

This selection formats the CF Card, erasing all files and removes file corruption, if present, by reprogramming the File Allocation Table (FAT).

Press the power button to start the unit. Clearing the registry files or formatting the card clears the registry to its default settings. The default registry starts the CAL client, and after pointing the workstation to a properly configured POS application server, the application can be obtained in minutes.

**WS5A Diagnostics**

Wipe Compact Flash (WCF) Utility - WINCE Only

---

# *Equipment Dimensions*

Workstation 5A and Peripheral Dimensional Drawings.

***In this appendix***

---

Workstation 5A Low Profile .....	A-2
Workstation 5A Low Profile /w Protégé Customer Display.....	A-3
WS5A on Adjustable Stand with Rear LCD Customer Display .....	A-4
Workstation 5A on Adjustable Stand /w 6” LCD Pole Display .....	A-5
Workstation 5A on Adjustable Stand /w Protégé Customer Display .....	A-6
Workstation 5A on Adjustable Stand and Protégé on 6” Pole.....	A-7
LCD Pole Display .....	A-8
Protégé Customer Display on 6” Pole .....	A-9
Cash Drawers .....	A-10

---

*Workstation 5A Low Profile*

**NOTES:**

1. Cables from IO Panel exit through bottom of unit.
2. Leave room at front/side of unit for card swipe and power button.
3. Orient unit to avoid glare on touchscreen from overhead lights.
4. Cash Drawers located at customer's discretion.
5. 77mm hole required under unit if Cash Drawer mounted under counter.
6. Optional Finger Printer Reader can be mounted to left or right of the Top Cover

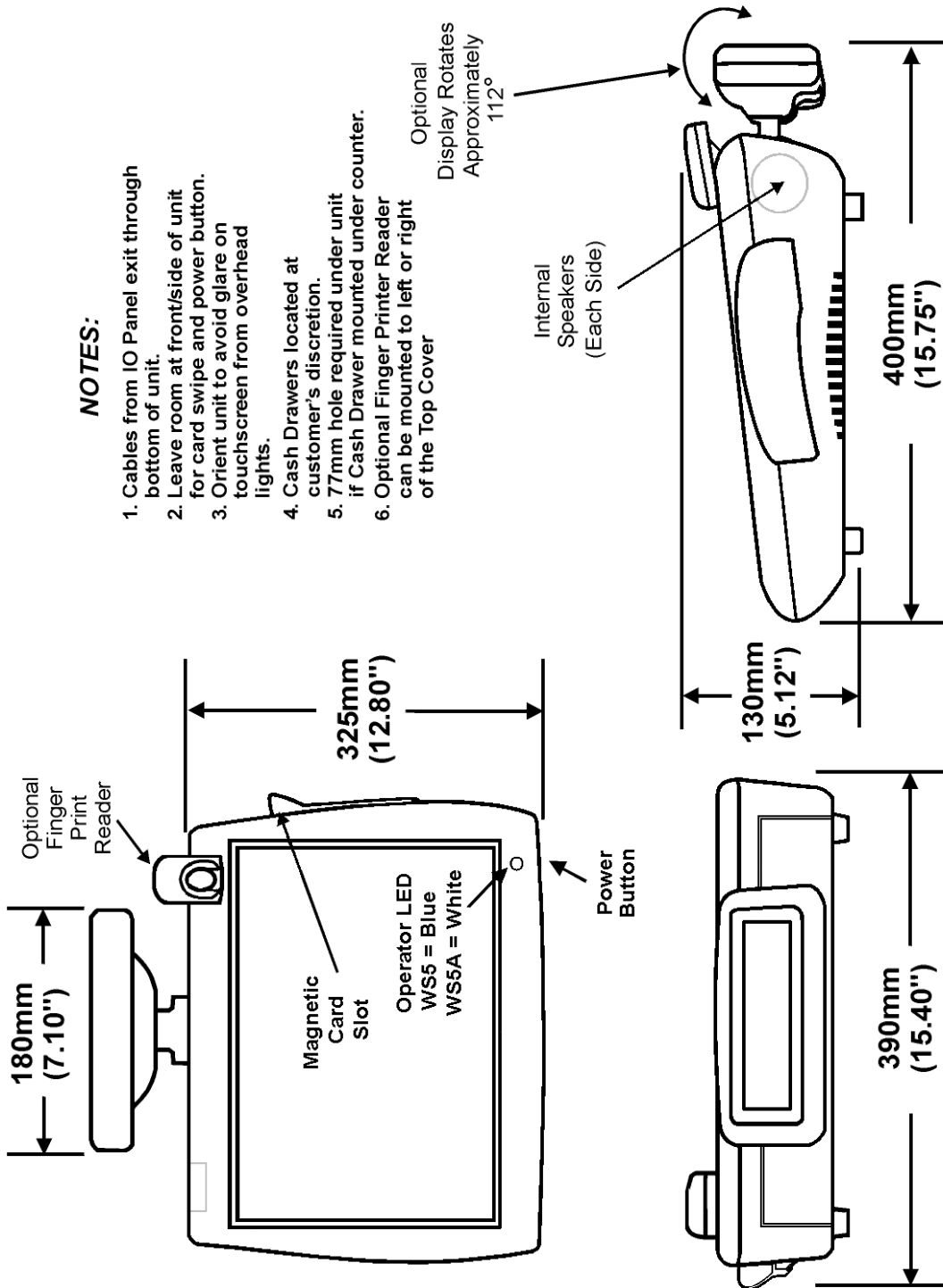

*Workstation 5A Low Profile /w Protégé Customer Display*

**NOTES:**

1. Cables from IO Panel exit through bottom of unit.
2. Leave room at front/side of unit for card swipe and power button.
3. Orient unit to avoid glare on touchscreen from overhead lights.
4. Cash Drawers located at customer's discretion.
5. 77mm hole required under unit if Cash Drawer mounted under counter.
6. Optional Finger Printer Reader can be mounted to left or right of the Top Cover

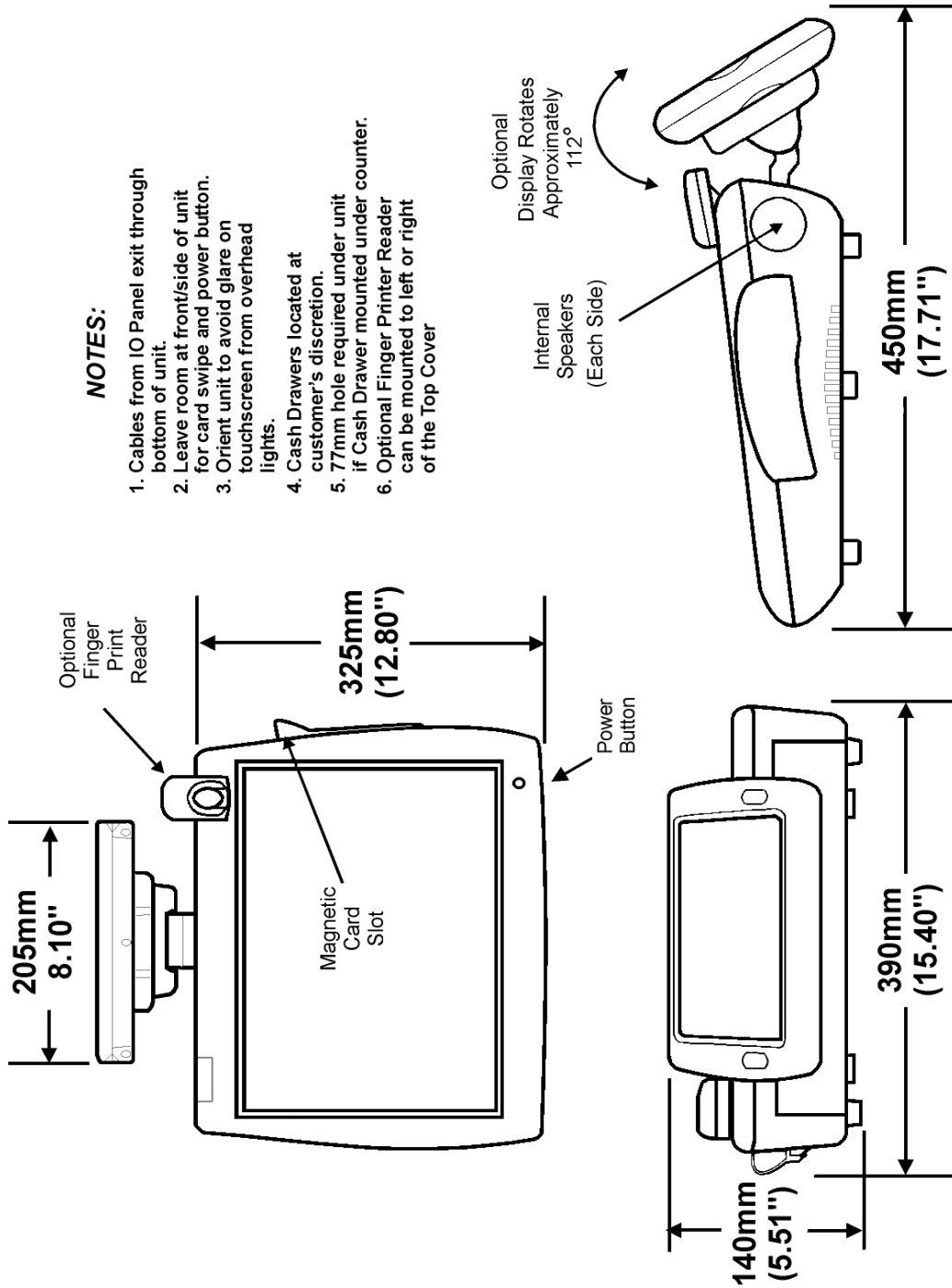

## Equipment Dimensions

WS5A on Adjustable Stand with Rear LCD Customer Display

### WS5A on Adjustable Stand with Rear LCD Customer Display

#### NOTES:

1. Cables from IO Panel routed through cable slot to exit stand
2. Leave room at front/side of unit for card swipe and power button.
3. Orient unit to avoid glare on touchscreen from overhead lights.
4. Cash Drawers located at customer's discretion.
5. 77mm hole required under unit if Cash Drawer mounted under counter.
6. Optional Finger Printer Reader can be mounted to left or right of the Top Cover

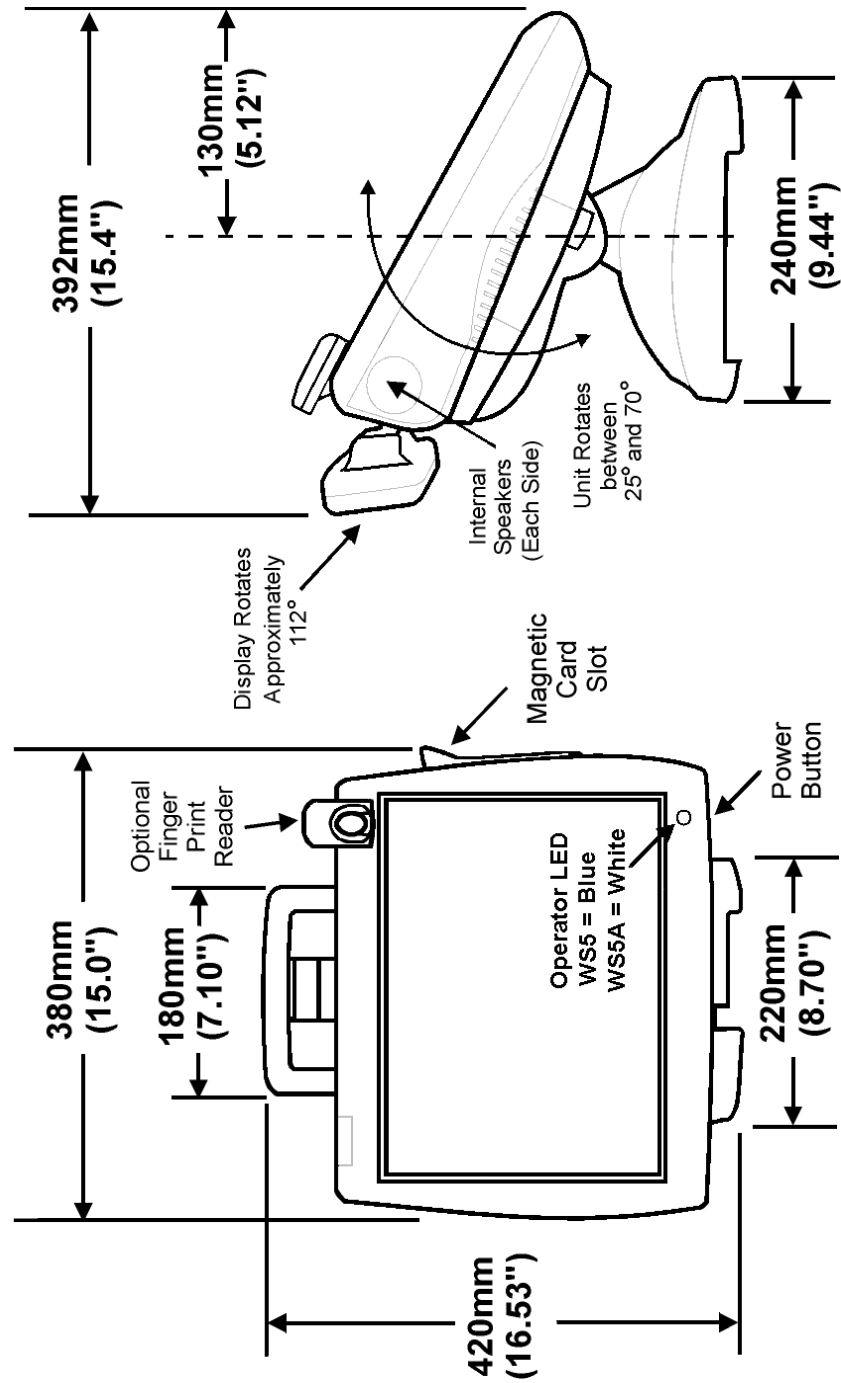

*Workstation 5A on Adjustable Stand /w 6" LCD Pole Display*

**NOTES:**

1. Cables from IO Panel routed through cable slot to exit stand
2. Leave room at front/side of unit for card swipe and power button.
3. Orient unit to avoid glare on touchscreen from overhead lights.
4. Cash Drawers located at customer's discretion.
5. 77mm hole required under unit if Cash Drawer mounted under counter.
6. Optional Finger Printer Reader can be mounted to left or right of the Top Cover

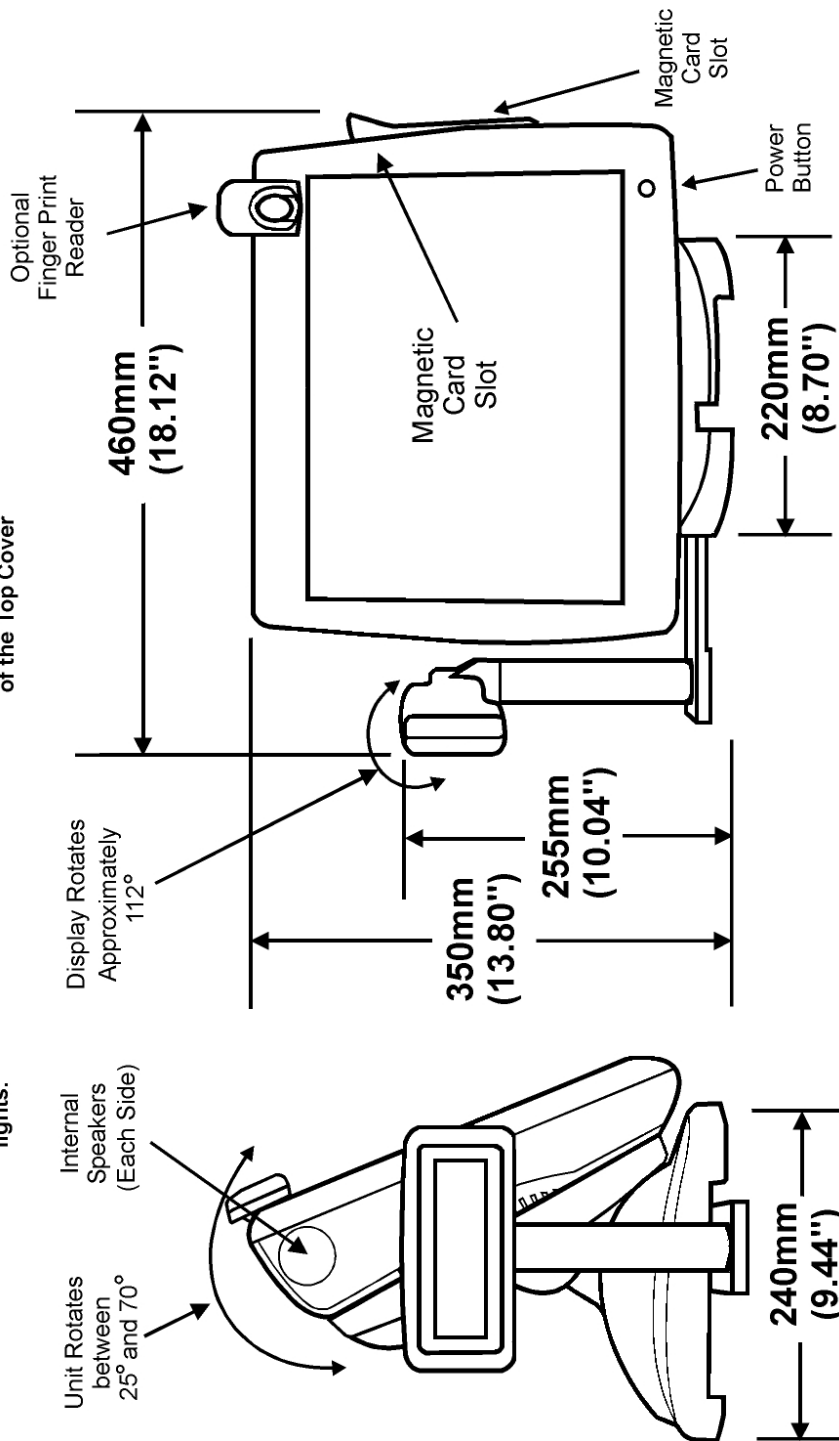



## Equipment Dimensions

Workstation 5A on Adjustable Stand /w Protégé Customer Display

### Workstation 5A on Adjustable Stand /w Protégé Customer Display

#### NOTES:

1. Cables from IO Panel routed through cable slot to exit stand
2. Leave room at front/side of unit for card swipe and power button.
3. Orient unit to avoid glare on touchscreen from overhead lights.
4. Cash Drawers located at customer's discretion.
5. 77mm hole required under unit if Cash Drawer mounted under counter.
6. Optional Finger Printer Reader can be mounted to left or right of the Top Cover

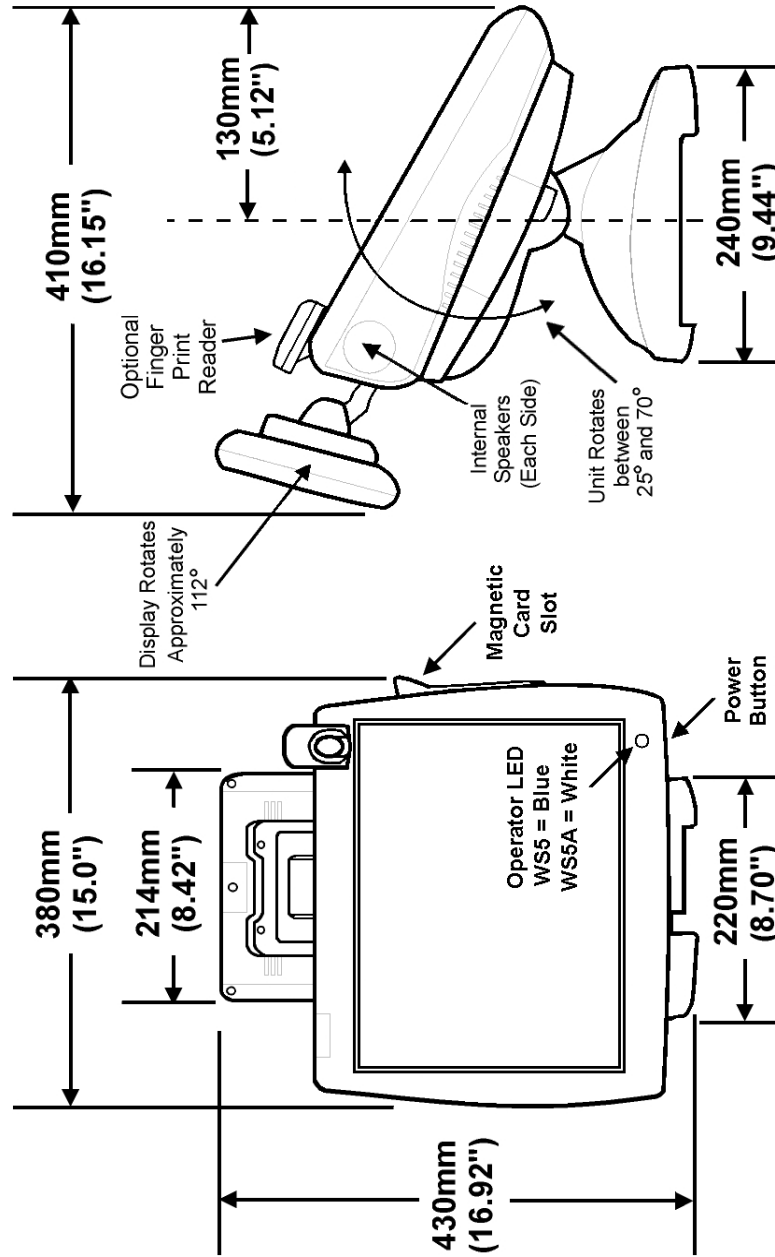

*Workstation 5A on Adjustable Stand and Protégé on 6" Pole*

**NOTES:**

1. Cables from IO Panel routed through cable slot to exit stand
2. Leave room at front/side of unit for card swipe and power button.
3. Orient unit to avoid glare on touchscreen from overhead lights.
4. Cash Drawers located at customer's discretion.
5. 77mm hole required under unit if Cash Drawer mounted under counter.
6. Optional Finger Printer Reader can be mounted to left or right of the Top Cover

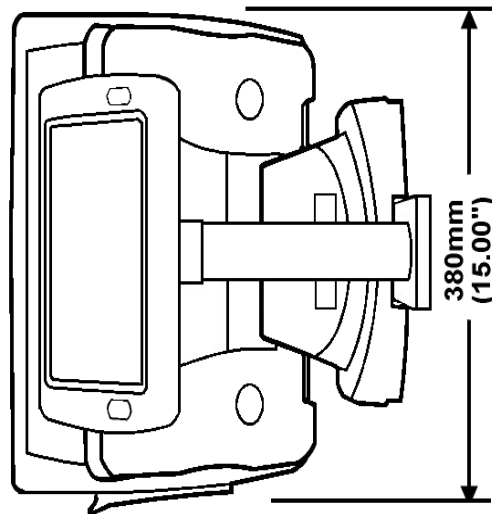
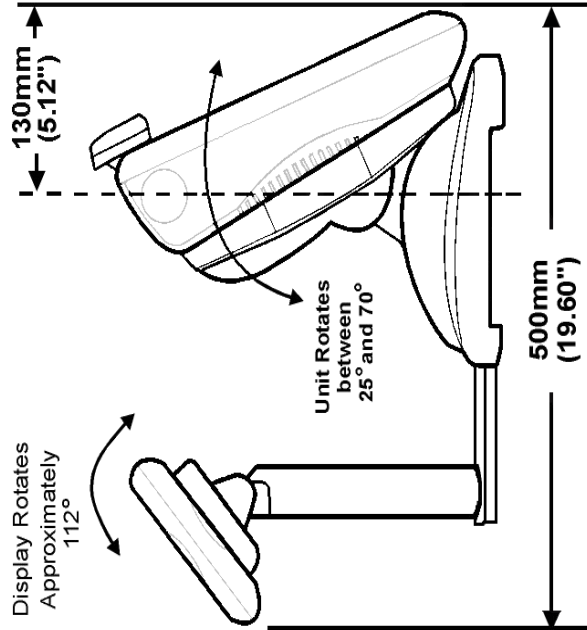
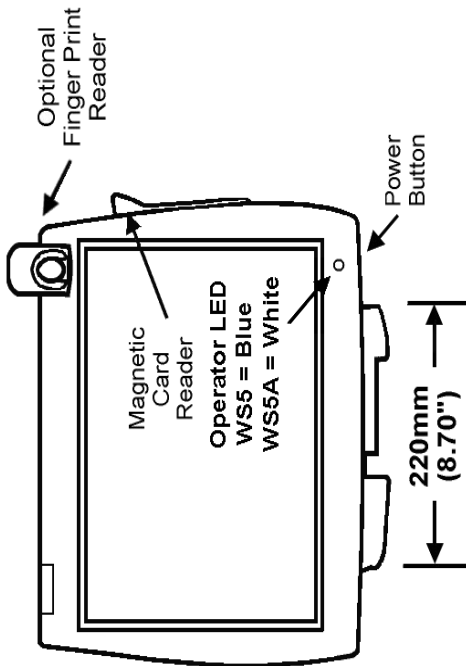

*LCD Pole Display*

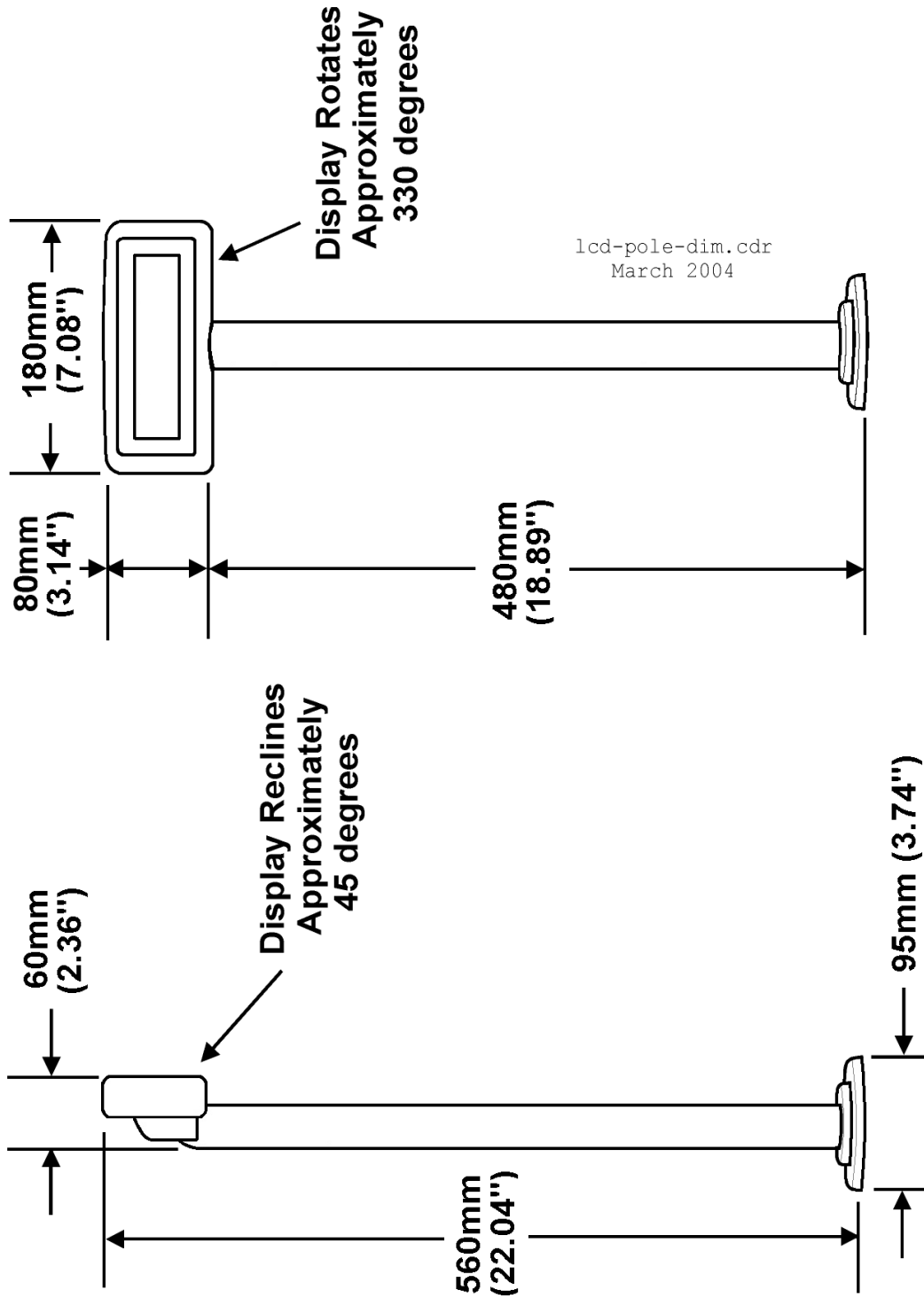

*Protégé Customer Display on 6" Pole*

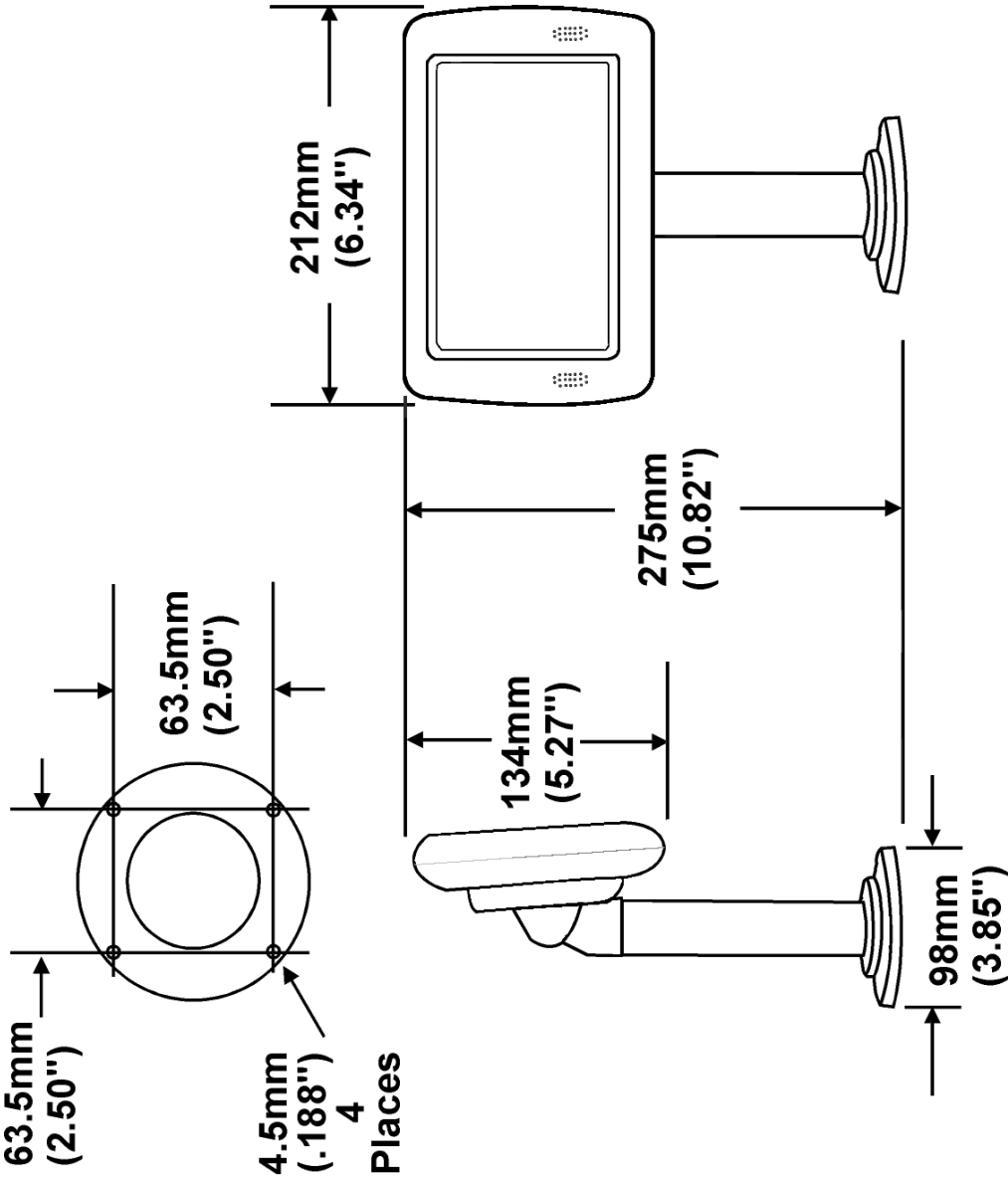

*Cash Drawers*

MICROS P/N	W	D	H
400018-026	18.0"	16.71"	4.17"
	457.2 mm	424.4 mm	106 mm
400018-027	18.0"	16.71"	4.17"
	457.2 mm	424.4 mm	106 mm
400018-028	18.8"	20.0"	4.17"
	477.5 mm	508mm	106 mm
400018-029	18.8"	20.0"	4.17"
	477.5 mm	508mm	106 mm
400018-033	13.0"	16.71"	4.17"
	330 mm	424.4 mm	106 mm

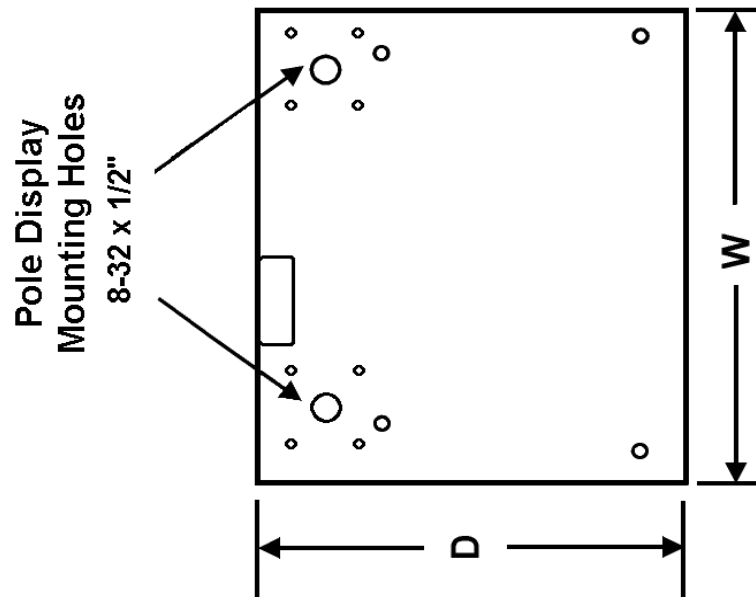
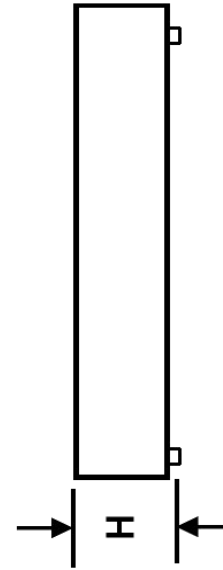

## *Connector and Cable Diagrams*

On the pages that follow, you will find diagrams of the Workstation 5A I/O Panel connectors, system board connectors, and commonly used hook-up cables. A description of how each cable or connector is used is provided.

### ***In this appendix***

---

IO Panel Connectors .....	B-2
System Board Connectors.....	B-6
Hook-up Cables .....	B-7

---

## IO Panel Connectors

The following connectors are located on the Workstation 5A IO Panel.

### IDN Port

The IDN connector is a combination RS422/RS232 port associated with COM4. This port is functionally equivalent to the RS422-A and RS422-B ports on the WS4 or WS4 LX. Two configurations are detailed in the following pages, configured through the POS application.



#### **WARNING:**

Do not insert a 6-Pin modular plug into the 8-Pin IDN Port. The 6-Pin plug can push pins 1 and 8 of the connector out of position. These pins are used by the RS232 Interface. Should you wish to use the RS232 Interface at a later time, it may not function. Always use an 8-Pin modular plug to connect an IDN printer to the workstation. Use P/N 300319-036 (3ft) or 300319-120 (10ft).

### IDN Port - IDN Printers

The most popular configuration of the IDN Port is the RS422 based IDN(+) mode. Figure B-1 shows the pin-out for this configuration.

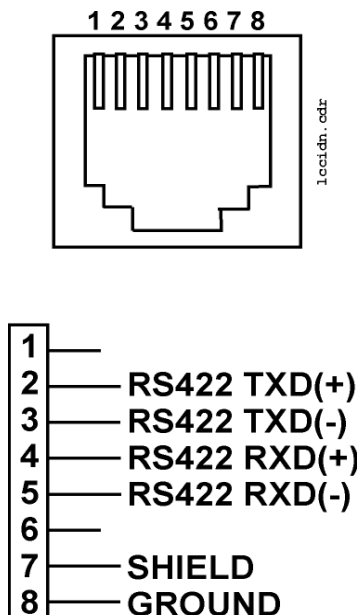

Figure B-1: IDN Connector Configured for RS422 IDN

**IDN Port - RS232 Peripheral**

Figure B-2 shows the IDN port configuration for a basic RS232 interface. Use cable P/N 300319-102 to convert this port to a DB9 connector.

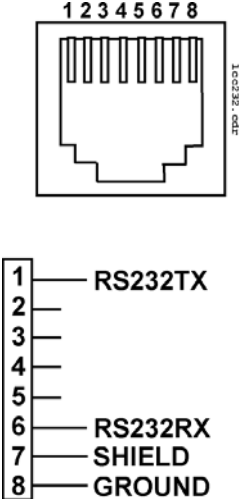

Figure B-2: IDN Port Configured for RS232

**COM 2 and COM 5**

The Workstation 5A includes two modular COM ports, COM2 and COM5. Each are full-featured RS232 modular COM ports similar to COM5 on the original Workstation 5, the PCWS Eclipse, and PCWS 2010. Use cable P/N 300319-103 to convert this port to a DB9 connector.

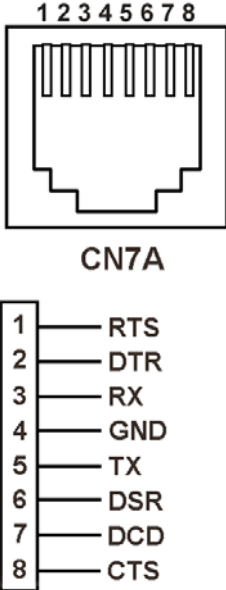
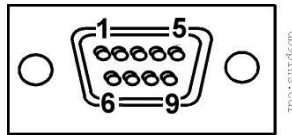

Figure B-3: COM5 Modular RS232 Connector



### RS232 Connector

A single DB9F RS232 connector assigned to COM1 is provided. The pin-out is shown below.



- 1 - DCD
- 2 - RXD
- 3 - TXD
- 4 - DTR
- 5 - GND
- 6 - DSR
- 7 - RTS
- 8- CTS
- 9- RI

*Figure B-4: DB9 RS232 Connector Diagram*

### Cash Drawer 1 and 2 Connectors

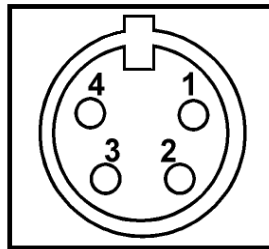

- 1 — +12V\*
- 2 — DRAWER OPEN
- 3 — GND
- 4 — DRAWER CLOSED

\* +24V is available through BIOS Setting  
See Chapter 3

*Figure B-5: Cash Drawer Connector Diagram*

### Remote Customer Display Connector

This port supports either the 2x20 VFD customer display or the graphics based LCD customer display.

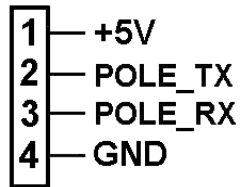
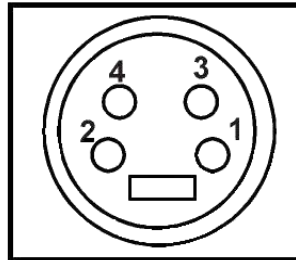

*Figure B-6: Customer Display Connector Diagram*

## *System Board Connectors*

This section details connectors located on the Workstation 5A system board.

---

### **Magnetic Stripe Interface**

The internal magnetic card reader connector is CN13, located on the system board. The pin-outs for this connector are shown in Figure B-7,

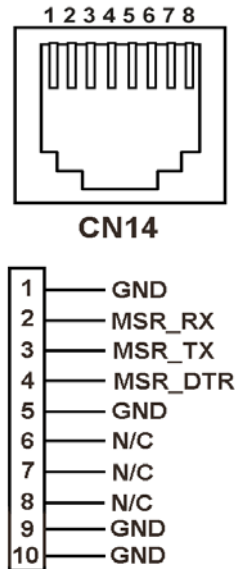

*Figure B-7: Workstation 5A System Board MSR Connector*

*Hook-up Cables*

The following pages show wiring diagrams of various hook-up cables that may be used with the Workstation 5A.

**IDN Port RS232 Cables**

Figure B-8 displays a cable that includes the RS232 signals from the IDN Port to a DB9 male connector. This cable is available from MICROS by ordering P/N 300319-102.

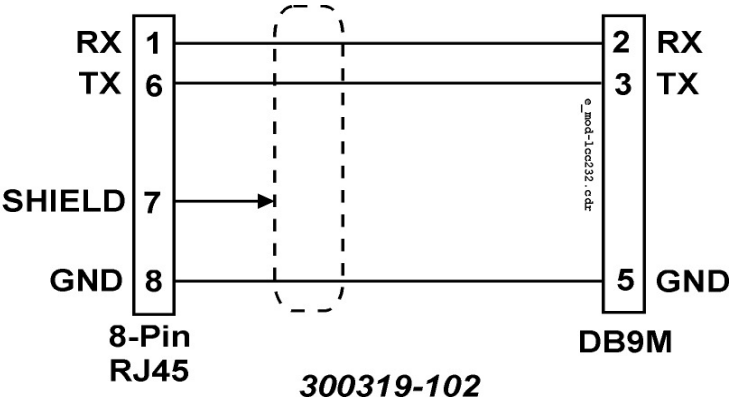

*Figure B-8: IDN Port to RS232 DB9 Male Connector*

Figure B-9 shows a cable diagram that adapts the IDN port to a DB25 connector.

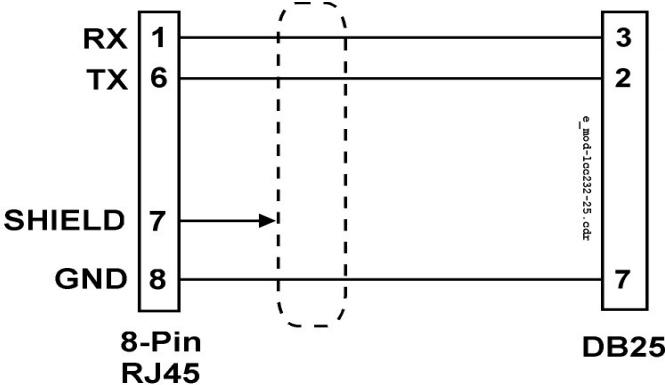

*Figure B-9: IDN Port to RS232 DB25 Connector*

**COM5 RS232 Cables**

Figure B-10 displays a diagram of an extension cable that brings all RS232 signals from the COM5 or COM2 port to a DB9 connector.

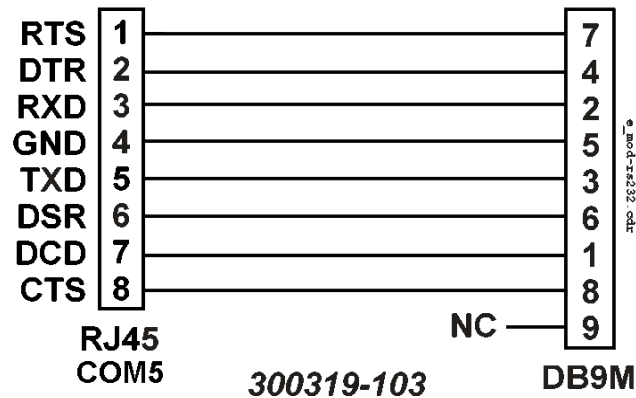

*Figure B-10: COM5 and COM2 RS232 Extension Cable (DB9M)*

**LCD Customer Display Cables**

The LCD based Customer Display includes two cable assemblies. The function of each cable is detailed in the following pages.

**LCD Customer Display Housing Interface Cable**

The LCD Customer Display Housing consists of the LCD Panel, Interface Board, mounting bracket and interface cable. A diagram of this interface cable is shown in Figure B-11.

When the LCD Customer Display is attached directly to the WS5A, this cable plugs into the 'Rear Display' IO Panel connector shown in Figure B-13.

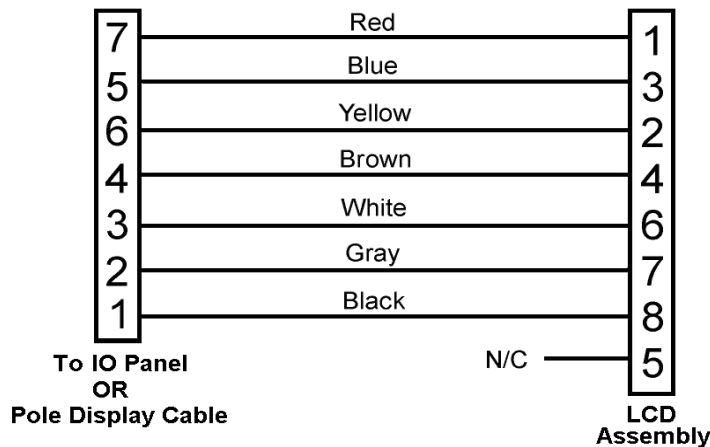

*Figure B-11: LCD Customer Display Housing Cable*

**Remote Pole LCD Customer Display**

The cable shown in Figure B-12 is supplied with the Pole LCD Customer Display or Adjustable Stand Pole Display kit. It attaches between the 4-pin Mini-DIN connector on the Workstation 5A I/O panel, through the pole to mate with the cable from the LCD Customer Display Housing Cable shown in Figure B-11.

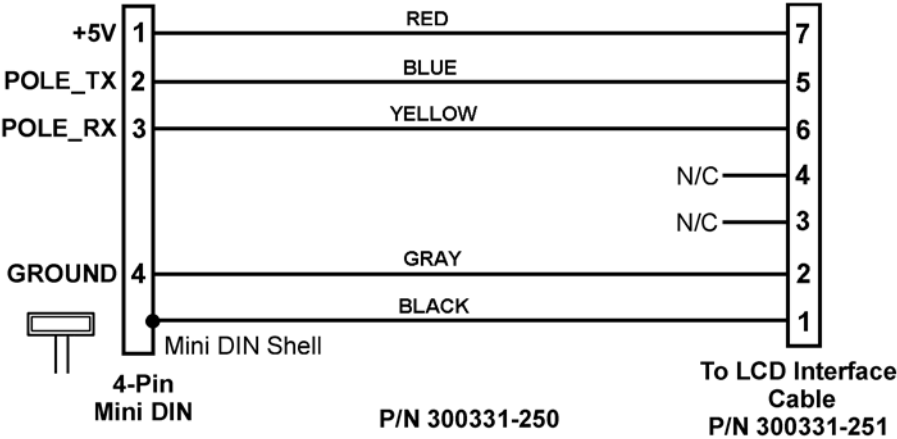

*Figure B-12: Remote Pole LCD Customer Display Assembly*

**IO Panel LCD Customer Display Connector**

The Workstation 5 and 5A places the integrated customer display connector on the IO Panel. It should not be used for the Protégé Customer Display. A diagram of this connector is shown below.

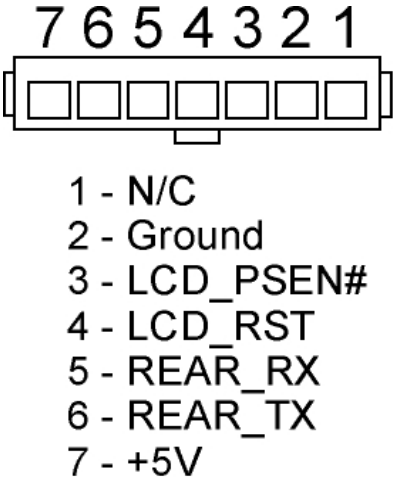

*Figure B-13: IO Panel Integrated LCD Connector*

**Ethernet**

Figure B-14 shows a diagram of a standard Cat 5 Ethernet hook-up cable. This cable would be connected from a workstation or server to the system hub.

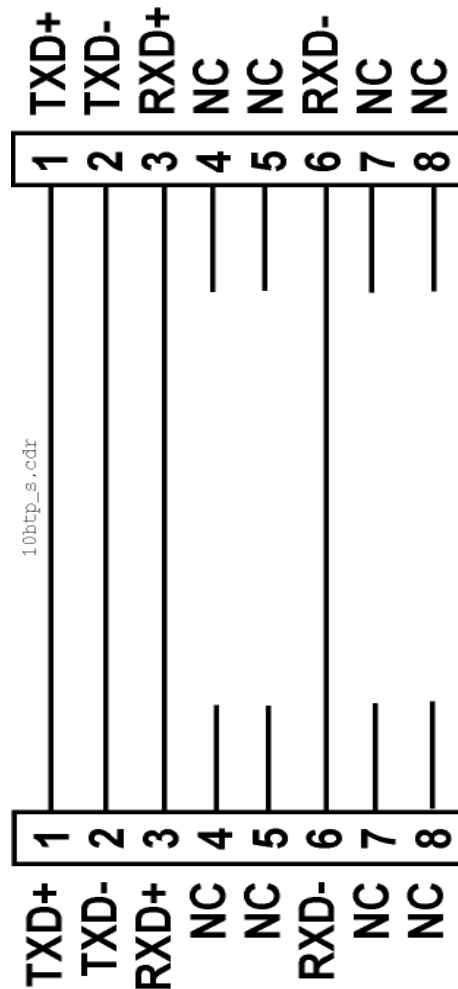

*Figure B-14: EIA/TIA-568-A Cat 5A Ethernet Hook-up Cable Diagram*

**Cross-over Pinning**

Figure B-15 shows a diagram of a typical Category 5 or later hook-up cable with the transmit/receive cross-over pinning implemented. This cable can be used when only two devices must be connected. For example, it can be used to connect two workstations, or a server connected to a single client.

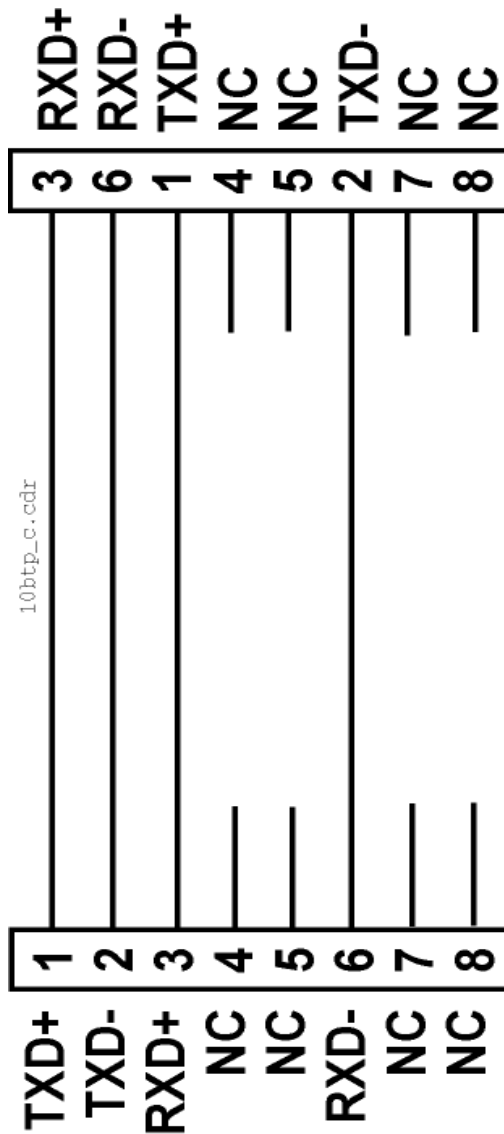
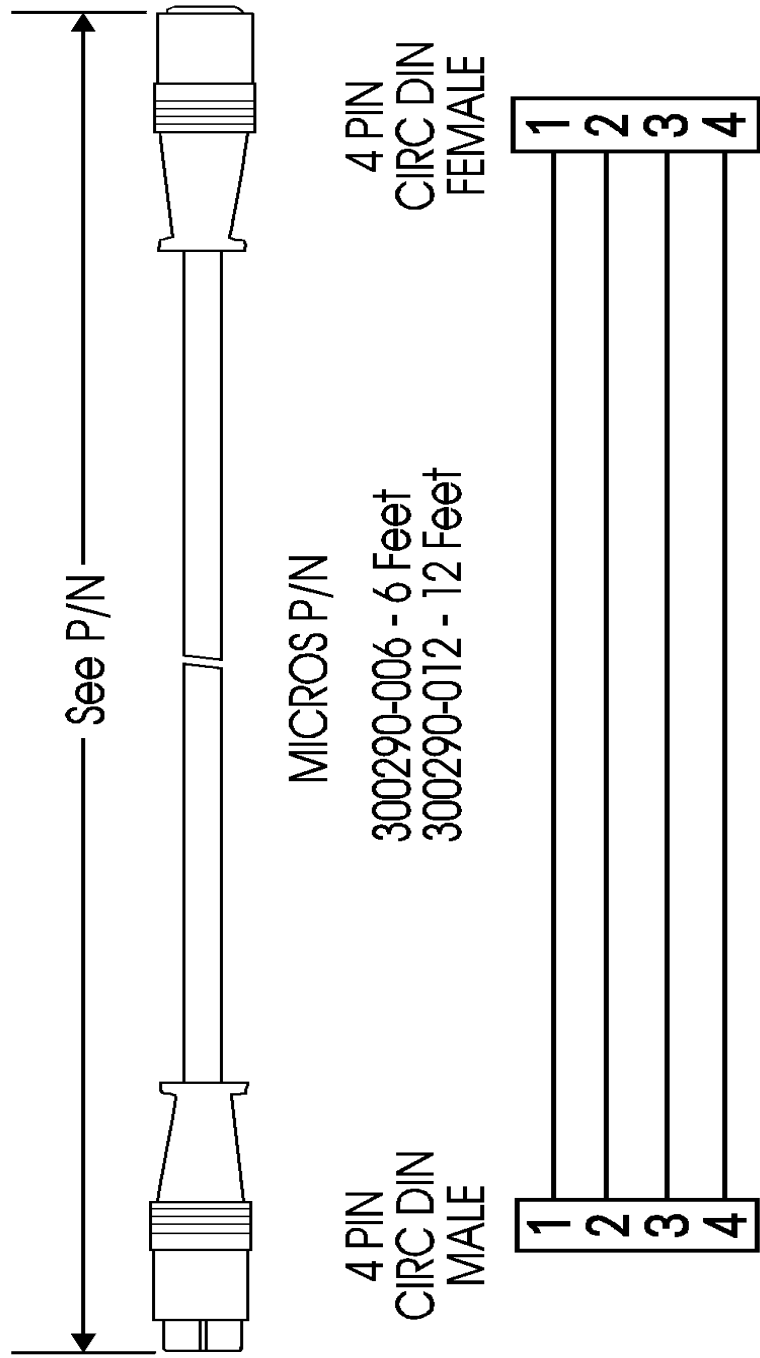

Figure B-15: Cat 5E Ethernet Hook-up Cable Diagram (cross-over)



Cash Drawer Extension Cable

---



---

## *Appendix C*

# *FCC/DOC Statement*

### **Federal Communications Commission Radio Frequency Interference Statement**

This equipment generates, uses, and can radiate radio frequency energy, and if not installed and used in accordance with the instruction manual, may cause interference to radio communications. It has been tested and found to comply with the limits for a Class A computing device pursuant to Subpart J of Part 15 of FCC Rules, which are designed to provide reasonable protection against such interference when operated in a commercial environment. Operation of this equipment in a residential area is likely to cause interference in equipment, in which case the user at his own expense will be required to take whatever measures may be required to correct the interference.

If this equipment appears to cause interference the user could consult the installer/dealer or an experienced radio television technician.

A booklet prepared by the Federal Communications Commission entitled "How to Identify and Resolve Radio - TV Interference Problems" may be useful. This booklet may be ordered from the Superintendent of Documents, U.S. Government Printing Office, Washington D.C. with stock number #004-000-00345-4.

**Caution**

Changes or modifications not expressly approved by the party responsible for compliance could void the user's authority to operate the equipment. Shielded interface cables must be used in order to comply with the emission limits.

---

**Canadian Department of Communications Statement**

This digital apparatus does not exceed the Class A/Class B (whichever applies) limits for radio noise emissions from digital apparatus as set out in the Radio Interference Regulations of the Canadian Department of Communications.

Le présent appareil numérique n'émet pas de bruits radioélectriques dépassant les limites applicables aux appareils numériques de Classe A/de Classe B (selon le cas) prescrites dans Le Règlement sur le Brouillage Radioélectrique Idicté par le Ministère des Communications du Canada.

**Attention:**

Tous changement ou modification, non expressément agréés par la partie responsable pour la conformité de l'installation, pourraient annuler l'autorisation de l'exploitation par l'utilisateur du matériel installé. Il est obligatoire d'utiliser pour la communication ou la réalisation d'interfaces un câble blindé, afin d'être en conformité avec les limites légales d'émission.

---

# *Oracle Linux for MICROS*

## *General Information*

### **Accessing Diagnostics on Workstations Running Oracle Linux for MICROS**

1. From Symphony OPS, press Ctrl+Alt+Fx (where x = 4, 5, or 6) to open another terminal window.
2. Log in as possupport user.
3. Type **startd** to open the Universal Diagnostic Utility.

#### **Available Diagnostics:**

- System Information
- LCD Display
- Customer Display
- Cash Drawer
- IDN Loopback
- IDN Print
- MSR
- Encrypted MSR
- RS232 Loopback
- RS232 Print
- Storage Device  
(Test internal and external drive write/read time and speed.)
- Touch Calibration
- Dump Config Data
- Devices

## Oracle Linux for MICROS Commands



### NOTE

Most deployments of Oracle Linux for MICROS do not require extensive Linux command line operations.

Oracle Linux for MICROS commands are case sensitive.

---

### OPEN ANOTHER TERMINAL

Press **Ctrl+Alt+F<sub>x</sub>** (where x = 4, 5, or 6) to open another terminal window.

Ctrl+Alt+F4: Log in as **possupport**.

### FIND LINUX IMAGE VERSION INFORMATION

```
cat /etc/micros-release
```

### FIND NETWORK ADDRESS OF DEVICE

```
ifconfig
```

### FIND NETWORK ADDRESS OF DEVICE

```
ip addr
```

### CHECK NETWORK STATUS

```
nmcli device status
```

### CONFIGURE NETWORK

```
nmtui
```

### VERIFY CONTACT TO A REMOTE HOST

```
ping 10.209.76.197
```

### MONITOR THE RUNNING PROCESSES, MEMORY, AND CPU USAGE

```
top
```

Press **q** to exit Top command

### END A RUNNING PROCESS

```
kill 4465
```

**EDIT A TEXT FILE**

nano webconfig.txt

**RESTART THE DEVICE**

reboot

**TURN OFF THE DEVICE**

shutdown now

- **Note for workstations running Oracle Linux for MICROS:** You can press and hold the workstation power button to perform a graceful shutdown. Shutdown can take up to 10 seconds to complete.

## Using the Recovery Button to Perform a System Recovery in Oracle Linux for MICROS

---

1. Turn off the workstation.
2. Remove the workstation from stand and unplug all cables except power and a keyboard.
3. Locate the recovery button on back of the workstation.
4. Use a hex wrench or paper clip to hold down the recovery button on the bottom of the workstation.
5. While holding down the recovery button for 5 seconds, press and hold the power button for 1 second, and then release both buttons to begin the system recovery process.
  - Ignore any *Invalid BIOS* messages that appear.
  - When prompted with *Y/N?*, press **Y**, and then press **Enter**.
  - Recovery continues for approximately six minutes.



### ***Attention!***

#### **System Recovery**

The Oracle MICROS Workstation 5A with Oracle Linux for MICROS supports system recovery only via the recovery button. BIOS-based system recovery available at a later date.

---