



FVT-2001 Version: 1

## 10/100BASE-TX to 100BASE-FX MMF SC Converter, 2km

The FVT-2001 MMF SC media converter is able to convert network signals between copper and fiber-optic based networks. The converter provides a 10/100Base-TX RJ-45 port, supports full duplex and half duplex switch connectivity and 10Base-T and 100Base-TX auto-sensing. Used in multi-mode with fibre-optic cabling, this can extend a network range up to 2km.

The device features built-in Dip switches for easy converter configuration, which function on the Smart LFP (Link Fault Pass-through), allowing the converter to monitor both the fiber and copper ports for signal loss, as well as converter transmission method, auto-negotiation mode for adjusting copper speed and full & half duplex mode.

The FVT-2001 is able to operate in temperatures from -10° up to 55° Celsius. The converter can be used as a standalone unit or as a slide-in module to the CHV-2000 19" Converter Chassis, which can accommodate up to 14 units for use in a central wiring closet.



1. 10/100Mbps Fiber Port
2. LED Indicators
3. 10/100Mbps RJ-45 Port



4. DC Power Jack
5. Dip Switch

### Key Features

- Transfers data from 10/100Base-TX copper to fiber interfaces
- Multi-mode fiber with SC connector for transmission of up to 2km
- Built-in LFP (Link Fault Pass-through) Technology



- IEEE 802.3x Flow Control protects against lost packets for reliable data transmission
- Dip switches for customized configuration
- Supports low-time lag transmission
- Supports the transmission of extra-long packets up to 1.6KB
- -10°C ~ 55°C operating temperature range

---

## Works Well With



**CVH-2000**  
14-Slot Media Converter Chassis



**FVT-2002**  
10/100BASE-TX to 100BASE-FX MMF ST Converter, 2km

---

## Specifications

### System Specifications

#### Connectors and Cabling:

1 x 100Base-FX Multi-mode duplex SC  
Fiber cable: 50/125um, 62.5/125um

1 x 10/100Base-TX RJ-45 Port, auto MDI/MDI-X and Auto-Negotiation

#### Wavelength(nm):

1310nm (FVT-2001)  
850nm (FVT-2001EF)

#### Indicator:

PWR, TX (FDX, 100, Link/Act), FX (100, Link/Act)

#### Transmission Method:

Store and forward (Default)

#### Power:

DC 5V/1A

#### Standards & Protocols:

IEEE 802.3 10-BASE-T, Ethernet  
IEEE 802.3u 100-BASE-TX, Fast Ethernet  
IEEE 802.3x Flow Control (full-duplex flow control)

### Features

#### General:

DIP Switch 1: LFP function  
DIP Switch 2: Transmission Mode  
DIP Switch 3: Auto/Force the UTP port work mode  
DIP Switch 4: 10/100M for UTP port  
DIP Switch 5: Full/Half Duplex mode for UTP port  
DIP Switch 6: Normally close

### Performance

Operating Distance:

2KM

## Environment

Temperature (°C):

Storage: -40 ~75 °C

Operating: -10 ~ 55 °C

Humidity (Non-condensing):

5 ~ 90 %

## Physical Specifications

Dimensions (W x D x H mm):

71 x 94 x 26 mm

Weight (g):

420 g

## Others

Approval and Compliance:

CE, FCC

Deployment:

Desk, chassis mounted



# Diagram

## Dimension Diagram

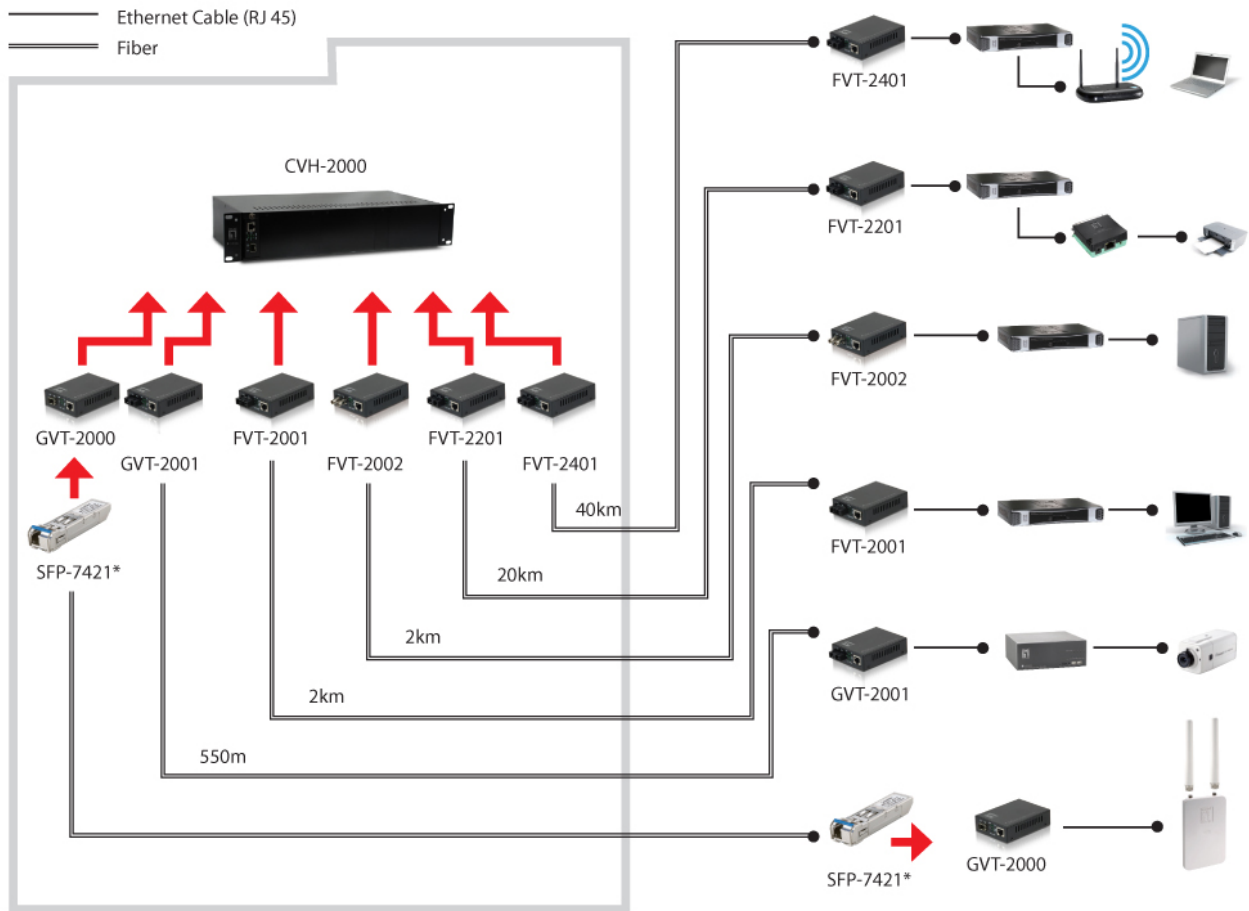

\*In above example diagram, converter modules at local and remote ends should be paired for proper connectivity, and the distance mainly depends on cable and transceiver selection accordingly.

## Order Information

FVT-2001: 1310nm  
 FVT-2001EF: 850nm

## Package Contents

Power Adapter  
 Quick Installation Guide

## Optional Accessory



**CVH-2000**  
 14-Slot Media Converter Chassis

No liability or responsibility for any errors or omissions in the content.  
 Specifications are subject to change without notice.

All mentioned brand names are registered trademarks and property of their owners.  
Copyright © Digital Data Communications GmbH, Germany. All Rights Reserved.