



2021

# Rambridge Wholesale Supply Catalog



**Rambridge Wholesale Supply**

8-8009 57 Street SE  
Calgary, AB Canada T2C 5K7  
Toll Free: 1-800-265-4769  
Toll Free Fax: 1-866-852-5475

# Who is Rambridge?

We're a family-run manufacturer and wholesale distributor based in Canada, focused on indoor & outdoor garden and greenhouse goods. Our partners receive our heartfelt dedication to accelerate every project.

While we have grown over the past 35+ years, we remain people-focused: your success is our success.

Our knowledgeable team provides education to small-scale and professional application growers to lead successful grows from start to finish.

## Planting the first seed

It all started in our backyards with garden greenhouse installations for our own grows.

We began to create and rigorously test nutrients and additives specifically designed to enhance growth in Canadian soil - and from our discoveries, we opened our very first warehouse in Calgary. We rapidly evolved to full-scale lighting and application engineering, and we didn't stop there.

From there, we continued to grow with the future and evolved to expand our operations in the US, and adding two additional Canadian warehouses.

We had one goal that still remains the same: provide growers of all sizes with innovative, reliable products proven to achieve optimal growth.



# Table of Contents



## Fertilizers & Additives

4-26

- Blossom Blood
- Veg Booster
- Dry Flower Products
  - ▶Green Up
  - ▶Liquid Black Crystal
  - ▶Liquid Gold
  - ▶Clearing Solution
- Bumper A&B
- Blossom A&B
- Potassium Silicate
- Wegener's Liquid
- Bionova & Bionova Veganics
- Terpenez

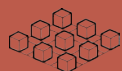

## Growing Substrates

27-30

- Bionova Coco
- Eazy Plug & HGA Propagators
- Gold Label Substrates



## Lighting

31-57

- SolarMAX DE
- SolarMAX Super HPS & MH
- SolarMAX Reflector
- Dutch Lighting Innovations
- FOHSE
- Gavita
- GROWstation LED
- Plantmax
- Solistek



## Environmental

58-72

- Anden Dehumidifiers
- Hurricane Fans
- Mammoth Grow Tents
- Turboklone
- Vortex Fans & Filters



## Gardening Supplies

73-81

- Air-Pot
- Chikamasa



## Hydroponics & Irrigation

82-84

- Blumat Digital Moisture Meter
- Tropf Blumat



## Testing Meters & Solutions

85-104

- Bumper Up & Down
- CannaMax Calibration Solutions
- Bluelab
- HM Digital



## Commercial Applications

105

- Brome Compost
- Bruin De Bruine
- Elpress
- NetLED
- PIPP
- Wachsen
- Benching Layouts
- Anden Specification Sheets
- Dehumidifer Layouts
- Lighting Layouts



# Fertilizers and Additives



# Blossom Blood and Veg Booster

## Blossom Blood

The addition of Blossom Blood to your feed schedule during the flowering stage of a plant will promote fuller buds and flowers utilizing selective pH control. Blossom Blood's reputation comes from over 25 years of positive results. Developed for stabilization and floral production in hydroponic applications, Blossom Blood may also be used in soilless growing mediums. Blossom Blood is a specific type of pH buffer salt and is compatible with all quality nutrients.

4190300	BLOSSOM PH CONTROL 20G
4190320	BLOSSOM PH CONTROL 300G
4190321	BLOSSOM PH CONTROL 1KG

Case Quantity: 20g 10/case; 300g 12/case; 1g 6/case

## Veg Booster

Enables young cuttings or seedlings to better promote stronger fuller plant growth during the vegetative stage. Add Veg-Booster directly to your reservoir only once at the beginning of a plant's vegetative cycle when the seedling/cuttings have gotten over transplant shock. Works on soil grown plants too.

4190310	VEG BOOSTER (20 GM PKG.)
4190312	VEG BOOSTER 270GM

Case Quantity: 20g 10/case; 270g 12/case

# Dry Flower Products



## Green Up

1-3.5-0



Green-Up is designed to reduce yellowing when cuttings are rooting. It has the ability to feed a cutting before the roots have developed. DO NOT foliar spray Green-Up directly on cuttings, seedlings or maturing plants. Green-Up is compatible with all quality brand name nutrients. Can be used on mature plants to reduce yellowing on lower leaves in flowering stage.

- 4220091 GREEN UP 1 L**
- 4220092 GREEN UP 4L**
- 4220093 GREEN UP 10 L**
- Case Quantity: 1L 12/case; 4L 4/case; 10L 2/case**

## Liquid Black Crystal

0 - 0.04 - 0.06



Liquid Black Crystal assists in increasing the ion exchange across the root membrane. It improves the plants ability to absorb nutrients. Liquid Black Crystal must be put into your reservoir or used as a substrate drench. It is most effective when it is applied to the root zone of a plant. DO NOT foliar spray with Liquid Black Crystal directly onto leaf tissue.

- 4220095 LIQUID BLACK CRYSTAL 1L**
- 4220096 LIQUID BLACK CRYSTAL 4L**
- 4220105 LIQUID BLACK CRYSTAL 10 L**
- 4220520 LIQUID BLACK CRYSTAL 20L**
- Case Quantity: 1L 12/case; 4L 4/case; 10L 2/case**



## Liquid Gold

0-0.04-0.06

Liquid Gold can be added directly to your reservoir water, or used as a foliar spray. It is compatible with any nutrient. Liquid Gold will increase the cell metabolic rate which translates into better growth. Liquid Gold is absorbed directly into the plant tissue and regular daily spraying will treat new growth cells.

- 4220097 LIQUID GOLD 1L**
- 4220098 LIQUID GOLD 4L**
- 4220099 LIQUID GOLD 10 L**
- 4220521 LIQUID GOLD 20L**
- Case Quantity: 1L 12/case; 4L 4/case; 10L 2/case**



## Clearing Solution

Clearing Solution is used to replace the nutrient in the final days before removing a floral crop from your growing system. Clearing Solution induces a stress on the plants system forcing reactions within the plant. DO NOT foliar spray Clearing Solution. DO NOT mix Clearing Solution with nutrients.

- 4190500 CLEARING SOLUTION 1 L**
- 4190501 CLEARING SOLUTION 4 L**
- 4190502 CLEARING SOLUTION 10 L**
- Case Quantity: 1L 12/case; 4L 4/case; 10L 2/case**

# Bumper Crop Specialty Hydroponics Nutrients:

# The First Choice for Hydroponic Growers!

Bumper Crop Nutrients are celebrating over 30 years of excellence! These nutrients were the first liquid foods in the market and are recognized for their quality. Rambridge has continued to improve the products' performance. Bumper Crop Nutrients are an easy to use two part nutrient specifically for vegetative growth and a simple two part specifically for flowering. They contain the natural minerals plants prefer for healthy energetic growth.



## Bumper A&B

### The Food for Vegetative Growth

Designed for feeding vegetative growth and fruit production, Bumper Crop is ideal for starting cuttings or for vegetables (like tomatoes and cucumbers, both which produce fruit and have on-going vegetative growth). High calcium and magnesium levels prevent blossom end rot and improve pollination.

Bumper Crop A&B formulation provides the N-P-K micro minerals plus the health minerals magnesium, sulphur and calcium.

- 4220041      **BUMPER A 0-3-4 1L**
- 4220042      **BUMPER A 0-3-4 4L**
- 4220045      **BUMPER A 0-3-4 10L**
- 4220043      **BUMPER A 0-3-4 20L**
- 4220051      **BUMPER B 4-0-3 1L**
- 4220052      **BUMPER B 4-0-3 4L**
- 4220053      **BUMPER B 4-0-3 10L**
- 4220054      **BUMPER B 4-0-3 20L**

Case Quantity: 1l 12/case; 4l 4/case; 10l 2/case

## Blossom A&B

### Bud Bursting Performance!

This is the formula that earned Bumper Crop its reputation for consistent flower yields crop after crop. It is loaded with the right stuff, in the right combination, without having to add other "nutrient supplements". Blossom A & B is recommended to growers who desire a simple, straight forward nutrient aimed at growing flowers. Blossom A&B are productive nutrient formulations for greenhouse production. To maximize both yields and crop quality it is recommended that you purchase a good nutrient meter to assist in maintaining nutrient levels in your nutrient solution.

- 4220061      **BLOSSOM A 0-5-4 1L**
- 4220062      **BLOSSOM A 0-5-4 4L**
- 4220065      **BLOSSOM A 0-5-4 10L**
- 4220063      **BLOSSOM A 0-5-4 20L**
- 4220071      **BLOSSOM B 3-0-4 1L**
- 4220072      **BLOSSOM B 3-0-4 4L**
- 4220075      **BLOSSOM B 3-0-4 10L**
- 4220073      **BLOSSOM B 3-0-4 20L**

Case Quantity: 1l 12/case; 4l 4/case; 10l 2/case

# Potassium Silicate

Nutrient Control for Fungus & Molds. Adding Potassium Silicate to your nutrient solution helps prevent the growth of mold and fungus in plants, helps raise the pH of the nutrient and is a source of potassium for your plant. Our Potassium Silicate mix is 16 times more concentrated than any other on the market. A smaller amount is required to get optimized results. Potassium Silicate can increase your plants tolerances of environmental stress, temperature changes, water and soil toxicity. It can also aid in the improved growth rate in the root zone and the foliage.

4230050 POTASSIUM SILICATE 500ML

4230052 POTASSIUM SILICATE 4L

Case Quantity: 500ml, 12/case; 4l, 4/case





# Wegener's Liquid

WEGENER'S  
*Liquid*



4220406      Wegener's Liquid 500 ml

4220407      Wegener's Liquid 1l

4220408      Wegener's Liquid 4l

4220409      Wegener's Liquid 10l

Case Quantity: 500ml, 12/case; 1l, 12/case; 4l,

4/case; 10l 2/case

Wegener's Liquid provides a balanced NPK (8-6-6) with calcium, magnesium, plus a formulation of trace minerals and elements including plant based extracts from bees wax and select foliage that help plants to absorb and use organic nutrients. Great for your lawn, garden or houseplants. Wegener's Liquid is a concentrate and must be diluted 200 times. One teaspoon (5 ml) to a quart (litre) of water will provide your plants with a healthy organic based diet they'll love.

**Use A Little - Grow A Lot:** Whether you are a commercial grower or a home gardener, you will find that Wegener's Liquid addresses nutrient imbalances and is ideal for helping plants recover from stress. Wegener's Liquid provides a gentle release of nutrients which will not burn plants.

**Environmentally Safe:** Wegener's does not easily leach into waterways making it a preferred choice for golf courses, lake front landscaping, around ponds and water gardens.

**Commercial Use:** Wegener's Liquid provides the complete nutrition required for growing in soilless mediums. This makes it ideal for interior plant maintenance, nursery stock, fruit, vegetables or herbs.

**Lawn Management:** Use Wegener's Liquid on recreational turf including golf courses, not only as a great fertilizer but as a biological thatch control. When the grass is cut, the cuttings form thatch which is slow in breaking down and decomposing. Apply Wegener's immediately after cutting and thatch breakdown speeds up. It has results you'll appreciate.

## Main Fertilizers

### Bionova Coco A&B

Coco Forte A+B fertilizer is the most simple solution for cultivating on cocofiber substrates like slabs, bricks and cocosubstrate (Cocopeat). One of the reasons which makes its application so easy is the combination of nutrients for growing and flowering within one product; two bottles/containers is all you need for the entire growth. This fertilizer is free of excess ingredients and contains only minerals plants are able to absorb directly.

In other words: Coco Forte A+B is a complete nutrient solution which has the same convenience of synthetic A/B-systems and the quality of the best organic fertilizers.

The basis for Coco Forte is Nutri Forte. All minerals are of a "Food-Grade"-quality and the trace elements are chelated so that they can be absorbed within a larger pH-range.

Especially for the coconut substrate, various elements have been added to this A+B fertilizer, which guarantee an optimal growth and flowering on coconut slabs, in particular in the case of re-use. Make sure that the slabs are free of diseases, plagues or viruses in case of re-use.

The application of these fertilizers is fairly easy and restricts itself to measuring off the proper amounts of A and B and mixing them into the water one at a time. After the mixing, it might be necessary to adjust the pH to 5.8 (5.5-6.5) by means of phosphoric acid. (check the pH-meter once a month by means of the proper pH tester) Coco Forte is the best coconut fertilizer available on the market today and excels comparable nutrients. Therefore, cultivating with Coco Forte leads to top results, especially when the other factors (light, air, and plant material) are optimal as well.

- 4246003**      **BIONOVA COCO FORTE 1L A&B SET**
- 4246004**      **BIONOVA COCO FORTE 5L A&B SET**
- 4246005**      **BIONOVA COCO FORTE 20L A&B SET**



## Bionova Soil Supermix

Soil-SuperMix is a one component mineral-organic fertilizer based on Hydro-SuperMix and especially adapted to systems with soil. Nutrients for growing and flowering, and A/B are combined within one product, which makes cultivating very easy.

This fertilizer consists of:

- Macro elements such as NO<sub>3</sub>, NH<sub>4</sub>, NH<sub>2</sub>, SO<sub>4</sub>, P, K, Ca.
- Mg and Si.
- Chelated micro elements such as Fe, Mn, Zn, B.
- Cu and Mo.
- Organic components.

All of the elements mentioned above are 100% pure and of an organic origin. Therefore this fertilizer is absorbed directly, and a low EC will suffice. Furthermore, the organic components work as a good buffer. Soil SuperMix enhances an optimal soil condition, actively stimulates the root development and provides as a complete fertilizer not only for growing but also for flowering. Apply a supplement of PK 13-14 as Superbloomer during the flowering period. In spite of the application of chelates (chelated micro elements) which makes this fertilizer virtually pH-independent, it could be necessary to adjust the pH. Use phosphoric acid to adjust the pH downwards. Use potassium-hydroxide solution to adjust the pH upwards. In this case you will need 4 grams of potassium per litre of soil per 0.5 pH. Since Soil SuperMix is partially organic, this fertilizer cannot be applied by means of a dripping system (organic substances contain a great number of coarse particles). Therefore, the mineral fertilizer Hydro SuperMix is applied as an alternative for dripping systems in order to reach the same result. These minerals are pure and do not clog the dripper.

<b>4246000</b>	<b>BIONOVA SOIL SUPERMIX 1L</b>
<b>4246001</b>	<b>BIONOVA SOIL SUPERMIX 5L</b>
<b>4246002</b>	<b>BIONOVA SOIL SUPERMIX 20L</b>

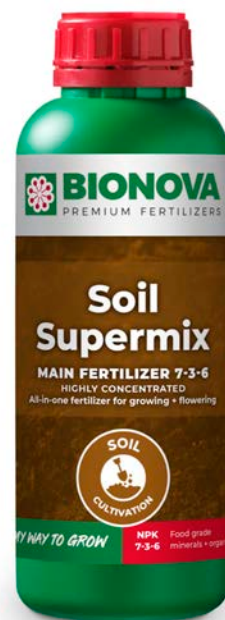

## Hydro-SuperMix

Hydro-SuperMix is a one component bio-mineral fertilizer especially developed for systems with artificial substrates such as rock wool, etc.

Nutrients for growing and flowering, and A/B are combined within one product, which makes cultivating very easy.

This fertilizer consists of:

- Macro elements such as NO<sub>3</sub>, NH<sub>4</sub>, NH<sub>2</sub>, SO<sub>4</sub>, P, K, Ca, Mg and Si.
- Chelated micro elements such as Fe, Mn, Zn, B, Cu and Mo.
- Vitalising organic extracts.

All of the elements mentioned above are 100 % pure, of an organic origin and free of any profuse ingredients. Therefore, this fertilizer is absorbed directly, and a low EC will suffice. Hydro SuperMix enhances an optimal soil condition, actively stimulates root development and provides as a complete fertilizer not only for growing but also for flowering. Apply a supplement of PK 13-14 as Superbloomer during the flowering period.

In spite of the application of chelates (chelated micro elements) which makes this fertilizer virtually pH-independent, it could be necessary to adjust the pH (preferably with pH- phosphoric acid ) in extreme cases. A pH-value of 5.8 (5.5 – 6.7) is recommended. (check the pH-meter once a month with the proper pH tester)

<b>4246054</b>	<b>BIONOVA HYDRO-SUPERMIX 1L</b>
<b>4246055</b>	<b>BIONOVA HYDRO-SUPERMIX 5L</b>
<b>4246056</b>	<b>BIONOVA HYDRO-SUPERMIX 20L</b>



## Stimulators

### Silution

Silicon Nutrient – The solution for the highest yield

Silution consists of a stabilized and bioavailable form of silicic acid. It is a highly plant-available and bio-active product that has positive effects on the plant. Silution results in a better harvest: higher yield and a better quality. The effectiveness of silicic acid in strengthening the plant and stimulating growth and flowering is particularly visible with growers that have less optimal growing conditions such as in greenhouses, indoor crops, growing in warm climates and high infection risk conditions. Silution should be given right from the start of the growing period for the plant's rooting system to grow bigger. Bigger roots take up more nutrients, which in turn allows the plant to grow better, faster and stronger and helps the plant to resist external influences and diseases.

<b>9651000</b>	<b>BIONOVA SILUTION 250ML</b>
<b>9651001</b>	<b>BIONOVA SILUTION 1L</b>
<b>9651021</b>	<b>BIONOVA SILUTION 5L</b>
<b>9651033</b>	<b>BIONOVA SILUTION 20L</b>



### X-ceL

BN X-ceL is a biological growing and flowering stimulator, which can be administered to all sorts of plants and significantly increases the quantity and quality of all tested crops. This sophisticated combination of components stimulates the bio-chemical functions on all levels. The organic extracts stimulate the metabolism, in particular the photosynthesis, and consequently the forming of carbohydrates. The hormone household of the crop is actively stimulated by the combination of amino acids. BN X-ceL contains the following ingredients: various vitamins, natural growing and flowering stimulators, amino acids, bacteria, trace elements, enzymes, kelp and humic acids.

BN X-ceL actively takes part in the growing and flowering process from the first day of planting. The crop strikes root more quickly which virtually rules out the dropping of leaves. The plant will grow more rapid and vital, while it simultaneously develops a very extensive root system. The potency of flowering is stimulated and eventually leads to a demonstrable increased yield (10-25% increased yield).

BN X-ceL is mixable with all fertilizers and can be applied to all types of substrate.

<b>9651002</b>	<b>BIONOVA X-CEL 1L GROW/BLOOM</b>
<b>9651003</b>	<b>BIONOVA X-CEL 5L GROW/BLOOM</b>
<b>9651004</b>	<b>BIONOVA X-CEL 20L GROW/BLOOM</b>



## TML

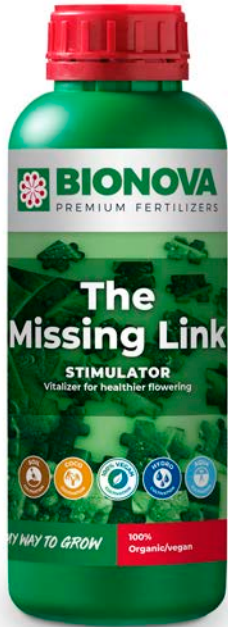

This premium product from Bio Nova laboratory, protects plants from damaging external influences, it stimulates the plant's natural defence system and demonstrably increases the yield. The Missing Link consists of a great number of special trace elements that have become essential for the growth and flowering of any living creature on this planet as a result of a process of millions of years of absorption and release by plants and animals, composting, re-absorption, microbe activities etc., Nowadays people cultivate all sorts of crops in our over cultivated environment. They disregard the needs of crops, and often disrespect the laws of nature.

These facts lead to deficiencies, which result into a great number of plagues and diseases among, not only animals and plants, but also human beings. Moreover, as a result of deficiencies of these essential nutrients, organisms are no longer able to fully develop themselves. The administration of these indispensable nutrients leads to an unprecedented positive effect on both the quality and the yield of treated crops. This product fills the hole in the foodchain which had not been discovered before. Justifiably this product can be called The Missing Link... The Missing Link can be used in combination with X-ceL Booster. This forms an ideal combination during the growing and flowering period.

**9651005                      BIONOVA TML 250ML**

**9651006                      BIONOVA TML 1L**

**9651007                      BIONOVA TML 5L**

**9651008                      BIONOVA TM 20L**

## Roots

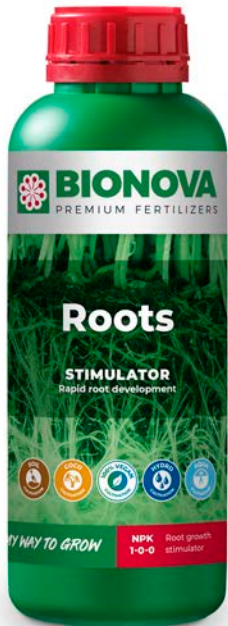

A great number of extensive research on root development and reinforcement done over a period of several years, show that the use of BN Roots leads to a larger root activity and therefore also a higher yield of all of the tested crops. This stimulator has already been applied with great success for many years in European horticulture and in the world of growing. BN Roots can be applied on the leaf as well as in the medium used for cultivating.

BN Roots consists of:

- Humic-acids (improves the absorption of oxygen, quickens the root and cell development, quickens the transport of ions).
- Kelp (healing of wounds and of chlorosis, increases the chlorophyll development, more root-hair development).
- Ascorbin-acid (vitamin C).
- Thiamin (vitamin B1).
- Myo-inositol (for the forming of cell walls).
- L-glycine (amino acid, for a better resistance and growth).

BN Roots makes for a better and quicker root development, a better food absorption, a higher stress resistance, a more effective use of nutrients, and higher yield in all tested crops. In short: a higher yield. BN Roots is mixable with all fertilizers and care products .

**9651009                      BIONOVA ROOTS 250ML**

**9651010                      BIONOVA ROOTS 1L**

**9651011                      BIONOVA ROOTS 5L**

**9651008                      BIONOVA ROOTS 20L**

## Zym

BN-Zym is a natural bio-catalyst (process accelerator), medium builder and medium improver based on specific enzymes. Enzymes stimulate the water-retaining ability of every medium and decreases the soil-tension of water, which enables a quicker and better penetration of water into the medium. While BN-Zym penetrates into the medium, it also brings more oxygen into it! Enzymes are specialized protein molecules and work as catalysts in several bio-chemical processes.

A few of the most conspicuous characteristics of enzymes is the specific way they work in, and in particular their speed. The conversion of sugar into alcohol by means of chemicals usually takes several weeks or even months, while by means of enzymes this merely takes several seconds! Enzymes always work without any waste matters or side-products. BN-Zym brings about an increased bacteria activity, which convert the nutrients and minerals in the soil into material that is directly absorbable by the crop. BN-Zym catalyzes the waste matters and delivers them back to the crop in the form of absorbable nutrients.

The result is a balanced crop and decreased sensitivity to all diseases! Moreover, the medium stays clean and free of all sorts of excess components. This is important for every cultivation, but especially for those in which soil and coconut are being re-used.



**9651013 BIONOVA ZYM 250ML CONCENTRATED**

**9651014 BIONOVA ZYM 1L CONCENTRATED**

**9651015 BIONOVA ZYM 5L CONCENTRATED**

**9651016 BIONOVA ZYM 20L CONCENTRATED**

## Vitasol

VitaSol is a liquid organic soil-improver based on potassium (6%). Its organic origin facilitates the absorption of VitaSol by the crop. Furthermore, it is extremely suitable as a converter of available nutrients. Especially in periods of high production and rapid growth (in case of artificially lighted crops) or in case of a stagnation in growth caused by a deficiency of nutrients, the use of VitaSol has proved to be very effectively. This product is absorbed by both roots and leaves, which practically rules out burning of the plant. VitaSol mixes easily with water and can be added to the plant by means of a dripping system, but then rinsing is recommended. A result of its organic basis, VitaSol establishes a stable and constant growth, a strong root-hair development, a healthy color and a high natural resistance to diseases. VitaSol contains lime, potassium, and a great number of trace elements. This product gives an extra sweet taste to fruits.



**9651022 BIONOVA VITASOL 250ML**

**9651023 BIONOVA VITASOL 1L**

**9651024 BIONOVA VITASOL 5L**

**9651025 BIONOVA VITASOL 20L**

## Universals

### FreeFlow



FreeFlow is a natural wetting agent based on Yucca-extract (Sarsaponin Schidigera). FreeFlow lowers the surface-tension of liquids, so that they can penetrate more easy in soil, rockwool, coconut and other media. For example, initial soaking of rock wool slabs used to take 24 hours while with FreeFlow this only takes 6 hours.

In case of vermin this product is more effective than other products. While other products usually only leave behind small drops on the leaf, FreeFlow puts a film on the entire leaf which makes pest control more effective. When you are applying FreeFlow to potting soil, you will be able to divide the nutrient solution in the pots or trays much more easily.

4246059	BIONOVA FREEFLOW 1L
4246040	BIONOVA FREEFLOW 20L
4246060	BIONOVA FREEFLOW 5L

### MicroLife

MicroLife is packed full of essential soil organisms like Mycorrhiza sp., Bacillus sp., yeasts and enzymes combined in an organic blend of algae, bone meal, cacao pellets, lime and compost. MicroLife not only stimulates the growth of micro-organisms, it also stimulates the growth and flowering of all plants with the addition of a variety of trace elements and natural hormones. The unique composition of MicroLife enriches and stimulates soil life, which in turn enhances the soil structure, rooting and overall health of all plants. In this enhanced environment, organic and inorganic soil particles blend optimally, creating a more efficient air/water economy. Nutrients are made more bio-available. Within a short period of time the effects are noticeable. With a nice woody smelling, airy, soil mixture, you have an environment in which any plant develops visibly better.

4246058	BIONOVA MICROLIFE 2KG
---------	-----------------------





## Foliar

NovaFoliar is a powerful and highly effective cleaner against pollution of the leaf surface and clogging of the leaf pores (stomata) by waste from pests. This leaf detergent cleans the crop of all organic pollution with the result that the crop is no longer attractive to all kinds of insects and fungi.

Caution!

NovaFoliar is a highly concentrated detergent. Higher concentrations are not recommended. Remove undiluted product or spillage immediately with water. The recommended concentration is not adverse effects on plants, however, it is recommended to test on an inconspicuous area before use. To keep the plants clean regular inspection and possible after-treatment is necessary.

9651017      BIONOVA FOLIAR 250ML 1:4 CONCENTRATED

9651018      BIONOVA FOLIAR 1L 1:4 CONCENTRATED

9651019      BIONOVA FOLIAR 5L 1:4 CONCENTRATED



## Bionova Reducer

Bionova pH- is a phosphoric acid solution containing 24.5%. It is crucial to manage pH values of the water/nutrient solution you feed to the plant. Plants only absorb all nutrients when applied in the correct pH value. When your pH is too low or too high, the plant won't be able to uptake all nutrients.

## Bionova Increaser

Bionova pH+ is a Potassium hydroxide solution containing 24.5%. It is crucial to manage pH values of the water/nutrient solution you feed to the plant. Plants only absorb all nutrients when applied in the correct pH value. When your pH is too low or too high, the plant won't be able to uptake all nutrients.

4246088      BIONOVA PH REDUCER 1L

4246089      BIONOVA PH REDUCER 5L

4246090      BIONOVA PH REDUCER 20L

4246094      BIONOVA PH INCREASER 1L

4246095      BIONOVA PH INCREASER 5L

4246096      BIONOVA PH INCREASER 20L



## Minerals

### PK 13-14



Phosphor makes for the development of a healthy, extensive root system and an exuberant flowering. Potassium prompts the flowering, the so-called flowering potency. The combination of these two components in a bio-mineral form can be rightfully called a superbloomer. Therefore, this is an essential component for every cultivation.

In Bio Nova's line of pure liquid mineral fertilizers (i.e. free of excess ingredients), Bio Nova has a very powerful and quick phosphor-potassium complex at her disposal called: PK 13-14, which is directly absorbable. This fertilizer should be used in combination with Hydro-SuperMix, Soil-SuperMix, LongFlower or NFT AQUA-SuperMix. A combination with one of these three, makes for a complete fertilization on hydro, soil or NFT-systems.

Available in 1L, 5L and 20L

<b>4246006</b>	<b>BIONOVA PK 13-14 1L</b>
<b>4246007</b>	<b>BIONOVA PK 13-14 5L</b>
<b>4246008</b>	<b>BIONOVA PK 13-14 20L</b>

### P20



Since ages, phosphor has been known for its role as an activator of root activity and blooming of plants. Phosphor also plays a role in the forming of cell membranes and it is a molecular building block for DNA and the energy carriers ATP and ADP. Furthermore, phosphor also establishes a good metabolism of sugars and makes for the forming of enzymes.

A deficiency of phosphor manifests itself in a slow growth and purple decolourisation of the nerves at the lower surface of the leaf and purple stems caused by an anthocyan-accumulation. An excess of phosphor results in an ill-growing plant with an induced shortage of zinc.

Before P 20, it used to be a problem to add any form of phosphor to crops that would be absorbed entirely and very fast without any harmful side-effects.

P 20 is absorbed fast, and does not have any side-effects.

P 20 is free of chlorides or other excess ingredients.

A dosage of 1:1000 increases the total amount of P by 3.5 mmol

<b>4246011</b>	<b>BIONOVA P 20 1L</b>
<b>4246012</b>	<b>BIONOVA P 20 5L</b>
<b>4246013</b>	<b>BIONOVA P 20 20L</b>

## K 20

Besides the basic elements N and P, also K (Potassium) is crucial for every cultivation. Potassium makes for the sturdiness of cells (water household), and prompts the blooming. Potassium also plays an important role in the forming of cells, the osmoses regulation and the carbohydrate household. Furthermore, potassium is important for the opening and closing of the stomata, which enable the drainage of excessive heat. A deficiency of potassium manifests itself when the plant does not open the stomata sufficiently for vaporization in order to cool down. This results into the development of chlorosis at the rims of the leaves which develops into necrosis (death) in a later stage. In case of an excess of potassium the plant will be curbed in its development and subsequently turn dark. An excess also hampers the absorption of other cations (Ca and Mg) which is caused by antagonistic effects.

K 20 is free of chlorides, works very fast, and most importantly: it is clean!  
K 20 is very economic!

A dosage of 1:1000 increases the total amount of K by 5 mmol.

**4246014 BIONOVA K 20 250ML**

**4246015 BIONOVA K 20 1L**

**4246016 BIONOVA K 20 5L**

**4246017 BIONOVA K 20 20L**

## Ca15

Calcium often appears in the cell walls and membranes and plays a special role in the ion-reactions within plants.

Calcium is transported in the plant by means of water conduction (xylem).

In situations with a high humidity or in a compact crop the rate of conduction is small and can lead to a deficiency of calcium.

A deficiency of calcium leads to softened cell walls which manifests itself immediately in an increased sensitivity to fungi, and the dying off of young leaves and growing points.

Also an excess of calcium can occur, which results into brown spots on the leaves.

-Ca 15 works very fast, does not change the pH-value, and is a pure product.

-Ca 15 is economic and contains 180 grams of pure lime per litre of liquid.

-Ca 15 can be combined with all fertilization schemes, does not clog or pollute.

A dosage of 1:1000 increases the amount of Ca by 3.2 mmol

**4246025 BIONOVA CA15 250ML**

**4246026 BIONOVA CA15 1L**

**4246027 BIONOVA CA15 5L**

**4246062 BIONOVA CA15 20L**



## MgO 10

This product contains 20% K<sub>2</sub>O. Besides the basic elements N and P, also K (Potassium) is crucial for every cultivation. Potassium makes for the sturdiness of cells (water household), and prompts the blooming. Potassium also plays an important role in the forming of cells, the osmoses regulation and the carbohydrate household. Furthermore, potassium is important for the opening and closing of the stomata, which enable the drainage of excessive heat.

This product contains 10% MgO. One of the elements that is indispensable in Bio Nova's line of liquid mineral fertilizers is magnesium. Magnesium forms the reactive nuclei in the chlorophyll, which converts light energy into chemical energy (ATP and ADP). A deficiency of magnesium manifests itself in chlorosis (slight decolourisation) between the nerves of old leaves and also an early dropping of leaves. An excess results into an ill-growing crop and small leaves. This product has the same characteristics as the other liquid mineral fertilizers offered by Bio Nova:

MgO 10 works very fast.

MgO 10 is economic and does not contain excess ingredients.

A dosage of 1:1000 increases the total amount of Mg by 2 mmol.

<b>4246024</b>	<b>BIONOVA MAG10 250ML</b>
<b>4246028</b>	<b>BIONOVA MAG10 1L</b>
<b>4246029</b>	<b>BIONOVA MAG10 5L</b>
<b>4246062</b>	<b>BIONOVA MAG10 20L</b>





# Terpenez 0-0-0 Essential Oil Intensifier

Terpenez represents a new class of horticultural products aimed at enhancing the aromatic experience associated with gardening. Many of the plants chosen for cultivation are selected based upon the value of their essential oils. With that knowledge, Terpenez has been purposefully formulated from all organic botanical extracts and is designed to assist the plant with processes associated with oil and resin production. Terpenez is blended in house in California USA and is made from the finest botanical inputs currently available. Versatile in its application, Terpenez is recommended to be applied during flush as part of your standard 11-14 day flush regimen but can be applied at a diluted rate throughout your flowering cycle for advanced results. Terpenez can also be used exclusively during the flush cycle to aid in the removal of residual nutrient salts and enhance the scent profile of your garden. Bottom line: it's an organic terpene enhancer. Boosts terpenoid profiles & increases overall aromatic effect. Terpenez alternatively uses bio-identical organic steam distilled plant extracts that the target plant identifies as its own. No undue stress, no heavy metals and no salts just extracts and an organic wetting agent.



4220501 TERPENEZ 500 ML

4220502 TERPENEZ 1L

4220503 TERPENEZ 4L

4220504 TERPENEZ 10L

4220505 TERPENEZ 20L

Case Quantity: 500ml, 12/case; 4l, 4/case; 10L, 2/case

**TERPENEZ**  
ESSENTIAL OIL INTENSIFIER

Terpenez represents a new class of horticultural products aimed at enhancing the aromatic experience associated with gardening. Many of the plants chosen for cultivation are selected based upon the value of their essential oils. With that knowledge, Terpenez has been purposefully formulated from all organic botanical extracts and is designed to assist the plant with processes associated with oil and resin production.

Terpenez is blended in house in California USA and is made from the finest botanical inputs currently available. Versatile in its application, Terpenez is recommended to be applied during flush as part of your standard 11-14 day flush regimen but can be applied at a diluted rate throughout your flowering cycle for advanced results.

As with all gardening products, results are variable and dependent upon a variety of conditions however the vast majority of users have experienced very favorable results that were not only more intense than they expected but far more pervasive than anyone could have hoped. If your goal is an overall increase in the intensity of the natural bouquet of your garden, Terpenez may be the answer.

### HOW DOES IT WORK?

Terpenez has been carefully formulated to provide essential oil bearing plants with both precursors (ex. metabolic building blocks, trace elements etc.) as well as readily available bio-identical organic plant compounds with the objectives of increased overall essential oil production and intensity. Precursors provide support to the pathways, essential for oil production, while bio-identical plant compounds augment in-situ concentrations through contact assimilation.

### WHY 0 - 0 - 0?

Terpenez was purposefully formulated as 0 - 0 - 0 from certified organic inputs ensuring it won't conflict with your existing schedule or contaminate your crop. Commercial Grade.

100% NATURAL PRODUCT

GROWSOLUTIONS.COM



# Growing Substrates

# Bionova Coco Mix Plus

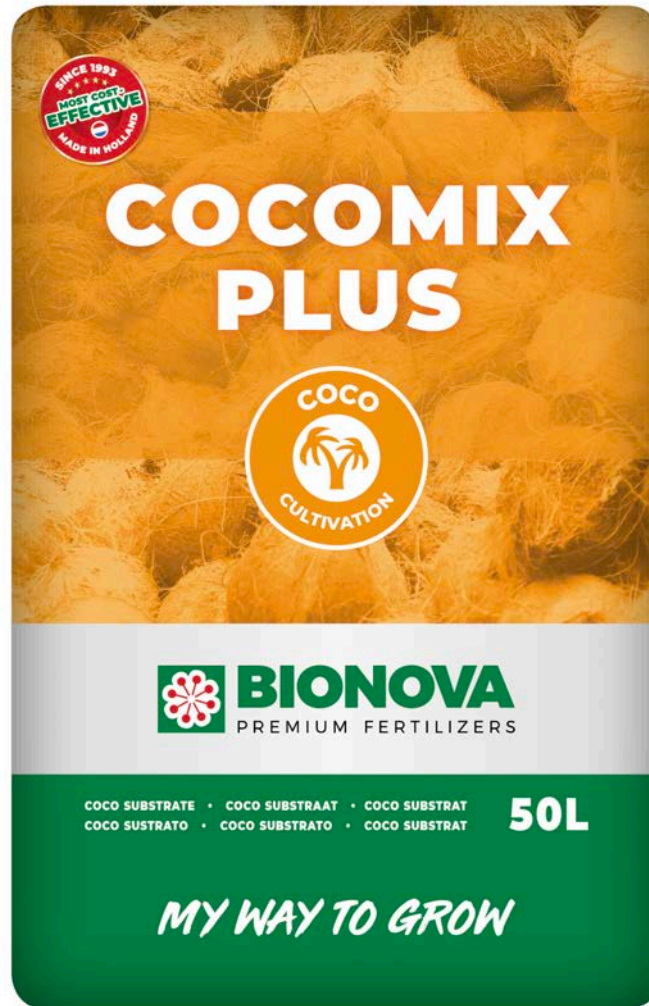

**Bionova Coco Mix Plus**  
unfertilized coco – 50L – NPK 0-0-0- 100% natural coco substrate

Bionova Cocomix Plus is an excellent natural 100% coco substrate. This coco mix consists of grinded and sieved cocopeat. The mix is delivered in recyclable plastic bags of 50 litres and is ready-to-use. Because this substrate is not fertilized, you have to start fertilizing after planting. Recommended is Coco Forte A+B. This mix is of a sublime quality and keeps its quality and airiness for a long period. This coco mix is perlite free, and therefore 100% compostable. Bio Cocomix plus contains: washed and buffered natural cocopeat derived from coco palm trees of Sri Lanka. EC  $\pm$  0.2. pH  $\pm$  6.5. This Cocomix Plus is free of chemical and animal ingredients

8632000 BIONOVA COCOSUBSTRATE 40L BAG  
8632001 BIONOVA COCO ONLY 50L BAG  
65/PALLET



Nature's Choice



## Eazy Plug System

Eazy Plug & Eazy Block are made of organic materials which are bonded and formed into an extensive product line of plugs and blocks for the professional horticulture and can be used for the production of a wide range of crops. HGA Garden manufactures this breakthrough, natural and sustainable growth solution for growing all of your plants. Our products are carefully balanced and have a predetermined pH, EC value and a fixed air- to - water ratio. Because of this, growing conditions are always optimal and a very fast and powerful rooting or germination is ensured. The Eazy Plug and Block are supplied dried, making them clean and lightweight, with limitless shelf life and no risk of molds. The dry Eazy Plug & Eazy Block take water back up very easily and quickly, retaining all of their former characteristics.

8631000	EAZY PLUG CT24	8631032	EAZY SYSTEM 9 SITE ACCESS COVER
8631001	EAZY PLUG CT77	8631033	EAZY SYSTEM 9 COMPLETE SYSTEM
8631002	EAZY BLOCK CASE 160	8631040	EASY SYSTEM FITTINGS
8631003	EAZY PYRAMID	8631041	EAZY SYSTEM PUMP
8631004	EAZY PLUG CT66 (10X20)		
8631005	EAZY PYRAMID MINI	5271000	HGA PROP64 KIT
8631020	EAZY SYSTEM 4 SITE PLANNER	5271001	HGA TRAY64- TRAY ONLY
8631021	EAZY SYSTEM 4 SITE NUTRIENT RESERVOIR	5271002	HGA COVER64- DOME ONLY
8631022	EASY SYSTEM 4 SITE ACCESS COVER	5271003	HGA PROP43 KIT
8631023	EAZY 4 COMPLETE SYSTEM	5271004	HGA TRAY43- TRAY ONLY
8631030	EAZY SYSTEM 9 SITE PLANNER	5271005	HGA COVER43- DOME ONLY
8631031	EAZY SYSTEM 9 SITE NUTRIENT RESERVOIR		



## Gold Label Substrates



Gold Label Coco is the best buffered coco in the market with a very low EC. This not only guarantees a clean and buffered substrate, but also a production process with respect for the environment. Gold Label Coco is an ideal hydroponics substrate: It's an organic rest material and a renewable resource, light and airy, can hold 8-10 times its weight in water, has a high capillary action, a stable pH and can be reused or recycled in the compost bin.

**8630110**                      **GOLD LABEL COCO 50L BAG**  
**70 PER PALLET**

Gold Label Hydro Clay Pebbles are manufactured using a mix of the best quality pure clay and are baked in an open furnace using high grade clean fuels. This guarantees absence of heavy metals or other contaminants. Gold Label Hydro carries the RHP for Horticulture quality certificate. Gold Label Hydrocorn is the inert hydroponics substrate of choice for professionals. The 16-25 mm size provides stability and the unique uneven shape of the pebble is an ideal surface for roots and beneficial bacteria. The porous structure has a high water capacity and is suitable for both ebb/flood and top irrigation systems.

**8630112**                      **GOLD LABEL HYDROCORN 8-16MM**

**8630113**                      **GOLD LABEL HYDROCORN 16-25MM**

**65 PER PALLET**

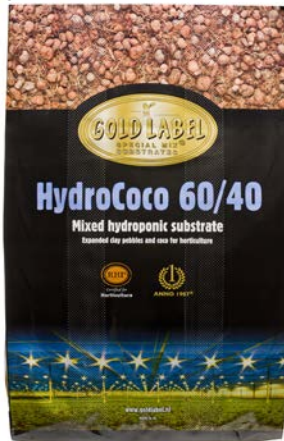

Gold Label 60/40 is 60% Hydrocorn and 40% Coco. It is an ideal match for high water capacity, lower watering frequency and better rooting. We utilize the 16-25mm Hydrocorn from Gold Label and the purest Gold Label Coco to give you the perfect ebb and flood growing substrate that also works well in any pot based systems. The 60/40 mix allows you to feed less frequently than in straight Hydrocorn. This gives you a buffer on the watering times but still allows you to feed regularly without over watering.

**8630114**                      **GOLD LABEL 60/40 HYDRO/COCO**

**60 PER PALLET**

60/40 Mix Grow Slab 12L are easy, Plug & Play grow trays for hydroponically cultivation. You can cut the bottom parts for drainage and plug in your system for automated irrigation. Gold Label HydroCoco 60/40 is an ideal match for high water capacity, lower watering frequency and better rooting. The 60/40 mix allows you to feed less frequently than in straight Hydrocorn and gives a buffer on the watering times.



**8630118**                      **HYDROCOCO 60/40 RHP GROW SLAB**



# Lighting

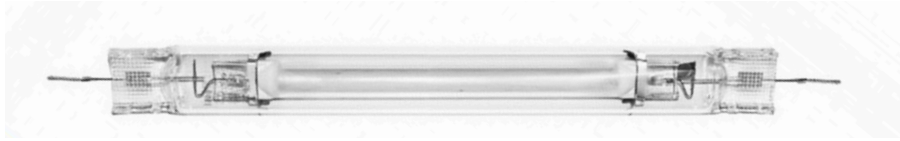

SolarMAX DE lamps are designed and manufactured in Europe for optimum plant production and lowest light depreciation. SolarMAX DE contain high quality components, making them suitable for stable operation in Dim and Boost mode. SolarMAX DE lamps have high light intensity and long lifetime to support plants during critical flowering stages to receive up to a 25% higher yield.

## SolarMAX DE 1950 $\mu\text{mol/s}$

Features:

- SolarMAX DE Flower 400v
- 1950  $\mu\text{mol/s}$
- Designed for conventional ANSI S52 based systems
- 2000K
- Rated 20,000 Lifetime hours
- Life maintenance 10,00 hrs >99%
- Made in Germany

**7450768 SOLARMAX 1000W HPS DE 1950MMOL LAMP**

## SolarMAX DE 2100 $\mu\text{mol/s}$

Features:

- SolarMAX DE Flower 400v
- 2100  $\mu\text{mol/s}$
- Designed for horticultural high frequency output ballasts
- 2000K
- Rated at 20,000 Lifetime hours
- Life maintenance 10,00 hrs >99%
- Made in Germany

**7450769 SOLARMAX 1000W HPS DE 2100MMOL LAMP**

# SolarMAX Super HPS

**solarMAX**<sup>TM</sup>  
HIGH OUTPUT HORTICULTURAL LAMPS

## Super HPS - 2100 K - FLOWERING

As plants approach maturity they require less “Blue Light” and depend more upon radiation from the “Red” portion of the spectrum between 610 nm - 720 nm.

SolarMAX HPS lamps have been engineered to constantly deliver 10% more targeted “Red Light” energy to the maturing plant to promote aggressive flowering.

Available in 400, 600, 1000w

**7450736 SOLARMAX HPS 400W SUPER**

**7450737 SOLARMAX HPS 600W SUPER**

**7450755 SOLARMAX HPS 1000W SUPER**

**12 Per Box**

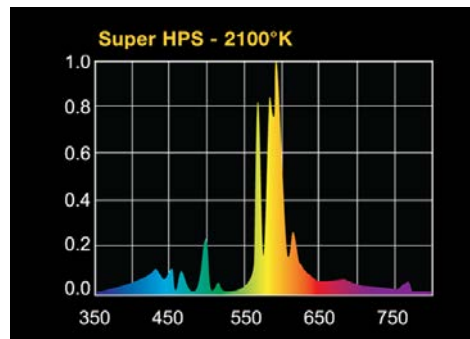

# SolarMAX Super MH

**solarMAX**<sup>TM</sup>  
HIGH OUTPUT HORTICULTURAL LAMPS

## Vegetative - 7200 K- VEGETATIVE and VEG CONVERSION

SolarMAX lamps deliver 30% more “nutritious” Blue light radiation than standard lamps. The result - more vigorous vegetative growth and stronger roots during the important early stages of a plant’s development.

Available in 400, 600, 1000w MH & Veg-Conversion



**7450738 SOLARMAX MH600W VEG CONV LAMP**

**7450757 SOLARMAX MH1000W VEG LAMP**

**7450758 SOLARMAX MH1000W VEG CONV LAMP**

**7450806 SOLARMAX MH 400W VEG LAMP**

**7450807 SOLARMAX MH 400W VEG CONV LAMP**

**12 Per Box**

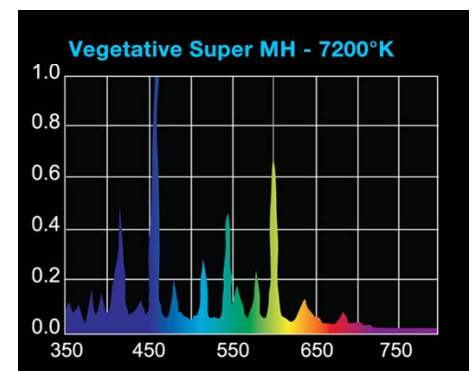

# solarMAX™

Reflector Series

HIGH OUTPUT HORTICULTURAL LAMPS

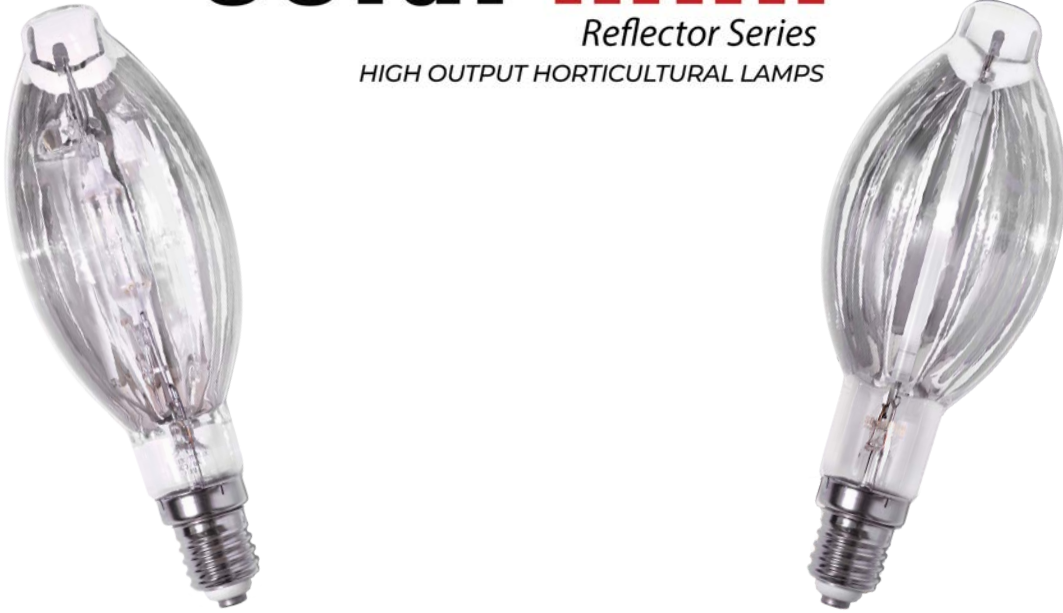

## SolarMAX Reflector Series

SUPER HPS 95% efficient. Amazing uniformity in light spread with 10% more light on the plant canopy. Reduce greenhouse shadowing and no shades/reflectors to assemble. Available in high output 400W (58,000 lumens) or 600W (95,000 lumens) HPS. Smaller than a 400 BT37 lamp. Available in high output 400W (58,000 lumens) or 600W (95,000 lumens) HPS.

VEG. LAMPS Operates on standard 400W or 600W HPS ballast. 95% efficient with amazing light uniformity. More vigorous vegetative growth and stronger roots.

Adjustable lamp base for perfect alignment. Available in high output 400W (32,000 lumens) or 600W (55,000 lumens) MH 7200°K.

<b>7450800</b>	<b>SOLARMAX 400W HPS REFLECTOR SERIES</b>
<b>7450801</b>	<b>SOLARMAX 600W HPS REFLECTOR SERIES</b>
<b>7450802</b>	<b>SOLARMAX MHT/R 400W REFLECTOR SERIES</b>
<b>7450803</b>	<b>SOLARMAX MHT/R 600W REFLECTOR SERIES</b>
<b>15 Per Box</b>	

# AUVL Lamps



AUVL Double Ended Sodium lamps create an even spread of light.

The construction design of AUVL Grow Green double-ended sodium lamps enable the lamp to spread light very evenly and allow for stable operation in Dim& Boost mode because of their high-quality components.

They have a higher light intensity and a longer lifetime in comparison to most conventional single-ended sodium vapour lamps.

AUVL Grow Green double-ended Sodium Lamps support the plants in crucial fruiting and flowering stages to receive up to 25% higher yield.



## ADVANTAGES

Long life of 10,000 hours (12B10)

Stable photon flow  $\geq 90\%$  over the lifetime

10-20% higher light intensity than conventional sodium vapour lamps

First choice for the flowering stage due to the high proportion of red light

More stable mounting due to 2-sided connection K12x30s – advantages in illumination

High photon flow of 2,100  $\mu\text{mol/s}$

Designed for operating with all major ECG's/ electronic ballasts

Stable operation in Dim & Boost mode possible

**7450950**

**LAMP AUVL DE 1000 HPS 2100**

**7450951**

**LAMP AUVL 6/750 DE HPS7450802**

# Dutch Lighting Innovations

DLI is a collective of great minds with decades of experience in the commercial and hobby horticultural industries. Their engineers have listened to customers, and developed a brand new range of horticultural lighting products which combine the tried and tested manufacturing techniques of existing commercial lighting products with modern manufacturing processes. The outcome; a suite of horticultural lighting products designed to improve user experience and enhance end results.



**1000W DE**

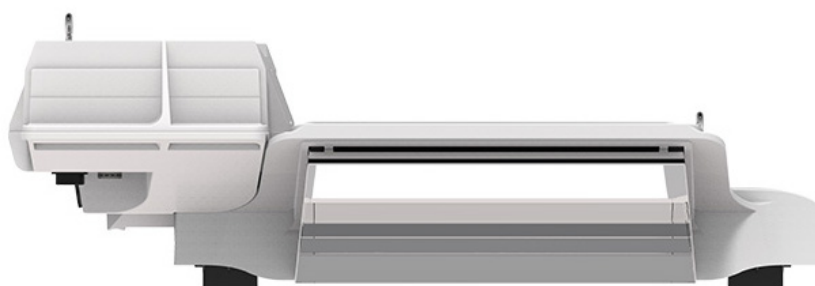

**1000W DE DIMMABLE**

## JOULE-Series

The new Dutch Lighting Innovations JOULE-Series 1000W Fixture is designed for the DLI Horticulture Plus 1000W De Lamp.

This Lamp is optimized by DLI to increase photosynthesis efficiency in flowering plants. By enhancing the gas chemistry of the lamp, the output maintains high light.

- 7500403 DLI 1000W 120-240V JOULE
- 7500404 DLI 1000W 208-240V JOULE
- 7500406 DLI 1000W 277-347V JOULE
- 7500407 DLI 6/750W 120-240V JOULE
- 7500408 DLI 6/750W 277-347V JOULE
- 7500400 DLI FIXTURE 1000DE 347V
- 7500409 DLI NON-DIM 6/750W 7277-347V
- 7450205 DLI 6/750W LAMP

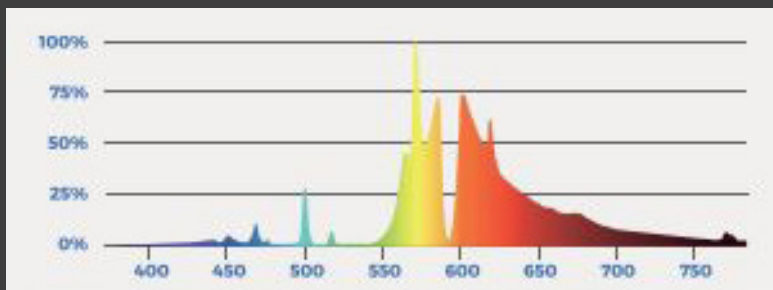



**315W CMH**

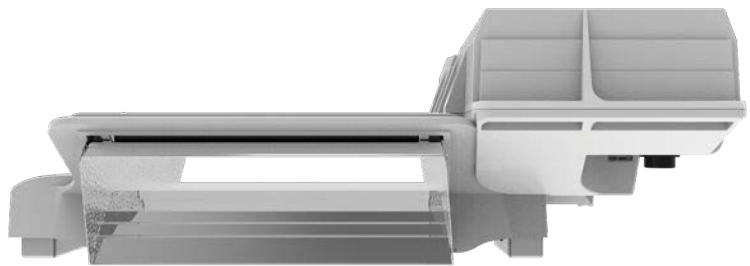

**630W CMH**

## **CRI-Series**

The DLI CRI-Series DE fixture is made to grow plants.

The output of the DLI CRI-Series 315W CMH fixture can not be adjusted. It can only be set to on/off and to the controller setting. By using the DLM-4 Zone Controller the fixture can be remotely switched and adjusted.

Available in 315W and 630W

<b>7500410</b>	<b>DLI CRI 315W 120-240V FIXTURE</b>
<b>7500412</b>	<b>DLI CRI 315W 240-347V FIXTURE</b>
<b>7500413</b>	<b>DLI CRI 630W 120-240V FIXTURE</b>
<b>7500414</b>	<b>DLI CRI 630W 240-347V FIXTURE</b>
<b>7450202</b>	<b>DLI 315W CMH 930 LAMP</b>
<b>7450204</b>	<b>DLI 315W CMH 942 LAMP</b>



## Top Lighting Fixture

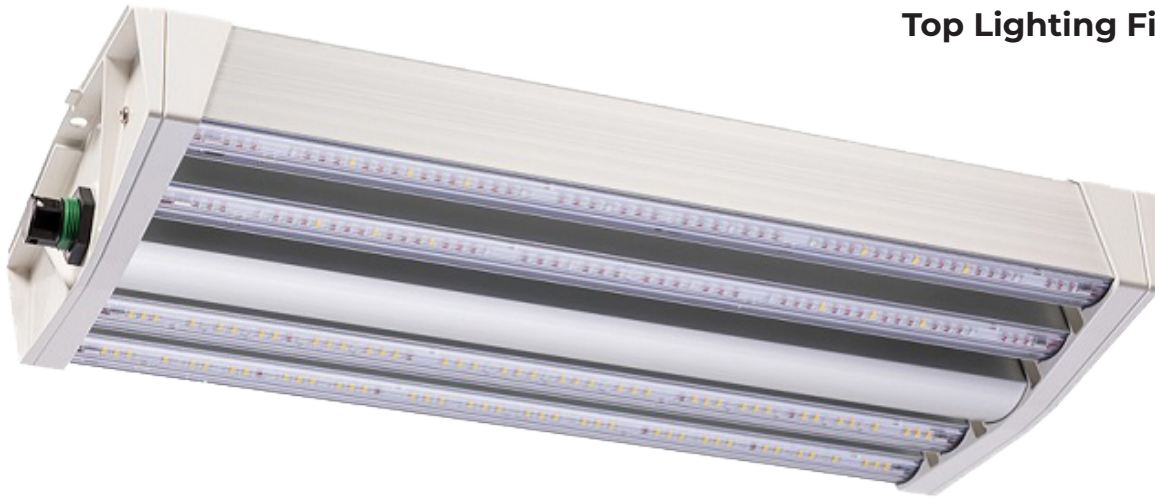

7500402

DLI TOPLIGHTING GH WHITE

7500415

DLI TOPLIGHTING IND WHITE

## DIODE-Series

DLI Toplighting fixtures are designed to deliver high levels of photosynthetic photon flux (PPF) values with optimal angled vertical light uniformity. The unique design of the lenses create a high uniform light distribution over the canopy.

The fixtures are constructed in a slim water-proof design and suspended above the plant canopy with the easy-hang system.

Indoor White Spectrum

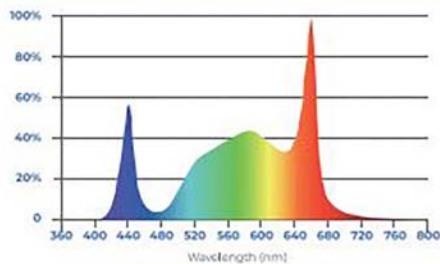

Greenhouse White Spectrum

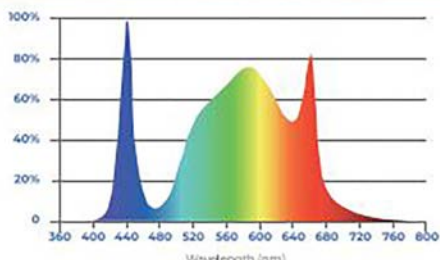

	PREPAID	ALBERTA	PREPAID	ONTARIO	PREPAID
BRITISH COLUMBIA		- CALGARY	\$ 1000.00	- ALL LOCATIONS	\$ 1500.00
-VANCOUVER LOWER MAINLAND	\$ 500.00	- ALL OTHER	1000.00		
FRASER VALLEY	1000.00				
-VANCOUVER ISLAND	1000.00	SASKATHEWAN / MANITOBA		QUEBEC	1000.00
-ORANGIASTLEY	1000.00	- ALL LOCATIONS	\$ 2000.00	- ALL LOCATIONS	1000.00
-KOOTENAYS	1000.00			ATLANTIC CANADA	2000.00
- ALL OTHER	2000.00			- ALL LOCATIONS	2000.00

Please consult us for freight terms on all grow media

### CONVERSION FACTORS

1 US gallon is equal to:	1 cup is equal to:	1 tablespoon is equal to:
4 quarts	8 ounces	1/2 ounce
256 tbsp	0.52 lbs	180 drops
8 pints	1/2 pint	15 ml
768 tsp	9.23 litre	15 grams
16 cups	16 tbsp	3 tsp
8.34 lbs	14.4 cu. in.	0.653 cup
128 ounces	48 tsp	
231 cu. in.	236 grams	
3.785 litres	236 ml	
1 litre is equal to:		
1000 ml	1 mho = 1 Siemen	mg/l = milligrams per litre
2.22 lbs	1 Siemen = 1000 mS	ppm = parts per million
2,104 pints	1 mS = 1000 uS	mho = conductivity
1000 grams	1 mS = 500 ppm	mS = millisiemen
0.264 gal	(standard)	uS = microsiemen
4.226 cups	1 mS = 650 ppm	tds = total dissolved solids
67.63 tbsp	(horticultural)	cc = electrical conductivity
	1 mg/litre = 1 ppm	pH = potential hydrogen

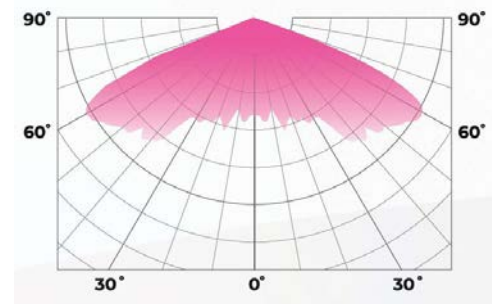



## DLI Lamps

The 1000W DE Horticulture Plus Lamp is optimized by DLI to increase photosynthesis efficiency. By enhancing the Red & Blue, the lamp encourages prolific growth of ALL types of consumption.

The 1000W DE Vegetative Plus Lamp is a 1000W Double Ended MH bulb. The high blue ratio and full spectrum output ensures healthy plant growth and robustness.

**7450200 DLI 1000W DE HPS LAMP HORTICULTURE PLUS**

**7450201 DLI 1000W DE MH LAMP VEG PLUS**

## DLM-4 ZONE CONTROLLER

The DLM-4 Zone Controller is specially designed to set up a Daily Lighting Management system for your Dutch Lighting Innovations fixtures.

**7150400 DLI DLM-4 CONTROLLER**

**7150401 DLI DLM-4 TEMP SENSOR**



## ASYMMETRIC REFLECTOR

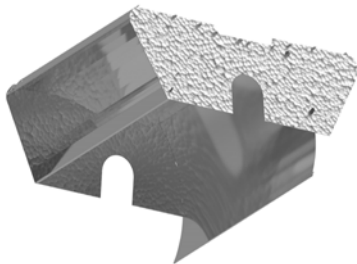

The Asymmetric Reflector has been developed especially for the outside rows of fixtures in a growroom. The asymmetric light beam will direct the light towards the plants instead of towards the sidewalls of the growroom. Use the Asymmetric Reflector in combination with the #FLOWERSONLY Reflector for the best results. Together they will create a uniform light distribution, even on the outside rows of the growroom

**7525010 DLI REFLECTOR 1000W ASYMMETRICAL**

**7525011 DLI 1000W REFLECTOR REPLACEMENT**

## REFLECTOR WIPES

This all-in-one BrightShine Reflector Wipe loosens dirt and lifts it off the reflector, pulling dirt and grime into the Wipe and locking it away for good. Give your reflector a good wipe with one clean BrightShine Wipe per reflector and throw the Wipe away. The exclusive Isopropyl formula is chemically altered for DLI aluminium and evaporates quickly giving you an amazing clean reflector.

**7450200 DLI 1000W DE HPS LAMP HORTICULTURE PLUS**





The Gavita Slim Line 2 (SL2) fixture includes the HR96 Reflector for maximum efficiency and uniformity, designed specifically with broad light dispersion in mind. This commercial style fixture features highly efficient passive ballast cooling that helps contribute to long fixture life. Other features include sealed housing with a Gore-Tex® ventilation plug, and controllable output up to 1150 W. The Gavita SL2 also features a dimming knob, so growers can manually adjust the light output to meet plants' changing needs. The SL2 is equipped with a Repeater Bus interface. This double-port connection enables control of the SL2 with a Gavita EL Controller (sold separately). Connect up to 100 fixtures in a single daisy chain series, up to five daisy chains per EL controller output. A single EL controller output can control up to five 100-fixture daisy chains, giving you room to grow.

- Manual dim knob
- Interchangeable optic with any Gavita brand reflector (Intensity Optic, W150 and HR96)
- Quick-release reflector bracket
- Operates from 208-240 volts
- Compatible with the Gavita e-Series Controller
- 3 year limited warranty
- Improved thermal capabilities thanks to a newly designed housing vs. the Gavita Slim Line 1000e

7500241

**GAVITA CT1930e LED 120-277V**

## Gavita 6/750 DE

The new Gavita 6/750e watt 400 V EL DE lamp has an efficiency of  $2 \mu\text{mol s}^{-1}$  per watt in a wide control range of 600-825 watt. Now that is flexibility! At 825 watt it rivals air cooled 1000 watt HPS fixtures with an output of  $1650 \mu\text{mol s}^{-1}$ , while outshining the best 600 watt lamps at 600 watt. When necessary it can be dimmed down to 375 watt. Our HR96 reflector is made of a very high grade Miro aluminum which provides optimal reflectance of light to your crop. This is the reflector provides uniform light in an overlapping plan with great plant penetration from all sides. The reflector is a medium wide reflector, providing optimal horizontal penetration of the crop. Of course it is suitable for the Gavita Master Controller, eliminating the need for timers and contactors. This fixture is suitable for lighting a 15 sq ft area with  $1000 \mu\text{mol s}^{-1} \text{m}^{-2}$ . Unit includes a 240 V power cord. A 120 V cord can be purchased separately. This professional fixture requires installation by a certified electrician in an industrial environment. 1 year warranty on the lamp.



7500223

**FIXTURE PRO 6/750E FLEX 120/240V**



**7500223**      **FIXTURE PRO 6/750E FLEX 120/240V**

### Gavita Pro 900e LED

The Pro 900e LED is the solution for indoor growing environments where ceiling height and distance from canopy are paramount. Featuring the same performance and 8-bar configuration of our bestselling Pro 1700e LED, the 900e is a great fit for use in vertical racks, low rooms, over benches, or even in tents. Push plants to their full potential with a fixture tailored to how you grow. At 900  $\mu\text{mol/s}$ , this LED by the leaders in horticultural lighting delivers impressive amounts of crop-loving light without overpowering plants in your setup. And because it operates at 345 W with 2.6  $\mu\text{mol/j}$ —half the power of our best-performing fixture—you get less ambient heat that has the potential to damage your crops at close proximity, and incredible energy efficiency. Great for your plants, great for your bottom line

### Gavita CT1930e LED

The revolutionary new Gavita CT 1930e is the first and only LED that is a direct replacement for HPS. With a footprint designed to fit seamlessly in existing HPS layouts, the CT 1930e is a highly energy efficient LED delivering serious growing power. It's designed to be a 1:1 layout replacement for the fixture that helped revolutionize the industry nearly three decades ago, the Gavita Pro 1000e DE HPS. Compatibility with wiring and electrical requirements for most indoor growing environments means this compact toplight is able to dramatically limit the cost and downtime required to convert facilities of every size. The CT 1930e delivers more crop-loving light in a broader spectrum at up to 20% energy savings than Gavita 1000 W DE and single ended HPS fixtures (based on average wattage of each fixture). Compatible with Gavita EL Master Controllers (sold separately) and most building automation systems. Patent-pending controller technology embedded within each fixture enables control of up to 2,000 fixtures per EL Master control channel and helps maintain unwavering output from light to light.

Power cords sold separately to operate at your desired voltage.

- Delivers 1930  $\mu\text{mol/s}$  and 2.5  $\mu\text{mol/j}$
- Can be used as a direct replacement for HID fixtures
- Uniform, full spectrum light output
- IP66 rated for wet environment and UL880 certified



**7500241**      **GAVITA CT1930e LED 120-277V**



### Gavita Pro 1700e LED

The Gavita Pro 1700e LED fixture operates at 645 watts with an output of 1700  $\mu\text{mol s}^{-1}$  PAR and an impressive efficacy of 2.6  $\mu\text{mol s}^{-1}$  per watt. The Pro 1700e delivers broad, intense light coverage with its 8 passively cooled LED bars allowing you to use it in low rooms, vertical racks, over benches, or even in tents. This powerful, full-spectrum light source is intended for full-term plant growth from the vegetative stage to the higher-light-requiring bloom and finishing stages. Built with premium Philips drivers, Samsung white LEDs and Osram deep-red LEDs, this fixture uses only the highest-quality components. The fixture is dimmable to 50% without any loss of efficiency using the Gavita E-Series LED Adapter and Gavita Master Controllers. The Gavita E-Series LED Adapter - 120-277 V (#906151, sold separately) is required for each fixture when using the controller; non-controlled fixtures simply operate at 100%. The Gavita Pro 1700e LED fixture and Gavita E-Series LED Adapter are FCC compliant, UL8800, and IP66 rated for use in wet environments with a maximum ambient operating temperature of 40°C. Sun Grip® light hangers included. Dimensions: 44.1 in x 43.7 in x 2.3 in. Weight: 28.4 lbs.

Each unit is eligible for a free 120-277v power cord and E-Series adapter.

DLC Listed

8 passively cooled bars eliminate moving parts and provide full-spectrum, broad-coverage light for full-term growth

High-output 1700  $\mu\text{mol s}^{-1}$  PAR and an impressive efficacy of 2.6  $\mu\text{mol s}^{-1}$  per watt

Dimmable to 50% when using the Gavita Master Controller and E-Series Adapter

FCC compliant, UL8800 and IP66 wet-rated for use in wet environments, allowing for versatile placement in growing spaces with low ceilings, vertical racks, benches or even in tents

Reliably sourced components including Philips Drivers, Samsung white LEDs and Osram deep-red LEDs make the 1700e built to last

Sun Grip® light hangers included for quick, easy installation

If connecting to the Gavita EL1 or 2 controller an HGC906717 or HGC906716 is required.

<b>7500235</b>	<b>FIXTURE PRO 1700E LED</b>
<b>7150240</b>	<b>GAVITA LED ADAPTER INTRCNT CBL 10FT RJ45 TO RJ9</b>
<b>7150241</b>	<b>GAVITA LED ADAPTER INTRCNT CBL 25FT RJ45 TO RJ9</b>
<b>7500232</b>	<b>GAVITA LED 120V 8' POWER CORD</b>
<b>7500238</b>	<b>GAVITA LED INTCT CBL RJ45 10'</b>
<b>7501209</b>	<b>GAVITA LED 240V 8FT POWER CORD (208-240)</b>

## Gavita Pro CMH 315e and 630e SE



The Gavita Pro 315e SE and Gavita Pro 630e SE are available with the Philips 315 watt 3000° Kelvin lamps (for flowering) or 4200° Kelvin lamps (for vegetative or supplemental use). They are a compact fixture with a new type of reflector mounting system: Instead of a bracket which holds the reflector on both sides, the reflector is now clipped on the ballast housing itself. This reduces size and weight, enables easy replacement and provides optimal positioning and stability of the small reflector. Ideal for fixed installation with brackets on Unistrut (C profile) systems, the Repeater Bus cabling system allows you to daisy-chain the fixtures in your installation. A Repeater Bus interconnect cable is included with every fixture. You can connect 5 strings of 100 fixtures per Master controller port. This enables you to control up to 1000 fixtures on one EL2 controller.

- The CMH ballasts can be remote controlled by the Gavita Master Controllers.
- The integration of ballast and reflector results in a compact fixture.
- All Gavita CMH fixtures are FCC tested and compliant.
- Compatible with Gavita EL controllers.
- This reflector is made of Miro® aluminum which provides optimal reflectance to your crop.

**7450836**                      **FIXTURE CMH 315 4200K GAV**

**7450839**                      **FIXTURE CMH 315 3100K GAV**

**7450837**                      **FIXTURE CMH 630 3100K GAV**

**7450838**                      **FIXTURE CMH 630 4200K GAV**

## Gavita Master Controllers Gen 2



Lighting control at your fingertips! The Master controller EL1 and EL2 Gen 2 are our entry-level systems for centrally controlling large rooms with e-series fixtures. The second generation of Master controllers features improved and expanded functionality that raises the bar including non-volatile memory, event logging, independent sunrise and sunset settings and independent light cycles on the EL2. The EL1 has one lighting control channel and the EL2 has two lighting control channels. The EL1 can control 500 max repeater bus fixtures and 40 max single bus fixtures without a booster. The EL2 can control 1000 max repeater bus fixtures and 80 max single bus fixtures without a booster.

- 7150233      MASTER CNTL EL1 GEN 2**
- 7150234      MASTER CNTL EL2 GEN 2**

### Don't Forget Your Master Controller Accessories!



- 7150204      GAVITA RJ9 25FT CONTROLLER CBL**
- 7150205      GAVITA RJ14 10FT INTRCNT CBL**
- 7150206      GAVITA TEMP. PROBE 5M**
- 7150207      GAVITA TEMP. PROBE 30M**
- 7150208      GAVITA 120V MC POWER CORD**
- 7150209      GAVITA RJ14 3W- SPLITTER**
- 7150211      GAVITA ECM 10FT CABLE**
- 7150212      GAVITA RJ9 16FT CONTROLLER CBL**
- 7150213      GAVITA RJ14 8FT INTRCNT CBL**
- 7150214      GAVITA RJ14 5FT INTRCNT CBL**
- 7150223      GAVITA REPEATER BUS CONNECTION KIT**
- 7150224      GAVITA 6P6C 10FT GREY INTRCNT CBLR BUS**
- 7150225      GAVITA 8X S/O FERRITE GREY INTRCNT CBL**
- 7150226      GAVITA 2X SNAPON FERRITE FOR CNTRL CBL**
- 7150229      GAVITA RST POWERCORD 3.3FT OPEN ENDED**
- 7150230      GAVITA INTRCNT CBL 6'6 FOR 1000E 277/347**
- 7150232      GAVITA RST POWERCORD 10FT OPEN ENDED**
- 7500238      GAVITA LED INTCT RJ45 10'**

### Gavita Pro 600W 400V EL

Specifications:

Brand: Gavita

Type: Pro EL 600 Watt

Power: 600 Watt

Lamp base: E40

Lumens: 85.000

Growlight ( $\mu\text{Mol}$ ): 1150

Light maintenance 1 year (5000 hours):: >95%

Voltage: 400V



**7450825 LAMP 600W HPS GAVITA PRO ELECTRONIC**

### Gavita Pro 6/750 W EL DE FLEX

Specifications:

Brand: Gavita

Type: Pro EL DE

Power: 750 Watt

Lamp base: K12 x 30S

Growlight ( $\mu\text{Mol}$ ): 1500

Light maintenance 1 year (5000 hours):: >95%

Voltage: 400V



**7450828 LAMP 6/750W GAVITA PRO FLEX 400V DE**

### Gavita Pro Plus 1000W EL DE

Professional European 1000 W high frequency horticultural lamp. No wireframe, quartz glass outer bulb for perfect optical quality. Double ended, K12 x 30S lamp base for accurate lamp positioning. Extremely high photosynthetic photon flux (ppf ): 2100  $\mu\text{mol}$  (see specs). Only suitable for high frequency, high voltage Electronic ballasts (Gavita Pro series). 1 year warranty on suitable electronic ballasts (Gavita Pro series)

Specifications:

Brand: Gavita

Type: Pro EL 1000 Watt

Power: 1000 Watt

Lamp base: K12 x 30S

**Growlight ( $\mu\text{Mol}$ ): 2100  $\mu\text{mol}$**

**Voltage: 400V**



**7450829 LAMP 1000W GAVITA PRO+400V DE 2100 $\mu\text{MOL}$**

### Ultra Sun® MH 1000 Watt DE 6,000° K Open Rated Lamp

The Ultra Sun 1000 Watt Metal Halide DE 6,000K open rated lamp emits a blue spectrum that boosts foliage growth during vegetative cycles and encourages tighter nodal spacing.. Specifically designed for high-frequency DE ballasts. DE lamp construction incorporates the electrical connection at each end of the lamp, removing the need for a frame inside.

The absence of the frame eliminates shadows in the beam. This bulb features a dual jacketed construction that allows it to be used in an open or closed fixture. For horizontal operation only. The jacket of this lamp is made from quartz glass. Oil from your hands can damage this lamp.



**7450833 LAMP 1000DE 6K ULTRA SUN MH**



# GrowStation 640W

**BETTER**OPTIONS®



- Growstation LED is powered by MeanWell drivers
- Excellent lighting performance certified by 3rd party laboratory SGS
- PPF: 1570 micromoles per second & 2.45 micromole/J
- Dimmable: dimmable range from 0 ~ 100% at 10% increments
- FCC Class A certified, ETL certified conforms to UL 1598: 2018 Ed.4 & CSA 02.2#250.0:2018 Ed.4
- The whole fixture is IP65 rated suitable for humid environment & wet location
- Reduce air conditioning usage up to 35% compared with 1,000W HID lighting
- Basic Dimmer: 0,,100% Range, Input Voltage: 11 av, Power Consumption: 2 watt, Operating temperature: 14~104F, Warranty: One year limited.
- Daisy Chain Dimming Cable is IP65 rated

## GROWStation 640W Specifications

- PPF: 1570 umole/s
- Input Power: 640W
- Efficacy: 2.45 umole/J
- Input Voltage: 110-277V
- Dimensions: 45' L x 42'W x 3' H
- Weight: 33 lbs
- Max. Ambient Temperature: 95 F
- Dimming: 0-10V
- Light Distribution: 120 x 115 Degree
- Average Life Hours: 50,000
- Power Factor: >0.9
- Certifications: FCC, cETL, Wet Location
- Warranty: 3 Years Limited
- Max. Current by 120V 5.6A
- Max. Current by 208V 3.2A
- Max. Current by 240V 2.77A
- Max. Current by 277V 2.42A

## Basic Dimmer

Input Voltage: 110V  
Power Consumption: 2 watt  
Operating temperature: 14~104F  
Warranty: One year limited.

**7502001**

**GROWSTATION DIMMER BASIC**



**7502000**

**GROWSTATION 640W LED**

# GrowStation 640W Pro 1800

## Introducing the latest Growstation PRO 1800 full-spectrum 640W LED fixture.

PRO 1800 640W LED fixtures are here to help you achieve better results!

- Same 640 watt energy consumption
- Higher light output
- IP65 rated
- Higher energy efficiency
- More yield for your garden
- DLC Hort Listed
- PPF: 1,800 umol/s
- Efficacy: 2.80 umol/J

GROWSTATION 640W PRO 1800 Specifications:

- PPF: 1800 umol/s
- Efficacy: 2.8 umol/J
- Dimensions (inches): 45.4 x 42.4 x 3.4
- Weight (lbs): 30
- Light distribution: 125° x 120°
- Average Life Hours: 50,000
- Power Factor: >0.95
- Input Voltage (V): Max. Current (A)
- 120: 5.60
- 208: 3.20
- 240: 2.77
- 277: 2.42
- Warranty: 5 years limited
- Certification: DLC, ETL, FCC
- Max. Ambient Temp.: 95°F

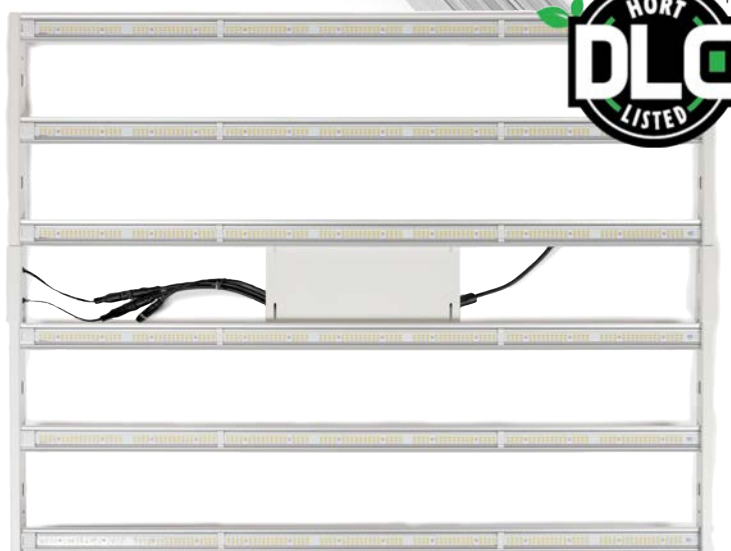

7502004

GROWSTATION 640W PRO 1800

## Programmable Dimmer

Product specifications:

Input Voltage: 110V

Power Consumption: 2 Watts

PWM Dimming Signal: 0-100% +/- 1%, 0-10V

Dimming Voltage: 0-10V +/- .1V

Operating Temperature: 14-104F

One-year Limited Warranty.

7502001

GROWSTATION DIMMER

7502002

GROWSTATION T-CABLE FOR DIMMER



## A3i

For heavy-yielding flowering cycles in single-tier cannabis applications.



Fohse, Inc. is a rising star in the world of indoor horticulture lighting application and research. The company engineers and manufactures LED grow lights specifically for commercial cannabis agriculture.

Over the past three years the Fohse team has been working closely with cannabis cultivators in the Nevada region. In that time we've developed the technology and grow methodology to consistently outgrow HPS. Whether the environment is a single-tier indoor farm, a vertical farm, or a greenhouse, Fohse provides both the LED technology and onsite staff training to ensure client success.

The A3i 1500W LED grow light is ideal for single-tier indoor grows.

The FIV 600W and 1000W LED models are prime choices for vertical farming.

The newest model - the O6i 1200W LED - is a re-imagining of greenhouse supplemental lighting.

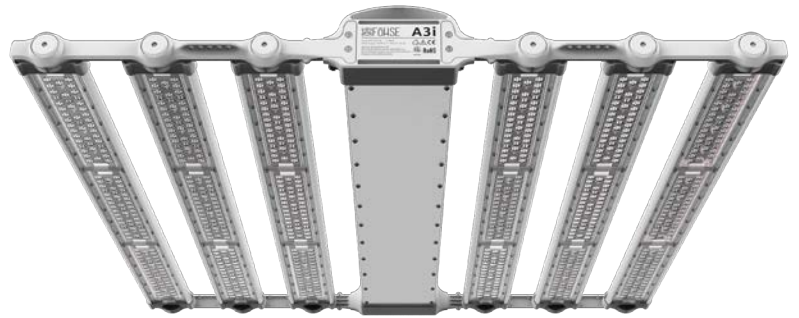

PPF: 4,200  $\mu\text{Mol/s}$

Light source: Samsung LEDs

Fixture Efficacy (100% - 50% power): 2.8 - 3.0  $\mu\text{Mol/J}$

Input power: 1500W

Input voltage: Options up to 480V

Fixture dimensions: 42.28L x 42.5W x 4H in

Weight: 70 lbs

Thermal management: Passive

Lens angle: 90°

Maximum Ambient Operating Temperature: 37.8°C

Dimming: 30%

Lens angle: 90°

CRI: 92

Control interface Wall-mounted OLED panel

L90: 50,000 hours

Power Supply Rating: 100,000 hours

Certifications: ETL, IP67, CE

Mounting: Universal Hanging

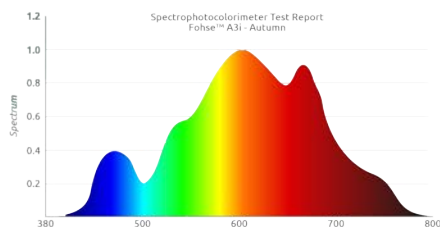
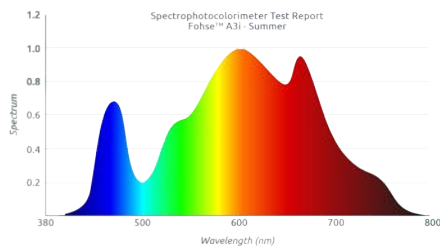
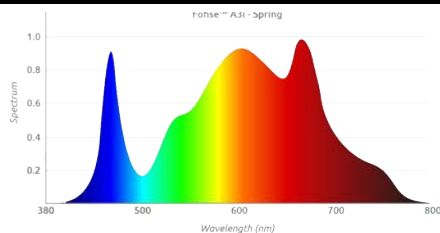

## FIV 600W LED

For accelerated vegetative growth in multi-tier vertical cannabis applications.

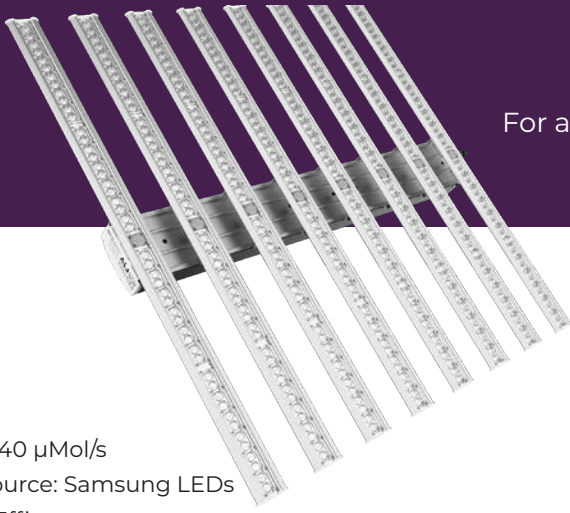

PPF: 1,440  $\mu\text{Mol/s}$   
Light source: Samsung LEDs  
Fixture Efficacy (100% - 50% power): 2.4-2.6  $\mu\text{Mol/J}$   
Input power: 600W  
Input voltage: Options up to 480V  
Fixture dimensions: 42L x 46.5W x 4.6H in  
Weight: 38 lbs  
Thermal management: Passive  
Maximum Ambient Air Temperature: 37.7°C  
BTUs/hours: 2,047

Dimming: 30%  
Lens angle: 100°  
CRI: 90  
Control interface Wall-mounted OLED panel  
L90: 50,000 hours  
Power Supply Rating: 100,000 hours  
Certifications: UL, IP65, CE  
Mounting: Universal Hanging  
Communication protocol: RS485, 0-10V w/Converter, or Ethernet w/Converter

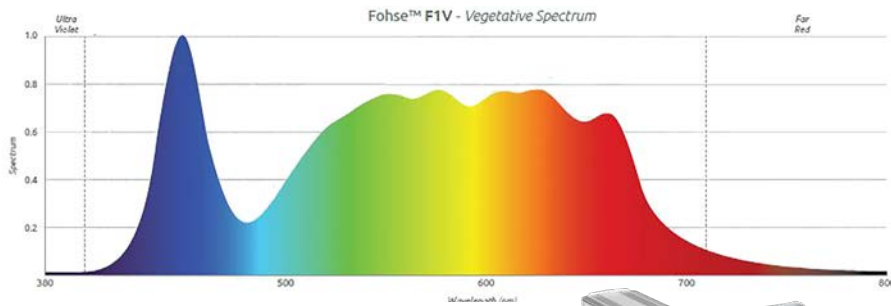

## FIV 1000W LED

For high-intensity flowering cycles in multi-tier cannabis applications.



PPF: 2,400  $\mu\text{Mol/s}$   
Light source: Samsung LEDs  
Fixture Efficacy (100% - 50% power): 2.4-2.6  $\mu\text{Mol/J}$   
Input power: 1000W  
Input voltage: Options up to 480V  
Fixture dimensions: 42L x 46.5W x 4.6H in  
Weight: 38 lbs  
Thermal management: Passive  
Maximum Ambient Air Temperature: 37.7°C  
BTUs/hours: 3,412

Dimming: 30%  
Lens angle: 100°  
CRI: 90  
Control interface Wall-mounted OLED panel  
L90: 50,000 hours  
Power Supply Rating: 100,000 hours  
Certifications: UL, IP65, CE  
Mounting: Universal Hanging  
Communication protocol: RS485, 0-10V w/Converter, or Ethernet w/Converter

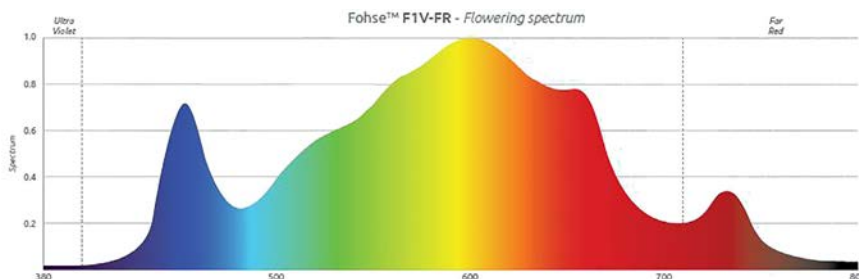

# Aries

## Fixture Specifications:

Light Source: Samsung LEDs  
PPF: 1,792  $\mu\text{Mol/s}$   
Fixture Efficacy (100% - 50% power): 2.8-3.0  $\mu\text{Mol/J}$   
Input power: 640W  
Input voltage: Options up to 480V  
Fixture dimensions: 33L x 34W x 4.25H in  
Weight: 34 lbs  
Thermal management: Passive  
BTUs/ hour: 2,183  
Dimming: 10%  
Lens angle: 100°  
CRI: 92  
Control interface: Wall-mounted OLED panel  
L90: 50,000 hours  
Power supply rating: 100,000 hours  
Certifications: IP67  
Communication protocol: RS485, 0-10V w/Converter, or Ethernet w/Converter  
Mounting: Universal Hanging



**7504007**      **FOHSE Aries 100-277V**

## FOHSE Central Control

- Daisy chain up to 100 fixtures per controller (or more with signal repeaters)
- Automate lighting schedules, brightness, and spectrum
- Wall-mounting bracket included
- Compact size : 9" x 6.7" x 1.68"
- Standard 110 volt outlet plug
- Input power : 10 Watts

**7504003**      **FOHSE DIGITAL CONTROLLER**

**7504010**      **FOHSE 6FT CONTROLLER CABLE**

**7504011**      **FOHSE 15FT CONTROLLER CABLE**

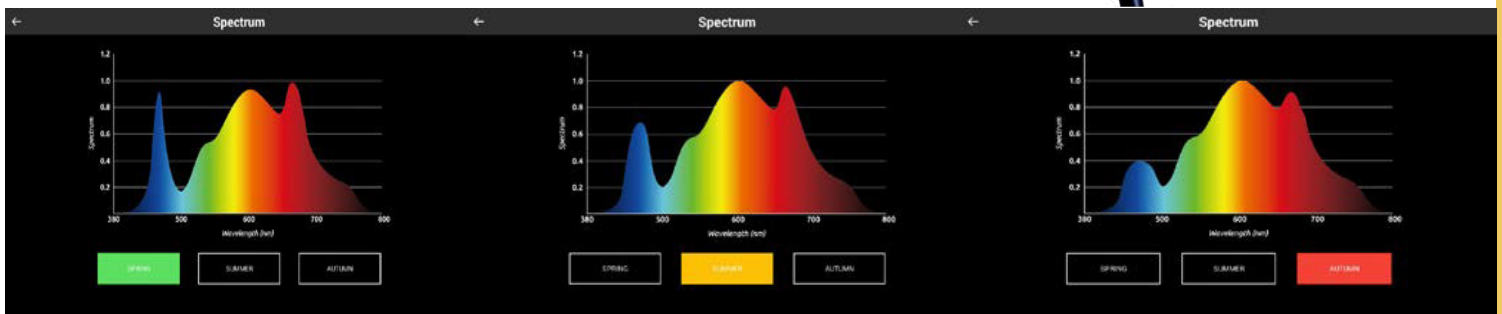

# Pleiades

## Fixture Specifications:

PPF: 900  $\mu\text{Mol/s}$

Dimming: 10%

Fixture Efficacy (100% - 50% power): 2.8 - 3.0  $\mu\text{Mol/J}$

Input power: 320W

Input voltage: Options up to 480V

LIGHT HARVESTING SENSORS FOR AUTO-DIMMING

Fixture dimensions: 28L x 4W x 6H in

Weight: 15 lbs

Thermal management: Passive

BTUs/ hour: 1,091

Lens angle: 100°

CRI: 90

Control interface: Wall-mounted OLED panel

L90: 50,000 hours

Power supply rating: 100,000 hours

Certifications: IP55

Communication protocol: CAN or BACNet

Mounting: Truss-mounting Spring Clip

**7504007**

**FOHSE Aries 100-277V**



## O6i 1200W LED

For supplementary, full-cycle light in greenhouse cannabis applications



PPF: 3,000  $\mu\text{Mol/s}$   
Fixture Efficacy(100% - 50% power): 2.5 - 2.7  $\mu\text{Mol/J}$   
Input power: 1200W  
Input voltage: Options up to 480V  
LIGHT HARVESTING SENSORS FOR AUTO-DIMMING  
Fixture dimensions: 16L x 8W x 13H in Weight: 45 lbs  
Thermal management: Passive & Active Maximum Ambient Operating Temp: 100°F

BTUs / hour: 4,094  
Dimming: 10%  
CRI: 80  
Control interface: Wall-mounted OLED panel  
L90: 50,000 hours  
Power supply rating: 100,000 hours  
Certifications: IP67  
Communication protocol: Wireless, 0-10V w/ converter, Ethernet w/converter, RS485  
Mounting: Universal Hanging

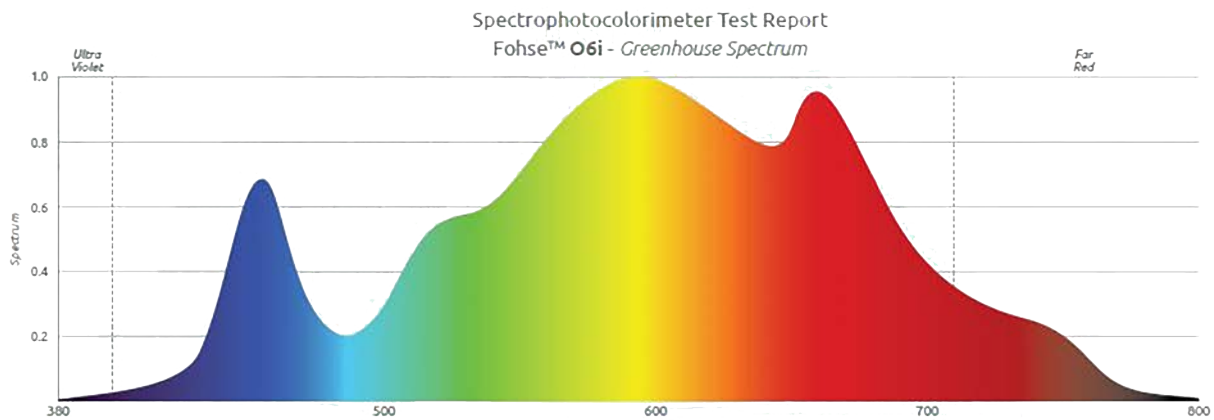



## Metal Halide Lamp

- Sky Blue Metal Halide provides an ideal spectrum to help plants grow in vegetative stages.
- 7,200K blue spectrum is perfect for young plants.
- Operating position: Universal with enclosed fixtures.
- Average life hours: 10,000.

**7450058 PLANTMAX MH 250W**

**7450059 PLANTMAX MH 400W**

**7450060 PLANTMAX MH 1000W**



## Metal Halide Conversion Lamp 7,200K

- Fits High Pressure Sodium ballast
- 7,200K spectrum for vegetative stage
- Operating position: Universal

**7450064 PLANTMAX CONVER 250W**

**7450065 PLANTMAX CONVER 400W**

**7450066 PLANTMAX 600W MH 7200K**

**7450067 PLANTMAX CONVER 1000W**



## High Pressure Sodium Conversion Lamp

- Fits Metal Halide ballast
- Great for flowering stage
- Operating position: Universal

**7450062 PLANTMAX CONVER 360W**

**7450063 PLANTMAX CONVER 940W**



## Plantmax High Pressure Sodium Lamps

- High Pressure Sodium with adjusted blue spectrum brings you the best yields in flowering and fruiting
- Quality, Values & Results
- Operating position: Universal

**7450053 PLANTMAX HPS 400W**

**7450054 PLANTMAX HPS 430W**

**7450055 PLANTMAX HPS 600W**

**7450057 PLANTMAX HPS 1000W**



## Double-Ended High Pressure Sodium 1,000 Watt Lamp

- Excellent lumen maintenance for maximum yields
- Commercial grade quality for professional growers
- Double – Ended design for optimal reflecting application
- Operating position: Horizontal

7450080 PLANTMAX HPS 1000W DE



## T5 Fluorescent HO Lamp

- T5 Fluorescent Lamps bring you high lumen output
- With extreme high efficacy and long life, you can expect great results for plant growth as well as energy savings
- Available in both cool (6,500K) and warm (3,000K) temperatures
- Operating position: Horizontal

7460041 T5 BULB 2FT 3K PLANTMAX

7460042 T5 BULB 2FT 6.5K PLANTMAX

7460043 T5 BULB 4FT 3K PLANTMAX

7460044 T5 BULB 4FT 6.5K PLANTMAX



## Heavy Duty Grounded Timer

For air conditioners, heaters and other heavy electrical loads. Three (3) on - three (3) off settings per day. Rating: 1.5 amp, 1 HP for use with air conditioners, with standard grounded plug.

3150021 TIMER INTERMATIC 15 AMP GRNDED

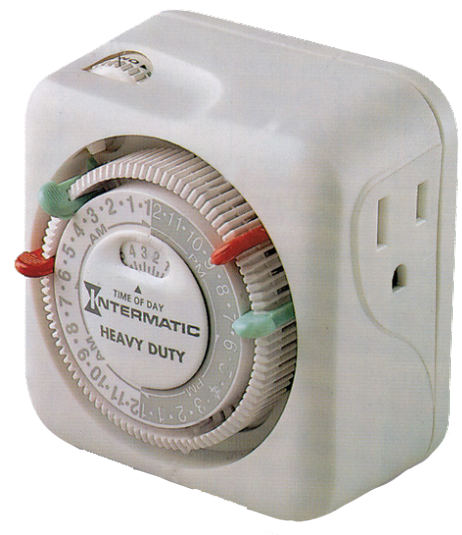



**SOLIS TEK®**  
DIGITAL LIGHTING

## Solistek Single Ended Lamps



### SOLISTEK SE MH LAMPS (Available in 600 and 1000W)

- 4K Metal Halide is a pulse-start full spectrum lamp used for all stages of growth and bloom.
- 6K Metal Halide is a pulse-start lamp popularly used for vegetative growth to encourage shorter node spacing and bushier plants.
- 10K Metal Halide is a pulse-start lamp used for the last 7 - 14 days of bloom to allow better ripening and finishing.

Featuring Low Iron (Low-E) glass for enhanced UV penetration to your plants for higher quality and yield.

SolisTek High Frequency MH offers:

- Color Enhanced Full Balanced Spectrum
- Less Depreciation of PAR and Lumen Output Over Time.
- Precise Gas Combination for Increased Blues, Reds & UV
- True High Frequency Technology & Proper UV Balance
- Advanced HID Lamp Design for Prolonged Lamp Life
- Made for Quality, Consistency & Yield



7450070	SOLISTEK 1000 MH SE- 10K
7450071	SOLISTEK 1000 MH SE-6K
7450072	SOLISTEK 1000 MH SE- 4K
7450073	SOLISTEK 600 MH SE- 10K
7450074	SOLISTEK 600 MH SE-6K
7450076	SOLISTEK 600 MH SE 4K



### Solistek SE HPS Lamps (Available in 600 and 1000W)

The 2K HPS is optimal for all stages of growth.

Features:

- Superior Photochemical Reactions
- Proper UV Balance
- Advanced HID Lamp Design
- Lamps made by Life Scientists for plants -Best Sunlight Replication
- Made for Quality, Consistency & Yield

7450068	SOLISTEK 1000 HPS SE
7450069	SOLISTEK 600 HPS SE

## Solistek Double Ended Lamps

### SOLISTEK DE MH LAMPS (Available in 600 and 1000W)

- 4K Metal Halide is a pulse-start full spectrum lamp used for all stages of growth and bloom
- 6K Metal Halide is a pulse-start lamp popularly used for vegetative growth to encourage shorter node spacing and bushier plants
- 10K Metal Halide is a pulse-start lamp used for the last 7 - 14 days of bloom to allow better ripening and finishing

SolisTek lamps contain enhanced UV Spectra. Exercise caution when working around any HID lamp that contains UV, always wear protective lenses.

SolisTek High Frequency MH offers:

- Color Enhanced Full Balanced Spectrum
- Less Depreciation of PAR and Lumen Output Over Time.
- Precise Gas Combination for Increased Blues, Reds & UV
- True High Frequency Technology & Proper UV Balance
- Advanced HID Lamp Design for Prolonged Lamp Life
- Made for Quality, Consistency & Yield

<b>7450772</b>	<b>SOLISTEK 1000 MH DE- 4K</b>
<b>7450773</b>	<b>SOLISTEK 1000 MH DE-6K</b>
<b>7450774</b>	<b>SOLISTEK 1000 MH DE- 10K</b>
<b>7450775</b>	<b>SOLISTEK 600 MH DE- 4K</b>
<b>7450776</b>	<b>SOLISTEK 600 MH DE- 6K</b>
<b>7450777</b>	<b>SOLISTEK 600 MH DE- 10K</b>



### Solistek DE HPS Lamps (Available in 600 and 1000W)

The 2K HPS is optimal for all stages of growth.

Features:

- Superior Photochemical Reactions
- Proper UV Balance
- Advanced HID Lamp Design
- Lamps made by Life Scientists for plants -Best Sunlight Replication
- Made for Quality, Consistency & Yield

<b>7450070</b>	<b>SOLISTEK 1000 MH SE- 10K</b>
<b>7450071</b>	<b>SOLISTEK 1000 MH SE-6K</b>



## Master Green™ 1000 Watt Electronic Ballast - 120-240 Volt

The Master Green™ 1000 watt HPS electronic ballast features high frequency 105 kHz micro processing technology optimized for operating double-ended 1000 watt HPS lamps. The Master Green™ can operate at 60%, 70%, 100%, or Super Charge. Extruded aluminum housing is lightweight and its compact design has active cooling (internal fan) and soft start technology, which promotes longer lamp life. Our Master Green™ electronic ballast lamp cord receptacle is designed specifically for Sun System® brand reflectors. The ballast operates at 120-240 volt power. Includes a 6.5 ft Convertible Smart Volt® dual ferrite, power cord and both 120 volt and 240 volts interchangeable plugs.



**7500297 BALLAST MASTER GREEN 1000W**

## SolisTek MATRIX SE/DE 1000W Digital Ballast 120/240V

The SolisTek SE/DE ballast will operate any single or double ended HPS or MH lamp at its optimal efficiency.

- Built in Digital Timer - Completely customizable on/off schedule settings for any grow cycle. Sync all SolisTek Ballasts on the same schedule with only 1 remote control. Eliminate unnecessary external components.
- Remote Control - The exclusive SolisTek remote control will allow you to wirelessly configure the wattage settings from over 70ft away and also set the integrated digital timer for your SolisTek Matrix Ballast(s). The Matrix remote control allows as many Matrix ballasts to be synced to the same schedule eliminating the need for an external controller.
- Green LCD Screen- Digital green read-out to visually display ballast settings and won't disrupt plant sleep cycle. Dark cycle-friendly!
- Ballast Life Timer - On board ballast 'odometer' that will count the number of hours the ballast has been used.

**7570040 SOLISTEK 1000 BALLAST MATRIX \*\* DISCONTINUED \*\***

**7150041 SOLISTEK MATRIX REMOTE CONTROL**



## SolisTek Digital Lamp Extension

SolisTek Digital Lamp Extensions

Features:

- High Quality Upgraded Tinned wiring
- 14 AWG wiring
- High quality connectors
- Rated for 600V
- Increases overall conductivity for higher performance
- Lowers impedance

SolisTek offers a full line of high quality lamp extensions. SolisTek lamp extensions are not created equally. They use completely upgraded 14 AWG tinned wiring for the least amount of resistance possible from the ballast to lamp. Using SolisTek digital lamp extensions prevents frequency output shifts to the lamp.

Using higher quality lamp extensions with ultra high conductivity you can expect:

- The ability to ignite lamps from further distances (up to 90ft @ 1000w, or up to 75ft @ 600w)
- No resistance between ballast and lamp resulting with proper spectrum

<b>7550500</b>	<b>SOLISTEK 15' TINNED LAMP EXTENSION</b>
<b>7550501</b>	<b>SOLISTEK 25' TINNED LAMP EXTENSION</b>
<b>7550502</b>	<b>SOLISTEK 50' TINNED LAMP EXTENSION</b>
<b>7440100</b>	<b>SOLISTEK DIGITAL SPLITTER (1000W/600WX2)</b>





# Environmental

Anden has been an innovator in the development of precise humidity control systems for commercial and residential applications since 1954. Trust Anden to deliver the reliable products and expert technical support that are critical to successful harvests. At capacities up to 300 pints per day and up to 500 cubic feet per minute of airflow, our dehumidifiers are the only products on the market specifically designed to pull moisture out of the air at lower temperatures.

### Industrial Dehumidifiers

Anden A-Series Dehumidifiers' capacities range from 70–130 pints per day of moisture removal. From the serious hobbyist to medium-sized commercial facilities, Anden industrial dehumidifiers are designed to operate effectively in the extreme conditions of any indoor cultivation environment.

<b>3097000</b>	<b>ANDEN A70 DEHUMIDIFIER</b>
<b>3097001</b>	<b>ANDEN A95 DEHUMIDIFIER</b>
<b>3097002</b>	<b>ANDEN A130 DEHUMIDIFIER</b>
<b>3097016</b>	<b>ANDEN A130F DEHUMIDIFIER</b>
<b>3097007</b>	<b>ANDEN HANGING KIT A70/A95</b>
<b>3097008</b>	<b>ANDEN HANGING KIT A130/H-E</b>

**A70**

**A95**

**A95F**

**A130F**

**A130**

## Industrial Grow-Optimized Dehumidifiers

Anden AV-Series Dehumidifiers range from 210-320 pints per day of moisture removal. Components utilize materials designed for the most extreme conditions and demanding enterprises. The included Model 77 remote control relays diagnostics from the dehumidifier, giving you simple control of the conditions in your cultivation space (upgrade options available). Sensors and controls can be custom-configured for each facility. Anden AV-Series are recommended for the large, ultrahigh volume industrial facilities.



**3097021      ANDEN A210V1 DEHUMIDIFIER 240V 03097022**

**3097022      ANDEN A320V1 DEHUMIDIFER 240V**

**3097023      ANDEN A320V3 277V DEHUMIDIFIER**

**3097042      ANDEN A710V3 277V DEHUMIDIFIER**

**3097029      ANDEN A77 DIGITAL DEHUM CONTROL**

**A77 Control**



**A210V1**



**A320V1**



**A320V3**



**A710**



# ANDEN Replacement Parts

Anden dehumidifiers are designed for maximum growth. Each filter is produced with a highly specialized, dual layered 100% synthetic media, specifically for use in Anden dehumidifiers. Anden filters are composed of an upstream electrostatically enhanced layer (the E-Layer), and a downstream mechanical layer (the M-Layer). These replacement filters are easy to install, with no assembly or reinforcements to worry about. Protect your equipment for optimal performance.

Anden duct kits are for applications where ducting your dehumidifier is required. This dehumidifier can be installed outside of the grow room and ducted to the room with a dedicated inlet and supply ducts.

Other Anden replacement parts available upon request.

- 30970020      ANDEN AS80 CANISTER**
- 3097024      ANDEN AS80LC CANISTER**



**3097028 ANDEN 5790 DUCT KIT**



**3097002 ANDEN 5807 DUCT KIT**



**3097002 ANDEN 5807 DUCT KIT**



**3097040 ANDEN FILTER A70**



**3097046 ANDEN FILTER A95**



**3097030 ANDEN FILTER A130**



**3097026 ANDEN A210V1 FILTER**



**3097027 ANDEN A210V1 FILTER**



**3097044 ANDEN FIL**



## Anden Steam Humidifier

Anden AS35/ AS35FP Steam Humidifier is a grow room solution that helps you achieve ideal conditions through humidity control. Fogger, mister, steam humidifier. Whatever you call it - this ductless solution is ideal for cultivation.

- High Capacity - 11.5 and 34.6 gallons per day of moisture to the air
- Illuminates service light when canister needs to be replaced. The steam canister may build up with minerals and change color but the steam humidifier produces clean sterile steam that won't leave a mineral residue on your plants
- Designed for easy install, and are fed automatically by a simple connection to a cold water supply. No need to ever fill the tank!
- Includes a fan pack.
- Designed for stand alone applications

19.49" W x 19.36" H x 30.07" D

**3097013                    ANDEN AS35FP STEAM HUMIDIFIER**

**3097015                    ANDEN REMOTE SENSOR SUPPORT 1 TEMP&RH**



## Anden Humidistat

This wall-mounted humidistat boasts a microcomputer design and offers a large LED digital display with a back-light and the ability to lock in your preferred relative humidity set-point from 0 - 100% RH.



- Celsius or Fahrenheit scale.
- Outputs controlling humidification and dehumidification equipment by means of on/off or proportional output signals for greater flexibility.
- Modulating Output Signal provides a 0-10Vdc or 2-10Vdc proportional control signal to the humidifier.
- Humidity set-point reset function based on outdoor temperature which helps prevent condensation in colder climates.
- Humidifier On-Off signal 24Vac dry contact capable of handling up to 1 amp.
- Proportional High Limit Override to prevent over-humidification within the duct and costly water damage.
- Multi-level lockable access menu and lockable set point to prevent accidental changes.

**3097010                    ANDEN 5558 DIGITAL HUMIDISTAT WALLMOUNTE**

**3097006                    ANDEN A76 DIGITAL DEHUMIDIFIER CONTROL**

## Anden Controllers and Thermostats

### Anden 8820 Thermostat

Monitor and adjust the most crucial aspects of the indoor growth environment with all-in-one, touchscreen control. You can dial in the optimal temperature and humidity levels to create a healthy, grow-optimized environment. The 4.5" display offers a range of benefits: constant monitoring of temperature and humidity, easy adjustments, notifications when systems are active, and filter replacement reminders. Plus, there's an app for iOS and Android to keep you in control on the go. It provides full access to controls using your mobile device, so you can monitor and adjust conditions anytime, anywhere.

Anden advanced features:

-2H/2C or 4H/2C HP

-All-in-One Control: Real-time updates on temperature and humidity, plus notifications when systems are active

-Humidity Control: Optimize the performance of your Anden humidity controls

-Temperature Monitoring: Reach your preferred temperature range for maximum growth

-Ventilation Control: Control the flow of fresh air for ideal growth conditions

-.5" Touchscreen: The touchscreen display makes it simple to monitor and adjust indoor conditions

-Large Font Size: The most important information is displayed front and center for easy monitoring

-Backlit Display: Easy to read, even in sunlight and includes a constant low-intensity light option

-Screen Lockout: Prevent inadvertent or unauthorized adjustments

-Permanent Memory: Settings, time, and date are maintained during a power outage

-Built to Last: Dependability is at the heart of what we do. That's why we offer a 5-year warranty on this product—so you can grow with confidence

3097011

ANDEN 8820 THERMOSTAT TCHSCRN WIFI IAQ



## Anden 8840 Control

The Anden 8840 Control Panel is our most advanced monitoring system, designed for the most demanding, grow-focused environments. It gives you the power to monitor and adjust the most crucial aspects of the indoor growth environment with all-in-one, touchscreen control. You can dial in the optimal temperature and humidity levels to create a healthy, grow-optimized environment. The 7" full color display offers a range of benefits: constant monitoring of temperature and humidity, easy adjustments, notifications when systems are active, and filter replacement reminders. Plus, there's an app for iOS and Android to keep you in control on the go. It provides full access to controls using your mobile device, so you can monitor and adjust conditions anytime, anywhere.

- All-in-One Control – Real-time updates on temperature and humidity, plus notifications when systems are active
- Humidity Control – Optimize the performance of your Anden humidity controls
- Temperature Monitoring – Reach your preferred temperature range for maximum growth
- Ventilation Control – Control the flow of fresh air for ideal growth conditions
- 7 inch Touchscreen – The full color display makes it simple to monitor and adjust indoor conditions
- Large Font Size – The most important information is displayed front and center for easy monitoring
- Backlit Display – Easy to read, even in sunlight and includes a constant low-intensity light option
- Screen Lockout – Prevent inadvertent or unauthorized adjustments
- Permanent Memory – Settings, time, and date are maintained during a power outage
- Built to Last – Dependability is at the heart of what we do. That's why we offer a 5-year warranty on this product—so you can grow with confidence

3097014

ANDEN 8840 COLOR THERMOSTAT TCHSCRN WIFI



## Hurricane Pro Wall Mount Fans

Available in 16" and 20", these fans ideal for homes, greenhouses, garages, workshops and other areas that may need a heavy-duty wall fan. They can be easily mounted with the included heavy-duty wall bracket and hardware. The Hurricane® Pro Wall Mount Fan has a thermally protected motor that will automatically shut off should it overheat for any reason. Made of rugged all-metal construction with a black powder-coated finish. The fan blades are made of aluminum. It has 3 speed settings with oscillation controls and adjustable tilt. Runs at 4500 CFM and 1400 RPM. Comes with a 6 ft 120 V power cord.

**3096100**      **FAN HURRICANE PRO 20" WALL MOUNT FAN**

**3096101**      **FAN HURRICANE PRO 16" WALL MOUNT FAN**

## SPECIFICATIONS

## Hurricane® Pro High Velocity Oscillating Wall Mount Fans - 20 Inch and 16 Inch



PART NUMBER	736474	736484
FAN DIAMETER	20 Inch	16 Inch
ETL LISTED	Yes	
Tested to UL Standard No. 507		
Tested to CSA Standard C22.2 No. 113		
VOLTAGE	120	
AMPS	1.20	0.53
WATTAGE	140	60
CFM RATING	4500	2400
RPM	1450	
POWER CORD	Integrated 6 foot	
WEIGHT	17.25 lbs.	14.1 lbs
WARRANTY	1 year	

**Hurricane**  
PRO

## Mammoth Grow Tents

Mammoth grow tents offer all options possible to growers from the novice to the advanced.

Quality assured with dual stitching, with reflective and durable Mylar, strong framing with plastic protective cornering.

Easy assembly with interlocking tent options. Mammoth grow tents have been designed for growing all types of plants, even those that require specific conditions (Orchids, Aloe Vera, citrus plants, carnivorous or tropical plants). These indoor grow tents incorporate a hammered effect Mylar in the material which acts as a barrier to toxins generated by PVC and also has a reflectivity value of over 95%.

Whether you are a beginner or a more experienced gardener, Mammoth grow tents will bring you total satisfaction in knowing you can reproduce plants and control the environment in a portable environment.



# Mammoth Grow Tents

a tent for every grower...

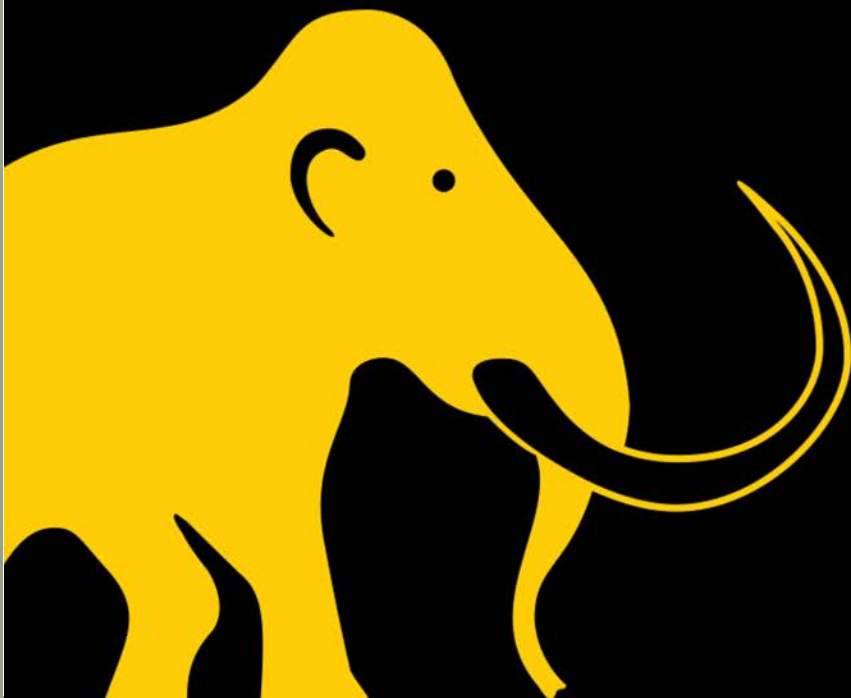



### Mammoth Classic+

NOW WITH 600D MYLAR  
AND 19MM POLES

- Better light proof design
- Quick and easy assembly
- Strong frame with high quality corners and connectors
- Available in a wide range of sizes
- Big doors for easy access
- Multiple inlets and outlets for flexible installation

A high quality tent for the hobby grower, this mid-range grow room has features normally associated with higher end tents.

- High light proofing (Level 1)
- Equipment tubes are strong enough to hold 20kg
- Large doors - easy to access and work in various intakes and exhausts make setup flexible
- Straps and hooks for easy integration

**5300730 CLASSIC60 2X2X4.6**

**5300731 CLASSIC90 3X3X5.3**

**5300732 CLASSIC120 4X4X6**

**5300733 CLASSIC150 5X5X6.6**



### Mammoth Pro+

NOW WITH 600D MYLAR  
AND 22MM POLES

- High light proofing (Level 2)
- Polypropylene corners for maximum rigidity
- Equipment tubes that have 30kg load capacity
- Large doors - easy to access and work in
- Material is washable inside and out
- Straps and hooks for easy integration of equipment
- Light, easy-to-transport material and is easy to assemble

**5300800 MAMMOTH PRO+ 80 2.6X2.6X6'**

**5300801 MAMMOTH PRO+ 90 3X3X6'**

**5300802 MAMMOTH PRO+100 3.3X3.3X6.6'**

**5300803 MAMMOTH PRO+ 120 4X4X6.6'**

**5300804 MAMMOTH PRO+ 150 5X5X6.6'**

**5300805 MAMMOTH PRO+240 8X8X6.6'**

**5300706 PRO240L 8X4X6.6**

**5300707 PRO300L 10X5X6.6**



### Mammoth Elite

The ultimate in quality for the professional grower.

- Heavy duty frame, corners and fabric, with stainless steel / aluminium click system
- Dual multiple intake and extraction socks
- Equipment tubes that have a 75kg load capacity
- Wide easy access door, with jam proof / waterproof zipper.
- Waterproof floor
- Large doors - easy to access and work in
- Material is washable inside and out
- Modular: customize your own grow room by combining different Elites sizes - unique linkable panels - your shape, your size

**5300770 ELITE480 16X8X7.9**

**5300771 ELITE600L20X10X7**

**5300772 ELITEHC900L 15X30X7.11**

**5300773ELITEHC300L 5X10X7.11**

**5300776 ELITEHC600L 10X20X7.11**



### **Mammoth Dual**

The Mammoth Dual is the ultimate growing environment. Thanks to the large doors, the Mammoth Dual is easily accessible and convenient to operate.

**5300750**                      **MAMMOTH DUAL90 3X3X6.3**

**5300751**                      **MAMMOTH DUAL120 4X4X7**



### **Mammoth Gavita G1**

The only tent made for Gavita DE! Now run one Gavita DE 1000W fixture in a tent with matching footprint at 3.6 ft x 5.9 ft x 7.88 ft. Rugged exterior, heavy duty 22mm steel frame, 2 front doors, 3 side windows, 95% reflective mylar coating 600D lightproof canvas, waterproof built in tray. Use with New Gavita M Style SR Small Room Reflector insert with Gavita DE fixtures for optimized growth.

**5300760**                      **GAVITA TENT G1 (3.6X5.9X7.9)**



### **Mammoth Gavita G2**

The only tent made for Gavita DE! Now run TWO Gavita DE 1000W fixtures in a tent with a matching footprint at 5.91 ft x 7.22 ft x 7.88 ft. Rugged exterior, Heavy duty 22mm steel frame, 2 front doors, 2 side doors, 3 side windows, 95% reflective mylar coating 600D lightproof canvas, waterproof built in tray. Use with New Gavita M Style SR Small Room Reflector insert with Gavita DE fixtures for optimized growth.

**5300761**                      **GAVITA TENT G2 (7.2X5.9X7.9)**

### **Mammoth Gavita G1 & G2 Additional Features**

- Deep Penetration of Light - Mammoth Elite reflective walls and tent shape maximize light in all directions
- FootPrint - tent matches the Gavita Light footprint
- More Ports! - Port on front allows access to Gavita Master Controller
- Never Overheat - at almost 8 feet tall this tent keeps its cool
- 100% Waterproof Flooring - built in water tray
- Heavy duty frame with 22 mm steel poles
- Rugged, light proof canvas exterior and reflective mylar interior



## Mammoth Accessories

### Mammoth Propagator

The Mammoth Propagator is a small propagation and germination grow box, ideal for keeping mother plants, germinate seeds, cutting propagation and for the small plants growth stage. Small and reflective, everything you need for your cuttings and seedlings. Lined with 190D Mylar (CRX 95%) material at a very high coefficient of light refraction. Provided with all the necessary tools for a professional growing, with ventilation diagonal window and metal strong structure to support lighting and filters smells (up to 20kg).



5300781 MAMMOTH PROPAGATOR 3X2X2

5300791 MAMMOTH PROPAGATOR125 4X2X4

### Mammoth WebIT

Adjustable Plant Support designed to fit the Pro Series tents Small fits Pro 60 - 90 Large Fits Pro 120 - 150.

5300782 MAMMOTH WEB 60-100

5300783 MAMMOTH WEB120-150

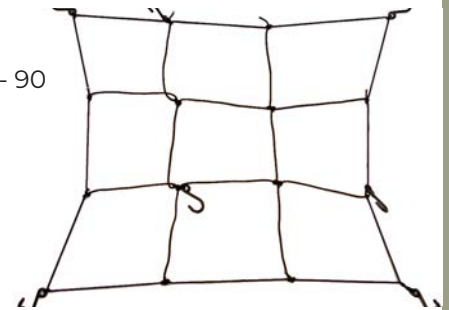

### Mammoth Dryer

31" 5 Layer Dryer you can dry your yields in the very same Mammoth grow tents in which you grew those plants! The Mammoth DryIT is a 31" dryer that is powerful enough to dry large amounts of yields simultaneously. The Mammoth DryIT hangs from the roof crossbars inside the DarkRoom. The DryIT is also compatible with the DarkDryer system, which when used in tandem team up to create one super-efficient and high-performance drying system.

5300780 MAMMOTH DRYER90 3X3X6

5300785 MAMMOTH DRY 45

5300786 MAMMOTH DRY 80



### Mammoth S Hooks

5 "S" hooks Mammoth Hook with a diameter of 16 mm or 25mm. Ideal for hanging objects and power cables in the grow room. Great way to hang accessories in your tent.

5300789 MAMMOTH S HOOK 16MM (5PC)

5300790 MAMMOTH S HOOK 23MM (5PC)

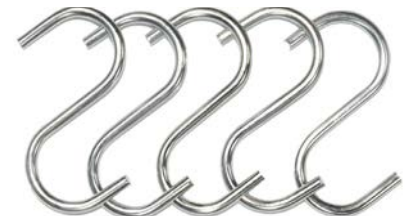

### Mammoth Strap and Adjust

Mammoth Straps are made of heavy duty nylon and are perfect suspending small to medium sized carbon filters in the tent.

5300788 MAMMOTH STRAP (2PC)



2 Pack Fully adjustable Light Hanger

5300787 MAMMOTH ADJUST (2PC)

rambridge.com

RAM  
BRIDGE

## Elite 96

The Elite 96 is a commercial-grade Cloning System with a patented, built-in cooling system. With 96 clone sites, it is everything you need to propagate clones in your medium-scale or small commercial growing environment. We've taken our widely respected Black Label T96 unit and made it even better. (Vented Humidity domes are available for all TurboKlone® Elite units)



- 5260054      **TURBOKLONE T96 DOME ONLY**
- 5260071      **TURBOKLONE E96D SITE & DOME**
- 5260070      **TURBOKLONE ELITE 96 SITE SYSTEM**
- 5260057      **TURBOKLONE T96 MANIFOLD**



## Elite 144

The TurboKlone® Elite 144 is currently the largest self-cooled Cloning System on the market. With 144 clone sites, it is everything you need to propagate clones in your large-scale or commercial growing environment. We've taken our widely respected Black Label T144 unit and made it even better. (Vented Humidity domes are available for all TurboKlone Elite units)



- 5260072      **TURBOKLONE ELITE144 SITE**
- 5260073      **TURBOKLONE E144D SITE & DOME**
- 5260076      **TURBOKLONE E144 DOME ONLY**
- 5260058      **TURBOKLONE T144 MANIFOLD**
- 5260062      **TURBOKLONE PUMP - T144**
- 5260074      **TURBOKLONE ELITE COLLARS 52 PACK**



## Parts

- 5260063      **TURBOKLONE SPRAY JETS**
- 5260064      **TURBOKLONE FAN POWER PAK**
- 5260059      **TURBOKLONE MANIFOLD CLIPS**
- 5260060      **TURBOKLONE SHROUD/FAN ASSEMBLY**



**Vortex VMF Inline Fan**

Vortex VMF Powerfans Inline Fan by Atmosphere are in-line duct fans specifically designed to maximize the airflow performance with minimal noise levels in a small, compact housing. These fans incorporate a powerful mixed flow impeller and internal air vanes located at the discharge end of the fan housing. This impeller and guide vane combination provides a smooth laminar air flow which in turn minimizes turbulence and noise and generates an excellent air flow to static pressure performance ratio.

Detailed Description:

- Quiet operation
- Available in duct diameter from 4" to 8"
- Airflow capacity from 157 to 617 CFM
- Can be mounted in any position
- Precisely balanced for vibration-free operation and longer life expectancy
- Speed controllable
- Inline mixed flow 4"



**3094000**      **VORTEX VMF400 4" IMF FAN (157CFM)**

**3094002**      **VORTEX VMF600 6" INLINE FAN**

**3094010**      **VORTEX VMF800 8" INLINE FAN**

**Vortex VTX Inline Fan**

When these inline duct blowers were conceived, reliability and efficiency were the main goal. Its more powerful motor combined with its aerodynamically designed shape make Vortex Powerfan the performance leader in its category. Made in Canada by Atmosphere, these high performance inline blowers feature superior steel construction with a hammertone powder coat finish. Speed controllable and balanced motors with permanently lubricated ball bearings ensure vibration-free operation. Never seen in the ventilation industry, the Vortex Powerfan VTX Series feature a 10 year warranty

Detailed Description:

- Brackets included for wall or ceiling mount
- Permanently lubricated sealed bearings
- External rotor motor with automatic reset thermal overload protection
- Suitable for airstream temperatures up to 140°F (60°C)
- 10 year warranty



**3094011**      **VORTEX VTX400 4" FAN**

**3094016**      **VORTEX VMTX600 6" FAN**

**3094017**      **VORTEX VTX800 8" FAN**

**3094018**      **VORTEX VTX1000 10" FAN**

## Vortex S Inline Fans

S-Line Mixed Flow Fans are designed for residential and light commercial ventilation applications. These compact, powerful, and quiet fans are available in 8 in. and 10 in. duct diameters and are ideally suited for either supply or exhaust ventilation systems. The fan and motor are precisely balanced for a quiet and vibration-free operation.

Powerful, compact and quiet mixed flow impeller  
Easy to install - mounting bracket included  
100% speed controllable  
May be mounted in any position  
Suitable for airstream temperatures up to 140°F  
Prewired with 120-Volt power cord



**3094001 VORTEX 4X12 PROLITE FILTER**

**3094008 VORTEX 4X16 PROLITE FILTER**

**3094003 VORTEX 6X16 PROLITE FILTER**

**3094009 VORTEX 10X40 PROLITE FILTER**

**3094007 VORTEX 8X24 PROLITE FILTER**

## Vortex Prolite Filters

The newest series of filters, the Vortex Pro-Lite™, are built for convenience and long life with 100% Australian granulated carbon, aluminum top and bottom, and integrated flange. This lightweight filter has been developed with ease of installation, durability, and effectiveness in mind. The difference is in the carbon; special low-density granulated carbon is used in the Vortex Pro-Lite™ as well as incorporating a built-in flange.

**3094001 VORTEX 4X12 PROLITE FILTER**

**3094003 VORTEX 6X16 PROLITE FILTER**

**3094007 VORTEX 8X24 PROLITE FILTER**



## Vortex Pro125 Reversible Filter

Most cylindrical-type air filters utilize 65% of the carbon available by only filtering through the top section of the carbon filter, leaving the bottom section unused. Vortex PROfilter's innovative patented design allows reversal of the filter, benefitting of 100% of the carbon available and extending the unit's lifespan. Manufactured with only the finest high porosity activated carbon, Vortex PROfilter effectively removes 99.5% of odors. Rated for a continuous worry-free operation, Vortex PROfilter can be used for industrial, commercial or residential applications.

**3094005 VORTEX PRO125 REVERSIBLE FILTER**



## Vortex Flanges

Available in 8", 10" and 12".

**3094006 VORTEX 8" FLANGE**

**3094004 VORTEX 10" FLANGE**

**3094015 VORTEX 12" FLANGE**





# Garden Supplies

# AIR-POT

For plants to thrive they need healthy roots, but standard pots deform roots which seriously compromises the plant. The Air-Pot system does the opposite, actively enhancing the plant, by making it develop a mass of healthy fibrous roots. This maximises its ability to absorb nutrients and water, leading to a healthier, faster growing plant. Nurseries in many countries are reaping the benefits of the Air-Pot system, from the small to the very large. The Air-Pot system is truly unique in its ability to containerise any size of plant.

## Cost benefits:

Using the Air-Pot® isn't just a choice of container – it is a decision to revolutionise the whole way that you grow. Compared to normal plant containers the Air-Pot® is not cheap, but the massive benefits gained from the superior plants that the Air-Pot system produces, far outweigh the initial investment.

- Air-Pot® grown plants are healthy plants and healthy plants sell quicker and for higher prices.
- Air-Pot® grown plants grow faster leading to faster turnover of stock, faster turnover of cash, and bigger profits.
- Air-Pot® grown plants are more resistant to disease, so there are less losses, and there is less expenditure on fungicides and pesticides.
- Air-Pot® grown plants need repotting less frequently, meaning less labour costs.
- The Air-Pot system gives you more flexibility. Plants can stay in the Air-Pot® for an extra season rather than be sold off at a discounted price. Or you can pot up for a more valuable plant next season.
- Air-Pot® grown plants establish better when planted out, so there are no losses to replace and happy customers return to order more.



5300400	AIR POT NO.1 (0.8 GAL ORANGE)
5300402	AIR POT NO.3 (2.4 GAL YELLOW)
5300403	AIR POT NO.5 (3.3 GAL GREEN)
5300404	AIR POT NO.7 (5.4 GAL BLUE)
5300407	AIR POT- PROP
5300408	AIR POT BASE FOR 5 GALLON NURSERY
5300409	AIR POT WALL 100G/ 375L
5300410	AIR POT NO.12 (10.1 GAL BLACK)
5300406	AIR POT NO.15 (15 GALLON)
5300398	AIR POT SMALL FIXING 100PK
5300399	AIR POT LARGE FIXING 25PK

Box Quantities: Prop, 25/ box; No. 1, 25/ box; No. 3, 25/ box; No.5, 12/ box; No. 7, 12/box; No.12, 8/ box; No. 15, 8/ box



Chikamasa CO. is a family owned pruner and garden scissor company located in Osaka, Japan. Chikamasa scissors hand crafted in Japan are the highest quality garden scissor available to trimmers and pruners. If your product is grapes, herbs or any agriculture, you are need of an efficient harvest tool that will help prevent wrist aches and pain caused by conventional garden scissors. Chikamasa is designed with bonsai sculpting in mind. Chikamasa has developed the perfect scissor for specialty gardeners who work long hours with attention to detail.

100 years ago founder SHOJIRO WADA (grandfather of current president) followed the family business of manufacturing flower shears when he was 15 years old at Zaimokucho, Sakai, Osaka. The idea was to produce high quality products. Chikamasa has more than 80 types original shears and scissors for agriculture use, gardening, handicrafts and office works etc. They have been developing useful products for users. Their products are supported overwhelmingly by professionals and amateurs.



**Chikamasa B-220S**

Total Length: 130mm  
 Blade Length: 33mm  
 Weight: 42g  
 Blade: high-quality carbon steel  
 Grip: elastomer resin

**5300614 CHIKAMASA B-220S**  
**6 PER BOX**



**Chikamasa B-300**

Total Length: 157mm  
 Blade Length: 35mm  
 Weight: 47g  
 Blade: high-quality carbon steel  
 Grip: ABS

**5300600 CHIKAMASA B-300 CARBON STEEL**  
**6 PER BOX**



**Chikamasa B-300S**

Total Length: 157mm  
 Blade Length: 35mm  
 Weight: 47g  
 Blade: high-quality stainless steel  
 Grip: ABS

**5300601 CHIKAMASA B-300S STAINLESS STEEL**

## Chikamasa B-300SF

The Chikamasa B-300SF is yet another creation from Chikamasa Japan's quality craftsmanship. Stainless steel coated with sap resistant Fluorine, the B300SF cuts with ease and efficacy.

Total Length: 157mm

Blade Length: 35mm

Weight: 48g

Blade: high-quality stainless steel / high-quality fluorine coating

Grip: ABS

**5300602                    CHIKAMASA B-300SF SS/ FLUORINE COATING**

**6 PER BOX**



## Chikamasa B-500H

Total Length: 155mm

Blade Length: 35mm

Weight: 42g

Blade: high-quality carbon steel

Grip: ABS

**5300603                    CHIKAMASA B-500H CARBON STEEL**

**6 PER BOX**



## Chikamasa B-500S

Total Length: 155mm

Blade Length: 35mm

Weight: 42g

Blade: high-quality stainless steel

Grip: elastomer

**5300604                    CHIKAMASA B-500S STAINLESS STEEL**

**6 PER BOX**



## Chikamasa B-500SL

Model B-500SL has a blade angled, which makes them convenient for working at high places.

Total Length: 155mm

Blade Length: 35mm

Weight: 42g

Blade: high-quality stainless steel

Grip: elastomer

**5300605                    CHIKAMASA B-500SL STAINLESS STEEL**

**6 PER BOX**







### Chikamasa B-500SF

Total Length: 157mm

Blade Length: 35mm

Weight: 47g

Blade: high-quality stainless steel / fluorine coating

Grip: ABS

**5300606**

**CHIKAMASA B-500SF SS/ FLUORINE COATING**

**6 PER BOX**



### Chikamasa B-500SLF

Total Length: 155mm

Blade Length: 35mm

Weight: 42g

Blade: high-quality stainless steel / fluorine coating

Grip: elastomer

**5300607**

**CHIKAMASA B-500SLF SS/ FLUORINE COATING**

**6 PER BOX**



### Chikamasa B-500SKF

Total Length: 155mm

Blade Length: 35mm

Weight: 42g

Blade: high-quality stainless steel / fluorine coating

Grip: elastomer

**5300608**

**CHIKAMASA B-500SKF ANTI-BACTERIAL**

**6 PER BOX**



### Chikamasa JP-2000

JP-2000 are gardening shears for wide range of uses. The jagged blade allows you to cut branches without sliding

Total Length: 195mm

Blade Length: 45mm

Weight: 150g

Blade: high-quality carbon steel

Grip: PA+GF, elastomer

**5300616**

**CHIKAMASA JP-2000**

**6 PER BOX**



### **Chikamasa CRI-160SP**

Total Length: 160mm  
Blade Length: 38mm  
Weight: 45g  
Blade: high-quality stainless steel  
Handle: elastomer/ CAP: PP

**5300617**

**CHIKAMASA CRI-160SP STNLS STEEL**



### **Chikamasa CRI-360SFV**

If you are looking for the perfect snip that will last you a life-time, consider the CRI360 for a sharp tip to pick a flower for your loved one or some fresh herbs from your garden. Equipped with a unique wire cutting groove to snip thin plant wire without damaging the scissors. The CRI360 series are ideal for wet trimming, cloning, de-leafing, as well as general harvest plant preparation.

Total Length: 160mm  
Blade Length: 45mm  
Weight: 60g  
Blade: high-quality stainless steel / high-quality fluorine coating

Handle: PVC / CAP : PP

**5300612**

**CHIKAMASA CRI-360SFV STNLS STEEL/ FLOURINE COATING**

**6 PER BOX**



### **Chikamasa CRI-550SRF**

With ergonomic comfort of the curved Chikamasa scissor, the NEW CRI550! Made from the highest quality stainless steel, this scissor offers a true curved blade! The CRI550 from Chikamasa features the innovative Fluorine Coating, a sap resistant layer, which prevents buildup on the scissors blades. This means longer use of scissors between cleanings, to allow for more proficiency for even the most elite user.

Total Length: 157mm  
Blade Length: 35mm  
Weight: 47g  
Blade: high-quality stainless steel / fluorine coating

Grip: ABS

**5300611**

**CHIKAMASA CRI-550SRF STNLS STEEL WIRE CUTTER**

**6 PER BOX**



### **Chikamasa T-550**

Total Length: 185mm  
Blade Length: 48mm  
Weight: 105g  
Blade: high-quality carbon steel

Grip: steel plate / non slip coating

**5300609**

**CHIKAMASA T-550 CARBON STEEL**

**6 PER BOX**

## Chikamasa T-550S

These unique and durable torsion spring loaded Chikamasa trim scissors boast a sharper point, as well as a lasting stainless steel blades. Equipped with a medium tension torsion spring, the T550 will outlast and out-perform cheaper traditional spring loaded trim scissors.

Total Length: 185mm

Blade Length: 48mm

Weight: 105g

Blade: high-quality stainless steel

Grip: steel plate / non slip coating

**5300613**

**CHIKAMASA T550S- STAINLESS STEEL**



## Chikamasa T-710GDX

Total Length: 220mm

Blade Length: 63mm

Weight: 145g

Blade: high-quality carbon steel / hard-chrome plating

Grip: steel plate / non slip coating

**5300618**

**CHIKAMASA T-710GDX**

**6 PER BOX**



## Chikamasa PSA-G8

Total Length: 210mm

Blade Length: 52mm

Weight: 255g

Blade: high-quality carbon steel upper blade / high-quality fluorine coating under blade / hard-chrome plating

Handle: die-cast aluminium

**5300610**

**CHIKAMASA PSA-G8 CARBON STEEL FLOURINE**



## Chikamasa PST-8

PST-8 blade makes sharp cut and the reinforcing rib is given near the rivet to enhance strength

Total Length: 190mm

Blade Length: 45mm

Weight: 150g

Blade: high-quality carbon steel

Handle: steel plate / non slip coating

**5300615**

**CHIKAMASA PST-8**

**6 PER BOX**





# Hydroponics & Irrigation

## Tropf Blumat (Drip Irrigation Systems)

The Tropf-Blumat (Drip-Blumat) is a sensor that supplies plants with drips of water via thin tubing. As the soil dries its natural suction power triggers the opening of the Tropf Blumat allowing the water to flow. When the soil is sufficiently moist, the Tropf Blumat automatically stops. The system functions fully automatically.

Every plant, every container or group of plants requires at least 1 Tropf-Blumat adjusted to the individual needs of the plant. Larger containers or surfaces require longer or more than one sensor. All Tropf-Blumats are connected using one supply tube, this allows for flexibility in the layout and is changeable at any time.

- Automatically waters individual plants and only when needed
- Connects directly to your hose tap or rain barrel
- Easily installed with a pair of scissors
- Inexpensive and works for years
- Ideal for small or larger grow areas

- |         |                                  |
|---------|----------------------------------|
| 2060210 | TROPF-BLUMAT                     |
| 2060211 | TROPF BLUMAT MAXI                |
| 2060215 | BLUMAT JR.                       |
| 2060216 | BLUMAT JR. 3 PACK                |
| 2060222 | TROPF BLUMAT 10M SET             |
| 2060225 | TROPF-BLUMAT PRESSURE REDUCER    |
| 2060230 | TROPF-BLUMAT END PIECE           |
| 2060249 | TROPF BLUMAT 8MM F/L TEE         |
| 2060250 | TROPF-BLUMAT TEE (3PKG)          |
| 2060251 | TROPF-BLUMAT HOSE COUPLER (3PKG) |
| 2060252 | TROPF-BLUMAT ELBOW (3PKG)        |
| 2060257 | TROPF BLUMAT SUPPORTS (10PKG)    |
| 2060258 | TROPF BLUMAT THRU-HULL           |
| 2060259 | TROPF BLUMAT STOPPER BULK        |
| 2060220 | PATIO AND BALCONY SET            |



## Blumat Digital Moisture Meter

The Blumat Digital is a professional moisture sensor to accurately determine soil pressure, which shows you how thirsty your plants are at the press of a button. In this way, sensitive plants can be given just the right amount of water. Also helpful in successfully overwintering your pot plants. Plants need less water at this time and Blumat Digital helps to prevent damaging overwatering.

### HOW BLUMAT-DIGITAL WORKS:

As roots absorb water from the soil, soil moisture tension increases. Water moves out through the ceramic tip, creating a sub-pressure that is displayed on the LCD. The ability of the soil to withdraw water from the tensiometer increases continuously as soil dries (high value). Irrigation reverses this action. Sub-pressure in the tensiometer draws water back from the soil into the sensor (low value).

The Blumat Digital Sensor functions in the same way as the Tropf-Blumat, however, it does not control watering, but rather serves as a device for measuring the levels of moisture and/ or dryness. It operates using the tensiometer principle and indicates the amount of force necessary for a plant to absorb water, by dryness the values will be correspondingly higher. The sensor should remain stationary for some time for observation purposes.

This method of measurement allows for very accurate recognition of the level of moisture near the roots and therefore, a more exact application of water - whether by hand in large container plantings, for example, for the over-wintering of plants, where it is often necessary to keep a moderate moisture level, or also for use in the summer for monitoring and adjusting the Blumat system. Assessing the moisture level in large containers is no longer a matter of guesswork and experience, but rather of concrete numerical data.

3090302

BLUMAT DIGITAL MOISTURE METER

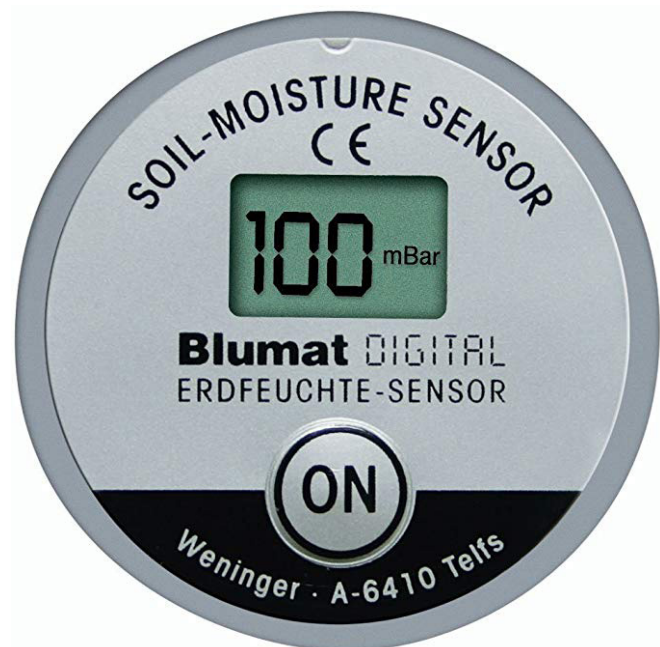

A dense, vibrant green background of various tropical leaves, including banana leaves and other broad-leafed plants, creating a lush, natural texture.

# Testing Meters & Solutions

## Bumper Up

Bumper Up works by raising the pH of plantfood solutions.

4230041 BUMPER UP 1L

4230042 BUMPER UP 4L

Case Quantity: 1L, 12/case; 4L, 4/case



## Bumper Down

Bumper Down helps your plants absorb nutrients by lowering the pH of the water around your plant's roots.

4230021 BUMPER DOWN 1L

4230022 BUMPER DOWN 4L

Case Quantity: 1L, 12/case; 4L, 4/case



## Calibration Solutions

CannaMax are accurate laboratory calibration standard solutions used to calibrate pH and PPM/EC meters. Black light proof bottle keeps CannaMax solutions fresh and ready when you need them.

3120010 REF. SOLUTION 1000PPM 500ML

3120020 REF. SOLUTION PH7 500ML

3120030 REF. SOLUTION PH4 500ML

Case Quantity: 500mL, 12/case







## Bluelab Conductivity Pen (EC or PPM)

The Bluelab Conductivity Pen simply tells you that your plants have the right amount of nutrient in your solution and lets you know if adjustments are needed. To feed plants well, we need to know what we're feeding them. Start with a quality nutrient.

Measuring the conductivity every day is the best way to avoid over-diluting or over-concentrating your nutrient solution. Completely change the reservoir solution every 7 days. Top up the nutrient level between changes - so your plants always have the right amount of food.

The Bluelab Conductivity Pen also measures the temperature of the solution, as root health is vital to the success of a crop. Temperature affects the growth rate and structure of a plant so a solution temperature of 18 - 22°C or 65 - 72°F is recommended.

### Features:

- Measures conductivity and temperature
- Selectable units for conductivity and temperature
- Backlit LCD display
- Calibration optional
- Successful EC or ppm calibration indicator
- Hold reading function
- Low battery indicator
- Fully waterproof
- Auto off function
- Automatic temperature compensation
- 1 x AAA alkaline battery included

3110495

BLUELAB METER PPM PEN

## Bluelab pH Pen

The Bluelab Conductivity Pen simply tells you that your plants have the right amount of nutrient in your solution and lets you know if adjustments are needed. To feed plants well, we need to know what we're feeding them. Start with a quality nutrient.

Measuring the conductivity every day is the best way to avoid over-diluting or over-concentrating your nutrient solution. Completely change the reservoir solution every 7 days. Top up the nutrient level between changes - so your plants always have the right amount of food.

The Bluelab Conductivity Pen also measures the temperature of the solution, as root health is vital to the success of a crop. Temperature affects the growth rate and structure of a plant so a solution temperature of 18 - 22 °C or 65 - 72 °F is recommended.

### Features:

- Measures conductivity and temperature
- Selectable units for conductivity and temperature
- Backlit LCD display
- Calibration optional
- Successful EC or ppm calibration indicator
- Hold reading function
- Low battery indicator
- Fully waterproof
- Auto off function
- Automatic temperature compensation
- 1 x AAA alkaline battery included

3110496

BLUELAB METER PH PEN



## Bluelab Soil pH Pen

The Bluelab Soil pH Pen provides a pH and temperature reading of soils and media, so you know that the right nutrients will be made available to your plants.

In soils or growing media, pH strongly influences the availability of the microorganisms to plants in the soil. Now you can closely monitor and adjust the pH levels to optimize plant health and performance. It will also measure solutions too... Now isn't that Handy!

Features:

- Direct pH and temperature measurements into soils/media
- Backlit LCD display
- Hold reading function
- Integrated storage cap/dibber
- Successful pH calibration indicator
- Low battery indicator
- Fully waterproof
- Auto off function
- Selectable units for temperature
- Automatic temperature compensation
- 1 x AAA alkaline battery included

3110516

BLUELAB SOIL PH PEN



## Bluelab Guardian Monitor Connect

The Bluelab Guardian Monitor Connect is not only a constant indicator of the desired levels of pH, conductivity, and temperature of your nutrient solution, it also data logs these critical parameters to your computer for you.

It does not stop there. You can access the data via the cloud from a remote mobile device or computer to check for extreme variances to ensure these critical parameters are hitting the mark for crop success.

Just one Bluelab Connect Stick is required to receive wireless data from one or more Guardian Monitor connects. For remote or cloud access, the computer you are already data logging to will need permanent internet access.

### Features:

- Data logging capability (ONE Bluelab Connect Stick is required, sold separately)
- Free Bluelab Connect Software available online
- View data and current status remotely via Connect Mobile App (A computer with permanent internet access is required)
- 'Plant safe' green LEDs
- Large easy to read display
- No calibration required for conductivity and temperature
- Simple push button pH calibration
- Selectable values for conductivity and temperature
- Flashing high and low alarms
- Greater tolerance to RF /electronic interference provided
- Water resistant design
- International power supply included
- Replaceable double junction pH probe included
- Adjustable display brightness
- Non-volatile memory
- Compatible with Bluelab Connect Stick and Bluelab Connect Range Extender

**3110517**            **BLUELAB GUARDIAN MONITOR CONNECT**

**3110522**            **BLUELAB GUARDIAN POWER SUPPLY**



## Bluelab pH Controller Connect

Sometimes the more you know, the better. And when it comes to managing the pH of your nutrient solution, exact knowledge makes a world of difference.

Our clever pH controller Connect automatically monitors and fine-tunes the pH levels for you. Set your pH parameters and let the Bluelab pH Controller keep you on point dosing in your set direction pH up or down solution, not both. You simply set it, and forget. The pH is taken care of. So you can relax...

Our Bluelab pH Controller Connect constantly monitors and fine-tunes the pH levels for you. But more than that, it wirelessly data logs to your computer too, putting continuous information at your fingertips in real time. Use the data to make system changes faster for the ultimate crop. You can also change the settings from your PC. Clever stuff...24 hour a day monitoring and control of your pH so you know your plants are able to get the most nutrient uptake.

Features:

- ONE Bluelab Connect Stick is required, sold separately
- Local and Cloud data logging capability (download free Bluelab Connect Software online)
- Adjustment of control settings from a local PC via Bluelab Connect Software
- Option to view data and current status remotely via Connect Mobile App
- Automatic control and monitoring of system pH with reservoirs up to 200 US gal / 760 L
- Plant-safe green backlit LCD with adjustable brightness
- Large, easy to read displays
- Easy to navigate menu to program and adjust settings
- Simple push-button pH calibration with on-screen guide
- Flashing high / low alarm with control lockouts
- Dosing lockouts to protect from over-dosing
- Auto resume dosing on restart after power loss
- Water resistant, wall mount design
- 13 foot (4 meters) acid/alkali resistant dosing tube supplied
- Use with either undiluted Bluelab pH Up or Down
- International power supply
- Replaceable double junction pH probe
- Separate Bluelab Temperature Probe (for pH ATC)
- Replaceable peristaltic pump and tubes

3110519

BLUELAB PH CONTROLLER CONNECT



## Connect Accessories

### Bluelab Connect 2 Stick

Improve crop performance and reduce errors with the power of data and remote monitoring - stay connected to your crop, wherever you are. Connect Stick 2 receives wireless data from Bluelab Connect devices for:

- 24/7 connection to facility and crops
- Easy device management in the Bluelab Connect software
- Local data logging with cloud data logging backup
- Remote monitoring through the Bluelab Connect mobile app.

If you're always connected, you're always improving. Send wireless data to and from Connect device:

- Up to 100m/330ft within the growing environment
- Up to 400m/1312ft in open space.

Connect Stick 2 has 2x the wireless range compared to Connect Stick 1, and pair with Connect Range Extender 2 to increase wireless by 4x.

For use with:

- Bluelab® Guardian Monitor Connect™
- Bluelab® Guardian Monitor Connect™ Inline
- Bluelab® pH Controller Connect™
- Bluelab® Pro Controller Connect™
- Bluelab® Connect™ Range Extender 1 & 2

Only one Connect™ Stick 2 required to receive wireless data from up to 50 Connect™ devices.

Features:

- Receive wireless data from Bluelab Connect devices to your computer and smartphone
- View data and device status remotely. (A computer with permanent internet access is required)
- View data and get alerts on your smartphone or tablet
- Send wireless data up to 100m/330ft (typical indoor)\*
- Send wireless data up to 400m/1312ft in open space (line-of-sight)\*
- Works with Connect Range Extenders for extra-long range (700m/2300ft)
- Free Bluelab® Connect™ Software available from [bluelab.com](http://bluelab.com)
- Receive data from up to 50 Connect devices with one Connect Stick
- Wireless range can be reduced by walls and plant canopies



3110523

BLUELAB CONNECT 2 STICK

## Bluelab Connect Range Extender 2

Send Bluelab Connect wireless data further in large growing facilities and environments.

Simply plug the Bluelab Connect™ Range Extender 2 into a power supply between Bluelab Connect™ devices and Bluelab Connect™ Stick 1 or 2 to increase the wireless signal range.

Increase the wireless range between Bluelab Connect™ devices and the computer by up to 4x when Connect™ Range Extender 2 is paired with Connect™ Stick 2.

For extra-long distances, use multiple Bluelab Connect™ Range Extender 2s - up to 700m/2300ft.

For use with:

- Bluelab® Guardian Monitor Connect™
- Bluelab® Guardian Monitor Connect™ Inline
- Bluelab® pH Controller Connect™
- Bluelab® Pro Controller Connect™
- Bluelab® Connect™ Stick 2

Features:

- Boost the wireless range of your Connect devices
- Increase Connect wireless range by a further 100m/330ft (typical indoor)\*
- Link multiple Range Extenders for extra-long range (up to 700m/2300ft)\*
- Water resistant for the growing environment
- International power supply included
- Wireless range can be affected by walls and plant canopies

3110524

BLUELAB RANGE EXTENDER 2 CONNECT



## Bluelab pH Controller

We know pH levels can be the difference between a great crop and well, a disaster. Measuring and adjusting nutrient solution levels constantly can be time-consuming. And let's face it; you have better things to do.

Our clever pH controller automatically monitors and fine-tunes the pH levels for you. Set your pH parameters and let the Bluelab pH Controller keep you on point dosing in your set direction pH up or down solution, not both. You simply set it, and forget. The pH is taken care of. So you can relax...

### Features:

- Automatic control and monitoring of system pH with reservoirs up to 200 US gal / 760 L
- Plant-safe green backlit LCD with adjustable brightness
- Large, easy to read displays
- Easy to navigate menu to program and adjust settings
- Simple push-button pH calibration with on screen guide
- Flashing high / low alarm with control lockouts
- Dosing lockouts to protect from over-dosing
- Auto resume dosing on restart after power loss
- Water resistant, wall mount design
- 13 foot (4 meters) acid/alkali resistant dosing tube supplied
- Use with either undiluted Bluelab pH Up or Down
- International power supply
- Replaceable double junction pH probe
- Separate Bluelab Temperature Probe (for pH ATC)
- Replaceable peristaltic pump and tubes

3110518

BLUELAB PH CONTROLLER





## Bluelab Pro Combo Meter

It's all you need for simple and reliable crop management.

The Bluelab Combo Meter is a portable pH, conductivity and temperature meter all in one. If you are experiencing problems with yellow leaves, or slow stunted growth, the Bluelab Combo Meter will soon tell you if each parameter is within the plants requirements. Adjustments can be quickly made to get your crop back on track.

The Bluelab Combo Meter has two probes, a Bluelab pH Probe and a Bluelab Conductivity/Temperature Probe. When taking a reading, simply place them into the solution and the selected reading is displayed on screen. As the Bluelab Combo Meter is portable and does not require a power supply to operate, it can be used anywhere, anytime to help you manage your crops' daily nutrient requirements.

Calibration of the pH probe is simple as instructions are supplied on the back of the meter and the easy push button method makes this one of the simplest meters to use.

The pH probe is replaceable so you can use this meter for years to come. The conductivity/temperature probe does not require calibration as this is locked in during manufacturing.

### Features:

- Measures pH, conductivity/nutrient (EC, CF, ppm 500 and ppm 700) and temperature (°C, °F)
- Lightweight and portable
- Large easy to read display
- Simple push button pH calibration
- Successful pH calibration indicator
- No calibration required for conductivity and temperature
- Replaceable double junction pH probe included
- Over range and under range indicators
- Low battery indicator
- 2 x AAA alkaline batteries included
- Auto off function

3110506

BLUELAB PRO COMBO METER



## Bluelab Quick Dip/ Truncheon Stick

The world's favourite nutrient meter! With its super tough, high quality, fully waterproof design, no calibration required, daylight readable blue LED's and no on/off buttons to worry about, the Bluelab Truncheon Nutrient Meter has proven itself as the world's favourite nutrient meter.

EC (0.2 – 3.6), CF (2 – 36) and ppm scales (TDS and 700 scale)

Fully waterproof

No calibration required

Auto sense on and off

No external switches or adjustable buttons

Battery life minimum 1 year (or shelf life of battery)

3110015

BLUELAB QUICK DIP/TRUNCHEON STICK



## Bluelab Probe Care Kit Conductivity

The instrument is only as accurate as the probe is clean. Accurate readings simplify crop management and provide improved growth.

Proper ppm/EC probe maintenance also ensures you maximize the life of the probe and instrument.

The probe surface is where the instrument takes the reading of the solution. If the probe face is dirty or contaminated, the readings may be inaccurate. Much like the windshield of a car, if it's dirty you can't see out! If the probe face is dirty, it cannot read the solution.

A tip... if the conductivity reads low, the probe needs cleaning.

-Features:

-Probe care instructions

-2x 20ml single-use Bluelab 2.77 EC Conductivity Standard Solution

-Plastic cup

-Bluelab Conductivity Probe Cleaner

-Bluelab Chamois (conductivity probe cleaning instrument)

3120016

BLUELAB PROBE CARE KIT- CONDUCTIVITY



## Bluelab Probe Care kit pH

The instrument is only as accurate as the probe is clean. Accurate readings simplify crop management and provide improved growth.

Probe cleaning and correctly storing pH probes ensures you get the most accurate readings possible and will maximize the life of a probe.

The probe surface is where the instrument takes the reading of the solution or soil/media. If the probe face is dirty or contaminated, the readings may be inaccurate. Much like the windshield of a car, if it's dirty you can't see out! If the probe face is dirty, it cannot read the solution or soil accurately.

pH probes specifically, should be kept wet at all times for optimal performance and life.

Features:

- Probe care instructions
- 20ml single-use Bluelab Solution Sachets, 2 each of: pH 7.0 & pH 4.0, KCl
- 3x plastic cups
- Bluelab pH Probe Cleaner
- Bluelab Toothbrush (pH probe cleaning instrument)

**3120017**      **BLUELAB PROBE CARE KIT-PH**



## Bluelab KCl Storage Solution

pH probes are sensitive glass instruments which age through everyday use. Add KCl solution to the cap of the pH pen/probe for storage, after use and hydrate in KCl solution monthly. Instructions are on the label of the bottle.

**3120021**      **BLUELAB KCl STORAGE SOLUTION 250ML**



## Bluelab 2.77EC Conductivity Solution

Bluelab® conductivity standard solutions are essential for use with all Bluelab® products.

Bluelab® Solutions are manufactured specifically for Bluelab® products and are referenced to high laboratory standards to ensure your Bluelab® products last longer and maintain accuracy.

**3120042**      **BLUELAB 2.77EC CONDUCTIVITY 500ML SOL**



## Bluelab pH7 Calibration Solution

pH 7.0 calibration solutions... a must in every grower's toolbox.

High quality solutions formulated for calibrating pH probes. Bluelab® calibration solutions are essential for use with all Bluelab® products.

Bluelab® Solutions are manufactured specifically for Bluelab® products and are referenced to high laboratory standards to ensure your Bluelab® products last longer and maintain accuracy.

**3120019**      **BLUELAB PH7 CALIBRATION SOL. 500ML**



## Bluelab pH4 Calibration Solution

pH 4.0 calibration solutions... a must in every grower's toolbox.

High quality solutions formulated for calibrating pH probes. Bluelab® calibration solutions are essential for use with all Bluelab® products.

Bluelab® Solutions are manufactured specifically for Bluelab products and are referenced to high laboratory standards to ensure your Bluelab® products last longer and maintain accuracy.

**3120018**      **BLUELAB PH4 CALIBRATION SOL. 500ML**





WATER TESTING INSTRUMENTS

## HM TDS-EZ Water Quality Tester Meter

### Features:

- Economy model that is ideal for end-users
- Highly efficient and accurate due to its advanced microprocessor technology
- Hold Function: saves measurements for convenient reading and recording
- Auto-off function: the meter shuts off automatically after 10 minutes of non-use to conserve batteries
- Measurement Range: 0-9990 ppm. From 0-999 ppm, the resolution is in increments of 1ppm. From 1000 to 9990 ppm, the resolution is in increments of 10ppm, indicated by a blinking 'x10' image
- Display: large and easy-to-read LCD screen
- Factory Calibrated: our meters are calibrated with a 342 ppm NaCl solution. Meters can be recalibrated with a mini-screwdriver
- Fun, translucent blue housing that's very strong and durable
- Includes a TDS chart sticker on the back of the meter that explains TDS values



3110034

HM METER TDS

## HM COM-80 EC/TDS/TEMP HYDRO TESTER

The COM-80 is easily the most advanced economically priced, reliable EC/TDS meter on the market. With its versatility and durability, it is ideal for testing applications such as hydroponics & gardening, pools & spas, aquariums & reef tanks, water ionizers, drinking water and more.

### FEATURES:

- Measures electrical conductivity (EC), total dissolved solids (TDS). Excellent for nutrient testing
- Four scales: EC:  $\mu\text{S}$ , mS; TDS: ppm, 0.5 (NaCl) & 0.7 (442™)
- Automatic Temperature Compensation (ATC)
- Water resistant
- Digital Calibration (push button) to any point within the meter's range
- Auto-off function, data-hold function and low-battery indicator
- Display: large and easy-to-read LCD screen includes simultaneous temperature reading.
- Factory Calibrated: The COM-80 meter is calibrated with a 1413  $\mu\text{S}$  solution.
- Includes a protective cap and batteries



3110492

HM COM-80 EC/TDS/TEMP HYDRO TESTER

## HM COM-100 EC/TDS METER

### Features:

Measures electrical conductivity (EC), total dissolved solids (TDS), salinity and temperature

UPGRADED: Four scales:  $\mu\text{S}$ , mS, ppm, ppt (mS and ppt are new)

Three different non-linear EC-to-TDS conversion factors (KCl, 442TM, NaCl)

Automatic Temperature Compensation (ATC) using three temperature coefficients

Waterproof housing (IP-67 rating)

Measurement Range: 0-9990  $\mu\text{S}$ ; 0-8560 ppm; 0-9.99 mS; 0-8.56 ppt

Digital Calibration (push button) to any point within the meter's range

Auto-off function, data-hold function and low-battery indicator

Display: large and easy-to-read LCD screen includes simultaneous temperature reading.

Replaceable Sensor (model SP-C1)

Factory Calibrated: The COM-100 meter is calibrated with a 1413  $\mu\text{S}$  solution. The meter can be recalibrated with digital calibration using the push buttons, rather than a screwdriver

Includes a cap, batteries and lanyard



3110030

HM METER EC/TDS/TEMP

## HM COM-300 PH/EC/TDS/TEMP METER

The COM-300 is a professional grade level pH/EC/TDS/Temp meter ideal for all water quality testing, hydroponics, water purification applications, wastewater regulation, aquaculture, colloidal silver, labs & scientific testing, pools & spas, ecology testing, boilers & cooling towers, water treatment and more.

### FEATURES:

-Measures Potential Hydrogen (pH), Electrical Conductivity (EC), Total Dissolved Solids (TDS), Salinity and Temperature

-Five scales: pH,  $\mu\text{S}$ , mS, ppm 0.5 (NaCl) Scale & 0.7 (442™) Scale

-Automatic Temperature Compensation (ATC) using three temperature coefficients

-Waterproof housing (IP-67 rating)

-Digital Calibration (push button) to any point within the meter's range

-Auto-off function, data-hold function and low-battery indicator

-Display: large and easy-to-read LCD screen includes simultaneous temperature reading

-Replaceable Sensor (model SP-C3)

-Factory Calibrated (pH/EC/TDS)

-Includes translucent cap, 2 (AAA) alkaline batteries, pH 4 & 7 calibration solutions, pH storage solution and lanyard



3110039

HM COM300 PH/EC/TDS/TEMP METER



## PH-80S: pH HydroTester Series

The PH-80S has proven to be the MOST reliable pH meter in its price range. It has become a favorite in such applications as hydroponics & gardening, pools & spas, aquariums & reef tanks, water ionizers, drinking water and more.

### FEATURES:

- Measures pH and Temperature
- One-touch automatic digital calibration
- Water resistant
- Simultaneous temperature display
- Large LCD display
- Automatic Temperature Compensation (ATC)
- Auto-off function, data-hold function and low-battery indicator
- Factory Calibrated: The PH-80 meter is factory calibration to pH 7.0.
- Includes a translucent cap, batteries, storage solution and pH 7.0 buffer (powder)

3110489

HM PH80S PH METER



## PH-200: Waterproof Professional Series pH/Temp Meter

The PH-200 is a professional grade pH/Temp meter ideal for all pH testing water. With its advanced microprocessor it provides highly accurate dependable readings in such applications as hydroponics, purification applications, wastewater regulation, aquaculture, colloidal silver, labs & scientific testing, pools & spas, ecology testing, boilers & cooling towers, water treatment, wine, coffee, and agriculture.

### FEATURES:

- Waterproof housing (IP-67 rating)
- Digital automatic calibration (one point), with digital fine tuning
- Automatic Temperature Compensation (ATC)
- Auto-off function, data-hold function and low-battery indicator
- Easy-to-read LCD screen with simultaneous temperature display
- Replaceable Sensor (model SP-P2)
- Factory Calibrated: The PH-200 meter is three-point checked and factory calibrated to pH 7.0.
- UPGRADED: Includes a translucent cap, 2 Triple A (AAA) batteries, lanyard, and pH 7.0 buffer (sachet)

3110031

HM PH/TEMP METER

## HM-500 HydroMaster: EC/TDS, pH, Temp Continuous Monitor

The HM-500 is the most versatile continuous monitor indicating EC/TDS, pH, and Temp providing accurate, stable readings the user can rely on. With its rechargeable battery this unit is portable or can be wall mounted.. To make is even more user friendly, it comes equipped with touch screen, high and low alarm set points, and recorded readings. It is ideal for hydroponics and other applications such as lab, pools, aquariums etc.

### FEATURES:

- Continuous pH/EC/TDS/Temp Monitor
- Rechargeable battery
- RF Resistant
- Portable/Wall Mount/Benchtop
- Data Storage: Up to 20 measurement readings
- Auto Shut-Off: After 5 minutes
- Alarm: Adjustable High & Low Set Point and on/off
- Display: LCD Touch-Type Screen with Auto Back lighting
- Probe: ABS with Platinum electrodes for EC / Single Junction pH Sensor

**3110491            HM HYDROMASTER PH/EC/TDS/TEMP MONITOR**

**3110493            HM REPLACEMENT EC/TDS PROBE**

**3110494            HM REPLACEMENT PH PROBE**







# Commercial Applications

## Commercial Cannabis

Rambridge is proud to be an industry leader in the development and planning of commercial cannabis production. With over 35 years of experience in all facets of commercial production, we are dedicated to providing high quality products and service. We work closely with horticultural experts to provide our customers with consultation, design and installation of commercial cannabis system

Our partners include leading experts in:

- Application Engineering
- Horticultural Lighting
- Environmental and Climate Control Solutions
- Ventilation / HVAC
- Benching Systems
- Cloning Solutions
- Growing Substrates
- Fertilizers and Additives
- Testing /Monitoring - PH / EC Solutions
- Composting
- Clean Entrances
- Professional Consultation
- Vertical Farming



## Brome Compost

### Composting Greenhouse Residues and Destroying Grow Waste

For greenhouses and for other types of agricultural producers, managing plant waste is a key issue that can result in added operating costs. This is even more true for licensed cannabis producers, who must ensure the complete destruction and denaturation of their plant waste in order to conform to government regulations. An industrial composting system, composed of a BROME composter, a shredder and other complimentary equipment, is both a simple and an effective solution for the management of harvested plant waste.

In greenhouse, composting offers several benefits.

Improve greenhouse grow waste disposal operations:

- All plant parts can be composted;
- Reduction of operating costs in comparison with other destruction methods;
- Better greenhouse production when finished compost is added to the substrate;
- Heat recovery from the composter for use in the greenhouse;
- Disposal of diseased plants through composting;
- Possible partnership with neighbors, allowing for the implementation of a resource pool for carbon or nitrogen feedstocks;
- Resale opportunity for surplus compost.

Conform to disposal standards

- Breakdown and denaturation of plant residues;
- Low cost compared to waste collection;
- Social acceptability of composting.

Easy operation

- Cleanliness;
- Minimal operating costs;
- Few workers needed;
- Simple installation;
- Better control over the composting process;
- Better control over odor management;
- Better control in all weather conditions : air temperature, precipitation, evaporation and the risk of unpleasant odors.

BROME Compost offers different composter models and complementary equipment as well as services to adapt to the composting needs of your greenhouse. For a growing facility, a made to measure composting system is a simple and efficient method to ensure the destruction and denaturing of plant residues in compliance of regulations.





## TECHNISCH BUREAU W.M. BRUINE DE BRUIN B.V.



### aluminium Growing Benches

All our growing benches are customer made and exist of an aluminium bench top, mounted on hot dip galvanised steel legs. The aluminium bench top can be supplied in an assembly model (which is very useful for export) or in a welding model. We can supply both designs with several side profiles and with any kind of bottom. Our benches are available in rolling or static design. Installation of our benches system belongs, of course, also to the possibilities.

#### Supports of the growing benches

The supports of our various models are made of hot dip galvanised steel tubing. As standard the supports are provided with adjustable cross rails. It is very easy to set the benches on waterlevel or under a small angle of inclination.

Also delivering of aluminium supports belongs to our skills. If desired we provide the supports with a special host-guide-system. It is also possible to deliver special supports for easy mounting in the "full ground".

#### Aluminium bench top of welding model

The aluminium bench top of the welding model will be supplied in parts of aprox. 6 -7 meters long and are mounted by means of couple joints. To give support for the bottom we weld special I-profiles in the bench top. As standard our rolling benches are provided of a anti-tipp construction. The more wider static tables are provided, as standard, with extra profiles to guaranty a stable construction. Standard side profiles of the welding model: 10,13,16 cm. Specifications on request.

#### Aluminium bench top of assembly model

The aluminium bench top of the assembly model exists of loose aluminium profiles, with a length of 6 - 7 meter, which have to be connected by screws right on the job. Owing to this the assembly model is very easy to transport and quite suitable for export. The I-profiles which give support to the bottom are mounted very easily by the customer. The rolling benches of this model are also provided, as standard, of an anti tipp construction. The more wider static tables are provided, as standard, with extra profiles to guaranty a

stable construction. Standard side profiles of the assembly model: 6, 9, 12, 18 cm. Specifications on request.

#### Cultivation bench bottoms

For each type of cultivation we provide your bench system with the correct bottom. Here is a selection of the bottoms on offer:

- ebb/flow bottoms in aluminium or plastic
- galvanised wire, extended metal bottoms
- tempex flat plate bottoms
- tempex bottoms with ventilation holes
- eternite plate bottoms
- plasticol, shinplay bottoms
- cultivation gutters
- aluminium bottoms

Various bottoms can be provided with heated top system and/or aluminium foil.



## HYGIENE PRODUCTS FOR GREENHOUSE HORTICULTURE

Greenhouse horticulture accounts for a significant share of the Dutch food industry. Cucumber and tomato growers are a well-known example. But within the greenhouse horticulture sector you will also find non-food growers such as roses and plant growers. Hygiene is crucial for both. Legally, these risks are controlled as much as possible by HACCP analyses, hygiene codes and/or overarching quality certificates. For a rose grower, the risk of spreading diseases is a reason to maintain a high level of hygiene.

## CONTAMINATION IN GREENHOUSE HORTICULTURE

Hygiene in greenhouse horticulture has been an important topic of discussion for many years. In addition, the trend of using as little crop protection as possible is continuing. The importance of hygiene is therefore becoming increasingly important. Protocols and training are of crucial importance here. Employees need to be aware of the risks and it is essential that they are given the means and working method to maintain the level of hygiene.

With over 40 years of experience, Elpress has built up the necessary experience in greenhouse horticulture. For every project, large or small, we increase our experience and share it to answer new hygiene issues.

## PERSONAL HYGIENE RISKS

In every sector of the food industry, personal hygiene is an important component. In addition, greenhouse horticulture is increasingly faced with the danger of bacteria, viruses and fungi that can cause disease in crops. Having a disease in the greenhouse has major commercial and therefore financial consequences. Fighting a disease in the greenhouse involves high costs. In most cases it is not even possible to fight a disease successfully. This means the end of your cultivation and is obviously disastrous for you as a business owner. However, hygiene protocols and hygiene locks are realistic solutions that actively contribute to the personal hygiene of employees.



### STRUCTURE

Light source	LED
LED Thermal Management	Passive or Water cooling
Estimated annual power consumption	59 MWh
Power peak	23 kW
Circuit breaker	40 A
Dimensions	8 m W x 6 m L x 3 m H
Required space	10 m W x 8 m L x 3.5 m H
Facility requirements	Insulation and utilities
Required utilities	Water, Sewage, Electricity, Internet
Rack material	Aluminium
Gutter material	PVC
Collector gutters material	Stainless steel

### VERA AUTOMATION

Interface	Touch screen panel and remote VPN access via HTML compatible device
Controls	Light levels, Light cycles, Mobile gutters, Irrigation, Nutrients, Dosing, Humidity, Temperature, CO <sup>2</sup>
Method	Fully automatic with recipes or set values manually
Data	Includes for example histograms of growing conditions and data export for example to ERP

### HARVEST AND IRRIGATION

Irrigation solutions	2 – 3 fertilizer solutions, pH agent, recirculating solution, control by EC and pH sensors
Capacity	5700 pots with 15 cm spacing
Growing time	27 – 35 days* *Varies depending on plant, variety and growing recipe

### GROWING CONDITIONS

PPFD	Set between 0 – 190 $\mu\text{mol}/\text{m}^2/\text{s}$
Day cycle	Day and night length can be adjusted
CO <sup>2</sup>	Adjustable 200 – 2000 ppm
Relative humidity	Adjustable 55 – 85 %
Growing temperature	Adjustable 15 – 30 °C



**Suitable for growing leafy greens, flowers and seedlings**

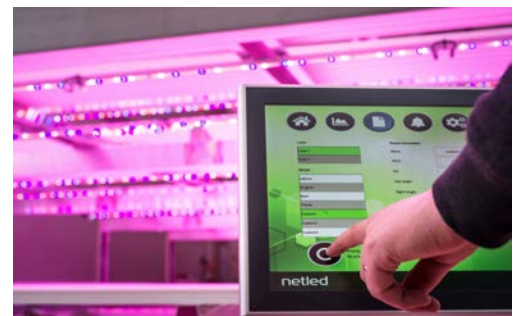

**MODULE STRUCTURE**

Light source	LED
LED Thermal Management	Passive
Annual power consumption	222 MWh (7300h and 6 layers)
Module dimensions	6 m W x 6 m L x 6,75 m H (6 layers)
Modularity	2-6 layers, 1-16 modules in series, any amount in parallel
Facility requirements	Insulation and utilities
Required utilities	Water, Sewage, Electricity, Internet
Frame material	Aluminium
Gutter material	PVC
Collector gutters material	Stainless steel

**VERA AUTOMATION**

Interface	Touch screen panel and remote VPN access via HTML compatible device
Controls	Light levels, Light cycles, Mobile gutters, Elevators, Irrigation, Nutrients, Dosing, Humidity, Temperature, Processing, CO <sup>2</sup>
Method	Fully automatic with recipes or set values manually
Data	Includes for example histograms of growing conditions and data export for example to ERP

**HARVEST AND IRRIGATION**

Irrigation solutions	2 – 3 fertilizer solutions, pH agent, recirculating solution, control by EC and pH sensors
Capacity	14 500 pots each module with 15 cm spacing
Growing cycle length	27 – 35 days* *Varies depending on plant, variety and growing recipe

**GROWING CONDITIONS**

PPFD	Set between 0 – 250 $\mu\text{mol}/\text{m}^2/\text{s}$
Day cycle	Day and night length can be adjusted
CO <sup>2</sup>	Adjustable 200 – 2000 ppm
Relative humidity	Adjustable 55 – 85 %
Growing temperature	Adjustable 15 – 30 °C



Suitable for growing leafy greens, flowers and seedlings



© 2019 Netled Oy. Designed and manufactured in Finland. All rights reserved. The information in this document is subject to change without notice. Datasheet is for distribution in EU countries only.

SPECIFICATIONS

Light Source	LED	
Spectrum	High blue to red ratio, extra high red to far red ratio	
PPF	1250 $\mu\text{mol/s}$	
Input Power	500 W	*Tolerance +/- 2%
Efficacy	2.5 $\mu\text{mol/J}$	
Input Voltage	120/277 VAC	
Input Frequency	60 Hz	
Inrush current	220 VAC: 4.7 A <sup>2</sup> s, 7.64 ms	
Fixture Dimensions	12.2" W x 8.3" L x 7.7" H	
Weight	17.9 lb	
Input connector	Wieland or free cable end	
Mounting Height	Trellis mounted	
Enclosure material	Tempered AR-glass, Powder coated steel enclosure	
Heat sink material	Anodized aluminum	
Thermal Management	Passive	
Dimming	0-10 V, PWM*	*on request
Dimming connector	M12	
Automation interface	Netled lighting automation	*Greenhouse automation compatible (0-10 V)
Beam angle	120°	
Lifetime (L90)	40 000 h	
Power Factor	99 %, 96 %	120 VAC, 277 VAC
Operating temperature	0-40 °C	
Storage temperature	-20-40 °C	
Ingress Protection Rating	IP55, suitable for wet locations	
Certifications	CE, RoHs	
C16 installation quantity	2, 2	120 VAC, 277 VAC
Warranty	3 Year Standard	

Suitable for indoor and greenhouse use



This luminaire is specifically designed for cultivation of Cannabis sativa L. based on top research data available for lighting effects on total cannabinoid yield.

Special features include high R:FR ratio and high blue content which is known to promote total cannabinoid yield up to 23%.

Coverage areas:

21 square foot at PPFD level of 700  $\mu\text{mol/s}^2\text{m}^2$  at 4 ft  
30 square foot at PPFD level of 500  $\mu\text{mol/s}^2\text{m}^2$  at 5 ft

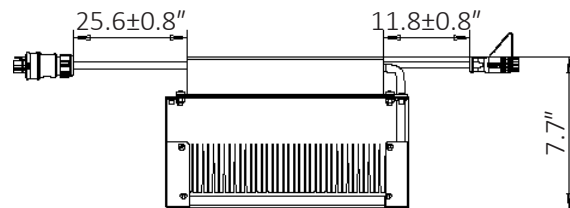
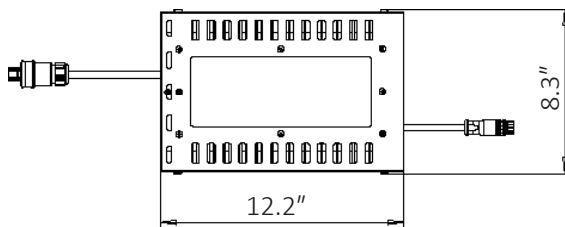

UL certification pending

© 2019 Netled Oy. Designed and manufactured in Finland. All rights reserved. The information in this document is subject to change without notice.



## SPECIFICATIONS

Light Source	LED	
Spectrum	Standard (S), Hybrid (H), White (W)	NOS2427V (S), NOH2427V (H), NOW2427V (W)
PPF	610, 580, 590 $\mu\text{mol/s}$	(S), (H), (W)
Input Power	240 W	Tolerance +/- 2%
Efficacy	2.54, 2.42, 2.46 $\mu\text{mol/J}$	(S), (H), (W)
Input Voltage	277/480 VAC	
Input Frequency	60 Hz	
Inrush current	480 VAC: 1.3 A <sup>2</sup> s, 1.43 ms	
Fixture Dimensions	11.7" W x 6.5" L x 3.2" H	
Weight	4.3 kg	
Input connector	Wieland RST20I3S S1 ZR1	
Mounting Height	Trellis mounted	
Enclosure material	Tempered AR-glass, Powder coated steel enclosure	
Heat sink material	Anodized aluminum	
Thermal Management	Passive	
Dimming	0 – 10V, PWM*	*on request
Dimming connector	M8	
Automation interface	Netled lighting automation	Greenhouse automation compatible (0-10 V)
Beam angle	80 °	
Lifetime (L90)	40 000 h	
Power Factor	96 %	277 VAC
Operating temperature	0 – 40 °C	
Storage temperature	-20 – 40 °C	
Ingress Protection Rating	IP55, suitable for wet locations	
Certifications	CE, RoHs, cETLus	
C16 Installation quantity	11, 4	277 VAC, 480 VAC

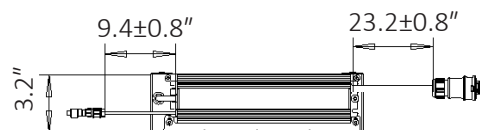
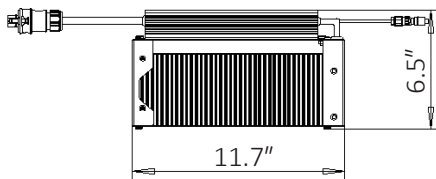
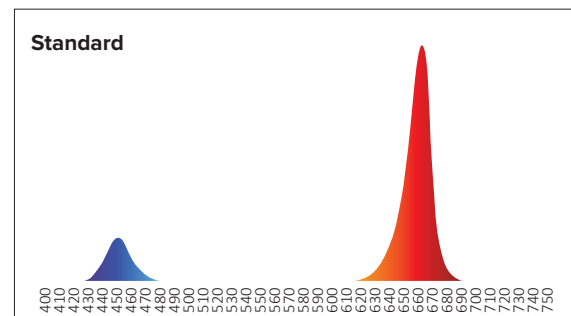
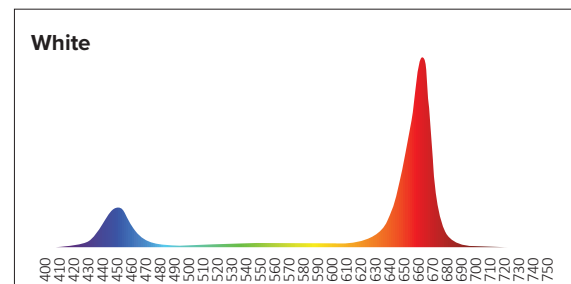
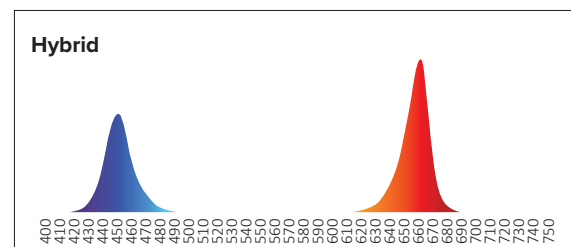

© 2019 Netled Oy. Designed and manufactured in Finland. All rights reserved. The information in this document is subject to change without notice.

Pipp Horticulture is the leading provider of movable vertical racking systems that maximize cultivation space.

With 40 years of experience serving the nation's top retailers, PIPP has engineered lower-cost solutions that can exponentially grow your production without adding an inch to your footprint. Double or triple your canopy by maximizing your cubic grow space with more efficient workflow. Their mobile multi-level rack and tray system is the most cost-effective investment you can make.

- NSF Certified
- Efficient
- Easy to Clean
- Lightweight
- ADA & Seismic Compliant
- Sustainable
- Safe & Durable
- Includes Full Design & Installation Services





Wachsen carts and racks are a masterpiece of engineering and manufacturing. They are designed in Canada and manufactured specifically for cannabis producers. Every feature, every material is engineered to give ultimate performance. With its unsurpassed reliability, Wachsen carts are built to last. Wachsen carts are backed with a lifetime warranty to ensure a high return on investment. Increase your efficiency with the best carts out there; Wachsen Professional Cannabis racks and carts.

Wachsen carts are made from 304 food grade stainless steel and treated with an electropolishing process for improved corrosion and abrasion resistance. This same process also makes our carts easy for cleaning and sanitizing. As Wachsen carts are built for commercial cannabis growers, they come standard with large, sealed bearing swivel casters for easy movement and hitch & pin brackets for trolley and automated system transport.

- No stagnant water after washing; all parts are built with drain angles
- Full stainless steel 304 construction; Food grade stainless steel and treated with an electropolishing process for improved corrosion and abrasion resistance
- 5" Sealed bearing casters – Front wheels swivel and lock
- Sealed poles prevent dirt and microbial build up
- Polished welds
- Reinforced corners
- Tow bar and tow pin, towable carts
- "Cart washer" friendly
- Limited lifetime warranty



## Custom Lighting Layouts

When considering supplemental lighting for your greenhouse operation, it is important to evaluate the following four factors:

1. Quantity (light intensity)
2. Duration
3. Quality (spectrum)
4. Distribution (uniformity)

When light is insufficient, it could hinder crop development and yields. Find out how much light is needed, how to measure existing light levels and the amount of light missing from your operation. Start your FREE personalized lighting layout today!

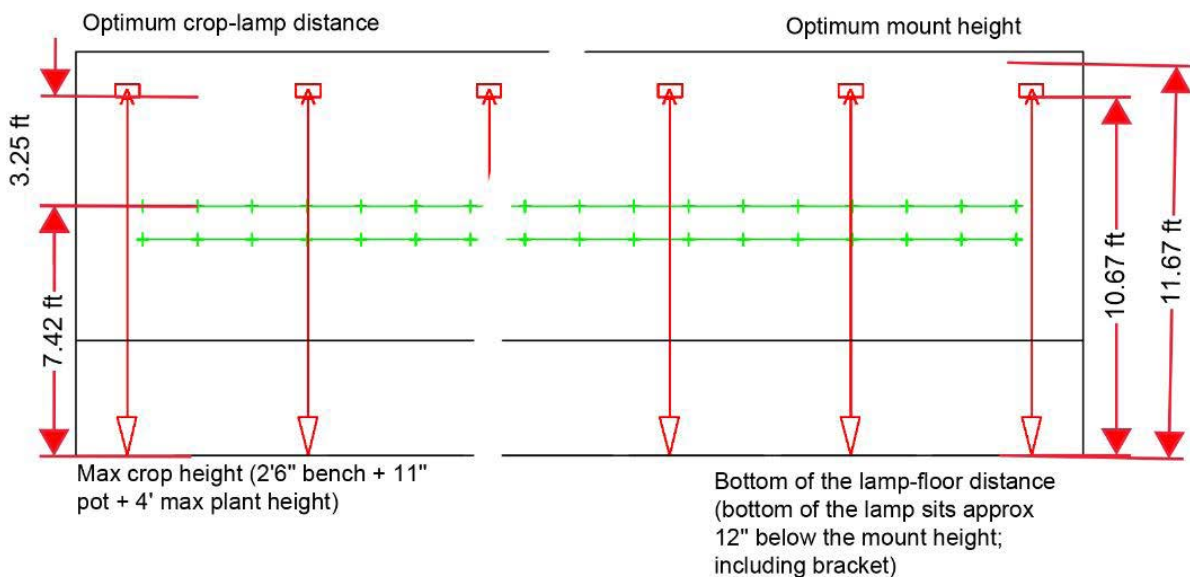
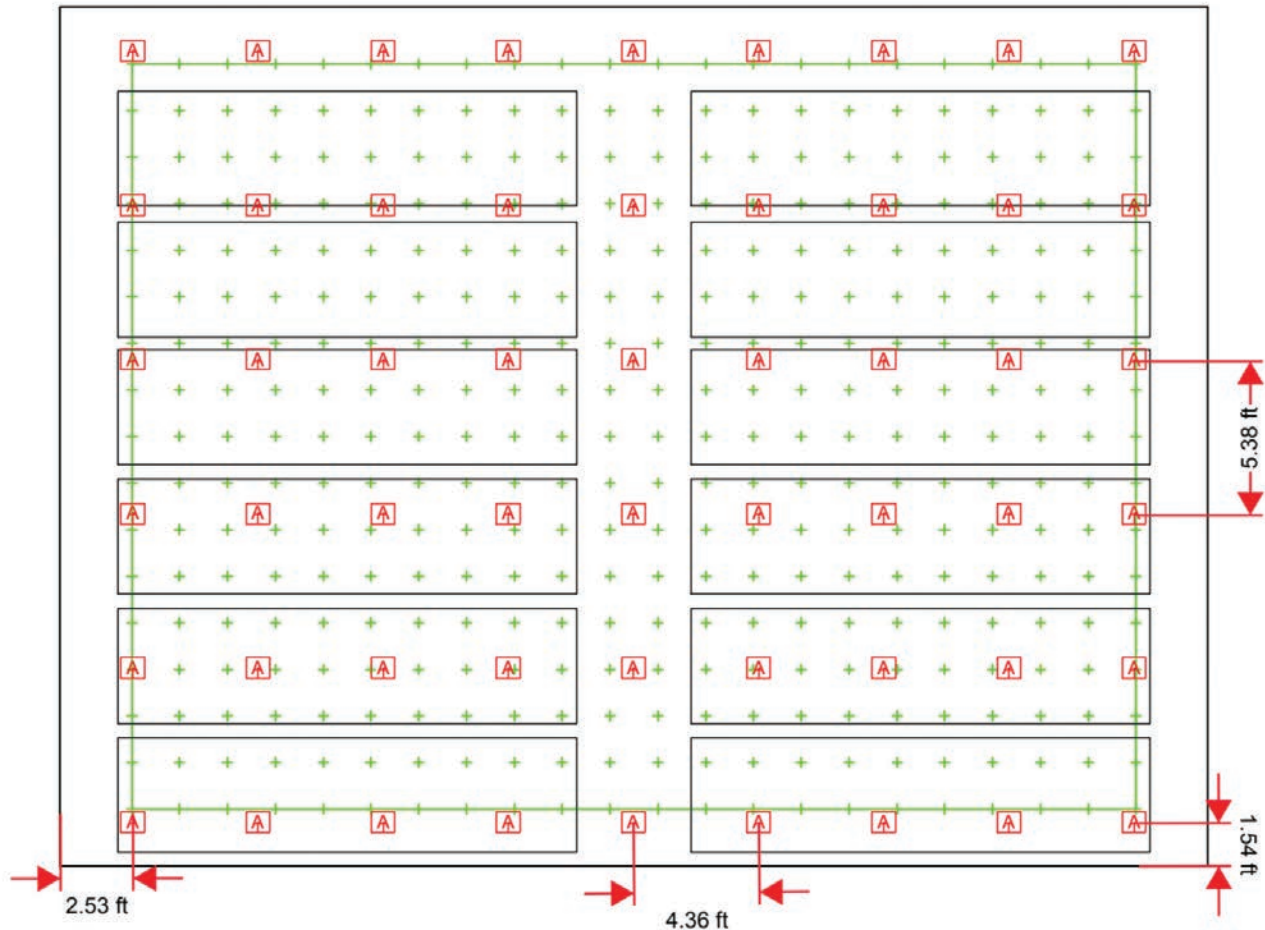

Dehumidifier placement is crucial to the efficient performance of your grow space.

It's all about creating predictable conditions, which are achieved by being intentional and specific about the placement and capabilities of your equipment.

Whether one unit is getting the job done, or you're up to 15 dehumidifiers and counting, take these tips into account so you can maximize predictability, efficiency, and growth.

- **Even Distribution**
- **Maximize Airflow**
- **Remote Control**
- **Placement Options**
  - Suspended
  - Freestanding
  - Ducted
- **A Helping Hand with Installation**



## SPECIFICATIONS

<b>Capacity<sup>(1)</sup> (water removal)</b>	70 ppd	
<b>Energy factor<sup>(1)</sup> (efficiency)</b>	2.1 L/kWh (4.4 pints/kWh)	
<b>Voltage, Phase, Frequency</b>	120VAC, 1 Phase, 60 Hz	
<b>Current draw<sup>(1)</sup></b>	5.8 Amps	
<b>Power (Watts)<sup>(1)</sup></b>	645 Watts	
<b>Noise</b>	53 dBA ducted	58 dBA unducted
<b>Dimensions: (cabinet only)<sup>(2)</sup></b>	Width: 12½" Height: 12½" Length: 25"	
<b>Weight</b>	56 lbs.	
<b>Inlet air operating conditions during:</b>		
<b>Dehumidification:</b>	50°F–104°F, 40°F dew point min.	
<b>Ventilation:</b>	40°F–140°F, 0%–99%RH (non-condensing)	

<sup>(1)</sup>Rated capacity and energy factor test done and current draw measured in accordance with AHAM DH-1 2008 at 80°F/60% RH inlet air at 0.0 ESP. <sup>(2)</sup>Height does not include adjustable feet. The width excludes the filter doors and length excludes the duct collars.

## FEATURES

<b>Control<sup>(3)</sup></b>	Built-in digital control with display
<b>Control mounting option</b>	Front mount only
<b>Air discharge orientation</b>	End of cabinet only
<b>Inlet/Outlet duct collars</b>	8"
<b>Backdraft damper at outlet</b>	No
<b>Filter</b>	MERV 11 disposable
<b>Refrigerant</b>	R410A
<b>Coil type</b>	Corrosion resistant aluminum
<b>8' Power cord</b>	Plug type
<b>Discharge air temperature rise</b>	10°F–30°F
<b>Drain connection</b>	¾" MNPT Threaded
<b>Warranty</b>	5 Years on all parts including refrigeration system

<sup>(3)</sup>Built-in automatic control capable to be set up for dehumidification and ventilation or zoning.

## INCLUDED ITEMS

<b>Drain fitting</b>	¾" MPT x ¾" barbed
<b>10 ft. Drain tubing</b>	¾" ID
<b>Duct collars</b>	8" Round
<b>Manual</b>	Installation instructions



## PRINCIPLE OF OPERATION

The Anden Model A70 Dehumidifier is designed to dehumidify the air coming into the unit by passing the incoming air over an evaporator coil to drop the air temperature below the dew point of the air. Moisture is removed from the air and drained out of the unit to a common floor or waste drain. The air is then reheated in the condenser coil and exits the unit.

Dehumidification occurs until the set point is reached, then shuts off until periodic sampling determines a need for operation.

## APPLICATION

The Anden Model A70 Dehumidifier is the perfect solution for the precise management of humidity required in an indoor growing environment.

## CIRCULATION

The Model A70 can also be programmed to circulate air within a grow facility. Proper air flow carries moisture away from the plants, helping to prevent fungus, disease and plant pests from damaging the crop. Circulating the air also maximizes the application of CO<sub>2</sub> in the grow facility.

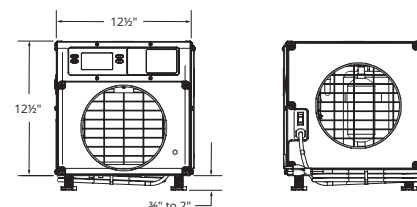
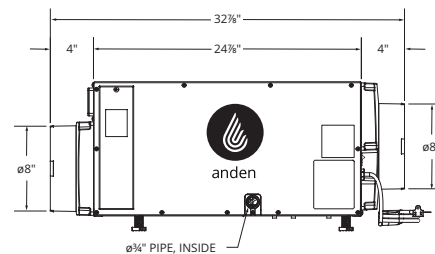

## SPECIFICATIONS

Model	A95 (ducted)	A95F (movable, with casters)
Capacity <sup>(1)</sup> (water removal)	95 ppd	
Energy factor <sup>(1)</sup> (efficiency)	2.1 L/kWh (4.4 pints/kWh)	
Voltage, Phase, Frequency	120VAC, 1 Phase, 60 Hz	
Current draw <sup>(1)</sup>	8.0 Amps	
Power (Watts) <sup>(1)</sup>	905 Watts	
Noise	54 dBA ducted	60 dBA
Dimensions: (cabinet only) <sup>(2)</sup>	Width:	12½"   12½"
	Height:	14½"   14½" cabinet 17½" with casters
	Length:	27½"   27½"
Weight	70 lbs.	
<b>Inlet air operating conditions during:</b>		
Dehumidification:	50°F–104°F, 40°F dew point min.	
Ventilation:	40°F–140°F, 0%–99% RH (non-condensing)	

<sup>(1)</sup>Rated capacity and energy factor test done and current draw measured in accordance with AHAM DH-1 2008 at 80°F/60% RH inlet air at 0.0 ESP. <sup>(2)</sup>Height does not include adjustable feet. The width excludes the filter doors and length excludes the duct collars.

## FEATURES

Model	A95 (ducted)	A95F (movable, with casters)
Control <sup>(3)</sup>	Built-in digital control with display	
Control mounting option	Field interchangeable from top to front	Top only
Cabinet insulation	½" EPS	
Air discharge orientation	Top or end	End
Inlet/Outlet duct collars	10" dia.	N/A
Backdraft damper at outlet	Included	N/A
Filter	MERV 11 disposable	
Refrigerant	R410A	
Coil type	Corrosion resistant aluminum	
8' Power cord	Plug type	
Discharge air temperature rise	10°F–30°F	
Drain connection	¾" MNPT Threaded	
Warranty	5 Years on all parts including refrigeration system	

<sup>(3)</sup>Built-in automatic control capable to be set up for dehumidification and ventilation or zoning.

## INCLUDED ITEMS

Drain fitting	¾" MPT x ¾" barbed
10 ft. Drain tubing	¾" ID
Duct collars	10" Round (A95 only)
Manual	Installation instruction

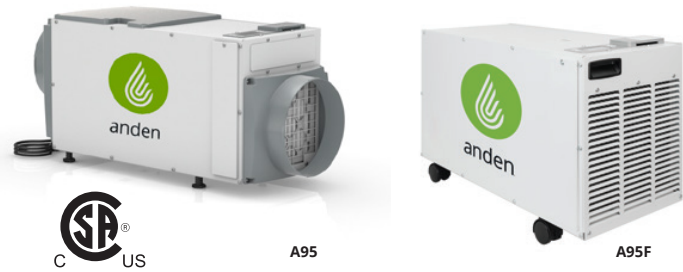

## PRINCIPLE OF OPERATION

The Anden Model A95 Series Dehumidifier is designed to dehumidify the air coming into the unit by passing the incoming air over an evaporator coil to drop the air temperature below the dew point of the air. Moisture is removed from the air and drained out of the unit to a common floor or waste drain. The air is then reheated in the condenser coil and exits the unit.

Dehumidification occurs until the set point is reached, then shuts off until periodic sampling determines a need for operation.

## APPLICATION

The Anden Model A95 Series is the perfect solution for the precise management of humidity required in an indoor growing environment.

## CIRCULATION

The Model A95 Series can also be programmed to circulate air within a grow facility. Proper air flow carries moisture away from the plants, helping to prevent fungus, disease and plant pests from damaging the crop. Circulating the air also maximizes the application of CO<sub>2</sub> in the grow facility.

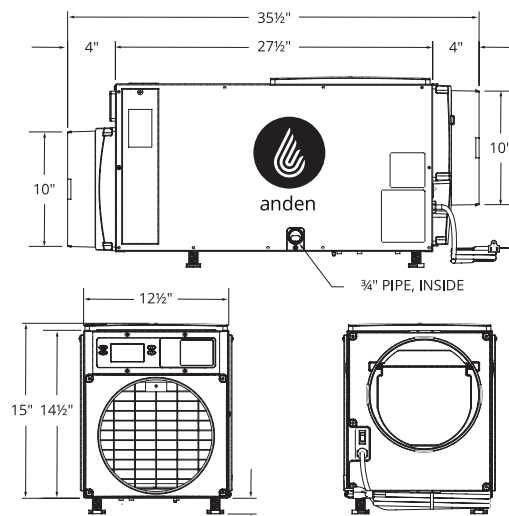

90-1971

### SPECIFICATIONS

Model	A130 (ducted)	A130F (movable, with casters)
Capacity <sup>(1)</sup> (water removal)	130 ppd	
Energy factor <sup>(1)</sup> (efficiency)	2.8 L/kWh (5.9 pints/kWh)	
Voltage, Phase, Frequency	120VAC, 1 Phase, 60 Hz	
Current draw <sup>(1)</sup>	8.3 Amps	
Power (Watts) <sup>(1)</sup>	920 Watts	
Noise	50 dBA	
Dimensions: (cabinet only) <sup>(2)</sup>	Width:	19½"   19½"
	Height:	18¾"   18¾" cabinet 21" with casters
	Length:	30⅞"   30⅞"
Weight	113 lbs.	114 lbs.

#### Inlet air operating conditions during:

Dehumidification:	50°F–104°F, 40°F dew point min.
Ventilation:	40°F–140°F, 0%–99% RH (non-condensing)

<sup>(1)</sup>Rated capacity and energy factor test done and current draw measured in accordance with AHAM DH-1 2008 at 80°F/60% RH inlet air at 0.0 ESP. <sup>(2)</sup>Height does not include adjustable feet. The width excludes the filter doors and length excludes the duct collars.

### FEATURES

Model	A130 (ducted)	A130F (movable, with casters)
Control <sup>(3)</sup>	Built-in digital control with display	
Control mounting option	Field interchangeable from top to front	Top only
Cabinet insulation	½" EPS	
Air discharge orientation	Top or end	End
Inlet/Outlet duct collars	10" dia.	N/A
Backdraft damper at outlet	Included	N/A
Filter	MERV 11 disposable	
Refrigerant	R410A	
Coil type	Corrosion resistant aluminum	
8' Power cord	Plug type	
Discharge air temperature rise	10°F–30°F	
Drain connection	¾" MNPT Threaded	
Warranty	5 Years on all parts including refrigeration system	

<sup>(3)</sup>Built-in automatic control capable to be set up for dehumidification and ventilation or zoning.

### INCLUDED ITEMS

Drain fitting	¾" MPT x ¾" barbed
10 ft. Drain tubing	¾" ID
Duct collars	10" Round (A130 only)
Manual	Installation instruction



#### ► PRINCIPLE OF OPERATION

The Anden Model A130 Series Dehumidifier is designed to dehumidify the air coming into the unit by passing the incoming air over an evaporator coil to drop the air temperature below the dew point of the air. Moisture is removed from the air and drained out of the unit to a common floor or waste drain. The air is then reheated in the condenser coil and exits the unit.

Dehumidification occurs until the set point is reached, then shuts off until periodic sampling determines a need for operation.

#### ► APPLICATION

The Anden Model A130 Series Dehumidifier is the perfect solution for the precise management of humidity required in an indoor growing environment.

#### ► CIRCULATION

The Model A130 Series can also be programmed to circulate air within a grow facility. Proper air flow carries moisture away from the plants, helping to prevent fungus, disease and plant pests from damaging the crop. Circulating the air also maximizes the application of CO<sub>2</sub> in the grow facility.

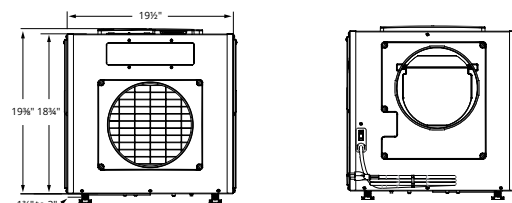
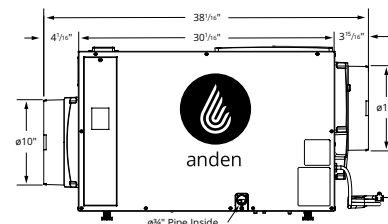



## SPECIFICATIONS

<b>Capacity<sup>(1)</sup> PPD AT 80°/60%RH</b>	210
<b>Energy factor<sup>(1)</sup></b>	3.0 L/kWh 6.3 pints/kWh
<b>Voltage, Phase, Frequency</b>	208-240VAC, 1 Phase, 60 Hz
<b>Current draw (amps)<sup>(1)</sup></b>	7.1
<b>Power (watts)<sup>(1)</sup></b>	1,450
	SJT, 6-15P, 10ft
<b>Power cord type and length</b>	
<b>Hardwire</b>	Field configurable
<b>Breaker size</b>	15 amp
<b>CFM</b>	525
<b>Dimensions</b>	Width: 19½" Height: 18¾" Length: 30½"
<b>Weight</b>	118 lbs.
<b>Operating range Temp/RH</b>	60/50 to 85/80

<sup>(1)</sup>Rated capacity and energy factor test done and current draw measured in accordance with AHAM DH-1 2008 at 80°F/60% RH inlet air at 0.0 ESP, 208 VAC.

## FEATURES

<b>Control</b>	On-Board digital with diagnostics
<b>Air supply orientation</b>	Horizontal
<b>Filter</b>	14"x18"x2" MERV 11
<b>Refrigerant</b>	R410A
<b>Coil type</b>	Copper tube, Aluminum fin with i-coat
<b>Drain connection</b>	¾" FNPT
<b>P-Trap required</b>	No
<b>Leveling feet</b>	Included
<b>Hanging brackets</b>	Included
<b>Warranty</b>	5 Years on all parts including refrigeration system

## INCLUDED ITEMS

<b>Control</b>	Model A77
<b>Drain fittings</b>	¾" MNPT x ¾" BARB
<b>Drain tubing (length, ID)</b>	10' - ¾" ID
<b>Thermostat wire</b>	30' 20 gauge 4-wire



## PRINCIPLE OF OPERATION

The Anden Model A210V1 Dehumidifier is designed to dehumidify the air coming into the unit by passing the incoming air over an evaporator coil to drop the air temperature below the dew point of the air. Moisture is removed from the air and drained out of the unit to a common floor or waste drain. The air is then reheated in the condenser coil and exits the unit.

Dehumidification occurs until the set point is reached, then shuts off until the control determines a need for operation.

## APPLICATION

The Anden Model A210V1 Dehumidifier is the perfect solution for the precise management of humidity required in an indoor growing environment.

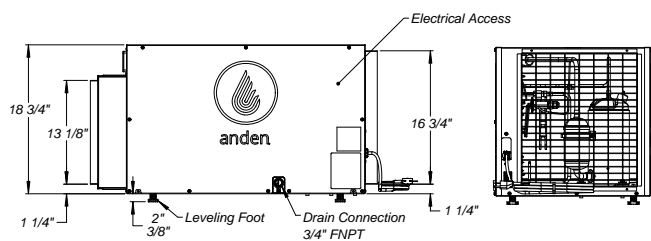
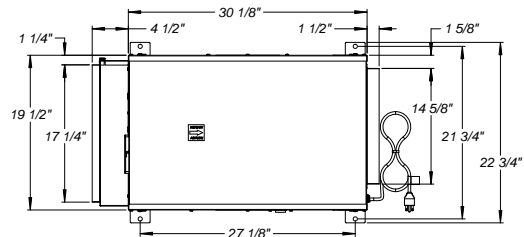

90-2430



# Industrial Grade Dehumidifier

Model A320V1 | Specification Sheet

## SPECIFICATIONS

<b>Capacity<sup>(1)</sup> PPD AT 80°/60%RH</b>	320
<b>Energy factor<sup>(1)</sup></b>	2.9 L/kWh 6.0 pints/kWh
<b>Voltage, Phase, Frequency</b>	208-240VAC, 1 Phase, 60 Hz
<b>Current draw(amps)<sup>(1)</sup></b>	11.1
<b>Power (watts)<sup>(1)</sup></b>	2,310
<b>Power cord type and length</b>	SJT, 6-20P, 10ft 
<b>Hardwire</b>	Field configurable
<b>Breaker size</b>	20 amp
<b>CFM</b>	830
<b>Dimensions</b>	Width: 32 $\frac{5}{8}$ " Height: 24" Length: 24 $\frac{1}{4}$ "
<b>Weight</b>	180 lbs.
<b>Operating range Temp/RH</b>	60/50 to 85/80

<sup>(1)</sup>Rated capacity and energy factor test done and current draw measured in accordance with AHAM DH-1 2008 at 80°F/60% RH inlet air at 0.0 ESP, 208 VAC.

## FEATURES

<b>Control</b>	On-Board digital with diagnostics
<b>Air supply orientation</b>	Horizontal
<b>Filter</b>	20"x22"x2" MERV 11
<b>Refrigerant</b>	R410A
<b>Coil type</b>	Copper tube, Aluminum fin with ElectroFin® E-coat
<b>Drain connection*</b>	$\frac{3}{4}$ " FNPT
<b>P-Trap required</b>	Yes (Included)
<b>Leveling feet</b>	Sold separately (Model #5789)
<b>Hanging brackets</b>	Included
<b>Warranty</b>	5 Years on all parts including refrigeration system

\*Requires drain trap

## INCLUDED ITEMS

<b>Control</b>	Model A77
<b>Drain fittings</b>	$\frac{3}{4}$ " MNPT x $\frac{3}{4}$ " BARB, $\frac{3}{4}$ " MNPT x $\frac{3}{4}$ " Female pipe, $\frac{3}{4}$ " FNPT x $\frac{3}{4}$ " Female pipe, $\frac{3}{4}$ " P-Trap
<b>Drain tubing (length, ID)</b>	10' - $\frac{3}{4}$ " ID
<b>Thermostat wire</b>	30' 20 gauge 4-wire

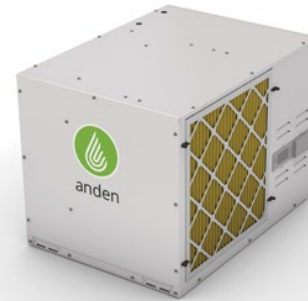

## PRINCIPLE OF OPERATION

The Anden Model A320V1 Dehumidifier is designed to dehumidify the air coming into the unit by passing the incoming air over an evaporator coil to drop the air temperature below the dew point of the air. Moisture is removed from the air and drained out of the unit to a common floor or waste drain. The air is then reheated in the condenser coil and exits the unit.

Dehumidification occurs until the set point is reached, then shuts off until the control determines a need for operation.

## APPLICATION

The Anden Model A320V1 Dehumidifier is the perfect solution for the precise management of humidity required in an indoor growing environment.

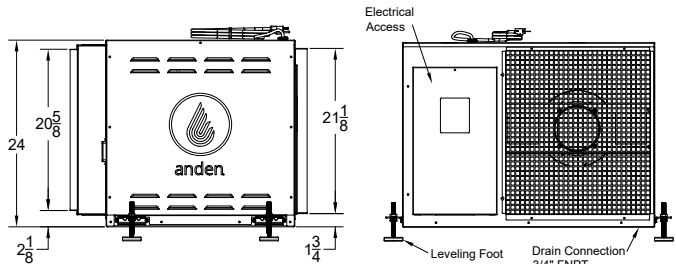
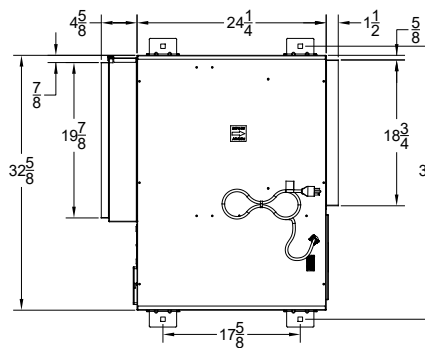

### SPECIFICATIONS

Capacity <sup>(1)</sup> PPD AT 80°/60%RH	315
Energy factor <sup>(1)</sup>	2.6 L/kWh 5.5 pints/kWh
Voltage, Phase, Frequency	277VAC, 1 Phase, 60 Hz
Current draw (amps) <sup>(1)</sup>	9.2
Power (watts) <sup>(1)</sup>	2,450
	SJT, L7-20P, 10ft
Power cord type and length	
Hardwire	Field configurable
Breaker size	20 amp
CFM	830
Dimensions	Width: 32 $\frac{5}{8}$ " Height: 24" Length: 24 $\frac{1}{4}$ "
Weight	180 lbs.
Operating range Temp/RH	60/50 to 85/80

<sup>(1)</sup>Rated capacity and energy factor test done and current draw measured in accordance with AHAM DH-1 2008 at 80°F/60% RH inlet air at 0.0 ESP, 277VAC.

### FEATURES

Control	On-Board digital with diagnostics
Air supply orientation	Horizontal
Filter	20"x22"x2" MERV 11
Refrigerant	R410A
Coil type	Copper tube, Aluminum fin with ElectroFin® E-coat
Drain connection*	¾" FNPT
P-Trap required	Yes (Included)
Leveling feet	Sold separately (Model #5789)
Hanging brackets	Included
Warranty	5 Years on all parts including refrigeration system

\*Requires drain trap

### INCLUDED ITEMS

Control	Model A77
Drain fittings	¾" MNPT x ¾" BARB, ¾" MNPT x ¾" Female pipe, ¾" FNPT x ¾" Female pipe, ¾" P-Trap
Drain tubing (length, ID)	10' - ¾" ID
Thermostat wire	30' 20 gauge 4-wire



### PRINCIPLE OF OPERATION

The Anden Model A320V3 Dehumidifier is designed to dehumidify the air coming into the unit by passing the incoming air over an evaporator coil to drop the air temperature below the dew point of the air. Moisture is removed from the air and drained out of the unit to a common floor or waste drain. The air is then reheated in the condenser coil and exits the unit.

Dehumidification occurs until the set point is reached, then shuts off until the control determines a need for operation.

### APPLICATION

The Anden Model A320V3 Dehumidifier is the perfect solution for the precise management of humidity required in an indoor growing environment.

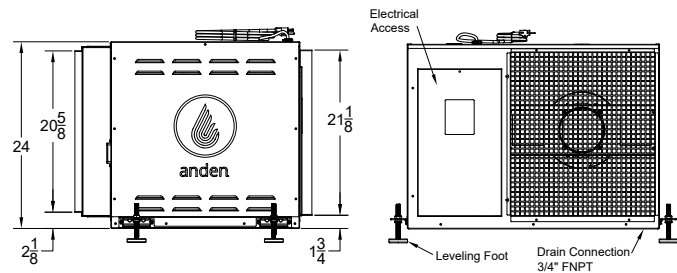
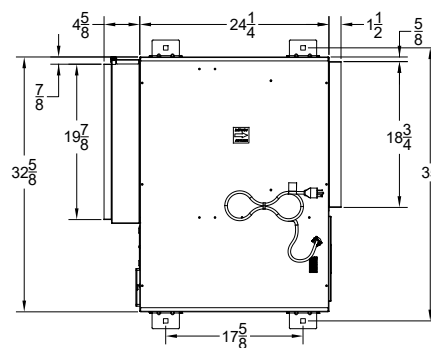

90-2428

### SPECIFICATIONS

Capacity <sup>(1)</sup> PPD AT 80°/60%RH	710
Energy factor <sup>(1)</sup>	3.0 L/kWh 6.35 pints/kWh
Voltage, Phase, Frequency	208-240VAC, 1 Phase, 60 Hz
Current draw (amps) <sup>(1)</sup>	19.6
Power (watts) <sup>(1)</sup>	4,706
Btu/h <sup>(2)</sup>	16,168
Power cord type and length	SJT, L6-30P, 10ft 
Hardwire	Field-configurable
Breaker size	30 amp
Wire size	10 Gauge Copper
CFM	0.0" w.c 1760    0.2" w.c 1677 0.4" w.c 1593    0.6" w.c 1510
Dimensions:	W: 44 7/8" H: 34 13/32" L: 31 23/32"
Weight	360 lbs.
Operating range Temp/RH	60/40 to 85/80

<sup>(1)</sup>Rated capacity and energy factor test done and current draw measured at 80°F/60% RH inlet air at 0.0 ESP, 240 VAC.

<sup>(2)</sup>Total cooling load @ 80°F/60% RH and 240 VAC.

### FEATURES

Control	Onboard digital with diagnostics
Air supply orientation	Horizontal
Filter	29.5"x31.5"x1.75" MERV 11 (Part #5825)
Refrigerant	R410A
Coil type	Copper tube, Aluminum fin with I-coat
Drain connection*	3/4" FNPT
P-Trap required	Yes (Included)
Leveling feet	Sold separately (Model #5789)
Hanging brackets	Built-in
Duct Kit	Part # 5859
Warranty	5 Years on all parts including refrigeration system

\* Requires drain trap

### INCLUDED ITEMS

Control	Model A77
Drain fittings	3/4" MNPT x 3/4" BARB, 3/4" MNPT x 3/4" Female pipe, 3/4" x 3/4" x 3/4" T-Fitting, 3/4" P-Trap
Thermostat wire	30' 20 gauge 4-wire



### ▶ ANDEN A710



The A710 features VLGR technology, which modulates the refrigeration system based on the load, allowing you to **maximize VPD** and provide greater control during late flower conditions.

### ▶ APPLICATION

The Anden Model A710V1 Dehumidifier is the perfect solution for the precise management of humidity required in an indoor growing environment.

### INCLUDED CONTROL



#### MODEL A77

Dedicated monitoring and control of each dehumidifier at canopy height

### MODEL A77 SPECIFICATIONS

<b>Electrical</b>	
Input voltage and current	Voltage: 35VDC (supplied by dehumidifier control board)
Output	Communication (RS485)
<b>Control</b>	
Control range	35%–80% RH
Accuracy	+/-5% RH
Differential	3% RH
Low limit	40°F dew point
High limit	99°F dry bulb

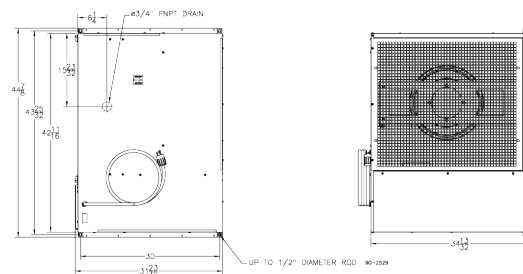

## TERMS AND CONDITIONS

Net 30 days from date of invoice on approval of credit, otherwise orders must be prepaid prior to shipping. Customers will be advised immediately when an order exceeds their credit limit so they can rectify the situation and the order can be shipped expediently.

### PRODUCT RETURNS

All returns must be authorized by Rambridge prior to shipping any return to our warehouse. Items returned to Rambridge without authorization and/or freight collect will be refused. All returns must be shipped freight prepaid. Items subject to freezing damage must be returned by heated carrier. Any replacement product will have freight prepaid back to your door.

### NON-DEFECTIVE RETURNS

Returned non-defective goods will only be accepted within 30 days from the date of purchase and must be in original packaging and in clean, resaleable condition. All non-defective returns will be subject to a 15% restocking charge unless otherwise authorized.

### WARRANTY RETURNS

Warranty returns must be accompanied by the original end user bill of sale, a clear explanation of why the product is being returned under warranty and a brief description of any inspection and evaluation performed prior to its return. Acceptance of a warranty return does not constitute acknowledgement of warranty given. Credit or replacement will only be authorized after warranty confirmation by the manufacturer or supplier. We reserve the right to issue credit or product, in lieu of credit. All returns should be pre-authorized and freight prepaid.

### FREIGHT AND CLAIMS

All orders are shipped F.O.B. our warehouse unless otherwise authorized. If you have a preferred carrier please inform us, otherwise we will ship with the best available carrier for the product being shipped. Heated service is required in the winter for some products. All shipments will be insured unless we are otherwise advised. If you have an account with us and have not completed the freight insurance advisory form please contact us immediately.

### CARRIER RESPONSIBILITY

The carrier is responsible for the safe delivery of the goods and any claims for damage or shortages should be made with the carrier.

### SHIPMENT INSPECTION

Inspect each shipment as soon as it arrives while the carrier is still present.

### WARRANTY AND LIABILITY LIMITATIONS

Rambridge Wholesale Supply makes no warranties, expressed or implied, including without limitation the implied warranties of merchantability and fitness for a particular purpose and in no event will be liable for any consequential, incidental or indirect damages arising out of the use or inability to use a product. All warranties shall be the warranties of the manufacturer or supplier and shall be limited to either the purchase price or product replacement with the same or equivalent product at the sole discretion of Rambridge.

## MINIMUM ORDERS / FREIGHT POLICY

	PREPAID		PREPAID		PREPAID
<b>BRITISH COLUMBIA</b>		<b>ALBERTA</b>		<b>ONTARIO</b>	
-VANCOUVER LOWER MAINLAND	\$ 500.00	- CALGARY	\$ 1500.00	- ALL LOCATIONS	\$ 1500.00
FRASER VALLEY	1500.00	- ALL OTHER	2000.00	-GTA	2000.00
- VANCOUVER ISLAND	2000.00			<b>QUEBEC</b>	
- OKANAGAN	2000.00	<b>SASKATHEWAN / MANITOBA</b>		- ALL LOCATIONS	1500.00
- KOOTNEYS	2000.00	- ALL LOCATIONS	\$ 3000.00	<b>ATLANTIC CANADA</b>	
- ALL OTHER	2500.00			- ALL AREAS	2500.00

Please consult us for freight terms on all grow media

## CONVERSION FACTORS

<b>1 US gallon is equal to:</b>	<b>1 cup is equal to:</b>	<b>1 tablespoon is equal to:</b>
4 quarts      256 tbsp	8 ounces      0.52 lbs	1/2 ounce      180 drops
8 pints        768 tsp	1/2 pint        0.23 litre	15 ml           15 grams
16 cups        8.34 lbs	16 tbsp        14.4 cu. in.	3 tsp            0.663 cup
128 ounces    231 cu. in.	48 tsp         236 grams	
3.785 litres	236 ml	
<b>1 litre is equal to:</b>		
1000 ml        2.22 lbs	1 mho = 1 Siemen	mg/1 = milligrams per litre
2.164 pints    202.88 tsp	1 Siemen = 1000 mS	ppm = parts per million
1000 grams    0.264 gal	1 mS = 1000 uS	mho = conductivity
4.328 cups    1.057 quart	1 mS = 500 ppm	mS = millisiemen
67.63 tbsp	(standard)	uS = microsiemen
	1 mS = 650 ppm	tds = total dissolved solids
	(horticultural)	cc = electrical conductivity
	1 mg/litre = 1 ppm	pH = potential hydrogen

