

Analog Linear Modulation and Demodulation

Goal:

The goal of this experiment is to study and analyze the analog linear modulation and demodulation techniques in communication systems.

Theory:

Analog linear modulation

In electronics and telecommunications, modulation is the process of varying one or more properties of a periodic waveform, called the carrier signal, with a modulating signal that typically contains information to be transmitted.

In telecommunications, modulation is the process of conveying a message signal, for example a digital bit stream or an analog audio signal, inside another signal that can be physically transmitted. Modulation of a sine waveform transforms a baseband message signal into a passband signal.

The aim of analog modulation is to transfer an analog baseband (or lowpass) signal, for example an audio signal or TV signal, over an analog bandpass channel at a different frequency, for example over a limited radio frequency band or a cable TV network channel.

In linear modulation, the amplitude of the transmitted signal varies linearly with the modulating digital signal, $m(t)$.

In this experiment, the AM, DSBSC and SSB modulation techniques are considered.

Since in all of the mentioned modulation techniques the envelope of the signal is transmitted, first we should elaborate the definition of the envelope.

Envelope definition:

When we talk of the envelopes of signals we are concerned with the appearance of signals in the time domain. Text books are full of drawings of modulated signals, and you already have an idea of what the term 'envelope' means. It will now be given a more formal definition.

Qualitatively, the envelope of a signal $y(t)$ is that boundary within which the signal is contained, when viewed in the time domain. It is an imaginary line.

This boundary has an upper and lower part. You will see these are mirror images of each other. In practice, when speaking of the envelope, it is customary to consider only one of them as 'the envelope' (typically the upper boundary).

Although the envelope is imaginary in the sense described above, it is possible to generate, from $y(t)$, a signal $e(t)$, having the same shape as this imaginary line. The circuit which does this is commonly called an envelope detector.

1. AM

a) AM Modulation:

In the early days of wireless, communication was carried out by telegraphy, the radiated signal being an interrupted radio wave. Later, the amplitude of this wave was varied in sympathy with (modulated by) a speech message (rather than on/off by a telegraph key), and the message was recovered from the envelope of the received signal. The radio wave was called a 'carrier', since it was seen to carry the speech information with it. The process and the signal were called amplitude modulation, or 'AM' for short.

In the context of radio communications, near the end of the 20th century, few modulated signals contain a significant component at 'carrier' frequency. However, despite the fact that a carrier is not radiated, the need for such a signal at the transmitter (where the modulated signal is generated), and also at the receiver, remains fundamental to the modulation and demodulation process respectively. The use of the term 'carrier' to describe this signal has continued to the present day.

As distinct from radio communications, present day radio broadcasting transmissions do have a carrier. By transmitting this carrier the design of the demodulator, at the receiver, is greatly simplified, and this allows significant cost savings.

The most common method of AM generation uses a 'class C modulated amplifier'; such an amplifier is not available in the BASIC TIMS set of modules. It is well documented in text books. This is a 'high level' method of generation, in that the AM signal is generated at a power level ready for radiation. It is still in use in broadcasting stations around the world, ranging in powers from a few tens of watts to many megawatts.

Unfortunately, text books which describe the operation of the class C modulated amplifier tend to associate properties of this particular method of generation with those of AM, and AM generators, in general. This gives rise to many misconceptions. The worst of these is the belief that it is impossible to generate an AM signal with a depth of modulation exceeding 100% without giving rise to serious RF distortion.

You will see in this experiment that there is no problem in generating an AM signal with a depth of modulation exceeding 100%, and without any RF distortion whatsoever. But we are getting ahead of ourselves, as we have not yet even defined what AM is!

The amplitude modulated signal is defined as:

$$AM = E[1 + m * \cos(\mu t)]\cos(\omega t) \quad (1)$$

$$= A[1 + m * \cos(\mu t)] * B\cos(\omega t) \quad (2)$$

$$= [\text{low frequency term } a(t)] * [\text{high frequency term } c(t)] \quad (3)$$

Here:

'E' is the AM signal amplitude. (A.B) = E.

'm' is a constant, which, as you will soon see, defines the 'depth of modulation'. Typically $m < 1$. Depth of modulation, expressed as a percentage, is $100.m$. There is no inherent restriction upon the size of 'm'. This point will be discussed later.

' μ ' and ' ω ' are angular frequencies in rad/s, where $\frac{\mu}{2\pi}$ is a low, or message frequency, say in the range 300 Hz to 3000 Hz; and $\frac{\omega}{2\pi}$ is a radio, or relatively high, 'carrier' frequency. In TIMS the carrier frequency is generally 100 kHz.

Notice that the term $a(t)$ in eqn. (3) contains both a DC component and an AC component. As will be seen, it is the DC component which gives rise to the term at ω - the 'carrier' - in the AM signal. The AC term ' $m * \cos(\mu t)$ ' is

generally thought of as the message, and is sometimes written as $m(t)$. But strictly speaking, to be compatible with other mathematical derivations, the whole of the low frequency term $a(t)$ should be considered the message.

Thus:

$$a(t) = DC + m(t) \tag{4}$$

Figure 1 below illustrates what the oscilloscope will show if displaying the AM signal. A block diagram representation of eqn. (2) is shown in Figure 6 below. In the experiment you will model eqn. (2) by the arrangement of Figure 2. The depth of modulation will be set to exactly 100% ($m = 1$). You will gain an appreciation of the meaning of ‘depth of modulation’, and you will learn how to set other values of ‘ m ’, including cases where $m > 1$.

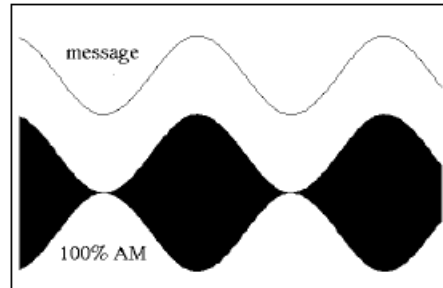

Figure 1 - AM, with $m = 1$, as seen on the oscilloscope

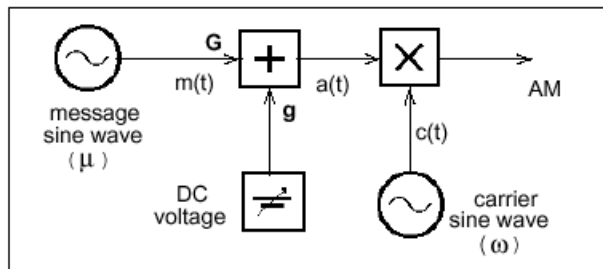

Figure 2: Generation of equation 2

Depth of modulation

100% amplitude modulation is defined as the condition when $m=1$. Just what this means will soon become apparent. It requires that the amplitude of the DC ($=A$) part of $a(t)$ is equal to the amplitude of the AC part ($=A*m$). This means that their ratio is unity at the output of the ADDER, which forces ‘ m ’ to a magnitude of exactly unity.

By aiming for a ratio of unity it is thus not necessary to know the absolute magnitude of A at all.

Measurement of ‘ m ’

The magnitude of ‘ m ’ can be measured directly from the AM display itself. Thus:

$$m = \frac{(P-Q)}{(P+Q)} \tag{5}$$

where P and Q are as defined in Figure 3.

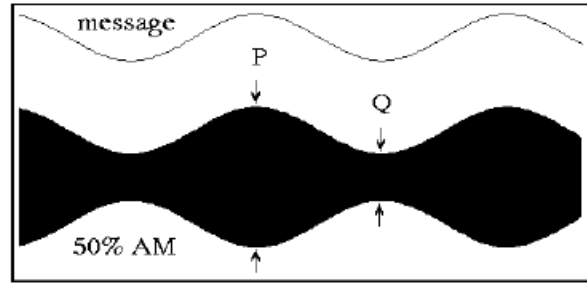

Figure 3: Oscilloscope display for the case $m = 0.5$

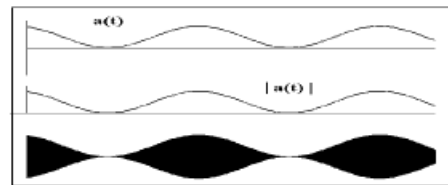

Figure 4: AM, with $m = 1$

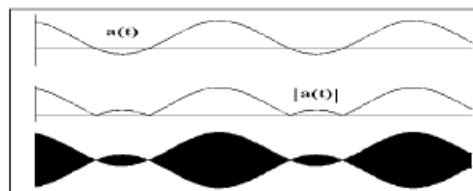

Figure 5: AM, with $m = 1.5$

b) AM Demodulation:

Envelope detector

Although the envelope is imaginary in the sense described above, it is possible to generate, from $y(t)$, a signal $e(t)$, having the same shape as this imaginary line. The circuit which does this is commonly called an envelope detector. A better word for envelope detector would be envelope generator, since that is what these circuits do.

In this experiment, you will model circuits which will generate these envelope signals.

Diode detector

The ubiquitous diode detector is the prime example of an envelope generator. It is well documented in most textbooks on analog modulation. It is synonymous with the term 'envelope demodulator' in this context.

But remember: the diode detector is an approximation to the ideal. We will first examine the ideal circuit.

Ideal envelope detector

The ideal envelope detector is a circuit which takes the absolute value of its input, and then passes the result through a low pass filter. The output from this low pass filter is the required envelope signal.

See Figure 6.

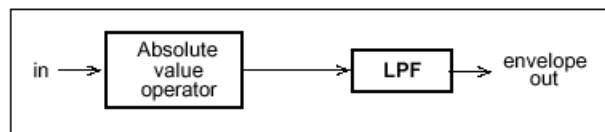

Figure 6: Ideal envelope recovery arrangement

The absolute value operation, being non-linear, must generate some new frequency components. Among them are those of the wanted envelope. Presumably, since the arrangement actually works, the unwanted components lie above those wanted components of the envelope.

It is the purpose of the low pass filter to separate the wanted from the unwanted components generated by the absolute value operation.

The analysis of the ideal envelope recovery circuit, for the case of a general input signal, is not a trivial mathematical exercise, the operation being non-linear. So it is not easy to define beforehand where the unwanted components lie.

Ideal rectifier

A circuit which takes an absolute value is a full wave rectifier. Note carefully that the operation of rectification is non-linear. The so-called ideal rectifier is a precision realization of a rectifier, using an operational amplifier and a diode in a negative feedback arrangement. It is described in text books dealing with the applications of operational amplifiers to analog circuits. An extension of the principle produces an ideal full wave rectifier.

You will find a half wave rectifier is generally adequate for use in an envelope recovery circuit.

Envelope bandwidth

You know what a low pass filter is, but what should be its cut-off frequency in this application? The answer: 'the cut-off frequency of the low pass filter should be high enough to pass all the wanted frequencies in the envelope, but no more'. So you need to know the envelope bandwidth.

In a particular case you can determine the expression for the envelope from the definition given before, and the bandwidth by Fourier series analysis. Alternatively, you can estimate the bandwidth, by inspecting its shape on an oscilloscope, and then applying rules of thumb which give quick approximations.

An envelope will always include a constant, or DC, term.

This is inevitable from the definition of an envelope - which includes the operation of taking the absolute value. It is inevitable also in the output of a practical circuit, by the very nature of rectification.

The presence of this DC term is often forgotten. For the case of an AM signal, modulated with music, the DC term is of little interest to the listener. But it is a direct measure of the strength of the carrier term, and so is used as an automatic gain control signal in receivers.

It is important to note that it is possible for the bandwidth of the envelope to be much wider than that of the signal of which it is the envelope. In fact, except for the special case of the envelope modulated signal, this is generally so. An obvious example is that of the DSBSC signal derived from a single tone message.

2. DSBSC

a) DSBSC modulation

Consider two sinusoids, or cosinusoids, $\cos(\mu t)$ and $\cos(\omega t)$. A double sideband suppressed carrier signal, or DSBSC, is defined as their product, namely:

$$DSBSC = E \cos(\mu t) \cos(\omega t) \quad (6)$$

Generally, and in the context of this experiment, it is understood that:

$$\omega \gg \mu \quad (7)$$

Equation (6) can be expanded to give:

$$E \cos(\omega t) \cos(\mu t) = \frac{E}{2} \cos(\omega - \mu) t + \frac{E}{2} \cos(\omega + \mu) t \quad (8)$$

Equation 3 shows that the product is represented by two new signals, one on the sum frequency $(\omega + \mu)$, and one on the difference frequency $(\omega - \mu)$, - see Figure 7.

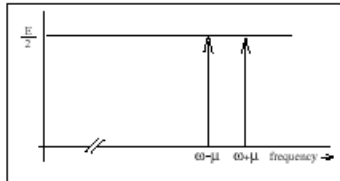

Figure 7: Spectral components

Remembering the inequality of eqn. (7) the two new components are located close to the frequency ω rad/s, one just below, and the other just above it. These are referred to as the lower and upper sidebands respectively. These two components were derived from a 'carrier' term on ω rad/s, and a message μ rad/s. Because there is no term at carrier frequency in the product signal it is described as a double sideband suppressed carrier (DSBSC) signal.

The term 'carrier' comes from the context of 'double sideband amplitude modulation' (commonly abbreviated to just AM). AM is introduced later (although, historically, AM preceded DSBSC).

The time domain appearance of a DSBSC is generally as shown in Figure 8.

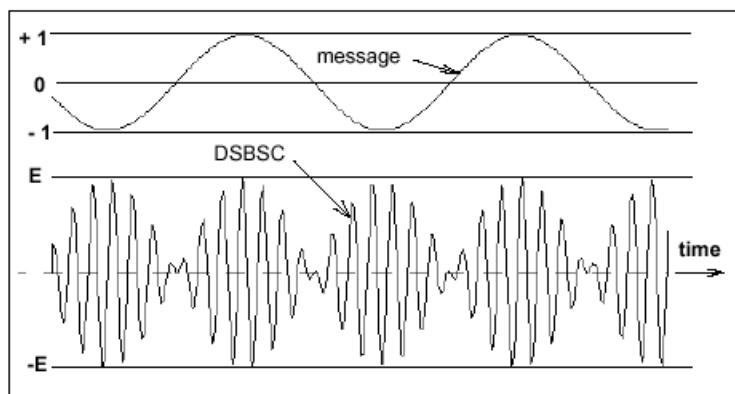

Figure 8: a DSBSC - seen in the time domain

Notice the waveform of the DSBSC in Figure 8, especially near the times when the message amplitude is zero. The fine detail differs from period to period of the message. This is because the ratio of the two frequencies ω and μ has been made non-integral.

Although the message and the carrier are periodic waveforms (sinusoids), the DSBSC itself need not necessarily be periodic.

A block diagram, showing how eqn. (8) could be modeled with hardware, is shown in Figure 9 below.

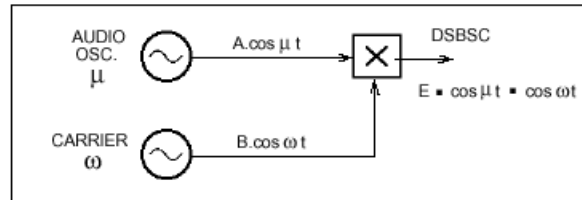

Figure 9: Block diagram to generate eqn. (8) with hardware

Multi-tone message

The DSBSC has been defined in eqn. (8), with the message identified as the low frequency term. Thus:

$$message = \cos(\mu t) \tag{9}$$

For the case of a multi-tone message, $m(t)$, where $m(t) = \sum_i a_i \cos(\mu_i t)$

then the corresponding DSBSC signal consists of a band of frequencies below ω , and a band of frequencies above ω . Each of these bands is of width equal to the bandwidth of $m(t)$. The individual spectral components in these sidebands are often called side frequencies.

If the frequency of each term in the expansion is expressed in terms of its difference from ω , and the terms are grouped in pairs of sum and difference frequencies, then there will be 'n' terms of the form of the right hand side of eqn. (8).

Note it is assumed here that there is no DC term in $m(t)$. The presence of a DC term in $m(t)$ will result in a term at ω in the DSB signal; that is, a term at 'carrier' frequency. It will no longer be a double sideband suppressed carrier signal. A special case of a DSB with a significant term at carrier frequency is an amplitude modulated signal, which will be examined later.

A more general definition still, of a DSBSC, would be:

$$DSBSC = E * m(t) \cos(\omega t) \tag{10}$$

where $m(t)$ is any (low frequency) message. By convention $m(t)$ is generally understood to have a peak amplitude of unity (and typically no DC component).

b) DSBSC demodulation

Productive demodulation

All of the modulated signals you have seen so far may be defined as narrow band. They carry message information. Since they have the capability of being based on a radio frequency carrier (suppressed or otherwise) they are suitable for radiation to a remote location. Upon receipt, the object is to recover –demodulate - the message from which they were derived.

In the discussion to follow the explanations will be based on narrow band signals. But the findings are in no way restricted to narrow band signals; they happen to be more convenient for purposes of illustration.

Frequency translation

When a narrow band signal $y(t)$ is multiplied with a sine wave, two new signals are created – on the ‘sum and difference’ frequencies.

Figure 10 illustrates the action for a signal $y(t)$, based on a carrier f_c , and a sinusoidal oscillator on frequency f_o .

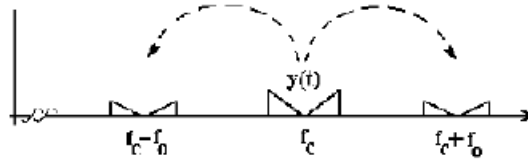

Figure 10. Figure 5: Sum and difference frequencies

Each of the components of $y(t)$ was moved up an amount f_o in frequency, and down by the same amount, and appear at the output of the multiplier.

Remember, neither $y(t)$, nor the oscillator signal, appears at the multiplier output. This is not necessarily the case with a ‘modulator’.

A filter can be used to select the new components at either the sum frequency (BPF preferred, or an HPF) or difference frequency (LPF preferred, or a BPF).

The combination of MULTIPLIER, OSCILLATOR, and FILTER is called a frequency translator.

When the frequency translation is down to baseband the frequency translator becomes a demodulator.

Synchronous demodulator $f_o = f_c$:

For successful demodulation of DSBSC and AM the synchronous demodulator requires a ‘local carrier’ of exactly the same frequency as the carrier from which the modulated signal was derived, and of fixed relative phase, which can then be adjusted, as required, by the phase changer shown.

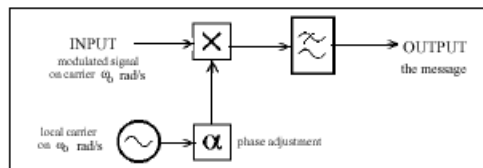

Figure 11: Synchronous demodulator;

3. SSB

a) SSB modulation

There are three well known methods of SSB generation using analog techniques, namely the filter method, the phasing method, and Weaver's method. This experiment will study the phasing method.

Filter method

We have already modeled a DSBSC signal. An SSB signal may be derived from this by the use of a suitable bandpass filter –commonly called, in this application, an SSB sideband filter. This, the filter method, is probably the most common method of SSB generation. Mass production has given rise to low cost, yet high performance, filters. But these filters are generally only available at 'standard' frequencies (for example 455 kHz, 10.7 MHz) and SSB generation by the filter method at other frequencies can be expensive. For this reason TIMS no longer has a 100 kHz SSB filter module, although a decade ago these were in mass production and relatively inexpensive.

Phasing method

The phasing method of SSB generation, which is the subject of this experiment, does not require an expensive filter, but instead an accurate phasing network, or quadrature phase splitter (QPS). It is capable of acceptable performance in many applications.

The QPS operates at baseband, no matter what the carrier frequency (either intermediate or final), in contrast to the filter of the filter method.

SSB signal

Recall that, for a single tone message $\cos(\mu t)$, a DSBSC signal is defined by:

$$DSBSC = A * \cos(\mu t) \cos(\omega t) \tag{11}$$

$$= \frac{A}{2} \cos(\omega - \mu) t + \frac{A}{2} \cos(\omega + \mu) t \tag{12}$$

$$= \text{lower sideband} + \text{upper sideband} \tag{13}$$

When, say, the lower sideband (LSB) is removed, by what ever method, then the upper sideband (USB) remains.

$$USB = \frac{A}{2} \cos(\omega + \mu) t \tag{14}$$

This is a single frequency component at frequency $(\omega + \mu)/(2\pi)$ Hz. It is a (co)sine wave. Viewed on an oscilloscope, with the time base set to a few periods of ω , it looks like any other sine wave. What is its envelope?

The USB signal of eqn. (14) can be written in the following form:

$$USB = a(t) \cos[(\omega + \mu)t + p(t)] \tag{15}$$

The envelope has been defined as:

$$\text{envelope} = |a(t)| = \frac{A}{2} \tag{16}$$

Thus the envelope is a constant (ie., a straight line) and the oscilloscope, correctly set up, will show a rectangular band of color across the screen.

This result may seem at first confusing. One tends to ask: 'where is the message information' ?

Answer: the message amplitude information is contained in the amplitude of the SSB, and the message frequency information is contained in the frequency offset, from ω , of the SSB.

An SSB derived from a single tone message is a very simple example. When the message contains more components the SSB envelope is no longer a straight line. Here is an important finding!

An ideal SSB generator, with a single tone message, should have a straight line for an envelope.

Any deviation from this suggests extra components in the SSB itself. If there is only one extra component, say some 'leaking' carrier, or an unwanted sideband not completely suppressed, then the amplitude and frequency of the envelope will identify the amplitude and frequency of the unwanted component.

A most important characteristic of any SSB generator is the amount of out-of-band energy it produces, relative to the wanted output. In most cases this is determined by the degree to which the unwanted sideband is suppressed. A ratio of wanted-to-unwanted output power of 40 dB was once considered acceptable commercial performance; but current practice is likely to call for a suppression of 60 dB or more, which is not a trivial result to achieve.

Phasing generator

The phasing method of SSB generation is based on the addition of two DSBSC signals, so phased that their upper sidebands (say) are identical in phase and amplitude, whilst their lower sidebands are of similar amplitude but opposite phase.

The two out-of-phase sidebands will cancel if added; alternatively the in-phase sidebands will cancel if subtracted.

The principle of the SSB phasing generator is illustrated in Figure 12.

Notice that there are two 90° phase changers. One operates at carrier frequency, the other at message frequencies.

The carrier phase changer operates at a single, fixed frequency, ω rad/s.

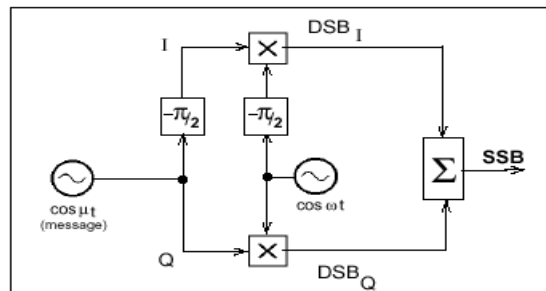

Figure 12: Principle of the SSB Phasing Generator

The message is shown as a single tone at frequency μ rad/s. But this can lie anywhere within the frequency range of speech, which covers several octaves. A network providing a constant 90° phase shift over this frequency range is very difficult to design. This would be a wideband phase shifter, or Hilbert transformer.

In practice a wideband phase splitter is used. This is shown in the arrangement of Figure 13.

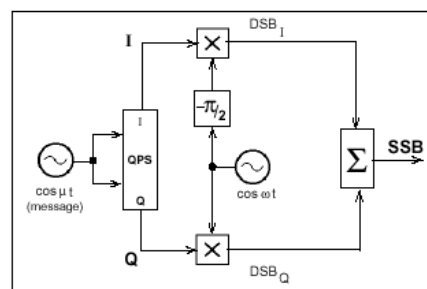

Figure 13: Practical realization of the SSB phasing generator

The wideband phase splitter consists of two complementary networks - say I (in-phase) and Q (quadrature). When each network is fed from the same input signal the phase difference between the two outputs is maintained at 90°

Note that the phase difference between the common input and either of the outputs is not specified; it is not independent of frequency. Study Figures 8 and 9 to ensure that you appreciate the difference.

At the single frequency $\mu\text{rad/s}$ the arrangements of Figure 12 and Figure 13 will generate two DSBSC. These are of such relative phases as to achieve the cancellation of one sideband, and the reinforcement of the other, at the summing output.

You should be able to confirm this. You could use graphical methods (phasors) or trigonometrical analysis.

The QPS may be realized as either an active or passive circuit, and depends for its performance on the accuracy of the components used. Over a wide band of audio frequencies, and for a common input, it maintains a phase difference between the two outputs of 90 degrees, with a small frequency- dependent error (typically equiripple).

Performance Criteria

As stated earlier, one of the most important measures of performance of an SSB generator is its ability to eliminate (suppress) the unwanted sideband. To measure the ratio of wanted-to-unwanted sideband suppression directly requires a SPECTRUM ANALYSER. In commercial practice these instruments are very expensive, and their purchase cannot always be justified merely to measure an SSB generator performance.

As always, there are indirect methods of measurement. One such method depends upon a measurement of the SSB envelope, as already hinted.

Suppose that the output of an SSB generator, when the message is a single tone of frequency $\mu\text{rad/s}$, consists only of the wanted sideband W and a small amount of the unwanted sideband U .

It may be shown that, for $U \ll W$, the envelope is nearly sinusoidal and of a frequency equal to the frequency difference of the two components.

Thus the envelope frequency is $2\mu\text{rad/s}$.

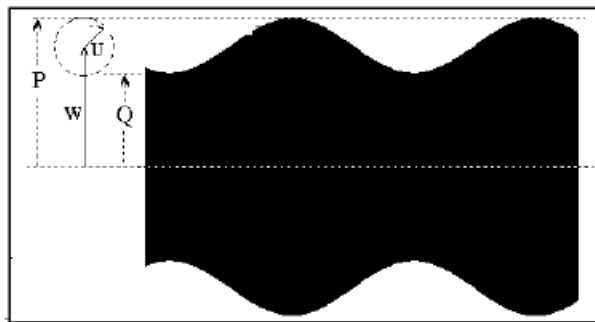

Figure 14: Measuring sideband suppression via the envelope

It is a simple matter to measure the peak-to-peak and the trough-to-trough amplitudes, giving twice P , and twice Q , respectively. Then:

$$P = W + U \quad (17)$$

$$Q = W - U \quad (18)$$

as seen from the phasor diagram. This leads directly to:

$$\text{sideband suppression} = 20 \log_{10} \left[\frac{P+Q}{P-Q} \right] \text{ (dB)} \quad (19)$$

U is in fact the sum of several small components then an estimate of the wanted to unwanted power ratio can still be made. Note that it would be greater (better) than for the case where U is a single component.

A third possibility, the most likely in a good design, is that the envelope becomes quite complex, with little or no stationary component at either μ or $\mu/2$; in this case the unwanted component(s) are most likely system noise.

Make a rough estimate of the envelope magnitude, complex in shape though it may well be, and from this can be estimated the wanted to unwanted suppression ratio. This should turn out to be better than 26 dB in TIMS, in which case the system is working within specification. The TIMS QPS module does not use precision components, nor is it aligned during manufacture. It gives only moderate sideband suppression, but it is ideal for demonstration purposes.

Within the 'working frequency range' of the QPS the phase error from 90 between the two outputs will vary with frequency (theoretically in an equi-ripple manner).

b) SSB demodulation

The demodulation types of SSB are the same as DSBSC demodulation.

PRELAB

1. Simulating the DSBSC

Submit a LTSPICE simulation of the block diagram shown in Figure 9. Use sinusoidal voltage sources for both the message and the carrier signal with amplitude of 5V and frequency of 1 kHz and 100 kHz respectively. Use transient analysis for the simulation. Submit your schematics and waveforms. The "behavioral voltage source" in LTspice can be used as an ideal multiplier.

2. Extracting the Envelope from the DSBSC

Submit a LTSPICE simulation of the block diagram shown in Figure 6. Design an envelope detector circuit using a rectifier and a capacitive low-pass filter. You may use your DSBSC signal from the previous experiment. Use transient analysis for the simulation. Submit your schematics and wave analysis.

Experiment

1. AM

T1 plug in the TUNEABLE LPF module. Set it to its widest bandwidth, which is about 12 kHz (front panel toggle switch to WIDE, and TUNE control fully clockwise). Adjust its passband gain to about unity. To do this you can use a test signal from the AUDIO OSCILLATOR, or perhaps the 2 kHz message from the MASTER SIGNALS module.

T2 model the generator of Figure 15, and connect its output to an ideal envelope detector, modeled as Figure 16. For the low pass filter use the TUNEABLE LPF module. Your whole system might look like that shown modeled in Figure 17.

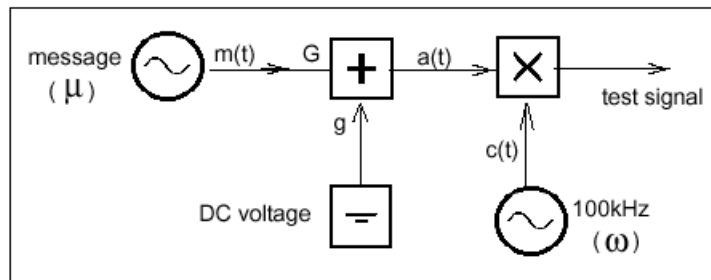

Figure 15: Generator for AM and DSBSC

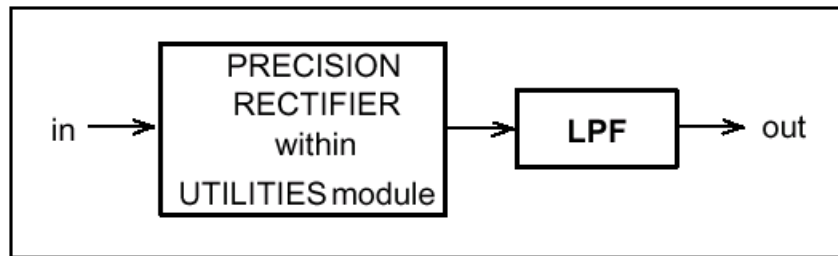

Figure 16: Modeling the ideal envelope detector with TIMS

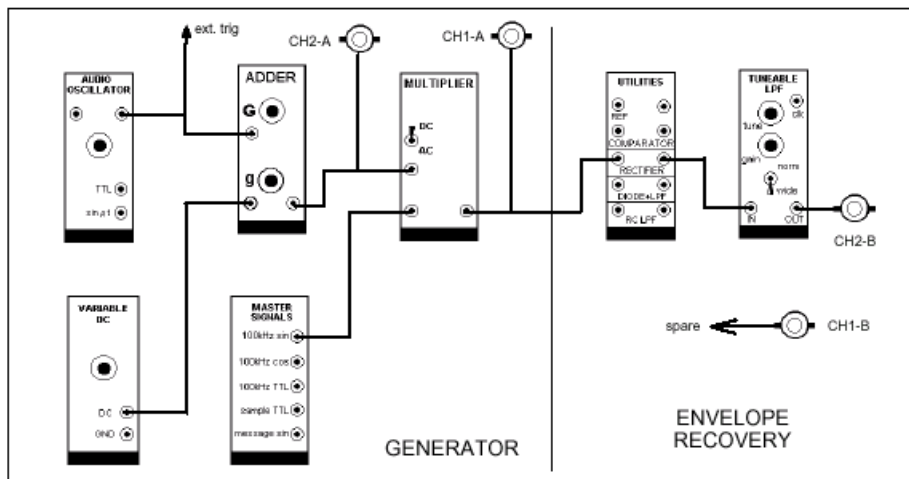

Figure 17: Modulated signal generator and envelope recovery

T3 set the frequency of the AUDIO OSCILLATOR to about 1 kHz. This is your message.

T4 adjust the triggering and sweep speed of the oscilloscope to display two periods of the message (CH2-A).

T5 adjust the generator to produce an AM signal, with a depth of modulation less than 100%. Don't forget to so adjust the ADDER gains that its output (DC + AC) will not overload the MULTIPLIER; that is, keep the MULTIPLIER input within the bounds of the TMS ANALOG REFERENCE LEVEL (4 volt peak-to-peak). This signal is not symmetrical about zero volts; neither excursion should exceed the 2 volts peak level.

T6 for the case $m < 1$ observe that the output from the filter (the ideal envelope detector output) is the same shape as the envelope of the AM signal, a sine wave.

2. DSBSC

Ideal envelope detector

Now let us test the ideal envelope detector on a more complex envelope - that of a DSBSC signal.

T7 remove the carrier from the AM signal, by turning 'g' fully anti-clockwise, thus generating DSBSC. Alternatively, and to save the DC level just used, pull out the patch cord from the 'g' input of the ADDER (or switch the MULTIPLIER to AC).

Were you expecting to see the waveforms of Figure 18? What did you see? You may not have seen the expected waveform. Why not?

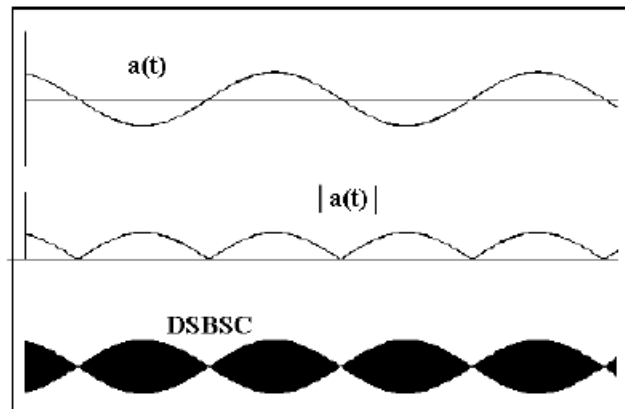

Figure 18: DSBSC signal

T8 (a) lower the frequency of the AUDIO OSCILLATOR, and watch the shape of the recovered envelope. When you think it is a better approximation to expectations, note the message frequency, and the filter bandwidth, and compare with predictions of the bandwidth of a full wave rectified sine wave.

(b) if you want to work with a 2 kHz message then replace the TUNEABLE LPF with a 60 kHz LOWPASS FILTER. Now the detector output should be a good copy of the envelope. Record the highest frequency that gives good envelope with this filter.

Diode detector

T9 connect an A_m signal with $m < 1$ directly to the ANALOG INPUT of the 'DIODE + LPF' in the UTILITIES MODULE, and the envelope (or its approximation) can be examined at the ANALOG OUTPUT. You should not add any additional low pass filtering, as the true 'diode detector' uses only a single RC network for this purpose, which is already included.

T10 repeat the previous Task, but with the RECTIFIER followed by a simple RC filter.

This compromise arrangement will show up the shortcomings of the RC filter. There is an independent RC LPF in the UTILITIES MODULE.

T11 you can examine various combinations of diode, ideal rectifier, RC and other Low pass filters, and lower carrier frequencies (use the VCO). The 60 kHz LPF is a very useful filter for envelope work.

T12 check by observation: is the RECTIFIER in the UTILITIES MODULE a half wave or full wave rectifier?

Product demodulator

T13 patch up the model of Figure 19. This shows $w_0 = w_1$. Before plugging in the PHASE SHIFTER, set the on-board switch to HI.

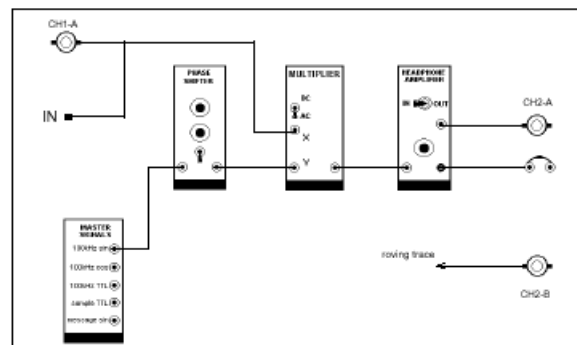

Figure 19: TIMS model of product demodulator

T14 create an A_m signal with $m=0.5$ and connect it to input of the synchronous demodulator. Examine the output of demodulator. Record your observation. Increase depth of modulation to 100% and 150%. Did this demodulator work for these signals? Remember that Envelope detector cannot use in these cases.

T15 create a DSB and connect it to input of the synchronous demodulator. Examine the output of demodulator. Record your observation.

3. SSB

T17 patch up a model of the phasing SSB generator, following the arrangement illustrated in Figure 20. Remember to set the on-board switch of the PHASE SHIFTER to the 'HI' (100 kHz) range before plugging it in and set the AUDIO OSCILLATOR to about 1 kHz

T18 switch the oscilloscope sweep to 'auto' mode, and connect the 'ext trig' to an output from the AUDIO OSCILLATOR. It is now synchronized to the message.

T19 connect an SSB signal to the demodulator input. Tune the VCO slowly around the 100 kHz region. Record output. Report results.

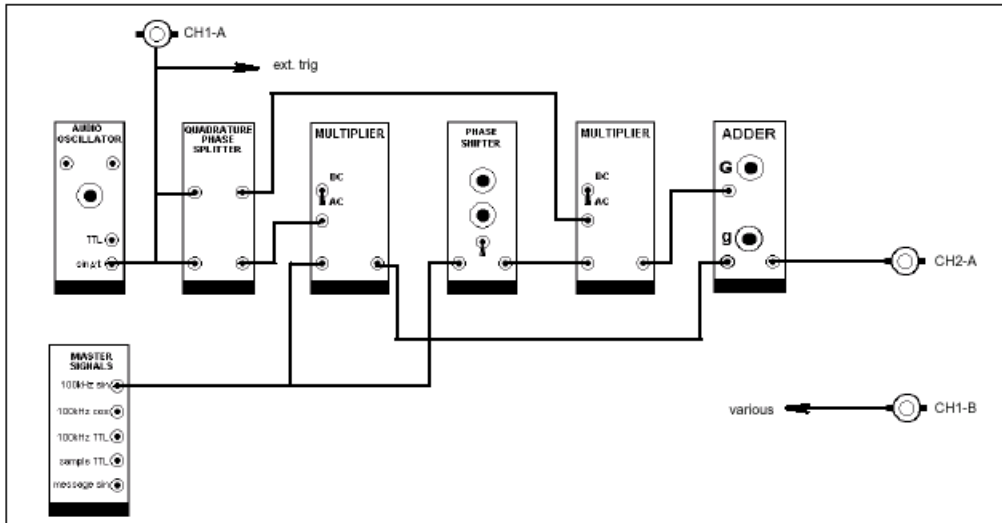

Figure 20: SSB phasing generator model

TUTORIAL QUESTIONS

Q1 how would you answer the question ‘what is the frequency of the signal $y(t) = E \cos(mt) \cos(\omega t)$?

Q2 what would the FREQUENCY COUNTER read if connected to the signal $y(t) = E \cos(mt) \cos(\omega t)$??

Q3 is a DSBSC signal periodic?

Q4 carry out the trigonometry to obtain the spectrum of a DSBSC signal when the message consists of three tones, namely:

$$\text{message} = A_1 \cos(\mu_1 t) + A_2 \cos(\mu_2 t) + A_3 \cos(\mu_3 t)$$

Show that it is the linear sum of three DSBSC, one for each of the individual message components.

Q5 derive eqn.(5), which relates the magnitude of the parameter ‘m’ to the peak-to-peak and trough-to-trough amplitudes of the AM signal.

Q6 there is no difficulty in relating the formula of eqn. (11) for values of ‘m’ less than unity. But the formula is also valid for $m > 1$, provided the magnitudes P and Q are interpreted correctly.

By varying ‘m’, and watching the waveform, can you see how P and Q are defined for $m > 1$?

Q7 an AM signal, depth of modulation 100% from a single tone message, has a peak-to- peak amplitude of 4 volts. What would an RMS voltmeter read if connected to this signal?

Q8 what simple modification(s) to your model would change the output from the current to the opposite sideband?

Q9 is the QPS an approximation to the Hilbert transformer? Explain.

Q10 sketch the output of an SSB transmitter, as seen in the time domain, when the message is two audio tones of equal amplitude. Discuss.

Q11 use phasors to construct the envelope of:

(a) an AM signal

(b) a DSBSC signal.

Q12 use phasors to construct the envelope of the sum of a DSBSC and a large carrier, when the phase difference between these two is not zero (as it is for AM). The technique should quickly convince you that the envelope is no longer a sine wave, although it may be tedious to obtain an exact shape.

Q13 explain the major differences in performance between envelope detectors with half and full wave rectifiers.

Q14 would you define the synchronous demodulator as an SSB demodulator? Explain.

Q15 if a ‘DSBSC’ signal had a small amount of carrier present what effect would this have as observed at the output of a synchronous demodulator?

Q16 suppose, while you were successfully demodulating a DSBSC based on 100 kHz carrier, a second DSBSC based on a 90 kHz carrier was added to it. Suppose the amplitude of this ‘unwanted’ DSBSC was much smaller than that of the wanted DSBSC.

a) would this new signal at the demodulator INPUT have any effect upon the message from the wanted signal as observed at the demodulator OUTPUT ?

- b) what if the unwanted DSBSC was of the same amplitude as the wanted DSBSC. Would it then have any effect?
- c) what if the unwanted DSBSC was ten times the amplitude of the wanted DSBSC.

Would it then have any effect? Explain!

Q17 what are the differences, and similarities, between a multiplier and a modulator?