

TA7
W34
no. ITL-
89-4
c.3



US Army Corps
of Engineers

COMPUTER-AIDED STRUCTURAL ENGINEERING (CASE) PROJECT

TECHNICAL REPORT ITL-89-4

CBASIN--STRUCTURAL DESIGN OF SAINT ANTHONY FALLS STILLING BASINS ACCORDING TO CORPS OF ENGINEERS CRITERIA FOR HYDRAULIC STRUCTURES

COMPUTER PROGRAM X0098

by

William A. Price

Information Technology Laboratory

DEPARTMENT OF THE ARMY

Waterways Experiment Station, Corps of Engineers

3909 Halls Ferry Road

Vicksburg, Mississippi 39180-6199

and

Edwin S. Alling

DEPARTMENT OF AGRICULTURE

Soil Conservation Service

Hyattsville, Maryland

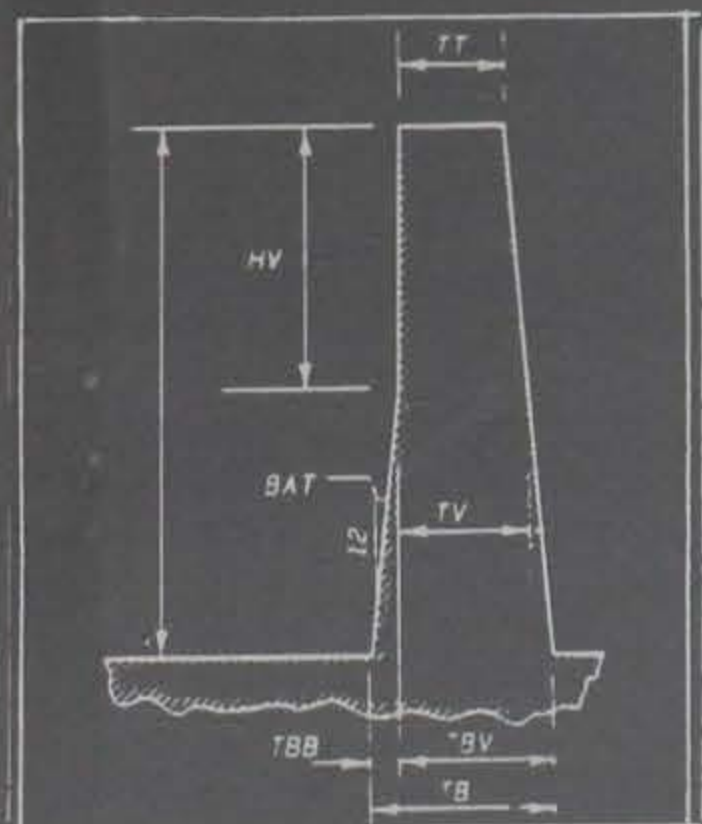
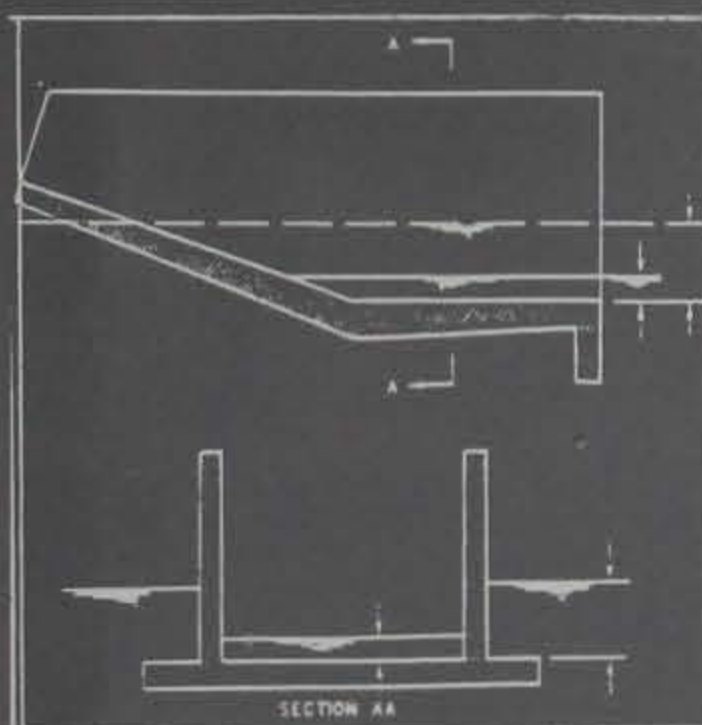

August 1989

Final Report

Approved For Public Release; Distribution Unlimited

Prepared for DEPARTMENT OF THE ARMY
US Army Corps of Engineers
Washington, DC 20314-1000

20368949

US-CE-C Property of the United States Government

W34
NO. ITR-89-4
C.3

Unclassified
SECURITY CLASSIFICATION OF THIS PAGE

REPORT DOCUMENTATION PAGE

Form Approved
OMB No 0704-0188
Exp. Date Jun 30, 1986

1a. REPORT SECURITY CLASSIFICATION Unclassified		1b. RESTRICTIVE MARKINGS	
2a. SECURITY CLASSIFICATION AUTHORITY		3. DISTRIBUTION/AVAILABILITY OF REPORT Approved for public release; distribution unlimited.	
2b. DECLASSIFICATION/DOWNGRADING SCHEDULE		5. MONITORING ORGANIZATION REPORT NUMBER(S)	
4. PERFORMING ORGANIZATION REPORT NUMBER(S) Technical Report ITR-89-4		7a. NAME OF MONITORING ORGANIZATION	
6a. NAME OF PERFORMING ORGANIZATION See reverse.	6b. OFFICE SYMBOL (If applicable) CEWES-IM-DA	7b. ADDRESS (City, State, and ZIP Code)	
6c. ADDRESS (City, State, and ZIP Code) See reverse.		9. PROCUREMENT INSTRUMENT IDENTIFICATION NUMBER	
8a. NAME OF FUNDING/SPONSORING ORGANIZATION US Army Corps of Engineers	8b. OFFICE SYMBOL (If applicable)	10. SOURCE OF FUNDING NUMBERS	
8c. ADDRESS (City, State, and ZIP Code) Washington, DC 20314-1000		PROGRAM ELEMENT NO.	PROJECT NO.
11. TITLE (Include Security Classification) CBASIN--Structural Design of Saint Anthony Falls Stilling Basins According to Corps of Engineers Criteria for Hydraulic Structures; Computer Program X0098		TASK NO.	WORK UNIT ACCESSION NO.
12. PERSONAL AUTHOR(S) Price, William A., Alling, Edwin S.			
13a. TYPE OF REPORT Final report	13b. TIME COVERED FROM _____ TO _____	14. DATE OF REPORT (Year, Month, Day) August 1989	15. PAGE COUNT 161
16. SUPPLEMENTARY NOTATION Available from National Technical Information Service, 5285 Port Royal Road, Springfield, VA 22161.			
17. COSATI CODES		18. SUBJECT TERMS (Continue on reverse if necessary and identify by block number)	
FIELD	GROUP	SUB-GROUP	
			Basins Soil Conservation Service
			Drainage Structural design
			Hydraulic structure
19. ABSTRACT (Continue on reverse if necessary and identify by block number)			
<p>The computer program CBASIN for stilling basins and its companion program CCHAN for U-Frame channels were obtained from the Soil Conservation Service (SCS) of the US Department of Agriculture for US Army Corps of Engineers (USACE) use in obtaining preliminary structural designs of important or unusual structures or complete designs of small, routine structures. These programs were adapted to Corps of Engineers criteria for hydraulic structures, and additional output information on member forces and moments was added.</p> <p>The SCS program document is included in this report as Appendix A. Information in the main text of this report supplements or supersedes portions of the SCS document.</p>			
20. DISTRIBUTION/AVAILABILITY OF ABSTRACT <input checked="" type="checkbox"/> UNCLASSIFIED/UNLIMITED <input type="checkbox"/> SAME AS RPT <input type="checkbox"/> DTIC USERS		21. ABSTRACT SECURITY CLASSIFICATION Unclassified	
22a. NAME OF RESPONSIBLE INDIVIDUAL		22b. TELEPHONE (Include Area Code)	22c. OFFICE SYMBOL

RESEARCH LIBRARY
US ARMY ENGINEER WATERWAYS
EXPERIMENT STATION
VICKSBURG, MISSISSIPPI

Unclassified

SECURITY CLASSIFICATION OF THIS PAGE

6a. NAME OF PERFORMING ORGANIZATION (Continued).

USAEWES, Information Technology Laboratory
and Soil Conservation Service

6c. ADDRESS (Continued)

3909 Halls Ferry Road
Vicksburg, MS 39180-6199
and Hyattsville, MD

Unclassified

SECURITY CLASSIFICATION OF THIS PAGE

ELECTRONIC COMPUTER PROGRAM ABSTRACT

TITLE OF PROGRAM X0098--CBASIN--Structural Design of SCS Saint Anthony Falls Stilling Basins According to CE Criteria

PROGRAM NO.
713-P-R0098

PREPARING AGENCY

CEWES Information Technology Laboratory

AUTHOR(S)

Edwin S. Alling
George Henson

DATE PROGRAM COMPLETED

Jan 1989

STATUS OF PROGRAM

PHASE

STAGE

A. PURPOSE OF PROGRAM

To perform preliminary or complete structural designs of stilling basins according to Technical Release No. 54, "Structural Design of SAF Stilling Basins," October 1974, of the Soil Conservation Service of the US Department of Agriculture, as modified for Corps of Engineers criteria.

B. PROGRAM SPECIFICATIONS

The program uses working stress analysis in accordance with Corps of Engineers EM 1110-1-2101, "Working Stresses."

C. METHODS

D. EQUIPMENT DETAILS

CBASIN runs on MS-DOS microcomputers. It does not use graphics. A math coprocessor is not required, but will be used if present.

E. INPUT-OUTPUT

Input is interactive, with full prompting.

Output is to the screen; use <Ctrl><PrtSc> to get a hard copy printout.

F. ADDITIONAL REMARKS

A user's guide is available from the Engineer Computer Program Library, WES, telephone (601) 634-2581. This user's guide includes Soil Conservation Service Technical Release No. 54.

PREFACE

The computer programs CBASIN and CCHAN were obtained by the US Army Corps of Engineers (USACE) from the Soil Conservation Service (SCS), US Department of Agriculture (USDA), for use in preliminary structural designs of important or unusual structures or complete design of routine structures.

The original program was written by Mr. Edwin S. Alling, Engineering Division, SCS, Hyattsville, MD. The program was later adapted to USACE criteria by Mr. Alling and Mr. George Henson, Structures Section, US Army Engineer District, Tulsa.

This project was a task of the U-Frame Basins and Channels Task Group of the Computer-Aided Structural Engineering (CASE) Project. Current membership of the CASE project is as follows:

Mr. Byron Bircher, General Chairman, CEMRK-ED-D
Mr. George Henson, Chairman, CESWT-ED-DT
Mr. Bill James, now retired from CESWD-ED-TS
Mr. Scott Snover, SCS, USDA
Mr. Tom Wright, CEMRK-ED-DT
Mr. Clifford Ford, CESPL-ED-DB
Mr. Donald R. Dressler, CEEC-ED
Mr. William A Price, CEWES-IM-DA

Mr. William A. Price, Information Technology Laboratory (ITL), coordinated the work at the US Army Engineer Waterways Experiment Station (WES) under the supervision of Mr. Paul K. Senter, Assistant Chief, ITL, and Dr. N. Radhakrishnan, Chief, ITL. The text of the report was written by Mr. Price, and Appendix A was written by Mr. Alling.

Acting Commander and Director of WES was LTC Jack R. Stephens, EN. Technical Director was Dr. Robert W. Whalin.

CONTENTS

	<u>Page</u>
PREFACE.....	1
CONVERSION FACTORS, NON-SI TO SI (METRIC) UNITS OF MEASUREMENT.....	3
PART I: INTRODUCTION.....	4
General.....	4
Capabilities.....	4
Limitations.....	4
PART II: DATA INPUT GUIDE.....	5
General.....	5
Narrative Input Guide.....	5
PART III: SPECIAL DISCUSSION OF USACE ADAPTATION.....	9
Channel Slope Restraint.....	9
Type "C" Stilling Basin Retaining Wall Stability Concern.....	9
Flotation Criteria.....	9
Concrete Cover Over Reinforcement.....	13
Froude Number Range.....	13
PART IV: OUTPUT.....	14
APPENDIX A: SCS TECHNICAL RELEASE NO. 54, "STRUCTURAL DESIGN OF SAF STILLING BASINS".....	A1
APPENDIX B: SAMPLE CBASIN RUN FOR SUMMARY DESIGNS.....	B1
APPENDIX C: SAMPLE CBASIN RUN FOR DETAILED DESIGN OF TYPE "A" BASIN...	C1
APPENDIX D: SAMPLE CBASIN RUN FOR DETAILED DESIGN OF TYPE "B" BASIN...	D1
APPENDIX E: SAMPLE CBASIN RUN FOR DETAILED DESIGN OF TYPE "C" BASIN...	E1

CONVERSION FACTORS, NON-SI TO SI (METRIC)
UNITS OF MEASUREMENT

Non-SI units of measurement used in this report can be converted to SI (metric) units as follows:

<u>Multiply</u>	<u>By</u>	<u>To Obtain</u>
cubic yards per foot	2.508	cubic metres per metre
feet	0.3048	metres
foot-pounds per foot	4.4482	joules per metre
inches	25.4	millimetres
pounds (force) per square foot	47.88026	pascals
pounds (force) per square inch	6894.757	pascals
pounds (mass) per cubic foot	16.01846	kilograms per cubic metre
square inches	6.4516	square metres

CBASIN--STRUCTURAL DESIGN OF SAINT ANTHONY FALLS
STILLING BASINS ACCORDING TO CORPS OF ENGINEERS
CRITERIA FOR HYDRAULIC STRUCTURES

COMPUTER PROGRAM X0098

PART I: INTRODUCTION

General

1. The computer program CBASIN for stilling basins and its companion program CCHAN for U-Frame channels were obtained from the Soil Conservation Service (SCS) of the US Department of Agriculture for US Army Corps of Engineers (USACE) use in obtaining preliminary structural designs of important or unusual structures or complete designs of small, routine structures. These programs were adapted to Corps of Engineers criteria for hydraulic structures, and additional output information on member forces and moments was added.

2. The SCS program document is included in this report as Appendix A. Information in the main text of this report supplements or supersedes portions of the SCS document.

Capabilities

3. This program performs the calculations for structural design of rectangular stilling basins in accordance with Corps of Engineers criteria for working stress design of hydraulic structures. Geometry is in accordance with the Saint Anthony Falls (SAF) stilling basin of the SCS, as illustrated in Figures 1-4 of Appendix A. Loadings are illustrated in Figures 5-9 of Appendix A.

Limitations

4. Program CBASIN (X0098) accepts as input the overall geometry, hydraulic data, and soils parameters; therefore, this information must all be determined before starting the program.

PART II: DATA INPUT GUIDE

General

5. Data are as defined for, and entered into, the original SCS program described in Appendix A--except as described below.

6. Data input was converted from the original SCS program's file input to on-line interactive, as a part of converting from mainframe time-sharing to personal computer hardware. An additional, optional data line was added to incorporate being able to select basic structural analysis parameters to conform to (a) the original SCS values, (b) the Corps of Engineers default values, or (c) any other values. Input prompting messages were expanded to present more recognizable help to the user. The user is led through data entry, line-by-line, as needed.

Narrative Input Guide

7. In response to the prompt line reading

ENTER TWO HEADER LINES, 80 CHAR. MAX EACH LINE,

the user must enter two lines with at least one nonblank character on each line. End each line with a carriage return.

8. Line number three is required. Its values are entered under the prompt reading

ENTER THE FOLLOWING

WIDTH	WALL	LENGTH	WALL	WATER	WATER	DESIGN	DFALTS
BASIN	D.S.	BASIN	U.S.	DEPTH	VELOC	PARAM	0=DEF
(FT)	(FT)	(FT)	(FT)	(FT)	(FT/SEC)	0,1,2,3	0,1
W	J	LB	N	D1	V1	DESIGN	DFALTS

The values should be separated by one or more blank spaces. Enough blank spaces may be used so that each value is spaced over under its own heading or they may be close together at the left end of the line. Each heading has three parts: an abbreviated description (i.e., "WALL D.S." to mean "wall height above top of downstream floor slab"), the units or a list of permissible values (i.e., "(FT)" or "0,1,2,3"), and the name of the value as used in the description herein and in Appendix A. See Figures 1-11 of Appendix A for

more complete descriptions. The variables in line three are defined as follows:

<u>Data Item Name and Definition</u>	<u>Units</u>	<u>Appendix A Figure</u>
W = Width of SAF basin	ft	1
J = Height of sidewall above top of floor slab	ft	1,11
LB = Length of SAF basin	ft	1,11
N = Height of sidewalls at upstream end	ft	1,11
D1 = Entrance depth of water to basin	ft	7,10
V1 = (Supercritical) entrance velocity of water	ft/sec	pp 11,12
DESIGN		
= 0, three preliminary designs performed (See Appendix B)		
= 1, detailed type A (See Appendix C)		1
= 2, detailed type B (See Appendix D)		2
= 3, detailed type C (See Appendix E)		3
DFALTS		
= 0, assign default values, lines four through eight omitted		
= 1, line four required		

9. Line four is used only if DFALTS was entered as 1 in line three. Its variables are entered in the following order, under the prompt headings listing them in the correct order:

DFALT1 DFALT2 DFALT3 DFALT4

where

DFALT1 = 0, use default values for line five
 = 1, line five must be provided
 DFALT2 = 0, use default values for line six
 = 1, line six must be provided
 DFALT3 = 0, use default values for line seven
 = 1, line seven must be provided
 DFALT4 = 0, use default values for line eight
 = 1, line eight must be provided

10. Line five is used only if DFALT1 was entered as 1 in line four. Its values are entered under the following prompting message:

HEIGHT FILL	TAILWATER	UPLIFT HD	TAILWATER	UPLIFT HD
DOWNSTREAM	LOAD CASE 2	LOAD C 2	LOAD C 1	LOAD C 1
FT	FT	FT	FT	FT
HB	HTW2	HUP2	HTW1	HUP1

where

<u>Name and Definition</u>	<u>Units</u>	<u>Appendix A Figure</u>
HB = Earthfill height above top of floor of basin at downstream end of basin (Default = .5J)	ft	5
HTW2 = Tailwater depth load condition 2 (Default = D2)	ft	7
HUP2 = Uplift head load condition 2 (Default = HTW2)	ft	7
HTW1 = Tailwater depth above top of floor of basin load condition 1 (Default = 0)	ft	6
HUP1 = Uplift head above top of floor of basin for load condition 1 (Default = .5 HUP2)	ft	6

11. Line six is used only if DFALT2 was entered as 1 in line four. Its values are entered under the following prompting message:

MAXIMUM	SAFETY	SAFETY	SLOPE PARAM	RATE BATTER
FOOTING	FACTOR	FACTOR	BASIN	INSIDE
PROJECT	FLOTATION	SLIDING	INCLINE	SIDEWALL
FT				
MAXFTG	FLOATR	SLIDER	ZS	BAT

where

<u>Name and Definition</u>	<u>Units</u>	<u>Appendix A Figure</u>
MAXFTG = Maximum acceptable sidewall footing projection (Default = .5W)	ft	
FLOATR = Safety factor against flotation (Default = 1.5)		
ZS = Slope parameter for inclined portion of basin (Default = 3.0)		1,2,3,11
BAT = Rate of batter inside surface of lower sidewall (Default = 3.75)	in./ft	11

12. Line seven is used only if DFALT3 was entered as 1 in line four. Its values are entered under the following prompting message:

UNIT WGT	UNIT WGT	LAF SOIL	COEF	DEPTH	WIDTH
MOIST	SATURATED	PRESSURE	FRICITION	TOE	TOE
BACKFILL	BACKFILL	RATIO	SOIL-CONC		
LB/CF	LB/CF		IN	FT	IN
GM	GS	KO	CFSC	HTW	TTW

where

Name and Definition	Units	Appendix A Figure
GM = Unit weight of moist backfill (Default = 120)	pcf	
GS = Unit weight of saturated backfill (Default = 140)	pcf	
KO = Lateral earth pressure ratio (Default = .8)		
CFSC = Coefficient of friction, soil to concrete (Default = .35)		
HTW = Depth of toe wall below top floor of basin (Default = 4)	ft	1,2,3,4
TTW = Thickness of toe wall (Default = 10)	in.	1,2,3,4

13. Line eight is used only if DFALT4 was entered as 1 in line four. Its values are entered under the following prompting message:

CONCRETE ULTIMATE STRENGTH (PSI) F'C	RATIO FC TO F'C COESF	ALLOWABLE STEEL STRESS (PSI) FSA	ALLOWABLE NET BEAR PRESSURE (PSF) ABP	MINIMUM CONCRETE THICKNESS (IN) TMIN
--	--------------------------------	--	---	--

where

Name and Definition (Default is for USACE)	Units	SCS Value
FPC = Concrete ultimate strength (Default = 3000)	psi	4000.0
COESF = Ratio fc/f'c (Default = .35)		0.4
FSA = Allowable steel stress (Default = 20000)	psi	20000.0
ABP = Allowable net bearing pressure (Default = 2000)	psf	2000.0
TMIN = Minimum concrete thickness (Default = 12)	in.	10.0

14. After all numeric data lines have been entered, and if a detailed design was requested (DESIGN in data line three is not 0), the program will ask the question

IS MOMENT, THRUST, SHEAR REPORT DESIRED? ENTER Y OR N...

Respond with a capital Y if the report (shown in Appendix C) is desired or with a capital N if it is not desired. Responding with a lower case letter will yield unpredictable results.

PART III: SPECIAL DISCUSSION OF USACE ADAPTATION

Channel Slope Restraint

15. The original SCS basin program had an imposed limit of 1:2 on the bottom slab slope value for the input variable ZS. While this was not a problem for typical basins, it reduced the usefulness of the program for rough estimates for drop structures. The limit was therefore removed and replaced by a warning message when ZS is entered with a value of less than 2.0. The rationale for this limit is shown graphically in Figure 1. The assumed behavior is seen to become invalid as ZS becomes less than a value around 2.0.

Type "C" Stilling Basin Retaining Wall
Stability Concern

16. The assumed water head inequalities shown on page A21 of Appendix A are especially important for the side walls of a type "C" basin. When the actual inequality deviates from the assumed relationships, type "C" wall stability is endangered. A test was added to detect this situation and to print a warning and a suggestion for correcting the design. This is illustrated in Figure 2.

Flotation Criterion

17. The original SCS program defined the factor of safety against flotation SF_f as

$$SF_f = \frac{\text{Sum of all forces down}}{\text{Sum of all forces up}}$$

When the program was converted to USACE criteria, in accordance with Engineer Technical Letter (ETL) 1110-2-307, the definition was changed. Figure 3 illustrates the adaptation of ETL 1110-2-307 to stilling basins and transforms the resulting equation to

$$SF_f = \frac{\text{Sum of all forces down} - \text{weight of water}}{\text{Sum of all forces up} - \text{weight of water}}$$

HYDRAULIC BEHAVIOR

Assumed

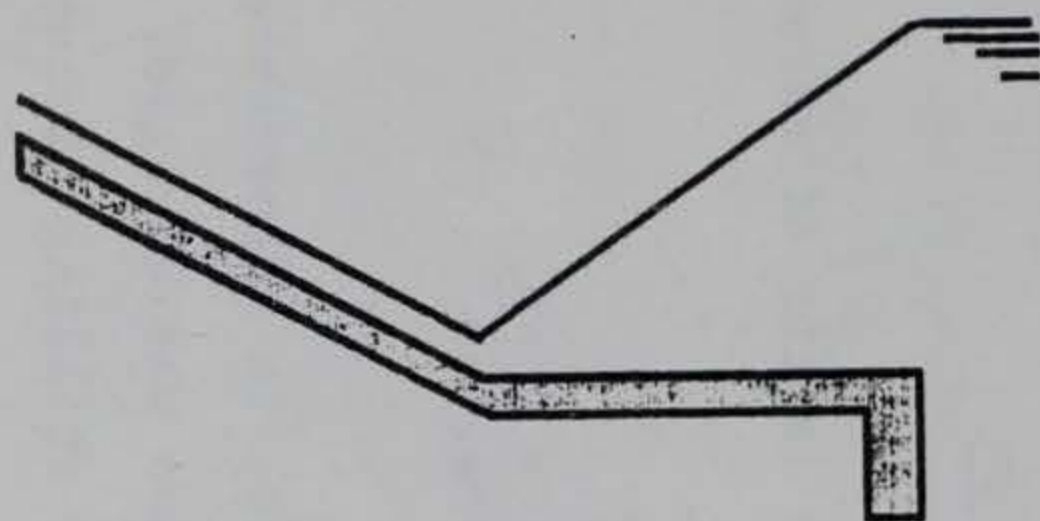

Actual – with Steep Channel Slope

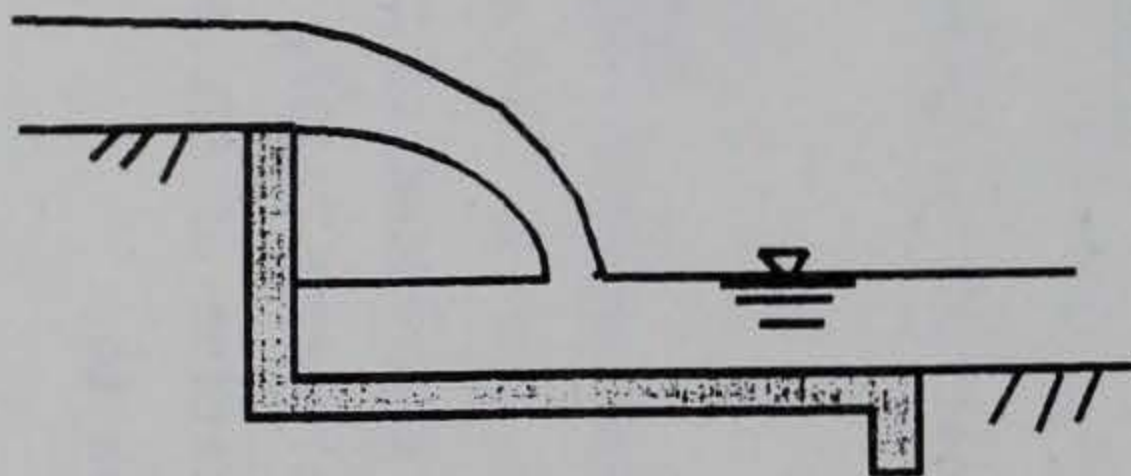

STRUCTURAL BEHAVIOR

Assumed

Channel section supported by sloping earth.

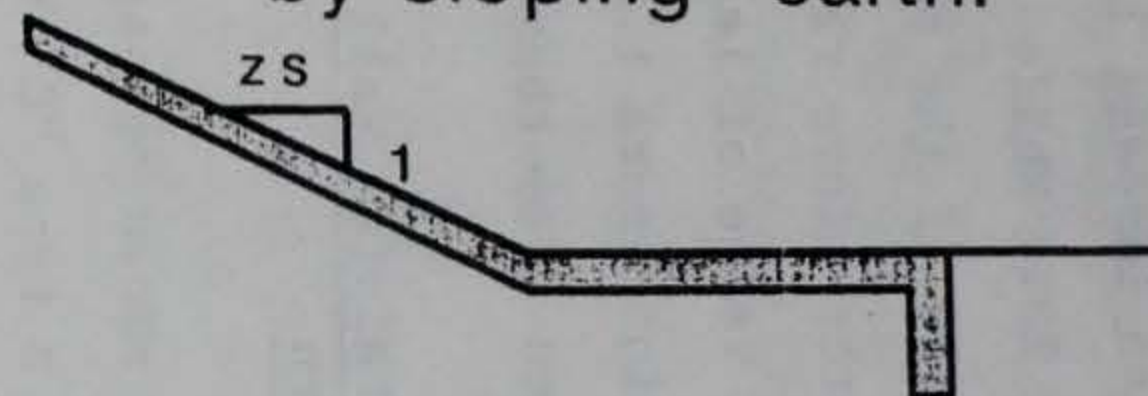

Actual – with Steep Channel Slope

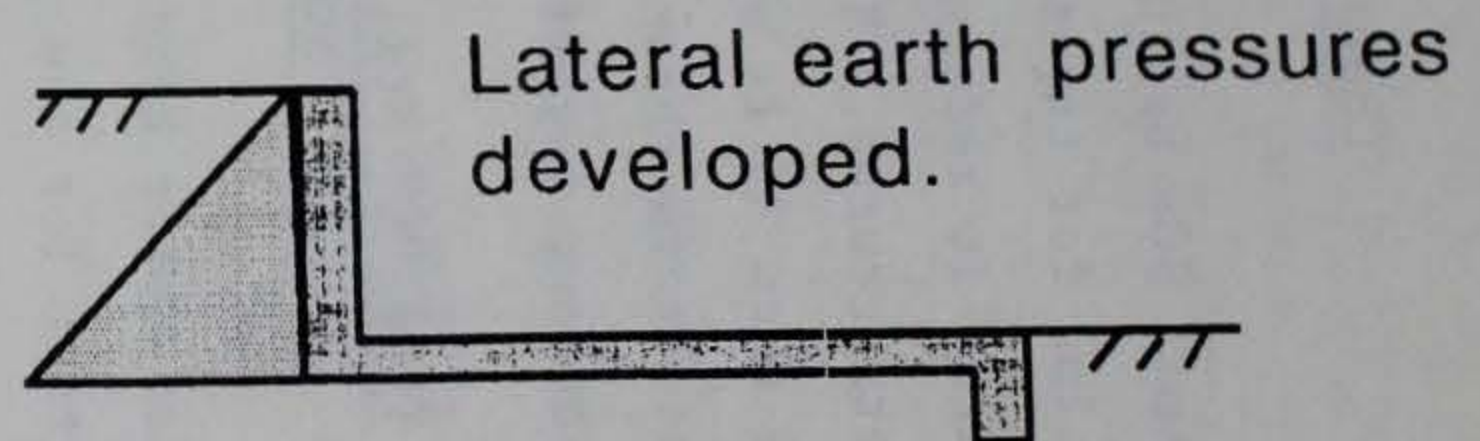

Therefore – when $ZS < 2$, a warning is given and design proceeds using assumed behavior.

Figure 1. Stilling basins, channel slope restraint

CAUTION CONCERNING RETAINING WALL PORTION STABILTY WHEN $HUP2 < HTW2$

Assumed

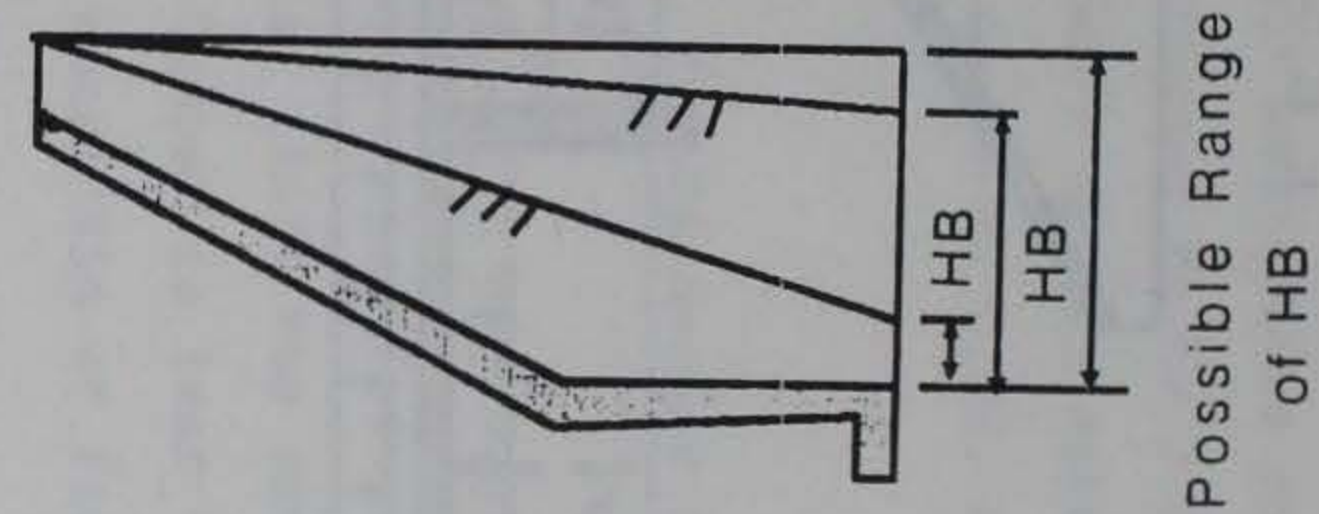
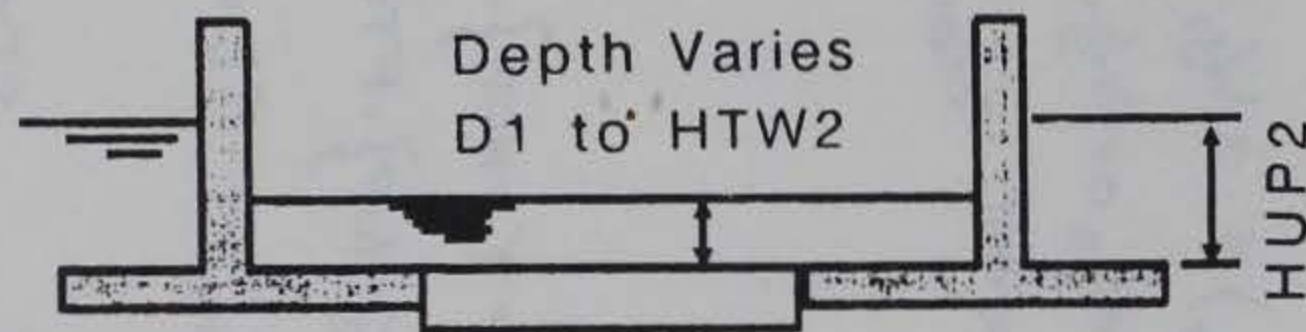

Possible Actual

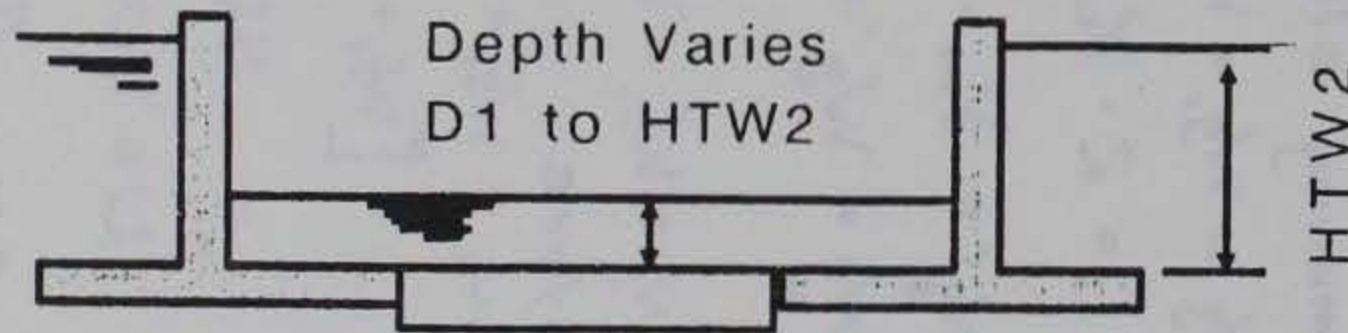

Retaining Wall Portion Analysis is three-dimensional. If $HUP2$ is higher than assumed, the stability could be in jeopardy. $HUP2 = HTW2$ is worst case condition.

Figure 2. Type "C" stilling basin

FLOTATION

STILLING BASINS

Either Load Condition can control.

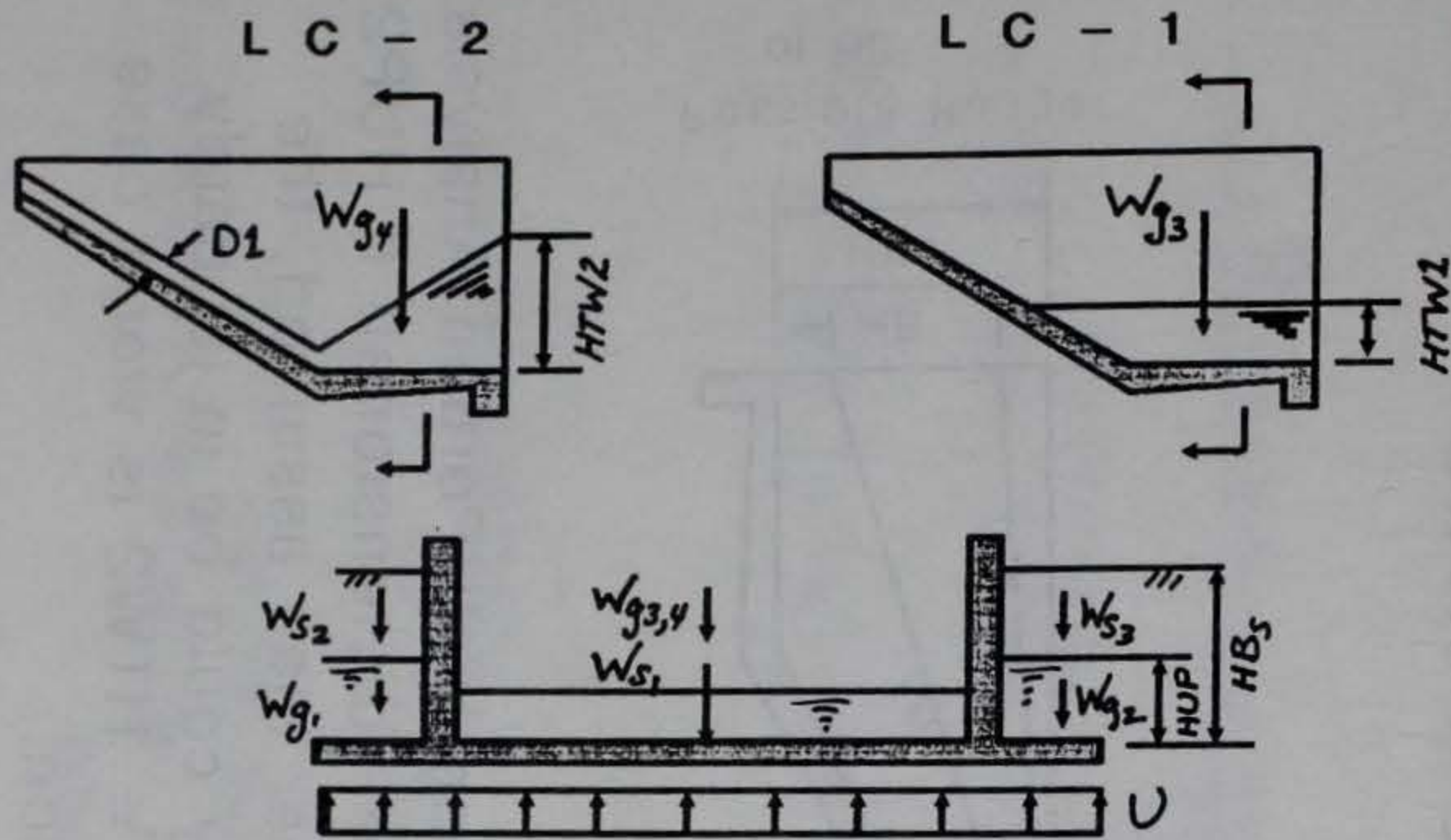

Per ETL 1110-2-307

$$SF_f = \frac{W_s + W_c + S}{U - W_g} \quad \therefore \text{here } SF_f = \frac{W_s}{U - W_g}$$

now, for a typical slice and recognizing need for summing slices:

$$W_g = W_{g1} + W_{g2} + (W_{g3} \text{ or } W_{g4}) = 2W_{g1} + (W_{g3} \text{ or } W_{g4}) \\ = 2 \cdot \gamma_w \cdot HUP \cdot FTG + (W_{g3} \text{ or } W_{g4})$$

let $W_{g'} = \gamma_w \cdot HUP \cdot FTG \cdot 2$ and $W_{bw} = W_{g3} \text{ or } W_{g4}$

so $W_g = W_{g'} + W_{bw}$

and

$$W_s = W_{s1} + W_{s2} + W_{s3}$$

as before

$$W_s = W_{s1} + \{ \gamma_m \cdot (HB_5 - HUP) + \gamma_s \cdot HUP \} \cdot FTG \cdot 2 - \gamma_w \cdot HUP \cdot FTG \cdot 2$$

$$= [W_{s1} + \{ \gamma_m \cdot (HB_5 - HUP) + \gamma_s \cdot HUP \} \cdot FTG \cdot 2 + W_{bw}] - W_{g'} - W_{bw}$$

$$= SDOWN - W_{g'} - W_{bw} \equiv SDOWN - W_g$$

and

$$U \equiv SUP$$

so

$$SF_f = \frac{SDOWN - W_{g'} - W_{bw}}{SUP - W_{g'} - W_{bw}} \equiv \frac{SDOWN - W_g}{SUP - W_g}$$

Figure 3. ETL 1110-2-307 adapted to stilling basins

Concrete Cover Over Reinforcement

18. The concrete clear cover over reinforcing steel was programmed in the SCS program as being 2 in.* everywhere except for bottom steel in the bottom slab where it was programmed to be 3 in. The USACE modifications added that it would be 3 in. everywhere if the data item COESF is less than 0.38. (If COESF is greater than or equal to 0.38, then the cover is not changed from the original SCS values.)

Froude Number Range

19. The SCS program restricts the Froude number to a minimum of 3.0. To permit the use of the USACE version for preliminary estimates of a wider range of structures, the forced limit was removed and replaced with a warning that reads "Warning - Froude Number is less than 3.0 - Hydraulic jump is inefficient and jump form is uncertain at Froude numbers between 1.0 and 3.0. Design continues."

* A table of factors for converting non-SI units of measurement to SI (metric) units is presented in page 3.

PART IV: OUTPUT

20. Output consists of three parts. Each part has its own heading; the first two parts, with headings expanded and rearranged for improved clarity, are as in the original program described in Appendix A. The third part, produced with the "Y" answer described in paragraph 14, is new.

21. The first part is essentially a summary of the input data. It is introduced with the printed line

DESIGN PARAMETERS

22. The second part has two alternate forms, depending on the value of DESIGN in data line three.

23. If DESIGN was given a value of "0" for "preliminary designs," part two will be introduced by the printed line

PRELIMINARY DESIGNS FOLLOW

This is illustrated in Appendix B.

24. If DESIGN was given a value of "1", "2", or "3" for detailed design of types "A", "B", or "C" basins, respectively, part two will be introduced by the printed line

DESIGN OF SPECIFIED TYPE BASIN FOLLOWS

It is ended with the printed line

```
=== END DETAIL DESIGN === WINGWALL PER TRNOTICE 54-1
```

This is illustrated in Appendices C, D, and E.

25. Part three, if requested as described in paragraph 14, is introduced by the printed line

MOMENT, THRUST, SHEAR REPORT

It starts with an echo of data lines one and two. This is followed with a message referring to Figures 42, 44, 45, 46, and 47 of Appendix A for illustration of location codes. This is illustrated in Appendix E.

APPENDIX A: SCS TECHNICAL RELEASE NO. 54,
"Structural Design of SAF Stilling Basins"

Page numbers at top of pages are as in the original Soil Conservation Service document. Page numbers at bottom of pages in this appendix are for this document.

U. S. Department of Agriculture
Soil Conservation Service
Engineering Division

Technical Release No. 54
Design Unit
October, 1974

STRUCTURAL DESIGN OF SAF STILLING BASINS

PREFACE

This technical release continues the effort to produce design aids which can serve to improve the efficiency and quality of design work. The technical release deals with the structural design of SAF stilling basins. TR-50 deals with the structural design of rectangular channels. Taken together, these two technical releases provide a means of obtaining structural designs for essentially all sections of ordinary, straight inlet, chute spillways on earth foundations. This material should be useful to both planning and design engineers since either preliminary or detail designs may be obtained.

A draft of the subject technical release dated July, 1974, was sent to the Engineering and Watershed Planning Unit Design Engineers for their review and comment.

This technical release was prepared by Mr. Edwin S. Alling, Head, Design Unit, Design Branch at Hyattsville, Maryland. He also wrote the computer program.

TECHNICAL RELEASE
NUMBER 54

STRUCTURAL DESIGN OF SAF STILLING BASINS

Contents

Introduction	1
Types of SAF Stilling Basins	2
Type (A)	3
Type (B)	4
Type (C)	5
Wingwalls	6
Loading Conditions	7
Surcharge	7
Load Condition No. 1	8
Load Condition No. 2	9
Flotation Requirements	10
Sliding Requirements	10
Sliding forces	10
Momentum considerations	11
Possible modification of load condition No. 2	13
Design Parameters	13
Primary Parameters	13
Secondary Parameters	13
Design Criteria	15
Preliminary Designs	17
Type (A)	17
Sidewall geometry and load variables	17
Sidewall bending	20
Flotation	23
Bearing pressures	26
Floor slab shear	28
Floor slab bending	28
Sliding	30
Momentum changes at break-in-grade	30
Type (B)	31
Sidewall bending	31
Flotation	32
Bearing pressures	33
Floor slab shear and bending	35
Sliding	35
Type (C)	
Pavement slab design	36
Flotation	36
Bearing pressures	36
Sliding	36
Longitudinal shear and bending	38

Retaining wall portions	39
Bearing pressures	41
Base slab shear and bending	43
Wingwalls	44
Loading conditions	45
Wingwall bending	47
Overturning	48
Sliding	50
Wingwall-to-basin tie	51
Detail Designs	53
Sidewall steel	53
Floor slab steel	56
Base slab steel	57
Pavement slab steel	58
Wingwall steel	58
Concrete Volumes	63
Basin Volumes	63
Wingwall Volumes	63
Sidewall stub adjustment	66
Toewall stub adjustment	66
Basin footing adjustment	66
Computer Designs	68
Input	68
Output	69
Messages	69
Preliminary designs	70
Detail designs	70
Type (A)	70
Type (B)	70
Type (C)	70
Wingwalls	70
Appendix	
Toewall thickness and steel for SAF stilling basins	75

Figures

Figure 1	Type (A) SAF stilling basin	3
Figure 2	Type (B) SAF stilling basin	4
Figure 3	Type (C) SAF stilling basin	5
Figure 4	Wingwall layout	6
Figure 5	Variation in earthfill surface	7
Figure 6	Load condition No. 1	8
Figure 7	Load condition No. 2	9
Figure 8	Horizontal components of hydrostatic forces, load condition No. 1	10
Figure 9	Sliding forces, load condition No. 2	11
Figure 10	Momentum relations in basin	11
Figure 11	Sidewall dimensions and thicknesses	18
Figure 12	Section and earthfill heights	19
Figure 13	Tailwater depths for load condition No. 2	20
Figure 14	Considerations for sidewall bending, type (A) basin	20
Figure 15	Thickness at bottom of section, when $HBW > HWW$	21
Figure 16	Determination of controlling thickness	23
Figure 17	Components of sidewall and slab volumes	24
Figure 18	Components of volume of water in basin	24
Figure 19	Footing pressures and load components for LC #1 or LC #2	25
Figure 20	Components of uplift for LC #1 or LC #2	25
Figure 21	Determination of bearing pressures for LC #2	27
Figure 22	Loads for floor slab shear and bending	29
Figure 23	Considerations for sidewall bending, type (B) basin	31
Figure 24	Some type (B) components	32
Figure 25	Distribution of bearing pressures, type (B)	33
Figure 26	Equivalent beam and loading	34
Figure 27	Division of horizontal force, LC #2	35
Figure 28	Pavement slab components	37
Figure 29	Determination of pavement slab bearing pressures, LC #1	38
Figure 30	Shear and moment in pavement slab, LC #2	39
Figure 31	Determination of retaining wall portion bearing pressures	40
Figure 32	Retaining wall portion lateral force moments, LC #2	42
Figure 33	Loadings for base slab shear and moment	43
Figure 34	Wingwall design section	44
Figure 35	Wingwall earthfill surfaces and slopes	45
Figure 36	Load conditions for wingwall design	46
Figure 37	Determination of wingwall thickness	47
Figure 38	Wingwall footing projections	48
Figure 39	Wingwall overturning and bearing	49
Figure 40	Longitudinal sliding of wingwall	50
Figure 41	Wingwall-to-basin tie steel area	51
Figure 42	Sidewall steel layout and point locations	54
Figure 43	Sidewall steel determination	55
Figure 44	Floor slab steel layout and point locations	56

Figure 45	Base slab steel layout and point locations	57
Figure 46	Pavement slab steel layout and point locations	58
Figure 47	Wingwall steel point locations	59
Figure 48	Wingwall section steel layout	60
Figure 49	Determination of force system at a point in wingwall	61
Figure 50	Determination of force system in wingwall footing	62
Figure 51	Wingwall volume without adjustments	64
Figure 52	Corner detail, wingwall-sidewall	65
Figure 53	Possible basin footing adjustment volumes	67
Figure 54	Computer output, preliminary designs	71
Figure 55	Computer output, type (A) detail design	72
Figure 56	Computer output, type (B) detail design	73
Figure 57	Computer output, type (C) detail design	74

Tables

Table 1	Secondary parameters and default values	14
Table 2	Input values per design run	68

NOMENCLATURE

Not all nomenclature is listed. Hopefully the meaning of any unlisted nomenclature may be ascertained from that shown. Trailing letters U or D are used with some variables. This signifies variables associated with the upstream or downstream portion of type (B) stilling basins.

A	≡ required reinforcing steel area
A_1	≡ area of right section at one end of prismatoid
A_2	≡ area of right section at opposite end of prismatoid
A_m	≡ area of mid-section of prismatoid
ARM	≡ distance from B-line to underside of upstream section; moment arm of wingwall-to-basin tie
ATIE	≡ required steel area of wingwall-to-basin tie
BACK	≡ distance used to define the wingwall footing extension back to the sidewall
BASEL	≡ horizontal length of basin projected bearing area
BAT	≡ rate of batter of inside surface of lower part of sidewall
BDN	≡ footing projection at downstream end of wingwall
BUP	≡ footing projection at upstream end of wingwall-section at articulation joint
b	≡ width of reinforced concrete member
CB	≡ direct compressive force in the floor slab between sidewalls
CC	≡ construction condition, a loading condition investigated in wingwall design
CF	≡ direct compressive force in the footing projection
CFSC	≡ coefficient of friction, soil to concrete
D	≡ effective depth of concrete section; diameter of reinforcing bar
D1	≡ entrance depth of water to SAF stilling basin
D2	≡ the sequent depth to depth D1
DS	≡ a sequent depth
DW	≡ depth of water in basin; tailwater depth in wingwall design
DWD	= $DW - D/12$
DZ	≡ depth of water in basin above section under consideration
E	≡ eccentricity of VNET
F_1	≡ Froude's number = $V1^2/gD1$
FBOT	≡ uniform tangential loading on bottom of pavement slab
FH1	≡ horizontal component of hydrostatic force due to HUP1
FH2	≡ horizontal component of hydrostatic force due to HUP2
FH2WD	≡ the part of FH2 x W carried by downstream portion of type (B) basin
FLOATR	≡ safety factor against flotation
FM	≡ force due to horizontal change in momentum
FML	≡ momentum force at section of depth D1
FM2	≡ momentum force at section of depth HW2
FS2	= $FH2 + FM$
FSLIDE	≡ resultant of the horizontal driving forces tending to cause sliding of the basin
FT1	≡ horizontal component of hydrostatic force due to HW1

FTG	≡ footing projection
FTOP	≡ uniform tangential loading on top of pavement slab
F_{x1}	≡ hydrostatic force due to depth D1
F_{x2}	≡ hydrostatic force due to depth HTW2
f_c	≡ compressive stress in concrete
f_s	≡ stress in reinforcing steel
GB	= GS - 62.4
GM	≡ moist unit weight of earthfill
GS	≡ saturated unit weight of earthfill
g	= 32.2 ft per sec ²
HB	≡ earthfill height above top of floor of basin at downstream end of basin
HBD	= HBW - D/12
HBn	≡ earthfill height at section n
HBW	≡ working value of height of earthfill
HBZ	≡ height of earthfill above section under consideration
HDIFF	= (HBW - HWW) or (HBW - HUW)
HN	≡ vertical component of distance N
HNET	≡ net horizontal force per unit length acting on wingwall design section
HS	≡ vertical projection of inclined floor slab
HSHV	= (HSW - HV) or (J - HV)
HSn	≡ height of section n
HSW	≡ working value of height of section
HTmn	≡ tailwater depth at section n for load condition m
HTW	≡ depth of toewall below top of floor of basin
HTW1	≡ tailwater depth above top of floor of basin for load condition No. 1
HUP	≡ uplift head above top of floor of basin for load condition under consideration
HUP1	≡ uplift head above top of floor of basin for load condition No. 1
HUm	≡ uplift head at section n for load condition m
HUW	≡ working value of uplift head at section under consideration
HV	≡ the distance over which the inside surface of the sidewall is vertical
HVZ	≡ battered height of sidewall above section under consideration
HW	≡ uplift head above top of wingwall footing at the articulation joint for load condition under investigation
HWALL	≡ shear at bottom of sidewall at section under investigation
HWD	= HWW - D/12
HWW	≡ working value of water head on outside of sidewall
HWZ	≡ height of water head above section under consideration
HX	≡ depth of water over top of pavement slab at XDN from downstream end
h	≡ perpendicular distance between right end sections
IIC	≡ intermediate load condition used in wingwall design
J	≡ height of sidewall above top of floor of basin
KO	≡ lateral earth pressure ratio
LB	≡ length of SAF stilling basin
LBOT	≡ length of bottom of type (A) basin

LC#1	≡ load condition No. 1
LEVEL	≡ distance used to locate the wingwall articulation joint with respect to the corner of the sidewall
LN	≡ horizontal component of distance N
LS	≡ horizontal projection of inclined floor slab
LTOP	≡ length of top of sidewall of type (A) basin
LTOT	≡ overall length of type (B) and (C) basins
M	≡ bending moment; moment of forces about some moment center
MA	≡ moment of forces about the A-line of type (C) basins
MAXFTG	≡ maximum acceptable sidewall footing projection
MB	≡ moment of forces about the B-line of type (C) basins
MC	≡ bending moment at the center of the floor slab
MDN	≡ resultant moment of the forces on the downstream portion about the hinge
MP	≡ bending moment in pavement slab
M_s	≡ equivalent moment, moment about axis at the tension steel
MTIE	≡ bending moment used to obtain ATIE at wingwall-to-basin tie
MUP	≡ resultant moment of the forces on the upstream portion about the hinge
MZ	≡ bending moment at section under consideration
N	≡ height of sidewalls at upstream end section; direct compressive force in sidewall
NLAT	≡ bearing force between pavement slab and retaining wall portion
NWALL	≡ direct force of wingwall
NZ	≡ direct compressive force at section under consideration
PALLOW	≡ maximum allowable bearing (contact) pressure
PARM	≡ distance between PWALL and vertical face of sidewall
PAVER	≡ average bearing pressure
PB	≡ bearing pressure at section under investigation
PBG	≡ bearing pressure at break-in-grade
PBH	≡ bearing pressure at heel of retaining wall portion
PBT	≡ bearing pressure at toe of retaining wall portion
PDH	≡ bearing pressure at heel of downstream end section
PDN	≡ bearing pressure at downstream end section
PDT	≡ bearing pressure at toe of downstream end section
PDW	≡ water pressure in basin
PF	≡ pressure on footing projection
PFn	≡ pressure on footing projection at section n
PLONG	≡ net longitudinal shearing forces assumed carried by sidewalls
PNET	≡ net uniform loading between sidewalls
PTS	≡ dead weight of floor slab
PUH	≡ bearing pressure at heel of upstream end section
PUP	≡ bearing pressure at upstream end section
PUT	≡ bearing pressure at toe of upstream end section
PUW	≡ uplift pressure on underside of slab
PWALL	≡ direct force of sidewall
PX	≡ bearing pressure on pavement slab at XDN from downstream end
pcf	≡ pounds per cubic foot
psf	≡ pounds per square foot

p_t	≡ temperature and shrinkage steel ratio
Q	≡ SAF stilling basin discharge
QUANT	≡ quantity, volume of stilling basin or associated wingwalls
q	≡ unit discharge
S	≡ maximum allowable spacing of reinforcing steel
SDOWN	≡ sum of all downward forces acting on a basin or portion
SLIDER	≡ safety factor against sliding
SUP	≡ sum of all uplift forces acting on a basin or portion
SZ	≡ maximum allowable spacing of reinforcing steel at section under consideration
T	≡ required thickness
T'	≡ required thickness at bottom of section due to T
T''	= HSHV x BAT
TABn	≡ required thickness at bottom of section n
TADD	≡ thickness to be added for cover
TB	≡ thickness at bottom of sidewall
TBB	≡ thickness at bottom of sidewall due to batter of inside face
TBV	≡ thickness at bottom of sidewall exclusive of TBB
TM	≡ required thickness due to bending moment
TPBG	≡ thickness of pavement slab at break-in-grade
TPDN	≡ thickness of pavement slab at downstream end section
TPUP	≡ thickness of pavement slab at upstream end section
TS	≡ thickness of slab; thickness required for shear
TSB	≡ thickness required at bottom of sidewall due to required TV at HV
TSBG	≡ slab thickness at break-in-grade
TSDN	≡ slab thickness at downstream end section
TSR	≡ required slab thickness
TSUP	≡ slab thickness at upstream end section
TSV	≡ thickness required at bottom of sidewall if HSW > HV
TT	≡ thickness at top of sidewall
TTW	≡ thickness of toewall
TV	≡ thickness of sidewall at HV from top of sidewall
TVn	≡ required thickness of sidewall at HV from top of sidewall at section n
TW	≡ working thickness of inclined floor slab at XBG from break-in-grade
TWF	≡ thickness of wingwall footing
TWT	≡ thickness of wingwall toewall
TWW	≡ thickness of wingwall
TX	≡ thickness of pavement slab at XDN from downstream end
ULONG	≡ net longitudinal shearing forces assumed carried by floor or base slab
UX	≡ uplift head on pavement slab at XDN from downstream end
u	≡ flexural bond stress in concrete
V	≡ concrete volume; shearing force at section under consideration
V1	≡ entrance velocity of water to SAF stilling basin
V2	= V1 x D1/HTW2
VFTG	≡ basin footing adjustment volume
VNET	= SDOWN - SUP

VP	≡ shear in pavement slab
VRDN	≡ resultant of the vertical forces acting on the downstream portion of type (B) basin
VRUP	≡ resultant of the vertical forces acting on the upstream portion of type (B) basin
VTOE	≡ toewall stub adjustment volume
VWALL	≡ sidewall stub adjustment volume
WING	≡ volume of wingwalls exclusive of VFTG; resultant vertical force on wingwall
WOAD	≡ wingwall volume without adjustments
VZ	≡ shear at section under consideration
v	≡ shearing stress in concrete
W	≡ width of SAF stilling basin
WDES	≡ perpendicular distance from sidewall to the point where the outside edge of the wingwall footing intersects the plane of the downstream end section
WEXT	≡ perpendicular distance from sidewall to the point on the outside edge of the wingwall footing that is in the plane of the articulation joint
WO	≡ overall width of stilling basin
WOB	≡ overall width of retaining wall base; overall width of wingwall base
WPROJ	≡ wingwall projection, the perpendicular distance from the sidewall to the farthest point on the outside edge of the wingwall footing
WTWT	≡ perpendicular distance from the sidewall to the point of intersection of wingwall toewall and plane of downstream end section
WWLB	≡ perpendicular distance from the plane of the downstream end section to the point where the wingwall footing extended backward would intersect the outer edge of the sidewall
X	≡ toe length of retaining wall base; distance from articulation joint to any vertical section of the wingwall
XBG	≡ distance from break-in-grade to any vertical section of the inclined floor slab
XDN	≡ distance from downstream end to any vertical section of the pavement slab or retaining wall portion
XP	≡ width of pavement slab
YB	≡ earthfill height above top of wingwall footing at distance X from articulation joint
YW	≡ height of water on back face of the wingwall at distance X from articulation joint
Z	≡ distance from moment center to VNET; distance from top of sidewall to section under consideration; distance from outer edge of wingwall footing to section under consideration
ZH	≡ slope hypotenuse parameter
ZNS	≡ slope parameter used to define an earthfill slope
ZNW	≡ a slope parameter used to define an earthfill slope
ZPS	≡ a slope parameter used to define an earthfill slope
ZS	≡ slope parameter for inclined portion of stilling basin
γ	= 62.4 pcf

TECHNICAL RELEASE
NUMBER 54

STRUCTURAL DESIGN OF SAF STILLING BASINS

Introduction

This technical release is concerned with the structural design of SAF stilling basins. The hydraulic criteria for the dimensions of SAF outlets were developed by Fred W. Blaisdell, Hydraulic Engineer, ARS, St. Anthony Falls Hydraulic Laboratory. These criteria are presented in National Engineering Handbook, Section 14, "Chute Spillways," written by Paul D. Doubt, formerly Head, Design Unit, SCS, Hyattsville, Maryland.

The material presented herein treats the structural design of rectangular stilling basins having the general layout indicated on Engineering Standard Drawing ES-86, sheet 1, contained in NEH-14. This material does not include hydraulic design which must precede structural design. It is assumed these structural designs will be obtained from computers although the basic approach is independent of computer usage. Technical Release No. 50, "Design of Rectangular Structural Channels," can be used to obtain preliminary and detail structural designs of chute spillway sections upstream of the stilling basin.

A computer program was written in FORTRAN for IBM 360 equipment to perform these SAF stilling basin designs. The program operates in two modes. It will execute preliminary designs to aid the designer in selecting the type of basin he desires to use in final design. The program will also execute the detail design of specified basins. Concrete thicknesses and distances are determined and steel requirements, in terms of required area and maximum spacing, are evaluated at various locations. Actual steel sizes and layouts are not selected, these are the prerogative of the designer.

This technical release documents the criteria and procedures used in the computer program, explains the input data required to obtain a design, and illustrates computer output for preliminary and detail designs. At the present time designs may be obtained by requests to the

Head, Design Unit
Engineering Division
Soil Conservation Service
Federal Center Building
Hyattsville, Maryland 20782.

Input information which must be provided for each design run, is discussed under the section, "Computer Designs, Input."

Types of SAF Stilling Basins

Three types of SAF stilling basins are treated herein. Each type may be thought of as a structural variation of the SAF outlet shown on ES-86, sheet 1, and each uses the alternate joint detail given in that drawing. All types are assumed symmetrical in both construction and loading about the longitudinal centerline of the basin as well as about the vertical centerline of any transverse cross section. Each basin is designed for the two loading conditions described in the next section, and each must satisfy both flotation (uplift) requirements and sliding requirements. See Figures 1-3 for definition sketches of the three types of basins. These sketches present idealized stilling basins and do not show chute blocks, floor blocks, end sills, fillets on toewalls, upstream floor joint steps, or wingwalls. The wingwalls are omitted from these sketches for clarity and because the wingwall and basin proper are designed to act essentially independently of each other.

Any one of the three types of SAF stilling basin may be most advantageous for a particular set of design conditions. Because of the large number of parameters involved, it is often not readily apparent which type will be best in a given situation.

Type (A)

This type, see Figure 1, most closely approximates the SAF outlet of ES-86. Structurally, the basin is a monolithic unit. The floor slab thicknesses vary uniformly from the downstream end of the basin to the break-in-grade, and from the break-in-grade to the upstream end.

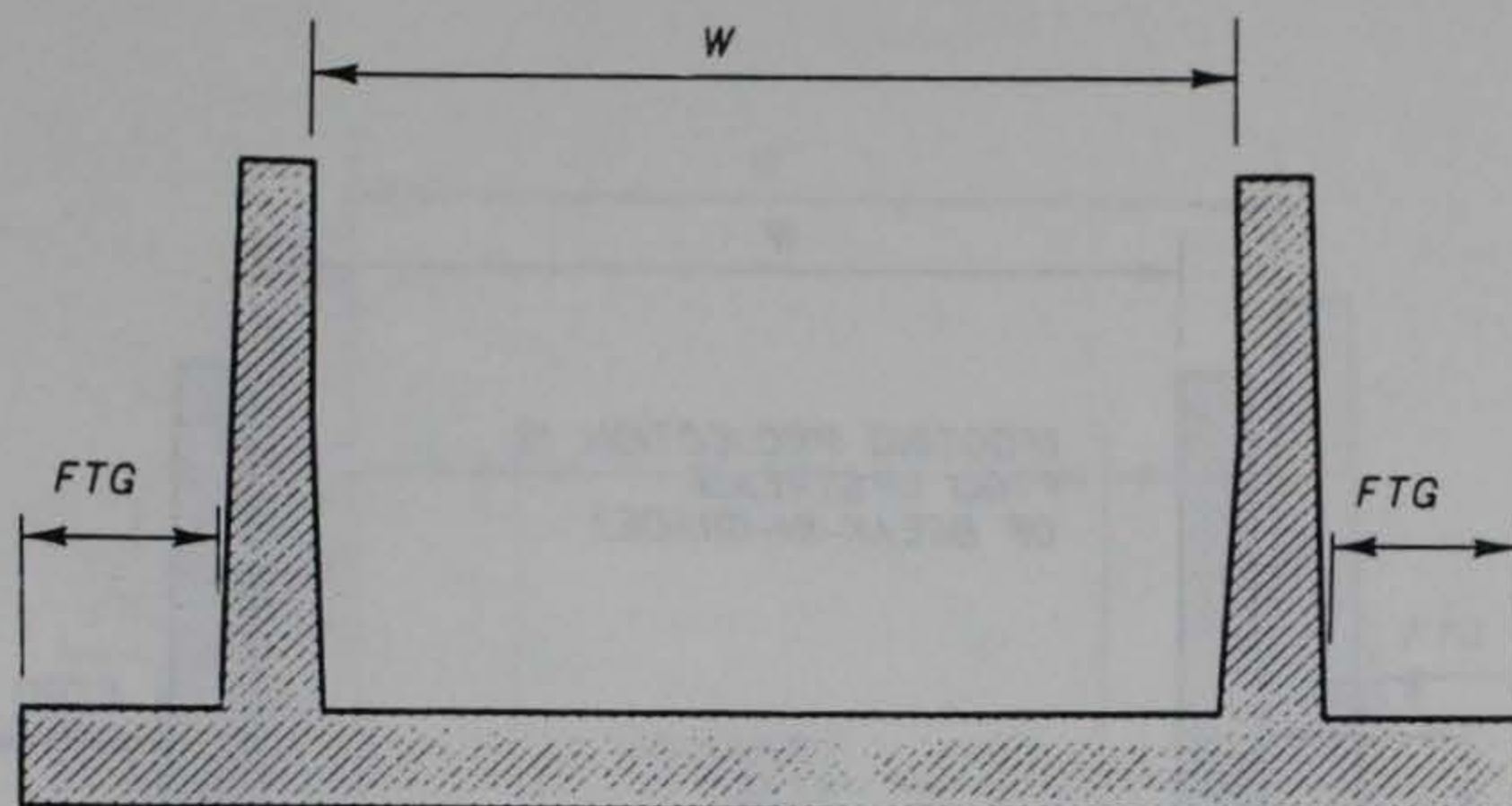

TRANSVERSE SECTION
THRU FLOOR OF BASIN

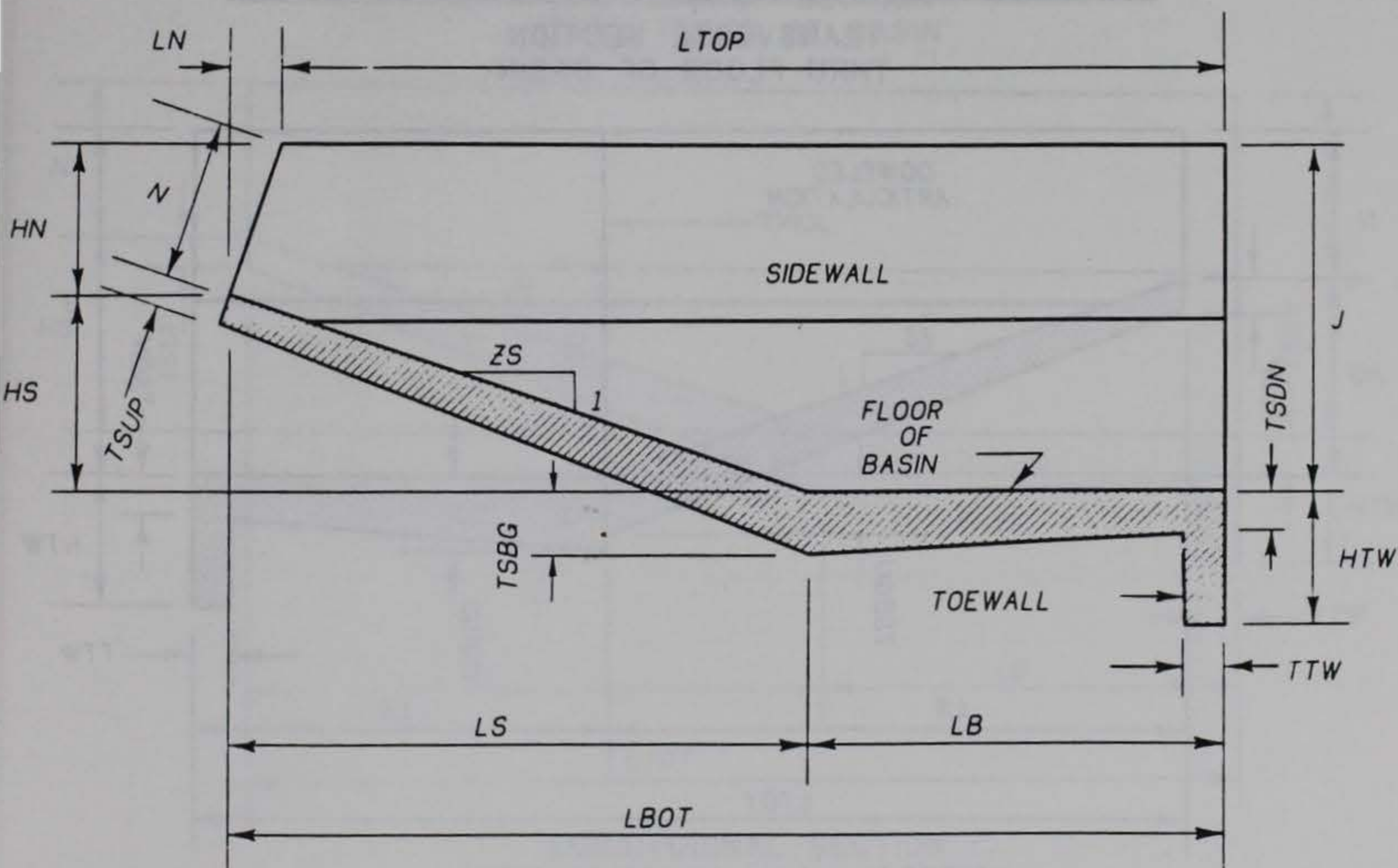

LONGITUDINAL SECTION

Figure 1. Type (A) SAF stilling basin

Type (B)

This type, see Figure 2, has a transverse articulated joint at the break-in-grade. Some form of floor joint step is normally used at this joint. The upstream end section is vertical, rather than normal to the plane of the inclined floor slab. The doweled, transverse articulation joint makes the structural behavior of this type of SAF differ from that of type (A).

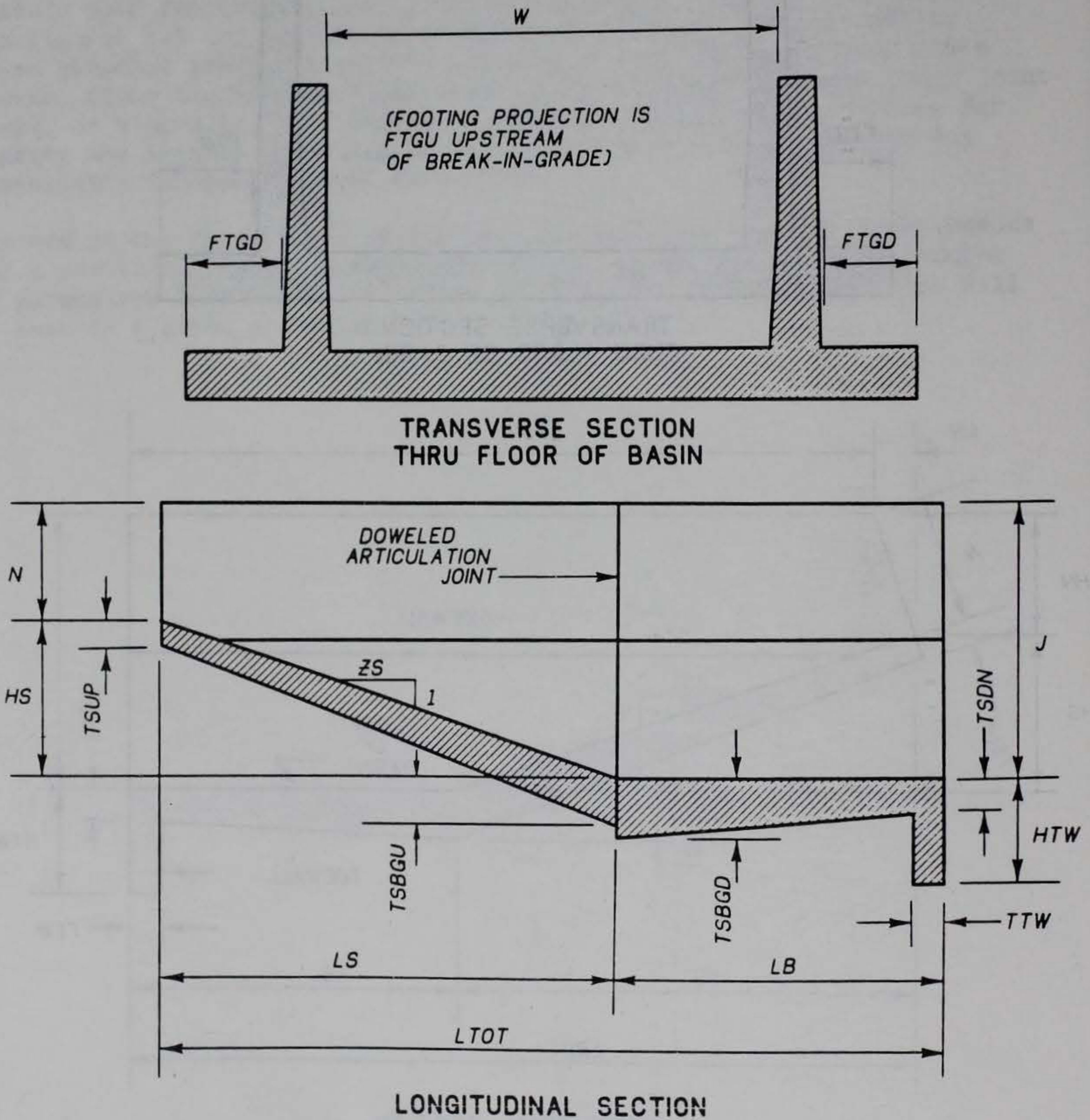
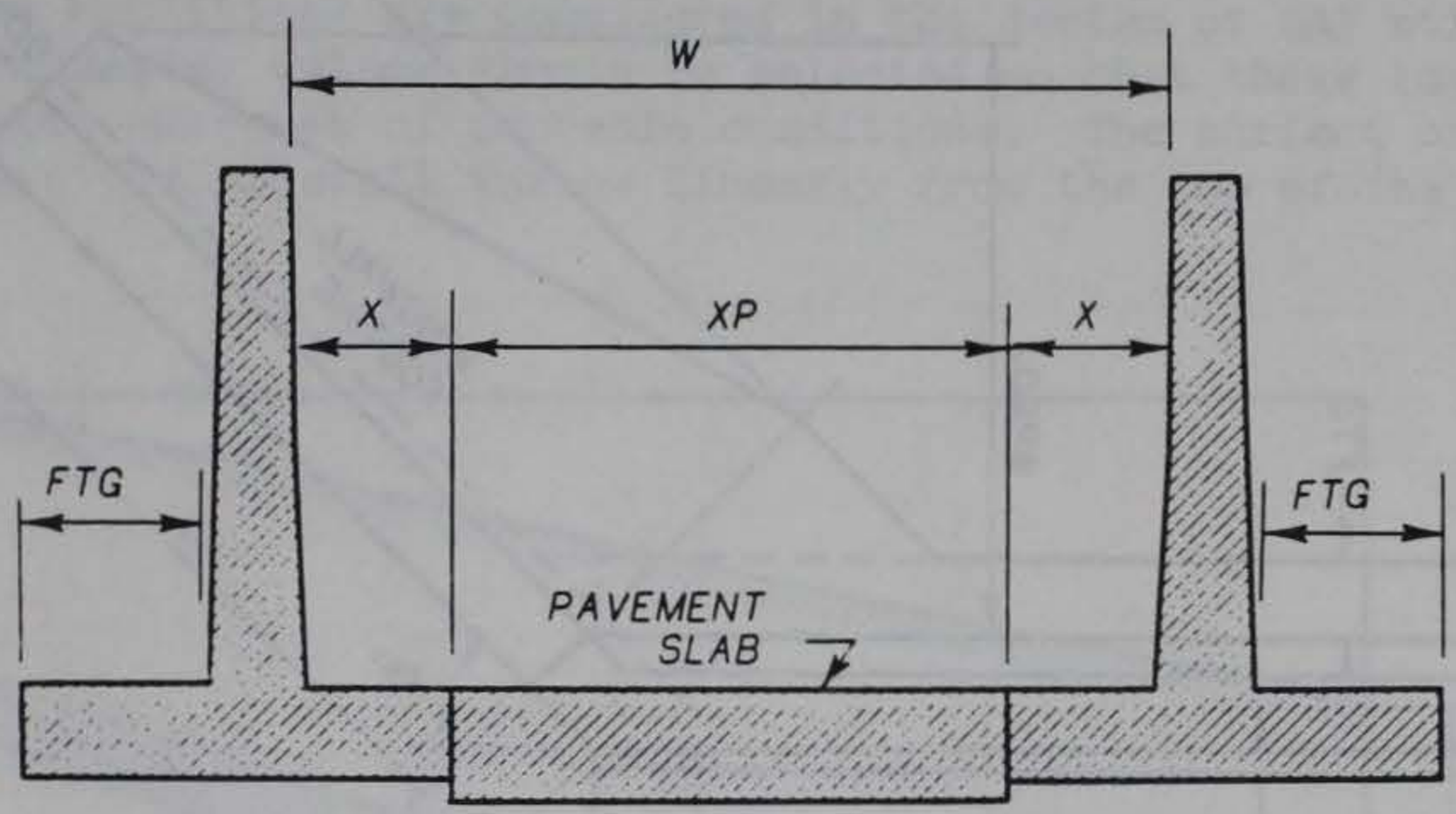

Figure 2. Type (B) SAF stilling basin

Type (C)

This type, see Figure 3, has independent retaining wall portions and pavement slab. The pavement slab resists any thrust imposed on it by the retaining wall portions. The most advantageous toe length, X , is determined in the design.



TRANSVERSE SECTION THRU FLOOR OF BASIN

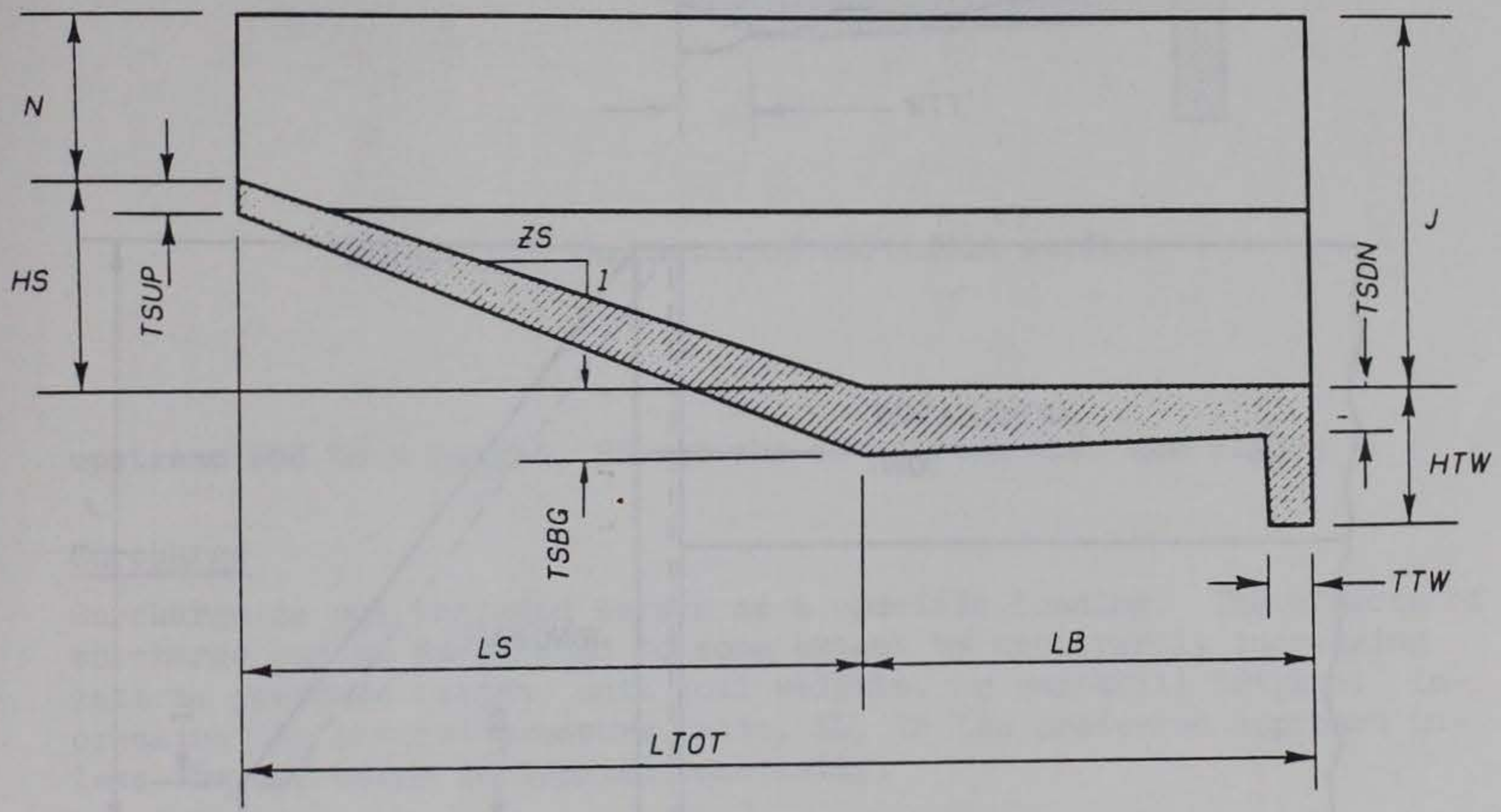

LONGITUDINAL SECTION THRU RETAINING WALL PORTION

Figure 3. Type (C) SAF stilling basin

Wingwalls

The wingwall is articulated from the basin sidewall. Hence each wall acts as a simple cantilever. The wingwalls with their footings are not included in the stability analyses of the basin proper. Figure 4 gives the wingwall

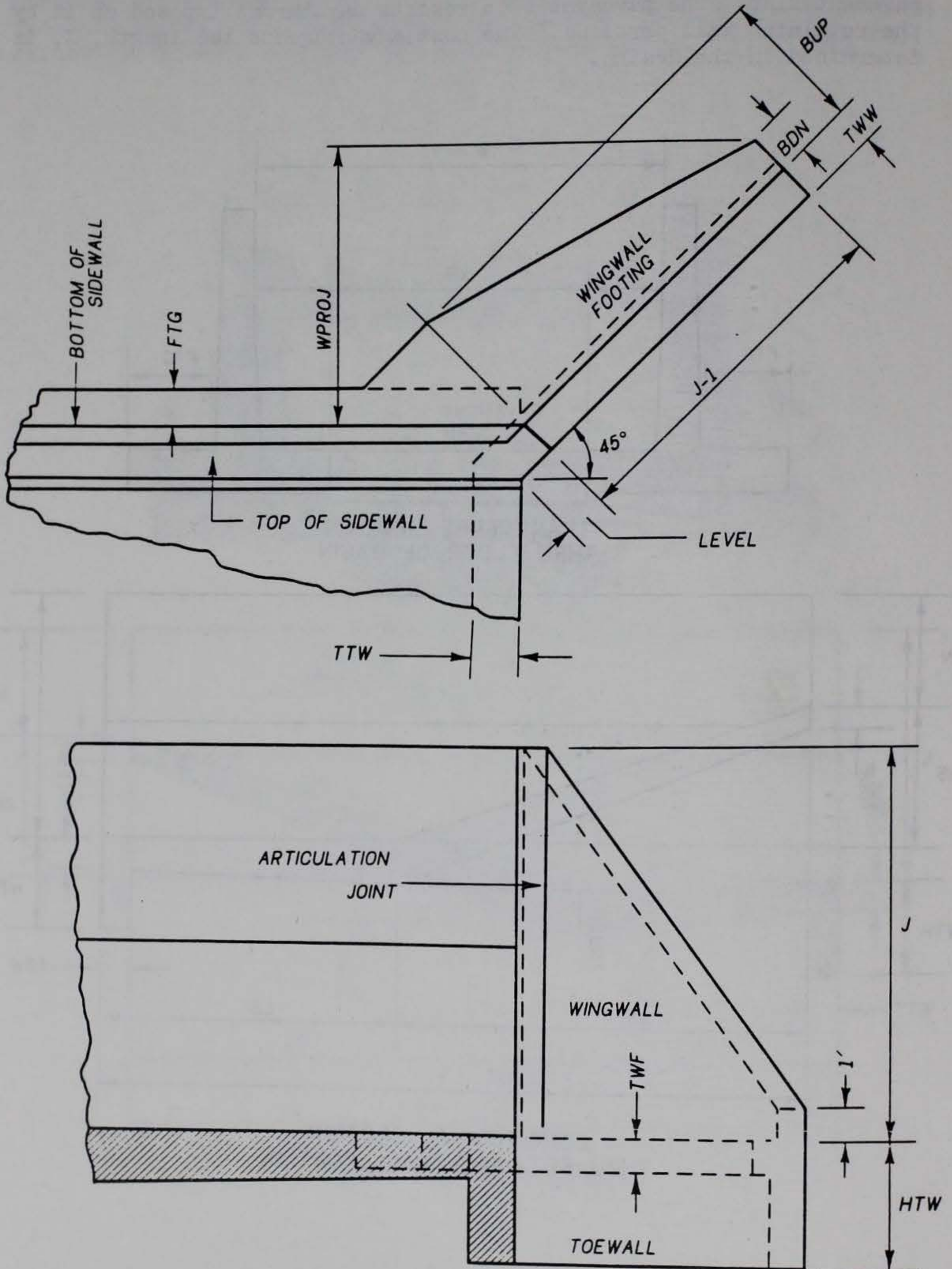

Figure 4. Wingwall layout

layout. The level distance locating the articulation joint varies depending on relative values of wingwall and sidewall thicknesses. This distance is discussed subsequently.

Loading Conditions

Two loading conditions are considered in the design of SAF stilling basins. Parameter values should be selected so that these loading conditions reflect extremes of probable conditions. The surface of the earthfill against the sidewall varies linearly from the top of the wall at the

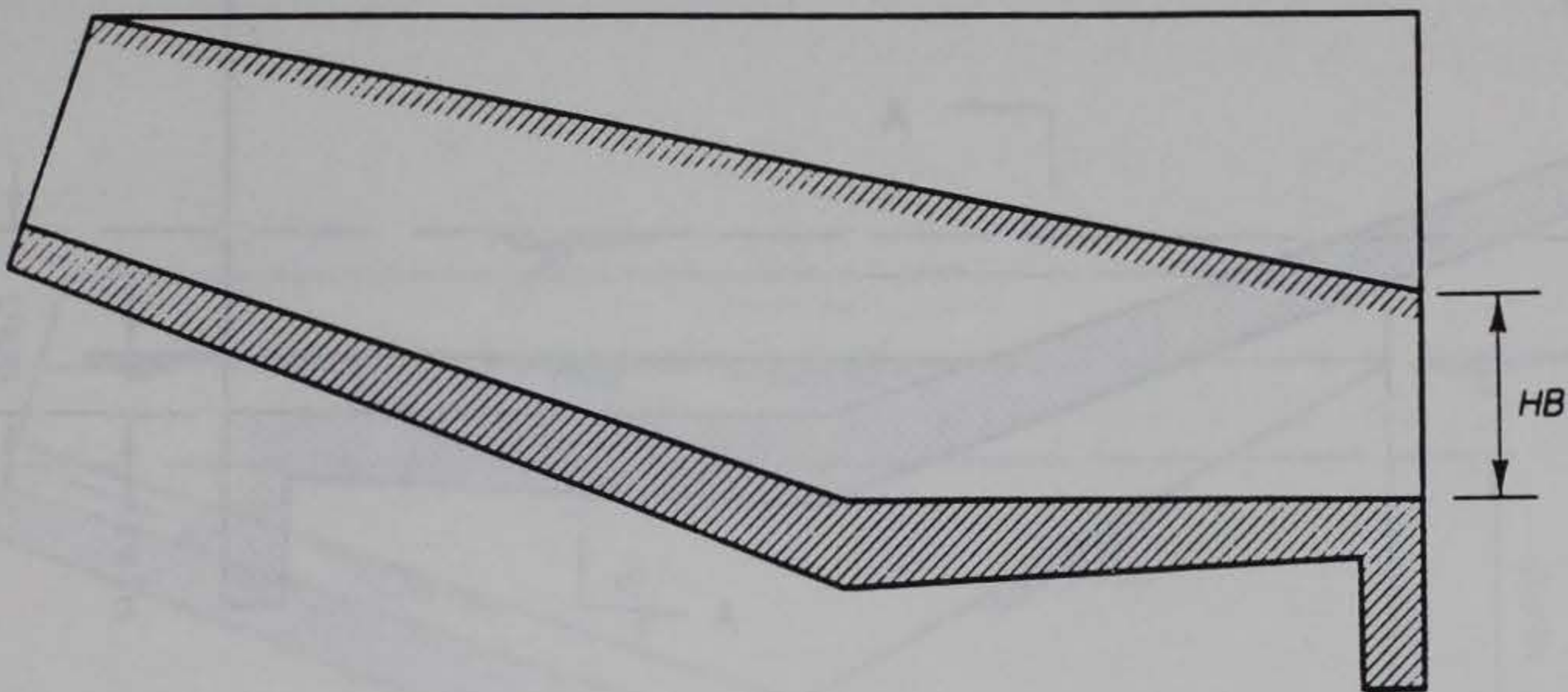

Figure 5. Variation of earthfill surface

upstream end to a height, HB , at the downstream end, see Figure 5.

Surcharge

Surcharge is not included herein as a specific loading. The effects of surcharge can be duplicated to some extent by arbitrarily increasing lateral pressure ratios, unit soil weights, or earthfill heights. Increasing the lateral pressure ratio, K_0 , is the preferred approach unless the surcharge is applied constantly.

Load Condition No. 1

This is the no flow loading, see Figure 6. It is meant to represent conditions following a rapid lowering of the water surface in the basin before the water table in the earthfill, and associated uplift, have lowered significantly from some higher level. The tailwater depth in the basin is HTWL. The uplift head above the top of the level floor slab and footings is HUPI. This loading should maximize the difference between HUPI and HTWL.

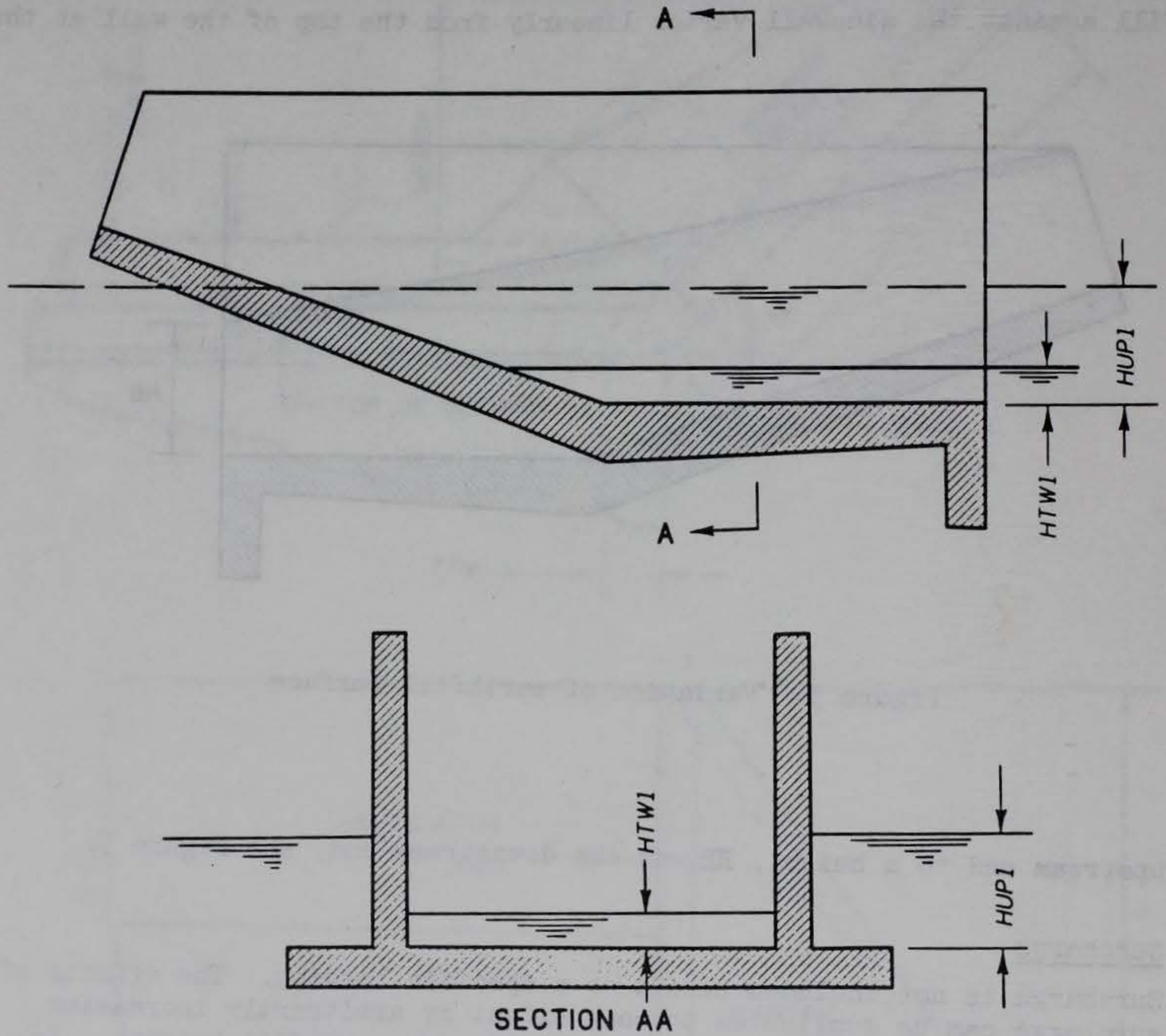

Figure 6. Load condition No. 1

Load Condition No. 2

This is the full flow loading, see Figure 7. Flow enters the stilling basin at a depth, D_1 , and velocity, V_1 . These are the hydraulic parameters discussed in NEH-14 on pages 2.193 and following. Although it is admittedly a rough approximation, the water surface in the basin is assumed to vary linearly from the depth, D_1 , at the break-in-grade to the tailwater depth, HTW_2 , at the downstream end. The uplift head above the top of the level floor slab and footings is HUP_2 . Load condition No. 2 is meant to represent governing conditions when the basin is operating at full flow. Thus this loading should maximize both HTW_2 and HUP_2 . The water surface on the outside of the basin walls is taken as HUP_2 for all analyses except sidewall bending. Observe that the following relations must exist between the various water height parameters:

$$HTW_2 \geq HUP_2 \geq HUP_1 \geq HTW_1.$$

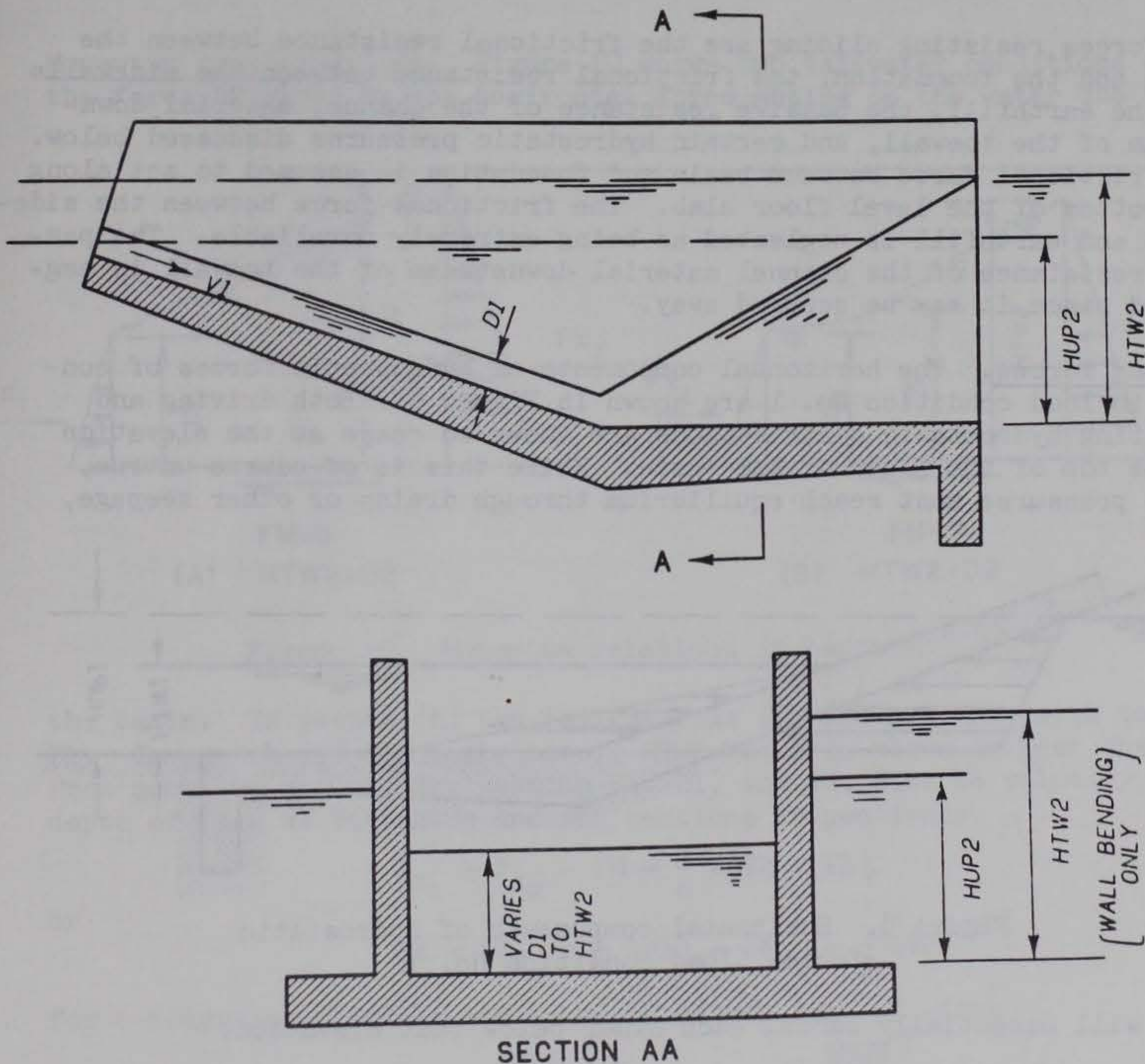

Figure 7. Load condition No. 2

Flotation Requirements

The total weight of the SAF stilling basin plus all downward forces acting on it must exceed the uplift forces by a suitable safety factor under all conditions of loading. Often the most critical case is load condition No. 2. However, with a sufficiently large difference between HUPI and HTWI, load condition No. 1 will control. Hence both load conditions are investigated. The flotation safety factor, FLOATR, is selected by the user. Footing projections are provided, when required, to develop necessary additional downward forces.

Sliding Requirements

The horizontal resisting forces that can be mobilized must exceed the horizontal driving forces acting on the basin in a downstream direction by a suitable safety factor under all conditions of loading. Either load condition can control, hence both are investigated. The sliding safety factor, SLIDER, is selected by the user.

The forces resisting sliding are the frictional resistance between the basin and the foundation, the frictional resistance between the sidewalls and the earthfill, the passive resistance of the channel material downstream of the toewall, and certain hydrostatic pressures discussed below. The frictional force between basin and foundation is assumed to act along the bottom of the level floor slab. The frictional force between the sidewalls and earthfill is neglected as being extremely unreliable. The passive resistance of the channel material downstream of the toewall is neglected since it may be scoured away.

Sliding forces. The horizontal components of hydrostatic forces of concern in load condition No. 1 are shown in Figure 8. Both driving and resisting hydrostatic distributions are shown to cease at the elevation of the top of the floor of the basin. While this is of course untrue, these pressures must reach equilibrium through drains or other seepage,

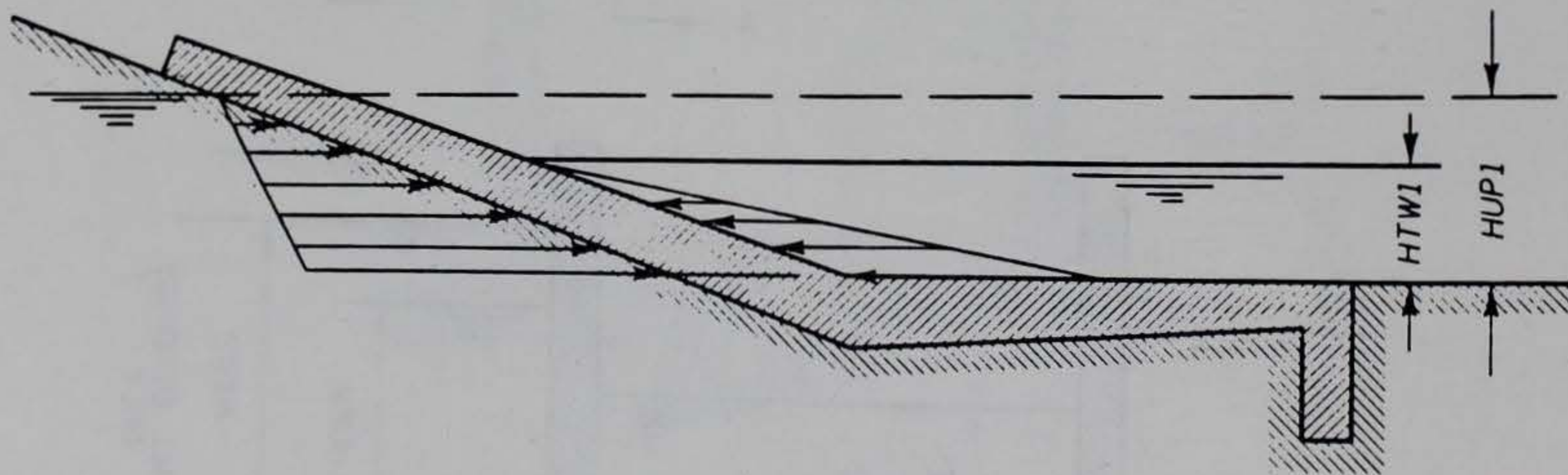

Figure 8. Horizontal components of hydrostatic forces, load condition No. 1

and will essentially cancel each other below that elevation.

In load condition No. 2, the horizontal force acting on the basin, due to the water in the basin, is shown in Figure 9 as FM. The force, FM, is due to the change in momentum, in a horizontal direction, of the water on the level floor slab of the basin.

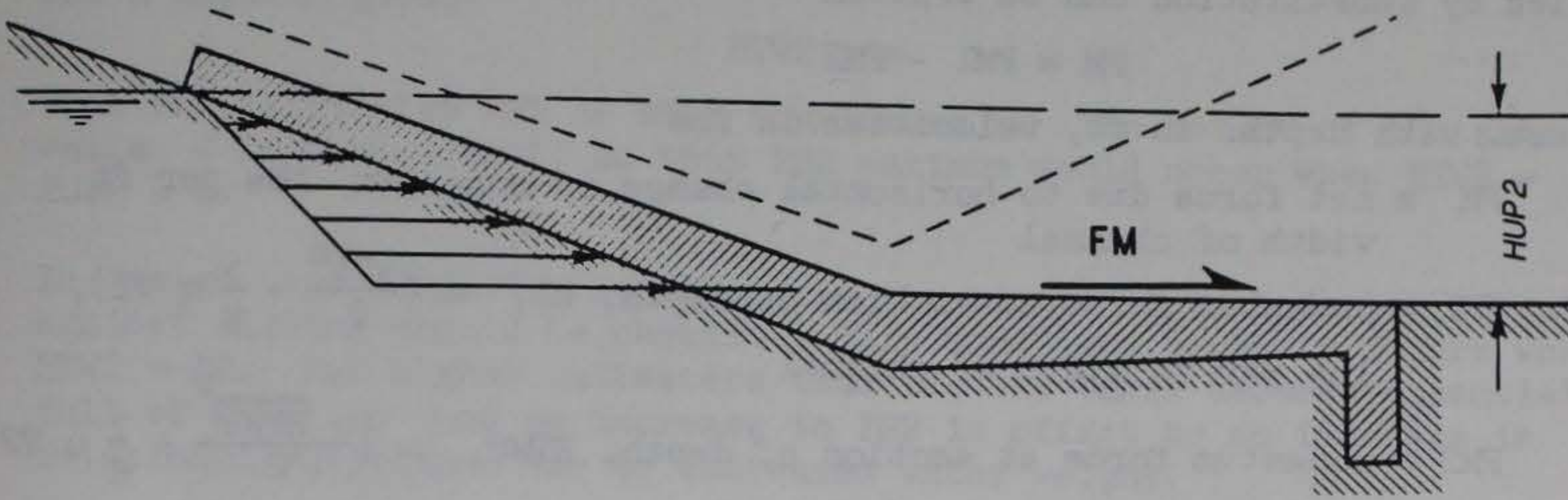

Figure 9. Sliding forces, load condition No. 2

Momentum considerations. Figure 10 shows two tailwater conditions with the force FM shown as the horizontal force acting on the water due to

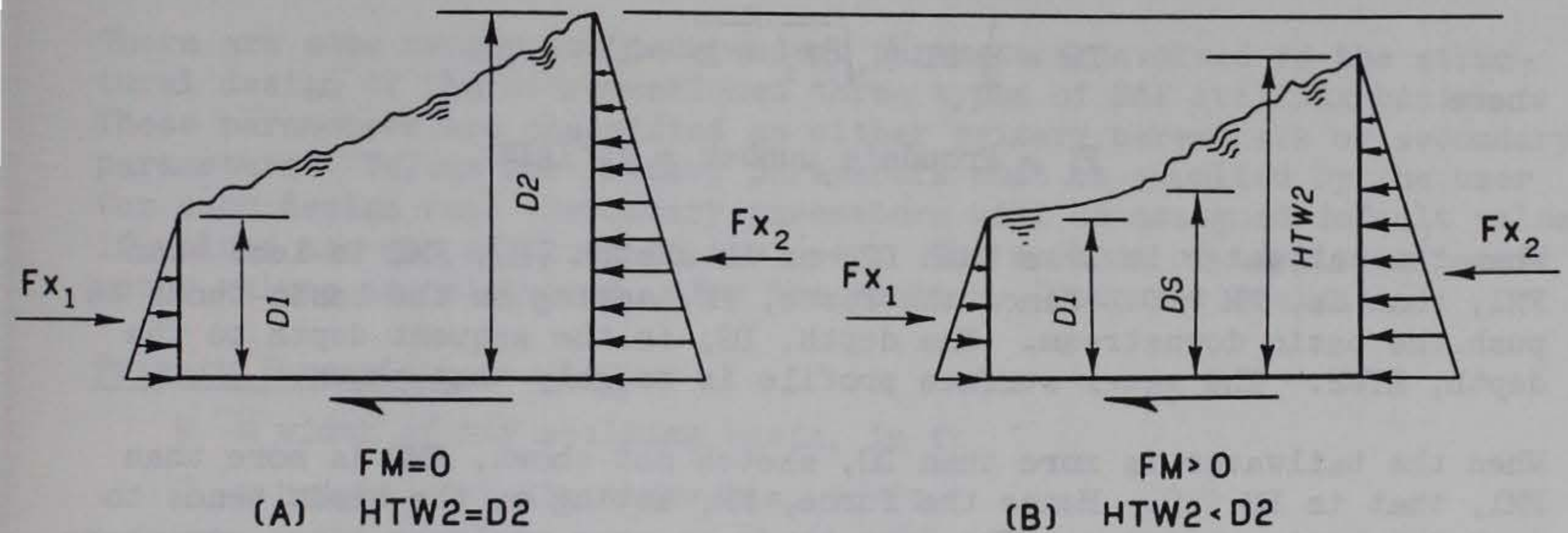

Figure 10. Momentum relations in basin

the basin. In sketch (A) the tailwater is D2, the sequent depth to depth, D1. In sketch (B) the tailwater is HTW2 which is shown as less than D2. From momentum principles, letting V1, D1, and V2, HTW2 be velocity and depth of flow at beginning and end sections respectively,

$$F_{x_1} - F_{x_2} - FM = \frac{\gamma}{g} Q(V_2 - V_1)$$

or

$$FM = (F_{x_1} + \frac{\gamma}{g} QV_1) - (F_{x_2} + \frac{\gamma}{g} QV_2)$$

for rectangular channels, and in terms of per foot of width

$$FM = (\frac{\gamma D_1^2}{2} + \frac{\gamma}{g} q V_1) - (\frac{\gamma HTW_2^2}{2} + \frac{\gamma}{g} q V_2)$$

which by substitution can be written

$$FM = FM1 - FM2$$

where, with depths in ft, velocities in fps

$FM \equiv$ net force due to horizontal change in momentum, lbs per ft width of channel

$FM1 \equiv$ momentum force at section of depth, $D1$, $= \left(\frac{\gamma D1^2}{2} + \frac{\gamma}{g} q V1 \right)$,
lbs per ft width of channel

$FM2 \equiv$ momentum force at section of depth, $HTW2$, $= \left(\frac{\gamma HTW2^2}{2} + \frac{\gamma}{g} q V2 \right)$,
lbs per ft of width of channel

$\gamma = 62.4$ lbs per cu ft

$g = 32.2$ ft per sec²

$q =$ discharge, cfs per ft width of channel

$V2 = V1 \times D1/HTW2$

Taking $FM = 0$ defines the case of a hydraulic jump. The beginning and end depths are sequent depths, the end depth is given by

$$D2 = \frac{1}{2} D1 \left(\sqrt{8F_1 + 1} - 1 \right)$$

where

$$F_1 = \text{Froude's number} = V1^2/gD1$$

When the tailwater is less than $D2$, as in sketch (B), $FM2$ is less than $FM1$, that is, $FM > 0$. Hence the force, FM , acting on the basin tends to push the basin downstream. The depth, DS , is the sequent depth to the depth, $HTW2$. The water surface profile is roughly that shown.

When the tailwater is more than $D2$, sketch not shown, $FM2$ is more than $FM1$, that is $FM < 0$. Hence the force, FM , acting on the basin tends to push the basin upstream. The jump tends to move upstream since somewhere between the depth, $D1$, and tailwater depth there is a depth, DS , that is sequent to $D1$.

However, the sum of FM and the horizontal component of the hydrostatic force due to $HUP2$, see Figure 9, is of more concern than consideration of the variation of FM alone. Let $FH2$ be the hydrostatic force and $FS2$ be the sum force, then in lbs per ft width of channel

$$FS2 = FH2 + FM.$$

For purposes of study, take the particular case of $HUP2 = HTW2$, then

$$FS2 = \frac{\gamma HTW2^2}{2} + FM1 - \left(\frac{\gamma HTW2^2}{2} + \frac{\gamma}{g} \frac{q^2}{HTW2} \right)$$

or

$$FS2 = FM1 - \frac{\gamma}{g} \frac{q^2}{HTW2}$$

differentiating with respect to $HTW2$ to find the value of $HTW2$ making

FS2 a maximum gives

$$HTW2 = \infty.$$

Thus FS2 approaches F_{M1} as HTW2 approaches ∞ . The height of the side-walls, J is the control, so that FS2 maximum would occur when HTW2 = HUP2 = J.

In design, the condition resulting in the minimum actual factor of safety against sliding should be checked. This condition probably occurs when HTW2 = D₂. For higher tailwaters than D₂, the basin becomes essentially full of water so that an increase in FS2 is offset by an increase in frictional resistance due to increased water weight.

Possible modification of load condition No. 2. As explained in the next section, HTW2 and HUP2 are selected by the user. If HUP2 and/or HTW2 are selected greater than the sequent depth, D₂, they are reduced during design to D₂. This is done for the reasons discussed immediately above, namely, HTW2 = D₂ represents a more critical situation than when HUP2 and/or HTW2 are more than D₂.

Design Parameters

There are some twenty-two independent parameters involved in the structural design of the aforementioned three types of SAF stilling basins. These parameters are classified as either primary parameters or secondary parameters. Values for primary parameters must be supplied by the user for each design run. Secondary parameters will be assigned default values if values are not supplied by the user. The methods of supplying parameter values are discussed under the section, "Computer Designs."

Primary Parameters

W \equiv width of SAF stilling basin, in ft

J \equiv height of basin sidewalls, in ft

LB \equiv length of basin, in ft

N \equiv height of sidewalls at upstream end section, in ft

D₁ \equiv entrance depth of water to SAF stilling basin, in ft

V₁ \equiv entrance velocity of water to SAF stilling basin, in fps

Secondary Parameters

The secondary parameters and their default values are listed in Table 1. The user should make an effort to evaluate the secondary parameter values he wishes to use. Use of default values may result in an overly conservative (or unconservative) design. Usage of the various parameters is explained where first encountered. The default value for HTW2 is a function of D₂, the sequent depth to depth D₁. The value of Froude's number is computed and it, and D₂ are output with the parameter values selected for the design run.

Table 1. Secondary parameters and default values

Parameter		Default Value
HTW2	≡ tailwater depth above top of floor of basin for load condition No. 2, in ft	D2
HUP2	≡ uplift head above top of floor of basin for load condition No. 2, in ft	HTW2
HTW1	≡ tailwater depth above top of floor of basin for load condition No. 1, in ft	0
HUP1	≡ uplift head above top of floor of basin for load condition No. 1, in ft	0.5 HUP2
HB	≡ earthfill height above top of floor of basin at downstream end of basin, in ft	0.5J
ZS	≡ slope parameter of inclined portion of stilling basin	3.0
HTW	≡ depth of toewall below top of floor of basin, in ft	4.0
TTW	≡ thickness of toewall, in inches	10.0
GM	≡ moist unit weight of earthfill, in pcf	120.
GS	≡ saturated unit weight of earthfill, in pcf	140.
KO	≡ lateral earth pressure ratio	0.8
BAT	≡ inside sidewall batter, in inches per ft of height	0.375
MAXFTG	≡ maximum acceptable footing projection, in ft	0.5W
FLOATR	≡ safety factor against flotation	1.5
SLIDER	≡ safety factor against sliding	1.0
CFSC	≡ coefficient of friction, soil to concrete	0.35

Design Criteria

Materials

Class 4000 concrete and intermediate grade steel are assumed.

Working Stress Design

Design of sections is in accordance with working stress methods. The allowable stresses in psi are

Extreme fiber stress in flexure	$f_c = 1600$
Shear, V/bD^*	$v = 70$
Flexural Bond tension top bars	$u = 3.4\sqrt{f_c'}/D$
other tension bars	$u = 4.8\sqrt{f_c'}/D$
Steel in tension	$f_s = 20,000$
in compression, axially loaded	$f_s = 16,000$

Minimum Slab Thicknesses

Walls	10 inches
Bottom slabs	11 inches

Temperature and Shrinkage Steel

The minimum steel ratios are
for unexposed faces

$$p_t = 0.001$$

for exposed faces

$$p_t = 0.002$$

Slabs more than 32 inches thick are taken as 32 inches.

Web Reinforcement

The necessity of providing some type of stirrup or tie in the slab because of bending action is avoided by

- (1) limiting the shear stress, as a measure of diagonal tension, so that web steel is not required, and
- (2) providing sufficient effective depth of sections so that compression steel is not required for bending.

Cover for Reinforcement

Steel cover is everywhere 2 inches except for outside steel in bottom slabs where cover is 3 inches.

*Shear sometimes critical at D from face, sometimes at face, see page 17 of TR-42.

Steel Required by Combined Bending Moment and Direct Force

Required area determined as explained on pages 31 - 34 of TR-42, "Single Cell Rectangular Conduits - Criteria and Procedures for Structural Design."

Spacing Required by Flexural Bond

Spacing determined as explained on page 47 of TR-42.

Spacing of Reinforcement

The maximum permissible spacing of any reinforcement is 18 inches.

Preliminary Designs

Trial concrete thicknesses are determined for various critical dimensions, and preliminary concrete volumes are computed, during the preliminary design phase of the structural design of SAF stilling basins. These quantities may be increased during detail design if computations for required steel areas indicate thicknesses are inadequate. Assumptions, criteria, and procedures for the several basin types are discussed below. Transverse strength of the toewall is neglected throughout these computations. Topics applicable to more than one basin type are presented most fully when first encountered.

Type (A)

Preliminary design of type (A) basins proceeds in an orderly manner. First, sidewall geometry, and load variables, are established. Next, required sidewall thicknesses for wall bending are determined. Next, the basin is checked for flotation. Footing projections, FTG, are provided if required. Then, bearing pressures are checked to insure positive pressures within allowable values. Then, floor slab thicknesses are checked for shear and transverse bending. Finally, the basin is checked for sliding. At any stage of design after sidewall thicknesses are determined, thicknesses or footing projections are incremented if found inadequate and the design is recycled accordingly.

Sidewall geometry and load variables. Sidewall dimensions and thicknesses are shown in Figure 11. The inside face of the sidewall is vertical from the top of the sidewall down a distance, HV. This distance is the larger of $J/2$ or HN. Below the distance, HV, the sidewall is battered for ice protection at the rate of BAT inches per foot. BAT may be set equal to zero if desired. The outside face of the sidewall is a plane surface.

The slope hypotenuse parameter, ZH, is

$$ZH = \sqrt{1 + ZS^2}$$

Thus, with all distances in feet

$$LN = N/ZH$$

$$HN = LN \times ZS$$

$$HS = J - HN$$

$$LS = HS \times ZS$$

$$LBOT = LS + LB$$

$$LTOP = LBOT - LN$$

If LTOP is less than LB, that is, N is too big, a message is given and the design is canceled.

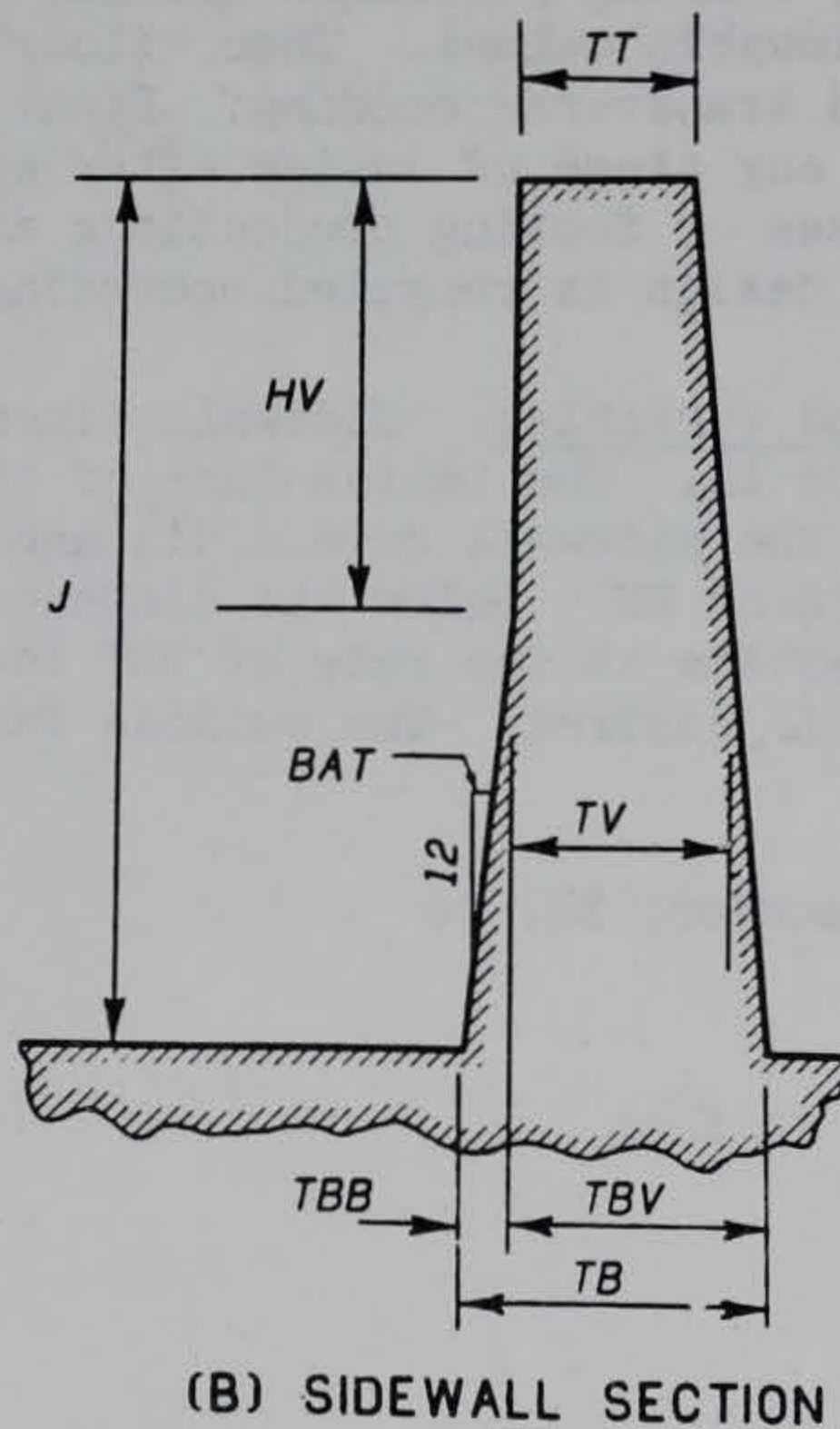
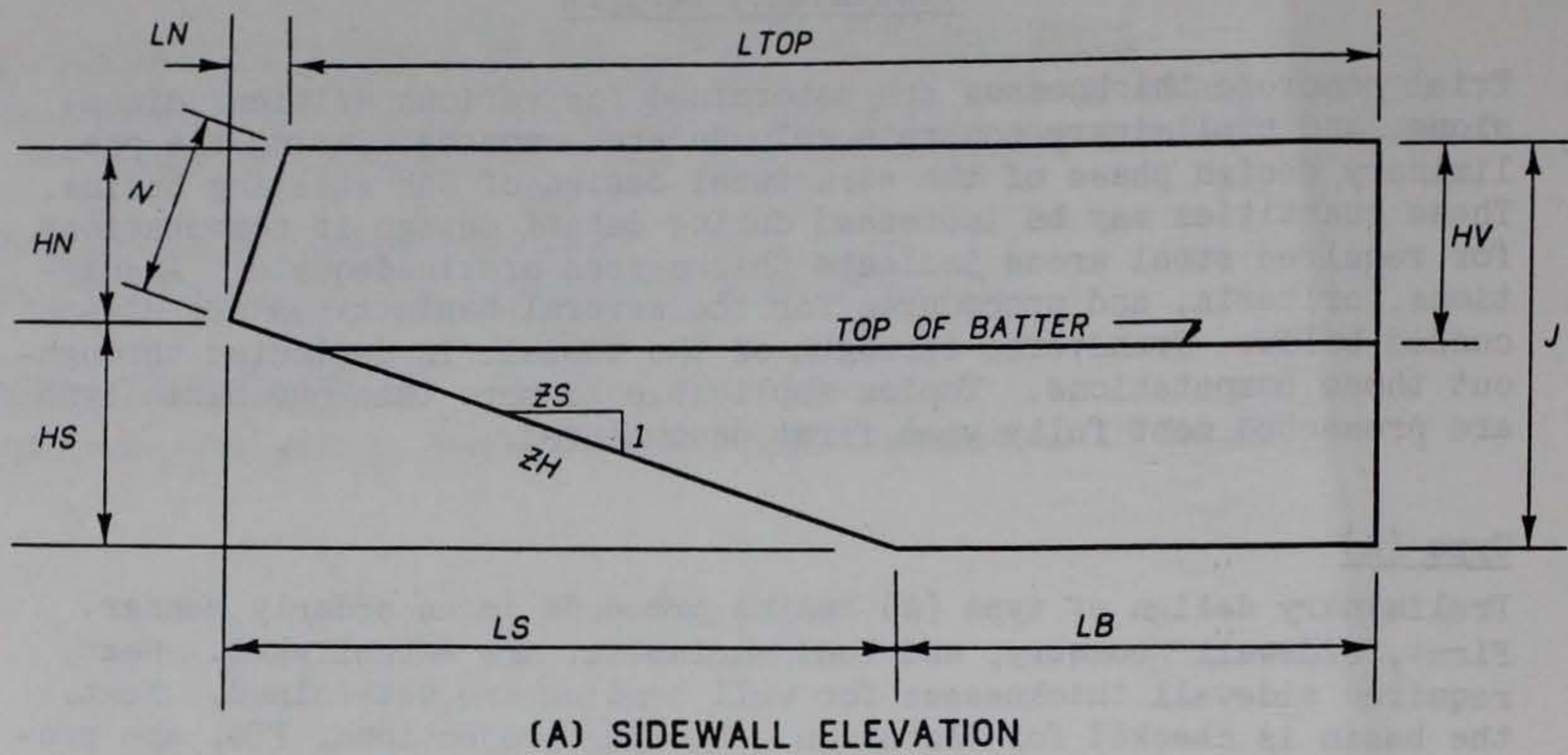

Figure 11. Sidewall dimensions and thicknesses

It is later shown that sidewall thicknesses may be controlled at any of the three sections shown in Figure 12. Hence it is desirable to pre-establish various section heights, earthfill heights, tailwater depths, and uplift heads.

Section 2 is midway between sections 1 and 3, hence for section heights, in feet

$$HS1 = N \times ZH/ZS$$

$$HS3 = J$$

$$HS2 = 0.5(HS1 + HS3)$$

similarly for earthfill heights, in feet

$$HB1 = HS1$$

$$HB3 = HB + (J - HB) \times LB/LTOP$$

$$HB2 = 0.5 (HB1 + HB3)$$

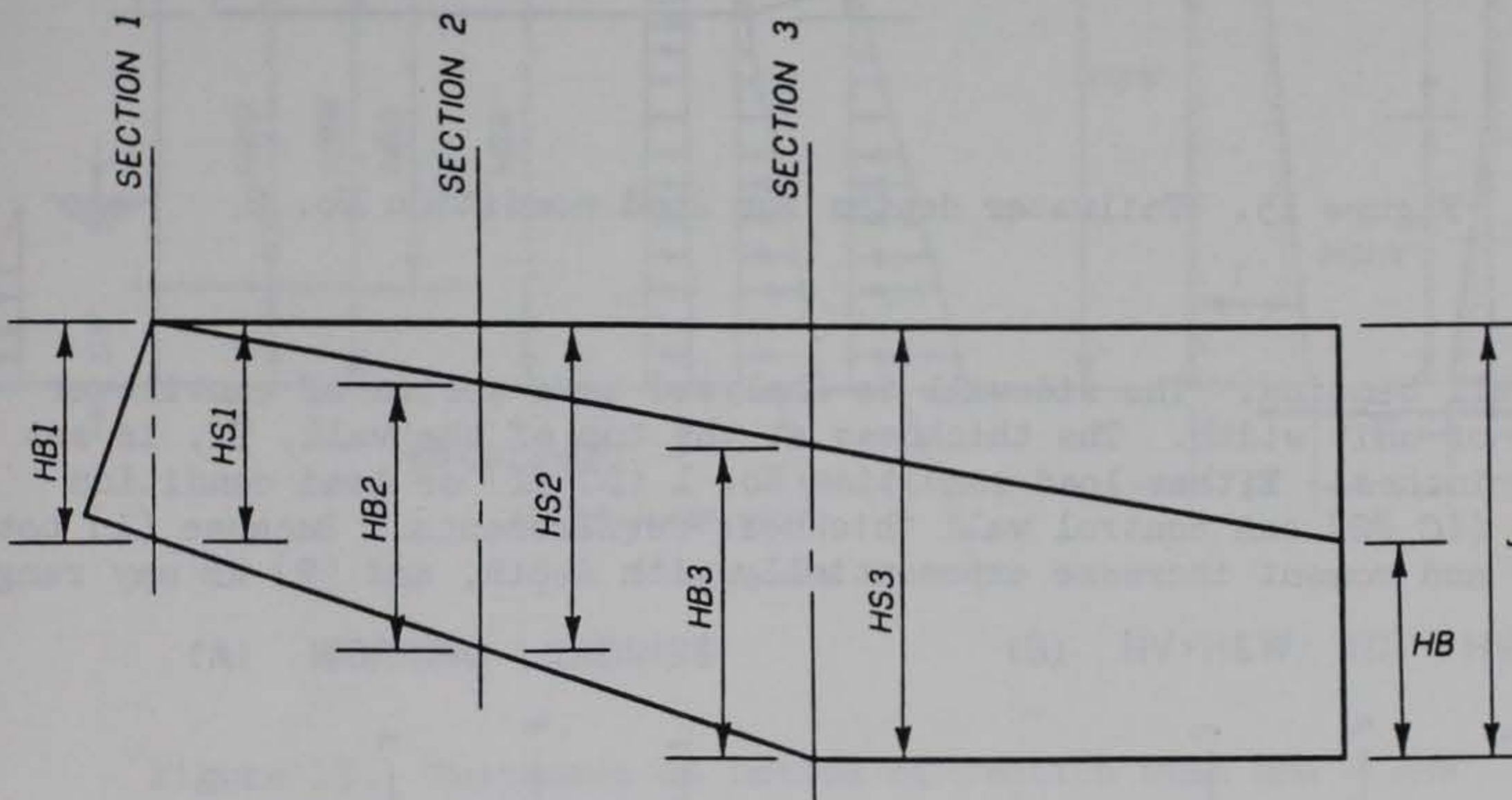

Figure 12. Section and earthfill heights

Tailwater depths, in feet, on the various sections can be obtained from Figure 13 for load condition No. 2 as

$$HT21 = HS1 - (J - HTW2)$$

$$HT23 = HTW2$$

$$HT22 = 0.5(HT21 + HT23)$$

if $HT21 < 0$ set $HT21 = 0$

if $HT22 < 0$ set $HT22 = 0$

Tailwater depths for load condition No. 1, $HT11$, $HT13$, and $HT12$ can be determined similarly, likewise for uplift heads $HU21$, $HU23$, $HU22$, and $HU11$, $HU13$, $HU12$.

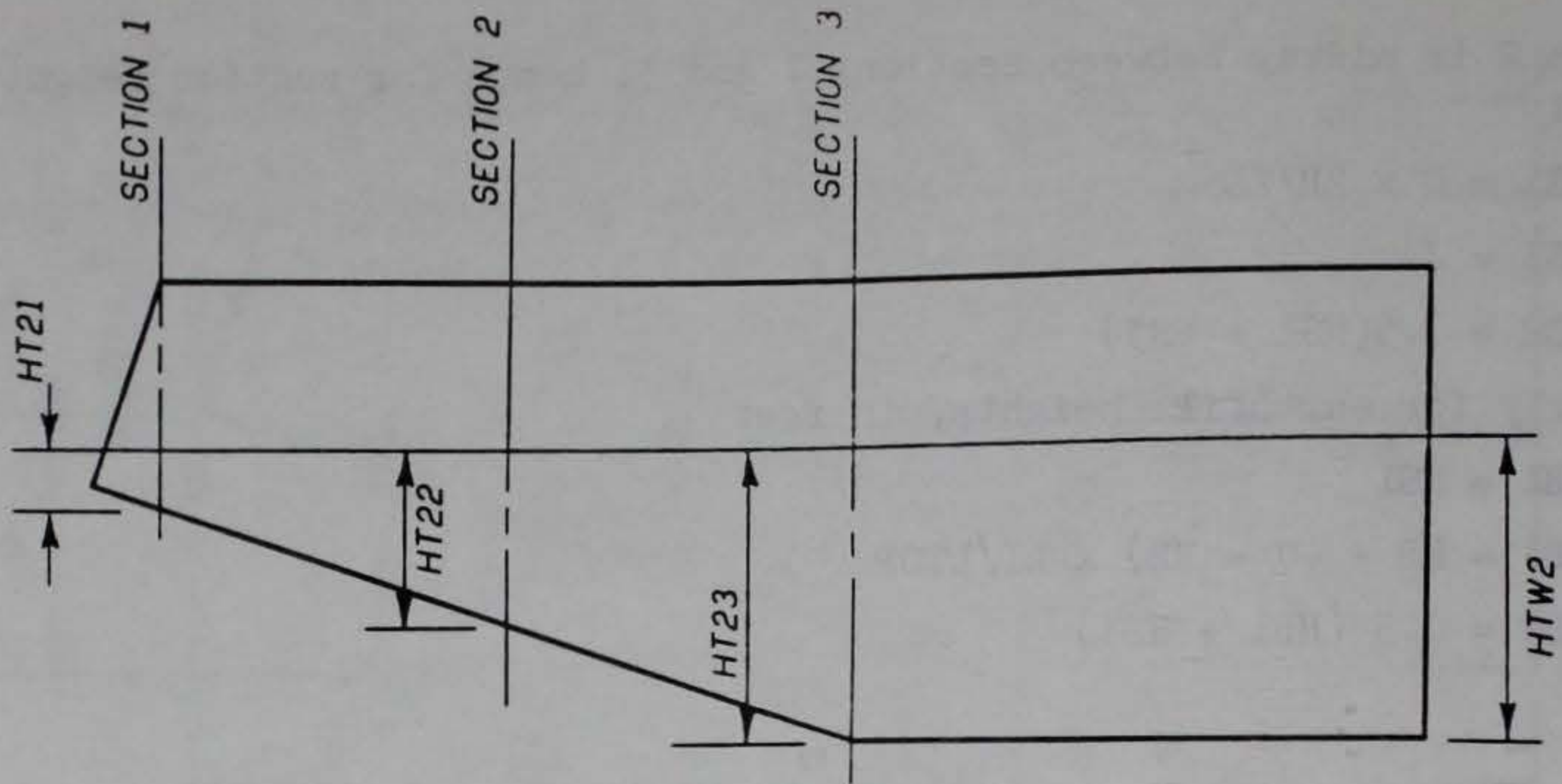

Figure 13. Tailwater depths for load condition No. 2

Sidewall bending. The sidewall is analyzed as a series of cantilever beams of unit width. The thickness at the top of the wall, TT , is set at 10 inches. Either load condition No. 1 (LC #1) or load condition No. 2 (LC #2) can control wall thickness requirements. Because (1) both shear and moment increase exponentially with depth, and (2) HB may range

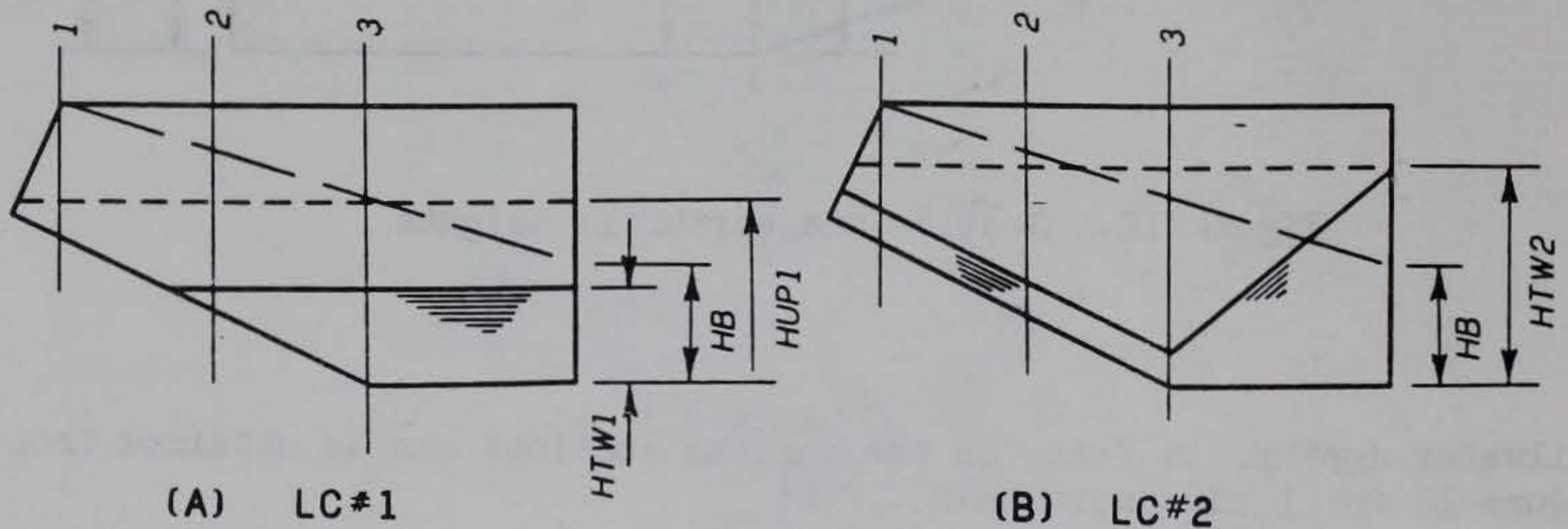

Figure 14. Considerations for sidewall bending, type (A) basin

from zero up to J , the following is true. The thickness required at the bottom of any section may be governed by the thickness required by flexure at the bottom of that section or by the thickness required at the bottom of either of the other two sections. Therefore the first step in designing the sidewall is to obtain the thicknesses required at the bottoms of sections 1, 2, and 3.

The thickness at the bottom of the wall at any section is selected as the largest thickness required by: shear for LC #1, moment and direct force for LC #1, shear for LC #2, or moment and direct force for LC #2. Illustrative computations for a section of height, HSW, and a possible loading case follow. See Figure 15 for definition of symbols.

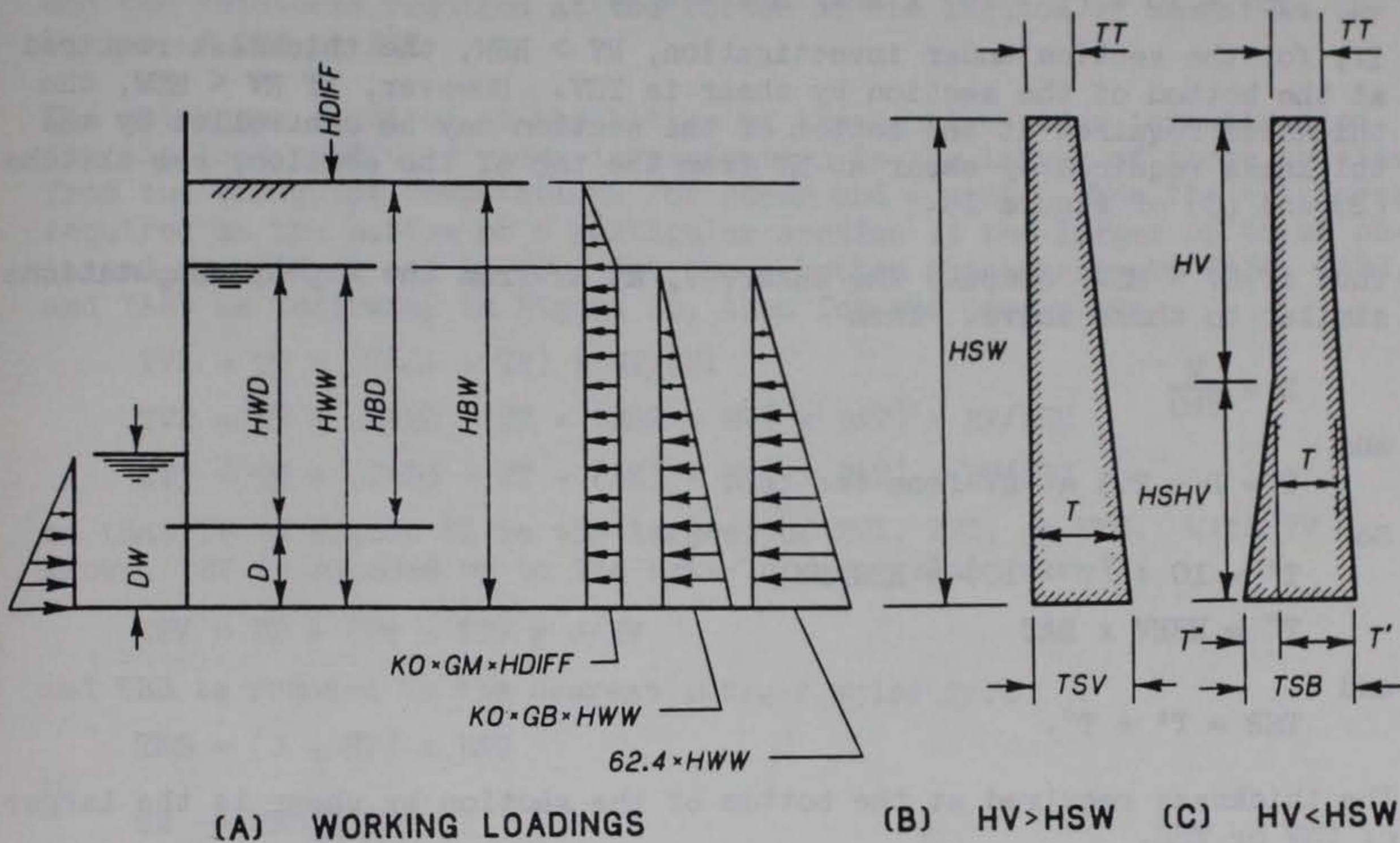

Figure 15. Thickness at bottom of section when $HBW > HWW$

The working values HSW, HBW, HWW, and DW are obtained from HSn, HBn, HULn or HT2n, and HTLn or D1 values as appropriate to the section under investigation.

Let $HDIFF = HBW - HWW$

For any effective depth, \bar{D} , in inches

$$HBD = HBW - \bar{D}/12$$

$$HWD = HWW - \bar{D}/12$$

$$DWD = DW - \bar{D}/12$$

Then the shear, in lbs per ft, at \bar{D} from the face for the case shown is:

$$V = 31.2 \times (HWD^2 - DWD^2) + KO \times GM \times HDIFF \times (0.5 \times HDIFF + HWD) + 0.5 \times KO \times GB \times HWD^2$$

where $GB = GS - 62.4$ is the buoyant weight of the earthfill, in pcf

so

$$D = \frac{V}{vb} = \frac{V}{70 \times 12} = \frac{V}{840}$$

An iterative process is required since the assumed D must agree with the computed required D. When the correct value of D is obtained, the thickness, T, at D from the face is

$$T = D + 2.5$$

and the thickness at the bottom is

$$TSV = 10 + (T - 10) \times HSW / (HSW - D/12).$$

If, for the section under investigation, $HV > HSW$, the thickness required at the bottom of the section by shear is TSV. However, if $HV < HSW$, the thickness required at the bottom of the section may be controlled by the thickness required by shear at HV from the top of the section, see sketches (B) and (C) of Figure 15.

Thus if $HV < HSW$, compute the shear, V, at HV from the top by computations similar to those above. Then

$$D = \frac{V}{840}$$

and

$$T = D + 2.5 \text{ at HV from the top.}$$

So

$$T' = 10 + (T - 10) \times HSW / HV$$

$$T'' = HSHV \times BAT$$

and

$$TSB = T' + T''.$$

The thickness required at the bottom of the section by shear is the larger of TSV or TSB.

The bending moment at the bottom of the sidewall, in ft lbs per ft, for the case shown is

$$\begin{aligned} M = 10.4 \times (HWW^3 - DW^3) + 0.5 \times KO \times GM \times HDIFF^2 \times (HDIFF/3 + HWW) \\ + 0.5 \times KO \times GM \times HDIFF \times HWW^2 \\ + 0.5 \times KO \times GB \times HWW^3/3. \end{aligned}$$

The direct compressive force due to the sidewall, in lbs per ft, for a bottom thickness, TSV, is

$$N = 6.25 \times HSW \times (TT + TSV)$$

The equivalent moment, M_s , is

$$M_s = M + N \times (0.5 \times TSV - 2.5)/12$$

So the required thickness at the bottom for balanced working stresses is

$$TSV = (0.003683 \times M_s)^{1/2} + 2.5$$

An iterative process is again required since the assumed TSV must agree with the computed required TSV.

Again, if $HV > HSW$, then TSV is the thickness required at the bottom of the section by moment. If $HV < HSW$, compute the moment and direct

force at HV from the top and get T and HV from the top by computations similar to those above.

Then

$$T' = 10 + (T - 10) \times HSW/HV$$

so

$$TSB = T' + T''$$

and the thickness required at the bottom of the section by moment is the larger of TSV or TSB.

The thickness required at the bottom of the section under investigation for the load condition under investigation is the larger of those obtained from the foregoing computations for shear and moment. Then the thickness required at the bottom of a particular section is the larger of those obtained from LC #1 and LC #2. Let these bottom thicknesses be TAB1, TAB2, and TAB3 as indicated in Figure 16, then for the case shown

$$TV1 = TT + (TAB1 - TT) \times HV/HS1$$

$$TV2 = TT + (TAB2 - TT - (HS2 - HV) \times BAT) \times HV/HS2$$

$$TV3 = TT + (TAB3 - TT - (HS3 - HV) \times BAT) \times HV/HS3$$

so that TV in Figure 11 is the largest of TV1, TV2, or TV3. With TV known, TBV is rounded up to the next integer value from

$$TBV = TT + (TV - TT) \times J/HV$$

and TBB is rounded to the nearest integer value from

$$TBB = (J - HV) \times BAT$$

so

$$TB = TBB + TBV$$

Thus the sidewall thicknesses are completely defined.

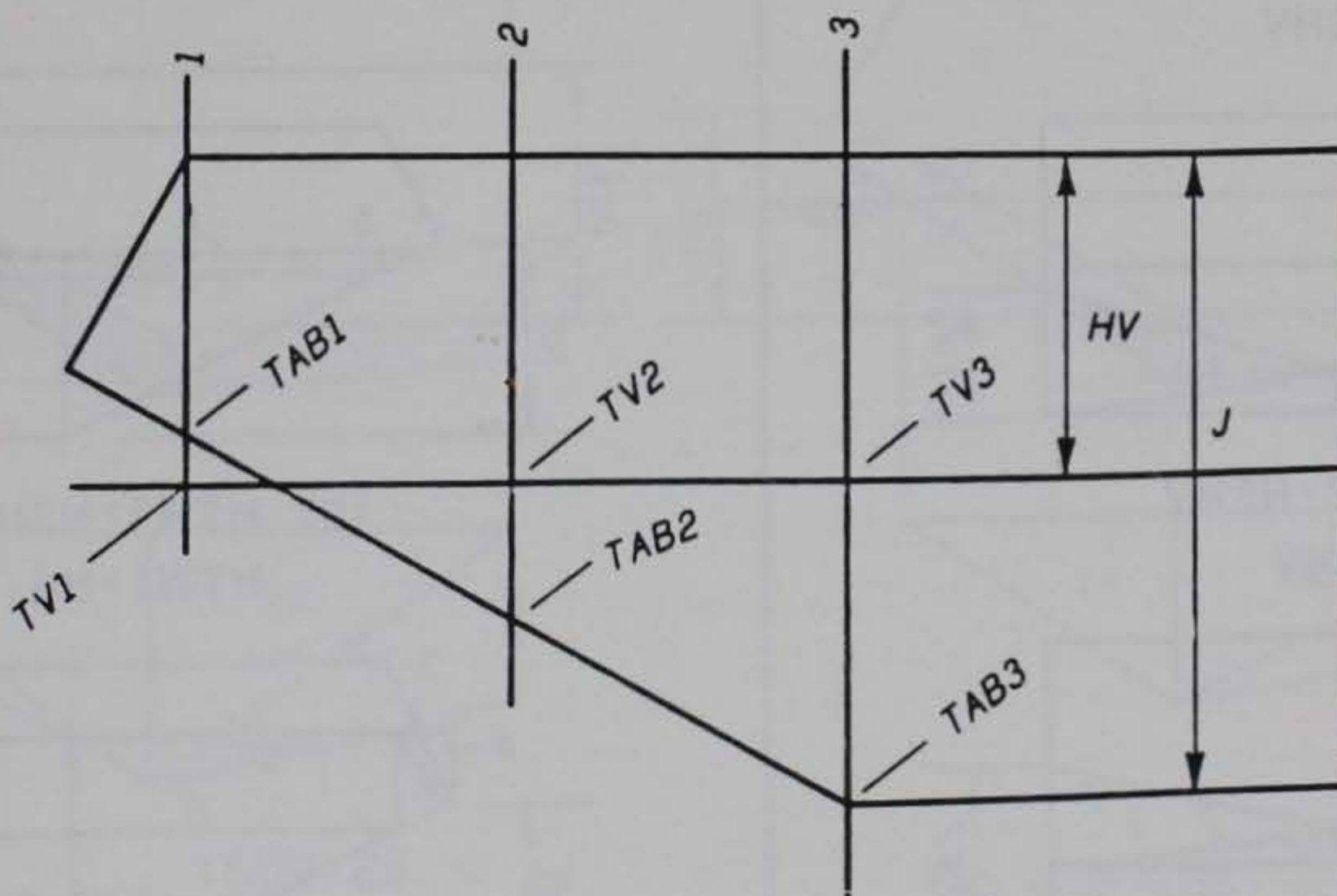
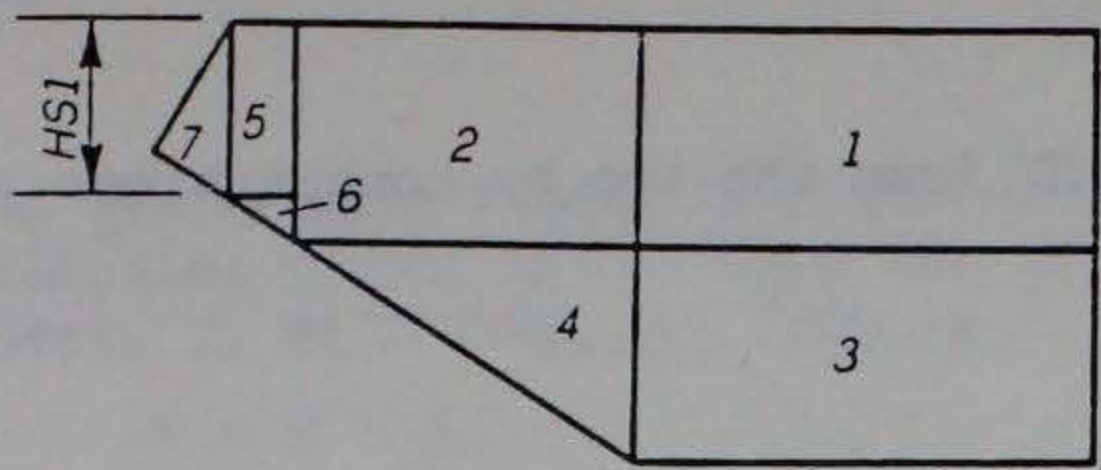
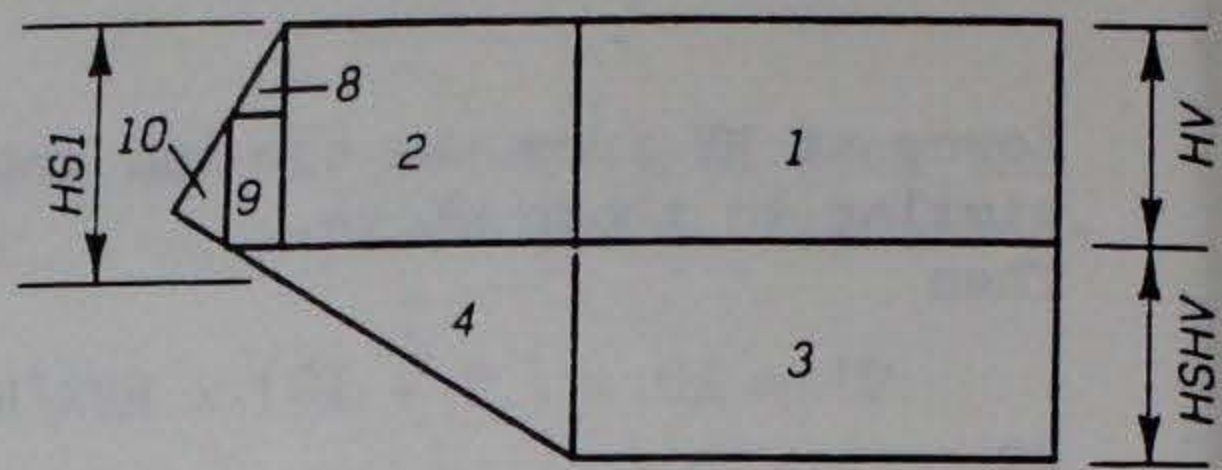

Figure 16. Determination of controlling thickness

Flotation. As previously noted, either LC #1 or LC #2 can be critical with regard to flotation. Figures 17 through 20 indicate the various



(A) $HS1 < HV$



(B) $HS1 > HV$

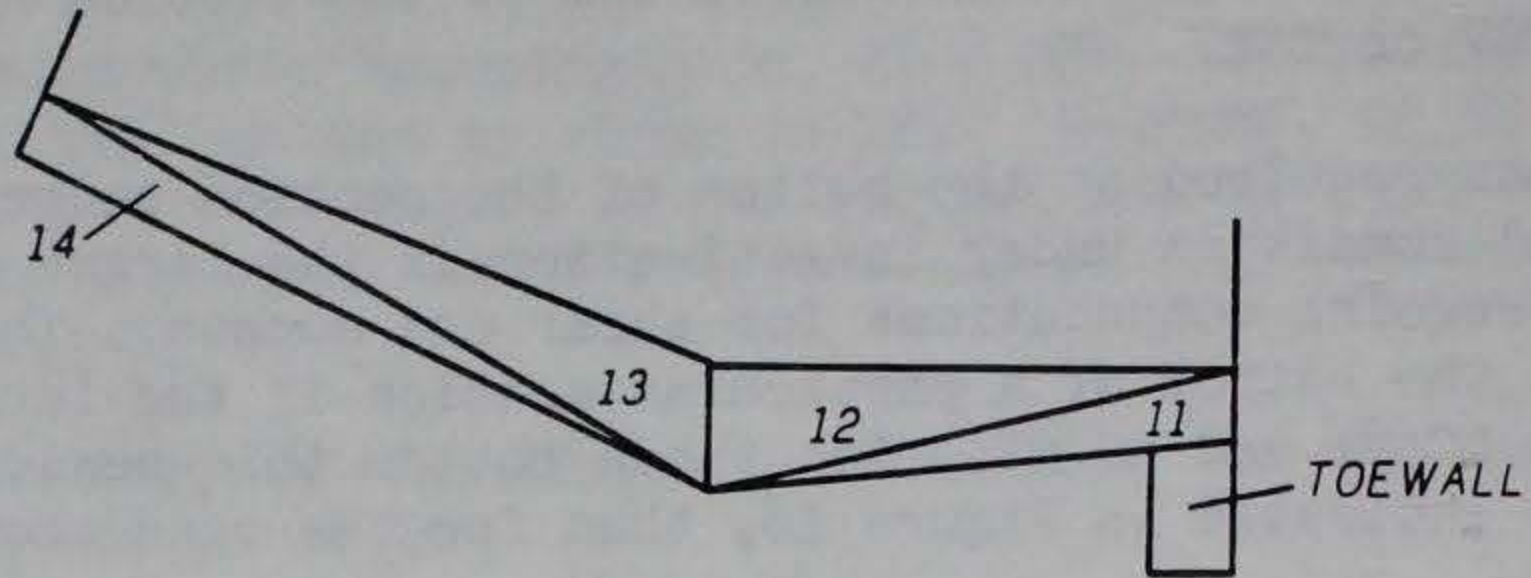

(C) FLOOR SLAB

Figure 17. Components of sidewall and slab volumes

LC#2

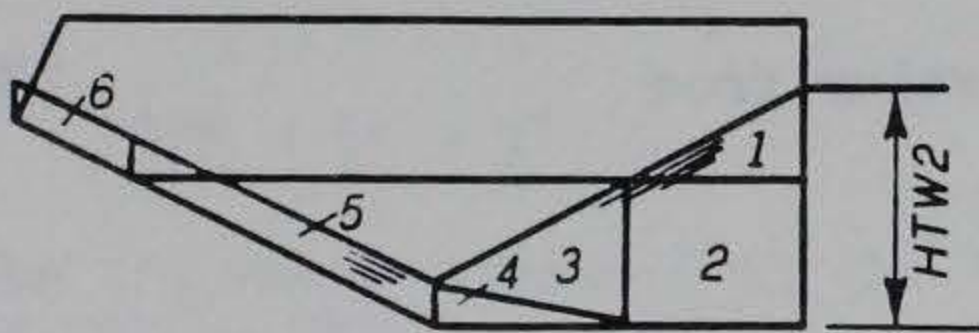

(A) $HTW2 > HSHV$
 $D1 < HSHV$

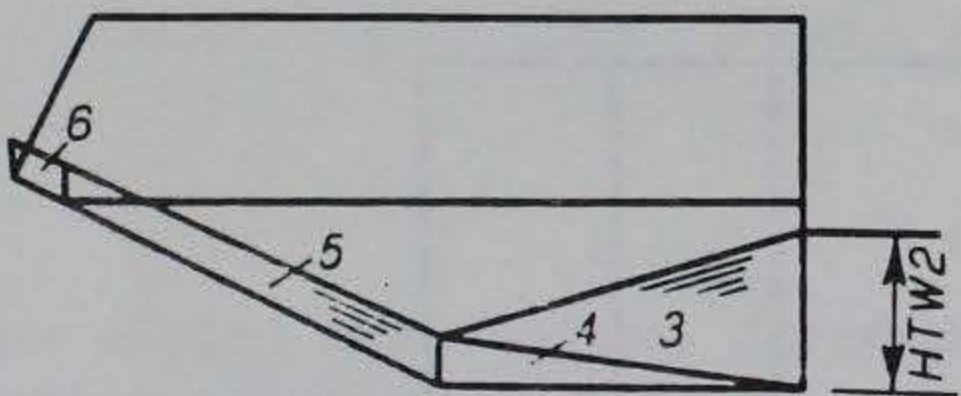

(B) $HTW2 < HSHV$
 $D1 < HSHV$

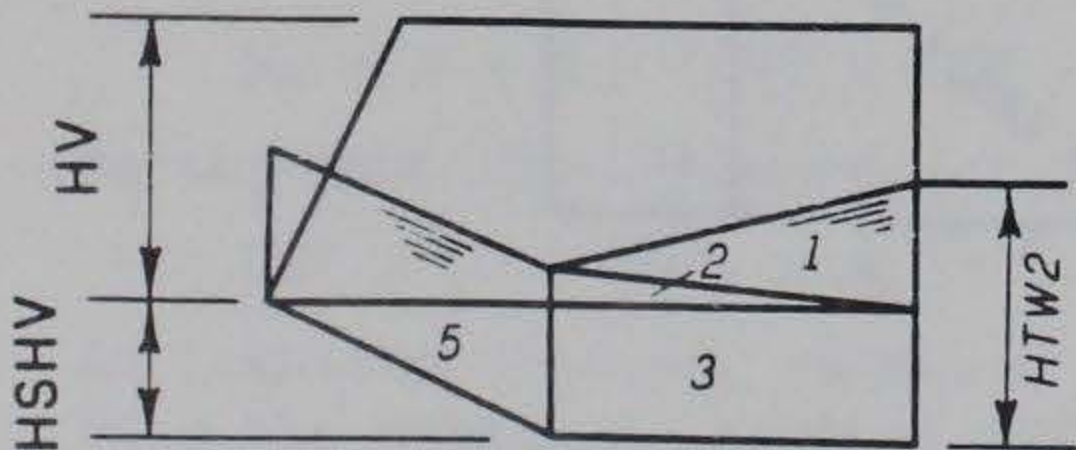

(C) $HTW2 > HSHV$
 $D1 > HSHV$

LC#1

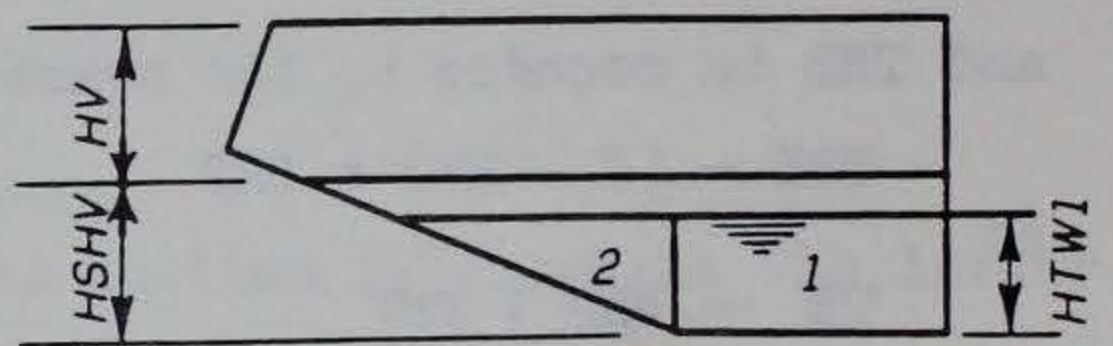

(D) $HTW1 < HSHV$

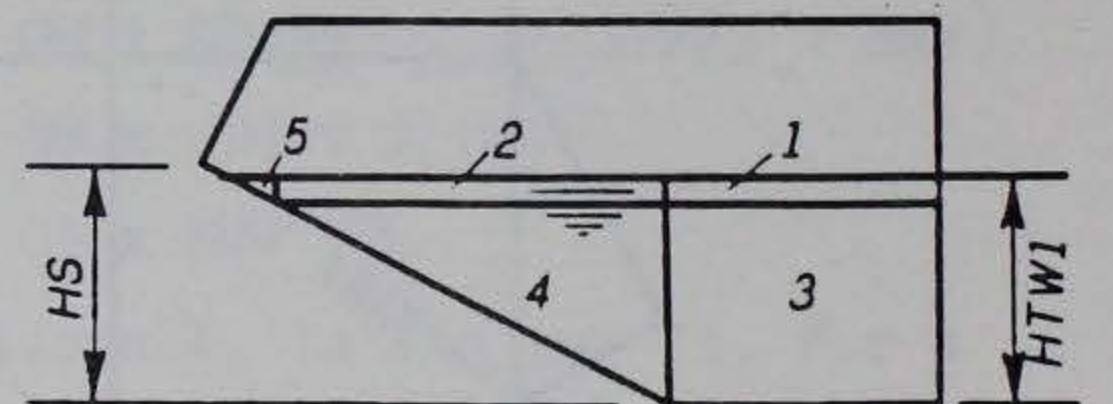

(E) $HTW1 > HSHV$
 $HTW1 < HS$

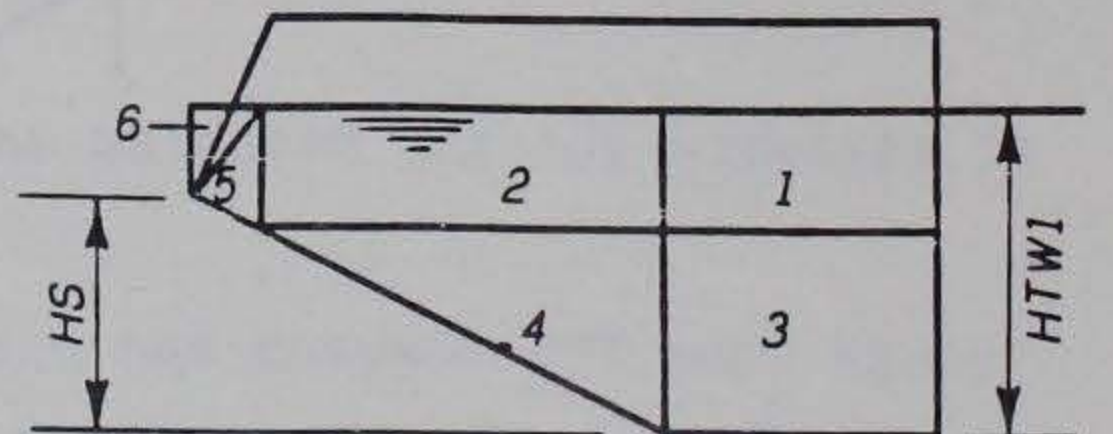

(F) $HTW1 > HS$

Figure 18. Components of volume of water in basin

components of weight and uplift that must be obtained to check flotation requirements. The magnitudes of these components are maintained for subsequent analyses. Figure 17 shows how the sidewalls are partitioned into components depending on relative values of HSl and HV. Figure 18 shows the partitioning of the water volumes in the basin depending on relative values of tailwater and basin dimensions. Figure 19 shows the variation of footing pressures along the stilling basin and how the loads on a footing are partitioned. Footing pressures, PF_n, are computed for both load conditions. The water pressures on any footing are a function of the corresponding head HUP1 or HUP2, this being consistent with the assumption that uplift is a function of HUP1 or HUP2. Figure 20 shows the partitioning of uplift components depending on relative values of the corresponding head HUP1 or HUP2 and basin dimensions.

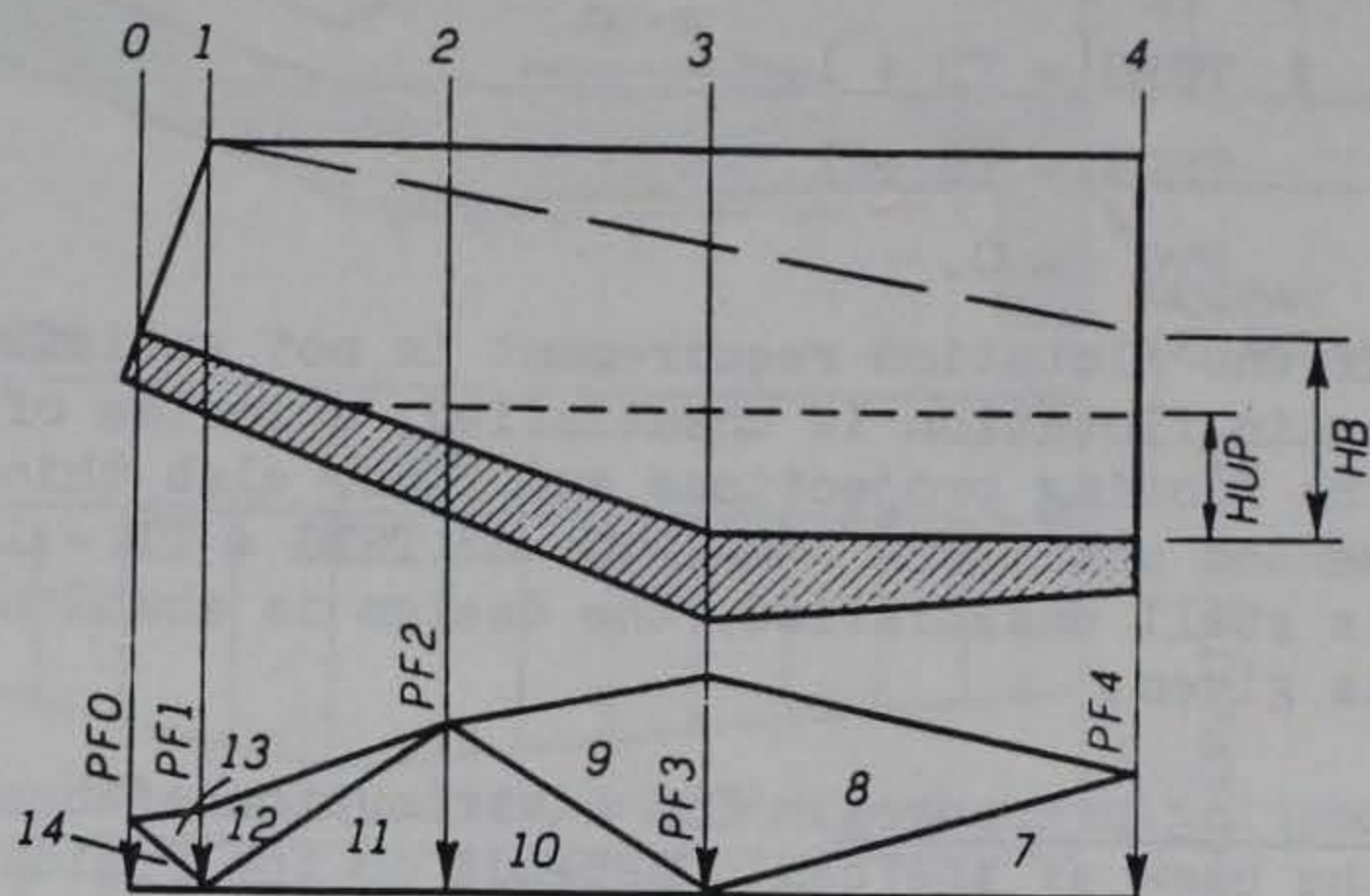

Figure 19. Footing pressures and load components for LC#1 or LC#2

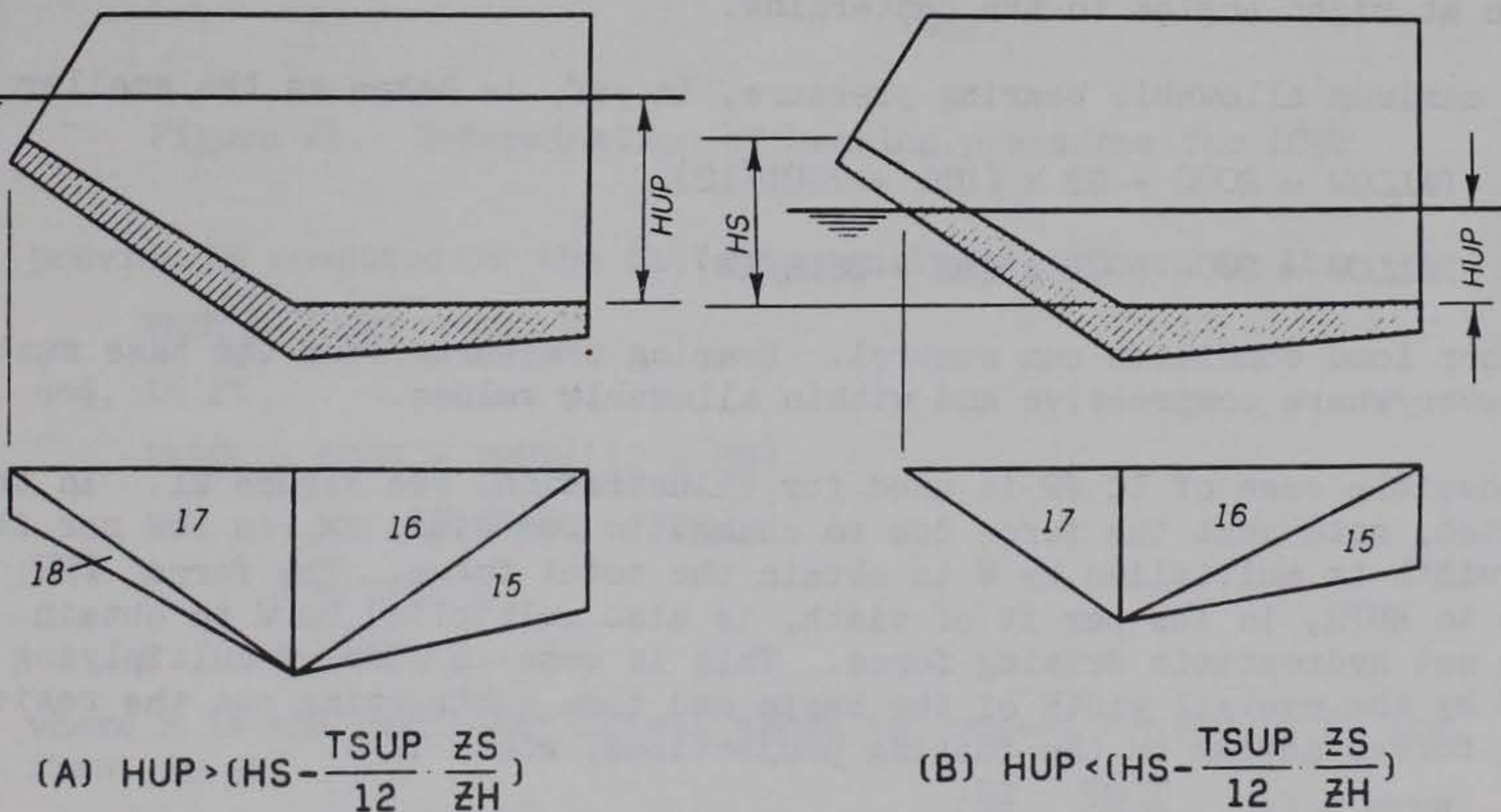

Figure 20. Components of uplift for LC#1 or LC#2

The toewall of Figure 17 is taken at the buoyant weight of concrete to compensate for its lack of consideration in Figure 20.

For each load condition, the sum of all downward forces, SDOWN, and the sum of the uplift forces, SUP, must satisfy the relation

$$\frac{SDOWN}{SUP} \geq FLOATR$$

The initial values of floor slab thicknesses and footing projections are

$$TSUP = TT + (TBV - TT) \times HN/J + 1$$

rounded up to the next integer value, and

$$TSBG = TB + 1.$$

$$TSDN = TB + 1.$$

$$FTG = 0.$$

If the flotation requirement is not satisfied, FTG is set at 1.0. If again flotation is unsatisfied, a series of attempts is begun in which the footing projections and floor slab thicknesses are variously incremented until $FTG = MAXFTG$ and $TSBG = TB + 10$. If the flotation criteria is still unsatisfied, the design is abandoned, and a cancellation message is given.

Bearing pressures. The distribution of bearing (contact) pressures over the base of the basin depends on the rigidity of the structure, the foundation material characteristics, and the magnitude and location of the resultant vertical force acting on the structure. The pressure distribution is three-dimensional and highly indeterminate. For this reason, no attempt is made herein to apply an elastic analysis to determine bearing pressures such as is done for floor slab bearing in TR-50. In accordance with common practice, the assumption is made that bearing pressures vary linearly along any section parallel to the longitudinal centerline of the outlet, and that these pressures are constant along any section at right angles to the centerline.

The maximum allowable bearing pressure, in psf, is taken as the smaller of

$$PALLOW = 2000 + GB \times (HBL + TSUP/12)$$

or

$$PALLOW = 2000 + GB \times (HB + TSDN/12).$$

Either load condition can control. Bearing pressures over the base must be everywhere compressive and within allowable values.

A possible case of IC #2 is used for illustration, see Figure 21. In the sketch, note that the force due to change in momentum, FM, in lbs per ft of width is multiplied by W to obtain the total force. The force, FH2 due to HUP2, in lbs per ft of width, is also multiplied by W to obtain the net hydrostatic driving force. This is done in lieu of multiplying FH2 by the overall width of the basin and then subtracting out the resisting forces acting on the footing projections, etc. If

$$HUP2 > \left(HS - \frac{TSUP}{12} \cdot \frac{ZS}{ZH} \right),$$

see Figure 20, it is assumed that the upper part of FH2 bears on the stilling basin through the upstream channel section. The resultant of the vertical forces including uplift, VNET, is located by taking moments about the indicated moment center of the horizontal forces and the vertical forces

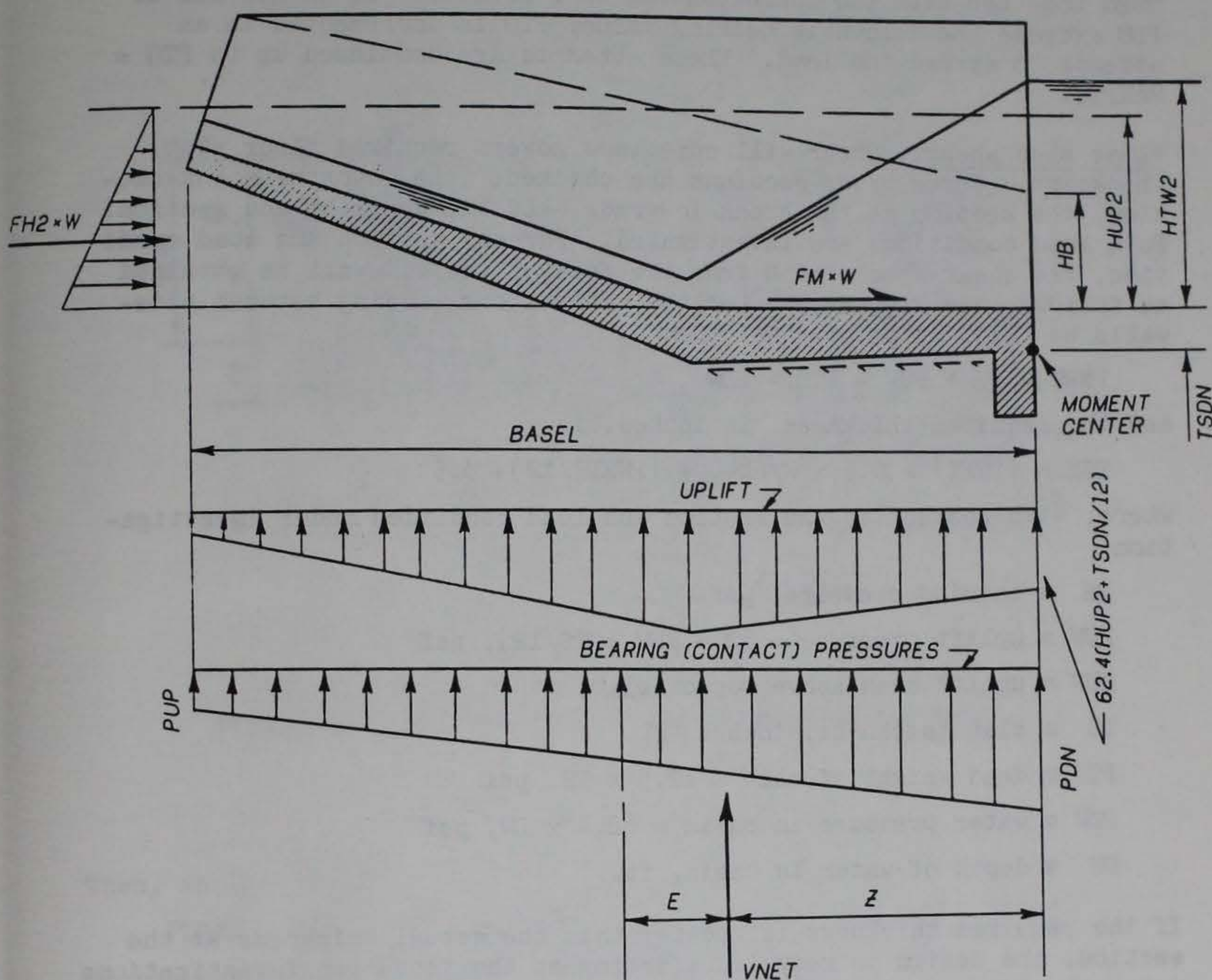

Figure 21. Determination of bearing pressures for IC#2

previously computed in the flotation analyses. Thus, in lbs

$$VNET = SDOWN - SUP$$

and, in ft

$$BASEL = LBOT + TSUP / (12 \times ZH)$$

$$WO = W + 2(TBV/12 + FTG)$$

$$Z = M / VNET$$

$$E = BASEL / 2 - Z$$

where M is the resultant moment about the moment center in ft lbs.

Then, in psf

$$PAVER = VNET / (BASEL \times WO)$$

$$PDN = PAVER(1 + 6E/BASEL)$$

$$PUP = PAVER(1 - 6E/BASEL).$$

If either PUP or PDN is negative, an attempt is made to increase the loading on the structure. This is done by incrementing FTG and also TSBG together with the corresponding TSUP or TSDN. If either PUP or PDN exceeds the allowable bearing value, FTG is incremented in an attempt to spread the load. These attempts are continued up to $FTG = MAXFTG$.

Floor slab shear. Shear will sometimes govern required floor slab thickness. Three cross sections are checked: the downstream end section, the section at the break-in-grade, and the upstream end section. Both load conditions are investigated. For any section and load condition, the shear stress at D from the face of the sidewall is obtained as follows, see Figure 22. Let the net uniform loading between sidewalls be $PNET$, in psf per ft, then

$$PNET = PB + PUW - PTS - PDW$$

and the required thickness, in inches, is

$$TSR = |PNET| \times 0.5 \times W / (840 + |PNET|/12) + 3.5$$

where, with respect to the section and load condition under investigation

PB \equiv bearing pressure, psf

PUW \equiv uplift pressure = $62.4(HUW + TS/12)$, psf

HUW \equiv uplift head above top of slab, ft

TS \equiv slab thickness, inches

PTS \equiv dead weight of slab = $12.5 \times TS$, psf

PDW \equiv water pressure in basin = $62.4 \times DW$, psf

DW \equiv depth of water in basin, ft.

If the required thickness is greater than the actual thickness at the section, the design is recycled starting at the flotation investigations using the increased thickness and other current slab thicknesses as initial values.

Floor slab bending. Transverse bending moment at the center of the floor slab will sometimes govern required floor slab thicknesses. The downstream end section, the break-in-grade section, and the upstream end section are checked for both load conditions. Note that in general, the sum of the vertical forces acting on any section under investigation will not equal zero unless longitudinal shearing forces on each side of the section are taken in account. The distribution of these shearing forces is unknown. They are therefore treated in two ways to determine their maximum probable effect. As shown by Figure 22, they are taken as longitudinal shearing forces, $PLONG$, carried by the sidewalls. Under this assumption, the moment at the center of the slab for any section and load condition is obtained as follows. Let

MWALL \equiv moment brought to floor slab by loads acting on sidewall stem, ft lbs per ft

PWALL \equiv sidewall direct force brought to floor slab, lbs per ft

PF \equiv pressure on footing projection, psf

WO \equiv overall width of basin = $W + 2(TBV/12 + FTG)$, ft

CB \equiv direct compression in floor slab, see pages 56-57, lbs per ft

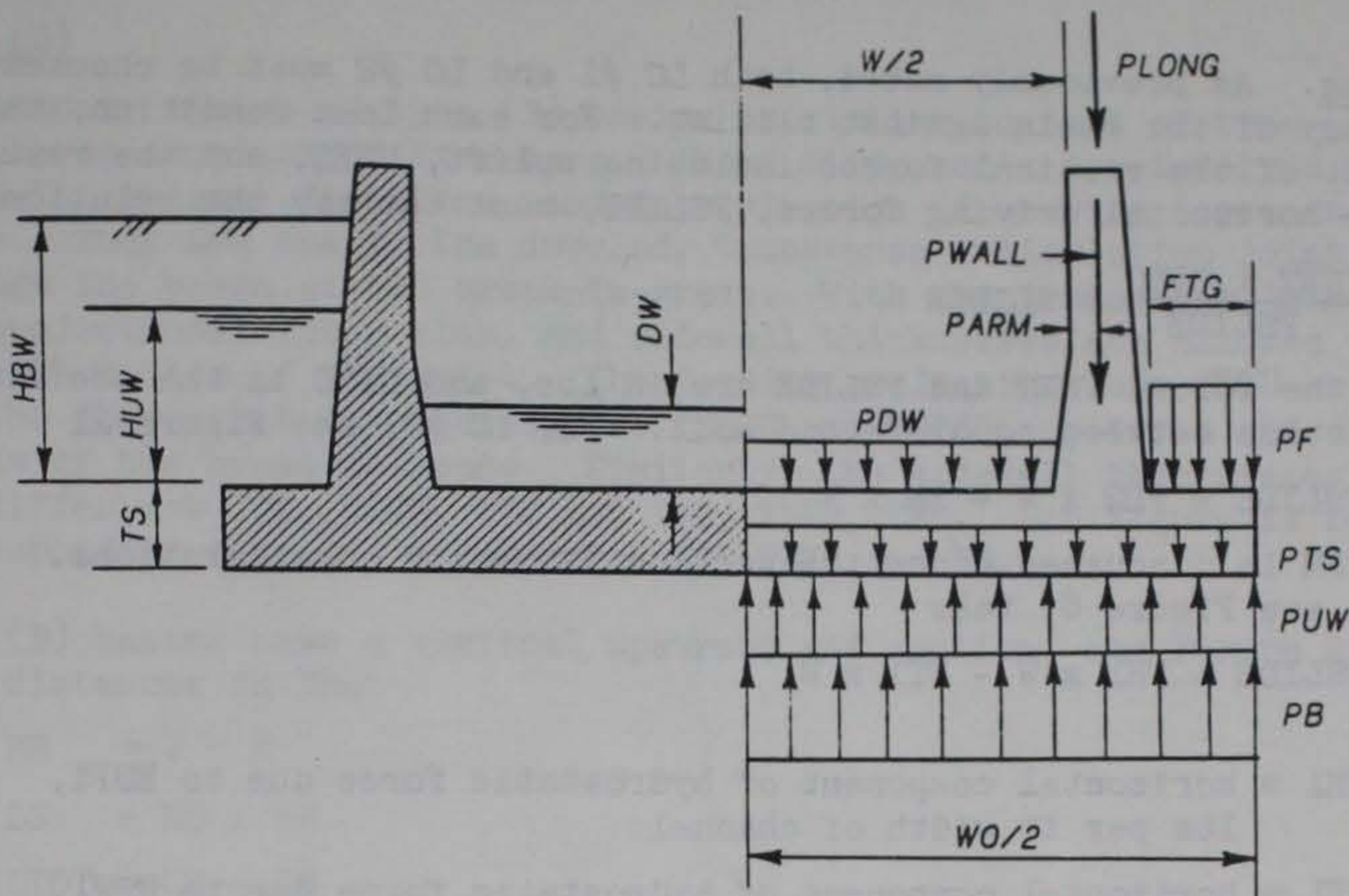

Figure 22. Loads for floor slab shear and bending

Then, in lbs per ft

$$P_{LONG} = (P_B + P_{UW} - P_{TS})W_0/2 - P_F \times FTG - P_{DW} \times W/2 - P_{WALL}$$

So the center moment, MC, in ft lbs per ft, is

$$MC = (P_B + P_{UW} - P_{TS})W_0^2/8 - P_F \times FTG(W_0/2 - FTG/2) - P_{DW} \times W^2/8 \\ - (P_{WALL} + P_{LONG})(W/2 + P_{ARM}) + M_{WALL}$$

Alternately, the longitudinal shearing forces are taken as uniformly distributed forces, U_{LONG} , carried by the floor slab. Under this assumption, in psf

$$U_{LONG} = P_{LONG}/(W_0/2)$$

and

$$MC = (P_B + P_{UW} - P_{TS} - U_{LONG})W_0^2/8 \\ - P_F \times FTG(W_0/2 - FTG/2) - P_{DW} \times W^2/8 \\ - P_{WALL}(W/2 + P_{ARM}) + M_{WALL}$$

the larger absolute moment governs and the required slab thickness for preliminary design is taken as

$$T_M = (0.003683(|MC| + CB(TS/2 - T_{ADD})/12))^{1/2} + T_{ADD}$$

where $T_{ADD} = 3.5$ if MC is positive, or 2.5 if MC is negative.

If the required thickness exceeds the actual section thickness, the design is recycled as explained for floor slab shear.

Sliding. As previously noted, both LC #1 and LC #2 must be checked for adequacy of the basin against sliding. For each load condition, the resultant of the vertical forces including uplift, VNET, and the resultant of the horizontal driving forces, FSLIDE, must satisfy the relation

$$\frac{VNET \times CFSC}{FSLIDE} \geq SLIDER$$

where the forces VNET and FSLIDE are in lbs, and CFSC is the coefficient of friction between concrete and soil. For LC #2, see Figure 21

$$FSLIDE = FH2 \times W + FM \times W$$

where FM is discussed under the section "Momentum considerations." For LC #1, see Figure 8, take

$$FSLIDE = FH1 \times W - FT1 \times W$$

where

FH1 \equiv horizontal component of hydrostatic force due to HUPL, lbs per ft width of channel

FT1 \equiv horizontal component of hydrostatic force due to HTWL, lbs per ft width of channel.

Both FH2 and FH1 are multiplied by W to obtain respective net hydrostatic driving forces.

If either load condition sliding requirement is not satisfied, the weight on the structure is increased. This is done by first incrementing FTG up to MAXFTG. If these attempts are unsuccessful, then the floor slab thicknesses are incremented several times. If the sliding criteria is still unsatisfied, the design is abandoned, and a cancellation message is given.

Momentum changes at break-in-grade. The preceding analyses dealing with LC#2 do not include effects of momentum change that take place due to, and in the vicinity of, the break-in-grade. The following discussion pertains to cases of HTW2 \leq D2. The force due to momentum change may be resolved into horizontal and vertical components. Both components decrease with the slope parameter, ZS. The horizontal component is of opposite sense to the momentum force, FM, discussed on pages 10-12 and hence would reduce the effect of FM. The vertical component acts downward on the basin and hence would reduce the basin weight required for flotation and would reduce the tendency for sliding of the basin. The vertical component would increase foundation bearing pressures. With the possible exception of this last effect in the presence of a weak foundation, it is probably conservative to neglect, that is, not to depend on, the effects of momentum change at the break-in-grade. This is especially so in view of the questionable nature of these forces.

Type (B)

Preliminary design of type (B) basins is similar to that of type (A) with three important differences. These differences are involved with sidewall bending, flotation, and determination of bearing (contact) pressures. They are due to the doweled, transverse articulation joint passing through the basin at the break-in-grade. With the transverse joint, footing projections, floor slab, and sidewall thicknesses are allowed to differ either side of the joint. The footing projections are FTGU and FTGD, and the floor slab thicknesses are TSBGU and TSBGD, upstream and downstream of the break-in-grade. Similarly, the sidewall thicknesses that may differ are TVU, TBVU, TBU and TVD, TBVD, TBD. See Figure 11 for corresponding type (A) thicknesses TV, TBV, and TB.

Type (B) basins have a vertical upstream end section, see Figure 2. Thus, with distances in feet

$$HS = J - N$$

$$LS = HS \times ZS$$

$$LTOT = LS + LB$$

Section heights, earthfill heights, tailwater depths, and uplift heads are obtained from the same expressions used with type (A), except that

$$HS1 = N$$

and

$$HB3 = HB + (J - HB) \times LB/LTOT.$$

Sidewall bending. Sidewall thicknesses upstream of the transverse joint are determined by the thicknesses required at the bottoms of sections 1, 2, and 3, see Figure 23, as was discussed earlier for type (A) basins.

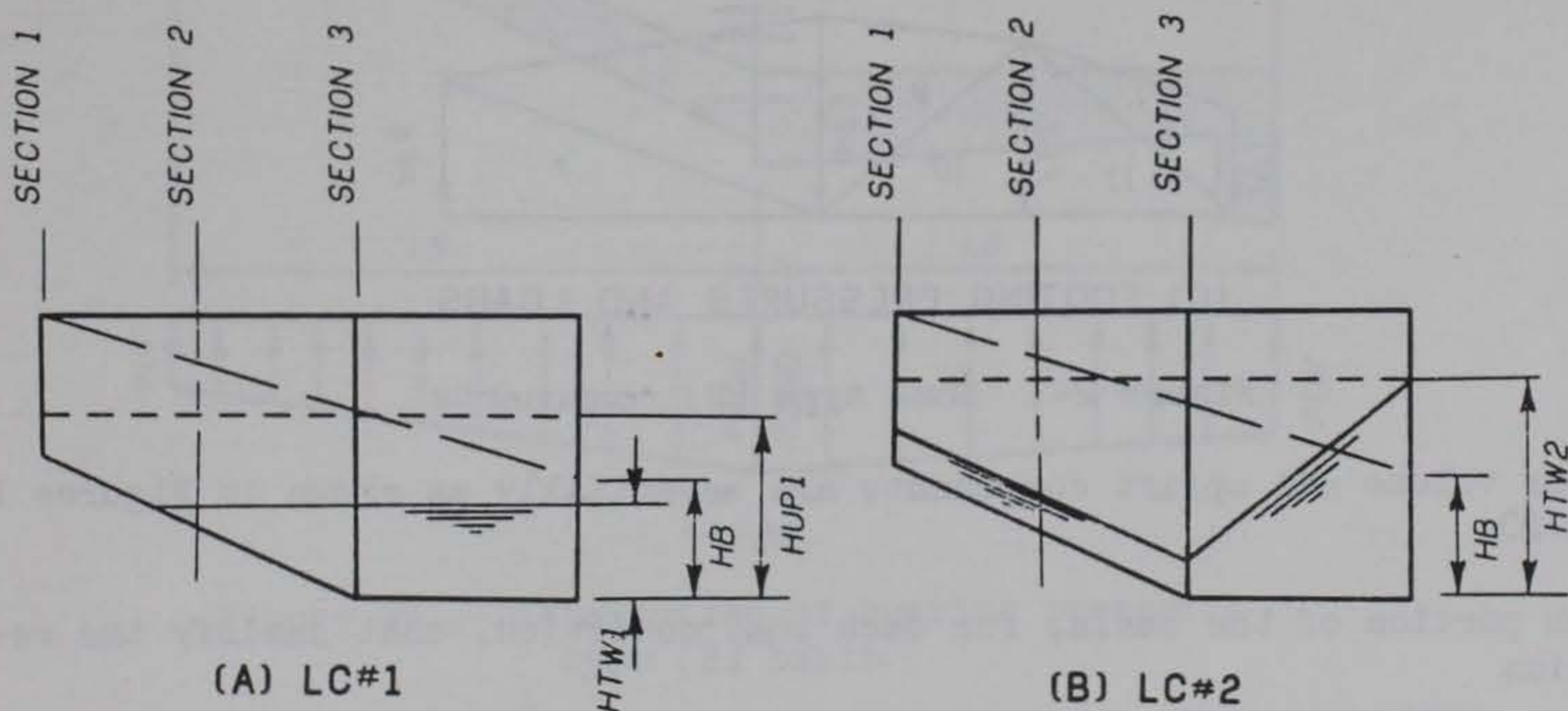
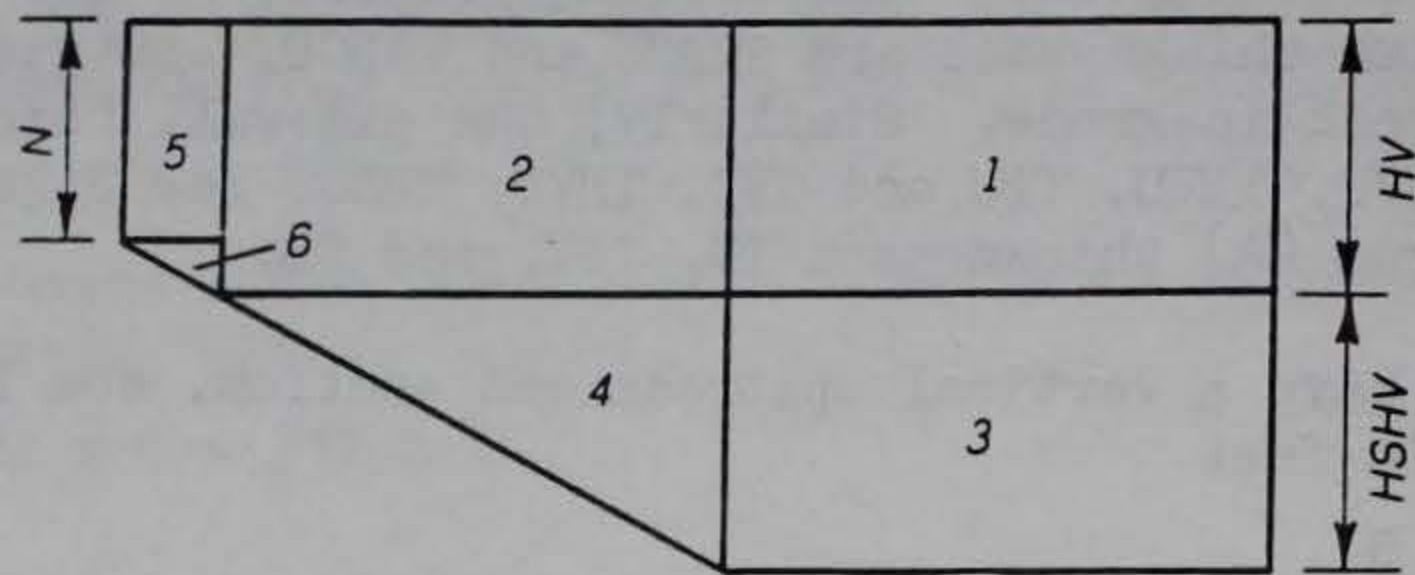

Figure 23. Considerations for sidewall bending, Type (B) basin

Thus, the upstream thicknesses TVU, TBVU, TBB, and TBU are obtained just as previously explained. Sidewall thicknesses downstream of the transverse joint are controlled by the thickness required at the bottom of section 3. Hence the downstream thicknesses TVD, TBVD, TBB, and TBD are

obtained from the procedure used to determine the thickness required at the bottom of a section.

Flotation. The upstream and the downstream portions of type (B) basins must satisfy flotation requirements separately. The various components of weight and uplift needed to make the flotation checks are similar to those for type (A) basins. Figure 24 indicates components of sidewall volumes, slab volumes, and footing pressures and loads.



(A) SIDEWALL VOLUMES

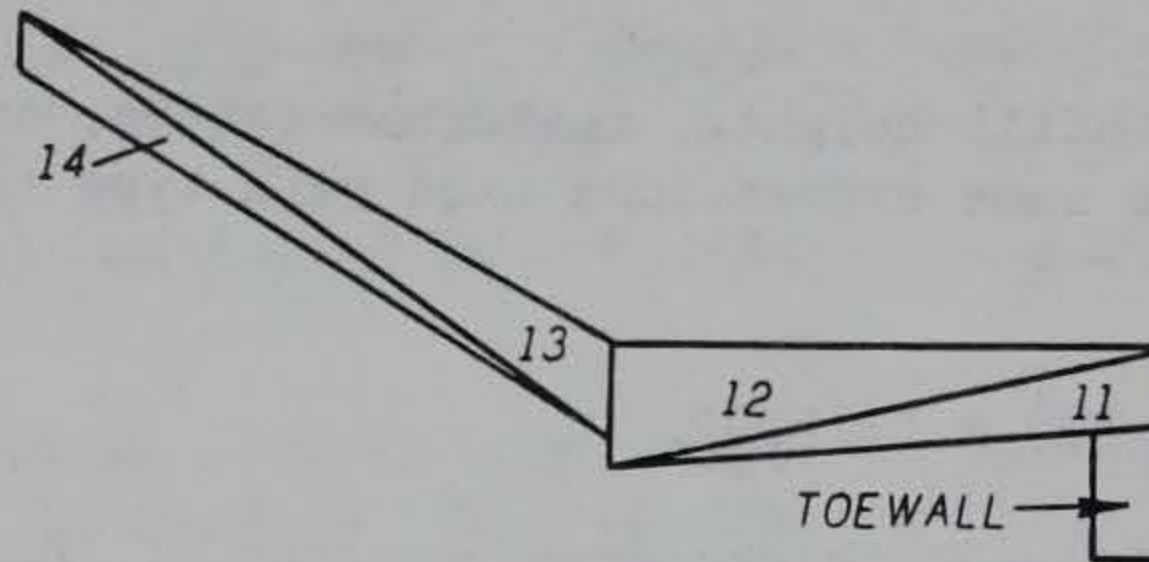

(B) SLAB VOLUMES

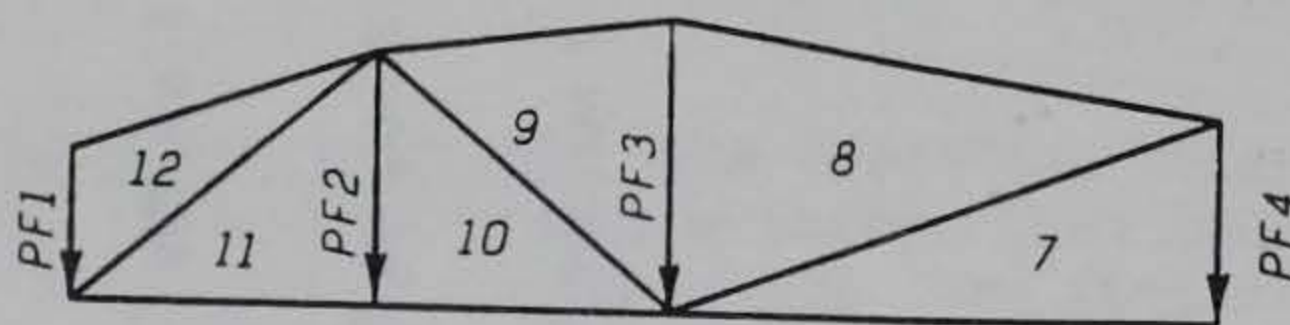

(C) FOOTING PRESSURES AND LOADS

Figure 24. Some type (B) components

Water volume and uplift components are essentially as shown in Figures 18 and 20.

Each portion of the basin, for each load condition, must satisfy the relation

$$\frac{SDOWN}{SUP} \geq FLOATR$$

where SDOWN is the sum of all downward forces for the portion and SUP is the sum of the uplift forces for the portion. Initial values for the upstream portion are

$$TSUP = TT + (TBVU - TT) \times N/J + 1$$

rounded up to the next integer, and

$$\text{TSBGU} = \text{TBU} + 1$$

$$\text{FTGU} = 0.$$

Initial values for the downstream portion are

$$\text{TSBGD} = \text{TBD} + 1.$$

$$\text{TSDN} = \text{TBD} + 1.$$

$$\text{FTGD} = 0.$$

If the flotation requirement is not satisfied for the portion under investigation, the corresponding footing projections and floor slab thicknesses are variously incremented up to MAXFTG and TBU + 10 or TBD + 10. If flotation remains unsatisfied the design is abandoned.

Bearing pressures. As previously noted, the transverse joint at the break-in-grade affects the structural behavior of this type of stilling basin. The precise behavior is admittedly uncertain. However, the doweled joint allows relative longitudinal translation of the two portions of the basin, does not allow relative transverse horizontal or vertical translation, and provides little moment resistance. The joint is therefore idealized as a hinge that is capable of transmitting shears and direct bearing between portions, but no moment. Figure 25 shows the resulting distribution of

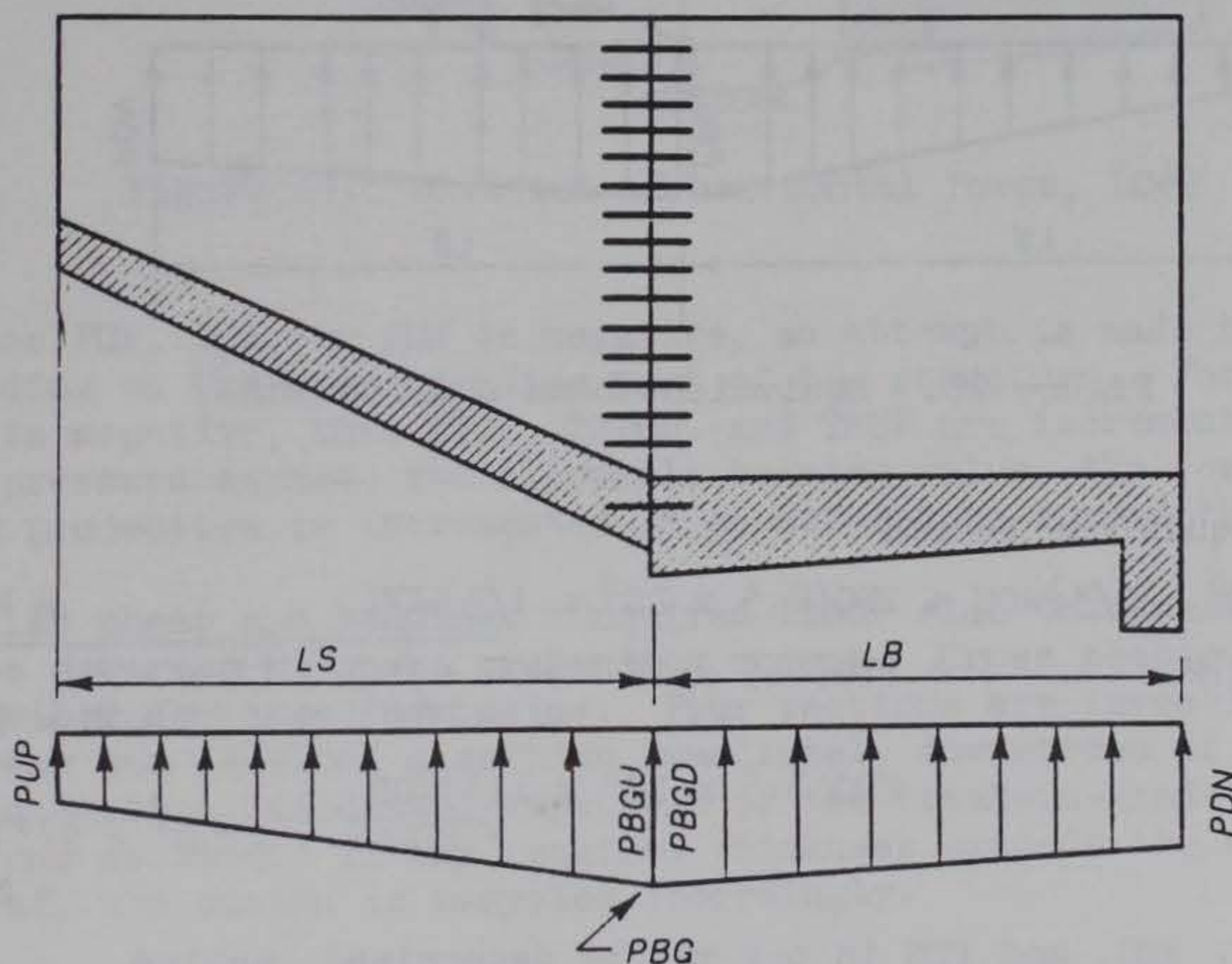

Figure 25. Distribution of bearing pressures type (B) basin

bearing pressures. There are four unknown pressures PUP, PBGU, PBGD, and PBD. By construction, vertical displacements immediately either side of the break-in-grade must be equal. Therefore bearing pressures immediately either side are equal assuming a constant modulus of the foundation. Thus

$$\text{PBG} \equiv \text{bearing pressure at the break-in-grade} = \text{PBGU} = \text{PBGD}, \text{ psf.}$$

The pressure distribution is therefore reduced to three unknowns. These unknowns may be evaluated by application of the statical equations

ΣM_{HU} \equiv sum of moments of forces upstream of hinge,
about the hinge = 0

ΣV \equiv sum of vertical forces = 0

ΣM_{HD} \equiv sum of moments of forces downstream of hinge,
about the hinge = 0.

For the load condition under investigation, let

$VRUP$ and $VRDN$ \equiv the resultants of the vertical forces
acting on the upstream and downstream
portions, respectively, lbs

MUP and MDN \equiv the resultant moments of the upstream
and downstream forces, respectively,
about the hinge, ft lbs.

Figure 26 shows the equivalent beam, with its loading, created by these assumptions and definitions.

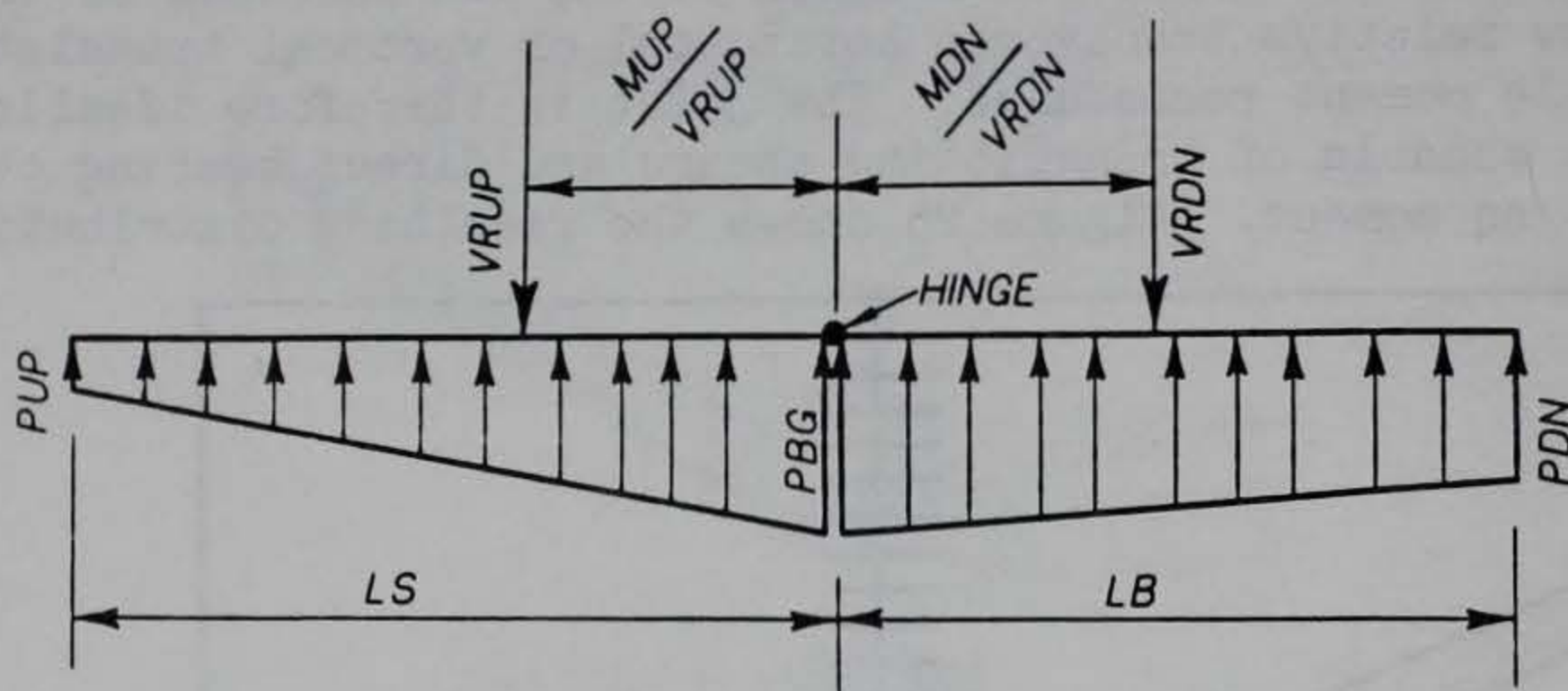

Figure 26. Equivalent beam and loading

The statical equations become

$$PUP(0.5 \times LS^2 \times 2/3)WOU + PBG(0.5 \times LS^2 \times 1/3)WOU = MUP$$

$$PUP(0.5 \times LS)WOU + PBG(0.5 \times LS \times WOU + 0.5 \times LB \times WOD) + PDN(0.5 \times LB)WOD = VRUP + VRDN$$

$$PBG(0.5 \times LB^2 \times 1/3)WOD + PDN(0.5 \times LB^2 \times 2/3)WOD = MDN$$

from which PUP, PBG, and PDN in psf may be determined, noting

$$WOU \equiv \text{overall width of upstream portion of basin} \\ = W + 2(TBVU/12 + FTGU), \text{ ft}$$

$$WOD \equiv \text{overall width of downstream portion of basin} \\ = W + 2(TBVD/12 + FTGD), \text{ ft}$$

The horizontal components of the hydrostatic forces of Figures 8 and 9 enter into the evaluation of the moments, MUP and MDN, as does the net momentum force $FM \times W$. The horizontal forces, $FH2 \times W$, $FH1 \times W$, and $FT1 \times W$, as the case may be, are effectively shared in some way by both portions of the basin. It is assumed that these forces are divided between the upstream and downstream portions, by direct bearing between

portions, in proportion to V_{NETU} and V_{NETD} where, for the portion

$$V_{NET} = S_{DOWN} - S_{UP}$$

from flotation analyses. Thus, see Figure 27, the part of $FH_2 \times W$ carried by the upstream portion is

$$FH_2W_U = FH_2 \times W \times V_{NETU} / (V_{NETU} + V_{NETD})$$

and the part carried by the downstream portion is

$$FH_2W_D = FH_2 \times W \times V_{NETD} / (V_{NETU} + V_{NETD}).$$

The forces due to FH_1 and FT_1 are similarly divided.

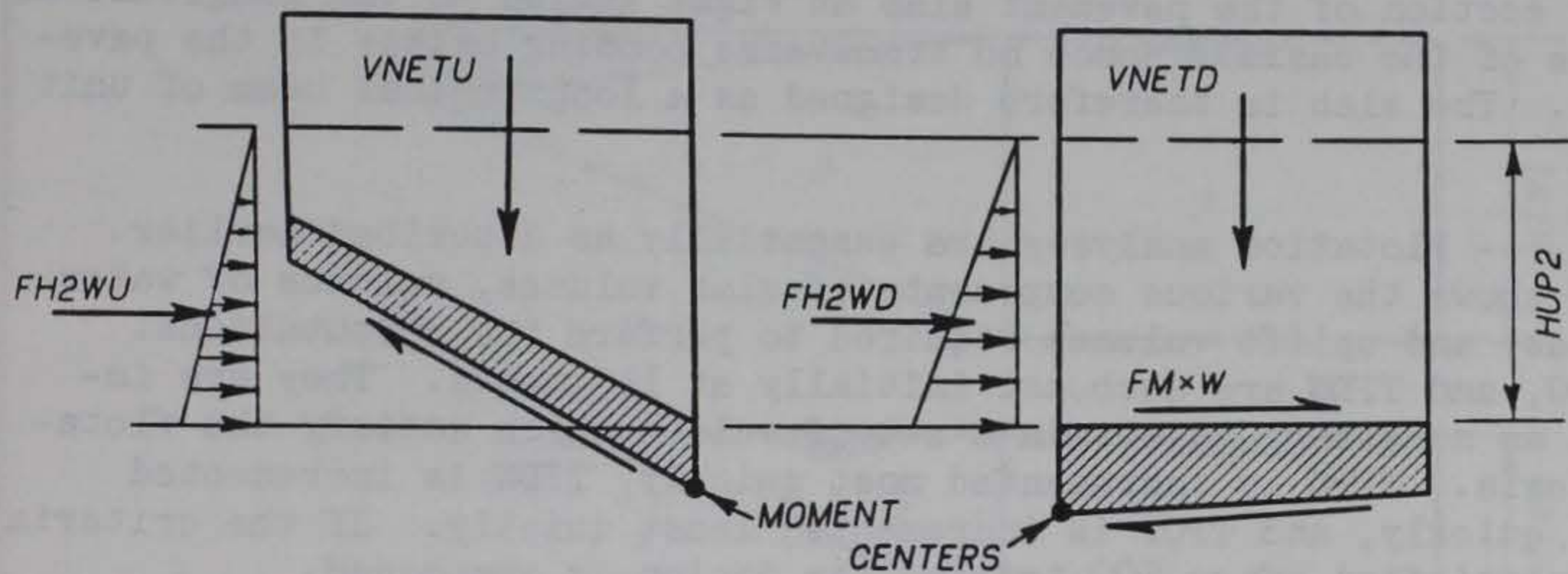

Figure 27. Division of horizontal force, IC#2

If either P_{UP} , P_{BG} , or P_{DN} is negative, an attempt is made to increase the loading on the corresponding part of the structure. For example, if P_{UP} is negative, then FT_{GU} , TS_{BGU} , and TS_{UP} are incremented. Similarly, if any pressure exceeds the allowable bearing value, the corresponding footing projection is incremented in an attempt to spread the load.

Floor slab shear and bending. Required floor slab thicknesses will sometimes be governed by shear or bending moment. Cross sections are checked as described for type (A) basins. Four sections are investigated: the downstream end section, a section immediately downstream of the break-in-grade, a section immediately upstream of the break-in-grade, and the upstream end section. If any required thickness exceeds the actual section thickness, the design is recycled accordingly.

Sliding. Investigations into the adequacy of the basin against sliding are treated the same as described for type (A). That is

$$\frac{V_{NET} \times CF_{SC}}{F_{SLIDE}} \geq SLIDER$$

where, for type (B) basins

$$V_{NET} = V_{NETU} + V_{NETD}$$

for the load condition under investigation.

Type (C)

Preliminary design of type (C) basins is accomplished in two parts, first the design of the pavement slab and second the design of the retaining wall portion. The pavement slab is designed per unit of width. It is subjected to longitudinal shear and moment and must satisfy flotation, bearing, and sliding requirements. The retaining wall portion includes the design of many trial configurations. The toe length, X, varies from W/2 to 0. * The design having the least volume is taken as best. For a particular value of X, the retaining wall portion is investigated for sidewall bending, flotation, bearing pressures, base slab shear and moment, and sliding. The bearing pressure distribution is three-dimensional and requires special treatment.

Pavement slab design. Loadings and bearing pressures are assumed constant along any section of the pavement slab at right angles to the longitudinal centerline of the basin. Hence no transverse bending exists in the pavement slab. The slab is therefore designed as a longitudinal beam of unit width.

Flotation. -- Flotation analyses are essentially as described earlier. Figure 28 shows the various components of slab volumes, volumes of water on the slab, and uplift volumes required to perform the computations. TPUP, TPBG, and TPDN are each set initially at 11 inches. They are incremented as necessary to obtain a set of values which satisfy the flotation criteria. TPBG is incremented most quickly, TPDN is incremented next most quickly, and TPUP is incremented least quickly. If the criteria remains unsatisfied after 500 trials, the design is abandoned.

Bearing pressures. -- The analysis of bearing pressures is straightforward. It parallels the procedure described for type (A) basins except on a per foot width basis. A possible case of LC #1 is illustrated in Figure 29. If the resultant vertical force per foot is VNET and the resultant moment about the moment center in ft lbs per ft is M, and other quantities are as previously defined, then

$$Z = M/VNET$$

$$E = LTOT/2 - Z$$

$$PAVER = VNET/LTOT$$

so, in psf

$$PDN = PAVER (1 + 6E/LTOT)$$

$$PUP = PAVER (1 - 6E/LTOT)$$

If either PUP or PDN is negative, corresponding slab thicknesses are incremented and the design is recycled. If either PUP or PDN exceeds the allowable bearing value, the design is abandoned.

Sliding. -- The pavement slab must satisfy

$$\frac{VNET \times CFSC}{FSLIDE} \geq SLIDER$$

where, for LC #1

$$FSLIDE = FHL - FTI$$

*Except that X may not exceed 40. ft.

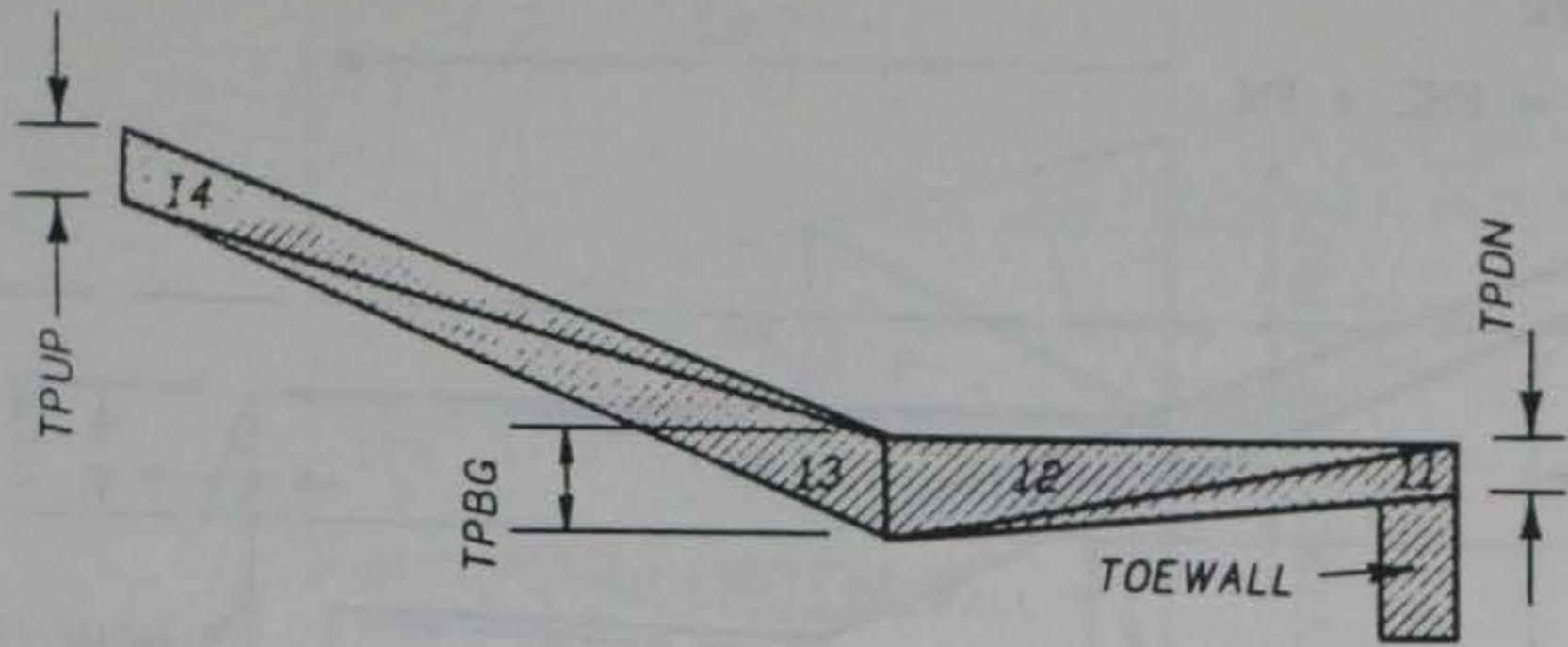

(A) PAVEMENT SLAB THICKNESSES AND VOLUMES

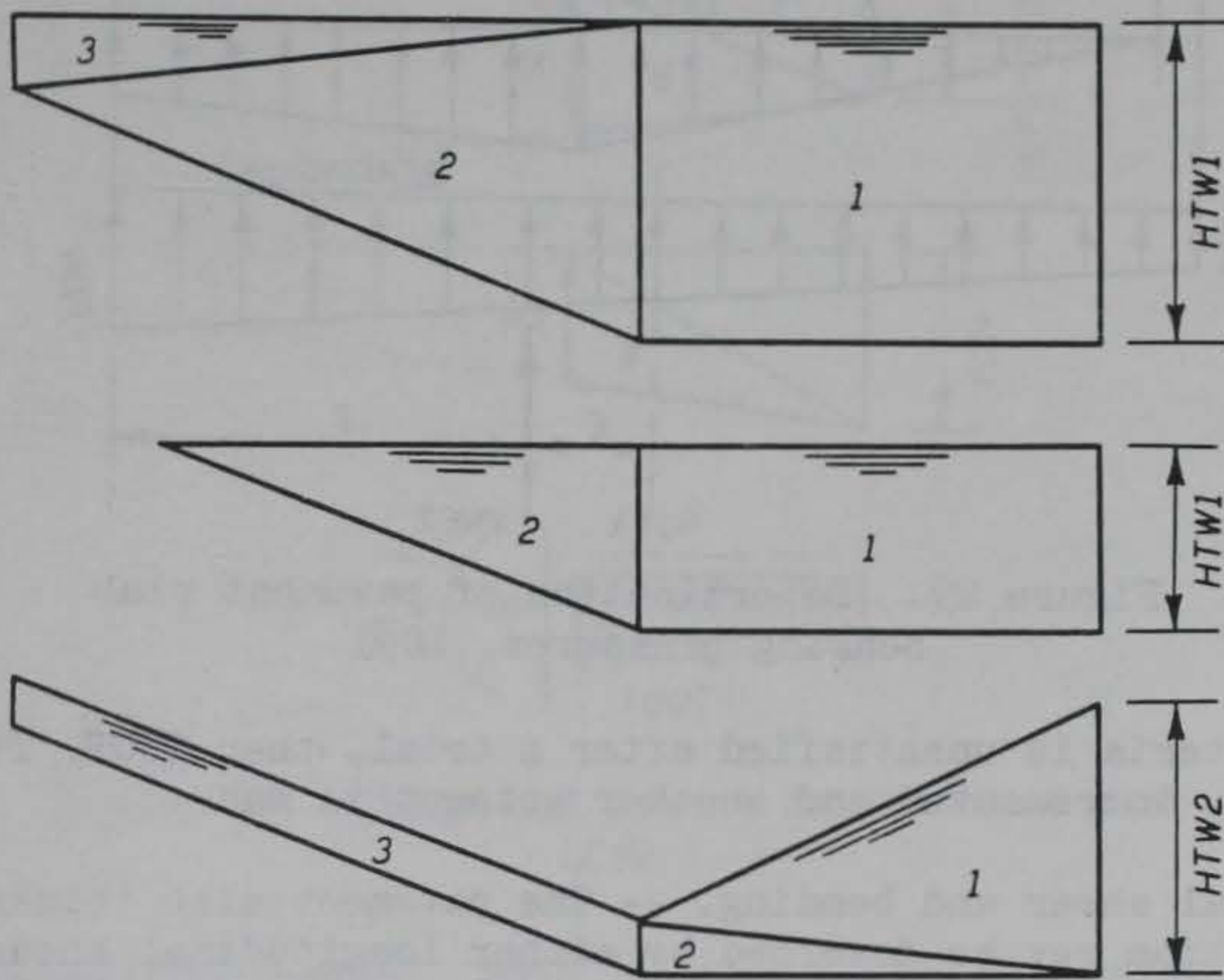

(B) POSSIBLE WATER VOLUMES, LC#1 AND LC#2.

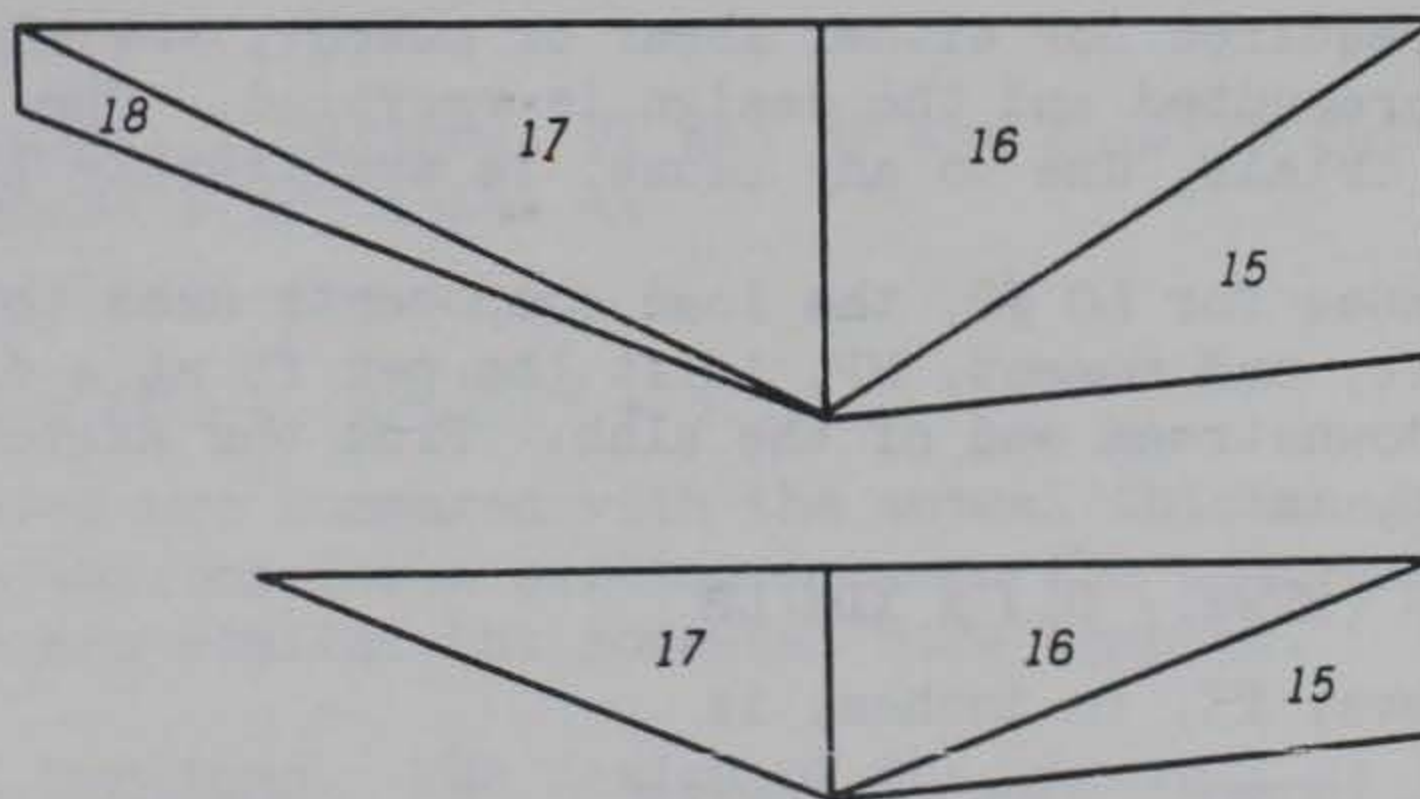

(C) POSSIBLE UPLIFT, LC#1 OR LC#2.

Figure 28. Pavement slab components

and for LC #2

$$FSLIDE = FH2 + FM$$

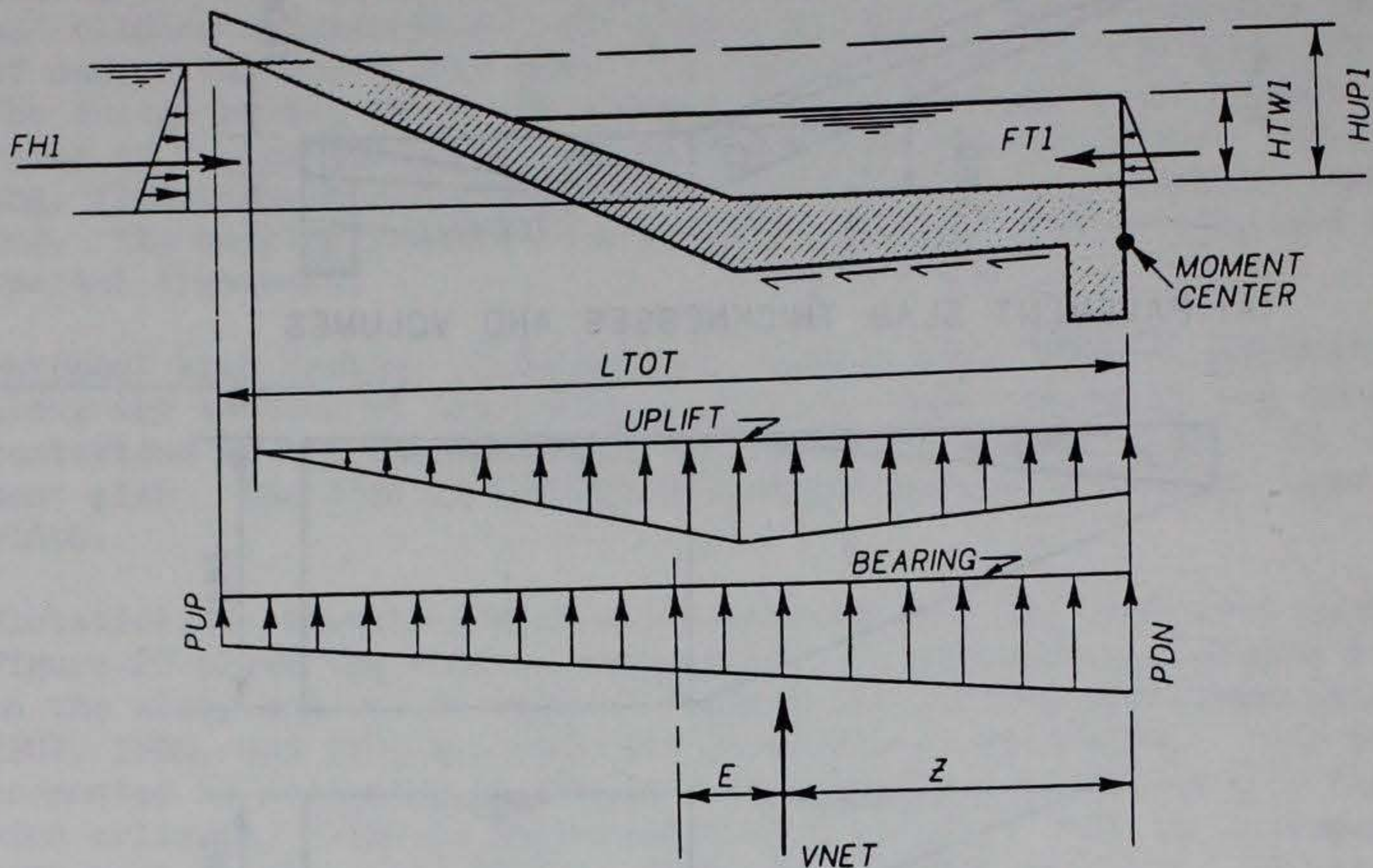

Figure 29. Determination of pavement slab bearing pressures, LC#1

If the criteria is unsatisfied after a trial, then TPUP, TPBG, and TPDN are equally incremented and another attempt is made.

Longitudinal shear and bending. -- The pavement slab thickness at any interior section may be governed by either longitudinal shear or bending moment. The thicknesses required by shear and moment are computed at a series of sections between the downstream end of the pavement slab and the break-in-grade, and at another series of sections between the upstream end and the break-in-grade. If at any section the actual thickness is less than that required for either shear or moment, the slab thicknesses are suitably incremented and the design is recycled. The total number of pavement design trials, due to any cause, is arbitrarily limited to 500.

Figure 30 indicates for LC #2, the load components used to obtain shear, VP, in lbs per ft, and moment, MP, in ft lbs per ft at a distance, XDN, in ft from the downstream end of the slab. From the sketch the water depth, HX, in ft, is

$$HX = HTW2 - (HTW2 - D1) \times XDN/LB$$

and slab thickness, TX, in inches, is

$$TX = TPDN + (TPBG - TPDN) \times XDN/LB$$

the uplift head, UX, in ft, is

$$UX = HUP2 + TX/12$$

and the bearing pressure, PX, in psf is

$$PX = PDN - (PDN - PUP) \times XDN/LTOT.$$

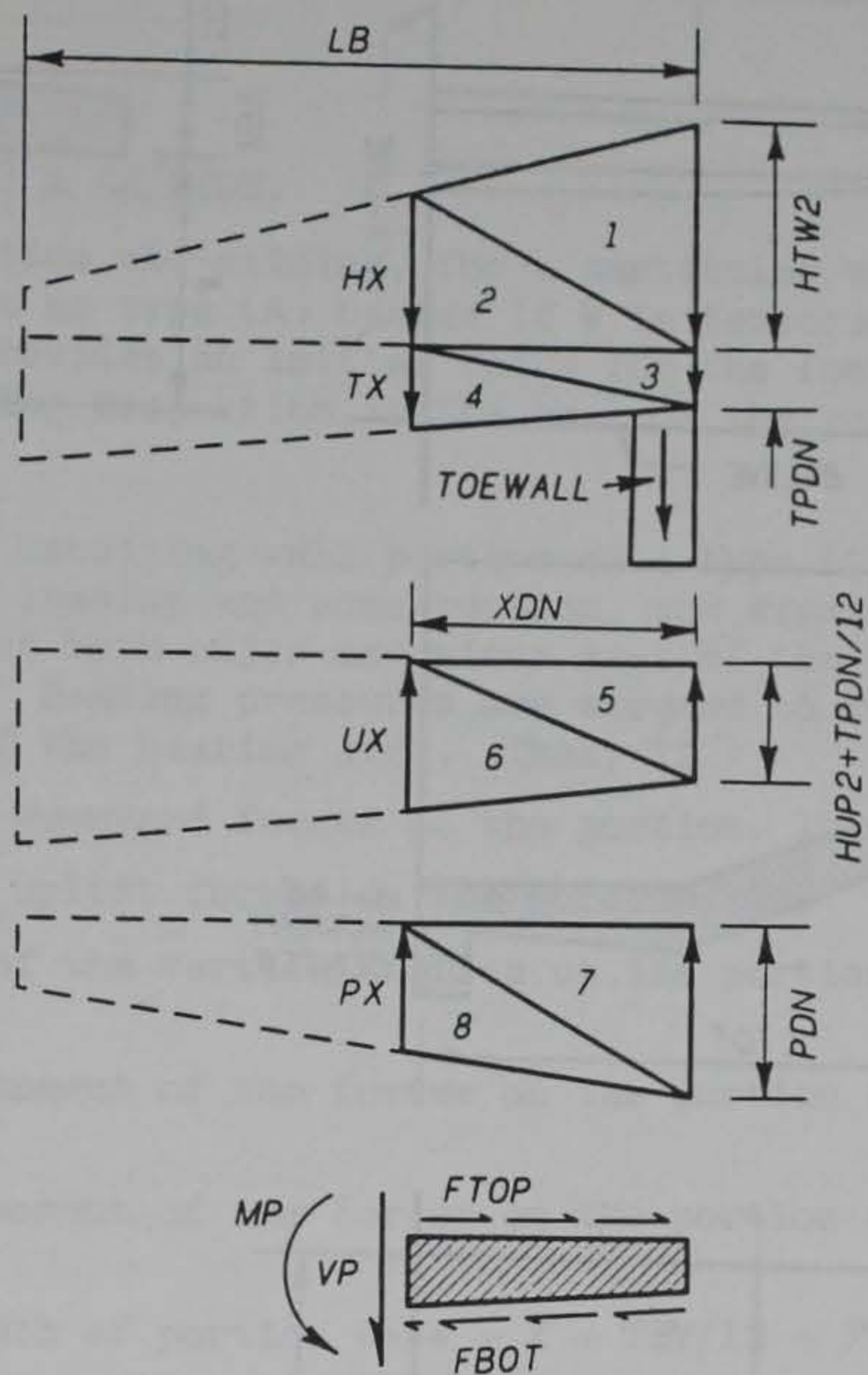

Figure 30. Shear and moment in pavement slab, LC#2

For LC #2, the uniform loading, F_{TOP} , in lbs per ft per ft of width, acting on the floor of the basin is

$$F_{TOP} = FM/LB$$

and

$$F_{BOT} = FH2/LB + F_{TOP}$$

with these quantities defined, VP and MP are readily determined. The required thicknesses are taken as

$$TXV = |VP|/840 + 3.5$$

$$TXM = (0.003683 \times |MP|)^{1/2} + 3.5$$

These thicknesses are compared with the actual thickness, TX , at the section. Computations for a section between the upstream end and the break-in-grade are similar but somewhat more complex.

Retaining wall portions. The design of the sidewall is the same as type (A) basins. However, the upstream end section is vertical, hence as with type (B) basins

$$HS = J - N$$

$$LS = HS \times ZS$$

$$LTOT = LS + LB$$

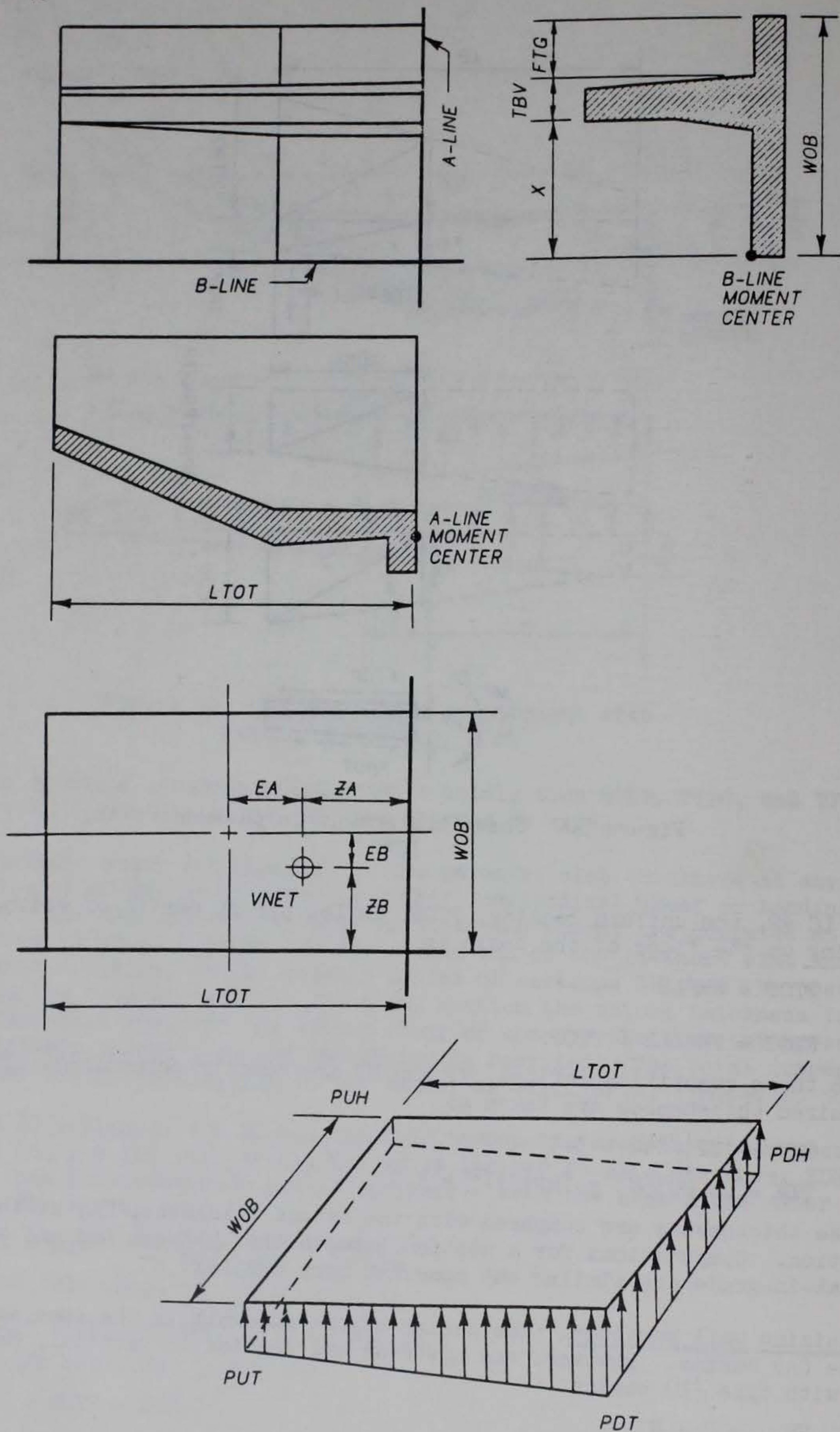

Figure 31. Determination of retaining wall portion bearing pressures

also

$$HS1 = N$$

$$HB3 = HB + (J - HB) \times LB/LTOT.$$

The treatments of flotation and sliding, for a particular value of X, are essentially the same as type (A) basins if W is temporarily taken as $W = 2X$. Flotation provides an initial value for the footing projection, FTG. The footing projection is the heel of the retaining wall base.

Bearing pressures. -- A retaining wall portion of a type (C) stilling basin lacks symmetry of loading and construction, see Figure 31. Therefore bending occurs about both major and minor axes of the horizontal projected bearing area. Bearing pressures are assumed to vary linearly from corner to corner of the bearing area. Thus, if

SDOWN \equiv sum of all downward forces on the portion, lbs

SUP \equiv sum of all uplift forces on the portion, lbs

VNET \equiv resultant of the vertical forces on the portion = SDOWN - SUP, lbs

MA \equiv resultant moment of the forces on the portion about the A-line, ft lbs

MB \equiv resultant moment of the forces on the portion about the B-line, ft lbs

WOB \equiv overall width of portion base = $X + TBV/12 + FTG$, ft

then in ft

$$ZA = MA/VNET$$

$$EA = LTOT/2 - ZA$$

$$ZB = MB/VNET$$

$$EB = WOB/2 - ZB$$

and the bearing pressures, in psf, for the load condition under investigation, are given by

$$PAVER = VNET/(LTOT \times WOB)$$

$$PDT = PAVER (1 + 6EA/LTOT + 6EB/WOB)$$

$$PDH = PAVER (1 + 6EA/LTOT - 6EB/WOB)$$

$$PUT = PAVER (1 - 6EA/LTOT + 6EB/WOB)$$

$$PUH = PAVER (1 - 6EA/LTOT - 6EB/WOB)$$

The moment about the A-line, MA, involves longitudinal horizontal forces and vertical forces as previously discussed for type (A) basins. The moment about the B-line involves transverse horizontal forces and the above vertical forces. The moment of the transverse lateral forces about the B-line requires further consideration. A possible case of LC #2 is used for illustration, see Figure 32. An expression for moment about the B-line, applicable to any section, D, between the downstream end section and the break-in-grade, is written in terms of the working values HBW, HWW, DW, and TSDN. Another moment expression, applicable to any section, U, between the break-in-grade and the upstream end section, is written

in terms of HBW, HWW, DW, TW, and ARM. These moments are summed over the respective distances LB and LS to obtain the total moment due to these lateral forces. Several simplifying assumptions are made to obtain these lateral forces.

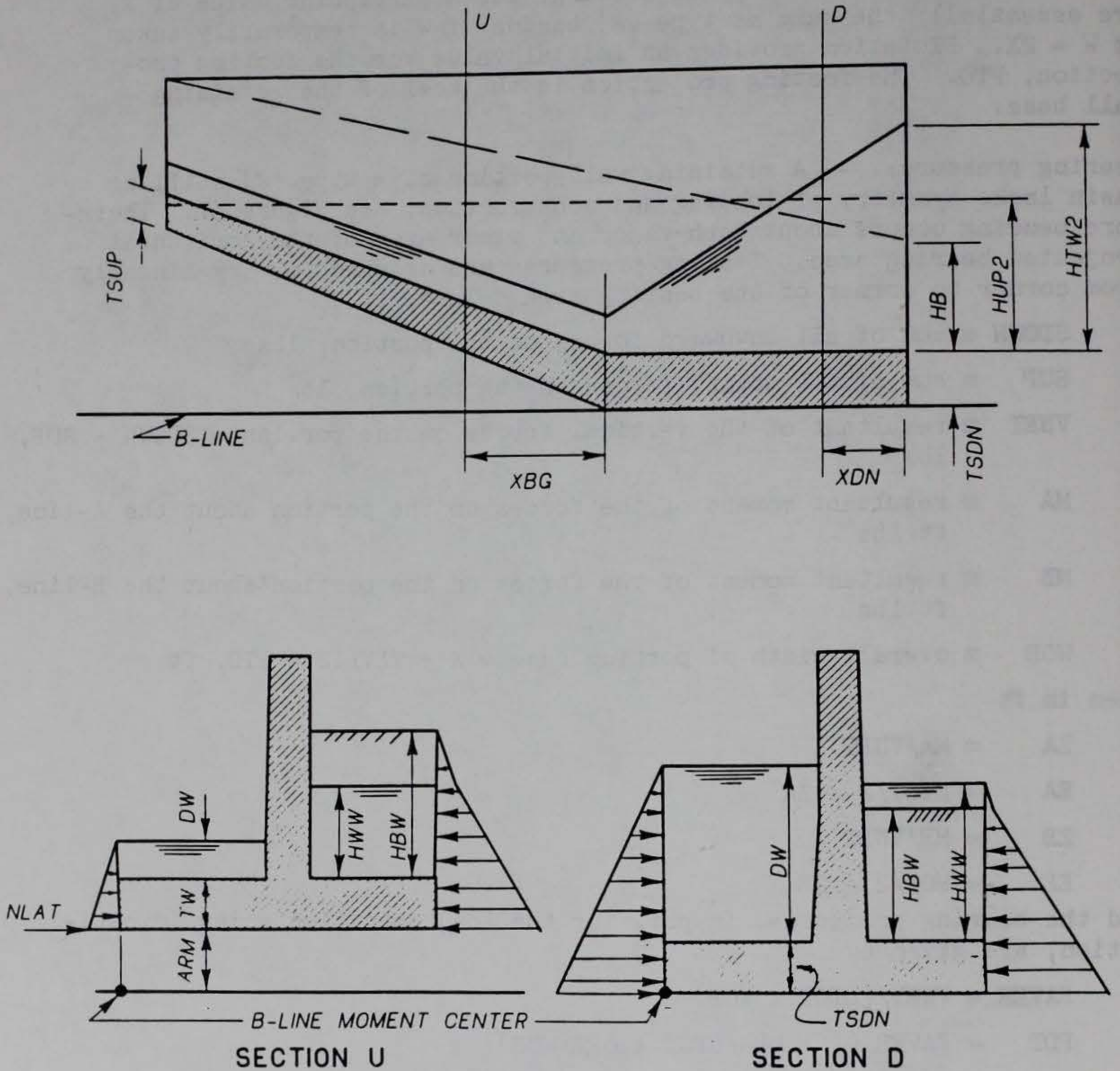

Figure 32. Retaining wall portion lateral force moments, LC#2

moment expressions. A waterstop between the pavement slab and the retaining wall base is assumed effective at the elevation of the bottom of the base slab. The thickness of the level base slab is taken as TSDN in these computations. The retaining wall portion is assumed to bear against the pavement slab. NLAT, shown on the upstream section, is this direct force. It is the force required for lateral equilibrium of the section. Thus the downstream section working values, for the case shown are

$$HBW = HB + (HB3 - HB) \times XDN/LB$$

$$HWW = HUP2$$

$$DW = HTW2 - (HTW2 - D1) \times XDN/LB.$$

The upstream section working values, for the case shown, are

$$HBW = HB3 - (HB3 - HB1) \times XBG/LS$$

$$HWW = HUP2 - XBG/ZS$$

$$DW = D1$$

$$TW = TSUP + (TSDN - TSUP) \times (LS - XBG)/LS$$

$$ARM = TSDN/12 + XBG/ZS - TW/12$$

Working values for load condition No. 1 are similar. With the working values known, the moments are readily expressed, the summations made, and the bearing pressures determined.

If any bearing pressure is negative, the corresponding base slab thickness and FTG are incremented. If any bearing pressure exceeds the allowable, FTG is incremented in an attempt to spread the total load.

Base slab shear and bending. -- Required base slab thicknesses will sometimes be governed by shear or bending moment. Three cross sections are checked: the downstream end section, the section at the break-in-grade, and the upstream end section. Both load conditions are investigated.

Figure 33 shows typical loadings. PBH and PBT are the bearing pressures at the heel and toe resulting from the preceding analyses of bearing. The other loadings are as defined for type (A) basins. Shear and moment are computed at the face of the sidewall. Longitudinal shears are treated both ways as previously described. If it is assumed carried by the sidewall, shears and moments at the faces of the sidewall are unaffected by PLONG. If the longitudinal shears are assumed carried by the base slab then

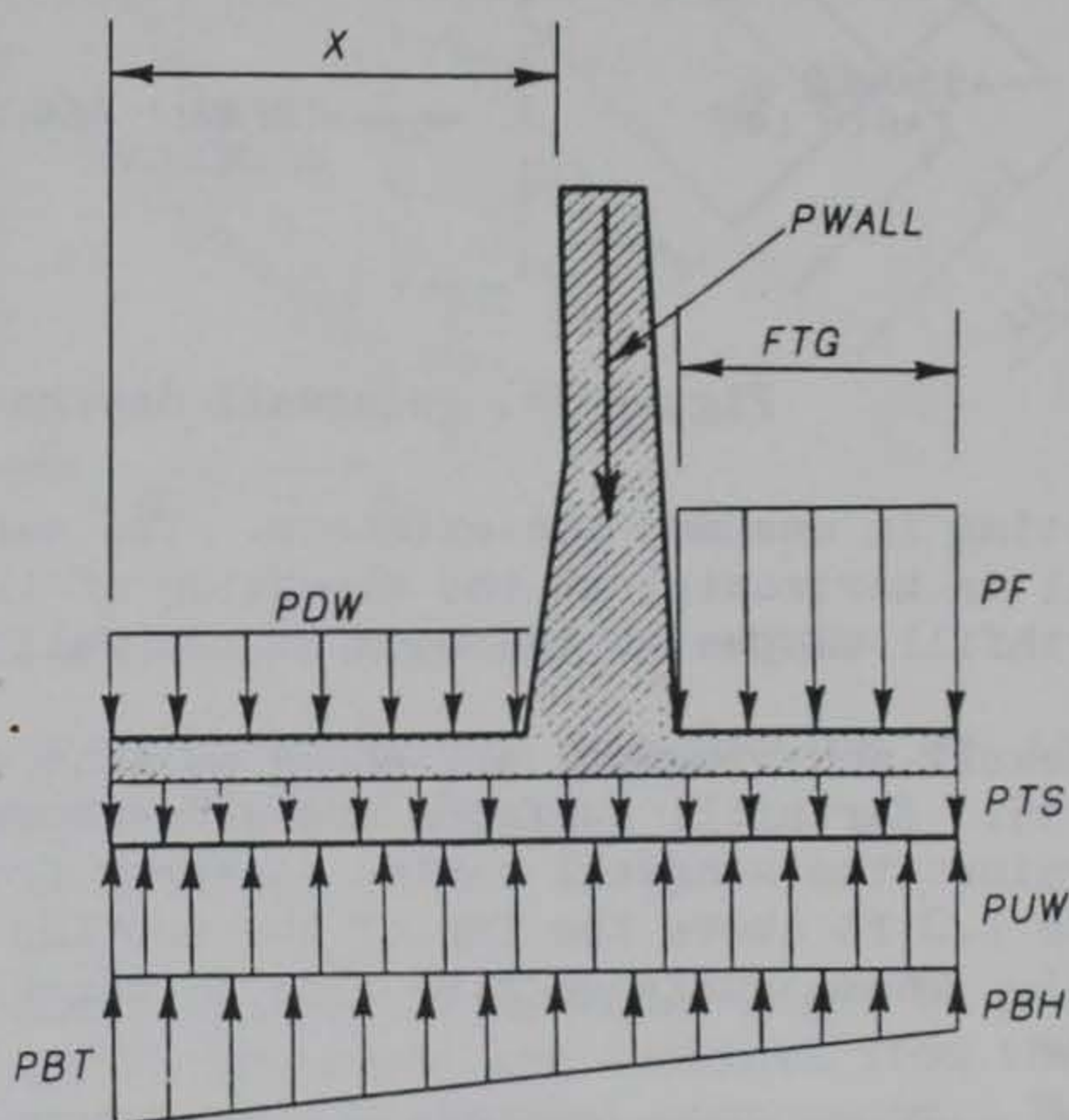

Figure 33. Loadings for base slab shear and moment

$$ULONG = (PBT + PBH)/2 + PUW - PTS - (PF \times FTG + PDW \times X - PWALL)/WOB$$

and the face shear and moment expressions must include ULONG. The assumption leading to the larger required thickness is taken as controlling. If any required thickness exceeds the actual slab thickness, the design is recycled accordingly.

Wingwall

The wingwall is considered to act essentially independently of the basin proper. The wingwall is vertical and of constant thickness. It is articulated from the basin sidewall as shown in the layout drawing of Figure 4. The wingwall footing and toewall are monolithic with the footing and toewall of the basin proper. Design investigations include bending of the wingwall and wingwall footing, overturning, and sliding. Figure 34 shows the wingwall section assumed for design. The toewall below

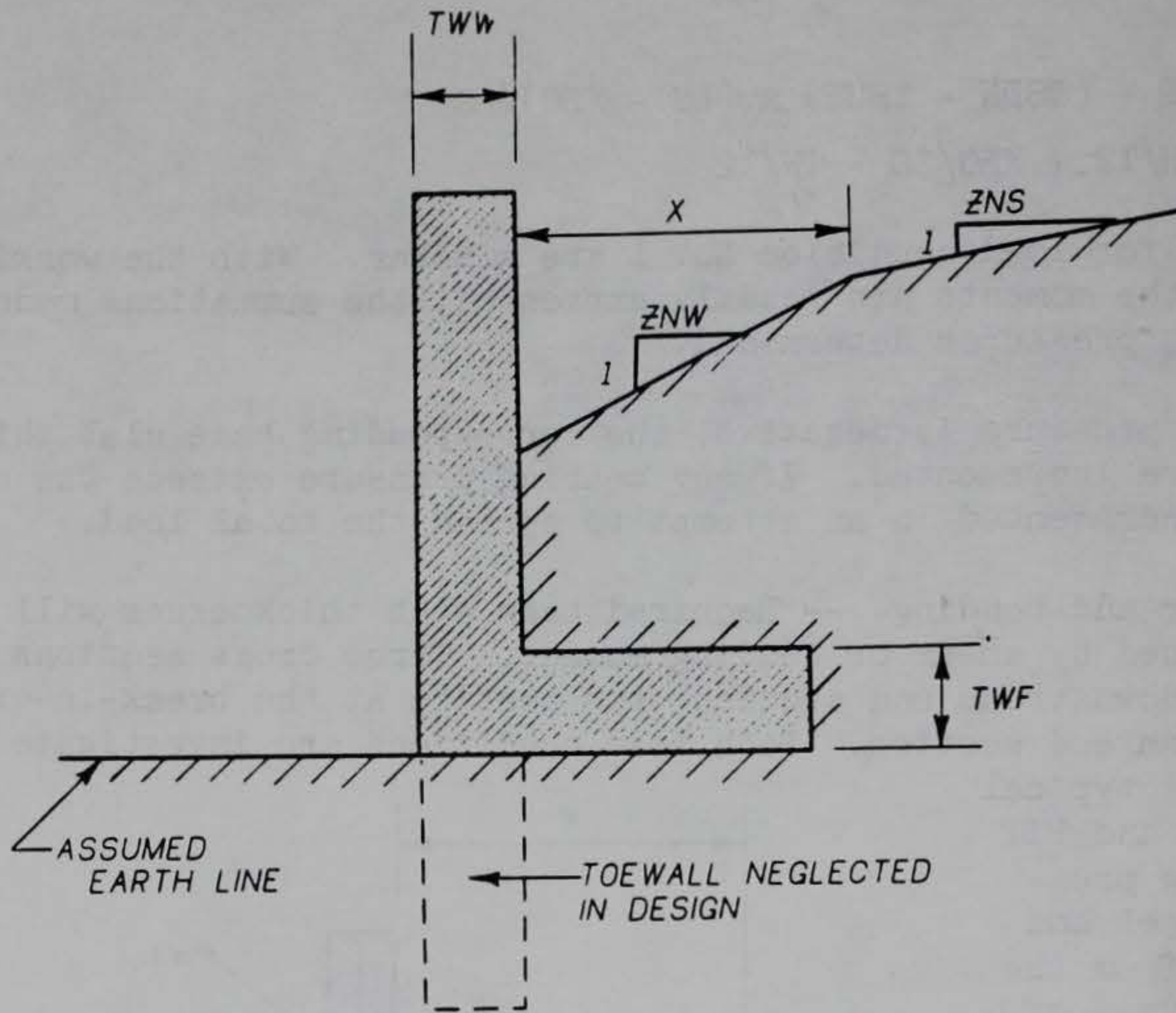

Figure 34. Wingwall design section

the footing is assumed non-existent. The earth line in front of the wingwall is horizontal at the elevation of the bottom of the footing. The earthfill slopes at the back of the wall are defined below.

The sidewall and wingwall are shown as line diagram idealizations in Figure 35. Earthfill surfaces are also shown. The surface of the earthfill against the wingwall varies linearly from HB at the articulation joint to 1.0 ft above the top of the footing at the downstream end of the wingwall. These surfaces give rise to three slope parameters of interest, they are

ZPS \equiv slope parameter for the earthfill adjacent to the sidewall in the direction parallel to the sidewall

ZNW \equiv slope parameter for the earthfill adjacent to the wingwall in the direction normal to the wingwall

ZNS \equiv slope parameter for the earthfill adjacent to the sidewall in the direction normal to the wingwall.

Thus,

$$ZPS = (LTOP \text{ or } LTOT) / (J - HB)$$

$$ZNW = (J - 1) / (HB - 1)$$

$$ZNS = ZPS \sqrt{2}$$

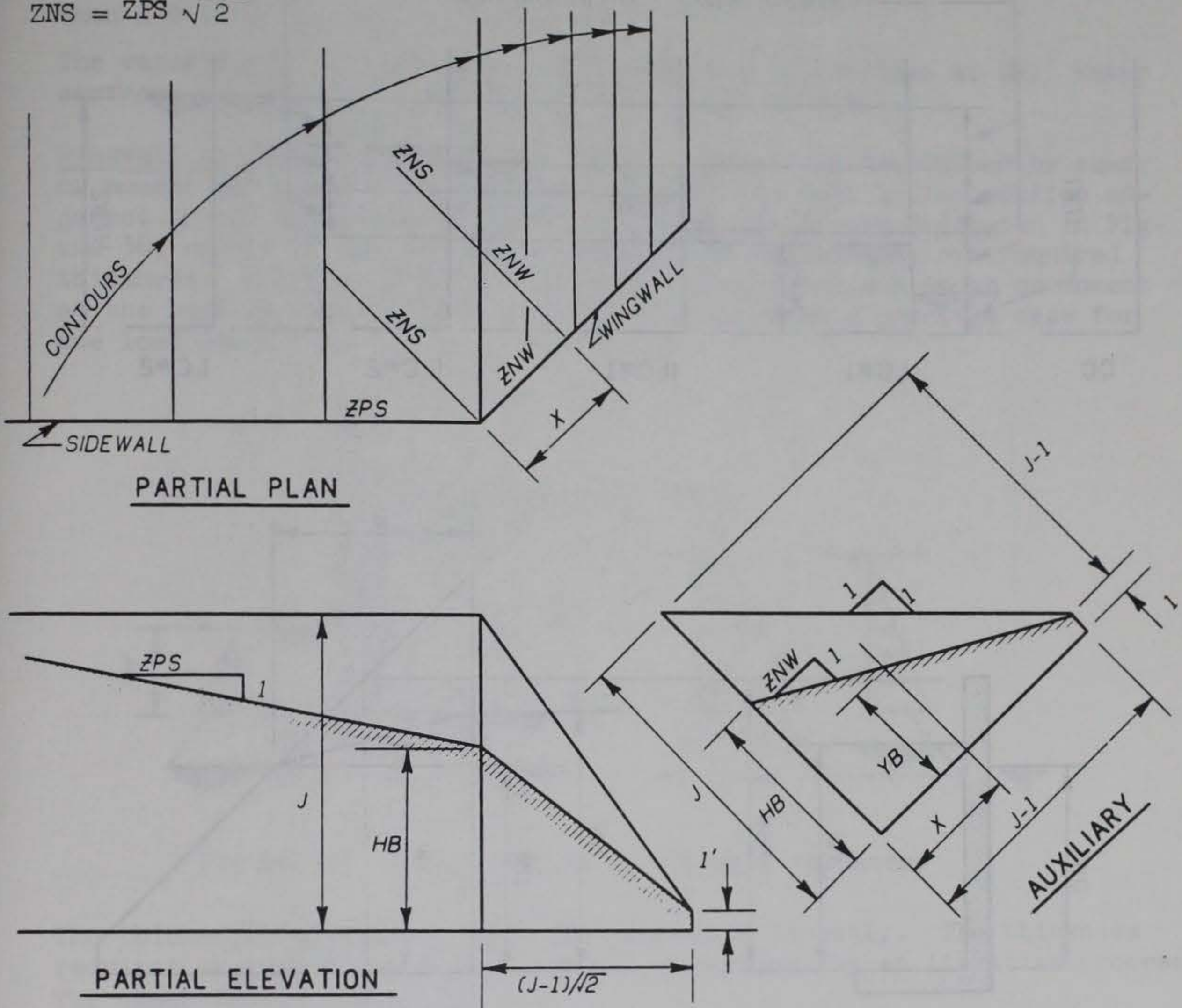

Figure 35. Wingwall earthfill surfaces and slopes

The earthfill height, YB , in ft above the top of the footing for any distance, X , in ft from the articulation joint is

$$YB = HB - X/ZNW.$$

With the sloping earthfill shown in Figure 34, a brief might be presented for assuming that lateral earth pressures are inclined from the horizontal. That is, they have vertical and horizontal components. This is not done herein. Lateral earth pressures are horizontal and vary directly with K_0 and distance below the surface. To include a vertical component would be unconservative since it would be a stabilizing force (in overturning and sliding analyses) whose existence and magnitude are uncertain.

Loading conditions. Wingwall design requires the investigation of more than the two load conditions necessary for the design of the basin proper. Critical loading often occurs at an intermediate load condition between

LC #1 and LC #2. Furthermore, different load conditions are critical for different functions. Therefore, as shown schematically in Figure 36,

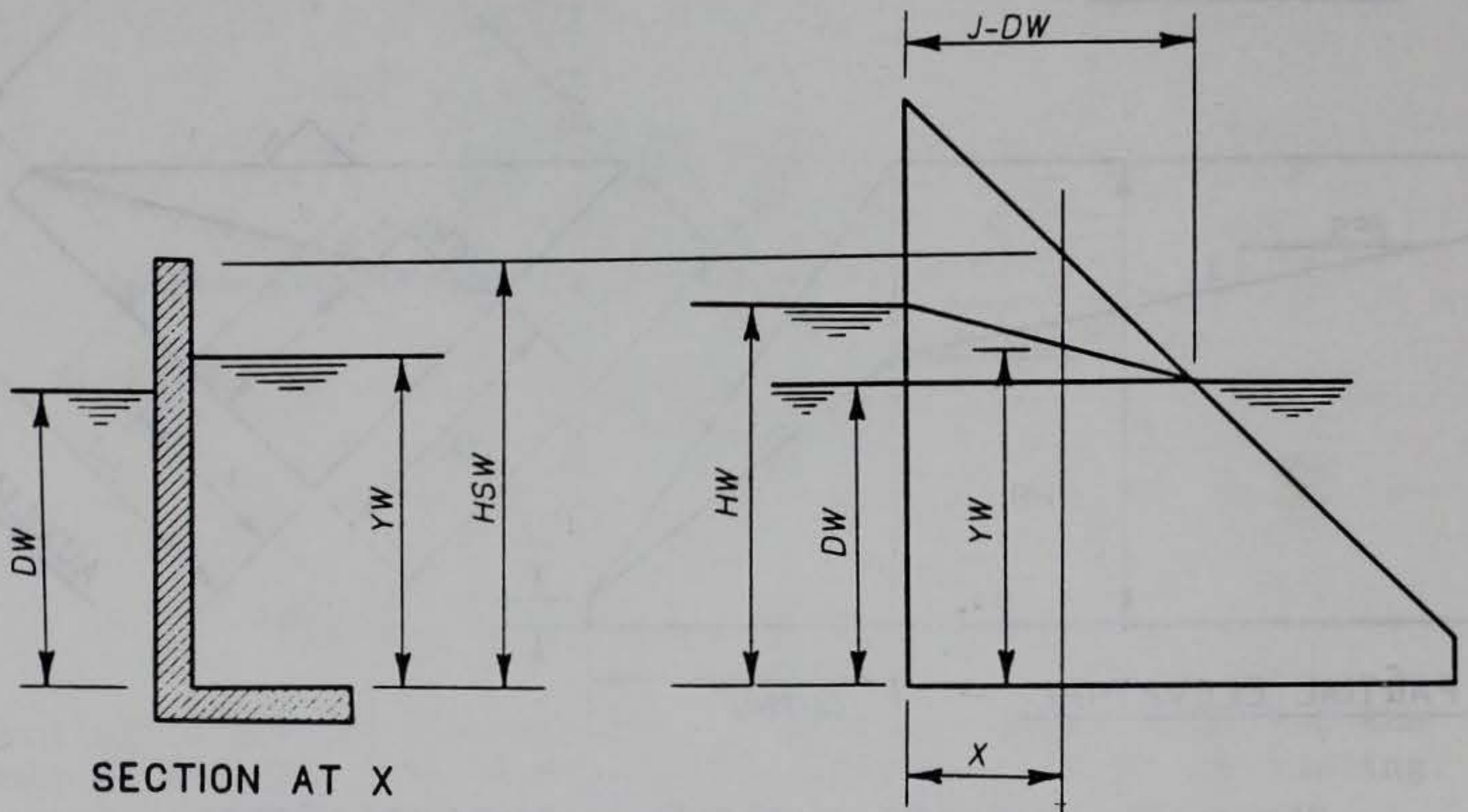
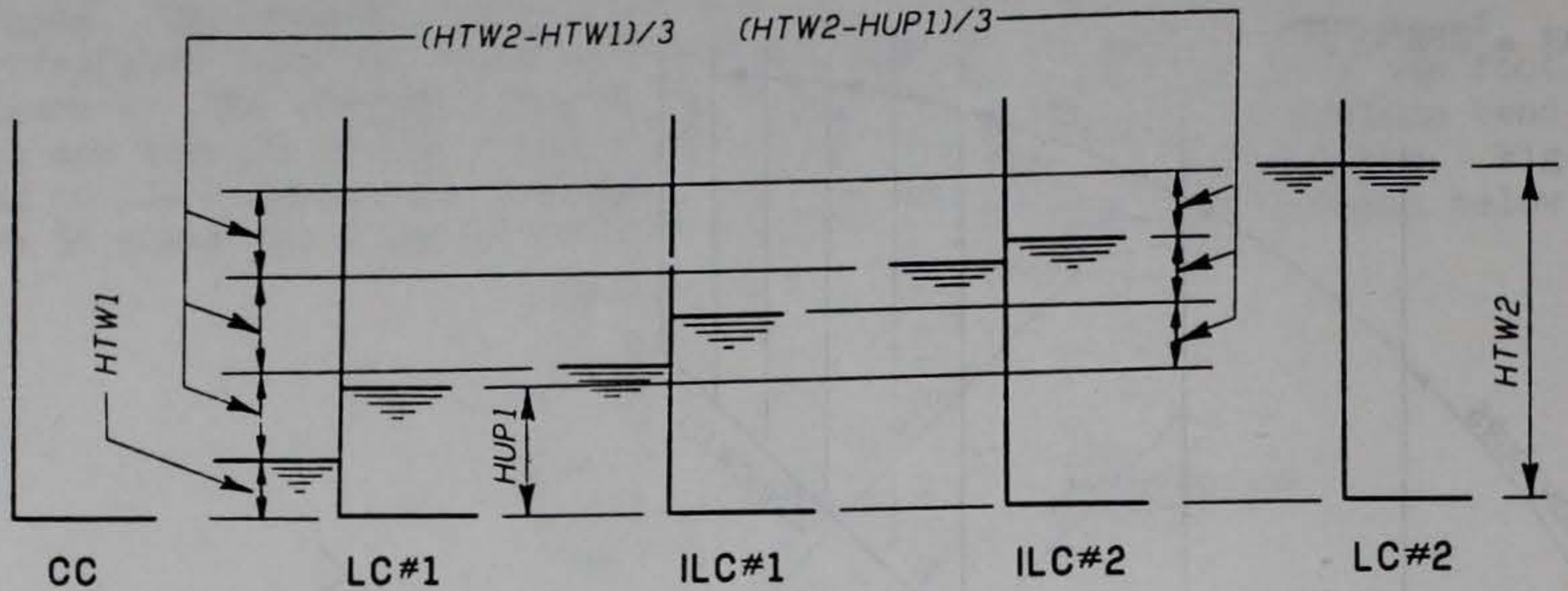

Figure 36. Load conditions for wingwall design

two intermediate load conditions are created for use in design of wingwalls. These are ILC #1 and ILC #2. The construction condition, CC, with no water either side of the wingwall, is included as still another loading since it will sometimes control a function. For LC #2 the water surface both sides of the wall is $HTW2$ above the top of the footing. Let

$HW \equiv$ uplift head above top of footing at the articulation joint, for the load condition under investigation, in ft

$DW \equiv$ tailwater depth above top of footing for the load condition under investigation, in ft.

Then the water height, YW , in ft on the back face of the wingwall for any distance, X , is

$$YW = HW - (HW - DW) \times X / (J - DW)$$

when $X < (J - DW)$. It is

$$YW = DW$$

when $X \geq (J - DW)$.

The water depth on the front face of the wall is constant at DW . Water surfaces are assumed horizontal normal to the wingwall.

Wingwall bending. The thickness of the wingwall is determined by shear or moment and direct force at the bottom of the wall at the section adjacent to the articulation joint. All load conditions indicated in Figure 36, except LC #2, are investigated to obtain the maximum required thickness. Load condition No. 2 cannot produce maximum shear or moment at the base of the section. Figure 37 illustrates a possible case for one load condition.

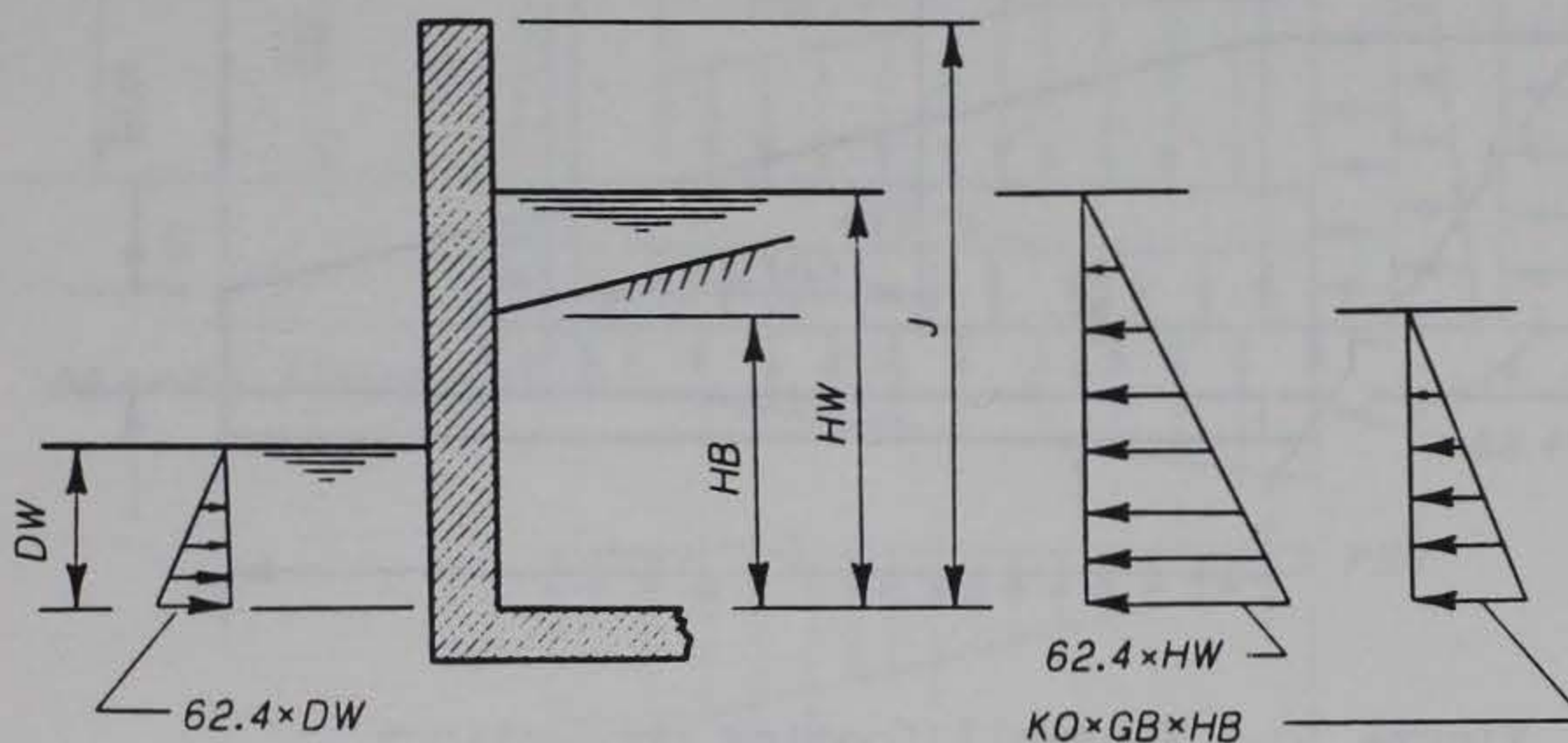

Figure 37. Determination of wingwall thickness

The thickness required by shear is determined directly. The thickness required by moment and direct force is determined by an iterative process. The shear is, in lbs per ft

$$V = 31.2(HW^2 - DW^2) + 0.5 \times KO \times GB \times HB^2$$

so the required thickness for shear is, in inches

$$TS = V/840 + 2.5$$

The moment is, in ft lbs per ft

$$M = 10.4(HW^3 - DW^3) + 0.5 \times KO \times GB \times HB^3/3.$$

The direct force for a thickness, TM , is

$$N = 12.5 \times J \times TM$$

so the equivalent moment is

$$M_s = M + N \times (0.5 \times TM - 2.5)/12$$

and the required thickness for moment and direct force is, in inches

$$TM = (0.003683 \times M_s)^{1/2} + 2.5$$

The computed required TM and the assumed TM must agree.

These computations are repeated for the four load conditions. The wing-wall thickness, TWW , is the largest of all of the above required thicknesses.

Overturning. Initial values of wingwall footing projections, BUP and BDN , are determined by considering the wingwall as an independent wall and making it stable against overturning. Required footing projections are determined by analyzing slices of unit width at the four sections indicated by Figure 38. Each slice must be stable by itself. Individual slices are analyzed, rather than the entire wingwall as a unit, because of the complexity of treating general bearing on an unsymmetrical bearing area.

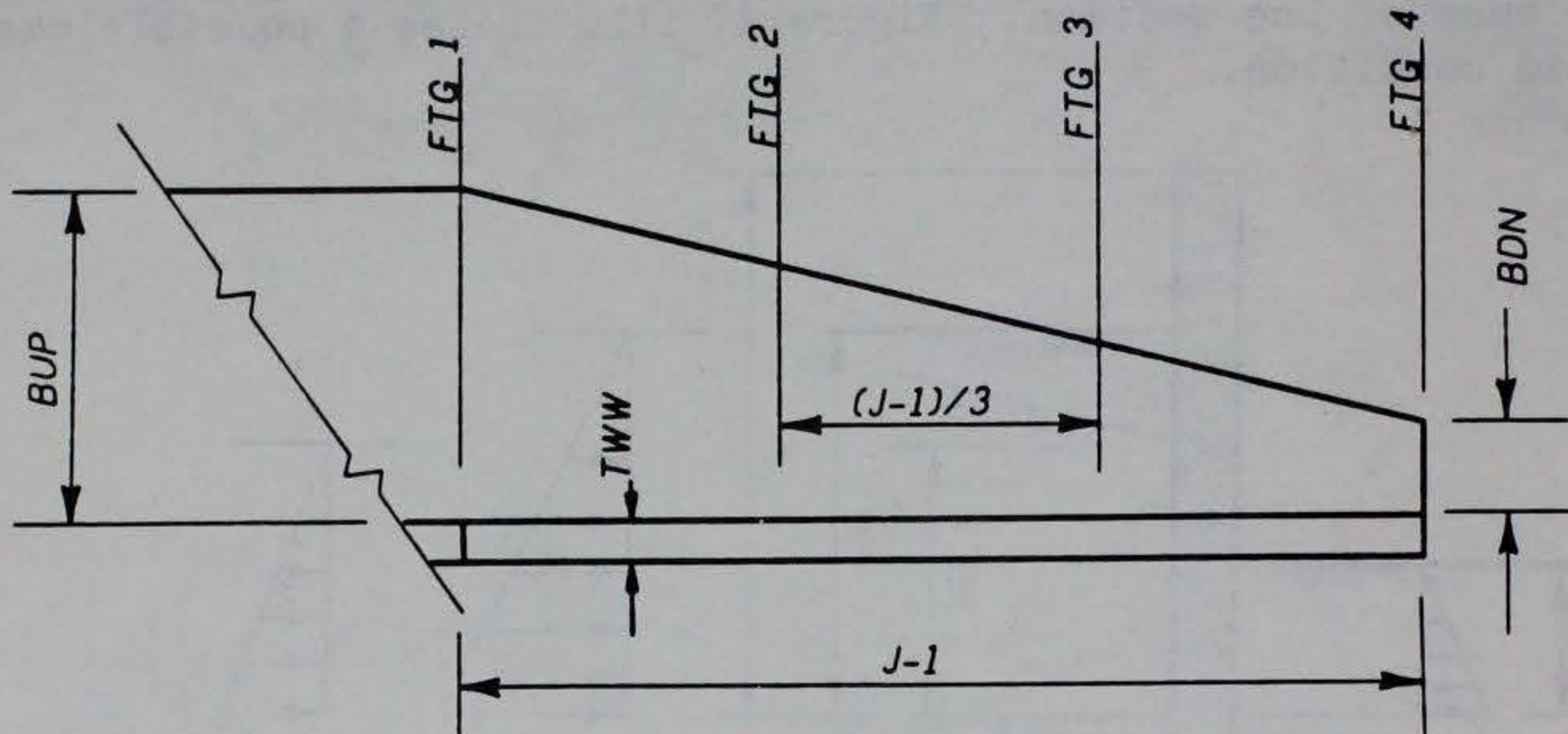

Figure 38. Wingwall footing projections

The required footing projections are found at each of the four sections. Then BUP and BDN are selected from the requirement that footing projections vary linearly between BUP and BDN . If any required projection at sections 2, 3, or 4 exceeds the required projection at section 1, the projection for the entire footing is made constant at the largest required value. Each section is investigated for all load conditions shown in Figure 36 to obtain the maximum required projection at the section. Figure 39 indicates the analysis for a possible case at a particular section and load condition. The distance from the section under consideration to the wingwall articulation joint is X . X is also the distance from the back of the wall to the break in earthfill slopes. Current values of footing thickness, TWF , and footing projection, FTG , are investigated. First trial values are $TWF = TWW$ and $FTG = 1$. Footing pressures, lateral water and earth pressures, uplift pressures, footing dead load, and wall weight are determined for the current values. Footing pressures vary linearly between the three points: back of the wall, X from the wall, and edge of footing.

With the loads known, moments about the toe and summation of vertical forces locates $VNET$ at Z from the toe. If $VNET$ is located outside the base width, WOB , that is Z is negative, then FTG is incremented for another trial. If $VNET$ is located within the base, within $WOB/3$ of the toe, then PBH would be negative so again FTG is incremented for another

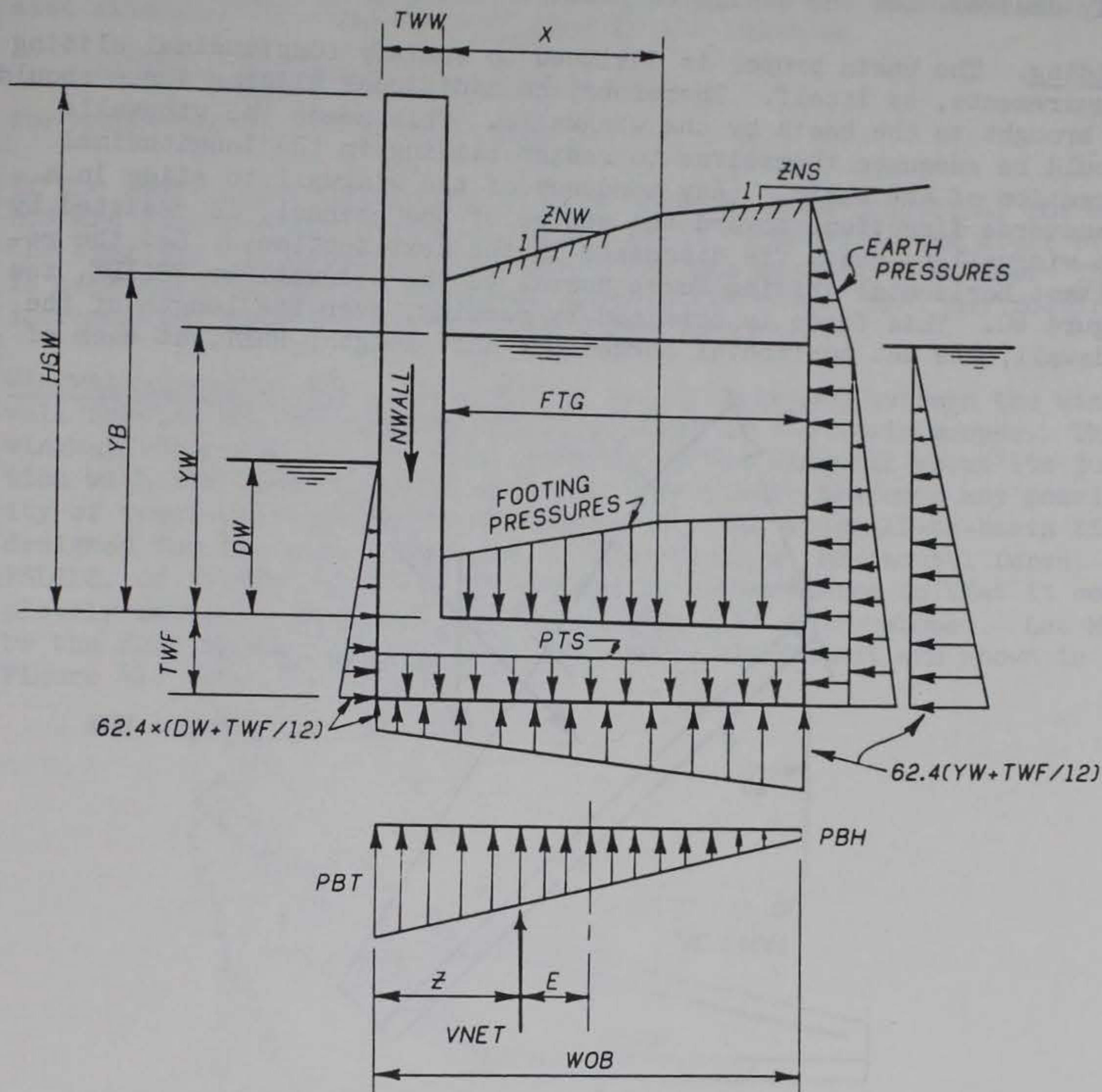

Figure 39. Wingwall overturning and bearing

trial. If VNET is located within the middle third of the base, the section is safe against overturning and the contact bearing pressures, PBT and PBH, are computed in the usual way. If the higher pressure exceeds the allowable value, taken as

$$P_{ALLOW} = 2000 + GB \times (YB + TWF/12)$$

FTG is again incremented. Each trial recycles the footing design back to the first load condition for the section under investigation.

When bearing pressure requirements are satisfied, footing thickness required for moment is determined. The critical section for moment is at the face of the wingwall. If the required thickness is more than the actual thickness, TWF is incremented and the footing design is recycled starting at the first location, (section 1 of Figure 38) and the first load condition. Analyses have shown that shear seldom controls footing thickness in these wingwalls. Hence the thickness required for shear is

only checked, and the design recycled if necessary, in detail design.

Sliding. The basin proper is designed to satisfy longitudinal sliding requirements, by itself. Therefore, no additional sliding force should be brought to the basin by the wingwalls. This means the wingwalls should be adequate themselves to resist sliding in the longitudinal direction of the basin. (Any tendency of the wingwall to slide in a transverse direction, toward the center of the channel, is resisted by the wingwall-to-basin tie discussed in the next section.) Let the resultant horizontal driving force normal to the sidewall be F_{SLIDE} , see Figure 40. This force is obtained by summing, over the length of the sidewall, the net horizontal forces per unit length, H_{NET} , at each of

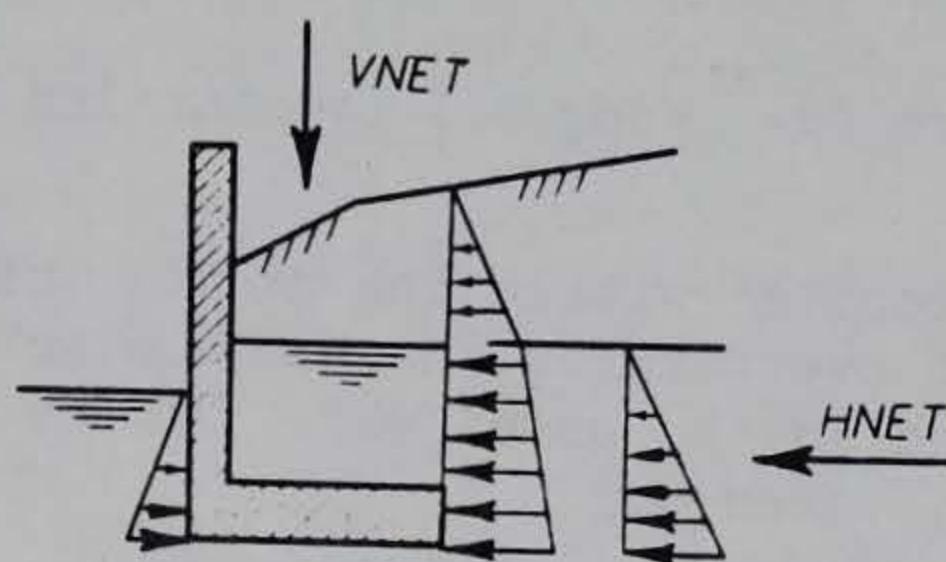
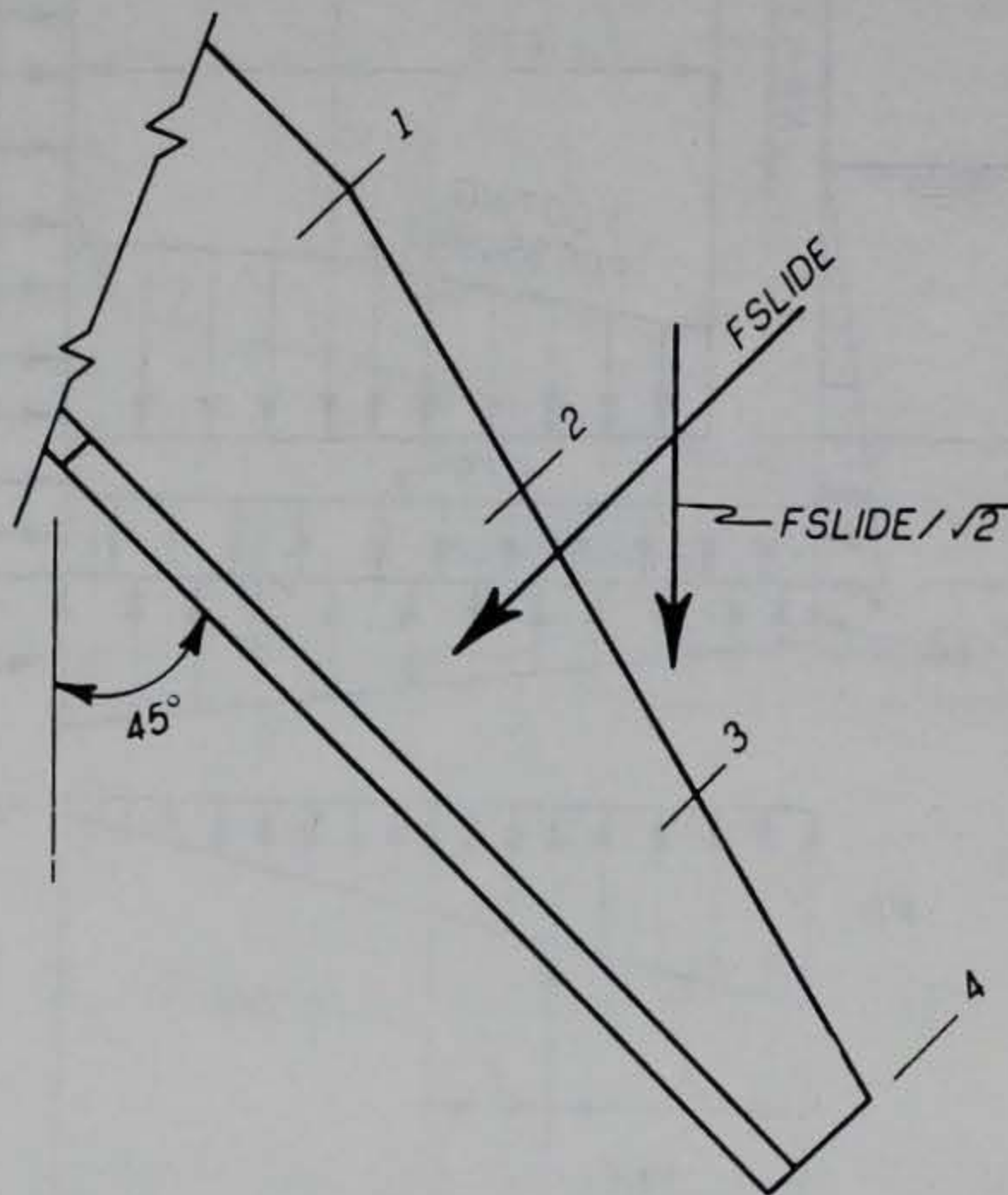

Figure 40. Longitudinal sliding of wingwall

the four sections. H_{NET} is obtained from the indicated horizontal forces, for a particular section and load condition. Thus

$$F_{SLIDE} = (H_{NET1}/2 + H_{NET2} + H_{NET3} + H_{NET4}/2) \times (J - 1)/3.$$

Similarly, if V_{WING} is the resultant vertical force on the wingwall, and V_{NET} is the resultant per unit length, then

$$V_{WING} = (V_{NET1}/2 + V_{NET2} + V_{NET3} + V_{NET4}/2) \times (J - 1)/3.$$

The longitudinal component of FSLIDE is $FSLIDE/\sqrt{2}$. To adequately resist sliding, the wingwall must satisfy the relation

$$\frac{1.4142 \times VWING \times CFSC}{FSLIDE} \geq SLIDER$$

for each load condition of Figure 36.

If the above relation is not satisfied for any load condition, BUP and BDN are incremented equally. The design is recycled to the start of the overturning analysis with the new footing projection values. This is necessary because the wingwall footing thickness, TWF, may require incrementing with the larger footing projections.

Wingwall-to-basin tie. A structural tie is provided between the wingwall footing and the footing and floor slab of the basin proper. This wingwall-to-basin tie prevents rotation of the wingwall about its junction with the basin sidewall and thus effectively prevents any possibility of transverse sliding of the wingwall. The wingwall-to-basin tie is designed for the full moment due to the resultant horizontal force, FSLIDE, of Figure 40. This is admittedly conservative in that it completely neglects any frictional resistance that is developed. Let MTIE be the full moment, in foot lbs, and ARM be the moment arm shown in Figure 41. Then, in inches

$$ARM = BUP \times 12 - 6 - TWW/2$$

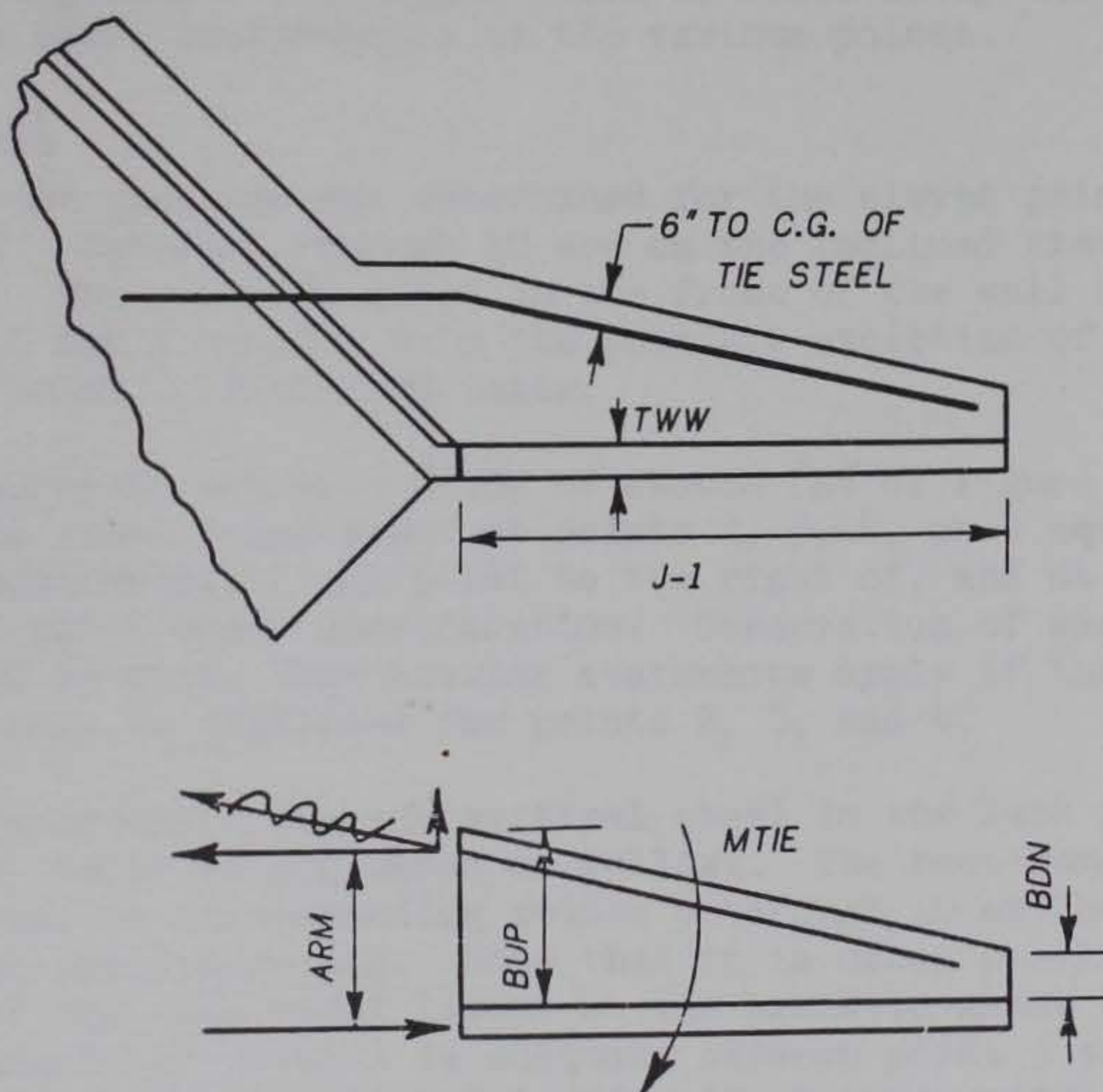

Figure 41. Wingwall-to-basin tie steel area

and the required area of the tie steel, in sq. in., just downstream of the section through the articulation joint is approximately

$$ATIE = \frac{MTIE \times 12}{20,000 \times ARM} \times \frac{((J - 1)^2 + (BUP - BDN)^2)^{1/2}}{(J - 1)}$$

Detail Designs

With the two exceptions of the longitudinal steel in the pavement slab of type (C) stilling basins and the wingwall-to-basin tie steel, detail design is concerned with the determination of requirements for transverse steel. Transverse steel in the pavement slab and longitudinal steel in all other elements need only satisfy temperature and shrinkage (T and S) requirements.

Each detail design begins with the set of trial dimensions obtained in the preliminary design. Thicknesses are incremented, and the design recycled, whenever it is discovered compression steel would otherwise be required to hold bending stresses to allowable working values. A wingwall detail design accompanies the detail design of every basin requested. Required steel area and maximum allowable steel spacing are computed at a sufficient number of points to adequately define the steel requirements of the stilling basin. Steel areas given always satisfy T and S requirements. In the sidewall, the points are the same for each stilling basin type. In the floor slabs of types (A) and (B) basins and in the base slab of type (C) basins, the points are similarly located and numbered so that there is little difficulty in switching thought from one type to another. Schematic steel layouts are shown for sidewalls, floor and base slabs, and wingwalls. The actual steel is selected by the designer once he knows the steel requirements at the various points.

Sidewall steel

Steel areas and spacings are determined for the eleven points defined in Figure 42. Points 1 through 10 are on the inclined steel in the back of the wall. The vertical steel in the front of the wall need only be provided in T and S amounts with the possible exception of steel in the vicinity of point 0, discussed later.

Refer to Figures 14 and 42. Study of sketch (A) of Figure 14 shows that for LC #1 the steel requirement at points 2, 3, 4, or 5 equals or exceeds the steel requirement at any point to the right of, and at the same elevation as, the point under consideration. Observation of sketch (B) of Figure 14 for LC #2 shows that similar statements apply if the water depth, D_1 , in the basin is neglected for points 2, 3, and 4.

The steel requirements for the vertical steel in the back face of the sidewall are therefore evaluated as follows. The requirements at points 1 through 5 and at corresponding points 6 through 10 at the break-in-grade section are determined. Note that it is often convenient or necessary to alter the wall steel layout at the break-in-grade section. The steel determined for point 3 is adequate between point 3 and point 8. The steel determined for point 8 is adequate between point 8 and the point on the downstream end section at the same elevation as point 8. Corresponding statements are true for similar pairs of points. The steel required at point 5 is reported for purposes of interpolation. Any interpolation should assume straight-line variation between points. For type (B) basins, the thicknesses of the upstream portion are used with points 1 through 5 whereas the thicknesses of the downstream portion are used with points 6 through 10. For types (A) and (C) basins, these thick-

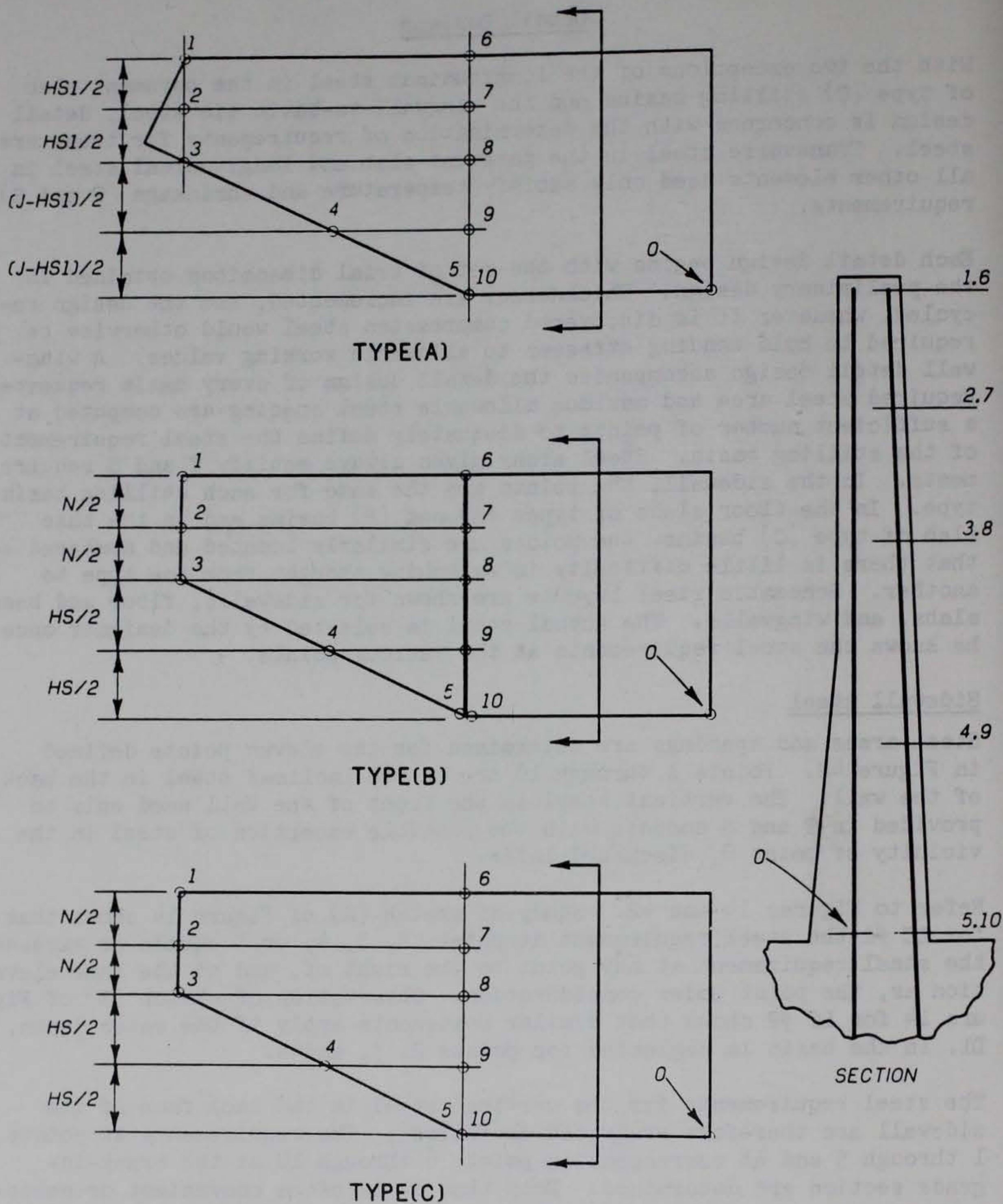

Figure 42. Sidewall steel layout and point locations

nesses are the same so points 5 and 10 are actually the same point.

Figure 43 illustrates a possible loading situation. It might be LC #1 or LC #2. The section under consideration is located at distance, Z,

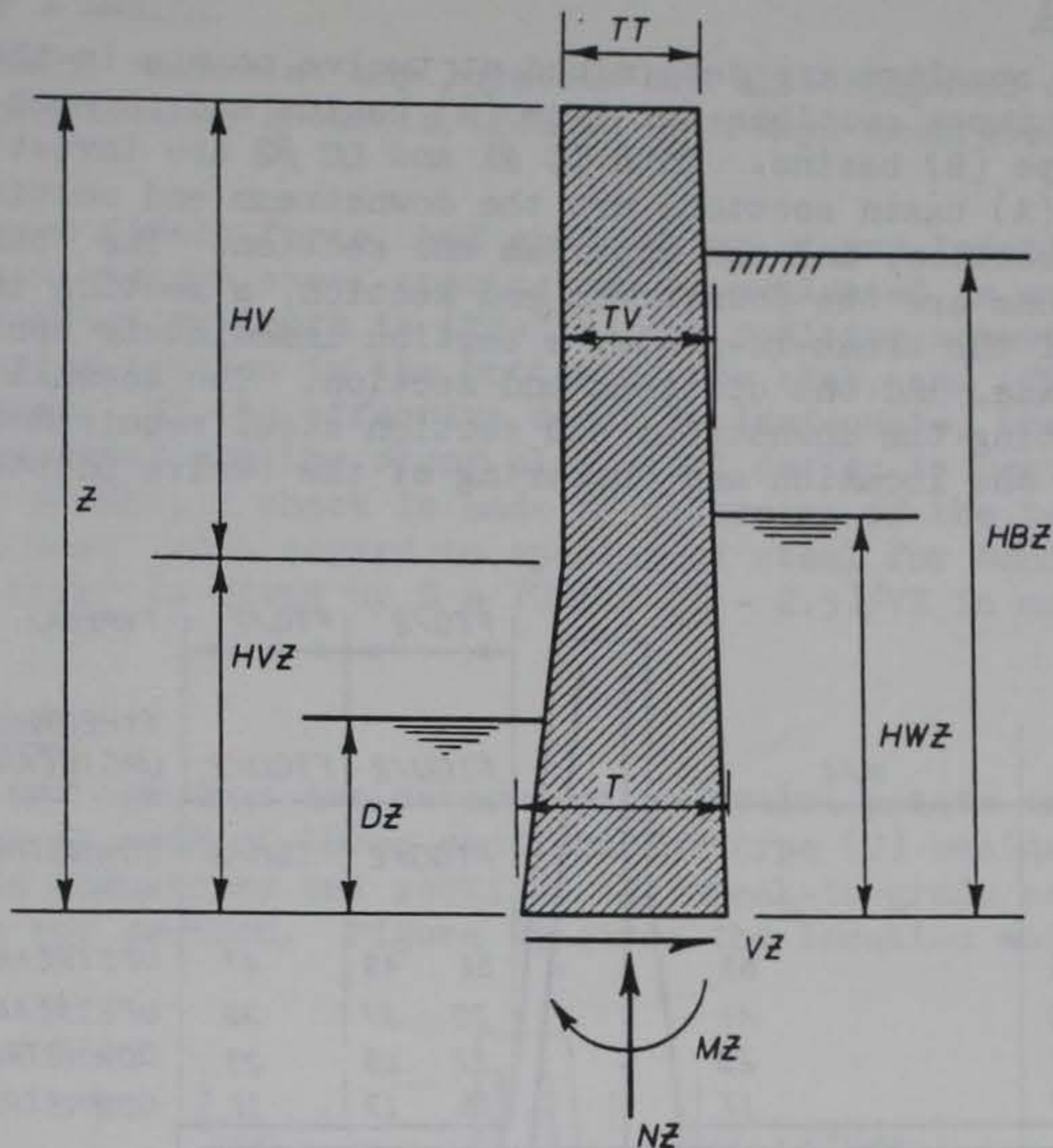

Figure 43. Sidewall steel design

from the top of the wall. Shear, VZ , in lbs per ft; moment, MZ , in ft lbs per ft; and direct force, NZ , in lbs per ft are determined for the section and loads. The required steel area for this MZ and NZ may be obtained as explained in TR-42. If the current effective depth is inadequate without using compression steel, the bottom thickness, TBV , and hence TB , is incremented and the wall steel design is begun again. When the effective depth is adequate, the maximum allowable spacing of the steel at this section is given, in inches, by

$$SZ = 10,015 \times (T - 2.5) / VZ$$

as explained on page 47 of TR-42.

As noted earlier, the water surface on the outside of the basin side-walls, for LC #2, is taken conservatively at $HTW2$ for sidewall bending analyses. However, when $HTW2 > HUP2$, tension may occur in the steel in the front of the wall at and in the vicinity of point 0 on the assumption the water surface on the outside of the wall is at $HUP2$. Therefore a steel requirement is reported for point 0 only when $HTW2 > HUP2$ and tension is computed to exist at this section with

$$Z = J$$

$$HBZ = HB$$

$$HWZ = HUP2$$

$$DZ = HTW2.$$

Floor slab steel

Steel areas and spacings are determined at twelve points in the floor slab in each of three sections for type (A) basins and in each of four sections for type (B) basins. Both LC #1 and LC #2 are investigated. The three type (A) basin sections are the downstream end section, the break-in-grade section, and the upstream end section. The four type (B) basin sections are the downstream end section, a section immediately downstream of the break-in-grade, a section immediately upstream of the break-in-grade, and the upstream end section. The toewall is neglected in computing the downstream end section steel requirements. Figure 44 gives the location and numbering of the twelve points in each section.

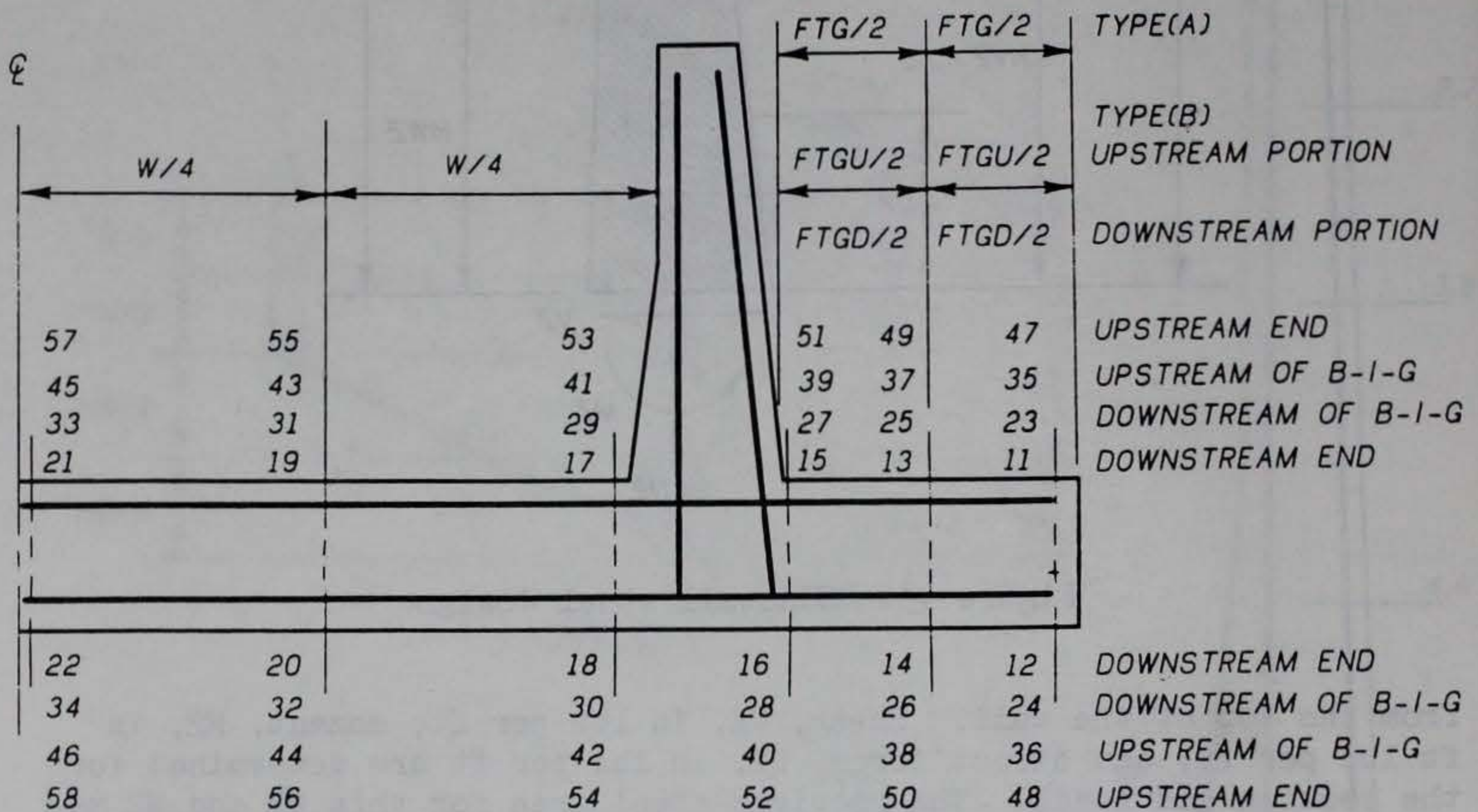

NOTE:

FOR TYPE(A) POINTS 35-46 ARE OMITTED AND POINTS 23-34 ARE AT BREAK-IN-GRADE SECTION.

Figure 44. Floor slab steel layout and point locations

In accordance with previous discussion, see page 26, bearing pressures are assumed constant along any transverse section of the basin. Figure 22 shows loads and pertinent variables involved. For the case shown, the direct compressive force in the footing projections, in lbs per ft, is

$$CF = (KO \times GM \times HDIFF + (KO \times GB + 62.4)(HUW + TS/24)) \times TS/12$$

where $HDIFF = HBW - HUW$. The horizontal loading on the wall is

$$HWALL = KO \times GM \times HDIFF \times (HDIFF/2 + HUW) + KO \times GB \times HUW^2/2 + 62.4(HUW^2 - DW^2)/2.$$

Thus the direct compressive force in the floor slab between the side-walls, in lbs per ft, is

$$CB = CF + HWALL.$$

Shear and moment values at any location are also computed directly by statics. Longitudinal shear is treated both ways described on pages 28 and 29.

With moment and direct force, and shear known at any location, required steel area and maximum steel spacing may be evaluated as explained in TR-42. The effective depth is (TS-3.5) for positive moment, that is, moment producing tension in the bottom of the slab, and (TS-2.5) for negative moment. If the effective depth is inadequate, the slab thickness is incremented and the floor slab steel design is begun again. For negative moment, a check is made to determine if the top steel qualifies as "top bars" with regard to spacing of steel for bond. The spacing of "top bars" is given by $S = 7093 \times (T - 2.5) / VZ$ in accordance with TR-42.

Base slab steel

Steel areas and spacings are determined at twelve points in the retaining wall base in each of three sections for type (C) basins. The sections are the downstream end section, the break-in-grade section, and the upstream end section. Figure 45 gives the location and numbering of the points.

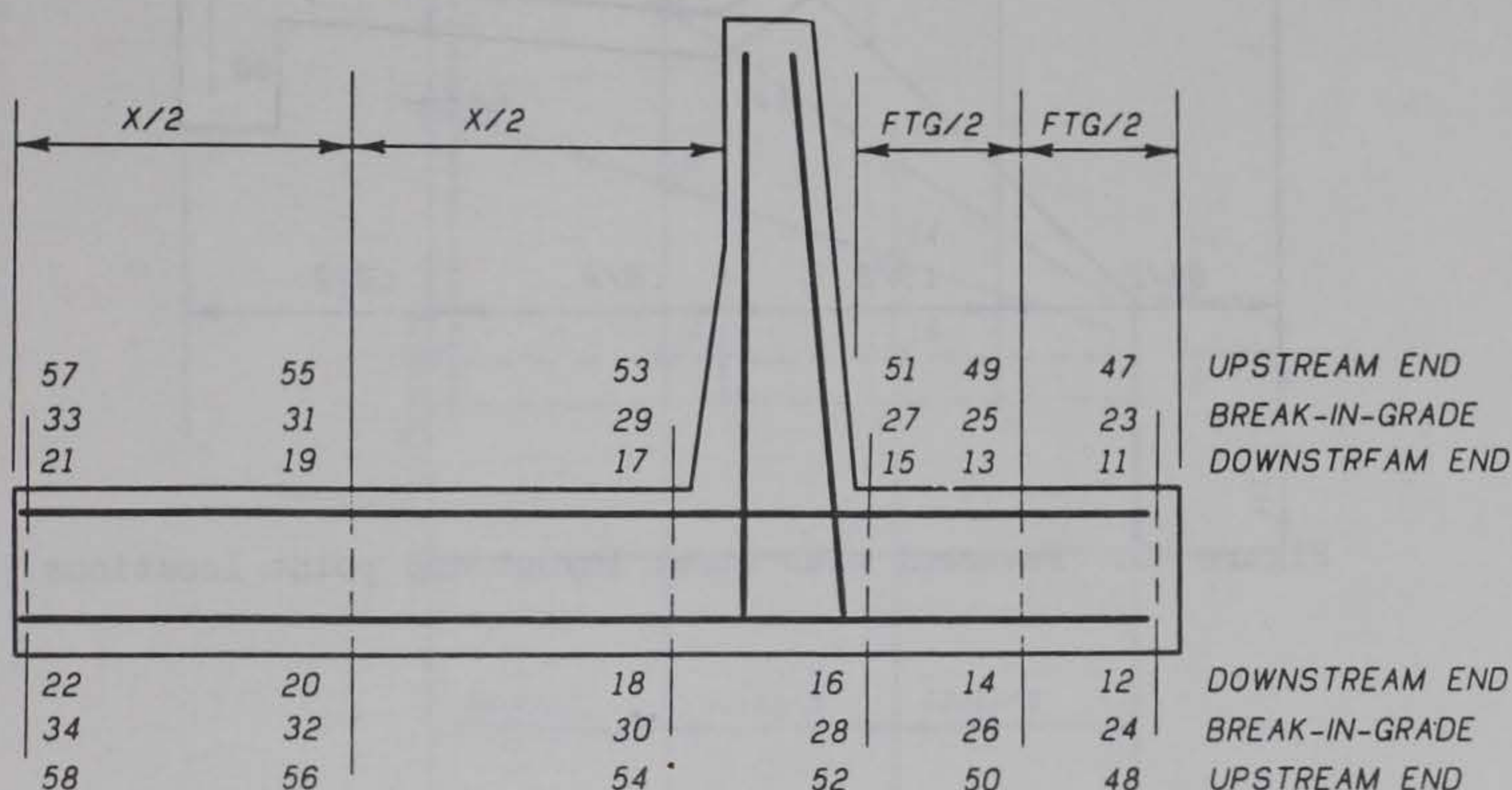

Figure 45. Base slab steel layout and point locations

Bearing pressures at the toe and heel of the upstream and downstream end sections are obtained as described for preliminary design of type (C) retaining wall portions. Bearing pressures at the break-in-grade section are obtained by interpolation. Shear and moment values at any location in the toe and heel of any section are computed by statics. Figure 33 shows the vertical loads involved. Direct compressive forces in footing projections and in the toe slab are computed as indicated above for floor slab steel. With the force system at a location known, steel requirements are readily ascertained. Longitudinal shear is again treated both ways.

Pavement slab steel

Longitudinal steel areas and spacings are determined at the ten points in the pavement slab shown in Figure 46. Shear and moment values for these locations are obtained during preliminary design at the same time slab thicknesses are checked throughout the slab for longitudinal shear and moment. Both LC #1 and LC #2 are investigated to obtain maximum requirements.

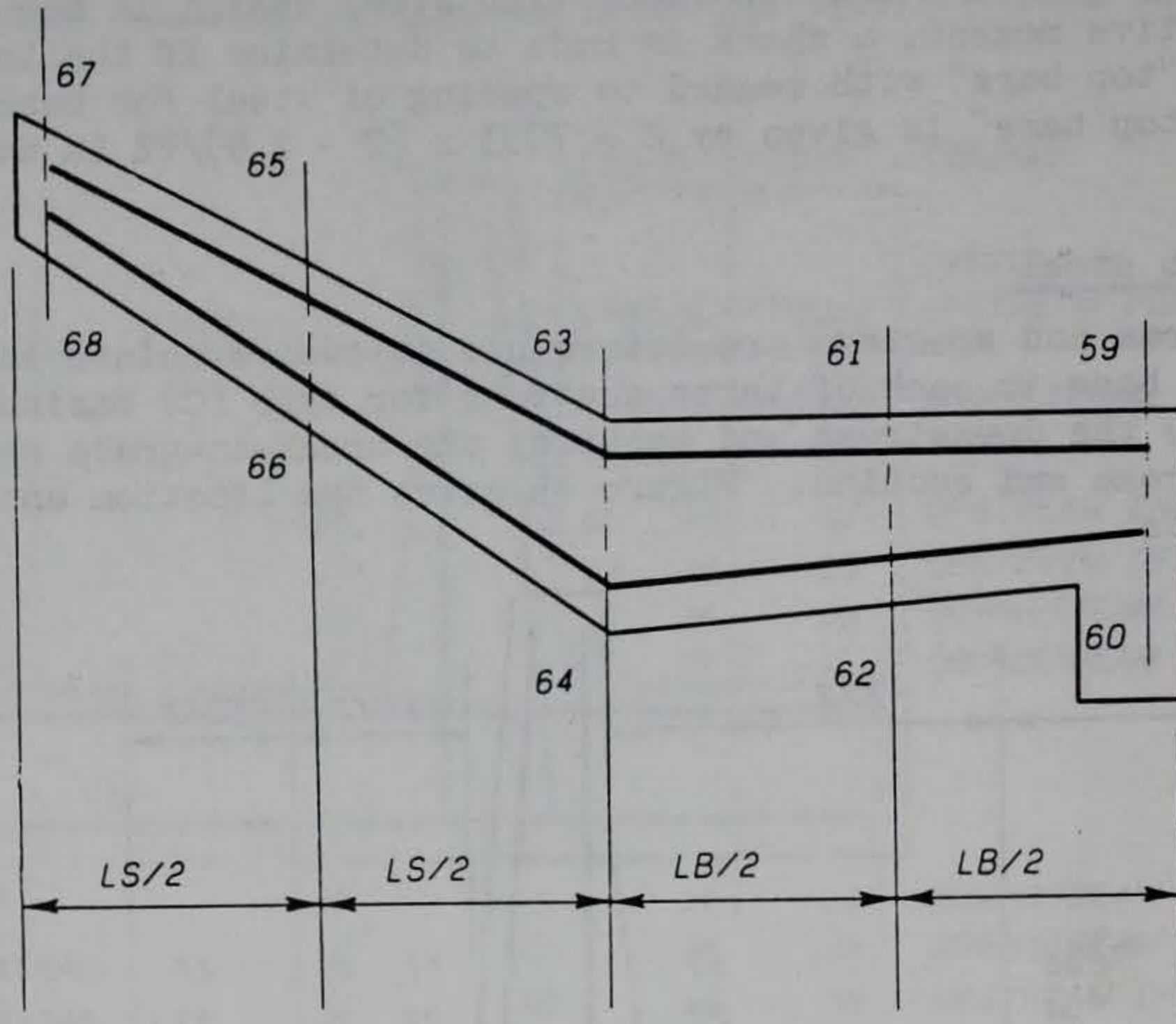

Figure 46. Pavement slab steel layout and point locations

Wingwall steel

Steel areas and spacings are determined at six points in each of three sections in the wingwall. Figure 47 gives the location of the sections and numbering of the points. The sections are adjacent to the articulation joint and at the interior third points of the wingwall span. Figure 48 gives the wingwall section steel layout and locates the six points where steel requirements are evaluated.

There are two lines of principal steel in a wingwall section. These lines are the vertical steel in the back face of the wingwall and the top steel in the wingwall footing. Detailing must ensure that adequate anchorage is provided these two lines at the junction of wingwall and wingwall footing. All other steel in the section is required

only in T and S amounts.

Determination of the steel requirements at point a, b, or c in any section necessitates the evaluation of the force system MZ , NZ , and VZ shown in Figure 49 where Z is the distance from the top of the section down to the point in question. Possible cases of DW , YW , and YB are illustrated from which MZ , NZ , and VZ are computed for a particular load condition. At interior sections where $X > (J - DW)$, the water depths, YW and DW , are equal and exceed the height of the section, HSW . All five load conditions of Figure 36 are investigated to determine maximum requirements.

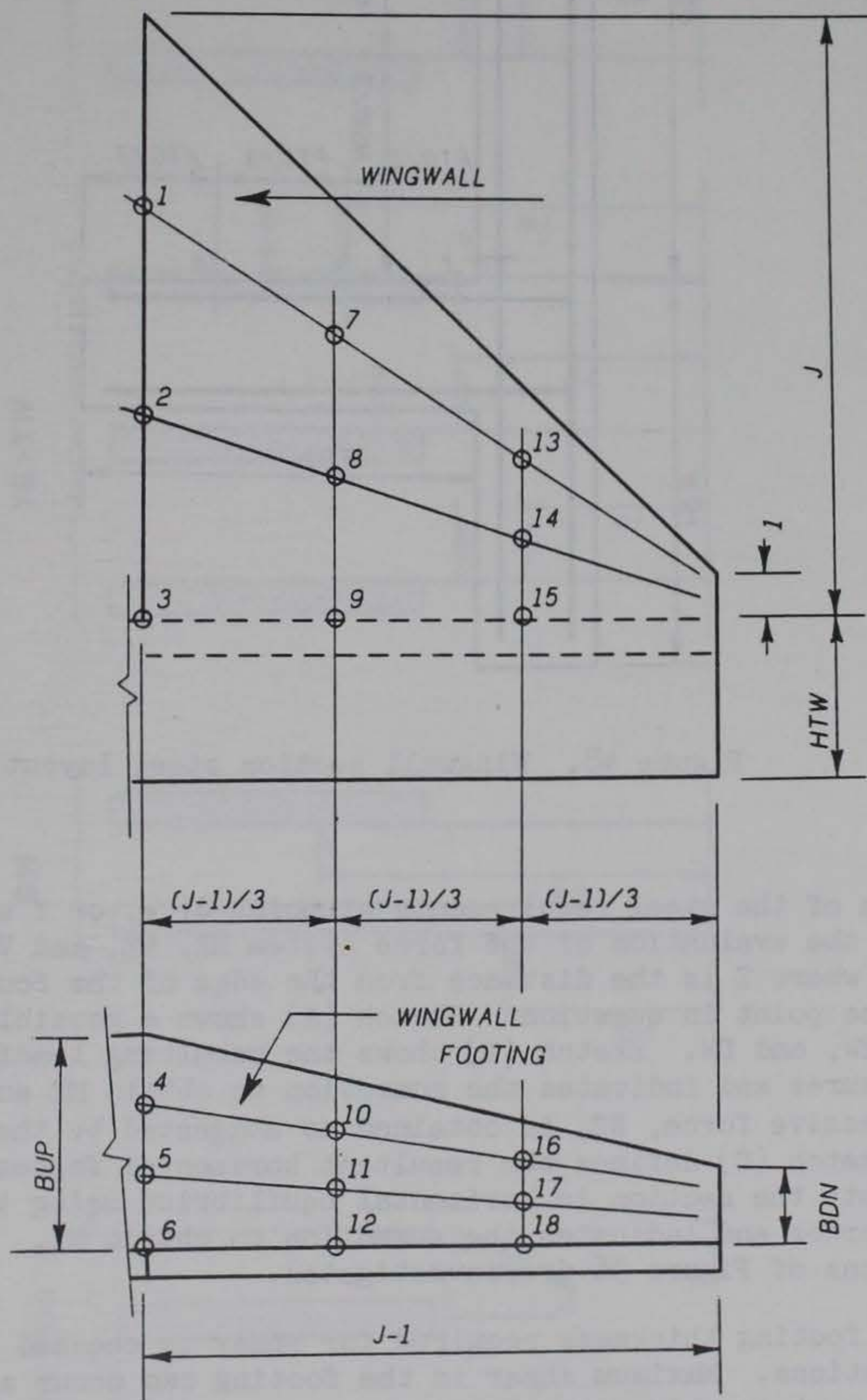

Figure 47. Wingwall steel point locations

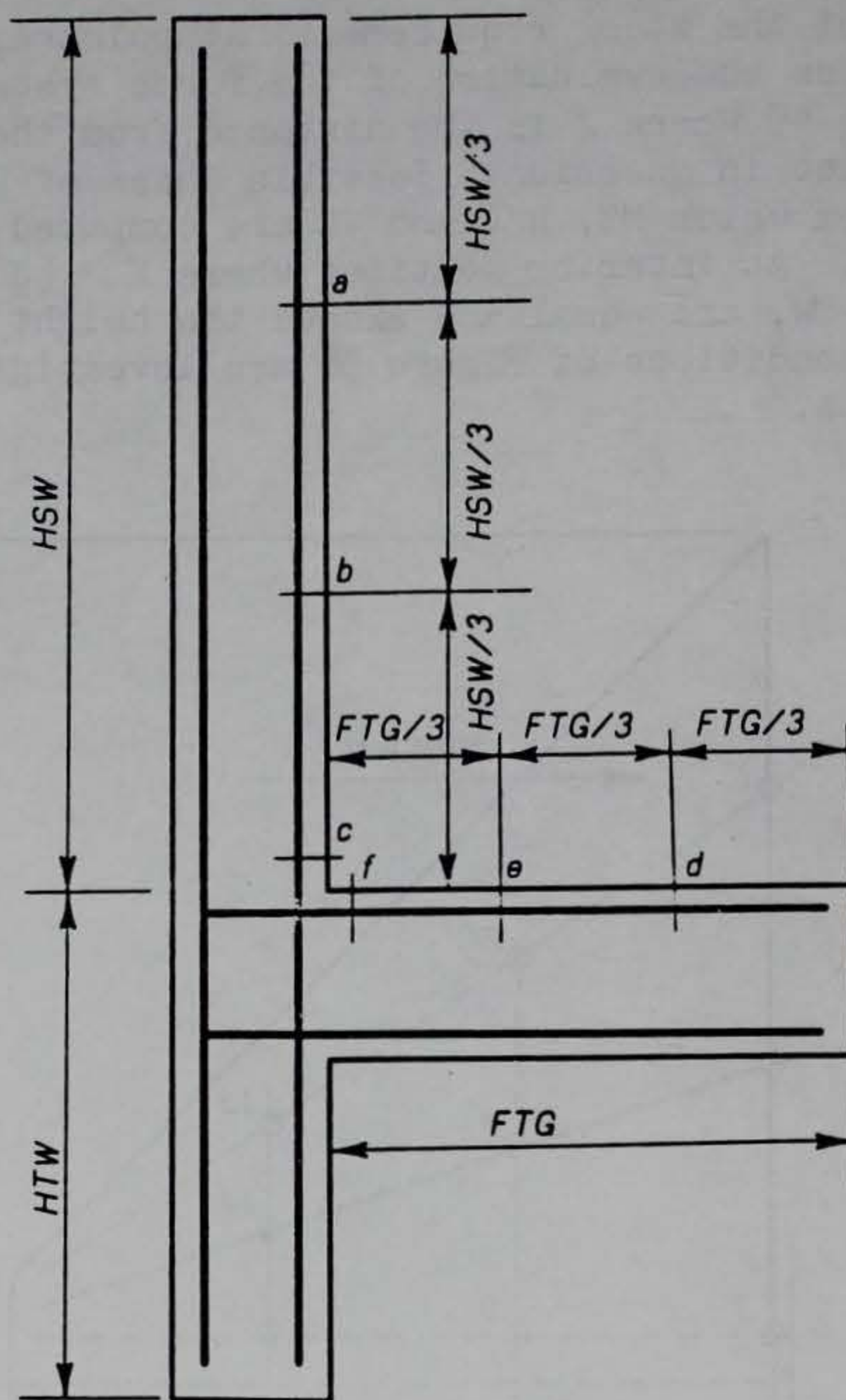

Figure 48. Wingwall section steel layout

Determination of the steel requirements at point d, e, or f similarly necessitates the evaluation of the force system MZ, NZ, and VZ shown in Figure 50 where Z is the distance from the edge of the footing projection to the point in question. Sketch (A) shows a possible combination of YB, YW, and DW. Sketch (B) shows the resulting loadings and bearing pressures and indicates the summation to obtain MZ and VZ. The direct compressive force, NZ, is obtained as suggested by the next two sketches. Sketch (C) defines the resultant horizontal forces involved. Sketch (D) puts the section in horizontal equilibrium using the resultant horizontal forces and indicates the summation to obtain NZ. All five load conditions of Figure 36 are investigated.

The wingwall footing thickness required for shear is checked during these computations. Maximum shear in the footing can occur at the face of the wall or at some interior location. Shear seldom controls thickness. When it does, the thickness is incremented and the footing steel design is begun again.

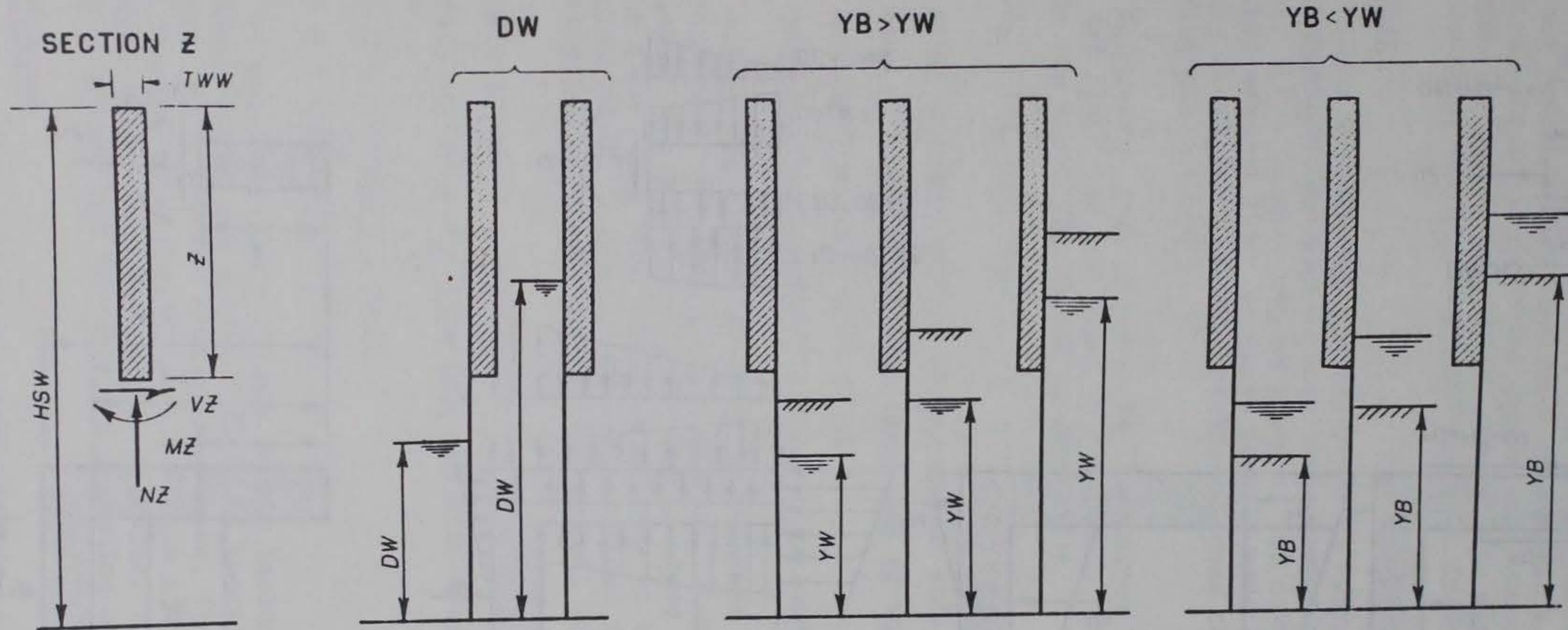

Figure 49. Determination of the force system at a point in wingwall

SEE FIGURE 39

A76

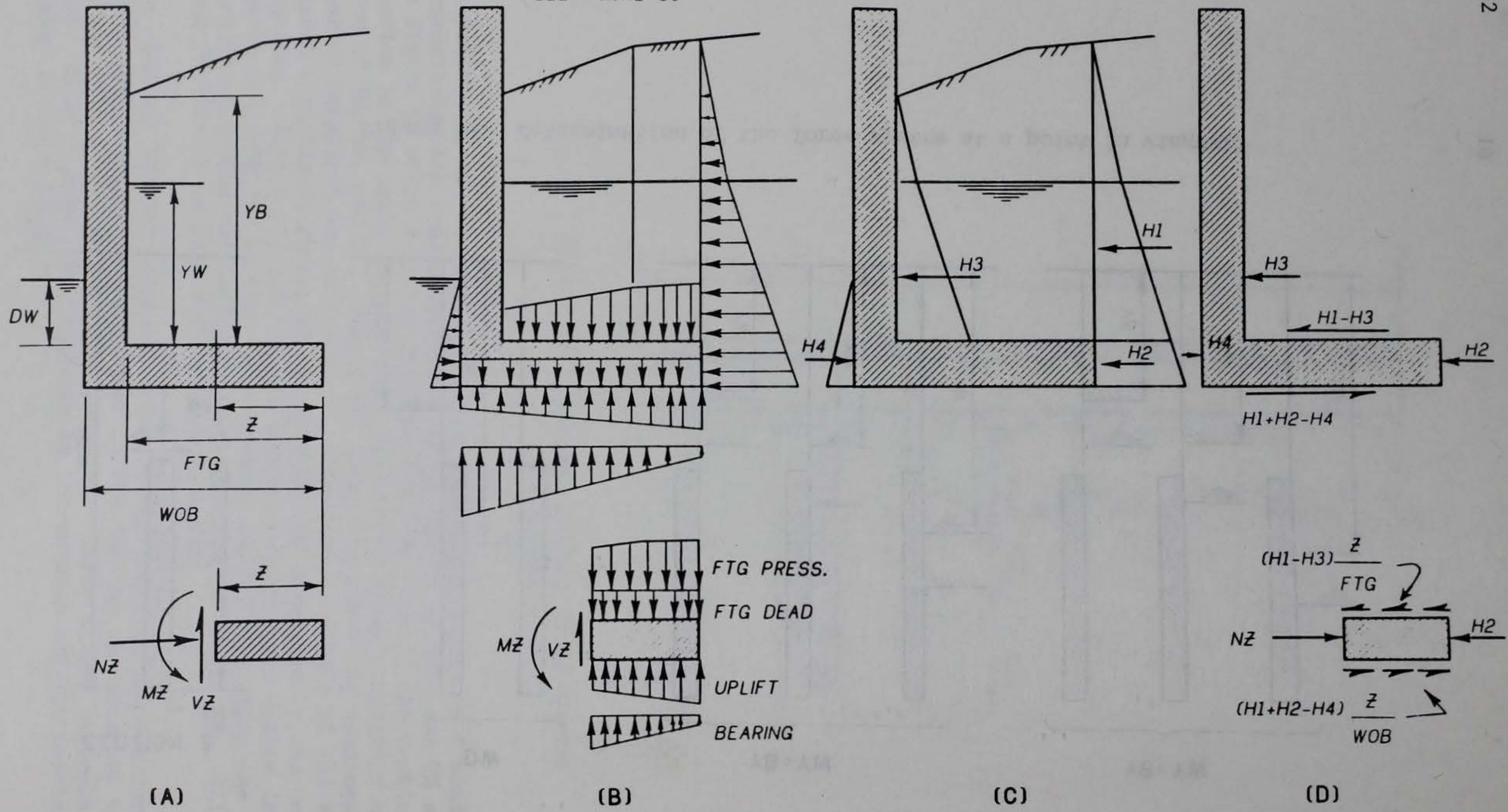

Figure 50. Determination of the force system in wingwall footing

Concrete Volumes

Concrete volumes, in cubic yards, are computed for both preliminary and detail designs. The volumes are given in two parts. The first is the volume of the basin proper, exclusive of wingwalls. The second is the volume of the wingwalls including several adjustments. These adjustments account for the mating of (1) sidewall to wingwall, (2) basin and wingwall toewalls, and (3) basin and wingwall footings.

Basin Volumes

The basin volume of each type of SAF stilling basin is readily obtained. Certain assumptions are made to facilitate computing this volume. It is assumed that the sidewalls end abruptly at the downstream end section. It is further assumed that the basin toewall ends abruptly at the outer edges of the sidewall, that is, the toewall does not extend under the basin footing projections.

The basin volume for type (A) outlets is obtained by partitioning the sidewalls and floor slab as shown by Figure 17. Component solids are prisms for which the volume in general is

$$V = (A_1 + 4A_m + A_2)h/6$$

where

A_1 \equiv area of right section at one end of solid

A_2 \equiv area of right section at other end of solid

A_m \equiv area of mid-section of solid

h \equiv perpendicular distance between right end sections.

The basin volume for a type (B) basin is obtained in accordance with the partitioning shown by Figure 24. Similarly, the volume of the retaining wall portion of a type (C) basin is also obtained in accordance with Figure 24, but with floor slab thickness of TSBG at the break-in-grade. The pavement slab volume of a type (C) basin follows from Figure 28, sketch (A). In calculating these volumes, the overall widths of the basin are taken as

$$WO = W + 2(TBV/12 + FTG)$$

for type (A), and also for type (C), but with W taken as $2X$. Type (B) widths are

$$WOU = W + 2(TBVU/12 + FTGU)$$

$$WOD = W + 2(TBVD/12 + FTGD).$$

It should be noted the basin volumes do not include volumes of chute blocks, floor blocks, end sills, fillets on toewalls, or upstream floor joint steps. It is assumed that chute blocks, floor blocks, and end sills are dimensioned during hydraulic design and that they are subject to some shape and/or size variation. Likewise, fillet size and joint step details are subject to variation depending on designer preference.

Wingwall Volumes

The computation of the wingwall volume with its adjustments is somewhat complicated. Figure 4 shows a typical wingwall layout. First the wing-

wall volume is computed without adjustments. As with the basin proper, certain assumptions are made to facilitate computing this volume. It is assumed that the wingwall and wingwall toewall begin at the articulation joint and extend outward a span of $(J-1)$. It is further assumed that the basin proper is without footing projections. The wingwall volume without adjustments, V_{WOAD} , thus consists of the volumes of (1) the wingwall, (2) the wingwall toewall, and (3) the wingwall footing with its extension back to the basin sidewall. Figure 51 delineates these volumes.

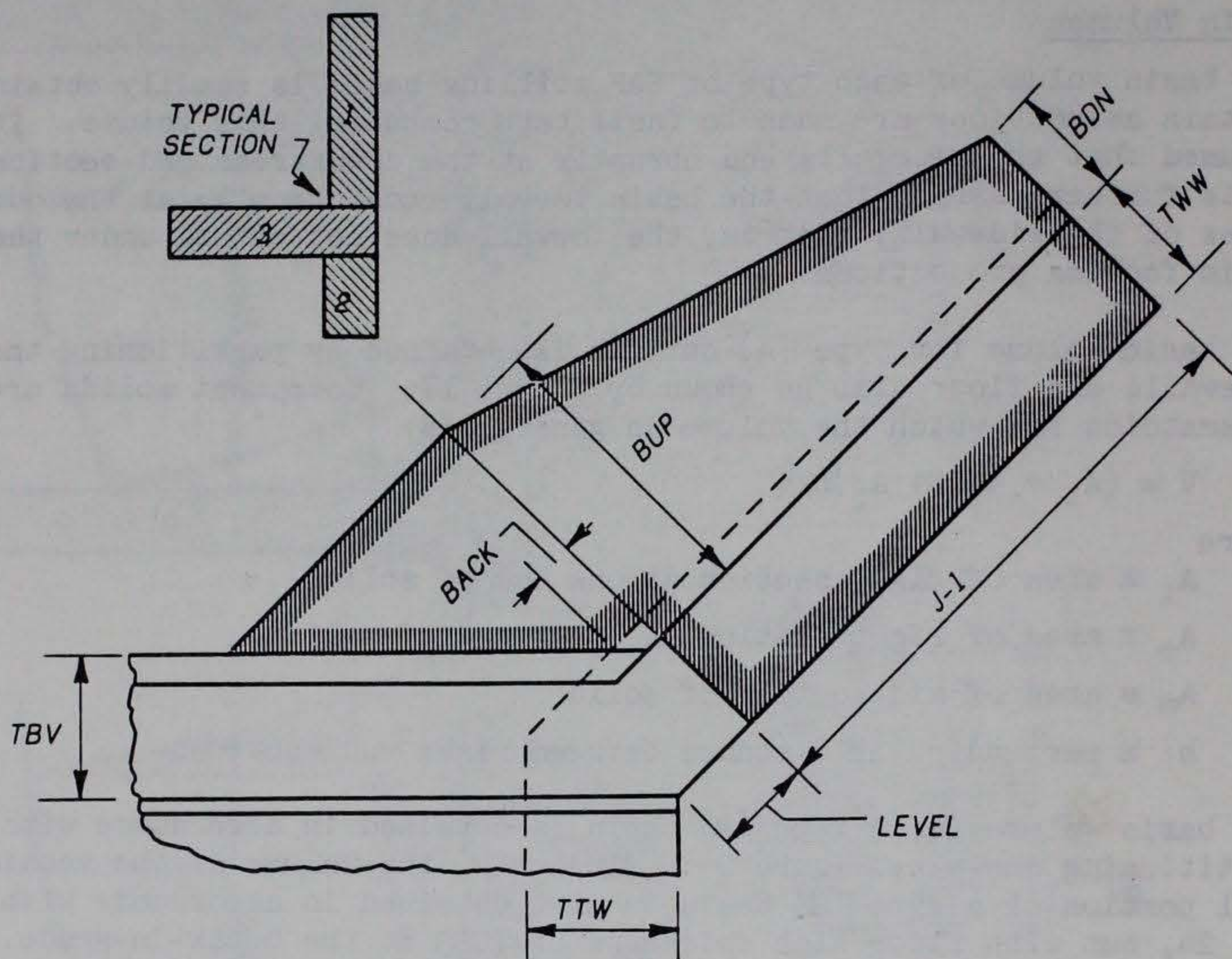

Figure 51. Wingwall volume without adjustments

The adjustments subsequently applied to the wingwall volume depend on the corner detail shown in Figures 4 and 51. The corner detail is shown to larger scale in Figure 52. The thickness of the wingwall toewall, TWT , is the larger of the thickness of the basin toewall, TTW , or the thickness of the wingwall, TWW . The level distance, $LEVEL$, which locates the articulation joint with respect to the corner of the sidewall, and the distance, $BACK$, which serves to define the wingwall footing extension back to the sidewall, are given in inches by

$$LEVEL = TBV/\sqrt{2}$$

$$BACK = TWT - LEVEL$$

when

$$TBV \leq TWW \times \sqrt{2}$$

otherwise

$$LEVEL = TBV \times \sqrt{2} - TWW$$

$$BACK = TWT - TWW$$

The former case is illustrated by Figure 51 and the upper sketch of Figure 52. The latter case is illustrated by Figure 4 and the lower sketch of Figure 52.

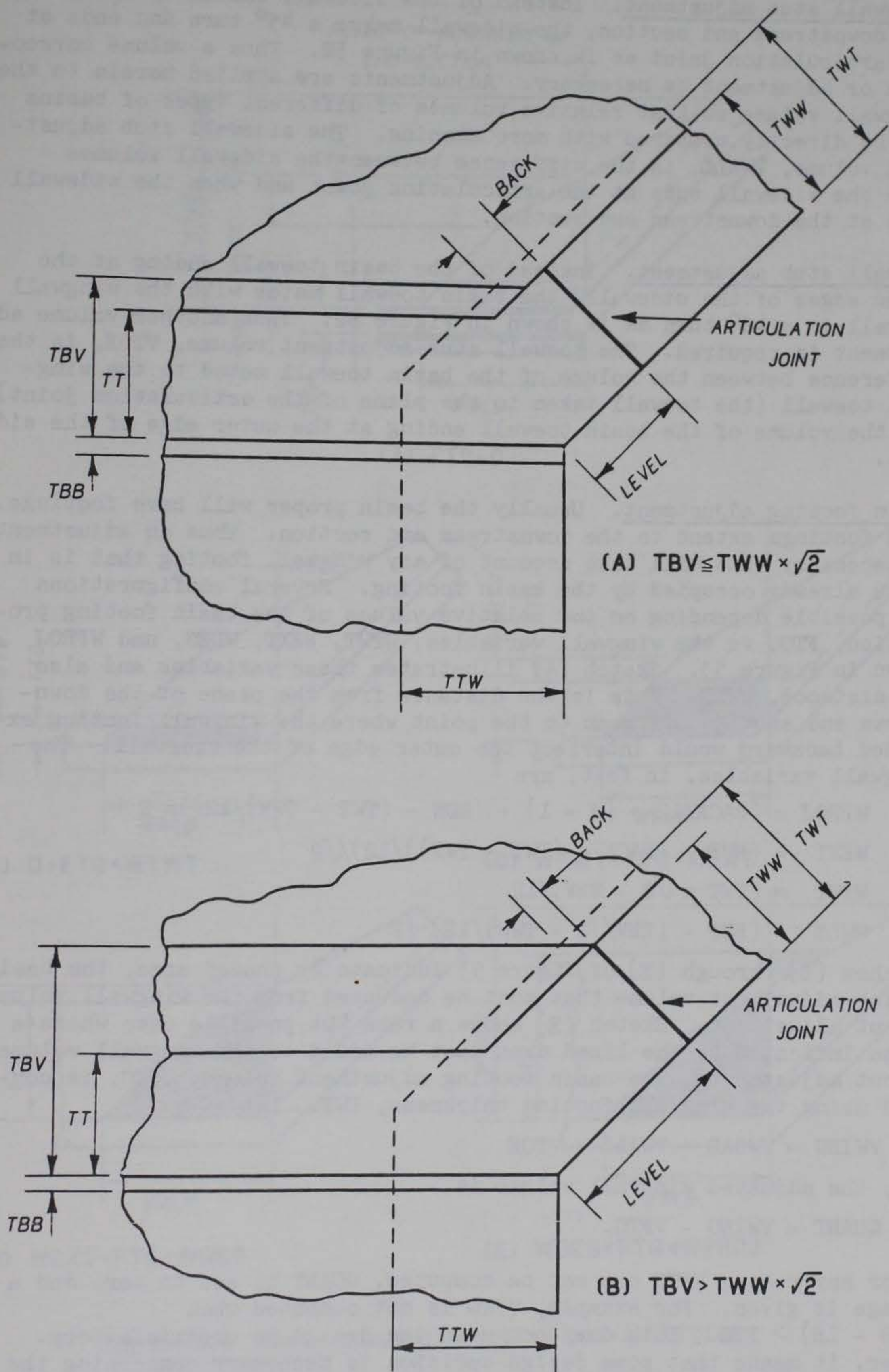

Figure 52. Corner detail, wingwall-to-sidewall

Sidewall stub adjustment. Instead of the sidewall ending abruptly at the downstream end section, the sidewall makes a 45° turn and ends at the articulation joint as is shown in Figure 52. Thus a volume correction or adjustment is necessary. Adjustments are applied herein to the wingwall volume so that relative volumes of different types of basins may be directly compared with more meaning. The sidewall stub adjustment volume, VWALL, is the difference between the sidewall volumes when the sidewall ends at the articulation joint and when the sidewall ends at the downstream end section.

Toewall stub adjustment. Instead of the basin toewall ending at the outer edges of the sidewall, the basin toewall mates with the wingwall toewall in a 45° turn as is shown in Figure 52. Thus another volume adjustment is required. The toewall stub adjustment volume, VTOE, is the difference between the volume of the basin toewall mated to the wingwall toewall (the toewall taken to the plane of the articulation joint) and the volume of the basin toewall ending at the outer edge of the sidewall.

Basin footing adjustment. Usually the basin proper will have footings. Such footings extend to the downstream end section. Thus an adjustment is necessary that will take account of any wingwall footing that is in space already occupied by the basin footing. Several configurations are possible depending on the relative values of the basin footing projection, FTG, vs the wingwall variables, WTWT, WEXT, WDES, and WPROJ shown in Figure 53. Sketch (A) illustrates these variables and also the distance, WWLB. This is the distance from the plane of the downstream end section upstream to the point where the wingwall footing extended backward would intersect the outer edge of the sidewall. The wingwall variables, in feet, are

$$\begin{aligned} \bullet \quad WPROJ &= (BACK/12 + (J - 1) + (BDN - (TWT - TWW)/12))/\sqrt{2} \\ WEXT &= (BUP + (BACK - (TWT - TWW))/12)/\sqrt{2} \\ WTWT &= (TWT \times \sqrt{2} - TBV)/12 \\ WWLB &= (BUP - (TBV/\sqrt{2} - TWW)/12) \sqrt{2} \end{aligned}$$

Sketches (B) through (E) of Figure 53 indicate by shaded area, the basin footing adjustment volume that must be deducted from the wingwall volume without adjustment. Sketch (E) shows a rare but possible case where a volume indicated by the lined area must be added to the wingwall volume without adjustment. The basin footing adjustment volume, VFTG, is computed using the wingwall footing thickness, TWF. Let

$$VWING = VWOAD + VWALL + VTOE$$

then, the adjusted wingwall volume is

$$QUANT = VWING - VFTG.$$

If for any reason VFTG can not be computed, QUANT is set to zero and a message is given. For example, VFTG is not computed when $(WWLB - LB) > FTG$. This does not mean the design is unsatisfactory. Rather, it means that some design decision is necessary concerning the layout of the wingwall footing.

(A) $FTG=0$ (B) $0 < FTG < WTWT$ (C) $WTWT < FTG < WEXT$ (D) $WEXT < FTG < WDES$ (E) $WDES < FTG < WPROJ$

Figure 53. Basin-wingwall footing possibilities

Computer Designs

Input

Two lines of alphanumeric information must precede all other data in the input for a computer job. A given computer job may include many design runs. From one to five lines of input data are required for each design run. A design run is made for a particular set of design conditions and takes one of two forms. The first form consists of three preliminary designs, one for each SAF stilling basin type, plus a preliminary design of the wingwalls. The second form consists of the detail design of one of the basin types plus a detail design of the wingwalls.

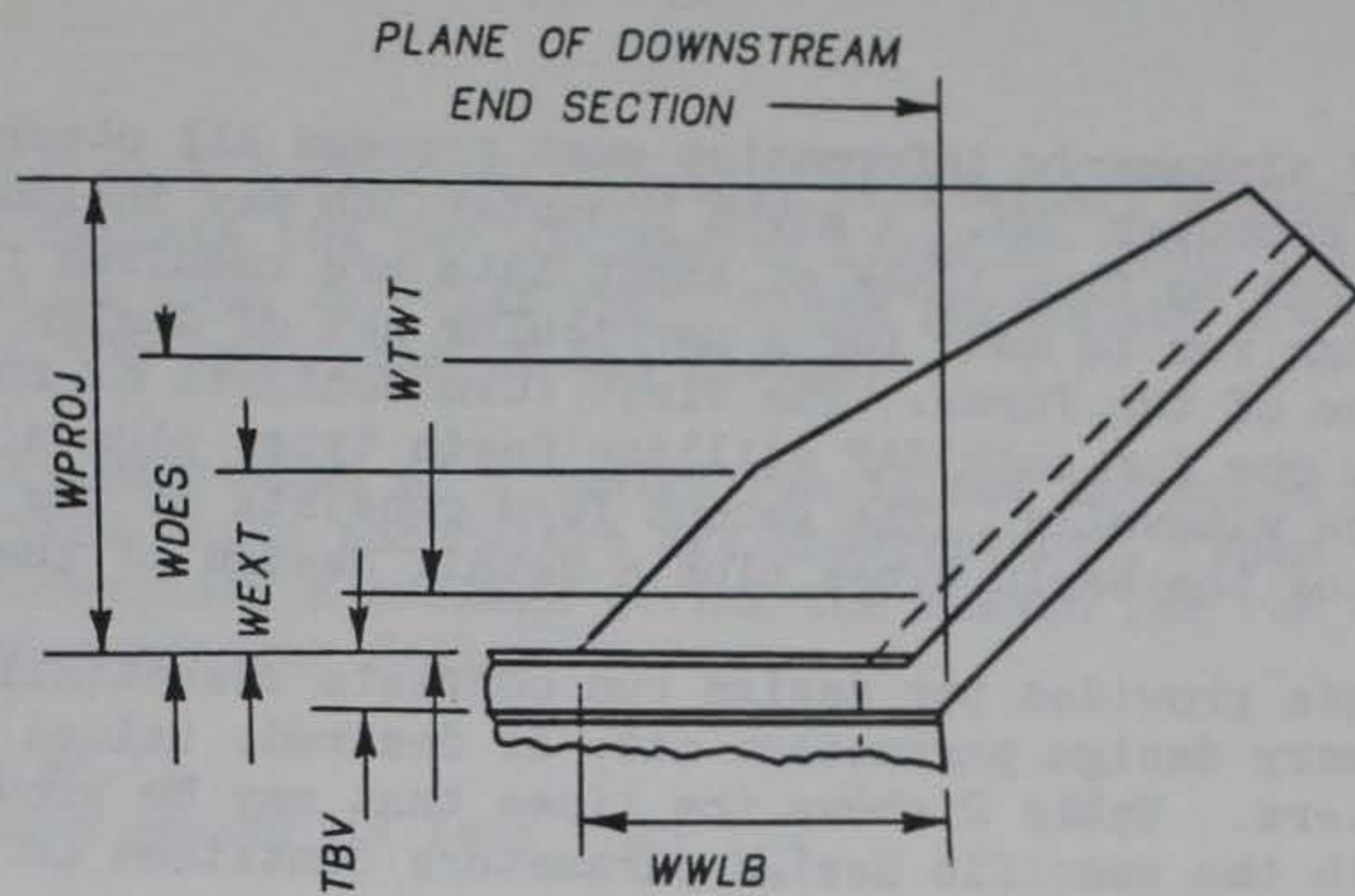
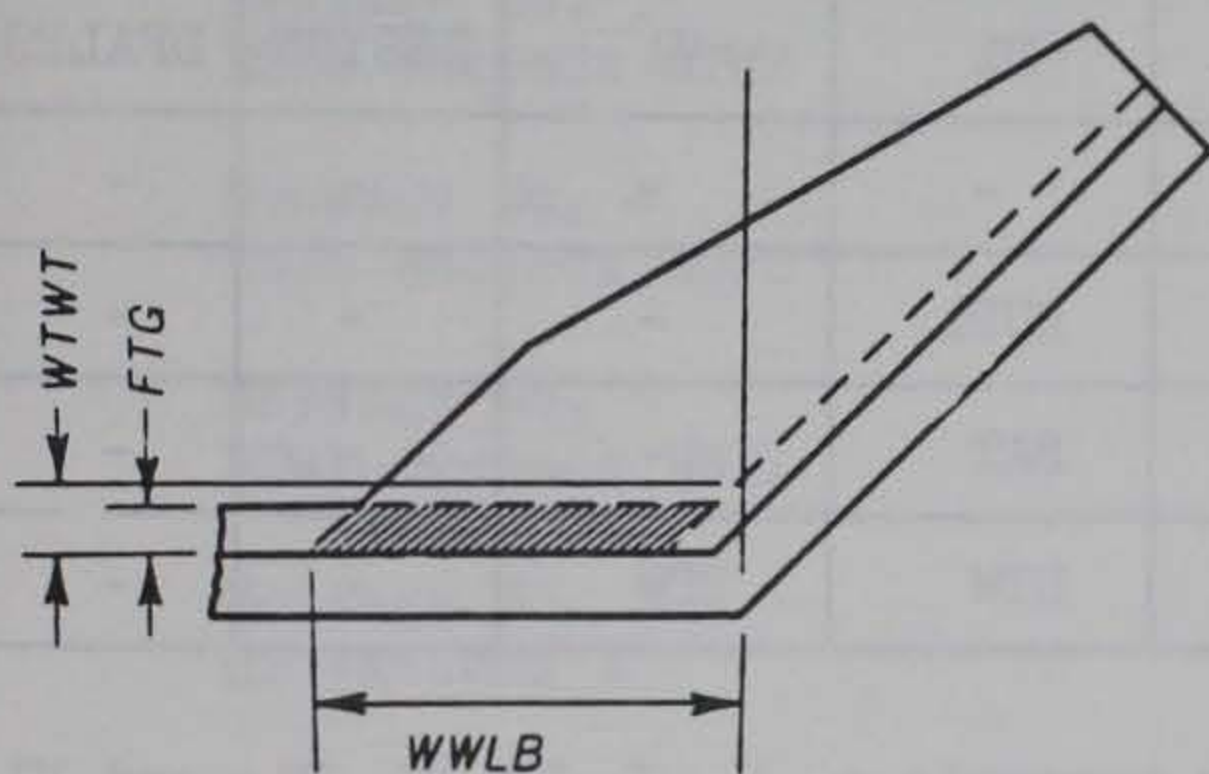
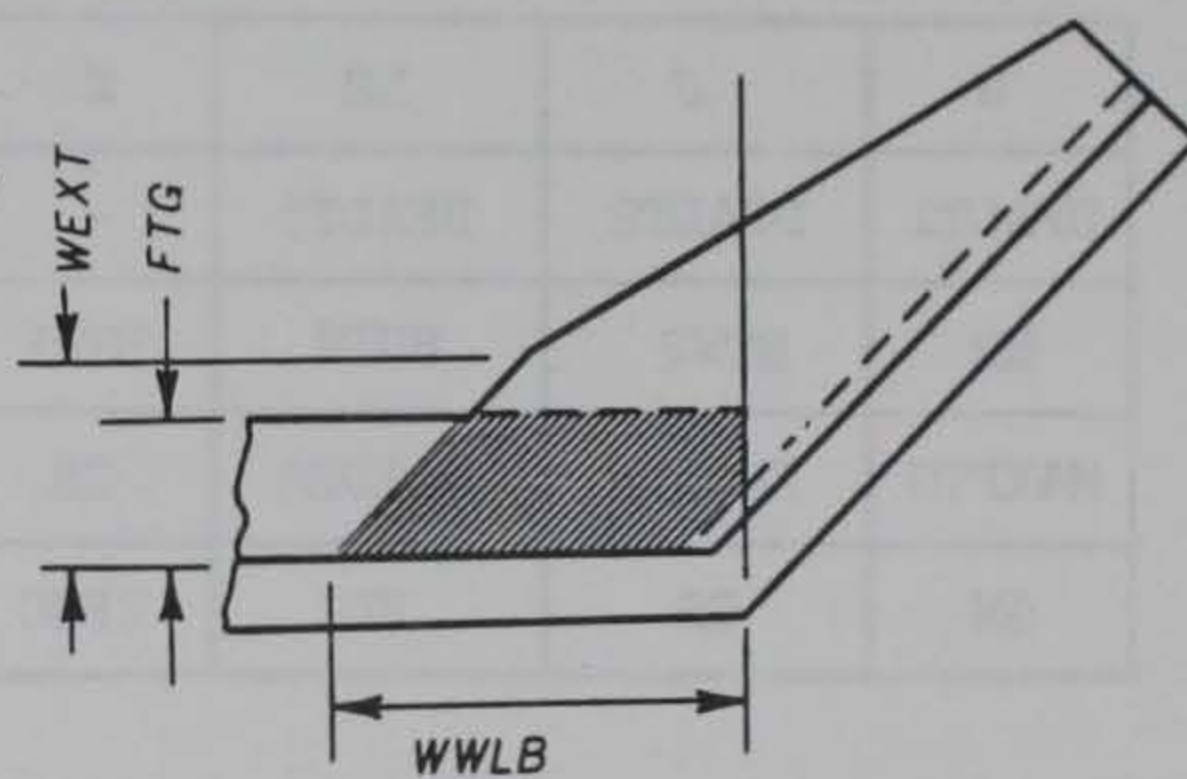
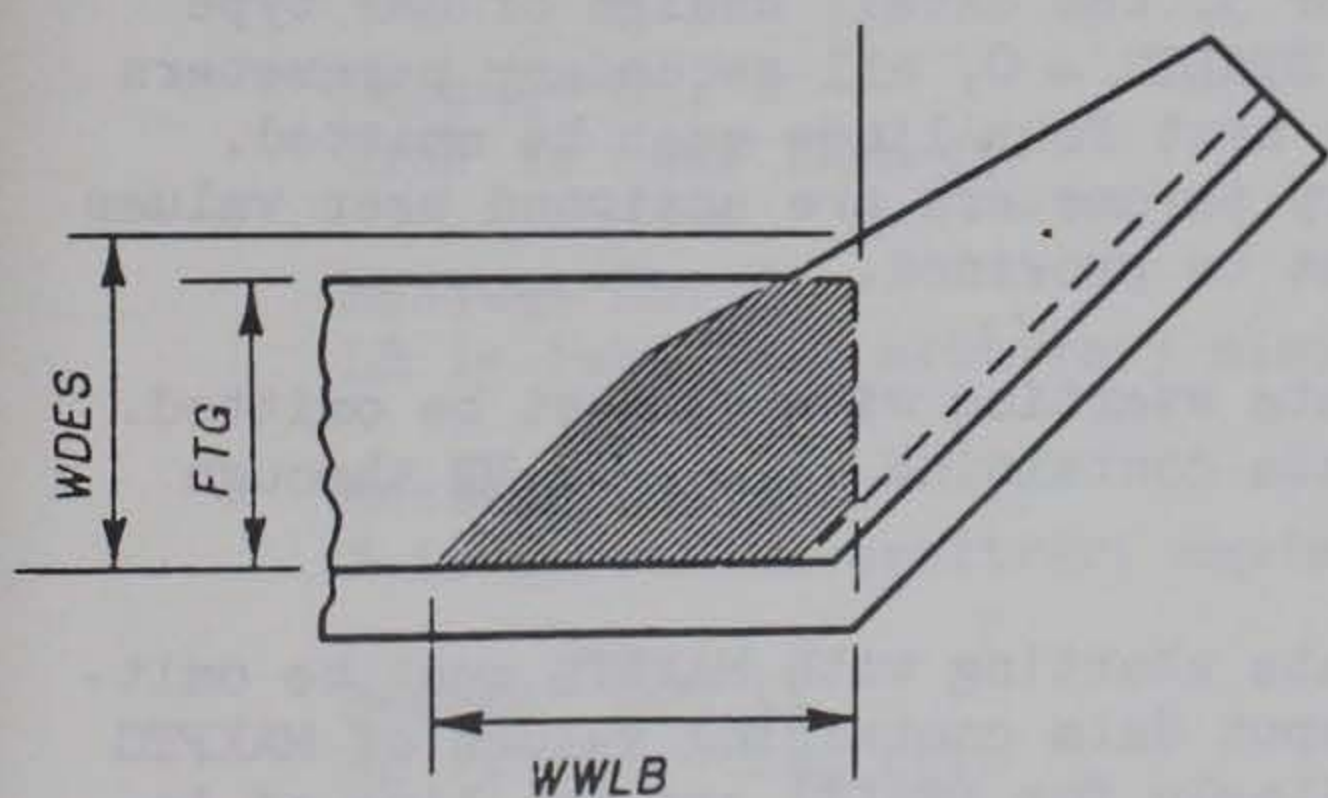
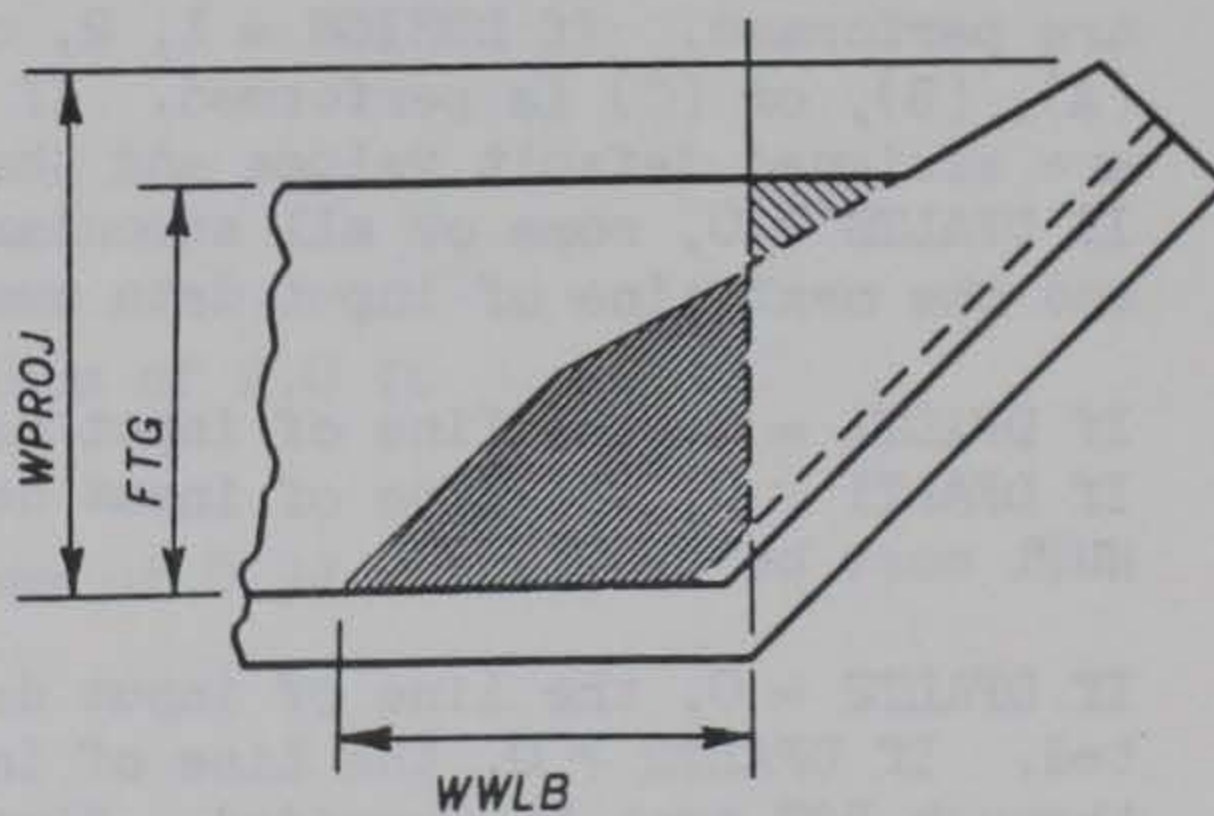
The input data provided per design run consists essentially of values for the primary design parameters and, if desired, values for the secondary parameters. Table 2 shows the lines that may be provided per run together with the specific design parameters contained on the first and last three lines.

Table 2. Input values per design run

W	J	LB	N	DL	V1	DESIGN	DFALTS
DFALT1	DFALT2	DFALT3	-	-	-	-	-
HB	HTW2	HUP2	HTW1	HUP1	-	-	-
MAXFTG	FLOATR	SLIDER	ZS	BAT	-	-	-
GM	GS	KO	CFSC	HTW	TTW	-	-

The first line contains the primary parameters, W, J, LB, N, DL, and V1 and is always required. If DESIGN = 0, the three preliminary designs are performed. If DESIGN = 1, 2, or 3, the detail design of SAF type (A), (B), or (C) is performed. If DFALTS = 0, all secondary parameters are assigned default values and the next four lines must be omitted. If DFALTS > 0, some or all secondary parameters are assigned user values and the next line of input data must be provided.

If DFALT1 = 0, the line of input data starting with HB must be omitted. If DFALT1 > 0, the line of input data containing values of HB through HUP1 must be provided.

If DFALT2 = 0, the line of input data starting with MAXFTG must be omitted. If DFALT2 > 0, the line of input data containing values of MAXFTG through BAT must be provided. Similarly for DFALT3 and the line of input data starting with GM.

Thus the number of lines of data that must be provided per design run will vary depending on whether the default values are acceptable or whether the user wishes to supply certain secondary parameter values. Note that although various lines may be omitted, those supplied must be complete and in the order indicated.

The two lines of alphameric data are used to provide information such as site number, watershed, state, date of design, and similar information desired by the requesting office.

Output

The output for each design run, whether preliminary designs or a detail design, repeats the two alphameric lines of input and gives the parameter values used for that run. These parameters are listed and identified at the beginning of the design.

Messages. The execution of a design run is not attempted when the computer recognizes input parameters are unacceptable. When this happens, the output references a message giving the reason the run was not executed. These messages follow.

Message No. 1

The Froude number is less than 3.0

Message No. 2

HTW2 exceeds J

Message No. 3

HUP2 exceeds HTW2

Message No. 4

HUP1 exceeds HUP2

Message No. 5

HTW1 exceeds HUP1

Message No. 6

HB exceeds J

Message No. 7

N is less than D1

Message No. 8

HTW2 is less than D1

Message No. 9

LB is less than arbitrary minimum of 2.0 ft

Message No. 10

N is more than arbitrary maximum of 0.9J

Message No. 11

HB is less than zero

Message No. 12

ZS is less than arbitrary minimum of 2.0

Sometimes an executing design can not be completed. This may occur during preliminary design or more rarely during detail design. When this happens, the output contains a short message which identifies

the basin or element involved and gives the underlying cause when possible.

Preliminary designs. Preliminary design results are listed in the order type (A), (B), (C) and wingwall, see Figure 54. Output values consist of distances, thicknesses, and concrete volumes. The units are feet, inches, and cubic yards respectively. Items may be identified by reference to various figures:

For type (A) see Figures 1 and 11

For type (B) see Figures 2 and 11

For type (C) see Figures 3, 11, and 28(A)

For wingwall see Figure 4.

Detail designs. The output for the detail design of any basin type includes several segments. The output repeats the preliminary design results. The output gives final distance and thickness values (these will often be identical to the preliminary design values). The output includes a listing of steel requirements giving required area and maximum allowable spacing in sq. in. per ft and inches. The output then provides similar detail information for the associated wingwalls.

Type (A). -- See Figure 55 for an output example. See Figures 42 and 44 for the steel locations listed.

Type (B). -- See Figure 56 for an output example. See Figures 42 and 44 for the steel locations listed.

Type (C). -- See Figure 57 for an output example. See Figures 42 and 45 for the retaining wall portion steel locations listed. See Figure 46 for the pavement slab steel locations listed.

Wingwalls. -- Wingwall detail designs are a part of Figures 55, 56, and 57. See Figures 4 and 53 for item identification. See Figures 41, 47, and 48 for the steel locations listed. The required area of the wingwall-to-basin tie is given in sq. inches. LEVEL is in inches, WPROJ and WWLB are in feet, and VWING is in cubic yards.

SAF STILLING BASIN
STRUCTURAL DESIGN
ELASTIC ANALYSIS AND WORKING STRESS DESIGN ARE USED

SPECIAL DESIGN PREPARED BY THE DESIGN UNIT AT HYATTSVILLE, MD.
FOR

EXAMPLE SPECIAL DESIGNS FOR STILLING BASIN TECHNICAL RELEASE
JOAN FOR ESA-----8/7/73

DESIGN PARAMETERS
W = 20.00 D1 = 1.75 HTW1 = 4.00 HB = 7.00 GH = 110.0 MAXFTG = 10.00
J = 18.75 V1 = 50.00 HUP1 = 6.00 ZS = 2.50 GS = 120.0 FLOATR = 1.25
LB = 16.75 FROUDE = 44.37 HTW2 = 13.50 HTW = 4.00 KO = 0.750 SLIDER = 1.10
N = 6.75 D2 = 15.63 HUP2 = 11.00 TTV = 12.00 BAT = 0.0 CFSC = 0.40

PRELIMINARY DESIGNS FOLLOW

TYPE (A) STILLING BASIN - TRIAL VALUES QUANT = 119.43
LTOP = 45.45 LN = 2.51 HN = 6.27 HV = 9.37
LBOT = 47.96 LS = 31.21 HS = 12.48
TT = 10.00 TV = 12.50 TBB = 0.0 TBV = 15.00 TR = 15.00
FTG = 3.00 TSUP = 13.00 TSRG = 16.00 TSDN = 16.00
ASSOCIATED WINGWALL QUANT = 27.19

TYPE (B) STILLING BASIN - TRIAL VALUES QUANT = 135.22
LTOT = 46.75 LS = 30.00 HS = 12.00 HV = 9.37
TT = 10.00 TVU = 12.50 TBB = 0.0 TBVU = 15.00 TRU = 15.00
TVD = 12.50 TBVD = 15.00 TRD = 15.00
FTGU = 4.00 TSUP = 13.00 TSBGU = 22.00
FTGD = 4.75 TSBGD = 22.00 TSDN = 16.00
ASSOCIATED WINGWALL QUANT = 25.70

TYPE (C) STILLING BASIN - TRIAL VALUES QUANT = 119.59
LTOT = 46.75 LS = 30.00 HS = 12.00 HV = 9.37
X = 10.00 XP = 0.0
TPUP = 50.00 TPRG = 88.00 TPDN = 69.00
TT = 10.00 TV = 12.50 TBB = 0.0 TRV = 15.00 TR = 15.00
FTG = 3.00 TSUP = 14.00 TSRG = 17.00 TSDN = 16.00
ASSOCIATED WINGWALL QUANT = 27.19

WINGWALL DESIGN TRIAL VALUES
TWI = 10.00 TWV = 10.00 BUP = 12.50 BDN = 3.50

----- END PRELIMINARY DESIGNS -----

SAF STILLING BASIN
STRUCTURAL DESIGN
ELASTIC ANALYSIS AND WORKING STRESS DESIGN ARE USED

SPECIAL DESIGN PREPARED BY THE DESIGN UNIT AT HYATTSVILLE, MD.
FOR

EXAMPLE SPECIAL DESIGNS FOR STILLING BASIN TECHNICAL RELEASE
JOAN FOR ESA-----8/7/73

DESIGN PARAMETERS
W = 20.00 D1 = 1.00 HTW1 = 2.00 HB = 5.00 GH = 120.0 MAXFTG = 10.00
J = 12.00 V1 = 35.00 HUP1 = 4.00 ZS = 3.00 GS = 140.0 FLOATR = 1.50
LB = 16.00 FROUDE = 38.04 HTW2 = 8.00 HTW = 4.00 KO = 0.800 SLIDER = 1.00
N = 4.00 D2 = 8.24 HUP2 = 6.00 TTV = 10.00 BAT = 0.375 CFSC = 0.35

PRELIMINARY DESIGNS FOLLOW

TYPE (A) STILLING BASIN - TRIAL VALUES QUANT = 63.91
LTOP = 39.35 LN = 1.26 HN = 3.79 HV = 6.00
LBOT = 40.62 LS = 24.62 HS = 8.21
TT = 10.00 TV = 10.00 TBB = 2.00 TBV = 10.00 TR = 12.00
FTG = 1.00 TSUP = 11.00 TSRG = 13.00 TSDN = 13.00
ASSOCIATED WINGWALL QUANT = 12.66

TYPE (B) STILLING BASIN - TRIAL VALUES QUANT = 66.83
LTOT = 40.00 LS = 24.00 HS = 8.00 HV = 6.00
TT = 10.00 TVU = 10.00 TBB = 2.00 TBVU = 10.00 TRU = 12.00
TVD = 10.00 TBVD = 10.00 TRD = 12.00
FTGU = 1.00 TSUP = 11.00 TSBGU = 14.00
FTGD = 3.00 TSBGD = 14.00 TSDN = 13.00
ASSOCIATED WINGWALL QUANT = 11.46

TYPE (C) STILLING BASIN - TRIAL VALUES QUANT = 69.29
LTOT = 40.00 LS = 24.00 HS = 8.00 HV = 6.00
X = 9.00 XP = 2.00
TPUP = 24.00 TPRG = 50.00 TPDN = 37.00
TT = 10.00 TV = 10.00 TBB = 2.00 TRV = 10.00 TR = 12.00
FTG = 1.00 TSUP = 11.00 TSBG = 13.00 TSDN = 13.00
ASSOCIATED WINGWALL QUANT = 12.66

WINGWALL DESIGN TRIAL VALUES
TWI = 10.00 TWV = 10.00 BUP = 8.00 BDN = 3.50

----- END PRELIMINARY DESIGNS -----

Figure 54. Computer output, preliminary designs

SAF STILLING BASIN
STRUCTURAL DESIGN
ELASTIC ANALYSIS AND WORKING STRESS DESIGN ARE USED

SPECIAL DESIGN PREPARED BY THE DESIGN UNIT AT HYATTSVILLE, MD.
FOR

EXAMPLE SPECIAL DESIGNS FOR STILLING BASIN TECHNICAL RELEASE
JOAN FOR ESA - - - - - 3/18/74

DESIGN PARAMETERS

W = 40.00	D1 = 1.00	HTV1= 4.00	HR = 2.67	GM =105.0	MAXFTG= 8.00
J = 12.00	V1 = 45.00	HUP1= 4.00	ZS = 3.00	GS =120.0	FLOATR= 1.20
LB= 10.00	FROUDE= 62.89	HTV2= 9.00	HTV= 4.00	K0 = 0.667	SLIDER= 1.00
V = 6.00	D2 = 10.73	HUP2= 5.00	TTV=10.00	RAT= 0.250	CFSC = 0.35

DESIGN OF SPECIFIED TYPE SAF FOLLOWS

TYPE (A) STILLING BASIN - TRIAL VALUES				QUANT= 86.69
LTOP= 27.03	LN= 1.90	HN= 5.69	HV= 6.00	
LROT= 28.92	LS= 18.92	HS= 6.31		
TT= 10.00	TV= 10.00	TBR= 2.00	TRV= 10.00	TR= 12.00
FTG= 1.00	TSUP= 15.00	TSRG= 18.00	TSDN= 14.00	

TYPE (A) STILLING BASIN - DETAIL DESIGN				QUANT= 86.69
TT= 10.00	TV= 10.00	TBR= 2.00	TRV= 10.00	TR= 12.00
FTG= 1.00	TSUP= 15.00	TSRG= 18.00	TSDN= 14.00	

STEEL REQUIREMENTS

WALL			
A(1)= 0.24	S(1)= 18.00	A(6)= 0.24	S(6)= 18.00
A(2)= 0.24	S(2)= 18.00	A(7)= 0.24	S(7)= 18.00
A(3)= 0.24	S(3)= 18.00	A(8)= 0.24	S(8)= 18.00
A(4)= 0.27	S(4)= 18.00	A(9)= 0.27	S(9)= 18.00
A(5)= 0.58	S(5)= 18.00	A(10)= 0.58	S(10)= 18.00
		A(0)= 0.49	S(0)= 18.00

BASE

SECTION AT DOWNSTREAM END			
A(11)= 0.17	S(11)= 18.00	A(17)= 0.45	S(17)= 18.00
A(12)= 0.17	S(12)= 18.00	A(18)= 0.17	S(18)= 18.00
A(13)= 0.17	S(13)= 18.00	A(19)= 0.95	S(19)= 18.00
A(14)= 0.17	S(14)= 18.00	A(20)= 1.16	S(20)= 18.00
A(15)= 0.17	S(15)= 18.00	A(21)= 1.27	S(21)= 18.00
A(16)= 0.17	S(16)= 18.00	A(22)= 1.69	S(22)= 18.00
SECTION AT BREAK-IN-GRADE			
A(23)= 0.22	S(23)= 18.00	A(29)= 0.43	S(29)= 18.00
A(24)= 0.22	S(24)= 18.00	A(30)= 0.22	S(30)= 18.00
A(25)= 0.22	S(25)= 18.00	A(31)= 1.79	S(31)= 18.00
A(26)= 0.22	S(26)= 18.00	A(32)= 0.22	S(32)= 18.00
A(27)= 0.22	S(27)= 18.00	A(33)= 2.48	S(33)= 18.00
A(28)= 0.22	S(28)= 18.00	A(34)= 0.22	S(34)= 18.00
SECTION AT UPSTREAM END			
A(47)= 0.18	S(47)= 18.00	A(53)= 0.36	S(53)= 18.00
A(48)= 0.18	S(48)= 18.00	A(54)= 0.18	S(54)= 18.00
A(49)= 0.18	S(49)= 18.00	A(55)= 0.36	S(55)= 18.00
A(50)= 0.18	S(50)= 18.00	A(56)= 1.08	S(56)= 18.00
A(51)= 0.18	S(51)= 18.00	A(57)= 0.45	S(57)= 18.00
A(52)= 0.18	S(52)= 18.00	A(58)= 1.40	S(58)= 18.00

WINGWALL DESIGN - TRIAL VALUES

TWW= 10.00	TWF= 10.00	RUP= 7.50	RDN= 1.50
------------	------------	-----------	-----------

WINGWALL DESIGN - DETAIL DESIGN

TWW= 10.00	TWF= 10.00	RUP= 7.50	RDN= 1.50	QUANT= 11.60
LEVEL= 7.07	WPROJ= 9.01	WHLR=10.95	VWING= 12.25	

STEEL REQUIREMENTS

AREA OF TIE= 0.17			
SECTION AT ARTICULATION JOINT			
A(1)= 0.24	S(1)= 18.00	A(4)= 0.12	S(4)= 18.00
A(2)= 0.24	S(2)= 18.00	A(5)= 0.20	S(5)= 18.00
A(3)= 0.12	S(3)= 18.00	A(6)= 0.18	S(6)= 18.00
SECTION AT UPPER THIRD POINT			
A(7)= 0.24	S(7)= 18.00	A(10)= 0.12	S(10)= 18.00
A(8)= 0.24	S(8)= 18.00	A(11)= 0.12	S(11)= 18.00
A(9)= 0.12	S(9)= 18.00	A(12)= 0.12	S(12)= 18.00
SECTION AT LOWER THIRD POINT			
A(13)= 0.24	S(13)= 18.00	A(16)= 0.12	S(16)= 18.00
A(14)= 0.12	S(14)= 18.00	A(17)= 0.12	S(17)= 18.00
A(15)= 0.12	S(15)= 18.00	A(18)= 0.12	S(18)= 18.00

===== END DETAIL DESIGN =====

Figure 55. Computer output, type (A) detail design

SAF STILLING BASIN
STRUCTURAL DESIGN
ELASTIC ANALYSIS AND WORKING STRESS DESIGN ARE USED
SPECIAL DESIGN PREPARED BY THE DESIGN UNIT AT HYATTSVILLE, MD.
FOR
EXAMPLE SPECIAL DESIGNS FOR STILLING BASIN TECHNICAL RELEASE
JOAN FOR ESA - - - - - 3/18/74

DESIGN PARAMETERS

W = 20.00	D1 = 2.00	HTW1 = 0.0	HR = 10.00	GM = 120.0	MAXFTG = 10.00
J = 20.00	V1 = 36.00	HUP1 = 5.86	ZS = 3.00	GS = 140.0	FLOATR = 1.50
LR = 24.00	FROUDE = 20.12	HTW2 = 11.73	HTW = 4.00	KN = 0.800	SLIDER = 1.00
N = 14.00	D2 = 11.73	HUP2 = 11.73	TTW = 10.00	RAT = 0.375	CFSC = 0.35

DESIGN OF SPECIFIED TYPE SAF FOLLOWS

LTOT = 42.00	TYPE (B) STILLING BASIN - TRIAL VALUES			QFANT = 150.36
TT = 10.00	LS = 18.00	HS = 6.00	HV = 14.00	
	TVU = 16.30	TRB = 2.00	TRVU = 19.00	TRU = 21.00
	TVN = 14.90		TRVN = 17.00	TRN = 19.00
FTGU = 3.50	TSUP = 18.00	TSRGU = 22.00		
FTGD = 4.75		TSRGN = 20.00	TSDN = 20.00	

TT = 10.00	TYPE (B) STILLING BASIN - DETAIL DESIGN			QUANT = 150.36
	TVU = 16.30	TRB = 2.00	TRVU = 19.00	TRU = 21.00
	TVN = 14.90		TRVN = 17.00	TRN = 19.00
FTGU = 3.50	TSUP = 18.00	TSRGU = 22.00		
FTGD = 4.75		TSRGN = 20.00	TSDN = 20.00	

STEEL REQUIREMENTS

WALL

A(1) = 0.24	S(1) = 18.00	A(6) = 0.24	S(6) = 18.00
A(2) = 0.30	S(2) = 18.00	A(7) = 0.30	S(7) = 18.00
A(3) = 2.16	S(3) = 14.00	A(8) = 0.76	S(8) = 18.00
A(4) = 2.27	S(4) = 13.85	A(9) = 1.61	S(9) = 16.36
A(5) = 2.47	S(5) = 13.54	A(10) = 2.82	S(10) = 12.07

BASE

SECTION AT DOWNSTREAM END

A(11) = 0.24	S(11) = 18.00	A(17) = 0.48	S(17) = 18.00
A(12) = 0.24	S(12) = 18.00	A(18) = 0.24	S(18) = 18.00
A(13) = 0.24	S(13) = 18.00	A(19) = 0.48	S(19) = 18.00
A(14) = 0.24	S(14) = 18.00	A(20) = 0.24	S(20) = 18.00
A(15) = 0.24	S(15) = 18.00	A(21) = 0.73	S(21) = 18.00
A(16) = 0.24	S(16) = 18.00	A(22) = 0.24	S(22) = 18.00

SECTION AT DOWNSTREAM SIDE OF BREAK-IN-GRADE

A(23) = 0.24	S(23) = 18.00	A(29) = 0.48	S(29) = 18.00
A(24) = 0.24	S(24) = 18.00	A(30) = 1.90	S(30) = 18.00
A(25) = 0.24	S(25) = 18.00	A(31) = 0.48	S(31) = 18.00
A(26) = 0.24	S(26) = 18.00	A(32) = 0.78	S(32) = 18.00
A(27) = 0.45	S(27) = 18.00	A(33) = 0.48	S(33) = 18.00
A(28) = 0.24	S(28) = 18.00	A(34) = 0.41	S(34) = 18.00

SECTION AT UPSTREAM SIDE OF BREAK-IN-GRADE

A(35) = 0.26	S(35) = 18.00	A(41) = 0.53	S(41) = 18.00
A(36) = 0.26	S(36) = 18.00	A(42) = 1.92	S(42) = 18.00
A(37) = 0.26	S(37) = 18.00	A(43) = 0.53	S(43) = 18.00
A(38) = 0.26	S(38) = 18.00	A(44) = 0.97	S(44) = 18.00
A(39) = 0.26	S(39) = 18.00	A(45) = 0.53	S(45) = 18.00
A(40) = 0.26	S(40) = 18.00	A(46) = 0.64	S(46) = 18.00

SECTION AT UPSTREAM END

A(47) = 0.22	S(47) = 18.00	A(53) = 0.43	S(53) = 18.00
A(48) = 0.22	S(48) = 18.00	A(54) = 1.45	S(54) = 18.00
A(49) = 0.22	S(49) = 18.00	A(55) = 0.43	S(55) = 18.00
A(50) = 0.22	S(50) = 18.00	A(56) = 0.56	S(56) = 18.00
A(51) = 0.23	S(51) = 18.00	A(57) = 0.43	S(57) = 18.00
A(52) = 0.22	S(52) = 18.00	A(58) = 0.28	S(58) = 18.00

TWV = 12.00	WINGWALL DESIGN - TRIAL VALUES		RDN = 6.75
	TWF = 16.00	RUP = 15.00	

TWV = 12.00	WINGWALL DESIGN - DETAIL DESIGN		QUANT = 44.01
LEVEL = 12.04	WPROJ = 18.21	WVLR = 21.21	RDN = 6.75
			VWING = 52.84

STEEL REQUIREMENTS

AREA OF TIE = 3.24

SECTION AT ARTICULATION JOINT

A(1) = 0.29	S(1) = 18.00	A(4) = 0.58	S(4) = 18.00
A(2) = 0.14	S(2) = 18.00	A(5) = 1.75	S(5) = 18.00
A(3) = 1.17	S(3) = 17.99	A(6) = 2.39	S(6) = 18.00

SECTION AT UPPER THIRD POINT

A(7) = 0.29	S(7) = 18.00	A(10) = 0.34	S(10) = 18.00
A(8) = 0.14	S(8) = 18.00	A(11) = 1.11	S(11) = 19.00
A(9) = 0.35	S(9) = 18.00	A(12) = 1.58	S(12) = 18.00

SECTION AT LOWER THIRD POINT

A(13) = 0.29	S(13) = 18.00	A(16) = 0.19	S(16) = 18.00
A(14) = 0.14	S(14) = 18.00	A(17) = 0.51	S(17) = 18.00
A(15) = 0.14	S(15) = 18.00	A(18) = 0.75	S(18) = 18.00

----- END DETAIL DESIGN -----

Figure 56. Computer output, type (B) detail design

SAF STILLING BASIN
STRUCTURAL DESIGN
ELASTIC ANALYSIS AND WORKING STRESS DESIGN ARE USED

SPECIAL DESIGN PREPARED BY THE DESIGN UNIT AT HYATTSVILLE, MD.
FOR

EXAMPLE SPECIAL DESIGNS FOR STILLING BASIN TECHNICAL RELEASE
JOAN FOR ESA-----8/7/73

DESIGN PARAMETERS

W = 32.00	D1 = 2.00	HTW1 = 0.0	HR = 8.00	GM = 120.0	MAXFTG = 16.00
J = 18.00	V1 = 36.00	HUP1 = 0.0	ZS = 3.00	GS = 140.0	FLOATR = 1.50
LB = 16.00	FROUDE = 20.12	HTW2 = 11.73	HTW = 4.00	KO = 0.800	SLIDER = 1.00
N = 6.00	D2 = 11.73	HUP2 = 7.00	TTW = 10.00	RAT = 0.375	CFSC = 0.35

DESIGN OF SPECIFIED TYPE SAF FOLLOWS

TYPE (C) STILLING BASIN - TRIAL VALUES				QUANT=131.51
LTOT = 52.00	LS = 36.00	HS = 12.00	HV = 9.00	
X = 12.00	XP = 8.00			
	TPUP = 14.00	TPBG = 20.00	TPDN = 17.00	
TT = 10.00	TV = 10.50	TRB = 3.00	TBV = 11.00	TB = 14.00
FTG = 0.0	TSUP = 12.00	TSBG = 15.00	TSDN = 15.00	

TYPE (C) STILLING BASIN - DETAIL DESIGN				QUANT=133.59
X = 12.00	XP = 8.00			
	TPUP = 14.00	TPBG = 20.00	TPDN = 17.00	
TT = 10.00	TV = 10.50	TRB = 3.00	TBV = 11.00	TB = 14.00
FTG = 0.0	TSUP = 12.00	TSRG = 16.00	TSDN = 15.00	

STEEL REQUIREMENTS

WALL			
A(1) = 0.24	S(1) = 18.00	A(6) = 0.24	S(6) = 18.00
A(2) = 0.24	S(2) = 18.00	A(7) = 0.24	S(7) = 18.00
A(3) = 0.26	S(3) = 18.00	A(8) = 0.25	S(8) = 18.00
A(4) = 0.74	S(4) = 18.00	A(9) = 0.18	S(9) = 18.00
A(5) = 1.76	S(5) = 14.44	A(10) = 1.76	S(10) = 14.44
		A(0) = 0.46	S(0) = 18.00

BASE			
SECTION AT DOWNSTREAM END			
A(11) = 0.0	S(11) = 18.00	A(17) = 0.41	S(17) = 18.00
A(12) = 0.0	S(12) = 18.00	A(18) = 0.84	S(18) = 18.00
A(13) = 0.0	S(13) = 18.00	A(19) = 0.36	S(19) = 18.00
A(14) = 0.0	S(14) = 18.00	A(20) = 0.18	S(20) = 18.00
A(15) = 0.0	S(15) = 18.00	A(21) = 0.36	S(21) = 18.00
A(16) = 0.0	S(16) = 18.00	A(22) = 0.18	S(22) = 18.00
SECTION AT BREAK-IN-GRADE			
A(23) = 0.0	S(23) = 18.00	A(29) = 0.38	S(29) = 18.00
A(24) = 0.0	S(24) = 18.00	A(30) = 1.64	S(30) = 18.00
A(25) = 0.0	S(25) = 18.00	A(31) = 0.38	S(31) = 18.00
A(26) = 0.0	S(26) = 18.00	A(32) = 0.26	S(32) = 18.00
A(27) = 0.0	S(27) = 18.00	A(33) = 0.38	S(33) = 18.00
A(28) = 0.0	S(28) = 18.00	A(34) = 0.19	S(34) = 18.00
SECTION AT UPSTREAM END			
A(47) = 0.0	S(47) = 18.00	A(53) = 0.29	S(53) = 18.00
A(48) = 0.0	S(48) = 18.00	A(54) = 0.56	S(54) = 18.00
A(49) = 0.0	S(49) = 18.00	A(55) = 0.29	S(55) = 18.00
A(50) = 0.0	S(50) = 18.00	A(56) = 0.14	S(56) = 18.00
A(51) = 0.0	S(51) = 18.00	A(57) = 0.29	S(57) = 18.00
A(52) = 0.0	S(52) = 18.00	A(58) = 0.14	S(58) = 18.00
PAVEMENT SLAB			
A(59) = 0.41	S(59) = 18.00	A(60) = 0.20	S(60) = 18.00
A(61) = 0.44	S(61) = 18.00	A(62) = 0.22	S(62) = 18.00
A(63) = 0.86	S(63) = 18.00	A(64) = 0.24	S(64) = 18.00
A(65) = 0.58	S(65) = 18.00	A(66) = 0.20	S(66) = 18.00
A(67) = 0.34	S(67) = 18.00	A(68) = 0.17	S(68) = 18.00

WINGWALL DESIGN - TRIAL VALUES			
TTW = 10.00	TVF = 11.00	BUP = 10.50	BDN = 6.00

WINGWALL DESIGN - DETAIL DESIGN				QUANT = 27.92
TTW = 10.00	TVF = 11.00	BUP = 10.50	BDN = 6.00	
LEVEL = 7.78	WPROJ = 16.39	WVLB = 15.11	VWING = 27.92	

STEEL REQUIREMENTS

AREA OF TIE = 1.99			
SECTION AT ARTICULATION JOINT			
A(1) = 0.24	S(1) = 18.00	A(4) = 0.39	S(4) = 18.00
A(2) = 0.12	S(2) = 18.00	A(5) = 1.15	S(5) = 18.00
A(3) = 0.66	S(3) = 18.00	A(6) = 1.52	S(6) = 18.00
SECTION AT UPPER THIRD POINT			
A(7) = 0.24	S(7) = 18.00	A(10) = 0.25	S(10) = 18.00
A(8) = 0.12	S(8) = 18.00	A(11) = 0.78	S(11) = 18.00
A(9) = 0.20	S(9) = 18.00	A(12) = 1.08	S(12) = 18.00
SECTION AT LOWER THIRD POINT			
A(13) = 0.24	S(13) = 18.00	A(16) = 0.13	S(16) = 18.00
A(14) = 0.12	S(14) = 18.00	A(17) = 0.35	S(17) = 18.00
A(15) = 0.12	S(15) = 18.00	A(18) = 0.50	S(18) = 18.00

----- END DETAIL DESIGN -----

Figure 57. Computer output, type (C) detail design

Appendix

Toewall Thickness and Steel for SAF Stilling Basins

The thickness of the basin toewall, TTW, and the depth of the toewall, HTW, are secondary parameters whose default values are 10.0 inches and 4.0 feet, respectively. Occasionally it may be desirable to increase one or both of these values. The vertical steel in the front face of the toewall must satisfy T and S requirements. It must also be able to resist the cantilever bending that might be induced by passive resistance of the channel material downstream of the toewall.

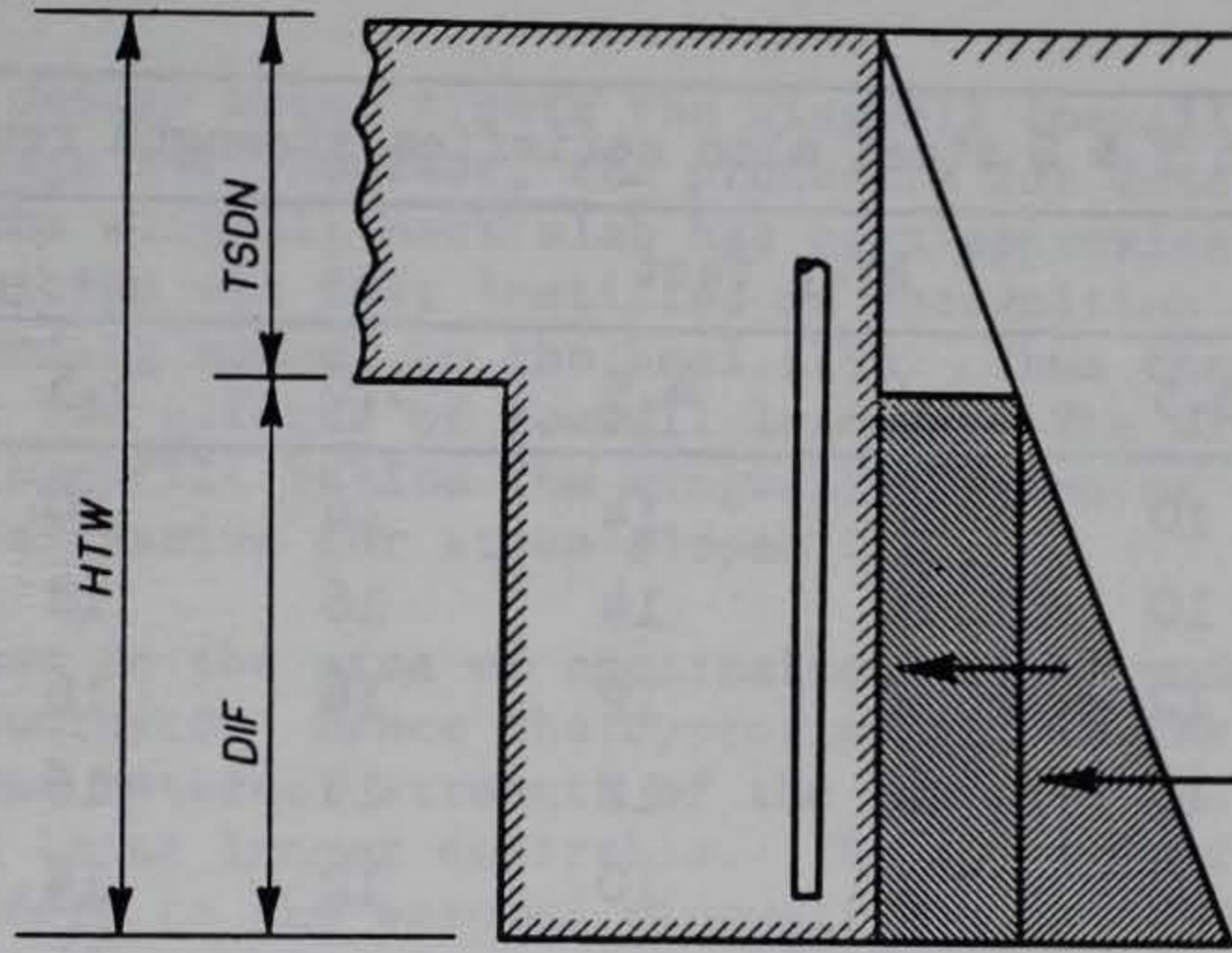

The thickness, TTW, and required vertical steel may be determined from the following analysis. Let

$KP \equiv$ passive lateral earth pressure ratio

$DIF = HTW - TSDN/12$, in ft

$V \equiv$ shear at face of support, in lbs per ft

$M \equiv$ moment at face of support, in ft lbs per ft

other nomenclature as previously defined.

Assume passive earth pressure against the downstream side of the toewall and zero earth pressure against the upstream side. Neglect water pressures on both sides and use moist unit soil weight. Then

$$V = KP \times GM \times DIF \times (TSDN/12 + DIF/2)$$

$$M = KP \times GM \times DIF \times (TSDN/24 + DIF/3) \times DIF$$

The minimum thicknesses, in inches, for shear and moment are

$$TS = V/840. + 2.5$$

$$TM = (0.003683 \times M)^{1/2} + 2.5$$

With TTW selected, the maximum steel spacing and minimum steel areas are

$$S = 10015 \times (\text{TTW} - 2.5)/V \leq 18.$$

$$A \approx 0.0006 \times M / (0.88 \times (\text{TTW} - 2.5)) \geq 0.024 \times \text{TTW}$$

at the critical section.

On taking, $KP = 2.0$ and $GM = 120$. pcf, analyses show that $\text{TTW} = 10.0$ inches provides adequate strength for all $\text{HTW} \leq 6.0$ ft. However, for the higher DIF values, required steel becomes excessive. An alternative approach is to select TTW so that steel required for T and S also satisfies strength requirements. The accompanying table accomplishes this by listing the minimum TTW for various combinations of HTW and TSDN .

Minimum TTW for which T & S steel also satisfies strength requirements							
TSDN inches	HTW, feet						
	3.0	3.5	4.0	4.5	5.0	5.5	6.0
10	10	10	12	14	16	20	22
16	10	10	10	14	16	18	20
20	10	10	10	12	14	16	20
24	10	10	10	12	14	16	18
28	10	10	10	10	12	14	18
32	10	10	10	10	12	14	16
36	--	10	10	10	10	12	14
40	--	10	10	10	10	10	14
44	--	--	10	10	10	10	12
48	--	--	--	10	10	10	10

$KP = 2.0$ $GM = 120$. pcf A for T & S = $0.024 \times \text{TTW}$



September 14, 1981

TECHNICAL RELEASE NOTICE 54-1

The principal purpose of this technical release notice is to update the wingwall design procedure contained in TR-54 by removing a previously existing conservative approximation.

The wingwall design model treats the wingwall toewall as non-existent, reference TR-54, page 44. However, the procedure for determining the required internal strength of the wingwall heel slab has been approximate, on the conservative side. This approximation was felt justified on recognition that the toewall might actually bring some bending moment to the heel slab. Thus the approximation provided an allowance for the effects of toewall loading. The allowance increased with increasing slope of backfill behind the wingwall, beginning at zero for horizontal slopes and becoming excessive for steep slopes.

With extensions to the area of application of the model, steep slopes are more commonly encountered. Hence the approximation in the moment summation for determining required internal strength of the wingwall heel slab tends to be too conservative and is no longer desirable. The approximation is now removed. The computations conform to the assumed wingwall design model, that is, an L-shaped wall retaining various combinations of backfill slope.

If a designer feels it desirable to include additional moment strength in the heel slab to resist toewall loading, that strength must be added overtly. Conditions which might occur over the life of the structure would need consideration.

Pages 49/50, 51/-, 59/60, and 61/62 should be removed from current copies of TR-54 and the enclosed four sheets should be inserted.

for Clout Basing

NEIL F. BOGNER
Acting Director of Engineering

Enclosure



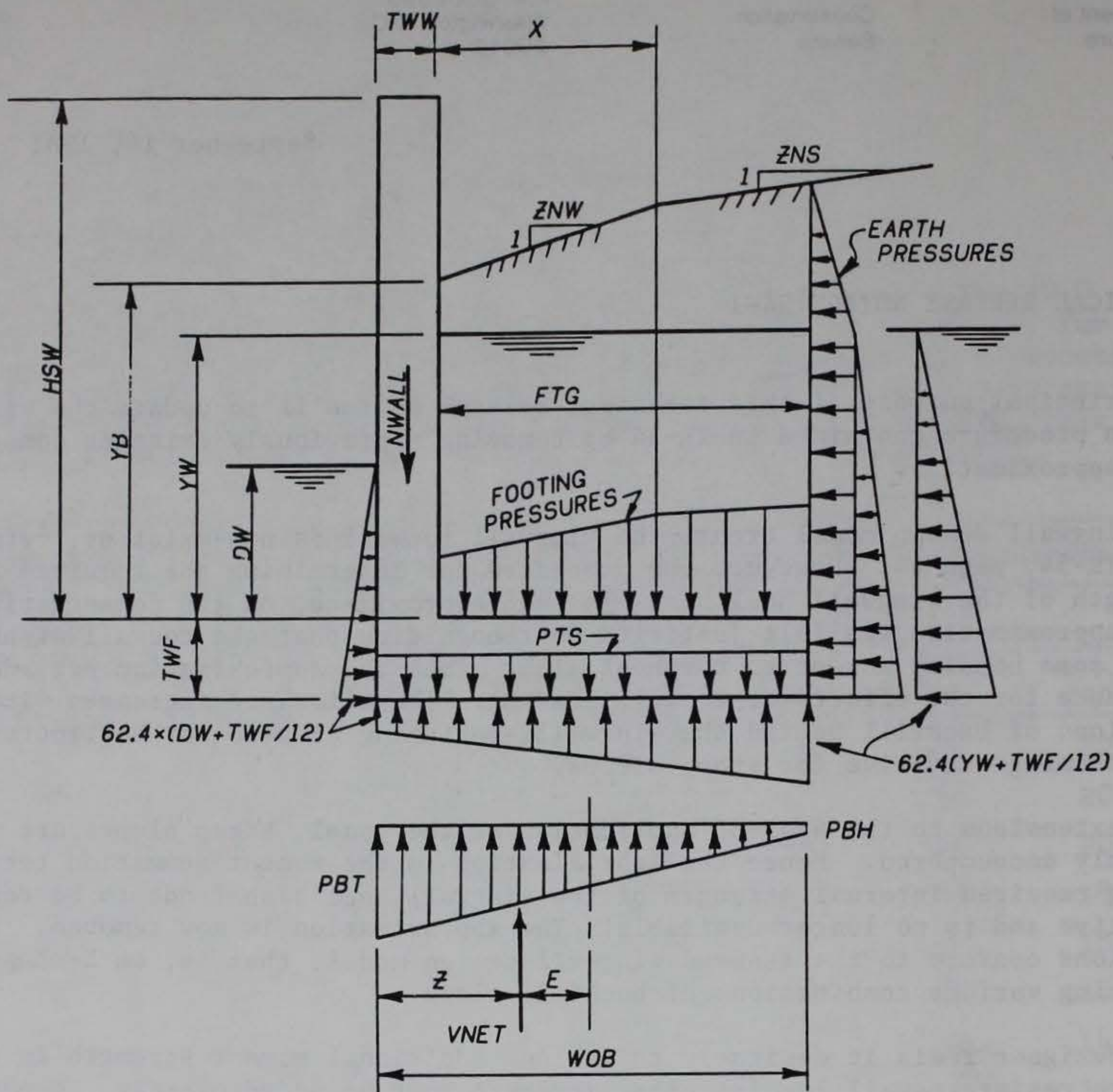

Figure 39. Wingwall overturning and bearing

trial. If VNET is located within the middle third of the base, the section is safe against overturning and the contact bearing pressures, PBT and PBH, are computed in the usual way. If the higher pressure exceeds the allowable value, taken as

$$P_{ALLOW} = 2000 + GB \times (YB + TWF/12)$$

FTG is again incremented. Each trial recycles the footing design back to the first load condition for the section under investigation.

When bearing pressure requirements are satisfied, footing thickness required for moment is determined. If the required thickness is more than the actual thickness, TWF is incremented and the footing design is recycled starting at the first location, (section 1 of Figure 38) and the first load condition. Analyses have shown that shear seldom controls footing thickness in these wingwalls. Hence the thickness required for shear is

only checked, and the design recycled if necessary, in detail design.

Sliding. The basin proper is designed to satisfy longitudinal sliding requirements, by itself. Therefore, no additional sliding force should be brought to the basin by the wingwalls. This means the wingwalls should be adequate themselves to resist sliding in the longitudinal direction of the basin. (Any tendency of the wingwall to slide in a transverse direction, toward the center of the channel, is resisted by the wingwall-to-basin tie discussed in the next section.) Let the resultant horizontal driving force normal to the sidewall be FSLIDE, see Figure 40. This force is obtained by summing, over the length of the sidewall, the net horizontal forces per unit length, HNET, at each of

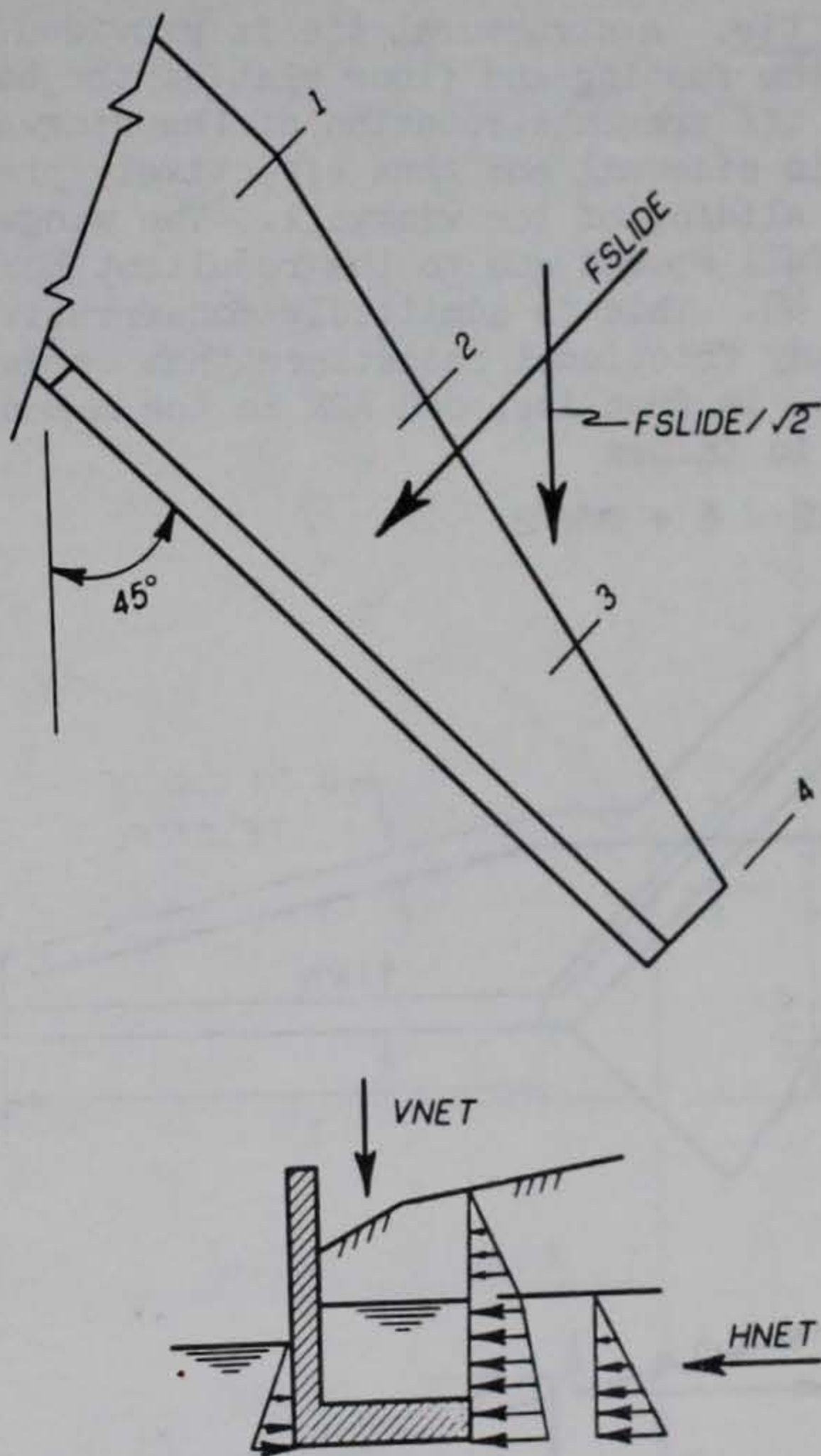

Figure 40. Longitudinal sliding of wingwall

the four sections. HNET is obtained from the indicated horizontal forces, for a particular section and load condition. Thus

$$FSLIDE = (HNET1/2 + HNET2 + HNET3 + HNET4/2) \times (J - 1)/3.$$

Similarly, if VWING is the resultant vertical force on the wingwall, and VNET is the resultant per unit length, then

$$VWING = (VNET1/2 + VNET2 + VNET3 + VNET4/2) \times (J - 1)/3.$$

The longitudinal component of FSLIDE is $FSLIDE/\sqrt{2}$. To adequately resist sliding, the wingwall must satisfy the relation

$$\frac{1.4142 \times VWING \times CFSC}{FSLIDE} \geq SLIDER$$

for each load condition of Figure 36.

If the above relation is not satisfied for any load condition, BUP and BDN are incremented equally. The design is recycled to the start of the overturning analysis with the new footing projection values. This is necessary because the wingwall footing thickness, TWF, may require incrementing with the larger footing projections.

Wingwall-to-basin tie. A structural tie is provided between the wingwall footing and the footing and floor slab of the basin proper. This wingwall-to-basin tie prevents rotation of the wingwall about its junction with the basin sidewall and thus effectively prevents any possibility of transverse sliding of the wingwall. The wingwall-to-basin tie is designed for the full moment due to the resultant horizontal force, FSLIDE, of Figure 40. This is admittedly conservative in that it completely neglects any frictional resistance that is developed. Let MTIE be the full moment, in foot lbs, and ARM be the moment arm shown in Figure 41. Then, in inches

$$ARM = BUP \times 12 - 6 + TWW/2$$

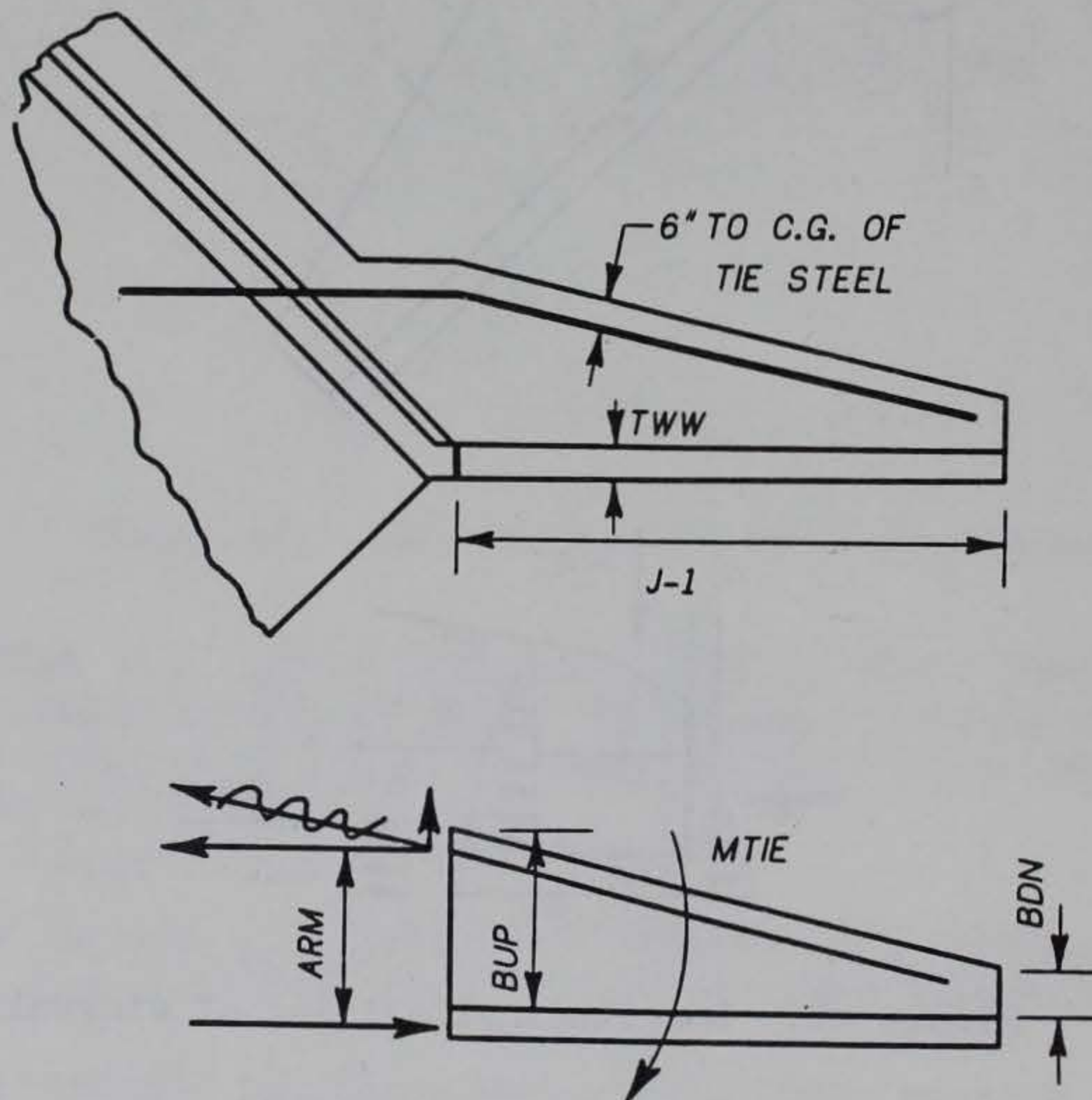

Figure 41. Wingwall-to-basin tie steel area and the required area of the tie steel, in sq. in., just downstream of the section through the articulation joint is approximately

$$ATIE = \frac{MTIE \times 12}{20,000 \times ARM} \times \frac{((J - 1)^2 + (BUP - BDN)^2)^{1/2}}{(J - 1)}$$

(TR Notice 54-1, September 1981)

only in T and S amounts.

Determination of the steel requirements at point a, b, or c in any section necessitates the evaluation of the force system MZ, NZ, and VZ shown in Figure 49 where Z is the distance from the top of the section down to the point in question. Possible cases of DW, YW, and YB are illustrated from which MZ, NZ, and VZ are computed for a particular load condition. At interior sections where $X > (J - DW)$, the water depths, YW and DW, are equal and exceed the height of the section, HSW. All five load conditions of Figure 36 are investigated to determine maximum requirements.

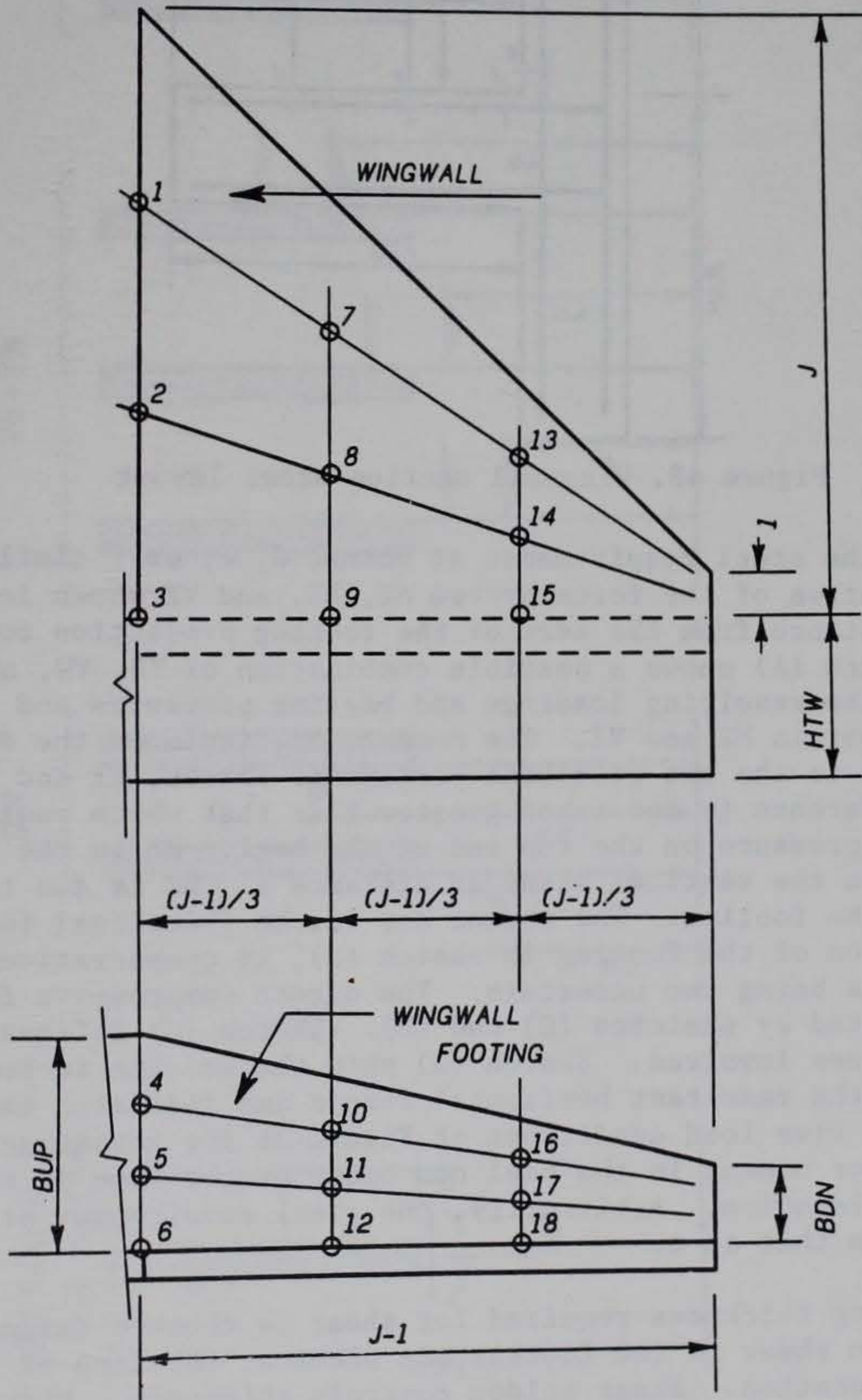

Figure 47. Wingwall steel point locations

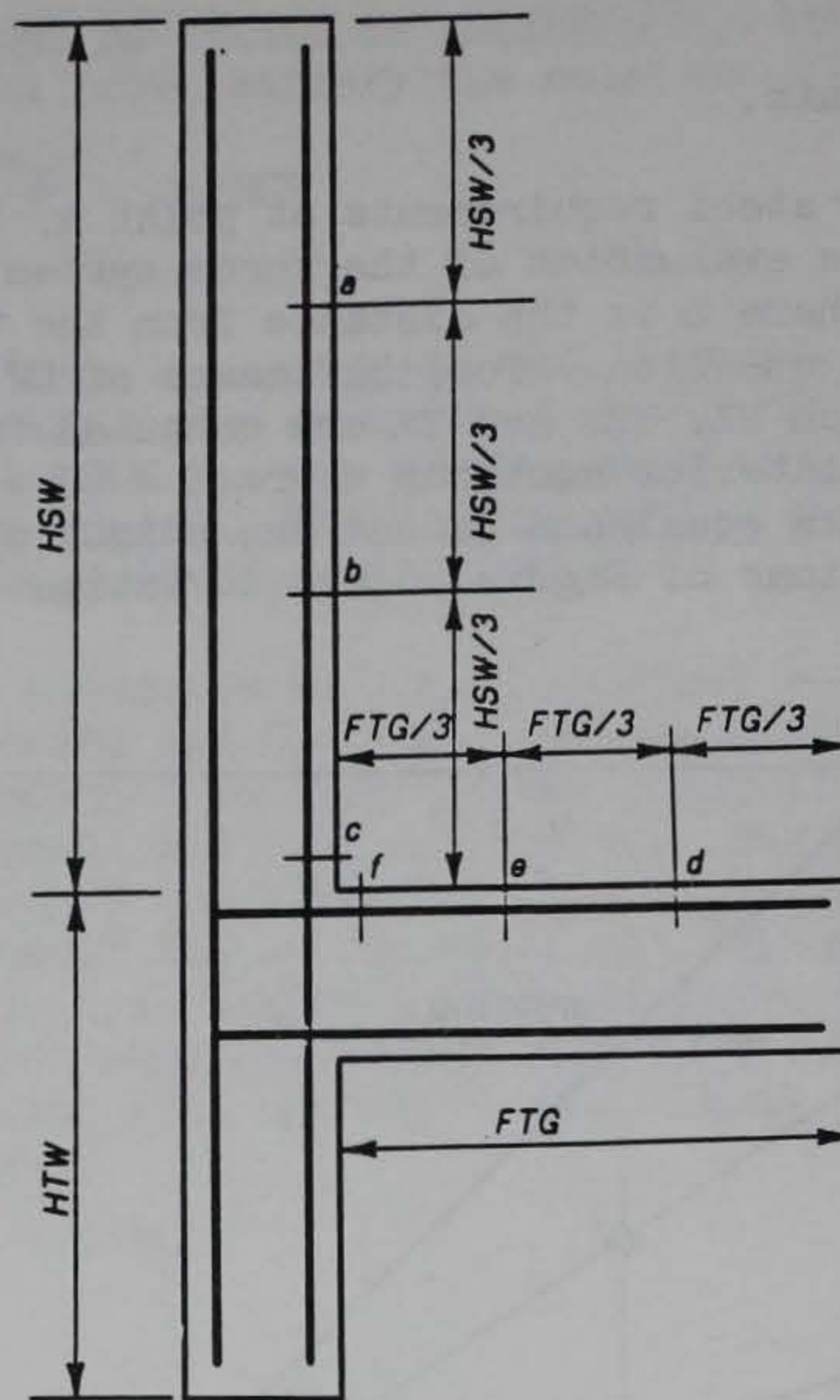

Figure 48. Wingwall section steel layout

Determination of the steel requirements at point, d, e, or f similarly necessitates the evaluation of the force system MZ , NZ , and VZ shown in Figure 50 where Z is the distance from the edge of the footing projection to the point in question. Sketch (A) shows a possible combination of YB , YW , and DW . Sketch (B) shows the resulting loadings and bearing pressures and indicates the summation to obtain MZ and VZ . The moment, MZ , includes the difference in the moments due to the two resultant horizontal forces, $H1$ and $H2$, shown. However, this difference is not taken greater than that which would just produce zero footing pressure on the top end of the heel. $H2$ is the resultant horizontal force on the vertical plane at distance Z . $H2$ is due to the material above the top of the footing. The moment due to the frictional force assumed acting on the bottom of the footing in sketch (D), is conservatively neglected in the summation as being too uncertain. The direct compressive force, NZ , is obtained as suggested by sketches (C) and (D). Sketch (C) defines the resultant horizontal forces involved. Sketch (D) puts the section in horizontal equilibrium using the resultant horizontal forces and indicates the summation to obtain NZ . All five load conditions of Figure 36 are investigated. The critical section for moment in the heel can occur at the face of the wingwall or at an interior location. Arbitrarily, the steel requirement at point f is not taken less than that at e.

The wingwall footing thickness required for shear is checked during these computations. Maximum shear in the footing can occur at the face of the wall or at some interior location. Shear seldom controls thickness. When it does, the thickness is incremented and the footing steel design is begun again.

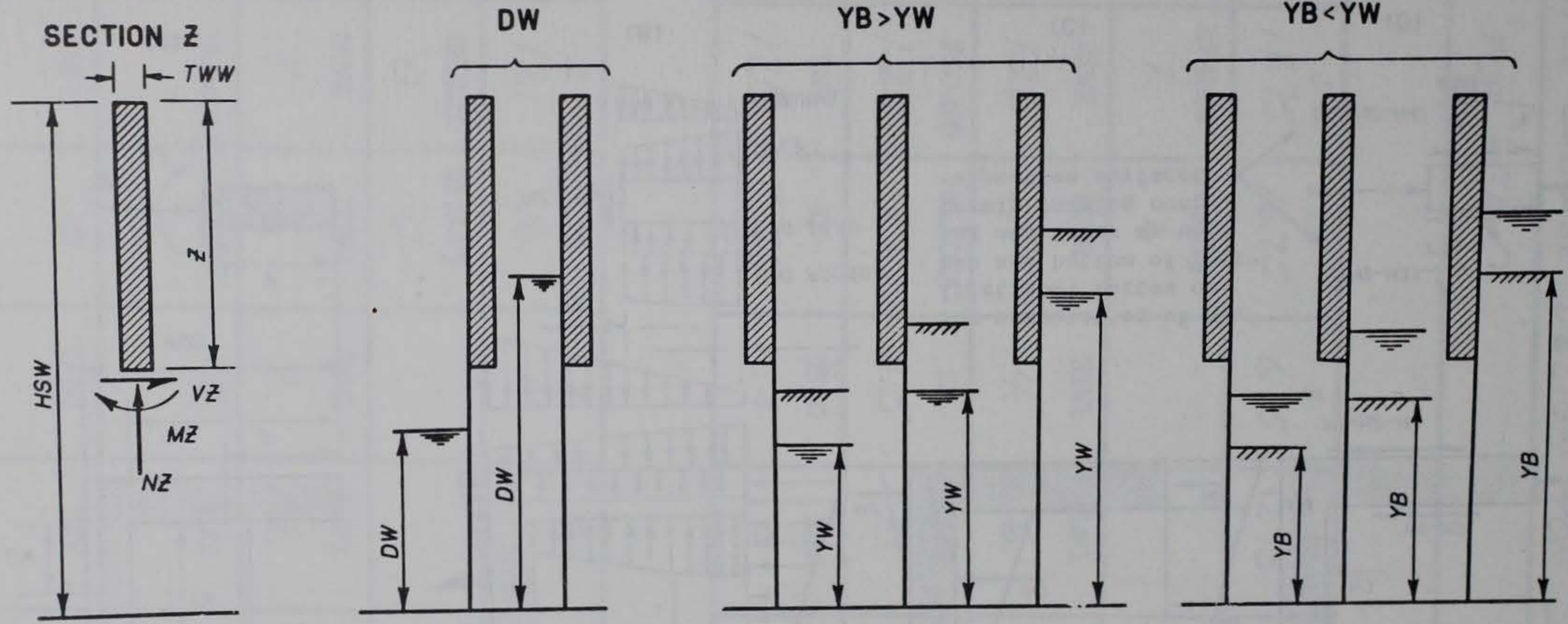

Figure 49. Determination of the force system at a point in wingwall

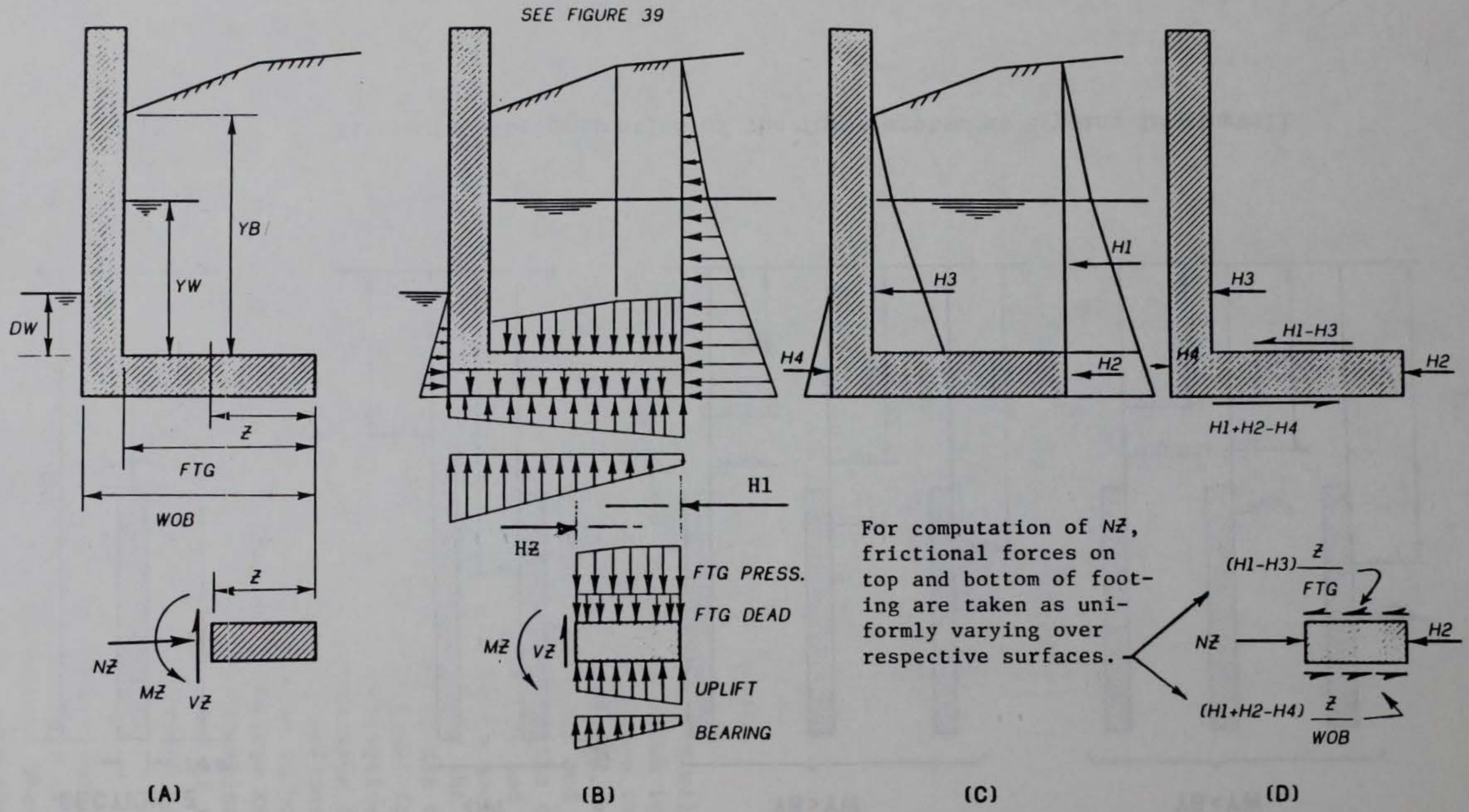

Figure 50. Determination of the force system in wingwall footing

EXAMPLE SPECIAL DESIGN FOR STILLING BASINS

JOAN FOR ESA

MARCH 15, 1983

W 20.	J 18.75	LB 16.75	N 6.75	D1 1.75	V1 50.	DESIGN 0.	DFALTS 1.
DFALT1 1.	DFALT2 1.	DFALT3 1.					
HB 7.	HTW2 13.5	HUP2 11.	HTW1 4.	HUP1 6.			
MAXFTG 10.	FLOATR 1.25	SLIDER 1.1	ZS 2.5	BAT 0.			
GM 110.	GS 120.	KO 0.75	CFSC 0.4	HTW 4.	TTW 12.		

W 20.	J 12.	LB 16.	N 4.	D1 1.	V1 35.	DESIGN 0.	DFALTS 1.
DFALT1 1.	DFALT2 0.	DFALT3 0.					
HB 5.	HTW2 8.	HUP2 6.	HTW1 2.	HUP1 4.			
MAXFTG	FLOATR	SLIDER	ZS	BAT			
GM	GS	KO	CFSC	HTW	TTW		

ALPHAMERIC INFORMATION

SAF (TR-54)

W	J	LB	N	D1	V1	DESIGN	DFALTS
40.	12.	10.	6.	1.	45.	1.	1.
DFALT1	DFALT2	DFALT3					
1.	1.	1.					
HB	HTW2	HUP2	HTW1	HUP1			
2.67	9.	5.	4.	4.			
MAXFTG	FLOATR	SLIDER	ZS	BAT			
8.	1.2	1.	3.	0.25			
GM	GS	KO	CFSC	HTW	TTW		
105.	120.	0.667	0.35	4.	10.		

W	J	LB	N	D1	V1	DESIGN	DFALTS
20.	20.	24.	14.	2.	36.	2.	1.
DFALT1	DFALT2	DFALT3					
1.	0.	0.					
HB	HTW2	HUP2	HTW1	HUP1			
10.	11.73	11.73	0.	5.86			
MAXFTG	FLOATR	SLIDER	ZS	BAT			
GM	GS	KO	CFSC	HTW	TTW		

ALPHABETIC INFORMATION

SAF (TR-54)

W 32.	J 18.	LB 16.	N 6.	D1 2.	V1 36.	DESIGN 3.	DFALTS 1.
DFALT1 1.	DFALT2 0.	DFALT3 0.					
HB 8.	HTW2 11.73	HUP2 7.	HTW1 0.	HUP1 0.			
MAXFTG	FLOATR	SLIDER	ZS	BAT			
GM	GS	KO	CFSC	HTW	TTW		

W	J	LB	N	D1	V1	DESIGN	DFALTS
DFALT1	DFALT2	DFALT3					
HB	HTW2	HUP2	HTW1	HUP1			
MAXFTG	FLOATR	SLIDER	ZS	BAT			
GM	GS	KO	CFSC	HTW	TTW		

EXECUTION DATE: 03/18/83
REVISION DATE: 09/01/82

SAF STILLING BASIN
STRUCTURAL DESIGN
ELASTIC ANALYSIS AND WORKING STRESS DESIGN ARE USED

SPECIAL DESIGN PREPARED BY
DESIGN UNIT, ENGINEERING, LANHAM, MARYLAND
FOR

EXAMPLE SAMPLE DESIGN FOR STILLING BASINS
JOAN FOR ESA ----- MARCH 15, 1983

DESIGN PARAMETERS

W = 20.00	D1 = 1.75	HTW1= 4.00	HB = 7.00	GM =110.0	MAXFTG=10.00
J = 18.75	V1 = 50.00	HUP1= 6.00	ZS = 2.50	GS =120.0	FLOATR= 1.25
LB= 16.75	FROUDE= 44.37	HTW2=13.50	HTW= 4.00	KO = 0.750	SLIDER= 1.10
N = 6.75	D2 = 15.63	HUP2=11.00	TTW=12.00	BAT= 0.0	CFSC = 0.40

PRELIMINARY DESIGNS FOLLOW

TYPE (A) STILLING BASIN - TRIAL VALUES					QUANT= 119.43
LTOT= 45.45	LN= 2.51	HN= 6.27	HV= 9.38		
LBOT= 47.96	LS= 31.21	HS= 12.48			
TT= 10.00	TV= 12.50	TBB= 0.0	TBV= 15.00	TB= 15.00	
FTG= 3.00	TSUP= 13.00	TSBG= 16.00	TSDN= 16.00		
ASSOCIATED WINGWALL					QUANT= 27.19

TYPE (B) STILLING BASIN - TRIAL VALUES					QUANT= 135.22
LTOT= 46.75	LS= 30.00	HS= 12.00	HV= 9.38		
TT= 10.00	TVU= 12.50	TBB= 0.0	TBVU= 15.00	TBU= 15.00	
	TVD= 12.50		TRVD= 15.00	TBD= 15.00	
FTGU= 4.00	TSUP= 13.00	TSBGU= 22.00			
FTGD= 4.75		TSBGD= 22.00	TSDN= 16.00		
ASSOCIATED WINGWALL					QUANT= 25.70

TYPE (C) STILLING BASIN - TRIAL VALUES					QUANT= 119.59
LTOT= 46.75	LS= 30.00	HS= 12.00	HV= 9.38		
X= 10.00	XP= 0.0				
	TPUP= 50.00	TPBG= 88.00	TPDN= 69.00		
TT= 10.00	TV= 12.50	TBB= 0.0	TBV= 15.00	TB= 15.00	
FTG= 3.00	TSUP= 14.00	TSBG= 17.00	TSDN= 16.00		
ASSOCIATED WINGWALL					QUANT= 27.19

WINGWALL DESIGN - TRIAL VALUES			
TWW= 10.00	TWF= 10.00	BUP= 12.50	BDN= 3.50

===== END PRELIMINARY DESIGNS =====
WINGWALL PER TRNOTICE 54-1

EXECUTION DATE: 03/18/83
REVISION DATE: 09/01/82

SAF-1

SAF STILLING BASIN
STRUCTURAL DESIGN
ELASTIC ANALYSIS AND WORKING STRESS DESIGN ARE USED

EXAMPLE SAMPLE DESIGN FOR STILLING BASINS
 JOAN FOR ESA ----- MARCH 15, 1983

20.	18.75	16.75	6.75	1.75	50.	0.	1.
1.	1.	1.					
7.	13.5	11.0	4.	6.			
10.	1.25	1.1	2.5	0.			
110.	120.	0.75	0.4	4.	12.		
20.	12.	16.	4.	1.	35.	0.	1.
1.	0.	0.					
5.	8.	6.	2.	4.			
40.	12.	10.	6.	1.	45.	1.	1.
1.	1.	1.					
2.67	9.	5.	4.	4.			
8.	1.2	1.	3.	0.25			
105.	120.	0.667	0.35	4.	10.		
20.	20.	24.	14.	2.	36.	2.	1.
1.	0.	0.					
10.	11.73	11.73	0.	5.86			
32.	18.	16.	6.	2.	36.	3.	1.
1.	0.	0.					
8.	11.73	7.	0.	0.			
(1)	(10) (11)	(20) (21)	(30) (31)	(40) (41)	(50) (51)	(60) (61)	(70) (71)

SPECIAL DESIGN PREPARED BY
 DESIGN UNIT, ENGINEERING, LANHAM, MARYLAND
 FOR

EXAMPLE SAMPLE DESIGN FOR STILLING BASINS
 JOAN FOR ESA ----- MARCH 15, 1983

DESIGN PARAMETERS

W = 20.00	D1 = 1.00	HTW1= 2.00	HB = 5.00	GM =120.0	MAXFTG=10.00
J = 12.00	V1 = 35.00	HUP1= 4.00	ZS = 3.00	GS =140.0	FLOATR= 1.50
LB= 16.00	FROUDE= 38.04	HTW2= 8.00	HTW= 4.00	KO = 0.800	SLIDER= 1.00
N = 4.00	D2 = 8.24	HUP2= 6.00	TTW=10.00	BAT= 0.375	CFSC = 0.35

PRELIMINARY DESIGNS FOLLOW

TYPE (A) STILLING BASIN - TRIAL VALUES					QUANT= 63.91
LTOT= 39.35	LN= 1.26	HN= 3.79	HV= 6.00		
LBOT= 40.62	LS= 24.62	HS= 8.21			
TT= 10.00	TV= 10.00	TBB= 2.00	TBV= 10.00	TB= 12.00	
FTG= 1.00	TSUP= 11.00	TSBG= 13.00	TSDN= 13.00		
ASSOCIATED WINGWALL					QUANT= 12.66

TYPE (B) STILLING BASIN - TRIAL VALUES					QUANT= 66.83
LTOT= 40.00	LS= 24.00	HS= 8.00	HV= 6.00		
TT= 10.00	TVU= 10.00	TBB= 2.00	TBVU= 10.00	TBU= 12.00	
	TVD= 10.00		TBVD= 10.00	TBD= 12.00	
FTGU= 1.00	TSUP= 11.00	TSBGU= 14.00			
FTGD= 3.00		TSBGD= 14.00	TSDN= 13.00		
ASSOCIATED WINGWALL					QUANT= 11.46

TYPE (C) STILLING BASIN - TRIAL VALUES					QUANT= 62.70
LTOT= 40.00	LS= 24.00	HS= 8.00	HV= 6.00		
X= 10.00	XP= 0.0				
	TPUP= 24.00	TPBG= 50.00	TPDN= 37.00		
TT= 10.00	TV= 10.00	TBB= 2.00	TBV= 10.00	TB= 12.00	
FTG= 1.00	TSUP= 11.00	TSBG= 13.00	TSDN= 13.00		
ASSOCIATED WINGWALL					QUANT= 12.66

WINGWALL DESIGN - TRIAL VALUES			
TWW= 10.00	TWF= 10.00	BUP= 8.00	BDN= 3.50

===== END PRELIMINARY DESIGNS =====
 WINGWALL PER TRNOTICE 54-1

EXECUTION DATE: 03/18/83
 REVISION DATE: 09/01/82

SAF STILLING BASIN
 STRUCTURAL DESIGN
 ELASTIC ANALYSIS AND WORKING STRESS DESIGN ARE USED

SPECIAL DESIGN PREPARED BY
 DESIGN UNIT, ENGINEERING, LANHAM, MARYLAND
 FOR

EXAMPLE SAMPLE DESIGN FOR STILLING BASINS
 JOAN FOR ESA ----- MARCH 15, 1983

SAF-2

DESIGN PARAMETERS

W = 40.00	D1 = 1.00	HTW1= 4.00	HB = 2.67	GM =105.0	MAXFTG= 8.00
J = 12.00	V1 = 45.00	HUP1= 4.00	ZS = 3.00	GS =120.0	FLOATR= 1.20
LB= 10.00	FROUDE= 62.89	HTW2= 9.00	HTW= 4.00	KO = 0.667	SLIDER= 1.00
N = 6.00	D2 = 10.73	HUP2= 5.00	TTW=10.00	BAT= 0.250	CFSC = 0.35

DESIGN OF SPECIFIED TYPE SAF FOLLOWS

TYPE (A) STILLING BASIN - TRIAL VALUES		QUANT= 86.79
LTOP= 27.03	LN= 1.90	HN= 5.69
LBOT= 28.92	LS= 18.92	HS= 6.31
TT= 10.00	TV= 10.00	TBB= 2.00
FTG= 1.00	TSUP= 15.00	TSBG= 18.00
		HV= 6.00
		TBV= 10.00
		TSDN= 14.00
		TB= 12.00

TYPE (A) STILLING BASIN - DETAIL DESIGN		QUANT= 86.79
TT= 10.00	TV= 10.00	TBB= 2.00
FTG= 1.00	TSUP= 15.00	TSBG= 18.00
		HV= 6.00
		TBV= 10.00
		TSDN= 14.00
		TB= 12.00

STEEL REQUIREMENTS

WALL

A(1)= 0.24	S(1)= 18.00	A(6)= 0.24	S(6)= 18.00
A(2)= 0.24	S(2)= 18.00	A(7)= 0.24	S(7)= 18.00
A(3)= 0.24	S(3)= 18.00	A(8)= 0.24	S(8)= 18.00
A(4)= 0.27	S(4)= 18.00	A(9)= 0.27	S(9)= 18.00
A(5)= 0.58	S(5)= 18.00	A(10)= 0.58	S(10)= 18.00
		A(0)= 0.49	S(0)= 18.00

BASE

SECTION AT DOWNSTREAM END

A(11)= 0.17	S(11)= 18.00	A(17)= 0.45	S(17)= 18.00
A(12)= 0.17	S(12)= 18.00	A(18)= 0.17	S(18)= 18.00
A(13)= 0.17	S(13)= 18.00	A(19)= 0.95	S(19)= 18.00
A(14)= 0.17	S(14)= 18.00	A(20)= 1.16	S(20)= 18.00
A(15)= 0.17	S(15)= 18.00	A(21)= 1.27	S(21)= 18.00
A(16)= 0.17	S(16)= 18.00	A(22)= 1.69	S(22)= 18.00

SECTION AT BREAK-IN-GRADE

A(23)= 0.22	S(23)= 18.00	A(29)= 0.43	S(29)= 18.00
A(24)= 0.22	S(24)= 18.00	A(30)= 0.22	S(30)= 18.00
A(25)= 0.22	S(25)= 18.00	A(31)= 1.79	S(31)= 18.00
A(26)= 0.22	S(26)= 18.00	A(32)= 0.22	S(32)= 18.00
A(27)= 0.22	S(27)= 18.00	A(33)= 2.48	S(33)= 18.00
A(28)= 0.22	S(28)= 18.00	A(34)= 0.22	S(34)= 18.00

SECTION AT UPSTREAM END

A(47)= 0.18	S(47)= 18.00	A(53)= 0.36	S(53)= 18.00
A(48)= 0.18	S(48)= 18.00	A(54)= 0.18	S(54)= 18.00
A(49)= 0.18	S(49)= 18.00	A(55)= 0.36	S(55)= 18.00
A(50)= 0.18	S(50)= 18.00	A(56)= 1.08	S(56)= 18.00
A(51)= 0.18	S(51)= 18.00	A(57)= 0.45	S(57)= 18.00
A(52)= 0.18	S(52)= 18.00	A(58)= 1.40	S(58)= 18.00

WINGWALL DESIGN - TRIAL VALUES

TWW= 10.00	TWF= 10.00	BUP= 7.50	BDN= 1.50
------------	------------	-----------	-----------

WINGWALL DESIGN - DETAIL DESIGN

TWW= 10.00	TWF= 10.00	BUP= 7.50	BDN= 1.50	QUANT= 11.60
LEVEL= 7.07	WPROJ= 9.01	WWLB= 10.95	VWING= 12.25	

STEEL REQUIREMENTS

AREA OF TIE= 0.15

SECTION AT ARTICULATION JOINT

A(1)= 0.24	S(1)= 18.00	A(4)= 0.12	S(4)= 18.00
A(2)= 0.24	S(2)= 18.00	A(5)= 0.13	S(5)= 18.00
A(3)= 0.12	S(3)= 18.00	A(6)= 0.13	S(6)= 18.00

SECTION AT UPPER THIRD POINT

A(7)= 0.24	S(7)= 18.00	A(10)= 0.12	S(10)= 18.00
A(8)= 0.24	S(8)= 18.00	A(11)= 0.12	S(11)= 18.00
A(9)= 0.12	S(9)= 18.00	A(12)= 0.12	S(12)= 18.00

SECTION AT LOWER THIRD POINT

A(13)= 0.24	S(13)= 18.00	A(16)= 0.12	S(16)= 18.00
A(14)= 0.12	S(14)= 18.00	A(17)= 0.12	S(17)= 18.00
A(15)= 0.12	S(15)= 18.00	A(18)= 0.12	S(18)= 18.00

SAF-3

EXECUTION DATE: 03/18/83
 REVISION DATE: 09/01/82

SAF STILLING BASIN
 STRUCTURAL DESIGN
 ELASTIC ANALYSIS AND WORKING STRESS DESIGN ARE USED

SPECIAL DESIGN PREPARED BY
 DESIGN UNIT, ENGINEERING, LANHAM, MARYLAND
 FOR

EXAMPLE SAMPLE DESIGN FOR STILLING BASINS
 JOAN FOR ESA ----- MARCH 15, 1983

DESIGN PARAMETERS

W = 20.00	D1 = 2.00	HTW1= 0.0	HB =10.00	GM =120.0	MAXFTG=10.00
J = 20.00	V1 = 36.00	HUP1= 5.86	ZS = 3.00	GS =140.0	FLCATR= 1.50
LB= 24.00	FROUDE= 20.12	HTW2=11.73	HTW= 4.00	KO = 0.800	SLIDER= 1.00
N = 14.00	D2 = 11.73	HUP2=11.73	TTW=10.00	BAT= 0.375	CFSC = 0.35

DESIGN OF SPECIFIED TYPE SAF FOLLOWS

TYPE (B) STILLING BASIN - TRIAL VALUES				QUANT= 150.36
LTOT= 42.00	LS= 18.00	HS= 6.00	HV= 14.00	
TT= 10.00	TVU= 16.30	TBB= 2.00	TBVU= 19.00	TBU= 21.00
	TVD= 14.90		TBVD= 17.00	TBD= 19.00
FTGU= 3.50	TSUP= 18.00	TSBGU= 22.00		
FTGD= 4.75		TSBGD= 20.00	TSDN= 20.00	

TYPE (B) STILLING BASIN - DETAIL DESIGN				QUANT= 150.36
TT= 10.00	TVU= 16.30	TBB= 2.00	TBVU= 19.00	TBU= 21.00
	TVD= 14.90		TBVD= 17.00	TBD= 19.00
FTGU= 3.50	TSUP= 18.00	TSBGU= 22.00		
FTGD= 4.75		TSBGD= 20.00	TSDN= 20.00	

STEEL REQUIREMENTS

WALL

A(1)= 0.24	S(1)= 18.00	A(6)= 0.24	S(6)= 18.00
A(2)= 0.30	S(2)= 18.00	A(7)= 0.30	S(7)= 18.00
A(3)= 2.16	S(3)= 14.00	A(8)= 0.76	S(8)= 18.00
A(4)= 2.27	S(4)= 13.85	A(9)= 1.61	S(9)= 16.36
A(5)= 2.47	S(5)= 13.54	A(10)= 2.82	S(10)= 12.07

BASE

SECTION AT DOWNSTREAM END

A(11)= 0.24	S(11)= 18.00	A(17)= 0.48	S(17)= 18.00
A(12)= 0.24	S(12)= 18.00	A(18)= 0.24	S(18)= 18.00
A(13)= 0.24	S(13)= 18.00	A(19)= 0.48	S(19)= 18.00
A(14)= 0.24	S(14)= 18.00	A(20)= 0.24	S(20)= 18.00
A(15)= 0.24	S(15)= 18.00	A(21)= 0.73	S(21)= 18.00
A(16)= 0.24	S(16)= 18.00	A(22)= 0.24	S(22)= 18.00

SECTION AT DOWNSTREAM SIDE OF BREAK-IN-GRADE

A(23)= 0.24	S(23)= 18.00	A(29)= 0.48	S(29)= 18.00
A(24)= 0.24	S(24)= 18.00	A(30)= 1.90	S(30)= 18.00
A(25)= 0.24	S(25)= 18.00	A(31)= 0.48	S(31)= 18.00
A(26)= 0.24	S(26)= 18.00	A(32)= 0.78	S(32)= 18.00
A(27)= 0.45	S(27)= 18.00	A(33)= 0.48	S(33)= 18.00
A(28)= 0.24	S(28)= 18.00	A(34)= 0.41	S(34)= 18.00

SAI = -4

SECTION AT UPSTREAM SIDE OF BREAK-IN-GRADE

A(35)= 0.26	S(35)= 18.00	A(41)= 0.53	S(41)= 18.00
A(36)= 0.26	S(36)= 18.00	A(42)= 1.92	S(42)= 18.00

A(37)= 0.26	S(37)= 18.00	A(43)= 0.53	S(43)= 18.00
A(38)= 0.26	S(38)= 18.00	A(44)= 0.97	S(44)= 18.00
A(39)= 0.26	S(39)= 18.00	A(45)= 0.53	S(45)= 18.00
A(40)= 0.26	S(40)= 18.00	A(46)= 0.64	S(46)= 18.00
SECTION AT UPSTREAM END			
A(47)= 0.22	S(47)= 18.00	A(53)= 0.43	S(53)= 18.00
A(48)= 0.22	S(48)= 18.00	A(54)= 1.45	S(54)= 18.00
A(49)= 0.22	S(49)= 18.00	A(55)= 0.43	S(55)= 18.00
A(50)= 0.22	S(50)= 18.00	A(56)= 0.56	S(56)= 18.00
A(51)= 0.23	S(51)= 18.00	A(57)= 0.43	S(57)= 18.00
A(52)= 0.22	S(52)= 18.00	A(58)= 0.28	S(58)= 18.00

VERTICAL SHEAR AT BREAK-IN-GRADE ARTICULATION JOINT
SHEAR FORCE FOR LC NO.1, LBS.= 4.8647E+03
SHEAR FORCE FOR LC NO.2, LBS.= -4.7794E+03

WINGWALL DESIGN - TRIAL VALUES
TWW= 12.00 TWF= 12.00 BUP= 14.50 BDN= 7.00

WINGWALL DESIGN - DETAIL DESIGN QUANT= 37.86
TWW= 12.00 TWF= 12.00 BUP= 14.50 BDN= 7.00
LEVEL= 12.04 WPROJ= 18.38 WWLB= 20.50 VWING= 44.24

STEEL REQUIREMENTS

AREA OF TIE= 2.89

SECTION AT ARTICULATION JOINT

A(1)= 0.29	S(1)= 18.00	A(4)= 0.34	S(4)= 18.00
A(2)= 0.14	S(2)= 18.00	A(5)= 1.47	S(5)= 18.00
A(3)= 1.17	S(3)= 17.99	A(6)= 1.93	S(6)= 18.00

SECTION AT UPPER THIRD POINT

A(7)= 0.29	S(7)= 18.00	A(10)= 0.22	S(10)= 18.00
A(8)= 0.14	S(8)= 18.00	A(11)= 0.68	S(11)= 18.00
A(9)= 0.35	S(9)= 18.00	A(12)= 0.79	S(12)= 18.00

SECTION AT LOWER THIRD POINT

A(13)= 0.29	S(13)= 18.00	A(16)= 0.14	S(16)= 18.00
A(14)= 0.14	S(14)= 18.00	A(17)= 0.19	S(17)= 18.00
A(15)= 0.14	S(15)= 18.00	A(18)= 0.25	S(18)= 18.00

===== END DETAIL DESIGN =====
WINGWALL PER TRNOTICE 54-1

EXECUTION DATE: 03/18/83
REVISION DATE: 09/01/82

SAF STILLING BASIN
STRUCTURAL DESIGN
ELASTIC ANALYSIS AND WORKING STRESS DESIGN ARE USED

SPECIAL DESIGN PREPARED BY
DESIGN UNIT, ENGINEERING, LANHAM, MARYLAND
FOR

EXAMPLE SAMPLE DESIGN FOR STILLING BASINS
JOAN FOR ESA ----- MARCH 15, 1983

SAI=-5

DESIGN PARAMETERS

W = 32.00	D1 = 2.00	HTW1= 0.0	HB = 8.00	GM = 120.0	MAXFTG=16.00
J = 18.00	V1 = 36.00	HUP1= 0.0	ZS = 3.00	GS = 140.0	FLOATR= 1.50
LB= 16.00	FROUDE= 20.12	HTW2=11.73	HTW= 4.00	KO = 0.800	SLIDER= 1.00
N = 6.00	D2 = 11.73	HUP2= 7.00	TTW=10.00	BAT= 0.375	CFSC = 0.35

DESIGN OF SPECIFIED TYPE SAF FOLLOWS

TYPE (C) STILLING BASIN - TRIAL VALUES QUANT= 131.51

LTOT= 52.00 LS= 36.00 HS= 12.00 HV= 9.00

X= 12.00 XP= 8.00

TPUP= 14.00 TPBG= 20.00 TPDN= 17.00

TT= 10.00 TV= 10.50 TBB= 3.00 TBV= 11.00 TB= 14.00

FTG= 0.0 TSUP= 12.00 TSBG= 15.00 TSDN= 15.00

TYPE (C) STILLING BASIN - DETAIL DESIGN QUANT= 133.59

X= 12.00 XP= 8.00

TPUP= 14.00 TPBG= 20.00 TPDN= 17.00

TT= 10.00 TV= 10.50 TBB= 3.00 TBV= 11.00 TB= 14.00

FTG= 0.0 TSUP= 12.00 TSBG= 16.00 TSDN= 15.00

STEEL REQUIREMENTS

WALL

A(1)= 0.24	S(1)= 18.00	A(6)= 0.24	S(6)= 18.00
A(2)= 0.24	S(2)= 18.00	A(7)= 0.24	S(7)= 18.00
A(3)= 0.26	S(3)= 18.00	A(8)= 0.25	S(8)= 18.00
A(4)= 0.74	S(4)= 18.00	A(9)= 0.18	S(9)= 18.00
A(5)= 1.76	S(5)= 14.44	A(10)= 1.76	S(10)= 14.44
		A(0)= 0.46	S(0)= 18.00

BASE

SECTION AT DOWNSTREAM END

A(11)= 0.0	S(11)= 18.00	A(17)= 0.36	S(17)= 18.00
A(12)= 0.0	S(12)= 18.00	A(18)= 1.20	S(18)= 18.00
A(13)= 0.0	S(13)= 18.00	A(19)= 0.36	S(19)= 18.00
A(14)= 0.0	S(14)= 18.00	A(20)= 0.26	S(20)= 18.00
A(15)= 0.0	S(15)= 18.00	A(21)= 0.36	S(21)= 18.00
A(16)= 0.0	S(16)= 18.00	A(22)= 0.18	S(22)= 18.00

SECTION AT BREAK-IN-GRADE

A(23)= 0.0	S(23)= 18.00	A(29)= 0.38	S(29)= 18.00
A(24)= 0.0	S(24)= 18.00	A(30)= 1.70	S(30)= 18.00
A(25)= 0.0	S(25)= 18.00	A(31)= 0.38	S(31)= 18.00
A(26)= 0.0	S(26)= 18.00	A(32)= 0.28	S(32)= 18.00
A(27)= 0.0	S(27)= 18.00	A(33)= 0.38	S(33)= 18.00
A(28)= 0.0	S(28)= 18.00	A(34)= 0.19	S(34)= 18.00

SECTION AT UPSTREAM END

A(47)= 0.0	S(47)= 18.00	A(53)= 0.29	S(53)= 18.00
A(48)= 0.0	S(48)= 18.00	A(54)= 0.88	S(54)= 18.00
A(49)= 0.0	S(49)= 18.00	A(55)= 0.29	S(55)= 18.00
A(50)= 0.0	S(50)= 18.00	A(56)= 0.24	S(56)= 18.00
A(51)= 0.0	S(51)= 18.00	A(57)= 0.29	S(57)= 18.00
A(52)= 0.0	S(52)= 18.00	A(58)= 0.14	S(58)= 18.00

PAVEMENT SLAB

A(59)= 0.41	S(59)= 18.00	A(60)= 0.20	S(60)= 18.00
A(61)= 0.44	S(61)= 18.00	A(62)= 0.22	S(62)= 18.00
A(63)= 0.86	S(63)= 18.00	A(64)= 0.24	S(64)= 18.00
A(65)= 0.58	S(65)= 18.00	A(66)= 0.20	S(66)= 18.00
A(67)= 0.34	S(67)= 18.00	A(68)= 0.17	S(68)= 18.00

WINGWALL DESIGN - TRIAL VALUES

TWW= 10.00 TWF= 10.00 BUP= 10.50 BDN= 6.00

WINGWALL DESIGN - DETAIL DESIGN

TWW= 10.00 TWF= 10.00 BUP= 10.50 BDN= 6.00 QUANT= 26.70

LEVEL= 7.78 WPROJ= 16.39 WWLB= 15.11 VWING= 26.70

STEEL REQUIREMENTS

AREA OF TIE= 1.79

SECTION AT ARTICULATION JOINT

A(1)= 0.24	S(1)= 18.00	A(4)= 0.25	S(4)= 18.00
A(2)= 0.12	S(2)= 18.00	A(5)= 0.91	S(5)= 18.00
A(3)= 0.66	S(3)= 18.00	A(6)= 1.15	S(6)= 18.00

SECTION AT UPPER THIRD POINT

A(7)= 0.24	S(7)= 18.00	A(10)= 0.15	S(10)= 18.00
A(8)= 0.12	S(8)= 18.00	A(11)= 0.42	S(11)= 18.00

501 = -6

A(9)= 0.20 S(9)= 18.00
SECTION AT LOWER THIRD POINT
A(13)= 0.24 S(13)= 18.00
A(14)= 0.12 S(14)= 18.00
A(15)= 0.12 S(15)= 18.00

A(12)= 0.50 S(12)= 18.00
A(16)= 0.12 S(16)= 18.00
A(17)= 0.12 S(17)= 18.00
A(18)= 0.16 S(18)= 18.00

=====
===== END DETAIL DESIGN =====
WINGWALL PER TRNOTICE 54-1

APPENDIX B: SAMPLE CBASIN RUN
FOR SUMMARY DESIGNS

 CBASIN -- SOIL CONSERVATION SERVICE PROGRAM SAFBASIN
 ADAPTED TO CORPS OF ENGINEERS CRITERIA BY CASE PROJECT

 * CORPS PROGRAM * X0098 *
 * MICRO VERSION * 89/02/01 *

ENTER TWO HEADER LINES, 80 CHAR. MAX. EACH LINE
 EXAMPLE SPECIAL DESIGN FOR STILLING BASIN
 from U.S.D.A. S.C.S. TR-54 -- Appendix A of USACE X0098 User Guide
 ENTER THE FOLLOWING

WIDTH BASIN (FT)	WALL D.S. (FT)	LENGTH BASIN (FT)	WALL U.S. (FT)	WATER DEPTH (FT)	WATER VELOC (FT/SEC)	DESIGN PARAM 0,1,2,3	DFALTS 0=DEF 0,1
W	J	LB	N	D1	V1	DESIGN	DFALTS
20.0	18.75	16.75	6.75	1.75	50.0	0	1

DFALT1	DFALT2	DFALT3	DFALT4
1	1	1	1

HEIGHT FILL DOWNSTREAM FT	TAILWATER LOAD CASE 2 FT	UPLIFT HD LOAD C 2 FT	TAILWATER LOAD C 1 FT	UPLIFT HD LOAD C 1 FT
HB	HTW2	HUP2	HTW1	HUP1
7.0	13.5	11.0	4.0	6.0

MAXIMUM FOOTING PROJECT FT	SAFETY FACTOR FLOATION	SAFETY FACTOR SLIDING	SLOPE PARAM BASIN INCLINE	RATE BATTER INSIDE SIDEWALL
MAXFTG	FLOATR	SLIDER	ZS	BAT
10.0	1.25	1.1	2.5	0.0

UNIT WGT MOIST BACKFILL LB/CF	UNIT WGT SATURATED BACKFILL LB/CF	LAT SOIL PRESSURE RATIO	COEF FRICTION SOIL-CONC	DEPTH TOE FT	WIDTH TOE IN
GM	GS	KD	CFSC	HTW	TTW
110.0	120.0	0.75	0.4	4.0	12.0

CONCRETE ULTIMATE STRENGTH (PSI)	RATIO FC TO F'C	ALLOWABLE STEEL STRESS (PSI)	ALLOWABLE NET BEAR PRESSURE (PSF)	MINIMUM CONCRETE THICKNESS (IN)
F'C	COESF	FSA	ABP	TMIN
4000.0	0.4	20000.0	2000.0	10.0

===== END OF INPUT =====

=====

CBASIN
CORPS OF ENGINEERS, CASE PROJECT MODIFIED
SOIL CONSERVATION SERVICE PROGRAM - STILLING BASIN

EXAMPLE SPECIAL DESIGN FOR STILLING BASIN
from U.S.D.A. S.C.S. TR-54 -- Appendix A of USACE X0098 User Guide

DESIGN PARAMETERS

WIDTH BASIN (FT) W	WALL D.S. (FT) J	LENGTH BASIN (FT) LB	WALL U.S. (FT) N	WATER DEPTH (FT) D1	WATER VELOC (FT/SEC) V1
20.00	18.75	16.75	6.75	1.75	50.00
FROUDE	WATER D2 (FT)	TAILWTR LC - 1 (FT)	UPLIFT LC - 1 (FT)	TAILWTR LC - 2 (FT)	UPLIFT LC - 2 (FT)
FROUDE 44.37	D2 15.63	HTW1 4.00	HUP1 6.00	HTW2 13.50	HUP2 11.00
HGT FILL D.STREAM (FT) HB	SLOPE FLOOR RATIO ZS	DEPTH TOE WALL (FT) HTW	THICKNES TOE WALL (IN) TTW	WGT MOIST FILL (LB/CF) GM	WGT SAT FILL (LB/CF) GS
7.00	2.50	4.00	12.00	110.00	120.00
LAT SOIL PRESSURE RATIO (RATIO) KO	BATTER INSIDE WALL (RATIO) BAT	MAXIMUM FOOTING PROJECT (FT) MAXFTG	SAFETY FACTOR FLOATION (RATIO) FLOATR	SAFETY FACTOR SLIDING (RATIO) SLIDER	COEF FRICTION SOIL-CONC (RATIO) CFSC
.75	.00	10.00	1.25	1.10	.40
CONCRETE ULTIMATE STRENGTH (PSI) F'C	RATIO FC TO F'C COESF	ALLOWABLE STEEL STRENGTH (PSI) FSA	ALLOWABLE NET BEAR PRESSURE (PSF) ABP	MINIMUM CONCRETE THICKNESS (IN) TMIN	
4000.00	.40	20000.00	2000.00	10.00	

PRELIMINARY DESIGNS FOLLOW

TYPE (A) STILLING BASIN - TRIAL VALUES

QUANT= 119.43

LGT TOP SIDEWALL (FT) LTOP	HORZ PROJ U.S. WALL (FT) LN	VERT COMP OF DIST N (FT) HN	DIST WALL VERT INSIDE (FT) HV
45.45	2.51	6.27	9.38
LGT BOT BASIN (FT) LBOT	HORIZ PROJ INCL SLAB (FT) LS	VERT PROJ INCL SLAB (FT) HS	
47.96	31.21	12.48	
THICK WALL AT TOP (FT) TT	THICK WALL AT HV (IN) TV	THICKNESS OF WALL BATTER (IN) TBB	THICK BOT WALL NO BAT (IN) TBV
10.00	12.50	.00	15.00
THICK AT BOTTOM (IN) TB			
15.00			
FTG PROJECT (FT) FTG	SLAB THICK U.S. END (IN) TSUP	SLAB THICK BREAK IN GRADE (IN) TSBG	SLAB THICK D.S. END (IN) TSDN
3.00	13.00	16.00	16.00

ASSOCIATED WINGWALL QUANT= 27.19

TYPE (B) STILLING BASIN - TRIAL VALUES

QUANT= 132.76

OVERALL BAS LGT (FT)	HORIZ PROJ SLAB (FT)	VERT PROJ INCL SLAB (FT)	DIST WALL VERT INSIDE (FT)	
LTOT	LS	HS	HV	
46.75	30.00	12.00	9.38	
THICK WALL AT TOP (FT)	THICK WALL AT HV-U (IN)	THICKNESS OF WALL BATTER (IN)	THICK BOT WALL NO BAT-U (IN)	THICK AT BOTTOM S.WALL-U (IN)
TT	TVU	TBB	TBVU	TBU
10.00	12.50	.00	15.00	15.00
THICK OF SIDEWALL AT HV-D (IN)		THICK BOT WALL NO BAT-D (IN)		THICK AT BOT SIDEWALL-D (IN)
TVD		TBVD		TBD
12.50		15.00		15.00
U.S. FTG PROJECT (FT)		SLAB THICK U.S. END (IN)		SLAB THICK U.S. BREAK GRADE (IN)
FTGU		TSUP		TSBGU
4.00		13.00		22.00
D.S. FTG PROJECT (FT)	SLAB THICK BREAK GRADE (IN)		SLAB THICK D.S. END (IN)	
FTGD	TSBGD		TSDN	
3.50	22.00		16.00	
ASSOCIATED WINGWALL QUANT= 26.74				

TYPE (C) STILLING BASIN - TRIAL VALUES

QUANT= 122.31

OVERALL BAS LGT (FT)	HORIZ PROJ SLAB (FT)	VERT PROJ INCL SLAB (FT)	DIST WALL VERT INSIDE (FT)	
LTOT	LS	HS	HV	
46.75	30.00	12.00	9.38	
TOE LENGTH WALL BASE X	WIDTH OF PAVEMENT SLAB XP			
10.00	.00			
THICK PAVE U.S. END (IN)	THICK PAVE B. IN GRADE (IN)	THICK PAVE D.S. END (IN)		
TPUP	TPBG	TPDN		
56.00	84.00	70.00		
THICK WALL AT TOP (FT)	THICK WALL AT HV (IN)	THICKNESS OF WALL BATTER (IN)	THICK BOT WALL NO BAT (IN)	THICK AT BOTTOM SIDEWALL (IN)
TT	TV	TBB	TBV	TB
10.00	12.50	.00	15.00	15.00
FTG PROJECT (FT)	SLAB THICK U.S. END, (IN)	SLAB THICK BREAK IN GRADE (IN)		SLAB THICK D.S. END (IN)
FTG	TSUP	TSBG		TSDN
3.00	14.00	18.00		17.00
ASSOCIATED WINGWALL QUANT= 27.19				

WINGWALL DESIGN - TRIAL VALUES

THICK OF WINGWALL IN TWW	THICK OF WALL FTG IN TWF	FTG PROJ AT U.S. END FT BUP	FTG PROJ AT D.S. END FT BDN
10.00	10.00	12.50	3.50

===== END PRELIMINARY DESIGNS =====

WINGWALL PER TR NOTICE 54-1

HUP2 IS GIVEN AS 11.00, THIS IS LESS THAN HTW2 GIVEN AS 13.50.
IT MAY BE APPROPRIATE TO CONSIDER AN ADDITIONAL TYPE (C) DESIGN
WITH HUP2 = HTW2.

Stop - Program terminated.

APPENDIX C: SAMPLE CBASIN RUN FOR DETAILED
DESIGN OF TYPE "A" BASIN

 CBASIN -- SOIL CONSERVATION SERVICE PROGRAM SAFBASIN
 ADAPTED TO CORPS OF ENGINEERS CRITERIA BY CASE PROJECT

 * CORPS PROGRAM * X0098 *
 * MICRO VERSION * 89/02/01 *

ENTER TWO HEADER LINES, 80 CHAR. MAX. EACH LINE

Example design from Appendix A
 Detailed design of type "A" basin
 ENTER THE FOLLOWING

WIDTH BASIN (FT)	WALL D.S. (FT)	LENGTH BASIN (FT)	WALL U.S. (FT)	WATER DEPTH (FT)	WATER VELOC (FT/SEC)	DESIGN PARAM 0,1,2,3	DFALTS 0=DEF 0,1
W	J	LB	N	D1	V1	DESIGN	DFALTS
40.0	12.0	10.0	6.0	1.0	45.0	1	1

DFALT1	DFALT2	DFALT3	DFALT4
1	1	1	1

HEIGHT FILL DOWNSTREAM FT	TAILWATER LOAD CASE 2 FT	UPLIFT HD LOAD C 2 FT	TAILWATER LOAD C 1 FT	UPLIFT HD LOAD C 1 FT
HB	HTW2	HUP2	HTW1	HUP1
2.67	9.0	5.0	4.0	4.0

MAXIMUM FOOTING PROJECT FT	SAFETY FACTOR FLOATION	SAFETY FACTOR SLIDING	SLOPE PARAM BASIN INCLINE	RATE BATTER INSIDE SIDEWALL
MAXFTG	FLOATR	SLIDER	ZS	BAT
8.0	1.2	1.0	3.0	0.25

UNIT WGT MOIST BACKFILL LB/CF	UNIT WGT SATURATED BACKFILL LB/CF	LAT SOIL PRESSURE RATIO	COEF FRICTION SOIL-CONC	DEPTH TOE FT	WIDTH TOE IN
GM	GS	KD	CFSC	HTW	TTW
105.0	120.0	0.667	0.35	4.0	10.0

CONCRETE ULTIMATE STRENGTH (PSI)	RATIO FC TO F'C	ALLOWABLE STEEL STRESS (PSI)	ALLOWABLE NET BEAR PRESSURE (PSF)	MINIMUM CONCRETE THICKNESS (IN)
F'C	COESF	FSA	ABP	TMIN
4000.0	0.4	20000.0	2000.0	10.0

IS MOMENT, THRUST, SHEAR REPORT DESIRED ? Enter either Y or N

Y

MTV WILL BE OUTPUT

===== END OF INPUT =====

=====

CBASIN
CORPS OF ENGINEERS, CASE PROJECT MODIFIED
SOIL CONSERVATION SERVICE PROGRAM - STILLING BASIN

Example design from Appendix A
Detailed design of type "A" basin

DESIGN PARAMETERS

WIDTH BASIN (FT) W	WALL D.S. (FT) J	LENGTH BASIN (FT) LB	WALL U.S. (FT) N	WATER DEPTH (FT) D1	WATER VELOC (FT/SEC) V1
40.00	12.00	10.00	6.00	1.00	45.00
FROUDE	WATER D2 (FT)	TAILWTR LC - 1 (FT)	UPLIFT LC - 1 (FT)	TAILWTR LC - 2 (FT)	UPLIFT LC - 2 (FT)
FROUDE 62.89	D2 10.73	HTW1 4.00	HUP1 4.00	HTW2 9.00	HUP2 5.00
HGT FILL D.STREAM (FT) HB	SLOPE FLOOR RATIO ZS	DEPTH TOE WALL (FT) HTW	THICKNES TOE WALL (IN) TTW	WGT MOIST FILL (LB/CF) GM	WGT SAT FILL (LB/CF) GS
2.67	3.00	4.00	10.00	105.00	120.00
LAT SOIL PRESSURE RATIO (RATIO) KO	BATTER INSIDE WALL (RATIO) BAT	MAXIMUM FOOTING PROJECT (FT) MAXFTG	SAFETY FACTOR FLOATION (RATIO) FLOATR	SAFETY FACTOR SLIDING (RATIO) SLIDER	COEF FRICTION SOIL-CONC (RATIO) CFSC
.67	.25	8.00	1.20	1.00	.35
CONCRETE ULTIMATE STRENGTH (PSI) F'C	RATIO FC TO F'C COESF	ALLOWABLE STEEL STRENGTH (PSI) FSA	ALLOWABLE NET BEAR PRESSURE (PSF) ABP	MINIMUM CONCRETE THICKNESS (IN) TMIN	
4000.00	.40	20000.00	2000.00	10.00	

DESIGN OF SPECIFIED TYPE BASIN FOLLOWS

TYPE (A) STILLING BASIN - TRIAL VALUES

QUANT= 87.36

LGT TOP SIDEWALL (FT) LTOP	HORZ PROJ U.S. WALL (FT) LN	VERT COMP OF DIST N (FT) HN	DIST WALL VERT INSIDE (FT) HV
27.03	1.90	5.69	6.00
LGT BOT BASIN (FT) LBOT	HORIZ PROJ INCL SLAB (FT) LS	VERT PROJ INCL SLAB (FT) HS	
28.92	18.92	6.31	
THICK WALL AT TOP (FT) TT	THICK WALL AT HV (IN) TV	THICKNESS OF WALL BATTER (IN) TBB	THICK BOT WALL NO BAT (IN) TBV
10.00	10.00	2.00	10.00
THICK AT BOTTOM SIDEWALL (IN) TB	SLAB THICK U.S. END (IN) TSUP	SLAB THICK BREAK IN GRADE (IN) TSBG	SLAB THICK D.S. END (IN) TSDN
12.00	15.00	18.00	15.00

TYPE (A) STILLING BASIN - DETAIL DESIGN

QUANT= 87.36

THICK WALL AT TOP (FT)	THICK WALL AT HV (IN)	THICKNESS OF WALL BATTER (IN)	THICK BOT WALL NO BAT (IN)	THICK AT BOTTOM SIDEWALL (IN)
TT	TV	TBB	TBV	TB
10.00	10.00	2.00	10.00	12.00

FTG PROJECT (FT)	SLAB THICK U.S. END (IN)	SLAB THICK BREAK IN GRADE (IN)	SLAB THICK D.S. END (IN)
FTG	TSUP	TSBG	TSDN
1.00	15.00	18.00	15.00

STEEL REQUIREMENTS

WALL---UPSTREAM END

HEIGHT ABOVE BASE (FT)	AREA STEEL REQUIRED (IN**2)	MAXIMUM SPACING (IN)
5.69	.24	18.00
2.85	.24	18.00
.00	.24	18.00
ON SLOPE		
.00	.27	18.00
BREAK IN GRADE--UPSTREAM SIDE		
.00	.58	18.00
BREAK IN GRADE--DOWNSTREAM SIDE		
12.00	.24	18.00
9.15	.24	18.00
6.31	.24	18.00
3.15	.27	18.00
.00	.58	18.00
INSIDE FACE OF DOWNSTREAM END		
.00	.49	18.00

BASE

SECTION AT DOWNSTREAM END

DIST FROM WALL (FT)	AREA REQD TOP FACE (IN**2)	MAX SPACING (IN)	AREA REQD BOT FACE (IN**2)	MAX SPACING (IN)
1.00	.18	18.00	.18	18.00
.50	.18	18.00	.18	18.00
.00	.18	18.00	.18	18.00
.00	.42	18.00	.18	18.00
10.00	.83	18.00	1.07	18.00
20.00	1.11	18.00	1.56	18.00
SECTION AT BREAK-IN-GRADE				
1.00	.22	18.00	.22	18.00
.50	.22	18.00	.22	18.00
.00	.22	18.00	.22	18.00
.00	.43	18.00	.22	18.00
10.00	1.81	18.00	.22	18.00
20.00	2.50	18.00	.22	18.00
SECTION AT UPSTREAM END				
1.00	.18	18.00	.18	18.00
.50	.18	18.00	.18	18.00
.00	.18	18.00	.18	18.00
.00	.36	18.00	.18	18.00
10.00	.36	18.00	1.10	18.00
20.00	.45	18.00	1.43	18.00

WINGWALL DESIGN - TRIAL VALUES

THICK OF WINGWALL	THICK OF WWALL FTG	FTG PROJ AT U.S. END	FTG PROJ AT D.S. END
IN	IN	FT	FT
TWW	TWF	BDN	BDN
10.00	10.00	7.50	1.50

WINGWALL DESIGN - DETAIL DESIGN

QUANT= 11.60

THICK OF WINGWALL	THICK OF WWALL FTG	FTG PROJ AT U.S. END	FTG PROJ AT D.S. END
IN	IN	FT	FT
TWW	TWF	BDN	BDN
10.00	10.00	7.50	1.50

DIST TO JT WINGWALL	WINGWALL FTG PROJ	WINGWALL FTG PERP	VOL OF WALL WITHOUT FTG ADJUST
FT	FT	FT	CY
LEVEL	WPROJ	WWLB	VWING
7.07	9.01	10.95	12.25

STEEL REQUIREMENTS

AREA OF TIE= .16

SECTION AT ARTICULATION JOINT

HEIGHT ABOVE BASE	AREA STEEL REQUIRED	MAXIMUM SPACING
FT	IN**2	IN
8.00	.24	18.00
4.00	.24	18.00
.00	.12	18.00
DISTANCE FROM WALL	AREA STEEL REQUIRED	MAXIMUM SPACING
FT	IN**2	IN
5.00	.12	18.00
2.50	.13	18.00
.00	.13	18.00

SECTION AT UPPER THIRD POINT

HEIGHT ABOVE BASE	AREA STEEL REQUIRED	MAXIMUM SPACING
FT	IN**2	IN
5.56	.24	18.00
2.78	.24	18.00
.00	.12	18.00
DISTANCE FROM WALL	AREA STEEL REQUIRED	MAXIMUM SPACING
FT	IN**2	IN
3.67	.12	18.00
1.83	.12	18.00
.00	.12	18.00

SECTION AT LOWER THIRD POINT

HEIGHT ABOVE BASE	AREA STEEL REQUIRED	MAXIMUM SPACING
FT	IN**2	IN
3.11	.24	18.00
1.56	.12	18.00
.00	.12	18.00
DISTANCE FROM WALL	AREA STEEL REQUIRED	MAXIMUM SPACING
FT	IN**2	IN
2.33	.12	18.00
1.17	.12	18.00
.00	.12	18.00

===== END DETAIL DESIGN

===== WINGWALL PER TRNOTICE 54-1

MOMENT, THRUST, SHEAR REPORT

Example design from Appendix A
Detailed design of type "A" basin

TYPE (A) STILLING BASIN

MOMENT, THRUST, SHEAR RESULTANTS AT STEEL DETERMINATION SECTIONS
CONSULT FIGS. 42, 44, 45, 46, & 47 OF REFERENCE DOCUMENT FOR LOCATIONS.
TABULATED MOMENT CAUSES TENSION IN STEEL AT INDICATED LOCATION.
DIRECT COMPRESSION IS POSITIVE, DIRECT TENSION IS NEGATIVE.

LOCATION NUMBER	LOAD CONDITION	EFFECTIVE DEPTH IN	BENDING MOMENT FT-LBS/FT	DIRECT THRUST LBS/FT	SHEAR FORCE LBS/FT
SIDEWALL					
1	1	.00	0.	0.	0.
2	1	7.50	369.	395.	350.
3	1	7.61	2953.	791.	1401.
4	1	8.55	2805.	1166.	1335.
5	1	9.50	2341.	1575.	1060.
6	1	.00	0.	0.	0.
7	1	7.50	0.	395.	0.
8	1	7.61	1.	791.	7.
9	1	8.55	405.	1166.	356.
10	1	9.50	2341.	1575.	1060.
1	2	.00	0.	0.	0.
2	2	7.50	369.	395.	351.
3	2	7.61	3141.	791.	1571.
4	2	8.55	4014.	1166.	1941.
5	2	9.50	9041.	1575.	3216.
6	2	.00	0.	0.	0.
7	2	7.50	0.	395.	0.
8	2	7.61	383.	791.	349.
9	2	8.55	2661.	1166.	1392.
10	2	9.50	9041.	1575.	3216.
0	1	.00	0.	0.	0.
0	2	7.50	6160.	1575.	1610.
BASE					
11	1	12.50	0.	519.	0.
12	1	.00	0.	0.	0.
13	1	12.50	11.	519.	42.
14	1	.00	0.	0.	0.
15	1	12.50	42.	519.	84.
16	1	.00	0.	0.	0.
17	1	12.50	1039.	656.	2042.
18	1	.00	0.	0.	0.
19	1	12.50	16139.	656.	1029.
20	1	.00	0.	0.	0.
21	1	12.50	21286.	656.	0.
22	1	.00	0.	0.	0.
11	2	12.50	0.	597.	0.
12	2	.00	0.	0.	0.
13	2	12.50	8.	597.	32.
14	2	.00	0.	0.	0.
15	2	12.50	32.	597.	64.
16	2	.00	0.	0.	0.
17	2	12.50	7576.	-1013.	919.
18	2	.00	0.	0.	0.
19	2	.00	0.	0.	0.
20	2	11.50	18040.	-1013.	1596.
21	2	.00	0.	0.	0.
22	2	11.50	26018.	-1013.	0.

23	1	15.50	0.	941.	0.
24	1	.00	0.	0.	0.
25	1	15.50	46.	941.	185.
26	1	.00	0.	0.	0.
27	1	15.50	185.	941.	370.
28	1	.00	0.	0.	0.
29	1	.00	0.	0.	0.
30	1	14.50	1825.	2001.	1653.
31	1	15.50	10544.	2001.	843.
32	1	.00	0.	0.	0.
33	1	15.50	14757.	2001.	0.
34	1	.00	0.	0.	0.
23	2	15.50	0.	987.	0.
24	2	.00	0.	0.	0.
25	2	15.50	69.	987.	278.
26	2	.00	0.	0.	0.
27	2	15.50	278.	987.	556.
28	2	.00	0.	0.	0.
29	2	.00	0.	0.	0.
30	2	14.50	2887.	2654.	1979.
31	2	15.50	43064.	2654.	2987.
32	2	.00	0.	0.	0.
33	2	15.50	58000.	2654.	0.
34	2	.00	0.	0.	0.
47	1	12.50	0.	584.	0.
48	1	.00	0.	0.	0.
49	1	12.50	79.	584.	315.
50	1	.00	0.	0.	0.
51	1	12.50	315.	584.	630.
52	1	.00	0.	0.	0.
53	1	.00	0.	0.	0.
54	1	11.50	2970.	2009.	688.
55	1	12.50	6693.	2009.	630.
56	1	.00	0.	0.	0.
57	1	12.50	9843.	2009.	0.
58	1	.00	0.	0.	0.
47	2	12.50	0.	584.	0.
48	2	.00	0.	0.	0.
49	2	12.50	88.	584.	354.
50	2	.00	0.	0.	0.
51	2	12.50	354.	584.	708.
52	2	.00	0.	0.	0.
53	2	.00	0.	0.	0.
54	2	11.50	4039.	1978.	2123.
55	2	.00	0.	0.	0.
56	2	11.50	19960.	1978.	1061.
57	2	.00	0.	0.	0.
58	2	11.50	25267.	1978.	0.

WINGWALL

1	1	7.50	0.	500.	0.
2	1	7.50	0.	1000.	0.
3	1	7.50	122.	1500.	137.
4	1	7.50	344.	319.	490.
5	1	7.50	1246.	237.	260.
6	1	7.50	722.	155.	692.
7	1	7.50	0.	347.	0.
8	1	7.50	0.	694.	0.
9	1	7.50	60.	1042.	86.
10	1	7.50	206.	290.	260.
11	1	7.50	577.	236.	131.
12	1	7.50	372.	183.	378.
13	1	7.50	0.	194.	0.
14	1	7.50	0.	389.	0.
15	1	7.50	24.	583.	47.
16	1	7.50	56.	278.	107.
17	1	7.50	159.	246.	74.
18	1	7.50	146.	215.	97.
1	2	7.50	0.	500.	0.
2	2	7.50	0.	1000.	0.
3	2	7.50	122.	1500.	137.
4	2	7.50	358.	567.	390.
5	2	7.50	1041.	487.	212.
6	2	7.50	624.	407.	534.
7	2	7.50	0.	382.	0.
8	2	7.50	0.	729.	0.
9	2	7.50	60.	1076.	86.
10	2	7.50	140.	550.	205.
11	2	7.50	434.	496.	118.
12	2	7.50	320.	443.	250.
13	2	7.50	0.	420.	0.
14	2	7.50	0.	614.	0.
15	2	7.50	24.	809.	47.
16	2	7.50	51.	538.	99.
17	2	7.50	147.	506.	72.
18	2	7.50	140.	475.	82.

===== END OF MOMENT, THRUST, SHEAR REPORT =====

Stop - Program terminated.

APPENDIX D: SAMPLE CBASIN RUN FOR DETAILED
DESIGN OF TYPE "B" BASIN

 CBASIN -- SOIL CONSERVATION SERVICE PROGRAM SAFBASIN
 ADAPTED TO CORPS OF ENGINEERS CRITERIA BY CASE PROJECT

 * CORPS PROGRAM * X0098 *
 * MICRO VERSION * 89/02/01 *

ENTER TWO HEADER LINES, 80 CHAR. MAX. EACH LINE
 Example design from Appendix A
 Detailed design of type "B" basin
 ENTER THE FOLLOWING

WIDTH BASIN (FT)	WALL D.S. (FT)	LENGTH BASIN (FT)	WALL U.S. (FT)	WATER DEPTH (FT)	WATER VELOC (FT/SEC)	DESIGN PARAM 0,1,2,3	DFALTS 0=DEF 0,1
W	J	LB	N	D1	V1	DESIGN	DFALTS
20.0	20.0	24.0	14.0	2.0	36.0	2	1

DFALT1	DFALT2	DFALT3	DFALT4
1	0	0	1

HEIGHT FILL DOWNSTREAM FT	TAILWATER LOAD CASE 2 FT	UPLIFT HD LOAD C 2 FT	TAILWATER LOAD C 1 FT	UPLIFT HD LOAD C 1 FT
HB	HTW2	HUP2	HTW1	HUP1
10.0	11.73	11.73	0.0	5.86

CONCRETE ULTIMATE STRENGTH (PSI)	RATIO FC TO F'C	ALLOWABLE STEEL STRESS (PSI)	ALLOWABLE NET BEAR PRESSURE (PSF)	MINIMUM CONCRETE THICKNESS (IN)
F'C	COESF	FSA	ABP	TMIN
4000.0	0.4	20000.0	2000.0	10.0

IS MOMENT, THRUST, SHEAR REPORT DESIRED ? Enter either Y or N

N
 MTV WILL NOT BE OUTPUT

===== END OF INPUT =====

=====

CBASIN
CORPS OF ENGINEERS, CASE PROJECT MODIFIED
SOIL CONSERVATION SERVICE PROGRAM - STILLING BASIN

Example design from Appendix A
Detailed design of type "B" basin

DESIGN PARAMETERS

WIDTH BASIN (FT) W	WALL D.S. (FT) J	LENGTH BASIN (FT) LB	WALL U.S. (FT) N	WATER DEPTH (FT) D1	WATER VELOC (FT/SEC) V1
20.00	20.00	24.00	14.00	2.00	36.00
FROUDE	WATER D2 (FT)	TAILWTR LC - 1 (FT)	UPLIFT LC - 1 (FT)	TAILWTR LC - 2 (FT)	UPLIFT LC - 2 (FT)
FROUDE	D2	HTW1	HUP1	HTW2	HUP2
20.12	11.73	.00	5.86	11.73	11.73
HGT FILL D.STREAM (FT) HB	SLOPE FLOOR RATIO ZS	DEPTH TOE WALL (FT) HTW	THICKNES TOE WALL (IN) TTW	WGT MOIST FILL (LB/CF) GM	WGT SAT FILL (LB/CF) GS
10.00	3.00	4.00	10.00	120.00	140.00
LAT SOIL PRESSURE RATIO (RATIO) KO	BATTER INSIDE WALL (RATIO) BAT	MAXIMUM FOOTING PROJECT (FT) MAXFTG	SAFETY FACTOR FLOATION (RATIO) FLOATR	SAFETY FACTOR SLIDING (RATIO) SLIDER	COEF FRICTION SOIL-CONC (RATIO) CFSC
.80	.38	10.00	1.50	1.00	.35
CONCRETE ULTIMATE STRENGTH (PSI) F'C	RATIO FC TO F'C COESF	ALLOWABLE STEEL STRENGTH (PSI) FSA	ALLOWABLE NET BEAR PRESSURE (PSF) ABP	MINIMUM CONCRETE THICKNESS (IN) TMIN	
4000.00	.40	20000.00	2000.00	10.00	

DESIGN OF SPECIFIED TYPE BASIN FOLLOWS

TYPE (B) STILLING BASIN - TRIAL VALUES

QUANT= 141.10

OVERALL BAS LGT (FT) LTOT 42.00	HORIZ PROJ SLAB (FT) LS 18.00	VERT PROJ INCL SLAB (FT) HS 6.00	DIST WALL VERT INSIDE (FT) HV 14.00		
THICK WALL AT TOP (FT) TT 10.00	THICK WALL AT HV-U (IN) TVU 16.30	THICKNESS OF WALL BATTER (IN) TBB 2.00	THICK BOT WALL NO BAT-U (IN) TBVU 19.00	THICK AT BOTTOM S.WALL-U (IN) TBU 21.00	
THICK OF SIDEWALL AT HV-D (IN) TVD 14.90		THICK BOT WALL NO BAT-D (IN) TBVD 17.00		THICK AT BOT SIDEWALL-D (IN) TBD 19.00	
U.S. FTG PROJECT (FT) FTGU 3.00		SLAB THICK U.S. END (IN) TSUP 18.00		SLAB THICK U.S. BREAK GRADE (IN) TSBGU 22.00	
D.S. FTG PROJECT (FT) FTGD 2.00	SLAB THICK D.S. BREAK GRADE (IN) TSBGD 20.00		SLAB THICK D.S. END (IN) TSDN 20.00		

TYPE (B) STILLING BASIN - DETAIL DESIGN

QUANT= 142.10

THICK WALL AT TOP (FT) TT	THICK WALL AT HV-U (IN) TVU	THICKNESS OF WALL BATTER (IN) TBB	THICK BOT WALL NO BAT-U (IN) TBVU	THICK AT BOTTOM S.WALL-U (IN) TBU
10.00	16.30	2.00	19.00	21.00
THICK OF SIDEWALL AT HV-D (IN) TVD		THICK BOT WALL NO BAT-D (IN) TBVD		THICK AT BOT SIDEWALL-D (IN) TBD
14.90		17.00		19.00
U.S. FTG PROJECT (FT) FTGU		SLAB THICK U.S. END (IN) TSUP		SLAB THICK U.S. BREAK GRADE (IN) TSBGU
3.00		18.00		22.00
D.S. FTG PROJECT (FT) FTGD	SLAB THICK D.S. BREAK GRADE (IN) TSBGD		SLAB THICK D.S. END (IN) TSDN	
2.00	21.00		20.00	

STEEL REQUIREMENTS

WALL---UPSTREAM END

HEIGHT ABOVE BASE FT	AREA STEEL REQUIRED IN**2	MAXIMUM SPACING IN
14.00	.24	18.00
7.00	.30	18.00
.00	2.16	13.91
ON SLOPE		
.00	2.27	13.76
BREAK IN GRADE--UPSTREAM SIDE		
.00	2.47	13.45
BREAK IN GRADE--DOWNSTREAM SIDE		
20.00	.24	18.00
13.00	.30	18.00
6.00	.76	18.00
3.00	1.61	16.26
.00	2.82	12.00

BASE--SECTION AT DOWNSTREAM END

DIST FROM WALL, FT	AREA REQD TOP FACE IN**2	MAX SPACING IN	AREA REQD BOT FACE IN**2	MAX SPACING IN
2.00	.24	18.00	.24	18.00
1.00	.24	18.00	.24	18.00
.00	.24	18.00	.24	18.00
.00	.48	18.00	.37	18.00
5.00	.48	18.00	.24	18.00
10.00	.48	18.00	.24	18.00

SECTION AT DOWNSTREAM SIDE OF BREAK-IN-GRADE

2.00	.25	18.00	.25	18.00
1.00	.25	18.00	.25	18.00
.00	.25	18.00	.25	18.00
.00	.50	18.00	2.39	18.00
5.00	.50	18.00	1.59	18.00
10.00	.50	18.00	1.31	18.00

SECTION AT UPSTREAM SIDE OF BREAK-IN-GRADE

3.00	.26	18.00	.26	18.00
1.50	.26	18.00	.26	18.00
.00	.26	18.00	.26	18.00
.00	.53	18.00	2.02	18.00
5.00	.53	18.00	1.28	18.00
10.00	.53	18.00	1.02	18.00

SECTION AT UPSTREAM END

3.00	.22	18.00	.22	18.00
1.50	.22	18.00	.22	18.00
.00	.22	18.00	.22	18.00
.00	.43	18.00	1.56	18.00
5.00	.43	18.00	.69	18.00
10.00	.43	18.00	.41	18.00

VERTICAL SHEAR AT BREAK-IN-GRADE ARTICULATION JOINT

SHEAR FORCE FOR LC NO.1, LBS.= -1.0135E+04 LC NO.2, LBS.= -1.9788E+04

WINGWALL DESIGN - TRIAL VALUES

THICK OF WINGWALL IN	THICK OF WWALL FTG IN	FTG PROJ AT U.S. END FT	FTG PROJ AT D.S. END FT
TWW	TWF	BUF	BDN
12.00	12.00	14.50	7.00

WINGWALL DESIGN - DETAIL DESIGN

QUANT= 41.35

THICK OF WINGWALL IN	THICK OF WWALL FTG IN	FTG PROJ AT U.S. END FT	FTG PROJ AT D.S. END FT
TWW	TWF	BUF	BDN
12.00	12.00	14.50	7.00

DIST TO JT WINGWALL FT LEVEL	WINGWALL FTG PROJ FT WPROJ	WINGWALL FTG PERF FT WWLB	VOL OF WALL WITHOUT FTG ADJUST CY VWING
12.04	18.38	20.50	44.24

STEEL REQUIREMENTS

AREA OF TIE= 2.88

SECTION AT ARTICULATION JOINT

HEIGHT ABOVE BASE	AREA STEEL REQUIRED	MAXIMUM SPACING
FT	IN**2	IN
13.33	.29	18.00
6.67	.14	18.00
.00	1.17	17.87
DISTANCE FROM WALL	AREA STEEL REQUIRED	MAXIMUM SPACING
FT	IN**2	IN
9.67	.34	18.00
4.83	1.47	18.00
.00	1.93	18.00

SECTION AT UPPER THIRD POINT

HEIGHT ABOVE BASE	AREA STEEL REQUIRED	MAXIMUM SPACING
FT	IN**2	IN
9.11	.29	18.00
4.56	.14	18.00
.00	.35	18.00
DISTANCE FROM WALL	AREA STEEL REQUIRED	MAXIMUM SPACING
FT	IN**2	IN
8.00	.22	18.00
4.00	.68	18.00
.00	.79	18.00

SECTION AT LOWER THIRD POINT

HEIGHT ABOVE BASE	AREA STEEL REQUIRED	MAXIMUM SPACING
FT	IN**2	IN
4.89	.29	18.00
2.44	.14	18.00
.00	.14	18.00
DISTANCE FROM WALL	AREA STEEL REQUIRED	MAXIMUM SPACING
FT	IN**2	IN
6.33	.14	18.00
3.17	.19	18.00
.00	.25	18.00

===== END DETAIL DESIGN =====

WINGWALL PER TRNOTICE 54-1

Stop - Program terminated.

APPENDIX E: SAMPLE CBASIN RUN FOR DETAILED
DESIGN OF TYPE "C" BASIN

 CBASIN -- SOIL CONSERVATION SERVICE PROGRAM SAFBASIN
 ADAPTED TO CORPS OF ENGINEERS CRITERIA BY CASE PROJECT

 * CORPS PROGRAM * X0098 *
 * MICRO VERSION * 89/02/01 *

ENTER TWO HEADER LINES, 80 CHAR. MAX. EACH LINE
 Example design from Appendix A
 Detailed design of type "C" basin
 ENTER THE FOLLOWING

WIDTH BASIN (FT)	WALL D.S. (FT)	LENGTH BASIN (FT)	WALL U.S. (FT)	WATER DEPTH (FT)	WATER VELOC (FT/SEC)	DESIGN PARAM 0,1,2,3	DFALTS 0=DEF 0,1
W	J	LB	N	D1	V1	DESIGN	DFALTS
32.0	18.0	16.0	6.0	2.0	36.0	3	1

DFALT1	DFALT2	DFALT3	DFALT4
1	0	0	1

HEIGHT FILL DOWNSTREAM FT HB	TAILWATER LOAD CASE 2 FT HTW2	UPLIFT HD LOAD C 2 FT HUP2	TAILWATER LOAD C 1 FT HTW1	UPLIFT HD LOAD C 1 FT HUP1
8.0	11.73	7.0	0.0	0.0

CONCRETE ULTIMATE STRENGTH (PSI) F'C	RATIO FC TO F'C COESF	ALLOWABLE STEEL STRESS (PSI) FSA	ALLOWABLE NET BEAR PRESSURE (PSF) ABP	MINIMUM CONCRETE THICKNESS (IN) TMIN
4000.0	0.4	20000.0	2000.0	10.0

IS MOMENT, THRUST, SHEAR REPORT DESIRED ? Enter either Y or N

N
 MTV WILL NOT BE OUTPUT

===== END OF INPUT =====

=====

CBASIN
CORPS OF ENGINEERS, CASE PROJECT MODIFIED
SOIL CONSERVATION SERVICE PROGRAM - STILLING BASIN

Example design from Appendix A
Detailed design of type "C" basin

DESIGN PARAMETERS

WIDTH BASIN (FT) W	WALL D.S. (FT) J	LENGTH BASIN (FT) LB	WALL U.S. (FT) N	WATER DEPTH (FT) D1	WATER VELOC (FT/SEC) V1
32.00	18.00	16.00	6.00	2.00	36.00
FROUDE	WATER D2 (FT)	TAILWTR LC - 1 (FT)	UPLIFT LC - 1 (FT)	TAILWTR LC - 2 (FT)	UPLIFT LC - 2 (FT)
FROUDE	D2	HTW1	HUP1	HTW2	HUP2
20.12	11.73	.00	.00	11.73	7.00
HGT FILL D.STREAM (FT) HB	SLOPE FLOOR RATIO ZS	DEPTH TOE WALL (FT) HTW	THICKNES TOE WALL (IN) TTW	WGT MOIST FILL (LB/CF) GM	WGT SAT FILL (LB/CF) GS
8.00	3.00	4.00	10.00	120.00	140.00
LAT SOIL PRESSURE RATIO (RATIO) KO	BATTER INSIDE WALL (RATIO) BAT	MAXIMUM FOOTING PROJECT (FT) MAXFTG	SAFETY FACTOR FLOATION (RATIO) FLOATR	SAFETY FACTOR SLIDING (RATIO) SLIDER	COEF FRICTION SOIL-CONC (RATIO) CFSC
.80	.38	16.00	1.50	1.00	.35
CONCRETE ULTIMATE STRENGTH (PSI) F'C	RATIO FC TO F'C COESF	ALLOWABLE STEEL STRENGTH (PSI) FSA	ALLOWABLE NET BEAR PRESSURE (PSF) ABP	MINIMUM CONCRETE THICKNESS (IN) TMIN	
4000.00	.40	20000.00	2000.00	10.00	

DESIGN OF SPECIFIED TYPE BASIN FOLLOWS

TYPE (C) STILLING BASIN - TRIAL VALUES

QUANT= 125.44

OVERALL BAS LGT (FT)	HORIZ PROJ SLAB (FT)	VERT PROJ INCL SLAB (FT)	DIST WALL VERT INSIDE (FT)
LTOT	LS	HS	HV
52.00	36.00	12.00	9.00

TOE LENGTH WALL BASE X	WIDTH OF PAVEMENT SLAB XP
12.00	8.00

THICK PAVE U.S. END (IN)	THICK PAVE B. IN GRADE (IN)	THICK PAVE D.S. END (IN)
TPUP	TPBG	TPDN
11.00	14.00	12.00

THICK WALL AT TOP (FT)	THICK WALL AT HV (IN)	THICKNESS OF WALL BATTER (IN)	THICK BOT WALL NO BAT (IN)	THICK AT BOTTOM SIDEWALL (IN)
TT	TV	TBB	TBV	TB
10.00	10.50	3.00	11.00	14.00

FTG PROJECT (FT)	SLAB THICK U.S. END, (IN)	SLAB THICK BREAK IN GRADE (IN)	SLAB THICK D.S. END (IN)
FTG	TSUP	TSBG	TSDN
.00	12.00	15.00	15.00

TYPE (C) STILLING BASIN - DETAIL DESIGN

QUANT= 127.52

TOE LENGTH WALL BASE X	WIDTH OF PAVEMENT SLAB XP
12.00	8.00

THICK PAVE U.S. END (IN)	THICK PAVE B. IN GRADE (IN)	THICK PAVE D.S. END (IN)
TPUP	TPBG	TPDN
11.00	14.00	12.00

THICK WALL AT TOP (FT)	THICK WALL AT HV (IN)	THICKNESS OF WALL BATTER (IN)	THICK BOT WALL NO BAT (IN)	THICK AT BOTTOM SIDEWALL (IN)
TT	TV	TBB	TBV	TB
10.00	10.50	3.00	11.00	14.00

FTG PROJECT (FT)	SLAB THICK U.S. END, (IN)	SLAB THICK BREAK IN GRADE (IN)	SLAB THICK D.S. END (IN)
FTG	TSUP	TSBG	TSDN
.00	12.00	16.00	15.00

STEEL REQUIREMENTS

WALL--UPSTREAM END

HEIGHT ABOVE BASE FT	AREA STEEL REQUIRED IN**2	MAXIMUM SPACING IN
6.00	.24	18.00
3.00	.24	18.00
.00	.26	18.00
ON SLOPE		
.00	.74	18.00
BREAK IN GRADE--UPSTREAM SIDE		
.00	1.76	14.35
BREAK IN GRADE--DOWNSTREAM SIDE		
18.00	.24	18.00
15.00	.24	18.00
12.00	.25	18.00
6.00	.18	18.00
.00	1.76	14.35
INSIDE FACE OF DOWNSTREAM END		
.00	.46	18.00

BASE--SECTION AT DOWNSTREAM END--TOE TO CENTER

DIST FROM WALL FT	AREA REQD TOP FACE IN**2	MAX SPACING IN	AREA REQD BOT FACE IN**2	MAX SPACING IN
.00	.00	18.00	.00	18.00
.00	.00	18.00	.00	18.00
.00	.00	18.00	.00	18.00
.00	.36	18.00	1.20	18.00
6.00	.36	18.00	.26	18.00
12.00	.36	18.00	.18	18.00
SECTION AT BREAK-IN-GRADE				
.00	.00	18.00	.00	18.00
.00	.00	18.00	.00	18.00
.00	.00	18.00	.00	18.00
.00	.38	18.00	1.70	18.00
6.00	.38	18.00	.28	18.00
12.00	.38	18.00	.19	18.00
SECTION AT UPSTREAM END				
.00	.00	18.00	.00	18.00
.00	.00	18.00	.00	18.00
.00	.00	18.00	.00	18.00
.00	.29	18.00	.88	18.00
6.00	.29	18.00	.24	18.00
12.00	.29	18.00	.14	18.00

PAVEMENT SLAB

LOCATION U.S. OF TOE FT	AREA REQD TOP FACE IN**2	MAX SPACING IN	AREA REQD BOT FACE IN**2	MAX SPACING IN
.00	.29	18.00	.14	18.00
8.00	.64	18.00	.16	18.00
16.00	1.36	18.00	.17	18.00
34.00	.84	18.00	.15	18.00
52.00	.26	18.00	.13	18.00

WINGWALL DESIGN - TRIAL VALUES

THICK OF WINGWALL IN TWW	THICK OF WWALL FTG IN TWF	FTG PROJ AT U.S. END FT BUP	FTG PROJ AT D.S. END FT BDN
10.00	10.00	10.50	6.00

WINGWALL DESIGN - DETAIL DESIGN

QUANT= 26.70

THICK OF WINGWALL IN TWW 10.00	THICK OF WWALL FTG IN TWF 10.00	FTG PROJ AT U.S. END FT BUP 10.50	FTG PROJ AT D.S. END FT BDN 6.00
DIST TO JT WINGWALL FT LEVEL 7.78	WINGWALL FTG PROJ FT WPROJ 16.39	WINGWALL FTG PERP FT WWLB 15.11	VOL OF WALL WITHOUT FTG ADJUST CY VWING 26.70

STEEL REQUIREMENTS

AREA OF TIE= 1.79

SECTION AT ARTICULATION JOINT

HEIGHT ABOVE BASE FT	AREA STEEL REQUIRED IN**2	MAXIMUM SPACING IN
12.00	.24	18.00
6.00	.12	18.00
.00	.66	18.00
DISTANCE FROM WALL FT	AREA STEEL REQUIRED IN**2	MAXIMUM SPACING IN
7.00	.25	18.00
3.50	.91	18.00
.00	1.15	18.00

SECTION AT UPPER THIRD POINT

HEIGHT ABOVE BASE FT	AREA STEEL REQUIRED IN**2	MAXIMUM SPACING IN
8.22	.24	18.00
4.11	.12	18.00
.00	.20	18.00
DISTANCE FROM WALL FT	AREA STEEL REQUIRED IN**2	MAXIMUM SPACING IN
6.00	.15	18.00
3.00	.42	18.00
.00	.50	18.00

SECTION AT LOWER THIRD POINT

HEIGHT ABOVE BASE FT	AREA STEEL REQUIRED IN**2	MAXIMUM SPACING IN
4.44	.24	18.00
2.22	.12	18.00
.00	.12	18.00
DISTANCE FROM WALL FT	AREA STEEL REQUIRED IN**2	MAXIMUM SPACING IN
5.00	.12	18.00
2.50	.12	18.00
.00	.16	18.00

=====
END DETAIL DESIGN
=====

WINGWALL PER TRNOTICE 54-1

HUP2 IS GIVEN AS 7.00, THIS IS LESS THAN HTW2 GIVEN AS 11.73.
IT MAY BE APPROPRIATE TO CONSIDER AN ADDITIONAL TYPE (C) DESIGN
WITH HUP2 = HTW2.

Stop - Program terminated.

**WATERWAYS EXPERIMENT STATION REPORTS
PUBLISHED UNDER THE COMPUTER-AIDED
STRUCTURAL ENGINEERING (CASE) PROJECT**

	Title	Date
Technical Report K-78-1	List of Computer Programs for Computer-Aided Structural Engineering	Feb 1978
Instruction Report O-79-2	User's Guide: Computer Program with Interactive Graphics for Analysis of Plane Frame Structures (CFRAME)	Mar 1979
Technical Report K-80-1	Survey of Bridge-Oriented Design Software	Jan 1980
Technical Report K-80-2	Evaluation of Computer Programs for the Design/Analysis of Highway and Railway Bridges	Jan 1980
Instruction Report K-80-1	User's Guide: Computer Program for Design/Review of Curvilinear Conduits/Culverts (CURCON)	Feb 1980
Instruction Report K-80-3	A Three-Dimensional Finite Element Data Edit Program	Mar 1980
Instruction Report K-80-4	A Three-Dimensional Stability Analysis/Design Program (3DSAD) Report 1: General Geometry Module Report 3: General Analysis Module (CGAM) Report 4: Special-Purpose Modules for Dams (CDAMS)	Jun 1980 Jun 1982 Aug 1983
Instruction Report K-80-6	Basic User's Guide: Computer Program for Design and Analysis of Inverted-T Retaining Walls and Floodwalls (TWDA)	Dec 1980
Instruction Report K-80-7	User's Reference Manual: Computer Program for Design and Analysis of Inverted-T Retaining Walls and Floodwalls (TWDA)	Dec 1980
Technical Report K-80-4	Documentation of Finite Element Analyses Report 1: Longview Outlet Works Conduit Report 2: Anchored Wall Monolith, Bay Springs Lock	Dec 1980 Dec 1980
Technical Report K-80-5	Basic Pile Group Behavior	Dec 1980
Instruction Report K-81-2	User's Guide: Computer Program for Design and Analysis of Sheet Pile Walls by Classical Methods (CSHTWAL) Report 1: Computational Processes Report 2: Interactive Graphics Options	Feb 1981 Mar 1981
Instruction Report K-81-3	Validation Report: Computer Program for Design and Analysis of Inverted-T Retaining Walls and Floodwalls (TWDA)	Feb 1981
Instruction Report K-81-4	User's Guide: Computer Program for Design and Analysis of Cast-in-Place Tunnel Linings (NEWTUN)	Mar 1981
Instruction Report K-81-6	User's Guide: Computer Program for Optimum Nonlinear Dynamic Design of Reinforced Concrete Slabs Under Blast Loading (CBARCS)	Mar 1981
Instruction Report K-81-7	User's Guide: Computer Program for Design or Investigation of Orthogonal Culverts (CORTCUL)	Mar 1981
Instruction Report K-81-9	User's Guide: Computer Program for Three-Dimensional Analysis of Building Systems (CTABS80)	Aug 1981
Technical Report K-81-2	Theoretical Basis for CTABS80: A Computer Program for Three-Dimensional Analysis of Building Systems	Sep 1981
Instruction Report K-82-6	User's Guide: Computer Program for Analysis of Beam-Column Structures with Nonlinear Supports (CBEAMC)	Jun 1982
Instruction Report K-82-7	User's Guide: Computer Program for Bearing Capacity Analysis of Shallow Foundations (CBEAR)	Jun 1982

(Continued)

**WATERWAYS EXPERIMENT STATION REPORTS
PUBLISHED UNDER THE COMPUTER-AIDED
STRUCTURAL ENGINEERING (CASE) PROJECT**

(Continued)

	Title	Date
Instruction Report K-83-1	User's Guide: Computer Program With Interactive Graphics for Analysis of Plane Frame Structures (CFRAME)	Jan 1983
Instruction Report K-83-2	User's Guide: Computer Program for Generation of Engineering Geometry (SKETCH)	Jun 1983
Instruction Report K-83-5	User's Guide: Computer Program to Calculate Shear, Moment, and Thrust (CSMT) from Stress Results of a Two-Dimensional Finite Element Analysis	Jul 1983
Technical Report K-83-1	Basic Pile Group Behavior	Sep 1983
Technical Report K-83-3	Reference Manual: Computer Graphics Program for Generation of Engineering Geometry (SKETCH)	Sep 1983
Technical Report K-83-4	Case Study of Six Major General-Purpose Finite Element Programs	Oct 1983
Instruction Report K-84-2	User's Guide: Computer Program for Optimum Dynamic Design of Nonlinear Metal Plates Under Blast Loading (CSDOOR)	Jan 1984
Instruction Report K-84-7	User's Guide: Computer Program for Determining Induced Stresses and Consolidation Settlements (CSETT)	Aug 1984
Instruction Report K-84-8	Seepage Analysis of Confined Flow Problems by the Method of Fragments (CFRAG)	Sep 1984
Instruction Report K-84-11	User's Guide for Computer Program CGFAG, Concrete General Flexure Analysis with Graphics	Sep 1984
Technical Report K-84-3	Computer-Aided Drafting and Design for Corps Structural Engineers	Oct 1984
Technical Report ATC-86-5	Decision Logic Table Formulation of ACI 318-77, Building Code Requirements for Reinforced Concrete for Automated Constraint Processing, Volumes I and II	Jun 1986
Technical Report ITL-87-2	A Case Committee Study of Finite Element Analysis of Concrete Flat Slabs	Jan 1987
Instruction Report ITL-87-1	User's Guide: Computer Program for Two-Dimensional Analysis of U-Frame Structures (CUFRAM)	Apr 1987
Instruction Report ITL-87-2	User's Guide: For Concrete Strength Investigation and Design (CASTR) in Accordance with ACI 318-83	May 1987
Technical Report ITL-87-6	Finite-Element Method Package for Solving Steady-State Seepage Problems	May 1987
Instruction Report ITL-87-3	User's Guide: A Three Dimensional Stability Analysis/Design Program (3DSAD), Report 1, Revision 1: General Geometry Module	Jun 1987
Instruction Report ITL-87-4	User's Guide: 2-D Frame Analysis Link Program (LINK2D)	Jun 1987
Technical Report ITL-87-4	Finite Element Studies of a Horizontally Framed Miter Gate Report 1: Initial and Refined Finite Element Models (Phases A, B, and C), Volumes I and II Report 2: Simplified Frame Model (Phase D) Report 3: Alternate Configuration Miter Gate Finite Element Studies—Open Section Report 4: Alternate Configuration Miter Gate Finite Element Studies—Closed Sections	Aug 1987

(Continued)

**WATERWAYS EXPERIMENT STATION REPORTS
PUBLISHED UNDER THE COMPUTER-AIDED
STRUCTURAL ENGINEERING (CASE) PROJECT**

(Concluded)

	Title	Date
Technical Report ITL-87-4	Finite Element Studies of a Horizontally Framed Miter Gate Report 5: Alternate Configuration Miter Gate Finite Element Studies—Additional Closed Sections Report 6: Elastic Buckling of Girders in Horizontally Framed Miter Gates Report 7: Application and Summary	Aug 1987
Instruction Report GL-87-1	User's Guide: UTEXAS2 Slope-Stability Package; Volume I, User's Manual	Aug 1987
Instruction Report ITL-87-5	Sliding Stability of Concrete Structures (CSLIDE)	Oct 1987
Instruction Report ITL-87-6	Criteria Specifications for and Validation of a Computer Program for the Design or Investigation of Horizontally Framed Miter Gates (CMITER)	Dec 1987
Technical Report ITL-87-8	Procedure for Static Analysis of Gravity Dams Using the Finite Element Method — Phase Ia	Jan 1988
Instruction Report ITL-88-1	User's Guide: Computer Program for Analysis of Planar Grid Structures (CGRID)	Feb 1988
Technical Report ITL-88-1	Development of Design Formulas for Ribbed Mat Foundations on Expansive Soils	Apr 1988
Technical Report ITL-88-2	User's Guide: Pile Group Graphics Display (CPGG) Post- processor to CPGA Program	Apr 1988
Instruction Report ITL-88-2	User's Guide for Design and Investigation of Horizontally Framed Miter Gates (CMITER)	Jun 1988
Instruction Report ITL-88-4	User's Guide for Revised Computer Program to Calculate Shear, Moment, and Thrust (CSMT)	Sep 1988
Instruction Report GL-87-1	User's Guide: UTEXAS2 Slope-Stability Package; Volume II, Theory	Feb 1989
Technical Report ITL-89-3	User's Guide: Pile Group Analysis (CPGA) Computer Group	Jul 1989
Technical Report ITL-89-4	CBASIN--Structural Design of Saint Anthony Falls Stilling Basins According to Corps of Engineers Criteria for Hydraulic Structures; Computer Program X0098	Aug 1989