

ឧបករណ៍

សម្រាប់យានយន្ត និងការពារ

FULL

AUTOMOTIVE EQUIPMENT RANGE







មាតិកាសៀវភៅកាតាឡុក / CONTENT

1. ប៉ុងលើកឡាន/Hydraulic Lift	ទំព័រ 05 - 09
2. ខ្នុយ និងដងស្នូច/Crane & Lift	ទំព័រ 10 - 11
3. ម៉ាស៊ីនតម្រង់កង់/ Alignment Wheel	ទំព័រ 12 - 14
4. សេវាកម្មសំបកកង់/Tyre Service	ទំព័រ 15 - 18
5. សេវាកម្មប្រេងម៉ាស៊ីន/Oil Service	ទំព័រ 19 - 23
6. សេវាកម្មប្រេងប្រអប់លេខ/ATF Machine	ទំព័រ 24 - 26
7. សេវាកម្មប្រេងប្រាំង /Brake FLuid	ទំព័រ 27 - 28
8. អាគុយកូរថយន្ត /Battery Charger	ទំព័រ 29 - 30
9. សេវាកម្មម៉ាស៊ីនត្រជាក់រថយន្ត /AC System	ទំព័រ 31 - 33
10. សេវាកម្មលាងសម្អាត/Washing & Cleaning	ទំព័រ 34 - 36
11. ផ្នែកតោន /Hydraulic Press	ទំព័រ 37 - 39
12. បន្ទប់បាញ់ថ្នាំ /Paint Booth	ទំព័រ 40 - 42
13. លិខិតអនុញ្ញាតិ /Approval Letter	ទំព័រ 43 - 44
14. កិច្ចព្រមព្រៀង/Contract Option	ទំព័រ 45 - 46
15. លិខិតធានា /Warranty	ទំព័រ 47- 48

ជូនចំពោះអតិថិជនជាទីរាប់អាន!

ខ្ញុំមានសេចក្តីសោមនស្សរីករាយក្នុងការបង្ហាញពីផលិតផលថ្មីៗដល់លោកអ្នកដែលយើងដាក់ឈ្មោះថា "ឧបករណ៍យានដ្ឋាន" សម្រាប់ផ្នែកយានយន្តទូទៅ។

វើសធី (Wuerth) តំណាងឱ្យផលិតផលមានគុណភាពខ្ពស់ ដូចគ្នានេះដែរចំពោះផលិតផលថ្មីទាំងនេះគឺយើងរក្សានូវគុណភាពខ្ពស់។ យើងរក្សាបានការសន្យាលើគុណភាព ជាពិសេសឧបករណ៍ប្រើប្រាស់នៅក្នុងយានដ្ឋានរថយន្ត និងម៉ូតូទាំងអស់នេះ មិនមែនមានន័យថា ត្រឹមតែគុណភាពនោះទេតែវាជាដំណោះស្រាយនិងជំនួយការងារប្រចាំថ្ងៃរបស់លោកអ្នកផងដែរ។

ជាមួយនឹងកាតាឡុកនេះយើងពង្រីកផលិតផលបន្ថែមទៀត ដែលបំពេញបានតាមគ្រប់តម្រូវការនៃយានដ្ឋាន ហើយផលិតផលទាំងអស់នេះ មានតម្លៃសមរម្យទៅតាមគុណភាពខ្ពស់នៃផលិតផលទាំងនោះ។

យើងប្រាកដថា ការបន្ថែមមុខផលិតផលនេះនៅក្នុងផ្នែកឧបករណ៍យានដ្ឋាននេះ នឹងជួយអ្នកឱ្យទទួលបានឧបករណ៍ដែលត្រូវនឹងអ្វីដែលអ្នកកំពុងស្វែងរក។

យើងសង្ឃឹមនិងជឿជាក់ថាអ្នកនឹងពេញចិត្តជាមួយផលិតផលWuerthជាពិសេសឧបករណ៍សម្រាប់យានដ្ឋានទាំងអស់នេះ។

សូមអរគុណ

Dear Customers,

I am delighted to present the new product line called "Workshop Equipment" in Automotive division to you.

Wuerth stands for uncompromising product quality. with this new product line we keep this promise. Especially equipment used in all car and motorbike workshop are more than means to an end, they are problems solvers and assist you in your daily work.

With this catalogue we expand our product lines which fit mostly all requirement in the workshop and beside the high quality equipment, they offer the absolutely perfect price performance ratio as well.

We are sure that this expansion of product range in the field of workshop equipment will help you to find the right tools you are looking for.

We hope you enjoy our Wuerth products and particularly the new workshop equipment line products.

Kind Regard



លោក ទេព ទីណូ / Mr.Tino Tep
នាយកគ្រប់គ្រង / Managing Director
ក្រុមហ៊ុន វើសធី (ខេមបូឌា) អិលធីឌី
Wuerth (Cambodia) LTD.

HYDRAULIC LIFTS

ប៉ូតលើកថ្នល់ / Two Post lift



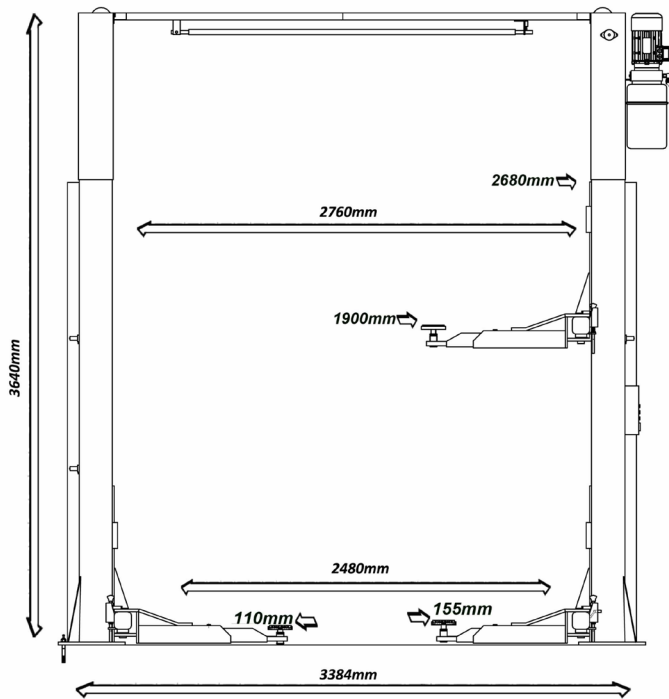

Technical Data

Lifting Capacity	4,000 kg
Max. Lifting Height	1900mm
Overall Height	3640mm
Overall Width	3384mm
Drive Through Clearance	2480mm
Front Supporting Arm Length	600-1100mm
Rear Supporting Arm Length	750-1330mm
Adapter Height Min.	110mm
Adapter Height Max.	155mm
Clear Size Column Spacing	2760mm
Switch Off Level	2680mm
Motor Performance	2.2kw
Electrical Connection 3 Phases	380v-415v
Lifting Time	≤60sec
Lowering Time	20-60sec
Ambient Air Temperature	+5°C ~ +40°C
Ambient Air Humidity	≤50%
Altitude	below 1,000 m above sea level
Storage Temperature	-25°C ~ +55°C
Noise	<70db

លេខកូដ/Art.No. 0900700140

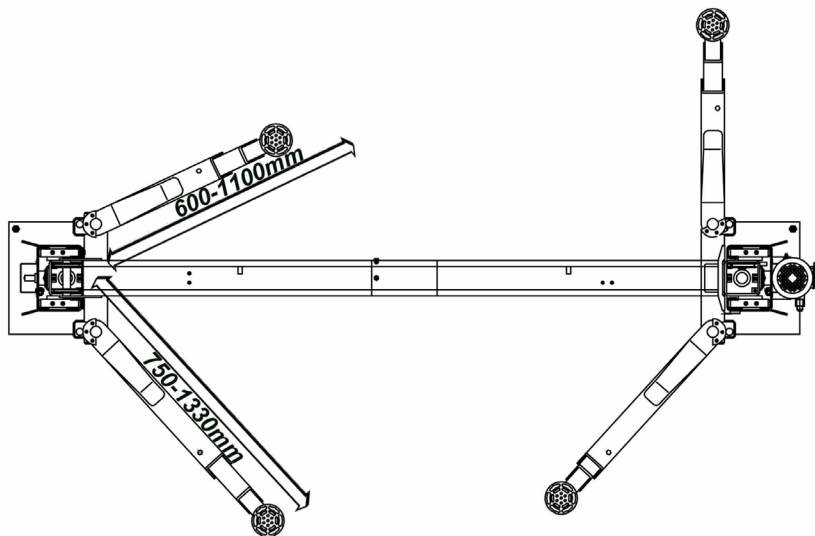

ប៉ុងលើករថយន្តជើង៤ តម្រង់/4 Post Lift

ប៉ុងលើករថយន្តជើង៤ តម្រង់ កង់ថយន្ត ប្រើបូមអេឡិចត្រូនិច ដែលមានភាពរឹងមាំប្រើប្រាស់ ថាមពលអគ្គិសនី ។

Wheel Alignment Electro-hydraulic 4 post lift, with mid rise Pneumatic lift.

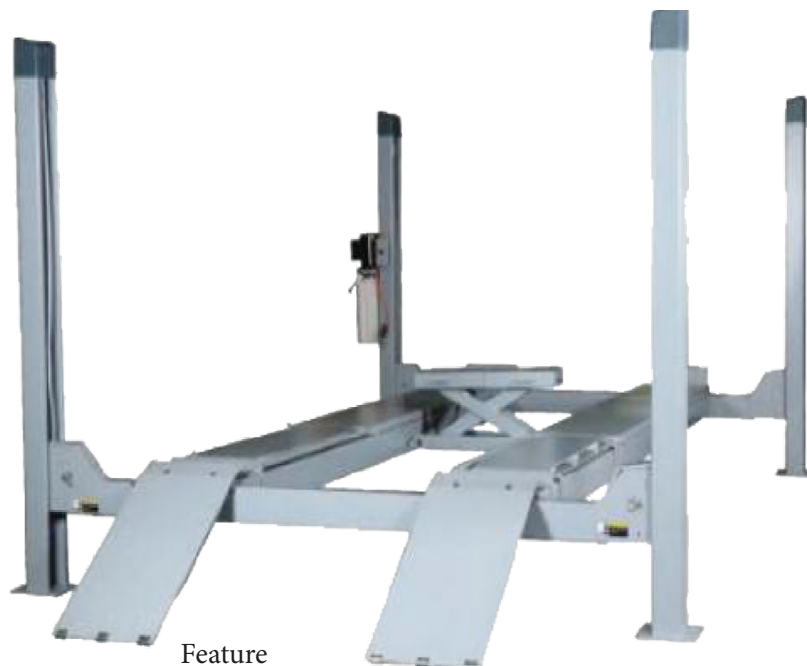

គុណសម្បត្តិ

- មានវ៉ាល់គ្រប់គ្រងបានល្អ
- មានវ៉ាល់សុវត្ថិភាព
- ប្រព័ន្ធសុវត្ថិភាពពេលធ្លាក់ចុះ
- 115% Dynamic load CE test (4600kg)
- 150% Static load CE test (6000Kg)
- 125% Unbalance load CE test (5000kg)
- ប្រព័ន្ធសុវត្ថិភាពប្រើលើសទម្ងន់

Feature

- Descent control valve.
- Pipe burst safety valve.
- Automatic disengagement of safety wedges prior to descent.
- 115% Dynamic load CE test (4600kg)
- 150% Static load CE test (6000Kg)
- 125% Unbalance load CE test (5000kg)
- Overload safety-drive.

Model	Art.No. 0900705113	Pneumatic Release
Wheel Alignment Electro-hydraulic 4 Post lift, with mid rise Pneumatic lift.		
Technical Data		
Standard	Lifting Capacity	4000kg
	Weight	1250kg
A	Rise/Floor to top of runway	1900mm
B	Length overall (Incl. access)	5880mm
C	Width overall	3430mm
D	Inside of columns	3040mm
E	Between columns	4630mm
F	Column height(Incl. cap)	2300mm
G	Width of runways	545mm
H	Height of runways	170mm
I	Width between runways Min./Max.	900mm-1280mm
Others	Motor performance	2.2kW
	Motor RPM	2800
	Electrical connection	380V-415V/(3 phases)/50-60Hz 215V-240V/(1 phases)/50-60Hz
	Lifting time	≤60 sec
	Lowering time	20-60 sec

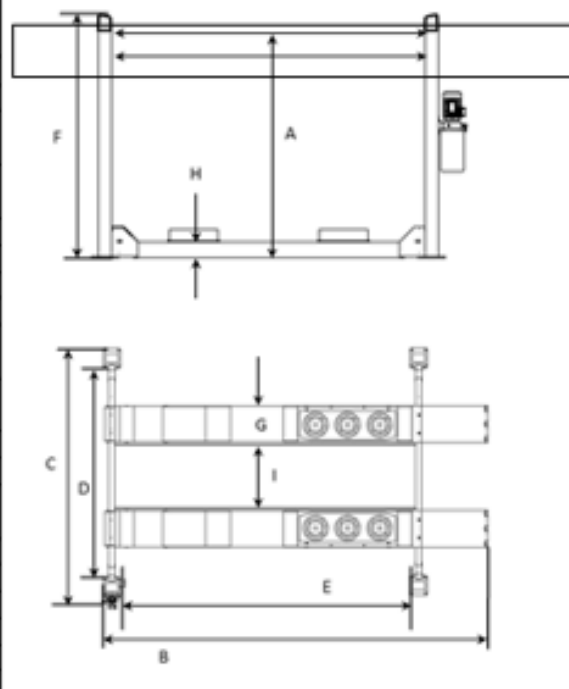

ប្លង់កង្រែ/PLATFORM SCISSOR LIFT 3.5 TON



នេះគឺជាឧបករណ៍ប៉ងលើករថយន្តដែលមានលក្ខណៈស្តង់ដារអឺរ៉ុប សម្រាប់ជួសជុលនិងធ្វើការត្រួតពិនិត្យគ្រឿងក្រោមរថយន្ត ប្រកបដោយសុវត្ថិភាព។ ចំណុចសំខាន់គឺសក្ខីសមប្រើប្រាស់នៅកន្លែងចង្អៀត និងធានាបាននូវសុវត្ថិភាពខ្ពស់ជាពិសេសវាមានប្រព័ន្ធដំណើរការដោយសំពាធបូមទាំងស្រុង។

Professional Lifting equipment for saloon car's maintenance and examining. It has the main characteristic of occupying small area, good security capability. Especially for the full hydraulic pressure working system, it is suitable for various situations.

លេខកូដ/Art.No. 1918 500 062 380V

Feature

- Scissor concealing platform structure which occupied small space.
- Device perform stable work is relay on imported hydraulic, pneumatic and electrical components.
- The Pneumatic wide-teeth self-locking insurance system and anti-explosion pipe equipment ensure the safety and reliability of device.
- Easy for tyre of mount and dismount and chassis maintenance.
- The highest lift height with 2M in the same kind product and adjustable platform length is suitable for various types of automobile.
- Enhanced joint structure complies with the American and European market standard.
- Enhanced cylinder with German seals.
- 115% Dynamic load CE Test (4025Kg)
- 150% Static load CE test (5250Kg)
- 125% Unbalance Load CE test (4375kg)

ពណ៌ / Color	លេខកូដ / Article No
ខៀវ/Blue	09007 705 158
ប្រផេះ /Grey	09007 705 159
ក្រហម/Red	09007 705 160

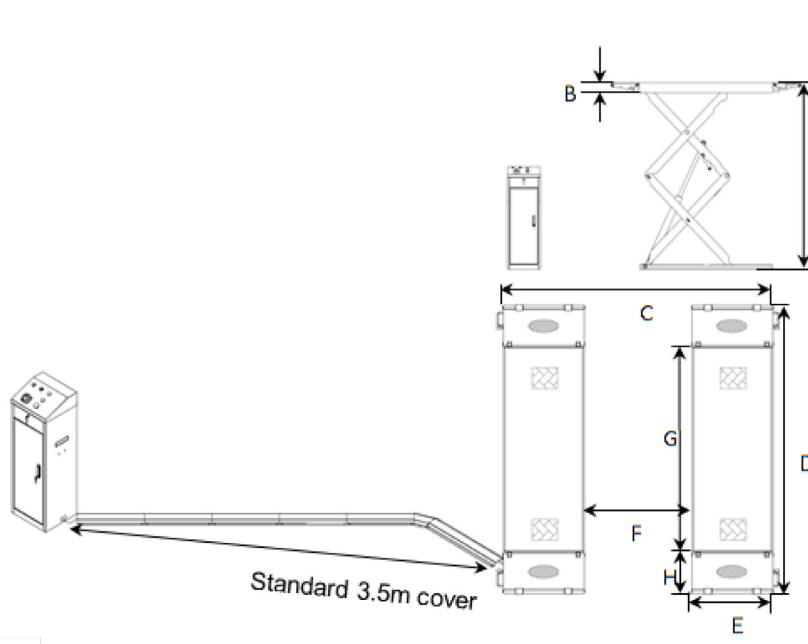

ដួយលើកប្រអប់លេខ / Gear Lifting Jack

1. ឈ្នានីសបំបូមឡើងទប់ប្រអប់លេខ / Pedal pump Chromium plate piston rod
2. ប្រព័ន្ធទម្លាក់ចុះដោយស្វ័យប្រវត្តិ / Lift-down control system "Automatic"
3. មានកង់រុញ / With wheels



ឧបករណ៍បន្ថែម
Accessory Auto
Gear lift
កូដ code 0715 9

ទំហំ / Size	លេខកូដ / Article No
1 Ton	1918 500 158
1.5 Ton	1918 500 159

ដងស្មូចម៉ាស៊ីន / Crane Overhaul

បូមពីតង់ជាមួយនិងប្រព័ន្ធសុវត្ថិភាព ដើម្បីការពារប្រើប្រាស់លើសទម្ងន់។ / Two stroke pump with safety valve to prevent overweight with an automatic stop system chromium plated hydraulic cylinder



ទំហំ / Size	លេខកូដ / Article No
1 Ton	1918 500 167
2 Tons	1918 500 166

កំណាត់រថយន្ត / Car Lift Stand

រឹងមាំនិងប្រើប្រាស់បានយូរភ្ជាប់មកជាមួយកង់និងកែបធំ / Strong and durable, comes with a wheel and large saddle



ទំហំ / Size	លេខកូដ / Article No
3 Tons	06915 39 703
6 Tons	06915 39 706
10 Tons	06915 39 710



375/570mm

ម៉ូដែលនេះអាចបត់ជើង ងាយស្រួលទុកជាក៏ / For the folding version, saving space, convenient and easy to store

ទំហំ / Size	លេខកូដ / Article No
3 Tons	06915 39 783

ដង hydraulic បត់បាន360ដឺក្រេ / Folding hydraulic overhead crane (360 Degree Rotation) 2tons 1t on /2,080mm



ខ្នុយលើកឡាន / Car Jack



ទ្រទម្ងន់ 2 តោន កម្ពស់ 80 មីលីម៉ែត្រ
សម្រាប់ ខ្នុយរថយន្តឡើង / 2 ton /
80mm hydraulic jack for car loading

ទំហំ / Size	លេខកូដ / Article No
2 Tons	1918 500 156

ទ្រទម្ងន់ 3 តោន កម្ពស់ 115 មីលីម៉ែត្រ
សម្រាប់ ខ្នុយរថយន្ត / 3 tons / 115mm
hydraulic jack for car loading



ទំហំ / Size	លេខកូដ / Article No
3 Tons	1918 500 157

*បន្ថែមកងជើងដើម្បីកាត់បន្ថយសំឡេងរំខាន / *Ultra low base nylon wheels to reduce noise

ប៉ុងសម្រាប់រថយន្តធុនធ្ងន់សម្រាប់យានយន្តកសិកម្ម និងសំណង់ Jack for heavy agricultural and construction vehicles

- គូខ្លួនធ្វើពីដែកក្រាស់ / Extra thick steel frame
- ដងលើកវែងនិងងាយស្រួលក្នុងការប្រើប្រាស់ប្រវែង 150 x 570 mm / Longer lifting point easy and convenient to use 150 x 570 mm



ទំហំ / Size	លេខកូដ / Article No
5 Tons	0715 54 313
10 Tons	0715 54314

ខ្នុយឡាន 10 តោន / 10-ton gearbox jack



ខ្នុយបីស្តង់មានមុខកាត់ 165 x 161mm
/ Hydraulic Jack chromium plate piston
surface 165x161mm.

ទំហំ / Size	លេខកូដ / Article No
10 Tons	0715 54 362

ខ្នុយ ឥដ្ឋាខ្នុប Twic screw hydraulic Jack

- គ្រោងដែករឹងមាំ / Structure is strong
 - សុវត្ថិភាពពេលលើកដាក់ / Safe Lifting
- ទុយោភ្លោះប្រើកម្លាំងតិចនិងលើកបានលឿន / Twin Pump use less power and can lift faster

ទ្រទម្ងន់ 2.5 តោន មានទុយោខ្លាំងទ្វេគុណ (លើកដាក់រថយន្ត)
/ 2.5 ton hydraulic jack, Double pump (Vehicle Loading)



Chrome Plated
Cylinder and special system seals



75 x 515mm

ទំហំ / Size	លេខកូដ / Article No
2.5 Tons double pump	0715 54 311

ទ្រទម្ងន់ 3 តោននិងទុយោភ្លោះ / 3 tons hydraulic jack, Twin pump

130 x 455mm



ទំហំ / Size	លេខកូដ / Article No
3 Tons double pump	10715 54 310

ខ្នុយលើកឡាន ចល័ត Hydraulic Jack



ខ្នុយ កម្ពស់ 150mm
ទម្ងន់ 680 គីឡូ / Lift Jack
150mm. 680kg



ទំហំ / Size	លេខកូដ / Article No
680 Kg	0715 98 051

បំពាក់

តម្រូវការ

ALIGNMENT

WHEEL

ម៉ាស៊ីនតម្រង់សំបកកង់ / Alignment Machine

ប្រព័ន្ធតម្រង់កង់ 3D ម៉ូដែល SEROS 9002 ប្រព័ន្ធប្រតិបត្តិការមានគុណខ្ពស់ពីប្រទេសអាល្លឺម៉ង់ / 3D System Alignment Machine SEROS Premium quality operating system from Germany

លេខកូដ/ Art.No. 5997 567 240

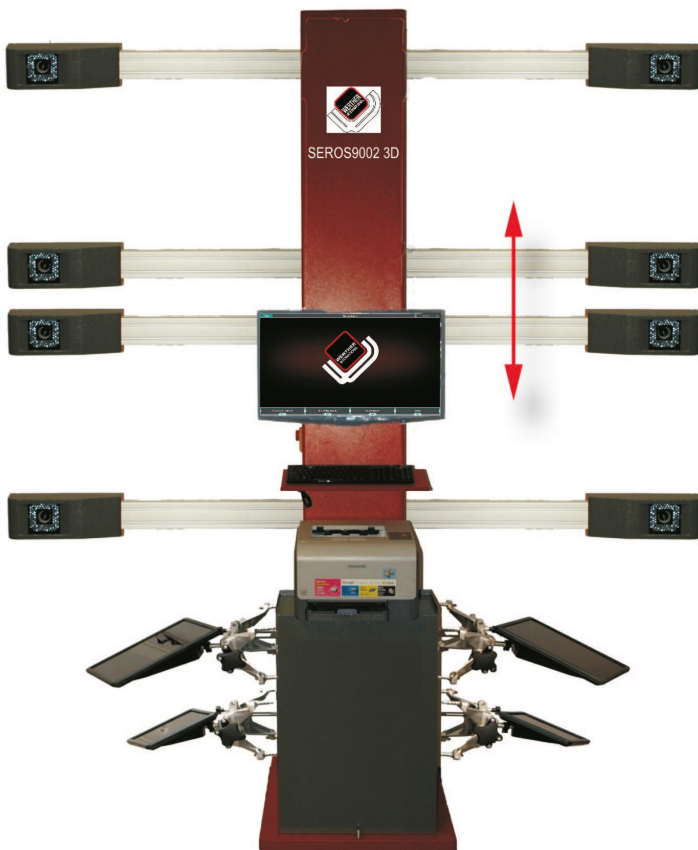

Article No. 5997567240

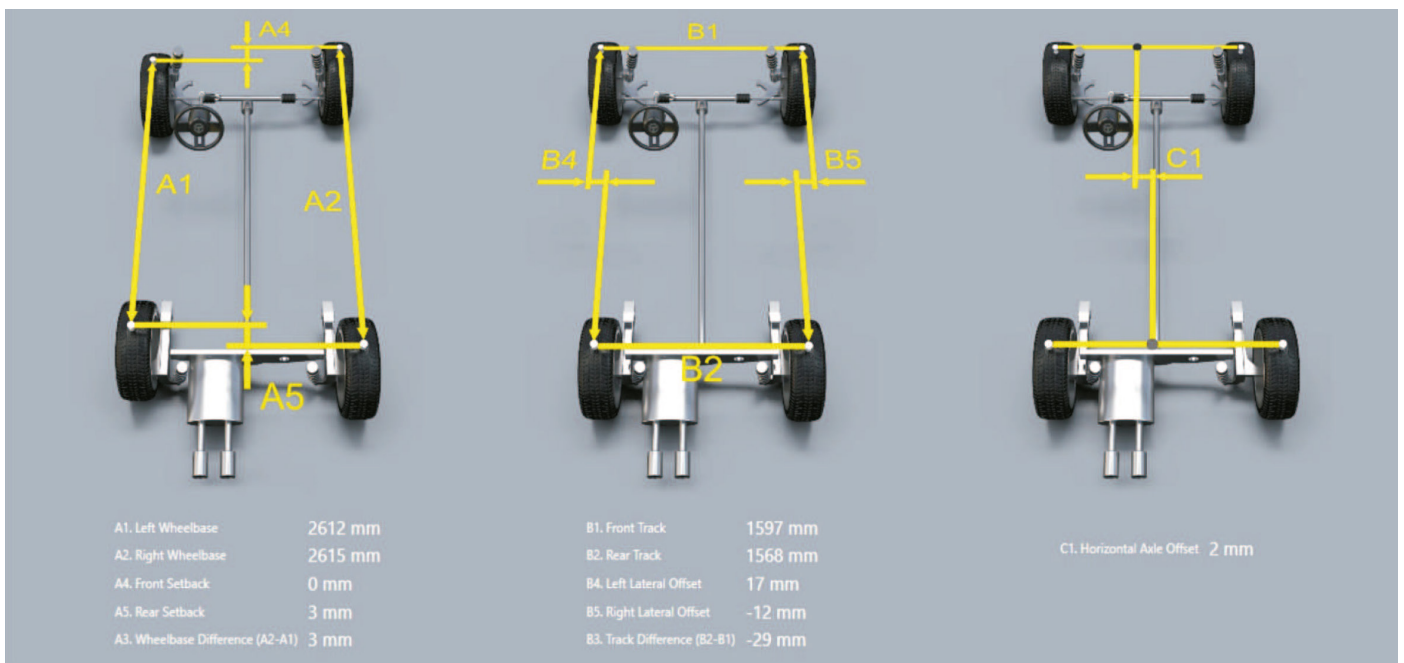
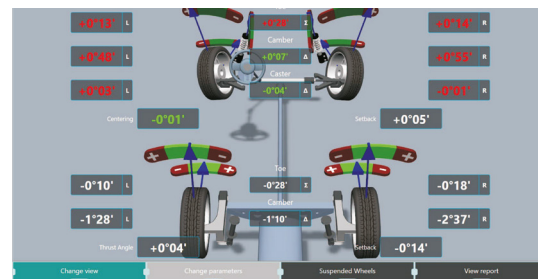

ប៉ុន្តប្រុងកងលើកក្រឡា / Scissor Alignment Lift

ប៉ុន្តប្រុងកង អាចទ្រទ្រង់ទម្ងន់ 4.5 តោន ងាយស្រួលប្រើប្រាស់ និងសាច់ដៃករឹងមាំ។

D35 /D45 /D55 Scissor Alignment Lift with Jacks

លេខកូដ/ Art. 5997 570 660

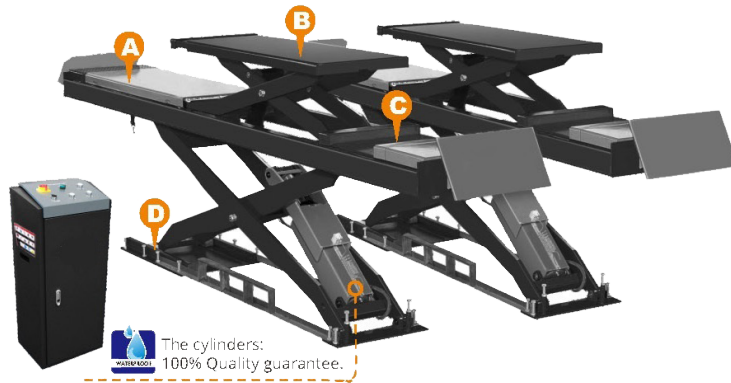

The cylinders:
100% Quality guarantee.



Descent alarm engaged



Four wheel alignment function



Pneumatic Release



Adopted high-strength wear resistant rolling bearing design, sliding flexible, especially for wheel alignment.



Extendable jack platform



Optional turntable can be placed in different positions to accommodate more vehicles



Sliding blocks adopt oil free super-wearable materials

Dimensions

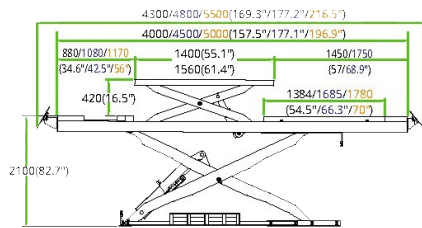

PL-D35 /D45 /D55

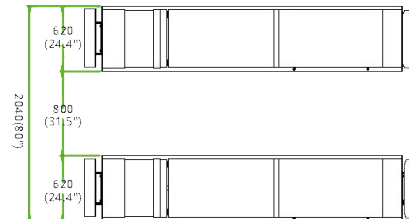

Parameters

MODEL	Lifting capacity	Lifting height	Secondary lifting height	Min height	Lifting time	Lowering time	Optional power supply	Motor power
PL-D35	≤3500kg (7716 lbs)	≤2100mm (82.7")	450mm (17.7")	330mm (13")	55 S	55 S	220v (1ph) /380v(3ph)	2.2 kw
PL-D45	≤4500kg (9921 lbs)	≤2100mm (82.7")	450mm (17.7")	330mm (13")	55 S	55 S	220v (1ph) /380v(3ph)	2.2 kw
PL-D55	≤5500kg (12100 lbs)	≤2200mm (86.6")	450mm (17.7")	380mm (15")	55 S	55 S	220v (1ph) /380v(3ph)	2.2 kw

សេវាកម្ម

សំបកកង់

TYRE

SERVICE

ម៉ាស៊ីនប្តូរសំបកកង់ Titanium 200 / 24 tyre changer

ម៉ាស៊ីនប្តូរសំបកកង់ងាយស្រួលប្រើប្រាស់

Mechanical arm helps to hold for more convenient operating

- រង្វល់ជុំល្បឿន (6-12 rpm)
- ស្នប់កង់
- កម្រិតសំពាធ ខ្ពស់រហូតដល់ 3.5 Ba(50 PSI)
- ទំពក់គាស់កង់មានប្លាស្ទិកការពារយ៉ាន់ស្ត័រ
- ក្រញាប់កង់កន្លែងដាក់ខ្លាញ់គោ
- ឧបករណ៍បំបែកកង់ពីយ៉ាន់មានប្លាស្ទិកការពារ។
- Double speed turnable (6-12 rpm)
- Inflating gun
- pressure limited Valve max. 3.5 bar (50 PSI)
- mounting lever with plastic protection
- lubricator + filter regulator assistant
- set of alloy rims protection
- Ring bracket and grease pot
- bead breaker with plastic protection for alloy rims



ទំហំ / Size	លេខកូដ / Article No
1 Ton	19185 001 53

Optionals:



Quick re-tooling kit



Motorcycle adapter kit



Assistant H Titanium
Art.No. 1918 500 153



Wheel Lift

Single-phase motor
(single speed)

ម៉ាស៊ីនថ្លឹងកង់រថយន្ត
Wheel balancer

ម៉ាស៊ីនថ្លឹងកង់ 3D Digital សម្រាប់ប្រើប្រាស់គ្រប់ទំហំសំបកកង់រថយន្ត / Premium 3D Digital display wheel balancer for frequent usage with full tire size coverage

Alpha 2040
Wheel balancer



លេខកូដ / Article No
5997 534 991

ម៉ាស៊ីនបូមខ្យល់ខ្នើជីថល
Digital Tyre Inflator

ម៉ាស៊ីនបូមខ្យល់ប្រើប្រាស់អគ្គិសនី ដោយប្រើលេខជាខ្នើជីថល / Digital electric inflator use electronicity.



លេខកូដ / Article No
5997 532 520

Alpha 4040
Wheel balancer



លេខកូដ / Article No
1918 500 154



លេខកូដ / Article No
5997 530 701

ម៉ាស៊ីនបូមកង់ខ្យល់នីត្រូហ្សែន
Nitrogen Inflator

220v/ 50 Hz/1PH
 Art. No. 5997 552 730



ក្ដារដេកជាមួយកន្លែងដាក់ឧបករណ៍
Car creeper with tool holder

Size : 1010 x 475 x 130 mm
 Art. No. 0715 93 007



Size : 901 x 120 x 425 mm
 Art. No. 0715 93 070



ធុងបាញ់ហ្វូមពពុះសាប៊ូ
Foam sprayer

ម៉ាស៊ីនបាញ់ហ្វូមប្រើខ្យល់ចំណុះ២៤លីត្រ
 24 Liters compressed air foam injection machine
 Art.No. 1918 500 164



ធុងបូមខ្យល់
Tire Inflating Tank

ធុងផ្ទុកខ្យល់ចំណុះ២៤លីត្រ
 24 Liters tire inflating tank
 Art.No. 1918 500 165



සෙවකප
ද්‍රව්‍යවිකල්ප

OIL
SERVICE

ធុងបូមប្រេងម៉ាស៊ីន Suction Oil

ចំណុះ 90 លីត្រ / Tank 90 litre

Art. No. 5966 554 015



ធុងត្រង់ប្រេងម៉ាស៊ីន Engine oil drain tank

ចំណុះ 80 លីត្រ / Tank 80 litre

Art. No. 0715 930 911



ធុងបូមប្រេងម៉ាស៊ីនចំណុះ 90 លីត្រ Oil scavenging tool 90L

ធុងចំណុះ 90 លីត្រ ជាមួយនឹងទុយោចំនួន ៧ ដើម/90
Liters tank with 7 suction pipes.

Art.No. 0715 93 91



ម៉ាស៊ីនបូមប្រេងប្រើស្នប់ដៃ Manual oil pump

ធុងផ្ទុកខ្យល់ចំណុះ ២៤ លីត្រ និងទុយោ 1,5
ម៉ែត្រ/ 24 Liters hand-filling oil tank 1.5 metter long fuel

Art.No. 0986 020 024



ធុងត្រង់ប្រេងពីម៉ាស៊ីនរថយន្ត Waste oil collection device

ចំណុះ 90 លីត្រ / Tank 90 litre

Art. No. 071593 90



វិទ្យុទ្រុយោខ្យល់ 1/2 អ៊ីញ Hose Reel 1/2 inch

ទុយោខ្យល់ប្រវែង ១០ម៉ែត្រ / full metal retractable motor oil hose reel Cable length 10 metter

Art. No. 5997 564 040



ប្រវែង 15ម៉ែត្រ / 15 metters

Art. No. 5997 587 346



ទុយោបូមប្រេងម៉ាស៊ីន Oil suction hoses

តំណរបូមប្រេងមានច្រើនខ្នាតច្រើនទំហំ/Suction pipes (soft /Hard pipes) come in many size .

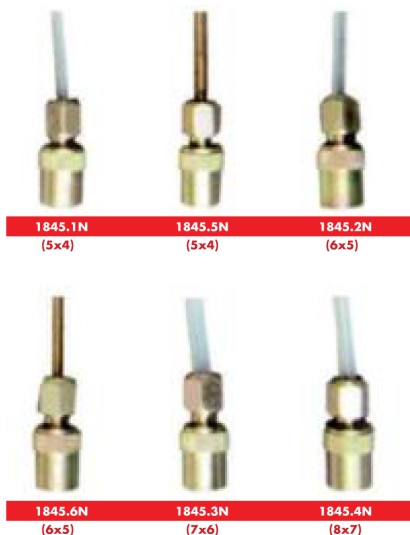

Technical data length	Structure	โครงสร้าง ราง	code
1,845.1N	5x700 มม.	อ่อน	1918 500 051
1,845.5N	5x700 มม.	แข็ง	1918 500 055
1,845.2N	6x700 มม.	อ่อน	1918 500 052
1,845.6N	6x700 มม.	แข็ง	1918 500 056
1,845.3N	7x1,000 มม.	อ่อน	1918 500 053
1,845.4N	8x700 มม.	อ่อน	1918 500 054

ស្តាប់បូមប្រេងដោយដៃ
Manual oil pump

ស្តាប់បូមប្រេងដោយដៃ សម្រាប់ធុងប្រេង
 ចំណុះ៖200លីត្រ / Hand-suction oil
 pump system for a 200 liter fuel tank
 Art. No. 1918 500 163



ស្តាប់បូមប្រេងប្រើខ្យល់-ឌីជីថល
Air distribution pump-Digital

ស្តាប់បូមប្រេងប្រើខ្យល់ សម្រាប់ធុងប្រេង
 ចំណុះ៖200លីត្រ / Air-suction oil pump
 with digital dispenser for a 200 liter fuel
 tank Art. No. 1918 500 057



ក្បាលបាញ់ប្រេង មានចំនួនលីត្រ
Oil Supply gun with meter

ក្បាលបាញ់ប្រេង ដើរជាលេខ / Oil
 supply gun with meter 70 bar digital
 system.
 Art. No. 5997 574 960



ជើងរុញធុងប្រេង ចល័ត
Trolley for oil drum

ជើងរុញធុងប្រេងចល័ត
 Trolley for oil tank, size 208 litre
 Art.No. 19185 000 58



ឧបករណ៍បូមប្រេងចល័ត
Mobile oil distribution pump

ឧបករណ៍បូមប្រេងចល័តជាមួយក្បាល បាញ់ប្រេង និងទុយោ10 ម៉ែត្រ / For 200 litre fuel tank with digital gun and 10 m pump.

Art. No. 5997 514 951



Art. No. 5997 514 951

ឧបករណ៍បូមខ្លាញ់គោ / Mobile grease dispenser kit, air system

ក្បាលបូមខ្លាញ់គោសម្រាប់ទម្ងន់60គីឡូ/Suction For a 60 kg grease bucket

Code 0986 58 032



ឆ្កុលបូមប្រេងចំណុះ13គីឡូ
Mobile greak & pump

ម៉ាស៊ីនបូមប្រេងចំណុះ13 គីឡូ ទុយោ2ម៉ែត្រ/ Pneumatic system for a 13kg capacity tank 400 bar with a length of 2 meters

Art. No. 0986 020 013



ម៉ាស៊ីនបូមខ្លាញ់ចំណុះ13 គីឡូ ទុយោ4ម៉ែត្រ/ Pneu- matic system for a 13kg capacity tank 5-8 bar with a length of 4 meters

Art. No. 0986 020 014



“အိတ်စီအိတ်စီ”
ပစ္စည်းများဖြင့်
ပြုပြင်ထိန်းသိမ်းရေး
ပစ္စည်းများ

ATF

MACHINE

ម៉ាស៊ីនប្តូរប្រេងប្រអប់លេខអូតូ / ATF service machine



ម៉ាស៊ីននេះត្រូវបានឌីហ្សាញសម្រាប់ប្តូរប្រេងប្រអប់លេខអូតូម៉ាទិកគ្រប់ប្រភេទរថយន្ត ធ្វើឲ្យសមត្ថភាពរបស់ប្រអប់លេខប្រសើរឡើងវិញ។ ការផ្លាស់ប្តូរល្បឿន ឲ្យរថយន្តមានភាពត្រឹមត្រូវ យោងទៅតាមវិស្វកម្ម និងគុណភាពនៃធាតុផ្សំ មិនធ្វើឲ្យប៉ះពាល់ប្រអប់លេខ។ (រហ័សនិងងាយស្រួលប្រើប្រាស់)។

This machine is designed to perform ATF oil changes on all car models with automatic transmission. In order to restore performance, speed and accuracy of your customers vehicles, we have not made any compromises regarding engineering and component quality. The machine comes fully assembled and is easy and time saving to use.

លេខកូដ / Art. No. W42697 101

Connector / តំណភ្ជាប់

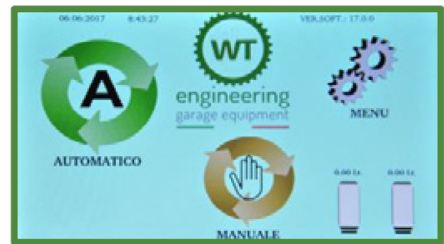

WTD BMW - Mercedes 200l	WTE Volvo 850	WTF GM
WTG GM	WTH Peugeot 405 - Austin 2000cc (con asta livello)	WTI Giapponesi - Coreana5
WTL Chrysler	WTM Fiat Croma	WTN VW - Austin (con asta livello)
WTO BMW - 1996	WTP Audi 05, 07	WTR 90° generico

WT21 Lancia Thesis - Epoca - CS	WT22 VW - Audi - Seat - Skoda	WT23 2F-BHP 80W/200mm
WT24 JATCO Mitsubishi - Nissan	WT25 RISEN WARNER Fiat - Opel - Chevrolet	WT26 POWERSHIFT Ford - Volvo
WT27 7G DCT New Mercedes 3-Class	WT28 7G TRONIC 782.9 Mercedes Benz	WT29 2F BHP
WT30		

WTI VW - Renault	WIT Audi - Renault	WIT3 SAAB-Citroen-Lancia	WIT4 SAAB-Citroen-Lancia
WIT5 BMW	WIT6 BMW SERIE 5	WIT7 BMW SERIE 3	WIT8 Mercedes - Sierra Lancia
WIT9 Mercedes - Chrysler (old mod)	WITR Alfa Romeo	WITB Volvo	WITC Japan - Coran - Opel
WIT9 WIT10 WIT12 Tubi di raccordo generici		WITR5 Tubo svuotamento	WITDT Dipstick

ម៉ាស៊ីនបម្រុងប្រេងប្រកបដោយល្បឿន / ATF service machine

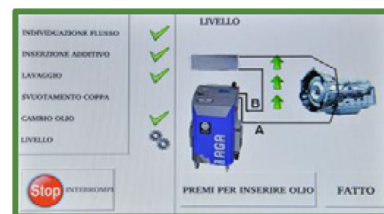

DATI TECNICI / TECHNICAL DATA / CHARACTERISTIC TECHNIQUES

Alimentazione / Power / Voltage	230 VAC
Pressione / Pression / Pressure	6-10 bar
Serbatoi / Tank / Reservoir	2 x 25 Lt
Dimensioni / Sizes / Dimension	36 x 44 x 94 cm
Peso netto / Net weight / Poids net	38 Kg

လေတဲကမ္ဘာ

ပြေစေ့ပြေစေ့

BRAKE

FLUID

ម៉ាស៊ីនបូរប្រេងប្រាំងដោយអគ្គិសនី / Electrical brake bleeder



ម៉ាស៊ីនបូរប្រេងប្រាំងដោយអគ្គិសនី ចំណុះ:12លីត្រ / Elec-
trical system brake oil dispenser size 12 litres
លេខកូដ/ Art. No. 0714 556 24



ម៉ាស៊ីនបូរប្រេងប្រាំងដោយអគ្គិសនីខ្នាតតូច ចំណុះ:5 លីត្រ
/ Electrical system brake oil dispenser small size 5 litres
លេខកូដ/ Art. No. 0714556



ម៉ាស៊ីនបូរប្រេងប្រាំងដោយអគ្គិសនី ចំណុះ:60 លីត្រ / Elec-
trical system brake oil dispenser size 60 litres
លេខកូដ/ Art. No. 0714 556 22

អាគុយក្រូច និងឆ្នាំខសាក

BATTERY CHARGER

អាគុយកូរ៉�ថយន្ត / Battery Charger



អាគុយកូរ៉�បញ្ជោះសម្រាប់រថយន្ត និងឡានដឹកទំនិញធុនធ្ងន់ / Jump starter 12V/24V-12000 cm³ can use for car & truck.

លេខកូដ/ Art. No. 07721224



ខ្សែរភ្លើង១៥ម៉ែត្រ

/ Cord length 15 meters.

លេខកូដ / Art. No. 1918 500 1600



អាគុយសាកនិងកូរ៉�បញ្ជោះសម្រាប់រថយន្ត និងឡានដឹកទំនិញធុនធ្ងន់ / Battery tester with booster cable 12/24V

លេខកូដ/ Art. No. 5966 506 516



ឆ្នាំងសាកអាគុយរថយន្ត 6/12/24V-35A/Car BatteryCharger 6/12/24V-35A

លេខកូដ/ Art. No. 0510955604



ឆ្នាំងសាកអាគុយរថយន្ត12/24V-35A / Car Battery Charger12/24V-35A

លេខកូដ/ Art. No. 0510955607



ឆ្នាំងសាកអាគុយរថយន្ត12V/70A Car Battery Charger12V/70A

លេខកូដ/ Art. No. 0510955607

សេវាកម្មប្រើប្រាស់
គ្រឿងកម្រិតយន្ត

**AIR CONDITIONING
SYSTEM**

ម៉ាស៊ីនធ្វើតេស្តនិចបញ្ចូលហ្គាសម៉ាស៊ីនត្រជាក់រថយន្ត Air conditioning system



ម៉ាស៊ីនបញ្ចូលត្រជាក់រថយន្ត A10 ងាយស្រួលប្រើនិងជាដៃគូចលំអរបស់អ្នក សម្រាប់អាជីវកម្មម៉ាស៊ីនត្រជាក់ប្រភេទ R134a។ ប្រើជាមួយប្រភេទរថយន្តធន់តូច ប្រភេទដឹកទំនិញ។ /The Coolius A10 is your easy to use and mobile companion for the air conditioning service on R134a systems. Ideal for service on cars, Vans.



កុងតាក់បញ្ជាងាយស្រួលប្រើ

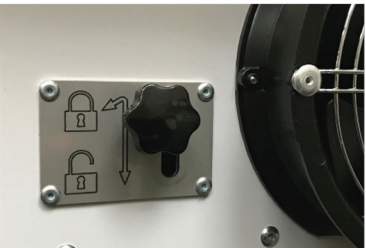

សោរសុវត្ថិភាព

លេខកូដ/ Art.No. W050 101 000



ឧបករណ៍បង្កើតគុណភាពខ្ពស់



កុងទ័រត្រួតពិនិត្យហ្គាសចូលនិងចេញ



ក្រឡាសម្រាប់ផ្ទុកធាតុខុសៗគ្នា

Designation	Art. no.	Description	Information
Maintenance contract	0900 400 159	Carried out annually by service technicians (materials, travel and working time incl.)	
External analyser for R134a	0900 870 096	Analyses the composition and purity of the refrigerant. With integrated printer.	
	W067 000 101	Analyses the composition and purity of the refrigerant. No printer included.	
Flushing kit	W067 200 013	Allows the flushing of the refrigerant circuit in WOW! air conditioning service units with refrigerant R134a and R1234yf.	
Extension kit service hoses	W067 200 030	Extension kit 3 m	

**ម៉ាស៊ីនបញ្ជូនប្រេសម៉ាស៊ីនត្រជាក់ជាក់រថយន្ត COOLIUS A05
WOW! A/C SERVICE UNIT COOLIUS A05**



អំពី ម៉ាស៊ីន COOLIUS A05

ម៉ាស៊ីន COOLIUS A05 បានផ្តល់ជូនអ្នកនៅសេវាកម្ម ម៉ាស៊ីនត្រជាក់ជាក់រថយន្តពេញលក្ខណៈ ជាមួយនឹងគ្រប់ប្រភេទ R134a។ ដូចទៅនឹងម៉ាស៊ីន COOLIUS ផ្សេងដែលផលិតនៅអឺរ៉ុប។ ម៉ាស៊ីន A05 បានបង្ហាញតម្លៃយ៉ាងល្អឥតខ្ចោះនិងគុណភាពកម្រិតខ្ពស់។

វាគឺជាម៉ាស៊ីនសម្រាប់សេវាលើរថយន្តតូចរថយន្តកូរ៉េស យានយន្តក្នុងវិស័យសំណង់ និងយានយន្តក្នុងវិស័យកសិកម្ម។

Highlights COOLIUS A05

The COOLIUS A05 offers you a fully automatic air conditioning service with the refrigerant R134a. Like all COOLIUS units manufactured in Europe, the A05 impresses with its excellent price-performance ratio and high-quality Construction.

Ideal for service on cars, Vans, Commercial vehicles, construction vehicles and agricultural vehicles.

លេខកូដ/ Art. No. W050 101 000

Simple operation and unique mobility

- Fully automatic air conditioning service unit
- Innovative scales construction allows easy mobile use
- Comfortable menu navigation and operation via buttons
- Clear and intuitive design
- High suction rate of the compressor allows recovery of almost 100% of the charged refrigerant

Service-friendly components

- Robust metal construction
- The use of high-quality and specially matched components allows a long service interval
- Fast and easy fault diagnosis with two analogue pressure gauges

សេវាកម្ម

លាងសម្អាត

**WASHING
& CLEANING**

ម៉ាស៊ីនលាងសម្អាតកម្រាលនិងព្រំក្នុងរថយន្ត SPRAY SUCTION DEVICE SEG 10-2



លេខកូដ Art. No. 0707 111 0

ម៉ាស៊ីនលាងសម្អាតកម្រាលនិងព្រំក្នុងរថយន្ត ដែលមានសមត្ថភាពខ្ពស់ក្នុងបូមធ្វើលី ក្តែលឬស្នាមប្រឡាក់ ចេញពីកម្រាលព្រំ ។

Powerful spray extraction device for cleaning upholstery and for removing stains from carpeted surfaces.

Very good back suction result As cleaning results in an extremely low amount of residual moisture, cleaned upholstery and carpets can be used again quickly. Ideal for cleaning upholstery and car interiors
Compact, space-saving design

Continuous checking of cleaning procedure and back suction performance

Large, transparent cover

Easy and straightforward transport Practical carry handle and holders for cable and nozzle

2 Years WÜRTH MASTERPLUS Warranty for wear damage The current WÜRTH MASTERPLUS warranty conditions must be observed.

3 Years Warranty on manufacturing and material defects Excluded are damages caused by improper use, overloading or failure to observe the operating instructions.

P. Qty.	1
Nominal voltage	230 V/AC
Motor output	1380 W
Flow capacity	1 l/min
Underpressure	230 mbar
Fresh water tank	8 l
Dirty water tank	7 l
Weight of machine	9.8 kg
Cable length	7.5 m

Contents for Art. No.	Designation	Art. No.	Number
0701 111 0	Suction hose 2.4 m	0701 111 001	1
	Joint nozzle	0701 111 003	1
	Hand nozzle	0701 111 004	1
	Handle	0701 111 007	1

Related products	Art. No.
Suction hose 4 m	0701 111 002
Floor nozzle	0701 111 005
Hard surface adapter	0701 111 006
Workshop cleaner BMF 5 l	0893 118 2
Workshop cleaner BMF 20 l	0893 118 3
Workshop cleaner BMF 60 l	0893 118 4
Universal cleaner R1 5 l	0893 125 005
Universal cleaner R1 20 l	0893 125 020
Universal cleaner R1 60 l	0893 125 060

ACTIVE FOAM WASH SET



DISPENSING UNIT FOR CLEANING AGENTS

Cleaning agent dispensing unit
DSP-CLR-PLA-19X29,5X12CM
Art.-no. 0891385020

SPECIFICATION

For simple and effective mixing of different cleaning agents at optimum application concentrations

Simple and effective mixing of aqueous cleaning agents

Resource-saving and clean application
Ensures a constant mix ratio
Easy operation

Not harmful to health

Clean mixing with no material transferred to the skin
No lifting of heavy canisters when mixing
Option to combine several dispensing devices with one another

Water connection for 1/2" water hose

COMPRESSED AIR CLEANING GUN TOP GUN

Cleaning gun, TOP gun
CLNGUN(TOP GUN)
Art.-no. 0891703140

PROFESSIONAL CLEANING GUN FOR CLEANING SURFACES ON THE VEHICLE

Thorough and effective cleaning

Micro-atomisation results in effective use of cleaning agent
Air and cleaning agent feed can be set manually

Safe, reliable and hassle-free

Ball-bearing-mounted drive creates a cyclone effect
Low wear and maintenance

Flexible handling

Ideal for hard-to-reach places thanks to jointed connection



ACTIVE FOAM WASH

Cleaning concentrate, active-foam wash
CLNCONCEN(ACTIVE CAR-SHAMP-FM)-25LTR
Art.-no. 08930252

PROFESSIONAL CLEANING GUN FOR CLEANING SURFACES ON THE VEHICLE

Intensive, highly concentrated foam cleaner for foam pre-treatment and wash of vehicles in car washes.

Highly concentrated active foam

The dirt is actively loosened from the vehicle surface as the foam bubbles burst
Outstanding cleaning power

Combination of special ingredients supports the brush sliding properties

Vehicle surfaces are protected
Recontamination of the brushes is prevented
Service life of the brushes is extended

No streaking when using preservers and drying aids

Can be used together with these aids in machines with water recycling systems

Free of phosphate, AOX and silicone

pH value in the concentrate: 7.0
Easily biodegradable in accordance with OECD*. Does not compromise the effectiveness of light fluid separators.



BMF SET

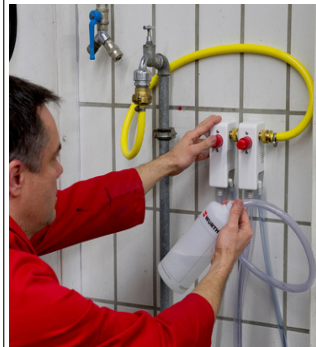

DISPENSING UNIT FOR CLEANING AGENTS

Cleaning agent dispensing unit
DSP-CLR-PLA-19X29,5X12CM
Art.-no. 0891385020

SPECIFICATION

For simple and effective mixing of different cleaning agents at optimum application concentrations

Simple and effective mixing of aqueous cleaning agents

Resource-saving and clean application
Ensures a constant mix ratio
Easy operation

Not harmful to health

Clean mixing with no material transferred to the skin
No lifting of heavy canisters when mixing
Option to combine several dispensing devices with one another

Water connection for 1/2" water hose

SPRAY SUCTION DEVICE SEG 10-2

Spray extraction device SEG 10-2
SPREXTRAKTIONDEV-EL(SEG 10-2)
MASTER
Art.-no. 07011110

Powerful spray extraction device for cleaning upholstery and for removing stains from carpeted surfaces.

VERY GOOD BACK SUCTION RESULT

As cleaning results in an extremely low amount of residual moisture, cleaned upholstery and carpets can be used again quickly.

Ideal for cleaning upholstery and car interiors

Large, transparent cover

Easy and straightforward transport

Practical carry handle and holders for cable and nozzle

Notice

The hand nozzle should be guided horizontal to the floor to achieve proper suction.

2 Years WÜRTH MASTERPLUS Warranty for wear damage

The current WÜRTH MASTERPLUS warranty conditions must be observed.

3 Years Warranty on manufacturing and material defects

Excluded are damages caused by improper use, overloading or failure to observe the operating instructions.



WORKSHOP CLEANER BMF

Workshop cleaner BMF
WRKSHPCCLR-BMF-5LTR
Art.-no. 08931182

ENVIRONMENTALLY FRIENDLY CLEANING AGENT FOR WORKSHOPS, MACHINERY AND VEHICLES

No phosphates, solvents and corrosive substances
Extremely biodegradable

Can be used mechanically, manually or in high-pressure units

Powerful at dissolving grease but is still mild and gentle on materials

Does not attack paints, rubber or plastics

Fast-separating in waste water in accordance with German Ecological Standard Test B 5105

pH value: 9.4

Silicone-free

AOX-free



မြို့ကတော့ကလေးဗယ်ဗု

BODY

WORK

HYDRAULIC SHOP PRESS



លេខកូដ / Art. W42697 100



8pcs press pin adapter kit

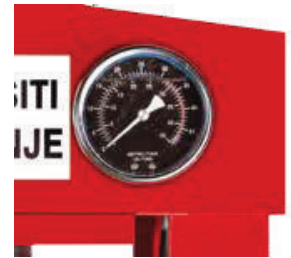

High Precision control manometer



Foot control pedal

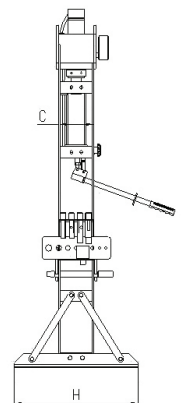
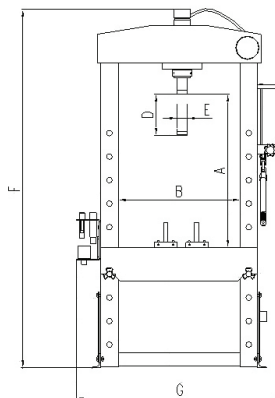

Art.	Description	Stroke (mm)	Work range (mm)	Weight (kg)
0715 97 120	Hydraulic shop press with foot and hand control 20t	190	0-1.000	120,50
0715 97 130	Hydraulic shop press with foot and hand control 30t	150	51-1.131	169,00
0715 97 150	Hydraulic shop press with foot and hand control 50t	200	68-920	280,00

	0715 97 120	0715 97 130	0715 97 150
A	0-1000	0-1130	0-920
B	550	550	710
C	160	160	220
D	190	150	190
E	Ø48	Ø54	Ø75
F	1610	1840	19440
G	895	895	1320
H	560	700	800

ឧបករណ៍តោនថយន្ត/Body repair kit 10 tons



ជាឈុតសម្រាប់ទាញ រុញ តោនដែលមាន 17 ឧបករណ៍ នៅក្នុង 1 ឈុត ក្រាស និង ងាយស្រួលប្រើប្រាស់។

- Thick walled extension tubes for added strength and longer life
- Perfect for lifting, pushing, pulling, bending, straightening and spreading
- Long handle provides ease for pumping
- Thick walled extension tubes for added strength and longer service life

លេខកូដ/ Art.No. 0715 57 010

ឧបករណ៍ទ្រម៉ាស៊ីន/Engine mounting stand



ឧបករណ៍ទ្រម៉ាស៊ីន សម្រាប់ដោះម៉ាស៊ីនចេញពីថយន្ត ជើងទ្រមានភាពរឹងមាំ អាចបង្វិលបាន 360 ឌីក្រេ យ៉ាងងាយស្រួល។

- Constructed of high-grade steel for quality and durability.
- Lead-free paint finish is applied to ensure a long-lasting finish and to help prevent rust.
- 360° rotating head locks with a pin for stability when needed.
- Long handle with rubber grips allows easy engine rotation.

លេខកូដ/ Art.No. 0715 97 011

පඤ්චායුධ්ම

PAINT

BOOTH

បន្ទប់បាញ់ថ្នាំប្រើពន្លឺអ៊ីនហ្វ្រារេដ/Infrared paint-spray-room



អាចប្រើប្រាស់ គ្រប់ការសេវាកម្មថែទាំ រថយន្តទាំងអស់ ប្រើប្រាស់បានយូរអង្វែង ដែលអាចប្រើប្រាស់ជួសជុលផ្នែកខាងក្រៅ រថយន្តគ្រប់ប្រភេទ។

Suitable for all types of automotive maintenance services for paint work-car body design, durable, can be used for repaircar covers.

Art.No. W374 600 200

SET Ceiling filter art code W374 500 021
 SET Floor filter Art.No. 5997 532 703

បន្ទប់បាញ់ថ្នាំ LPG/ LPG Spray point room(Water base)



រចនាសម្ព័ន្ធបន្ទប់បាញ់ថ្នាំមាន តុល្យភាពខ្ពស់និងមានគុណភាព រឹងមាំ។

Balanced structure highly secure, quality objects strong
 Art.NoW374 600 400

Complete with filters
 Art.No. W341 000 002

*additional equipment can be custimized as required.

សារពីអតិថិជនរបស់យើង / Wuerth customer's message

សារបញ្ជាក់ពីអតិថិជនដែលបានជឿជាក់លើគុណភាពនៃផលិតផល វើសធី។

Confirming from one of the customers who trust in the quality of Wuerthberg products.



យើងផ្តល់ជូនការរៀបចំបន្ទប់ប្រាក្រាំ និង គន្លែងខាត់ស្នូតតាមទំហំទីតាំងរបស់អ្នក ។

We also offer customized preparation booths and dry sanding stations

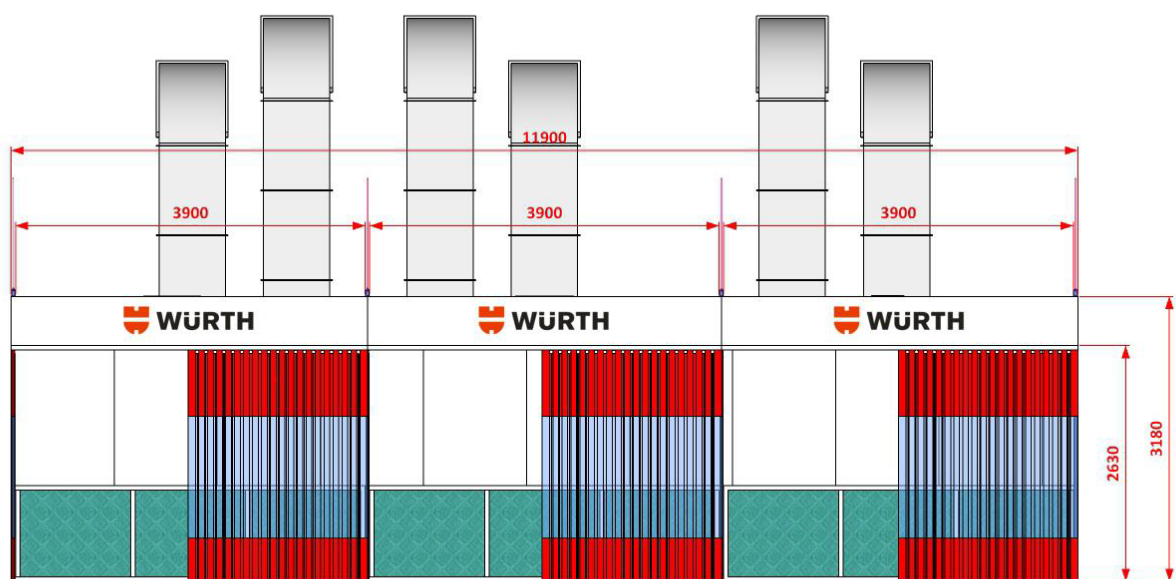

លិខិត

អនុញ្ញាតិ

APPROVAL

LETTER



Mercedes-Benz



MBTh Body & Paint Technical Support

Requirements of a Painting Facility
for
Mercedes-Benz Passenger Cars
(Combined Spray and Drying Booth)

Dec 2019

weerasak.charoenthinnaphruet@daimler.com Phone +66 2762 7133
Mercedes-Benz (Thailand) Mobile +669 4909 0707

APPROVED AND RECOMMENDED - WHAT FOR ?

សាកសួរព័ត៌មានបន្ថែមពីពួកយើង ដោយ
ស្វែងយល់ថា ហេតុអ្វីផលិតផលរបស់
វើសធី ត្រូវជឿជាក់ ដោយពេញចិត្ត
អតិថិជនរបស់ពួកយើងជុំវិញពិភពលោក។

Contact us to find out more about why
our product are trusted by our satisfied
customer around the world.

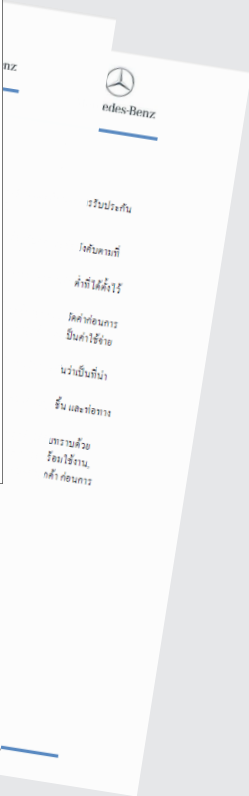

កិច្ចព្រមព្រៀង

**CONTRACT
OPTION**

WE CAN PROVIDE FOR FREE, IF YOU

គ្រប់ឧបករណ៍និងបរិក្ខារទាំងអស់នេះ យើងអាចផ្តល់ជូនអ្នកប្រើប្រាស់ដោយឥតគិតថ្លៃជាមួយកិច្ចព្រមព្រៀងទិញផលិតផល។ សូមទំនាក់ទំនងពួកយើងដើម្បីទទួលបានការផ្តល់ជូន។

All our equipment products we can provide to you for free use with a contract for related consumable products. Please contact us to get a customized offer.

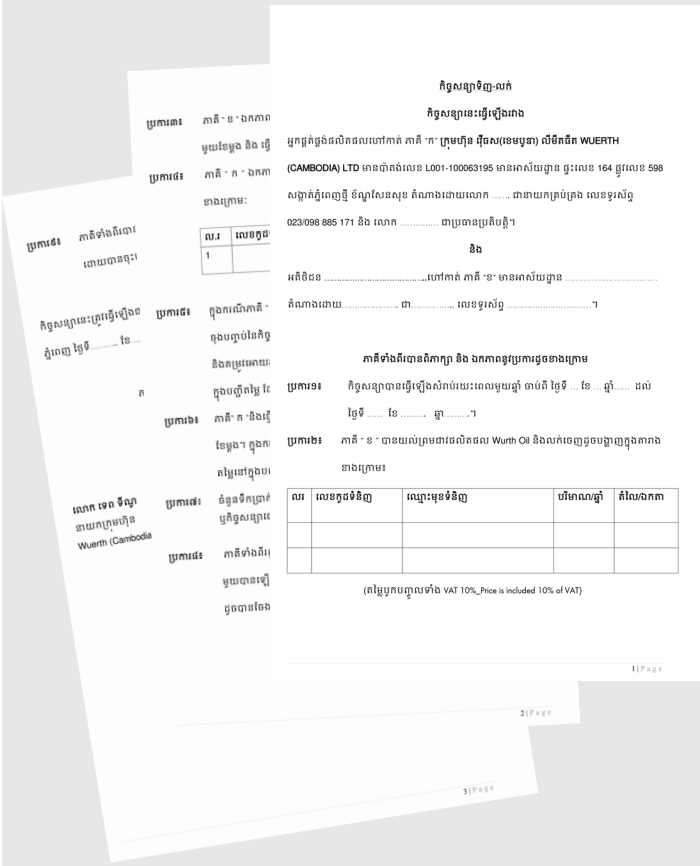

විවිසතා

WARRANTY



EQUIPMENT WARRANTY

This Equipment Warranty applies to all Würth new, used and repaired machines, components or accessories that have been supplied by Würth, under the following warranty policies, extended to the original purchaser only.

1. Warranty 1 year 2 years 5 years

Würth warrants that all parts and equipment supplied by Würth shall be free from defects in material and workmanship under normal use and service for the above selected period from ship date. Würth's obligation under this warranty shall be limited to the repair or replacement of any parts or equipment that, upon examination by Würth, shall be deemed defective. Würth shall assign supplier warranties for parts and equipment manufactured by others, such as motors, engines, tires, etc. Purchaser shall use Würth parts or equipment according to the directions or operating manual furnished. Any failure by the purchaser to properly use the parts or equipment shall absolve Würth of all warranty liabilities and obligations hereunder.

Würth confirms that the equipment covered by this warranty operates according to the specification of the equipment and shall not damage or affect the performance of serviced products in any way. This does not cover the mis- or wrong use of the equipment by the purchaser.

2. Warranty Limitations

Würth warranties do not extend normal wear, tear and maintenance, or to any parts or equipment subjected to misuse, neglect, accident improper maintenance, altered or modified. No person, agent, distributor, dealer, service station or company is authorized to change, modify, or extend the terms of these warranties in any matter whatsoever. The repair warranty is limited to the items replaced at the time of repair.

- Service and claims should be conducted within 24 to 48 hours after Purchaser notification call by email or phone, unless agreed otherwise by the two parties.
- All major spare parts are available at Würth Thailand in case of repair. In case of unavailability of any special parts the purchaser will be informed immediately.

THE WARRANTIES AND REMEDIES CONTAINED HERIN ARE IN LIEU OF ALL OTHER WARRANTIES EXPRESSED, IMPLIED, OR STATUTORY OF WÜRTH, INCLUDING THE WARRANTIES OF MERCHANTABILITY AND FITNESS FOR A PARTICULAR PURPOSE. IN NO EVENT SHALL WÜRTH BE LIABLE FOR SPECIAL, INCIDENTAL OR CONSEQUENTIAL DAMAGES.

3. Purchaser Responsibilities

Würth warranties are expressly subject to the following conditions:

- You must notify Würth of any defect you may discover in parts or equipment within the warranty period (of ship date) and such notice must be made to Würth at:

Address: Wuerth (Cambodia) Ltd.
 #164, St. 598, Phnom Penh Thmei,
 Sen Sok, Phnom Penh, 12101
 Phone: +855 23 885 171
 Fax: +855 23 880 697
 Email: info@wuerth.com.kh

Customer completing this from:

First name: _____ Last name: _____ Job title: _____

Are you responsible for recommending, specifying and/or purchasing equipment and services? YES NO

If you answered NO to the previous question please specify who is responsible for those activities.

First name: _____ Last name: _____ Job title: _____

Company Name: _____	Invoice/Sales Order Number
Address: _____	
PO Box: _____	Machine Model Number
City/State/Province: _____	
ZIP/Postal Code: _____	
Country: _____	Serial Number
Business Phone: _____	
Business Fax: _____	
E-Mail Address: _____	

All contact information provided on this form is considered CONFIDENTIAL and will not be distributed to anyone outside of Würth.

ក្រុមហ៊ុន វើសធី (ខេមបូឌា) អិលធីឌី

Wuerth (Cambodia) LTD

ទំនាក់ទំនង

អគារលេខ 164, ផ្លូវ 598, សង្កាត់ភ្នំពេញថ្មី,
ខណ្ឌសែនសុខ, រាជធានីភ្នំពេញ

ទូរសព្ទ 023 885 171 / 098 88 51 71

ទូរសារ 023 880 697

អ៊ីម៉ែល info@wuerth.com.kh

ហ្វេសប៊ុក Wuerth Cambodia

គេហទំព័រ www.wuerth.com.kh

Contact us

#164, St. 598, Phnom Penh Thmei,
Sen Sok, Phnom Penh, 12101

Phone: +855 23 885 171 / 098 88 51 71

Fax: +855 23 880 697

Email : info@wuerth.com.kh

Facebook: Wuerth Cambodia

Website: www.wuerth.com.kh

ផលិតផល វើសធី មាននៅជានានាគ្រប់ទ្រទ្រង់

និងក្រុមហ៊ុនផ្តល់សេវាកម្មផ្សេងៗ ជាង ៤០០ ក្រុមហ៊ុន នៅលើគ្រប់ទ្រទ្រង់។



ព័ត៌មានលម្អិត

Find us : **Wuerth Cambodia**

