

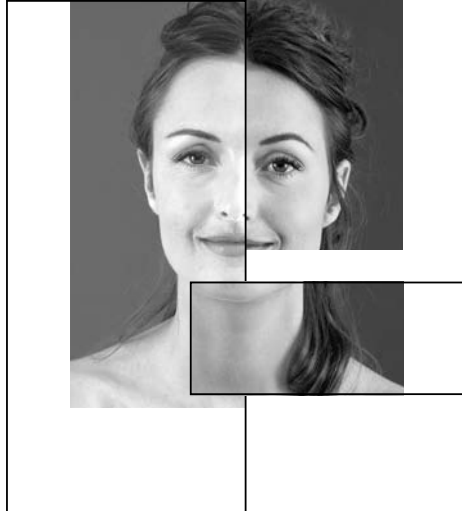

Instruction
handbook



THE HYDRO ELECTRONIC UNIT
FOR FACIAL EXERCISE



Acknowledgement: Our special thanks go to Dr Andrea Paolorosso for his involvement in the development and testing of Tua VISO and for writing the Tua VISO handbook and also to Tina Richards, skin and health expert, for contributing to and editing the handbook's content.

Welcome to the world of Tua.

TUA health and beauty products are dedicated to revitalising and enhancing the appearance of your face and body to achieve a revived and more youthful look. Implementing TUA into your lifestyle is easy and practical: the units are used at home for a few minutes each day and are battery-powered allowing flexibility of use.

Their carefully developed ergonomic lines make them very easy to use and their innovative designs are elegant and pleasant to touch. In the TUA community you will find all the technical and scientific experience of a leading group in the manufacture of professional electrical medical equipment used in hospitals and university centres. With the expertise and confidence derived from an efficient respected research team, and the guarantee given by the strictest international quality controls, **we are pleased to welcome you to TUA.**

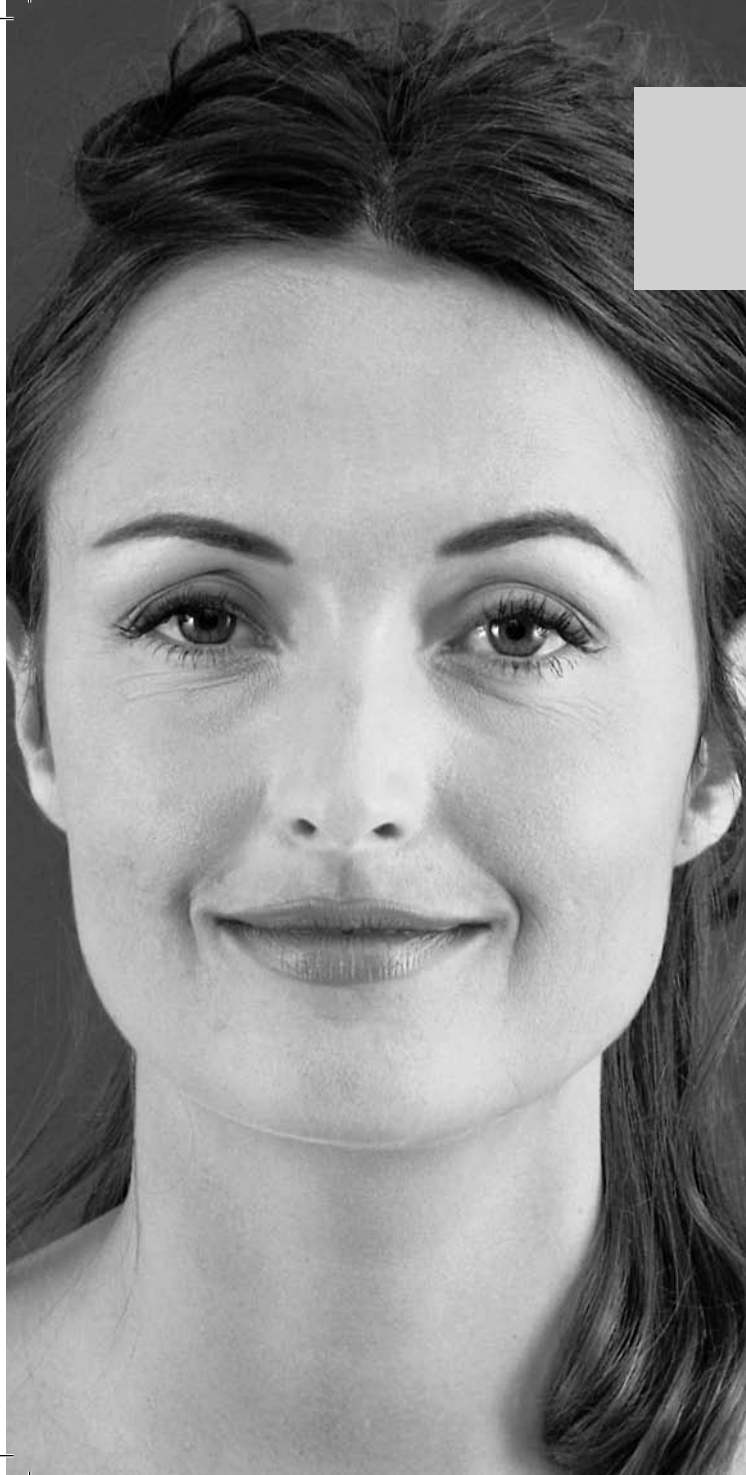

Index

Welcome to the world of TUA _____ 3

AN EASY-TO-USE HANDBOOK

Read this handbook carefully _____ 6/7

OUR SYMBOLS

Some symbols are used in
this handbook ... _____ 8/9

TUA VISO ...

Description of the unit _____ 10/11

UNPACKING _____ 12/13

A CLOSER LOOK

Tua Viso _____ 14/15

The accessories _____ 16/17

The V.P. Box electrodes _____ 18/19

HOW TUA VISO WORKS

Learning to use TUA Viso _____ 20/21

How to put TUA Viso to use _____ 22/23

MAINTENANCE

Battery replacement _____ 24/25

Cleaning and replacing

Sponges _____ 26/27

WHAT THE DOCTOR SAYS

Muscles ...

Facial Muscles ... _____ da 28 a 33

WHAT THE DOCTOR SAYS

EXERCISES WITH TUA da 34 a 53

PRECAUTIONS AND

CONTRAINDICATIONS _____ 54/55

GLOSSARY _____ 56/57

TECHNICAL DATA _____ 58/59



AN EASY-TO-USE HANDBOOK

Read
this
handbook
carefully...

This handbook is divided into three fundamental parts:

• **PART ONE**

Introduces TUA Viso; its design, components, functions and usage.

• **PART TWO**

Takes a look at your face's muscular anatomy and explains the physiological benefits of facial treatment with TUA Viso.

• **PART THREE**

The Tua Viso facial "workout" comprising of a series of exercises tailored to your main structural facial muscles.

Lastly, PRECAUTIONS, contraindications and glossary.

TUA VISO's ergonomic design together with this handbook and the mini handbook, greatly facilitate easy and regular use of the product to ensure the achievement of excellent results.



OUR SYMBOLS



While reading
this handbook,
you will see
the following
symbols...

We have used simple symbols which can easily be identified even when briefly browsing through this handbook. These symbols are repeated throughout the handbook to attract your attention; here's what they all mean:

An exclamation mark: ATTENTION

Instruction to be followed exactly for the correct use of Tua Viso

Pencil: NOTE

Draws attention to information and suggestions to be remembered while using Tua Viso;

A flash of lightning: CAUTION

Emphasises very important information on how to avoid damage to the Tua Viso unit or incorrect operation of the unit.

ATTENTION



NOTE



CAUTION





TUA VISO 000

TUA VISO is a hydro electronic unit for facial exercise. The exercise of facial muscles, which are connected directly to the skin, makes them more toned, giving a more lifted appearance to the face, smoothing the skin and diminishing the look of fine lines and wrinkles. The extremely advanced miniaturised electronic circuitry generates trains of modulated micro-current sine wave pulses which are specific for delicate facial muscles and indicated by a green LED.

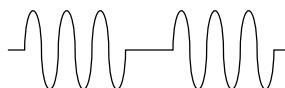

Due to their particular form and frequency, these waves induce precise muscular exercises without provoking any unpleasant pain, even at higher intensities and with very evident subsequent facial muscle movements. Alternating sustained 3 second pulses and 3 second pauses produces a rapid increase in muscular tone and volume and at the same time improves tissue oxygenation without any strain or build-up of toxins in the facial muscle. The pulses are transmitted to the skin by two patented spring-loaded spherical electrodes covered in soft sponge domes.

The electrodes are self-moistening and have their own reservoir containing sufficient water for a full treatment session.

TUA VISO is easy to use.

After having filled the reservoirs with normal tap water, simply turn on the unit and position it on the area of the face to be treated.

The numbered micro-current regulator starts the pulse feed and regulates its intensity.

TUA VISO is practical.

Its shape makes it easy to hold, keeps the micro-current regulator under constant control and enables the electrodes to be positioned on any part of the face immediately.

A luminous digital timer allows treatment time to be set, shows remaining time and indicates the end of treatment by making a beeping sound, switching the unit off.

The watertight reservoir of each electrode is sufficient for an entire 'workout' session and avoids having to repeatedly wet the sponge domes: to do this, just press the sponge domes or simply apply a few drops of water externally to the sponges using the water dispenser bottle provided.

TUA VISO is safe.

It is powered by a normal 9 Volt alkaline battery, supplied in a special compartment.

A yellow LED indicator shows when the battery is beginning to lose its charge.

TUA VISO can be taken anywhere.

Its compact dimensions, light weight build, illuminated panel and battery power, enable easy use anywhere and under any circumstances - even in the dark!

TUA VISO is contained in a stylish case along with a water dispenser bottle, spare sponge domes and instruction handbook.

TUA VISO comes complete with a demo DVD showing possible applications and facilitating correct use of the unit.



UNPACKING

As you take the various parts out of the box, check that all those shown in the illustration are there and make certain that they haven't been damaged during transport.

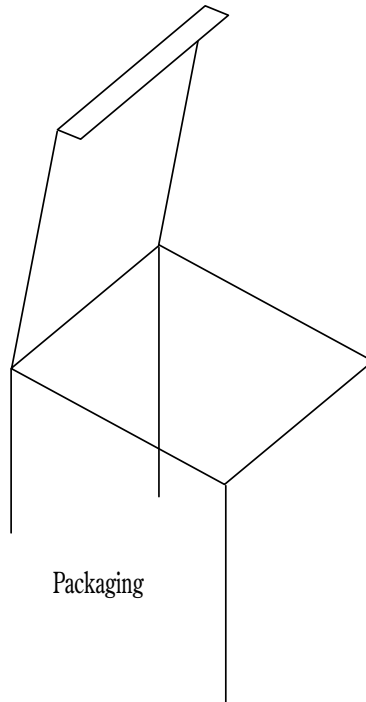

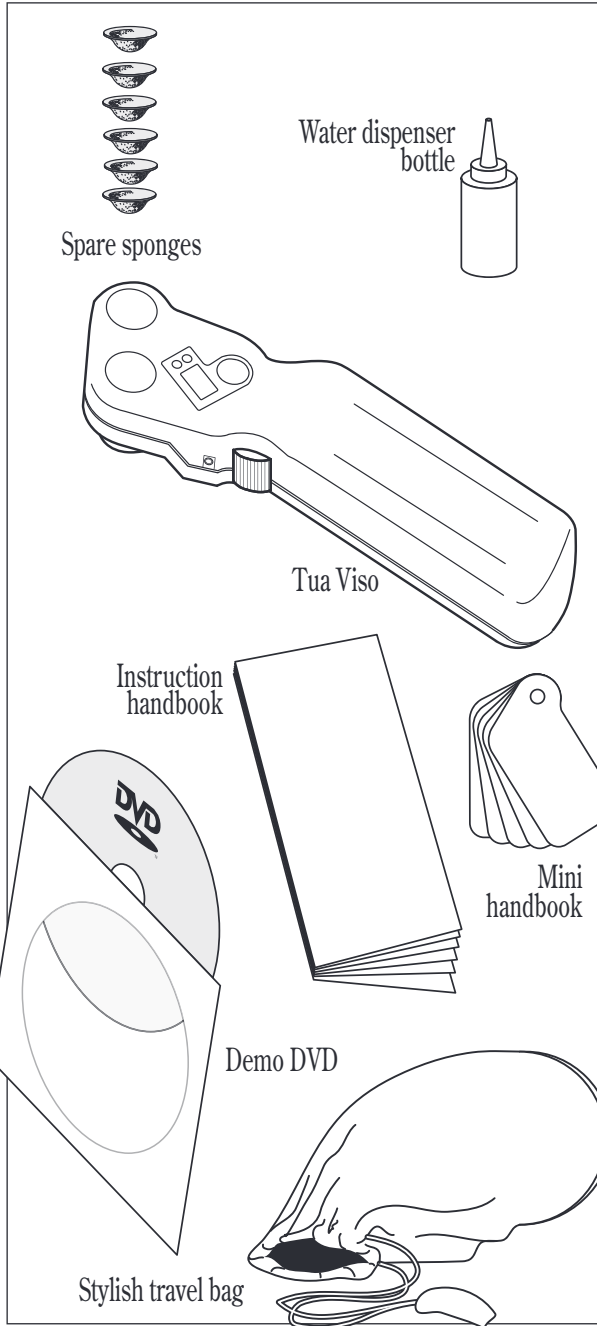



Tua VISO

A CLOSER LOOK

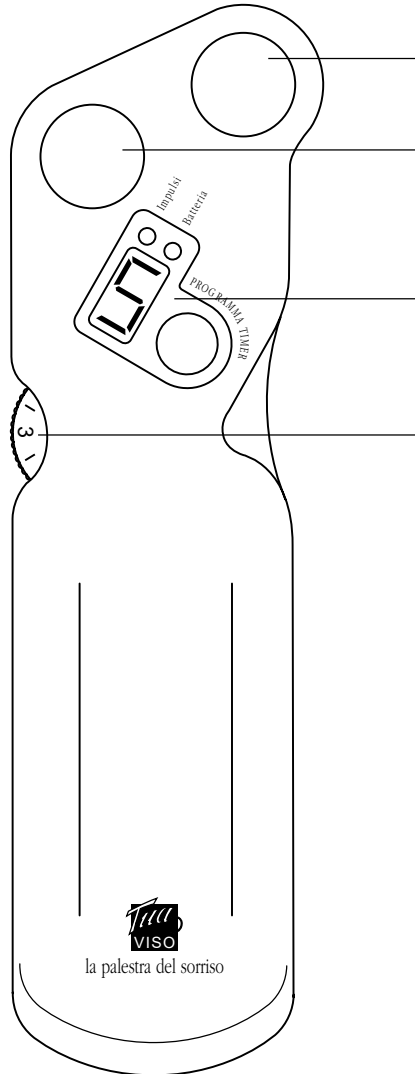

Tua Viso's patented design has smooth ergonomic lines and a personal feel. The design was developed, following extensive study, to naturally follow the contours of the face and to be easily and comfortably held.

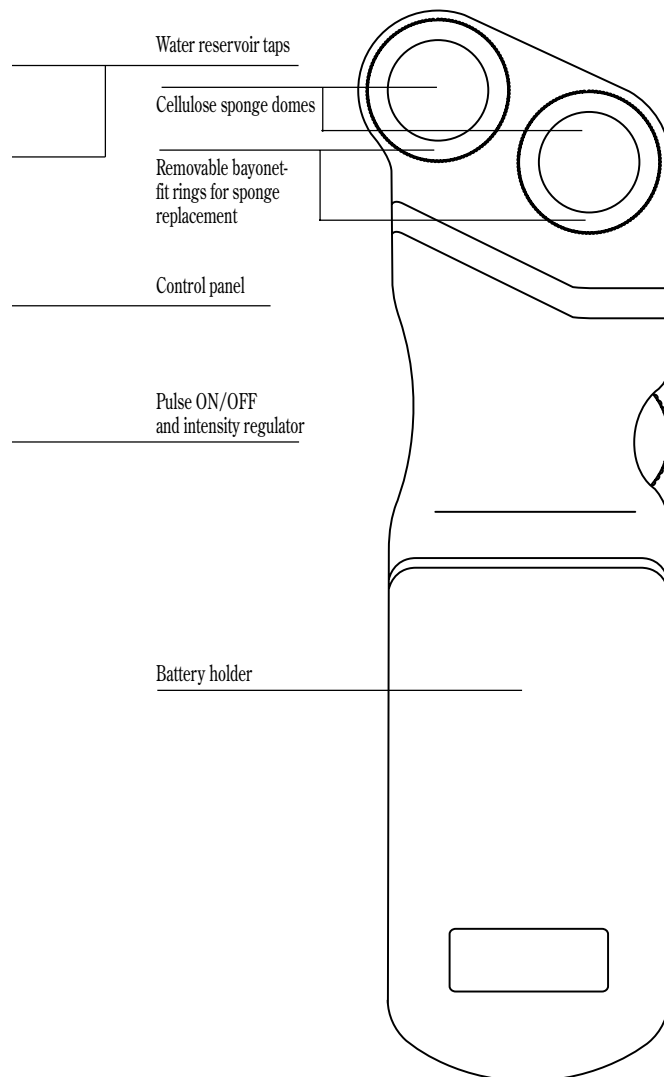



The Accessories

Tua VISO's packaging has been designed to guarantee the utmost protection for the material inside.

A CLOSER LOOK

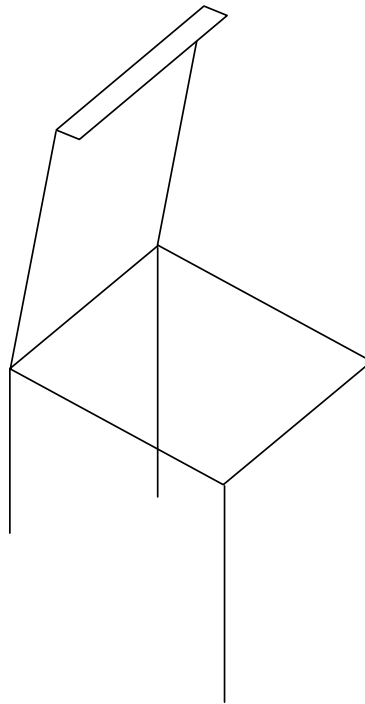

Tua Viso comes complete with a series of accessories which enhance its usability and application.



Water dispenser bottle and 6 cellulose sponge domes.

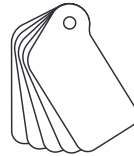

The extremely useful mini handbook is quick and easy to consult.

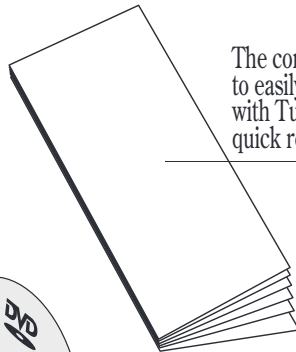

The complete handbook to easily familiarise yourself with Tua Viso and for quick reference

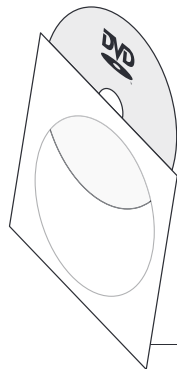

Demo DVD to view the possible applications and to facilitate the correct use of the unit.

Handy stylish travel bag.

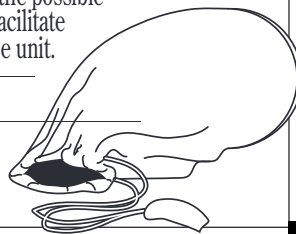



A CLOSER LOOK

The V.P. Box Electrodes

The electrodes are of fundamental importance, since they are the means by which the micro-current pulses reach the skin and the underlying facial muscle. TUA VISO has special patented VP BOX electrodes. The spring-loaded electrode spheres covered in soft sponge enable practical positioning on every area of the face and delicate contact with the skin; moreover, as they operate with water, the unit can be used immediately, without any need for special conductive gels or creams.



During use, the sponge domes must always be adequately moistened with water and kept in good contact with the skin; if not properly moistened through, they tend to insulate the pulses instead of conducting them.

The VP BOX electrodes are self-moistening and each has its own reservoir containing the water necessary for a complete treatment session; this avoids having to repeatedly re-fill the reservoirs; to proficiently moisten the sponge domes, just press down on them or simply apply a few drops of water to them externally using the water dispenser bottle provided. The sponge domes are hand washable. An anti-microbial hand wash is the ideal cleansing medium; use tepid water and always remember to rinse through thoroughly with clean water. You should replace the sponge domes only when they have worn thin and have lost their cushioning effect.

The extractable bayonet-fit rings enable fast replacement of the sponge domes.

V.P. Box is a Vupiesse patent

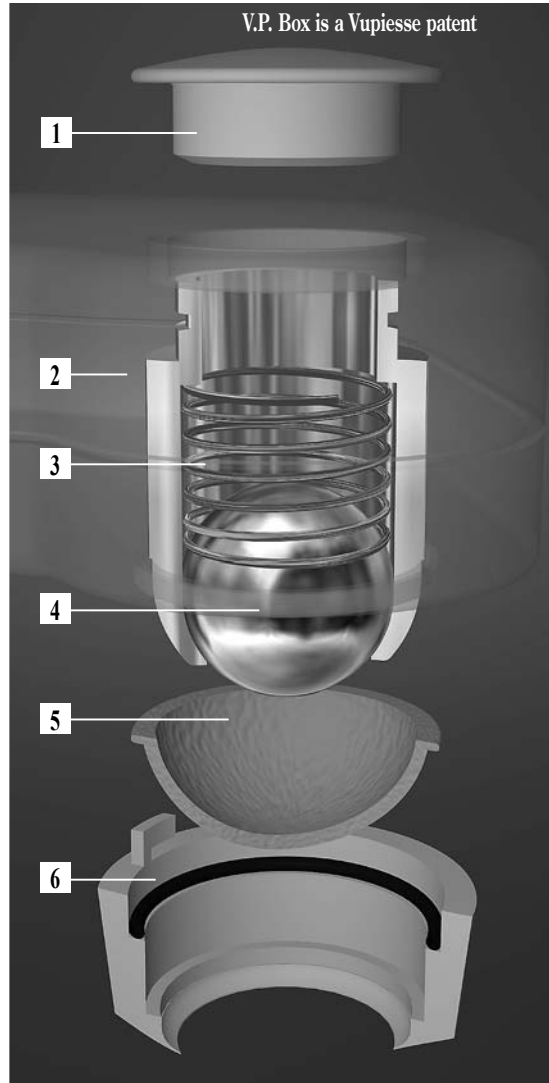

- 1) RUBBER CAP
- 2) BODY
- 3) STAINLESS STEEL SPRING
- 4) SPHERICAL ELECTRODE

- 5) CELLULOSE SPONGE DOME
- 6) EXTRACTABLE BAYONET-FIT RING FOR SPONGE DOME REPLACEMENT



HOW TUA VISO WORKS

Learning To Use Tua VISO



With the Tua VISO unit switched off, remove the reservoir rubber caps, fill the reservoirs just above the level of the reservoir internal steel ring with normal tap water using the water dispenser bottle provided and then fit the reservoir caps back in place. Never fill the reservoirs by immersing Tua VISO or holding it under a tap; always use the special water dispenser bottle provided.

PULSES:
the flashing green LED indicates the pulse sequence

BATTERY:
the yellow LED shows that the battery is starting to lose its charge.

Luminous green display shows the treatment time in minutes.

Button for selecting treatment time (from 1-9 minutes)

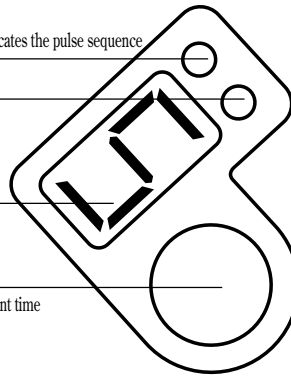

The timer enables treatment to be carried out for precise periods of time on each part of the face without having to worry about checking your watch.

Press on the electrodes' sponges several times until they are perfectly moistened through (or apply drops of water externally through the sponges using the water dispenser bottle provided). The sponge domes must always be completely hydrated with water during use. TUA VISO is ready for use. Switch on the unit by turning the numbered intensity regulator anti-clockwise with your thumb. Start each exercise on intensity number 3 for placement of your Tua Viso on to your face and then you **MUST GRADUALLY TURN UP THE INTENSITY** (with the possible exception of the under eye and neck areas) until you achieve a **COMFORTABLE VISIBLE CONTRACTION**. You will only achieve good results if you achieve a visible contraction – let what you are seeing and feeling guide you, (not any specific intensity value); treat this as the rule of thumb. As soon as you have switched the unit on, the panel automatically lights up indicating "1" (treatment time in minutes) and a beeping sound indicates that the unit is on. Set the treatment time by pressing the (Program Timer) button with your index finger - each time it is pressed the timer increases by a minute and when it is released the time automatically starts counting down. The time remaining is then indicated by a flashing number showing the minutes; the green LED (Pulses) lights up for the micro-current pulses being emitted at the electrodes and stays off for the pauses in between. The timer indicates treatment time left; at the end of the time count down, it zeros, turns off the micro-current pulse feed and indicates the end of treatment with a beeping sound.

After each exercise you have to return the intensity regulator back to zero before embarking on the next exercise. This is a safety measure for your comfort - it ensures that you always return to the low baseline intensity of 3 before placing the Tua Viso to a new point on your face.

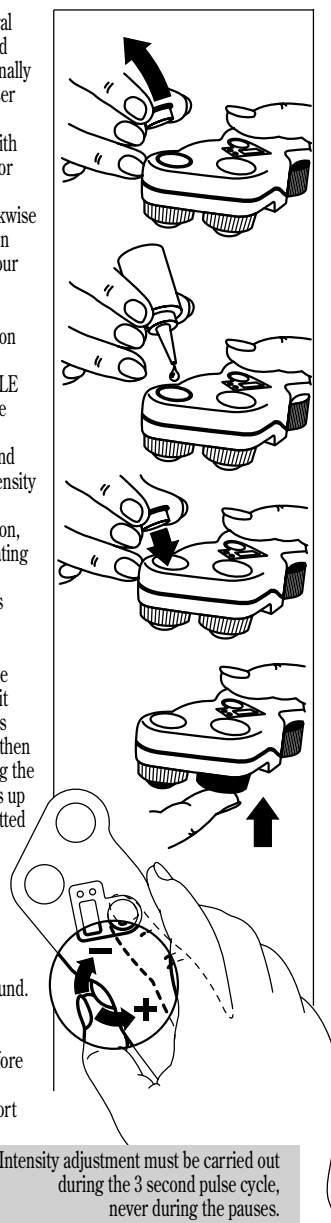

Intensity adjustment must be carried out during the 3 second pulse cycle, never during the pauses.



HOW TUA VISO WORKS

How To Put Tua Viso To Use



It is a good idea to prepare to use the unit by removing make-up and washing your face.

However an effective treatment can be achieved with thoroughly damp sponges, allowing spontaneous treatment over makeup (remember to hand wash sponges in tepid water using an anti-microbial hand cleanser, after use over make-up).

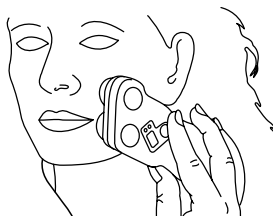

At the beginning, it is also advisable to carry out the exercises in front of a mirror; experience and a good knowledge of the application points will

later enable you to treat your face anywhere without having to use a mirror. Once the unit has been switched on and intensity and suggested time set (see the EXERCISE part of this handbook), position the unit on the area of the face to be treated (application points are shown On the EXERCISE pages).

HOW TO ADJUST THE INTENSITY OF TUA VISO

It must be remembered that individual sensitivity to micro-current varies considerably and also depends on one's physiological conditions at that moment, the cleanliness of the sponge domes and the battery's charge

level. It is therefore highly recommended that you start each exercise on intensity number 3 for placement of your Tua Viso on to your face and then you must gradually turn up the intensity (with the possible exception of the under eye and neck areas) until you achieve a comfortable visible contraction. Since the rhythm of emission of the stimulus is 3 seconds followed by a 3-second pause, the regulation of the intensity, up or down, must obviously be done during the 3 seconds of stimulus, not during pauses.

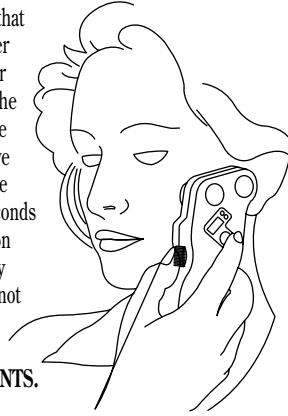

HOW TO LOCATE APPLICATIONPOINTS.

Once the unit has been turned on, the intensity control set to 3 and the timer set at the suitable treatment time, gently press TUA VISO to the area to be stimulated. The most suitable application points for obtaining muscular contraction are shown further on this handbook. Remember however that every person has completely individual anatomic characteristics and slight differences are often found between people when locating the active points. To do this, just move TUA VISO for a few centimetres around the points suggested until the muscular contraction described in the handbook's exercises is obtained. Remember that you will need to gradually increase the intensity control until a comfortable visible contraction is achieved.



Two minutes is the optimum treatment time per application point, but in the beginning set the timer to several minutes to allow for exploration of the application point areas. To facilitate the search, another function of the unit can be put to use:

When you keep the timer button pressed down, the stimulus emission is continuous (with no pauses), thus giving you more time to locate the points. Once they have been found, release the timer button and TUA VISO will automatically revert to the rhythm of 3 seconds of stimulus followed by a 3-second pause.



Always keep the intensity regulator wheel under the control of your thumb or finger in order to adapt the intensity to each specific application point.

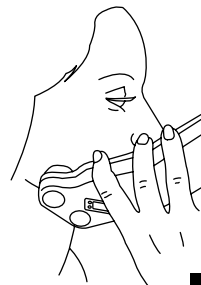



Battery Replacement



Tua VISO is supplied with a 9 Volt alkaline battery.

The yellow indicator light on the control panel shows that the battery is undercharged and is starting to run low. **The battery must be replaced when muscular contraction is not sufficiently felt or visible.** If this happens, remember to first check the cleanliness of the sponge domes, as the pulses can be considerably reduced if they are dirty. If the sponge domes are dirty, hand wash them carefully in tepid water using an anti-microbial hand cleanser and then rinse thoroughly with clean water or replace them.



Use only normal 9 Volt alkaline batteries (6LR61 type).

To change the battery: Slide back the battery cover as shown in the illustration and give a firm tap of the body of the unit on to the palm of your hand to dislodge the battery from its holder.

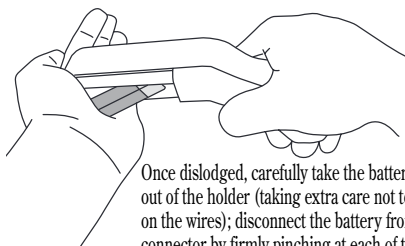

Once dislodged, carefully take the battery out of the holder (taking extra care not to tug on the wires); disconnect the battery from its connector by firmly pinching at each of the two poppa connections with your thumb and forefinger (this gently breaks the battery poppa connections). Finally, connect the new battery to the connector and gently place it in the battery holder. Close the cover.



If Tua VISO remains unused for long periods, remove the battery from the battery holder.

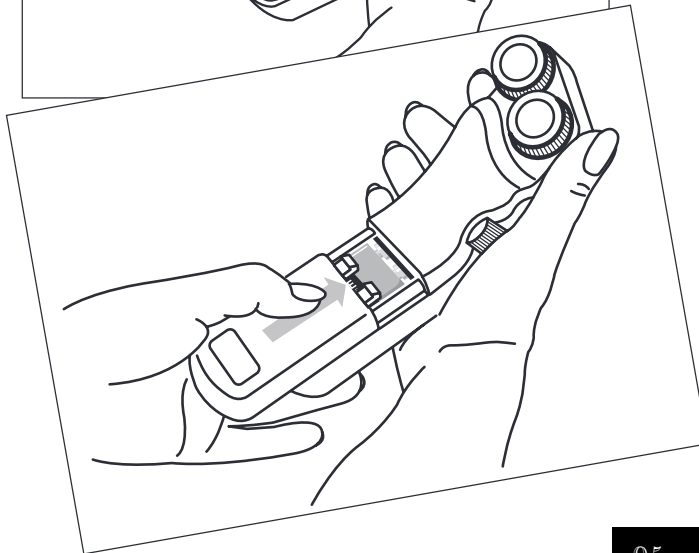
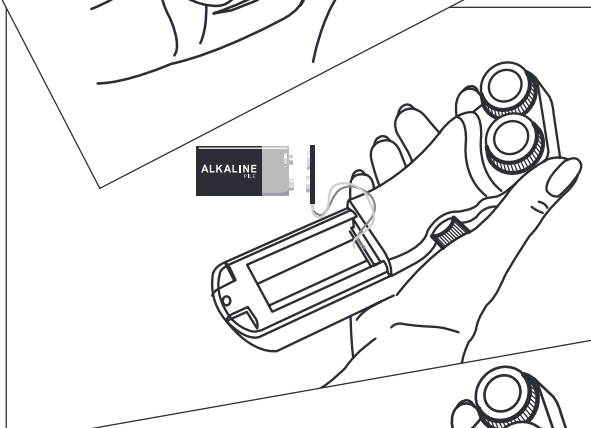
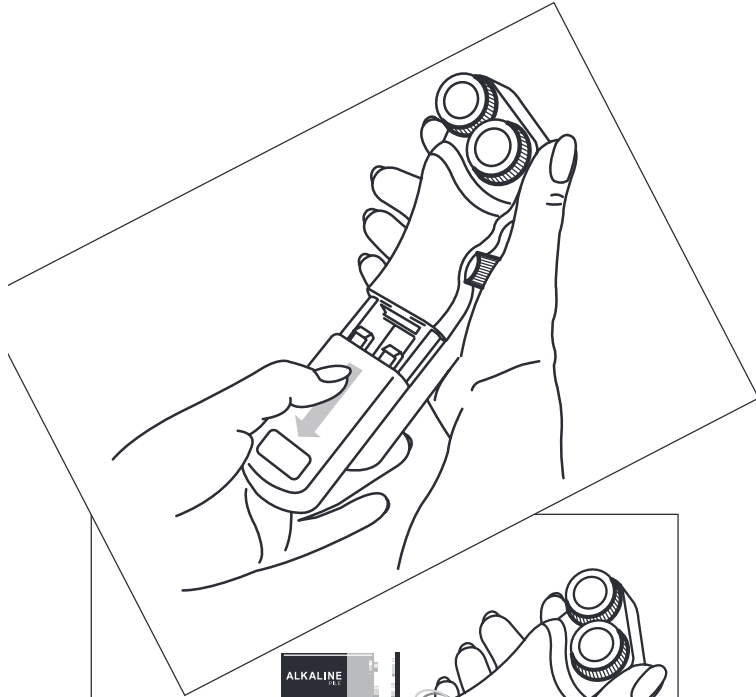



MAINTENANCE

Cleaning And Sponge Replacement



To clean the unit use a clean lint free cloth lightly sprayed with a detergent which is not foamy, alcoholic or abrasive.

Tua Viso is supplied with a pair of sponge domes already fitted for use. The sponge domes are hand washable. An anti-microbial hand wash is the ideal cleansing medium; use tepid water and always remember to rinse through thoroughly with clean water. You only need to wash the sponge domes when they become dirty so you should not need to wash them after every use (unless you use your Tua Viso over makeup). You are provided with six spare sponges with your Tua Viso. If it appears that you have only two, this is because they are all fitted together; simply separate them out.

You should replace the sponge domes only when they have worn thin and have lost their cushioning effect.

Proceed as follows to remove the sponge domes from your Tua Viso and re-fit with washed or replacement sponge domes:



Switch off the unit, remove the rubber reservoir caps and empty out any water left in the reservoirs.

Turn the bayonet-fit rings clockwise and extract them (fig. 1); **do not force the turning; the bayonet-fit rings turn only for few millimetres to lock or unlock**; remove the sponge domes from the rings to then wash or replace. If necessary, clean the surface of the spherical steel electrodes and the various components with a clean cloth. If replacing the sponge domes, it is much easier if you wet the

new ones first with tap water before inserting them into the bayonet rings. Close the rings. (fig. 2). Do not bend the teeth of the bayonet rings by forcing too hard when inserting them or you will break the teeth. It is recommended for good hygiene that you always empty the water from the Tua Viso reservoirs when you have finished using your Tua Viso for the day. Also do not leave wet sponges in the unit; remove the bayonet-fit rings and store them (still carrying the sponge domes) in a small open cup/pot together with the reservoir caps. Store your Tua Viso by laying it horizontally with the empty reservoirs pointing downward on a flat surface in a clean dry place.

Figure 1

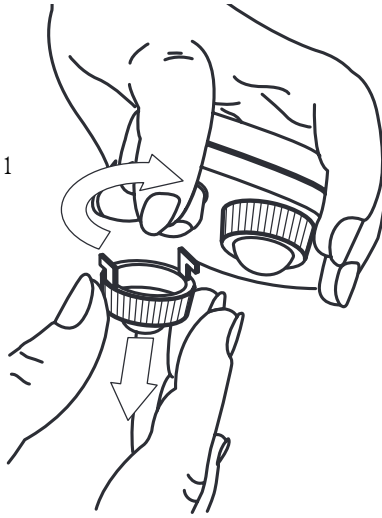
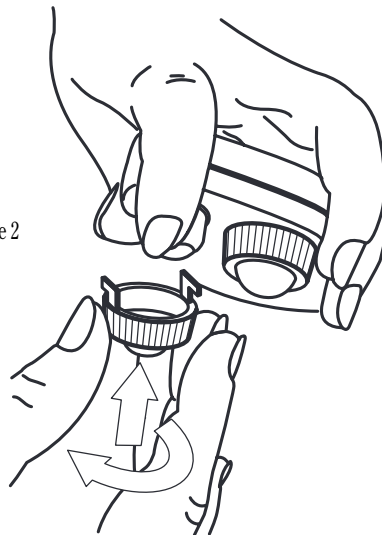

Figure 2





... keeping volume and trophism sufficient, particularly at the level of the less-used fibres, means restoring a face's youthful looks.

WHAT THE DOCTOR SAYS

Muscles... Facial Muscles

By Andrea Paolorosso, consultant
clinical dermatologist



During life, if no action is taken, the following signs of ageing typically occur: wrinkles appear and become more accentuated, facial contours lose definition, the skin loses elasticity and becomes superfluous, causing bags under the eyes, flabby cheeks and relaxation on the neck. These signs are the consequence of precise anatomical changes:

- **The skin's water content is greatly reduced**, as well as its microcirculation and its elastic,

supportive and connective tissue components; it is therefore less turgid, less trophic and less elastic;

- **The muscles** which serve as a solid base on which the skin lies, lose tone, volume and elasticity; the face's skin is no longer so firmly attached to them and the skin's underlying supportive structure is compromised;

- **Bones and cartilage decrease in volume** and are partially reabsorbed, particularly at mouth and nose level, accentuating the loss of support already mentioned due to the atrophy of the facial muscles. Cosmetics can moisturise and to some extent smooth the skin, but this is just a superficial effect; to give a more lifted and contoured appearance to the face, work must be done on the deep structural parts, in other words on the facial muscles.

There are over thirty facial muscles, some extremely superficial and



delicate, others deeper and quite large; Converse to skeletal muscles, head and neck muscles are referred to as 'cutaneous' because at least one of their extremities is directly inserted in the skin and hence they directly have an effect on the turgidity of the skin. Your facial skin therefore lies on and is anchored to a structural "carpet" made up of numerous muscles: their loss of tone and compactness is the main cause of loose skin. Managing to keep sufficient volume and trophism, particularly at the level of less-used muscle fibres, will give your face a more contoured and youthful appearance and greatly help you to maintain it. It is well-known that suitable manual facial exercises or "facial gymnastics", used a great deal by actors for example, keep little-used muscular fasciae active and develop others, to prevent a dropping chin line and the formation of bags or wrinkles and hence maintain a youthful look. Manual facial exercises are however often tricky to learn to do properly and for that reason require patient training. Electrical stimulation on the other hand, due to its motor/stimulant effect,

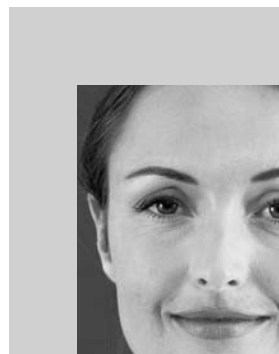



can efficiently increase muscular tone in a harmless, selective and rapid manner and much more potently than manual physical exercise



WHAT THE DOCTOR SAYS

or massage. The motor/stimulant effect produces visible contractions, with a hypertrophic effect on muscle fibres and a consequent increase in their volume. The passage of micro-current through the skin also has an effect on trophism: local circulation increases, the oxygenation, nutrition and detoxification of the tissues improves; the metabolism is excited by this and the formation of elastic fibres and fundamental support substance is stimulated.

TUA VISO has been carefully designed with the above requirements in mind. Its current, represented by a suitably modulated sine wave, is able to induce comfortable sustained muscular contraction. Its structure was specially designed for the stimulation of the delicate muscles of the face and neck. The easy positioning of the active

components of the Tua Viso unit on to the precise activation points of facial muscle fasciae, the linear regulation of the stimulus intensity and the electronic control of treatment time, all enable rapid selective results to be achieved.

A single session carried out on one half of the face enables the difference in tone compared with the untreated part to be appreciated; and just 8-10 sessions gives a significant improvement which can be calculated using recognised methods of clinical analysis (muscular ultrasonography and computerised image analysis).

For the aforementioned reasons, TUA VISO is mainly suitable in the following situations:

- **Prevention and correction of the loss of facial muscle tone and skin tone** with slackening of the neck and cheeks, folds of excess skin and bags under the eyes;
- **Prevention and reduction of the appearance of fine lines and wrinkles;**
- **Improvement of the nutrition and vascularisation of the skin,** with relative detoxification, cell replacement and improved surface appearance;
- **Improved drainage of excess lymphatic fluid** by the

contractions of the facial muscles; noticeably reduces facial puffiness and the look of under eye bags which are related to fluid stasis.



WHAT THE DOCTOR SAYS

“Our face’s skin therefore lies on and is attached to a structural “carpet” made up of numerous muscles: their loss of tone and firmness is the main reason for loose skin. Managing to maintain them with sufficient volume and trophism, particularly that of the less used muscle fibres, means restoring the face’s youthful looks.”

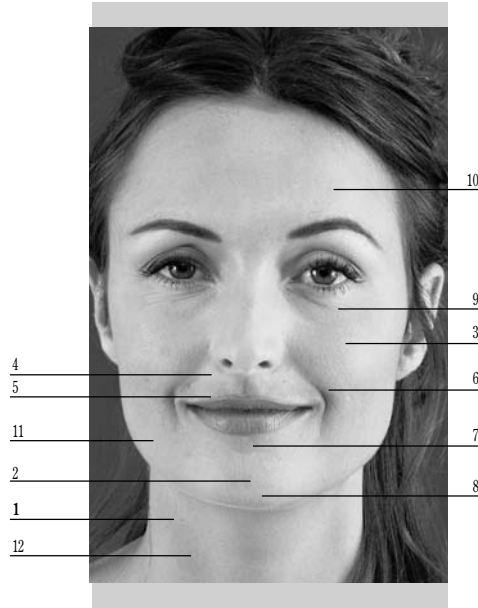

- 1 Platysma (subcutaneous neck muscle); pulls the lower jawbone down slightly and pulls down the lower lip until the teeth are bared.
Also prevents the superficial necks veins from being crushed.
- 2 Quadratus labii inferioris: pulls the down and everts the lower lip.
The protuberance of the lip is also aided by the action of the incisive muscle, located below the quadratus.
- 3 Zygomatic of the upper lip: pulls the down of the joint of the lips upwards and outwards, as in a smile.
- 4 Quadratus labii superioris: lifts the upper lip and part of the ala of the nose.
- 5 Caninus: below the quadratus, raises the skin at the angles of the mouth.
- 6 Buccinator: muscular foundation of the cheek.
Pulls the joint of the lips inwards and during chewing compresses cheeks and lips against the dental arch.
- 7 Orbicularis oris: closes the mouth, tightens the line formed by the junction of the lips and wrinkles the lips.
- 8 Mentalis: raises and wrinkles the chin, raises the lower lip and curves it downwards.
- 9 Orbicularis oculi: closes the eyelids.
- 10 Frontalis: raises the eyebrows and opens the eyes wide.
- 11 Masseter: a skeletal muscle which raises the lower jawbone as when chewing.
- 12 Sternocleidomastoid: another skeletal muscle which flexes the head, tilting it to the side it is on and turning the face to the opposite side.



EXERCISES WITH TUA

TUA VISO is easy to use: once the unit has been prepared for use and the intensity regulator set to intensity 3, TUA VISO is lightly pressed on the area to be treated. With the possible exception of the under eye and neck areas, you must turn up the intensity until you achieve a comfortable visible contraction of the muscle/s; the intensity to achieve this will differ between individuals so always go by what you are feeling and seeing. It is sufficient to stimulate each area for just one minute a day, but the usual application times are 2-4 minutes for each point. Remember to switch off the unit and go back to intensity 3 before placing the unit on to the next point.



Due to the individual disposition of muscular fasciae and nervous fibres, each person has specific points for obtaining the best possible contraction.

Shortly we will show you which points on the face are normally most suitable for achieving valid exercises, but moving slightly from these areas will enable you to find your own personal most active points. Movement with your Tua Viso must be made during the 3 seconds of pulse emission, not during the 3 second pause. To make things easier, the search for your active points can be carried out while keeping the timer button continuously pressed down with your index finger. This makes the pulse continuous (without any pauses) which gives you all the time necessary for locating your points. When the button is released, normal operation of TUA VISO is automatically resumed. The application points have been chosen with the objective of activating the less used facial muscle fibres and reinforcing those which tend to drop and slacken most with the passage of time.

When a revitalising, nourishing and detoxifying effect is preferred for the skin rather than precise facial muscle exercises, the unit can be slowly passed over the entire face and neck, over thoroughly cleansed skin (not suitable over makeup). When using Tua Viso in this way, apply more water than usual to the sponge domes using the water dispenser bottle, so they are thoroughly wet (this produces glide) and press the timer button down continuously with your index finger to keep the micro-current pulse constant as you go.



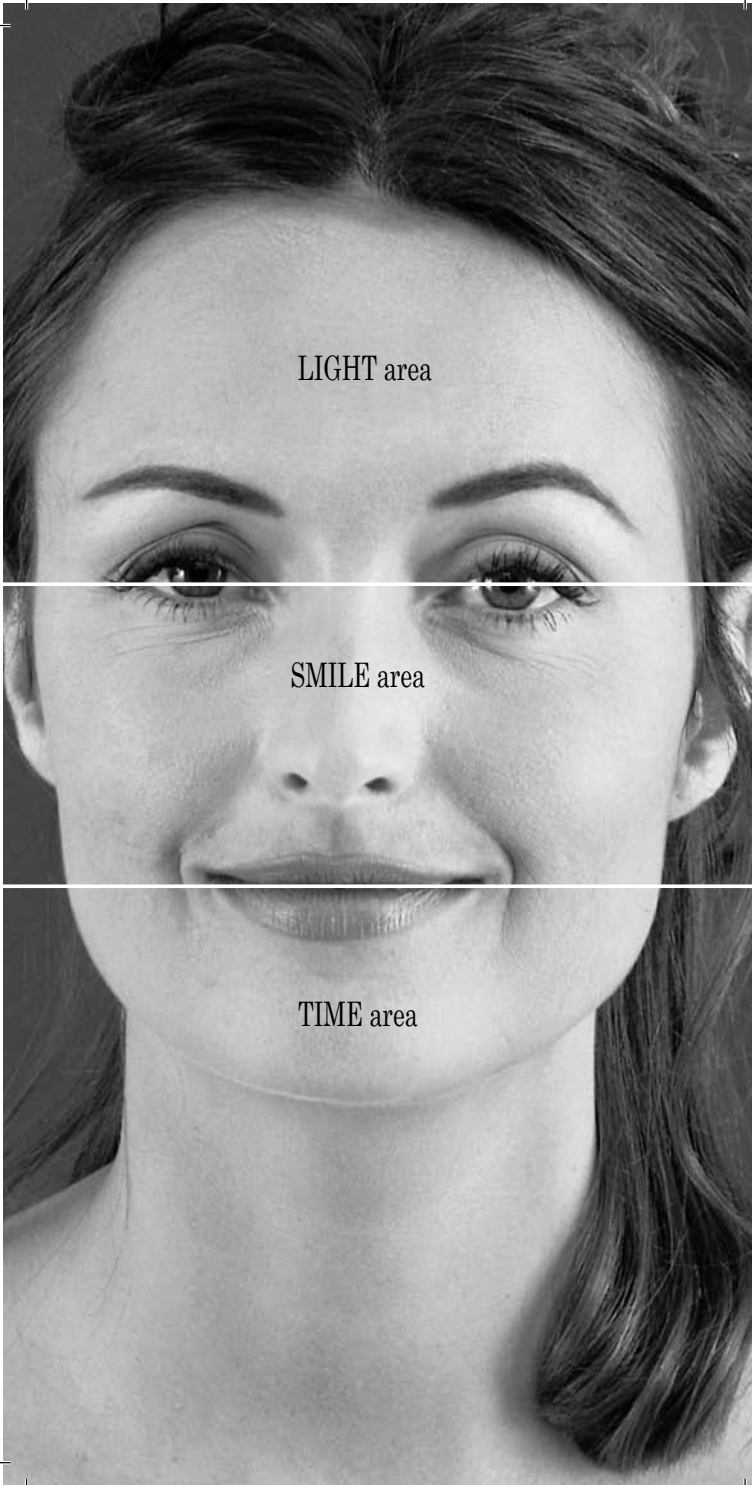

LIGHT area

SMILE area

TIME area



EXERCISES WITH TUA

1

LIGHT
AREA



**STARTING
INTENSITY 3
TIME: 3 min.**

POSITION:
on the temporal region, with
the two electrodes placed
obliquely between the auricle
of the ear (external ear) and
the edge of the eyebrow,
slightly above the latter.

**Raises the eyebrow and 3/4
of the brow.**







EXERCISES WITH TUA

2

LIGHT
AREA



**STARTING
INTENSITY 3
TIME: 2÷3 min.**

POSITION:
as an alternative to the
previous exercise, with the
electrodes on either side of
the zygomatic arch (cheek
bone), with the bottom one
touching the ear and the top
one in the temporal region.

**Raises the eyebrow and the
upper eyelid.**







EXERCISES WITH TUA

3

SMILE
AREA



**STARTING
INTENSITY 3
TIME: 2 min.**

POSITION:

Vertically immediately behind
the auricle of the ear.

**Pulls the auricle and the edge
of the cheek upwards and
outwards. This exercise has a
lifting effect on the cheek.**







EXERCISES WITH TUA

4

SMILE
AREA



**STARTING
INTENSITY 3**

TIME: 2 min.

POSITION:

Horizontally on the cheek-
bone

Contracts (without lowering)
all the lower eyelid and the
bag under it. In this way has
a “squeezing” and draining
effect on the bags under the
eyes.



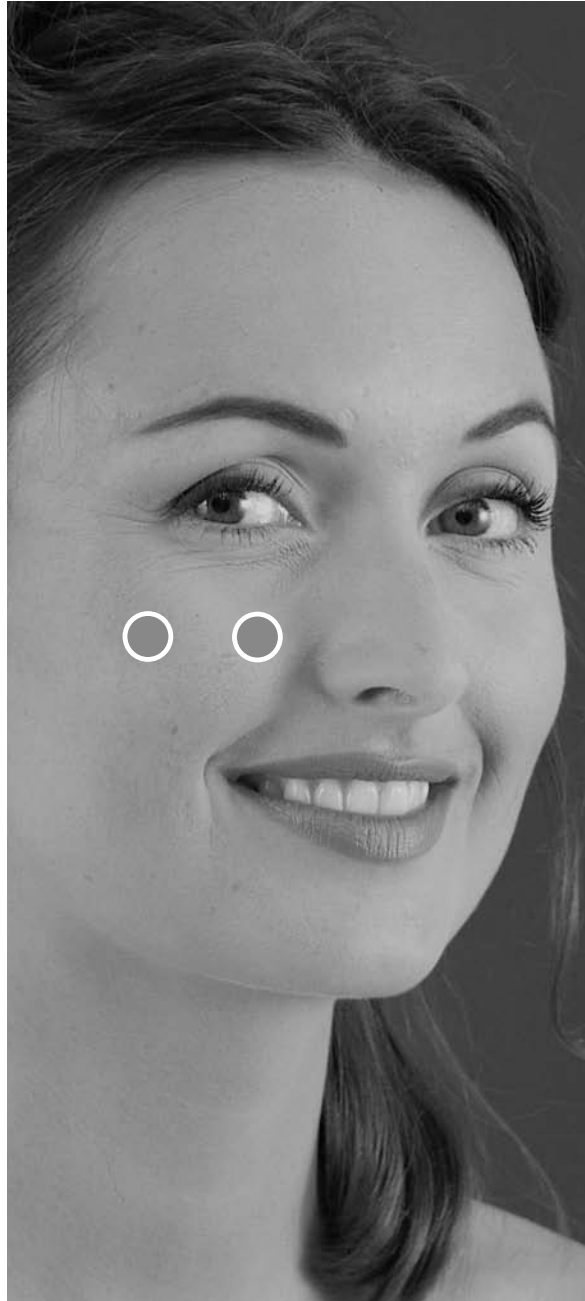



EXERCISES WITH TUA

5

SMILE
AREA



**STARTING
INTENSITY 3
TIME: 3 min.**

POSITION:
obliquely between the ear
and the corner of the mouth,
staying up against the lower
edge of the zygomatic arch
(cheek bone).

Contracts and raises the upper
lip, the cheek and the bag under
the lower eyelid. Tones up the
part just like when you smile
slightly.



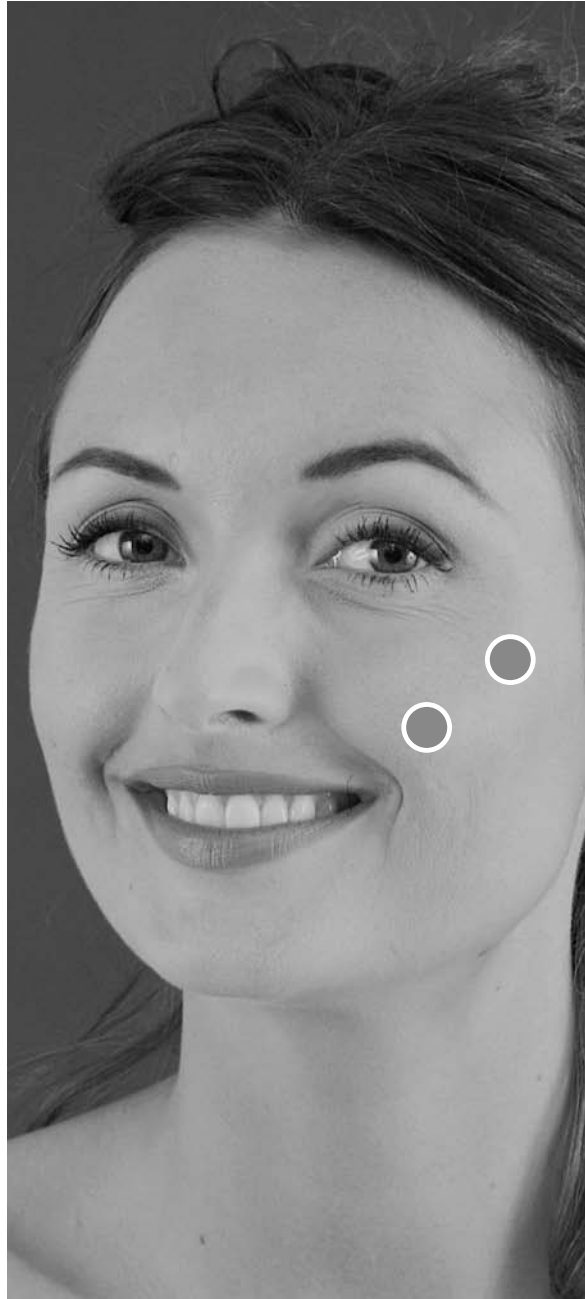



EXERCISES WITH TUA

6

SMILE
AREA



**STARTING
INTENSITY 3
TIME: 3 min.**

POSITION:
Obliquely with the bottom
exactly on the corner of the jaw.

Stretches the upper lip and
the lower part of the ala of
the nose (external side of the
nose) upwards and outwards.
Increases the volume of the lip
and combats the appearance of
the vertical wrinkles typical of
advancing age.







EXERCISES WITH TUA

7

TIME
AREA



**STARTING
INTENSITY 3
TIME: 2 min.**

POSITION:
horizontally immediately
below the lower lip.

**Contracts and pulls the
lower lip outwards. In this
manner makes the lip turgid
and combats its atrophy
(decrease in size).**



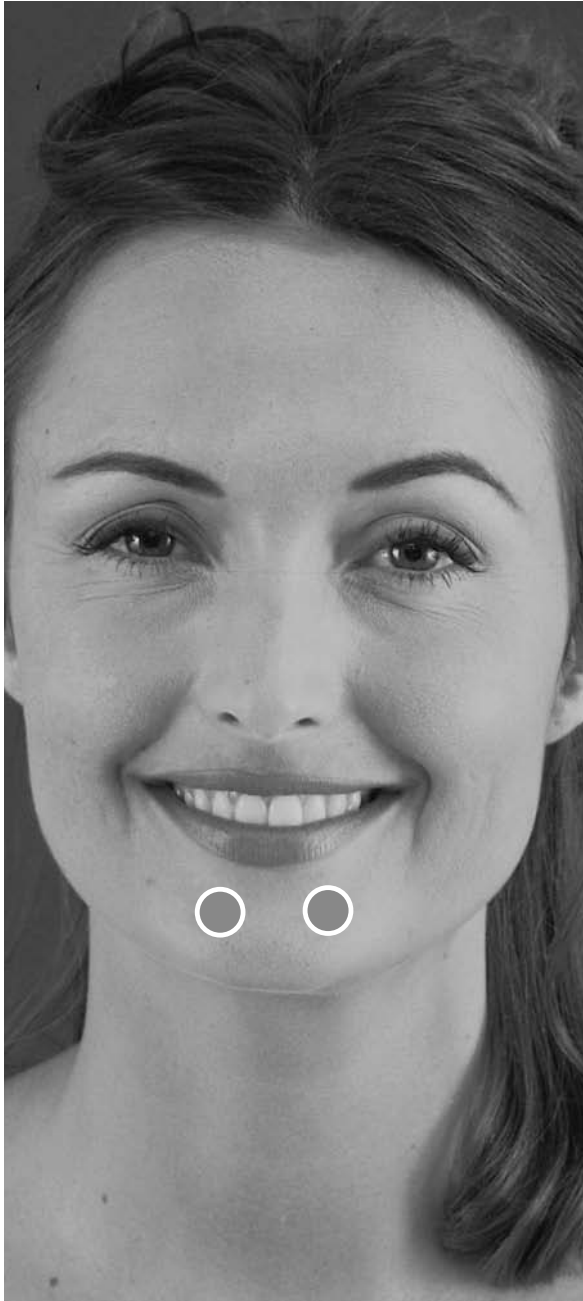



EXERCISES WITH TUA



TIME
AREA



**STARTING
INTENSITY 3
TIME: 2 min.**

POSITION:
immediately underneath the
mandibular arch (lower jaw),
between the corner (where the
lower jaw turns a corner before
reaching the ear) and the apex
(point of the chin), following its
shape.

**Contracts the chin and pulls
the lower lip outwards and
downwards.**

**Models the oval, reducing the
stretching caused by the drop
of the Bichat fat pad.**



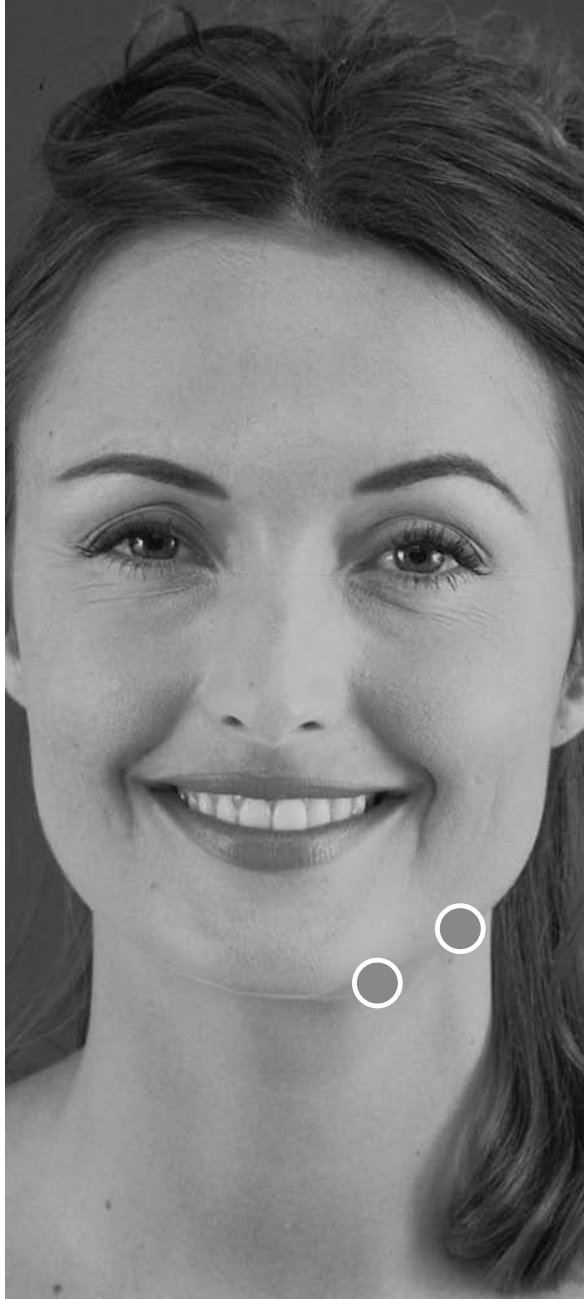



EXERCISES WITH TUA

9

TIME
AREA



**STARTING
INTENSITY 3
TIME: 3 min.**

POSITION:
vertically on the
sternocleidomastoid.

Contracts the neck and in part the zone under the chin. In this manner, helps to make the delicate neck tissues firmer.







PRECAUTIONS AND CONTRAINDICATIONS

Precautions

The sponge domes must always be perfectly moistened with water and kept perfectly in contact with the skin. If they are not adequately moistened, they tend to insulate the pulses and not conduct them.



The steel domes must never come into direct contact with the skin.

Do not immerse your Tua Viso in water.

Do not fill the reservoirs with any liquid apart from normal tap water.

Do not fill the reservoirs from the tap; always use the water dispenser bottle provided

Keep out of children's reach.

Contraindications

Pathological facial conditions (eg. herpes, tumours, abscesses)

Prolonged contact with nevi

Cuts

Pacemakers

For external use only

Keep away from the eyes and mouth

Do not use when in poor psychophysical condition,

When in doubt, consult your doctor.







GLOSSARY

COMPUTERIZED IMAGE ANALYSIS

An objective analysis method which enables a photographic image to be transformed into a digital one, which is processed by feeding it into a computer.

ATROPHY

Loss of trophism (the normal state of nourishment of a tissue). Atrophy causes a macroscopic reduction of thickness and volume of the muscles of the skin and other organs.

COMMISSURA LABIORUM ORIS

The junction of the upper and lower lip on either side of the mouth.

BICHAT FAT PAD

A build-up of fat in the cheek between the buccinator and the masseter facial muscles. As years pass, this tends to move downwards and lose consistence, causing a lowering of the oval of the face on either side of the chin.

MUSCULAR ULTRASONOGRAPHY

A laboratory examination which uses ultrasonic energy to control and graphically reproduce the volume of muscles (or other tissues or cavities).

MOTOR/STIMULANT EFFECT

Effect characteristic of electric current, able to cause the involuntary contraction of a muscle, by direct action on the fibre and on the motor nerve.

ERGONOMICS

A science which studies the problems of human beings' work in relation to machines in order to adapt them to suit users' physical requirements.

HYPERTROPHY

Increase of the state of nutrition of a tissue, observed by an increase in its volume and tone.

METABOLISM

The total of all bio-chemical processes of the organism or

sectors of it which results in the production and preservation of living substance and its transformation for energetic purposes.

CUTANEOUS MUSCLES

Muscles which are inserted with at least one of their ends directly into the skin. In man, they are to be found only on the head and neck.

SKELETAL MUSCLES

Muscles inserted with their muscular or tendinous heads on bones.

WRINKLES

Linear depressions of the skin divisible into different types (lines, furrows, folds, etc.) connected with individual expressive movements, aggressive external factors and the sagging of certain support structures of the skin.

TROPHISM

Refers to the state of nutrition of tissues.



TECHNICAL DETAILS

No. of outputs: _____ 1
OUTPUT VOLTAGE: _____ 56V
WAVE SHAPE: _____ SINUSOIDAL
WIDTH OF IMPULSES: _____ 140 μ Sec.
NO. OF PROGRAMS: _____ 1
OUTPUT CURRENT : _____ 56 mA (load 1kohm)MAX
CARRIER FREQUENCY: _____ 7.500 Hz
MODULATION FREQUENCY : 70 Hz
SUPPLY VOLTAGE: _____ 9V (alkaline battery)
CONTRACTION TIME: _____ 3 Sec.
RECOVERY TIME: _____ 3 Sec.
WEIGHT: _____ 222 g (with battery)
DIMENSIONS: _____ 184 x 55 x 445
OPERATING CONDITIONS: _____ Temperature: from 0 to 35 °C
Humidity: from 20 to 65% RH

STORAGE: _____ Temperature: from 5 to 40 °C
Humidity: from 10 to 85% RH

MARKING: _____  

DISPOSAL

TUA VISO is an electronic device and as such contains electronic components that could be harmful for the environment and for human health if disposed of in a way not in conformity with applicable legal provisions. Discard TUA VISO, the parts it contains and the accessories in compliance with local regulations on waste disposal. In particular, always discard old batteries into special containers. Directive No. 2002/96/EC requires product owners to dispose of it by delivering it to a local Waste Electrical and Electronic Equipment (WEEE) Collection centre or giving it back to the dealer on making a new purchase and in any case forbids discarding the product as domestic waste.

The directive establishes fines for the unlawful discarding of such wastes.

The symbol shown below (crossed waste basket on wheels) and on the TUA VISO data plate indicates that the waste of electrical and electronic equipment must be collected separately.



CLASSIFICATION

TUA VISO is an internally powered appliance. Applied part BF type.
Degree of protection against the penetration of liquids: IPX0.
Not suitable for use with anaesthetic mixtures inflammable with air, oxygen or nitrous oxide.

CONFORMITY WITH REGULATIONS

TUA VISO bears the CE mark and TÜV SUD quality mark.
TUA VISO has been designed and manufactured in conformity with the requirements of the company quality system certified according to UNI EN ISO 9001:2000 and UNI EN ISO 13485:2004 standards.
For product audit, the EN60335-2-32:2003 electrical safety standard has been applied.
Conformity with electromagnetic compatibility has been determined by applying standards
EN50366:2003
EN55014-1
EN55014-2
EN61000-3-2
EN61000-3-3

This manual is subjected to copyright by Vupiesse Italia who reserves all rights. According to current copyright laws, this handbook cannot be copied even in part or translated into any language without written consent from Vupiesse Italia. TUA is a Vupiesse Italia registered trademark. Use for commercial purposes of the above trademark without prior written consent from Vupiesse Italia can constitute trademark violation and unfair practice which violates current laws.

© Vupiesse Italia 1993-2008

BONFIGLIOLI

VAVI10NG Rev.01 02/08

Vupiesse Italia - Rimini Italy

