

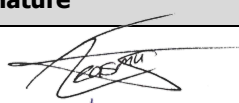


# AVIATOR 200S/700S

## User Manual

**Document : 98-158752**

**Revision : B**

Type text here

Activity	Function	Role	Name	Date	Signature
Prepared	System Engineer	DE	Adrian Erasmus	29-OCT-2021	
Reviewed	System Engineer	CVE	Jorge Perez	29-OCT-2021	
Reviewed	Program Manager	PM	Marcin Kazmierczak	29-OCT-2021	

**Copyright© Thrane & Thrane A/S**  
Lundtoftegaardsvej 93D, DK-2800 Kgs. Lyngby, Denmark

ALL RIGHTS RESERVED

**REVISION HISTORY**

<b>Revision</b>	<b>Author</b>	<b>Date</b>	<b>Section</b>	<b>Description of Change</b>
A	AER	21 Apr 2021	All	Initial release.
B	AER	28 Oct 2021	2.1	Update to the RF Exposure safe distances.

**© Thrane & Thrane A/S trading as Cobham Aerospace Communication**

This Document and any other appended documents and drawings are of © copyright to Thrane & Thrane A/S. It contains proprietary information which is disclosed for information purposes only. The contents of this document shall not in whole or in part be used for any other purpose; be disclosed to any member of the recipient's organisation not having a need to know such information or to any third party, individual, organisation or Government; be stored in any retrieval system or be produced or transmitted in any form by photocopying or any optical, mechanical or other means without prior permission of Thrane & Thrane A/S.

**TABLE OF CONTENTS**

	<b>PAGE</b>
<b>1 INTRODUCTION.....</b>	<b>11</b>
1.1 GENERAL.....	11
1.1.1 Purpose.....	11
1.1.2 Scope.....	11
1.2 GLOSSARY .....	11
1.2.1 Acronyms .....	11
1.3 REFERENCES .....	14
1.3.1 External References .....	14
1.3.2 Internal References.....	14
<b>2 REGULATORY INFORMATION.....</b>	<b>15</b>
2.1 RADIOFREQUENCY RADIATION EXPOSURE INFORMATION.....	15
2.1.1 AVIATOR 200S.....	15
2.1.2 AVIATOR 700S.....	15
2.2 FEDERAL COMMUNICATIONS COMMISSION (FCC) .....	16
2.3 JAPANESE RADIO LAW AND JAPANESE TELECOMMUNICATIONS BUSINESS LAW COMPLIANCE .....	16
<b>3 SWIFTBROADBAND SAFETY SYSTEM OVERVIEW .....</b>	<b>17</b>
3.1 INMARSAT SATELLITE NETWORK.....	17
3.1.1 SwiftBroadband-Safety (SB-S) for the Cockpit.....	17
3.1.2 SwiftBroadband (SBB) for the Cabin .....	17
3.1.3 SwiftBroadband Satellites and Coverage Map.....	17
3.2 AVIATOR S SATCOM SYSTEM FUNCTIONS AND FEATURES.....	18
3.2.1 System Overview – AVIATOR 200S .....	18
3.2.2 System Overview – AVIATOR 700S .....	19
3.2.3 Configuration.....	20
3.3 SAFETY VOICE SERVICES .....	20
3.3.1 Call Priorities – Ground-to-Air (G2A).....	20
3.3.2 Call Priorities – Air-to-Ground (A2G).....	21
3.3.3 Pre-emption.....	21
3.4 SAFETY DATA SERVICES .....	21
3.4.1 ACARS Data.....	21
3.5 NON-SAFETY DATA SERVICES .....	21
3.5.1 Electronic Flight Bag (EFB).....	21

**COBHAM PRIVATE**

Document: **98-158752**  
Revision: **B**

Page: **3** of **105**  
Level: **COM** CC: **1**  
(T: 99-161853-F)

3.5.2	Cabin Data.....	22
3.5.2.1	Service Class.....	22
3.5.2.2	Service Class Selection .....	22
<b>4</b>	<b>SERVICE ACTIVATION .....</b>	<b>23</b>
4.1	IMSI AND SMART CARD INFORMATION .....	24
4.2	PUBLIC KEY INFRASTRUCTURE (PKI) SECURITY CERTIFICATE.....	24
<b>5</b>	<b>INTERPRETING THE SYSTEM STATUS .....</b>	<b>25</b>
5.1	MULTI-PURPOSE CONTROL AND DISPLAY UNIT (MCDU) .....	25
5.2	RADIO MANAGEMENT PANEL (RMP).....	25
5.3	VOICE AVAILABILITY .....	26
5.3.1	Not Available .....	26
5.3.2	Safety Voice Services - Ready to Connect .....	27
5.3.3	Safety Data Services - Available .....	27
5.4	SATCOM CONFIG.....	28
5.4.1	Logging On Auto/Logged On Auto/Logged Off .....	28
5.4.2	SATCOM INOP .....	30
5.5	SATCOM SETTINGS .....	30
5.5.1	IMSI Config .....	31
<b>6</b>	<b>SATELLITE SELECTION .....</b>	<b>32</b>
6.1.1	Log Off & Auto/Manual Log On .....	32
6.1.2	Ocean Region Change (ORC) .....	33
<b>7</b>	<b>SAFETY VOICE SERVICES .....</b>	<b>34</b>
7.1	MCDU INTERFACE.....	34
7.1.1	Outgoing Calls – Air-to-Ground (A2G).....	34
7.1.1.1	Manual Dial.....	34
7.1.1.2	Directory Dial .....	35
7.1.1.3	Initiating an Outgoing Call.....	36
7.1.1.4	Ending an Outgoing Call.....	38
7.1.2	Incoming Calls – Ground-to-Air (G2A) .....	39
7.1.2.1	Cockpit Alerting .....	39
7.1.2.2	Identifying the calling party and priority.....	39
7.1.2.3	Answering an Incoming Call.....	40
7.1.2.4	Ending an Incoming Call.....	41
7.1.2.5	Pre-emption .....	42
7.2	RMP INTERFACE .....	43

**COBHAM PRIVATE**

7.2.1	Outgoing Calls – Air-to-Ground (A2G).....	43
7.2.1.1	Manual Dial.....	43
7.2.1.2	Directory Dial.....	44
7.2.1.3	Initiating an Outgoing Call.....	45
7.2.1.4	Ending an Outgoing Call.....	47
7.2.2	Incoming Calls – Ground-to-Air (G2A).....	48
7.2.2.1	Cockpit Alerting.....	48
7.2.2.2	Identifying the calling party and priority.....	48
7.2.2.3	Answering an Incoming Call.....	49
7.2.2.4	Ending an Incoming Call.....	49
7.2.2.5	Pre-emption.....	49
<b>8</b>	<b>SAFETY DATA SERVICES.....</b>	<b>50</b>
8.1	ACARS DATA.....	50
<b>9</b>	<b>NON-SAFETY DATA SERVICES.....</b>	<b>51</b>
9.1	ELECTRONIC FLIGHT BAG (EFB) CONNECTIVITY.....	51
9.2	CABIN DATA CONNECTIVITY.....	51
9.2.1	PPPoE Connections.....	52
9.2.2	Connection Authentication.....	53
9.2.3	PPPoE Service Name.....	53
9.2.4	Connection Control using TELNET.....	54
9.2.4.1	Primary PDP Contexts.....	54
9.2.4.2	Secondary PDP Contexts.....	54
9.2.4.3	Out-of-band Control Port Connection and Configuration.....	55
9.2.4.4	List of Supported AT-Commands.....	55
9.2.4.5	Binding to an active Primary PDP context.....	56
9.2.4.6	Adding a Secondary PDP Context.....	56
9.2.4.7	Traffic Flow Templates.....	56
9.2.4.8	Modifying/Scaling of Streaming Class PDP Contexts.....	57
9.2.4.9	Deactivating PDP contexts.....	57
<b>10</b>	<b>TROUBLESHOOTING.....</b>	<b>58</b>
10.1	LOG FILE EXTRACTION.....	58
10.2	SYSTEM TEST - FLASHING CALL LIGHTS.....	58
<b>APPENDIX A.</b>	<b>AISD SNMP INTERFACE.....</b>	<b>59</b>
<b>APPENDIX B.</b>	<b>PIESD SNMP INTERFACE.....</b>	<b>65</b>
<b>APPENDIX C.</b>	<b>SNMP OBJECT ID DEFINITIONS.....</b>	<b>72</b>

APPENDIX C.1.	ASLI <code>ACTLINKSTATUS</code> (4) .....	72
APPENDIX C.2.	ASLI <code>HISTLINKENTRYNUMBERS</code> (6) .....	72
APPENDIX C.3.	ASU <code>SDUINFOVENDOR</code> (2) .....	72
APPENDIX C.4.	ASU <code>SDUINFOFAILURECODE</code> (11) .....	72
APPENDIX C.5.	ASU <code>SDUINFOFAILUREREASON</code> (12) .....	73
<b>APPENDIX D.</b>	<b>AT-COMMANDS</b> .....	<b>74</b>
APPENDIX D.1.	GENERAL COMMANDS.....	74
Appendix D.1.1	List all Available AT Commands .....	74
Appendix D.1.2	Command Echo.....	74
APPENDIX D.2.	SYSTEM INFORMATION .....	75
Appendix D.2.1	Request Manufacturer Identification .....	75
Appendix D.2.2	Request Model Identification .....	75
Appendix D.2.3	Request Revision Identification .....	76
Appendix D.2.4	Request Serial Number Identification .....	76
Appendix D.2.5	Request International Mobile Subscriber Identity.....	76
APPENDIX D.3.	PACKET DATA CONNECTIONS .....	77
Appendix D.3.1	Define Primary PDP Context.....	77
Appendix D.3.2	3G Quality of Service Profile (Requested).....	79
Appendix D.3.3	2G Quality of Service Profile (Requested).....	83
Appendix D.3.4	3G Quality of Service Profile (Negotiated) .....	87
Appendix D.3.5	3G Quality of Service Profile (Minimum Acceptable).....	90
Appendix D.3.6	PDP Context Activation .....	94
Appendix D.3.7	Show PDP IP Address .....	94
Appendix D.3.8	Define Secondary PDP Context.....	95
Appendix D.3.9	Define Traffic Flow Template .....	97
Appendix D.3.10	Modify PDP Context .....	99
Appendix D.3.11	Binding a TCP Session to a Primary PDP Context .....	100
<b>APPENDIX E.</b>	<b>LOG FILE EXTRACTION</b> .....	<b>101</b>
APPENDIX E.1.	PREREQUISITES .....	101
APPENDIX E.2.	PROCEDURE TO EXTRACT THE LOG FILES VIA USB.....	102
Appendix E.2.1	Find system log entries on the LRU unit .....	103
Appendix E.2.2	Select file and export .....	103
APPENDIX E.3.	FURTHER EXAMPLES IN MAINTENANCE PHASE.....	104
Appendix E.3.1	List of commands available.....	104

---

Appendix E.3.2	Make new log file .....	104
Appendix E.3.3	Add a text line in current log .....	105

**LIST OF FIGURES**

	<b>PAGE</b>
Figure 3-1: INMARSAT SwiftBroadband Coverage .....	18
Figure 3-2: AVIATOR 200S SATCOM System – Block Diagram .....	19
Figure 3-3: AVIATOR 700S SATCOM System .....	19
Figure 4-1: AVIATOR S SCM   IMSI & Smart Card Identification .....	24
Figure 5-1: SATCOM MCDU Pages .....	25
Figure 5-2: ARINC 739 MCDU Line Select Keys .....	25
Figure 5-3: SATCOM RMP Pages .....	25
Figure 5-4: RMP TEL & MENU Keys .....	25
Figure 5-5: MCDU - SATCOM Main Menu - Voice Not Available .....	26
Figure 5-6: RMP - TEL Page - Voice Not Available .....	26
Figure 5-7: MCDU - SATCOM Main Menu - Safety Voice Availability - Ready to Connect .....	27
Figure 5-8: RMP - TEL Page - Safety Voice Availability - Manual .....	27
Figure 5-9: MCDU - SATCOM Settings - Safety Data Available .....	27
Figure 5-10: RMP - SATCOM Settings - Safety Data Available .....	27
Figure 5-11: MCDU - SATCOM Config - Status - Logging On .....	28
Figure 5-12: MCDU - SATCOM Config - Status - Logged On Auto .....	28
Figure 5-13: MCDU - SATCOM Config - Status - Logged Off .....	28
Figure 5-14: RMP - SATCOM Config - Status - Logging On .....	29
Figure 5-15: RMP - SATCOM Config - Status - Logged On Auto .....	29
Figure 5-16: RMP - SATCOM Config - Status - Logged Off .....	29
Figure 5-17: MCDU - SATCOM Config - Status - SATCOM INOP .....	30
Figure 5-18: MCDU - SATCOM Settings - Status - Logged On .....	30
Figure 5-19: RMP - SATCOM Settings - Status – Logged On .....	30
Figure 5-20: AVIATOR 200S - IMSI Config .....	31
Figure 5-21: AVIATOR 700S - IMSI Config .....	31
Figure 6-1: MCDU - SATCOM Config - Auto Log On .....	32
Figure 6-2: MCDU - SATCOM Settings - Manual Log On .....	32
Figure 6-3: RMP - SATCOM Config - Auto Log On .....	32
Figure 6-4: RMP - SATCOM Settings - Manual Log On .....	32
Figure 7-1: MCDU - SATCOM Main Menu - Manual Dial - International Number .....	34
Figure 7-2: MCDU - SATCOM Main Menu - Manual Dial - Short Code .....	34
Figure 7-3: MCDU - SATCOM Directory .....	35

**COBHAM PRIVATE**

Document: **98-158752**  
Revision: **B**

Page: **8** of **105**  
Level: **COM** CC: **1**  
(T: 99-161853-F)



Figure 7-4: MCDU - SATCOM Directory Entries .....	35
Figure 7-5: ACP - Initiating a call.....	36
Figure 7-6: ACP - Call connected - Steady green .....	36
Figure 7-7: MCDU - SATCOM Main Menu - Outgoing Call - Connecting.....	36
Figure 7-8: MCDU - SATCOM Main Menu - Outgoing Call - Connected .....	36
Figure 7-9: MCDU - SATCOM Main Menu - Outgoing Call - Call Failed .....	37
Figure 7-10: ACP - Ending a call.....	38
Figure 7-11: ACP - Call terminating - Flashing green .....	38
Figure 7-12: ACP - No active calls .....	38
Figure 7-13: MCDU - SATCOM Main Menu - Channel released .....	38
Figure 7-14: MCDU - SATCOM Main Menu - Incoming call - Unknown caller identity.....	39
Figure 7-15: ACP - Incoming Call - Flashing amber.....	39
Figure 7-16: ACP - Incoming Call - Steady green.....	40
Figure 7-17: MCDU - SATCOM Main Menu - Incoming Call - Connected .....	40
Figure 7-18: ACP - Ending a call.....	41
Figure 7-19: ACP - Call terminating - Flashing amber.....	41
Figure 7-20: ACP - No active calls .....	41
Figure 7-21: MCDU - SATCOM Main Menu - Channel released .....	41
Figure 7-22: MCDU - SATCOM Main Menu - Call failed - Pre-empted.....	42
Figure 7-23: SATCOM Main Menu - Manual Dial - International Number .....	43
Figure 7-24: SATCOM Main Menu - Manual Dial - Short Code.....	43
Figure 7-25: RMP - Directory .....	44
Figure 7-26: RMP - TEL Page - Initiating a call .....	45
Figure 7-27: RMP - TEL Page - Outgoing Call – Connecting.....	45
Figure 7-28: RMP - TEL Page - Outgoing Call - Connected .....	45
Figure 7-29: RMP - TEL Page - Outgoing Call - Call Failed.....	46
Figure 7-30: RMP - TEL Page - Ending a call .....	47
Figure 7-31: RMP - TEL Page - Call Ended .....	47
Figure 7-32: RMP - TEL Page - Incoming call - Alerting.....	48
Figure 7-33: RMP - TEL Page - Incoming Call - Connected .....	49
Figure 7-34: RMP - TEL Page - Call Ended .....	49
Figure 8-1: MCDU - SATCOM Settings - ACARS Data Available .....	50
Figure 8-2: RMP - SATCOM Settings - ACARS Data Available.....	50
Figure 9-1: MCDU - SATCOM Config - Cabin calls enabled .....	52

Figure 9-2: MCDU - SATCOM Config - Cabin calls disabled .....	52
Figure 9-3: RMP - SATCOM Config - Cabin calls enabled .....	52
Figure 9-4: RMP - SATCOM Config - Cabin calls disabled.....	52
Figure 10-1: USB connector under the maintenance connector cover .....	101
Figure 10-2: Find System log entries on the LRU unit - Maintenance phase .....	103
Figure 10-3: Select file and export - Maintenance phase .....	103
Figure 10-4: Reception via z-modem - manual receive .....	103
Figure 10-5: List of commands available - Maintenance phase .....	104
Figure 10-6: Make new log file - Maintenance phase .....	104
Figure 10-7: Add a text line in current log - Maintenance phase .....	105

### **LIST OF TABLES**

	<b>PAGE</b>
Table 1-1: Document Scope.....	11
Table 1-2: List of Acronyms .....	11
Table 1-3: List of External References .....	14
Table 1-4: List of Internal References.....	14
Table 3-1: Call Priorities .....	20
Table 9-1: PPPoE Service Name Options.....	54
Table 9-2: AVIATOR S Supported AT-Commands .....	55
Table 10-1: AISD SNMP MIB OID Support .....	59
Table 10-2: PIESD SNMP MIB OID Support.....	65
Table 10-3: Failure group of asuSduInfoFailureCode .....	72
Table 10-4: TFT Parameter Combinations .....	99

# 1 INTRODUCTION

## 1.1 GENERAL

### 1.1.1 Purpose

This document provides a guide for users intending to make voice calls or data connections via the AVIATOR S SATCOM System.

The use of voice and data services as well as the use of advanced data features is demonstrated by means of examples.

An installed and configured Aeronautical Earth Station (AES) is assumed throughout.

### 1.1.2 Scope

This document is scoped to the items defined in Table 1-1.

Table 1-1: Document Scope		
Equipment	Part Number	Description
CSDU-5045	405045-00000 405045-00001	Compact Satellite Data Unit 405045
SCM-5055	405055-00000	SDU Configuration Module 405055
LGA-5005	405005-00000	Low Gain Antenna 405005
HPA-5015	405015-00000	High Power Amplifier 405015
DLNA	405013A	Type F Diplexer/Low Noise Amplifier 405013A

## 1.2 GLOSSARY

### 1.2.1 Acronyms

Table 1-2: List of Acronyms	
Acronym	Description
A2G	Air-to-Ground
AAC	Airline Administrative Control
ACARS	Aircraft Communications, Addressing and Reporting System
ACD	Aircraft Control Domain
ACP	Audio Control Panel
ADL	Airborne Data Loader
AES	Aircraft Earth Station
AISD	Airline Information and Services Domain
AMER	Americas
AOC	Aeronautical Operational Control
APAC	Asia-Pacific
APN	Access Point Name

<b>Table 1-2: List of Acronyms</b>	
<b>Acronym</b>	<b>Description</b>
ATC	Air Traffic Control
AUTO	Automatically
CFDS	Central Fault Display System
CHAP	Challenge Handshake Authentication Protocol
CID	Context ID
CMU	Communication Management Unit
CSDU	Compact Satellite Data Unit
CSP	Communication Service Provider
CSR	Certificate Signing Request
CTTIC	China Transport Telecommunications & Information Centre
dB	Decibels
DL	Downlink
DLNA	Diplexer/Low Noise Amplifier
EFB	Electronic Flight Bag
EMEA	Europe, Middle East and Africa
FWS	Flight Warning System
G2A	Ground-to-Air
GES	Ground Earth Station
HELGA	HLD and Enhanced Low Gain Antenna
HDR	High Data Rate
HLD	HPA/LNA/Duplexer
HMI	Human Machine Interface
HPA	High Power Amplifier
Hz	Hertz
IANA	Internet Assigned Numbers Authority
ICAO	International Civil Aviation Organisation
ID	Identity
IFE	In-Flight Entertainment
IM	Installation Manual
IMSI	International Mobile Subscriber Identity
INOP	Inoperable
IP	Internet Protocol
IPCP	Internet Protocol Control Protocol
LGA	Low Gain Antenna
LNA	Low Noise Amplifier
LSK	Line Select Key

<b>Table 1-2: List of Acronyms</b>	
<b>Acronym</b>	<b>Description</b>
MB	Megabyte
MCDU	Multi-purpose Control and Display Unit
MEAS	Middle East and Asia
MIB	Management Information Base
NAT	Network Address Translation
ORC	Ocean Region Change
OID	Object ID
ORT	Owner Requirements Table
PAP	Password Authentication Protocol
PDL	Portable Data Loader
PDP	Packet Data Protocol
PIESD	Passenger Information and Entertainment Services Domain
PKI	Public Key Infrastructure
PPPoE	Point-to-Point Protocol over Ethernet
QoS	Quality of Service
RMP	Radio Management Panel
SAT	Satellite
SATCOM	Satellite Communication
SB / SBB	SwiftBroadband
SB-S	SwiftBroadband-Safety
SCM	SDU Configuration Module
SDU	Satellite Data Unit
SNMP	Simple Network Management Protocol
SPI	Security Parameter Index
TCP	Transmission Control Protocol
TFT	Traffic Flow Template
UDP	User Datagram Protocol
UL	Uplink
UM	User Manual
UMTS	Universal Mobile Telecommunications System
VPN	Virtual Private Network

## 1.3 REFERENCES

### 1.3.1 External References

Table 1-3: List of External References			
Reference Tag	Document	Revision	Document Title
[3GPP_TS27]	3GPP TS 27.007	10.3.0	Digital cellular telecommunications system (Phase 2+); Universal Mobile Telecommunications System (UMTS); AT command set for User Equipment (UE)
[A781]	ARINC 781	7	ARINC Characteristic 781 - Mark 3 Aviation Satellite Communication Systems
[ITU-T_V.250]	ITU-T	V.250	Serial asynchronous automatic dialling and control
[PKI_CON]	PKI CONOPS	0.3	SwiftBroadband Safety 2.0 Overview and PKI Concept of Operations
[PKI_OPS]	PKI INMARSAT	0.9	Inmarsat SB-S Service – Airline Ops Handbook
[GOLD]	ICAO GOLD	Second Edition	International Civil Aviation Organization (ICAO) - Global Operational Data Link Document (GOLD)
[SVGM]	ICAO SVGM	First Edition	International Civil Aviation Organization (ICAO) - Satellite Voice Guidance Material (SVGM)
[A739A]	ARINC 739A	1	ARINC Characteristic 739A - Multi-purpose Control and Display Unit

### 1.3.2 Internal References

Table 1-4: List of Internal References			
Reference Tag	Document	Revision	Document Title
[200S_IM]	98-145168	Latest	AVIATOR 200S Installation Manual
[700S_IM]	98-158751	Latest	AVIATOR 700S Installation Manual
[UORTT]	99-176198	Latest	AVIATOR S User ORT Tool Manual

---

## **2 REGULATORY INFORMATION**

### **2.1 RADIOFREQUENCY RADIATION EXPOSURE INFORMATION**

#### **2.1.1 AVIATOR 200S**

This equipment complies with FCC and IC radiation exposure limits set forth for an uncontrolled environment. This equipment should be installed and operated with minimum distance of 50 cm between the radiator and your body.

This transmitter must not be co-located or operating in conjunction with any other antenna or transmitter.

Cet équipement est conforme aux limites d'exposition aux rayonnements IC établies pour un environnement non contrôlé. Cet équipement doit être installé et utilisé avec un minimum de 50 cm de distance entre la source de rayonnement et votre corps.

Ce transmetteur ne doit pas être placé au même endroit ou utilisé simultanément avec un autre transmetteur ou antenne.

#### **2.1.2 AVIATOR 700S**

This equipment complies with FCC and IC radiation exposure limits set forth for an uncontrolled environment. This equipment should be installed and operated with minimum distance of 235 cm between the radiator and your body.

This transmitter must not be co-located or operating in conjunction with any other antenna or transmitter.

Cet équipement est conforme aux limites d'exposition aux rayonnements IC établies pour un environnement non contrôlé. Cet équipement doit être installé et utilisé avec un minimum de 235 cm de distance entre la source de rayonnement et votre corps.

Ce transmetteur ne doit pas être placé au même endroit ou utilisé simultanément avec un autre transmetteur ou antenne.

## **2.2 FEDERAL COMMUNICATIONS COMMISSION (FCC)**

This equipment has been tested and found to comply with the limits for a Class A digital device, pursuant to Part 15 of the FCC Rules. These limits are designed to provide reasonable protection against harmful interference when the equipment is operated in a commercial environment. This equipment generates, uses, and can radiate radio frequency energy and, if not installed and used in accordance with the instruction manual, may cause harmful interference to radio communications.

**NOTICE:**

Changes or modifications made to this equipment not expressly approved by Cobham may void the FCC authorization to operate this equipment.

**NOTICE:**

This device complies with Part 15 of the FCC Rules and with Industry Canada license-exempt RSS standard(s).

Operation is subject to the following two conditions:

- (1) this device may not cause harmful interference, and
- (2) this device must accept any interference received, including interference that may cause undesired operation.

Le présent appareil est conforme aux CNR d'Industrie Canada applicables aux appareils radio exempts de licence. L'exploitation est autorisée aux deux conditions suivantes:

- (1) l'appareil ne doit pas produire de brouillage, et
- (2) l'appareil doit accepter tout brouillage radioélectrique subi, même si le brouillage est susceptible d'en compromettre le fonctionnement.

## **2.3 JAPANESE RADIO LAW AND JAPANESE TELECOMMUNICATIONS BUSINESS LAW COMPLIANCE**

This device is granted pursuant to the Japanese Radio Law (電波法) and the Japanese Telecommunications Business Law (電気通信事業法).

This device should not be modified (otherwise the granted designation number will become invalid).



## 3 SWIFTBROADBAND SAFETY SYSTEM OVERVIEW

### 3.1 INMARSAT SATELLITE NETWORK

#### 3.1.1 SwiftBroadband-Safety (SB-S) for the Cockpit

SB-S is a comprehensive upgrade of the Classic Aero service, which is a voice and data safety service, used by more than 200 major airlines, jet operators and government agencies, onboard over 13,000 aircraft, processing over 50 million position reports annually.

Classic Aero has been the gold standard for aviation safety communications for the past three decades. However, technology has evolved and SB-S promises to revolutionise the safe flight of airplanes through the skies.

SB-S has global coverage, abundant capacity, full redundancy, unrivalled cybersecurity, and over 99.9% availability worldwide, meeting International Civil Aviation Organisation (ICAO) GOLD communications and surveillance performance requirements.

Refer to the INMARSAT website for further information: <https://www.inmarsat.com/>

#### 3.1.2 SwiftBroadband (SBB) for the Cabin

SwiftBroadband enables passengers to access online services from anywhere in the sky and provides flight crews with real-time information to improve flight operations.

SwiftBroadband is secure, functional and compatible with government-grade encryption standards. Delivering up to 432 kbps (AVIATOR 700S configuration), it's always on to meet the needs of its customers.

SwiftBroadband solutions provide IP data communication capability to the crew and passengers – from full access to on-board router, email, media streaming services to in-seat mobile phone and text services.

Refer to the INMARSAT website for further information: <https://www.inmarsat.com/>

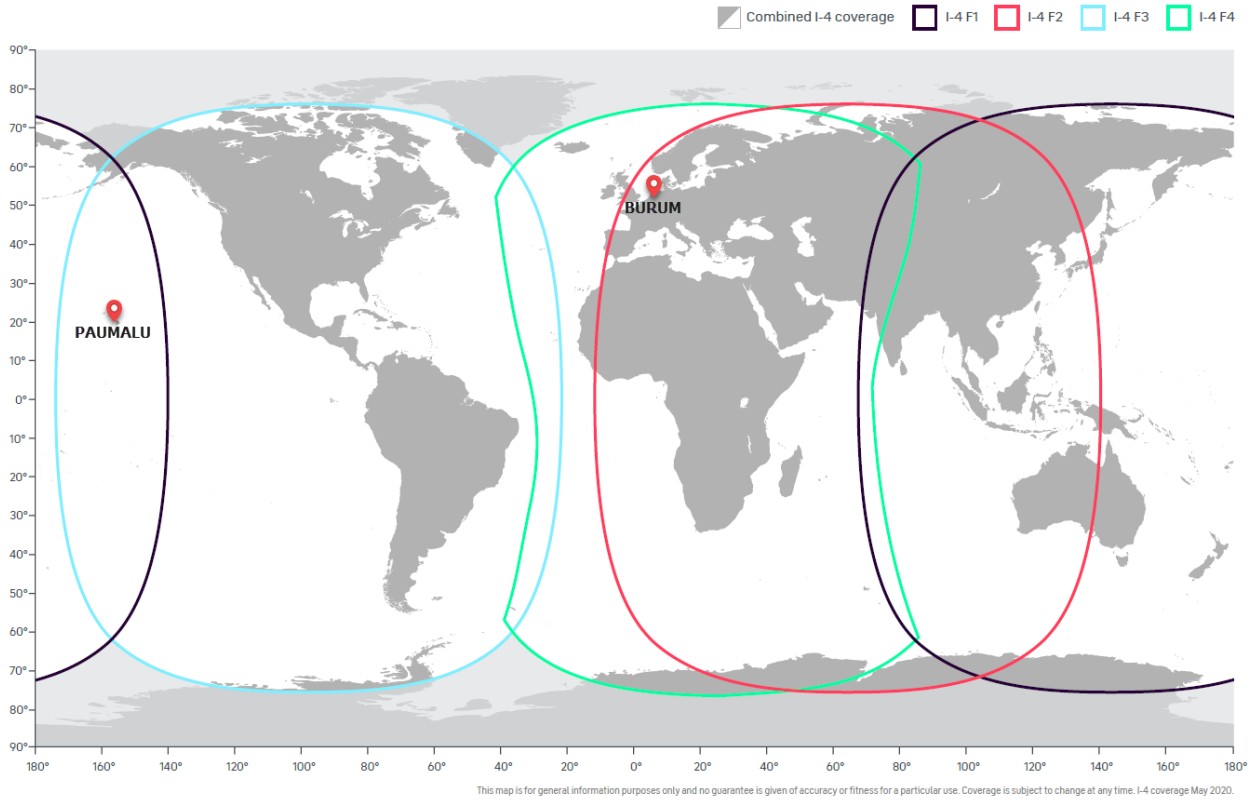
#### 3.1.3 SwiftBroadband Satellites and Coverage Map

The INMARSAT Satellite Network provides near-global coverage between +/-76 degrees latitude from four satellites in geostationary orbit. The satellites are 4th generation (I-4) Inmarsat satellites, nominally located at the following longitudes:

- Europe, Middle East and Africa (EMEA) 25 degrees East
- Middle East and Asia (MEAS) 64 degrees East
- Asia-Pacific (APAC) 143.5 degrees East
- Americas (AMER) 98 degrees West

Each satellite provides a large number of overlapping beams (similar to cells) on the earth for users to access the network, similar in operation to terrestrial cellular networks.

The part of the earth's surface covered by each satellite is termed its "footprint".



**Figure 3-1: INMARSAT SwiftBroadband Coverage**

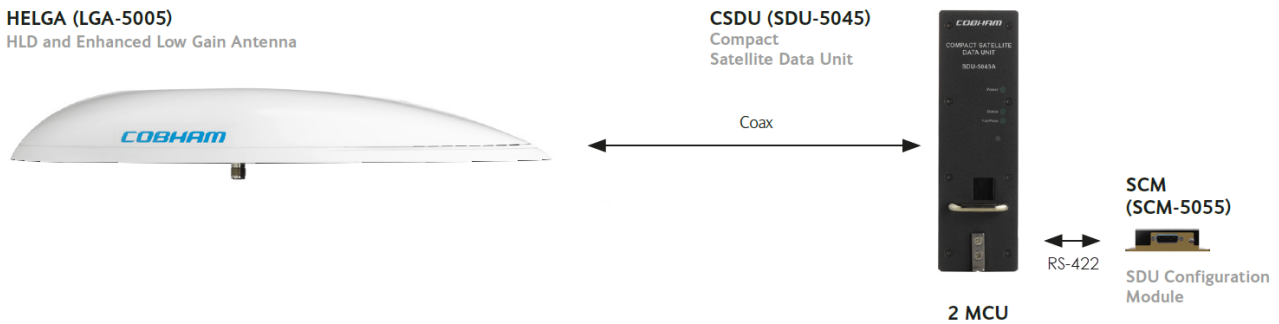
## **3.2 AVIATOR S SATCOM SYSTEM FUNCTIONS AND FEATURES**

### **3.2.1 System Overview – AVIATOR 200S**

The AVIATOR 200S System services the Cockpit by providing SB-S (refer to section 3.1.1) voice and data connectivity to keep the aircraft connected, even in areas with a high concentration of aircraft:

- Two simultaneous voice calls supported by multiple aircraft audio configurations.
- ACARS Data capability for secure message exchanges between Air Traffic Control (ATC), Aeronautical Operational Control (AOC) and Airline Administrative Control (AAC).
- Cockpit Data connectivity (up to 200 kbps) for Electronic Flight Bag (EFB) applications keeping the crew informed and up-to-date at all times.

**AVIATOR 200S** (Class 4 system)



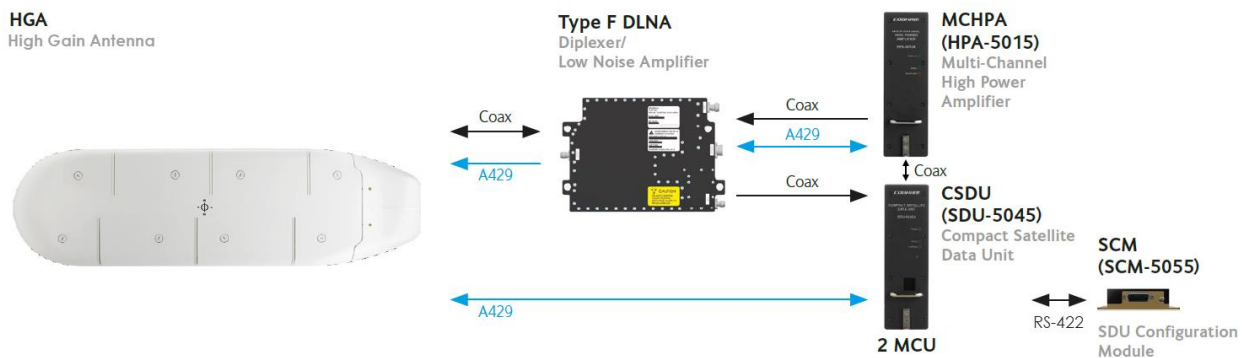
**Figure 3-2: AVIATOR 200S SATCOM System – Block Diagram**

**3.2.2 System Overview – AVIATOR 700S**

The AVIATOR 700S System improves on the SB-S (refer to section 3.1.1) services provided by the AVIATOR 200S configuration with increased data capability for the EFB connection and a dedicated Cabin Data connection (refer to section 3.1.2) through a separate channel card:

- Two simultaneous voice calls supported by multiple aircraft audio configurations.
- ACARS Data capability for secure message exchanges between Air Traffic Control (ATC), Aeronautical Operational Control (AOC) and Airline Administrative Control (AAC).
- Cockpit Data connectivity (up to 432 kbps) for Electronic Flight Bag (EFB) applications keeping the crew informed and up-to-date at all times.
- Cabin Data connectivity (up to 432 kbps) for Cabin Router or In-Flight Entertainment (IFE) applications.

**AVIATOR 700S** (Class 6 system)



**Figure 3-3: AVIATOR 700S SATCOM System**

### 3.2.3 Configuration

The AVIATOR S System configuration is managed by loading Owner Requirement Tables (ORT) via the Airborne Data Loader (ADL) or Portable Dataloader (PDL).

The configuration is made up of two parts (separate ARINC-665 Media):

- Secure ORT
- User ORT

The Secure ORT is typically managed by the aircraft manufacturer and forms part of the certified installation. The Secure ORT configures the AVIATOR S System for a specific aircraft configuration.

The User ORT is typically managed by the airline or aircraft operator. The User ORT does not form part of the certified aircraft configuration, but is often important in ensuring the system operates in the desired way. Changes to the User ORT may be frequent, potentially based on aircraft route or charter.

The User ORT also defines the phonebook/directory available to the crew with a list of pre-programmed numbers with associated call priority (refer to section 3.3.1).

A laptop computer with an installation of the ORT Tool may be used to modify and create ARINC-665 media for use with the ADL/PDL. Refer to the ORT Tool User Guide **[UORTT]** for further guidance.

## 3.3 SAFETY VOICE SERVICES

### 3.3.1 Call Priorities – Ground-to-Air (G2A)

In order to keep communication towards the aircraft (including voice calls) controlled and secure, a particular Aircraft (identified by its ICAO address) may be reached by placing a call through a 'two-stage dialler' managed by SITA or ARINC (CSP). In order to access these services, the caller (or organisation) must be registered (for billing purposes) with the selected Communication Service Provider (CSP) in order to be granted access in the form of a unique pin code(s).

Calls placed over the SB-S network require a call priority<sup>1</sup> and is selected by the calling party at the time of dialling. In some cases, a unique pin code may be linked to a particular call priority.

Table 3-1: Call Priorities		
Description	Priority Level	Priority Number
Emergency / Distress	Highest	P1/Q15
High / Safety		P2/Q12
Low / Company / Non-Safety		P3/Q10
Public	Lowest	P4/Q9

Public priority calls may not be permitted to reach the cockpit and may be disabled through User ORT configuration (refer to section 3.2.3).

<sup>1</sup> Refer to the ICAO document **[SVGM]** for further clarification of the call priority definition.

### **3.3.2 Call Priorities – Air-to-Ground (A2G)**

Calls initiated by the crew on-board the aircraft are assigned a call priority (refer to Table 3-1), typically selected on the MCDU before initiating the call<sup>2</sup>. The default MCDU call priority is configured by Secure ORT configuration.

Outgoing Public priority calls may not be permitted and may be disabled through User ORT configuration (refer to section 3.2.3).

### **3.3.3 Pre-emption**

Four levels of call priority (described in section 3.3.1) allows for call pre-emption<sup>3</sup>, where an incoming call may only reach and alert the crew when all the available channels are in-use and the incoming call priority is higher than the current active calls. When a lower priority call is pre-empted, the MCDU/RMP will display the updated incoming call information.

## **3.4 SAFETY DATA SERVICES**

### **3.4.1 ACARS Data**

One of the fundamental communication systems in the aircraft is the Aircraft Communications, Addressing and Reporting System (ACARS). This messaging system, managed by the Communication Management Unit (CMU), is key to the efficient and safe operation of the aircraft on the ground as well as in the air.

The CMU may select between various communication systems on-board in order to send ACARS messages, one of those being the AVIATOR S SATCOM System.

The benefit of the INMARSAT SB-S network is the improved speed, availability and reliability over the legacy VHF, UHF and Classic Aero systems.

The ACARS data connection is connected to the AVIATOR S Aircraft Control Domain (ACD) which segregates this and all other secure data streams from the AISD (EFB) and PIESD<sup>4</sup> data traffic. All ACARS data exchanged with the ground network is secured via a Virtual Private Network (VPN).

Refer to **[GOLD]** for further information regarding data link operations and capabilities.

## **3.5 NON-SAFETY DATA SERVICES**

The AVIATOR S System provides non-safety AISD data for the cockpit (AVIATOR 200/700S) as well as the cabin PIESD (AVIATOR 700S).

### **3.5.1 Electronic Flight Bag (EFB)**

The EFB data connection is connected to the AVIATOR S Airline Information and Services Domain (AISD) Ethernet port, which segregates AISD (EFB) data traffic from the secure data streams (ACD).

AISD Clients are required to have a known static IPv4 configuration (defined by User ORT) for its Ethernet interface in order to access a routed and network address translated (NAT) Background Class data connection.

---

<sup>2</sup> In aircraft fitted with Radio Management Panels (RMP), the outgoing call priority is set by User ORT configuration and cannot be modified via the RMP HMI interface.

<sup>3</sup> Refer to the ICAO document **[SVGM]** for further clarification on call pre-emption.

<sup>4</sup> Applicable only to the AVIATOR 700S configuration.

A Simple Network Management Protocol (SNMP) interface provides the capability for retrieving AVIATOR S system and operational status information as well as link status and history (refer to Appendix A).

### **3.5.2 Cabin Data**

The cabin data connection is connected to the AVIATOR S Passenger Information and Entertainment Services Domain (PIESD) Ethernet port which segregates PIESD (cabin) data traffic from all other data streams (ACD, AISD).

A Point-to-Point Protocol over Ethernet (PPPoE) capable client is required to access the PIESD channel card. The cabin router is responsible for managing the data connection availability and Quality of Service (QoS).

A Simple Network Management Protocol (SNMP) interface provides the capability for retrieving AVIATOR S system and operational status information as well as link status and history (refer to Appendix B).

An out-of-band control interface provides status monitoring of established SB packet data connections as well as connection control using AT-commands over a Telnet/TCP/IP/Ethernet connection (refer to section 9.2.4). "Out-of-band" refers to the control session being independent of the PPPoE session carrying the user data. Refer to Appendix D for the list of supported AT-commands.

The PIESD Ethernet port and related services may be configured through the User ORT (see section 3.2.3).

#### **3.5.2.1 Service Class**

The INMARSAT non-safety SwiftBroadband (SBB) network provides two classes (types) of data connections:

- Background Class
  - A "pay per usage" service where the user is charged per Megabyte (MB) for the combined amount of data transferred (both the upload/download directions).
  - The maximum data rate (speed) is determined by the class of system installed:
    - AVIATOR 700S | Class 6 | Up to 432 kbps
  - Background Class is a 'contended service' where a number of users (aircraft) may share network resources. The network manages the available resources to ensure best effort for all users within the same region.
- Streaming Class
  - A "pay per minute" service where the user is charged for the time duration of the connection.
  - The available data rates (speed) are class specific:
    - AVIATOR 700S | Class 6
      - 8/16/32/64/128 kbps
      - X-Stream/Half-HDR/Full-HDR <sup>5</sup>
  - Data rates for the download/upload (forward/return) direction may be 'symmetric' (identical) or 'asymmetric' (different).

#### **3.5.2.2 Service Class Selection**

The default<sup>6</sup> PPPoE service class may be configured through the User ORT (refer to section 3.2.3).

If preferred, the user may select a specific service class when creating the PPPoE (refer to section 9.2.3).

---

<sup>5</sup> If required, check with your selected CSP for activation of these high data rate services.

<sup>6</sup> The User ORT configured default is used when a PPPoE connection is created using a blank (empty) service name field.

## 4 SERVICE ACTIVATION

In order to access the INMARSAT SB-S/SBB Network, an active service agreement is required between the aircraft owner/operator and a Communication Service Provider (CSP):

- SwiftBroadband-Safety (SB-S) | Flight Deck Services:
  - Primary
    - ARINC DIRECT
      - <https://www.arincdirect.com>
    - SITA
      - <https://www.sita.aero>
  - Regional
    - China Transport Telecommunications & Information Centre (CTTIC)
- SwiftBroadband (SBB) | Passenger Services
  - Primary
    - ARINC DIRECT
      - <https://www.arincdirect.com>
    - SITA
      - <https://www.sita.aero>
  - Regional
    - China Transport Telecommunications & Information Centre (CTTIC)

The CSP and the appointed Airline Designator/Device Sponsor (See section 4.2) will require the following information during the activation process:

- AVIATOR S Information
  - System Type
    - AVIATOR 200S (Class 4) or
    - AVIATOR 700S (Class 6).
  - SIM Card Information
    - International Mobile Subscriber Identity (IMSI)
      - IMSI 0 is for Cockpit Voice and Data | ACD + AISD
      - IMSI 1 is for Cabin Data | PIESD
      - IMSI 2 is reserved for future use
      - IMSI 3 is reserved for future use
  - Smart Card Information
    - The smart card serial number for the PKI Security Certificate | ACD
- Aircraft or Owner Information
  - International Civil Aviation Organization (ICAO) Address
  - Registered Aircraft Identity | Tail Number
  - Billing information

As an outcome of the activation process, the CSP must provide the permitted Access Point Name (APN) for the AVIATOR S EFB (AISD) and Cabin Data<sup>7</sup> (PIESD) connections. The APN provided by the CSP must be configured in the User ORT (refer to section 3.2.3).

---

<sup>7</sup> Applicable only to AVIATOR 700S configuration.



## 4.1 IMSI AND SMART CARD INFORMATION

The IMSI and smart card information is typically available through the following methods:

- Documentation included with the Satellite Data Unit (SDU) Configuration Module (SCM)
- Label information on the SCM itself (see Figure 4-1)
- SATCOM->MCDU Screens reflecting the IMSI information<sup>8</sup>

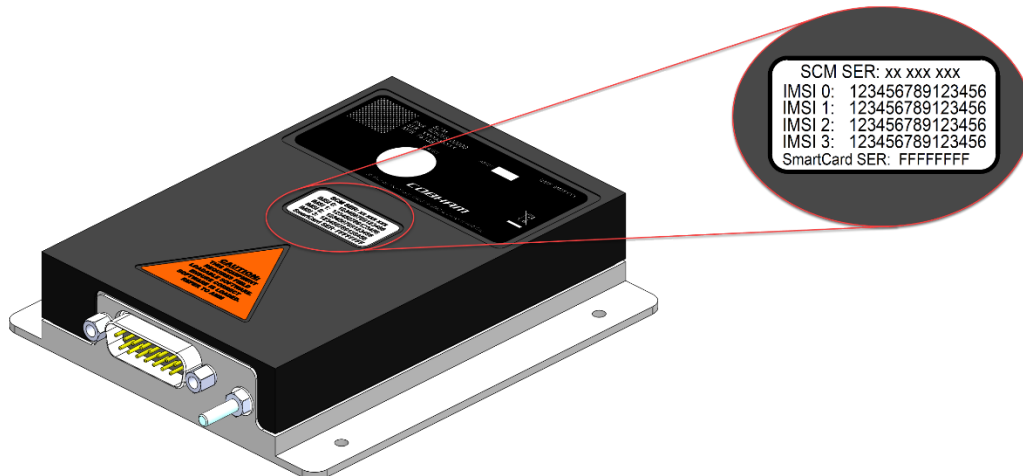


Figure 4-1: AVIATOR S SCM | IMSI & Smart Card Identification

## 4.2 PUBLIC KEY INFRASTRUCTURE (PKI) SECURITY CERTIFICATE

SwiftBroadband Safety security measures include a smart card inserted into each SCM, used to authenticate the AVIATOR S system when connecting to the INMARSAT SB-S network.

A valid digital public key infrastructure (PKI) security certificate is required before SB-S connectivity is available. The User ORT configured "Airline Designator" (See section 3.2.3) will receive a certificate signing request (CSR) when the AVIATOR S system has successfully acquired the satellite and attempts to authenticate SB-S services.

The Airline Designator will appoint a "Device Sponsor" who is responsible for the issuing of the PKI certificate.

Once the Device Sponsor has issued the certificate, the AVIATOR S system will automatically retrieve the certificate, allowing SB-S services to proceed.

Refer to the INMARSAT PKI - Airline Ops Handbook **[PKI\_OPS]** and the INMARSAT PKI Concept of Operations **[PKI\_CON]** for more details regarding PKI activation and usage.

<sup>8</sup> The MCDU screens do not provide the smart card serial number information.

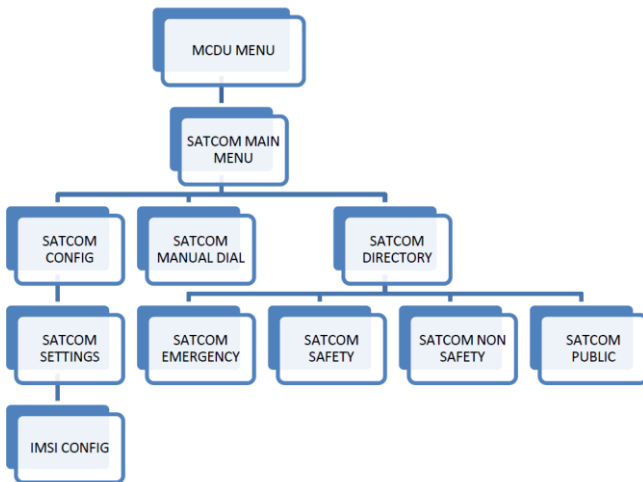


## 5 INTERPRETING THE SYSTEM STATUS

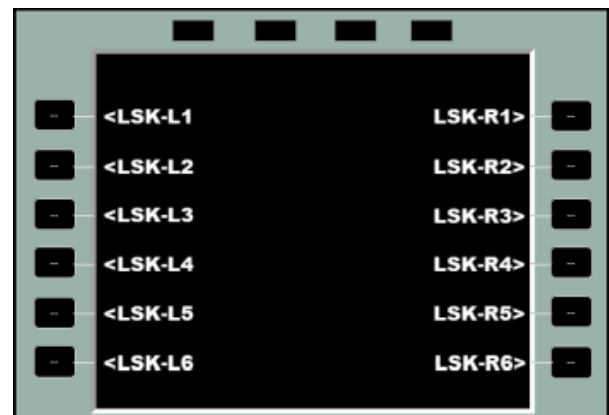
This User Manual provides operational descriptions to allow flight crew to manage the AVIATOR S system. Depending on the aircraft type, one of the following control & display units may be installed:

- Multi-purpose Control and Display Unit (MCDU)
  - Refer to section 5.1 for the MCDU pages menu tree.
- Radio Management Panel (RMP)
  - Refer to section 5.2 for the RMP pages menu tree.

### 5.1 MULTI-PURPOSE CONTROL AND DISPLAY UNIT (MCDU)

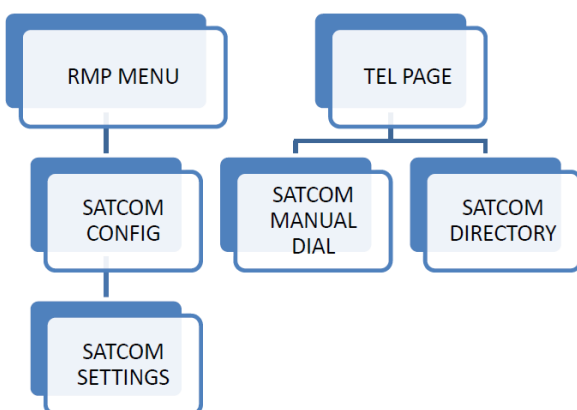


**Figure 5-1: SATCOM MCDU Pages**



**Figure 5-2: ARINC 739 MCDU Line Select Keys**

### 5.2 RADIO MANAGEMENT PANEL (RMP)



**Figure 5-3: SATCOM RMP Pages**



**Figure 5-4: RMP TEL & MENU Keys**

### 5.3 VOICE AVAILABILITY

The AVIATOR S voice availability status indicates when the system is able to initiate a voice call. The availability status is associated to the voice channel number:

**MCDU:** Select the "SATCOM MAIN MENU" page. "SAT 1" is for the first voice channel, and "SAT 2" for the second voice channel.

**RMP:** Select the "TEL" page. "TEL1" is for the first voice channel, and "TEL2" for the second voice channel.

#### 5.3.1 Not Available

When the AVIATOR S system and/or other aircraft systems (e.g. navigation data) are initialising or unable to provide service:

**MCDU:** SAT 1 and SAT 2 status will indicate "NOT AVAILABLE" (See Figure 5-5).

**RMP:** TEL1 and TEL2 status will indicate "DIALING NOT AVAIL" (See Figure 5-6).



Figure 5-5: MCDU - SATCOM Main Menu - Voice Not Available



Figure 5-6: RMP - TEL Page - Voice Not Available

### 5.3.2 Safety Voice Services - Ready to Connect

When the AVIATOR S system has successfully acquired and registered on the INMARSAT network:

- MCDU:** SAT 1 and SAT 2 status will indicate "READY TO CONNECT" (See Figure 5-7).
- RMP:** TEL1 and TEL2 status will indicate that dialling is permitted (See Figure 5-8).

The AVIATOR S system is now able to make or receive voice calls.



**Figure 5-7: MCDU - SATCOM Main Menu - Safety Voice Availability - Ready to Connect**



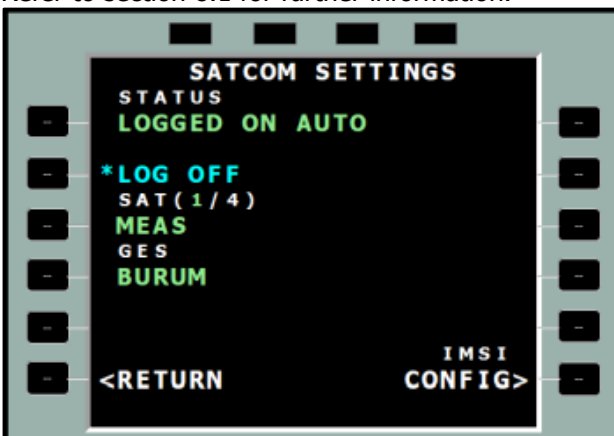
**Figure 5-8: RMP - TEL Page - Safety Voice Availability - Manual**

### 5.3.3 Safety Data Services - Available

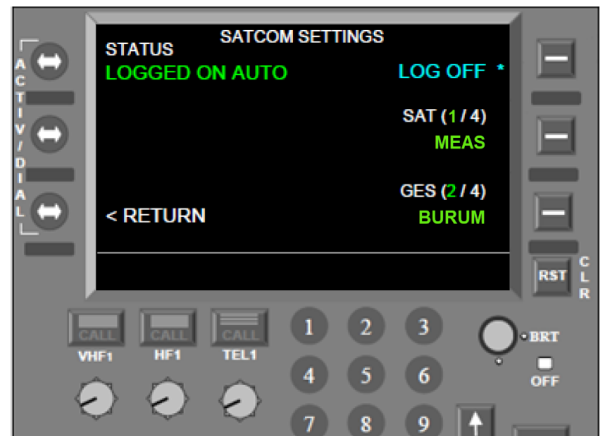
When the AVIATOR S system has created the virtual private network (VPN) (described in section 3.4.1), the Ground Earth Station (GES) assigned by the INMARSAT network is displayed on the:

- MCDU:** SATCOM SETTINGS page at position LSK-L4.
- RMP:** SATCOM SETTINGS page at position LSK-R3.

Refer to section 8.1 for further information.



**Figure 5-9: MCDU - SATCOM Settings - Safety Data Available**



**Figure 5-10: RMP - SATCOM Settings - Safety Data Available**

## 5.4 SATCOM CONFIG

The SATCOM CONFIG page provides further system information and functions:

**MCDU:** SATCOM MAIN MENU→SATCOM CONFIG page by pressing LSK-L6.

**RMP:** MENU→SATCOM CONFIG page by pressing LSK-R3.

### 5.4.1 Logging On Auto/Logged On Auto/Logged Off

The status of the connection to the INMARSAT satellite is shown at LSK-L1. The system will perform an automatic (AUTO) log on after initial power on.

By pressing LOG OFF (LSK-L2 on MCDU, LSK-R1 on RMP), the SATCOM system will disconnect from the INMARSAT network, and all services will be unavailable. This is termed a “manual log off”.

Press AUTO LOG ON (LSK-L2 on MCDU, LSK-R1 on RMP) to reconnect to the INMARSAT network. The system status will indicate LOGGING ON AUTO while reconnecting, followed by the LOGGED ON AUTO status when complete.

Refer to section 6 for additional guidance relating to a “manual log on” procedure.

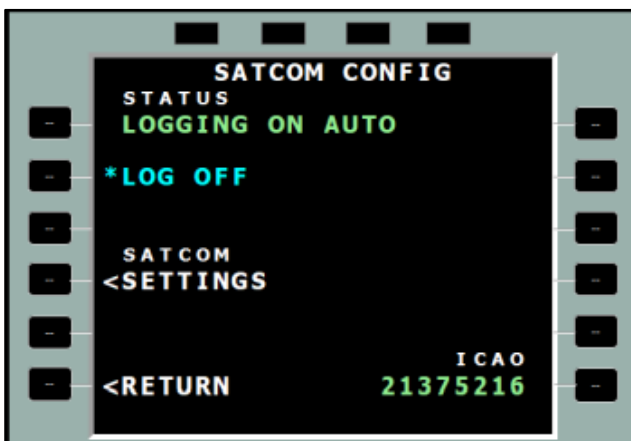


Figure 5-11: MCDU - SATCOM Config - Status - Logging On

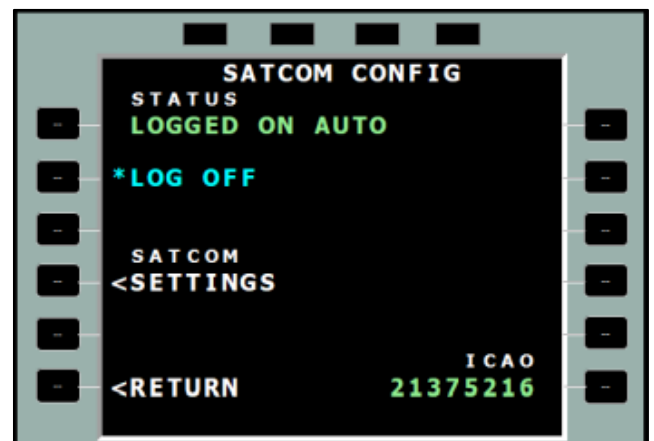


Figure 5-12: MCDU - SATCOM Config - Status - Logged On Auto

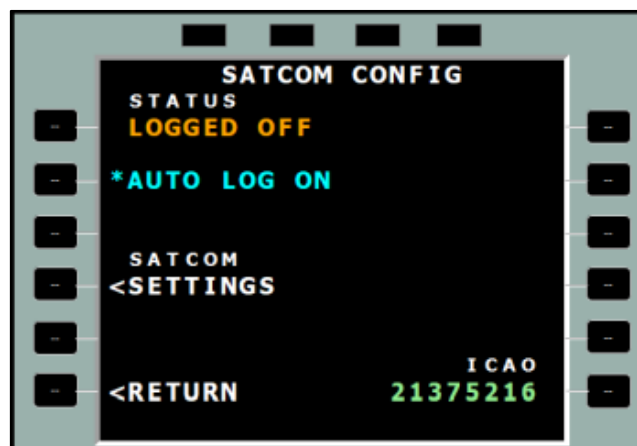


Figure 5-13: MCDU - SATCOM Config - Status - Logged Off



Figure 5-14: RMP - SATCOM Config - Status - Logging On

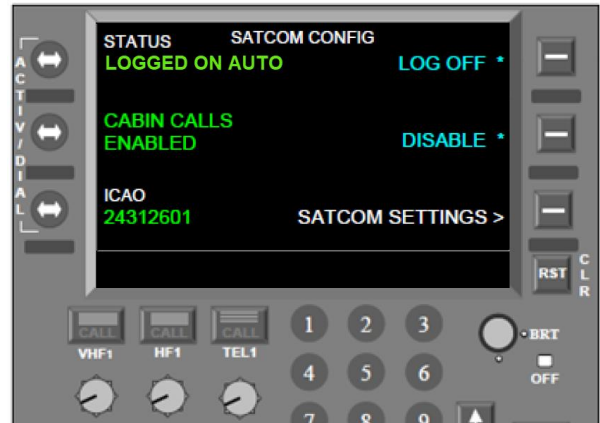


Figure 5-15: RMP - SATCOM Config - Status - Logged On Auto



Figure 5-16: RMP - SATCOM Config - Status - Logged Off

### 5.4.2 SATCOM INOP

When the AVIATOR S system has an error and unable to provide service, the voice channel status will indicate that calls are not possible (refer to section 5.3.1).

By accessing the SATCOM CONFIG page, the system will indicate if it is attempting to log on or has declared a fault condition with the status "SATCOM INOP"<sup>9</sup> (See Figure 5-17).

Further troubleshooting to determine the failure related to the SATCOM INOP status may be performed via the Aircraft's Central Fault Display System (CFDS) and is beyond the scope of this manual.

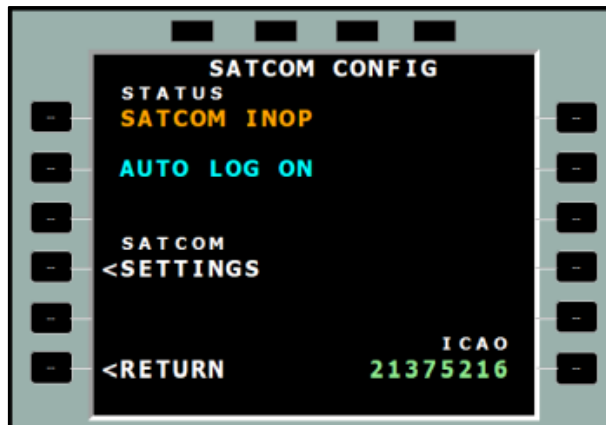


Figure 5-17: MCDU - SATCOM Config - Status - SATCOM INOP

### 5.5 SATCOM SETTINGS

The SATCOM SETTINGS page provides detailed system information and functions (See Figure 5-18, Figure 5-19).

The current satellite that is in use (refer to section 3.1.3), as well as the Ground Earth Station (GES) assigned<sup>10</sup> by the INMARSAT network. Refer to section 6 for additional guidance on satellite selection.

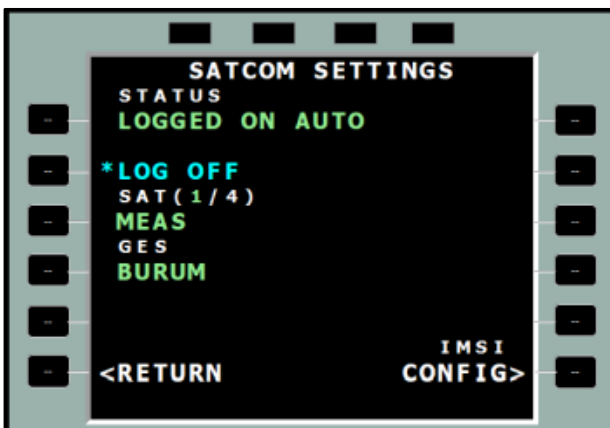


Figure 5-18: MCDU - SATCOM Settings - Status - Logged On

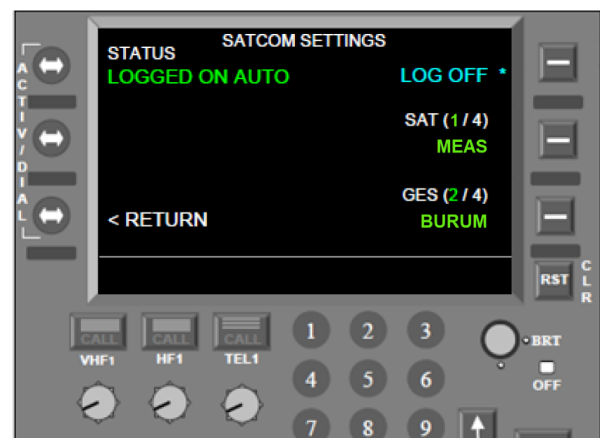


Figure 5-19: RMP - SATCOM Settings - Status - Logged On

<sup>9</sup> This page is not available in aircraft fitted with Radio Management Panels (RMP).

<sup>10</sup> The SwiftBroadband GES is not user selectable as in Classic Aero systems.

### 5.5.1 IMSI Config

The IMSI CONFIG page<sup>11</sup> (accessed by pressing LSK-R6) provides the IMSI information for activation or troubleshooting purposes (See Figure 5-20 and Figure 5-21).

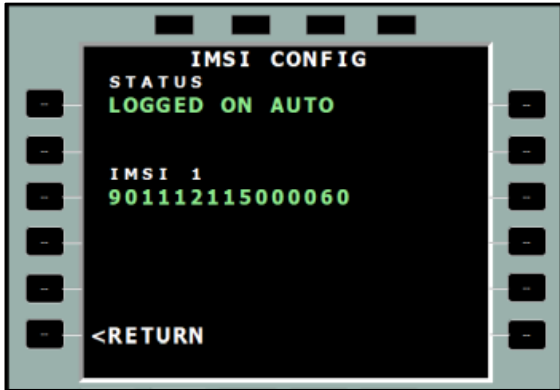


Figure 5-20: AVIATOR 200S - IMSI Config



Figure 5-21: AVIATOR 700S - IMSI Config

<sup>11</sup> This page is not available in aircraft fitted with Radio Management Panels (RMP).

## 6 SATELLITE SELECTION

### 6.1.1 Log Off & Auto/Manual Log On

The INMARSAT satellite used by the AVIATOR S system can be automatically or manually selected through the SATCOM SETTINGS page. Typical system configuration will be to perform automatic (AUTO) logon.

When the aircraft is operating in a region where more than one satellite may be used, a situation may arise where the current satellite is not the preferred satellite. An example of this would be a known flight path where a particular satellite's footprint does not provide full coverage, and switching to an alternate satellite may provide extended coverage without the need for changing satellites, termed an ocean region change (ORC), mid-flight or at an inconvenient time or position.

The selected satellite may be modified through the following sequence:

1. Log off from either the SATCOM CONFIG or the SATCOM SETTINGS page.
2. Once in the logged off state, modify the selected satellite from the SATCOM SETTINGS page by pressing the "slew-up" / "slew-down" key on the MCDU, or "up" / "down" arrow on the RMP.
3. Once the desired satellite is displayed, the decision must be made to perform an automatic or manual log on by one of the following:
  - a. Pressing AUTO LOG ON from the SATCOM CONFIG page (Figure 6-1).
    - i. The AVIATOR S system will select the INMARSAT satellite.
  - b. Pressing MANUAL LOG ON from the SATCOM SETTINGS page (Figure 6-2).
    - i. The crew must select the desired INMARSAT satellite.

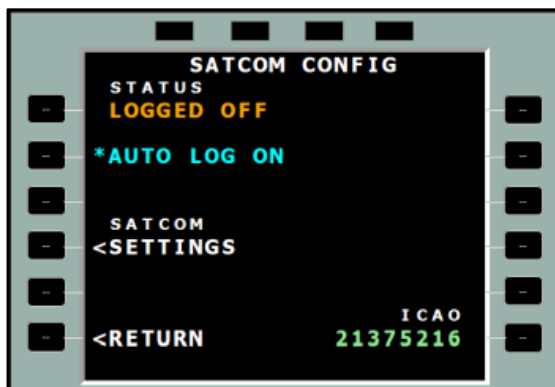


Figure 6-1: MCDU - SATCOM Config - Auto Log On

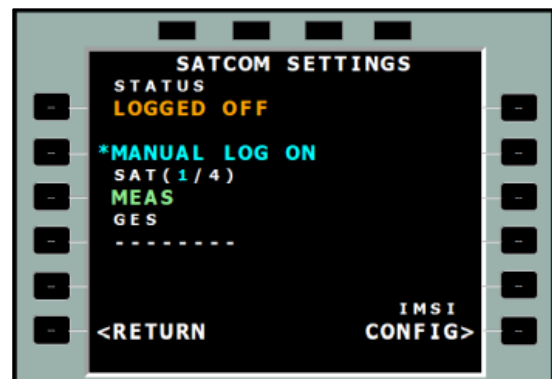


Figure 6-2: MCDU - SATCOM Settings - Manual Log On

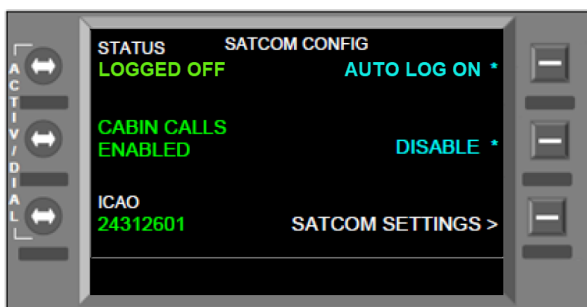


Figure 6-3: RMP - SATCOM Config - Auto Log On

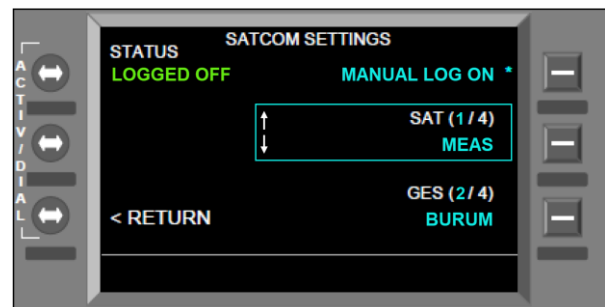


Figure 6-4: RMP - SATCOM Settings - Manual Log On



### **6.1.2 Ocean Region Change (ORC)**

An ocean region change (ORC) occurs when the AVIATOR S system transitions from one satellite coverage area into another. This action may be performed manually or automatically as described in section 6.1.1.

In both cases, voice and data services (Cockpit and Cabin) are disconnected for the duration of time the AVIATOR S system requires to complete the ORC.

When the aircraft flight path or position has left the coverage area of the current satellite, the system will experience a loss of signal scenario and automatically search for alternate satellites that may be in view, or attempt to re-acquire the satellite that was 'lost' in order to resume communications. When the AVIATOR S system experiences loss of coverage (no signal), the MCDU display will indicate "NOT AVAILABLE" as described in section 5.3.1. In a typical ORC scenario, voice and data services may be restored in under 5 minutes.

## 7 SAFETY VOICE SERVICES

The AVIATOR S system supports up to two simultaneous voice calls (incoming/outgoing/mixed) and various aircraft audio configurations:

- 1) Audio via the Audio Control Panel (ACP) and call management functions performed via the Multi-purpose Control and Display Unit (MCDU). Refer to section 7.1.
- 2) Audio and call management functions performed via the Radio Management Panel (RMP). Refer to section 7.2.

### 7.1 MCDU INTERFACE

#### 7.1.1 Outgoing Calls – Air-to-Ground (A2G)

In order to place an outgoing call, often referred to as an air-to-ground call, the crew can choose between:

- Manual Dial - a phone number<sup>12</sup> or short code may be entered via the MCDU, or
- Directory Dial - select the identity from the directory list defined by User ORT (see section 3.2.3 for ORT Configuration).

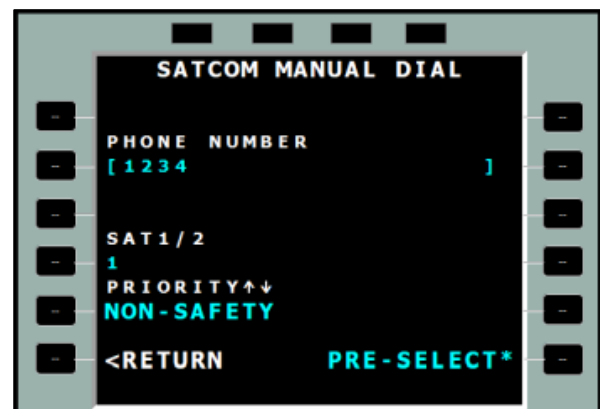
##### 7.1.1.1 Manual Dial

1. From the SATCOM MAIN MENU, press LSK-R5 to enter the MANUAL DIAL page.
2. Enter the destination number into the scratchpad (max 18 digits) and press LSK-L2 to select the number:
  - a) International number
  - b) Short code
3. To edit the number, i.e. in case of an error, press LSK-L2 to return the number to the scratchpad for editing and press LSK-L2 again to select the modified number.
4. Enter on the scratchpad the audio channel number (1/2) for placing the call and press LSK-L4 to select the audio channel number.
5. To modify the call priority, press LSK-L5 and press the “slew-up” or “slew-down” button to scroll through the available<sup>13</sup> call priorities.
6. Press LSK-R6 to pre-select the call information and return to the SATCOM MAIN MENU page.

Refer to section 7.1.1.3 for guidance on dialling/initiating the call.



**Figure 7-1: MCDU - SATCOM Main Menu - Manual Dial - International Number**



**Figure 7-2: MCDU - SATCOM Main Menu - Manual Dial - Short Code**

<sup>12</sup> User ORT configuration may limit manual dialling to short codes only.

<sup>13</sup> Outgoing Public priority calls may be disabled by User ORT configuration.

## 7.1.1.2 Directory Dial

**NOTE:** The directory group names and entries are User ORT configurable and may differ from the examples.

1. From the SATCOM MAIN MENU, press LSK-R6 to enter the SATCOM DIRECTORY page.
2. Press the LSK matching the group name to be displayed.
  - a. For example, press LSK-L3 to access the NON-SAFETY group.
3. Browse the directory using the "page up" and "page down" buttons to display the various pages of the directory.
  - a. The current page / total page count may be shown in the top right corner of the display.
  - b. To sort the directory alphabetically, press SORT (LSK-R4).
  - c. To search the directory for a specific entry, enter the first three letters in the scratchpad and press FIND (LSK-R5).
  - d. The current audio channel is displayed at LSK-R1. To modify, enter the desired audio channel number (1/2) in the scratchpad and press LSK-R1.
    - i. The default channel for MCDU#1 is audio channel 1.
    - ii. The default channel for MCDU#2 is audio channel 2.
    - iii. The default channel for MCDU#3 (if enabled by Secure ORT) is audio channel 1.
4. Once the desired entry is displayed on the screen and the audio channel has been selected, press the LSK matching the entry.
  - a. For example, press LSK-L3 to pre-select the third entry in the list.

Refer to section 7.1.1.3 for guidance on dialling/initiating the call.



Figure 7-3: MCDU - SATCOM Directory

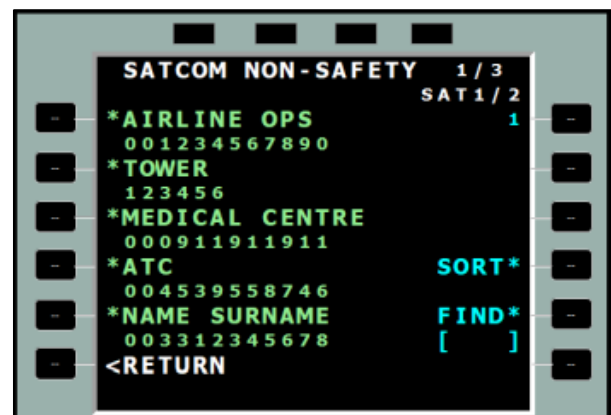


Figure 7-4: MCDU - SATCOM Directory Entries

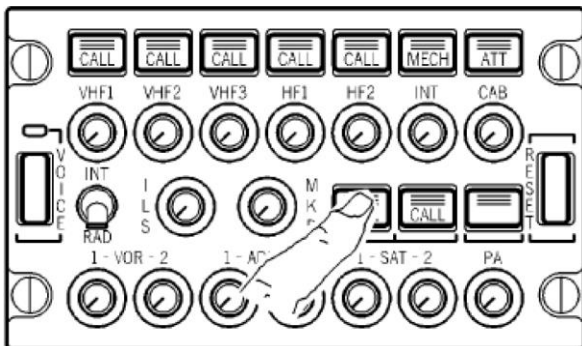
**7.1.1.3 Initiating an Outgoing Call**

Once the outgoing calling information has been pre-selected as described in sections 7.1.1.1 or 7.1.1.2 the call can be initiated by:

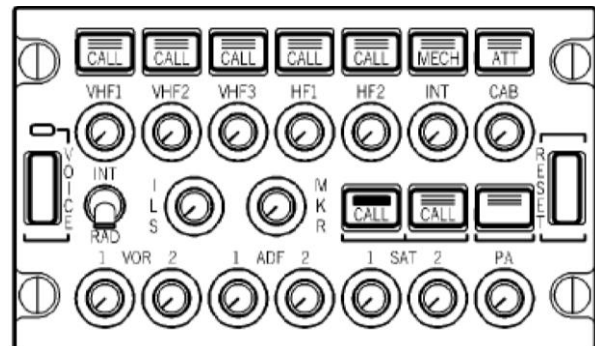
1. Press the associated audio channel (SAT 1/2) call button on the ACP.

Once the call has been initiated, the SATCOM MAIN MENU will display the call progress:

- CONNECTING (Figure 7-7)
  - The number has been dialled and a connection to the called party is being attempted.
  - The ACP SAT call button flashes green during the call establishment phase.
  - Ringing may be heard by the crew before the call is answered.
  - The call may be cancelled by pressing the associated audio channel (SAT 1/2) call button on the ACP. Within 3 seconds, the flashing will stop and the call will be ended.
- CONNECTED (Figure 7-8)
  - The connection to the called party has been established.
  - The ACP SAT call button will stop flashing green and show steady green state indicating the SAT channel is active and connected (Figure 7-6).
  - Voice communication between the two parties is now possible using the ACP to control the audio path and volume functions.



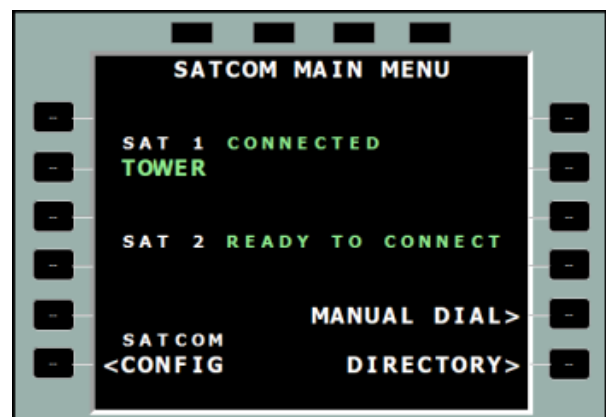
**Figure 7-5: ACP - Initiating a call**



**Figure 7-6: ACP - Call connected - Steady green**



**Figure 7-7: MCDU - SATCOM Main Menu - Outgoing Call - Connecting**



**Figure 7-8: MCDU - SATCOM Main Menu - Outgoing Call - Connected**

In some instances, the call may not be connected and the SATCOM MAIN MENU will display CALL FAILED and a cause on the line below:

- CALL FAILED (Figure 7-9)
  - INVALID NUMBER | Number entered is invalid.
  - NO SERVICE | Number entered could not be reached.
  - GRND FAILURE | An error occurred in the ground network.
  - GRND CONGEST | Calling party could not be reached due to user busy/congestion.

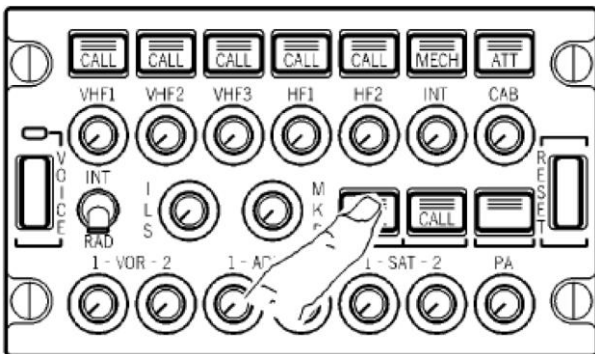


Figure 7-9: MCDU - SATCOM Main Menu - Outgoing Call - Call Failed

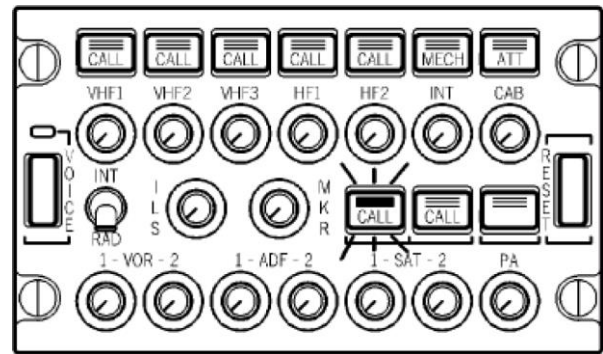
**7.1.1.4 Ending an Outgoing Call**

Calls may be ended (terminated) by either the calling party (airborne side) or the called party (ground side). In both cases, the airborne side (the crew) must:

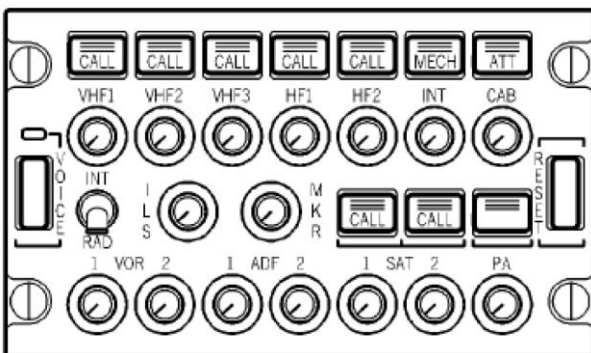
1. Release the call by pressing the associated audio channel (SAT 1/2) call button on the ACP, else the channel will remain active/engaged and may prevent incoming calls from alerting the crew.
  - The ACP SAT call button flashes green while the call termination is in progress (Figure 7-11).
  - Call ended side tone may be heard by the crew.
  - Within 3 seconds, the flashing will stop and the call will be ended (Figure 7-12).
  - The SATCOM MAIN MENU SAT 1/2 status will return to "READY TO CONNECT" once the channel has been released (Figure 7-13).



**Figure 7-10: ACP - Ending a call**



**Figure 7-11: ACP - Call terminating - Flashing green**



**Figure 7-12: ACP - No active calls**



**Figure 7-13: MCDU - SATCOM Main Menu - Channel released**

## 7.1.2 Incoming Calls – Ground-to-Air (G2A)

### 7.1.2.1 Cockpit Alerting

As described in section 3.3.1, calls towards the aircraft may only be placed through controlled access measures. When a call reaches the aircraft, it may alert the crew:

1. Audibly - though a single stroke chime<sup>14</sup>
2. Visually - Call information displayed on the SATCOM->MCDU page (Figure 7-14).
  - The audio channel (SAT 1/2) call button on the ACP flashes amber (Figure 7-15).
  - Aircraft fitted with a Failure Warning System (FWS) will also display an information message relevant to the call priority.

### 7.1.2.2 Identifying the calling party and priority

When an incoming call (G2A) is in the alerting (ringing) phase, the SATCOM MAIN MENU will display the call priority alongside the audio channel SAT 1/2, and the identity of the calling party on the line below<sup>15</sup>:

- Call Priority
  - Refer to section 3.3.1, Table 3-1.
- Caller Identity
  - The calling parties' phone number will be displayed when the number does not exist in the directory.
  - When the calling parties' number is in the directory, the associated identity will be displayed in place of the number.
  - If the calling party has disabled their phone number presentation, the caller identity will be displayed as EXTERNAL.

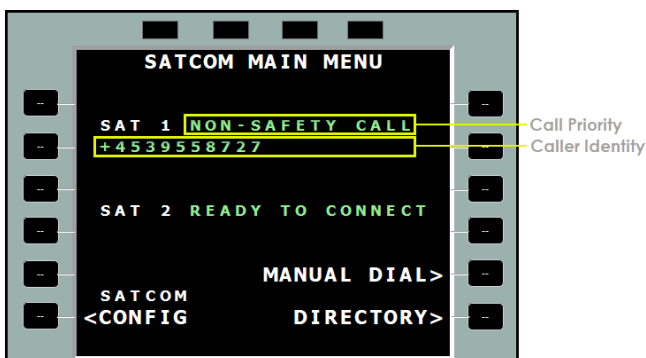


Figure 7-14: MCDU - SATCOM Main Menu - Incoming call - Unknown caller identity

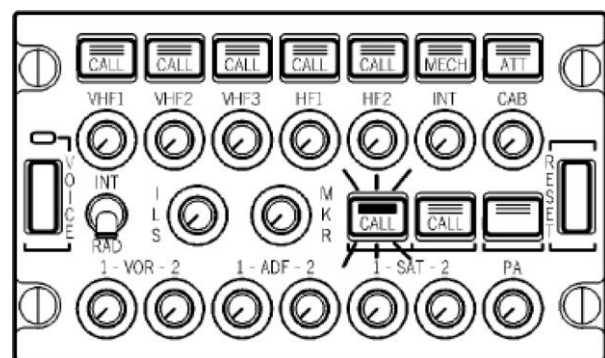


Figure 7-15: ACP - Incoming Call - Flashing amber

<sup>14</sup> In some aircraft, the chime alert (managed external to the AVIATOR S system) may be inhibited during critical phases of flight.

<sup>15</sup> ORT Configuration does permit Caller Identity to be hidden. In this configuration, INCOMING CALL is displayed alongside SAT 1/2 and the priority used to identify the calling party. E.g. NON-SAFETY EXTERNAL.



### 7.1.2.3 Answering an Incoming Call

To answer the incoming call:

1. Press the associated audio channel (SAT 1/2) on ACP.
  - The ACP SAT call button will stop flashing amber and show steady green state indicating the SAT channel is active and connected (Figure 7-16).
  - Voice communication between the two parties is now possible using the ACP to control the audio path and volume functions.
  - The SATCOM MAIN MENU SAT 1/2 status will show "CONNECTED" (Figure 7-17).

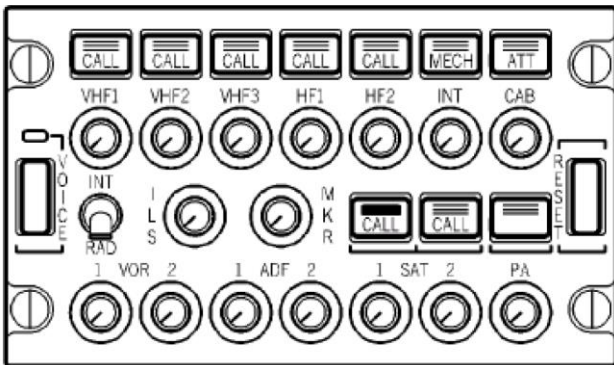


Figure 7-16: ACP - Incoming Call - Steady green



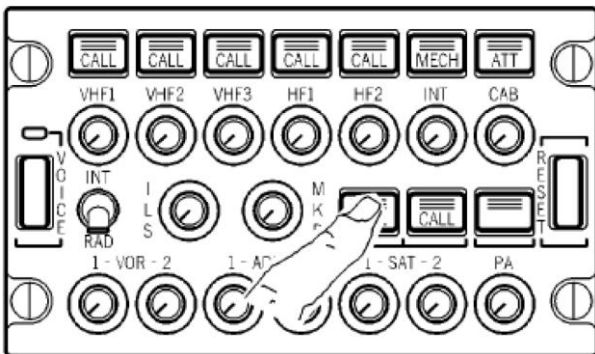
Figure 7-17: MCDU - SATCOM Main Menu - Incoming Call - Connected



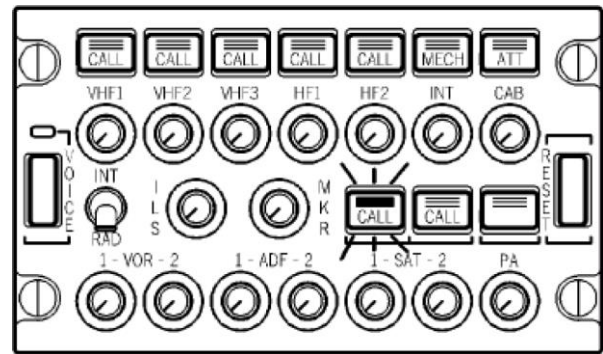
**7.1.2.4 Ending an Incoming Call**

Calls may be ended (terminated) by either the calling party (ground side) or the called party (airborne side). In both cases, the airborne side (the crew) must:

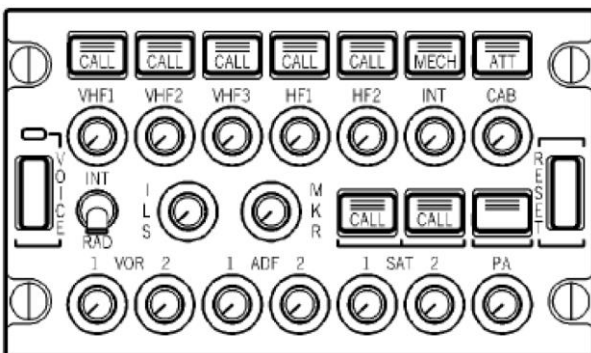
1. Release the call by pressing the associated audio channel (SAT 1/2) call button on the ACP, else the channel will remain active/engaged and may prevent incoming calls from alerting the crew.
  - The ACP SAT call button flashes green while the call termination is in progress (Figure 7-19).
  - Call ended side tone may be heard by the crew.
  - Within 3 seconds, the flashing will stop and the call will be ended (Figure 7-12).
  - The SATCOM MAIN MENU SAT 1/2 status will return to "READY TO CONNECT" once the channel has been released (Figure 7-13).



**Figure 7-18: ACP - Ending a call**



**Figure 7-19: ACP - Call terminating - Flashing amber**



**Figure 7-20: ACP - No active calls**



**Figure 7-21: MCDU - SATCOM Main Menu - Channel released**

### 7.1.2.5 Pre-emption

When pre-emption occurs (see section 3.3.3), an active call will be disconnected and the SATCOM MAIN MENU SAT 1/2 status will show "CALL FAILED" with the reason "PRE-EMPTED" on the line below (Figure 7-22).

To answer a pre-emption incoming call:

1. Press the associated audio channel (SAT 1/2) on the ACP.
  - The ACP SAT call button will stop flashing amber and show steady green state indicating the SAT channel is active and connected.
  - Voice communication between the two parties is now possible using the ACP to control the audio path and volume functions.
  - The SATCOM MAIN MENU SAT 1/2 status will show "CONNECTED" (Figure 7-17).



Figure 7-22: MCDU - SATCOM Main Menu - Call failed - Pre-empted

## 7.2 RMP INTERFACE

### 7.2.1 Outgoing Calls – Air-to-Ground (A2G)

In order to place an outgoing call, often referred to as an air-to-ground call, the crew can choose between:

- Manual Dial - a phone number<sup>16</sup> or short code may be entered via the RMP, or
- Directory Dial - select the identity from the directory list defined by User ORT (see section 3.2.3 for ORT Configuration).

#### 7.2.1.1 Manual Dial

1. The SATCOM telephone page is accessible by pressing the TEL page button.
2. Enter the destination number into the scratchpad (max 18 digits) and press LSK-R1/R2 to pre-select the number to the desired audio channel:
  - a) International number
  - b) Short code
3. The call priority cannot be modified via the RMP interface and the priority is set based on:
  - a) If the manual dial number is defined in the directory, the priority defined by the directory entry will be used.
  - b) If the manual dial number is not defined in the directory, the priority is set to a default priority configured by User ORT.

Refer to section 7.2.1.3 for guidance on dialling/initiating the call.



Figure 7-23: SATCOM Main Menu - Manual Dial - International Number



Figure 7-24: SATCOM Main Menu - Manual Dial - Short Code

<sup>16</sup> User ORT configuration may limit manual dialling to short codes only.

### 7.2.1.2 Directory Dial

**NOTE:** The directory entries are User ORT configurable and may differ from the examples.

1. From the TEL page, select the desired audio channel by pressing the TEL1/TEL2 button. Press the "down" button to enter the directory pages with entries sorted in alphabetical order.
2. Browse the directory using the "up" and "down" buttons to display the various entries in the directory or enter the list number into the scratchpad and press LSK-R1 to display the specific index.
3. Once the desired entry is selected press LSK-R2 to pre-select the entry.

Refer to section 7.2.1.3 for guidance on dialling/initiating the call.



**Figure 7-25: RMP - Directory**

**7.2.1.3 Initiating an Outgoing Call**

Once the outgoing calling information has been pre-selected as described in sections 7.2.1.1 or 7.2.1.2 the call can be initiated by:

1. Press the Dial button (LSK-L1/2) of the associated audio channel (TELx) on the radio management panel (RMP), Figure 7-26.

Once the call has been initiated, the TEL page will display the call progress:

- CONNECTING (Figure 7-27)
  - The number has been dialled and a connection to the called party is being attempted.
  - Ringing may be heard by the crew before the call is answered.
  - The call may be cancelled by pressing the End button (LSK-L1/2) of the associated audio channel (TELx) on the radio management panel (RMP). Within 3 seconds, the flashing will stop and the call will be ended.
- CONNECTED (Figure 7-28)
  - The connection to the called party has been established.
  - Voice communication between the two parties is now possible using the RMP to control the audio path and volume functions.



**Figure 7-26: RMP - TEL Page - Initiating a call**



**Figure 7-27: RMP - TEL Page - Outgoing Call – Connecting**



**Figure 7-28: RMP - TEL Page - Outgoing Call - Connected**

In some instances, the call may not be connected and the TELx status will display CALL FAILED (Figure 7-29).



Figure 7-29: RMP - TEL Page - Outgoing Call - Call Failed

### 7.2.1.4 Ending an Outgoing Call

Calls may be ended (terminated) by either the calling party (airborne side) or the called party (ground side). For an airborne side release (initiated by the crew):

1. Press the End button (LSK-L1/2) of the associated audio channel (TELx) on the radio management panel (RMP)
  - Call ended side tone may be heard by the crew.
  - The TELx status will display "CALL ENDED" once the channel has been released (Figure 7-31).



Figure 7-30: RMP - TEL Page - Ending a call



Figure 7-31: RMP - TEL Page - Call Ended

## 7.2.2 Incoming Calls – Ground-to-Air (G2A)

### 7.2.2.1 Cockpit Alerting

As described in section 3.3.1, calls towards the aircraft may only be placed through controlled access measures. When a call reaches the aircraft, it may alert the crew:

1. Audibly - through a single stroke chime<sup>17</sup>
2. Visually - Call information displayed on the RMP TEL page (Figure 7-32).
  - The TELx call button on the Radio Management Panel (RMP) flashes amber (Figure 7-32).
  - Aircraft fitted with a Failure Warning System (FWS) will also display an information message relevant to the call priority.

### 7.2.2.2 Identifying the calling party and priority

When an incoming call (G2A) is in the alerting (ringing) phase, the TEL page will display the call priority below the audio channel TELx, and the identity of the calling party to the right:

- Call Priority
  - Refer to section 3.3.1, Table 3-1.
- Caller Identity
  - The calling parties' phone number will be displayed when the number does not exist in the directory.
  - When the calling parties' number is in the directory, the associated identity will be displayed in place of the number.
  - If the calling party has disabled their phone number presentation, the caller identity will be displayed as EXTERNAL.



Figure 7-32: RMP - TEL Page - Incoming call - Alerting

<sup>17</sup> In some aircraft, the chime alert (managed external to the AVIATOR S system) may be inhibited during critical phases of flight.



### 7.2.2.3 Answering an Incoming Call

To answer the incoming call:

1. Press the associated audio channel (TELx) on the RMP.
  - Voice communication between the two parties is now possible using the RMP to control the audio path and volume functions.
  - The TELx status will show "CONNECTED" (Figure 7-33).



Figure 7-33: RMP - TEL Page - Incoming Call - Connected

### 7.2.2.4 Ending an Incoming Call

Calls may be ended (terminated) by either the calling party (ground side) or the called party (airborne side). For an airborne side release (initiated by the crew):

1. Press the End button (LSK-L1/2) of the associated audio channel (TELx) on the RMP.
  - Call ended side tone may be heard by the crew.
  - The TELx status will display "CALL ENDED" once the channel has been released (Figure 7-31).



Figure 7-34: RMP - TEL Page - Call Ended

For a ground side release, the call will automatically be disconnected and the audio channel will return to allow dialling.

### 7.2.2.5 Pre-emption

When pre-emption occurs (see section 3.3.3), an active call will be disconnected and the TELx status will show "CALL ENDED". Answer the pre-emption incoming call as per section 7.2.2.3, Answering an Incoming Call.

## 8 SAFETY DATA SERVICES

### 8.1 ACARS DATA

This messaging system is automatically managed by the Communication Management Unit (CMU) and requires no crew interaction through the MCDU SATCOM pages<sup>18</sup> provided that:

1. The system is Logged On (Auto or Manual) as described in section 6.1.1,
2. The Ground Earth Station (GES) assigned by the INMARSAT network is displayed on the SATCOM SETTINGS page at position LSK-L4:
  - a. BURUM, or
  - b. PAUMALU.

**NOTE:** The GES ID number (e.g. 356) is permitted to be shown at position LSK-L4 in place of the GES name.

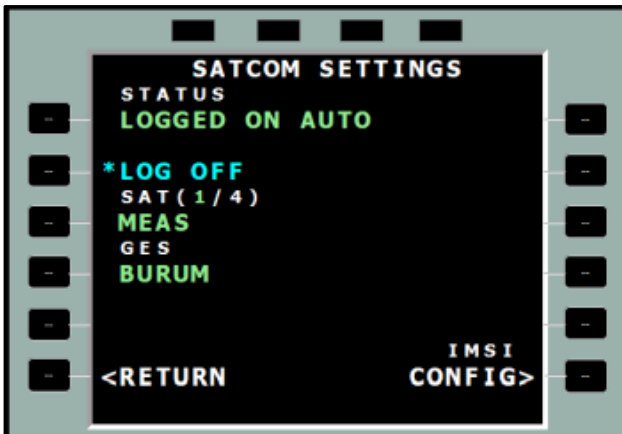


Figure 8-1: MCDU - SATCOM Settings - ACARS Data Available

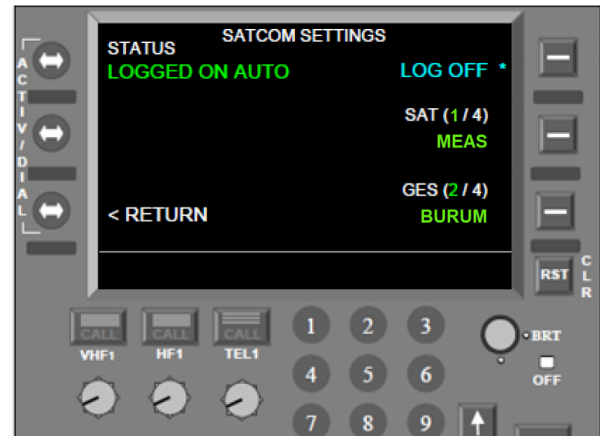


Figure 8-2: RMP - SATCOM Settings - ACARS Data Available

<sup>18</sup> The CMU may be accessed by its own dedicated MCDU pages or HMI.

## **9 NON-SAFETY DATA SERVICES**

### **9.1 ELECTRONIC FLIGHT BAG (EFB) CONNECTIVITY**

The AVIATOR S Airline Information and Services Domain (AISD) provides a routed Ethernet interface with access to a Background Class connection that is managed by the Aircraft Control Domain (ACD).

When enabled by Secure ORT (see section 3.2.3), this Ethernet interface provides segregated data capability to the cockpit for EFB applications.

ACD Voice and data traffic has a higher priority than AISD data traffic, ensuring that all SB-S functions are not impacted by AISD data requests.

The AISD/EFB data connection availability is linked to the ACD connectivity state:

- When the AVIATOR S ACD is "logged on" the AISD data connection will be active.
- Similarly, when the AVIATOR S ACD is "logged off" the AISD data connection will be inactive.

Refer to section 6.1.1 for further guidance regarding logging off/on.

The AISD/EFB Ethernet interface provides read only access to a Simple Network Management Protocol (SNMP) for retrieving AVIATOR S system and operational status information as well as link status and history. Refer to Appendix A for the list of available Object Identifiers (OID's).

### **9.2 CABIN DATA CONNECTIVITY**

The cabin data connection, connected to the AVIATOR S Passenger Information and Entertainment Services Domain (PIESD) Ethernet port, segregates PIESD (cabin) data traffic from all other data streams through a separate channel card, only available in the AVIATOR 700S system configuration.

The Cabin Data connection availability is however linked to the ACD connectivity state:

- When the AVIATOR S ACD is "logged on" the PIESD data connection will be active.
- Similarly, when the AVIATOR S ACD is "logged off" the PIESD data connection will be inactive.

Refer to section 6.1.1 for further guidance regarding logging off/on.

Additionally, cabin audio communication can be enabled/disabled through the SATCOM CONFIG page by:

**MCDU:** Pressing LSK-R3 to toggle the Cabin Calls state (Figure 9-1 & Figure 9-2)<sup>19</sup>.

**RMP:** Pressing LSK-R2 to toggle the Cabin Calls state (Figure 9-3 & Figure 9-4)<sup>19</sup>.

The PIESD Ethernet interface provides read only access to a Simple Network Management Protocol (SNMP) for retrieving AVIATOR S system and operational status information as well as link status and history. Refer to Appendix B for the list of available Object Identifiers (OID's).

---

<sup>19</sup> Cabin Call enable/disable functionality is only visible in the AVIATOR-700S system configuration when PIESD is enabled by Secure ORT configuration.



Figure 9-1: MCDU - SATCOM Config - Cabin calls enabled

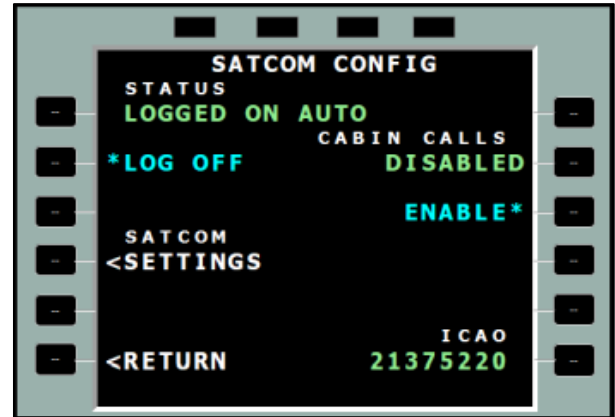


Figure 9-2: MCDU - SATCOM Config - Cabin calls disabled

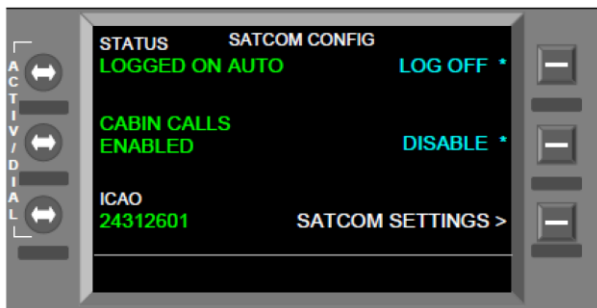


Figure 9-3: RMP - SATCOM Config - Cabin calls enabled

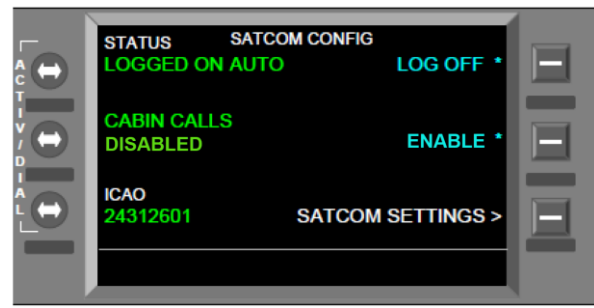


Figure 9-4: RMP - SATCOM Config - Cabin calls disabled

### 9.2.1 PPPoE Connections

A Point-to-Point Protocol over Ethernet (PPPoE) capable client is required to access the PIESD channel card. The cabin router is responsible for managing the data connection availability and Quality of Service (QoS).

PPPoE Access allows a Client to obtain one or more dedicated data connections, not shared by other users on the aircraft, with direct control over the key characteristics of each connection:

- Choose the Class (Background or Streaming Class) of every connection, and the required bit rate for each Streaming Class PDP context.
- Associate and direct the data for a particular application to go over a specific connection. Individual connections may then be optimised for their intended use, for example by setting up one Background Class connection for browsing and e-mail and another simultaneous Streaming Class connection for audio or video applications.
- Select a specific network Access Point Name (APN) specified by the Communication Service Provider (CSP), as opposed to the default configured by the System Administrator. (APNs are the gateways available to access the Internet, and a CSP may allocate these depending on specific service or performance requirements.)
- Access services which require authentication by the CSP.
- Change or modify the connection type and bandwidths mid-stream as required.
- Create secondary PDP contexts and Traffic Flow Templates (TFT).

It is assumed that the user is familiar with the concepts outlined in [3GPP\_TS27], and has a working knowledge of the Hayes AT command set.

There is a one-to-one mapping between each PPPoE connection and each primary PDP context activated by the SATCOM system. A maximum of 11 PDP contexts is supported, comprising of both primary and secondary contexts.

### **9.2.2 Connection Authentication**

User Authentication may be required for some connections. In such cases, a user name and password may be supplied in the PPPoE connection instance. Before attempting such connections, the user should verify with their Communication Service Provider (CSP) whether authentication is required for a particular service or type of IP address.

The AVIATOR S system supports the exchange of a username and password during the PPPoE/PPP negotiation (IPCP Phase) using PAP/CHAP authentication.

### **9.2.3 PPPoE Service Name**

A PPPoE service name may be used to customize the connection type, properties and quality-of-service (QoS) by specifying a series of AT strings or parameters in the Service Name field of by the PPPoE client connection properties (the connecting device).

When the service name is left blank/empty, User ORT configured defaults are used in order to create the PDP context with known properties.

Refer to Table 9-1 for the list of supported service name options.

As an alternative to a predefined service name option, the PPPoE client may define the full AT string. The letters "AT" must be present and the command string needs to specify both the CGEQREQ and CGEQMIN to ensure the desired QoS is provided. See [A781] section 3.3.11.3.1.

Example:

```
SBB:AT+CGDCONT=1,"bgan.inmarsat.com";+CGEQREQ=1,1,64,64,64,64;+CGEQMIN=1,1,64,64,64,64
```

<b>Table 9-1: PPPoE Service Name Options</b>		
<b>IP Service</b>	<b>Service Name Option</b>	<b>Description</b>
IP Background	SBB:BACKGROUND	Places a Primary Background PDP Context
8 kbps Streaming	SBB:STREAM8K	Places a Primary Streaming class PDP Context at the data rate of 8 kbps.
16 kbps Streaming	SBB:STREAM16K	Places a Primary Streaming class PDP Context at the data rate of 16 kbps.
32 kbps Streaming	SBB:STREAM32K	Places a Primary Streaming class PDP Context at the data rate of 32 kbps.
64 kbps Streaming	SBB:STREAM64K	Places a Primary Streaming class PDP Context at the data rate of 64 kbps.
128 kbps Streaming	SBB:STREAM128K	Places a Primary Streaming class PDP Context at the data rate of 128 kbps.
BGAN X-Stream	SBB:XSTREAM	Places a Primary Streaming class PDP Context with a dedicated 200 kHz bearer. Elevation angle dependant, with max data rate of 512 kbps.
HDR Half symmetric	N/A	No SBB Option Name defined. Use AT-Commands.
HDR Full symmetric	N/A	No SBB Option Name defined. Use AT-Commands.
HDR Half asymmetric	N/A	No SBB Option Name defined. Use AT-Commands.
HDR Full asymmetric	N/A	No SBB Option Name defined. Use AT-Commands.

## 9.2.4 Connection Control using TELNET

### 9.2.4.1 Primary PDP Contexts

Primary PDP contexts **must** be created through the establishment of a PPPoE connection between the AVIATOR S system and the Client.

### 9.2.4.2 Secondary PDP Contexts

Secondary PDP contexts are used if differentiated QoS characteristics are desired for different traffic types. Although they share the APN and IP address of the primary PDP context to which they have been associated, each secondary PDP context may be specified to have a different QoS. A Traffic Flow Template (TFT) must be specified for each secondary PDP context to inform both the network and the Satcom System about the different types of traffic filter to each PDP context. All traffic that is not explicitly filtered (tied) into a secondary PDP context is sent via the associated primary PDP context by default. Different traffic types are typically identified by application (strictly protocol type), although filtering by IP address and TCP/UDP port numbers is also possible.

Secondary PDP Contexts and associated Traffic Flow Template (TFT) may be created, modified, activated and de-activated using the out-of-band control interface.

**9.2.4.3 Out-of-band Control Port Connection and Configuration**

The out-of-band control port is User ORT configurable (refer to section 3.2.3). The following parameters must have a known configuration to connect to the interface:

- AVIATOR S PIESD Ethernet interface IPv4 IP address | 192.168.0.200 (Default Value)
- AVIATOR S PIESD Ethernet interface IPv4 subnet mask | 255.255.255.0 (Default Value)
- AVIATOR S PIESD Out-of-band control/TELNET port number | 22222 (Default Value)

A TELNET client/application is required to connect to the out-of-band control port at the configured IP address and port number.

The client/application must be connected to the PIESD Ethernet interface with static IPv4 configuration in the defined subnet.

**9.2.4.4 List of Supported AT-Commands**

The out-of-band control interface provides status monitoring as well as connection control using 3G/INMARSAT AT-commands over a Telnet/TCP/IP/Ethernet connection. "Out-of-band" refers to independent of the PPPoE session carrying the user data.

Table 9-2 lists the AT-commands supported by the AVIATOR S PIESD out-of-band control interface.

Refer to Appendix D for the detailed definition of each AT-command.

<b>Table 9-2: AVIATOR S Supported AT-Commands</b>	
<b>AT-Command</b>	<b>Description</b>
+CLAC	List all available AT-commands
E	Local Echo
+CGMI	Request Manufacturer Identification
+CGMM	Request Model Identification
+CGMR	Request Revision Identification
+CGSN	Request Product Serial Number Identification
+CIMI	Request International Mobile Subscriber Identity
_IPDPS	Binding Telnet session to PPPoE context
+CGDCONT	Define PDP Context (Read only)
+CGDSCONT	Define Secondary PDP Context
+CGTFT	Traffic Flow Template
+CGEQREQ	3G Quality of Service Profile, Requested
+CGQREQ	2G Quality of Service Profile, Requested
+CGEQMIN	3G Quality of Service Profile, Minimum
+CGEQNEG	3G Quality of Service Profile, Negotiated
+CGACT	PDP Context Activate or Deactivate
+CGCMOD	PDP Context Modify
+CGPADDR	Show PDP Address

#### 9.2.4.5 Binding to an active Primary PDP context

Before being able to modify, control or add a secondary PDP to a primary PDP context, the TELNET session needs to be linked to a primary PDP through the use of the AT\_IPDS AT-command. This indicates that all subsequent AT commands are related to the chosen PPPoE session and related PDP contexts.

A connection to the out-of-band control interface must be established as described in section 9.2.4.3.

Refer to Appendix D.3.11 for further guidance regarding the AT\_IPDPS AT-command.

#### 9.2.4.6 Adding a Secondary PDP Context

As described in section 9.2.1, a secondary PDP context and Traffic Flow Template (TFT) may be used to isolate specific traffic types or data that require a different QoS.

Example: A 16 kbps streaming class PDP context for UDP type traffic in the port range 50000 to 50005.

##### Method 1

The AT-commands may be sent separately:

- AT+CGDSCONT=2,1 Attached a secondary CID to the primary CID number 1.
- AT+CGEQREQ=2,1,16,16,16,16 Defines the PDP context type and the requested maximum and guaranteed QoS.
- AT+CGEQMIN=2,1,16,16,16,16 Defines the requested minimum QoS.
- AT+CGTFT=2,1,0,,17,50000.50005 Defines the downlink TFT (UDP port range 50000 to 50005).
- AT+CGACT=1,2 Activates the secondary PDP context.

##### Method 2

The AT commands may be sent together, separated by a ";"

- AT+CGDSCONT=2,1;+CGEQREQ=2,1,16,16,16,16;+CGEQMIN=2,1,16,16,16,16;+CGTFT=2,1,0,,17,50000.50005;+CGACT=1,2

#### 9.2.4.7 Traffic Flow Templates

A Traffic Flow Template (TFT) is used in conjunction with a secondary PDP context. Multiple TFT's may be linked to the same secondary PDP context, however each must be uniquely identified by:

<packet\_filter\_identifier>

- TFT identifier between 1 & 8.
- Multiple (max 8) TFTs may be applied to a single secondary.
- Starts with '1'.
- Does not indicate TFT precedence, only identifier.
- Multiple TFTs may be added to a single secondary context by incrementing the <packet\_filter\_identifier> allowing multiple 'groups' of traffic to be routed to the secondary context.

<evaluation\_precedence\_index>

- The index must be a unique number within all TFTs associated with the same primary PDP.
- The evaluation precedence index defines the precedence given to a filter when routing traffic.
- The filter with the precedence index of 0 is the first to be applied; the filter with the precedence index of 1 is next and so on. The lowest possible evaluation precedence index is 255. Traffic that may be applicable to more than one TFT will be routed over the TFT with the highest precedence i.e. whichever TFT is evaluated first.

Refer to Appendix D.3.9 for further guidance reading the +CGTFT AT-command.



#### 9.2.4.8 Modifying/Scaling of Streaming Class PDP Contexts

The requested bit rates of an active Streaming Class PDP context may be re-negotiated, while the context remains active.

The Context Identifier (CID) for the connection must be known in order to modify the correct PDP context.

To renegotiate a specific PDP context the following AT-command is used:

AT-command: AT+CGEQREQ=<CID#>, <Connection\_Class>, <Max\_Bitrate\_Up>,  
<Max\_Bitrate\_Down>,<Guaranteed\_Bitrate\_Up>,  
<Guaranteed\_Bitrate\_Down>

AT-response: <echo response of command>  
OK

Where:

<Connection\_Class> is defined by:

- 1 = Streaming Class,
- 3 = Background Class

<Max\_Bitrate\_Up> and <Max\_Bitrate\_Down> specify the requested Maximum Bitrate (the preferred bitrate).

<Guaranteed\_Bitrate\_Up> and <Guaranteed\_Bitrate\_Down> specify the requested Guaranteed Bitrate (acceptable bitrate).

After the AT+CGEQREQ command has been sent, the context will not immediately use the rates requested. An additional command is required to modify the context.

To action the modification the following AT-command must be used:

AT-command: AT+CGCMOD=<CID#>  
AT-response: <echo response of command>  
OK

At this point, the renegotiation will take place and if successful, the new bitrate request will be applied.

Verify that the re-negotiation was successful using the AT+CGEQNEG=<CID#> command.

#### 9.2.4.9 Deactivating PDP contexts

Deactivation of a PDP context may be performed using AT-commands.

The CID for the connection **must** be known in order to deactivate the correct primary or secondary PDP context, primary or secondary.

To deactivate a specific PDP context the following AT-command may be used:

AT-command: AT+CGACT=0,<CID#>  
AT-response: <echo response of command>  
OK

## 10 TROUBLESHOOTING

### 10.1 LOG FILE EXTRACTION

For AVIATOR S log file extraction, refer to Appendix E.

### 10.2 SYSTEM TEST - FLASHING CALL LIGHTS

While performing a System Test, the call lights are 'flashed'. When the test has completed, additional crew action may be required to clear the call lights before the system can return to the operational state:

**MCDU:** Clear the ACP call lights by pressing the SAT 1 and SAT 2 call buttons.

**RMP:** No further action required.

## Appendix A. AISD SNMP Interface

Table 10-1: AISD SNMP MIB OID Support

Level 1	Level 2	Level 3	Level 4	Level 5	Description
.asLinks(2)	.aslServices(1)	.aslsNumbers(1)			The number of data services types available. Integer = 1
		.aslsTable(2)	.aslsIndex(1)		Index number to each service. Integer = 1
			.aslsName(2)		Name for each index. Index 1 = "SBB:BACKGROUND"
			.aslsInUse(3)		Number of instances of this service currently in use. Integer [0..1]
			.aslsAvailable(4)		Number of instances of this service currently available. Integer [0..1]
			.aslsMaxChannels(5)		Max number of instances of this service available. Integer = 1
	.aslInfos(2)	.asliSatState(1)			This object shows, if the satellite is locked or not. The type is an enumerated integer value. 1 = Connected to Sat, 2 = Not connected.
		.asliSatID(2)			This object shows, which satellite is connected by the satcom system: " "EMEA" "MEAS" "AMER" "APAC" String [0..32]
		.asliSatIDNum(3)			Unique numeric identifier for the connected satellite: 3 (MEAS)

**COBHAM PRIVATE**

Document: **98-158752**  
Revision: **B**

Page:  
Level: **COM**

Page: **59** of **105**  
CC: **1**  
(T: 99-161853-F)

					6 (EMEA) 5 (APAC) 7 (AMER) Integer [0..63]
		.asliActLinkEntryNumbers(4)			Indicates the number of the entries in the first table and has a range from 0 to 50. Integer [0..50]
		.asliActLinkTable(5)	.asliActLinkIndex(1)		This object is a unique identifier for the current link entry and can be considered a handle for the session. With each new link, this number is to be incremented by one, wrapping around (but avoiding conflicts). Integer [1..32767]
			.asliActLinkReleaseType(2)		This object shows the release type of the current link as numeric codes as described in <b>[A781]</b> Attachment 5, Section 6. Integer [1..32767]
			.asliActLinkReleaseReason(3)		Variable string based on asliActLinkReleaseType String [0..128]
			.asliActLinkStatus(4)		This object shows if the current link is up or not. Because entries are only removed 30 seconds after going down, it is important to check this field while reading the active link table.
			.asliActLinkChanNo(5)		This object shows which channel is being used by the current link: Integer = 1 (AISD)
			.asliActLinkContextID(6)		Virtual context ID specific to that user session (tied to a primary PDP). Integer [0..255]
			.asliActLinkActualContextID(7)		The NSAPI used over the air. This ID is unique per channel card in the system while it is active. The association between a ContextID and the ActualContextID remains for the duration of the primary PDP. Integer [0..255]

			.asliActLinkConnectionID(8)	Variable string used when creating the PPPoE session. String [0..128]
			.asliActLinkNegotiatedBW(9)	Integer = 0 (Best effort connection)
			.asliActLinkIpAddress(10)	This object contains the IP-Address of the current link. E.g. aaa.bbb.ccc.ddd.
			.asliActLinkTxTrafficVol(11)	This object contains the information about the total transmitted bytes over this link in kBytes
			.asliActLinkRxTrafficVol(12)	This object contains the information about the total received bytes over this link in kBytes
			.asliActLinkBeamID(13)	This object shows, which beam ID is connected by the current link. Integer [0..255]
			.asliActLinkSigQual(14)	This object shows the Quality in dBHz*10 of the current link. Integer [0..32767]
			.asliActLinkMaxSigQual(15)	Expected maximum values for Link Signal Quality in dBHz*10. 64 dBHz BGAN Global Beam 68 dBHz BGAN Regional Beam 80 dBHz BGAN Narrow Beam Integer [0..32767]
			.asliActLinkMainIndex(16)	Integer = 0 (No secondary PDP contexts)
			.asliActLinkStartTime(20)	UTC Time at which the link was brought up. AS_Datetime [RFC3339]
			.asliActLinkEndTime(21)	UTC Time at which the link was brought down. AS_Datetime [RFC3339]
			.asliActLinkPPPoEID(22)	PPPoE Session ID which started the call. Integer [0..32767]
		.asliHistLinkEntryNumbers(6)		Indicates the number of the entries in the second table. Integer [0..250]

		.asliHistLinkTable(7)	.asliHistLinkIndex(1)		This object is a unique identifier for the link entry and can be considered a handle for the session. With each new link, this number is to be incremented by one, wrapping around (but avoiding conflicts). Integer [0..32767]
			.asliHistLinkReleaseType(2)		This object shows the release type of the link as numeric codes as described in <b>[A781]</b> Attachment 5, Section 6. Integer [1..32767]
			.asliHistLinkReleaseReason(3)		Variable string based on asliHisLinkReleaseType String [0..128]
			.asliHistLinkStatus(4)		This object shows if the link is up or not.
			.asliHistLinkChanNo(5)		This object shows which channel is being used by the link: Integer = 2 (AISD)
			.asliHistLinkContextID(6)		Virtual context ID specific to that user session (tied to a primary PDP). Integer [0..255]
			.asliHistLinkActualContextID(7)		The NSAPI used over the air. This ID is unique per channel card in the system while it was active. The association between a ContextID and the ActualContextID remains for the duration of the primary PDP. Integer [0..255]
			.asliHistLinkConnectionID(8)		Variable string used when creating the PPPoE session. String [0..128]
			.asliHistLinkNegotiatedBW(9)		Integer = 0 (Best effort connection)
			.asliHistLinkIpAddress(10)		This object contains the IP-Address of the link. E.g. aaa.bbb.ccc.ddd.
			.asliHistLinkTxTrafficVol(11)		This object contains the information about the total transmitted bytes over this link in kBytes

			.asliHistLinkRxTrafficVol(12)		This object contains the information about the total received bytes over this link in kBytes
			.asliHistLinkBeamID(13)		This object shows, which beam ID is connected by the link. Integer [0..255]
			.asliHistLinkSigQual(14)		This object shows the Quality in dBHz*10 of the link. Integer [0..32767]
			.asliHistLinkMaxSigQual(15)		Expected maximum values for Link Signal Quality in dBHz*10. 64 dBHz BGAN Global Beam 68 dBHz BGAN Regional Beam 80 dBHz BGAN Narrow Beam Integer [0..32767]
			.asliHistLinkMainIndex(16)		Integer = 0 (No secondary PDP contexts)
			.asliHistLinkStartTime(20)		UTC Time at which the link was brought up. AS_Datetime [RFC3339]
			.asliHistLinkEndTime(21)		UTC Time at which the link was brought down. AS_Datetime [RFC3339]
			.asliHistLinkPPPoEID(22)		PPPoE Session ID which started the call. Integer [0..32767]
.asUnits(4)	.asuSDU(2)	.asuSduInfo(1)	.asuSduInfoTableNumbers(1)		Indicates the number of entries in the table. Integer [1]
			.asuSduInfoTable(2)	.asuSduInfoIndex(1)	This object describes the unique identifier for the current unit. Integer [1..2]
				.asuSduInfoOverallStatus(8)	CSDU Overall Status: 1 ~ Passed 2 ~ Failed 3 ~ Absent (Initial)
				.asuSduInfoFailureCode(11)	CSDU overall status failure code - see Appendix C. Integer [0..32767]
				.asuSduInfoFailureReason(12)	CSDU overall status failure group based on the failure code - see Appendix C.

**COBHAM PRIVATE**

					String [0..255]
				.asuSduInfoCC1Status(15)	Cockpit Channel Card overall status: 1 ~ Passed 2 ~ Failed 3 ~ Absent (initial value)
				.asuSduInfoCC2Status(16)	Cabin Channel Card overall status: Integer [3] (Absent)
				.asuSduInfoUTCDateTime(35)	Current UTC date and time in RFC3339 format.
	.asuAntenna(8)	.asuAntInfo(1)	.asuAntInfoTableNumbers(1)		Indicates the number of entries in the table. Integer [1]
			.asuAntInfoTable(2)	.asuAntInfoIndex(1)	This object describes the unique identifier for the current antenna. Integer [1]
				.asuAntInfoOverallStatus(8)	Overall Antenna status 1 ~ Passed 2 ~ Failed 3 ~ Absent (initial value)
				.asuAntInfoGain(10)	The antenna gain (dB/10) currently utilized from 0.0 to 31.5 dB. ("-1" indicates invalid data). Integer [-1..315]



## Appendix B. PIESD SNMP Interface

Table 10-2: PIESD SNMP MIB OID Support

Level 1	Level 2	Level 3	Level 4	Level 5	Description
.asLinks(2)	.aslServices(1)	.aslsNumbers(1)			The number of data services types available. Integer [7]
		.aslsTable(2)	.aslsIndex(1)		Index number to each service. Integer [1..7]
			.aslsName(2)		Name for each index. Index 1 = "SBB:BACKGROUND" Index 2 = "SBB:STREAM8K" Index 3 = "SBB:STREAM16K" Index 4 = "SBB:STREAM32K" Index 5 = "SBB:STREAM64K" Index 6 = "SBB:STREAM128K" Index 7 = "SBB:XSTREAM"
			.aslsInUse(3)		Number of instances of this service currently in use. Integer [0..127]
	.aslInfos(2)	.asliSatState(1)			This object shows, if the satellite is locked or not. The type is an enumerated integer value. 1 = Connected to Sat, 2 = Not connected.
		.asliSatID(2)			This object shows, which satellite is connected by the satcom system: "" "EMEA" "MEAS" "AMER" "APAC" String [0..32]

**COBHAM PRIVATE**

Document: **98-158752**  
Revision: **B**

Page:  
Level: **COM**

**65** of **105**  
CC: **1**  
(T: 99-161853-F)

		.asliSatIDNum(3)			Unique numeric identifier for the connected satellite: 3 (MEAS) 6 (EMEA) 5 (APAC) 7 (AMER) Integer [0..63]
		.asliActLinkEntryNumbers(4)			Indicates the number of the entries in the first table and has a range from 0 to 50. Integer [0..50]
		.asliActLinkTable(5)	.asliActLinkIndex(1)		This object is a unique identifier for the current link entry and can be considered a handle for the session. With each new link, this number is to be incremented by one, wrapping around (but avoiding conflicts). Integer [1..32767]
			.asliActLinkReleaseType(2)		This object shows the release type of the current link as numeric codes as described in <b>[A781]</b> Attachment 5, Section 6. Integer [1..32767]
			.asliActLinkReleaseReason(3)		Variable string based on asliActLinkReleaseType String [0..128]
			.asliActLinkStatus(4)		This object shows if the current link is up or not. Because entries are only removed 30 seconds after going down, it is important to check this field while reading the active link table.
			.asliActLinkChanNo(5)		This object shows which channel is being used by the current link: Integer = 2 (PIESD)
			.asliActLinkContextID(6)		Virtual context ID specific to that user session (tied to a primary PDP). Integer [0..255]
			.asliActLinkActualContextID(7)		The NSAPI used over the air. This ID is unique per channel card in the system while it is active.

**COBHAM PRIVATE**

Document: **98-158752**  
Revision: **B**

Page:  
Level: **COM**

Page: **66** of **105**  
CC: **1**  
(T: 99-161853-F)

					The association between a ContextID and the ActualContextID remains for the duration of the primary PDP. Integer [0..255]
			.asliActLinkConnectionID(8)		Variable string used when creating the PPPoE session. String [0..128]
			.asliActLinkNegotiatedBW(9)		This object shows the currently negotiated bandwidth of the link in this table entry. Integer [0..2048] 0 ~ Background Class / Best effort connection
			.asliActLinkIpAddress(10)		This object contains the IP-Address of the current link. E.g. aaa.bbb.ccc.ddd.
			.asliActLinkTxTrafficVol(11)		This object contains the information about the total transmitted bytes over this link in kBytes
			.asliActLinkRxTrafficVol(12)		This object contains the information about the total received bytes over this link in kBytes
			.asliActLinkBeamID(13)		This object shows, which beam ID is connected by the current link. Integer [0..255]
			.asliActLinkSigQual(14)		This object shows the Quality in dBHz*10 of the current link. Integer [0..32767]
			.asliActLinkMaxSigQual(15)		Expected maximum values for Link Signal Quality in dBHz*10. 64 dBHz BGAN Global Beam 68 dBHz BGAN Regional Beam 80 dBHz BGAN Narrow Beam Integer [0..32767]
			.asliActLinkMainIndex(16)		If this link entry is part of bundle (e.g., a secondary context), this object refers the main entry (e.g., the primary context) in this table to which this subentry is related. Integer [0..32767]

**COBHAM PRIVATE**

Document: **98-158752**  
Revision: **B**

Page:  
Level: **COM**

Page: **67** of **105**  
CC: **1**  
(T: 99-161853-F)

			.asliActLinkServiceIndex(17)		This object is a link to the asliIndex by referring the used Service. Integer [0..100]
			.asliActLinkStartTime(20)		UTC Time at which the link was brought up. AS_Datetime [RFC3339]
			.asliActLinkEndTime(21)		UTC Time at which the link was brought down. AS_Datetime [RFC3339]
			.asliActLinkPPPoEID(22)		PPPoE Session ID which started the call. Integer [0..32767]
		.asliHistLinkEntryNumbers(6)			This object is a unique identifier for the link entry and can be considered a handle for the session. With each new link, this number is to be incremented by one, wrapping around (but avoiding conflicts). Integer [1..250]
		.asliHistLinkTable(7)	.asliHistLinkIndex(1)		This object is a unique identifier for the link entry and can be considered a handle for the session. With each new link, this number is to be incremented by one, wrapping around (but avoiding conflicts). Integer [1..32767]
			.asliHistLinkReleaseType(2)		This object shows the release type of the link as numeric codes as described in <b>[A781]</b> Attachment 5, Section 6. Integer [1..32767]
			.asliHistLinkReleaseReason(3)		Variable string based on asliHisLinkReleaseType String [0..128]
			.asliHistLinkStatus(4)		This object shows if the link is up or not.
			.asliHistLinkChanNo(5)		This object shows which channel is being used by the link: Integer = 2 (PIESD)
			.asliHistLinkContextID(6)		Virtual context ID specific to that user session (tied to a primary PDP).

					Integer [0..255]
			.asliHistLinkActualContextID(7)		The NSAPI used over the air. This ID is unique per channel card in the system while it was active. The association between a ContextID and the ActualContextID remains for the duration of the primary PDP. Integer [0..255]
			.asliHistLinkConnectionID(8)		Variable string used when creating the PPPoE session. String [0..128]
			.asliHistLinkNegotiatedBW(9)		This object shows the negotiated bandwidth of the link in this table entry. Integer [0..2048] 0 ~ Background Class / Best effort connection
			.asliHistLinkIpAddress(10)		This object contains the IP-Address of the link. E.g. aaa.bbb.ccc.ddd.
			.asliHistLinkTxTrafficVol(11)		This object contains the information about the total transmitted bytes over this link in kBytes
			.asliHistLinkRxTrafficVol(12)		This object contains the information about the total received bytes over this link in kBytes
			.asliHistLinkBeamID(13)		This object shows, which beam ID is connected by the link. Integer [0..255]
			.asliHistLinkSigQual(14)		This object shows the Quality in dBHz*10 of the link. Integer [0..32767]
			.asliHistLinkMaxSigQual(15)		Expected maximum values for Link Signal Quality in dBHz*10. 64 dBHz BGAN Global Beam 68 dBHz BGAN Regional Beam 80 dBHz BGAN Narrow Beam Integer [0..32767]

			.asliHistLinkMainIndex(16)		If this link entry is part of bundle (e.g., a secondary context), this object refers the main entry (e.g., the primary context) in this table to which this subentry is related. Integer [0..32767]
			.asliHistLinkServiceIndex(17)		This object is a link to the asliIndex by referring the used Service. Integer [0..100]
			.asliHistLinkStartTime(20)		UTC Time at which the link was brought up. AS_Datetime [RFC3339]
			.asliHistLinkEndTime(21)		UTC Time at which the link was brought down. AS_Datetime [RFC3339]
			.asliHistLinkPPPoEID(22)		PPPoE Session ID which started the call. Integer [0..32767]
.asUnits(4)	.asuSDU(2)	.asuSduInfo(1)	.asuSduInfoTableNumbers(1)		Indicates the number of entries in the table. Integer [1]
			.asuSduInfoTable(2)	.asuSduInfoIndex(1)	This object describes the unique identifier for the current unit. Integer [1..2]
				.asuSduInfoVendor(2)	Short Name of the LRU supplier. String [0..22] = "Cobham Aerospace"
				.asuSduInfoOverallStatus(8)	CSDU Overall Status: 1 ~ Passed 2 ~ Failed 3 ~ Absent (Initial)
				.asuSduInfoFailureCode(11)	CSDU overall status failure code - see Appendix C. Integer [0..32767]
				.asuSduInfoFailureReason(12)	CSDU overall status failure group based on the failure code - see Appendix C. String [0..255]
				.asuSduInfoCC1Status(15)	Cockpit Channel Card overall status: Integer [3] (Absent)

				.asuSduInfoCC2Status(16)	Cabin Channel Card overall status: 1 ~ Passed 2 ~ Failed 3 ~ Absent (initial value)
				.asuSduInfoUTCDateTime(35)	Current UTC date and time in RFC3339 format.
	.asuAntenna(8)	.asuAntInfo(1)	.asuAntInfoTableNumbers(1)		Indicates the number of entries in the table. Integer [1]
			.asuAntInfoTable(2)	.asuAntInfoIndex(1)	This object describes the unique identifier for the current antenna. Integer [1]
				.asuAntInfoOverallStatus(8)	Overall Antenna status Integer [3] (Absent)
				.asuAntInfoGain(10)	The antenna gain (dB/10) currently utilized from 0.0 to 31.5 dB. ("-1" indicates invalid data). Integer [-1..315]

## Appendix C. SNMP Object ID Definitions

### Appendix C.1. asliActLinkStatus(4)

asliActLinkStatus shows if the current link is up or not. The values are:

- Up(1)
- Down(2)
- Unconnected(3)

### Appendix C.2. asliHistLinkEntryNumbers(6)

asliHistLinkEntryNumbers(6) indicates the number of the entries in the second table and has an open range. The value is maximum 250.

### Appendix C.3. asuSduInfoVendor(2)

asuSduInfoVendor is the name of the AVIATOR S supplier and has the value "Cobham Aerospace".

### Appendix C.4. asuSduInfoFailureCode(11)

asuSduInfoFailureCode indicates a unique failure code. The failure code consists of a fault group and a fault bit to indicate individual faults. The value range of the failure code determines the fault group as listed in Table 10-3.

Table 10-3: Failure group of asuSduInfoFailureCode	
Failure Code	Fault Group (in prioritized order)
1000 – 1999	No Power
2000 – 2999	Critical Temperature
3000 – 3999	No SATCOM
4000 – 4999	External Interface Failed
5000 – 5999	No ACARS
6000 – 6999	No Cockpit Voice
7000 – 7999	No Cockpit Data
8000 – 8999	No Cabin Data

For the "No Power" fault group the following fault bits are defined:

- DegradedPowerHoldUp (Bit 0)

For the "Critical Temperature" fault group the following fault bits are defined:

- DegradedACDTemperatureCriticalHigh (Bit 0)
- DegradedACDTemperatureShutdownHigh (Bit 1)
- DegradedCockpitRMTempCriticalHigh (Bit 2)
- DegradedPSMTemperatureCriticalHigh (Bit 3)
- DegradedAISDTemperatureCriticalHigh (Bit 4)
- DegradedPIESDTemperatureCriticalHigh (Bit 5)
- DegradedHPATemperatureCriticalHigh (Bit 6)



For the "No SATCOM" fault group the following fault bits are defined:

- DegradedNoSATCOM (Bit 0)
- DegradedPosLost (Bit 1)
- DegradedNO\_OR\_T (Bit 2)

For the "External Interface Failed" fault group the following fault bits are defined:

- DegradedNo615-3 (Bit 0)
- Degraded615-3Lost (Bit 1)
- DegradedCMULost (Bit 2)
- DegradedMCDULost (Bit 3)
- DegradedCFDSLost (Bit 4)
- DegradedFWSLost (Bit 5)
- DegradedMCDUFailure (Bit 6)

For the "No ACARS" fault group the following fault bits are defined:

- DegradedNoACARS (Bit 0)

For the "No Cockpit Voice" fault group the following fault bits are defined:

- DegradedCockpitVoiceFailure (Bit 0)

For the "No Cockpit Data" fault group the following fault bits are defined:

- DegradedAISDNotWorking (Bit 0)
- DegradedAISDFailure (Bit 1)
- DegradedNoCockpitData (Bit 2)

For the "No Cabin Data" fault group the following fault bits are defined:

- DegradedPIESDNotWorking (Bit 0)
- DegradedCabinRMNotWorking (Bit 1)
- DegradedCabinRMFailure (Bit 2)
- DegradedPIESDFailure (Bit 3)
- DegradedCabinDataFailure (Bit 4)

As an example:

If the CMU and MCDU are lost, it will set the fault bits "2" and "3" in the "External Interface Failed" fault group to combine into failure code "400C".

## Appendix C.5. **asuSduInfoFailureReason(12)**

asuSduInfoFailureReason is a failure message equal to the failure code in asuSduInfoFailureCode(11).

## Appendix D. AT-Commands

### Appendix D.1. General Commands

#### Appendix D.1.1 List all Available AT Commands

List all available AT commands. Ref : [3GPP\_TS27]

Command	Possible response(s)
+CLAC	<AT Command1> [<CR> <LF> <AT Command2>[...]] +CME ERROR: <err>
+CLAC=?	

Defined Values:

<AT Command >:

Defines the AT command including the prefix AT. Text shall not contain the sequence 0<CR> or OK<CR>

#### Appendix D.1.2 Command Echo

Command Echo. Ref : [ITU-T\_V.250]

Command	Possible response(s)
ATE [<value>]	OK

Defined Values:

<value>

- 0 DCE does not echo characters during command state and online command state.
- 1 DCE echoes characters during command state and online command state.

Recommended default setting :

- 1 DCE echoes characters during command state and online command state

Supported Values:

(0,1)

## Appendix D.2. System Information

### Appendix D.2.1 Request Manufacturer Identification

Request Manufacturer Identification. Ref : [3GPP\_TS27]

Command	Possible response(s)
+CGMI	<manufacturer> +CME ERROR: <err>
+CGMI=?	

Defined Values:

<manufacturer>

the total number of characters, including line terminators, in the information text shall not exceed 2048 characters.

Text shall not contain the sequence 0<CR> or OK<CR>

### Appendix D.2.2 Request Model Identification

Request Model Identification. Ref : [3GPP\_TS27]

Command	Possible response(s)
+CGMM	<model> +CME ERROR: <err>
+CGMM=?	

Defined Values:

<model>

The total number of characters, including line terminators, in the information text shall not exceed 2048 characters.

Text shall not contain the sequence 0<CR> or OK<CR>

### Appendix D.2.3 Request Revision Identification

Request Revision Identification. Ref : [3GPP\_TS27]

Command	Possible response(s)
+CGMR	<revision> +CME ERROR: <err>
+CGMR=?	

Defined Values:

<revision>

The total number of characters, including line terminators, in the information text shall not exceed 2048 characters. Text shall not contain the sequence 0<CR> or OK<CR>.

### Appendix D.2.4 Request Serial Number Identification

Request Product Serial Number Identification. Ref : [3GPP\_TS27]

Command	Possible response(s)
+CGSN	<sn> +CME ERROR: <err>
+CGSN=?	

Defined Values:

<sn>

the total number of characters, including line terminators, in the information text shall not exceed 2048 characters. Text shall not contain the sequence 0<CR> or OK<CR>

### Appendix D.2.5 Request International Mobile Subscriber Identity

Request International Mobile Subscriber Identity. Ref : [3GPP\_TS27]

Command	Possible response(s)
+CIMI	<IMSI> +CME ERROR: <err>
+CIMI=?	

Defined Values:

<IMSI>

International Mobile Subscriber Identity (string without double quotes)

## Appendix D.3. Packet Data Connections

### Appendix D.3.1 Define Primary PDP Context

Define PDP Context. [3GPP\_TS27]

Command	Possible response(s)
+CGDCONT=[<cid> [,<PDP_type>[,<APN> [,<PDP_addr> [,<d_comp> [,<h_comp> [,<pd1> [,...[,pdN]]]]]]]]]]	OK ERROR
+CGDCONT?	+CGDCONT: <cid>, <PDP_type>, <APN>, <PDP_addr>, <data_comp>, <head_comp>[,<pd1>[,...[,pdN]]]
+CGDCONT=?	+CGDCONT: (range of supported <cid>s), <PDP_type>,,, (list of supported <d_comp>s), (list of supported <h_comp>s)[, (list of supported <pd1>s)[,...[, (list of supported <pdN>s)]]]

Defined Values:

<cid>

(PDP Context Identifier) a numeric parameter which specifies a particular PDP context definition. The parameter is local to the TE-MT interface and is used in other PDP context-related commands. The range of permitted values (minimum value = 1) is returned by the test form of the command.

<PDP\_type>

(Packet Data Protocol type) a string parameter which specifies the type of packet data protocol

IP Internet Protocol (IETF STD 5)

IPv6<sup>20</sup> Internet Protocol, version 6 (IETF RFC 2460)

PPP Point to Point Protocol (IETF STD 51)

<APN>

(Access Point Name) a string parameter which is a logical name that is used to select the GGSN or the external packet data network. If the value is null or omitted, then the subscription value will be requested.

<PDP\_address>

a string parameter that identifies the MT in the address space applicable to the PDP. If the value is null or omitted, then a value may be provided by the TE during the PDP startup procedure or, failing that, a

<sup>20</sup> IPv6 is not supported by the Inmarsat network.

dynamic address will be requested. The read form of the command will continue to return the null string even if an address has been allocated during the PDP startup procedure. The allocated address may be read using the +CGPADDR command.

<d\_comp>

a numeric parameter that controls PDP data compression

0 off (default if value is omitted)

1 on

Other values are reserved.

<h\_comp>

a numeric parameter that controls PDP header compression

0 off (default if value is omitted)

1 on

Other values are reserved.

NOTE: At present only one data compression algorithm (V.42bis) is provided in SNDCP. If and when other algorithms become available, a command will be provided to select one or more of these.

<pd1>, ... <pdN>

zero to N string parameters whose meanings are specific to the <PDP\_type>

For PDP type OSP:IHOSS the following parameters are defined:

<pd1> = <host>

the fully formed domain name extended hostname of the Internet host

<pd2> = <port >

the TCP or UDP port on the Internet host

<pd3> = <protocol>

the protocol to be used over IP on the Internet - "TCP" or "UDP"



Defined Values:

<cid>

a numeric parameter which specifies a particular PDP context definition (see+CGDCONT and +CGDSCONT commands).

The following parameters are defined in 3GPP TS 23.107 -

<Traffic class>

a numeric parameter that indicates the type of application for which the UMTS bearer service is optimised.

- 0 conversational
- 1 streaming
- 2 interactive
- 3 background
- 4 subscribed value

Other values are reserved.

<Maximum bitrate UL>

a numeric parameter that indicates the maximum number of kbits/s delivered to UMTS (up-link traffic) at a SAP. As an example a bitrate of 32kbit/s would be specified as '32' (e.g. AT+CGEQREQ=...,32, ...).

<Maximum bitrate DL>

a numeric parameter that indicates the maximum number of kbits/s delivered by UMTS (down-link traffic) at a SAP. As an example a bitrate of 32kbit/s would be specified as '32' (e.g. AT+CGEQREQ=...,32, ...). If the parameter is set to '0' the subscribed value will be requested.

<Guaranteed bitrate UL>

a numeric parameter that indicates the guaranteed number of kbits/s delivered to UMTS (up-link traffic) at a SAP (provided that there is data to deliver). As an example a bitrate of 32kbit/s would be specified as '32' (e.g. AT+CGEQREQ=...,32, ...). If the parameter is set to '0' the subscribed value will be requested.

<Guaranteed bitrate DL>

a numeric parameter that indicates the guaranteed number of kbits/s delivered by UMTS (down-link traffic) at a SAP (provided that there is data to deliver). As an example a bitrate of 32kbit/s would be specified as '32' (e.g. AT+CGEQREQ=...,32, ...). If the parameter is set to '0' the subscribed value will be requested.



<Delivery order>

a numeric parameter that indicates whether the UMTS bearer shall provide in- sequence SDU delivery or not.

- 0 no
- 1 yes
- 2 subscribed value.

Other values are reserved.

<Maximum SDU size>

a numeric parameter (1,2,3,...) that indicates the maximum allowed SDU size in octets. If the parameter is set to '0' the subscribed value will be requested.

<SDU error ratio>

a string parameter that indicates the target value for the fraction of SDUs lost or detected as erroneous. SDU error ratio is defined only for conforming traffic. The value is specified as 'mEe'. As an example a target SDU error ratio of  $5 \times 10^{-3}$  would be specified as '5E3' (e.g. AT+CGEQREQ=..., "5E3",...).

'0E0' means subscribed value.

<Residual bit error ratio>

a string parameter that indicates the target value for the undetected bit error ratio in the delivered SDUs. If no error detection is requested, Residual bit error ratio indicates the bit error ratio in the delivered SDUs. The value is specified as 'mEe'. As an example a target residual bit error ratio of  $5 \times 10^{-3}$  would be specified as '5E3' (e.g. AT+CGEQREQ=..., "5E3",...). '0E0' means subscribed value.

<Delivery of erroneous SDUs>

a numeric parameter that indicates whether SDUs detected as erroneous shall be delivered or not.

- 0 no
- 1 yes
- 2 no detect
- 3 subscribed value

Other values are reserved.

<Transfer delay>

a numeric parameter (0,1,2,...) that indicates the targeted time between request to transfer an SDU at one SAP to its delivery at the other SAP, in milliseconds. If the parameter is set to '0' the subscribed value will be requested.

<Traffic handling priority>

a numeric parameter (1,2,3,...) that specifies the relative importance for handling of all SDUs belonging to the UMTS bearer compared to the SDUs of other bearers. If the parameter is set to '0' the subscribed value will be requested.

<PDP\_type> (see +CGDCONT and +CGDSCONT commands).

If a value is omitted for a particular class then the value is considered to be unspecified.

Supported Values:

<cid> (1-11)	<Maximum SDU size> (0-1520)
<Traffic class> (0-4)	<SDU error ratio> ("1E6"- "1E1", "0E0").
<Maximum bitrate UL> (0-8640)	<Residual bit error ratio> ("6E8"- "5E2", "0E0")
<Maximum bitrate DL> (0-8640)	<Delivery of erroneous SDUs> (0-3)
<Guaranteed bitrate UL> (0-8640)	<Transfer delay> (0-4000)
<Guaranteed bitrate DL> (0-8640)	<Traffic handling priority> (0-3)
<Delivery order> (0-2)	<PDP_type> "IP"



Defined Values:

<cid>

a numeric parameter which specifies a particular PDP context definition (see+CGDCONT and +CGDSCONT commands).

The following parameters are defined in 3GPP TS 23.107 -

<Traffic class>

a numeric parameter that indicates the type of application for which the UMTS bearer service is optimised.

- 0 conversational
- 1 streaming
- 2 interactive
- 3 background
- 4 subscribed value

Other values are reserved.

<Maximum bitrate UL>

a numeric parameter that indicates the maximum number of kbits/s delivered to UMTS (up-link traffic) at a SAP. As an example a bitrate of 32kbit/s would be specified as '32' (e.g. AT+CGQREQ=...,32, ...).

<Maximum bitrate DL>

a numeric parameter that indicates the maximum number of kbits/s delivered by UMTS (down-link traffic) at a SAP. As an example a bitrate of 32kbit/s would be specified as '32' (e.g. AT+CGQREQ=...,32, ...). If the parameter is set to '0' the subscribed value will be requested.

<Guaranteed bitrate UL>

a numeric parameter that indicates the guaranteed number of kbits/s delivered to UMTS (up-link traffic) at a SAP (provided that there is data to deliver). As an example a bitrate of 32kbit/s would be specified as '32' (e.g. AT+CGQREQ=...,32, ...). If the parameter is set to '0' the subscribed value will be requested.

<Guaranteed bitrate DL>

a numeric parameter that indicates the guaranteed number of kbits/s delivered by UMTS (down-link traffic) at a SAP (provided that there is data to deliver). As an example a bitrate of 32kbit/s would be specified as '32' (e.g. AT+CGQREQ=...,32, ...). If the parameter is set to '0' the subscribed value will be requested.

<Delivery order>

a numeric parameter that indicates whether the UMTS bearer shall provide in- sequence SDU delivery or not.

- 0 no
- 1 yes
- 2 subscribed value.

Other values are reserved.

<Maximum SDU size>

a numeric parameter (1,2,3,...) that indicates the maximum allowed SDU size in octets. If the parameter is set to '0' the subscribed value will be requested.

<SDU error ratio>

a string parameter that indicates the target value for the fraction of SDUs lost or detected as erroneous. SDU error ratio is defined only for conforming traffic. The value is specified as 'mEe'. As an example a target SDU error ratio of  $5 \times 10^{-3}$  would be specified as '5E3' (e.g. AT+CGQREQ=..., "5E3",...).

'0E0' means subscribed value.

<Residual bit error ratio>

a string parameter that indicates the target value for the undetected bit error ratio in the delivered SDUs. If no error detection is requested, Residual bit error ratio indicates the bit error ratio in the delivered SDUs. The value is specified as 'mEe'. As an example a target residual bit error ratio of  $5 \times 10^{-3}$  would be specified as '5E3' (e.g. AT+CGQREQ=..., "5E3",...). '0E0' means subscribed value.

<Delivery of erroneous SDUs>

a numeric parameter that indicates whether SDUs detected as erroneous shall be delivered or not.

- 0 no
- 1 yes
- 2 no detect
- 3 subscribed value

Other values are reserved.

<Transfer delay>

a numeric parameter (0,1,2,...) that indicates the targeted time between request to transfer an SDU at one SAP to its delivery at the other SAP, in milliseconds. If the parameter is set to '0' the subscribed value will be requested.

<Traffic handling priority>

a numeric parameter (1,2,3,...) that specifies the relative importance for handling of all SDUs belonging to the UMTS bearer compared to the SDUs of other bearers. If the parameter is set to '0' the subscribed value will be requested.

<PDP\_type> (see +CGDCONT and +CGDSCONT commands).

If a value is omitted for a particular class then the value is considered to be unspecified.

Supported Values:

<cid> (1-11)	<Maximum SDU size> (0-1520)
<Traffic class> (0-4)	<SDU error ratio> ("1E6"- "1E1", "0E0").
<Maximum bitrate UL> (0-8640)	<Residual bit error ratio> ("6E8"- "5E2", "0E0")
<Maximum bitrate DL> (0-8640)	<Delivery of erroneous SDUs> (0-3)
<Guaranteed bitrate UL> (0-8640)	<Transfer delay> (0-4000)
<Guaranteed bitrate DL> (0-8640)	<Traffic handling priority> (0-3)
<Delivery order> (0-2)	<PDP_type> "IP"

### Appendix D.3.4 3G Quality of Service Profile (Negotiated)

3G Quality of Service Profile (Negotiated) Ref : [3GPP\_TS27]

Command	Possible response(s)
+CGEQNEG = [<cid>[, <cid>[, ...]]]	+CGEQNEG: <cid>, <Traffic class> , <Maximum bitrate UL>, <Maximum bitrate DL> , <Guaranteed bitrate UL>, <Guaranteed bitrate DL> , <Delivery order> , <Maximum SDU size> , <SDU error ratio> , <Residual bit error ratio> , <Delivery of erroneous SDUs> , <Transfer delay> , <Traffic handling priority>
+CGEQNEG=?	+CGEQNEG: (list of <cid>s associated with active contexts)

Defined Values:

<cid>

a numeric parameter which specifies a particular PDP context definition (see +CGDCONT and +CGDSCONT commands).

The following parameters are defined in 3GPP TS 23.107 -

<Traffic class>

a numeric parameter that indicates the type of application for which the UMTS bearer service is optimised.

- 0 conversational
- 1 streaming
- 2 interactive
- 3 background

Other values are reserved.

<Maximum bitrate UL>

a numeric parameter that indicates the maximum number of kbits/s delivered to UMTS (up-link traffic) at a SAP. As an example a bitrate of 32kbit/s would be specified as '32' (e.g. +CGEQNEG:...,32, ...).

<Maximum bitrate DL>

a numeric parameter that indicates the maximum number of kbits/s delivered by UMTS (down-link traffic) at a SAP. As an example a bitrate of 32kbit/s would be specified as '32' (e.g. +CGEQNEG:...,32, ...).

<Guaranteed bitrate UL>

a numeric parameter that indicates the guaranteed number of kbits/s delivered to UMTS (up-link traffic) at a SAP (provided that there is data to deliver). As an example a bitrate of 32kbit/s would be specified as '32' (e.g. +CGEQNEG:...,32, ...).

<Guaranteed bitrate DL>

a numeric parameter that indicates the guaranteed number of kbits/s delivered by UMTS (down-link traffic) at a SAP (provided that there is data to deliver). As an example a bitrate of 32kbit/s would be specified as '32' (e.g. +CGEQNEG:...,32, ...).

<Delivery order>

a numeric parameter that indicates whether the UMTS bearer shall provide in-sequence SDU delivery or not.

0 no

1 yes

Other values are reserved.

<Maximum SDU size>

a numeric parameter that (1,2,3,...) indicates the maximum allowed SDU size in octets.

<SDU error ratio>

a string parameter that indicates the target value for the fraction of SDUs lost or detected as erroneous. SDU error ratio is defined only for conforming traffic. The value is specified as 'mEe'. As an example a target SDU error ratio of  $5 \times 10^{-3}$  would be specified as '5E3' (e.g. +CGEQNEG:..., "5E3", ...).

<Residual bit error ratio>

a string parameter that indicates the target value for the undetected bit error ratio in the delivered SDUs. If no error detection is requested, Residual bit error ratio indicates the bit error ratio in the delivered SDUs. The value is specified as 'mEe'. As an example a target residual bit error ratio of  $5 \times 10^{-3}$  would be specified as '5E3' (e.g. +CGEQNEG:..., "5E3", ...).

<Delivery of erroneous SDUs>

a numeric parameter that indicates whether SDUs detected as erroneous shall be delivered or not.

---

**COBHAM PRIVATE**



- 0 - no
- 1 - yes
- 2 - no detect

Other values are reserved.

<Transfer delay>

a numeric parameter (0,1,2,...) that indicates the targeted time between request to transfer an SDU at one SAP to its delivery at the other SAP, in milliseconds.

<Traffic handling priority>

a numeric parameter (1,2,3,...) that specifies the relative importance for handling of all SDUs belonging to the UMTS bearer compared to the SDUs of other bearers. If a value is omitted for a particular class then the value is considered to be unspecified.

Supported Values:

<cid>

(1-11)



<Traffic class>

a numeric parameter that indicates the type of application for which the UMTS bearer service is optimised.

- 0 conversational
- 1 streaming
- 2 interactive
- 3 background

Other values are reserved.

<Maximum bitrate UL>

a numeric parameter that indicates the maximum number of kbits/s delivered to UMTS (up-link traffic) at a SAP. As an example a bitrate of 32kbit/s would be specified as '32' (e.g. AT+CGEQMIN=...,32, ...).

<Maximum bitrate DL>

a numeric parameter that indicates the maximum number of kbits/s delivered by UMTS (down-link traffic) at a SAP. As an example a bitrate of 32kbit/s would be specified as '32' (e.g. AT+CGEQMIN=...,32, ...).

<Guaranteed bitrate UL>

a numeric parameter that indicates the guaranteed number of kbits/s delivered to UMTS (up-link traffic) at a SAP (provided that there is data to deliver). As an example a bitrate of 32kbit/s would be specified as '32' (e.g. AT+CGEQMIN=...,32, ...).

<Guaranteed bitrate DL>

a numeric parameter that indicates the guaranteed number of kbits/s delivered by UMTS (down-link traffic) at a SAP (provided that there is data to deliver). As an example a bitrate of 32kbit/s would be specified as '32' (e.g. AT+CGEQMIN=...,32, ...).

<Delivery order>

a numeric parameter that indicates whether the UMTS bearer shall provide in-sequence SDU delivery or not.

- 0 no
- 1 yes

Other values are reserved.

<Maximum SDU size>

a numeric parameter (1,2,3,...) that indicates the maximum allowed SDU size in octets.

<SDU error ratio>

a string parameter that indicates the target value for the fraction of SDUs lost or detected as erroneous. SDU error ratio is defined only for conforming traffic. The value is specified as 'mEe'. As an example a target SDU error ratio of  $5 \times 10^{-3}$  would be specified as '5E3' (e.g. AT+CGEQMIN=..., "5E3", ...).

<Residual bit error ratio>

a string parameter that indicates the target value for the undetected bit error ratio in the delivered SDUs. If no error detection is requested, Residual bit error ratio indicates the bit error ratio in the delivered SDUs. The value is specified as 'mEe'. As an example a target residual bit error ratio of  $5 \times 10^{-3}$  would be specified as '5E3' (e.g. AT+CGEQMIN=..., "5E3", ...).

<Delivery of erroneous SDUs>

a numeric parameter that indicates whether SDUs detected as erroneous shall be delivered or not.

- 0 no
- 1 yes
- 2 no detect

Other values are reserved.

<Transfer delay>

a numeric parameter (0,1,2,...) that indicates the targeted time between request to transfer an SDU at one SAP to its delivery at the other SAP, in milliseconds.

<Traffic handling priority>

a numeric parameter (1,2,3,...) that specifies the relative importance for handling of all SDUs belonging to the UMTS bearer compared to the SDUs of other bearers.

<PDP\_type>

(see +CGDCONT and +CGDSCONT commands). If a value is omitted for a particular class then the value is considered to be unspecified.

Supported Values:

<cid> (1-11)	<Maximum SDU size> (1-1520)
<Traffic class> (0-3)	<SDU error ratio> ("1E6"-"1E1").
<Maximum bitrate UL> (1-8640)	<Residual bit error ratio> ("6E8"-"5E2")
<Maximum bitrate DL> (1-8640)	<Delivery of erroneous SDUs> (0,1,2)
<Guaranteed bitrate UL> (1-8640)	<Transfer delay> (1-4000)
<Guaranteed bitrate DL> (1-8640)	<Traffic handling priority> (1-3)
<Delivery order> (0,1)	<PDP_type> "IP"

### Appendix D.3.6 PDP Context Activation

PDP context activate or deactivate. Ref : [3GPP\_TS27]

Command	Possible response(s)
+CGACT=[<state> [,<cid>[, <cid>[, .]]]]	OK ERROR
+CGACT?	+CGACT: <cid>, <state> [<CR><LF>+CGACT: <cid>,<state>[...]]
+CGACT=?	+CGACT: (list of supported <state>s)

Defined Values:

<state>

indicates the state of PDP context activation

0 deactivated

1 activated

Other values are reserved and will result in an ERROR response to the execution command.

<cid>

a numeric parameter which specifies a particular PDP context definition (see the +CGDCONT and +CGDSCONT commands).

### Appendix D.3.7 Show PDP IP Address

Show PDP address. Ref : [3GPP\_TS27] section 10.1.14

Command	Possible response(s)
+CGPADDR=[<cid> [,<cid> [,...]]]	+CGPADDR: <cid>,<PDP_addr> [...]
+CGPADDR=?	+CGPADDR: (list of defined <cid>s)

Defined Values:

<cid>

a numeric parameter which specifies a particular PDP context definition

(see the +CGDCONT and +CGDSCONT commands). If no <cid> is specified, the addresses for all defined contexts are returned.

<PDP\_address>

a string that identifies the MT in the address space applicable to the PDP.

The address may be static or dynamic. For a static address, it will be the one set by the +CGDCONT and +CGDSCONT commands when the context was defined.

For a dynamic address it will be the one assigned during the last PDP context activation that used the context definition referred to by <cid>.

<PDP\_address> is omitted if none is available.

**Supported Values**

<cid>

(1-11)

<PDP\_address>

(0.0.0.0-255.255.255.255)

**Appendix D.3.8 Define Secondary PDP Context**

Define Secondary PDP Context. Ref : TS 27.007 - 460 section 10.1.2

Command	Possible response(s)
+CGDSCONT=[<cid> ,<p_cid> [, <d_comp> [,<h_comp>]]]	OK ERROR
+CGDSCONT?	+CGDSCONT: <cid>, <p_cid>, <data_comp>, <head_comp>
+CGDSCONT=?	+CGDSCONT: (range of supported <cid>s), (list of <cid>s for active primary contexts), <PDP_type>,,, (list of supported <d_comp>s), (list of supported <h_comp>s)

**Defined Values:**

<cid>

(PDP Context Identifier) a numeric parameter which specifies a particular PDP context definition. The parameter is local to the TE-MT interface and is used in other PDP context-related commands. The range of permitted values (minimum value = 1) is returned by the test form of the command.

<p\_cid>

(Primary PDP Context Identifier) a numeric parameter which specifies a particular PDP context definition which has been specified by use of the +CGDCONT command. The parameter is local to the TE-MT interface. The list of permitted values is returned by the test form of the command.

<PDP\_type>

(Packet Data Protocol type) a string parameter which specifies the type of packet data protocol

IP Internet Protocol (IETF STD 5)

IPV6<sup>21</sup> Internet Protocol, version 6 (IETF RFC 2460)

PPP Point to Point Protocol (IETF STD 51)

<d\_comp>

a numeric parameter that controls PDP data compression (applicable to GPRS only)

0 off (default if value is omitted)

1 on

Other values are reserved.

<h\_comp>

a numeric parameter that controls PDP header compression

0 off (default if value is omitted)

1 on

Other values are reserved.

NOTE. At present only one data compression algorithm (V.42bis) is provided in SMDCP. If and when other algorithms become available, a command will be provided to select one or more of these.  
(GPRS only)

Supported Values:

<cid>

(1-11)

<d\_comp>

0 off (default if value is omitted)

<p\_cid>

(1-11)

<h\_comp>

0 off (default if value is omitted)

<PDP\_type>

1 on

PPP Point to Point Protocol (IETF STD 51)

---

<sup>21</sup> IPv6 is not supported by the Inmarsat network.



### Appendix D.3.9 Define Traffic Flow Template

Define Traffic Flow Template. Ref : [3GPP\_TS27]

**NOTE:** source and destination fields are from the networks perspective.

Command	Possible response(s)
+CGTFT=[<cid>, [<packet filter identifier>, <evaluation precedence index> [,<source address and subnet mask> [,<protocol number (ipv4) / next header (ipv6)> [,<destination port range> [,<source port range> [,<ipsec security parameter index (spi)> [,<type of service (tos) (ipv4) and mask / traffic class (ipv6) and mask> [,<flow label (ipv6)> ]]]]]]]]]]	OK ERROR
+CGTFT?	+CGTFT: <cid>, <packet filter identifier>, <evaluation precedence index>, <source address and subnet mask>, <protocol number (ipv4) / next header (ipv6)>, <destination port range>, <source port range>, <ipsec security parameter index (spi)>, <type of service (tos) (ipv4) and mask / traffic class (ipv6) and mask>, <flow label (ipv6)>
+CGTFT=?	+CGTFT: <PDP_type>, (list of supported <packet filter identifier>s), (list of supported <evaluation precedence index>s), (list of supported <source address and subnet mask>s), (list of supported <protocol number (ipv4) / next header (ipv6)>s), (list of supported <destination port range>s), (list of supported <source port range>s), (list of supported <ipsec security parameter index (spi)>s), (list of supported <type of service (tos) (ipv4) and mask / traffic class (ipv6) and mask>s), (list of supported <flow label (ipv6)>s)

Defined Values:

<cid>: a numeric parameter which specifies a particular PDP context definition (see the +CGDCONT and +CGDSCONT commands).

<packet filter identifier>: Numeric parameter, value range from 1 to 8.

<source address and subnet mask>: Consists of dot-separated numeric (0-255) parameters on the form 'a1.a2.a3.a4.m1.m2.m3.m4', for IPv4 and 'a1.a2.a3.a4.a5.a6.a7.a8.a9.a10.a11.a12.a13.a14.a15.a16.m1.m2.m3.m4.m5.m6.m7.m8.m9.m10.m11.m12.m13.m14.m15.m16', for IPv6<sup>22</sup>.

<protocol number (ipv4) / next header (ipv6)<sup>22</sup>>: Numeric parameter, value range from 0 to 255.

Refer to the Assigned Internet Protocol Number as defined by the Internet Assigned Numbers Authority (IANA). <http://www.iana.org/assignments/protocol-numbers/protocol-numbers.xhtml>

<destination port range>: Consists of dot-separated numeric (0-65535) parameters on the form 'f.t'.

<source port range>: Consists of dot-separated numeric (0-65535) parameters on the form 'f.t'.

<ipsec security parameter index (spi)>: Hexadecimal parameter, value range from 00000000 to FFFFFFFF.

<type of service (tos) (ipv4) and mask / traffic class (ipv6)<sup>22</sup> and mask>:

Dot-separated numeric (0-255) parameters on the form 't.m'.

<flow label (ipv6)>: Hexadecimal parameter, value range from 00000 to FFFFF. Valid for IPv6 only.

<evaluation precedence index>: Numeric parameter, value range from 0 to 255.

In addition to the Packet Filter and Evaluation Precedence Index, each TFT must contain at least one of the following parameters. Some parameters are mutually exclusive; the table below shows which parameters can be used together.

---

<sup>22</sup> IPv6 is not supported by the Inmarsat network.

For example, if you want to define a "Source address and subnet mask", and an "IPSec SPI", the only combination that allows the use of these two parameters together is combination 2.

Combination 2 also gives you the option to define "Protocol number" and "Type of service", if required, but no other parameter is available in this combination.

**Table 10-4: TFT Parameter Combinations**

Parameter	Combination 1	Combination 2	Combination 3
Destination/Source address and subnet mask	✓	✓	✓
Protocol number	✓	✓	
Destination port range	✓		
Source port range	✓		
IPSec SPI		✓	
Type of service	✓	✓	✓
Flow level			✓

### Appendix D.3.10 Modify PDP Context

PDP Context Modify. Ref : [3GPP\_TS27]

Command	Possible response(s)
+CGCMOD=[<cid>[,<cid>[,...]]]	OK ERROR
+CGCMOD=?	+CGCMOD: (list of <cid>s associated with active contexts)

Defined Values:

<cid>

a numeric parameter which specifies a particular PDP context definition (see the +CGDCONT and +CGDSCONT commands).

Supported Values:

<cid>

(1-11)

### **Appendix D.3.11 Binding a TCP Session to a Primary PDP Context**

The AT command for binding between a TCP Session and one or more PPPoE Sessions is "\_IPDPS."

- "\_I" means it is part of the Inmarsat BGAN AT command extension.
- "PDPS" means Primary PDP Context Select.

The purpose of this select command is to select a particular PPPoE Session from one or more PPPoE Sessions established with the Server.

This AT command/response shall be used over a TCP session; it shall not be available via PPPoE.

<b>Command</b>	<b>Possible response(s)</b>
_IPDPS=<IP_addr> _IPDPS=PPPoE_Session_ID	OK ERROR
_IPDPS?	_IPDPS: <PPPoE_Session_ID>,<IP_addr>
_IPDPS=?	ERROR

The set command can select the primary PDP using either:

- The PPPoE Session ID.
- The IPv4 address obtained by the PPPoE client in the IPCP phase of the PPP set up.

All subsequent PDP Context related AT commands from the TCP Session are applicable to the specified PPPoE Session.

AT commands that are unrelated to PDP Context are not affected by the set command.

Returns ERROR if the primary PDP does not exist.

If the primary PDP is already in use, the previous owner of the primary PDP is notified of the loss of ownership through at spontaneous \_IPDPS:0,0.0.0.0 message.

The same \_IPDPS:0,0.0.0.0 is also used when the call is torn down (as it is not possible to send further commands to a call which no longer exists).

The read command returns the currently selected primary PDP by the TCP Session that sends the read command. If no PPPoE Session selected, 0, 0.0.0.0 is returned.

#### Defined Values

<PDP\_addr>: a string parameter that identifies the PPPoE by the address of the Primary PDP Context.

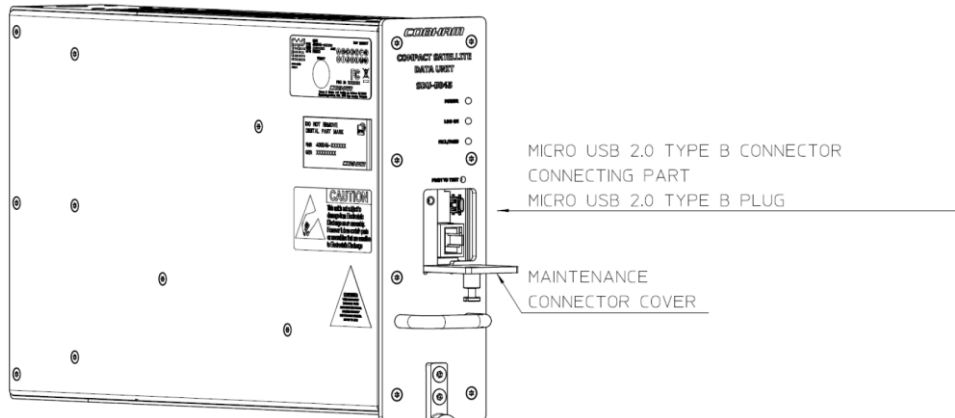
Two values are possible, the PPPoE session ID or the IP address associated with that primary PDP. The two are recognized by their format. The PPPoE session ID is a simple number, while the IP address is an IPv4 address in the form aaa.bbb.ccc.ddd.

## Appendix E. Log File Extraction

This section describes how to collect System, Security logs and Diagnostic reports from the AVIATOR S CSDU. The system and security logs are collected in system and security log files that are captured per concluded flight leg; one per Air and Ground segment. A snapshot of the troubleshooting data is captured per System Emergency Event in a diagnostic report.

### Appendix E.1. Prerequisites

1. To collect the log files connect a PC to the USB connector under the lid on the front of the AVIATOR S CSDU using an USB connection cable type A."



**Figure 10-1: USB connector under the maintenance connector cover**

**NOTE:** Due to the gap between USB connector and front face cut out, MAKE SURE that USB Cable is well connected to CSDU Front USB.

In normal operation, no log retrieval is needed. Airframe manufacturer will request log extraction (system logs, security logs and diagnostic reports) to the airline in case of issues.

2. Use a standard laptop PC with Microsoft Windows and a serial terminal program such as Microsoft HyperTerm, TeraTerm or similar to extract the log files. It might be necessary to install UART drivers.
3. To find a UART driver refer to: [WWW.FTDIchip.com](http://WWW.FTDIchip.com).
4. Select a VCP driver for your operating system.
5. You can configure TeraTerm in the TeraTerm.ini to auto receive via Zmodem

```
; ZMODEM auto receive
ZmodemAuto=on
; ZMODEM parameters for sending
ZmodemDataLen=1024
ZmodemWinSize=32767
; Escape all control characters in ZMODEM
ZmodemEscCtl=off
; ZMODEM log
ZmodemLog=off
; ZMODEM receive command
ZmodemRcvCommand=rz
; ZMODEM Timeout value (v1,v2,v3,v4) by seconds
; v1=Timeout value for serial port
; v2=Timeout value for TCP/IP port
; v3=Timeout value for initial packet
; v4=Timeout value for final packet
ZmodemTimeouts=10,0,10,3
PrnConvFF=off
```

Log files are extracted from each of the two (AVIATOR 200S) or three (AVIATOR 700S) domain processors (ACD, AISD, PIESD) located in the CSDU.

6. When the PC is connected to the CSDU USB port, four new serial ports will appear.
7. Connect an instance of the terminal program to each of the serial ports using 115.200 baud, 8 databits, 1 stopbit, no parity.
8. Press `enter` to display a command prompt.

The following commands are supported on each command prompt:

- `<help>` : Shows available commands.
- `<{log} -h>` : Shows available commands for {log} in {system, security, diagnostic}.
- `<{log} -d>` : `dir`: lists all files available for {log} in {system, security, diagnostic}.
- `<{log} -p [name]>` : prints file with [name] for {log} in {system, security, diagnostic}.
- `<{log} -x dir.txt>` : Extracts the file list in a file with the name `dir.txt` for {log} in {system, security, diagnostic} by starting a file transfer using Z-Modem protocol.

**NOTE:** The size of the `dir.txt` files can be large, approx. 100-200 kB for a CSDU with full log system.

System and security log files are not compressed.

Only completed log files can be extracted. Current System and Security Log files cannot be extracted.

## Appendix E.2. Procedure to extract the log files via USB

Follow the steps below:

1. Make sure that the CSDU is in Normal Operating Mode (on wing).
2. Plug in the USB cable (connected to a PC) at the front of the CSDU.
3. Using the terminal program on your PC, open a command shell to ACD, AISD and PIESD.
4. Press `enter` in all 3 shells.
5. Check that the prompt "`CSDU MAINTENANCE: /$`" is displayed.
6. Type "`help`" in the ACD shell.
7. Check that only these commands are listed: `diagnostic`, `security`, `system`, `help`, `debug`, `loggen` and `reboot`.
8. Type "`help`" in the AISD shell.
9. Check that only these commands are listed: `diagnostic`, `security`, `system`, `securityMirror`, `help`, `debug`, `loggen` and `reboot`

**NOTE:** Connecting USB cable while on ground triggers the CSDU to enter Maintenance mode.

### Appendix E.2.1 Find system log entries on the LRU unit

Use "system -d 6" command to displays the last 6 system log files.

```
CSDU MAINTENANCE:/$ system -d 6
ACD_sys_log_19700101_0004_1319_OY-3TC_ground.txt
ACD_sys_log_19700101_0003_1319_OY-3TC_ground.txt
ACD_sys_log_20200131_0801_OY-3TC_ground.txt
ACD_sys_log_20200131_0801_OY-3TC_air.txt
ACD_sys_log_19700101_0000_1316_NA_ground.txt
ACD_sys_log_19700101_0000_1314_NA_air.txt
CSDU MAINTENANCE:/$ system -x
```

Figure 10-2: Find System log entries on the LRU unit - Maintenance phase

### Appendix E.2.2 Select file and export

Select a file (highlight the file name) and use the command "system -x " and add filename (paste in).  
(with TeraTerm configured to auto receive and save into default directory).

```
ACD_sys_log_19700101_0003_1320_OY-3TC_ground.txt
CSDU MAINTENANCE:/$ system -x ACD_sys_log_19700101_0003_1320_OY-3TC_ground.txt
[ZMODEM] Waiting to send file ...
**
[ZMODEM] File was transferred successfully
Press <ENTER> key to return to shell ...
CSDU MAINTENANCE:/$
```

Figure 10-3: Select file and export - Maintenance phase

**NOTE:** If TeraTerm has not been configured for auto z-modem reception, user has to select Transfer/Zmodem/Receive.

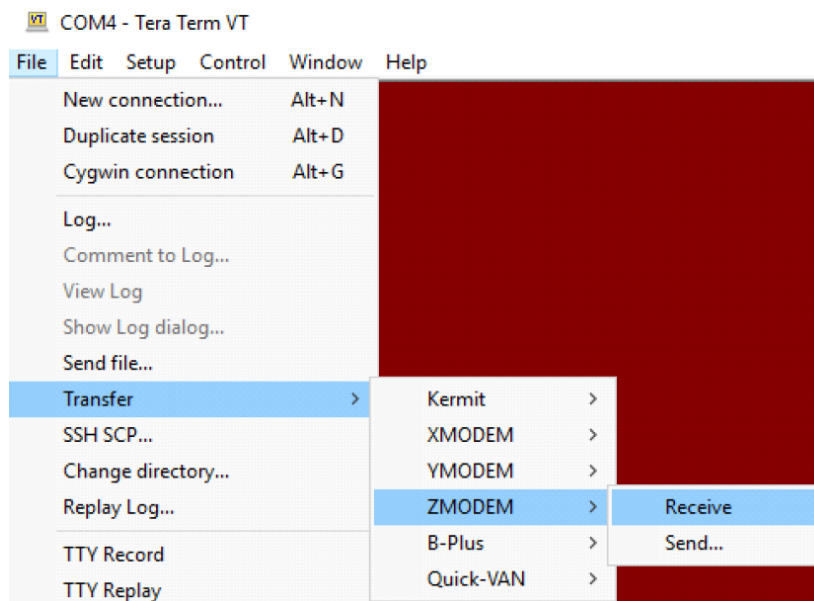


Figure 10-4: Reception via z-modem - manual receive



## Appendix E.3. Further Examples in Maintenance Phase

The same commands are used for system log, security log and diagnostic log/report.

### Appendix E.3.1 List of commands available

```
CSDU MAINTENANCE:/$ system
System log command
help          : Show help
status       : Show current status
-c           : Close the active file
-d           : List files in log
-l [text]    : Write to current log file
-m           : Toggle mirroring of log
-n [file_name] : Close and create a new file named [file_name] or auto generated name if empty.
-o           : Toggle printing output from log
-p [file_name] : Print log file [file_name] or current open if empty.
-s [file cn]  : Show last [cn] files.
-t [number]  : Change rate limit to [number] blocks of 4k size (0 i no limit). Empty is reset
-u [number]  : Resize NVM area to [number] blocks of 4k size. Empty is reset
-v [number]  : Change file size to [number] blocks of 4k size (0 i no limit). Empty is reset
-x [file_name] : Export log file on USB port using ZMODEM protocol
-y [i1] [i2] : List blocks [i1..i2] in Log
-z [index]   : Delete blocks [0..index] in Log

CSDU MAINTENANCE:/$ diagnostic
Diagnostic Report command
help          : Show help
status       : Show current status
-d           : List files in log
-k           : Toggle Diagnostic Report Always allow flag
-p [file_name] : Print log file [file_name] or current open if empty.
-s [file cn]  : Show last [cn] files.
-x [file_name] : Export log file on USB port using ZMODEM protocol
-y [i1] [i2] : List blocks [i1..i2] in Log
-z [index]   : Delete blocks [0..index] in Log
```

**Figure 10-5: List of commands available - Maintenance phase**

System log and Maintenance phase have the same command set.

### Appendix E.3.2 Make new log file

Use the command "system -n filename" to save the current log in filename and start new logfile.

If file name is not provided in the entered command (e.g "system -n"), a new log file name will be auto generated.

```
CSDU MAINTENANCE:/$ system -d 5
ACD_sys_log_19700101_0003_1319_OY-3TC_ground.txt
ACD_sys_log_20200131_0801_OY-3TC_ground.txt
ACD_sys_log_20200131_0801_OY-3TC_air.txt
ACD_sys_log_19700101_0000_1316_NA_ground.txt
ACD_sys_log_19700101_0000_1314_NA_air.txt

CSDU MAINTENANCE:/$ system -n
CSDU MAINTENANCE:/$ system -d 6
ACD_sys_log_19700101_0004_1319_OY-3TC_ground.txt
ACD_sys_log_19700101_0003_1319_OY-3TC_ground.txt
ACD_sys_log_20200131_0801_OY-3TC_ground.txt
ACD_sys_log_20200131_0801_OY-3TC_air.txt
ACD_sys_log_19700101_0000_1316_NA_ground.txt
ACD_sys_log_19700101_0000_1314_NA_air.txt
```

**Figure 10-6: Make new log file - Maintenance phase**



### Appendix E.3.3 Add a text line in current log

Use command "system -l text" to add a comment in the current logfile.

```
CSDU MAINTENANCE:/$ system -l Screendump_test
Writing: Screendump_test
CSDU MAINTENANCE:/$ █
```

**Figure 10-7: Add a text line in current log - Maintenance phase**

The result is a new line in the log without log level <-> and with process ACD13, see example below:

```
<->1 1970-01-01T00:07:30.814Z - ACD 13 - - (55.793896,12.523556,39.014400)
Screendump_test
<4>1 1970-01-01T00:07:30.814Z CSDU ACD 13 1003 - (55.793896,12.523556,39.014400)
Log Entry was truncated: ID:0
```