

Date: July 31<sup>st</sup>, 2019

Prepared by: **GCME, Inc.**

TO: RS&H, Inc.  
3125 W Commercial Boulevard, Suite 130  
Fort Lauderdale, FL 33309

Attention: Mr. Paul Heeg, P.E.  
Senior Transportation Engineer

SUBJECT: **Geotechnical Services Report**  
PD&E Study – SW 10<sup>th</sup> Street / SR-869  
From Powerline Road to West of Military Trail  
Broward County, Florida  
FPID No.: 439891-1-22-02  
GCME Project No.: 2000-01-17003

---

Dear Mr. Heeg,

**GCME, Inc.** has completed the PD&E Geotechnical Report – Roadway Soil Survey and Bridge Structures in connection with the subject project. The scope of our services for this report included gathering existing information along the project corridor, and field exploration authorized in Optional Services (OPT) #4 dated January 22, 2018. The purpose of this report is to provide geotechnical information to the roadway and structural engineers for preparation of the PD&E study documents for the proposed improvements. The following report includes the methods of study and evaluations concerning geotechnical aspects of the proposed improvements.

The work was completed following our contract with your firm and followed the basic guidelines of the Florida Department of Transportation (FDOT) Soils and Foundations Handbook, 2017. This report is written using English units.

We are pleased to be of continued service to RS&H and the Florida Department of Transportation (FDOT). If you have any questions or comments regarding the contents of the following report, please call.

Very truly yours,

**GCME, INC.**

Zhiyun Pan, P.E.  
Project Engineer  
FL. Reg. No. 70634

ZP/PG: mg  
2000-01-17003\_PD&E\_GeoRpt



Partha Ghosh, P.E.  
Principal Engineer  
FL Reg. No. 51377

**TABLE OF CONTENTS**

<b><u>ITEM</u></b> .....	<b><u>PAGE NUMBER</u></b>
LETTER OF TRANSMITTAL .....	1
TABLE OF CONTENTS.....	2
1.0 INTRODUCTION.....	4
2.0 USDA, SCS SOIL SURVEY.....	4
3.0 EXISTING SOIL BORING INFORMATION.....	4
4.0 FIELD INVESTIGATION.....	5
4.1 Bridge Structures .....	5
4.2 Roadway.....	6
5.0 SUBSURFACE CONDITIONS .....	6
5.1 Stratigraphy – Bridge Structures.....	6
5.2 Stratigraphy - Roadway .....	6
5.3 Groundwater .....	8
5.4 Laboratory Test Results .....	8
5.5 BHP Test.....	9
5.6 DRIT Test .....	9
6.0 BRIDGE STRUCTURE FOUNDATION ALTERNATIVES.....	9
6.1. Foundation Alternatives for Bridge Structures .....	9
7.0 BRIDGE STRUCTURE FOUNDATION EVALUATIONS .....	11
7.1 Precast Concrete Driven Piles.....	11
7.1.1 Axial Capacity of Precast Concrete Piles .....	11
7.1.2 Construction Considerations.....	11
7.2 Drilled Shafts .....	12
7.2.1 Axial Capacity of Drilled Shaft Foundations.....	12
7.2.2 Construction Considerations –Drilled Shafts.....	12
7.3 Soil Parameters for FB-Pier Analysis .....	13
7.4 Soil Parameters for Sheet Pile Wall Analysis.....	13
8.0 ROADWAY EMBANKMENT PRELIMINARY EVALUATION .....	13
9.0 LIMITATIONS OF STUDY.....	15
SITE VICINITY MAP .....	PLATE 1
APPROXIMATE BORING LOCATION PLAN .....	PLATES 2 THRU 5
REPORT OF CORE BORINGS -BRIDGE STRUCTURES.....	FIGURES 1 THRU 3

**TABLE OF CONTENTS (cont'd)**

<b><u>ITEM</u></b> .....	<b><u>PAGE NUMBER</u></b>
CROSS SECTION SOIL SURVEY FOR THE DESIGN OF ROADS.....	FIGURE RSS-1
ROADWAY SOIL PROFILES .....	FIGURES R-1 & R-2
SUMMARY OF LABORATORY TEST RESULTS.....	TABLE - 1
SUMMARY OF CORROSION TEST RESULTS .....	TABLE - 2
BHP TEST RESULTS .....	TABLE - 3
DRIT TEST RESULTS.....	TABLE - 4
USDA, SCS SOIL INFORMATION.....	APPENDIX - A
EXISTING INFORMATION.....	APPENDIX - B
GROUNDWATER INFORMATION .....	APPENDIX – C
VERTICAL CAPACITY ANALYSIS OF PRECAST CONCRETE DRIVEN PILES [FB-Deep OUTPUTS].....	APPENDIX - D
GRAPHS - VERTICAL CAPACITY ANALYSIS OF PRECAST CONCRETE DRIVEN PILES.....	APPENDIX - E
VERTICAL CAPACITY ANALYSIS OF DRILLED SHAFTS [FB-Deep OUTPUTS].....	APPENDIX - F
GRAPHS - VERTICAL CAPACITY ANALYSIS OF DRILLED SHAFTS .....	APPENDIX - G
FB-PIER SOIL PARAMETERS .....	APPENDIX – H
SHEET PILE WALL SOIL PARAMETERS.....	APPENDIX - I

## **1.0 INTRODUCTION**

This entire project corridor runs along SR-869 / SW 10<sup>th</sup> Street from west of Powerline Road to west of Military Trail, in Broward County, Florida, a distance of about 2.0 miles. The project includes widening SW 10<sup>th</sup> Street and new bridge alternatives. All improvements will be within the existing right of way.

The entire project site is located in Broward County on SR-869 / SW 10<sup>th</sup> Street between Powerline Road and Military Trail. Land in the project vicinity is urban. Terrain in the area is relatively flat.

The purpose of this study was to explore the subsurface conditions, groundwater information and drainage information within the general vicinity of the proposed roadway and bridge structures in order to catalog the general subsurface stratigraphy and provide geotechnical recommendations to guide the design and construction of the proposed roadway and bridge structures. Based on available information and field exploration performed, we have prepared an engineering report summarizing our field and laboratory testing, the subsurface soil and groundwater conditions encountered and evaluation and preliminary design recommendations for roadway and bridge foundation design and construction.

The Site Vicinity Map, Plate 1, presents the project limits.

## **2.0 USDA, SCS SOIL SURVEY**

Research of the U.S. Department of Agriculture (USDA), Soil Conservation Service (SCS) Soil Survey of the Broward County area indicates the presence of different soil map units along the roadway sections. The soil map units present along the project corridor are described in details in Appendix – A.

The soil map units present along the project corridor are as follows:

- Immokalee fine sand, 0 to 2 percent slopes
- Margate fine sand, occasionally ponded, 0 to 1 percent slopes
- Pomello fine sand, 0 to 2 percent slopes
- Pompano fine sand, 0 to 2 percent slopes
- Udorthents

Based on the SCS Map, no unsuitable soils are found in this area.

A segment of the USDA Soils Map showing the proposed roadway section and the surrounding areas is presented in Appendix – A.

## **3.0 EXISTING SOIL BORING INFORMATION**

Based on the existing geotechnical information received from your office, we have separated the available information proximate to the proposed project corridor into four (4) segments as follows:

- Segment-1: Roadway soil survey from east of Powerline Road to West of Military Trail.
- Segment-2: SPT soil borings at the intersection of SW 10<sup>th</sup> Street and Waterway Boulevard.
- Segment-3: SPT soil boring along SW 10<sup>th</sup> Street from SW 28<sup>th</sup> Avenue to SW 24<sup>th</sup> Avenue.
- Segment-4: SPT soil borings at the intersection of SW 10<sup>th</sup> Street and Powerline Road.

The existing soil boring information applicable to each Segment are presented in Appendix – B.

Based on existing information and our present experience along the corridor, we understand that the project corridor is chiefly underlain by mineral soils (i.e., sandy soils and limestone). Organic soils were encountered at some isolated locations. We anticipate that the proposed improvements will not encounter major organic/unsuitable subsoil deposits. However, organic/unsuitable subsoils will require some special considerations during the design phase. We understand that the subsoils have moderate to high capacity to transmit water. Bridge structures within the corridor could be replaced or widened using prestressed concrete pile (PSC) foundations, as detailed in later sections of this report.

#### **4.0 FIELD INVESTIGATION**

##### **4.1 Bridge Structures**

The scope of services authorized consisted of drilling six (6) Standard Penetration Test (SPT) borings widely spaced on land for the proposed bridge locations. The borings were generally located at strategic locations along the project corridor. The bridge borings were extended to 100 feet below existing grade.

- SR-869/SW 10<sup>th</sup> Street: Six (6) Bridge Structure Borings, numbered B-101 through B-601.

The locations of the bridge borings B-101 through B-601 are presented in Plate – 2 through Plate – 5 of the plates titled ‘Approximate Boring Location Plan’. For this report, the boring location plans are presented on Google Earth maps for your review. The station and offset information at the boring locations were not available at the time of writing this report. The elevation information are provided by the project surveyor.

The subsurface geologic profiles encountered at the boring location along with the SPT results, are presented in Figure 1 through 3 for bridge borings. The soil profiles are drawn with reference to elevation.

The SPT boring was advanced using mud rotary procedures. The boring was drilled to depth of 100 feet below grade. Samples of the in-place materials were recovered with a standard split barrel advanced with a 140-pound hammer falling 30 inches (the SPT after ASTM D 1586). Soil samples were field classified, placed in sealed containers and transported to our laboratory for further analysis by a soils engineer. Classification of the subsoils found in the borings followed the Unified Soil Classification System (ASTM D 2487). The borehole was filled with cement grout at the completion of the drilling activities.

## **4.2 Roadway**

To evaluate the subsurface condition along the proposed roadway alignment, roadway borings were performed along or proximate to the proposed roadway alignment. Subsoil along the proposed roadway alignments was explored by drilling roadway profile borings to nominal depths of 15 feet below the existing ground surface as per negotiated scope of work.

The following scope of services were authorized for the roadway and drainage. The numbering schedule and locations of the borings drilled for the proposed roadway widening are as follows:

- SR-869/SW 10<sup>th</sup> Street: Ten (10) Borings, numbered RD-1 through RD-10;  
Two (2) BHP Tests, numbered BHP-1 & BHP-2;  
Two (2) DRIT Tests, numbered DRIT-1 & DRIT-2

Boring location plans showing the approximate location of the borings drilled for the project roadway corridor are presented on the plates titled “Approximate Boring Location Plan”, Plates 2 through 5. For this report, the boring location plans are presented on google earth maps for your review. The station and offset information at the boring locations were not available at the time of writing this report. The elevation information are provided by the project surveyor.

The above subsurface description is of a generalized nature provided to highlight the major soil strata encountered. The records of subsurface exploration included in the boring logs should be reviewed for specific information as to individual boring locations. The stratifications shown on the records of subsurface exploration represent the conditions only at the actual boring location. The stratifications represent the proximate boundary between subsurface materials and the transition may be gradual.

## **5.0 SUBSURFACE CONDITIONS**

### **5.1 Stratigraphy – Bridge Structures**

The bridge borings drilled along the project alignment generally indicated the site to be underlain with interlayering of sands, silty sands and limestone. The SPT results (N-value) for the borings drilled along the SW 10<sup>th</sup> Street indicate that the subsoils are generally loose followed by medium dense to very dense soils.

Details regarding the interlayering of the subsoil layers are shown on the soil profile sheets titled “Report of Core Borings”, are presented in Figure 1 through 3.

### **5.2 Stratigraphy – Roadway**

Soils and soil profiles found in borings drilled for the roadway alignment study generally consisted of seven (7) general types:

Stratum 1: Light brown to brown sand with trace roots and trace limerock fragments (Topsoil; A-8).

Stratum 2: Light brown to brown sand with silt, with trace to little limerock fragments (A-3).

Stratum 2A: Light brown to brown sand and some limestone fragments, with silt to silty (A-1-b).

Stratum 2B: Dark brown sand with silt, with trace organic (A-3).

Stratum 3: Light brown sandy to silty limestone.

Stratum 4: Light brown to brown silty sand with little to some limerock fragments (A-2-4).

Stratum 5: Dark brown to black sand with silt, with few organic (A-8).

Based on the widely spaced roadway borings, the majority of the project corridor is underlain with interlayering of Strata 1, 2, 2A and 3. However, Stratum 4 soils were found at numerous boring locations at various depths along the project corridor. Stratum 2B soils were found at only one boring locations at 4 feet below grade. Stratum 5 soils were found at only two boring locations between 4 and 6 feet depth interval.

Stratum 1 is topsoil and shall be removed during clearing and grubbing in accordance with section 110 of the FDOT Standard Specifications.

Stratum 2 consists of select material and is adequate for subgrade and embankment support, and should be utilized according to Standard Plans, Index 120-001.

Stratum 2A soils classified as A-1-b, consist of select material and is adequate for subgrade and embankment support, however these soils have high fine content ranging between 6 to 22 percent and are likely to retain some excess moisture and could be difficult to handle, place and compact compared to ordinary A-3 materials.

Stratum 2B soils are slightly organic stained and have organic contents ranging between 0.7 and 1.8 percent.

Stratum 3 consists of limestone. Specialized tools and equipment are necessary to excavate and/or penetrate the limestone layer.

Stratum 4 soils have fine content ranging between 12 to 23 percent. Stratum 4 soils classified as A-2-4, consist mainly of soils with high fines content and are likely to retain some excess moisture and could be difficult to handle, place and compact compared to ordinary A-3 materials. Hence, these soils may be used in the subgrade with extra caution, and proper supervision and quality control.

Stratum 5 soils are classified as A-8. However only two (2) sample is classified as A-8 with organic content 6.0 percent and are between 4 and 6 feet below existing grade. As per FDOT Standard Plans, Index 120-002, these soils need to be removed and replaced with select embankment fill. However, we believe that based on the project corridor proposed improvements, and the location, extent, depth, and organic content of these soils; removal and replacement of the organic soils with select fill materials (if feasible and applicable) will be determined during final design phase.

Figure RSS-1, Cross Section Soil Survey for the Design of Roads, describes the various strata that were found during the PD&E study, presents test results for each stratum and provides preliminary design recommendations.

The details of the subsoil existing along the project alignment can be gleaned from the soil profile sheets. Figures R-1 and R-2 show the soil profiles of borings drilled along SW 10<sup>th</sup> Street, which are plotted to depth. Groundwater levels and the dates they were recorded are shown adjacent to the borings.

### **5.3 Groundwater**

The depths of groundwater tables were measured at the locations of the structural and roadway borings drilled along the project corridor.

In the bridge structure and roadway borings, groundwater was encountered at the depth of 2.0 to 7.7 feet below existing ground surface, i.e., elevation +5.3 feet to +9.5 feet NAVD. Fluctuations of the groundwater should be anticipated. The groundwater table levels measured are shown on the “Report of Core Borings” sheets and “Roadway Soil Profiles” sheets, Figures 1 through 3, R-1 and R-2 adjacent to the boring logs.

Available Broward County Water Table Map shows that the Seasonal High Groundwater Table (SHGWT) elevations along the project corridor (from Powerline Road to Military Trail) varied from +8.5 feet to +6.5 feet NAVD. The details are presented in Appendix – C.

Based on review of the above mentioned information, we estimate the Seasonal High Groundwater Table (SHGWT) elevations along the project Corridor to be about +8.5 feet NAVD from Powerline Road (begin of project), gradually decreased to +6.5 feet to Military Trail (end of project).

Groundwater levels were reported in each of the borings. Based on our experience, water levels encountered in the test borings may not have sufficient time to achieve equilibrium prior to reading measurements. Therefore, groundwater levels encountered in the field during construction may be higher (or lower) than that indicated on the test boring logs. Fluctuation should be anticipated due to environmental variation and seasonal condition, such as the frequency and magnitude of rainfall patterns, as well as man-made influences, such as existing canals, swales, drainage ponds, and under drains. We recommend that the contractors determine the actual groundwater levels prior to the time of the construction to evaluate groundwater impact on their construction procedure.

### **5.4 Laboratory Test Results**

Index property tests such as moisture content, organic content and grain size distribution are being performed on representative samples from the bridge and roadway borings. All the available laboratory test results will be provided in Table – 1.

The corrosion parameters of pH, resistivity, sulfates and chlorides were measured for selected soil samples from the bridge and roadway borings and water sample from the canal. The test results were compared with FDOT criteria for corrosivity to enable the materials to be classified accordingly. Corrosion series tests results are also presented in Table – 2.



### **5.5 Borehole Permeability Test**

Two (2) Borehole Permeability Test (BHP) were performed using the usual open-hole, constant head methodology advocated by SFWMD. The boreholes were 10 feet deep and completed as an open well with gravel pack (6-20 silica sand). The well screen slot width was 0.020 inches. Water from the drill rig tank was then pumped into the open well, and the amount of water required to maintain a constant head in the pipe was recorded. The BHP results are also presented in Table – 3.

### **5.6 Double Ring Infiltration Test**

Double Ring Infiltration Tests (DRIT) were performed two (2) locations along the proposed roadway corridor. The tests were performed at the ground surface in general accordance with the procedures outlined in ASTM Standard Method D-3385. The infiltration test values were determined from the test results and are graphically presented in Table – 4.

## **6.0 BRIDGE STRUCTURE FOUNDATION ALTERNATIVES**

### **6.1 Foundation Alternatives for Bridge Structures**

The borings generally indicated that the project site was underlain by thick deposits of loose to dense granular soils. Foundation alternatives for the project considered the results of our preliminary field study and the location of the proposed bridge improvements. Based on our experience with similar projects, we initially considered the following foundation alternatives:

- i. Shallow Foundations
- ii. Precast Pre-stressed Concrete Piles
- iii. Steel Piles, Including Pipe and H Sections
- iv. Straight Sided Drilled Shafts

Each of these foundation alternatives will be discussed individually.

#### **i. Shallow Foundations**

Where appropriate, the use of shallow foundations is typically the most cost effective. With this foundation system, the structure loads are transmitted to the subsoil at a pressure suited for the properties of the soil. These properties are typically governed by the allowable soil pressure and the total and differential settlement criteria. The surficial soils throughout the project site will most likely require densification to achieve an adequate bearing resistance. This densification may require excavation with sheet piling, dewatering, and densification techniques which will impact the economy of this foundation system tremendously.

Maintenance of traffic impacts, prolonged construction timing and staging requirements for construction adjacent to existing traffic usually interfere with the efficiencies of this densification process. These impacts also apply between future and existing construction in areas where proposed or future widening of the facility is anticipated. Differential settlements with the existing deep foundation system are also expected to occur. Based on these difficulties and resultant high costs, shallow foundations will not be considered for these bridge structures.

ii. Precast Pre-stressed Concrete Piles

Pre-stressed concrete (PSC) piles are a feasible foundation alternative. They are a widely used and proven foundation system in South Florida. Precast pre-stressed piles are readily available and generally have a lower cost per ton of capacity than other pile types. Because of the dense subsoil conditions found at some of the boring locations, it is our opinion that driving of the piles to the recommended depths may be difficult, and induce high driving stresses which could potentially damage the piles. However, these concerns of driving through dense soils can be minimized through the use of pre-drilled pile holes or jetting to achieve the recommended penetration.

The minimum size for pre-stressed concrete piles should be 18 inches as referenced in the Structures Design Guidelines. A disadvantage of the precast pre-stressed concrete piles is the potential impact the driving operation may have on nearby structures.

iii. Steel Piles

Steel pile types include pipe piles and H-sections. Previous experience has shown that steel piles are generally more expensive per linear foot than precast pre-stressed concrete piles. Steel piles are well suited to conditions with high variability in anticipated penetration depths where frequent splicing is expected. In some instances, steel piles may be easier to penetrate dense layers if necessary to achieve a desired penetration depth. In general, the cost of steel pile is relatively higher than concrete pile for the same required design capacity. Steel H-sections are inappropriate for this project because of inferior capacities compared to pipe piles at similar costs. Steel piles although structurally viable, are susceptible to corrosion in aggressive environments. A disadvantage of the steel pipe piles is the potential impact the driving operation may have on existing nearby structures. Based on these difficulties and resultant high costs, steel piles will not be considered for these bridge structures.

iv. Drilled Shafts

Drilled cast-in place straight sided concrete shafts are a feasible foundation alternative. Drilled shafts have the advantage of being able to develop high axial and lateral capacities in a single unit. However, the quality control of drilled shaft installation requires more engineering judgement and precaution compared with driven piles to ensure that the specifications are complied. This type of foundation system may become a favorite alternative for sites where limestone or very dense bearing strata are present at a relatively shallow depth. Significant concrete volume overruns may also occur during construction as evidenced by loss of drilling fluid. As a result, the temporary casing method of installation should be used. Shafts could be drilled and socketed into the limestone stratum (if applicable).

## **7.0 BRIDGE STRUCTURE FOUNDATION EVALUATIONS**

### **7.1 Precast Concrete Driven Piles**

#### **7.1.1. Axial Capacity of Precast Concrete Piles**

We have considered 18-inch and 24-inch square, precast concrete piles of various lengths in order to provide a range of design compressive capacities. The capacities were estimated from a computer-generated analysis based on a method to predict Davisson vertical pile capacity versus depth in sand. Computer program “FB-Deep Version 2.05” developed by Florida Bridge Software Institute, University of Florida was utilized to perform the axial capacity analysis of the driven concrete piles. The analysis was done for each individual boring drilled at the project site. The capacities (program outputs) for 18-inch and 24-inch square piles with reference to pile tip elevations at the boring locations for the bridge site are presented in Appendix – D. The corresponding FB-Deep output graphs are presented in Appendix – E.

The preliminary vertical capacity analysis at the bridge location was completed with ground lines set approximately at the elevation of the boring locations, i.e., ground elevations for borings B-101 through B-601 drilled on land.

We recommend using a resistance factor ( $\Phi$ ) equal to 0.65 for Load Resistance Factor Design (LRFD) for driven precast piles assuming PDA monitoring will be used in the test pile program. Please note that the pile tip elevations mentioned in Appendix- C are based on ground elevations at the boring locations.

For portions of the piles within MSE wall volume (if applicable), we recommend that portion be wrapped with polyethylene sheeting, per FDOT Standard Specifications for Road and Bridge Construction, Section 459. We recommend that the piles in a group be driven such that the center-to-center spacing between adjacent piles is at least 3 times the butt width. We recommend that the ultimate capacity of a pile group be determined by summing the single pile capacities in that group.

#### **7.1.2 Construction Considerations**

We recommend the piles be installed according to the latest edition of Standard Specifications for Road and Bridge Construction. Precast, concrete pile foundations are common in South Florida and can be constructed by local contractors. However, we believe that the driven pile option should involve monitoring of test piles using the Pile Driving Analyzer, with associated wave equation studies. The test program would confirm design capacities, required penetration, and driving criteria.

Vibrations resulting from pile driving at the project location should be carefully monitored to limit the impact of ground motion on existing structures. A precondition survey is often prudent to evaluate existing conditions (if any) before pile driving operations. Also, during pile driving operation, vibration resulting from the operation and its impact on the existing structures (if any) should be monitored constantly in order to limit/avoid any impact of ground motion on the existing structures.

During driving operations, records should be kept for each pile that detail pertinent information such as the pile type, length, date driven and blows count per foot. The capacity of each pile should be reviewed based on its final tip elevation and driving record. We recommend that pile-driving operations be continuously monitored by experienced technical personnel working under the direct supervision of a professional geotechnical engineer.

Temporary and/or permanent sheet pile wall (if applicable) proposed during construction of bridge foundation should strictly adhere to the following guidelines.

Construction of ‘Temporary’ and/or ‘Permanent’ sheet pile walls less than three (3) times the size of the pile (i.e., 6 feet) measured from the near face of the pile should be notified to us prior to the test pile program and construction of the production pile. This is due to the fact that such sheet pile wall will interfere with the capacity of the proposed pile foundations and we need to evaluate the proposed impact during the test pile program and recommend driving criteria accordingly.

## **7.2 Drilled Shafts**

### **7.2.1. Axial Capacity of Drilled Shaft Foundations**

Drilled cast-in-place straight-sided concrete shafts are also a technically feasible foundation alternative for the project. Installation procedures for drilled shafts in cohesionless soils normally involve helical auger drilling in combination with bentonite slurry and sometimes steel casing for stabilization of borehole walls. Drilled shaft diameter 4 and 5 feet were considered for our analysis. Vertical (axial) capacity of drilled shafts is normally obtained through a combination of side shear and end bearing.

The ultimate vertical capacities were calculated by utilizing the computer program “FB-Deep, Version 2.05” developed by Florida Bridge Software Institute, University of Florida. The analysis was done using SPT N-values and subsoil information developed from each individual boring drilled at the proposed bridge site and with varying shaft lengths in order to provide a range of design compressive capacities.

The vertical shaft capacities for 48-inch and 60-inch diameter shafts are computed allowing 0.5 inch settlement (i.e. 1.0% for 48-inch diameter shafts and 0.8% for 60-inch diameter shafts). The vertical capacities reported equals to side friction plus end bearing. The FB-Deep program computer outputs showing vertical capacities considering 0.5 inch settlement and ultimate capacities (i.e., ultimate capacity = ultimate skin friction + fully mobilized ultimate end bearing) are presented in Appendix – F. The ultimate capacities for 48-inch and 60-inch diameter drilled shafts are graphically presented in Appendix – G. The drilled shaft length mentioned in our analysis results indicates shaft length embedded in the ground at the respective bridge boring location.

### **7.2.2 Construction Considerations- Drilled Shafts**

Review of the soil profiles from the borings drilled for this project indicates that the subsoils at the location of the bridge piers are generally underlain by loose to dense sands,

followed by layers of sand with cemented sand at greater depths. The subsoils would lend themselves to excavation utilizing conventional drilled shaft construction equipment. We anticipate sidewall caving during drilled shaft construction and, therefore, anticipate the use of a steel casing for stabilization purposes during construction. We anticipate that the casing may not be sealed into an impermeable stratum. The shaft hole should be drilled, the reinforcing steel cage set, and the foundation concrete poured by tremie and/or pump methods. The casing must then be pulled only after fresh concrete, free of soil cuttings, flows out the top of the casing. The shafts should be installed in accordance with the latest FDOT Specification 455.

### **7.3 Soil Parameters for FB-Pier Analysis**

In reference to the request from the structural engineers, we have considered 18-inch and 24-inch square, precast concrete piles and prepared the soil parameters required for FB-Pier analysis. The parameters are presented in Appendix – H.

### **7.4 Soil Parameters for Sheet Pile Wall Analysis**

In reference to the request from the structural engineers, we have prepared the soil parameters required for Sheet Pile Wall analysis at the locations of the bridge borings. The parameters are presented in Appendix – I.

## **8.0 ROADWAY EMBANKMENT EVALUATION**

The findings of field and laboratory analytical data for this study indicate that the roadway alignment is generally suitable for the planned construction when viewed from a geotechnical engineering perspective. Based on the widely spaced borings drilled for the PD&E Study, the subsurface conditions of the roadway alignment are not expected to impose any significant constraints or limitations on the design or construction of the planned project from a soil mechanics, foundation engineering or engineering geology standpoint. The position of the groundwater table must also be generally considered during final design phase and construction.

The existing soils along the majority of the project alignments should have modest subgrade strength for pavement support. Subgrade preparation in these areas should consist of normal clearing, stripping, and compacting.

The majority of the project corridor is underlain with interlayering of Strata 1, 2, 2A, 3 and 4. Strata 2B and 5 soils were only encountered in some isolated borings.

Stratum 2 consists of select materials and are adequate for subgrade and embankment support. However, portions may have slightly fine content and are likely to retain some excess moisture and could be difficult to handle, place and compact compared to ordinary A-3 materials.

Stratum 2A consists of select materials and are adequate for subgrade and embankment support. These soils (Stratum 2A) due to high fines content (with average fines content at 12.6 percent) are likely to retain excess moisture and could be difficult to handle, place and compact. These soils may be used in the roadway subgrade with extra caution, and proper supervision and quality

control as applicable for Stratum 4 soils.

Stratum 2B consists of trace organic and is classified as A-3 materials. These soils are found at only one (1) isolated location at varied depths below grade with organic content varied from 0.7% to 1.8%. These soils may not be permitted to be used in the subgrade portion of the roadbed.

Stratum 4 soils are silty soils with average fines content at 17.1 percent. These soils (Stratum 4) due to high fines content are likely to retain excess moisture and could be difficult to handle, place and compact. These soils may be used in the roadway subgrade with extra caution, and proper supervision and quality control. However, the District Materials Engineer (along with the CEI team) has the authority to approve or disapprove the use of these soils based on existing site conditions during construction and efficiency of the contractor's means and methods for handling these soils.

Stratum 5 consists of organic soils classified as A-8 materials. These soils are found at only two (2) isolated location between 4 and 6 feet below grade with organic content 6.0%. As per FDOT Standard Plans, Index 120-002, these soils need to be removed and replaced with select embankment fill. However, we believe that based on the project corridor proposed improvements, and the location, extent, depth, and organic content of these soils; removal and replacement of the organic soils with select fill materials (if feasible and applicable) will be determined during final design phase.

Figure RSS-1, Cross Section Soil Survey for the Design of Roads, describes the various strata that were found during the PD&E study, presents test results for each stratum and provides preliminary design recommendations applicable for PD&E Study phase. We understand detailed roadway soil survey with closely spaced borings will be performed during the final design phase, and final recommendation will be provided.

Embankment fill will be required for construction of the new roadway shoulder. Subgrade preparation should consist of the stripping of existing vegetation, roots, tree stumps, and grubbing/raking the areas to thoroughly remove organic matter. New embankment fill should meet the gradation requirements of the FDOT Standard Plans, Index 120-001 "Embankment Utilization". Embankment construction for the proposed roadway should follow applicable latest edition of FDOT Standard Specifications for Road and Bridge Construction.

We expect some ground settlement at the base of raised and/or widened portions of the existing fills, and for new fills, as an elastic response as the sand strata deform under the increase in embankment weight. The largest deformations should occur within the shallow subsoils, particularly those that are relatively loose. We believe the settlement will be concurrent with embankment fill construction for the subsoils and new fill which are granular in nature.

## **9.0 LIMITATIONS OF STUDY**

The geotechnical engineer warrants that the findings, recommendations, specifications, or professional advice contained herein have been presented after being prepared following generally accepted professional engineering practice in the fields of foundation engineering, soil mechanics and engineering geology. This company is not responsible for the conclusion, opinion, or recommendations made by others based on this data. No other warranties are expressed or implied.

The scope of the investigation was intended to evaluate soil conditions within the influence of foundations and does not include an evaluation of potential deep soil problems such as sinkholes. The analysis and recommendations submitted in this report are based upon the data obtained from the soil borings performed at the locations indicated. If any subsoil variations become evident during the course of this project, a re-evaluation of the recommendations contained in this report will be necessary after we have had an opportunity to observe the characteristics of the conditions encountered. This report is prepared for the PD&E Study of the project corridor, and hence final alignment of the proposed roadway, design details and additional design consideration are not available at this phase of the project. We understand that during the final design phase, based on final proposed alignment of the project corridor, additional roadway borings should be drilled at close intervals (spacing) and laboratory tests performed in order to evaluate the suitability of the existing subsoils and delineate the horizontal and vertical extents of the unsuitable soils. Also during the final design phase, additional bridge borings will be required based on final alignment of the bridge widenings/replacements and final analysis and design of bridge foundations has to be performed. The applicability of the report should also be reviewed in the event significant changes occur in the design, nature, or location of the proposed roadway and structures.

The scope of our services does not include any environmental assessment or investigation for the presence or absence of hazardous or toxic materials in the soil, groundwater, or surface water within or beyond the site studied. Any statements in the report regarding odors, staining of soils, or other unusual conditions observed are strictly for the information of our client.

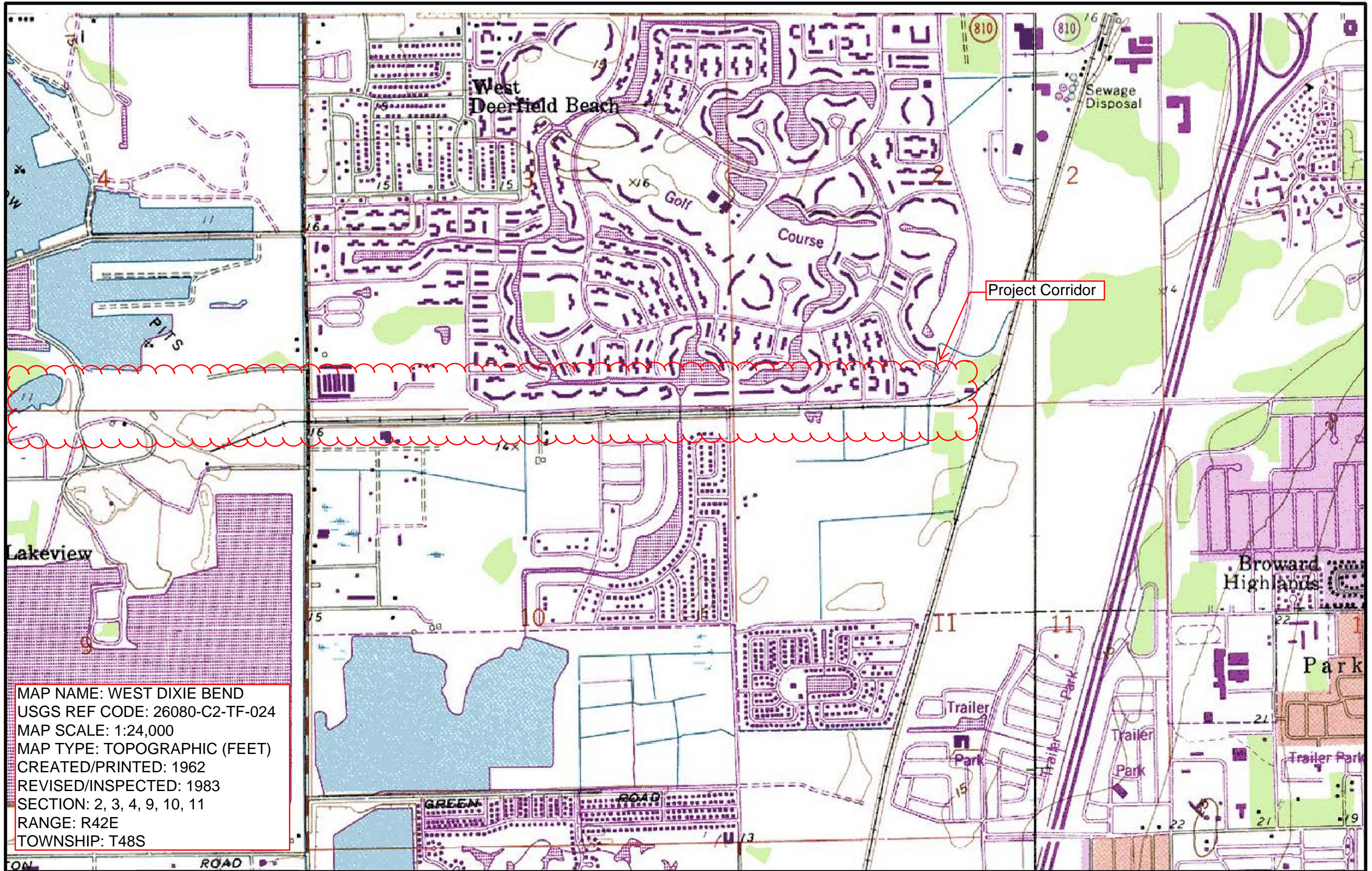

MAP NAME: WEST DIXIE BEND  
 USGS REF CODE: 26080-C2-TF-024  
 MAP SCALE: 1:24,000  
 MAP TYPE: TOPOGRAPHIC (FEET)  
 CREATED/PRINTED: 1962  
 REVISED/INSPECTED: 1983  
 SECTION: 2, 3, 4, 9, 10, 11  
 RANGE: R42E  
 TOWNSHIP: T48S

REVISIONS					
DATE	BY	DESCRIPTION	DATE	BY	DESCRIPTION

ENGINEER OF RECORD:  
 PARTHA GHOSH, P.E. LICENSE NO. 51377  
 GCME, INC.  
 1730 W. 10TH STREET  
 RIVIERA BEACH, FLORIDA 33404  
 CERTIFICATE OF AUTHORIZATION NO. 9076

STATE OF FLORIDA DEPARTMENT OF TRANSPORTATION		
ROAD NO.	COUNTY	FINANCIAL PROJECT ID
SR 869	BROWARD	439891-1-22-02

SITE VICINITY MAP  
 PLATE-1

SHEET  
 NO.







Google Earth

REVISIONS					
DATE	BY	DESCRIPTION	DATE	BY	DESCRIPTION
LEGEND:			LEGEND:		
		<ul style="list-style-type: none"> <li><span style="color: green;">+</span> BHP - Borehole Permeability Test</li> <li><span style="color: blue;">+</span> DRIT - Double Ring Infiltration Test</li> </ul>			<ul style="list-style-type: none"> <li><span style="color: black;">+</span> B - Bridge Boring (100')</li> <li><span style="color: black;">+</span> RD - Roadway Boring (15')</li> </ul>

ENGINEER OF RECORD:  
 PARTHA GHOSH, P.E. LICENSE NO. 51377  
 GCME, INC.  
 1730 W. 10TH STREET  
 RIVIERA BEACH, FLORIDA 33404  
 CERTIFICATE OF AUTHORIZATION NO. 9076

STATE OF FLORIDA DEPARTMENT OF TRANSPORTATION		
ROAD NO.	COUNTY	FINANCIAL PROJECT ID
SR 869	BROWARD	439891-1-22-02

**APPROXIMATE BORING LOCATION PLAN  
 PLATE-3**

SHEET NO.

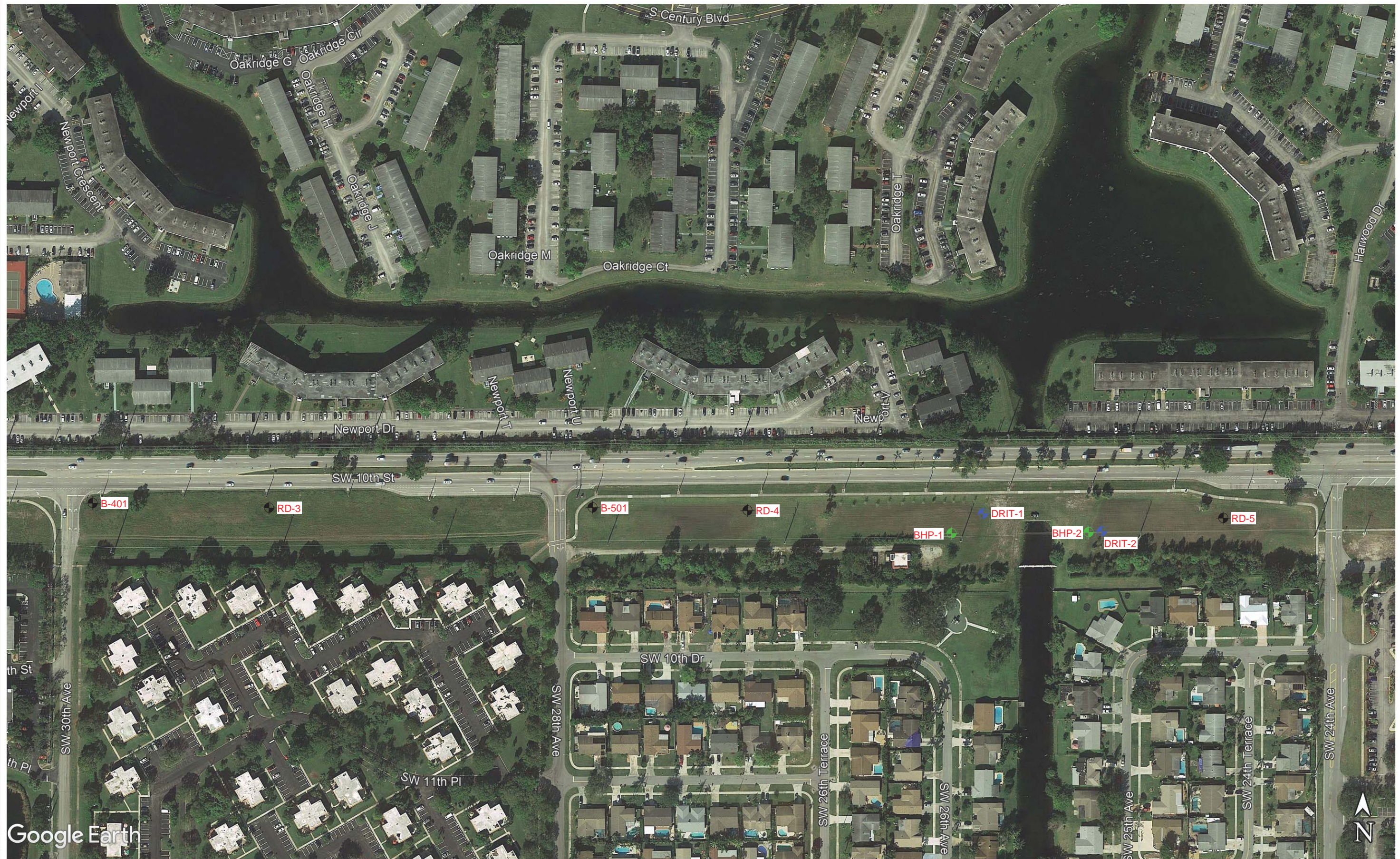

REVISIONS	
DATE	DESCRIPTION

DATE	BY	DESCRIPTION

ENGINEER OF RECORD:  
 PARTHA GHOSH, P.E. LICENSE NO. 51377  
 GCME, INC.  
 1730 W. 10TH STREET  
 RIVIERA BEACH, FLORIDA 33404  
 CERTIFICATE OF AUTHORIZATION NO. 9076

STATE OF FLORIDA DEPARTMENT OF TRANSPORTATION		
ROAD NO.	COUNTY	FINANCIAL PROJECT ID
SR 869	BROWARD	439891-1-22-02

**APPROXIMATE BORING LOCATION PLAN  
 PLATE-4**

SHEET NO.

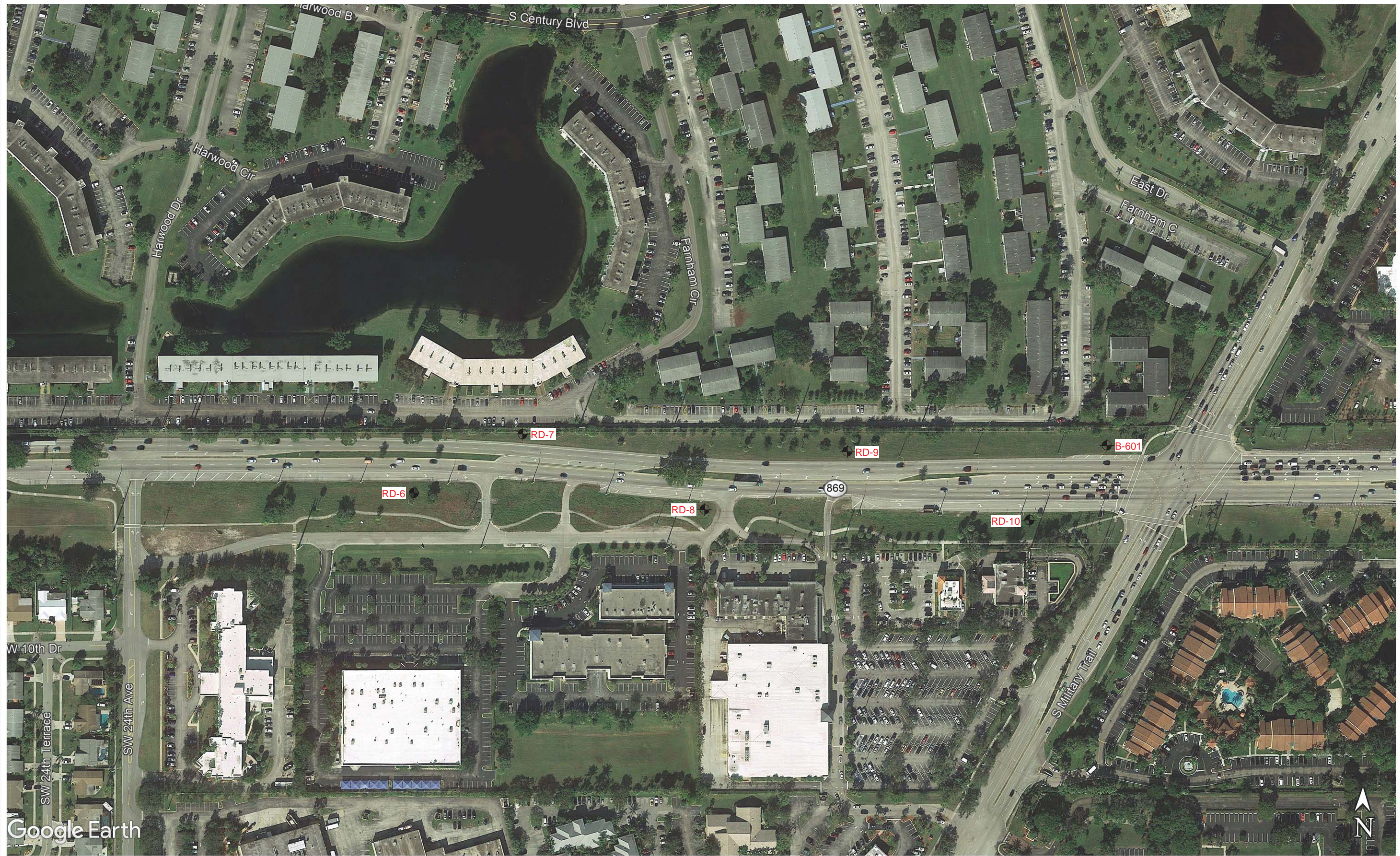

REVISIONS					
DATE	BY	DESCRIPTION	DATE	BY	DESCRIPTION
LEGEND:			LEGEND:		
		<ul style="list-style-type: none"> <li><span style="color: green;">+</span> BHP - Borehole Permeability Test</li> <li><span style="color: blue;">+</span> DRIT - Double Ring Infiltration Test</li> </ul>			<ul style="list-style-type: none"> <li><span style="color: black;">●</span> B - Bridge Boring (100')</li> <li><span style="color: black;">●</span> RD - Roadway Boring (15')</li> </ul>

ENGINEER OF RECORD:  
 PARTHA GHOSH, P.E. LICENSE NO. 51377  
 GCME, INC.  
 1730 W. 10TH STREET  
 RIVIERA BEACH, FLORIDA 33404  
 CERTIFICATE OF AUTHORIZATION NO. 9076

STATE OF FLORIDA DEPARTMENT OF TRANSPORTATION		
ROAD NO.	COUNTY	FINANCIAL PROJECT ID
SR 869	BROWARD	439891-1-22-02

**APPROXIMATE BORING LOCATION PLAN  
 PLATE-5**

SHEET  
NO.

# LEGEND

- (SP) UNIFIED SOIL CLASSIFICATION SYSTEM SYMBOL
- N STANDARD PENETRATION RESISTANCE IN BLOWS PER 12 inches UNLESS OTHERWISE NOTED. 50/3 INDICATES (50) BLOWS REQUIRED TO DRIVE A SAMPLING SPOON 3 INCHES.
- $\nabla$  2/2/18 WATER LEVEL WITH DATE OF READING
- LOSS OF CIRCULATION
- WR SAMPLER DROPPED DUE TO WEIGHT OF ROD
- WH SAMPLER DROPPED DUE TO WEIGHT OF HAMMER
- HA DRILLED WITH A HAND AUGER IN ORDER TO CLEAR LOCATION FROM UNDERGROUND UTILITIES
- NR NO RECOVERY- NO SOIL/ROCK WAS RECOVERED IN THE SAMPLING SPOON

- STATION / OFFSET / ELEVATION / COORDINATE INFORMATION ARE PROVIDED BY SURVEYORS.
- MC= NATURAL MOISTURE CONTENT (%)
- 200= FINES PASSING #200 SIEVE (%)
- OC= ORGANIC CONTENT (%)
- LL= LIQUID LIMIT (%)
- PI= PLASTICITY INDEX (%)
- NP= INDICATES NON-PLASTIC

NOTES: STRATA BOUNDARIES ARE APPROXIMATE AND MAY VARY BETWEEN OR AWAY FROM BORING LOCATIONS.

DRILLER: FAUSTINO  
 STANDARD PENETRATION TEST DATA  
 SPOON INSIDE DIA. 1.375 inches  
 SPOON OUTSIDE DIA. 2.0 inches  
 AVG. HAMMER DROP 30.0 inches  
 HAMMER WEIGHT 140.0 pounds

**SPT CONSISTENCY CHART**

SILTS AND CLAYS-	SAFETY HAMMER	AUTOMATIC HAMMER
CONSISTENCY	SPT (BLOWS/1.0 ft)	SPT (BLOWS/1.0 ft)
VERY SOFT	LESS THAN 2	LESS THAN 1
SOFT	2 - 4	1 - 3
FIRM	4 - 8	3 - 6
STIFF	8 - 15	6 - 12
VERY STIFF	15 - 30	12 - 24
HARD	GREATER THAN 30	GREATER THAN 24

**SPT DENSITY CHART**

GRANULAR MATERIALS-	SAFETY HAMMER	AUTOMATIC HAMMER
RELATIVE DENSITY	SPT (BLOWS/1.0 ft)	SPT (BLOWS/1.0 ft)
VERY LOOSE	LESS THAN 4	LESS THAN 3
LOOSE	4 - 10	3 - 8
MEDIUM DENSE	10 - 30	8 - 24
DENSE	30 - 50	24 - 40
VERY DENSE	GREATER THAN 50	GREATER THAN 40

ENVIRONMENTAL CLASSIFICATION:  
 SUBSTRUCTURE: MODERATELY AGGRESSIVE (STEEL)  
 MODERATELY AGGRESSIVE (CONCRETE)  
 SUPERSTRUCTURE: SLIGHTLY AGGRESSIVE

**SOIL TYPE SYMBOLS:**

	SAND		PEAT/MUCK
	LIMESTONE		SILTY SAND
	GRAVELLY SAND		SHELLY SAND
	GRAVEL		CLAYEY SAND
	CLAY		SILT

BOR # B-101  
 ELEV. 11.1'  
 DATE 2/2/2018  
 HAMMER Auto  
 RIG CME-55  
 COORDINATES 26.3057°  
 -80.1612°

BOR # B-201  
 ELEV. 13.6'  
 DATE 2/5/2018  
 HAMMER Auto  
 RIG CME-55  
 COORDINATES 26.3041°  
 -80.1563°

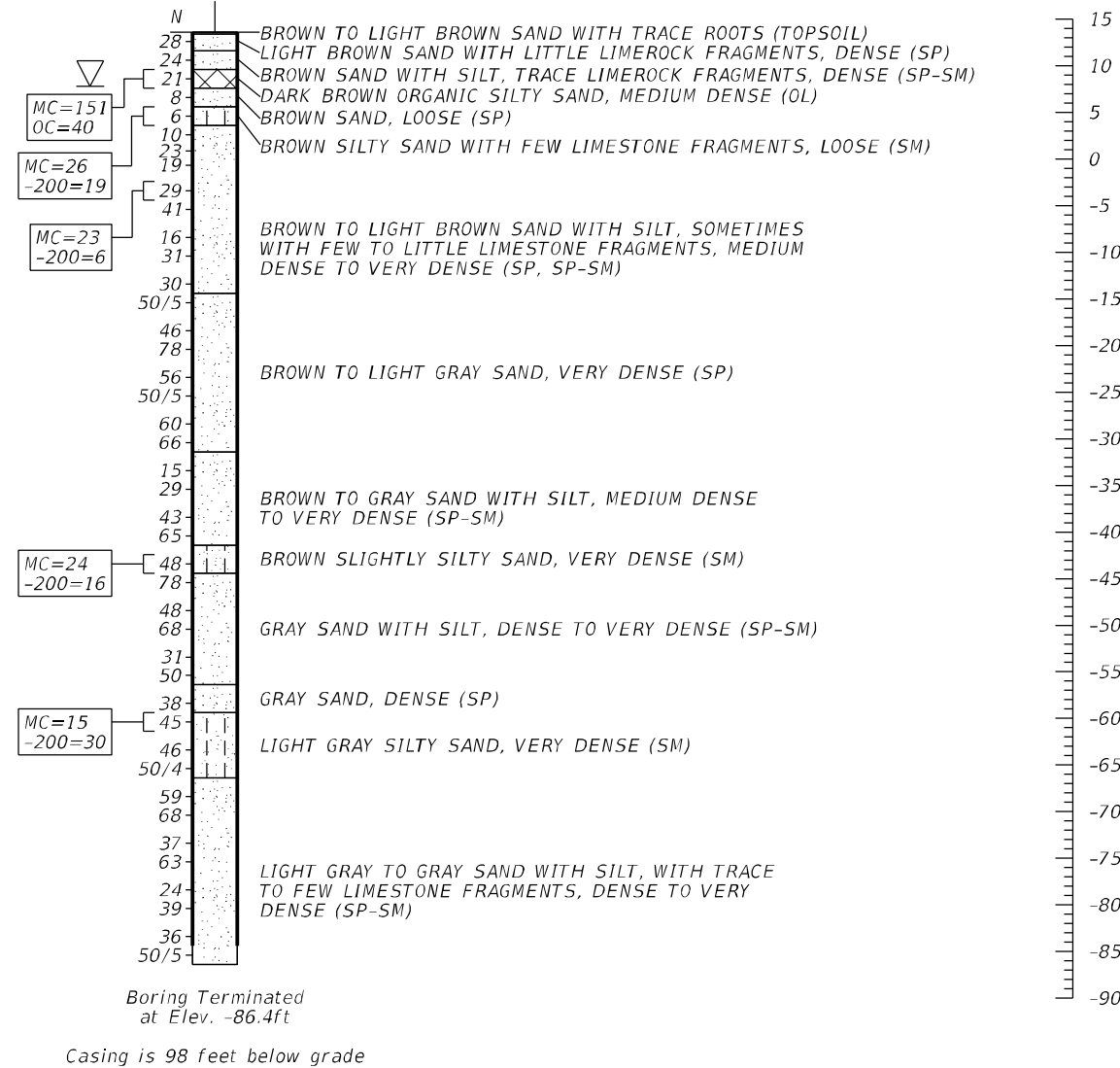
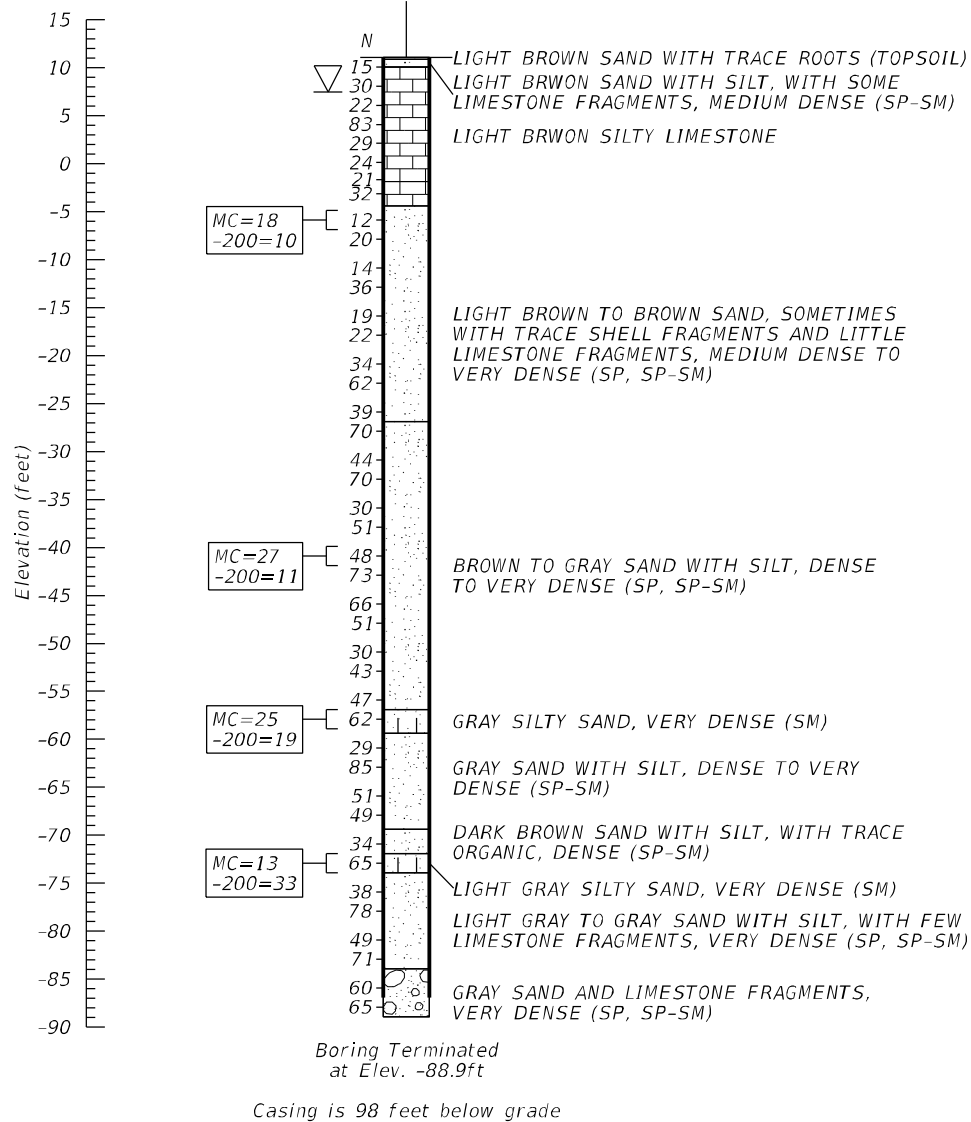

SCALE: 1"=20'V

REVISIONS						ENGINEER OF RECORD:			STATE OF FLORIDA			SHEET TITLE:		REF. DWG. NO.
DATE	BY	DESCRIPTION	DATE	BY	DESCRIPTION	PARTHA GHOSH, P.E. LICENSE NO. 51377			DEPARTMENT OF TRANSPORTATION			REPORT OF CORE BORINGS		
						GCME, INC.			ROAD NO.	COUNTY	FINANCIAL PROJECT ID	PROJECT NAME:		SHEET NO.
						1730 W. 10TH STREET			869	BROWARD	439891-1-22-02	SW 10TH STREET PD&E STUDY		
						RIVIERA BEACH, FLORIDA 33404								
						CERTIFICATE OF AUTHORIZATION NO. 9076								

### LEGEND

- (SP) UNIFIED SOIL CLASSIFICATION SYSTEM SYMBOL
- N STANDARD PENETRATION RESISTANCE IN BLOWS PER 12 inches UNLESS OTHERWISE NOTED. 50/3 INDICATES (50) BLOWS REQUIRED TO DRIVE A SAMPLING SPOON 3 INCHES.
- $\nabla$  2/1/18 WATER LEVEL WITH DATE OF READING
- LOSS OF CIRCULATION
- WR SAMPLER DROPPED DUE TO WEIGHT OF ROD
- WH SAMPLER DROPPED DUE TO WEIGHT OF HAMMER
- HA DRILLED WITH A HAND AUGER IN ORDER TO CLEAR LOCATION FROM UNDERGROUND UTILITIES
- NR NO RECOVERY - NO SOIL/ROCK WAS RECOVERED IN THE SAMPLING SPOON

- STATION / OFFSET / ELEVATION / COORDINATE INFORMATION ARE PROVIDED BY SURVEYORS.
- MC= NATURAL MOISTURE CONTENT (%)
- 200= FINES PASSING #200 SIEVE (%)
- OC= ORGANIC CONTENT (%)
- LL= LIQUID LIMIT (%)
- PI= PLASTICITY INDEX (%)
- NP= INDICATES NON-PLASTIC

NOTES: STRATA BOUNDARIES ARE APPROXIMATE AND MAY VARY BETWEEN OR AWAY FROM BORING LOCATIONS.

DRILLER: FAUSTINO  
**STANDARD PENETRATION TEST DATA**  
 SPOON INSIDE DIA. 1.375 inches  
 SPOON OUTSIDE DIA. 2.0 inches  
 AVG. HAMMER DROP 30.0 inches  
 HAMMER WEIGHT 140.0 pounds

**SPT CONSISTENCY CHART**

SILTS AND CLAYS-	SAFETY HAMMER	AUTOMATIC HAMMER
CONSISTENCY	SPT (BLOWS/1.0 ft)	SPT (BLOWS/1.0 ft)
VERY SOFT	LESS THAN 2	LESS THAN 1
SOFT	2 - 4	1 - 3
FIRM	4 - 8	3 - 6
STIFF	8 - 15	6 - 12
VERY STIFF	15 - 30	12 - 24
HARD	GREATER THAN 30	GREATER THAN 24

**SPT DENSITY CHART**

GRANULAR MATERIALS-	SAFETY HAMMER	AUTOMATIC HAMMER
RELATIVE DENSITY	SPT (BLOWS/1.0 ft)	SPT (BLOWS/1.0 ft)
VERY LOOSE	LESS THAN 4	LESS THAN 3
LOOSE	4 - 10	3 - 8
MEDIUM DENSE	10 - 30	8 - 24
DENSE	30 - 50	24 - 40
VERY DENSE	GREATER THAN 50	GREATER THAN 40

**ENVIRONMENTAL CLASSIFICATION:**

SUBSTRUCTURE: MODERATELY AGGRESSIVE (STEEL)  
 MODERATELY AGGRESSIVE (CONCRETE)

SUPERSTRUCTURE: SLIGHTLY AGGRESSIVE

**SOIL TYPE SYMBOLS:**

	SAND		PEAT/MUCK
	LIMESTONE		SILTY SAND
	GRAVELLY SAND		SHELLY SAND
	GRAVEL		CLAYEY SAND
	CLAY		SILT

BOR # B-301  
 ELEV. 13.3'  
 DATE 2/1/2018  
 HAMMER Auto  
 RIG CME-55  
 COORDINATES 26.3045°  
 -80.1529°

BOR # B-401  
 ELEV. 12.3'  
 DATE 2/6/2018  
 HAMMER Auto  
 RIG CME-55  
 COORDINATES 26.3040°  
 -80.1443°

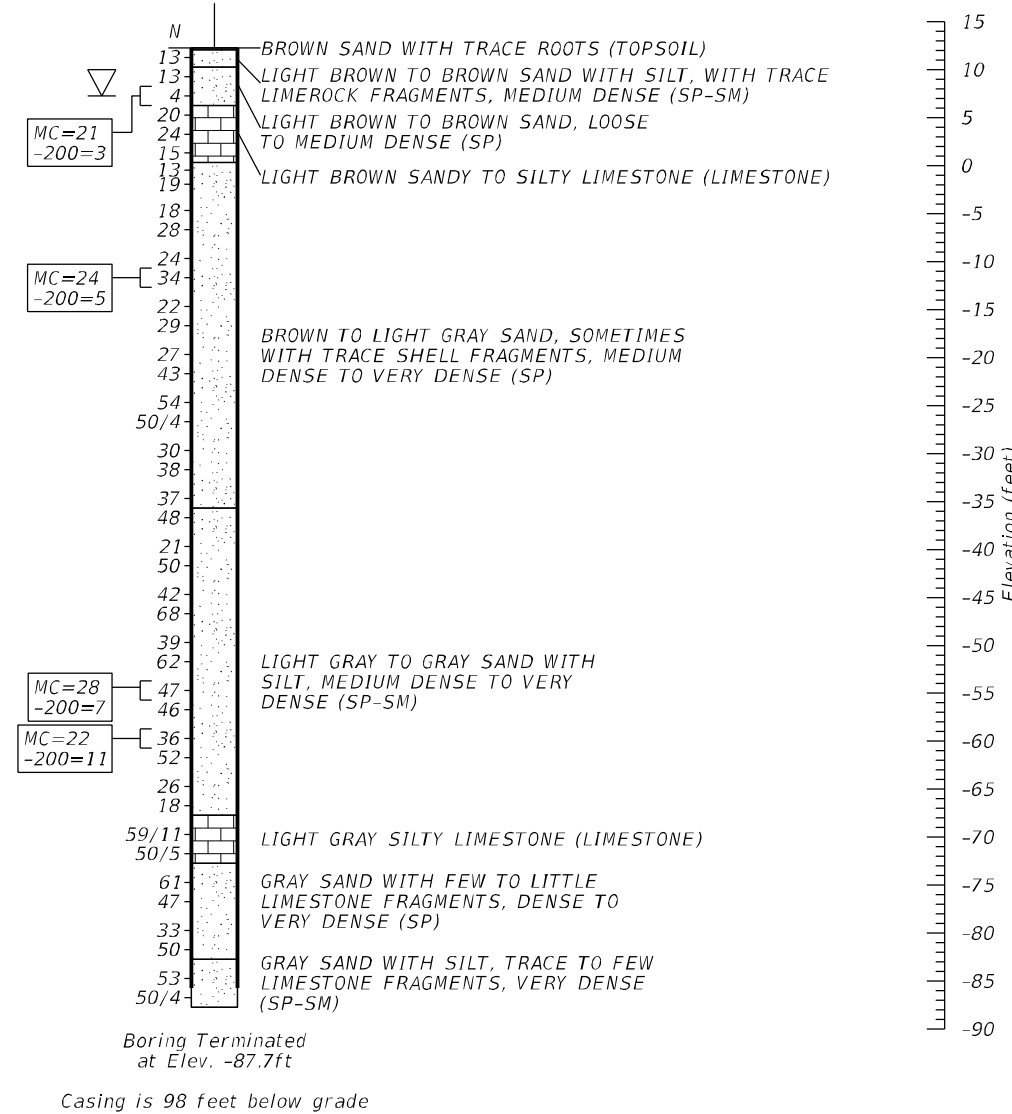
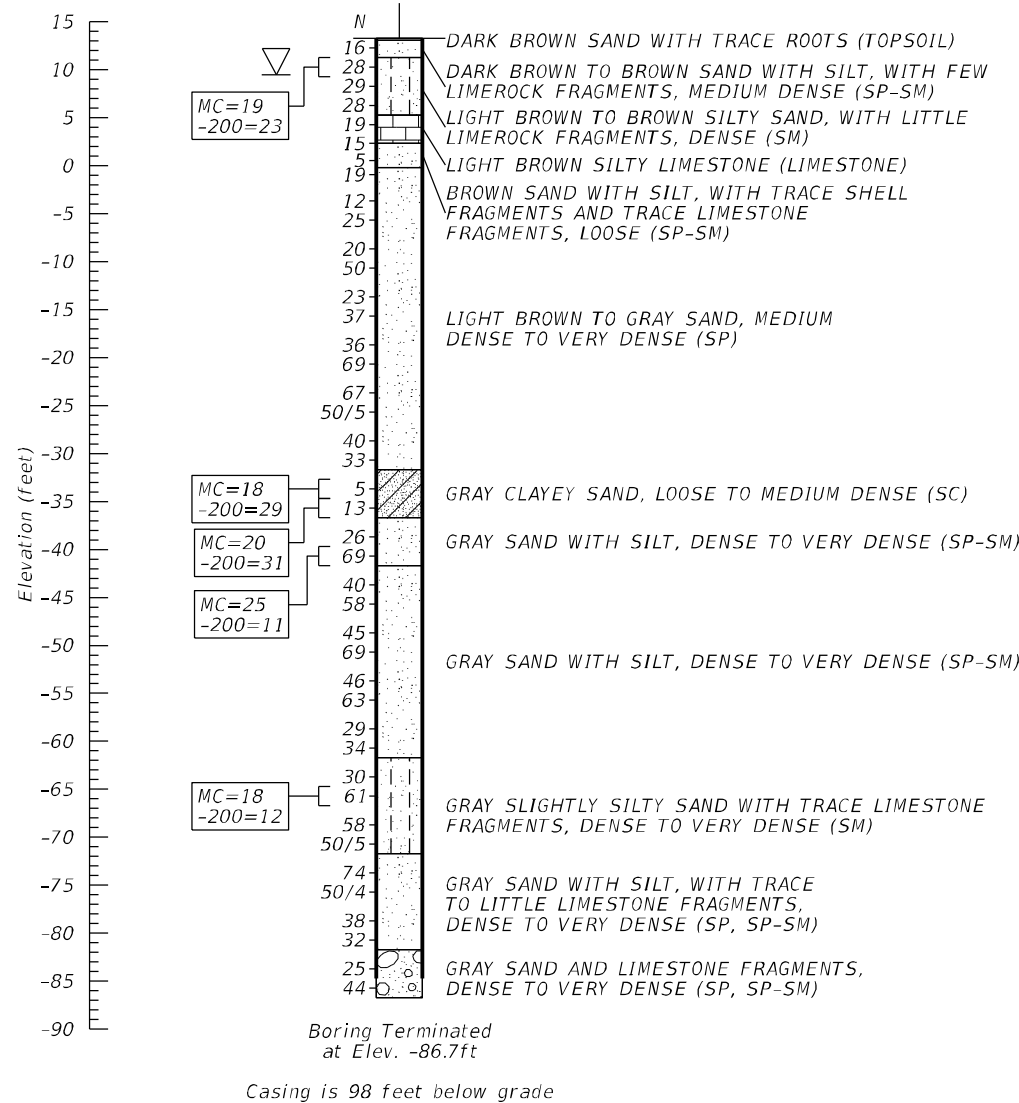

SCALE: 1"=20'V

REVISIONS						ENGINEER OF RECORD:			STATE OF FLORIDA			SHEET TITLE:		REF. DWG. NO.
DATE	BY	DESCRIPTION	DATE	BY	DESCRIPTION	PARTHA GHOSH, P.E. LICENSE NO. 51377			DEPARTMENT OF TRANSPORTATION			REPORT OF CORE BORINGS		
						GCME, INC.								
						1730 W. 10TH STREET						PROJECT NAME:		SHEET NO.
						RIVIERA BEACH, FLORIDA 33404						SW 10TH STREET PD&E STUDY		
						CERTIFICATE OF AUTHORIZATION NO. 9076								
						DRAWN BY:	FP 02-18	ROAD NO.	COUNTY	FINANCIAL PROJECT ID				
						CHECKED BY:	ZP 02-18	869	BROWARD	439891-1-22-02				
						DESIGNED BY:	XXX MM-YY							
						CHECKED BY:	XXX MM-YY							

# LEGEND

- (SP) UNIFIED SOIL CLASSIFICATION SYSTEM SYMBOL
- N STANDARD PENETRATION RESISTANCE IN BLOWS PER 12 inches UNLESS OTHERWISE NOTED. 50/3 INDICATES (50) BLOWS REQUIRED TO DRIVE A SAMPLING SPOON 3 INCHES.
- $\nabla$  2/7/18 WATER LEVEL WITH DATE OF READING
- $\rightarrow$  LOSS OF CIRCULATION
- WR SAMPLER DROPPED DUE TO WEIGHT OF ROD
- WH SAMPLER DROPPED DUE TO WEIGHT OF HAMMER
- HA DRILLED WITH A HAND AUGER IN ORDER TO CLEAR LOCATION FROM UNDERGROUND UTILITIES
- NR NO RECOVERY- NO SOIL/ROCK WAS RECOVERED IN THE SAMPLING SPOON

STATION / OFFSET / ELEVATION / COORDINATE INFORMATION ARE PROVIDED BY SURVEYORS.

MC= NATURAL MOISTURE CONTENT (%)  
 -200= FINES PASSING #200 SIEVE (%)  
 OC= ORGANIC CONTENT (%)  
 LL= LIQUID LIMIT (%)  
 PI= PLASTICITY INDEX (%)  
 NP= INDICATES NON-PLASTIC

NOTES: STRATA BOUNDARIES ARE APPROXIMATE AND MAY VARY BETWEEN OR AWAY FROM BORING LOCATIONS.

DRILLER: FAUSTINO

STANDARD PENETRATION TEST DATA  
 SPOON INSIDE DIA. 1.375 inches  
 SPOON OUTSIDE DIA. 2.0 inches  
 AVG. HAMMER DROP 30.0 inches  
 HAMMER WEIGHT 140.0 pounds

SPT CONSISTENCY CHART

SILTS AND CLAYS-	SAFETY HAMMER	AUTOMATIC HAMMER
CONSISTENCY	SPT (BLOWS/1.0 ft)	SPT (BLOWS/1.0 ft)
VERY SOFT	LESS THAN 2	LESS THAN 1
SOFT	2 - 4	1 - 3
FIRM	4 - 8	3 - 6
STIFF	8 - 15	6 - 12
VERY STIFF	15 - 30	12 - 24
HARD	GREATER THAN 30	GREATER THAN 24

SPT DENSITY CHART

GRANULAR MATERIALS-	SAFETY HAMMER	AUTOMATIC HAMMER
RELATIVE DENSITY	SPT (BLOWS/1.0 ft)	SPT (BLOWS/1.0 ft)
VERY LOOSE	LESS THAN 4	LESS THAN 3
LOOSE	4 - 10	3 - 8
MEDIUM DENSE	10 - 30	8 - 24
DENSE	30 - 50	24 - 40
VERY DENSE	GREATER THAN 50	GREATER THAN 40

ENVIRONMENTAL CLASSIFICATION:

SUBSTRUCTURE: MODERATELY AGGRESSIVE (STEEL)  
 MODERATELY AGGRESSIVE (CONCRETE)

SUPERSTRUCTURE: SLIGHTLY AGGRESSIVE

SOIL TYPE SYMBOLS:

	SAND		PEAT/MUCK
	LIMESTONE		SILTY SAND
	GRAVELLY SAND		SHELLY SAND
	GRAVEL		CLAYEY SAND
	CLAY		SILT

BOR # B-501  
 ELEV. 12.9'  
 DATE 2/7/2018  
 HAMMER Auto  
 RIG CME-55  
 COORDINATES 26.3040°  
 -80.1410°

BOR # B-601  
 ELEV. 13.0'  
 DATE 1/31/2018  
 HAMMER Auto  
 RIG CME-55  
 COORDINATES 26.3045°  
 -80.1299°

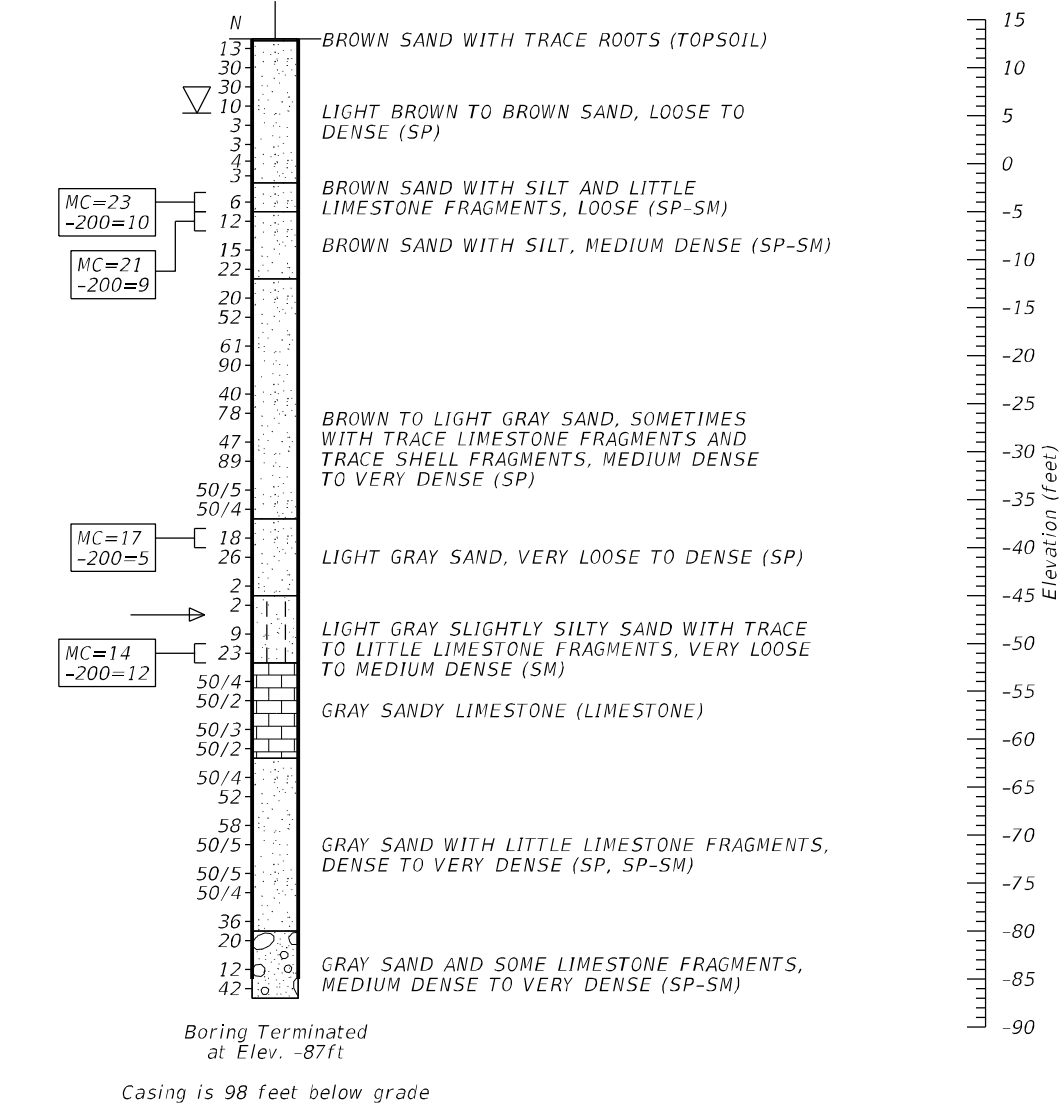
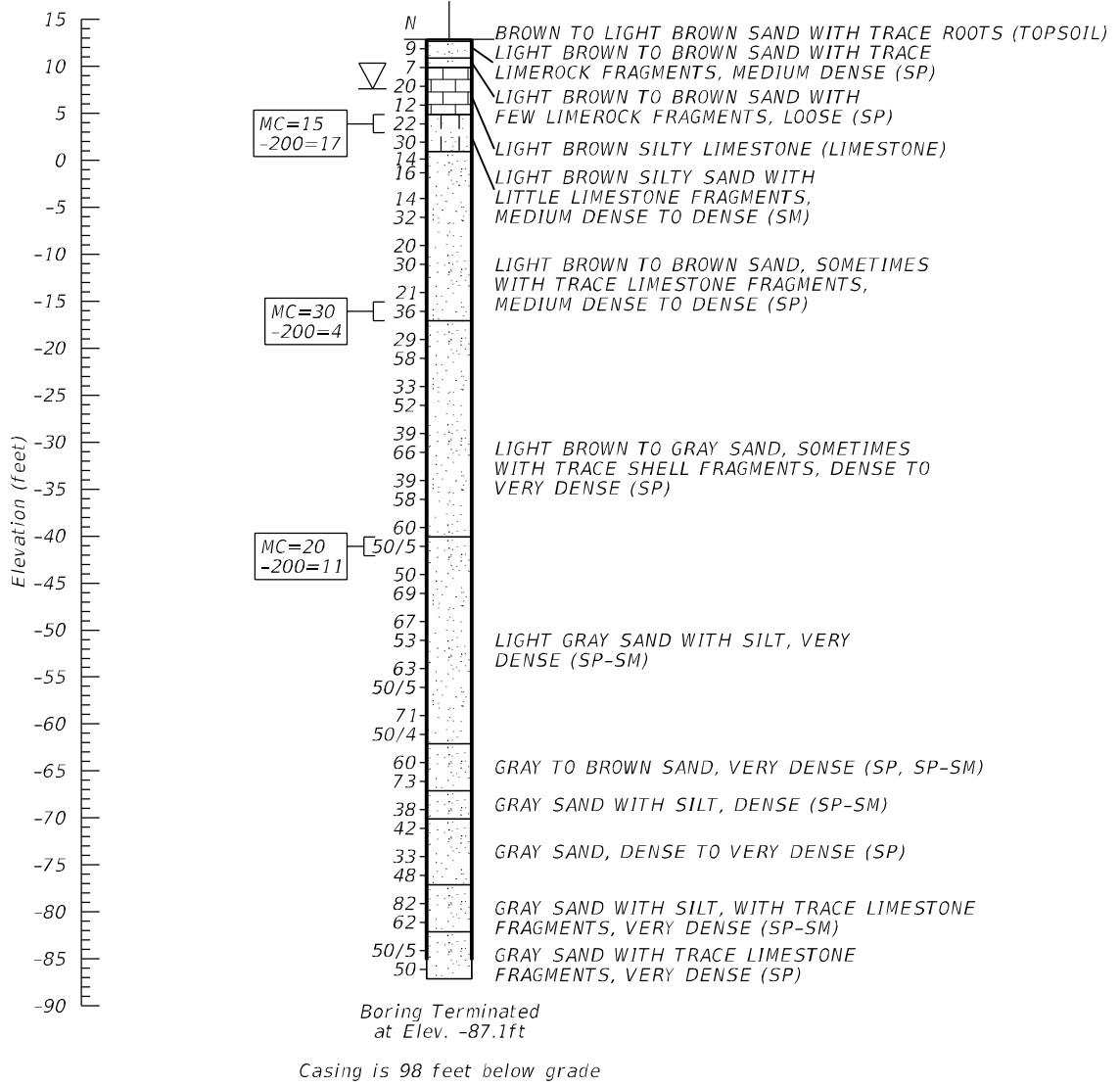

SCALE: 1"=20'V

GCME PROJECT NO. 2000-01-17003

NOTICE: THE OFFICIAL RECORD OF THIS SHEET IS THE ELECTRONIC FILE DIGITALLY SIGNED AND SEALED UNDER RULE 61G15-23.004, F.A.C. FIGURE: 3

REVISIONS						ENGINEER OF RECORD:			STATE OF FLORIDA			SHEET TITLE:		REF. DWG. NO.
DATE	BY	DESCRIPTION	DATE	BY	DESCRIPTION	PARTHA GHOSH, P.E. LICENSE NO. 51377			DEPARTMENT OF TRANSPORTATION			REPORT OF CORE BORINGS		
						GCME, INC.			FINANCIAL PROJECT ID					
						1730 W. 10TH STREET			ROAD NO.	COUNTY	FINANCIAL PROJECT ID	PROJECT NAME:		SHEET NO.
						RIVIERA BEACH, FLORIDA 33404			869	BROWARD	439891-1-22-02	SW 10TH STREET PD&E STUDY		
						CERTIFICATE OF AUTHORIZATION NO. 9076								

DATE OF SURVEY: 2/8/18 - 2/14/18  
 SURVEY MADE BY: GCME, INC.  
 SUBMITTED BY: PARTHA GHOSH, P.E.

**STATE OF FLORIDA  
 DEPARTMENT OF TRANSPORTATION  
 MATERIALS AND RESEARCH**

DISTRICT: 4  
 ROAD NO.: -  
 COUNTY: BROWARD

FINANCIAL PROJECT ID : 439891-1-22-02  
 PROJECT NAME: PD&E STUDY - SW 10TH STREET FROM  
 POWERLINE ROAD TO MILITARY TRAIL  
 CROSS SECTION SOIL SURVEY FOR THE DESIGN OF ROADS

SURVEY BEGINS STA. : - SURVEY ENDS STA. : -

REFERENCE: -

STRATUM NO.	ORGANIC CONTENT		MOISTURE CONTENT		SIEVE ANALYSIS RESULTS PERCENT PASS (%)					ATTERBERG LIMITS (%)				DESCRIPTION	CORROSION TEST RESULTS					
	NO. OF TESTS	% ORGANIC	NO. OF TESTS	MOISTURE CONTENT	NO. OF TESTS	10 MESH	40 MESH	60 MESH	100 MESH	200 MESH	NO. OF TESTS	LIQUID LIMIT	PLASTIC INDEX		AASHTO GROUP	NO. OF TESTS	RESISTIVITY ohm-cm	CHLORIDE ppm	SULFATES ppm	pH
1	-	-	-	-	-	-	-	-	-	-	-	-	-	A-8	LIGHT BROWN TO BROWN SAND WITH TRACE ROOTS AND TRACE LIMEROCK FRAGMENTS (TOPSOIL)	-	-	-	-	-
2	-	-	14	5-24	14	75-100	52-93	17-51	3-15	2-9	-	-	-	A-3	LIGHT BROWN TO BROWN SAND WITH SILT, WITH TRACE TO LITTLE LIMEROCK FRAGMENTS	2	3310-7600	6-8	21-61	7.6-8.1
2A	-	-	12	13-22	12	47-67	33-48	15-34	7-24	6-22	-	-	-	A-1-b	LIGHT BROWN TO BROWN SAND AND SOME LIMESTONE FRAGMENTS, WITH SILT TO SILTY	-	-	-	-	-
2B	3	0.7-1.8	3	23-27	-	-	-	-	-	-	-	-	-	A-3	DARK BROWN SAND WITH SILT, WITH TRACE ORGANIC	-	-	-	-	-
3	-	-	-	-	-	-	-	-	-	-	-	-	-	-	LIGHT BROWN SANDY TO SILTY LIMESTONE	-	-	-	-	-
4	-	-	9	12-35	9	64-84	51-69	22-38	15-28	12-23	-	-	-	A-2-4	LIGHT BROWN TO BROWN SILTY SAND WITH LITTLE TO SOME LIMEROCK FRAGMENTS	-	-	-	-	-
5	1	6.0	2	30-31	1	100	83	41	15	6	-	-	-	A-8	DARK BROWN TO BLACK SAND WITH SILT, WITH FEW ORGANIC	-	-	-	-	-
-	-	-	-	-	-	-	-	-	-	-	-	-	-	-	-	-	-	-	-	-

EMBANKMENT AND SUBGRADE MATERIAL

STRATA BOUNDARIES ARE APPROXIMATE. MAKE FINAL CHECK AFTER GRADING.

∇ - WATER TABLE ENCOUNTERED

GNE - GROUNDWATER NOT ENCOUNTERED

- NOTES: (1) THE MATERIAL FROM STRATUM 1 IS TOPSOIL (A-8) AND CONSIDERED TO BE UNSUITABLE (MUCK). IT SHALL BE REMOVED DURING CLEARING AND GRUBBING IN ACCORDANCE WITH SECTION 110 OF THE FDOT STANDARD SPECIFICATIONS.  
 (2) STRATUM 2 CONSISTS OF SELECT MATERIALS AND ARE ADEQUATE FOR SUBGRADE AND EMBANKMENT SUPPORT, AND SHOULD BE UTILIZED ACCORDING TO STANDARD PLANS, INDEX 120-001. HOWEVER, PORTIONS MAY RETAIN EXCESS MOISTURE DUE TO SLIGHTLY HIGH FINES CONTENT AND COULD BE MORE DIFFICULT TO HANDLE, PLACE AND COMPACT THAN ORDINARY A-3 MATERIAL.  
 (3) STRATUM 2A AND 4 CONSIST OF SELECT MATERIALS AND ARE GENERALLY ADEQUATE FOR SUBGRADE AND EMBANKMENT SUPPORT, AND SHOULD BE UTILIZED ACCORDING TO STANDARD PLANS, INDEX 120-001. HOWEVER, SOME PORTIONS OF THESE SOILS HAVE HIGH FINES CONTENT, AND HENCE WILL RETAIN EXCESS MOISTURE, AND WILL BE DIFFICULT TO HANDLE, PLACE AND COMPACT. THESE MATERIALS MAY BE USED IN THE ROADWAY SUBGRADE WITH EXTRA CAUTION AND PROPER SUPERVISION AND QUALITY CONTROL.  
 (4) STRATUM 2B CONSISTS OF SELECT MATERIALS WITH ORGANIC CONTENT BETWEEN 0.7% AND 1.8%.  
 (5) STRATUM 3 CONSISTS OF LIMESTONE. SPECIALIZED TOOLS AND EQUIPMENT ARE NECESSARY TO EXCAVATE AND/OR PENETRATE THE LIMESTONE LAYER.  
 (6) STRATUM 5 (A-8) CONSISTS OF ORGANIC MATERIALS WITH ORGANIC CONTENT OVER 5%. THESE SOILS GENERALLY SHOULD BE REMOVED AND REPLACED WITH SELECT FILL IN ACCORDANCE WITH STANDARD PLANS, INDEX 120-002.

GCME PROJECT NO. 2000-01-17003

FIGURE: PSS-1 NOTICE: THE OFFICIAL RECORD OF THIS SHEET IS THE ELECTRONIC FILE DIGITALLY SIGNED AND SEALED UNDER RULE 61G5-23.004, F.A.C.

REVISIONS				ENGINEER OF RECORD: PARTHA GHOSH, P.E. LICENSE NO. 51377 GCME, INC. 1730 W. 10TH STREET RIVIERA BEACH, FLORIDA 33404 CERTIFICATE OF AUTHORIZATION NO. 9076	STATE OF FLORIDA DEPARTMENT OF TRANSPORTATION			<b>ROADWAY SOIL SURVEY</b>	SHEET NO.
DATE	DESCRIPTION	DATE	DESCRIPTION		ROAD NO.	COUNTY	FINANCIAL PROJECT ID		
					869	BROWARD	439891-1-22-02		



BORING NO.	RD-1	RD-2	RD-3	RD-4	RD-5	RD-6	RD-7	RD-8	RD-9	RD-10
STATION	-	-	-	-	-	-	-	-	-	-
OFFSET	-	-	-	-	-	-	-	-	-	-
ELEVATION	+12.0'	+12.5'	+11.6'	+9.6'	+8.9'	+11.6'	+13.0'	+12.5'	+11.9'	+9.5'
LATITUDE	26.3045°	26.3043°	26.3040°	26.3040°	26.3040°	26.3042°	26.3045°	26.3041°	26.3045°	26.3041°
LONGITUDE	-80.1495°	-80.1466°	-80.1431°	-80.1401°	-80.1370°	-80.1344°	-80.1337°	-80.1325°	-80.1316°	-80.1304°
HAMMER	AUTOMATIC	AUTOMATIC	AUTOMATIC	AUTOMATIC	AUTOMATIC	AUTOMATIC	AUTOMATIC	AUTOMATIC	AUTOMATIC	AUTOMATIC
DATE	2/8/18	2/8/18	2/8/18	2/8/18	2/8/18	2/8/18	2/9/18	2/8/18	2/9/18	2/9/18

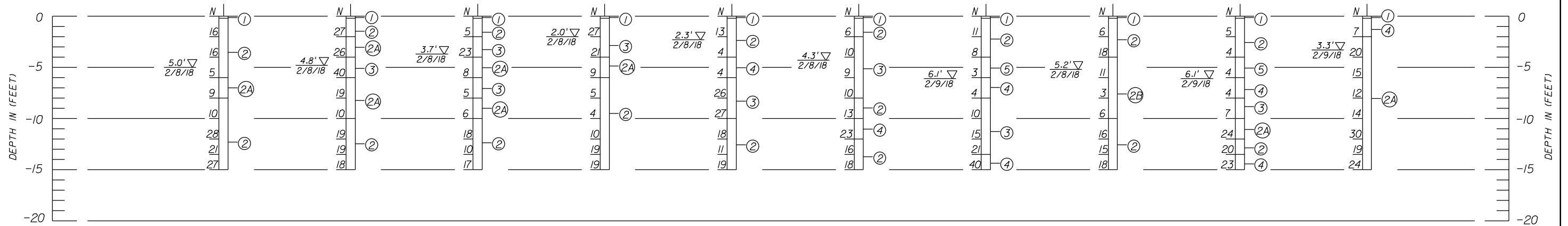

**LEGEND**

1. LIGHT BROWN TO BROWN SAND WITH TRACE ROOTS AND TRACE LIMEROCK FRAGMENTS (TOPSOIL)
2. LIGHT BROWN TO BROWN SAND WITH SILT, WITH TRACE TO LITTLE LIMEROCK FRAGMENTS (A-3)
- 2A. LIGHT BROWN TO BROWN SAND AND SOME LIMESTONE FRAGMENTS, WITH SILT TO SILTY (A-1-b)
- 2B. DARK BROWN SAND WITH SILT, WITH TRACE ORGANIC (A-3)
3. LIGHT BROWN SANDY TO SILTY LIMESTONE
4. LIGHT BROWN TO BROWN SILTY SAND WITH LITTLE TO SOME LIMEROCK FRAGMENTS (A-2-4)
5. DARK BROWN TO BLACK SAND WITH SILT, WITH FEW ORGANIC (A-8)

**NOTES**

- $\nabla$  GROUNDWATER LEVEL RECORDED ON THE DATE OF DRILLING.
- GWT: WATER TABLE NOT ENCOUNTERED WITHIN THE DEPTH OF EXPLORATION.
- DRILLED BY: FAUSTINO
- COORDINATES INFORMATION ARE MEASURED BY HANDHELD GPS.
- STATION / OFFSET / ELEVATION INFORMATION ARE PROVIDED BY SURVEYORS.
- N - STANDARD PENETRATION RESISTANCE IN BLOWS PER 12 INCHES.
- (A-3) - AASHTO SOIL SYMBOL

SCALE: 1"=10'V

GCME PROJECT NO. 2000-01-17003

REVISIONS					
DATE	BY	DESCRIPTION	DATE	BY	DESCRIPTION

ENGINEER OF RECORD:  
 PARTHA GHOSH, P.E. LICENSE NO. 51377  
 GCME, INC.  
 1730 W. 10TH STREET  
 RIVIERA BEACH, FLORIDA 33404  
 CERTIFICATE OF AUTHORIZATION NO. 9076

STATE OF FLORIDA DEPARTMENT OF TRANSPORTATION		
ROAD NO.	COUNTY	FINANCIAL PROJECT ID
869	BROWARD	439891-1-22-02

**SOIL PROFILES**

SHEET NO.

BORING NO.  
STATION  
OFFSET  
ELEVATION  
LATITUDE  
LONGITUDE  
HAMMER  
DATE

BHP-1  
-  
+9.6'  
26.3039°  
-80.1387°  
AUTOMATIC  
2/14/18

BHP-2  
-  
+9.3'  
26.3039°  
-80.1378°  
AUTOMATIC  
2/14/18

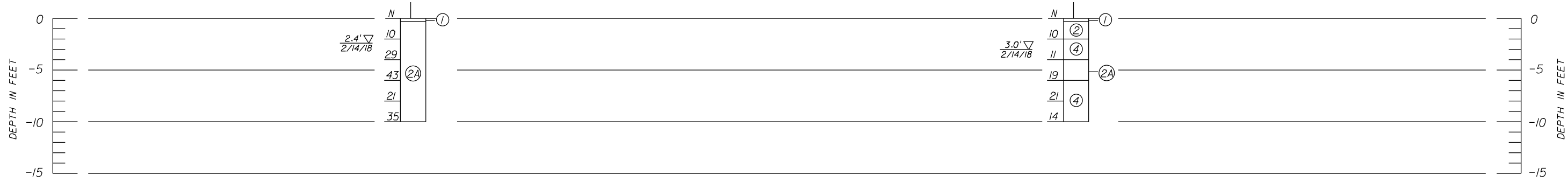

**LEGEND**

1. LIGHT BROWN TO BROWN SAND WITH TRACE ROOTS AND TRACE LIMEROCK FRAGMENTS (TOPSOIL)
2. LIGHT BROWN TO BROWN SAND WITH SILT, WITH TRACE TO LITTLE LIMEROCK FRAGMENTS (A-3)
- 2A. LIGHT BROWN TO BROWN SAND AND SOME LIMESTONE FRAGMENTS, WITH SILT TO SILTY (A-1-b)
- 2B. DARK BROWN SAND WITH SILT, WITH TRACE ORGANIC (A-3)
3. LIGHT BROWN SANDY TO SILTY LIMESTONE
4. LIGHT BROWN TO BROWN SILTY SAND WITH LITTLE TO SOME LIMEROCK FRAGMENTS (A-2-4)
5. DARK BROWN TO BLACK SAND WITH SILT, WITH FEW ORGANIC (A-8)

**NOTES**

- $\nabla$  GROUNDWATER LEVEL RECORDED ON THE DATE OF DRILLING.
- GNE: WATER TABLE NOT ENCOUNTERED WITHIN THE DEPTH OF EXPLORATION.
- DRILLED BY: FAUSTINO
- COORDINATES INFORMATION ARE MEASURED BY HANDHELD GPS.
- STATION / OFFSET / ELEVATION INFORMATION ARE PROVIDED BY SURVEYORS.
- N - STANDARD PENETRATION RESISTANCE IN BLOWS PER 12 INCHES.
- (A-3) - AASHTO SOIL SYMBOL

SCALE: 1"=10'V

GCME PROJECT NO. 2000-01-17003

FIGURE R-2 NOTICE: THE OFFICIAL RECORD OF THIS SHEET IS THE ELECTRONIC FILE DIGITALLY SIGNED AND SEALED UNDER RULE 61G15-23.004, F.A.C

REVISIONS						ENGINEER OF RECORD: PARTHA GHOSH, P.E. LICENSE NO. 51377 GCME, INC. 1730 W. 10TH STREET RIVIERA BEACH, FLORIDA 33404 CERTIFICATE OF AUTHORIZATION NO. 9076	STATE OF FLORIDA DEPARTMENT OF TRANSPORTATION			SHEET NO.
DATE	BY	DESCRIPTION	DATE	BY	DESCRIPTION		ROAD NO.	COUNTY	FINANCIAL PROJECT ID	
							869	BROWARD	439891-1-22-02	

**SOIL PROFILES**

**TABLE - 1****SUMMARY OF LABORATORY TESTING RESULTS [BRIDGE STRUCTURES]****Project Name: PD&E Study - SW 10th Street From Powerline Road to Military Trail**

Boring No.	Sample Depth (ft)		USCS Symbol	Natural Moisture Content (%)	Organic Content (%)	Atterberg Limits			Sieve Analysis								
						LL (%)	PL (%)	PI (%)	3/4"	3/8"	#4	#10	#20	#40	#60	#100	#200
B-101	16.0	- 18.0	SP-SM	18.0					87.5	83.4	80.5	76.2	72.7	60.1	32.6	18.8	10.0
B-101	51.0	- 53.0	SP-SM	27.4					100.0	100.0	100.0	99.8	99.8	99.0	97.5	66.2	11.4
B-101	68.0	- 70.0	SM	25.4					100.0	100.0	100.0	100.0	99.9	99.3	98.7	97.3	19.2
B-101	83.0	- 85.0	SM	12.8					100.0	100.0	100.0	99.9	98.5	88.2	67.5	44.9	33.3
B-201	4.0	- 6.0	OL	150.5	39.5												
B-201	8.0	- 10.0	SM	25.5					100.0	91.1	87.9	85.1	81.3	67.3	39.7	25.2	18.7
B-201	16.0	- 18.0	SP-SM	23.1					100.0	100.0	100.0	99.8	98.5	64.6	12.7	7.9	6.0
B-201	56.0	- 58.0	SM	24.4					100.0	100.0	100.0	100.0	99.9	99.2	97.9	63.1	16.1
B-201	73.0	- 75.0	SM	14.5					100.0	100.0	100.0	99.9	98.8	92.5	71.9	43.3	30.4
B-301	2.0	- 4.0	SM	18.6					90.9	82.9	74.4	68.5	63.4	55.0	38.4	28.9	23.1
B-301	46.0	- 48.0	SC	18.4					100.0	100.0	100.0	100.0	98.3	90.1	78.6	41.3	28.6
B-301	48.0	- 50.0	SC	19.5					100.0	100.0	100.0	100.0	98.1	88.3	68.2	40.4	31.1
B-301	53.0	- 55.0	SP-SM	25.4					100.0	100.0	100.0	100.0	100.0	99.7	99.1	56.2	11.3
B-301	78.0	- 80.0	SM	18.3					100.0	97.0	95.7	93.7	90.6	81.4	62.6	20.4	12.3
B-401	4.0	- 6.0	SP	21.1					100.0	100.0	99.9	99.9	98.9	79.8	31.9	8.9	3.3
B-401	23.0	- 25.0	SP	23.8					100.0	100.0	100.0	100.0	99.5	86.7	40.6	9.0	4.9
B-401	66.0	- 68.0	SP-SM	28.4					100.0	100.0	99.9	99.9	99.6	98.5	95.5	53.0	7.0
B-401	71.0	- 73.0	SP-SM	22.3					100.0	98.6	98.0	97.6	95.9	83.5	70.9	56.1	10.9

**TABLE - 1**

**SUMMARY OF LABORATORY TESTING RESULTS [BRIDGE STRUCTURES]**

**Project Name: PD&E Study - SW 10th Street From Powerline Road to Military Trail**

Boring No.	Sample Depth (ft)		USCS Symbol	Natural Moisture Content (%)	Organic Content (%)	Atterberg Limits			Sieve Analysis								
						LL (%)	PL (%)	PI (%)	3/4"	3/8"	#4	#10	#20	#40	#60	#100	#200
B-501	8.0	- 10.0	SM	14.9					97.4	88.6	80.9	77.3	72.9	55.9	29.1	20.6	16.5
B-501	28.0	- 30.0	SP	30.0					100.0	100.0	100.0	99.9	99.7	98.0	83.2	25.3	4.1
B-501	53.0	- 55.0	SP-SM	19.7					100.0	100.0	100.0	100.0	98.7	85.6	60.3	25.1	11.0
B-601	16.0	- 18.0	SP-SM	23.2					96.8	88.5	83.4	76.1	68.7	56.8	28.6	13.3	10.3
B-601	18.0	- 20.0	SP-SM	20.9					100.0	100.0	100.0	99.9	97.9	83.9	42.9	12.4	9.1
B-601	51.0	- 53.0	SP	16.9					100.0	100.0	100.0	100.0	97.2	69.1	27.2	8.3	4.5
B-601	63.0	- 65.0	SM	13.8					88.4	79.0	71.2	64.6	60.3	46.4	23.1	16.0	12.0

# GCME

Geotechnical - Consulting - Engineering - Testing

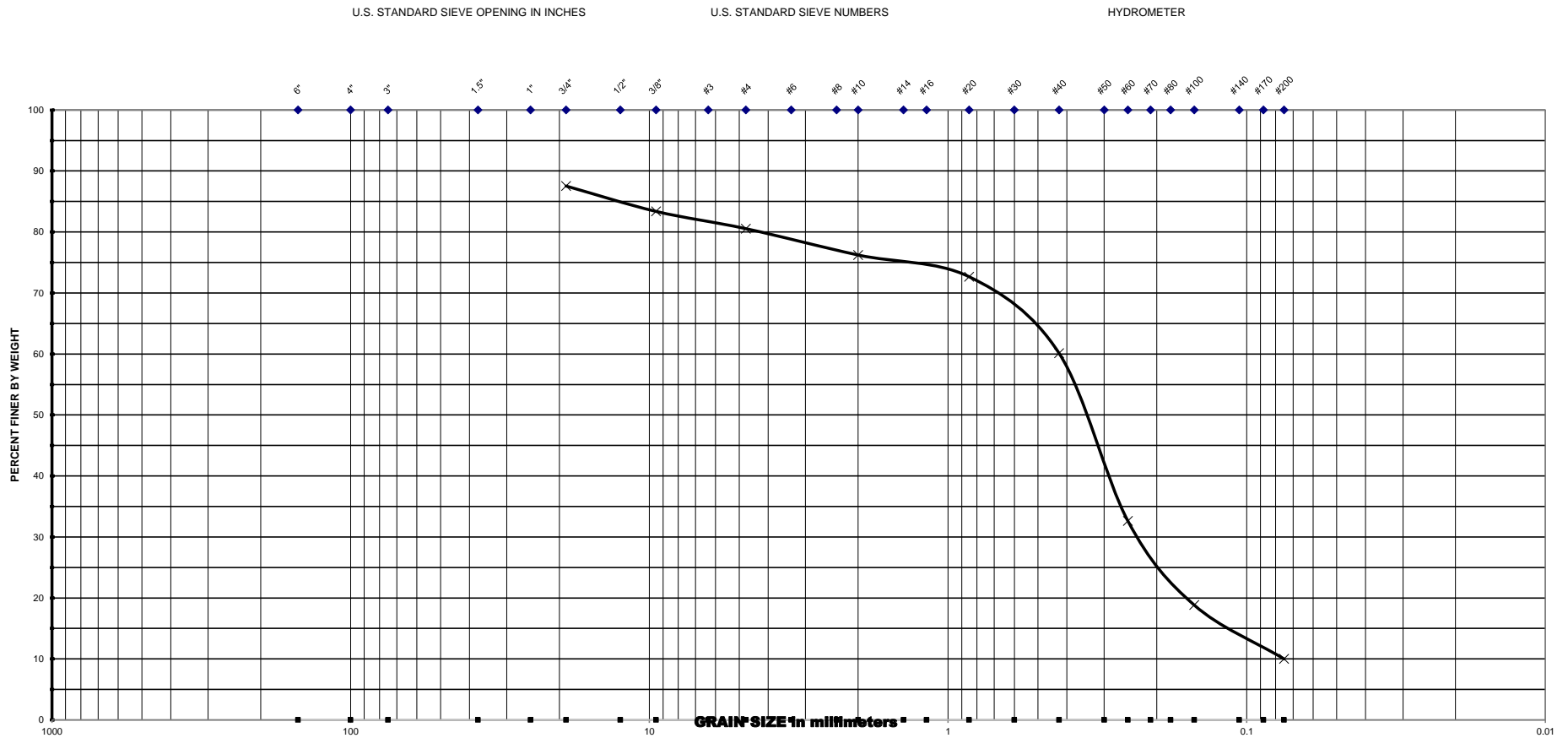

Project Name : <u>PD&amp;E Study - SW 10th Street, From Powerline Road to Military Trail</u>					U.S. SIEVE NO.	CUMM. % PASSING
Project No. : <u>2000-01-17003</u> Date : <u>2/27/2018</u>					3/4"	87.5
					3/8"	83.4
					#4	80.5
BORING NO.	DEPTH INTERVAL [FT]	SOIL DESCRIPTION	MC	OC	#10	76.2
B-101	16.0 - 18.0	SP-SM	18.0		#20	72.7
					#40	60.1
					#60	32.6
Note : MC - Moisture Content (%) OC - Organic Content (%)					#100	18.8
					#200	10.0

# GCME

Geotechnical - Consulting - Engineering - Testing

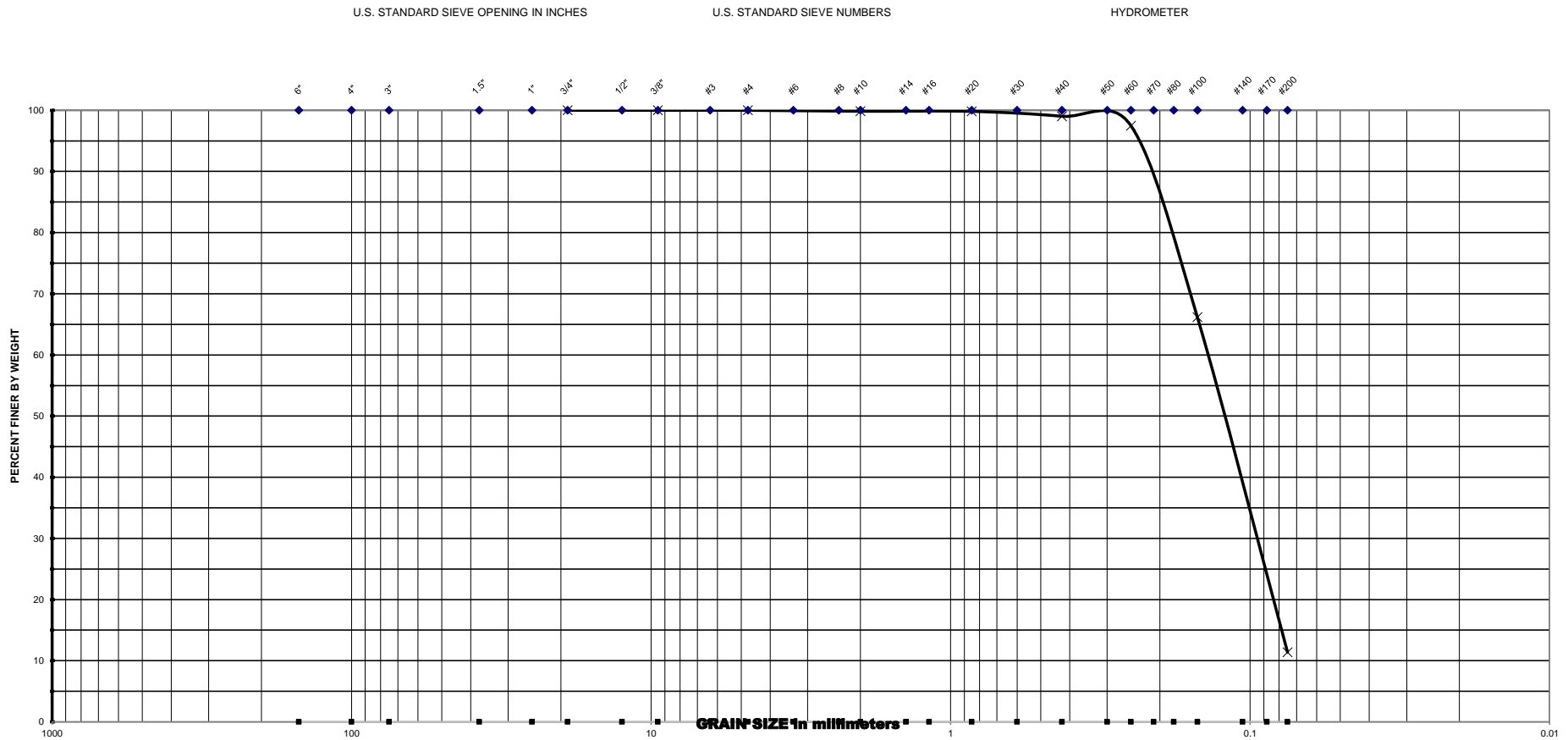

Project Name : <u>PD&amp;E Study - SW 10th Street, From Powerline Road to Military Trail</u>					<b>U.S SIEVE NO.</b>	<b>CUMM. % PASSING</b>
Project No. : <u>2000-01-17003</u> Date : <u>2/27/2018</u>					3/4"	100.0
					3/8"	100.0
					#4	100.0
<b>BORING NO.</b>	<b>DEPTH INTERVAL [FT]</b>	<b>SOIL DESCRIPTION</b>	<b>MC</b>	<b>OC</b>	#10	99.8
B-101	51.0 - 53.0	SP-SM	27.4		#20	99.8
					#40	99.0
					#60	97.5
<p style="text-align: right;">Note : MC - Moisture Content (%) OC - Organic Content (%)</p>					#100	66.2
					#200	11.4

# GCME

Geotechnical - Consulting - Engineering - Testing

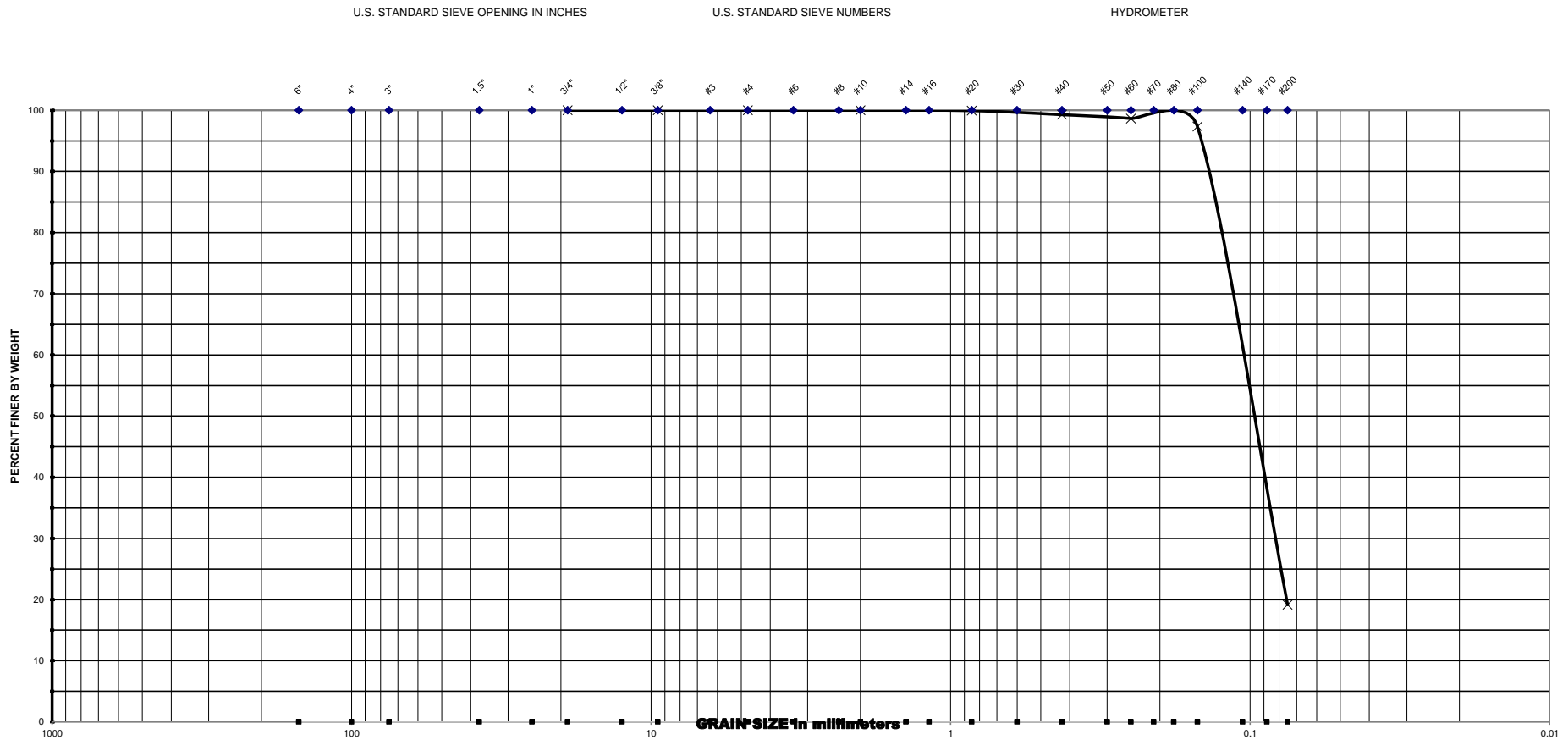

Project Name : PD&E Study - SW 10th Street, From Powerline Road to Military Trail

Project No. : 2000-01-17003

Date : 2/27/2018

U.S SIEVE NO.	CUMM. % PASSING
3/4"	100.0
3/8"	100.0
#4	100.0
#10	100.0
#20	99.9
#40	99.3
#60	98.7
#100	97.3
#200	19.2

BORING NO.	DEPTH INTERVAL [FT]	SOIL DESCRIPTION	MC	OC
B-101	68.0 - 70.0	SM	25.4	

Note : MC - Moisture Content (%)  
OC - Organic Content (%)

# GCME

Geotechnical - Consulting - Engineering - Testing

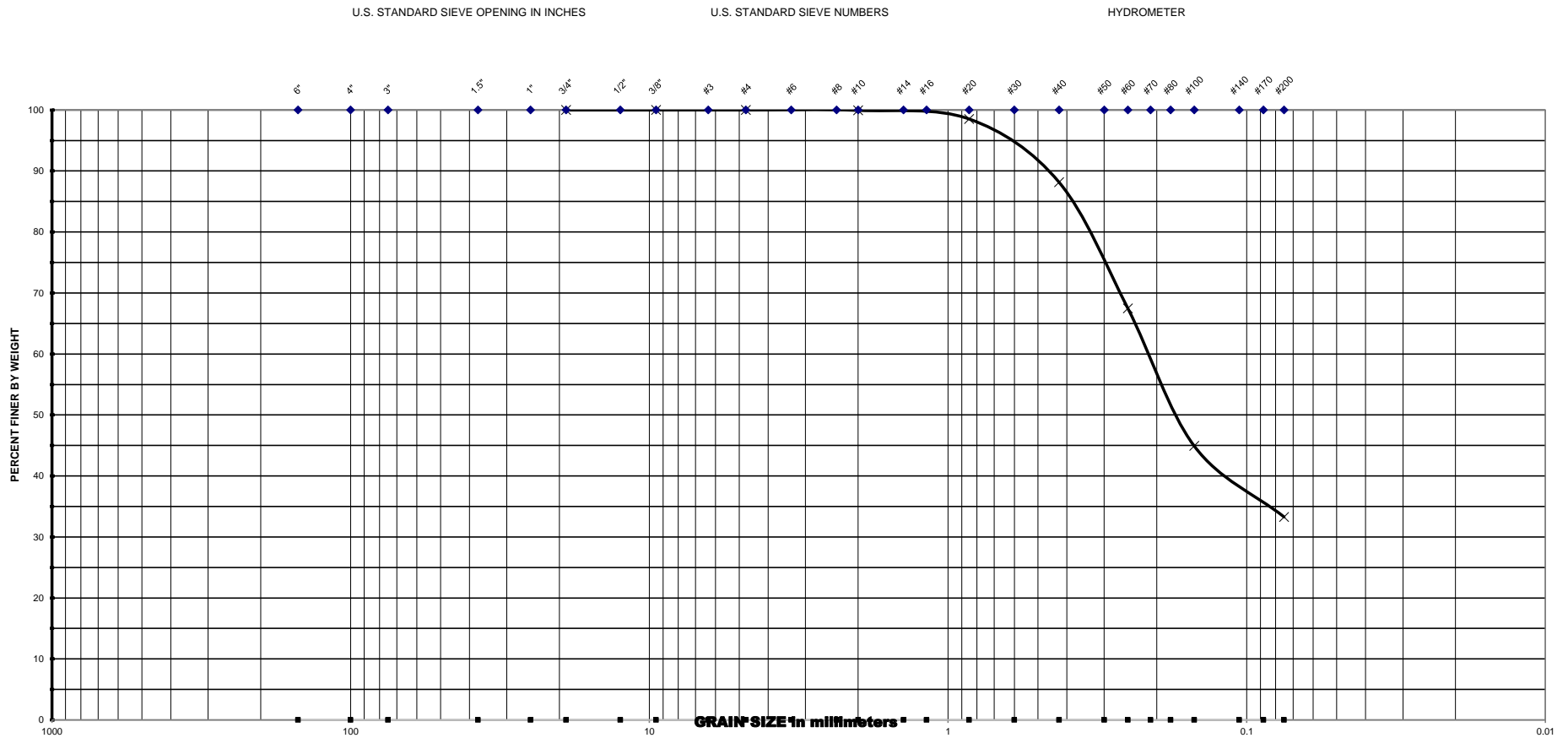

Project Name : PD&E Study - SW 10th Street, From Powerline Road to Military Trail

Project No. : 2000-01-17003

Date : 2/27/2018

U.S SIEVE NO.	CUMM. % PASSING
3/4"	100.0
3/8"	100.0
#4	100.0
#10	99.9
#20	98.5
#40	88.2
#60	67.5
#100	44.9
#200	33.3

BORING NO.	DEPTH INTERVAL [FT]	SOIL DESCRIPTION	MC	OC
B-101	83.0 - 85.0	SM	12.8	

Note : MC - Moisture Content (%)  
OC - Organic Content (%)



# GCME

Geotechnical - Consulting - Engineering - Testing

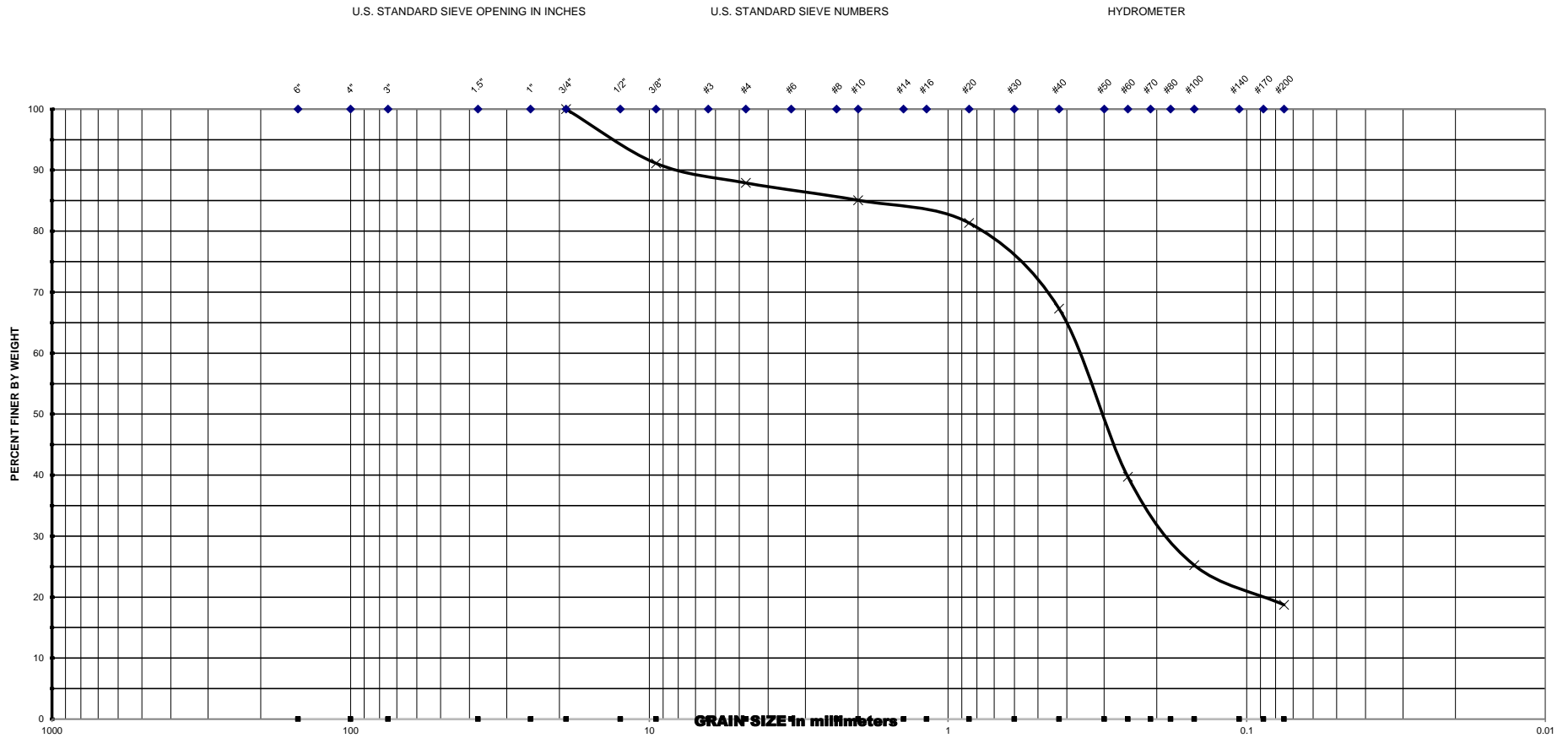

Project Name : PD&E Study - SW 10th Street, From Powerline Road to Military Trail

Project No. : 2000-01-17003

Date : 2/27/2018

U.S SIEVE NO.	CUMM. % PASSING
3/4"	100.0
3/8"	91.1
#4	87.9
#10	85.1
#20	81.3
#40	67.3
#60	39.7
#100	25.2
#200	18.7

BORING NO.	DEPTH INTERVAL [FT]	SOIL DESCRIPTION	MC	OC
B-201	8.0 - 10.0	SM	25.5	

Note : MC - Moisture Content (%)  
OC - Organic Content (%)

# GCME

Geotechnical - Consulting - Engineering - Testing

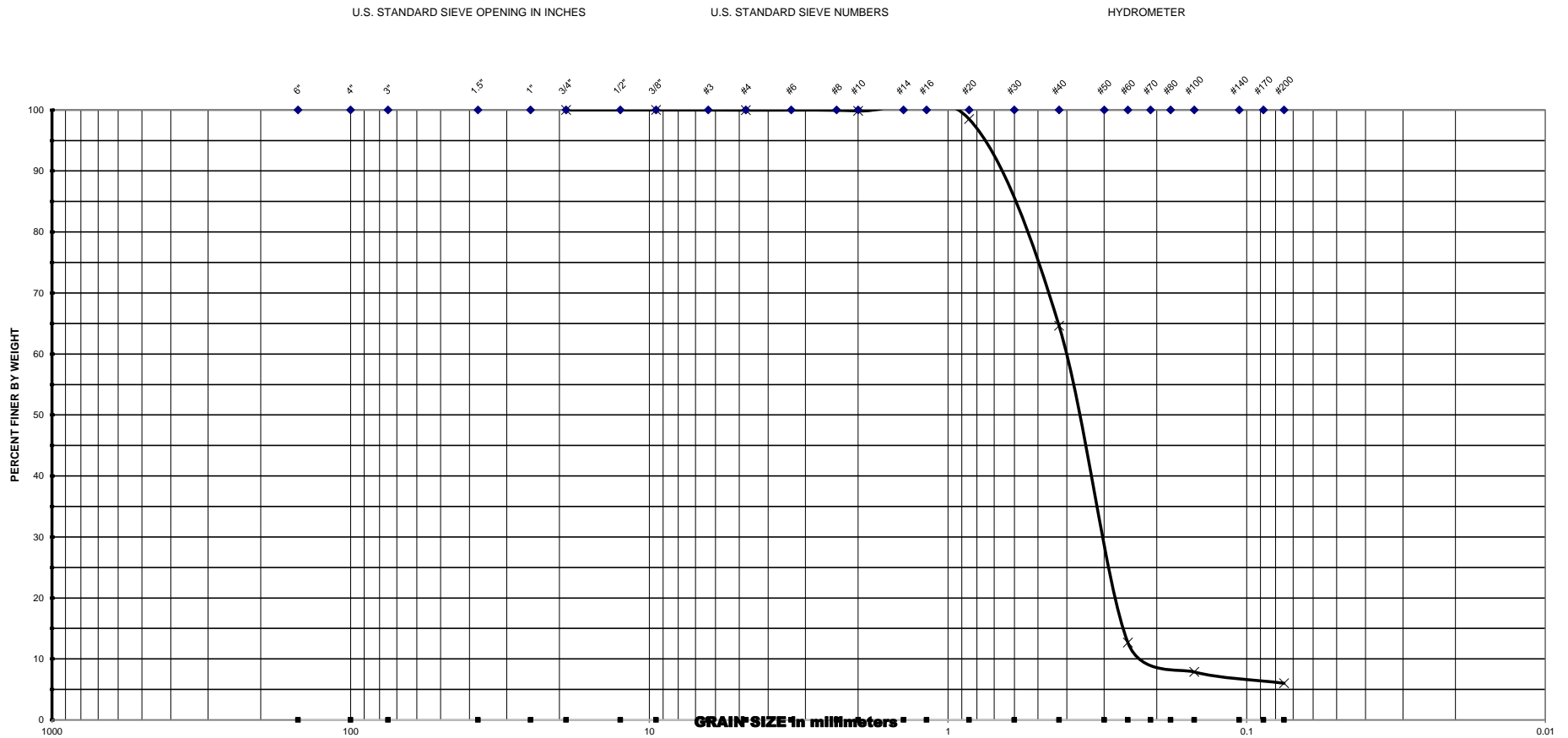

Project Name : <u>PD&amp;E Study - SW 10th Street, From Powerline Road to Military Trail</u>					<b>U.S SIEVE NO.</b>	<b>CUMM. % PASSING</b>
Project No. : <u>2000-01-17003</u> Date : <u>2/27/2018</u>					<u>3/4"</u>	100.0
					<u>3/8"</u>	100.0
					<u>#4</u>	100.0
<b>BORING NO.</b>	<b>DEPTH INTERVAL [FT]</b>	<b>SOIL DESCRIPTION</b>	<b>MC</b>	<b>OC</b>	<u>#10</u>	99.8
B-201	16.0 - 18.0	SP-SM	23.1		<u>#20</u>	98.5
					<u>#40</u>	64.6
					<u>#60</u>	12.7
<b>Note :</b> MC - Moisture Content (%) OC - Organic Content (%)					<u>#100</u>	7.9
					<u>#200</u>	6.0

# GCME

Geotechnical - Consulting - Engineering - Testing

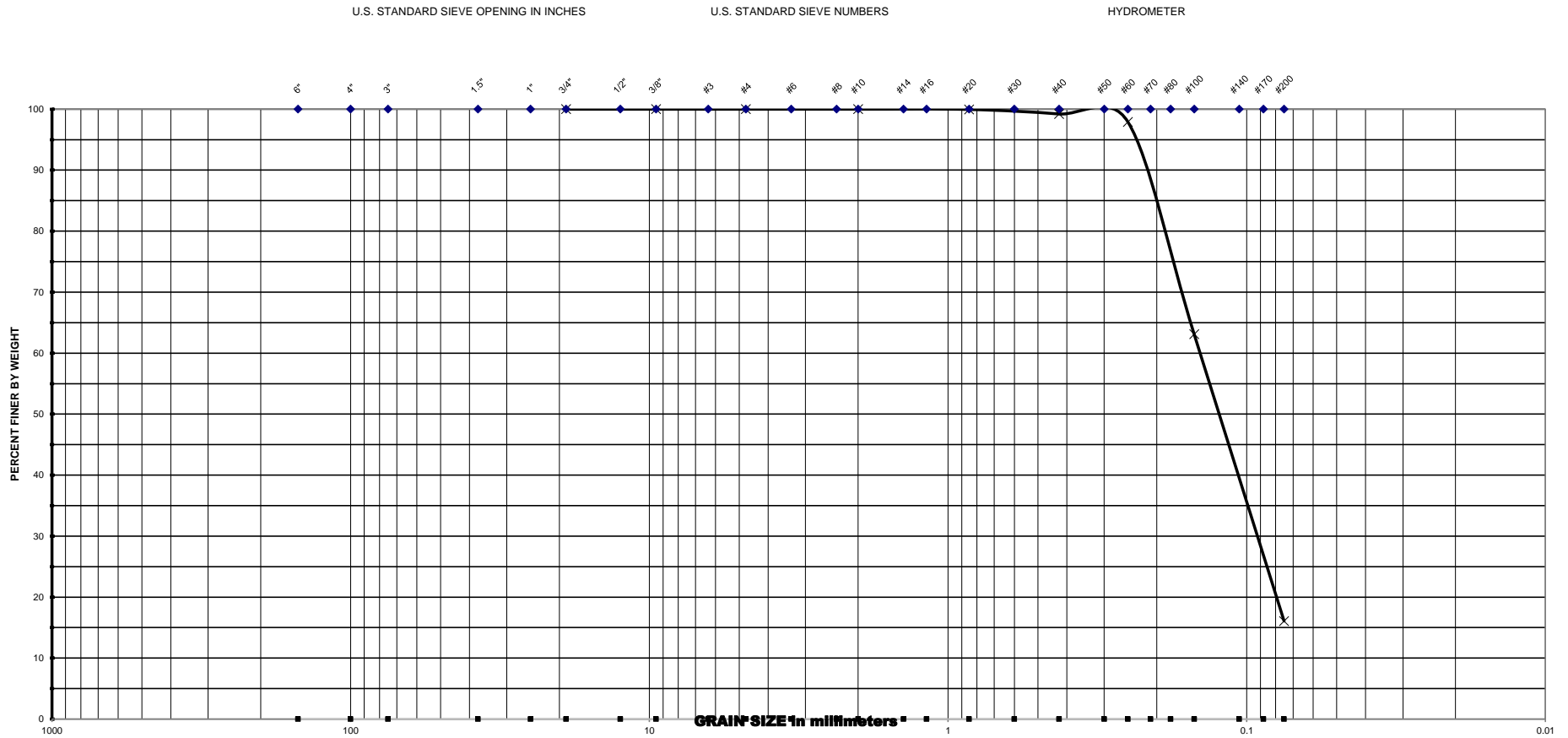

Project Name : <u>PD&amp;E Study - SW 10th Street, From Powerline Road to Military Trail</u>					<b>U.S SIEVE NO.</b>	<b>CUMM. % PASSING</b>
Project No. : <u>2000-01-17003</u> Date : <u>2/27/2018</u>					3/4"	100.0
					3/8"	100.0
					#4	100.0
<b>BORING NO.</b>	<b>DEPTH INTERVAL [FT]</b>	<b>SOIL DESCRIPTION</b>	<b>MC</b>	<b>OC</b>	#10	100.0
B-201	56.0 - 58.0	SM	24.4		#20	99.9
					#40	99.2
					#60	97.9
Note : MC - Moisture Content (%) OC - Organic Content (%)					#100	63.1
					#200	16.1

# GCME

Geotechnical - Consulting - Engineering - Testing

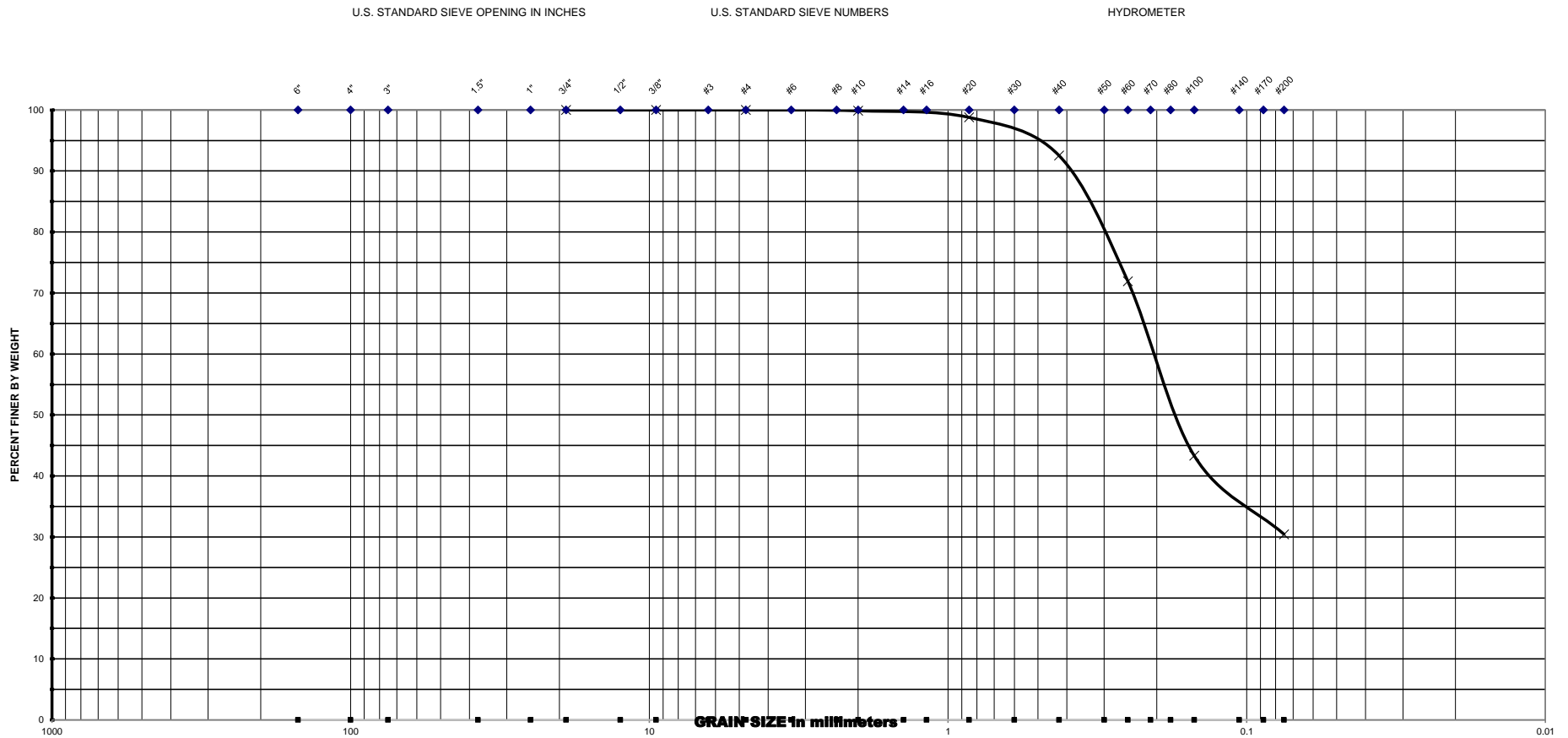

Project Name : PD&E Study - SW 10th Street, From Powerline Road to Military Trail

Project No. : 2000-01-17003

Date : 2/27/2018

U.S SIEVE NO.	CUMM. % PASSING
3/4"	100.0
3/8"	100.0
#4	100.0
#10	99.9
#20	98.8
#40	92.5
#60	71.9
#100	43.3
#200	30.4

BORING NO.	DEPTH INTERVAL [FT]	SOIL DESCRIPTION	MC	OC
B-201	73.0 - 75.0	SM	14.5	

Note : MC - Moisture Content (%)  
OC - Organic Content (%)

# GCME

Geotechnical - Consulting - Engineering - Testing

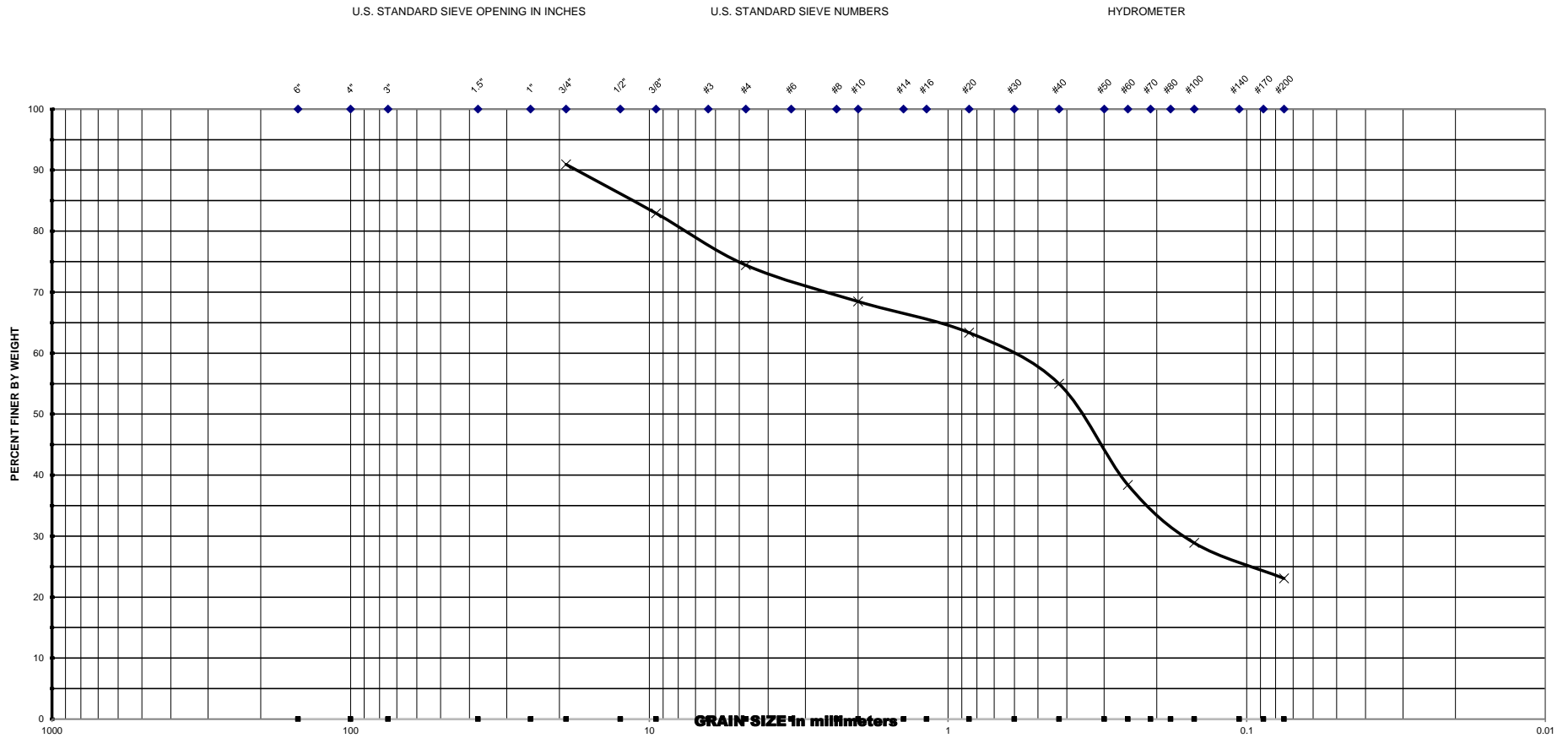

<b>Project Name :</b> <u>PD&amp;E Study - SW 10th Street, From Powerline Road to Military Trail</u>					<b>U.S. SIEVE NO.</b>	<b>CUMM. % PASSING</b>
					<u>3/4"</u>	90.9
<b>Project No. :</b> <u>2000-01-17003</u>					<b>Date :</b> <u>2/27/2018</u>	
<b>BORING NO.</b>	<b>DEPTH INTERVAL [FT]</b>	<b>SOIL DESCRIPTION</b>	<b>MC</b>	<b>OC</b>	<b>#10</b>	68.5
B-301	2.0 - 4.0	SM	18.6		<b>#20</b>	63.4
					<b>#40</b>	55.0
					<b>#60</b>	38.4
<b>Note :</b> MC - Moisture Content (%) OC - Organic Content (%)					<b>#100</b>	28.9
					<b>#200</b>	23.1

# GCME

Geotechnical - Consulting - Engineering - Testing

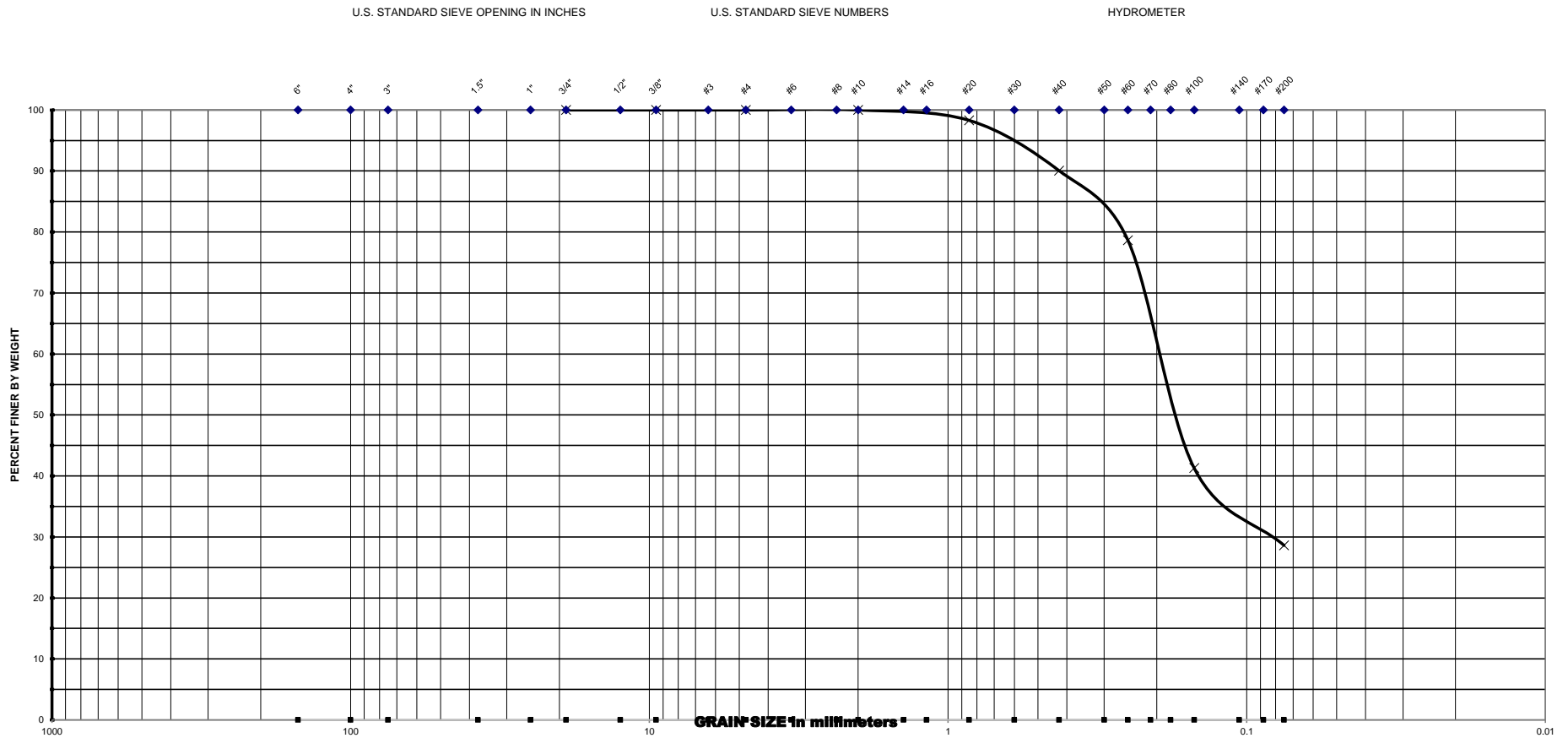

Project Name : PD&E Study - SW 10th Street, From Powerline Road to Military Trail

Project No. : 2000-01-17003

Date : 2/27/2018

U.S SIEVE NO.	CUMM. % PASSING
3/4"	100.0
3/8"	100.0
#4	100.0
#10	100.0
#20	98.3
#40	90.1
#60	78.6
#100	41.3
#200	28.6

BORING NO.	DEPTH INTERVAL [FT]	SOIL DESCRIPTION	MC	OC
B-301	46.0 - 48.0	SC	18.4	

Note : MC - Moisture Content (%)  
OC - Organic Content (%)

# GCME

Geotechnical - Consulting - Engineering - Testing

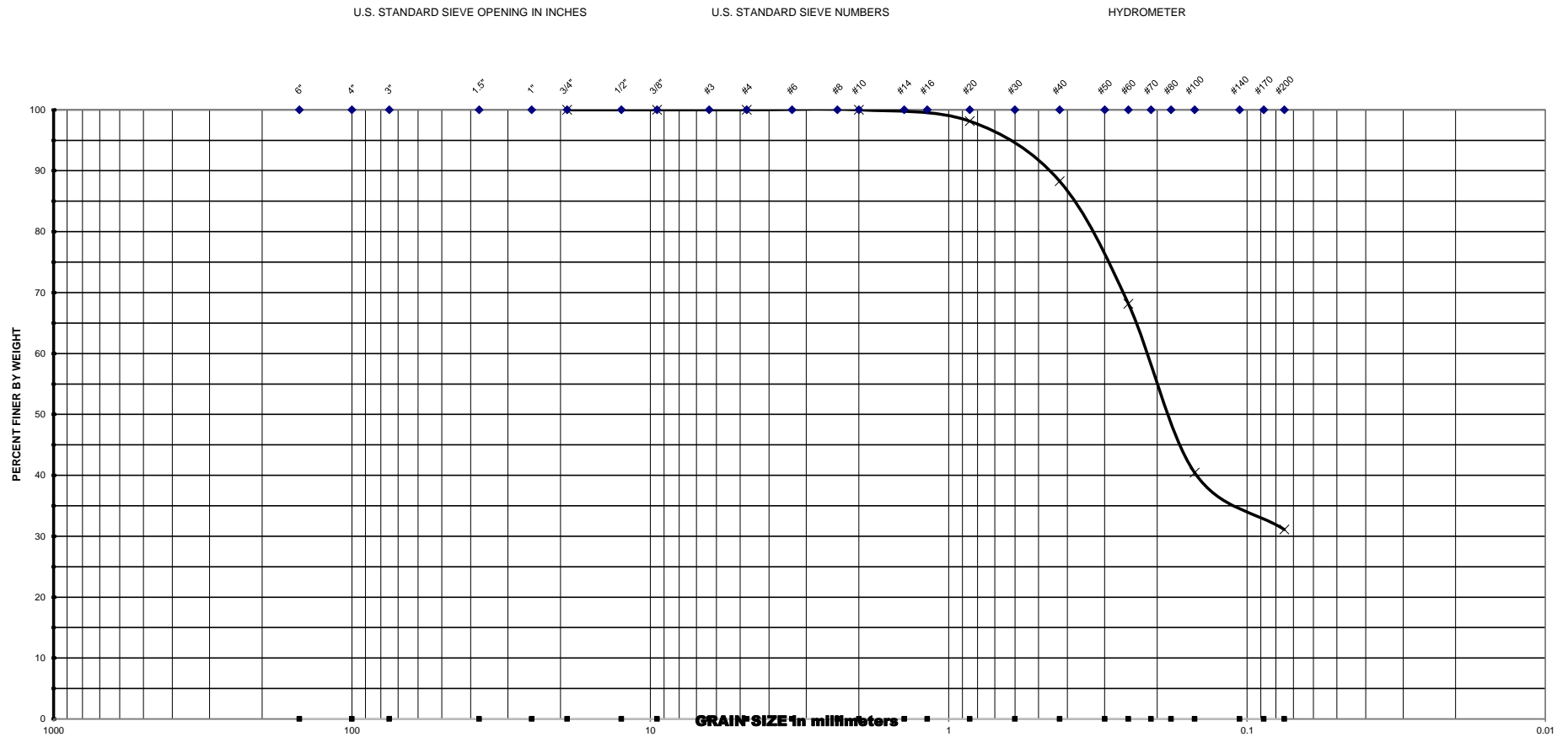

Project Name : PD&E Study - SW 10th Street, From Powerline Road to Military Trail

Project No. : 2000-01-17003

Date : 2/27/2018

U.S SIEVE NO.	CUMM. % PASSING
3/4"	100.0
3/8"	100.0
#4	100.0
#10	100.0
#20	98.1
#40	88.3
#60	68.2
#100	40.4
#200	31.1

BORING NO.	DEPTH INTERVAL [FT]	SOIL DESCRIPTION	MC	OC
B-301	48.0 - 50.0	SC	19.5	

Note : MC - Moisture Content (%)  
OC - Organic Content (%)

# GCME

Geotechnical - Consulting - Engineering - Testing

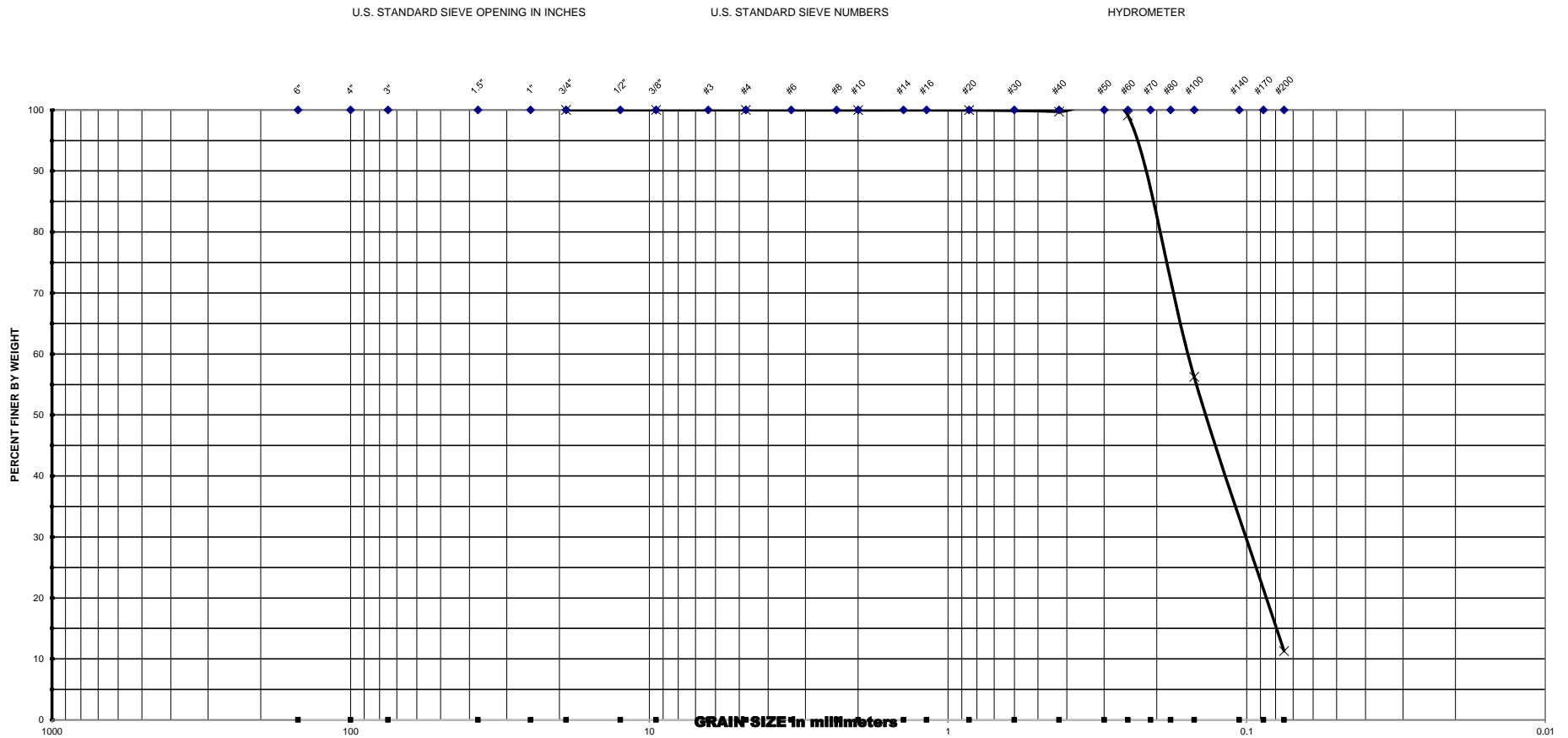

Project Name : <u>PD&amp;E Study - SW 10th Street, From Powerline Road to Military Trail</u>					U.S SIEVE NO.	CUMM. % PASSING
Project No. : <u>2000-01-17003</u> Date : <u>2/27/2018</u>					3/4"	100.0
					3/8"	100.0
					#4	100.0
BORING NO.	DEPTH INTERVAL [FT]	SOIL DESCRIPTION	MC	OC	#10	100.0
B-301	53.0 - 55.0	SP-SM	25.4		#20	100.0
					#40	99.7
					#60	99.1
Note : MC - Moisture Content (%) OC - Organic Content (%)					#100	56.2
					#200	11.3



# GCME

Geotechnical - Consulting - Engineering - Testing

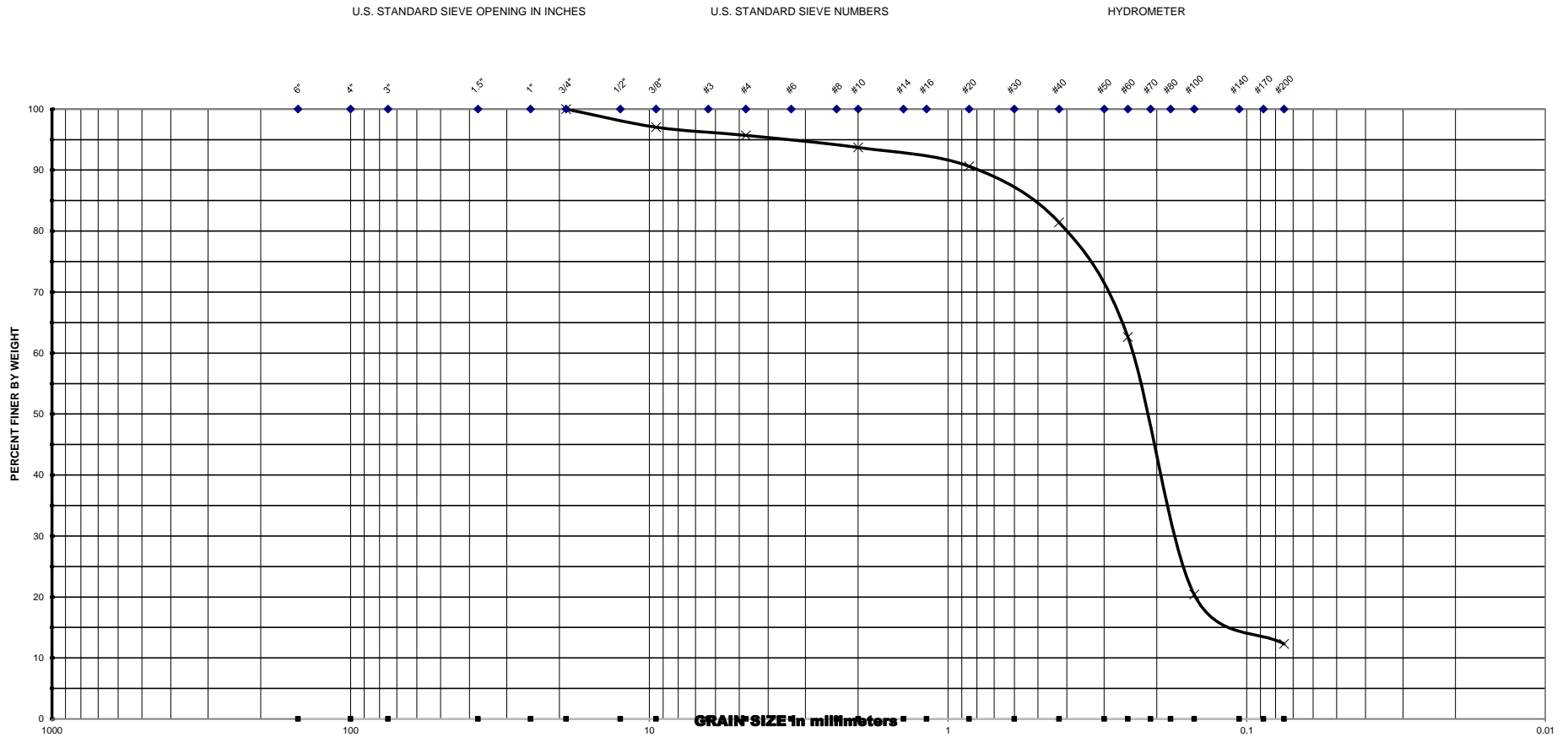

Project Name : PD&E Study - SW 10th Street, From Powerline Road to Military Trail

Project No. : 2000-01-17003

Date : 2/27/2018

U.S SIEVE NO.	CUMM. % PASSING
3/4"	100.0
3/8"	97.0
#4	95.7
#10	93.7
#20	90.6
#40	81.4
#60	62.6
#100	20.4
#200	12.3

BORING NO.	DEPTH INTERVAL [FT]	SOIL DESCRIPTION	MC	OC
B-301	78.0 - 80.0	SM	18.3	

Note : MC - Moisture Content (%)  
OC - Organic Content (%)

# GCME

Geotechnical - Consulting - Engineering - Testing

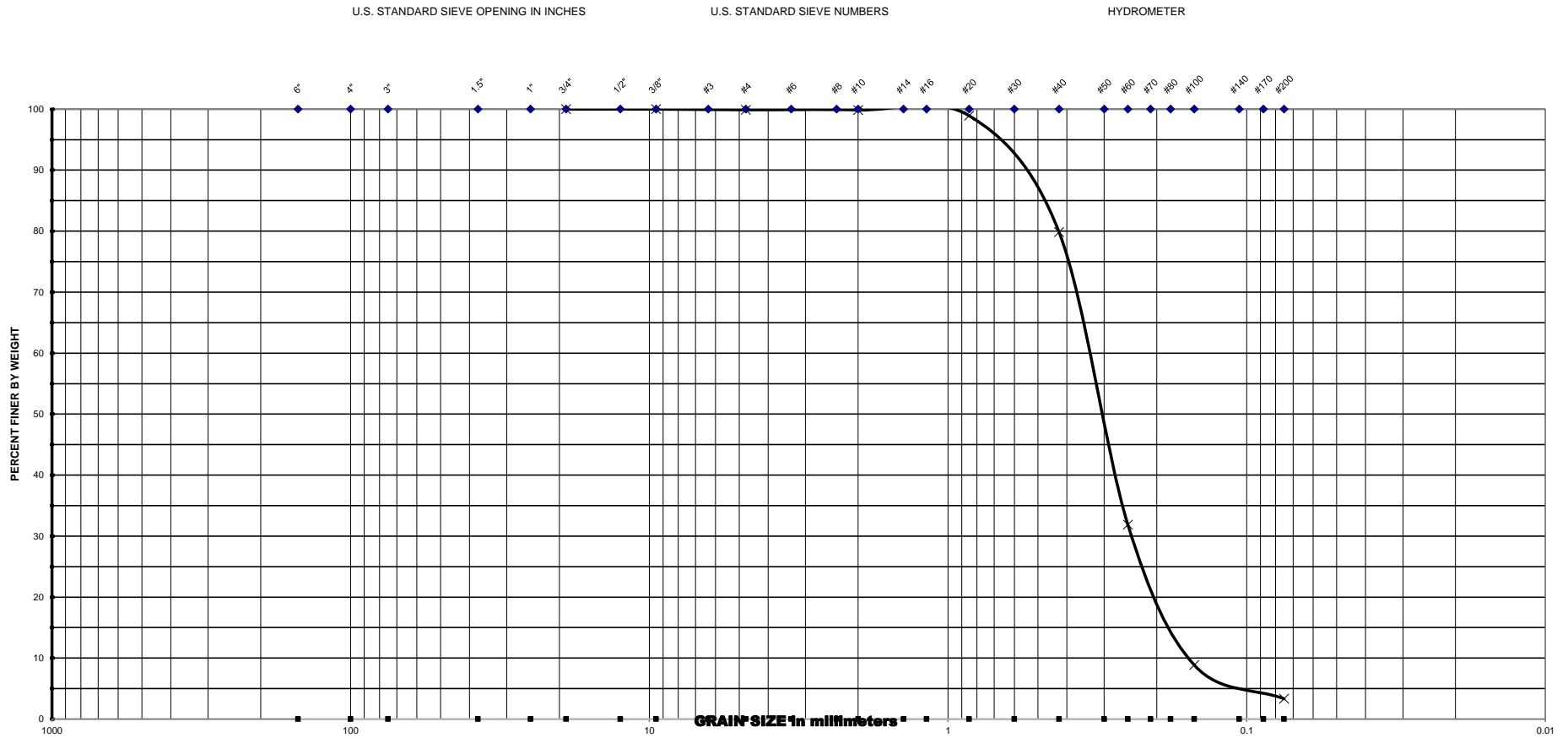

Project Name : PD&E Study - SW 10th Street, From Powerline Road to Military Trail

Project No. : 2000-01-17003

Date : 2/27/2018

U.S SIEVE NO.	CUMM. % PASSING
3/4"	100.0
3/8"	100.0
#4	99.9
#10	99.9
#20	98.9
#40	79.8
#60	31.9
#100	8.9
#200	3.3

BORING NO.	DEPTH INTERVAL [FT]	SOIL DESCRIPTION	MC	OC
B-401	4.0 - 6.0	SP	21.1	

Note : MC - Moisture Content (%)  
OC - Organic Content (%)

# GCME

Geotechnical - Consulting - Engineering - Testing

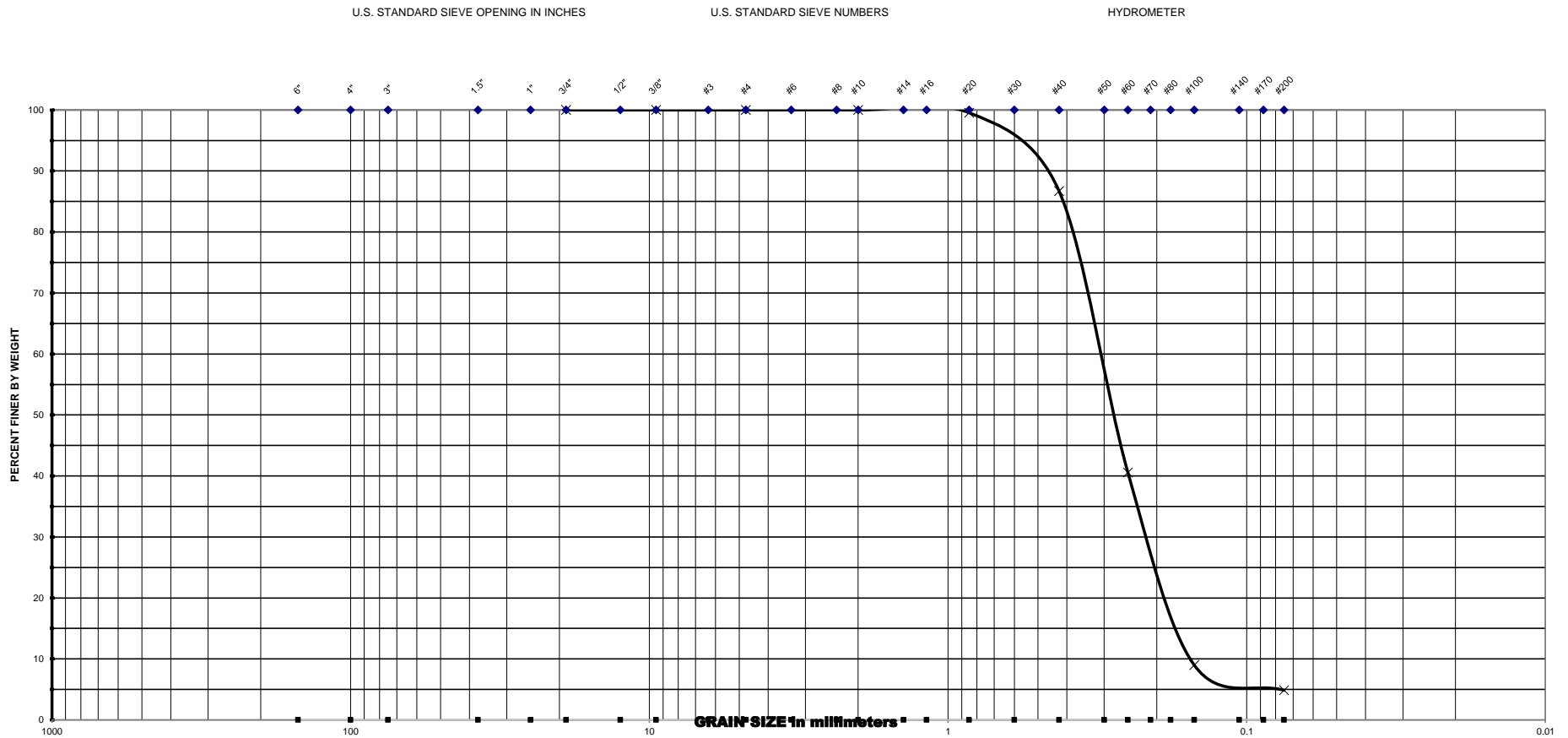

Project Name : PD&E Study - SW 10th Street, From Powerline Road to Military Trail

Project No. : 2000-01-17003

Date : 2/27/2018

U.S. SIEVE NO.	CUMM. % PASSING
3/4"	100.0
3/8"	100.0
#4	100.0
#10	100.0
#20	99.5
#40	86.7
#60	40.6
#100	9.0
#200	4.9

BORING NO.	DEPTH INTERVAL [FT]	SOIL DESCRIPTION	MC	OC
B-401	23.0 - 25.0	SP	23.8	

Note : MC - Moisture Content (%)  
OC - Organic Content (%)

# GCME

Geotechnical - Consulting - Engineering - Testing

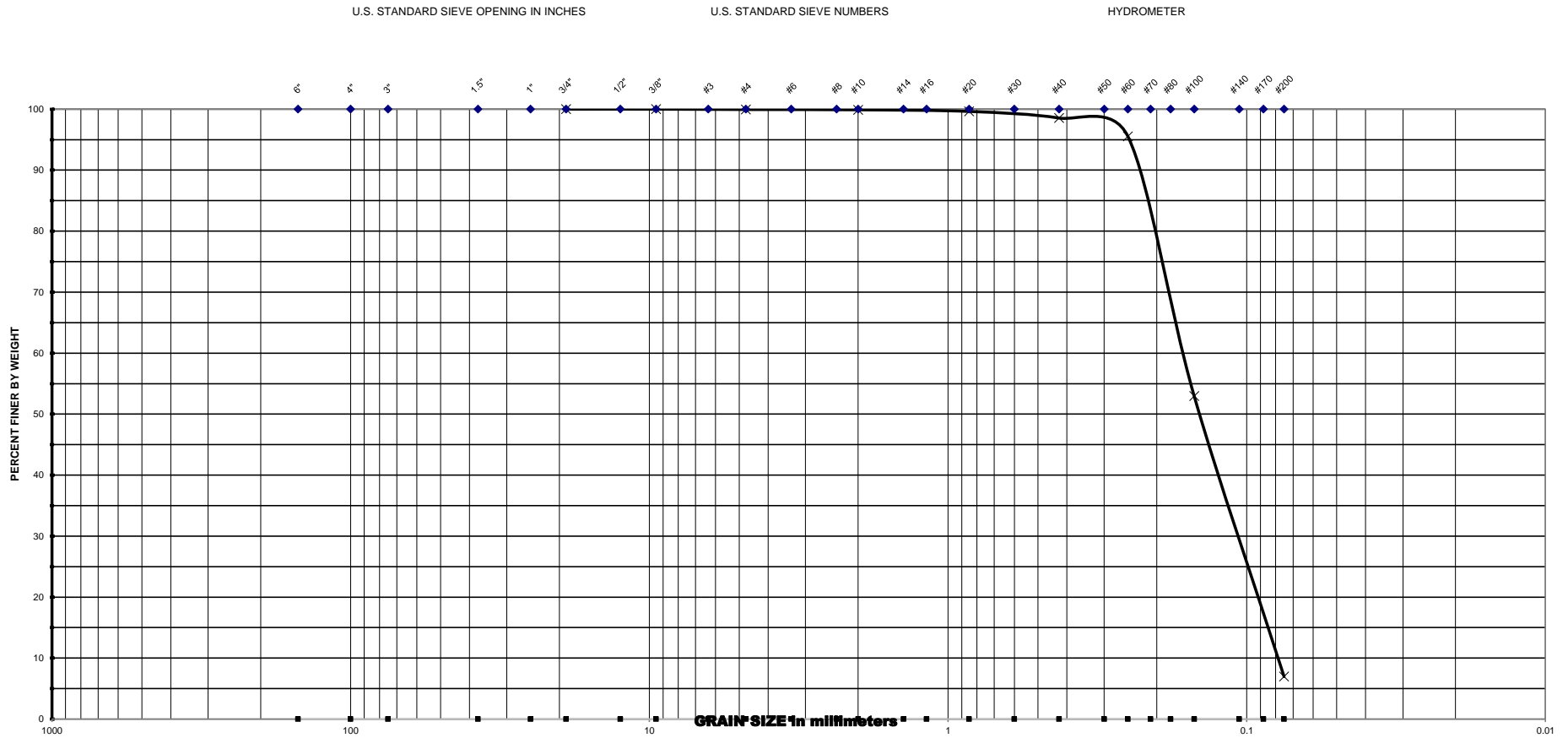

Project Name : <u>PD&amp;E Study - SW 10th Street, From Powerline Road to Military Trail</u>					<b>U.S SIEVE NO.</b>	<b>CUMM. % PASSING</b>
Project No. : <u>2000-01-17003</u> Date : <u>2/27/2018</u>					3/4"	100.0
					3/8"	100.0
					#4	99.9
<b>BORING NO.</b>	<b>DEPTH INTERVAL [FT]</b>	<b>SOIL DESCRIPTION</b>	<b>MC</b>	<b>OC</b>	#10	99.9
B-401	66.0 - 68.0	SP-SM	28.4		#20	99.6
					#40	98.5
					#60	95.5
<p style="text-align: right;">Note : MC - Moisture Content (%) OC - Organic Content (%)</p>					#100	53.0
					#200	7.0

# GCME

**Geotechnical - Consulting - Engineering - Testing**

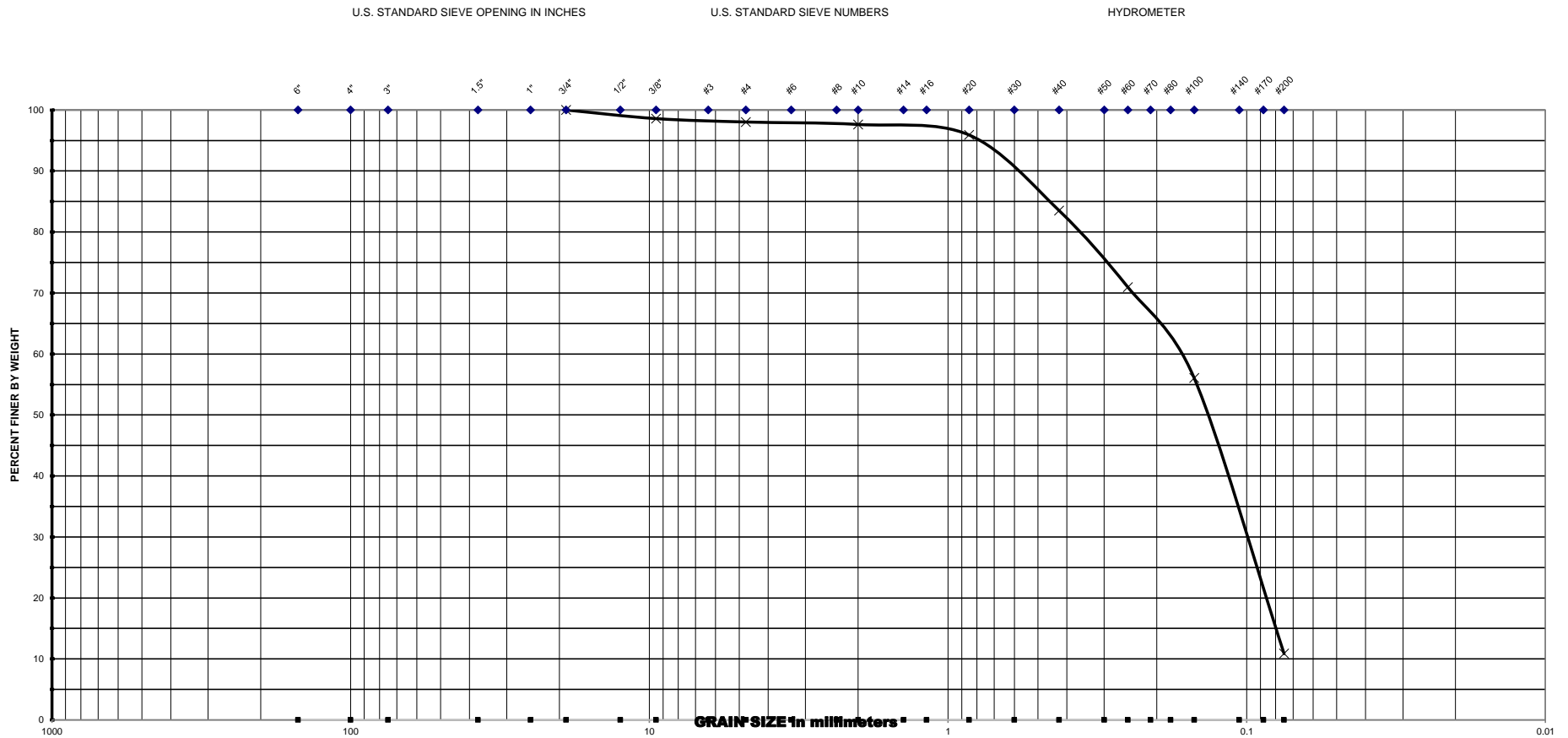

**Project Name :** PD&E Study - SW 10th Street, From Powerline Road to Military Trail

**Project No. :** 2000-01-17003

**Date :** 2/27/2018

U.S SIEVE NO.	CUMM. % PASSING
3/4"	100.0
3/8"	98.6
#4	98.0
#10	97.6
#20	95.9
#40	83.5
#60	70.9
#100	56.1
#200	10.9

BORING NO.	DEPTH INTERVAL [FT]	SOIL DESCRIPTION	MC	OC
B-401	71.0 - 73.0	SP-SM	22.3	

**Note :** MC - Moisture Content (%)  
OC - Organic Content (%)

# GCME

Geotechnical - Consulting - Engineering - Testing

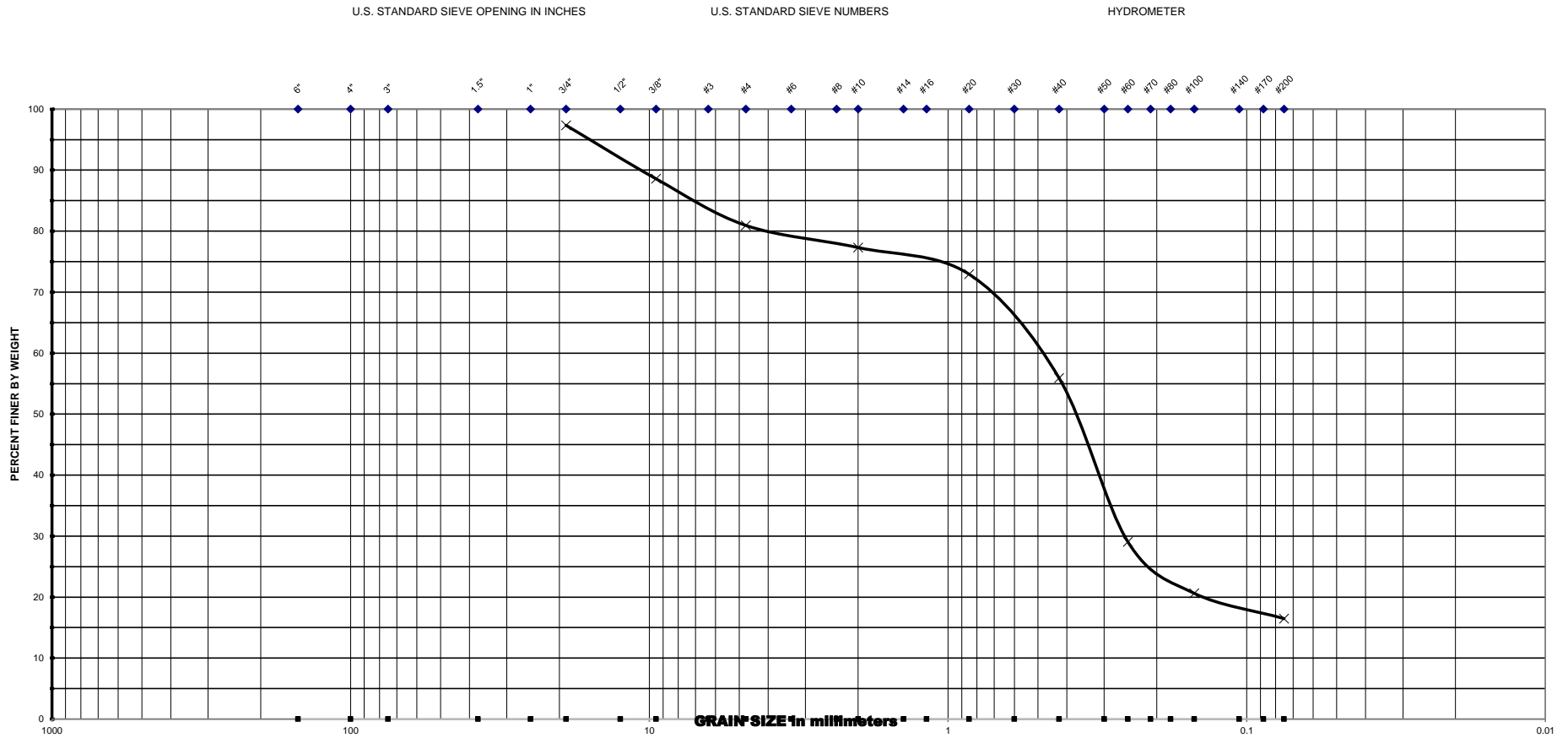

Project Name : <u>PD&amp;E Study - SW 10th Street, From Powerline Road to Military Trail</u>					<b>U.S SIEVE NO.</b>	<b>CUMM. % PASSING</b>
Project No. : <u>2000-01-17003</u> Date : <u>2/27/2018</u>					<u>3/4"</u>	97.4
					<u>3/8"</u>	88.6
					<u>#4</u>	80.9
<b>BORING NO.</b>	<b>DEPTH INTERVAL [FT]</b>	<b>SOIL DESCRIPTION</b>	<b>MC</b>	<b>OC</b>	<u>#10</u>	77.3
B-501	8.0 - 10.0	SM	14.9		<u>#20</u>	72.9
					<u>#40</u>	55.9
					<u>#60</u>	29.1
Note : MC - Moisture Content (%) OC - Organic Content (%)					<u>#100</u>	20.6
					<u>#200</u>	16.5

# GCME

Geotechnical - Consulting - Engineering - Testing

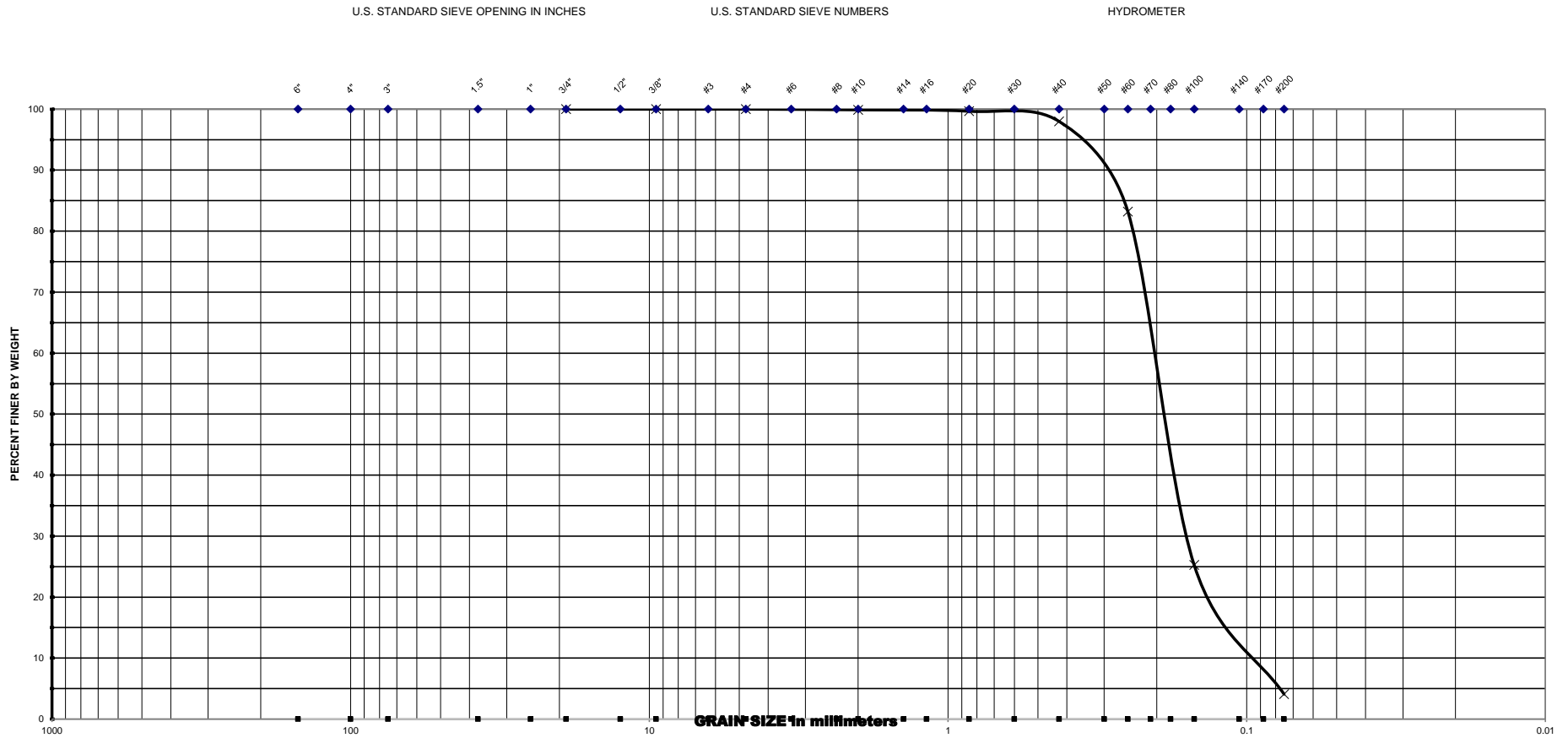

Project Name : <u>PD&amp;E Study - SW 10th Street, From Powerline Road to Military Trail</u>					<b>U.S SIEVE NO.</b>	<b>CUMM. % PASSING</b>
Project No. : <u>2000-01-17003</u> Date : <u>2/27/2018</u>					3/4"	100.0
					3/8"	100.0
					#4	100.0
<b>BORING NO.</b>	<b>DEPTH INTERVAL [FT]</b>	<b>SOIL DESCRIPTION</b>	<b>MC</b>	<b>OC</b>	#10	99.9
B-501	28.0 - 30.0	SP	30.0		#20	99.7
					#40	98.0
					#60	83.2
Note : MC - Moisture Content (%) OC - Organic Content (%)					#100	25.3
					#200	4.1

# GCME

Geotechnical - Consulting - Engineering - Testing

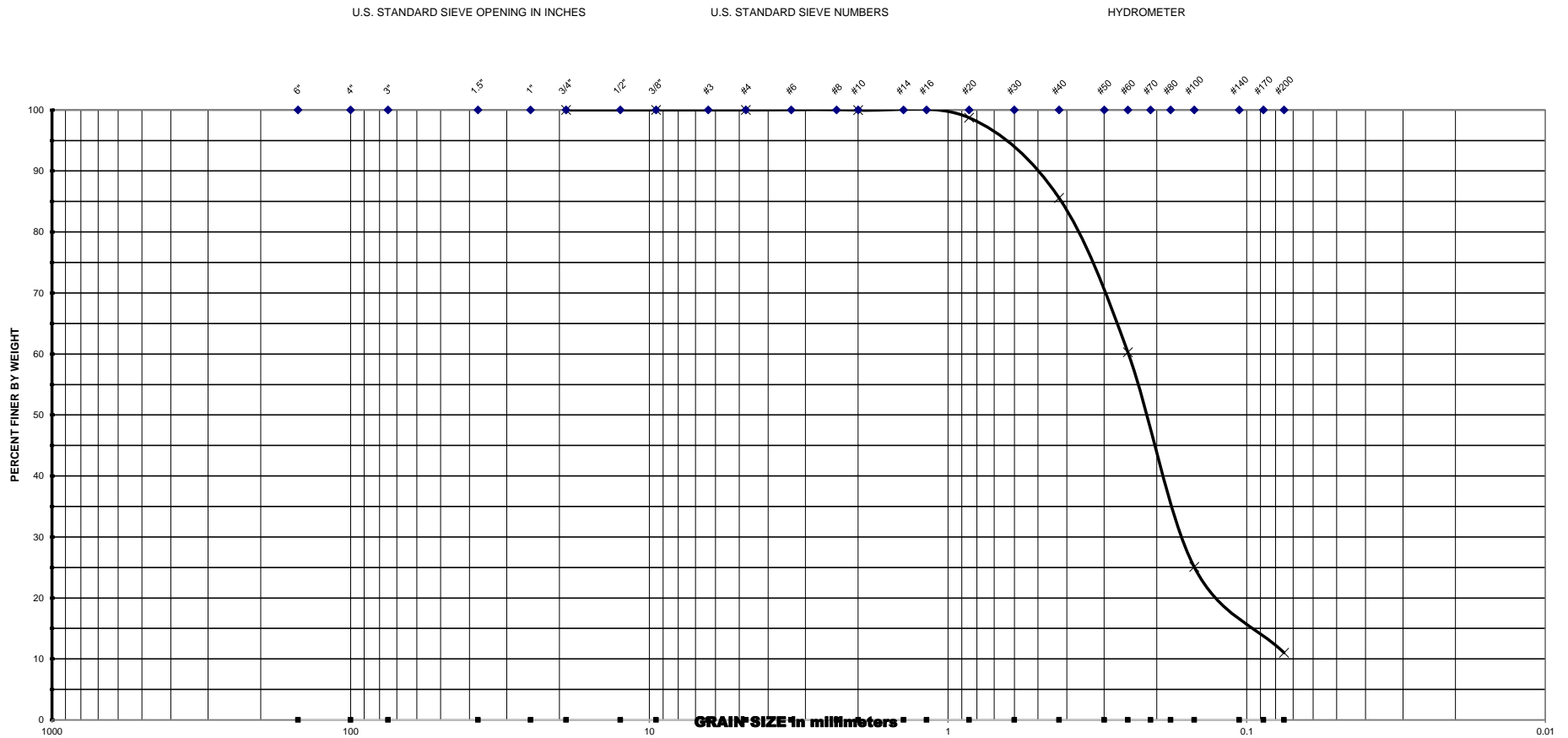

Project Name : <u>PD&amp;E Study - SW 10th Street, From Powerline Road to Military Trail</u>					<b>U.S SIEVE NO.</b>	<b>CUMM. % PASSING</b>
Project No. : <u>2000-01-17003</u>					Date : <u>2/27/2018</u>	
<b>BORING NO.</b>	<b>DEPTH INTERVAL [FT]</b>	<b>SOIL DESCRIPTION</b>	<b>MC</b>	<b>OC</b>	<b>#10</b>	100.0
B-501	53.0 - 55.0	SP-SM	19.7		<b>#20</b>	98.7
					<b>#40</b>	85.6
					<b>#60</b>	60.3
					<b>#100</b>	25.1
					<b>#200</b>	11.0

Note : MC - Moisture Content (%)  
OC - Organic Content (%)



# GCME

Geotechnical - Consulting - Engineering - Testing

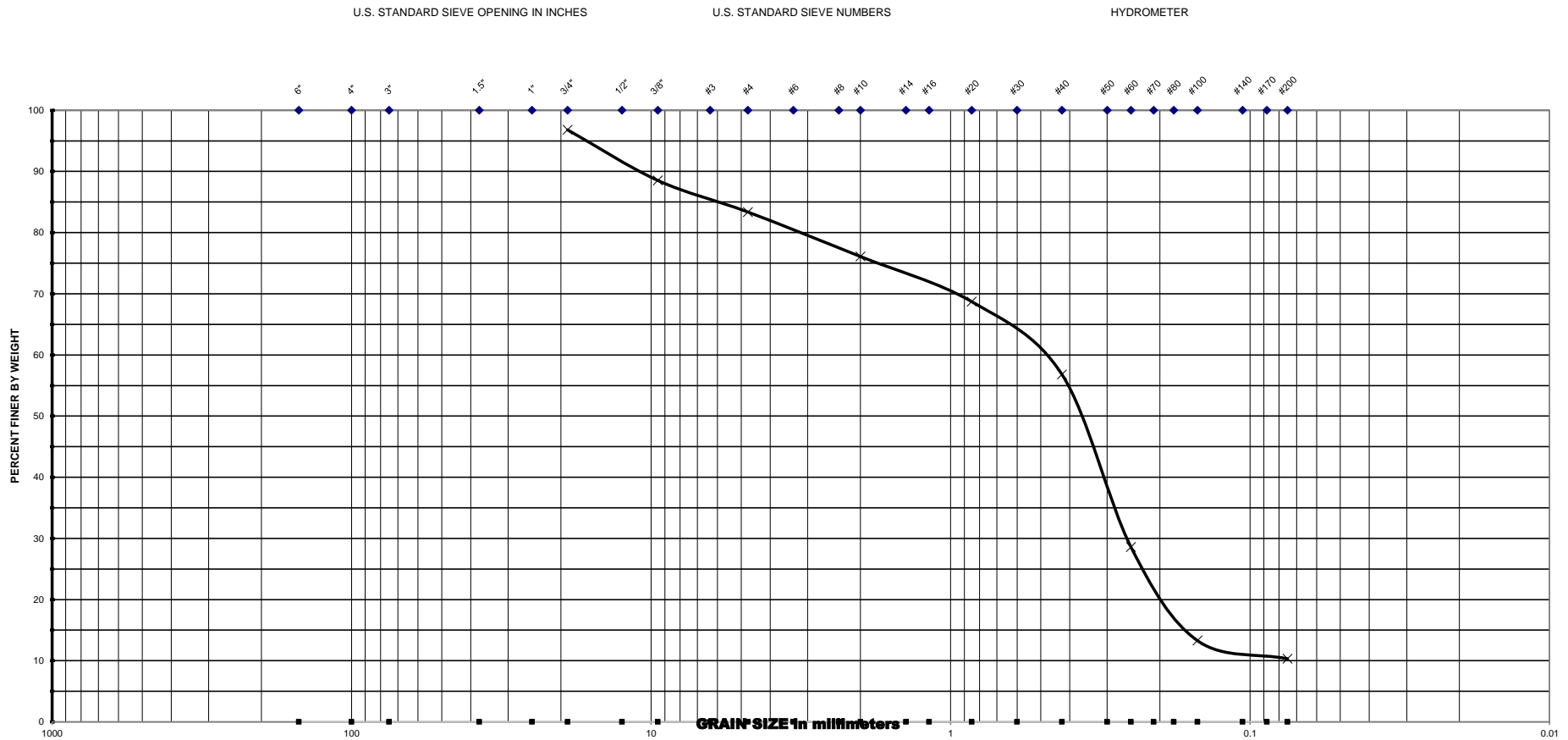

Project Name : <u>PD&amp;E Study - SW 10th Street, From Powerline Road to Military Trail</u>					<b>U.S SIEVE NO.</b>	<b>CUMM. % PASSING</b>
Project No. : <u>2000-01-17003</u> Date : <u>2/27/2018</u>					3/4"	96.8
					3/8"	88.5
					#4	83.4
<b>BORING NO.</b>	<b>DEPTH INTERVAL [FT]</b>	<b>SOIL DESCRIPTION</b>	<b>MC</b>	<b>OC</b>	#10	76.1
B-601	16.0 - 18.0	SP-SM	23.2		#20	68.7
					#40	56.8
					#60	28.6
Note : MC - Moisture Content (%) OC - Organic Content (%)					#100	13.3
					#200	10.3

# GCME

Geotechnical - Consulting - Engineering - Testing

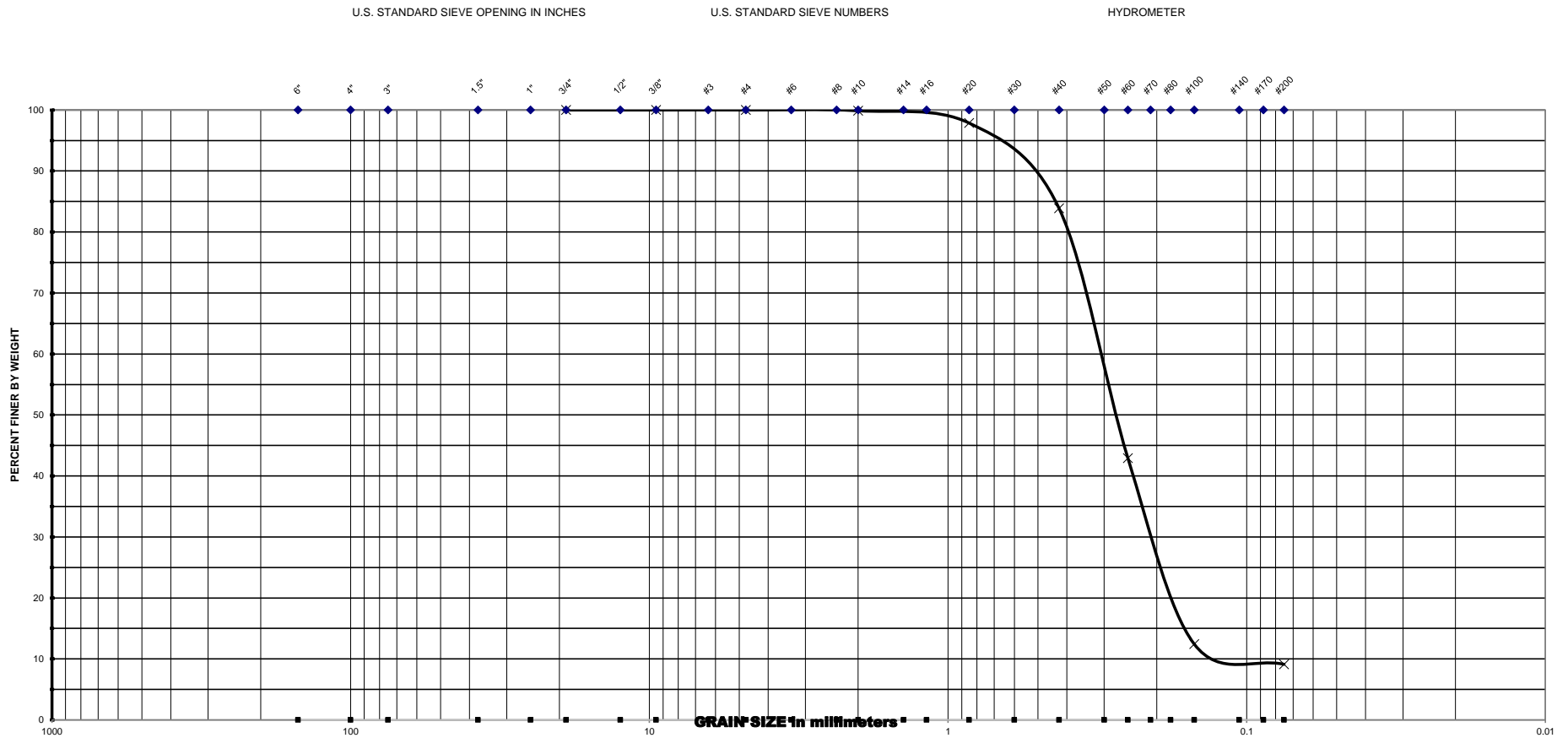

Project Name : <u>PD&amp;E Study - SW 10th Street, From Powerline Road to Military Trail</u>					<b>U.S SIEVE NO.</b>	<b>CUMM. % PASSING</b>
Project No. : <u>2000-01-17003</u>						
Date : <u>2/27/2018</u>					<b>3/4"</b>	100.0
					<b>3/8"</b>	100.0
					<b>#4</b>	100.0
<b>BORING NO.</b>	<b>DEPTH INTERVAL [FT]</b>	<b>SOIL DESCRIPTION</b>	<b>MC</b>	<b>OC</b>	<b>#10</b>	99.9
B-601	18.0 - 20.0	SP-SM	20.9		<b>#20</b>	97.9
					<b>#40</b>	83.9
					<b>#60</b>	42.9
Note : MC - Moisture Content (%) OC - Organic Content (%)					<b>#100</b>	12.4
					<b>#200</b>	9.1

# GCME

Geotechnical - Consulting - Engineering - Testing

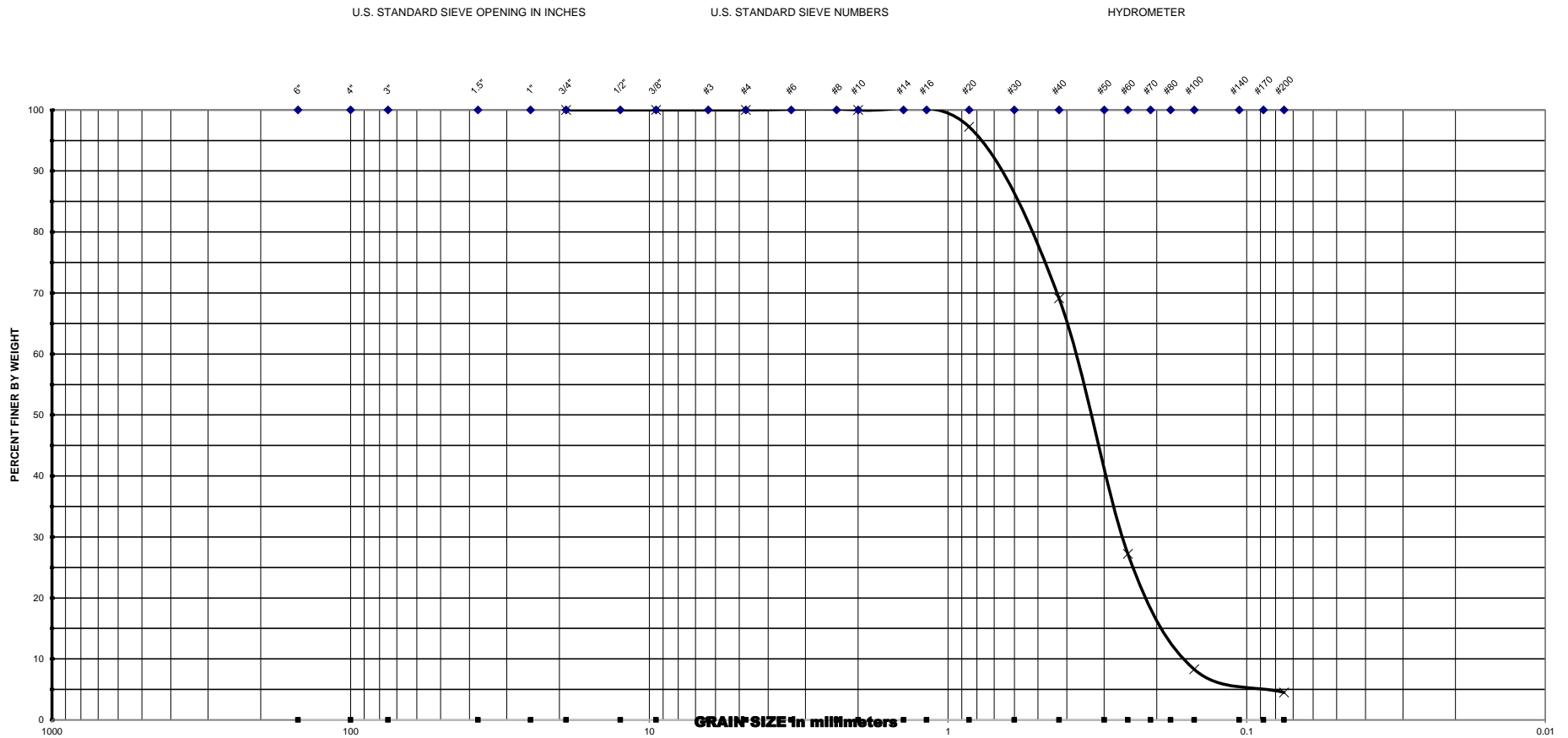

Project Name : <u>PD&amp;E Study - SW 10th Street, From Powerline Road to Military Trail</u>					<b>U.S SIEVE NO.</b>	<b>CUMM. % PASSING</b>
Project No. : <u>2000-01-17003</u> Date : <u>2/27/2018</u>					3/4"	100.0
					3/8"	100.0
					#4	100.0
<b>BORING NO.</b>	<b>DEPTH INTERVAL [FT]</b>	<b>SOIL DESCRIPTION</b>	<b>MC</b>	<b>OC</b>	#10	100.0
B-601	51.0 - 53.0	SP	16.9		#20	97.2
					#40	69.1
					#60	27.2
Note : MC - Moisture Content (%) OC - Organic Content (%)					#100	8.3
					#200	4.5

# GCME

Geotechnical - Consulting - Engineering - Testing

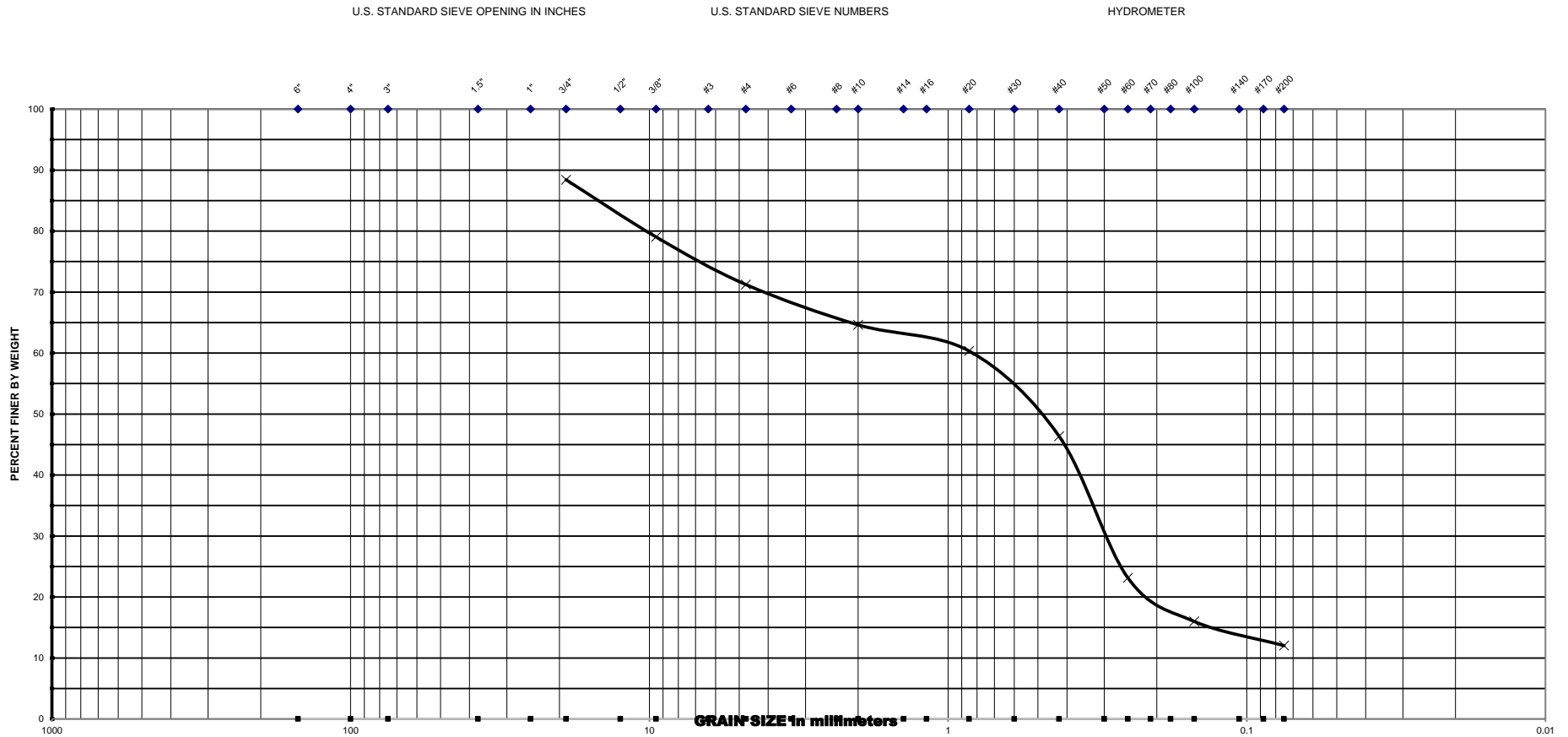

Project Name : <u>PD&amp;E Study - SW 10th Street, From Powerline Road to Military Trail</u>					<b>U.S SIEVE NO.</b>	<b>CUMM. % PASSING</b>
Project No. : <u>2000-01-17003</u> Date : <u>2/27/2018</u>					3/4"	88.4
					3/8"	79.0
					#4	71.2
<b>BORING NO.</b>	<b>DEPTH INTERVAL [FT]</b>	<b>SOIL DESCRIPTION</b>	<b>MC</b>	<b>OC</b>	#10	64.6
B-601	63.0 - 65.0	SM	13.8		#20	60.3
					#40	46.4
					#60	23.1
					#100	16.0
					#200	12.0

**Note :** MC - Moisture Content (%)  
 OC - Organic Content (%)

**TABLE - 1****SUMMARY OF LABORATORY TESTING RESULTS [ROADWAY]****Project Name: PD&E Study - SW 10th Street From Powerline Road to Military Trail**

Boring No.	Sample Depth (ft)		Stratum	AASHTO Symbol	Natural Moisture Content (%)	Organic Content (%)	Atterberg Limits			Sieve Analysis							
							LL (%)	PL (%)	PI (%)	3/4"	3/8"	#4	#10	#20	#40	#60	#100
RD-1	0.0	- 2.0	2	A-3	12.7				93.2	90.9	89.0	86.9	84.6	69.9	32.9	13.7	7.4
RD-1	6.0	- 8.0	2A	A-1-b	17.0				87.3	70.4	63.7	59.4	56.0	44.3	21.0	12.5	10.0
RD-1	10.0	- 12.0	2	A-3	16.9				100.0	100.0	98.9	97.8	94.9	73.4	27.4	9.1	5.0
RD-1	13.5	- 15.0	2	A-3	15.3				100.0	98.8	98.5	98.1	96.3	78.0	30.6	9.3	5.0
RD-2	2.0	- 4.0	2A	A-1-b	18.9				84.1	71.6	66.7	62.5	58.0	46.9	30.1	24.0	21.6
RD-2	6.0	- 8.0	2A	A-1-b	13.4				74.8	59.6	52.5	47.1	42.5	32.9	17.4	10.9	8.4
RD-2	13.5	- 15.0	2	A-3	23.1				100.0	100.0	100.0	99.9	99.8	93.1	16.9	5.3	3.1
RD-3	4.0	- 6.0	2A	A-1-b	21.6				71.2	66.8	59.9	55.2	49.4	34.8	16.2	11.1	9.3
RD-3	8.0	- 10.0	2A	A-1-b	13.0				82.8	70.5	65.3	61.7	58.2	43.5	14.8	7.4	5.7
RD-3	12.0	- 13.5	2	A-3	16.7				100.0	87.2	81.5	78.8	75.6	57.7	23.2	10.1	6.7
RD-3	13.5	- 15.0	2	A-3	17.8				100.0	96.9	96.8	96.8	96.0	78.8	25.7	6.1	3.2
RD-4	4.0	- 6.0	2A	A-1-b	18.2				78.3	65.2	57.4	54.2	49.8	40.5	24.7	14.8	12.0
RD-4	8.0	- 10.0	2	A-3	19.4				100.0	97.4	95.1	94.4	92.5	71.9	32.6	8.3	3.0
RD-4	12.0	- 13.5	2	A-3	20.2				100.0	100.0	100.0	100.0	97.5	65.6	16.8	3.1	1.9
RD-5	2.0	- 4.0	2	A-3	24.3				100.0	100.0	99.9	99.8	98.8	82.0	43.0	14.1	4.4
RD-5	4.0	- 6.0	4	A-2-4	35.2				84.0	84.0	83.4	83.0	81.2	68.9	33.8	15.9	12.7
RD-5	10.0	- 12.0	2	A-3	15.8				83.9	80.6	78.3	76.6	72.4	54.9	25.3	10.9	8.1
RD-5	12.0	- 13.5	2	A-3	16.6				93.7	85.3	78.8	74.7	69.8	52.2	17.8	10.8	9.0
RD-6	8.0	- 10.0	2	A-3	19.1				100.0	91.3	88.8	88.1	86.0	69.0	29.8	11.2	8.1
RD-6	10.0	- 12.0	4	A-2-4	12.3				85.8	73.2	68.2	64.3	60.3	51.4	33.2	23.1	20.0
RD-6	12.0	- 13.5	2	A-3	17.0				100.0	97.3	91.6	85.1	78.7	58.2	25.7	11.2	8.3
RD-7	4.0	- 6.0	5	A-8	30.2				100.0	100.0	100.0	99.9	98.8	82.8	41.1	14.7	6.5
RD-7	6.0	- 8.0	4	A-2-4	24.4				94.5	88.6	85.1	83.6	81.7	68.2	38.5	27.8	23.3
RD-7	13.5	- 15.0	4	A-2-4	12.0				100.0	85.5	77.6	71.8	66.9	54.7	33.6	24.4	20.6
RD-8	0.0	- 2.0	2	A-3	5.3				100.0	100.0	99.9	99.7	98.8	86.8	50.9	15.4	4.3
RD-8	4.0	- 6.0	2B	A-3	22.7	1.8											

**TABLE - 1****SUMMARY OF LABORATORY TESTING RESULTS [ROADWAY]****Project Name: PD&E Study - SW 10th Street From Powerline Road to Military Trail**

Boring No.	Sample Depth (ft)		Stratum	AASHTO Symbol	Natural Moisture Content (%)	Organic Content (%)	Atterberg Limits			Sieve Analysis								
							LL (%)	PL (%)	PI (%)	3/4"	3/8"	#4	#10	#20	#40	#60	#100	#200
RD-8	6.0	- 8.0	2B	A-3	26.0	1.4												
RD-8	8.0	- 10.0	2B	A-3	27.2	0.7												
RD-9	4.0	- 6.0	5	A-8	31.0	6.0												
RD-9	6.0	- 8.0	4	A-2-4	22.9				82.0	75.8	72.8	70.4	67.2	54.0	29.3	17.4	13.2	
RD-9	10.0	- 12.0	2A	A-1-b	15.9				84.5	74.9	69.6	64.7	59.3	48.2	27.8	19.6	16.7	
RD-9	13.5	- 15.0	4	A-2-4	14.1				100.0	84.2	75.8	71.3	66.8	55.5	35.1	22.0	18.0	
RD-10	0.0	- 2.0	4	A-2-4	16.4				88.6	81.7	75.2	69.9	64.4	51.6	29.2	18.6	15.0	
RD-10	4.0	- 6.0	2A	A-1-b	20.9				79.7	68.7	62.8	59.4	55.9	47.8	32.9	15.3	12.3	
RD-10	10.0	- 12.0	2A	A-1-b	12.8				97.0	86.4	74.1	63.1	54.8	45.9	33.8	23.8	19.0	
BHP-1	2.0	- 4.0	2A	A-1-b	18.2				81.9	67.9	58.2	50.5	45.1	35.2	21.4	16.0	13.6	
BHP-1	6.0	- 8.0	2A	A-1-b	12.9				67.6	58.2	52.9	48.5	43.3	33.0	18.6	13.0	11.3	
BHP-2	2.0	- 4.0	4	A-2-4	22.2				80.7	76.0	71.9	69.3	66.4	55.4	22.0	15.4	12.4	
BHP-2	4.0	- 6.0	2A	A-1-b	20.5				90.1	76.1	70.3	66.8	62.9	47.6	18.8	13.7	11.5	
BHP-2	8.0	- 10.0	4	A-2-4	14.7				100.0	87.9	81.6	77.1	73.2	61.1	33.2	22.7	19.1	

**TABLE - 1****SUMMARY OF LABORATORY TESTING RESULTS [ROADWAY] [STRATUM - 2]****Project Name: PD&E Study - SW 10th Street From Powerline Road to Military Trail**

Boring No.	Sample Depth (ft)		Stratum	AASHTO Symbol	Natural Moisture Content (%)	Organic Content (%)	Atterberg Limits			Sieve Analysis							
							LL (%)	PL (%)	PI (%)	3/4"	3/8"	#4	#10	#20	#40	#60	#100
RD-1	0.0	- 2.0	2	A-3	12.7				93.2	90.9	89.0	86.9	84.6	69.9	32.9	13.7	7.4
RD-1	10.0	- 12.0	2	A-3	16.9				100.0	100.0	98.9	97.8	94.9	73.4	27.4	9.1	5.0
RD-1	13.5	- 15.0	2	A-3	15.3				100.0	98.8	98.5	98.1	96.3	78.0	30.6	9.3	5.0
RD-2	13.5	- 15.0	2	A-3	23.1				100.0	100.0	100.0	99.9	99.8	93.1	16.9	5.3	3.1
RD-3	12.0	- 13.5	2	A-3	16.7				100.0	87.2	81.5	78.8	75.6	57.7	23.2	10.1	6.7
RD-3	13.5	- 15.0	2	A-3	17.8				100.0	96.9	96.8	96.8	96.0	78.8	25.7	6.1	3.2
RD-4	8.0	- 10.0	2	A-3	19.4				100.0	97.4	95.1	94.4	92.5	71.9	32.6	8.3	3.0
RD-4	12.0	- 13.5	2	A-3	20.2				100.0	100.0	100.0	100.0	97.5	65.6	16.8	3.1	1.9
RD-5	2.0	- 4.0	2	A-3	24.3				100.0	100.0	99.9	99.8	98.8	82.0	43.0	14.1	4.4
RD-5	10.0	- 12.0	2	A-3	15.8				83.9	80.6	78.3	76.6	72.4	54.9	25.3	10.9	8.1
RD-5	12.0	- 13.5	2	A-3	16.6				93.7	85.3	78.8	74.7	69.8	52.2	17.8	10.8	9.0
RD-6	8.0	- 10.0	2	A-3	19.1				100.0	91.3	88.8	88.1	86.0	69.0	29.8	11.2	8.1
RD-6	12.0	- 13.5	2	A-3	17.0				100.0	97.3	91.6	85.1	78.7	58.2	25.7	11.2	8.3
RD-8	0.0	- 2.0	2	A-3	5.3				100.0	100.0	99.9	99.7	98.8	86.8	50.9	15.4	4.3

**TABLE - 1****SUMMARY OF LABORATORY TESTING RESULTS [ROADWAY] [STRATUM - 2A]****Project Name: PD&E Study - SW 10th Street From Powerline Road to Military Trail**

Boring No.	Sample Depth (ft)		Stratum	AASHTO Symbol	Natural Moisture Content (%)	Organic Content (%)	Atterberg Limits			Sieve Analysis							
							LL (%)	PL (%)	PI (%)	3/4"	3/8"	#4	#10	#20	#40	#60	#100
RD-1	6.0	- 8.0	2A	A-1-b	17.0				87.3	70.4	63.7	59.4	56.0	44.3	21.0	12.5	10.0
RD-2	2.0	- 4.0	2A	A-1-b	18.9				84.1	71.6	66.7	62.5	58.0	46.9	30.1	24.0	21.6
RD-2	6.0	- 8.0	2A	A-1-b	13.4				74.8	59.6	52.5	47.1	42.5	32.9	17.4	10.9	8.4
RD-3	4.0	- 6.0	2A	A-1-b	21.6				71.2	66.8	59.9	55.2	49.4	34.8	16.2	11.1	9.3
RD-3	8.0	- 10.0	2A	A-1-b	13.0				82.8	70.5	65.3	61.7	58.2	43.5	14.8	7.4	5.7
RD-4	4.0	- 6.0	2A	A-1-b	18.2				78.3	65.2	57.4	54.2	49.8	40.5	24.7	14.8	12.0
RD-9	10.0	- 12.0	2A	A-1-b	15.9				84.5	74.9	69.6	64.7	59.3	48.2	27.8	19.6	16.7
RD-10	4.0	- 6.0	2A	A-1-b	20.9				79.7	68.7	62.8	59.4	55.9	47.8	32.9	15.3	12.3
RD-10	10.0	- 12.0	2A	A-1-b	12.8				97.0	86.4	74.1	63.1	54.8	45.9	33.8	23.8	19.0
BHP-1	2.0	- 4.0	2A	A-1-b	18.2				81.9	67.9	58.2	50.5	45.1	35.2	21.4	16.0	13.6
BHP-1	6.0	- 8.0	2A	A-1-b	12.9				67.6	58.2	52.9	48.5	43.3	33.0	18.6	13.0	11.3
BHP-2	4.0	- 6.0	2A	A-1-b	20.5				90.1	76.1	70.3	66.8	62.9	47.6	18.8	13.7	11.5



**TABLE - 1**

**SUMMARY OF LABORATORY TESTING RESULTS [ROADWAY] [STRATUM - 2B]**

**Project Name: PD&E Study - SW 10th Street From Powerline Road to Military Trail**

Boring No.	Sample Depth (ft)		Stratum	AASHTO Symbol	Natural Moisture Content (%)	Organic Content (%)	Atterberg Limits			Sieve Analysis								
							LL (%)	PL (%)	PI (%)	3/4"	3/8"	#4	#10	#20	#40	#60	#100	#200
RD-8	4.0	- 6.0	2B	A-3	22.7	1.8												
RD-8	6.0	- 8.0	2B	A-3	26.0	1.4												
RD-8	8.0	- 10.0	2B	A-3	27.2	0.7												

**TABLE - 1****SUMMARY OF LABORATORY TESTING RESULTS [ROADWAY] [STRATUM - 4]****Project Name: PD&E Study - SW 10th Street From Powerline Road to Military Trail**

Boring No.	Sample Depth (ft)		Stratum	AASHTO Symbol	Natural Moisture Content (%)	Organic Content (%)	Atterberg Limits			Sieve Analysis							
							LL (%)	PL (%)	PI (%)	3/4"	3/8"	#4	#10	#20	#40	#60	#100
RD-5	4.0	- 6.0	4	A-2-4	35.2				84.0	84.0	83.4	83.0	81.2	68.9	33.8	15.9	12.7
RD-6	10.0	- 12.0	4	A-2-4	12.3				85.8	73.2	68.2	64.3	60.3	51.4	33.2	23.1	20.0
RD-7	6.0	- 8.0	4	A-2-4	24.4				94.5	88.6	85.1	83.6	81.7	68.2	38.5	27.8	23.3
RD-7	13.5	- 15.0	4	A-2-4	12.0				100.0	85.5	77.6	71.8	66.9	54.7	33.6	24.4	20.6
RD-9	6.0	- 8.0	4	A-2-4	22.9				82.0	75.8	72.8	70.4	67.2	54.0	29.3	17.4	13.2
RD-9	13.5	- 15.0	4	A-2-4	14.1				100.0	84.2	75.8	71.3	66.8	55.5	35.1	22.0	18.0
RD-10	0.0	- 2.0	4	A-2-4	16.4				88.6	81.7	75.2	69.9	64.4	51.6	29.2	18.6	15.0
BHP-2	2.0	- 4.0	4	A-2-4	22.2				80.7	76.0	71.9	69.3	66.4	55.4	22.0	15.4	12.4
BHP-2	8.0	- 10.0	4	A-2-4	14.7				100.0	87.9	81.6	77.1	73.2	61.1	33.2	22.7	19.1

**TABLE - 1**

**SUMMARY OF LABORATORY TESTING RESULTS [ROADWAY] [STRATUM - 5]**

**Project Name: PD&E Study - SW 10th Street From Powerline Road to Military Trail**

Boring No.	Sample Depth (ft)		Stratum	AASHTO Symbol	Natural Moisture Content (%)	Organic Content (%)	Atterberg Limits			Sieve Analysis							
							LL (%)	PL (%)	PI (%)	3/4"	3/8"	#4	#10	#20	#40	#60	#100
RD-7	4.0	- 6.0	5	A-8	30.2				100.0	100.0	100.0	99.9	98.8	82.8	41.1	14.7	6.5
RD-9	4.0	- 6.0	5	A-8	31.0	6.0											

# GCME

Geotechnical - Consulting - Engineering - Testing

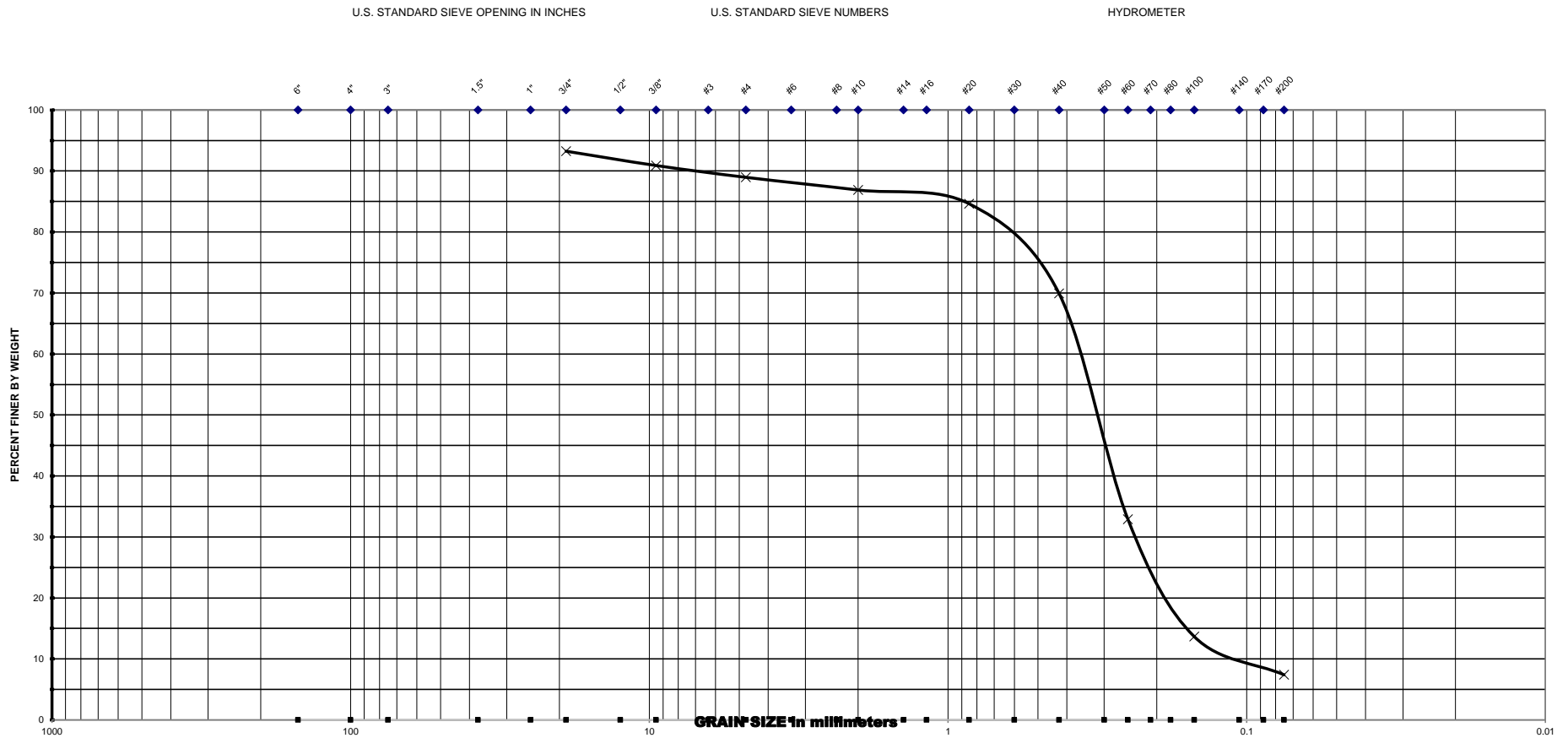

Project Name : PD&E Study - SW 10th Street From Powerline Road to Military Trail

Project No. : 2000-01-17003

Date : 3/13/2018

U.S SIEVE NO.	CUMM. % PASSING
3/4"	93.2
3/8"	90.9
#4	89.0
#10	86.9
#20	84.6
#40	69.9
#60	32.9
#100	13.7
#200	7.4

BORING NO.	DEPTH INTERVAL [FT]	SOIL DESCRIPTION	MC	OC
RD-1	0.0 - 2.0	A-3	12.7	

Note : MC - Moisture Content (%)  
OC - Organic Content (%)



# GCME

Geotechnical - Consulting - Engineering - Testing

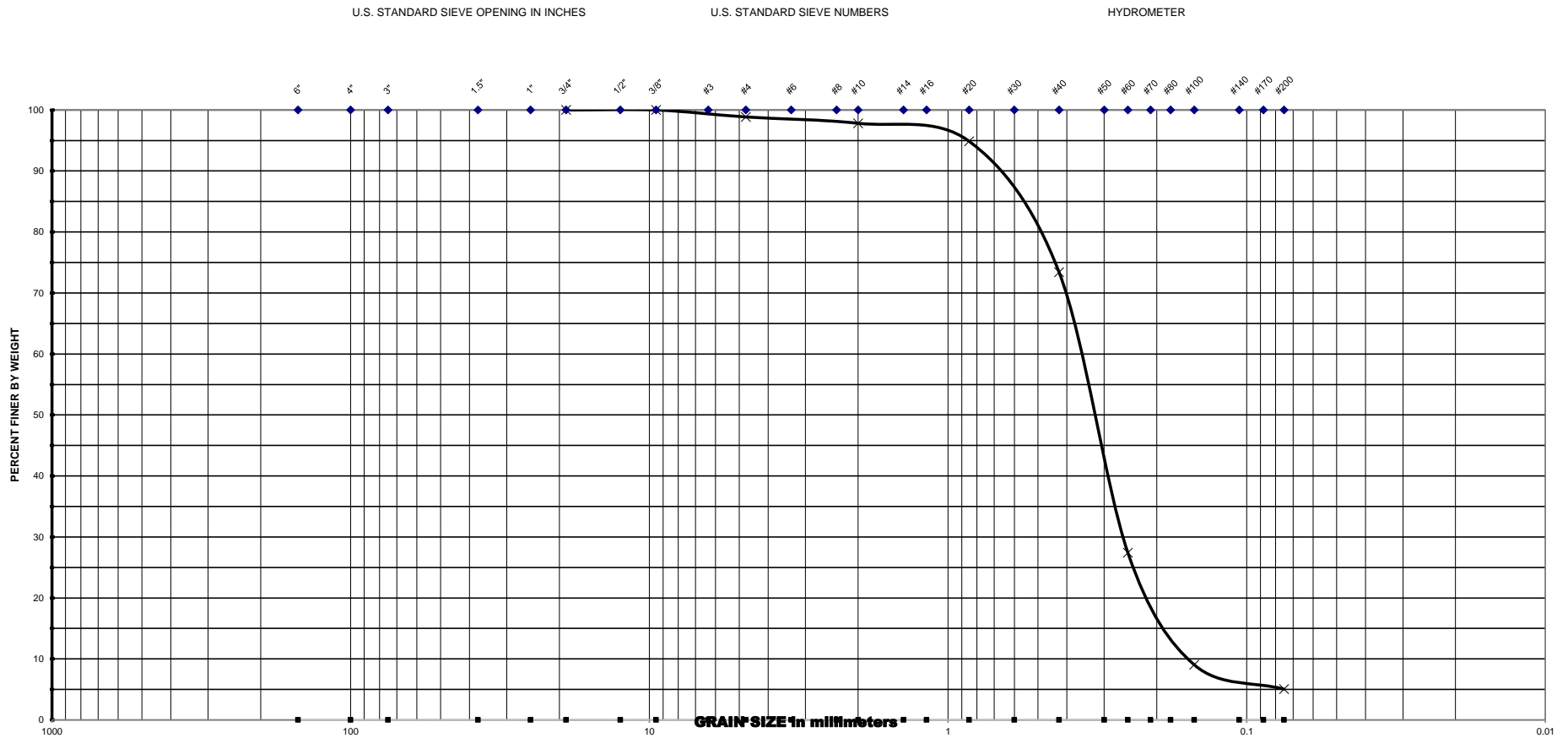

Project Name : PD&E Study - SW 10th Street From Powerline Road to Military Trail

Project No. : 2000-01-17003

Date : 4/5/2018

U.S SIEVE NO.	CUMM. % PASSING
3/4"	100.0
3/8"	100.0
#4	98.9
#10	97.8
#20	94.9
#40	73.4
#60	27.4
#100	9.1
#200	5.0

BORING NO.	DEPTH INTERVAL [FT]	SOIL DESCRIPTION	MC	OC
RD-1	10.0 - 12.0	A-3	16.9	

Note : MC - Moisture Content (%)  
OC - Organic Content (%)

# GCME

Geotechnical - Consulting - Engineering - Testing

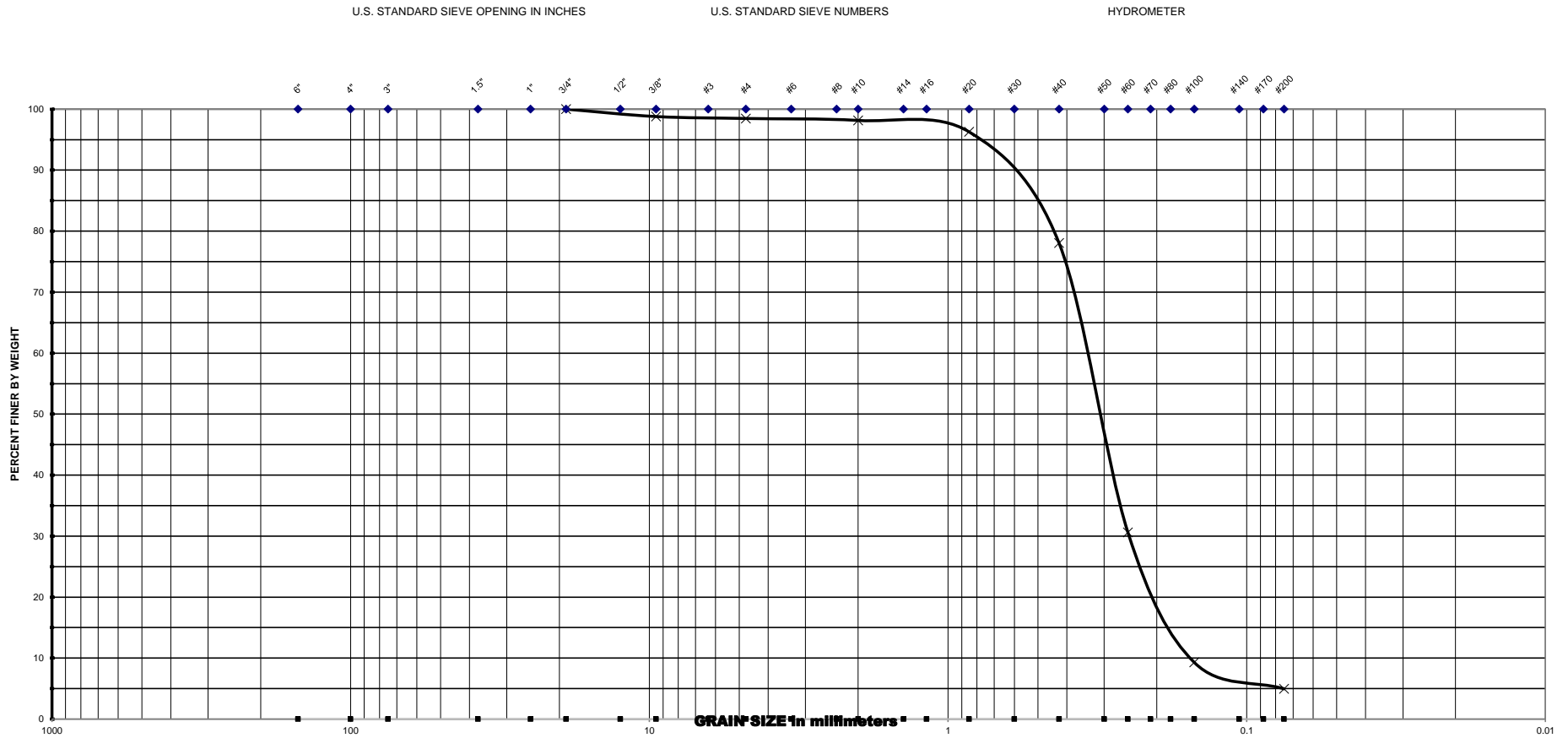

Project Name : <u>PD&amp;E Study - SW 10th Street From Powerline Road to Military Trail</u>					<b>U.S SIEVE NO.</b>	<b>CUMM. % PASSING</b>
Project No. : <u>2000-01-17003</u> Date : <u>4/5/2018</u>					3/4"	100.0
					3/8"	98.8
					#4	98.5
<b>BORING NO.</b>	<b>DEPTH INTERVAL [FT]</b>	<b>SOIL DESCRIPTION</b>	<b>MC</b>	<b>OC</b>	#10	98.1
RD-1	13.5 - 15.0	A-3	15.3		#20	96.3
					#40	78.0
					#60	30.6
<p style="text-align: right;">Note : MC - Moisture Content (%) OC - Organic Content (%)</p>					#100	9.3
					#200	5.0

# GCME

Geotechnical - Consulting - Engineering - Testing

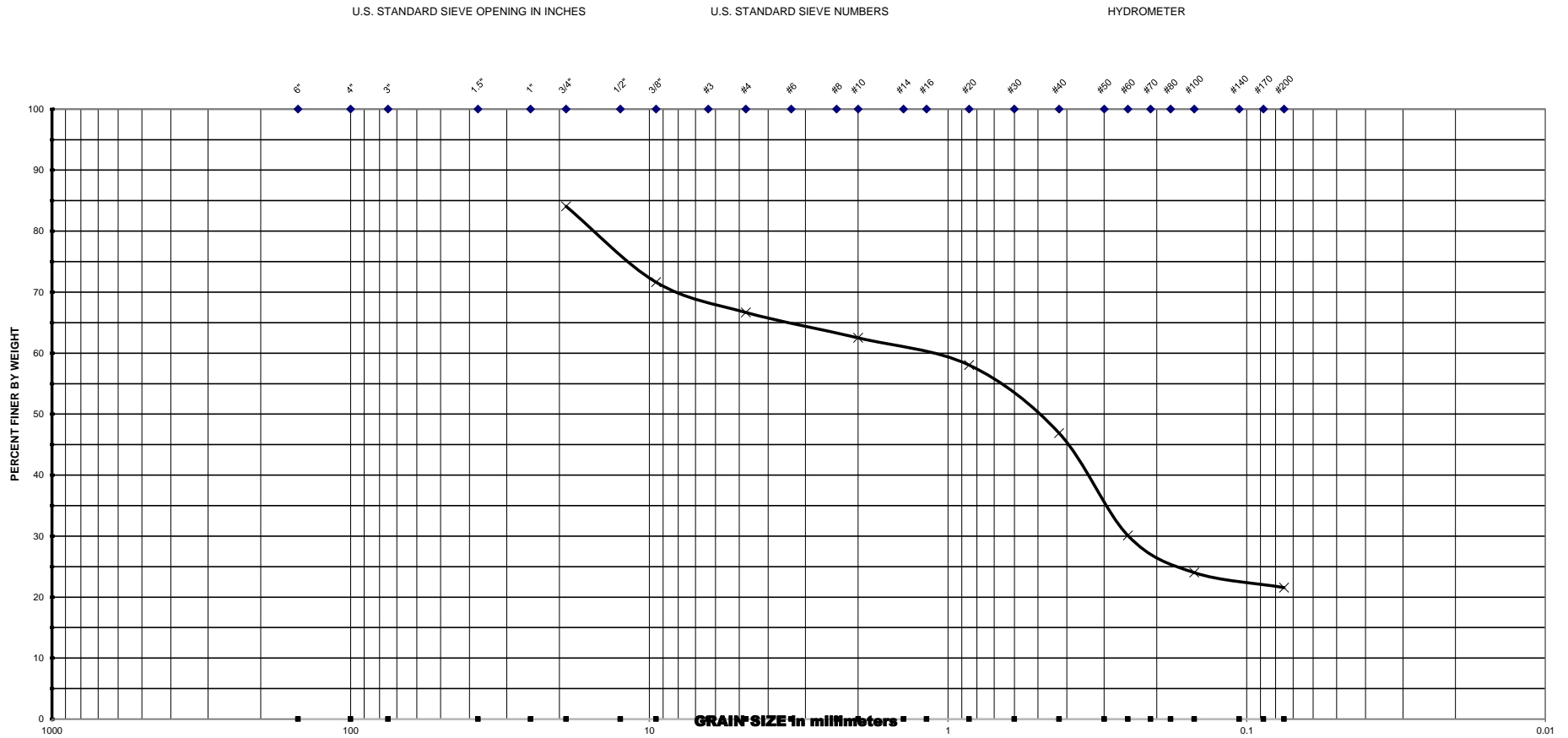

Project Name : PD&E Study - SW 10th Street From Powerline Road to Military Trail

Project No. : 2000-01-17003

Date : 3/13/2018

U.S SIEVE NO.	CUMM. % PASSING
3/4"	84.1
3/8"	71.6
#4	66.7
#10	62.5
#20	58.0
#40	46.9
#60	30.1
#100	24.0
#200	21.6

BORING NO.	DEPTH INTERVAL [FT]	SOIL DESCRIPTION	MC	OC
RD-2	2.0 - 4.0	A-1-b	18.9	

Note : MC - Moisture Content (%)  
OC - Organic Content (%)



# GCME

Geotechnical - Consulting - Engineering - Testing

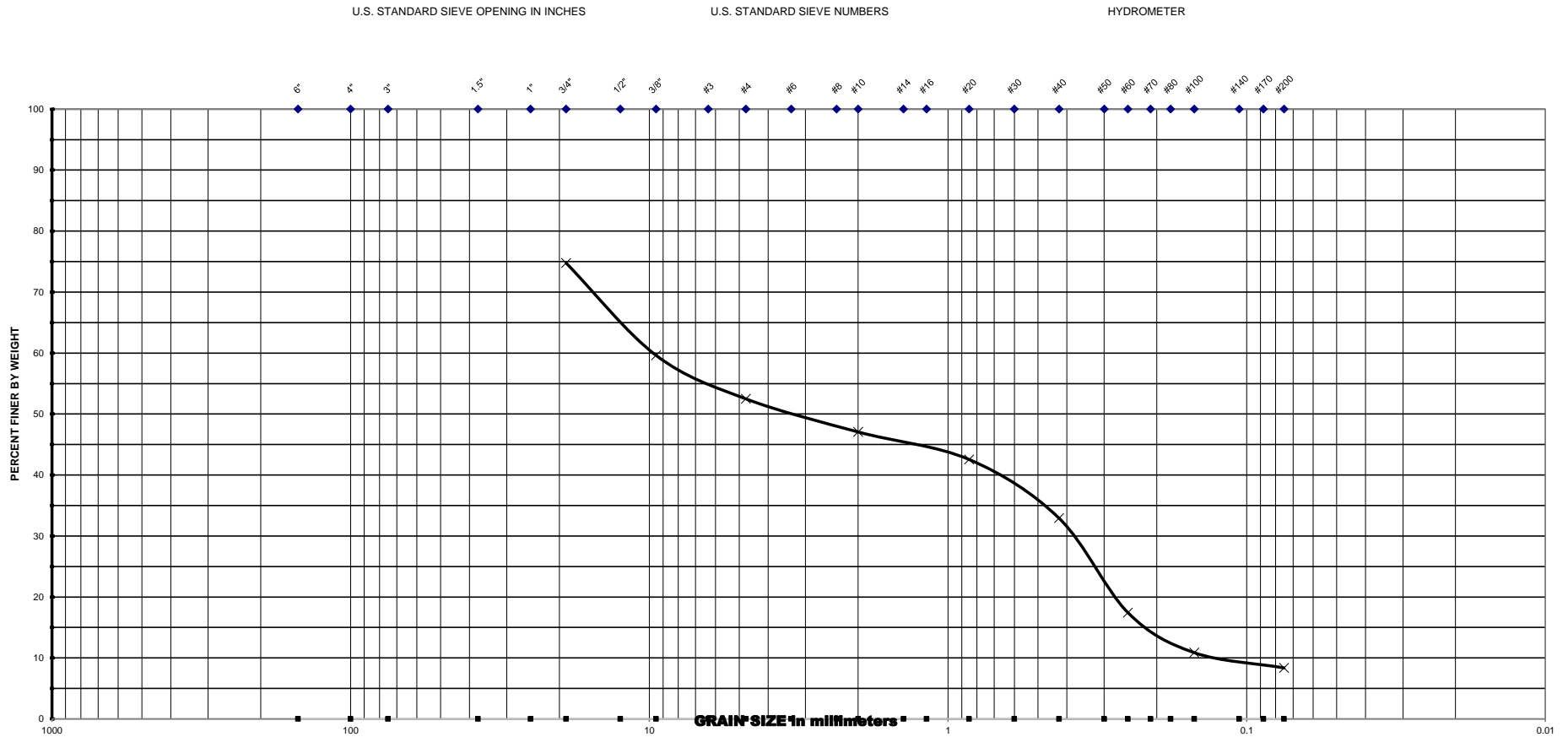

Project Name : <u>PD&amp;E Study - SW 10th Street From Powerline Road to Military Trail</u>					U.S. SIEVE NO.	CUMM. % PASSING
Project No. : <u>2000-01-17003</u> Date : <u>4/5/2018</u>					3/4"	74.8
					3/8"	59.6
					#4	52.5
BORING NO.	DEPTH INTERVAL [FT]	SOIL DESCRIPTION	MC	OC	#10	47.1
RD-2	6.0 - 8.0	A-1-b	13.4		#20	42.5
					#40	32.9
					#60	17.4
Note : MC - Moisture Content (%) OC - Organic Content (%)					#100	10.9
					#200	8.4

# GCME

Geotechnical - Consulting - Engineering - Testing

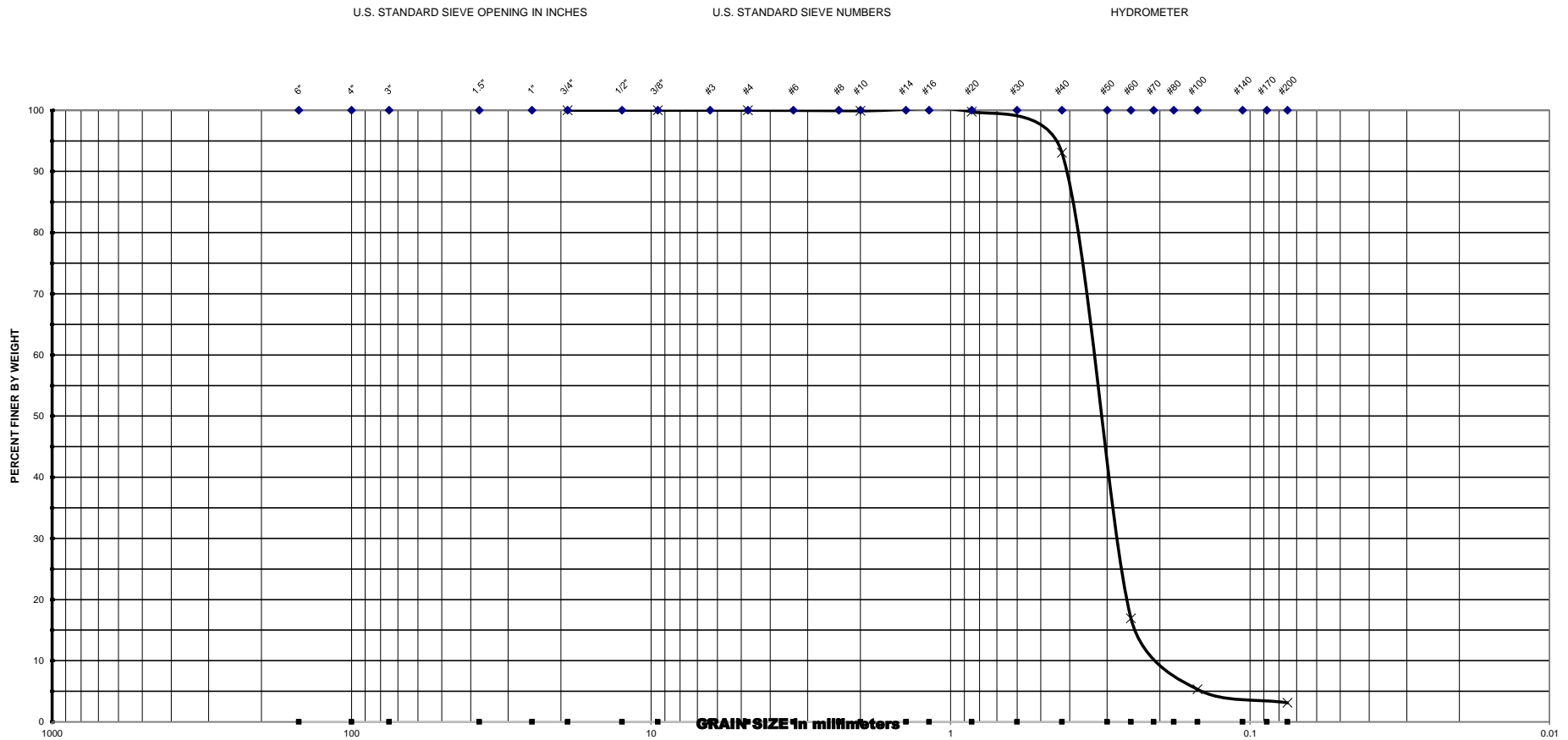

Project Name : <u>PD&amp;E Study - SW 10th Street From Powerline Road to Military Trail</u>					U.S. SIEVE NO.	CUMM. % PASSING
Project No. : <u>2000-01-17003</u>					3/4"	100.0
Date : <u>3/13/2018</u>					3/8"	100.0
BORING NO.	DEPTH INTERVAL [FT]	SOIL DESCRIPTION	MC	OC	#4	100.0
RD-2	13.5 - 15.0	A-3	23.1		#10	99.9
					#20	99.8
					#40	93.1
					#60	16.9
Note : MC - Moisture Content (%) OC - Organic Content (%)					#100	5.3
					#200	3.1

# GCME

Geotechnical - Consulting - Engineering - Testing

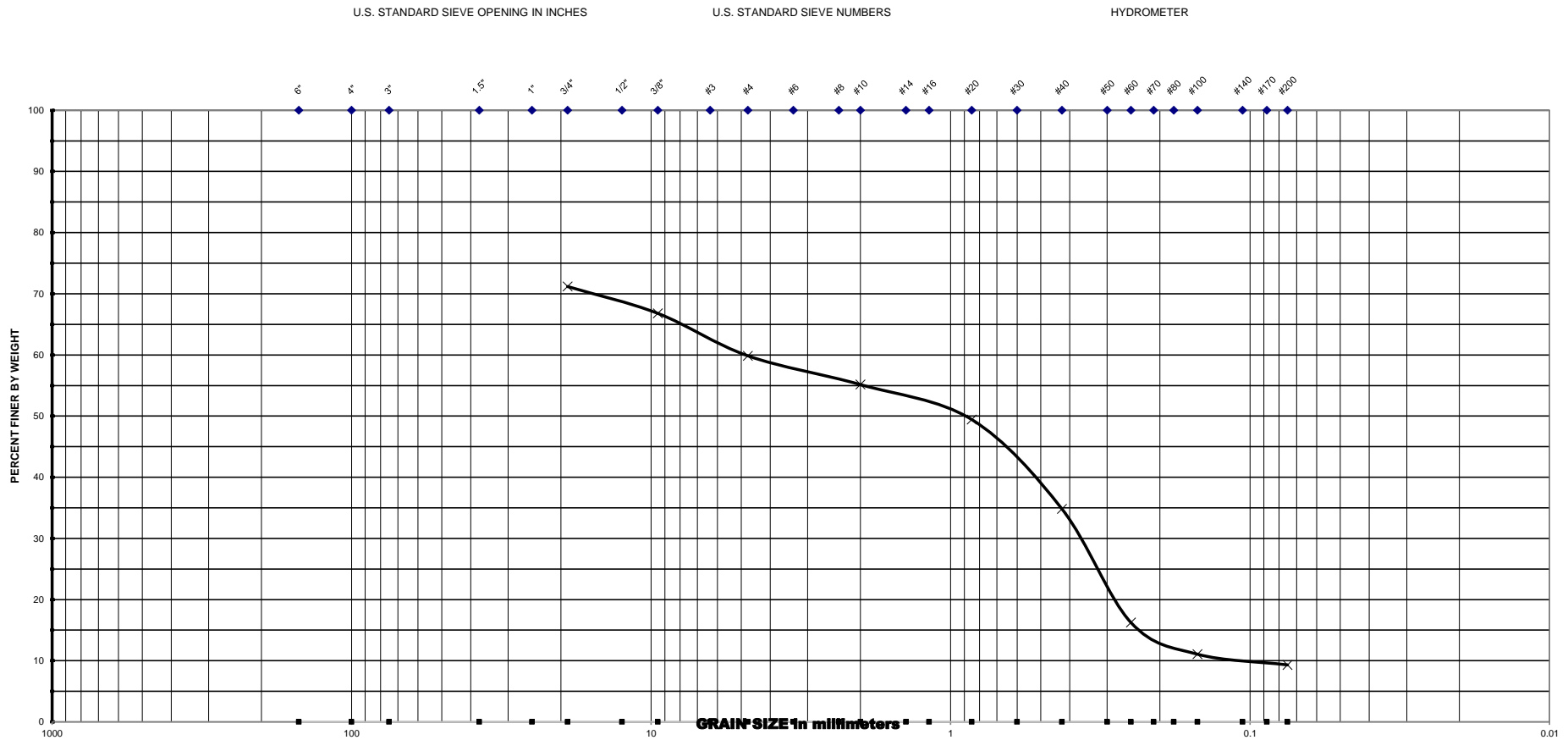

Project Name : <u>PD&amp;E Study - SW 10th Street From Powerline Road to Military Trail</u>					<b>U.S SIEVE NO.</b>	<b>CUMM. % PASSING</b>
Project No. : <u>2000-01-17003</u> Date : <u>3/13/2018</u>					3/4"	71.2
					3/8"	66.8
					#4	59.9
<b>BORING NO.</b>	<b>DEPTH INTERVAL [FT]</b>	<b>SOIL DESCRIPTION</b>	<b>MC</b>	<b>OC</b>	#10	55.2
RD-3	4.0 - 6.0	A-1-b	21.6		#20	49.4
					#40	34.8
					#60	16.2
Note : MC - Moisture Content (%) OC - Organic Content (%)					#100	11.1
					#200	9.3

# GCME

Geotechnical - Consulting - Engineering - Testing

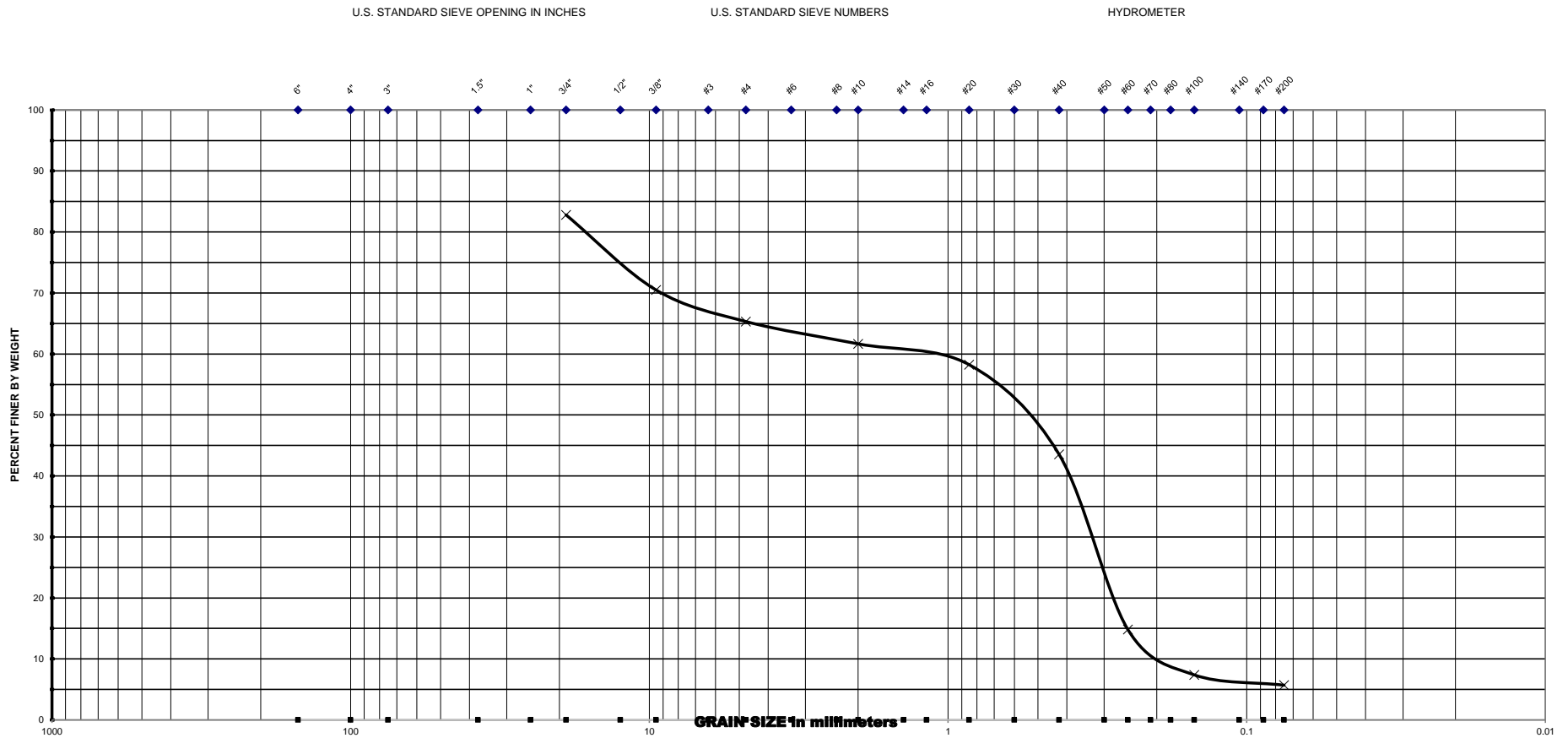

Project Name : <u>PD&amp;E Study - SW 10th Street From Powerline Road to Military Trail</u>					U.S. SIEVE NO.	CUMM. % PASSING
Project No. : <u>2000-01-17003</u>						
Date : <u>3/13/2018</u>						
BORING NO.	DEPTH INTERVAL [FT]	SOIL DESCRIPTION	MC	OC		
RD-3	8.0 - 10.0	A-1-b	13.0		#10	61.7
					#20	58.2
					#40	43.5
					#60	14.8
					#100	7.4
					#200	5.7

Note : MC - Moisture Content (%)  
OC - Organic Content (%)

# GCME

Geotechnical - Consulting - Engineering - Testing

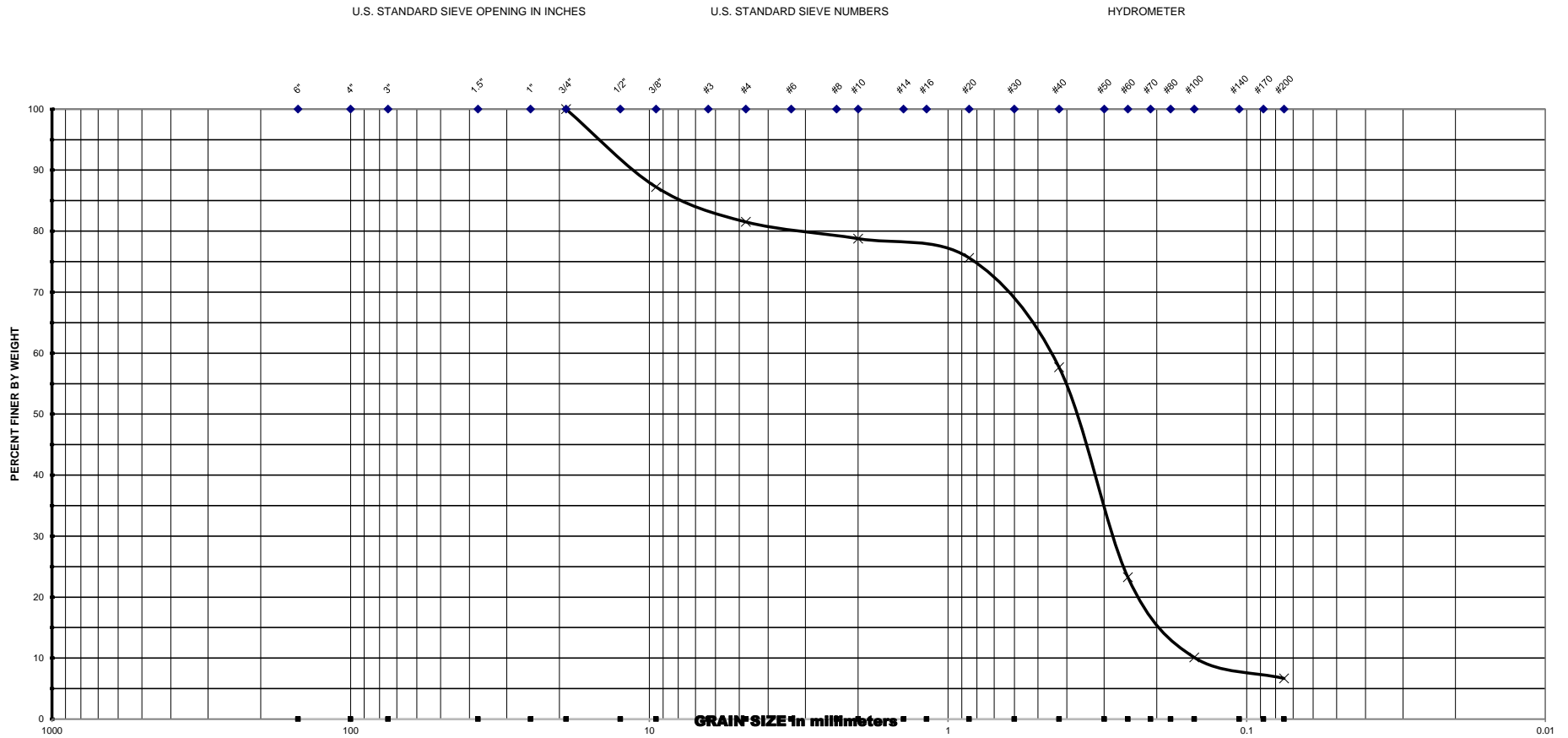

Project Name : <u>PD&amp;E Study - SW 10th Street From Powerline Road to Military Trail</u>					<b>U.S SIEVE NO.</b>	<b>CUMM. % PASSING</b>
Project No. : <u>2000-01-17003</u> Date : <u>4/5/2018</u>					3/4"	100.0
					3/8"	87.2
					#4	81.5
<b>BORING NO.</b>	<b>DEPTH INTERVAL [FT]</b>	<b>SOIL DESCRIPTION</b>	<b>MC</b>	<b>OC</b>	#10	78.8
RD-3	12.0 - 13.5	A-3	16.7		#20	75.6
					#40	57.7
					#60	23.2
Note : MC - Moisture Content (%) OC - Organic Content (%)					#100	10.1
					#200	6.7

# GCME

Geotechnical - Consulting - Engineering - Testing

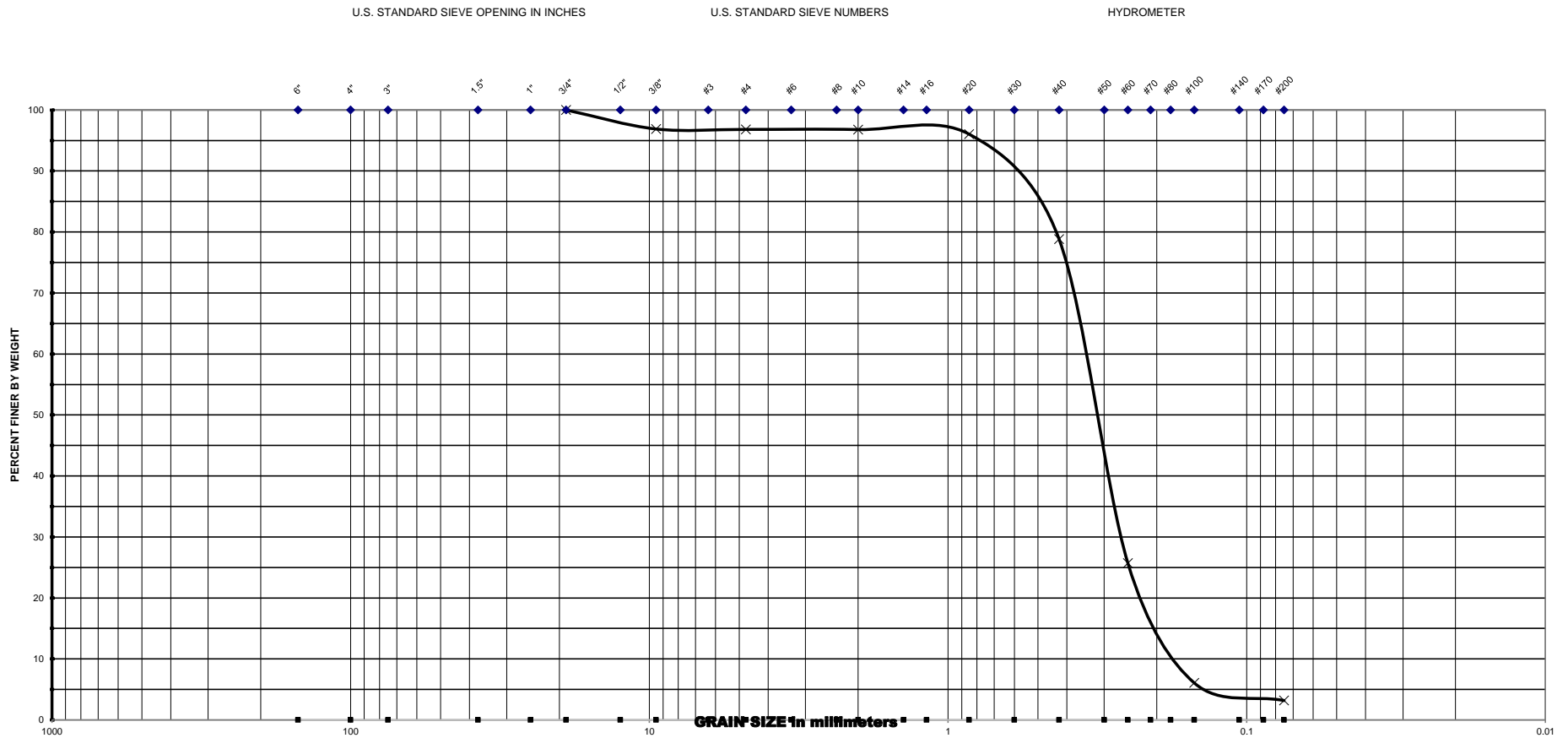

Project Name : PD&E Study - SW 10th Street From Powerline Road to Military Trail

Project No. : 2000-01-17003

Date : 4/5/2018

U.S. SIEVE NO.	CUMM. % PASSING
3/4"	100.0
3/8"	96.9
#4	96.8
#10	96.8
#20	96.0
#40	78.8
#60	25.7
#100	6.1
#200	3.2

BORING NO.	DEPTH INTERVAL [FT]	SOIL DESCRIPTION	MC	OC
RD-3	13.5 - 15.0	A-3	17.8	

Note : MC - Moisture Content (%)  
OC - Organic Content (%)

# GCME

Geotechnical - Consulting - Engineering - Testing

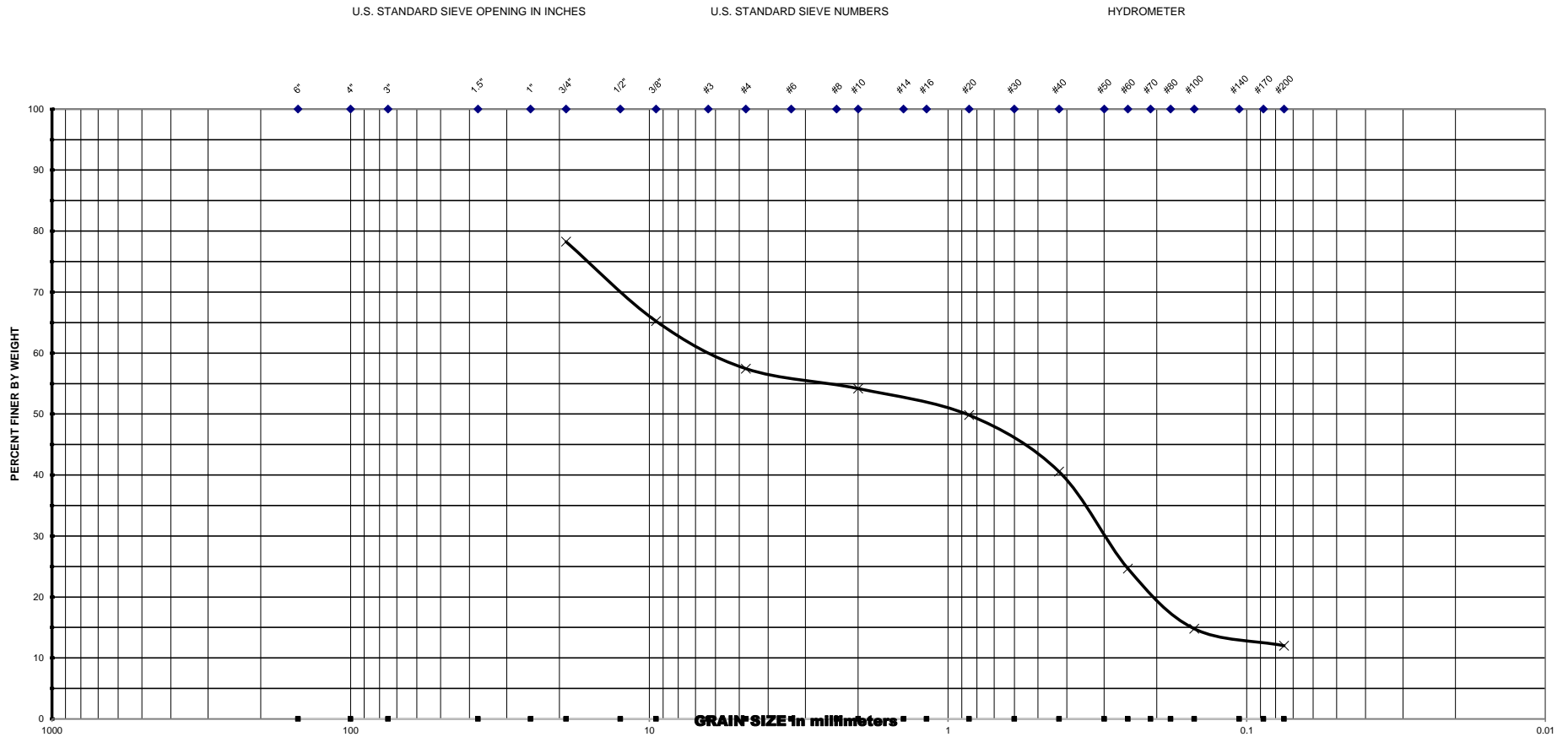

Project Name : <u>PD&amp;E Study - SW 10th Street From Powerline Road to Military Trail</u>					<b>U.S SIEVE NO.</b>	<b>CUMM. % PASSING</b>
Project No. : <u>2000-01-17003</u> Date : <u>4/5/2018</u>					3/4"	78.3
					3/8"	65.2
					#4	57.4
<b>BORING NO.</b>	<b>DEPTH INTERVAL [FT]</b>	<b>SOIL DESCRIPTION</b>	<b>MC</b>	<b>OC</b>	#10	54.2
RD-4	4.0 - 6.0	A-1-b	18.2		#20	49.8
					#40	40.5
					#60	24.7
Note : MC - Moisture Content (%) OC - Organic Content (%)					#100	14.8
					#200	12.0

# GCME

Geotechnical - Consulting - Engineering - Testing

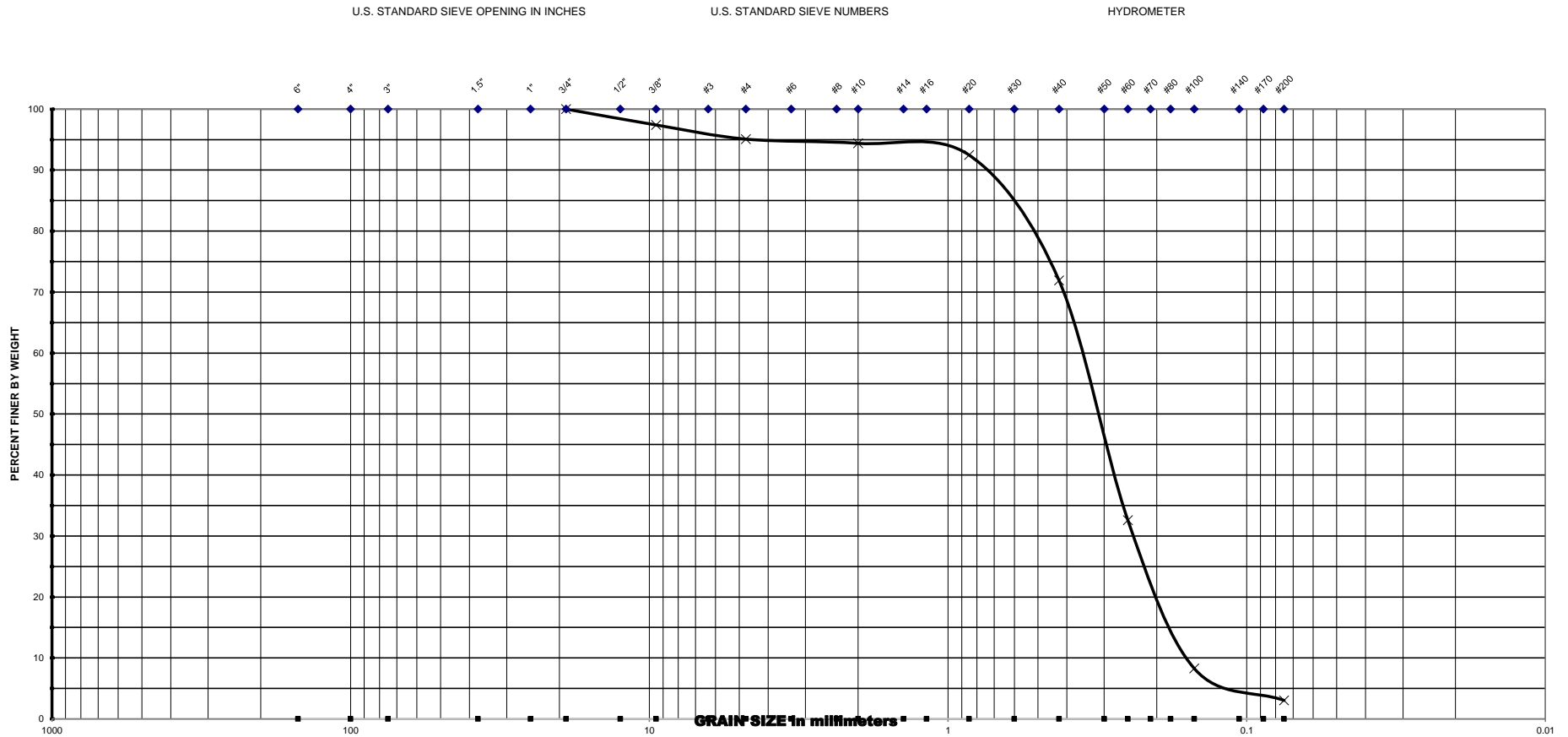

Project Name : PD&E Study - SW 10th Street From Powerline Road to Military Trail

Project No. : 2000-01-17003

Date : 4/5/2018

U.S SIEVE NO.	CUMM. % PASSING
3/4"	100.0
3/8"	97.4
#4	95.1
#10	94.4
#20	92.5
#40	71.9
#60	32.6
#100	8.3
#200	3.0

Note : MC - Moisture Content (%)

OC - Organic Content (%)

BORING NO.	DEPTH INTERVAL [FT]	SOIL DESCRIPTION	MC	OC
RD-4	8.0 - 10.0	A-3	19.4	



# GCME

Geotechnical - Consulting - Engineering - Testing

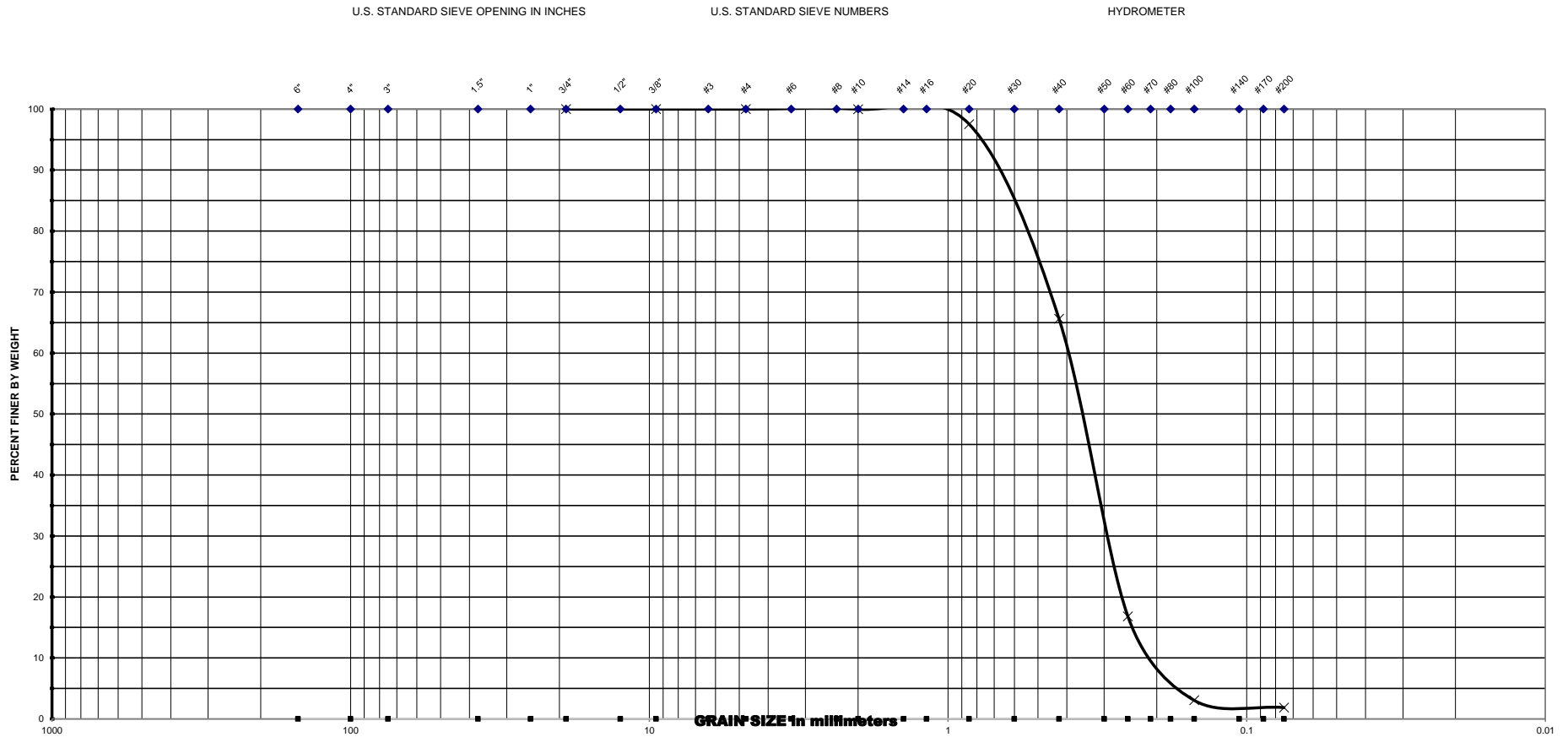

Project Name : PD&E Study - SW 10th Street From Powerline Road to Military Trail

Project No. : 2000-01-17003

Date : 4/5/2018

U.S SIEVE NO.	CUMM. % PASSING
3/4"	100.0
3/8"	100.0
#4	100.0
#10	100.0
#20	97.5
#40	65.6
#60	16.8
#100	3.1
#200	1.9

BORING NO.	DEPTH INTERVAL [FT]	SOIL DESCRIPTION	MC	OC
RD-4	12.0 - 13.5	A-3	20.2	

Note : MC - Moisture Content (%)  
OC - Organic Content (%)

# GCME

Geotechnical - Consulting - Engineering - Testing

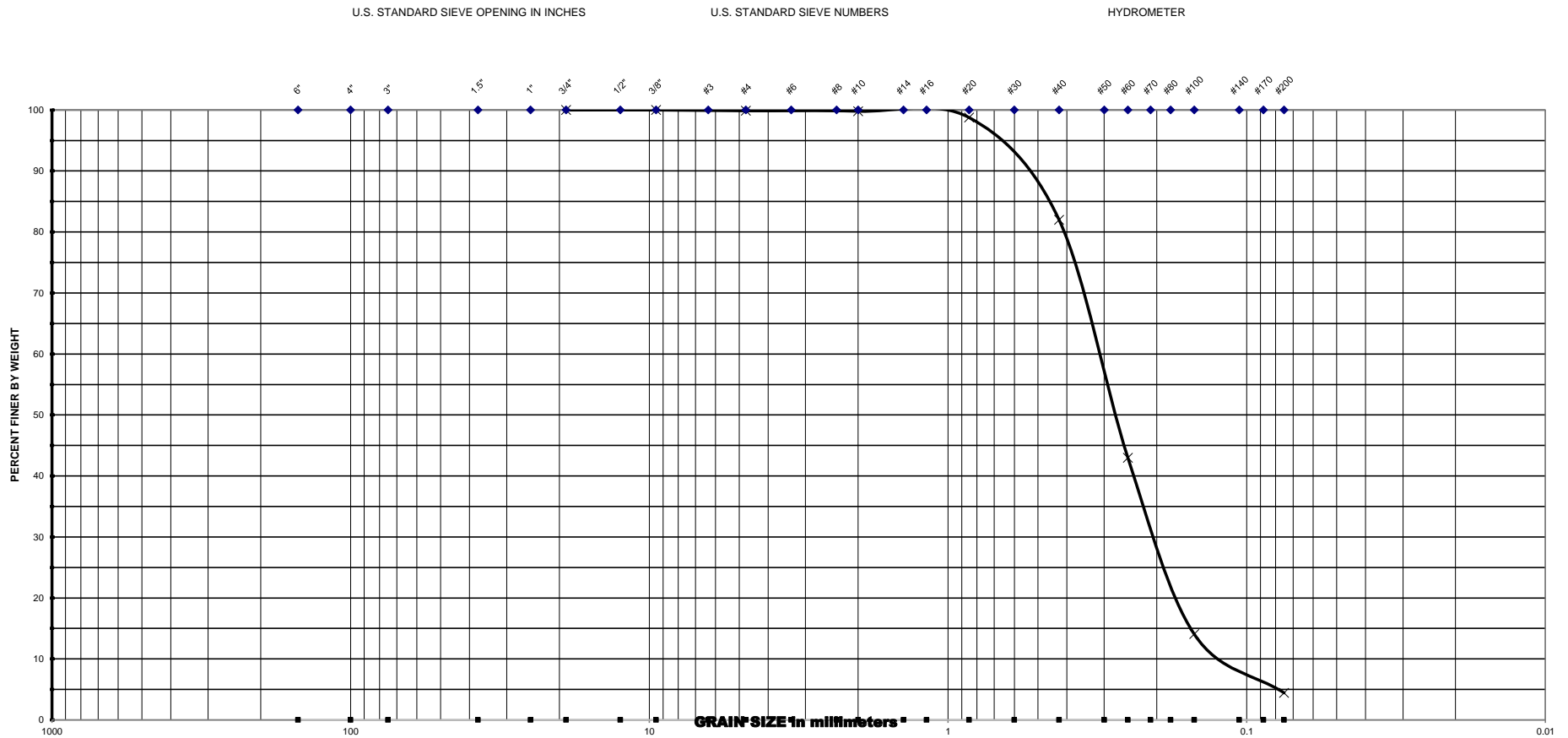

Project Name : PD&E Study - SW 10th Street From Powerline Road to Military Trail

Project No. : 2000-01-17003

Date : 4/5/2018

U.S SIEVE NO.	CUMM. % PASSING
3/4"	100.0
3/8"	100.0
#4	99.9
#10	99.8
#20	98.8
#40	82.0
#60	43.0
#100	14.1
#200	4.4

BORING NO.	DEPTH INTERVAL [FT]	SOIL DESCRIPTION	MC	OC
RD-5	2.0 - 4.0	A-3	24.3	

Note : MC - Moisture Content (%)  
OC - Organic Content (%)

# GCME

Geotechnical - Consulting - Engineering - Testing

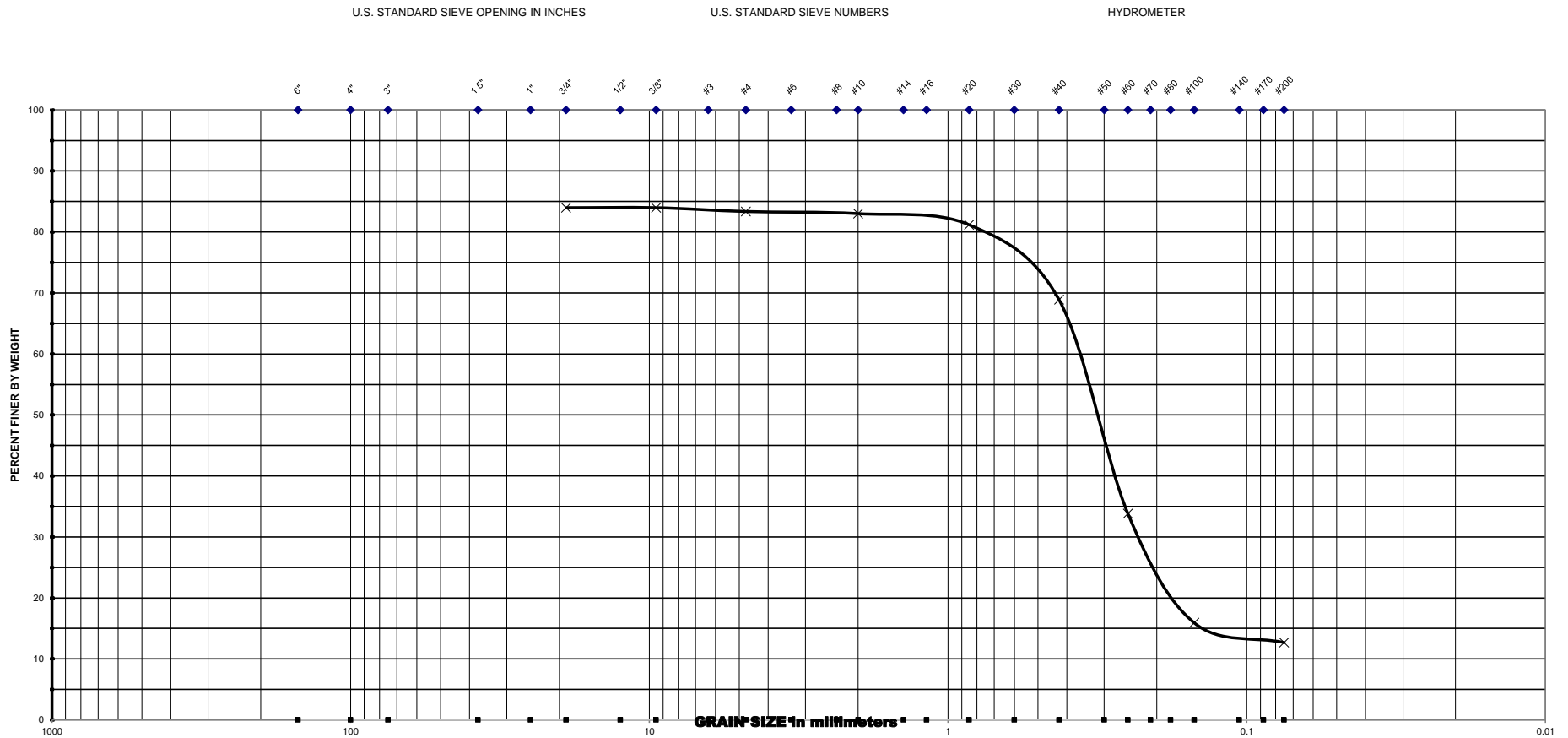

Project Name : <u>PD&amp;E Study - SW 10th Street From Powerline Road to Military Trail</u>					U.S. SIEVE NO.	CUMM. % PASSING
Project No. : <u>2000-01-17003</u>					3/4"	84.0
Date : <u>3/13/2018</u>					3/8"	84.0
BORING NO.	DEPTH INTERVAL [FT]	SOIL DESCRIPTION	MC	OC	#4	83.4
RD-5	4.0 - 6.0	A-2-4	35.2		#10	83.0
					#20	81.2
					#40	68.9
					#60	33.8
Note : MC - Moisture Content (%) OC - Organic Content (%)					#100	15.9
					#200	12.7

# GCME

Geotechnical - Consulting - Engineering - Testing

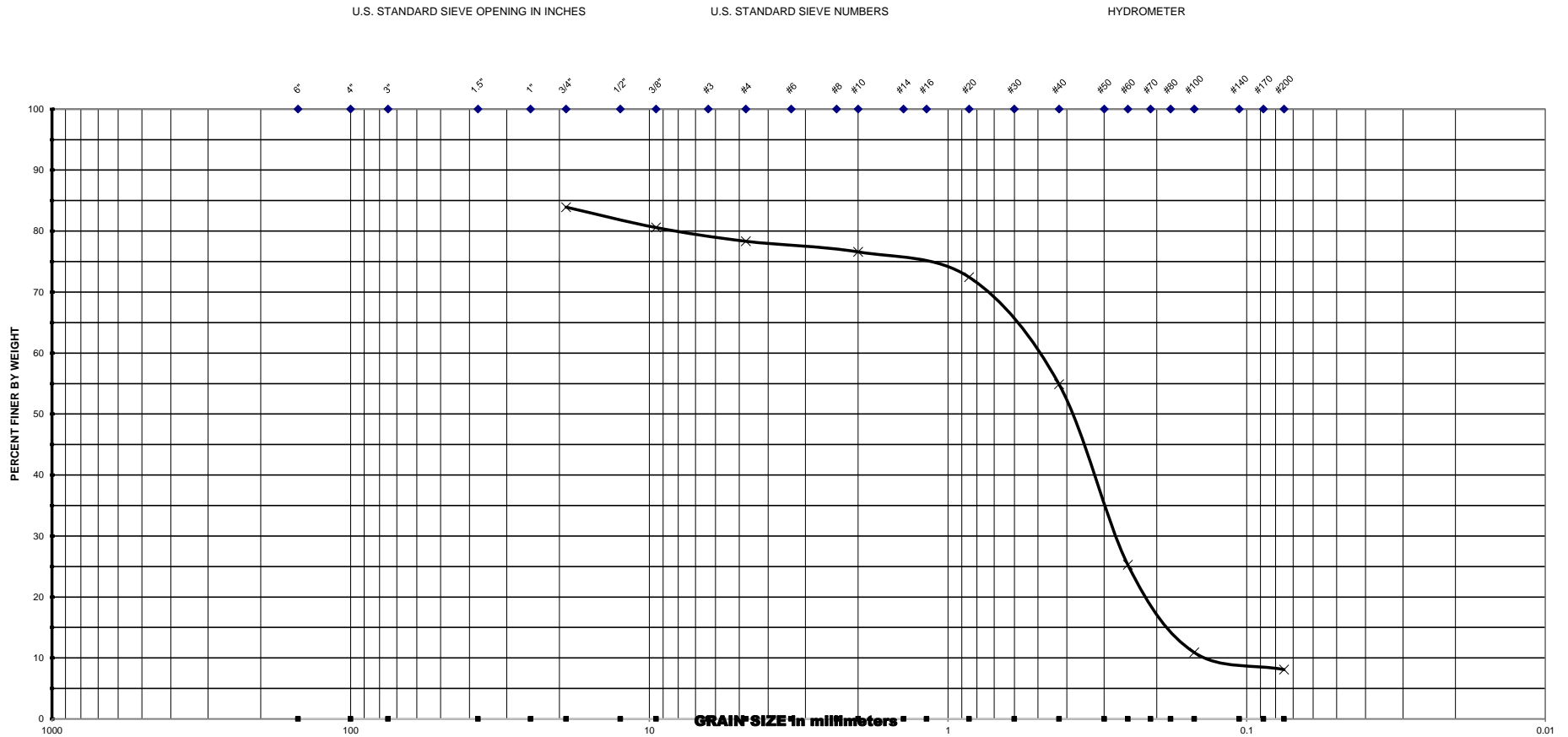

Project Name : <u>PD&amp;E Study - SW 10th Street From Powerline Road to Military Trail</u>					U.S SIEVE NO.	CUMM. % PASSING
Project No. : <u>2000-01-17003</u> Date : <u>4/5/2018</u>					3/4"	83.9
					3/8"	80.6
					#4	78.3
BORING NO.	DEPTH INTERVAL [FT]	SOIL DESCRIPTION	MC	OC	#10	76.6
RD-5	10.0 - 12.0	A-3	15.8		#20	72.4
					#40	54.9
					#60	25.3
Note : MC - Moisture Content (%) OC - Organic Content (%)					#100	10.9
					#200	8.1

# GCME

Geotechnical - Consulting - Engineering - Testing

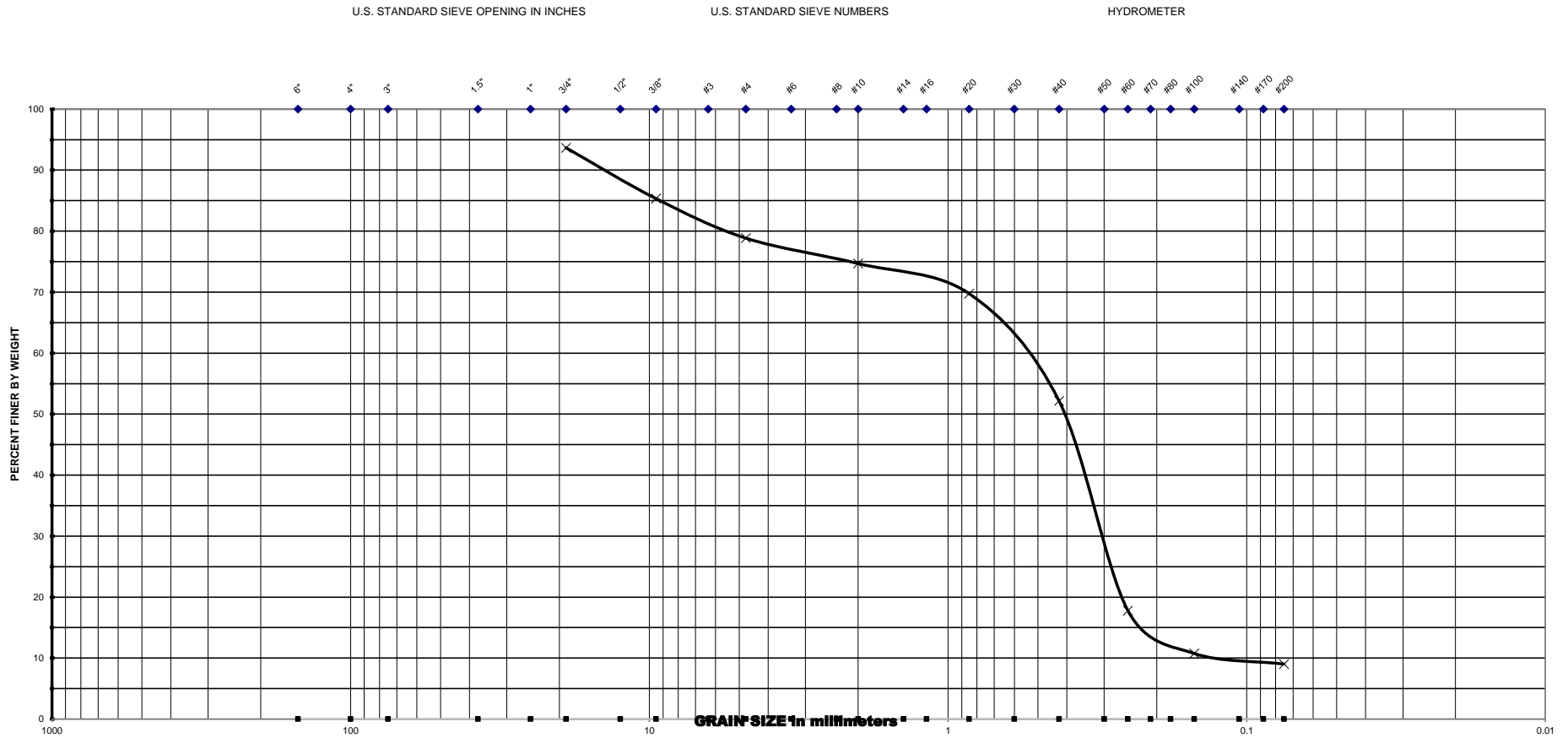

Project Name : PD&E Study - SW 10th Street From Powerline Road to Military Trail

Project No. : 2000-01-17003

Date : 3/13/2018

U.S SIEVE NO.	CUMM. % PASSING
3/4"	93.7
3/8"	85.3
#4	78.8
#10	74.7
#20	69.8
#40	52.2
#60	17.8
#100	10.8
#200	9.0

BORING NO.	DEPTH INTERVAL [FT]	SOIL DESCRIPTION	MC	OC
RD-5	12.0 - 13.5	A-3	16.6	

Note : MC - Moisture Content (%)  
OC - Organic Content (%)

# GCME

Geotechnical - Consulting - Engineering - Testing

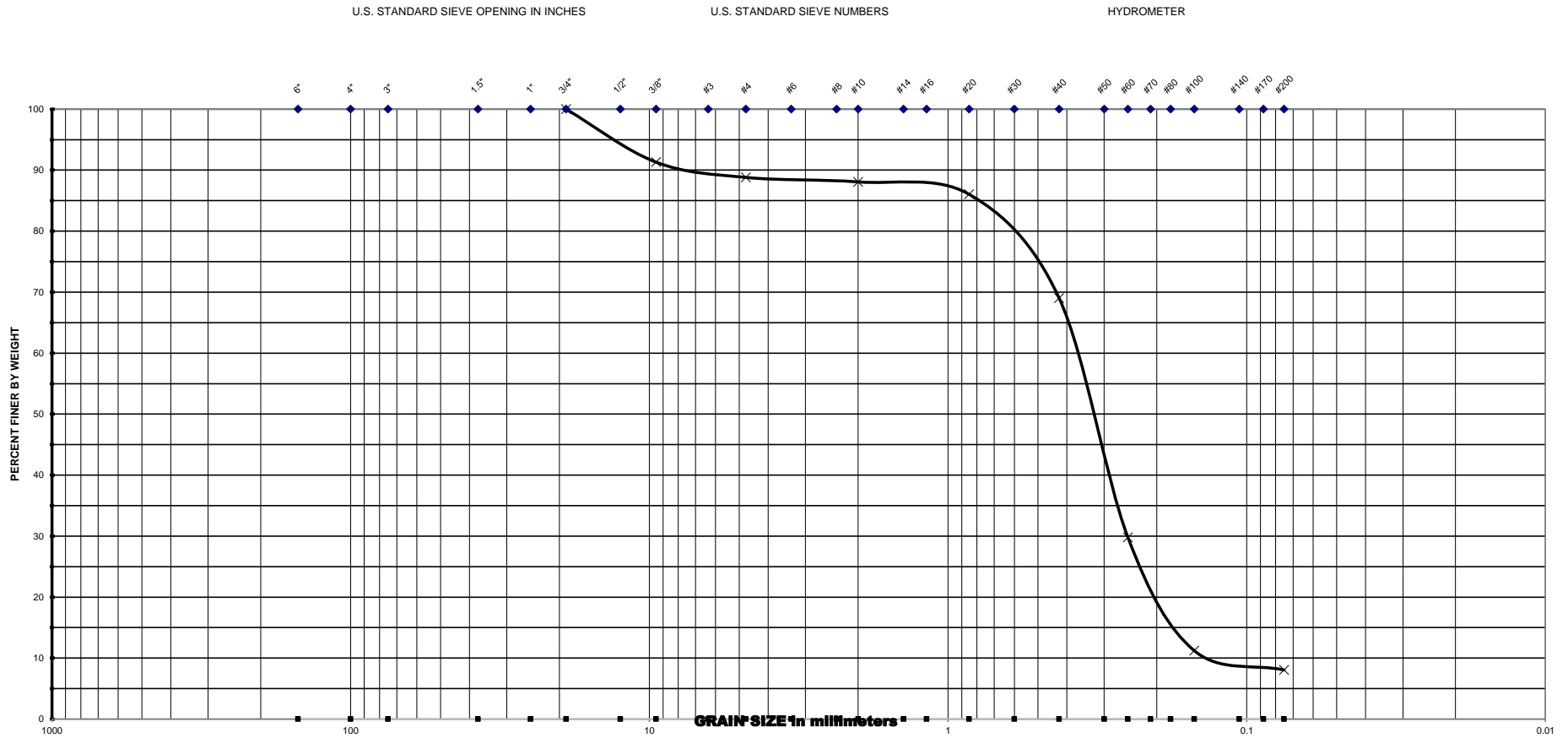

Project Name : PD&E Study - SW 10th Street From Powerline Road to Military Trail

Project No. : 2000-01-17003

Date : 3/13/2018

U.S. SIEVE NO.	CUMM. % PASSING
3/4"	100.0
3/8"	91.3
#4	88.8
#10	88.1
#20	86.0
#40	69.0
#60	29.8
#100	11.2
#200	8.1

BORING NO.	DEPTH INTERVAL [FT]	SOIL DESCRIPTION	MC	OC
RD-6	8.0 - 10.0	A-3	19.1	

Note : MC - Moisture Content (%)  
OC - Organic Content (%)

# GCME

**Geotechnical - Consulting - Engineering - Testing**

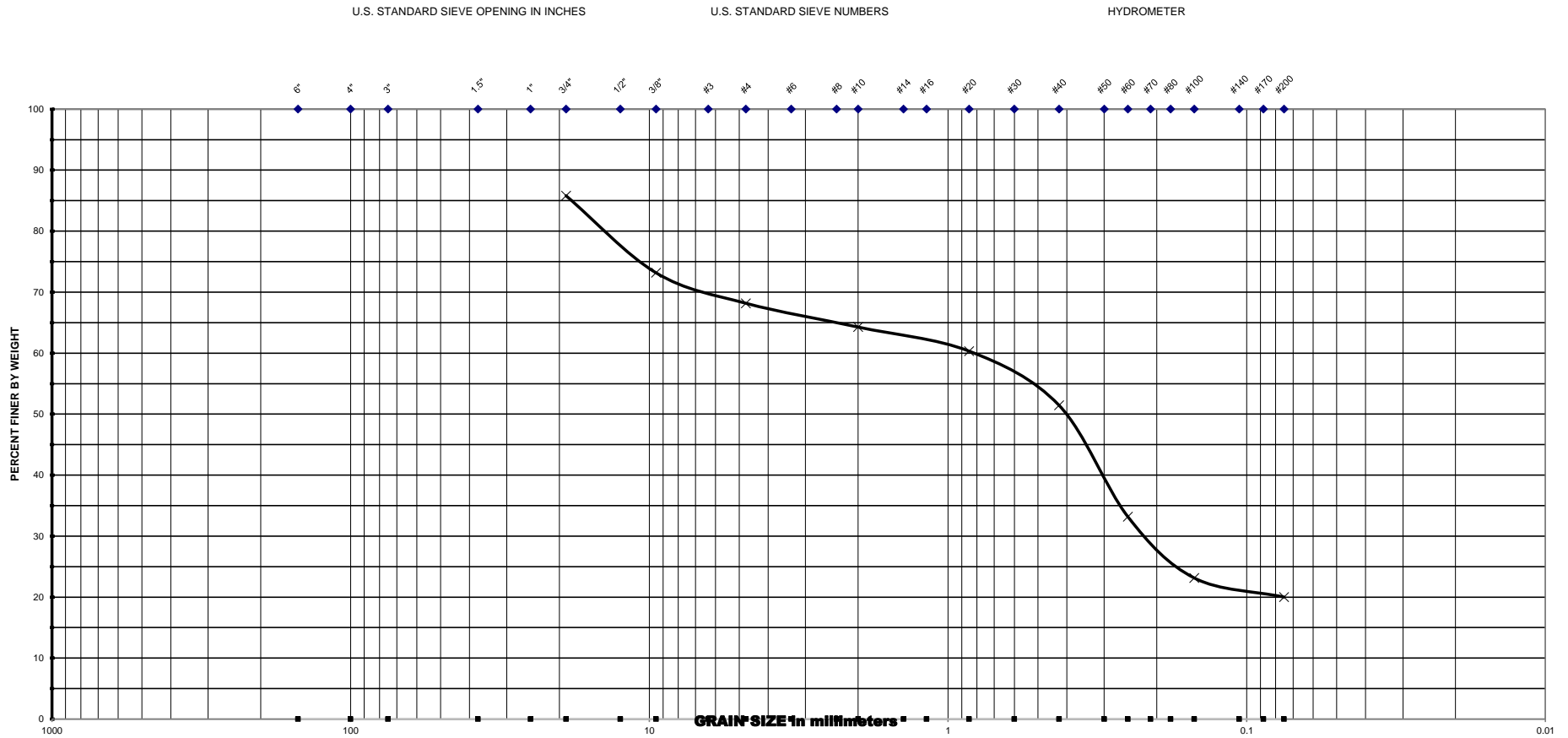

<b>Project Name :</b> <u>PD&amp;E Study - SW 10th Street From Powerline Road to Military Trail</u>					<b>U.S SIEVE NO.</b>	<b>CUMM. % PASSING</b>
<b>Project No. :</b> <u>2000-01-17003</u>					<u>3/4"</u>	85.8
<b>Date :</b> <u>3/13/2018</u>					<u>3/8"</u>	73.2
<b>BORING NO.</b>	<b>DEPTH INTERVAL [FT]</b>	<b>SOIL DESCRIPTION</b>	<b>MC</b>	<b>OC</b>	<b>#4</b>	68.2
RD-6	10.0 - 12.0	A-2-4	12.3		<b>#10</b>	64.3
					<b>#20</b>	60.3
					<b>#40</b>	51.4
					<b>#60</b>	33.2
					<b>#100</b>	23.1
					<b>#200</b>	20.0

**Note :** MC - Moisture Content (%)  
OC - Organic Content (%)

# GCME

Geotechnical - Consulting - Engineering - Testing

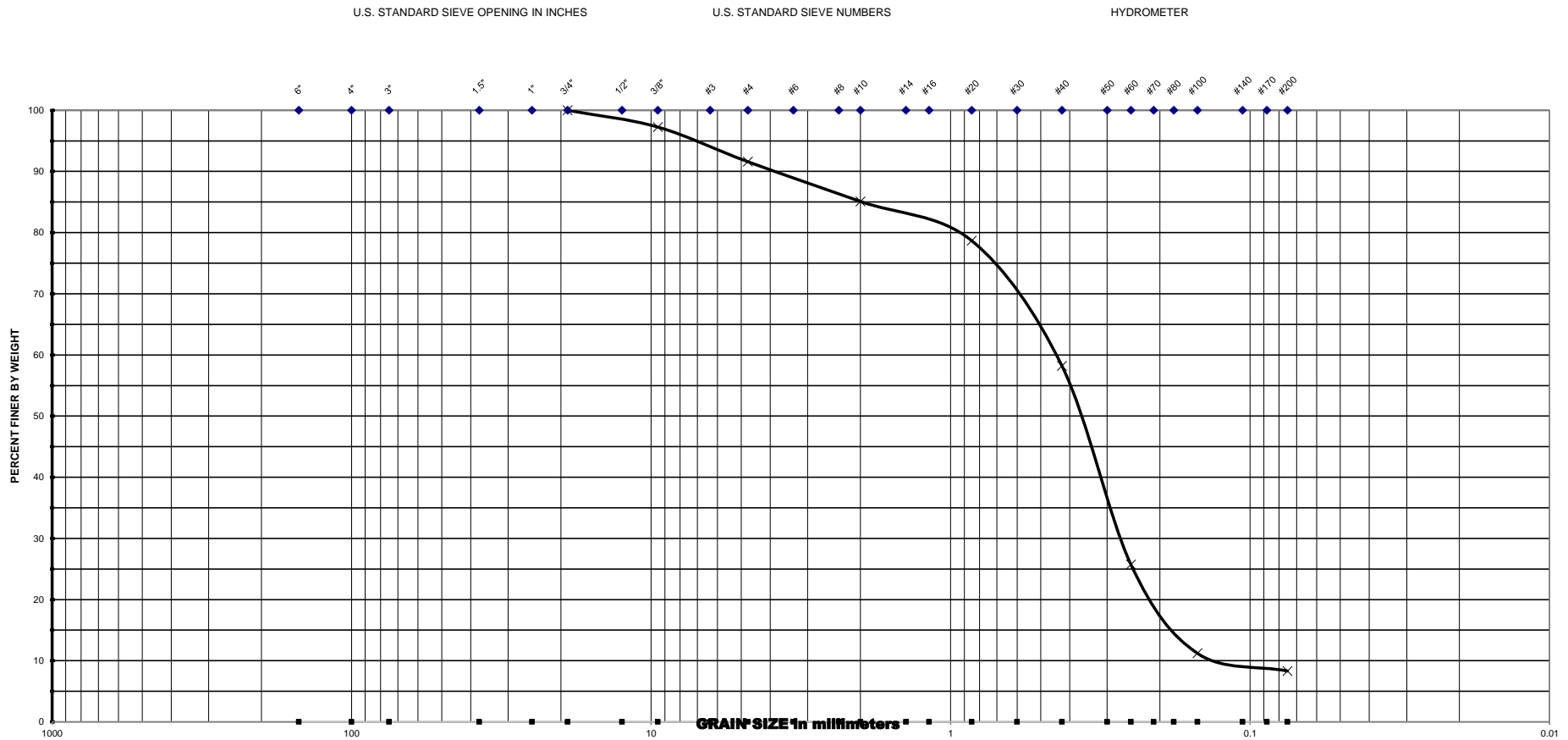

Project Name : <u>PD&amp;E Study - SW 10th Street From Powerline Road to Military Trail</u>					<b>U.S SIEVE NO.</b>	<b>CUMM. % PASSING</b>
Project No. : <u>2000-01-17003</u> Date : <u>4/5/2018</u>					<u>3/4"</u>	100.0
					<u>3/8"</u>	97.3
					<u>#4</u>	91.6
<b>BORING NO.</b>	<b>DEPTH INTERVAL [FT]</b>	<b>SOIL DESCRIPTION</b>	<b>MC</b>	<b>OC</b>	<u>#10</u>	85.1
RD-6	12.0 - 13.5	A-3	17.0		<u>#20</u>	78.7
					<u>#40</u>	58.2
					<u>#60</u>	25.7
Note : MC - Moisture Content (%) OC - Organic Content (%)					<u>#100</u>	11.2
					<u>#200</u>	8.3



# GCME

Geotechnical - Consulting - Engineering - Testing

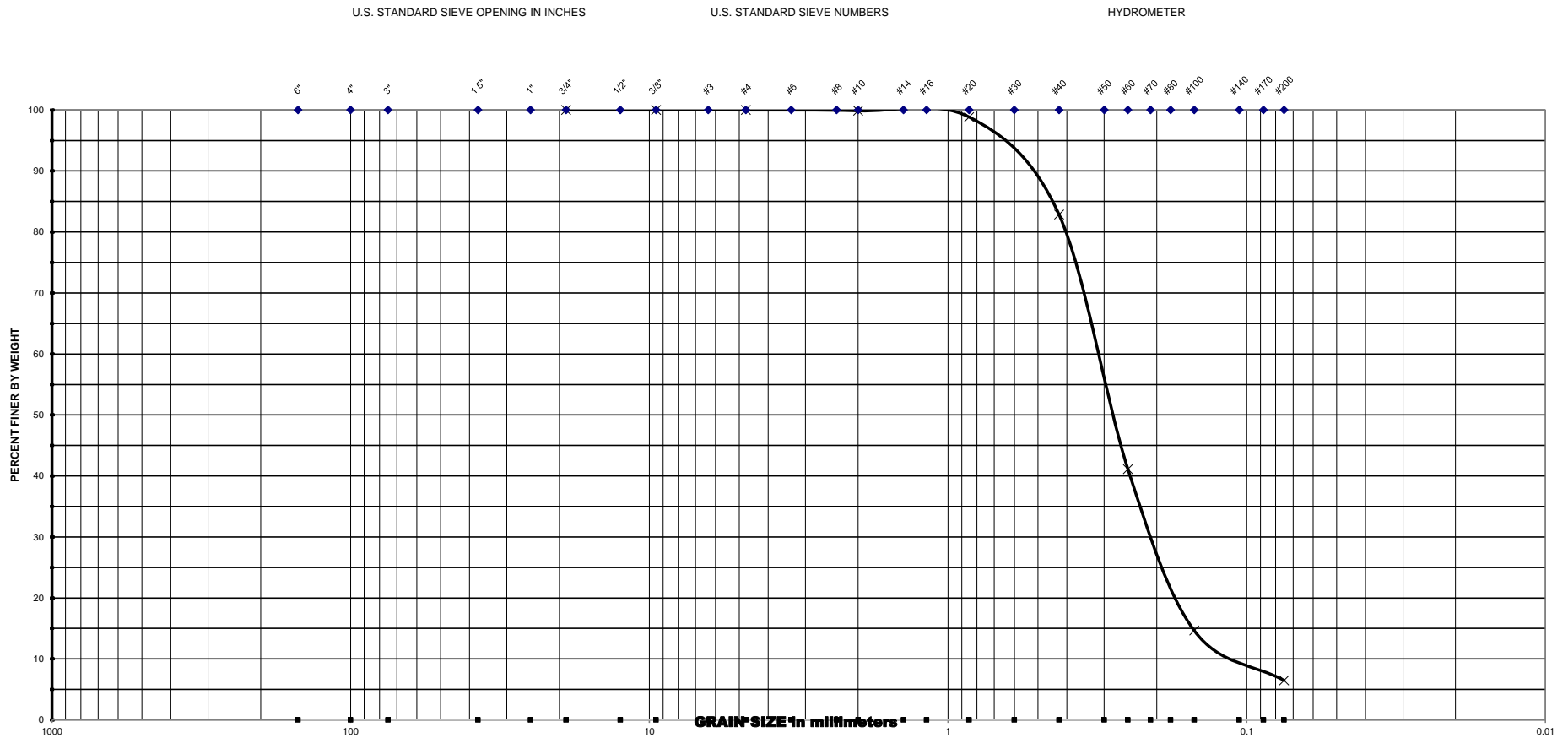

Project Name : <u>PD&amp;E Study - SW 10th Street From Powerline Road to Military Trail</u>					<b>U.S SIEVE NO.</b>	<b>CUMM. % PASSING</b>
Project No. : <u>2000-01-17003</u>						
Date : <u>3/13/2018</u>						
<b>BORING NO.</b>	<b>DEPTH INTERVAL [FT]</b>	<b>SOIL DESCRIPTION</b>	<b>MC</b>	<b>OC</b>	<b>#10</b>	<b>99.9</b>
RD-7	4.0 - 6.0	A-8	30.2		<b>#20</b>	<b>98.8</b>
					<b>#40</b>	<b>82.8</b>
					<b>#60</b>	<b>41.1</b>
					<b>#100</b>	<b>14.7</b>
					<b>#200</b>	<b>6.5</b>

Note : MC - Moisture Content (%)  
OC - Organic Content (%)

# GCME

Geotechnical - Consulting - Engineering - Testing

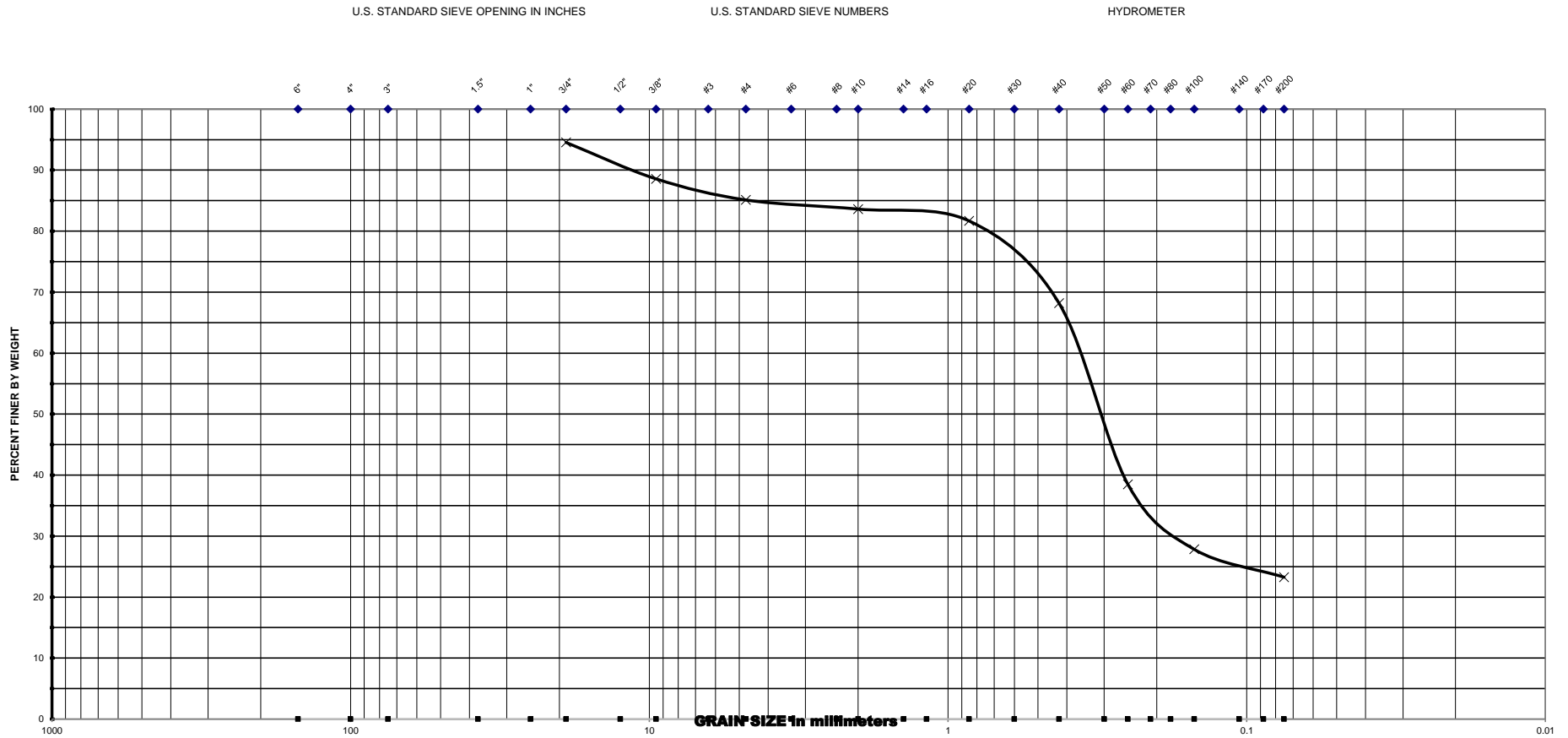

Project Name : <u>PD&amp;E Study - SW 10th Street From Powerline Road to Military Trail</u>					U.S. SIEVE NO.	CUMM. % PASSING
Project No. : <u>2000-01-17003</u>						
Date : <u>3/13/2018</u>						
BORING NO.	DEPTH INTERVAL [FT]	SOIL DESCRIPTION	MC	OC		
RD-7	6.0 - 8.0	A-2-4	24.4		#10	83.6
					#20	81.7
					#40	68.2
					#60	38.5
					#100	27.8
					#200	23.3

Note : MC - Moisture Content (%)  
OC - Organic Content (%)

# GCME

Geotechnical - Consulting - Engineering - Testing

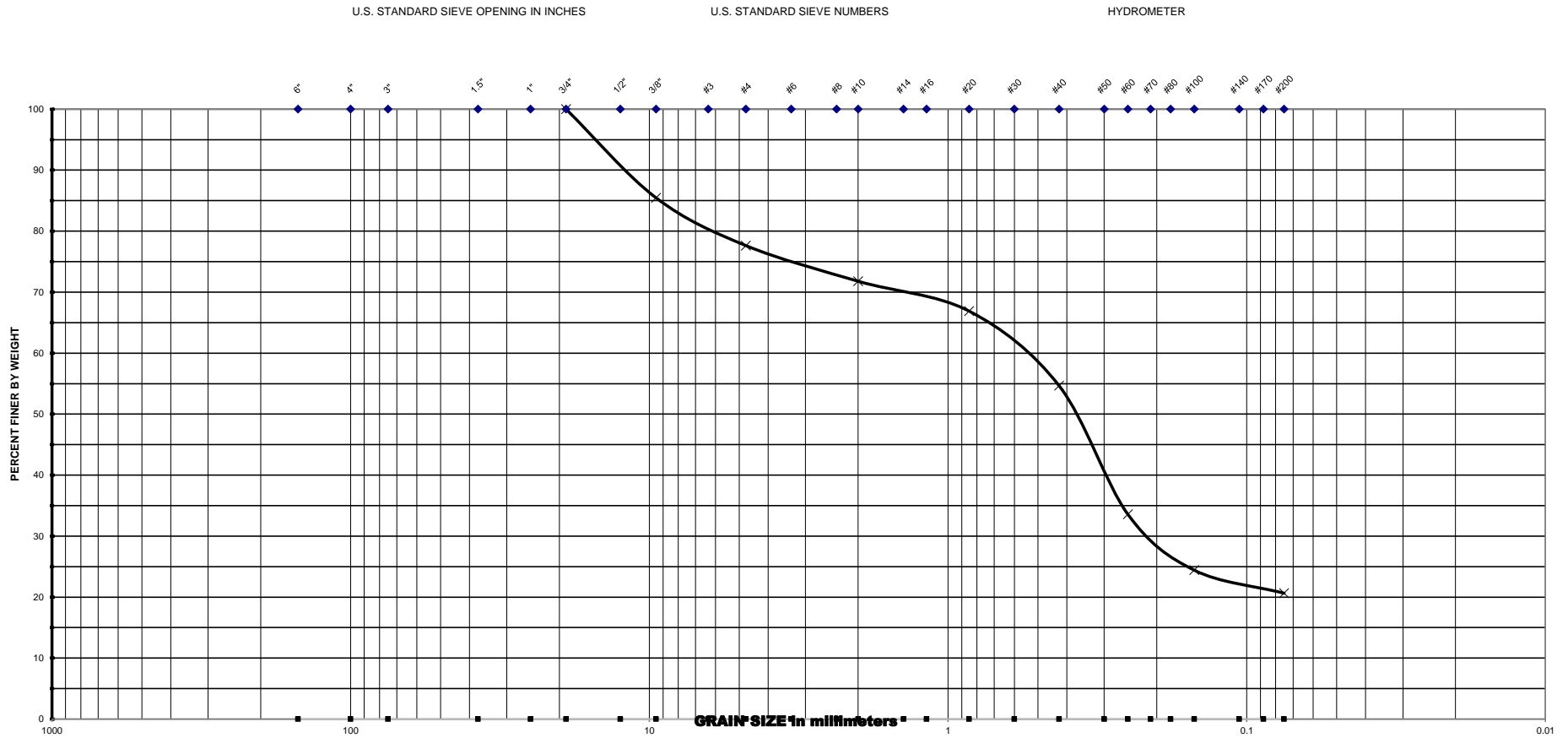

Project Name : <u>PD&amp;E Study - SW 10th Street From Powerline Road to Military Trail</u>					<b>U.S SIEVE NO.</b>	<b>CUMM. % PASSING</b>
Project No. : <u>2000-01-17003</u> Date : <u>4/5/2018</u>					3/4"	100.0
					3/8"	85.5
					#4	77.6
<b>BORING NO.</b>	<b>DEPTH INTERVAL [FT]</b>	<b>SOIL DESCRIPTION</b>	<b>MC</b>	<b>OC</b>	<b>#10</b>	<b>71.8</b>
RD-7	13.5 - 15.0	A-2-4	12.0		<b>#20</b>	<b>66.9</b>
					<b>#40</b>	<b>54.7</b>
					<b>#60</b>	<b>33.6</b>
Note : MC - Moisture Content (%) OC - Organic Content (%)					<b>#100</b>	<b>24.4</b>
					<b>#200</b>	<b>20.6</b>

# GCME

Geotechnical - Consulting - Engineering - Testing

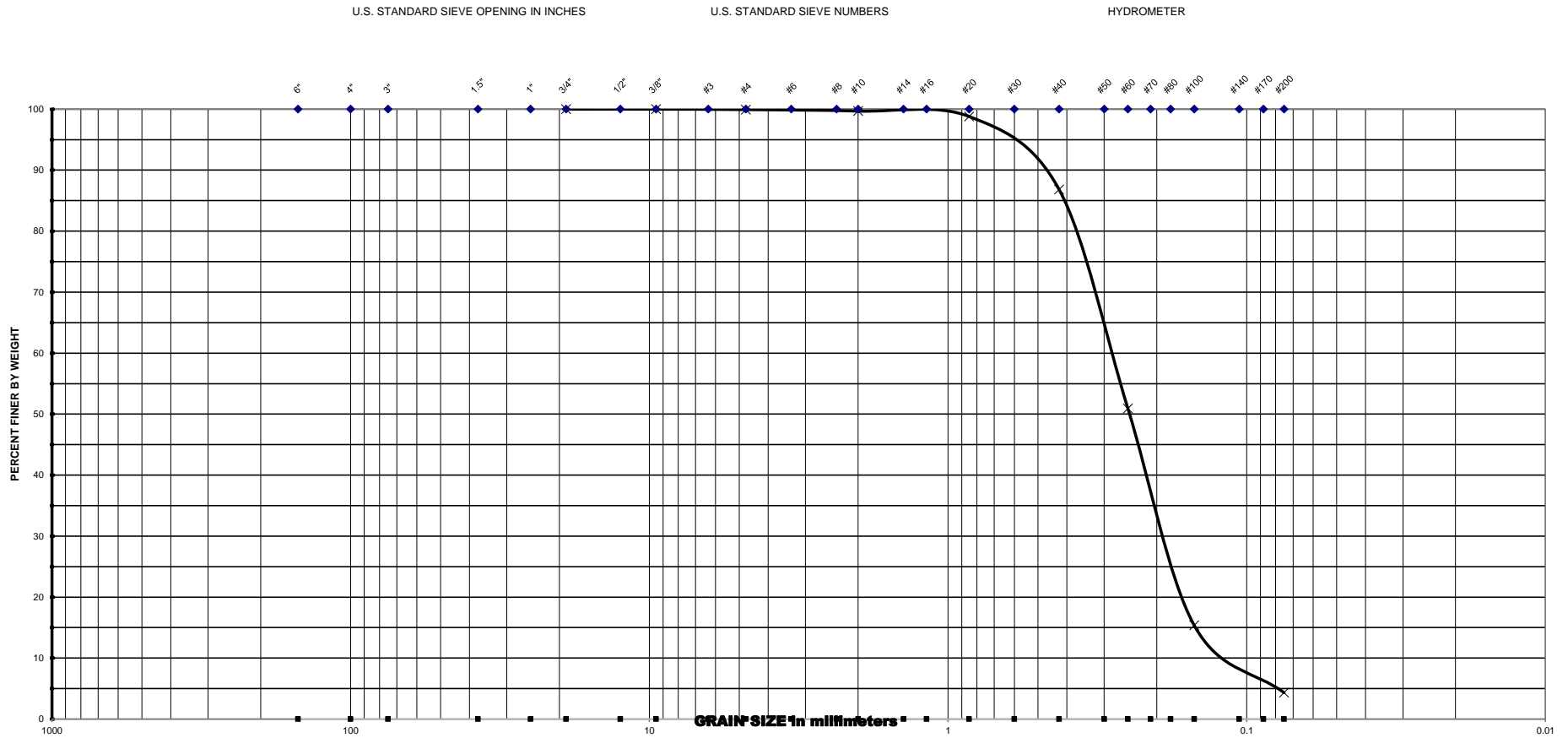

Project Name : PD&E Study - SW 10th Street From Powerline Road to Military Trail

Project No. : 2000-01-17003

Date : 3/13/2018

U.S SIEVE NO.	CUMM. % PASSING
3/4"	100.0
3/8"	100.0
#4	99.9
#10	99.7
#20	98.8
#40	86.8
#60	50.9
#100	15.4
#200	4.3

BORING NO.	DEPTH INTERVAL [FT]	SOIL DESCRIPTION	MC	OC
RD-8	0.0 - 2.0	A-3	5.3	

Note : MC - Moisture Content (%)  
OC - Organic Content (%)

# GCME

Geotechnical - Consulting - Engineering - Testing

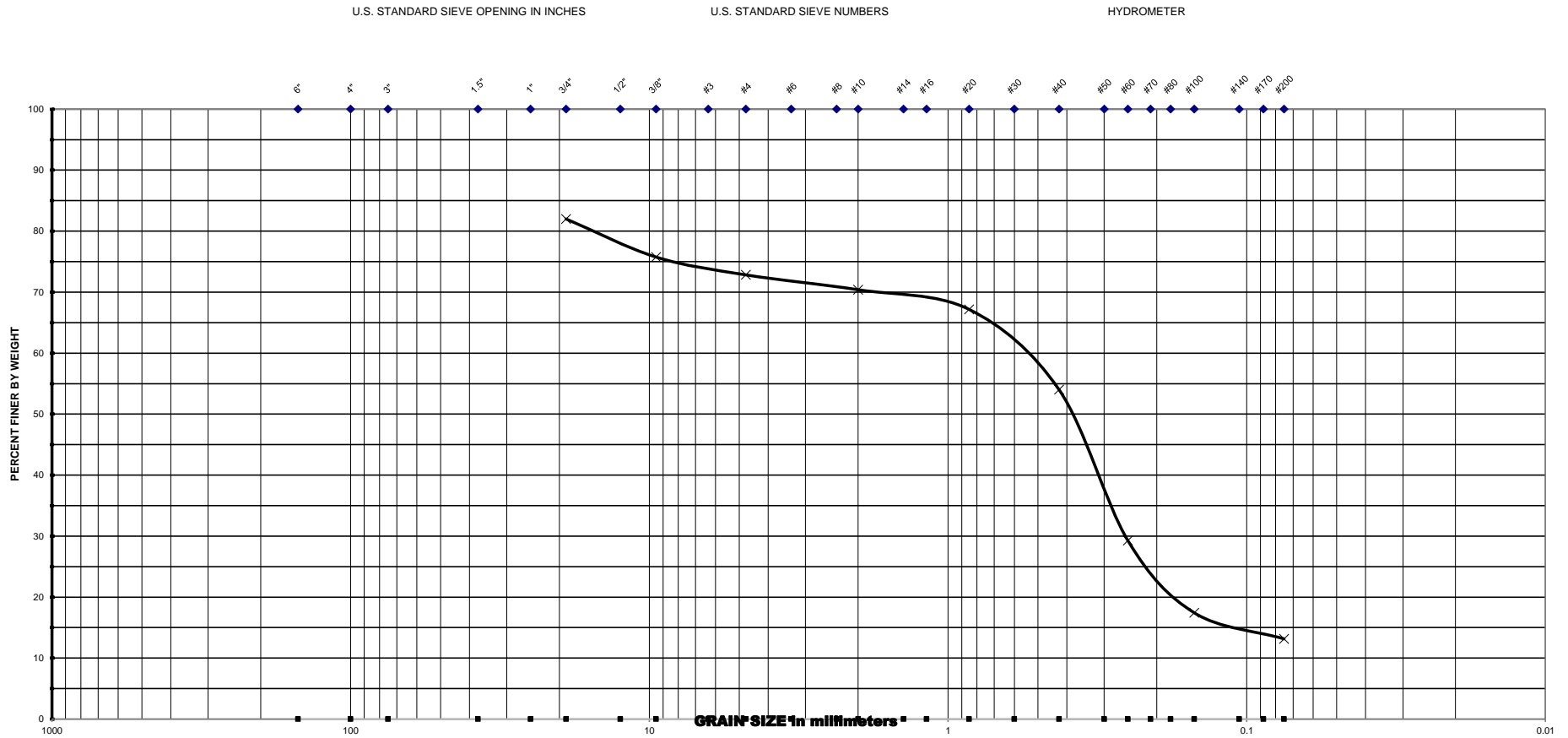

Project Name : <u>PD&amp;E Study - SW 10th Street From Powerline Road to Military Trail</u>					<b>U.S SIEVE NO.</b>	<b>CUMM. % PASSING</b>
Project No. : <u>2000-01-17003</u>						
Date : <u>3/13/2018</u>						
<b>BORING NO.</b>	<b>DEPTH INTERVAL [FT]</b>	<b>SOIL DESCRIPTION</b>	<b>MC</b>	<b>OC</b>	<b>#10</b>	70.4
RD-9	6.0 - 8.0	A-2-4	22.9		<b>#20</b>	67.2
					<b>#40</b>	54.0
					<b>#60</b>	29.3
					<b>#100</b>	17.4
					<b>#200</b>	13.2

Note : MC - Moisture Content (%)  
OC - Organic Content (%)

# GCME

Geotechnical - Consulting - Engineering - Testing

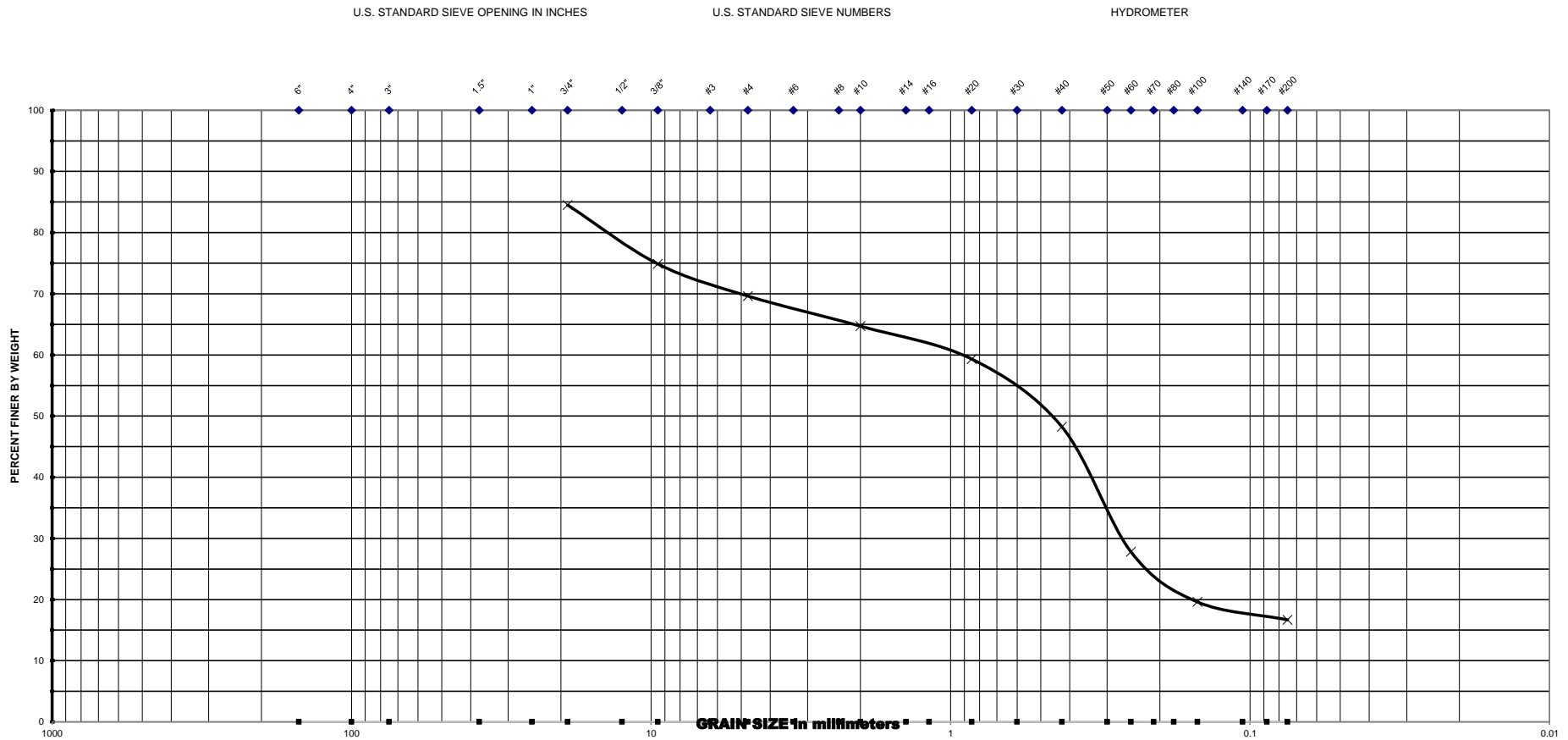

Project Name : <u>PD&amp;E Study - SW 10th Street From Powerline Road to Military Trail</u>					U.S. SIEVE NO.	CUMM. % PASSING
Project No. : <u>2000-01-17003</u> Date : <u>3/13/2018</u>					3/4"	84.5
					3/8"	74.9
					#4	69.6
BORING NO.	DEPTH INTERVAL [FT]	SOIL DESCRIPTION	MC	OC	#10	64.7
RD-9	10.0 - 12.0	A-1-b	15.9		#20	59.3
					#40	48.2
					#60	27.8
Note : MC - Moisture Content (%) OC - Organic Content (%)					#100	19.6
					#200	16.7

# GCME

Geotechnical - Consulting - Engineering - Testing

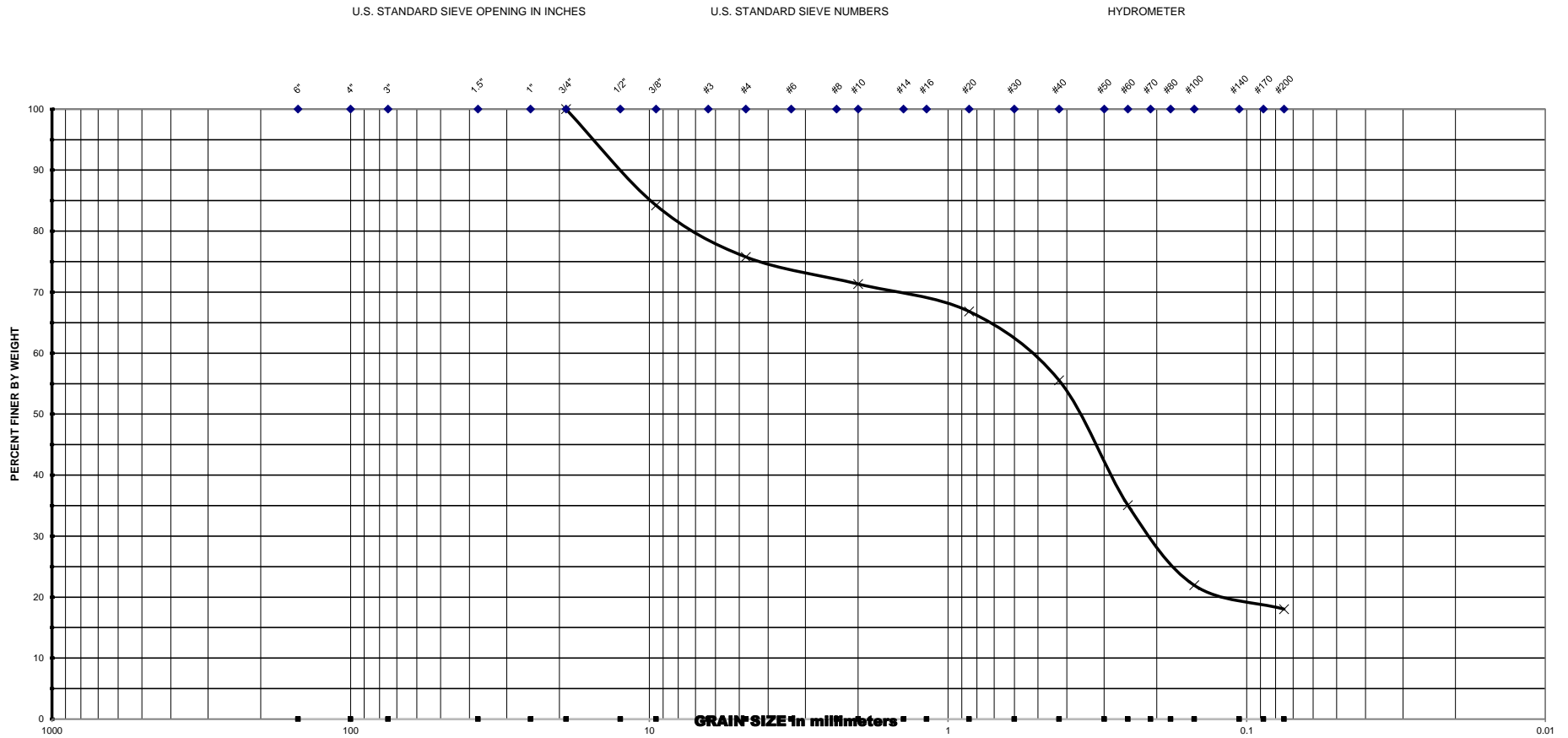

Project Name : <u>PD&amp;E Study - SW 10th Street From Powerline Road to Military Trail</u>					<b>U.S SIEVE NO.</b>	<b>CUMM. % PASSING</b>
Project No. : <u>2000-01-17003</u> Date : <u>4/5/2018</u>					3/4"	100.0
					3/8"	84.2
					#4	75.8
<b>BORING NO.</b>	<b>DEPTH INTERVAL [FT]</b>	<b>SOIL DESCRIPTION</b>	<b>MC</b>	<b>OC</b>	<b>#10</b>	<b>71.3</b>
RD-9	13.5 - 15.0	A-2-4	14.1		<b>#20</b>	<b>66.8</b>
					<b>#40</b>	<b>55.5</b>
					<b>#60</b>	<b>35.1</b>
Note : MC - Moisture Content (%) OC - Organic Content (%)					<b>#100</b>	<b>22.0</b>
					<b>#200</b>	<b>18.0</b>

# GCME

Geotechnical - Consulting - Engineering - Testing

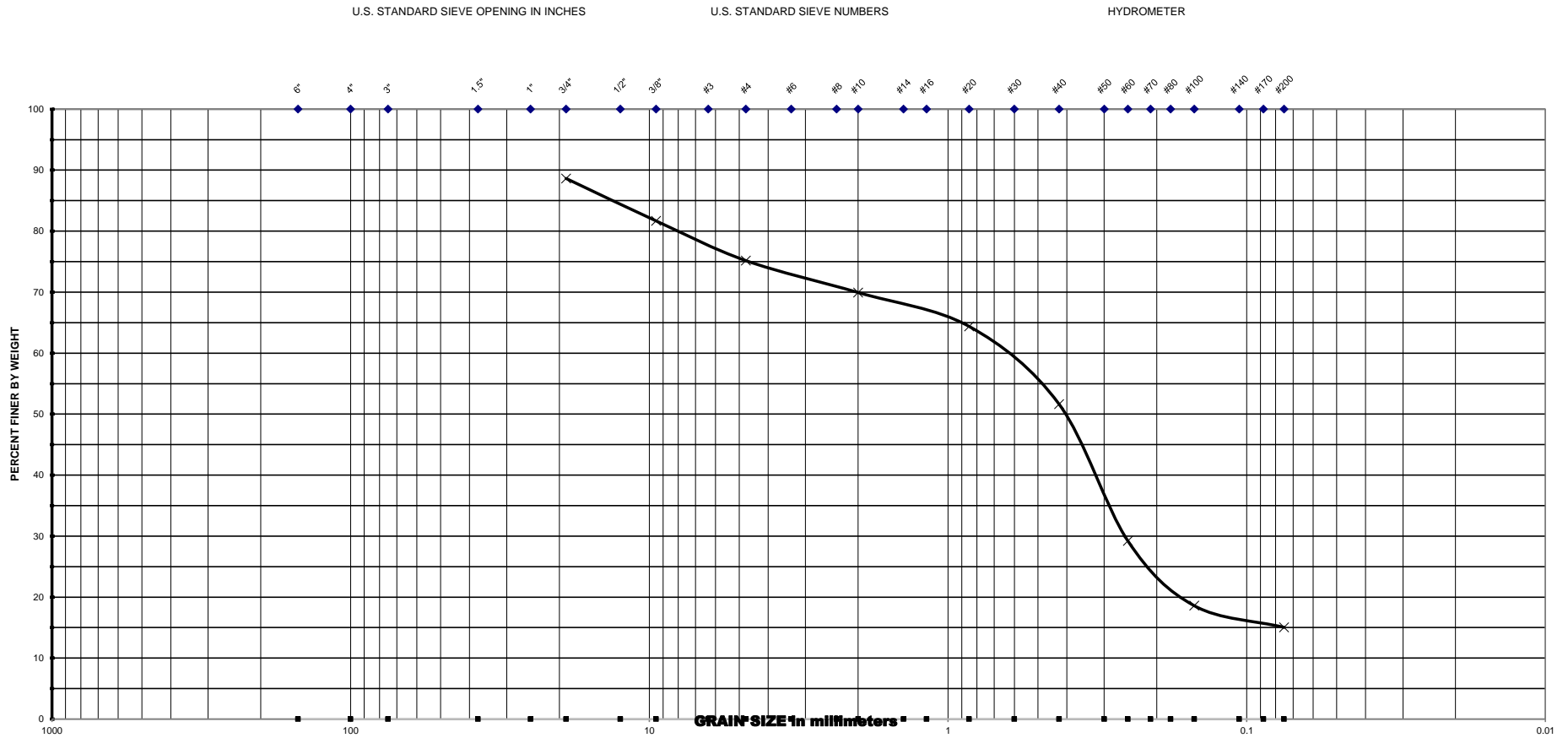

Project Name : <u>PD&amp;E Study - SW 10th Street From Powerline Road to Military Trail</u>					<b>U.S SIEVE NO.</b>	<b>CUMM. % PASSING</b>
Project No. : <u>2000-01-17003</u> Date : <u>3/13/2018</u>					3/4"	88.6
					3/8"	81.7
					#4	75.2
<b>BORING NO.</b>	<b>DEPTH INTERVAL [FT]</b>	<b>SOIL DESCRIPTION</b>	<b>MC</b>	<b>OC</b>	#10	69.9
RD-10	0.0 - 2.0	A-2-4	16.4		#20	64.4
					#40	51.6
					#60	29.2
Note : MC - Moisture Content (%) OC - Organic Content (%)					#100	18.6
					#200	15.0



# GCME

Geotechnical - Consulting - Engineering - Testing

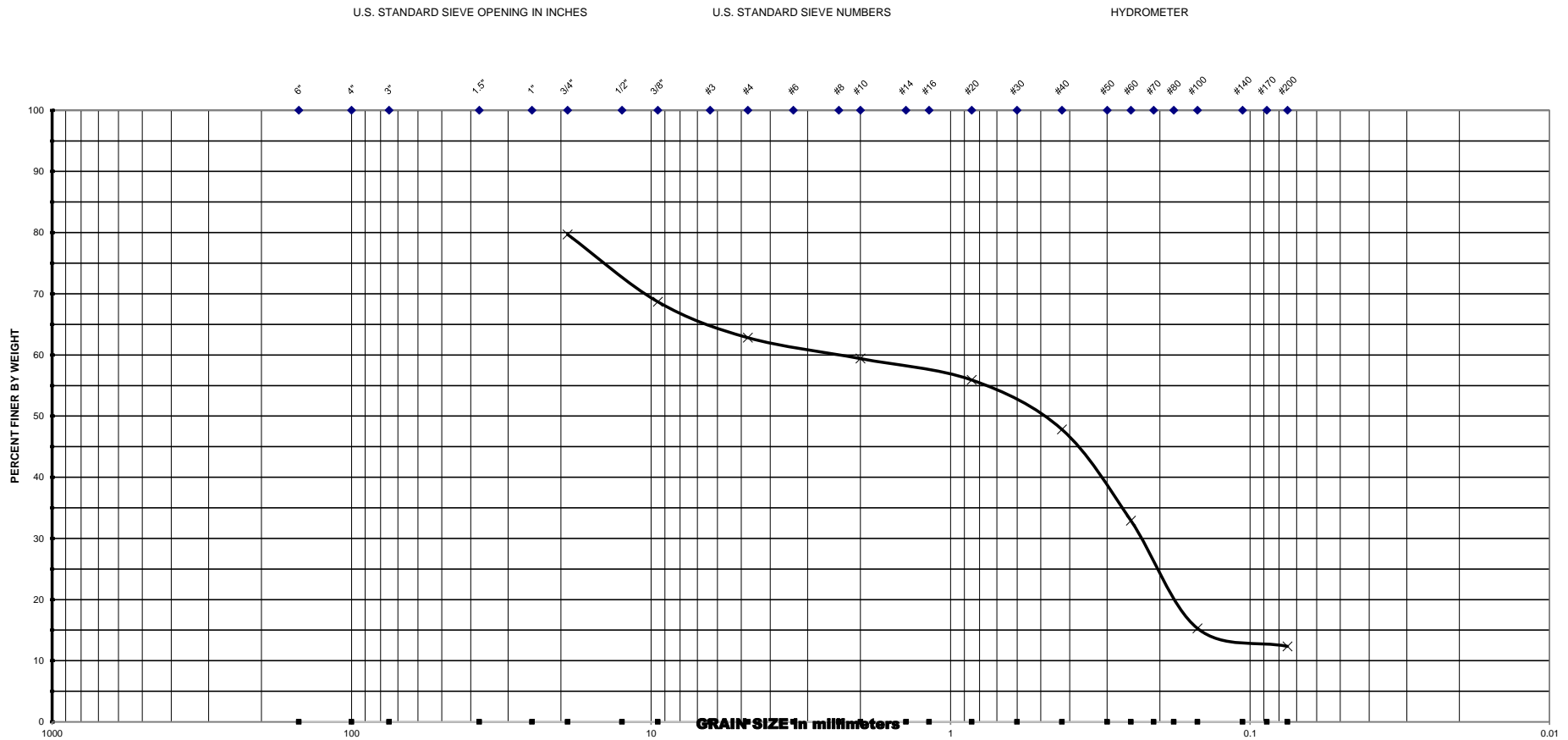

Project Name : PD&E Study - SW 10th Street From Powerline Road to Military Trail

Project No. : 2000-01-17003

Date : 4/5/2018

U.S. SIEVE NO.	CUMM. % PASSING
3/4"	79.7
3/8"	68.7
#4	62.8
#10	59.4
#20	55.9
#40	47.8
#60	32.9
#100	15.3
#200	12.3

BORING NO.	DEPTH INTERVAL [FT]	SOIL DESCRIPTION	MC	OC
RD-10	4.0 - 6.0	A-1-b	20.9	

Note : MC - Moisture Content (%)  
OC - Organic Content (%)

# GCME

Geotechnical - Consulting - Engineering - Testing

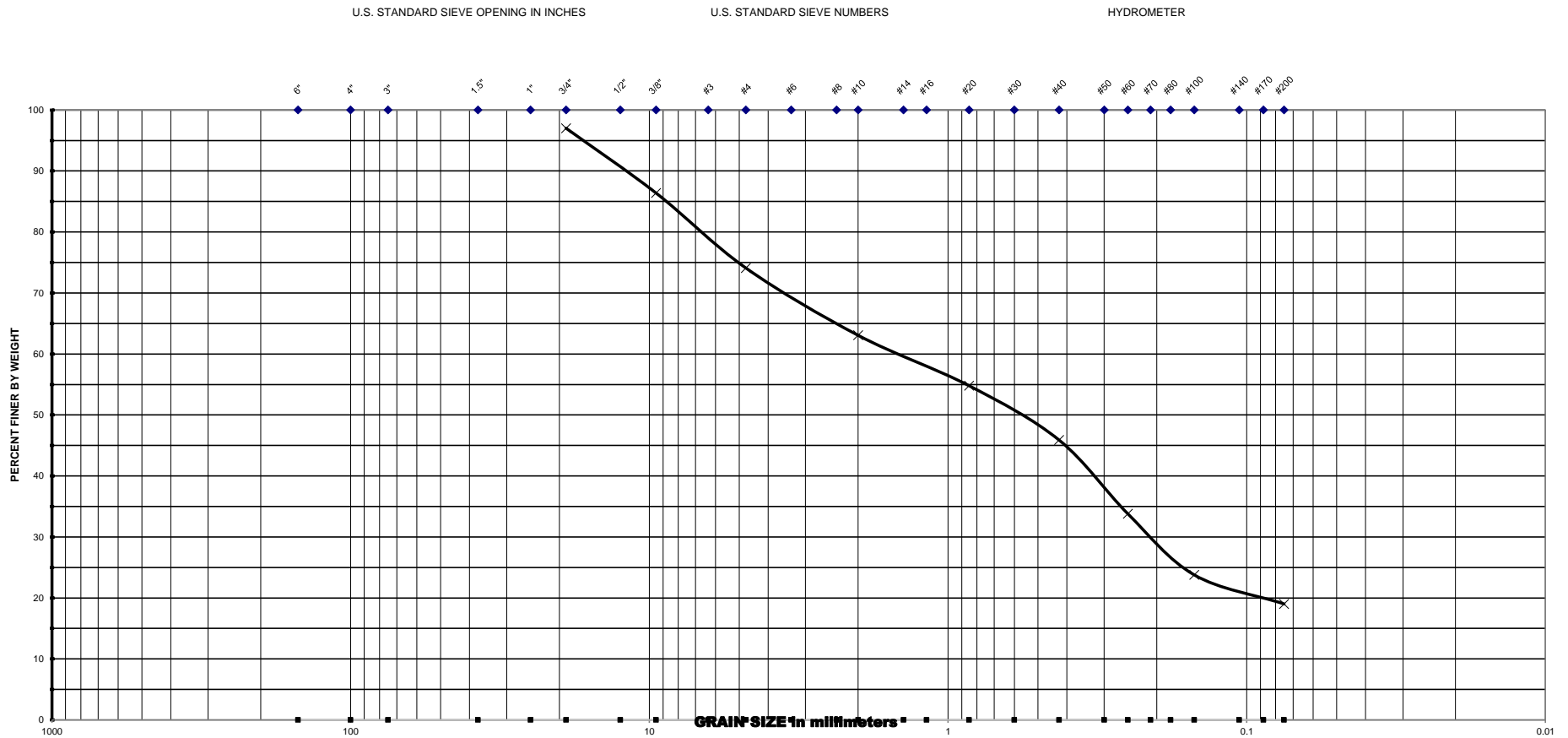

Project Name : <u>PD&amp;E Study - SW 10th Street From Powerline Road to Military Trail</u>					<b>U.S SIEVE NO.</b>	<b>CUMM. % PASSING</b>
Project No. : <u>2000-01-17003</u> Date : <u>4/5/2018</u>					3/4"	97.0
					3/8"	86.4
					#4	74.1
<b>BORING NO.</b>	<b>DEPTH INTERVAL [FT]</b>	<b>SOIL DESCRIPTION</b>	<b>MC</b>	<b>OC</b>	<b>#10</b>	63.1
RD-10	10.0 - 12.0	A-1-b	12.8		<b>#20</b>	54.8
					<b>#40</b>	45.9
					<b>#60</b>	33.8
Note : MC - Moisture Content (%) OC - Organic Content (%)					<b>#100</b>	23.8
					<b>#200</b>	19.0

# GCME

Geotechnical - Consulting - Engineering - Testing

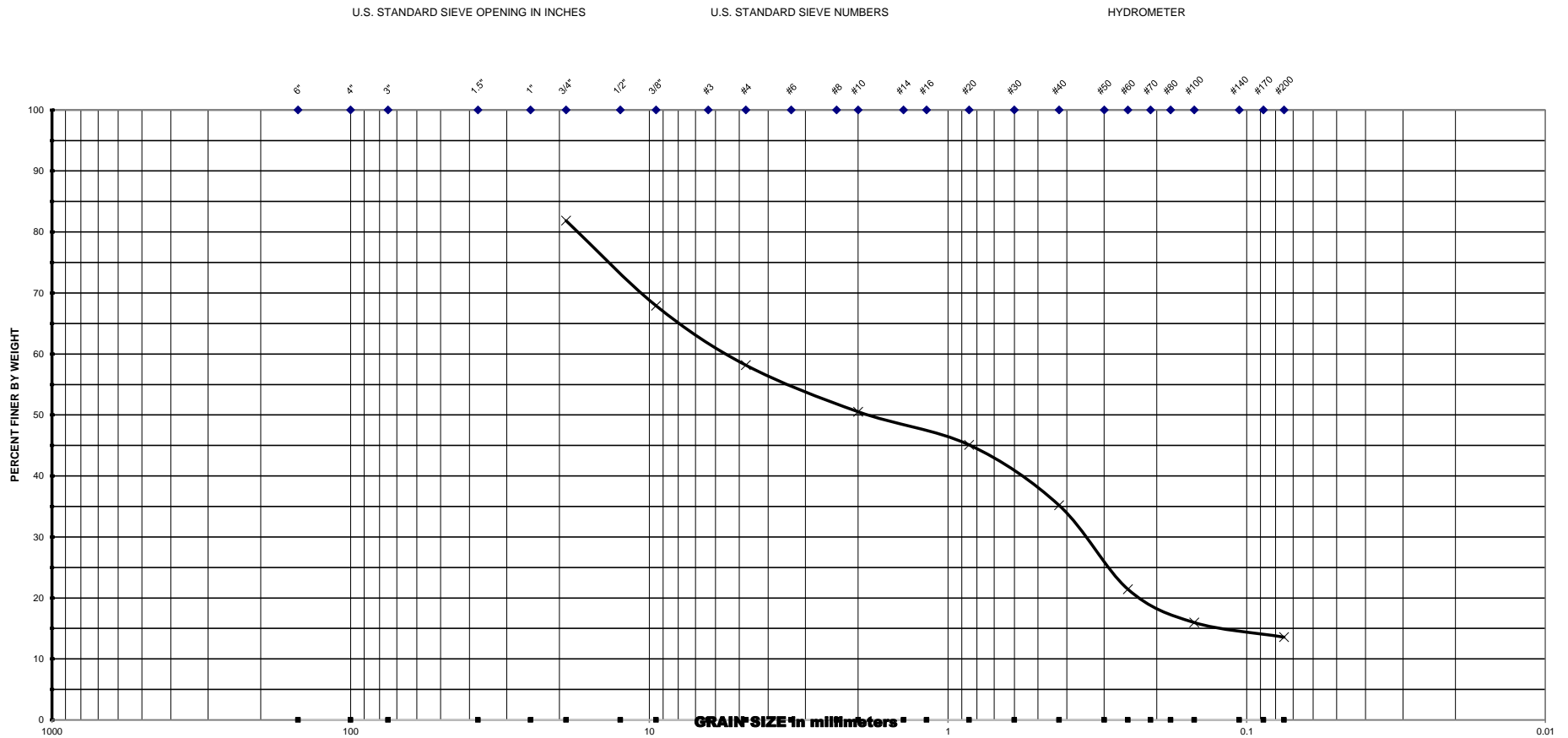

Project Name : <u>PD&amp;E Study - SW 10th Street From Powerline Road to Military Trail</u>					<b>U.S SIEVE NO.</b>	<b>CUMM. % PASSING</b>
Project No. : <u>2000-01-17003</u> Date : <u>3/13/2018</u>					3/4"	81.9
					3/8"	67.9
					#4	58.2
<b>BORING NO.</b>	<b>DEPTH INTERVAL [FT]</b>	<b>SOIL DESCRIPTION</b>	<b>MC</b>	<b>OC</b>	#10	50.5
BHP-1	2.0 - 4.0	A-1-b	18.2		#20	45.1
					#40	35.2
					#60	21.4
Note : MC - Moisture Content (%) OC - Organic Content (%)					#100	16.0
					#200	13.6

# GCME

Geotechnical - Consulting - Engineering - Testing

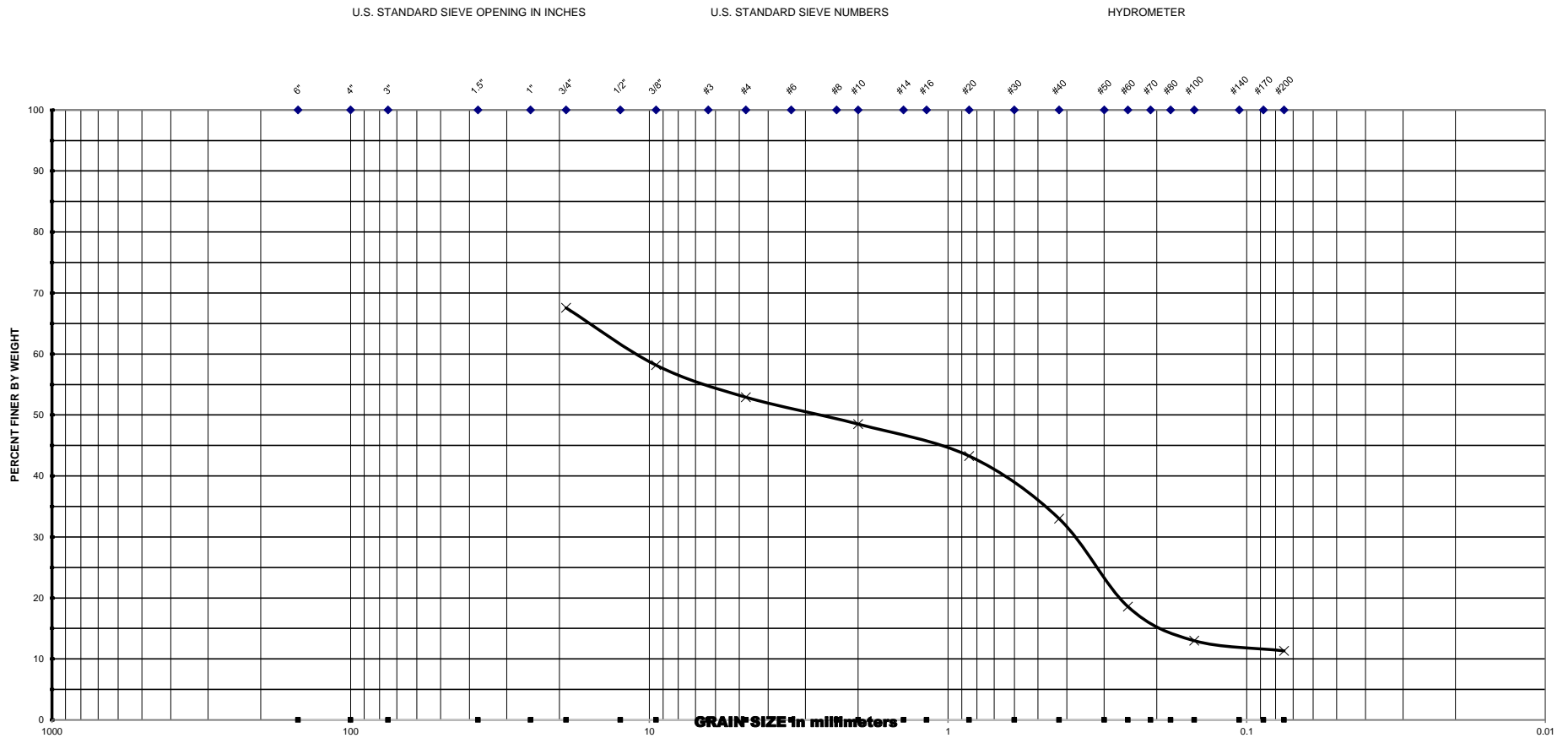

<b>Project Name :</b> <u>PD&amp;E Study - SW 10th Street From Powerline Road to Military Trail</u>					<b>U.S SIEVE NO.</b>	<b>CUMM. % PASSING</b>
					3/4"	67.6
<b>Project No. :</b> <u>2000-01-17003</u>					<b>Date :</b> <u>3/13/2018</u>	
					3/8"	58.2
<b>BORING NO.</b>	<b>DEPTH INTERVAL [FT]</b>	<b>SOIL DESCRIPTION</b>	<b>MC</b>	<b>OC</b>	#4	52.9
BHP-1	6.0 - 8.0	A-1-b	12.9		#10	48.5
					#20	43.3
					#40	33.0
					#60	18.6
					#100	13.0
					#200	11.3

**Note :** MC - Moisture Content (%)  
 OC - Organic Content (%)

# GCME

Geotechnical - Consulting - Engineering - Testing

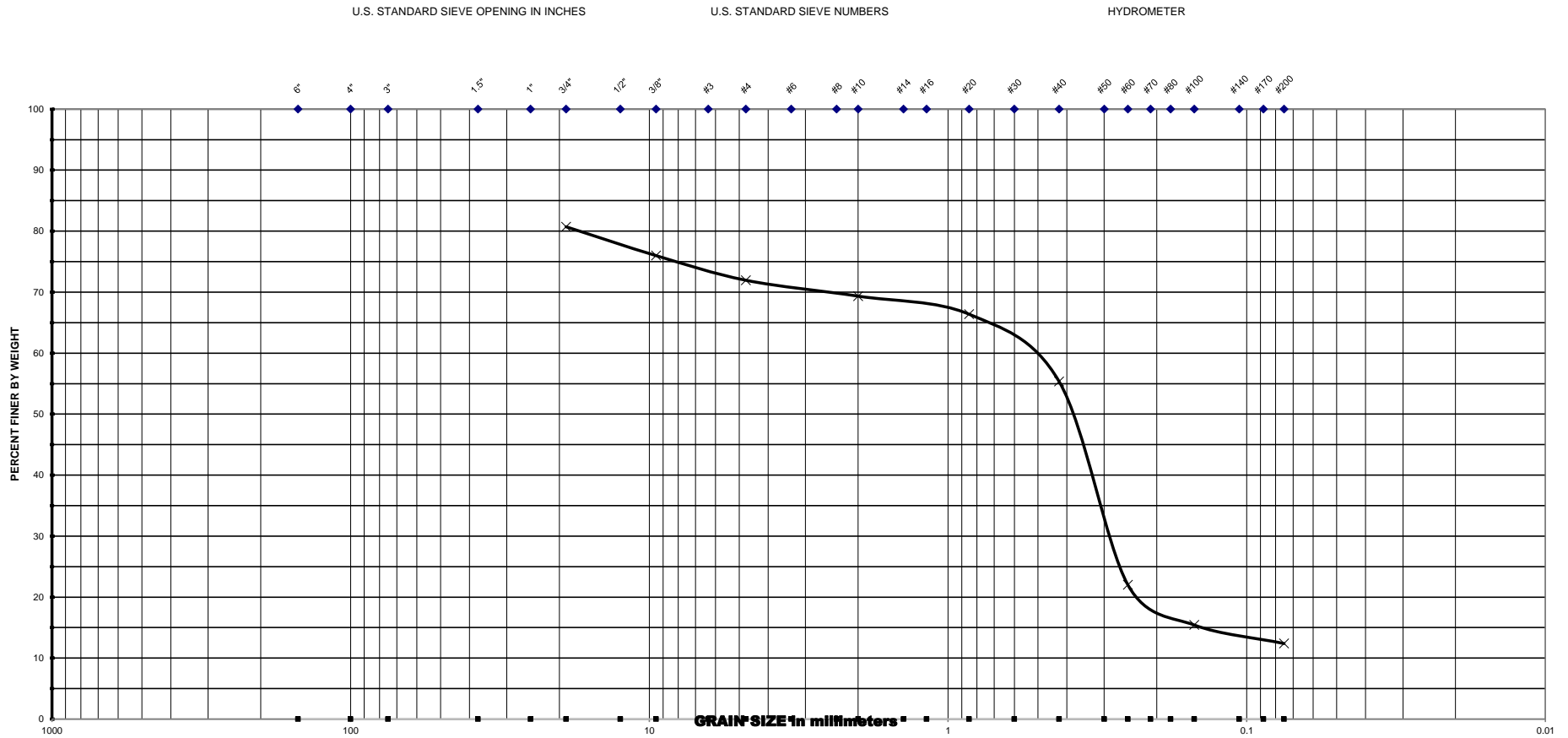

Project Name : <u>PD&amp;E Study - SW 10th Street From Powerline Road to Military Trail</u>					U.S. SIEVE NO.	CUMM. % PASSING
Project No. : <u>2000-01-17003</u> Date : <u>4/5/2018</u>					3/4"	80.7
					3/8"	76.0
					#4	71.9
BORING NO.	DEPTH INTERVAL [FT]	SOIL DESCRIPTION	MC	OC	#10	69.3
BHP-2	2.0 - 4.0	A-2-4	22.2		#20	66.4
					#40	55.4
					#60	22.0
Note : MC - Moisture Content (%) OC - Organic Content (%)					#100	15.4
					#200	12.4

# GCME

Geotechnical - Consulting - Engineering - Testing

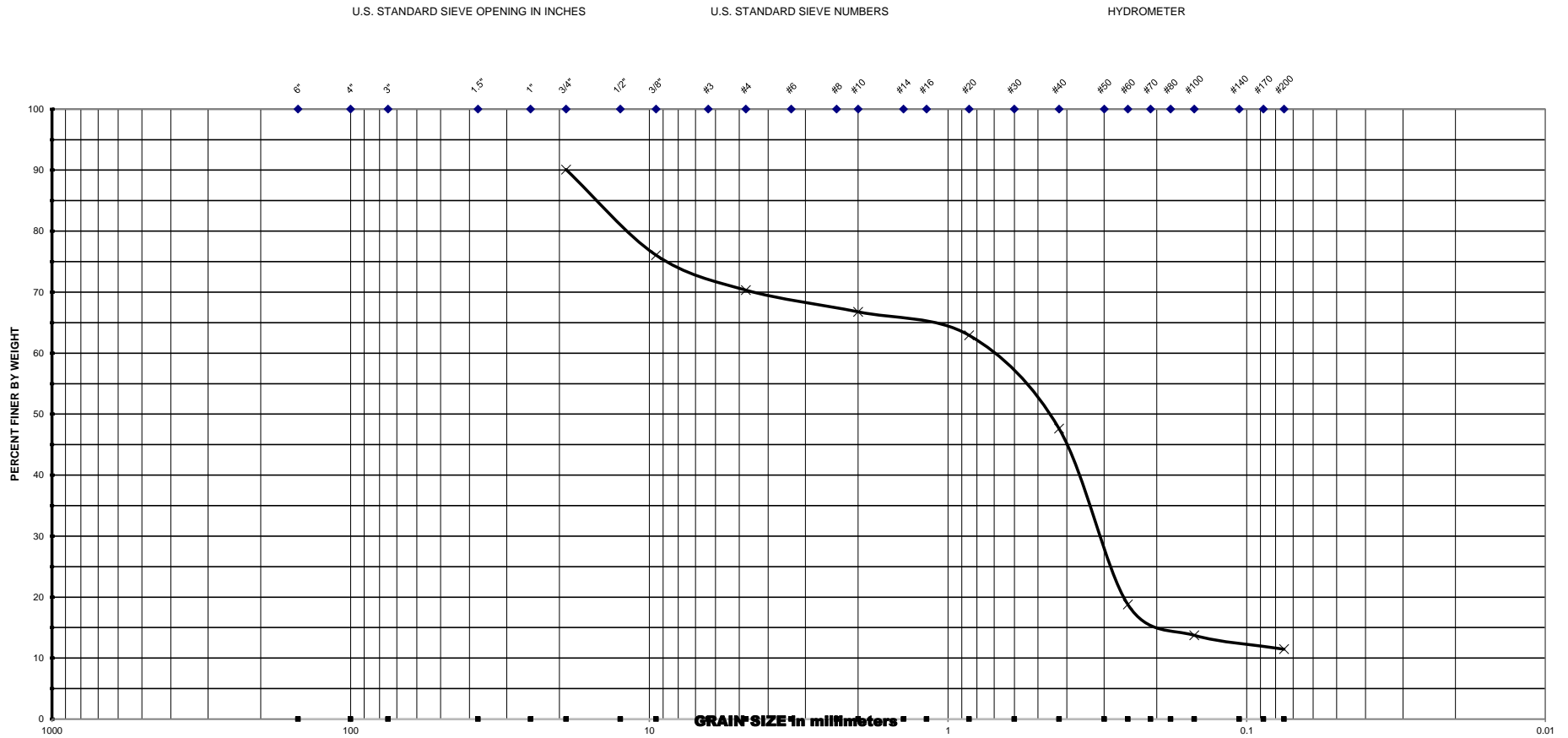

Project Name : <u>PD&amp;E Study - SW 10th Street From Powerline Road to Military Trail</u>					<b>U.S SIEVE NO.</b>	<b>CUMM. % PASSING</b>
Project No. : <u>2000-01-17003</u> Date : <u>3/13/2018</u>					3/4"	90.1
					3/8"	76.1
					#4	70.3
<b>BORING NO.</b>	<b>DEPTH INTERVAL [FT]</b>	<b>SOIL DESCRIPTION</b>	<b>MC</b>	<b>OC</b>	<b>#10</b>	66.8
BHP-2	4.0 - 6.0	A-1-b	20.5		<b>#20</b>	62.9
					<b>#40</b>	47.6
					<b>#60</b>	18.8
Note : MC - Moisture Content (%) OC - Organic Content (%)					<b>#100</b>	13.7
					<b>#200</b>	11.5

# GCME

Geotechnical - Consulting - Engineering - Testing

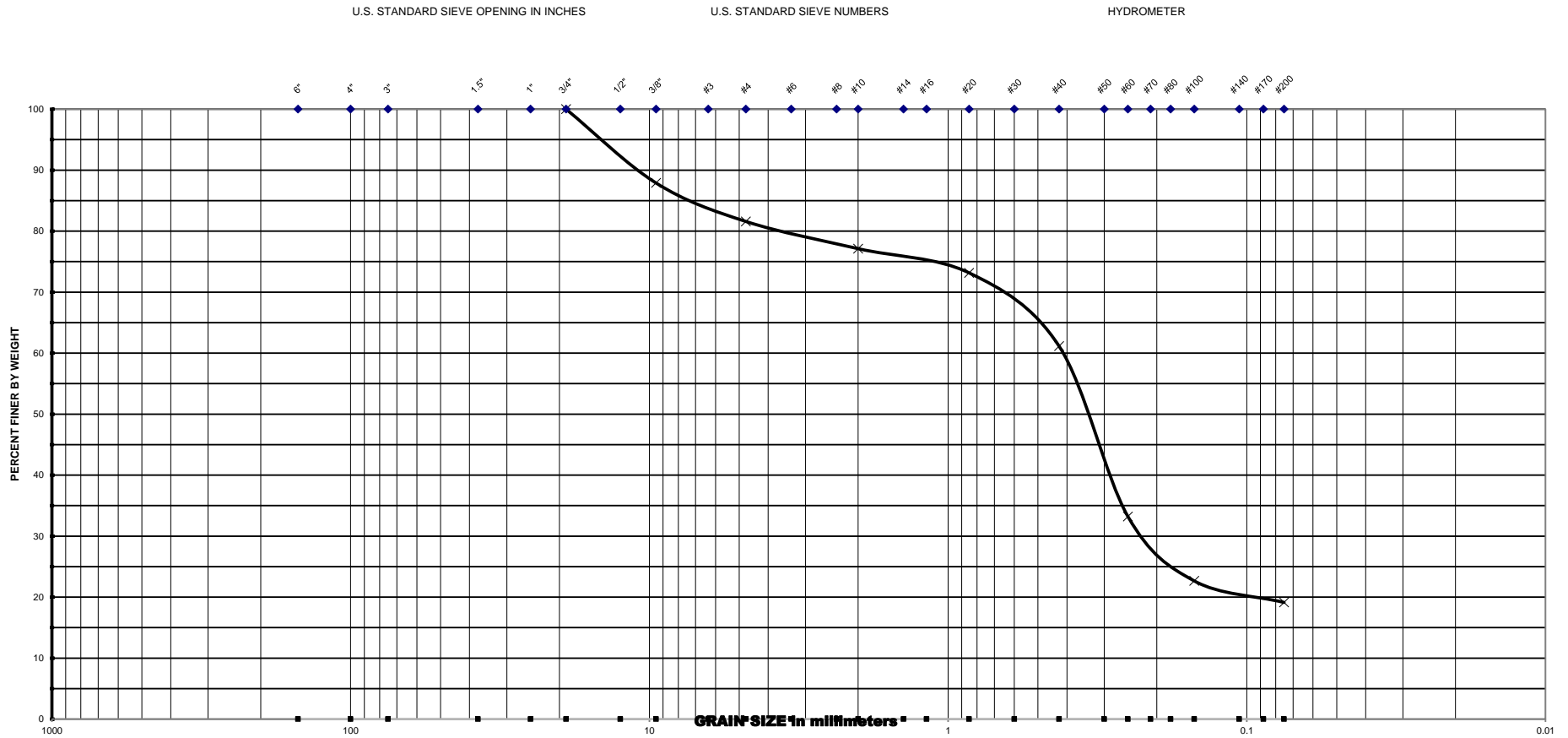

Project Name : PD&E Study - SW 10th Street From Powerline Road to Military Trail

Project No. : 2000-01-17003

Date : 3/13/2018

U.S SIEVE NO.	CUMM. % PASSING
3/4"	100.0
3/8"	87.9
#4	81.6
#10	77.1
#20	73.2
#40	61.1
#60	33.2
#100	22.7
#200	19.1

BORING NO.	DEPTH INTERVAL [FT]	SOIL DESCRIPTION	MC	OC
BHP-2	8.0 - 10.0	A-2-4	14.7	

Note : MC - Moisture Content (%)  
OC - Organic Content (%)

**TABLE - 2****SUMMARY OF CORROSION TEST RESULTS****Project Name: PD&E Study - SW 10th Street From Powerline Road to Military Trail**

Boring No.	Soil Type	Sample	Depth Interval	pH	Resistivity (ohm-cm)	Chloride (ppm)	Sulfate (ppm)	Environmental Classification (Substructure)	
								Steel	Concrete
RD-2	A-3 (SP, SP-SM)	Soil	8.0 - 12.0	8.1	7600	8.3	21.1	Slightly Aggressive	Slightly Aggressive
RD-4	A-3 (SP-SM)	Soil	6.0 - 8.0	7.6	3310	6.4	61.4	Moderately Aggressive	Slightly Aggressive
B-201	SP	Soil	6.0 - 8.0	7.7	2410	4.6	170.0	Moderately Aggressive	Moderately Aggressive
B-601	SP	Soil	8.0 - 10.0	8.0	8080	3.6	3.3	Slightly Aggressive	Slightly Aggressive
Canal Water		Water		7.7	1730	57.5	22.0	Moderately Aggressive	Moderately Aggressive

Classification	Environmental Condition	Units	Steel		Concrete	
			Water	Soil	Water	Soil
Extremely Aggressive (If any of these conditions exist)	pH		< 6.0		< 5.0	
	Cl	ppm	> 2000		> 2000	
	SO <sub>4</sub>	ppm	N.A.		> 1500	> 2000
	Resistivity	Ohm-cm	< 1000		< 500	
Slightly Aggressive (If all of these conditions exist)	pH		> 7.0		> 6.0	
	Cl	ppm	< 500		< 500	
	SO <sub>4</sub>	ppm	N.A.		< 150	< 1000
	Resistivity	Ohm-cm	> 5000		> 3000	
Moderately Aggressive	This classification must be used at all sites not meeting requirements for either slightly aggressive or extremely aggressive environments.					
pH = acidity (-log <sub>10</sub> H <sup>+</sup> ; potential of Hydrogen), Cl = chloride content, SO <sub>4</sub> = Sulfate content.						



**TABLE - 3**

**BOREHOLE PERMEABILITY TEST RESULTS**

**Project Name: PD&E Study - SW 10th Street from Powerline Rd to Military Trail**

**SFWMD METHOD**

<b>BHP No.</b>	<b>Date</b>	<b>Approx. Station</b>	<b>Approx. Offset</b>	<b>Bore Hole Dia (in)</b>	<b>Depth of Hole (ft)</b>	<b>GWT Depth (ft)</b>	<b>Flow Rate Q [gal/min]</b>	<b>K [cfs/ft<sup>2</sup>]</b>	<b>K [ft/day]</b>
BHP-1	02/14/18	Please see Plate-4 for location.		8.00	10.0	2.42	0.3800	1.47E-05	1.27
BHP-2	02/14/18	Please see Plate-4 for location.		8.00	10.0	3.00	0.5000	2.05E-05	1.77

**TABLE - 4**

**Project Name: PD&E Study - SW 10th Street from Powerline Rd to Military Trail**

**DOUBLE RING INFILTRATION TEST RESULTS SUMMARY**

<b>TEST NUMBER</b>	<b>BASELINE</b>	<b>STATION</b>	<b>OFFSET</b>	<b>GWT (ft)</b>	<b>Infiltration Rate Summary [inch/hour]</b>	<b>Infiltration Rate Summary [ft/day]</b>
DRIT-1	Please see Plate-4 for location.			GNE	1.08	2.2
DRIT-2	Please see Plate-4 for location.			GNE	0.81	1.6

**TABLE-4A**  
**DOUBLE RING INFILTRATION TEST RESULTS**

TEST No.:	<b>DRIT-1</b>
DATE:	2/5/2018
FPID No.:	439891-1-22-02
LIQUID USED:	Water
pH:	5
GROUND TEMPERATURE (°F):	73

Project Name: PD&E Study - SW 10th Street from Powerline Rd to Military Trail	
TEST LOCATION:	26°18'14.43"N 80°8'18.63"W
STATION:	
OFFSET:	
GROUND ELEVATION:	+9.5' (NAVD)

GENERAL SUBSURFACE PROFILE		
DEPTH (FEET)	SOIL DESCRIPTION	STRATUM No.
0-0.3	A-8	1
0.3-2	A-3	2
2-3	A-1-b	2A

DEPTH TO WATER TABLE (Feet):	N/A		
PENETRATION OF RINGS INTO GROUND (Inches):		INNER: 3	OUTER: 6
INTERNAL DIAMETER OF RINGS (Inches):		INNER: 12	OUTER: 24
THICKNESS OF RING WALL (Inches):		INNER: 0.125	OUTER: 0.125
AREA OF RINGS (Inches ^2):		INNER: 113.10	ANNULAR: 339.29

INCREMENT No.	ELAPSED TIME (MIN.)	TOTAL TIME (MIN.)	FLOW READINGS (ml)		LIQUID TEMPERATURE (°F)	INCREMENTAL INFILTRATION RATE (IN/HOUR)		REMARKS
			INNER RING	ANNULAR SPACE		INNER RING	ANNULAR SPACE	
0		0						
1	15	15	600	1750		1.29	1.26	Sunny
2	15	30	600	1750		1.29	1.26	Sunny
3	15	45	600	1750		1.29	1.26	Sunny
4	15	60	600	1700		1.29	1.22	Sunny
5	15	75	500	1700		1.08	1.22	Sunny
6	15	90	500	1700		1.08	1.22	Sunny
7	15	105	500	1700		1.08	1.22	Sunny
8	15	120	500	1700		1.08	1.22	Sunny
9	30	150	1000	3250		1.08	1.17	Sunny
10	30	180	1000	3250		1.08	1.17	Sunny
11	30	210	1000	3250		1.08	1.17	Sunny
12	30	240	1000	3250		1.08	1.17	Sunny
13	30	270	1000	3250		1.08	1.17	Sunny
14	30	300	1000	3250		1.08	1.17	Sunny
15	30	330	1000	3250		1.08	1.17	Sunny
16	30	360	1000	3250		1.08	1.17	Sunny

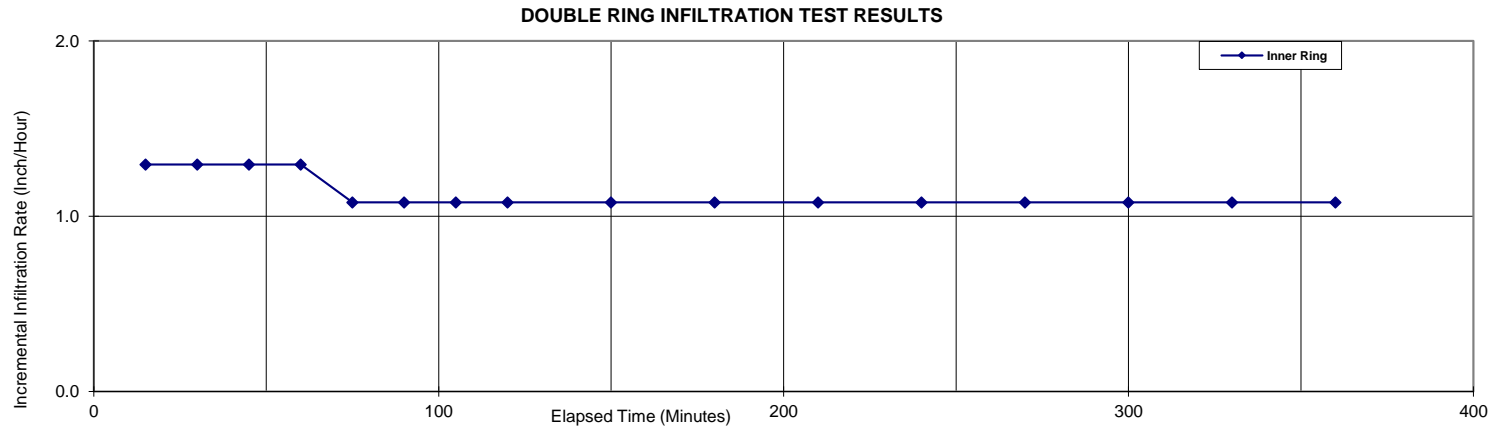

**TABLE-4B**  
**DOUBLE RING INFILTRATION TEST RESULTS**

TEST No.:	DRIT-2
DATE:	2/5/2018
FPID No.:	439891-1-22-02
LIQUID USED:	Water
pH:	5
GROUND TEMPERATURE (°F):	73

Project Name: PD&E Study - SW 10th Street from Powerline Rd to Military Trail
TEST LOCATION: 26°18'14.13"N 80°8'15.94"W
STATION:
OFFSET:
GROUND ELEVATION: +9.1' (NAVD)

GENERAL SUBSURFACE PROFILE		
DEPTH (FEET)	SOIL DESCRIPTION	STRATUM No.
0-0.3	A-8	1
0.3-1	A-3	2
1-2	A-1-b	2A

DEPTH TO WATER TABLE (Feet):	N/A		
PENETRATION OF RINGS INTO GROUND (Inches):		INNER: 3	OUTER: 6
INTERNAL DIAMETER OF RINGS (Inches):		INNER: 12	OUTER: 24
THICKNESS OF RING WALL (Inches):		INNER: 0.125	OUTER: 0.125
AREA OF RINGS (Inches ^2):		INNER: 113.10	ANNULAR: 339.29

INCREMENT No.	ELAPSED TIME (MIN.)	TOTAL TIME (MIN.)	FLOW READINGS (ml)		LIQUID TEMPERATURE (°F)	INCREMENTAL INFILTRATION RATE (IN/HOUR)		REMARKS
			INNER RING	ANNULAR SPACE		INNER RING	ANNULAR SPACE	
0		0						
1	15	15	500	1500		1.08	1.08	Sunny
2	15	30	400	1500		0.86	1.08	Sunny
3	15	45	400	1500		0.86	1.08	Sunny
4	15	60	400	1500		0.86	1.08	Sunny
5	15	75	400	1500		0.86	1.08	Sunny
6	15	90	400	1250		0.86	0.90	Sunny
7	15	105	400	1250		0.86	0.90	Sunny
8	15	120	400	1250		0.86	0.90	Sunny
9	30	150	750	2500		0.81	0.90	Sunny
10	30	180	750	2500		0.81	0.90	Sunny
11	30	210	750	2500		0.81	0.90	Sunny
12	30	240	750	2500		0.81	0.90	Sunny
13	30	270	750	2500		0.81	0.90	Sunny
14	30	300	750	2500		0.81	0.90	Sunny
15	30	330	750	2500		0.81	0.90	Sunny
16	30	360	750	2500		0.81	0.90	Sunny

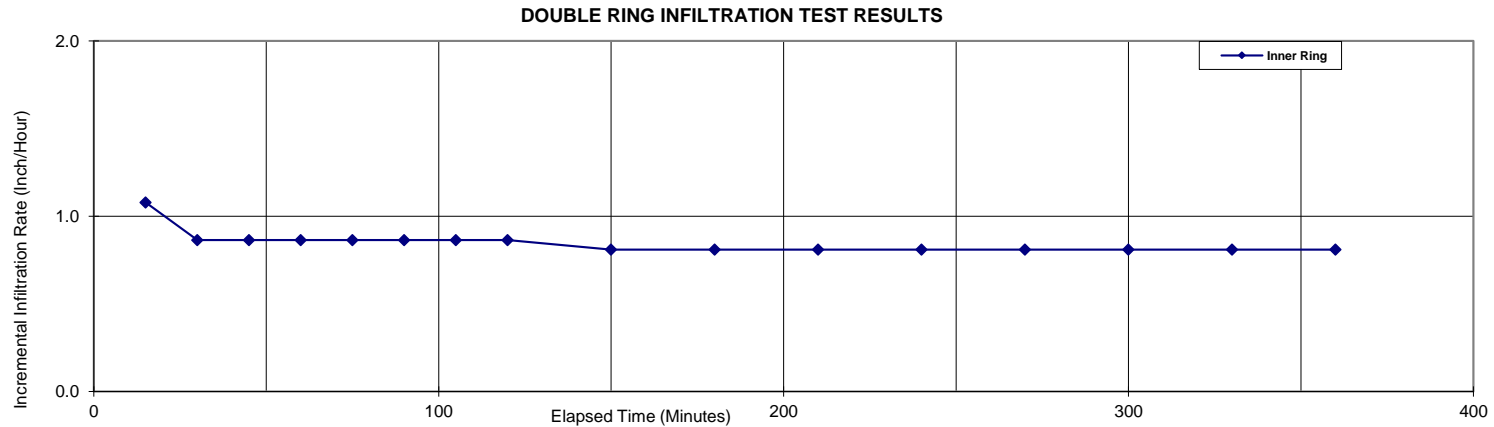

**APPENDIX – A**

**USDA, SCS SOIL INFORMATION**



United States  
Department of  
Agriculture

**NRCS**

Natural  
Resources  
Conservation  
Service

A product of the National  
Cooperative Soil Survey,  
a joint effort of the United  
States Department of  
Agriculture and other  
Federal agencies, State  
agencies including the  
Agricultural Experiment  
Stations, and local  
participants

# Custom Soil Resource Report for **Broward County, Florida, East Part**

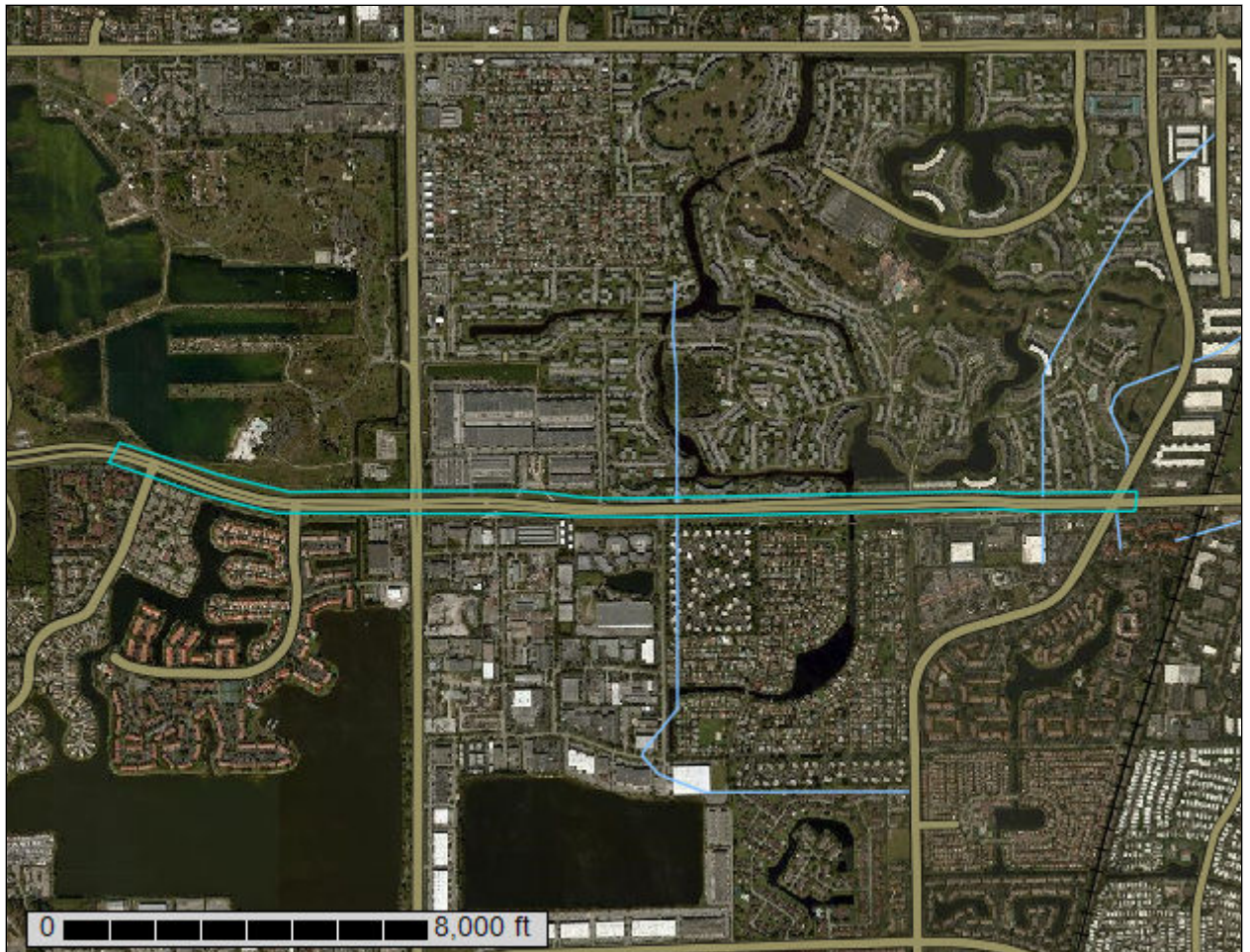

# Preface

---

Soil surveys contain information that affects land use planning in survey areas. They highlight soil limitations that affect various land uses and provide information about the properties of the soils in the survey areas. Soil surveys are designed for many different users, including farmers, ranchers, foresters, agronomists, urban planners, community officials, engineers, developers, builders, and home buyers. Also, conservationists, teachers, students, and specialists in recreation, waste disposal, and pollution control can use the surveys to help them understand, protect, or enhance the environment.

Various land use regulations of Federal, State, and local governments may impose special restrictions on land use or land treatment. Soil surveys identify soil properties that are used in making various land use or land treatment decisions. The information is intended to help the land users identify and reduce the effects of soil limitations on various land uses. The landowner or user is responsible for identifying and complying with existing laws and regulations.

Although soil survey information can be used for general farm, local, and wider area planning, onsite investigation is needed to supplement this information in some cases. Examples include soil quality assessments (<http://www.nrcs.usda.gov/wps/portal/nrcs/main/soils/health/>) and certain conservation and engineering applications. For more detailed information, contact your local USDA Service Center (<https://offices.sc.egov.usda.gov/locator/app?agency=nrcs>) or your NRCS State Soil Scientist ([http://www.nrcs.usda.gov/wps/portal/nrcs/detail/soils/contactus/?cid=nrcs142p2\\_053951](http://www.nrcs.usda.gov/wps/portal/nrcs/detail/soils/contactus/?cid=nrcs142p2_053951)).

Great differences in soil properties can occur within short distances. Some soils are seasonally wet or subject to flooding. Some are too unstable to be used as a foundation for buildings or roads. Clayey or wet soils are poorly suited to use as septic tank absorption fields. A high water table makes a soil poorly suited to basements or underground installations.

The National Cooperative Soil Survey is a joint effort of the United States Department of Agriculture and other Federal agencies, State agencies including the Agricultural Experiment Stations, and local agencies. The Natural Resources Conservation Service (NRCS) has leadership for the Federal part of the National Cooperative Soil Survey.

Information about soils is updated periodically. Updated information is available through the NRCS Web Soil Survey, the site for official soil survey information.

The U.S. Department of Agriculture (USDA) prohibits discrimination in all its programs and activities on the basis of race, color, national origin, age, disability, and where applicable, sex, marital status, familial status, parental status, religion, sexual orientation, genetic information, political beliefs, reprisal, or because all or a part of an individual's income is derived from any public assistance program. (Not all prohibited bases apply to all programs.) Persons with disabilities who require

alternative means for communication of program information (Braille, large print, audiotape, etc.) should contact USDA's TARGET Center at (202) 720-2600 (voice and TDD). To file a complaint of discrimination, write to USDA, Director, Office of Civil Rights, 1400 Independence Avenue, S.W., Washington, D.C. 20250-9410 or call (800) 795-3272 (voice) or (202) 720-6382 (TDD). USDA is an equal opportunity provider and employer.



# Contents

---

<b>Preface</b> .....	2
<b>How Soil Surveys Are Made</b> .....	5
<b>Soil Map</b> .....	8
Soil Map.....	9
Legend.....	10
Map Unit Legend.....	11
Map Unit Descriptions.....	11
Broward County, Florida, East Part.....	13
15—Immokalee fine sand, 0 to 2 percent slopes.....	13
19—Margate fine sand, occasionally ponded, 0 to 1 percent slopes.....	15
28—Pomello fine sand, 0 to 2 percent slopes.....	16
29—Pompano fine sand, 0 to 2 percent slopes.....	18
36—Udorthents.....	20
<b>Soil Information for All Uses</b> .....	22
Soil Reports.....	22
Soil Physical Properties.....	22
Engineering Properties.....	22
<b>References</b> .....	27

# How Soil Surveys Are Made

---

Soil surveys are made to provide information about the soils and miscellaneous areas in a specific area. They include a description of the soils and miscellaneous areas and their location on the landscape and tables that show soil properties and limitations affecting various uses. Soil scientists observed the steepness, length, and shape of the slopes; the general pattern of drainage; the kinds of crops and native plants; and the kinds of bedrock. They observed and described many soil profiles. A soil profile is the sequence of natural layers, or horizons, in a soil. The profile extends from the surface down into the unconsolidated material in which the soil formed or from the surface down to bedrock. The unconsolidated material is devoid of roots and other living organisms and has not been changed by other biological activity.

Currently, soils are mapped according to the boundaries of major land resource areas (MLRAs). MLRAs are geographically associated land resource units that share common characteristics related to physiography, geology, climate, water resources, soils, biological resources, and land uses (USDA, 2006). Soil survey areas typically consist of parts of one or more MLRA.

The soils and miscellaneous areas in a survey area occur in an orderly pattern that is related to the geology, landforms, relief, climate, and natural vegetation of the area. Each kind of soil and miscellaneous area is associated with a particular kind of landform or with a segment of the landform. By observing the soils and miscellaneous areas in the survey area and relating their position to specific segments of the landform, a soil scientist develops a concept, or model, of how they were formed. Thus, during mapping, this model enables the soil scientist to predict with a considerable degree of accuracy the kind of soil or miscellaneous area at a specific location on the landscape.

Commonly, individual soils on the landscape merge into one another as their characteristics gradually change. To construct an accurate soil map, however, soil scientists must determine the boundaries between the soils. They can observe only a limited number of soil profiles. Nevertheless, these observations, supplemented by an understanding of the soil-vegetation-landscape relationship, are sufficient to verify predictions of the kinds of soil in an area and to determine the boundaries.

Soil scientists recorded the characteristics of the soil profiles that they studied. They noted soil color, texture, size and shape of soil aggregates, kind and amount of rock fragments, distribution of plant roots, reaction, and other features that enable them to identify soils. After describing the soils in the survey area and determining their properties, the soil scientists assigned the soils to taxonomic classes (units). Taxonomic classes are concepts. Each taxonomic class has a set of soil characteristics with precisely defined limits. The classes are used as a basis for comparison to classify soils systematically. Soil taxonomy, the system of taxonomic classification used in the United States, is based mainly on the kind and character of soil properties and the arrangement of horizons within the profile. After the soil

## Custom Soil Resource Report

scientists classified and named the soils in the survey area, they compared the individual soils with similar soils in the same taxonomic class in other areas so that they could confirm data and assemble additional data based on experience and research.

The objective of soil mapping is not to delineate pure map unit components; the objective is to separate the landscape into landforms or landform segments that have similar use and management requirements. Each map unit is defined by a unique combination of soil components and/or miscellaneous areas in predictable proportions. Some components may be highly contrasting to the other components of the map unit. The presence of minor components in a map unit in no way diminishes the usefulness or accuracy of the data. The delineation of such landforms and landform segments on the map provides sufficient information for the development of resource plans. If intensive use of small areas is planned, onsite investigation is needed to define and locate the soils and miscellaneous areas.

Soil scientists make many field observations in the process of producing a soil map. The frequency of observation is dependent upon several factors, including scale of mapping, intensity of mapping, design of map units, complexity of the landscape, and experience of the soil scientist. Observations are made to test and refine the soil-landscape model and predictions and to verify the classification of the soils at specific locations. Once the soil-landscape model is refined, a significantly smaller number of measurements of individual soil properties are made and recorded. These measurements may include field measurements, such as those for color, depth to bedrock, and texture, and laboratory measurements, such as those for content of sand, silt, clay, salt, and other components. Properties of each soil typically vary from one point to another across the landscape.

Observations for map unit components are aggregated to develop ranges of characteristics for the components. The aggregated values are presented. Direct measurements do not exist for every property presented for every map unit component. Values for some properties are estimated from combinations of other properties.

While a soil survey is in progress, samples of some of the soils in the area generally are collected for laboratory analyses and for engineering tests. Soil scientists interpret the data from these analyses and tests as well as the field-observed characteristics and the soil properties to determine the expected behavior of the soils under different uses. Interpretations for all of the soils are field tested through observation of the soils in different uses and under different levels of management. Some interpretations are modified to fit local conditions, and some new interpretations are developed to meet local needs. Data are assembled from other sources, such as research information, production records, and field experience of specialists. For example, data on crop yields under defined levels of management are assembled from farm records and from field or plot experiments on the same kinds of soil.

Predictions about soil behavior are based not only on soil properties but also on such variables as climate and biological activity. Soil conditions are predictable over long periods of time, but they are not predictable from year to year. For example, soil scientists can predict with a fairly high degree of accuracy that a given soil will have a high water table within certain depths in most years, but they cannot predict that a high water table will always be at a specific level in the soil on a specific date.

After soil scientists located and identified the significant natural bodies of soil in the survey area, they drew the boundaries of these bodies on aerial photographs and

## Custom Soil Resource Report

identified each as a specific map unit. Aerial photographs show trees, buildings, fields, roads, and rivers, all of which help in locating boundaries accurately.

# Soil Map

---

The soil map section includes the soil map for the defined area of interest, a list of soil map units on the map and extent of each map unit, and cartographic symbols displayed on the map. Also presented are various metadata about data used to produce the map, and a description of each soil map unit.

Custom Soil Resource Report  
Soil Map

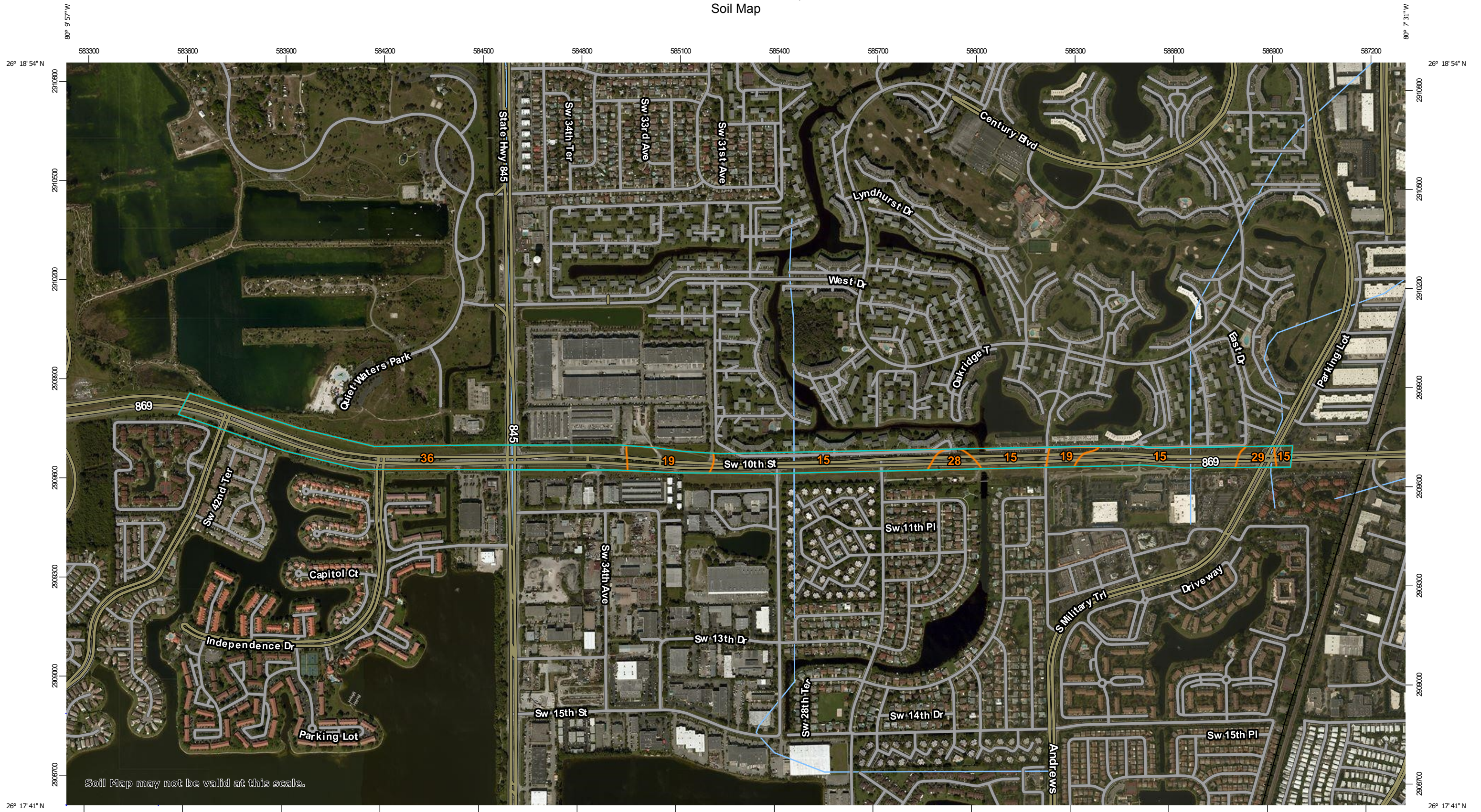

Soil Map may not be valid at this scale.

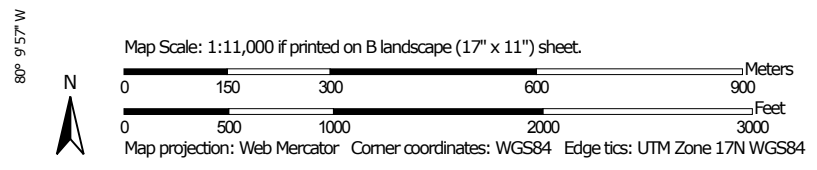

### MAP LEGEND

**Area of Interest (AOI)**

 Area of Interest (AOI)



















**Soils**







 Soil Map Unit Polygons

 Soil Map Unit Lines

 Soil Map Unit Points

**Special Point Features**





-  Blowout
-  Borrow Pit
-  Clay Spot
-  Closed Depression
-  Gravel Pit
-  Gravelly Spot
-  Landfill
-  Lava Flow
-  Marsh or swamp
-  Mine or Quarry
-  Miscellaneous Water
-  Perennial Water
-  Rock Outcrop
-  Saline Spot
-  Sandy Spot
-  Severely Eroded Spot
-  Sinkhole
-  Slide or Slip
-  Sodic Spot

-  Spoil Area
-  Stony Spot
-  Very Stony Spot
-  Wet Spot
-  Other
-  Special Line Features

**Water Features**

 Streams and Canals

**Transportation**

-  Rails
-  Interstate Highways
-  US Routes
-  Major Roads
-  Local Roads

**Background**

 Aerial Photography

### MAP INFORMATION

The soil surveys that comprise your AOI were mapped at 1:20,000.

Warning: Soil Map may not be valid at this scale.

Enlargement of maps beyond the scale of mapping can cause misunderstanding of the detail of mapping and accuracy of soil line placement. The maps do not show the small areas of contrasting soils that could have been shown at a more detailed scale.

Please rely on the bar scale on each map sheet for map measurements.

Source of Map: Natural Resources Conservation Service  
 Web Soil Survey URL:  
 Coordinate System: Web Mercator (EPSG:3857)

Maps from the Web Soil Survey are based on the Web Mercator projection, which preserves direction and shape but distorts distance and area. A projection that preserves area, such as the Albers equal-area conic projection, should be used if more accurate calculations of distance or area are required.

This product is generated from the USDA-NRCS certified data as of the version date(s) listed below.

Soil Survey Area: Broward County, Florida, East Part  
 Survey Area Data: Version 13, Oct 2, 2017

Soil map units are labeled (as space allows) for map scales 1:50,000 or larger.

Date(s) aerial images were photographed: Dec 17, 2014—Feb 11, 2015

The orthophoto or other base map on which the soil lines were compiled and digitized probably differs from the background imagery displayed on these maps. As a result, some minor shifting of map unit boundaries may be evident.

## Map Unit Legend

Map Unit Symbol	Map Unit Name	Acres in AOI	Percent of AOI
15	Immokalee fine sand, 0 to 2 percent slopes	21.7	38.2%
19	Margate fine sand, occasionally ponded, 0 to 1 percent slopes	6.1	10.7%
28	Pomello fine sand, 0 to 2 percent slopes	1.8	3.2%
29	Pompano fine sand, 0 to 2 percent slopes	1.7	3.1%
36	Udorthents	25.4	44.9%
<b>Totals for Area of Interest</b>		<b>56.7</b>	<b>100.0%</b>

## Map Unit Descriptions

The map units delineated on the detailed soil maps in a soil survey represent the soils or miscellaneous areas in the survey area. The map unit descriptions, along with the maps, can be used to determine the composition and properties of a unit.

A map unit delineation on a soil map represents an area dominated by one or more major kinds of soil or miscellaneous areas. A map unit is identified and named according to the taxonomic classification of the dominant soils. Within a taxonomic class there are precisely defined limits for the properties of the soils. On the landscape, however, the soils are natural phenomena, and they have the characteristic variability of all natural phenomena. Thus, the range of some observed properties may extend beyond the limits defined for a taxonomic class. Areas of soils of a single taxonomic class rarely, if ever, can be mapped without including areas of other taxonomic classes. Consequently, every map unit is made up of the soils or miscellaneous areas for which it is named and some minor components that belong to taxonomic classes other than those of the major soils.

Most minor soils have properties similar to those of the dominant soil or soils in the map unit, and thus they do not affect use and management. These are called noncontrasting, or similar, components. They may or may not be mentioned in a particular map unit description. Other minor components, however, have properties and behavioral characteristics divergent enough to affect use or to require different management. These are called contrasting, or dissimilar, components. They generally are in small areas and could not be mapped separately because of the scale used. Some small areas of strongly contrasting soils or miscellaneous areas are identified by a special symbol on the maps. If included in the database for a given area, the contrasting minor components are identified in the map unit descriptions along with some characteristics of each. A few areas of minor components may not have been observed, and consequently they are not mentioned in the descriptions, especially where the pattern was so complex that it was impractical to make enough observations to identify all the soils and miscellaneous areas on the landscape.



## Custom Soil Resource Report

The presence of minor components in a map unit in no way diminishes the usefulness or accuracy of the data. The objective of mapping is not to delineate pure taxonomic classes but rather to separate the landscape into landforms or landform segments that have similar use and management requirements. The delineation of such segments on the map provides sufficient information for the development of resource plans. If intensive use of small areas is planned, however, onsite investigation is needed to define and locate the soils and miscellaneous areas.

An identifying symbol precedes the map unit name in the map unit descriptions. Each description includes general facts about the unit and gives important soil properties and qualities.

Soils that have profiles that are almost alike make up a *soil series*. Except for differences in texture of the surface layer, all the soils of a series have major horizons that are similar in composition, thickness, and arrangement.

Soils of one series can differ in texture of the surface layer, slope, stoniness, salinity, degree of erosion, and other characteristics that affect their use. On the basis of such differences, a soil series is divided into *soil phases*. Most of the areas shown on the detailed soil maps are phases of soil series. The name of a soil phase commonly indicates a feature that affects use or management. For example, Alpha silt loam, 0 to 2 percent slopes, is a phase of the Alpha series.

Some map units are made up of two or more major soils or miscellaneous areas. These map units are complexes, associations, or undifferentiated groups.

A *complex* consists of two or more soils or miscellaneous areas in such an intricate pattern or in such small areas that they cannot be shown separately on the maps. The pattern and proportion of the soils or miscellaneous areas are somewhat similar in all areas. Alpha-Beta complex, 0 to 6 percent slopes, is an example.

An *association* is made up of two or more geographically associated soils or miscellaneous areas that are shown as one unit on the maps. Because of present or anticipated uses of the map units in the survey area, it was not considered practical or necessary to map the soils or miscellaneous areas separately. The pattern and relative proportion of the soils or miscellaneous areas are somewhat similar. Alpha-Beta association, 0 to 2 percent slopes, is an example.

An *undifferentiated group* is made up of two or more soils or miscellaneous areas that could be mapped individually but are mapped as one unit because similar interpretations can be made for use and management. The pattern and proportion of the soils or miscellaneous areas in a mapped area are not uniform. An area can be made up of only one of the major soils or miscellaneous areas, or it can be made up of all of them. Alpha and Beta soils, 0 to 2 percent slopes, is an example.

Some surveys include *miscellaneous areas*. Such areas have little or no soil material and support little or no vegetation. Rock outcrop is an example.

## Broward County, Florida, East Part

### 15—Immokalee fine sand, 0 to 2 percent slopes

#### Map Unit Setting

*National map unit symbol:* 2s3lk  
*Elevation:* 0 to 130 feet  
*Mean annual precipitation:* 44 to 56 inches  
*Mean annual air temperature:* 70 to 77 degrees F  
*Frost-free period:* 350 to 365 days  
*Farmland classification:* Not prime farmland

#### Map Unit Composition

*Immokalee and similar soils:* 90 percent  
*Minor components:* 10 percent  
*Estimates are based on observations, descriptions, and transects of the mapunit.*

#### Description of Immokalee

##### Setting

*Landform:* Flatwoods on marine terraces  
*Landform position (three-dimensional):* Riser, talf  
*Down-slope shape:* Linear  
*Across-slope shape:* Linear  
*Parent material:* Sandy marine deposits

##### Typical profile

*A - 0 to 6 inches:* fine sand  
*E - 6 to 35 inches:* fine sand  
*Bh - 35 to 54 inches:* fine sand  
*BC - 54 to 80 inches:* fine sand

##### Properties and qualities

*Slope:* 0 to 2 percent  
*Depth to restrictive feature:* More than 80 inches  
*Natural drainage class:* Poorly drained  
*Runoff class:* High  
*Capacity of the most limiting layer to transmit water (Ksat):* Moderately high to high (0.57 to 1.98 in/hr)  
*Depth to water table:* About 6 to 18 inches  
*Frequency of flooding:* None  
*Frequency of ponding:* None  
*Salinity, maximum in profile:* Nonsaline to very slightly saline (0.0 to 2.0 mmhos/cm)  
*Sodium adsorption ratio, maximum in profile:* 4.0  
*Available water storage in profile:* Low (about 5.9 inches)

##### Interpretive groups

*Land capability classification (irrigated):* None specified  
*Land capability classification (nonirrigated):* 4w  
*Hydrologic Soil Group:* B/D  
*Forage suitability group:* Sandy soils on flats of mesic or hydric lowlands (G155XB141FL)  
*Other vegetative classification:* South Florida Flatwoods (R155XY003FL)  
*Hydric soil rating:* No

## Minor Components

### Basinger

*Percent of map unit:* 4 percent  
*Landform:* Depressions on marine terraces  
*Landform position (three-dimensional):* Tread, dip  
*Down-slope shape:* Concave, linear  
*Across-slope shape:* Concave, linear  
*Hydric soil rating:* Yes

### Wabasso

*Percent of map unit:* 2 percent  
*Landform:* Flatwoods on marine terraces  
*Landform position (three-dimensional):* Tread, talf  
*Down-slope shape:* Linear, convex  
*Across-slope shape:* Linear  
*Other vegetative classification:* South Florida Flatwoods (R155XY003FL)  
*Hydric soil rating:* No

### Pomello

*Percent of map unit:* 2 percent  
*Landform:* Knolls on marine terraces, ridges on marine terraces  
*Landform position (two-dimensional):* Backslope, summit  
*Landform position (three-dimensional):* Side slope, interfluve, riser  
*Down-slope shape:* Convex, linear  
*Across-slope shape:* Linear  
*Ecological site:* Sand Pine Scrub (R155XY001FL)  
*Other vegetative classification:* Sand Pine Scrub (R155XY001FL)  
*Hydric soil rating:* No

### Margate

*Percent of map unit:* 1 percent  
*Landform:* Drainageways on marine terraces  
*Landform position (three-dimensional):* Tread, dip  
*Down-slope shape:* Linear  
*Across-slope shape:* Concave  
*Hydric soil rating:* Yes

### Placid

*Percent of map unit:* 1 percent  
*Landform:* Depressions on marine terraces, drainageways on marine terraces  
*Landform position (three-dimensional):* Tread, dip  
*Down-slope shape:* Concave  
*Across-slope shape:* Concave  
*Other vegetative classification:* Freshwater Marshes and Ponds (R155XY010FL)  
*Hydric soil rating:* Yes

## 19—Margate fine sand, occasionally ponded, 0 to 1 percent slopes

### Map Unit Setting

*National map unit symbol:* 2sm5l  
*Elevation:* 0 to 30 feet  
*Mean annual precipitation:* 60 to 70 inches  
*Mean annual air temperature:* 72 to 81 degrees F  
*Frost-free period:* 360 to 365 days  
*Farmland classification:* Not prime farmland

### Map Unit Composition

*Margate and similar soils:* 85 percent  
*Minor components:* 15 percent  
*Estimates are based on observations, descriptions, and transects of the mapunit.*

### Description of Margate

#### Setting

*Landform:* Flats on marine terraces, rises on marine terraces  
*Landform position (three-dimensional):* Tread, tal, rise  
*Down-slope shape:* Linear  
*Across-slope shape:* Concave, convex  
*Parent material:* Sandy marine deposits over limestone

#### Typical profile

*A - 0 to 8 inches:* fine sand  
*E - 8 to 16 inches:* fine sand  
*Bw - 16 to 28 inches:* fine sand  
*C - 28 to 32 inches:* very gravelly fine sand  
*2R - 32 to 42 inches:* bedrock

#### Properties and qualities

*Slope:* 0 to 1 percent  
*Depth to restrictive feature:* 20 to 40 inches to lithic bedrock  
*Natural drainage class:* Poorly drained  
*Runoff class:* Negligible  
*Capacity of the most limiting layer to transmit water (Ksat):* High to very high (1.98 to 19.98 in/hr)  
*Depth to water table:* About 0 inches  
*Frequency of flooding:* None  
*Frequency of ponding:* Occasional  
*Calcium carbonate, maximum in profile:* 4 percent  
*Salinity, maximum in profile:* Nonsaline to very slightly saline (0.0 to 2.0 mmhos/cm)  
*Sodium adsorption ratio, maximum in profile:* 4.0  
*Available water storage in profile:* Very low (about 2.6 inches)

#### Interpretive groups

*Land capability classification (irrigated):* None specified  
*Land capability classification (nonirrigated):* 4w

## Custom Soil Resource Report

*Hydrologic Soil Group:* A/D

*Forage suitability group:* Sandy soils on stream terraces, flood plains, or in depressions (G156AC145FL)

*Hydric soil rating:* Yes

### Minor Components

#### Basinger

*Percent of map unit:* 5 percent

*Landform:* Drainageways on marine terraces

*Landform position (three-dimensional):* Tread, dip

*Down-slope shape:* Linear

*Across-slope shape:* Concave

*Other vegetative classification:* Slough (R155XY011FL)

*Hydric soil rating:* Yes

#### Plantation

*Percent of map unit:* 5 percent

*Landform:* Marshes on marine terraces

*Landform position (three-dimensional):* Tread, dip

*Down-slope shape:* Linear

*Across-slope shape:* Concave

*Hydric soil rating:* Yes

#### Matlacha

*Percent of map unit:* 5 percent

*Landform:* Flats on marine terraces

*Landform position (three-dimensional):* Tread, talf

*Down-slope shape:* Convex, linear

*Across-slope shape:* Linear

*Hydric soil rating:* No

## 28—Pomello fine sand, 0 to 2 percent slopes

### Map Unit Setting

*National map unit symbol:* 2tzw1

*Elevation:* 0 to 110 feet

*Mean annual precipitation:* 42 to 60 inches

*Mean annual air temperature:* 68 to 77 degrees F

*Frost-free period:* 350 to 365 days

*Farmland classification:* Not prime farmland

### Map Unit Composition

*Pomello and similar soils:* 85 percent

*Minor components:* 15 percent

*Estimates are based on observations, descriptions, and transects of the mapunit.*

### Description of Pomello

#### Setting

*Landform:* Knolls on marine terraces, ridges on marine terraces

## Custom Soil Resource Report

*Landform position (two-dimensional):* Backslope, summit  
*Landform position (three-dimensional):* Side slope, interfluve, riser  
*Down-slope shape:* Convex, linear  
*Across-slope shape:* Linear  
*Parent material:* Sandy marine deposits

### Typical profile

*A - 0 to 4 inches:* fine sand  
*E - 4 to 42 inches:* fine sand  
*Bh - 42 to 54 inches:* fine sand  
*B/C - 54 to 80 inches:* fine sand

### Properties and qualities

*Slope:* 0 to 2 percent  
*Depth to restrictive feature:* More than 80 inches  
*Natural drainage class:* Moderately well drained  
*Runoff class:* Negligible  
*Capacity of the most limiting layer to transmit water (Ksat):* High (2.00 to 6.00 in/hr)  
*Depth to water table:* About 24 to 42 inches  
*Frequency of flooding:* None  
*Frequency of ponding:* None  
*Salinity, maximum in profile:* Nonsaline to very slightly saline (0.0 to 2.0 mmhos/cm)  
*Sodium adsorption ratio, maximum in profile:* 4.0  
*Available water storage in profile:* Low (about 5.5 inches)

### Interpretive groups

*Land capability classification (irrigated):* None specified  
*Land capability classification (nonirrigated):* 6s  
*Hydrologic Soil Group:* A  
*Ecological site:* Sand Pine Scrub (R155XY001FL)  
*Forage suitability group:* Sandy soils on rises and knolls of mesic uplands (G155XB131FL)  
*Other vegetative classification:* Sand Pine Scrub (R155XY001FL)  
*Hydric soil rating:* No

### Minor Components

#### Immokalee

*Percent of map unit:* 5 percent  
*Landform:* Flatwoods on marine terraces  
*Landform position (three-dimensional):* Riser, talf  
*Down-slope shape:* Linear  
*Across-slope shape:* Linear  
*Other vegetative classification:* South Florida Flatwoods (R155XY003FL)  
*Hydric soil rating:* No

#### Duette

*Percent of map unit:* 5 percent  
*Landform:* Flatwoods on marine terraces  
*Landform position (three-dimensional):* Tread, rise  
*Down-slope shape:* Linear, convex  
*Across-slope shape:* Linear  
*Other vegetative classification:* Sand Pine Scrub (R155XY001FL)  
*Hydric soil rating:* No

**Jonathan**

*Percent of map unit:* 3 percent  
*Landform:* Knolls on marine terraces, ridges on marine terraces  
*Landform position (two-dimensional):* Summit  
*Landform position (three-dimensional):* Interfluve, tread, rise  
*Down-slope shape:* Convex  
*Across-slope shape:* Linear  
*Hydric soil rating:* No

**Tavares**

*Percent of map unit:* 2 percent  
*Landform:* Knolls on marine terraces, ridges on marine terraces, flats on marine terraces, hills on marine terraces  
*Landform position (two-dimensional):* Summit  
*Landform position (three-dimensional):* Interfluve, side slope, tread, rise  
*Down-slope shape:* Linear, convex  
*Across-slope shape:* Convex, linear  
*Other vegetative classification:* Longleaf Pine-Turkey Oak Hills (R155XY002FL), Sand Pine Scrub (R155XY001FL)  
*Hydric soil rating:* No

**29—Pompano fine sand, 0 to 2 percent slopes**

**Map Unit Setting**

*National map unit symbol:* 2tzw3  
*Elevation:* 0 to 100 feet  
*Mean annual precipitation:* 44 to 65 inches  
*Mean annual air temperature:* 68 to 77 degrees F  
*Frost-free period:* 350 to 365 days  
*Farmland classification:* Not prime farmland

**Map Unit Composition**

*Pompano and similar soils:* 80 percent  
*Minor components:* 20 percent  
*Estimates are based on observations, descriptions, and transects of the mapunit.*

**Description of Pompano**

**Setting**

*Landform:* Drainageways on marine terraces  
*Landform position (three-dimensional):* Tread, dip  
*Down-slope shape:* Linear  
*Across-slope shape:* Linear, concave  
*Parent material:* Sandy marine deposits

**Typical profile**

*A - 0 to 4 inches:* fine sand  
*C - 4 to 80 inches:* fine sand

## Custom Soil Resource Report

### Properties and qualities

*Slope:* 0 to 2 percent  
*Depth to restrictive feature:* More than 80 inches  
*Natural drainage class:* Poorly drained  
*Runoff class:* High  
*Capacity of the most limiting layer to transmit water (Ksat):* High to very high (6.00 to 20.00 in/hr)  
*Depth to water table:* About 0 to 6 inches  
*Frequency of flooding:* None  
*Frequency of ponding:* None  
*Calcium carbonate, maximum in profile:* 2 percent  
*Salinity, maximum in profile:* Nonsaline to very slightly saline (0.0 to 2.0 mmhos/cm)  
*Sodium adsorption ratio, maximum in profile:* 4.0  
*Available water storage in profile:* Low (about 4.8 inches)

### Interpretive groups

*Land capability classification (irrigated):* None specified  
*Land capability classification (nonirrigated):* 4w  
*Hydrologic Soil Group:* A/D  
*Forage suitability group:* Sandy soils on flats of mesic or hydric lowlands (G155XB141FL)  
*Other vegetative classification:* Slough (R155XY011FL)  
*Hydric soil rating:* Yes

### Minor Components

#### Valkaria

*Percent of map unit:* 4 percent  
*Landform:* Drainageways on flatwoods on marine terraces  
*Landform position (three-dimensional):* Tread, dip, talf  
*Down-slope shape:* Linear  
*Across-slope shape:* Linear, concave  
*Other vegetative classification:* Slough (R155XY011FL)  
*Hydric soil rating:* Yes

#### Anclote

*Percent of map unit:* 4 percent  
*Landform:* Depressions on marine terraces  
*Landform position (three-dimensional):* Tread, dip  
*Down-slope shape:* Concave, convex  
*Across-slope shape:* Concave, linear  
*Other vegetative classification:* Freshwater Marshes and Ponds (R155XY010FL)  
*Hydric soil rating:* Yes

#### Malabar

*Percent of map unit:* 4 percent  
*Landform:* — error in exists on —  
*Landform position (three-dimensional):* Tread, dip, talf  
*Down-slope shape:* Linear, concave  
*Across-slope shape:* Linear, concave  
*Ecological site:* Slough (R155XY011FL)  
*Other vegetative classification:* Slough (R155XY011FL)  
*Hydric soil rating:* Yes



## Custom Soil Resource Report

### **Myakka**

*Percent of map unit:* 3 percent  
*Landform:* Drainageways on flatwoods on marine terraces  
*Landform position (three-dimensional):* Tread, dip, talf  
*Down-slope shape:* Linear  
*Across-slope shape:* Linear, concave  
*Other vegetative classification:* South Florida Flatwoods (R155XY003FL)  
*Hydric soil rating:* No

### **Immokalee**

*Percent of map unit:* 3 percent  
*Landform:* Flatwoods on marine terraces  
*Landform position (three-dimensional):* Riser, talf  
*Down-slope shape:* Linear  
*Across-slope shape:* Linear  
*Other vegetative classification:* South Florida Flatwoods (R155XY003FL)  
*Hydric soil rating:* No

### **Riviera**

*Percent of map unit:* 2 percent  
*Landform:* Drainageways on marine terraces, flatwoods on marine terraces  
*Landform position (three-dimensional):* Tread, dip, talf  
*Down-slope shape:* Linear  
*Across-slope shape:* Linear, concave  
*Ecological site:* Slough (R155XY011FL)  
*Other vegetative classification:* Slough (R155XY011FL)  
*Hydric soil rating:* Yes

## **36—Udorthents**

### **Map Unit Setting**

*National map unit symbol:* 1hn9j  
*Mean annual precipitation:* 60 to 68 inches  
*Mean annual air temperature:* 72 to 79 degrees F  
*Frost-free period:* 358 to 365 days  
*Farmland classification:* Not prime farmland

### **Map Unit Composition**

*Udorthents and similar soils:* 100 percent  
*Estimates are based on observations, descriptions, and transects of the mapunit.*

### **Description of Udorthents**

#### **Setting**

*Landform:* Marine terraces  
*Landform position (three-dimensional):* Interfluve  
*Down-slope shape:* Convex  
*Across-slope shape:* Linear  
*Parent material:* Altered marine deposits

## Custom Soil Resource Report

### Typical profile

*C - 0 to 57 inches: cobbly sand*

### Properties and qualities

*Slope: 2 to 40 percent*

*Depth to restrictive feature: More than 80 inches*

*Natural drainage class: Well drained*

*Runoff class: Negligible*

*Capacity of the most limiting layer to transmit water (Ksat): High to very high (5.95 to 19.98 in/hr)*

*Depth to water table: More than 80 inches*

*Frequency of flooding: None*

*Frequency of ponding: None*

*Salinity, maximum in profile: Nonsaline to very slightly saline (0.0 to 2.0 mmhos/cm)*

*Sodium adsorption ratio, maximum in profile: 4.0*

*Available water storage in profile: Very low (about 2.3 inches)*

### Interpretive groups

*Land capability classification (irrigated): None specified*

*Land capability classification (nonirrigated): 7s*

*Hydrologic Soil Group: A*

*Forage suitability group: Forage suitability group not assigned (G156AC999FL)*

*Hydric soil rating: No*

# Soil Information for All Uses

---

## Soil Reports

The Soil Reports section includes various formatted tabular and narrative reports (tables) containing data for each selected soil map unit and each component of each unit. No aggregation of data has occurred as is done in reports in the Soil Properties and Qualities and Suitabilities and Limitations sections.

The reports contain soil interpretive information as well as basic soil properties and qualities. A description of each report (table) is included.

## Soil Physical Properties

This folder contains a collection of tabular reports that present soil physical properties. The reports (tables) include all selected map units and components for each map unit. Soil physical properties are measured or inferred from direct observations in the field or laboratory. Examples of soil physical properties include percent clay, organic matter, saturated hydraulic conductivity, available water capacity, and bulk density.

## Engineering Properties

This table gives the engineering classifications and the range of engineering properties for the layers of each soil in the survey area.

*Hydrologic soil group* is a group of soils having similar runoff potential under similar storm and cover conditions. The criteria for determining Hydrologic soil group is found in the National Engineering Handbook, Chapter 7 issued May 2007 (<http://directives.sc.egov.usda.gov/OpenNonWebContent.aspx?content=17757.wba>). Listing HSGs by soil map unit component and not by soil series is a new concept for the engineers. Past engineering references contained lists of HSGs by soil series. Soil series are continually being defined and redefined, and the list of soil series names changes so frequently as to make the task of maintaining a single national list virtually impossible. Therefore, the criteria is now used to calculate the HSG using the component soil properties and no such national series lists will be maintained. All such references are obsolete and their use should be discontinued. Soil properties that influence runoff potential are those that influence the minimum rate of infiltration for a bare soil after prolonged wetting and when not frozen. These properties are depth to a seasonal high water table, saturated hydraulic conductivity after prolonged wetting, and depth to a layer with a very slow water transmission

## Custom Soil Resource Report

rate. Changes in soil properties caused by land management or climate changes also cause the hydrologic soil group to change. The influence of ground cover is treated independently. There are four hydrologic soil groups, A, B, C, and D, and three dual groups, A/D, B/D, and C/D. In the dual groups, the first letter is for drained areas and the second letter is for undrained areas.

The four hydrologic soil groups are described in the following paragraphs:

*Group A.* Soils having a high infiltration rate (low runoff potential) when thoroughly wet. These consist mainly of deep, well drained to excessively drained sands or gravelly sands. These soils have a high rate of water transmission.

*Group B.* Soils having a moderate infiltration rate when thoroughly wet. These consist chiefly of moderately deep or deep, moderately well drained or well drained soils that have moderately fine texture to moderately coarse texture. These soils have a moderate rate of water transmission.

*Group C.* Soils having a slow infiltration rate when thoroughly wet. These consist chiefly of soils having a layer that impedes the downward movement of water or soils of moderately fine texture or fine texture. These soils have a slow rate of water transmission.

*Group D.* Soils having a very slow infiltration rate (high runoff potential) when thoroughly wet. These consist chiefly of clays that have a high shrink-swell potential, soils that have a high water table, soils that have a claypan or clay layer at or near the surface, and soils that are shallow over nearly impervious material. These soils have a very slow rate of water transmission.

*Depth* to the upper and lower boundaries of each layer is indicated.

*Texture* is given in the standard terms used by the U.S. Department of Agriculture. These terms are defined according to percentages of sand, silt, and clay in the fraction of the soil that is less than 2 millimeters in diameter. "Loam," for example, is soil that is 7 to 27 percent clay, 28 to 50 percent silt, and less than 52 percent sand. If the content of particles coarser than sand is 15 percent or more, an appropriate modifier is added, for example, "gravelly."

*Classification* of the soils is determined according to the Unified soil classification system (ASTM, 2005) and the system adopted by the American Association of State Highway and Transportation Officials (AASHTO, 2004).

The Unified system classifies soils according to properties that affect their use as construction material. Soils are classified according to particle-size distribution of the fraction less than 3 inches in diameter and according to plasticity index, liquid limit, and organic matter content. Sandy and gravelly soils are identified as GW, GP, GM, GC, SW, SP, SM, and SC; silty and clayey soils as ML, CL, OL, MH, CH, and OH; and highly organic soils as PT. Soils exhibiting engineering properties of two groups can have a dual classification, for example, CL-ML.

The AASHTO system classifies soils according to those properties that affect roadway construction and maintenance. In this system, the fraction of a mineral soil that is less than 3 inches in diameter is classified in one of seven groups from A-1 through A-7 on the basis of particle-size distribution, liquid limit, and plasticity index. Soils in group A-1 are coarse grained and low in content of fines (silt and clay). At the other extreme, soils in group A-7 are fine grained. Highly organic soils are classified in group A-8 on the basis of visual inspection.

If laboratory data are available, the A-1, A-2, and A-7 groups are further classified as A-1-a, A-1-b, A-2-4, A-2-5, A-2-6, A-2-7, A-7-5, or A-7-6. As an additional refinement, the suitability of a soil as subgrade material can be indicated by a group

## Custom Soil Resource Report

index number. Group index numbers range from 0 for the best subgrade material to 20 or higher for the poorest.

*Percentage of rock fragments* larger than 10 inches in diameter and 3 to 10 inches in diameter are indicated as a percentage of the total soil on a dry-weight basis. The percentages are estimates determined mainly by converting volume percentage in the field to weight percentage. Three values are provided to identify the expected Low (L), Representative Value (R), and High (H).

*Percentage (of soil particles) passing designated sieves* is the percentage of the soil fraction less than 3 inches in diameter based on an oven-dry weight. The sieves, numbers 4, 10, 40, and 200 (USA Standard Series), have openings of 4.76, 2.00, 0.420, and 0.074 millimeters, respectively. Estimates are based on laboratory tests of soils sampled in the survey area and in nearby areas and on estimates made in the field. Three values are provided to identify the expected Low (L), Representative Value (R), and High (H).

*Liquid limit and plasticity index (Atterberg limits)* indicate the plasticity characteristics of a soil. The estimates are based on test data from the survey area or from nearby areas and on field examination. Three values are provided to identify the expected Low (L), Representative Value (R), and High (H).

### References:

American Association of State Highway and Transportation Officials (AASHTO). 2004. Standard specifications for transportation materials and methods of sampling and testing. 24th edition.

American Society for Testing and Materials (ASTM). 2005. Standard classification of soils for engineering purposes. ASTM Standard D2487-00.

Custom Soil Resource Report

Absence of an entry indicates that the data were not estimated. The asterisk '\*' denotes the representative texture; other possible textures follow the dash. The criteria for determining the hydrologic soil group for individual soil components is found in the National Engineering Handbook, Chapter 7 issued May 2007(<http://directives.sc.egov.usda.gov/OpenNonWebContent.aspx?content=17757.wba>). Three values are provided to identify the expected Low (L), Representative Value (R), and High (H).

Engineering Properties—Broward County, Florida, East Part														
Map unit symbol and soil name	Pct. of map unit	Hydrologic group	Depth	USDA texture	Classification		Pct Fragments		Percentage passing sieve number—				Liquid limit	Plasticity index
					Unified	AASHTO	>10 inches	3-10 inches	4	10	40	200		
			<i>In</i>				<i>L-R-H</i>	<i>L-R-H</i>	<i>L-R-H</i>	<i>L-R-H</i>	<i>L-R-H</i>	<i>L-R-H</i>	<i>L-R-H</i>	<i>L-R-H</i>
15—Immokalee fine sand, 0 to 2 percent slopes														
Immokalee	90	B/D	0-6	Fine sand	SP-SM, SM	A-3, A-2-4	0- 0- 0	0- 0- 0	100-100 -100	100-100 -100	89-94-1 00	8-10- 16	0-0 -0	NP
			6-35	Fine sand	SP-SM, SM	A-3, A-2-4	0- 0- 0	0- 0- 0	100-100 -100	100-100 -100	88-94- 99	7- 9- 14	0-0 -0	NP
			35-54	Fine sand	SP-SM, SM	A-3, A-2-4	0- 0- 0	0- 0- 0	100-100 -100	100-100 -100	89-94-1 00	9-11- 17	0-0 -0	NP
			54-80	Fine sand, loamy fine sand, sand	SM, SP-SM	A-2-4, A-3	0- 0- 0	0- 0- 0	100-100 -100	100-100 -100	88-94-1 00	9-12- 20	0-0 -0	NP
19—Margate fine sand, occasionally ponded, 0 to 1 percent slopes														
Margate	85	A/D	0-8	Fine sand	SP-SM, SM	A-2-4, A-3	0- 0- 0	0- 0- 0	100-100 -100	100-100 -100	90-94-1 00	9-11- 17	0-0 -0	NP
			8-16	Fine sand, sand	SM, SP-SM	A-3, A-2-4	0- 0- 0	0- 0- 0	100-100 -100	100-100 -100	88-94-1 00	9-11- 16	0-0 -0	NP
			16-28	Fine sand, sand	SP-SM, SM	A-2-4, A-3	0- 0- 0	0- 0- 0	100-100 -100	100-100 -100	88-94-1 00	9-11- 17	0-0 -0	NP
			28-32	Very gravelly fine sand, very gravelly sand	GP-GM, GW	A-2-4, A-1-b, A-1-a	0- 6- 11	0- 6- 11	35-48- 57	29-43- 53	26-41- 52	3- 7- 11	0-0 -0	NP
			32-42	Bedrock	—	—	—	—	—	—	—	—	—	—

Custom Soil Resource Report

Engineering Properties—Broward County, Florida, East Part														
Map unit symbol and soil name	Pct. of map unit	Hydrologic group	Depth	USDA texture	Classification		Pct Fragments		Percentage passing sieve number—				Liquid limit	Plasticity index
					Unified	AASHTO	>10 inches	3-10 inches	4	10	40	200		
			<i>In</i>				<i>L-R-H</i>	<i>L-R-H</i>	<i>L-R-H</i>	<i>L-R-H</i>	<i>L-R-H</i>	<i>L-R-H</i>	<i>L-R-H</i>	<i>L-R-H</i>
28—Pomello fine sand, 0 to 2 percent slopes														
Pomello	85	A	0-4	Fine sand	SM, SP-SM	A-2-4, A-3	0-0-0	0-0-0	100-100-100	100-100-100	90-94-100	9-11-17	0-0-0	NP
			4-42	Fine sand	SP-SM, SM	A-3, A-2-4	0-0-0	0-0-0	100-100-100	100-100-100	90-94-100	8-10-15	0-0-0	NP
			42-54	Fine sand, sand	SP-SM, SM	A-3, A-2-4	0-0-0	0-0-0	100-100-100	100-100-100	88-94-100	9-12-18	0-0-0	NP
			54-80	Sand, fine sand	SP-SM, SM	A-3, A-2-4	0-0-0	0-0-0	100-100-100	100-100-100	87-94-100	8-10-16	0-0-0	NP
29—Pompano fine sand, 0 to 2 percent slopes														
Pompano	80	A/D	0-4	Fine sand	SP-SM, SM	A-2-4, A-3	0-0-0	0-0-0	100-100-100	100-100-100	89-94-100	6-10-16	0-0-0	NP
			4-80	Fine sand, sand	SM, SP-SM	A-3, A-2-4	0-0-0	0-0-0	100-100-100	100-100-100	87-94-100	6-10-16	0-0-0	NP
36—Udorthents														
Udorthents	100	A	0-57	Cobbly sand	GP-GM, SP, SP-SM	A-1-b	0-1-2	5-10-15	50-60-70	40-50-60	30-40-50	2-7-12	0-7-14	NP

# References

---

- American Association of State Highway and Transportation Officials (AASHTO). 2004. Standard specifications for transportation materials and methods of sampling and testing. 24th edition.
- American Society for Testing and Materials (ASTM). 2005. Standard classification of soils for engineering purposes. ASTM Standard D2487-00.
- Cowardin, L.M., V. Carter, F.C. Golet, and E.T. LaRoe. 1979. Classification of wetlands and deep-water habitats of the United States. U.S. Fish and Wildlife Service FWS/OBS-79/31.
- Federal Register. July 13, 1994. Changes in hydric soils of the United States.
- Federal Register. September 18, 2002. Hydric soils of the United States.
- Hurt, G.W., and L.M. Vasilas, editors. Version 6.0, 2006. Field indicators of hydric soils in the United States.
- National Research Council. 1995. Wetlands: Characteristics and boundaries.
- Soil Survey Division Staff. 1993. Soil survey manual. Soil Conservation Service. U.S. Department of Agriculture Handbook 18. [http://www.nrcs.usda.gov/wps/portal/nrcs/detail/national/soils/?cid=nrcs142p2\\_054262](http://www.nrcs.usda.gov/wps/portal/nrcs/detail/national/soils/?cid=nrcs142p2_054262)
- Soil Survey Staff. 1999. Soil taxonomy: A basic system of soil classification for making and interpreting soil surveys. 2nd edition. Natural Resources Conservation Service, U.S. Department of Agriculture Handbook 436. [http://www.nrcs.usda.gov/wps/portal/nrcs/detail/national/soils/?cid=nrcs142p2\\_053577](http://www.nrcs.usda.gov/wps/portal/nrcs/detail/national/soils/?cid=nrcs142p2_053577)
- Soil Survey Staff. 2010. Keys to soil taxonomy. 11th edition. U.S. Department of Agriculture, Natural Resources Conservation Service. [http://www.nrcs.usda.gov/wps/portal/nrcs/detail/national/soils/?cid=nrcs142p2\\_053580](http://www.nrcs.usda.gov/wps/portal/nrcs/detail/national/soils/?cid=nrcs142p2_053580)
- Tiner, R.W., Jr. 1985. Wetlands of Delaware. U.S. Fish and Wildlife Service and Delaware Department of Natural Resources and Environmental Control, Wetlands Section.
- United States Army Corps of Engineers, Environmental Laboratory. 1987. Corps of Engineers wetlands delineation manual. Waterways Experiment Station Technical Report Y-87-1.
- United States Department of Agriculture, Natural Resources Conservation Service. National forestry manual. [http://www.nrcs.usda.gov/wps/portal/nrcs/detail/soils/home/?cid=nrcs142p2\\_053374](http://www.nrcs.usda.gov/wps/portal/nrcs/detail/soils/home/?cid=nrcs142p2_053374)
- United States Department of Agriculture, Natural Resources Conservation Service. National range and pasture handbook. <http://www.nrcs.usda.gov/wps/portal/nrcs/detail/national/landuse/rangepasture/?cid=stelprdb1043084>



## Custom Soil Resource Report

United States Department of Agriculture, Natural Resources Conservation Service. National soil survey handbook, title 430-VI. [http://www.nrcs.usda.gov/wps/portal/nrcs/detail/soils/scientists/?cid=nrcs142p2\\_054242](http://www.nrcs.usda.gov/wps/portal/nrcs/detail/soils/scientists/?cid=nrcs142p2_054242)

United States Department of Agriculture, Natural Resources Conservation Service. 2006. Land resource regions and major land resource areas of the United States, the Caribbean, and the Pacific Basin. U.S. Department of Agriculture Handbook 296. [http://www.nrcs.usda.gov/wps/portal/nrcs/detail/national/soils/?cid=nrcs142p2\\_053624](http://www.nrcs.usda.gov/wps/portal/nrcs/detail/national/soils/?cid=nrcs142p2_053624)

United States Department of Agriculture, Soil Conservation Service. 1961. Land capability classification. U.S. Department of Agriculture Handbook 210. [http://www.nrcs.usda.gov/Internet/FSE\\_DOCUMENTS/nrcs142p2\\_052290.pdf](http://www.nrcs.usda.gov/Internet/FSE_DOCUMENTS/nrcs142p2_052290.pdf)

**APPENDIX – B**

**EXISTING INFORMATION**

**TABLE - B1**

**Project Name: PD&E Study - SW 10th Street From Powerline Road to Military Trail**

**Broward County, Florida**

**FPID No.: 439891-1-22-02**

Existing Information								
No.	FPID#	Year	Existing Information	Limit (Along SR-869/SW 10th Street)		Depth (ft)	Boring Soil Profiles	Comments
1	424655-1-52-01	2009	RSS Sheet	Station 103+00 to 171+00	From East of Powerline Road to West of Military Trail			No soil profiles of the soil borings are included.
2	NA	1992	SPT Soil Boring Logs	Station 68+65 to 69+50	May be located at SW 10th Street & Waterway Blvd.	67.75 to 68.5	4 SPT (SP & Limestone)	
3	228229-3-52-01	2005	SPT Soil Boring Logs		From SW 28th Ave. to SW 24th Ave.	25	1 SPT (SP & Limestone)	
4	NA	2000	SPT Soil Boring Logs		Intersection @ Powerline Road & SW 10th Street	9.6 meter = 31.5 ft	2 SPT (SP)	

STATE OF FLORIDA  
DEPARTMENT OF TRANSPORTATION  
MATERIALS AND RESEARCH

DATE OF SURVEY: AUGUST 2009  
SURVEY MADE BY: NODARSE & ASSOCIATES, INC.  
SUBMITTED BY: JULIO DE BLAS, P.E.

FINANCIAL PROJECT NO.: 424665-1-52-01

DISTRICT: FOUR  
ROAD NO.: SR 869  
COUNTY: BROWARD

CROSS SECTION SOIL SURVEY FOR THE DESIGN OF ROADS

SURVEY BEGINS STA.: 103+00 SURVEY ENDS STA.: 171+00

REFERENCE: BASELINE SURVEY

STRATUM NO.	LBR		ORGANIC CONTENT		SIEVE ANALYSIS RESULTS % PASS							ATTERBERG LIMITS (%)			MATERIAL DESCRIPTION	CORROSION TEST RESULTS				
	NO. OF TESTS	MAX LBR	NO. OF TESTS	% ORGANIC	MOISTURE CONTENT	NO. OF TESTS	10 MESH	40 MESH	60 MESH	100 MESH	200 MESH	NO. OF TESTS	LIQUID LIMIT	PLASTIC INDEX		AASHTO GROUP	NO. OF TESTS	RESISTIVITY ohm-cm	CHLORIDES ppm	SULFATES ppm
1	-	-	-	-	-	-	-	-	-	-	-	-	-	-	A-8	-	-	-	-	-
2	-	-	-	-	4	2	92-98	67-72	32	5-6	1	-	-	-	A-3	-	-	-	-	-
3	-	-	-	-	4	1	58	35	22	9	4	-	-	-	A-1-b	-	-	-	-	-
4	-	-	-	-	9-29	3	95-97	62-71	22-29	5-9	1-3	-	-	-	A-3	-	-	-	-	-
5	-	-	4	3-11	14-32	4	100	73-81	39-46	9	1-5	-	-	-	A-3	-	-	-	-	-
6	-	-	-	-	-	-	-	-	-	-	-	-	-	-	-	-	-	-	-	-

EMBANKMENT AND SUBGRADE MATERIAL

STRATA BOUNDARIES ARE APPROXIMATE MAKE FINAL CHECK AFTER GRADING

▼ = WATER TABLE ENCOUNTERED  
GNE = GROUNDWATER NOT ENCOUNTERED

NOTES:

- 1) SOIL BOUNDARIES ARE APPROXIMATE AND REPRESENT SOIL STRATA AT EACH BORING LOCATION ONLY.
- 2) WATER TABLE SHOWN AS ▼ WHERE ENCOUNTERED AT TIME OF SURVEY. GROUNDWATER NOT ENCOUNTERED SHOWN AS "GNE".
- 3) SOIL ANALYSIS INCLUDES DATA FROM ROADWAY AREA ONLY.
- 4) THE SYMBOL "-" REPRESENTS AN UNMEASURED PARAMETER.
- 5) THE MATERIAL FROM STRATUM NUMBER 1 IS TOPSOIL (A-8) AND CONSIDERED TO BE UNSUITABLE. IT SHALL BE REMOVED DURING CLEARING AND GRUBBING IN ACCORDANCE WITH SECTION 110 OF THE FDOT STANDARD SPECIFICATIONS.
- 6) THE MATERIAL FROM STRATA NUMBERS 2 AND 4 (A-3) IS CONSIDERED TO BE SELECT AND SHOULD BE UTILIZED IN ACCORDANCE WITH FDOT STANDARD INDEX 505.
- 7) THE MATERIAL FROM STRATUM NUMBER 3 (A-1-b) IS CONSIDERED TO BE SELECT AND SHOULD BE UTILIZED IN ACCORDANCE WITH FDOT STANDARD INDEX 505.
- 8) THE MATERIAL FROM STRATUM NUMBER 5 (A-3) IS CONSIDERED TO BE SELECT AND SHOULD BE UTILIZED IN ACCORDANCE WITH FDOT STANDARD INDEX 505. THIS MATERIAL IS CONSIDERED ORGANIC STAINED GIVEN THE AVERAGE ORGANIC CONTENT IS 5%. HOWEVER, AT BORING LOCATION A-31 (STA. 163+00, 22' RT), THIS MATERIAL HAD AN INDIVIDUAL ORGANIC CONTENT OF 11% DUE TO THE FEW ORGANIC FIBERS FOUND. NONETHELESS, FROM VISUAL CLASSIFICATION, THIS MATERIAL CONSISTS ALMOST ENTIRELY OF SAND AND SUITABLE FROM A GEOTECHNICAL STAND POINT. THIS MATERIAL SHALL NOT BE USED IN THE SUBGRADE PORTION OF THE ROADBED BUT CAN BE USED IN THE PORTION OF THE EMBANKMENT INSIDE THE CONTROL LINE.
- 9) THE MATERIAL FROM STRATUM NUMBER 6 IS THE NATURAL LIMESTONE FORMATION. THIS MATERIAL MAY BE DIFFICULT TO EXCAVATE, PENETRATE OR DEWATER AND SPECIAL TOOLS MAY BE REQUIRED TO DO SO.

Existing Information - No.1

REVISIONS					STATE OF FLORIDA DEPARTMENT OF TRANSPORTATION			<h2 style="margin: 0;">ROADWAY SOIL SURVEY</h2>	SHEET NO.
DATE	DESCRIPTION	DATE	DESCRIPTION		ROAD NO.	COUNTY	FINANCIAL PROJECT ID		
					SR 869	BROWARD	424665-1-52-01		

NOTICE: THE OFFICIAL RECORD OF THIS SHEET IS THE ELECTRONIC FILE SIGNED AND SEALED UNDER RULE 61G5-23.003, F.A.C.

Drawn By : MG 09-09  
Checked By : JB 09-09  
Designed By : XXX MM-YY  
Checked By : XXX MM-YY

Soil Borings By: Florida Testing and Engineering  
 877 N.W. 61st Street  
 Fort Lauderdale, Florida

Drillers: Drillers: Brown / Jones

Hammer Weight: 140 Pounds

Hammer Drop: 30 inches

Split Spoon Size: 2 inch Diameter, 2 feet long

Drill Rig: Truck Mounted ACKER

LEGEND

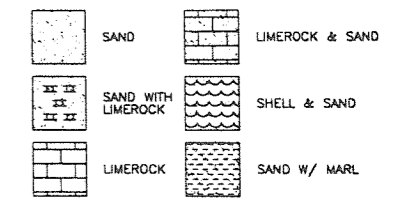

BORING No. 1  
 STA. No. 68+65 40' LEFT  
 (ELEV. +15.91 N.G.V.D.)

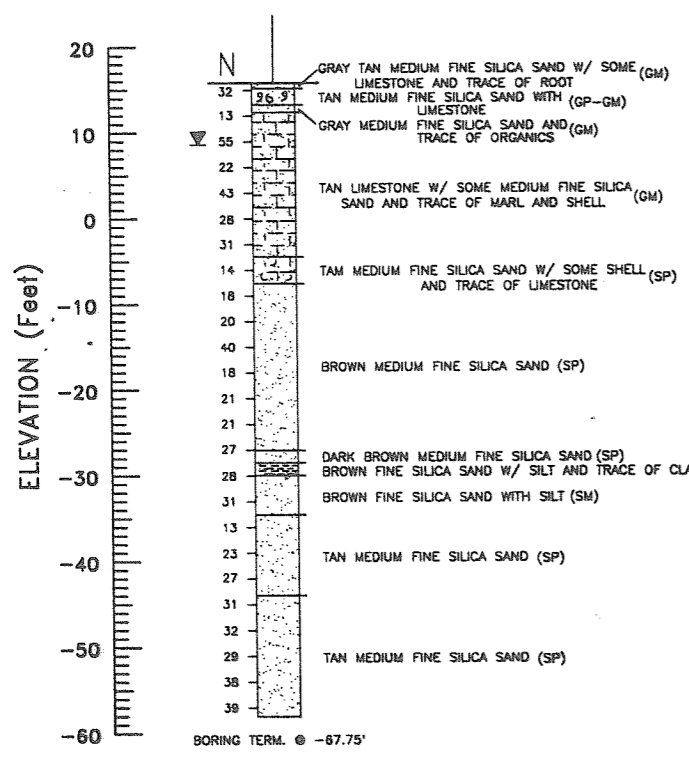

BORING No. 2  
 STA. No. 68+65 27' LEFT  
 (ELEV. +15.26 N.G.V.D.)

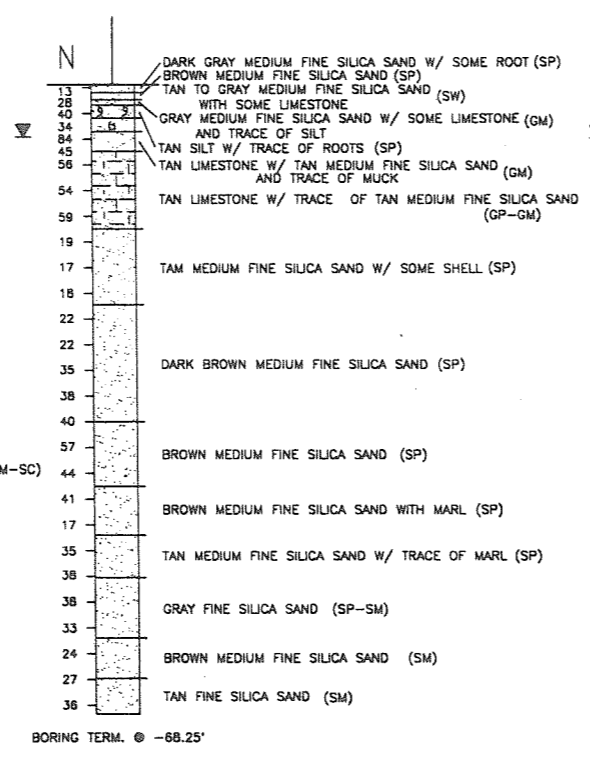

BORING No. 3  
 STA. No. 69+50 40' LEFT  
 (ELEV. +16.28 N.G.V.D.)

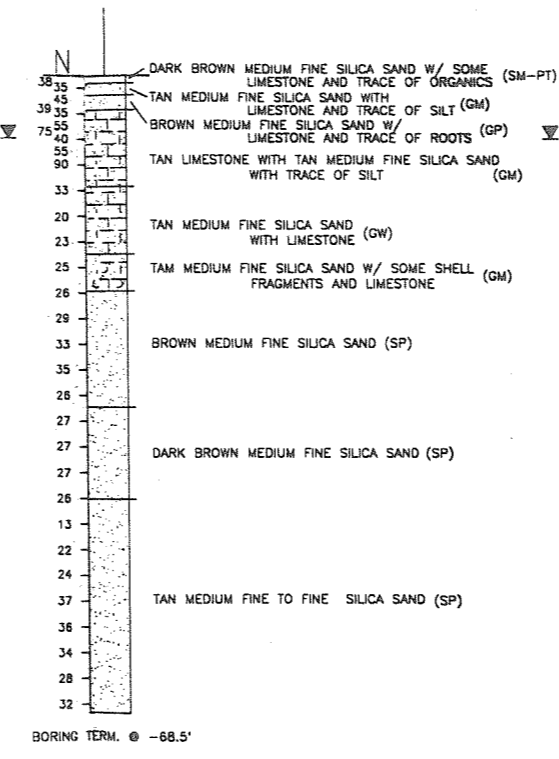

BORING No. 4  
 STA. No. 69+50 25' LEFT  
 (ELEV. +15.60 N.G.V.D.)

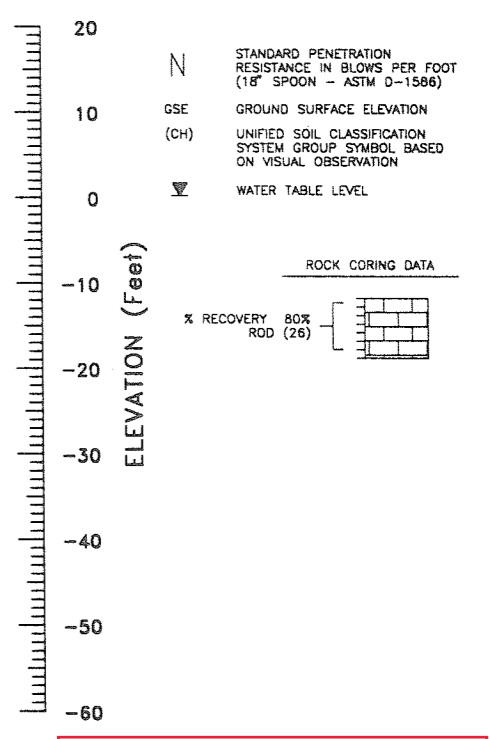
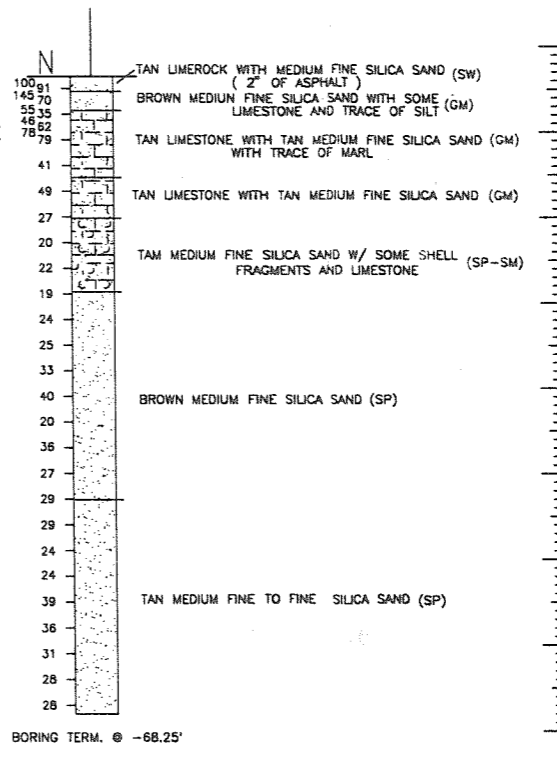

Existing Information - No.2

REVISIONS			
DATE	BY	DESCRIPTION	DATE

**FTE**  
 877 N.W. 61st STREET  
 FT. LAUDERDALE, FLORIDA  
 EST. 1958  
 FLORIDA TESTING & ENGINEERING, INC.

STATE OF FLORIDA DEPARTMENT OF TRANSPORTATION STRUCTURES				APPROVED BY: PAUL R. MARGOLIES, P.E. #19350	
S.R. 869 - S.W. 10th STREET WPI No. 4120264					
ROAD NO. 91	COUNTY PALM BEACH	PROJECT No. 92DOT401	DESIGNED BY H.A.O.	DATE 8/18/92	DESIGNED BY 
CHECKED BY E.H.D.	DATE 8/18/92	CHECKED BY 	DATE 	DATE 	DATE 
SUPERVISED BY			APPROVED BY		

S.R. 869 - S.W. 10th STREET  
 SPT / SOIL BORING LOGS-1

# LEGEND

- DARK BROWN ORGANIC SILTY FINE SAND (TOPSOIL)
- BROWN CLEAN TO SILTY FINE TO COARSE SAND WITH LIMEROCK FRAGMENTS (FILL; SP/SM/GM)
- BROWN SLIGHTLY SILTY TO SILTY FINE TO COARSE SAND WITH SOME LIMEROCK FRAGMENTS (SP-SM/SM)
- LIGHT BROWN SANDY LIMESTONE AND SANDSTONE

- NOTES:**
- ↘ WATER TABLE AT TIME OF DRILLING
  - N NUMBERS TO THE LEFT OF BORINGS INDICATE SPT VALUE FOR 12" PENETRATION. (UNLESS OTHERWISE NOTED.)
  - || CASING USED
  - 200 FINES PASSING NO. 200 SIEVE (%)
  - NMC NATURAL MOISTURE CONTENT (%)

THE BORINGS PRESENTED ON THIS SHEET WERE PERFORMED BY GEOSOL, INC. & PREPARED UNDER THE AREA-WIDE MATERIALS TESTING CONTRACT # 8815 (FM #230061-1-62-12); FOR TWO # 64

## Existing Information - No.3

**ENVIRONMENTAL CLASSIFICATION**  
 SUPERSTRUCTURE: SLIGHTLY AGGRESSIVE  
 SUBSTRUCTURE: MODERATELY AGGRESSIVE

**WATER:**  
 pH: 7.14  
 CHLORIDE: 37.2 PPM  
 SULFATE: 14.8 PPM  
 RESISTIVITY: 1,370 OHM-CM

GRANULAR MATERIALS- RELATIVE DENSITY	SPT (BLOWS/FT.)
VERY LOOSE	LESS THAN 4
LOOSE	5-10
MEDIUM	11-30
DENSE	31-50
VERY DENSE	GREATER THAN 50
SILTS AND CLAYS CONSISTENCY	SPT (BLOWS/FT.)
VERY SOFT	LESS THAN 2
SOFT	3-4
FIRM	5-9
STIFF	9-15
VERY STIFF	16-30
HARD	GREATER THAN 30

BORING NO. B-1  
 STATION N/A  
 OFFSET N/A  
 ELEV. N/A  
 NORTHING 717235.041  
 EASTING 938203.451  
 DATE 4/13/05  
 HAMMER SAFETY  
 TYPE OF RIG B-53

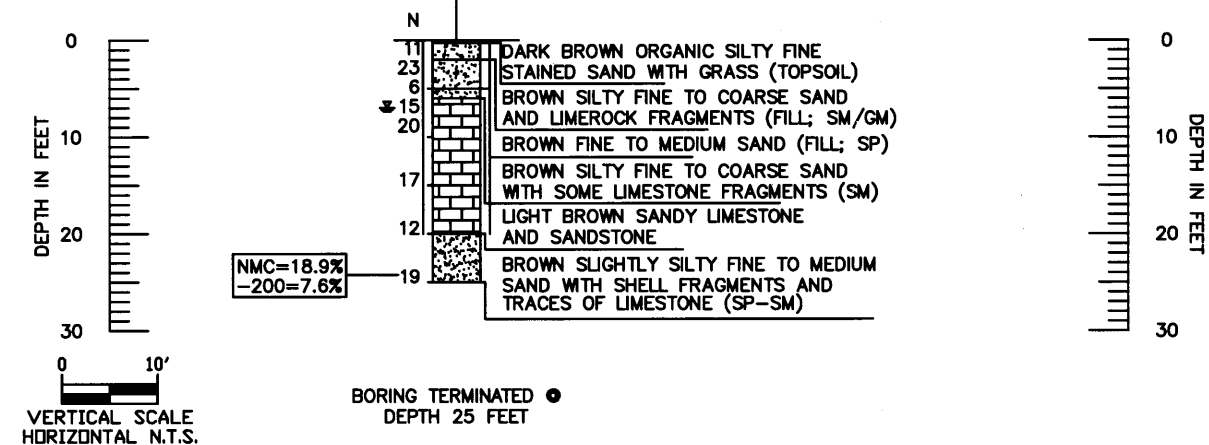

VERTICAL SCALE  
 HORIZONTAL N.T.S.

**NOTES FOR DRILL SHAFT FOUNDATION CONSTRUCTION:**

- SUPER MUD OR POLYMER SLURRY ARE NOT ALLOWED.
- THE CONTRACTOR IS ADVISED THAT CAVING SOILS MAY BE ENCOUNTERED DURING THE EXCAVATION OF THE DRILL SHAFT.
- IF CASING IS REQUIRED TO STABILIZE THE EXCAVATION THE CONTRACTOR SHALL FURNISH CASING AND PROPER EQUIPMENT TO INSTALL IT AND REMOVE IT. CORRUGATED CASING SHALL NOT BE ALLOWED FOR THE CONSTRUCTION OF THESE SHAFTS.
- PRIOR TO PLACING CONCRETE, THE FLUID IN THE SHAFT EXCAVATION SHALL BE SAMPLED AND TESTED IN ACCORDANCE WITH SECTION 455-15.8.2 AND MUST MEET THE REQUIREMENTS SPECIFIED IN THIS SECTION.

*Oracio Riccobono*  
4/19/05

REVISIONS						ENGINEER OF RECORD:			FLORIDA DEPARTMENT OF TRANSPORTATION			SHEET TITLE:	
Date	By	Description	Date	By	Description	Drawn by	Name	Date	ROAD NO.	COUNTY	FINANCIAL PROJECT ID	PROJECT NAME	
						ABR	ORACIO RICCOBONO, P.E.	4/05	869	BROWARD	228229-3-52-01	SR-869/SW 10TH STREET FROM SW 28TH TO SW 24TH AVENUES	
						OR	ORACIO RICCOBONO, P.E.	4/05				SHEET NO.	
						OR	ORACIO RICCOBONO, P.E.	4/05				SHEET NO.	
						OR	ORACIO RICCOBONO, P.E.	4/05				SHEET NO.	

NOTICE: THE OFFICIAL RECORD OF THIS SHEET IS THE ELECTRONIC FILE SIGNED AND SEALED UNDER RULE 61G15-23.003, F.A.C.

FINANCIAL PROJ. NO.	STATE PROJ. NO.	SHEET NO.
227900-1-52-01	86065-3511	

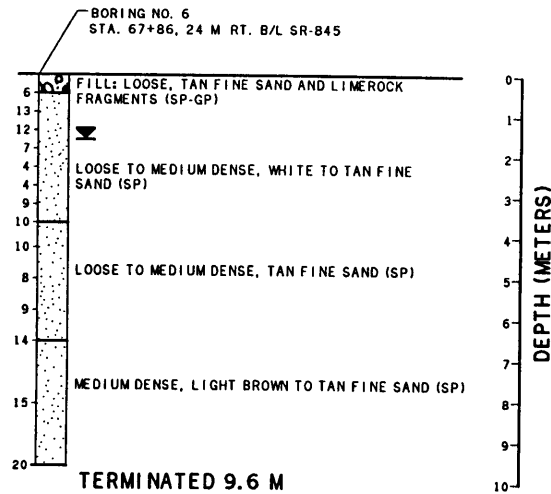
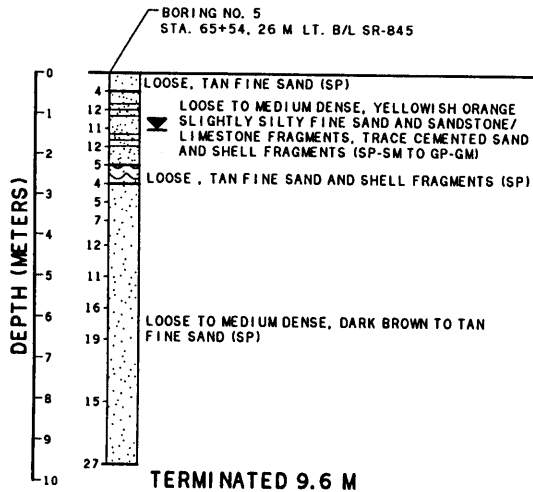

Powerline Road  
& SW 10th Street

Existing Information - No.4

DAVID C. MIRO, P. E.  
REGISTRATION NO. 16689

DATE

STATE OF FLORIDA DEPARTMENT OF TRANSPORTATION REPORT OF CORE BORING FOR STRUCTURES		
<b>MAST ARMS - POWERLINE ROAD FROM NORTH OF SAMPLE ROAD TO NORTH OF SW 10 ST</b>		
PROJ. NO.: 86065-3511	BORINGS DATE: 3-2-/3-22-00	
ROAD NO.: SR-845	BORINGS BY: B.SWIDARSKI/G.MACHADO	
COUNTY: BROWARD	SUBMITTED BY: D. C. MIRO	
APPROVED BY: _____	DRAWING NO.: 1 OF 2	INDEX NO.: DESIGNED BY: NEWTON WILSON

**APPENDIX – C**

**GROUNDWATER INFORMATION**

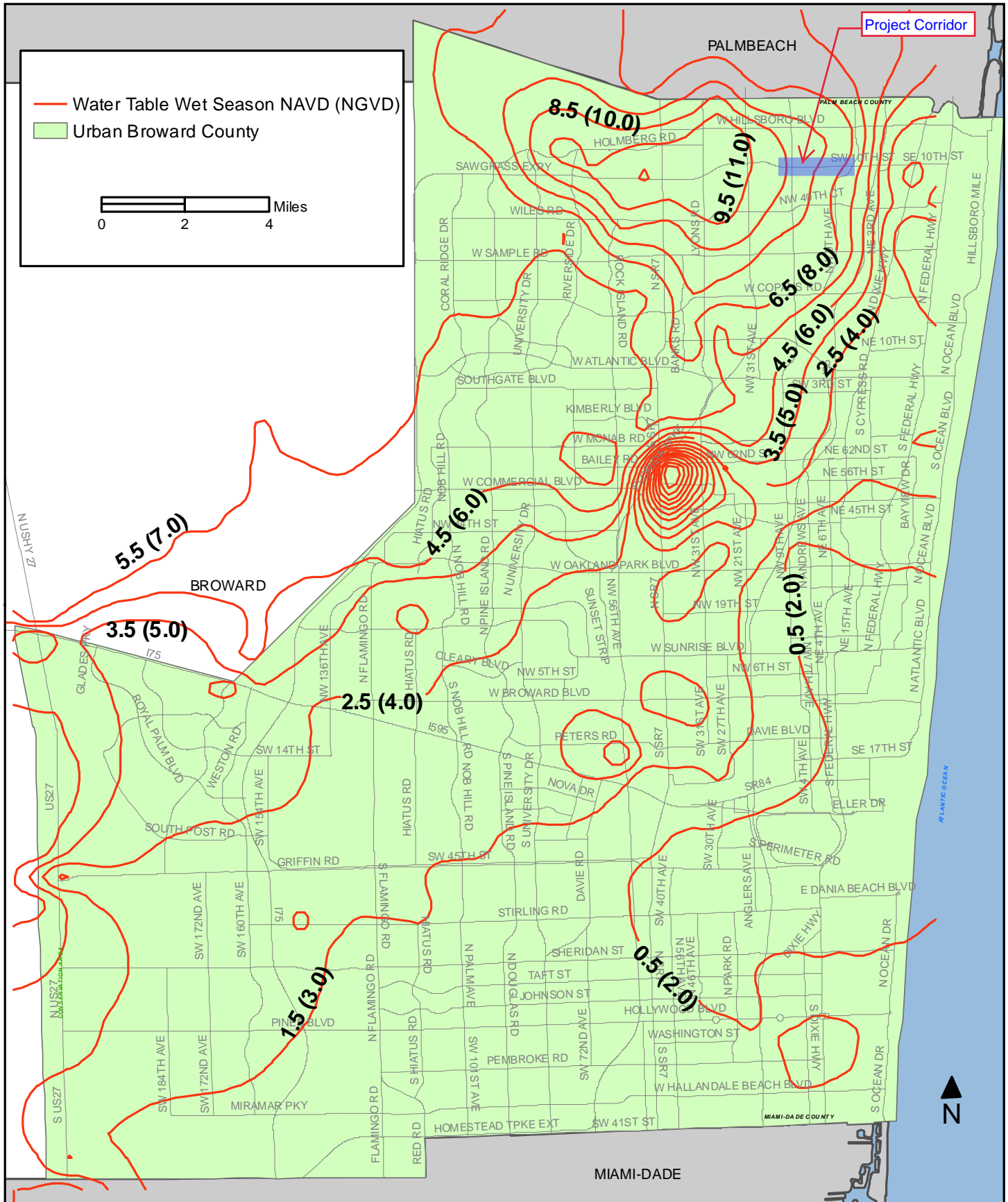

**TABLE - C1**

**Groundwater Information**

**Project Name: PD&E Study - SW 10th Street From Powerline Road  
to Military Trail**

Boring #	Date	GWT (ft)	GWT-Ele. (ft)	Provided by Surveyor		
				Station	Offset	Elevation
RD-1	2/8/18	5.0	7.0	Plate-3 for location.		12.0334
RD-2	2/8/18	4.8	7.7	Plate-3 for location.		12.4752
RD-3	2/8/18	3.7	7.9	Plate-4 for location.		11.6044
RD-4	2/8/18	2.0	7.6	Plate-4 for location.		9.6483
RD-5	2/8/18	2.3	6.6	Plate-4 for location.		8.8979
RD-6	2/8/18	4.3	7.3	Plate-5 for location.		11.5612
RD-7	2/9/18	6.1	6.9	Plate-5 for location.		12.9986
RD-8	2/8/18	5.2	7.4	Plate-5 for location.		12.5215
RD-9	2/9/18	6.1	5.8	Plate-5 for location.		11.8684
RD-10	2/9/18	3.3	6.2	Plate-5 for location.		9.5038
BHP-1	2/14/18	2.4	7.1	Plate-4 for location.		9.5647
BHP-2	2/14/18	3.0	6.3	Plate-4 for location.		9.3385
B-101	2/2/18	3.6	7.5	Plate-2 for location.		11.0542
B-201	2/5/18	5.8	7.8	Plate-2 for location.		13.6137
B-301	2/1/18	3.8	9.5	Plate-2 for location.		13.3492
B-401	2/6/18	5.0	7.3	Plate-3 for location.		12.3438
B-501	2/7/18	5.3	7.6	Plate-4 for location.		12.8574
B-601	1/31/18	7.7	5.3	Plate-5 for location.		12.9847



**APPENDIX – D**

**FB DEEP OUTPUTS – VERTICAL CAPACITY ANALYSIS OF**

**PRECAST CONCRETE DRIVEN PILES**

General Information:

=====  
 Input file: .....tary\_RS&H)\Analysis\_Structure\FB-Deep\Pile\B-101\_Void-10ft.spc  
 Project number: 2000-01-17003  
 Job name: SW 10th Street, from Powerline Rd. to Military Trail  
 Engineer: JB Henry  
 Units: English

Analysis Information:

=====  
 Analysis Type: SPT

Soil Information:

=====  
 Boring date: 2/2/2018, Boring Number: B-101  
 Station number:    Offset:

Ground Elevation: 11.100(ft)

Hammer type: Automatic Hammer, Correction factor = 1.24

ID	Depth (ft)	No. of Blows (Blows/ft)	Soil Type
1	0.00	15.00	5- Cavity layer
2	2.00	30.00	5- Cavity layer
3	4.00	22.00	5- Cavity layer
4	6.00	83.00	5- Cavity layer
5	8.00	29.00	5- Cavity layer
6	10.00	24.00	4- Lime Stone/Very shelly sand
7	12.00	21.00	4- Lime Stone/Very shelly sand
8	13.50	32.00	4- Lime Stone/Very shelly sand
9	15.50	12.00	3- Clean sand
10	18.00	20.00	3- Clean sand
11	20.50	14.00	3- Clean sand
12	23.00	36.00	3- Clean sand
13	25.50	19.00	3- Clean sand
14	28.00	22.00	3- Clean sand
15	30.50	34.00	3- Clean sand
16	33.00	62.00	3- Clean sand
17	35.50	39.00	3- Clean sand
18	38.00	70.00	3- Clean sand
19	40.50	44.00	3- Clean sand
20	43.00	70.00	3- Clean sand
21	45.50	30.00	3- Clean sand
22	48.00	51.00	3- Clean sand
23	50.50	48.00	3- Clean sand
24	53.00	73.00	3- Clean sand
25	55.50	66.00	3- Clean sand
26	58.00	51.00	3- Clean sand
27	60.50	30.00	3- Clean sand
28	63.00	43.00	3- Clean sand
29	65.50	47.00	3- Clean sand
30	68.00	62.00	2- Clay and silty sand
31	70.50	29.00	3- Clean sand
32	73.00	85.00	3- Clean sand
33	75.50	51.00	3- Clean sand
34	78.00	49.00	3- Clean sand
35	80.50	34.00	3- Clean sand
36	83.00	65.00	2- Clay and silty sand
37	85.50	38.00	3- Clean sand
38	88.00	78.00	3- Clean sand
39	90.50	49.00	3- Clean sand
40	93.00	71.00	3- Clean sand
41	95.50	60.00	3- Clean sand
42	98.00	65.00	3- Clean sand
43	100.00	65.00	3- Clean sand

Blowcount Average Per Soil Layer

Layer Num.	Starting Elevation (ft)	Bottom Elevation (ft)	Thickness (ft)	Average Blowcount (Blows/ft)	Soil Type
1	11.10	1.10	10.00	35.80	5-Void
2	1.10	-4.40	5.50	26.09	4-Limestone, Very Shelly Sand
3	-4.40	-56.90	52.50	41.95	3-Clean Sand
4	-56.90	-59.40	2.50	62.00	2-Clay and Silty Sand

				B-101_Void-10ft. out	
5	-59.40	-71.90	12.50	49.60	3-Clean Sand
6	-71.90	-74.40	2.50	65.00	2-Clay and Silty Sand
7	-74.40	-88.90	14.50	60.00	3-Clean Sand

Driven Pile Data:

=====  
Pile unit weight = 150.00(pcf), Section Type: Square

Pile Geometry:

Width (in)	Length (ft)	Tip Elev. (ft)
18.00	25.00	-13.90
18.00	26.00	-14.90
18.00	27.00	-15.90
18.00	28.00	-16.90
18.00	29.00	-17.90
18.00	30.00	-18.90
18.00	31.00	-19.90
18.00	32.00	-20.90
18.00	33.00	-21.90
18.00	34.00	-22.90
18.00	35.00	-23.90
18.00	36.00	-24.90
18.00	37.00	-25.90
18.00	38.00	-26.90
18.00	39.00	-27.90
18.00	40.00	-28.90
18.00	41.00	-29.90
18.00	42.00	-30.90
18.00	43.00	-31.90
18.00	44.00	-32.90
18.00	45.00	-33.90
18.00	46.00	-34.90
18.00	47.00	-35.90
18.00	48.00	-36.90
18.00	49.00	-37.90
18.00	50.00	-38.90
18.00	51.00	-39.90
18.00	52.00	-40.90
18.00	53.00	-41.90
18.00	54.00	-42.90
18.00	55.00	-43.90
18.00	56.00	-44.90
18.00	57.00	-45.90
18.00	58.00	-46.90
18.00	59.00	-47.90
18.00	60.00	-48.90
18.00	61.00	-49.90
18.00	62.00	-50.90
18.00	63.00	-51.90
18.00	64.00	-52.90
18.00	65.00	-53.90
18.00	66.00	-54.90
18.00	67.00	-55.90
18.00	68.00	-56.90
18.00	69.00	-57.90
18.00	70.00	-58.90
18.00	71.00	-59.90
18.00	72.00	-60.90
18.00	73.00	-61.90
18.00	74.00	-62.90
18.00	75.00	-63.90
18.00	76.00	-64.90
18.00	77.00	-65.90
18.00	78.00	-66.90
18.00	79.00	-67.90
18.00	80.00	-68.90
18.00	81.00	-69.90
18.00	82.00	-70.90
18.00	83.00	-71.90
18.00	84.00	-72.90
18.00	85.00	-73.90
18.00	86.00	-74.90
18.00	87.00	-75.90
18.00	88.00	-76.90
18.00	89.00	-77.90
18.00	90.00	-78.90
18.00	91.00	-79.90
18.00	92.00	-80.90
18.00	93.00	-81.90
18.00	94.00	-82.90
24.00	25.00	-13.90
24.00	26.00	-14.90
24.00	27.00	-15.90
24.00	28.00	-16.90

24.00	29.00	-17.90
24.00	30.00	-18.90
24.00	31.00	-19.90
24.00	32.00	-20.90
24.00	33.00	-21.90
24.00	34.00	-22.90
24.00	35.00	-23.90
24.00	36.00	-24.90
24.00	37.00	-25.90
24.00	38.00	-26.90
24.00	39.00	-27.90
24.00	40.00	-28.90
24.00	41.00	-29.90
24.00	42.00	-30.90
24.00	43.00	-31.90
24.00	44.00	-32.90
24.00	45.00	-33.90
24.00	46.00	-34.90
24.00	47.00	-35.90
24.00	48.00	-36.90
24.00	49.00	-37.90
24.00	50.00	-38.90
24.00	51.00	-39.90
24.00	52.00	-40.90
24.00	53.00	-41.90
24.00	54.00	-42.90
24.00	55.00	-43.90
24.00	56.00	-44.90
24.00	57.00	-45.90
24.00	58.00	-46.90
24.00	59.00	-47.90
24.00	60.00	-48.90
24.00	61.00	-49.90
24.00	62.00	-50.90
24.00	63.00	-51.90
24.00	64.00	-52.90
24.00	65.00	-53.90
24.00	66.00	-54.90
24.00	67.00	-55.90
24.00	68.00	-56.90
24.00	69.00	-57.90
24.00	70.00	-58.90
24.00	71.00	-59.90
24.00	72.00	-60.90
24.00	73.00	-61.90
24.00	74.00	-62.90
24.00	75.00	-63.90
24.00	76.00	-64.90
24.00	77.00	-65.90
24.00	78.00	-66.90
24.00	79.00	-67.90
24.00	80.00	-68.90
24.00	81.00	-69.90
24.00	82.00	-70.90
24.00	83.00	-71.90
24.00	84.00	-72.90
24.00	85.00	-73.90
24.00	86.00	-74.90
24.00	87.00	-75.90
24.00	88.00	-76.90
24.00	89.00	-77.90
24.00	90.00	-78.90
24.00	91.00	-79.90
24.00	92.00	-80.90
24.00	93.00	-81.90
24.00	94.00	-82.90

Driven Pile Capacity:

=====

Section Type: Square  
 Pile Width: 18.00 (in)

Test Pile Length (ft)	Pile Width (in)	Ultimate Side Friction (tons)	Mobilized End Bearing (tons)	Estimated Davi sson Capacity (tons)	Allowable Pile Capacity (tons)	Ultimate Pile Capacity (tons)
25.00	18.0	32.59	54.22	86.82	43.41	195.26
26.00	18.0	34.23	57.85	92.08	46.04	207.77
27.00	18.0	35.57	63.36	98.93	49.46	225.64
28.00	18.0	36.87	71.02	107.88	53.94	249.92

B-101\_Void-10ft. out

29.00	18.0	38.78	78.82	117.60	58.80	275.25
30.00	18.0	41.56	85.63	127.19	63.60	298.45
31.00	18.0	45.09	91.86	136.95	68.47	320.67
32.00	18.0	49.25	98.86	148.11	74.05	345.83
33.00	18.0	54.12	106.52	160.64	80.32	373.68
34.00	18.0	59.56	111.51	171.07	85.54	394.09
35.00	18.0	64.92	113.62	178.54	89.27	405.77
36.00	18.0	70.06	115.83	185.90	92.95	417.56
37.00	18.0	75.54	118.91	194.45	97.23	432.27
38.00	18.0	81.47	122.52	203.99	102.00	449.04
39.00	18.0	87.55	124.60	212.15	106.08	461.34
40.00	18.0	93.50	124.71	218.22	109.11	467.65
41.00	18.0	99.35	123.76	223.11	111.55	470.62
42.00	18.0	105.37	123.95	229.32	114.66	477.23
43.00	18.0	111.62	125.27	236.90	118.45	487.44
44.00	18.0	117.59	126.90	244.49	122.24	498.28
45.00	18.0	122.75	128.94	251.68	125.84	509.55
46.00	18.0	127.27	131.71	258.99	129.49	522.41
47.00	18.0	132.44	134.11	266.55	133.28	534.78
48.00	18.0	138.47	135.73	274.20	137.10	545.67
49.00	18.0	144.94	136.45	281.38	140.69	554.27
50.00	18.0	151.41	136.72	288.12	144.06	561.55
51.00	18.0	157.89	136.88	294.77	147.38	568.52
52.00	18.0	164.39	137.24	301.64	150.82	576.12
53.00	18.0	170.94	137.68	308.62	154.31	583.98
54.00	18.0	177.50	136.44	313.95	156.97	586.83
55.00	18.0	184.08	132.90	316.99	158.49	582.79
56.00	18.0	190.68	128.63	319.30	159.65	576.56
57.00	18.0	197.28	126.63	323.91	161.95	577.16
58.00	18.0	203.90	126.75	330.65	165.32	584.15
59.00	18.0	210.07	127.52	337.59	168.80	592.63
60.00	18.0	215.35	129.00	344.35	172.17	602.35
61.00	18.0	219.91	130.56	350.46	175.23	611.58
62.00	18.0	224.91	129.06	353.98	176.99	612.10
63.00	18.0	230.56	124.27	354.83	177.42	603.36
64.00	18.0	236.64	118.58	355.22	177.61	592.38
65.00	18.0	242.92	113.16	356.08	178.04	582.41
66.00	18.0	249.44	108.70	358.14	179.07	575.55
67.00	18.0	256.37	107.63	364.00	182.00	579.26
68.00	18.0	294.36	99.38	393.74	196.87	592.50
69.00	18.0	301.46	93.71	395.17	197.58	582.58
70.00	18.0	306.87	99.98	406.85	203.43	606.81
71.00	18.0	311.45	118.99	430.44	215.22	668.42
72.00	18.0	316.40	119.35	435.75	217.88	674.46
73.00	18.0	322.21	120.00	442.20	221.10	682.20
74.00	18.0	328.64	120.50	449.14	224.57	690.14
75.00	18.0	335.47	120.48	455.95	227.98	696.91
76.00	18.0	342.92	119.67	462.59	231.30	701.93
77.00	18.0	350.33	116.23	466.56	233.28	699.02
78.00	18.0	357.17	110.07	467.24	233.62	687.39
79.00	18.0	363.61	106.15	469.76	234.88	682.06
80.00	18.0	369.23	105.84	475.07	237.53	686.75
81.00	18.0	374.29	108.32	482.60	241.30	699.24
82.00	18.0	380.31	112.41	492.72	246.36	717.54
83.00	18.0	387.56	112.14	499.69	249.85	723.97
84.00	18.0	394.91	102.25	497.17	248.58	701.67
85.00	18.0	401.28	110.87	512.15	256.07	733.89
86.00	18.0	406.83	126.77	533.60	266.80	787.14
87.00	18.0	412.69	126.89	539.59	269.79	793.38
88.00	18.0	419.13	127.04	546.16	273.08	800.24
89.00	18.0	425.87	127.15	553.03	276.51	807.33
90.00	18.0	432.63	127.27	559.89	279.95	814.43
91.00	18.0	439.30	127.49	566.80	283.40	821.78
92.00	18.0	445.78	128.01	573.79	286.89	829.81
93.00	18.0	452.00	128.94	580.93	290.47	838.81
94.00	18.0	457.98	130.30	588.29	294.14	848.89

Section Type: Square  
 Pile Width: 24.00 (in)

Test Pile Length (Ft)	Pile Width (in)	Ultimate Side Friction (tons)	Mobilized End Bearing (tons)	Estimated Davi sson Capacity (tons)	Allowable Pile Capacity (tons)	Ultimate Pile Capacity (tons)
25.00	24.0	41.05	92.19	133.24	66.62	317.62
26.00	24.0	42.45	99.09	141.54	70.77	339.72
27.00	24.0	44.03	106.69	150.71	75.36	364.09
28.00	24.0	46.01	114.37	160.39	80.19	389.13
29.00	24.0	48.65	121.57	170.23	85.11	413.37
30.00	24.0	52.00	128.84	180.85	90.42	438.53
31.00	24.0	55.87	137.45	193.32	96.66	468.22
32.00	24.0	60.47	146.80	207.26	103.63	500.85
33.00	24.0	66.09	155.15	221.24	110.62	531.55
34.00	24.0	72.14	162.98	235.12	117.56	561.07

B-101\_Void-10ft. out

35.00	24.0	77.82	172.12	249.94	124.97	594.18
36.00	24.0	83.17	183.11	266.28	133.14	632.50
37.00	24.0	89.22	193.32	282.55	141.27	669.19
38.00	24.0	96.45	199.47	295.92	147.96	694.86
39.00	24.0	104.45	201.99	306.44	153.22	710.41
40.00	24.0	112.22	203.79	316.01	158.00	723.59
41.00	24.0	119.79	206.97	326.76	163.38	740.71
42.00	24.0	127.60	212.20	339.79	169.90	764.19
43.00	24.0	135.70	216.96	352.66	176.33	786.57
44.00	24.0	143.48	222.07	365.55	182.77	809.68
45.00	24.0	150.29	228.29	378.58	189.29	835.16
46.00	24.0	156.34	234.95	391.29	195.65	861.19
47.00	24.0	163.17	239.66	402.82	201.41	882.13
48.00	24.0	171.06	241.87	412.92	206.46	896.65
49.00	24.0	179.50	242.36	421.86	210.93	906.57
50.00	24.0	187.96	242.72	430.68	215.34	916.11
51.00	24.0	196.44	243.72	440.16	220.08	927.61
52.00	24.0	204.96	243.78	448.74	224.37	936.30
53.00	24.0	213.54	240.56	454.10	227.05	935.21
54.00	24.0	222.16	234.51	456.67	228.34	925.70
55.00	24.0	230.80	229.67	460.48	230.24	919.82
56.00	24.0	239.47	227.09	466.56	233.28	920.74
57.00	24.0	248.16	226.01	474.17	237.08	926.19
58.00	24.0	256.86	225.32	482.18	241.09	932.81
59.00	24.0	265.02	225.21	490.24	245.12	940.66
60.00	24.0	272.05	224.19	496.25	248.12	944.64
61.00	24.0	278.18	222.17	500.36	250.18	944.70
62.00	24.0	284.87	218.93	503.81	251.90	941.67
63.00	24.0	292.38	214.40	506.78	253.39	935.58
64.00	24.0	300.42	208.93	509.36	254.68	927.23
65.00	24.0	308.73	205.19	513.92	256.96	924.29
66.00	24.0	317.34	204.34	521.68	260.84	930.36
67.00	24.0	326.47	206.63	533.10	266.55	946.37
68.00	24.0	392.47	196.51	588.98	294.49	982.00
69.00	24.0	401.94	173.58	575.52	287.76	922.68
70.00	24.0	409.41	184.17	593.59	296.79	961.93
71.00	24.0	415.29	222.47	637.76	318.88	1082.71
72.00	24.0	422.10	222.64	644.74	322.37	1090.02
73.00	24.0	430.57	222.52	653.09	326.54	1098.12
74.00	24.0	439.75	217.89	657.64	328.82	1093.41
75.00	24.0	448.87	211.58	660.44	330.22	1083.60
76.00	24.0	457.99	205.00	662.99	331.49	1072.98
77.00	24.0	467.11	199.68	666.79	333.39	1066.15
78.00	24.0	476.23	195.85	672.08	336.04	1063.77
79.00	24.0	484.81	193.79	678.60	339.30	1066.17
80.00	24.0	492.30	194.03	686.33	343.16	1074.38
81.00	24.0	499.05	196.75	695.79	347.90	1089.28
82.00	24.0	507.08	201.09	708.17	354.08	1110.35
83.00	24.0	516.74	213.52	730.26	365.13	1157.29
84.00	24.0	526.55	186.16	712.71	356.36	1085.04
85.00	24.0	535.04	199.48	734.52	367.26	1133.47
86.00	24.0	542.42	225.69	768.11	384.05	1219.48
87.00	24.0	550.06	226.07	776.14	388.07	1228.29
88.00	24.0	558.36	226.62	784.98	392.49	1238.21
89.00	24.0	567.08	227.11	794.19	397.10	1248.40
90.00	24.0	575.87	227.53	803.40	401.70	1258.46
91.00	24.0	584.68	227.95	812.63	406.32	1268.53
92.00	24.0	593.51	228.37	821.88	410.94	1278.62
93.00	24.0	602.35	228.79	831.14	415.57	1288.73
94.00	24.0	Soil Elevations Must Extend At or Below Contribution Zone				

NOTES

1. MOBILIZED END BEARING IS 1/3 OF THE ORIGINAL RB-121 VALUES.
2. DAVISSON PILE CAPACITY IS AN ESTIMATE BASED ON FAILURE CRITERIA, AND EQUALS ULTIMATE SIDE FRICTION PLUS MOBILIZED END BEARING.
3. ALLOWABLE PILE CAPACITY IS 1/2 THE DAVISSON PILE CAPACITY.
4. ULTIMATE PILE CAPACITY IS ULTIMATE SIDE FRICTION PLUS 3 x THE MOBILIZED END BEARING.  
EXCEPTION: FOR H-PILES TIPPED IN SAND OR LIMESTONE, THE ULTIMATE PILE CAPACITY IS ULTIMATE SIDE FRICTION PLUS 2 x THE MOBILIZED END BEARING.



General Information:

=====  
 Input file: .....tary\_RS&H)\Analysis\_Structure\FB-Deep\Pile\B-201\_Void-10ft.spc  
 Project number: 2000-01-17003  
 Job name: SW 10th Street, from Powerline Rd. to Military Trail  
 Engineer: JB Henry  
 Units: English

Analysis Information:

=====  
 Analysis Type: SPT

Soil Information:

=====  
 Boring date: 2/5/2018, Boring Number: B-201  
 Station number: Offset:  
 Ground Elevation: 13.600(ft)  
 Hammer type: Automatic Hammer, Correction factor = 1.24

ID	Depth (ft)	No. of Blows (Blows/ft)	Soil Type
1	0.00	28.00	5- Cavity layer
2	2.00	24.00	5- Cavity layer
3	4.00	21.00	5- Cavity layer
4	6.00	8.00	5- Cavity layer
5	8.00	6.00	3- Clean sand
6	10.00	10.00	3- Clean sand
7	12.00	23.00	3- Clean sand
8	13.50	19.00	3- Clean sand
9	15.50	29.00	3- Clean sand
10	18.00	41.00	3- Clean sand
11	20.50	16.00	3- Clean sand
12	23.00	31.00	3- Clean sand
13	25.50	30.00	3- Clean sand
14	28.00	60.00	3- Clean sand
15	30.50	46.00	3- Clean sand
16	33.00	78.00	3- Clean sand
17	35.50	56.00	3- Clean sand
18	38.00	60.00	3- Clean sand
19	40.50	60.00	3- Clean sand
20	43.00	66.00	3- Clean sand
21	45.50	15.00	3- Clean sand
22	48.00	29.00	3- Clean sand
23	50.50	43.00	3- Clean sand
24	53.00	65.00	3- Clean sand
25	55.50	48.00	2- Clay and silty sand
26	58.00	78.00	3- Clean sand
27	60.50	48.00	3- Clean sand
28	63.00	68.00	3- Clean sand
29	65.50	31.00	3- Clean sand
30	68.00	50.00	3- Clean sand
31	70.50	38.00	3- Clean sand
32	73.00	45.00	2- Clay and silty sand
33	75.50	46.00	2- Clay and silty sand
34	78.00	60.00	2- Clay and silty sand
35	80.50	59.00	3- Clean sand
36	83.00	68.00	3- Clean sand
37	85.50	37.00	3- Clean sand
38	88.00	63.00	3- Clean sand
39	90.50	24.00	3- Clean sand
40	93.00	39.00	3- Clean sand
41	95.50	36.00	3- Clean sand
42	98.00	60.00	3- Clean sand
43	100.00	60.00	3- Clean sand

Blowcount Average Per Soil Layer

Layer Num.	Starting Elevation (ft)	Bottom Elevation (ft)	Thickness (ft)	Average Blowcount (Blows/ft)	Soil Type
1	13.60	5.60	8.00	20.25	5-Void
2	5.60	-41.90	47.50	40.36	3-Clean Sand
3	-41.90	-44.40	2.50	48.00	2-Clay and Silty Sand
4	-44.40	-59.40	15.00	52.17	3-Clean Sand

				B-201_Void-10ft.out	
5	-59.40	-66.90	7.50	50.33	2-Clay and Silty Sand
6	-66.90	-86.40	19.50	47.95	3-Clean Sand

Driven Pile Data:

=====

Pile unit weight = 150.00(pcf), Section Type: Square

Pile Geometry:

-----

Width (in)	Length (ft)	Tip Elev. (ft)
18.00	25.00	-11.40
18.00	26.00	-12.40
18.00	27.00	-13.40
18.00	28.00	-14.40
18.00	29.00	-15.40
18.00	30.00	-16.40
18.00	31.00	-17.40
18.00	32.00	-18.40
18.00	33.00	-19.40
18.00	34.00	-20.40
18.00	35.00	-21.40
18.00	36.00	-22.40
18.00	37.00	-23.40
18.00	38.00	-24.40
18.00	39.00	-25.40
18.00	40.00	-26.40
18.00	41.00	-27.40
18.00	42.00	-28.40
18.00	43.00	-29.40
18.00	44.00	-30.40
18.00	45.00	-31.40
18.00	46.00	-32.40
18.00	47.00	-33.40
18.00	48.00	-34.40
18.00	49.00	-35.40
18.00	50.00	-36.40
18.00	51.00	-37.40
18.00	52.00	-38.40
18.00	53.00	-39.40
18.00	54.00	-40.40
18.00	55.00	-41.40
18.00	56.00	-42.40
18.00	57.00	-43.40
18.00	58.00	-44.40
18.00	59.00	-45.40
18.00	60.00	-46.40
18.00	61.00	-47.40
18.00	62.00	-48.40
18.00	63.00	-49.40
18.00	64.00	-50.40
18.00	65.00	-51.40
18.00	66.00	-52.40
18.00	67.00	-53.40
18.00	68.00	-54.40
18.00	69.00	-55.40
18.00	70.00	-56.40
18.00	71.00	-57.40
18.00	72.00	-58.40
18.00	73.00	-59.40
18.00	74.00	-60.40
18.00	75.00	-61.40
18.00	76.00	-62.40
18.00	77.00	-63.40
18.00	78.00	-64.40
18.00	79.00	-65.40
18.00	80.00	-66.40
18.00	81.00	-67.40
18.00	82.00	-68.40
18.00	83.00	-69.40
18.00	84.00	-70.40
18.00	85.00	-71.40
18.00	86.00	-72.40
18.00	87.00	-73.40
18.00	88.00	-74.40
18.00	89.00	-75.40
18.00	90.00	-76.40
18.00	91.00	-77.40
18.00	92.00	-78.40
18.00	93.00	-79.40
18.00	94.00	-80.40
24.00	25.00	-11.40
24.00	26.00	-12.40
24.00	27.00	-13.40
24.00	28.00	-14.40
24.00	29.00	-15.40

24.00	30.00	-16.40
24.00	31.00	-17.40
24.00	32.00	-18.40
24.00	33.00	-19.40
24.00	34.00	-20.40
24.00	35.00	-21.40
24.00	36.00	-22.40
24.00	37.00	-23.40
24.00	38.00	-24.40
24.00	39.00	-25.40
24.00	40.00	-26.40
24.00	41.00	-27.40
24.00	42.00	-28.40
24.00	43.00	-29.40
24.00	44.00	-30.40
24.00	45.00	-31.40
24.00	46.00	-32.40
24.00	47.00	-33.40
24.00	48.00	-34.40
24.00	49.00	-35.40
24.00	50.00	-36.40
24.00	51.00	-37.40
24.00	52.00	-38.40
24.00	53.00	-39.40
24.00	54.00	-40.40
24.00	55.00	-41.40
24.00	56.00	-42.40
24.00	57.00	-43.40
24.00	58.00	-44.40
24.00	59.00	-45.40
24.00	60.00	-46.40
24.00	61.00	-47.40
24.00	62.00	-48.40
24.00	63.00	-49.40
24.00	64.00	-50.40
24.00	65.00	-51.40
24.00	66.00	-52.40
24.00	67.00	-53.40
24.00	68.00	-54.40
24.00	69.00	-55.40
24.00	70.00	-56.40
24.00	71.00	-57.40
24.00	72.00	-58.40
24.00	73.00	-59.40
24.00	74.00	-60.40
24.00	75.00	-61.40
24.00	76.00	-62.40
24.00	77.00	-63.40
24.00	78.00	-64.40
24.00	79.00	-65.40
24.00	80.00	-66.40
24.00	81.00	-67.40
24.00	82.00	-68.40
24.00	83.00	-69.40
24.00	84.00	-70.40
24.00	85.00	-71.40
24.00	86.00	-72.40
24.00	87.00	-73.40
24.00	88.00	-74.40
24.00	89.00	-75.40
24.00	90.00	-76.40
24.00	91.00	-77.40
24.00	92.00	-78.40
24.00	93.00	-79.40
24.00	94.00	-80.40

Driven Pile Capacity:

=====

Section Type: Square  
 Pile Width: 18.00 (in)

Test Pile Length (ft)	Pile Width (in)	Ultimate Side Friction (tons)	Mobilized End Bearing (tons)	Estimated Davisson Capacity (tons)	Allowable Pile Capacity (tons)	Ultimate Pile Capacity (tons)
25.00	18.0	34.62	99.42	134.04	67.02	332.88
26.00	18.0	38.19	109.65	147.84	73.92	367.14
27.00	18.0	42.78	114.09	156.87	78.44	385.06
28.00	18.0	48.10	117.01	165.12	82.56	399.14
29.00	18.0	53.82	118.90	172.72	86.36	410.51

B-201\_Void-10ft. out

30.00	18.0	59.55	120.34	179.89	89.94	420.56
31.00	18.0	65.28	122.22	187.50	93.75	431.93
32.00	18.0	71.15	125.22	196.37	98.19	446.81
33.00	18.0	77.18	129.07	206.25	103.12	464.38
34.00	18.0	83.32	132.34	215.65	107.83	480.33
35.00	18.0	89.50	134.87	224.37	112.18	494.10
36.00	18.0	95.74	137.05	232.78	116.39	506.87
37.00	18.0	102.01	139.28	241.29	120.64	519.84
38.00	18.0	108.33	141.32	249.64	124.82	532.28
39.00	18.0	114.67	139.85	254.52	127.26	534.21
40.00	18.0	121.05	133.68	254.73	127.36	522.09
41.00	18.0	127.46	124.84	252.30	126.15	501.98
42.00	18.0	133.89	117.54	251.43	125.71	486.50
43.00	18.0	140.34	111.91	252.26	126.13	476.08
44.00	18.0	146.06	108.85	254.91	127.46	472.62
45.00	18.0	150.27	109.39	259.66	129.83	478.43
46.00	18.0	153.20	112.93	266.13	133.07	491.99
47.00	18.0	156.49	116.59	273.08	136.54	506.27
48.00	18.0	160.40	119.87	280.28	140.14	520.02
49.00	18.0	164.96	120.44	285.41	142.70	526.29
50.00	18.0	170.17	117.36	287.53	143.77	522.24
51.00	18.0	176.00	112.24	288.24	144.12	512.71
52.00	18.0	182.14	109.30	291.43	145.72	510.03
53.00	18.0	188.55	108.69	297.23	148.62	514.61
54.00	18.0	195.27	109.43	304.70	152.35	523.57
55.00	18.0	202.35	111.69	314.04	157.02	537.42
56.00	18.0	246.18	113.79	359.97	179.98	587.54
57.00	18.0	253.13	115.37	368.49	184.25	599.23
58.00	18.0	260.76	125.23	385.99	192.99	636.45
59.00	18.0	267.48	125.34	392.83	196.41	643.51
60.00	18.0	274.26	125.38	399.64	199.82	650.40
61.00	18.0	281.18	124.35	405.53	202.77	654.24
62.00	18.0	287.99	123.29	411.28	205.64	657.85
63.00	18.0	294.82	123.43	418.25	209.12	665.11
64.00	18.0	301.17	123.50	424.67	212.33	671.67
65.00	18.0	306.53	123.24	429.77	214.89	676.24
66.00	18.0	311.16	122.93	434.10	217.05	679.97
67.00	18.0	316.53	121.27	437.80	218.90	680.34
68.00	18.0	322.88	117.71	440.58	220.29	676.00
69.00	18.0	329.42	112.56	441.98	220.99	667.10
70.00	18.0	335.38	106.92	442.30	221.15	656.14
71.00	18.0	340.95	101.47	442.42	221.21	645.35
72.00	18.0	347.34	97.11	444.46	222.23	638.68
73.00	18.0	354.75	69.28	424.03	212.02	562.59
74.00	18.0	362.52	69.53	432.05	216.02	571.10
75.00	18.0	369.40	71.56	440.96	220.48	584.08
76.00	18.0	375.48	76.33	451.81	225.91	604.48
77.00	18.0	381.40	83.56	464.96	232.48	632.07
78.00	18.0	387.51	93.11	480.62	240.31	666.83
79.00	18.0	394.05	103.84	497.89	248.94	705.57
80.00	18.0	401.38	107.42	508.80	254.40	723.64
81.00	18.0	416.03	111.55	527.58	263.79	750.68
82.00	18.0	422.87	110.71	533.58	266.79	755.00
83.00	18.0	429.71	111.58	541.29	270.65	764.45
84.00	18.0	436.23	111.93	548.15	274.08	772.01
85.00	18.0	442.10	111.00	553.11	276.55	775.11
86.00	18.0	447.49	109.49	556.98	278.49	775.95
87.00	18.0	453.37	108.96	562.33	281.17	780.26
88.00	18.0	459.89	109.32	569.21	284.60	787.85
89.00	18.0	466.04	110.27	576.31	288.15	796.85
90.00	18.0	470.81	112.38	583.19	291.59	807.94
91.00	18.0	473.49	114.16	587.66	293.83	815.98
92.00	18.0	476.82	115.83	592.64	296.32	824.30
93.00	18.0	481.20	117.30	598.50	299.25	833.11
94.00	18.0	485.95	118.87	604.82	302.41	842.56

Section Type: Square  
Pile Width: 24.00 (in)

Test Pile Length (ft)	Pile Width (in)	Ultimate Side Friction (tons)	Mobilized End Bearing (tons)	Estimated Davissson Capacity (tons)	Allowable Pile Capacity (tons)	Ultimate Pile Capacity (tons)
25.00	24.0	40.79	140.68	181.47	90.73	462.82
26.00	24.0	44.41	153.81	198.22	99.11	505.85
27.00	24.0	48.99	166.30	215.29	107.64	547.88
28.00	24.0	54.71	177.26	231.97	115.99	586.50
29.00	24.0	61.09	187.82	248.90	124.45	624.53
30.00	24.0	67.61	199.19	266.80	133.40	665.18
31.00	24.0	74.37	210.49	284.86	142.43	705.83
32.00	24.0	81.55	221.18	302.73	151.37	745.10
33.00	24.0	89.26	223.70	312.95	156.48	760.34
34.00	24.0	97.12	225.31	322.44	161.22	773.06
35.00	24.0	105.08	227.36	332.44	166.22	787.17

B-201_Void-10ft. out							
36.00	24.0	113.12	231.06	344.19	172.09	806.31	
37.00	24.0	121.24	233.56	354.80	177.40	821.93	
38.00	24.0	129.42	230.36	359.78	179.89	820.49	
39.00	24.0	137.66	222.00	359.67	179.83	803.68	
40.00	24.0	145.96	214.41	360.37	180.19	789.20	
41.00	24.0	154.31	209.00	363.31	181.66	781.31	
42.00	24.0	162.70	205.61	368.31	184.16	779.54	
43.00	24.0	171.14	203.28	374.42	187.21	780.99	
44.00	24.0	178.68	203.11	381.80	190.90	788.02	
45.00	24.0	184.38	206.23	390.61	195.31	803.07	
46.00	24.0	188.51	212.65	401.16	200.58	826.46	
47.00	24.0	193.05	217.07	410.12	205.06	844.26	
48.00	24.0	198.37	216.49	414.86	207.43	847.85	
49.00	24.0	204.47	211.80	416.28	208.14	839.89	
50.00	24.0	211.39	208.61	420.00	210.00	837.22	
51.00	24.0	219.07	208.00	427.07	213.54	843.08	
52.00	24.0	227.15	208.66	435.81	217.90	853.13	
53.00	24.0	235.56	208.80	444.37	222.18	861.97	
54.00	24.0	244.38	209.71	454.09	227.04	873.51	
55.00	24.0	253.66	212.73	466.39	233.19	891.85	
56.00	24.0	328.29	215.19	543.47	271.74	973.85	
57.00	24.0	338.02	215.81	553.84	276.92	985.47	
58.00	24.0	347.68	216.26	563.93	281.97	996.45	
59.00	24.0	356.78	210.36	567.14	283.57	987.86	
60.00	24.0	365.86	207.57	573.43	286.71	988.57	
61.00	24.0	374.91	209.64	584.56	292.28	1003.84	
62.00	24.0	383.99	214.04	598.02	299.01	1026.10	
63.00	24.0	393.09	216.26	609.35	304.68	1041.88	
64.00	24.0	401.47	216.36	617.83	308.91	1050.55	
65.00	24.0	408.71	215.37	624.08	312.04	1054.82	
66.00	24.0	414.88	211.90	626.78	313.39	1050.58	
67.00	24.0	422.04	205.33	627.37	313.69	1038.04	
68.00	24.0	430.50	196.94	627.44	313.72	1021.32	
69.00	24.0	439.23	187.98	627.21	313.60	1003.16	
70.00	24.0	447.17	180.70	627.87	313.94	989.26	
71.00	24.0	454.60	176.14	630.75	315.37	983.04	
72.00	24.0	463.13	175.98	639.11	319.55	991.08	
73.00	24.0	473.00	138.77	611.78	305.89	889.32	
74.00	24.0	483.56	138.46	622.02	311.01	898.94	
75.00	24.0	492.91	141.18	634.09	317.05	916.45	
76.00	24.0	501.48	146.08	647.57	323.78	939.74	
77.00	24.0	509.78	153.02	662.80	331.40	968.84	
78.00	24.0	518.26	161.06	679.32	339.66	1001.43	
79.00	24.0	526.78	170.03	696.82	348.41	1036.89	
80.00	24.0	534.99	181.00	715.99	358.00	1077.99	
81.00	24.0	554.69	204.09	758.78	379.39	1166.97	
82.00	24.0	563.73	204.17	767.90	383.95	1176.25	
83.00	24.0	572.95	201.81	774.75	387.38	1178.37	
84.00	24.0	581.64	194.39	776.03	388.02	1164.82	
85.00	24.0	589.47	189.24	778.71	389.36	1157.20	
86.00	24.0	596.66	187.77	784.43	392.21	1159.97	
87.00	24.0	604.49	187.21	791.70	395.85	1166.11	
88.00	24.0	613.18	186.21	799.39	399.69	1171.80	
89.00	24.0	621.38	186.62	808.00	404.00	1181.24	
90.00	24.0	627.74	191.19	818.93	409.46	1201.30	
91.00	24.0	632.64	199.25	831.88	415.94	1230.37	
92.00	24.0	637.24	205.64	842.88	421.44	1254.17	
93.00	24.0	641.79	209.30	851.09	425.54	1269.68	
94.00	24.0	Soil Elevations Must Extend At or Below Contribution Zone					

NOTES

1. MOBILIZED END BEARING IS 1/3 OF THE ORIGINAL RB-121 VALUES.
2. DAVISSON PILE CAPACITY IS AN ESTIMATE BASED ON FAILURE CRITERIA, AND EQUALS ULTIMATE SIDE FRICTION PLUS MOBILIZED END BEARING.
3. ALLOWABLE PILE CAPACITY IS 1/2 THE DAVISSON PILE CAPACITY.
4. ULTIMATE PILE CAPACITY IS ULTIMATE SIDE FRICTION PLUS 3 x THE MOBILIZED END BEARING.  
EXCEPTION: FOR H-PILES TIPPED IN SAND OR LIMESTONE, THE ULTIMATE PILE CAPACITY IS ULTIMATE SIDE FRICTION PLUS 2 x THE MOBILIZED END BEARING.

General Information:

=====  
 Input file: .....tary\_RS&H)\Analysis\_Structure\FB-Deep\Pile\B-301\_Void-10ft.spc  
 Project number: 2000-01-17003  
 Job name: SW 10th Street, from Powerline Rd. to Military Trail  
 Engineer: JB Henry  
 Units: English

Analysis Information:

=====  
 Analysis Type: SPT

Soil Information:

=====  
 Boring date: 2/1/2018, Boring Number: B-301  
 Station number: Offset:  
 Ground Elevation: 13.300(ft)  
 Hammer type: Automatic Hammer, Correction factor = 1.24

ID	Depth (ft)	No. of Blows (Blows/ft)	Soil Type
1	0.00	16.00	5- Cavity layer
2	2.00	28.00	5- Cavity layer
3	4.00	29.00	5- Cavity layer
4	6.00	28.00	5- Cavity layer
5	8.00	19.00	5- Cavity layer
6	10.00	15.00	3- Clean sand
7	12.00	5.00	3- Clean sand
8	13.50	19.00	3- Clean sand
9	15.50	12.00	3- Clean sand
10	18.00	25.00	3- Clean sand
11	20.50	20.00	3- Clean sand
12	23.00	50.00	3- Clean sand
13	25.50	23.00	3- Clean sand
14	28.00	37.00	3- Clean sand
15	30.50	36.00	3- Clean sand
16	33.00	69.00	3- Clean sand
17	35.50	67.00	3- Clean sand
18	38.00	60.00	3- Clean sand
19	40.50	40.00	3- Clean sand
20	43.00	33.00	3- Clean sand
21	45.50	5.00	2- Clay and silty sand
22	48.00	13.00	2- Clay and silty sand
23	50.50	26.00	3- Clean sand
24	53.00	69.00	3- Clean sand
25	55.50	40.00	3- Clean sand
26	58.00	58.00	3- Clean sand
27	60.50	45.00	3- Clean sand
28	63.00	69.00	3- Clean sand
29	65.50	46.00	3- Clean sand
30	68.00	63.00	3- Clean sand
31	70.50	29.00	3- Clean sand
32	73.00	34.00	3- Clean sand
33	75.50	30.00	2- Clay and silty sand
34	78.00	61.00	2- Clay and silty sand
35	80.50	58.00	2- Clay and silty sand
36	83.00	60.00	2- Clay and silty sand
37	85.50	74.00	3- Clean sand
38	88.00	60.00	3- Clean sand
39	90.50	38.00	3- Clean sand
40	93.00	32.00	3- Clean sand
41	95.50	25.00	3- Clean sand
42	98.00	44.00	3- Clean sand
43	100.00	44.00	3- Clean sand

Blowcount Average Per Soil Layer

Layer Num.	Starting Elevation (ft)	Bottom Elevation (ft)	Thickness (ft)	Average Blowcount (Blows/ft)	Soil Type
1	13.30	3.30	10.00	24.00	5-Void
2	3.30	-32.20	35.50	35.37	3-Clean Sand
3	-32.20	-37.20	5.00	9.00	2-Clay and Silty Sand
4	-37.20	-62.20	25.00	47.90	3-Clean Sand

5	-62.20	-72.20	10.00	B-301_Void-10ft.out	
6	-72.20	-86.70	14.50	52.25	2-Clay and Silty Sand
				45.55	3-Clean Sand

Driven Pile Data:

=====

Pile unit weight = 150.00(pcf), Section Type: Square

Pile Geometry:

-----

Width (in)	Length (ft)	Tip Elev. (ft)
18.00	25.00	-11.70
18.00	26.00	-12.70
18.00	27.00	-13.70
18.00	28.00	-14.70
18.00	29.00	-15.70
18.00	30.00	-16.70
18.00	31.00	-17.70
18.00	32.00	-18.70
18.00	33.00	-19.70
18.00	34.00	-20.70
18.00	35.00	-21.70
18.00	36.00	-22.70
18.00	37.00	-23.70
18.00	38.00	-24.70
18.00	39.00	-25.70
18.00	40.00	-26.70
18.00	41.00	-27.70
18.00	42.00	-28.70
18.00	43.00	-29.70
18.00	44.00	-30.70
18.00	45.00	-31.70
18.00	46.00	-32.70
18.00	47.00	-33.70
18.00	48.00	-34.70
18.00	49.00	-35.70
18.00	50.00	-36.70
18.00	51.00	-37.70
18.00	52.00	-38.70
18.00	53.00	-39.70
18.00	54.00	-40.70
18.00	55.00	-41.70
18.00	56.00	-42.70
18.00	57.00	-43.70
18.00	58.00	-44.70
18.00	59.00	-45.70
18.00	60.00	-46.70
18.00	61.00	-47.70
18.00	62.00	-48.70
18.00	63.00	-49.70
18.00	64.00	-50.70
18.00	65.00	-51.70
18.00	66.00	-52.70
18.00	67.00	-53.70
18.00	68.00	-54.70
18.00	69.00	-55.70
18.00	70.00	-56.70
18.00	71.00	-57.70
18.00	72.00	-58.70
18.00	73.00	-59.70
18.00	74.00	-60.70
18.00	75.00	-61.70
18.00	76.00	-62.70
18.00	77.00	-63.70
18.00	78.00	-64.70
18.00	79.00	-65.70
18.00	80.00	-66.70
18.00	81.00	-67.70
18.00	82.00	-68.70
18.00	83.00	-69.70
18.00	84.00	-70.70
18.00	85.00	-71.70
18.00	86.00	-72.70
18.00	87.00	-73.70
18.00	88.00	-74.70
18.00	89.00	-75.70
18.00	90.00	-76.70
18.00	91.00	-77.70
18.00	92.00	-78.70
18.00	93.00	-79.70
18.00	94.00	-80.70
24.00	25.00	-11.70
24.00	26.00	-12.70
24.00	27.00	-13.70
24.00	28.00	-14.70
24.00	29.00	-15.70

24.00	30.00	-16.70
24.00	31.00	-17.70
24.00	32.00	-18.70
24.00	33.00	-19.70
24.00	34.00	-20.70
24.00	35.00	-21.70
24.00	36.00	-22.70
24.00	37.00	-23.70
24.00	38.00	-24.70
24.00	39.00	-25.70
24.00	40.00	-26.70
24.00	41.00	-27.70
24.00	42.00	-28.70
24.00	43.00	-29.70
24.00	44.00	-30.70
24.00	45.00	-31.70
24.00	46.00	-32.70
24.00	47.00	-33.70
24.00	48.00	-34.70
24.00	49.00	-35.70
24.00	50.00	-36.70
24.00	51.00	-37.70
24.00	52.00	-38.70
24.00	53.00	-39.70
24.00	54.00	-40.70
24.00	55.00	-41.70
24.00	56.00	-42.70
24.00	57.00	-43.70
24.00	58.00	-44.70
24.00	59.00	-45.70
24.00	60.00	-46.70
24.00	61.00	-47.70
24.00	62.00	-48.70
24.00	63.00	-49.70
24.00	64.00	-50.70
24.00	65.00	-51.70
24.00	66.00	-52.70
24.00	67.00	-53.70
24.00	68.00	-54.70
24.00	69.00	-55.70
24.00	70.00	-56.70
24.00	71.00	-57.70
24.00	72.00	-58.70
24.00	73.00	-59.70
24.00	74.00	-60.70
24.00	75.00	-61.70
24.00	76.00	-62.70
24.00	77.00	-63.70
24.00	78.00	-64.70
24.00	79.00	-65.70
24.00	80.00	-66.70
24.00	81.00	-67.70
24.00	82.00	-68.70
24.00	83.00	-69.70
24.00	84.00	-70.70
24.00	85.00	-71.70
24.00	86.00	-72.70
24.00	87.00	-73.70
24.00	88.00	-74.70
24.00	89.00	-75.70
24.00	90.00	-76.70
24.00	91.00	-77.70
24.00	92.00	-78.70
24.00	93.00	-79.70
24.00	94.00	-80.70

Driven Pile Capacity:

=====

Section Type: Square  
 Pile Width: 18.00 (in)

Test Pile Length (ft)	Pile Width (in)	Ultimate Side Friction (tons)	Mobilized End Bearing (tons)	Estimated Davisson Capacity (tons)	Allowable Pile Capacity (tons)	Ultimate Pile Capacity (tons)
25.00	18.0	28.46	75.03	103.49	51.74	253.54
26.00	18.0	31.15	82.61	113.76	56.88	278.97
27.00	18.0	34.26	91.63	125.89	62.95	309.16
28.00	18.0	37.99	102.04	140.03	70.02	344.11
29.00	18.0	42.48	107.75	150.23	75.12	365.74



B-301\_Void-10ft. out

30.00	18.0	47.00	112.89	159.89	79.95	385.67
31.00	18.0	51.61	117.78	169.39	84.70	404.95
32.00	18.0	56.68	122.24	178.92	89.46	423.39
33.00	18.0	62.30	125.91	188.21	94.11	440.04
34.00	18.0	68.23	127.31	195.54	97.77	450.17
35.00	18.0	74.23	126.35	200.59	100.29	453.29
36.00	18.0	80.30	124.41	204.72	102.36	453.54
37.00	18.0	86.43	122.93	209.36	104.68	455.23
38.00	18.0	92.61	121.59	214.20	107.10	457.38
39.00	18.0	98.65	117.36	216.01	108.00	450.72
40.00	18.0	104.37	109.51	213.88	106.94	432.89
41.00	18.0	109.76	99.50	209.26	104.63	408.26
42.00	18.0	114.86	90.33	205.19	102.59	385.84
43.00	18.0	119.65	82.08	201.73	100.87	365.89
44.00	18.0	123.82	76.21	200.03	100.02	352.46
45.00	18.0	127.03	73.89	200.92	100.46	348.70
46.00	18.0	161.08	24.85	185.93	92.97	235.63
47.00	18.0	163.49	33.79	197.28	98.64	264.86
48.00	18.0	165.47	39.38	204.85	102.43	283.61
49.00	18.0	167.59	49.16	216.75	108.38	315.07
50.00	18.0	169.96	61.85	231.81	115.91	355.52
51.00	18.0	178.71	94.56	273.27	136.64	462.38
52.00	18.0	183.51	94.73	278.24	139.12	467.71
53.00	18.0	189.40	95.07	284.47	142.23	474.61
54.00	18.0	195.55	95.55	291.10	145.55	482.20
55.00	18.0	201.03	96.31	297.34	148.67	489.95
56.00	18.0	205.79	97.62	303.42	151.71	498.67
57.00	18.0	210.37	99.81	310.18	155.09	509.80
58.00	18.0	214.92	102.97	317.89	158.94	523.82
59.00	18.0	219.53	106.64	326.17	163.08	539.45
60.00	18.0	223.98	110.78	334.76	167.38	556.32
61.00	18.0	228.46	115.18	343.63	171.82	573.98
62.00	18.0	233.30	119.52	352.83	176.41	591.87
63.00	18.0	238.62	123.59	362.21	181.10	609.38
64.00	18.0	244.73	125.98	370.71	185.36	622.67
65.00	18.0	251.73	125.84	377.57	188.79	629.26
66.00	18.0	259.36	123.94	383.30	191.65	631.18
67.00	18.0	267.06	122.23	389.29	194.65	633.76
68.00	18.0	274.86	120.71	395.57	197.78	636.99
69.00	18.0	281.91	117.01	398.92	199.46	632.93
70.00	18.0	287.21	111.22	398.44	199.22	620.88
71.00	18.0	291.67	105.10	396.77	198.38	606.97
72.00	18.0	296.21	99.96	396.17	198.08	596.10
73.00	18.0	300.99	95.64	396.63	198.32	587.92
74.00	18.0	306.31	91.94	398.25	199.13	582.13
75.00	18.0	312.48	89.28	401.75	200.88	580.31
76.00	18.0	330.73	57.60	388.34	194.17	503.55
77.00	18.0	338.13	61.90	400.03	200.02	523.84
78.00	18.0	345.83	65.25	411.08	205.54	541.57
79.00	18.0	352.66	67.69	420.35	210.17	555.72
80.00	18.0	358.78	72.73	431.51	215.75	576.97
81.00	18.0	364.65	81.18	445.83	222.92	608.19
82.00	18.0	371.68	89.94	461.62	230.81	641.50
83.00	18.0	379.52	97.11	476.63	238.31	670.85
84.00	18.0	387.17	102.83	490.00	245.00	695.66
85.00	18.0	394.46	105.91	500.36	250.18	712.18
86.00	18.0	406.89	105.10	511.99	255.99	722.18
87.00	18.0	413.73	104.50	518.23	259.12	727.23
88.00	18.0	420.57	103.99	524.56	262.28	732.53
89.00	18.0	427.12	102.76	529.88	264.94	735.41
90.00	18.0	433.08	100.95	534.03	267.01	735.93
91.00	18.0	438.48	99.57	538.06	269.03	737.20
92.00	18.0	443.51	100.68	544.19	272.10	745.54
93.00	18.0	448.21	104.25	552.46	276.23	760.95
94.00	18.0	451.38	107.07	558.45	279.23	772.60

Section Type: Square  
Pile Width: 24.00 (in)

Test Pile Length (ft)	Pile Width (in)	Ultimate Side Friction (tons)	Mobilized End Bearing (tons)	Estimated Davissson Capacity (tons)	Allowable Pile Capacity (tons)	Ultimate Pile Capacity (tons)
25.00	24.0	33.94	106.62	140.55	70.28	353.79
26.00	24.0	36.52	117.91	154.44	77.22	390.26
27.00	24.0	39.65	130.02	169.67	84.83	429.71
28.00	24.0	43.53	142.70	186.24	93.12	471.64
29.00	24.0	47.94	155.48	203.42	101.71	514.38
30.00	24.0	52.61	168.00	220.61	110.31	556.61
31.00	24.0	57.52	181.39	238.91	119.45	601.68
32.00	24.0	63.18	194.38	257.56	128.78	646.32
33.00	24.0	69.80	205.06	274.86	137.43	684.99
34.00	24.0	77.11	213.43	290.55	145.27	717.42
35.00	24.0	84.71	213.24	297.95	148.97	724.43

B-301_Void-10ft. out						
36.00	24.0	92.42	212.32	304.74	152.37	729.37
37.00	24.0	100.24	208.61	308.85	154.43	726.08
38.00	24.0	108.15	198.70	306.85	153.42	704.24
39.00	24.0	115.93	183.30	299.24	149.62	665.85
40.00	24.0	123.36	168.48	291.84	145.92	628.79
41.00	24.0	130.41	156.63	287.04	143.52	600.31
42.00	24.0	137.12	148.53	285.65	142.82	582.70
43.00	24.0	143.47	143.36	286.84	143.42	573.56
44.00	24.0	149.08	141.87	290.95	145.48	574.70
45.00	24.0	153.54	145.87	299.41	149.70	591.15
46.00	24.0	214.78	61.87	276.65	138.32	400.38
47.00	24.0	218.24	80.09	298.33	149.16	458.50
48.00	24.0	222.56	93.42	315.97	157.99	502.80
49.00	24.0	226.06	100.95	327.00	163.50	528.90
50.00	24.0	229.13	112.81	341.94	170.97	567.56
51.00	24.0	238.28	186.97	425.25	212.62	799.18
52.00	24.0	244.68	187.21	431.89	215.95	806.32
53.00	24.0	252.76	187.42	440.18	220.09	815.03
54.00	24.0	261.47	187.51	448.97	224.49	823.98
55.00	24.0	269.40	187.78	457.18	228.59	832.74
56.00	24.0	276.55	188.47	465.01	232.51	841.95
57.00	24.0	284.02	189.36	473.38	236.69	852.10
58.00	24.0	292.13	190.26	482.38	241.19	862.90
59.00	24.0	300.35	191.28	491.63	245.82	874.20
60.00	24.0	307.76	193.16	500.92	250.46	887.23
61.00	24.0	314.13	196.46	510.58	255.29	903.50
62.00	24.0	320.49	200.37	520.85	260.43	921.59
63.00	24.0	327.93	203.14	531.07	265.53	937.34
64.00	24.0	336.25	204.60	540.85	270.42	950.04
65.00	24.0	344.54	205.92	550.46	275.23	962.29
66.00	24.0	352.90	206.99	559.89	279.94	973.86
67.00	24.0	362.35	206.29	568.65	284.32	981.24
68.00	24.0	373.92	202.06	575.98	287.99	980.09
69.00	24.0	386.71	194.81	581.52	290.76	971.15
70.00	24.0	397.72	188.35	586.07	293.03	962.77
71.00	24.0	404.31	183.53	587.85	293.92	954.92
72.00	24.0	410.15	179.34	589.49	294.75	948.16
73.00	24.0	416.37	174.30	590.67	295.33	939.26
74.00	24.0	423.39	169.30	592.69	296.34	931.28
75.00	24.0	431.63	165.75	597.37	298.69	928.87
76.00	24.0	440.98	103.33	544.31	272.16	750.98
77.00	24.0	450.84	112.11	562.95	281.48	787.17
78.00	24.0	460.46	120.51	580.97	290.48	822.00
79.00	24.0	468.31	126.31	594.63	297.31	847.26
80.00	24.0	475.96	134.54	610.50	305.25	879.59
81.00	24.0	483.70	145.06	628.76	314.38	918.87
82.00	24.0	491.85	157.22	649.07	324.54	963.51
83.00	24.0	500.67	170.00	670.67	335.34	1010.67
84.00	24.0	510.36	178.83	689.19	344.60	1046.86
85.00	24.0	520.11	181.92	702.02	351.01	1065.86
86.00	24.0	542.53	183.25	725.78	362.89	1092.28
87.00	24.0	551.65	179.53	731.18	365.59	1090.24
88.00	24.0	560.77	174.63	735.39	367.70	1084.65
89.00	24.0	569.49	169.27	738.76	369.38	1077.29
90.00	24.0	577.44	167.63	745.07	372.54	1080.33
91.00	24.0	584.64	170.96	755.60	377.80	1097.53
92.00	24.0	591.35	177.31	768.66	384.33	1123.28
93.00	24.0	597.61	183.79	781.40	390.70	1148.99
94.00	24.0	Soil Elevations Must Extend At or Below Contribution Zone				

NOTES

1. MOBILIZED END BEARING IS 1/3 OF THE ORIGINAL RB-121 VALUES.
2. DAVISSON PILE CAPACITY IS AN ESTIMATE BASED ON FAILURE CRITERIA, AND EQUALS ULTIMATE SIDE FRICTION PLUS MOBILIZED END BEARING.
3. ALLOWABLE PILE CAPACITY IS 1/2 THE DAVISSON PILE CAPACITY.
4. ULTIMATE PILE CAPACITY IS ULTIMATE SIDE FRICTION PLUS 3 x THE MOBILIZED END BEARING.  
EXCEPTION: FOR H-PILES TIPPED IN SAND OR LIMESTONE, THE ULTIMATE PILE CAPACITY IS ULTIMATE SIDE FRICTION PLUS 2 x THE MOBILIZED END BEARING.

General Information:

=====  
 Input file: .....tary\_RS&H)\Analysis\_Structure\FB-Deep\Pile\B-401\_Void-10ft.spc  
 Project number: 2000-01-17003  
 Job name: SW 10th Street, from Powerline Rd. to Military Trail  
 Engineer: JB Henry  
 Units: English

Analysis Information:

=====  
 Analysis Type: SPT

Soil Information:

=====  
 Boring date: 2/6/2018, Boring Number: B-401  
 Station number: Offset:

Ground Elevation: 12.300(ft)

Hammer type: Automatic Hammer, Correction factor = 1.24

ID	Depth (ft)	No. of Blows (Blows/ft)	Soil Type
1	0.00	13.00	5- Cavity layer
2	2.00	13.00	5- Cavity layer
3	4.00	4.00	5- Cavity layer
4	6.00	20.00	5- Cavity layer
5	8.00	24.00	5- Cavity layer
6	10.00	15.00	4- Lime Stone/Very shelly sand
7	12.00	13.00	3- Clean sand
8	13.50	19.00	3- Clean sand
9	15.50	18.00	3- Clean sand
10	18.00	28.00	3- Clean sand
11	20.50	24.00	3- Clean sand
12	23.00	34.00	3- Clean sand
13	25.50	22.00	3- Clean sand
14	28.00	29.00	3- Clean sand
15	30.50	27.00	3- Clean sand
16	33.00	43.00	3- Clean sand
17	35.50	54.00	3- Clean sand
18	38.00	60.00	3- Clean sand
19	40.50	30.00	3- Clean sand
20	43.00	38.00	3- Clean sand
21	45.50	37.00	3- Clean sand
22	48.00	48.00	3- Clean sand
23	50.50	21.00	3- Clean sand
24	53.00	50.00	3- Clean sand
25	55.50	42.00	3- Clean sand
26	58.00	68.00	3- Clean sand
27	60.50	39.00	3- Clean sand
28	63.00	62.00	3- Clean sand
29	65.50	47.00	3- Clean sand
30	68.00	46.00	3- Clean sand
31	70.50	36.00	3- Clean sand
32	73.00	52.00	3- Clean sand
33	75.50	26.00	3- Clean sand
34	78.00	18.00	3- Clean sand
35	80.50	60.00	4- Lime Stone/Very shelly sand
36	83.00	60.00	4- Lime Stone/Very shelly sand
37	85.50	61.00	3- Clean sand
38	88.00	47.00	3- Clean sand
39	90.50	33.00	3- Clean sand
40	93.00	50.00	3- Clean sand
41	95.50	53.00	3- Clean sand
42	98.00	60.00	3- Clean sand
43	100.00	60.00	3- Clean sand

Blowcount Average Per Soil Layer

Layer Num.	Starting Elevation (ft)	Bottom Elevation (ft)	Thickness (ft)	Average Blowcount (Blows/ft)	Soil Type
1	12.30	2.30	10.00	14.80	5-Void
2	2.30	0.30	2.00	15.00	4-Limestone, Very Shelly Sand
3	0.30	-68.20	68.50	37.30	3-Clean Sand
4	-68.20	-73.20	5.00	60.00	4-Limestone, Very Shelly Sand



24.00	31.00	-18.70
24.00	32.00	-19.70
24.00	33.00	-20.70
24.00	34.00	-21.70
24.00	35.00	-22.70
24.00	36.00	-23.70
24.00	37.00	-24.70
24.00	38.00	-25.70
24.00	39.00	-26.70
24.00	40.00	-27.70
24.00	41.00	-28.70
24.00	42.00	-29.70
24.00	43.00	-30.70
24.00	44.00	-31.70
24.00	45.00	-32.70
24.00	46.00	-33.70
24.00	47.00	-34.70
24.00	48.00	-35.70
24.00	49.00	-36.70
24.00	50.00	-37.70
24.00	51.00	-38.70
24.00	52.00	-39.70
24.00	53.00	-40.70
24.00	54.00	-41.70
24.00	55.00	-42.70
24.00	56.00	-43.70
24.00	57.00	-44.70
24.00	58.00	-45.70
24.00	59.00	-46.70
24.00	60.00	-47.70
24.00	61.00	-48.70
24.00	62.00	-49.70
24.00	63.00	-50.70
24.00	64.00	-51.70
24.00	65.00	-52.70
24.00	66.00	-53.70
24.00	67.00	-54.70
24.00	68.00	-55.70
24.00	69.00	-56.70
24.00	70.00	-57.70
24.00	71.00	-58.70
24.00	72.00	-59.70
24.00	73.00	-60.70
24.00	74.00	-61.70
24.00	75.00	-62.70
24.00	76.00	-63.70
24.00	77.00	-64.70
24.00	78.00	-65.70
24.00	79.00	-66.70
24.00	80.00	-67.70
24.00	81.00	-68.70
24.00	82.00	-69.70
24.00	83.00	-70.70
24.00	84.00	-71.70
24.00	85.00	-72.70
24.00	86.00	-73.70
24.00	87.00	-74.70
24.00	88.00	-75.70
24.00	89.00	-76.70
24.00	90.00	-77.70
24.00	91.00	-78.70
24.00	92.00	-79.70
24.00	93.00	-80.70
24.00	94.00	-81.70

Driven Pile Capacity:

=====

Section Type: Square  
 Pile Width: 18.00 (in)

Test Pile Length (ft)	Pile Width (in)	Ultimate Side Friction (tons)	Mobilized End Bearing (tons)	Estimated Davi sson Capaci ty (tons)	Al lowable Pile Capaci ty (tons)	Ul ti mate Pile Capaci ty (tons)
25.00	18.0	32.19	64.20	96.40	48.20	224.81
26.00	18.0	34.66	68.37	103.03	51.52	239.78
27.00	18.0	37.19	74.00	111.19	55.59	259.18
28.00	18.0	39.95	81.20	121.15	60.58	283.56
29.00	18.0	42.94	89.31	132.25	66.13	310.87
30.00	18.0	46.03	98.25	144.28	72.14	340.78

B-401\_Void-10ft. out

31.00	18.0	49.84	104.13	153.96	76.98	362.21
32.00	18.0	54.20	109.34	163.54	81.77	382.22
33.00	18.0	59.24	113.58	172.82	86.41	399.98
34.00	18.0	64.77	115.23	180.01	90.00	410.47
35.00	18.0	70.59	113.96	184.55	92.28	412.47
36.00	18.0	76.67	111.19	187.86	93.93	410.25
37.00	18.0	82.83	109.79	192.63	96.31	412.21
38.00	18.0	89.05	109.74	198.80	99.40	418.28
39.00	18.0	94.91	110.23	205.14	102.57	425.59
40.00	18.0	99.99	111.42	211.41	105.70	434.25
41.00	18.0	104.40	113.72	218.12	109.06	445.57
42.00	18.0	109.03	117.03	226.06	113.03	460.11
43.00	18.0	114.02	120.92	234.95	117.47	476.79
44.00	18.0	119.19	122.06	241.26	120.63	485.38
45.00	18.0	124.32	119.41	243.74	121.87	482.56
46.00	18.0	129.49	114.87	244.36	122.18	474.11
47.00	18.0	135.10	112.37	247.48	123.74	472.23
48.00	18.0	141.25	111.92	253.17	126.59	477.02
49.00	18.0	147.04	112.30	259.34	129.67	483.95
50.00	18.0	151.55	113.68	265.23	132.62	492.59
51.00	18.0	155.10	116.49	271.58	135.79	504.56
52.00	18.0	159.62	119.57	279.19	139.60	518.33
53.00	18.0	165.47	122.32	287.79	143.90	532.44
54.00	18.0	171.84	123.61	295.45	147.72	542.67
55.00	18.0	177.91	123.85	301.75	150.88	549.44
56.00	18.0	183.75	123.75	307.50	153.75	554.99
57.00	18.0	189.84	124.39	314.23	157.12	563.01
58.00	18.0	196.25	125.63	321.88	160.94	573.13
59.00	18.0	202.60	126.67	329.28	164.64	582.62
60.00	18.0	208.49	127.62	336.11	168.06	591.35
61.00	18.0	214.04	129.26	343.31	171.65	601.83
62.00	18.0	219.95	131.68	351.63	175.82	615.00
63.00	18.0	226.33	134.36	360.69	180.34	629.41
64.00	18.0	232.91	134.92	367.83	183.91	637.66
65.00	18.0	239.44	133.07	372.50	186.25	638.64
66.00	18.0	245.90	130.36	376.26	188.13	636.99
67.00	18.0	252.32	129.37	381.69	190.84	640.42
68.00	18.0	258.69	129.95	388.65	194.32	648.55
69.00	18.0	264.79	129.23	394.02	197.01	652.47
70.00	18.0	270.39	126.28	396.67	198.34	649.23
71.00	18.0	275.63	121.79	397.41	198.71	640.99
72.00	18.0	281.35	116.19	397.54	198.77	629.92
73.00	18.0	287.70	109.42	397.12	198.56	615.96
74.00	18.0	293.81	105.64	399.45	199.73	610.74
75.00	18.0	298.77	107.40	406.17	203.09	620.97
76.00	18.0	302.68	113.55	416.23	208.12	643.33
77.00	18.0	306.08	120.53	426.62	213.31	667.69
78.00	18.0	309.07	128.06	437.13	218.57	693.26
79.00	18.0	312.19	133.81	446.00	223.00	713.61
80.00	18.0	316.01	135.91	451.92	225.96	723.74
81.00	18.0	350.69	159.64	510.33	255.17	829.61
82.00	18.0	355.16	154.18	509.34	254.67	817.70
83.00	18.0	359.62	147.20	506.82	253.41	801.21
84.00	18.0	364.56	138.42	502.98	251.49	779.81
85.00	18.0	370.45	129.55	500.00	250.00	759.10
86.00	18.0	377.02	129.21	506.24	253.12	764.67
87.00	18.0	383.70	129.32	513.01	256.51	771.65
88.00	18.0	390.31	129.41	519.72	259.86	778.53
89.00	18.0	396.50	129.49	525.99	263.00	784.98
90.00	18.0	401.87	129.64	531.51	265.75	790.79
91.00	18.0	406.45	130.11	536.56	268.28	796.78
92.00	18.0	411.49	130.93	542.42	271.21	804.27
93.00	18.0	417.37	131.82	549.19	274.59	812.83
94.00	18.0	423.75	132.65	556.39	278.20	821.69

Section Type: Square  
 Pile Width: 24.00 (in)

Test Pile Length (ft)	Pile Width (in)	Ultimate Side Friction (tons)	Mobilized End Bearing (tons)	Estimated Davi sson Capacity (tons)	Allowable Pile Capacity (tons)	Ultimate Pile Capacity (tons)
25.00	24.0	42.38	99.62	142.00	71.00	341.24
26.00	24.0	44.40	107.50	151.90	75.95	366.90
27.00	24.0	46.70	116.54	163.23	81.62	396.31
28.00	24.0	49.47	126.43	175.90	87.95	428.77
29.00	24.0	52.52	137.21	189.73	94.86	464.15
30.00	24.0	55.70	148.56	204.26	102.13	501.39
31.00	24.0	59.08	160.67	219.75	109.87	541.09
32.00	24.0	63.52	171.41	234.93	117.46	577.74
33.00	24.0	69.33	178.59	247.92	123.96	605.09
34.00	24.0	76.23	182.41	258.64	129.32	623.45
35.00	24.0	83.64	186.12	269.77	134.88	642.01
36.00	24.0	91.43	190.77	282.19	141.10	663.73

B-401\_Void-10ft. out

37.00	24.0	99.35	190.68	290.03	145.01	671.39	
38.00	24.0	107.36	189.90	297.26	148.63	677.06	
39.00	24.0	114.97	189.31	304.28	152.14	682.91	
40.00	24.0	121.65	191.79	313.44	156.72	697.03	
41.00	24.0	127.53	198.01	325.54	162.77	721.57	
42.00	24.0	133.67	203.26	336.93	168.46	743.45	
43.00	24.0	140.26	203.44	343.70	171.85	750.58	
44.00	24.0	147.07	199.81	346.88	173.44	746.49	
45.00	24.0	153.84	199.20	353.05	176.52	751.45	
46.00	24.0	160.66	202.83	363.49	181.75	769.15	
47.00	24.0	168.05	207.22	375.26	187.63	789.70	
48.00	24.0	176.10	208.80	384.90	192.45	802.49	
49.00	24.0	183.71	209.28	392.98	196.49	811.54	
50.00	24.0	189.74	212.07	401.80	200.90	825.94	
51.00	24.0	194.55	217.18	411.74	205.87	846.10	
52.00	24.0	200.59	220.01	420.60	210.30	860.63	
53.00	24.0	208.29	219.05	427.34	213.67	865.43	
54.00	24.0	216.65	216.13	432.78	216.39	865.03	
55.00	24.0	224.64	215.42	440.06	220.03	870.90	
56.00	24.0	232.35	217.76	450.11	225.06	885.63	
57.00	24.0	240.38	221.29	461.67	230.83	904.25	
58.00	24.0	248.82	223.76	472.57	236.29	920.09	
59.00	24.0	257.18	225.62	482.80	241.40	934.04	
60.00	24.0	264.97	227.89	492.87	246.43	948.65	
61.00	24.0	272.33	230.68	503.01	251.50	964.37	
62.00	24.0	280.14	232.00	512.14	256.07	976.15	
63.00	24.0	288.56	230.39	518.94	259.47	979.72	
64.00	24.0	297.24	226.62	523.86	261.93	977.09	
65.00	24.0	305.85	224.94	530.79	265.40	980.67	
66.00	24.0	314.39	227.04	541.43	270.71	995.50	
67.00	24.0	322.87	229.80	552.68	276.34	1012.28	
68.00	24.0	331.30	227.91	559.21	279.61	1015.03	
69.00	24.0	339.38	221.56	560.94	280.47	1004.06	
70.00	24.0	346.82	213.88	560.71	280.35	988.47	
71.00	24.0	353.80	206.03	559.83	279.91	971.90	
72.00	24.0	361.40	200.12	561.52	280.76	961.77	
73.00	24.0	369.81	198.93	568.75	284.37	966.62	
74.00	24.0	377.91	203.08	580.98	290.49	987.13	
75.00	24.0	384.54	209.98	594.52	297.26	1014.48	
76.00	24.0	389.81	219.26	609.06	304.53	1047.57	
77.00	24.0	394.42	229.08	623.50	311.75	1081.67	
78.00	24.0	398.50	237.63	636.12	318.06	1111.38	
79.00	24.0	402.75	242.85	645.59	322.80	1131.28	
80.00	24.0	407.89	244.00	651.89	325.95	1139.90	
81.00	24.0	467.59	273.35	740.94	370.47	1287.64	
82.00	24.0	473.54	260.33	733.88	366.94	1254.54	
83.00	24.0	479.50	244.59	724.08	362.04	1213.25	
84.00	24.0	486.08	233.25	719.33	359.66	1185.82	
85.00	24.0	493.93	228.59	722.53	361.26	1179.72	
86.00	24.0	502.60	225.20	727.80	363.90	1178.19	
87.00	24.0	511.11	225.79	736.89	368.45	1188.47	
88.00	24.0	519.55	226.35	745.91	372.95	1198.61	
89.00	24.0	527.58	226.79	754.36	377.18	1207.94	
90.00	24.0	534.67	227.13	761.80	380.90	1216.06	
91.00	24.0	540.88	227.69	768.56	384.28	1223.93	
92.00	24.0	547.64	228.71	776.35	388.18	1233.78	
93.00	24.0	555.38	229.99	785.37	392.68	1245.34	
94.00	24.0	Soil Elevations Must Extend At or Below Contribution Zone					

NOTES

1. MOBILIZED END BEARING IS 1/3 OF THE ORIGINAL RB-121 VALUES.
2. DAVISSON PILE CAPACITY IS AN ESTIMATE BASED ON FAILURE CRITERIA, AND EQUALS ULTIMATE SIDE FRICTION PLUS MOBILIZED END BEARING.
3. ALLOWABLE PILE CAPACITY IS 1/2 THE DAVISSON PILE CAPACITY.
4. ULTIMATE PILE CAPACITY IS ULTIMATE SIDE FRICTION PLUS 3 x THE MOBILIZED END BEARING.  
EXCEPTION: FOR H-PILES TIPPED IN SAND OR LIMESTONE, THE ULTIMATE PILE CAPACITY IS ULTIMATE SIDE FRICTION PLUS 2 x THE MOBILIZED END BEARING.

General Information:

=====  
 Input file: .....tary\_RS&H)\Analysis\_Structure\FB-Deep\Pile\B-501\_Void-10ft.spc  
 Project number: 2000-01-17003  
 Job name: SW 10th Street, from Powerline Rd. to Military Trail  
 Engineer: JB Henry  
 Units: English

Analysis Information:

=====  
 Analysis Type: SPT

Soil Information:

=====  
 Boring date: 2/7/2018, Boring Number: B-501  
 Station number: Offset:  
 Ground Elevation: 12.900(ft)  
 Hammer type: Automatic Hammer, Correction factor = 1.24

ID	Depth (ft)	No. of Blows (Blows/ft)	Soil Type
1	0.00	9.00	5- Cavity layer
2	2.00	7.00	5- Cavity layer
3	4.00	20.00	5- Cavity layer
4	6.00	12.00	5- Cavity layer
5	8.00	22.00	5- Cavity layer
6	10.00	30.00	2- Clay and silty sand
7	12.00	14.00	3- Clean sand
8	13.50	16.00	3- Clean sand
9	15.50	14.00	3- Clean sand
10	18.00	32.00	3- Clean sand
11	20.50	20.00	3- Clean sand
12	23.00	30.00	3- Clean sand
13	25.50	21.00	3- Clean sand
14	28.00	36.00	3- Clean sand
15	30.50	29.00	3- Clean sand
16	33.00	58.00	3- Clean sand
17	35.50	33.00	3- Clean sand
18	38.00	52.00	3- Clean sand
19	40.50	39.00	3- Clean sand
20	43.00	66.00	3- Clean sand
21	45.50	39.00	3- Clean sand
22	48.00	58.00	3- Clean sand
23	50.50	60.00	3- Clean sand
24	53.00	60.00	3- Clean sand
25	55.50	50.00	3- Clean sand
26	58.00	69.00	3- Clean sand
27	60.50	67.00	3- Clean sand
28	63.00	53.00	3- Clean sand
29	65.50	63.00	3- Clean sand
30	68.00	60.00	3- Clean sand
31	70.50	71.00	3- Clean sand
32	73.00	60.00	3- Clean sand
33	75.50	60.00	3- Clean sand
34	78.00	73.00	3- Clean sand
35	80.50	38.00	3- Clean sand
36	83.00	42.00	3- Clean sand
37	85.50	33.00	3- Clean sand
38	88.00	48.00	3- Clean sand
39	90.50	82.00	3- Clean sand
40	93.00	62.00	3- Clean sand
41	95.50	60.00	3- Clean sand
42	98.00	50.00	3- Clean sand
43	100.00	50.00	3- Clean sand

Blowcount Average Per Soil Layer

Layer Num.	Starting Elevation (ft)	Bottom Elevation (ft)	Thickness (ft)	Average Blowcount (Blows/ft)	Soil Type
1	12.90	2.90	10.00	14.00	5-Void
2	2.90	0.90	2.00	30.00	2-Clay and Silty Sand
3	0.90	-87.10	88.00	48.27	3-Clean Sand



Driven Pile Data:

=====

Pile unit weight = 150.00(pcf), Section Type: Square

Pile Geometry:

-----

Width (in)	Length (ft)	Tip Elev. (ft)
18.00	25.00	-12.10
18.00	26.00	-13.10
18.00	27.00	-14.10
18.00	28.00	-15.10
18.00	29.00	-16.10
18.00	30.00	-17.10
18.00	31.00	-18.10
18.00	32.00	-19.10
18.00	33.00	-20.10
18.00	34.00	-21.10
18.00	35.00	-22.10
18.00	36.00	-23.10
18.00	37.00	-24.10
18.00	38.00	-25.10
18.00	39.00	-26.10
18.00	40.00	-27.10
18.00	41.00	-28.10
18.00	42.00	-29.10
18.00	43.00	-30.10
18.00	44.00	-31.10
18.00	45.00	-32.10
18.00	46.00	-33.10
18.00	47.00	-34.10
18.00	48.00	-35.10
18.00	49.00	-36.10
18.00	50.00	-37.10
18.00	51.00	-38.10
18.00	52.00	-39.10
18.00	53.00	-40.10
18.00	54.00	-41.10
18.00	55.00	-42.10
18.00	56.00	-43.10
18.00	57.00	-44.10
18.00	58.00	-45.10
18.00	59.00	-46.10
18.00	60.00	-47.10
18.00	61.00	-48.10
18.00	62.00	-49.10
18.00	63.00	-50.10
18.00	64.00	-51.10
18.00	65.00	-52.10
18.00	66.00	-53.10
18.00	67.00	-54.10
18.00	68.00	-55.10
18.00	69.00	-56.10
18.00	70.00	-57.10
18.00	71.00	-58.10
18.00	72.00	-59.10
18.00	73.00	-60.10
18.00	74.00	-61.10
18.00	75.00	-62.10
18.00	76.00	-63.10
18.00	77.00	-64.10
18.00	78.00	-65.10
18.00	79.00	-66.10
18.00	80.00	-67.10
18.00	81.00	-68.10
18.00	82.00	-69.10
18.00	83.00	-70.10
18.00	84.00	-71.10
18.00	85.00	-72.10
18.00	86.00	-73.10
18.00	87.00	-74.10
18.00	88.00	-75.10
18.00	89.00	-76.10
18.00	90.00	-77.10
18.00	91.00	-78.10
18.00	92.00	-79.10
18.00	93.00	-80.10
18.00	94.00	-81.10
24.00	25.00	-12.10
24.00	26.00	-13.10
24.00	27.00	-14.10
24.00	28.00	-15.10
24.00	29.00	-16.10
24.00	30.00	-17.10
24.00	31.00	-18.10
24.00	32.00	-19.10

24.00	33.00	-20.10
24.00	34.00	-21.10
24.00	35.00	-22.10
24.00	36.00	-23.10
24.00	37.00	-24.10
24.00	38.00	-25.10
24.00	39.00	-26.10
24.00	40.00	-27.10
24.00	41.00	-28.10
24.00	42.00	-29.10
24.00	43.00	-30.10
24.00	44.00	-31.10
24.00	45.00	-32.10
24.00	46.00	-33.10
24.00	47.00	-34.10
24.00	48.00	-35.10
24.00	49.00	-36.10
24.00	50.00	-37.10
24.00	51.00	-38.10
24.00	52.00	-39.10
24.00	53.00	-40.10
24.00	54.00	-41.10
24.00	55.00	-42.10
24.00	56.00	-43.10
24.00	57.00	-44.10
24.00	58.00	-45.10
24.00	59.00	-46.10
24.00	60.00	-47.10
24.00	61.00	-48.10
24.00	62.00	-49.10
24.00	63.00	-50.10
24.00	64.00	-51.10
24.00	65.00	-52.10
24.00	66.00	-53.10
24.00	67.00	-54.10
24.00	68.00	-55.10
24.00	69.00	-56.10
24.00	70.00	-57.10
24.00	71.00	-58.10
24.00	72.00	-59.10
24.00	73.00	-60.10
24.00	74.00	-61.10
24.00	75.00	-62.10
24.00	76.00	-63.10
24.00	77.00	-64.10
24.00	78.00	-65.10
24.00	79.00	-66.10
24.00	80.00	-67.10
24.00	81.00	-68.10
24.00	82.00	-69.10
24.00	83.00	-70.10
24.00	84.00	-71.10
24.00	85.00	-72.10
24.00	86.00	-73.10
24.00	87.00	-74.10
24.00	88.00	-75.10
24.00	89.00	-76.10
24.00	90.00	-77.10
24.00	91.00	-78.10
24.00	92.00	-79.10
24.00	93.00	-80.10
24.00	94.00	-81.10

Driven Pile Capacity:

=====

Section Type: Square  
 Pile Width: 18.00 (in)

Test Pile Length (ft)	Pile Width (in)	Ultimate Side Friction (tons)	Mobilized End Bearing (tons)	Estimated Davissson Capacity (tons)	Allowable Pile Capacity (tons)	Ultimate Pile Capacity (tons)
25.00	18.0	41.14	65.09	106.23	53.11	236.40
26.00	18.0	43.37	70.38	113.75	56.88	254.51
27.00	18.0	45.99	77.24	123.22	61.61	277.69
28.00	18.0	49.18	85.62	134.80	67.40	306.03
29.00	18.0	52.88	93.09	145.97	72.99	332.16
30.00	18.0	56.72	98.85	155.57	77.79	353.28
31.00	18.0	60.73	100.25	160.98	80.49	361.47
32.00	18.0	65.40	102.84	168.24	84.12	373.93

B-501\_Void-10ft. out

33.00	18.0	70.88	106.32	177.21	88.60	389.85
34.00	18.0	76.52	109.04	185.56	92.78	403.64
35.00	18.0	81.60	111.18	192.77	96.39	415.12
36.00	18.0	86.23	113.56	199.78	99.89	426.90
37.00	18.0	91.36	116.65	208.01	104.01	441.31
38.00	18.0	97.19	120.06	217.25	108.62	457.36
39.00	18.0	103.20	122.21	225.41	112.70	469.82
40.00	18.0	108.83	123.15	231.98	115.99	478.28
41.00	18.0	114.18	123.88	238.06	119.03	485.82
42.00	18.0	119.86	125.50	245.36	122.68	496.37
43.00	18.0	125.99	127.75	253.73	126.87	509.22
44.00	18.0	132.15	129.49	261.63	130.82	520.61
45.00	18.0	137.90	130.87	268.76	134.38	530.50
46.00	18.0	143.34	132.59	275.94	137.97	541.13
47.00	18.0	149.13	134.64	283.76	141.88	553.04
48.00	18.0	155.36	136.65	292.02	146.01	565.32
49.00	18.0	161.84	137.80	299.64	149.82	575.23
50.00	18.0	168.33	138.18	306.51	153.26	582.87
51.00	18.0	174.85	138.41	313.26	156.63	590.08
52.00	18.0	181.37	139.11	320.49	160.24	598.71
53.00	18.0	187.92	140.16	328.08	164.04	608.39
54.00	18.0	194.48	140.86	335.33	167.67	617.05
55.00	18.0	201.05	141.09	342.14	171.07	624.32
56.00	18.0	207.63	141.32	348.95	174.48	631.60
57.00	18.0	214.23	142.02	356.25	178.12	640.29
58.00	18.0	220.83	143.07	363.90	181.95	650.04
59.00	18.0	227.45	143.77	371.21	185.61	658.75
60.00	18.0	234.07	144.00	378.07	189.04	666.07
61.00	18.0	240.71	144.00	384.71	192.35	672.71
62.00	18.0	247.35	144.00	391.35	195.67	679.35
63.00	18.0	254.00	144.00	398.00	199.00	686.00
64.00	18.0	260.65	144.00	404.65	202.33	692.65
65.00	18.0	267.32	144.00	411.32	205.66	699.32
66.00	18.0	273.99	144.00	417.99	208.99	705.99
67.00	18.0	280.66	144.00	424.66	212.33	712.66
68.00	18.0	287.35	144.00	431.35	215.67	719.35
69.00	18.0	294.03	144.00	438.03	219.02	726.03
70.00	18.0	300.73	144.00	444.73	222.36	732.73
71.00	18.0	307.43	144.00	451.43	225.71	739.43
72.00	18.0	314.13	144.00	458.13	229.06	746.13
73.00	18.0	320.84	143.96	464.80	232.40	752.73
74.00	18.0	327.55	143.08	470.63	235.31	756.79
75.00	18.0	334.26	141.02	475.28	237.64	757.32
76.00	18.0	340.98	138.24	479.22	239.61	755.70
77.00	18.0	347.71	135.86	483.57	241.78	755.29
78.00	18.0	354.43	133.89	488.33	244.16	756.11
79.00	18.0	360.90	131.65	492.55	246.27	755.84
80.00	18.0	366.83	129.05	495.88	247.94	753.97
81.00	18.0	372.32	126.74	499.06	249.53	752.53
82.00	18.0	377.93	125.90	503.83	251.91	755.63
83.00	18.0	383.74	126.46	510.20	255.10	763.12
84.00	18.0	389.42	127.69	517.11	258.55	772.49
85.00	18.0	394.64	129.54	524.17	262.09	783.24
86.00	18.0	399.54	131.80	531.34	265.67	794.93
87.00	18.0	405.07	133.29	538.36	269.18	804.94
88.00	18.0	411.37	133.83	545.20	272.60	812.87
89.00	18.0	418.07	133.88	551.96	275.98	819.72
90.00	18.0	424.80	133.91	558.71	279.35	826.52
91.00	18.0	431.55	134.17	565.72	282.86	834.05
92.00	18.0	438.30	134.94	573.24	286.62	843.12
93.00	18.0	445.05	136.14	581.19	290.60	853.47
94.00	18.0	451.81	137.23	589.04	294.52	863.50

Section Type: Square  
 Pile Width: 24.00 (in)

Test Pile Length (ft)	Pile Width (in)	Ultimate Side Friction (tons)	Mobilized End Bearing (tons)	Estimated Davissson Capacity (tons)	Allowable Pile Capacity (tons)	Ultimate Pile Capacity (tons)
25.00	24.0	54.67	102.38	157.04	78.52	361.79
26.00	24.0	56.52	111.42	167.95	83.97	390.79
27.00	24.0	59.23	120.51	179.74	89.87	420.76
28.00	24.0	63.13	128.00	191.13	95.56	447.12
29.00	24.0	67.59	134.41	202.00	101.00	470.82
30.00	24.0	71.62	142.72	214.34	107.17	499.79
31.00	24.0	75.34	153.67	229.01	114.50	536.35
32.00	24.0	80.07	164.54	244.61	122.30	573.69
33.00	24.0	86.31	172.44	258.75	129.37	603.62
34.00	24.0	93.12	178.37	271.50	135.75	628.25
35.00	24.0	99.18	186.46	285.64	142.82	658.57
36.00	24.0	104.54	197.99	302.53	151.26	698.50
37.00	24.0	111.22	203.75	314.98	157.49	722.48
38.00	24.0	118.75	206.31	325.06	162.53	737.68

B-501_Void-10ft. out							
39.00	24.0	126.52	206.89	333.40	166.70	747.18	
40.00	24.0	133.85	209.29	343.14	171.57	761.73	
41.00	24.0	140.85	214.31	355.16	177.58	783.79	
42.00	24.0	148.28	219.84	368.12	184.06	807.79	
43.00	24.0	156.26	223.77	380.04	190.02	827.58	
44.00	24.0	164.29	226.72	391.01	195.51	844.45	
45.00	24.0	171.84	230.19	402.03	201.02	862.42	
46.00	24.0	179.02	234.73	413.75	206.87	883.21	
47.00	24.0	186.62	238.92	425.53	212.77	903.37	
48.00	24.0	194.79	241.24	436.03	218.01	918.50	
49.00	24.0	203.27	241.88	445.15	222.57	928.91	
50.00	24.0	211.78	242.39	454.17	227.08	938.95	
51.00	24.0	220.32	243.92	464.24	232.12	952.07	
52.00	24.0	228.90	246.20	475.10	237.55	967.51	
53.00	24.0	237.50	247.73	485.23	242.61	980.69	
54.00	24.0	246.12	248.24	494.36	247.18	990.84	
55.00	24.0	254.77	248.55	503.32	251.66	1000.42	
56.00	24.0	263.44	249.48	512.92	256.46	1011.88	
57.00	24.0	272.13	250.88	523.01	261.50	1024.76	
58.00	24.0	280.84	251.81	532.65	266.32	1036.26	
59.00	24.0	289.56	252.12	541.68	270.84	1045.92	
60.00	24.0	298.30	252.43	550.73	275.37	1055.59	
61.00	24.0	307.06	253.36	560.42	280.21	1067.14	
62.00	24.0	315.83	254.76	570.59	285.30	1080.11	
63.00	24.0	324.62	255.69	580.31	290.15	1091.69	
64.00	24.0	333.42	256.00	589.42	294.71	1101.42	
65.00	24.0	342.23	256.00	598.23	299.11	1110.23	
66.00	24.0	351.05	256.00	607.05	303.52	1119.05	
67.00	24.0	359.88	256.00	615.88	307.94	1127.88	
68.00	24.0	368.72	256.00	624.72	312.36	1136.72	
69.00	24.0	377.58	256.00	633.58	316.79	1145.58	
70.00	24.0	386.44	256.00	642.44	321.22	1154.44	
71.00	24.0	395.31	256.00	651.31	325.65	1163.31	
72.00	24.0	404.19	255.21	659.40	329.70	1169.83	
73.00	24.0	413.07	252.86	665.93	332.97	1171.65	
74.00	24.0	421.97	249.21	671.18	335.59	1169.59	
75.00	24.0	430.87	245.89	676.76	338.38	1168.53	
76.00	24.0	439.78	243.17	682.95	341.47	1169.29	
77.00	24.0	448.69	240.08	688.77	344.38	1168.92	
78.00	24.0	457.61	235.62	693.24	346.62	1164.48	
79.00	24.0	466.20	230.70	696.90	348.45	1158.30	
80.00	24.0	474.10	228.48	702.58	351.29	1159.53	
81.00	24.0	481.43	229.25	710.68	355.34	1169.19	
82.00	24.0	488.90	231.00	719.91	359.95	1181.92	
83.00	24.0	496.65	232.47	729.12	364.56	1194.07	
84.00	24.0	504.22	234.21	738.43	369.21	1206.84	
85.00	24.0	511.20	236.71	747.91	373.95	1221.33	
86.00	24.0	517.76	239.73	757.49	378.75	1236.95	
87.00	24.0	525.14	241.72	766.86	383.43	1250.31	
88.00	24.0	533.52	242.44	775.96	387.98	1260.85	
89.00	24.0	542.42	242.51	784.93	392.46	1269.95	
90.00	24.0	551.35	242.54	793.89	396.95	1278.98	
91.00	24.0	560.31	242.55	802.85	401.43	1287.95	
92.00	24.0	569.27	242.55	811.82	405.91	1296.91	
93.00	24.0	578.24	242.55	820.79	410.39	1305.88	
94.00	24.0	Soil Elevations Must Extend At or Below Contribution Zone					

NOTES

1. MOBILIZED END BEARING IS 1/3 OF THE ORIGINAL RB-121 VALUES.
2. DAVISSON PILE CAPACITY IS AN ESTIMATE BASED ON FAILURE CRITERIA, AND EQUALS ULTIMATE SIDE FRICTION PLUS MOBILIZED END BEARING.
3. ALLOWABLE PILE CAPACITY IS 1/2 THE DAVISSON PILE CAPACITY.
4. ULTIMATE PILE CAPACITY IS ULTIMATE SIDE FRICTION PLUS 3 x THE MOBILIZED END BEARING.  
EXCEPTION: FOR H-PILES TIPPED IN SAND OR LIMESTONE, THE ULTIMATE PILE CAPACITY IS ULTIMATE SIDE FRICTION PLUS 2 x THE MOBILIZED END BEARING.

General Information:

=====  
 Input file: .....tary\_RS&H)\Analysis\_Structure\FB-Deep\Pile\B-601\_Void-10ft.spc  
 Project number: 2000-01-17003  
 Job name: SW 10th Street, from Powerline Rd. to Military Trail  
 Engineer: JB Henry  
 Units: English

Analysis Information:

=====  
 Analysis Type: SPT

Soil Information:

=====  
 Boring date: 1/31/2018, Boring Number: B-601  
 Station number: Offset:

Ground Elevation: 13.000(ft)

Hammer type: Automatic Hammer, Correction factor = 1.24

ID	Depth (ft)	No. of Blows (Blows/ft)	Soil Type
1	0.00	13.00	5- Cavity layer
2	2.00	30.00	5- Cavity layer
3	4.00	30.00	5- Cavity layer
4	6.00	10.00	5- Cavity layer
5	8.00	3.00	5- Cavity layer
6	10.00	3.00	3- Clean sand
7	12.00	4.00	3- Clean sand
8	13.50	3.00	3- Clean sand
9	15.50	6.00	3- Clean sand
10	18.00	12.00	3- Clean sand
11	20.50	15.00	3- Clean sand
12	23.00	22.00	3- Clean sand
13	25.50	20.00	3- Clean sand
14	28.00	52.00	3- Clean sand
15	30.50	61.00	3- Clean sand
16	33.00	90.00	3- Clean sand
17	35.50	40.00	3- Clean sand
18	38.00	78.00	3- Clean sand
19	40.50	47.00	3- Clean sand
20	43.00	89.00	3- Clean sand
21	45.50	60.00	3- Clean sand
22	48.00	60.00	3- Clean sand
23	50.50	18.00	3- Clean sand
24	53.00	26.00	3- Clean sand
25	55.50	2.00	3- Clean sand
26	58.00	2.00	2- Clay and silty sand
27	60.50	9.00	2- Clay and silty sand
28	63.00	23.00	2- Clay and silty sand
29	65.50	60.00	4- Lime Stone/Very shelly sand
30	68.00	60.00	4- Lime Stone/Very shelly sand
31	70.50	60.00	4- Lime Stone/Very shelly sand
32	73.00	60.00	4- Lime Stone/Very shelly sand
33	75.50	60.00	3- Clean sand
34	78.00	52.00	3- Clean sand
35	80.50	58.00	3- Clean sand
36	83.00	60.00	3- Clean sand
37	85.50	60.00	3- Clean sand
38	88.00	60.00	3- Clean sand
39	90.50	36.00	3- Clean sand
40	93.00	20.00	3- Clean sand
41	95.50	12.00	3- Clean sand
42	98.00	42.00	3- Clean sand
43	100.00	42.00	3- Clean sand

Blowcount Average Per Soil Layer

Layer Num.	Starting Elevation (ft)	Bottom Elevation (ft)	Thickness (ft)	Average Blowcount (Blows/ft)	Soil Type
1	13.00	3.00	10.00	17.20	5-Void
2	3.00	-45.00	48.00	36.73	3-Clean Sand
3	-45.00	-52.50	7.50	11.33	2-Clay and Silty Sand
4	-52.50	-62.50	10.00	60.00	4-Limestone, Very Shelly Sand

Driven Pile Data:

=====  
Pile unit weight = 150.00(pcf), Section Type: Square

Pile Geometry:

-----

Width (In)	Length (ft)	Tip Elev. (ft)
18.00	25.00	-12.00
18.00	26.00	-13.00
18.00	27.00	-14.00
18.00	28.00	-15.00
18.00	29.00	-16.00
18.00	30.00	-17.00
18.00	31.00	-18.00
18.00	32.00	-19.00
18.00	33.00	-20.00
18.00	34.00	-21.00
18.00	35.00	-22.00
18.00	36.00	-23.00
18.00	37.00	-24.00
18.00	38.00	-25.00
18.00	39.00	-26.00
18.00	40.00	-27.00
18.00	41.00	-28.00
18.00	42.00	-29.00
18.00	43.00	-30.00
18.00	44.00	-31.00
18.00	45.00	-32.00
18.00	46.00	-33.00
18.00	47.00	-34.00
18.00	48.00	-35.00
18.00	49.00	-36.00
18.00	50.00	-37.00
18.00	51.00	-38.00
18.00	52.00	-39.00
18.00	53.00	-40.00
18.00	54.00	-41.00
18.00	55.00	-42.00
18.00	56.00	-43.00
18.00	57.00	-44.00
18.00	58.00	-45.00
18.00	59.00	-46.00
18.00	60.00	-47.00
18.00	61.00	-48.00
18.00	62.00	-49.00
18.00	63.00	-50.00
18.00	64.00	-51.00
18.00	65.00	-52.00
18.00	66.00	-53.00
18.00	67.00	-54.00
18.00	68.00	-55.00
18.00	69.00	-56.00
18.00	70.00	-57.00
18.00	71.00	-58.00
18.00	72.00	-59.00
18.00	73.00	-60.00
18.00	74.00	-61.00
18.00	75.00	-62.00
18.00	76.00	-63.00
18.00	77.00	-64.00
18.00	78.00	-65.00
18.00	79.00	-66.00
18.00	80.00	-67.00
18.00	81.00	-68.00
18.00	82.00	-69.00
18.00	83.00	-70.00
18.00	84.00	-71.00
18.00	85.00	-72.00
18.00	86.00	-73.00
18.00	87.00	-74.00
18.00	88.00	-75.00
18.00	89.00	-76.00
18.00	90.00	-77.00
18.00	91.00	-78.00
18.00	92.00	-79.00
18.00	93.00	-80.00
18.00	94.00	-81.00
24.00	25.00	-12.00
24.00	26.00	-13.00
24.00	27.00	-14.00
24.00	28.00	-15.00
24.00	29.00	-16.00
24.00	30.00	-17.00

24.00	31.00	-18.00
24.00	32.00	-19.00
24.00	33.00	-20.00
24.00	34.00	-21.00
24.00	35.00	-22.00
24.00	36.00	-23.00
24.00	37.00	-24.00
24.00	38.00	-25.00
24.00	39.00	-26.00
24.00	40.00	-27.00
24.00	41.00	-28.00
24.00	42.00	-29.00
24.00	43.00	-30.00
24.00	44.00	-31.00
24.00	45.00	-32.00
24.00	46.00	-33.00
24.00	47.00	-34.00
24.00	48.00	-35.00
24.00	49.00	-36.00
24.00	50.00	-37.00
24.00	51.00	-38.00
24.00	52.00	-39.00
24.00	53.00	-40.00
24.00	54.00	-41.00
24.00	55.00	-42.00
24.00	56.00	-43.00
24.00	57.00	-44.00
24.00	58.00	-45.00
24.00	59.00	-46.00
24.00	60.00	-47.00
24.00	61.00	-48.00
24.00	62.00	-49.00
24.00	63.00	-50.00
24.00	64.00	-51.00
24.00	65.00	-52.00
24.00	66.00	-53.00
24.00	67.00	-54.00
24.00	68.00	-55.00
24.00	69.00	-56.00
24.00	70.00	-57.00
24.00	71.00	-58.00
24.00	72.00	-59.00
24.00	73.00	-60.00
24.00	74.00	-61.00
24.00	75.00	-62.00
24.00	76.00	-63.00
24.00	77.00	-64.00
24.00	78.00	-65.00
24.00	79.00	-66.00
24.00	80.00	-67.00
24.00	81.00	-68.00
24.00	82.00	-69.00
24.00	83.00	-70.00
24.00	84.00	-71.00
24.00	85.00	-72.00
24.00	86.00	-73.00
24.00	87.00	-74.00
24.00	88.00	-75.00
24.00	89.00	-76.00
24.00	90.00	-77.00
24.00	91.00	-78.00
24.00	92.00	-79.00
24.00	93.00	-80.00
24.00	94.00	-81.00

Driven Pile Capacity:

=====

Section Type: Square  
 Pile Width: 18.00 (in)

Test Pile Length (ft)	Pile Width (in)	Ultimate Side Friction (tons)	Mobilized End Bearing (tons)	Estimated Davi sson Capaci ty (tons)	Al lowable Pile Capaci ty (tons)	Ul ti mate Pile Capaci ty (tons)
25.00	18.0	11.28	65.37	76.65	38.33	207.38
26.00	18.0	13.24	78.10	91.34	45.67	247.54
27.00	18.0	16.08	90.31	106.39	53.20	287.01
28.00	18.0	20.03	101.38	121.41	60.70	324.17
29.00	18.0	24.74	105.63	130.36	65.18	341.62
30.00	18.0	29.66	108.62	138.28	69.14	355.53

B-601\_Void-10ft. out

31.00	18.0	34.76	110.98	145.75	72.87	367.71
32.00	18.0	40.03	114.08	154.11	77.05	382.27
33.00	18.0	45.43	117.92	163.35	81.68	399.20
34.00	18.0	50.79	121.87	172.66	86.33	416.39
35.00	18.0	55.94	125.84	181.78	90.89	433.46
36.00	18.0	60.93	130.02	190.95	95.48	450.99
37.00	18.0	66.22	134.05	200.27	100.13	468.36
38.00	18.0	71.90	137.60	209.50	104.75	484.70
39.00	18.0	77.78	139.76	217.54	108.77	497.06
40.00	18.0	83.67	140.59	224.27	112.13	505.46
41.00	18.0	89.57	140.79	230.37	115.18	511.95
42.00	18.0	95.56	140.93	236.49	118.24	518.34
43.00	18.0	101.66	140.86	242.52	121.26	524.24
44.00	18.0	107.82	138.28	246.10	123.05	522.66
45.00	18.0	114.02	132.25	246.27	123.14	510.77
46.00	18.0	120.26	124.21	244.47	122.24	492.89
47.00	18.0	126.53	117.35	243.89	121.94	478.59
48.00	18.0	132.83	111.60	244.43	122.22	467.62
49.00	18.0	138.49	104.63	243.12	121.56	452.39
50.00	18.0	142.81	96.24	239.05	119.53	431.54
51.00	18.0	145.97	87.20	233.17	116.58	407.56
52.00	18.0	149.27	77.92	227.19	113.59	383.03
53.00	18.0	152.91	68.20	221.11	110.56	357.51
54.00	18.0	156.14	59.37	215.51	107.75	334.24
55.00	18.0	158.15	52.64	210.79	105.40	316.07
56.00	18.0	159.10	47.91	207.01	103.51	302.84
57.00	18.0	159.86	44.18	204.04	102.02	292.40
58.00	18.0	194.87	16.49	211.36	105.68	244.33
59.00	18.0	195.44	16.50	211.94	105.97	244.94
60.00	18.0	196.32	20.88	217.21	108.60	258.98
61.00	18.0	197.57	31.30	228.87	114.44	291.48
62.00	18.0	199.65	47.01	246.66	123.33	340.67
63.00	18.0	202.88	67.56	270.44	135.22	405.56
64.00	18.0	207.00	92.28	299.28	149.64	483.85
65.00	18.0	211.52	104.35	315.87	157.93	524.57
66.00	18.0	225.11	173.44	398.55	199.28	745.44
67.00	18.0	229.57	173.44	403.02	201.51	749.90
68.00	18.0	234.04	172.46	406.50	203.25	751.42
69.00	18.0	238.50	169.52	408.02	204.01	747.05
70.00	18.0	242.97	164.85	407.82	203.91	737.53
71.00	18.0	247.43	159.95	407.38	203.69	727.27
72.00	18.0	251.89	155.04	406.94	203.47	717.02
73.00	18.0	256.36	150.13	406.49	203.25	706.76
74.00	18.0	261.30	146.21	407.51	203.75	699.92
75.00	18.0	267.19	144.25	411.43	205.72	699.92
76.00	18.0	273.91	144.00	417.91	208.95	705.91
77.00	18.0	280.75	144.00	424.75	212.37	712.75
78.00	18.0	287.59	144.00	431.59	215.79	719.59
79.00	18.0	294.43	144.00	438.43	219.21	726.43
80.00	18.0	301.27	144.00	445.27	222.63	733.27
81.00	18.0	308.11	144.00	452.11	226.05	740.11
82.00	18.0	314.95	144.00	458.95	229.47	746.95
83.00	18.0	321.79	143.96	465.74	232.87	753.66
84.00	18.0	328.63	142.90	471.53	235.77	757.34
85.00	18.0	335.47	140.45	475.91	237.96	756.80
86.00	18.0	342.31	136.47	478.78	239.39	751.71
87.00	18.0	349.15	130.69	479.84	239.92	741.22
88.00	18.0	355.99	123.13	479.11	239.56	725.37
89.00	18.0	362.48	114.79	477.27	238.64	706.86
90.00	18.0	368.27	106.35	474.61	237.31	687.31
91.00	18.0	373.33	99.02	472.35	236.18	670.40
92.00	18.0	377.52	95.96	473.47	236.74	665.38
93.00	18.0	380.80	97.20	478.00	239.00	672.41
94.00	18.0	383.40	100.18	483.57	241.79	683.92

Section Type: Square  
 Pile Width: 24.00 (in)

Test Pile Length (ft)	Pile Width (in)	Ultimate Side Friction (tons)	Mobilized End Bearing (tons)	Estimated Davi sson Capacity (tons)	Allowable Pile Capacity (tons)	Ultimate Pile Capacity (tons)
25.00	24.0	12.43	90.66	103.09	51.55	284.41
26.00	24.0	14.43	104.71	119.14	59.57	328.57
27.00	24.0	17.38	117.83	135.21	67.61	370.87
28.00	24.0	21.50	129.00	150.50	75.25	408.49
29.00	24.0	26.42	139.02	165.44	82.72	443.49
30.00	24.0	31.66	150.27	181.93	90.97	482.48
31.00	24.0	37.22	162.92	200.14	100.07	525.98
32.00	24.0	43.12	176.36	219.47	109.74	572.19
33.00	24.0	49.37	189.81	239.18	119.59	618.79
34.00	24.0	55.81	203.58	259.39	129.69	666.55
35.00	24.0	62.25	210.25	272.51	136.25	693.01
36.00	24.0	68.56	217.47	286.03	143.02	720.97



B-601_Void-10ft. out							
37.00	24.0	75.25	224.03	299.28	149.64	747.33	
38.00	24.0	82.42	229.44	311.86	155.93	770.75	
39.00	24.0	89.87	234.10	323.96	161.98	792.15	
40.00	24.0	97.36	238.70	336.06	168.03	813.46	
41.00	24.0	104.89	243.53	348.42	174.21	835.47	
42.00	24.0	112.56	245.85	358.41	179.20	850.11	
43.00	24.0	120.38	241.83	362.21	181.11	845.88	
44.00	24.0	128.30	232.02	360.32	180.16	824.35	
45.00	24.0	136.30	221.74	358.04	179.02	801.52	
46.00	24.0	144.35	212.68	357.03	178.51	782.38	
47.00	24.0	152.47	202.25	354.72	177.36	759.22	
48.00	24.0	160.63	187.90	348.53	174.26	724.32	
49.00	24.0	168.03	171.39	339.43	169.71	682.21	
50.00	24.0	173.81	157.26	331.07	165.54	645.59	
51.00	24.0	178.19	145.86	324.05	162.02	615.76	
52.00	24.0	182.71	134.94	317.65	158.82	587.53	
53.00	24.0	187.65	123.61	311.26	155.63	558.47	
54.00	24.0	192.07	113.21	305.28	152.64	531.70	
55.00	24.0	195.00	105.80	300.81	150.40	512.41	
56.00	24.0	196.59	101.48	298.07	149.04	501.03	
57.00	24.0	197.94	101.57	299.51	149.75	502.64	
58.00	24.0	259.82	65.04	324.86	162.43	454.93	
59.00	24.0	260.59	55.70	316.29	158.15	427.69	
60.00	24.0	262.43	68.55	330.97	165.49	468.07	
61.00	24.0	264.73	78.84	343.58	171.79	501.26	
62.00	24.0	267.87	94.58	362.45	181.23	551.62	
63.00	24.0	272.07	115.41	387.48	193.74	618.29	
64.00	24.0	276.81	141.29	418.10	209.05	700.68	
65.00	24.0	281.56	170.71	452.27	226.13	793.69	
66.00	24.0	300.15	307.03	607.18	303.59	1221.25	
67.00	24.0	306.10	303.11	609.21	304.60	1215.42	
68.00	24.0	312.05	296.89	608.94	304.47	1202.73	
69.00	24.0	318.00	290.35	608.35	304.18	1189.05	
70.00	24.0	323.96	283.81	607.76	303.88	1175.37	
71.00	24.0	329.91	277.26	607.17	303.59	1161.70	
72.00	24.0	335.86	270.72	606.58	303.29	1148.02	
73.00	24.0	341.81	264.18	605.99	302.99	1134.35	
74.00	24.0	348.40	258.94	607.34	303.67	1125.23	
75.00	24.0	356.25	256.33	612.58	306.29	1125.23	
76.00	24.0	365.21	256.00	621.21	310.61	1133.21	
77.00	24.0	374.33	256.00	630.33	315.17	1142.33	
78.00	24.0	383.45	256.00	639.45	319.73	1151.45	
79.00	24.0	392.57	256.00	648.57	324.29	1160.57	
80.00	24.0	401.69	256.00	657.69	328.85	1169.69	
81.00	24.0	410.81	256.00	666.81	333.41	1178.81	
82.00	24.0	419.93	255.06	675.00	337.50	1185.12	
83.00	24.0	429.05	252.26	681.31	340.65	1185.82	
84.00	24.0	438.17	247.51	685.68	342.84	1180.69	
85.00	24.0	447.29	240.41	687.70	343.85	1168.51	
86.00	24.0	456.41	230.89	687.30	343.65	1149.07	
87.00	24.0	465.53	219.56	685.09	342.54	1124.20	
88.00	24.0	474.65	207.01	681.67	340.83	1095.69	
89.00	24.0	483.30	194.43	677.74	338.87	1066.60	
90.00	24.0	491.02	186.70	677.73	338.86	1051.13	
91.00	24.0	497.78	184.74	682.52	341.26	1052.00	
92.00	24.0	503.35	186.44	689.80	344.90	1062.68	
93.00	24.0	507.73	189.38	697.11	348.55	1075.87	
94.00	24.0	Soil Elevations Must Extend At or Below Contribution Zone					

NOTES

1. MOBILIZED END BEARING IS 1/3 OF THE ORIGINAL RB-121 VALUES.
2. DAVISSON PILE CAPACITY IS AN ESTIMATE BASED ON FAILURE CRITERIA, AND EQUALS ULTIMATE SIDE FRICTION PLUS MOBILIZED END BEARING.
3. ALLOWABLE PILE CAPACITY IS 1/2 THE DAVISSON PILE CAPACITY.
4. ULTIMATE PILE CAPACITY IS ULTIMATE SIDE FRICTION PLUS 3 x THE MOBILIZED END BEARING.  
EXCEPTION: FOR H-PILES TIPPED IN SAND OR LIMESTONE, THE ULTIMATE PILE CAPACITY IS ULTIMATE SIDE FRICTION PLUS 2 x THE MOBILIZED END BEARING.

**APPENDIX – E**



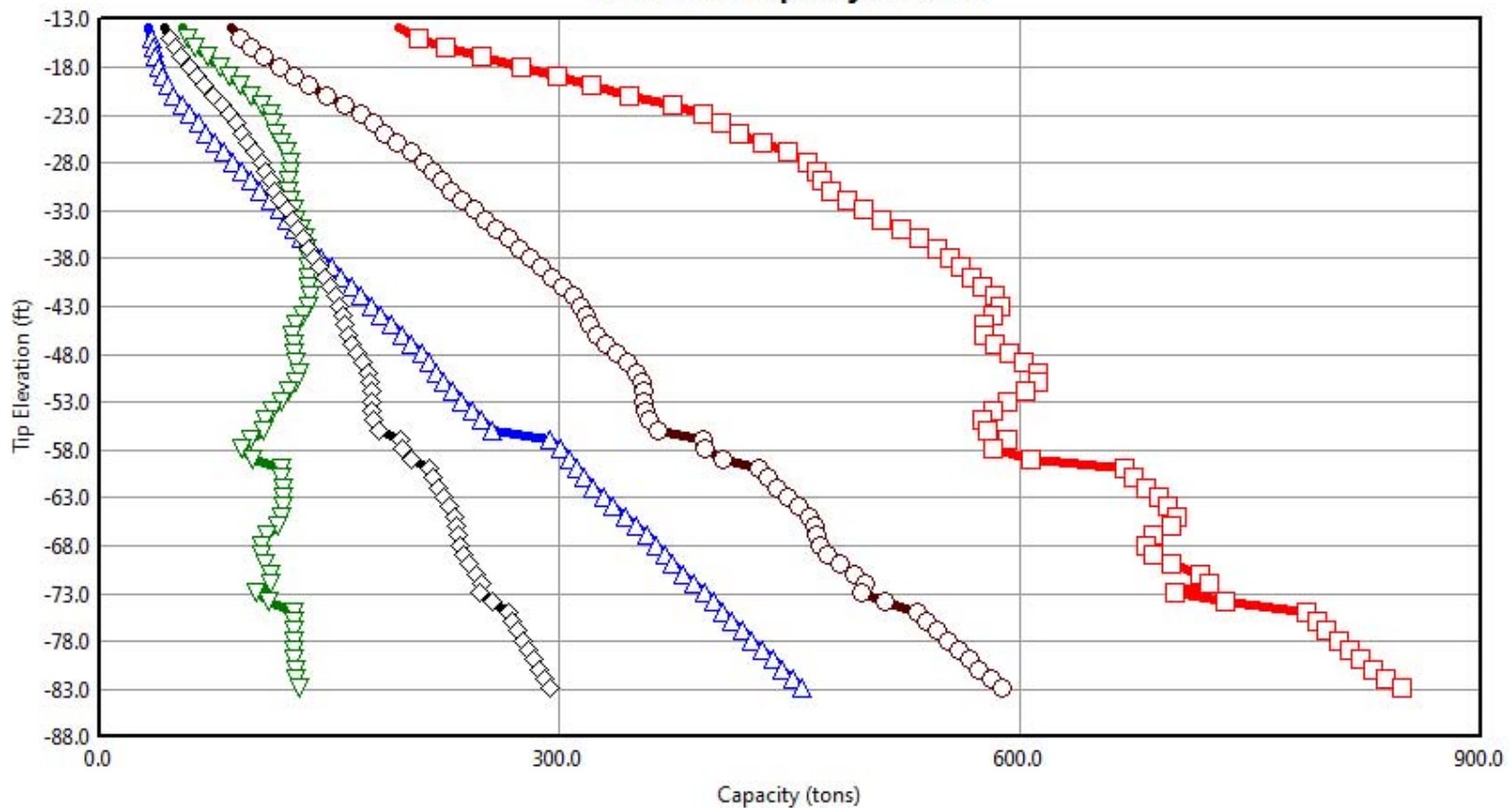

**GRAPHS – VERTICAL CAPACITY ANALYSIS OF**

**PRECAST CONCRETE DRIVEN PILES**

### Driven Pile Capacity: IDs 1-70



#### Curves

-  Ultimate Side Friction
-  Mobilized End Bearing
-  Ultimate Pile Capacity
-  Estimated Davisson Capacity
-  Allowable Pile Capacity

\*The 'Save to File' button saves the currently selected Curves to a text file.

#### Driven Pile Data

Boring Number: B-101  
 Ground Surface Elevation: 11.10 (ft)  
 Section: Square  
 Width: 18.00 (in)

#### Project Data

File: B-101\_Void-10ft  
 Date: Apr 19, 2018  
 Engineer: JB Henry

#### Analysis Data

Analysis Type: SPT

#### Plot Options

Customize

Update Plot

Print Plot

Print Window

Save To File

Close

### Driven Pile Capacity: IDs 71-140

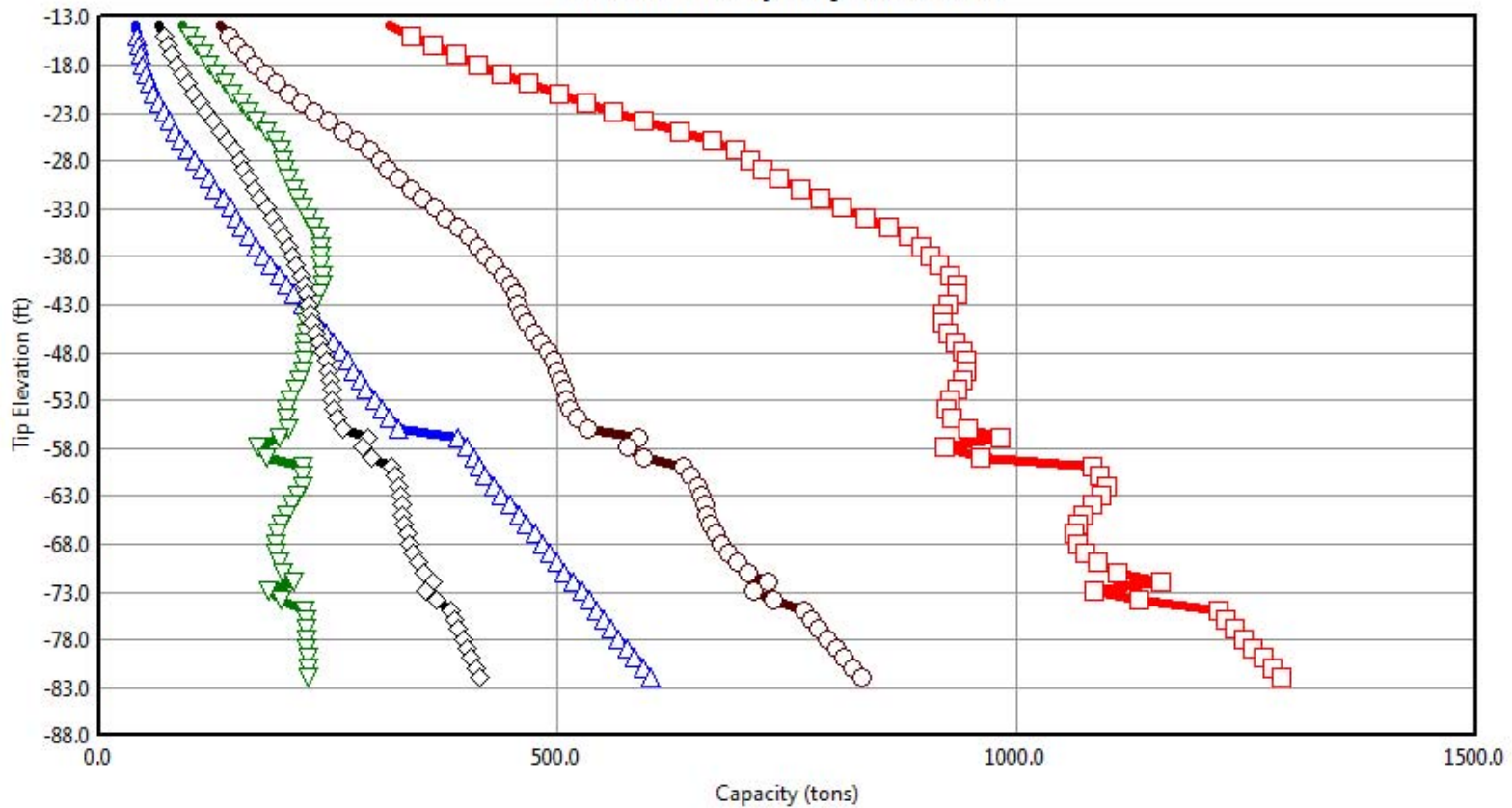

#### Curves

-  Ultimate Side Friction
-  Mobilized End Bearing
-  Ultimate Pile Capacity
-  Estimated Davisson Capacity
-  Allowable Pile Capacity

\*The 'Save to File' button saves the currently selected Curves to a text file.

#### Driven Pile Data

Boring Number: B-101  
 Ground Surface Elevation: 11.10 (ft)  
 Section: Square  
 Width: 24.00 (in)

#### Project Data

File: B-101\_Void-10ft  
 Date: Apr 19, 2018  
 Engineer: JB Henry

#### Analysis Data

Analysis Type: SPT

#### Plot Options



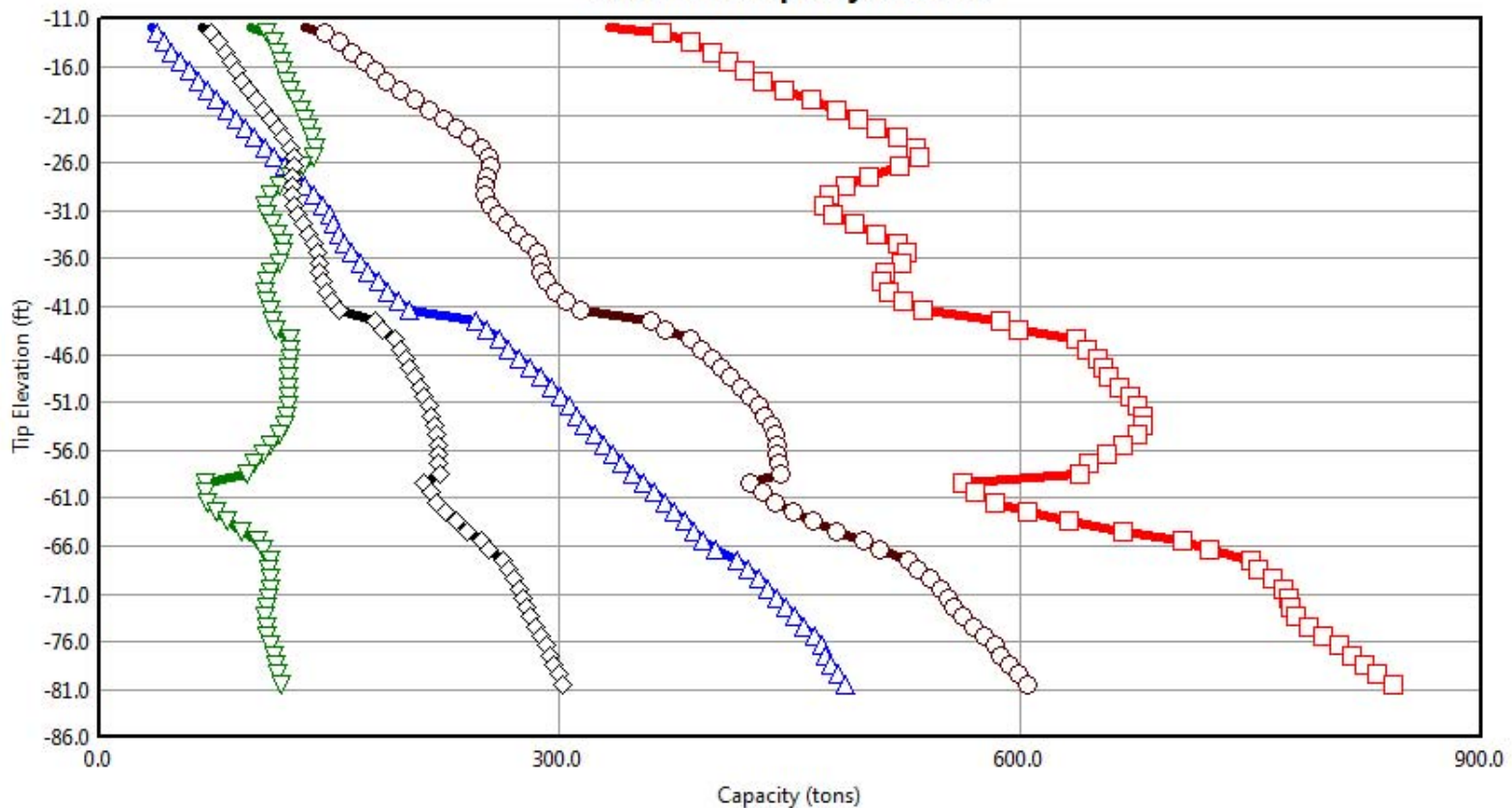

Customize    Update Plot    Print Plot    Print Window    Save To File

Close

### Driven Pile Capacity: IDs 1-70



#### Curves

-  Ultimate Side Friction
-  Mobilized End Bearing
-  Ultimate Pile Capacity
-  Estimated Davisson Capacity
-  Allowable Pile Capacity

\*The 'Save to File' button saves the currently selected Curves to a text file.

#### Driven Pile Data

Boring Number: B-201  
 Ground Surface Elevation: 13.60 (ft)  
 Section: Square  
 Width: 18.00 (in)

#### Project Data

File: B-201\_Void-10ft  
 Date: Apr 19, 2018  
 Engineer: JB Henry

#### Analysis Data

Analysis Type: SPT

#### Plot Options

Customize    Update Plot    Print Plot    Print Window    Save To File

Close

### Driven Pile Capacity: IDs 71-140

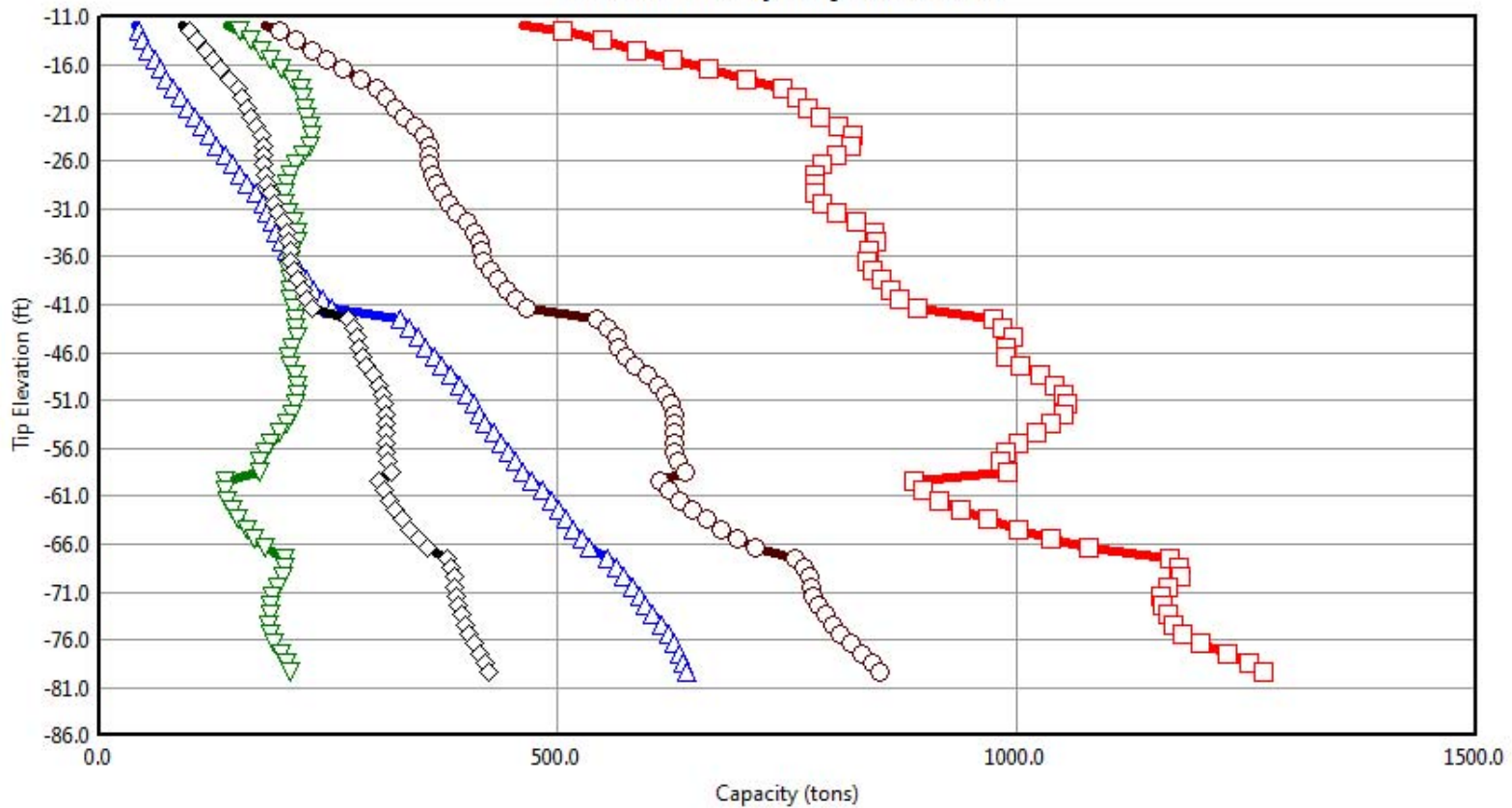

#### Curves

- Ultimate Side Friction
- Mobilized End Bearing
- Ultimate Pile Capacity
- Estimated Davisson Capacity
- Allowable Pile Capacity

\*The 'Save to File' button saves the currently selected Curves to a text file.

#### Driven Pile Data

Boring Number: B-201  
 Ground Surface Elevation: 13.60 (ft)  
 Section: Square  
 Width: 24.00 (in)

#### Project Data

File: B-201\_Void-10ft  
 Date: Apr 19, 2018  
 Engineer: JB Henry

#### Analysis Data



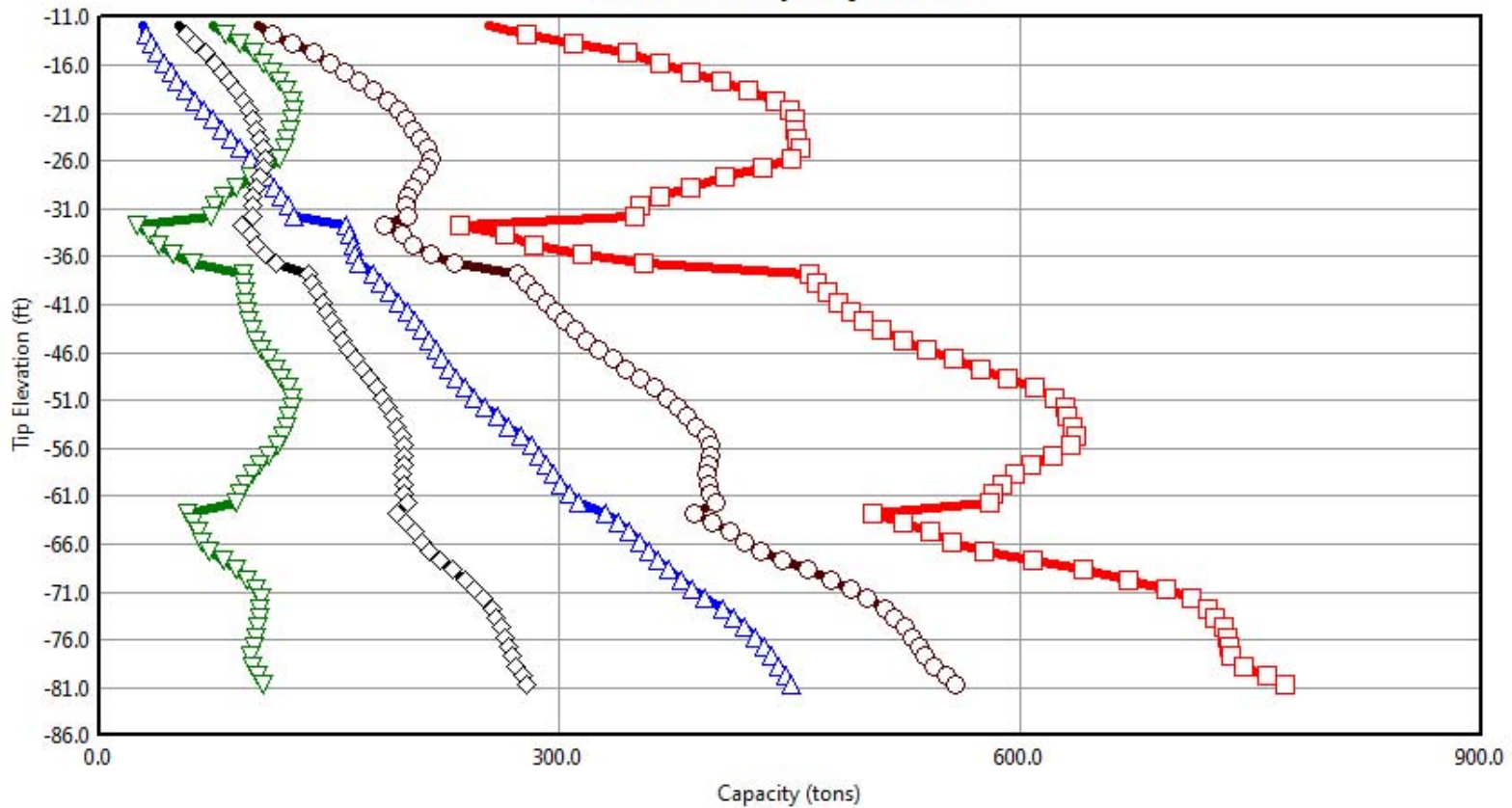

Analysis Type: SPT

#### Plot Options

### Driven Pile Capacity: IDs 1-70



#### Curves

-  Ultimate Side Friction
-  Mobilized End Bearing
-  Ultimate Pile Capacity
-  Estimated Davisson Capacity
-  Allowable Pile Capacity

\*The 'Save to File' button saves the currently selected Curves to a text file.

#### Driven Pile Data

Boring Number: B-301  
 Ground Surface Elevation: 13.30 (ft)  
 Section: Square  
 Width: 18.00 (in)

#### Project Data

File: B-301\_Void-10ft  
 Date: Apr 19, 2018  
 Engineer: JB Henry

#### Analysis Data



Analysis Type: SPT

#### Plot Options

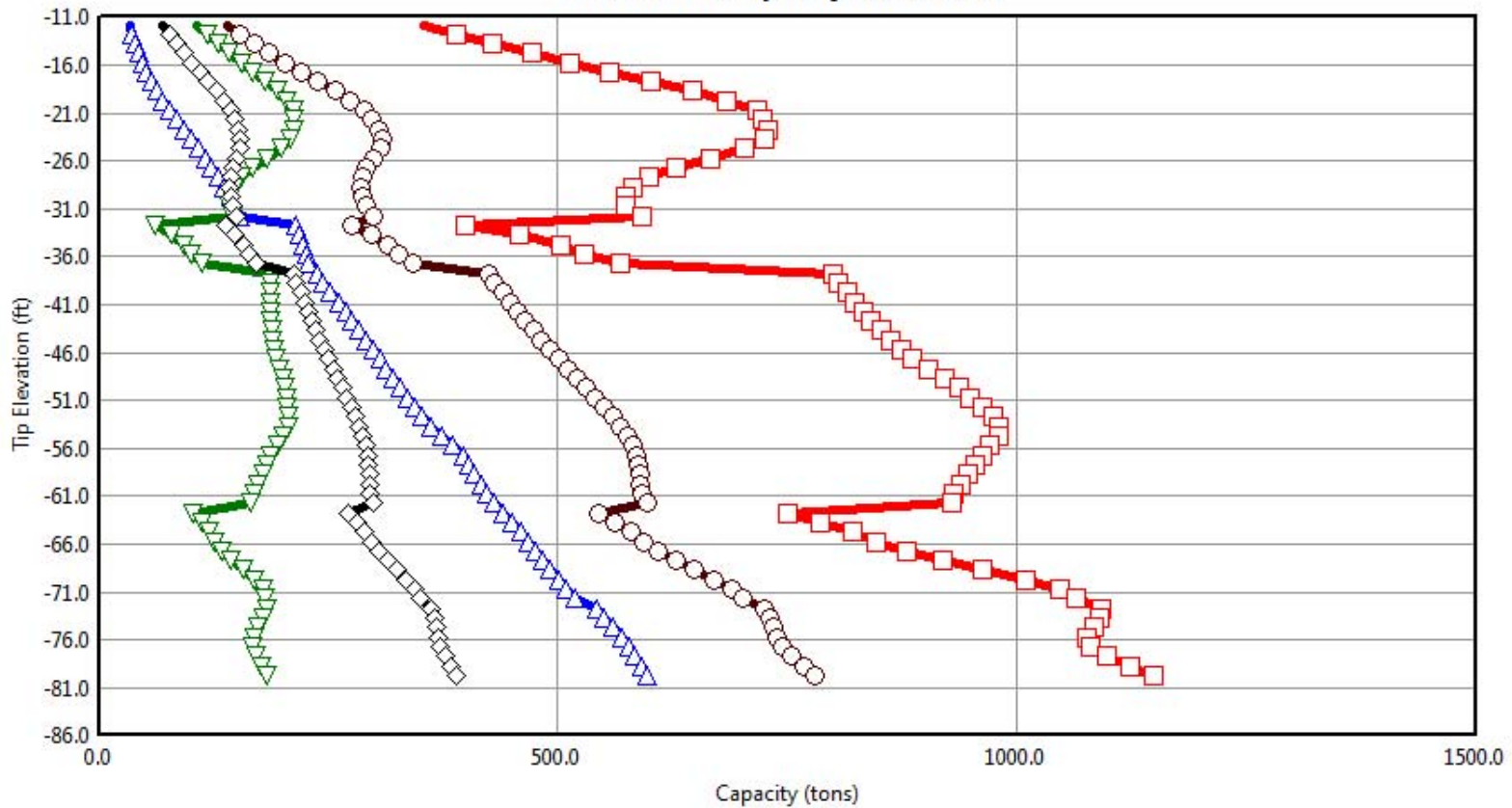
### Driven Pile Capacity: IDs 71-140



#### Curves

-  Ultimate Side Friction
-  Mobilized End Bearing
-  Ultimate Pile Capacity
-  Estimated Davisson Capacity
-  Allowable Pile Capacity

\*The 'Save to File' button saves the currently selected Curves to a text file.

#### Driven Pile Data

Boring Number: B-301  
 Ground Surface Elevation: 13.30 (ft)  
 Section: Square  
 Width: 24.00 (in)

#### Project Data

File: B-301\_Void-10ft  
 Date: Apr 19, 2018  
 Engineer: JB Henry

#### Analysis Data

Analysis Type: SPT

#### Plot Options

Customize    Update Plot    Print Plot    Print Window    Save To File

Close



### Driven Pile Capacity: IDs 1-70

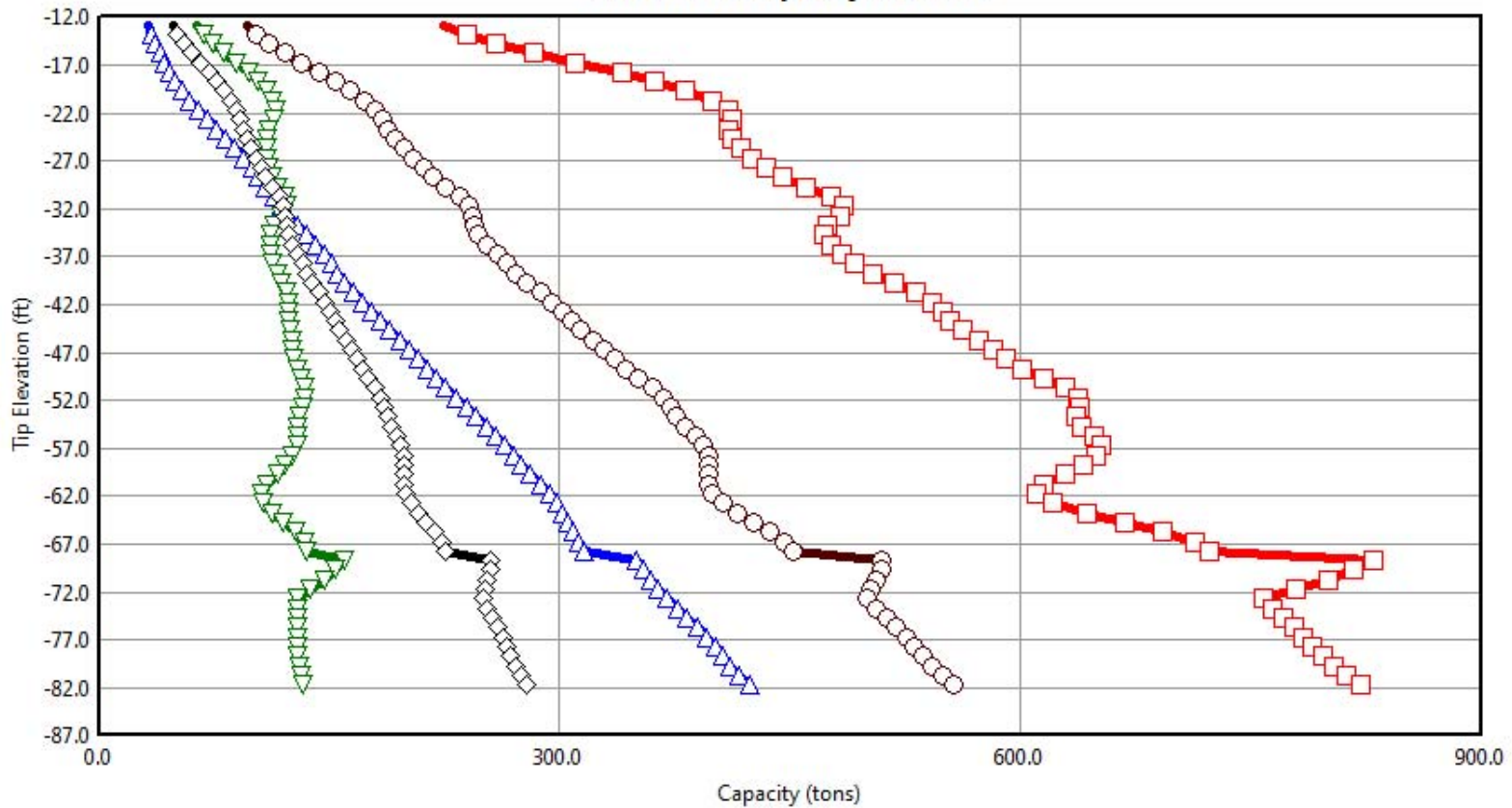

#### Curves

-  Ultimate Side Friction
-  Mobilized End Bearing
-  Ultimate Pile Capacity
-  Estimated Davisson Capacity
-  Allowable Pile Capacity

\*The 'Save to File' button saves the currently selected Curves to a text file.

#### Driven Pile Data

Boring Number: B-401  
 Ground Surface Elevation: 12.30 (ft)  
 Section: Square  
 Width: 18.00 (in)

#### Project Data

File: B-401\_Void-10ft  
 Date: Apr 19, 2018  
 Engineer: JB Henry

#### Analysis Data



Analysis Type: SPT

#### Plot Options

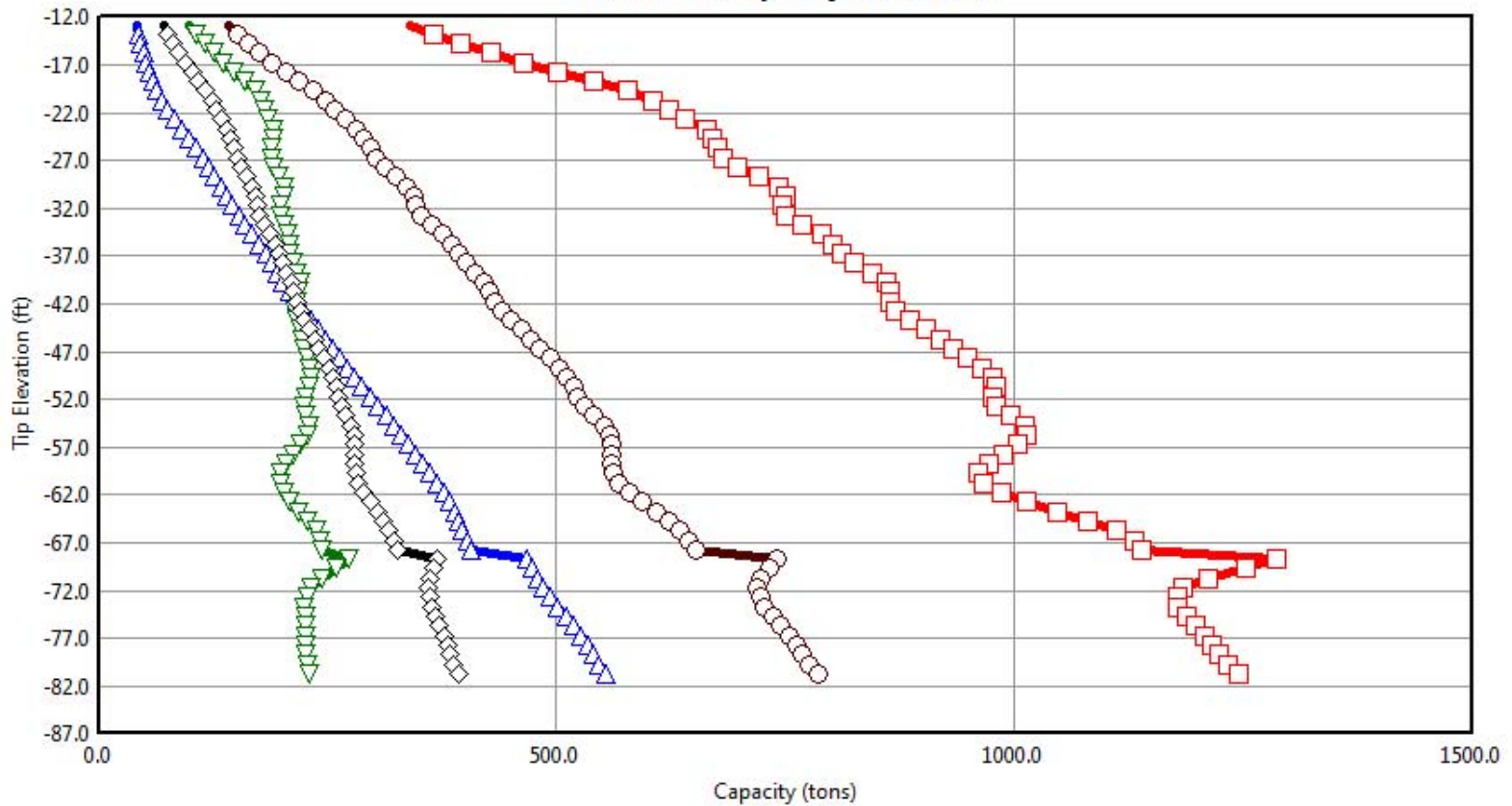
### Driven Pile Capacity: IDs 71-140



#### Curves

-  Ultimate Side Friction
-  Mobilized End Bearing
-  Ultimate Pile Capacity
-  Estimated Davisson Capacity
-  Allowable Pile Capacity

\*The 'Save to File' button saves the currently selected Curves to a text file.

#### Driven Pile Data

Boring Number: B-401  
 Ground Surface Elevation: 12.30 (ft)  
 Section: Square  
 Width: 24.00 (in)

#### Project Data

File: B-401\_Void-10ft  
 Date: Apr 19, 2018  
 Engineer: JB Henry

#### Analysis Data

Analysis Type: SPT

#### Plot Options

### Driven Pile Capacity: IDs 1-70

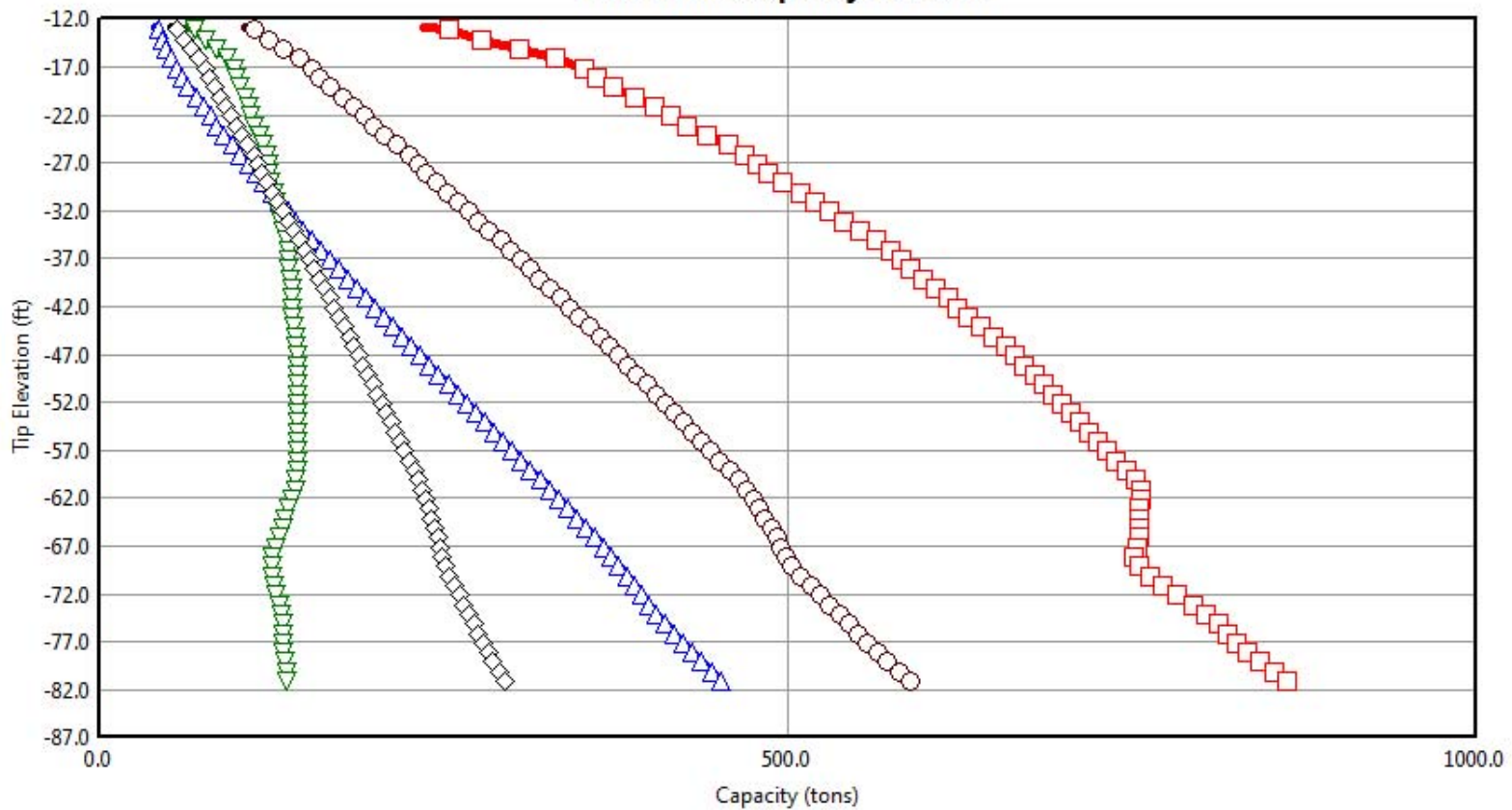

#### Curves

- Ultimate Side Friction
- Mobilized End Bearing
- Ultimate Pile Capacity
- Estimated Davisson Capacity
- Allowable Pile Capacity

\*The 'Save to File' button saves the currently selected Curves to a text file.

#### Driven Pile Data

Boring Number: B-501  
 Ground Surface Elevation: 12.90 (ft)  
 Section: Square  
 Width: 18.00 (in)

#### Project Data

File: B-501\_Void-10ft  
 Date: Apr 19, 2018  
 Engineer: JB Henry

#### Analysis Data

Analysis Type: SPT

#### Plot Options

### Driven Pile Capacity: IDs 71-140

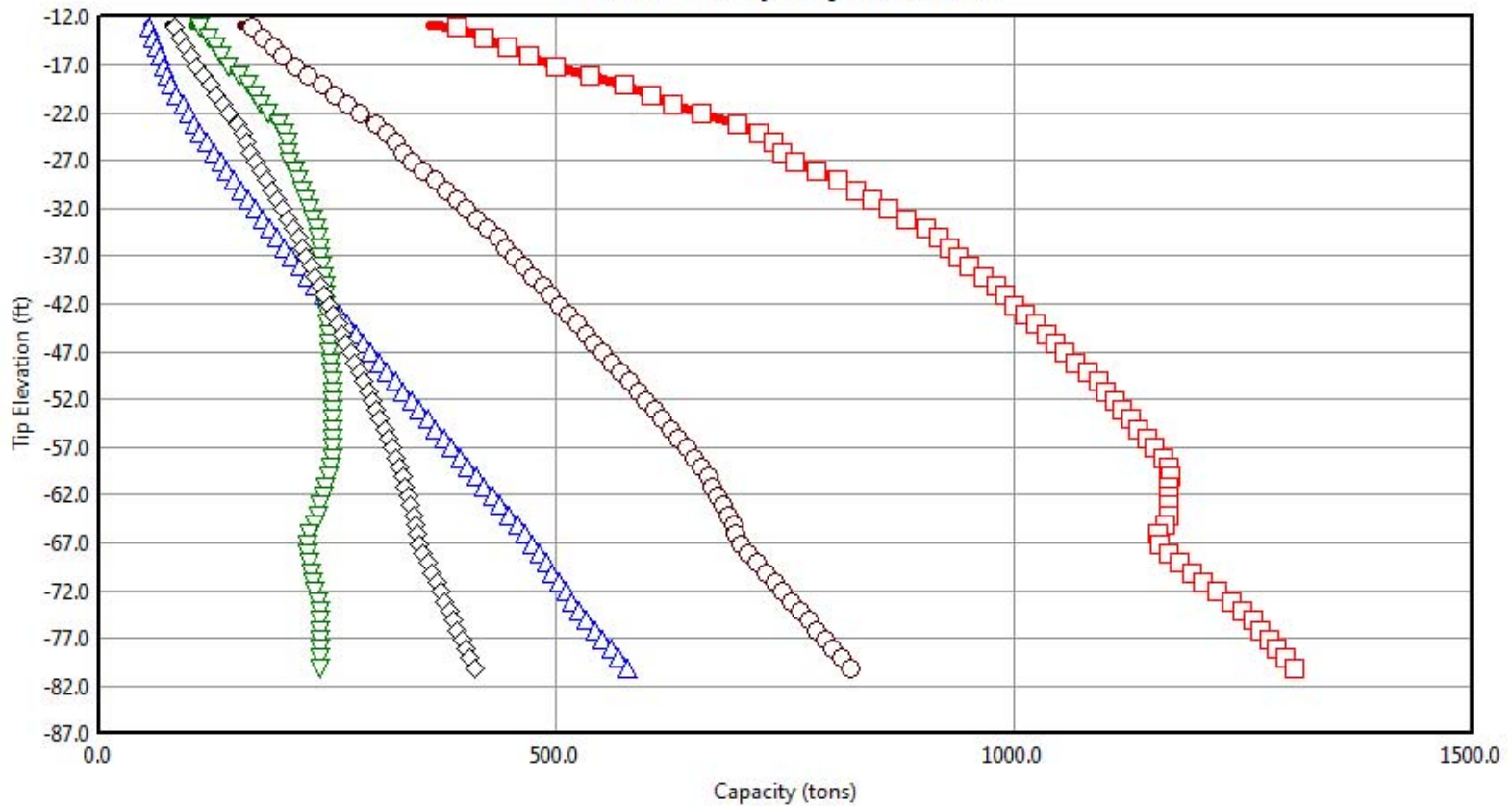

#### Curves

-  Ultimate Side Friction
-  Mobilized End Bearing
-  Ultimate Pile Capacity
-  Estimated Davisson Capacity
-  Allowable Pile Capacity

\*The 'Save to File' button saves the currently selected Curves to a text file.

#### Driven Pile Data

Boring Number: B-501  
 Ground Surface Elevation: 12.90 (ft)  
 Section: Square  
 Width: 24.00 (in)

#### Project Data

File: B-501\_Void-10ft  
 Date: Apr 19, 2018  
 Engineer: JB Henry

#### Analysis Data

Analysis Type: SPT

#### Plot Options



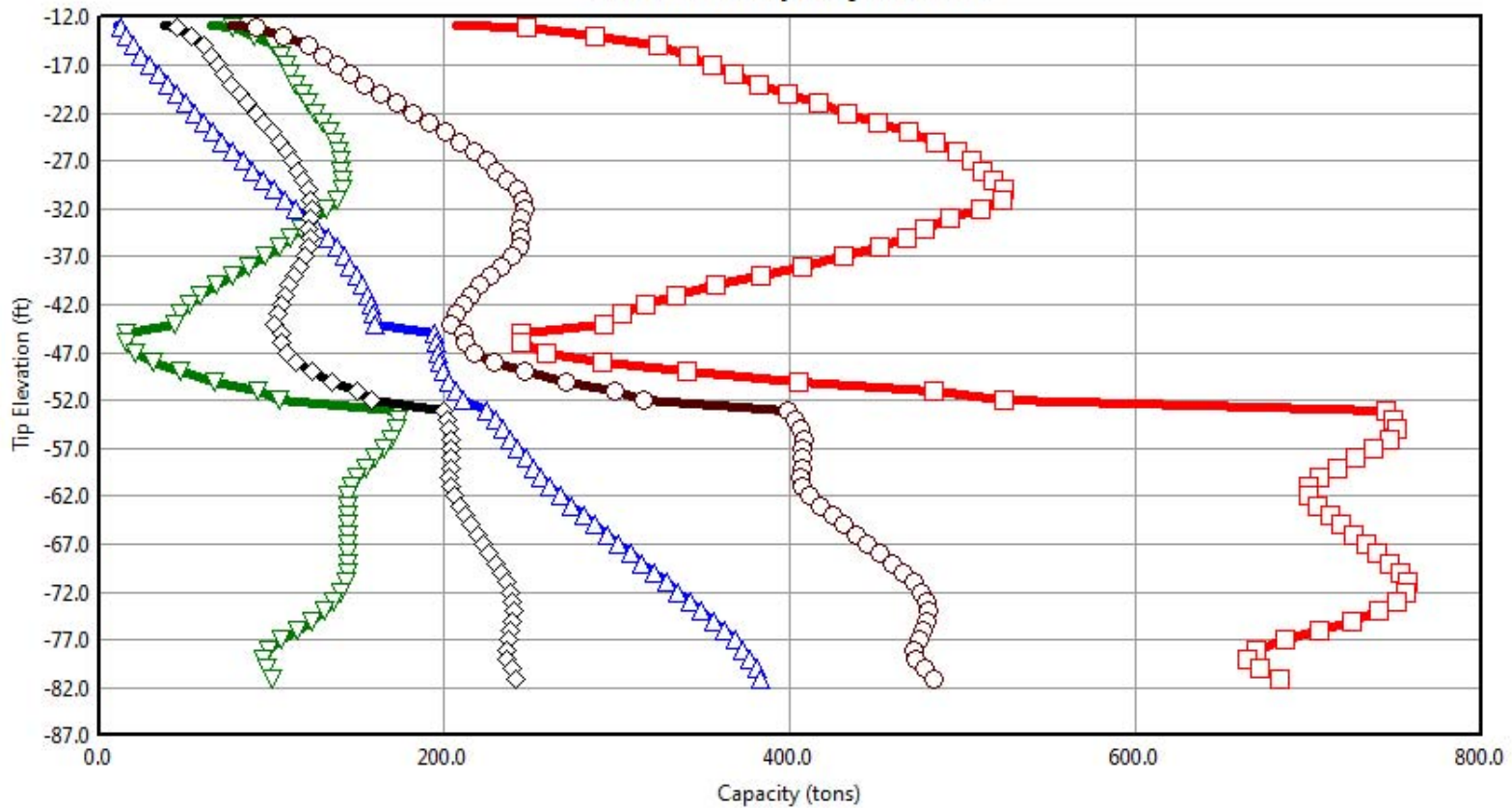

Customize    Update Plot    Print Plot    Print Window    Save To File

Close

### Driven Pile Capacity: IDs 1-70



#### Curves

-  Ultimate Side Friction
-  Mobilized End Bearing
-  Ultimate Pile Capacity
-  Estimated Davisson Capacity
-  Allowable Pile Capacity

\*The 'Save to File' button saves the currently selected Curves to a text file.

#### Driven Pile Data

Boring Number: B-601  
 Ground Surface Elevation: 13.00 (ft)  
 Section: Square  
 Width: 18.00 (in)

#### Project Data

File: B-601\_Void-10ft  
 Date: Apr 19, 2018  
 Engineer: JB Henry

#### Analysis Data

Analysis Type: SPT

#### Plot Options



Customize    Update Plot    Print Plot    Print Window    Save To File

Close

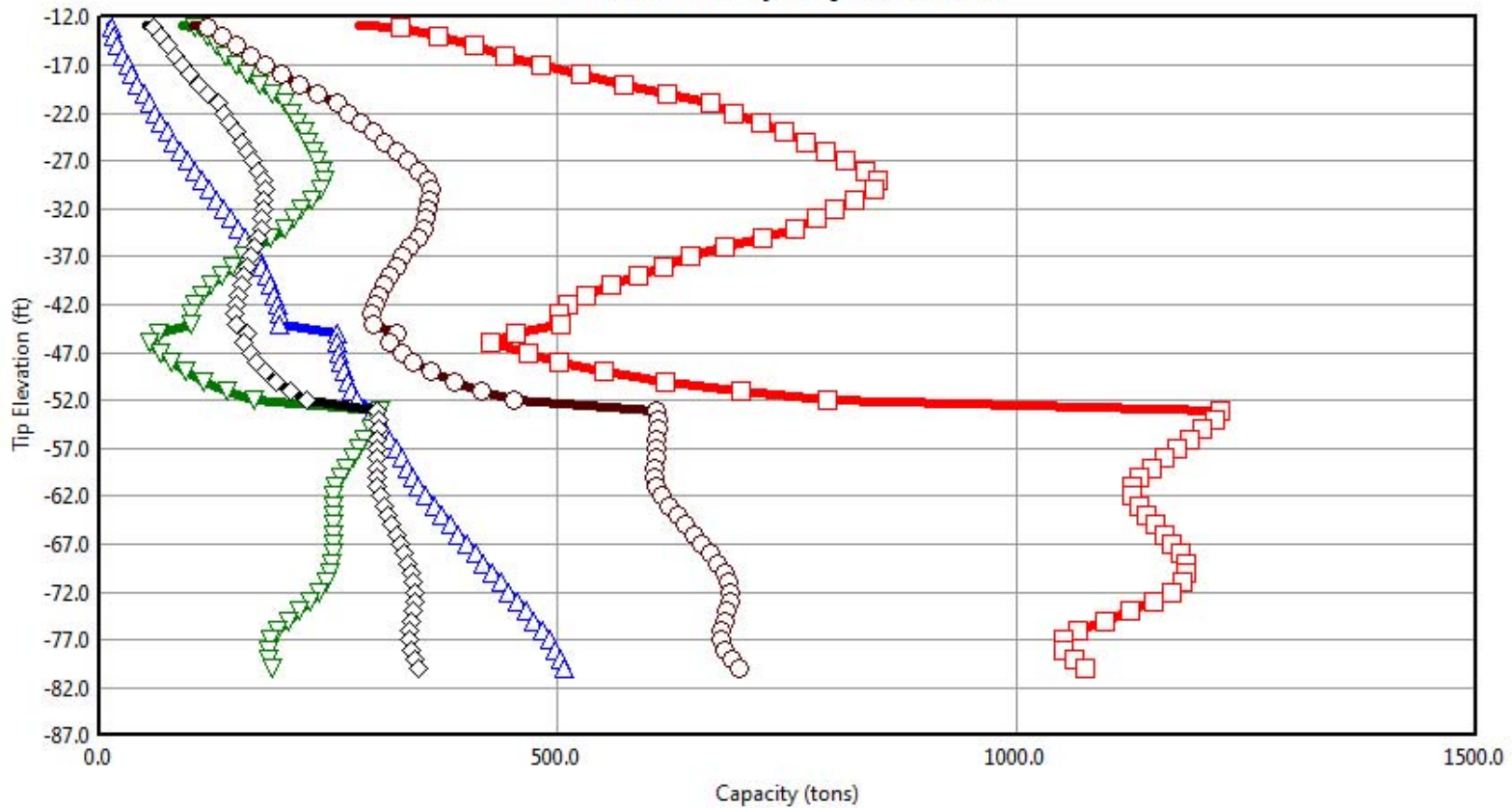
### Driven Pile Capacity: IDs 71-140



#### Curves

-  Ultimate Side Friction
-  Mobilized End Bearing
-  Ultimate Pile Capacity
-  Estimated Davisson Capacity
-  Allowable Pile Capacity

\*The 'Save to File' button saves the currently selected Curves to a text file.

#### Driven Pile Data

Boring Number: B-601  
 Ground Surface Elevation: 13.00 (ft)  
 Section: Square  
 Width: 24.00 (in)

#### Project Data

File: B-601\_Void-10ft  
 Date: Apr 19, 2018  
 Engineer: JB Henry

#### Analysis Data

Analysis Type: SPT

#### Plot Options

Customize

Update Plot

Print Plot

Print Window

Save To File

Close

**APPENDIX – F**

**FB DEEP OUTPUTS – VERTICAL CAPACITY ANALYSIS OF**

**DRILLED SHAFTS**

General Information:

=====  
 Input file: .....H)\Analysis\_Structure\FB-Deep\Drilled Shaft\B-101Shaft48in.spc  
 Project number: 2000-01-17003  
 Job name: SW 10th Street, from Powerline Rd. to Military Trail  
 Engineer: JB Henry  
 Units: English

Analysis Information:

=====  
 Analysis Type: Drilled Shaft Analysis

Soil Information:

=====  
 Boring date: 2/2/2018  
 Boring number: B-101  
 Station number:    Offset:  
  
 Ground Elevation: 11.10(ft)  
 Water table Elevation = 11.10(ft)  
  
 Hammer type: Automatic Hammer, Correction factor = 1.24

ID	Depth (ft)	Elevation (ft)	SPT Blows (Blows/ft)	Unit Weight (pcf)	Soil Type
1	0.00	11.10	N/A	0.00	5- Cavity layer
2	2.00	9.10	N/A	0.00	5- Cavity layer
3	4.00	7.10	N/A	0.00	5- Cavity layer
4	6.00	5.10	N/A	0.00	5- Cavity layer
5	8.00	3.10	N/A	0.00	5- Cavity layer
6	10.00	1.10	24.00	115.00	3- Clean sand
7	12.00	-0.90	21.00	115.00	3- Clean sand
8	13.50	-2.40	32.00	120.00	3- Clean sand
9	15.50	-4.40	12.00	110.00	3- Clean sand
10	18.00	-6.90	20.00	115.00	3- Clean sand
11	20.50	-9.40	14.00	110.00	3- Clean sand
12	23.00	-11.90	36.00	125.00	3- Clean sand
13	25.50	-14.40	19.00	115.00	3- Clean sand
14	28.00	-16.90	22.00	115.00	3- Clean sand
15	30.50	-19.40	34.00	125.00	3- Clean sand
16	33.00	-21.90	62.00	130.00	3- Clean sand
17	35.50	-24.40	39.00	125.00	3- Clean sand
18	38.00	-26.90	70.00	130.00	3- Clean sand
19	40.50	-29.40	44.00	125.00	3- Clean sand
20	43.00	-31.90	70.00	130.00	3- Clean sand
21	45.50	-34.40	30.00	120.00	3- Clean sand
22	48.00	-36.90	51.00	130.00	3- Clean sand
23	50.50	-39.40	48.00	125.00	3- Clean sand
24	53.00	-41.90	73.00	130.00	3- Clean sand
25	55.50	-44.40	66.00	130.00	3- Clean sand
26	58.00	-46.90	51.00	130.00	3- Clean sand
27	60.50	-49.40	30.00	120.00	3- Clean sand
28	63.00	-51.90	43.00	125.00	3- Clean sand
29	65.50	-54.40	47.00	125.00	3- Clean sand
30	68.00	-56.90	62.00	130.00	3- Clean sand
31	70.50	-59.40	29.00	120.00	3- Clean sand
32	73.00	-61.90	85.00	130.00	3- Clean sand
33	75.50	-64.40	51.00	130.00	3- Clean sand
34	78.00	-66.90	49.00	130.00	3- Clean sand
35	80.50	-69.40	34.00	125.00	3- Clean sand
36	83.00	-71.90	65.00	130.00	3- Clean sand
37	85.50	-74.40	38.00	125.00	3- Clean sand
38	88.00	-76.90	78.00	130.00	3- Clean sand
39	90.50	-79.40	49.00	130.00	3- Clean sand
40	93.00	-81.90	71.00	130.00	3- Clean sand
41	95.50	-84.40	60.00	130.00	3- Clean sand
42	98.00	-86.90	65.00	130.00	3- Clean sand
43	100.00	-88.90	65.00	130.00	3- Clean sand

ID	Cu-Dir (tsf)	qu (tsf)	qt (tsf)	Em (ksi)	qb (tsf)
1	N/A	N/A	N/A	N/A	N/A
2	N/A	N/A	N/A	N/A	N/A
3	N/A	N/A	N/A	N/A	N/A
4	N/A	N/A	N/A	N/A	N/A
5	N/A	N/A	N/A	N/A	N/A
6	N/A	N/A	N/A	N/A	N/A
7	N/A	N/A	N/A	N/A	N/A
8	N/A	N/A	N/A	N/A	N/A



B-101Shaft48i n. out

9	N/A	N/A	N/A	N/A	N/A
10	N/A	N/A	N/A	N/A	N/A
11	N/A	N/A	N/A	N/A	N/A
12	N/A	N/A	N/A	N/A	N/A
13	N/A	N/A	N/A	N/A	N/A
14	N/A	N/A	N/A	N/A	N/A
15	N/A	N/A	N/A	N/A	N/A
16	N/A	N/A	N/A	N/A	N/A
17	N/A	N/A	N/A	N/A	N/A
18	N/A	N/A	N/A	N/A	N/A
19	N/A	N/A	N/A	N/A	N/A
20	N/A	N/A	N/A	N/A	N/A
21	N/A	N/A	N/A	N/A	N/A
22	N/A	N/A	N/A	N/A	N/A
23	N/A	N/A	N/A	N/A	N/A
24	N/A	N/A	N/A	N/A	N/A
25	N/A	N/A	N/A	N/A	N/A
26	N/A	N/A	N/A	N/A	N/A
27	N/A	N/A	N/A	N/A	N/A
28	N/A	N/A	N/A	N/A	N/A
29	N/A	N/A	N/A	N/A	N/A
30	N/A	N/A	N/A	N/A	N/A
31	N/A	N/A	N/A	N/A	N/A
32	N/A	N/A	N/A	N/A	N/A
33	N/A	N/A	N/A	N/A	N/A
34	N/A	N/A	N/A	N/A	N/A
35	N/A	N/A	N/A	N/A	N/A
36	N/A	N/A	N/A	N/A	N/A
37	N/A	N/A	N/A	N/A	N/A
38	N/A	N/A	N/A	N/A	N/A
39	N/A	N/A	N/A	N/A	N/A
40	N/A	N/A	N/A	N/A	N/A
41	N/A	N/A	N/A	N/A	N/A
42	N/A	N/A	N/A	N/A	N/A
43	N/A	N/A	N/A	N/A	N/A

ID RQD F. M. S. R. I. Rock Recovery

ID	RQD F. M.	S. R. I.	Rock Recovery
1	N/A	N/A	N/A
2	N/A	N/A	N/A
3	N/A	N/A	N/A
4	N/A	N/A	N/A
5	N/A	N/A	N/A
6	N/A	N/A	N/A
7	N/A	N/A	N/A
8	N/A	N/A	N/A
9	N/A	N/A	N/A
10	N/A	N/A	N/A
11	N/A	N/A	N/A
12	N/A	N/A	N/A
13	N/A	N/A	N/A
14	N/A	N/A	N/A
15	N/A	N/A	N/A
16	N/A	N/A	N/A
17	N/A	N/A	N/A
18	N/A	N/A	N/A
19	N/A	N/A	N/A
20	N/A	N/A	N/A
21	N/A	N/A	N/A
22	N/A	N/A	N/A
23	N/A	N/A	N/A
24	N/A	N/A	N/A
25	N/A	N/A	N/A
26	N/A	N/A	N/A
27	N/A	N/A	N/A
28	N/A	N/A	N/A
29	N/A	N/A	N/A
30	N/A	N/A	N/A
31	N/A	N/A	N/A
32	N/A	N/A	N/A
33	N/A	N/A	N/A
34	N/A	N/A	N/A
35	N/A	N/A	N/A
36	N/A	N/A	N/A
37	N/A	N/A	N/A
38	N/A	N/A	N/A
39	N/A	N/A	N/A
40	N/A	N/A	N/A
41	N/A	N/A	N/A
42	N/A	N/A	N/A
43	N/A	N/A	N/A

Drilled Shaft Data:

=====

Shaft Geometry:

B-101Shaft48in. out

ID	Length (ft)	Tip Elev. (ft)	Case Len. (ft)	Diameter (in)	Base Diam. (in)	Bell Len. (ft)
1	15.00	-3.90	6.00	48.00	48.00	0.00
2	16.00	-4.90	6.00	48.00	48.00	0.00
3	17.00	-5.90	6.00	48.00	48.00	0.00
4	18.00	-6.90	6.00	48.00	48.00	0.00
5	19.00	-7.90	6.00	48.00	48.00	0.00
6	20.00	-8.90	6.00	48.00	48.00	0.00
7	21.00	-9.90	6.00	48.00	48.00	0.00
8	22.00	-10.90	6.00	48.00	48.00	0.00
9	23.00	-11.90	6.00	48.00	48.00	0.00
10	24.00	-12.90	6.00	48.00	48.00	0.00
11	25.00	-13.90	6.00	48.00	48.00	0.00
12	26.00	-14.90	6.00	48.00	48.00	0.00
13	27.00	-15.90	6.00	48.00	48.00	0.00
14	28.00	-16.90	6.00	48.00	48.00	0.00
15	29.00	-17.90	6.00	48.00	48.00	0.00
16	30.00	-18.90	6.00	48.00	48.00	0.00
17	31.00	-19.90	6.00	48.00	48.00	0.00
18	32.00	-20.90	6.00	48.00	48.00	0.00
19	33.00	-21.90	6.00	48.00	48.00	0.00
20	34.00	-22.90	6.00	48.00	48.00	0.00
21	35.00	-23.90	6.00	48.00	48.00	0.00
22	36.00	-24.90	6.00	48.00	48.00	0.00
23	37.00	-25.90	6.00	48.00	48.00	0.00
24	38.00	-26.90	6.00	48.00	48.00	0.00
25	39.00	-27.90	6.00	48.00	48.00	0.00
26	40.00	-28.90	6.00	48.00	48.00	0.00
27	41.00	-29.90	6.00	48.00	48.00	0.00
28	42.00	-30.90	6.00	48.00	48.00	0.00
29	43.00	-31.90	6.00	48.00	48.00	0.00
30	44.00	-32.90	6.00	48.00	48.00	0.00
31	45.00	-33.90	6.00	48.00	48.00	0.00
32	46.00	-34.90	6.00	48.00	48.00	0.00
33	47.00	-35.90	6.00	48.00	48.00	0.00
34	48.00	-36.90	6.00	48.00	48.00	0.00
35	49.00	-37.90	6.00	48.00	48.00	0.00
36	50.00	-38.90	6.00	48.00	48.00	0.00
37	51.00	-39.90	6.00	48.00	48.00	0.00
38	52.00	-40.90	6.00	48.00	48.00	0.00
39	53.00	-41.90	6.00	48.00	48.00	0.00
40	54.00	-42.90	6.00	48.00	48.00	0.00
41	55.00	-43.90	6.00	48.00	48.00	0.00
42	56.00	-44.90	6.00	48.00	48.00	0.00
43	57.00	-45.90	6.00	48.00	48.00	0.00
44	58.00	-46.90	6.00	48.00	48.00	0.00
45	59.00	-47.90	6.00	48.00	48.00	0.00
46	60.00	-48.90	6.00	48.00	48.00	0.00
47	61.00	-49.90	6.00	48.00	48.00	0.00
48	62.00	-50.90	6.00	48.00	48.00	0.00
49	63.00	-51.90	6.00	48.00	48.00	0.00
50	64.00	-52.90	6.00	48.00	48.00	0.00
51	65.00	-53.90	6.00	48.00	48.00	0.00
52	66.00	-54.90	6.00	48.00	48.00	0.00
53	67.00	-55.90	6.00	48.00	48.00	0.00
54	68.00	-56.90	6.00	48.00	48.00	0.00
55	69.00	-57.90	6.00	48.00	48.00	0.00
56	70.00	-58.90	6.00	48.00	48.00	0.00
57	71.00	-59.90	6.00	48.00	48.00	0.00
58	72.00	-60.90	6.00	48.00	48.00	0.00
59	73.00	-61.90	6.00	48.00	48.00	0.00
60	74.00	-62.90	6.00	48.00	48.00	0.00
61	75.00	-63.90	6.00	48.00	48.00	0.00
62	76.00	-64.90	6.00	48.00	48.00	0.00
63	77.00	-65.90	6.00	48.00	48.00	0.00
64	78.00	-66.90	6.00	48.00	48.00	0.00
65	79.00	-67.90	6.00	48.00	48.00	0.00
66	80.00	-68.90	6.00	48.00	48.00	0.00
67	81.00	-69.90	6.00	48.00	48.00	0.00
68	82.00	-70.90	6.00	48.00	48.00	0.00
69	83.00	-71.90	6.00	48.00	48.00	0.00
70	84.00	-72.90	6.00	48.00	48.00	0.00
71	85.00	-73.90	6.00	48.00	48.00	0.00
72	86.00	-74.90	6.00	48.00	48.00	0.00
73	87.00	-75.90	6.00	48.00	48.00	0.00
74	88.00	-76.90	6.00	48.00	48.00	0.00
75	89.00	-77.90	6.00	48.00	48.00	0.00
76	90.00	-78.90	6.00	48.00	48.00	0.00
77	91.00	-79.90	6.00	48.00	48.00	0.00
78	92.00	-80.90	6.00	48.00	48.00	0.00
79	93.00	-81.90	6.00	48.00	48.00	0.00
80	94.00	-82.90	6.00	48.00	48.00	0.00
81	95.00	-83.90	6.00	48.00	48.00	0.00

Drilled Shaft Capacity (sorted by shaft diameter):

B-101Shaft48i n. out

Strength reduction factors: Skin-friction = 1.00, End-bearing = 1.00

ID	Diameter (in)	Length (ft)	Skin Fric. (tons)	End Bearing (tons)	Capacity (tons)
1	48.00	15.00	4.205	88.965	93.170
2	48.00	16.00	6.013	205.336	211.349
3	48.00	17.00	8.071	205.258	213.329
4	48.00	18.00	10.375	203.583	213.958
5	48.00	19.00	12.943	199.830	212.773
6	48.00	20.00	15.769	192.286	208.055
7	48.00	21.00	18.839	192.402	211.241
8	48.00	22.00	22.120	203.271	225.391
9	48.00	23.00	25.607	217.285	242.892
10	48.00	24.00	29.327	230.644	259.971
11	48.00	25.00	33.315	243.845	277.161
12	48.00	26.00	37.555	258.371	295.926
13	48.00	27.00	41.996	273.405	315.401
14	48.00	28.00	46.630	282.676	329.306
15	48.00	29.00	51.444	285.907	337.351
16	48.00	30.00	56.435	289.603	346.038
17	48.00	31.00	61.602	299.631	361.233
18	48.00	32.00	66.971	314.725	381.696
19	48.00	33.00	72.543	330.157	402.700
20	48.00	34.00	78.317	344.848	423.165
21	48.00	35.00	84.299	357.099	441.398
22	48.00	36.00	90.478	364.327	454.805
23	48.00	37.00	96.828	365.700	462.528
24	48.00	38.00	103.342	363.176	466.518
25	48.00	39.00	110.018	360.542	470.559
26	48.00	40.00	116.863	359.541	476.405
27	48.00	41.00	123.866	360.160	484.026
28	48.00	42.00	131.003	361.087	492.090
29	48.00	43.00	138.269	361.705	499.974
30	48.00	44.00	145.660	361.509	507.169
31	48.00	45.00	153.184	360.303	513.487
32	48.00	46.00	160.827	358.493	519.321
33	48.00	47.00	168.555	357.287	525.842
34	48.00	48.00	176.359	356.885	533.244
35	48.00	49.00	184.248	356.885	541.133
36	48.00	50.00	192.236	358.493	550.729
37	48.00	51.00	200.313	362.113	562.425
38	48.00	52.00	208.458	365.732	574.190
39	48.00	53.00	216.668	365.128	581.796
40	48.00	54.00	224.938	363.118	588.056
41	48.00	55.00	233.276	361.911	595.188
42	48.00	56.00	241.673	361.911	603.585
43	48.00	57.00	250.122	361.911	612.034
44	48.00	58.00	258.620	361.911	620.532
45	48.00	59.00	267.156	361.509	628.665
46	48.00	60.00	275.727	360.303	636.030
47	48.00	61.00	284.323	357.170	641.493
48	48.00	62.00	292.916	351.994	644.910
49	48.00	63.00	301.501	345.637	647.138
50	48.00	64.00	310.075	341.668	651.742
51	48.00	65.00	318.643	341.953	660.596
52	48.00	66.00	327.199	346.778	673.977
53	48.00	67.00	335.736	354.017	689.753
54	48.00	68.00	344.253	358.842	703.095
55	48.00	69.00	352.746	360.010	712.755
56	48.00	70.00	361.219	358.686	719.905
57	48.00	71.00	369.662	355.963	725.625
58	48.00	72.00	378.052	352.423	730.475
59	48.00	73.00	386.385	348.656	735.041
60	48.00	74.00	394.662	346.440	741.102
61	48.00	75.00	402.894	347.465	750.359
62	48.00	76.00	411.072	352.487	763.559
63	48.00	77.00	419.192	359.612	778.804
64	48.00	78.00	427.251	363.683	790.934
65	48.00	79.00	435.238	364.387	799.625
66	48.00	80.00	443.153	363.377	806.530
67	48.00	81.00	450.988	362.268	813.256
68	48.00	82.00	458.730	361.529	820.260
69	48.00	83.00	466.377	361.283	827.660
70	48.00	84.00	473.923	361.193	835.116
71	48.00	85.00	481.372	361.906	843.279
72	48.00	86.00	488.719	364.455	853.174
73	48.00	87.00	496.111	368.617	864.728
74	48.00	88.00	503.603	371.482	875.085
75	48.00	89.00	511.196	372.467	883.663
76	48.00	90.00	518.896	372.829	891.725
77	48.00	91.00	526.701	373.915	900.616
78	48.00	92.00	534.613	375.543	910.157
79	48.00	93.00	Soil Elevations	Must Extend At or Below	Contribution Zone
80	48.00	94.00	Soil Elevations	Must Extend At or Below	Contribution Zone
81	48.00	95.00	Soil Elevations	Must Extend At or Below	Contribution Zone

B-101Shaft48i n. out

Drilled Shaft Capacity at User-Defined Settlement (sorted by shaft diameter):

\*\*\*\*\* Capacity is NOT modified by the strength reduction factors \*\*\*\*\*

User-Defined Settlement = 1.04%

ID	Diameter (in)	Length (ft)	Skin Fric. (tons)	End Bearing (tons)	Capacity (tons)
1	48.00	15.00	4.113	28.282	32.395
2	48.00	16.00	5.881	65.276	71.158
3	48.00	17.00	7.895	65.252	73.146
4	48.00	18.00	10.148	64.719	74.867
5	48.00	19.00	12.660	63.526	76.186
6	48.00	20.00	15.424	61.128	76.552
7	48.00	21.00	18.426	61.165	79.591
8	48.00	22.00	21.636	64.620	86.256
9	48.00	23.00	25.047	69.075	94.122
10	48.00	24.00	28.685	73.322	102.007
11	48.00	25.00	32.586	77.519	110.105
12	48.00	26.00	36.733	82.136	118.869
13	48.00	27.00	41.077	86.916	127.992
14	48.00	28.00	45.610	89.863	135.472
15	48.00	29.00	50.318	90.890	141.208
16	48.00	30.00	55.200	92.065	147.265
17	48.00	31.00	60.254	95.253	155.506
18	48.00	32.00	65.505	100.051	165.556
19	48.00	33.00	70.956	104.957	175.912
20	48.00	34.00	76.602	109.627	186.230
21	48.00	35.00	82.454	113.522	195.976
22	48.00	36.00	88.498	115.820	204.318
23	48.00	37.00	94.709	116.256	210.965
24	48.00	38.00	101.080	115.454	216.534
25	48.00	39.00	107.610	114.616	222.226
26	48.00	40.00	114.305	114.298	228.604
27	48.00	41.00	121.155	114.495	235.650
28	48.00	42.00	128.136	114.790	242.926
29	48.00	43.00	135.242	114.986	250.229
30	48.00	44.00	142.472	114.924	257.395
31	48.00	45.00	149.831	114.540	264.371
32	48.00	46.00	157.307	113.965	271.272
33	48.00	47.00	164.865	113.582	278.447
34	48.00	48.00	172.499	113.454	285.953
35	48.00	49.00	180.215	113.454	293.669
36	48.00	50.00	188.028	113.965	301.993
37	48.00	51.00	195.928	115.116	311.044
38	48.00	52.00	203.896	116.266	320.162
39	48.00	53.00	211.925	116.074	328.000
40	48.00	54.00	220.015	115.435	335.450
41	48.00	55.00	228.170	115.052	343.222
42	48.00	56.00	236.384	115.052	351.435
43	48.00	57.00	244.648	115.052	359.699
44	48.00	58.00	252.959	115.052	368.011
45	48.00	59.00	261.308	114.924	376.232
46	48.00	60.00	269.692	114.540	384.232
47	48.00	61.00	278.100	113.545	391.644
48	48.00	62.00	286.505	111.899	398.404
49	48.00	63.00	294.901	109.878	404.780
50	48.00	64.00	303.288	108.616	411.904
51	48.00	65.00	311.668	108.707	420.375
52	48.00	66.00	320.037	110.241	430.278
53	48.00	67.00	328.388	112.542	440.930
54	48.00	68.00	336.718	114.076	450.794
55	48.00	69.00	345.025	114.447	459.472
56	48.00	70.00	353.312	114.026	467.339
57	48.00	71.00	361.571	113.161	474.731
58	48.00	72.00	369.777	112.035	481.813
59	48.00	73.00	377.928	110.838	488.766
60	48.00	74.00	386.024	110.133	496.157
61	48.00	75.00	394.075	110.459	504.534
62	48.00	76.00	402.075	112.056	514.130
63	48.00	77.00	410.017	114.321	524.338
64	48.00	78.00	417.899	115.615	533.514
65	48.00	79.00	425.711	115.839	541.550
66	48.00	80.00	433.453	115.518	548.971
67	48.00	81.00	441.117	115.165	556.282
68	48.00	82.00	448.689	114.930	563.620
69	48.00	83.00	456.169	114.852	571.021
70	48.00	84.00	463.550	114.823	578.373
71	48.00	85.00	470.836	115.050	585.886
72	48.00	86.00	478.022	115.860	593.882
73	48.00	87.00	485.253	117.183	602.436
74	48.00	88.00	492.580	118.094	610.674
75	48.00	89.00	500.007	118.407	618.414
76	48.00	90.00	507.538	118.522	626.060
77	48.00	91.00	515.173	118.868	634.040

				B-101Shaft48in.out			
78	48.00	92.00	522.912	119.385	642.297		
79	48.00	93.00	Soil Elevations Must Extend At or Below Contribution Zone				
80	48.00	94.00	Soil Elevations Must Extend At or Below Contribution Zone				
81	48.00	95.00	Soil Elevations Must Extend At or Below Contribution Zone				

General Information:

=====  
 Input file: .....H)\Analysis\_Structure\FB-Deep\Drilled Shaft\B-101Shaft60in.spc  
 Project number: 2000-01-17003  
 Job name: SW 10th Street, from Powerline Rd. to Military Trail  
 Engineer: JB Henry  
 Units: English

Analysis Information:

=====  
 Analysis Type: Drilled Shaft Analysis

Soil Information:

=====  
 Boring date: 2/2/2018  
 Boring number: B-101  
 Station number: Offset:  
 Ground Elevation: 11.10(ft)  
 Water table Elevation = 11.10(ft)  
 Hammer type: Automatic Hammer, Correction factor = 1.24

ID	Depth (ft)	Elevation (ft)	SPT Blows (Blows/ft)	Unit Weight (pcf)	Soil Type
1	0.00	11.10	N/A	0.00	5- Cavity layer
2	2.00	9.10	N/A	0.00	5- Cavity layer
3	4.00	7.10	N/A	0.00	5- Cavity layer
4	6.00	5.10	N/A	0.00	5- Cavity layer
5	8.00	3.10	N/A	0.00	5- Cavity layer
6	10.00	1.10	24.00	115.00	3- Clean sand
7	12.00	-0.90	21.00	115.00	3- Clean sand
8	13.50	-2.40	32.00	120.00	3- Clean sand
9	15.50	-4.40	12.00	110.00	3- Clean sand
10	18.00	-6.90	20.00	115.00	3- Clean sand
11	20.50	-9.40	14.00	110.00	3- Clean sand
12	23.00	-11.90	36.00	125.00	3- Clean sand
13	25.50	-14.40	19.00	115.00	3- Clean sand
14	28.00	-16.90	22.00	115.00	3- Clean sand
15	30.50	-19.40	34.00	125.00	3- Clean sand
16	33.00	-21.90	62.00	130.00	3- Clean sand
17	35.50	-24.40	39.00	125.00	3- Clean sand
18	38.00	-26.90	70.00	130.00	3- Clean sand
19	40.50	-29.40	44.00	125.00	3- Clean sand
20	43.00	-31.90	70.00	130.00	3- Clean sand
21	45.50	-34.40	30.00	120.00	3- Clean sand
22	48.00	-36.90	51.00	130.00	3- Clean sand
23	50.50	-39.40	48.00	125.00	3- Clean sand
24	53.00	-41.90	73.00	130.00	3- Clean sand
25	55.50	-44.40	66.00	130.00	3- Clean sand
26	58.00	-46.90	51.00	130.00	3- Clean sand
27	60.50	-49.40	30.00	120.00	3- Clean sand
28	63.00	-51.90	43.00	125.00	3- Clean sand
29	65.50	-54.40	47.00	125.00	3- Clean sand
30	68.00	-56.90	62.00	130.00	3- Clean sand
31	70.50	-59.40	29.00	120.00	3- Clean sand
32	73.00	-61.90	85.00	130.00	3- Clean sand
33	75.50	-64.40	51.00	130.00	3- Clean sand
34	78.00	-66.90	49.00	130.00	3- Clean sand
35	80.50	-69.40	34.00	125.00	3- Clean sand
36	83.00	-71.90	65.00	130.00	3- Clean sand
37	85.50	-74.40	38.00	125.00	3- Clean sand
38	88.00	-76.90	78.00	130.00	3- Clean sand
39	90.50	-79.40	49.00	130.00	3- Clean sand
40	93.00	-81.90	71.00	130.00	3- Clean sand
41	95.50	-84.40	60.00	130.00	3- Clean sand
42	98.00	-86.90	65.00	130.00	3- Clean sand
43	100.00	-88.90	65.00	130.00	3- Clean sand

ID	Cu-Dir (tsf)	qu (tsf)	qt (tsf)	Em (ksi)	qb (tsf)
1	N/A	N/A	N/A	N/A	N/A
2	N/A	N/A	N/A	N/A	N/A
3	N/A	N/A	N/A	N/A	N/A
4	N/A	N/A	N/A	N/A	N/A
5	N/A	N/A	N/A	N/A	N/A
6	N/A	N/A	N/A	N/A	N/A
7	N/A	N/A	N/A	N/A	N/A
8	N/A	N/A	N/A	N/A	N/A

B-101Shaft60in. out

9	N/A	N/A	N/A	N/A	N/A
10	N/A	N/A	N/A	N/A	N/A
11	N/A	N/A	N/A	N/A	N/A
12	N/A	N/A	N/A	N/A	N/A
13	N/A	N/A	N/A	N/A	N/A
14	N/A	N/A	N/A	N/A	N/A
15	N/A	N/A	N/A	N/A	N/A
16	N/A	N/A	N/A	N/A	N/A
17	N/A	N/A	N/A	N/A	N/A
18	N/A	N/A	N/A	N/A	N/A
19	N/A	N/A	N/A	N/A	N/A
20	N/A	N/A	N/A	N/A	N/A
21	N/A	N/A	N/A	N/A	N/A
22	N/A	N/A	N/A	N/A	N/A
23	N/A	N/A	N/A	N/A	N/A
24	N/A	N/A	N/A	N/A	N/A
25	N/A	N/A	N/A	N/A	N/A
26	N/A	N/A	N/A	N/A	N/A
27	N/A	N/A	N/A	N/A	N/A
28	N/A	N/A	N/A	N/A	N/A
29	N/A	N/A	N/A	N/A	N/A
30	N/A	N/A	N/A	N/A	N/A
31	N/A	N/A	N/A	N/A	N/A
32	N/A	N/A	N/A	N/A	N/A
33	N/A	N/A	N/A	N/A	N/A
34	N/A	N/A	N/A	N/A	N/A
35	N/A	N/A	N/A	N/A	N/A
36	N/A	N/A	N/A	N/A	N/A
37	N/A	N/A	N/A	N/A	N/A
38	N/A	N/A	N/A	N/A	N/A
39	N/A	N/A	N/A	N/A	N/A
40	N/A	N/A	N/A	N/A	N/A
41	N/A	N/A	N/A	N/A	N/A
42	N/A	N/A	N/A	N/A	N/A
43	N/A	N/A	N/A	N/A	N/A

ID RQD F. M. S. R. I. Rock Recovery

ID	RQD F. M.	S. R. I.	Rock Recovery
1	N/A	N/A	N/A
2	N/A	N/A	N/A
3	N/A	N/A	N/A
4	N/A	N/A	N/A
5	N/A	N/A	N/A
6	N/A	N/A	N/A
7	N/A	N/A	N/A
8	N/A	N/A	N/A
9	N/A	N/A	N/A
10	N/A	N/A	N/A
11	N/A	N/A	N/A
12	N/A	N/A	N/A
13	N/A	N/A	N/A
14	N/A	N/A	N/A
15	N/A	N/A	N/A
16	N/A	N/A	N/A
17	N/A	N/A	N/A
18	N/A	N/A	N/A
19	N/A	N/A	N/A
20	N/A	N/A	N/A
21	N/A	N/A	N/A
22	N/A	N/A	N/A
23	N/A	N/A	N/A
24	N/A	N/A	N/A
25	N/A	N/A	N/A
26	N/A	N/A	N/A
27	N/A	N/A	N/A
28	N/A	N/A	N/A
29	N/A	N/A	N/A
30	N/A	N/A	N/A
31	N/A	N/A	N/A
32	N/A	N/A	N/A
33	N/A	N/A	N/A
34	N/A	N/A	N/A
35	N/A	N/A	N/A
36	N/A	N/A	N/A
37	N/A	N/A	N/A
38	N/A	N/A	N/A
39	N/A	N/A	N/A
40	N/A	N/A	N/A
41	N/A	N/A	N/A
42	N/A	N/A	N/A
43	N/A	N/A	N/A

Drilled Shaft Data:

=====

Shaft Geometry:

B-101Shaft60in. out

ID	Length (ft)	Tip Elev. (ft)	Case Len. (ft)	Diameter (in)	Base Diam. (in)	Bell Len. (ft)
1	15.00	-3.90	6.00	60.00	60.00	0.00
2	16.00	-4.90	6.00	60.00	60.00	0.00
3	17.00	-5.90	6.00	60.00	60.00	0.00
4	18.00	-6.90	6.00	60.00	60.00	0.00
5	19.00	-7.90	6.00	60.00	60.00	0.00
6	20.00	-8.90	6.00	60.00	60.00	0.00
7	21.00	-9.90	6.00	60.00	60.00	0.00
8	22.00	-10.90	6.00	60.00	60.00	0.00
9	23.00	-11.90	6.00	60.00	60.00	0.00
10	24.00	-12.90	6.00	60.00	60.00	0.00
11	25.00	-13.90	6.00	60.00	60.00	0.00
12	26.00	-14.90	6.00	60.00	60.00	0.00
13	27.00	-15.90	6.00	60.00	60.00	0.00
14	28.00	-16.90	6.00	60.00	60.00	0.00
15	29.00	-17.90	6.00	60.00	60.00	0.00
16	30.00	-18.90	6.00	60.00	60.00	0.00
17	31.00	-19.90	6.00	60.00	60.00	0.00
18	32.00	-20.90	6.00	60.00	60.00	0.00
19	33.00	-21.90	6.00	60.00	60.00	0.00
20	34.00	-22.90	6.00	60.00	60.00	0.00
21	35.00	-23.90	6.00	60.00	60.00	0.00
22	36.00	-24.90	6.00	60.00	60.00	0.00
23	37.00	-25.90	6.00	60.00	60.00	0.00
24	38.00	-26.90	6.00	60.00	60.00	0.00
25	39.00	-27.90	6.00	60.00	60.00	0.00
26	40.00	-28.90	6.00	60.00	60.00	0.00
27	41.00	-29.90	6.00	60.00	60.00	0.00
28	42.00	-30.90	6.00	60.00	60.00	0.00
29	43.00	-31.90	6.00	60.00	60.00	0.00
30	44.00	-32.90	6.00	60.00	60.00	0.00
31	45.00	-33.90	6.00	60.00	60.00	0.00
32	46.00	-34.90	6.00	60.00	60.00	0.00
33	47.00	-35.90	6.00	60.00	60.00	0.00
34	48.00	-36.90	6.00	60.00	60.00	0.00
35	49.00	-37.90	6.00	60.00	60.00	0.00
36	50.00	-38.90	6.00	60.00	60.00	0.00
37	51.00	-39.90	6.00	60.00	60.00	0.00
38	52.00	-40.90	6.00	60.00	60.00	0.00
39	53.00	-41.90	6.00	60.00	60.00	0.00
40	54.00	-42.90	6.00	60.00	60.00	0.00
41	55.00	-43.90	6.00	60.00	60.00	0.00
42	56.00	-44.90	6.00	60.00	60.00	0.00
43	57.00	-45.90	6.00	60.00	60.00	0.00
44	58.00	-46.90	6.00	60.00	60.00	0.00
45	59.00	-47.90	6.00	60.00	60.00	0.00
46	60.00	-48.90	6.00	60.00	60.00	0.00
47	61.00	-49.90	6.00	60.00	60.00	0.00
48	62.00	-50.90	6.00	60.00	60.00	0.00
49	63.00	-51.90	6.00	60.00	60.00	0.00
50	64.00	-52.90	6.00	60.00	60.00	0.00
51	65.00	-53.90	6.00	60.00	60.00	0.00
52	66.00	-54.90	6.00	60.00	60.00	0.00
53	67.00	-55.90	6.00	60.00	60.00	0.00
54	68.00	-56.90	6.00	60.00	60.00	0.00
55	69.00	-57.90	6.00	60.00	60.00	0.00
56	70.00	-58.90	6.00	60.00	60.00	0.00
57	71.00	-59.90	6.00	60.00	60.00	0.00
58	72.00	-60.90	6.00	60.00	60.00	0.00
59	73.00	-61.90	6.00	60.00	60.00	0.00
60	74.00	-62.90	6.00	60.00	60.00	0.00
61	75.00	-63.90	6.00	60.00	60.00	0.00
62	76.00	-64.90	6.00	60.00	60.00	0.00
63	77.00	-65.90	6.00	60.00	60.00	0.00
64	78.00	-66.90	6.00	60.00	60.00	0.00
65	79.00	-67.90	6.00	60.00	60.00	0.00
66	80.00	-68.90	6.00	60.00	60.00	0.00
67	81.00	-69.90	6.00	60.00	60.00	0.00
68	82.00	-70.90	6.00	60.00	60.00	0.00
69	83.00	-71.90	6.00	60.00	60.00	0.00
70	84.00	-72.90	6.00	60.00	60.00	0.00
71	85.00	-73.90	6.00	60.00	60.00	0.00
72	86.00	-74.90	6.00	60.00	60.00	0.00
73	87.00	-75.90	6.00	60.00	60.00	0.00
74	88.00	-76.90	6.00	60.00	60.00	0.00
75	89.00	-77.90	6.00	60.00	60.00	0.00
76	90.00	-78.90	6.00	60.00	60.00	0.00
77	91.00	-79.90	6.00	60.00	60.00	0.00
78	92.00	-80.90	6.00	60.00	60.00	0.00
79	93.00	-81.90	6.00	60.00	60.00	0.00
80	94.00	-82.90	6.00	60.00	60.00	0.00
81	95.00	-83.90	6.00	60.00	60.00	0.00

Drilled Shaft Capacity (sorted by shaft diameter):



B-101Shaft60i n. out

Strength reduction factors: Skin-friction = 1.00, End-bearing = 1.00

ID	Diameter (in)	Length (ft)	Skin Fric. (tons)	End Bearing (tons)	Capacity (tons)
1	60.00	15.00	5.256	128.219	133.475
2	60.00	16.00	7.516	132.084	139.601
3	60.00	17.00	10.089	135.128	145.217
4	60.00	18.00	12.969	264.321	277.290
5	60.00	19.00	16.179	264.727	280.906
6	60.00	20.00	19.712	267.888	287.600
7	60.00	21.00	23.548	268.541	292.089
8	60.00	22.00	27.650	273.489	301.139
9	60.00	23.00	32.009	289.877	321.886
10	60.00	24.00	36.658	309.837	346.495
11	60.00	25.00	41.644	325.498	367.142
12	60.00	26.00	46.943	337.711	384.655
13	60.00	27.00	52.495	351.587	404.082
14	60.00	28.00	58.288	367.975	426.263
15	60.00	29.00	64.305	382.537	446.842
16	60.00	30.00	70.544	390.930	461.474
17	60.00	31.00	77.002	394.680	471.683
18	60.00	32.00	83.713	402.937	486.651
19	60.00	33.00	90.679	417.226	507.906
20	60.00	34.00	97.896	432.734	530.630
21	60.00	35.00	105.374	444.647	550.021
22	60.00	36.00	113.098	453.256	566.354
23	60.00	37.00	121.035	460.300	581.334
24	60.00	38.00	129.177	466.068	595.246
25	60.00	39.00	137.522	470.173	607.695
26	60.00	40.00	146.079	472.226	618.305
27	60.00	41.00	154.833	472.536	627.369
28	60.00	42.00	163.754	472.965	636.720
29	60.00	43.00	172.836	473.824	646.660
30	60.00	44.00	182.075	474.264	656.339
31	60.00	45.00	191.480	473.437	664.916
32	60.00	46.00	201.034	471.605	672.640
33	60.00	47.00	210.694	470.349	681.042
34	60.00	48.00	220.449	469.930	690.379
35	60.00	49.00	230.310	468.673	698.983
36	60.00	50.00	240.294	464.903	705.198
37	60.00	51.00	250.391	459.667	710.058
38	60.00	52.00	260.573	459.248	719.821
39	60.00	53.00	270.835	464.694	735.529
40	60.00	54.00	281.173	471.396	752.569
41	60.00	55.00	291.595	474.747	766.342
42	60.00	56.00	302.092	475.166	777.258
43	60.00	57.00	312.653	475.166	787.819
44	60.00	58.00	323.275	475.166	798.441
45	60.00	59.00	333.944	473.369	807.313
46	60.00	60.00	344.658	467.977	812.635
47	60.00	61.00	355.404	459.889	815.293
48	60.00	62.00	366.145	454.497	820.643
49	60.00	63.00	376.876	452.700	829.576
50	60.00	64.00	387.593	452.700	840.293
51	60.00	65.00	398.303	452.700	851.004
52	60.00	66.00	408.998	453.119	862.118
53	60.00	67.00	419.670	456.470	876.141
54	60.00	68.00	430.317	463.172	893.489
55	60.00	69.00	440.932	468.645	909.578
56	60.00	70.00	451.523	468.309	919.832
57	60.00	71.00	462.078	463.196	925.274
58	60.00	72.00	472.565	459.509	932.074
59	60.00	73.00	482.981	458.280	941.261
60	60.00	74.00	493.328	457.997	951.325
61	60.00	75.00	503.617	457.149	960.766
62	60.00	76.00	513.840	456.336	970.176
63	60.00	77.00	523.990	459.163	983.154
64	60.00	78.00	534.063	466.232	1000.295
65	60.00	79.00	544.047	473.327	1017.374
66	60.00	80.00	553.941	476.233	1030.174
67	60.00	81.00	563.735	475.538	1039.272
68	60.00	82.00	573.413	474.768	1048.181
69	60.00	83.00	582.971	474.511	1057.482
70	60.00	84.00	592.404	474.417	1066.821
71	60.00	85.00	601.715	474.134	1075.850
72	60.00	86.00	610.898	473.967	1084.865
73	60.00	87.00	620.139	475.737	1095.876
74	60.00	88.00	629.503	479.747	1109.251
75	60.00	89.00	638.995	483.852	1122.847
76	60.00	90.00	648.619	485.905	1134.524
77	60.00	91.00	Soil Elevations	Must Extend At or Below	Contribution Zone
78	60.00	92.00	Soil Elevations	Must Extend At or Below	Contribution Zone
79	60.00	93.00	Soil Elevations	Must Extend At or Below	Contribution Zone
80	60.00	94.00	Soil Elevations	Must Extend At or Below	Contribution Zone
81	60.00	95.00	Soil Elevations	Must Extend At or Below	Contribution Zone

B-101Shaft60in.out

Drilled Shaft Capacity at User-Defined Settlement (sorted by shaft diameter):

\*\*\*\*\* Capacity is NOT modified by the strength reduction factors \*\*\*\*\*

---

User-Defined Settlement = 0.83%

ID	Diameter (in)	Length (ft)	Skin Fric. (tons)	End Bearing (tons)	Capacity (tons)
1	60.00	15.00	5.122	33.477	38.599
2	60.00	16.00	7.325	34.486	41.811
3	60.00	17.00	9.832	35.281	45.113
4	60.00	18.00	12.638	69.012	81.650
5	60.00	19.00	15.767	69.118	84.885
6	60.00	20.00	19.209	69.944	89.153
7	60.00	21.00	22.948	70.114	93.062
8	60.00	22.00	26.945	71.406	98.351
9	60.00	23.00	31.193	75.685	106.878
10	60.00	24.00	35.724	80.896	116.620
11	60.00	25.00	40.582	84.985	125.567
12	60.00	26.00	45.747	88.174	133.920
13	60.00	27.00	51.157	91.797	142.953
14	60.00	28.00	56.802	96.075	152.877
15	60.00	29.00	62.666	99.877	162.543
16	60.00	30.00	68.746	102.069	170.814
17	60.00	31.00	75.039	103.048	178.087
18	60.00	32.00	81.579	105.204	186.783
19	60.00	33.00	88.367	108.935	197.302
20	60.00	34.00	95.400	112.983	208.383
21	60.00	35.00	102.688	116.094	218.782
22	60.00	36.00	110.215	118.342	228.556
23	60.00	37.00	117.949	120.181	238.130
24	60.00	38.00	125.884	121.687	247.571
25	60.00	39.00	134.016	122.759	256.775
26	60.00	40.00	142.355	123.294	265.649
27	60.00	41.00	150.886	123.375	274.261
28	60.00	42.00	159.580	123.488	283.067
29	60.00	43.00	168.430	123.712	292.141
30	60.00	44.00	177.433	123.827	301.260
31	60.00	45.00	186.598	123.611	310.209
32	60.00	46.00	195.909	123.132	319.042
33	60.00	47.00	205.322	122.804	328.127
34	60.00	48.00	214.829	122.695	337.524
35	60.00	49.00	224.438	122.367	346.805
36	60.00	50.00	234.168	121.383	355.551
37	60.00	51.00	244.007	120.016	364.023
38	60.00	52.00	253.930	119.906	373.836
39	60.00	53.00	263.930	121.328	385.258
40	60.00	54.00	274.005	123.078	397.083
41	60.00	55.00	284.161	123.953	408.114
42	60.00	56.00	294.390	124.062	418.452
43	60.00	57.00	304.682	124.062	428.744
44	60.00	58.00	315.034	124.062	439.096
45	60.00	59.00	325.431	123.593	449.024
46	60.00	60.00	335.872	122.185	458.057
47	60.00	61.00	346.343	120.073	466.417
48	60.00	62.00	356.811	118.666	475.477
49	60.00	63.00	367.268	118.196	485.464
50	60.00	64.00	377.712	118.196	495.908
51	60.00	65.00	388.149	118.196	506.346
52	60.00	66.00	398.572	118.306	516.877
53	60.00	67.00	408.972	119.181	528.152
54	60.00	68.00	419.346	120.931	540.277
55	60.00	69.00	429.691	122.360	552.051
56	60.00	70.00	440.012	122.272	562.284
57	60.00	71.00	450.298	120.937	571.235
58	60.00	72.00	460.518	119.974	580.492
59	60.00	73.00	470.668	119.653	590.321
60	60.00	74.00	480.751	119.579	600.330
61	60.00	75.00	490.778	119.358	610.136
62	60.00	76.00	500.741	119.146	619.887
63	60.00	77.00	510.632	119.884	630.516
64	60.00	78.00	520.448	121.730	642.177
65	60.00	79.00	530.178	123.582	653.760
66	60.00	80.00	539.819	124.341	664.160
67	60.00	81.00	549.363	124.159	673.522
68	60.00	82.00	558.794	123.958	682.753
69	60.00	83.00	568.109	123.891	692.000
70	60.00	84.00	577.301	123.867	701.168
71	60.00	85.00	586.375	123.793	710.168
72	60.00	86.00	595.324	123.749	719.073
73	60.00	87.00	604.330	124.211	728.541
74	60.00	88.00	613.455	125.258	738.713
75	60.00	89.00	622.705	126.330	749.035
76	60.00	90.00	632.084	126.866	758.950
77	60.00	91.00	Soil Elevations	Must Extend At or Below	Contribution Zone

B-101Shaft60in.out

78	60.00	92.00	Soil Elevations	Must Extend At or Below	Contribution Zone
79	60.00	93.00	Soil Elevations	Must Extend At or Below	Contribution Zone
80	60.00	94.00	Soil Elevations	Must Extend At or Below	Contribution Zone
81	60.00	95.00	Soil Elevations	Must Extend At or Below	Contribution Zone

General Information:

=====  
 Input file: .....H)\Analysis\_Structure\FB-Deep\Drilled Shaft\B-201Shaft48in.spc  
 Project number: 2000-01-17003  
 Job name: SW 10th Street, from Powerline Rd. to Military Trail  
 Engineer: JB Henry  
 Units: English

Analysis Information:

=====  
 Analysis Type: Drilled Shaft Analysis

Soil Information:

=====  
 Boring date: 2/5/2018  
 Boring number: B-201  
 Station number: Offset:  
 Ground Elevation: 13.60(ft)  
 Water table Elevation = 13.60(ft)  
 Hammer type: Automatic Hammer, Correction factor = 1.24

ID	Depth (ft)	Elevation (ft)	SPT Blows (Blows/ft)	Unit Weight (pcf)	Soil Type
1	0.00	13.60	N/A	0.00	5- Cavity layer
2	2.00	11.60	N/A	0.00	5- Cavity layer
3	4.00	9.60	N/A	0.00	5- Cavity layer
4	6.00	7.60	N/A	0.00	5- Cavity layer
5	8.00	5.60	N/A	0.00	5- Cavity layer
6	10.00	3.60	10.00	110.00	3- Clean sand
7	12.00	1.60	23.00	115.00	3- Clean sand
8	13.50	0.10	19.00	115.00	3- Clean sand
9	15.50	-1.90	29.00	120.00	3- Clean sand
10	18.00	-4.40	41.00	125.00	3- Clean sand
11	20.50	-6.90	16.00	110.00	3- Clean sand
12	23.00	-9.40	31.00	120.00	3- Clean sand
13	25.50	-11.90	30.00	120.00	3- Clean sand
14	28.00	-14.40	60.00	130.00	3- Clean sand
15	30.50	-16.90	46.00	125.00	3- Clean sand
16	33.00	-19.40	78.00	130.00	3- Clean sand
17	35.50	-21.90	56.00	130.00	3- Clean sand
18	38.00	-24.40	60.00	130.00	3- Clean sand
19	40.50	-26.90	60.00	130.00	3- Clean sand
20	43.00	-29.40	66.00	130.00	3- Clean sand
21	45.50	-31.90	15.00	110.00	3- Clean sand
22	48.00	-34.40	29.00	120.00	3- Clean sand
23	50.50	-36.90	43.00	125.00	3- Clean sand
24	53.00	-39.40	65.00	130.00	3- Clean sand
25	55.50	-41.90	48.00	125.00	3- Clean sand
26	58.00	-44.40	78.00	130.00	3- Clean sand
27	60.50	-46.90	48.00	125.00	3- Clean sand
28	63.00	-49.40	68.00	130.00	3- Clean sand
29	65.50	-51.90	31.00	120.00	3- Clean sand
30	68.00	-54.40	50.00	130.00	3- Clean sand
31	70.50	-56.90	38.00	125.00	3- Clean sand
32	73.00	-59.40	45.00	125.00	3- Clean sand
33	75.50	-61.90	46.00	125.00	3- Clean sand
34	78.00	-64.40	60.00	130.00	3- Clean sand
35	80.50	-66.90	59.00	130.00	3- Clean sand
36	83.00	-69.40	68.00	130.00	3- Clean sand
37	85.50	-71.90	37.00	125.00	3- Clean sand
38	88.00	-74.40	63.00	130.00	3- Clean sand
39	90.50	-76.90	24.00	115.00	3- Clean sand
40	93.00	-79.40	39.00	125.00	3- Clean sand
41	95.50	-81.90	36.00	125.00	3- Clean sand
42	98.00	-84.40	60.00	130.00	3- Clean sand
43	100.00	-86.40	60.00	130.00	3- Clean sand

ID	Cu-DIR (tsf)	qu (tsf)	qt (tsf)	Em (ksi)	qb (tsf)
1	N/A	N/A	N/A	N/A	N/A
2	N/A	N/A	N/A	N/A	N/A
3	N/A	N/A	N/A	N/A	N/A
4	N/A	N/A	N/A	N/A	N/A
5	N/A	N/A	N/A	N/A	N/A
6	N/A	N/A	N/A	N/A	N/A
7	N/A	N/A	N/A	N/A	N/A
8	N/A	N/A	N/A	N/A	N/A

B-201Shaft48i n. out

9	N/A	N/A	N/A	N/A	N/A
10	N/A	N/A	N/A	N/A	N/A
11	N/A	N/A	N/A	N/A	N/A
12	N/A	N/A	N/A	N/A	N/A
13	N/A	N/A	N/A	N/A	N/A
14	N/A	N/A	N/A	N/A	N/A
15	N/A	N/A	N/A	N/A	N/A
16	N/A	N/A	N/A	N/A	N/A
17	N/A	N/A	N/A	N/A	N/A
18	N/A	N/A	N/A	N/A	N/A
19	N/A	N/A	N/A	N/A	N/A
20	N/A	N/A	N/A	N/A	N/A
21	N/A	N/A	N/A	N/A	N/A
22	N/A	N/A	N/A	N/A	N/A
23	N/A	N/A	N/A	N/A	N/A
24	N/A	N/A	N/A	N/A	N/A
25	N/A	N/A	N/A	N/A	N/A
26	N/A	N/A	N/A	N/A	N/A
27	N/A	N/A	N/A	N/A	N/A
28	N/A	N/A	N/A	N/A	N/A
29	N/A	N/A	N/A	N/A	N/A
30	N/A	N/A	N/A	N/A	N/A
31	N/A	N/A	N/A	N/A	N/A
32	N/A	N/A	N/A	N/A	N/A
33	N/A	N/A	N/A	N/A	N/A
34	N/A	N/A	N/A	N/A	N/A
35	N/A	N/A	N/A	N/A	N/A
36	N/A	N/A	N/A	N/A	N/A
37	N/A	N/A	N/A	N/A	N/A
38	N/A	N/A	N/A	N/A	N/A
39	N/A	N/A	N/A	N/A	N/A
40	N/A	N/A	N/A	N/A	N/A
41	N/A	N/A	N/A	N/A	N/A
42	N/A	N/A	N/A	N/A	N/A
43	N/A	N/A	N/A	N/A	N/A

ID RQD F. M. S. R. I. Rock Recovery

ID	RQD F. M.	S. R. I.	Rock Recovery
1	N/A	N/A	N/A
2	N/A	N/A	N/A
3	N/A	N/A	N/A
4	N/A	N/A	N/A
5	N/A	N/A	N/A
6	N/A	N/A	N/A
7	N/A	N/A	N/A
8	N/A	N/A	N/A
9	N/A	N/A	N/A
10	N/A	N/A	N/A
11	N/A	N/A	N/A
12	N/A	N/A	N/A
13	N/A	N/A	N/A
14	N/A	N/A	N/A
15	N/A	N/A	N/A
16	N/A	N/A	N/A
17	N/A	N/A	N/A
18	N/A	N/A	N/A
19	N/A	N/A	N/A
20	N/A	N/A	N/A
21	N/A	N/A	N/A
22	N/A	N/A	N/A
23	N/A	N/A	N/A
24	N/A	N/A	N/A
25	N/A	N/A	N/A
26	N/A	N/A	N/A
27	N/A	N/A	N/A
28	N/A	N/A	N/A
29	N/A	N/A	N/A
30	N/A	N/A	N/A
31	N/A	N/A	N/A
32	N/A	N/A	N/A
33	N/A	N/A	N/A
34	N/A	N/A	N/A
35	N/A	N/A	N/A
36	N/A	N/A	N/A
37	N/A	N/A	N/A
38	N/A	N/A	N/A
39	N/A	N/A	N/A
40	N/A	N/A	N/A
41	N/A	N/A	N/A
42	N/A	N/A	N/A
43	N/A	N/A	N/A

Drilled Shaft Data:

=====

Shaft Geometry:

B-201Shaft48in. out

ID	Length (ft)	Tip Elev. (ft)	Case Len. (ft)	Diameter (in)	Base Diam. (in)	Bell Len. (ft)
1	15.00	-1.40	6.00	48.00	48.00	0.00
2	16.00	-2.40	6.00	48.00	48.00	0.00
3	17.00	-3.40	6.00	48.00	48.00	0.00
4	18.00	-4.40	6.00	48.00	48.00	0.00
5	19.00	-5.40	6.00	48.00	48.00	0.00
6	20.00	-6.40	6.00	48.00	48.00	0.00
7	21.00	-7.40	6.00	48.00	48.00	0.00
8	22.00	-8.40	6.00	48.00	48.00	0.00
9	23.00	-9.40	6.00	48.00	48.00	0.00
10	24.00	-10.40	6.00	48.00	48.00	0.00
11	25.00	-11.40	6.00	48.00	48.00	0.00
12	26.00	-12.40	6.00	48.00	48.00	0.00
13	27.00	-13.40	6.00	48.00	48.00	0.00
14	28.00	-14.40	6.00	48.00	48.00	0.00
15	29.00	-15.40	6.00	48.00	48.00	0.00
16	30.00	-16.40	6.00	48.00	48.00	0.00
17	31.00	-17.40	6.00	48.00	48.00	0.00
18	32.00	-18.40	6.00	48.00	48.00	0.00
19	33.00	-19.40	6.00	48.00	48.00	0.00
20	34.00	-20.40	6.00	48.00	48.00	0.00
21	35.00	-21.40	6.00	48.00	48.00	0.00
22	36.00	-22.40	6.00	48.00	48.00	0.00
23	37.00	-23.40	6.00	48.00	48.00	0.00
24	38.00	-24.40	6.00	48.00	48.00	0.00
25	39.00	-25.40	6.00	48.00	48.00	0.00
26	40.00	-26.40	6.00	48.00	48.00	0.00
27	41.00	-27.40	6.00	48.00	48.00	0.00
28	42.00	-28.40	6.00	48.00	48.00	0.00
29	43.00	-29.40	6.00	48.00	48.00	0.00
30	44.00	-30.40	6.00	48.00	48.00	0.00
31	45.00	-31.40	6.00	48.00	48.00	0.00
32	46.00	-32.40	6.00	48.00	48.00	0.00
33	47.00	-33.40	6.00	48.00	48.00	0.00
34	48.00	-34.40	6.00	48.00	48.00	0.00
35	49.00	-35.40	6.00	48.00	48.00	0.00
36	50.00	-36.40	6.00	48.00	48.00	0.00
37	51.00	-37.40	6.00	48.00	48.00	0.00
38	52.00	-38.40	6.00	48.00	48.00	0.00
39	53.00	-39.40	6.00	48.00	48.00	0.00
40	54.00	-40.40	6.00	48.00	48.00	0.00
41	55.00	-41.40	6.00	48.00	48.00	0.00
42	56.00	-42.40	6.00	48.00	48.00	0.00
43	57.00	-43.40	6.00	48.00	48.00	0.00
44	58.00	-44.40	6.00	48.00	48.00	0.00
45	59.00	-45.40	6.00	48.00	48.00	0.00
46	60.00	-46.40	6.00	48.00	48.00	0.00
47	61.00	-47.40	6.00	48.00	48.00	0.00
48	62.00	-48.40	6.00	48.00	48.00	0.00
49	63.00	-49.40	6.00	48.00	48.00	0.00
50	64.00	-50.40	6.00	48.00	48.00	0.00
51	65.00	-51.40	6.00	48.00	48.00	0.00
52	66.00	-52.40	6.00	48.00	48.00	0.00
53	67.00	-53.40	6.00	48.00	48.00	0.00
54	68.00	-54.40	6.00	48.00	48.00	0.00
55	69.00	-55.40	6.00	48.00	48.00	0.00
56	70.00	-56.40	6.00	48.00	48.00	0.00
57	71.00	-57.40	6.00	48.00	48.00	0.00
58	72.00	-58.40	6.00	48.00	48.00	0.00
59	73.00	-59.40	6.00	48.00	48.00	0.00
60	74.00	-60.40	6.00	48.00	48.00	0.00
61	75.00	-61.40	6.00	48.00	48.00	0.00
62	76.00	-62.40	6.00	48.00	48.00	0.00
63	77.00	-63.40	6.00	48.00	48.00	0.00
64	78.00	-64.40	6.00	48.00	48.00	0.00
65	79.00	-65.40	6.00	48.00	48.00	0.00
66	80.00	-66.40	6.00	48.00	48.00	0.00
67	81.00	-67.40	6.00	48.00	48.00	0.00
68	82.00	-68.40	6.00	48.00	48.00	0.00
69	83.00	-69.40	6.00	48.00	48.00	0.00
70	84.00	-70.40	6.00	48.00	48.00	0.00
71	85.00	-71.40	6.00	48.00	48.00	0.00
72	86.00	-72.40	6.00	48.00	48.00	0.00
73	87.00	-73.40	6.00	48.00	48.00	0.00
74	88.00	-74.40	6.00	48.00	48.00	0.00
75	89.00	-75.40	6.00	48.00	48.00	0.00
76	90.00	-76.40	6.00	48.00	48.00	0.00
77	91.00	-77.40	6.00	48.00	48.00	0.00
78	92.00	-78.40	6.00	48.00	48.00	0.00
79	93.00	-79.40	6.00	48.00	48.00	0.00
80	94.00	-80.40	6.00	48.00	48.00	0.00
81	95.00	-81.40	6.00	48.00	48.00	0.00

Drilled Shaft Capacity (sorted by shaft diameter):

B-201Shaft48i n. out

Strength reduction factors: Skin-friction = 1.00, End-bearing = 1.00

ID	Diameter (in)	Length (ft)	Skin Fric. (tons)	End Bearing (tons)	Capacity (tons)
1	48.00	15.00	3.805	134.211	138.017
2	48.00	16.00	5.511	234.686	240.197
3	48.00	17.00	7.526	248.657	256.183
4	48.00	18.00	9.849	258.544	268.393
5	48.00	19.00	12.475	268.512	280.987
6	48.00	20.00	15.415	280.329	295.745
7	48.00	21.00	18.646	288.692	307.338
8	48.00	22.00	22.092	293.991	316.082
9	48.00	23.00	25.741	296.883	322.624
10	48.00	24.00	29.607	296.793	326.400
11	48.00	25.00	33.712	298.650	332.363
12	48.00	26.00	38.048	308.120	346.168
13	48.00	27.00	42.603	324.332	366.935
14	48.00	28.00	47.375	338.205	385.580
15	48.00	29.00	52.372	347.806	400.178
16	48.00	30.00	57.617	355.225	412.842
17	48.00	31.00	63.095	362.956	426.051
18	48.00	32.00	68.779	370.557	439.336
19	48.00	33.00	74.661	375.383	450.044
20	48.00	34.00	80.739	376.991	457.730
21	48.00	35.00	87.022	376.991	464.013
22	48.00	36.00	93.499	374.032	467.530
23	48.00	37.00	100.160	365.154	465.314
24	48.00	38.00	107.002	351.506	458.508
25	48.00	39.00	114.011	339.981	453.992
26	48.00	40.00	121.184	331.729	452.912
27	48.00	41.00	128.512	326.436	454.947
28	48.00	42.00	135.985	323.789	459.775
29	48.00	43.00	143.602	323.458	467.060
30	48.00	44.00	151.347	322.472	473.819
31	48.00	45.00	159.219	319.513	478.732
32	48.00	46.00	167.201	314.963	482.164
33	48.00	47.00	175.228	311.122	486.350
34	48.00	48.00	183.292	308.371	491.663
35	48.00	49.00	191.400	306.607	498.007
36	48.00	50.00	199.569	309.670	509.239
37	48.00	51.00	207.794	321.397	529.192
38	48.00	52.00	216.082	339.595	555.677
39	48.00	53.00	224.431	354.961	579.392
40	48.00	54.00	232.838	365.964	598.802
41	48.00	55.00	241.310	373.021	614.332
42	48.00	56.00	249.838	375.461	625.298
43	48.00	57.00	258.401	372.633	631.034
44	48.00	58.00	266.996	367.730	634.726
45	48.00	59.00	275.619	364.462	640.081
46	48.00	60.00	284.277	363.372	647.649
47	48.00	61.00	292.960	363.101	656.061
48	48.00	62.00	301.650	362.287	663.936
49	48.00	63.00	310.343	361.065	671.409
50	48.00	64.00	319.037	359.888	678.925
51	48.00	65.00	327.736	358.527	686.263
52	48.00	66.00	336.430	356.892	693.322
53	48.00	67.00	345.093	355.803	700.896
54	48.00	68.00	353.720	355.440	709.160
55	48.00	69.00	362.315	355.349	717.664
56	48.00	70.00	370.888	356.531	727.418
57	48.00	71.00	379.430	360.481	739.912
58	48.00	72.00	387.928	366.747	754.675
59	48.00	73.00	396.376	371.015	767.390
60	48.00	74.00	404.766	372.467	777.234
61	48.00	75.00	413.098	372.829	785.927
62	48.00	76.00	421.364	373.527	794.890
63	48.00	77.00	429.558	373.990	803.549
64	48.00	78.00	437.680	373.329	811.009
65	48.00	79.00	445.725	372.526	818.251
66	48.00	80.00	453.696	372.137	825.833
67	48.00	81.00	461.586	370.230	831.816
68	48.00	82.00	469.390	364.507	833.898
69	48.00	83.00	477.106	355.884	832.990
70	48.00	84.00	484.724	349.723	834.447
71	48.00	85.00	492.242	346.809	839.051
72	48.00	86.00	499.655	345.103	844.758
73	48.00	87.00	507.115	342.890	850.005
74	48.00	88.00	514.673	340.449	855.122
75	48.00	89.00	522.333	338.297	860.630
76	48.00	90.00	530.099	336.402	866.502
77	48.00	91.00	537.969	335.081	873.050
78	48.00	92.00	545.924	335.401	881.325
79	48.00	93.00	Soil Elevations	Must Extend At or Below	Contribution Zone
80	48.00	94.00	Soil Elevations	Must Extend At or Below	Contribution Zone
81	48.00	95.00	Soil Elevations	Must Extend At or Below	Contribution Zone

B-201Shaft48i n. out

Drilled Shaft Capacity at User-Defined Settlement (sorted by shaft diameter):

\*\*\*\*\* Capacity is NOT modified by the strength reduction factors \*\*\*\*\*

---

User-Defined Settlement = 1.04%

ID	Diameter (in)	Length (ft)	Skin Fric. (tons)	End Bearing (tons)	Capacity (tons)
1	48.00	15.00	3.722	42.666	46.388
2	48.00	16.00	5.390	74.607	79.997
3	48.00	17.00	7.361	79.048	86.410
4	48.00	18.00	9.634	82.191	91.825
5	48.00	19.00	12.202	85.360	97.562
6	48.00	20.00	15.078	89.117	104.195
7	48.00	21.00	18.237	91.775	110.013
8	48.00	22.00	21.608	93.460	115.068
9	48.00	23.00	25.178	94.379	119.557
10	48.00	24.00	28.959	94.351	123.309
11	48.00	25.00	32.975	94.941	127.916
12	48.00	26.00	37.215	97.951	135.167
13	48.00	27.00	41.671	103.105	144.776
14	48.00	28.00	46.338	107.515	153.853
15	48.00	29.00	51.226	110.568	161.793
16	48.00	30.00	56.356	112.926	169.282
17	48.00	31.00	61.714	115.384	177.098
18	48.00	32.00	67.273	117.800	185.074
19	48.00	33.00	73.027	119.334	192.361
20	48.00	34.00	78.972	119.846	198.818
21	48.00	35.00	85.117	119.846	204.963
22	48.00	36.00	91.452	118.905	210.357
23	48.00	37.00	97.968	116.082	214.050
24	48.00	38.00	104.660	111.744	216.404
25	48.00	39.00	111.515	108.080	219.595
26	48.00	40.00	118.531	105.457	223.988
27	48.00	41.00	125.699	103.774	229.473
28	48.00	42.00	133.009	102.933	235.942
29	48.00	43.00	140.458	102.828	243.286
30	48.00	44.00	148.034	102.514	250.548
31	48.00	45.00	155.734	101.573	257.307
32	48.00	46.00	163.541	100.127	263.668
33	48.00	47.00	171.393	98.906	270.299
34	48.00	48.00	179.280	98.031	277.311
35	48.00	49.00	187.211	97.470	284.681
36	48.00	50.00	195.201	98.444	293.645
37	48.00	51.00	203.246	102.172	305.419
38	48.00	52.00	211.352	107.957	319.310
39	48.00	53.00	219.518	112.842	332.361
40	48.00	54.00	227.742	116.340	344.082
41	48.00	55.00	236.029	118.584	354.612
42	48.00	56.00	244.369	119.359	363.728
43	48.00	57.00	252.745	118.460	371.205
44	48.00	58.00	261.152	116.902	378.053
45	48.00	59.00	269.586	115.863	385.449
46	48.00	60.00	278.055	115.516	393.571
47	48.00	61.00	286.547	115.430	401.977
48	48.00	62.00	295.047	115.171	410.218
49	48.00	63.00	303.551	114.783	418.333
50	48.00	64.00	312.054	114.408	426.463
51	48.00	65.00	320.563	113.976	434.538
52	48.00	66.00	329.066	113.456	442.522
53	48.00	67.00	337.540	113.110	450.649
54	48.00	68.00	345.978	112.994	458.972
55	48.00	69.00	354.385	112.966	467.350
56	48.00	70.00	362.770	113.341	476.111
57	48.00	71.00	371.125	114.597	485.723
58	48.00	72.00	379.437	116.589	496.026
59	48.00	73.00	387.700	117.946	505.646
60	48.00	74.00	395.907	118.407	514.314
61	48.00	75.00	404.056	118.522	522.578
62	48.00	76.00	412.141	118.744	530.885
63	48.00	77.00	420.156	118.892	539.048
64	48.00	78.00	428.100	118.681	546.782
65	48.00	79.00	435.969	118.426	554.395
66	48.00	80.00	443.765	118.303	562.068
67	48.00	81.00	451.483	117.696	569.179
68	48.00	82.00	459.116	115.877	574.993
69	48.00	83.00	466.663	113.136	579.799
70	48.00	84.00	474.114	111.177	585.291
71	48.00	85.00	481.468	110.251	591.718
72	48.00	86.00	488.719	109.708	598.427
73	48.00	87.00	496.015	109.005	605.020
74	48.00	88.00	503.408	108.229	611.637
75	48.00	89.00	510.900	107.545	618.445
76	48.00	90.00	518.497	106.942	625.439
77	48.00	91.00	526.194	106.522	632.716



				B-201Shaft48in.out		
78	48.00	92.00	533.975	106.624	640.599	
79	48.00	93.00	Soil Elevations	Must Extend At	or Below	Contribution Zone
80	48.00	94.00	Soil Elevations	Must Extend At	or Below	Contribution Zone
81	48.00	95.00	Soil Elevations	Must Extend At	or Below	Contribution Zone

General Information:

=====  
 Input file: .....H)\Analysis\_Structure\FB-Deep\Drilled Shaft\B-201Shaft60in.spc  
 Project number: 2000-01-17003  
 Job name: SW 10th Street, from Powerline Rd. to Military Trail  
 Engineer: JB Henry  
 Units: English

Analysis Information:

=====  
 Analysis Type: Drilled Shaft Analysis

Soil Information:

=====  
 Boring date: 2/5/2018  
 Boring number: B-201  
 Station number:     Offset:  
  
 Ground Elevation: 13.60(ft)  
 Water table Elevation = 13.60(ft)  
  
 Hammer type: Automatic Hammer, Correction factor = 1.24

ID	Depth (ft)	Elevation (ft)	SPT Blows (Blows/ft)	Unit Weight (pcf)	Soil Type
1	0.00	13.60	N/A	0.00	5- Cavity layer
2	2.00	11.60	N/A	0.00	5- Cavity layer
3	4.00	9.60	N/A	0.00	5- Cavity layer
4	6.00	7.60	N/A	0.00	5- Cavity layer
5	8.00	5.60	N/A	0.00	5- Cavity layer
6	10.00	3.60	10.00	110.00	3- Clean sand
7	12.00	1.60	23.00	115.00	3- Clean sand
8	13.50	0.10	19.00	115.00	3- Clean sand
9	15.50	-1.90	29.00	120.00	3- Clean sand
10	18.00	-4.40	41.00	125.00	3- Clean sand
11	20.50	-6.90	16.00	110.00	3- Clean sand
12	23.00	-9.40	31.00	120.00	3- Clean sand
13	25.50	-11.90	30.00	120.00	3- Clean sand
14	28.00	-14.40	60.00	130.00	3- Clean sand
15	30.50	-16.90	46.00	125.00	3- Clean sand
16	33.00	-19.40	78.00	130.00	3- Clean sand
17	35.50	-21.90	56.00	130.00	3- Clean sand
18	38.00	-24.40	60.00	130.00	3- Clean sand
19	40.50	-26.90	60.00	130.00	3- Clean sand
20	43.00	-29.40	66.00	130.00	3- Clean sand
21	45.50	-31.90	15.00	110.00	3- Clean sand
22	48.00	-34.40	29.00	120.00	3- Clean sand
23	50.50	-36.90	43.00	125.00	3- Clean sand
24	53.00	-39.40	65.00	130.00	3- Clean sand
25	55.50	-41.90	48.00	125.00	3- Clean sand
26	58.00	-44.40	78.00	130.00	3- Clean sand
27	60.50	-46.90	48.00	125.00	3- Clean sand
28	63.00	-49.40	68.00	130.00	3- Clean sand
29	65.50	-51.90	31.00	120.00	3- Clean sand
30	68.00	-54.40	50.00	130.00	3- Clean sand
31	70.50	-56.90	38.00	125.00	3- Clean sand
32	73.00	-59.40	45.00	125.00	3- Clean sand
33	75.50	-61.90	46.00	125.00	3- Clean sand
34	78.00	-64.40	60.00	130.00	3- Clean sand
35	80.50	-66.90	59.00	130.00	3- Clean sand
36	83.00	-69.40	68.00	130.00	3- Clean sand
37	85.50	-71.90	37.00	125.00	3- Clean sand
38	88.00	-74.40	63.00	130.00	3- Clean sand
39	90.50	-76.90	24.00	115.00	3- Clean sand
40	93.00	-79.40	39.00	125.00	3- Clean sand
41	95.50	-81.90	36.00	125.00	3- Clean sand
42	98.00	-84.40	60.00	130.00	3- Clean sand
43	100.00	-86.40	60.00	130.00	3- Clean sand

ID	Cu-Dir (tsf)	qu (tsf)	qt (tsf)	Em (ksi)	qb (tsf)
1	N/A	N/A	N/A	N/A	N/A
2	N/A	N/A	N/A	N/A	N/A
3	N/A	N/A	N/A	N/A	N/A
4	N/A	N/A	N/A	N/A	N/A
5	N/A	N/A	N/A	N/A	N/A
6	N/A	N/A	N/A	N/A	N/A
7	N/A	N/A	N/A	N/A	N/A
8	N/A	N/A	N/A	N/A	N/A

B-201Shaft60i n. out

9	N/A	N/A	N/A	N/A	N/A
10	N/A	N/A	N/A	N/A	N/A
11	N/A	N/A	N/A	N/A	N/A
12	N/A	N/A	N/A	N/A	N/A
13	N/A	N/A	N/A	N/A	N/A
14	N/A	N/A	N/A	N/A	N/A
15	N/A	N/A	N/A	N/A	N/A
16	N/A	N/A	N/A	N/A	N/A
17	N/A	N/A	N/A	N/A	N/A
18	N/A	N/A	N/A	N/A	N/A
19	N/A	N/A	N/A	N/A	N/A
20	N/A	N/A	N/A	N/A	N/A
21	N/A	N/A	N/A	N/A	N/A
22	N/A	N/A	N/A	N/A	N/A
23	N/A	N/A	N/A	N/A	N/A
24	N/A	N/A	N/A	N/A	N/A
25	N/A	N/A	N/A	N/A	N/A
26	N/A	N/A	N/A	N/A	N/A
27	N/A	N/A	N/A	N/A	N/A
28	N/A	N/A	N/A	N/A	N/A
29	N/A	N/A	N/A	N/A	N/A
30	N/A	N/A	N/A	N/A	N/A
31	N/A	N/A	N/A	N/A	N/A
32	N/A	N/A	N/A	N/A	N/A
33	N/A	N/A	N/A	N/A	N/A
34	N/A	N/A	N/A	N/A	N/A
35	N/A	N/A	N/A	N/A	N/A
36	N/A	N/A	N/A	N/A	N/A
37	N/A	N/A	N/A	N/A	N/A
38	N/A	N/A	N/A	N/A	N/A
39	N/A	N/A	N/A	N/A	N/A
40	N/A	N/A	N/A	N/A	N/A
41	N/A	N/A	N/A	N/A	N/A
42	N/A	N/A	N/A	N/A	N/A
43	N/A	N/A	N/A	N/A	N/A

ID RQD F. M. S. R. I. Rock Recovery

ID	RQD F. M.	S. R. I.	Rock Recovery
1	N/A	N/A	N/A
2	N/A	N/A	N/A
3	N/A	N/A	N/A
4	N/A	N/A	N/A
5	N/A	N/A	N/A
6	N/A	N/A	N/A
7	N/A	N/A	N/A
8	N/A	N/A	N/A
9	N/A	N/A	N/A
10	N/A	N/A	N/A
11	N/A	N/A	N/A
12	N/A	N/A	N/A
13	N/A	N/A	N/A
14	N/A	N/A	N/A
15	N/A	N/A	N/A
16	N/A	N/A	N/A
17	N/A	N/A	N/A
18	N/A	N/A	N/A
19	N/A	N/A	N/A
20	N/A	N/A	N/A
21	N/A	N/A	N/A
22	N/A	N/A	N/A
23	N/A	N/A	N/A
24	N/A	N/A	N/A
25	N/A	N/A	N/A
26	N/A	N/A	N/A
27	N/A	N/A	N/A
28	N/A	N/A	N/A
29	N/A	N/A	N/A
30	N/A	N/A	N/A
31	N/A	N/A	N/A
32	N/A	N/A	N/A
33	N/A	N/A	N/A
34	N/A	N/A	N/A
35	N/A	N/A	N/A
36	N/A	N/A	N/A
37	N/A	N/A	N/A
38	N/A	N/A	N/A
39	N/A	N/A	N/A
40	N/A	N/A	N/A
41	N/A	N/A	N/A
42	N/A	N/A	N/A
43	N/A	N/A	N/A

Drilled Shaft Data:

=====

Shaft Geometry:

B-201Shaft60in. out

ID	Length (ft)	Tip Elev. (ft)	Case Len. (ft)	Diameter (in)	Base Diam. (in)	Bell Len. (ft)
1	15.00	-1.40	6.00	60.00	60.00	0.00
2	16.00	-2.40	6.00	60.00	60.00	0.00
3	17.00	-3.40	6.00	60.00	60.00	0.00
4	18.00	-4.40	6.00	60.00	60.00	0.00
5	19.00	-5.40	6.00	60.00	60.00	0.00
6	20.00	-6.40	6.00	60.00	60.00	0.00
7	21.00	-7.40	6.00	60.00	60.00	0.00
8	22.00	-8.40	6.00	60.00	60.00	0.00
9	23.00	-9.40	6.00	60.00	60.00	0.00
10	24.00	-10.40	6.00	60.00	60.00	0.00
11	25.00	-11.40	6.00	60.00	60.00	0.00
12	26.00	-12.40	6.00	60.00	60.00	0.00
13	27.00	-13.40	6.00	60.00	60.00	0.00
14	28.00	-14.40	6.00	60.00	60.00	0.00
15	29.00	-15.40	6.00	60.00	60.00	0.00
16	30.00	-16.40	6.00	60.00	60.00	0.00
17	31.00	-17.40	6.00	60.00	60.00	0.00
18	32.00	-18.40	6.00	60.00	60.00	0.00
19	33.00	-19.40	6.00	60.00	60.00	0.00
20	34.00	-20.40	6.00	60.00	60.00	0.00
21	35.00	-21.40	6.00	60.00	60.00	0.00
22	36.00	-22.40	6.00	60.00	60.00	0.00
23	37.00	-23.40	6.00	60.00	60.00	0.00
24	38.00	-24.40	6.00	60.00	60.00	0.00
25	39.00	-25.40	6.00	60.00	60.00	0.00
26	40.00	-26.40	6.00	60.00	60.00	0.00
27	41.00	-27.40	6.00	60.00	60.00	0.00
28	42.00	-28.40	6.00	60.00	60.00	0.00
29	43.00	-29.40	6.00	60.00	60.00	0.00
30	44.00	-30.40	6.00	60.00	60.00	0.00
31	45.00	-31.40	6.00	60.00	60.00	0.00
32	46.00	-32.40	6.00	60.00	60.00	0.00
33	47.00	-33.40	6.00	60.00	60.00	0.00
34	48.00	-34.40	6.00	60.00	60.00	0.00
35	49.00	-35.40	6.00	60.00	60.00	0.00
36	50.00	-36.40	6.00	60.00	60.00	0.00
37	51.00	-37.40	6.00	60.00	60.00	0.00
38	52.00	-38.40	6.00	60.00	60.00	0.00
39	53.00	-39.40	6.00	60.00	60.00	0.00
40	54.00	-40.40	6.00	60.00	60.00	0.00
41	55.00	-41.40	6.00	60.00	60.00	0.00
42	56.00	-42.40	6.00	60.00	60.00	0.00
43	57.00	-43.40	6.00	60.00	60.00	0.00
44	58.00	-44.40	6.00	60.00	60.00	0.00
45	59.00	-45.40	6.00	60.00	60.00	0.00
46	60.00	-46.40	6.00	60.00	60.00	0.00
47	61.00	-47.40	6.00	60.00	60.00	0.00
48	62.00	-48.40	6.00	60.00	60.00	0.00
49	63.00	-49.40	6.00	60.00	60.00	0.00
50	64.00	-50.40	6.00	60.00	60.00	0.00
51	65.00	-51.40	6.00	60.00	60.00	0.00
52	66.00	-52.40	6.00	60.00	60.00	0.00
53	67.00	-53.40	6.00	60.00	60.00	0.00
54	68.00	-54.40	6.00	60.00	60.00	0.00
55	69.00	-55.40	6.00	60.00	60.00	0.00
56	70.00	-56.40	6.00	60.00	60.00	0.00
57	71.00	-57.40	6.00	60.00	60.00	0.00
58	72.00	-58.40	6.00	60.00	60.00	0.00
59	73.00	-59.40	6.00	60.00	60.00	0.00
60	74.00	-60.40	6.00	60.00	60.00	0.00
61	75.00	-61.40	6.00	60.00	60.00	0.00
62	76.00	-62.40	6.00	60.00	60.00	0.00
63	77.00	-63.40	6.00	60.00	60.00	0.00
64	78.00	-64.40	6.00	60.00	60.00	0.00
65	79.00	-65.40	6.00	60.00	60.00	0.00
66	80.00	-66.40	6.00	60.00	60.00	0.00
67	81.00	-67.40	6.00	60.00	60.00	0.00
68	82.00	-68.40	6.00	60.00	60.00	0.00
69	83.00	-69.40	6.00	60.00	60.00	0.00
70	84.00	-70.40	6.00	60.00	60.00	0.00
71	85.00	-71.40	6.00	60.00	60.00	0.00
72	86.00	-72.40	6.00	60.00	60.00	0.00
73	87.00	-73.40	6.00	60.00	60.00	0.00
74	88.00	-74.40	6.00	60.00	60.00	0.00
75	89.00	-75.40	6.00	60.00	60.00	0.00
76	90.00	-76.40	6.00	60.00	60.00	0.00
77	91.00	-77.40	6.00	60.00	60.00	0.00
78	92.00	-78.40	6.00	60.00	60.00	0.00
79	93.00	-79.40	6.00	60.00	60.00	0.00
80	94.00	-80.40	6.00	60.00	60.00	0.00
81	95.00	-81.40	6.00	60.00	60.00	0.00

Drilled Shaft Capacity (sorted by shaft diameter):

B-201Shaft60i n. out

Strength reduction factors: Skin-friction = 1.00, End-bearing = 1.00

ID	Diameter (in)	Length (ft)	Skin Fric. (tons)	End Bearing (tons)	Capacity (tons)
1	60.00	15.00	4.757	177.055	181.812
2	60.00	16.00	6.888	178.044	184.932
3	60.00	17.00	9.408	178.409	187.817
4	60.00	18.00	12.312	335.442	347.754
5	60.00	19.00	15.594	353.789	369.383
6	60.00	20.00	19.269	365.816	385.085
7	60.00	21.00	23.307	377.503	400.810
8	60.00	22.00	27.615	389.062	416.676
9	60.00	23.00	32.176	397.780	429.956
10	60.00	24.00	37.008	403.199	440.207
11	60.00	25.00	42.141	404.861	447.002
12	60.00	26.00	47.560	404.328	451.888
13	60.00	27.00	53.254	410.967	464.222
14	60.00	28.00	59.218	426.340	485.559
15	60.00	29.00	65.465	443.645	509.110
16	60.00	30.00	72.021	456.081	528.102
17	60.00	31.00	78.869	464.296	543.165
18	60.00	32.00	85.974	472.187	558.160
19	60.00	33.00	93.327	480.402	573.728
20	60.00	34.00	100.924	484.021	584.945
21	60.00	35.00	108.777	478.124	586.901
22	60.00	36.00	116.873	464.326	581.200
23	60.00	37.00	125.200	452.322	577.522
24	60.00	38.00	133.753	443.725	577.478
25	60.00	39.00	142.514	438.212	580.726
26	60.00	40.00	151.480	435.455	586.935
27	60.00	41.00	160.640	435.111	595.750
28	60.00	42.00	169.982	435.111	605.092
29	60.00	43.00	179.502	435.111	614.613
30	60.00	44.00	189.184	434.083	623.267
31	60.00	45.00	199.024	431.000	630.024
32	60.00	46.00	209.001	426.261	635.262
33	60.00	47.00	219.036	422.260	641.295
34	60.00	48.00	229.115	419.394	648.509
35	60.00	49.00	239.250	417.557	656.807
36	60.00	50.00	249.461	416.638	666.099
37	60.00	51.00	259.743	417.550	677.293
38	60.00	52.00	270.102	425.771	695.873
39	60.00	53.00	280.538	442.212	722.750
40	60.00	54.00	291.048	459.356	750.404
41	60.00	55.00	301.638	469.685	771.323
42	60.00	56.00	312.297	473.876	786.173
43	60.00	57.00	323.001	475.985	798.986
44	60.00	58.00	333.745	476.688	810.432
45	60.00	59.00	344.524	476.405	820.929
46	60.00	60.00	355.346	475.557	830.903
47	60.00	61.00	366.200	474.284	840.484
48	60.00	62.00	377.062	473.436	850.498
49	60.00	63.00	387.929	473.153	861.083
50	60.00	64.00	398.797	472.775	871.572
51	60.00	65.00	409.670	471.640	881.310
52	60.00	66.00	420.537	469.938	890.475
53	60.00	67.00	431.366	468.803	900.169
54	60.00	68.00	442.150	468.425	910.575
55	60.00	69.00	452.894	468.330	921.224
56	60.00	70.00	463.610	468.048	931.657
57	60.00	71.00	474.288	468.002	942.290
58	60.00	72.00	484.909	470.745	955.655
59	60.00	73.00	495.470	476.704	972.174
60	60.00	74.00	505.958	482.352	988.310
61	60.00	75.00	516.372	484.165	1000.537
62	60.00	76.00	526.704	482.818	1009.522
63	60.00	77.00	536.948	482.358	1019.306
64	60.00	78.00	547.100	483.462	1030.562
65	60.00	79.00	557.156	482.983	1040.139
66	60.00	80.00	567.120	477.775	1044.895
67	60.00	81.00	576.983	468.888	1045.870
68	60.00	82.00	586.738	462.604	1049.342
69	60.00	83.00	596.382	459.973	1056.356
70	60.00	84.00	605.904	458.668	1064.573
71	60.00	85.00	615.302	456.363	1071.665
72	60.00	86.00	624.569	453.348	1077.918
73	60.00	87.00	633.894	451.365	1085.259
74	60.00	88.00	643.341	450.704	1094.045
75	60.00	89.00	652.916	450.042	1102.958
76	60.00	90.00	662.624	448.055	1110.679
77	60.00	91.00	Soil Elevations	Must Extend At or Below	Contribution Zone
78	60.00	92.00	Soil Elevations	Must Extend At or Below	Contribution Zone
79	60.00	93.00	Soil Elevations	Must Extend At or Below	Contribution Zone
80	60.00	94.00	Soil Elevations	Must Extend At or Below	Contribution Zone
81	60.00	95.00	Soil Elevations	Must Extend At or Below	Contribution Zone

B-201Shaft60in.out

Drilled Shaft Capacity at User-Defined Settlement (sorted by shaft diameter):

\*\*\*\*\* Capacity is NOT modified by the strength reduction factors \*\*\*\*\*

User-Defined Settlement = 0.83%

ID	Diameter (in)	Length (ft)	Skin Fric. (tons)	End Bearing (tons)	Capacity (tons)
1	60.00	15.00	4.636	46.228	50.863
2	60.00	16.00	6.713	46.486	53.198
3	60.00	17.00	9.168	46.581	55.749
4	60.00	18.00	11.998	87.581	99.579
5	60.00	19.00	15.197	92.371	107.568
6	60.00	20.00	18.778	95.512	114.290
7	60.00	21.00	22.713	98.563	121.276
8	60.00	22.00	26.911	101.581	128.492
9	60.00	23.00	31.356	103.857	135.213
10	60.00	24.00	36.065	105.272	141.337
11	60.00	25.00	41.066	105.706	146.772
12	60.00	26.00	46.348	105.567	151.915
13	60.00	27.00	51.896	107.300	159.197
14	60.00	28.00	57.709	111.314	169.023
15	60.00	29.00	63.796	115.832	179.628
16	60.00	30.00	70.185	119.079	189.264
17	60.00	31.00	76.859	121.224	198.083
18	60.00	32.00	83.782	123.284	207.066
19	60.00	33.00	90.947	125.429	216.376
20	60.00	34.00	98.351	126.374	224.725
21	60.00	35.00	106.004	124.834	230.839
22	60.00	36.00	113.894	121.232	235.126
23	60.00	37.00	122.008	118.098	240.106
24	60.00	38.00	130.343	115.853	246.196
25	60.00	39.00	138.880	114.414	253.294
26	60.00	40.00	147.618	113.694	261.312
27	60.00	41.00	156.544	113.604	270.148
28	60.00	42.00	165.648	113.604	279.252
29	60.00	43.00	174.926	113.604	288.530
30	60.00	44.00	184.361	113.336	297.696
31	60.00	45.00	193.950	112.531	306.481
32	60.00	46.00	203.673	111.294	314.966
33	60.00	47.00	213.452	110.249	323.700
34	60.00	48.00	223.274	109.501	332.774
35	60.00	49.00	233.151	109.021	342.171
36	60.00	50.00	243.102	108.781	351.883
37	60.00	51.00	253.121	109.019	362.140
38	60.00	52.00	263.216	111.165	374.382
39	60.00	53.00	273.387	115.458	388.845
40	60.00	54.00	283.628	119.934	403.562
41	60.00	55.00	293.948	122.631	416.579
42	60.00	56.00	304.335	123.725	428.061
43	60.00	57.00	314.767	124.276	439.042
44	60.00	58.00	325.236	124.459	449.696
45	60.00	59.00	335.741	124.386	460.126
46	60.00	60.00	346.287	124.164	470.451
47	60.00	61.00	356.864	123.832	480.696
48	60.00	62.00	367.450	123.610	491.060
49	60.00	63.00	378.040	123.537	501.576
50	60.00	64.00	388.630	123.438	512.068
51	60.00	65.00	399.226	123.142	522.368
52	60.00	66.00	409.816	122.697	532.514
53	60.00	67.00	420.369	122.401	542.770
54	60.00	68.00	430.878	122.302	553.180
55	60.00	69.00	441.348	122.277	563.625
56	60.00	70.00	451.791	122.204	573.994
57	60.00	71.00	462.197	122.192	584.388
58	60.00	72.00	472.547	122.908	595.455
59	60.00	73.00	482.839	124.464	607.302
60	60.00	74.00	493.059	125.938	618.998
61	60.00	75.00	503.208	126.412	629.620
62	60.00	76.00	513.277	126.060	639.337
63	60.00	77.00	523.259	125.940	649.199
64	60.00	78.00	533.153	126.228	659.381
65	60.00	79.00	542.952	126.103	669.055
66	60.00	80.00	552.662	124.743	677.405
67	60.00	81.00	562.273	122.423	684.696
68	60.00	82.00	571.780	120.782	692.562
69	60.00	83.00	581.179	120.095	701.274
70	60.00	84.00	590.458	119.755	710.213
71	60.00	85.00	599.616	119.153	718.769
72	60.00	86.00	608.647	118.366	727.013
73	60.00	87.00	617.734	117.848	735.581
74	60.00	88.00	626.940	117.675	744.615
75	60.00	89.00	636.271	117.502	753.774
76	60.00	90.00	645.732	116.984	762.715
77	60.00	91.00	Soil Elevations	Must Extend At or Below	Contribution Zone

B-201Shaft60in.out

78	60.00	92.00	Soil Elevations Must Extend At or Below Contribution Zone
79	60.00	93.00	Soil Elevations Must Extend At or Below Contribution Zone
80	60.00	94.00	Soil Elevations Must Extend At or Below Contribution Zone
81	60.00	95.00	Soil Elevations Must Extend At or Below Contribution Zone

General Information:

=====  
 Input file: .....H\Analysis\_Structure\FB-Deep\Drilled Shaft\B-301Shaft48in.spc  
 Project number: 2000-01-17003  
 Job name: SW 10th Street, from Powerline Rd. to Military Trail  
 Engineer: JB Henry  
 Units: English

Analysis Information:

=====  
 Analysis Type: Drilled Shaft Analysis

Soil Information:

=====  
 Boring date: 2/1/2018  
 Boring number: B-301  
 Station number:     Offset:  
  
 Ground Elevation: 13.30(ft)  
 Water table Elevation = 13.30(ft)  
  
 Hammer type: Automatic Hammer, Correction factor = 1.24

ID	Depth (ft)	Elevation (ft)	SPT Blows (Blows/ft)	Unit Weight (pcf)	Soil Type
1	0.00	13.30	N/A	0.00	5- Cavity layer
2	2.00	11.30	N/A	0.00	5- Cavity layer
3	4.00	9.30	N/A	0.00	5- Cavity layer
4	6.00	7.30	N/A	0.00	5- Cavity layer
5	8.00	5.30	N/A	0.00	5- Cavity layer
6	10.00	3.30	15.00	110.00	3- Clean sand
7	12.00	1.30	5.00	105.00	3- Clean sand
8	13.50	-0.20	19.00	115.00	3- Clean sand
9	15.50	-2.20	12.00	110.00	3- Clean sand
10	18.00	-4.70	25.00	120.00	3- Clean sand
11	20.50	-7.20	20.00	115.00	3- Clean sand
12	23.00	-9.70	50.00	130.00	3- Clean sand
13	25.50	-12.20	23.00	115.00	3- Clean sand
14	28.00	-14.70	37.00	125.00	3- Clean sand
15	30.50	-17.20	36.00	125.00	3- Clean sand
16	33.00	-19.70	69.00	130.00	3- Clean sand
17	35.50	-22.20	67.00	130.00	3- Clean sand
18	38.00	-24.70	60.00	130.00	3- Clean sand
19	40.50	-27.20	40.00	125.00	3- Clean sand
20	43.00	-29.70	33.00	125.00	3- Clean sand
21	45.50	-32.20	5.00	105.00	3- Clean sand
22	48.00	-34.70	13.00	110.00	3- Clean sand
23	50.50	-37.20	26.00	120.00	3- Clean sand
24	53.00	-39.70	69.00	130.00	3- Clean sand
25	55.50	-42.20	40.00	125.00	3- Clean sand
26	58.00	-44.70	58.00	130.00	3- Clean sand
27	60.50	-47.20	45.00	125.00	3- Clean sand
28	63.00	-49.70	69.00	130.00	3- Clean sand
29	65.50	-52.20	46.00	125.00	3- Clean sand
30	68.00	-54.70	63.00	130.00	3- Clean sand
31	70.50	-57.20	29.00	120.00	3- Clean sand
32	73.00	-59.70	34.00	125.00	3- Clean sand
33	75.50	-62.20	30.00	120.00	3- Clean sand
34	78.00	-64.70	61.00	130.00	3- Clean sand
35	80.50	-67.20	58.00	130.00	3- Clean sand
36	83.00	-69.70	60.00	130.00	3- Clean sand
37	85.50	-72.20	74.00	130.00	3- Clean sand
38	88.00	-74.70	60.00	130.00	3- Clean sand
39	90.50	-77.20	38.00	125.00	3- Clean sand
40	93.00	-79.70	32.00	125.00	3- Clean sand
41	95.50	-82.20	25.00	120.00	3- Clean sand
42	98.00	-84.70	44.00	125.00	3- Clean sand
43	100.00	-86.70	44.00	125.00	3- Clean sand

ID	Cu-Dir (tsf)	qu (tsf)	qt (tsf)	Em (ksi)	qb (tsf)
1	N/A	N/A	N/A	N/A	N/A
2	N/A	N/A	N/A	N/A	N/A
3	N/A	N/A	N/A	N/A	N/A
4	N/A	N/A	N/A	N/A	N/A
5	N/A	N/A	N/A	N/A	N/A
6	N/A	N/A	N/A	N/A	N/A
7	N/A	N/A	N/A	N/A	N/A
8	N/A	N/A	N/A	N/A	N/A



B-301Shaft48i n. out

9	N/A	N/A	N/A	N/A	N/A
10	N/A	N/A	N/A	N/A	N/A
11	N/A	N/A	N/A	N/A	N/A
12	N/A	N/A	N/A	N/A	N/A
13	N/A	N/A	N/A	N/A	N/A
14	N/A	N/A	N/A	N/A	N/A
15	N/A	N/A	N/A	N/A	N/A
16	N/A	N/A	N/A	N/A	N/A
17	N/A	N/A	N/A	N/A	N/A
18	N/A	N/A	N/A	N/A	N/A
19	N/A	N/A	N/A	N/A	N/A
20	N/A	N/A	N/A	N/A	N/A
21	N/A	N/A	N/A	N/A	N/A
22	N/A	N/A	N/A	N/A	N/A
23	N/A	N/A	N/A	N/A	N/A
24	N/A	N/A	N/A	N/A	N/A
25	N/A	N/A	N/A	N/A	N/A
26	N/A	N/A	N/A	N/A	N/A
27	N/A	N/A	N/A	N/A	N/A
28	N/A	N/A	N/A	N/A	N/A
29	N/A	N/A	N/A	N/A	N/A
30	N/A	N/A	N/A	N/A	N/A
31	N/A	N/A	N/A	N/A	N/A
32	N/A	N/A	N/A	N/A	N/A
33	N/A	N/A	N/A	N/A	N/A
34	N/A	N/A	N/A	N/A	N/A
35	N/A	N/A	N/A	N/A	N/A
36	N/A	N/A	N/A	N/A	N/A
37	N/A	N/A	N/A	N/A	N/A
38	N/A	N/A	N/A	N/A	N/A
39	N/A	N/A	N/A	N/A	N/A
40	N/A	N/A	N/A	N/A	N/A
41	N/A	N/A	N/A	N/A	N/A
42	N/A	N/A	N/A	N/A	N/A
43	N/A	N/A	N/A	N/A	N/A

ID RQD F. M. S. R. I. Rock Recovery

ID	RQD F. M.	S. R. I.	Rock Recovery
1	N/A	N/A	N/A
2	N/A	N/A	N/A
3	N/A	N/A	N/A
4	N/A	N/A	N/A
5	N/A	N/A	N/A
6	N/A	N/A	N/A
7	N/A	N/A	N/A
8	N/A	N/A	N/A
9	N/A	N/A	N/A
10	N/A	N/A	N/A
11	N/A	N/A	N/A
12	N/A	N/A	N/A
13	N/A	N/A	N/A
14	N/A	N/A	N/A
15	N/A	N/A	N/A
16	N/A	N/A	N/A
17	N/A	N/A	N/A
18	N/A	N/A	N/A
19	N/A	N/A	N/A
20	N/A	N/A	N/A
21	N/A	N/A	N/A
22	N/A	N/A	N/A
23	N/A	N/A	N/A
24	N/A	N/A	N/A
25	N/A	N/A	N/A
26	N/A	N/A	N/A
27	N/A	N/A	N/A
28	N/A	N/A	N/A
29	N/A	N/A	N/A
30	N/A	N/A	N/A
31	N/A	N/A	N/A
32	N/A	N/A	N/A
33	N/A	N/A	N/A
34	N/A	N/A	N/A
35	N/A	N/A	N/A
36	N/A	N/A	N/A
37	N/A	N/A	N/A
38	N/A	N/A	N/A
39	N/A	N/A	N/A
40	N/A	N/A	N/A
41	N/A	N/A	N/A
42	N/A	N/A	N/A
43	N/A	N/A	N/A

Drilled Shaft Data:

=====

Shaft Geometry:

B-301Shaft48i n. out

ID	Length (ft)	Tip Elev. (ft)	Case Len. (ft)	Diameter (in)	Base Diam. (in)	Bell Len. (ft)
1	15.00	-1.70	6.00	48.00	48.00	0.00
2	16.00	-2.70	6.00	48.00	48.00	0.00
3	17.00	-3.70	6.00	48.00	48.00	0.00
4	18.00	-4.70	6.00	48.00	48.00	0.00
5	19.00	-5.70	6.00	48.00	48.00	0.00
6	20.00	-6.70	6.00	48.00	48.00	0.00
7	21.00	-7.70	6.00	48.00	48.00	0.00
8	22.00	-8.70	6.00	48.00	48.00	0.00
9	23.00	-9.70	6.00	48.00	48.00	0.00
10	24.00	-10.70	6.00	48.00	48.00	0.00
11	25.00	-11.70	6.00	48.00	48.00	0.00
12	26.00	-12.70	6.00	48.00	48.00	0.00
13	27.00	-13.70	6.00	48.00	48.00	0.00
14	28.00	-14.70	6.00	48.00	48.00	0.00
15	29.00	-15.70	6.00	48.00	48.00	0.00
16	30.00	-16.70	6.00	48.00	48.00	0.00
17	31.00	-17.70	6.00	48.00	48.00	0.00
18	32.00	-18.70	6.00	48.00	48.00	0.00
19	33.00	-19.70	6.00	48.00	48.00	0.00
20	34.00	-20.70	6.00	48.00	48.00	0.00
21	35.00	-21.70	6.00	48.00	48.00	0.00
22	36.00	-22.70	6.00	48.00	48.00	0.00
23	37.00	-23.70	6.00	48.00	48.00	0.00
24	38.00	-24.70	6.00	48.00	48.00	0.00
25	39.00	-25.70	6.00	48.00	48.00	0.00
26	40.00	-26.70	6.00	48.00	48.00	0.00
27	41.00	-27.70	6.00	48.00	48.00	0.00
28	42.00	-28.70	6.00	48.00	48.00	0.00
29	43.00	-29.70	6.00	48.00	48.00	0.00
30	44.00	-30.70	6.00	48.00	48.00	0.00
31	45.00	-31.70	6.00	48.00	48.00	0.00
32	46.00	-32.70	6.00	48.00	48.00	0.00
33	47.00	-33.70	6.00	48.00	48.00	0.00
34	48.00	-34.70	6.00	48.00	48.00	0.00
35	49.00	-35.70	6.00	48.00	48.00	0.00
36	50.00	-36.70	6.00	48.00	48.00	0.00
37	51.00	-37.70	6.00	48.00	48.00	0.00
38	52.00	-38.70	6.00	48.00	48.00	0.00
39	53.00	-39.70	6.00	48.00	48.00	0.00
40	54.00	-40.70	6.00	48.00	48.00	0.00
41	55.00	-41.70	6.00	48.00	48.00	0.00
42	56.00	-42.70	6.00	48.00	48.00	0.00
43	57.00	-43.70	6.00	48.00	48.00	0.00
44	58.00	-44.70	6.00	48.00	48.00	0.00
45	59.00	-45.70	6.00	48.00	48.00	0.00
46	60.00	-46.70	6.00	48.00	48.00	0.00
47	61.00	-47.70	6.00	48.00	48.00	0.00
48	62.00	-48.70	6.00	48.00	48.00	0.00
49	63.00	-49.70	6.00	48.00	48.00	0.00
50	64.00	-50.70	6.00	48.00	48.00	0.00
51	65.00	-51.70	6.00	48.00	48.00	0.00
52	66.00	-52.70	6.00	48.00	48.00	0.00
53	67.00	-53.70	6.00	48.00	48.00	0.00
54	68.00	-54.70	6.00	48.00	48.00	0.00
55	69.00	-55.70	6.00	48.00	48.00	0.00
56	70.00	-56.70	6.00	48.00	48.00	0.00
57	71.00	-57.70	6.00	48.00	48.00	0.00
58	72.00	-58.70	6.00	48.00	48.00	0.00
59	73.00	-59.70	6.00	48.00	48.00	0.00
60	74.00	-60.70	6.00	48.00	48.00	0.00
61	75.00	-61.70	6.00	48.00	48.00	0.00
62	76.00	-62.70	6.00	48.00	48.00	0.00
63	77.00	-63.70	6.00	48.00	48.00	0.00
64	78.00	-64.70	6.00	48.00	48.00	0.00
65	79.00	-65.70	6.00	48.00	48.00	0.00
66	80.00	-66.70	6.00	48.00	48.00	0.00
67	81.00	-67.70	6.00	48.00	48.00	0.00
68	82.00	-68.70	6.00	48.00	48.00	0.00
69	83.00	-69.70	6.00	48.00	48.00	0.00
70	84.00	-70.70	6.00	48.00	48.00	0.00
71	85.00	-71.70	6.00	48.00	48.00	0.00
72	86.00	-72.70	6.00	48.00	48.00	0.00
73	87.00	-73.70	6.00	48.00	48.00	0.00
74	88.00	-74.70	6.00	48.00	48.00	0.00
75	89.00	-75.70	6.00	48.00	48.00	0.00
76	90.00	-76.70	6.00	48.00	48.00	0.00
77	91.00	-77.70	6.00	48.00	48.00	0.00
78	92.00	-78.70	6.00	48.00	48.00	0.00
79	93.00	-79.70	6.00	48.00	48.00	0.00
80	94.00	-80.70	6.00	48.00	48.00	0.00
81	95.00	-81.70	6.00	48.00	48.00	0.00

Drilled Shaft Capacity (sorted by shaft diameter):

B-301Shaft48i n. out

Strength reduction factors: Skin-friction = 1.00, End-bearing = 1.00

ID	Diameter (in)	Length (ft)	Skin Fric. (tons)	End Bearing (tons)	Capacity (tons)
1	48.00	15.00	2.987	107.717	110.704
2	48.00	16.00	4.586	180.547	185.134
3	48.00	17.00	6.437	191.647	198.084
4	48.00	18.00	8.537	204.521	213.059
5	48.00	19.00	10.918	218.377	229.294
6	48.00	20.00	13.588	229.093	242.680
7	48.00	21.00	16.531	242.662	259.194
8	48.00	22.00	19.717	259.214	278.931
9	48.00	23.00	23.137	274.068	297.205
10	48.00	24.00	26.817	285.841	312.658
11	48.00	25.00	30.792	296.029	326.821
12	48.00	26.00	35.042	307.235	342.277
13	48.00	27.00	39.496	319.799	359.294
14	48.00	28.00	44.142	328.106	372.249
15	48.00	29.00	48.993	330.587	379.580
16	48.00	30.00	54.069	332.522	386.591
17	48.00	31.00	59.360	339.792	399.153
18	48.00	32.00	64.857	351.450	416.307
19	48.00	33.00	70.556	360.031	430.587
20	48.00	34.00	76.454	362.977	439.430
21	48.00	35.00	82.558	362.261	444.819
22	48.00	36.00	88.861	357.766	446.626
23	48.00	37.00	95.350	346.830	442.180
24	48.00	38.00	102.023	329.262	431.285
25	48.00	39.00	108.865	311.153	420.018
26	48.00	40.00	115.874	294.215	410.089
27	48.00	41.00	123.039	279.641	402.679
28	48.00	42.00	130.334	267.625	397.959
29	48.00	43.00	137.755	258.141	395.896
30	48.00	44.00	145.290	250.602	395.892
31	48.00	45.00	152.936	244.280	397.216
32	48.00	46.00	158.451	237.863	396.315
33	48.00	47.00	161.805	232.005	393.810
34	48.00	48.00	165.225	228.635	393.860
35	48.00	49.00	173.043	228.321	401.364
36	48.00	50.00	180.892	234.548	415.441
37	48.00	51.00	188.771	250.566	439.337
38	48.00	52.00	196.700	275.010	471.710
39	48.00	53.00	204.679	299.479	504.159
40	48.00	54.00	212.717	322.001	534.717
41	48.00	55.00	220.825	341.225	562.050
42	48.00	56.00	228.995	356.379	585.374
43	48.00	57.00	237.208	367.448	604.656
44	48.00	58.00	245.458	374.131	619.589
45	48.00	59.00	253.744	376.363	630.107
46	48.00	60.00	262.070	376.413	638.484
47	48.00	61.00	270.428	375.241	645.669
48	48.00	62.00	278.799	371.497	650.297
49	48.00	63.00	287.180	365.509	652.689
50	48.00	64.00	295.568	360.111	655.679
51	48.00	65.00	303.966	355.832	659.799
52	48.00	66.00	312.367	351.671	664.038
53	48.00	67.00	320.754	346.574	667.328
54	48.00	68.00	329.124	340.960	670.084
55	48.00	69.00	337.472	336.900	674.372
56	48.00	70.00	345.804	334.370	680.174
57	48.00	71.00	354.109	332.324	686.433
58	48.00	72.00	362.364	330.508	692.872
59	48.00	73.00	370.564	329.082	699.646
60	48.00	74.00	378.707	327.695	706.402
61	48.00	75.00	386.797	327.760	714.557
62	48.00	76.00	394.825	331.182	726.007
63	48.00	77.00	402.779	338.161	740.940
64	48.00	78.00	410.656	345.022	755.678
65	48.00	79.00	418.457	350.727	769.185
66	48.00	80.00	426.191	356.277	782.468
67	48.00	81.00	433.850	362.801	796.651
68	48.00	82.00	441.429	369.471	810.900
69	48.00	83.00	448.925	372.832	821.757
70	48.00	84.00	456.329	371.681	828.011
71	48.00	85.00	463.640	367.519	831.159
72	48.00	86.00	470.853	361.838	832.691
73	48.00	87.00	478.120	354.521	832.641
74	48.00	88.00	485.494	346.219	831.713
75	48.00	89.00	492.973	340.757	833.730
76	48.00	90.00	500.559	338.694	839.253
77	48.00	91.00	508.250	338.206	846.456
78	48.00	92.00	516.040	337.286	853.326
79	48.00	93.00	Soil Elevations	Must Extend At or Below	Contribution Zone
80	48.00	94.00	Soil Elevations	Must Extend At or Below	Contribution Zone
81	48.00	95.00	Soil Elevations	Must Extend At or Below	Contribution Zone

B-301Shaft48i n. out

Drilled Shaft Capacity at User-Defined Settlement (sorted by shaft diameter):

\*\*\*\*\* Capacity is NOT modified by the strength reduction factors \*\*\*\*\*

---

User-Defined Settlement = 1.04%

ID	Diameter (in)	Length (ft)	Skin Fric. (tons)	End Bearing (tons)	Capacity (tons)
1	48.00	15.00	2.922	34.243	37.165
2	48.00	16.00	4.486	57.396	61.882
3	48.00	17.00	6.296	60.925	67.221
4	48.00	18.00	8.350	65.017	73.368
5	48.00	19.00	10.679	69.422	80.101
6	48.00	20.00	13.290	72.829	86.119
7	48.00	21.00	16.170	77.142	93.312
8	48.00	22.00	19.285	82.404	101.690
9	48.00	23.00	22.631	87.126	109.757
10	48.00	24.00	26.230	90.869	117.099
11	48.00	25.00	30.118	94.108	124.226
12	48.00	26.00	34.275	97.670	131.945
13	48.00	27.00	38.631	101.664	140.295
14	48.00	28.00	43.176	104.305	147.481
15	48.00	29.00	47.920	105.094	153.014
16	48.00	30.00	52.885	105.709	158.594
17	48.00	31.00	58.061	108.020	166.081
18	48.00	32.00	63.438	111.726	175.164
19	48.00	33.00	69.012	114.454	183.466
20	48.00	34.00	74.780	115.390	190.171
21	48.00	35.00	80.751	115.163	195.914
22	48.00	36.00	86.916	113.734	200.649
23	48.00	37.00	93.263	110.257	203.520
24	48.00	38.00	99.790	104.673	204.462
25	48.00	39.00	106.482	98.916	205.398
26	48.00	40.00	113.338	93.531	206.869
27	48.00	41.00	120.345	88.898	209.243
28	48.00	42.00	127.481	85.078	212.559
29	48.00	43.00	134.740	82.063	216.803
30	48.00	44.00	142.110	79.666	221.776
31	48.00	45.00	149.588	77.657	227.245
32	48.00	46.00	154.983	75.617	230.600
33	48.00	47.00	158.263	73.754	232.017
34	48.00	48.00	161.609	72.683	234.292
35	48.00	49.00	169.255	72.583	241.839
36	48.00	50.00	176.933	74.563	251.496
37	48.00	51.00	184.639	79.655	264.294
38	48.00	52.00	192.394	87.426	279.820
39	48.00	53.00	200.199	95.205	295.404
40	48.00	54.00	208.061	102.364	310.425
41	48.00	55.00	215.992	108.475	324.467
42	48.00	56.00	223.983	113.293	337.276
43	48.00	57.00	232.016	116.812	348.828
44	48.00	58.00	240.086	118.936	359.022
45	48.00	59.00	248.190	119.646	367.836
46	48.00	60.00	256.334	119.662	375.996
47	48.00	61.00	264.509	119.289	383.798
48	48.00	62.00	272.697	118.099	390.796
49	48.00	63.00	280.895	116.195	397.090
50	48.00	64.00	289.098	114.480	403.578
51	48.00	65.00	297.313	113.119	410.432
52	48.00	66.00	305.530	111.796	417.326
53	48.00	67.00	313.734	110.176	423.910
54	48.00	68.00	321.920	108.391	430.311
55	48.00	69.00	330.086	107.101	437.186
56	48.00	70.00	338.235	106.296	444.531
57	48.00	71.00	346.358	105.646	452.004
58	48.00	72.00	354.433	105.069	459.501
59	48.00	73.00	362.454	104.615	467.069
60	48.00	74.00	370.418	104.174	474.592
61	48.00	75.00	378.330	104.195	482.525
62	48.00	76.00	386.183	105.283	491.466
63	48.00	77.00	393.963	107.501	501.465
64	48.00	78.00	401.668	109.683	511.350
65	48.00	79.00	409.298	111.496	520.795
66	48.00	80.00	416.862	113.260	530.123
67	48.00	81.00	424.354	115.335	539.689
68	48.00	82.00	431.767	117.455	549.222
69	48.00	83.00	439.099	118.523	557.623
70	48.00	84.00	446.341	118.158	564.499
71	48.00	85.00	453.492	116.834	570.326
72	48.00	86.00	460.547	115.028	575.575
73	48.00	87.00	467.655	112.702	580.357
74	48.00	88.00	474.867	110.063	584.930
75	48.00	89.00	482.183	108.327	590.509
76	48.00	90.00	489.602	107.671	597.274
77	48.00	91.00	497.125	107.516	604.641

				B-301Shaft48in.out			
78	48.00	92.00	504.745	107.223	611.968		
79	48.00	93.00	Soil Elevations	Must Extend At	or Below	Contribution Zone	
80	48.00	94.00	Soil Elevations	Must Extend At	or Below	Contribution Zone	
81	48.00	95.00	Soil Elevations	Must Extend At	or Below	Contribution Zone	

General Information:

=====  
 Input file: .....H)\Analysis\_Structure\FB-Deep\Drilled Shaft\B-301Shaft60in.spc  
 Project number: 2000-01-17003  
 Job name: SW 10th Street, from Powerline Rd. to Military Trail  
 Engineer: JB Henry  
 Units: English

Analysis Information:

=====  
 Analysis Type: Drilled Shaft Analysis

Soil Information:

=====  
 Boring date: 2/1/2018  
 Boring number: B-301  
 Station number:     Offset:  
  
 Ground Elevation: 13.30(ft)  
 Water table Elevation = 13.30(ft)

Hammer type: Automatic Hammer, Correction factor = 1.24

ID	Depth (ft)	Elevation (ft)	SPT Blows (Blows/ft)	Unit Weight (pcf)	Soil Type
1	0.00	13.30	N/A	0.00	5- Cavity layer
2	2.00	11.30	N/A	0.00	5- Cavity layer
3	4.00	9.30	N/A	0.00	5- Cavity layer
4	6.00	7.30	N/A	0.00	5- Cavity layer
5	8.00	5.30	N/A	0.00	5- Cavity layer
6	10.00	3.30	15.00	110.00	3- Clean sand
7	12.00	1.30	5.00	105.00	3- Clean sand
8	13.50	-0.20	19.00	115.00	3- Clean sand
9	15.50	-2.20	12.00	110.00	3- Clean sand
10	18.00	-4.70	25.00	120.00	3- Clean sand
11	20.50	-7.20	20.00	115.00	3- Clean sand
12	23.00	-9.70	50.00	130.00	3- Clean sand
13	25.50	-12.20	23.00	115.00	3- Clean sand
14	28.00	-14.70	37.00	125.00	3- Clean sand
15	30.50	-17.20	36.00	125.00	3- Clean sand
16	33.00	-19.70	69.00	130.00	3- Clean sand
17	35.50	-22.20	67.00	130.00	3- Clean sand
18	38.00	-24.70	60.00	130.00	3- Clean sand
19	40.50	-27.20	40.00	125.00	3- Clean sand
20	43.00	-29.70	33.00	125.00	3- Clean sand
21	45.50	-32.20	5.00	105.00	3- Clean sand
22	48.00	-34.70	13.00	110.00	3- Clean sand
23	50.50	-37.20	26.00	120.00	3- Clean sand
24	53.00	-39.70	69.00	130.00	3- Clean sand
25	55.50	-42.20	40.00	125.00	3- Clean sand
26	58.00	-44.70	58.00	130.00	3- Clean sand
27	60.50	-47.20	45.00	125.00	3- Clean sand
28	63.00	-49.70	69.00	130.00	3- Clean sand
29	65.50	-52.20	46.00	125.00	3- Clean sand
30	68.00	-54.70	63.00	130.00	3- Clean sand
31	70.50	-57.20	29.00	120.00	3- Clean sand
32	73.00	-59.70	34.00	125.00	3- Clean sand
33	75.50	-62.20	30.00	120.00	3- Clean sand
34	78.00	-64.70	61.00	130.00	3- Clean sand
35	80.50	-67.20	58.00	130.00	3- Clean sand
36	83.00	-69.70	60.00	130.00	3- Clean sand
37	85.50	-72.20	74.00	130.00	3- Clean sand
38	88.00	-74.70	60.00	130.00	3- Clean sand
39	90.50	-77.20	38.00	125.00	3- Clean sand
40	93.00	-79.70	32.00	125.00	3- Clean sand
41	95.50	-82.20	25.00	120.00	3- Clean sand
42	98.00	-84.70	44.00	125.00	3- Clean sand
43	100.00	-86.70	44.00	125.00	3- Clean sand

ID	Cu-DIR (tsf)	qu (tsf)	qt (tsf)	Em (ksi)	qb (tsf)
1	N/A	N/A	N/A	N/A	N/A
2	N/A	N/A	N/A	N/A	N/A
3	N/A	N/A	N/A	N/A	N/A
4	N/A	N/A	N/A	N/A	N/A
5	N/A	N/A	N/A	N/A	N/A
6	N/A	N/A	N/A	N/A	N/A
7	N/A	N/A	N/A	N/A	N/A
8	N/A	N/A	N/A	N/A	N/A

B-301Shaft60in. out

9	N/A	N/A	N/A	N/A	N/A
10	N/A	N/A	N/A	N/A	N/A
11	N/A	N/A	N/A	N/A	N/A
12	N/A	N/A	N/A	N/A	N/A
13	N/A	N/A	N/A	N/A	N/A
14	N/A	N/A	N/A	N/A	N/A
15	N/A	N/A	N/A	N/A	N/A
16	N/A	N/A	N/A	N/A	N/A
17	N/A	N/A	N/A	N/A	N/A
18	N/A	N/A	N/A	N/A	N/A
19	N/A	N/A	N/A	N/A	N/A
20	N/A	N/A	N/A	N/A	N/A
21	N/A	N/A	N/A	N/A	N/A
22	N/A	N/A	N/A	N/A	N/A
23	N/A	N/A	N/A	N/A	N/A
24	N/A	N/A	N/A	N/A	N/A
25	N/A	N/A	N/A	N/A	N/A
26	N/A	N/A	N/A	N/A	N/A
27	N/A	N/A	N/A	N/A	N/A
28	N/A	N/A	N/A	N/A	N/A
29	N/A	N/A	N/A	N/A	N/A
30	N/A	N/A	N/A	N/A	N/A
31	N/A	N/A	N/A	N/A	N/A
32	N/A	N/A	N/A	N/A	N/A
33	N/A	N/A	N/A	N/A	N/A
34	N/A	N/A	N/A	N/A	N/A
35	N/A	N/A	N/A	N/A	N/A
36	N/A	N/A	N/A	N/A	N/A
37	N/A	N/A	N/A	N/A	N/A
38	N/A	N/A	N/A	N/A	N/A
39	N/A	N/A	N/A	N/A	N/A
40	N/A	N/A	N/A	N/A	N/A
41	N/A	N/A	N/A	N/A	N/A
42	N/A	N/A	N/A	N/A	N/A
43	N/A	N/A	N/A	N/A	N/A

ID RQD F. M. S. R. I. Rock Recovery

1	N/A	N/A	N/A
2	N/A	N/A	N/A
3	N/A	N/A	N/A
4	N/A	N/A	N/A
5	N/A	N/A	N/A
6	N/A	N/A	N/A
7	N/A	N/A	N/A
8	N/A	N/A	N/A
9	N/A	N/A	N/A
10	N/A	N/A	N/A
11	N/A	N/A	N/A
12	N/A	N/A	N/A
13	N/A	N/A	N/A
14	N/A	N/A	N/A
15	N/A	N/A	N/A
16	N/A	N/A	N/A
17	N/A	N/A	N/A
18	N/A	N/A	N/A
19	N/A	N/A	N/A
20	N/A	N/A	N/A
21	N/A	N/A	N/A
22	N/A	N/A	N/A
23	N/A	N/A	N/A
24	N/A	N/A	N/A
25	N/A	N/A	N/A
26	N/A	N/A	N/A
27	N/A	N/A	N/A
28	N/A	N/A	N/A
29	N/A	N/A	N/A
30	N/A	N/A	N/A
31	N/A	N/A	N/A
32	N/A	N/A	N/A
33	N/A	N/A	N/A
34	N/A	N/A	N/A
35	N/A	N/A	N/A
36	N/A	N/A	N/A
37	N/A	N/A	N/A
38	N/A	N/A	N/A
39	N/A	N/A	N/A
40	N/A	N/A	N/A
41	N/A	N/A	N/A
42	N/A	N/A	N/A
43	N/A	N/A	N/A

Drilled Shaft Data:

=====

Shaft Geometry:

B-301Shaft60in. out

ID	Length (ft)	Tip Elev. (ft)	Case Len. (ft)	Diameter (in)	Base Diam. (in)	Bell Len. (ft)
1	15.00	-1.70	6.00	60.00	60.00	0.00
2	16.00	-2.70	6.00	60.00	60.00	0.00
3	17.00	-3.70	6.00	60.00	60.00	0.00
4	18.00	-4.70	6.00	60.00	60.00	0.00
5	19.00	-5.70	6.00	60.00	60.00	0.00
6	20.00	-6.70	6.00	60.00	60.00	0.00
7	21.00	-7.70	6.00	60.00	60.00	0.00
8	22.00	-8.70	6.00	60.00	60.00	0.00
9	23.00	-9.70	6.00	60.00	60.00	0.00
10	24.00	-10.70	6.00	60.00	60.00	0.00
11	25.00	-11.70	6.00	60.00	60.00	0.00
12	26.00	-12.70	6.00	60.00	60.00	0.00
13	27.00	-13.70	6.00	60.00	60.00	0.00
14	28.00	-14.70	6.00	60.00	60.00	0.00
15	29.00	-15.70	6.00	60.00	60.00	0.00
16	30.00	-16.70	6.00	60.00	60.00	0.00
17	31.00	-17.70	6.00	60.00	60.00	0.00
18	32.00	-18.70	6.00	60.00	60.00	0.00
19	33.00	-19.70	6.00	60.00	60.00	0.00
20	34.00	-20.70	6.00	60.00	60.00	0.00
21	35.00	-21.70	6.00	60.00	60.00	0.00
22	36.00	-22.70	6.00	60.00	60.00	0.00
23	37.00	-23.70	6.00	60.00	60.00	0.00
24	38.00	-24.70	6.00	60.00	60.00	0.00
25	39.00	-25.70	6.00	60.00	60.00	0.00
26	40.00	-26.70	6.00	60.00	60.00	0.00
27	41.00	-27.70	6.00	60.00	60.00	0.00
28	42.00	-28.70	6.00	60.00	60.00	0.00
29	43.00	-29.70	6.00	60.00	60.00	0.00
30	44.00	-30.70	6.00	60.00	60.00	0.00
31	45.00	-31.70	6.00	60.00	60.00	0.00
32	46.00	-32.70	6.00	60.00	60.00	0.00
33	47.00	-33.70	6.00	60.00	60.00	0.00
34	48.00	-34.70	6.00	60.00	60.00	0.00
35	49.00	-35.70	6.00	60.00	60.00	0.00
36	50.00	-36.70	6.00	60.00	60.00	0.00
37	51.00	-37.70	6.00	60.00	60.00	0.00
38	52.00	-38.70	6.00	60.00	60.00	0.00
39	53.00	-39.70	6.00	60.00	60.00	0.00
40	54.00	-40.70	6.00	60.00	60.00	0.00
41	55.00	-41.70	6.00	60.00	60.00	0.00
42	56.00	-42.70	6.00	60.00	60.00	0.00
43	57.00	-43.70	6.00	60.00	60.00	0.00
44	58.00	-44.70	6.00	60.00	60.00	0.00
45	59.00	-45.70	6.00	60.00	60.00	0.00
46	60.00	-46.70	6.00	60.00	60.00	0.00
47	61.00	-47.70	6.00	60.00	60.00	0.00
48	62.00	-48.70	6.00	60.00	60.00	0.00
49	63.00	-49.70	6.00	60.00	60.00	0.00
50	64.00	-50.70	6.00	60.00	60.00	0.00
51	65.00	-51.70	6.00	60.00	60.00	0.00
52	66.00	-52.70	6.00	60.00	60.00	0.00
53	67.00	-53.70	6.00	60.00	60.00	0.00
54	68.00	-54.70	6.00	60.00	60.00	0.00
55	69.00	-55.70	6.00	60.00	60.00	0.00
56	70.00	-56.70	6.00	60.00	60.00	0.00
57	71.00	-57.70	6.00	60.00	60.00	0.00
58	72.00	-58.70	6.00	60.00	60.00	0.00
59	73.00	-59.70	6.00	60.00	60.00	0.00
60	74.00	-60.70	6.00	60.00	60.00	0.00
61	75.00	-61.70	6.00	60.00	60.00	0.00
62	76.00	-62.70	6.00	60.00	60.00	0.00
63	77.00	-63.70	6.00	60.00	60.00	0.00
64	78.00	-64.70	6.00	60.00	60.00	0.00
65	79.00	-65.70	6.00	60.00	60.00	0.00
66	80.00	-66.70	6.00	60.00	60.00	0.00
67	81.00	-67.70	6.00	60.00	60.00	0.00
68	82.00	-68.70	6.00	60.00	60.00	0.00
69	83.00	-69.70	6.00	60.00	60.00	0.00
70	84.00	-70.70	6.00	60.00	60.00	0.00
71	85.00	-71.70	6.00	60.00	60.00	0.00
72	86.00	-72.70	6.00	60.00	60.00	0.00
73	87.00	-73.70	6.00	60.00	60.00	0.00
74	88.00	-74.70	6.00	60.00	60.00	0.00
75	89.00	-75.70	6.00	60.00	60.00	0.00
76	90.00	-76.70	6.00	60.00	60.00	0.00
77	91.00	-77.70	6.00	60.00	60.00	0.00
78	92.00	-78.70	6.00	60.00	60.00	0.00
79	93.00	-79.70	6.00	60.00	60.00	0.00
80	94.00	-80.70	6.00	60.00	60.00	0.00
81	95.00	-81.70	6.00	60.00	60.00	0.00

Drilled Shaft Capacity (sorted by shaft diameter):



B-301Shaft60i n. out

Strength reduction factors: Skin-friction = 1.00, End-bearing = 1.00

ID	Diameter (in)	Length (ft)	Skin Fric. (tons)	End Bearing (tons)	Capacity (tons)
1	60.00	15.00	3.734	152.857	156.591
2	60.00	16.00	5.733	159.844	165.577
3	60.00	17.00	8.047	166.783	174.830
4	60.00	18.00	10.671	261.920	272.592
5	60.00	19.00	13.647	281.074	294.721
6	60.00	20.00	16.984	302.182	319.166
7	60.00	21.00	20.664	316.938	337.603
8	60.00	22.00	24.646	331.611	356.257
9	60.00	23.00	28.921	351.826	380.747
10	60.00	24.00	33.521	371.999	405.520
11	60.00	25.00	38.490	386.545	425.036
12	60.00	26.00	43.802	396.514	440.317
13	60.00	27.00	49.370	408.195	457.564
14	60.00	28.00	55.178	422.634	477.812
15	60.00	29.00	61.241	435.075	496.316
16	60.00	30.00	67.586	440.759	508.345
17	60.00	31.00	74.201	441.064	515.264
18	60.00	32.00	81.072	444.260	525.332
19	60.00	33.00	88.195	451.727	539.922
20	60.00	34.00	95.567	455.647	551.214
21	60.00	35.00	103.198	448.205	551.404
22	60.00	36.00	111.076	431.106	542.182
23	60.00	37.00	119.187	414.575	533.762
24	60.00	38.00	127.529	400.316	527.844
25	60.00	39.00	136.081	388.061	524.142
26	60.00	40.00	144.843	377.542	522.385
27	60.00	41.00	153.798	368.906	522.705
28	60.00	42.00	162.917	363.042	525.959
29	60.00	43.00	172.194	360.097	532.291
30	60.00	44.00	181.612	357.436	539.048
31	60.00	45.00	191.170	352.424	543.593
32	60.00	46.00	198.064	345.458	543.522
33	60.00	47.00	202.256	338.928	541.183
34	60.00	48.00	206.531	333.230	539.761
35	60.00	49.00	216.304	329.612	545.915
36	60.00	50.00	226.115	329.321	555.436
37	60.00	51.00	235.964	333.223	569.187
38	60.00	52.00	245.875	346.512	592.387
39	60.00	53.00	255.849	370.053	625.903
40	60.00	54.00	265.896	397.409	663.305
41	60.00	55.00	276.031	422.141	698.172
42	60.00	56.00	286.244	444.054	730.298
43	60.00	57.00	296.510	461.969	758.478
44	60.00	58.00	306.823	475.689	782.512
45	60.00	59.00	317.180	483.610	800.790
46	60.00	60.00	327.588	484.125	811.713
47	60.00	61.00	338.035	478.324	816.359
48	60.00	62.00	348.499	472.754	821.253
49	60.00	63.00	358.976	468.506	827.482
50	60.00	64.00	369.460	464.380	833.840
51	60.00	65.00	379.958	459.176	839.134
52	60.00	66.00	390.459	453.342	843.801
53	60.00	67.00	400.943	449.572	850.515
54	60.00	68.00	411.405	448.315	859.720
55	60.00	69.00	421.840	447.856	869.696
56	60.00	70.00	432.255	446.477	878.732
57	60.00	71.00	442.636	444.346	886.982
58	60.00	72.00	452.955	442.454	895.409
59	60.00	73.00	463.206	440.968	904.174
60	60.00	74.00	473.384	439.523	912.907
61	60.00	75.00	483.496	437.753	921.249
62	60.00	76.00	493.531	436.264	929.795
63	60.00	77.00	503.474	438.683	942.157
64	60.00	78.00	513.320	445.615	958.936
65	60.00	79.00	523.072	453.710	976.782
66	60.00	80.00	532.739	459.616	992.355
67	60.00	81.00	542.313	463.587	1005.900
68	60.00	82.00	551.786	467.142	1018.929
69	60.00	83.00	561.156	470.535	1031.692
70	60.00	84.00	570.412	471.319	1041.731
71	60.00	85.00	579.550	467.048	1046.598
72	60.00	86.00	588.566	458.820	1047.386
73	60.00	87.00	597.650	453.224	1050.874
74	60.00	88.00	606.867	451.359	1058.225
75	60.00	89.00	616.216	451.264	1067.481
76	60.00	90.00	625.698	450.982	1076.680
77	60.00	91.00	Soil Elevations	Must Extend At or Below	Contribution Zone
78	60.00	92.00	Soil Elevations	Must Extend At or Below	Contribution Zone
79	60.00	93.00	Soil Elevations	Must Extend At or Below	Contribution Zone
80	60.00	94.00	Soil Elevations	Must Extend At or Below	Contribution Zone
81	60.00	95.00	Soil Elevations	Must Extend At or Below	Contribution Zone

B-301Shaft60in.out

Drilled Shaft Capacity at User-Defined Settlement (sorted by shaft diameter):

\*\*\*\*\* Capacity is NOT modified by the strength reduction factors \*\*\*\*\*

User-Defined Settlement = 0.83%

ID	Diameter (in)	Length (ft)	Skin Fric. (tons)	End Bearing (tons)	Capacity (tons)
1	60.00	15.00	3.638	39.910	43.548
2	60.00	16.00	5.587	41.734	47.321
3	60.00	17.00	7.842	43.546	51.387
4	60.00	18.00	10.399	68.385	78.785
5	60.00	19.00	13.299	73.386	86.685
6	60.00	20.00	16.551	78.897	95.449
7	60.00	21.00	20.138	82.750	102.888
8	60.00	22.00	24.018	86.581	110.599
9	60.00	23.00	28.184	91.859	120.043
10	60.00	24.00	32.666	97.126	129.792
11	60.00	25.00	37.509	100.924	138.433
12	60.00	26.00	42.685	103.527	146.212
13	60.00	27.00	48.111	106.576	154.687
14	60.00	28.00	53.771	110.346	164.118
15	60.00	29.00	59.680	113.595	173.274
16	60.00	30.00	65.863	115.079	180.942
17	60.00	31.00	72.309	115.158	187.467
18	60.00	32.00	79.005	115.993	194.998
19	60.00	33.00	85.947	117.942	203.889
20	60.00	34.00	93.131	118.966	212.097
21	60.00	35.00	100.567	117.023	217.590
22	60.00	36.00	108.244	112.558	220.802
23	60.00	37.00	116.149	108.242	224.391
24	60.00	38.00	124.277	104.519	228.797
25	60.00	39.00	132.612	101.320	233.932
26	60.00	40.00	141.150	98.573	239.723
27	60.00	41.00	149.877	96.319	246.196
28	60.00	42.00	158.764	94.787	253.551
29	60.00	43.00	167.804	94.018	261.822
30	60.00	44.00	176.982	93.324	270.306
31	60.00	45.00	186.296	92.015	278.311
32	60.00	46.00	193.014	90.196	283.211
33	60.00	47.00	197.099	88.491	285.591
34	60.00	48.00	201.266	87.004	288.270
35	60.00	49.00	210.789	86.059	296.848
36	60.00	50.00	220.351	85.983	306.334
37	60.00	51.00	229.948	87.002	316.950
38	60.00	52.00	239.606	90.472	330.078
39	60.00	53.00	249.327	96.618	345.945
40	60.00	54.00	259.117	103.760	362.877
41	60.00	55.00	268.994	110.218	379.212
42	60.00	56.00	278.947	115.939	394.885
43	60.00	57.00	288.951	120.616	409.567
44	60.00	58.00	299.001	124.199	423.200
45	60.00	59.00	309.094	126.267	435.361
46	60.00	60.00	319.237	126.401	445.638
47	60.00	61.00	329.418	124.887	454.304
48	60.00	62.00	339.615	123.432	463.047
49	60.00	63.00	349.824	122.323	472.147
50	60.00	64.00	360.041	121.246	481.287
51	60.00	65.00	370.271	119.887	490.158
52	60.00	66.00	380.505	118.364	498.869
53	60.00	67.00	390.721	117.380	508.101
54	60.00	68.00	400.917	117.052	517.968
55	60.00	69.00	411.086	116.932	528.018
56	60.00	70.00	421.235	116.572	537.807
57	60.00	71.00	431.352	116.015	547.367
58	60.00	72.00	441.408	115.521	556.929
59	60.00	73.00	451.397	115.133	566.530
60	60.00	74.00	461.316	114.756	576.072
61	60.00	75.00	471.170	114.294	585.464
62	60.00	76.00	480.950	113.905	594.855
63	60.00	77.00	490.639	114.537	605.175
64	60.00	78.00	500.234	116.347	616.581
65	60.00	79.00	509.737	118.460	628.197
66	60.00	80.00	519.157	120.002	639.159
67	60.00	81.00	528.487	121.039	649.526
68	60.00	82.00	537.719	121.967	659.686
69	60.00	83.00	546.851	122.853	669.704
70	60.00	84.00	555.870	123.058	678.928
71	60.00	85.00	564.775	121.943	686.718
72	60.00	86.00	573.562	119.794	693.356
73	60.00	87.00	582.414	118.333	700.747
74	60.00	88.00	591.396	117.846	709.242
75	60.00	89.00	600.507	117.822	718.328
76	60.00	90.00	609.747	117.748	727.495
77	60.00	91.00	Soil Elevations	Must Extend At or Below	Contribution Zone

B-301Shaft60in.out

78	60.00	92.00	Soil Elevations Must Extend At or Below Contribution Zone
79	60.00	93.00	Soil Elevations Must Extend At or Below Contribution Zone
80	60.00	94.00	Soil Elevations Must Extend At or Below Contribution Zone
81	60.00	95.00	Soil Elevations Must Extend At or Below Contribution Zone

General Information:

=====  
 Input file: .....H\Analysis\_Structure\FB-Deep\Drilled Shaft\B-401Shaft48in.spc  
 Project number: 2000-01-17003  
 Job name: SW 10th Street, from Powerline Rd. to Military Trail  
 Engineer: JB Henry  
 Units: English

Analysis Information:

=====  
 Analysis Type: Drilled Shaft Analysis

Soil Information:

=====  
 Boring date: 2/6/2018  
 Boring number: B-401  
 Station number:     Offset:  
  
 Ground Elevation: 12.30(ft)  
 Water table Elevation = 12.30(ft)  
  
 Hammer type: Automatic Hammer, Correction factor = 1.24

ID	Depth (ft)	Elevation (ft)	SPT Blows (Blows/ft)	Unit Weight (pcf)	Soil Type
1	0.00	12.30	N/A	0.00	5- Cavity layer
2	2.00	10.30	N/A	0.00	5- Cavity layer
3	4.00	8.30	N/A	0.00	5- Cavity layer
4	6.00	6.30	N/A	0.00	5- Cavity layer
5	8.00	4.30	N/A	0.00	5- Cavity layer
6	10.00	2.30	15.00	110.00	3- Clean sand
7	12.00	0.30	13.00	110.00	3- Clean sand
8	13.50	-1.20	19.00	115.00	3- Clean sand
9	15.50	-3.20	18.00	110.00	3- Clean sand
10	18.00	-5.70	28.00	120.00	3- Clean sand
11	20.50	-8.20	24.00	120.00	3- Clean sand
12	23.00	-10.70	34.00	125.00	3- Clean sand
13	25.50	-13.20	22.00	115.00	3- Clean sand
14	28.00	-15.70	29.00	120.00	3- Clean sand
15	30.50	-18.20	27.00	120.00	3- Clean sand
16	33.00	-20.70	43.00	125.00	3- Clean sand
17	35.50	-23.20	54.00	130.00	3- Clean sand
18	38.00	-25.70	60.00	130.00	3- Clean sand
19	40.50	-28.20	30.00	120.00	3- Clean sand
20	43.00	-30.70	38.00	125.00	3- Clean sand
21	45.50	-33.20	37.00	125.00	3- Clean sand
22	48.00	-35.70	48.00	125.00	3- Clean sand
23	50.50	-38.20	21.00	115.00	3- Clean sand
24	53.00	-40.70	50.00	130.00	3- Clean sand
25	55.50	-43.20	42.00	125.00	3- Clean sand
26	58.00	-45.70	68.00	130.00	3- Clean sand
27	60.50	-48.20	39.00	125.00	3- Clean sand
28	63.00	-50.70	62.00	130.00	3- Clean sand
29	65.50	-53.20	47.00	125.00	3- Clean sand
30	68.00	-55.70	46.00	125.00	3- Clean sand
31	70.50	-58.20	36.00	125.00	3- Clean sand
32	73.00	-60.70	52.00	130.00	3- Clean sand
33	75.50	-63.20	26.00	120.00	3- Clean sand
34	78.00	-65.70	18.00	115.00	3- Clean sand
35	80.50	-68.20	59.00	130.00	3- Clean sand
36	83.00	-70.70	60.00	130.00	3- Clean sand
37	85.50	-73.20	61.00	130.00	3- Clean sand
38	88.00	-75.70	47.00	125.00	3- Clean sand
39	90.50	-78.20	33.00	125.00	3- Clean sand
40	93.00	-80.70	50.00	130.00	3- Clean sand
41	95.50	-83.20	53.00	130.00	3- Clean sand
42	98.00	-85.70	60.00	130.00	3- Clean sand
43	100.00	-87.70	60.00	130.00	3- Clean sand

ID	Cu-DIR (tsf)	qu (tsf)	qt (tsf)	Em (ksi)	qb (tsf)
1	N/A	N/A	N/A	N/A	N/A
2	N/A	N/A	N/A	N/A	N/A
3	N/A	N/A	N/A	N/A	N/A
4	N/A	N/A	N/A	N/A	N/A
5	N/A	N/A	N/A	N/A	N/A
6	N/A	N/A	N/A	N/A	N/A
7	N/A	N/A	N/A	N/A	N/A
8	N/A	N/A	N/A	N/A	N/A

B-401Shaft48i n. out

9	N/A	N/A	N/A	N/A	N/A
10	N/A	N/A	N/A	N/A	N/A
11	N/A	N/A	N/A	N/A	N/A
12	N/A	N/A	N/A	N/A	N/A
13	N/A	N/A	N/A	N/A	N/A
14	N/A	N/A	N/A	N/A	N/A
15	N/A	N/A	N/A	N/A	N/A
16	N/A	N/A	N/A	N/A	N/A
17	N/A	N/A	N/A	N/A	N/A
18	N/A	N/A	N/A	N/A	N/A
19	N/A	N/A	N/A	N/A	N/A
20	N/A	N/A	N/A	N/A	N/A
21	N/A	N/A	N/A	N/A	N/A
22	N/A	N/A	N/A	N/A	N/A
23	N/A	N/A	N/A	N/A	N/A
24	N/A	N/A	N/A	N/A	N/A
25	N/A	N/A	N/A	N/A	N/A
26	N/A	N/A	N/A	N/A	N/A
27	N/A	N/A	N/A	N/A	N/A
28	N/A	N/A	N/A	N/A	N/A
29	N/A	N/A	N/A	N/A	N/A
30	N/A	N/A	N/A	N/A	N/A
31	N/A	N/A	N/A	N/A	N/A
32	N/A	N/A	N/A	N/A	N/A
33	N/A	N/A	N/A	N/A	N/A
34	N/A	N/A	N/A	N/A	N/A
35	N/A	N/A	N/A	N/A	N/A
36	N/A	N/A	N/A	N/A	N/A
37	N/A	N/A	N/A	N/A	N/A
38	N/A	N/A	N/A	N/A	N/A
39	N/A	N/A	N/A	N/A	N/A
40	N/A	N/A	N/A	N/A	N/A
41	N/A	N/A	N/A	N/A	N/A
42	N/A	N/A	N/A	N/A	N/A
43	N/A	N/A	N/A	N/A	N/A

ID RQD F. M. S. R. I. Rock Recovery

ID	RQD	F. M.	S. R. I.	Rock Recovery
1	N/A	N/A	N/A	N/A
2	N/A	N/A	N/A	N/A
3	N/A	N/A	N/A	N/A
4	N/A	N/A	N/A	N/A
5	N/A	N/A	N/A	N/A
6	N/A	N/A	N/A	N/A
7	N/A	N/A	N/A	N/A
8	N/A	N/A	N/A	N/A
9	N/A	N/A	N/A	N/A
10	N/A	N/A	N/A	N/A
11	N/A	N/A	N/A	N/A
12	N/A	N/A	N/A	N/A
13	N/A	N/A	N/A	N/A
14	N/A	N/A	N/A	N/A
15	N/A	N/A	N/A	N/A
16	N/A	N/A	N/A	N/A
17	N/A	N/A	N/A	N/A
18	N/A	N/A	N/A	N/A
19	N/A	N/A	N/A	N/A
20	N/A	N/A	N/A	N/A
21	N/A	N/A	N/A	N/A
22	N/A	N/A	N/A	N/A
23	N/A	N/A	N/A	N/A
24	N/A	N/A	N/A	N/A
25	N/A	N/A	N/A	N/A
26	N/A	N/A	N/A	N/A
27	N/A	N/A	N/A	N/A
28	N/A	N/A	N/A	N/A
29	N/A	N/A	N/A	N/A
30	N/A	N/A	N/A	N/A
31	N/A	N/A	N/A	N/A
32	N/A	N/A	N/A	N/A
33	N/A	N/A	N/A	N/A
34	N/A	N/A	N/A	N/A
35	N/A	N/A	N/A	N/A
36	N/A	N/A	N/A	N/A
37	N/A	N/A	N/A	N/A
38	N/A	N/A	N/A	N/A
39	N/A	N/A	N/A	N/A
40	N/A	N/A	N/A	N/A
41	N/A	N/A	N/A	N/A
42	N/A	N/A	N/A	N/A
43	N/A	N/A	N/A	N/A

Drilled Shaft Data:

=====

Shaft Geometry:

B-401Shaft48i n. out

ID	Length (ft)	Tip Elev. (ft)	Case Len. (ft)	Diameter (in)	Base Diam. (in)	Bell Len. (ft)
1	15.00	-2.70	6.00	48.00	48.00	0.00
2	16.00	-3.70	6.00	48.00	48.00	0.00
3	17.00	-4.70	6.00	48.00	48.00	0.00
4	18.00	-5.70	6.00	48.00	48.00	0.00
5	19.00	-6.70	6.00	48.00	48.00	0.00
6	20.00	-7.70	6.00	48.00	48.00	0.00
7	21.00	-8.70	6.00	48.00	48.00	0.00
8	22.00	-9.70	6.00	48.00	48.00	0.00
9	23.00	-10.70	6.00	48.00	48.00	0.00
10	24.00	-11.70	6.00	48.00	48.00	0.00
11	25.00	-12.70	6.00	48.00	48.00	0.00
12	26.00	-13.70	6.00	48.00	48.00	0.00
13	27.00	-14.70	6.00	48.00	48.00	0.00
14	28.00	-15.70	6.00	48.00	48.00	0.00
15	29.00	-16.70	6.00	48.00	48.00	0.00
16	30.00	-17.70	6.00	48.00	48.00	0.00
17	31.00	-18.70	6.00	48.00	48.00	0.00
18	32.00	-19.70	6.00	48.00	48.00	0.00
19	33.00	-20.70	6.00	48.00	48.00	0.00
20	34.00	-21.70	6.00	48.00	48.00	0.00
21	35.00	-22.70	6.00	48.00	48.00	0.00
22	36.00	-23.70	6.00	48.00	48.00	0.00
23	37.00	-24.70	6.00	48.00	48.00	0.00
24	38.00	-25.70	6.00	48.00	48.00	0.00
25	39.00	-26.70	6.00	48.00	48.00	0.00
26	40.00	-27.70	6.00	48.00	48.00	0.00
27	41.00	-28.70	6.00	48.00	48.00	0.00
28	42.00	-29.70	6.00	48.00	48.00	0.00
29	43.00	-30.70	6.00	48.00	48.00	0.00
30	44.00	-31.70	6.00	48.00	48.00	0.00
31	45.00	-32.70	6.00	48.00	48.00	0.00
32	46.00	-33.70	6.00	48.00	48.00	0.00
33	47.00	-34.70	6.00	48.00	48.00	0.00
34	48.00	-35.70	6.00	48.00	48.00	0.00
35	49.00	-36.70	6.00	48.00	48.00	0.00
36	50.00	-37.70	6.00	48.00	48.00	0.00
37	51.00	-38.70	6.00	48.00	48.00	0.00
38	52.00	-39.70	6.00	48.00	48.00	0.00
39	53.00	-40.70	6.00	48.00	48.00	0.00
40	54.00	-41.70	6.00	48.00	48.00	0.00
41	55.00	-42.70	6.00	48.00	48.00	0.00
42	56.00	-43.70	6.00	48.00	48.00	0.00
43	57.00	-44.70	6.00	48.00	48.00	0.00
44	58.00	-45.70	6.00	48.00	48.00	0.00
45	59.00	-46.70	6.00	48.00	48.00	0.00
46	60.00	-47.70	6.00	48.00	48.00	0.00
47	61.00	-48.70	6.00	48.00	48.00	0.00
48	62.00	-49.70	6.00	48.00	48.00	0.00
49	63.00	-50.70	6.00	48.00	48.00	0.00
50	64.00	-51.70	6.00	48.00	48.00	0.00
51	65.00	-52.70	6.00	48.00	48.00	0.00
52	66.00	-53.70	6.00	48.00	48.00	0.00
53	67.00	-54.70	6.00	48.00	48.00	0.00
54	68.00	-55.70	6.00	48.00	48.00	0.00
55	69.00	-56.70	6.00	48.00	48.00	0.00
56	70.00	-57.70	6.00	48.00	48.00	0.00
57	71.00	-58.70	6.00	48.00	48.00	0.00
58	72.00	-59.70	6.00	48.00	48.00	0.00
59	73.00	-60.70	6.00	48.00	48.00	0.00
60	74.00	-61.70	6.00	48.00	48.00	0.00
61	75.00	-62.70	6.00	48.00	48.00	0.00
62	76.00	-63.70	6.00	48.00	48.00	0.00
63	77.00	-64.70	6.00	48.00	48.00	0.00
64	78.00	-65.70	6.00	48.00	48.00	0.00
65	79.00	-66.70	6.00	48.00	48.00	0.00
66	80.00	-67.70	6.00	48.00	48.00	0.00
67	81.00	-68.70	6.00	48.00	48.00	0.00
68	82.00	-69.70	6.00	48.00	48.00	0.00
69	83.00	-70.70	6.00	48.00	48.00	0.00
70	84.00	-71.70	6.00	48.00	48.00	0.00
71	85.00	-72.70	6.00	48.00	48.00	0.00
72	86.00	-73.70	6.00	48.00	48.00	0.00
73	87.00	-74.70	6.00	48.00	48.00	0.00
74	88.00	-75.70	6.00	48.00	48.00	0.00
75	89.00	-76.70	6.00	48.00	48.00	0.00
76	90.00	-77.70	6.00	48.00	48.00	0.00
77	91.00	-78.70	6.00	48.00	48.00	0.00
78	92.00	-79.70	6.00	48.00	48.00	0.00
79	93.00	-80.70	6.00	48.00	48.00	0.00
80	94.00	-81.70	6.00	48.00	48.00	0.00
81	95.00	-82.70	6.00	48.00	48.00	0.00

Drilled Shaft Capacity (sorted by shaft diameter):

B-401Shaft48i n. out

Strength reduction factors: Skin-friction = 1.00, End-bearing = 1.00

ID	Diameter (in)	Length (ft)	Skin Fric. (tons)	End Bearing (tons)	Capacity (tons)
1	48.00	15.00	3.809	119.241	123.050
2	48.00	16.00	5.460	203.602	209.063
3	48.00	17.00	7.371	212.250	219.621
4	48.00	18.00	9.532	220.207	229.739
5	48.00	19.00	11.956	228.310	240.266
6	48.00	20.00	14.668	235.059	249.727
7	48.00	21.00	17.657	242.168	259.826
8	48.00	22.00	20.912	249.404	270.316
9	48.00	23.00	24.427	254.722	279.148
10	48.00	24.00	28.199	259.511	287.710
11	48.00	25.00	32.240	265.544	297.784
12	48.00	26.00	36.531	273.631	310.161
13	48.00	27.00	41.023	282.779	323.802
14	48.00	28.00	45.707	289.901	335.608
15	48.00	29.00	50.582	294.102	344.684
16	48.00	30.00	55.658	298.459	354.117
17	48.00	31.00	60.925	305.343	366.268
18	48.00	32.00	66.376	313.702	380.077
19	48.00	33.00	72.005	319.780	391.785
20	48.00	34.00	77.812	325.531	403.343
21	48.00	35.00	83.806	332.372	416.178
22	48.00	36.00	89.979	340.654	430.634
23	48.00	37.00	96.340	348.729	445.069
24	48.00	38.00	102.886	353.142	456.028
25	48.00	39.00	109.603	353.651	463.254
26	48.00	40.00	116.489	352.056	468.546
27	48.00	41.00	123.531	347.966	471.496
28	48.00	42.00	130.687	339.804	470.491
29	48.00	43.00	137.952	328.878	466.831
30	48.00	44.00	145.324	321.612	466.936
31	48.00	45.00	152.810	320.393	473.204
32	48.00	46.00	160.403	324.614	485.017
33	48.00	47.00	168.094	331.554	499.648
34	48.00	48.00	175.881	336.974	512.855
35	48.00	49.00	183.752	339.278	523.029
36	48.00	50.00	191.705	338.985	530.690
37	48.00	51.00	199.729	337.720	537.449
38	48.00	52.00	207.791	337.418	545.209
39	48.00	53.00	215.885	337.523	553.408
40	48.00	54.00	224.027	337.577	561.604
41	48.00	55.00	232.238	340.434	572.672
42	48.00	56.00	240.509	349.466	589.975
43	48.00	57.00	248.821	363.015	611.836
44	48.00	58.00	257.169	372.048	629.217
45	48.00	59.00	265.550	375.008	640.557
46	48.00	60.00	273.970	374.853	648.823
47	48.00	61.00	282.419	374.116	656.535
48	48.00	62.00	290.881	372.446	663.327
49	48.00	63.00	299.350	370.121	669.471
50	48.00	64.00	307.824	368.606	676.430
51	48.00	65.00	316.307	368.307	684.614
52	48.00	66.00	324.792	367.251	692.043
53	48.00	67.00	333.260	363.157	696.417
54	48.00	68.00	341.710	355.591	697.300
55	48.00	69.00	350.130	345.389	695.519
56	48.00	70.00	358.520	332.775	691.296
57	48.00	71.00	366.874	321.582	688.457
58	48.00	72.00	375.186	315.859	691.045
59	48.00	73.00	383.452	315.039	698.491
60	48.00	74.00	391.671	314.481	706.152
61	48.00	75.00	399.844	313.481	713.325
62	48.00	76.00	407.964	312.773	720.737
63	48.00	77.00	416.008	312.391	728.400
64	48.00	78.00	423.973	310.376	734.349
65	48.00	79.00	431.846	307.571	739.417
66	48.00	80.00	439.621	308.063	747.684
67	48.00	81.00	447.297	313.686	760.983
68	48.00	82.00	454.889	322.031	776.920
69	48.00	83.00	462.398	331.832	794.230
70	48.00	84.00	469.815	345.410	815.225
71	48.00	85.00	477.138	358.468	835.606
72	48.00	86.00	484.363	365.424	849.787
73	48.00	87.00	491.642	366.294	857.936
74	48.00	88.00	499.027	366.294	865.321
75	48.00	89.00	506.514	366.009	872.523
76	48.00	90.00	514.100	365.153	879.253
77	48.00	91.00	521.784	363.869	885.653
78	48.00	92.00	529.566	363.014	892.580
79	48.00	93.00	Soil Elevations	Must Extend At or Below	Contribution Zone
80	48.00	94.00	Soil Elevations	Must Extend At or Below	Contribution Zone
81	48.00	95.00	Soil Elevations	Must Extend At or Below	Contribution Zone

B-401Shaft48i n. out

Drilled Shaft Capacity at User-Defined Settlement (sorted by shaft diameter):

\*\*\*\*\* Capacity is NOT modified by the strength reduction factors \*\*\*\*\*

---

User-Defined Settlement = 1.04%

ID	Diameter (in)	Length (ft)	Skin Fric. (tons)	End Bearing (tons)	Capacity (tons)
1	48.00	15.00	3.725	37.907	41.632
2	48.00	16.00	5.341	64.725	70.066
3	48.00	17.00	7.210	67.474	74.684
4	48.00	18.00	9.323	70.004	79.327
5	48.00	19.00	11.694	72.580	84.274
6	48.00	20.00	14.347	74.725	89.072
7	48.00	21.00	17.271	76.985	94.256
8	48.00	22.00	20.454	79.286	99.740
9	48.00	23.00	23.892	80.976	104.868
10	48.00	24.00	27.582	82.499	110.081
11	48.00	25.00	31.534	84.416	115.951
12	48.00	26.00	35.731	86.987	122.719
13	48.00	27.00	40.125	89.895	130.020
14	48.00	28.00	44.706	92.160	136.866
15	48.00	29.00	49.475	93.495	142.970
16	48.00	30.00	54.439	94.880	149.320
17	48.00	31.00	59.592	97.069	156.660
18	48.00	32.00	64.923	99.726	164.649
19	48.00	33.00	70.429	101.658	172.087
20	48.00	34.00	76.109	103.486	179.595
21	48.00	35.00	81.972	105.661	187.633
22	48.00	36.00	88.010	108.294	196.304
23	48.00	37.00	94.231	110.861	205.092
24	48.00	38.00	100.634	112.264	212.898
25	48.00	39.00	107.204	112.426	219.630
26	48.00	40.00	113.940	111.919	225.859
27	48.00	41.00	120.827	110.618	231.445
28	48.00	42.00	127.827	108.024	235.851
29	48.00	43.00	134.933	104.550	239.483
30	48.00	44.00	142.143	102.241	244.384
31	48.00	45.00	149.466	101.853	251.319
32	48.00	46.00	156.892	103.195	260.087
33	48.00	47.00	164.415	105.401	269.816
34	48.00	48.00	172.031	107.124	279.155
35	48.00	49.00	179.730	107.856	287.586
36	48.00	50.00	187.509	107.763	295.272
37	48.00	51.00	195.357	107.361	302.718
38	48.00	52.00	203.243	107.265	310.508
39	48.00	53.00	211.160	107.299	318.458
40	48.00	54.00	219.123	107.316	326.439
41	48.00	55.00	227.155	108.224	335.379
42	48.00	56.00	235.245	111.095	346.340
43	48.00	57.00	243.374	115.403	358.777
44	48.00	58.00	251.540	118.274	369.814
45	48.00	59.00	259.737	119.215	378.952
46	48.00	60.00	267.973	119.166	387.139
47	48.00	61.00	276.238	118.932	395.169
48	48.00	62.00	284.514	118.401	402.915
49	48.00	63.00	292.798	117.662	410.460
50	48.00	64.00	301.086	117.180	418.266
51	48.00	65.00	309.384	117.085	426.469
52	48.00	66.00	317.683	116.749	434.432
53	48.00	67.00	325.966	115.448	441.414
54	48.00	68.00	334.230	113.042	447.273
55	48.00	69.00	342.466	109.799	452.266
56	48.00	70.00	350.673	105.789	456.462
57	48.00	71.00	358.844	102.231	461.075
58	48.00	72.00	366.974	100.412	467.386
59	48.00	73.00	375.059	100.151	475.210
60	48.00	74.00	383.098	99.974	483.071
61	48.00	75.00	391.092	99.656	490.748
62	48.00	76.00	399.034	99.431	498.465
63	48.00	77.00	406.903	99.309	506.212
64	48.00	78.00	414.693	98.668	513.362
65	48.00	79.00	422.394	97.777	520.171
66	48.00	80.00	429.999	97.933	527.932
67	48.00	81.00	437.507	99.721	537.227
68	48.00	82.00	444.933	102.374	547.306
69	48.00	83.00	452.277	105.489	557.767
70	48.00	84.00	459.532	109.806	569.338
71	48.00	85.00	466.694	113.957	580.651
72	48.00	86.00	473.761	116.169	589.930
73	48.00	87.00	480.881	116.445	597.326
74	48.00	88.00	488.104	116.445	604.549
75	48.00	89.00	495.428	116.354	611.782
76	48.00	90.00	502.847	116.082	618.929
77	48.00	91.00	510.363	115.674	626.037



				B-401Shaft48in.out			
78	48.00	92.00	517.975	115.402	633.377		
79	48.00	93.00	Soil Elevations Must Extend At or Below Contribution Zone				
80	48.00	94.00	Soil Elevations Must Extend At or Below Contribution Zone				
81	48.00	95.00	Soil Elevations Must Extend At or Below Contribution Zone				

General Information:

=====  
 Input file: .....H)\Analysis\_Structure\FB-Deep\Drilled Shaft\B-401Shaft60in.spc  
 Project number: 2000-01-17003  
 Job name: SW 10th Street, from Powerline Rd. to Military Trail  
 Engineer: JB Henry  
 Units: English

Analysis Information:

=====  
 Analysis Type: Drilled Shaft Analysis

Soil Information:

=====  
 Boring date: 2/6/2018  
 Boring number: B-401  
 Station number:    Offset:  
  
 Ground Elevation: 12.30(ft)  
 Water table Elevation = 12.30(ft)  
  
 Hammer type: Automatic Hammer, Correction factor = 1.24

ID	Depth (ft)	Elevation (ft)	SPT Blows (Blows/ft)	Unit Weight (pcf)	Soil Type
1	0.00	12.30	N/A	0.00	5- Cavity layer
2	2.00	10.30	N/A	0.00	5- Cavity layer
3	4.00	8.30	N/A	0.00	5- Cavity layer
4	6.00	6.30	N/A	0.00	5- Cavity layer
5	8.00	4.30	N/A	0.00	5- Cavity layer
6	10.00	2.30	15.00	110.00	3- Clean sand
7	12.00	0.30	13.00	110.00	3- Clean sand
8	13.50	-1.20	19.00	115.00	3- Clean sand
9	15.50	-3.20	18.00	110.00	3- Clean sand
10	18.00	-5.70	28.00	120.00	3- Clean sand
11	20.50	-8.20	24.00	120.00	3- Clean sand
12	23.00	-10.70	34.00	125.00	3- Clean sand
13	25.50	-13.20	22.00	115.00	3- Clean sand
14	28.00	-15.70	29.00	120.00	3- Clean sand
15	30.50	-18.20	27.00	120.00	3- Clean sand
16	33.00	-20.70	43.00	125.00	3- Clean sand
17	35.50	-23.20	54.00	130.00	3- Clean sand
18	38.00	-25.70	60.00	130.00	3- Clean sand
19	40.50	-28.20	30.00	120.00	3- Clean sand
20	43.00	-30.70	38.00	125.00	3- Clean sand
21	45.50	-33.20	37.00	125.00	3- Clean sand
22	48.00	-35.70	48.00	125.00	3- Clean sand
23	50.50	-38.20	21.00	115.00	3- Clean sand
24	53.00	-40.70	50.00	130.00	3- Clean sand
25	55.50	-43.20	42.00	125.00	3- Clean sand
26	58.00	-45.70	68.00	130.00	3- Clean sand
27	60.50	-48.20	39.00	125.00	3- Clean sand
28	63.00	-50.70	62.00	130.00	3- Clean sand
29	65.50	-53.20	47.00	125.00	3- Clean sand
30	68.00	-55.70	46.00	125.00	3- Clean sand
31	70.50	-58.20	36.00	125.00	3- Clean sand
32	73.00	-60.70	52.00	130.00	3- Clean sand
33	75.50	-63.20	26.00	120.00	3- Clean sand
34	78.00	-65.70	18.00	115.00	3- Clean sand
35	80.50	-68.20	59.00	130.00	3- Clean sand
36	83.00	-70.70	60.00	130.00	3- Clean sand
37	85.50	-73.20	61.00	130.00	3- Clean sand
38	88.00	-75.70	47.00	125.00	3- Clean sand
39	90.50	-78.20	33.00	125.00	3- Clean sand
40	93.00	-80.70	50.00	130.00	3- Clean sand
41	95.50	-83.20	53.00	130.00	3- Clean sand
42	98.00	-85.70	60.00	130.00	3- Clean sand
43	100.00	-87.70	60.00	130.00	3- Clean sand

ID	Cu-DIR (tsf)	qu (tsf)	qt (tsf)	Em (ksi)	qb (tsf)
1	N/A	N/A	N/A	N/A	N/A
2	N/A	N/A	N/A	N/A	N/A
3	N/A	N/A	N/A	N/A	N/A
4	N/A	N/A	N/A	N/A	N/A
5	N/A	N/A	N/A	N/A	N/A
6	N/A	N/A	N/A	N/A	N/A
7	N/A	N/A	N/A	N/A	N/A
8	N/A	N/A	N/A	N/A	N/A

B-401Shaft60in. out

9	N/A	N/A	N/A	N/A	N/A
10	N/A	N/A	N/A	N/A	N/A
11	N/A	N/A	N/A	N/A	N/A
12	N/A	N/A	N/A	N/A	N/A
13	N/A	N/A	N/A	N/A	N/A
14	N/A	N/A	N/A	N/A	N/A
15	N/A	N/A	N/A	N/A	N/A
16	N/A	N/A	N/A	N/A	N/A
17	N/A	N/A	N/A	N/A	N/A
18	N/A	N/A	N/A	N/A	N/A
19	N/A	N/A	N/A	N/A	N/A
20	N/A	N/A	N/A	N/A	N/A
21	N/A	N/A	N/A	N/A	N/A
22	N/A	N/A	N/A	N/A	N/A
23	N/A	N/A	N/A	N/A	N/A
24	N/A	N/A	N/A	N/A	N/A
25	N/A	N/A	N/A	N/A	N/A
26	N/A	N/A	N/A	N/A	N/A
27	N/A	N/A	N/A	N/A	N/A
28	N/A	N/A	N/A	N/A	N/A
29	N/A	N/A	N/A	N/A	N/A
30	N/A	N/A	N/A	N/A	N/A
31	N/A	N/A	N/A	N/A	N/A
32	N/A	N/A	N/A	N/A	N/A
33	N/A	N/A	N/A	N/A	N/A
34	N/A	N/A	N/A	N/A	N/A
35	N/A	N/A	N/A	N/A	N/A
36	N/A	N/A	N/A	N/A	N/A
37	N/A	N/A	N/A	N/A	N/A
38	N/A	N/A	N/A	N/A	N/A
39	N/A	N/A	N/A	N/A	N/A
40	N/A	N/A	N/A	N/A	N/A
41	N/A	N/A	N/A	N/A	N/A
42	N/A	N/A	N/A	N/A	N/A
43	N/A	N/A	N/A	N/A	N/A

ID RQD F. M. S. R. I. Rock Recovery

ID	RQD F. M.	S. R. I.	Rock Recovery
1	N/A	N/A	N/A
2	N/A	N/A	N/A
3	N/A	N/A	N/A
4	N/A	N/A	N/A
5	N/A	N/A	N/A
6	N/A	N/A	N/A
7	N/A	N/A	N/A
8	N/A	N/A	N/A
9	N/A	N/A	N/A
10	N/A	N/A	N/A
11	N/A	N/A	N/A
12	N/A	N/A	N/A
13	N/A	N/A	N/A
14	N/A	N/A	N/A
15	N/A	N/A	N/A
16	N/A	N/A	N/A
17	N/A	N/A	N/A
18	N/A	N/A	N/A
19	N/A	N/A	N/A
20	N/A	N/A	N/A
21	N/A	N/A	N/A
22	N/A	N/A	N/A
23	N/A	N/A	N/A
24	N/A	N/A	N/A
25	N/A	N/A	N/A
26	N/A	N/A	N/A
27	N/A	N/A	N/A
28	N/A	N/A	N/A
29	N/A	N/A	N/A
30	N/A	N/A	N/A
31	N/A	N/A	N/A
32	N/A	N/A	N/A
33	N/A	N/A	N/A
34	N/A	N/A	N/A
35	N/A	N/A	N/A
36	N/A	N/A	N/A
37	N/A	N/A	N/A
38	N/A	N/A	N/A
39	N/A	N/A	N/A
40	N/A	N/A	N/A
41	N/A	N/A	N/A
42	N/A	N/A	N/A
43	N/A	N/A	N/A

Drilled Shaft Data:

=====

Shaft Geometry:

B-401Shaft60in. out

ID	Length (ft)	Tip Elev. (ft)	Case Len. (ft)	Diameter (in)	Base Diam. (in)	Bell Len. (ft)
1	15.00	-2.70	6.00	60.00	60.00	0.00
2	16.00	-3.70	6.00	60.00	60.00	0.00
3	17.00	-4.70	6.00	60.00	60.00	0.00
4	18.00	-5.70	6.00	60.00	60.00	0.00
5	19.00	-6.70	6.00	60.00	60.00	0.00
6	20.00	-7.70	6.00	60.00	60.00	0.00
7	21.00	-8.70	6.00	60.00	60.00	0.00
8	22.00	-9.70	6.00	60.00	60.00	0.00
9	23.00	-10.70	6.00	60.00	60.00	0.00
10	24.00	-11.70	6.00	60.00	60.00	0.00
11	25.00	-12.70	6.00	60.00	60.00	0.00
12	26.00	-13.70	6.00	60.00	60.00	0.00
13	27.00	-14.70	6.00	60.00	60.00	0.00
14	28.00	-15.70	6.00	60.00	60.00	0.00
15	29.00	-16.70	6.00	60.00	60.00	0.00
16	30.00	-17.70	6.00	60.00	60.00	0.00
17	31.00	-18.70	6.00	60.00	60.00	0.00
18	32.00	-19.70	6.00	60.00	60.00	0.00
19	33.00	-20.70	6.00	60.00	60.00	0.00
20	34.00	-21.70	6.00	60.00	60.00	0.00
21	35.00	-22.70	6.00	60.00	60.00	0.00
22	36.00	-23.70	6.00	60.00	60.00	0.00
23	37.00	-24.70	6.00	60.00	60.00	0.00
24	38.00	-25.70	6.00	60.00	60.00	0.00
25	39.00	-26.70	6.00	60.00	60.00	0.00
26	40.00	-27.70	6.00	60.00	60.00	0.00
27	41.00	-28.70	6.00	60.00	60.00	0.00
28	42.00	-29.70	6.00	60.00	60.00	0.00
29	43.00	-30.70	6.00	60.00	60.00	0.00
30	44.00	-31.70	6.00	60.00	60.00	0.00
31	45.00	-32.70	6.00	60.00	60.00	0.00
32	46.00	-33.70	6.00	60.00	60.00	0.00
33	47.00	-34.70	6.00	60.00	60.00	0.00
34	48.00	-35.70	6.00	60.00	60.00	0.00
35	49.00	-36.70	6.00	60.00	60.00	0.00
36	50.00	-37.70	6.00	60.00	60.00	0.00
37	51.00	-38.70	6.00	60.00	60.00	0.00
38	52.00	-39.70	6.00	60.00	60.00	0.00
39	53.00	-40.70	6.00	60.00	60.00	0.00
40	54.00	-41.70	6.00	60.00	60.00	0.00
41	55.00	-42.70	6.00	60.00	60.00	0.00
42	56.00	-43.70	6.00	60.00	60.00	0.00
43	57.00	-44.70	6.00	60.00	60.00	0.00
44	58.00	-45.70	6.00	60.00	60.00	0.00
45	59.00	-46.70	6.00	60.00	60.00	0.00
46	60.00	-47.70	6.00	60.00	60.00	0.00
47	61.00	-48.70	6.00	60.00	60.00	0.00
48	62.00	-49.70	6.00	60.00	60.00	0.00
49	63.00	-50.70	6.00	60.00	60.00	0.00
50	64.00	-51.70	6.00	60.00	60.00	0.00
51	65.00	-52.70	6.00	60.00	60.00	0.00
52	66.00	-53.70	6.00	60.00	60.00	0.00
53	67.00	-54.70	6.00	60.00	60.00	0.00
54	68.00	-55.70	6.00	60.00	60.00	0.00
55	69.00	-56.70	6.00	60.00	60.00	0.00
56	70.00	-57.70	6.00	60.00	60.00	0.00
57	71.00	-58.70	6.00	60.00	60.00	0.00
58	72.00	-59.70	6.00	60.00	60.00	0.00
59	73.00	-60.70	6.00	60.00	60.00	0.00
60	74.00	-61.70	6.00	60.00	60.00	0.00
61	75.00	-62.70	6.00	60.00	60.00	0.00
62	76.00	-63.70	6.00	60.00	60.00	0.00
63	77.00	-64.70	6.00	60.00	60.00	0.00
64	78.00	-65.70	6.00	60.00	60.00	0.00
65	79.00	-66.70	6.00	60.00	60.00	0.00
66	80.00	-67.70	6.00	60.00	60.00	0.00
67	81.00	-68.70	6.00	60.00	60.00	0.00
68	82.00	-69.70	6.00	60.00	60.00	0.00
69	83.00	-70.70	6.00	60.00	60.00	0.00
70	84.00	-71.70	6.00	60.00	60.00	0.00
71	85.00	-72.70	6.00	60.00	60.00	0.00
72	86.00	-73.70	6.00	60.00	60.00	0.00
73	87.00	-74.70	6.00	60.00	60.00	0.00
74	88.00	-75.70	6.00	60.00	60.00	0.00
75	89.00	-76.70	6.00	60.00	60.00	0.00
76	90.00	-77.70	6.00	60.00	60.00	0.00
77	91.00	-78.70	6.00	60.00	60.00	0.00
78	92.00	-79.70	6.00	60.00	60.00	0.00
79	93.00	-80.70	6.00	60.00	60.00	0.00
80	94.00	-81.70	6.00	60.00	60.00	0.00
81	95.00	-82.70	6.00	60.00	60.00	0.00

Drilled Shaft Capacity (sorted by shaft diameter):

B-401Shaft60i n. out

Strength reduction factors: Skin-friction = 1.00, End-bearing = 1.00

ID	Diameter (in)	Length (ft)	Skin Fric. (tons)	End Bearing (tons)	Capacity (tons)
1	60.00	15.00	4.761	159.757	164.517
2	60.00	16.00	6.826	162.427	169.253
3	60.00	17.00	9.214	164.132	173.345
4	60.00	18.00	11.915	278.016	289.931
5	60.00	19.00	14.945	289.581	304.526
6	60.00	20.00	18.335	300.639	318.974
7	60.00	21.00	22.072	308.754	330.826
8	60.00	22.00	26.140	318.897	345.036
9	60.00	23.00	30.533	333.500	364.033
10	60.00	24.00	35.249	348.223	383.473
11	60.00	25.00	40.300	358.727	399.027
12	60.00	26.00	45.664	365.771	411.434
13	60.00	27.00	51.279	373.921	425.199
14	60.00	28.00	57.133	383.937	441.070
15	60.00	29.00	63.227	391.926	455.153
16	60.00	30.00	69.572	393.993	463.565
17	60.00	31.00	76.157	391.744	467.900
18	60.00	32.00	82.969	394.813	477.782
19	60.00	33.00	90.006	404.807	494.814
20	60.00	34.00	97.265	417.006	514.271
21	60.00	35.00	104.757	426.688	531.446
22	60.00	36.00	112.474	434.352	546.826
23	60.00	37.00	120.425	442.977	563.402
24	60.00	38.00	128.607	453.060	581.667
25	60.00	39.00	137.004	458.939	595.943
26	60.00	40.00	145.612	454.950	600.562
27	60.00	41.00	154.413	442.997	597.410
28	60.00	42.00	163.359	434.495	597.854
29	60.00	43.00	172.440	431.347	603.788
30	60.00	44.00	181.655	430.835	612.491
31	60.00	45.00	191.013	430.242	621.255
32	60.00	46.00	200.504	430.031	630.535
33	60.00	47.00	210.117	432.978	643.095
34	60.00	48.00	219.851	439.545	659.396
35	60.00	49.00	229.689	445.679	675.368
36	60.00	50.00	239.631	447.325	686.956
37	60.00	51.00	249.661	445.323	694.984
38	60.00	52.00	259.738	444.697	704.435
39	60.00	53.00	269.856	446.286	716.142
40	60.00	54.00	280.033	448.443	728.477
41	60.00	55.00	290.297	449.522	739.819
42	60.00	56.00	300.636	450.441	751.077
43	60.00	57.00	311.026	456.714	767.739
44	60.00	58.00	321.461	469.259	790.720
45	60.00	59.00	331.937	481.225	813.162
46	60.00	60.00	342.462	485.758	828.220
47	60.00	61.00	353.024	483.932	836.956
48	60.00	62.00	363.601	482.193	845.794
49	60.00	63.00	374.188	481.613	855.800
50	60.00	64.00	384.780	479.869	864.649
51	60.00	65.00	395.384	474.638	870.023
52	60.00	66.00	405.990	466.167	872.156
53	60.00	67.00	416.575	455.930	872.505
54	60.00	68.00	427.137	444.175	871.312
55	60.00	69.00	437.663	433.989	871.651
56	60.00	70.00	448.151	428.457	876.608
57	60.00	71.00	458.593	427.042	885.635
58	60.00	72.00	468.982	426.516	895.498
59	60.00	73.00	479.316	426.340	905.656
60	60.00	74.00	489.588	425.759	915.347
61	60.00	75.00	499.805	424.016	923.821
62	60.00	76.00	509.955	421.349	931.304
63	60.00	77.00	520.011	419.197	939.208
64	60.00	78.00	529.967	417.799	947.766
65	60.00	79.00	539.808	416.091	955.899
66	60.00	80.00	549.526	413.008	962.535
67	60.00	81.00	559.121	409.527	968.648
68	60.00	82.00	568.611	411.502	980.114
69	60.00	83.00	577.998	419.910	997.908
70	60.00	84.00	587.269	432.832	1020.101
71	60.00	85.00	596.422	448.352	1044.774
72	60.00	86.00	605.453	465.238	1070.691
73	60.00	87.00	614.552	476.108	1090.660
74	60.00	88.00	623.783	479.731	1103.515
75	60.00	89.00	633.143	479.434	1112.577
76	60.00	90.00	642.625	478.542	1121.167
77	60.00	91.00	Soil Elevations	Must Extend At	or Below Contribution Zone
78	60.00	92.00	Soil Elevations	Must Extend At	or Below Contribution Zone
79	60.00	93.00	Soil Elevations	Must Extend At	or Below Contribution Zone
80	60.00	94.00	Soil Elevations	Must Extend At	or Below Contribution Zone
81	60.00	95.00	Soil Elevations	Must Extend At	or Below Contribution Zone

B-401Shaft60in.out

Drilled Shaft Capacity at User-Defined Settlement (sorted by shaft diameter):

\*\*\*\*\* Capacity is NOT modified by the strength reduction factors \*\*\*\*\*

User-Defined Settlement = 0.83%

ID	Diameter (in)	Length (ft)	Skin Fric. (tons)	End Bearing (tons)	Capacity (tons)
1	60.00	15.00	4.639	41.711	46.351
2	60.00	16.00	6.652	42.408	49.060
3	60.00	17.00	8.979	42.853	51.832
4	60.00	18.00	11.611	72.588	84.199
5	60.00	19.00	14.564	75.607	90.171
6	60.00	20.00	17.868	78.494	96.362
7	60.00	21.00	21.509	80.613	102.122
8	60.00	22.00	25.473	83.261	108.735
9	60.00	23.00	29.755	87.074	116.829
10	60.00	24.00	34.351	90.918	125.269
11	60.00	25.00	39.273	93.661	132.933
12	60.00	26.00	44.500	95.500	139.999
13	60.00	27.00	49.971	97.628	147.599
14	60.00	28.00	55.677	100.243	155.920
15	60.00	29.00	61.615	102.329	163.944
16	60.00	30.00	67.798	102.868	170.667
17	60.00	31.00	74.215	102.281	176.496
18	60.00	32.00	80.854	103.083	183.937
19	60.00	33.00	87.712	105.692	193.404
20	60.00	34.00	94.786	108.877	203.663
21	60.00	35.00	102.087	111.405	213.492
22	60.00	36.00	109.607	113.406	223.013
23	60.00	37.00	117.355	115.658	233.012
24	60.00	38.00	125.329	118.290	243.619
25	60.00	39.00	133.511	119.825	253.337
26	60.00	40.00	141.900	118.784	260.684
27	60.00	41.00	150.477	115.663	266.140
28	60.00	42.00	159.194	113.443	272.638
29	60.00	43.00	168.044	112.621	280.666
30	60.00	44.00	177.024	112.488	289.512
31	60.00	45.00	186.143	112.333	298.476
32	60.00	46.00	195.392	112.278	307.670
33	60.00	47.00	204.761	113.047	317.808
34	60.00	48.00	214.246	114.762	329.008
35	60.00	49.00	223.834	116.363	340.197
36	60.00	50.00	233.522	116.793	350.315
37	60.00	51.00	243.296	116.270	359.566
38	60.00	52.00	253.117	116.107	369.224
39	60.00	53.00	262.977	116.522	379.498
40	60.00	54.00	272.894	117.085	389.979
41	60.00	55.00	282.897	117.367	400.263
42	60.00	56.00	292.972	117.607	410.579
43	60.00	57.00	303.097	119.244	422.341
44	60.00	58.00	313.266	122.520	435.785
45	60.00	59.00	323.475	125.644	449.119
46	60.00	60.00	333.732	126.828	460.559
47	60.00	61.00	344.024	126.351	470.375
48	60.00	62.00	354.331	125.897	480.228
49	60.00	63.00	364.648	125.745	490.394
50	60.00	64.00	374.971	125.290	500.261
51	60.00	65.00	385.304	123.924	509.229
52	60.00	66.00	395.639	121.712	517.352
53	60.00	67.00	405.955	119.040	524.995
54	60.00	68.00	416.248	115.971	532.218
55	60.00	69.00	426.505	113.311	539.816
56	60.00	70.00	436.726	111.867	548.592
57	60.00	71.00	446.902	111.497	558.399
58	60.00	72.00	457.026	111.360	568.386
59	60.00	73.00	467.096	111.314	578.410
60	60.00	74.00	477.107	111.162	588.269
61	60.00	75.00	487.063	110.707	597.771
62	60.00	76.00	496.954	110.011	606.965
63	60.00	77.00	506.754	109.449	616.203
64	60.00	78.00	516.456	109.084	625.540
65	60.00	79.00	526.046	108.638	634.684
66	60.00	80.00	535.517	107.833	643.350
67	60.00	81.00	544.867	106.924	651.792
68	60.00	82.00	554.116	107.440	661.556
69	60.00	83.00	563.263	109.635	672.898
70	60.00	84.00	572.297	113.009	685.306
71	60.00	85.00	581.218	117.061	698.279
72	60.00	86.00	590.018	121.470	711.488
73	60.00	87.00	598.885	124.308	723.193
74	60.00	88.00	607.881	125.254	733.135
75	60.00	89.00	617.002	125.176	742.178
76	60.00	90.00	626.242	124.944	751.186
77	60.00	91.00	Soil Elevations	Must Extend At or Below	Contribution Zone

B-401Shaft60in.out

78	60.00	92.00	Soil Elevations Must Extend At or Below Contribution Zone
79	60.00	93.00	Soil Elevations Must Extend At or Below Contribution Zone
80	60.00	94.00	Soil Elevations Must Extend At or Below Contribution Zone
81	60.00	95.00	Soil Elevations Must Extend At or Below Contribution Zone

General Information:

=====  
 Input file: .....H\Analysis\_Structure\FB-Deep\Drilled Shaft\B-501Shaft48in.spc  
 Project number: 2000-01-17003  
 Job name: SW 10th Street, from Powerline Rd. to Military Trail  
 Engineer: JB Henry  
 Units: English

Analysis Information:

=====  
 Analysis Type: Drilled Shaft Analysis

Soil Information:

=====  
 Boring date: 2/7/2018  
 Boring number: B-501  
 Station number:    Offset:  
  
 Ground Elevation: 12.90(ft)  
 Water table Elevation = 12.90(ft)  
  
 Hammer type: Automatic Hammer, Correction factor = 1.24

ID	Depth (ft)	Elevation (ft)	SPT Blows (Blows/ft)	Unit Weight (pcf)	Soil Type
1	0.00	12.90	N/A	0.00	5- Cavity layer
2	2.00	10.90	N/A	0.00	5- Cavity layer
3	4.00	8.90	N/A	0.00	5- Cavity layer
4	6.00	6.90	N/A	0.00	5- Cavity layer
5	8.00	4.90	N/A	0.00	5- Cavity layer
6	10.00	2.90	30.00	120.00	3- Clean sand
7	12.00	0.90	14.00	110.00	3- Clean sand
8	13.50	-0.60	16.00	110.00	3- Clean sand
9	15.50	-2.60	14.00	110.00	3- Clean sand
10	18.00	-5.10	32.00	120.00	3- Clean sand
11	20.50	-7.60	20.00	115.00	3- Clean sand
12	23.00	-10.10	30.00	120.00	3- Clean sand
13	25.50	-12.60	21.00	115.00	3- Clean sand
14	28.00	-15.10	36.00	125.00	3- Clean sand
15	30.50	-17.60	29.00	120.00	3- Clean sand
16	33.00	-20.10	58.00	130.00	3- Clean sand
17	35.50	-22.60	33.00	125.00	3- Clean sand
18	38.00	-25.10	52.00	130.00	3- Clean sand
19	40.50	-27.60	39.00	125.00	3- Clean sand
20	43.00	-30.10	66.00	130.00	3- Clean sand
21	45.50	-32.60	39.00	125.00	3- Clean sand
22	48.00	-35.10	58.00	130.00	3- Clean sand
23	50.50	-37.60	60.00	130.00	3- Clean sand
24	53.00	-40.10	60.00	130.00	3- Clean sand
25	55.50	-42.60	50.00	130.00	3- Clean sand
26	58.00	-45.10	69.00	130.00	3- Clean sand
27	60.50	-47.60	67.00	130.00	3- Clean sand
28	63.00	-50.10	53.00	130.00	3- Clean sand
29	65.50	-52.60	63.00	130.00	3- Clean sand
30	68.00	-55.10	60.00	130.00	3- Clean sand
31	70.50	-57.60	71.00	130.00	3- Clean sand
32	73.00	-60.10	60.00	130.00	3- Clean sand
33	75.50	-62.60	60.00	130.00	3- Clean sand
34	78.00	-65.10	73.00	130.00	3- Clean sand
35	80.50	-67.60	38.00	125.00	3- Clean sand
36	83.00	-70.10	42.00	125.00	3- Clean sand
37	85.50	-72.60	33.00	125.00	3- Clean sand
38	88.00	-75.10	48.00	125.00	3- Clean sand
39	90.50	-77.60	82.00	130.00	3- Clean sand
40	93.00	-80.10	62.00	130.00	3- Clean sand
41	95.50	-82.60	60.00	130.00	3- Clean sand
42	98.00	-85.10	50.00	130.00	3- Clean sand
43	100.00	-87.10	50.00	130.00	3- Clean sand

ID	Cu-Dir (tsf)	qu (tsf)	qt (tsf)	Em (ksi)	qb (tsf)
1	N/A	N/A	N/A	N/A	N/A
2	N/A	N/A	N/A	N/A	N/A
3	N/A	N/A	N/A	N/A	N/A
4	N/A	N/A	N/A	N/A	N/A
5	N/A	N/A	N/A	N/A	N/A
6	N/A	N/A	N/A	N/A	N/A
7	N/A	N/A	N/A	N/A	N/A
8	N/A	N/A	N/A	N/A	N/A



B-501Shaft48i n. out

9	N/A	N/A	N/A	N/A	N/A
10	N/A	N/A	N/A	N/A	N/A
11	N/A	N/A	N/A	N/A	N/A
12	N/A	N/A	N/A	N/A	N/A
13	N/A	N/A	N/A	N/A	N/A
14	N/A	N/A	N/A	N/A	N/A
15	N/A	N/A	N/A	N/A	N/A
16	N/A	N/A	N/A	N/A	N/A
17	N/A	N/A	N/A	N/A	N/A
18	N/A	N/A	N/A	N/A	N/A
19	N/A	N/A	N/A	N/A	N/A
20	N/A	N/A	N/A	N/A	N/A
21	N/A	N/A	N/A	N/A	N/A
22	N/A	N/A	N/A	N/A	N/A
23	N/A	N/A	N/A	N/A	N/A
24	N/A	N/A	N/A	N/A	N/A
25	N/A	N/A	N/A	N/A	N/A
26	N/A	N/A	N/A	N/A	N/A
27	N/A	N/A	N/A	N/A	N/A
28	N/A	N/A	N/A	N/A	N/A
29	N/A	N/A	N/A	N/A	N/A
30	N/A	N/A	N/A	N/A	N/A
31	N/A	N/A	N/A	N/A	N/A
32	N/A	N/A	N/A	N/A	N/A
33	N/A	N/A	N/A	N/A	N/A
34	N/A	N/A	N/A	N/A	N/A
35	N/A	N/A	N/A	N/A	N/A
36	N/A	N/A	N/A	N/A	N/A
37	N/A	N/A	N/A	N/A	N/A
38	N/A	N/A	N/A	N/A	N/A
39	N/A	N/A	N/A	N/A	N/A
40	N/A	N/A	N/A	N/A	N/A
41	N/A	N/A	N/A	N/A	N/A
42	N/A	N/A	N/A	N/A	N/A
43	N/A	N/A	N/A	N/A	N/A

ID RQD F. M. S. R. I. Rock Recovery

ID	RQD	F. M.	S. R. I.	Rock Recovery
1	N/A	N/A	N/A	N/A
2	N/A	N/A	N/A	N/A
3	N/A	N/A	N/A	N/A
4	N/A	N/A	N/A	N/A
5	N/A	N/A	N/A	N/A
6	N/A	N/A	N/A	N/A
7	N/A	N/A	N/A	N/A
8	N/A	N/A	N/A	N/A
9	N/A	N/A	N/A	N/A
10	N/A	N/A	N/A	N/A
11	N/A	N/A	N/A	N/A
12	N/A	N/A	N/A	N/A
13	N/A	N/A	N/A	N/A
14	N/A	N/A	N/A	N/A
15	N/A	N/A	N/A	N/A
16	N/A	N/A	N/A	N/A
17	N/A	N/A	N/A	N/A
18	N/A	N/A	N/A	N/A
19	N/A	N/A	N/A	N/A
20	N/A	N/A	N/A	N/A
21	N/A	N/A	N/A	N/A
22	N/A	N/A	N/A	N/A
23	N/A	N/A	N/A	N/A
24	N/A	N/A	N/A	N/A
25	N/A	N/A	N/A	N/A
26	N/A	N/A	N/A	N/A
27	N/A	N/A	N/A	N/A
28	N/A	N/A	N/A	N/A
29	N/A	N/A	N/A	N/A
30	N/A	N/A	N/A	N/A
31	N/A	N/A	N/A	N/A
32	N/A	N/A	N/A	N/A
33	N/A	N/A	N/A	N/A
34	N/A	N/A	N/A	N/A
35	N/A	N/A	N/A	N/A
36	N/A	N/A	N/A	N/A
37	N/A	N/A	N/A	N/A
38	N/A	N/A	N/A	N/A
39	N/A	N/A	N/A	N/A
40	N/A	N/A	N/A	N/A
41	N/A	N/A	N/A	N/A
42	N/A	N/A	N/A	N/A
43	N/A	N/A	N/A	N/A

Drilled Shaft Data:

=====

Shaft Geometry:

B-501Shaft48in. out

ID	Length (ft)	Tip Elev. (ft)	Case Len. (ft)	Diameter (in)	Base Diam. (in)	Bell Len. (ft)
1	15.00	-2.10	6.00	48.00	48.00	0.00
2	16.00	-3.10	6.00	48.00	48.00	0.00
3	17.00	-4.10	6.00	48.00	48.00	0.00
4	18.00	-5.10	6.00	48.00	48.00	0.00
5	19.00	-6.10	6.00	48.00	48.00	0.00
6	20.00	-7.10	6.00	48.00	48.00	0.00
7	21.00	-8.10	6.00	48.00	48.00	0.00
8	22.00	-9.10	6.00	48.00	48.00	0.00
9	23.00	-10.10	6.00	48.00	48.00	0.00
10	24.00	-11.10	6.00	48.00	48.00	0.00
11	25.00	-12.10	6.00	48.00	48.00	0.00
12	26.00	-13.10	6.00	48.00	48.00	0.00
13	27.00	-14.10	6.00	48.00	48.00	0.00
14	28.00	-15.10	6.00	48.00	48.00	0.00
15	29.00	-16.10	6.00	48.00	48.00	0.00
16	30.00	-17.10	6.00	48.00	48.00	0.00
17	31.00	-18.10	6.00	48.00	48.00	0.00
18	32.00	-19.10	6.00	48.00	48.00	0.00
19	33.00	-20.10	6.00	48.00	48.00	0.00
20	34.00	-21.10	6.00	48.00	48.00	0.00
21	35.00	-22.10	6.00	48.00	48.00	0.00
22	36.00	-23.10	6.00	48.00	48.00	0.00
23	37.00	-24.10	6.00	48.00	48.00	0.00
24	38.00	-25.10	6.00	48.00	48.00	0.00
25	39.00	-26.10	6.00	48.00	48.00	0.00
26	40.00	-27.10	6.00	48.00	48.00	0.00
27	41.00	-28.10	6.00	48.00	48.00	0.00
28	42.00	-29.10	6.00	48.00	48.00	0.00
29	43.00	-30.10	6.00	48.00	48.00	0.00
30	44.00	-31.10	6.00	48.00	48.00	0.00
31	45.00	-32.10	6.00	48.00	48.00	0.00
32	46.00	-33.10	6.00	48.00	48.00	0.00
33	47.00	-34.10	6.00	48.00	48.00	0.00
34	48.00	-35.10	6.00	48.00	48.00	0.00
35	49.00	-36.10	6.00	48.00	48.00	0.00
36	50.00	-37.10	6.00	48.00	48.00	0.00
37	51.00	-38.10	6.00	48.00	48.00	0.00
38	52.00	-39.10	6.00	48.00	48.00	0.00
39	53.00	-40.10	6.00	48.00	48.00	0.00
40	54.00	-41.10	6.00	48.00	48.00	0.00
41	55.00	-42.10	6.00	48.00	48.00	0.00
42	56.00	-43.10	6.00	48.00	48.00	0.00
43	57.00	-44.10	6.00	48.00	48.00	0.00
44	58.00	-45.10	6.00	48.00	48.00	0.00
45	59.00	-46.10	6.00	48.00	48.00	0.00
46	60.00	-47.10	6.00	48.00	48.00	0.00
47	61.00	-48.10	6.00	48.00	48.00	0.00
48	62.00	-49.10	6.00	48.00	48.00	0.00
49	63.00	-50.10	6.00	48.00	48.00	0.00
50	64.00	-51.10	6.00	48.00	48.00	0.00
51	65.00	-52.10	6.00	48.00	48.00	0.00
52	66.00	-53.10	6.00	48.00	48.00	0.00
53	67.00	-54.10	6.00	48.00	48.00	0.00
54	68.00	-55.10	6.00	48.00	48.00	0.00
55	69.00	-56.10	6.00	48.00	48.00	0.00
56	70.00	-57.10	6.00	48.00	48.00	0.00
57	71.00	-58.10	6.00	48.00	48.00	0.00
58	72.00	-59.10	6.00	48.00	48.00	0.00
59	73.00	-60.10	6.00	48.00	48.00	0.00
60	74.00	-61.10	6.00	48.00	48.00	0.00
61	75.00	-62.10	6.00	48.00	48.00	0.00
62	76.00	-63.10	6.00	48.00	48.00	0.00
63	77.00	-64.10	6.00	48.00	48.00	0.00
64	78.00	-65.10	6.00	48.00	48.00	0.00
65	79.00	-66.10	6.00	48.00	48.00	0.00
66	80.00	-67.10	6.00	48.00	48.00	0.00
67	81.00	-68.10	6.00	48.00	48.00	0.00
68	82.00	-69.10	6.00	48.00	48.00	0.00
69	83.00	-70.10	6.00	48.00	48.00	0.00
70	84.00	-71.10	6.00	48.00	48.00	0.00
71	85.00	-72.10	6.00	48.00	48.00	0.00
72	86.00	-73.10	6.00	48.00	48.00	0.00
73	87.00	-74.10	6.00	48.00	48.00	0.00
74	88.00	-75.10	6.00	48.00	48.00	0.00
75	89.00	-76.10	6.00	48.00	48.00	0.00
76	90.00	-77.10	6.00	48.00	48.00	0.00
77	91.00	-78.10	6.00	48.00	48.00	0.00
78	92.00	-79.10	6.00	48.00	48.00	0.00
79	93.00	-80.10	6.00	48.00	48.00	0.00
80	94.00	-81.10	6.00	48.00	48.00	0.00
81	95.00	-82.10	6.00	48.00	48.00	0.00

Drilled Shaft Capacity (sorted by shaft diameter):

B-501Shaft48i n. out

Strength reduction factors: Skin-friction = 1.00, End-bearing = 1.00

ID	Diameter (in)	Length (ft)	Skin Fric. (tons)	End Bearing (tons)	Capacity (tons)
1	48.00	15.00	4.284	112.266	116.550
2	48.00	16.00	6.001	201.304	207.305
3	48.00	17.00	7.971	199.551	207.522
4	48.00	18.00	10.191	204.031	214.221
5	48.00	19.00	12.672	214.146	226.818
6	48.00	20.00	15.442	226.021	241.463
7	48.00	21.00	18.483	238.662	257.146
8	48.00	22.00	21.765	250.213	271.977
9	48.00	23.00	25.279	256.630	281.910
10	48.00	24.00	29.025	259.589	288.614
11	48.00	25.00	33.014	263.557	296.571
12	48.00	26.00	37.230	271.265	308.496
13	48.00	27.00	41.646	281.080	322.726
14	48.00	28.00	46.256	288.519	334.775
15	48.00	29.00	51.069	294.438	345.508
16	48.00	30.00	56.109	301.367	357.477
17	48.00	31.00	61.362	311.436	372.798
18	48.00	32.00	66.801	323.768	390.569
19	48.00	33.00	72.419	333.011	405.431
20	48.00	34.00	78.226	337.968	416.194
21	48.00	35.00	84.242	341.416	425.658
22	48.00	36.00	90.454	346.618	437.072
23	48.00	37.00	96.836	353.406	450.242
24	48.00	38.00	103.382	357.718	461.100
25	48.00	39.00	110.089	358.967	469.056
26	48.00	40.00	116.965	359.799	476.764
27	48.00	41.00	123.998	362.990	486.989
28	48.00	42.00	131.165	367.970	499.135
29	48.00	43.00	138.460	371.342	509.802
30	48.00	44.00	145.879	372.431	518.311
31	48.00	45.00	153.432	372.483	525.915
32	48.00	46.00	161.105	372.869	533.975
33	48.00	47.00	168.878	373.642	542.520
34	48.00	48.00	176.746	374.209	550.955
35	48.00	49.00	184.704	374.415	559.119
36	48.00	50.00	192.761	374.621	567.383
37	48.00	51.00	200.909	375.239	576.148
38	48.00	52.00	209.138	376.167	585.304
39	48.00	53.00	217.446	376.785	594.231
40	48.00	54.00	225.821	376.991	602.812
41	48.00	55.00	234.262	376.991	611.253
42	48.00	56.00	242.760	376.991	619.751
43	48.00	57.00	251.308	376.991	628.299
44	48.00	58.00	259.903	376.991	636.894
45	48.00	59.00	268.534	376.991	645.525
46	48.00	60.00	277.199	376.991	654.190
47	48.00	61.00	285.890	376.991	662.881
48	48.00	62.00	294.601	376.991	671.592
49	48.00	63.00	303.329	376.991	680.320
50	48.00	64.00	312.063	376.991	689.054
51	48.00	65.00	320.801	376.991	697.792
52	48.00	66.00	329.536	376.991	706.528
53	48.00	67.00	338.262	376.991	715.253
54	48.00	68.00	346.976	376.991	723.967
55	48.00	69.00	355.667	376.991	732.658
56	48.00	70.00	364.334	376.991	741.325
57	48.00	71.00	372.970	376.720	749.690
58	48.00	72.00	381.568	375.905	757.474
59	48.00	73.00	390.127	374.684	764.811
60	48.00	74.00	398.636	373.870	772.506
61	48.00	75.00	407.094	373.598	780.692
62	48.00	76.00	415.493	372.742	788.236
63	48.00	77.00	423.829	370.175	794.004
64	48.00	78.00	432.097	366.324	798.422
65	48.00	79.00	440.290	363.666	803.956
66	48.00	80.00	448.405	362.539	810.944
67	48.00	81.00	456.435	362.132	818.567
68	48.00	82.00	464.367	361.861	826.228
69	48.00	83.00	472.199	361.770	833.969
70	48.00	84.00	479.921	361.485	841.406
71	48.00	85.00	487.533	360.991	848.524
72	48.00	86.00	495.030	360.793	855.823
73	48.00	87.00	502.572	361.566	864.138
74	48.00	88.00	510.213	362.366	872.579
75	48.00	89.00	517.951	362.728	880.680
76	48.00	90.00	525.788	363.869	889.658
77	48.00	91.00	533.725	367.292	901.017
78	48.00	92.00	541.766	372.427	914.193
79	48.00	93.00	Soil Elevations	Must Extend At	or Below Contribution Zone
80	48.00	94.00	Soil Elevations	Must Extend At	or Below Contribution Zone
81	48.00	95.00	Soil Elevations	Must Extend At	or Below Contribution Zone

B-501Shaft48i n. out

Drilled Shaft Capacity at User-Defined Settlement (sorted by shaft diameter):

\*\*\*\*\* Capacity is NOT modified by the strength reduction factors \*\*\*\*\*

---

User-Defined Settlement = 1.04%

ID	Diameter (in)	Length (ft)	Skin Fric. (tons)	End Bearing (tons)	Capacity (tons)
1	48.00	15.00	4.191	35.689	39.880
2	48.00	16.00	5.869	63.995	69.864
3	48.00	17.00	7.797	63.437	71.234
4	48.00	18.00	9.968	64.861	74.829
5	48.00	19.00	12.395	68.077	80.472
6	48.00	20.00	15.104	71.852	86.956
7	48.00	21.00	18.079	75.871	93.949
8	48.00	22.00	21.288	79.543	100.831
9	48.00	23.00	24.726	81.583	106.309
10	48.00	24.00	28.390	82.523	110.913
11	48.00	25.00	32.291	83.785	116.076
12	48.00	26.00	36.416	86.235	122.651
13	48.00	27.00	40.735	89.355	130.090
14	48.00	28.00	45.243	91.720	136.964
15	48.00	29.00	49.952	93.602	143.554
16	48.00	30.00	54.881	95.805	150.686
17	48.00	31.00	60.019	99.005	159.025
18	48.00	32.00	65.339	102.926	168.265
19	48.00	33.00	70.834	105.864	176.699
20	48.00	34.00	76.514	107.440	183.954
21	48.00	35.00	82.398	108.536	190.935
22	48.00	36.00	88.474	110.190	198.664
23	48.00	37.00	94.716	112.348	207.064
24	48.00	38.00	101.119	113.719	214.838
25	48.00	39.00	107.679	114.116	221.795
26	48.00	40.00	114.405	114.380	228.785
27	48.00	41.00	121.284	115.395	236.679
28	48.00	42.00	128.294	116.978	245.272
29	48.00	43.00	135.429	118.050	253.479
30	48.00	44.00	142.686	118.396	261.082
31	48.00	45.00	150.073	118.412	268.486
32	48.00	46.00	157.579	118.535	276.114
33	48.00	47.00	165.182	118.781	283.963
34	48.00	48.00	172.877	118.961	291.838
35	48.00	49.00	180.662	119.027	299.688
36	48.00	50.00	188.542	119.092	307.634
37	48.00	51.00	196.511	119.289	315.800
38	48.00	52.00	204.560	119.584	324.144
39	48.00	53.00	212.686	119.780	332.467
40	48.00	54.00	220.878	119.846	340.724
41	48.00	55.00	229.134	119.846	348.980
42	48.00	56.00	237.446	119.846	357.292
43	48.00	57.00	245.807	119.846	365.653
44	48.00	58.00	254.214	119.846	374.060
45	48.00	59.00	262.656	119.846	382.502
46	48.00	60.00	271.131	119.846	390.977
47	48.00	61.00	279.633	119.846	399.478
48	48.00	62.00	288.153	119.846	407.999
49	48.00	63.00	296.690	119.846	416.535
50	48.00	64.00	305.232	119.846	425.078
51	48.00	65.00	313.779	119.846	433.625
52	48.00	66.00	322.324	119.846	442.169
53	48.00	67.00	330.858	119.846	450.704
54	48.00	68.00	339.381	119.846	459.227
55	48.00	69.00	347.882	119.846	467.728
56	48.00	70.00	356.359	119.846	476.205
57	48.00	71.00	364.806	119.759	484.566
58	48.00	72.00	373.217	119.500	492.717
59	48.00	73.00	381.588	119.112	500.700
60	48.00	74.00	389.911	118.853	508.764
61	48.00	75.00	398.183	118.767	516.950
62	48.00	76.00	406.399	118.495	524.894
63	48.00	77.00	414.552	117.679	532.231
64	48.00	78.00	422.640	116.455	539.094
65	48.00	79.00	430.653	115.610	546.263
66	48.00	80.00	438.590	115.251	553.842
67	48.00	81.00	446.445	115.122	561.567
68	48.00	82.00	454.203	115.036	569.239
69	48.00	83.00	461.863	115.007	576.870
70	48.00	84.00	469.417	114.916	584.333
71	48.00	85.00	476.862	114.759	591.621
72	48.00	86.00	484.195	114.696	598.891
73	48.00	87.00	491.572	114.942	606.514
74	48.00	88.00	499.045	115.196	614.242
75	48.00	89.00	506.614	115.311	621.926
76	48.00	90.00	514.280	115.674	629.954
77	48.00	91.00	522.043	116.762	638.805

B-501Shaft48in.out  
78 48.00 92.00 529.908 118.395 648.303  
79 48.00 93.00 Soil Elevations Must Extend At or Below Contribution Zone  
80 48.00 94.00 Soil Elevations Must Extend At or Below Contribution Zone  
81 48.00 95.00 Soil Elevations Must Extend At or Below Contribution Zone

General Information:

=====  
 Input file: .....H\Analysis\_Structure\FB-Deep\Drilled Shaft\B-501Shaft60in.spc  
 Project number: 2000-01-17003  
 Job name: SW 10th Street, from Powerline Rd. to Military Trail  
 Engineer: JB Henry  
 Units: English

Analysis Information:

=====  
 Analysis Type: Drilled Shaft Analysis

Soil Information:

=====  
 Boring date: 2/7/2018  
 Boring number: B-501  
 Station number:    Offset:  
  
 Ground Elevation: 12.90(ft)  
 Water table Elevation = 12.90(ft)  
  
 Hammer type: Automatic Hammer, Correction factor = 1.24

ID	Depth (ft)	Elevation (ft)	SPT Blows (Blows/ft)	Unit Weight (pcf)	Soil Type
1	0.00	12.90	N/A	0.00	5- Cavity layer
2	2.00	10.90	N/A	0.00	5- Cavity layer
3	4.00	8.90	N/A	0.00	5- Cavity layer
4	6.00	6.90	N/A	0.00	5- Cavity layer
5	8.00	4.90	N/A	0.00	5- Cavity layer
6	10.00	2.90	30.00	120.00	3- Clean sand
7	12.00	0.90	14.00	110.00	3- Clean sand
8	13.50	-0.60	16.00	110.00	3- Clean sand
9	15.50	-2.60	14.00	110.00	3- Clean sand
10	18.00	-5.10	32.00	120.00	3- Clean sand
11	20.50	-7.60	20.00	115.00	3- Clean sand
12	23.00	-10.10	30.00	120.00	3- Clean sand
13	25.50	-12.60	21.00	115.00	3- Clean sand
14	28.00	-15.10	36.00	125.00	3- Clean sand
15	30.50	-17.60	29.00	120.00	3- Clean sand
16	33.00	-20.10	58.00	130.00	3- Clean sand
17	35.50	-22.60	33.00	125.00	3- Clean sand
18	38.00	-25.10	52.00	130.00	3- Clean sand
19	40.50	-27.60	39.00	125.00	3- Clean sand
20	43.00	-30.10	66.00	130.00	3- Clean sand
21	45.50	-32.60	39.00	125.00	3- Clean sand
22	48.00	-35.10	58.00	130.00	3- Clean sand
23	50.50	-37.60	60.00	130.00	3- Clean sand
24	53.00	-40.10	60.00	130.00	3- Clean sand
25	55.50	-42.60	50.00	130.00	3- Clean sand
26	58.00	-45.10	69.00	130.00	3- Clean sand
27	60.50	-47.60	67.00	130.00	3- Clean sand
28	63.00	-50.10	53.00	130.00	3- Clean sand
29	65.50	-52.60	63.00	130.00	3- Clean sand
30	68.00	-55.10	60.00	130.00	3- Clean sand
31	70.50	-57.60	71.00	130.00	3- Clean sand
32	73.00	-60.10	60.00	130.00	3- Clean sand
33	75.50	-62.60	60.00	130.00	3- Clean sand
34	78.00	-65.10	73.00	130.00	3- Clean sand
35	80.50	-67.60	38.00	125.00	3- Clean sand
36	83.00	-70.10	42.00	125.00	3- Clean sand
37	85.50	-72.60	33.00	125.00	3- Clean sand
38	88.00	-75.10	48.00	125.00	3- Clean sand
39	90.50	-77.60	82.00	130.00	3- Clean sand
40	93.00	-80.10	62.00	130.00	3- Clean sand
41	95.50	-82.60	60.00	130.00	3- Clean sand
42	98.00	-85.10	50.00	130.00	3- Clean sand
43	100.00	-87.10	50.00	130.00	3- Clean sand

ID	Cu-Dir (tsf)	qu (tsf)	qt (tsf)	Em (ksi)	qb (tsf)
1	N/A	N/A	N/A	N/A	N/A
2	N/A	N/A	N/A	N/A	N/A
3	N/A	N/A	N/A	N/A	N/A
4	N/A	N/A	N/A	N/A	N/A
5	N/A	N/A	N/A	N/A	N/A
6	N/A	N/A	N/A	N/A	N/A
7	N/A	N/A	N/A	N/A	N/A
8	N/A	N/A	N/A	N/A	N/A

B-501Shaft60in. out

9	N/A	N/A	N/A	N/A	N/A
10	N/A	N/A	N/A	N/A	N/A
11	N/A	N/A	N/A	N/A	N/A
12	N/A	N/A	N/A	N/A	N/A
13	N/A	N/A	N/A	N/A	N/A
14	N/A	N/A	N/A	N/A	N/A
15	N/A	N/A	N/A	N/A	N/A
16	N/A	N/A	N/A	N/A	N/A
17	N/A	N/A	N/A	N/A	N/A
18	N/A	N/A	N/A	N/A	N/A
19	N/A	N/A	N/A	N/A	N/A
20	N/A	N/A	N/A	N/A	N/A
21	N/A	N/A	N/A	N/A	N/A
22	N/A	N/A	N/A	N/A	N/A
23	N/A	N/A	N/A	N/A	N/A
24	N/A	N/A	N/A	N/A	N/A
25	N/A	N/A	N/A	N/A	N/A
26	N/A	N/A	N/A	N/A	N/A
27	N/A	N/A	N/A	N/A	N/A
28	N/A	N/A	N/A	N/A	N/A
29	N/A	N/A	N/A	N/A	N/A
30	N/A	N/A	N/A	N/A	N/A
31	N/A	N/A	N/A	N/A	N/A
32	N/A	N/A	N/A	N/A	N/A
33	N/A	N/A	N/A	N/A	N/A
34	N/A	N/A	N/A	N/A	N/A
35	N/A	N/A	N/A	N/A	N/A
36	N/A	N/A	N/A	N/A	N/A
37	N/A	N/A	N/A	N/A	N/A
38	N/A	N/A	N/A	N/A	N/A
39	N/A	N/A	N/A	N/A	N/A
40	N/A	N/A	N/A	N/A	N/A
41	N/A	N/A	N/A	N/A	N/A
42	N/A	N/A	N/A	N/A	N/A
43	N/A	N/A	N/A	N/A	N/A

ID RQD F. M. S. R. I. Rock Recovery

1	N/A	N/A	N/A
2	N/A	N/A	N/A
3	N/A	N/A	N/A
4	N/A	N/A	N/A
5	N/A	N/A	N/A
6	N/A	N/A	N/A
7	N/A	N/A	N/A
8	N/A	N/A	N/A
9	N/A	N/A	N/A
10	N/A	N/A	N/A
11	N/A	N/A	N/A
12	N/A	N/A	N/A
13	N/A	N/A	N/A
14	N/A	N/A	N/A
15	N/A	N/A	N/A
16	N/A	N/A	N/A
17	N/A	N/A	N/A
18	N/A	N/A	N/A
19	N/A	N/A	N/A
20	N/A	N/A	N/A
21	N/A	N/A	N/A
22	N/A	N/A	N/A
23	N/A	N/A	N/A
24	N/A	N/A	N/A
25	N/A	N/A	N/A
26	N/A	N/A	N/A
27	N/A	N/A	N/A
28	N/A	N/A	N/A
29	N/A	N/A	N/A
30	N/A	N/A	N/A
31	N/A	N/A	N/A
32	N/A	N/A	N/A
33	N/A	N/A	N/A
34	N/A	N/A	N/A
35	N/A	N/A	N/A
36	N/A	N/A	N/A
37	N/A	N/A	N/A
38	N/A	N/A	N/A
39	N/A	N/A	N/A
40	N/A	N/A	N/A
41	N/A	N/A	N/A
42	N/A	N/A	N/A
43	N/A	N/A	N/A

Drilled Shaft Data:

=====

Shaft Geometry:

B-501Shaft60in. out

ID	Length (ft)	Tip Elev. (ft)	Case Len. (ft)	Diameter (in)	Base Diam. (in)	Bell Len. (ft)
1	15.00	-2.10	6.00	60.00	60.00	0.00
2	16.00	-3.10	6.00	60.00	60.00	0.00
3	17.00	-4.10	6.00	60.00	60.00	0.00
4	18.00	-5.10	6.00	60.00	60.00	0.00
5	19.00	-6.10	6.00	60.00	60.00	0.00
6	20.00	-7.10	6.00	60.00	60.00	0.00
7	21.00	-8.10	6.00	60.00	60.00	0.00
8	22.00	-9.10	6.00	60.00	60.00	0.00
9	23.00	-10.10	6.00	60.00	60.00	0.00
10	24.00	-11.10	6.00	60.00	60.00	0.00
11	25.00	-12.10	6.00	60.00	60.00	0.00
12	26.00	-13.10	6.00	60.00	60.00	0.00
13	27.00	-14.10	6.00	60.00	60.00	0.00
14	28.00	-15.10	6.00	60.00	60.00	0.00
15	29.00	-16.10	6.00	60.00	60.00	0.00
16	30.00	-17.10	6.00	60.00	60.00	0.00
17	31.00	-18.10	6.00	60.00	60.00	0.00
18	32.00	-19.10	6.00	60.00	60.00	0.00
19	33.00	-20.10	6.00	60.00	60.00	0.00
20	34.00	-21.10	6.00	60.00	60.00	0.00
21	35.00	-22.10	6.00	60.00	60.00	0.00
22	36.00	-23.10	6.00	60.00	60.00	0.00
23	37.00	-24.10	6.00	60.00	60.00	0.00
24	38.00	-25.10	6.00	60.00	60.00	0.00
25	39.00	-26.10	6.00	60.00	60.00	0.00
26	40.00	-27.10	6.00	60.00	60.00	0.00
27	41.00	-28.10	6.00	60.00	60.00	0.00
28	42.00	-29.10	6.00	60.00	60.00	0.00
29	43.00	-30.10	6.00	60.00	60.00	0.00
30	44.00	-31.10	6.00	60.00	60.00	0.00
31	45.00	-32.10	6.00	60.00	60.00	0.00
32	46.00	-33.10	6.00	60.00	60.00	0.00
33	47.00	-34.10	6.00	60.00	60.00	0.00
34	48.00	-35.10	6.00	60.00	60.00	0.00
35	49.00	-36.10	6.00	60.00	60.00	0.00
36	50.00	-37.10	6.00	60.00	60.00	0.00
37	51.00	-38.10	6.00	60.00	60.00	0.00
38	52.00	-39.10	6.00	60.00	60.00	0.00
39	53.00	-40.10	6.00	60.00	60.00	0.00
40	54.00	-41.10	6.00	60.00	60.00	0.00
41	55.00	-42.10	6.00	60.00	60.00	0.00
42	56.00	-43.10	6.00	60.00	60.00	0.00
43	57.00	-44.10	6.00	60.00	60.00	0.00
44	58.00	-45.10	6.00	60.00	60.00	0.00
45	59.00	-46.10	6.00	60.00	60.00	0.00
46	60.00	-47.10	6.00	60.00	60.00	0.00
47	61.00	-48.10	6.00	60.00	60.00	0.00
48	62.00	-49.10	6.00	60.00	60.00	0.00
49	63.00	-50.10	6.00	60.00	60.00	0.00
50	64.00	-51.10	6.00	60.00	60.00	0.00
51	65.00	-52.10	6.00	60.00	60.00	0.00
52	66.00	-53.10	6.00	60.00	60.00	0.00
53	67.00	-54.10	6.00	60.00	60.00	0.00
54	68.00	-55.10	6.00	60.00	60.00	0.00
55	69.00	-56.10	6.00	60.00	60.00	0.00
56	70.00	-57.10	6.00	60.00	60.00	0.00
57	71.00	-58.10	6.00	60.00	60.00	0.00
58	72.00	-59.10	6.00	60.00	60.00	0.00
59	73.00	-60.10	6.00	60.00	60.00	0.00
60	74.00	-61.10	6.00	60.00	60.00	0.00
61	75.00	-62.10	6.00	60.00	60.00	0.00
62	76.00	-63.10	6.00	60.00	60.00	0.00
63	77.00	-64.10	6.00	60.00	60.00	0.00
64	78.00	-65.10	6.00	60.00	60.00	0.00
65	79.00	-66.10	6.00	60.00	60.00	0.00
66	80.00	-67.10	6.00	60.00	60.00	0.00
67	81.00	-68.10	6.00	60.00	60.00	0.00
68	82.00	-69.10	6.00	60.00	60.00	0.00
69	83.00	-70.10	6.00	60.00	60.00	0.00
70	84.00	-71.10	6.00	60.00	60.00	0.00
71	85.00	-72.10	6.00	60.00	60.00	0.00
72	86.00	-73.10	6.00	60.00	60.00	0.00
73	87.00	-74.10	6.00	60.00	60.00	0.00
74	88.00	-75.10	6.00	60.00	60.00	0.00
75	89.00	-76.10	6.00	60.00	60.00	0.00
76	90.00	-77.10	6.00	60.00	60.00	0.00
77	91.00	-78.10	6.00	60.00	60.00	0.00
78	92.00	-79.10	6.00	60.00	60.00	0.00
79	93.00	-80.10	6.00	60.00	60.00	0.00
80	94.00	-81.10	6.00	60.00	60.00	0.00
81	95.00	-82.10	6.00	60.00	60.00	0.00

Drilled Shaft Capacity (sorted by shaft diameter):



B-501Shaft60i n. out

Strength reduction factors: Skin-friction = 1.00, End-bearing = 1.00

ID	Diameter (in)	Length (ft)	Skin Fric. (tons)	End Bearing (tons)	Capacity (tons)
1	60.00	15.00	5.355	149.082	154.437
2	60.00	16.00	7.501	153.449	160.950
3	60.00	17.00	9.964	156.979	166.943
4	60.00	18.00	12.738	273.400	286.139
5	60.00	19.00	15.840	282.612	298.452
6	60.00	20.00	19.302	294.691	313.993
7	60.00	21.00	23.104	304.737	327.841
8	60.00	22.00	27.206	317.436	344.642
9	60.00	23.00	31.599	334.514	366.113
10	60.00	24.00	36.282	349.604	385.886
11	60.00	25.00	41.267	356.338	397.605
12	60.00	26.00	46.538	356.621	403.159
13	60.00	27.00	52.058	361.894	413.952
14	60.00	28.00	57.820	374.062	431.882
15	60.00	29.00	63.837	387.610	451.447
16	60.00	30.00	70.137	397.022	467.159
17	60.00	31.00	76.703	403.335	480.038
18	60.00	32.00	83.501	412.773	496.274
19	60.00	33.00	90.524	426.373	516.897
20	60.00	34.00	97.783	439.162	536.945
21	60.00	35.00	105.303	446.165	551.468
22	60.00	36.00	113.068	448.504	561.572
23	60.00	37.00	121.045	452.910	573.955
24	60.00	38.00	129.227	460.505	589.732
25	60.00	39.00	137.611	467.803	605.414
26	60.00	40.00	146.206	471.317	617.524
27	60.00	41.00	154.998	471.833	626.830
28	60.00	42.00	163.956	474.049	638.005
29	60.00	43.00	173.075	478.749	651.824
30	60.00	44.00	182.349	483.450	665.799
31	60.00	45.00	191.789	485.666	677.455
32	60.00	46.00	201.382	485.775	687.157
33	60.00	47.00	211.098	486.044	697.142
34	60.00	48.00	220.932	486.849	707.781
35	60.00	49.00	230.880	487.707	718.588
36	60.00	50.00	240.952	488.137	729.089
37	60.00	51.00	251.136	488.244	739.380
38	60.00	52.00	261.422	488.673	750.096
39	60.00	53.00	271.807	489.532	761.339
40	60.00	54.00	282.276	490.391	772.667
41	60.00	55.00	292.827	490.820	783.647
42	60.00	56.00	303.450	490.874	794.324
43	60.00	57.00	314.135	490.874	805.009
44	60.00	58.00	324.879	490.874	815.752
45	60.00	59.00	335.667	490.874	826.541
46	60.00	60.00	346.498	490.874	837.372
47	60.00	61.00	357.363	490.874	848.237
48	60.00	62.00	368.252	490.874	859.126
49	60.00	63.00	379.161	490.874	870.035
50	60.00	64.00	390.079	490.874	880.953
51	60.00	65.00	401.001	490.874	891.875
52	60.00	66.00	411.921	490.874	902.794
53	60.00	67.00	422.828	490.874	913.702
54	60.00	68.00	433.720	490.874	924.594
55	60.00	69.00	444.583	490.591	935.175
56	60.00	70.00	455.417	489.743	945.160
57	60.00	71.00	466.212	488.471	954.683
58	60.00	72.00	476.961	487.622	964.583
59	60.00	73.00	487.659	487.340	974.999
60	60.00	74.00	498.295	486.448	984.743
61	60.00	75.00	508.867	483.774	992.641
62	60.00	76.00	519.366	479.762	999.129
63	60.00	77.00	529.786	477.088	1006.874
64	60.00	78.00	540.122	476.197	1016.318
65	60.00	79.00	550.363	476.102	1026.465
66	60.00	80.00	560.506	475.820	1036.326
67	60.00	81.00	570.544	475.396	1045.940
68	60.00	82.00	580.459	475.113	1055.572
69	60.00	83.00	590.249	475.019	1065.267
70	60.00	84.00	599.901	474.721	1074.623
71	60.00	85.00	609.416	473.830	1083.246
72	60.00	86.00	618.788	472.587	1091.375
73	60.00	87.00	628.215	472.450	1100.665
74	60.00	88.00	637.766	473.661	1111.426
75	60.00	89.00	647.439	475.169	1122.608
76	60.00	90.00	657.235	475.922	1133.158
77	60.00	91.00	Soil Elevations	Must Extend At or Below	Contribution Zone
78	60.00	92.00	Soil Elevations	Must Extend At or Below	Contribution Zone
79	60.00	93.00	Soil Elevations	Must Extend At or Below	Contribution Zone
80	60.00	94.00	Soil Elevations	Must Extend At or Below	Contribution Zone
81	60.00	95.00	Soil Elevations	Must Extend At or Below	Contribution Zone

B-501Shaft60in.out

Drilled Shaft Capacity at User-Defined Settlement (sorted by shaft diameter):

\*\*\*\*\* Capacity is NOT modified by the strength reduction factors \*\*\*\*\*

---

User-Defined Settlement = 0.83%

ID	Diameter (in)	Length (ft)	Skin Fric. (tons)	End Bearing (tons)	Capacity (tons)
1	60.00	15.00	5.219	38.924	44.143
2	60.00	16.00	7.310	40.064	47.374
3	60.00	17.00	9.710	40.986	50.696
4	60.00	18.00	12.414	71.383	83.796
5	60.00	19.00	15.436	73.788	89.224
6	60.00	20.00	18.810	76.941	95.751
7	60.00	21.00	22.515	79.564	102.079
8	60.00	22.00	26.512	82.880	109.392
9	60.00	23.00	30.794	87.339	118.133
10	60.00	24.00	35.357	91.279	126.636
11	60.00	25.00	40.215	93.037	133.252
12	60.00	26.00	45.352	93.111	138.463
13	60.00	27.00	50.731	94.488	145.219
14	60.00	28.00	56.346	97.665	154.010
15	60.00	29.00	62.209	101.202	163.411
16	60.00	30.00	68.349	103.659	172.008
17	60.00	31.00	74.748	105.308	180.055
18	60.00	32.00	81.373	107.772	189.144
19	60.00	33.00	88.216	111.323	199.539
20	60.00	34.00	95.290	114.662	209.952
21	60.00	35.00	102.618	116.490	219.109
22	60.00	36.00	110.185	117.101	227.286
23	60.00	37.00	117.959	118.251	236.210
24	60.00	38.00	125.933	120.234	246.167
25	60.00	39.00	134.103	122.140	256.242
26	60.00	40.00	142.479	123.057	265.536
27	60.00	41.00	151.046	123.192	274.238
28	60.00	42.00	159.776	123.770	283.547
29	60.00	43.00	168.662	124.998	293.660
30	60.00	44.00	177.700	126.225	303.925
31	60.00	45.00	186.900	126.804	313.704
32	60.00	46.00	196.248	126.832	323.080
33	60.00	47.00	205.716	126.902	332.618
34	60.00	48.00	215.300	127.112	342.412
35	60.00	49.00	224.994	127.337	352.331
36	60.00	50.00	234.809	127.449	362.258
37	60.00	51.00	244.733	127.477	372.210
38	60.00	52.00	254.758	127.589	382.346
39	60.00	53.00	264.878	127.813	392.691
40	60.00	54.00	275.080	128.037	403.117
41	60.00	55.00	285.362	128.149	413.511
42	60.00	56.00	295.714	128.163	423.877
43	60.00	57.00	306.126	128.163	434.290
44	60.00	58.00	316.596	128.163	444.760
45	60.00	59.00	327.110	128.163	455.273
46	60.00	60.00	337.665	128.163	465.828
47	60.00	61.00	348.252	128.163	476.416
48	60.00	62.00	358.864	128.163	487.027
49	60.00	63.00	369.495	128.163	497.659
50	60.00	64.00	380.134	128.163	508.297
51	60.00	65.00	390.778	128.163	518.942
52	60.00	66.00	401.419	128.163	529.583
53	60.00	67.00	412.048	128.163	540.212
54	60.00	68.00	422.663	128.163	550.826
55	60.00	69.00	433.249	128.089	561.339
56	60.00	70.00	443.807	127.868	571.675
57	60.00	71.00	454.327	127.536	581.863
58	60.00	72.00	464.801	127.314	592.116
59	60.00	73.00	475.227	127.241	602.467
60	60.00	74.00	485.592	127.008	612.600
61	60.00	75.00	495.894	126.310	622.204
62	60.00	76.00	506.126	125.262	631.388
63	60.00	77.00	516.280	124.564	640.844
64	60.00	78.00	526.352	124.331	650.683
65	60.00	79.00	536.332	124.307	660.638
66	60.00	80.00	546.217	124.233	670.450
67	60.00	81.00	555.999	124.122	680.121
68	60.00	82.00	565.661	124.048	689.710
69	60.00	83.00	575.201	124.024	699.225
70	60.00	84.00	584.608	123.946	708.554
71	60.00	85.00	593.880	123.713	717.593
72	60.00	86.00	603.013	123.389	726.402
73	60.00	87.00	612.200	123.353	735.553
74	60.00	88.00	621.507	123.669	745.176
75	60.00	89.00	630.934	124.063	754.996
76	60.00	90.00	640.480	124.260	764.740
77	60.00	91.00	Soil Elevations	Must Extend At or Below	Contribution Zone

B-501Shaft60in.out

78	60.00	92.00	Soil Elevations Must Extend At or Below Contribution Zone
79	60.00	93.00	Soil Elevations Must Extend At or Below Contribution Zone
80	60.00	94.00	Soil Elevations Must Extend At or Below Contribution Zone
81	60.00	95.00	Soil Elevations Must Extend At or Below Contribution Zone

General Information:

=====  
 Input file: .....H\Analysis\_Structure\FB-Deep\Drilled Shaft\B-601Shaft48in.spc  
 Project number: 2000-01-17003  
 Job name: SW 10th Street, from Powerline Rd. to Military Trail  
 Engineer: JB Henry  
 Units: English

Analysis Information:

=====  
 Analysis Type: Drilled Shaft Analysis

Soil Information:

=====  
 Boring date: 1/31/2018  
 Boring number: B-601  
 Station number:     Offset:  
  
 Ground Elevation: 13.00(ft)  
 Water table Elevation = 13.00(ft)  
  
 Hammer type: Automatic Hammer, Correction factor = 1.24

ID	Depth (ft)	Elevation (ft)	SPT Blows (Blows/ft)	Unit Weight (pcf)	Soil Type
1	0.00	13.00	N/A	0.00	5- Cavity layer
2	2.00	11.00	N/A	0.00	5- Cavity layer
3	4.00	9.00	N/A	0.00	5- Cavity layer
4	6.00	7.00	N/A	0.00	5- Cavity layer
5	8.00	5.00	N/A	0.00	5- Cavity layer
6	10.00	3.00	3.00	100.00	3- Clean sand
7	12.00	1.00	4.00	105.00	3- Clean sand
8	13.50	-0.50	3.00	100.00	3- Clean sand
9	15.50	-2.50	6.00	105.00	3- Clean sand
10	18.00	-5.00	12.00	110.00	3- Clean sand
11	20.50	-7.50	15.00	110.00	3- Clean sand
12	23.00	-10.00	22.00	115.00	3- Clean sand
13	25.50	-12.50	20.00	115.00	3- Clean sand
14	28.00	-15.00	52.00	130.00	3- Clean sand
15	30.50	-17.50	61.00	130.00	3- Clean sand
16	33.00	-20.00	90.00	130.00	3- Clean sand
17	35.50	-22.50	40.00	125.00	3- Clean sand
18	38.00	-25.00	78.00	130.00	3- Clean sand
19	40.50	-27.50	47.00	125.00	3- Clean sand
20	43.00	-30.00	89.00	130.00	3- Clean sand
21	45.50	-32.50	60.00	130.00	3- Clean sand
22	48.00	-35.00	60.00	130.00	3- Clean sand
23	50.50	-37.50	18.00	115.00	3- Clean sand
24	53.00	-40.00	26.00	120.00	3- Clean sand
25	55.50	-42.50	2.00	100.00	3- Clean sand
26	58.00	-45.00	2.00	100.00	3- Clean sand
27	60.50	-47.50	9.00	110.00	3- Clean sand
28	63.00	-50.00	23.00	115.00	3- Clean sand
29	65.50	-52.50	60.00	130.00	3- Clean sand
30	68.00	-55.00	60.00	130.00	3- Clean sand
31	70.50	-57.50	60.00	130.00	3- Clean sand
32	73.00	-60.00	60.00	130.00	3- Clean sand
33	75.50	-62.50	60.00	130.00	3- Clean sand
34	78.00	-65.00	52.00	130.00	3- Clean sand
35	80.50	-67.50	58.00	130.00	3- Clean sand
36	83.00	-70.00	60.00	130.00	3- Clean sand
37	85.50	-72.50	60.00	130.00	3- Clean sand
38	88.00	-75.00	60.00	130.00	3- Clean sand
39	90.50	-77.50	36.00	125.00	3- Clean sand
40	93.00	-80.00	20.00	115.00	3- Clean sand
41	95.50	-82.50	12.00	110.00	3- Clean sand
42	98.00	-85.00	42.00	130.00	3- Clean sand
43	100.00	-87.00	42.00	130.00	3- Clean sand

ID	Cu-Dir (tsf)	qu (tsf)	qt (tsf)	Em (ksi)	qb (tsf)
1	N/A	N/A	N/A	N/A	N/A
2	N/A	N/A	N/A	N/A	N/A
3	N/A	N/A	N/A	N/A	N/A
4	N/A	N/A	N/A	N/A	N/A
5	N/A	N/A	N/A	N/A	N/A
6	N/A	N/A	N/A	N/A	N/A
7	N/A	N/A	N/A	N/A	N/A
8	N/A	N/A	N/A	N/A	N/A

B-601Shaft48i n. out

9	N/A	N/A	N/A	N/A	N/A
10	N/A	N/A	N/A	N/A	N/A
11	N/A	N/A	N/A	N/A	N/A
12	N/A	N/A	N/A	N/A	N/A
13	N/A	N/A	N/A	N/A	N/A
14	N/A	N/A	N/A	N/A	N/A
15	N/A	N/A	N/A	N/A	N/A
16	N/A	N/A	N/A	N/A	N/A
17	N/A	N/A	N/A	N/A	N/A
18	N/A	N/A	N/A	N/A	N/A
19	N/A	N/A	N/A	N/A	N/A
20	N/A	N/A	N/A	N/A	N/A
21	N/A	N/A	N/A	N/A	N/A
22	N/A	N/A	N/A	N/A	N/A
23	N/A	N/A	N/A	N/A	N/A
24	N/A	N/A	N/A	N/A	N/A
25	N/A	N/A	N/A	N/A	N/A
26	N/A	N/A	N/A	N/A	N/A
27	N/A	N/A	N/A	N/A	N/A
28	N/A	N/A	N/A	N/A	N/A
29	N/A	N/A	N/A	N/A	N/A
30	N/A	N/A	N/A	N/A	N/A
31	N/A	N/A	N/A	N/A	N/A
32	N/A	N/A	N/A	N/A	N/A
33	N/A	N/A	N/A	N/A	N/A
34	N/A	N/A	N/A	N/A	N/A
35	N/A	N/A	N/A	N/A	N/A
36	N/A	N/A	N/A	N/A	N/A
37	N/A	N/A	N/A	N/A	N/A
38	N/A	N/A	N/A	N/A	N/A
39	N/A	N/A	N/A	N/A	N/A
40	N/A	N/A	N/A	N/A	N/A
41	N/A	N/A	N/A	N/A	N/A
42	N/A	N/A	N/A	N/A	N/A
43	N/A	N/A	N/A	N/A	N/A

ID RQD F. M. S. R. I. Rock Recovery

ID	RQD	F. M.	S. R. I.	Rock Recovery
1	N/A	N/A	N/A	N/A
2	N/A	N/A	N/A	N/A
3	N/A	N/A	N/A	N/A
4	N/A	N/A	N/A	N/A
5	N/A	N/A	N/A	N/A
6	N/A	N/A	N/A	N/A
7	N/A	N/A	N/A	N/A
8	N/A	N/A	N/A	N/A
9	N/A	N/A	N/A	N/A
10	N/A	N/A	N/A	N/A
11	N/A	N/A	N/A	N/A
12	N/A	N/A	N/A	N/A
13	N/A	N/A	N/A	N/A
14	N/A	N/A	N/A	N/A
15	N/A	N/A	N/A	N/A
16	N/A	N/A	N/A	N/A
17	N/A	N/A	N/A	N/A
18	N/A	N/A	N/A	N/A
19	N/A	N/A	N/A	N/A
20	N/A	N/A	N/A	N/A
21	N/A	N/A	N/A	N/A
22	N/A	N/A	N/A	N/A
23	N/A	N/A	N/A	N/A
24	N/A	N/A	N/A	N/A
25	N/A	N/A	N/A	N/A
26	N/A	N/A	N/A	N/A
27	N/A	N/A	N/A	N/A
28	N/A	N/A	N/A	N/A
29	N/A	N/A	N/A	N/A
30	N/A	N/A	N/A	N/A
31	N/A	N/A	N/A	N/A
32	N/A	N/A	N/A	N/A
33	N/A	N/A	N/A	N/A
34	N/A	N/A	N/A	N/A
35	N/A	N/A	N/A	N/A
36	N/A	N/A	N/A	N/A
37	N/A	N/A	N/A	N/A
38	N/A	N/A	N/A	N/A
39	N/A	N/A	N/A	N/A
40	N/A	N/A	N/A	N/A
41	N/A	N/A	N/A	N/A
42	N/A	N/A	N/A	N/A
43	N/A	N/A	N/A	N/A

Drilled Shaft Data:

=====

Shaft Geometry:

B-601Shaft48in. out

ID	Length (ft)	Tip Elev. (ft)	Case Len. (ft)	Diameter (in)	Base Diam. (in)	Bell Len. (ft)
1	15.00	-2.00	6.00	48.00	48.00	0.00
2	16.00	-3.00	6.00	48.00	48.00	0.00
3	17.00	-4.00	6.00	48.00	48.00	0.00
4	18.00	-5.00	6.00	48.00	48.00	0.00
5	19.00	-6.00	6.00	48.00	48.00	0.00
6	20.00	-7.00	6.00	48.00	48.00	0.00
7	21.00	-8.00	6.00	48.00	48.00	0.00
8	22.00	-9.00	6.00	48.00	48.00	0.00
9	23.00	-10.00	6.00	48.00	48.00	0.00
10	24.00	-11.00	6.00	48.00	48.00	0.00
11	25.00	-12.00	6.00	48.00	48.00	0.00
12	26.00	-13.00	6.00	48.00	48.00	0.00
13	27.00	-14.00	6.00	48.00	48.00	0.00
14	28.00	-15.00	6.00	48.00	48.00	0.00
15	29.00	-16.00	6.00	48.00	48.00	0.00
16	30.00	-17.00	6.00	48.00	48.00	0.00
17	31.00	-18.00	6.00	48.00	48.00	0.00
18	32.00	-19.00	6.00	48.00	48.00	0.00
19	33.00	-20.00	6.00	48.00	48.00	0.00
20	34.00	-21.00	6.00	48.00	48.00	0.00
21	35.00	-22.00	6.00	48.00	48.00	0.00
22	36.00	-23.00	6.00	48.00	48.00	0.00
23	37.00	-24.00	6.00	48.00	48.00	0.00
24	38.00	-25.00	6.00	48.00	48.00	0.00
25	39.00	-26.00	6.00	48.00	48.00	0.00
26	40.00	-27.00	6.00	48.00	48.00	0.00
27	41.00	-28.00	6.00	48.00	48.00	0.00
28	42.00	-29.00	6.00	48.00	48.00	0.00
29	43.00	-30.00	6.00	48.00	48.00	0.00
30	44.00	-31.00	6.00	48.00	48.00	0.00
31	45.00	-32.00	6.00	48.00	48.00	0.00
32	46.00	-33.00	6.00	48.00	48.00	0.00
33	47.00	-34.00	6.00	48.00	48.00	0.00
34	48.00	-35.00	6.00	48.00	48.00	0.00
35	49.00	-36.00	6.00	48.00	48.00	0.00
36	50.00	-37.00	6.00	48.00	48.00	0.00
37	51.00	-38.00	6.00	48.00	48.00	0.00
38	52.00	-39.00	6.00	48.00	48.00	0.00
39	53.00	-40.00	6.00	48.00	48.00	0.00
40	54.00	-41.00	6.00	48.00	48.00	0.00
41	55.00	-42.00	6.00	48.00	48.00	0.00
42	56.00	-43.00	6.00	48.00	48.00	0.00
43	57.00	-44.00	6.00	48.00	48.00	0.00
44	58.00	-45.00	6.00	48.00	48.00	0.00
45	59.00	-46.00	6.00	48.00	48.00	0.00
46	60.00	-47.00	6.00	48.00	48.00	0.00
47	61.00	-48.00	6.00	48.00	48.00	0.00
48	62.00	-49.00	6.00	48.00	48.00	0.00
49	63.00	-50.00	6.00	48.00	48.00	0.00
50	64.00	-51.00	6.00	48.00	48.00	0.00
51	65.00	-52.00	6.00	48.00	48.00	0.00
52	66.00	-53.00	6.00	48.00	48.00	0.00
53	67.00	-54.00	6.00	48.00	48.00	0.00
54	68.00	-55.00	6.00	48.00	48.00	0.00
55	69.00	-56.00	6.00	48.00	48.00	0.00
56	70.00	-57.00	6.00	48.00	48.00	0.00
57	71.00	-58.00	6.00	48.00	48.00	0.00
58	72.00	-59.00	6.00	48.00	48.00	0.00
59	73.00	-60.00	6.00	48.00	48.00	0.00
60	74.00	-61.00	6.00	48.00	48.00	0.00
61	75.00	-62.00	6.00	48.00	48.00	0.00
62	76.00	-63.00	6.00	48.00	48.00	0.00
63	77.00	-64.00	6.00	48.00	48.00	0.00
64	78.00	-65.00	6.00	48.00	48.00	0.00
65	79.00	-66.00	6.00	48.00	48.00	0.00
66	80.00	-67.00	6.00	48.00	48.00	0.00
67	81.00	-68.00	6.00	48.00	48.00	0.00
68	82.00	-69.00	6.00	48.00	48.00	0.00
69	83.00	-70.00	6.00	48.00	48.00	0.00
70	84.00	-71.00	6.00	48.00	48.00	0.00
71	85.00	-72.00	6.00	48.00	48.00	0.00
72	86.00	-73.00	6.00	48.00	48.00	0.00
73	87.00	-74.00	6.00	48.00	48.00	0.00
74	88.00	-75.00	6.00	48.00	48.00	0.00
75	89.00	-76.00	6.00	48.00	48.00	0.00
76	90.00	-77.00	6.00	48.00	48.00	0.00
77	91.00	-78.00	6.00	48.00	48.00	0.00
78	92.00	-79.00	6.00	48.00	48.00	0.00
79	93.00	-80.00	6.00	48.00	48.00	0.00
80	94.00	-81.00	6.00	48.00	48.00	0.00
81	95.00	-82.00	6.00	48.00	48.00	0.00

Drilled Shaft Capacity (sorted by shaft diameter):

B-601Shaft48i n. out

Strength reduction factors: Skin-friction = 1.00, End-bearing = 1.00

ID	Diameter (in)	Length (ft)	Skin Fric. (tons)	End Bearing (tons)	Capacity (tons)
1	48.00	15.00	0.857	61.538	62.395
2	48.00	16.00	1.356	89.715	91.071
3	48.00	17.00	2.119	100.973	103.092
4	48.00	18.00	2.993	112.494	115.488
5	48.00	19.00	4.968	128.528	133.496
6	48.00	20.00	7.180	149.855	157.035
7	48.00	21.00	9.628	172.871	182.500
8	48.00	22.00	12.306	195.138	207.444
9	48.00	23.00	15.199	216.168	231.367
10	48.00	24.00	18.307	235.523	253.830
11	48.00	25.00	21.642	253.319	274.961
12	48.00	26.00	25.194	270.205	295.398
13	48.00	27.00	28.952	287.290	316.242
14	48.00	28.00	32.914	303.876	336.791
15	48.00	29.00	37.104	319.129	356.233
16	48.00	30.00	41.554	333.679	375.233
17	48.00	31.00	46.253	348.889	395.142
18	48.00	32.00	51.191	363.853	415.044
19	48.00	33.00	56.362	373.353	429.715
20	48.00	34.00	61.752	376.507	438.259
21	48.00	35.00	67.357	376.470	443.826
22	48.00	36.00	73.164	376.413	449.577
23	48.00	37.00	79.148	376.375	455.524
24	48.00	38.00	85.303	376.363	461.666
25	48.00	39.00	91.625	376.363	467.988
26	48.00	40.00	98.122	376.413	474.535
27	48.00	41.00	104.783	373.955	478.738
28	48.00	42.00	111.584	366.355	477.939
29	48.00	43.00	118.518	354.348	472.866
30	48.00	44.00	125.583	343.224	468.807
31	48.00	45.00	132.787	333.920	466.707
32	48.00	46.00	140.121	322.746	462.867
33	48.00	47.00	147.575	305.962	453.537
34	48.00	48.00	155.148	284.270	439.418
35	48.00	49.00	162.825	261.007	423.832
36	48.00	50.00	170.605	236.005	406.611
37	48.00	51.00	178.475	210.377	388.852
38	48.00	52.00	186.386	186.714	373.100
39	48.00	53.00	194.333	165.514	359.847
40	48.00	54.00	202.314	146.759	349.072
41	48.00	55.00	210.335	132.884	343.219
42	48.00	56.00	216.404	127.991	344.394
43	48.00	57.00	220.536	132.688	353.224
44	48.00	58.00	224.728	139.616	364.344
45	48.00	59.00	228.979	144.830	373.809
46	48.00	60.00	233.289	153.082	386.371
47	48.00	61.00	238.389	169.428	407.817
48	48.00	62.00	244.225	193.340	437.565
49	48.00	63.00	250.045	219.278	469.324
50	48.00	64.00	257.846	246.437	504.283
51	48.00	65.00	265.630	273.854	539.485
52	48.00	66.00	273.397	300.271	573.668
53	48.00	67.00	281.170	324.402	605.572
54	48.00	68.00	288.951	344.443	633.394
55	48.00	69.00	296.728	360.121	656.849
56	48.00	70.00	304.501	370.918	675.419
57	48.00	71.00	312.262	376.316	688.578
58	48.00	72.00	320.005	376.991	696.996
59	48.00	73.00	327.727	376.991	704.718
60	48.00	74.00	335.417	376.991	712.408
61	48.00	75.00	343.076	376.991	720.067
62	48.00	76.00	350.695	376.991	727.686
63	48.00	77.00	358.268	376.991	735.259
64	48.00	78.00	365.793	376.991	742.784
65	48.00	79.00	373.260	376.991	750.251
66	48.00	80.00	380.668	376.991	757.659
67	48.00	81.00	388.009	376.486	764.495
68	48.00	82.00	395.279	374.970	770.249
69	48.00	83.00	402.474	372.103	774.578
70	48.00	84.00	409.585	365.838	775.423
71	48.00	85.00	416.611	355.832	772.444
72	48.00	86.00	423.547	343.022	766.570
73	48.00	87.00	430.540	328.342	758.882
74	48.00	88.00	437.638	312.854	750.492
75	48.00	89.00	444.843	302.755	747.598
76	48.00	90.00	452.154	298.940	751.094
77	48.00	91.00	459.570	297.984	757.554
78	48.00	92.00	467.085	295.896	762.981
79	48.00	93.00	Soil Elevations	Must Extend At or Below	Contribution Zone
80	48.00	94.00	Soil Elevations	Must Extend At or Below	Contribution Zone
81	48.00	95.00	Soil Elevations	Must Extend At or Below	Contribution Zone

B-601Shaft48i n. out

Drilled Shaft Capacity at User-Defined Settlement (sorted by shaft diameter):

\*\*\*\*\* Capacity is NOT modified by the strength reduction factors \*\*\*\*\*

---

User-Defined Settlement = 1.04%

ID	Diameter (in)	Length (ft)	Skin Fric. (tons)	End Bearing (tons)	Capacity (tons)
1	48.00	15.00	0.839	19.563	20.402
2	48.00	16.00	1.327	28.520	29.847
3	48.00	17.00	2.072	32.099	34.172
4	48.00	18.00	2.928	35.762	38.690
5	48.00	19.00	4.859	40.859	45.719
6	48.00	20.00	7.022	47.639	54.661
7	48.00	21.00	9.418	54.956	64.373
8	48.00	22.00	12.036	62.034	74.071
9	48.00	23.00	14.866	68.720	83.586
10	48.00	24.00	17.907	74.873	92.779
11	48.00	25.00	21.168	80.530	101.699
12	48.00	26.00	24.642	85.898	110.540
13	48.00	27.00	28.318	91.330	119.648
14	48.00	28.00	32.194	96.602	128.796
15	48.00	29.00	36.292	101.451	137.743
16	48.00	30.00	40.644	106.077	146.721
17	48.00	31.00	45.241	110.912	156.153
18	48.00	32.00	50.070	115.669	165.739
19	48.00	33.00	55.128	118.689	173.817
20	48.00	34.00	60.400	119.692	180.092
21	48.00	35.00	65.882	119.680	185.562
22	48.00	36.00	71.563	119.662	191.225
23	48.00	37.00	77.416	119.650	197.066
24	48.00	38.00	83.436	119.646	203.082
25	48.00	39.00	89.619	119.646	209.265
26	48.00	40.00	95.975	119.662	215.636
27	48.00	41.00	102.490	118.880	221.370
28	48.00	42.00	109.141	116.464	225.606
29	48.00	43.00	115.924	112.647	228.571
30	48.00	44.00	122.835	109.111	231.946
31	48.00	45.00	129.881	106.153	236.034
32	48.00	46.00	137.054	102.601	239.655
33	48.00	47.00	144.345	97.265	241.611
34	48.00	48.00	151.752	90.370	242.121
35	48.00	49.00	159.261	82.974	242.235
36	48.00	50.00	166.871	75.026	241.897
37	48.00	51.00	174.568	66.879	241.447
38	48.00	52.00	182.307	59.356	241.663
39	48.00	53.00	190.080	52.617	242.696
40	48.00	54.00	197.886	46.655	244.540
41	48.00	55.00	205.731	42.244	247.975
42	48.00	56.00	211.667	40.688	252.355
43	48.00	57.00	215.709	42.182	257.891
44	48.00	58.00	219.809	44.384	264.193
45	48.00	59.00	223.967	46.041	270.008
46	48.00	60.00	228.182	48.665	276.847
47	48.00	61.00	233.171	53.861	287.032
48	48.00	62.00	238.880	61.463	300.343
49	48.00	63.00	244.572	69.709	314.281
50	48.00	64.00	252.203	78.342	330.545
51	48.00	65.00	259.816	87.058	346.875
52	48.00	66.00	267.413	95.456	362.870
53	48.00	67.00	275.016	103.128	378.144
54	48.00	68.00	282.626	109.499	392.125
55	48.00	69.00	290.233	114.483	404.716
56	48.00	70.00	297.836	117.915	415.751
57	48.00	71.00	305.427	119.631	425.058
58	48.00	72.00	313.000	119.846	432.846
59	48.00	73.00	320.553	119.846	440.399
60	48.00	74.00	328.076	119.846	447.921
61	48.00	75.00	335.566	119.846	455.412
62	48.00	76.00	343.019	119.846	462.864
63	48.00	77.00	350.426	119.846	470.272
64	48.00	78.00	357.786	119.846	477.632
65	48.00	79.00	365.090	119.846	484.936
66	48.00	80.00	372.335	119.846	492.181
67	48.00	81.00	379.517	119.685	499.202
68	48.00	82.00	386.627	119.203	505.830
69	48.00	83.00	393.665	118.292	511.957
70	48.00	84.00	400.620	116.300	516.920
71	48.00	85.00	407.493	113.119	520.612
72	48.00	86.00	414.277	109.047	523.324
73	48.00	87.00	421.116	104.380	525.496
74	48.00	88.00	428.059	99.456	527.515
75	48.00	89.00	435.106	96.246	531.352
76	48.00	90.00	442.257	95.033	537.290
77	48.00	91.00	449.510	94.729	544.240



				B-601Shaft48in.out			
78	48.00	92.00	456.861	94.065	550.927		
79	48.00	93.00	Soil Elevations	Must Extend At	or Below	Contribution Zone	
80	48.00	94.00	Soil Elevations	Must Extend At	or Below	Contribution Zone	
81	48.00	95.00	Soil Elevations	Must Extend At	or Below	Contribution Zone	

General Information:

=====  
 Input file: .....H\Analysis\_Structure\FB-Deep\Drilled Shaft\B-601Shaft60in.spc  
 Project number: 2000-01-17003  
 Job name: SW 10th Street, from Powerline Rd. to Military Trail  
 Engineer: JB Henry  
 Units: English

Analysis Information:

=====  
 Analysis Type: Drilled Shaft Analysis

Soil Information:

=====  
 Boring date: 1/31/2018  
 Boring number: B-601  
 Station number: Offset:  
 Ground Elevation: 13.00(ft)  
 Water table Elevation = 13.00(ft)  
 Hammer type: Automatic Hammer, Correction factor = 1.24

ID	Depth (ft)	Elevation (ft)	SPT Blows (Blows/ft)	Unit Weight (pcf)	Soil Type
1	0.00	13.00	N/A	0.00	5- Cavity layer
2	2.00	11.00	N/A	0.00	5- Cavity layer
3	4.00	9.00	N/A	0.00	5- Cavity layer
4	6.00	7.00	N/A	0.00	5- Cavity layer
5	8.00	5.00	N/A	0.00	5- Cavity layer
6	10.00	3.00	3.00	100.00	3- Clean sand
7	12.00	1.00	4.00	105.00	3- Clean sand
8	13.50	-0.50	3.00	100.00	3- Clean sand
9	15.50	-2.50	6.00	105.00	3- Clean sand
10	18.00	-5.00	12.00	110.00	3- Clean sand
11	20.50	-7.50	15.00	110.00	3- Clean sand
12	23.00	-10.00	22.00	115.00	3- Clean sand
13	25.50	-12.50	20.00	115.00	3- Clean sand
14	28.00	-15.00	52.00	130.00	3- Clean sand
15	30.50	-17.50	61.00	130.00	3- Clean sand
16	33.00	-20.00	90.00	130.00	3- Clean sand
17	35.50	-22.50	40.00	125.00	3- Clean sand
18	38.00	-25.00	78.00	130.00	3- Clean sand
19	40.50	-27.50	47.00	125.00	3- Clean sand
20	43.00	-30.00	89.00	130.00	3- Clean sand
21	45.50	-32.50	60.00	130.00	3- Clean sand
22	48.00	-35.00	60.00	130.00	3- Clean sand
23	50.50	-37.50	18.00	115.00	3- Clean sand
24	53.00	-40.00	26.00	120.00	3- Clean sand
25	55.50	-42.50	2.00	100.00	3- Clean sand
26	58.00	-45.00	2.00	100.00	3- Clean sand
27	60.50	-47.50	9.00	110.00	3- Clean sand
28	63.00	-50.00	23.00	115.00	3- Clean sand
29	65.50	-52.50	60.00	130.00	3- Clean sand
30	68.00	-55.00	60.00	130.00	3- Clean sand
31	70.50	-57.50	60.00	130.00	3- Clean sand
32	73.00	-60.00	60.00	130.00	3- Clean sand
33	75.50	-62.50	60.00	130.00	3- Clean sand
34	78.00	-65.00	52.00	130.00	3- Clean sand
35	80.50	-67.50	58.00	130.00	3- Clean sand
36	83.00	-70.00	60.00	130.00	3- Clean sand
37	85.50	-72.50	60.00	130.00	3- Clean sand
38	88.00	-75.00	60.00	130.00	3- Clean sand
39	90.50	-77.50	36.00	125.00	3- Clean sand
40	93.00	-80.00	20.00	115.00	3- Clean sand
41	95.50	-82.50	12.00	110.00	3- Clean sand
42	98.00	-85.00	42.00	130.00	3- Clean sand
43	100.00	-87.00	42.00	130.00	3- Clean sand

ID	Cu-Dir (tsf)	qu (tsf)	qt (tsf)	Em (ksi)	qb (tsf)
1	N/A	N/A	N/A	N/A	N/A
2	N/A	N/A	N/A	N/A	N/A
3	N/A	N/A	N/A	N/A	N/A
4	N/A	N/A	N/A	N/A	N/A
5	N/A	N/A	N/A	N/A	N/A
6	N/A	N/A	N/A	N/A	N/A
7	N/A	N/A	N/A	N/A	N/A
8	N/A	N/A	N/A	N/A	N/A

B-601Shaft60i n. out

9	N/A	N/A	N/A	N/A	N/A
10	N/A	N/A	N/A	N/A	N/A
11	N/A	N/A	N/A	N/A	N/A
12	N/A	N/A	N/A	N/A	N/A
13	N/A	N/A	N/A	N/A	N/A
14	N/A	N/A	N/A	N/A	N/A
15	N/A	N/A	N/A	N/A	N/A
16	N/A	N/A	N/A	N/A	N/A
17	N/A	N/A	N/A	N/A	N/A
18	N/A	N/A	N/A	N/A	N/A
19	N/A	N/A	N/A	N/A	N/A
20	N/A	N/A	N/A	N/A	N/A
21	N/A	N/A	N/A	N/A	N/A
22	N/A	N/A	N/A	N/A	N/A
23	N/A	N/A	N/A	N/A	N/A
24	N/A	N/A	N/A	N/A	N/A
25	N/A	N/A	N/A	N/A	N/A
26	N/A	N/A	N/A	N/A	N/A
27	N/A	N/A	N/A	N/A	N/A
28	N/A	N/A	N/A	N/A	N/A
29	N/A	N/A	N/A	N/A	N/A
30	N/A	N/A	N/A	N/A	N/A
31	N/A	N/A	N/A	N/A	N/A
32	N/A	N/A	N/A	N/A	N/A
33	N/A	N/A	N/A	N/A	N/A
34	N/A	N/A	N/A	N/A	N/A
35	N/A	N/A	N/A	N/A	N/A
36	N/A	N/A	N/A	N/A	N/A
37	N/A	N/A	N/A	N/A	N/A
38	N/A	N/A	N/A	N/A	N/A
39	N/A	N/A	N/A	N/A	N/A
40	N/A	N/A	N/A	N/A	N/A
41	N/A	N/A	N/A	N/A	N/A
42	N/A	N/A	N/A	N/A	N/A
43	N/A	N/A	N/A	N/A	N/A

ID RQD F. M. S. R. I. Rock Recovery

ID	RQD F. M.	S. R. I.	Rock Recovery
1	N/A	N/A	N/A
2	N/A	N/A	N/A
3	N/A	N/A	N/A
4	N/A	N/A	N/A
5	N/A	N/A	N/A
6	N/A	N/A	N/A
7	N/A	N/A	N/A
8	N/A	N/A	N/A
9	N/A	N/A	N/A
10	N/A	N/A	N/A
11	N/A	N/A	N/A
12	N/A	N/A	N/A
13	N/A	N/A	N/A
14	N/A	N/A	N/A
15	N/A	N/A	N/A
16	N/A	N/A	N/A
17	N/A	N/A	N/A
18	N/A	N/A	N/A
19	N/A	N/A	N/A
20	N/A	N/A	N/A
21	N/A	N/A	N/A
22	N/A	N/A	N/A
23	N/A	N/A	N/A
24	N/A	N/A	N/A
25	N/A	N/A	N/A
26	N/A	N/A	N/A
27	N/A	N/A	N/A
28	N/A	N/A	N/A
29	N/A	N/A	N/A
30	N/A	N/A	N/A
31	N/A	N/A	N/A
32	N/A	N/A	N/A
33	N/A	N/A	N/A
34	N/A	N/A	N/A
35	N/A	N/A	N/A
36	N/A	N/A	N/A
37	N/A	N/A	N/A
38	N/A	N/A	N/A
39	N/A	N/A	N/A
40	N/A	N/A	N/A
41	N/A	N/A	N/A
42	N/A	N/A	N/A
43	N/A	N/A	N/A

Drilled Shaft Data:

=====

Shaft Geometry:

B-601Shaft60In. out

ID	Length (ft)	Tip Elev. (ft)	Case Len. (ft)	Diameter (in)	Base Diam. (in)	Bell Len. (ft)
1	15.00	-2.00	6.00	60.00	60.00	0.00
2	16.00	-3.00	6.00	60.00	60.00	0.00
3	17.00	-4.00	6.00	60.00	60.00	0.00
4	18.00	-5.00	6.00	60.00	60.00	0.00
5	19.00	-6.00	6.00	60.00	60.00	0.00
6	20.00	-7.00	6.00	60.00	60.00	0.00
7	21.00	-8.00	6.00	60.00	60.00	0.00
8	22.00	-9.00	6.00	60.00	60.00	0.00
9	23.00	-10.00	6.00	60.00	60.00	0.00
10	24.00	-11.00	6.00	60.00	60.00	0.00
11	25.00	-12.00	6.00	60.00	60.00	0.00
12	26.00	-13.00	6.00	60.00	60.00	0.00
13	27.00	-14.00	6.00	60.00	60.00	0.00
14	28.00	-15.00	6.00	60.00	60.00	0.00
15	29.00	-16.00	6.00	60.00	60.00	0.00
16	30.00	-17.00	6.00	60.00	60.00	0.00
17	31.00	-18.00	6.00	60.00	60.00	0.00
18	32.00	-19.00	6.00	60.00	60.00	0.00
19	33.00	-20.00	6.00	60.00	60.00	0.00
20	34.00	-21.00	6.00	60.00	60.00	0.00
21	35.00	-22.00	6.00	60.00	60.00	0.00
22	36.00	-23.00	6.00	60.00	60.00	0.00
23	37.00	-24.00	6.00	60.00	60.00	0.00
24	38.00	-25.00	6.00	60.00	60.00	0.00
25	39.00	-26.00	6.00	60.00	60.00	0.00
26	40.00	-27.00	6.00	60.00	60.00	0.00
27	41.00	-28.00	6.00	60.00	60.00	0.00
28	42.00	-29.00	6.00	60.00	60.00	0.00
29	43.00	-30.00	6.00	60.00	60.00	0.00
30	44.00	-31.00	6.00	60.00	60.00	0.00
31	45.00	-32.00	6.00	60.00	60.00	0.00
32	46.00	-33.00	6.00	60.00	60.00	0.00
33	47.00	-34.00	6.00	60.00	60.00	0.00
34	48.00	-35.00	6.00	60.00	60.00	0.00
35	49.00	-36.00	6.00	60.00	60.00	0.00
36	50.00	-37.00	6.00	60.00	60.00	0.00
37	51.00	-38.00	6.00	60.00	60.00	0.00
38	52.00	-39.00	6.00	60.00	60.00	0.00
39	53.00	-40.00	6.00	60.00	60.00	0.00
40	54.00	-41.00	6.00	60.00	60.00	0.00
41	55.00	-42.00	6.00	60.00	60.00	0.00
42	56.00	-43.00	6.00	60.00	60.00	0.00
43	57.00	-44.00	6.00	60.00	60.00	0.00
44	58.00	-45.00	6.00	60.00	60.00	0.00
45	59.00	-46.00	6.00	60.00	60.00	0.00
46	60.00	-47.00	6.00	60.00	60.00	0.00
47	61.00	-48.00	6.00	60.00	60.00	0.00
48	62.00	-49.00	6.00	60.00	60.00	0.00
49	63.00	-50.00	6.00	60.00	60.00	0.00
50	64.00	-51.00	6.00	60.00	60.00	0.00
51	65.00	-52.00	6.00	60.00	60.00	0.00
52	66.00	-53.00	6.00	60.00	60.00	0.00
53	67.00	-54.00	6.00	60.00	60.00	0.00
54	68.00	-55.00	6.00	60.00	60.00	0.00
55	69.00	-56.00	6.00	60.00	60.00	0.00
56	70.00	-57.00	6.00	60.00	60.00	0.00
57	71.00	-58.00	6.00	60.00	60.00	0.00
58	72.00	-59.00	6.00	60.00	60.00	0.00
59	73.00	-60.00	6.00	60.00	60.00	0.00
60	74.00	-61.00	6.00	60.00	60.00	0.00
61	75.00	-62.00	6.00	60.00	60.00	0.00
62	76.00	-63.00	6.00	60.00	60.00	0.00
63	77.00	-64.00	6.00	60.00	60.00	0.00
64	78.00	-65.00	6.00	60.00	60.00	0.00
65	79.00	-66.00	6.00	60.00	60.00	0.00
66	80.00	-67.00	6.00	60.00	60.00	0.00
67	81.00	-68.00	6.00	60.00	60.00	0.00
68	82.00	-69.00	6.00	60.00	60.00	0.00
69	83.00	-70.00	6.00	60.00	60.00	0.00
70	84.00	-71.00	6.00	60.00	60.00	0.00
71	85.00	-72.00	6.00	60.00	60.00	0.00
72	86.00	-73.00	6.00	60.00	60.00	0.00
73	87.00	-74.00	6.00	60.00	60.00	0.00
74	88.00	-75.00	6.00	60.00	60.00	0.00
75	89.00	-76.00	6.00	60.00	60.00	0.00
76	90.00	-77.00	6.00	60.00	60.00	0.00
77	91.00	-78.00	6.00	60.00	60.00	0.00
78	92.00	-79.00	6.00	60.00	60.00	0.00
79	93.00	-80.00	6.00	60.00	60.00	0.00
80	94.00	-81.00	6.00	60.00	60.00	0.00
81	95.00	-82.00	6.00	60.00	60.00	0.00

Drilled Shaft Capacity (sorted by shaft diameter):

B-601Shaft60i n. out

Strength reduction factors: Skin-friction = 1.00, End-bearing = 1.00

ID	Diameter (in)	Length (ft)	Skin Fric. (tons)	End Bearing (tons)	Capacity (tons)
1	60.00	15.00	1.072	89.910	90.982
2	60.00	16.00	1.695	99.043	100.738
3	60.00	17.00	2.648	111.051	113.700
4	60.00	18.00	3.742	160.786	164.527
5	60.00	19.00	6.210	185.045	191.255
6	60.00	20.00	8.975	209.261	218.236
7	60.00	21.00	12.035	234.183	246.219
8	60.00	22.00	15.382	259.295	274.677
9	60.00	23.00	18.999	283.758	302.756
10	60.00	24.00	22.884	306.801	329.686
11	60.00	25.00	27.053	327.656	354.709
12	60.00	26.00	31.492	346.690	378.182
13	60.00	27.00	36.190	366.111	402.301
14	60.00	28.00	41.143	386.285	427.428
15	60.00	29.00	46.380	405.700	452.080
16	60.00	30.00	51.942	422.843	474.785
17	60.00	31.00	57.817	438.078	495.895
18	60.00	32.00	63.988	453.598	517.586
19	60.00	33.00	70.453	469.766	540.219
20	60.00	34.00	77.189	482.948	560.137
21	60.00	35.00	84.196	489.506	573.702
22	60.00	36.00	91.455	490.272	581.727
23	60.00	37.00	98.935	490.232	589.168
24	60.00	38.00	106.628	490.219	596.848
25	60.00	39.00	114.531	487.502	602.033
26	60.00	40.00	122.653	479.349	602.002
27	60.00	41.00	130.979	466.698	597.677
28	60.00	42.00	139.479	455.163	594.643
29	60.00	43.00	148.147	445.681	593.828
30	60.00	44.00	156.979	434.251	591.230
31	60.00	45.00	165.984	416.872	582.856
32	60.00	46.00	175.151	394.290	569.440
33	60.00	47.00	184.469	370.963	555.432
34	60.00	48.00	193.934	347.637	541.571
35	60.00	49.00	203.531	324.257	527.788
36	60.00	50.00	213.257	300.770	514.026
37	60.00	51.00	223.093	277.696	500.789
38	60.00	52.00	232.983	258.159	491.142
39	60.00	53.00	242.916	242.680	485.596
40	60.00	54.00	252.892	230.365	483.257
41	60.00	55.00	262.919	220.320	483.238
42	60.00	56.00	270.505	213.166	483.671
43	60.00	57.00	275.671	212.637	488.308
44	60.00	58.00	280.910	219.355	500.265
45	60.00	59.00	286.224	228.682	514.905
46	60.00	60.00	291.611	235.979	527.590
47	60.00	61.00	297.986	242.618	540.604
48	60.00	62.00	305.282	256.814	562.095
49	60.00	63.00	312.557	279.937	592.494
50	60.00	64.00	322.308	308.227	630.535
51	60.00	65.00	332.038	337.923	669.961
52	60.00	66.00	341.747	368.565	710.312
53	60.00	67.00	351.463	397.394	748.857
54	60.00	68.00	361.188	423.951	785.140
55	60.00	69.00	370.910	447.100	818.010
56	60.00	70.00	380.626	465.703	846.329
57	60.00	71.00	390.327	479.627	869.954
58	60.00	72.00	400.006	488.062	888.068
59	60.00	73.00	409.658	490.874	900.532
60	60.00	74.00	419.272	490.874	910.146
61	60.00	75.00	428.845	490.874	919.718
62	60.00	76.00	438.368	490.874	929.242
63	60.00	77.00	447.835	490.874	938.709
64	60.00	78.00	457.241	490.874	948.115
65	60.00	79.00	466.575	490.348	956.922
66	60.00	80.00	475.834	488.769	964.603
67	60.00	81.00	485.012	485.783	970.794
68	60.00	82.00	494.099	479.256	973.354
69	60.00	83.00	503.093	468.834	971.926
70	60.00	84.00	511.982	455.490	967.471
71	60.00	85.00	520.764	440.198	960.962
72	60.00	86.00	529.434	424.064	953.498
73	60.00	87.00	538.175	413.720	951.895
74	60.00	88.00	547.048	410.272	957.320
75	60.00	89.00	556.053	410.097	966.150
76	60.00	90.00	565.192	409.571	974.763
77	60.00	91.00	Soil Elevations	Must Extend At	or Below Contribution Zone
78	60.00	92.00	Soil Elevations	Must Extend At	or Below Contribution Zone
79	60.00	93.00	Soil Elevations	Must Extend At	or Below Contribution Zone
80	60.00	94.00	Soil Elevations	Must Extend At	or Below Contribution Zone
81	60.00	95.00	Soil Elevations	Must Extend At	or Below Contribution Zone

B-601Shaft60in.out

Drilled Shaft Capacity at User-Defined Settlement (sorted by shaft diameter):

\*\*\*\*\* Capacity is NOT modified by the strength reduction factors \*\*\*\*\*

---

User-Defined Settlement = 0.83%

ID	Diameter (in)	Length (ft)	Skin Fric. (tons)	End Bearing (tons)	Capacity (tons)
1	60.00	15.00	1.044	23.475	24.519
2	60.00	16.00	1.652	25.859	27.511
3	60.00	17.00	2.581	28.995	31.575
4	60.00	18.00	3.646	41.980	45.626
5	60.00	19.00	6.052	48.314	54.366
6	60.00	20.00	8.746	54.636	63.382
7	60.00	21.00	11.729	61.143	72.872
8	60.00	22.00	14.990	67.700	82.690
9	60.00	23.00	18.514	74.087	92.601
10	60.00	24.00	22.301	80.103	102.404
11	60.00	25.00	26.363	85.549	111.912
12	60.00	26.00	30.689	90.518	121.207
13	60.00	27.00	35.267	95.589	130.856
14	60.00	28.00	40.094	100.856	140.950
15	60.00	29.00	45.197	105.925	151.123
16	60.00	30.00	50.618	110.401	161.019
17	60.00	31.00	56.343	114.379	170.721
18	60.00	32.00	62.357	118.431	180.788
19	60.00	33.00	68.656	122.652	191.309
20	60.00	34.00	75.222	126.094	201.315
21	60.00	35.00	82.049	127.806	209.855
22	60.00	36.00	89.124	128.006	217.130
23	60.00	37.00	96.413	127.996	224.409
24	60.00	38.00	103.910	127.992	231.903
25	60.00	39.00	111.611	127.283	238.894
26	60.00	40.00	119.526	125.154	244.680
27	60.00	41.00	127.640	121.851	249.491
28	60.00	42.00	135.924	118.840	254.763
29	60.00	43.00	144.371	116.364	260.734
30	60.00	44.00	152.977	113.379	266.357
31	60.00	45.00	161.752	108.842	270.595
32	60.00	46.00	170.686	102.946	273.632
33	60.00	47.00	179.766	96.856	276.622
34	60.00	48.00	188.990	90.765	279.756
35	60.00	49.00	198.342	84.661	283.003
36	60.00	50.00	207.820	78.529	286.349
37	60.00	51.00	217.406	72.504	289.910
38	60.00	52.00	227.043	67.403	294.447
39	60.00	53.00	236.724	63.362	300.085
40	60.00	54.00	246.445	60.146	306.592
41	60.00	55.00	256.216	57.524	313.740
42	60.00	56.00	263.609	55.656	319.265
43	60.00	57.00	268.643	55.518	324.161
44	60.00	58.00	273.749	57.272	331.021
45	60.00	59.00	278.927	59.707	338.634
46	60.00	60.00	284.177	61.612	345.789
47	60.00	61.00	290.390	63.346	353.735
48	60.00	62.00	297.499	67.052	364.551
49	60.00	63.00	304.589	73.089	377.678
50	60.00	64.00	314.091	80.476	394.567
51	60.00	65.00	323.573	88.229	411.802
52	60.00	66.00	333.035	96.229	429.264
53	60.00	67.00	342.503	103.757	446.259
54	60.00	68.00	351.980	110.690	462.671
55	60.00	69.00	361.454	116.734	478.189
56	60.00	70.00	370.922	121.591	492.514
57	60.00	71.00	380.377	125.227	505.603
58	60.00	72.00	389.808	127.429	517.237
59	60.00	73.00	399.215	128.163	527.378
60	60.00	74.00	408.583	128.163	536.746
61	60.00	75.00	417.912	128.163	546.075
62	60.00	76.00	427.193	128.163	555.356
63	60.00	77.00	436.418	128.163	564.581
64	60.00	78.00	445.584	128.163	573.748
65	60.00	79.00	454.680	128.026	582.706
66	60.00	80.00	463.704	127.614	591.317
67	60.00	81.00	472.647	126.834	599.481
68	60.00	82.00	481.502	125.130	606.632
69	60.00	83.00	490.267	122.409	612.676
70	60.00	84.00	498.929	118.925	617.854
71	60.00	85.00	507.488	114.932	622.420
72	60.00	86.00	515.937	110.720	626.657
73	60.00	87.00	524.455	108.019	632.474
74	60.00	88.00	533.101	107.119	640.220
75	60.00	89.00	541.878	107.073	648.951
76	60.00	90.00	550.783	106.936	657.719
77	60.00	91.00	Soil Elevations	Must Extend At or Below	Contribution Zone

B-601Shaft60in.out

78	60.00	92.00	Soil Elevations Must Extend At or Below Contribution Zone
79	60.00	93.00	Soil Elevations Must Extend At or Below Contribution Zone
80	60.00	94.00	Soil Elevations Must Extend At or Below Contribution Zone
81	60.00	95.00	Soil Elevations Must Extend At or Below Contribution Zone

**APPENDIX – G**

**GRAPHS – VERTICAL CAPACITY ANALYSIS OF**

**DRILLED SHAFTS**



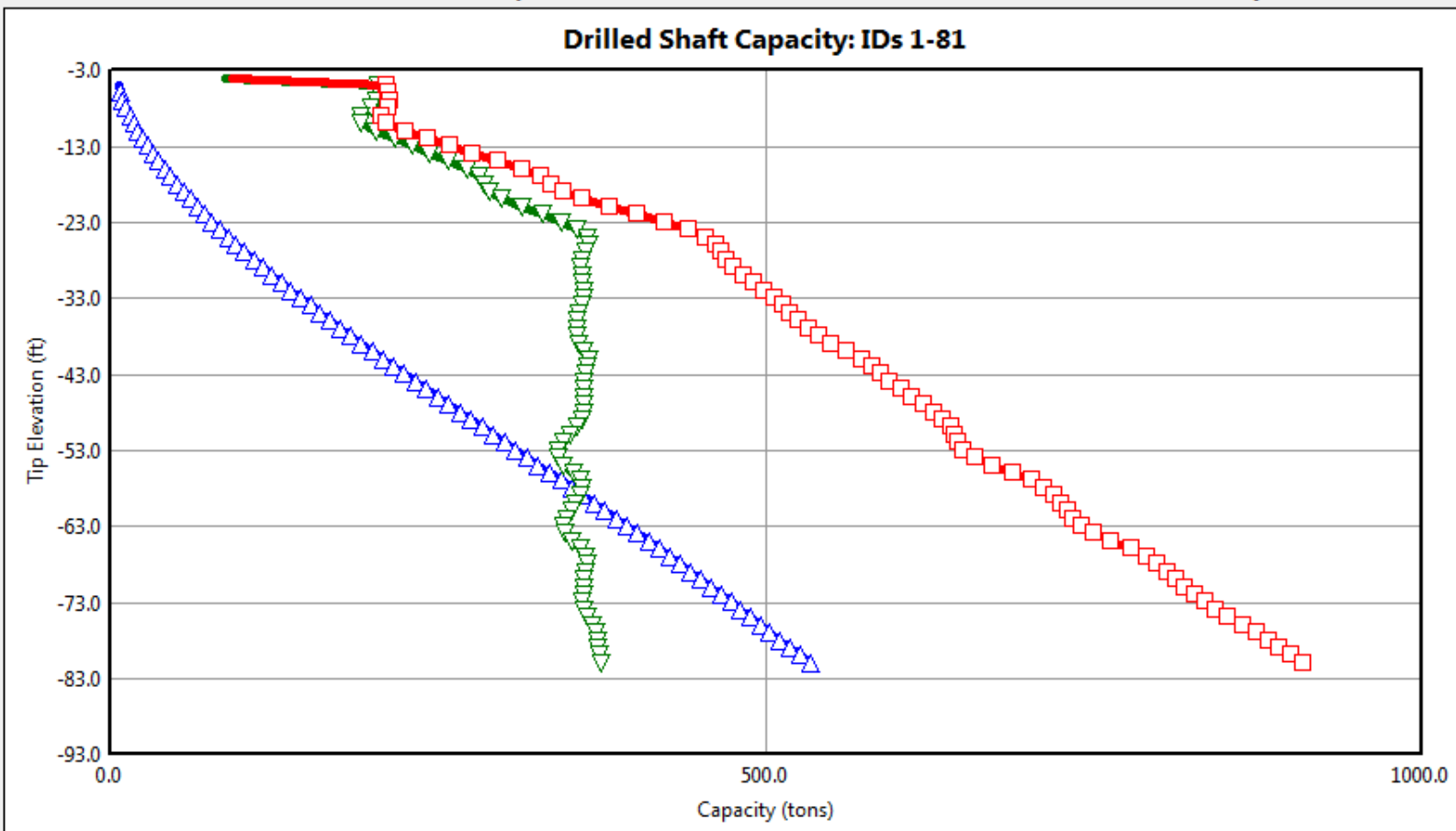

Curves

- Ultimate Side Friction
- Mobilized End Bearing
- Ultimate Shaft Capacity

\*The 'Save to File' button saves the currently selected Curves to a text file.

Drilled Shaft Data

Boring Number:	B-101
Ground Surface Elevation:	11.10 (ft)
Diameter	48.00 (in)
Bell Diameter	48.00 (in)
Bell Length	0.00 (ft)
Case Length	6.00 (ft)

Project Data

File:	B-101Shaft48in
Date:	Apr 19, 2018
Engineer:	JB Henry
Water Table Elevation:	11.10 (ft)

Analysis Data

Analysis Type:	SPT
----------------	-----

Plot Options



Customize    Update Plot    Print Plot    Print Window    Save To File

Close

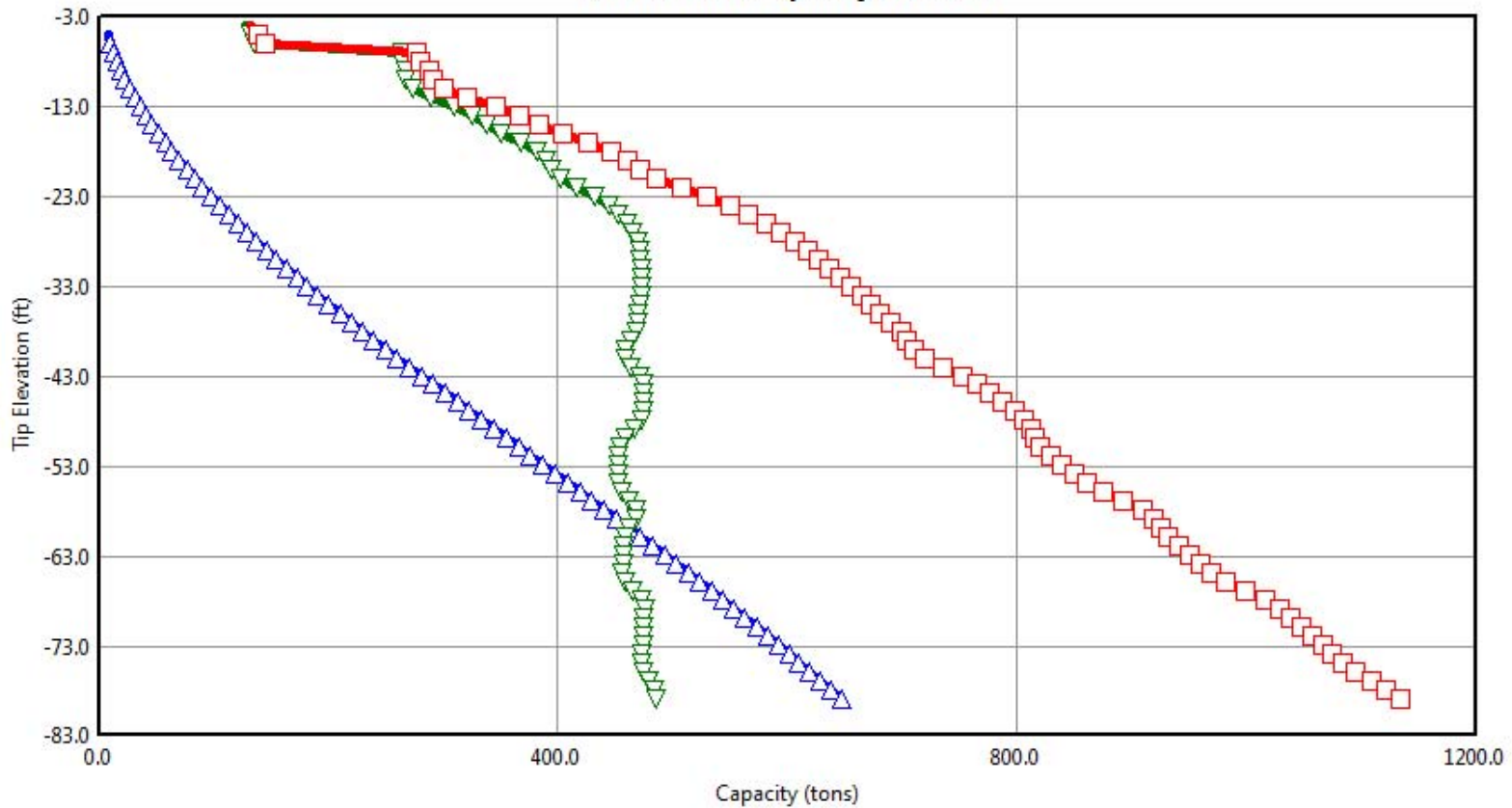
### Drilled Shaft Capacity: IDs 1-81



#### Curves

-  Ultimate Side Friction
-  Mobilized End Bearing
-  Ultimate Shaft Capacity

\*The 'Save to File' button saves the currently selected Curves to a text file.

#### Drilled Shaft Data

Boring Number:	B-101
Ground Surface Elevation:	11.10 (ft)
Diameter	60.00 (in)
Bell Diameter	60.00 (in)
Bell Length	0.00 (ft)
Case Length	6.00 (ft)

#### Project Data

File:	B-101Shaft60in
Date:	Apr 19, 2018
Engineer:	JB Henry
Water Table Elevation:	11.10 (ft)

#### Analysis Data



Analysis Type:	SPT
----------------	-----

#### Plot Options

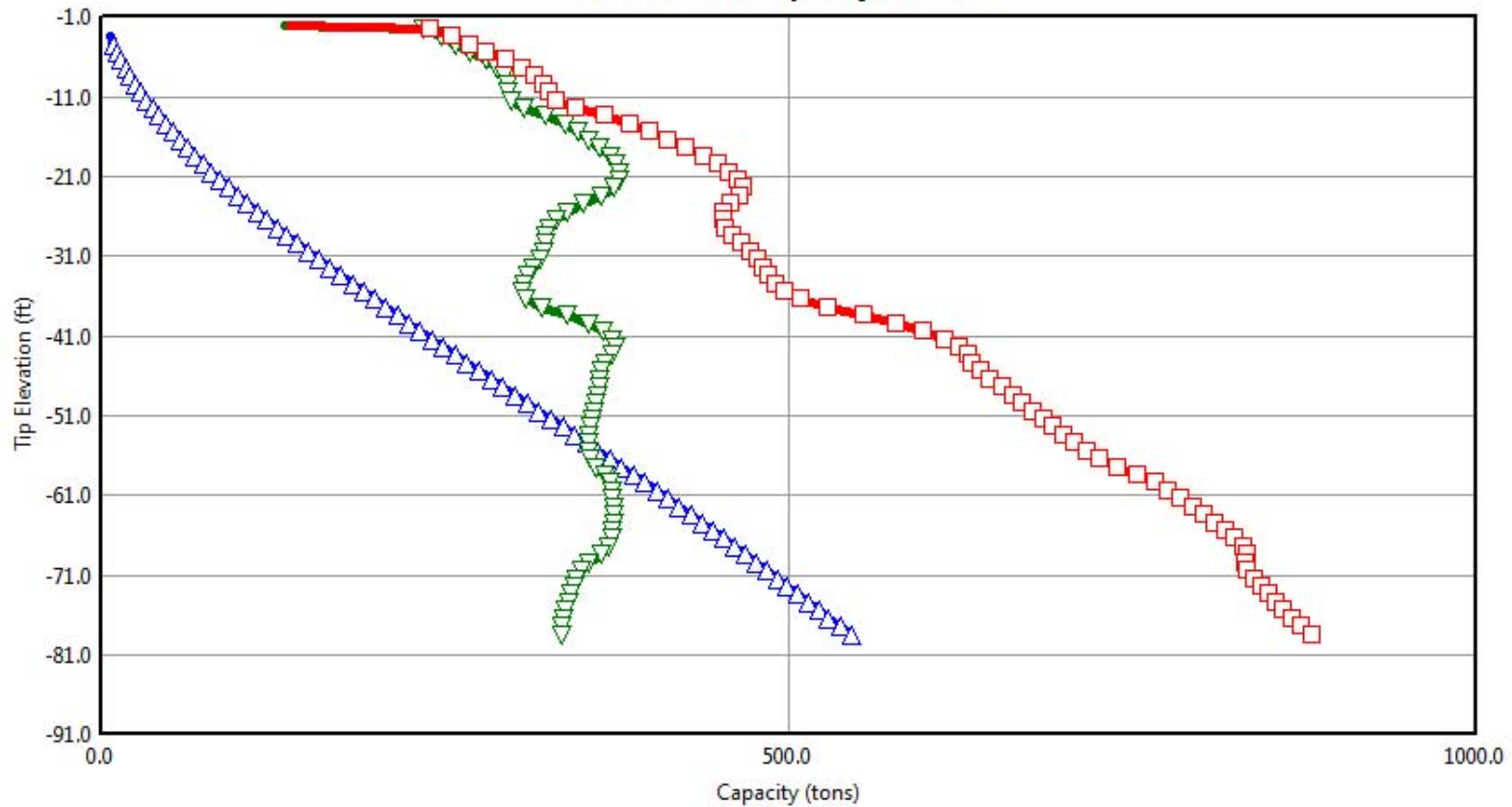
### Drilled Shaft Capacity: IDs 1-81



#### Curves

-  Ultimate Side Friction
-  Mobilized End Bearing
-  Ultimate Shaft Capacity

\*The 'Save to File' button saves the currently selected Curves to a text file.

#### Drilled Shaft Data

Boring Number:	B-201
Ground Surface Elevation:	13.60 (ft)
Diameter	48.00 (in)
Bell Diameter	48.00 (in)
Bell Length	0.00 (ft)
Case Length	6.00 (ft)

#### Project Data

File:	B-201Shaft48in
Date:	Apr 19, 2018
Engineer:	JB Henry
Water Table Elevation:	13.60 (ft)

#### Analysis Data

Analysis Type:	SPT
----------------	-----



#### Plot Options

-

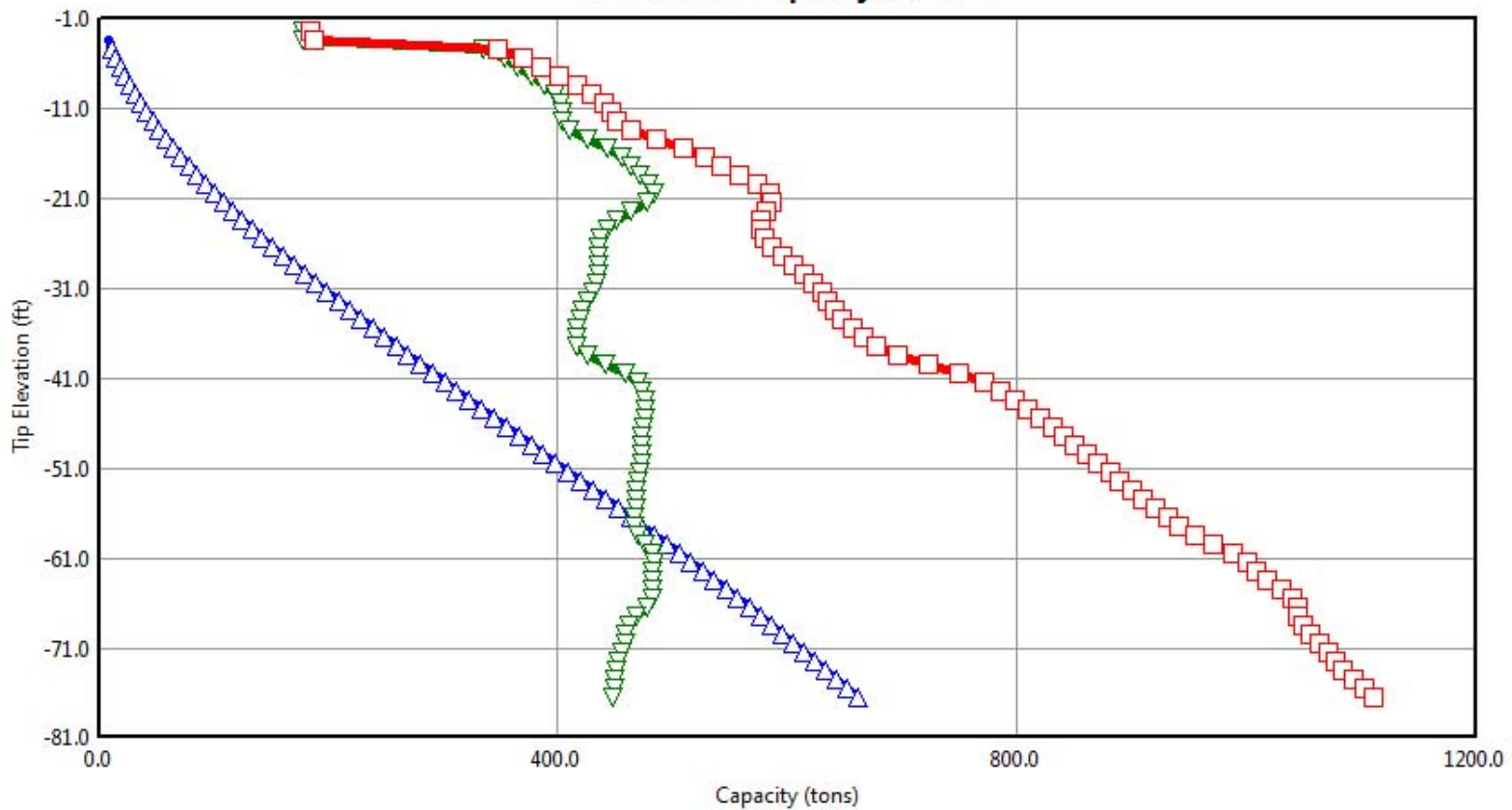
### Drilled Shaft Capacity: IDs 1-81



#### Curves

-  Ultimate Side Friction
-  Mobilized End Bearing
-  Ultimate Shaft Capacity

\*The 'Save to File' button saves the currently selected Curves to a text file.

#### Drilled Shaft Data

Boring Number:	B-201
Ground Surface Elevation:	13.60 (ft)
Diameter	60.00 (in)
Bell Diameter	60.00 (in)
Bell Length	0.00 (ft)
Case Length	6.00 (ft)

#### Project Data

File:	B-201Shaft60in
Date:	Apr 19, 2018
Engineer:	JB Henry
Water Table Elevation:	13.60 (ft)

#### Analysis Data



Analysis Type:	SPT
----------------	-----

#### Plot Options

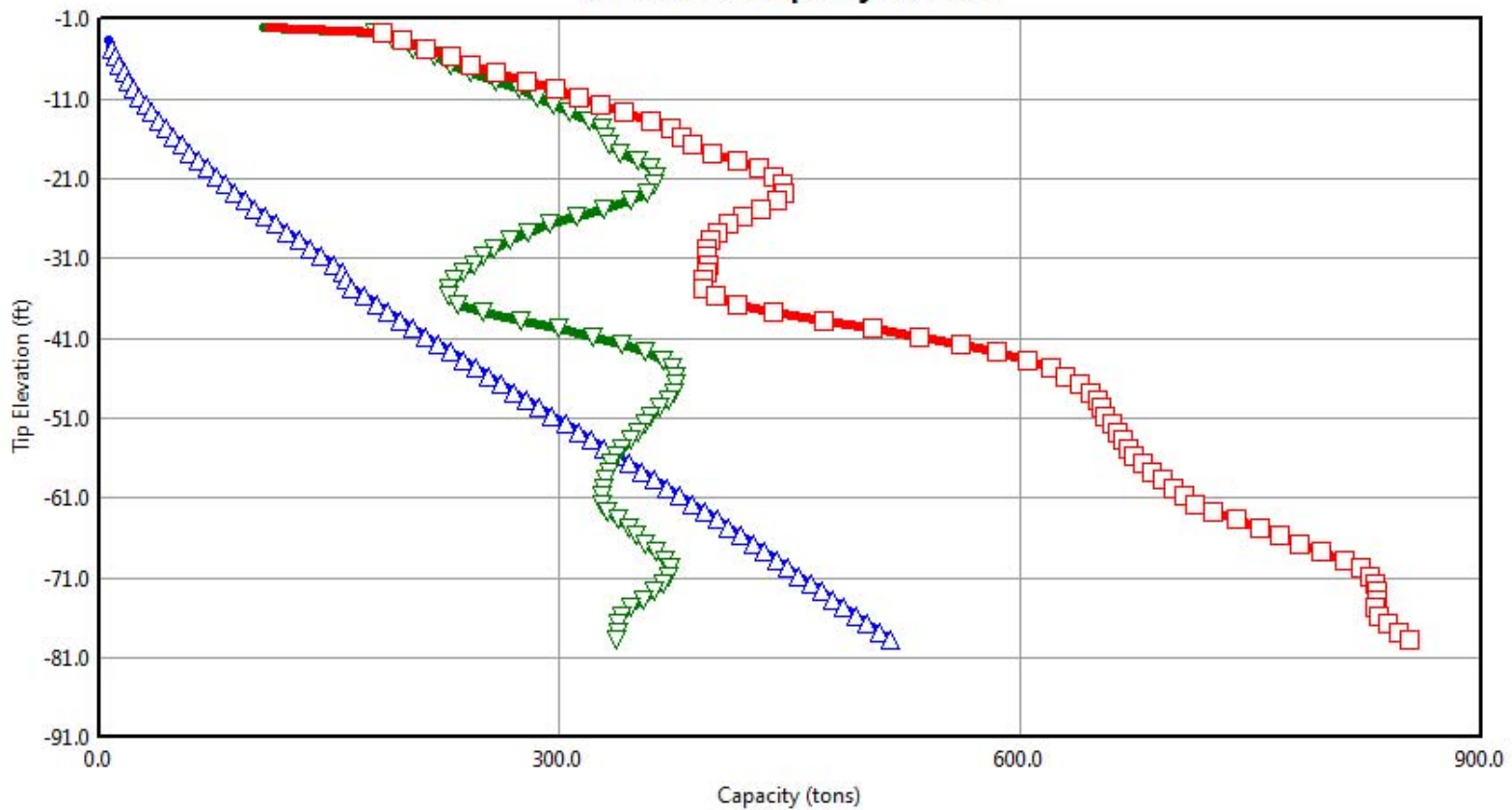
### Drilled Shaft Capacity: IDs 1-81



#### Curves

-  Ultimate Side Friction
-  Mobilized End Bearing
-  Ultimate Shaft Capacity

\*The 'Save to File' button saves the currently selected Curves to a text file.

#### Drilled Shaft Data

Boring Number:	B-301
Ground Surface Elevation:	13.30 (ft)
Diameter	48.00 (in)
Bell Diameter	48.00 (in)
Bell Length	0.00 (ft)
Case Length	6.00 (ft)

#### Project Data

File:	B-301Shaft48in
Date:	Apr 19, 2018
Engineer:	JB Henry
Water Table Elevation:	13.30 (ft)

#### Analysis Data

Analysis Type:	SPT
----------------	-----



#### Plot Options

-

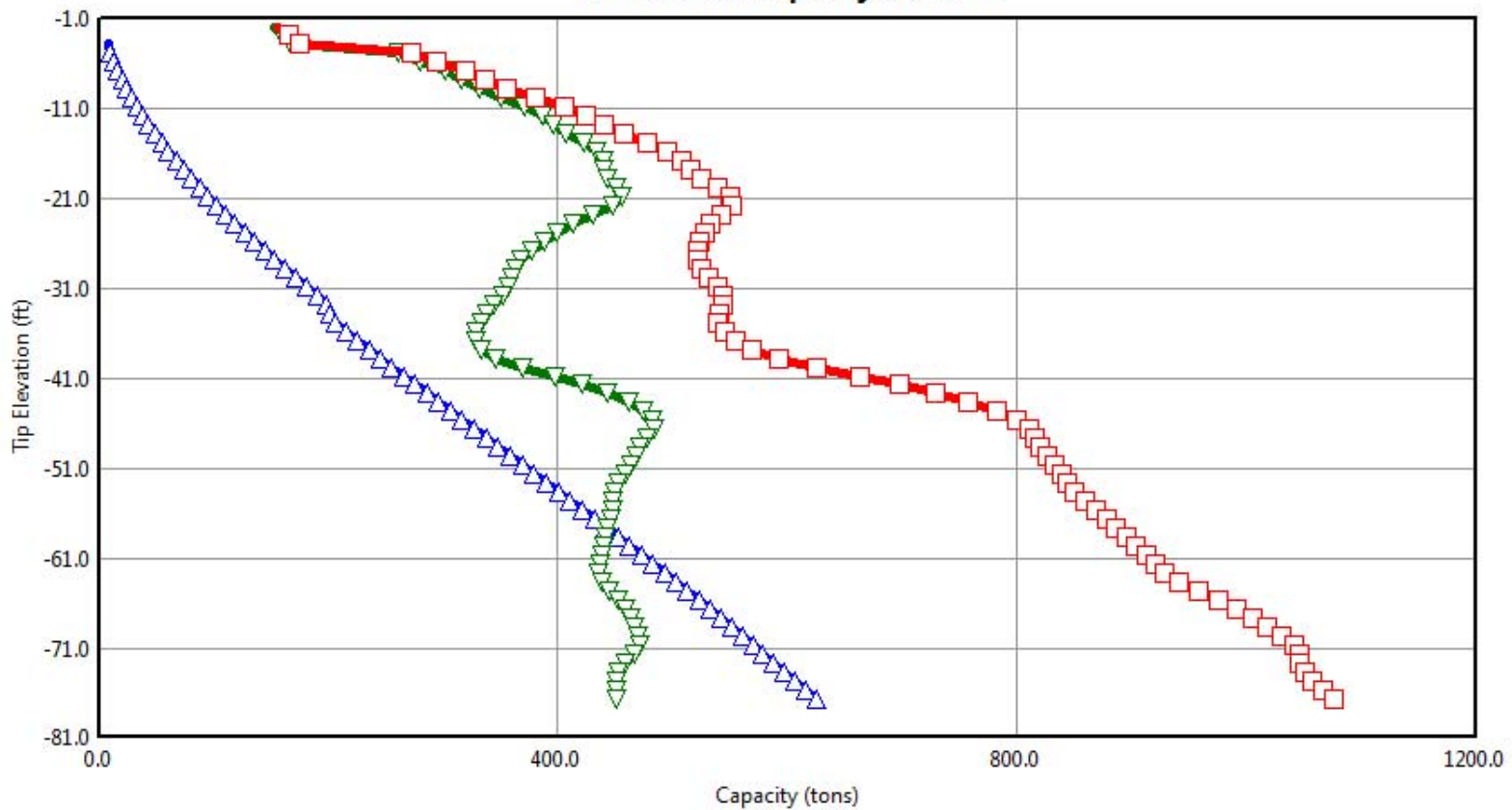
### Drilled Shaft Capacity: IDs 1-81



#### Curves

-  Ultimate Side Friction
-  Mobilized End Bearing
-  Ultimate Shaft Capacity

\*The 'Save to File' button saves the currently selected Curves to a text file.

#### Drilled Shaft Data

Boring Number:	B-301
Ground Surface Elevation:	13.30 (ft)
Diameter	60.00 (in)
Bell Diameter	60.00 (in)
Bell Length	0.00 (ft)
Case Length	6.00 (ft)

#### Project Data

File:	B-301Shaft60in
Date:	Apr 19, 2018
Engineer:	JB Henry
Water Table Elevation:	13.30 (ft)

#### Analysis Data

Analysis Type:	SPT
----------------	-----



#### Plot Options

-

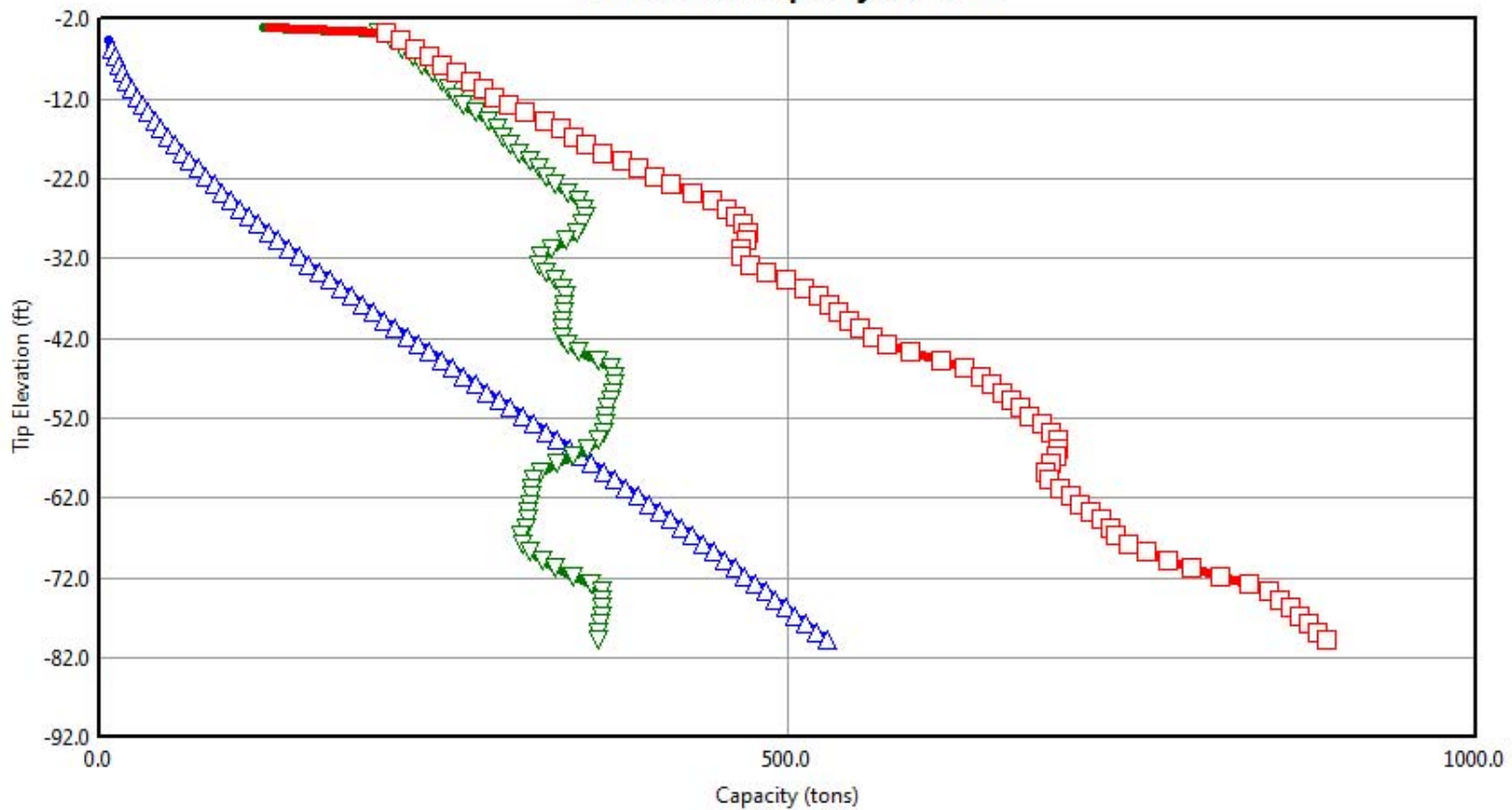
### Drilled Shaft Capacity: IDs 1-81



#### Curves

-  Ultimate Side Friction
-  Mobilized End Bearing
-  Ultimate Shaft Capacity

\*The 'Save to File' button saves the currently selected Curves to a text file.

#### Drilled Shaft Data

Boring Number:	B-401
Ground Surface Elevation:	12.30 (ft)
Diameter	48.00 (in)
Bell Diameter	48.00 (in)
Bell Length	0.00 (ft)
Case Length	6.00 (ft)

#### Project Data

File:	B-401Shaft48in
Date:	Apr 19, 2018
Engineer:	JB Henry
Water Table Elevation:	12.30 (ft)

#### Analysis Data



Analysis Type:	SPT
----------------	-----

#### Plot Options

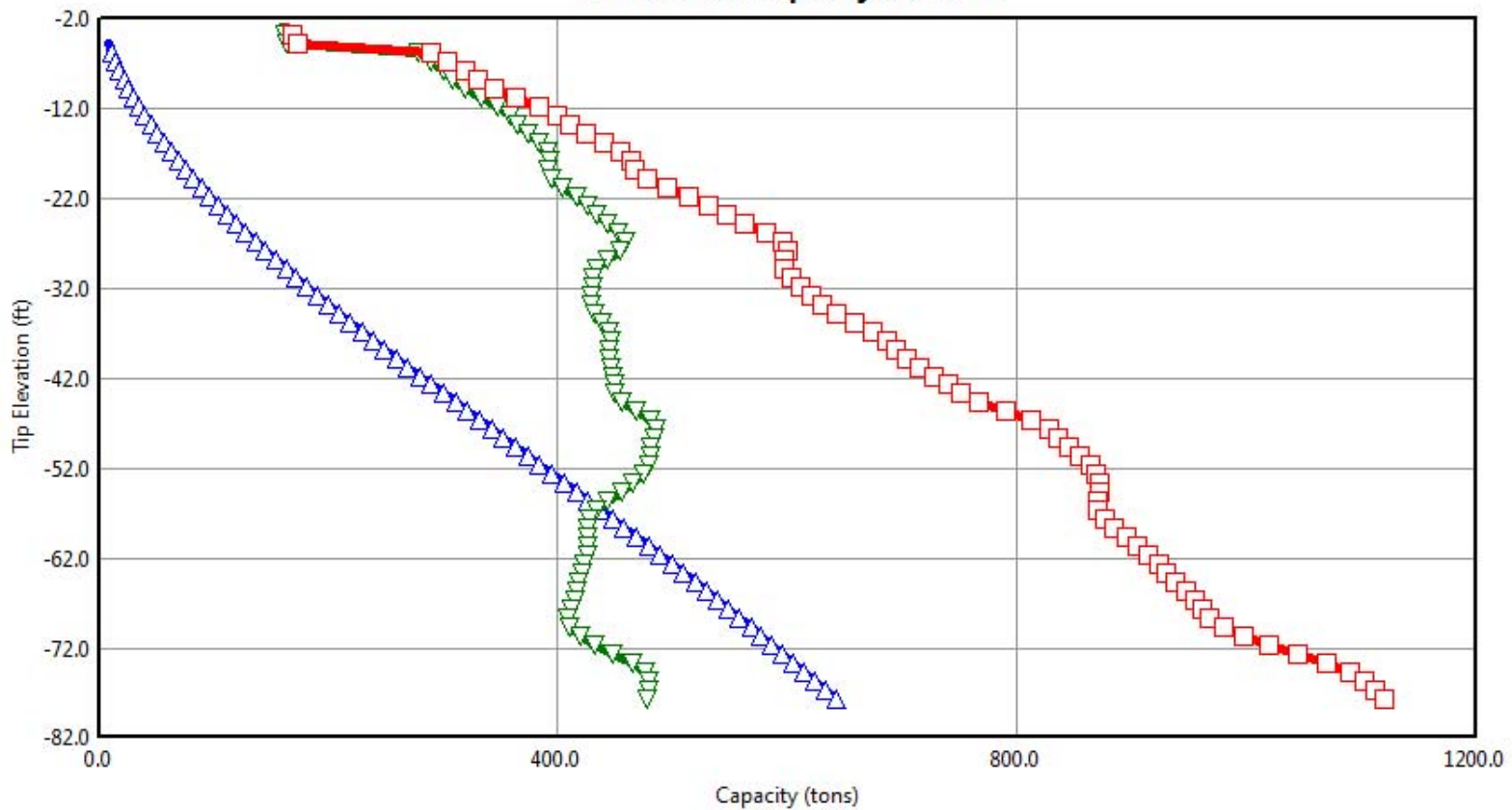
### Drilled Shaft Capacity: IDs 1-81



#### Curves

-  Ultimate Side Friction
-  Mobilized End Bearing
-  Ultimate Shaft Capacity

\*The 'Save to File' button saves the currently selected Curves to a text file.

#### Drilled Shaft Data

Boring Number:	B-401
Ground Surface Elevation:	12.30 (ft)
Diameter	60.00 (in)
Bell Diameter	60.00 (in)
Bell Length	0.00 (ft)
Case Length	6.00 (ft)

#### Project Data

File:	B-401Shaft60in
Date:	Apr 19, 2018
Engineer:	JB Henry
Water Table Elevation:	12.30 (ft)

#### Analysis Data

Analysis Type:	SPT
----------------	-----

#### Plot Options



-

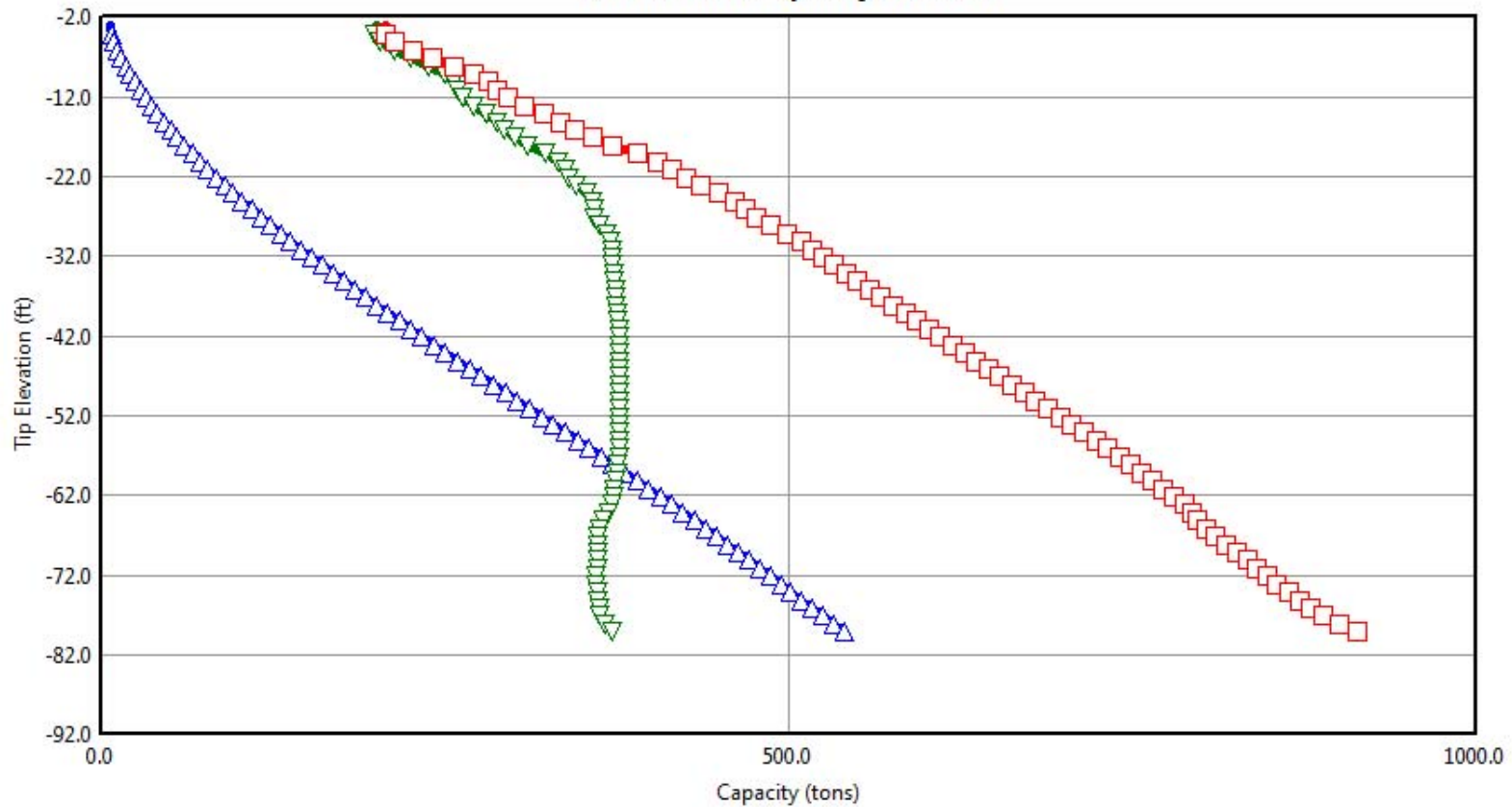

### Drilled Shaft Capacity: IDs 1-81



#### Curves

-  Ultimate Side Friction
-  Mobilized End Bearing
-  Ultimate Shaft Capacity

\*The 'Save to File' button saves the currently selected Curves to a text file.

#### Drilled Shaft Data

Boring Number:	B-501
Ground Surface Elevation:	12.90 (ft)
Diameter	48.00 (in)
Bell Diameter	48.00 (in)
Bell Length	0.00 (ft)
Case Length	6.00 (ft)

#### Project Data

File:	B-501Shaft48in
Date:	Apr 19, 2018
Engineer:	JB Henry
Water Table Elevation:	12.90 (ft)

#### Analysis Data



Analysis Type:	SPT
----------------	-----

#### Plot Options

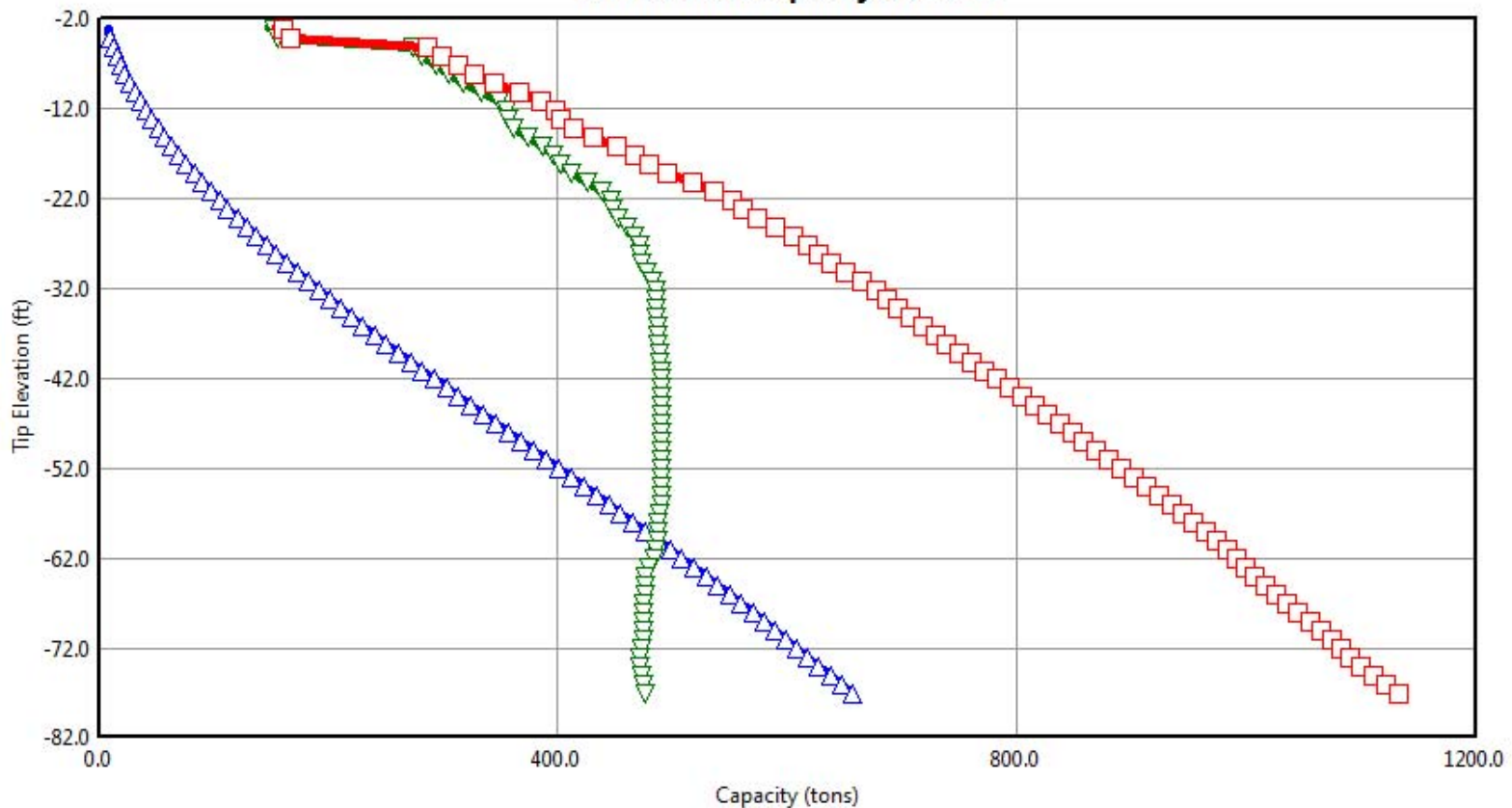
### Drilled Shaft Capacity: IDs 1-81



Curves

-  Ultimate Side Friction
-  Mobilized End Bearing
-  Ultimate Shaft Capacity

\*The 'Save to File' button saves the currently selected Curves to a text file.

Drilled Shaft Data

Boring Number:	B-501
Ground Surface Elevation:	12.90 (ft)
Diameter	60.00 (in)
Bell Diameter	60.00 (in)
Bell Length	0.00 (ft)
Case Length	6.00 (ft)

Project Data

File:	B-501Shaft60in
Date:	Apr 19, 2018
Engineer:	JB Henry
Water Table Elevation:	12.90 (ft)

Analysis Data



Analysis Type:	SPT
----------------	-----

Plot Options

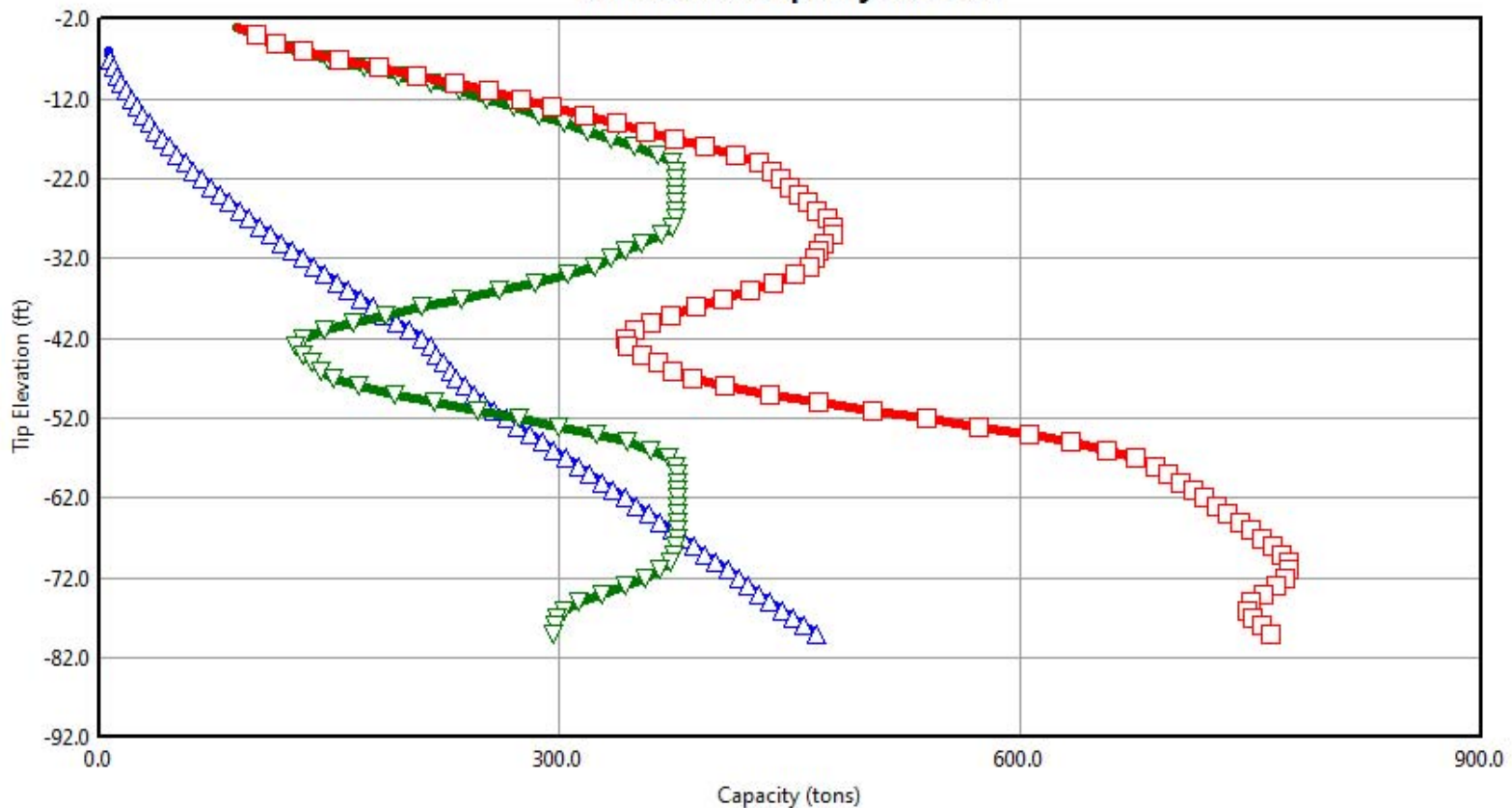
### Drilled Shaft Capacity: IDs 1-81



#### Curves

-  Ultimate Side Friction
-  Mobilized End Bearing
-  Ultimate Shaft Capacity

\*The 'Save to File' button saves the currently selected Curves to a text file.

#### Drilled Shaft Data

Boring Number:	B-601
Ground Surface Elevation:	13.00 (ft)
Diameter	48.00 (in)
Bell Diameter	48.00 (in)
Bell Length	0.00 (ft)
Case Length	6.00 (ft)

#### Project Data

File:	B-601Shaft48in
Date:	Apr 19, 2018
Engineer:	JB Henry
Water Table Elevation:	13.00 (ft)

#### Analysis Data



Analysis Type:	SPT
----------------	-----

#### Plot Options

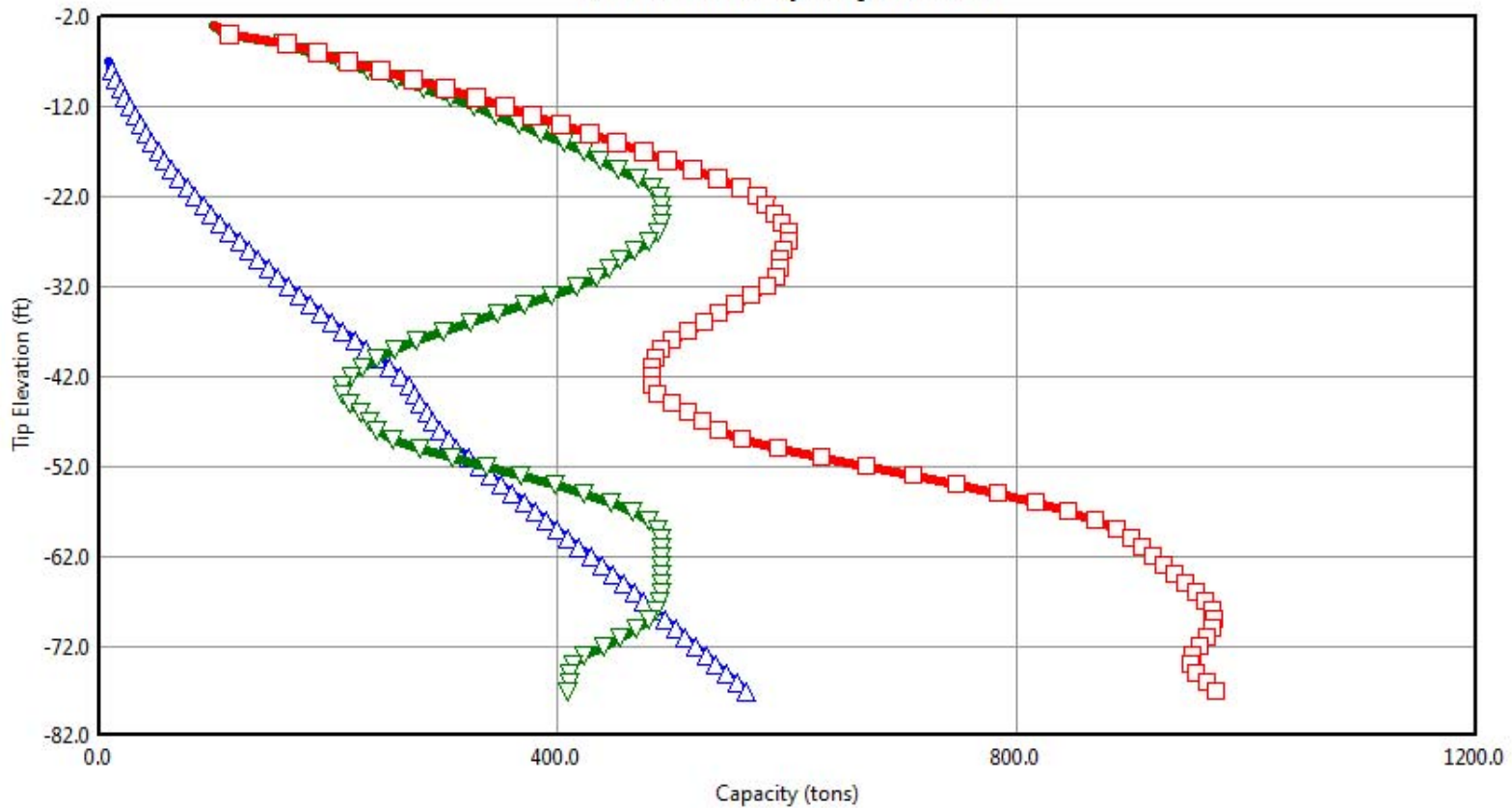
### Drilled Shaft Capacity: IDs 1-81



Curves

-  Ultimate Side Friction
-  Mobilized End Bearing
-  Ultimate Shaft Capacity

\*The 'Save to File' button saves the currently selected Curves to a text file.

Drilled Shaft Data

Boring Number:	B-601
Ground Surface Elevation:	13.00 (ft)
Diameter	60.00 (in)
Bell Diameter	60.00 (in)
Bell Length	0.00 (ft)
Case Length	6.00 (ft)

Project Data

File:	B-601Shaft60in
Date:	Apr 19, 2018
Engineer:	JB Henry
Water Table Elevation:	13.00 (ft)

Analysis Data

Analysis Type:	SPT
----------------	-----

Plot Options

**APPENDIX – H**

**FB-PIER SOIL PARAMETERS**

**TABLE - H1**

**Project Name: PD&E Study - SW 10th Street From Powerline Road to Military Trail**

**[Reference Borings: B-101]**

**Summary of Recommended Soil Parameters for FB-Pier Analysis for Driven Piles (18&24in)**

Note: Reduction of N-Values is applied for soil in the predrilling zone (0 to 10').

<b>Elevations and Soil Type:</b>	Layer 0	Layer 1	Layer 2	Layer 3	Layer 4	Layer 5	Layer 6	Layer 7	Layer 8	Layer 9	Layer 10
Depth at top of layer (ft) Ground Level		0	1	15	20	35	45	53	63	70	95
Depth at bottom of layer (ft)		1	15	20	35	45	53	63	70	95	100
Depth at water table (ft)		3.6									
Elevation at top of layer (ft, NAVD)		11.1	10.1	-3.9	-8.9	-23.9	-33.9	-41.9	-51.9	-58.9	-83.9
Elevation at bottom of layer (ft, NAVD)		10.1	-3.9	-8.9	-23.9	-33.9	-41.9	-51.9	-58.9	-83.9	-88.9
Water Table Elevation (ft, NAVD)		7.5									
Soil Layer Type (Cohesionless, Rock)	Cohesionless	Cohesionless	Rock	Cohesionless	Cohesionless	Cohesionless	Cohesionless	Cohesionless	Cohesionless	Cohesionless	Cohesionless
USCS Soil Layer Type	Fill	SP-SM	LS	SP-SM	SP	SP, SP-SM	SP, SP-SM	SP-SM	SP-SM, SM	SP-SM	SP, SP-SM+LS (Modele as Sandy Gravel)
Average SPT N value (Blows/ft) (Safety)		9.3	21.3	19.8	38.7	69.1	53.3	68.2	62.8	68.1	77.5
<b>Soil Properties for Lateral Soil Model:</b>											
Lateral Soil Model		1 (O'Neill)	1 (O'Neill)	1 (O'Neill)	1 (O'Neill)	1 (O'Neill)	1 (O'Neill)	1 (O'Neill)	1 (O'Neill)	1 (O'Neill)	1 (O'Neill)
Internal Friction Angle, $\Phi$ (degrees)		30	38	33	38	38	38	38	38	38	40
Subgrade Soil Modulus, RK (pci)		26	59	55	107	125	125	125	125	125	125
Total Unit Weight, $\gamma$ (pcf)		105	125	110	120	125	125	125	125	125	130
<b>Soil Properties for Axial Soil Model:</b>											
Axial Soil Model		1 (McVay)	1 (McVay)	1 (McVay)	1 (McVay)	1 (McVay)	1 (McVay)	1 (McVay)	1 (McVay)	1 (McVay)	1 (McVay)
Poisson's Ratio, $\mu$		0.20	0.23	0.25	0.30	0.30	0.30	0.30	0.30	0.30	0.30
Young's Modulus, Eem (psf)		180,000	2,130,000	390,000	770,000	1,000,000	1,000,000	1,000,000	1,000,000	1,000,000	1,000,000
Shear Modulus, Gem (ksi)		0.5	6.0	1.1	2.1	2.7	2.7	2.7	2.7	2.7	2.7
Vertical Failure Shear Stress (psf)		353	427	754	1469	2627	2026	2592	2388	2587	2945
<b>Soil Properties for Torsional Soil Model:</b>											
Torsional Soil Model		Hyperbolic	Hyperbolic	Hyperbolic	Hyperbolic	Hyperbolic	Hyperbolic	Hyperbolic	Hyperbolic	Hyperbolic	Hyperbolic
Torsional Shear Stress (psf)		353	427	754	1469	2627	2026	2592	2388	2587	2945
<b>Soil Properties for Tip Soil Model:</b>											
Tip Soil Model		1 (McVay)	1 (McVay)	1 (McVay)	1 (McVay)	1 (McVay)	1 (McVay)	1 (McVay)	1 (McVay)	1 (McVay)	1 (McVay)
Shear Modulus, G (ksi)		0.54	6.03	1.10	2.06	2.67	2.67	2.67	2.67	2.67	2.67
Poisson's Ratio, $\mu$		0.2	0.23	0.25	0.3	0.3	0.3	0.3	0.3	0.3	0.3
Axial Bearing Failure Load, Qult (kip), 18" Pile		134	346	286	557	995	768	982	905	980	1116
Axial Bearing Failure Load, Qult (kip), 24" Pile		238	615	508	989	1770	1365	1746	1608	1743	1984
<b>Table 1. P-Y Curves for Rock</b>											
Unconfined Compressive Strength, $q_u$ (psf)			21000								
Undrained Strength, $S_u$ (psi) =			74								

**TABLE - H2**  
**Project Name: PD&E Study - SW 10th Street From Powerline Road to Military Trail**  
**[Reference Borings: B-201]**  
**Summary of Recommended Soil Parameters for FB-Pier Analysis for Driven Piles (18&24in)**

Note: Reduction of N-Values is applied for soil in the predrilling zone (0 to 10').

<b>Elevations and Soil Type:</b>	Layer 0	Layer 1	Layer 2	Layer 3	Layer 4	Layer 5	Layer 6	Layer 7	Layer 8	Layer 9	Layer 10	Layer 11	Layer 12
Depth at top of layer (ft) Ground Level		0	4	6	12	20	23	45	50	70	75	90	93
Depth at bottom of layer (ft)		4	6	12	20	23	45	50	70	75	90	93	100
Depth at water table (ft)		5.8											
Elevation at top of layer (ft, NAVD)		13.6	9.6	7.6	1.6	-6.4	-9.4	-31.4	-36.4	-56.4	-61.4	-76.4	-79.4
Elevation at bottom of layer (ft, NAVD)		9.6	7.6	1.6	-6.4	-9.4	-31.4	-36.4	-56.4	-61.4	-76.4	-79.4	-86.4
Water Table Elevation (ft, NAVD)		7.8											
Soil Layer Type (Cohesionless, Rock)	Cohesionless	Cohesionless	Cohesionless	Cohesionless	Cohesionless	Cohesionless	Cohesionless	Cohesionless	Cohesionless	Cohesionless	Cohesionless	Cohesionless	Cohesionless
USCS Soil Layer Type	Fill	SP, SP-SM	OL (Muck)	SP-SM, SM	SP-SM	SP	SP	SP-SM	SP-SM	SP, SP-SM	SP-SM, SM	SP	SP-SM
Average SPT N value (Blows/ft) (Safety)		16.1	1.0	5.0	34.7	19.8	67.1	27.3	66.8	51.5	68.8	29.8	55.8
<b>Soil Properties for Lateral Soil Model:</b>													
Lateral Soil Model		1 (O'Neill)	1 (O'Neill)	1 (O'Neill)	1 (O'Neill)	1 (O'Neill)	1 (O'Neill)	1 (O'Neill)	1 (O'Neill)	1 (O'Neill)	1 (O'Neill)	1 (O'Neill)	1 (O'Neill)
Internal Friction Angle, $\Phi$ (degrees)		32	24	29	37	33	38	35	38	38	38	35	38
Subgrade Soil Modulus, RK (pci)		45	3	14	96	55	125	76	125	125	125	83	125
Total Unit Weight, $\gamma$ (pcf)		110	100	105	120	110	125	115	125	125	125	115	125
<b>Soil Properties for Axial Soil Model:</b>													
Axial Soil Model		1 (McVay)	1 (McVay)	1 (McVay)	1 (McVay)	1 (McVay)	1 (McVay)	1 (McVay)	1 (McVay)	1 (McVay)	1 (McVay)	1 (McVay)	1 (McVay)
Poisson's Ratio, $\mu$		0.25	0.20	0.20	0.30	0.25	0.30	0.25	0.30	0.30	0.30	0.25	0.30
Young's Modulus, Eem (psf)		320,000	20,000	90,000	690,000	390,000	1,000,000	540,000	1,000,000	1,000,000	1,000,000	590,000	1,000,000
Shear Modulus, Gem (ksi)		0.9	0.1	0.3	1.9	1.1	2.7	1.5	2.7	2.7	2.7	1.7	2.7
Vertical Failure Shear Stress (psf)		613	38	188	1319	754	2550	1037	2539	1955	2615	1131	2120
<b>Soil Properties for Torsional Soil Model:</b>													
Torsional Soil Model		Hyperbolic	Hyperbolic	Hyperbolic	Hyperbolic	Hyperbolic	Hyperbolic	Hyperbolic	Hyperbolic	Hyperbolic	Hyperbolic	Hyperbolic	Hyperbolic
Torsional Shear Stress (psf)		613	38	188	1319	754	2550	1037	2539	1955	2615	1131	2120
<b>Soil Properties for Tip Soil Model:</b>													
Tip Soil Model		1 (McVay)	1 (McVay)	1 (McVay)	1 (McVay)	1 (McVay)	1 (McVay)	1 (McVay)	1 (McVay)	1 (McVay)	1 (McVay)	1 (McVay)	2 (McVay)
Shear Modulus, G (ksi)		0.90	0.06	0.29	1.85	1.10	2.67	1.52	2.67	2.67	2.67	1.65	2.67
Poisson's Ratio, $\mu$		0.25	0.2	0.2	0.3	0.25	0.3	0.25	0.3	0.3	0.3	0.25	0.3
Axial Bearing Failure Load, Qult (kip), 18" Pile		232	14	71	500	286	966	393	962	741	991	429	804
Axial Bearing Failure Load, Qult (kip), 24" Pile		413	26	127	889	508	1718	698	1710	1317	1762	762	1428
<b>Table 1. P-Y Curves for Rock</b>													
Unconfined Compressive Strength, $q_u$ (psf)													
Undrained Strength, $S_u$ (psi) =													

**TABLE - H3**

**Project Name: PD&E Study - SW 10th Street From Powerline Road to Military Trail**

**[Reference Borings: B-301]**

**Summary of Recommended Soil Parameters for FB-Pier Analysis for Driven Piles (18&24in)**

Note: Reduction of N-Values is applied for soil in the predrilling zone (0 to 10').

<b>Elevations and Soil Type:</b>	Layer 0	Layer 1	Layer 2	Layer 3	Layer 4	Layer 5	Layer 6	Layer 7	Layer 8	Layer 9	Layer 10	Layer 11
Depth at top of layer (ft) Ground Level		0	2	6	8	10	13.5	18	45	50	85	90
Depth at bottom of layer (ft)		2	6	8	10	13.5	18	45	50	85	90	100
Depth at water table (ft)		3.8										
Elevation at top of layer (ft, NAVD)		13.3	11.3	7.3	5.3	3.3	-0.2	-4.7	-31.7	-36.7	-71.7	-76.7
Elevation at bottom of layer (ft, NAVD)		11.3	7.3	5.3	3.3	-0.2	-4.7	-31.7	-36.7	-71.7	-76.7	-86.7
Water Table Elevation (ft, NAVD)		9.5										
Soil Layer Type (Cohesionless, Rock)	Cohesionless	Cohesionless	Cohesionless	Cohesionless	Rock	Cohesionless	Cohesionless	Cohesionless	Cohesionless	Cohesionless	Cohesionless	Cohesionless
USCS Soil Layer Type	Fill	SP, SP-SM	SM	SM, SP-SM	LS	SM, SP-SM	SP, SP-SM	SP	SC	SP-SM	SP-SM, SM	SP-SM
Average SPT N value (Blows/ft) (Safety)		9.9	18.0	17.4	11.8	12.4	19.2	51.9	11.2	60.9	83.1	43.1
<b>Soil Properties for Lateral Soil Model:</b>												
Lateral Soil Model		1 (O'Neill)	1 (O'Neill)	1 (O'Neill)	1 (O'Neill)	1 (O'Neill)	1 (O'Neill)	1 (O'Neill)	1 (O'Neill)	1 (O'Neill)	1 (O'Neill)	1 (O'Neill)
Internal Friction Angle, $\Phi$ (degrees)		30	32	32	36	31	33	38	31	38	38	38
Subgrade Soil Modulus, RK (pci)		28	50	48	33	34	53	125	31	125	125	120
Total Unit Weight, $\gamma$ (pcf)		105	110	110	120	110	110	125	110	125	125	125
<b>Soil Properties for Axial Soil Model:</b>												
Axial Soil Model		1 (McVay)	1 (McVay)	1 (McVay)	1 (McVay)	1 (McVay)	1 (McVay)	1 (McVay)	1 (McVay)	1 (McVay)	1 (McVay)	1 (McVay)
Poisson's Ratio, $\mu$		0.20	0.25	0.25	0.23	0.25	0.25	0.30	0.25	0.30	0.30	0.30
Young's Modulus, Eem (psf)		190,000	350,000	340,000	1,170,000	240,000	380,000	1,000,000	220,000	1,000,000	1,000,000	860,000
Shear Modulus, Gem (ksi)		0.6	1.0	1.0	3.3	0.7	1.1	2.7	0.6	2.7	2.7	2.3
Vertical Failure Shear Stress (psf)		377	683	660	236	471	730	1970	424	2316	3157	1637
<b>Soil Properties for Torsional Soil Model:</b>												
Torsional Soil Model		Hyperbolic	Hyperbolic	Hyperbolic	Hyperbolic	Hyperbolic	Hyperbolic	Hyperbolic	Hyperbolic	Hyperbolic	Hyperbolic	Hyperbolic
Torsional Shear Stress (psf)		377	683	660	236	471	730	1970	424	2316	3157	1637
<b>Soil Properties for Tip Soil Model:</b>												
Tip Soil Model		1 (McVay)	1 (McVay)	1 (McVay)	1 (McVay)	1 (McVay)	1 (McVay)	1 (McVay)	1 (McVay)	1 (McVay)	1 (McVay)	2 (McVay)
Shear Modulus, G (ksi)		0.57	1.00	0.96	3.33	0.69	1.07	2.67	0.62	2.67	2.67	2.30
Poisson's Ratio, $\mu$		0.2	0.25	0.25	0.23	0.25	0.25	0.3	0.25	0.3	0.3	0.3
Axial Bearing Failure Load, Qult (kip), 18" Pile		143	259	250	191	179	277	747	161	878	1196	620
Axial Bearing Failure Load, Qult (kip), 24" Pile		254	460	444	339	317	492	1327	286	1560	2127	1103
<b>Table 1. P-Y Curves for Rock</b>												
Unconfined Compressive Strength, $q_u$ (psf)						11000						
Undrained Strength, $S_u$ (psi) =						41						



**TABLE - H4**  
**Project Name: PD&E Study - SW 10th Street From Powerline Road to Military Trail**  
**[Reference Borings: B-401]**

**Summary of Recommended Soil Parameters for FB-Pier Analysis for Driven Piles (18&24in)**

Note: Reduction of N-Values is applied for soil in the predrilling zone (0 to 10').

<b>Elevations and Soil Type:</b>	Layer 0	Layer 1	Layer 2	Layer 3	Layer 4	Layer 5	Layer 6	Layer 7	Layer 8	Layer 9	Layer 10	Layer 11
Depth at top of layer (ft) Ground Level		0	6	8	10	12	33	48	53	75	80	85
Depth at bottom of layer (ft)		6	8	10	12	33	48	53	75	80	85	100
Depth at water table (ft)		5.0										
Elevation at top of layer (ft, NAVD)		12.3	6.3	4.3	2.3	0.3	-20.7	-35.7	-40.7	-62.7	-67.7	-72.7
Elevation at bottom of layer (ft, NAVD)		6.3	4.3	2.3	0.3	-20.7	-35.7	-40.7	-62.7	-67.7	-72.7	-87.7
Water Table Elevation (ft, NAVD)		7.3										
Soil Layer Type (Cohesionless, Rock)	Cohesionless	Cohesionless	Rock	Rock	Rock	Cohesionless	Cohesionless	Cohesionless	Cohesionless	Cohesionless	Rock	Cohesionless
USCS Soil Layer Type	Fill	SP, SP-SM	LS	LS	LS	SP	SP	SP, SP-SM	SP-SM	SM, SP-SM	LS	SP, SP-SM
Average SPT N value (Blows/ft) (Safety)		5.6	12.4	14.9	18.6	33.2	54.2	42.8	60.9	27.3	74.4	62.8
<b>Soil Properties for Lateral Soil Model:</b>												
Lateral Soil Model		1 (O'Neill)	1 (O'Neill)	1 (O'Neill)	1 (O'Neill)	1 (O'Neill)	1 (O'Neill)	1 (O'Neill)	1 (O'Neill)	1 (O'Neill)	1 (O'Neill)	1 (O'Neill)
Internal Friction Angle, $\Phi$ (degrees)		29	36	37	38	36	38	38	38	35	40	38
Subgrade Soil Modulus, RK (pci)		16	34	41	52	92	125	119	125	76	125	125
Total Unit Weight, $\gamma$ (pcf)		105	120	120	120	120	125	125	125	115	135	125
<b>Soil Properties for Axial Soil Model:</b>												
Axial Soil Model		1 (McVay)	1 (McVay)	1 (McVay)	1 (McVay)	1 (McVay)	1 (McVay)	1 (McVay)	1 (McVay)	1 (McVay)	1 (McVay)	1 (McVay)
Poisson's Ratio, $\mu$		0.20	0.23	0.25	0.23	0.30	0.30	0.30	0.30	0.25	3.23	0.30
Young's Modulus, Eem (psf)		110,000	1,240,000	290,000	1,860,000	660,000	1,000,000	850,000	1,000,000	540,000	7,440,000	1,000,000
Shear Modulus, Gem (ksi)		0.3	3.5	0.8	5.3	1.8	2.7	2.3	2.7	1.5	6.1	2.7
Vertical Failure Shear Stress (psf)		212	248	565	372	1260	2058	1626	2314	1037	1488	2388
<b>Soil Properties for Torsional Soil Model:</b>												
Torsional Soil Model		Hyperbolic	Hyperbolic	Hyperbolic	Hyperbolic	Hyperbolic	Hyperbolic	Hyperbolic	Hyperbolic	Hyperbolic	Hyperbolic	Hyperbolic
Torsional Shear Stress (psf)		212	248	565	372	1260	2058	1626	2314	1037	1488	2388
<b>Soil Properties for Tip Soil Model:</b>												
Tip Soil Model		1 (McVay)	1 (McVay)	1 (McVay)	1 (McVay)	1 (McVay)	1 (McVay)	1 (McVay)	1 (McVay)	1 (McVay)	1 (McVay)	3 (McVay)
Shear Modulus, G (ksi)		0.32	3.50	0.83	5.25	1.77	2.67	2.29	2.67	1.52	6.11	2.67
Poisson's Ratio, $\mu$		0.2	0.23	0.25	0.23	0.3	0.3	0.3	0.3	0.25	3.23	0.3
Axial Bearing Failure Load, Qult (kip), 18" Pile		80	201	214	301	478	780	616	877	393	1205	905
Axial Bearing Failure Load, Qult (kip), 24" Pile		143	357	381	536	849	1386	1095	1559	698	2143	1608
<b>Table 1. P-Y Curves for Rock</b>												
Unconfined Compressive Strength, $q_u$ (psf)			12000		18000						50000	
Undrained Strength, $S_u$ (psi) =			43		65						174	

**TABLE - H5**  
**Project Name: PD&E Study - SW 10th Street From Powerline Road to Military Trail**  
**[Reference Borings: B-501]**  
**Summary of Recommended Soil Parameters for FB-Pier Analysis for Driven Piles (18&24in)**

Note: Reduction of N-Values is applied for soil in the predrilling zone (0 to 10').

<b>Elevations and Soil Type:</b>	Layer 0	Layer 1	Layer 2	Layer 3	Layer 4	Layer 5	Layer 6	Layer 7	Layer 8	Layer 9	Layer 10	Layer 11	Layer 12
Depth at top of layer (ft) Ground Level		0	3	8	12	18	25	30	55	78	80	83	90
Depth at bottom of layer (ft)		3	8	12	18	25	30	55	78	80	83	90	100
Depth at water table (ft)		5.3											
Elevation at top of layer (ft, NAVD)		12.9	9.9	4.9	0.9	-5.1	-12.1	-17.1	-42.1	-65.1	-67.1	-70.1	-77.1
Elevation at bottom of layer (ft, NAVD)		9.9	4.9	0.9	-5.1	-12.1	-17.1	-42.1	-65.1	-67.1	-70.1	-77.1	-87.1
Water Table Elevation (ft, NAVD)		7.7											
Soil Layer Type (Cohesionless, Rock)	Cohesionless	Cohesionless	Rock	Cohesionless	Cohesionless	Cohesionless	Cohesionless	Cohesionless	Cohesionless	Cohesionless	Cohesionless	Cohesionless	Cohesionless
USCS Soil Layer Type	Fill	SP, SP-SM	LS	SM	SP	SP	SP, SP-SM	SP	SP-SM	SP	SP-SM	SP	SP, SP-SM
Average SPT N value (Blows/ft) (Safety)		5.0	9.9	16.1	18.2	33.9	35.3	61.3	76.2	90.5	47.1	50.8	78.7
<b>Soil Properties for Lateral Soil Model:</b>													
Lateral Soil Model		1 (O'Neill)	1 (O'Neill)	1 (O'Neill)	1 (O'Neill)	1 (O'Neill)	1 (O'Neill)	1 (O'Neill)	1 (O'Neill)	1 (O'Neill)	1 (O'Neill)	1 (O'Neill)	1 (O'Neill)
Internal Friction Angle, $\Phi$ (degrees)		29	35	32	33	36	37	38	38	38	38	38	38
Subgrade Soil Modulus, RK (pci)		14	28	45	51	94	98	125	125	125	125	125	125
Total Unit Weight, $\gamma$ (pcf)		105	115	110	110	120	120	125	125	125	125	125	125
<b>Soil Properties for Axial Soil Model:</b>													
Axial Soil Model		1 (McVay)	1 (McVay)	1 (McVay)	1 (McVay)	1 (McVay)	1 (McVay)	1 (McVay)	1 (McVay)	1 (McVay)	1 (McVay)	1 (McVay)	1 (McVay)
Poisson's Ratio, $\mu$		0.20	0.23	0.25	0.25	0.30	0.30	0.30	0.30	0.30	0.30	0.30	0.30
Young's Modulus, Eem (psf)		90,000	990,000	320,000	360,000	670,000	700,000	1,000,000	1,000,000	1,000,000	940,000	1,000,000	1,000,000
Shear Modulus, Gem (ksi)		0.3	2.8	0.9	1.0	1.8	1.9	2.7	2.7	2.7	2.5	2.7	2.7
Vertical Failure Shear Stress (psf)		188	198	613	691	1288	1343	2328	2895	3440	1791	1932	2992
<b>Soil Properties for Torsional Soil Model:</b>													
Torsional Soil Model		Hyperbolic	Hyperbolic	Hyperbolic	Hyperbolic	Hyperbolic	Hyperbolic	Hyperbolic	Hyperbolic	Hyperbolic	Hyperbolic	Hyperbolic	Hyperbolic
Torsional Shear Stress (psf)		188	198	613	691	1288	1343	2328	2895	3440	1791	1932	2992
<b>Soil Properties for Tip Soil Model:</b>													
Tip Soil Model		1 (McVay)	1 (McVay)	1 (McVay)	1 (McVay)	1 (McVay)	1 (McVay)	1 (McVay)	1 (McVay)	1 (McVay)	1 (McVay)	2 (McVay)	3 (McVay)
Shear Modulus, G (ksi)		0.29	2.80	0.90	1.01	1.81	1.89	2.67	2.67	2.67	2.52	2.67	2.67
Poisson's Ratio, $\mu$		0.2	0.23	0.25	0.25	0.3	0.3	0.3	0.3	0.3	0.3	0.3	0.3
Axial Bearing Failure Load, Qult (kip), 18" Pile		71	161	232	262	488	509	882	1097	1303	679	732	1134
Axial Bearing Failure Load, Qult (kip), 24" Pile		127	286	413	466	868	905	1568	1950	2317	1206	1302	2016
<b>Table 1. P-Y Curves for Rock</b>													
Unconfined Compressive Strength, $q_u$ (psf)			9000										
Undrained Strength, $S_u$ (psi) =			34										

**TABLE - H6**  
**Project Name: PD&E Study - SW 10th Street From Powerline Road to Military Trail**  
**[Reference Borings: B-601]**  
**Summary of Recommended Soil Parameters for FB-Pier Analysis for Driven Piles (18&24in)**

Note: Reduction of N-Values is applied for soil in the predrilling zone (0 to 10').

<b>Elevations and Soil Type:</b>	Layer 0	Layer 1	Layer 2	Layer 3	Layer 4	Layer 5	Layer 6	Layer 7	Layer 8	Layer 9	Layer 10	Layer 11	Layer 12
Depth at top of layer (ft) Ground Level		0	6	15	18	28	50	55	63	67	75	93	98
Depth at bottom of layer (ft)		6	15	18	28	50	55	63	67	75	93	98	100
Depth at water table (ft)		7.7											
Elevation at top of layer (ft, NAVD)		13	7	-2	-5	-15	-37	-42	-50	-54	-62	-80	-85
Elevation at bottom of layer (ft, NAVD)		7	-2	-5	-15	-37	-42	-50	-54	-62	-80	-85	-87
Water Table Elevation (ft, NAVD)		5.3											
Soil Layer Type (Cohesionless, Rock)	Cohesionless	Cohesionless	Cohesionless	Cohesionless	Cohesionless	Cohesionless	Cohesionless	Cohesionless	Cohesionless	Rock	Cohesionless	Cohesionless	Cohesionless
USCS Soil Layer Type	Fill	SP	SP	SP-SM	SP, SP-SM	SP	SP, SP-SM	SP, SP-SM	SP-SM, SM	LS	SP-SM	SP, SP-SM	SP, SP-SM
Average SPT N value (Blows/ft) (Safety)		15.1	5.7	7.4	21.4	79.5	27.3	5.4	28.5	74.4	68.4	19.8	52.1
<b>Soil Properties for Lateral Soil Model:</b>													
Lateral Soil Model		1 (O'Neill)	1 (O'Neill)	1 (O'Neill)	1 (O'Neill)	1 (O'Neill)	1 (O'Neill)	1 (O'Neill)	1 (O'Neill)	1 (O'Neill)	1 (O'Neill)	1 (O'Neill)	1 (O'Neill)
Internal Friction Angle, $\Phi$ (degrees)		32	29	30	33	38	35	29	35	40	38	33	38
Subgrade Soil Modulus, RK (pci)		42	16	21	59	125	76	15	79	125	125	55	125
Total Unit Weight, $\gamma$ (pcf)		110	105	105	115	125	115	105	115	135	125	110	125
<b>Soil Properties for Axial Soil Model:</b>													
Axial Soil Model		1 (McVay)	1 (McVay)	1 (McVay)	1 (McVay)	1 (McVay)	1 (McVay)	1 (McVay)	1 (McVay)	1 (McVay)	1 (McVay)	1 (McVay)	1 (McVay)
Poisson's Ratio, $\mu$		0.25	0.20	0.20	0.25	0.30	0.25	0.20	0.25	1.23	0.30	0.25	0.30
Young's Modulus, Eem (psf)		300,000	110,000	140,000	420,000	1,000,000	540,000	100,000	570,000	7,440,000	1,000,000	390,000	1,000,000
Shear Modulus, Gem (ksi)		0.8	0.3	0.4	1.2	2.7	1.5	0.3	1.6	11.6	2.7	1.1	2.7
Vertical Failure Shear Stress (psf)		573	217	283	813	3021	1037	204	1084	1488	2598	754	1979
<b>Soil Properties for Torsional Soil Model:</b>													
Torsional Soil Model		Hyperbolic	Hyperbolic	Hyperbolic	Hyperbolic	Hyperbolic	Hyperbolic	Hyperbolic	Hyperbolic	Hyperbolic	Hyperbolic	Hyperbolic	Hyperbolic
Torsional Shear Stress (psf)		573	217	283	813	3021	1037	204	1084	1488	2598	754	1979
<b>Soil Properties for Tip Soil Model:</b>													
Tip Soil Model		1 (McVay)	1 (McVay)	1 (McVay)	1 (McVay)	1 (McVay)	1 (McVay)	1 (McVay)	1 (McVay)	1 (McVay)	1 (McVay)	1 (McVay)	2 (McVay)
Shear Modulus, G (ksi)		0.84	0.33	0.43	1.19	2.67	1.52	0.31	1.58	11.58	2.67	1.10	2.67
Poisson's Ratio, $\mu$		0.25	0.2	0.2	0.25	0.3	0.25	0.2	0.25	1.23	0.3	0.25	0.3
Axial Bearing Failure Load, Qult (kip), 18" Pile		217	82	107	308	1145	393	77	411	1205	985	286	750
Axial Bearing Failure Load, Qult (kip), 24" Pile		386	146	190	548	2035	698	137	730	2143	1751	508	1333
<b>Table 1. P-Y Curves for Rock</b>													
Unconfined Compressive Strength, $q_u$ (psf)										50000			
Undrained Strength, $S_u$ (psi) =										174			

**APPENDIX – I**

**SHEET PILE WALL SOIL PARAMETERS**

**TABLE - I1**

**SOIL PARAMETERS [Sheet Pile Wall Structures]**

**Project Name: PD&E Study - SW 10th Street From Powerline Road to Military Trail**

Boring Number	Depth (feet)	Elevation (feet)	SPT "N" Range (Auto)	SPT "N" Ave. (Auto)	Soil Classification	Approximate Soil Unit Weight (pcf)		Soil Angle of Friction (degrees)	Undrained Shear Strength, c (psf)	Earth Pressure Coefficient		Soil Modulus k-value (pci)	
						$\gamma_{sat}$ (pcf)	$\gamma_{submerged}$ (pcf)*			Active ( $k_a$ )	Passive ( $k_p$ )		
B-101	0-1	11.1 ~ 10.1	15	15.0	SP-SM	110	47.6	33	0	0.295	3.39	50	
	1-15	10.1 ~ -3.9	21-83	34.4	LS (Modeled as Sandy Gravel)	135	72.6	40	0	0.217	4.60	120	
	15-20	-3.9 ~ -8.9	12-20	16.0	SP-SM	110	47.6	33	0	0.295	3.39	55	
	20-35	-8.9 ~ -23.9	14-62	31.2	SP	120	57.6	38	0	0.238	4.20	105	
	35-45	-23.9 ~ -33.9	39-70	55.8	SP, SP-SM	125	62.6	38	0	0.238	4.20	125	
	45-53	-33.9 ~ -41.9	30-51	43.0	SP, SP-SM	125	62.6	38	0	0.238	4.20	125	
	53-63	-41.9 ~ -51.9	30-73	55.0	SP-SM	125	62.6	38	0	0.238	4.20	125	
	63-70	-51.9 ~ -58.9	43-62	50.7	SP, SP-SM	125	62.6	38	0	0.238	4.20	125	
	70-95	-58.9 ~ -83.9	29-85	54.9	SP-SM	125	62.6	38	0	0.238	4.20	125	
95-100	-83.9 ~ -88.9	60-71	62.5	SP-SM+LS (Modeled as Sandy Gravel)	130	67.6	40	0	0.217	4.60	125		
<b>B-101</b>	<b>0-100' Recommended Values: <math>N_{auto}=45</math>, <math>\gamma_{sat}=125</math>pcf, <math>\gamma_{sub}=62.6</math>pcf, <math>\Phi=38^\circ</math>, <math>K_a=0.238</math>, <math>K_p=4.204</math>, <math>K_o=0.384</math>, <math>k=115</math>pci, <math>\mu=0.6</math> (for concrete), <math>\mu=0.3</math> (for Steel)</b>												
B-201	0-4	13.6 ~ 9.6	21-28	26.0	SP, SP-SM	120	57.6	36	0	0.260	3.85	90	
	4-6	9.6 ~ 7.6	6-8	0.8	OL (Muck)	100	37.6	24	0	0	0	0	
	6-12	7.6 ~ 1.6	10-41	8.0	SP, SP-SM	105	42.6	30	0	0.333	3.00	25	
	12-20	1.6 ~ -6.4	16	28.0	SP-SM	120	57.6	37	0	0.249	4.02	95	
	20-23	-6.4 ~ -9.4	30-78	16.0	SP	110	47.6	33	0	0.295	3.39	55	
	23-45	-9.4 ~ -31.4	15-29	54.1	SP	125	62.6	38	0	0.238	4.20	125	
	45-50	-31.4 ~ -36.4	31-78	22.0	SP-SM	115	52.6	35	0	0.271	3.69	75	
	50-70	-36.4 ~ -56.4	38-45	53.9	SP-SM	125	62.6	38	0	0.238	4.20	125	
	70-75	-56.4 ~ -61.4	37-68	41.5	SP, SP-SM	125	62.6	38	0	0.238	4.20	125	
	75-90	-61.4 ~ -76.4	37-68	55.5	SP-SM	125	62.6	38	0	0.238	4.20	125	
90-93	-76.4 ~ -79.4	37-68	24.0	SP	115	52.6	35	0	0.271	3.69	85		
93-100	-79.4 ~ -86.4	24-50	45.0	SP-SM	125	62.6	38	0	0.238	4.20	125		
<b>B-201</b>	<b>0-100' Recommended Values: <math>N_{auto}=42</math>, <math>\gamma_{sat}=120</math>pcf, <math>\gamma_{sub}=57.6</math>pcf, <math>\Phi=36^\circ</math>, <math>K_a=0.260</math>, <math>K_p=3.852</math>, <math>K_o=0.412</math>, <math>k=105</math>pci, <math>\mu=0.6</math> (for concrete), <math>\mu=0.3</math> (for Steel)</b>												
B-301	0-2	13.3 ~ 11.3	16	16.0	SP, SP-SM	110	47.6	33	0	0.295	3.39	55	
	2-6	11.3 ~ 7.3	28-29	29.0	SM	120	57.6	35	0	0.271	3.69	100	
	6-8	7.3 ~ 5.3	28	28.0	SM, SP-SM	120	57.6	37	0	0.249	4.02	95	
	8-10	5.3 ~ 3.3	19	19.0	LS (Modeled as Sandy Gravel)	125	62.6	39	0	0.228	4.40	65	
	10-13.5	3.3 ~ -0.2	5-15	10.0	SM, SP-SM	110	47.6	31	0	0.320	3.12	35	
	14-18	-0.2 ~ -4.7	12-19	15.5	SP, SP-SM	110	47.6	33	0	0.295	3.39	50	
	18-45	-4.7 ~ -31.7	20-69	41.8	SP	125	62.6	38	0	0.238	4.20	125	
	45-50	-31.7 ~ -36.7	5-13	9.0	SC	110	47.6	31	0	0.320	3.12	30	
	50-85	-36.7 ~ -71.7	5-13	49.1	SP-SM	125	62.6	38	0	0.238	4.20	125	
85-90	-71.7 ~ -76.7	26-69	67.0	SP, SP-SM	125	62.6	38	0	0.238	4.20	125		
90-100	-76.7 ~ -86.7	25-74	34.8	SP-SM	125	62.6	38	0	0.238	4.20	125		
<b>B-301</b>	<b>0-100' Recommended Values: <math>N_{auto}=40</math>, <math>\gamma_{sat}=120</math>pcf, <math>\gamma_{sub}=57.6</math>pcf, <math>\Phi=36^\circ</math>, <math>K_a=0.260</math>, <math>K_p=3.852</math>, <math>K_o=0.412</math>, <math>k=105</math>pci, <math>\mu=0.6</math> (for concrete), <math>\mu=0.3</math> (for Steel)</b>												

**TABLE - I1**

**SOIL PARAMETERS [Sheet Pile Wall Structures]**

**Project Name: PD&E Study - SW 10th Street From Powerline Road to Military Trail**

Boring Number	Depth (feet)	Elevation (feet)	SPT "N" Range (Auto)	SPT "N" Ave. (Auto)	Soil Classification	Approximate Soil Unit Weight (pcf)		Soil Angle of Friction (degrees)	Undrained Shear Strength, c (psf)	Earth Pressure Coefficient		Soil Modulus k-value (pci)	
						$\gamma_{sat}$ (pcf)	$\gamma_{submerged}$ (pcf)*			Active ( $k_a$ )	Passive ( $k_p$ )		
B-401	0-6	12.3 ~ 6.3	4-13	9.0	SP, SP-SM	110	47.6	31	0	0.320	3.12	30	
	6-8	6.3 ~ 4.3	20	20.0	LS (Modeled as Sandy Gravel)	125	62.6	39	0	0.228	4.40	70	
	8-10	4.3 ~ 2.3	24	24.0	SP-SM	115	52.6	35	0	0.271	3.69	85	
	10-12	2.3 ~ 0.3	15	15.0	LS (Modeled as Sandy Gravel)	120	57.6	38	0	0.238	4.20	50	
	12-48	0.3 ~ -35.7	13-54	26.8	SP	120	57.6	36	0	0.260	3.85	90	
	48-53	-35.7 ~ -40.7	21-48	43.7	SP	125	62.6	38	0	0.238	4.20	125	
	53-75	-40.7 ~ -62.7	36-68	34.5	SP, SP-SM	125	62.6	38	0	0.238	4.20	120	
	75-80	-62.7 ~ -67.7	18-26	49.1	SP-SM	125	62.6	38	0	0.238	4.20	125	
	80-80	-67.7 ~ -67.7	18-26	22.0	SM, SP-SM	115	52.6	35	0	0.271	3.69	75	
	80-83	-67.7 ~ -70.7	59	60.0	LS (Modeled as Sandy Gravel)	135	72.6	40	0	0.217	4.60	125	
83-100	-70.7 ~ -87.7	33-61	50.7	SP, SP-SM	125	62.6	38	0	0.238	4.20	125		
<b>B-401</b>	<b>0-100' Recommended Values: Nauto=34, <math>\gamma_{sat}</math>=120pcf, <math>\gamma_{sub}</math>=57.6pcf, <math>\Phi</math>=36°, <math>K_a</math>=0.260, <math>K_p</math>=3.852, <math>K_o</math>=0.412, <math>k</math>=100pci, <math>\mu</math>=0.6 (for concrete), <math>\mu</math>=0.3 (for Steel)</b>												
B-501	0-4	12.9 ~ 8.9	7-9	8.0	SP, SP-SM	105	42.6	30	0	0.333	3.00	30	
	4-8	8.9 ~ 4.9	12-20	16.0	LS (Modeled as Sandy Gravel)	120	57.6	38	0	0.238	4.20	55	
	8-12	4.9 ~ 0.9	22-30	26.0	SP-SM	120	57.6	36	0	0.260	3.85	90	
	12-18	0.9 ~ -5.1	14-16	14.7	SP	110	47.6	33	0	0.295	3.39	50	
	18-25	-5.1 ~ -12.1	20-32	27.3	SP	120	57.6	36	0	0.260	3.85	95	
	25-30	-12.1 ~ -17.1	21-36	28.5	SP, SP-SM	120	57.6	37	0	0.249	4.02	100	
	30-55	-17.1 ~ -42.1	29-66	49.4	SP	125	62.6	38	0	0.238	4.20	125	
	55-78	-42.1 ~ -65.1	50-71	61.4	SP-SM	125	62.6	38	0	0.238	4.20	125	
	78-80	-65.1 ~ -67.1	73	73.0	SP	125	62.6	38	0	0.238	4.20	125	
	80-83	-67.1 ~ -70.1	38	38.0	SP-SM	125	62.6	38	0	0.238	4.20	125	
	83-90	-70.1 ~ -77.1	33-48	41.0	SP	125	62.6	38	0	0.238	4.20	125	
80-100	-67.1 ~ -87.1	50-82	63.5	SP, SP-SM	125	62.6	38	0	0.238	4.20	125		
<b>B-501</b>	<b>0-100' Recommended Values: Nauto=45, <math>\gamma_{sat}</math>=120pcf, <math>\gamma_{sub}</math>=57.6pcf, <math>\Phi</math>=37°, <math>K_a</math>=0.249, <math>K_p</math>=4.023, <math>K_o</math>=0.398, <math>k</math>=110pci, <math>\mu</math>=0.6 (for concrete), <math>\mu</math>=0.3 (for Steel)</b>												
B-601	0-6	13.0 ~ 7.0	13-30	24.3	SP	120	57.6	36	0	0.260	3.85	85	
	6-15	7.0 ~ -2.0	3-10	4.6	SP	105	42.6	29	0	0.347	2.88	15	
	15-18	-2.0 ~ -5.0	6-20	6.0	SM	105	42.6	30	0	0.333	3.00	20	
	18-28	-5.0 ~ -15.0	6-20	17.3	SP, SP-SM	115	52.6	33	0	0.295	3.39	60	
	28-50	-15.0 ~ -37.0	40-89	64.1	SP	125	62.6	38	0	0.238	4.20	125	
	50-55	-37.0 ~ -42.0	18-26	22.0	SP,SP-SM	115	52.6	35	0	0.271	3.69	75	
	55-63	-42.0 ~ -50.0	2-9	4.3	SP,SP-SM	105	42.6	29	0	0.347	2.88	15	
	63-67	-50.0 ~ -54.0	23	23.0	SP-SM	115	52.6	35	0	0.271	3.69	80	
	67-75	-54.0 ~ -62.0	60	60.0	LS (Modeled as Sandy Gravel)	135	72.6	40	0	0.217	4.60	125	
	75-93	-62.0 ~ -80.0	36-60	55.1	SP-SM	125	62.6	38	0	0.238	4.20	125	
	93-98	-80.0 ~ -85.0	12-18	16.0	SP,SP-SM	110	47.6	33	0	0.295	3.39	55	
98-100	-85.0 ~ -87.0	12-42	42.0	SP,SP-SM	125	62.6	38	0	0.238	4.20	125		
<b>B-601</b>	<b>0-100' Recommended Values: Nauto=35, <math>\gamma_{sat}</math>=115pcf, <math>\gamma_{sub}</math>=52.6pcf, <math>\Phi</math>=35°, <math>K_a</math>=0.271, <math>K_p</math>=3.690, <math>K_o</math>=0.426, <math>k</math>=85pci, <math>\mu</math>=0.6 (for concrete), <math>\mu</math>=0.3 (for Steel)</b>												