

Selection Guide | VACON® NXP Liquid Cooled | 90 kW – 5.3 MW

Robust, silent and space-saving control for all drive needs in demanding applications



Up to

25%

savings in total
life cycle costs
compared to air
cooled solutions



Quiet. Compact. Cool.

VACON® NXP Liquid Cooled AC drives are the ultimate in space-saving, high power density AC drives. These drives are tried and tested over decades with proven reliability in thousands of installations, perfectly optimizing performance and efficiency in any motor drive or power conversion system.

The robust, modular design makes VACON® NXP a suitable platform for demanding applications. Meet any need, with power range from 90 kW to 5.3 MW, 380-690 VAC supply voltage range, and a comprehensive range of cooling options.

Power packed

As no air ducts are required, liquid cooled drives are extremely compact and suitable for a wide variety of heavy industries with harsh operating conditions such as marine & offshore, pulp & paper, renewable energy and mining & metal.

Thanks to the high degree of protection achieved with these drives, they can be installed almost anywhere in the plant or vessel. This reduces the load on the air-conditioning system in the electrical rooms – an important cost and space consideration in many retrofit applications. And since liquid

cooled drives do not require large cooling fans, they are also among the most silent AC drives on the market.

We are committed to providing you with the ultimate in high power density. VACON® NXP liquid cooled products have one of the best power/size ratios on the market. For example, our compact 12 pulse, 1.5 MW drive includes a built-in rectifier, inverter and optional brake all in the same package, and all this can be mounted in an 800 mm wide enclosure.

Our liquid cooled range offers the ultimate in motor control, for both induction and permanent magnet

motors, gearless drive applications and paralleling solutions for high power motors.

Certification and grid expertise

Our VACON® NXP liquid cooled portfolio fulfills all relevant international standards and global requirements, including marine, safety and EMC & Harmonics approvals. VACON® NXP liquid cooled AC drives can be used in regenerative energy and smart grid applications, which ensures customers can effectively monitor and control energy use and costs.

Typical segments

- Marine and offshore
- Renewable energy
- Mining and metals
- Water and wastewater
- Energy management
- Pulp and paper
- Oil and gas
- Machine building
- Energy storage
- Power-to-X

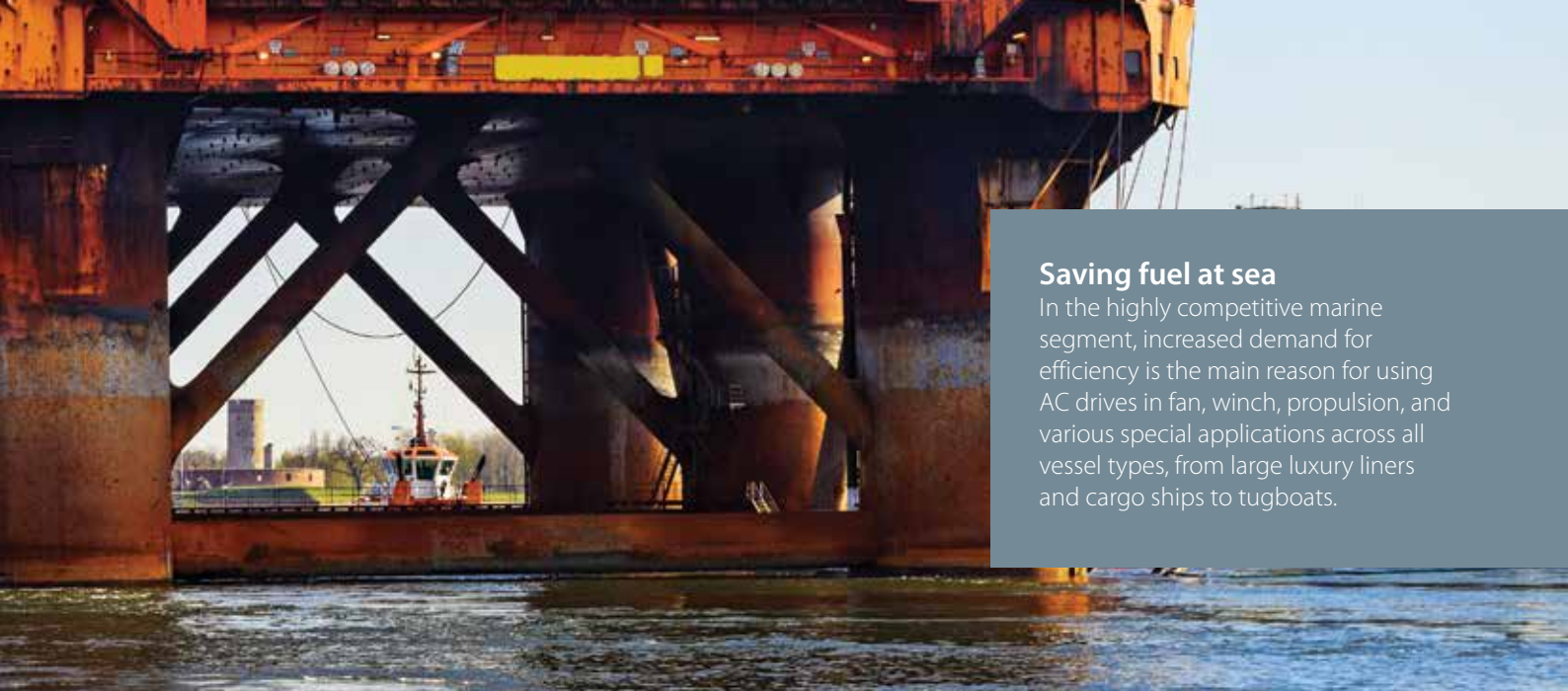

Saving fuel at sea

In the highly competitive marine segment, increased demand for efficiency is the main reason for using AC drives in fan, winch, propulsion, and various special applications across all vessel types, from large luxury liners and cargo ships to tugboats.

What's in it for you



Minimizes investment and operation costs



Saves floor space and infrastructure needs



Saves time and money



Compact and easy to install



Virtually silent operation



Benefits

- Compact size and high power density
- No large air conditioning systems needed as state-of-the-art liquid cooled AC drive design allows heat loss to be transferred to the most convenient place with no need for vast amounts of filtered air
- Easy to adapt to various uses due to ready-to-use applications
- Flexible and scalable system for additional I/O, fieldbus and functional safety boards with five built-in expansion slots
- Silent operation due to eliminated need for large cooling fans
- Use VACON® NXP in dedicated applications to perfectly optimize electric and hybrid systems, including DC/DC Converter, Grid Converter and DCGuard.
- Industrial IoT-ready
- Grid code compliance for smart grid applications, such as energy storage

Typical applications

- Propeller and thrusters systems
- Compressors
- Wind turbines
- Extruders
- Pumps and fans
- Test bench systems
- Cranes and winch systems
- Power conversion systems
- Production lines
- Oil rigs
- Crushers
- Conveyors
- Battery energy storage
- Shore supply
- Wind power
- Vessel charging
- Fast DC selectivity in common DC power systems for marine (DCGuard)



The liquid way to stay cool

VACON® NXP Liquid Cooled AC drives have been pioneering for more than a decade in demanding industries with a proven track record of highly reliable products. We have successfully mitigated the common risks of leakage and reliability in our product design.

Climate considerations

When comparing cooling technology solutions, it is important to understand the effects on the infrastructure of the electrical room, and the room's requirements. Additional comparison parameters are the geographical location, relevant industry and process.

In warm climates it is extremely important to observe the amount of heat load transferred to the electrical room because of its indirect effect on electrical energy consumption.

The type-tested switchgears standard EN 60439-1 specifies that the electrical room's 24-hour average temperature

should be below +35 °C and the maximum temporary temperature cannot exceed +40 °C. As a result, the cooling system in electrical rooms is typically comprised of air conditioning chillers, which are dimensioned according to the maximum heat load, the temperature inside the electrical room and the maximum temperature outdoors. The typical electrical energy consumption of air conditioning is approx. 25-33% of the cooling power.

The higher the power, the greater the savings

In many cases liquid cooled drives are the most cost-effective option, simply due to the fact that there is no need for

additional air conditioning capacity or extra ventilation for the areas in which they are used. The related savings enable shorter payback times and the higher the power, the greater the savings potential.

The continuously growing cost of energy certainly supports a wider use of liquid cooled drives technology, and the number of installations is growing rapidly.



A driving force in wind energy

VACON® AC drives are designed to provide proven performance in demanding environments. Our drives are serving the wind energy industry globally with a combined installed capacity of almost one gigawatt.

Exclusively designed for liquid cooling

Many other liquid cooled drives on the market are based on modifications of an air cooled drive, rather than exclusively designed for the purpose. The VACON® NXP Liquid Cooled dissipates only 0.1 -0.15% of its heat losses to air.* A state-of-the-art cooling heatsink enables the cooling efficiency of the components to be higher than ever.

Cooling technology advantages

Up to **25%** savings in total life cycle costs compared to air cooled solutions

20dBA

less noise than air cooled drive



25% smaller unit can deliver the same or better performance

*400 kW, 690 VAC liquid cooled drive

Extensive portfolio of liquid cooled drive modules

Significant energy savings and optimal performance can be achieved with the right configuration. Liquid cooled AC drives can be used in a multitude of combinations – from a single dedicated frequency converter to large-scale Common DC bus systems.

Dedicated frequency converter

The VACON® NXP Liquid Cooled drives are available as 6- or 12-pulse frequency converters. In addition, our largest unit, the CH74, can also be used as an 18-pulse converter. The AC drive consists of a power unit, control unit and possibly one or more input chokes.

An internal brake chopper is available as an option for enclosure sizes CH72 (6-pulse only) and CH74. For all other enclosure sizes, the brake chopper is available as an option installed externally.

Front-end units

The front-end units convert a mains AC voltage and current into a DC voltage and current. The power is transferred from the mains to a common DC bus and, in certain cases, vice versa.

Active front-end (AFE)

The AFE unit is a bi-directional (regenerative) power converter (supply unit) for the front-end of a common liquid cooled DC bus drive line-up. An external LCL filter is used at the input. This unit is suitable for applications where a low level of mains harmonics and high power factor are required. AFE units can operate in parallel to provide increased power and/or redundancy without any drive to drive communication between the units. AFE units can also be connected to the same fieldbus with inverters, and controlled and monitored via fieldbus. Fuses, LCL filters, pre-charging rectifiers and resistors can be specified and ordered separately.

The LCL filter guarantees that harmonics are not an issue in any network. With a power factor > 0.99 and low harmonics, the supply chain transformers, generators, etc. can be sized very accurately without reserving margins for the reactive power. This can

mean a saving of 10% in supply chain investments. Likewise the payback time is faster as regenerative energy is fed back to the grid.

Use the AFE hardware and Grid Converter application for more advanced AC/DC power conversion applications, such as energy storage or micro grid control.

Non-regenerative front-end (NFE)

The NFE unit is an unidirectional (motoring) power converter for the front-end of a common DC bus drive line-up. The NFE is a device that operates as a diode bridge. A dedicated external choke is used at the input. This unit is suitable as a 6 or 12 pulse rectifying device when a normal level of harmonics is accepted and no regeneration to the mains is required. NFE units can be paralleled to increase power without any drive to drive communication between the units.



Inverter unit (INU)

The INU is a bidirectional DC-fed power inverter for the supply and control of AC motors. The INU is supplied from a common DC bus drive line-up. A charging circuit is needed in case a connection to a live DC bus is required. The DC-side charging circuit is external for inverter types.

Pre-charging resistors and switches or fuses are not included in an INU delivery and must be specified and ordered separately.

Brake chopper unit (BCU)

The BCU is a unidirectional power converter for the supply of excessive energy from a common DC bus drive line-up or big AC drive to resistors where the energy is dissipated as heat. External resistors are required. However, resistors or fuses are not included in a BCU delivery and can be specified and ordered separately.

BCU's improve a drive's dynamic performance in a regenerative operating point and protect common DC bus voltage level from overvoltage. In some cases they also reduce the need for AFE investments.

A regenerative common DC bus system

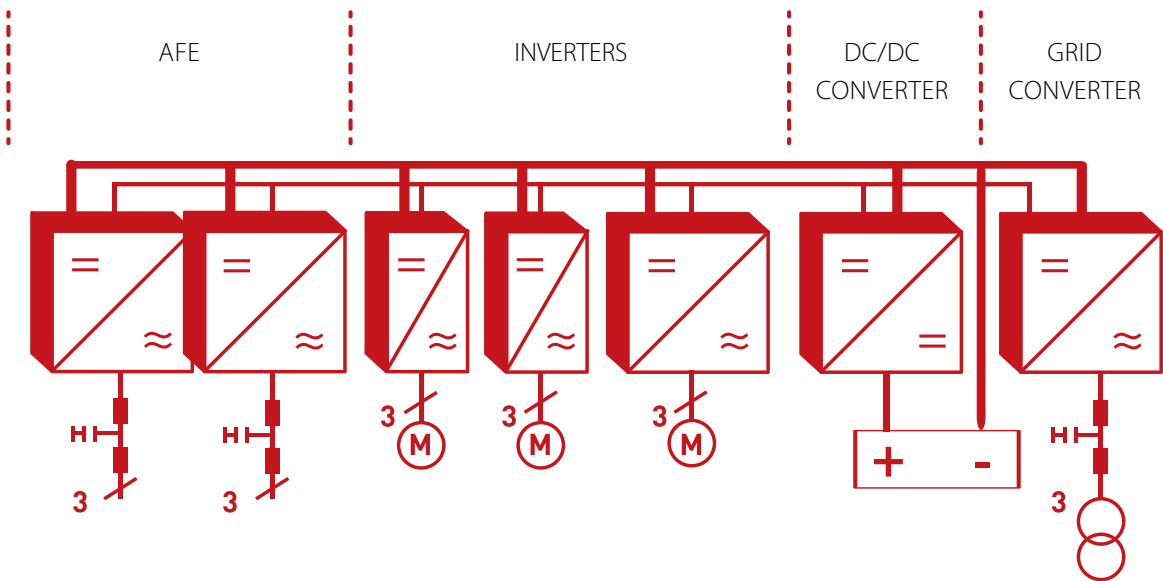

A non-regenerative common DC bus system

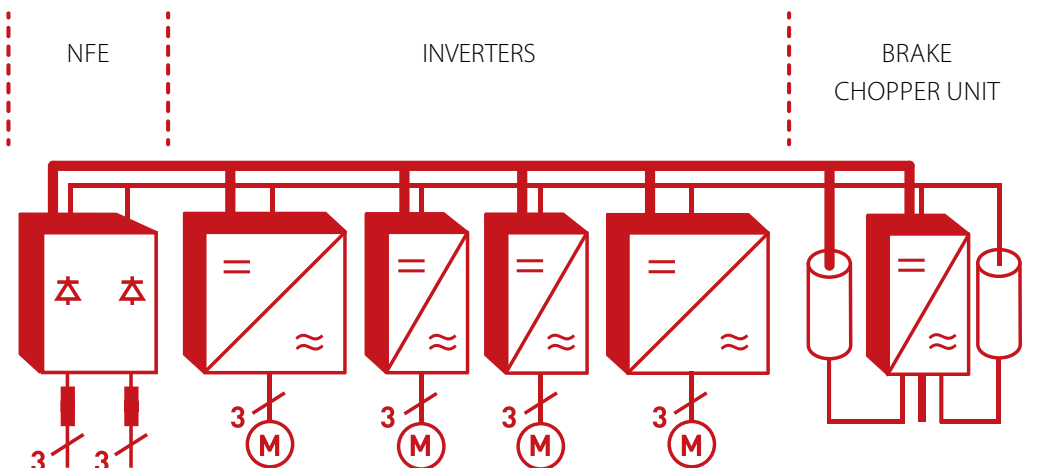

DC/DC Converter (DC/DC)

The DC/DC converter is a bi-directional power converter which can flexibly convert power between different levels of DC-voltage. The DC/DC converter is based on the same inverter hardware and filter chokes, together with an advanced power conversion application.

A typical use case is to connect batteries or other energy storage to a common DC-link drive system. The advantage of the DC/DC converter is its wide input voltage range which enables connection of any battery in the system. Bi-directional power conversion enables peak shaving in hybrid propulsion systems onboard marine vessels.

Discover more [↗](#)

VACON® NXP Grid Converter

This dedicated application provides advanced bi-directional AC/DC power conversion, with advanced load sharing and droop control. Ideal for battery energy storage, micro grid forming, black-out prevention, shore supply, shaft generator and marine energy management applications.

Discover more: VACON® NXP Grid Converter Selection Guide [↗](#)

Benefits

- Fuel savings with hybridization and peak shaving
- Flexible power management with multiple control and reference options
- Patented independent paralleling, eliminating the need for drive-to-drive communication

VACON® DCGuard

This semiconductor protection device enables fast disconnection and full selectivity between DC grids for all VACON® NXP series drives.

VACON® NXP DCGuard™ maintains the stability of the DC grid by detecting and cutting off any faulty DC currents, fast. It isolates the faulty part of the system within 5 microseconds, protecting the surrounding equipment and ensuring uninterrupted operation.

Discover more: VACON® NXP DCGuard™ fact sheet [↗](#)



Dedicated applications

Intelligent system interfaces for heavy industries

VACON® System Interface Application (SIA) provides a flexible and extensive interface for use in coordinated drives, which have an overriding control system. VACON® SIA utilizes the most advanced functions of our VACON® NXP motor control software and is suitable for demanding drive systems such as those in the pulp & paper and metal industries, processing lines as well as many other standard applications.

Benefits

- Power extension with VACON® DriveSynch
- Master Follower functions for torque sharing
- Freely configurable PLC logic

Dedicated marine application

Our Marine Application provides flexibility and performance across all marine segment applications. VACON® Liquid Cooled drives bring many benefits to this segment in particular such as energy efficiency, improved process availability due to high redundancy, better process quality and control, as well as silent operation and substantially reduced emissions.

Benefits

- Black-out prevention logic
- Cost savings in electric propulsion system
- State-of-the-art load sharing and load drooping

High power and improved redundancy

VACON® DriveSynch is a patented control concept for running standard drives in parallel to control high-power AC motors or increase the redundancy of a system. This concept suits high power single or multiple winding motors, typically above 1 MW. High power AC drives above 5 MW can be built using standard drive components.

Benefits

- System redundancy is higher than in a conventional drive because each unit can run independently
- Identical units and standard modules reduce overall costs by reducing need for spares and specialist skills in engineering, installation, commissioning and maintenance

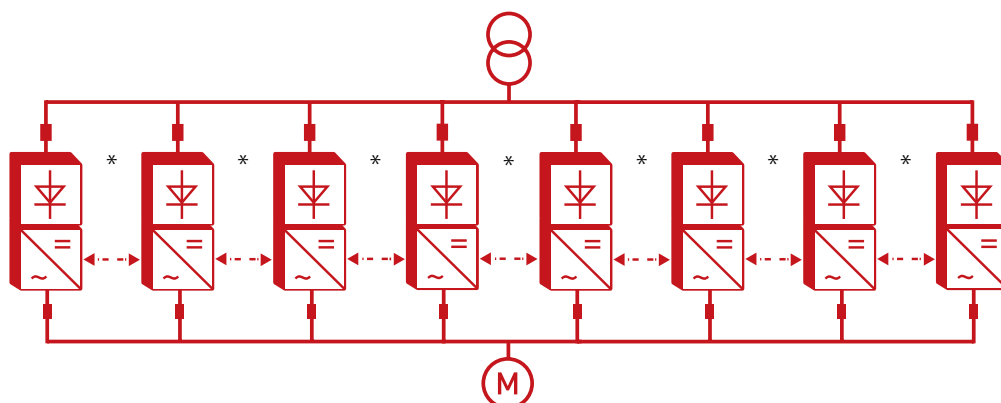

* Fiber optic link



VACON® NXP Liquid Cooled Enclosed drive

The low harmonic and regenerative VACON® NXP Liquid Cooled Enclosed Drives range has been developed especially with ease of use in mind. Packed full of features, these fully standardized, compact and robust AC drives with a full power range help maximize the utilization of space while minimizing overall costs.

These enclosed drives are the ideal solution for applications and locations where space is at a premium. The sturdy cabinet makes it ideal for harsh environments. See technical ratings and dimensions for further information.

High power density

VACON® NXP Liquid Cooled Enclosed Drive can be used with AC motors in power sizes from 800–1550 kW. However, using the patented VACON® DriveSynch control concept, four enclosed drives can be run in parallel taking the power range up to an outstanding 5 MW.

Fast installation

VACON® NXP Liquid Cooled Enclosed Drives are pre-designed and engineered. That means they're good to go as soon as you receive them. Simply connect to the cooling system and the power and motor supplies. Being liquid cooled, the product is virtually silent and you'll have greater flexibility with where to put it. You don't have to worry about leaving space for air flow, and you'll save on air-conditioning energy costs.

Packed with cool performance

The enclosed unit comes equipped with the same advantages of efficient and quiet cooling performance as the

rest of the VACON® NXP product family. When we say that this product is liquid cooled, we are talking about the entire product. The modules and also all its main components, such as LCL and dU/dt filters, are liquid cooled as standard. The reliable heat exchanger is offered as an option to provide a worry-free life cycle for the product.

You can also enjoy the same fast commissioning with the aid of the easy to use Startup Wizard. The slide-out racks provide easy access for maintenance. Leakage indicators alert the operator to any potential issues in the cooling system.



A solution for all your needs

We provide enclosed solutions to any segment and application. And while we focus on the drives, you can concentrate on your performance.

Eliminate production disturbances

Continuous energy supply is important to ensure your processes are optimized. Distortions in the energy supply, caused by the presence of harmonic currents and voltages, can trigger equipment disturbances and create energy losses. VACON® front-end drives with low harmonic technology maintain a constant energy supply and eliminate the disruption harmonics can cause to production.

Advanced monitoring

The VACON® NXP Liquid Cooled Enclosed Drive's built-in Fieldbus interface communicates effectively with your process automation system. This reduces the need for cabling and gives you increased monitoring and control of process equipment.

Safety is a given

One of the most visible features of the enclosed product is the integrated main breaker switch. This simple on/off switch quickly and easily disconnects and activates the power supply as and when necessary.

Benefits

- Saves floor space and infrastructure needs
- Saves time and money in installation
- Faster and easier servicing
- Improves safety
- Enhances reliability
- Low harmonic input
- Virtually silent operation

Key features

- Optimized design with power range up to 5 MW
- All standard protection components included
- Silent design with no large cooling fans needed
- Slide-out feature
- Leakage detector
- AFE technology
- Pre-engineered solution with all-liquid-cooled design (including filters)
- Cooling system monitoring

Multiple options

VACON® NXP control

High-performance control platform for all demanding drive applications

- Excellent processing and calculation power
- Supports induction and permanent magnet motors
- Maximum utilization of control features over wide power and voltage range
- Built-in PLC functionality allows you to customize the functionality of the converter. A programmed VACON® NXP drive can even replace a simple external PLC.
- Same control interface for any VACON®NXP drive from 0.5 kW to more than 5.3 MW
- Same control interface and hardware for all applications such as motor drives, Grid Converter and DC/DC Converter.
- Integration of customer-specific functionalities
- Bumpless transfer between open loop and closed loop control

Option boards

VACON® NXP control provides exceptional modularity

- 5 plug-in extension slots
- Fieldbus boards
- Encoder boards
- IO boards
- Easy plug-in without need to remove other components

Fieldbus options

Easy integration with plant automation systems

- PROFIBUS DP
- DeviceNet™
- Modbus RTU
- CANopen

Ethernet connectivity

Ethernet connectivity allows remote drive access for monitoring, configuring and troubleshooting

- Modbus/TCP
- Modbus UDP
- PROFINET IO
- EtherNet/IP™
- EtherCAT





Functional safety and reliability SIL3, PI e, Cat. 4

Safe Torque Off (STO)

Available for all VACON® NXP drives

- Prevents drive from generating torque on motor shaft
- Prevents unintentional start-ups
- Corresponds to an uncontrolled stop
- In accordance with stop category 0, EN60204-1

Safe Stop 1 (SS1)

Available for all VACON® NXP drives

- Initiates motor deceleration
- Initiates STO function after application specific time delay
- Corresponds to an uncontrolled stop
- In accordance with stop category 1, EN60204-1

Advanced Safety Options

Support more safety functions

Safe Stop functions::

- STO – Safe Torque Off
- SS1 – Safe Stop 1
- SS2 – Safe Stop 2
- SBC – Safe Brake Control
- SQS – Safe Quick Stop

Safe Speed functions:

- SLS – Safely-limited Speed
- SSM – Safe Speed Monitor
- SSR – Safe Speed Range
- SMS – Safe Maximum Speed

Conformal coating

- Conformal coated circuit boards as standard
- Improved performance
- Increased durability
- Reliable protection against dust and moisture
- Extended lifetime of drive and components

ATEX- certified thermistor input

Especially designed for motor temperature supervision

- Stops feeding energy to motor in case of over-heating
- Certified and compliant with the European ATEX directive 2014/34/EU

Commissioning made easy

User-friendly keypad

- Removable panel with plug-in connection
- Graphical and text keypad with multiple language support
- Text display multi-monitoring function
- Parameter backup and copy function with the panel's internal memory
- The startup wizard ensures a hassle-free set up

Software modularity

All-in-One application package

- Seven built-in software applications

Several segment-specific and advanced applications such as:

- System Interface
- Marine
- DC/DC converter
- Grid converter
- and much more

VACON® NCDrive

Includes handy Datalogger function

- Track failure modes & perform root cause analysis
- Monitor your process with a graphical view

Communicates with drive via:

- RS232
- Ethernet TCP/IP
- CAN (fast multiple drive monitoring)
- CAN@Net (remote monitoring)

Independent paralleling

Our patented independent paralleling configuration of front-end (AFE) units:

- Offer high redundancy
- Eliminate need for drive-to-drive communication
- Enables automatic load sharing



Intelligent
 monitoring and
 maintenance
 functions embedded
 in the drive

Achieve maximum availability of your system – with **condition-based monitoring**

Equipped with intelligent monitoring functionality, the VACON® drive enables you to use the drive as a smart sensor. It can monitor the condition of your motor and application in real time, detect when current operation status is drifting away from the defined limits, and alert the operator to changes before they impact your process.

Condition-based monitoring

During installation, the condition-based monitoring (CBM) function establishes a baseline defining the recorded operation conditions for each monitoring element of the system, and threshold values are defined. During operation, CBM monitors motor stator windings, sensors and load-envelope conditions, all adjusted according to the actual speed of the system. When actual operation conditions exceed the defined limits, CBM sends alerts to notify personnel to take action.

The CBM function complies with relevant standards and guidelines, such as

- ISO 13373 standard for Condition Monitoring and Diagnostics of Machines
- VDMA 24582 guideline for condition monitoring
- ISO 10816/20186 standards for measurement and evaluation of mechanical vibration.

The unique embedded functionality means that the VACON® drive performs CBM monitoring inside the drive. When required, activate cloud or PLC connectivity to enable monitoring of numerous conditions or to send alerts when required.

Feature	Benefit
Condition-based monitoring functionality embedded in the drive	<ul style="list-style-type: none"> - No cloud connection required: high security level and no subscription fee - Reduced installation costs, since no external controller or PLC required to generate the CBM observation and notification - Documentation of system stability
Motor-stator-winding monitoring	<ul style="list-style-type: none"> - More uptime due to early detection and action on faults in the motor stator winding, before the fault develops into a crippling failure and unscheduled operational stop
Load-envelope monitoring Application baseline (run / online)	<ul style="list-style-type: none"> - Process optimization/maximized efficiency thanks to ability to compare actual system performance with baseline data and trigger maintenance actions
Sensor application monitoring (external) Application baseline (run / online)	<ul style="list-style-type: none"> - More uptime due to early detection and action on signs of mechanical misalignment, wear-out and looseness - Higher precision since sensor monitoring relates to motor speed

 [Read the white paper here](#)

Motor-stator-winding condition monitoring

Motor-winding failures do not occur suddenly; they develop over time. They start with a small single-turn shortcircuit fault which causes additional heating. The damage then spreads to a level where the overcurrent protection activates, and the operation stops, causing unwanted downtime.

The unique winding condition monitoring function allows you to shift from reactively performing corrective maintenance of faulty motors, to proactively detecting motor isolation faults at an early stage and dealing with them during scheduled maintenance. In this way, you can avoid unwanted and potentially costly machine downtime caused by 'burned' motors.

Sensor selection

One condition-based monitoring sensor input is defined by the analogue inputs. Using condition-based monitoring parameterization, you can scale the inputs to monitor the sensor signals where the vibration sensor is the most commonly used sensor type. Bearing, pressure and flow sensors could also be selected, provided that sensor selection is related to the drive speed of the system.

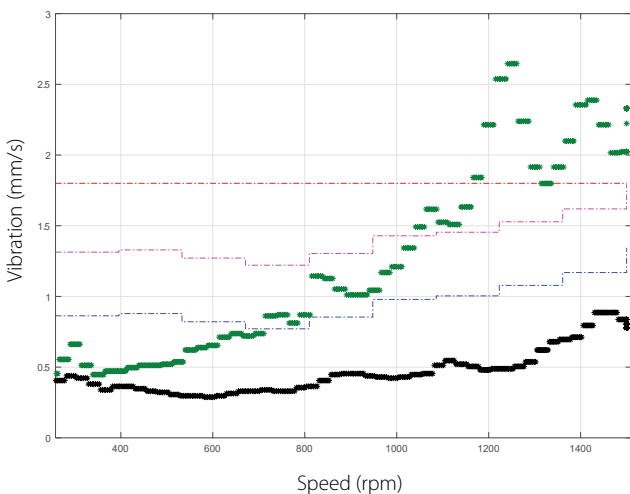

Application example showing changes in vibration signal

- Baseline data
- Faulty data
- - - Alarm Level
- - - Warning Stage 2 Level
- - - Warning Stage 1 Level

Mechanical-vibration monitoring

Avoid accelerated wear of the mechanical parts of a drive system by using CBM together with an external vibration transducer, to monitor the vibration level in a motor or application, related to the actual speed or rotation of the system.

Vibration monitoring is performed using standardized methods and threshold levels given in standards such as ISO13373 for Condition Monitoring and Diagnostics of Machines or ISO10816/20816 for Measurement and Classification of Mechanical Vibration.

Baseline measurement of min/max and average values indicate the stability of a system at different speeds and are very useful as a hand-over test from contractor to end-user.

Load-envelope monitoring

Use the VACON® drive to compare the actual load curve to the initial values determined during commissioning. This empowers you to detect unexpected operating conditions, such as

- leakage in an HVAC system. Inadequate or excessive power consumption indicates a problem, defined at individual speeds.
- pumps which have become fouled or sanded
- clogged air filters in ventilation systems

When a part has worn out, the load curve changes compared to the initial baseline, and a maintenance warning is triggered allowing you to quickly and effectively remedy the issue. Load-envelope monitoring can also help you to save energy by ensuring the equipment always runs in optimal conditions.

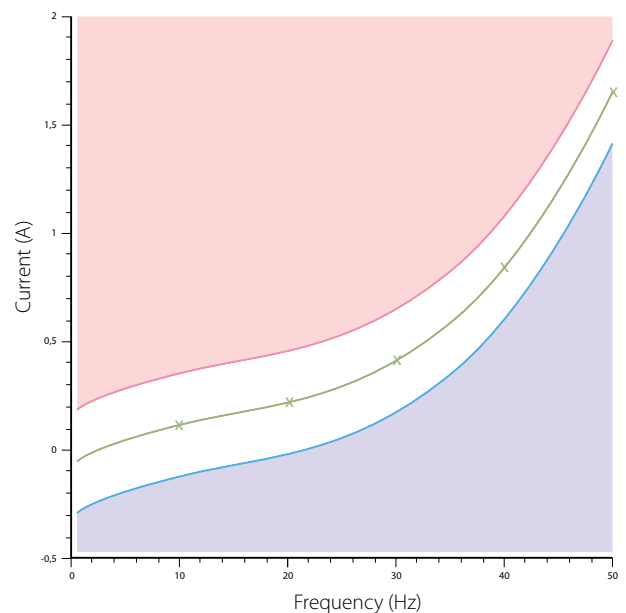

Baseline - Load envelope monitoring of energy consumption.

- Energy consumption above the limit
- Energy consumption below the limit

Highly compact cooling unit

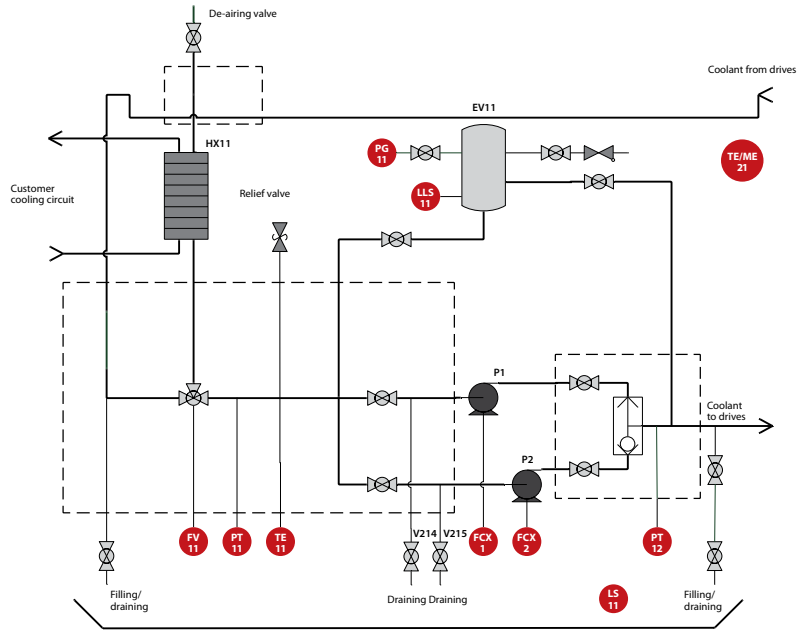

The liquid-cooled system modules empower you to pack a lot of power into a small space, to optimize your systems – and give you new application opportunities. At the heart of this groundbreaking technology is the cooling unit.

The cooling unit is service-friendly despite its extremely compact design, making it fast and easy to work with.

The cooling unit gives you especially easy access to the pump, as well as providing pump shut-off valves.

What's included in the cooling unit

- Liquid cooling temperature control with integrated 3-way valve
- Extensive sensor package with humidity and ambient temperature measurement

Compatibility

- Compatible with diverse Ethernet-based fieldbuses

Type approvals (pending)

- DNV-GL, ABS, LR, BV and CCS

Technical information

System pressure

- Customer side: max 1000 kPa
- Drive side working pressure: 50-350 kPa, maximum 600 kPa

Cooling

- Ambient temperature: -15-55 °C
- Coolant temperature: -15-38 °C (lth) (nominal); 38-55 °C with limited performance

- Cooling unit supply distance: 15-25 m, optionally up to 40 m
- Drive-side temperature control with 3-way valve and actuator

Sensor measurements on the drive side

- Pressure
- Flow (pressure sensor-based)
- Temperature

- Leakage detection
- Condensation (humidity/ambient temperature sensor-based.)

Optional extras

- Enclosure IP23 (without enclosure) and IP54
- Double/redundant pump
- Coolant connectors positioned on left or right side of the cooling unit

Cooling unit ¹⁾					
Model code	Cooling power [kW]	Coolant flow [l/min]	Pump quantity	Dimensions IP23 enclosures W x H x D [mm]	Dimensions IP54 enclosures W x H x D [mm]
iC7-60SLLQxx-0076...	76	190	1 and 2	300/500 x 1900 x 550	408/608 x 2060 x 608
iC7-60SLLQxx-0152...	152	360	1 and 2	300/500 x 1900 x 550	408/608 x 2060 x 608

¹⁾ Performance data of the cooling unit is preliminary. For more information, contact your local Danfoss office or Danfoss partner

Ratings and dimensions

VACON® NXP Liquid Cooled AC drives, 6-pulse and 12-pulse, mains voltage 400-500 VAC

AC drive type 6-pulse	AC drive type 12-pulse	Drive output current			Motor shaft power		Power loss c/a/T* [kW]	Chassis	Choke type 6-pulse*	Choke type 12-pulse
		Thermal I _{th} [A]	Rated cont. I _L [A]	Rated cont. I _H [A]	Optimum motor at I _{th} (400 V) [kW]	Optimum motor at I _{th} (500 V) [kW]				
NXP01685A0N0SWV		168	153	112	90	110	4.0/0.4/4.4	CH5	CHK-0261-6-DL	
NXP02055A0N0SWV		205	186	137	110	132	5.0/0.5/5.5	CH5	CHK-0261-6-DL	
NXP02615A0N0SWV		261	237	174	132	160	6.0/0.5/6.5	CH5	CHK-0261-6-DL	
NXP03005A0N0SWG		300	273	200	160	200	4.5/0.5/5.0	CH61	CHK-0400-6-DL	
NXP03855A0N0SWG		385	350	257	200	250	6.0/0.5/6.5	CH61	CHK-0400-6-DL	
NXP04605A0N0SWG	NXP04605A0N0TWG	460	418	307	250	315	6.5/0.5/7.0	CH72	CHK-0520-6-DL	2 x CHK-0261-6-DL
NXP05205A0N0SWG	NXP05205A0N0TWG	520	473	347	250	355	7.5/0.6/8.1	CH72	CHK-0520-6-DL	2 x CHK-0261-6-DL
NXP05905A0N0SWG	NXP05905A0N0TWG	590	536	393	315	400	9.0/0.7/9.7	CH72	CHK-0650-6-DL	2 x CHK-0400-6-DL
NXP06505A0N0SWG	NXP06505A0N0TWG	650	591	433	355	450	10.0/0.7/10.7	CH72	CHK-0650-6-DL	2 x CHK-0400-6-DL
NXP07305A0N0SWG	NXP07305A0N0TWG	730	664	487	400	500	12.0/0.8/12.8	CH72	CHK-0750-6-DL	2 x CHK-0400-6-DL
NXP08205A0N0SWG		820	745	547	450	560	12.5/0.8/13.3	CH63	CHK-0820-6-DL	
NXP09205A0N0SWG		920	836	613	500	600	14.4/0.9/15.3	CH63	CHK-1030-6-DL	
NXP10305A0N0SWG		1030	936	687	560	700	16.5/1.0/17.5	CH63	CHK-1030-6-DL	
NXP11505A0N0SWG		1150	1045	766	600	750	18.5/1.2/19.7	CH63	CHK-1150-6-DL	
NXP13705A0N0SWG	NXP13705A0N0TWG	1370	1245	913	700	900	19.0/1.2/20.2	CH74	3 x CHK-0520-6-DL	2 x CHK-0750-6-DL
NXP16405A0N0SWG	NXP16405A0N0TWG	1640	1491	1093	900	1100	24.0/1.4/25.4	CH74	3 x CHK-0650-6-DL	2 x CHK-0820-6-DL
NXP20605A0N0SWG	NXP20605A0N0TWG	2060	1873	1373	1100	1400	32.5/1.8/34.3	CH74	3 x CHK-0750-6-DL	2 x CHK-1030-6-DL
NXP23005A0N0SWG		2300	2091	1533	1250	1500	36.3/2.0/38.3	CH74	3 x CHK-0820-6-DL	
NXP24705A0N0SWG	NXP24705A0N0TWG	2470	2245	1647	1300	1600	38.8/2.2/41.0	2 x CH74	6 x CHK-0520-6-DL	4 x CHK-0650-6-DL
NXP29505A0N0SWG	NXP29505A0N0TWG	2950	2681	1967	1550	1950	46.3/2.6/48.9	2 x CH74	6 x CHK-0520-6-DL	4 x CHK-0750-6-DL
NXP37105A0N0SWG	NXP37105A0N0TWG	3710	3372	2473	1950	2450	58.2/3.0/61.2	2 x CH74	6 x CHK-0650-6-DL	4 x CHK-1030-6-DL
NXP41405A0N0SWG	NXP41405A0N0TWG	4140	3763	2760	2150	2700	65.0/3.6/68.6	2 x CH74	6 x CHK-0750-6-DL	4 x CHK-1150-6-DL
2 x NXP24705A0N0SWG	2 x NXP24705A0N0TWG	4700	4300	3100	2450	3050	73.7/4.2/77.9	4 x CH74	12 x CHK-0520-6-DL	8 x CHK-0650-6-DL
2 x NXP29505A0N0SWG	2 x NXP29505A0N0TWG	5600	5100	3700	2900	3600	88/5/93	4 x CH74	12 x CHK-0520-6-DL	8 x CHK-0750-6-DL
2 x NXP37105A0N0SWG	2 x NXP37105A0N0TWG	7000	6400	4700	3600	4500	110.6/5.7/116.3	4 x CH74	12 x CHK-0650-6-DL	8 x CHK-1030-6-DL
2 x NXP41405A0N0SWG	2 x NXP41405A0N0TWG	7900	7200	5300	4100	5150	123.5/6.9/130.4	4 x CH74	12 x CHK-0750-6-DL	8 x CHK-1150-6-DL

I_{th} = Thermal maximum continuous RMS current. Dimensioning can be done according to this current if the process does not require any overloadability or the process does not include any load variation or margin for overloadability.

I_L = Low overloadability current. Allows +10% load variation. 10% exceeding can be continuous.

I_H = High overloadability current. Allows +50% load variation. 50% exceeding can be continuous.

All values with cosφ = 0,83 and efficiency = 97%

*) c = power loss into coolant; a = power loss into air; T = total power loss; power losses of input chokes not included. All power losses obtained using max. supply voltage, I_{th} and switching frequency of 3.6 kHz and Closed Loop control mode. All power losses are worst case losses.

If some other mains voltage is used, apply the formula $P = \sqrt{3} \times U_n \times I_n \times \cos\phi \times \text{eff}\%$ to calculate the NX Liquid-Cooled drive output power.

The enclosure class for all NX Liquid-Cooled AC drives is IP00.

If the motor is continuously run at frequencies below 5 Hz (besides start and stop ramps), please pay attention to the drive dimensioning for low frequencies, i.e. maximum I = 0.66 * I_{th} or choose drive according to I_H. It is recommended to check the rating with your distributor or Vacon.

Drive overrating may also be necessary if the process requires high starting torque.

VACON® NXP Liquid Cooled AC drives, 6-pulse and 12-pulse, mains voltage 525-690 VAC

AC drive type 6-pulse	AC drive type 12-pulse	Drive output current			Motor shaft power		Power loss c/a/T* [kW]	Chassis	Choke type 6-pulse	Choke type 12-pulse
		Thermal I _{th} [A]	Rated I _L [A]	Rated I _R [A]	Optimum motor at I _{th} (525 V) [kW]	Optimum motor at I _{th} (690 V) [kW]				
NXP01706A0T0SWG		170	155	113	110	160	4.0/0.2/4.2	CH61	CHK-0261-6-DL	
NXP02086A0T0SWG		208	189	139	132	200	4.8/0.3/5.1	CH61	CHK-0261-6-DL	
NXP02616A0T0SWG		261	237	174	160	250	6.3/0.3/6.6	CH61	CHK-0261-6-DL	
NXP03256A0T0SWG	NXP03256A0T0TWG	325	295	217	200	300	7.2/0.4/7.6	CH72	CHK-0400-6-DL	2 x CHK-0261-6-DL
NXP03856A0T0SWG	NXP03856A0T0TWG	385	350	257	250	355	8.5/0.5/9.0	CH72	CHK-0400-6-DL	2 x CHK-0261-6-DL
NXP04166A0T0SWG	NXP04166A0T0TWG	416	378	277	250	355	9.1/0.5/9.6	CH72	CHK-0520-6-DL	2 x CHK-0261-6-DL
NXP04606A0T0SWG	NXP04606A0T0TWG	460	418	307	300	400	10.0/0.5/10.5	CH72	CHK-0520-6-DL	2 x CHK-0261-6-DL
NXP05026A0T0SWG	NXP05026A0T0TWG	502	456	335	355	450	11.2/0.6/11.8	CH72	CHK-0520-6-DL	2 x CHK-0261-6-DL
NXP05906A0T0SWG		590	536	393	400	560	12.4/0.7/13.1	CH63	CHK-0650-6-DL	
NXP06506A0T0SWG		650	591	433	450	600	14.2/0.8/15.0	CH63	CHK-0650-6-DL	
NXP07506A0T0SWG		750	682	500	500	700	16.4/0.9/17.3	CH63	CHK-0750-6-DL	
NXP08206A0T0SWG	NXP08206A0T0TWG	820	745	547	560	800	17.3/1.0/18.3	CH74	3 x CHK-0400-6-DL	2 x CHK-0520-6-DL
NXP09206A0T0SWG	NXP09206A0T0TWG	920	836	613	650	850	19.4/1.1/20.5	CH74	3 x CHK-0400-6-DL	2 x CHK-0520-6-DL
NXP10306A0T0SWG	NXP10306A0T0TWG	1030	936	687	700	1000	21.6/1.2/22.8	CH74	3 x CHK-0400-6-DL	2 x CHK-0520-6-DL
NXP11806A0T0SWG	NXP11806A0T0TWG	1180	1073	787	800	1100	25.0/1.3/26.3	CH74	3 x CHK-0400-6-DL	2 x CHK-0650-6-DL
NXP13006A0T0SWG	NXP13006A0T0TWG	1300	1182	867	900	1200	27.3/1.5/28.8	CH74	3 x CHK-0520-6-DL	2 x CHK-0650-6-DL
NXP15006A0T0SWG	NXP15006A0T0TWG	1500	1364	1000	1050	1400	32.1/1.7/33.8	CH74	3 x CHK-0520-6-DL	2 x CHK-0820-6-DL
NXP17006A0T0SWG	NXP17006A0T0TWG	1700	1545	1133	1150	1550	36.5/1.9/38.4	CH74	3 x CHK-0650-6-DL	2 x CHK-1030-6-DL
NXP18506A0T0SWG	NXP18506A0T0TWG	1850	1682	1233	1250	1650	39.0/2.0/41.0	2 x CH74	6 x CHK-0400-6-DL	4 x CHK-0520-6-DL
NXP21206A0T0SWG	NXP21206A0T0TWG	2120	1927	1413	1450	1900	44.9/2.4/47.3	2 x CH74	6 x CHK-0400-6-DL	4 x CHK-0650-6-DL
NXP23406A0T0SWG	NXP23406A0T0TWG	2340	2127	1560	1600	2100	49.2/2.6/51.8	2 x CH74	6 x CHK-0400-6-DL	4 x CHK-0650-6-DL
NXP27006A0T0SWG	NXP27006A0T0TWG	2700	2455	1800	1850	2450	57.7/3.1/60.8	2 x CH74	6 x CHK-0520-6-DL	4 x CHK-0750-6-DL
NXP31006A0T0SWG	NXP31006A0T0TWG	3100	2818	2066	2150	2800	65.7/3.4/69.1	2 x CH74	6 x CHK-0520-6-DL	4 x CHK-0820-6-DL
2 x NXP18506A0T0SWG	2 x NXP18506A0T0TWG	3500	3200	2300	2400	3150	74,2/3,8/77,9	4 x CH74	12 x CHK-0400-6-DL	8 x CHK-0520-6-DL
2 x NXP21206A0T0SWG	2 x NXP21206A0T0TWG	4000	3600	2700	2750	3600	85,4/4,5/89,9	4 x CH74	12 x CHK-0400-6-DL	8 x CHK-0650-6-DL
2 x NXP23406A0T0SWG	2 x NXP23406A0T0TWG	4400	4000	2900	3050	3950	93,4/5,0/98,4	4 x CH74	12 x CHK-0400-6-DL	8 x CHK-0650-6-DL
2 x NXP27006A0T0SWG	2 x NXP27006A0T0TWG	5100	4600	3400	3500	4600	109,7/5,8/115,5	4 x CH74	12 x CHK-0520-6-DL	8 x CHK-0750-6-DL
2 x NXP31006A0T0SWG	2 x NXP31006A0T0TWG	5900	5400	3900	4050	5300	124,8/6,5/131,3	4 x CH74	12 x CHK-0520-6-DL	8 x CHK-0820-6-DL

Standard chokes for VACON® NX Liquid Cooled product range

Choke type	Heat losses [W]	Dimensions W x H x D [mm]	Weight [kg]
CHK-0261-6-DL	323	308 x 500 x 270	70
CHK-0400-6-DL	484	308 x 497 x 276	75
CHK-0520-6-DL	574	450 x 502 x 276	104
CHK-0650-6-DL	468	450 x 505 x 284	121
CHK-0750-6-DL	816	450 x 557 x 284	135
CHK-0820-6-DL	731	450 x 506 x 282	118
CHK-1030-6-DL	777	450 x 642 x 274	124
CHK-1150-6-DL	882	450 x 647 x 308	162

VACON® NXP Liquid Cooled inverter units, DC bus voltage 465-800 VDC

AC drive type	Drive output current			Motor shaft power		Power loss c/a/T*) [kW]	Chassis
	Thermal I _{th} [A]	Rated cont. I _L [A]	Rated cont. I _H [A]	Optimum motor at I _{th} (540 VDC) [kW]	Optimum motor at I _{th} (675 VDC) [kW]		
NXP01685A0T0I WV	168	153	112	90	110	2.5/0.3/2.8	CH5
NXP02055A0T0I WV	205	186	137	110	132	3.0/0.4/3.4	CH5
NXP02615A0T0I WV	261	237	174	132	160	4.0/0.4/4.4	CH5
NXP03005A0T0I WG	300	273	200	160	200	4.5/0.4/4.9	CH61
NXP03855A0T0I WG	385	350	257	200	250	5.5/0.5/6.0	CH61
NXP04605A0T0I WG	460	418	307	250	315	5.5/0.5/6.0	CH62
NXP05205A0T0I WG	520	473	347	250	355	6.5/0.5/7.0	CH62
NXP05905A0T0I WG	590	536	393	315	400	7.5/0.6/8.1	CH62
NXP06505A0T0I WG	650	591	433	355	450	8.5/0.6/9.1	CH62
NXP07305A0T0I WG	730	664	487	400	500	10.0/0.7/10.7	CH62
NXP08205A0T0I WG	820	745	547	450	560	12.5/0.8/13.3	CH63
NXP09205A0T0I WG	920	836	613	500	600	14.4/0.9/15.3	CH63
NXP10305A0T0I WG	1030	936	687	560	700	16.5/1.0/17.5	CH63
NXP11505A0T0I WG	1150	1045	766	600	750	18.4/1.1/19.5	CH63
NXP13705A0T0I WG	1370	1245	913	700	900	15.5/1.0/16.5	CH64
NXP16405A0T0I WG	1640	1491	1093	900	1100	19.5/1.2/20.7	CH64
NXP20605A0T0I WG	2060	1873	1373	1100	1400	26.5/1.5/28.0	CH64
NXP23005A0T0I WG	2300	2091	1533	1250	1500	29.6/1.7/31.3	CH64
NXP24705A0T0I WG	2470	2245	1647	1300	1600	36.0/2.0/38.0	2 x CH64
NXP29505A0T0I WG	2950	2681	1967	1550	1950	39.0/2.4/41.4	2 x CH64
NXP37105A0T0I WG	3710	3372	2473	1950	2450	48.0/2.7/50.7	2 x CH64
NXP41405A0T0I WG	4140	3763	2760	2150	2700	53.0/3.0/56.0	2 x CH64
2 x NXP24705A0T0I WG	4700	4300	3100	2450	3050	69.1/3.9/73	4 x CH64
2 x NXP29505A0T0I WG	5600	5100	3700	2900	3600	74.4/4.6/79	4 x CH64
2 x NXP37105A0T0I WG	7000	6400	4700	3600	4500	90.8/5.2/96	4 x CH64
2 x NXP41405A0T0I WG	7900	7200	5300	4100	5150	101.2/5.8/107	4 x CH64

The voltage classes for the inverter units used in the tables above have been defined as follows:

Input 540 VDC = Rectified 400 VAC supply

Input 675 VDC = Rectified 500 VAC supply

VACON® NXP Liquid Cooled inverter units, DC bus voltage 640-1100 VDC ¹⁾

AC drive type	Drive output current			Motor shaft power		Power loss c/a/T* [kW]	Chassis
	Thermal I _{th} [A]	Rated cont. I _L [A]	Rated cont. I _H [A]	Optimum motor at I _{th} (710 VDC) [kW]	Optimum motor at I _{th} (930 VDC) [kW]		
NXP01706A0T0IWG	170	155	113	110	160	3.6/0.2/3.8	CH61
NXP02086A0T0IWG	208	189	139	132	200	4.3/0.3/4.6	CH61
NXP02616A0T0IWG	261	237	174	160	250	5.4/0.3/5.7	CH61
NXP03256A0T0IWG	325	295	217	200	300	6.5/0.3/6.8	CH62
NXP03856A0T0IWG	385	350	257	250	355	7.5/0.4/7.9	CH62
NXP04166A0T0IWG	416	378	277	250	355	8.0/0.4/8.4	CH62
NXP04606A0T0IWG	460	418	307	300	400	8.7/0.4/9.1	CH62
NXP05026A0T0IWG	502	456	335	355	450	9.8/0.5/10.3	CH62
NXP05906A0T0IWG	590	536	393	400	560	10.9/0.6/11.5	CH63
NXP06506A0T0IWG	650	591	433	450	600	12.4/0.7/13.1	CH63
NXP07506A0T0IWG	750	682	500	500	700	14.4/0.8/15.2	CH63
NXP08206A0T0IWG	820	745	547	560	800	15.4/0.8/16.2	CH64
NXP09206A0T0IWG	920	836	613	650	850	17.2/0.9/18.1	CH64
NXP10306A0T0IWG	1030	936	687	700	1000	19.0/1.0/20.0	CH64
NXP11806A0T0IWG	1180	1073	787	800	1100	21.0/1.1/22.1	CH64
NXP13006A0T0IWG	1300	1182	867	900	1200	24.0/1.3/25.3	CH64
NXP15006A0T0IWG	1500	1364	1000	1050	1400	28.0/1.5/29.5	CH64
NXP17006A0T0IWG	1700	1545	1133	1150	1550	32.1/1.7/33.8	CH64
NXP18506A0T0IWG	1850	1682	1233	1250	1650	34.2/1.8/36.0	2 x CH64
NXP21206A0T0IWG	2120	1927	1413	1450	1900	37.8/2.0/39.8	2 x CH64
NXP23406A0T0IWG	2340	2127	1560	1600	2100	43.2/2.3/45.5	2 x CH64
NXP27006A0T0IWG	2700	2455	1800	1850	2450	50.4/2.7/53.1	2 x CH64
NXP31006A0T0IWG	3100	2818	2066	2150	2800	57.7/3.1/60.8	2 x CH64
2 x NXP18506A0T0IWG	3500	3200	2300	2400	3150	64,9/3,5/68,4	4 x CH64
2 x NXP21206A0T0IWG	4000	3600	2700	2750	3600	71,8/3,8/75,6	4 x CH64
2 x NXP23406A0T0IWG	4400	4000	2900	3050	3950	82,1/4,4/86,5	4 x CH64
2 x NXP27006A0T0IWG	5100	4600	3400	3500	4600	95,8/5,1/100,9	4 x CH64
2 x NXP31006A0T0IWG	5900	5400	3900	4050	5300	109,7/5,8/115,5	4 x CH64

¹⁾ High power 525-690V AFE, INU and BCU units available as wide voltage range version (NX_8 models) with DC bus voltage 640-1200 VDC. The units are ordered with the nominal mains voltage code 8 instead of 6 as for the standard version.

The following additional requirements applies to the wide voltage version:

- output filter with an inductance of at least 0.7% needed
- external 24VDC supply for the control unit

The voltage classes for the inverter units used in the tables above have been defined as follows:

Input 710 VDC = Rectified 525 VAC supply
 Input 930 VDC = Rectified 690 VAC supply

VACON® NXP Liquid Cooled dimensions: drives consisting of one module

Chassis	Width [mm]	Height [mm]	Depth [mm]	Weight [kg]
CH5	246	553	264	40
CH60	246	673	374	55
CH61/62	246	658	372	55
CH63	505	923	375	120
Ch64	746	923	375	180
CH72	246	1076	372	90
Ch74	746	1175	385	280

One-module drive dimensions (mounting base included). Please note that AC chokes are not included.

VACON® NXN Liquid Cooled non regenerative front-end, DC bus voltage 465-800 V DC, 6/12-pulse

AC drive type	AC current			DC power				Power loss c/a/T*) [kW]	Chassis
	Thermal I _{th} [A]	Rated I _L [A]	Rated I _H [A]	400 VAC mains I _{th} [kW]	500 VAC mains I _{th} [kW]	400 VAC mains I _L [kW]	500 VAC mains I _L [kW]		
NXN20006A0T0	2000	1818	1333	1282	1605	1165	1458	5.7/0.5/6.2	CH60

VACON® NXN Liquid Cooled non regenerative front-end, DC bus voltage 640-1100 V DC, 6/12-pulse

AC drive type	AC current			DC power				Power loss c/a/T*) [kW]	Chassis
	Thermal I _{th} [A]	Rated I _L [A]	Rated I _H [A]	525 VAC mains I _{th} [kW]	690 VAC mains I _{th} [kW]	525 VAC mains I _L [kW]	690 VAC mains I _L [kW]		
NXN20006A0T0	2000	1818	1333	1685	2336	1531	2014	5.7/0.5/6.2	CH60

VACON® NXN Liquid Cooled non regenerative front-end line filters

Choke type	Suitability	Power loss c/a/T*) [kW]	Dimensions 1 pc W x H x D	Total weight [kg]	Pcs for NXN	Cooling
CHK-1030-6-DL	NXN20006A0T0WVVA1A2BHB100	1.18/0.5/1.68	506 x 676 x 302	237	2	Liquid

VACON® NXA Liquid Cooled Active Front-end and Grid Converter, DC bus voltage 465-800 VDC

AC drive type	AC current			DC power				Power loss c/a/T*) [kW]	Chassis
	Thermal I _{th} [A]	Rated I _L [A]	Rated I _H [A]	400 VAC mains I _{th} [kW]	500 VAC mains I _{th} [kW]	400 VAC mains I _L [kW]	500 VAC mains I _L [kW]		
NXA01685A0T02WV	168	153	112	113	142	103	129	2.5/0.3/2.8	CH5
NXA02055A0T02WV	205	186	137	138	173	125	157	3.0/0.4/3.4	CH5
NXA02615A0T02WV	261	237	174	176	220	160	200	4.0/0.4/4.4	CH5
NXA03005A0T02WG	300	273	200	202	253	184	230	4.5/0.4/4.9	CH61
NXA03855A0T02WG	385	350	257	259	324	236	295	5.5/0.5/6.0	CH61
NXA04605A0T02WG	460	418	307	310	388	282	352	5.5/0.5/6.0	CH62
NXA05205A0T02WG	520	473	347	350	438	319	398	6.5/0.5/7.0	CH62
NXA05905A0T02WG	590	536	393	398	497	361	452	7.5/0.6/8.1	CH62
NXA06505A0T02WG	650	591	433	438	548	398	498	8.5/0.6/9.1	CH62
NXA07305A0T02WG	730	664	487	492	615	448	559	10.0/0.7/10.7	CH62
NXA08205A0T02WG	820	745	547	553	691	502	628	10.0/0.7/10.7	CH63
NXA09205A0T02WG	920	836	613	620	775	563	704	12.4/0.8/12.4	CH63
NXA10305A0T02WG	1030	936	687	694	868	631	789	13.5/0.9/14.4	CH63
NXA11505A0T02WG	1150	1045	767	775	969	704	880	16.0/1.0/17.0	CH63
NXA13705A0T02WG	1370	1245	913	923	1154	839	1049	15.5/1.0/16.5	CH64
NXA16405A0T02WG	1640	1491	1093	1105	1382	1005	1256	19.5/1.2/20.7	CH64
NXA20605A0T02WG	2060	1873	1373	1388	1736	1262	1578	26.5/1.5/28.0	CH64
NXA23005A0T02WG	2300	2091	1533	1550	1938	1409	1762	29.6/1.7/31.3	CH64

VACON® NXA Liquid Cooled Active Front-end and Grid Converter, DC bus voltage 640-1100 VDC ¹⁾

AC drive type	AC current			DC power				Power loss c/a/T* [kW]	Chassis
	Thermal I _{th} [A]	Rated I _L [A]	Rated I _H [A]	525 VAC mains I _{th} [kW]	690 VAC mains I _{th} [kW]	525 VAC mains I _L [kW]	690 VAC mains I _L [kW]		
NXA01706A0T02WG	170	155	113	150	198	137	180	3.6/0.2/3.8	CH61
NXA02086A0T02WG	208	189	139	184	242	167	220	4.3/0.3/4.6	CH61
NXA02616A0T02WG	261	237	174	231	303	210	276	5.4/0.3/5.7	CH61
NXA03256A0T02WG	325	295	217	287	378	261	343	6.5/0.3/6.8	CH62
NXA03856A0T02WG	385	350	257	341	448	310	407	7.5/0.4/7.9	CH62
NXA04166A0T02WG	416	378	277	368	484	334	439	8.0/0.4/8.4	CH62
NXA04606A0T02WG	460	418	307	407	535	370	486	8.7/0.4/9.1	CH62
NXA05026A0T02WG	502	456	335	444	584	403	530	9.8/0.5/10.3	CH62
NXA05906A0T02WG	590	536	393	522	686	474	623	10.9/0.6/11.5	CH63
NXA06506A0T02WG	650	591	433	575	756	523	687	12.4/0.7/13.1	CH63
NXA07506A0T02WG	750	682	500	663	872	603	793	14.4/0.8/15.2	CH63
NXA08206A0T02WG	820	745	547	725	953	659	866	15.4/0.8/16.2	CH64
NXA09206A0T02WG	920	836	613	814	1070	740	972	17.2/0.9/18.1	CH64
NXA10306A0T02WG	1030	936	687	911	1197	828	1088	19.0/1.0/20.0	CH64
NXA11806A0T02WG	1180	1073	787	1044	1372	949	1247	21.0/1.1/22.1	CH64
NXA13006A0T02WG	1300	1182	867	1150	1511	1046	1374	24.0/1.3/25.3	CH64
NXA15006A0T02WG	1500	1364	1000	1327	1744	1207	1586	28.0/1.5/29.5	CH64
NXA17006A0T02WG	1700	1545	1133	1504	1976	1367	1796	32.1/1.7/33.8	CH64

¹⁾ DC bus voltage 640-1200 VDC for wide range voltage version (NX_8).

* C = power loss into coolant, A = power loss into air, T = total power loss

VACON® Liquid Cooled regenerative line filters

LCL filter type	Suitability	Power loss c/a/T* [kW]	Dimensions L _{net} 1 pcs WxHxD [mm]	Dimensions L _{drive} 1 pcs (total 3pcs) WxHxD [mm]	Dimensions C _{bank} 1 pcs WxHxD [mm]	Total weight [kg]
RLC-0385-6-0	CH62/690VAC: 325A & 385A	2,6/0,8/3,4	580 x 450 x 385	410 x 415 x 385	360 x 265 x 150	458
RLC-0520-6-0	CH62/500-690VAC	2,65/0,65/3,3	580 x 450 x 385	410 x 415 x 385	360 x 265 x 150	481
RLC-0750-6-0	CH62/500VAC, CH63/690VAC	3,7/1/4,7	580 x 450 x 385	410 x 450 x 385	360 x 275 x 335	508
RLC-0920-6-0	CH63/500VAC, CH64/690VAC	4,5/1,4/5,9	580 x 500 x 390	410 x 500 x 400	360 x 275 x 335	577
RLC-1180-6-0	CH63/500VAC, CH64/690VAC	6,35/1,95/8,3	585 x 545 x 385	410 x 545 x 385	350 x 290 x 460	625
RLC-1640-6-0	CH64/500-690VAC	8,2/2,8/11	585 x 645 x 385	420 x 645 x 385	350 x 290 x 460	736
RLC-2300-5-0	CH64/500VAC: 2060A & 2300A	9,5/2,9/12,4	585 x 820 x 370	410 x 820 x 380	580 x 290 x 405	896

The RLC filter contains a 3-phase choke on the mains side, capacitors and 3pcs 1-phase chokes on the AFE side.

VACON® NXP Liquid Cooled DC/DC Converter, DC-bus voltage 465-800 V DC

Model code	Chassis	750 V DC-bus voltage		
		DC bus		DC source
		$I_{DC\ bus}$ [A]	$P_{DC}^{1)}$ [kW]	$I_{DC\ source}^{2)}$ [A]
NXP01685A0T0IWV	CH5	195	146	336
NXP02055A0T0IWV	CH5	238	179	410
NXP02615A0T0IWV	CH5	306	230	522
NXP03005A0T0IWG	CH61	352	264	600
NXP03855A0T0IWG	CH61	456	342	770
NXP04605A0T0IWG	CH62	545	409	920
NXP05205A0T0IWG	CH62	616	462	1040
NXP05905A0T0IWG	CH62	699	524	1180
NXP06505A0T0IWG	CH62	770	578	1300
NXP07305A0T0IWG	CH62	865	649	1460
NXP08205A0T0IWG	CH63	972	729	1640
NXP09205A0T0IWG	CH63	1090	818	1840
NXP10305A0T0IWG	CH63	1221	916	2060
NXP11505A0T0IWG	CH63	1378	1034	2200
NXP13705A0T0IWG	CH64	1642	1232	2740
NXP16405A0T0IWG	CH64	1965	1474	3280
NXP20605A0T0IWG	CH64	2469	1852	4120
NXP23005A0T0IWG	CH64	2756	2067	4200

¹⁾ Maximum DC power with 750 V DC-bus voltage, limited by the DC-bus current

²⁾ Thermal current at 5 kHz switching frequency and 35° C coolant temperature

Further power extension available based on paralleling with droop control or master-follower

VACON® NXP Liquid Cooled DC/DC Converter, DC-bus voltage 640-1100 V DC

Model code	Chassis	1025 V DC-bus voltage		
		DC bus		DC source
		$I_{DC\ bus}$ [A]	$P_{DC}^{1)}$ [kW]	$I_{DC\ source}^{2)}$ [A]
NXP01706A0T0IWG	CH61	199	204	340
NXP02086A0T0IWG	CH61	244	250	416
NXP02616A0T0IWG	CH61	309	317	500
NXP03256A0T0IWG	CH62	385	395	650
NXP03856A0T0IWG	CH62	456	467	770
NXP04166A0T0IWG	CH62	493	505	832
NXP04606A0T0IWG	CH62	545	559	920
NXP05026A0T0IWG	CH62	595	610	975
NXP05906A0T0IWG	CH63	699	716	1180
NXP06506A0T0IWG	CH63	770	789	1300
NXP07506A0T0IWG	CH63	889	911	1500
NXP08206A0T0IWG	CH64	972	996	1640
NXP09206A0T0IWG	CH64	1090	1117	1840
NXP10306A0T0IWG	CH64	1221	1252	2060
NXP11806A0T0IWG	CH64	1414	1449	2360
NXP13006A0T0IWG	CH64	1558	1597	2600
NXP15006A0T0IWG	CH64	1798	1843	3000
NXP17006A0T0IWG	CH64	2040	2091	3400

¹⁾ Maximum DC power with 1025 V DC-bus voltage, limited by the DC-bus current

²⁾ Thermal current at 5 kHz switching frequency and 35° C coolant temperature

Further power extension available based on paralleling with droop control or master-follower

DC/DC filters

For selection of DC/DC filters, refer to the selection criteria and selection tables in the VACON® NXP DC Filters Design Guide.

VACON® NXB Liquid Cooled external brake chopper, DC bus voltage 460-800 VDC

AC drive type	Current				Braking power		Power loss c/a/T*) [kW]	Chassis
	BCU rated cont. braking current I _{br} [A]	Rated min resistance 800 VDC (Ω)	Rated min resistance 600 VDC (Ω)	Rated max input current (Adc)	Rated cont. braking power 2*R 800 VDC [kW]	Rated cont. braking power 2*R 600 VDC [kW]		
NXB01685A0T08WV	2*168	4.7	3.6	336	267	203	2.5/0.3/2.8	CH5
NXB02055A0T08WV	2*205	3.9	3.0	410	326	248	3.0/0.4/3.4	CH5
NXB02615A0T08WV	2*261	3.1	2.3	522	415	316	4.0/0.4/4.4	CH5
NXB03005A0T08WG	2*300	2.7	2.0	600	477	363	4.5/0.4/4.9	CH61
NXB03855A0T08WG	2*385	2.1	1.6	770	613	466	5.5/0.5/6.0	CH61
NXB04605A0T08WG	2*460	1.7	1.3	920	732	556	5.5/0.5/6.0	CH62
NXB05205A0T08WG	2*520	1.5	1.2	1040	828	629	6.5/0.5/7.0	CH62
NXB05905A0T08WG	2*590	1.4	1.1	1180	939	714	7.5/0.6/8.1	CH62
NXB06505A0T08WG	2*650	1.2	1.0	1300	1035	786	8.5/0.6/9.1	CH62
NXB07305A0T08WG	2*730	1.1	0.9	1460	1162	833	10.0/0.7/10.7	CH62

VACON® NXB Liquid Cooled external brake chopper, DC bus voltage 640-1100 VDC ¹⁾

AC drive type	Current				Braking power		Power loss c/a/T*) [kW]	Chassis
	BCU rated cont. braking current I _{br} [A]	Rated min resistance 1100 VDC (Ω)	Rated min resistance 840 VDC (Ω)	Rated max input current (Adc)	Rated cont. braking power 2*R 1100 VDC [kW]	Rated cont. braking power 2*R 840 VDC [kW]		
NXB01706A0T08WG	2*170	6.5	4.9	340	372	282	4.5/0.2/4.7	CH61
NXB02086A0T08WG	2*208	5.3	4	416	456	346	5.5/0.3/5.8	CH61
NXB02616A0T08WG	2*261	4.2	3.2	522	572	435	5.5/0.3/5.8	CH61
NXB03256A0T08WG	2*325	3.4	2.6	650	713	542	6.5/0.3/6.8	CH62
NXB03856A0T08WG	2*385	2.9	2.2	770	845	643	7.5/0.4/7.9	CH62
NXB04166A0T08WG	2*416	2.6	2	832	913	693	8.1/0.4/8.4	CH62
NXB04606A0T08WG	2*460	2.4	1.8	920	1010	767	8.5/0.4/8.9	CH62
NXB05026A0T08WG	2*502	2.2	1.7	1004	1100	838	10.0/0.5/10.5	CH62

1) DC bus voltage 640-1136 VDC for wide range voltage version (NX_8).

NOTE: The rated currents in given ambient (+50 °C) and coolant (+30 °C) temperatures are achieved only when the switching frequency is equal to or less than the factory default.

NOTE: Braking power: $P_{brake} = 2 * U_{brake}^2 / R_{resistor}$, when 2 resistors are used

NOTE: Max input DC current: $I_{in,max} = P_{brake,max} / U_{brake}$

VACON® NXP Liquid Cooled AC drive, internal brake chopper unit, braking voltage 460-800 VDC

Converter Type	Loadability	Braking capacity 600 VDC		Braking capacity 800 VDC		Chassis
	Rated min resistance [Ω]	Rated cont. braking power [kW]	BCU rated cont. braking current, I _{br} [A]	Rated cont. braking power [kW]	BCU rated cont. braking current, I _{br} [A]	
NX_460-730 5 ¹⁾	1.3	276	461	492	615	CH72
NX_1370-2300 5	1.3	276	461	492	615	CH74

1) Only 6 pulse drives

VACON® NXP Liquid Cooled AC drive, internal brake chopper unit, braking voltage 840-1100 VDC

Converter Type	Loadability	Braking capacity 840 VDC		Braking capacity 1100 VDC		Chassis
	Rated min resistance [Ω]	Rated cont. braking power [kW]	BCU rated cont. braking current, I _{br} [A]	Rated cont. braking power [kW]	BCU rated cont. braking current, I _{br} [A]	
NX_325-502 6 ¹⁾	2.8	252	300	432	392	CH72
NX_820-1700 6	2.8	252	300	432	392	CH74

1) Only 6 pulse drives

The internal brake chopper can also be used in motor application where 2...4 x Ch7x drives are used for a single motor, but in this case the DC connections of the power modules must be connected together.

VACON® external brake resistors for liquid cooled CH72 (CH74) drives – IP20

Product code	Voltage range [VDC]	Maximum brake power [kW]	Maximum average power [kW] (1 puls/2min)	Resistance [Ω]	Maximum energy [kJ] (predefined power pulse)	Dimensions W x H x D [mm]	Weight [kg]
BRW-0730-LD-5 ¹⁾	465...800 VDC	637 ³⁾	13.3	1.3	1594	480 x 600 x 740	55
BRW-0730-HD-5 ²⁾	465...800 VDC	637 ³⁾	34.5	1.3	4145	480 x 1020 x 740	95
BRW-0502-LD-6 ¹⁾	640...1100 VDC	516 ⁴⁾	10.8	2.8	1290	480 x 760 x 530	40
BRW-0502-HD-6 ²⁾	640...1100 VDC	516 ⁴⁾	28	2.8	3354	480 x 1020 x 740	85

NOTE: Thermal protection switch included

1) LD = Light Duty: 5s nominal torque braking from nominal speed reduced linearly to zero once per 120s

2) HD = Heavy duty: 3s nominal torque braking at nominal speed + 7s nominal torque braking from nominal speed reduced linearly to zero once per 120s.

3) at 911 VDC

4) at 1200 VDC

VACON® NXP Liquid Cooled Enclosed drive

AC drive type	Rated current			Electrical output power		Chassis	Dimensions W x H x D W/O Cooling unit [in]
	Thermal I _{TH} [A]	Cont. I _L [A]	Cont. I _H [A]	Motor at I _{th} (400 VAC) [kW]	Motor at I _{th} (500 VAC) [kW]		
NXP13705A5T0RWN-LIQC	1370	1245	913	700	900	CH64	2000 x 2100 x 900
NXP16405A5T0RWN-LIQC	1640	1491	1093	900	1100	CH64	2000 x 2100 x 900

AC drive type	Rated current			Electrical output power		Chassis	Dimensions W x H x D W/O Cooling unit [in]
	Thermal I _{TH} [A]	Cont. I _L [A]	Cont. I _H [A]	Motor at I _{th} (525 VAC) [kW]	Motor at I _{th} (690 VAC) [kW]		
NXP08206A5T0RWN-LIQC	820	745	547	560	800	CH64	2000 x 2100 x 900
NXP09206A5T0RWN-LIQC	920	836	613	650	850	CH64	2000 x 2100 x 900
NXP10306A5T0RWN-LIQC	1030	936	687	700	1000	CH64	2000 x 2100 x 900
NXP11806A5T0RWN-LIQC	1180	1073	787	800	1100	CH64	2000 x 2100 x 900
NXP13006A5T0RWN-LIQC	1300	1182	867	900	1200	CH64	2000 x 2100 x 900
NXP15006A5T0RWN-LIQC	1500	1364	1000	1000	1400	CH64	2000 x 2100 x 900
NXP17006A5T0RWN-LIQC	1700	1545	1133	1150	1550	CH64	2000 x 2100 x 900

Technical data

Mains connection	Input voltage U_{in}	NX_5: 400...500 VAC (-10%...+10%); 465...800 VDC (-0%...+0%) NX_6: 525...690 VAC (-10%...+10%); 640...1100 VDC (-0%...+0%) NX_8: 525...690 VAC (-10%...+10%); 640...1136 VDC (-0%...+0%) ¹⁾ NX_8: 525...690 VAC (-10%...+10%); 640...1200 VDC (-0%...+0%) ²⁾
	Input frequency	45...66 Hz
Motor connections	Output voltage	0- U_{in}
	Output frequency	0...320 Hz
	Output filter	VACON® liquid cooled NX_8 unit must be equipped with a output filter with an inductance of at least 0.7%.
Control characteristics	Control method	Frequency control U/f Open loop vector control (5-150% of base speed): speed control 0.5%, dynamic 0.3%sec, torque lin. <2%, torque rise time ~5 ms Closed loop vector control (entire speed range): speed control 0.01%, dynamic 0.2% sec, torque lin. <2%, torque rise time ~2 ms
	Switching frequency	NX_5: 1...6 kHz; Factory default 3.6 kHz (1...10 kHz with special application) NX_6/NX_8: 1...6 kHz; Factory default 1.5 kHz
	Field weakening point	8...320 Hz
	Acceleration time	0...3000 sec
	Deceleration time	0...3000 sec
	Braking	DC brake: 30% of TN (without brake resistor), flux braking
	Ambient conditions	Ambient operating temperature
Installation temperature		0...+70 °C
Storage temperature		-40 °C...+70 °C; no liquid in heatsink under 0 °C
Relative humidity		5 to 96% RH, non-condensing, no dripping water
Air quality - chemical vapours - mechanical particles ^{*)}		No corrosive gases IEC 60721-3-3 Edition 2.2, AC drive in operation, class 3C3 IEC 60721-3-3 Edition 2.2, AC drive in operation, class 3S2 (no conductive dust allowed)
Altitude		NX_5: (380...500 V): 3000 m ASL; in case network is not corner grounded NX_6/NX_8: (525...690 V) max. 2000 m ASL. For further requirements, contact factory 100% load capacity (no derating) up to 1,000 m; above 1,000 m derating of maximum ambient operating temperature by 0,5 °C per each 100 m is required.
Vibration		5...150 Hz
EN50178/EN60068-2-6		Displacement amplitude 0.25 mm (peak) at 3...31 Hz Max acceleration amplitude 1 G at 31...150 Hz
Shock EN50178, EN60068-2-27		UPS Drop Test (for applicable UPS weights) Storage and shipping: max 15 G, 11 ms (in package)
Enclosure class		IP00 / standard in entire kW/HP range
EMC	Immunity	Fulfils all EMC immunity requirements
	Emissions	EMC level N, T (IT networks)
Safety		EN 50178, EN 60204-1, IEC 61800-5-1, CE, UL, CUL; (see unit nameplate for more details)
Functional safety *)	STO	EN/IEC 61800-5-2 Safe Stop 1 (SS1) SIL3, EN ISO 13849-1 PLe Category 4, EN 62061: SILCL3, IEC 61508: SIL3
	SS1	EN/IEC 61800-5-2 Safe Stop 1 (SS1) SIL3, EN ISO 13849-1 PLe Category 4, EN 62061: SILCL3, IEC 61508: SIL3
	ATEX Thermistor input	2014/34/EU, CE 0537 Ex 11 (2) GD
	Advanced safety option	STO(+SBC), SS1, SS2, SOS, SLS, SMS, SSM, SSR
Approvals	Type tested	CE, UL
	Type approval	DNV, BV, Lloyd's Register (other marine societies delivery based approvals)
	Approvals our partners have	Ex, SIRA
Liquid cooling	Allowed cooling agents	Drinking water Water-glycol mixture
	Temperature of cooling agent	0...35 °C (I_{in})(input); 35...55 °C, please see manual for further details Temperature rise during circulation max. 5 °C No condensation allowed
	System max. working pressure	6 bar/ 30 bar peak
	Pressure loss (at nominal flow)	Varies according to size, please see manual for further details
Protections		Overvoltage, undervoltage, earth fault, mains supervision, motor phase supervision, overcurrent, unitover-temperature, motor overload, motor stall, motor underload, short-circuit of +24V and +10V reference voltages.

*) with OPT-AF board (SS1 requires external safety relay)

1) NX_8 drives only available as Ch6x NXB units.

2) NX_8 drives only available as Ch6x NXA/NXP units.

Typecode key

VACON® NXP Liquid Cooled drives

NXP	0000	5	A	0	N	1	S	W	V	A1 A2 00 00 C3
-----	------	---	---	---	---	---	---	---	---	----------------

NXP	■	Product Range NXP = AC drive or inverter unit NXA = Active front-end unit NXB = Brake-chopper unit NXXN = Non Regenerative Front End (NFE)
0000	■	Nominal current 0007 = 7 A 0022 = 22 A 0205 = 205 A etc.
5	■	Nominal mains voltage 5 = 380-500 VAC 6 = 525-690 VAC
A	■	Control keypad A = standard alpha-numeric B = no local control keypad F = dummy panel G = graphical keypad
0	■	Enclosure class 0 = IP00 5 = IP54
N	■	EMC emission levels N = No EMC emission protection; to be installed on enclosures T = Fulfills standard 61800-3 for IT-networks
1	■	Brake chopper 0 = no brake chopper 1 = integrated brake chopper (CH72 (6-pulse) & CH74 only)
S	■	Hardware modifications: supply I = Inverter unit; DC-supply 2 = Active front-end unit S = 6-pulse with A/C chokes Y = 6-pulse with L/C chokes N = 6-pulse, no chokes T = 12-pulse with A/C chokes U = 12-pulse, no chokes W = 12-pulse with L/C chokes R = Low harmonic
W	■	Hardware modifications: cooling W = Liquid-cooled module with aluminium heatsink P = Liquid-cooled module with nickel-coated aluminium heatsink
V	■	Hardware modifications: boards G = Fiber connection, varnished (from CH61) V = Direct connection, varnished If OPT-AF option board is used O = IP54 control box, fiber connection, varnished boards, (from CH61)
A1		Option boards; each slot is represented by two characters: A = basic I/O boards, B = expander I/O boards E = fieldbus boards D = special boards
A2		
00		
00		
E3		
+LCBM	■	Condition Based Monitoring available for MultiPurpose, SIA II and Marine applications

*) Note, the control unit of NX_8 drives need to be supplied with a external 24Vdc power source.



Marine approvals

Type approvals



Delivery based approvals



ClassNK



Option boards

Type	Description	Card slot					I / O signal																								
		A	B	C	D	E	DI	DO	DI/DO	AI (mA/V/±V)	AI (mA) isolated	AO (mA/V)	AO (mA) isolated	RO (NO/NC)	RO (NO)	+10Vref	Therm	+24V/EXT +24V	pt100	KTY84	42-240 VAC input	DI/DO (10...24V)	DI/DO (RS422)	DI ~ 1Vp-p	Resolver	Out +5V/+15V/+24V	Out +15V/+24V	Out +5V/+12V/+15V			
Basic I/O cards (OPTA)																															
OPTA1	DI/DO/AI/AO/ 10V/ 24V						6	1		2		1																			
OPTA2	Relay output (NO/NC)														2																
OPTA3	Relay output + Thermistor input													1	1		1														
OPTA4	Encoder TTL type						2																3/0			1					
OPTA5	Encoder HTL type						2																3/0				1				
OPTA7	Double encoder HTL type																						6/2				1				
OPTA8	*OPTA1 + Analogue signals galvanically isolated as a group*						6	1		2		1				1		2													
OPTA9	OPTA1 + 2,5mm ² connectors						6	1		2		1				1		2													
OPTAE	Encoder HTL type (Divider + direction)														2								3/0				1				
OPTAF	STO, ATEX therm						2									1	1		1												
OPTAK	Sin/Cos encoder interface																							3			1				
OPTAN	DI/AI/AO						6			2		2																			
I/O expander cards (OPTB)																															
OPTB1	Programmable I/O											6						1													
OPTB2	Relay output + Thermistor input															1	1		1												
OPTB4	*Analog input/output Analogue signals galvanically isolated separately*											1		2					1												
OPTB5	Relay output																3														
OPTB8	*Temperature Measurement option PT100*																	1	3												
OPTB9	DI + Relay output						2									1							5								
OPTBC	Resolver, 3xDO (Wide range)																						3/3		1						
OPTBH	*Temperature Measurement option pt100, pt1000, Ni1000, KTY84*																						3	3							
OPTBE	EnDat/SSI/BISS C																														
OPTBL	Advanced safety option						4	2											1												
OPTBM	OPTBL+ HTL/TTL encoder						4	2											1												
OPTBN	OPTBL+ Sin/Cos encoder						4	2											1												
Fieldbus cards (OPTC and OPTE)																															
OPTE2	RS485 with screw terminal																														
OPTE3	PROFIBUS DP with screw terminal																														
OPTE5	PROFIBUS DP with D9-connector																														
OPTE6	CANopen																														
OPTE7	DeviceNet																														
OPTE8	RS485 with D9-connector																														
OPTE9	Dual-port Ethernet																														
OPTEA	Advanced Dual-port Ethernet																														
OPTC4	LonWorks																														
OPTCJ	BACnet MS/TP																														
OPTEC	EtherCAT																														
Communication cards (OPTD)																															
OPT-D1	SystemBus adapt, 2xfibre-optic																														
OPT-D2	SystemBus (1xfiber), isol. CAN																														
OPT-D3	RS232 adapter (no galv.isol.)																														
OPT-D6	CAN-Bus (galv. decoupled)																														
OPT-D7	Line voltage measurement																														



You're covered

with DrivePro® Life Cycle service products



DrivePro® Retrofit

Minimize the impact and maximize the benefit

Manage the end of product lifecycle efficiently, with professional help to replace your legacy drives. The DrivePro® Retrofit service ensures optimal uptime and productivity during the smooth replacement process.



DrivePro® Start-up

Fine-tune your drive for optimal performance today

Save on installation and commissioning time and cost. Get help from professional drives experts during start-up, to optimize drives safety, availability and performance.



DrivePro® Spare Parts

Plan ahead with your spare part package

In critical situations, you want no delays. With DrivePro® Spare Parts you always have the right parts on hand, on time. Keep your drives running at top efficiency, and optimize system performance.



DrivePro® Preventive Maintenance

Take preventive action

You receive a maintenance plan and budget, based on an audit of the installation. Then our experts perform the maintenance tasks for you, according to the defined plan.



DrivePro® Extended Warranty

Long-term peace of mind

Get the longest coverage available in the industry, for peace of mind, a strong business case and a stable, reliable budget. You know the annual cost of maintaining your drives, up to six years in advance.



DrivePro® Remote Expert Support

You can rely on us every step of the way

DrivePro® Remote Expert Support offers speedy resolution of on-site issues thanks to timely access to accurate information. With the secure connection, our drives experts analyze issues remotely reducing the time and cost involved in unnecessary service visits.



DrivePro® Exchange

The fast, most cost-efficient alternative to repair

You obtain the fastest, most cost-efficient alternative to repair, when time is critical. You increase uptime, thanks to quick and correct replacement of the drive.



DrivePro® Remote Monitoring

Fast resolution of issues

DrivePro® Remote Monitoring offers you a system that provides online information available for monitoring in real time. It collects all the relevant data and analyzes it so that you can resolve issues before they affect your processes.



DrivePro® Upgrade

Maximize your AC drive investment

Use an expert to replace parts or software in a running unit, so your drive is always up-to-date. You receive an on-site evaluation, an upgrade plan and recommendations for future improvements.

To learn which products are available in your region, please reach out to your local Danfoss Drives sales office or visit our website <http://drives.danfoss.com/danfoss-drives/local-contacts/>



Need to fit **more power** into less space?

VACON® NXP Liquid Cooled delivers the ultimate in space savings and reliable performance in tough conditions. Ideal for vessels, high altitude applications, or anywhere where space is at a premium. With robust modular design, you can use this platform equally well in motor control or power conversion for hybrid and electrification tasks.

Maximum power for excavating uphill tunnels

FRANCE: Powerful VACON® NXP drives power a tunnel boring machine (TBM) used to dig a tunnel with a 22% gradient.



[Read the case story](#)

Generating energy from green waste to fuel a city

AUSTRALIA: The biochar byproduct of green waste generates renewable energy, with zero emissions.



[Read the case story](#)

Where smart ferry charging begins with a smart grid

NORWAY: Discover how SEAM cut CO₂ emissions by 7000 tonnes each year when electrifying the Hareid-Sulesund ferry route.



[Read the case story](#)

Follow us and learn more about AC drives

