

# PP-100N

## *Administrator's Guide*

M00113600EN

**Disc** producer™

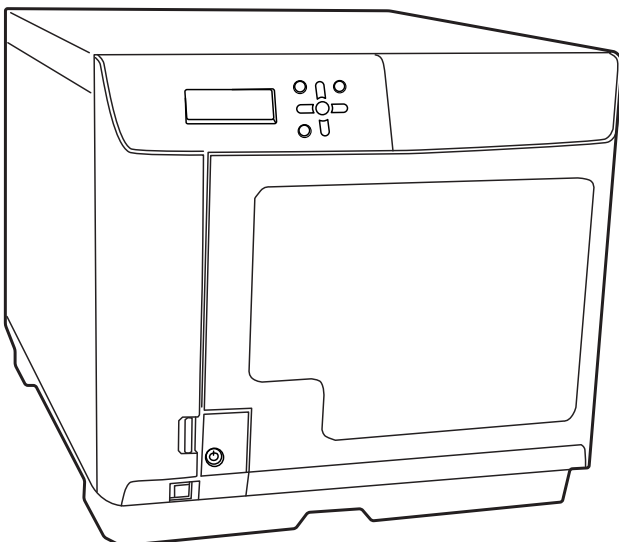

All rights reserved. No part of this publication may be reproduced, stored in a retrieval system, or transmitted in any form or by any means, electronic, mechanical, photocopying, recording, or otherwise, without the prior written permission of Seiko Epson Corporation. No patent liability is assumed with respect to the use of the information contained herein. While every precaution has been taken in the preparation of this manual, Seiko Epson Corporation assumes no responsibility for errors or omissions. Neither is any liability assumed for damages resulting from the use of the information contained herein.

Neither Seiko Epson Corporation nor its affiliates shall be liable to the purchaser of this product or third parties for damages, losses, costs, or expenses incurred by purchaser or third parties as a result of: accident, misuse, or abuse of this product or unauthorized modifications, repairs, or alterations to this product, or (excluding the U. S.) failure to strictly comply with Seiko Epson Corporation's operating and maintenance instructions.

Seiko Epson Corporation shall not be liable against any damages or problems arising from the use of any options or any consumable products other than those designated as Original Epson Products or Epson Approved Products by Seiko Epson Corporation.

**NOTICE:** The contents of this manual are subject to change without notice.

©Seiko Epson Corporation 2019. All rights reserved.

## Trademarks

- Microsoft, Windows, Windows Server, and Internet Explorer are registered trademarks of Microsoft Corporation in the United States and/or other countries.
- EPSON is a registered trademark of Seiko Epson Corporation.
- Exceed Your Vision is a registered trademark or trademark of Seiko Epson Corporation.

All other trademarks are the property of their respective owners and used for identification purpose only.

## Marks used in this guide

The following marks are used in this guide to indicate important information.



Indicates information with which you must comply when using this product. Ignoring this information and mishandling the product may cause it to fail or malfunction.

### **Notes**

Indicates an additional explanation or information we want you to know.

## Screens and Procedures in This Guide

Depending on your environment, the screen shots used in this guide may differ from the actual screens displayed. However, you can still use the same procedures described in this guide.

## Organization of this manual

The following instruction guides are included with this product.

PP-100N Setup Guide	Briefly describes how to set up this product with illustrations. See the <b>PP-100N Administrator's Guide</b> for more information.
PP-100N User's Guide (PDF)	Presents detailed information users need to know such as how to install the software, the product functions and operations, as well as maintenance information. It is included on the Discproducer Utility & Documents Disc.
PP-100N Administrator's Guide (PDF)	Presents detailed information necessary for setting up, operating, and managing this product. It also describes how to troubleshoot various problems.

# Table of Contents

Trademarks.....	2
Marks used in this guide.....	2
Screens and Procedures in This Guide.....	2
Organization of this manual .....	3

## Before Using This Product.....6

■ For safe use .....	6
Cautions for the power source.....	8
Cautions for using .....	9
■ Cautions for CD/DVD discs .....	11
■ Uses of this product.....	11
■ Incidental loss arising from the use of this product.....	11
■ Restriction of Use .....	11
■ Open source software license.....	11

## Preparation .....12

■ Installation.....	12
Installation location requirements .....	13
Installation space .....	13
■ Setup procedure .....	14
■ Connecting the Ethernet cable .....	15
■ Connecting the power cord.....	15
■ Installing the ink cartridges.....	16
■ Setting the security lock switch.....	19
■ Setting the Publish Mode.....	20
Types of Publish Modes .....	20
Installing the stackers.....	23
Setting procedure.....	25
■ Network settings .....	26
■ Registering an administrator.....	31
■ System settings .....	33
Output device settings .....	33
Notification email transmission settings.....	36
Setting the date and time .....	40
■ Setting the language .....	42

## Administration and Management.....43

■ Managing jobs .....	43
Checking job information.....	43
Checking the job processing status.....	44
Pausing jobs .....	45
Resuming jobs .....	46
Canceling jobs .....	47
Priority Publishing.....	48
Deleting jobs .....	49
■ Managing users.....	51
Checking user information.....	51
Registering users .....	52
Changing user information .....	55
Deleting user information.....	57
Changing password.....	58
■ Changing the Publish Mode.....	60

## Maintaining Your Product.....62

■ Backing up and restoring data.....	62
Backing up data .....	62
Restoring data.....	64
■ Restoring to initial state .....	65
■ Checking maintenance information.....	68
Checking device information .....	68
Downloading operation log.....	69

## Troubleshooting.....70

■ Error messages and remedies .....	70
■ Problems and their remedies.....	76
Power/Control Panel problems .....	76
Disc writing problems .....	78
Label printing problems.....	79
Password problems .....	81
Other problems .....	81
■ Checking with EPSON Total Disc Monitor.....	83
■ When discs cannot be published.....	85

■ Disc does not come out.....	87
Drive tray does not come out.....	87
Printer tray does not come out .....	88
■ Disc recording surface is stained with ink .....	91

---

## **Appendix .....94**



■ Where to get help.....	94
Before Contacting Epson.....	94
Help for Users in the United States and Canada .....	94
Help for Users in the Europe (EMEA).....	94
Help for Users in Australia .....	95
Help for Users in Southeast Asia .....	95
■ Product specifications .....	97
Basic specifications.....	97
■ Ink and Disc .....	101
Ink cartridges .....	101
Discs .....	101







# Before Using This Product

## For safe use

- To use this product safely, be sure to read this guide as well as the other instruction guides included with this product before using it.
- Keep this guide at hand so that you can resolve any questions you have about this product.

To prevent harm to customers and other people or damage to property, this guide contains the following symbols and warning displays for operations and use that may be dangerous. Please read the guide after thoroughly understanding this information.





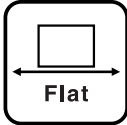
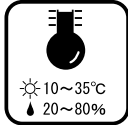

 <b>WARNING</b>	If this display is ignored and the product is mishandled, it may result in death or serious injury.
 <b>CAUTION</b>	If this display is ignored and the product is mishandled, it may result in bodily harm or physical damage.

	Indicates action that should not be performed (prohibited).		Indicates items (instruction, action) that must be performed.
	Indicates that disassembly is prohibited.		Indicates that the plug should be disconnected from the outlet.
	Indicates that touching the product with wet hands is prohibited.		Indicates that the product must be used with the power cord grounded.
	Indicates that the product must not come in contact with water.		













Install this product in the following type of place.

Place that is flat and stable	Place with the following temperature and humidity range
	

<ul style="list-style-type: none"> <li>• <b>When using this product in a place where static electricity is easily generated, use an antistatic mat or other product to prevent static electricity.</b></li> <li>• <b>Do not install on a surface that is smaller than the base of the product.</b> If the rubber bases on the bottom of the product extend beyond this surface, it places stress on the internal mechanisms, which negatively affects disc writing, printing and transporting. Be sure to install on a flat surface that is wider than the product so that all of the feet on the base of the product rest firmly on it.</li> </ul>	
---	---











 <b>WARNING</b>	<p><b>Do not block the air vents on this product.</b> Blocking the air vents may result in internal heat build-up and fire. Do not install in the following types of places.</p> <ul style="list-style-type: none"> <li>• Tight spaces where ventilation is poor, such as in a closet or on a bookshelf</li> <li>• On a rug or bed</li> </ul> <p>If you place the product by a wall, leave more than 10 cm between the back of the product and the wall. It is also necessary to leave enough space in front of the product to open and close the disc cover.</p>	
	<p><b>Do not install in a place where volatile substances, such as alcohol or paint thinner, are present or in a place where there is fire.</b> This may result in electric shock or fire.</p>	
 <b>CAUTION</b>	<p><b>Do not install or store in an unstable place (such as on a wobbly or tilted surface), in reach of children, or in a place subject to vibration from other machines.</b> There is a risk that it could drop or fall over, resulting in injury.</p>	
	<p><b>Do not install in places where there is excessive moisture or dust, risk of getting wet, direct sunlight, severe changes in temperature and humidity, or close to heating and cooling devices.</b> There is a risk of electric shock, fire, and malfunction or failure of this product.</p>	





## Cautions for the power source

 <b>WARNING</b>	<p><b>Do not connect or disconnect the power plug with wet hands.</b> This may result in electric shock.</p>	
	<p><b>Use only the type of power source indicated on the product's label.</b> Use of the wrong type of power source may result in electric shock or fire.</p>	
	<p><b>Do not plug the power cord into an outlet with many other cords connected to it.</b> This may result in heat build-up and fire.</p>	
	<p><b>Do not use a damaged power cord.</b> This may result in electric shock or fire. If the power cord is damaged, consult your dealer for repairs. Observe the following when handling the power cord.</p> <ul style="list-style-type: none"> <li>• Do not modify the power cord</li> <li>• Do not place heavy objects on the power cord</li> <li>• Do not bend, twist or pull the power cord by force</li> <li>• Do not wire heating appliances nearby</li> </ul>	
	<p><b>Be careful when handling the power plug.</b> Mishandling may result in fire.</p> <ul style="list-style-type: none"> <li>• Do not leave plugged into a power source having foreign matter such as dust</li> <li>• Firmly insert the prongs of the power plug all the way</li> </ul>	
	<p><b>When you disconnect the power plug from the outlet, be sure to turn off the power and hold the plug as you pull.</b> If you stretch the power cord, it may become damaged, which could result in electric shock or fire.</p>	
	<p><b>Be sure your AC power cord meets the relevant local safety standard. Also, do not use the power cord included with this product with any other devices.</b> This may result in electric shock or fire.</p>	
	<p><b>For safety reasons, be sure to ground the power cord.</b> The power code included with the product is a 3-pin cable with a power system grounding (PE) terminal, so connect it to an outlet with a grounding electrode and ground it securely.</p>	
	<p><b>Regularly disconnect the power plug from the outlet and clean the base of the prongs and between the prongs.</b> If you leave the power plug connected to an outlet for a long time, the base of the power plug prongs may become dusty, which may result in short circuit and fire.</p>	
 <b>CAUTION</b>	<p><b>For safety, be sure to disconnect the power plug from the outlet when you will not be using the product for a long time.</b></p>	



## Cautions for using

 <b>WARNING</b>	<p><b>Do not continue to use under abnormal conditions such as smoke, unusual odors or sounds.</b></p> <p>This may result in electric shock or fire. Immediately turn off the power, disconnect the power plug from the outlet, and contact your dealer or the Epson Repair Center about repairs. Servicing the product yourself is dangerous, so never attempt it.</p>	
	<p><b>If a foreign object, water or other liquid enters the product, do not continue to use it.</b></p> <p>This may result in electric shock or fire. Immediately turn off the power, disconnect the power plug from the outlet, and contact your dealer or the Epson Repair Center about repairs.</p>	
	<p><b>Do not attempt to service the product yourself.</b></p> <p>This may result in injury, electric shock, fire or malfunction.</p>	
	<p><b>Do not use flammable gas sprays inside or around this product.</b></p> <p>There is a risk that gas will build up and a spark may cause a fire.</p>	
	<p><b>Do not connect the cables (cords) to the product in a way other than that specified in the instruction guide.</b></p> <p>This may result in fire. Also, the connected devices may be damaged.</p>	
	<p><b>Do not insert or drop metal or flammable objects into the air vents or other openings.</b></p> <p>This may result in electric shock or fire.</p>	
	 <b>CAUTION</b>	<p><b>Do not step or place heavy objects on top of the product.</b></p> <p>Be especially careful in households with small children. There is a risk that it could fall over or break, resulting in injury.</p>
<p><b>When connecting this product to a computer (or other devices) using a cable, be careful to orient the connector the right way.</b></p> <p>The connectors on the cables have a specific orientation. If you connect incorrectly oriented connectors to both this product and the computer (or other devices), this may result in the malfunction of both connected devices.</p>		
<p><b>Do not connect a telephone line to the Ethernet interface connector.</b></p> <p>This may result in damage to the telephone line or this product.</p>		
<p><b>When storing or transporting this product, do not tilt it, stand it on end, or turn it upside down.</b></p> <p>When transporting the product, be sure to package it in the original box to protect it from any impact.</p>		

	<p><b>For safety reasons, if you move this product, first check that the power is off, the power plug is disconnected from the outlet, and all of the wires are disconnected.</b></p>	
	<p><b>When replacing the ink cartridges, be careful that the ink does not contact your eyes or skin.</b> If ink gets into your eyes, immediately flush them with water, and if it gets onto your skin, immediately wash the area with soap and water. Otherwise you may have bloodshot eyes or a mild inflammation. In the rare event that there is a problem, immediately consult a physician.</p>	
	<p><b>Do not disassemble the ink cartridges to replenish or refill the ink.</b></p>	
	<p><b>Do not shake the ink cartridge too hard.</b> The ink cartridge may leak if you shake it too much.</p>	
	<p><b>Store ink cartridges out of the reach of children. Also, do not ingest the ink.</b></p>	

## ***Cautions for CD/DVD discs***

Before using this product, run an operation check to make sure it is functioning normally. Also, back up the data on CD/DVD discs onto separate media as necessary. Data may be damaged or lost at the following times:

- When there is static electricity or electrical noise
- During improper use
- During a malfunction or repair
- When there is damage due to a natural disaster

Even if the product is still under warranty, Epson accepts no responsibility for data that is lost or damaged due to causes not limited to those listed above.

## ***Uses of this product***

This product is for business use and not for household use.

## ***Incidental loss arising from the use of this product***

Should you not obtain the results you expect from this product, including the bundled software, we cannot provide compensation for incidental loss arising from that fact, such as expenses required for the use of this product and lost earnings that would have been gained through the use of this product.

## ***Restriction of Use***

When this product is used for applications requiring high reliability / safety, such as transportation devices related to aviation, rail, marine, automotive, etc.; disaster prevention devices; various safety devices, etc.; or functional / precision devices, etc., you should use this product only after giving consideration to including fail-safes and redundancies into your design to maintain safety and total system reliability. Because this product was not intended for use in applications requiring extremely high reliability / safety, such as aerospace equipment, main communication equipment, nuclear power control equipment, or medical equipment related to direct medical care, etc., please make your own judgment on this product's suitability after a full evaluation.

## ***Open source software license***

This product uses open source software in addition to Epson proprietary software. For a list of the open source software used in this product as well as license terms for this software, see Open Source Software License Agreement on the Discproducer Utility & Documents Disc included with the product.

# Preparation

## Installation

Install this product in a suitable location with adequate space.



- **Make sure that the product is lifted by two people.**

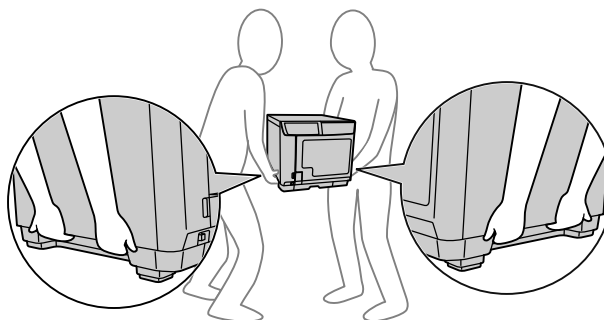

- The weight of this product is approximately 26 kg. When this product is lifted, it should be lifted on both sides by two people holding the recesses on the sides as shown in the illustration on the left. Holding any part other than the ones indicated in the illustration on the left when carrying the product may result in damage to the product. In particular, carrying the product while the disc cover, ink cartridge cover, or Stacker 4 is open may result in the product being dropped, or deformed and damaged.

Furthermore, when putting down this product, take care not to trap a finger between the product and installation surface.

- **When lifting this product, make sure that, for example, you sufficiently bend your knees and your posture is such that excessive stress is not placed on your body.**  
An unnatural posture when lifting the product may result in an injury, or the product being damaged.
- **When moving the product, do not tilt it 10 or more degrees in a forward or backward direction, or sideways direction.**  
The dropping or other mishandling of the product may result in an accident.
- **Do not place a heavy object on the top of the product.**  
Subjecting this product to excessive force may result in a malfunction.  
However, it is possible to place one unit of this product on top of another. In such a case, make sure the tops and bottoms are oriented the same, and the exterior of the units are aligned.  
**Take sufficient care to prevent a unit from dropping or falling. Also, do not place more than one unit on top of another.**



- In a location where static electricity is easily generated, use an antistatic mat and other product to prevent static electricity.
- Do not install this product in locations with large amounts of dust, dirt, or cigarette smoke.
- Do not use or store in high-temperature, high-humidity environments. This can cause the label surfaces to blur and stick together.

## Installation location requirements

Install this product in the following type of location.

- Flat, stable location that can fully support the product weight (approx. 26 kg)
- Location that is wide enough to fully hold the product base
- Location where the air vents on the product are not blocked
- Location where the product is not subjected to vibrations or jolts
- Location where the product has access to its own dedicated power outlet
- Location that allows disc loading and unloading
- Location with sufficient space for attaching accessories, replacing consumables, and enabling regular maintenance and care
- Location that satisfies the following requirements

Temperature	Operation: 10 to 35°C, Storage: -20 to 40°C (Less than one month if at 40°C)
Humidity	Operation: 20 to 80% RH, Storage: 5 to 85% RH (no condensation)

## Installation space

Provide enough installation space for facilitating the installation work. If you place the product by the wall, leave more than 10 cm between the back of the product and the wall. It is also necessary to leave enough space in front of the product to open and close the disc cover.

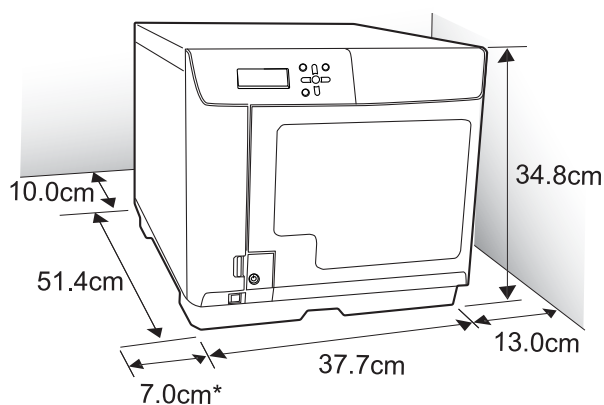

\* Be sure to leave at least 7 cm on the product left side for opening the ink cartridge cover.

## Setup procedure

This section describes the setup procedure for this product (PP-100N).



Before starting setup, check that all protective tape and protective materials attached to this product have been removed. See *PP-100N Setup Guide* for the procedure to remove the protective materials.

1. *Connecting the Ethernet cable on page 15 in this guide*



2. *Connecting the power cord on page 15 in this guide*



3. *Installing the ink cartridges on page 16 in this guide*



4. *Setting the security lock switch on page 19 in this guide*



5. *Setting the Publish Mode on page 20 in this guide*



6. *Network settings on page 26 in this guide*



7. *Registering an administrator on page 31 in this guide*



8. *System settings on page 33 in this guide*

After setup of this product is complete, install the software required for using this product to the client computer. See the *PP-100N User's Guide* for details on the installation procedure.

### Notes

If you are using more than one unit of this product in the same environment and back up the first unit and then restore the backup data on the second and subsequent units, the configuration information of the first unit is saved, so you do not need to perform the following work. See "Backing up and restoring data" on page 62 in this guide for details on the backup and restoration procedure.

- "Output device settings" on page 33 in this guide
- "Notification email transmission settings" on page 36 in this guide
- "Registering users" on page 52 in this guide

## Connecting the Ethernet cable

Connect the Ethernet cable to the Ethernet interface connector on the rear side.

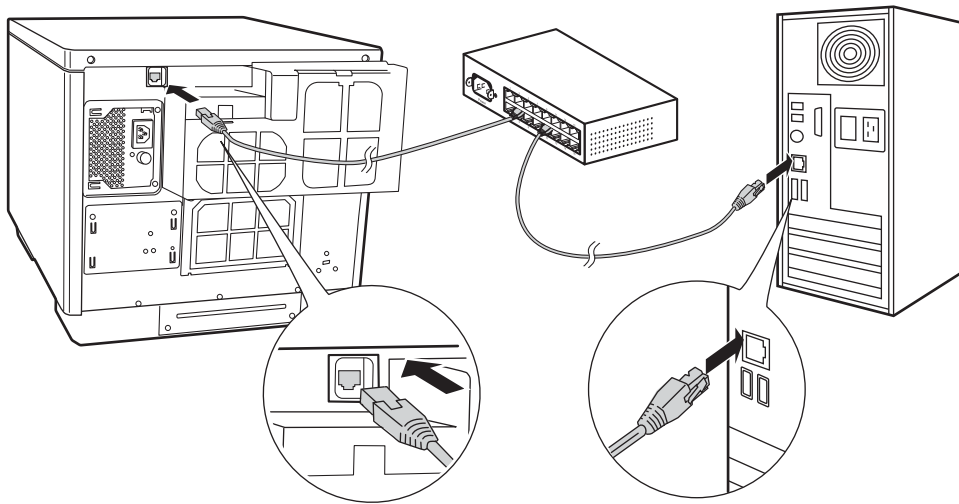

## Connecting the power cord

- 1 Connect the power cord connector to the AC inlet on the product rear side. (See (1) in the figure below.)
- 2 Insert the power plug into the outlet. (See (2) in the figure below.)

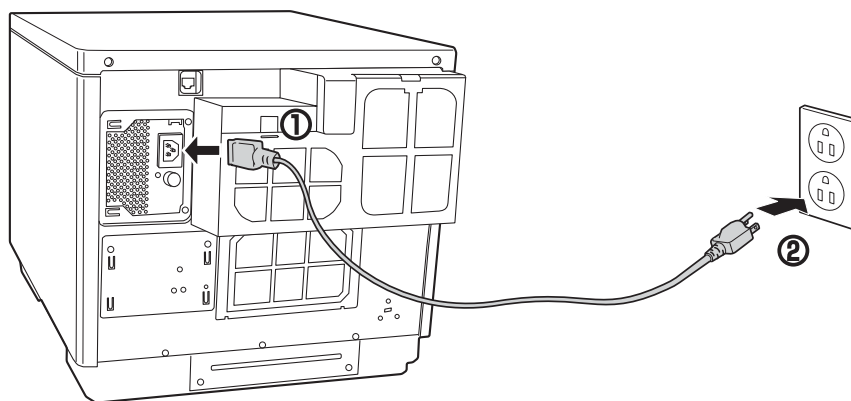

## Installing the ink cartridges

This section describes the procedure for installing the ink cartridges for the first time.

See “Changing the ink cartridge” in the *PP-100N User’s Guide* for the procedure to change the ink cartridge in daily operation.



- Use of Epson brand ink cartridges is recommended. Use of non-Epson brand ink cartridges can result in problems that will not be covered by the warranty.
- Epson cannot guarantee the quality and reliability of non-Epson brand products. Repairs for any damage or breakdown of this product due to the use of non-Epson brand products will not be free of charge even if the warranty period is still valid.
- This product performs color adjustment based on use of Epson brand ink cartridges. Use of non-Epson brand ink products can adversely affect the printing quality and prevent the product from realizing its maximum performance.
- Do not store ink cartridges in environments exposed to high temperatures, freezing temperatures, or to direct sunlight.
- Even when Black is selected in the printer driver, all the ink colors are used in an operation designed to maintain the printing and print head quality.

- 1 Open the ink cartridge cover by pressing the knob at the bottom right of the cover.

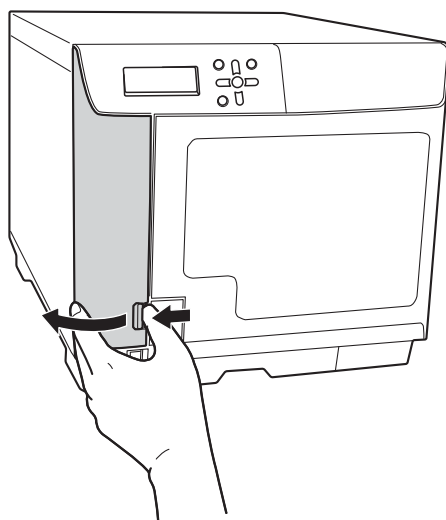



## 2 Remove the ink cartridge from its package.

- The first time you install ink cartridges, use the ink cartridges supplied with the product or use ink cartridges in which there is a sufficient amount of ink remaining.
- For optimum printing quality, do not open the transparent plastic package until immediately before installation. Also, after opening the package, try to use it up within six months. Using an ink cartridge that has been left opened for an extended period of time can result in poor printing quality.
- When opening the plastic package, be careful that the ink cartridge does not drop. This could cause the ink to leak.
- Do not place the ink cartridge with the ink supply holes facing downward. This could cause stains on a desk or other surface. Also, dust and other substances can adhere to the ink cartridge so that it does not function properly.
- Do not shake the ink cartridges too hard. The ink cartridges may leak if you shake them around too much.
- Do not touch the green chip section attached to the ink cartridge. Also, never peel off the labels and film affixed to the ink cartridge. This could prevent proper installation, operation, or printing with the ink cartridge, and cause a leak.

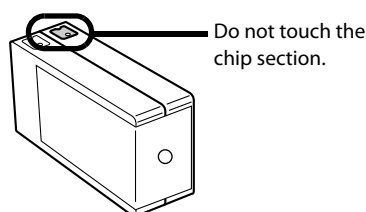

- Use up the ink cartridge before the expiration date labeled on the ink cartridge.

## 3 Insert all six color ink cartridges into the ink cartridge holders by gently pressing them in until they click into place.

Check the label color of the ink cartridge and the label color of the ink cartridge holder, and install the ink cartridge in the same color position.

Press  section of the ink cartridge, and push straight in firmly.

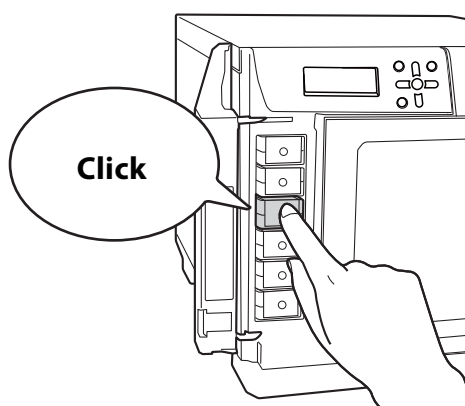

Install all six ink cartridges. If any of the colors is not installed, disc publishing (writing/printing) cannot be performed.

#### 4 Close the ink cartridge cover.

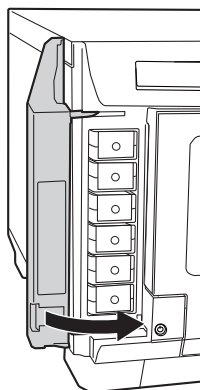

#### 5 Press the power button to turn on the power.

The Power LED flashes, and ink filling (loading ink) is started.

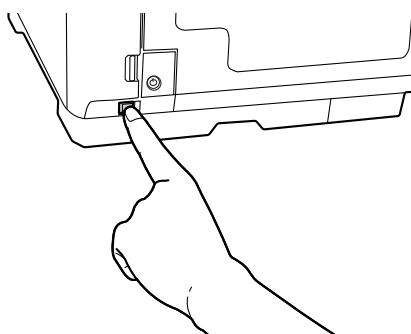

- When using for the first time, the product operates to prepare the internal components of the product (loading ink).
- While ink is being loaded (approximately 5 minutes), do not turn off the power or open the ink cartridge cover. These actions would make it necessary to perform the loading ink operation again, resulting in the consumption of a substantial amount of ink. Also, printing may be unable to be performed properly.
- If the ink cartridges are not recognized even though they are installed correctly, dust or another object may be adhering to the green chip surface. Use a soft cloth to wipe off the object, and then reinstall the cartridge.
- If printing cannot be performed properly even though the ink cartridges are installed, perform head cleaning. See "Head cleaning" in the *PP-100N User's Guide* for details on the head cleaning procedure.
- When the power is turned off using the power button on the main unit, the print head is automatically capped to prevent drying of the ink. After the ink cartridge is installed, be sure to use the power button on the main unit to turn off the power whenever the product is not used. Do not disconnect the power plug or shut off the circuit breaker while the power is still on.
- If moving or transporting the product after the ink cartridges are installed, leave them installed during the moving or transporting process.
- The ink cartridges should only be removed when replacing them.

#### Notes

When the ink cartridges are installed for the first time (during setup), ink is consumed for filling (loading ink), and so the ink cartridge will need to be replaced earlier than normal.

## Setting the security lock switch

Set the security lock switch for automatically locking the disc cover. In the initial state, the security lock switch is set to off.

- 1 Open the disc cover.

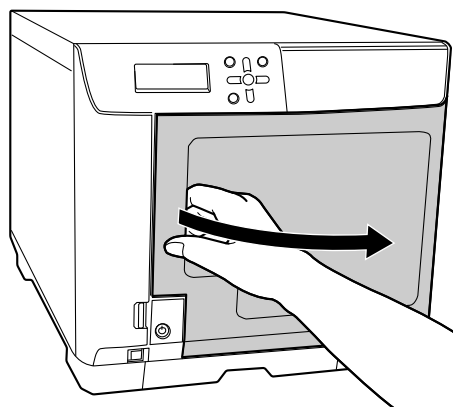

- 2 Set the security lock switch to ON or OFF.

When set to ON: The disc cover is locked automatically each time it is closed. To unlock the lock, use the disc cover key.

When set to OFF: The disc cover is always unlocked.

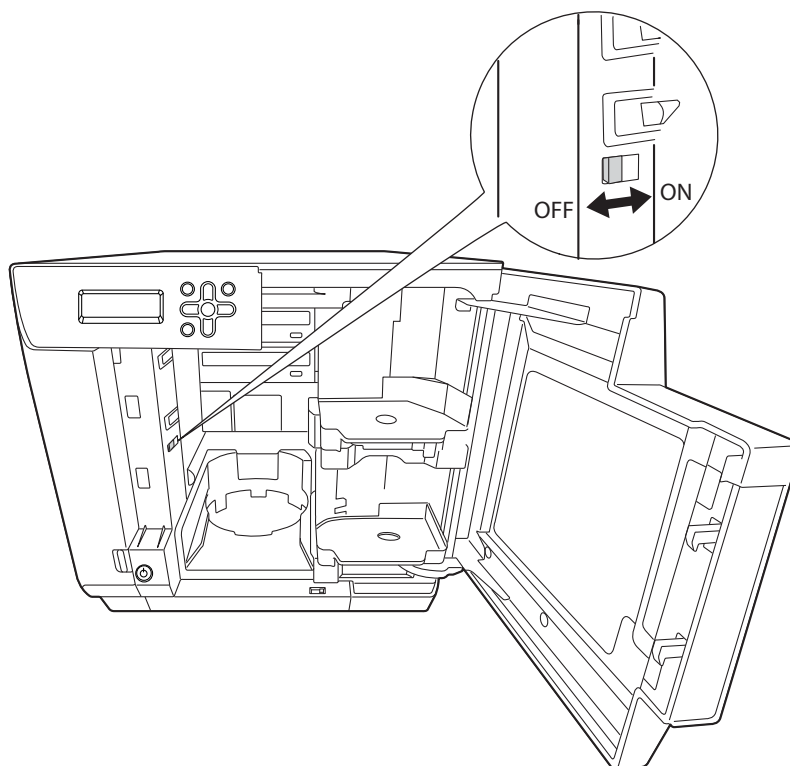

## Setting the Publish Mode

This product has the following Publish Modes: Standard Mode, External Output Mode, and Batch Mode. Select the mode that is used based on the disc publishing quantity and application. Mount the stackers based on the selected mode, and set the Publish Mode.

### Types of Publish Modes

#### Standard Mode

This mode uses Stacker 1 as the input stacker for discs. You can select Stacker 2 or Stacker 4 as the output stacker.

If you select Stacker 2 as the output stacker, you can publish up to 50 discs without having to replenish the discs or take out published discs.

If you select Stacker 4 as the output stacker, you can easily take out published discs without even having to pause a job during publishing.

Repeatedly replenishing and removing discs allows for the continuous publishing of up to 1,000 discs.

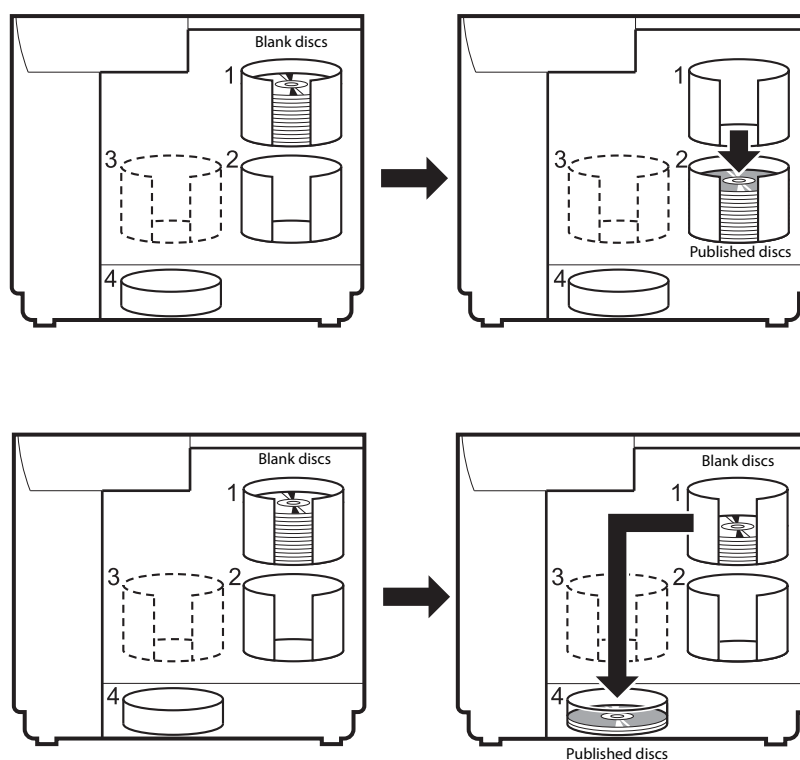

## External Output Mode

You can select Stacker 3 or Stacker 4 as the output stacker. If you select Stacker 4 as the output stacker, you can easily take out published discs without even having to pause a job during publishing. The External Output Mode allows you to use the product in the following ways according to the application.

- Loading a different type of disc into each stacker

If, for example, CD-Rs are loaded in Stacker 1 and DVD-Rs are loaded in Stacker 2, a publisher can just select a stacker as necessary to publish the required discs without having to change the discs.

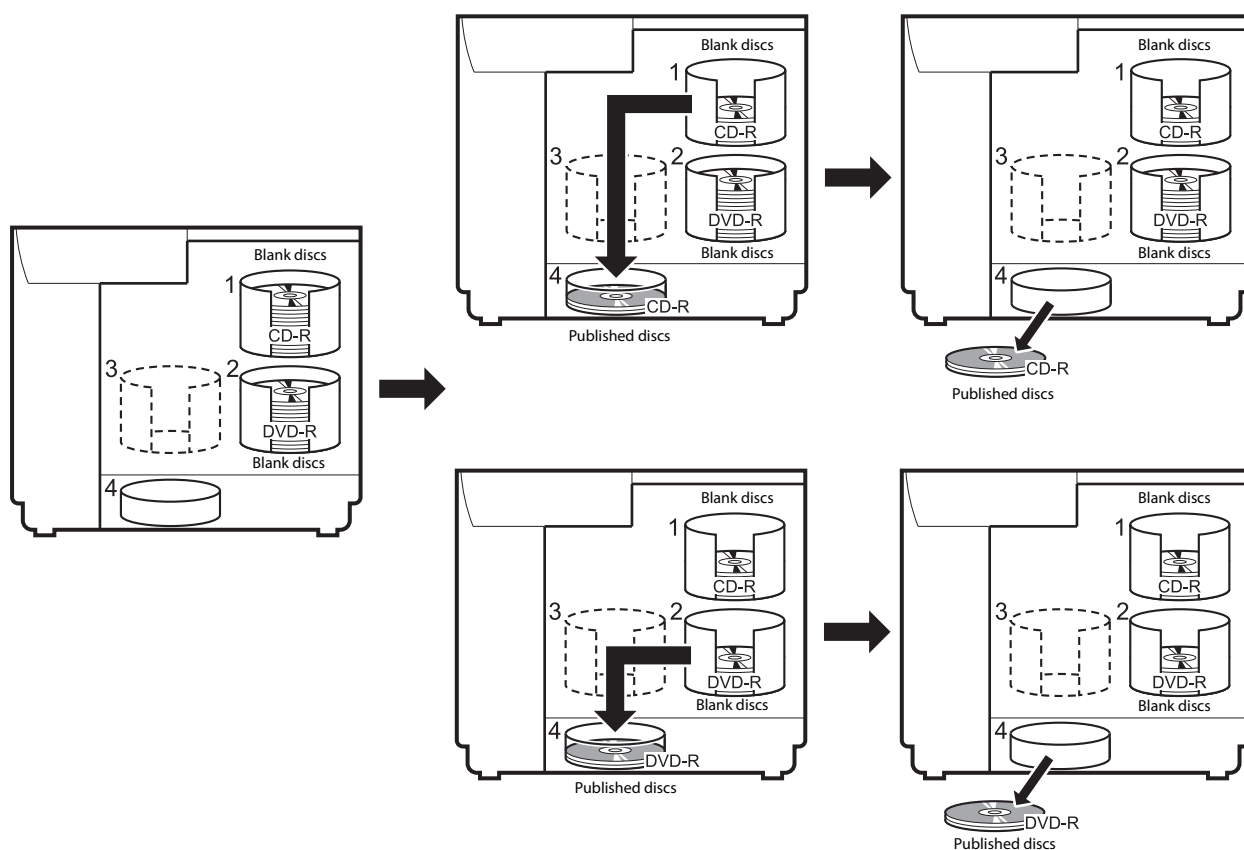

- Continuous publishing of the same type of disc

If the same type of discs are loaded in Stacker 1 and Stacker 2 and [Auto] is selected for the input stacker setting, up to 100 CDs/DVDs can be continuously published by taking out published discs without replenishing discs. Up to 1000 CDs/DVDs can be continuously published in a single job by replenishing discs and taking out published discs.

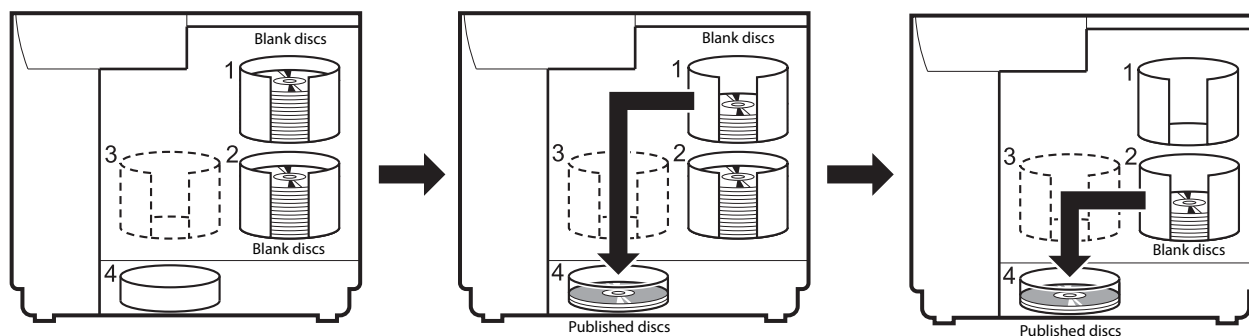

## Batch Mode

This mode uses Stacker 1 and Stacker 2 as the input stackers for discs, and Stacker 2 and Stacker 3 as the output stackers.

Loading 50 discs in each of Stacker 1 and Stacker 2 allows for the continuous publishing of 100 copies of the same disc without having to replenish the discs or take out published discs. Repeatedly replenishing and taking out discs allows for the continuous publishing of up to 1,000 discs. If you use this mode, be sure to insert Stacker 3.

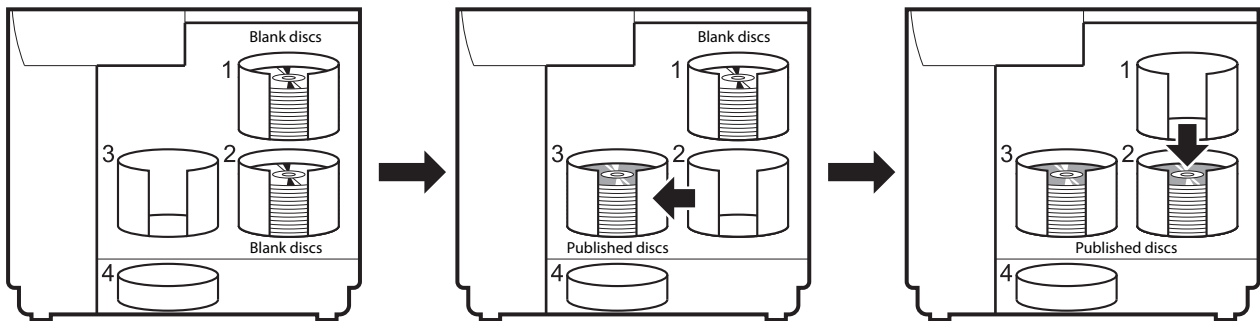

## Installing the stackers

After the Publish Mode is determined, use the procedure below to install the stackers for the selected mode.

- 1 Insert Stacker 1 by aligning with the recesses.

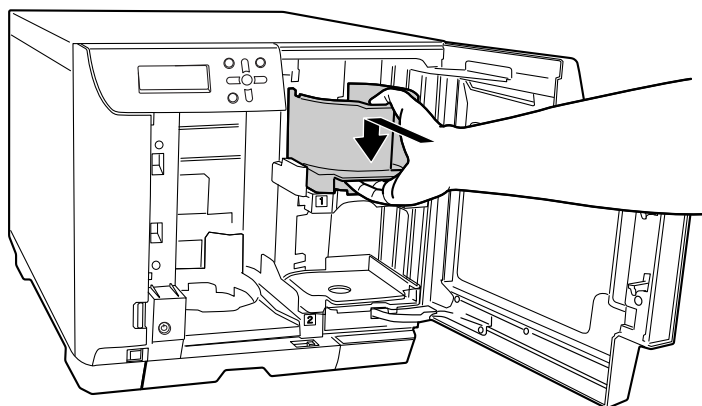

- 2 Insert Stacker 2 by aligning with the recesses.

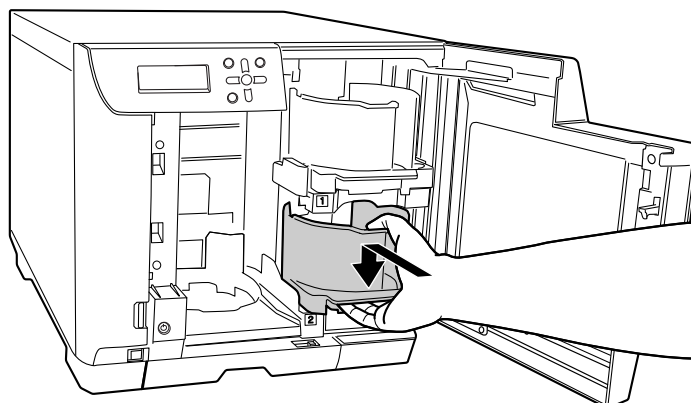

- 3** If using Batch Mode, or when Stacker 3 is set as the output stacker in External Output Mode, grasp the handle of Stacker 3, and insert by aligning with the recesses.

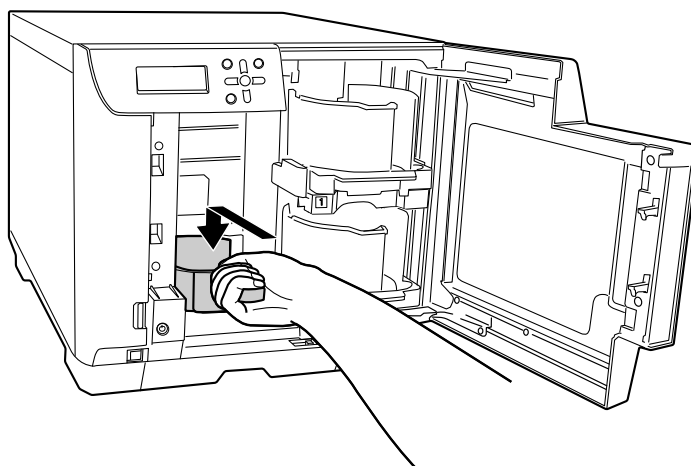

- When using Stacker 3, set the lock lever to the [LOCK] position, and do not pull out Stacker 4.

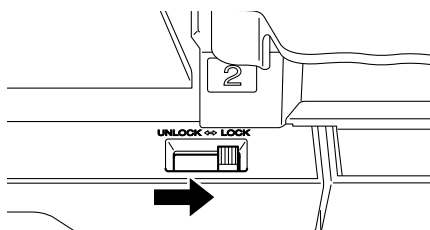

- Stacker 3 is not used in Standard Mode and when Stacker 4 is set as the output stacker in External Output Mode. Set the lock lever to the [UNLOCK] position.

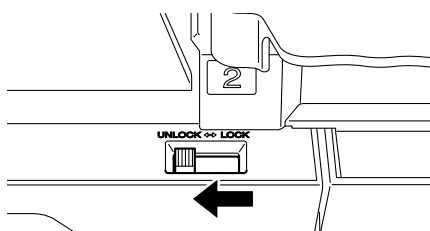

- 4** Close the disc cover.

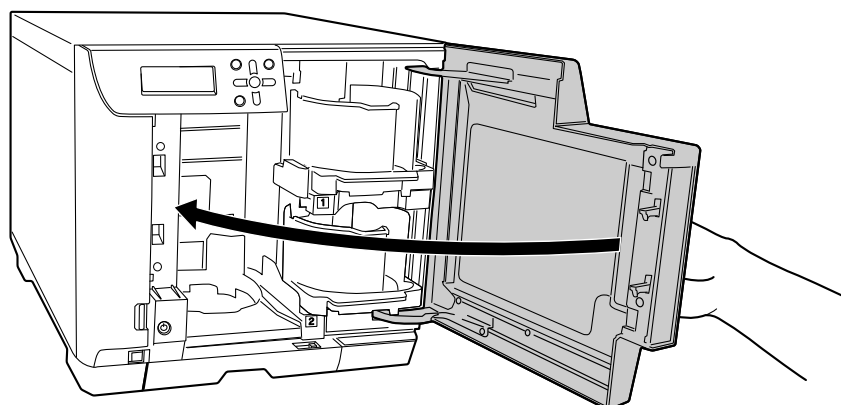



## Setting procedure

After installing the stackers, use the procedure below to set the Publish Mode.

- 1 In the mode selection screen displayed on the LCD, use ▲/▼ to display the Publish Mode to use, and press the ↵ button.

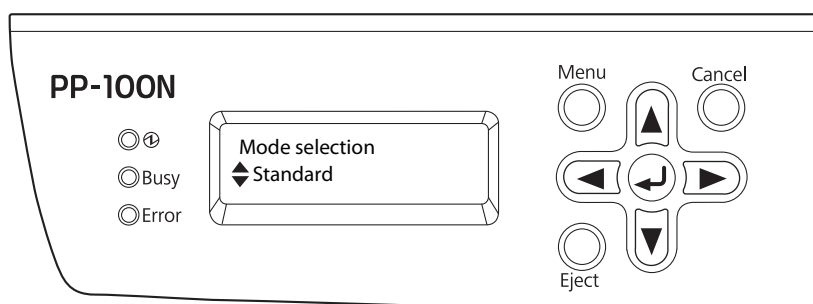

- 2 When the confirmation message appears, press the ↵ button.

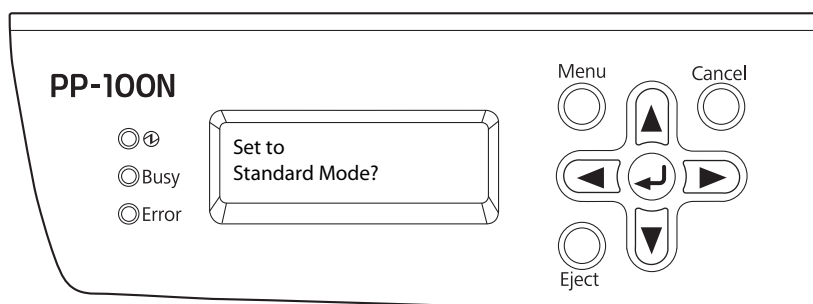

The initialization operation begins. Initialization takes two to three minutes.

When initialization is finished, [Please register an administrator] appears on the LCD.



- Never turn the power off during initialization.
- An administrator needs to be registered to use this product. After you finish configuring the network settings (see page 26 in this guide), be sure to register an administrator. See "Registering an administrator" on page 31 in this guide for the procedure for registering an administrator.
- The operation of this product differs depending on the Publish Mode setting. To prevent the occurrence of an unexpected warning or error, check that the correct Publish Mode has been set after you set or change the Publish Mode.

### Notes

After you set the Publish Mode, you can change the language setting for messages displayed on the LCD of this product from English to Spanish, French, Italian, Dutch, Portuguese, Japanese, or German. See "Setting the language" on page 42 in this guide if you want to change the language setting.

## Network settings

The network can be set in the following two ways.

- Performing an operation from a PC
- Performing an operation with the product's control panel

When performing the setup for the first time, carry out the network setup using the control panel.

### Notes

The network settings cannot be made using a computer until an administrator is registered. See page 31 in this guide for the procedure to register the administrator.

### Performing an operation with the product's control panel

- 1 Press the MENU button.  
The top menu appears.
- 2 Use the ▲/▼ buttons to display the Network settings ("Top menu Network") screen, and press the ↶ button.

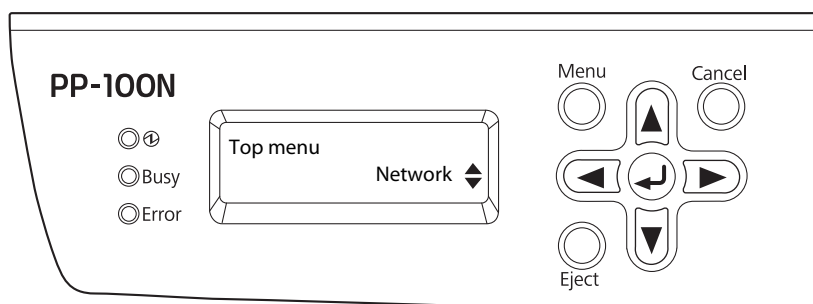

- 3 Use the ▲/▼ buttons to display the change settings ("Network Change settings") screen for the network, and press the ↶ button.

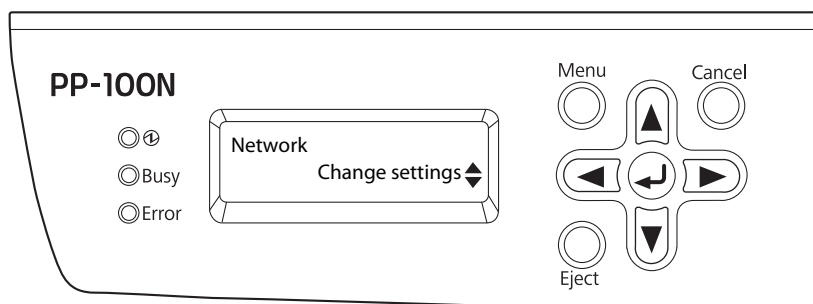

- 4 Use the ▲/▼ buttons to display the change settings (“Change settings IP address”) screen for the IP address, and press the ↵ button.

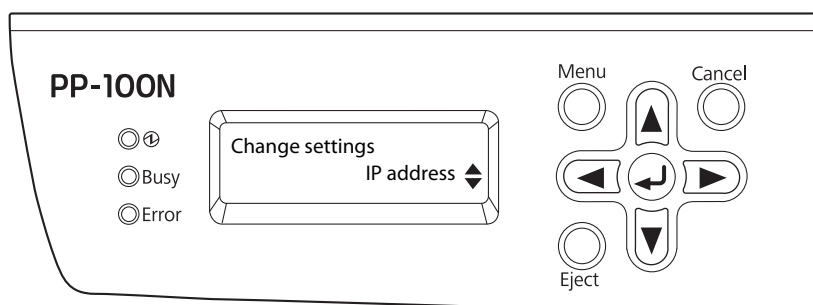

- 5 Use the ▲/▼ buttons to select the setting method, and press the ↵ button.

When “Manual” is selected: The settings are made manually. Proceed to step 6.

When “Auto” is selected: The network settings are made automatically by DHCP. Proceed to step 9.

When “Manual” is selected

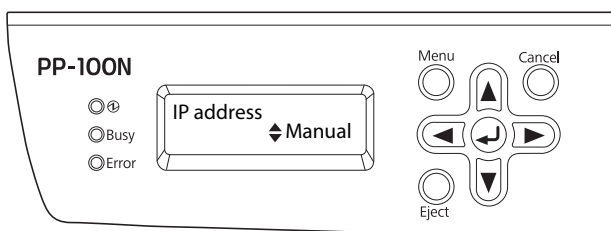

When “Auto” is selected

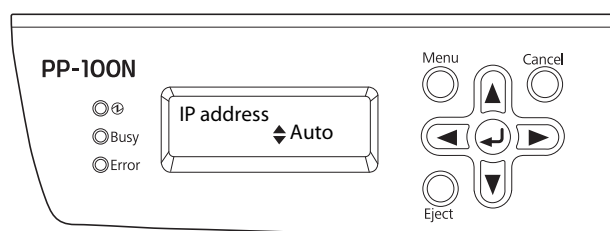

- 6 Use the ▲/▼/ ◀ / ▶ buttons to enter the IP address, and press the ↵ button.

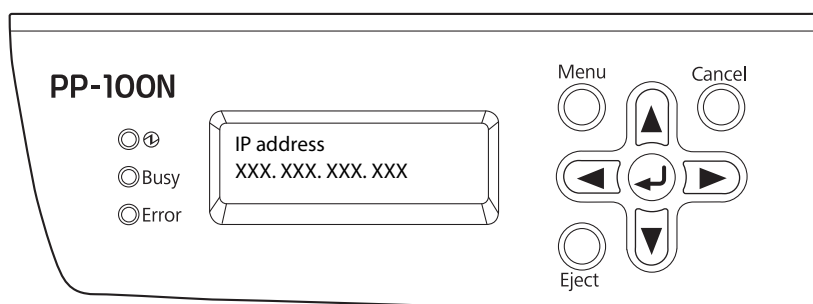

- 7 Use the ▲/▼/ ◀ / ▶ buttons to enter the subnet mask, and press the ↵ button.

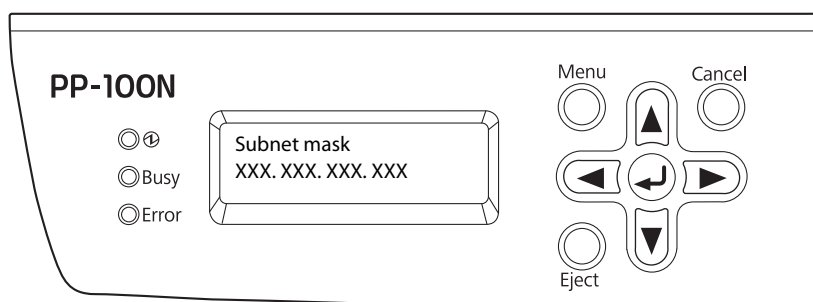

- 8 Use the ▲/▼/ ◀ / ▶ buttons to enter the default gateway, and press the ↵ button.

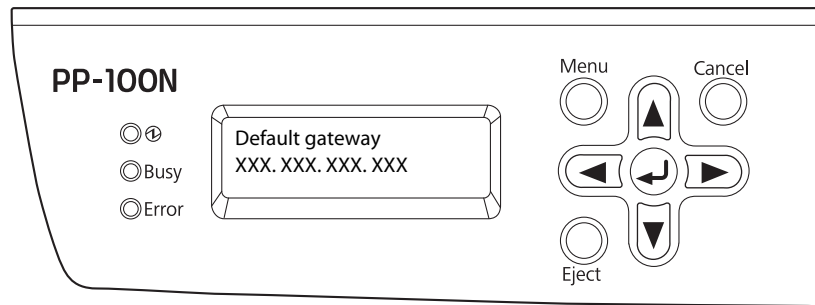

- 9 When the change setting confirmation message (“Change network settings?”) appears, press the ↵ button.

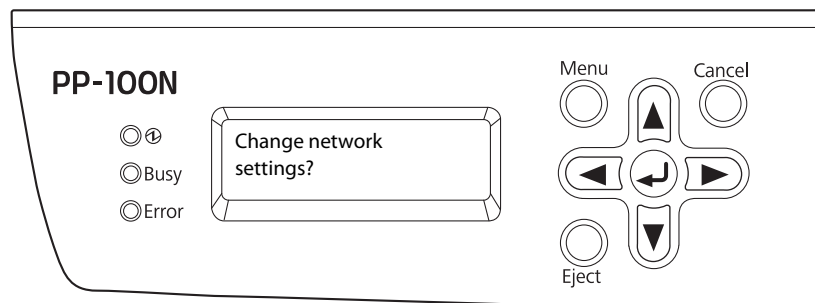

**Notes**

- If necessary, set the Jumbo Frame. (“Top menu” - “Network” - “Change Settings” - “JUMBO FRAME”) In the initial state, Jumbo Frame is set to off.
- If [Receiving job Cannot proceed] appears on the LCD, wait until job processing is finished and then try again.

## Performing an operation from a PC

### Notes

- The network settings first become able to be set using a PC when an administrator is registered after the network settings have been set using the control panel. See page 31 in this guide for the procedure for registering an administrator.
- The link speed and Jumbo Frame cannot be set using a PC. Use this product's control panel ("Top menu" – "Network" – "Change settings" – "Link speed/JUMBO FRAME").

- 1 Log in to EPSON Total Disc Net Administrator.  
See "Logging in to EPSON Total Disc Net Administrator" in the *PP-100N User's Guide* for the login procedure.
- 2 Click the [Network] tab in the [System settings] screen.

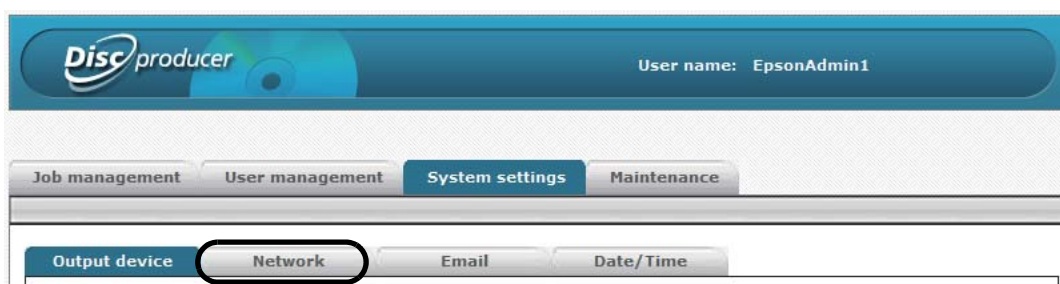

- 3 Either manually enter the IP address, DNS server setup method, and host and domain name setup method, or set them to [Auto], and click [Save].

**4** Click [OK].

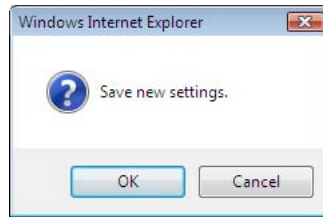

## Registering an administrator

Register an administrator who will administer and manage the product. After registering the administrator, other users who will use the product can be registered. (See “Registering users” on page 52 in this guide for the procedure to register the user.)

- 1 Start Internet Explorer on the computer, and enter the IP address (`http://xxx.xxx.xxx.xxx`) that was set for the product into the address bar.

In this example, we enter `http://192.168.192.168`.



Total Disc Net Administrator may not start correctly depending on your environment. If this happens, add this product's IP address to your "Trusted sites" or "Local Intranet".

### Notes

The IP address setting can be checked with the product's control panel (“Top menu” – “Network” – “Check settings”).

- 2 Enter the user name and password, and then enter the password again for confirmation, and click [Save].

The screenshot shows the 'Disc producer' logo at the top. Below it is a 'User registration' form with the following fields:

- User name\***: Input field containing 'EpsonAdmin1'.
- Password\***: Input field with masked characters (dots).
- Confirm password\***: Input field with masked characters (dots).
- Full name**: Empty input field.
- Email address**: Empty input field.
- Authority**: Radio button selection with 'Administrator' selected.

A note at the bottom left of the form states: '\*are required fields.' A 'Save' button is located at the bottom right.



- Enter 5 to 16 alphanumeric characters for the user name.
- Enter 5 to 16 alphanumeric characters or symbols (", " -", " \_") for the password.
- The password is case-sensitive.
- Do not set a date of birth, employee number, or anything else that is easy to guess for the password.
- Manage the password so that it cannot be used by anyone other than you.

**Notes**

- The user name and password that were set are used to log in to EPSON Total Disc Net Administrator.
- Enter a full name and email address if necessary. An email address needs to be entered if notification email transmission is set. See “Notification email transmission settings” on page 36 in this guide for details on the notification email transmission settings.
- See “Registering users” on page 52 in this guide for details on registration of the second and subsequent administrators.

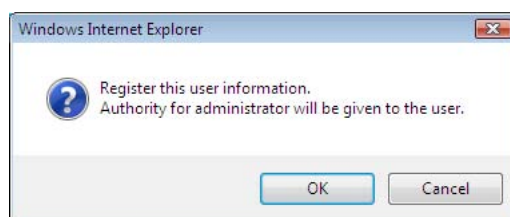
**3** Click [OK].

After registration of the administrator is completed, the administrator is automatically logged in to EPSON Total Disc Net Administrator, and the top screen ([Job management] screen) is displayed.

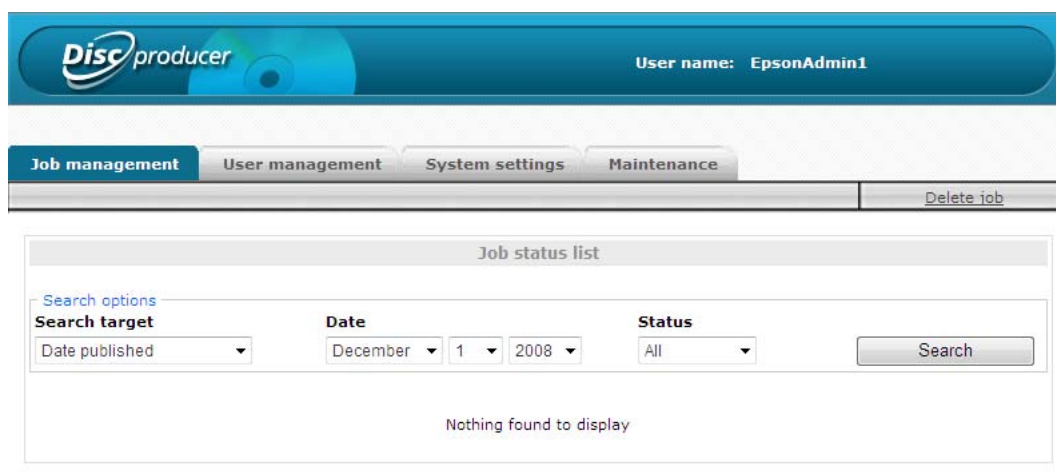
**Notes**

- Clicking the [User management] tab displays the user list where you can check that the administrator is registered correctly.
- Clicking [Edit] allows you to change the full name and email address of the administrator.
  - In this case, clicking [Delete] does not delete the user information because only one administrator is registered. At least one administrator must be registered at all times.



## System settings

Make the settings to match the usage purpose and operating environment of the product.

### Output device settings

This is used to select the type of disc that is used, make the drive settings, and make the settings when a write error occurs.

- 1 Log in to EPSON Total Disc Net Administrator.  
See “Logging in to EPSON Total Disc Net Administrator” in the *PP-100N User’s Guide* for the login procedure.
- 2 Click the [System settings] tab.



- 3 Set the information for each item, and click [Save].

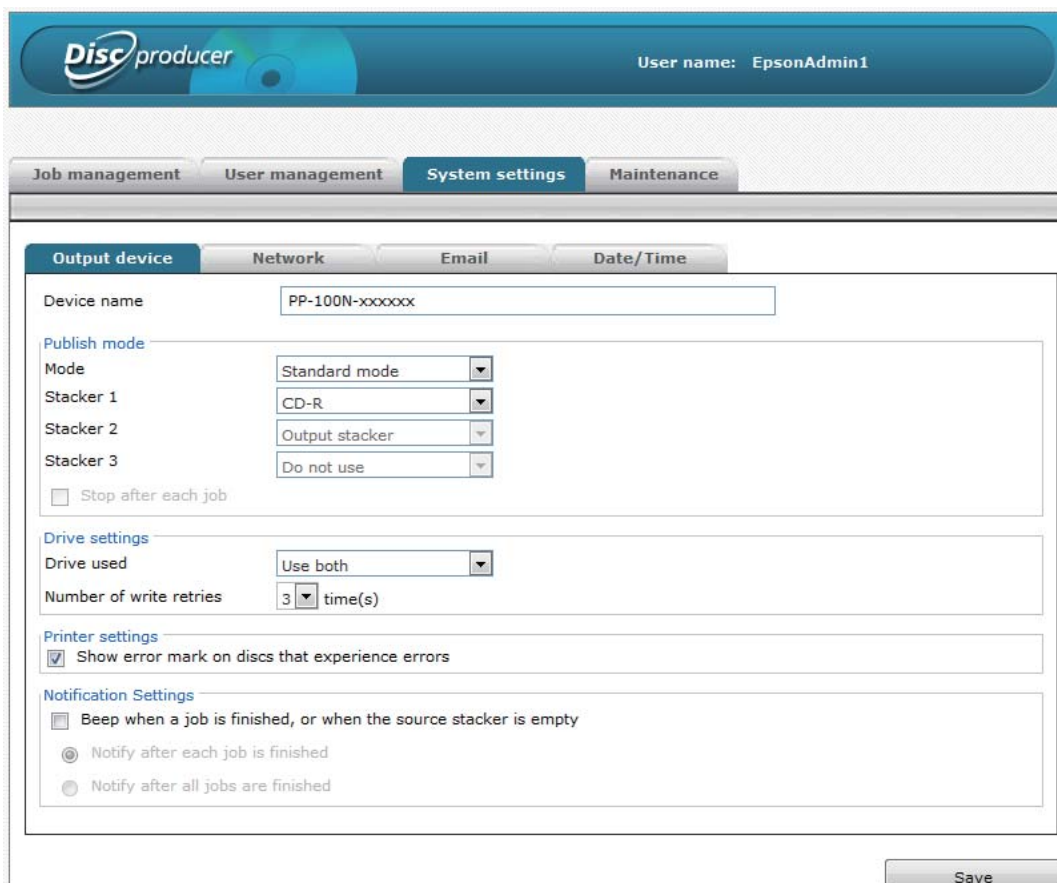

### Device name:

The name of the connected product can be set.

### Publish Mode

- Mode: This displays the Publish Mode that was set. The Publish Mode can also be changed.
- Stacker 1: Select the type of disc that is used.
- Stacker 2: If set to External Output Mode, select the type of disc that is used.
- Stacker 3: If set to External Output Mode, select either one of the following options:

Item	Description
Output stacker	Select if you want to eject published discs to Stacker 3.
Do not use	Select if you want to eject published discs to Stacker 4.

- Stop after each job (when set to Batch Mode)

If you check this check box, publishing process stops after each job. Taking out published discs (operating Stacker 2) starts processing the next job.

<b>Notes</b>	<ul style="list-style-type: none"> <li>• If Standard Mode is selected, [Stacker 2] displays [Output Stacker].</li> <li>• If Batch Mode is selected, [Stacker 2] displays the disc type selected for [Stacker 1].</li> <li>• See "Changing the Publish Mode" on page 60 in this guide to change the Publish Mode.</li> <li>• If you remove and install Stacker 2 in Batch Mode, the next job is started with Stacker 2 as the output stacker even when published discs remain in it. If you check for [Stop after each job], you can avoid such a trouble by taking out published discs after each job, when more than one users are sharing this product.</li> </ul>
--------------	--

### Drive settings

- Drive used: Select the drive that will be used from the drives below.

Item	Description
Use both	Both Drive 1 and Drive 2 are used to write the disc. Jobs will be efficiently processed by using two drives. If trouble occurs on either drive and it cannot write data, the other drive will be used automatically.
Use Drive 1 Only	Use only Drive 1
Use Drive 2 Only	Use only Drive 2

- Number of write retries: The number of write retries after an error occurs during disc writing is selected from zero to nine.

**Notes**

- Setting the number of write retries enables a job to be executed again without job processing pausing even if an error occurs during writing. The error disc is output to the output stacker.
- When a write error occurs based on a preset number of write retries, use of the drive is automatically stopped, and [Drive operation paused DRV1/2] is displayed on the LCD. To resume use of the stopped drive, make the setting at [Drive Settings].
- See “Disc writing problems” on page 78 in this guide for details on the causes and remedy procedures for write errors.

**Printer settings**

- Show error mark on discs that experience errors

If you check this check box, an error mark will be printed on any disc with a write error. This is useful to identify the disc which encountered the write error.

**Notes**

The error mark will not be printed in the following cases.

- The job was cancelled in the EPSON Total Disc Monitor.
- Not enough ink was left to print the error mark
- Fatal error

**Notification settings**

- Beep when a job is finished, or when the source stacker is empty

If you check this check box, the product produces a beep to notify you when a job (jobs) is finished or when you need to replenish discs.

Also, select either one of the options to notify after each job is finished or after all jobs are finished.

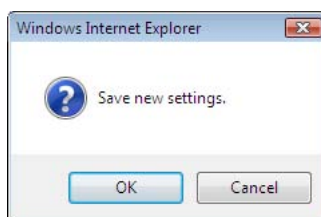
**4** Click [OK].

## Notification email transmission settings

Settings can be made for sending emails, which pertain to disc publishing, notify when the ink must be replaced, or notify about problems that have occurred, to the administrator.



- When a notification email is received, measures must be taken by following the instructions contained in the email.
- An email address must be set to receive a notification email. See “Registering users” on page 52 in this guide or “Checking user information” on page 51 in this guide for the procedure to set the email address.
- If spam blocking software is used, change the settings so that the email containing the URL sent from the email address set in [Sender’s email address] can be received.

### Notes

If you want to cancel the notification email transmission settings (see page 38 in this guide) after setting them, clear the [SMTP server] field in the [Email] screen, and then save the settings. The other input values of the mail settings are automatically cleared and the settings are saved.

## Notification email types

The following types of notification email can be sent.

### *Emails pertaining to disc publishing*

- Emails notifying that the input stacker is empty
- Emails notifying that the input stacker is full
- Emails notifying that written discs are loaded to the input stacker
- Emails notifying that a different disc type than that specified for the job is loaded to the input stacker
- Emails notifying that a write error has occurred on the disc
- Emails notifying that the power off sequence by the auto power off function has started

### *Emails pertaining to ink*

- Emails notifying when it is nearly time to change an ink cartridge
- Emails notifying when it is time to change an ink cartridge
- Emails notifying when it is nearly time to change the ink pad
- Emails notifying when it is time to change the ink pad

### *Emails pertaining to hardware*

- Emails notifying that disc transfer has failed
- Emails notifying that opening or closing of the printer tray or drive has failed
- Emails notifying an internal error has occurred in the autoloader, printer, or drive
- Emails notifying that a printer maintenance error has occurred

And so on

<Example of a notification email>

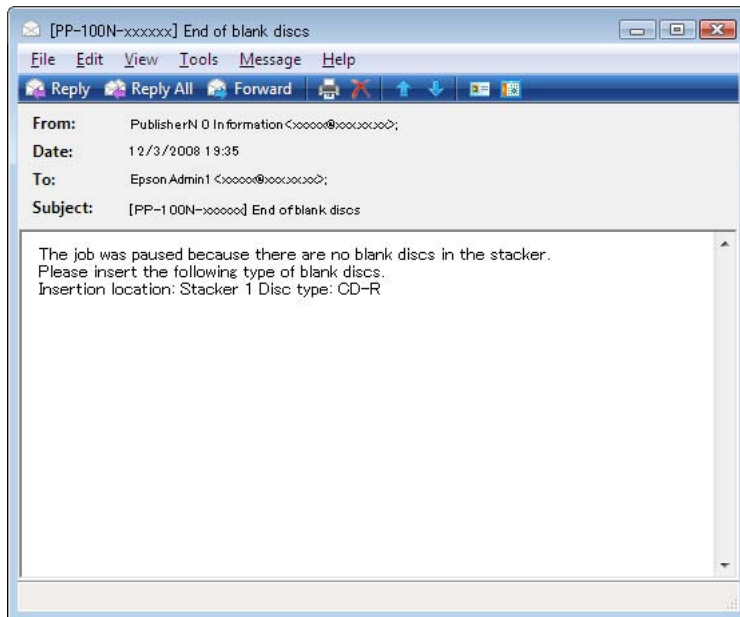

## Setting procedure

Use the procedure below to make the notification email settings.

- 1 Log in to EPSON Total Disc Net Administrator.  
See “Logging in to EPSON Total Disc Net Administrator” in the *PP-100N User’s Guide* for the login procedure.
- 2 Click the [Email] tab in the [System settings] screen.

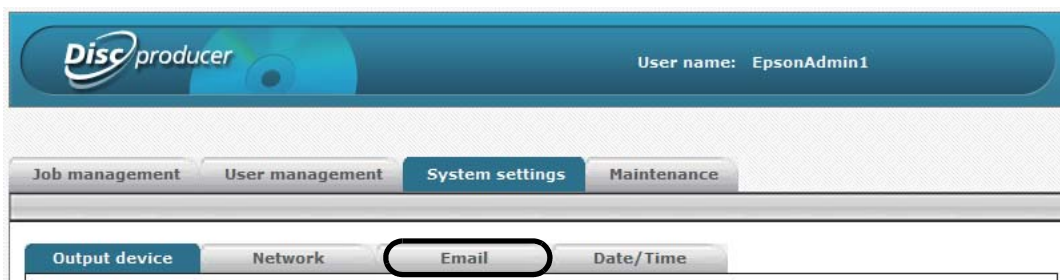

- 3 Set the information for each item, and click [Save].

 A screenshot of the EPSON Total Disc Net Administrator web interface, showing the 'Email settings' configuration screen. The top header and navigation bars are identical to the previous screenshot. The 'Email' sub-tab is selected. The main content area is titled 'Email settings' and contains the following fields:
 

- 'Language for outgoing mail' with a dropdown menu set to 'English'.
- 'SMTP server' and 'POP server' text input fields, each followed by a 'Port' text input field.
- 'Sender's email address' and 'Sender's name' text input fields.
- 'Email authentication' with a dropdown menu set to 'None'.
- 'Authentication account' and 'Authentication password' text input fields.

 Below these fields is a section titled 'Email transmission settings' containing three checked checkboxes:
 

- Send email regarding disc publishing
- Send email regarding ink status
- Send email regarding hardware status

 At the bottom right of the form area, there is a 'Save' button.

## Email settings

- Language for outgoing mail: Select the language to use in notification email from the languages below. Japanese, German, English, Spanish, French, Italian, Dutch, Portuguese
- SMTP server: Enter the IP address or host name and port number of the SMTP server that is used to send notification email.
- POP server: If [POP before SMTP] or [APOP before SMTP] is selected in [Email authentication], enter the IP address or host name and port number of the POP server that is accessed.
- Sender's email address: Enter the notification email address of the sender.
- Sender's name: Enter the sender name of the notification email.
- Email authentication: Select the notification email authentication method from the methods below. None, POP before SMTP, APOP before SMTP, SMTP-AUTH (PLAIN), SMTP-AUTH (LOGIN), SMTP-AUTH (Digest-MD5)
- Authentication account: Enter the authentication account of the email server.
- Authentication password: Enter the authentication password of the email server.

## Email transmission settings

Select the check boxes for the types of email that you want to send.

- 4 Click [OK].

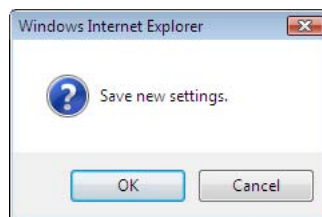

## Setting the date and time

This sets the product's internal clock.

- 1 Log in to EPSON Total Disc Net Administrator.  
See "Logging in to EPSON Total Disc Net Administrator" in the *PP-100N User's Guide* for the login procedure.
- 2 Click the [Date/Time] tab in the [System settings] screen.

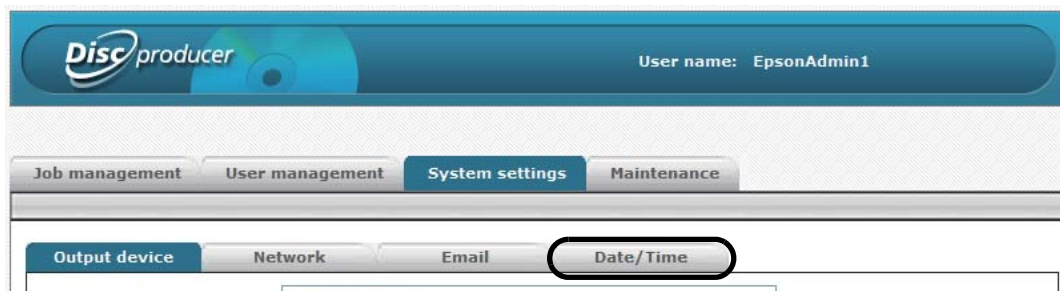

- 3 Select [Manual setting] or [Automatic setting].  
 When [Manual setting] is selected: Select the date, and enter the time.  
 When [Automatic setting] is selected: Select one of the NTP server setting methods below.
  - To set the NTP server manually, select [Manual], and enter the IP address or host name of the NTP server into [NTP server].
  - To set the NTP server from the DHCP server, select [Auto].

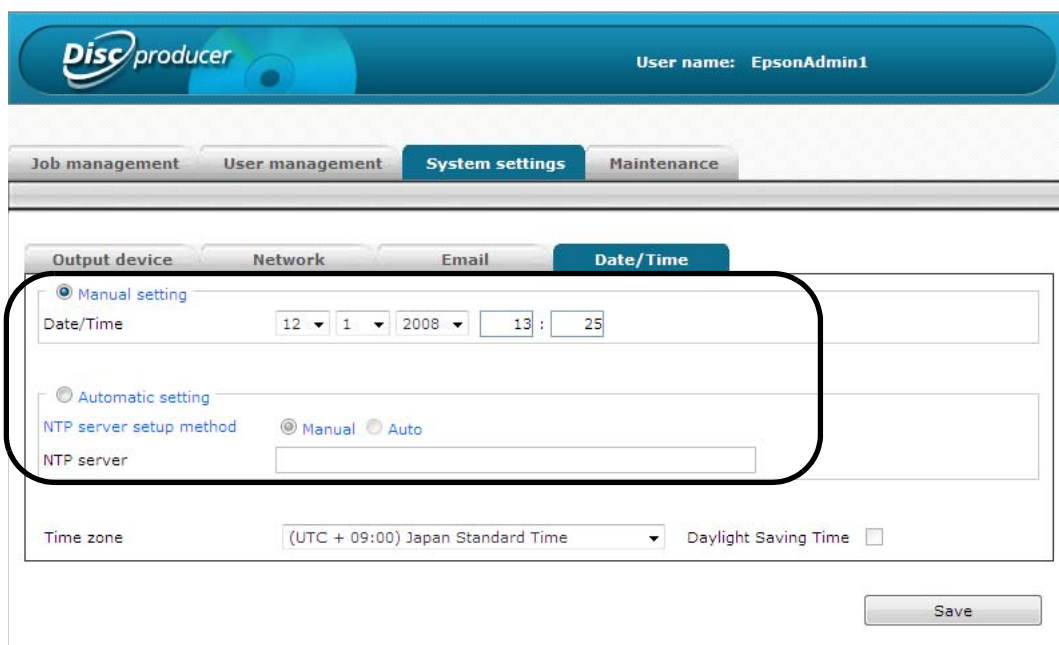



- 4 Select [Time zone], and if daylight saving time is used, select the check box for [Daylight Saving Time], and click [Save].

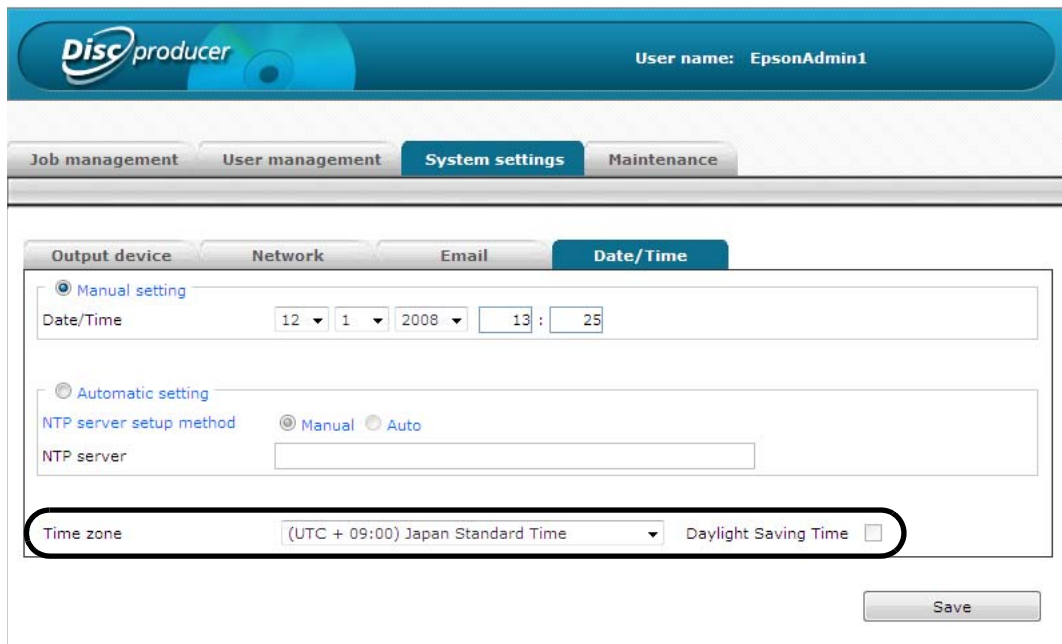

The screenshot shows the 'Disc producer' web interface. At the top, the user name is 'EpsonAdmin1'. The main navigation bar includes 'Job management', 'User management', 'System settings', and 'Maintenance'. The 'System settings' page has tabs for 'Output device', 'Network', 'Email', and 'Date/Time'. The 'Date/Time' tab is active, showing 'Manual setting' selected. The 'Date/Time' field is set to 12:01:25 on 1/13/2008. Under 'Automatic setting', 'NTP server setup method' is set to 'Manual'. The 'Time zone' is set to '(UTC + 09:00) Japan Standard Time' and the 'Daylight Saving Time' checkbox is unchecked. A 'Save' button is at the bottom right.

- 5 Click [OK].

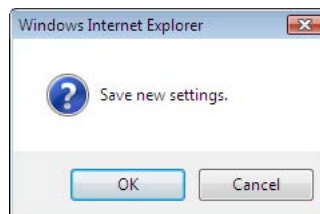

## Setting the language

After you set the Publish Mode (see page 20 in this guide), you can change the language setting for messages displayed on the LCD of this product from English to Spanish, French, Italian, Dutch, Portuguese, Japanese, or German.

Use the procedure below to change the language setting.

- 1 Press the MENU button.  
The top menu appears.

- 2 Use the ▲/▼ buttons to display the language settings (“Top menu Language”) screen, and press the ↩ button.

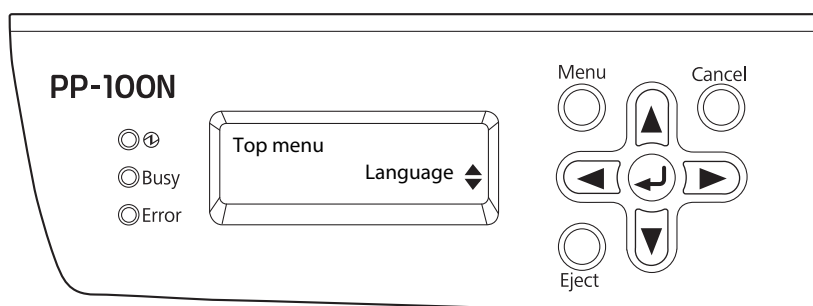

- 3 Use the ▲/▼ buttons to display the language that you want to change, and press the ↩ button.

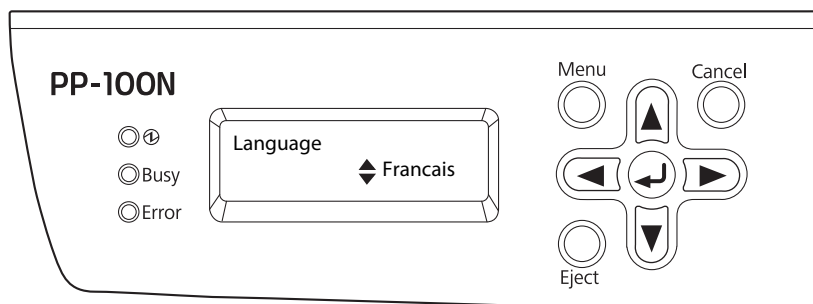

# Administration and Management

## Managing jobs

This section describes how to check, pause, resume, and cancel published jobs, and delete job data.

### Checking job information

You can check the history and detailed information of jobs on the [Job management] screen after logging in to EPSON Total Disc Net Administrator. See “Logging in to EPSON Total Disc Net Administrator” in the *PP-100N User's Guide* for the login procedure.

The screenshot displays the 'Job management' interface. At the top, the 'Disc producer' logo and 'User name: EpsonAdmin1' are visible. Below the navigation tabs (Job management, User management, System settings, Maintenance), there is a 'Delete job' button. The main area is titled 'Job status list' and contains a search section with 'Search options' for 'Search target' (Date published), 'Date' (December 3, 2008), and 'Status' (All). A 'Search' button is present. The table below shows the following data:

	Date published	Job name	Status
Details	Dec 3, 2008	DVD_Video	Publishing
Details	Dec 3, 2008	sample_data	Completed
Details	Dec 2, 2008	Untitled	Completed
Details	Dec 2, 2008	20090101	Completed

At the bottom of the table area, it indicates '1/1' and 'Jobs that can be republished: 1'.

The job list displays all jobs with the following status that were published to this product.

- Waiting
- Publishing
- Completed
- Paused
- Pausing
- Canceling
- Standby
- Recovering



The job status display is not updated automatically. To update the display, click [Refresh] on the [View] menu of Internet Explorer.

#### Notes

- If you use search options, a job list of the search results is displayed in accordance with the conditions specified.
- Click [Details] of the job you want to check to display more detailed job information.

## Checking the job processing status

Use the following procedure to check the job processing status.

- 1 Start EPSON Total Disc Monitor.  
See “Starting EPSON Total Disc Monitor” in the *PP-100N User’s Guide* for the start procedure.
- 2 Click the [Unfinished Job] tab or [Finished Job] tab.  
The [Unfinished Job] screen or [Finished Job] screen appears.

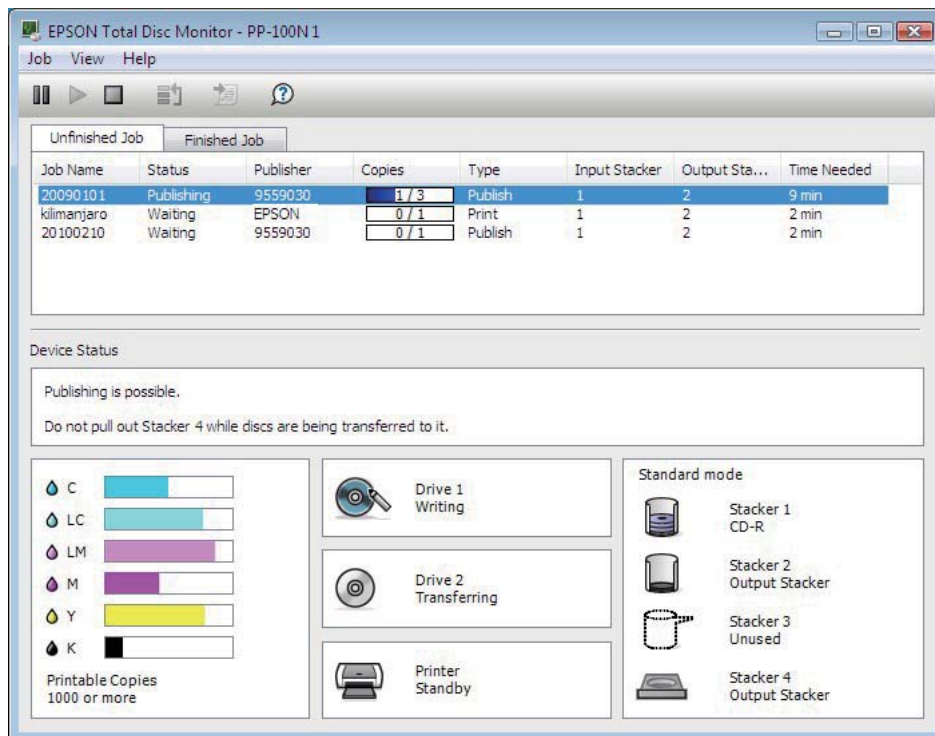

[Unfinished Job] screen: Displays a list of jobs for which the status is Waiting, Publishing, Paused, Pausing, Canceling, Standby, or Recovering.

[Finished Job] screen: Displays a list of jobs for which the status is Published and Cancel (up to 50 jobs from the most recent).

## Pausing jobs

When a job is being processed, be sure to pause job processing before you perform a disc cover operation or other operation of the product unit.

Use the following procedure to pause a job.



Only a job for which the status is Waiting, Publishing, Standby, or Recovering can be paused.

- 1 Start EPSON Total Disc Monitor.  
See “Starting EPSON Total Disc Monitor” in the *PP-100N User's Guide* for the start procedure.
- 2 Select the job for which you want to pause processing, and click [Pause].

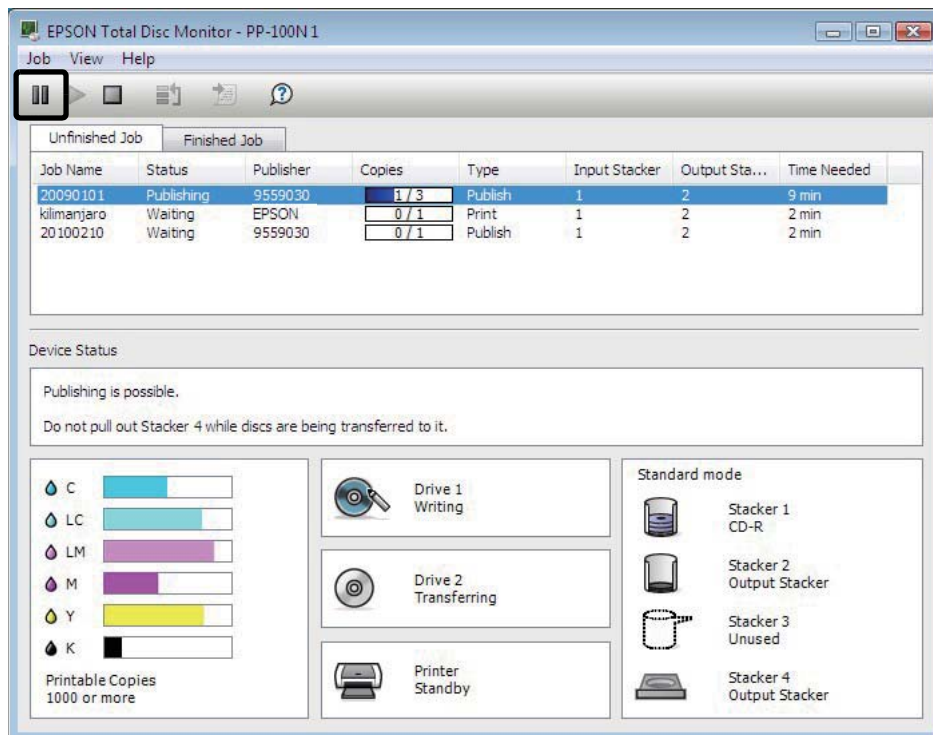

When the job is paused, the job status display changes from Pausing to Paused.



- If there is a disc being published, the job is paused after the processing is finished.
- The processing of any subsequent job also does not start while the job is paused.

### Notes

Selecting a paused job and clicking [Cancel] allows you to cancel the job without resuming processing.

## Resuming jobs

Use the following procedure to resume processing of a paused job.



Only a job for which the status is Paused or Pausing can be resumed.

- 1 Start EPSON Total Disc Monitor.  
See “Starting EPSON Total Disc Monitor” in the *PP-100N User’s Guide* for the start procedure.
- 2 Select the job for which you want to resume processing, and click  [Resume].

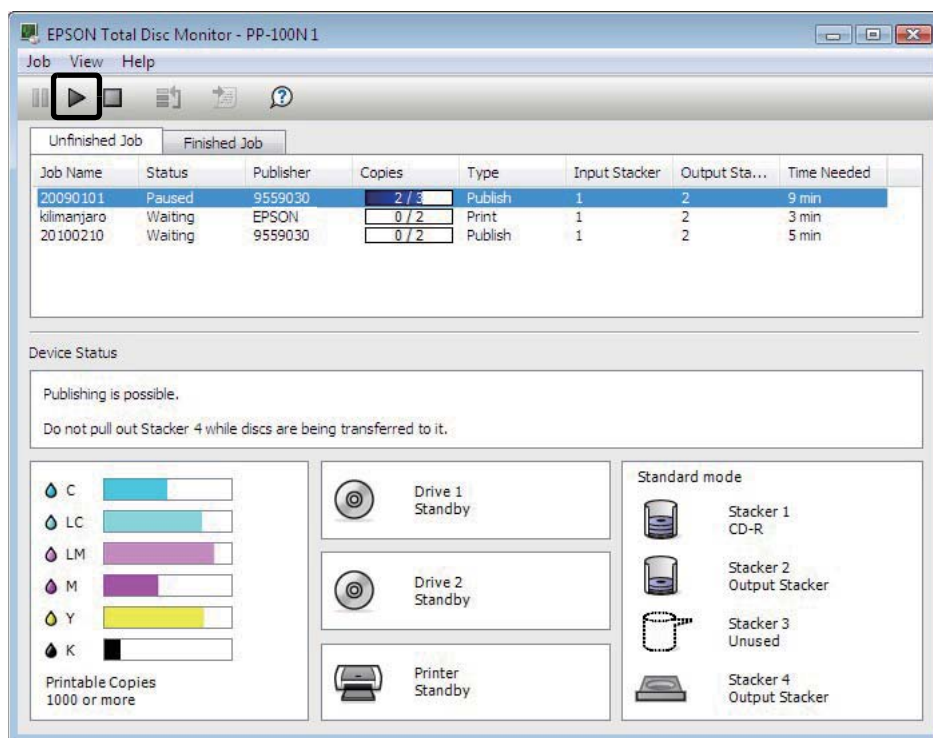

When the job is resumed, the job status display changes from Paused to Publishing or Waiting.

## Canceling jobs

Use the following procedure to cancel processing of a job.



Only a job for which the status Waiting, Publishing, Paused, Pausing, Standby, or Recovering can be canceled.

- 1 Start EPSON Total Disc Monitor.  
See “Starting EPSON Total Disc Monitor” in the *PP-100N User’s Guide* for the start procedure.
- 2 Select the job you want to cancel, and click  [Cancel].

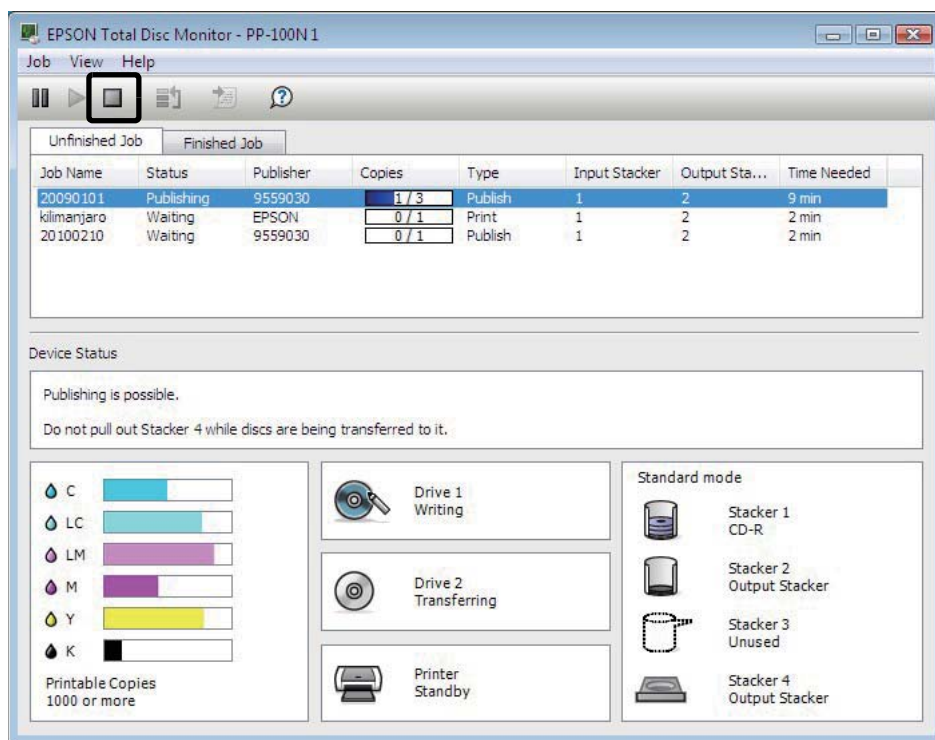

- 3 Click [Yes].

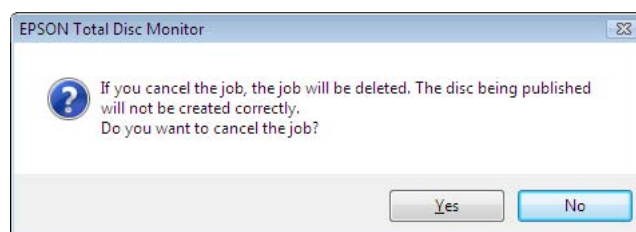

When the job is canceled, the job disappears from the [Unfinished Job] screen.



If a disc is being published, that processing is stopped, and the disc is output to the output stacker.

## Priority Publishing

If you need to process a job before the others when more than one job is being published, use the following procedure.

- 1 Start EPSON Total Disc Monitor.  
See “Starting EPSON Total Disc Monitor” in the *PP-100N User’s Guide* for the start procedure.
- 2 Select the job you want to give priority to, and click  [Priority Publishing].

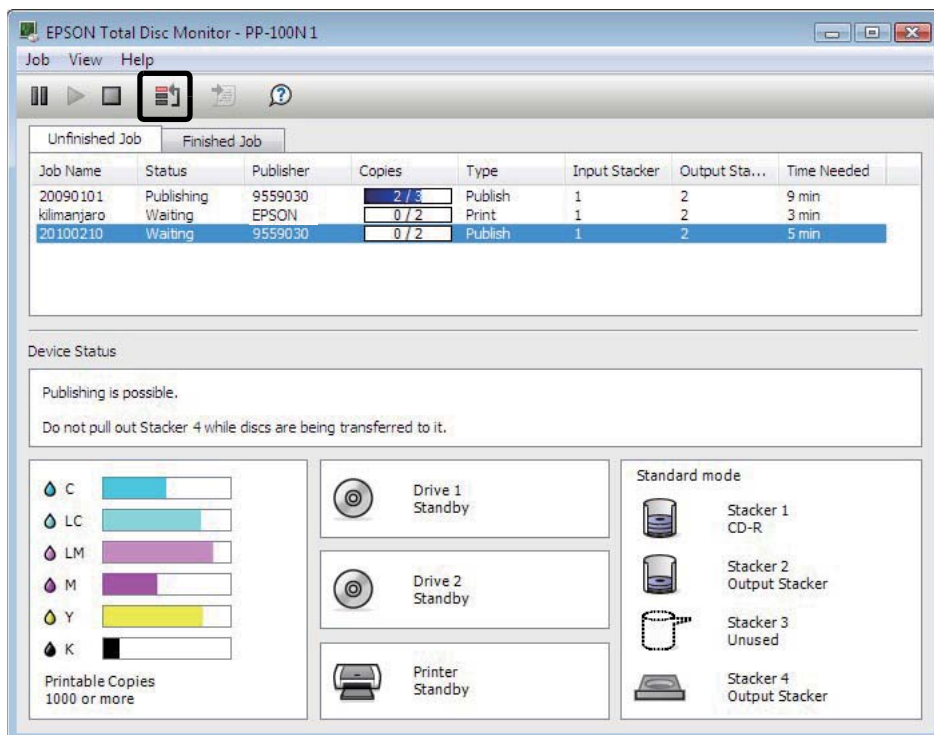

The selected job will be processed after the job in progress.

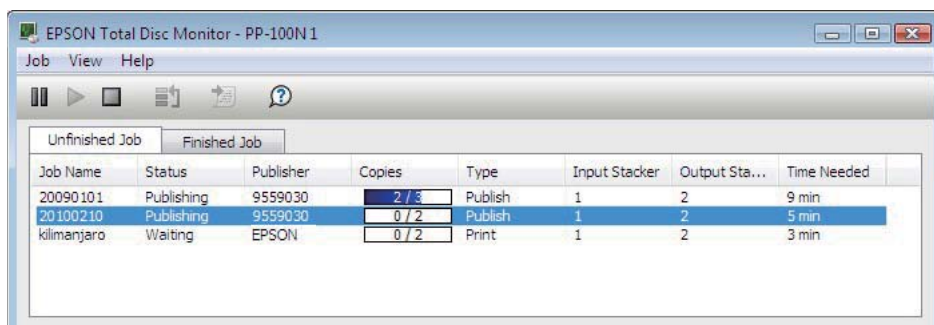

### Notes

Any job cannot be given priority before such operations as nozzle checking, aligning print head, and correcting printing position.



## Deleting jobs

Use the following procedure to delete spool data and job history when, for example, there is little free space remaining on the product's hard disk.

- 1 Log in to EPSON Total Disc Net Administrator.  
See "Logging in to EPSON Total Disc Net Administrator" in the *PP-100N User's Guide* for the login procedure.
- 2 Click [Delete job].

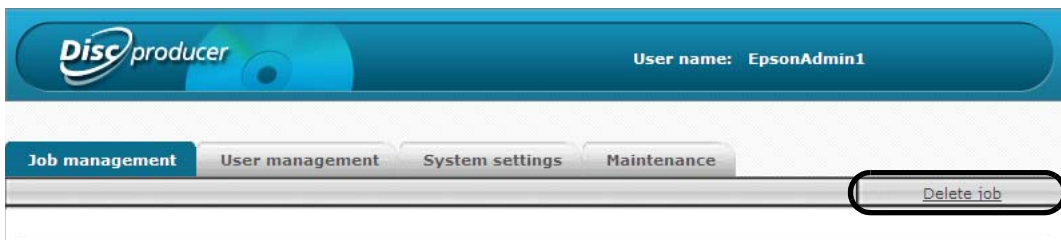

- 3 Use the search options to find the job you want to delete.

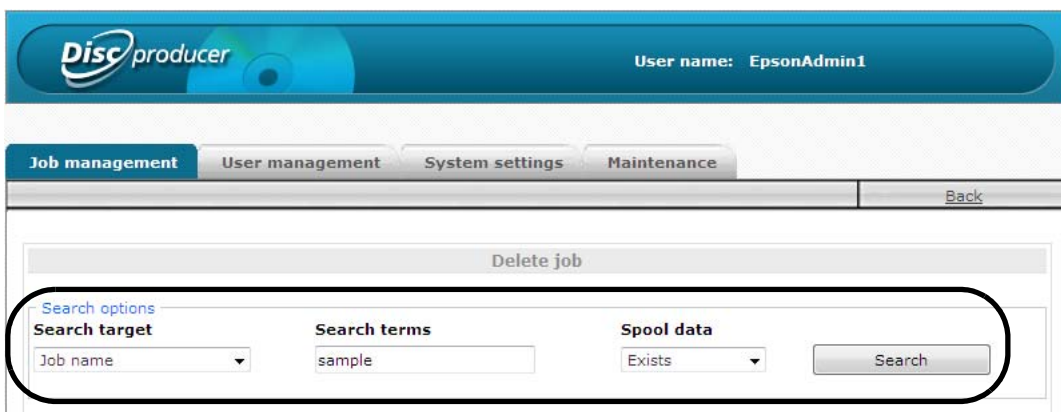

- 4 Select the check box for the job you want to delete, and click [Delete spool data] or [Delete spool data and job history].

Disc producer User name: EpsonAdmin1

Job management User management System settings Maintenance Back

Delete job

Search options

Search target Search terms Spool data

Job name sample Exists Search

Select all Deselect all [Select all] and [Deselect all] are only valid for this page.

	Date published	Job name	Spool data
<input checked="" type="checkbox"/>	Dec 3, 2008	sample_data	15 MB

1/1

Delete spool data Delete spool data and job history

- 5 Click [OK] in the deletion confirmation message that appears.

# Managing users

## Checking user information

Use the following procedure to check registered user information.

- 1 Log in to EPSON Total Disc Net Administrator.  
See “Logging in to EPSON Total Disc Net Administrator” in the *PP-100N User's Guide* for the login procedure.
- 2 Click the [User management] tab.

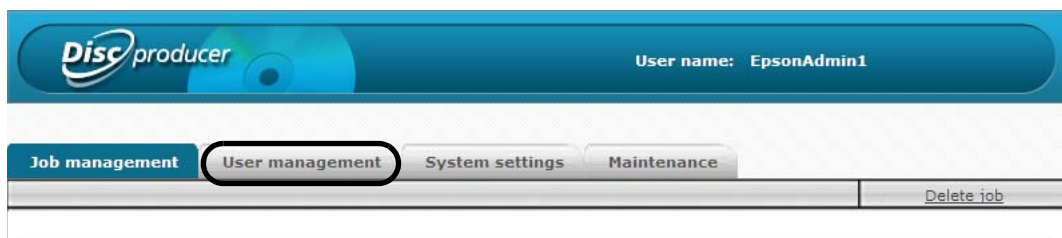

The [User management] screen appears.

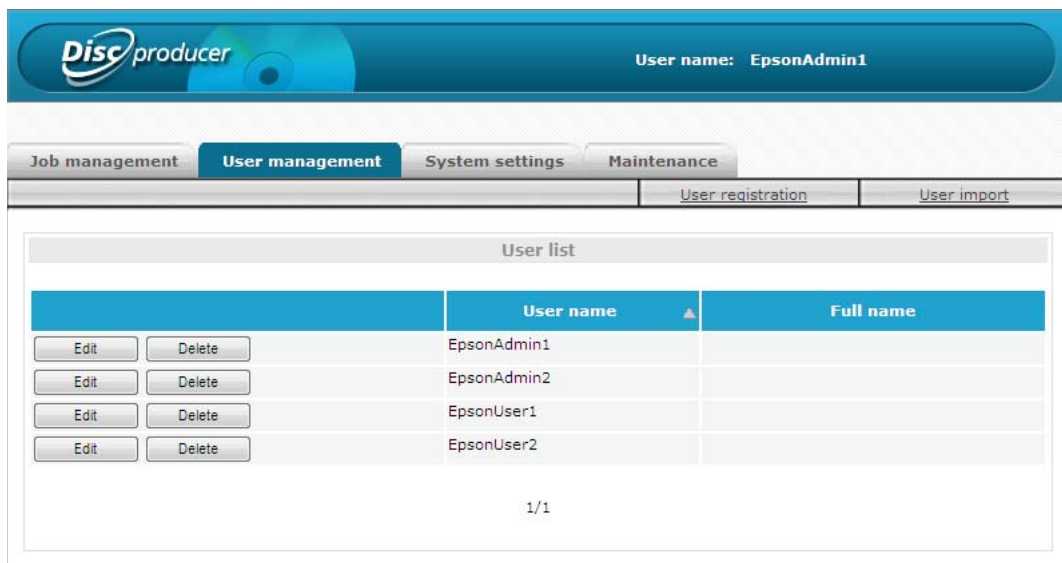

The user list displays the user name and full name of a registered user.

### Notes

- Clicking [Edit] allows you to change the full name, mail address, and authority of a registered user.
- Clicking [Delete] allows you to delete the registered user information.

## Registering users

Use the following procedure to register a second or subsequent administrator or publisher.

- 1 Log in to EPSON Total Disc Net Administrator.  
See “Logging in to EPSON Total Disc Net Administrator” in the *PP-100N User’s Guide* for the login procedure.
- 2 Click the [User management] tab.

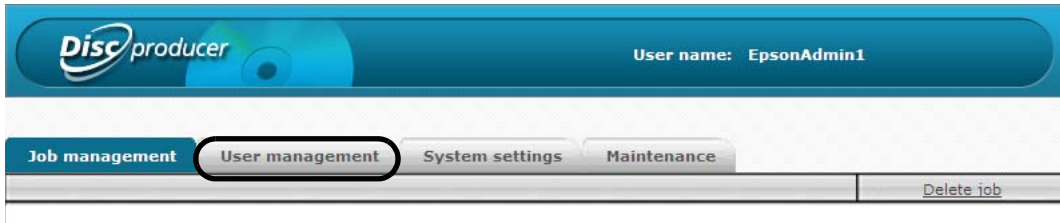

- 3 Click [User registration].

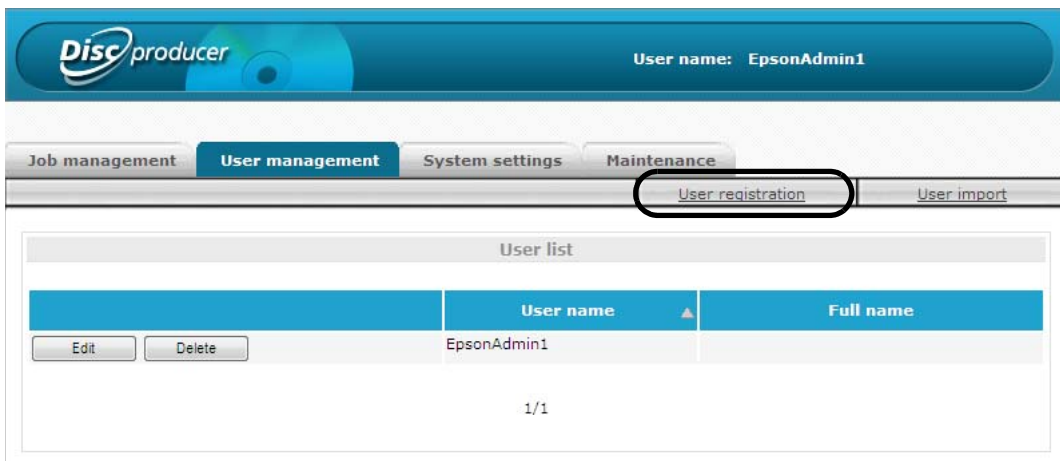

- 4 Enter the user name and password, and then enter the password again for confirmation, and click [Save].

The screenshot shows the 'User registration' form in the Disc producer interface. The form includes the following fields and options:

- User name\***: Text input field containing 'EpsonUser1'.
- Password\***: Password input field with masked characters (dots).
- Confirm password\***: Password input field with masked characters (dots).
- Full name**: Text input field.
- Email address**: Text input field.
- Authority**: Check box labeled 'Administrator'.

A note at the bottom left of the form states: '\*are required fields.' A 'Save' button is located at the bottom right of the form.



- To add an administrator, select the [Administrator] check box.
- Enter 5 to 16 alphanumeric characters for the user name.
- Enter 5 to 16 alphanumeric characters or symbols (", " -, " \_") for the password.
- The password is case-sensitive.
- Do not set a date of birth, employee number, or anything else that is easy to guess for the password.
- Manage the password so that it cannot be used by anyone other than the user.
- You can register the information for up to 100 users.

### Notes

Enter a full name and email address if necessary. An email address needs to be entered if notification email transmission is set. See "Notification email transmission settings" on page 36 in this guide for details on setting the notification email transmission.

## 5 Click [OK] in the confirmation message that appears.

The user list of the [User management] screen appears.

Check that the user is registered correctly.

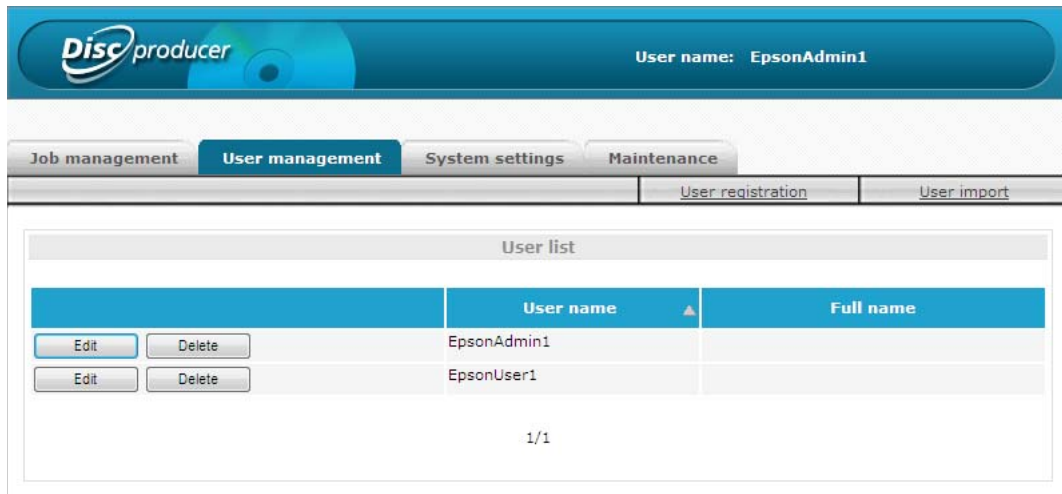

Inform the user of the set user name and password. The user changes the password after logging in.

### Notes

- Clicking [Edit] allows you to change the full name, mail address, and authority of a registered user.
- Clicking [Delete] allows you to delete the registered user information.

## Changing user information

Use the following procedure to change registered user information.

- 1 Log in to EPSON Total Disc Net Administrator.  
See “Logging in to EPSON Total Disc Net Administrator” in the *PP-100N User's Guide* for the login procedure.
- 2 Click the [User management] tab.

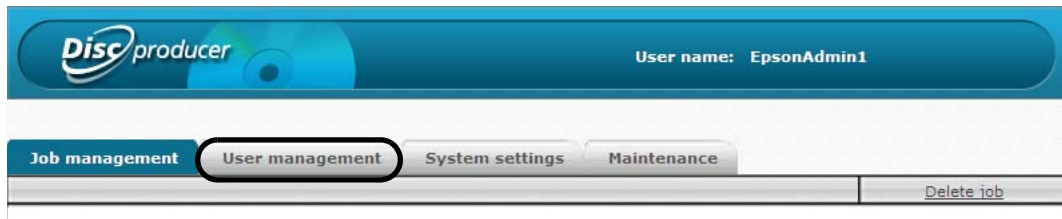

- 3 Click [Edit] of the user for which you want to change the information.

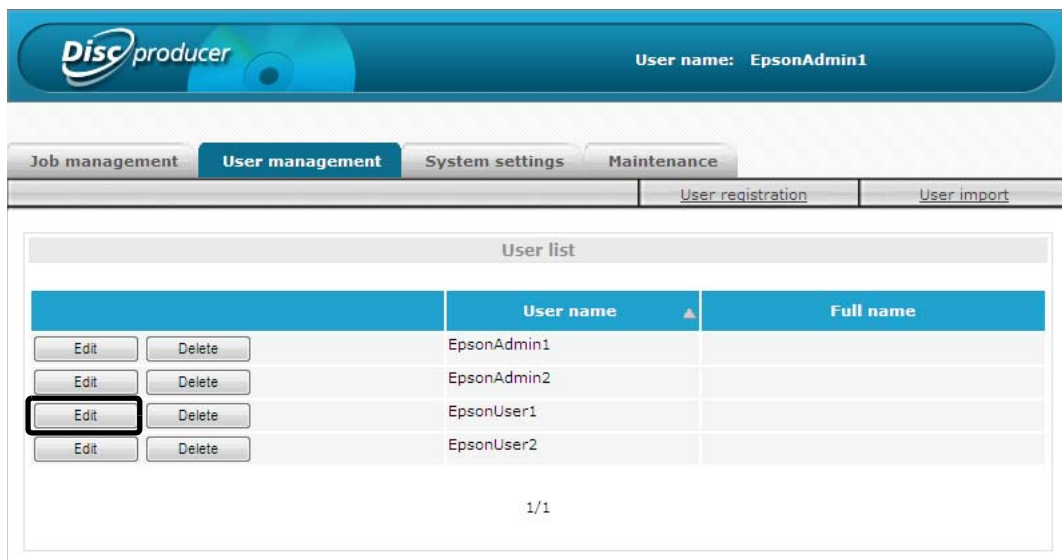

- 4 Change the full name, mail address, and authority of the user as necessary, and click [Save].

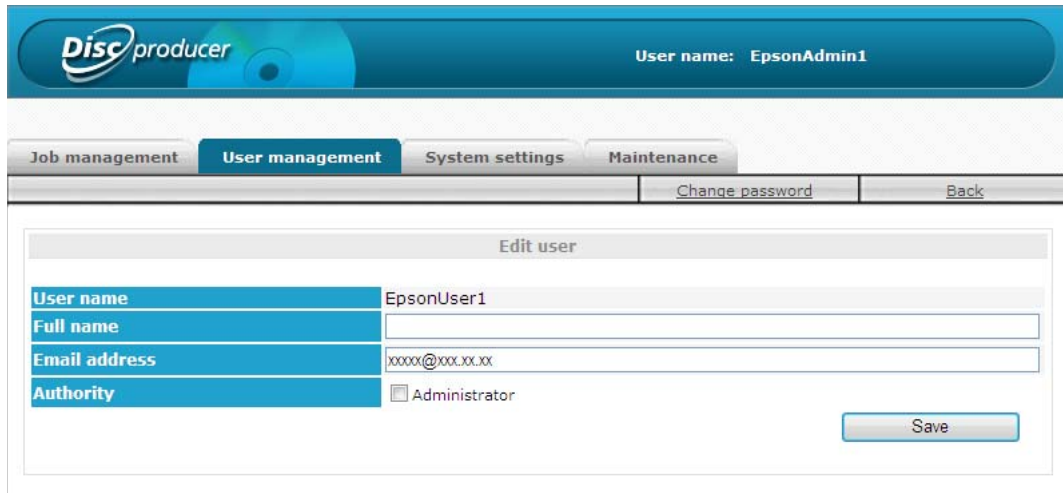

The screenshot shows the 'Disc producer' software interface. At the top, there is a blue header with the 'Disc producer' logo on the left and 'User name: EpsonAdmin1' on the right. Below the header is a navigation bar with tabs for 'Job management', 'User management' (which is selected), 'System settings', and 'Maintenance'. To the right of the 'User management' tab are two buttons: 'Change password' and 'Back'. The main content area is titled 'Edit user' and contains a form with the following fields:

User name	EpsonUser1
Full name	<input type="text"/>
Email address	xxxxx@xxx.xx.xx
Authority	<input type="checkbox"/> Administrator

A 'Save' button is located at the bottom right of the form.

- 5 Click [OK] in the update confirmation message that appears.



## Deleting user information

Use the following procedure to delete registered user information.

- 1 Log in to EPSON Total Disc Net Administrator.  
See “Logging in to EPSON Total Disc Net Administrator” in the *PP-100N User's Guide* for the login procedure.
- 2 Click the [User management] tab.

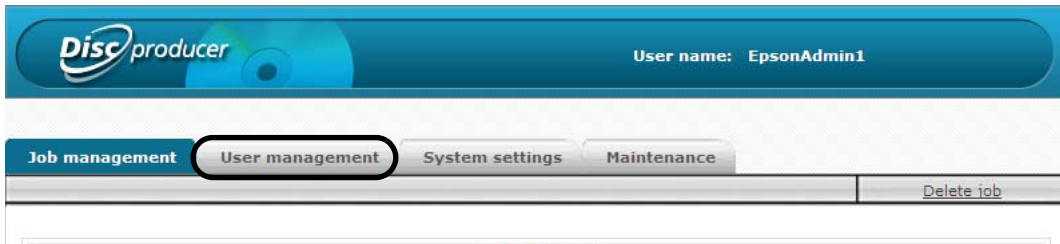

- 3 Click [Delete] for the user for which you want to delete the information.

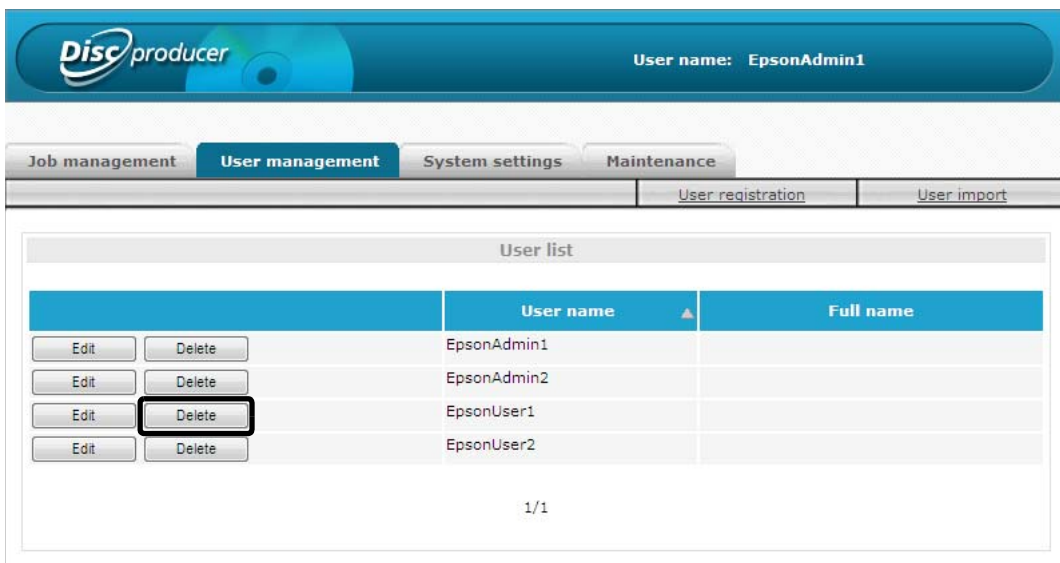

- 4 Click [OK].

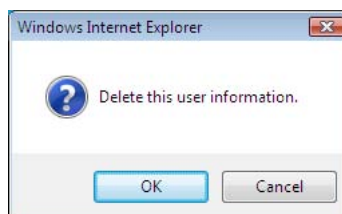

The user list of the [User management] screen appears.  
Check that the user was deleted.

## Changing password

Use the following procedure to change the password of a registered user.



Manage the password so that it cannot be used by anyone other than the user.

- 1 Log in to EPSON Total Disc Net Administrator.  
See “Logging in to EPSON Total Disc Net Administrator” in the *PP-100N User’s Guide* for the login procedure.
- 2 Click the [User management] tab.

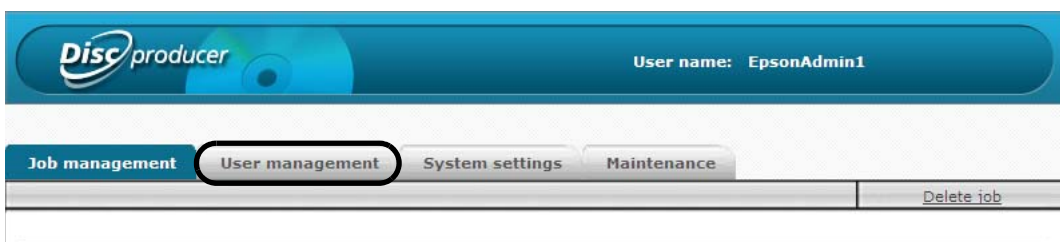

- 3 Click [Edit] of the user for which you want to change the password.

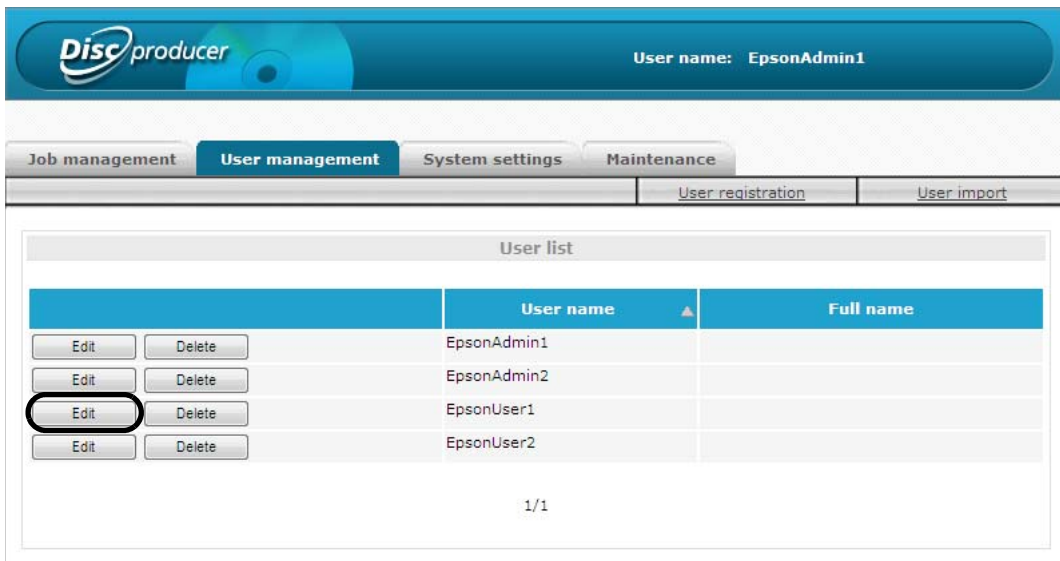

4 Click [Change password].

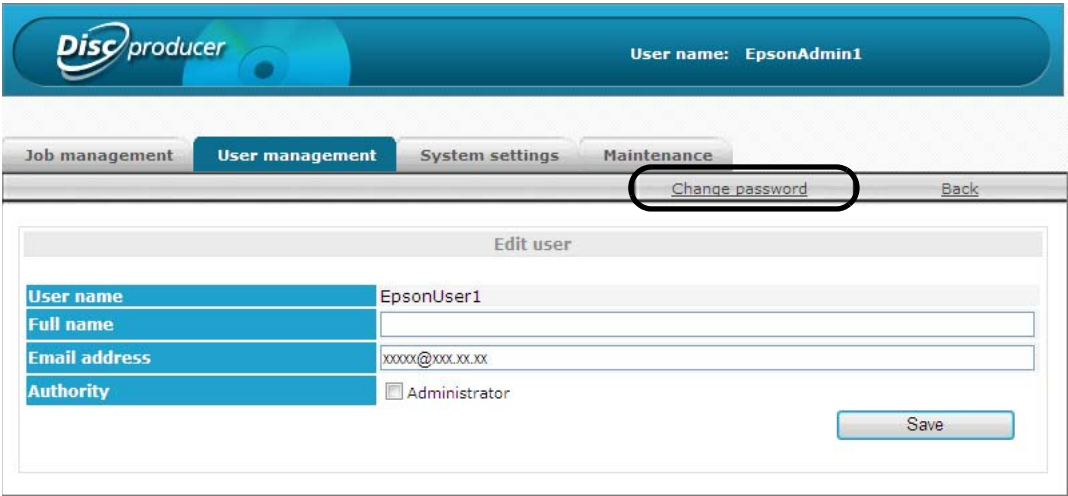

5 Enter the new password, and click [Save].

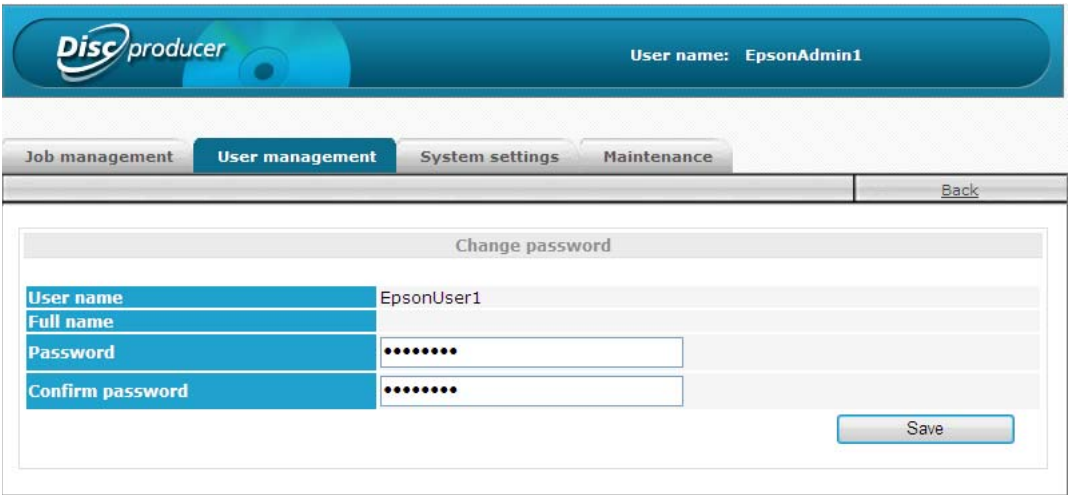

 • Enter 5 to 16 alphanumeric characters or symbols ("", " ", " ") for the password.  
• The password is case-sensitive.  
• Do not set a date of birth, employee number, or anything else that is easy to guess for the password.

6 Click [OK].

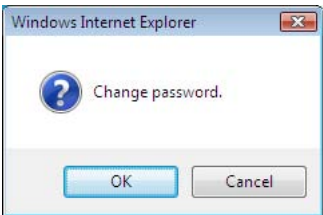

## Changing the Publish Mode

This section describes how to change the Publish Mode.



Changing the Publish Mode deletes the pool data.

- 1 Check that all jobs are finished.  
See “Checking the job processing status” on page 44 in this guide for details on the check procedure.
- 2 Log in to EPSON Total Disc Net Administrator.  
See “Logging in to EPSON Total Disc Net Administrator” in the *PP-100N User's Guide* for the login procedure.
- 3 Click the [System settings] tab.

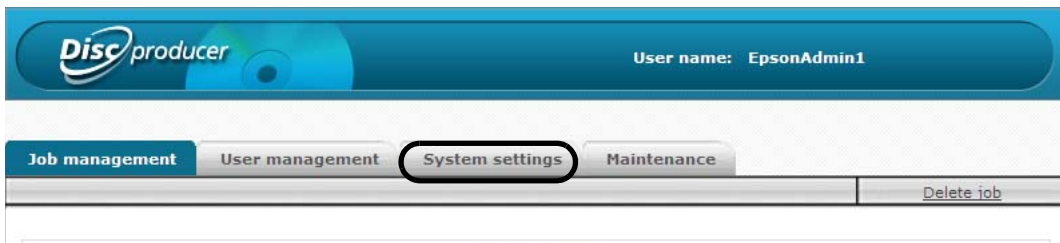

- 4 Change [Mode] to the Publish Mode to use, and click [Save].

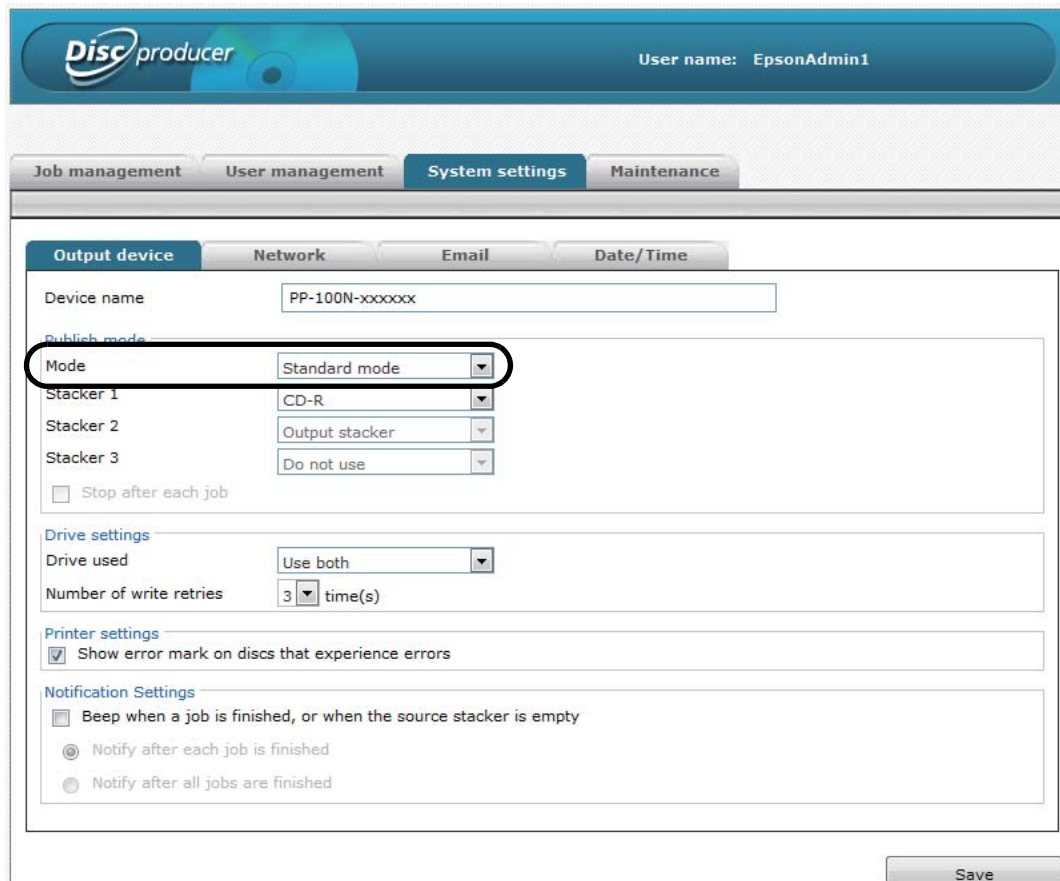

**5** Click [OK].

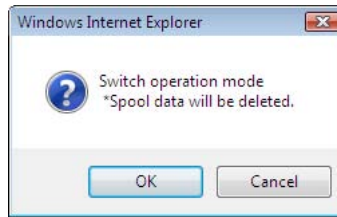

**6** Insert a stacker in accordance with the Publish Mode.  
See "Installing the stackers" on page 23 in this guide.



The operation of this product differs depending on the Publish Mode setting. To prevent the occurrence of an unexpected warning or error, check that the correct Publish Mode has been set after you change the Publish Mode.

# Maintaining Your Product

## Backing up and restoring data

This section describes how to back up your product's configuration information, job history, and other data, and how to restore backup data.

### Backing up data

The following data is saved when a backup is performed.

- Job history
- User information
- Output device settings
- Notification email transmission settings
- Date and time settings

Use the following procedure to back up data.



- The spool data (job data) and network configuration information are not saved to a backup file.
- When you want to create the same disc as an already published disc (see "Convenient Features" in the *PP-100N User's Guide*), the spool data (job data) on this product's internal hard disk is required. We recommend saving the data file (.tdd file) and write data to a computer via [Save As] of the [File] menu for files of EPSON Total Disc Maker.

- 1 Log in to EPSON Total Disc Net Administrator.  
See "Logging in to EPSON Total Disc Net Administrator" in the *PP-100N User's Guide* for the login procedure.
- 2 Click the [Data] tab on the [Maintenance] screen.

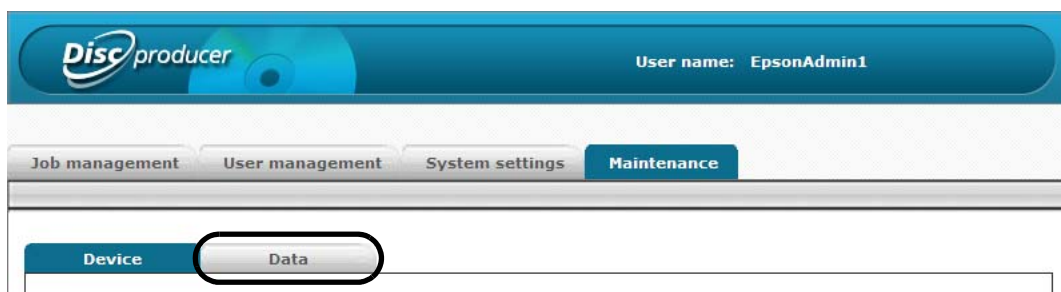

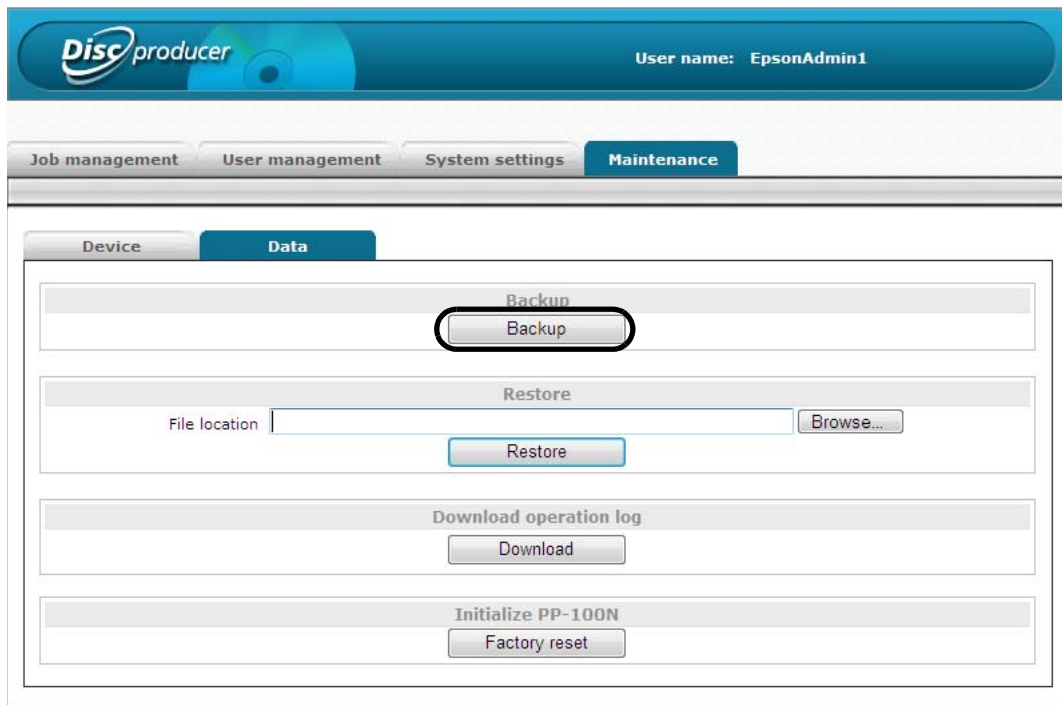
**3** Click [Backup].**4** Click [OK].**5** Specify the save location for the backup file, and then save the backup file.

## Restoring data

Use the following procedure to restore a backup file created in “Backing up data” on page 62 of this guide.



- If you perform a restoration, the restored data overwrites configuration data other than the network configuration information and maintenance information, and overwrites the job history.
- A backup file of a different Publish Mode cannot be restored.

- 1** Log in to EPSON Total Disc Net Administrator.  
See “Logging In to EPSON Total Disc Net Administrator” in the *PP-100N User's Guide* for the login procedure.
- 2** Click the [Data] tab on the [Maintenance] screen.
- 3** Click [Browse] to specify the backup file, and click [Restore].

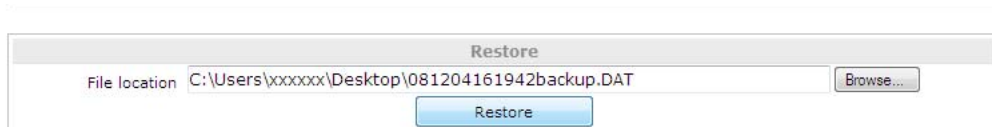

- 4** Click [OK].

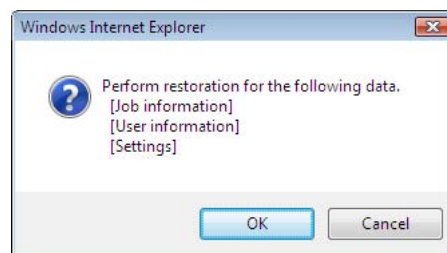

The BUSY LED flashes, and the restoration begins.  
When the BUSY LED goes out, the restoration is finished.



## Restoring to initial state

This section describes how to restore the product to the initial state.



- The product should be restored to the initial state by the administrator, and should not be left unattended until the work is finished.
- Before starting work to restore the product to the initial state, perform a backup (see “Backing up data” on page 62 in this guide) as necessary. Restoring the product to the initial state deletes all of the set information, including the user information and system settings, as well as all job history. The backup file can be restored (see “Restoring data” on page 64 in this guide) after initialization is finished.

### Notes

Even if the product is restored to the initial state, the product’s usage status data is not deleted. See “Checking maintenance information” on page 68 in this guide for details on the usage status.

There are two ways of restoring the product to the initial state as follows:

- Performing the operation on a PC
- Performing an operation with the product’s control panel

### Performing the operation on a PC

- 1 Check that all jobs are finished.  
See “Checking the job processing status” on page 44 in this guide for details on the check procedure.
- 2 Log in to EPSON Total Disc Net Administrator.  
See “Logging in to EPSON Total Disc Net Administrator” in the *PP-100N User’s Guide* for the login procedure.
- 3 Click the [Data] tab on the [Maintenance] screen.

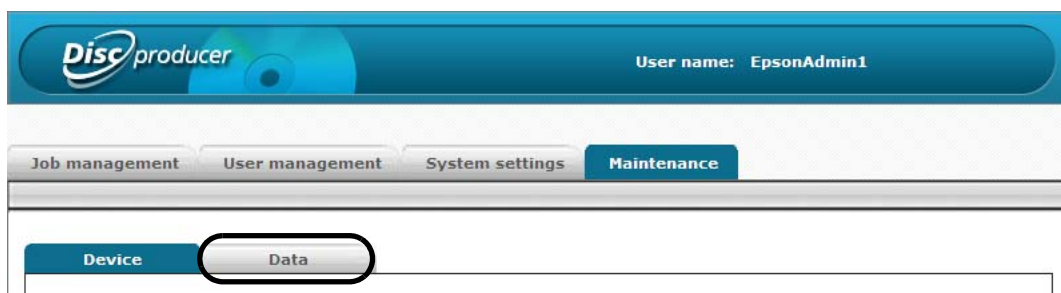

#### 4 Click [Factory reset].

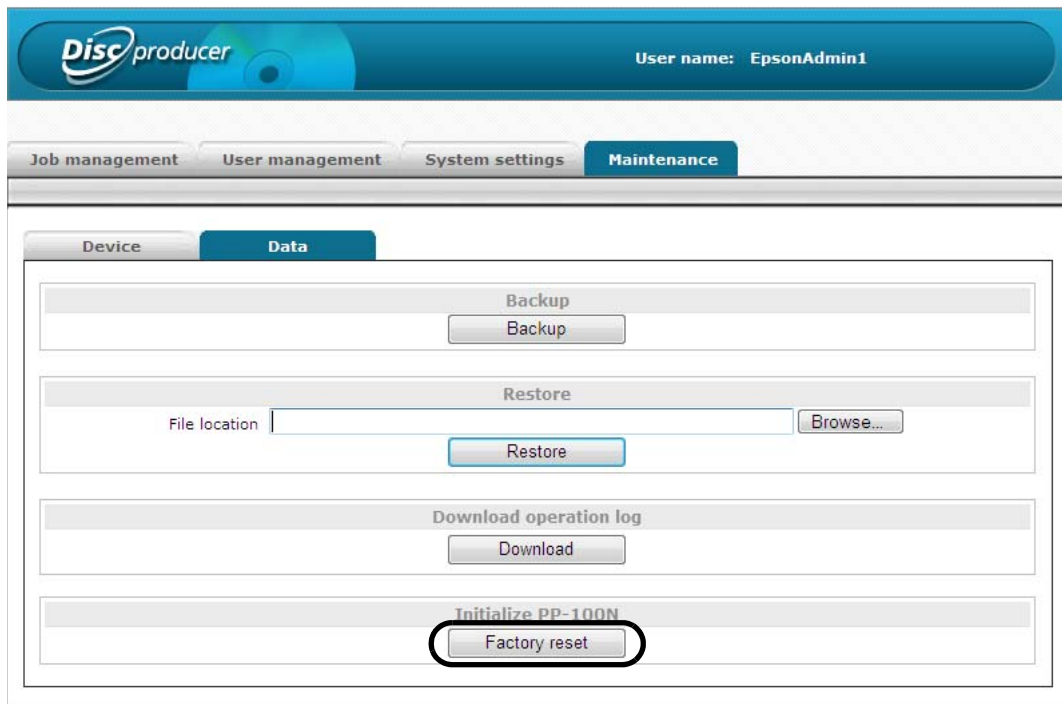

#### 5 Click [OK].

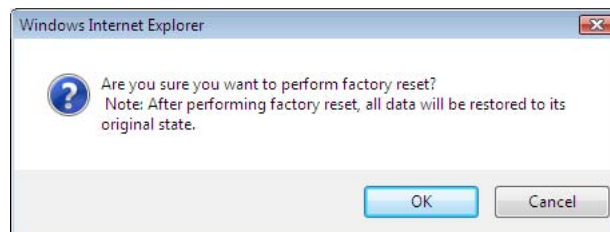

The BUSY LED flashes, and initialization begins. Initialization takes two to three minutes.



Never turn the power off during initialization.

When initialization is finished, the mode selection screen appears on the LCD.

## Performing an operation with the product's control panel

- 1 Check that all jobs are finished.  
See "Checking the job processing status" on page 44 in this guide for details on the check procedure.
- 2 Press the MENU button.  
The top menu appears.
- 3 Use the ▲/▼ button to display [Initialize], and press the ↵ button.

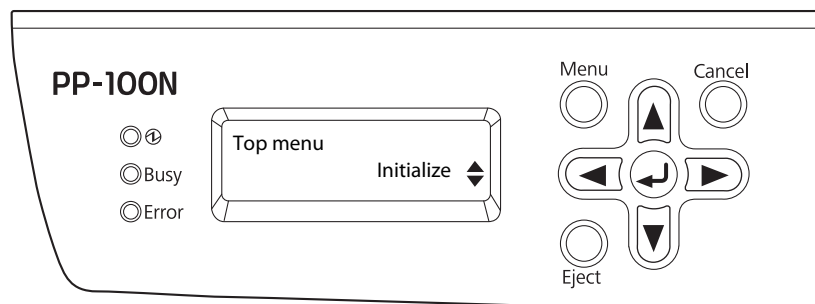

- 4 When the confirmation message appears, press the ↵ button.

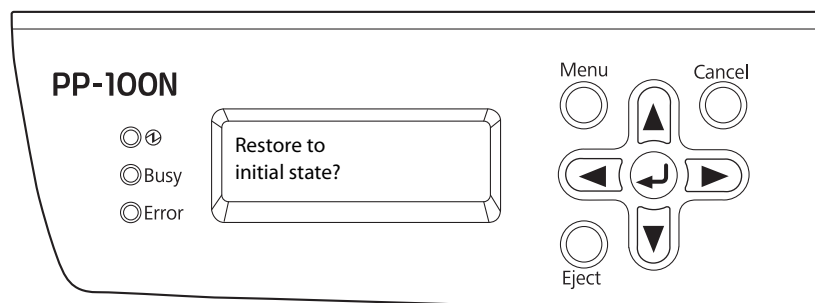

The BUSY LED flashes, and initialization begins. Initialization takes two to three minutes.



Never turn the power off during initialization.

### Notes

If [Receiving job Cannot proceed] appears on the LCD, wait until job processing is finished and then try again.

When initialization is finished, the mode selection screen appears on the LCD.

## Checking maintenance information

This section describes how to check information that is useful when carrying out maintenance and providing support for this product.

### Checking device information

Use the following procedure to check the usage status of the internal drives and the number of published discs.

- 1 Log in to EPSON Total Disc Net Administrator.  
See “Logging in to EPSON Total Disc Net Administrator” in the *PP-100N User’s Guide* for the login procedure.
- 2 Click the [Maintenance] tab.

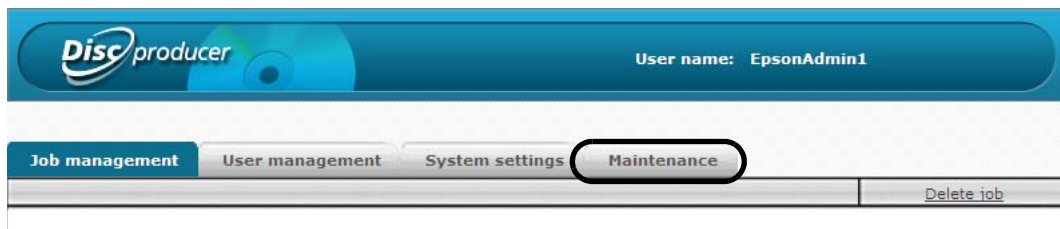

The usage statuses of drivers 1 and 2, and the number of published discs appear in the [Device] screen.

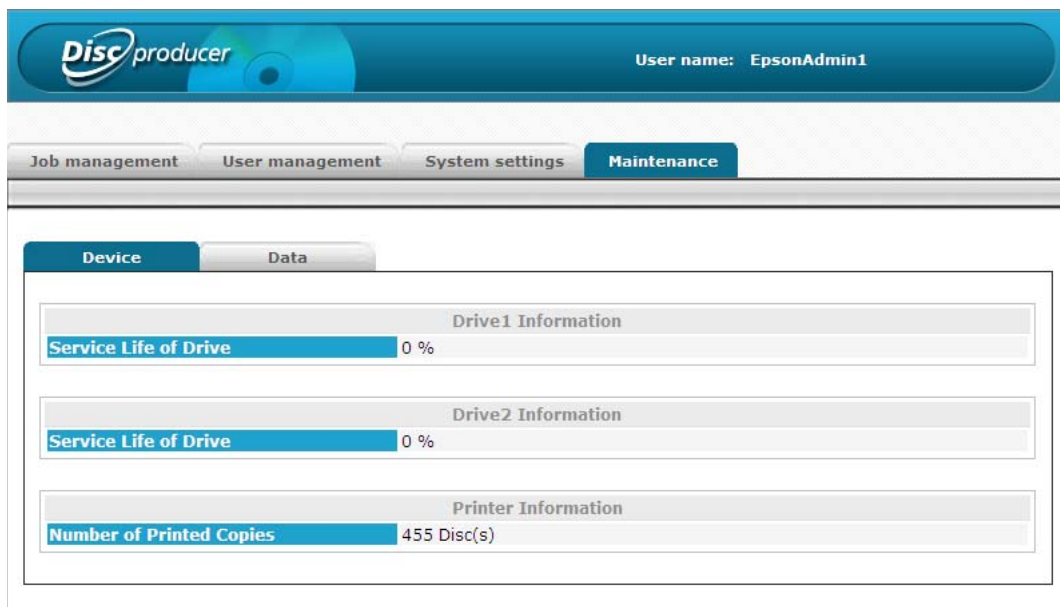

#### Notes

You can also display the usage statuses of drivers 1 and 2, and the number of published discs by clicking the [Maintenance Info] tab in the [Properties] screen of EPSON Total Disc Setup.

## Downloading operation log

The history of operations and actions on this product are recorded as an operation log. You can download the operation log file for 30 days of operation. Use the operation log file for maintenance and support.

Use the following procedure to download the operation log file.

- 1 Log in to EPSON Total Disc Net Administrator.  
See “Logging in to EPSON Total Disc Net Administrator” in the *PP-100N User’s Guide* for the login procedure.
- 2 Click the [Data] tab on the [Maintenance] screen.

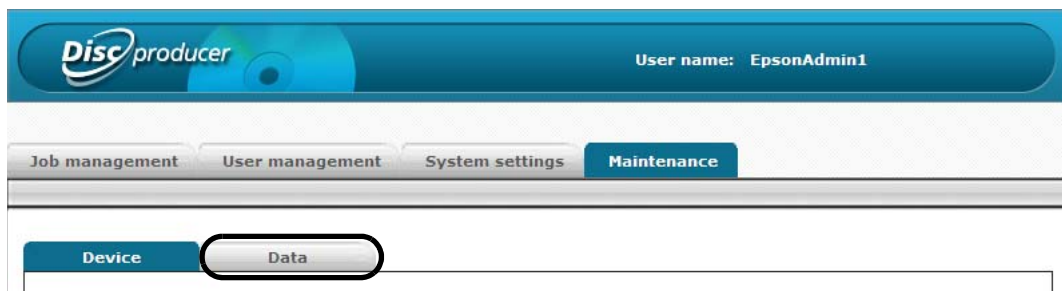

- 3 Click [Download].

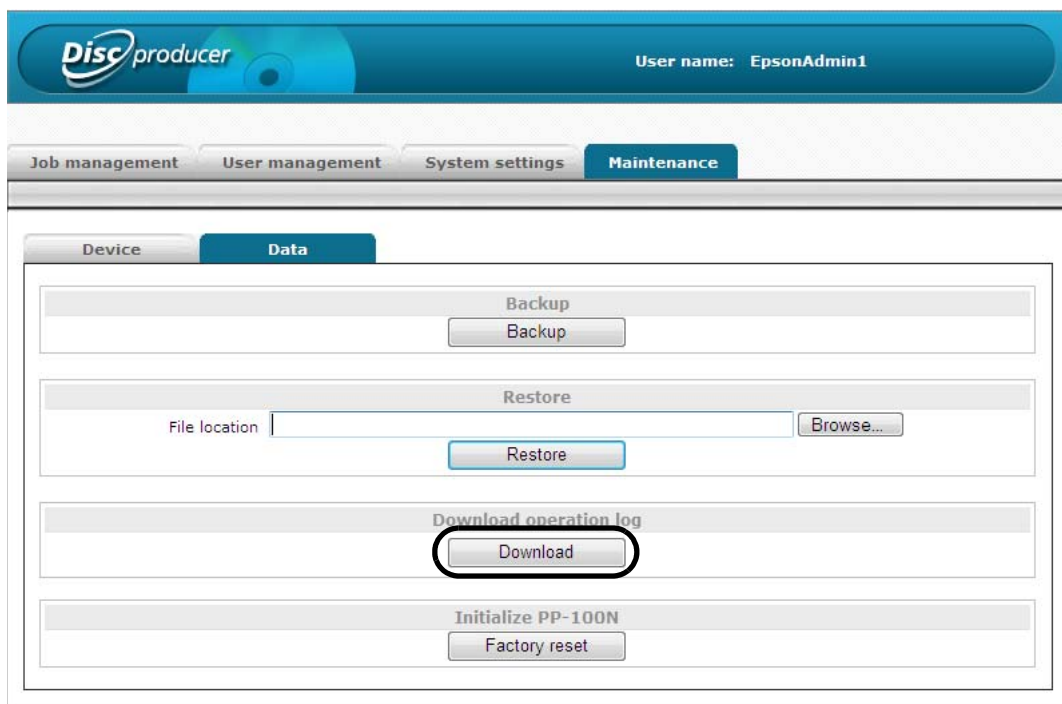

- 4 Specify the save location for the operation log file, and then save the operation log file.



# Troubleshooting

**Notes** Refer to this information together with the Help file for EPSON Total Disc Monitor.



## Error messages and remedies

When a problem occurs with this product, the ERROR LED turns on or flashes, and an error message appears on the LCD. Check the message, and perform the proper remedy.

 The alarm tone sounds.

Error Message	Remedy	Notification Sound
<b>Arm move error</b>	<p>The arm cannot be moved.</p> <p><b>Perform the procedure below.</b></p> <ol style="list-style-type: none"> <li><b>1. Turn off the power.</b></li> <li><b>2. Open the disc cover, and remove any dust or foreign objects that are inside.</b></li> <li><b>3. Turn on the power.</b></li> </ol> <p>If the same error message still appears, repair is required. Please contact Customer Support.</p>	
<b>Cannot unlock disc cover</b>	<p><b>Press the  or CANCEL button, and perform the unlock operation of the disc cover again.</b> Open the disc cover after "Disc cover can be opened" appears on the LCD. See "Unlocking the Disc Cover" in the <i>PP-100N User's Guide</i> for the disc cover unlocking procedure.</p>	
<b>CMOS Checksum error</b>	<p>If the same error message appears repeatedly, repair is required. Please contact Customer Support. Also, in some cases, the product's internal clock may not be operating correctly. Check the clock setting, and make the correct setting if necessary. (See "Setting the date and time" on page 40 in this guide.)</p>	
<b>Disc cover open</b>	<p><b>Close the disc cover.</b></p> <p>This product is currently operating.</p> <p><b>Close the disc cover.</b></p> <ul style="list-style-type: none"> <li>Do not open the disc cover while a job is being processed (BUSY LED is flashing). This could adversely affect the writing or printing quality.</li> <li>To ensure safety during arm operation, never insert your hands.</li> <li>Do not operate any stackers while the arm is moving. This could damage the arm.</li> </ul>	

Error Message	Remedy	Notification Sound
<b>Disc drop error</b>	The arm dropped the disc while transferring it. <b>Remove the dropped disc, turn off the power, and then turn on the power again.</b>	
<b>Disc feed error DRV 1/2</b>	The disc was not transferred properly to the drive. <b>Perform the procedure below.</b> <b>1. Remove the discs from the drive tray.</b> <b>2. Fully separate and reload the discs in the input stacker.</b> <b>3. Close the disc cover.</b>	
<b>Disc feed error PRN</b>	The disc was not transferred properly to the printer. <b>Perform the procedure below.</b> <b>1. Remove the discs from the printer tray.</b> <b>2. Fully separate and reload the discs in the input stacker.</b> <b>3. Close the disc cover.</b>	
<b>Disc is not writable</b>	Processing of the job is paused. <b>Perform the procedure below.</b> <b>1. Open the disc cover.</b> <b>2. Remove the disc that cannot be written or the disc that is already written from the input stacker (Stacker 1 or Stacker 2).</b> <b>3. Load a disc that can be written.</b> (See "Writable Disc Types" in the <i>PP-100N User's Guide</i> .) <b>4. Close the disc cover.</b>  Processing of the job is automatically resumed.	
<b>Disc is wrong type</b>	Processing of the job is paused. <b>Perform the procedure below.</b> <b>1. Open the disc cover.</b> <b>2. Remove the disc from the input stacker (Stacker 1 or Stacker 2) that is a different type from the disc type that was set.</b> <b>3. Load the correct disc type.</b> (See "Disc Loading" in the <i>PP-100N User's Guide</i> .) <b>4. Close the disc cover.</b>  Processing of the job is automatically resumed.	
<b>Disc pickup error (DRV 1/2)</b>	The disc in the drive tray cannot be picked up. <b>Turn off the power, and then turn it on again.</b> If the same error message still appears, repair is required. Please contact Customer Support.	
<b>Disc pickup error (PRN)</b>	The disc in the printer tray cannot be picked up. <b>Turn off the power, and then turn it on again.</b> If the same error message still appears, repair is required. Please contact Customer Support.	

Error Message	Remedy	Notification Sound
<b>Disc pickup error (ST1/2)</b>	The arm cannot pick up the disc in the stacker. <b>If the indicated stacker is an input stacker, fully separate and reload the discs in the stacker.</b>	
<b>Disc release error</b>	The arm cannot release the disc. <b>Do not remove the disc by hand. This could damage the arm. Turn off the power of the product, and then turn it on again. During the initialization operation of the product, the arm releases the disc.</b> If the same error message still appears, repair is required. Please contact Customer Support.	
<b>Discs ejected from ST2?</b>	<b>Perform the procedure below.</b> <b>1. Remove the published discs from Stacker 2.</b> <b>2. Refill the discs if necessary.</b> <b>3. Press the  button.</b> Note: In Batch Mode, if Stacker 2 is removed during publishing progress, it is always recognized as the input stacker when loaded again.	
<b>Drive tray open/close error</b>	<b>-When the drive tray does not come out-</b> <b>Turn off the power, and then turn it on again. If the drive trays still does not come out, see “Drive tray does not come out” on page 87 in this guide.</b> If the same error message appears again, repair is required. Please contact Customer Support. <b>-When the drive tray does not close-</b> <b>Remove any remaining discs, turn off the power, and then turn on the power again.</b> If the same error message still appears, repair is required. Please contact Customer Support.	
<b>Fan control error</b>	<b>Turn off the power, and then turn it on again.</b> If the same error message still appears, repair is required. Please contact Customer Support.	
<b>Ink cartridge cover open</b>	<b>Close the ink cartridge cover.</b>	
	This product is currently operating. <b>Close the ink cartridge cover.</b>	
<b>Ink problem (C,LC,LM,M,Y,K)</b>	An invalid ink cartridge is installed. <b>Replace the cartridge of the displayed color.</b> (See “Changing the Ink Cartridge” in the <i>PP-100N User’s Guide</i> .)	
<b>Internal drive error (DRV 1/2)</b>	<b>Turn off the power, and then turn it on again.</b> If the same error message still appears, repair is required. Please contact Customer Support.	



Error Message	Remedy	Notification Sound
<b>Internal printer error</b>	<b>Turn off the power, and then turn it on again.</b> If the same error message still appears, repair is required. Please contact Customer Support.	
<b>Internal autoloader error</b>	<p><b>Perform the procedure below.</b></p> <ol style="list-style-type: none"> <li><b>1. Turn off the power.</b></li> <li><b>2. Open the disc cover, and check if any dust or foreign objects are inside.</b></li> <li><b>3. Turn on the power.</b></li> </ol> <p>If the same error message still appears, repair is required. Please contact Customer Support.</p>	
<b>Invalid state error</b>	<b>Turn off the power, and then turn it on again.</b> If the same error message still appears, repair is required. Please contact Customer Support.	
<b>No disc ST1, ST2</b>	<b>Load discs into the input stacker (Stacker 1 or Stacker 2).</b> (See "Disc Loading" in the <i>PP-100N User's Guide</i> .)	
<b>No ink cartridge (C,LC,LM,M,Y,K)</b>	<p>The ink cartridge of the displayed color is not installed, or is not installed correctly.</p> <p><b>Correctly install the cartridge of the displayed color.</b> (See "Changing the Ink Cartridge" in the <i>PP-100N User's Guide</i>.)</p>	
<b>No stacker ST1, ST2, ST3</b>	<b>Load the displayed stacker, and close the disc cover.</b> (See "Installing the stackers" on page 23 in this guide.)	
<b>Non-standard ink Continue?</b>	<p><b>To use the ink cartridge, press the  button (Yes). To change to a Epson brand ink cartridge, press the CANCEL button (No), and change the ink cartridge.</b></p> <p>Use of non-Epson brand ink cartridges is not recommended.</p> <ul style="list-style-type: none"> <li>• Use of non-Epson brand ink cartridges can result in problems that will not be covered by the warranty.</li> <li>• Epson cannot guarantee the quality and reliability of non-Epson brand products. Repairs for any damage or breakdown of this product due to the use of non-Epson brand products will not be free of charge even if the warranty period is still valid.</li> <li>• This product performs color adjustment based on use of Epson brand ink cartridges. Use of non-Epson brand ink products can adversely affect the printing quality and prevent the product from realizing its maximum performance.</li> </ul> <p>See "Changing the Ink Cartridge" in the <i>PP-100N User's Guide</i> for the ink cartridge changing procedure.</p>	

Error Message	Remedy	Notification Sound
<b>Print tray open/close error</b>	<p><b>-When the printer tray does not come out-</b>  <b>Turn off the power, and then turn it on again. If the drive trays still does not come out, see “Printer tray does not come out” on page 88 in this guide.</b> If the same error message appears again, repair is required. Please contact Customer Support.</p> <p><b>-When the printer tray does not close-</b>  <b>Remove any remaining discs, turn off the power, and then turn on the power again.</b> If the same error message still appears, repair is required. Please contact Customer Support.</p>	
<b>Printer maint. error</b>	<p>Repair is required.  <b>Please contact Customer Support.</b></p>	
<b>Replace ink (C,LC,LM,M,Y,K)</b>	<p>The ink in the cartridge is out.  <b>Replace the cartridge of the displayed color.</b> (See “Changing the Ink Cartridge” in the <i>PP-100N User’s Guide</i>.)</p>	
<b>Replace inkpad</b>	<p>It is time to replace the ink pad.  <b>Please contact Customer Support.</b> The ink pad cannot be replaced by the customer.</p>	
<b>Stacker 3 installed</b>	<p><b>Remove Stacker 3, and close the disc cover.</b> Stacker 3 is not used in Standard Mode or External Output Mode (when Stacker 4 is set as the output stacker).</p>	
<b>Stacker 3 not installed</b>	<p><b>Load Stacker 3, and close the disc cover.</b> Stacker 3 is used in Batch Mode or External Output Mode (when Stacker 3 is set as the output stacker)</p>	
<b>Stacker 4 full</b>	<p>The initialization operation cannot be performed because Stacker 4 is full.  <b>Remove the discs from Stacker 4.</b></p>	
<b>Stacker 4 open</b>	<p><b>Close Stacker 4.</b></p>	
<b>Stacker full ST2, ST3, ST4</b>	<p>The disc cannot be ejected because the output stacker is full.  <b>Remove the discs from the output stacker (Stacker 2, Stacker 3, or Stacker 4).</b></p>	
<b>Too many discs ST1, ST2, ST3</b>	<p><b>Remove excess discs so that the height of the discs in the indicated stacker is below the dotted red line of the stacker, and then close the disc cover.</b></p>	
<b>Transferred disc detection error</b>	<p>A disc could not be detected after transfer to a printer or drive.  <b>Turn off the power, and then turn it on again.</b> If the same error message still appears, repair is required. Please contact Customer Support.</p>	

Error Message	Remedy	Notification Sound
<b>Wait a moment and try again</b>	<b>Press the  button or CANCEL button.</b> Do not unlock the disc cover repeatedly within a short time. Wait a moment before unlocking.	
<b>Write error</b>	Processing of the job is paused. <b>See “Disc writing problems” on page 78 in this guide, and after removing the cause of the error, restart the job.</b> (See “Resuming jobs” on page 46 in this guide for the job restarting procedure.)	

## Problems and their remedies

### Power/Control Panel problems

Symptom/Problem Status	Check/Remedy Procedure
<b>The power does not turn on.</b>	<b>Hold down the power button for a moment.</b>
	<b>Is the power plug disconnected from the outlet?</b> Check if the plug is inserted only halfway or inserted at a slant.
	<b>Are you using a power strip or similar device?</b> Insert the power plug directly into the wall outlet.
	<b>Is power being supplied from the outlet?</b> Insert the power plug for another electronic product to check if power is being supplied.
<b>The power does not turn off.</b>	<b>Is a job being processed?</b> The power cannot be turned off while a job is being processed. The power turns off automatically when the processing of all jobs finishes. If you hold down the power button for a moment (at least 3 seconds), the power off process begins immediately. The jobs are cancelled.
	<b>Did you just turn on the power?</b> The power cannot be turned off for about 15 minutes once the power is turned on. The power turns off automatically 15 minutes after "Power off Please wait" appears on the LCD. If you hold down the power button for a moment (at least 3 seconds), the power off process begins immediately.
	<b>Are the power LED and ERROR LED flashing?</b> If the power LED and ERROR LED are flashing, hold down the power button for a moment (at least 3 seconds). If the power still does not turn off, unplug the power from the outlet. Then, turn on the power again, and be sure to use the power button to turn off the power. Leaving the power on can cause drying and clogging of the print head.
<b>A rattling sound is made when the power is turned on.</b>	<b>Is there a foreign object (such as blue protective tape for transporting) inside the product?</b> Press the power button to turn off the power, and then open the disc cover and check that there are no foreign objects inside.
<b>"EPSON PP-100N" remains displayed and the product does not work when the power is turned on.</b>	<b>Repair is required.</b> Please contact Customer Support.

Symptom/Problem Status	Check/Remedy Procedure
ERROR LED flashes/turns on.	<b>An error has occurred.</b> See "Error messages and remedies" on page 70 in this guide.

## Disc writing problems

Symptom/Problem Status	Check/Remedy Procedure
A writing error has occurred.	<p><b>Is the disc scratched or dirty?</b> Scratched or dirty discs cannot be used. Replace with another disc.</p>
	<p><b>The quality of the data recording surface may vary depending on the disc.</b> Replace with another disc and try again.</p>
	<p><b>Is there dust adhering to the filter of the product rear fan?</b> Clean the filter. See "Cleaning the Air Vents" in the <i>PP-100N User's Guide</i> for the filter cleaning procedure.</p>
Unable to write to disc	<p><b>Is the disc being handled correctly?</b></p> <ul style="list-style-type: none"> <li>• Handle the disc correctly by following the disc user's guide.</li> <li>• Do not affix adhesive stickers to the disc. This may make recording and playback of data no longer possible.</li> <li>• Do not use this product in locations with large amounts of dust or smoke. This can cause drive writing errors.</li> </ul> <p>See "Disc Handling" in the <i>PP-100N User's Guide</i> for details on disc handling.</p>
	<p><b>Was the cover opened or the product jolted during publishing?</b> Do not subject the product to jolts or impacts during disc publishing. The drive may malfunction, or the disc may become unusable. Also, do not open the cover during publishing. This could adversely affect the printing and writing quality of the disc. Pause the job and then open the cover. See "Pausing jobs" on page 45 in this guide for the procedure for pausing jobs.</p>
	<p><b>Is your computer compatible with the operating environment of this product?</b> Use and connect this product to a computer compatible with the operating environment. See "Before Installation" in the <i>PP-100N User's Guide</i> for details.</p>
	<p><b>Is the printer tray dirty?</b> Clean the printer tray. See "Disc recording surface is stained with ink" on page 91 in this guide for the printer tray cleaning procedure.</p>

**Notes**

If you set [Write Verification] to [Compare] when publishing discs in EPSON Total Disc Maker, you can check whether data was written to the discs correctly. See the Help file for EPSON Total Disc Maker for details.

## Label printing problems

Symptom/Problem Status	Check/Remedy Procedure
<ul style="list-style-type: none"> <li>• Rubbing</li> <li>• Lines or streaks are formed</li> <li>• Blurriness</li> <li>• Text or lines are shaky</li> <li>• Incorrect color tones</li> <li>• Some colors are not printed</li> <li>• Unevenness in the printing</li> <li>• Mosaic-like patterns are printed</li> <li>• Printing is grainy (jagged)</li> </ul>	<p><b>Are the print head nozzles clogged?</b></p> <p>Perform a nozzle check to confirm the status of the print head, and if it is clogged, perform head cleaning.</p> <p>See the information below for further details.</p> <ul style="list-style-type: none"> <li>• Nozzle Check in the <i>PP-100N User's Guide</i></li> <li>• Head Cleaning in the <i>PP-100N User's Guide</i></li> </ul>
	<p><b>Are you using a recommended ink cartridge (Epson brand product)?</b></p> <p>This product performs color adjustment based on use of Epson brand ink cartridges. Use of non-Epson brand products can result in poor printing quality. Use of Epson brand ink cartridges is recommended.</p>
	<p><b>Are you using an old ink cartridge?</b></p> <p>Use of an old ink cartridge can result in poor printing quality. The usage period for ink cartridges is printed on the packaging of individual ink cartridges. After opening the cartridge, try to use it up within six months.</p>
	<p><b>Is there a difference in the print head gaps during bidirectional printing?</b></p> <p>When bidirectional printing is set, printing is performed at a high speed, and ink is discharged when the print head moves to both the right or left. On rare occasions, however, the printing position when moving from right to left is shifted from the printing position when moving from left to right, leading to shifting of the vertical rule lines and blurred printing results.</p> <p>Use the print head alignment function to check and adjust for differences in the gap.</p> <p>See "Print Head Alignment" in the <i>PP-100N User's Guide</i> for details.</p>
	<p><b>Are you using discs with different thicknesses?</b></p> <p>The thickness varies depending on the disc product. When discs with different thicknesses are used, the gaps of the print head can be shifted. Use the print head alignment function to check and adjust for differences in the gap. When publishing multiple discs, the use of the same disc product type is recommended.</p> <p>See "Print Head Alignment" in the <i>PP-100N User's Guide</i> for details.</p>
	<p><b>Are you printing on inkjet printer discs?</b></p> <p>The product supports discs for inkjet printers. This product does not support thermal transfer printer discs. Also, the printing quality may vary depending on the quality of the printing discs. Use of Epson specified CD and DVD discs is recommended.</p> <p>Epson offers specified CD-R and DVD-R discs for all your printing needs.</p>

Symptom/Problem Status	Check/Remedy Procedure
<ul style="list-style-type: none"> <li>• Rubbing</li> <li>• Lines or streaks are formed</li> <li>• Blurriness</li> <li>• Text or lines are shaky</li> <li>• Incorrect color tones</li> <li>• Some colors are not printed</li> <li>• Unevenness in the printing</li> <li>• Mosaic-like patterns are printed</li> <li>• Printing is grainy (jagged)</li> </ul>	<p><b>Is there dirt on the disc?</b></p> <p>Gently wipe off any dust or dirt adhering to the label side using a soft cloth or commercial CD cleaner. Do not use benzene, thinner, or antistatic agents.</p> <p>See "Disc Handling" in the <i>PP-100N User's Guide</i> for details.</p>
	<p><b>Is the printing surface fully dry?</b></p> <p>Do not let other discs get in contact with the printing surface until the ink on the published disc is dry. Otherwise, marks can be left where contact is made.</p>
	<p><b>Is the ink drying time set too short?</b></p> <p>The ink drying time is the time after label printing is completed until the disc ink is dried in the printer tray. Set a longer ink drying time.</p> <p>See "Printer Driver Settings" in the <i>PP-100N User's Guide</i> for details.</p>
	<p><b>Are you comparing the display on the computer to the printing results?</b></p> <p>The colors shown on the display and the results printed by the printer use different coloring methods, and this produces differences in color tones.</p>
<p><b>Unable to print correctly in the print area of the disc.</b></p>	<p>Set the inside diameter and outside diameter of the print area so that they match the print area of the disc to be printed.</p> <p>See "Printable Area" in the <i>PP-100N User's Guide</i> for details. See "Changing the Printable Area" in the <i>PP-100N User's Guide</i> for the inner diameter and outer diameter setting procedure.</p>
<p><b>Printing position is shifted.</b></p>	<p>Correct the printing position if it is shifted.</p> <p>See "Printing Position Correction" in the <i>PP-100N User's Guide</i> for details.</p>
<p><b>The disc recording surface is stained with ink.</b></p>	<p><b>Is the ink drying time set too short?</b></p> <p>The ink drying time is the time after label printing is completed until the disc ink is dried in the printer tray. Set a longer ink drying time. See "Printer Driver Settings" in the <i>PP-100N User's Guide</i> for details.</p>
	<p><b>Is the printer tray dirty?</b></p> <p>When the disc recording surface is stained by ink, the printer tray may be dirty. Clean the printer tray.</p> <p>See "Disc recording surface is stained with ink" on page 91 in this guide for the printer tray cleaning procedure.</p>
<ul style="list-style-type: none"> <li>• After printing, the label surface ink is sticky or peels off.</li> <li>• Discs stick together.</li> </ul>	<p><b>Was printing performed outside the recommended print area?</b></p> <p>If printing is performed outside the recommended print area, after printing, the label surface ink may be sticky or peel off, or discs may stick to each other.</p> <p>See "Printable Area" in the <i>PP-100N User's Guide</i> for details.</p>



## Password problems

Symptom/Problem Status	Check/Remedy Procedure
User name or password cannot be used.	<p><b>Was the user name or password entered incorrectly?</b></p> <p>Enter the correct user name and password. These entries are case sensitive.</p>
You forgot the password.	Please ask another administrator to change the password.

## Other problems

Symptom/Problem Status	Check/Remedy Procedure
Cannot install software	<p><b>Is there enough available HDD space?</b></p> <p>The software cannot be installed unless there is at least 10 GB of available HDD space. Check the amount of available HDD space, and if there is not enough space, increase the amount of available space. Available HDD space needs to be enough to enable the software to run normally.</p> <p>See "Before installation" in the PP-100N User's Guide for software operating requirements.</p>
	<p><b>Are you logged on to Windows with a "computer administrator" account (user with administrator privileges)?</b></p> <p>When installing the software, log on as a user with administrator privileges (belonging to the administrator group). The software cannot be installed if you log on with user privileges. You may be asked for an administrator password or confirmation. When asked for a password, enter the password to proceed with operation.</p>
The EPSON Total Disc Net Administrator login screen is not displayed.	<p><b>Is the power of the product turned off?</b></p> <p>Turn on the power of the product.</p>
	<p><b>Is the product connected to the network correctly?</b></p> <p>Check that this product and the client computer are connected correctly to the network.</p>
	<p><b>Is the correct address entered?</b></p> <p>Check that the IP address, host name, or FQDN of the product was correctly entered in the Internet Explorer address bar.</p>

Symptom/Problem Status	Check/Remedy Procedure
<p><b>The drive cannot be used.</b></p>	<p><b>Is use of the drive stopped?</b>                      When a write error occurs based on a preset write retry count, use of the drive is automatically stopped, and [Drive operation paused DRV1/2] is displayed on the LCD. See "Output device settings" on page 33 in this guide for the drive use restarting procedure.</p>
<p><b>Head cleaning does not work.</b></p>	<p><b>Has an error occurred in the product?</b>                      If an error has occurred, clear the error.</p> <p><b>Is there enough ink?</b>                      Head cleaning cannot be performed unless there is enough ink. Replace with a new ink cartridge.                      See "Changing the ink cartridge" in the <i>PP-100N User's Guide</i> for the ink cartridge changing procedure.</p>
<p><b>The printing speed slowed down during continuous printing.</b></p>	<p>When printing is performed for an extended period of time, disc transfer and printing may be stopped temporarily. This is for slowing the printing speed to prevent overheating and damage to the product.                      Although printing can be continued when this occurs, it is recommended that you stop product operation and leave it with the power on for about 30 minutes. (The product will recover after about 3 hours with the power off.)</p>
<p><b>Cannot publish discs.</b></p>	<p>See "When discs cannot be published" on page 85 in this guide.</p>



## Checking with EPSON Total Disc Monitor



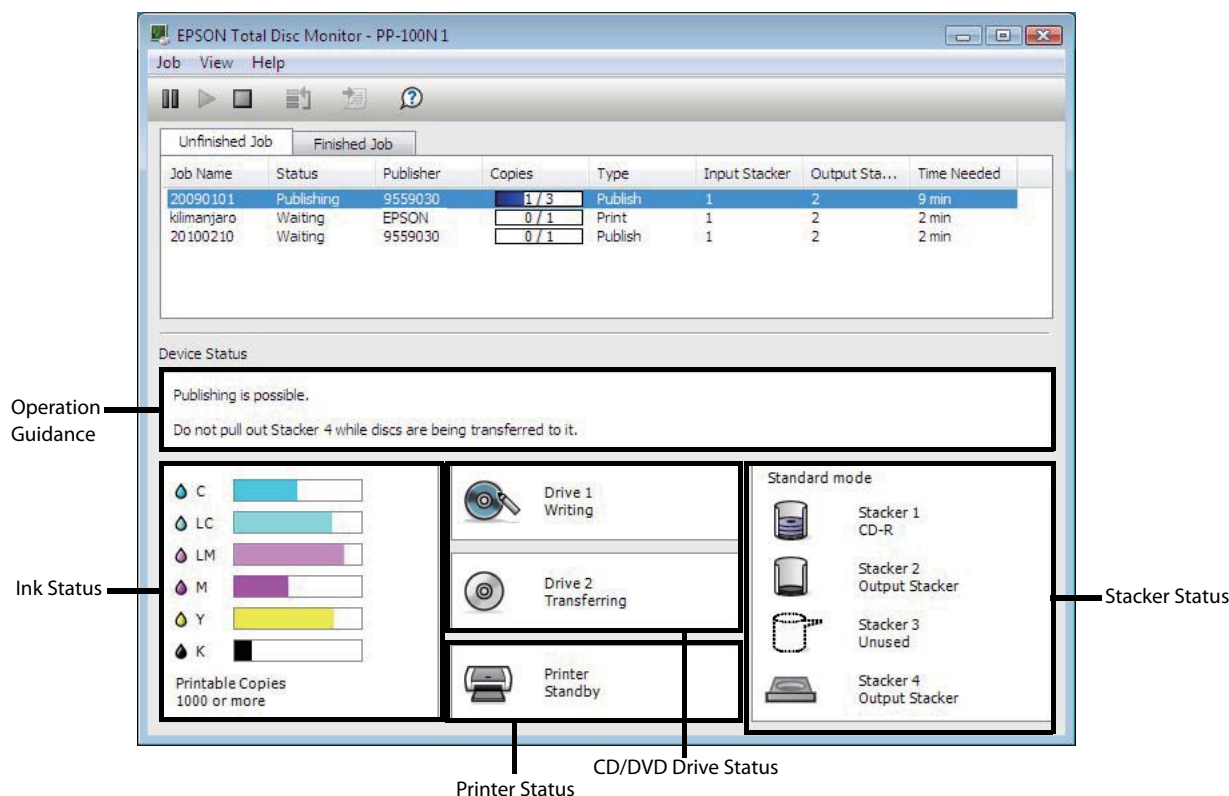

EPSON Total Disc Monitor is a utility that enables checking of the status of this product (PP-100N) and the remedy procedures for errors.

See “Starting EPSON Total Disc Monitor” in the *PP-100N User’s Guide* for details on the EPSON Total Disc Monitor startup procedure.

EPSON Total Disc Monitor can also be automatically started by clicking [Publish] in EPSON Total Disc Maker.



<p>Operation Guidance</p>	<p>This displays the status of this product (PP-100N), error descriptions and messages. Check the product (PP-100N) by referring to the displayed remedy procedure.</p>
<p>Ink Status</p>	<p>This displays the remaining ink level.</p> <p>The ink level is low when  is displayed. Obtain a replacement ink cartridge.</p> <p>The ink should be replaced when  is displayed. Replace with a new ink cartridge.</p> <p>See “Changing the Ink Cartridge” in the <i>PP-100N User’s Guide</i> for the ink cartridge changing procedure.</p> <p>The number of printable labels is an estimate of how many more of the same type of labels as last time can be printed. This value may differ slightly from the actual value due to factors such as the printing data and printing environment. Values of 1000 or more are displayed as “1000 or more,” and quantities fewer than 1000 discs are displayed in 10-disc units.</p>

<p>CD/DVD Drive Status</p>	<p>This displays the CD/DVD drive status.                  When  is displayed on the drive icon, check the product drive by referring to the displayed message.</p>
<p>Printer Status</p>	<p>This displays the printer status.                  When  is displayed on the printer icon, check the product printer by referring to the displayed message.</p>
<p>Stacker Status</p>	<p>This displays the stacker status.                  When  is displayed, either the number of discs in the input stacker is low, or the output stacker is nearly full of discs.                  If the number of discs in the input stacker is low, obtain new discs.                  If the output stacker is nearly full of discs, the ejecting of discs is recommended before publishing the next job.                  When  is displayed, check the stacker and discs by referring to the displayed message.</p>

## ***When discs cannot be published***

If the disc is not published by clicking [Publish] in the Publish view of EPSON Total Disc Maker, or if the product does not work, check the points below.

---

### ***Check 1: Check of EPSON Total Disc Monitor***

#### ***Is an error message displayed in EPSON Total Disc Monitor?***

Check the status of this connected product in EPSON Total Disc Monitor, and perform the remedy if an error has occurred.

See the references below for details on EPSON Total Disc Monitor.

- “EPSON Total Disc Monitor” of *PP-100N User’s Guide*
- Help file for EPSON Total Disc Monitor

If performing the above checks still does not fix the problem, check the items below.

---

### ***Check 2: Check of the product***

#### ***Is the power LED turned on?***

If the power LED is not turned on, the power for the product is turned off.

Turn on the power by referring to “Power/Control Panel problems” on page 76 in this guide.

#### ***Is the ERROR LED flashing/turned on?***

If the ERROR LED is flashing/turned on, an error has occurred in the product.

See “Checking with EPSON Total Disc Monitor” on page 83 in this guide for the error checking and remedy procedures.

If performing the above checks still does not fix the problem, check the items below.

---

### ***Check 3: Check of connection between the product and computer***

#### ***Is the Ethernet cable disconnected?***

Check that the Ethernet cable is connected. Also, check if the Ethernet cable has a broken wire or is bent.

#### ***Is the Ethernet cable compatible with the computer and product specifications?***

Check that the Ethernet cable being used is compatible with one of the specifications below.

- 100Base-TX
- 1000Base-T

### *Are the link speed and Jumbo Frame set correctly?*

If the link speed and Jumbo Frame are set, check that the product settings match the client computer settings.

If performing the above checks still does not fix the problem, check the items below.

---

## **Check 4: Check of printer driver settings**

### *Is the printer driver installed?*

The following procedure is for Windows 10. The procedure to display the printer driver may differ depending on your operating system. Check the specifications for your system.

- 1 Click [Start], [Settings], [Devices], then [Printers & Scanners].
- 2 Check that this product icon (EPSON PP-100NPRN) is found in [Printers & Scanners].  
If the icon is not found, the printer driver is not installed. See “Installation” in the PP-100N User’s Guide to install the printer driver.

### *Is the Print Manager status set to Pause?*

If [Paused] is displayed for the product’s icon (EPSON PP-100NPRN), right-click the icon and click [Resume Printing].

If performing all of the above checks still does not resolve the problem, the software may not be installed correctly. Uninstall (delete) the software, and then reinstall.

See “Software Uninstallation” in the *PP-100N User’s Guide* for the software uninstallation procedure.

See “Installation” in the *PP-100N User’s Guide* for the software installation procedure.

Please contact Customer Support if this still does not resolve the problem. When making inquiries, please provide information about your operating environment (including the computer model, names and versions of software applications, and other peripheral models), name of this product, and its serial number.

## Disc does not come out

Perform the procedure below if the disc cannot be ejected because the drive tray or printer tray does not come out.

### Drive tray does not come out

Turn the power of the product off and then on again. If the drive tray still does not come out, perform the procedure below.

- 1 Press the power button to turn off the power.
- 2 After the power LED goes off, disconnect the power plug from the outlet.
- 3 Wait about one minute until the disc stops rotating, and then open the disc cover.
- 4 Insert a hard pin into the eject hole of the drive to open the tray.

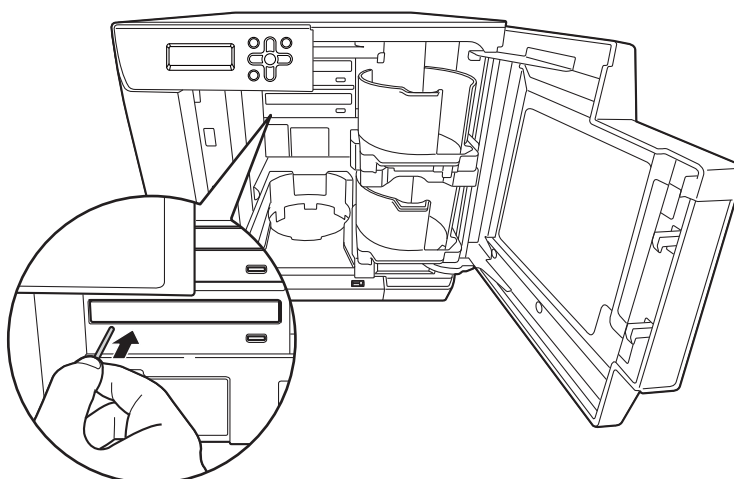

When inserting the pin into the eject hole, be sure that the power of the product is off.

- 5 Pull out the disc, and gently push in the drive tray to close.



The product can be damaged if you leave the drive tray open when turning on the power of the product.

Be sure to always close the drive tray.

- 6 Close the disc cover.
- 7 Insert the power plug into the outlet, and turn on the power.

## Printer tray does not come out

Turn the power of the product off and then on again. If the printer tray still does not come out, perform the procedure below.

- 1 Press the power button to turn off the power.
- 2 After the power LED goes off, disconnect the power plug from the outlet.
- 3 Open the disc cover.

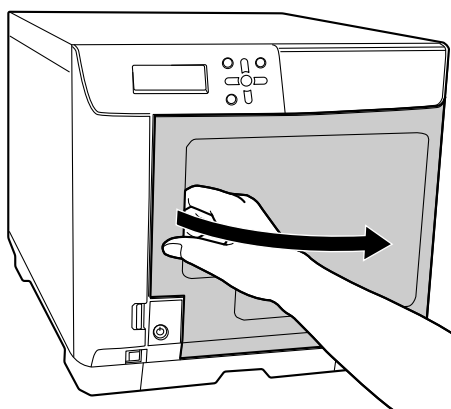

- 4 Remove the two screws on the product rear that secure the top plate.

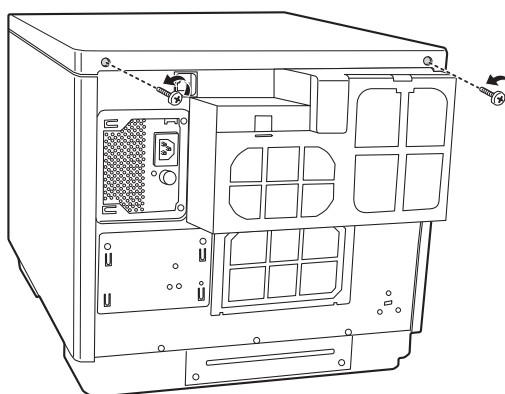



- 5** Slide the top plate backwards slightly to remove it.

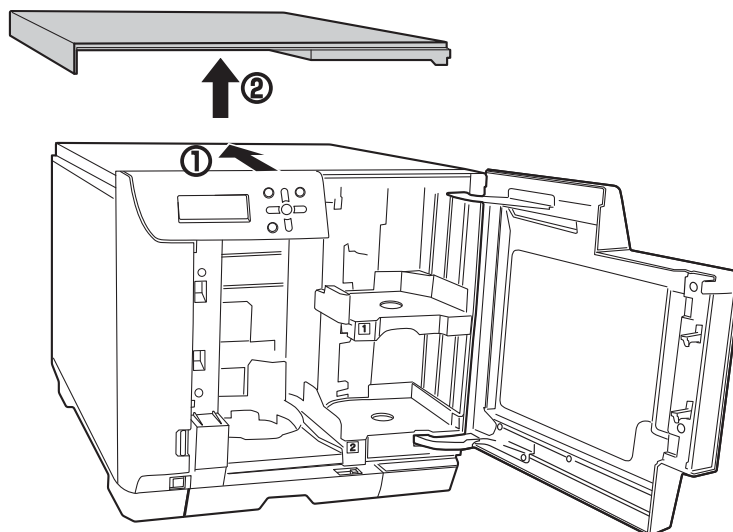

- 6** Remove the four screws on the product rear, and then remove the air vent cover.

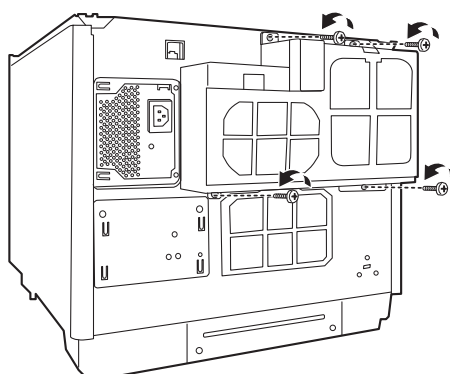

- 7** Remove the screw, and then remove the rear printer cover.

If the disc can be removed, eject the disc and attach the rear printer cover. If the disc cannot be removed, proceed to the procedure below.

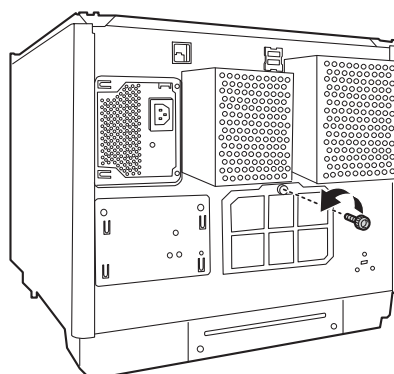

- 8** Grasp the fixture as shown in the figure below, and pull out the printer tray towards you.

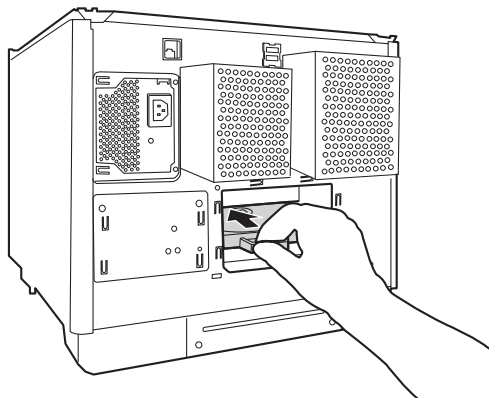

- 9** Pull out the printer tray.

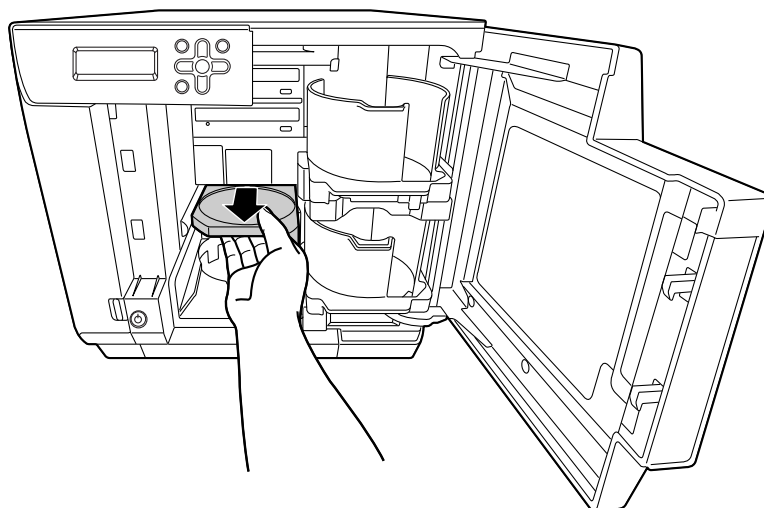

- 10** Remove the disc, and close the disc cover.  
The printer tray automatically closes when the power is turned on.
- 11** Reattach the rear printer cover, air vent cover, and top plate.
- 12** Insert the power plug into the outlet, and turn on the power.

## ***Disc recording surface is stained with ink***

When the disc recording surface is stained with ink, the printer tray may be dirty. Clean the printer tray by following the procedure below.

- 1** Press the power button to turn off the power.
- 2** After the power LED is off, disconnect the power plug from the outlet.
- 3** Open the disc cover.

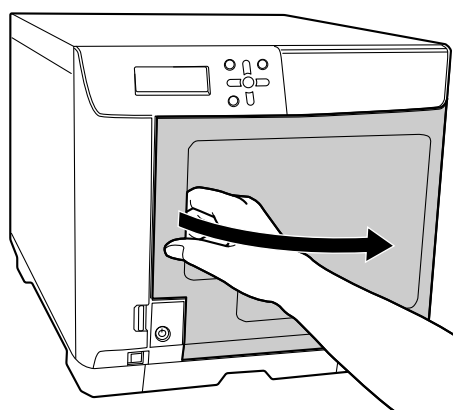

- 4** Remove the two screws on the product rear that secure the top plate.

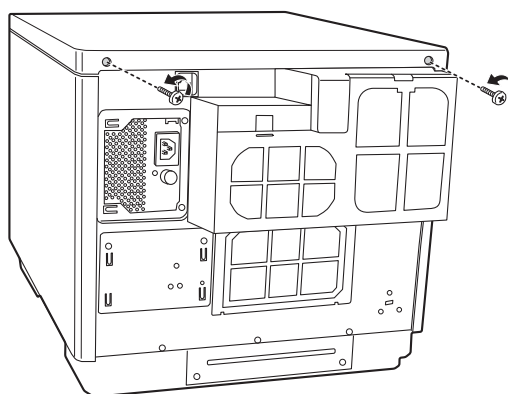

5 Slide the top plate backwards slightly to remove it.

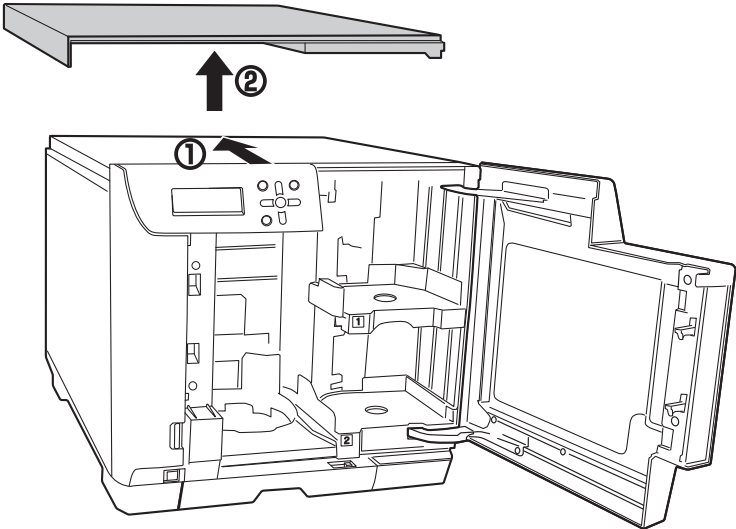

6 Remove the four screws on the product rear, and then remove the air vent cover.

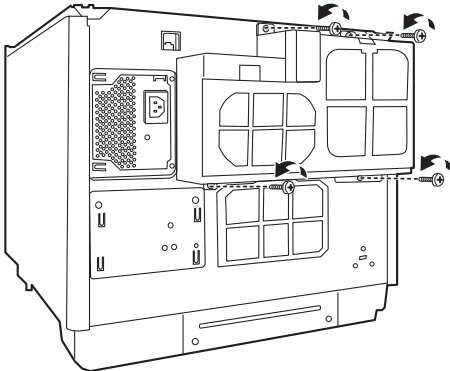

7 Remove the screw, and then remove the rear printer cover.

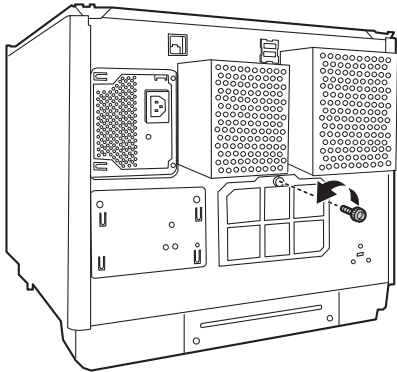

- 8 Grasp the fixture as shown in the figure below, and pull out the printer tray towards you.

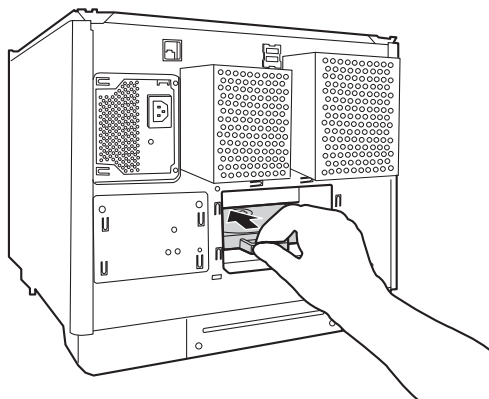

- 9 Pull out the printer tray.

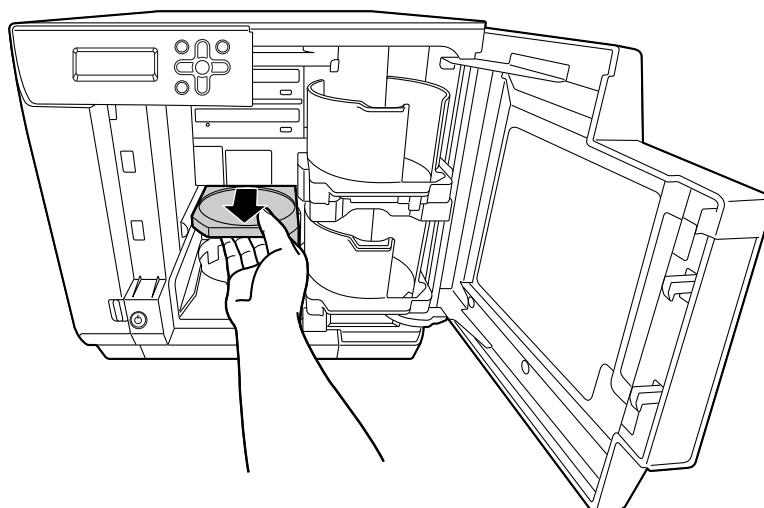

- 10 Use a soft cloth to wipe off any dirt on the printer tray.
- 11 Close the disc cover.  
The printer tray automatically closes when the power is turned on.
- 12 Reattach the rear printer cover, air vent cover, and top plate.
- 13 Insert the power plug into the outlet, and turn on the power.

# Appendix

## Where to get help

### Before Contacting Epson

If your Epson product is not operating properly and you cannot solve the problem using the troubleshooting information in your product documentation, contact customer support services for assistance. If customer support for your area is not listed below, contact the dealer where you purchased your product.

Customer support will be able to help you much more quickly if you give them the following information:

- Product serial number  
(The serial number label is usually on the back of the product.)
- Product model
- Product software version  
(Click About, Version Info, or similar button in the product software.)
- Brand and model of your computer
- Your computer operating system name and version
- Names and versions of the software applications you normally use with your product

### Help for Users in the United States and Canada

Contacts for information, support, and services are:

Discproducer Technical Support: 562-276-1360

Location: Epson America Inc.

Web site URL: [www.epson.com/support/](http://www.epson.com/support/)

This site will provide the end user with access to the latest drivers and FAQs.

### Help for Users in the Europe (EMEA)

Contacts for information, support, and services are:

Web site URL: [www.epson-europe.com](http://www.epson-europe.com)

Or contact your local distributor or Epson sales company.

If you need the latest drivers, FAQs, manuals, or other downloadable, access the site at:

[www.epson-biz.com/](http://www.epson-biz.com/)

## ***Help for Users in Australia***

Contacts for information, support, and services are:

Epson Australia Pty Ltd

3 Talavera Road

North Ryde NSW 2113

Australia

Phone: 02-8899-3666

Fax: 02-8899-3777

If you need the latest drivers, FAQs, manuals, or other downloadable, access the site at:

[www.epson.com.au](http://www.epson.com.au)

## ***Help for Users in Southeast Asia***

Contacts for information, support, and services are:

### ***PT Epson Indonesia***

CIBIS Tower 9, 3rd floor

Cibis Business Park

Jalan T.B.Simatupang No. 2

Jakarta 12560

Tel: 021 572 3161

Fax: 021 572 4357

Helpdesk: 0807 11 37766

[www.epson.co.id](http://www.epson.co.id)

### ***Epson Singapore Pte Ltd***

1 HarbourFront Place

#03-02 HarbourFront Tower 1

Singapore 098633

Helpdesk: 6586 3111

[www.epson.com.sg](http://www.epson.com.sg)

### ***Epson Malaysia Sdn Bhd***

3rd Floor, East Tower,

Wisma Consplant 1,

No.2 Jalan SS 16/4,

47500 Subang Jaya, Selangor DE,

Malaysia

Tel: 03-5628 8288

Fax: 03-5621 2088

Helpdesk: 03-5521 5888

[www.epson.com.my](http://www.epson.com.my)

### *Epson (Thailand) CO., Ltd.*

195 Empire Tower 42nd Floor,

South Sathorn Road Yannawa

Sathorn, Bangkok 10120

Thailand,

Tel: 0-2685-9888

Fax: 0-2685-9889

Helpdesk: 0-2685-9899

[www.epson.co.th](http://www.epson.co.th)

### *Epson Philippines Corporation*

8th Floor, Anson's Centre

#23 ADB Avenue,

Pasig City 1605, Philippines

Trunkline: 63-2 706-2609

Customer Care:

Trunkline: 63-2 706-2609 (Press 2)

Fax: 63-2 706-2663

Toll-Free No.: 1-800-1068-EPSON (37766)

[www.epson.com.ph](http://www.epson.com.ph)



## Product specifications

### Basic specifications

#### External dimensions and weight

Item	Description
External dimensions	377 mm (W) x 514 mm (D) x 348 mm (H)
Weight	Approx. 26 kg (including the stackers and ink cartridges, but not including the power cord and discs)

#### Notes

Since this product uses galvanized sheet metal, rusting may occur at the edges, but this will not harm the functionality of the product.

<External View>

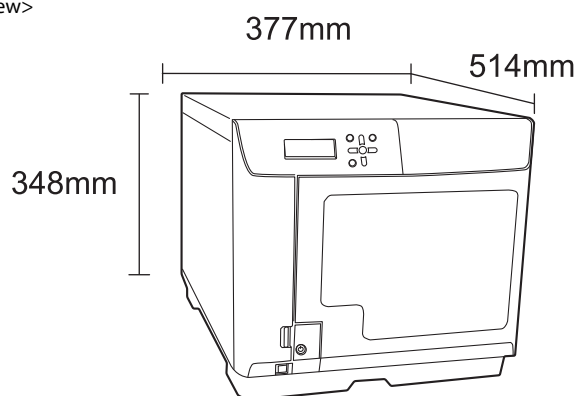

#### Overall specifications

Item			Description
Job processing speed	Write and print	CD	30 discs per hour Conditions: When using Epson specified CD-Rs, drive speed of 40x, writing data of 600 MB, and speed/bidirectional printing
		DVD	17 discs per hour Conditions: When using Epson specified DVD-Rs, drive speed of 12x, writing data of 3.8 GB, and speed/bidirectional printing
	Print only	Quality/Speed: [2]	59 discs per hour Condition: When bidirectional printing
		Quality/Speed: [1]	42 discs per hour Condition: When bidirectional printing

#### Notes

- The above processing capacities do not include the time for transferring a job via the network.
- Depending on the operating environment and discs used, the write speed may become slower than the set speed.

## Printing specifications

Item		Description	
Printing method		On demand inkjet	
Head	Number of nozzles	Black	: 180 nozzles
		Cyan	: 180 nozzles
		Magenta	: 180 nozzles
		Yellow	: 180 nozzles
		Light cyan	: 180 nozzles
		Light magenta	: 180 nozzles
Printing resolution		Print Mode Setting (Quality/Speed)	[1]: 1,440 x 1,440 dpi [2]: 1,440 x 720 dpi
Printing direction		Bidirectional, unidirectional	

dpi: number of dots every 25.4 mm (dots per inch)

## Ink cartridge

Item		Description	
Form		Separate ink cartridge for each color	
Color		Black, cyan, magenta, yellow, light cyan, light magenta	
Recommended expiration date		Use within the expiration date labeled on the ink cartridge. Use within 6 months of opening the package.	
Temperature	When stored packaged individually	-20°C~40°C	Within 1 month at 40°C
	When installed in the product	-20°C~50°C	Within 1 month at 50°C
	When transported packaged individually	-20°C~60°C	Within 5 days at 60°C
Dimensions		42.0 mm (W) x 83.0 mm (D) x 26.4 mm (H)	
Ink		Dye-based ink	

## Drive specifications

Item	Description	
Number of drives installed	2 drives	
Loading type	Tray	
Write speed	CD-R	40x/32x/24x/16x/10x/4x
	DVD-R	12x/8x/6x/4x/2.4x/2x
	DVD+R	12x/8x/6x/4x/2.4x/2x
	DVD-R DL	8x/6x/4x/2.4x/2x
	DVD+R DL	8x/6x/4x/2.4x/2x



- CD/DVD discs created with this product's drive may not be able to be recognized, played, and read depending on the compatibility of the drive or player.
- Do not subject the product to vibration or impacts while a disc is being read or written. The drive may malfunction, or the disc may become unable to be played.
- Do not insert a flat-tip screwdriver, clip, or other foreign object into the CD/DVD drive. Doing so may result in a malfunction.

### Notes

- Depending on the operating environment and discs used, the writing speed may become slower than the set speed. (This is to ensure recording quality is maintained.)
- If you select 2.4x for DVD-R/DVD-R DL, write speed will be set to 2x.
- If you select 2x for DVD+R/DVD+R DL, write speed will be set to 2.4x.

## Electrical specifications

Item	Description	
Rated voltage	AC 100 to 240 V	
Rated frequency	50 to 60Hz	
Rated current	1.5 A	
Power consumption	Average during operation	Approx. 71 W
	Average during standby	Approx. 35 W
Power cord	Power cord (supplied with product)	

## Lifetime

Epson estimates lifetime for components of this product to be as follows:

### Expected Lifetime:

Ink pad life: About 30,000 discs printed

The ink pad is estimated to need replacing after about 30,000 discs. Based on printing 2,000 discs per month, bi-directional. Actual results will vary based on such factors as images printed, print settings, media type, frequency of use and temperature.

## Environmental conditions

Item		Description	
Temperature/ humidity	During operation	10°C~35°C	Within 1 month at 40°C Within 120 hours at 60°C
	During storage	-20°C~40°C	
	During transportation	-20°C~60°C	
	During operation	20%~80%RH	No condensation
	During storage	5%~85%RH	No condensation
	During transportation	5%~85%RH	No condensation
	Guaranteed operating range	<p>Based on the following conditions</p>	
Elevation	2000 m or less		

## Interfaces

Item	Description	
Ethernet	1	<ul style="list-style-type: none"> <li>• 100Base-TX</li> <li>• 1000Base-T</li> </ul>

## ***Ink and Disc***

### ***Ink cartridges***

You can use the following ink cartridges with this product:

<b>Ink cartridge</b>	<b>Product name</b>
Cyan	PJIC1(C)
Light Cyan	PJIC2(LC)
Light Magenta	PJIC3(LM)
Magenta	PJIC4(M)
Yellow	PJIC5(Y)
Black	PJIC6(K)

To purchase a PP-100 Series exclusive ink cartridge, check with the dealer where you purchased your PP-100N or access either of the following urls:

[www.epson-europe.com](http://www.epson-europe.com) (Europe)

[www.epson.com/support/](http://www.epson.com/support/) (United States and Canada)

### ***Discs***

Epson offers the specified CD-R and DVD-R discs for all your printing needs.