

Forgotten Books

— www.forgottenbooks.com —

Copyright © 2016 FB &c Ltd.

All rights reserved. No part of this publication may be reproduced, distributed, or transmitted in any form or by any means, including photocopying, recording, or other electronic or mechanical methods, without the prior written permission of the publisher, except in the case of brief quotations embodied in critical reviews and certain other noncommercial uses permitted by copyright law.

EARLY EGYPTIAN RECORDS OF TRAVEL

VOL. II

SOME TEXTS OF THE XVIIITH DYNASTY, EXCLUSIVE OF THE
ANNALS OF THUTMOSIS III

BY

DAVID PATON

14 2884
2 | 6117

PRINCETON UNIVERSITY PRESS
PRINCETON

LONDON: HUMPHREY MILFORD
OXFORD UNIVERSITY PRESS

1916

Copyright, 1916, by
PRINCETON UNIVERSITY PRESS

Published October, 1916



Mr. George Vincent Welter has continued the excellent work done for Volume I in preparing the proof sheets of this volume for the photographer.

TABLE No. XII. AHMES I (Ἰσῆς) I. (Ἄμωσις) THUTMOSIS (ΘΟΥΤΜΩΣ) I. (Ἄμωσις) Life of Ahmes (Ἰσῆς), Son of I

Tomb No. 5 at el Kâb on the Nile, East Bank, 44 miles South of Luxor. (Map:- MASPERO, Struggle of the Nations, (1897), I, KIEPERT, Atlas Antiquus, (1892), Tab. III, f.

el Kâb was formerly Nokheh (Nhb) (Table No. III; line a) then Ἐλευθεῖα πόλις, (Ptolemaeus, n. s. Ed. MÜLLER, (1901), II. p. 725. (1906), I, p. 386. Directly across the Nile was its twin-city, Nekhen (Nhn) (Table No. III, line 3) or Ἱερᾶκων πόλις, (STRAB

Described:- BAEDEKER, op. cit. (1908), p. 331; (1914), p. 333. BUDGE, The Nile, (1898), p. 327. WEIGALL, Antiquities of Upper Egypt, (1898), p. 893. MURRAY, op. cit. p. 893. MASPERO, op. cit. pp. 85, ff. CHAMPOLLION (FIGEAC), L'Égypte ancienne, (1840). LEPSIUS, Denkmä

The tombs, 31 in all, are on a hill about a mile from the steamboat landing, to the Northeast of the town. (See view of the burial room leads. On the North or end wall, is a picture of Ahmes and his wife seated and receiving presents from as shown below.

Text:- (1844), CHAMPOLLION, Notices Descr. I, pp. 665, ff. (26 lines), (1867), pp. 168, 300. BUNSEN, Egypt's Place in Universal History (1849-1852), (Expedition, 1842-5); LEPSIUS, Denkmäler, etc. III, Pl. 12a (Relief of Deceased, etc.) ibid, 12, b, (lines 32-4 lines 32-66). (1883), LEMM, Aeg. Lesentücke, Part I, Pl. p. 67; (Copy of L. D. III, 12d, (i. e. lines 1-31) & b, (lines 32-40). (1804), ERMAN, Aeg. Chrestomathie, pp. 122, ff. No. L, (lines 1-24). (1901), LEPSIUS, Denkmäler, Texte, (NAVILLE-SETHE), IV. pp. 50, L. D. III, 12d, b: lines 41-66 = ibid, o.) (1910), LORET, l'Inscription d'Ahmes, file d'Abana; Bib. d'Étude, III, pp. 1-8, (lin

transcription:- BUDGE, First Steps in Egyptian, (op. cit.), pp. 126, ff. (lines 1-31) BUNSEN, as above. LORET, (Glossaire), op. cit.

Corrections & Renderings:- DE ROUGÉ, Examen de l'ouvrage de M. le Chevalier de Bunsen, intitulé "Aegyptens Stelle in der Weltge- Mémoire sur l'Inscr. du Tombeau d'Ahmes; Mém. de l'Acad. des Inscr. savants étrangers, III, (1844) (lines 10, 11, 14, 29) PISHL, S. B. A. Proc. XV, (1893), pp. 256, ff. ibid. Sphinx, III, (1900), pp. 7, ff. LORET

Translations:- BRUGSCH, Reiseberichte aus Aegyptens, (1855), pp. 217, ff. Gesch. Aeg. (1877), pp. 230, ff. Egypt under the Pharaohs, CHASSAS, Les Pasteurs en Égypte, (1869), pp. 19, ff. Mém. de l'Acad. des Inscr. et Bellees Lettres, Sér. I, III, pp. 1, ff. CESARE DI CARA, Gli Hyksos o re Pastori dell'Egitto, pp. 324, ff. BUDGE, First Steps in Egyptian, (op. cit.), pp. 12 MAERENE, Struggle of the Nations, (1897), pp. 85, ff. (Summary, lines 1-40) ERMAN, Life in Ancient Egypt, (1894), (GIT RANKE, (in von GRESSMANN), Altorientalische Texte und Bilder, (1909), pp. 235, ff.

See SETHE, (Duration of Siege of Saruhan), Zeits. Aeg. Spr. XLII, (1905), p. 136. (Comment) SCHÄFER, Z. Aeg. 52: id. (lines 4-12) Ancient E

Note:- The Text is to be found as follows:- Lines 1-31, Right Wall of Tomb: Lines 32-40, Entrance

For Titles see Appendix *

hr-r(N.1) xn(=D.51)-n-y-t(A.89)(pl.) idh(=N.28)-má(=M.80)-s sa(=G.67)
 f(A.91)-b-ba(=G.58)-n-a maâ(=Q.58)-hrw(=P.22)
 d-d-f d-d-A.89 n-t-n(pl.) r-f(A.89)(pl.) nb-t rdî(=D.63)-A.89
 r-h(Y.2)-t-n(pl.) hsl [GAUTHIER, Bib. d'Ét. IV. p. 101](=W.4) mhîî hîî
 hpr(=L.4)-r-t n-A.89

 d-d-f r n-t-t ir(=D.10)-n-A.89 hpr(=L.4)-r(A.27)(pl.)
 i-m d-mî(=W.29)-î(N.47) n nhb(=M.22)-(O.1)-b [sic.] iw i-t-f(A.89)-
 -A.89 m w-â-w(D.69) n nsû-t dît [SETHE, Z. A. 49, p. 19] (râ-s-q-n-n nht
 (=D.69)) maâ(=Q.58)-hrw(=P.22) ba(=W.39)(G.58) sp(=X.14)-î (A.117)
 sa(=G.67) râ-în(=K.1)-n-t(N.40)(A.118) rn-f âhâ(=P.19)-â-n-A.89 hr
 ir-t wâw(D.69) r gba(=Q.28)-b(Y.2)-f m pa wîa(=P.1) n pa s-ma(=U.8)
 (E.8)[sic.](P.2) m h-a-w(Y.2)(pl.) nb fawî(=N.39)
 (râ-nb-ph(=F.15)-t-t) maâ(=Q.58)-hrw(=P.22)

10. Geographical Names, (Context).

XII Aahmes Son of Abana. (1)

BAEDEKER, Egypt, (1908), p. 239: (1914), p. 244. MURRAY, Egypt, (1900), p. 892. LEPSIUS, Denkmäler, I, Pl. 99-100.
 Eg. Exp. Fund, An Atlas of Ancient Egypt, (1894), Pl. V. Encyclopædia Britannica, (Xith. Ed. 1910), Vol. IX, p. 40, B. 2.
 BRASSO, XVII, §47, (Casaubon, 817) Edit. MEINEKE, (1904), p. 1139; Probably the "Leucothese oppidum" of PLINY, (V, 60, Ed. MAYHOF,
 op. cit.) now Kôm el Aqmar, (BAEDEKER, Egypt, (1914), p. 337). As to these identifications and this District, see Appendix "E".
 pp. 306, 311, 318, 324. CHAMPOLLION, (Letters), Lettres Écrites d'Égypte, (IIe. Éd.) pp. 194, ff.
 Texte (NAVILLE-SETHE, 1901), IV, p. 36.
 Hill, MASPERO, op. cit. p. 87). The fifth tomb from the South is that now in question. It consists of a chamber from which
 relatives. On the right wall is a large picture of Aahmes facing the main inscription which continues around the walls

50-55), V, p. 732. (lines 1-5). (See DE ROOS, "Examen de l'ouvrage de M. le Chevalier de Bunsen" etc. below)
 ibid, 12c, (lines 41-66), ibid, 12d, (lines 1-31). (1873-5), REINISCH, Chrestomathie, Part I, Pl. 6, (Copy of L. D. III, 12b, c. (i. e.
), BUDGE, First Steps in Egyptian, pp. 126, ff. (lines 1-31), (Geographical Names in part, ibid, Hist. Egypt, III, (1902), pp. 184, ff.
 Parts of L. D. III, 12a, i. e. Relief Texts.). (Entire) (1908), SETHE, Urk. d. XVIII Dyn. pp. 1-11 (lines 1-66, i. e. lines 1-40 =
 1-40 = L. D. III, 12d, b.)

7-24.

ichte", Annales de Philosophie Chrétienne, XIII, XIV, (1846-7), pp. 1-74 1-85. (Bib. Ég. XXI, (1907), pp. 1, ff. See pp. 128, ff.
 pp. 1-196. (Bib. Ég. XXII, (1908), pp. 1, ff. (Reviewed), BRUGSCH, Zeits. d. D. M. G. VI, (1852), pp. 449, ff.
 Glossaire, as above. BUDGE, as above. BRUGSCH, Hist. d'Ég. (1859), pp. 80, 86, 90. ERMANN, Chrest. (op. cit.), p. 60*

1), pp. 112, ff. (lines 1-40). MAURY, Revue Arch. Sér. I, VIII, 2, p. 691 (lines 1-40). LORET, Glossaire, op. cit.
 Ég. XI, (1903), pp. 367, ff. (See pp. 390, ff.) (lines 1-40). LE PAGE RENOUF, Records of the Past, (o. s.), VI, (1876), pp. 7, ff.
 (lines 1-31). ibid. Hist. Egypt, III, (1902), pp. 184, ff. PETRIE, Hist. Egypt, II, (1899), pp. 21, ff. 47, ff. 61, ff. (lines 1-40).
 of the Deceased), p. 119. BREASTED, Anc. Records of Egypt, II, (1906), pp. 6, ff. 17, ff. 83, ff. (lines 1-40).

III, (1916), p. 78.

k, Left Half: Lines 41-66, Entrance Wall, Right Half.

is Sa Ibbana naā-ḥrw

rmt nbt rdt-I

t n-I

.....

.....

gd-f n ntt [Gram. §581] irn-I

Bib. d'Ég. VI, p. 108] in dml n

itf-I n wāw n ḥst Bit

Naā-ḥrw Sa-ba

it) rn-f Iḥn-I hr ir-t wāw r

n Pa-Sna (ka) (wia) n haw

itī-Rē) Naā-ḥrw

Chief of the Sailors, [Lit. "Steersmen"] Aahmes, Son of Abana,
 triumphant, saith:-

"I will tell to all you people, I will cause ye to know of the honors
 "that happened to me

.....
 (Summary of Rewards)

..... He saith:- "Verily I made [my] appearance in the City of
 "Ḥḥ. My father was an officer of the King of Upper and Lower Egypt,
 "(Seqenen-Ra the Mighty) [Dyn. XVII], Justified.

(1) Ḥḥ
 [Egyptian]

"Sa-ba,
 "Son of Reluct (land ?) was his name. Then I became officer instead of
 "him in the "Ship of the Wild Steer" in the time of the Lord of the
 "Two Lands, (Aahmes I), Justified.

(2) Raḥnt (?)

In irt-ī pnt iw sgr-ī m sāt šns
 .]]
 [449] m ht grgn-ī pr [LORET, p.21:
 p.140] ĩhān-ī ĩft-kwi
 itī hr qn-ī wn hr i [GAUTHIER, Bib.
 29, No.18] hr šns ĩtiy ĩ. N. S. hr
 šwtwt-f hr

hr dmi n ht-wārt (nwt)
 nnt rdī m dah ĩm-f ĩhān-ī

-Xnnfr (wia)
 ĩha hr m Pa-d-d-k-w (Xr) m

[LORET, p.17]-ī
 wāt ĩhān whm āha m

 Wnīn-tw hr āha m ta km-t (nwt)
 m
 sgr-ānh s wāw ĩan-ī r pa m mōh
 h hr ta wat pa

xr-f hr m šns n whm šwt āhān
 ĩ m nō šnnwī snīa-tw

ār-t (nwt) snīn-ī hr ĩnt hoqt ĩm
 hntz Dmā fdw Wnīn ĩm-f hr rdīt št
 [BAILLET, Rec.de Trav.27, p.193]

hst hr Šarāhāna (hošt) m rnpwt
 SETHE, Z.Aeg.42, p.138] Wnīn ĩm-f
 ĩhān ĩnn-ī hoqt ĩm št štī grt
 to.

hr nht šmān ĩm-f ĩntīw št-t (hošt)
 ec.de Trav.32, p.58]
 hntīyt [Gramm. §406] r ĩntħnnfr
 hsk ĩntīw-štīw

hr irt xast āa ĩm-m

..... n-ī-
 p.14] m dā ĩn ĩm-f ĩd-f awt m qnt
 hšīw hntīw
 [LORET, p.7] ĩm n Rš

ħšm-f ĩtrw šāw hr am-f
 ĩm-f m ĩnttaā (nw)
 hr ĩntw-f

.....
 ... ĩhān hrw

"I was a youth. I had not taken a wife. I was sleeping in the garmoot
 "of hair.
 "After I had established a house, I was transferred to the "Ship of the
 "North" on account of my Valor, and
 "I was following the King, Life! Health! Strength! on my two feet
 "behind his driving out in his
 "chariot.
 "One besieged the City of ht-wārt, and
 "I was brave on my feet before His Majesty:
 "I was appointed to the "Shining in Xnnfr" [Memphis] (Ship)
 "One fought on the water in the Paḏkw Canal of
 "ht-sārt
 "Then I took plunder.
 "I brought away Hand 1 Again there was fighting in
 "that place Rewards
 "One fought in this Kmt [Egypt]
 "to the South of this City, and lo!
 "I brought away a living captive, 1 man. I went down into the water,
 "and mark you! he was brought in as captured on the road of this
 "City, [or, beside this City: SCHÄFER, Z.Aeg.52]
 "[although] I had crossed over the water carrying him. [But when] it
 "was explained to the Royal Herald, then I was rewarded with gold
 "twofold.
 "One captured ĩtwār-t, and I took booty therein, 1 man, 3 women,
 "total 4. His Majesty gave them to me as slaves.
 "One
 "besieged Šarāhāna for three years. His Majesty captured it. Then I
 "took booty therein; Wosen, 2, Hand 1, etc. etc.
 "Now after His Majesty had slaughtered the Mentiw
 "Sathet,
 "he was on the going up stress to ĩntħnnfr
 "to slaughter the Antiw Stitiw (ĩntīw-štīw)
 "His Majesty sate great slaughter among them
 (Captives) Sailed
 "down stream, and verily His Majesty rejoiced in the strength of
 "Victory. He had seized the Southerners and the Northerners.
 "Then an enemy came from the South,
 "Pets and his doom drew near, and the Gods of the South took him.
 "He was found by His Majesty in ĩnttaā (water)
 "It was His Majesty who brought him
 "as a living captive (Captives & Rewards)
 "..... Then, that fallen one

Geographical Names

- (3) ht-wārt [Delta]
- (4) Xnnfr [Memphis]
- (5) Paḏkw ĩr [Canal]
- (6) ht-wārt [Delta]
- (7) Kmt [Egypt]
- (8) ĩtwār-t [Delta]
- (9) Šarāhāna
- (10) ĩntīw-št-t: " št-t-t.
- (11) ĩntħnnfr
- (12) ĩntīw-štīw
- (13) Ršīw [South-folk]
- (14) ĩhtīw [North-folk]
- (15) ĩnttaā [water]

in n-f shun-f n-f xake-ib
] Nnān n-f hr ēna-f

 nt Nswt Bīt (Dsr-ka-Rā) māā-hre
 y t r Kē (hast) r ēwēh

nt)
 qv Inw-stit pn m ib aās-f Inw m |
 nhw-ēn wthw

mī ntīw nn hpr Iāt in m tp n
 in Shan-ī r [LORET, Bib. d'Ét. III,
 6 Man n-f qnt-ī in-ī drt

SCHEV, Bib. d'Ét. II, p. 95] n hē-f
 hē rmtt-f mnnwt-f Ghān inn-ī
 ' n hē-f Inn-ī hē[-f] m hrw
 (nwt)

ET, p. 18] hrw (pt) Ghān-tw hr

 .. nnin-tw hr rdīt [LORET, p. 16]-ī
 loss. p. 24] n hqa Nnān-ī xant
 ' h-pr-ka-Rā) māā-hrw in-f m
 hē-nfr (nwt)

[LORET, p. 18] ht hast r dr bē n ā
 qnt m bap-f m pa. hē Bīn m pa

a) hr ta Pnāyt (nr)
 rdīt-ī r hrw Inyt

. N. S.
 ... Not Chiselled]
 rē mī aby [GARDINER, Lit. T. I, 1, p. 21
 hē-f sār tpī Nnān m šndt
 Lec. de Trav. 33, p. 222] ntī hrw pf
 Not Chiselled]
 in m Nsrt-f irw in m at hbyt Innw
 šqr-ānbw

[Gramm. §286] hē-f hēwt nbt m
 m m šbd m ba-t bīn n hē-f rdīw

(nwt)
 r Rinnw (hast) r Iāt id-f ht
 hē-f r Nharīna (hast)
 . N. S. hrw pf hē-f hē Nnān hē-f
 hē in-ēn In

"case, ftīānīn his name, and gathered to himself enemies,
 "His Majesty slew him
 Rewards
 "I sailed the King of Upper and Lower Egypt, (Zeser-ka-Rā)
 [Amenhotep I] "Triumphant. He went up-stream to Kush to
 "extend
 "the boundaries of Egypt.
 "He captured this Inw-stit in the midst of his army. Taken by
 "surrounding, none escaped; and the troops
 "in being taken on the side ["Flank"] were as those who do not
 "exist. Behold I was at the head of our army and I fought
 "beyond belief. His Majesty saw my bravery, [for] I took
 "2 hands,
 "and brought [them] to His Majesty. One was on a raid for His
 "people and his herds, and lo! I took [him ?] a living captive,
 "and brought [his] to His Majesty. I brought His Majesty in
 "2 days to Kmt [Egypt]
 "from the Upper Well, and I was rewarded with gold
 other rewards
 [I] was appointed "Champion of the Chief",
 "and I steered the King of Upper and Lower Egypt,
 "(As-Kheper-Ka-Ra)[Thutmose] I, Triumphant. He was on the
 "journey up-stream to Khent-hennefer
 "to cause to atone for the fighting throughout the strange
 "land, and to put down the revolt in [that] region of the
 "country. I was brave in his presence on the Bad Water
 "in the attack
 "of the ships at the Bend (of the Channel)
 "Then it was that I was appointed Chief of the Sailors [See
 line 1].
 "His Majesty, Life, Health, Strength, was
 [.....Not Chiselled]
 "His Majesty himself raged like a panther. His Majesty hurled
 "his first spear. It remained in the body of that fallen
 "Chief (of the foe).
 " Not Chiselled]
 "..... powerless before his Uraeus; so wade in a asent of
 "carnage. Their people were led away as living captives.
 "Sailing to the Northward was His Majesty; all of the countries
 "in his grasp.
 "That wretched Anu-Stit hung head downwards on the prow of the
 "Royal Barge of His Majesty, was landed [lit. given to earth].
 "at Ipt-Isut [Karnak City][GARDINER, Zeits. Aeg. XLV, p. 128, note]
 "After these things one journeyed to Rīnnw to wash his heart
 "after the deserts (?). His Majesty arrived at Nharīna.
 "He found that conquered foe. He arrayed his troops. His Majesty
 "made great slaughter among them. There was no

XII Aahms Son of Abana.(3)
 Geographical Names
 (16) Kē [African]
 (17) Kmt [Egypt]
 (18) Inw-Stit [African]
 (19) Kmt [Egypt]
 (20) Inst hrw
 (21) hntnfr
 (22) hē Bīn
 (23) Pnāyt
 (24) In-Stit [African]
 (25) Ipt-Isut [Karnak]
 (26) Rīnnw
 (27) Nharīna

THIS PAGE IS LOCKED TO FREE MEMBERS
Purchase full membership to immediately unlock this page



Never be without a book!

Forgotten Books Full Membership gives universal access to 797,885 books from our apps and website, across all your devices: tablet, phone, e-reader, laptop and desktop computer

A library in your pocket for \$8.99/month

Continue

*Fair usage policy applies

7	7	38	62	34	80	9	38	Thutmosis I.	t-n-nw-t(Y.2)(pl.) = s-q-sqr(=Z.22)(A.84)-anh(=S.43)(pl.) in(=W.22)-n(=S.11) hm-f = n-ht-h-t-w(D.69)(pl.)-f i-s-t i-w = tp(=D.1)-p n msa(=A.82)(pl.)-n(pl.) ma(D.10)-n hm-f qn-n(D.69)-A.89 in-n-A.89 wr(=G.79)-r-y-t(T.45) s-s-m(E.2) s n-t-i hr-r-s = s-q-sqr(=Z.22)(A.84)-anh = rdi(=D.63) sbi(=O.71) n hm-f wn(=M.67)[sic.][n]-i[n]-t-w hr iw(=E.14)-w(D.69)[sic.][LORET,p.8]-A.89 = nb(=U.50)(N.53,N.53,N.53) hr II-nw-si [LORET,p.19] t-n-i(A.30)-h-w-i ph(=F.40)-n-A.89 i-a-w-i(A.30) hsi(=W.4) hsi hsi-i si(=W.29) tp s[...]II[wr(=U.12)]-r(N.58) [.....]i[.....]htp(=G.17)-t-p]-i = hr(=D.3)-r-t(Q.23) ir(=D.10)-t n-A.89 d-s-A.89	twt [LORE nhtw-f ist qnn-f inn- = rdi sbi snwsi
9	9	40				40			Tni-kwi ph N[r....]i[

TABLE No. XIII. AAHMES (I^hhssé) I. 'Amw:c. Karnak Stele: Cairo. Geographical Names. (Context)

White Limestone Stole: Found at Karnak, near the South face of Pylon VIII, in 1901. See LEGRAIN, Annales du Service des Ant.
Journal d'Entrée du Musée, No.88246: (Registered No. 34001). See LACAU, Catalogue Général des Antiquités Égypt. du Musée.
Rounded Top: Height, 2.96 m. Breadth, 1.05 m. In the arch a winged Disc and two Uraeus, under Uraeus conventional text. Under

Test:- [sonata, op.cit. SETHE, Urkunden der XVIII Dynasty, (1906), p.14. LACAU, op.cit. Translation:-

SETHE: Line	LEGRAIN: Line	Text, SETHE.	
1	1	hrw(=G.8) āa(=T.41) hpr(=L.4)-w nb-ti(=G.83) t-t-twt(=A.27) ms(=M.80)-t-w hrw-nb(=G.13) [nb =U.50, Gram. §16] fs(=O.73)-s tawi(=N.39) nst bit [SETHE, Z. Aeg. 49, p.19] nb(=W.43) tawi(=N.39) (rā-nb-ph(=E.15)-t-t) sa(=G.67) rā wr(=N.58)-f (iāh(=N.30)ms(=M.80)-s) ānx d-t(N.37)	hrw [HERODOTUS, II, 144] āa h hrw-nb fsw tawi nst bit w- sa Rā wr-f (iāhssé) ānx dt
2-12	2-12	Conventional Eulogy.	Conventional Eulogy
12	12 i-w has-t(=N.40)tiw(?=G.5 ?)[sic.] āaw(=T.1)(A.85)(pl.) = h-i-s- -(=M.80)-s(D.96)(pl.) wā(=U.37)-ā āhā(=P.19)-ā r iw haset hase l hins [PIERRET, p.326] wā
13	13	ā-r-r-y-t(O.3)-f ā-w s-ā-t(D.38)(T.12)(pl.)-f = hnt(=W.8)-t-h-hn(=Q.31)-n-nfr- -(=Y.9)(T.1)(A.85)(pl.) h-m-h-w-t(A.89)(pl.)-f = ta(=N.37)ta ta f-n-h-w(V.10)(T.1) (has-t)(pl.) sng(=G.91)-t hm(A.113)-f = xn(=E.22)nw(=W.21) ta(=N.37) p-n si(=W.29) mhw(=O.75)(C.10)	ārryt-f iw sāt-f = hnt hnt = ta Pahw (hošt) [MÜLLER, A SETHE, Z. Aeg. 45, p.85] sngt h mhw [MASPERO, Bib. d'Ét. I, p.1 Conventional Eulogy
14	14
14-21	14-21	Conventional Eulogy.	Conventional Eulogy
21-27	21-27	Exhortation to the various classes of the King's subjects. No Geographical Names.	
27	27	i-w g-r-t wq(=M.73)-w(Y.2)-n hm(A.117)-f ir(=D.10)-t mn-nw(=W.21)nw-nw n t-f i-mn-n rā(=N.7).....(List).....	iw grt wqen hm-f irt mnnw n [HERODOTUS, II, 42].....
31	31	i-w wq-w-n hm(A.117)[sic.] ir-t wia(=P.1) āa(=T.41) n]	iw wqen hm[irt wia āa n]
32	32	tp(=D.1)-i-f-r(N.58)-w i-mn-n wsr(=S.66) ha(=F.16)-t(M.9) r-n-f = ā-s(V.45) ma(=U.8)(Y.2)[sic.] n tp(=D.1) ht(=M.9)-h-t-w(M.9)(pl.)[sic.] r ir-t xn(=D.51)-t(P.1)[-f] nfr[-r-t n-t tp rnp(=M.13)-ts]	tp-ītrw (wr) wsr-hat-īmn rn htw (ht) [sic.] r irt Int[- rnp āhān-f wph = ās Kaps (?) s, B
33	33	āhā(=P.19, a man holds the ladder)-n-A.89 =-h-w(M.9)(pl.) = ā-s(V.45) kap(=S.47)[MASPERO, Bib. d'Étude, I, p.169]-p-w s-sa(=G.67)-t(M.9) = si(=W.29)-t-t (Y.2) r-āi-n-A.113 [..... End] [Note:- For the form of sâhân as above noted, see Thutmosis III, Obelisk, Constantinople, North Front. Table No. XXXIX.]	

XII Ahmes Son of Abana. (4)

.23] m sgr-ânhw inn #m-f m
m tp n mšâw-n(pl.) man #m-f
ryt' ésm é ntî hr-s m sgr-ânh
z-f snin-tw hr iwâ-l m Nb hr

"estimating the living captives His Majesty brought from his
"Campaigns. Lo! I was at the head of our army, and His Majesty saw my
"bravery. I took a chariot, a horse, and the man belonging to it as a
"living captive, causing it to be led to His Majesty.
"One rewarded me with gold twofold.

iawî #siw mi tp tp (? =sp II ?)
hpt]-i m prt irt n-l: gš-l

"I grew old, and I reached ripe years. My honors were as [those] of the
"very highest. [I] was beloved, and [..... I rest] in a toab made by me
"myself.

XIII Ahmes I.

és de l'Égypte; IV, (1903), p.27. Now in the Cairo Museum, No. 348: MASPERO (QUISELL), Guide to the Cairo Museum, (1903), p.185.
aire: Stèles du Nouvel Empire, pp.1, ff.
wing Bpd-t (nwt) Nb Pt i.e. Edfu, Lord of Heaven. Under arch, text of 33 horizontal lines reading Left to Right.
nes 12-13) BREASTED, Ancient Records of Egypt, II, (1906), p.13, §30.

Borne [ὄρεος = 'Ανάλλων] the Great Creator. [Lord of Diadems] κύριος διαδημάτων, Image
of those who are Here. #ra ἀντικάλων ὑπερτερος [Who Triumphs over the foe] Hinder of
the Two Lands. King of Upper and Lower Egypt. Lord of the Two Lands, (Neb-Pheti-Ra),
Son of Ra, His Lever (Ahmes), Life Forever !

(1) Fawî

Conventional Eulogy.

.....The countries of the Iamw come bowing down alone, standing
before

(2) Iamw

His Gate [i.e. Place of Judgment]. His sword is among the Khentennefer.

(3) Khentennefer (pl.)

His shouting in the Lands of the Fenkhu [φενχου] Country.

(4) Fakhw

The fear of His Majesty is in this land like

Min [Min (Miv)] (God of the Desert):.....

Conventional Eulogy.

Moreover His Majesty commanded to be made Monuments for

Father Iamw Ra ['Αμμών = Δία; Ζεύς] (Llat)

The Majesty commanded to be made a Great Ship for

the "Beginning of the River". [Inundation] Wer Nat Iamw was its name, out of sound

(5) Iš [Cedar]

cedar of the choicest of the Foothills [lit. Terraces] to make [His] joyous

voyage, which is of the First of the Year.

I caused to be set up pillars of cedar ? ? ? the floor likewise.

I gave [.....-End]

TABLE No. XIV. AAHMES (Iâhmss) I. 'Aahmēt: Inscription of Meferpert (Nfr-Pr-r-t); Quarry of Ma'sara-Tura. Geographic

Rock Stela in Quarries of Ma'sara, near Helwân.

The Quarries of Ma'sara and Tûra or Turra, lie about 7 miles North of two groups, those to the North, to which there is a railroad spur, are bearing a block of stone and drawn by six oxen. The inscription is much

See:- BAEDERER, Egypt, (1908), p.165: (1914), p.170. MURRAY, Egypt, (1900), p.425. LEPSIUS, Denkmäler; Text, (NAVILLE-SETHE), (1

Text:- YOUNG, Hieroglyphics, II, (1828), Pl.88. VYSE, Operations at the Pyramids, III, (1840), pp.94, 99. CHAMPOLLION, Notices [BRUGSCH, (lines 2-3) op.cit., p.92. SETHE, Urk.d.XVIII Dyn.(1905), p.24. LEPSIUS, Denkmäler, III

Translation:- BRUGSCH, op.cit.(1867), Reiseberichte aus Aegypten; (1855), p.47: Histoire d'Égypte; (1859), p.85: Geschichte

See:- PETRIE, Hist.Egypt, II, (1899), p.36. BUOGE, Hist.Egypt, III, (1902), p.190. WIEDEMANN, Aeg.Gesch.(1884), p.310. PATOM, Syria & Palestine, (1901), p.73. MÜLLER, Asian und Europa; (1893), p.209.

For Official etc. Titles, See Appendix "A".

Line		
a	(On Pediment). nsw-t bit [SETHE, Z. Aeg. 49, p.19] (râ-nb-ph(=F.15)-t-t) di(=X.22) ân(=S.48)	Nswt Bit (Nb-ph-ti-Râ) Di ân
b	t-tm(=U.14)[sic.](A.113) nb in(=Q.29)-nw(=W.21)(O.1) mr(=U.12)-y	Itm Nb Inw (not) Mry
c	p-t-h rs(=M.24) inb(=O.36)-f nb maâ(=Q.58)-t mr(=U.12)-y	Pth Râ Inb-f Nb Maât Mry
d	iâh(=N.28) m(=M.80)[sic.] nfr(=Z.9)-t-i-r-i) ân(=S.48) t(=U.19)[sic.] q-t(N.87)	(Iâhâs Nfrtirî) ânhtî q
e	nfr(=R.13) hm(=D.95)-t nsw(=M.24) hm-t wr-r-t sh-t tawî	Hnt Nfr Hnt Nswt wrt Nbt Tanî
f-h Titles Titles
1	(Face of Stela) hat-sp(=M.13)[sic.][var.] XXI h-r hm n nsw-t bit sa(=G.87) râ (iâh(=N.28) m(=M.80)-s)[sic.] di ân wn(=E.58)-n	Hat-sp qit snwâ hr hm n Nswt Bit Sa Râ (Iâhmss) di ân Wnn
2	(O.69)(D.69) h-t-w-t(O.9)(pl.) m [ma(=U.8)-w]-t(Y.2) šd(=V.17)-d-t i-n-r w(=M.77) nfr(=Y.9)	(â) htwt m [ma]-wt šdt inr wq nfr
3	n nw(=W.21)-š-in(=D.15) r h-t(=O.12) h-t h-t-f n-t h(=A.106)(pl.) m [rnp-t(=M.13)][.....] h-t(=O.12) p-t-h h-t(=O.12)(A.113) nfr(=R.13) nfr(=Y.9)	n Innw [See Stela of Necho, DARESSY, Ann. du Serv. XI, p.260] hwt-f nt[Gramm. §217] hhw m [rapt] [.....] ht Pth ht Nfr Nfr
4	i-m-n n m i-p-t(O.1) rs(=M.24)[.....] h-t(=O.12) m mn nw nw nb ir(=D.10)-n-f hm-f i-t-h-	Inn m Ipt Râ [.....] ht m mnw nb in-f hm-f Ith-
5	-t-w i-n-r(N.51) m ih(=E.9)(N.53, N.53, N.53) in(=W.22)[.....]-f [.....] ht(=M.9) ta ta ta f-n-h-	-tw inr m ih in[.....]-f [.....] ht taw Fnh-
6	-w(T.1)(pl.) ir(=D.10) xr(=Q.20)-â n r-p-â-t ha-t(=F.16) [.....] Frag. Titles	-w(T.1)[See Table X, line 13] Ir xri n Irâ-pât[?] Rpât i] Hatî-â [.... Frag. Titles
7	[... hrp(=S.50)(?)] rs(=T.2)(?) [SETHE; p.25, n.b] tp(=D.1) n nb tawî(=N.39) m š-mn-h(U.27) mn-nw-nw-nw n h[N.47 h][.....] wr(=G.79)-t [mh(=V.15) ib(=W.23) ...]	[... Hrp...] Tp Râ (?) n Nb Tawî m šmnh mnw n h[h] [.....] wrt [mh ib]
8	n nfr nfr bit(=L.4)-t(S.44) š-mr(=U.31) m wâ(=U.38) mr(=S.87) qast(=S.45) nfr(=Y.9)-pr(=O.8)-r-t	n Nfr Nfr Bitî Hm Šm m Wâ [sic.] Imi-ra Qast Nfr Prt

Names (Context)

wān, but are reached from El Masara Station on the Railroad to Cairo. See Map, BAEDER, Egypt, (1914), p.118. The quarries are in led Tura, and those to the South, Messrs. The text in question is in the latter group, and is cut with a relief of a sledge faced.

, I, p.223. BRUGSCH, Zeits. Aeg. Spr. V, (1867), p.89.

riptides, II, (1844), p.488. ROSELLINI, Mon. Storici; (1832-1844), Pl. XV, & pp.195, ff.
b. BERLIN MUSEUM; 547, 548.

gyptens; (Ie. Aufl. 1877); p.258: Egypt under the Pharaohs; (1891), p.180. BREASTED, Anc. Ego. Egypt, II, (1906), p.12, §27.

MASPERO, Struggle of the Nations, (1897), p.93. BREASTED, Hist. Egypt, (1905), p.252.

Geographical Name.

King of Upper and Lower Egypt, (Neb-Phefi-Ra), ["Ahmes I"]. Given Life.

of Itum [Ἰτμω], Lord of Anu [Heliopolis], Beloved
of Ptah-South-of His-Wall, Lord of Truth, Beloved.
[Also] (Ahmes Nefertari) living forever.

(1) Inw [Heliopolis]

Divine Spouse; The Great Royal Wife. Lady of the Two Lands.

(2) Fawī

..... Titles

Year 22 under the Majesty of the King of Upper and Lower Egypt, Son of Rā (Iâhmés)
Given Life.

Opened were the Chambers [See Swunson, Z. Aeg. V, p.92] [of the Quarry] anew. What was taken out
was excellent white stone

of Anas, for his Temples of millions of [years][.....]. The Temple of Ptah.

(3) Annw

The Temple of the excellent God

Amn in Southern Ipt [Luxor ?] [.....] The Temple of all the Monuments sate by His Majesty.

(4) Ipt Rá [?]
[S. Thebes ?]

The stone was dragged by oxen. He brought (?) [.....] [.....] lands of
the Penkh- (Pnh-)

(5) Fnhw

-n (Φο(ν)ισ(ς)). Assistant [i.e. "Underworker"] to the Hereditary Prince. Count

..... Frag. Titles

Director] of the South for the Lord of the Two Lands to restore the Monuments for Eternity .. ? .. ?
Fulfilling the will of

(6) Ip Rá (?)
[Upper Egypt]

the Good God, Royal Chancellor (?) Sole as [ain-] Companion, Controller of the Royal
Purse; Nefert-pert.

THIS PAGE IS LOCKED TO FREE MEMBERS
Purchase full membership to immediately unlock this page

DELVE INTO FANTASY, MAGIC, MYTHOLOGY & FOLKLORE

Forgotten Books'
Full Membership gives
access to 797,885 ancient
and modern, fiction and
non-fiction books.

Continue

*Fair usage policy applies

TABLE No. XV. AASHES I, THUTMOSIS (Ἰουθμοῦσις) III. (Μισσημοῦσις) Life of Ashes (iâhsís) called Pen-nekht-bet

Collated from the following sources:- 1. Tomb No. 2 at El-Kâb: (Formerly Mekheh) on the Nile, 44 miles South of Luxo
 Described:- BAEDER, Egypt, (1908), p.334:(1914), p.336. WEIGALL, Guide to the Antiquities of Upper Egypt, (1910) p.32
 LEPSIUS, Denkmäler; Text, (NAVILLE-SETHE), (1900), Vol. IV, p.46.

The Tomb is the second in order from the South, and consists of one rectangular chamber on which are

II. Status Base, Louvre, C.46. OF ROOSE, Notice des Monuments dans la Galerie d'Antiquités Ég. du Louvre: (VIIIe. Éd.),
 "Two fragments of limestone, measuring:- Height 5 m. Breadth 3 m. which seems to have de
 "lists of rewards."

III. Statue Base found at El Kâb by "Mr. Finlay". MASPERO, Zeits. Aeg. Spr. XXI, (1883), p.77: says:- "An English traveller,
 "a duplicate of the inscription which is borne by the statue of Abuse Pennekhab, preserv

The following are the contents and location of the Text:-

I. A. Title (Lines 1 - 7) (Over Entrance) Text:- CHAMPOLLION, Notices Descriptives; I, 659. LEPSIUS, Denkmäler, Text
 B. Biography. (Lines 1 - 20) (Left of Door). " LEPSIUS, Denkmäler, III, 43a, (lines 10 - 20) (Corrected: SETHE, Unter

II. C. Record of Military Exploits of Deceased. (lines 1 - 10) III Copies: II, Louvre Statue Base, C.46 (= C.46): III,
 II. Text:- LEPSIUS, Auswahl, XIV, a. PRISSE, Monuments Égyptiens; IV. III. Text:- MASPERO, Zeits. Aeg.

III. D. Summary of Life's History: Louvre C.46: LEPSIUS, Auswahl, XIVb, Finlay: MASPERO, as above. Tomb Door.

Translation:- PETRIE, (in part), Hist. Egypt, II, (1899), pp.47, 62, 73. SETHE, (in part, as above), Untersuchu

Monument.	Contents.	Lines	Lepsius, Denkmäler, III, 43a.	Sethe, Unterzuch. I, p. 86	Lepsius, Denkm. Text, IV, p. 46	Maspero, Z. Aeg. XXI, p. 77	Sethe, Urk. XVIII Dyn. pp. 32, ff.	Text, SETHE.			
								L.	L.		
Tomb, Left of Door Biography Title]	a					32	a	[.....]	(1 an	
		1						1	t-n m [.....]	gmw	
		2							2	gm(=G.46)m(=N.50)-w-t [.....]	gr sn
		3							3	h-r sn(=V.6)-n-y-t(A.29)(pl.) s-f-â-w [MASPERO, Bib. d'Ét. V, p. 97]	hfâ-
		4							4	h-f-â-w [sic. =hfâs: Gloss. p. 137] (D.82)(D.62) hr has-t nb-t	
		5							5	tm(=U.14)-m	
		6							6	t-s-t(Z.7)(D.96) r nb tawî(=N.89) hr p-r-i(M.18)(D.69)	tâs :
		7							7	nb q-r-s-t(Q.25) m(=N.50) hsi(=N.4) hsi hsi sw(=M.24)-t-n	no q:
		8	1-7						33	mr(=S.87) (das-t =S.45)	
		9							34	iâh(=N.30)-ms(=M.80)-s q-d-t-w-n-f p-n-nhb(=M.22)-nw(=W.21)-	iâh:
		10	10	a					10	-t-b [sic.]	
		11	11	b					11	Fragments: No Geographical Names.	iawt
12	12	c					12	iaw(=F.35)-t nb-t xr(=Q.20)-r s-t(=Q.1)-t(0.3) hr[sic.=D.3]-f	IV.p		
								Bi-t(=L.1)-t(S.44)[.....]	Qnî		
								q-n-i(D.69) n sw(=M.24)-t-n iâh(=N.30)-ms(=M.80)-s(A.110)	Pnnh		
								maâ(=Q.58)hrw(=P.22) q-[d][n-f p-n-nhb(=M.22)-nw-t-b]	qd-f		
								q-d-f i-w sms(=U.42)-s(D.96)-A.89 stn(=M.24)-t-n-y-[w(A.117)	Biti		
								(pl.) bi-t(=L.1)]-t[sw(=G.5)[sic.](A.117)(pl.)	Nfrw		
								nfr(=R.13) nfr nfr (A.119)(pl.) hpr(=L.4)-r-n-A.89	-sâ		
								[h-r-s-n(pl.) r iâ(=D.86)-t(pl.)]-			
								-s-n(pl.) hr has-t-t rs(=M.90)-t mh(=V.15)-t-t m b-w nb			
								[hpr-r-n]-s-n(pl.)			

ht-dt) Geographical Names. (Contest).

XV Pennekhtbet. (1)

de Table No.XII)

CHAMPOLLION, Notices Descr.I, 659, ff. MURRAY, Egypt, (1900), p.896. MASPERO, Struggle of the Nations, (1897), p.87 (View).

inscriptions together with pictures, now badly damaged.

No.49; also (ibid) Description Sommaire des Salles du Musée Ég.(1895), p.47, C.49.

and the two sides of the seat of a little statue. On the left face are the exploits of the deceased, and on the right face the

inlay, has found, this year, among the ruins of El Kab, a fragment of a granite statue, of which the inscription is very nearly the Musée du Louvre."

.cit.), IV.p.46. SETHE, Urkunden d. XVIII Dynastie, (1905), p.32

ngen etc.I, p.85) LEPSION, Denkmäler, Text, (op.cit.), IV.p.46. SETHE, Urk.d.XVIII Dyn.(op.cit.), p.32.

ay Statue Base, (= F.S.) I. Tesh, El Kab.(On the Left Arch of Door): (= Tesh).

op.cit.)XXI, (1883), pp.77, 78. I. Text:- SETHE, as below.

ext of all three, and Variants) SETHE, Urkunden d. XVIII Dyn.(op.cit.), p.37.

etc.I, (1896), p.52. BREASTED, Ancient Records of Egypt, II, (1906), pp.10, ff.

BREASTED.

Geographical Names

ragments).

(1 and 2 Fragments).

f-a
nbt sz

free the Court. I attacked and
I subdued every country, not

awī hr drī
hsm nšwt imi-Ra (gast)

failing the Lord of the Two Lands on any field of battle.
The Tomb as of Royal distinction [is that of] The Keeper of the
Purse (?)

(1) fawī

en-f Pn-nht-dt

Ashasa, who was called Pennekhtbet.

r šst hr-f [GAUTHIER, Bib.d'Ég.
štī (hsm) [.....]
ššmšš mšw-hrw g[dn-f

every office was under his supervision, Keeper of the Seal.
[.....]
Mighty man of-the King, Ashasa Justified, call[ed Pnshbht]
Pennekhtbet

š-i nšwyt [SETHE, Z.Aeg.49, p.32]

saith:- "I followed the Divine Royalties of Upper and Lower
"Egypt,

ī [hr-šn r šwt]-

"I was with them for their goings

t šst nhtc m bw nb [hprn]-šn

"to the Country of the South and North, in every place they [were]

Tomb, Left of Door.	13	13	d		34	13	i-w nsw-t bit [SETHE, Z. Aeg. 49, p. 19] (râ-nb-ph-t(=F.15)ph-t) maâ-hrw nsw-t bit (râ-dsr(=D.49)-ka(=D.46)) [maâ-hrw] nsw-t bit	iw Nswt Bit (D.6)		
	14	14	e			14	(râ-âa(=F.41) hpr(=L.4)-ka(=D.46)) maâ-hrw nfr(=Y.9)-y-t r nfr(=R.13) nfr(=Y.9)-p-n nsw-t bit (râ-mn-hpr)	(âa-hpr) Nswt Bi		
	15	15	f			15	di(=X.22) ânhy(=S.43) q-t i-w ph(D.96)-n-A.89 smsw(=A.29)-t afr-f-r-t i-w-A.89 m	Di ânhy i-w phn-ânhy h		
	16	16	g			16	ânhy-n-h-n h-r stn-t-n i-w m hs(=W.4)-w-t(pl.) h-[r] hm(=W.6) hm hm-s-n(pl.)	ânhy h		
	17	17	h			17	i-w mr(=U.12)-r-m-t(A.91)-A.89 m stp(=U.3)-p-sa(=V.28)(O.3) ânhy wga snb whm(=F.52)-m-n n-	iw mrwt whm n-		
	18	18	i			18	-A.89 nfr hm(=D.95)-t hs(=W.4)-w-t(pl.) sw(=M.24) hnt wr(=G.79)-r-t (râ-maâ-t(=C.54)-ka(=D.46)) maâ-hrw i-w sd(=V.17)-d-	-I hnt (Maât-k		
	19	19	j			19	(D.89)-n-A.89 sa[sic.=G.67]s wr(=G.79)-r-t sw(=M.24) sa-t (râ nfr nfr nfr (C.54)) maâ-hrw i-w-s m	-n-I So SETHE, U		
	20	20	k			20	xrd(=A.71) im(=R.28)[m-i] mn-n-d(D.39)[(D.39)] mr[Gloss.p.52] (=S.37)[Gramm.p.53, §84](S.45) whm(=F.52)(A.91) k-f-â[sic.](D.82) (D.69) iâh-es-s q-d-t-w p-n-nhb(=M.22)-nw-t-b [sic.]	Xrd imi iâh-es-s		
	Statues, Door of Tomb.	20	LEPSIUS, Auswähl, XIV, a 1.		77	1	35	1	r-p-â pa(=F.16)-â bi-t(=L.1)-t(S.44) s-mr(=U.31)[sic.][U.31=U.24, GRIFFITH, Hierog. p. 49, No. 107] wâ(=U.38)t[.....]	Rpât I
		21						2	mr[Gloss.p.52](S.45) whm(=F.52)-w k-f-â-w(D.82)(D.69) iâh-es-s(A.117) q-d-w-n-f p-n-nhb-nw-t-b(A.117) maâ-hrw	imi-Ra Pn-nhb-
		22				78	2	3	q-d-f	Qd-f
									Reign of Iâhmes I.	
								3	i-w sm(=U.42)-s(D.96)-n nsw-t bit (râ-nb-ph-t-t) maâ-hrw k-f-â(D.82)-A.89 n-f hr qa(=U.21)-h-i(N.40)	iw Sm n-f hr
		23						4	ânhy[sic. =S.43] I q-r-t(=D.76)-t(D.109) I	
									Reign of Amenhotep I.	
							4	36	i-w sm(D.96)-s-n nsw-t bit (râ-dsr(=D.49)ka) maâ-hrw k-f-â(D.82)-A.89 n-f m K-s (has-t)	iw Sm n-f m K
		24					5	6	ânhy[sic.](A.84) I whm(=F.52)-m lr(=D.10)-n n nsw-t bit (râ-dsr-ka) maâ-hrw k-f-â(D.82)-A.89 n-f hr ph(=V.15)-t-i iam(=M.1)-w-	Bit (D.6) iam-
		25					6	7	-k-h-k(N.40) [N.B. Variants: - FINLAY, iam-w(O.1); Tomb; - iam iam iam] q-r-t(D.109) III.	-khh (i qrt hm
								Reign of Thutmose I.		
	26					8	7	i-w sm-s(D.96)-n nsw-t bit (râ-âa-hpr-ka) maâ-hrw k-f-â(D.82)-A.89 n-f m k-s (N.40)	iw sm k-f-â	
					9	8	ânhy(A.84) II hr-r-w(N.49) r sgr(=Z.22) ânhy(A.84)(pl.) in-A.89 m k-s (N.40) nn(=D.47) psb(=V.45)-(Y.2)-n-A.89 s-t whm(=F.52)-m lr(=D.10)-n nsw-t bit (râ-âa-hpr-ka) maâ-hrw k-f-â(D.82)-A.89 n-f hr has-t [sic.] n-t n-a-h-r-i-	ânhy(A.84) (has-t) whm ir k-f-â		
27					10	8	-n-a (N.40) q-r-t(D.109)[sic.] XXI ktr(=E.2) I wr(=G.79)-r-r-y-t(T.45) I	-na qrt		
28					11	9				
							Reign of Thutmose II.			
29					12	10	i-w sm-s-n nsw-t bit (râ-âa-hpr-n) maâ-hrw in(=W.22)-n-t-n [Gramm. §268b] hr sa(=M.37)-sw(=M.24)-w(N.40) s-sgr(=Z.22)(T.7) ânhy(A.84)(pl.) âsa(=I.2)(pl.) wr(=G.79)-t nn(=D.47) psb(=V.45)(Y.2)-n-A.89 s-t -	iw sm Intn h psb-n-I		

		XV Pennekhtbet, (2)		Geographical Names
(Nb-phēti-Rā) maō-hrw NŠwt ā)(maō-hrw) NŠwt Bīt	25	13	"The King of Upper and Lower Egypt, (Neb-phēti-Ra)[Aahmes I.] "Justified. The King of Upper and Lower Egypt, (Zeser-ka-Ra) "[Amenhotep I.] Justified. The King of Upper and Lower Egypt,	
Rā) maō-hrw wryt r nfr nfrpn n-hpr-Rā)		14	"(Aa-kheper-ka-Ra)[Thutmōsis I.] Justified, to the time of this Holy "and Good King of Upper and Lower Egypt, (Men-kheper-Ra)[Thutmōsis III]	
šwt nfrt im-ī n t im n šwt hr hmw-s-n		15	"given Life Forever!" "I have reached a good age, and I lived with the King;	
tp-sa [Gloss.p.123] A. N. S.		16	"being according to the praises of their Majesties,	
šwt šwt-NŠwt wrp) maō-hrw im ša- wrt Sat-NŠwt (Nfrw-Rā)[sic. such.I, p.52] maō-hrw im-s n ī imi-Ra (dast) Wm šfā w Pa-nhb-bt	344	17	"and the favor of me was in the Royal Court, Life, Health, Strength!	
š Bītī (htw) Šwr-Wa-tī [.....] it) Wm šfāw lāhšš dāw-f maō-hrw	20	18	"Renewed to "me the Divine Consort the praise of the Great Royal Wife, "(Yaāt-Ra-Rā) Justified. I fostered	
š Bīt (Nb-phēti-Rā) maō-hrw Kfā-ī ī (hast) [šqr]-ānh wāw grt wāt		19	"her oldest daughter, the Royal Princess (Nfrw-Rā), "Justified. She was a	
t Bīt (Dšr-ka-Rā) maō-hrw Kfā-ī ast) ānh(A.34) wāw Wm lrn NŠwt -Rā) maō-hrw Kfā-ī n-f hr šptī	41	20	"child at the breast." Keeper of the Seal, Recorder of Booty, Aahnes, called Pennekhtbet.	
t Bīt (Aa-hpr-ka-Rā) maō-hrw Kš (hast) "wāw hrw r šqr-ānhw lnn-ī n Kš šbn-ī št	84	1	Prince [Hereditary]. Count [of a None]. Keeper of the Seal, Sole Companion, [.....]	
t Bīt (Aa-hpr-ka-Rā) maō-hrw r hast nti Wahrī- t-wāt hr wāw wryt wāt	85	2	Keeper of the Purse, Recorder of Booty; Aahnes, who is called Pennekhtbet, Justified. Seith:-	
wt Bīt (Aa-hpr-s-Rā) maō-hrw šw (hast) šqr ānhw ššw wrt Wn	124	3	"I followed the King of Upper and Lower Egypt, (Neb-phēti-Ra)[Aahmes I], "Justified. I captured for him in Dahi, Living [Captive] 1, Hand 1.	(2) Dahi
		4	"I followed the King of Upper and Lower Egypt, (Zeser-ka-Ra) [Amenhotep I], "Justified. I captured for him in the country of Kush,	(3) Kš [African]
		5	"Living Captive 1. Again I was with the King of Upper and Lower "Egypt (Zeser-ka-Ra), Justified. I captured for him in the North of	(4) šamkhh (5) šamw, [Not šamw]
		6	"šamw- "-khh-land [or, šamw (City), or šamw] Hands 3.	
		7	"I followed the King of Upper and Lower Egypt, (Aa-kheper-ka-Ra) [Thutmōsis I], "I captured for him in Kuah	(6) Kš [African]
		8	"Living Captives 2, exclusive of the living captives I brought "from Kush; [for] I did not count them.	(7) Kš [African]
		9	"Again I was with the King of Upper and Lower Egypt, (Aa-kheper-ka-Ra), "Justified. I captured for him in the Country of Wahrī-	(8) Wahrīna Horse.
		10	"-na, Bands 21, Horse 1, Chariot 1.	
		11		
			"I followed the King of Upper and Lower Egypt, (Aa-Kheper-en-Ra) "Justified. There were brought from the Country of šamw living "prisoners; a great number. I did not count them.	(9) šamw

THIS PAGE IS LOCKED TO FREE MEMBERS
Purchase full membership to immediately unlock this page



Never be without a book!

Forgotten Books Full Membership gives universal access to 797,885 books from our apps and website, across all your devices: tablet, phone, e-reader, laptop and desktop computer

A library in your pocket for \$8.99/month

Continue

*Fair usage policy applies

Status,
Door of
Tomb.

LEPSIUS,
Auswahl,
XIV, b
1.

37
38

78 1
2
3
4
5

1 [r-p-â] (a(=F.16)-d] é-mr [See above] wâ(=U.38)-t-î s[âa](Y.2)
[n] rē(=M.24)-t(A.113) é-î-q-r(Y.2) [n] bit-t(=L.1)(A.117)
2 [.....ka] mn-n(Y.2) mr(=U.12)-r-t m stn(=M.24)-t-n(=O.8)
nb hēi(=W.4) hēi hēi m stp(=U.8)-sa(=V.29) ānh wga énb
3 [.....] (a(=M.42)(D.1)(O.3)[.....] āsa(=I.2)t(pl.)
wln(=F.52)(A.91)-f r [...] hi-t-t(A.117) n éōp(pl.)-f
mr [Gloss, p.52](S.45)
4 [wln]-w k-f-â-w(D.82) iāh(=N.30) es-s(A.117) q-d-n-f
p-n-nhb-[nw]-t-d q-d-f war(=V.37)-p(Y.2) pa-[a]
5 (hqa(=S.62)-q(A.117)) ānh q-t(N.37) iw nn t-s(Z.7)(D.96)-A.89
r éw-t(A.113) hr p-r-î(M.15)(D.69)(pl.) sa(=M.37)-â(Y.2) m
6 nēw-t bit (rā-nd-pp-t-t) maā-hrw n/r-y-t(Y.2) r nēw-t bit
(rā-ās-hpr-n) maā-hrw i-w-A.89 m
7 hēi(=W.4)-é-t n-t h-r éw-t(A.113) n/r-y-t r nēw-t bit
(rā-mn-hpr) ānh q-t (N.37).

[Rpātī] yat
Sīqr [n] p
[.....]
hsw m stp-
[.....]
[...] bitī

[Wln]w Kfā
qd-f War p
(hqa) ānh
saā m
Nswt Bit (I
Nswt Bit (I
hat ntī hr
(Nn-hpr-Rā

N.B. lines 8 - 11 contain List of Rewards given by the Pharaohs. No G

Šur-wâti š(š) [n] šš

mnw nrt n ššst Pr šš

š; š;
] ššast whw-f r
 šw-f šm-Ra (šast)

ššš šdn-f Pn-šhb-bt

nn šš-š r ššst šr pri

tš-Rš) mš-šrw nšryt r
 r-n-Rš) mš-šrw šw-š n
 nšryt r ššst šit
 šš

phical Names.

IV Pennakhtbet, (8)

Hereditary Prince, Sole Royal Friend, Enlarger of the South.
 Counsellor of the King of Lower Egypt.

[.....] Always abiding in Love in the Royal Palace. Lord of
 praise in the Court of the King's Palace. Life, Health, Strength.
 [.....] toab [.....] many [...] and he told to the King of Lower
 Egypt for his nobles. Keeper of the Seal.

21

4 Recorder of Booty, Ashmes called Pennakhtbet. Saith:-

"Increase to the

5 "(Chief) Living Forever. I failed not the King on the field of

"battle from the ties of

8 "the King of Upper and Lower Egypt, (Neb-pheti-Ra) [Ashmes I], Justified;

"to that of the King of Upper and Lower Egypt, (As-kheper-en-ra)

7 [Thutmosis II] "Justified. (Line 7) I was in favor before the King from

"the time of the King of Upper and Lower Egypt, (Men-kheper-Ra)

[Thutmosis III], "living forever."

Stela cut in a Rock on the Island of Teehee, near Keruān on the Nile near the head of the IIIrd. Cataract; 173 miles South o
 See:- BAEDEKER, Egypt, (1902), p.382. BUDGE, The Egyptian Sudan; I, (1907), p.588. LEPSIUS, Denkmäler, III, 5a; & Texte, (NAVILLE-WRESZ
 Text:- LEPSIUS, Denkmäler, III, 5a; & Texte, (NAVILLE-WRESZINSKI), V, (1913), p.244. PIEHL, Petites Études Égyptologiques. SETHE, Urk.d.
 Translation:- BRUGSCH, Gesch. Aeg. p.265 & Egypt under the Pharaohs, p.134. BREASTED, Anc. Rec. Egypt, II, p.29, §69, ff. BUDGE, (in pa

Stela.	Leptisus, Denkmäler, III, 5a.	Text, SETHE.	Translated.	
Line	Line		§	
1	1	ḥat-sp(=M.13)-t(N.7) II ibd(=N.30) II ša(=M.37)-t(N.7) ššw XV ḥ-r ḥm n ḥrw(=G.8) ka(=D.46) nḥt(=A.31) ma-ā-t(=C.54) nr(=U.12) Titles nšw-t bit [SETHE, Z. Aeg. 49, p.19] (rā-āa-ḥpr-ka) di(=X.22) ānh(=S.43) ea(=G.67) rā (ḏḥwtī(=G.48) mš(=M.80)-š) ḏ-t(N.37)...	ḥat-sp šnwā ibd šueā šat ššw nḏ-dwa ḥr ḥm n ḥrw[HERODOTUS, II, 144] Ka Nḥt Ma-ā-t Nr Titles Nšwt Bit (Rā-ḥpr-ka-Rā) di ānh Sa Rā (ḏḥwtī-mš-š) ḏt	69
2	2 Conventional Conventional	70
3	3 iḥ(=V.44)-t(D.69)-n-f iw(=E.14)-m-ā-t(F.63)(Y.2)-f ḥtp(=Q.17)-t-p-n-f ḥrw(=G.8) ḥ-n-t-t(=O.68)[sic.] r š-w-s-ḥ(W.31) t-ta(=W.60)-a-š-w(Z.7)(N.48)(pl.) maš-t(=S.85)-t(O.1) ḥ-ḥn(=M.41)-n-b-t(N.48)(pl.) ḥ-f-t-t-ḥr-nb-š(O.1) r bk(=G.53)-k(D.69) n-s ḥr(=D.3) r-w-š-ā-i(N.53)(pl.)(T.1)(A.89) (pl.) ḥas-t(N.40)-t-tiw(=G.5) āaw(T.1)(A.89)(pl.) nḥr(=R.13) (A.118) b-w-y-tiw(=G.5)(K.1)(G.80)(pl.) ḥa-a-w(pl.)-nb-t(N.53, N.53, N.53)[sic.] r-t-ḥ-w(U.1)(pl.) a-q-b-t(F.41)(N.53, N.53, N.53) āaw(?=T.1)(A.89)(N.53, N.53, N.53) rš(=M.30)-w(N.48)(T.1)(A.89) m ḥ-d(P.2) mḥ(=V.15)-t(N.48)(T.1)(A.89)(N.53, N.53, N.53) m ḥnt(=W.8)-n-t(P.2) ḥes-t-t(pl.) nb-t dmd(=S.41)-d-y(Y.2)(pl.) xr(=Q.20)-r in(=W.22)(W.31)[sic.](pl.) iḥn-f iwāt-f ḥtpn-f ḥrw ḥnḥt [Gloss. p.147] r šwš tašw Maš (nwt) ḥabt [PIERRET, p.364] ḥftt-ḥr-nb-š (nwt) [BRUGSCH, Z. Aeg. I, p.38] r bk n-š ḥrrwšāiw [Appendix "Q"]	
4	4	(pl.) ḥas-t(N.40)-t-tiw(=G.5) āaw(T.1)(A.89)(pl.) nḥr(=R.13) (A.118) b-w-y-tiw(=G.5)(K.1)(G.80)(pl.) ḥa-a-w(pl.)-nb-t(N.53, N.53, N.53)[sic.] r-t-ḥ-w(U.1)(pl.) a-q-b-t(F.41)(N.53, N.53, N.53) āaw(?=T.1)(A.89)(N.53, N.53, N.53) rš(=M.30)-w(N.48)(T.1)(A.89) m ḥ-d(P.2) mḥ(=V.15)-t(N.48)(T.1)(A.89)(N.53, N.53, N.53) m ḥnt(=W.8)-n-t(P.2) ḥes-t-t(pl.) nb-t dmd(=S.41)-d-y(Y.2)(pl.) xr(=Q.20)-r in(=W.22)(W.31)[sic.](pl.)	ḥastiw āaw ḥr bwytiw [MASPERO, Bib. d'Ét. V, 49] ḥa-awwt[SETHE, Untersuch. III, p.133] Rḥw ḏqwt ḏam(?)=w Ršiw [GAUTHIER, Bib. d'Ét. IV, p.91] m ḥd ḥntiw m ḥntī ḥaswt nbt dmdy [Gramm. §321] xr inw	
5	5	-s-n(pl.) n nḥr nḥr(A.117) s-p(X.14)-tp(=D.1)-ī (rā-āa-ḥpr-ka) ānh(=S.43) ḏ-t(N.37) n-ḥt(=M.9)-ḥ-t ḥrw(=G.8) nb tawi(=N.39)...	-šn n ḥr ḥr sp-tpi (Rā-ḥpr-ka-Rā) ānh ḏt Nḥt ḥrw Nb Tawi	
6	6 ḥ-ḥ-r(A.133)-n-f wr(=A.29) st(=T.31)-t-tiw(=G.5)(T.1) (A.89)(N.53, N.53, N.53) n-[SETHE, p.84, n. "a"]-nḥ(=G.7)-ḥ-s-ī(T.1) (A.89) s-š-r(G.80) ḥnr(=P.5)[? See GARDINER, Admon. p.47]-tiw (=G.5 ?)(G.80) n šsp(=P.23)-p(N.28)-f s-ḥ-ī-w(G.75)(Y.2)-n-f t-ta(=W.60)-a-š ḥḥrn-f ḥr St-tiw[NAVILLE, Rec. de Tr. 32, p.54] ḥḥšī wšr [GARDINER, Admon. p.24] ḥnrḥis n šsp-f ḥḥrn-f taš-	71
7	7	-w(Z.7)(N.48)(pl.) ḡā(=N.50)-m-ī-f-ī nn(=D.47) ḥpr(=L.4) n-ḥ-w (G.80) m n-b-d(D.5)(N.53, N.53, N.53)-qd(=Q.25)-d-nw(=W.21)(Y.2) (T.1)(A.89)(pl.) iw(=D.96)w(N.53, N.53, N.53) r n-ḥ(D.69)[sic.]-f nn(=D.47) s-p(X.14) wā(=U.37)-ā(A.89) i-m in(=Q.29)(N.53, N.53, N.53) stit(=T.26)-t [NAVILLE, Rec. de Trav. 32, p.53, p.61](N.40) (T.1)(A.89)(N.53, N.53, N.53) ḥ-r(A.133) n š-ā-t(D.38)(N.53, N.53, N.53)	-w ḡšwī-f Ḥn ḥpr nḥi m Nbd-qd-nw [PIEHL, Sphinx, VI, p.20] iw r nḥ[?]-f Ḥn sp wā iw Inw stit[NAVILLE, Rec. de Trav. 32, p.61, n.4] ḥr n šat	
8-10	8-10	q-ma(=U.12)-a-m(T.1)(Y.2)-n[Gramm. §263] nb-w(N.53, N.53, N.53) ḥ-t-ā a-t(=O.16)-t(O.3) m-n-n-w-w(O.3) n mšā(=A.82)(A.89)(N.53, N.53, N.53)-f t-tm(=U.14)-m(Y.2)-ḥ-ḥs(=W.4)-š-ī(D.96) šw(=M.24)w qmaw Nb ḥtāt mnnw n šāw-f ḥm-ḥšī-šw-	72

IVI Thutmosis I, Tombos. (1)

adi Halfa, and 540 miles South of Thebes. Text of 18 lines.

(1), (1913), p. 244.

II, Dyn. pp. 82-86. Berlin Museum Squeeze; (No. 554) No. 284.

, op. cit.

ar 2, Month 2 of Šat, Day 15 under the Majesty of Horus [Ἄροϋ = 'Απόλλων], Mighty Bull.

Loved of Neât.

..... Titles

ng of Upper and Lower Egypt, (Aa-kheper-ka-Ra) [Thutmosis I], given life, Son of Râ,
wtiâss) forever.

..... Conventional

... He hath taken his inheritance. He hath established himself upon the Horus Canopied Throne
order to extend the boundaries of Thebes and the territory of Kheftet-her-nehe [District of
original Necropolis in W. Thebes; see Appendix "N"] so that there shall labor for her the
id Dwellers and

(1) *Was-t* [Thebes]

(2) *gftt-kr-ubé* [W. Thebes]

(3) *grrwšâi*

countries of the *Īamw*. God abominated are the *gawwnt*.

oked up are the *Aqbt*, and the

..

Southfolk come downstream.

Northfolk upstream.

the countries are united bearing their tribute

(4) *Īam*

(5) *gawwnt*

(6) *Aqbt*

(7) *Īamw*

(8) *Bšiw* [South-folk]

(9) *Whtiw* [North-folk]

the Good God, Who endureth from the beginning (Aa-kheper-ka-Ra)[Thutmosis I]. Living forever!

mighty Horns, Lord of the Two Lands.

..... Conventional

.... He hath overthrown the Chief of the Nubians

Negroes are powerless and hold back because of His reach.

hath united the boundaries of

(10) *rowi* [Egypt]

(11) *Sto-tiw* [Nubians]

(12) *Whtiw* [Negroes]

[two] frontiers. There doth not exist anything of the *Wbd-qdes* ["Curly Haired"] cosing to
sok (?) his.

(13) *Wbd-qdes* [Curly-haired]

re doth not survive a single one among [them].

Īaw-stit[Nubians] fall by the sword

..... Conventional

.....

Lords of the Palace made a fortress for his army [called]

(14) *Īaw-stit* [Nubians]

(15) *atit* [Nubia]

THIS PAGE IS LOCKED TO FREE MEMBERS
Purchase full membership to immediately unlock this page

DELVE INTO FANTASY, MAGIC, MYTHOLOGY & FOLKLORE

Forgotten Books'
Full Membership gives
access to 797,885 ancient
and modern, fiction and
non-fiction books.

Continue

*Fair usage policy applies

11	11	-m-pd-t(=T.28)-IIIIIIII-dnd(=S.41)-d(Y.2) mi(=W.29) lab[sic. =R.28]-b[Panther] r-n-p-i(M.16)(A.71) m dr(=W.40)-r ih(=E.9)(N.53, N.53, W.53) h-n-i(G.75) s-p(D.10)-n-s-t bam(=G.54) hm(G.15)-f in(=W.22)-n dr(=W.40)-r-m(N.49)(N.53, N.53, N.53) ta(=N.37) hr n-d-b-t(N.49)(N.53, N.53, W.53)-f h-n-d(D.99)(D.96) ph(=F.48)-m-i-f-i	-N Pdt Pédé Dnd Hí Ab rapí m dr íh hñí ápnst daw hñ-f
12	12	m h-p-s(F.49)(D.69)-f n-ht(=M.9)-h-i(A.31) hr h-h-i(D.96) āha(=D.52)-a(D.69) nn(=D.47) gn(=G.46)-m-n-f h-hs(=W.4)-s(D.96)- i(D.96)-t-f-i hr i-m-f(A.89) s-d-bh(=F.44)(Z.7)(D.69) i-in(=K.1)-n-t(N.40)(N.53, N.53, N.53) h-m-nn(=D.47)-n imi(=R.28)-m-m(N.53, N.53, N.53)	m hps-f nht hr hñí [Gramm. §259][SETHE, Verbum, II, §967] āha an gn-f hetifí hr im-f šabh [ibid, I, §294] inot hñ imim [BAILLET, Rec. de Trav. 28, 130]
13	13	mt(=D.90)(Y.2) špei(=A.131) nn(=D.47) ma(=U.12)-(D.10)-o-o s-t m-f-o-m(Q.54)(D.69)(pl.) nb-ti(=G.33) t-ta(=W.60)-o-s(Z.7)- (N.48)-f rs(=M.24)-i(N.48) r hn-t(=W.8)-n-t-tiw(=G.5 ?)(N.48) ta(=N.37) p-n mh(=W.15)-t-i mw(=N.55)-p-f qd(=Q.77)-d(W.21)-m (D.96) h-d-d-i(P.2) m hnt(=W.8)-n-t-	mt špei na mao ét wšew #dtí faš-f Rší r hnttie ta pn
14	14	-ti(=U.19)-y(P.14) nn(=D.47) hpr(=L.4) mi(=W.29)-t-t(Y.2) n h-i-m-i-[sic.] bit(=L.1)(S.11)[sic.](A.113)(N.53, N.53, N.53)	-iy [MASPERO, Bib. d'Ét. I, p.143] Vn hpr mitt n kwí Bitim Rn-f špr r
14-16	14-16	r-n-f špr(=D.31)-r(D.96) r dbn(=V.41)n-nw(=W.21)-m(D.96)n p-t(N.1)	dbnww Pt
16	16 ti(=U.19)-i[GARDINER, Rec. de Trav. 28, p.186] hm(G.15)-f m G.15 (A.113) i(=V.44)-t-m(D.96) m šw(=M.24)-t-n-y-t(Y.2) (N.53, N.53, N.53)-f n-t h(=A.106)(N.53, N.53, N.53) m rnp-t(M.13)- -t(pl.) g-n-x(=T.43)(W.35)-m-f iw(=N.66)-m(N.48)(pl.) šn(=V.6)-n-wr(=G.79)-r(N.58) ta(=N.37)(N.48) r dr-r-f xr(=Q.20)-r fb-t(=S.28) .fb-t-f-i Íst hm-f m G.15 itt m n-šwt [SETHE, Z. Aeg. 49, p.32]-f nti hñ m rnpwt guxn-f Iww Šn-Wr (Nr)
17	17	sa(=G.67) rā n x(=T.43)-t-f mr(=M.58)-f (dhwiti(=G.48)ms(=M.80)-s) ānh d-t(N.37)	Ta r dr-f xr fdt-fí Sa Rā a xt-f Nr-f (Dhwiti-ms-s) Ānh dt
18	18 Conventional Conventional

"None approacheth him of the 9 Hows United". Like a young panther among the startled cattle, the fame of his Royal Majesty blindeth them.

The confines of the earth brought [gifts] because of his invasion. He traversed his two Uttermost

Parts with His Sword of Victory. In seeking battle He found not one who opposed his face to him.

He set in order valleys [of which] the members of his household

and the Royal Seed knew not, and those who bore the Double Diadem had not seen. His Southern Boundary was at the Beginnings of this Land [i.e. "Sud", "Nubia"].

The Northern at that Circling Water which flows Down-

-stream Southwards [GARDINER, Rec. de Trav. 34, p. 63; i.e. "the Euphrates"]

The like hath not happened to other Kings of Lower Egypt. [sic.] His name hath reached unto the circuit of Heaven

Lo! His Majesty is like a God [Horus] seizing upon his Kingship

of a sillion years. He ? ? ? the Isles of the Sn-wr [Great Circle] [Ocean]

The whole earth is under his two sandals;

Son of Râ, of his body. His beloved

Thutmosis, Living Forever.

..... Conventional

XVI Thutmosis I, Tombos. (2)
Geographical Name
(17) 9 Bows.

(18) Nw qdw hdî m hntiy
[Euphrates]

(19) Iw(pl.) Sn-wr
[Isles of Ocean]

(20) Sn-wr [Ocean]

Dêr el Bahari lies in the sides of the great sandstone ridge, Gâbel el Ourn, which encloses the amphitheatre West of Asaif on Pt. III, (1898), pp. 9:17. LEPSIUS, Denkmäler; Texte, (NAVILLE-SETHE, 1900), III, pp. 101, ff. BAEDEKER, Egypt, (1908), p. 295: *ibid* the Nations, (1897), pp. 240, ff. (Plates). MURRAY, Egypt, (1900), p. 874, (Plan). PIET, Inscriptions of the Nile Monuments, (1908) PETRIE, Hist. Egypt, II, (1899), p. 81. NAVILLE, Deir el Bahari, (Eg. Exp. Fund Mem. XII), (1894), Front, and Pl. IV-XIII.

There are two ruined temples at Dêr el Bahari; the one now in question, and another known as the "Xith. Dynasty Temple" built Temple at Deir el Bahari." (Eg. Exp. Fund, XXVIII) Parts I-III): the "Great Temple of Hatshepsut" (For the name of the Queen see (See their report, "Description de l'Égypte"; (Ind. Edit. of PANCKOUCKE, Paris, (1821), Vol. II, pp. 341, ff. also the Plan topogr WILKINSON (Topography of Thebes, (1835), p. 90) says:- "Below the cliffs of the Libyan Mountain is an ancient temple, whose mod "the early Christians." He made some clearing excavations then. Other names used by the natives are:- "Deir el Asasif", and material taken from the old temples, which they damaged lamentably. In 1843 LEPSIUS made a plan of the ruins of the Great Te uncovering a portion of the building, and discovering the real purpose of these temples. (MARIETTE, Deir el Bahari, (1877), Pt. The plan is simple: A series of 3 terraces or platforms was cut into the rock. On the Lower and "Middle" or "Central" Terrace enclosed court or Pronaos and the Sanctuary. On the Lower Terrace the Colonnades are designated respectively as the North and being so named from the subjects of the pictures therein. On the Right (Northwest) end of the Upper Terrace is a Chapel of T $\text{mâ} (=Q.58) - \hat{a} - t \text{ ka} (=D.46) \text{ râ}$ i.e. ($\text{Mâ} \hat{a} \text{ ka} \text{ Râ}$) has been almost obliterated, is offering to a God; over then are four lines i.e. $\text{Im} - \text{wt}$ (wt) [SETHE, Z. Aeg. 44, p. 6] $\text{Nb} \text{ Ta} \text{ Qsr}$ (ib) (4) $\text{hr} \text{ ib} \text{ Qsr} - \text{Qsrw}$ (pr) i.e. "Anubis [BUDGE, Gods of Egypt, II, (1904), Deir el Bahari of Amon [SETHE, Urk. XVIII, Dyn. p. 279. NAVILLE, *op. cit.* I, Pl. 19], who is called $\text{Im} \text{ Râ} \text{ Nb} \text{ Nswt} \text{ Tawî} \text{ Int} \text{ Qsr} - \text{Qsr}$ NAVILLE, (*id.* V, p. 3: Xith. Dyn. Temple, p. 10) says that "zâser-zâseru-Amon" ("Holy of Holies of Amon") is the ancient name of the "for Deir el Bahari generally." Hather as the "Cow-Goddess" was the ruler of the whole district of West Thebes or "Imntt" (II Ind. Ed. 1907), p. 319 = New Light on Ancient Egypt, (1909), p. 272. BUONE, Gods of Egypt, I, (1904), p. 428] (See also Appendix "N" duplicate texts read in part as follows:- ($\text{In} - \text{hpr} - \text{râ}$) $\text{irn} - s \text{ n} \text{ nnn} - s \text{ n} \text{ If} - s \text{ Im} \text{ Nb} \text{ Nswt} - \text{Tawî} \text{ irt} \text{ n} - f \text{ sba}$ (O. 43) $\hat{a} \text{ Im} \text{ Qsr}$ = "[sic.] Memorial for her [sic.] Father Amon, Lord of Karnak [See Appendix "N"] to make for him the Great Door "Amon is Holy Note:- As to the names of Hatshepsut: This Queen was called by the following names, recorded, e.g. in Deir el Bahari.

- | | | | |
|------|--------------|---|---|
| (1) | Hat-shep-sat | ($\text{Hâ} \hat{a} \text{ špsât}$) | NAVILLE, Deir el Bahari, II, Pl. 47. SETHE, Urk. XVIII, Dyn. p. 221. BREASTED, Anc. Rec. Egypt |
| | | | i.e. "Utterance of Im , Lord of Karnak in her presence:- ($\text{Im} - \text{Im} \text{ Hâ} \hat{a} \text{ špsât}$) shall be |
| (2) | Mast-ka-Ra | ($\text{Mâ} \hat{a} - t - \text{ka} - \text{Râ}$) | NAVILLE, <i>op. cit.</i> Pl. 48. SETHE, <i>op. cit.</i> p. 222. BREASTED, <i>op. cit.</i> §201. (1) $\text{gd} - \text{mdw} \text{ qdn}$ - |
| | | | i.e. "Utterance:- "I have formed this, thy daughter, ($\text{Mâ} \hat{a} - t - \text{ka} - \text{Râ}$) for Life, Health, |
| (3a) | Kaw-usert | ($\text{Kaw} - \text{wâ} \hat{r} - t$) | Coronation Inscription. NAVILLE, <i>op. cit.</i> III, pp. 62, 8 SETHE, <i>op. cit.</i> p. 261. BREASTED, |
| | | | (32) $\text{n} \text{ Nswt} \text{ Bit}$ (34) $\text{mâ} \hat{a}$ (See above) $\text{in} \text{ sn} \text{ rrw} - \hat{a} \text{ n} \text{ Nswt} \text{ Bit} \text{ isk} \text{ n} \text{ hr}$ (35) rt |
| | | | i.e. Commanded His Majesty to bring the readers of the Holy Book to celebrate (?) Her |
| | | | (34) Verily they proclaimed Her Names of the King of Upper and Lower Egypt. For |
| | | | (36) Her Great Name of Hrw is ($\text{Kaw} - \text{wâ} \hat{r} - t$)..... Than follows below:- $\text{rn} - s$ |
| (3b) | Kaw-usert. | ($\text{Kaw} - \hat{a} - \text{wâ} \hat{r} - t$) | NAVILLE, <i>op. cit.</i> III, Pl. 63, 64. SETHE, <i>op. cit.</i> p. 341. BREASTED, <i>op. cit.</i> §285. (1) Hrw |
| | | | i.e. " Hrw ($\text{Kaw} - \hat{a} - \text{wâ} \hat{r} - t$) Lord of Diadems. Green in Years. She who Triumphs over the For |
| | | | (See also Table No. XVIII. "Obelisk Base", Karnak.) |

The text of Thutmosis I, now in question, is engraved upon the South Wall of the Central or Middle Terrace; i.e. the "Punt of a giraffe, and it long remained unnoticed until SETHE called attention to its importance (Untersuchungen etc. I, (1896), p. "naturally, not present the precise wording of the text, but only give the general sense, which may be inferred with probab As to the date of this text, SETHE (Urk. XVIII Dyn. p. 104) says that it was improperly restored by DUMICHEN and MARIETTE. wh

West Bank of the Nile, known as the "Plain of Thebes". See NAVILLE, Deir el Bahari; (VI Parts, Eg. Exp. Fund Memôirs, 1895-1908) I, p. 299, (Plan p. 298). WEIGALL, Guide to the Antiquities of Upper Egypt, (1910), pp. 263, ff. (Plan p. 267). MASPERO, Struggle of Egypt, (Views). GARAER, L'Art Égyptien, (1909), Pl. 51, (General View). HENNESSY, Egypt and its Monuments, (1909), p. 148.

Deir el Bahari (Neb-hotep-Ra), and rediscovered in 1903 by MALL & NAVILLE, (S.B.A. Proc. XV VII, (1905), p. 178. "The XIth. Dynasty (see below) was visited by MM. JOLLOIS & DEVILLIERS, engineers attached to the "Expedition de l'armée française", in 1798 (see, ibid "Antiquités", "Planches", Vol. II, (1812), Pl. 88) (Plan reproduced, NAVILLE, Deir el Bahari; (Eg. Expl. Fund, XII, (1894), Pl. I.) The name, "Dayr el Bahari" or the Northern Convent, indicates its having served as a church and monastery of the "Sultan", "Deir" meaning "Convent". This was constructed by the Copts or Christians circ. VIIth. Century, A.D. out of (Denksäler, I, 87) (NAVILLE, D. el Bah. (1894), Pl. II.) MARIETTE conducted some excavations on this site in 1858: 1862: & 1866, (see Pl. I: also in NAVILLE, op. cit. (1894), Pl. III) The final and complete clearing was made by NAVILLE in 1893 ff. (op. cit. above). The transverse colonnades along the backwalls. These are divided by steps leading to the Upper Terrace, where there is an "Upper Terrace" South Colonnade. On the Central Terrace the Colonnades are "Punt" Colonnade on the left, and "Birth" Colonnade on the right, (see Pl. I, (NAVILLE, op. cit. Pt. I, Pl. 1) and therein, on the East Wall (op. cit. Pl. X) the Queen whose cartouche (ma=U.8) perpendicular text. (line 3):- *im(-R.28)-t(0.1) nb ta(=N.37) qsr(=D.56)(N.68) (4) hr ib qsr(=D.56) qsr-r-w(0.3)* "I am, Lord of the Deser (island), and, who is in the Donor of Deseru." The names, *Qsr Qsrw (pr)* are also found in the titles at Deir el Bahari. Thus the titles likewise of Hathor [Sethe, id. p. 301: NAVILLE, id. IV, 88]:- *ht-ht hr tpt wast hr ib Qsr-Qsrw (pr)* "The Temple of Queen Hatshepsu at Deir el Bahari, and the shortened form "Zesret" was from the time of Hatshepsu onwards used as "Zesret" or Kingdom of the Dead, which was a vast burial ground and included the whole Gebel el Gurn. [MASPERO, Causeries d'Égypte, p. 100] At the Temple of Queen Hatshepsut was dedicated to Amon; on both Jambs of the Granite Doorway leading to the "Upper Terrace" (see Pl. I) *mnw m neât ir-s di ânq qt* i.e. "(Men-kheper-Ra)[Thutmosis III over obliteration of Hatshepsut] "She [sic.] caused as her memorial in truth she [sic.] wade, giving Life Forever." (SEYNE, Urk. XVIII Dyn. p. 295, B.)

193. (3) *gd-mde i-n im Nb Nst fawî hft-s (Im(=W.11)t Im Nat(=P.16)-spêd(=A.131)mt) m hat rn a sat pn wdr-I m xt-[?]*fn
Name of this daughter whom I have placed in [thy] body."

See, Bib. d'É. IV. p. 130]-A. 181 m se-t[-k]-fn (*Na-t(=O.54)-ka(=D.46)-Râ*) (2) a ânq wde snb
th."

t. 220. (31) *wd hr-f ia-t Yri-hw r ma(=U.8)-t(W.23)[See WEILL, Sphinx, I, pp. 13, ff.] rna-s wrw nw šsp šâhu šynti-s*
hr hr m ib-sn irt rna-s ni qd ira-f im m bap (36) rna-s wr hrw (Nsr-t-Kaw) q-t

Names of the assumption of the honors of Her Double Crown (32) of the King of Upper and Lower Egypt.

i.e. the God had caused to be in their hearts to make Her Names altogether as he made therein before.

Nst Bit (râ-na-t-ka) di ânq. i.e. Her Great Name of the King of Upper and Lower Egypt is (*Na-t-Ka-Râ*) Given Life.

(S. 68)-s-t-ka(=D.46)-ka-ka) *Nb-ti Nqt rapst hrw Nbtî Nsr-t Jâw Nst Bit (Na-t-ka-Râ)*

Name in Diadem. King of Upper and Lower Egypt. (*Na-t-ka-Râ*)."

made". It consists only of the tops of nine lines to the right of the "Punt" reliefs over a broken space and in front of (see Pl. I) (2). He gives it with many restorations and remarks (Urk. XVIII Dyn. p. 105):- "The above proposed restorations will, from the preserved remains."

"*Na-hpr-ka-Râ*" [Thutmosis II] whereas the name is in fact, "*Na-hpr-ka-Râ*" [Thutmosis I]

THIS PAGE IS LOCKED TO FREE MEMBERS
Purchase full membership to immediately unlock this page



Never be without a book!

Forgotten Books Full Membership gives universal access to 797,885 books from our apps and website, across all your devices: tablet, phone, e-reader, laptop and desktop computer

A library in your pocket for \$8.99/month

Continue

*Fair usage policy applies

Text:- NAVILLE, Ueir el Bahari, Pt. III, (1898), Pl. LXX. DOMICHEN, Historische Inschriften, II, (1869), Pl. 17 MARIETTE, Deir el

Translation:- BREASTED, Anc. Rec. Egypt, II, (1906), §125. (Restored in part: Dated Thutmosis II)

§

The ends of the existing text are **ma**

baw(=G.54) éw(=M.24)-t-n (rā-ā-hpr[N]-[ka] maā-hrw
in-n-n-f ab(=U.31)-b-w(F.44)(pl.)-i-p-n m n-ht-h-t]-
-w(D.69)(pl.)-[N][-f hr has-t-t(pl.) rś(=M.30)-t(N.47)
(pl.) mh(=V.15)-t-t(pl.) i-s-ḫ hm-f q-s-f b-ḫ-s(D.96)-n-f
[a cardinal No.] n]
ab(=U.31)-w (Elephant)[N] [m has-t-t n-t n-h-a-r-i-n-a
(N.40) i-w-f hr]
ḫ-t-r-i(E.2)-[N] [-f m ht(=M.9)-ḫ-t(D.96)
qa(=U.21)-w(D.96) hm-f r s-ḫ-r-t(A.133) r-ḫ-n-nw]
(N.40) hr-t(=N.1)-t m [N] [wd(=M.79)-y-t(D.96)-f
[a cardinal No.] -t n-t n-ht-h-t(D.69) spr(D.31)-r(D.96)
hm-f r has-t-t]
n-t n-i-y [N] [(N.40) gm(=G.46)-n-f nn(=M.22)-n
ab(=U.31)-b-w (Elephant)(pl.) i-m nn(=D.47) s-p(X.14)
hpr(=L.4) mi(=W.29)-t-t n]
éw(=M.24)-y-w [N] [(A.117)(pl.) tp(=D.1)-p-â(A.131)(pl.)
i-s-ḫ i-r nn(=M.22)-n ab(=U.31)-w(F.44)(pl.) in-n n]
hm-f m [N] [has-t-t ḫ-n r rai(=D.63)-n-f s-t r pr(=O.3)
t-f i-mn-n nb nś-t nś-t nś-t(=W.42)-tawi(=N.39) m
ht(=M.9) ḫ-t(D.96)]
iw(=D.96)-w-f [N] [m wsr(=S.66)-s-r(D.69) m n-ht-h-t(D.96)
m maā(=Q.58)-hrw(=P.22) s-ḫ-r(A.133)-n-f
ḫ-f-t(A.133)(pl.)-f]

Baw Hswt (Ia-hpr[N][ka-Bâ) maā-hrw inn-f
abw-ipn m nht]-
-w-[N][-f hr haswt Rśit Nhtit Ist hm-f
qs-f bhsn-f [a cardinal No.] n]

abw (Elephant) [N] [m hošt ntī Mharina
(has) iw-f hr]
htr [N] [-f m ht egos hm-f r šhrt Rḫnnw]

(has) Hrt [N] [m wdyt [.....]nt nht
Spr hm-f r hošt]

ntī Niy [N] [(has) Gmn-f abw im Nn sp
hpr mitt n]

Hyswt [N] [tp-âwī Ist ir nn abw inn n]

hm-f m [N] [hešt ḫn r rdin-f st r pr Tf
Imn [HERODOTUS, II, 42] Nb Hswt-Tawi m ht]

iw-f [N] [m wsr m nht m maā-hrw šhrn-f
hfwf-f]

XVII.Thutmosis I, Dâr el B. (2)

(1977), Pl.VII SERME, Untersuch. etc. I, (1898), p.102: id. Urk. XVIII Dyn. (1906), p.103 (with "train of thought" restored)

SERME, Untersuchungen etc. I, (1896), p.40

]°

f the King, (Aa-kheper-[ka-Ra])[Thutmosis I] Triumphant, who brought these tusks from his victories]
 e Countries of the South and North. Behold, His Majesty himself hunted] [.....]

at [N] [in the country of Nhr̄iso. He was
 is]

(1) Nhr̄ina

[N] [after the going of His Majesty to overthrow Nf̄ass]

(2) Rf̄nne f̄rt

[N] [on the [.....] campaign of victory.
 arrived at the country]

[N] [He found this elephant therein. The like had never happened in] the

(3) N̄iy

[N] [of his ancestors. Lo! verily these tusks brought]

esty from [N] [that country so that he gave them to the House of Father Anon, [Ἄμμών = Δία = Ζεὺς]
 f Karnak. Afterwards]

(4) N̄Sw̄t-f̄awī [Karnak]

e in [N] [Might, in Victory, in Triumph. He overthrew all his enemies.]

Inscription on the Base of the Southern, now fallen, Obelisk in the Colonnade of the Great Temple of Anon at Karnak. In the "Thutmosis I" [Thutmose I]. A plan of the early Temple of Anon at Karnak may be found on Table No. XIXV. It was a small Temple of Thutmosis III. Thutmosis I surrounded it with a wall extending its precincts to the Northwest, where they terminated at a wood. (As to the records and details see Appendix "O") In this "Court" or "Colonnade" of Thutmosis I, Queen Hatshepsut erected on a limestone block found by M. LEGRAIN (1899) (See NAVILLE, Revue Egyptologique, IX, (1900), p.108. It was found near Pylon, Cairo Museum, (1910), p.158. In this picture the Queen is making offerings to Anon, and among the gifts are two Obelisks, which (1) Nfr nfr Nb fowi (Ra-Naut-Ka) (2) Nswt gsf sahâ Thn Thn (3) m hnt wadyt (pr) spat bk m qm (4) awrt Qa-sn dm n Hrt i.e. Benign God, Lord of the Two Lands, (Naut-ka-Ra) [i.e. Hatshepsut, See Table No. XVII.] (2) The King himself [sic.] caused great quantity. Their height pierces to Heaven, causing the Two Lands to glow like (5) the Itn [Sun] See:- Thutmosis III built walls around these Obelisks so as to conceal them up to the roof of the Court. These walls however, took geographical information. The other, which stood upon the base containing the text now in question, has fallen, and the shaft L.D. III, 24, a-c]

See:- BAEOKES, Egypt, (1908), Plan p.268 & p.269: id. (1914), Plan p.269, & p.273. MURRAY, Egypt, (1900), Plan p.637 & p.639. LEPsius, Denkmäler, (Text), (NAVILLE-SETHE, 1900), III, p.23. GORRINGE, Egyptian Obelisks, (1882), p.121. NAVILLE, (DAVIS), BUDGE, History of Egypt, IV, (1902), p.15.

Text:- (North Side. Fragments of West, South and East sides: Beginnings of lines only) SETHE, (with restorations) Urk. XVI Translation:- (East Side), BREASTED, Anc. Rec. Egypt, II, (1906), §321. NAVILLE, op.cit. p.50

anh(=S.43) hrw(=G.8)-t wsr(=S.66)-t ka(=D.46) ka ka nb-ti(=G.33) wad(=M.47)-t rnp-t(=M.13) rnp-t rnp-t hrw-t(=G.8) nb [nfr-t xâ (pl.) nsw-t] biê [SETHE, Z. Aeg. 49, p.19] (râ-mâ-t(=C.54)-ka) sa-t râ (i-mn-n xnm(=N.11)-t ha(=F.16) špsâ(=A.131)-t) anh g-t(N.37) Fragments..... Conventional [nw(=W.21)-k iw(=E.14)-â(F.63)-f] mn-n-h(U.27)(Y.2) mr(=U.12)-y hm-f r-rdi-n-f sw(=M.24)-t-y-A.117 km(=I.8)-t(O.1) dšr(=G.64)-t (N.40) has-t(=N.40) has-t has-t nb dmq(=S.41)(Y.2) xr(=Q.29)-r-w fb-t(=S.38) tb-t-A.117 t-ta(=W.60)-s(Z.7)(N.47)-A.117 rš(=M.30) r iab(=X.21) iab iab nw p-wn-n-t(N.40) [nfr(=R.13) ta(=N.37)(N.40) m h-f-] â(D.82) [t-ta-š(Z.7)(N.47) iab(=R.26)-b-t-î r bia(=N.70) bia bia šf(=S.31)-t-t (N.66) mn-n-tiw(=Q.5)(A.117)(pl.) nw št(=S.31)-t-t(N.66) m a-m-m-t(D.62) -A.117 t-ta-š(Z.7)(N.47) imn(=S.56)-t-î r ma(=U.8)-nw(=W.21)-nw -nw(N.40) hq(=S.62)-q(Y.2)-n [fhn(=T.1)-nw(=W.21)-nw-nw(N.66)] [t-ta-š(Z.7)(N.47) mh(=V.15)-t-î r] [.....] baw(=G.54)-A.117 m hr-r-w-š-â(N.53, N.53, N.53) dmq(=S.41)-d-y in(=W.22)-n-n-t-m n-A.117 â-n-tiw(=G.5) nw p-wn-n-t(N.40) mî(=W.29)-î xn(=D.51)-n(P.1) ârf(=V.8) ârf ârf ît(=W.53)- [.....] -w b-i-w [sic.](U.14)(pl.) nb šps(=A.131)-â (Y.2)(pl.) nw has-t(=N.40)-t f-n h-r-p(D.72)-t-w r âhâ(=O.29)-â -A.117 m h-t(Y.2)(pl.) wâ(=U.37)-t-â h-r-p(D.72)-n šf(=S.31)- -t-t-t iw(=G.5)(T.1)(pl.) [.....] m-â-f-k-t(N.53, N.53, N.53) hr has-t(=N.40) r-ša(=M.37)-w-t(N.40) in(=W.22)-n-n-š-n(pl.) n-A.117 štp(=U.3)-p-w(Y.2)(pl.) nw ššm(=T.12)-w [.....](N.40) m âš[Needle leaf] w-â-n[Needle leaf] mr(=U.12)-r[Needle leaf] [.....] ha(=M.68)] w(M.9)(pl.) nb afr-f-r nw nfr(=Z.9)-ta (N.40) i-w in-n-A.117 in-nw(N.13=N.21)(pl.) nw fhn(=T.1) nw-nw-nw (N.66) m ab(=U.31)-b-w(F.44)(pl.) i-b-h(F.44) CCCCCO wn-n i-m [m i-in(=K.1)-n-nâ(=Z.30)-m-w](F.58)(pl.) âšâ(=I.2)(pl.) n ab(=U.31)-b(E.36) n mh(=O.62) VI hr p-š-d(V.4)[sic.] mh(=O.62) IV m šn(=V.6)-nw-w-w-f n ab(=U.31)-b(F.44) šmâ(=M.26[sic.]) hr-r-w (N.49) r in(=W.22)-nw(N.13=N.21)(pl.) ab nw ha(=M.42)-š-t(N.40) t-n [.....] Conventional [.....] Conventional

anh hrwt [HEROCLITUS, II, 144] Kaw-wsr-t [See Table nb-ti Nwt Rnpw hrwt Nb [Nfrt Kaw Nswt] Bit (Naut-t-ka-Ra) Sat Ra (Xnm-Ian Hat-špsât) Anh g-t Fragments Conventional Link [Gramm. §152] iwâ-f] anh mry hm-f Rdin-f Nswyt-A.117 Knt (nwt) Dšrt (hwt) Yawst nb dmq xrw fbtî-î Taš-î Rš r Idhw nw Pant (hwt) [SETHE, Untersuch. etc. V, III, p.VIII] [Ta-Nfr (hwt) m hf] â [Ta] š fadtî r Biam šf-t-t [See Appendix "C"] Mn-tiw nw šf-t-t m asst-î Taš Yastî r Nane (hwt) Hqn [fhnw (iw)] [Taš mptî r] [.....] Baw-î m hr-w-š-â dmq Inntw n-î iatie nw Pant (hwt) mî xnn (wia) ârf ît- L.....] w Biam nb špsšw nw hasc fn hrp r âhâ-î m ihwt wâtî yrpn šf-t-tiw [NAVILLE, Rec. Trav. 32, p.55] [.....] mkat hr hasc kšawz (hwt) in n-î nw štpw ššm [.....] (hwt) m âš wân mr [.....] ha] w (ht) ab afr nw Ta-Nfr (hwt) in-î inw fhnw [NAVILLE, Rec. de Trav. 32, p.55] m îbâ sat(VII) wnwn im [m inw âšâw n ab n mh šis hr pšd mh faw m šnw- ab šmâ [sic.] hrw r inw nb nw hasc fn [.....] Conventional

The names of Queen Hatshepsut see Table No. XVII.

XVII. Hatshepsut, Karnak.

at Temple at Karnak [See Appendix "Q"] the space between the IVth. and Vth. Pylons is known as the "Great Colonnade of the Middle Empire, and stood in the space now between the so called "Apartments of Hatshepsut" and the later Postal Hall V. He also built Pylon IV, and over the unoccupied space between he added a roof supported by columns of cedar (âš) two Obelisks, removing part of the roof for that purpose. She recorded this in the texts quoted in Appendix "P"(q.v.) also at of the Great Hypostyle Hall. The stone is now in the Cairo Museum, Room L, No.360; See MASPERO, (QUIBELL), Guide to the thought by many to be the pair now in question. The accompanying [SETHE, Urk. XVIII Dyn. p.374] memorandum reads in part:-
fawī mi' (5) itn

set up two great Obelisks to Her [sic.] Father (3) in front of the splendid Papyrus Column House wrought with Gold (4) of LE, B. Aeg. 37, p.53: id. (LEGRAIN), Annales du Musée Guimet, XXV, Pl. XIII. SETHE, Urk. XVIII Dyn. p.374. BREASTED, Anc. Rec. Eg. II, §305. with the roof have disappeared. One Obelisk, i.e. the Northern now remains standing, but the texts thereon contain no disappeared, excepting some unimportant fragments. (SETHE, Urk. XVIII Dyn. p.359, p.360. LEGRAIN, Rec. de Trav. X, p.142

The Nile, (1898), Plan p.297 & p.291: id. (1901), Plan p.391 & p.385. WEIGALL, Antiq. of Upper Egypt, (1910), Plan p.85 & p.98. of Hatshepsut, (1906), p.50. PETRIE, Hist. Egypt, II, (1899), p.131. MASPERO, Struggle of the Nations, (1897), p.244.

n. (1906), pp.369-373. (East Side), LEGRAIN, Rec. de Trav. XXIII, (1901), pp.195-6.
Official Titles, etc. See Appendix "A".

Live first [i.e. the female Horus Ὠρος Ἀπόλλων], Kaw-usert, Lord of Diadems. Green in Years. She who triumphs over the foe. Goddess of Light. King of Upper and Lower Egypt (Mast-ka-Ra); (Khonḥ-Anon; Hat-shep-sat), Life Forever.

..... Fragments Conventional

[I His Hair] as rewarded being beloved of His Majesty. He hath given as my Kingdom, Keat [i.e. "The Black"], and Desheret ["The Red"]. All countries are united under my two sandals. My boundary South is to the shores of Punt [Sonal-Land].

(1) Keat [Egypt]
(2) Desheret [Non-Egypt]
(3) Punt [Red Sea Coast]

[Ta-neter [i.e. "God's Country"] is grasped. The Easterly [Boundary is to the Marshes (?) of Statt (Island)

(4) Ta-Ntr
(5) Biatw Št-t-t
(6) Nntiw nw Št-t-t
(7) Nanw. [Sun-set Land]

The Mentiw of Statt [Nubia] are in my grasp. The Western Boundary is to the Land of the going down of the Sun. I ruled

the [Tehenu (Island)] [The Northern Boundary is to] [.....]

My feast is among the Sand Dwellers united

One has brought to me Frankincense [See Coronation, line 14] of Punt just as are shipped the little sacks of grain [gum].

(8) Thnw [African]
(9) Trwšā
(10) Pent [Red Sea Coast]

[.....] All of the splendid marvels of that country are brought to my Royal Palace in a single collection. The Stattiw brought

(11) Šftiw

[.....] malachite belonging to the country [i.e. native] of Reshawt They have brought to me the choicest things of Ššmw[...]-land, in Cedar and Nān [Plant], and Nrw [wood] [See Appendix "D"]

(12) Ršawt
(13) Ššmw[...]

[.....] all good woods of Ta-neter

To me was brought tribute of the Tehenu

consisting of ivory. 700 tesks were therein,

[and easy skins of the panther of 8 elle [ell = 22-26 inches] along the back, 4 elle in his girth, the panther of Upper Egypt, not including all of the tribute of that country.

(14) Ta-Ntr
(15) Thnnw

(16) Smā [Egypt]

[.....] Conventional

THIS PAGE IS LOCKED TO FREE MEMBERS
Purchase full membership to immediately unlock this page

DELVE INTO FANTASY, MAGIC, MYTHOLOGY & FOLKLORE

Forgotten Books'
Full Membership gives
access to 797,885 ancient
and modern, fiction and
non-fiction books.

Continue

*Fair usage policy applies

TABLE No. XIX. HATSHEPSUT (ḤATŠPŠAT) Speos Artemidos. Geographical Names. (Context)

Inscription over the Entrance of a Rock Temple of Pakht (Pht), called Speos Artemidos, near Beni-hasan. The Σείος "Αἰγύπτιοι οὐκ ἀναξ τοῦ ἐνιαυτοῦ, πανηγύριας δὲ συχνάς, μάλιστα μὲν καὶ προθυμώτατα ἐς Βούβαστιν πόλιν τῆ Ἀρτεμιδι, . . . "only once in the year a public festival, but several: and the most esteemed is at Bubastis, the City of Artemis"..... (H.21)(O.1) or "House of Bast", and the Pibeseth of Ezek.XXX,17. The site is at Tell Basta, about 2 miles Southeast of and was worshipped on the Delta in the most remote antiquity. The Σείος or Grotto of Artemis, or Bešt, is the site of "Ištabil 'Antar" (Stable of Antar, a local Hero), and lies in a valley a short distance Southeast of the modern village by a corridor to an inner rectangular chamber which contained eight columns, of which only three remain.

See:- BAEDEKER, Egypt, (1908), p.209; id. (1914), p.227. MURRAY, Egypt, (1900), p.675. BUDGE, The Nile, (1898), p.256; id. (1901)

The text now in question was discovered by M. GOLÉNISCHÉV in 1881, high up on the rock above the entrance (Rec.de Trav and Thutmosis III. As to the various names of Queen Hatshepsut, see Table No. XVII.

Text:- GOLÉNISCHÉV, Rec.de Trav.III, (1872), pp.2,3. VI, (1875), p.20. SETHE, Urk.d.XVIII Dyn.(1906), pp.383, ff.(p.390)

Translation:- BREASTED, Anc.Rec.Egypt, II, (1906), pp.123, ff. §§297-303. WEILL, op.cit.

383 [..... Fragments, No Date, No Titles.]
 [š]-mn-n(Y.2) r-n-s wr(=G.79)-r(Z.19) mi(=W.29)-i p-t(N.1)
 š-mn-n-ḥ(U.27)(Y.2) grs(=U.45) grs grs q-n-n[sic.](O.69)-s ḥr-w
 d-r [sic.]-t(N.40) n-t tp(=D.1)-t-p ḡw(=N.42)(N.51)(I.11)
 [GARDINER, Hier.Pap.V, p.9, n.9] r w-b-
 -n(N.13)(N.7) nb[.....] ḥr wr(=U.12)-r-t-w rdī(=D.63)-n
 b-i-w[sic.](W.38)(pl.)-f ḥr ša(=T.38) qn(=Z.15)-t-i ḥas-t(=N.40)
 ḥas-t w-š(Z.7)(D.96)[sic.] ḡ-ḥ-w [sic.](R.2)(R.2)(R.2)
 ḡ-w-š-ḥ(W.81)(Y.2) ḥm(=O.74)-ḥ-m-
 -w(O.3)[pl.] š-t(=Q.1)-t(O.3)-ib(=W.23) nfr(=R.13) nfr nfr
 nb-w(pl.)
 Pious Acts
 ša(=M.37)-a[sic.](Y.2)-n r-ā(N.7) m s-n-t [sic.](V.25)-f
 N.47, N.47, N.47 dmq(=S.41)-a(Y.2) xr(=Q.20)-t š-t(=Q.1)-ḥr-i
 km(=I.8)-t(O.1) d-š-[r-t(N.40)] xr(=Q.20) ḥr-y-t(Z.10)(D.69)-i
 daw(=G.54)-w(pl.)-i ḥr s[sic.]-k-s(A.19) ḡb(=D.62)(G.80)[sic.]
 ḥas-t(=N.40)-t(pl.) i-w ḡ-r-t [sic.](I.11) tp(=D.1)-t-p
 ha(=F.16)-t(I.11)-i ḥr š[n-nr(=H.3)]-r-y-t(Y.2) m ta(=N.37)
 ta ta nb
 r-ša(=M.37)-a-t-w(T.1)(N.40)

384 Pious Acts
 šcan Bā m snfī-f N.47(pl.) dmq xrt šḥrī Kt
 Dš[rt (ḥas-t)] xr ḥr-ḥ-ī
 Baw-ī ḥr šks [Gramm. §289] ḡb ḥaswt f-w iārt tp ḥai
 š[nr]-y-t [PIERRET, p.272: Gramm. §269] n tow nb
 R-ša-a-tw (ḥas-t) ["Ra-ša-u" = MÜLLER, As.u.Eur.p.1.
 "Ra-ša-w = Ru-ša-ty" = BREASTED, p.124, n. "a".
 "Roshau" = PETRIE, p.81. "Rushau" = BUDGE, p.20.
 See also Table No.XVIII, (Obelisk, Wats-pst); and
 Ramesses III, "Treasury" D.H.I; I, XXXIII and id.
 Medinet Habu; (Rec.de Trav.XIX, 19)] fww (ḥas-t)
 [Yww = Yu, BREASTED, fww PETAIS, BUDGE] nn šdga-š
 [MASPERO, Bib.d'Ét.I, p.181] r ḥm-ī Pwnt (ḥas-t) w
 ty n-ī ḥr aḥwt
 aḥwt xri āntīw wdg ḥḥnw enne šri [GAUTHIER, Bib.d
 IV, p.128] ḥr watī ḥwi
 i-w(=D.96)w-w(T.1)(N.40) nn(=D.47) š-d-g-a(A.94)(D.96)-s-n(pl.)
 r ḥm(=W.6)(A.117)-i p-wn(=E.58)-n-t(N.40) wbn(=N.13)[See SETHE,
 p.385, n. "b"]-n-t-ī(=U.19)-i n-i ḥr a-ḥ-t(N.48)(pl.)
 n-ḥ-t-w(M.1)(M.9)(pl.) xr(=Q.20)-r ḡ-n-tiw(=G.5)(N.53)(pl.) wdg
 (=M.48) n-ḡ-ḥ-n-nw-w(N.49)(pl.) wn-n-nw-w(pl.) š-r-ī(O.36)(D.69)
 ḥr wa(=V.26)-t-ī(N.49)(N.49) ḥ(A.31)(D.69)

[..... Fragments, No Date, No Titles.]
 [š]mn rn-š wr mi Pt Sanḥ grsḥ [GOLÉNISCHÉV, Bib.d
 p.207] qn-š ḥr Dšrt (ḥas-t) ntī fpt ḡw(iḡrt)[GARDINER,
 Rec.de Trav.32, p.17: Kamal, id.p.214] r w-b-
 -n nb[.....] ḥr wrw
 Bāin bīw [sic.] (ner ?)-f ḥr ša Qntī ḥas-tī
 šis Sni ḥaswt šwš ḥm-
 -w š-t-ib nfrw nbw
 Pious Acts
 šcan Bā m snfī-f N.47(pl.) dmq xrt šḥrī Kt
 Dš[rt (ḥas-t)] xr ḥr-ḥ-ī
 Baw-ī ḥr šks [Gramm. §289] ḡb ḥaswt f-w iārt tp ḥai
 š[nr]-y-t [PIERRET, p.272: Gramm. §269] n tow nb
 R-ša-a-tw (ḥas-t) ["Ra-ša-u" = MÜLLER, As.u.Eur.p.1.
 "Ra-ša-w = Ru-ša-ty" = BREASTED, p.124, n. "a".
 "Roshau" = PETRIE, p.81. "Rushau" = BUDGE, p.20.
 See also Table No.XVIII, (Obelisk, Wats-pst); and
 Ramesses III, "Treasury" D.H.I; I, XXXIII and id.
 Medinet Habu; (Rec.de Trav.XIX, 19)] fww (ḥas-t)
 [Yww = Yu, BREASTED, fww PETAIS, BUDGE] nn šdga-š
 [MASPERO, Bib.d'Ét.I, p.181] r ḥm-ī Pwnt (ḥas-t) w
 ty n-ī ḥr aḥwt
 aḥwt xri āntīw wdg ḥḥnw enne šri [GAUTHIER, Bib.d
 IV, p.128] ḥr watī ḥwi

XIX. Hatshepsut, Specs Artemidos. (1)

μηδεις ("Grotto of Artemis") probably was known to HERODOTUS, who says:- (II,59)(KALLENBERG,Leipzig,1906) "πανηγυρ(ζουσι δὲ
 ." and again, (id.II,137):- "ἡ δὲ Βούβαστις σατὶ Ἑλλάδα γλωσσῶν ἐστὶ Ἀρτεμις." i.e.(II,59):- "The Egyptians do not observe
 I,137):- "Bubastis, according to the Greek speech, is Artemis." Note:- Bubastis, the old Egyptian City of Pr(=0.3) Bast(=W.1)
 zik on the Delta. Bust, represented as having the head of a cat (BUDGE,Gods of Egypt,I,p.444) was Goddess of Fire, or the Sun,
 k Temple dedicated to the Goddess Pakht (Ph-t)(Lion)[a local deity. See BUDGE,op.cit.p.517]. It is known to the Arabs as
 i Hassan el Chorouk. It is hewn out of the slope of rocky foothills among several quarries, and consists of a vestibule joined

4. LEPSIUS,Denkmäler, Text;(NAVILLE-SETHE,1900),p.109. GOLÉWISCHNEV,Rec.de Trav.III,(1882),p.1.

p.2). It consisted of 43 vertical columns, but is now much obliterated. It notes that the Temple was built by Queen Hatshepsut

lines 35-38) WELLS, Journ.Asiatique,Sér.X,Tome XVI,p.281

also:- BUNES, Hist.Egypt,IV,(1902),p.19. PETRIE, Hist. Egypt,II,(1899),p.81.

[..... Fragments, No Date, No Titles.]

Established was her Great Royal name like the Heavens. Made excellent were the memorials of her
 Might over the Deshert [Red Land] of the Mistress of the [Red] Mountain to illuminate

(1) Dšrt

(2) Dm (iârt)

[Red Mount]

the Mistre[ss(?).] who is loved. His (?) (flame ?) was set behind the Entrances of the Two
 Countries. Opened are the altars; enlarged the holy sanctuaries,

[which was] the fond wish of all the Gods.

..... Pious Acts in reestablishing Religion & Government

..... RĜ began it in his foundation of the Lands united under my control. Kent [The Black Land] and
 Deshert [The Red Land] are under fear of me.

(3) Knt [Egypt]

(4) Dšrt [Non Egypt]

My fame causeth to bow down the miserable of the Countries. The Uraeus on my forehead causeth terror
 in all lands.

Ršcatw-land and iu-u-land cannot hide themselves from my Majesty.

(5) Ršcatw

(6) iu-u-land

Punt was glowing for me on the meadows of

(7) Punt

myocnores [Boswellia Carteri; See Appendix "D"] bearing fresh incense. The roads were repaired (?)
 in the two directions (?)

884	15	mšâ(=A.82)(A.89)(pl.)-î m-m-t m(=D.47) e[sic.] âpr(=S.48)-r(Y.2) xr(=Q.20)-r špsâ(=A.131)-š-š yr(=W.40)-r ja(=H.23)-â-t(Y.2)-î m š(=M.24)-t-m	mšâ-î want m (sp) âpr xr špsâ dr jât-î m šst
	15-35 Restoration of Temples Restoration of Temples
	35 šm(=P.48)-m(pl.) i-r-f-n(pl.) p-â-t(H.21) sb-t rhy(=G.81)-t(pl.) mî(=W.29)-î šša(=I.2)(pl.)-s îr(=D.10)-m-î nn(=M.22) m k-t ib(=W.23)- šm îrf [Gramm. §493] řn pâwt nbt rxywt mî îrn-î nn m k[â]t [BREASTED, §303, n. "b"] lb-
	36	-î m(=D.47) [.....] m îr(=D.10)-m-î m-m(=D.65)-h-y(G.80) š-r-m-d(V.27)-m-î m(=E.58)-m-t mš(=S.64)-m(G.80) i-m f-s(Q.54) (D.69)-m-î štp(=U.8)-p-t pu(=P.16)-â	-î m [.....] m îrn-î mhy šrdn-î want eše řn štpť patîâ
	37	dr(=W.40)-r m šm(=T.1)-m-m(A.89)(pl.) m q-b [sic.](V.41) m ta(=N.87) idh(=M.43)(O.1) k-t(=O.12)-t(O.3)-mâr(=D.99)-t(N.40) š-ma(=U.8)-a-m-m(A.31)(A.89)(pl.) m q-b [sic.](V.41)-m-n(pl.)	Dr m šms m qab n ta řdhs (nwt) ř-t-t-wârt (jâst) Šesame [SETHE, Z. Aeg. 45, p. 38] m
	38	pr š[.....]n(O.37)(D.69) îr(=D.10)-y-t(pl.) šqa(=S.62)-q-m-m(pl.) m p-mt(=D.90)(pl.) nn(=D.47) r-â(N.7) m(=D.47) îr-f m wđ(=M.77)-m nřr(=R.19) nřr(=Z.9)-y-t(N.7) řm(=W.6)-t(I.11)	pr š[.....]n(O.37) iryt řqn-šn m řat nn řâ řn îr-f [sic.] m wđ nřr ařyt řat(řârt)
	39-42 Conventional Conventional

My army conquered; which was a thing that never had occurred under the Lordship since my accession
 as King

 Restoration of Temples
 Bear then, all ye men and subjects as many as it may be! I did this according to the design
 of my heart [B̄EASTED].

Nor [.....] as I shaped the forgotten, caused to restore what was fallen in ruins, and raised
 high that which was of first importance.

Since the Isms were in the Land of the Delta, and
 #taârt, The Foreigners (?)
 were in their midst
 to [...(Overthrow)...] what was [established], and
 they ruled, as thinking not of Râ.
 He [sic.] did not do according to the Will of God, until my Uraeus Majesty

Conventional

Geographical Names

- (8) Iamw
- (9) Iâhw [Delta]
- (10) #twârt

THIS PAGE IS LOCKED TO FREE MEMBERS
Purchase full membership to immediately unlock this page



Never be without a book!

Forgotten Books Full Membership gives universal access to 797,885 books from our apps and website, across all your devices: tablet, phone, e-reader, laptop and desktop computer

A library in your pocket for \$8.99/month

Continue

*Fair usage policy applies

TABLE No. XX. HATSHEPSUT (ḤḤṢṢṢṢṢṢ) - THUTMOSIS (ṬḤṬṬṬṬṬṬ) III. Tomb of Sennaferi (Sn-nfr-i), Lord Treasurer (fwi-re-

Tomb No. 99 in the Cemetery of the "Sheikh 'abdel Qurna" in the Necropolis of West Thebes. The Egyptian name for the City East Bank of the Nile, and together with "Int-Isut" i.e. Karnak Temple, and "Int-Rsūt" i.e. Luxor [GARDINER, Z.Aeg.45,p.127,n.2: lying between the "Ta Nhtī" (The "North-land") and "Ta Rsi" ("South-land") It was the original Feeff of the God Amen [LEGRAIN, Rec and Διοσκολις [PTOLEMAEUS, IV, 5, 31] [See also Appendix "N"] From the earliest period the burying place for *Wasit* (*nwt*) was on the Z.Aeg. I, (1863), p. 38: Dict. géographique, (1879), p. 574: MARIETTE, Karnak, Pl. 11: [=SERME, Urk. XVIII Dyn. (1906), p. 611, line 6] MASP

This district is included in a semicircular area containing several large isolated hills of stone in which the tombs of th of the Libyan Mountains. In the Valley beyond lie the so called "Tombs of the Kings". On the East the Necropolis is bounded by t thousands of graves of the common people, but the rocky elevations were reserved for groups of "Mortuary" or "Funerary" Tomb Chs as shown in the following diagram, to which are added a few of the greater Mortuary Temples of Royalty to serve as landmarks. [See Catalogue, Private Tombs of Thebes, (1913), (Views), Pl. I-XV: Plan des Nécropoles Thebaines. É. BARAISE, (Publications du Service d add Literatures, XXXII, (1915-6), pp. 1, ff. (Plan p. 8): MASPERO, Struggle of the Nations, (1897), (Plan), p. 507: LEPsius, Denkmäler, I,



Geographical Names. (Context).

XX. Hâtsheput-Thutmosis III. Sennefer.(1)

Thebes [Gardiner, *Strabo*, Geogr. XVII, I, §46; C. B15] was *Wâst* (*nwt*) or *Nwt* The City. [Schäfer, *Z. Aeg.* 41, p. 140]. This was on the *Wâst*, *Z. Aeg.* 44, p. 31, n. 2: LÉGRAND, *Rec. Trav.* 26, p. 84, 27, p. 183] was contained in *Nwt Râit* i. e. "The District of the South", *Z. Aeg.* 27, p. 183]: hence the names "*Nwt In*" "Anon of No." (Jeremiah: XLVI, 25; Ezekiel: XXX, 14, 15) and "No-Anon" (Nahum: III, 8) Bank of the Nile (*In* (=S. 56) - t-t (N. 40 or N. 48) in the region called *Hftt-hk-wd-s* ["opposite to his Lord"] (BRUNNEN, *Struggle of the Nations*, (1897), p. 506, n. 1: BRUNNEN, *Gods of Egypt*, I, (1904), p. 437. The latter class were cut. On the West the floor of the amphitheatre rises to and is shut in by the perpendicular cliffs and spurs of the ancient bank of the Nile now the limit of the cultivable land where the outcrop of stone begins. In this Necropolis are the tombs of the Nobility, Officials and richer classes, which groups now take their names from those of the hills in which they are, BRUNNEN, *Egypt*, (1914), p. 280, p. 254: MURRAY, *Handbook for Egypt*, (1900), p. 773: (1907), p. 378: GARDINER-WEIGALL, *Topographical Dictionary of Egypt*, IV Parts, 1904, 1907, 1908, 1913: WINKLOCK, *The Theban Necropolis in the Middle Kingdom*, *Am. Jour. Sem. Languages* (Thebes), I, Pl. 67-8 (Gurna): Description de l'Égypte, (1812), Tome II, Pl. 1-3 (Plan and Views).

West Bank.		Tombs.
I.	Drah 'Abul Negga ("The Arm of 'Abul Negga")	49
II.	El Khôkha (Elwet el Khôkha = "Hill of the Nectarine")	39
III.	N. Asaîf (? ? ?)	21
IV.	Sheikh 'Abd el Gurna (Elwet S. A. el O. = "Hill of the Saint 'A. el Q.")	115
V.	Dâr el Medinêb ("Monastery of el Medinêb")	22
VI.	Gurnet Murraf ("Peek of Murraf")	4
VII.	S. Asaîf (? . ? . ?)	2

Total 1913 252

[Note:- No. VII so placed by GARDINER - WEIGALL, op. cit. p. 12]

- X = Bihân el-Barfû ("Tombs of the Queens")
 Y = Bihân el Mulûk ("Tombs of the Kings"; East Valley)
 Z = " " " (" " " " West ")

Mortuary Temples. (Shown here only as landmarks)

- S = Sety I.
 T = Thutmosis III.
 R = Ramesses
 M.H. = Medinet Habu
 D.B. = Dâr el Bahari
- East Bank.
 A = Temple of Anon
 K = " " Khons
 Mt = " " Mont
 M = " " Mut
 L = " " Luxor
 H.T. = Hotel Tewfikieh
 B.C. = Race Course

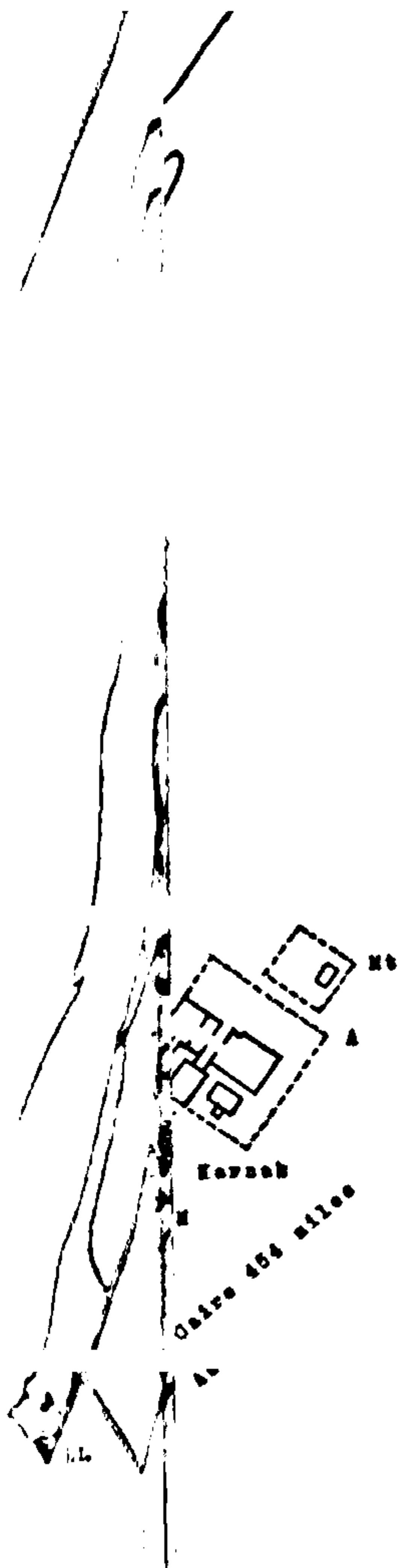

The word "Tomb" is the popular designation for all of the units of these groups, but the term is sometimes misleading, but exclusively for funerary ritual and memorial purposes. The actual burial place, i.e. where the sunny (*sâhu*(S.44)(A.131) [Bucoε, Mortuary Temple or Chapel, as for example, the "Tombs of the Kings" in Bibân el Mulûk, and of the Queens in Bibân el Harîa, also the Tomb Chambers were connected. [See GARDINER-WEIGALL, op.cit.p.5: and MOND, Ann.du Serv.VI,(1905),pp.65,ff] Both were usually of the Chapels however, allowed more elaboration of plan. They were in fact, smaller structures in the class of the great Mortua built on the surface, their ground plans could not well vary much save in dimensions, from a simple type. The façade was general or columns from floor to ceiling. At one end of its axis, usually the left, was a stele of the deceased. The other walls were us status of the deceased. In some cases a chamber was added on each side of this corridor, thus forming a second chamber or Rear H funerary ritual-

Sheikh 'Abd el Qurus: Tomb No.99, of Senneferi, now in question, is one of by far the largest group of Mortuary Cha the arc of the amphitheatre. This Hill, or "Elwet", has on its summit a ruin known as the Tomb of the Sheikh or Saint named "Abd The interior pictures and decorations in the Tombs are all painted; the quality of the limestone in this cemetery is not suitabl The accompanying diagram shows the location of the tomb now in question, and of those in the Cemetery described elsewhere in thi

See:- Plans: BAEDEKER, Egypt,(1902),p.289: (1908),p.304 MURRAY, Handbook for Egypt,(1907),p.437 (Photos).
LEPSIUS, Denkmäler, I, Pl.73: Sect.XV-XVI: (See L.D. Text, NAVILLE-SETHE,(1900),III,p.236,pp.251,ff.

Note:- The location of "Tombs" 76, 75, 74 is shown differently in BAEDEKER and MURRAY (whose numbers are 18 and ? ?

Tomb No. 57	(Old No.40: 120)	Kha-em-hat (<i>ḫâ-m-ḥat</i>) -----
74	(" " 104)	Thanuni (<i>ḥa(=G.87)-n(pl.)n-î</i> ["Zenen" No.11] "Scribe of the Army." -----
75	(" " 102)	Amenhotep-sa-se (<i>îmn-ḥtp-sa-s</i>): Entrance to No.76 ;
76	(" " (BAED. 1898), 17)	Thanone (<i>ḥa-n(pl.)-n-a</i>)["Zenen" No.I] "Fan Bearer". -----
78	(" " 16)	Horemheb (<i>ḥrw-m-ḥb</i>) General of Thutmosis III- Amenhotep III. Not the King of Table XLIX. He
81	(" " 26)	Anena (<i>î(A.91)-n-n-î</i>) (Used as a Guidemark).
85	(" " 36)	Amenemheb (<i>îmn-m-ḥb</i>) -----
86	(" " 34)	Men-kheper-Ra-senb (<i>Râ-mn-ḥpr-snb</i>) -----
93	(" " 48)	Gen-amen (<i>îmn-qn</i>) -----
98 A & B	(" " 50)	Bonnefer (<i>šn-nfr</i>) Mayor of Thebes -----
99	(" " ? ?)	Sennefer (<i>šn-nfr</i> and <i>šn-nfr-î</i>) Chancellor -----
100	(" " 35)	Rekhmira (<i>Rḫ-mi-Râ</i>) -----

There are now extant a number of texts containing the name "Sennefer", among which those concerning the person now in qu The following is a list of said texts, together with their distinguishing data.

The authorities cited are:-

SCHIAPARELLI,	Antiq. egizie Mus. archeol. Firenze, (1887)	DÉVERIA,	Antiq. Ég. du Musée de Lyon, in
LIEBLEIN,	Dictionnaire de Noms hiéroglyphiques; (1892)	BOESER,	Beschreibung der Aegyptischen Reichsmuseums der Altertümer in
DE ROUGÉ,	Notice sommaire des Mon. Ég. Musée du Louvre, (1876)		III, (1910): IV, (1911): V, VI, (1
LANZONE,	Antiq. egizie R. Mus. Torino: I, (1882), II, (1898)		Egyptian Inscr. from the Br. Mus
WRĘSZYŃSKI,	Aeg. Insch. K. K. Hofmus. in Wien; (1908)	SHARPE,	Urkunden d. XVIII Dyn. (1906)
V. BERGMANN,	Ibid in Rec. de Trav. VII, (1898), pp. 177, ff.	SETHE,	"G. & W." GARDINER-WEIGALL, Topographica
MORET,	Annales du Mus. Guimet; (1909) (Gal. Ég.) Tome XXXII	"G. & W."	Thebes. (1913)
WIEDEMANN,	"On some Egyptian Inscriptions in the Musée Guimet at Paris." in S. B. A. Proc. XIV, (1892), pp. 331, ff.	NEWBERRY,	S. B. A. Proc. XXII, (1900), pp. 59, f
LEGRAIS,	"Statues Rois et particuliers", I, (1906), II, (1909): (Cat. Gén. Mus. Caire).	CARTER,	Annales du Service des Antiq. c
BOURIANT,	"Les Tombeaux d'Assouan", Rec. de Trav. X, (1888), pp. 181, ff.	"HIER. T. "	Hieroglyphic Texts from Egypti
MARJETTE,	Catalogue du Musée de Boulaq; (1876)		II, (1912): III, (1912)· IV, (191
"GUIDE, (1909)"	Guide to the Egyptian Galleries, (Br. Mus.), (1909)	"F. P. Coll. "	"Flinders Petrie Collection."
LEGRAIN, (Rép.)	Répertoire généalogique eto. du Mus. du Caire; (1908), (Service des Antiq. de l'Ég.)	DARESSY, (C. P.)	Recueil des Cônes funéraires

XX. Hatshepsut-Thutmosis III. Sennefer (2)

Some of the "Tombs" are not places for the burial of the dead. They were the eternal homes of the "Ka", and therefore used as such. [GARDINER-WEIGALL, op.cit., p.173] was placed in the Tomb proper, which was quite apart from and sometimes at a distance from the Tomb of Amenemhat, Sheikh 'Abd el Gurna, No. 41, and Grave Bibâh el Mulûk, No.48: and sometimes near to the Chapels with which they are hewn in the solid rock, but the Tomb proper was always a narrow rectangular chamber approached by a corridor. The purpose was for the use of Royalty; e.g. of Sety I, Thutmosis III, of the Ramesseum, Medinet Habu etc. But being hewn in the rock instead of being a separate monument, the entrance opened into a transverse rectangular chamber or "Vestibule", which sometimes contained pillars filled with biographical pictures and texts. Opposite to the entrance a long narrow corridor led back to the place for the burial. In this corridor or second chamber the pictures and texts are usually all devoted to subjects in connection with the

discovered at Thebes. They are hewn in the sides of a low, bare, isolated hill of sandstone, standing at about the middle of the Gurna or Gurnab, which gives the name to the Cemetery of which 115 "Tombs" had been cleared in 1913. [GARDINER-WEIGALL, op.cit.] The sculptor, so that the walls have been covered by a coating of lime, which was then whitened in preparation for the painter. It is but a tentative sketch, because no two published plans agree in either the location or numbering of the Tombs.

GARDINER-WEIGALL, op.cit. Pl.III-VII.

BARAISE, (Plan) op.cit.1904-1913.

3). The text of BATEKES, (1914), and Pl.II-VI of GARDINER-WEIGALL indicate the localities here shown.

-----	Table No.	XLIX
-----	"	XXXV
-----	See	"
-----	"	XXXV
-----	as a Guideserk.	
-----	"	XXXIII
-----	"	XXXIII
-----	"	XLIX
-----	See	"
-----	"	XX
-----	"	XX
-----	"	XXXIV

must be identified.

IV, pp.58, ff.

ing des Niederländischen
 in: Band I, (1908): II, (1909)
 II, (1915): (The Hague, Nitjhoff).
 37): II, (1855)

logue of the Private Tombs at

gypte: II, (1901), pp.144-5
 in the Br.Mus. I, (1911)
 (1914).

Miss. franç. au Caire, VIII, II.)

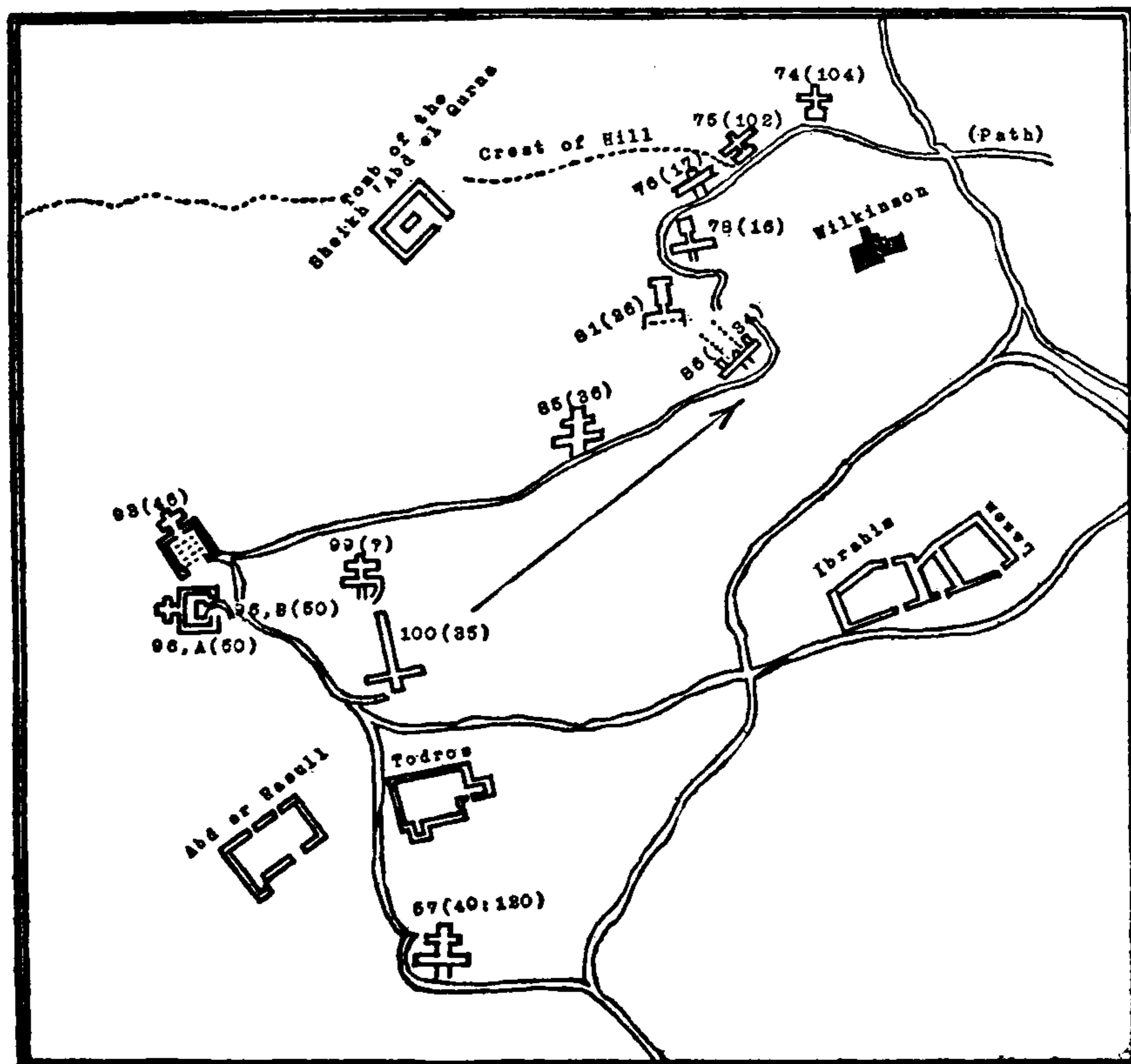

THIS PAGE IS LOCKED TO FREE MEMBERS
Purchase full membership to immediately unlock this page

DELVE INTO FANTASY, MAGIC, MYTHOLOGY & FOLKLORE

Forgotten Books'
Full Membership gives
access to 797,885 ancient
and modern, fiction and
non-fiction books.

Continue

*Fair usage policy applies

No.	Lieblein	Location	Monument	Published		
1	235:235Ad	Leiden Mus. Cat. =	S U.45 #103	{BOESER Pl. XVIII, #21 LIEBLEIN, 235, " 234(Ad),	VI 6 74 942	Offering to Osiris by (Reg. I, Top) Sx S(A.89) and Sx Nb-stay (Reg. II, Right, line 5) Sn-nfr-f-r(A.89) (8) mē-s s (7) nb-t-pr (B.7) (4) irt nswt di htp (3) wab(=N.25)-d ? -i sa-n (2) pa (1) (A.89) [See BOESER, VI, p.28] (Left) (2) Sx S(A.89) (3) irt nswt di htp (4) in wr-f i-a-n-i (Reg. III, R. to L.) sa-f in-m-hb(A.89) sa-f inn-mē-s(A.89) sat-f t-a-i(A.91) di(=D.59) m-t-s(B.7) Sat n Sat-f Sv(=N.24)-w-t [BOESER p. XXVIII] (Reg. IV.) nswt di htp ir-ist etc. (Reg. V, Bottom) wab Rā Nb in Sx Rā(A.117) Sa Sx Nb-sn(pl.) y-d-d-mē Nb-nfr-t sām r-n-s ? ? [Note: - Nefertiri was Queen of Ahmes I, (Dyn. XVIII, No.1) See: - Imahy sn(=R.22)-nfr(=Y.9)(A.110) (b) Nswt Sx Nr-f Hs n Nfr nfr Bk-n-Im(A.110) (c) Nbt-Pr Ipw(B.7) (Upper) (1) Ir-ist Nb etc. (2) Imi-ra Ipw (Nfrt-iri) (8) Sx Dhwimss (Middle) (Fig. 2) It-f Sx Sn-nfr (a) (Right) (Rā-āe-hpr-ka) (Rā-mn-hpr) (b) (Left) (Rā-gsr-ka) (Iah-mē-nfr-t-i-r-i) Nfr hnt Sa-pa-irt Maāhrw imahy n Nfr Nfr. Sn-n(A.89)-nfr(A.89) maāhre Sn(=R.22)-n(=S.11)-nfr-f-r [sic.] hnt-f Nbt-Pr Dhwitī [sic.] Sat rn-f T-a-wsr-s-r-t B.7)
2	536	Louvre	S O.71	LIEBLEIN, (DE ROUGÉ,	I 177 VIII 106)	
3	573	Leiden Mus. Cat. =	S U.9 #69	{BOESER, Pl. VII	VI 3	
4	592	Turin	S 1455	LANZONE	I 121	
5	637	Stockholm	S 27	LIEBLEIN	I 212	
6	768	Florence	S 2586	SCHIAPARELLI	(1887) 277	
7	880	Vienna	S 9	LIEBLEIN	II 284	
8	1710	Cairo	S 220	LIEBLEIN	III 670	
9	1964	Cairo	St.	LIEBLEIN	III 763	
10	1974	Guimet Paris	S C.29	MORET	Text 44 Plate 18	
11	1996	Assuan	T.C.	BOURIANT	198	
12	2011		S	MARIETTE	1113	
13	2177	Lyon Palais des Arts	S 83	{DÉVERIA Pl. II. }	69	
14	2231	Turin	St. 3089	LANZONE	I 424	
15	..	Br. Mus.	S [256]	Guide, (1909)	44	
16	..	Br. Mus.	S [579]	Guide, (1909) Hier. T.	36 II XV	
17	..	Sr. Mus.	St [497]	Guide, (1909)	43	
18	..	Near Tôshkeh		(TOSKIL BAEDERER, Eg. (1914), p.403) Mentioned by WEIGALL, Antiq. Upper Eg. (1910), p.561: Rock-relief Sen		
19	..	F.P. Coll.	St	Seated Statue. Noted PÉRIE. Hist. Eg. II. p.163. "Sennefer, the Noble of the South City" (i.e. "May		
20	..	Cairo	St 42126	LEGRAIN " " (Rép.)	I 76 - - 203	
21	..	Br. Mus.	St [113]	(Guide, 1909)	187	
22	..	El-Bersheh	S	SHARPE SETHE	II 33, A 597	

(5) Iai-ra Iam(=M.1)-w-wr(=G.79) IIIII [sic.] [.....]
Ihw (?) [.....] Sn-n-nfr(A.110) [Note: - The Stele was defaced

i.e. The Scribe S, and the Scribe Neb-setay.

Sennefer, born of the Lady of the House, Bakt

(4) making the Royal Gift, an Offering (3) for the mummy (?) of Saenpawahu.

(Left) The Scribe S makes the Royal giving for the mummy (?) of Iani.

(Reg. III, R. to L.) his son Amenemheb, his son Amen-mes, his daughter Faidjutes, the daughter of his daughter Suut.

(Reg. IV.) A Royal giving, offering for Osiris. (Offerings).

(Reg. V, Bottom) The Neb priest of Ra the Lord, namely the Scribe Ra and the Scribe Nebesny-zedenef-pay, born of Nebnefert to cause her name to live ? ?

[Hist. Egypt, II, p. 40: WIEDERMANN, Aeg. Gesch. p. 315: and Table No. XIV, line 3]

Honored in Sennefer, (b) Scribe of the King and His Beloved, Praised of the Good God [by] Bekenamon [and by]

(c) the Lady of the House Ipu.

(1) Osiris, Lord, etc. receives offerings of deceased. (2) Superintendent of the Cattle of (Nefertiri)

(3) the Scribe Thutmosis, and his wife ~~Nb-nfert~~ i.e. Nebnefert. (Middle) (Fig. 2) his Father was Sennefer.

(a) (Right) (Aa-kheper-ra) [Thutmosis II] (Men-kheper-ra) [Thutmosis III] (b) (Left) (Zeser-ka-ra) [Aahmes I] (Aahmes Nefertari) Divine Wife and Sa-pa-irt [LIESLEIN, II, 520] Justified. [Adoration for] the Good God Sennefer Justified.

[Note: - PEYRIE (Hist. Eg. II, p. 163) identifies this Sennefer as "Mayor of Thebes". See No. 20 below.]

Sennefer: His wife, the Lady of the House, Thuti. [LIESLEIN, II, p. 552] His daughter, causing his name to live, is Tausert.

[For Tansart see LIESLEIN, II, p. 540] [Here follow names of 5 daughters and 7 sons. Then a memorial of "Kiwil....."]

XIIIth. Dynasty. (SCHIAPELLI).

Kias and the Lady of the House, Sennefer.

His Father Wen-her (b) The Bearer of the Standard. Hero-hatep His sister, the Lady of the House. Sennofer.

The Petty officer of the ship "Lion of the Chief", Sennefer. His wife is Thensti.

[Names of 4 men, 1 woman, 6 "Sailors"]

[.....] his wife Sennefer.

Khaan: Sennefer (Woman)

(Above) Scribe of the Grains of the Lord of the Two Lands, Nefer-Ptah, and the Lady of the House Honura.

(Below) The Scribe Sennaar, His brother the scribe of the Grain of the Lord of the Two Lands, Sennefer.

[Por] was Justified; His brother for causing his name to live, Sennefer.

Senneferu, Son of Satisfu; [Period of] (Neb-kaw-Ra) [Amenemhat II]

(To Osiris) for the Ka of User-ur;

His son, Sennefer. (XII Dyn.)

(Figure of Hathor ?) offered by the ship Captain Senneferu, born of Makut.

[Period of] (Neb-kaw-Ra) [Amenemhat II].

III.

(Thebes?).

ed man and woman. Daughter standing between)

..... to the Ka of the Prefect. [or Mayor ?] of the City of the South [Thebes], Sennefer.

..... to the Ka of the Royal Nurse Sennay [See No. 21 below]

This daughter a singer belonging to Anon Mut-nefert; Justified.

Count [Mayor ?] of the Southern City [Thebes] Sennefer (Guide, "Remp-nefer")

His wife the Royal Nurse Sentenay.

His Daughter Nefertiri.

Year XXIII, Month IV of Shawu, Day XII. Forefront of millions in the Jubilee of great numbers (?)

[.....] for the King Himself, as Scribe over His Fruit Trees [because of the name of]

the King of Upper and Lower Egypt, (Men-kheper-Ra), Son of Ra (Thutmosis [III]) upon the Throne of Horus of the Living, like unto Ra forever.

Superintendent of Trees ? ? ? [.....], Superintendent of Cattle (?) [.....] Sennefer [.....]

91. Shawu's copies are very poor.]

No.	LIEBLEIN	Location	Monument	Published
23	.	Sh. A. E. Q.	T. C. 96, A. B.	G. and W. 24. No. 96, B.
24	.	B. el M.	T	CARTER II 196-200 LEGRAIN, 205 (Rép.)

"Tomb of the Vines" (VIREY, Rec. de Trav. XX, (1898), p. 211; XXI, (1899) Tomb. CARCINES-WEIGALL, op. cit. p. 24, Note.] LEPSIUS, Denkmäler, Teil MURRAY, Handbook for Egypt, (1907), p. 439, No. 50. WEIGALL, Antiquities No. 96, B: (Scene on Left of Entrance to Antechamber) (VIREY) (Sennefer Rpatî Rntî-â n(Y.2) Rsw Âa Nrt Rntî-â n Nwt Rsi Imi-ra Snwtî n Imi-ra Ihw n Imn Sn-nfr Raâhrw sat-f nr-f n ist ib-f Smât ntî Imn Nwt-Twy

(Scene on Right of entrance to Main Hall) (Sennefer and wife seated) Rbt-Pr Šeât ntî Imn Nr-t Raâhrw

(Scenes on Right Hand Pillars, Main Hall.) (Sennefer Seated, Meret) (Râ-âa-hprw)

No. 96, A. (Not published in full (1915) See GARDINER-WEIGALL, op. cit. No. 96, B. WEIGALL, Annales du Service, IX, (1909), p. 124, p. 135, No. 95. Rntî-â Nwt Rsi Sn-nfr (A. 110)..... (Father) Rsw (Y. 2) m-â-y (A. 110) Im-nfr Rnt [Nother] Nb (A. 110)..... Sn (A. 89)-f Imi-ra Nwt Rnt Imn-m-ipt qdn-f Pa-i-r (Y. 2)

Note:- The Tomb Chapel of this Amenemipt was discovered by newson Portrait of Senusert seated with his wife:- Rnt-f Nwt Rsi Nfr Nrt Sn-n-t-n-y (A. 110)

Tomb of Sennefer containing Canopic Jars and Vases, inscribed:- (Jars) Rnt Nwt Rsi Sn-n-t-n-y (B. 7) (also "Sn-n-t-n-y (B. 7)") (Vases) Rntî-â n Nwt Rsi Sn-nfr (A. 110) Rnt-f Nwt Nwt Sn-n-t-n-y

See also mention of Granite False Door, Louvre, and Funeral Coffin Relief of Senusert III near Toshkeh WEIGALL, Antiquities of Upper Egypt of the XVIIIth. Dynasty at Abydos; (See MACIVER-MACE, El Amrah and LEGRAIN, (Rép.), No. 204.

Inscriptions of Senneferi [and Sennefer, See No. 1.], Lord Treasurer [Imi-ra Rst] of Hatshepsut-Thutmose III.

L. Statue of Black Granite: British Museum No. [49], Northern Egyptian Gallery, Central Saloon. Guide to the Egyptian Galleries, op. cit. and text below, line 12, viz. "qn snnfr" etc.] and the Lady Tehuti-Sat, Height 2ft. 9in. found behind the "Vocal Chamber" p. 16, Pl. XXVIII. [There also "qn (D. 69)-nfr" see above] Text:- (Photo in part) BUDGE, Eg. Sculp. etc. op. cit. Pl. XXVIII. S. B. A. Proc. XXII, (1900), p. 61, No. 6. This statue was identified by NEWBERRY (op. cit.) as that of the Senneferi now in question. For Titles etc. See MURRAY, Index of Names and Titles of the Old Kingdom, (Br. School of Arch. in Eg. Studies, p. 100)

Sethe

Line	Fragment	Text	Fragment
1	544	1	Lines 1-5: A conventional votive inscription beginning:- Rsw (=M. 24) rdi (=X. 22) Rtp (=Q. 17)-t-p
			(Title No.) Rps (=Q. 5)-ir (=D. 10) (A. 113) Rnt (=W. 8) Imn (=S. 58)-t-tiw (=G. 5) (N. 53, N. 53, N. 53)
	545	5	1-3 n ka (=D. 46) n (1) r-p-â (2) Ra (=F. 16)-â (3) bit (=L. 1)-t qdâ (=S. 44)-t
		4	(4) é-mr (=U. 31) wâ (=U. 37)
		6	(5) 6 hr (=D. 3)-qada (=D. 1) âa (=T. 1) m šw (=M. 24)-t-n pr (=O. 3) (6) é-hnt (=W. 8)-t
		7	nst (=T. 42)-t (O. 3) m bit (=L. 1)-t pr (=O. 3) (7) an-n t-b-y-t [sic.] (S. 38) (S. 38) m
			â-xn (=E. 22)-n-nw (=W. 21)-t-î (O. 3)
		7	(8) wâ (=M. 73) (line 7)-mdw (=D. 35)-d (pl.) n šn (=V. 6)-n-y-t (A. 29) (pl.)
		9	é-h-r-r p-â-t (H. 21) Rhyt (=3. 81)-t (N. 53, N. 53, N. 53)
	546	10	nswt (=M. 24) whm (=F. 52) (11) mšqr (=F. 46) mšqr-t (N. 53, N. 53, N. 53) wâ (=U. 37)
		8	12 âa (=G. 71)-q xr (=Q. 20)-r nfr (=Y. 9)-r-t (pl.) (line 8) pr (=O. 3)-r xr (=Q. 20)-r
		13	hs (=W. 4)-w-t (pl.) (13) hr ir (=D. 10)-t é-h-r-w (pl.) nw (=W. 21) ta (=N. 37) a-n m
			w-â-â-w-t (G. 80) (N. 53, N. 53, N. 53) na (=D. 46) ma (=U. 8) (D. 10) nn (=D. 46) šqm (=F. 46)
		9	14 h-r-r-w hr d-d-t-f nb-t Rtp (=Q. 17)-t-w hr pr (=O. 3)-r-w n Ra (=D. 29)-f
		(15)	nr (=U. 12)-r n šw (=M. 24)-t-n m nt (=D. 90)-t-t
		10	(D. 84) (D. 84) ib (=W. 29)-f
		16	nr (=U. 12)-t-f m nb (=U. 50) (N. 53, N. 53, N. 53) [sic.] (N. 53, N. 53, N. 53) [sic.] hr
			h-s-b-d (N. 53, N. 53, N. 53)
			Rdi Rsw Rtp Nwt
		 n ka n (1
			(3) bit qdâ (4)
			(5) hr-qada âa m
			m bit pr (7) Nwt
			(8) wd (line 7)-md
			(9) šhrr [GOLÉNISCHEV
			Rhyt (10) whm Rsw
			(12) âa xr nfrnt
			(13) hr irt šhrw
			nn šqm
			(14) Rrrw [GOLÉNISCHEV
			qdm-t-f nbt Rtp
			[GOLÉNISCHEV, id.]
			(16) Nrt-f m nb R
			ib Rrrw [MASPERO,

.127:p.137:XXII,(1900),p.83)[Note:- No.96,A is the Upper Rock Chapel, and 96,B in the Courtyard of 96,A is the Subterranean
(NAVILLE-SETHE,1900),III,p.279:[72]. NEWSBERRY, S.B.A.Proc.XXII,(1900),p.59,No.5. BAEDERER,Egypt,(1908),p.308:(914),p.310.
of Upper Egypt,(1910),p.117:No.96,A: ibid,Annales du Service,IX,(1908),p.135,No.96. MONO, Annales du Service,V,(1904),p.100,\$3.
seated facing a girl and 10 men bringing offerings)

Hereditary Prince. Count abiding in favor. Great of Love. Prefect [or Mayor] of the Southern City [Thebes].
Superintendent of the Double Granary of Aken. Superintendent of the Cattle of Anon. Sennefer Justified: and
his daughter, a singer belonging to Amon, Mut-Taui.

and standing)(over Wife)

The Lady of the House, a singer belonging to Anon; Meret, Justified
standing)On the Pectoral worn by Sennefer:—

(Aa-kheperu-Ra) [Amenhotep II.]

WEIGALL, Antiquities of Upper Egypt,(1910),p.119.

MONO, ibid,V,(1904),p.100,\$3. NEWSBERRY, S.B.A.Proc.XXII,(1900),p.59,No.5.

-Pr Prefect [or Mayor] of the Southern City. [Thebes]. Sennefer(Father) Hussy, Steward of the Divine Wife
(Mother) Neb..... His brother Prefect [Mayor] of the City, and Visier Amenemipt, he was called
Pair.

in 1895 (S.B.A.Proc.XXII,p.60) at Sheikh Abd'el Qurna. It is No.41,(GARDINER-WEIGALL,op.cit.p.16). In it is a scene.

His wife the Royal Nurse, Beloved of the God: Senteny.

The Royal Nurse, Sennaty (also "Sennay")

Prefect [Mayor] of the Southern City, Sennefer: and his sister, the Royal Nurse, Sentenay.

NEWSBERRY, S.B.A.Proc.XXII,(1900),p.60 and note * also of figure of "Sennefer, Watchman of the Cattle of Horus", on
Egypt,p.562.Other monuments bearing the name Sennefer are:-the Ushabti-figure of stone found 1899-1901 in the Tombs
ydow,(Eg.Exp.Fund Special,1903),p.71,p.86,Pl.XXXIX,No.1, Top row). and Funeral Cone from Qurna: (DARESSY,(C.F.),No.78,

(Sculpture),(1909),p.154,No.556. Seated figures of Sennefer [In Guide, "Gen-nefer" ("Qn-(D.69)n/r") but see SETHE,
non" (Colossus of Amenhotep III), West Thebes; (Salt Collection). See BUOCC, Egyptian Sculptures in the Br. Mus. (1914),
CARPE, Egyptian Inscriptions,I,(1832),Pl.55,56,a. SETHE, Urk.XVIII Dyn.(1906),p.544,No.177. NEWSBERRY, (lines 12, 13, 14)
on; i.e. the owner of Tomb Chapel No.99 at Sheikh 'abd el Qurna. (See No.VI, below)
I.)(1908).

nt tantis	A Royal Giving of the Offering of Osiris, Head of the Dead
.....
âtî (2) Natî-â to the Ka of the (1) Hereditary Prince,(2) Count,
Natî	(3) Chancellor, (4) Sole Companion.
Pr (6) Šhat Nat (Pr)	(5) Major Domus in the Royal Palace, (6) He was approached to the Throne in the House
n Šxnatî (pr)	of the King of Lower Egypt. (7) Stable of feet in the Royal Cabinet.
ann.\$437] n Šnnyr	(8) Issu(line 7)ing orders for the Court, and
ib.š'št.II,61,n.2] Pât	(9) (Always) Rejoicing men and Subjects.
) Šgr šgrut š	(10) Royal Herald, (11) Sole ear of cars.
8) pr r xr šest:	(12) Eating aseng the fortunate (line 8) and proceeding among the praised
pn n šst nn ma	(13) to shape the policies of this Land to unique things (?) never seen nor heard.
, as above, "(9)" pr	(14) He (ever) satisfied with all his sords, <u>one</u> was content with the utterances of
n n r-f (15) Nrr	his mouth.
nt n mt šb-f	(15) (Ever) loved by the King in the innermost of his heart.
-b-g (17) pr šbagn-f	(16) Approved by Gold on Lapis Lazali
š'št.VI,123] inn	(17) A Great man; he opened the heart of the Common Folk; waiting to be granted what he

THIS PAGE IS LOCKED TO FREE MEMBERS
Purchase full membership to immediately unlock this page



Never be without a book!

Forgotten Books Full Membership gives universal access to 797,885 books from our apps and website, across all your devices: tablet, phone, e-reader, laptop and desktop computer

A library in your pocket for \$8.99/month

Continue

*Fair usage policy applies

No.	Sethe	Title No.			
I.	546	10	(17)	wr(=A.29) wba(=U.29)-b-y-n-f ib(=W.23) t-tm(=U.14)-w-w	[GARDINER, Z. Aeg. 49, p. 101, (Bib. d'Ét. II, p. 231, No. 7) (1 Bib. d'Ét. IV, p. 108) Nfr (19) Imi-ra hmw Nfr n Nnw (20) Iri wdn n hrw nb m Pr (21) Wâb âwâw [? ERMAN, Z. Aeg. (1894), p. 292, n. 1] ia gb Gods of Eg. I, p. 412] (10) N No. 24] (23) Qn Sn-nfr Naâ Irn Imi-ra Ist [MASPERO, Ét. Prw-watt (nwt) [SETHE, Z. Aeg. ns n Xkr-Nswt Dhwti-sat No
		11		i-in(=K.1)-n rai(=D.59) d-d-t n-f	
		18		ha(=F.16)-â n shm(=O.74)-t(O.1) nfr(=R.13)	
		19		imi-ra(=S.37) nfr hm(=W.6)(pl.) n mnw(=O.75) gb(=V.8)-b-tiw(=G.5)(O.1)	
		12	20	i-r-i(B.12) wdn(=V.39)-n n hrw(=N.7) nb w pr(=O.3) i-mn-n ra(=N.7)	
	21		wâb(=W.25)-b â-â i-â(N.55) gbâ(=D.84) gbâ-gbâ hr d-r-p(D.69)		
		547	22	i-â-h(N.28)(A.117) dhwti(=G.48) (10) nswt(=M.24) whm(=F.52)	
	23		imi-ra(=S.37) dast(=S.45)		
		13		q-n(D.69) sn(=R.22)-nfr(=Y.9)[sic.] maâ(=Q.59)-hrw(=P.22)	
			14	[Lines 13-14: See also NEWBERRY, S. B. A. Proc. XXII, (1900), p. 61, No. 6] ir(=D.10)-n imi-ra(=S.37) ist(=Q.1)(O.3) m hrw(=G.8) wa(=N.49)-t-t(N.40) dhwti(=G.48)-ha(=M.42)-y(D.1)(A.110) maâ-hrw msâ(=M.80)-s n sw(=M.24)-t-n xkr(=O.61)(Y.2) dhwti(=G.48)-sa(=G.67)-t(B.7) maâ-t-hrw h-r ir(=D.10)-ist(=Q.1)(A.113) [Lines 15-21, (End) Sennefer is promised the future of a holy deceased.]	

II. Fragment from Tomb No. 57 at Gebel Silsileh (West Side) on the Nile circ. 90 miles South of Luxor: (Railroad Station, "Kagug" NAVILLE-SETHE, IV, (1901), p. 85, §m: BAEDER, Egypt, (1914), p. 338: MURRAY, Handbook for Egypt, (1907), p. 493: WEIGALL, Antiqu (a):- Door Lintel: Text, GRIFFITH, S. B. A. Proc. XII, (1890), p. 106, No. LVII: and see LEPSIUS, Denkmäler, III, 28, No. 6. ân nfr nfr (b):- Door Jamb: (South). Text, GRIFFITH, op. cit. LEPSIUS, Denkmäler, Text, (op. cit.) p. 89, No. 9. Beginnings of 8 fragmentary 22 23 n ka n imi-ra dast (23) Qnâ Sn-nfr-i(A.110) Maâhrw To the Ka of the (22) Controller of the Purse: (23

III. (See above, No. 9) LIEBLEIN, op. cit. No. 1964 notes "Statue de Gournah, XVIII Dyn. Communication de M. DARESSY." [Titles as above

		24 25	(24) bit(=L.1) dast(=S.45) (Title No. 4) (25) nfr(=R.13) wr(=U.12)-t	(24) Bit dast [Cf. No. 22] ra r dr-f (27) ff Mnât S. dast Sn-nfr-i
		26 27	(26) hr(=D.3) daga(=D.1) ta(=N.37) r dr(=W.40)-f (27) t-f[sic.] mn-n-â-t(D.39) nswt(=M.24) sa(=G.67) i-mn-n sa	
		22	imi-ra(=S.37) dast(=S.45) sn(=R.22)-nfr(=Y.9)-i(A.89)	

Note:- This text is not found in that of No. I above, and the present location of the "Statue" is not

IV. Relief at Sarbût (or Serabit) el Khadem in the Peninsula of Sinai: (See Table No. I) Temple of "Hathor of the Mafkat", Pylon: PETRIE, Recherches in Sinai, (1906), pp. 55, ff. pp. 72, ff. Pl. 85-94, (Pylon), p. 79, Pl. 96.

Text:- Ordnance Survey of the Peninsula of Sinai, (1869), Photo, III, Pl. 7: E. H. PALMER, "Note Book" (Library of the Palestine) ibid, Recueil des Inscr.-Égypt. du Sinai; (Paris, 1904), p. 197: SETHE, Urk. d. XVIII Dyn. (1906), p. 548, No. 178.

See:- BIRCH, Account of the Survey etc. (Library, Pal. Exp. Fund), p. 192

548	22	(a)(1) Nfr nfr Nb fawî Nb [ir(=D.10) h-t] (Nn-hpr-[Bâ]) Sa Râ	(22) Imi-ra dast Sn-nfr (c) Imi-ra Pr Wr N Nswt Knnw
		(2) n xt-f wr-f [Dhwti-mâ-s Nfr hpr] di ân nî Râ d-t	
		(3) (Before the Goddess) h-t-hrw [nbt] m(=D.63)-f-k[t (N.53, N.53, N.53) wr] y Nbt P-t	
		(b) [Titles as above: Nos. 1, 2, 4.] imi-ra dast-t sn(=R.22)-nfr(=Y.9)[sic.]	
		(c) imi-ra pr wr(=G.79)-r n nswt k-n(pl.)-n-a	

V. Titles etc. of Senneferi, Controller of the Purse (Hatshepsut-Thutmose III), as given by SETHE, Urk. d. XVIII Dyn. pp. 539, ff.

"Titles."

Sethe.

[Titles as above: Nos. 1, 2, 3, 4.]

539	a	28 29	(28) mn-n(Y.2) hs(=W.4)-w-t(pl.) (29) âa(=T.41)-â(Y.2) wr(=U.12)-r-t	(28) Mn hswt (29) âa wrt (30) Wâ n hrw (31) imi ib [N (32) hnt Rhiwt n âat n mn-h-f (33) imi [ib] imi âhâ (34) Aââ [GARDINER, S. B. A. Proc. Sarî mdu sn [.....] (35) [ra shr]r [See No. 9] m [
		30 31	(30) wâ(=U.37)-â n hrw(=G.8) (31) i-imi(=R.28) ib(=W.23)[nb(=W.43)(G.15)]-f	
		32	(32) hnt(=W.8) rhi(=G.81)-t(pl.) n âa(=T.41)-t n mn-n-h(U.27)-f	
		33	dago ib [Not "hri-ib"] (33) imi(=R.28) [ib(=W.23)] imi(=R.28)	
		34	âhâ(=O.29)-â(O.3) (34) aââ(=W.23)[GARDINER, Lit. T. I, 1, p. 40, (28.6)]-w(A.91) [.....] s-â-r-i(N.49) mdw(=D.35)-w(pl.) s-n(pl.) [.....]	
540		35	[ra(=D.29) s-h-r]-r(Y.2) m [ta(=N.37) r dr-f	

		Geographical Names
<p>-di ddt n-r [GOLENISCHEV, stī-ā n Shm-t [GAUTMIER, n (nmt) Rā p.100: Life in Anc. r drp jh-Dhwti [BUDE, Swt (22) imi-ra Dast [cf. Égyptol, II, p.129] n p.73] Dhwti-hay Naâhrw w hr Ir-ist</p>	<p>said. [lit. "what was the saying of him"] (18) Primate of the Holy Sanctuary. (19) Director of the Priests of [the God] Min of Koptos. (Cf. No. 48) (20) In charge of the offering of each day in the House of Anon-Ra. (21) Hereditary (?) Libation Priest [See ERMAN, Handbk. Eg'n Relig. (1907), p.54] purifying tens of thousands at the time of the offering for Aah-Thuti [The New Moon: God of Measuring] (10) Royal Herald, (22) Controller of the Purse. (23) The Strong: Sennefer, Justified. Begat by the Deputy in the Capital [lit. "Seat"] in Heru-watet, Thoti-hay Justified. and born of the Ornament of the King, Thuti-Sat, Justified.</p>	<p>(1) Gbtw (2) hrw-Watt</p>
<p>e. the ancient City of Khenyt (xn(=D.51)y-t (nmt)) See LEPSIUS, Denkmäler, VI, 23, No. 7: ibid, Text, s of Upper Egypt, (1910), p. 356, p. 365. Apr-Rā) etc. [Thutmosis III]. Note:- This name is cut over that of (Naât-ka-Rā) i.e. Hatshepsut. s and:- Strong: Senneferi Justified.</p>		
<p>Nos. 1: 2: followed by:- Hr Hrt (28) Hr Dage t Sa Inn (22) imi-ra</p>	<p>(24) Chancellor of the Exchequer of the King of Lower Egypt. (25) Whom the God loveth. (26) Chief of the Entire Land. (27) Father of the Nurse of the Son of the King, the Son of AMQN. (22) Controller of the Purse, Sennefer.</p>	
<p>Half West front. BAEDERKE, Palestine & Syria, (1912), p. 211: MURRAY, Handbook for Egypt, (1907), p. 239: Exploration fund) p. 13: WEILL, Inscriptions égyptiennes du Sinai; Revue Archéologique, IV, (1903).</p>		
<p>Inscriptions in his Tomb."</p>	<p>Good God, Lord of the Two Lands. The efficient Lord (Men-kheper-Ra), Son of Ra; (2) of his body, and [whom] He loves. [Thutmosis [III]] Given Life like unto Ra Forever. (3) Hathor [Lady] of the Malachite [Be]loved Mistress of Heaven. (22) Controller of the Purse, Sennefer. (c) Superintendent of the Great House of the King, Kenuna.</p>	
<p>(See 43 below) [.....] [.....]</p>	<p>(28) Abiding in Favor. (29) Great to love. (30) One for Horus (?) (31) Favorite of [his Lord] and (32) Foremost of People for the greatness of his worth of head and heart. (33) Favorite within the Palace. (34) Interpreter [PEER, S. B. A. Proc. 37, (1915), p. 224] [.....] and Bringer of their words [.....] he was (35) [A voice] ever satisfying [in the entire earth</p>	

V.O. No.		Sethu.	
540	a	36	
		37 38	
		39	
		40	
541	a	41	
	d	42 43	
	e	44 45	
		46	
		47 48	
		49	
		50	
		51	
		52	
		53	
		54	
		55	

(36) *imī-ra* *ḡbā*(=S.44)-t *sn-nfr-i*(A.110) *maāhrw*
(37) *ra*(=D.29) n *św*(=M.24)-t-n (38) *ānh*(=S.43) *ānh*(F.46)(F.46) n
bit(=L.1)-t(S.11) (39) *imī*(=R.28) *ib*(=W.24) n *nfr nfr*
imī-ra(=S.37) *ḡst*(=N.40)-t(pl.) *nb*(=U.50)(N.53,N.53,N.53) [n-t i-mn-n]
Titles 10: 36: *sn-[nfr-i maāhrw]* *ir*(=D.10)-n *sob*(=E.49) [*ḡḡstī*(=G.48)
ḡḡa(=M.42)-y *maāhrw*
imī(=R.28)-*ib*(=W.28) *o-w* n *nb tawī*(=N.39)
er(=U.12)-r n *św*(=M.24)-t-n (43) *h-ḡs*(=W.4)-*ś* n *bit*(=L.1) n
āa(=T.41)-t n *mn-n-h*(U.27)(Y.2)-r *ḡḡo* [Nak *ḡri-ib*]
imī-ra(=R.28) *āb*(=F.37)(?) *whm*(=F.52) (45) *imī-ra*(=R.28) *św*(=R.13) *ḡa*?
See GRIFFITH, Hierog. p.25, No.72] (46) *imī-ra* *ih*(=S.28)[BAILLET, Rec.Tr.27,
p.203] n-t i-mn-h (47) *hr ḡḡb* n *āa*(=T.41)-t(H.21) *nb-t* (48) *ḡa*(=F.16)-*ō*
imī-ra(=R.28) *nfr ḡm*(=W.6) *ḡm ḡm* n t-tm(=U.14) (49) *ś-śsm*(=T.20)
ḡb(=W.49) n(=S.11) [nfr nfr nfr] *nh*(pl.) *īwn*(=Q.29) *nm*(=W.21)(O.1)
(50) *ir*(=D.10)-r-r *ḡs*(=W.4)-*ś-ś-t*(pl.) *ḡḡ*(? =N.8)-t [eic.] [nfr nfr nfr]
āa(=T.41)-*ḡ-t* (51) *hr ḡḡa*(=D.1) *ś-mr*(=U.31) III *āḡā*(=O.29)(O.3)
imī-ra(=R.28) *o-h* t(N.47)(pl.) n-t i-mn-n
(53) *imī-ra*(=R.28) *nfr ḡm*(=W.6) n *nfr nfr nfr nb* (pl.)
(54) *mḡ*(=V.15)-*ib*(=W.23)(Y.2) *św-t-n ḡt*(=M.9)-*ḡ-t* *tawī*(=N.39)
(55) *mḡ*(=V.15)-*ib*(=W.23)(Y.2) n *nb tawī*(=N.39)

(36) *imī-ra* [Cl.No.3] *ḡḡāt sn-i*
(37) *Ra* n *ḡḡst* (38) *ānhī* n *Bit*
(39) *imī-ib* n *nfr nfr*
(40) *imī-ra ḡḡst ḡb* [nti *īwn*]
sn-nfr-i maāhrw irn Sob [*ḡḡstī*]
(41) *imī-ib* *pw* n *ḡb* *ḡawī*
(42) *ḡr* n *ḡḡst* (43) *ḡs* n *Bit* n
ib [See Nos.31:32]
(44) *imī-rs* *āb* ? *whm* (45) *imī-*
(46) *imī-ra* *ihst* [DEVAUD, Sphin.
(47) *hr ḡḡa* n *āot ḡbt* (48) *ḡi*
n *ḡm* (49) *śśm ḡb* n *ḡḡre nbt* *ī*
(50) *īrr* [Gramm. §264] *ḡḡst* [M
ḡḡt (?) *ḡḡra* *āat* (51) *hr ḡḡa*
(52) *imī-ra* *ihst* [Cl.No.48: DE
(53) *imī-ra* *ḡm* *ḡḡr* n *ḡḡr* *nb*
(54) *ḡḡ-ib* *ḡḡst* *ḡt* [GARDINER, AC
(55) *ḡḡ-ib* n *ḡb* *ḡawī*

Note: - SETHE remarks (p.542, "N.B.") that the title "*ī-r-ī*(A.128) = *ḡa*(=W.68)t(Q.48)(See NEWBERRY, S.B.A

As to Nos. 44, 45,  compare NEWBERRY, Beni Hasan, I, p.11; (GRIFFITH as above); For the See also Appendix "A".

VI. Texts in Tomb No.99. Sheikh 'abd el Qurna: i.e. of Senneferi, "Controller of the Purse." (*imī-ra ḡst*)(Title No.21), Son of T

Mr. NEWBERRY says (S.B.A.Proc.XXII,(1900),p.61,No.6):- "In 1895 I discovered the Tomb of this Officer in the Sheikh 'abd el Ku Tomb of Sen-nefera, and in it I found fragments of papyrus, the rifled mummy, a sandstone face of a statue, the wooden face o "surrounding this Tomb I discovered fragments of a painted limestone stela in bas-relief and a small papyrus roll (a charm ?) "Tomb the pit of which was cleared by MOND." GARDINER AND WEIGALL, (Topographical Catalogue of the Private Tombs at Thebes,(1 the present main entrance to the Cemetery. Tomb No.99 is noticed by few as being "without interest", but SETHE, (Sitzungs. der p p.358, published a small diagram as shown below. The plan is that of the usual Tomb-Chapel, The vestibule is at the foot of a

Description and Notices of Tomb:- SETHE, op.cit.pp.358,ff. ibid, Urk.d.XVIII Dyn.pp.528,ff. WEIGALL, Annalee du Service, MOND, " " "

A 528 172

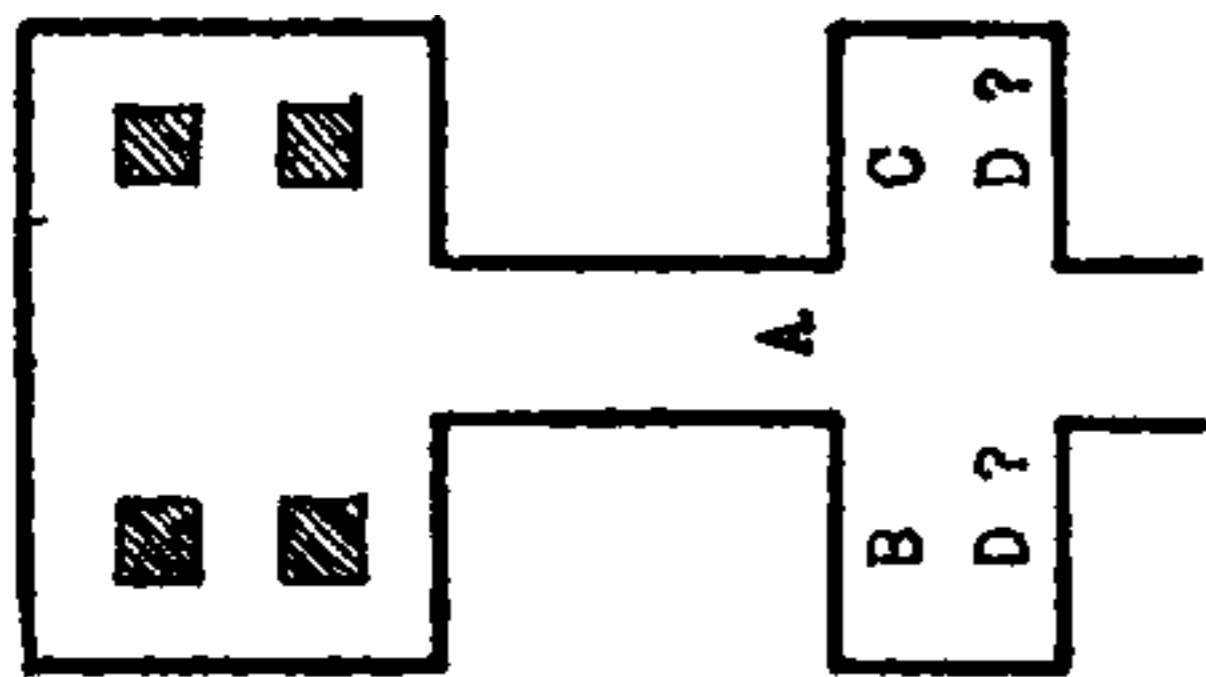

A: Opposite the entrance and over the corridor leading to the rear Walls B & C: The Expedition to Byblos and the Lebanon.

531 173

SETHE says (Sitzungsberichte etc.(op.cit.) p.358):- "The expedition which "The representations which immortalize [him] occupy the whole of "tombs of this period was reserved as a rule for the public even "see, on this wall, on both sides of the door which leads to the "walks the deceased; in one case from the left and in the other

531 173

SETHE (Urk.d.XVIII Dyn.p.531,No.173) gives the following heading to the texts:- "*sn-nfr-i* is sent by the King "reports to the King after the return home. Represented in two pictures on the two sides of a door in h

B 533 A

B. "Before the Voyage" (Left of the Door: "B" on Diagram) Text published, SETHE, Urkunden d. XVIII Dyn.(1906

a

(1) [.....] *ḡnt*(=W.8) [.....] [*ḡt*(=M.9)-*ḡ-t-tiw*(=G.5)

(2) (O.68 =  (painted green) see note 1 below) *śpśi*(=A.131)[-s(pl.)
nm(=W.21) *ḡ-ś* (needle leaf)] [.....]

(3) *ś-mn* [.....] (4) [.....] *i*[.....] (5) *r ḡ*[.....]

(1) [.....] *ḡnt* [.....] *ḡttiw*

(2) *śpśiw* [.....] *nm ḡś* [.....

(3) *śmn* [.....] (4) [.....] *i*[.....

Note 1:- SETHE says (Sitzungsber. etc.p.358):- "The green color in which the symbol for the "Terraces" ("Treppe")

" 2:- Probably the full word is as in Text "C", lines 8 and 13 below, viz. *ḡnt*(=W.8)(F.5)-*ś*(N.47)(N.40) i.e.

XX. Hatshepsut-Thutmosis III. Sennefer (6)

[Egyptian text]

- (36) Keeper of the Seal, Senneferi, Justified.
- (37) Mouth of the King of Upper Egypt, (38) Ears of the King of Lower Egypt.
- (39) Beloved of the Good God.
- (40) Superintendent of the Gold-Countries [belonging to Amon].
Senneferi Justified, born of the Judge [Thuti-Hay] Justified.

[Egyptian text]

- Favorite, this one, of the Two Lands.
- (42) Beloved by the King. (43) Praised by the King of Lower Egypt for the greatness of his worth of head and heart
- (44) Superintendent of Horn and Hoof (?) (45) Superintendent of the Waste [Land] and Sheila (?) [See Note] (46) Superintendent of the (cultivated) Fields belonging to Amon.
- (47) Foreman for all precious stones. (48) Chief Director of the Divine Priests (Cf. No. 19) of Tum (49) Leader of the Festival of all the Gods of Heliopolis.

[Egyptian text]

- (50) Maker of songs of the Cycle of the Great [Gods] (?)
- (51) Chief of the 3 *Snr* Nobles of the Palace.
- (52) Superintendent of the (untilled) Fields.
- (53) Director of the Priests of all the Gods.
- (54) Who fulfilleth the Will of the King throughout the Two Lands.
- (55) Who fulfilleth the Will of the Lord of the Two Lands.

[Egyptian text]

[Egyptian text]

[Egyptian text]

[Egyptian text]

[Egyptian text]

... does not belong to Senneferi." Further Titles are given below in connection with the texts.

[Egyptian text]

M. ROBERT MONO says (Annales du Service, V, (1904), p. 101, §4):- "I opened up (1903) and examined the large pit of the sarcophagus, and fragments of a limestone stela bearing the name of Gn-Amen. [Tomb No. 93, (Old No. 46)] In the debris requires to be unrolled." Mr. WEIGALL says (Annales du Service, IX, (1908), p. 135, No. 99):- "I think that this is the tomb of the pharaoh, p. 24 & Pl. III: (A. 2) show the Tomb as directly in the rear of that of Rekhmara (No. 100) (See Table No. XXXIV.) which faces the pharaohisch-historischen Classe vom 22 März 1906, in "Sitzungsberichte der Kgl. Preussischen Akademie der Wissenschaften, 1906, p. 185, (p. 124), No. 99: GARDINER-WEIGALL, Topogr. Cat. (op. cit.), p. 24, No. 99, Pl. III, (A. 2) (1904), p. 101, § 4.

... ("A" on Diagram) is the Cartouche of (Nn-hpr-Râ) [Thutmosis III] (SETHE).

... undertook on the commission of his King to the Lebanon must have been an event of first importance in his life. ... length of the rear wall of the great cross hall of the tomb-structure, (A & B in the sketch) a position which in the life of the deceased, presumably because they first fall under the eye of the visitor. Almost everywhere we find the Ruling King sitting under his Throne Canopy, next to and turning his back upon the doorway. Before him

... sea to Byblos to fetch Piag-masts for the Temple of Amon out of Lebanon. He executes his commission and

... 532-4, No. 173. (a) "Inscription of the King." (Restorations by SETHE)

- (1) [.....] the forest (? See note 2)
- (2) Splendid [Green] Terraces [of Cedar (?)
- (3) sake stable [.....] (4) [.....] [.....] (5) [.....]

Geographical Names.

â [Cedar]

... leaves no doubt that we there have to do with the place symbol for Coast Range." "Forest". [ERMAN, Aeg. Glossar, p. 96]



THIS PAGE IS LOCKED TO FREE MEMBERS
Purchase full membership to immediately unlock this page

DELVE INTO FANTASY, MAGIC, MYTHOLOGY & FOLKLORE

Forgotten Books'
Full Membership gives
access to 797,885 ancient
and modern, fiction and
non-fiction books.

Continue

*Fair usage policy applies

B 532 A (b) "Inscription of Senneferi" SETHE's heading is:- "He praises the King for this his resolution." 15 lines b
 b (1) wn(=E.58) [i-(A.13)n][.....] [šn(=R.32)-nfr(=Y.9)-i(A.110) w-s-b(Z.7)(A.91)-f (1) wn [in šn
 h-r hm-f] (2) qd-i (?) [.....]
 (2) qd-i [.....] faw(or nfr ?=P.16)-w [.....] below]

Lines 2-15 are very fragmentary and evidently conventional. No geographic names excepting:(line 15) [fa]-
 "not directly bear relation to the commission of the King. That it is this commission for which he thanks

C 534 B C. "After the Voyage" (Right of Door: "C" on Diagram) (Heading by SETHE):- "šn-nfr-i turns, followed by the so
 "and on sleds, back to the King, and makes his report." (ibid, Sitzungsber.(op.cit.),p.358):- "over Sen-nufo h
 Text published:- SETHE, Urk.XVIII Dyn.(1906),pp.534-6,No.173,B: ibid, Sitzungsberichte Kgl.Preuss.Akad.
 Translations:- SETHE, Sitzungsber.(op.cit.),pp.360-1. RANKE, in VON GRESSMANN, Altorientalische

(1)	i-s-t i-n(=S.11) r-p-a ha-a bitī(=L.1) qast(=S.45)[-t s-mr(=U.31) wā-t-i šn(=R.22)-nfr(=Y.9)-i(A.110) iw(=D.96)-w m htp(=Q.17)t-p s-qd(=O.77)-d (W.21)(P.1)-n-f m wad(=M.48) wr(=G.79)(N.55)]	ist in (1) Apāti (2) Natī-ā (24) (4)[šmr-Natī šn-nfr-i iw m htp s m wad-wr]
(2)	(N.58) s-sa[-a-h(V.4)(D.96)-n-f ta(=N.37)[.....][hpr]	šuhn-f ta [.....]
(6)	-r m b[xr(=Q.20)]-r(A.110) hq(=M.74)-d ["Sitz",p.360,n.4] hr [n mšā(=A.82)(pl.) (A.110) i-w]-	-r m bw[x]r-i [BUDGE, Eg. Rdg. Bk. 2 Hd hr[n nšōw-i -i šm-kwi hr sp ?]-i p[n.....]
(7)	-A.110 šm(=N.61)-m(D.96)-k-w(A.110) h-[r..... "Sitz" p.360,n.4 restores "sh"(=O.62)](A.110)p[n.....]	hr goda šnti ["Sitz" p.360,1.8] r hnt-[š] [.....]
(8)	hr qada(=D.1) šn(=V.6)-t-i(N.5) i-w-A.110 āq(=G.71)-q(D.96)-k-w(A.110) r hnt(=W.8)-[t(F.5)-š(N.47)(N.40)..... r-di(=D.63)-n-A.110]	moā n-s wdn m h-h m [GARDINER, Z. hwt hr-qada ["Sitz"p.360,1.9][ū. m [Gramm.§454] rdi kpn (hast) : 535,n.b) n hrw-s [id.n.c] n šst[m štos iri inn-i mš šišiw (?) [r n.d] m aw-šn [.....]
(9)	ma(=U.8)-maā(=Q.58)-ā n-s w-d-n(V.40)(Y.2) m hā(=A.106)(pl.) m h-t(Y.2)(pl.) hr-qada(=D.1) [ānh wda šnb hm-k]	špdt št r wšm ["Sitz",361,n.1] ir[i] wst [.....]
(10)	m-m rdi(=D.63) kp(=S.47)-p-n-[i](N.40) s-f n hrw(=G.9)(A.117)-s n ist(=Q.1)-t [ib(=W.23)]-s r-di(=D.59) [.....]	-i št hr hast nw nfr-ta špr r h otp r āhōw (wia) šodn-i m
(11)	m štp(=U.3)-p-w(Y.2)(pl.) i-r-i in(=W.22)-n-n-A.110 mh(=V.15)-ū [XX]X[XX]X m aw(=V.5)-[w-s-n(pl.).....]	-wr m moām faw nfr [VOGELSANG,U p.66] hr šah fa-[wri ? ? ...
(12)	špdt(=N.14)(Y.2) s-t r w-s-m(H.8 ? ↗)(M.41) hr qada i-r-[i]w-mt(=D.90) [..... s-h-a(D.96)-n]-	
(13)	-A.110 s-t hr qast(=N.40)-t nw nfr(=R.13) ta(=N.37)(N.47)(N.40) špr(=D.31)-r(D.96) r r [sic.] rdi(=D.59) hnt(=W.8)-t(F.5)š [N.47)(N.40) a-t-p(A.105) r āhā(=P.19)-a-w(P.1)(pl.) s-qd(=O.77)-d(P.1)-n-A.110 m wad(=M.48)-d]-	
(14)	-wr(=G.79)-r(N.55)(N.58) m ma(=U.8)-maā(=Q.58)-ā-w faw(=P.16) nfr(=Y.9) hr s-sa(=T.38)-a-h(V.4)[(D.96) ta(N.37).....][end]	

C 536 B	(b) "Inscription of the King." SETHE says (Sitzungsber.etc.p.362):- "Upon the report of Sen-nufs, the King "The few words which are preserved of his speech are however of little account. For a single one of "line of the King's speech begins. Without doubt it must be restored to šn(=R.22) šn [šn-t(M.9)(pl.) "texts preserved near the niches furnished for them in Karnak and Medinet Habu set forth, used to be		
b	2	[.....] (1) šn(=R.22) šn [šn-t(M.9)(pl.)] ↓ ↓ [↓ ↗] [.....]	[.....] (1) šn[nw] [.....
	1	mś(=M.80) [.....] šw(=M.24)-w [.....]	mś [BUDGE, Eg. Rdg. B'k. (1896), p p.149,1.12, p.156,1.6, p. XLVI,1. ...] šw [.....]
	2	m tp(=D.1)-f pšq(=N.26)-t nfr(=Y.9) nfr nfr [.....]	m tp-f pšqt [GAUTHIER, Bib.d'Ét nfrw [.....]
	3	ma(=U.12)-maā(=Q.58)-ā(Y.2)(pl.)-s-n[(pl.).....]	soām-šs [.....]
	4		

ing:-

i mšd-f hr hm-f (1) Then it was that [.....] [Senneferi made answer unto His Majesty

See Text C, line 14, (2) I (?) say [or saying] [.....] [favoring] breeze [.....]

met). SETHE says (Sitzungsberichte, etc. (op.cit.), p.358) "What is preserved of it (not much indeed), does master w must read between the lines." (3) [fa]-Nri [Egypt]

Behold! The (1) Hereditary Prince, (2) Count, (24) Chancellor of the Exchequer of the King of Lower Egypt (4)[Senneferi, who came in safety. He sailed in the Great Green]

(4) Wad-wr

and landed [.....][happened] in the place where I was. [SETHE reads:- "[happened (?) near my residence"] The countenance [of my soldiers] became glad] I went forth from this my [tent ?]

above the clouds (?) I entered into the Forest, [.....[Here the Goddess of the locality must be named "Urk", p.535, n.a].,.... I made] offering to her of a countless number consisting of things [for the Life, Health, Strength of Thy Majesty] Therewith the Country of Kpn [Byblos, i.e. of the Goddess Hathor] gave them to her Horus of the Place of her [heart], and donated] consisting of the choicest among [them]. I took those of [60] ells in [their length [.....

(5) Kpn

to prepare them for ? ? On the top[s] thereof [they] were thick (?) [.....]

I [transported] them over the mountain-country of fa-Nfr, and coming forth from the forest [..... laden on gha ships, I sailed on the] Great

(6) fa-Nfr
(7) Wad-Wr

[Green] with a favoring sailing wind, and drew nigh to fa-[Nri ?]

(8) fa-[Nri ?]

... takes up the discourse, doubtless to express to his faithful servant his approval of the performance. ... we be thankful for its preservation; that is the word sn(=R.22) sn[.....] with which the first extant ... the word for the gigantic flag masts on the Temple of the New Empire. These masts in fact as the ... from "Cedar-wood from the Forest", or "from the Terraces", i.e. from Lebanon."

[.....] (1) Flagmasts [.....] howa (?) [.....] his [.....]

as his Chief. The Nine of the Gods [.....]

their offerings [.....]

VII. SETME's heading is:- "Other pictures from the Life of Sn-nfr-i likewise exhibited in his Tomb." SETME

A. He [Sn-nfr-i] receives valuables [kostbarkeiten] (among which are gold rings), for the Treasury (šsp(=P.23) ša(=M.37)-a-*y*[-t(pl.)] = h_d(=U.53)(N.53,N.53,N.53) nb(=U.50) (N.53,N.53,N.53)] [.....] šsp šay[wt = B_d Nb][.....] āa(=T.41)-t(H.21) nb-t špāi(=A.131)-š-t(Y.2) mn(=Y.12) [aw(=W.21) n_w nb nfr(=Y.9)-f-r] [.....] hā(=N.23)-ā-w(M.9)(pl.) nb [.....] i(A.13)-n hālm nb [.....] in (Title 40) imī-ra(=S.37) hāst(=N.40) nb(=U.50)(N.53,N.53,N.53) [n i-mn-n (Title 40) imī-ra hūst Nb [n šn(=R.22)]-nfr(=Y.9)-i (58) Imī-rā Dbw [(?) See SETME or GARDINER, Lit. Texts, I, 1, p. 6 Sn-nfr-i (Line 6) (57) Imī-ra (38) Imī-ra Dhāt Sn-nfr-i (58) Ššm Nb n Itm (58, a) Hatī-ā Imī-ra hmw Nfr

SETME's heading:- "Senneferi inspects the Tomb fittings presented to him by the King, and the Statue "Amenemheb." (See Table XXXII)

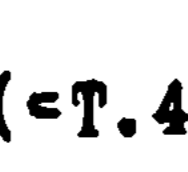
š-ndm(=M.98)-m m pr[-f n tp(=D.1)-p ta(=N.37) n-t-i mn(=Y.12)n(Y.2) m] šngs [GOLÉNISCHÉV, Bib. d'Ét. I] [BUDGE, Eg. R. Bk. 112, L. 10: NEWB 93] nti mn m] (L. 2) wošt (nwi iī-t m Prw-āa [Ā. w. Š. tn] wašt(=S.65)-t(O.1) m š-ša(=P.38)-[h-t(V.4) hrw(=G.8) ht(=O.22) m (1) Rpātī (2) Hntī-ā (59) H: ht(=M.9)-h-t] [(36) Imī-ra Dhāt Sn-nfr-i] iī(=M.34)-i-i-t(D.96) m āa(=T.41) pr(=O.3) pr [ānh wda šnb i(A.13)-n] r ma(=U.8)(D.10) hā(=N.23)(pl.)-f nw(=M.24) qrsw(=Q.25) šsp(=P.23) (1) r-p-ā (2) hā-ā (59) hš(=W.4)-y n nfr(=R.13) nfr(=Y.9) mn(=Y.12) nw(=M.24) nw n_w-f nw sma(=R.20)(D.69) ta(=N.37) [(36) Imī-ra Dhāt Sn-nfr-i] t-w-t()-f nw āa(=T.41)-t(H.21) nb-t hrp(=D.72)[-t(pl.) r ra(=D.29) r ma(=U.8)(D.10) hā(=N.23)(pl.)-f nw(=M.24) qrsw(=Q.25) šsp(=P.23) mn(=Y.12) nw(=M.24) nw n_w-f nw sma(=R.20)(D.69) ta(=N.37) t-w-t()-f nw āa(=T.41)-t(H.21) nb-t hrp(=D.72)[-t(pl.) r ra(=D.29) (pl.) pr(=O.3) pr pr m hš(=W.4)-w-t n nfr nfr] fwt hnt ?-f nw āat nbt hrp[w n Nfr Nfr] šn(=R.22)-n-f [..... ?] qd-f n ka(=D.46)-k Šn-f [..... ?] qd-f ñ Conventional and fragmentary 4 + lines.

SETME's heading:- "Inscription of a man who approaches Senneferi." Conventional and fragmentary 4 + lines.

SETME's heading:- "Senneferi receives the New Years gifts of his relations." "Inscription of Senn ma(=U.8)(D.10)-a n_d(=U.36)-d hr in(=W.22)-n-n-t hm(=D.95)-t-f Maa nd hr innt hnt-f Mšw-f Š mš(=M.80)-w(pl.)-f šn(=R.22)-nw(=W.21)-w(pl.)-f hm(=U.28)[See M_p-rnpt Hb N_h [BUDGE, Canopus L. 24), p. 170-1(Greek, L. 49)] k GARDINER, Admon. pp. 37-8]-t-w(pl.)-f hrw(=N.7) n w_p-rnpt rnpt Prt špdt in (=P.37) hb(=W.49) nh(=G.7)[= ]-h ka(=D.46)(pl.)-b hb(=W.49) hrw(=N.7) tpī(=T.9) rnp(=M.13)-t pr(=O.3)-r-t špd(=N.14)-t(N.35) Titles 1, 2, 4. (60) Šmr āa n Nrt (61) Šr m (62) Nr hswt m Pr Nšwt (63) Ph Šr m iawt tn mnj (35) Ra shrr m ta r dr-f (36) Imī-ra Dhāt [Šn-nfr-i] i-n(=S.11) Titles 1, 2, 4. (60) š-mr(=U.31) āa(=T.41) n mr(=U.12)-r-t (61) s-r(A.29) m wda(=U.29)-b-n-f īb(=W.24) (62) wr(=G.79)-r hš(=W.4)-w-t m šw(=M.24)-t-n pr(=O.3) (63) ph(=F.48) šr(=A.29) m iawt(=F.35)-t t-n mnj-[t] (35) ra(=D.29) s-h-r-r(Y.2) m ta(=N.37) r dr(=W.40)-f (36) imī-ra dhāt [šn-nfr-i]

Inscription of those bringing offerings.

m rdi(=D.63) sb(=O.71) n_d(=U.35)-d hr i-n(=S.11) hm(=D.95)-t-f M rdi sb nd hr in hnt-f m-r-t m r(=N.58)-f nb-t pr(=O.3) a-t-iam(=M.1)w(B.7) qd-s n ka(=D.46)-k s-f(V.8) N ka-k Sf-*hb* [MURRAY, Saggar hbknw [Id. No. 4: GOLENISCHÉV Xnmw [MURRAY, Id. p. 36, No. 5] hb(=O.65) h-k-nw(=W.21) xnm(=W.11) IIII n-nw(=U.4)-nw(=W.21) d-(W.1) III PIERRET, p. 271] nw šwi [pr[nw(=W.21) i-īs(=O.34)-š-w-i pr(=O.3) [pr] m hā(=M.68) nb [sic.] p-m [sic.] S. B. A. Proc. XXII, 99] Nb pn [SETME, Urk. 539, n. a: "read "k""] n rnp(=M.13)-t w_d(=M.73)-w(Y.2)-n n-k Nb-k Imn [Rā] Iw-k m Pr-k nb(A.113)-k [i]-mn-n [rā(=N.7)] i-w-k m pn(=O.3)-k n ānh(=S.43)-w(pl.) ndm(=M.99)-m īb(=W.24)-k i-m[š-n]

the specific locations. The texts are from his own copies, and the headings and restorations are also by him.

Taking possession of the fixed amounts of Silver and Gold [.....]

of all splendid stones and of every goodly tree [.....]

all weapons [..... to wit]

(Title 40) Superintendent of every Gold Country [of Amon, Sen]neferi,

(58) Commander of the Wings [or "Bows"] [of the Army]

(36) Keeper of the Seal, Senneferi.

(57) Superintendent of the Offices concerning all affairs. (36) Keeper of the Seal, Senneferi

(59) Leader of the Feast of Atua.

(58, a) first Director of the Priests of all the Gods.

SETME, note "a": - "Restored after the similarly vocalised text in the Tomb of

Reposing in [his] House [of the Living, which is established]

(Line 2) in #aš: [Thebes City] in the precincts of the Temple of Horus

after the things were done from the Pharaoh [L. H. S. to wit]

(1) Hereditary Prince, (2) Count, (59) Praised of the Good God,

[(36) Keeper of the Seal, Senneferi]

Viewing the magnificence of the Sarcophagus, and accepting his Memorial of the burial,

the 3 (?) Statues of every costly stone, and the offerings for the voices of the Houses in praise for the Good God.]

His brother [..... ?] Salth unto thy Ka

Witnessing the attention in the coming of his wife and his children,

his brothers and his artisans

the day of the New Year and the Festival of the supplication of [ἀξιωτικ] the Kas of

the place (?) The Festival of the First day of the Year of the Rising of Sirius [Σωθικ]

Titles 1, 2, 4.

(60) Companion Great of Loving. (61) Great in his opening of the Heart.

(62) Chief of Praises in the House of the King.

(63) He reached great rank in those excellent offices, and was

(35) a Voice ever satisfying in the entire Earth.

(36) Keeper of the Seal [Senneferi].

In providing for the arrival of a greeting: verily his wife, whom he loveth, the Lady of the House, Atianu saith:- "To thy Ka Festival Perfume and Hekenu [a sacred oil],

"4 Khnum-vases. incensing (?) of the Double Tomb according to this [or thy] official

"rank (?) for the year [which] commanded for thee thy father Amon [Ra]. Thou art in thy

"House of the Living. Happy is thy Heart among [them]."

THIS PAGE IS LOCKED TO FREE MEMBERS
Purchase full membership to immediately unlock this page



Never be without a book!

Forgotten Books Full Membership gives universal access to 797,885 books from our apps and website, across all your devices: tablet, phone, e-reader, laptop and desktop computer

A library in your pocket for \$8.99/month

Continue

*Fair usage policy applies

The general Biography [(D ? D ?) on Diagram] begins with a list of titles, some of which are not give

(64) i-in(=R.1)-n-q tawi(=N.39) n nb ahâ(=O.29)-â(0.3)
 (65) s-dr(=N.40)-r(Q.7) apr(=S.48)-w ir(=D.10) hr h-b-[i(D.98)]
 iah(=G.57)-h-t adat(=Y.2) r[.....]
 (65a) wr(=G.79) wr(pl.) = ta(=M.37) r dr(=W.40)-f
 (66) ir(=D.10)-r-n-f, nswt(=M.24) spsi(=A.131)(pl.) rmn(=R.17) [.....]
 (67) wr(=U.12) ma(=U.8) maâ(=Q.58)-â-t(Y.2)(pl.) m-â(=D.68)-k
 (68) ha(=M.42)(T.1) i-is(=Q.34)-s-f-t(G.80)
 dd-f i-w ir(=D.10)-A.89 iaw(=F.35)-t tp(=D.1)-p-t ti(=U.19)-w-A.89
 = hr(=D.8)-r(N.1) = [.....][nn(=D.47) iw(=D.96)-w-t]
 qd(=0.7)-d-d(D.13) h-r ir(=D.10) ir-A.89 mh(=V.15)(D.69)-n-A.89 =
 tp(=D.1)-rd(=D.99)(Y.2)-n hr(=D.8)-r(N.1) dada(=T.1)[.....]
 (69) imi-ra(=S.37) imi-re imi-ra(A.89)(pl.) hb(=U.13)-â pr(=0.3)(pl.)
 xrf(=Q.20) ist(=Q.1)-t(0.3) hr(=D.3)-A.89 s-sa(=T.38)-a-r(Y.2)n-A.89
 r-h(Y.2)-A.89 mn-n-h(0.27)(Y.2)n-A.89 [... iaw(=F.35)-t II-nw(=W.21)-t =]
 (86) imi-rq(=S.37) dbâ(=S.44)-t(Y.2) i-in(=W.22)-n-k-w(A.89) r
 was(=S.65)-t(0.1) in(=Q.29)-nw(=W.21)(0.1) smâ(=M.27)(0.1)
 r-di(=D.62)-k-w(A.89) r (70) imi-ra(=S.37) snw(=M.88)t-i(0.3 0.3)
 ssp(=P.23)-p(D.69) n hh(=A.106)[.....]
 dk(=G.53)-k-t(Y.2)-s-n(pl.) = sa(=M.37)-a[-y]-t(Y.2)(pl.) n-t
 nwt(=0.1)-t(pl.)-s-n(pl.) = h-t-r(M.15)(Y.2) n t-n-nw(=W.21)(T.1)
 rnp(=M.13)-t [.....]
 (71) mt(=D.90)-t maâ(=H.13)[Gloss.p.47]-t(Y.2)(pl.) dwa(=N.35)(A.5)-t-w
 n-A.89 [nfr(=R.13) hr(=D.3)-r]-s [ias(=F.35)-t] III-nw-t =
 (48) ha(=F.16)-â imi-ra(=S.37) nfr hm(pl.) n s-k-b(I.7 ? [= ~~sw~~]
 n i-n[-p-w] [.....]
 was(=S.65)-t(0.1) = (72) hr(=D.3) dada(=D.1) nw(=W.21)
 ha(=F.16)-â-tiw(=G.5)(pl.) s [sio.](pl.) = (46) imi-ra ih(=S.28)-t(N.47)
 (pl.) n-t i-mn-n(A.113) h-hw(=D.58)-w-s(Y.2)-n-A.89 [.....]
 n nb(=U.50)-b-t-i(0.1) hnt(=W.8)n-t-i ta(=M.37) smâ(=M.27)(0.1) n
 nfr(=R.13) nfr nfr nb(pl.) spa(=N.46)-t f-n ir(=D.10)-n-A.89
 he(=W.4)-s-s-t[(pl.)]-s-n(pl.) nb-t hr(=D.3) dada(=D.1) [anh(=S.43)
 wda(=U.21) snb(=Q.9) nsu(=M.24)-t bit(=L.1)(râ(=N.7)mn(=Y.12)-hpr(=L.4))
 rdî(=X.22) anh d-t(M.37)] [.....]
 g-s-r(D.56)(Y.2) n r-k(N.7) nfr(=R.13)(A.113) hb(=W.49) nb(=U.50)(N.6)
 (N.53,N.53,N.53) âsa(=I.2)(pl.) âa(=T.41)-t(H.21)[N.53,N.53,N.53] See
 SETHE, Urk. XVIII Dyn. p. 531, n. 2] spsi(=A.131)-s-t [.....]
 s-dr(G.67)(?) (N.66)(pl.)-n-A.89 dw(=N.42)(N.51) p-n = [.....]
 [pictures of treasures]end]

(64) Inna Tawi n Nb Ahâ (pr)
 (65) Sdr Aprw ir (?) hr h[î] i
 (65a) Wr Wrw m fa r dr-f
 (66) irrn-f [GOLÉWISCHEV, Bib. d'
 Nswt rmn [.....] (67) Wr Maâwt
 (68) ha [VOGELSANG, Untersuch. VI
 Dd-f Is ir-I Iswt tpt ti-I = hr
 [Nn iwt]
 qdd hr mrti-I Nhn-I = tp-rd n h
 (69) Iaim-ra Nbâ-prw xr ist hr-
 Nhn-I [..... Iawt snset =
 (86) Imi-ra Dbât in-kwi r Was(=
 Smâ (nwt) Bdi-kwi r
 Imi-ra Ssnwti(prî) ssp [GARDINER
 p.18(Mes)] n hh [.....]
 bkt-sn = Sa[y]t ntî Nwt-sn = ht
 [.....]
 (71) Mt [GARDINER, Rec. Trav. 34, p
 [Gloss. p.47] dwa-tw n-I [Nfr hr
 (48) Heti-â Imi-ra Hnw Nfr n Sb
 II, 354] n In[pr] [E. MEYER, Gesch
 [.....] (line 15) Was(=
 nw Hativ-â sw (?) = (46) Imi-r
 Hwsn-I [.....
 n Nbtî (nwt) hntî [GAUTHIER, Bit
 Smâ (nwt) n Nfrw nbw Spat tn Ir
 dngs [A. W. S. Nswt Bit (Nn-hpr
 [.....]
 dsr n rh Nfr Nb Nb âsam Iat sp
 sdrn-I dw pn = [.....]

XX. Hatshepsut-Thutmose III. Sennefer (9)

Geographical Names

- ve. (64) Embracing the Two Lands for the Lord of the Palace.
- dat r[.....] (65) Spending the night he provided for the making (?) for the necessary examination, the Book to [.....]
- (65a) Great of the Great in the entire Land.
- .61,n.2] špáiw (66) He ever gave form to the splendor of the King [.....]
- (67) a Lover of Truth, Lo! he was
- .L.127] isft (68) Without injustice.
-] He saith:- "I found myself in the highest office when I was Headman in [.....]"
"There was no coming]
- ada [.....] "of sleep to my two eyes, and I possessed myself of the direction [authority] of
"a high official [.....]
- rn-ī Rb-ī (69) "The superintendents of the store-houses were under the place of my face
i.e. "my supervision", "I was honored, I was known, I was rewarded [.....]"
"the second term [of office] as]
-) Inw (nwt) (36) "Keeper of the Seal, and I was brought to Wašt [Thebes], Heliopolis, and the
"City of the South. I was appointed to be the (10) Wašt [Thebes]
- tersuch. IV, Pt. II, (70) "Superintendent of the Double Granary, succeeding [to it] for many
"[terms ?] [.....]"
- gnnw rnpt "their produce in the beginning, belonging to their cities according to the
"assessment of the estimate for the year [.....]"
- L. 221] Maāt (71) "Celebrated of Truth. One beseeched the God for me for a third official
[fant] hatnst n "term as
- JUDGE, Gods of Eg. (48) "First Director of Priests of Sebek [i.e. Σοῦχος, the Crocodile God] and
Alt. I, §§179:180] "Anubis [.....]"
-) M (72) nr gada (72) "Wašt [Thebes] as (72) Chief of the Pirat of men (?) and as (46) Superintendent
ant ntī inn "of the [cultivated] fields belonging to Amon. I protected [.....]" (11) Wašt [Thebes]
-]
- st. IV, 108] Pa "for the God of Ombos, who is before the Lord of Šmā [the South], and for all the (12) Šmā
hséwt-šn nbt hr "Gods of that Nome. I made all their praises upon [L. H. S. the King of Upper
ânḥ dt] "and Lower Egypt (Men-Kheper-Ra), [Thutmose III] Giving Life Forever]
"[.....]"
-] "making splendid the reign of the God, Lord of Gold, and of a multitude of
"gorgeous precious stones-
-] "I provided this Mountain according to [.....]"
- End] ".....]"

THIS PAGE IS LOCKED TO FREE MEMBERS
Purchase full membership to immediately unlock this page

DELVE INTO FANTASY, MAGIC, MYTHOLOGY & FOLKLORE

Forgotten Books'
Full Membership gives
access to 797,885 ancient
and modern, fiction and
non-fiction books.

Continue

*Fair usage policy applies

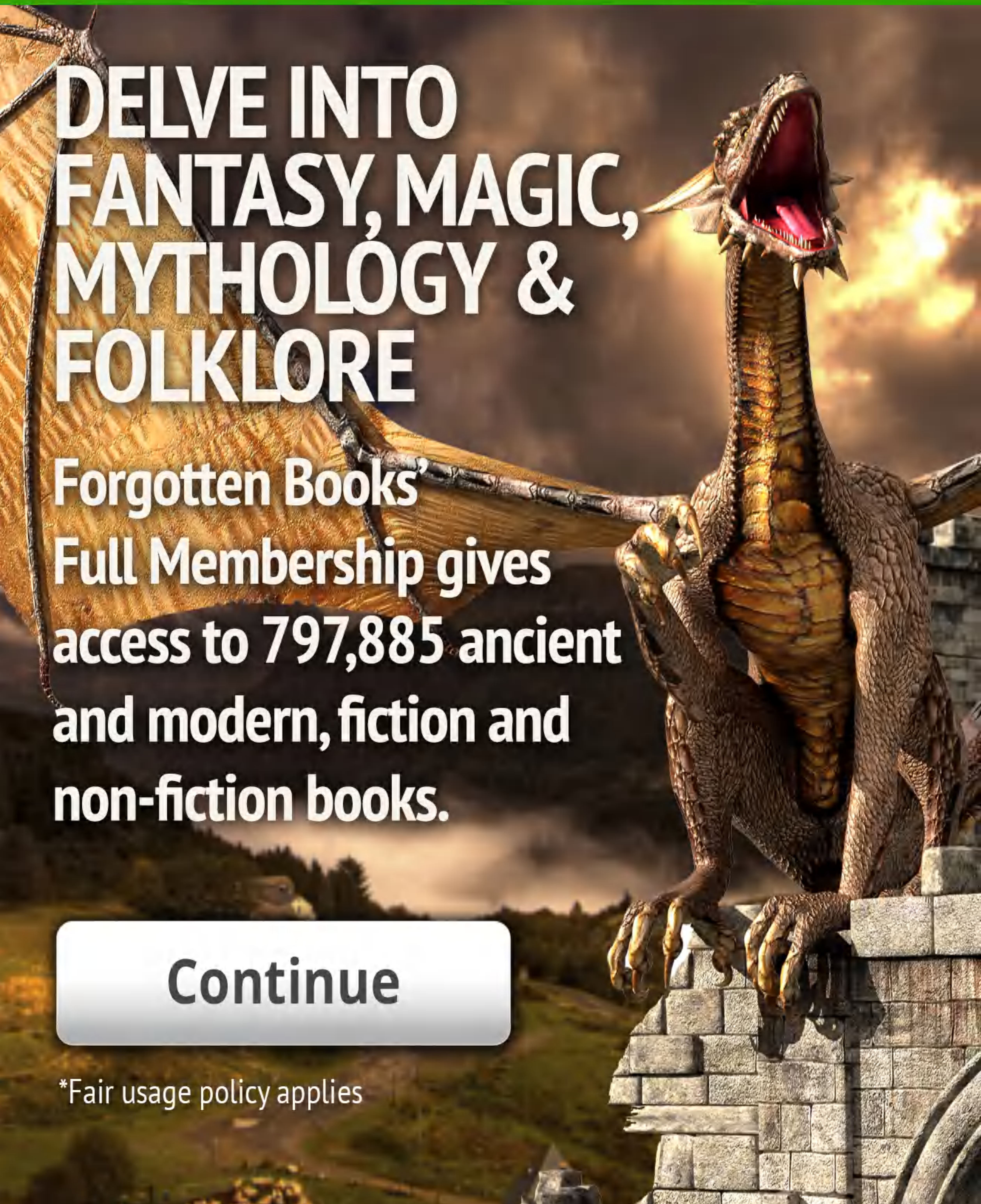

TABLE NO. XXI. THUTMOSIS (ḤWTḤS) III. (Siege of Megiddo) Geographical Names. (Context)

"Fragment on the Siege of Megiddo." DÜMICHEN, H.I. II, 38. Text on the West on outer side of the wall extending not number it. See the description and diagram No. 2 on Table No. XXIV.

Relief:- The King offers to Anon the spoils of his Ist. Syrian Campaign. Text:- (A) Title in large script before

Text:- DÜMICHEN, Hist. Inschr. II, (1869), Pl. 38a: (lines 1-3; 10-35) (R to L.) (line 35 = Title) (lines 34-1 = Text) SETHE, Ur. BRUGSCH, Reo. des Mon. I, (1862), 27, No. 1: id. Thesaurus, V, (1891), p. 1187: (lines 1-9: Middles of lines = DÜMICHEN, lines 24- entirely lost.

Translation:- BREASTED, Anc. Rec. Egypt, II, (1906), §§ 439-443: (lines 1-25) (i.e. Title and Inscription "B")

SETHE, Urk. XVIII Dyn. II.		DÜMICHEN, Hist. Inschr. II.		BRUGSCH, Rec. I Thes. V		Text, SETHE.
L.	p.	Pl.	L.	Pl.	p.	
A	757	Title. [r-di(=Y.22)-t ma(=U.9)-maâ(=Q.58)-â(Y.2) nfr(=R.13) htp(=Q.17)(W.33)(W.13)(N.68)(pl.) i-n šw(=M.24)-t-n q-s-f] i-mn-n rā(=N.7) nb ns-t(=W.42) ns-t ns-t tawi(=N.39) h-f-t š-hr(=A.131)-t r-f-n-nw(=W.21)(N.40) x-s-t
B	758	Inscription "A". (1) [šw(=M.24)-t-n q-s-f q-d-f ... i-w waph(=V.37)-h(Y.2)-n hm-A.117 nfr(=R.13) htp(=Q.17)(W.33)(W.13)](N.66)(pl.) m ma(=U.8)-t-w(Y.2) n t-f(G.15) i-mn-n [nb ns-t(=W.42) ns-t ns-t tawi(=N.39) hnt(=W.8)-t i-p-t š-t(=Q.1)-t(pl.)(O.1) [h-f-t i-i(=M.34)-t(D.96) hm-A.117 m wd(=M.73)-y-t tp(=D.1)-t n-t n-h-t-h-t(D.69) hr d-r(D.69) b-š-t-w(F.5)(pl.) hr-r-A.117 m] ta(=N.37) ta ta f-n-h-w-w(A.128)(pl.) wn(=E.58)-n-nw (=W.21)-w(pl.) wa(=V.28)-a(N.49) r t-k-k(D.69) t-ta(=W.60)-š(Z.7)(N.47)(pl.)(G.15) [..... ts(=O.73)-s-w(D.69)]-n-f š-šk(V.37 = V.34)-w(P.19 + V.10)(D.69)(pl.)(PIERRET, p.551) r mš(=M.80)-š-d-d(G.80) hm(G.15) h-r(A.133) i-n-s-n(pl.) hr hr hr(=D.3) hr-s-n [..... d-mi(=W.29)-i](N.47) n m-â(=D.59)-k-ti (=U.19)(T.1)[sic.](N.40)
2			24	27:1	1187	[h-f-t i-i(=M.34)-t(D.96) hm-A.117 m wd(=M.73)-y-t tp(=D.1)-t n-t n-h-t-h-t(D.69) hr d-r(D.69) b-š-t-w(F.5)(pl.) hr-r-A.117 m] ta(=N.37) ta ta f-n-h-w-w(A.128)(pl.) wn(=E.58)-n-nw (=W.21)-w(pl.) wa(=V.28)-a(N.49) r t-k-k(D.69) t-ta(=W.60)-š(Z.7)(N.47)(pl.)(G.15) [..... ts(=O.73)-s-w(D.69)]-n-f š-šk(V.37 = V.34)-w(P.19 + V.10)(D.69)(pl.)(PIERRET, p.551) r mš(=M.80)-š-d-d(G.80) hm(G.15) h-r(A.133) i-n-s-n(pl.) hr hr hr(=D.3) hr-s-n [..... d-mi(=W.29)-i](N.47) n m-â(=D.59)-k-ti (=U.19)(T.1)[sic.](N.40)
3			23	2		[..... ts(=O.73)-s-w(D.69)]-n-f š-šk(V.37 = V.34)-w(P.19 + V.10)(D.69)(pl.)(PIERRET, p.551) r mš(=M.80)-š-d-d(G.80) hm(G.15) h-r(A.133) i-n-s-n(pl.) hr hr hr(=D.3) hr-s-n [..... d-mi(=W.29)-i](N.47) n m-â(=D.59)-k-ti (=U.19)(T.1)[sic.](N.40)
4			22	3		[..... ts(=O.73)-s-w(D.69)]-n-f š-šk(V.37 = V.34)-w(P.19 + V.10)(D.69)(pl.)(PIERRET, p.551) r mš(=M.80)-š-d-d(G.80) hm(G.15) h-r(A.133) i-n-s-n(pl.) hr hr hr(=D.3) hr-s-n [..... d-mi(=W.29)-i](N.47) n m-â(=D.59)-k-ti (=U.19)(T.1)[sic.](N.40)
5-10	759		21-16			[N.B. For lines 4 & 5 see "Annals" Additional Text "A" following line 93 (Table No. XXIV.) [Theu [s]ššm(=T.20)-m k-w-i r wa(=N.49)-t nfr(=Y.9)-f-r-t [..... ta(=N.37) ta ta nb-w(pl.) i-r-f(V.8)(D.69) m [h-f-â(D.82)-G.15] qa(=U.21)-a-ra(N.40) [Now destroyed, and given from DUMICHEN's Copy](B.7)(B.7)(B.7) [.....] nn(=M.22)-n [.....] š-r-d(M.94 ?)] (D.69) m ht(=M.9)-t bnr(? =M.93 ?) nb [.....] š-n ir(=D.10)-n-G.15 nn(=M.22) [.....] âpr(=E.48)] (Y.2) k-w-i. [m..... m šw(=M.24)-t-n âa(=T.41) n-h-t-h-t](D.69) m ta(=N.37) ta ta nb-w(pl.) hâ(=N.23)-â hr š-t(=Q.1)-hrw (=G.8) n-t ânh(=S.48)-w(pl.) [nb-w(pl.)] rā(=N.7) mî(=W.29) q-t(N.37)
11	760		14	[s]ššm(=T.20)-m k-w-i r wa(=N.49)-t nfr(=Y.9)-f-r-t [..... ta(=N.37) ta ta nb-w(pl.) i-r-f(V.8)(D.69) m [h-f-â(D.82)-G.15] qa(=U.21)-a-ra(N.40) [Now destroyed, and given from DUMICHEN's Copy](B.7)(B.7)(B.7) [.....] nn(=M.22)-n [.....] š-r-d(M.94 ?)] (D.69) m ht(=M.9)-t bnr(? =M.93 ?) nb [.....] š-n ir(=D.10)-n-G.15 nn(=M.22) [.....] âpr(=E.48)] (Y.2) k-w-i. [m..... m šw(=M.24)-t-n âa(=T.41) n-h-t-h-t](D.69) m ta(=N.37) ta ta nb-w(pl.) hâ(=N.23)-â hr š-t(=Q.1)-hrw (=G.8) n-t ânh(=S.48)-w(pl.) [nb-w(pl.)] rā(=N.7) mî(=W.29) q-t(N.37)
12			13-12			[..... ta(=N.37) ta ta nb-w(pl.) i-r-f(V.8)(D.69) m [h-f-â(D.82)-G.15] qa(=U.21)-a-ra(N.40) [Now destroyed, and given from DUMICHEN's Copy](B.7)(B.7)(B.7) [.....] nn(=M.22)-n [.....] š-r-d(M.94 ?)] (D.69) m ht(=M.9)-t bnr(? =M.93 ?) nb [.....] š-n ir(=D.10)-n-G.15 nn(=M.22) [.....] âpr(=E.48)] (Y.2) k-w-i. [m..... m šw(=M.24)-t-n âa(=T.41) n-h-t-h-t](D.69) m ta(=N.37) ta ta nb-w(pl.) hâ(=N.23)-â hr š-t(=Q.1)-hrw (=G.8) n-t ânh(=S.48)-w(pl.) [nb-w(pl.)] rā(=N.7) mî(=W.29) q-t(N.37)
13			11			[..... ta(=N.37) ta ta nb-w(pl.) i-r-f(V.8)(D.69) m [h-f-â(D.82)-G.15] qa(=U.21)-a-ra(N.40) [Now destroyed, and given from DUMICHEN's Copy](B.7)(B.7)(B.7) [.....] nn(=M.22)-n [.....] š-r-d(M.94 ?)] (D.69) m ht(=M.9)-t bnr(? =M.93 ?) nb [.....] š-n ir(=D.10)-n-G.15 nn(=M.22) [.....] âpr(=E.48)] (Y.2) k-w-i. [m..... m šw(=M.24)-t-n âa(=T.41) n-h-t-h-t](D.69) m ta(=N.37) ta ta nb-w(pl.) hâ(=N.23)-â hr š-t(=Q.1)-hrw (=G.8) n-t ânh(=S.48)-w(pl.) [nb-w(pl.)] rā(=N.7) mî(=W.29) q-t(N.37)
14			10			[..... ta(=N.37) ta ta nb-w(pl.) i-r-f(V.8)(D.69) m [h-f-â(D.82)-G.15] qa(=U.21)-a-ra(N.40) [Now destroyed, and given from DUMICHEN's Copy](B.7)(B.7)(B.7) [.....] nn(=M.22)-n [.....] š-r-d(M.94 ?)] (D.69) m ht(=M.9)-t bnr(? =M.93 ?) nb [.....] š-n ir(=D.10)-n-G.15 nn(=M.22) [.....] âpr(=E.48)] (Y.2) k-w-i. [m..... m šw(=M.24)-t-n âa(=T.41) n-h-t-h-t](D.69) m ta(=N.37) ta ta nb-w(pl.) hâ(=N.23)-â hr š-t(=Q.1)-hrw (=G.8) n-t ânh(=S.48)-w(pl.) [nb-w(pl.)] rā(=N.7) mî(=W.29) q-t(N.37)
15			4			[..... ta(=N.37) ta ta nb-w(pl.) i-r-f(V.8)(D.69) m [h-f-â(D.82)-G.15] qa(=U.21)-a-ra(N.40) [Now destroyed, and given from DUMICHEN's Copy](B.7)(B.7)(B.7) [.....] nn(=M.22)-n [.....] š-r-d(M.94 ?)] (D.69) m ht(=M.9)-t bnr(? =M.93 ?) nb [.....] š-n ir(=D.10)-n-G.15 nn(=M.22) [.....] âpr(=E.48)] (Y.2) k-w-i. [m..... m šw(=M.24)-t-n âa(=T.41) n-h-t-h-t](D.69) m ta(=N.37) ta ta nb-w(pl.) hâ(=N.23)-â hr š-t(=Q.1)-hrw (=G.8) n-t ânh(=S.48)-w(pl.) [nb-w(pl.)] rā(=N.7) mî(=W.29) q-t(N.37)
16-20						[..... ta(=N.37) ta ta nb-w(pl.) i-r-f(V.8)(D.69) m [h-f-â(D.82)-G.15] qa(=U.21)-a-ra(N.40) [Now destroyed, and given from DUMICHEN's Copy](B.7)(B.7)(B.7) [.....] nn(=M.22)-n [.....] š-r-d(M.94 ?)] (D.69) m ht(=M.9)-t bnr(? =M.93 ?) nb [.....] š-n ir(=D.10)-n-G.15 nn(=M.22) [.....] âpr(=E.48)] (Y.2) k-w-i. [m..... m šw(=M.24)-t-n âa(=T.41) n-h-t-h-t](D.69) m ta(=N.37) ta ta nb-w(pl.) hâ(=N.23)-â hr š-t(=Q.1)-hrw (=G.8) n-t ânh(=S.48)-w(pl.) [nb-w(pl.)] rā(=N.7) mî(=W.29) q-t(N.37)
21						[..... ta(=N.37) ta ta nb-w(pl.) i-r-f(V.8)(D.69) m [h-f-â(D.82)-G.15] qa(=U.21)-a-ra(N.40) [Now destroyed, and given from DUMICHEN's Copy](B.7)(B.7)(B.7) [.....] nn(=M.22)-n [.....] š-r-d(M.94 ?)] (D.69) m ht(=M.9)-t bnr(? =M.93 ?) nb [.....] š-n ir(=D.10)-n-G.15 nn(=M.22) [.....] âpr(=E.48)] (Y.2) k-w-i. [m..... m šw(=M.24)-t-n âa(=T.41) n-h-t-h-t](D.69) m ta(=N.37) ta ta nb-w(pl.) hâ(=N.23)-â hr š-t(=Q.1)-hrw (=G.8) n-t ânh(=S.48)-w(pl.) [nb-w(pl.)] rā(=N.7) mî(=W.29) q-t(N.37)
22						[..... ta(=N.37) ta ta nb-w(pl.) i-r-f(V.8)(D.69) m [h-f-â(D.82)-G.15] qa(=U.21)-a-ra(N.40) [Now destroyed, and given from DUMICHEN's Copy](B.7)(B.7)(B.7) [.....] nn(=M.22)-n [.....] š-r-d(M.94 ?)] (D.69) m ht(=M.9)-t bnr(? =M.93 ?) nb [.....] š-n ir(=D.10)-n-G.15 nn(=M.22) [.....] âpr(=E.48)] (Y.2) k-w-i. [m..... m šw(=M.24)-t-n âa(=T.41) n-h-t-h-t](D.69) m ta(=N.37) ta ta nb-w(pl.) hâ(=N.23)-â hr š-t(=Q.1)-hrw (=G.8) n-t ânh(=S.48)-w(pl.) [nb-w(pl.)] rā(=N.7) mî(=W.29) q-t(N.37)
23						[..... ta(=N.37) ta ta nb-w(pl.) i-r-f(V.8)(D.69) m [h-f-â(D.82)-G.15] qa(=U.21)-a-ra(N.40) [Now destroyed, and given from DUMICHEN's Copy](B.7)(B.7)(B.7) [.....] nn(=M.22)-n [.....] š-r-d(M.94 ?)] (D.69) m ht(=M.9)-t bnr(? =M.93 ?) nb [.....] š-n ir(=D.10)-n-G.15 nn(=M.22) [.....] âpr(=E.48)] (Y.2) k-w-i. [m..... m šw(=M.24)-t-n âa(=T.41) n-h-t-h-t](D.69) m ta(=N.37) ta ta nb-w(pl.) hâ(=N.23)-â hr š-t(=Q.1)-hrw (=G.8) n-t ânh(=S.48)-w(pl.) [nb-w(pl.)] rā(=N.7) mî(=W.29) q-t(N.37)
24						[..... ta(=N.37) ta ta nb-w(pl.) i-r-f(V.8)(D.69) m [h-f-â(D.82)-G.15] qa(=U.21)-a-ra(N.40) [Now destroyed, and given from DUMICHEN's Copy](B.7)(B.7)(B.7) [.....] nn(=M.22)-n [.....] š-r-d(M.94 ?)] (D.69) m ht(=M.9)-t bnr(? =M.93 ?) nb [.....] š-n ir(=D.10)-n-G.15 nn(=M.22) [.....] âpr(=E.48)] (Y.2) k-w-i. [m..... m šw(=M.24)-t-n âa(=T.41) n-h-t-h-t](D.69) m ta(=N.37) ta ta nb-w(pl.) hâ(=N.23)-â hr š-t(=Q.1)-hrw (=G.8) n-t ânh(=S.48)-w(pl.) [nb-w(pl.)] rā(=N.7) mî(=W.29) q-t(N.37)

Inscription "C" contains no Geographical Names, and is a List of Trib

XXI. Thutmosis III, Siege of Megiddo.

only from Pylon VI at Karnak. (The numbering of the Pylon is MARIETTE'S (Karnak, Pl. 2), as LEPSIUS (Denkmäler, I, 74:6) does

King. (B) Inscription (Vertical) 24 lines. (C) List of offerings: - 12 + 9 + 8 + 3 + 7 lines in V Columns.

VIII Dyn. (1907), pp. 757 ff.

Tops of lines lost: lines 13-16 (i.e. 13-10) and 22-24 (i.e. 4-2) only 2 or 3 lower symbols left: lines 17-21 (i.e. 9-5)

BREASTED.	Geographical Names	
S, 439	[Title. Holy offerings caused to be presented by the King himself.] Amon Ra, Lord of Nst-fesi [Karnak], when he overthrew the land of Rnnw the wretched.	(1) Nst-fawi [Karnak] (2) Rnnw
-f	[The King himself said My Majesty hath increased the Holy Offerings	
wt	"in truth to Father Amon [Lord of Nst-fawi [Karnak] (Temple)] "Prime of /pt-fst [Karnak (District)] (Luxor)	(3) Nst-fawi [Karnak] (4) fst [Karnak]
.	"[When name My Majesty from the First Campaign of those Victories "to chastise the rebellious against me in]	
eg.	"the Lands of the Pajs (Shepherds), who were setting themselves to sieze upon the "Royal Boundaries.	(5) Pnhw
V, és	"[..... He disposed of the strife [which existed] because of hatred of the "Royal Majesty, and they fell on their faces	
	"[..... the City of Xnti.	(6) Xnti.
ines 6-10	see ibid, following line 94]	
	"caused me to be led to a pleasant road "[..... all the countries] closed in the Royal "[fist] Country of [? ? ?] gare "[.....] (vosen) "[.....] this [.....] "..... "..... planted] with every pleasant tree	(7) [??]gara
	"[.....] I did this "[..... adorned] me "[with for the Great King of Victory] in every country, glorious upon the "Horus-Throne, belonging to the living: like unto Ra forever."	

THIS PAGE IS LOCKED TO FREE MEMBERS
Purchase full membership to immediately unlock this page



Never be without a book!

Forgotten Books Full Membership gives universal access to 797,885 books from our apps and website, across all your devices: tablet, phone, e-reader, laptop and desktop computer

A library in your pocket for \$8.99/month

Continue

*Fair usage policy applies

TABLE No. XXII. THUTMOSIS. (ḤḤḤḤḤ) III. Black Granite Stela found in Temple of Ptah. (Restorations by Sety I.)

Found by M. LÉCRAIN in 1900 (Annales du Service, III, (1902), p. 38, p. 107) and now in the Cairo Museum, No. 314 (Cat. Gen. 3) "(Ptḥ-Ré-Ínbw-F)" i.e. Ptah South of His Wall (See Text line 3) which lies North of Pylons VI and VII of the Great Temp.

See: - SAEDER, op.cit. p. 277. WEIGALL, Antiquities of Upper Egypt, (1910), p. 106.

The stela is of Black Granite; Height 1.50 m. Breadth 74 cm. (MASPERO, op.cit. "Height 90 cm.") Thickness 32 cm. LACAU, It is rounded at the top, where it contains a relief of four figures, viz. (Right) the King offers wine to Ptah and his Below is a text of twenty seven horizontal lines.

Text: - MASPERO, Comptes Rendus de l'Académie des Inscr. etc. (1900), I, pp. 113-123; Bulletin de l'Institut Ég. (1900), p. 79

Translation: - BREASTED, Ancient Records of Egypt, II, (1906), § 613. See: - MASPERO, "Le Temple de Ptah Thébain a Karnak", (Ruins

L.	Page	Transcription: Text, SETHE.	
1	764	Left side, over King. [Under Solar Disc] nb tawi (rā-mn-hpr) (ḡḥwti-mš-s) di ānh mi Rā	Nb tawi (Mn-hpr-Rā) (Ḥḥwti-mš-s) di ānh mi Rā
4		over Queen. ḥmt Ḥḥr (iah(=N.28) sa(=G.67)-t) ānh-ti(=U.19)-t	ḥmt Ḥḥr (Sat-iah) ānh-ti
1	765	[Main Inscription] ānh ḥrw ka nht ... Titles ... nšw-t bit nb tawi (rā-mn-hpr) p-t-h(C.4)	ānh ḥrw ka nht ... Titles ... (Mn-hpr-Rā) Ptḥ Rš Ínbw-f m W
2		rš(=M.30) ínb(=O.36)-f m wš-t(=S.65) wr(=U.12)-y di(=X.22) ānh x-t(N.37)	Ḥḡ Ḥm(G.15) qd Ḥt Ḥḥr ntī Ptḥ
2		wd(=M.73)-w ḥm(G.15) qd(=A.51) nḥr ḥ-t(=O.12)-t(0.3) n-t p-t-h(C.4) rš ínb(=O.36)-f m	ntt [Gramm. §551] m wḥyt [Vol VI, p. 127] ntī ff Imā Rā Nb W
2		wš-t(=S.65) n-t-t m wḥ(=V.37)-ḥ-y-t(pl.) n-t t-f(G.15) i-mš-n rā nb nš-t nš-t nš-t	im-s ḥrw n Ḥḥr sāqn [Gramm. §
2		tawi rdi(=D.63) II [sic.]-f i-m-s ḥrw(=N.7) m ntr(=R.18) s-āq(=G.71)-q(D.96) m	n xrt [GAUTHIER, Bib. d'Ét. IV, I
2		ḥ-b-w(W.40) [sic.]-f nb(pl.)	wḡ-f r Pr-ḡd n Tp Rš Íst ḡ
3		n x(=Q.20)-r-t rnp(=M.13)-t ḥ-f-t w-ḡa(=U.21)(D.96)-f r pr-ḡd(=O.7)(0.3) n tp rš(N.47)	Ḥḥr tn m qd m ḡbst šham šbtī
3		i-s-t ḡm(=G.46)-n ḥm(G.15) nḥr ḥ-t-t(0.3) t-n m qd(=A.51) m ḡb(=G.73)-b-t(N.51)(pl.)	ḡm [GAUTHIER, Bib. d'Ét. IV, p.
3		w-ḡa(=G.68)-w(M.9) s-b(0.43) II [sic.]-s ḥḥt(=M.9)-t wa(=N.49) r	Ḥḡ Ḥm(G.15) pḡ šs ḥr Ḥt Ḥḥr
3		ḡm(=S.64)-m(G.80).	m inr wḡ nḥr n rwdt ínbw ḥa-
4		wḡ-w ḥm(G.15) pḡ(=T.28) šs(=V.6) ḥr nḥr ḥ-t-t(0.3) f-m m wa(=U.8)-w-t(Y.2)	rwdt n ḡt íw
4		s-āḥ-ā-ti(=U.19) [sic.] m i-n-r(N.51) wḡ(=M.77) nḥr(=Y.9) n rwd(=V.27)-t(N.51)	
4		ínb(=O.36)(pl.) ḥa(=M.42)(D.1)-s m ḡb(=G.73)-b-t(N.51) m ka(=D.46)-t(A.105)(Y.2)(pl.)	
4		rwd(=V.27)-t(N.51) [sic.] m [sic.] ḡ-t(N.37) i-w	
5		s-āḥ-ā-n n-s ḥm(G.15) āa(=T.41) āa(=O.69)(pl.) m ā-s [Needle Leaf] wa(=U.8)(Y.2) n tp	sāḥqn n-s ḥm(G.15) āa āaw m
5	766	ḥt-ḥ-t-tiw(=G.5)(O.63) n-d-b-w m ḥmt(N.53, N.53, N.53) sḥ(=S.31)-t-t	ndbw [SETHE, Verb. I, 211] m ḥm
5-8	 Furniture and fittings of Temple. No Geographical Names.	
8	767 i-w ḥḥ(=V.15)(Y.2)-n rā(=D.29)-pr(=O.3) [sic.]-f m ḥ-t nb-t nḥr-t m	iw ḥḥ Rā-Pr-f [SETHE, Z. Aeg.
8		iwa(=E.3)(pl.) wa(pl.) nḥr(=R.18)-šn(=R.22)-n-t-r(N.53, N.53, N.53) i-r-p(W.17)	m ḥt nbt n sḥt m íwis saw íl
8		ḥnk(=D.66)-t(pl.)	ḥnkwt [Gramm. §184]
9		rnp(=M.17)-t(W.40) nb-t ḥ-f-t iī(=M.34)-t(D.96) ḥm(G.15) ḥr ḡa-s-t. r-f-n-nw(N.40) m	rnpwt nbt ḥḥt iīt Ḥm ḥr ḡa-s-t
9		s-p(X.14) tp(=D.1)-p n n-ḥt-ḥ-t-w(D.69)(pl.)	m sp tḥi n nḥtw
		N.B. For lines 9-11 see "Annals", line 93, "Text B", Table No. XXIV. (Year XXIII).	Lines 11-27 contain descriptions

o Museum.

XIII. Thutmose III, Stole, Temple of Ptah

Journal d'entrées 34842)(MASPERO (QUINELL), Guide to the Cairo Museum,(1903),p.127:(1910),p.131) in the Temple of Ptah Karnak. (BAEDEKER, Egypt,(1914), Plan p.264. LEPSIUS, Denkmäler, I, 82; Texte (NAVILLE-SETNE, 1900), III, p.5.)

elles de Nouvel-Empire" (1909), (Cat. Gen. des Antiq. Eg. du Musée du Caire, XLV, (1909), p.27, gives:- "Height 1.44 m. Breadth 75 cm. offers ointment: (Left) the King offers water-libation to Ptah and his wife offers ointment. (See Lacau, op.cit. Photo. Pl. IX).

w, Ann. du Serv. III, (1902), p.107. SETNE, Urk. d. XVIII. Dyn. (1906), p.763. LACAU, op.cit. p.27, Pl. IX.

t Paysages d'Égypte, (1910), p.135)

Geographical Names

Lord of the Two Lands, (Men-kheper-Ra)[Thutmose III], Given Life, like unto Ra
Divine Lady (Satiakh) (i.e. "Daughter of the Moon), the living:
Live! Horus! Mighty Bull ...Titles... King of Upper and Lower Egypt, Lord of the Two
Lands (Men-kheper-Ra), Ptah South of His Wall in West [Thebes] Beloved: Given Life Forever.
The Royal Majesty commanded [that] a Temple be built to "Ptah South of His Wall" in West
[Thebes], which is a halting place of Father Anon Ra, Lord of the Two Lands.

(1) fawī

He appointed therein a day for the God, and caused to be introduced all of His Feasts and
those belonging to the year when He comes to the Treasure House of the Province of the
South [Upper Egypt]. Lo! the Royal Majesty found that this Temple was built of bricks,
and that the columns of its wall were of mud and were going to ruin.

His Royal Majesty commanded to stretch the cord over this Temple anew, and cause to be set
up in beautiful white stone of hardness, and the walls around it in brick as a work
sound for ever.

And the Royal Majesty set up for it Great Gates of new Cedar of the best foot hills
[Terraces] overlaid with copper.

.29, n.1]
irp

..... I filled His Temple with every good thing, with oxen, geese, resin, [JEQUIER,
Sphinx, XVI, p.24] wine, libations;

nw (hast)

every fruit after the coming of the Majesty from the country of Rjnnw

(2) Rjnnw

.....

at the time of the first of the campaigns

of Offerings etc. No Geographical Names.

THIS PAGE IS LOCKED TO FREE MEMBERS
Purchase full membership to immediately unlock this page

DELVE INTO FANTASY, MAGIC, MYTHOLOGY & FOLKLORE

Forgotten Books'
Full Membership gives
access to 797,885 ancient
and modern, fiction and
non-fiction books.

Continue

*Fair usage policy applies

TABLE No. XXIII. THUTWOSIS (ḤḤḤḤḤ) III. Fragments of Granite Doorway in Pylon VII, Kernek, now in situ. (West Soffit of D.

Pylon VII; the first South of the Central Court of the Great Temple at Karnak, is so numbered by MARIETTE (Karnak, 1875, Pl. id. Texte (NAVILLE-SEYME, 1900) III, p. 43. The text in question was first noticed by M. LEGRAM in 1901 (Ann. du Service, II, (to the ground. But the confusion of the débris was such that it was impossible to coordinate the fragments into a single collated as shown on the following Table, adding thereto further readings as found thereafter. The separate fragments are

Text:- LEGRAM, Annales du Service etc. II, (1901), pp. 272-279: IV, (1903), Pl. III: (Text quoted below, pp. 276-277, Vol. II.)

Translation:- BREASTED, Ancient Records of Egypt, II, (1906), §§594, ff. (Various Fragments as indicated)

[r-di-n n-A.117 i-t-f(G.15)]-A.117 i-mn-n rā(=N.7) hrw ah(=N.66)
 ah-t hā-ā(Y.2) [hr išt(=Q.1) hrw n-t ānh(=S.43)-w
 b-s(K.1)(D.98)-A-w] xr(=Q.20)-r ha(=F.16)-t-f r xn(=E.22)-n(O.3)
 ra(=D.29) pr(=O.3) s-r(E.65)-n-G.15 hqa(=S.62)-q-t tawi(=N.39)
 ns-t(=W.42)-t ns-t ns-t gb(=G.67)-b iaw(=F.35)-t hpr(=I.4)-r-i
 r qš(=N.50) i-t-f-A.117 nfr nfr nsw-t bit (rā-āa(=T.41)-hpr-n)
 di ānh q-t(N.37)
 i-s-t r-f(A.89)(B.7)(pl.) nb [.....]
 ha(=M.13)[t][sic.]-sp(=X.14) I (?) tpi(=T.9) š-mw(=N.55) šsw(=N.7)
 IIII hpr(=L.4) ns(=M.24)-w-t hā-ā-t ns(=M.24)w sa(=G.67) [.....
] (ghwti(=G.48)ws-s) ānh q-t(N.37) r n-h(N.7)-h [w
 nsw-t bit]

[Rdin n-I Itf(G.1
 Ānhw
 hqat Tawi Nswt Gb
 (Āa-hpr-n-Rā) di
 Išt rmt nb [.....
 ha[t]-sp wāt tpi
 Z.Aeg.40.p.19] Sa
] (D.

Fragments of speech of thanks to Amon reported by the King to his assembled nobles.
 Reply of the nobles.

Command of His Majesty to build at Karnak "r rdit wn İpt-İsūt (nwt) mi İrt anti hr šhnwt(
 He also commands feasts etc. to be established:-

..... ga(=U.21)-w(D.98) hm-f r] r-f-n-nw-w(N.40) r d-r(D.98)
 hast(=N.40)-t(pl.) mh(=V.15)-t-tiw(=G.5) m wd(=M.73)-y-t(D.98)-f
 tp(=D.1)-t-p n-t n-ht(=M.9)-h-t(D.98) h-t-f wd(=M.73)-w(Y.2)
 n-f i-an-n rā nb nst nst nst tawi

..... wda hm-
 wdyt-f Td nti Nht

For lines 6 & 7 see Table No. XXXV, "Annals", lines 93, ff. For lines 8 & 9 see ibid, lin

[.....][i-w g-r-t r-di-n hm-A.117 d-m-i(N.47) III n
 t-f(A.117) i-mn i-n-i-w-g-sa(=T.38)(N.40) r-n n wā(=U.38)-ā
 y-n-nw(=U.4)-nw(=W.21)-āa(=T.41)-mw(=N.55)(N.40) r-n n h-y
 hw(=F.44)(Y.2)r-n-ka(=D.46)-rw(=E.38)(N.40)] r-n n h-y
 h-r-p(D.69)-t-w bh(=G.53)-k(pl.)-s-n(pl.) r nfr h-t(=O.15) n-t
 t-f(A.117) i-mn-n w h-t-r(M.15)(Y.2) r-f-n-nw-w dmq(=Y.2)
 rnp-t(=M.13) i-s-t ha-q(D.69) [n] hm(A.113) n-a n
 hm(=D.95)-t(B.7)(pl.) n-t h-r-w(A.133) n qd-d-š-w(N.40)[.....]
 [.....] t-f(A.113) i-mn-n h-t-r-w(M.15)(Y.2) w bh(=G.53)-k(D.98)
 n xr(=Q.20)-r-t rnp(=M.13)-t(N.7) i-s-t [.....](pl.) nw
 km(=I.8)-t(O.1) hr s-w-s-h(W.31)(Y.2) t-ta(=W.60)-a-s(Z.7)(W.48)-e
 n q-t(M.37)[h(N.7)-h āhā(=P.19)]-ā-n r-di-n hm(A.113) āpr(=S.48)-
 -r-w(Y.2) p-n r h-fa(=G.87)(D.84)(D.69)(Q.54)-t [...] nfr(=Y.9)
 (pl.)[-f] i-s[t wia(=P.1)] āa(=W.41) n tp(=D.1)-p i-t-r-rw(=E.38)
 (N.53)(N.48) i-mn-n wsr(=S.66)-s-ha(=F.16)-t š-ā-d(T.14)[ā-š
 (needle leaf) ma(=U.8) māā(=Q.58)
 r ir(=D.10)-t-f m ma(=U.8)-w-t.....] (Conventional)
 xr(=Q.20)-r ha(=F.16)-t hm(A.113 wn(=E.58)-n-i]-n nwt(=O.1)-t(pl.)-
 -s-n(pl.) ha(=M.42)-q[-w(D.69)
 (4 Groups) ...] b-x-w-ir(=D.10)(N.40) nn-n āhā(=P.19)-ā(D.98)
 m h-a-w(Y.2)(pl.) hm-A.113

[.....][i-w gr
 (hust) rn n wā Inu
 (hast)] rn n ky
 hrptw bkw-šn r h-
 Išt haq [n] hm na

 [.....] Tf İm
 nw km hr šwsh Tai
 hfa-t [BURCHARDT,
 İāt wia] āa n Td
 māā
 r İrt-f m mast ...
 xr hat hm[İ wn-i]

] İ

Lines 12-15 Appointment of Feasts.
 [hat-sp(=M.13, X.14) XXXIII i-s-t hm-f m s(N.47)]s n q-d-m-a(N.40) m
 wd(=M.73)-y-t(D.98) IIIIIII nsw(=W.21)-t n-t n-ht-h-t(D.69)
 r-di(=D, 59 ?) r [.....]

[hat-sp māda-hat
 Ndyt hms nwt nht

(See SEYME'S Restoration to the "Annals". Year XXXIII, line 19. Table No. XXXIX.

A
o
d

A
o
d

A
o
d

ray).

LEPSIUS, who did not give a number to the Pylon (VI) next to the Hall of Records, noted this Pylon as No. VI; (L.D.I, 74-76), pp. 273, ff.) on the West Interior Surface of the Arch of the Gateway through the Pylon, and on some stones which had fallen ruined text. LEPSIUS therefore published (op.cit.) what he found in situ, and separate fragments, which SERSE afterwards referred to below as "Sep. Frag."

LEPSIUS, Urkunden der XVIII Dynastie, (1906), p. 178. (Text quoted below pp. 180, ff.)

Granted.

Geographic Names

ī īan Rā Hr̄w Iahoti [hr̄w īst Hr̄w ntī s-hwi] xr̄ hat-f r̄ Inw Ra-Pr̄ s̄rn-ī ut̄ ḥpri r̄ q̄s̄ īst-ī Hr̄w Hr̄w ḤSut̄ Bit̄ q̄t̄

[Granted to me my Father] Amon Ra, Horns of the Two Horizons; [on the Throne of Horus, who is the Living and to conduct me] before Him to the Inner Temple Precincts, and to proclaim me Ruler of the Two Lands, and of the Thrones of Gb [K̄r̄ḥ, the Earth God] and the Offices of Khepri ["Scarabaeus" "Sun God"] at the side of my Father, the Good God, King of Upper and Lower Egypt, (Thutmosis II) given Life Forever.

.....
S̄m̄ r̄dw̄ ḥpr̄ Ḥḡt̄ ḥat̄ ḤSut̄ [SERSE,
.....
-m̄s̄) ānh̄ q̄t̄ r̄ nh̄h̄ [m̄ ḤSut̄ Bit̄
.....]

Then all the people [.....]
Year 1, the first of Shemu, Day 4, happened the accession to the Throne of the Royal Son [.....]
.....] (Thutmosis) given Life for ever and ever [as King of Upper and Lower Egypt]

s̄ i.e. "to cause ḥpt-īst̄ to be like unto Heaven, established on its four columns."

R̄ḥnm̄ (ḥast̄) r̄ dr̄ ḥast̄ aḥl̄w̄ n̄ w̄ḡn-f̄ īan-Rā Ḥb̄ ḤSut̄ Pawī

..... His Majesty went to] the country of R̄ḥnm̄ to chastise the Northern Countries on the First Campaign of Victory, when commanded him Amon Ra, Lord of Karnak.

(1) R̄ḥnm̄

4, ff.
in ḥm̄-ī d̄w̄i ḥat̄ n̄ ḥḥ̄ īan Iniw̄ḡs̄a n̄w̄ (ḥast̄) r̄n̄ n̄ ḥy ḥurnk̄ar̄w̄

[.....][However, my Majesty gave 3 Cities to Father Amon: Iniw̄ḡs̄a the name of one, Innw̄ḡam̄w̄ the uses of another, ḥurnk̄ar̄w̄] the name of the other.

(2) Iniw̄ḡs̄a
(3) Innw̄ḡam̄w̄
(4) ḥurnk̄ar̄w̄

r̄ ntī ḥḥ̄ īan n̄ ḥtr̄ R̄ḥn̄s̄ d̄w̄ḡ r̄apt̄
ut̄ ntī ḥr̄w̄ n̄ Qd-d-ḡ-w̄ (ḥast̄)[.....
n̄ ḡk̄ n̄ s̄rt̄ r̄apt̄ īst̄[.....]
n̄ q̄t̄ [ḥḥ̄ ḥḡā] n̄ rd̄in̄ ḥm̄-ī ḡpr̄w̄ p̄n̄ r̄ an.Frendw.No.706] n̄r̄w̄-[f̄]

Brought were their offerings to the Temple of Father Amon as tribute of R-ḥ-n-nw, altogether for the year.
Behold! The booty [of] His Majesty in women of the fallen foe of Qd-d-ḡ-w̄ land [.....]
[.....] Father Amon taxes in produce for the year in question, Lo [....] of Egypt to extend Her boundaries for ever [and ever. The] n̄ My Majesty prepared this for enhancing his splendor.

(5) R̄ḥnm̄
(6) Qd-d-ḡ-w̄

w̄ īan Ḥr̄-ḡ ḥat̄ ḡḡd̄ [ḡḡ (Needle Leaf)

Behold! a great [ship] of the Inundation [Beginning of the River] hewn from real [Cedar

.....] (Conventional)
t-ḡn̄ ḥad̄w̄.....
r̄ (ḥast̄) n̄n̄ ḡḥā n̄ ḥaw̄ ḥm̄-ī

to make it anew] (Conventional)
before my Majesty [their Cities] were plund[ered, the Land of
.....] ḡxw̄ir̄ did not stand in the time of My Majesty

(7) ḡxw̄ir̄

ḥm̄-f̄ n̄ w̄(N.47) a Qd̄na (ḥast̄) n̄
r̄ [.....
.....]

[Tear 33 Behold His Majesty in the District] of Qdes land on Campaign 8 of Victory to cause to [.....]

(8) Qd̄na

THIS PAGE IS LOCKED TO FREE MEMBERS
Purchase full membership to immediately unlock this page



Never be without a book!

Forgotten Books Full Membership gives universal access to 797,885 books from our apps and website, across all your devices: tablet, phone, e-reader, laptop and desktop computer

A library in your pocket for \$8.99/month

Continue

*Fair usage policy applies

TABLE No. XXV. THUTMOSIS (ḏḥwtjms) III. Description of Buildings erected for Amon in thankfulness for Victory. Inscription on the sides of, and over the doorway. See also Diagram No.2, Table No. XXIV.

- I. Fragment on both sides of Granite Door: (SETHE, Plan, p.625, "1" & "n") - LEGRAIN, Ann. du Serv. II, p.228.
 II. " over the door; (SETHE "m") SETHE, op.cit. p.737, B (12 lines mutilated). LEGRAIN, op.cit. p.229.

Note:- SETHE restores the text sufficiently to show (lines 1-4) mention of a granite door.

Line	Page	Text	Text
4	737 i-w š-âḥâ(=P.19)-n n-f Im šâḥân n-f
5		[ḥm(A.113) šn(=R.22) šn šn-t(M.9)(pl.) âša(=I.2)-t(pl.) m â-š (Needle Leaf) n	[ḥm šnut âšat m âš m Ramn]nni. (ḥâst) :
6		ra(=D.29)-mn]-n-n-i[sic.](N.40) r b-ḥ-n-t-î(0.3)(0.3)	
		[wr(=G.79)-e-tî..... Unimportant]	[wrti.....]

TABLE No. XXV. THUTMOSIS (ḏḥwtjms) III. Inscription on the sockets for the Flag Mast (R) on S. Façade of Pylon VII of MARIETTE, (Karnak, Pl.5). Not inscribed. On the Right niche of the Northwest Tower is the following text.

777	[ḥrw(=G.8) nšw-t bit (râ-mn-ḥpr) ir(=D.10)-n-f m mn nw nw nw-f n t-f i-mn-n] râ nb p-t(=N.1) [š]âḥâ(=P.19)-n-f [šn(=R.22) šn] šn špsî(=A.131) s-t-štp(=U.3)-n-f m ḥnt(=W.8)-š šta(=V.2)(D.98) ḥr ḡw(=N.42)(pl.) [nw(=W.21)] [nḥr(=R.13)] ta(=N.37)(N.40) n i-âam(=T.1)-m(A.123)(pl.) nw r-ḥ-n[nw](N.40)	[ḥrw Nšwt Bit (Nn-ḥpr-Râ) irn-f Nb Pt [š]âḥân-f šnut špsî štan-f m ḥnt ḥr[-Nḥr] (ḥâst) n [sic.] Imw Rḥn[nw]]
-----	--	---

TABLE No. XXVI. THUTMOSIS (ḏḥwtjms) III. Inscription in a "Destroyed Chamber" North from "K" of MARIETTE, (Karnak, Pl.5). See 1
 Text:- SETHE, Urkunden d. XVIII Dynastie, p.778: ibid, Z.Aeg. Sprache, 42, p.142

1	778	sa(=G.67) n x-t mr(=N.53) (râ-mn-ḥpr)	Sa n Xt Mr (Nn-ḥpr-Râ)
2		ir-n mn-nw-nw-nw nfr(=Y.9)-w(pl.) mādḥ(T.7)(D.69)	irn nns nfrw mādḥ [MASPERO, Bib. d'Ét.
3		m štp(=U.3)-p-w n ḥt-ḥ-t-tiw(0.63)	m štpe n ḥttiw
4		nw â-š (Needle Leaf) bk(=G.53)-k(D.69) m	nw âš (Needle Leaf) bk m
5		ḡam(N.53, N.53, N.53) ntp ḥâš-t(pl.) m n-ḥt-	ḡam n tp ḥâst m nḥ-
6		-t-w(D.69)[(pl.)	-tw
7		wḡ-w(Y.2)-n n-k di(=X.22)-n n k]	[wḡw n-k din n k]

TABLE No. XXVII. THUTMOSIS (ḏḥwtjms) III. Superscriptions to Triumphal Lists, Pylon VII, South Façade.
 The West Façade of Pylon VI (MARIETTE and BAEDER) and Pylon VII (VI, L.D.I, 46, 7) on both North and South façades.
 South:- The "North Folk" (Palestine) List. (Nos. 1-119) MARIETTE, Karnak, Pl.18. SETHE, Urk. XVIII Dyn.
 North:- Duplicate of above Palestine List (Nos. 1-119) MARIETTE, Karnak, Pl.19, 20. SETHE, op.cit. pp.781,
 MÜLLER, Egyptological Researches, (1906), pp.39, ff. Pl. XLIV. Duplicate of above List of "South Folk", (MARIETTE, Karnak, Pl.25-26. SETHE, op.cit. pp.801, ff.
 Pylon VI bears on its West Façade duplicates of these Lists, which may be found in Table No. XLIV. together with
 of Pylon VII, and over the Lists. On the West Tower the King slaughters Syrians before Amon, while the "Oodess:
 Text:- MARIETTE, Karnak, Plates 18-23. SETHE, Urkunden d. XVIII Dynastie, pp.772, ff.

(Over the Syrians)

18	š-šqr(=Z.22) wr(=G.79) wr wr nw r-t-n-nw-w(T.1)(N.40)	Šqr Wrw nw Rtnnw (ḥâst)
	ḥâš-t(=N.40) ḥâš-t ḥâš-t nb-t	ḥâst nbt
	š-ta(=W.60)-t-t(Y.2) ta(=N.37) ta ta nb(pl.) f-n-ḥ-w(A.117)(pl.)	Štat Taw nbw Fnhw
	(The speech of Amon is conventional, and contains no geographical names.)	
	in(=W.22)-n n-k ḥâš-t(=N.40) nb	Inn n-k ḥâst nb
	š-ta(=W.60)-t-t ta(=N.37) ta ta nb f-n-	štat Taw nb Fn-
	-ḥ-w-w(pl.)	ḥw
	d-na(=U.8)-(W.40) xr(=Q.20) ḥb-t(=S.33) ḥb-t-k	dna [PIERRET, p.710 comp. GOLEMSIC ḥbt-k

all of Records No. I, (West) S. Wall, East of Pylon VI. *l*, *m*, *n* on plan of SETNE, (Urk. d. XVIII Dyn. p. 625) i.e. on both

SETNE, Urk. d. XVIII Dyn. p. 736 (No. Geographical Names) (7 lines badly mutilated)

Thutmosis III, Tables XXIV-XXVII,

; (lines 4-7) as below; (lines 7-9) Obelisks; (lines 9-13) Restoration of a Temple. (Fragmentary).

Geographical Names

re (Karnak, Pl. 2), and VI of LEPSIUS (Denkmäler, I, Pl. 74). Each of the towers of the Pylon contain two niches. Two are SETNE, Urkunden d. XVIII Dyn. p. 777, No. 214, A.

<p>nnw-f n tf fan] Bā što hr gw [nw] ist) [..... </p>	<p>[Horus... King of Upper and Lower Egypt (Hn-hpr-Rā) [Thutmosis III] . He made in memorial of Father fan] Rā, Lord of Heaven; and he caused to be erected splendid (Flag)-staffs. He selected them from the forest, and dragged them on the mountains [of] the Land of fa-hpr [God's Country] of the fanw of Rfn[nw]-land.[.....]</p>	<p>(1) fa-hpr of the fanw of Rfnnw.</p>
---	---	---

ram No. 1, Table No. XXXV. (So SETNE, Z. Aeg. 42, p. 142: and "in one of the Northerly side rooms" at Karnak. (id.), Urk. XVIII Dyn. p. 778)

57]

Son of the Body (Men-kheper-Ra) [Thutmosis III]
 Made beautiful Memorials, hewn
 from the choicest of the foot-hills [? Terraces]
 of Cedar wrought with
 Gold of the best of the countries for the Victories

Cedar.

.....] [decreed to Thee, and given to Thee.]

are sculptured with the Triumphal Geographical Lists of Thutmosis III. Pylon VII bears upon its Façades the following:-
 781, ff. List of "South Polk" (Nos. 1-117) MARIETTE, Karnak, 23. SETNE, Urk. XVIII Dyn. pp. 796, ff.

Additional List of "North Polk" (N. Syria, Nos. 120-359) MARIETTE, Karnak, Pl. 20, 21. SETNE, op. cit. pp. 788, ff.
 1-117), MARIETTE, Karnak, Pl. 24-26. SETNE, op. cit. pp. 796, ff. Additional List of "South Polk", (Nos. 118-269),

ir Introductory Texts. The texts now in question, however, accompany the two Great Reliefs which are on the South Façade
 the West" leads the Chief of the Northfolk in chains. On the East Tower, the King slays Africans before Amon.

Smiting the Princes of Rtnnw,
 all impassable countries,
 and all the lands of the Fuhj.

(1) Rtnnw

(2) Fuhj

Cometh to Thee every inaccessible
 country, and all the Lands of the Fn
 h

(3) Fnhw

b. d'Ét. II, p. 224] xr

are stretched out beneath Thy two feet.

THIS PAGE IS LOCKED TO FREE MEMBERS
Purchase full membership to immediately unlock this page

DELVE INTO FANTASY, MAGIC, MYTHOLOGY & FOLKLORE

Forgotten Books'
Full Membership gives
access to 797,885 ancient
and modern, fiction and
non-fiction books.

Continue

*Fair usage policy applies

TABLE No. XXVIII. THUTMOSIS (DENTINSS) III. "Feasts and Offerings"; Pylon VI, S. Wing, Karnak. Geographical Names. (Conte

A "List of Feasts and Offerings" to Amon for the Ist. Campaign of Victory. Text on the S. Half of the W. Wall (Pylon Diagram No.2, Table No. XXIV. and description therewith. The number of the Pylon is MARIETTE'S (Karnak, Pl.2), as LEPSIUS (Den Note:- The nature of the gifts etc. as well as those mentioned in the rest of the Annals and other inscriptions, is well ill text of the Annals as above described. See:- SETHE, Urk. XVIII Dyn. pp.625, ff. CHAMPOLLION, Monuments; IV, 316-7 ROSELIGNI, Mc BIGNON, Archæologia, XXIV, 155.

Text:- LEPSIUS, Denkmäler, III, 30b. BRUGSCH, Recueil des Monuments, I, Pl. XLIII-XLIV. SETHE, Urkunden d. XVIII Dynastie; pp.73

Translation:- BIGNON, Archæologia, XXIV, (1853), pp.116, ff. & Records of the Past, (o.n.) II, (1874), pp.53, ff. BREASTED, Anc. Rec. Egypt,

See:- WIEDEMANN, Aeg. Gesch. (1884), p.342

Libe	Page	Page	Line	Line	Text, SETHE.	
1	739	[hat-sp(=M.13:K.14) XIIII 1.92 m. iī(=M.34)-t(D.96) hm(A.117) m md(=M.73)-y-t(D.96) tp(=D.1)-t n-t n-ht-h-t (D.69) iā(=V.44)(D.69)-n-f iā(=N.30+N.35)(N.7)(pl.) III] hr has-t(=N.40)-t r-f-n-nw(=W.21)(N.40) m mn-n-n-nw(=W.21)-w(O.3) qd(=O.77)(A.51)-n hm(A.113) m n-ht-h-t(D.69)(pl.)-f hr-r iā(=W.23) n wr(=A.29)(pl.) nw r-mn-n-n(N.40) n-t-ī r-n-f r (rā(=N.7)-en-hpr(=L.4)) w-ā-f-w š-ma(=U.8)(A.31+V.6)(N.40)[BRUGSCH = mn(=Y.12)-ma(U.8)(A.5)(N.40)] i-š-t mn-n-i(O.77)(P.2)-n-f r was(=S.65)-t(O.1) i-w i-t-f(A.113) i-mn-n [m iw(=V.5)-t(W.23) 1.93 m. i-p-t š-t(=Q.1)-t(pl.)](O.1) i-w wa(=V.37)-h(Y.2)-n n-f hm(A.113) hb(=O.65) n-ht-h-t(D.69) m ma(=U.8)-t-w h-f-t iī(=M.34)-t(D.96) hm(A.113) m md(=M.73)-y-t(D.96) tp(=D.1)-t n-t n-ht-h-t hr š-h-r-t(A.133) r-f-n-nw(N.40) x-s-t hr š-w-š-h(W.81) t-ta(=W.60)-š(Y.7)(N.47)(pl.) km(=I.8)-t(O.1) m hat-sp(=M.13: K.14) XIIII m ? ? n-ht-h-t(D.69)(pl.) md-w(Y.2) n-f n A.113 [.....] ir(=D.10) tp-p m hb(=O.65) m pa(=G.73) hb n-ht-h-t(D.69) Three "Feasts of Victory." List of Offerings at "Feast of Victory." Voyage of Amon "m i-p-t(Z.25)-f rš(=M.30)-t [...](N.47)".....	[hat-sp qut hat iīz hm m wdyt tpt ntī h hat] hr has-t Rfnnw (h hm m uhts-f hr iān nra n ra-f r (N-n-hpr-Rā)-wāf-w [GARDINER, Z. Aeg. 42, p.118 iāt mn(n-wā)-f [MASPESO r has-t (nut) iw iīf iān 1.93 m. i-w wa(=V.37)-h(Y.2)-n n-f hm(A.113) hb(=O.65) n-ht-h-t(D.69) m ma(=U.8)-t-w hm m wdyt tpt ntī nht hr xst hr šwš Pašw iāt (n
2	740	30b	1	1 Three "Feasts of Victory." List of Offerings at "Feast of Victory." Voyage of Amon "m i-p-t(Z.25)-f rš(=M.30)-t [...](N.47)"..... Three Fea Offering Voyage of Amon ' [.....] Rht iān iāt wāsi wāsyut rāin hm-f n hat-sp qut hat nryt r š harw ha šat (5) hnnw h [..... 2.09 m. i-w irwt iā wāt m iā n] šmā (nut) ha (nut) [SETH irwt iā šnt m iā n qah wāt m iā n iā (has-t) Da iīi [Gramm. §233] (pl.) r Altkan. Fremd. II, 26, No.4 nt rā nb r rdit wā n iī [iān 2.1 -dīn n-f hm dāi hat m B] iīniwā (has-t) rn n wā Ynnwāann (has-t) rn n ky wurnkarn (has-t) rn n ky
3			3	3 Three "Feasts of Victory." List of Offerings at "Feast of Victory." Voyage of Amon "m i-p-t(Z.25)-f rš(=M.30)-t [...](N.47)"..... Three Fea Offering Voyage of Amon ' [.....] Rht iān iāt wāsi wāsyut rāin hm-f n hat-sp qut hat nryt r š harw ha šat (5) hnnw h [..... 2.09 m. i-w irwt iā wāt m iā n] šmā (nut) ha (nut) [SETH irwt iā šnt m iā n qah wāt m iā n iā (has-t) Da iīi [Gramm. §233] (pl.) r Altkan. Fremd. II, 26, No.4 nt rā nb r rdit wā n iī [iān 2.1 -dīn n-f hm dāi hat m B] iīniwā (has-t) rn n wā Ynnwāann (has-t) rn n ky wurnkarn (has-t) rn n ky
5	741		5	5 Three "Feasts of Victory." List of Offerings at "Feast of Victory." Voyage of Amon "m i-p-t(Z.25)-f rš(=M.30)-t [...](N.47)"..... Three Fea Offering Voyage of Amon ' [.....] Rht iān iāt wāsi wāsyut rāin hm-f n hat-sp qut hat nryt r š harw ha šat (5) hnnw h [..... 2.09 m. i-w irwt iā wāt m iā n] šmā (nut) ha (nut) [SETH irwt iā šnt m iā n qah wāt m iā n iā (has-t) Da iīi [Gramm. §233] (pl.) r Altkan. Fremd. II, 26, No.4 nt rā nb r rdit wā n iī [iān 2.1 -dīn n-f hm dāi hat m B] iīniwā (has-t) rn n wā Ynnwāann (has-t) rn n ky wurnkarn (has-t) rn n ky
7-8	743	7-8	7-8	7-8 Three "Feasts of Victory." List of Offerings at "Feast of Victory." Voyage of Amon "m i-p-t(Z.25)-f rš(=M.30)-t [...](N.47)"..... Three Fea Offering Voyage of Amon ' [.....] Rht iān iāt wāsi wāsyut rāin hm-f n hat-sp qut hat nryt r š harw ha šat (5) hnnw h [..... 2.09 m. i-w irwt iā wāt m iā n] šmā (nut) ha (nut) [SETH irwt iā šnt m iā n qah wāt m iā n iā (has-t) Da iīi [Gramm. §233] (pl.) r Altkan. Fremd. II, 26, No.4 nt rā nb r rdit wā n iī [iān 2.1 -dīn n-f hm dāi hat m B] iīniwā (has-t) rn n wā Ynnwāann (has-t) rn n ky wurnkarn (has-t) rn n ky
8			8	8 Three "Feasts of Victory." List of Offerings at "Feast of Victory." Voyage of Amon "m i-p-t(Z.25)-f rš(=M.30)-t [...](N.47)"..... Three Fea Offering Voyage of Amon ' [.....] Rht iān iāt wāsi wāsyut rāin hm-f n hat-sp qut hat nryt r š harw ha šat (5) hnnw h [..... 2.09 m. i-w irwt iā wāt m iā n] šmā (nut) ha (nut) [SETH irwt iā šnt m iā n qah wāt m iā n iā (has-t) Da iīi [Gramm. §233] (pl.) r Altkan. Fremd. II, 26, No.4 nt rā nb r rdit wā n iī [iān 2.1 -dīn n-f hm dāi hat m B] iīniwā (has-t) rn n wā Ynnwāann (has-t) rn n ky wurnkarn (has-t) rn n ky
9			9	9 Three "Feasts of Victory." List of Offerings at "Feast of Victory." Voyage of Amon "m i-p-t(Z.25)-f rš(=M.30)-t [...](N.47)"..... Three Fea Offering Voyage of Amon ' [.....] Rht iān iāt wāsi wāsyut rāin hm-f n hat-sp qut hat nryt r š harw ha šat (5) hnnw h [..... 2.09 m. i-w irwt iā wāt m iā n] šmā (nut) ha (nut) [SETH irwt iā šnt m iā n qah wāt m iā n iā (has-t) Da iīi [Gramm. §233] (pl.) r Altkan. Fremd. II, 26, No.4 nt rā nb r rdit wā n iī [iān 2.1 -dīn n-f hm dāi hat m B] iīniwā (has-t) rn n wā Ynnwāann (has-t) rn n ky wurnkarn (has-t) rn n ky

XXVIII. Thutmose III, Feasts & Offerings. (1)

rear) of Hall of Records No. I (West Hall), Karnak; being wall "o" on SETHE's plan, (Ork. d. XVIII Dyn. p. 625) See also
 er, I, 74-6) did not number it. Amon sits enthroned on the Right of the Relief, and receives from the Pharaoh the gifts.
 stated in the large Relief on the North Wall of the East Hall of Records (No. II) (See Diagram No. 2, Table No. XXV) over the
 orici, Text, III, 1, Pl. p. 125: id. Mon. Civili; 57 BURROU, Excerpta Hieroglyphica; 29. BRUGSCH, Thesaurus, V, 1185, ff.

6.

1906), 55548, ff. BRUGSCH, Rec. de Mon. I, (1862), pp. 52, ff. (See *ibid.*, *Gesch. Aeg.* p. 328. Egypt under the Pharaohs, I, p. 388)

Breasted.		Geographical Names	
	§		
1.92 m.		[Year 23, 1.92 m.	
..... <i>tjān-r fctw</i>		Returned The Majesty from the First Campaign of Victory	
.....		He conquered for 3 months	
<i>n nnn-nb (pr)</i>	548] in the Country of <i>Rfnns</i> , in a Fortress which The Majesty built	(1) <i>Rfnns</i>
<i>nn (hast) nt</i>		in His Victories in the midst of the Chiefs of <i>Rann</i> , of which the name was	(2) <i>Rann</i>
<i>(nins)(hast)</i>		<i>(In-hpr-Rā)-Wān-Sma</i> [Thutmose III, Binder of the Country of <i>Sma</i>] [(Foreigner)	(3) <i>Sma</i>
<i>mg, Z. Aeg. 45, p. 38]</i>		(Herdsman)]	
<i>.de Trav. 29, p. 107]</i>	549	Then He "moored-[ship]" at <i>Wast</i> [Thebes] and His Father Amon did	(4) <i>Wast</i> [Thebes]
<i>nt</i>		[with food offering	
<i>.. Ipt-Ist (nst)</i>	 1.93 m. <i>Ipt-Ist</i> [Karnak District]	(5) <i>Ipt-Ist</i> [Karnak]
<i>hrt iit</i>		Established for His The Majesty a Feast of Victory anew when The Majesty came	(6) <i>Rfnns</i>
<i>t Rfnns (hast)</i>		from the First Campaign of that Victory which overthrew the Country of <i>Rfnns</i>	(7) <i>Ist</i> [Egypt]
<i>hat-sp qut hat</i>		the wretched, and extended the Boundaries of <i>Ist</i> [Egypt] in the Year 23 as	
.....]		[the First ?] of Victory	
.....	550	He decreed for me [.....]	
.....		instituted was the First of the Festival of "The Feast of Victory."	
.....	 Three "Feasts of Victory."	[Luxor]
.....	 Offerings	
<i>t-r Bat [...]"</i>	555 Voyage of Amon to "His <i>Ipt</i> " [Luxor] of the South.	(8) <i>Ipt-Rstl....</i> a
<i>Ian šāā</i>		[.....] List of <i>Ian</i> (Men), and <i>Iast</i> (Women)	(9) <i>Ian, Iast</i>
<i>wq on hr t-r pn</i>		of <i>Wsi</i> and <i>Wsyet</i> [Negro and Negresses] The Majesty gave to His Father Amon	(10) <i>Wsi, Wsyet.</i>
<i>n-r In</i>	556	Year 23, to the establishing of this memorial in this Temple	(11) <i>Yaru</i>
<i>Aeg. 44, pp. 8, 13]</i>		The <i>Yaru</i> ,	
<i>t) Iryt ipw [sic.]</i>		[..... 2.09 m. The Majesty offered to Him	(12) <i>Sāā</i> [Upper and
<i>yt ip fdt r šxr irtt</i>		1 Milch Cow of the Cattle of <i>Sāā</i>	(13) <i>Pa</i> Lower Egypt]
<i>(?)(pl.) [BUSCHARDT,</i>		and <i>Pa</i> [Upper and Lower Egypt]. 2 Milch Cows of the Cattle of	(14) <i>Dah</i>
<i>no qān a xrt pro</i>		<i>Dah</i> -land; 1 Milch Cow of the Cattle of	(15) <i>Kē</i> [Nubia]
..... <i>is r]-</i>		<i>Kē</i> -land. Total, Milch Cows, 4, to cause to be drawn the milk thereof into	
<i>hrt</i>		silk pots (?) of Gold each day	
<i>a bk s xrt rant ...</i>		in order to be offered to Father	
<i>stones: 17, Peseta & Offerings: 19, The Temple Garden: 20, Temple Administration: 23, Feasts of the Seasons.</i>		[<i>Ian</i> 2.10 m. Then]	(16) <i>Rfnns</i>
		gave The Majesty to Him, 3 Cities in <i>Rfnns</i> -land:	(17) <i>Iniwša</i>
		<i>Iniwša</i> was the name of one,	(18) <i>Inwān</i>
		<i>Inwān</i> was the name of another.	(19) <i>Wnrkar</i>
		<i>Wnrkar</i> was the name of another. Impost in produce for the needs of the year	

THIS PAGE IS LOCKED TO FREE MEMBERS
Purchase full membership to immediately unlock this page



Never be without a book!

Forgotten Books Full Membership gives universal access to 797,885 books from our apps and website, across all your devices: tablet, phone, e-reader, laptop and desktop computer

A library in your pocket for \$8.99/month

Continue

*Fair usage policy applies

[.....] [Verification] nn(=D.47) q-d-A.113 ô-b-â(F.41)(Y.2) r š-m-h(A.91) n
 ir(=D.10)-t-n-A.117 r q-d ir(=D.10)-n-A.117 h-n(G.75)(Y.2) i-m nn(=D.47)
 ir(=D.10) šm(=M.24)-m hm-A.113 nn(=D.47)-n ir(=D.10)-n-A.117 n r-f [sic.]
 (A.89)(B.7)(pl.) q-d-t-m ô-b-â(F.41)(Y.2) r s ir(=D.10)-n-A.117
 nn(=M.22)-n n i-t-f-A.117
 [nb nfr(=R.13) nfr nfr ... 1.98 m. nn(=D.47) h-m(D.47)[GOLÉNISCHÉV,
 Bib.d'Ét.II,p.164]-n-f pa(=G.73)]
 q-d h-n(G.75)(Y.2) n-t-i nn(=G.47) ir(=D.10)-t-m-f r n-t-t šm(=M.24)-m
 r-h(Y.2) p-t(N.1) r-h(Y.2) ta(=N.37)(N.47) ma(=U.8)(D.10)-f ta(N.37)(N.47)
 r qr(=W.40)-r-f n wn(=E.59)-n-nw(=W.21)-t(N.35) ânḥ(=S.43) n-A.113
 nr(=U.12)-y-m rā(=N.7)(A.113) ḥ-hs(=W.4)-š-m i-t-f-A.113 i-mn-n(A.118)
 h-mn(=M.67)-n(A.71) hnt(=F.5)-A.117 m ânḥ(=S.43) was(=S.64) i-m
 ir(=D.10)-n-A.117 nn(=M.22)-n [r maâ(=Q.58)-t
 2.09 m.] Instructions to the Priests
 Offerings for the IV Obelisks.

[.....] [Verificati
 [GAUTHIER,Bib.d'Ét.IV
 irn-ī hn iw nn ir šm
 qdtw âbâ r š
 irn-ī nn n itf-ī
 [nb nfrw 1.98 m.
 qd hn ntī nn irtw-f R
 Maaf Ta r dr-f n wn
 Ânḥ n [sic.]-ī. nryw R
 hwn hnt-ī m ânḥ was i

Created

§

XVIII. Thutmose III, Feasts & Offerings, (2)

in gd-i ad r swka
[6] n irtn-i r gd
in irn-i n rapt

570

[.....] [Verification] I do not speak boastfully for announcement of what I have done, by saying:- "I have done a thing", when it is that My Majesty hath not done it. Nor have I done [anything] for people who have spoken boastfully about it.

I have done this for My Father

[Lord of the Gods 1.23 a. He hath never overlooked the]

telling of a thing which hath not been done. For He knoweth the Heaven, and he knoweth the Earth, and He seeth the whole Earth hourly.

[By] the life of Me, as Ra loveth; and as my Father Amon praiseth: as refreshed are my nostrils with Life and Youth, I did this [in truth

.....
.....
.....
.....
.....

.....
.....
.....
.....
.....

THIS PAGE IS LOCKED TO FREE MEMBERS
Purchase full membership to immediately unlock this page

DELVE INTO FANTASY, MAGIC, MYTHOLOGY & FOLKLORE

Forgotten Books'
Full Membership gives
access to 797,885 ancient
and modern, fiction and
non-fiction books.

Continue

*Fair usage policy applies

TABLE No. XXIX. THUTMOSIS (DEUTINSS) III. Obelisk; Constantinople. Geographical Names. (Context).

Monolith known as "The Obelisk of Theodosius", now in the At Meidan in Constantinople, a public plaza about 200 metres long at St. Sophia. See:- BAECKES, Konstantinopel und Kleinasien, (1905), Plan p.70, (H.7) and p.94. Id. Das Mittelmeer, (1909), plan (IIIrd.Ed.1890), Pt.I, plan p.93, (F.4) and p.96. Encyclopedia Britannica, (Xith.Ed.1910-11), Vol.VII, plan p.4.

At Meidan ("Place of Horses") is on the site of the ancient "Hippodrome", which was about 1200-1300 feet in length, surrounding was begun by Severus (193-211 A.D.), modelled after the Circus Maximus in Rome, and finished by Constantine the Great (306-337 A.D.) at the First Cataract of the Nile. Commander GORRINGE (Egyptian Obelisks, (1882), p.145) gives the "probable" measurements of it. But the stone is only the upper part broken from a longer monolith. Estimates as to its original size differ from that of Prof. Weight circa 800 tons, to that of Dr. SMOER (Konstantinopel etc. op.cit.p.94), Height circa 30 metres (98 + ft.), Base 2 metres. The Pedestal Texts and Reliefs:- The monolith rests on four bronze cubes, each 1 ft. 6 in. high, standing upon a pedestal or base. The cubes contain the following:-

- A. Upper Course. On all four faces reliefs of the "Kathisma" or "Grand Stand" of the Hippodrome, consisting of long upper balconies of the Empress and the Imperial Family. All are attended by Courtiers, Guards etc. In the Lower balconies the Emperor is thus depicted performing various duties; (East Face) enthroned in state in his Tribune receiving the homage of his subjects. (West Face) seated on a throne receiving the homage of his subjects. (North Face) seated on a throne receiving the homage of his subjects. (South Face) seated on a throne receiving the homage of his subjects.
- B. Lower Course. (1) (North Face) The Obelisk being dragged through the Hippodrome by 16 men using ropes, blocks, and rollers. (2) (South Face) The Obelisk being dragged through the Hippodrome by 16 men using ropes, blocks, and rollers. (3) (East Face) The Obelisk being dragged through the Hippodrome by 16 men using ropes, blocks, and rollers. (4) (West Face) The Obelisk being dragged through the Hippodrome by 16 men using ropes, blocks, and rollers.
- The Greek Inscription is as follows:- "KIONA TETPAΔAIEYPON AEI XΘONI KEIMENON AXΘOC MOYNOC ANACTHCAI ΘE
i.e.: - "[This] quadrilateral ever lying on the ground a dead weight, King of Kings, I, Proclus, Emperor of the Romans, unwilling once was I Imperial Lords to mind when ordered, and though I, conquered and bound, under decree of Proclus, to the lofty sky I was raised up."
- The Latin Inscription reads:- "DIFICILIS QVONDAM DOMINIS PARERE SERENIS IVSSVS ET EXTINCTVS PALATII SVPERAS ELATVS AD AVRAS."
i.e.: - "Unwilling once was I Imperial Lords to mind when ordered, and though I, conquered and bound, under decree of Proclus, to the lofty sky I was raised up."

These texts are generally understood to mean that the stone as brought from Egypt was erected by Proclus in the reign of the Emperor Constantine (308-337 A.D.) and that the stone formerly stood elsewhere in the City, was thrown down by an earthquake and broken; that it laid on the ground for a long time.

The history of the Journey from Egypt is rather uncertain. The Emperor Julian (361-363 A.D.) in a "Letter to the Citizens of Constantinople" had brought there intending to forward it to Constantinople. Julian urges the Alexandrians to send the stone to Athens and that the shaft was brought thence to Constantinople in the reign of Theodosius (379-395 A.D.) (See WIEDEMANN, Aeg., p.109).

AMMIANUS MARCELLINUS, the companion and historian of Julian (Rerum Gestarum, Lib.XVII, Ch.4, §8 Edit. CLARK, (1910), p.109: "down and broken." He then describes the moving to Alexandria of the Obelisk now in front of the Lateran in Rome. But he does not mention the Obelisk with one of the pair shown in the Relief on the North Wall of the Easterly Hall of Records at Karnak, (See Table No. XXVIII, South Front of Pylon VII, where the base thereof is still found."

An early account of this monolith is given by PETER GYLLIUS or GYLLE, a French traveller of the XVIth. Century in his work on Egypt, copy by MONTFAUCON, (L'Antiquité Expliquée, III, p.187) of a drawing by SROM and WHEELER (Voyage d'Italie, Lyons, 1678) in which the drawing is misleading. See also Pet. Angelus BARGAEUS Commentarius de oboliscis ad Sixtum V, V, P.M. Romae, 1586: reprint GRAEVIUS, Thesaurus Zoega, de origine et usu obeliscorum ad Pium VI, V, P.M. (Romae 1797): LONG, Egyptian Antiquities in the British Museum (London, 1818), p.218: Obelisk of the Atmeidan, ibid, Vol.II, (1842), p.218: YATES, Remarks on the Obelisks of Ancient Egypt; Original Papers of the Society of Dilettanti, (1838), p.171. BRUGSCH, Reiseberichte aus Aegypten, (1855), p.171. ibid, Geschichte Aegyptens, (1877), p.385. GORRINGE, Egyptian Obelisks, New Series, (1882), p.145. PETRIE, History of Egypt, II, (1889), pp.132, ff. SCHULTZE, Konstantinopel (Altkristliche Städte und Landschaften, (Leipzig, 1911), p.1185.

The shaft contains a vertical line of hieroglyphic text on each face. Just below the Pyramidion or top on each face are the hieroglyphs. Records at Karnak furnishes the lost end of the text on the South front.

Text (Constantinople):- LEPRIUS, Denkmäler, III, Pl.60. SHARPE, Egyptian Inscriptions, (1855), II, Pl.65. CONSIDERE, Egyptian Inscriptions, (1855), II, Pl.65. (South Front) BREASTED, Zeits.f. Aeg. Spr. XXXIX, (1901), Pl. III, p.56, No.1.

Translation:- GORRINGE, op.cit. BREASTED, Anc.Rev.Egypt, II, (1906), §680. (East Face) BRUGSCH, Geschichte Aegyptens, (1877), p.385.

Text (Relief, Karnak):- CHAMPOLLION, Monuments, IV, (1845), Pl.316: id. Description de l'Égypte, (no text), III, Pl.35. BRUGSCH, Thesaurus, (1891), p.1185. SETHE, op.cit.p.642.

XXIX. Thutmosis III, Obelisk, Constantinople. (1)

leading past the Northwest front of the Mosque of Sultan Ahmed I to the Aya Sofia Meidan or Plaza on the Southwest side of
(H.7) and p.577. MURRAY, Constantinople, Breen & the Troad, (1900), plan Front, (F.4) and p.39, § 12. Id. Mediterranean,

arena, through the middle of which ran the "Spina" or low wall dividing the two sides of the race track. The Hippodrome
.). The Obelisk was cut from the "Syenite" or red granite ("Naf", see text below, "South Front") found at Syene (Assuan)
tone as it now stands:- viz. Height 55 feet 4 inches (16 + m.); Thickness at base, 7 feet (2 + m.); Weight 229000 lbs.
RIE (History of Egypt, II, (1889), p.132), viz. Height 172 feet, Width:- Top 5 feet 6 inches, Base 10 feet 2 inches,
(6 ft. 6 in.)

formed By an upper course of two marble blocks upon a lower course of four blocks of red granite. These courses or "Blocks"

lower balconies, the former containing the Imperial Tribune in which appears the Emperor. In the upper balconies also are
spectators, musicians, dancers, and foreigners bearing tribute. The upper relief on the East Face contains 57 figures. The
the homage of barbarians, (South Face) presiding at games, (North Side) standing up to confer prizes.
pstairs; spectators watch the proceedings. (2) The Obelisk is erected. (3) (South Face) A chariot race around the "Spina"
re bronze pillar. (4) (West Face) The Greek Inscription quoted below. (5) (East Face) The Latin inscription quoted below,
, p.94) and a square bronze pillar.

DO BAGIAEYC TOAMHCAC IPOKAZ ENEKEKAEITO KAI TOCOO EOTH KIQN HEAIOIC EN TPTAKONTA AYO

Thodosius alone venturing to erect, gave orders to Proclus so [that] the column stood erect in 32 days."

OSTARE TYRANNIS OMNIA THEDVOSIO CEDVNT SOBOLIQVE PERENNI TER DENIS SIC VICTVS EGO DOMITVSQVE DIEBYS IVDICE SVB PROCLO

the palm for tyrants then no more. All things to Theodosius yield, and to his deathless race. Thus in thrice ten days,
as raised."

or Theodosius (379-395 A.D.) But BIRCH (Notes on Obelisks, 1853), and BUCCE (History of Egypt, IV, (1902), p.60) say that
siderable time, and Proclus, not being able to join the fragments, transported the largest and set it up in the

"Alexandria", Epistola 58 [Edition HERTZLEIN, Leipzig, 1875] mentions a monolith then lying at that City, and which the
ward it to its destination. ZOTEA (see below) records that the ship carrying the Obelisk was wrecked on the coast near
, (1884), p.365).

lated, YONCE, (1902), p.130) records that at Thebes "we saw several obelisks in their places and others which had been thrown
mention the monolith now in question. BREASTED however (Zeits.f.Aeg.Spr. XXXIX, (1901), p.57) identifies this Constantinople
and SETNE (Urk.d.XVIII Dyn., (1906), p.588) says:- "The Obelisk of Constantinople, in all probability stood before the

Constantinopoleos Topographia" (1562) (BALL's translation). It is quoted by GORRINGE, (op.cit. p.159), who also publishes a
reliefs on the North and South sides of the base are combined in three rows: both the account and the drawing however are
Equitt Romanorum (Utrecht, 1696), pp.1893 ff. NIESUMR, Reisebeschreibung nach Arabian etc. (Kopenhagen, 1774), Pl.4, p.32
, I, p.331. BONOMI, "Notes of Obelisks" in the Transactions of the Royal Society of Literature, Ser.II, Vol.I, (1841): ibid,
Egyptian Society, Vol.I, Pt.1 (London, 1845), pp.12-20: BIRCH, Notes on Obelisks, (1842), Trans.Roy.Soc.Lit.Ser.II Vol.II, p.218.
, (1882), pp.124, ff.p.145, pp.159, ff. WIEDEMANN, Aegyptische Geschichte, (1883), p.365. BONES, History of Egypt, IV, (1902), p.60.

are reliefs representing the Pharaoh adoring and giving wine to Amon. As noted above the relief in the East Chamber of

shs, (1862), (Photo), p.42. SETNE, Urk.XVIII Dyn. (1906), pp.586, ff.

577), p.365. id. Egypt under the Pharaohs, (1881), p.449, (1891), p.190.

rpta Hieroglyphica, (1825), Pl.29. BREASTEN, Zeits.Aeg.Spr. XXXIX, (1901), Pl.p.56, No.2.

THIS PAGE IS LOCKED TO FREE MEMBERS
Purchase full membership to immediately unlock this page



Never be without a book!

Forgotten Books Full Membership gives universal access to 797,885 books from our apps and website, across all your devices: tablet, phone, e-reader, laptop and desktop computer

A library in your pocket for \$8.99/month

Continue

*Fair usage policy applies

Thutmosis III, Constantinople Obelisk Continued.

Table Text, SERAP.

"Front" (South)	<p>hrw(=G.8) (ka(=E.8) nht(=D.69) hâ(=N.23) m wašt(=S.65)) nb-ti(=G.88) waf(=V.37) šw(=M.24) rā(=N.7) mi p-t(=N.1) hrw(=G.8) nb(=U.50) đsr(=D.56) hâ(=N.23)(pl.) hrp(=S.50) nht(=D.69) pñ-t(=P.15) pñ-t nšwt bit (râ-mn-hpr-râ štp(=V.3)-n) ir(=D.10)-n m mn-nw(=N.21)-nw-nw-f i-mñ-n rā nb nšt(=N.42) nšt nšt tawī(=N.39) [Note:- Here ends the Constantinople text. Following is the continuation from the Karnak Relief.] š-âpâ(=P.19)(A.29)-n-f tñn(=O.53)-tñn-tñn âa(=N.41)-â(pl.) wr(=G.79)(pl.) m ma(=U.8)-t (N.23) b-n-b-n-t m đm(=S.64)(U.50)(N.53,N.53,N.53) ir-f đí ânñ rā mi s-t(M.87) [Nota:- The stone waf(W.23) is mentioned by Una in his inscription (line 39) as follows:-</p>	<p>hrw (ka nht hâ m wašt) nbtī hrw nb Đsr hâw [GAUTHIER, Bib. d'Ét. I Phtī Nšwt Bit (Mn hpr Râ Štp n Tf Imn-Râ Nb Nšwt Tawī</p>
"Right" (East.)	<p>hrw(=G.8) (p-d-t(=S.7) q-qa(=A.8) rā(=C.27) wr(=U.12)) nšt bit nbtī(=G.83) š-hâ(=N.23) maâ-t(=C.54) wr(=U.10)-y tawī(=N.39) (râ-mn-hpr-râ-štp(=V.3)) nb nht(=M.9)-ñ-t(D.69) w-â-f ta(=N.37) nb ir(=D.10) t-ta(=N.60)-š(Z.7)(N.48)-f r wp(=P.33)-t ta(=N.37) bía(=N.70) bía bía [See Appendix "C"] r n-h-r-n [(N.40)]..... </p>	<p>hrw (hdt qa rā wr) Nšwt Bit (Mn hpr Râ Štp Râ) Nb Nht Wā Ta Btām r Wñn (hast) [..... </p>
"Rear" (North)	<p>(Entirely Conventional, no Geographical Names.)</p>	
"Left" (West)	<p>hrw (ka nht hâ maât m) nšwt bit (râ-mn-hpr rā ir(=D.10)-n) đa(=U.21)(P.2) pñr(=V.41)-r wr(=G.79)(N.58) n-h-r-n(N.40) m q-n-t(D.69) m n-ñt(=M.9)-ñ-t(D.69) r ha(=P.16)-t mšâ(pl.)-f ir(=D.10) ha(=M.68)-y-t(pl.) đa(=P.41)-â [m h-r-w(A.138)(A.85)(pl.) has-t(=N.40)-t t-n] [.....]</p>	<p>hrw (ka nht hâ m maât) Nšwt Đa [MASPERO, Bib. d'Ét. I, p. 182 Qnt m Nht r hat Nšwt-f ir ha [.....]</p>

XXIX. Thutmosis III, Obelisk, Constantinople. (2)

Geographical Names

św Râ ni Pt	Horus (Mighty Bull. Resplendent in Thebes.) Lord of Diademe. Ra magnifieth him like unto Heaven.	(1) Wost [Thebes]
105] Jrp Npt â) irn n Knnw-f	Who triumphs over the foe. Splendid at Coronations. Powerful Leader, the Valorous King of Upper and Lower Egypt, (Men-kheper Ra Sehotep en Ra) [Thutmosis III], made it as His Memorial for Father Anon Ra, Lord of Karnak.	(2) Wst fawî [Karnak]
10, line 33, Table	He caused to erect <u>very</u> great Obelisks of Red Granite,	
f Wst. * i.e. *His Majesty i ũh) râ ni xt	ty sent me to Abu-land [Elephantine, near Syene-Assuan] to fetch a Red Granite Gate.*] the pyramidions of gold, that he be given Life like unto Ra forever.	
šhâ Kcât Kxy fawî nb Ir faw-f r Wpt]	Horus, (Exalter of the Crown of Upper Egypt, Beloved of Ra) King of Upper and Lower Egypt, Lord of Diadems, Causing Truth to shine, Beloved of the Two Lands (Men kheper Ra Sehotep Ra) , Lord of Victory, Binder of every Land. He made his boundary at the Horns of the Earth, and the Marshes (?) to Whrn [.....]	(3) Wpt Ta (4) Bîaw (5) Whrn
Kn Jpp-Râ ir n Râ) Wr Whrn (hast) n [n Jrw (hast) tn]]	Horus (Mighty Bull, Shining with Truth) King of Upper and Lower Egypt, (Men kheper Ra, created of Ra). He crossed the Great Bend of Whrs country in force and in Victory at the head of his Army, and made great slaughter [among the fallen foe of that land] [.....]	(6) Pxp Wr Whrn

THIS PAGE IS LOCKED TO FREE MEMBERS
Purchase full membership to immediately unlock this page

DELVE INTO FANTASY, MAGIC, MYTHOLOGY & FOLKLORE

Forgotten Books'
Full Membership gives
access to 797,885 ancient
and modern, fiction and
non-fiction books.

Continue

*Fair usage policy applies

Inscription cut on the pillar of the Southernmost of two Temples on the West Bank of the Nile, South of Wadi-Halfa. I, p. 576 (Photos.) CHAMPOLLION, Notices Descr. (1844), I, 30 & 37 (Plan) LEPSIUS, Denkmäler, Texte (NAVILLE-WRESZINSKI, ROSELLINI, Mon. Storici, III, (1888), 1, (Plan of Wadi-Halfa).

Wady-Halfa is on the East Bank of the Nile at the end of the IInd. Cataract, and 347 miles by river South of Thebes an ancient town called Beheni or Buhen (b-h-n (ḥst)(nwt) BRUCSCH, Dictionnaire géographique, (1879), p. 198.) Here are two SCHIAPARELLI, "Antichità egizia" Pt. I, (1887), p. 248, No. 1542 (2450). The South Temple, containing the text now in question

- A. On the inside of the first portal of the Temple:- (SETHE, Urk. XVIII Dyn. p. 213, No. 80, B) "(...Cartouche...) sa rā (ḤḤwt-ḤḤ) [GARDINER, Zeits. Aeg. Spr. XLV, p. 128, p. 189, n. 1] ḤḤwt-ḤḤ n[ḥ] ḤḤwt-ḤḤ i.e. (Cartouche) Son of Ra, (Thutmose III) [built as a temple between the two Cataracts] that he might make for [his Life Forever]. [Note:- The text restored is all found in the other]
- B. On a door in the second Hall:- (SETHE, op. cit. p. 213, No. 8, C) A similar text, but the name in the cartouche has been altered
- C. Speech of a God in the same Temple:- (SETHE, op. cit. p. 214) Here a relief shows the God addressing Hatshepsut herself. The
- D. Stele of Thutmose III, found in this Temple, now in the Cairo Museum:- (SETHE, op. cit. p. 820) (line 7) qdḥ-ḥ ḤḤwt-ḤḤ n[ḥ] i
- E. Name of the second principal portal in this Temple (SETHE, op. cit. p. 382) (Right Post) šba (ḤḤwt-ḤḤ) n[ḥ] ḤḤwt-ḤḤ i.e. with cartouche of (ḤḤwt-ḤḤ) i.e. Thutmose III, which however is the original name without alteration

SETHE (op. cit. p. 382) concludes that the Temple was built by Hatshepsut and Thutmose III. The Inscription now in question

Text:- SETHE, Urkunden der XVIII Dynastie, (1907), p. 806

Transl.

For Official Titles etc. see Appendix "A"

1	ḥa-t-sp(M. 13: X. 14) XXIII ḥ-r ḥm ḥrw(=G. 8) ka(=E. 8) n-ḥt-ḥ-t(D. 96) ḥā(=N. 23) n	Ḥat-sp ḥwt ḥwt ḥr ḥm ḥrw Ka ḤḤt Ḥā
	was-t(=S. 65)-t (n-t) n šw-t bit [SETHE, Z. Aeg. 49, p. 19] (rā-mn-ḥpr) Conventional ...	Titles and Conventional
3	sa(=G. 67) rā(=N. 7) (ḤḤwt-ḤḤ)(=G. 48) mś(=M. 80)-s[sic.] nfr(=Y. 9) ḥpr(=L. 4) ḥrw(=G. 8)	Sa Rā (ḤḤwt-ḤḤ) mś-s nfr ḥpr [See SET
	nb ḥ-h-n(O. 1) wr(=U. 12)-y Conventional	Eb Bhn (nwt) nry Con
9 ḥā(=P. 19)-
10	-d(D. 96) ḥm(A. 113)-f ḥr wp(=F. 23)-t ta r s-ḥ-r-t[sic.](A. 132) mn-n-t-w(T. 1)(A. 89)	Ḥm-f ḥr npt fa r šḥrt mnwp-w-št-t (
	(pl.) šf(=S. 31)-t-t(N. 40) Titles and Conventional	Conventional
12	nśw(=M. 24)(A. 113) a-s-f šsp(=P. 29)-p-ā[sic.]-f wa(=N. 49)-t mśā(=A. 62)-w(A. 89)(pl.)-f	Nśw [SETHE, Z. Aeg. 49, p. 19] ḡs-f šsp
	q-n(D. 69) r ḥa(=F. 16)-t-f mī(=W. 29)-ī ḥ-h(W. 37) nśw(=M. 24)(A. 113) nḥt(=D. 69)	hh Nśw nḥt ir n ḥpš-f Prā nn
	ir(=D. 10) n ḥpš(=F. 49)-f pr(=O. 3)-r-[ā] nn-n	
13	t-w-t(A. 27)-n-f s-na(=U. 8)[sic.]-w(Z. 30)[sic.] ḥas-t-t(pl.) p-t-p-t(Z. 7)(D. 96)	twt n-f śna ḥośwt ptpt Rtnnwt (ḥas
	r-t[sic.]-n-nw-w-t[sic.](T. 1)(N. 40) in wr(=A. 29)(pl.) n s-q-a[sic.](A. 65)	dkw
	ānh wr(=G. 79)-r-y(M. 9)-s-n(pl.) dk(=G. 53)-k-	
14	-w-ā n nb(=U. 50)(N. 53, N. 53, N. 53) n-h-b-w-w(D. 69) ḥr s-s-m-t(E. 2)-s-n	n no nḥbw ḥr asset-śn
	i-p-t ḥas-t-t(pl.) nw tī-ḥ-nw-w(T. 1)(N. 40) n kś(=A. 19) n baw(=G. 54) ḥm(A. 113)-f	Ipt [GAUTHIER, Bib. d'Ét. IV, p. 33] ḥa
	in(=W. 22)(W. 17)(pl.) i-r-ī ḥr p-s-d[sic.](D. 27)(D. 109)(pl.)-s-n(pl.)	baw ḥm-f inw irī ḥr pśdw-śn
15	[f-s-m](Dog)[(D. 96)(pl.)] mī(=W. 29) ir(=D. 10) t-s-m-w(Dog)(pl.) sb(=O. 71)(Y. 2)t-w	ten[s (?)] mī ir tens ebtw rdīt n
	r-dī(=D. 63)-t n śn(pl.) faw(=P. 16) n ānh Conventional Conventional
18	r-p-ā ḥa(=F. 16)-ā [.....]rw(?=G. 8?) nb tamī(=N. 39) nśw(=M. 24) sa(=M. 67)	Rpātī Ḥatīa [.....]rw (?) Nb Pa
	imī-ra(=S. 37)[Gramm. §84] ḥas-t(pl.) rś(=M. 30) nḥ(=G. 6)-h-ī(A. 131)	Nḥī

XXX. Thutmosis III, "Nehi".

BAEDENKER, Egypt, (1908), p.402: id. (1914), p.412, (Map p.386). Buses, The Nile, (1901), p.480 (Map): id. The Egyptian Sudan, (1907), (19), V, p.186. WATCALL, Antiquities of Upper Egypt, (1910), p.451. MURRAY, Egypt, (1900), p.979: id. (1907), p.543.

It however is a modern town, having been founded by the British. On the opposite bank about two miles South is the site of temples, the North Temple was built by Senwosret I of the XIIth. Dynasty (See State of *Senwosret I*, Museo archeologico de Firenze: claimed by three builders. The records of its origin are:-

hpr (See below, lines 1 & 3) [*irn-f m swn-f n f-f hrw nb Bhn (nwt) irt n-f ht-nfr*] = *inr wd nfr n fa St (=T.31)-t (N.66)* made for his Father Horus, Lord of the City of Behen to make for him a Temple] of the good white stone of *fa St* [the region of the inscriptions]

from Hatshepsut to (.....*ns-s*)

it is conventional.

[*n rwdt* i.e. He built the Temple of hard white stone.

(Hatshepsut) at peace under Horus. Here the cartouche has been altered to (*Ma-hpr-n-Ra*) i.e. Thutmosis II. (Left Post) Same

cut out on a pillar in the First Hall of this same Temple which is dedicated to Horus, Lord of the City of Behen.

See also: Seastedt, Ancient Records of Egypt, II, (1906), §412. (in part: lines 10-15)

<p><i>st Hst Bit (Nn-hpr-Ra)</i> k.XVIII Dyn.p.215] <i>hrw</i> onal<i>ah</i> Titles and <i>t msh-f qn r hat-f ni</i> <i>hrw m sgr-ah wrryt</i> <i>fihn (hst) m ksw n</i> <i>m m ah</i> <i>sw imi-Ra hst R</i></p>	<p>Year XXIII under the Majesty of <i>hrw</i> [Horus], Nighty Bull, Shining in <i>Wast</i> [Thebes], King of Upper and Lower Egypt (Men-kheper-Ra). Conventional ... Son of Ra (Thutmosis III), of Horus, Lord of Behen (City) Beloved Conventional His Majesty stationed at the Horns of the Earth to overthrow the <i>Kunf-s-t</i> Titles and Conventional He, The King Himself led the route of his army, strong at its head like a plane; a King who works with the sword. He marched forth, none like unto him, slaughtering the countries, suiting <i>R-t-n-n-t</i>, bringing their Chiefs as living captives, and their chariots worked with gold, harnessed to their horses. The Homelands of the <i>fihn</i> bow down to the Fame of His Majesty, the tribute belonging to them on their backs; dogging (?) as dog[s] do, that it may bring the giving to them the the breath of life Conventional Hereditary Prince, Count [of a Nome], [.....Ho]rus (?), Lord of the Two Lands. Royal Son, Viceroy of the Countries of the South; Nehi.</p>	<p>(1) <i>Wast</i> [Thebes] (2) <i>Bhn</i> [Behen] (3) <i>Hpt fa</i> [Horns of Earth] (4) <i>Kunf-s-t</i> (5) <i>Rtnwt</i> (6) <i>fihn</i> [African] (7) <i>fa</i></p>
---	--	--

THIS PAGE IS LOCKED TO FREE MEMBERS
Purchase full membership to immediately unlock this page



Never be without a book!

Forgotten Books Full Membership gives universal access to 797,885 books from our apps and website, across all your devices: tablet, phone, e-reader, laptop and desktop computer

A library in your pocket for \$8.99/month

Continue

*Fair usage policy applies

10060. (Rev.Pl.I-III).

), writing of Papyrus Harris No. 501 (Br.Mus.No.19942), says:- "It was purchased in 1855 by Mr. A. C. Harris, H. B. Majesty's (Br.Mus.No.9999) and several other papyri, in a box in the foundations of a Temple In 1872 the papyrus was purchased by 500 was "lately acquired by the British Museum from Miss Harris." At all events, BRUGSCH, Wörterbuch, No.1292, stated that (1909), pp.74,5 etc.

7, 3/4 inches (19.70 cm.). The height of the text varies from 6, 1/3 inches (16.04 cm.) to over 7 inches (17.80 cm.) its color is quite light, and the document is a palimpsest: traces of a poetical text appearing underneath. MÜLLER, (Die Papyrus in style the script of the XVIII-XIX Dynasties, possibly circa Amenhotep IV." That on the Reverse, including the text BRUGSCH, op.cit.) Reverse Pl.I-III, "Thutia takes Joppa", the text now in question. Pl.IV-VIII "The Tale of the Predestined Prince", His tomb has not yet been identified. The sources of his present fame are:- (1) Louvre No.1, Salle Historique, No.358, (Inv.713). with figures of flowers, papyrus and fish in repoussé. It weighs [PETRIE, Egyptian Tales, II, p.11] 5729 grains or nearly 100 grains. See Monuments Égyptiens etc.(1876), p.74 This patera comes from the Drovetti Collection (No.260), and bears a text for which BRUGSCH, Not.Descr.(1827), I, p.95, No.123. Translation by CHABAS, Bibliothéque Égyptologique, IX, p.225: SETHE, Urk.d.XVIII

Pr) = ḥsbd nb(=U.50) (ḥd = U.53) ḥmi-ra(=S.37) ḥšw ḥsy n ḥfr nfr ḥrn nb ḥwḥ ḥa-f ḥšwt sz ḥḥwti(=G.48)(A.131) naḥ-ḥre" Prince, Count of the Divine Father, Beloved of the God. Who fulfilleth the wish of the King in every country and the Isles and God. The Lord of the Two Lands made him his Ka, [Double] Royal Scribe, Thuti.

of which the decoration is analogous to that of the tray described above. From the Anastasi Collection, LENORMANT, Catalogue, BRUGSCH, op.cit.p.87, No.359: Engraving, DEVÉRIA, (as below) A fragment of text gives him another title, viz. "ḥmi-ra ḥšwt ḥḥwti" BRUGSCH, 1857: Sér.III, Tome IV, pp.75, ff. = Bib.Égyptologique, IV, (1896), p.44. SETHE, Urk.d.XVIII Dyn.p.1000, A. 1000, B. found at Thebes. See MASPERO, Études Égypt.I, (1879), p.89 and n.2 SETHE, Urk.d.XVIII Dyn.p.1000, B.

id. The text on the mounting is a conventional funerary ritual of eleven lines: the name of the deceased is "ḥmi-ra ḥšwt ḥḥwti" (BRUGSCH, 1840), p.202: O, 86. DEVÉRIA, op.cit.p.36. MASPERO, op.cit.p.69. SETHE, op.cit.p.1001, P. found in Thebes". Two short lines. No new titles. LEEMANS, op.cit.Pl.58, id.Description raisonnée etc.(Leyden, 1840), p.89,

MASPERO, op.cit.I, p.69. DEVÉRIA, op.cit.p.42. SETHE, op.cit.p.1001, O and 1002, C. Two lines, no new titles. p.1000, E, p.1001, C. BRUGSCH, Thesaurus, (1891), p.1424, "a" MASPERO, Rec.de Trav.IV, (1883), p.187, No.2. (9) SETHE, op.cit. p.cit.p.1424, "c". MASPERO, op.cit.p.137, No.3. (11) SETHE, op.cit.p.1000, H p.1001, k. (H) Each have two lines of text, the 10. "Companion of the King in every country." (11, H) "ḥmi-ra ḥw(=E.14)ḥt (pr)" i.e. "Director of the Farm." (BAILLET,

op.cit.p.1000, J-M, p.1002, "o"(J.M) Conventional ritual, no new titles.

1), p.84: SETHE, op.cit.p.1001, Q and g(Q), p.1002, a-b: The texts are:- ḥn(=W.22)-ḥrt(=W.1) ḥb ḥn (nwt) rdī-f ḥnb ḥm ḥb

ing to the reign of Thotmes the Third. in S.B.A.Trans.III, (1874), pp.840, ff. also Journal Asiatique, X, (1877), pp.239, ff. Études Égyptiennes, I, (1879), pp.80, ff.Rev.Pl.I-III.(facsimile Hieratic Text), pp.49, ff.Hieroglyphic Transcription. Rev.Éd.1911), pp.115, ff. WIEBEMANN, Altaegyptische Sagen und Märchen, (Leipzig, 1906), pp.112, ff.

gypt, (1905), p.312, pp.322, ff. MASPERO, Struggle of the Nations, (1897), p.277

script reads from Right to Left, and on Page I the right hand script or beginnings of the lines is missing. On Pages II beginning of the tale. MASPERO, PETRIE and WIEBEMANN (as cited above) give tentative suggestions as to this missing part.

THIS PAGE IS LOCKED TO FREE MEMBERS
Purchase full membership to immediately unlock this page

DELVE INTO FANTASY, MAGIC, MYTHOLOGY & FOLKLORE

Forgotten Books'
Full Membership gives
access to 797,885 ancient
and modern, fiction and
non-fiction books.

Continue

*Fair usage policy applies

(Text and Restorations: MASPERO, Ét. Ég. I, pp. 53, ff. (who gives no line numbers))

[.....] n-a htp(=Q.17)-t-p[(Z.10)](pl.) [.....] [ś]-n (pl.) mī(=W.29)-ī
 r-rdī(=D.59) n htp(Z.10)(pl.)[.....]
 [.....] ghwtī(=G.48)-ī(A.89)[.....]f t-a iw(=E.14)-â-y-t(Y.2)(D.69)(A.89)
 (pl.) âa(=T.41)pr(=O.3)(O.3) ânĥ wġa śnb
 [.....] hr(pl.)[sic.]-ś-n(pl.) ĥ-r ĩ-r hr śa(=T.38) wn(=E.58)-n
 nw(=W.21)-t(N.35)(N.7)-ś-n(pl.) t-ĥ-w(Y.2)(D.69)
 ĩ-w ghwtī(=G.48)-ī(A.89) hr ġ-d n [pa(=G.73) ĥ-r-y(A.80) n y-p-w(T.1)(N.40)
 ĥa(=M.42)-a-n(pl.)ra(=D.29)(A.91)-k
 ĩ-w-A.89 ĥm(=D.95)-s(A.92)]k-w(A.89) ĥ-n-â ĥm(=D.95)-t(B.7) xrd(=A.71)(A.89)(B.7)
 (pl.) pa(=G.73)-y-k d-mī-ī-t(N.48)(N.40) n ĥ-â-t(D.111)(pl.)-k
 ĩ-m-m-â ś-âq(=G.71)-q(D.96) n-a m-â-
 [-h-a-w(A.89)(pl.)-A.89 ĥ-n-â ĥ-t-r-ī(M.13)(F.58)(pl.)-ś-n(pl.) m t-w]-t-w
 [rdī(=D.63)]-t n-ś-n(pl.) imī(=R.28)-m-w(W.53) m ra(=D.29)-p-w ĩr(=D.10)
 wâ(=U.37)-â n â-p-w-ra(=D.29)(T.1)(N.40) s-n-n-ī(Z.20)(D.96)
 [r pa(=G.73) n-t-ī ĩ-w-ś-n(pl.) ĩ-m-ī-w-t-w hr ś-âq-
 -q(D.96-ś)]-n(pl.) ĩ-w-t-w hr ĥ-f-â(Y.2)(D.69) n-a n ĥ-t-r-ī ĩ-w-t-w hr rdī(=D.63)-t
 n-ś-n(pl.) imī(=R.28)-m-w(W.53)(pl.) ĩ-w-
 [-t-w hr ġm(=G.46)-m(Y.2) t-a â-wn(=E.58)-n-t(M.9) âa(=T.41)-t[sic.] n]
 nśw(=M.24)-t-n(A.113)(râ-mn-ĥpr) ânĥ wġa śnb ĩ-w-t-w hr ĩī(=M.34)-y-ī(D.96) hr
 ś-mī(=W.29)-[w(A.91) ś-t n] ghwtī(=G.48)-ī(A.89) ĥ-r
 [m śa(=T.38) n-a-ī wn(=E.58)-n-ī-n pa ĥ-r-y(A.80) n y-]-
 -p-w(T.1)(N.40) hr ġd n ghwtī-ī(A.89) ĩb(=W.23)-A.89 r p-t-r-ī(M.13)(D.11) t-a
 â-wn(=E.58)-n-t(M.9) âa(=T.41)-t(Y.2) n nśw(=M.24)-t-n(A.113) (râ-mn-ĥpr) ânĥ wġa śnb
 [.....]-tī(=U.19)-ī-w-t nfr(=Y.9)-f-r(Y.2)(A.113) r-n-(A.91)-ś waĥ(=V.37)-ĥ(Y.2)
 ka(=D.46) n nśw(=M.24)-t-n(A.113) (râ-mn-ĥpr) ânĥ wġa śnb ĩ-w-ś n-k m pa(=G.73)
 h-r-w(N.7)
 [.....] nfr(=Y.9)-f-r(Y.2) m p-w k ĩn(=W.22)-n ś-w n-A.89(?) ĩ-w-f hr
 ĩr(=D.10)-r-t m mī(=N.29)-t-t(Y.2) ĩ-w-f hr ĩn(=W.22)-n-t
 t-a â-wn(=E.58)-n-nw(=W.21)-w(M.9) n nśw(=M.24)-t-n(A.113) (râ-mn-ĥpr) ânĥ wġa śnb
 [ĩ-w-f hr a-m(D.82)(D.69) pa(=G.73) ĥ-r-y(A.80) n y-p-w(T.1)(N.40) hr] pa(=G.73)-y-f
 Z.10(? = ĥśb GRAPOW, Z. Aeg. 49, p. 116)-N.42[sic.]-y(V.6) ĩ-w-f hr âĥâ(=P.19)-â(D.96) m
 â-wn(=E.58)-n(D.96)-f hr ġ-d-ī(A.91) n-nw(=U.4)-nw(=W.21)(D.11) ĩ-m(Y.2) pa ĥ-r-y-
 (A.80) n
 [y-p-w(T.1)(N.40) t-a â-wn(=E.58)-n-t(M.9) âa(=T.41)-t n nśw(=M.24)-t-n](A.113)
 (râ-mn-ĥpr) ânĥ wġa śnb pa(=G.73) ma(=U.8)-a ĩ-w(F.58) ĥ-ś-śa(=T.38)-a-w(Y.2)(D.96)
 sa(=G.67) śĥm(=S.50)-ĥ-t(A.113)-ī-w rdī(=D.63)-f-t[sic.] ĩ-m-n(A.113)
 pa(=G.73)-y-f
 [ĩ-t-f(A.89) ĥ-ĥt(=M.9)-ĥ-t(D.69) ĥ-n-â wśr(=S.66)-ś-r(D.69) ĩ-w-f hr] f-a(A.105)
 (D.69) [d]-t(E.111)-f ĩ-w-f hr ĥ(A.31)(U.7)(D.69) ma(=U.8)-maâ(=Q.58)-â-[t](F.41)
 pa(=G.73) ĥ-r-y(A.80) n y-p-w(T.1, N.40) ĩ-w-f hr h-a-y-ī(D.96)
 m [b-g-a-ś(A.92)(G.80) m baĥ(=D.90)(Y.2)-f ĩ-w-f hr rdī(=D.63)-t-f m pa(=G.73)
 [.....] m [.....](pl.) d-ĥr-r-ī-w(F.58)(pl.)
 ĩ-w-f hr q-n-ī-w[(D.41)(D.69)[.....]
 pa(=G.73) â n ĥmt(=W.59)(N.53)(pl.) ĩ(A.91)[.....] p-a-y mr(=U.12)(D.69)[sic.]
 n pa(=G.73)-a
 ĥ-r-y(A.80) n y-p-w(T.1)(N.40) ĩ-w-t-w hr rdī(=D.63)-t pa â n ĥmt(=W.59)(N.53)(pl.)
 n IIII n-m-m-ś-t(N.8) m r-f [sic.] (D.99, D.99)(D.111)-f ĩ-w-f hr rdī(=D.63)-t
 ĩn(=W.22)-n-t-w
 pa CCCCC n
 ĩ-a-ĥ-b-w-śd(=T.38)-tī(=U.19)-ī(V.45)(pl.) ĩ(A.91) rdī(=D.63)-t-f. f
 wġ(=M.73)-w(N.7) ĩ-w-f hr rdī(=D.63)-t h-a-y-ī(D.96) CC n w-â-w(Y.2)(D.69)(A.89)(pl.)

XXXI. Thutmose III, Papyrus Harris 500. (2)

Geographical Names

[.....] the panniers [.....] their [.....] as is done
to the panniers

[.....] Thutia [.....] the troops of Pharaoh, L. H. S.

[.....] their heads. Now then, after it was their time
for drinking,

Thutia said to [the Fallen Foe of *Ypw*; "If it pleaseth thee, (1) *Ypw*

"I am living with the women and children of thy City and of thy
"body.

"Grant that these my tri-

"[besmen may make entry with their horses likewise (?)

"[to giv]e to them fodder;

"or that one of *Āpura* may run over (2) *Āpura*

"[to the place where they are:" It was allowed that]

they [make entry]. The horses were tethered and to them was
given fodder. [Then] there was

[found the staff of the King of Upper Egypt (Men-kheper-Ra) L.
H. S. and one went who should te[ll of it to] Thutia. And

[after that it was that the Fallen Foe of *Y*]-

-pm said to Thutia; "My wish is to see the great staff of the (3) *Ypw*

"King of Upper Egypt (Men-kheper-Ra) L. H. S.

"[.....]ist *Nfr* its name. Long live the Ka of the King of

"Upper Egypt, (Men-kheper-Ra), L. H. S. It is for thee [i.e.

"thou hast it now] at this time

"[.....] luck (?) with it [so] fetch thou it to me."

Then he [Thutia] did so. He brought

the staff of the King of Upper Egypt (Men-kheper-Ra) L. H. S.

[and he siezed the fallen foe of *Ypw* by] his garment (?) (4) *Ypw*

and he stood at his full height and spake: "Look

"thereat, Fallen One of

"[*Ypw*, the great staff of the King of Upper Egypt, (Men-kheper- (5) *Ypw*

"Ra), L. H. S. the fierce lion, Son of Sekhmet, [i.e. The Lion
or Cat-headed God, i.e. Sokhit or Bast, See Table No. XIX]

"Amon his

"[Pather gave him Strength with Power." And he smote the

temple (?) of the Fallen Foe of *Ypw* [so that] (6) *Ypw*

he fell as helpless before him. He put him in the [.....]

and into the [.....] skins

and wrapped [.....]

the chain (?) of metal which [.....] this binding of the

Fallen Foe of *Ypw*. And one put the chain of metal of four

links (?) on his two feet. He caused one to bring (7) *Ypw*

The 500 of

"sacks" [Pεραιε] which he had brought to light, and he made to
get down 200 of the soldiers

f hr hr ma[ti]
w[ai] (BUDGE, E'gn.

ba[hr]-f i[hr]-f hr
a[hr]i[hr]

i (BUDGE, E'gn.
Z. Aeg. 51, p. 118,
hr rdit pa a
i[hr]-tu

no. 1128] (?)
it n. a[hr]u

THIS PAGE IS LOCKED TO FREE MEMBERS
Purchase full membership to immediately unlock this page



Never be without a book!

Forgotten Books Full Membership gives universal access to 797,885 books from our apps and website, across all your devices: tablet, phone, e-reader, laptop and desktop computer

A library in your pocket for \$8.99/month

Continue

*Fair usage policy applies

II

r pa(=D.29)(pl.)-s-n(pl.) i-w-t-w hr mh(=V.15)-n q-n-i-w(D.41)(D.69)(pl.)-s-n(pl.)
 [n] m-a-ha(=M.68)-a(V.6)(pl.) hr q-a-ha(=M.42)-a(M.9)(pl.)
 i-w-t-w hr h-t-m-r(S.39)(D.69) w(pl.)[GAUTHIER,Bib.d'Ét.IV,p.47]
 hr h-t-m-r(S.39) i-w-t-w hr rdi(=D.63)-t n sn(pl.) n-a-y(pl.)[sic.]-s-n(pl.)
 f(=U.19)-d-w(V.45)(pl.) h-n-a n-a-y(pl.)-s[page 62]-n(pl.)
 ma(=U.8)-a-wd(=M.73)-w(M.9)(pl.) i(A.81) h(?)-m-rw(=E.58)-rw[...] (pl.)
 i-w-t-w hr rdi(=D.63)-t w-a-w(Y.2)(D.69)(A.89)(pl.) nb-t nfr(=Y.9)-f-r
 xr(=Q.20)(Y.2) s-n(pl.) htp(=Q.17) s(A.89) CCCCC
 i-w-t-w hr g-d n s-n wn(=E.58)-n t-n(pl.) hr aq(=G.71)-q(D.96) r pa(=G.73)
 d-mi(=N.29)-t(N.47)(O.1) i-w-t-n(pl.) hr wn(=E.58)-n(O.69)(D.69) n-a-y(pl.)-t-n(pl.)
 i-r-i(B.12)(A.89)(pl.)-t-w-t-n(pl.) mh(=U.15)(Y.2) m r-f[sic.](A.89)(B.7)(pl.)
 nb(=N.43) n-t-i m pa(=G.73) d-mi(=N.29)-i-t(N.47)(O.1) i-w-t-n(pl.)
 rdi(=D.63)-t-w n-a m-a-ha(=M.68)-a-w(V.6)(pl.)
 hr-r a i-w-t-w hr pr(=O.3)-r(D.96) r g-d n pa(=G.73) ka(=D.46)-fa(=G.87)-a-n-a(D.99)
 (D.96) n pa h-r-y(A.80) n y-p-w(T.1)(N.40) h-r-w(A.133)(D.96) pa[page 63]-y-k
 nb i(A.91)-sm(=N.61)-m-t(D.96) g-d n t-a-y-k h-hnw(=W.31)-t(A.113) nqm(=M.98)-m
 ib(=N.23) i(D.91) rdi(=D.63)-t n(pl.) sw(=M.24)-w[-t-h](A.113) ghwti(=G.48)-i(A.89)
 h-n-a hm(=D.95)-t(B.7)-f xrd(=A.71)(A.89)(B.7)(pl.)-f
 p-t-r-i(M.13)(D.11) d-t(D.111)(?) [or a-t(D.111) MASPERO,Ét.Ég.I,p.63,n.3: GOODWIN,
 PETRIE, ir(=D.10)-r-w(pl.)] bk(=G.53)[MASPERO,Ét.Ég.I,p.63,n.3]-k-w(Y.2)(D.69)-s-n
 k-a(A.91) n-s r pa(=G.73)-a CC n t-h-b-m-sa(=T.36)-
 -ti(=U.19)(V.45) n-t-i mh(=V.15)(Y.2) m r-f[sic.](A.89)(B.7)(pl.)
 hr q-a-ha(=M.42)-a(M.9)(pl.) hr m-a-ha(=M.68)-a(V.6)(pl.) wn(=E.58)-n-i-f hr
 sz(=N.61)-m-t(D.96) r ha(=F.16)-t-s-n(pl.) r s-nqm(=M.98)-m(Y.2) ib(=N.23)(Y.2)
 n t-a-y-f h-hnw(=W.31)-t(A.113)
 r g-d mh(=U.15)(Y.2)-n(pl.) m ghwti(=G.48)-i(A.89) i-w-t-w hr wn(=E.58)-n(O.69)(D.69)
 n-a n h-t-m-r(S.39)(O.3) n pa d-mi(=N.29)-i-t(N.47)(O.1) r ha(=F.16)-t n
 w-a-w(Y.2)(D.69)(A.89)(pl.)
 i-w-s-n(pl.) hr aq(=G.71)-q(D.96) r [page 65] pa d-mi(=N.29)-i-t(N.47)(O.1) [i-w-s-n
 (pl.)] (2) hr wn(=E.58)-n(O.69)(D.69) n-a-y(pl.)-s-n(pl.) i-r-i(B.12)(A.89)(pl.)
 i-w-s-n(pl.) hr mh(=U.15)(Y.2)[m pa]
 a-mi-i-t(N.47)(O.1) m s-r-i(G.80)(pl.) m a(=T.41)-a-y(Y.2)(pl.) i-w-s-n(pl.) hr
 rdi(=D.63)-t-w n-a
 m-a-ha(=M.68)-a-w(V.6)(pl.) m q-a-ha(=M.42)(M.9)(pl.) hr-r a i-w pa
 f-n-ti(=U.19)-n(pl.)-ra(=D.29)(D.69) n a(=T.41) pr(=O.3)(O.3) anh wda snb hr
 mh(=V.15)(Y.2)[m pa] d-mi(=N.29)-i-t(N.47)(O.1)
 s-dr(=N.40)-r(O.8) ghwti(=G.48)-i(A.89) i-w h-a-b
 (D.96)-f r kz(=I.8)-m-t(O.1) n
 nsb(=M.24)-t-n(A.113) (ra-nn-hpr) anh wda snb pa-y-f nb r g-d nqm(=M.98)-m(Y.2)
 r k rdi(=D.63)-w n k i-mn-n(A.113) pa-y-k i-t-f(A.113) nfr(=Y.9)-f-r pa h-r-y(A.80) m
 y-p-w(T.1)(N.40) h-n-a r-f[sic.](A.89)(A.87)(pl.)-f nb-t mi(=N.29)[sic.]-t-t(Y.2)
 pa-y-f (10) d-mi-t(N.47)(O.1) i-w-k-a iw(=D.96)-w(D.96) r-t[sic.](A.89)(B.7)(pl.) r
 i-fa(=G.87)-a(D.96)-w-t[sic.] w (pl.)
 m ha(=M.42)-a-q-a[= w ?](Z.7)(Y.2) mh(=V.15)(Y.2)-k pr(=O.3) n i-t-f(A.113)-k
 i-mn-n(A.113) ra(=N.7)(A.113) nsb(=M.24)-t-n(A.113) nfr(=R.13) nfr nfr(A.113)(pl.)
 m hn(=N.6)-w(A.89)(pl.) wr(=N.58)(N.47)(B.7)(pl.) i-w(pl.) h-r-w(A.133)(D.69)
 xr(=Q.20)-r(Y.2) r-f(D.99)(D.99)(D.111)-k
 r n-h(N.7)h g-t(N.37) iw(=D.96)-w-s p-w
 nfr(=Y.9)-f-r i-m ka(=D.46)
 n sx(=Y.1) i-q-r(Y.2) m h-hs(=N.4) s-w-i
 sx(=Y.1) [..... ?]

III

r [Gramm.§446,b] ra-
 mshaw [GARDINER,Admon
 [PIERRET,p.610] i-w-
 hr htw i-w-tw hr rdit
 (R.38)(laced) sandals
 mawdw [Cf. mawdw(H.17
 ihwrrw (?)] [See MASP
 rdit waww[LORET,Bib.d
 [BUDGE,op.cit.492] s
 n sn wa-ta hr aq r pa
 iritu[SETHE,Z.Aeg.47,
 mh m rwt nb nti m pa
 ditw na mahaw
 hr a [BUDGE,E.R.Bk.36
 kašana n pa hry n Ypa
 nb isst [Gramm.§381,1
 i rdit n(pl.) Sethe]

 Ptri drt [or at or i
 de Tr.32,p.73,33 p.7
 thwšati [See above]

 hr qahaw hr mshaw [se
 sn r snqm ib n tay-f

 r gd mh-n(pl.) m ghwt
 (pr) n pa dait r hat

 iw-sn hr aq r pa dmš
 hr wn nay-sn iri-w-sn

 dait m sriw m aay iw

 mshaw m qahaw hr a f
 fn-ra [BUDGE,Eg.R.Bk
 mh [m pa] dmš
 sdr ghwti iw hab-
 -f r kut (nut) n
 NSwt (Nn-hpr-Ra) A.
 r k rdiw n k iwn pay
 Ypw (hast) hnā rwt-
 dmš iwā iw rwt r

 m haqw (?)
 mh-k Pr n Itf-k Inw
 m hnw [BAILLET,Rec.É
 hrw xr rdi-k
 r nhp dt iw[Gramm.§2
 nfr in[Gramm.§453] m
 n Sx iqr m hswi
 sx [..... ?]

Note:- An interesting discussion of the historical value of this tale may be found in MASPERO, Études Égyptiennes,

	Petrie	Wiedemann	Cont. Pop. p. 4		Geographical Names
in qnīw-śn [w hr qahaw (h pl.) ḫbw [Cf. ḫbt	4	115	120	into their mouths, and their bindings were filled in [consisting of] cords (?) [lit. "binders"] on wooden fetters. They were sealed with seals	
Bk.158, line 12] text] i-w-tw hr bt nfr xr śn ḫtp 8] i-w-tw w n nwy-tn	5		121	and for then were provided their lashings (?) with their hearing poles (?) ? ? ?	
hr r ḡd n pa		116		Then were placed all the brave officers among them, altogether 500 men. [line 8] And it was said to them: "When ye enter into the "City, ye shall open yours and [those] of your "companions, "sieve all the people who are in the city, and you are to "put on the cords "forthwith." [Then] one went forth to tell to the charioteer of the Fallen Foe of Ipw; "Fallen is thy "Lord! Go say to thy Mistress: "Joy of heart! for Sutech hath given "us Thutia with his wife and his children.	(8) Ipw
DIMER, Rec.				"Behold their handiwork [booty] [Thus] explaining for her as to the "200 sacks of those filled	
hr śnt-r ḫat				"with people and wooden fetters and cords." [So] he went before them to give joy of heart to that Mistress	
n ḫtes				by saying "We have captured Thutia." [Then] were opened the locked places of the city before the officers and they entered into the City [They] opened those of their companions, laid hands up[on the]	
na				City with the small and the great and there were put upon them the cords with wooden fetters forthwith. When the Force of Pharaoh L. H. S. had siezed [upon the] City	
n. S. hr				Thutia rested, and sent a message to Egypt to the King of Upper Egypt (Men-kheper-Ra), his Lord, to say:- "Joy "to Thee, Amon thy blessed Father hath given to thee the Fallen Foe "of Ipw with all of his people, likewise his "City. Grant that people shall come to lead them forth "into captivity. "Mayst Then fill the House of Thy Pather Amon Ra, King of the Gods, "with servitors and serfs who are fallen under thy two feet. "for ever and ever." It came to perfection [by] the cleverness of a scribe excelling in etymology. The Scribe [..... ?	(9) Int (10) Ipw
[id. p. 211] is					
HE, Unters. V, 60] Sphinx, XVII, 42]					

THIS PAGE IS LOCKED TO FREE MEMBERS
Purchase full membership to immediately unlock this page

DELVE INTO FANTASY, MAGIC, MYTHOLOGY & FOLKLORE

Forgotten Books'
Full Membership gives
access to 797,885 ancient
and modern, fiction and
non-fiction books.

Continue

*Fair usage policy applies

TABLE No. XXXII. THUTMOSIS (DHWYXSS) III - AMENHOTEP (IHWHTP) II. Life of

Tomb; Sheikh 'abd el Qurna. Present Number 85: (Also Numbered 12, 86, 37, 64 See The Tomb of Amenemheb is reached by passing through the entrance to the enclosure behi du Service etc. IX, (1908), p. 133) "No. 85, Amenemheb, the well known General of Thothme about 12 metres (40 ft.) in width by about 6 metres (20 ft.) in depth.

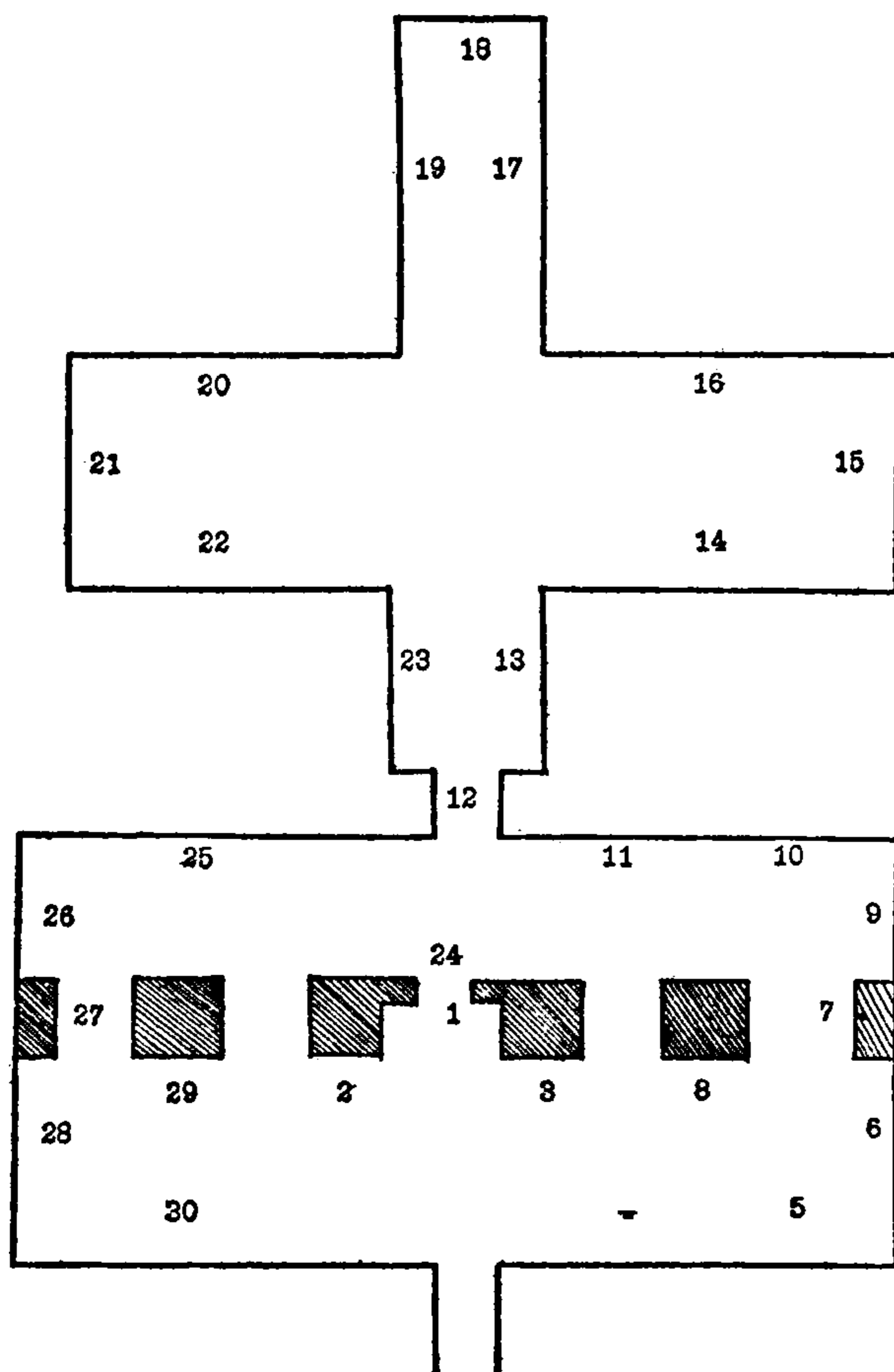

Plan	Weigall.	Baedeker.	Piehl.
1	.	.	f-g
2	.	.	g
3	.	.	r
4	1	.	d
5	2	.	d
6	3	.	c
7	.	.	b
8	.	.	e
9	4	.	a
10-11	5-6	.	m
12	.	.	.
13	.	.	n
14	10	e	y
15	11	.	x
16	12	d	v
17	15	g	u
18	.	.	t
19	14	f	s
20-21	.	.	.
22	13	c	p
23	9	c	o
24	.	.	i
25	.	.	i
26-28	.	.	.
29	.	.	.
30	.	.	.

XXXII. Thutmosis III-Amenhotep II, Amenemheb.(1)

res", including the Cemetery of Sheikh abd 'el Gurna, has been fully described in Table No. XX above.

ms of Rekhmara (No.100, & Table XXXIV, below) and Senofer (No.99 & Table XX, above). WEIGALL identifies it (Annales
 Notes:- To these should be added the No. 12 of CHAMPOLLION: (Not. Descr. I, p.505)] The first Hall or Vestibule measures

atures.

emheb and Baki his wife. (2 Scenes)

3 sides)

" ")

. (Two texts)

908 C = ξ 918 M = v

PIÉHL, 1, 2 pp. 88-91

ibid. Amon. (3) Amon seated.

es).

II, adore Osiris.

ach. (See below).

SETHE, p. 919 O = λ 917 S = i

Text "A" below].

EBERS, Zeits. D.M.G. 39, p. 401.

(See Bibliog. below. WRZINSKI,
 Taf. 24.

ext).

etc. (No text)

eral Barge etc. (No text).

lintel).

flowers which Amenhotep brings.

ow).

WRZINSKI, 21 VIREY, II, 5.

VIREY, 279.

nd "wnit". Other scenes defaced.

Commissary.

SETHE, p. 918 N = φ

THIS PAGE IS LOCKED TO FREE MEMBERS
Purchase full membership to immediately unlock this page



Never be without a book!

Forgotten Books Full Membership gives universal access to 797,885 books from our apps and website, across all your devices: tablet, phone, e-reader, laptop and desktop computer

A library in your pocket for \$8.99/month

Continue

*Fair usage policy applies

MAPS & PLANS:

(The Necropolis of West Thebes): BAEDEKER, Egypt, (1908), p.278: (1914), p.280. MURRAY, Handbook for Egypt
GARDINER & WEIGALL, Topographical Catalogue of the Private Tombs in West
(Sheikh 'Abd el Gurna.): BAEDEKER, Egypt, (1908), p.305 (Tomb of Amenemheb, No.36) id. (1914), (No plan
(Tomb of Amenemheb.) ESAWS, Zeits.d.D.Morg.Gesell. XX, (1876), p.393 PIEHL, Inscriptions hiér.
BAEDEKER, Egypt, (1908), p.309: (1914), p.311: id. Egypten, (1913), p.298 VIREY

Discovery etc. CHAMPOLLION, Notices Desor. I, (1844), 505 (Tomb No.12) VIREY, Records of the Past, (n.s.) IV, (1890), p.1

Descriptions. CHAMPOLLION, op.cit. PIEHL, op.cit. ESAWS, op.cit. VIREY, op.cit. MURRAY, op.cit. WEIGALL

Photographs etc. (Scene No. 10)(Asiatic):- VIREY, Mémoires de la Mission française au Caire, V, 2: Pl.1-3 & Rec.Past, (op.cit.),
(Scenes 14-15)(Netting in Swamp):- VIREY, op.cit.V, 2: 278-4 WRESZINSKI, op.cit.Pl.24 WILKINSON, Manners and

Texts. (Scenes):- PIEHL, Insor.Hiér. I, 1, (Planches, 1886), Pl.CIX, F.- CXIII, G. Pl.CXIV, O.- CXVII, P. ESAWS, (Scene 14)
(Titles):- PIEHL, op.cit. VIREY, op.cit. SETHE, op.cit.pp.898-906 (Baki), 919-922
(Historical Biography), (Scenes 10-11):- ESAWS, op.cit.Pl.I-III. & Zeits.f.Aeg.Spr. XI, (1873), pp.3, ff. (Corrected by
W.MAX.MÜLLER, Egyptological Researches, I, (1906), Pl.89 SETHE, op.cit.;

Transliteration. ESAWS, Zeits.d.D.M.G. (op.cit.), pp.410, ff. & Zeits.Aeg.Spr. (op.cit.), pp.8, ff.

Translation. ESAWS, op.cit. and in BRUGSCH, Geschichte Aegyptens etc. (1877), pp.335, ff. id. Egypt under the Pharaohs, I, (1878),
pp.155, ff. id. Mélanges Égyptologiques Sér. III, II, pp.279, ff. = Bib.Égyptol. XII, (1905), pp.830, ff. BIRCH,
BREASTED, Ancient Records of Egypt, II, (1906), §§579, ff. RANKE in VON GRESSMANN, Altorientalische Texte

Summary and Comment. ESAWS, Zeits.d.D.M.G. (op.cit.), 31, (1877), pp.489, ff. (Comment) STERN, as above, SJÖNESS, as above
BREASTED, History of Egypt, (1905), pp.301, ff. pp.311, ff. (Summary) WRESZINSKI, as above.

As to hunting with nets (Scenes 14.15) see ERMAN, Aegypten und Aegyptisches Leben im Altertum, (1885), p.328: id. Lif
BÉNÉDITE, Zeits.f.Aeg.Spr. 48, (1911), pp.1, ff. WILKINSON, Manners and

Text "A" Various Titles taken

No.	SETHE, Urk. XVIII Dyn. pp. 898-919	VIREY, Mémoires de la Mission française au Caire, V, 229-285	PIEHL, Insor. Hiér. I, 1,
1- 4	(1) r-p-â (2) ḥa(=P.16)-â (3) bit(=L.1)-t qast(=S.45) (4) é-mr(=U.31) âa(=T.41) n mr(=U.12)-r-t	(1) Rpâti (2) Ḥa-â (3) Bit Došt (4) Šmr m n Hrt	
5- 6	é-mr(=U.31) wâ(=U.27) (6) ra(=D.29) n šw(=M.24)-t-n (7)	(5) Šmr Natı (6) Ra n Ššwt	
7- 8	ânḥ(=S.43)(P.46)(F.46) n bit(=L.1)-t (8) mh(=V.15) id(=W.29) mn(=Y.12)-n-ḥ(=U.27) s nb(=W.43) tasi	(7) Ânḥi n Bit (8) Mḥ-id mḥ n Nḏ Fawī	
9	nšwt(=M.24) šms(=U.42)-š r iw(=D.96)-t(pl.)-f ḥr mw(=N.55) ḥr ta(=N.37) ḥr ḥast(=N.40)(pl.) nb(=W.43)-t ḥr išt(=Q.1.)-t(O.3) nb-t	(9) Šmš-ššwt [Gramm. §42: SETHE, Z. Aeg. 49, p.19] r išt-f ḥr Nw ḥr Fa ḥr ḥast nbt ḥr išt nbt ḥnd [...] n ḥn-f(9s) Kfâ gn n šwt Fawī Dm n (10) Tpi n Šmr-f n	
9a	ḥ-n-d(D.99)[...](D.96) n ḥn-f(9a) ḥ-f-â(D.82)(D.69) ḥ-n(D.69) n ša(=T.38)	(11) Ḥr dada n Imw-ḥt-f šia-f šw n Irw laht rḥn-f mḥr-f mât-n-f	
10	nb tawi di(=X.22)-w m (10) tp(=D.1)-p-ī n é-mr(=U.31)-mr-mr-f m	(12) Idm n Kšw [See "Biography", line 49]	
11	ḥr(=D.3) (11) qa-da(=D.1) n im(=R.28)-w(pl.)-ḥt(=M.9)-ḥ-t(D.96)(pl.)-f šia(=Y.11)-a-f šw(=M.24)-w m ir(=D.10)-w iah(=G.57)-ḥ-t r-ḥ(Y.2)-n-f mḥr(? =Q.39 ?)(D.69)-f m-â-t-n(N.49)-f	(9) Šmš Nḏ-f r išt-f ḥr ḥast Rst Nḥtt m tsit [sic.] r Nḏ Fawī ḥr pris mnt atī ḥšf s ḥḥ	
12	(12) idn(=F.48)-nw(=W.21) n mšâ(=A.82)(pl.)	(13) Fati (Ninw)[See Thutmosis III Annals, line 71, Table No. XXXV] rdi n Nḏ Fawī Ninw rdi-f ḥr m ḥr ta ḥr ḥust nbt	
9	šms(=U.42)-š nb(=W.43)(A.117)-f r iw(=D.96)-t(pl.)-f ḥr ḥast(=N.40)-t rs(=M.80)-t(N.43) mh(=V.15)-t-t t-tm(=U.14) t-š-ī[sic.]-t(D.96) r nb tawi(=N.39) ḥr p-r-ī(M.17)(D.69)(pl.) mn(=E.58)-n-nw(=W.21)-t(N.85)(M.7) n-t ḥšf(=M.79)-f(D.69) s(A.89) ḥḥ(=A.106)		
13	(13) ḥa(=P.16) t-ī (A.128) [GARDINER, Z. Aeg. 42, p.119] r-d(D.99)(D.99)(D.96) n nb tasi minw(=A.128)(Y.2) r-d(D.99)(D.99)-f ḥr mw(=N.55) ḥr ta(=N.37) ḥr(=D.3) ḥast(=N.40)-t(pl.) nb-t(pl.)	(13a) rs dade mḥ n Nḏ-f (14) Ra n Ššwt n [šš]m rḥyt	
13a	[13a]rs(=T.2)(D.10) dago(=D.1)[SETHE, Untersuch. V, p.53] mn-n-ḥ(U.27) n nb-f		
14	(14) ra(=D.29) n šw(=M.24)-t-n m [s-šm(=T.20)]-m(D.96) r-ḥ-y-t(G.82)(pl.)		

- the Sudan, (1900), p. 774: (1907), p. 379. LEPNINS, Deaküller, I, 73 (General Map of Thebes): I, 57-8 (Panorama of Guras).
 (London, 1913), Plates I-XV.
- Tomb number is 85), p. 311. MURRAY, Handbook for Egypt etc. (1907), p. 347 (also No. 34). GARDINER-WEIGALL, op. cit. Pl. I-VII.
- ptiques, I, 2, (Commentaire, 1888), p. 88 WEIGALL, Antiquities of Upper Egypt, (1910), p. 127 MURRAY, Egypt, (1907), p. 440
 , Émoires de la Mission française au Caire, V, (1889), p. 229
- s Zeits. d. D. M. G. (op. cit.) BEBASTES, Ancient Records of Egypt, II, (1906), §574, n. g.
- pit. BAEDEKER, op. cit. WRESZINSKI, (See below).
- p. 2 WRESZINSKI, Atlas sur alt-ägyptischen Kulturgeschichte, (1914), Pl. 4
 as Customs of the Ancient Egyptians, III, (1847), p. 38, p. 53. (Scene 24) (Byena): - WRESZINSKI, op. cit. Pl. 21
- ts. d. D. M. G. (op. cit.) p. 401 VIREY, op. cit. V, (1889), 228-285 SETHE, Urk. XVIII Dyn. (1907), pp. 906-919 (Baki), pp. 923-925
- es, id. p. 64, & XIII, (1875), p. 175) VIREY, op. cit. pp. 238, ff. (Corrected by SJÖNESS, Sphinx, I, (1897), pp. 18, ff.)
 2(399)
-), 345, (1891), pp. 163, ff. CHARAS, Comptes Rendus des Séances de l'Académie des Insor. et des Belles Lettres, Sér. IV, I, (1873),
 Past, (o. s.), II, (1874), pp. 61, ff. VIREY, op. cit. & Rec. Past, (n. s.), IV, pp. 7, ff. PETRIE, History of Egypt, II, (1899), pp. 254, ff.
 Her, (1909), pp. 242, ff. (lines 2-32)
- LEDEMANN, Aeg. Gesch. (1884), p. 344, (Summary) BUOGE, History of Egypt, IV, (1902), pp. 47, ff. (Summary and text of Geogr. names)
- ncient Egypt, (1894), p. 286 MASPERO, Au temps de Ramsès et d'Assourbanipal, (1910), p. 109
 cs of the Ancient Egyptians, III, (1847), pp. 38, 53.

Tomb of Deceased.

3: 125-127.

	PLAN	SETHE	PIEHL	VIREY	
(1) Hereditary Prince: (2) Count: (3) Chancellor of the Exchequer of the King of Lower Egypt; (4) Companion Great of loving.	4	a	898	ā 113	254
(5) Sole Companion; (6) Mouth of the King.	13	b	899	o 125	275
(7) Ears of the King of Lower Egypt. (8) Complete Fulfiller of the Will of the Lord of the Two Lands.					
(9) Attendant upon the King (10) His goings on the Water, on the Land, in all the Countries, and in every place of the marching of His Majesty (9a) he held the power behind the Lord of the Two Lands. Created as (10) First of his [i.e. the King's] Nobles, and as the (11) Chief of his Followers. [i.e. The King] recognized him as one doing what is excellent, and he knew that he [i.e. Amenesheb] pressed His road [i.e. "was loyal"] He was (12) Deputy for the Army.	4	a	898	ā 113	254
(13) Attendant upon His Lord in His goings in the Country of the South and North; He did not fail the Lord of the Two Lands (14) He was in the field of battle at the hour when the man fought a million.	3 0	b o	899 899	o 125 a 109	275 245
(15) Chief Herdsman [i.e. "Marshal"?] of the feet of the Lord of the Two Lands. (16) He shepherded His feet on the Water and on the Land, and in all the Countries. [Note:- In the Orient the shepherd follows the flock.] (17) He was the excellent Watch for his Lord. (18) Mouth of the King in [leading] the People. He was the		g h l i	900 " 901 "		261 280 271

THIS PAGE IS LOCKED TO FREE MEMBERS
Purchase full membership to immediately unlock this page

DELVE INTO FANTASY, MAGIC, MYTHOLOGY & FOLKLORE

Forgotten Books'
Full Membership gives
access to 797,885 ancient
and modern, fiction and
non-fiction books.

Continue

*Fair usage policy applies

15, 15a *ir*(=D.10) *ir hrw*(=G.8) (15a) *wr*(=G.79)-*r*(A.29) *im iaw*(=F.35)-[*r*]-*f*
 15b *āa*(=T.41)-*ā*(Y.2) *w śah-f* (15b) *ś-r*(A.29) *m ha*(=F.13)-*t* A.110 [sic.] *s-s*
św(=M.24)-*t-n*
 9 (9) *nśwt*(=M.24)[*SETHE*, Z. Aeg. 49, p. 19] *śms*(=U.42)(D.96) *hr hnt*(=W.8)-*n-t*
 (N.47) *n ta*(=N.37)(pl.) *ph*(=F.43) *pxr*(=V.40) *w*(=N.47)(pl.) *im*(=R.23)
hnt(=W.8) *hr* [sic.] *nfr*(=Y.9) *n-b-n-b i-in*(=K.1)-*n*(N.40)[sic.] *n*
 9 *r-n*[sic.] *-ti*(=U.19)-*i-nw*(=W.21)-*w*(T.1)(N.40) *hr śms*(=U.42)-*ś*(D.96)
hrw(=G.8) *nb āhā*(=O.29)-*ā*[sic.] (9) *nśwt śms* [as above] [*hr*]
hašt(=N.40)-*t*(pl.) *nb-t ph*(=F.48) *w-w*(N.47)[sic.] *m n-h-r-n*(N.40)
 [*hnt*(=W.8)-*n-t*(N.47) *m*] *hašt*(=N.40)-*t n-t*
ka(=D.46)[*ra*(=D.29)-*y*(T.1)(N.40).....]
 16 *nśwt*(=M.24)-*t*(D.96) *śms*(=U.42) *m i-im* (=R.28) *i s-š-i*(G.90)
 17 *w-ā-sw*(=O.71)-*i* *hpš*(=F.49) *n ntr*(=R.13) *nfr*(=Y.9) *r-rdī*(=D.59)-*w n-f*
nb(=U.50)(N.53, N.53, N.53) *n hs*(=W.4)-*t-w*(pl.) *n* [sic.]
 12 (12) *idn*(=F.46) *n[nw*(=W.21)]-*w*(D.69) *n mšā*(=A.82)(pl.)
 16 (18) *i-im*(=R.28)-*ib*(=W.23) *n hrw*(=G.8) *m pr*(=O.3)-*f*
 19, 20 (19) *hs*(=W.4)-*y* *n ntr nfr* (20) *iāh*(=G.57)-*ib*(=W.23) *n św*(=M.24)-*t-n*
 21 (21) *maā*(=Q.58)-*ma*(=U.8)-*ā*(Y.2) *n bit*(=L.1)-*t*(S.11) *ir*(=D.10)
hs(=W.4)-*s-s-t* (pl.) *ntr nfr m wbn*(=N.13)-*t* *n hrw*(=N.7) *nb*(=W.43)
 21a (21a) *śms*(=U.42)-*ś b-i-t*(W.31)(F.44)(Y.2) *n-t nb tawī*
 22 (22) *āq*(=G.71)-*q* *m h-r-w*(Y.2)(pl.) *n i-im*(=R.28) *āhā*(=O.29)-*ā*(O.3)
 23 (23) *mh*(=V.15) *ānh*(=S.43) *ānh hrw*(=G.8) *m maāt*(=C.54[sic.])
 24, 24a (24) *āa*(=T.41)-*ā* *m [pr*(=O.3) *nśwt*(=M.24) (24a) *ś-hnt*(=W.8)-*t*]
nšt(=W.42)-*t*(O.3) *m kā*(=U.37) [.....] *hrī*(=N.1) *pd*(=T.21)-*t*
 25 (25) *imāh*(=V.4)-*h-y* *hr ir*(=D.10) *ist*(=Q.1)(A.113) *ph*(=F.48)(D.96)
i-a-w-i(A.30) *m hs*(=W.4)-*w-t*(pl.) *hr św*(=M.24)-*t-n*
 26 (26) *nb*(=W.43) *q-r-ś-t*(Q.25)(D.69) *hr imn*(=S.56) *n waš*(=S.65)-*t*(O.1)

Irta hrw (15a) *hr m iawt*-*f*
āa m śah-f (15b) *śr m hat es*[?]
Nśwt
 (9) *Śmsw Nśwt hr* [Gramm. §412] *hnt*[GARDINER, Admon. p.49] *n iaw Ph Pxr Ww im hr hnt*
Nfr [Nfr ?] hbb [SETHE, Verb. I, p.338:6]
imn (hašt) hnt inw (hašt) hr śms
hrw Nb (9) *Śmsw Nśwt [hr] hušwt*
nb t ph w m Nhrs (hašt)
[hnt m] hašt ntī
Ka[ray (hašt)
 (16) *Śms Nśwt m imī Sīī* [See Tomb Scene No.1]
 (17) *Mašwī hpš n Ntr Nfr rdī w n-f*
nb n hswt m
 (12) *Idn m Nšāw*
 (18) *i-m-i-b n hrw m pr-f*
 (19) *hsy n Ntr Nfr* (20) *iāh-ib n Nśwt*
 (21) *Maā n Bit ir*
hsst Ntr Nfr m wbn n hrw nb
 (21a) *Śms Bit ntī*
Nb Tawī (22) *āq m hrw n im āhā (pr)*
 (23) *mh ānhī hrw m Maāt*
 (24) *āa m [Pr-Nśwt (24a) šnt] Nšt (pr)*
m wā [.....] Prī Pd
 (25) *Imāhy hr Iršt ph iawī*
m hwt hr Nśwt
 (26) *Nb grēt hr imn n wašt (nwt)*

Note:- A title (23) of obscure meaning appears often in the Tomb; e.g. SETHE, Urk. XVIII Dyn. p.899, c PIENL, I, 109, a VIREY, M
 it is written uniformly in the following symbols:- "A.71 n S.47-p(0.3)" which may be read "xrd n kap (pr)" "Child of t
 and possible rendering see Appendix "A"

Text "B" Amenemheb's Wife. (1) Titles. SETHE, pp.920-5.

św(=M.24)-*t-n hm*(=W.6)-*t*(N.7) *ba*(=G.53)-*k*
nśwt(=M.24)-*t xkr*(=O.61) *ba*(=G.53)-*k-i maā*(=Q.58)-*hrw*(=P.22)-*t*
šn(=R.22)-*n-t-f wr*(=N.58)-*t-f n-t ist*(=Q.1)-*t*(O.3) *ib-f*
 (2) Titles and scenes in Tomb.
 [*śmā*(=M.27)-*y*-[*t imn-n*]
śd(=V.17)-*d-t*(D.69) *ntr*(=R.13)(A.113)[sic.] *ba*(=G.53)-*k-i*
maā(=Q.58) *hrw*(=P.22) *wn-n-ā-t*(D.99) *nśwt*(=M.24)(A.117) *śd*(=V.17)-*d-t wr-t*
wn-n-ā-t(D.39) *wr*(=G.79)-*r-t n-t nb tawī*(=N.39) *śd*(=V.17)-*d-t*
i-im(=R.28) *āhā*(=O.29)-*ā*(O.3) *šn*(=D.41)-*t*(D.69) *ā-ā-w-i-ś hr ntr nfr*
nfr(=Y.9)[*r-t s-n*]-*q*(D.39) *xnk*(=W.11)(Y.2)-*n hrw*(=G.8)
šn(=V.6)-*b-t*[(D.109)]-*s ngm*(=M.98)-*m-t mn-n-d*(D.39)(D.109) *ś-n-b*
s-n-q(D.39) *w-d-t*(Z.7) *r s-p*(X.14) *nfr*(=Y.9) *nśwt*(=M.24)-*t xkr*(=O.61)
nb-t pr(=O.3)
nb-t q-r[sic.] *t hr imn*(=S.56)[*n waš-t*(=S.65)] [SETHE, p.921, n: See "Titles
 of Amenemheb"] *hs*(=W.4)-*y-t n-t*[sic.] *ntr*(=R.13) *nfr*(=Y.9) *śd*(=V.17)-*d-t*
ntr(A.113) *q-r-s-t*(Q.25)(D.69) *m hs*(=W.4)-*w-t*(pl.) *nśwt*(=M.24)-*t-n*
ir(=D.10)-*w n-s ir*(=D.10)-*r-t*(pl.) *n śāh*(=E.19)

Hst Nśwt Bak
Xkr Nśwt Bukī seāhrwt
Šnt-f Nrt-f ntī ist ib-f
 [*Śmā*] *y[t imn]*
Šdt Ntr Bakī maā-hrw
Mnāt Nśwt Šdt Wrt
Muāt wrt ntī Nb wašī Šdt
im āhā šnt āwī-ś hr Ntr Nfr
Nfrt śng Imn hrw
šnbt-s [GARDINER, Rec. de Tr. 38, p.222] *Nđwt m*
šnbt śng wdt [GARDINER, id. 82, p.221] *m sp nfr*
Xkr Nśwt Nbt Pr
Nbt Qrls [GOLEMISCH, Bib. d'Ét. II, p.207]
Imn [n waš]
Hsynt ntī Ntr Nfr Šdt Ntr grst m hest Nśwt
irw n-ś irwt n śāh

In scene No. 25 Bakī offers to and receives from Amenhotep II bouquets of flowers, while a servant brings other offerings [VIREY, 235-6; SETHE, p.293, No.272] All of the texts save those quoted below are conventional. In scene No. 4 the Son and Daughter are shown, illustrating the two varieties of sistrum, viz. the sšš(Y.8) and the mnt(S.46). [See Tale of Sanehat, Tabl

XXXII. Thutmosis III-Amenhotep II, Amenemheb.(3)

) Eyes of Horus. (15a) A magnate in his official life, (15b) A grandee in his aristocracy; a Prince before the men (?) the King.

) Attendant upon the King when he went forth to the Lands of the End of the Bend and the district therein, when the Good [God] journeyed to trample on the Wndy-country of the Land of Rntinw; when he followed

us, Lord of the Palace. (9) Attendant upon the King [in] all countries of the end of the districts in Nhrn-land and going forth into] the country which belongeth to Nhrn-land

) Attendant upon the King in what pertains to the [wild fowl] (17) Bearer of the sword of the Good God,

re was given to him the gold of honor as

) Deputy for the Army

) Beloved of Horus in his House.

) Praised of the Good God. (20) Useful of mind for the King, and (21) Faithful to the King of Lower Egypt. He made praise for the Good God at the sunrise of each day.

la) Attendant of the quarrying [or Mining] pertaining to the Lord of the Two Lands. He is (22) Initiated in the law of what is within the Palace (23) he filleth the ears of Horus with Justice.

b) A Grandee in the[Royal Palace (24a) He was approached] to the King as one [.....] Head Bowman.

) Honored under Osiris he reached old age in favor under the King, and was

) Lord of a Tomb-Chapel in the West of Was't [Thebes].

SETHE,p.900,g VIREY,260 SETHE,p.901,k VIREY,282 etc. etc.

House" or "Neophyte of the House of Mystery", As to the reading

vant of the King [Maid of Honor ?] Bak

ament of the King, Bakī, Triumphant.

) Sister, His Beloved. who is in the place of his heart.

) Sister of Amon.

) Sister of the God, Bakī Justified.

) Nurse of the King. Great Nurse,

) Nurse to the Lord of the Two Lands.

) Nurse mother attached to the Palace, her two arms embrace

) Good God. Wholesome of nursing, Horus

) Protected her bosom. Sweet of breast,

) Plentiful of suckling,devoting [herself] to kindness (?) Royal Ornament

) Dresser). Mistress of the House.

) Mistress of a Mortuary Chapel in the

) West [of Thebes]

) Praised by Him who is (?) the Good God, Divine Nurse, [she was]

) Praised with Royal Honors, doing for her the things done for Nobility.

à vis with this is a text of 24 + 3 lines, entirely conventional.

is named: " [aw(=M.1)-w " and in No.26 two musical instruments

no 296]

Plan	Sethe	Piehl	Virey	Geographical Names
4	m 902	ō 113	261	(1) Taw Ph (2) Pxr (3) Ph Pxr (4) Pxr (5) Rntinw (6) Nhrn (7) Ka[ray]
4	a 898	ō 113	254	
13	b 899	o 125	275	
8	p 903	x 110	281	
29	w 905	χ 113	229	
9	s 904	δ 109	248	
	u 905		267	
	v 905		285	
				(8) Was't [Thebes]
	a 920		236	
	b		279	
8	e 922	η 110	260	
	a 920		236	
1	d 921	ρ 112	259	
9	c 920	α 109	245	
	a 920	236	
2	b 920	υ 111	279	
13	g 921	10 125	275	
9	c 921	α 109	245	
	a 920	236	
1	d 921	π 111, ρ 112.	259	

THIS PAGE IS LOCKED TO FREE MEMBERS
Purchase full membership to immediately unlock this page



Never be without a book!

Forgotten Books Full Membership gives universal access to 797,885 books from our apps and website, across all your devices: tablet, phone, e-reader, laptop and desktop computer

A library in your pocket for \$8.99/month

Continue

*Fair usage policy applies

Text "C" Scenes Nos. 14 & 15: "Hunting and Fishing."

h-n-s(D.96) ša(=M.37) ša ša h-b-h-b(D.96) sš(=G.90) sš sš š-m-h [sic.]-h
 (W.23) šf(=F.60)-t-t mh(=V.15)-p-t(K.1)(pl.) m bia(=N.70) bia bia(N.58)
 (pl.) i-n(A.13) mr(=U.12)y šh(=M.35)-t(B.7)[sic.] sma(=R.20)y n nb-t
 h-hb(=W.49)-b sa(=G.67)(pl.) rw(=K.1)(pl.)

šns šaw [GAUTHIER, Bib. d'Ét. II, p. 121] [Sethe, Verb. I, §338:6] sšw šhwh šft mhy [See Appendix "C"] In mry šht(B.7)[Gardiner, op. cit. p. 34, p. 63] Smoy n Wbt hb saw rw

Text "D" Scene No. 17: "Amenemheb visits his Garden."

1 pr(=O.3)-r-t(D.96) r nwt(=O.3)-t ma(=U.8)(D.10) [i-m-n] šsp(=P.23)
 iah(=G.57)w(N.13)(pl.) n
 2 di(=D.63)-di i-t-n(N.8)-f s-h-m-h(W.23) m ša(=M.37)(N.47)
 ixn(=S.58)-t-i(N.47) āq(=G.71)-q(D.96)
 3 pr(=O.8)-r-t(D.96) m ā-āb(=F.41)(Y.2) š(N.47)-f š-q-b-b(W.5) ib(=W.23)
 xr(=G.20)
 4 n-h-t(M.1)(M.1)(M.1)-f ir(=D.10)-t š-šh-t(=M.35)[.....] m(=N.50)
 h[sic.]-r-r-t-f š-wr(=G.79)-i mw(=N.55)
 5 [ngm(=M.98)]-m m(=N.50) sš(=G.90)-f s-s-n-t(F.5) s-š-n-w(M.63)(pl.)
 f-d-(Z.7)(D.69) nh(=G.7)-t(M.58)[sic.]-b(pl.)
 6 i-n r-p-ā etc. etc. etc. (Titles)

Prt r nwt ma [Imn] šsp iahw n
 didi itn-f šhwh (ib) m ša
 Imnti āq
 prt m āb š-f šqbb ib xr
 [n-h-t]w-f irt šht [.....] m
 harrt [i.e. M.42-r-r-t(M.41)] G [See App. "A"]
 [ngm] m sš-f šnt sšnw(M.63) f [See App. "A"]
 In Rpāti etc. etc. etc. (Titles)

Text "E" Scene No. 30. "Amenemheb leads to the Pharaoh (Amenophis II) the Comissary Officers."

1 (a) (Title of the Scene) š-ta(=W.60)(V.2)[(D.96)] šr(=A.29)[(pl.)] nw
 mnyf(A.29)(pl.) šr(=A.29)(pl.)
 2 ānh(=S.43)-w[(pl.)] nw mšā(pl.) r āa(=T.41)pr(=O.3)(O.3) ānh wāa šnb
 r s-
 3 -nm(=Z.80)-m(A.89) š-t m ta(=W.38 + W.35)(X.1)(pl.)
 4 i-f(D.109, D.109, D.109) n i-w-a(=V.28)(pl.) i-r-p(W.23)(pl.) š-ā-t(N.53,
 N.58, N.58) rnp(=M.17)-t[Gloss. p.78](pl.) nb-t nfr[-t][sic.]:
 5 h-t nb-t nfr-r-t n-t
 6 š-htp(=Q.17)-t-p ib(=W.23) m dah(=D.90)-ā nfr [p] nfr [sic.] n i-n(=S.11)
 7 r-p-ā ha(=F.16)-a[.....]
 8 [.....] idn(=F.46)-nw(=W.21) n [mšā(=A.82)](pl.)
 9 xrd(? =A.71) n kap(=S.47)[p](pr) [i-mn-n-m-h-hb(=W.49)-b]
 (b) (Over one of the Scribes) sx(=Y.1) š-ā-t(V.10) n idn(=F.46)-n-nw
 m(=N.50)-ā-hw(=F.44)(Y.2)(A.117)

šta [GAUTHIER, Bib. d'Ét. IV, p. 121] nw
 mnyf [GAUTHIER, id. p. 69] šrw
 ānhw [MASPERO, Bib. d'Ét. V, p. 34] šnb
 ā. W. Š. r
 snw [GARDINER, Admonitions, p. 63] m
 ifw n imaw irpw šat
 rnpwt nbt nfr[t]
 ht nbt nfrt ntī
 Nfr Nfr [p]n in [Orenm. §494]
 Rpāti Hatī-a[.....]
 [.....] Idnnw n Mšāw
 Xrd (?) n Kap (pr)[See App. "A"]
 Sx-šat [GARDINER, Lit. T. I, 1, p. 3] m idnw
 Mšhw

Note: Mšhw is understood by SETHE (Urk. XVIII Dyn. p. 889) as a surname for Amenemheb: it occurs elsewhere, i.e. "Chief of the Bow[men] and Idnnw." See also SETHE, id. p. 904, s: PIENL, d, 109: VIREY, V, 284: al. p. 908,

(c) (Over Amenemheb before Amenhotep II.) idn-nw n mšāw i-ms-n-m-hb-b
 d-d-f ma(=U.8)(D.10)-n-k i-w h-t(Y.2) āša(=I.2)(pl.) xr(=Q.20)-r-ā-k
 t-tm(=U.14) n(pl.) ir(=D.10)-t ra(=D.29) ā(=D.59) r wā(=U.37) m-ā-k
 pa(=G.73) mšā(=A.82)(pl.) wp(=F.83)[...]t-w[...] r dr(=W.40)-r-f
 nn(=D.48)-n wā(=U.37)-ā t-š(Z.7)-w(D.96) i-m-f
 (d) (Over a man opposite Amenemheb) imi-ra(=S.37).šnw-t(=M.68) n nb
 tawī(=N.37) hšb(=V.45) p-f-š-w(W.38) ta(=W.33 + W.23)(N.66)

Idnnw n Mšāw Imn-m-hb
 dd-f Man-k iw ht āšaw xrā-k
 tm-n(pl.) irt ra ā r wā Māk [Gardiner, op. cit. p. 34]
 Mšāw wp[...]tw[...] r dr-f
 nn wā tšw im-f
 imi-ra [Gramm. §84] šnw t n nb t
 hšb pšw ta

Scenes 10 & 11. On the lower portion of the wall are three horizontal rows of Asiatics following Amenemheb in right to be or gifts, mostly in the form of costly vases. All are in attitudes of obeisance, some kneeling on the ground, and but their beards are red. Evidently high dignitaries, they are richly dressed in white robes and are accompanied by short texts, e.g.:-

Wandering through the swamps, treading on the [wild fowl] sedge,
and livened by the casting [i.e. of the net] for fish in the
Marshes. The poulteress will like the gathering for the Mistress
a feast of wildfowl and fish.

To go out towards the village to see [Amon] welcome the rays of

His disc. To refresh the heart in the
Westerly field.

To go in and come forth from the curve [lit."horn"] of his lake;
cooling the heart under his
[sycomore]s. To make fields with flowers (?) To increase
the [sweet] water for his
[wild fowl] marsh. To breathe in the lotus and to pluck the
buds.

The Hereditary Prince etc. etc. etc. (Titles)

"
r Pr-âa Introducing the High Officers of the Infantry, the Officials of
the Commissary [lit."living"] of the Army
to the Pharaoh, L. H. S.

to feed them with bread,
flesh of cattle, wine, cooked food,
every good fruit,
and every excellent thing
of those that rejoice the heart before this Good God,
the Hereditary Prince, Count
[.....] Deputy for the Army.

-bb] See note above.
Idnnw Secretary [lit. "Scribe of Letter(s)"] of the Deputy
Nâpu

ETHE, op.cit.p. 901, l: VIREY, Miss. Fr. V. 271) as "pr(=N.1)-pd(=N.28)-t idnnw"
, p. 906, aa, bb, VIREY, V. 268 where he is "pr-pd" and "idnnw" but not "Idnnw n Nâpu."

The Deputy for the Army, Amenemheb,
saith:- "Thou hast seen that the supply is adequate, and Thou dost
"allot our parts of the doing of speech and deed for each one.
"Behold, [when] the entire Army is ordered,
"no one holds back in it."
The Superintendent of the Granaries of the Two Lands
reckons what is cooked, and the bread.

right to left to be presented to the Pharaoh. They are bringing tribute
be ground, and some leading their children. They have Semitic features,
enclosed by colored borders. 20 figures are now distinguishable, and some

THIS PAGE IS LOCKED TO FREE MEMBERS
Purchase full membership to immediately unlock this page

DELVE INTO FANTASY, MAGIC, MYTHOLOGY & FOLKLORE

Forgotten Books'
Full Membership gives
access to 797,885 ancient
and modern, fiction and
non-fiction books.

Continue

*Fair usage policy applies

Text "F" (a) (Before the 3 rows of Asiatics.)

1 r-di(=D.59)-t i-a-w(A.5) n nb m [sic.] s-n-nw(=W.21)(F.5) ta(=N.37) n
 hā(=N.23)-ā(Y.2) [m was-t(=S.64) iī(=M.33)t(D.96) i-n wr(=G.79)-r(pl.)
 nw(=W.21) r-f-n-nw(=W.21)(N.40) in(=W.22)]nw(=W.23)(pl.)-s-n(pl.) hr
 p-s-d[(D.37)-s-n(pl.)] m 10 groups of symbols
 2 i-r-p(W.23)(pl.)-s-n(pl.) h-b-s-w(S.32)(pl.) ih(=E.3)(pl.)
 nfr(=R.13)-sn(=R.22)-n-f-r(N.53,N.53,N.53)[3 groups r d(F.44)-b-h
 (A.91)] htp(=Q.17)-t-p-w(pl.) h-r hm(=W.6)(A.117)[f ms(=O.71)(Y.2)-t]-w
 r-[t]-di(=D.59, sic.) [n s-h](pl.) taw taw(=P.16)-w(pl.) n
 ānh(=S.43)-n-h r f-n-d(F.5)(pl.)-s-n(pl.)
 (b) (Before 1st. row)
 3 wr(=G.79)-r(pl.) nb(pl.) nw(=W.21) r-f-n-nw(=W.21)-w(N.40) hr(=D.1)r-t(N.40)
 (c) (Before 2nd. Row)
 4 wr(=G.79)-r-w(pl.) nb(pl.) nw r-f-n-nw(=W.21)-w(N.40) xr(=Q.20)-r-t(N.40)
 (d) (Speech of the Chiefs over the Three rows.)
 5 d-d-s-n wr(=G.79)-r-w-i āaw(=G.54)(pl.)-k
 6 rdi(=D.63)-n-k sng(=G.91)-k m ta(=N.37) ta ta nb(pl.)
 7 m rdi(=D.63) n(pl.) g-r-t xr(=Q.20) f-b[sic.](S.38)(S.38)-k-i
 8 šw(=M.24)-t-n n-h-t(=M.9)-h-t i-ti(=U.19)-y wr(=U.12)-r-r[sic.]
 hrī(=Z.10)-t-y(pl.)-k ht(=M.9)-h-t(D.96)
 9 [hašt(=N.40)-t(pl.) nb]
 10 h-f-ti(=U.19)-w(N.40) [...] nw(=W.21) mi(=W.29) hašt(=N.40)-t(pl.) nb
 m dng(=S.41)(Y.2)
 11 r-ā(N.7)(A.118)
 12 [.....] nb-t

Rdit iaw n Nb m šnw Ta n hā[m wašt iīt i
 [Gramm. §494] Wrw nw Rfnnw (hašt) inn]w-š
 hr psd[-šn m [GARDINER, Z. Aeg. 43, p. 32]...

 Irpw-šn hšw ih šnr [GAUTHIER, Bib. d'Ét.
 p. 122]..... r ddb htpw hr hm[-f
 ms-t]w rdi[t] [n-šn] tow n ānh r fnd-šn

 Wrw nbw nw Rfnnw Hrt (hašt)

 Wrw nbw Rfnnw Xrt (hašt)

 Dd-sn Wrwī Baw-k
 Rdin-k Sng-k m taw nb
 m rdi n(pl.) grt xr fbtī-k
 NSwt Hht Itiy Hr hryt-k ht

 [hašt nb]
 Hrtiw (hašt) [...] nw mi hašet nb m dng

 Rā
 [.....] nb-t

Text "G" The Autobiography (Scenes 10 and 11, Entire Upper portion of Wall.) Amenemheb narrates to the Pharaoh the history of white ground. EAERS says that the script is "in the grand style of the XVIIIth. Dynasty."

Line	R	M	S	Text	Interpretation
1	890	w-ā-[w i-mn-m-h-hb(=W.49)]-b maā(=Q.58)-hrw(=P.22) d-d-f	Wā[m [LORET, Bib. d'Ét. III, p. 11] hm
2	1	33		nw(=W.21)-k(A.89) maā(=Q.58)(Y.2) wr(=G.79)-t n i-ti(=U.19)-y ānh wda šnb p-h-ha(=M.68)(Y.2) ha(=F.16)-t-i (W.23) n nšw(=M.24)-t-n iah(=G.57)-h(Y.2) ib n bit(=L.1)-t i-w šms(=U.42)-š n	Nwk maā wrt n Itiy ā. W. S. Pha [29, p. 98] Hatī (ib) NSwt Iah ib n
3	2			nb(A.117)-i r iw(=D.96)-t(pl.)-f hr hašt(=N.40)-t mh(=V.15)-t-t rś(=M.30)(N.40) wr(=U.12)-r-f i-w-A.89 m i-r minw(=A.128, GARDINER, Z. Aeg. 42, p. 116](Y.2) r-d(D.99)(D.99)-f ti(=U.19) šw(=M.24)-w	Nb-i [Gramm. §140] r iwst-f hr hašt m i-r Minw [See GARDINER, id. p. 12 Gramm. §466] šw
4	3			hr p-r-i(M.17)(D.69)(pl.) n-h-t(=M.9)-h-t(D.69)(pl.)-f ph(=F.48)ph-f hr š-w mt(=D.90)-t(D.84)(D.84) ib(=W.23) i-w h-f-ā(D.82)(D.69)n hr hašt(=N.40)-t n-f n-	hr prim nhtw-f phī-f hr šw mt [St ib iw hfan hr hašt ntī W-
5	4			-g-b-ba(=G.53)(N.40) in(=W.22)-n āam(=T.1)-m-w(pl.) s(A.89) III m š-q-šqr(=Z.22)-ānh(=S.43)(A.85) h-f-t špr(=D.91)-r hm(A.117)-f r	-gbhu (hašt) in šaw s (A.89) haw Hft špr hm-f r Whrn (hašt)
6	5	891		n-h-r-n in-n s(A.89) III m h-f-ā(D.82)(D.69) i-w rdi(=X.22)-A.89 s-t m bah(=D.90) hm(A.117)-k m š-q-r(Z.22) ānh-n-h(A.85)	in e hnt m hfa im rdi-i št m bah
7	6			whm(=F.52)-m(Y.2) h-f-ā(D.82)(D.69) n wd(=M.53)-w-y-t(D.96) t-n hr hš-t-tiw(=G.5) ts(=O.78)-t(N.47) w-ā-n(V.45)(M.1 + M.9)(N.40) hr imn(=S.56)-t-i(N.47) h-a-r-a(=D.29)-b-w(N.40) in-n-n[sic.]-A.89	Whm hfa n wdyt tn hr haštīw Tst Haarabw (hašt) inn-i
8	7			āam(=T.1)-m(A.85) m š-q-r(Z.22) ānh(A.85) s(A.89) XIII āa(D.90)-w(E.67)(pl.) ānh(=S.43)-w XXXXX hsmn(=U.20)(N.53)(N.53)(N.53) mi(=N.58)-n-b[GARDINER, Rec. de Tr. 33, p. 74] (W.59)(N.53)(N.53)(N.53) XIII hsmn(N.53)(N.53)(N.53) bk(=G.53)-k(D.89) m nb(=U.50)[(N.53)(N.53)(N.53)]	šaw m šqr-ānh s wd-hnt šaw ānh minw [GARDINER, op. cit.] wd hnt
9	8			[.....] whm(=F.52)-m(Y.2) k-f-ā(D.82)(D.69) n wd(=M.53)-w-y-t(D.96) f-n hr hašt(=N.40)-t n-t q-a-r-i-q-a-m-i-ā-ša(=M.37)-a(T.1)(N.40) in-n-n-A.89	[.....] whm hfa n wdyt fn hr hašt qa-r-i-qa-m-i-ā-ša (hašt) inn-i
10	34			[.....] m š-q(Z.22)(D.69) ānh(A.85) da(=U.21)-a(P.2)-n-A.89 pa(=G.73) mw(=N.55) n n-h-r-n(N.40) i-w-š-n(pl.) m d-t-A.89 [.....]	[.....] m šqr-ānh wdon-i pw mw iw-šn m dt-i [.....]

To give praise unto the Lord in kissing the earth of the
 Glorious one [= Wašt [Thebes] the Chiefs of Rḫnnw, their gifts]
 upon [their] back[s], consisting of.....]
 their wines, garments, cattle and resin
 to beg for peace from [His] Majesty
 may it coes to give to them the breath of life for their nostrils.

(9) Rḫnnw

All Chiefs of Rḫnaw the Upper.

(10) Rḫnaw Rrt

All Chiefs of Rḫanw the Lower.

(11) Rḫnnw Rrt

They said:- "Great is Thy Fame,
 Thou hast caused the Fear of Thee to be in all Countries
 in causing us to be silent under Thy feet
 Mighty King, Beloved Sovereign. Terror of Thee is behind

[every land].
 The Kḫtīm-country [...] ? ? all lands
 are in union and (?)
 Rḫ
 all

(12) Kḫtīm

life in a text of 47 vertical lines painted in blue symbols on a

	B.		
b māḥ-hrw Dd-f o, Rec. de Trav. : Šms a	579	The Officer Amenemheb, Justified, saith:- "I was very faithful to the Sovereign, L. H. S. Dividing the Heart of the "King of Upper Egypt. Light of the Heart of the King of Lower Egypt. I was "follower of "my Lord to his cosing to the Country of the North and South. He wished "that I be as him (?) who is Shepherd of His Feet while he was on the	
: Rḫi hr-f im-ī i-f ti [ERMAN, Aug. 45, p. 38]	580	"battle-fields of His Might and His Strength [Note:- In the Orient the Shepherd follows the flock]."As to His [my] heart is a witness (?). I took booty in the "Country of the W- "-gbbā, bringing ḫens 3 men as living captive[s]	(13) ḫgbbā (14) ḫanw (15) ḫhrn
r-ḫnh m šqr-ḫnh	581	"When His Majesty proceeded to ḫhrn-land, "I brought 3 men as booty therein. I caused them to be before Thy [alc.] "Majesty as living captives.	
ast) hr imtī	582	"Again I took booty on this campaign in the countries of The Height of Wān "on the West of ḫcarabs-land, and I brought "ḫan as living captives, men 13, living asses 70, Bronze Axes (?) 13 "The Bronze was wrought with Gold.	(16) Rst Wān (17) ḫaarabw (18) ḫan
san a a fḫ m (ḫast)	583	"[.....] Again I plundered on this expedition to the country of "Qariqamiḫša, I brought away "[.....] as living captives, and I crossed over the Water of ḫhrn, they "being in my hand [.....]	(19) ḫhrn

THIS PAGE IS LOCKED TO FREE MEMBERS
Purchase full membership to immediately unlock this page



Never be without a book!

Forgotten Books Full Membership gives universal access to 797,885 books from our apps and website, across all your devices: tablet, phone, e-reader, laptop and desktop computer

A library in your pocket for \$8.99/month

Continue

*Fair usage policy applies

[wahn-p(Y.2)[sic.]-n-A.89 s-t] m(=N.50) bah(=D.90)(Y.2) nb(A.117)-i [sic.]
ahâ(=P.19)-n f-q-a-w(N.66)(pl.)-n-f w-i m f-q-a(Y.2) âa-â(Y.2) r-h-t
i-r-[i.....]
i-w ma(D.10)[sic.]-n-A.89 n-ht-h-tw(pl.)(D.69)(pl.)(sic.) n nsw(=M.24)-t
bit (râ-mn-hpr) di ân h hr hašt-t sn(=R.22)-n-qa(=U.21)-a-r(T.1)(N.40)
ir(=D.10)-n-f ha(=M.68)-y-[t(A.133)]
[âa-t i-m]-s-n(pl.) hfâ(=D.82)(D.69)-n-A.89 m bah nsw(=M.24)-t-n in-n
n q-t i-m r-di(=D.59)-n-f n-A.89 nb(=U.50)(N.53,N.53,N.53) n hs(=W.4)-t-w
(pl.) r-h-t i-r[i] [.....]
[.....] hq(=M.74) (U.50) (N.53,N.53,N.53) qd(=N.8) II i-w
whm(=F.52)-m(Y.2)-n-A.89 n[sic.] ma(D.10)-a-a q-n-n(D.69)-f i-w-A.89 m
šms(=U.42)-t-w(pl.)-f ha(=M.42)-q(D.69)-n-[f] [d-mi-i(N.47) n]
qa(=O.77)-d-š-w(T.1)(N.40) nn t-š-t(Z.7)(D.96)-A.89 r b-w xr(=Q.20)-r-f
in-n-i m-â-ra-y-n-a s(A.113) II m [s-q(Z.22) ân h(A.85) rdi-A.89 s-t]
m bah(=D.90)(Y.2) nsw-t-n nb tawî (Zhwiti(=G.49)ms(=M.80) hqa(=S.62)
was-t(=S.65)) ân h q-t(N.37) r-di-n-f n nb(=U.50)(N.53,N.53,N.53) hr
q-n-n(D.69) m bah â(=D.59) b-w nb(=W.43) A.89-B.7 [sic.][pl.]
[..... "About three Groups"]
r-h-t(Y.2) i-r-i nb(N.53,N.53,N.53) n qn(=Z.15)-n maâ(=E.36) š-b-y
II [sic.] â-f-f [a fly] II â-w-â-w(N.8) IIII i-w ma(D.10)-n nb(A.117)-i
hr [.....]
[.....] m hpr-r-w(A.27)(pl.)-f nb(pl.) hr hašt(=N.40)-t ph(=F.48)-w-w(N.47
n f[...])ml..... 4 or 5 Groups]
ha(=M.42)[.....](T.1)(N.40) h-r-t-w r-f nw-k t-s(Q.54)(D.96) r
pa(=G.73)[.....]n(O.37) m [hâ(=M.68)]h(D.96) n mšâ(pl.) mi-i
qd(=O.77)[d(N.8)(Y.2)-f i-w]
whm(=F.52)-m(Y.2)-n-A.89 ma(D.10)-a-a n-ht-h-t(D.69)(pl.)-f hr hašt-t-t
n-t ti(=U.19)-h-š-i(N.40) x-s-t(G.80) m d-mi-i(N.47) n mr(=U.12)-r-i[or
šw(=M.24) SETHE, o.892, n. "f"-w(N.58)[....]
k-f-â(A.69)-n-A.89 i-m-f m bah(=D.90)(Y.2) nsw-t(A.117) in-n-n-A.89
âam(=T.1)-m [slo.] s(A.113) III m s-q-r(Z.22) ân h(A.85) âhâ-â-n
r-di-n n-A.89
np(A.117)-i nb(N.53,N.53,N.53) n hs(=W.4)-t-w(pl.) r-h-t(Y.2) i-r-i
nb(=U.50)[sic.] š-b-y-w (Collar) II â-w-â-w(N.8) IIII i-f-f (Fly) II
ma(=U.8)a-a(E.36) f hm-t(B.7) hm(A.89)
whm-m[(Y.2)-n ma(D.10)] k-y s-p(X.14) mn-n-h(U.27) ir-n nb tawî(=N.39)
n-i-y(T.1)(N.40) b-h-š(D.96)-n-f CXX n ab(=U.31)-b-w [Elephant] hr
b-bh(=F.44)-t-t(V.45)(F.45)[sic.]-s-n(pl.) ahâ(=P.19)-â-[n]
šsp(=P.23)-p(D.69)-n pa ab(=U.31)[sic.]-b-w âa(=T.41)-â(Y.2) n-t-i
i-m-s-n âha(=D.52) r h-f-t hm(A.117)-f nw-k š-â-d(T.12)(D.69)
d-t [sic.]-f i-w-f ân h-n-[h]
m bah(=D.90)(Y.2) hm(A.117)-f i-w-A.89 ahâ(=P.19)-â(D.96)-k m pa(=G.73)
mw(=N.55) i-imî(=R.28)-t-w i-n-r(N.51)(N.51) ahâ(=P.19)-â-n
f-q-a(Y.2)(pl.)-n w-i nb(A.117)-i m nb(=U.50)(N.53,N.53,N.53)
r-r (?)[.....](pl.)-i[.....]w(pl.) h-b-š-w(S.32) III â IIIII ahâ-n
r-di(=D.59)-n pa wr(=A.29) n qd(=O.77)-š-w(T.1) pr(=O.3)-r(D.96)
wâ(=U.38)-t-â s-s-mw(=G.30)-t(E.2)
i-w[s ha(=M.69)-h(D.96)-ti(=U.19)] hr r-d(D.99)(D.99)-s i-w-s hr
âq(=G.71)-q(D.96) m xn(=E.22)-n-nw(O.3) pa mšâ(pl.) i-w-A.89
hr š-h-š-h(D.96) m ša(=T.38)-š
hr r-d(D.99)(D.99) xr-r pa-y-A.89 m-â-š-w(W.59) i-w-A.89 hr
wn(=E.58)-n(O.69)(D.69) x(=T.43)-t-s š-â-d(U.24 ?)(T.14)(D.69)-n-A.89
š-d(X.21)-s r-di(=D.59)-
-n-A.89 šw(=M.24)-w m bah(=D.90) nsw(=M.24)-t(A.117) dwa(=N.35)-t(A.5)
[sic.] hr-r-w n nfr s rdi(=D.59)-n-f r-š-t-w(F.5)(pl.)
mh(=V.15)(Y.2)-n-s x(=T.43)-t-A.89 t-h-h-t-w(Y.2)(pl.)
xnm(=W.11)-m(Y.2)-n[sic.]-f h-â(D.109)(D.109)(D.109)-A.89

[... wahn-i [sic.] st] m bah
m fqa âa Rht ir[i.....]
iw sahn-i nhtw NŠwt Bit (N-n-
hašt Snngaar (hašt) irn-f hašt
[âat im]-sn hfân-i m bah NŠwt
n-i Nb n Bstw Rht iri [.....]
[.....] hâ qd snwâ iw whm-n-f
šmswt-f haqn-f [dmi n]
Qd-d-š-w (hašt) nn tšt-i r b
[BURCHARDT, Altkan. Frenfw. No. 47
Rdi-i st] (16) m bah NŠwt Nb
ân h dt rdin-f n
Nb hr qn m bah â bw nb rmtt [.
Rht iri Nb n Qn Maâ šby snwâ
iw maan nb-i hr [.....]
[.....] m hprw-f nb hr hašt Ph
ha[.....](hašt) hrtw [Gramm. 9
pa[.....]n(O.37) m [hâ]h(D.9
n mšâw mi qd[-f i-w]
whm-i maa nhtw-f hr hašt ntî
n Kriw [or Krsu; SETHE] (nr)[.
30, p. 59, No. 99]
kfin-i im-f m bah NŠwt inn-i i
ân h rdin n-i
Nb-i Nb n hs-tw Rht iri Nb šb
iff snwâ maa wâw Bmt Bm
Whm n maa ky ep mn h irn Nb Pa
šat-đut n abw hr hšt-šn ân h
Šepn pa abw âa ntî im-šn âha
iw-f ân h
m bah hm-f iw-i ahâ-kwi m pa
fqaan wi Nb-i m nb
[? ? ?] hšw hnt â dwa ân h
pr satâ ššwt
iw-[š hahti] hr rdi-š iw-š hr
hr šhšh [Gramm. §273 Ann] m ša
hr rdi xr pay-i [Gramm. §171]
iw-i hr wn xt-š Šâdn-i šd-š r
-n-š šw m bah NŠwt Dsot hr Bt
šhrš xt-i tħwt xnm-n-f hâw-i

XXIII. Thutmose III-Anenhotep II: Anenamheb (6)

ân Paqan-f wi	" [... {I} took them] before my Lord. Then he rewarded me with a great reward. "List thereof [.....]	Geographical Names
âd	"I saw the Victories of the King of Upper and Lower Egypt, Men-kheper-Ra, [Thutmose III] "Given Life, in the Country of Snngaar. He made	(20) Snngaar
st im-Rdin-f	"great slaughter among them. I plundered before the King, taking a hand there. "He gave to me the Gold of Honor. List thereof; [.....]	
k-f	"[.....] Silver 2 rings. I repeated the seeing of his bravery [when] I was "among his followers. He captured the [City of]	
ân-f Narayna ânwâ = [sqr-ân hwtîmê hqa wašt,]	"Qd-d-šw, I did not weaken from the place under him. I took of Syrian Nobles "men 2 as [living captives. "before the King, Lord of the Two Lands, (Thutmose, Ruler of Thebes) Life "Forever, He gave of "Gold on account of bravery in the front place of all the people [.....]	(21) Qd-d-šw (22) Wašt
âd awî (qd) faw	"List thereof; Gold of perfection [i.e. 1st. quality], a Lion, Collar [PIERRET, p.578] "2, Fly 2, Arm-rings 4. [Note:- As to "Fly" see BREASTED, S.B.A. Proc. XXII, (1900), p.95. As to šby, "Collar", the group is repeated in line 22 with a determinative in the form of a collar of metal.] "I saw my Lord on [.....] (18) "[.....] with all his happenings in the Hinter Lands [.....]	(23) Wašt Phm
[.....]	"the Country of h[.....] It was mentioned to him, and I was raised to "the [.....] for the mobility (?) of the army as a whole.	(24) h[.....]
k-f inh below, line 27]	"Again I witnessed His Victories in the land fihšî. the wretched, in the City of "Nris [or Nrsê] (Lake)[.....][or Region of Lake Nris, MÜLLER, As.u.Eur.p.258]	(25) fihšî (26) Nris-or Nrsê
(Wašt) xst = Dwi CLAUSE, Z.d.D.Pal.	"I fought therein before the King; I brought away Nam, men 3 as living captives. "Then gave to me my Lord	(27) Nam
mat = sqr-ân	"the Gold of Honor. List thereof:- Gold Collars 2, Arm-rings 4, Plies 2, "a Lion, a Female Slave, a Male Slave.	
âd awî (qd) faw	"A repetition of seeing another time an excellent thing which the Lord of the "Two Lands did at Niy; he hunted 120 Elephants on account of their tusks.	(28) Niy
iy (Wašt) hân-f	"I took the Great Elephant of those among them, and attacked in the presence "of His Majesty. I cut off its hand [while] it was alive,	
ân-f inh šad dt-f	"before His Majesty, and as I was standing in the water between two rocks. "Then the Lord rewarded me with Gold.	
wtî inr šasâ inh	"[? ? ?] 3 [suits of] raiment, and 5 hands (?). Then the Chief of Qdšw "caused to send alone a mare,	(29) Qdšw
ba	"she was swift on her feet, and she was going into the midst of the army. "I ran up behind her	
khw ba ašs î-f	"on foot carrying that dagger of mine and [ripped] open her belly.	
PIERRET, p.199]	[Then] "I cut off her tail and I set it before the King. Praises were to the "God for it, and he caused exultation to fill my body, and rejoicing to possess "my limbs.	
ân-f rēst		

THIS PAGE IS LOCKED TO FREE MEMBERS
Purchase full membership to immediately unlock this page

DELVE INTO FANTASY, MAGIC, MYTHOLOGY & FOLKLORE

Forgotten Books'
Full Membership gives
access to 797,885 ancient
and modern, fiction and
non-fiction books.

Continue

*Fair usage policy applies

E.	M.	S.	
30	29	36	394 r-t-di(=D.59) [sic.] i(A.13)-n hm(A.117)-f pr-r(D.96) q-n(D.69) nb n mšā(pl.)-f r s-d(Z.7)(D.69) pa s-b-t-ī(0.36) n [sic.] ma(=U.8)-a-m-t (Y:2) ir-n qd-d-š-w(T.1)(N.40) nw-k
31	30	37	895 s-d(Z.7)(D.69) s-w i-w-A.89 m ha-w-t-ī(D.96) n q-n(D.69) nb nn ir k-y [sic.] hā-t-A.89 pr(=0.3)-r(D.96)-n in(=W.22)-n-p-i m-ā-ra-y- -n-a(T.1)(A.89) s(A.89) II m s-q-r(Z.22)-ānh(A.85) whm(=F.52)-m(Y.2) i(A.13)-n nb(A.117)-i r [sic.] r-q-a(Y.2)(pl.)-A.89 hr-r-š m b-w nb nfr-r n s-htp(=Q.17) ib h-r nšw(=M.24)-w-t ir(=D.10)-n-A.89 nn(=M.22)-n n k-f-ā(D.82)(D.69) i-w m(=N.50) w-ā-w(A.89) [n i]-wn-n [wšr(=S.66) ha(=F.16)-t] wia(=P.1) nw-k(A.89) ts(=Q.73)-s-w(D.69) ā-q-a-w(V.1) [...] m i[mn-n wšr ha-t wia] i[w] A.89 m tp(=D.1)-p n i-r(A.128) s(=A.89)(pl.)-f hr xn(=D.51)-n[t] i-mn-[n] (N.1 ? or Z.14 See SETHE, note, p.895) [.....] m h-hb(=W.49)-b nfr-r-r(Y.2) n i-p-t (?) (pr) tawī(=N.39) t-tm(=U.14) A.89 B.7 (pl.) m i-h-a-a [.....](pl.) i-s-t nšw-t-n km-m(Y.2)-n-f āhā(=P.19)-ā-w(N.7)-f m rnp-t(=M.13)-t(pl.) āšā(=I.2)-t(pl.) nfr-r-r(Y.2)(pl.)[sic.] m q-n-t(D.69) m [wšr-š-]r(D.69) m ma(Q.58)-ā-hrw(=P.22)-w šā-ā(Y.2) m hq-t-sp(=M.13 + X.14) I nfr-r-r-y-t.r ho-t-sp LIV ibd III pr-r-t(N.7) ārq(=V.10)-y h-r [hm n] nšw-t bit (rā-mn-hpr) maā(=Q.58)-hrw(=P.22) s-hr-r(N.49)-f r p-t(N.1) xnm(=W.11) m i-t-n(N.7) nfr hā(=D.111) hā [hā] ab(=U.31)-h(Z.7)-b [sic.](D.69) m iršw-w hq(=M.74)-d(N.13)-n r-f ta dwa(=N.35)-a-w(N.7) hpr(=L.4)-r i-f-n(N.7) w-b-n(N.13) p-t(N.1) b-ba(=G.53)-q-a(Y.2) ti(=U.19)-i [GAUTHIER, Bib. d'Ét. IV, p.139, No.2] nšw-t bit (rā-āa-hpr)(pl.) sa rā (i-mn-htp nfr [hqa] waš-t) di(=X.22) ānh(=S.43) s-mn-n-nw(=W.21)-w hr nš(=W.42)-t(0.3) n-f i-t-f(A.113)-f htp(=Q.17)-f s-r-h (𐎓𐎎𐎏) ja(=G.87)-a-i-r(V.27)(D.69)[sic.]-f nb-t [sic.] ab(=U.31)-h(Z.7)-b[sic.]n-f q-a-t(T.1)(A.85)[.....] d-r-t [sic.](G.64) d-ma(=U.8)-a(T.14)-n-f qdā(=D.1) qado qada wr(=A.29)(pl.)-s-n(pl.) hā(=N.23)-ā-w(Y.2) w hrw(=G.8) sa(=G.67) išt(=Q.1)-t(H.21) išt(=W.44)-t(D.69) n [.....] [.....](A.85) g [sic.] -n [pn: See BREASTED, note "c"] wn(=E.58)-n-t-tiw (=G.5)(pl.) k-n-nm(=Z.30)-m-t-tiw(=G.5)(pl.)(N.40) ta(=M.37) nb m k-s-w(A.19)(pl.) n daw(=G.54)(pl.)-f in(=W.22)nw(=W.23)(pl.)-s-n(pl.) hr p-s-d-w(D.35)(pl.)-s-n [ms(=0.71)(Y.2)-t-w r-t]-di[sic.] n s-n(pl.) jaw(=P.16)-w(pl.) n ānh-n-h āhā(=P.19)-ā-n ma(=U.8)-a(D.10) w-i hm(A.117)-f hr xn(=D.51)-n-t(D.69) xr(=Q.20)-r-f m b-i- -k(P.1)-f (i-mn-n wšr(=S.66) hqa(=S.62) wašt(=S.65)) hā(=N.23)-ā m wia(=𐎓𐎎𐎏)-r-n-f i-w-A.89 hr xn(=D.51)[t](D.69)[.....] hā(=N.23)-ā-ā m h-hb(=W.49)-b nfr(=Y.9)-f-r n ip(=Z.25)-t(0.3) rš(=M.30)-t m mi(=W.29)-t-t(Y.2) r qšr-r [ah-t(=N.44) sāh(=V.4)] n ta(=N.37) [s-]ā-r(N.49)(D.96) k-w-i r hnt(=F.5)-t(0.3) āhā(=0.29)-ā(0.3) r-di(=D.59)-w [sic.] āhā(=P.19)-ā(D.96)-i m bah(=D.90)(Y.2) sa(=G.67) i-mn-[n] ([rā-ā-] -hpr(=L.4)(pl.)) p-w [wr(=G.79)] ph(=F.48) ph wn(=E.58)-n-i-n p-t-h(D.96) k-w-i hr ta(=N.37) m bah(=D.90) ā hm(A.117)-f q-d-i-n-f n-A.89 r-h(Y.2) n qd(=0.77)-d-nw(=W.21)(Y.2)-k ti(=U.19) w-i m e-š-ī [For G.88 See Grams. §466] m wn(=E.58)-n-k w šms(=U.42)-t-w i-t-f-A.117 rdi(=D.59) m hr k m iaw(=F.35)-t m(?)=M.12 ?)-t idn(=F.46)-nw(=W.21)(D.96) k [sic. but see BREASTED, n. "c"] n mšā(=A.82) (pl.) mi(=W.29) q-d-ti(=U.19)-i s-r-s(=Q.54)(0.12)-k q-n-y-t(pl.) nšw(=M.24)-t-n wn(=E.58)-n-i-n idn(=F.46)nw(=W.21) m-ā-hw(=F.44)(Y.2) hr ir(=D.10)-t q-d-t(pl.) nb-f
32	31		
33	32		
34	33		
35	34		
36	35	38	
37	36		
38	37	896	
39	38		
40	39		
41			
42			
43	39	897	
44			
45	44		
46	45		
47	46		

rdit in hm-f pr qn nb n wšw-f r
irn qd-d-šw (hast) ink

šā šw i-w-ī m hantī [Gramm. §227] n
hāt-ī Prn [Gramm. §354] inn-ī hāra
-na [See line 15] s šnwā m šar-ān
§286] Nb-ī ir fqa-w-ī hr-š m bw
nb nfr n šhtp ib hr Ngut Irn-ī nn
[n i]mn [wšr-ht] wia

ink rsw [GARDINER, Rec. Tr. 34, p.63, l
(šnt)[VOGEL'SANG, Untersuch. VI, p.14
wia] i-w-ī m r p n irw [GARDINER, Z.
id.47, p.18] w-f (35) hr xnt im
m hō nfr n ipt hantī tm rntt m iha
išt Nšwt kmn-f āhās-f m rnpwt āšā
[wš]r
m maū-hrw šāū m hat-sp wām nfrwt
ibd hnt Prt ārqy hr [hm n] šwt di
(Mn-hpr-Rā) maū-hrw šhr-f r Pt Xn
abh m iršw hdn r-f [Gramm. §446] r

hpr iŕn wbn Pt baqa [EMBER, Z. Aeg.
w šwt bit (ā-hprw-Rā) Sa ū (imn-
wašt) di ānh
šwns hr Nšt ntī iŕt-f htp-f [MASP
p.101] šrh Tair-f [See SETHE, Verb. §
abh-n-f [MASPERO, Bib. d'Ét. I, p.43]
Drt dman-f qada wnw-šn hāw m hrw
n [.....]

[.....](A.85)-pn (?) wntiw Kinnēt
m kšw n daw-f innw-šn hr pšdw-šn

[se-ts r]dit n šn jaw n ānh.
āhān maā wī hm-f. hr xnt xr-f m bi
-k(wia)-f (imn wšr hqa wašt) hā m
xn[t] [.....] hāā [GAUTHIER, Bib. d
m hō nfr n ipt Ršt [SETHE, Z. Aeg. 4
mitt r qšr
[Aht Sah] n Ta sār kwī r hnt āhā
āhā-ī m bah Sa imn (ā-hprw-Rā) p
[wr] phī wnīn [Gramm. §476] pth Au
hm-f qdin-f R) n qdnw-k ti wī m s
m wn-k m
Šwšwt i-t-f-ī rdi m hr k m iawt
Nšw Ni qdti-ī šrs-k qnyt Nšwt hr
hr iŕt qdwt Nb-f

Note:- There is a Statuette in the Cairo Museum of "imn-m-hb-b(W.49) or Nāhs" (Catalogue Gén. des Antiquités Musées du
the same Museum is of "imn-m-hb(=W.50)" (Cat. Gén. etc. op.cit. p.68, No.42120) LEGRAIN (Annales du Service, IV, (13)

590
 591
 592
 808
 809
 810
 811
 812
 813
 814
 815
 816
 817
 818
 819
 820
 821
 822
 823
 824
 825
 826
 827
 828
 829
 830
 831
 832
 833
 834
 835
 836
 837
 838
 839
 840
 841
 842
 843
 844
 845
 846
 847
 848
 849
 850
 851
 852
 853
 854
 855
 856
 857
 858
 859
 860
 861
 862
 863
 864
 865
 866
 867
 868
 869
 870
 871
 872
 873
 874
 875
 876
 877
 878
 879
 880
 881
 882
 883
 884
 885
 886
 887
 888
 889
 890
 891
 892
 893
 894
 895
 896
 897
 898
 899
 900

"Caused His Majesty to march out all the strength in his army to break through
 "the wall newly built by Qd-d-šw.
 "T'was I who smashed through it, I was first of all the brave. None other did
 [it] "before me. Thereupon I took Sýrian Nobles,
 "Man 2 as living captives. Again my Lord rewarded me on account of it with
 "every good thing for satisfying the heart, proceeding from the King. I made
 "this capture being as Officer of the ship *Ian šer Hat*
 "I was Commander of the Towing line (?) in the ship Anon User-Hat. I was as
 "First of the men who accompanied Him on the voyage up stream of Amon in the
 "beautiful Festival of *ipt* (see line 44) The Two Lands were full of people
 "in gladness [.....]
 "Lo! the King ended his life in full years, worthy in valor, in [nigh]t, and
 "in triumph, beginning in
 "the [Regnal] Year 1 and into the Year 54, the 3rd month of *Prt* and the last
 "day under the [Majesty] of the King of Upper and Lower Egypt,
 "(Men-kheper-Ra) Triumphant; He withdrew to Heaven; took his place with the
 "Disc and the Divine Members singled with Him who formed him. [Then] the
 "earth lightened, it was morning,
 "the Sun waxed and the radiant Heaven shone when the King of Upper and Lower
 "Egypt, (Aa-kheperu-Ra), Son of Ra, (Amenhotep, God, Ruler of *Wašt* [Thebes]
 "[Amenhotep II] giving Life,
 "ascended the Throne of His Father and united the heraldry (?) He ? ? ?
 "all. He penetrated to (?) the Highlanders (?) [.....]
 "the Red[land] and cut off the beads of their Chiefs. Diademed like Horus,
 "Son of Isis, he siezed for [.....]
 "this (?) [.....] and those who are of the *Knnwtjw* [land]. Every land
 "bowed down to His Paze, their tribute on their backs
 "that it sight bring to grant to them the breath of life.
 "Then His Majesty saw me rowing under Him in his Royal
 "Barge, "(Amon, strong and Ruler of *Wašt*) shining in the [Royal] Barge"
 "its name. I was rowing [in] splendor in the beautiful Feast of Apet of
 "the South [Thebes], and to the celebration of
 "[the *Aht Šah*] of the Earth. I was taken to the inner part of the Palace
 "and made to stand before the Son of Anon, this (Aa-kheperu-Ra)
 [Amenhotep II], "the Great and Strong
 "I threw myself upon the ground before the Arm of His Majesty. He
 "said:- "Knowing of thy character since I was in the nest, and that
 "thou wert in the following of my Father, thou art promoted [lit."given
 forward"] to the
 "coveted (?) office of Deputy for the Lord of the Army. Thus have I
 "spoken. Do thou watch over the Forces of the King." [i.e. Lieutenant
 General ?]
 It was the Deputy *Mahu* who shaped the sayings of his Lord.

Geographical Names
 (30) Qd-d-šw
 (31) *Wašt* [Thebes]
 (32) *Knnwtjw*
 (33) *ipt-Ršt*

Statues et Statuettes I, p. 60, No. 42112) LEGRAIN however, dates it in the reign of Thutmosis II. Another statuette in
 (182) does not believe that this is the Amenemheb now in question.

THIS PAGE IS LOCKED TO FREE MEMBERS
Purchase full membership to immediately unlock this page



Never be without a book!

Forgotten Books Full Membership gives universal access to 797,885 books from our apps and website, across all your devices: tablet, phone, e-reader, laptop and desktop computer

A library in your pocket for \$8.99/month

Continue

*Fair usage policy applies

Tomb (Mortuary Chapel) No.86 (Old Nos.34 & 63) in the Cemetery of Sheikh 'abd el Gurna in the Necropolis of West. A description of the Necropolis and its group of cemeteries is given in Table No.XX. See also Plans:- BAEDEKER, see Table No.XX and BAEDEKER, op.cit.(1908), Plan p.305 (There Tomb No.34). The plan is not given in the edition of du Service, IX, (1908), pp.123, ff. Men-kheper-ra-senb, called *Nâhw*, High Priest of Anon, whose tomb is now being desc

I. Texts containing mention of *Mn-hpr-Râ-snb*, *Mn-hpr-Râ* (not in Cartouche), or *Mn-hpr*:- S. = Stele: St. = Statue: T. BAEDEKER = Egypt, (1908:1914) BOESER = Beschreibung etc. Niederländisch.Kgl.Mus.Leiden;(1909-1915) BR.MUS. = Ge BRUGSCH, Hist.Eg. = History Eg. under the Pharaohs, (1881) BRUGSCH, Reise. = Reisenach der grossen Oase, (1878) Private Tombs, Nest Thebes, (1913) GRIFFITH = RANDALL, MAOIVER, MACE & GRIFFITH, el Amrah & Abydos, (Eg.E.Fund Special M. F. Salvolini sur les Mon.Ég. etc. Leyde (1838) LIEBLEIN, = Dictionnaire de Noms Hiérog. (1871-1892) LEPsius (Mém.Miss.Franc. au Caire;1) DE MORGAN = Monuments et Inscriptions MURRAY = Handbook Egypt (1900;1907) PETRI Nouvelle éd. par PAUL PIERRET (1895) ROEDER = Aeg. Inschr. aus den Kgl. Mus. zu Berlin, VII, (1913) DE ROUGÉ = SETHE = Urk.XVIII Dyn.(1908) SPIEGELBERG = Aeg.Gra.und Denksteine aus süddeutschen Sammlung.II München, (DYROFF-WEIGALL = Antiquities of Upper Egypt (1910) WEIGALL, A.D.S. = Annales du Service, etc. WIEDEMANN = Aeg.Gesch. (1908), (Serv.des Antiq.de l'Ég.) DARESSY, (C.F.) = Recueil des Cônes funéraires, (Mém.Miss.franc.du Caire, VII

Leiden

BOESER, VI, (1913), p. 2, No. 3, Pl. XIV.
LIEBLEIN, I, (1871), p. 197, No. 595
WIEDEMANN, (1884), p. 357
PETRIE, II, (1899), p. 141
LEEMANS, (1840), p. 269
" (Salv.) (1838), p. 53, No. 85, Pl. VIII
SETHE, IV, (1909), p. 1175, No. 342

A. (Upper Relief) The deceased and
(6) n ka n (7) *îni-ra*(=S.27)-*pr*
naâ-hr (9) *sn-t-f* *Nbt-pr* (10) *ni*(=N.2
B. (Lower Relief) Two officials with
idn(=F.46)-*n-nw*(=N.21)-*w n pr*(=O.3) *îni-n-m*(= sic.)-*pr*(pl.)-*f*
(Same Title) *Qhwti-m* *Sn-t-f* *Nbt-pr* *M*
[Note:- SETHE (op.cit.p.1176,n) calls

British Museum

BR.MUS. (1909), p. 211, No. 767.
GRIFFITH, (1902), p. 94, Pl. XXXI, XXXIV.
PETRIE, III, (1905), p. 213

Osiris, Horus and Isis adored by *Pa-sb*
i.e., Pasebkhanut Justified, son of the

XXXIII. Thutmosis III. Men-kheper-ra-senb(1)

is that of *Mn-hpr-Râ-snb* or *Râ-m-hpr-snb*, High Priest of Anon (*Ntr Hm.Tpi n Imn Râ*) under Thutmosis III. (192), p.288: (1908), p.276: (1914), p.280 MURRAY, Handbook of Egypt, (1900), p.774: (1907), p.379. As to Sheikh 'abd el Gurna, MURRAY, Handbook of Egypt, (1907), p.437, (Tomb "34"). The present No., 86, is that of WEIGALL in his list of Tombs, Annales must be distinguished among the persons whose names are similar, as shown in the following Table.

T.C. = Tomb Chapel: F.C. = Funeral Cones.
 G. Galleries, (Sculpture), (1909) BRUGSCH = Recueil des Mon. égypt. I, (1862) BRUGSCH, Gesch. = Geschichte Aegyptens, (1877)
 Ubersichtliche Erklärung Aeg. Denkmäler d. Kgl. Mus. z. Berlin, (1850) GARDINER-WEIGALL = Topographical Catalogue of the
 Description raisonnée des Mon. Ég. du Musée d'Antiq. des Pays-bas à Leyde (1840) LEEMANS, Salv. = Lettre à
 Mon. Ég. du Musée d'Antiq. des Pays-bas à Leyde, (1840) LEEMANS, Salv. = Lettre à
 Mon. Ég. du Musée d'Antiq. des Pays-bas à Leyde, (1840) LEEMANS, Salv. = Lettre à
 History of Egypt (1899-1905) RIEHL = Inscr. Hiérog. (1886) PIERRET = Oesor. Sommaire des Sallen de Mus. Ég. par E. de Rougé,
 Mon. du Louvre, (1st. Ed. = 1855) (VIIth. Ed.) SCHIAPARELLI = Museo Archeol. di Firenze: Antichità egezie I (1887)
 Verzeichn. d. Aeg. Altert. (1899) VIREY = Mém. Miss. Franc. au Caire, V, II, pp. 197, ff.
 Xith. Dynasty Temple at Deir el Bahari, I-III, (1907-1913) LEGRAIN, (Rép.) = Répertoire généalogique etc. du Mus. du
 Catalogue d'Abydos, (1886): MARIETTE, (Ab.) = Abydos, (1880)

represented at a table, which is loaded with food, receive offerings from a Priest. (Lines 1-5 Conventional)
 (=87)-t (8) *Mn-hpr* (6) to the ka of (7) the steward of the Vizier, (8) Men-kheper
 (11) (B.7) *Nbt Imh* [sic.] Justified. (9) His sister, the Lady of the House, (10) Mia, (11) Lady of Honor.
 seated. Between the groups is a table loaded with food.
 Deputy for the House of (Men-kheper-Ra) [Thutmosis III],
 Given Life, Amen-em-mer-ef.
 (=P.44) *sqât-hrw* (Same title) Thutimes. His sister, the Lady of the House, Mahu, Justified.
 to the "m" in the name *Imn*; Turned about it is a characteristic of the writing in the 1st. half of the XVIIIth. Dynasty.]

(Three Lines) (Over Deceased) *Mn-hpr* (A.89) (Over Wife) *Kwi* (B.7) (Over Child) *Twr*.
 (3) n ka n *Mn-hpr* (A.89) (1) A Royal giving of an offering to Osiris (2) (3) to the ka of Men-kheper.
 His wife, the Lady of the House, Kaia, and his son Tur.

(2pl.) n *Nb Tawi* Messenger of the King to every Land. The Master of Horse of the Lord
 of the Two Lands [(User-Maat-sehotep-en-Ra)] [Ramses II]; Men-kheper.

containing food etc., 1 man and 2 women adoring. (Middle) Deceased and wife before table containing food, 3 men and 1 woman bring
 before table etc. 3 men and 1 woman bring offerings.

(A.110) (110) *Hwt-f Nâ-â-ti-i* [sic.] *sa-f Ta-srit pa-sr* (A.89) Men-kheper, His wife Waty, his son Tha-serit Pa-ser.

whose names are identical with the names in No. 4. His son's wife is *Nbt-pr Iwy*.
 the presence of three Goddesses by:-
Pa-sr Hwt-f Nbt-pr i-v-y Menkheper, his wife, the Lady of the House, Waty, and by Tha-serit-Pa-ser [See No.4], and his
 (B.7) (3) *sat-f* wife, the Lady of the House, Iwy, (1) his son Hay, (2) his daughter Mawy, (3) his daughter
 (B.7) Uny, (4) his daughter Tay, (5) his daughter Waty.

low stool, the shoulders against a small pillar, arms crossed on knees. On the right shoulder above the panther skin may be
 II]. On the pillar is a votive text ending, n *Nr-hrp-hwt Pt-mś* (A.110) i.e. for the High Priest of Memphis Ptah-mes. On the
 ends:- *Nr-hrp hwt Pt-mś* (A.110) *irn Hm-Ntr Tpi Mn-hpr-[Râ Naâhrw]* i.e. The High Priest of Memphis, Ptah-mes, born of the

(=O.1) *Naâhrw sa* (=H.21) *Hm Ntr Tpi n mn-Râ-Su-Ntrw Râ-Mn-hpr* (1)
 Priest of Anon-Ra-su-nether Men-kheper ra Justified. [XXIst. D]

THIS PAGE IS LOCKED TO FREE MEMBERS
Purchase full membership to immediately unlock this page

DELVE INTO FANTASY, MAGIC, MYTHOLOGY & FOLKLORE

Forgotten Books'
Full Membership gives
access to 797,885 ancient
and modern, fiction and
non-fiction books.

Continue

*Fair usage policy applies

No.	Present Location	Published	
8	Louvre	DE ROUGÉ, (1855), p. 117 PIERRET, (1895), p. 48, C. 100 BRUGSCH, I, II, (1862), p. 39, Pl. XXII " (Reise) (1878), p. 84, Pl. XXII " (Gesch.) (1877), p. 645 " (Hist. Eg.) (1881), p. 203 BREASTED, Anc. Rec. Eg. IV, (1906), p. 317 PETRIE, III, (1905), p. 211	Stele found at Thebes by "Mr. Maunier" long lines of horizontal text. (line 4 i. e. Year 23, First Month King (Mer-Amon Panezem) [Dynasty XXI]. (a) Luxor: In situ (?) from Wall of IV, § 859. (b) Berlin Museum, No. 1572 III, p. 88) WIEDEMANN, Äg. Gesch. (1884), See WIEDEMANN, op. cit. BREASTED, op. cit. Monuments, Pl. 23 (c) el Hibeh: BAEDEKER, II, p. 48. Now in Berlin Mus. Nos. 1570, op. cit. XXIII: id. Rev. Archéol. Sér. I, I, 2; Island of Bigga: PETRIE, op. cit. p. 210, p. 103, No. 450, (Inv. 2258), Vitrine R.
11	Sh. 'Abd el Qurna	GARDINER-WEIGALL, (1913), p. 22, No. 79 WEIGALL, (1910), p. 139, No. 79. " (A. D. S.), IX, (1908), p. 131, No. 79, (30). PIEHL, I, (1886), p. 109, No. 138. VIREY, V, p. 830. SETHE, IV, (1906), p. 1196, No. 353. SETHE, IV, (1906), p. 1201, No. 354. SETHE, IV, (1906), p. 1181, No. 347: VIREY, V, p. 828: CHAMPOLLION, I, p. 839: PIEHL, I, (1886), p. 109, No. 140B	(SETHE, p. 1196) (Stele in Tomb) (line 21 [SPIEGELBERG, Rec. de Tr. 19, (1897), p. 8] SETHE, Urk. XVIII Dyn. pp. 741, 895 etc.] <i>Mn-hpr</i> (A. 110) <i>Naâ-hrw</i> <i>n ka</i> [sic.] <i>Naâ-hrw</i> Ibid. scene. Deceased receives a bouq <i>Htp Imn-Râ</i> <i>Imi Yrt Nfr Hswt</i> (Scene in Tomb) <i>It-f Nr-f Qb</i> [SETHE, <i>Hsy n Nfr Nfr Sab</i> (=E. 49) <i>Sx Hswt Imi Min</i> (=O. 75) - <i>nh</i> (A. 110) <i>Naâ-hrw</i>
12	Sh. 'Abd el Qurna a	VERZ. (1899), p. 450, Nos. 8779, 8780. DARESSY, VIII, p. 287, Nos. 162: 289: 185. MOND, (Ann. d. Serv.), VI, (1905), p. 93, No. 185. SETHE, IV, (1906), p. 1204, No. 356. ROEDER, VII, (1913), p. 299, Nos. 8779, 8780. " " " " " " " SETHE, <i>ibid</i> , p. 1205.	Note: - Funeral Cones bearing texts w "cleaning out the Tomb of Ra-men-khe No. 185). As to this SETHE says in a "their origin in the Tomb of the Fir (1) <i>Sx Hswt</i> (2) <i>Imi-ra Šnnwti n Šmâ</i> (4) <i>Naâ-hrw hr Nfr Åa</i> (1) <i>Imi-ra Im n Imn</i> (2) <i>Minw</i> (=A. 128 (3) <i>Nfr Nfr Sx Wdhw</i> [NEWBERRY, Beni F <i>ta</i> (=X. 1) <i>w n</i> (4) <i>Nb Tawi Mn-hpr-Râ-š</i>
14	Sh. 'Abd el Qurna	GARDINER-WEIGALL, (1913), p. 24, No. 87 WEIGALL, (1910), p. 125, No. 87 " (A. D. S.), IX, (1908), pp. 124-133, No. 87. BAEDEKER, (1914), p. 312, No. 97. MURRAY, (1907), p. 440, No. 34. VIREY, V, pp. 316-317 SETHE, IV, (1906), p. 1177, p. 1205	Tomb of Min-nekht. (See 11, b above) (SETHE, p. 1177, a) <i>Imi-ra Šnnwt nw Šmâ</i> <i>Naâ-hrw</i> (SETHE, p. 1205, a) <i>sa-f Nr-f Sx Nfr</i> [
15	Cairo	SETHE, IV, (1906), p. 991, No. 291	"Granite Statue", Cairo "547": [But (SETHE, p. 994, line 16) <i>Mn-hpr-Râ-šnb</i> Rec. Tr. 29, (1907), p. 20] <i>Nfr-hat Hs n</i>

statues called "The Stele of the Banishment". The top is broken off, but two figures remain, and underneath then are twenty three
 (5) *Hm Hpr Hpt Imn-Râ Hswt Hprw Imi-ra Nsâ Hr Mn-hpr-Râ Wuâhrs sa Hswt (Mr-Imn Po-ndm)*
 the Chief Priest of Anon-Ra, King of the Gods, Commander in Chief of the Army, Men-kheper-ra, Justified, son of the
 Other inscriptions of this personage may be noted as follows:-

MASPERO, Les Monies royales de Deir el Bahari: Mém. Miss. franç. au Caire, I, 4: p. 702: Rev. Archéol. XXVIII, p. 86. BREASTED, Anc. Rec. Eg.
 Verzeich. (1899), p. 450: from Luxor Wall. LEPSIUS, Denkmäler, III, 251, k (There "Karnak", but see ibid, Text, (NAVILLE-SETHE, 1900),
 n. 5 PETRIE, History of Egypt, III, (1905), p. 210 (c) Karnak: Sandstone Block: LEGRAIN, Rec. de Trav. XXII, (1900), p. 53
 \$880 (d) Karnak: Temple of Khonsu: CHAMPOLLION, Not. II, p. 225-2 LEPSIUS, Denk. Text (op. cit.), III, p. 58, p. 59, n. 1 Cf. PRISSE,
 Egypt, (1914), p. 207 MURRAY, Egypt, (1907), p. 308 LEPSIUS, Denkmäler, III, 251, i. Bricks from wall of Temple. ibid, Text, (op. cit.)
 516: Ausfuhr. Verzeich. (op. cit.), p. 450. Also No. 1567 (imperfect) WIEDEMANN, op. cit. p. 538, n. 4 PETRIE, op. cit. p. 210 PRISSE, op.
 ff. (f) Gebelân: Temple Walls: FRASER, S. B. A. Proc. XV, (1893), p. 498, Pl. XVIII, fig. XXI. PETRIE, op. cit. p. 210 (g) Bîgeh or
 see Text No. 9 below. (h) Louvre Mummy bandage of leather: PIERRET, Catalogue de la Salle historique de la Galerie Ég. (1873),
 WIEDEMANN, op. cit. p. 538, n. 2 PETRIE, op. cit. p. 211 (see also id. p. 212) (i) Memphis: Scarab: Wiedemann Coll. WIEDEMANN, op. cit. p. 538, n. 3.

1907), p. 517. *Mn-hpr-Râ sa (Āa-hprw-Râ)* Men-kheper-ra [or Ra-men-kheper], son of (Aa-kheperu-Ra) [Amenhotep II].

<p>Stele containing a Prayer to Amon. XVII, (1913), pp. 1, ff.] <i>Hswt Hatî-â</i></p>	<p>To wit, Scribe of the King. Under the immediate orders of the King, Prefect [or Mayor] of Memphis, Men-kheper.</p>
<p><i>a n Wâb n Imn-n</i> (26) * <i>Hnkt-ânh</i> (Pr) BREASTED, Anc. Rec. Eg. II, (1906), p. 552: <i>a Hsnt n Nb Tawî Heg n Hpr Hpr</i> <i>-ra Hsnt n Nb Tawî Mn-hpr-Râ-snb</i></p> <p>son his son. (Over son) <i>Rdi Hswt</i> <i>-Râ) Di-ânh</i></p> <p>\$58, \$359, n. 1] * <i>Hwt-f gr n Pr-f</i> <i>antî n H (nwt) Šmâ (nwt)</i></p>	<p>(25) [for the Ka of the Libation Priest of Anon] (28) in the House [called] "Offerings of Life" [i.e. name of the Tonh-Temple of Thutmose III at West Thebes] [BAEDEKER, Eg. (1914), p. 309; MURRAY, Eg. (1907), p. 418: WEIGALL, Ann. d. S. VII, (1906), pp. 121, ff. LEGRAIN, ibid, p. 183] Superintendent of the Granaries of the Lord of the Two Lands. Praised of the Good God; Men-kheper, Justified. to the Ka of the Superintendent of the Granaries of the Lord of the Two Lands, Men-kheper-ra-senb, Justified Giving of the King an Offering of Amon-Ra who is within the Royal Necropolis of (Men-kheper-ra) [Thutmose III], Given Life. His Father, his beloved; Who is refreshed (?) [VIREY] in his City, and also in his Home. Praised of the Good God. Judge, Scribe of the King. Superintendent of the Double Granaries of Upper and Lower Egypt. Min-nokht, Justified.</p>
<p>PETRIE attributes to <i>Mn-hpr-Râ-snb</i>, son of <i>Min-nht</i> (See No. 11). MOND however (Ann. d. Serv. VI, pp. 92, ff.) says:- "Dec. 28th. 1903, senb, as well as his courtyard, I found 185 of his funeral cones". Of these he publishes the text of one cone (p. 95, Urk. XVIII Dyn. p. 1204, n. "d") "MOND, Ann. du Serv. VI, 92, seems to assume (anzunehmen) from his discovery that the cones had sphet of Anon."</p> <p>at nwt) (3) <i>Mn-hpr-Râ-snb</i></p> <p><i>Hpr) n Imn Hm-kay</i> (D. 699 [sic.] n p. 48: GARDINER, Admon. p. 27) (4) (5) <i>Naâ-hrw hr Hpr Ia</i></p>	<p>(1) Scribe of the King (2) Superintendent of the Double Granary of Upper and Lower Egypt. (3) Men-kheper-ra-senb, (4) Justified under the Good God. (1) Superintendent of the Cattle of Anon. (2) Guardian of the House of Anon. Servitor of provisions for the (3) Good God. Scribe of the Bread Tables of (4) the Lord of the Two Lands, Men-kheper-ra-senb (5) Justified, under the Great God.</p>
<p>WIEDEMANN: "Aeg. Inschr. aus Agram." <i>Hsnt (A. 89) Wâb n [.....]</i> ques, Supp. Index, p. 1151]</p>	<p>Hereditary Prince, Count ? ? Scribe of Amon, Men-kheper-ra-senb. Libation Priest of [.....] Denu-ra-ga.</p>
<p><i>H (nwt) Min (= 0.75) -nht (= D. 69)</i> <i>an-n]-Râ Mn-hpr Naâhrw</i></p>	<p>Superintendent of the Granaries of Upper and Lower Egypt, Min-nokht, Justified; his son, his beloved, Divine Scribe of the Offering [for Amon]-Ra, Men-kheper, Justified.</p>

side to Cairo Mus. (1910), p. 142, No. 505 [547]. [Not found in LEGRAIN, Répertoire, nor Cat. Gén. Mus. Cairo]
Naâhrw sa Šr n Nâdaw [BAILLET,
Wiw Râ (= T. 2) irtî (B. 7)
 Men-kheper-ra-senb, Justified, Son of the Chief of the Mazoi [Constabulary] Nefer-khat, and born of the Lady of the House Buiu-Resitti,

THIS PAGE IS LOCKED TO FREE MEMBERS
Purchase full membership to immediately unlock this page



Never be without a book!

Forgotten Books Full Membership gives universal access to 797,885 books from our apps and website, across all your devices: tablet, phone, e-reader, laptop and desktop computer





A library in your pocket for \$8.99/month

Continue

*Fair usage policy applies

II. Titles of the Men-kheper-ra-senb now in question; taken from the Texts in his Tomb Chapel at Sheikh 'Abd el Qurni

Note:- The following titles are from the list given by SETHE, Urk.d. XVIII Dyn.(1907), pp.926, ff. Many others given by SETHE Appendix "A": VITREY, Mém.de la Mission franç.au Caire, V, pp.200-215: DARESSY, ibid, VIII, 277: 38
GARDINER-WEIGALL, Topogr. Cat. of the Private Tombs at Thebes, (1913), (= "G & W")

Title No.	Sethe p.	L.		
1	926	9 a	Table XX, Nos. 1, 2, 24. (1) <i>Nṯr</i> (=R.13) <i>hm</i> (=W.6) <i>tpi</i> (=T.9)	(1) <i>Hm-Nṯr tpi</i>
		b	<i>n i-mn-n</i> (Table XX, Nos.35: 5; 60)	<i>n Imn</i> [G & W p.43]
2		12 c	(2) <i>ḏār</i> (=M.9) [SETHE, p.926, n. "a"] (Y.2) <i>n nb tawi</i> (=N.39) <i>hr</i> (=D.3)	(2) <i>ḏār n Nb Tawi hr qd-f</i> [MAS Table V, L.55] (3) <i>šhnt n-f m</i>
3		14	<i>qd</i> (=O.77)- <i>d</i> (W.21)(Y.2)- <i>f</i> (3) <i>s-hnt</i> (=W.8)- <i>n-t n-f m</i> [q-b](V.41)	(4) <i>stpn-f m ābw</i>
4		15	<i>s-mr</i> (=U.31)- <i>mr-mr</i> (4) <i>štp</i> (=U.3)- <i>p-n-f m ā-b</i> (W.31)(I.4) [] (pl.)	(5) <i>s[āa]-n-f</i> [.....]
5		16	(5) <i>s[āa</i> (=T.41)]- <i>ā-n-f</i> [=  "not šw": SETHE, n. "b"]	<i>ṯi šw m wḏh šhntn-f</i>
		17	<i>ti</i> (=U.19) <i>šw</i> (=M.24) <i>m wḏ</i> (=M.78)- <i>h</i> (A.71) <i>š-hnt</i> (=W.8)- <i>t-n-f</i>	<i>ist-f m āhā</i>
	927	1	<i>ist</i> (=O.1)- <i>t</i> (O.3)- <i>f m āhā</i> (=O.29)- <i>ā</i> (Table XX, No.3)	(6) <i>Imi-ra hmw Nṯr nw Šmā Nṯr</i>
6		2	<i>imi-ra</i> (=S.37) <i>nṯr</i> (=R.13) <i>hm</i> (=W.6) <i>hm hm nw</i> (=W.21) <i>šmā</i> (=M.26)	(7) [.....] <i>Nṯr Nšwti</i>
7		3	<i>mḥ</i> (=M.42)(O.3)(O.3) (7) <i>nṯr</i> (=R.13)[.....] <i>nšt</i> (=W.42) <i>nšt</i>	(8) <i>Imi-ra Iaw[t hntt]</i> [.....]
8		4	(8) <i>imi-ra</i> (=S.37) <i>iaw</i> (=F.35)-[t(pl.) <i>hnt</i> (=W.8)- <i>t-t</i> ... ? ... ? ...]	(9) <i>Imi-ra Pri Nb</i>
9		5	(9) <i>imi-ra</i> (=S.37) <i>pr</i> (=O.3) <i>pr nb</i> (=U.50)(N.53, N.53, N.53)	(10) <i>Imi-ra Pri Ḥd</i>
10			(10) <i>imi-ra</i> (=S.37) <i>pr</i> (=O.3) <i>pr ḥd</i> (=M.74)(U.50)(N.53, N.53, N.53)	(11) <i>Imi-ra Kawt m [Imn]. Nṯsw</i>
11		6	(11) <i>imi-ra</i> (=S.37) <i>ka</i> (=D.48)- <i>t</i> (pl.) <i>m [i-mn-n] wṯs</i> (=Q.53)- <i>w ḥā</i> (=N.23)	(12) <i>Sab n Wadti</i>
12		7	<i>pr</i> (=O.3) (12) <i>sab</i> (=E.49) <i>n wad</i> (=I.16)[SCHAEFER, Untersuch. IV, p.81] <i>wad</i>	(13) <i>Hm-Nṯr tpi [n Imn] Mn-hpw</i>
13		8	(13)(See No.1) <i>nṯr</i> (=R.13) <i>hm</i> (=W.8) <i>tpi</i> (=T.9) [<i>n i-mn-n</i>] <i>rā</i> (=N.7)	<i>n Nšwt Nbt Ta Wadhrw</i>
			<i>mn</i> (=Y.12)- <i>hpr</i> (=L.4)- <i>s-n-b</i> (Y.2) <i>maā</i> (=Q.58) <i>hrw</i> (=P.22)	Note:- The title <i>Šnt-Hnt</i> :
		9	<i>ms</i> (=M.80) <i>n</i> (=S.11) <i>šn</i> (=R.22)- <i>n-t hnt</i> (=D.95) <i>n šw</i> (=M.24)- <i>t-n nb</i> (=W.43)- <i>t</i>	Romischen zeit, (1904)
			<i>ta</i> (=N.37) <i>maā</i> (=Q.58)- <i>t hrw</i> (=P.22)	(14) <i>Šmr āa Ḍrryt</i> [MÜLLER, Z. Ä. p.46, L.4] (15) <i>hamn n-f N[m]š</i>
14		11 d	(Table XX, No.25) (14) <i>s-mr</i> (=U.31) <i>āa</i> (=T.41) <i>ā-r-r-y-t</i>	(16) <i>ib</i> [SETHE, Verb. II, §588, B]
15		12	(15) <i>ḥa</i> (=M.68)- <i>m</i> (H.17)- <i>n n-f šw</i> (=M.24)- <i>t-n</i> (A.110)[sic.][Y(pl.)] <i>r-mn-n</i> (H.17)	(17) <i>Ip ntt</i> (18) <i>Ḥsb wn ntī i</i>
16		13	(16) <i>ib</i> (=W.23) <i>n šw</i> (=M.24)- <i>t-n m ta</i> (=N.37) <i>r ḏr</i> (=W.40)- <i>r-f</i>	(19) <i>Imi-ra Šnnwt [Imn]</i>
17, 18		14, 15	(17) <i>i-p</i> (Y.2) <i>n-t-t</i> (18) <i>ḥsb</i> (=V.45)(Y.2) <i>wn</i> (=E.58)- <i>n n-t ht</i> (=M.9)- <i>h-t</i>	(20) <i>Imi-ra Nrwṯ Ḥdt Nt</i>
19		16	<i>nwt</i> (=O.1) <i>nwt nwt šmā</i> (=M.26) <i>mḥ</i> (=M.43) (19) <i>imi-ra</i> (=S.37) <i>šnnwt</i> [<i>i-mn-n</i>]	
20		17	<i>imi-ra</i> (=S.37) <i>mrt</i> (=N.58) <i>ḥdt</i> (=S.8) 	
			[Note :- SETHE (Untersuch. V, p.53, No.3, line 16: p.55, No.18: and p.87, No.18) gives the equat	
21	923	1, 3 e	(Title No.19, Table XXXII) (Titles Nos 1, 2 Table XX) (21) <i>mḥ</i> (=V.15)	(21) <i>Ḥp-ib n Nšwt m šmḥ Nnnu</i>
			<i>ib</i> (=W.23) <i>n šw</i> (=M.24)- <i>t-n m s-mn-n-h</i> (U.27) <i>mn-nw</i> (=W.21)- <i>nw-nw-f</i>	
22		4	(22) <i>hr</i> (=D.3)- <i>ḏaḏa</i> (=D.1) <i>imi-ra</i> (=S.37)(pl.) <i>hm</i> (=U.23 = )- <i>t-w</i> (Table XXXIII, No.11, No.1)	(22) <i>hr-ḏaḏa Imiw-ra Ḥmwt</i>

III. Statue of the Men-kheper-ra-senb now in question: (viz. *Hm Nṯr tpi n Imn*: i.e. High Priest of Anon) now in the in 1901 by M. LEGRAM in front of Pylon VII of the Great Temple of Anon at Karnak. (Annales du Service etc. IV, which he is writing. On the right shoulder and breast are cartouches of (*Aa-hprw-Rā*) [Amenhotep II] in whose r
Text:- On the papyrus 12 lines: On the face of the pedestal, 1 line.

Published:- LEGRAM, Cat.gén.(op.cit.), p.75: SETHE, (the line on pedestal counted as line 13) Urk.d.XVIII.Dyn.(1907).

See:- BREASTED, Anc.Rec.Eg.II, (1906), § 772, n. "b" LEGRAM, Répertoire généalogique etc. Mus. du Caire, (1908), No.:

3, for which see IV below.

er, have appeared before in this work. As to these references are made to the Tables and Title Numbers thereon. See also
Inscr. Hiérog. I, (1886), pp. CXXVII-CXXIX: CHAMPOLLION, Not. Descr. I, 558:

ib. d'Ét. I, p. 171: kw	(1) High Priest of Anon. (2) Sought by the Lord of the Two Lands because of his example, (3) he was Advanced by Him in the circle of the Nobles [as] he was (4) Chosen from the throng. he (5) magnified [.....] While he was in youth he advanced his place in the palace
ant)	(6) Director of the Priests of Upper and Lower Egypt. (7) [.....] priest (?) of the Two Thrones.
(NEWSERRY, Beni Hasan, I, 75]	(8) Superintendent of the leading offices. [NEWSERRY] (9) Superintendent of the Double Silver House. (10) Superintendent of the Double Gold House.
ib. Maâhrw né n Snt Jnt	(11) Superintendent of Works in the House [called] "Anon who weareth the Diadem." (12) Judge of the Two Crowns of Egypt. (13) High Priest [of Anon], Men-kheper-Ra-senb, Justified: born of the Sister-Wife of the King, Mistress of the Earth. Justified.
-Wife" occurs in the Decree of Canopus (line 4, hierogl.) (BUOGE, Canopus, III, (1904), p. 40, line 4: ΣΕΤΗΕ, Urk. Griechisch- 27) and is rendered (line 26, Greek (BUOGE, id. p. 158, L. 8) ἡ ἀδελφή καὶ γυνή. See Text, Statue, Cairo (No. IV below), line 13] 74: BOURIANT, Rec. Tr. 6,	(14) Great Friend in the Court of Justice; (15) for his Royalty inclined the shoulder. (16) Will of the King in the Entire Earth, (17) Numbering what exists. (18) Reckoning what there was of the property of the Cities of Upper and Lower Egypt. (19) Superintendent of the Granary of Anon. (20) Superintendent of the Serfs of the Crown of Upper and Lower Egypt.
st a fa r gr-f Sâ n	
ⲙⲓ ⲛⲓ ⲛⲓ ⲛⲓ = art "sklaven"]	(21) Puffiller of the Will of the King in perfecting His Monuments (22) Chief of the Superintendents of the Artizans.

Musem. (See Catalogue général des Antiq. Égypt. du Musée du Caire, I, (1906), p. 75, No. 42125, Journal d'entrée No. 38371) Found
pp. 8, 9) A seated figure of the deceased (Cat. gén. (op. cit.) Pl. LXXIV) with legs crossed tailorwise, whereon is a papyrus, on
p. 75) (Cat. gén. (op. cit.), p. 75) dates the statue.

Virev, Sept. Tombeaux Thébaines, (Méa. Miss. franc. V.), p. 197

THIS PAGE IS LOCKED TO FREE MEMBERS
Purchase full membership to immediately unlock this page

DELVE INTO FANTASY, MAGIC, MYTHOLOGY & FOLKLORE

Forgotten Books'
Full Membership gives
access to 797,885 ancient
and modern, fiction and
non-fiction books.

Continue

*Fair usage policy applies

Title	line		
	1	(On papyrus) [ir(=D.10)-t] h-p-w(pl.) s-mn-n(Y.2)[sic.] tp(=D.1) rd(=D.99)	[irt] Hpw [See Titl
	2	s-mn-h(U.27) maât(=O.54) n	p.180] smnh [MASPER
	3	i-mn-n râ(=N.7) rdi(=D.59)[-t-f] âw(=V.5)-w-f ht(=M.9)-h-t w(=N.47[Gloss.p.26])w	Imn-Râ rdi-t-f aww-f
	4	s-f-s-f-t(F.8)	šfšft-f
	5-6	h-r nfr(=R.13) nfr nfr s-wa(=V.26)-s hm(=W.6)-f m hnmst(=N.13)-t s-htp(=Q.17)	hr Nfrw šwaš hm-f m
	7	ka(=D.46) = h	
	8	n hrw(=N.7) nb(=W.43) ir(=D.10)-t-s-n s-w (?) n dada(=D.1)-f nfr(=Y.9)	n hrw nb irt-sn šw
	9	s-âa(=T.41) daw(=G.54)(Y.2)(pl.)-f r	
23	10-11	t-r(M.15)(N.7) nb(=T.43) (6) hr(=D.8) dada(=D.1) ânh(=S.43) wda(=U.21) šnb(=Q.9)	tr nb (6) hr dada 7
	12	nsw(=M.24)-t bit(=S.11)[sic.]-t (râ(=N.7)-âa(=T.41)-hpr(=L.4)(pl.)) i-mn-n mr(=U.12)-y	šwt Bit (âa-hprw-R
	13	rdi(=X.22) ânh	šsm-t iawt nbt r [š
		s-šsm(=T.20)-t iaw(=F.35)-t(pl.) nb(=T.43)-t r [hn(=Q.31)-t(pl.)-s-n(pl.) rdi(=D.59)-t	[š] iaw-f m [št-Nfr
		r-h(Y.2)]	
		[s](A.89). iw(=D.96) iw iw-f m [nfr(=R.13) h-t(=O.12)](O.3) n-t i-mn-n [sic.] i-p-t	i[n,R]pâtî hatî-â [
		ist(=Q.1)[sic.]	hmw ntî [sic.] Imn
		i[n r]-p-i ha(=F.16)-â [.....] (11) [..... (Title No.23) hrp(=S.50) ka(=D.46)-t	Bit [Dât hm-Nfr 7]
		(A.105)(pl.) hr(=D.3) h-s(pl.) [= hmw SETHE, n. "c"] n-t [sic.] i-mn-n [.....]	
		bit(=L.1) [dât(=S.44)-t nfr(=R.13) hm(=W.6) tpî(=T.9)] n i-mn-n râ(=N.7)-mn(=Y.12)-hpr-	
		(=L.4)-s-n-b maâ(=Q.58)-hrw(=P.22)	
		(On Pedestal) ir(=D.10)-n sab(=E.49) imah(=V.4)-h-y i-mn-n-m-ha(=F.16)-t maâ-hrw	irn Sab imahy Imn-k
		ms(=M.80)-s mâ(=M.27)-y-t n-t [i-mn-n sn(=R.22)-n-t hmt(=D.95) n šw(=M.24)-t-n	šwt Nbt Ta Maâthrw
		nb(=T.43)-t ta(=N.37) maâ-t-hrw]	

Note:- This text has been cited as showing that Menkheperassenb was a son of Rekhmara (Table No. XXXIV) (See of SETHE and LEGRAIN do not furnish this information. See however, in this connection, a Tomb-Chapel Sa-f Sx htpw tpî n [sic.] Mn-hpr-Râ-šnb(A.89) sa-f Nsr-t-sn(A.89) i.e. His son, Chief Scribe of (

IV. Tomb No.112, Sheikh 'Abd el Qurna; BAEDEKER, Egypt, (1914), p.313: GARDINER-WEIGALL, Topograph.Cat.Private Tombs at

V. Funeral Cone from Qurna; VIREY, Mém. Miss. Franç. au Caire, V, p.215: DARESSY, Recueil de Cônes funéraires, No.38: LEU Rpatî hntî-â Bit Dât hm Nfr Tpî. n Imn Mn-hpr-Râ-šnb: Hereditary Prince, Count,

VI. Tomb of Men-kheper-ra-senb, High Priest of Amon: No.86 (Old numbers 34 and 63) in the cemetery of the Sheikh 'Abd and its cemeteries see Table No. XX.

A-G = Table XXXIII
1-7 = WEIGALL
a-d = PIEHL.

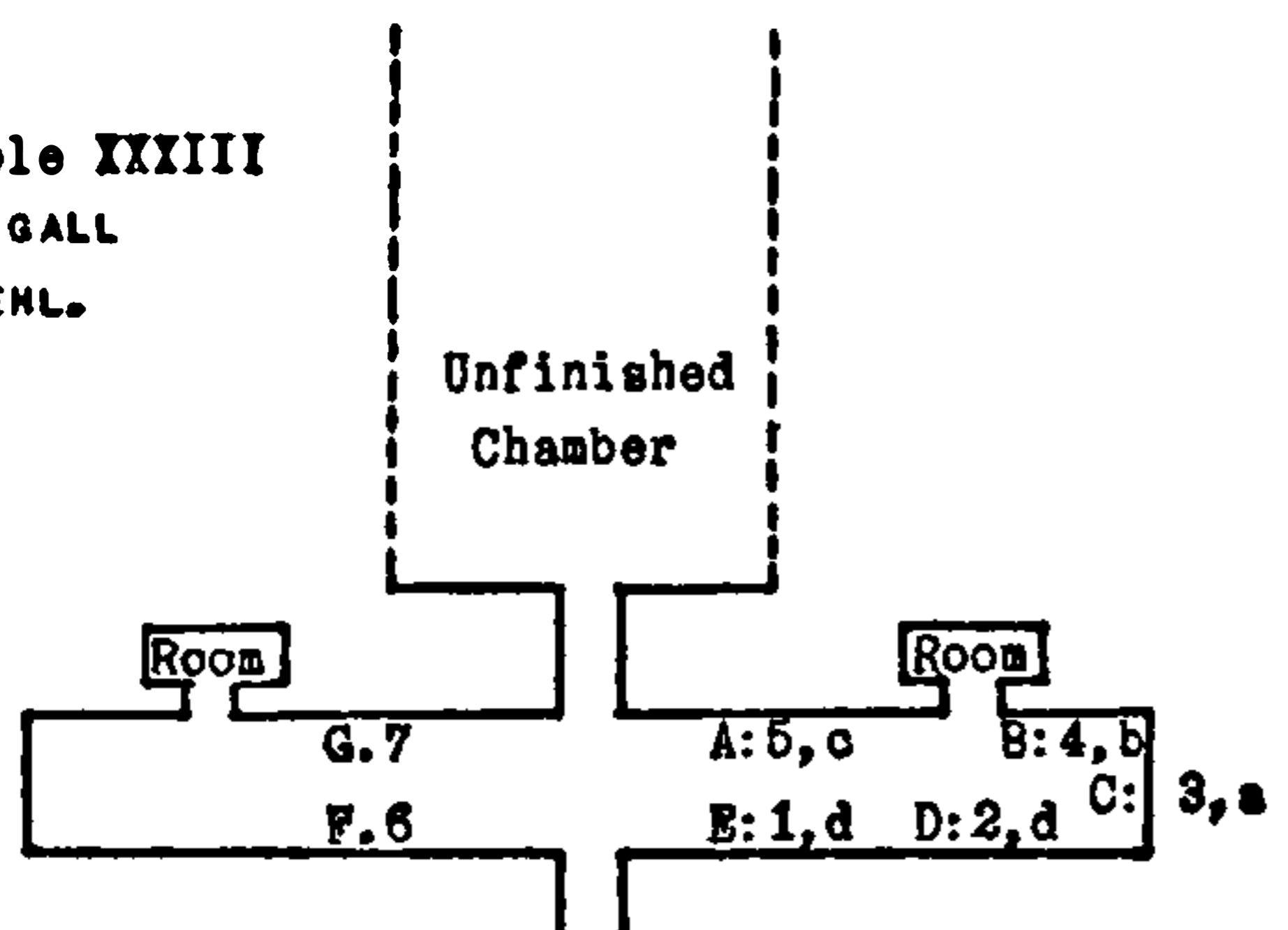

As to the location of this Tomb, No.86: See GARDINER-WEIGALL, Topogr. BAEDEKER, Egypt, (1902), p.292, plan p.288, (there No.84): (1908), p.30 BARAIZE, Plan des Nécropoles Thébaines; (Serv. des Antiq. de la Égypte Plans of the Tomb may be found, WEIGALL, Antiquities of Upper Egypt de la Miss. franç. au Caire, V, fasc. II, p.198. The texts accompanying the scenes on the walls of the Tomb are pub SETHE, Urk. d. XVIII Dyn. (1907), pp.928, ff. Translated:- PIEHL, op.cit. I, 2, pp.103, ff. (in part): BREASTED,

	Plans		Publication				Title No.	Plans. "W" = Weigall: "P" = Piehl.
	W.	P.	Piehl	Virey	Sethe	No.		
A			Pl.		p.	L.	"A" Heading by SETHE:- "Men-kheper-ra-senb leads before Thutmose III, As iî(=M.84)-t(D.96) m htp(=Q.17)-t-p r b-m xr(=Q.20) šw(=M.24)-t-n xr ânh(=S.43) ârq(=V.10) (f i) n [i]-mn-n [nb(=W.43) nst(=W.42) nst nst tawî(=N.37)] m i-p-[t] ist(=Q.1)(pl.) m ht(=M.9)-h-t ir(=D.10)-t hs(=W.6)-s-s-t(pl.) i-mn-n râ(=N.7) m hb(=O.65)-f n. dâr(=D.56) iah(=N.44)-t(O.9)	
1	5	c	127 ß	201	928	1		iit m htp r bw xr šwt xr ânh ârq n [i]an [NB m ip[t]-išwt m n Dâr iah
					929	3		

Table XXXII] smn[h] sp-rd [SPIEGELBERG, Rec.Tr. 28,
 [Ét. VI, p. 117] Naât n
 [ARDINER, Admon. p. 21, (I, 8), p. 25, II, 6] Nî
 shtp ka-f
 nîada-f nfr sâa baw-f r
 Hdi Inb
 [GANTNER, Bib. d'Ét. IV, p. 97] rdit rj]
 Inn [sic.] ipt-îst [sic.]
 (11) [..... (Title 23) Grp Kawt] hr
 [.....]
 In-ppr-Râ-énb Naâhrw
 Naâhrw mé smâyt ntî [Inn snt-hnt n
 [.....]

To shape the [Civil] Law, to perpetuate the Canon, to restore the Truth of Anon-Ra: he caused its spreading throughout the Two Districts of his Authority under the Gods, and His Majesty honored [him] among the people, and rejoiced his ka in each day. They modelled (?) him for his beautiful face, and he increased his fame for all time (6) Upon the L. H. S. of the King of Upper and Lower Egypt, (Aa-kheperu-ra) [Amenhotep II] Of Amon Beloved. Given Life To administer all the offices in accordance with their functions; he caused naukind to know of his comings into the Temple which is of Anon [of] Ipt I'swt [Karnak City] To [wit the Her]editary Prince, Count, [.....] (11) [.....]; (Title 23) Regulator of Works] in the Sanctuary [SERME, n. "c"] which is of Anon [.....] (line 12) Royal [Chancellor, High Priest] of Amon, Men-kheper-ra-senb, Justified. Fecit the Honored Judge, Amen-em-hat Justified, born of the Musician of [Amon, Sister-wife of the King; Mistress of the Earth, Justified]

WEIGALL, Ann. du Serv. IX, (1908), p. 133, No. 86; but as appears above, the transcript quoted by LIESLEIN, No. 1924, containing the name and titles of Rekhmara, to which are added: - Men-kheper-ra-senb; and his son Senusert. See also Table No. XXXIV. §2 Scene XII and Note 1.

(1913), p. 26: noted as that of Men-kheper-ra-senb "Hn-Nfr Tpi n Inn;" "First Prophet of Amon." No further details.
 Répertoire généalogique etc. (Serv. des Antiq. Miss. Caire), No. 201: Chancellor, High Priest of Amon, Men-kheper-ra-senb.

West Thebes, a short distance up hill from the Tomb of Amenemheb of Table No. XXXII. As to the Neropolis of West Thebes
 Catalogue of the Private Tombs of Thebes, (1913), p. 24, Pl. 111, No. 86: WEIGALL, Antiquities of Upper Egypt, (1910), p. 125: (1914), p. 311, No. 86, (No plan): MURRAY, Handbook for Egypt, (1907), p. 440, (there No. 34), plan p. 437: (1913).
 PIENL, Inscr. Hiérog. I, 2, (1888), p. 108: VIREY, Tombeaux thébains de la XVIIIe et XIXe dynastie: Mém. p. 125: PIENL, Inscr. Hiérog. I, 1, (1886), CXXVII-CXXIX: VIREY, op. cit. pp. 200-215:
 Egypt, II, (1906), §774, ff. (in part): VIREY, op. cit. (as above)

				Geographical Names
Offering Tribute."	"No. 1" "Inscription of Hn-ppr-Râ-énb, who offers a bouquet to the King. The coming in peace to the place under the King, bearing the vow sworn to [a bouquet ? Bubes, Eg. R'dg. 8k. (1898), p. 374] [A]mon, [Lord of Karnak Temple] in Luxor after making the praises of Amon-Ra at his Feast of "The Horizon Gloweth	p. 103	§ ...	(1) Nst-Pawî (2) Ipt-I'swt

THIS PAGE IS LOCKED TO FREE MEMBERS
Purchase full membership to immediately unlock this page



Never be without a book!

Forgotten Books Full Membership gives universal access to 797,885 books from our apps and website, across all your devices: tablet, phone, e-reader, laptop and desktop computer

A library in your pocket for \$8.99/month

Continue

*Fair usage policy applies

m ha(=N.23)(pl.)-f (5) [.....]a m xn(=D.51)-t-f n-t
tp(=D.1) rnp(=M.13)[sic.] i-n
r-p-â [ha(=F.16)-]â [bit(=L.1) dbâ(=S.44)-t] nfr(=R.13)
hm(=W.6) tpi(=T.9) n i-mn-n râ(=N.7) mn(=Y.12) hpr(=L.4)
s-n-b(A.110) šsp(=P.23)-p ânh(=S.43) ârq(=V.10)[♀ ↗]

[sic.] n [t]-f-[k i-mn-n ps(=W.4)-y-f t-w
nr(=U.12)-y-f t-w s-wah(=V.37)(Y.2)-f t-w]

SETHE heading: "Upper row of bringers of tribute. Over the supplicating Pri
r-di(=X.22)-t iaw(=A.5)(Y.2) n nb(=W.43) tawi(=N.39) s-n(F.4) Rdit iaw n
ta(=N.37) n nfr(=R.13) nfr(=Y.9) i(A.13)-n wr(=G.79)(pl.) Ta n nfr nfr
nw(=W.21) ta(=N.37) nb
s-wa(=V.28)-š(A.5)-s-n ht(=M.9)[sic.]-h-t(D.69)(pl.)
hm(=W.6)-f in(=W.22)nw(=W.21)(pl.)-s-n hr p-s-d(D.35)(pl.)-
-s-n m [šs(=V.6)] nb n nfr(=R.13) ta(=N.37)(N.40)
hd(=M.74)(U.50)(N.53,N.53,N.53) nb(=U.50)(N.53,N.53,N.53)
h-s-b-d(N.53,N.53,N.53) m(=D.63)-â-f-k-t(N.53,N.53,N.53)
âa(=T.41)-t(N.51) nb špâi(=A.110)-s (8) ms(=O.71)(Y.2)-t-w
r-râi(=D.59)-t n s-n taw(=P.16) n ânh(=S.43)

m yâw-f [.....
in
Rpâti [Patî]-š
Imn Mn-hpr-Râ

n [t]-f-[k i-mn

Šwaš-šn nht
hm-f innw-š
-šn m [šs]
ra-nfr (has
(8) Hd nb
lat nb špai
rdit n-šn

(Third row of tribute bearers: Title of the scene)
šsp(=P.23)-p(D.69) in(=W.22)nw(=W.21)(pl.) [n]
n-ht(=M.9)-h-t[(D.69)(pl.) hm(=W.6)-f h-r]
(Title No.24) hrp(=D.72)-p [n] i-ti(=U.19)-y
n-ht(=M.9)-h-t n t-[f i-mn-n i(A.13)-n]
r-[p]-â ha(=F.16)-â [nfr hm tpi n i-mn-n
râ-mn-hpr-šnb]

(Over Asiatics, who bring horses, chariots, parts of chariots,
[.....] ha(=M.42)nb(=W.43)nb nb-[t] hr(=D.3)-[r-y-t(2.10)
(pl.)]-k n w(=S.14)-t-[PIEM]-š pxx(=V.41) wr(=G.79)
mr(=N.58)(N.40) šnd(=G.91)(pl.)-k m ta(=M.37) ta ta nb(pl.)
s-šk(=V.37)-s-šk(=V.37)-k(D.69)-n ta(=N.37) ta ta
m(=D.63)-f-n [sic.] h-b(2.7)-n-k nwt(=O.1) nwt nwt-š-n(pl.)
šr(=A.29)(pl.)-š-n(pl.) m b-ba(=G.53)-w(0.3)[(pl.)][.....]

XXXIII. Thutmosis III. Men-kheper-ra-senb (5)

nt-f ntī fpi rnp[sic.]

from His Diadem in His Journeying at the Beginning of the Years;

ḥbwt] ḥm ḥfr fpi n

To wit

ḥbwt] arq [see line 2]

Hereditary Prince, [Coun]t, [Chancellor], High Priest of
Amon, Men-kheper-ra-senb: fetching the vow sworn [or bouquet ?] to
thy Father Amon. Praised this one. Beloved this one. Magnified
this one.

ḥbwt] ḥfr f to ḥbwt-f to]

ḥn

Giving Homage for the Lord of the Two Lands. Kissing
the Earth of the Good God, To wit: the Chiefs of every Land

ḥn nḥ fa nb

ḥn

celebrate the Victories of
His Majesty, their Tribute upon their backs
according to [the allotment] of the Lord of
God's Country.

ḥn, Bib.d'Ét. IV, 128] ḥn n

(3) fa ḥfr

ḥt

Silver, Gold, Lapis Lazuli, Malachite,
every Splendid Stone (6) that he might be brought to
give to them the Breath of Life.

ḥt

ḥt

ḥn-f ḥr]

Fetching the Tribute [for] the Victor[ies of His Majesty
..... under]

ḥt] ḥt n ḥr [ḥn ḥn]

(Title 24) the Leader for the King of Victory for Fa[ther Amon
to wit]

ḥfr fpi n ḥn

Hereditary Prince, Count, [High Priest of Amon,
Men-kheper-ra-senb]

(ḥn)

ḥt] [MÜLLER, AS. U. EUR.

[.....] All of the ḥndw, and Thy Terror is in her Districts
and the Great Circle of the Sea-Land. Thy Fear is in all the
Lands, and Thou hast utterly destroyed the Countries of ḥfr.
Thou hast diminished their Cities, their Grandees are in
Cave[a] [.....]

(8) ḥndw

ḥt-ḥ ḥr ḥr (ḥst)

ḥn-k n ḥn nḥ

(9) ḥfr

sic.] ḥn-k nḥ-ḥn

[.....]

THIS PAGE IS LOCKED TO FREE MEMBERS
Purchase full membership to immediately unlock this page

DELVE INTO FANTASY, MAGIC, MYTHOLOGY & FOLKLORE

Forgotten Books'
Full Membership gives
access to 797,885 ancient
and modern, fiction and
non-fiction books.

Continue

*Fair usage policy applies

	W.	P.	Piehl	Virey	Sethe		Title			
C.	3	a	127	P	206	931	B.	1	<p>Scene: "Men-kheper-ra-senb receives the Tribute of the South-folk, part adjusts a scale and another takes notes. Other men bring bows and officials prostrate themselves.</p> <p>(Inscription of <i>Mn-hpr-Râ-snb.</i>)</p> <p>šsp(=P.23)-p(D.69) nb(=U.50)(N.53,N.53,N.53) n hašt(=N.40)-t gb(=V.8)-b(N.53)[sic.]-tiw(=G.5)(O.1) m ā-b(W.31) nb(=U.50)(N.53,N.53,N.53) n k-š [sic.] x(=T.43)-s-t m h-t-r(Y.2) r t-n-[nw(=W.21)] rnp(=M.13)-t i-n bit(=L.1) dbā(=S.44)-t nfr hm tpī n [i-mn-n](A.113) rā-mn-hpr-š-n-b maā(=Q.58)hrw(=P.22)</p>	šsp Nb n ga I,p.30,No.4 Xst m htr r n [Imn] Mn-
	3	a	206	931	2	a b c	<p>(Subordinates who come to him) (the two bowing figures)</p> <p>(Title No.25) hr(=D.3)(N.1) m-ā-da(=U.21)-w [sic.] n gb(=V.8)-b-tiw(=G.5)(O.1)</p> <p>(Title No.26) imi-ra(=S.37) hašt(=N.40)-t(pl.) nb(=U.50)(N.53,N.53,N.53) n gb(=V.8)-b-tiw(=G.5)(O.1)</p> <p>(Man advancing, bears in his right hand a bunch of feathers</p> <p>(Title No.27) imi-ra(=S.37) n-nw(=U.4)-nw(=W.21) w(=G.83)-w(pl.)</p> <p>Note: - NEWBERRY, Beni Hasan, I, p.49, (Pl. XXX), gives: - "n-nw(=U.4)-nw(=W.2</p>	(25) hrī mā n Gbtīw (nw (26) Imi-ra Beni Hasan, (27) Imi-ra
	3	a	931	B	3 1 2 3-6	<p>(Destroyed Scene: Inscription as restored by SETHE)</p> <p>šsp(=P.23) in(=W.22)nw(=W.21)(pl.) n hašt(=N.40)-[t(pl.) rś(=M.30)-t(N.47)(pl.) m ā-b(W.31) in(=W.22)nw(=W.21)n] hašt(=N.40)-t n-[t p-wn(=E.58)-n-t(N.40) i(A.15)-n (e,4) Titles 1,2] 3 [and 4] Mn-(5)hpr-Râ-(6)šnb</p>	šsp innw n hašt n[ti P
D.	2	d	128	e	211	931	C	1 2 3 4-10 11 12 13	<p>Scene: "Mn-hpr-Râ-snb inspects the Artizans for the works of Art for the kulturgesch. (1914), I, Pl.17) "b" (Middle) Makers of Bows and are embossed or adorned with gold, which is being weighed by scribes</p> <p>ma(=U.8)(D.10)-a-a i-is(=Q.34)-š n ka(=D.48)-t(A.105)(pl.) nw nfr(=R.13) h-t(=O.12) i[mn-n](A.113) h-hn(=M.41)-n-t(Y.2) hm(=U.28)-t(pl.)</p> <p>m h-s-d(N.53,N.53,N.53)-b[sic.] maā(=Q.58)ma(=U.8) m(=D.83)-f-k-t(N.53,N.53,N.53) ma(=U.8)-t[sic.](Y.2) ir(=D.10)-n hm(=W.6)-f m k-t[sic.] ib(=W.23)-f r mn(=Y.12) [nw(=W.21)-nw-nw]</p> <p>n t-f i-mn-[n] m i-p-t išt(=Q.1)(pl.)(O.1) mn(=Y.12)-n rwd(=V.27) m ka(=D.46)-t n h(N.7)-h i(A.15)-n [Titles Nos. 1,2,21,22,4] Mn-hpr-râ-snb Maāhrw</p> <p>g-t-f i-w ma(=U.8)(D.10)-n-A.89 š-āhā(=P.19) nb(=W.43)(G.15) hawt(=N.1)[MASPERO, Bib.d'Ét.VI, p.97] nsw(=M.24)-t bit(=L.1) (rā(=N.7)mn(=Y.12)-hpr(=L.4)) [ānh(=S.43) g-t(N.37) h-hm(=O.74)-m(O.3) gsr(=D.56)-r m ma(=U.8)-t(Y.2)[sic. see line 1] m nfr(=R.13) h-t(=O.15)-t(O.3) n-t t-f i-mn-n nb(=W.43) nst(=W.42) nst nst tawi(=W.39) m i-p-t išt(=Q.1)(pl.)(O.3)]</p> <p>hayt(=N.1) (rā-mn-hpr) i-mn-n is(=Q.53) hā(=N.23)(pl.) m ma(=U.8)-t(W.23)[= compare WEILL, Sphinx, X, (1906), p.19] rwd(=V.27)-t m i-n-r(N.51) wā(=U.37) hr(=D.3) wa(=N.49)[-t-f nb(=W.43)</p> <p>bk(=G.53)-k-ti(=U.19) m gām(=S.64) [LACAU, Rec.Tr.35, p.230, No.64](U.50)(N.53,N.53,N.53) hawt (= ) [See MASPERO, Bib.d'Ét.VI, p.97] m i-n-r(N.51) n rwd(=V.27)-t bk(=G.53)-k m nb(=U.50)(N.53,N.53,N.53) n tp(=D.1) tp tp n hašt(=N.40)-[t](pl.) [v.....]</p>	Maā is [Bāi nw ht nfr-l m gšbd maā GARDINER, Rec mn[nw] n Tf Imn m p.127, n.2] In etc. Dt-f iw ma (Mn-hpr-Râ ht-nfr ntī d'Ét.I, p.1 Hawt (Mn-h pr wa[t-f bktī m Qā in rwdt [II, p.123, 1 p.39] bk :

<p>Gold. Officials bring gold on plates, in purses and boxes. A scribe feathers, an ostrich and ostrich eggs, desert animals etc. Two</p>	P.	B.	Geographical Names.	
<p>(<i>nat</i>) [NEWBERRY, Beni Hasan, SETHE, Verb. I, §111] <i>nb n kš</i> <i>nat In Bit Dbât n-Nr Tpi</i> <i>nb Naâhrw</i></p>	<p>Fetching Gold of the Country of <i>Gbtw</i>, together with Gold of <i>kš</i> the wretched, according to the estimate for the apportionment of the year. To wit: the Chancellor, High Priest of [Amon], Men-kheper-Ra-senb. Justified.</p>	103	...	<p>(10) <i>Gbtw</i> (11) <i>kš</i></p>
<p>[See above, Text I, No. 15]</p> <p><i>nb n Gbtw (nat)</i> [NEWBERRY, No. 4] [a bow and arrows.</p> <p>(<i>nat</i>) "i.e. <i>nat</i> = "Huntsmen". But this group is written (<i>nat</i>)</p>	<p>(25) Chief of the <i>Wâdaw</i> [Constabulary] of <i>Gbtw</i>.</p> <p>(26) Superintendent of the Gold Countries of <i>Gbtw</i></p> <p>(27) Superintendent of these Districts (?) or of Hunters [PIEHL]</p>	103	774	<p>(12) <i>Wâdaw</i> (13) <i>Gbtw</i> (14) <i>Gbtw</i></p>
<p><i>nat n âb Innw</i> <i>nat In</i> etc.</p>	<p>Fetching the Tribute of the [Southern Countries, together with the Tribute] of the Country belonging to <i>Punt</i>: To wit, etc.</p>	<p>(15) <i>Punt</i></p>
<p>of Amon." III Horizontal Rows: "a" (Top) Chariot sakare: (See WRESZINSKI, Atlas altägypt. "e" (Bottom) Makers of Vases, Chess-boards, axes etc. and other objects which are to be</p> <p>c. Fr. 28, p. 115, No. 6] <i>nat</i> <i>nat</i></p> <p><i>nat In n-f n kat</i> [See p. 73] <i>id-f r</i></p> <p><i>nat (nat)</i> [GARDINER, Z. Aeg. 45, <i>nat n hh</i></p> <p><i>nat (G. 15) Nat Nat Bit</i> <i>nat (pr) nat n nat n</i> <i>nat Nat Nat</i> [MASPERO, Bib. <i>nat</i> [see line 3]</p> <p><i>nat nat nat nat n nat</i> [Untersuch. V, p. 13, n. 2] [.....]</p> <p>[Aeg. 51, p. 120, No. 95] <i>nat n</i> [Memphis etc. I, p. 225: [Untersuch. V, p. 13, <i>nat</i> [.....]</p>	<p>Inspecting the equipment for the works of the Temple of A[mon] and to furnishing the artisans</p> <p>with real Lapis Lazuli and genuine Malachite. His Majesty did [this] according to the plan of his heart for a monument</p> <p>for Father Amon in <i>ipt-îswt</i> [Karnak] lasting and solid in construction for all time. To wit: etc. He saith:- "I inspected when the Royal Lord set up the Hall "of the King of Upper and Lower Egypt (Men-kheper-Ra) [Thutmosis III] "Living Forever, and the splendid Sanctuary "indeed in the Temple of Father Amon, Lord of Karnak [Temple] "in Karnak [City]</p> <p>"the shrine [called] "(Men-kheper-Ra) Who Weareth the Diadem", "was of hard granite [of Syene, Assuan] in one stone and on "[every] side [of it] [.....]</p> <p>"wrought with gold. The Colonnade was in hard stone [<i>στερεὸς λίθος</i>] [Sandstone]"wrought with Gold of the very best [quality] "of the Countries [.....]</p>	104	775	<p>(16) <i>ipt-îswt</i></p>

THIS PAGE IS LOCKED TO FREE MEMBERS
Purchase full membership to immediately unlock this page



Never be without a book!

Forgotten Books Full Membership gives universal access to 797,885 books from our apps and website, across all your devices: tablet, phone, e-reader, laptop and desktop computer

A library in your pocket for \$8.99/month

Continue

*Fair usage policy applies

bk(=G.53)-k = nb(=U.50)(N.53,N.53,N.53) i-w ma(=U.8)(D.10)-n
 s-âhâ(=P.19)-â hm(=W.6)(A.117)-f sh(=O.80 ? = $\bar{\Gamma}$) âa(=T.41)
 n dâa(=S.64)(N.53,N.53,N.53) (râ-mn-hpr) i-mn-n âa
 mr(=U.12)-r-t = pr(=O.3) i-w ma(=U.8)(D.10)-n ir(=D.10)-t

hm(=W.6)-f whaiw(? = $\bar{\Gamma}$ $\bar{\Gamma}$ $\bar{\Gamma}$ $\left\{ \begin{array}{l} \text{White} \\ \text{Green} \\ \text{White} \end{array} \right\}$ [See BORCHARDT, Z. Aeg. 40,

(1902), p. 48, n. 6] âa(=T.41)(pl.)[... ? ..]-i dâa(=S.64)(U.50)
 (N.53,N.53,N.53) r s-h(?) -r [... 1 Group ... i-w]

ma(=U.8)(D.10)-n s-âhâ(=P.19) hm(=W.6)-f

Gold → $\bar{\Gamma}$ $\bar{\Gamma}$ $\bar{\Gamma}$

tjhw(=O.53 i.e. (Gold with red sprinklings → $\bar{\Gamma}$ $\bar{\Gamma}$ $\bar{\Gamma}$)

snw(=R.22 i.e. $\downarrow \downarrow \downarrow$) $\bar{\Gamma}$ sâa(=I.2)(pl.) n t-f i-mn-n i-w-A.89 =

(Title No. 28) mh(=V.15) ib(=W.23) mnh(=U.27) n sw(=W.24)-t-n

hr(=D.8) (Title No. 29) hrp(=S.50) ka(=D.46)-t(pl.) =

mn(=Y.12) nw(=W.21)-nw-nw-f ir(=D.10)-n-A.89 nn(=W.22)-n

nn(=D.48) x(=T.43)-s(G.80)-A.89 dâa(=D.3) ib(=W.23)

h-hs(=W.4) [k-w(A.89)] [or h-hs-s-k SETHE, note "f"]

[hr(=D.3)-r-s]

(Officials who are weighing metal)

(Title No. 30) hri(=N.1)(pl.) hm(=U.28)-w-t(pl.) nfr(=R.13)

h-t(=O.12) (Title No. 31) imi-ra(=S.37) imi-ra imi-ra

[hm(=U.28)-w-t(pl.) nw(=W.21) nfr(=R.13) h-t(=O.12)]

(Inscription on a Gold Vase) (PIEHL says "On an axe.")

nfr(=R.13) nfr(=Y.9) nb(=W.43) tawi(=N.39) nb(=W.43)

ir(=D.10) h-t (râ-mn-hpr) sa(=G.67) râ(=N.7)

(dhwî(=G.48)-ms(=M.80)-s) i-mn-n mr(=U.12)[sic.] nb(=W.43)

nst(=W.42) nst nst tawi(=N.39) ir(=D.10)-f rdi(=X.22)

ânh(=S.43) d-t(N.37)

(Scene: - Cattle and Geese led in. Text almost all destroyed.)

dâ(=U.21) = [D.98] r ma(=U.8)(D.10)-a-a i-wa(=V.26)(E.4)(pl.)

..... in(=W.22)-n n hm(=W.6)-f =

n-h(=M.9)-h-t(D.69)(pl.)-f hr(=D.3)]

hast(=W.40) n [.....]

wr(=G.79)-r [..... ma(=U.8) maâ(=G.58)-â(Y.2) n]

t-f i-mn-[n nb(=W.43) nst(=W.42) nst nst tawi(=N.39) =]

i-p-t ist(=G.1)[-t(pl.)(O.1) hr(=D.3) dâa(=D.1) ânh(=S.43)

wâa(=U.21) snb(=G.9)]

nsw(=M.24)-t bit(=L.1)-t [(râ-mn-hpr) ânh(=S.43) d-t(N.37)

i(A.15)-n r-p-â ha(=F.16)-â]

ib(=W.23) = [.....]

sâ(=M.27)[..... râ-mn-hpr-snb]

(Scenes of Harvesting)

(Throne of a personage who is now defaced) The deceased receives $\bar{\Gamma}$

(A man offers to him a bouquet.

A boy brings a bunch of vegetables, and a girl fetches a sistrum.

He receives gifts of the offerings of Amon. (Restored from CHAMPOL

NONE of the figures are named, and there are no biographical items of

SETHE does not locate a text entitled "He makes offering to the Gc

XXXIII. Thutmose III. Men-kheper-Ra-senb. (7)

		P.	B.	Geographical Names.
<p>špā šm-f šp āa n Qām šs Hrt n Pr šw maan (?) [Compare wadyt p.6 and BREASTED, Untersuch. 4) šaw [...]] n Qām r NISCHÉV, Bib. d'Ét. II, p.93]</p> <p>špāw šaw ššāw n r r šm šp šm n nšwt šr</p> <p>šm-f šm-f šp šs</p>	<p>"wrought with Gold. And Lol [I] inspected when His Majesty set up "the Great Shrine of Gold"(Men-kheper-Ra) of Great Amon, Beloved "in the House." And [I] inspected [when] His Majesty made great "Plant Columns [...] with Gold for a plating (?) "..... and I]</p> <p>"inspected when His Majesty set up Obelisks and Columns "in great numbers for Father Amon. "I was as (28) Complete Fulfiller of the Will of the King "while (29) Regulator of Works concerning His Monuments. "I accomplished these things, nor was I infirm of "countenance nor will. "[I] was praised [or Thou praisedst] [me] [on account of it]."</p>	104	775	
<p>št-šr [See Title No.22] šwt nš št-šr]</p>	<p>(30) Foremen of the Artizans of the Temple. (31) Superintendents [of the Artizans of the Temple]</p>	105	...	
<p>šp šr-šwt [Gramm. §436] šš (šwt-šš-š) šm šwt-šwt šr-f rdī šm</p>	<p>The Good God, Lord of the Two Lands, the Lord "the Efficient" (Men-kheper-Ra) Son of Ra, [Thutmose III.] of Amon, Beloved Lord of Karnak made [it]. Given Life Forever.</p>			
<p>(ng.) š inn r]</p> <p>.....] šā n] -šwt š] šā š. v. š]</p> <p>šp-Rā) šm šr šn]] šn-šp-Rā-šnb]</p>	<p>Sent [to inspect the Cattle His Majesty brought from His Campaigns in] the Country of [.....] great[..... given of] Father Amon [Lord of Karnak [Temple] in Karnak [City] [On the L. H. S.] of the King of Upper and Lower Egypt [(Men-kheper-Ra) [Thutmose III], Life Forever. To wit: Hereditary Prince, Count,] heart [.....] Upper Egypt [..... Men-kheper-Ra-senb]</p>			

his relatives, whose names are not preserved.

ices Descr. I, 558)

The texts are entirely conventional.

Prayers for the well being of the King." (Two lines, conventional)

THIS PAGE IS LOCKED TO FREE MEMBERS
Purchase full membership to immediately unlock this page

DELVE INTO FANTASY, MAGIC, MYTHOLOGY & FOLKLORE

Forgotten Books'
Full Membership gives
access to 797,885 ancient
and modern, fiction and
non-fiction books.

Continue

*Fair usage policy applies

TABLE No. XXXIV. THUTMOSIS (*ḏwtjms*) III - AMENHOTEP (*imh-ḥtp*) II. Tomb-Chapel of Rekhmara (*Rḥ-mi-rā*): Geographical

Tomb-Chapel No 100 (Old Nos. 15:35) in the Cemetery of Sheikh 'Abd el Onrus in West Thebes. Note:- See description of Tomb-Chapel No. 100 faces the main entrance to the Cemetery of Sheikh 'Abd el Gurna (See Plan, Table No. IX). It was discovered by J. F. Champollion in 1828. See also *Métiers, les usages de la vie Civile et Domestique des Anciens Peuples de l'Égypte, de la Nubie, et de l'Éthiopie* recueillies par Champollion.

The Tomb-Chapel was visited thereafter by the following scholars, who described it, and copied scenes from it etc.
 1828: SIR GARDNER WILKINSON, CHAMPOLLION, ROSELLINI. 1832: BONOMI (Hay Mss.), G. A. HOSKINS. 1842: LEPSIUS.

Descriptions etc.	BAEDEKER, <i>Egypt</i> , (1902), p. 290; (1908), p. 307; (1914), p. 310; <i>ibid</i> , <i>Ägypten</i> , (1913), p. 297. BREASTED, <i>Ancient Egypt</i> , (1906), p. 107. CHAMPOLLION, <i>Notices Descriptives</i> etc. (Paris, 1844), I, pp. 505-510 (Description of Vestibule). GARDNER, <i>Excursions in Upper and Lower Egypt</i> , (London, 1863). MURRAY, <i>Handbook for Egypt</i> , (1900), p. 82, (No. 35); (1907), p. 107. VIREY, <i>Mém. Mission franç. au Caire</i> , V, (1889), pp. 1, ff. WEIGALL, <i>Annales du Service</i> , IX, (1908), p. 124. WILKINSON, <i>Modern Egypt and Thebes</i> , II, (1843), pp. 234, ff. (Tomb No. 35) BRUSSON, <i>Thesaurus</i> etc. (1891).				
Plans of Tomb-Chapel.	VIREY, <i>op. cit.</i>	NEWBERRY, <i>op. cit.</i> p. 22 & Pl. I.	BAEDEKER, <i>op. cit.</i>	MURRAY, <i>op. cit.</i>	LEPSIUS, <i>Ägypten</i> , I, p. 107.
Text.	CAILLIAUD, <i>Recherches sur les Art et Métiers</i> etc. (as above), (1831)		CHAMPOLLION, <i>Monuments</i> etc. 13		
	VIREY, <i>Mémoires de la Mission Franç. au Caire</i> , V, (1889), Ier. Fasc.		PRISSE D'AVENNES, <i>Histoire de l'Égypte</i> , I, p. 124.		
	NEWBERRY, <i>Life of Rekhmara</i> , (1900)		SETHE, <i>Urkunden der XVIII Dyn.</i>		
Translation.	PIEHL, <i>op. cit.</i>	VIREY, <i>op. cit.</i>	NEWBERRY, <i>op. cit.</i>	BREASTED, <i>Ancient Records of Egypt</i> , II, (1906), p. 107.	

NEWBERRY'S
Plan and Sections.

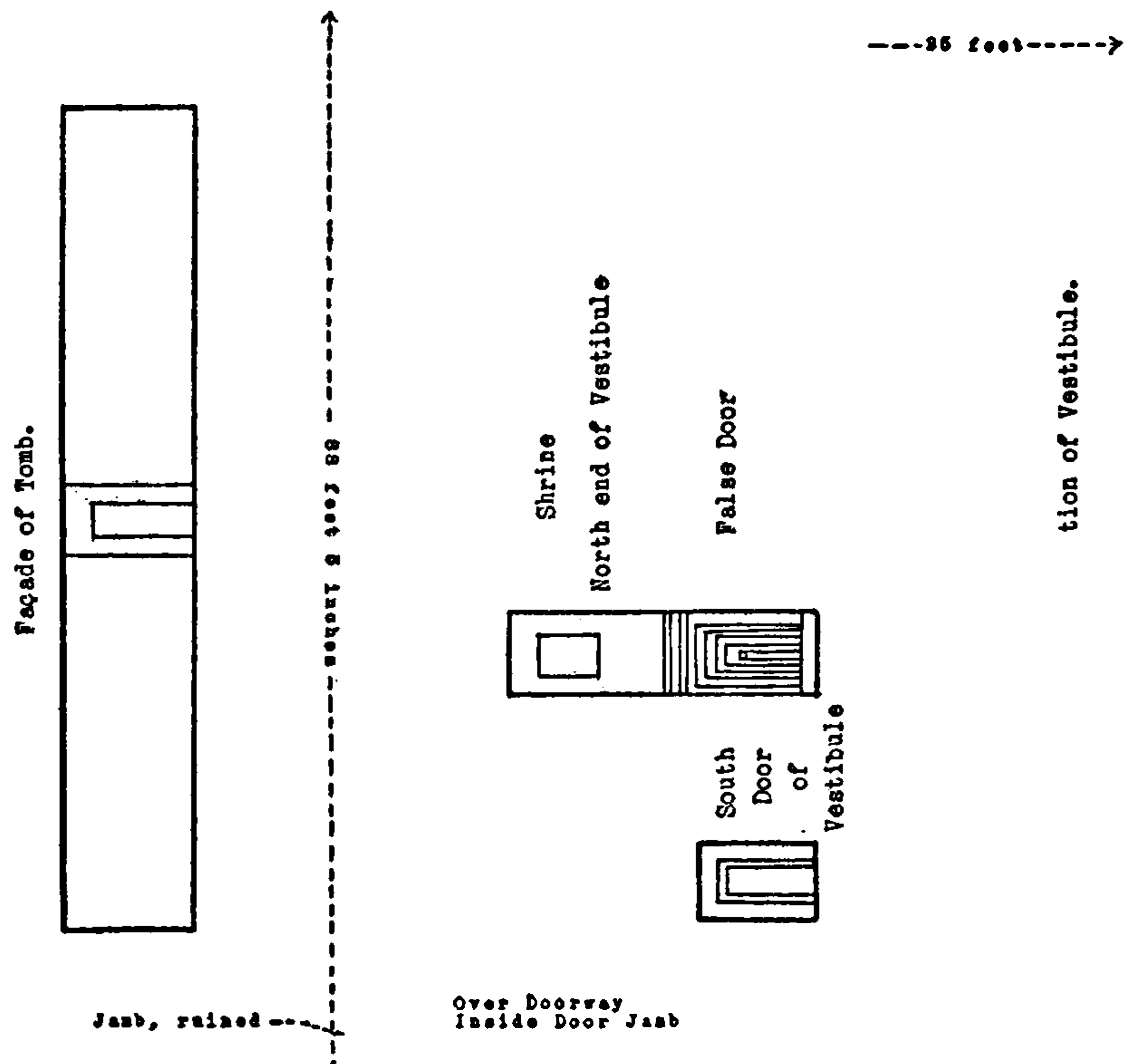

the Necropolis of West Thebes in Table No. XX.

1819-1821 by FRÉDÉRIC CAILLIAUD, who published several scenes without further description in "Recherches sur les Arts et les Lieux par l'Auteur dans les Années 1819 à 1822" (Paris, 1831-1837)

shown in the bibliography and Table below, viz:-

SKINS, and thereafter PRISSE D'AVENNES, PIEHL, (1884-5) SCHIAPARELLI, VIREY (1888). NEWSERRY (1896).

ards of Egypt, II, §663, note "d" BUDGE, The Nile, (1898), p. 315: (1901), p. 422: ibid, History of Egypt, IV, (1902), pp. 63, ff.

WEIGALL, Topogr. Cat. Private Tombs at Thebes, (1913), No. 100. G. A. MOSKINS, Travels in Ethiopia etc. (1 Plate): ibid; A winter (No. 35). NEWSERRY, Life of Rekhmara, (London, 1900), pp. 11, ff. pp. 21, ff. PRISSE, Histoire de l'art Égyptien, (1863), passim.

ibid. Antiquities of Upper Egypt, (1910), p. 115. WILKINSON, Manners and Customs of the Ancient Egyptians, (1837), (No. 35) 108, ff.

Mer. I. (1849) Pl. LXXIII, (Section XVI, k) WEIGALL, Antiquities of Upper Egypt, (op. cit.) p. 115

CHAMPOLLION, Not. descr. I, p. 505, (Tomb No. 15, T)

f. (1835-1845) LEPSIUS, Denkmäler, (1849-1858), III, 39, a-b: 40: 41: (Brickmakers & Sculptors) 42 (Feast in Harem) Text, III, pp. 270, ff

Égyptien, (1863) PIEHL, Inscriptions Hiéroglyphiques, (1886), 113, 114. pp. 53, ff.

pp. 1071 ff. 1094, a; 1150, c. ibid; (Installation) Untersuch. z. Gesch. u. Altertumskunde Aeg. V, 2, (1909), pp. 4, ff. (Restorations: DAVIES)

MR NEWSERRY (The Life of Rekhmara, London, 1900) says that the shrine in the upper part of the rear wall of the long passage probably contained the statue of the deceased, and was closed by a granite false door, which was removed from the tomb by CHAMPOLLION and is now preserved in the Louvre. He adds:-

"In the floor of the long narrow passage have been cut two vertical shafts which lead to the Sarcophagi Chambers. These were both opened by the officials of the Gizeh Museum in 1894, and I am told that they were each about sixteen feet in depth. No remains of any kind were found in thee."

"With the exception of some incised hieroglyphs upon the lintel and Jambs of the doorway to the long narrow passage, and upon the false door at the inner end of the tomb, there is no sculptured ornamentation. The decoration consists entirely of painting applied to the limestone, which had been prepared for its reception by a thin layer of stucco."

Before turning to the detail of the texts in the Tomb Chapel, the following may be found useful:-

Note 1. As to Men-kheper-Ra-senb, Son of Rekhmara. Men-kheper-Ra-senb, as appears on the accompanying Table, is mentioned as follows:-

(VIREY, p. 110) *Sa-f Sx Htpw Hpr Hpi n Imn* [.....] *Ra (snb (?))* i.e. His son, the First Scribe of Divine Offerings for Amon, Men-kheper-Ra-senb.

II. (VIREY, p. 122: LIESLEIN, Dict. des Noms hiér. No. 1924) *Sa-f Sx Htpw Hpi s* [sic.] *Mn-hpr-Ra-snb* i.e. His son, the First Scribe of offerings of [sic.] Men-kheper-Ra-senb.

III. (VIREY, p. 171: SETHE, p. 1157, No. 3) *Sa-f Sx Htpw Hpr Mn-hpr-Ra-snb* i.e. as in Scene X.

See SETHE, p. 1157, No. 3 = NEWSERRY, p. 15, p. 39.

In Scene XII occurs the text cited by LIESLEIN, No. 1924: (See Table XXXIII, Title No. 12) VIREY says: (p. 122, n. 2) "It seems to me that the name of Amon or of Ra is wanting before the name of Ramenkhepersenb perhaps the name Ra has been omitted the first time." Comparison with the other parallel texts in Scenes X and XXIII results in favor of surmising the omission of *Imn*, in the text should read *Sa-f Sx Htpw Hpi n Imn*

Note 2. In the following Tables it appears that all of the titles of Rekhmara are civil or religious. No military titles are mentioned. Furthermore, neither in the Biographical text below cited [Table "A", Scene I] nor in any other text is there anything to suggest that Rekhmara was a military or naval leader. Consequently it seems most probable that he never led expeditions into Western Asia, thus the only records which bear upon the subject of this work are those accompanying Scene III in the Tomb Chapel, i.e. "The Reception of Tribute from Foreign Nations."

Note 3. One possible exception to this statement is the following text:-

Berlin P. 10621: Limestone Ostrakon in the Berlin Museum, No. P. 10621. Obverse 6 lines, Reverse 7 lines. Hieratic Text in horizontal lines reading Right to Left.

Ed: SETHE, Urkunden d. XVIII Dyn. pp. 1174-5 (Transcript into Hieroglyphics by GAROINER)

The Obverse are the remains of a specification for stone to be delivered and set in a wall. The Reverse contains a broken list of employees in the Refectory, the Kitchen etc. including (line 3):-

Ma (=G. 68)-a-rs (=E. 38)(T. 1)(A. 89)(pl.) III. i.e. "also those of the fare 30."

(a) Jarw

Attention is now directed to the Scenes and Texts in the Tomb-Chapel.

THIS PAGE IS LOCKED TO FREE MEMBERS
Purchase full membership to immediately unlock this page



Never be without a book!

Forgotten Books Full Membership gives universal access to 797,885 books from our apps and website, across all your devices: tablet, phone, e-reader, laptop and desktop computer

A library in your pocket for \$8.99/month

Continue

*Fair usage policy applies

664
666

712

675
716
717
729
...
...
748

Autobiographical: 45 lines:-
"Installation of the Vizier"
GARDINER, Text, Translation: 2
"Reception of the Tribute of"
"Office of Vizier and his Duties"
NEWSBERRY (p.23) gives Plan of
Text to above: 38 lines. Various
"Rekhmara inspects taxes of Upper
Taxes South from Thebes: Text,
Taxes North from Thebes: Text,
Sketch Plan of S.W. Wall of room
Sketch Map of same wall: i.e.
(Scene) R. seated on right and
grain in heaps and baskets. II
A: (3 rows of Ship-Captains and
Descriptive memoranda.
(Under VII,A) "Care for and use
and ointment to the captives."
MAY-BONOMI, Brit.Mus.Add.Mss.2
(Right of VII,A) Sketch Plan of
(Upper Scene) R. stands on right
and their handiwork:" viz. I,
"o" Bars of metal. LEPSIUS,
(Lower Scene) R. (Destroyed) II
II, Sculptors as mentioned: I
See CHAMPOLLION, Monuments de
(1882), II. WILKINSON, *Mann
l'art dans l'antiquité*, (1882),
d'Assourbanipal, (1910), p.147.
WRESZINSKI, *Atlas fur Altaeg.
egyptienne*; (Leroux, Paris, 1878)
Sketch Plan of Scene IX: "The
horizontal panel containing sp
I, (lowest panel) Hathor facing
II, Anubis facing (8 rows) the
should be offered to R. after
III, Osiris facing the Mystery
IV, (Top Panel) The Horne star
"Offerings by Priests and Ment
each (VIREY, p.100) a kneeling
other Priests and Lectors bear
3 lines: (VIREY, p.104, n.1) (LEP
before table of offerings: Ex
Scribe of the Seal [.....] be
by Rekhmara's son *sa-f* [.....
n.3) *sa-f* *Sx* *Htpw* *Hr* *tpi* *a* *i*
Translation, VIREY, p.110)
Rear Wall of Corridor: Lower
Red Granite Stela: Louvre C.7
p.107). R. and wife sit at a
Geographical Names. PIERRET, R
Northeast Wall of Corridor: L
Presentation of offerings: 2.
LIEBLEIN, *Dict. noms hier. No.19*
N.B. VIREY notes the omission
IIrd Presentation: by his son
IIIrd Presentation by [Destro

...
754

757

es: 4-8 Honors: 8-10 Praise of Thutmose III: 11-45 Attributes of deceased. No Geographical Names.

es: - No Geographical Names. N.B. VIREY gives lines 9-24 as lines 4-19 (Backwards) Variants from other tomb texts by SETHE, Untersuchungen etc. V, (1909) pp.52, ff. GARDINER, Rec. de Trav. 26, (1904) pp.1, ff.

(Destroyed) faces five rows of officials, petitioners etc. Text over R. 10 lines: on pillar 5 lines: (SETHE, p.1119)
Audience Hall. See LEPSIUS, Denkmäler, Text, III, p.270.

SETHE and NEWBERRY from other tomb-texts. No Geographical Names.

"Lower Egypt".

: Pictures of Tribute (4 Rows) Transliterations by NEWBERRY, (pp.27, ff) Descriptions by SETHE.

: Pictures of Tribute (4 Rows) Transliterations by NEWBERRY, (p.30) Descriptions by SETHE.

for from Doorway to Scene X as below.

I, A-B entire: "Rekhmara receives the tithes for the Temple of Amon."

es of text. Behind him 3 rows of officials. Before him are 3 rows of bearers of tribute and workers, viz. I, Delivery of
g of grain and honey into pastry. III, Fetching wine and other products of Lower Egypt and the "Southerly Oasis".

isance) Text, 11 lines. B: (1 row of bearers of wine jugs). C: Wine and other commodities stored in 4 warehouses.

Offerings to the Temple of Amon": R. (Destroyed) under text (Destroyed) facing 2 rows: I, Annual distribution of clothing
every of woven stuffs to the captives. LEPSIUS, Denkmäler, Text, III, p.271: PIEHL, Inscr. hiér. I, 2, p.93; I, 1 Pl. CXIII, G, 8
and 29827:75

VIII.

ng Left. (Text of 7 lines above and behind him) Behind him 4 rows of officials. Before him 3 rows of "Artisans of the Temple
of ornament and stone vases: II, Leatherwork: III, Cabinet work: IV, Metal work: "a" Gold in Rings: "b" Vases:
er, III, 39, a, Text, III, p.270 BRUGSCH, Thesaurus, pp.1113-1114. ROSELLINI, Mon. Civ. Pl. L.

Text of 8 lines: Behind him 2 rows of officials: Before him sculptors making a statue. 4 rows of artisans, viz. I, Builders:
men working on large block IV, Unfinished. LEPSIUS, Denkmäler, III, 40, 41: Text, III, p.270.

e, II, (1845), Pl. CLXI. CAILLIAUD, Recherches sur les arts, etc. (1823 & 1837) Pl. XV. PRISES D'AVENNES, Histoire de l'art, etc.

Customs etc. III, p.338: ibid, (BIRCH) II, p.311: ibid, Popular Account etc. (1890), p.314, No.458. PERROT ET CHIFFREZ, Histoire de

ROSELLINI, Monumenti Civili, II, (1834), Pl. XLVII. MASPERO, Histoire ancienne, etc. I, p.405: ibid, Au temps de Ramses et
Egyptian methods of working hard stone. S. B. A. Proc. XXXI, (1909), pp.172, ff. (Plate XXIII, p.180). SCHÄFER, Kunstgeschichte, 32:10.

esch. (1915), Pl. 3. SOLDI (EMILE ARTHUR), Les arts méconnus; IIe Éd. (Leroux, Paris, 1881) pp.491, 493: ibid, La sculpture

29, 41. BAEDERER, Egypt, (1914), p. CLXXII.

Ceremonies": (Scene) On right, 4 symbolic figures of divinities in vertical column, each figure marking the space of 4
scenes as follows:-

(a) the procession arriving at the Temple and sacrifice.

of Anubis, offerings: voyage of sacred bark. Note:- SETHE gives only 16 names of "The divinities from whose gifts a portion
th."

undance, Renaissance.

ing (2 rows) the 14 doors to Light and Truth.

the Family for the Deceased." (Description by VIREY, pp.100, ff.) A: The preliminary purification: scenes in two panels. In
performs "The Washing of the Bands". Behind him a standing Priest pours water over his head into a basin. Then behind come
bols of the ritual. B: The Offerings: (Same panels) List 1, 30 lines: List 2, 32 lines: (VIREY, p.103) explanatory memoranda
Denkmäler, Text, III, p.271, n.1) C: Presentation to Deceased: (Description by VIREY) (Scene) R. and companion (woman) seated
y son. (VIREY, p.104, n.4) Presentation by *Nâb Sa-f Hr-f Sx Hr Ht* [.....] *Ht* i.e. His son, whom he loveth, the Divine
) Prayer 10 lines: (Text and Translation, VIREY, p.105) (II) (Similar Scene), Explanatory mem. (VIREY, p.107, n.7) Presentation
his son [destroyed]. Prayer 10 lines (Text and Translation, VIREY, p.108) (III) (Similar Scene) Presentation by (VIREY, p.110,
..) *šnb* [.....] i.e. His son, first Scribe of Divine offerings for Amon, [...] [.....] *Râ-snb* (?) Prayer 10 lines. (Text and

False Door (XI, A) Upper Portion, Niche for Shrine formerly closed by Stela. Louvre, C.74 (XI, B)

a. high by 0.40 m. wide. Removed from rear wall of Corridor by CHAMPOLLION (See de Rougé, Notice des Mon. etc. du Louvre; (1855)

offerings. Over them (8 lines) Prayer to Amon Ba and Titles. Around and below are 7 lines of text. Conventional: No

Inscr. II, Pl. 11 BRUGSCH, Thesaurus, p.1109 LIEBLEIN, Dict. des Noms prop, (1871), No. 914

(Continuation of Scene X) I, Consecration etc. of offerings. Text 15 lines. II, Lists of offerings (VIREY, pp.120-121) III,

mother seated on a divan. Lists of offerings VIREY, p.120; PIEHL, Inscr. Hiér. I, 2, p.93 1st Presentation by (VIREY, p.122, n.2

f ex Ht *Ht* [sic.] *Râ-an-ḥr-šnb Nâḥr* i.e. His son, First scribe of offerings of [sic.] Men-kheper-Ra-snb, Justified.

before the case Men-kheper-Ra-snb; See Note I, above. Prayer 10 lines, (VIREY, p.122)

(LIEBLEIN, op.cit. No.1924) i.e. Senwosret. (VIREY, p.124, n.2) Prayer 10 lines. (VIREY, p.125)

Prayer 10 lines. (VIREY, p.127)

THIS PAGE IS LOCKED TO FREE MEMBERS
Purchase full membership to immediately unlock this page

DELVE INTO FANTASY, MAGIC, MYTHOLOGY & FOLKLORE

Forgotten Books'
Full Membership gives
access to 797,885 ancient
and modern, fiction and
non-fiction books.

Continue

*Fair usage policy applies

TABLE No. XXXIV, A, Continued.

Scene No.	Text				Translation			Guides				
	Virey Plate	P.	Newberry Plate	Beths Page No.	Virey P.	Presented S	Rev by No.	N. No.	E. P.	S. No.		
XIII	XXX XXXI-XXXVI	1169-1173	339	Same Wall: (To Right of Scene XI Pl. XXXI: The Mummy and the Offi Note: SETNE gives "Titulary and See HAYS-BONOMI, Br. Mus. Add. Mss. Under Scene XIII (Left) Two retai Under scene XIII (Right of XIV, retainers to feast." Scene: R. deceased, towed by men on the Under scene XIII. (to Right of Inscr. hiérog. I, Pt. 2, p. 92: I, Pt. MASPERO, Struggle of the Nation	
XIV, A B	XXXVII XXXVIII	1167 1158-1159	337, C 334	156	9	439	2		
C	XXXIX.		
XV, A	XL-XLII	1162-1164	337, A	159	Same Wall: (Right of XIII) "The Before R. women of harim in 3 Over servants 7 lines + 2 line: ibid, 29: 817; 38 CHAMPOLLION, CAILLIAUD, Recherches sur les a (Under XV, A) Feast with men 5 lines: Song of Harper, 5 line	
XV, B		1164-1168	337, B	163	..	10	439	3		
XVI	XLIV	1159-1160	335	164	762	9	439	9	Same Wall by Entrance: (Upper A ship with sail set, and 24:0. The text begins: - (1) <i>fít in' ánh dt</i> etc. i. e. coming, to w forth for the reception of His HAYS-BONOMI, Br. Mus. Add. Mss. 2981 Note: - The City of <i>K-t</i> (or <i>ka</i>) I, 2, p. 721, n. BRUGSCH, Dict. BAEDERER, (1914), p. 244 MURRAY	
XVI	...	165	XV	1139-1140 1167-1168	331 337, D	165	715	35	Same Wall: (Near Doorway) "R. Scribe, Attendants, 3 women. (SETNE, p. 1167, No. 337, D. (Over a (Door-post, Inside) Text. Conv (String-Course: Inside) Text. (Doorway: Outside) Text: Gods Outer Chamber: N. E. Wall: Def "satisfaction of R. considerin Ibid; N. W. end Wall: Defaced: Lists of Offerings and Titles. wife <i>fim</i> (VIREY, p. 170, n. 1-9): Sheen (?) [or <i>nhwtw</i> , i. e. Menk (e) of a son Aahmes: (f) of a (j) of a daughter <i>nb-int</i> (<i>nt</i>)
XVII	...	167	167	
XVIII	...	168	168	
XIX	...	169	169	
XX	169	
XXI	...	170	170	
XXII	...	170	...	1160	336	170	
XXIII	...	171	XXII	1155-1157	333	171	752	38	Ibid. (Right of No. XXII) "R. i (Scene) R. (destroyed) (on axes, shields, helmets, n of the Storehouse. The Texts I. Inscription over R. (8 line <i>ft-ht n [im] Ram-prw Itw</i> [Gr i. e. Inspection of the Divine God, Lord of the Two Lands. (To wit, the [Titles] II. Over the Tribute Bearers: III. Another man notes offerin IV. The Bread piled up before

Rekhmara (3)

ch-Plan: - "Ceremony of the opening of the Mouth" (VIREY, PL. XIX)

XXXI-XXXII: The Purification: XXXII-XXXIII: Evocation of the spirit of deceased: XXXIV-XXXVI: The Offering and prayers: notes of R. in VIREY, pp. 104-170, Pl. XXVI-XXXVI." (No Geographical Names) Texts by VIREY in full. All conventional ritual.

figures bearing flowers, fruit, cakes etc. 18 short lines

cent)("R's Garden") (VIREY, p. 156; MURRAY, p. 439) SETHE gives "R, according to the arrangement of his service, causes his eyes closed) under 10 lines. To left, Garden surrounded by trees. In middle a lake, in which is a barge containing statue of

rows of men bearing fruit etc. then after a destroyed space, Scribes and 5 lines of text. No Geographical Names. See PIEHL, III, G, a. HAYS-BONOMI, Br. Mus. Add. Mss. 29817:44; Photo of R's Garden: WRZSZINSKI, Atlas zur Altäg. Kulturgesch. Pl. 3 : Archéol. Ég. (1937), p. 180, (English Edition, 1895), p. 187 WILKINSON, Pop. Account etc. (1890), I, p. 25

in the Harim": R. and wife seated at table spread with fruits and flowers: 4 young girls present necklaces and sistrams. Sicians and dancers. Over R. and wife 7 lines: over girls offering sistrams etc. 7 lines: over the acther of R. 1 line. Harper, 4 lines. Over Lute player, 6 lines. Over Lyre player, 3 lines. See HAY-BONOMI: Brit. Mus. Add. Mss. 29852, A:99, 109-112

LEPSIUS, Denkmäler, III, Pl. 42: Text, p. 271 ROSELLINI, Mon Civ. (1834), Pl. LXXVII-LXXIX
etiers, (1823)(1837), Pl. 64 WRZSZINSKI, Atlas zur Altäg. Kulturgesch. etc. Pl. 10: (Photo)

rows and two rows of women and men: Over R's wife, 6 lines. Their son brings garden fruits etc. 8 lines. Song of 3 Singers, of Lute player, 2 lines. See PIEHL, Inscr. hiér. I, 2, p. 93: I, 1, Pl. CXIV. G, 3, γ. HAY-BONOMI, Br. Mus. Add. Mss. 29817:39

Rekhmara returns in a sailing vessel from Diospolis Parva, whither he went to welcome King Amenhotep II.

on one bank of oars: Pilot with pole at hom. Steersman and 2 men with whips urging crew of rowers. Text 25 lines

(2) *fai Rh* [mi Ra Naâhrw] (3) *n iur-f n ft-š-hm* (Hwt) (4) *n šz-f r šept hm-f* (5) *r rdit ânḥ* (M. 41) *n šwt Bit* (*Āa-hprw-Râ*) di
reflect of the City (2) and Visier Rekh[mira Justified] (3) in his goings from the City of *ft-š-hm* (4) and in his going
(5) so as to give a bouquet (?) to the King, Sovereign of Upper and Lower Egypt, *Aa-kheperu-Ra*, Given Life Forever, etc.

(Lower Panel: VIREY, Pl. XLIV) A vessel, sail lowered, no crew, and bearing a sarcophagus (?)

ter Diospolis Parva, Chief City of the *Nomus Διοσπολις*, or VIIth Nome of Lower Egypt. (PTOLEMAEUS, Geogr. IV, 6, § 31: Ed. MÜLLER, 1038) Its sacred name was Pr (or Pi) Hathor: Modern site near "Hou" or "Hu", circ. 31 miles above Abydos (W. Bank).

p. 366

the Petitions of the Poor" Scene: R. (Destroyed) standing. 4 rows of petitioners (Lower two destroyed)(Upper) Officer, on approach, two bowing, two kneeling before officer and one raising his arms. Text, 6 lines. Also 2 Texts: VIREY, p. 165
erson) (2 lines) ("Over a Son") *Hr hmnti* [n *hm*] (A. 113) [*hm-mdat* (=Y. 2)] i.e. Second Priest[of Amon Medat](?) (2 lines)
salutation: Titles.

lines.

esses invoked. See CHAMPOLLION, Not. Descr. I, p. 510

REY says: - "I appear to see a hunting scene in a marsh with illegible text, then another inscription indicating the good things coming into his cellars."

ays: - "Thought to be a false door." (Above) Traces of a personage and wife seated on a divan before offerings. Illegible

Similar scene defaced. Text (VIREY, p. 170, n. 1-9) Titles of deceased (VIREY, p. 169, n. 2-3) Titles of and name of: - (a) his a son [.....]: (c) of his son *Sx ftw Hr n hm-šs* [LACAU, Rec. de Trav. 35, p. 229, No. 42] - *n* i.e. Scribe Priest of Amon
(d) of a son, *Hr hm n hm n šsr* (=D. 56) *šsr* [??] *Hr* [.....] i.e. Priest of Amon in the Double Splendor (?) Mery[.....]
Hr hm-m [.....] (g) of [.....] Aahmes: (h) of a daughter [.....] Lower down] (i) of a daughter Aahmes:

ib-int or Lady of Heliopolis.

herds of cattle, and overlooks the tilling of the fields." Text. No Geographical Names.

the Offerings and Sacrificial Gifts which King Thutmosis III donated to the Temple of Amon and to other Theban Temples."

ght, 4 rows: (2 Upper) Ebony Statues of the King, seated, standing, running, kneeling. Then to Right, Stores of spears, res, censers, castanets, (2 Lower rows) Bakers, Priest with Censer: Attendants bringing offerings to the Superintendent

hae šdw n ftw Hr šdw a hrw nb Naâ (2) [*hâw*]-*f* *hass hrw hrw-f n itiy Hr Hr nb tamî* (3) (*Râ-âa-hpr*) *di ânḥ dt r*
(4) [*r ht* (=M. 9)]-*t-f* *hm* etc. (Titles)

is offered for every day. Inspection of his (2) [weapons] and beautiful Monuments which he brought for the King; the Good *Aa-kheper-Ra*[Thutmosis III], Given Life Forever, and for the Temple of [Amon] and the Precincts (4) which are around it (?)

onal Presentation by a son of R. [SETHE, p. 1157, N. B.] restored as "[*hm-m-hat*]"

hep. šz-f Sx Hr ftw Râ-ma-hpr-šnb i.e. His son, Divine Scribe of Offerings, Men-kheper-Ra-senb.

. List: SETHE, p. 1157.

THIS PAGE IS LOCKED TO FREE MEMBERS
Purchase full membership to immediately unlock this page



Never be without a book!

Forgotten Books Full Membership gives universal access to 797,885 books from our apps and website, across all your devices: tablet, phone, e-reader, laptop and desktop computer

A library in your pocket for \$8.99/month

Continue

*Fair usage policy applies

TABLE XXXIV. B: Scene III. "Reception of the Tribute of Foreigners."

Scene and Texts on the N. E. Wall of the S. half of the "Vestibule" or Outer Chamber: (Left of Doorway to Rear Chamber)
 Scene:- BAEDERER, Egypt, (1914), p. 310: "b" 1-5 MURRAY, Handbook for Egypt, (1908), p. 437 WEIGALL, Antiq. Upper Egypt
 of Foreign Dignitaries and Bearers of Tribute, viz. Row I (Upper) People of "Punt" II, Princes of "Keftiw" and
 V, Children of the Nobles of the "Countries of the South."

Published: HOSKINS, Travels in Ethiopia, 1st. Ed. (1825): II, (1835), p. 328: Chap. XXI CHAMPOLLION, Monuments etc. (1835-1845),
 Egyptians, 1st. Series, (1837), Plate at End: I Ind. Ser. (1841): II Ird. Ser. (1847): (Ed. 1878), I, Pl. II, A, II, B: LI
 BRUGSCH, Thesaurus etc. V, (1891), pp. 1110-1113 (Description and short texts) HAY-SOSOMI, Brit. Mus. Add. Mss. 25
 VIREY, Mém. Miss. franç. au Caire, V, (1894), Pl. IV-VIII.

Translation: (Entire) VIREY, op. cit. pp. 28-44 (lines 1-5, Text I, a below) BREASTED, Anc. Rec. Eg. II, (1906), §761

See: HAMY, Étude sur les peintures ethniques d'un tombeau thébain de la XVIIIe Dynastie: ibid, Bulletin Société d'Égyptologie

1, a

I, Inscription of Rekhmara and his attendants. "a" Title of the Scene.
 ššp(=P. 23)-p(D. 69) in(=W. 22)(W. 21)(pl.) n ḥst(=N. 40)-t rš(=M. 30)-t(N. 47) ■
 ā-b(W. 31)(Y. 2) in(=W. 22)(W. 21)(pl.) n p-
 -wn(=E. 58)-n-t(N. 40) in(=W. 22)(W. 21)(pl.) n r-ḥ-n-nw(=W. 21)-w(N. 40)
 in(=W. 22)(W. 21)(pl.) n k-f-tiw(=G. 5)(N. 40) ■
 ā-b(W. 31)(Y. 2) ḥa(=M. 42)-q-[t(pl.)](D. 69) n ḥst(=N. 40) ḥst ḥst
 nb(=W. 43)-t in(=W. 22)-n-n-w baw(=G. 54)
 ḥm(=W. 3)-f nšw(=M. 24)-t bit(=L. 1) (rā-mn-ḥpr) ānh q-t(N. 37) i-n (1) r-p-ā
 (2) ḥa(=F. 18)-ā (3) wr(=G. 79)
 wr(=G. 79) wr wr (4) šāh(=E. 19) š-mr(=U. 31) mr mr (5) imi-ra(=S. 37)
 iawt(=F. 35)-t(pl.) ḥnt(=W. 8)-n-t-t (6) mh(=V. 15)-id(=W. 23)
 mn-n-ḥ(U. 27) n
 i-ti(=U. 19)-y(A. 117) ir(=D. 10) (7) ḥs(=W. 4)-ti(=U. 19) im(=R. 28)
 āhā(=O. 29)-ā(O. 3) rdi(=D. 63) šw(=M. 24)-w m (8) tp(=D. 1)-p n
 š-mr(=U. 31) mr mr (9) ḥr(=D. 3) ḡḡa(=D. 1) n ta(=N. 37) r ḡr(=W. 40)-r-f
 šia-a(A. 91)-n-f šw(=M. 24)-w m (10) ir(=D. 10)-w
 iah(=G. 57)-t(Y. 2)(pl.) mn-n-t(Y. 2) n-f imah(=V. 4)-f m ḡḡa(=D. 3)-f
 imi-ra(=S. 37) nwt(=O. 1) [(12) ḥa(=G. 87)-t r-ḥ(Y. 2)-rā(=N. 7)-mi(=W. 29)]

"b" Inscription of the Attendants.

1, b

š-mr(=U. 31) mr mr āa(=T. 41) pr(=O. 3) pr ānh(=S. 43) wḡa(=U. 21) šnb(=Q. 9)
 pr(=O. 3)-r(D. 96)-s-n xr(=Q. 20)-r ḥa(=F. 16)-t (12) ḥa(=G. 87)-t ḥr(=D. 3)
 w-ša(=M. 37)[(A. 91)]
 ḥ-k-nw(=W. 21)-w ḥ-n(G. 75) n n-ḥ-m(A. 91) ḡ-d-w-s-n(pl.)
 ḥq(=S. 62)-q(A. 117) nfr(=Y. 9)-f-r mn(=Y. 12)-nw(=W. 21)-nw-nw (Rā-mn-ḥpr)
 š-mn-n(Y. 2) iawt(=F. 35)-t nb-t xr(=Q. 20)-r [(pl.)]
 pr(=O. 3) pr pr nwt(=O. 1) nwt nwt ḥ-p-w(Y. 2)(pl.) tp(=D. 1) rd(=D. 99)
 nb mn-n r išt(=Q. 1)-t(O. 3)-f mš(=M. 80)-w(A. 71)
 nw(=W. 21) š-ā-ḥ-w(E. 19)(pl.) ■ išt(=Q. 1)-t(O. 3) t-f t-f t-f š-n(pl.)
 whm(=F. 52)-m(Y. 2)-f
 ir(=D. 10)-t mi(=W. 29)-t-t n ḥh(=A. 106)(pl.) ■ rnp(=M. 13) rnp rnp i-w-f
 mn-n(Y. 2) ḡḡ(=R. 18) ḡḡ(Y. 2)
 ḥr išt(=Q. 1)-t(O. 3) ḥrw(=G. 8) ir(=D. 10)-f whm(=F. 52)-m(Y. 2)-f
 ir(=D. 10)-t š-d(X. 21) ḥb-šd(=  =D. 63) ḥb(=D. 65)
 ḥb ḥb š-šm(=T. 20)-m(D. 96)-f ānh(=S. 43) ānh ānh-w(pl.) n q-t(N. 37)

), p.116, No.4 Rekhmara (Defaced) seated (Upper Right) Attendants standing: Scribes take Inventories: Pacing them V Rows of the Sea" III. People of the "Country of the South" and of South and North Nubia IV. Notables of "Retennu"

KXVI: CLXXXIX: CXCI: ibid, Not.Descr.(1844,ff),I,506-509:843 WILKINSON, Manners and Customs of the Ancient , Denkmäler,III,(1844),Pl.39,b (one text see below): See ibid,Text,p.270,n.3
2-35; 29827:76; 29852:A,120 SETHE, Urk.XVIII Dyn.(1909),pp.1094-1103 (N.8. Not given in NEWBERRY, "Rekhmara")

ologie de Paris: Tome I: STEINDORFF, Die Blütezeit des Pharaonenreichs,(1900),p.30,Abb.27

	V. page		Geographical Names
<p>n ħst Rst m āb rst) innw n Rfnnw (ħst) rftiw (ħst) m st) m ħstwt nbt inns daw</p> <p>at Bit (Hn-ħpr-Rā) ħnh dt ipati (2) ħati-ā (3) wr Sāp Sarn (5) ħni-ra ħant e Table 33, Title 8] (6) ħh-id</p> <p>le 33, No.28] ir (7) ħsti [Gramm. ħhā (pr) rai św m (8) rpi n le 20, No.51] (9) ħr dada n Ta r No.28] Sian-f św m (10) irw LUTMIER, Bib.d'Ēt.IV,30][Table 32, int n-f ħnh-f m dada-f ħ-ra Nut [(12) Tat ħh-mi-Rā]</p>	41 42	<p>Receiving the Tribute of the South Country together with the Tribute of the Country of P- unt, and the Tribute of Rfnnw-land, also the Tribute of Kftie-land, together with the booty of all the countries which the fame of His Majesty brought, the King of Upper and Lower Egypt, (Men-kheper-Ra)[Thutmose III], Life Forever, to wit: (1) Hereditary Prince, (2) Count, (3) Mighty of the Mighty, (Line 5) (4) A Noble of Nobles. (5) Superintendent of the Leading Offices. (6) Complete Fulfiller of the Will of the King, [who] caused him to be (7) Praised within the Palace, and made him to be (8) First of the Royal Friends and (9) Chief of the Entire Land. He recognized him as the (10) Maker of useful things to testify for him, his worth in His face (sight) (11) Prefect of the City, [(12) the Vizier, Rekhmara]</p>	(1) Punt (2) Rfnnw
<p>ħa ħ. n. S. hat (12) Tat ħr wšo (?)</p> <p>n ngn Qda sn nnn (Hn-ħpr-Rā) nbt xrw ħpw ħp-rdw nb nn r ħst(pr)-f m ħst rfw-šn whm-f n ħh m rnpst ħw-f nn Qdī rw ir-f whm-f irf ħw m ħt</p>	4	<p>The Courtiers of Pharaoh, L. H. S. come forth before (12) the Vizier in order to acclaim (VIZIER) the praise and exultation for the triumph. They say: A goodly Chieftain, and a Memorial of (Men-kheper-Ra) [Thutmose III] All of the Offices are devolved upon [him] and under [him] are the Houses and the Cities. The Civil Laws and the Canon Law endure by his foundation [so that] the children of the Nobility are in the place of their Fathers; and he renews what is done, even for countless ages in years. He it is who guaranteeth stability on the Throne of Horus; and he causeth and reneweth the making of the Jubilee of the King, and the festivals. He leadeth the living for ever.</p>	

THIS PAGE IS LOCKED TO FREE MEMBERS
Purchase full membership to immediately unlock this page

DELVE INTO FANTASY, MAGIC, MYTHOLOGY & FOLKLORE

Forgotten Books'
Full Membership gives
access to 797,885 ancient
and modern, fiction and
non-fiction books.

Continue

*Fair usage policy applies

ii(=M.34)-i-t(D.96) m htp(=Q.17)-t-p m stp(=U.3) sa(=V.29)(O.3) anh wda snb
i-n (1) r-p-a

(2) ha-a (13) ra(=D.29) nhn(=X.3) (14) nfr(=R.13) hm maat(=R.13)

(11) imi-ra(=S.37) nwt (12) fa-t [r-h-ra-mi] maâ-hrw

[N.B. VIREY gives lines 19-21 as lines 1-3: text on p.43, No.5]

[šsp(=P.23)-p] rdi(=D.63)[sic.] n-f hnt (?) (?= ) nb(=W.43)



âhâ(=O.29)-a(O.3) špd(=N.4)w m [hr(=D.3)-f r]

[š-h]-r(Y.2) [n-f] tawi(=N.39) ir(=D.10)-t m xr(=Q.20)-r-w(Y.2)(pl.)



[idb(=N.47) idb mi(=W.29)-i] wn(=E.58)-n-t m hr(=D.3) n t-f imi-ra(=S.37)

nwt(=O.1) fa-t âa(=T.41)-m(=D.63)-t-[w maâ-hrw]

2: First (Upper) Row: Tribute of Punt. a: Gifts piled before an Egyptian Sc

(1) Gold Rings: =  (S.64)(U.50)(N.8)(N.53,N.53,N.53)(= ) (

(3) Oval Red Articles in a Basket: h-n-t(N.8)(N.53,N.53,N.53)(= ) [See SETHE



(= ) [SETHE, id. p. 335, line 9, p. 695, line 7] (5) Red Purse,  (As i

"b" Scene: (Top Row) Negroes (Colored Red) bring Myrrh, Panther skins, Tail
living panther, monkeys and steinbock.

Text over Foreigners:

ii(=M.34)-i-t(D.96) m htp(=Q.17) htp htp i-n wr(=G.79)(pl.) nw(=W.21)
p-wn(=E.58)-n-t(N.40) m [k-]š-w(A.19) [m] wah(=V.37) dada(=D.1) xr(=Q.20)-r
in(=W.22)(W.21)(pl.)-š-n(pl.) r b-w xr(=Q.20)-r hm(=W.6)-f(A.117)
nšw(=M.24)-t bit(=L.1) (râ-mn-hpr) anh d-t(N.37) ma(=U.8)maâ(=O.58)-a-w(Y.2)
nb nfr(=Y.9) n hašt(=N.40)-t-s-n(pl.) t-tm(=U.14)-mm(sic. = ) h-n-d
(D.99)(D.96) i-n k-w-i n âa(=T.41)-t n daw(=G.54)[-f] ht(=M.9)-h-t
hašt(=N.40)-t(pl.)-[s]-n(pl.) i-š-t hašt(=N.40)-t(pl.) nb-t m n-d-t
hm(=W.6)(A.117)-f i-n (1) r-p-a (2) ha-a (15) mh(=V.15) ib(=W.23) n
nšw(=M.24)-t(A.117) hnt(=W.8) [tawi(=N.39)] imi-ra(=S.37) nwt(=O.1)
(12) fa(=G.87)-t r-h(Y.2)-râ-mi][End of VIREY,](SETHE adds):-
šsp(=P.23)-p(D.69) in(=W.22)(W.21)(pl.) nb n hašt(=N.40)-t(pl.) nbt
in(=W.22)-n-n-w n [daw(=G.54)] hm(A.117)-f m n-ht(=M.9)-h-t(pl.)[-f]
[SETHE, n. "d"]

Scene: 2nd. Row: "Tribute from Keftiu and the other Isles of the Sea."

(1) Silver shaped  hd(=M.74)(U.50)(N.53,N.53,N.53)  (2) Silver

(4) Ceremonial Vases in shapes of Lions, heads of oxen, and rams, [See SETHE,
shaped  [See SETHE, id. p. 637, VII, 28]

"Text over the Foreigners" who fetch similar objects, as well as chains o

ii(=M.34)-i-t(D.96) m htp(=Q.17) htp htp i-n wr(=G.79)(pl.) nw(=W.21)
k-f-tiw(=G.5)(N.40) iw(=N.66)(N.47)(pl.) hr(=D.3) ib(=W.23)(pl.)[sic.]
nw(=W.21) wad(=M.47) wr(=G.79)(N.58) m k-š-w(A.19) m wah(=V.37) dada(=D.1)
n daw(=G.54) hm-f(A.117) nšw(=M.24)-t bit(=L.1)-t (râ-mn-hpr) di(=X.22)
anh dt(N.37) sdm(=F.46)-m-š-n(pl.) n-ht(=M.9)-h-t(D.69)(pl.)-f hr(=D.3)
hašt(=N.40)-t(pl.) nb-t in(=W.22)(W.21)(pl.)-š-n(pl.) hr(=D.3)
p-s-d-w(pl.)-š-n(pl.) ms(=O.71)-t-w r-rdi(=D.85)-t n š-n(pl.) fa(=P.16)
n anh m wr(=U.12)-y-t wn(=E.58)-n-n hr(=D.3) mm(=N.55) n hm(A.117)-f r
r-rdi(=D.85)-t m-â(?=D.85)-k š-t daw(=G.54)-f i-n mh ib n i-ti(=U.19)-y
imi-ra nwt fa-t [r-h(Y.2)-râ-mi] šsp(=P.23)-p(D.69) in(=W.22)(W.21)(pl.)
nb n hašt-t(pl.) nbt in-n-n-w n daw n hm(A.117)-f

	V. page		Geographical Names
<p>htp n Stp-sa I. W. S. Hpâti i-â (13) Ra Nhn (14) Hn-Ntr (11) Inî-ra Nut (12) Fat -Râ] Naâhrw rdî n-f hnt Nb Îhâ (pr) spdw [f] [n-f] Pawî irt n xrw [n] wnt n hr n Tf Inî-ra Nut [w Naâhrw]</p>	<p>42</p>	<p>Coming in peace into the Palace; L. H. S. to wit: Hereditary Prince, (2) Count, (13) Mouth of Nekhen, (14) Priest of Maat, (11) Prefect of the City, (12) Vizier [Rekh-ma-ra] Justified. [Reception] was given to him (?) before (?) the Lord of the Palace; and he prepared before [him to] pacify for him the Two Lands, and to do for those under him of the Two Banks as if it were in the presence of his Father Prefect of the City, Vizier, -Aath[u Justified]</p>	
<p>and Red Lumps in Baskets or in heaps: ā-n-tiw = G.5) (𓆎!) [Myrrh] VIII Dyn.p.638, Nos.30,31 (4) Ibid, Brown, in 2 Baskets: ka(=D.46)-a-a [BRUGSCH: VIREY, "a"] (I.8)(N.53,N.53,N.53) (6) White ◡ in a Basket: [Name Defaced] Two Obelisks of Frankincense sprinkled Red and White.</p>			
<p>Animals, Elephant tusks, Red Chains, Ebony sticks, Ostrich eggs and feathers, a Myrrh tree, Boomerangs, a htpw in Wru nw Punt (hast) [n] wab-gaga xr innu-ân -f Hsot Bit (Hn-hpr-Râ) Hâw n Hast-ân Taw (?) hnd in Kwi n [SERVUS, Z, Aeg.40, p.92] daw[-f] ht [n] Ist Hast nbt n Hgt (1) Hpâti (2) Hatî-â (15) Hn-ib hnt [Pawî (11) Inî-ra Nut [at Hn-nî-râ] hnt nbt n Hast nbt in-nw n [daw] [f]</p>		<p>Coming in Peace, to wit: The Chiefs of Punt, as they sake obeisance [by] lowering the head, (? ?) bearing their Tribute to the place where His Majesty is, King of Upper and Lower Egypt (Men-kheper-Ra)[Thutmosis III] Life Forever. All (?) the goodly (?) offerings of their country [which] another does not (?) exceed because of the Greatness of [his] Fame throughout Their Country. Lol all countries are in subjection to (?) His Majesty. To wit: (1) Hereditary Prince, (2) Count, (15) Fulfiller of the Will of the King beyond [the Two Lands. (11) Prefect of the City, (12) Vizier Rekhmara] Receiving all the Tribute of all the Countries brought for [the Pane] of His Majesty by means of [his] Victories.</p>	<p>(3) Punt</p>
<p>offerings piled before an Egyptian Scribe. (3) Basket full of sky blue sasses. d-a-b-d(N.8)(N.53,N.53,N.53) : Lapis-lazuli:</p>			
<p>VIII Dyn.p.680, p.718, p.722] wads of Gold, Silver, and different materials. Great bars of Gold and Silver- and blue pearls and an elephants tusk. htpw in Wru nw Iftiw (hast) Iw [n] Wad Nr n Hsu n wab-gaga n Hw Hsot Bit -Râ) Si Iny Dt Sga-ân Hptw-f hr nbt Innu-ân hr padu-ân rdî n-â-n Taw n Iny n hnt hr nw n Hn-f [at Hn-â-t Bos-f -id n Itiy Inî-ra Nut Fat [n-Râ] Ssp Innu nbt n Hast nbt [n] Hw n Hn-f</p>	<p>33</p>	<p>Coming in Peace. To wit: the Chiefs of Iftiw-land, and of the Islands in the Midst of the Great Green: waking obeisance by lowering the head (?) to the Fame of His Majesty, King of Upper and Lower Egypt, (Men-kheper-Ra)[Thutmosis III], given Life Forever. They heard of the Victories over all the Countries, and, their tribute on their backs, drawing nigh that there might be given to them the Breath of Life for favor as being on the Water of His Majesty, and to cause that His Fame may protect thes. To wit: Fulfiller of the Will of the King, Prefect of the City, [Rekhmara]. Receiving all the Tribute of every country brought for the Fame of His Majesty.</p>	<p>(4) Iftiw (5) Iw hr ib nw Wad-Nr (6) Wad-Nr</p>

THIS PAGE IS LOCKED TO FREE MEMBERS
Purchase full membership to immediately unlock this page



Never be without a book!

Forgotten Books Full Membership gives universal access to 797,885 books from our apps and website, across all your devices: tablet, phone, e-reader, laptop and desktop computer

A library in your pocket for \$8.99/month

Continue

*Fair usage policy applies

3rd Row: Tribute of Nubia and the Sudan: "a" Gifts piled before an E
 (1) Ostrich Feathers and (2) Eggs, (3) Panther skins, (4) Dog's head Vases, (in Baskets. $\overline{D\hat{a}}$ (U.50)(N.53,N.53,N.53) (7) White Jugs \overline{U} with inscription &
 (9) Ebony (10) Basket filled with dark red grains, $\overline{f-n-g-t}$ (N.53,N.53,

"Inscription over the Foreigners" who bring similar objects, as well as
 $i\ddot{i}$ (=M.34)- i -t(D.96) = $h\dot{t}p$ (=Q.17) $h\dot{t}p$ $h\dot{t}p$ i -n wr (=G.79)(pl.) nw (=W.21) $\overline{f\dot{i}t}$
 $h\dot{a}st$ (=N.40)-t(pl.) $r\acute{s}$ (=M.30)-t(N.47) $i\dot{n}$ (=Q.29) ta (=N.37) ta (=N.37) $\overline{f\dot{a}}$
 (N.53,N.53,N.53) st (=T.31)(N.66) [nw (=W.21)] $h\dot{n}t$ (=W.8)- $h\dot{n}$ (=Q.31)- nfr (=Y.9) $\overline{n.1}$
 = $k-\acute{s}$ -w(A.19) hr (=D.3) $d-h-n$ (D.1) ta (=N.37)[sic.] xr (=Q.20)- r $\overline{m.k}$
 $i\dot{n}$ (=W.22)(W.21)(pl.)- $s-n$ [r $b-w$ xr (=Q.20)- r hm (A.117)- f] $n\acute{s}w$ (=M.24)- t $\overline{i\dot{n}}$
 $b\dot{i}t$ (=L.1)- t ($r\hat{a}$ - m - hpr) $\hat{a}n\dot{h}$ dt (N.37) ms (=O.71)- $t-w$ $r-r\dot{d}\dot{i}$ (=D.63)- t n $\overline{b\dot{i}}$
 \acute{s} -n(pl.) faw (=P.16) n $\hat{a}n\dot{h}$ (=S.43) i -n (1) $r-p-\hat{a}$ (2) $ha-\hat{a}$ $\overline{n.}$
 (16) $b\dot{i}t$ (=L.1)- t $h\dot{t}m$ (=S.44) (17) \acute{s} - wr (=U.24) $m\hat{a}$ (=U.38) (11) $i\dot{m}\ddot{i}$ - ra (=S.37) $\overline{(11)}$
 nwt (=O.1) fa (=G.87)- t $r-h$ (Y.2)- $r\hat{a}$ - $m\dot{i}$ $\acute{s}sp$ (=P.23)- p (D.69) $i\dot{n}$ (=W.22)(W.21)(pl.) $\overline{f\dot{a}}$
 n $h\dot{a}st$ (=N.40)-t(pl.) nb -t $i\dot{n}$ (=W.22)- $n-n-w$ n baw (=G.54) n (?) hm (A.117)- f $\overline{m.}$
 = ph (=F.15) ph [$t-f$ i - m - n (A.113) r $r\dot{d}\dot{i}$ (=D.63)- $n-f$ $q-n-t$ (D.69) $n-h\dot{t}$ (=M.9)- $h-t$ $\overline{m.}$
 (D.69) r $h\dot{a}st$ (=N.40)-t(pl.) nb -t n wr (=G.79)- r n] $m-n-h$ (U.27)(Y.2)- f $\overline{f\dot{a}}$
 $r\hat{a}$ (=N.7) $m\dot{i}$ (=W.29) [\acute{d} -t(N.37)] $\overline{R\hat{a}}$

4th Row: The Tribute of Retennu: "a" Gifts piled before an Egyptian
 (1) Ceremonial Vases of Gold and Silver. (2) Dishes of Silver. (3) Gold Ring
 the lower, wr (=U.12). (5) Two bundles of white staffs \overline{f} (6) Basket, with
 (7) Restored object next thereto ha (=F.16)-[$-t-f$] n [$-t$] wr (=U.12) [SEYME,
 (9) Bars shaped \overline{U} inscribed ex (=Y.1) (10) Basket with
 (11) Yellow Bars shaped \overline{U} inscribed $\downarrow \dots$ (12) Basket with
 (13) Small sacks \overline{U} with contents \overline{f}
 (15) nfr (=R.13)- $\acute{s}n$ (=R.27)- $t-r$ i.e. $\acute{s}nfr$, af (=R.13)- $\acute{s}n$ (=R.27)- $t-r$ (N.53,N.53,
 (16) \acute{s} - f - t i.e. "Sacred oil or perfume" [MURRAY, ibid, p.32] (17) $b\dot{i}t$ (=L.1)

$i\ddot{i}$ (=M.34)- i -t(D.96) = $h\dot{t}p$ (=Q.17) $h\dot{t}p$ $h\dot{t}p$ i -n wr (=G.79)(pl.) nw (=W.21) $\overline{f\dot{i}t}$
 $r-f-n-nw$ (=T.1)(N.40) $h\dot{a}st$ (=N.40)-t(pl.) nb -t mh (=V.15)- $t-t$ nw (=W.21) $\overline{R\dot{f}n}$
 ph (=F.48)- w - i $\acute{s}f$ (=S.31)- $t-t$ = $k-\acute{s}$ -w(A.19) = wah (=V.37) $dada$ (=D.1) $\overline{P\dot{h}w}$
 $i\dot{n}$ (=W.22)(W.21)(pl.)- \acute{s} -n(pl.) hr (=D.3) $p-\acute{s}$ - d (D.35)- \acute{s} -n(pl.) ms (=O.71)- $t-w$ $\overline{i\dot{n}n}$
 $r-r\dot{d}\dot{i}$ (=D.63)- t n \acute{s} -n(pl.) faw (=P.16) n $\hat{a}n\dot{h}$ (=S.43) n wr (=U.12)- $r-t-w$ $\overline{r\dot{d}\dot{i}}$
 wr (=E.58)- $n-n$ hr (=D.3) mw (=N.55) n hm (=W.6)(A.117)- f ma (=U.8)(D.10)- \acute{s} -n(pl.) $\overline{m\dot{a}n}$
 $n-h\dot{t}$ (=M.9)- $h-t-w$ (D.69)(pl.)- f $\hat{a}a$ (=T.41)- t wr (=G.79)- $r-t$ $\overline{h\dot{t}}$
 hr (=D.3)- $r-y-t$ (Z.10)(D.69)(pl.)- f $\acute{s}hm$ (=S.50)- $m-\acute{s}$ ib (=W.23) ib $ib-\acute{s}$ -n(pl.) $\overline{f\dot{r}r}$
 $i-\acute{s}$ -t i -n (1) $r-p-\hat{a}$ -t [sic.] (2) ha (=F.16)- \hat{a} (18) nfr (=R.13) wr (=U.12)- t $\overline{i\dot{a}t}$
 (19) mh (=V.15) ib (=W.23) $\hat{a}a$ (=T.41) n nb $taw\dot{i}$ (=N.39) (11) $i\dot{m}\ddot{i}$ - ra (=S.37) $\overline{(19)}$
 nwt (=O.1) [(12) fa (=G.87)- t $r-h$ (Y.2)- $r\hat{a}$ - $m\dot{i}$] $\acute{s}sp$ (=P.23)- p (D.69) \overline{nwt}
 $i\dot{n}$ (=W.22)(W.21)(pl.) n $h\dot{a}st$ (=N.40)-t(pl.) nb -[t][.....] \overline{n}

5th Row: "Captives and Hostages whom the King led away from the conquered
 [\acute{s} -t- $\acute{s}fa$ (=V.2) ms (=M.60)]- \acute{s} -w [wr (=A.29)](pl.) nw (=W.21) $h\dot{a}st$ (=N.40)-t(pl.) $\overline{[s\dot{f}]}$
 $r\acute{s}$ (=M.30)-t(N.47)(pl.) = \hat{a} -b(N.31) ms (=M.60)- \acute{s} -w(pl.) [wr (=A.29) wr wr] $\overline{h\dot{a}t}$
 nw (=W.21) $h\dot{a}st$ (=N.40)-t(pl.) mh (=V.15)- $t-t$ $i\dot{n}$ (=W.22)- $n-n-w$ = $tp\dot{i}$ (=D.1)(pl.) \overline{nw}
 ha (=M.42)- $a-q-t$ [(D.69)(pl.)] $hm-f$ $n\acute{s}w$ (=M.24)- t $b\dot{i}t$ (=L.1)- t ($r\hat{a}$ - m - hpr) $\overline{h\dot{a}q}$
 $d\dot{i}$ (=X.22) anh hr (=D.3) $h\dot{a}st$ (=N.40)-t(pl.) nb -t r mh (=V.15)(Y.2) hb (=U.13)- \hat{a} $\overline{D\dot{i}}$
 (O.3) r wr (=U.12)- $r-t$ (A.89)(B.7) $n-t$ nfr (=R.13) $h\dot{t}p$ (=Q.17)- $t-p$ \overline{r}
 n $t-f$ [i - m - n] nb $n\acute{s}t$ (=W.42)(pl.) $taw\dot{i}$ (=N.39) $m\dot{i}$ (=W.29)- i $r-r\dot{d}\dot{i}$ (=D.63)- t $n-f$ $\overline{nt\dot{i}}$
 $h\dot{a}st$ -t(pl.) nb -t dmd (=S.41)(Y.2) = $h-f-\hat{a}$ (D.82) $hm-f$ wr (=G.79) wr $wr-\acute{s}n$ (pl.) $\overline{h\dot{i}}$
 $x-d$ [$b-w$ (A.133)] xr (=Q.20) $t-p$ [fb (=S.38) fb]- $f-i$ i -n (1) $r-p-\hat{a}$ (2) $ha-\hat{a}$ $\overline{w\dot{r}w}$
 (20) $i-i\dot{m}\ddot{i}$ (=R.28)- ib (=W.23) n $i-i\dot{m}\ddot{i}$ (=R.28) $\hat{a}h\hat{a}$ (=O.29)- \hat{a} (O.3) (11) $i\dot{m}\ddot{i}$ - ra nwt $\overline{(2)}$
 (12) fa -t [$r-h$ (Y.2)- $r\hat{a}$ - $m\dot{i}$] $\acute{s}sp$ (=P.23)- p (D.69) ha (=M.42)- $q-t$ (pl.) $h\dot{a}st$ -t(pl.) $\overline{(11)}$
 nb -t $i\dot{n}$ (=W.22)- $n-n-w$ = $n-h\dot{t}$ (=M.9)- $h-t$ (D.69)(pl.) $hm-f$ $\overline{\acute{s}sp}$

the Scribe.

(d in Rings and Bars shaped [] nb(=U.50)(N.53,N.53,N.53) (6) Red and Yellow Purses laid alternately
31)-t-i(N.53,N.53,N.53) (8) Elephant tusks Ab(=U.31)-b-w or ab(=U.31)-w
3 (11) Basket filled with a green substance, šs(=V.6)-s-m-t(N.53,N.53,N.53)

of animals, Monkeys, Panther, a Giraffe, Dogs and Cattle.
[w in [w]w n[]w š[]st R[]t Inw
GARDINER, Z. Aeg. 45, p. 128, p. 139,
[]nt-[]h-[]nfr
[]dh[]m Fa xr
[]r š[]w xr []m-f] Nšwt
[]pr-Rā) In[]h Dt n[]st[]w rd[]t
[]n In[]h In (1) Rp[]t[]i. (2) Hat[]i-ā
[]t[]m (17) Šur-šat[]i (11) Im[]i-ra
[]š[]t Rh-ni-Rā Šsp innw
[]bt innw n š[]w n (?) []m-f
[]f Inw rd[]m-f q[]t N[]ht r
[]t n []r n] m[]h-f m[]i

34

Coming in peace. To wit: The Chiefs of the South Countries;
the Inw of Fa St[]i and of Inthn[]nfr [i.e. South Nubia and
North Nubia]
making obeisance, and greeting:-
the earth laden with their tribute [to the place where His
Majesty is, the King of Upper and Lower Egypt, (Men-kheper-Ra)
[Thutmosis III]; Life Forever. They draw nigh that there might
be given to them the Breath of Life. To wit: (1) Hereditary
Prince, (2) Count, (16) Chancellor of Lower Egypt, (17) Sole
Companion, (11) Prefect of the City (12) Vizier Rekhmara:
Receiving the Tribute of all the Countries, Brought for the
Pane of (?) His Majesty according to the Might [of Father Anon,
who hath given the strength of Victory to all the Countries of
the Chief for] his excellence, like unto Ra [Forever].

(7) šaswt R[]t
(8) Fa St[]i
(9) Inthn[]nfr

(=U.50)(N.53,N.53,N.53)-n-ā (4) Timbers or Planks of a yellow, fine grained wood; on the upper ā[]š, on
dark red articles ha(=F.16)-t-t n-t ā-š "Oil of Cedar", [MURRAY, Saqqara Mastabas; p. 34, No. 27]
[]m "aru: Tree oil"] (8) Two slate colored bars shaped [] D-A(N.8)(N.53,N.53,N.53) []
[]ts destroyed n(=Y.12)-n(N.53,N.53,N.53) []
[] masses n(=D.65)-f-ka(=D.46)[-t](N.53,N.53,N.53) [] i.e. Malachite.
(14) Jug[] with inscription. [SETME, note "d" "baq mag or n[]m (?)"] i.e. Green or sweet oil. []

i.e. š[]r i.e. "Resin" [GAUTHIER, Bib. d'Ét. IV, p. 122] "Incense" [MURRAY, Saqqara Mastabas, p. 32]
Honey.

[w in [w]w n[]w
[]st) š[]st n[]t N[]ht n[]w
[]w š[]w n w[]h d[]g[]s
[]w p[]d-š[]n n[]st[]w
[]w n []h[] n n[]rt[]w
[] n []m-f l[]o-š[]n
[]t n[]rt
[]š[]h[]-s i[]b[]-š[]n
(1) Rp[]t[]i (2) Hat[]i-ā (18) Nrt N[]r
[]b š[]a a N[]b š[]w i (11) Im[]i-ra
[]š[]t Rhmirā) Šsp innw
[]b[]t [] []

36

37

Coming in peace. To wit: the Chiefs of Retennu-land,
and all the Northern Countries of the two
Ends of š[]t as they make obeisance by lowering the head,
their tribute on their backs, they come
that there might be given to them the Breath of Life,
for being favored as being on the Water of His Majesty.
They behold his grand Victories, and the greatness of his
Terror taketh possession of their hearts.
Lo! to wit: (1) Hereditary Prince, (2) Count, (18) Whom the God
Loweth. (19) Fulfiller of the Will of the Lord of the Two Lands.
(11) Prefect of the City, [(12) Rekhmara]. Receiving the
Tribute of all the Countries []

(10) R[]nnw
(11) šaswt N[]ht
(12) š[]t

series, and had assigned to the Temple Foundation of Amon."

[] []w n[]w š[]st
[] š[]w []w
[]ht[]t In[]es n[] tp[]s
[]-f Nšwt š[]t (In-š[]pr-Rā)
[] š[]st n[]t r n[]h N[]ā (pr)
LILLET, Rec. de Trav. 27, p. 211
[]š[]r n[] r[]f []nn[] N[]b Nšwt-š[]w i
[]-f š[]st n[]t d[]g[] n[] š[]ā []m-f
[](b[]w) xr š[]t[]i-f In (1) Rp[]t[]i
[]ā (20) Im[]i-ib n[] im[]i š[]h[]
[]ra š[]t (12) š[]t []h[]-ni-Rā)
[] š[]st n[]t innw n[] N[]ht[]w []m-f

39

[Leading forward the chil]dren of the Mag[nates] of the Southern
Countries, together with the Children [of the Magnates] of the
Northern Countries, fetching according to the choicest the booty
of His Majesty, King of Upper and Lower Egypt, (Men-kheper-Ra)
Given Life. in all the Countries, to fill the storehouse
and by the serfs which belong to a Divine Offering for Father
[Amon], Lord of Nšwt-š[]w i [Karnak]. Thus to cause for Him all
the Countries to be united in the grasp of His Majesty. Their
Magnetas are bla[in] under his feet. To wit: (1) Hereditary
Prince, (2) Count, (20) Favorite of [Him] Within the Palace.
(11) Prefect of the City, (12) Vizier [Rekhmara]. Receiving
the booty of all the Countries brought from the Victories of
His Majesty.

THIS PAGE IS LOCKED TO FREE MEMBERS
Purchase full membership to immediately unlock this page

DELVE INTO FANTASY, MAGIC, MYTHOLOGY & FOLKLORE

Forgotten Books'
Full Membership gives
access to 797,885 ancient
and modern, fiction and
non-fiction books.

Continue

*Fair usage policy applies

TABLE XXXIV: C:

Rekhmara:

Titles.

Title No.	YIRRY		Br. Mus. Add. Mus. No.	SETHE Page	In addition to the Titles of Rekhmara, the following are given by SETHE, Urk. XVIII are not repeated, references being made to their nanhera on said Tables.
	Plate	Page			
21	168	1169, a	(Table XXXIV, Nos. 1, 2, 17) (21) t-k-n(D.96) = nfr(=R.13) ḥā(=A.109) ḥā ḥā (Table XI, (Table XX, No. 61)(Table VII, A, No. 8)
22		(22) sab(=E.49) taytī(=O.44)[ERMAN][But sbhtī: SETHE, in MURRAY, Saq. Mast. p. 43, No. 42
23		(23) ra(=D.29) nḥn(=X.3) (Table XXXIV, No. 14)
24		(24) wp(=F.33) maūt(=H.13) n nb(=T.43) tawī(=N.39) = wbn(=N.13) n-t hrw(=N.7) nb (Table XXXIV, 11, 12)
25	XXVIII 107 29817:29	1170, b 1170, c	(24) wp(=F.33)-p(Z.7) maā(=Q.58)-t(H.13) n nb tawī (Table VII, A, No. 23) (25) imī(=R.28)-ib(=W.23) hrw(=G.8) nb ta(=N.37) p-n (24) wp seāt (as above) t-tm(=U.14) r-rdī(=D.63) hr ḡś(=N.50) r-rdī(=D.63) pr(=O.3)-r s(A.89)(A.89) ḥtp(=Q.17)
26	167	1170, d	(26) imī-ra(=S.37) ḥt(=O.15) ḥt ḥt wr(=G.79)-t(O.8) IIIIII
27	XXVIII	124	29817:57;4	1170, e	(27) sab(=E.49)
28					(28) imī-ra(=S.37) ax(=Y.1)
29					(29) hrī-sāta(=E.55) n pr(=O.3) nswt(=M.24) (Table XX, No. 26, No. 23, No. 35)
30	121	29817:57;3	1171, g	(30) hrp(=S.50) ka-t(=A.105) nb-t [n i-p-t išt(=Q.1)-t(pl.)(O.1)] (Table XX, No. 24; Table XXXIII, Nos. 8, 9, 10; Table XXXIV, No. 4)
31	127	1172, m	(31) mh(=V.15) ib(=W.23) mn-n-h(U.27)(Y.2) n i-ti(=U.19) y(A.127)(SETHE, 1172, "n")
32	104	29817:30	o	(32) ḡ-ā(=T.41)-ā n nsw(=M.24)-t
33				(33) ḡ-i-q-r n dit(=L.1)
34				(34) ḡ-ḥnt(=W.8) n nb tawī(=N.39) išt(=Q.1)-t(O.3)-f
35				(35) imī(=R.28) ib(=W.23) mḡw(=D.35)-d(A.91) = wā(=U.37)-ā-ā-w (Table XXXII, No. 23
36	XXXV	1173, r	(36) imī-ra(=S.37) hm(=U.28 ? = ḥ) [or wba(=U.29 ?) nb-t n-t i-mn-n
37	XXVIII	s	(37) sx(=Y.1) ḥtp(=Q.17)(X.19)(W.17) [nfr(=R.13)] tp(=D.1)-p n i-mn-n

Rekhmara (7)

pp. 1169-1173: VIREY, Mém. Miss. franc. V, pp. 104-170: Pl. XXVI-XXXVI. Those which have appeared on the preceding Tables of this work

- | | |
|---|--|
| (21) <i>ḥn n ḥw ḥr</i> | (21) Who Approacheth with the Divine [Sacrificial] Flesh. |
| (22) <i>Sob Taytī</i> [or, "sdḥtī"] | (22) Judge at the Gate (?) [or, "Chief Judge", MURRAY-SETHE] |
| (23) <i>Ra ḥn</i> | (23) Mouth of <i>ḥn</i> [El Kab] |
| (24) <i>ḥp</i> [MASPERO, Bib. d'Ét. VI, p. 63] | (24) Who declareth the Truth for the Lord of the Two Lands at the Dawn of every Day. |
| <i>ḥwāt n ḥb faḥi n wbn ntī ḥw nb</i> | |
| (24) <i>ḥp ḥwāt n ḥb faḥi</i> | (24) Who declareth the Truth for the Lord of the Two Lands. |
| (25) <i>ḥmī-ib ḥw nb fa pn</i> | (25) Favorite of Borus, Lord of this Land. |
| (24) <i>ḥp ḥwāt tm rdī ḥr gš rdī pr</i> | (24) Declarer of the Truth, he was not partial, causing to go forth the two parties |
| <i>swtī</i> [GARDINER, Untersuch. IV, p. 105, No. 42] <i>ḥp</i> | satisfied. |
| (26) <i>ḥmī-rn ḥwt ḥrt š</i> | (26) Superintendent of the 6 Great Temples. |
| (27) <i>Sob</i> | (27) Judge. |
| (28) <i>ḥmī-ra š</i> | (28) Superintendent of Writing. |
| (29) <i>ḥrī-ššte n Pr ḥšwt</i> | (29) Who is over the Secrets of the King's House. |
| (30) <i>ḥrp ḥwt nbt</i> [= <i>ḥpt-ḥšwt (nbt)</i>] | (30) Regulator of all the works in [<i>ḥpt ḥšwt</i>] [Karnak City] |
| (31) <i>ḥb-ib mḥ n ḥtiy</i> | (31) Perfect Fulfiller of the Will of the King. |
| (32) <i>šāa n ḥšwt</i> | (32) Magnifier of the King of Upper Egypt. |
| (33) <i>šiqr n Bit</i> | (33) Efficient for the King of Lower Egypt. |
| (34) <i>šḥnt n ḥb faḥi ḥst-f</i> | (34) Promoting for the Lord of the Two Lands His Throne. |
| (35) <i>ḥmī-ib mḥ n ḥw</i> [CALICE, Z. Aeg. 52, p. 116] | (35) A favorite [topic] of speech with the [Infantry] Officers. [or "Foot-soldiers"] |
| (36) <i>ḥmī-ra ḥwt</i> [or <i>ḥdat</i>] <i>nbt ntī ḥm</i> | (36) Superintendent of all the artisans [or "Women-servants"] of Amon. |
| (37) <i>š ḥtpw</i> [<i>ḥr</i>] <i>ḥpī n ḥm</i> | (37) first Scribe of the Divine Offerings for Amon. |

THIS PAGE IS LOCKED TO FREE MEMBERS
Purchase full membership to immediately unlock this page



Never be without a book!

Forgotten Books Full Membership gives universal access to 797,885 books from our apps and website, across all your devices: tablet, phone, e-reader, laptop and desktop computer

A library in your pocket for \$8.99/month

Continue

*Fair usage policy applies

Omitted Texts: C: After Pepy II read (Hfr-ka-Râ) for (Hr-n-Râ) -

Thati-hstop. Tomb Chapel at el Bersheh.

MR. BLACKMAN, in the Journal of Egyptian Archaeology, Vol. II, (1915), p. 13 calls attention to "An indirect reference to Ses el Bersheh, in the Wady Nakhleh, 182 miles South of Cairo. (BAEDEKER, Egypt, (1914), p. 210, (Map p. 230) MURRAY, Handboo detail by NEWBERRY, (FRASER-GRIFFITH), "el Bersheh", (Arch. Survey, Egypt, (Special), 1893). The scene and text in question.

The scene is part of a series of pictures representing an inspection of cattle by the deceased. The explanatory text rea-

(over First Official, Right to Left) Sx Hn i.e. Scribe of the Sarcophagus: (Second Official) Imi-ra Idr Hsnt i.e. S (Fourth & Fifth Officials, Left to Right) h-s[...]w(Z.11)(Y.2) ih i.e. ?? of the Cattle: (Over Herders, Left to R: From this point to Left end of scene, 1 long line of text. (Right to Left):-

Dd-mdw (=D.35) n [.....] p-s-h [.....] ih (=E.3) (pl.) r-t-n-w (T.1) m f-n-nw (=W.21)-w [...] h(A.31 ?)-n-f-n s-â (N.53, N.53, N.53) h-n-d (D.99)-f-n s-m-w (M.41) q-q (A.91)-f-n s-n (=V.6)-nw (=W.21)-w (D.5) (pl.) [...] w sa (=T.38)-t-n nfr (=Y.9)-f-r n h-â-w (M.86)-f-n w [.....] q-ma (=U.8) (T.1) zwj (=A.27)-f-n [.....] ph (=F.48) (pl.)-f-n s-n-b [?.] [?:.....] [...] b-w-t n ma (=U.8)-h (pl.)-f-n n-d-nqm (=M.98) n pr (=O.3)-r (D.96) (pl.)-f-n s-s-r-t-tn xr (=Q.20)-r w-b-w (pl.)-f-n w-wd (? = W | W = M.73 ?) ra (=D.29) n n-nr (=G.30) [.....]-f-n [...] -t-m (S.44) ra (=D.29) r h [...] (I.4) [.....] ha (=F.16)-â dhwti (=G.48)-h tp [...] -p ii (=M.84) m htp-t-p r f-n [.....]

Dd-mdw n [.....] psh [EMBER, Z. Aeg.: [BLACKMAN] m funw [.....] fwn-fn Sâ hn snnw [...] w sa-fn [VOGELSANG, Untere Bib. d'Ét. IV, 79] n hâw [BUDGE, Canopus, qma fwt-fn [.....] phw-fn snb [?.] sah-w-fn ndw n prw-fn srt [SETHE, Ver Gebrawi, II, Pl. XIX, Row 4]-fn xr wdw-f [h]tm ra r hn [...] [VOGELSANG, Untere hwti-â dhwti-htp ii m htp r fn [nwt ô

Further details as to this Tomb-Chapel will be given in a succeeding volume.

MR. BLACKMAN notes that "The verb h-w-n-fn is past tense "ye trod", whereas the succeeding verbs, hnd-fn, wnw-fn are in the fo of these cattle in Syria and their present luxurious existence in Egypt ?"

THIS PAGE IS LOCKED TO FREE MEMBERS
Purchase full membership to immediately unlock this page

DELVE INTO FANTASY, MAGIC, MYTHOLOGY & FOLKLORE

Forgotten Books'
Full Membership gives
access to 797,885 ancient
and modern, fiction and
non-fiction books.

Continue

*Fair usage policy applies

Hyksos Period: Carnarvon Tablet No. I. Note:- The following text, of interest to students of the "Hyksos" Period is given.

THE EARL OF CARNARVON and MR. HOWARD CARTER (Five Years Explorations at Thebes; a Record of work done edge, between the hills of Drah abu'l Negga and the cultivated land (See Plan, Table XX) adjoining the (Nos. I and II). One (No. II) is in fragments, and is inscribed with a Hieratic Text which has not yet contains 8 lines of horizontal hieratic text, being the introduction to the famous "Proverbs of Ptahhotep" lines of a draught board in squares 10 x 3 having on some of the squares hieratic signs indicating the "us of one line and the greater part of two more."

Published: (Hieratic Text) as above. Translated: (With suggestions by CAROISER) op.cit.pp.36,37

Hieroglyphic Transcription: MASPERO, Rec.de Trav.XXXI, (1909), pp.146, ff. BUDGE, (Text parallel with PRISSE) Eg. Gardiner, op.cit.(1916), pp.97, ff.

Translation: CARNARVON-GRIFFITH, op.cit.(1912), pp.36,37 MASPERO, op.cit. CARBENER, op.cit. (In part) W. Comment etc NEWBERRY, S.B.A.Proc.XXXV, (1913), pp.117, ff. The date and historical value of the text are given by NEWBERRY-GARDINER, "Copy of an earlier historical document made in the XVIIIth Dynasty."

It begins (GARDINER, op.cit.p.97):- (line 1) *ḥat-sp III ḥrw* Titles *Ḥst Bit [(Ḥd(=M.47)] ḥpr[-Ḥā)] [(Ka(=D.46)]* -m Titles

(line 2)(ibid,p.98) *Ḥst Ḥt m xn* [sic.] *Ḥst (Ka-mé-s)* *Rā* *šwādn n-f Ḥt ... Iw mdwn ḥm-f m āḥā-f Ddsw*
(line 3) *m ḥt-f*

[He begins by sketching the military situation of Egypt's foes]

(p.99) *Wr(A.89) m ḥt(=O.12)-wār(=D.99)-t(O.3) (nwt) Ḥv(A.89) m Kš (ḥst) ḥm ḥwi š(?)ma(R.20)-ḥwi* [GARDINER *Ḥšī s(A.89) nb xr f(?)dq if m ta Ḥt (nwt) nn sny* [doubtful, CARBENER (p.102) reads:- *nn sn(Z.20)(D šw šā r P-th(A.113)-Ḥt (pr) (nwt) m n (?) Ḥt Nik Šw xr ḥmw(≡≡) (nwt)* [BRUGSCH, Dict.géogr.p.749: There is *s(A.89) fḥw ma ḥw Šī(=F.60)-t-tiw(G.5)(T.1)(A.89)(B.7)(pl.)* (4) *ib-A.89 r ḥm Ḥt (nwt) ḥw* (5) *ḥmw*

(line 5)(ibid,p.102) *Iw mdwn ḥrw m Ddwt-f* (p.103) *Ḥāh mḥ(=N.55)-pw n Ḥmw šā r Qs(=A.56)-š-ī. (nwt)* [BRUGSCH *ḥt ḥw (6) (ḥst) ḥrī-ib ḥnā n(pl.) šā r Qšī (nwt)*

(line 10)(ibid,p.104) *Ḥdn-A.89 m (?) Ḥt(A.31)(A.89) r šōša* [GARDINER, p.105] *Ḥmw*

(line 11) *pdtw ntī Ḥāday* r *ḥī. Šī(=F.60)-t-t-tiw(=G.5)(T.1)(A.89)(A.79)(pl.) r dr išt-šn*

(line 12) *sdn-A.89 pdtī ḥtt ntī Ḥāday iw-A.89 m wr(=G.79)-āyt(N.7) [wāḥ(=V.87 ?)]-ḥ-y-t N.7) r ḡā-*
XVIII Dyn.p.661] n *ḥsf(=M.79)* [GARDINER, Rec.de Trav.34, p.70] [or *ḥd(=M.75)* ibid, Admonitions, p.41] [.....

(line 13) *r-t-ī(A.89) pa sa(A.89) P-p-ī(A.89) m xnw (pr) Ḥfr(=Y.9)-f-r-w-š-ī (nwt) Ḥn ā-A.89 ḥh(G.80)* [VOGELSANG, Unt [sic.]-A.89 *Ḥoww* *šḥa-*

(line 14) *-n(N.2)-A.89 m wia-A.89 Ib-A.89 nfr Ḥdn ḥrw n' Ḥa iw-A.89 ḥr-f mī wn dik(G.9) šnsā-A.89 šw ḥbān-ī*
rnt-f āḥā-A.89 iw(=D.96) ḥnt-f

(line 15) r *mryt(N.48) Ḥšāw-A.89 mī wn māw xr ḥqat-šn xr nr(=U.12)wt(A.89)(B.7) mntt ir(?)wt ḡnd(=V.20) m bit ḥr pā*

THIS PAGE IS LOCKED TO FREE MEMBERS
Purchase full membership to immediately unlock this page



Never be without a book!

Forgotten Books Full Membership gives universal access to 797,885 books from our apps and website, across all your devices: tablet, phone, e-reader, laptop and desktop computer

A library in your pocket for \$8.99/month

Continue

*Fair usage policy applies