

REPAIR INSTRUCTIONS

IH5-I USA

1	INTRODUCTION.....	2	5.3	Coil checks.....	44
1.1	Purpose of the document.....	3	5.4	Induction unit checks (ELIN)	45
1.2	Pictograms	3	5.5	Radio interference	46
2	SAFETY	4	5.6	Checking the level of supplied power Problem	48
2.1	Safety warnings	5	5.7	Checking the flatness of the hobs	57
2.2	Repair warnings	6	5.8	Checking standard operation noises.....	68
2.3	EGB	7	5.9	Checking pot detection	69
3	COMPONENTS AND FUNCTION	10	5.10	Checking of broken glass	71
3.1	Electronic Induction (ELIN).....	11	5.11	Cookware for induction and recommendations.....	73
3.2	Glass Frame	15	5.12	Checking the replacement part is correct	76
3.3	Fan	16	5.13	Stains on glass surface or the inductors	81
3.4	NTC	17	5.14	What is to be considered when using induction cookware	84
3.5	Inductors.....	20			
3.6	Module of relays for 32 cm inductor	26			
3.7	Cooking sensor	27			
3.8	Frying Sensor	30			
3.9	Supply wire with flexible conduit	33			
3.10	Connections	34			
4	FAULT DIAGNOSTICS.....	38			
4.1	Mistakes and Service-Program.....	39			
5	CHECK AND INSTALLATION	40			
5.1	NTC sensor checks.....	41			
5.2	Fan checks	43			

1 INTRODUCTION

1.1 Purpose of the document

The repair manual provides support for the official technician to help diagnose faults and repair the electrical appliances.

Apart from the repair manual, the technician may also use the following documents:

- Blow-up diagram of parts of the appliance.
- Diagrams
- List of parts
- Associated technical reports on specific occasions



The diagnosis of faults plus their repair should only be carried out by an officially authorised technician.

1.2 Pictograms



Warning!



Components sensitive to electrostatic shock:
Respect EGB reference



Sharp edges:
Use protective gloves!



Information or advice



Electrical hazard!

2.1 Safety warnings



Electrical hazard!

Repairs should only be carried out by the manufacturer's technical staff.

Inadequate repairs can harm the users.

The sheath and framework may be subjected to voltage in case of failure.

The appliance should be disconnected from the mains before dismantling. It contains parts inside that are subjected to high voltage.



Electrical hazard!

Touching the terminals of power cord immediately after mains disconnection could produce a small electric shock, this is caused by the charged capacitors from the EMC filter included in all induction boards (ELIN).

The capacitors need time for discharging over the electronic load into the board, that time depends on the hob variant and it is between 2 and 3 seconds. That means, the voltage in the terminals will be less than 34V (This voltage is considered not dangerous according to EN60335) after 3 seconds and then there is not risk.

If one module was defected (ELIN), we could have two condensators more and the time would be 8-9 sg.

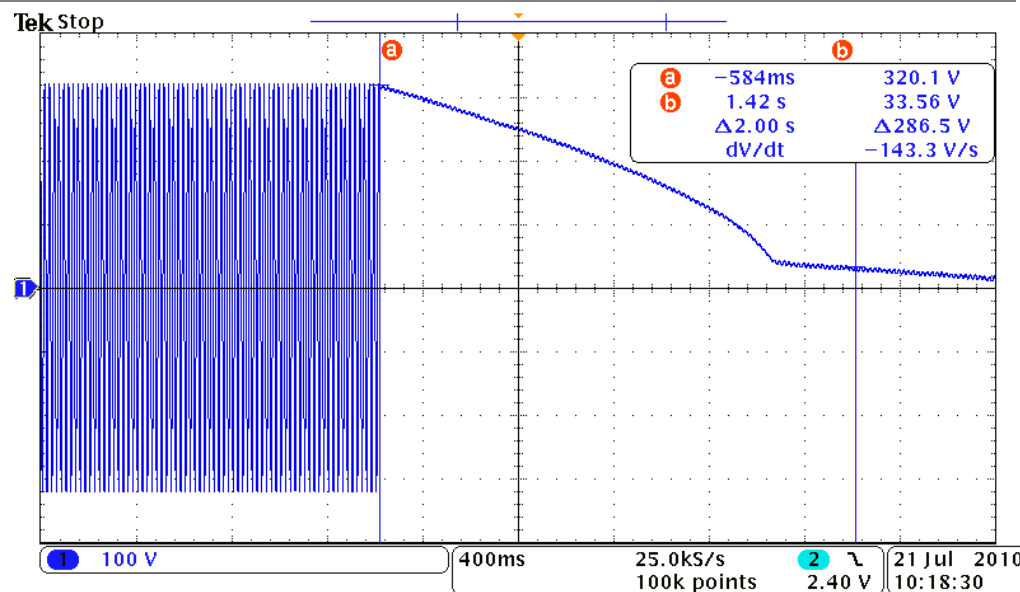

Always use a current-breaker switch if it is necessary to conduct low-voltage tests.

The earth connection should not exceed standardised values. This is of the utmost importance for people's safety and normal working conditions of the appliance.

Once the appliance has been repaired, it should be subjected to tests VDE 0701 or the specific regulations that are in force in the country concerned.

These appliances have been tested in accordance with ANSI/UL 858 Standard for Safety for Household Electric Ranges and CAN /CSA-22.2 No.61 National Standard of Canada for Household cooking ranges. It is the responsibility of the owner and installer to determine if additional requirements and standards apply in specific installations.

The replacement of the power cable can only be carried out by authorised technical staff, using the replacement cable.

Special warnings for induction hobs!



Induction hobs comply with the safety and electromagnetic compatibility regulations currently in force (EN50366). People with fitted pacemakers should abstain from using or repairing such an appliance. The operation of the appliance may interfere with the operation of the pacemaker.

People with hearing aids may experience discomfort.

2.2 Repair warnings



Warning!

Never attempt to carry out repairs involving the indiscriminate exchange of component parts.

Proceed in a systematic way, with reference to the technical specifications supplied with the appliance.

The electronic plates should not be repaired, but replaced with original spare parts. Exceptions are indicated in separate documents.



Components sensitive to electrostatic shock:

Respect EGB reference



Sharp edges:

Use protective gloves!

2.3 EGB

2.3.1 Concept

EGB = “Elektrostatisch Gefährdete Bauelemente“ (Electrostatic-Sensitive Devices)
(Component sensitive to electrostatic shock)

2.3.2 Pictogram



Electronic devices with components that are sensitive to electrostatic shock (EGB in German) are marked with the pictogram shown here.

2.3.3 General specifications

The use of cutting-edge electronic technology in current electrical appliances guarantees high levels of profitability, protection of the environment, easy handling, operability and safety. Such high-performance technology can only be handled by qualified technicians with specialised knowledge.

All electronic modules and constructive units incorporate elements with a potentially dangerous electrostatic voltage.

2.3.4 Dangerous components

Amongst others, these constructive elements are threatened by electrostatic voltage:

- ▶ μ Processors

- ▶ ICs
- ▶ Transistors
- ▶ Tiristors
- ▶ Triacs
- ▶ Diodes
- ▶ etc.

2.3.5 Causes and effect

The human body can generate electrostatic charges in certain environmental situations. This charge is favoured by dry air and the coating on insulated floors.

People can transfer an electrostatic voltage:

- ▶ of up to 35,000 volts when standing on a non-conductive carpet.
- ▶ of up to 12,000 volts when standing on a non-conductive PVC floor.
- ▶ of up to 1.800 volts when sitting in a padded chair.

The electrostatic voltage in the human body is transferred to electronic devices and components that are sensitive to electrostatic shock by touching them, sometimes resulting in damage depending on the circumstances.

2.3.6 Indications for components sensitive to electrostatic shock

In all electronic modules and constructive units there are components that are sensitive to electrostatic shock.

In order to protect such components, the following steps should be taken:

1. Read the corresponding label for the modules and constructive units with care.
2. Before touching and measuring any components that are sensitive to electrostatic shock, apply an electrostatic protection system (wristband with earth block).
3. Avoid touching these components with electrostatically-sensitive plastics (plastic sheeting, etc.).
4. Constructive units, modules and plate should be picked up as far as possible without touching the printed circuit boards and connections.
5. Components that are sensitive to electrostatic shock should not be located close to monitors or televisions.
6. For transport purposes, only conductive materials or the original packing should be used.

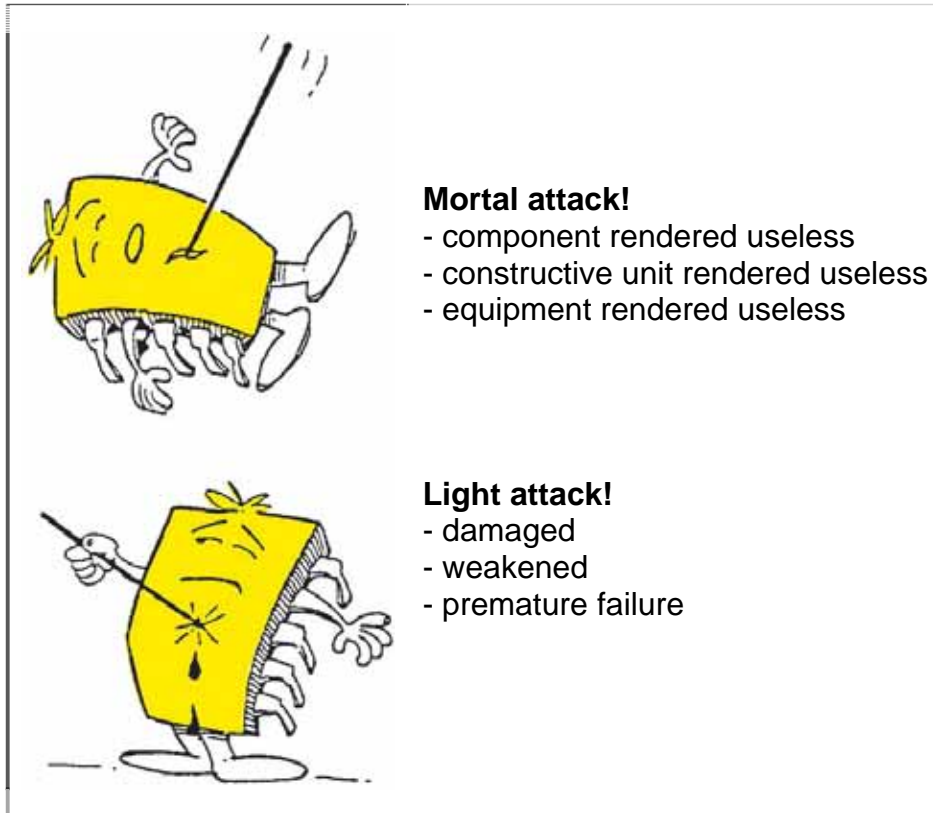

2.3.7 Electrostatic protection system

There are several different electrostatic protection systems.

These electrostatic protection systems act to prevent the electrostatic shock from affecting the human body or by shunting the existing electrostatic voltage to earth.

In the electrostatic protection system used at the after-sales customer service, the electrostatic voltage in the body is transferred by means of a wristband and earth block.



For safety reasons, this is not carried out directly but using a combination of elements

The connection with the earthwire conductor or protective conductor should be in perfect condition

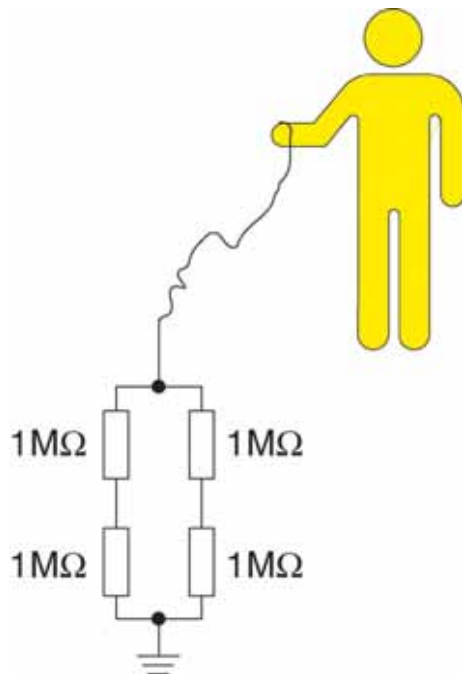

Combination of elements with wristband

3 COMPONENTS AND FUNCTION

3.1 Electronic Induction (ELIN)

There are two types of elin (electronic induction).

- One with its own power supply (“left or main elin”)
- Another one without its own power supply (“right or secondary elin”), which is powered by the main elin.

They are attached to the elin bracket with clips, plus a couple of screws.

They communicate with the TouchControl through the LIN connector.

The TouchControl sends power level orders for each burner and the elin returns the state of the burner (pan recognition, error detection, etc.)

Depending on the type of model there are:

Domino	1 main elin
2l 60 cm	1 main elin
4l 60cm	1 main elin / 1 secondary elin
4l 70 cm	1 main elin / 1 secondary elin
4l 80cm	1 main elin / 1 secondary elin
3l	1 main elin / 1 secondary elin
5l 90cm	2 main elin / 1 secondary elin

3.1.1 ELIN with own power supply (“left Elin”)

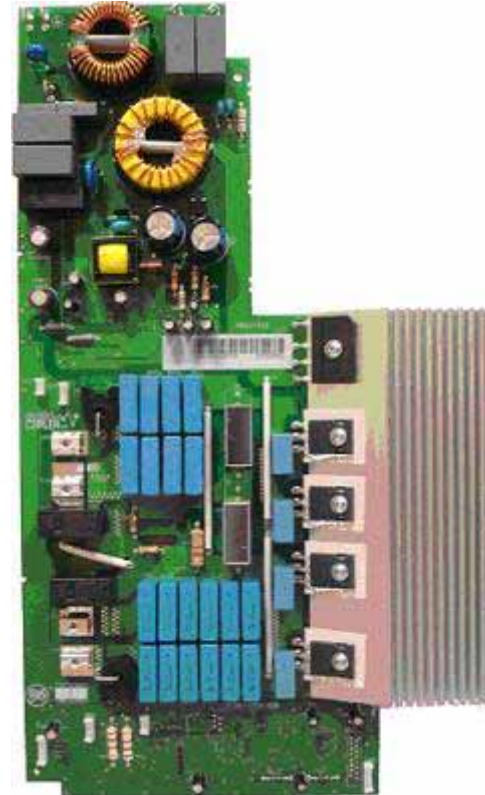

3.1.1.1 Components of Elin with own power supply

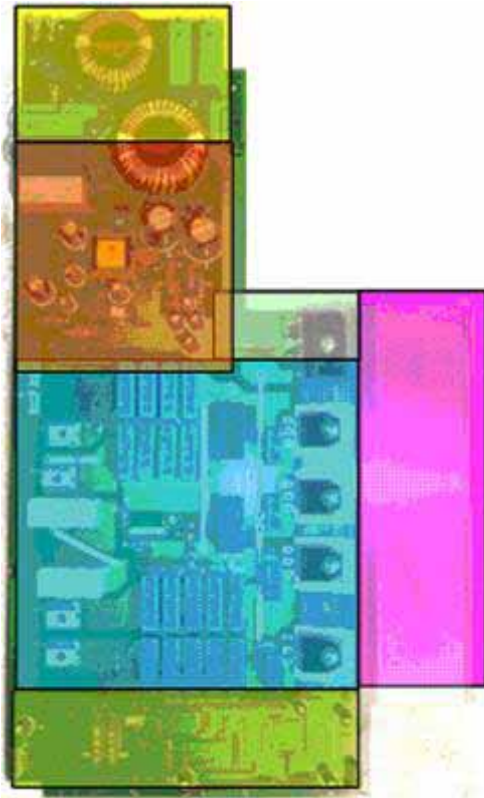

- 1- Interference filter (yellow)
- 2- Power supply (red)
- 3- Rectifier (light green)
- 4- Power inverter (blue)
- 5- Control (green)
- 6- Cooling element (pink)

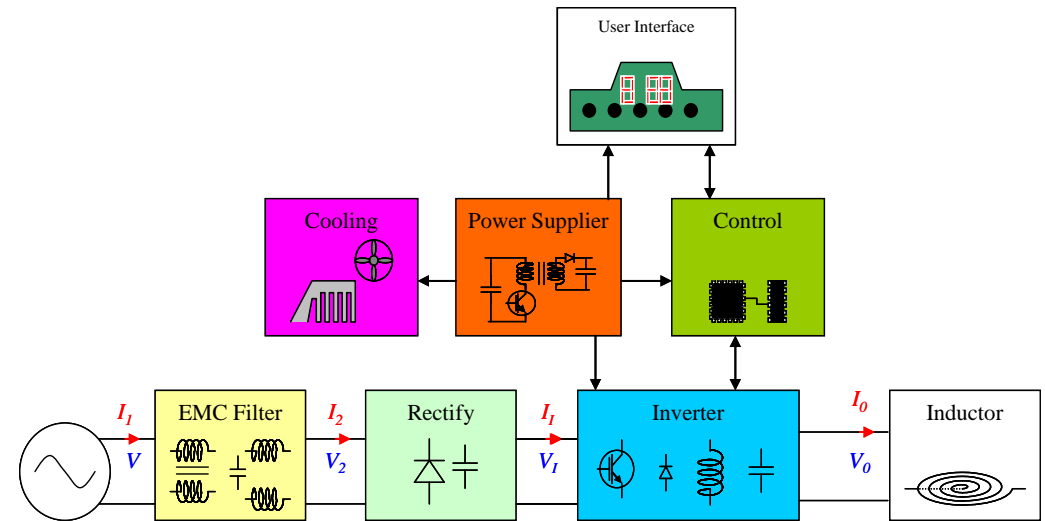

3.1.2 ELIN without own power supply (“right ELIN”)

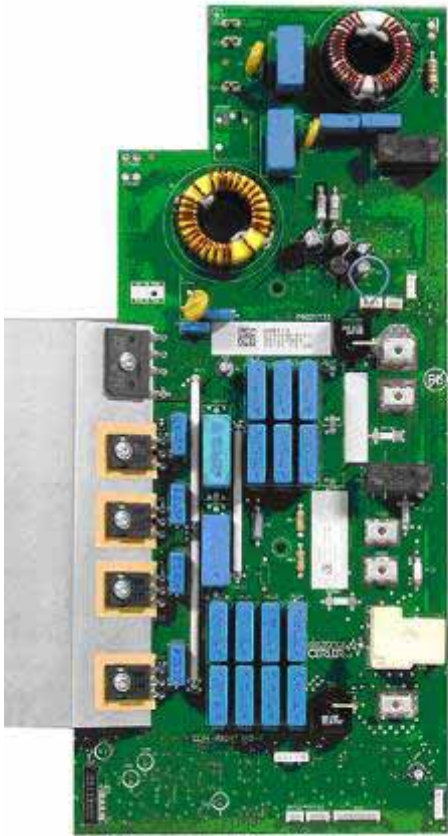

3.1.2.1 Components of elin without own power supply

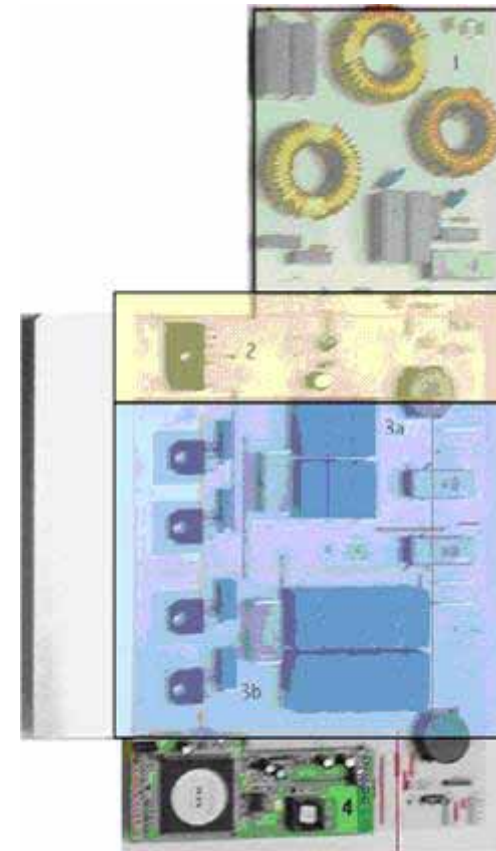

- 1- Interference filter (light green)
- 2- Rectifier (light yellow)
- 3- Power inverter (blue)
- 4- Control (green, bottom part)
- 5- Cooling element (left grey)

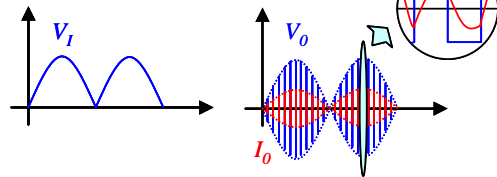
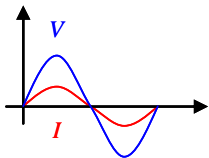
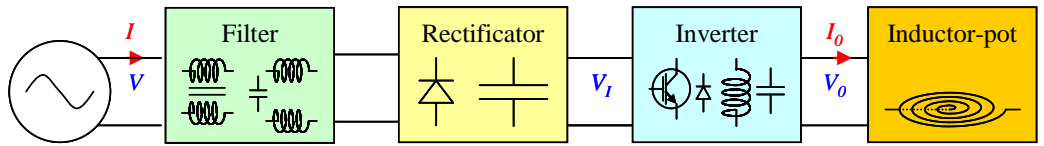

25-75 kHz

3.1.3 ELIN functions

3.1.3.1 Power supply

Elins with their own power supply power the various components of the induction hob (fan, touchControl, elin without its own power supply, etc...)

3.1.3.2 Regulation

The elin regulates the power of the inductors by means of the IGBTs (insulated-gate bipolar transistors) and coordinates the signals given by the user through the control panel with the various induction zones.

3.1.3.3 Communication

- The elin returns the state of the burner.
For example, if the pan is not detected, the power selected starts flashing (See pan recognition)
- It indicates the warnings and errors sent by the elin (See errors and warnings)
- It communicates with the touchControl by means of the 4-cable LIn connector.

3.2 Glass Frame

3.2.1 Characteristics

The inner framework of the glass frame units consists of 4 frames stuck together.

This design improves the tension that might be created.



Besides, it is blued an internal frame of steel above the glass, which is the base.



3.3 Fan

3.3.1 Characteristics and assembly

The fan used operates on direct current (without dynamo brushes) and contains electronic components.

It is connected to the ELIN plate by means of a 3-wire connection with some of the ends soldered to the fan's circuit board

+24V

GND = earth

TACHO = tachograph

It is attached by means of clips (dominos and 2l). In other models it is attached to a bracket, which is screwed into place.



1.1.2 Function

To cool the electronic components.



Warning!

Between the content of the housing and the entrance of the fan there should be a gap of at least 2 cm.

Do not keep small objects and papers in the box, since these could be absorbed by the fan and reduce the cooling effect, or damage the fan.

3.4 NTC

3.4.1 Types

There are two types of NTCs.

- NTCs for the inductors.
- NTCs for the electronic module (ELIN)

3.4.2 Characteristics and assembly

3.4.2.1 NTCs for the inductors

In both IH4-I (previous project) and IH5-I (current project) the NTCs measure the temperature directly on top of the glass.

The difference lies in the way the NTC is mounted in the inductor and the fact that they have polarity (i.e. 3 channels for the frying function NTC).

For mounting purposes, a silicon support bracket is used instead of a metal spring. This reduces the time taken to assemble the component.

The external NTC has a 3-wire connector and controls the frying sensor function.

They are both interchangeable and have a different code number (internal 2-wire NTC connector and external 3-wire NTC connector) and can be supplied as spare parts.

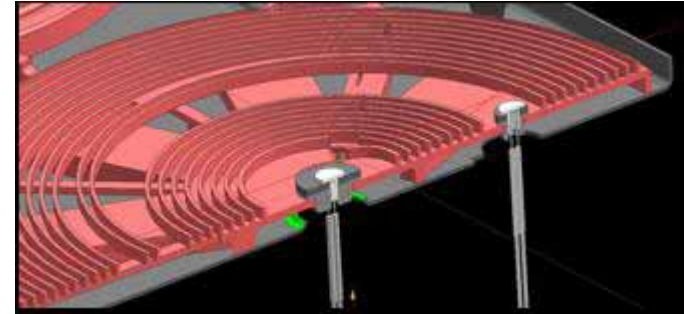
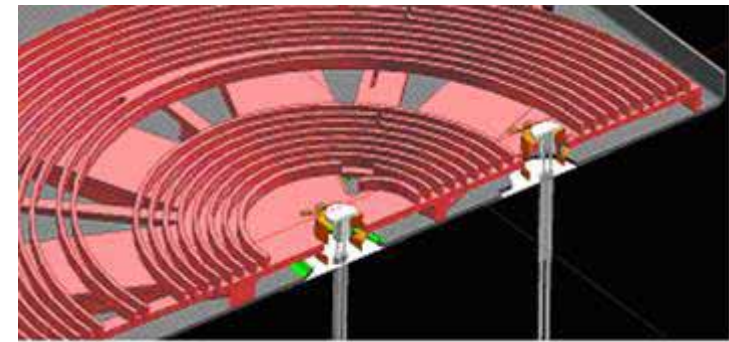

Photo of NTC and cross section of new IH5-I project

IH4-I



1.1.2.2 NTCs for induction module

These are two NTCs located behind the induction module, next to the bolts. They are not interchangeable.

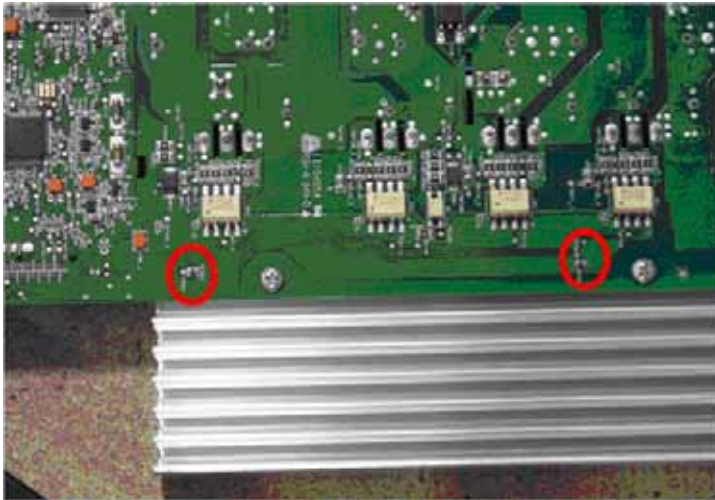

1.1.2 Function of inductor NTCs

These measure the operating temperature for the inductors. If the temperature limits are exceeded, the power supply is cut off, with a warning being sent to the TouchControl panel. Once the NTCs have cooled down again, the power supply is renewed.

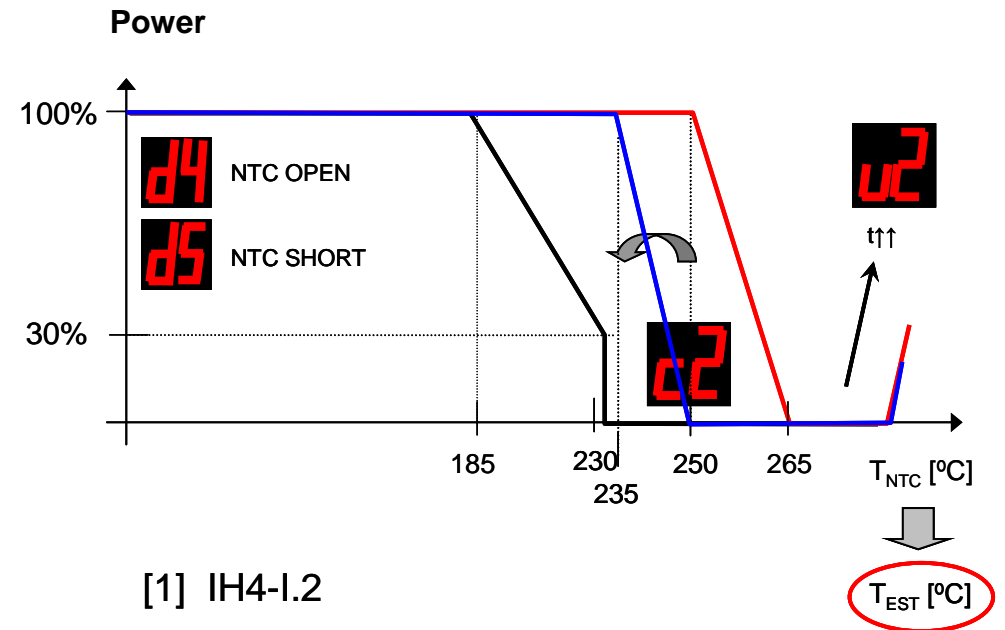

[1] IH4-I.2

[2] IH5-I

[3] IH5-I critical modules

3.4.3 Function of NTCs for electronic module

These measure the temperature of the IGBTs (insulated-gate bipolar transistor, the element that supplies power to the electronic module) and cut off the power supply if they reach the maximum temperature.

IH4-I.2

IH5-I

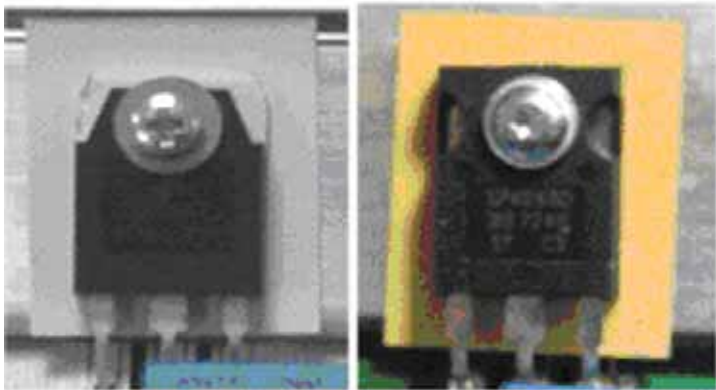

IGBTs.

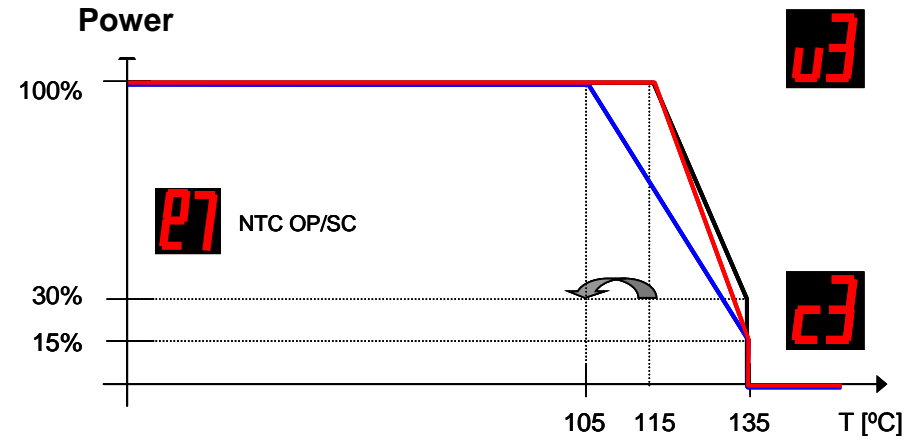











[1] IH4-I.2

[2] IH5-I

[3] IH5-I critical modules

3.5 Inductors

3.5.1 Characteristics, types and assembly

Type	name
 145 mm	
 180 mm	
 180 mm	Bräter
 180x280 mm	
 210 mm	
 180 mm	28cm double
 280 mm	
 280 mm	
 210 mm	Triple 32 cm
 260 mm	(NEW for IH5-l)
 320 mm	

The 145,180 and 210 mm inductors have been changed, to include the function of frying and to improve the efficiency, heat distribution and recipient detection. (Before, there was only frying in the 210mm inductor).

In the **frying models**, the 180 and 210 inductors have a second NTC (3-way connector). In the case of the 145mm inductor it is necessary to insert into the ELIN a short-circuited 3-way connector (a type of jumper with its own code).



Warning!

When changing the part of the ELIN of the 145mm inductor with frying function, the jumper of the original part should be taken and installed in the new ELIN.

If we do not install the jumper, the frying will not operate.

Does not come with spare.



Mount upon the inductor assembly.

In case of damage, the complete assembly must be replaced.

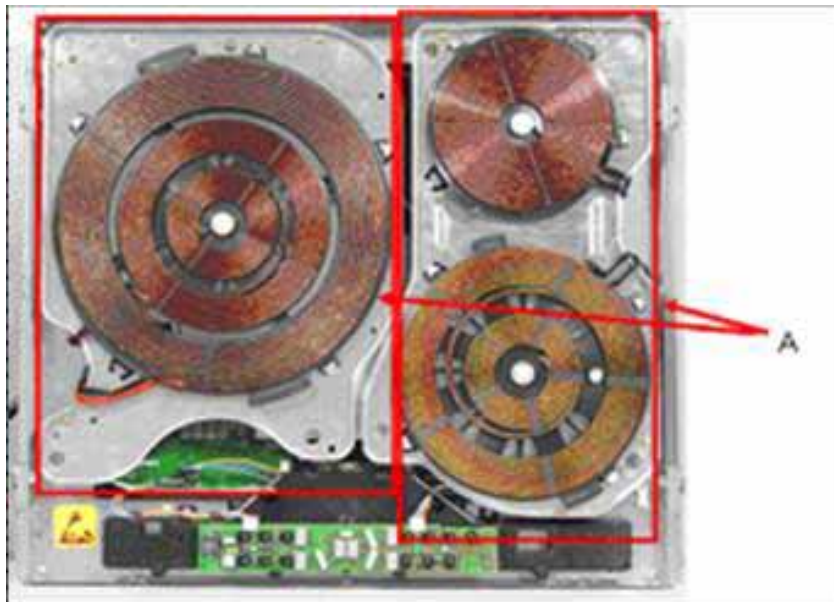

A- Inductor assembly

1.1.2 32 cm triple inductor (New feature IH5-I)

Made up of 3 rings: internal, middle and external.

Internal ring = 210mm

Middle ring = 260mm

External ring= 320mm

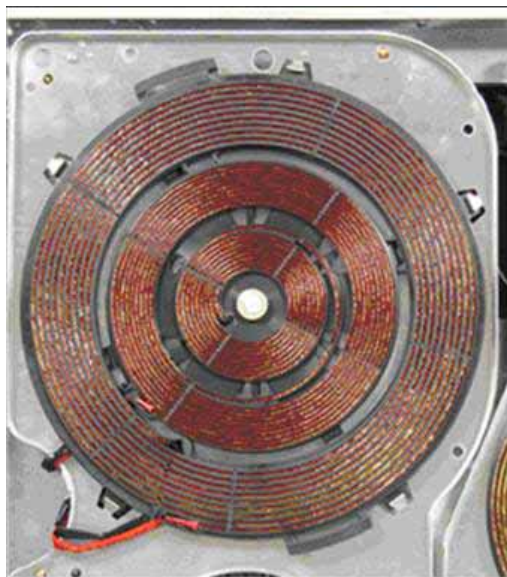

3.5.1.1 Power table in Watts.

Power/diameter	210 mm	260 mm	320 mm
P Standard	2200	2600	3300
P booster	3300	3400	3600
P Superbooster	-	-	4600

In order to activate the superbooster of the triple inductor, an auxiliary plate is needed. See relay plate.

The superbooster can only be activated on the external ring.

3.5.2 28 cm Double Inductor

The auxiliary plate of the double inductor in order to activate the superbooster has been integrated into the ELIN, simplifying the connection diagram.

3.5.2.1 Power table in Watts

Power/diameter	180 mm	280 mm
P Standard	1800	2800
P booster	2500	3000
P Superbooster	-	4400

3.5.3 Bräter Inductor

The auxiliary plate of the Bräter inductor in order to activate the booster has been integrated into the ELIN, simplifying the connection diagram.

The Bräter zone warms first the zone extension and later the small ring. If the customer uses a too big Bräter, the cooking is not good.

It is important to use a Bräter of correct measure and to position it correctly in the cooking zone. (Accessory: Z9410X0 = 464746)

3.5.3.1 Power table in Watts

Power/diameter	180 mm	280 mm
P Standard	1800	2000
P booster	2500	2600
P Superbooster	-	-

3.5.3 Double, triple or Bräter cooking zones

These zones can recognize recipients of different sizes. Depending on the material and the properties of the recipient, the zone will adapt automatically; either only the simple zone or its entirety and supplying the adequate power to obtain good cooking results. There is no light indicator indicating how many rings are active. Even if the external ring is not active, the internal ring can supply more power than if the external one were active.



Warning!

The double, triple and Bräter (multiples) inductors have **polarity**, that is, the connection of its elements cannot be inverted. If this is not taken into account, the detection of the recipient could fail and if the ring were activated or the auxiliary element the correct power will not be supplied. For this reason, the cables of the inductor are of a different colour.

3.5.4 Booster in multiple inductors

The booster is always possible. A b appears on the display, but the power depends on the elements which are active.

The detection of the number of active rings is not indicated with any light signal.

The superbooster can only be activated in the external ring.

For example:

4.6 kW inductors on the right disconnected and external ring active

3.6 kW a right inductor connected and external ring active

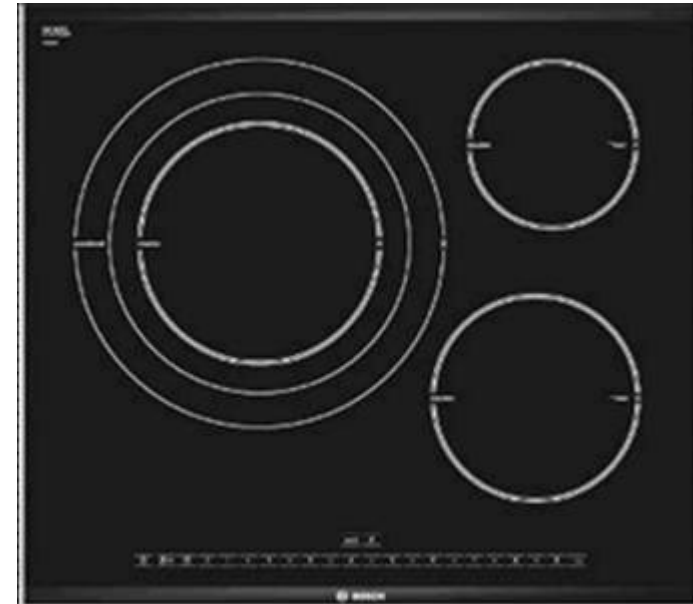

3.5.5 Booster in Bräter

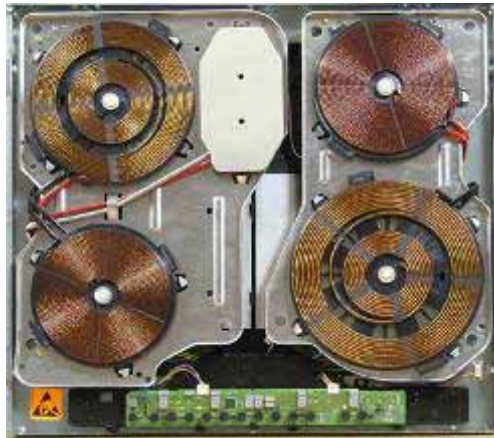

For IH5-I the Bräter has a booster power of 2.6 kW (2 kW of nameplate power) when the left front inductor is turned off.

For IH4-I (Ind IV) there was no booster and the nameplate power was of 2.6 kw.

The detection of the Bräter is not indicated on the touchControl.

3.5.6 Powers table level 9, booster and superbooster

		Level 9	PowerBoost	SuperBoost
145 mm	1.400 W	1.800 W (+28%)		New
180 mm	1.800 W	2.500 W (+38%)		New
180 mm	1.800 W	2.500 W (+38%)		
180x280 mm	2.000 W	2.600 W (+30%)		
210 mm	2.200 W	3.300 W (+50%)		New
180 mm	1.800 W	2.500 W (+38%)		
280 mm	2.800 W	From 3.600 W (+21%)	to 4.400 W (+57%)	
280 mm	2.400 W	3.600 W (+50%)		
210 mm	2.200 W	3.300 W (+50%)		
260 mm	2.600 W	3.400 W (+11%)		New
320 mm	3.300 W	From 3.600 W (+9%)	to 4.600 W (+28%)	

3.5.7 Layout changes : Bräter 80cm without cooking sensor

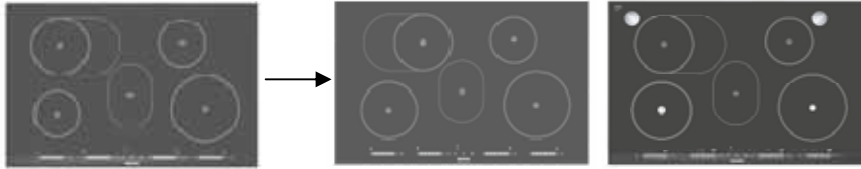

La única diferencia en esta modificación radica en el esquema de conexionado. Y en que el inductor inferior ha pasado de 150 mm a 180mm.

The only difference in this modification is on the electrical diagram. And besides the small inductor on the left has been also modified from 150 mm to 180mm.

PIB885N24E	→	PIC885N24E
PIB801N24E		PIC801N24E
NIB875T14E	→	NIC875T14E
PIB875N24E	→	PIC875N24E
PIB875T14E		PIC875T14E

3.5.7.1 Siemens hobs

EH845EB11	→	EH845EC11
EH845EB11E	→	EH845EC11E
EH845EB15E	→	EH845EC15E
EH885DB11E	→	EH885DC11E
EH885DB12E	→	EH885DC12E
EH885MB11E	→	EH885MC11E
EH885MB21E	→	EH885MC21E
EH801SB11	→	EH801SC11
EH801TB11	→	EH801TC11
EH875SB11E	→	EH875SC11E
EH875SB31E	→	EH875SC31E
EH879SB11	→	EH879SC11
EI875TB11E	→	EI875TC11E

3.6 Module of relays for 32 cm inductor

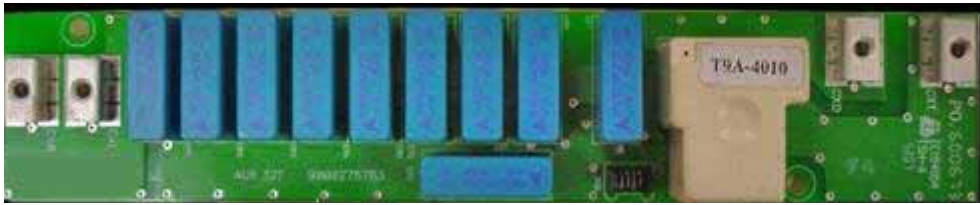

All the induction models which have this 32 cm inductor have this additional module. It is fastened to the plastic base by two screws.

3.6.1 Function

The function of this module is the activation of the most external ring of the 32 cm inductor.

See 32 cm inductor.

3.6.2 Location

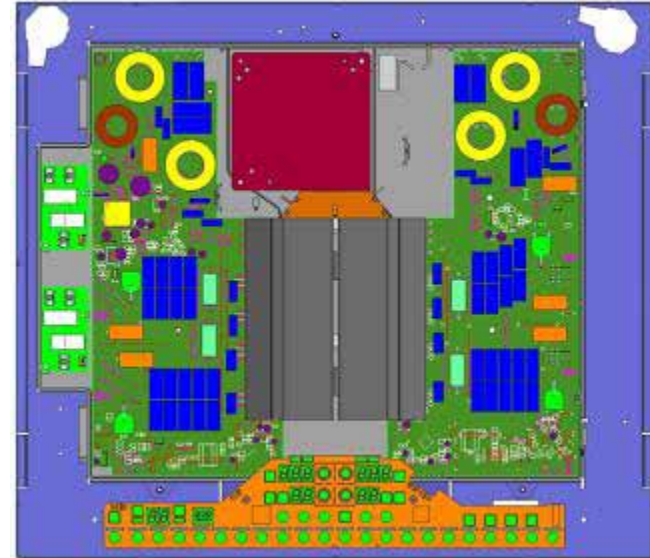
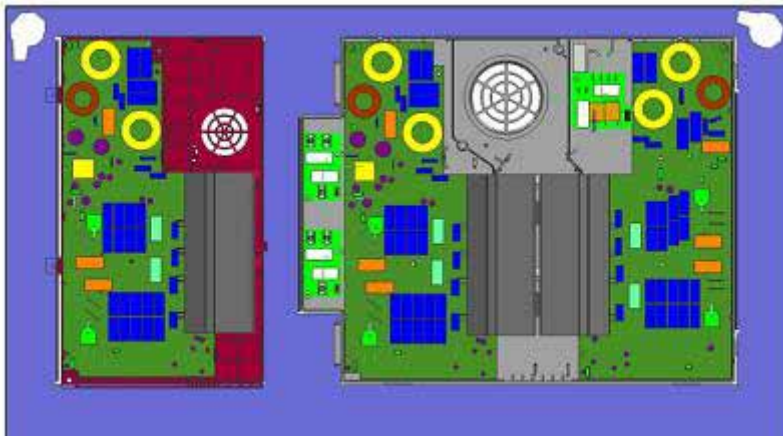

3.7 Cooking sensor

This function is only found in 150 mm or 180 mm rear with turrets which measure the infrared rays emitted by the recipient.

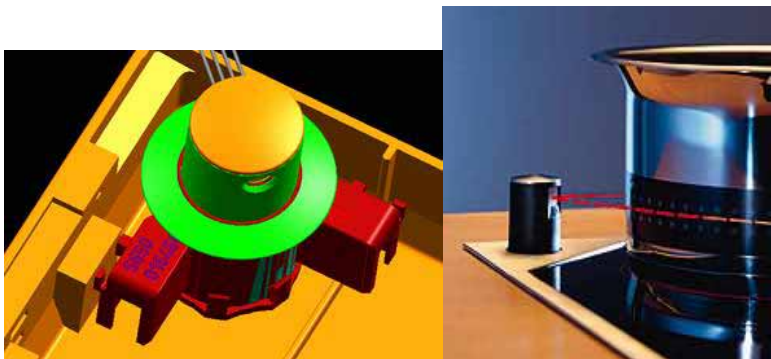

The turrets are located on the rear ends. There is a recess in the metal plate to put the turrets into.

On the lower part, the covers can be seen, fastened with two screws.

To dismantle it, we must release the lower cover, take off the glass and take it out from underneath.



3.7.1 Components

3.7.1.1 Infrared turrets



The turret comes as a single component. The external ring is red in colour (except in the trademark thermador, which is blue).

This infrared sensor measures the temperature of the recipient.

If the red light does not work the complete component must be changed.

Check the connections first.

To activate this function the turret must be taken out manually.

3.7.1.2 Stickers



If the sticker is not put in place, the liquid inside the recipient can overflow.

Steps to put the sticker in place:

- On the card with the drawing of the recipient, there is a cutout part which must be removed.
- Support the sticker from the base of the recipient and with a pencil we mark a line on the recipient on the cutout part of the sticker.
- Remove the sticker and stick it from the marked line upwards.

3.7.1.3 Appropriate recipients for this function



On curved recipients the sticker does not stick well (bubbles remain). This function is indicated for straight recipients.



Moreover, for the temperature of the recipient to be measured properly, the liquid inside must be above the level of the sticker, as otherwise, the temperature measured is not real and the liquid could overflow.

3.7.2 Operating principle

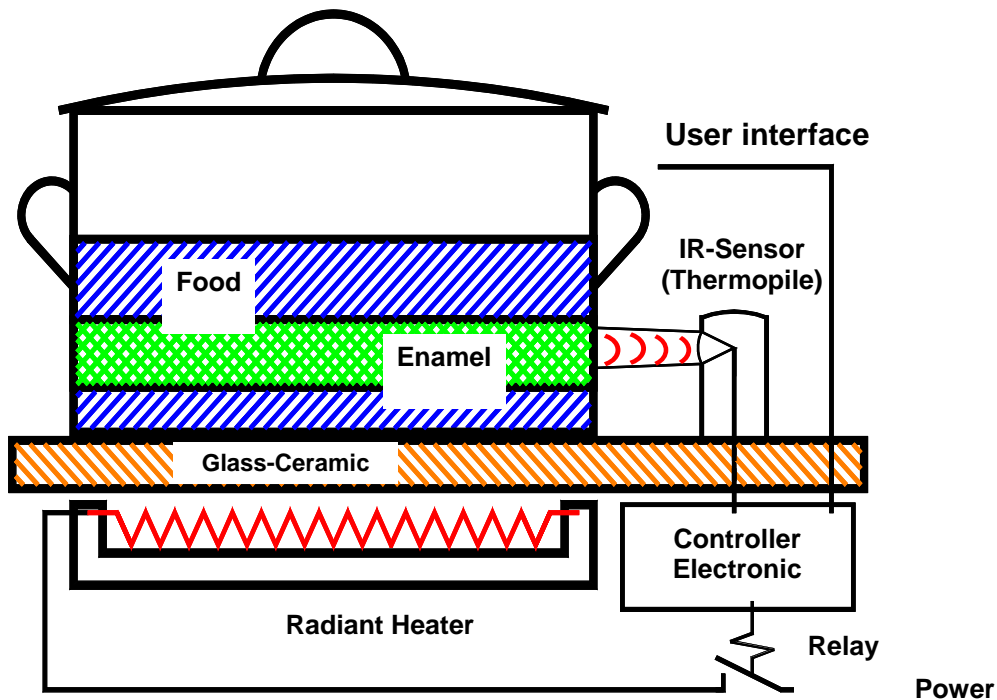

(although they are “black” bodies for the infrared light) to change the properties of the material.

Black-coloured recipients and recipients with enamel have good emission. But other materials, such as stainless steel, need the sticker oriented toward the turret for the system to function.

3.7.2.1 Temperature levels

There are 5 temperature levels for cooking all dishes with the cooking-sensor:

- 70 ° C
- 90 ° C
- 100 ° C
- 120 ° C
- 170 ° C

Moreover, there are 9 automatic programmes, where we choose what we wish to make and begin to cook.

There is a turret which constantly measures the temperature in the recipient through a system of infrared rays. This turret supplies this information to the control unit, which regulates the power depending on this information and then the recipient heats to a specific temperature.

The cooking-sensor system works with infrared sensors, for which a recipient with good emission is needed.

In some cases the material of the recipient is not a good transmitter of heat; thus, it is necessary to stick some stickers which are transparent

3.8 Frying Sensor

In the previous project, only the 210 mm inductor had this function. Now, this function is available in the following inductors:

- **145 mm**, although with only one NTC. To activate the frying function, a jumper (“bridge”) is needed connected to the ELIN on the 3-way connector. See inductors.
- **180 mm**, with two NTCs with polarity. The external NTC is the one which controls the frying function and has a 3-way connector, although with two wires. And the internal one has a 2-way connector.
- **210 mm**, with two NTCs with polarity.

In order to guarantee correct operation, the recommended accessory is needed; it is not included with the device. See items for induction and recommendations.

In case the recommended pans are not used, safety is guaranteed (maximum temperature reached 250 °C), but it is possible that:

- Times until reaching the desired temperature may increase.
- Overheating may occur in the pan and the food may burn.
- The heat may be lower than that programmed and the result of the cooking may not be ideal.

3.8.1 Components

3.8.1.1 2 NTCs, except the 145 mm inductor

In this case, the inductors on the right are the ones which have the frying sensor function.

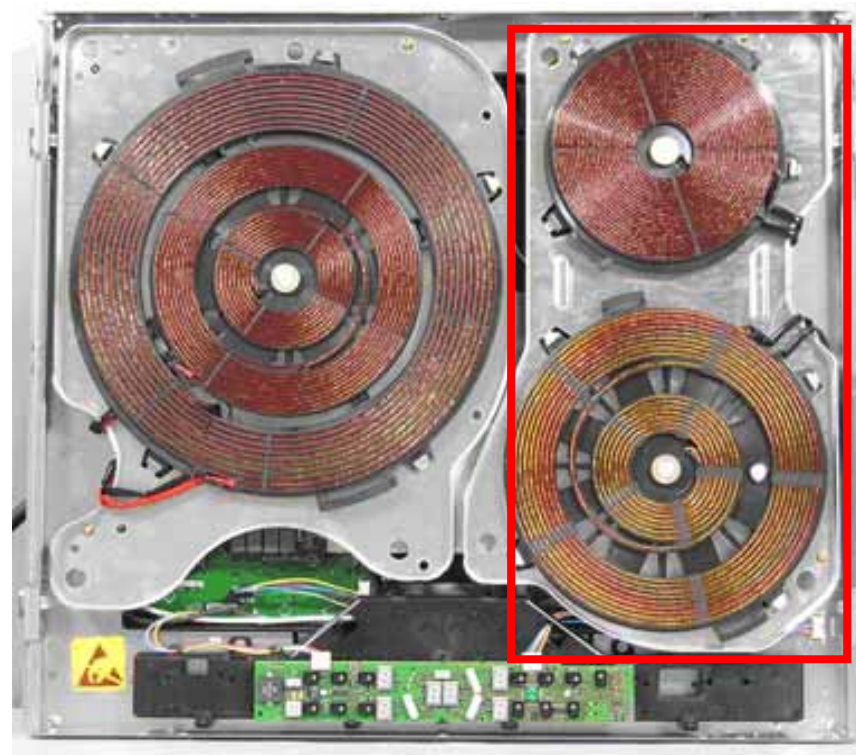

There are two temperature sensors for a more precise control.

3.8.2 Diagram of operation

3.8.1.2 The ELIN has two connectors for NTCs

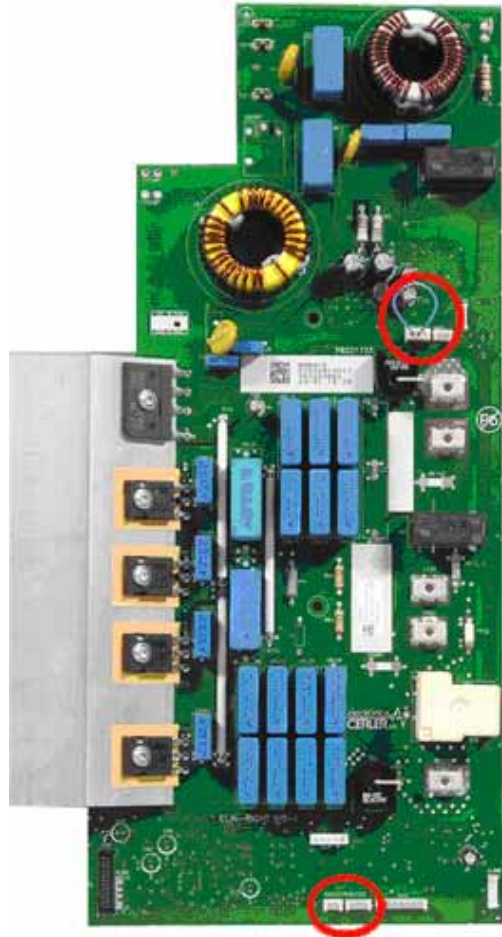

We have two connectors for the NTCs, a two-way one, for the central NTC and another 3-way one, which activates the frying function and which is the most external NTC. Marked with a red circle.

The frying sensor keeps the temperature of the recipient constant.

A sensor (external NTC) in the inductor constantly measures the temperature of the recipient. This sensor gives the information to the control unit (located in the ELIN), which regulates the power depending on this information and then the recipient heats to a specific temperature and does not ever exceed 250 °C (even if not using the recommended recipient).

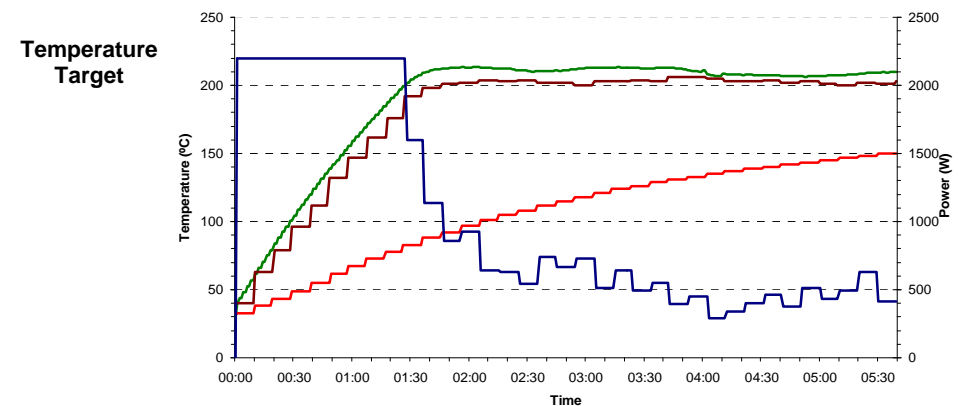
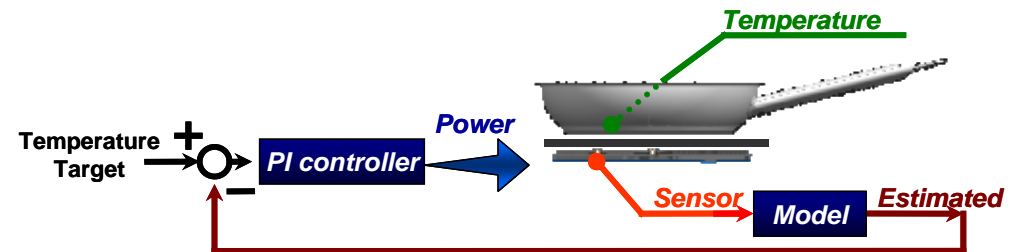

Heating times until reaching the desired temperature vary according to the value selected (4 possible levels: min, low, medium and

maximum). Once the desired temperature is reached, an acoustic signal sounds.

Moreover, up to nine programmes can be selected, which choose one of the 4 possible levels.

When the frying sensor function is active there appears an “A” on the display.

3.9 Supply wire with flexible conduit

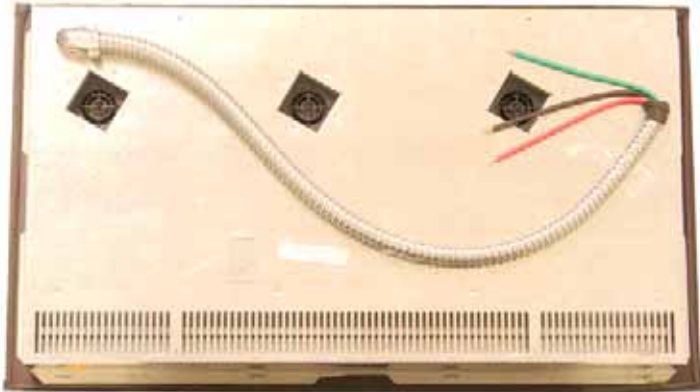

The supply wire comes with a flexible conduit., which is fixed to the hob base with 2 screws.

The supply wire consists of 3 different color wires, Red, green and black and it has a length of 1,5 m.=59,05 “

The way to connect this, it is explained in the assembly instructions and in the next chapter.



3.10 Connections

3.10.1 Supply connection

black (L1) to black
red (L2) to red
green wire to ground

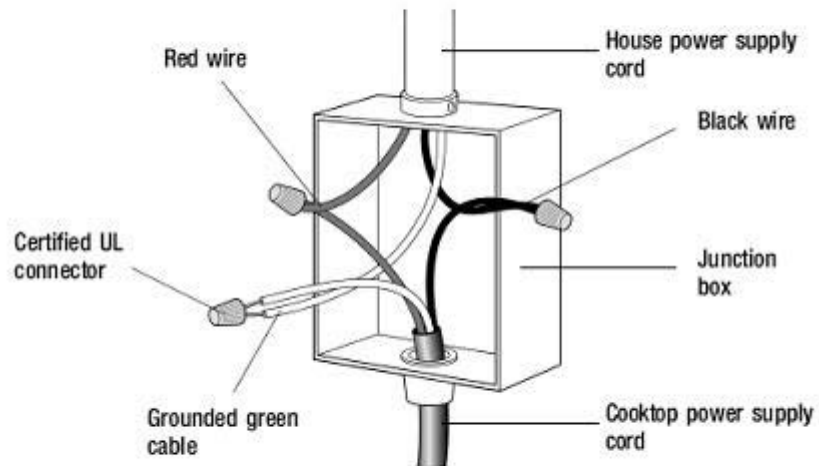

If the cooktop is installed and connected as specified above, it will be completely grounded in compliance with the National Electrical Code.

3.10.2 Touch Control feed connection

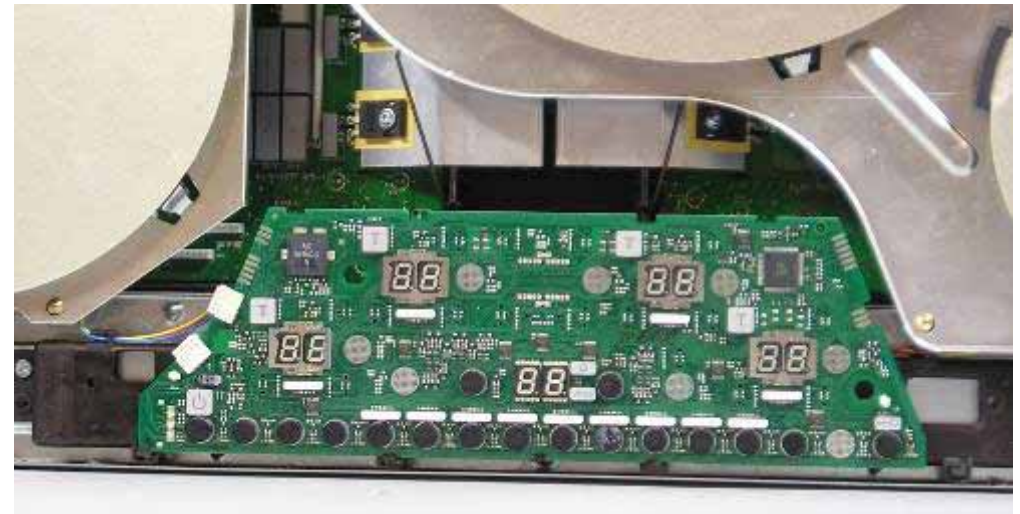

The 4-wire connector between the ELIN and Touch Control is the one which feeds Touch Control.

3.10.3 Jumper connector for 15 cm frying sensor

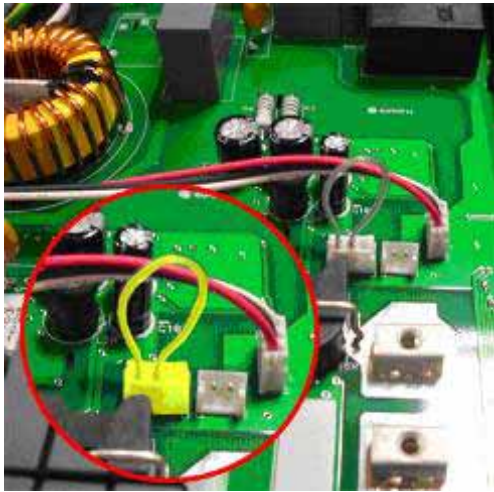

In order for the frying sensor function of this 15 cm inductor to work it is necessary to connect this jumper; if not, the frying sensor function is not activated.

For the rest of the inductors with frying it is not necessary, because we connect the 3-way NTC, which controls the frying and activates the function.

3.10.4 Connection of the Cooking Sensor

The outer part must be positioned to prevent excessive overheating.

Example of bad positioning

Example of good positioning

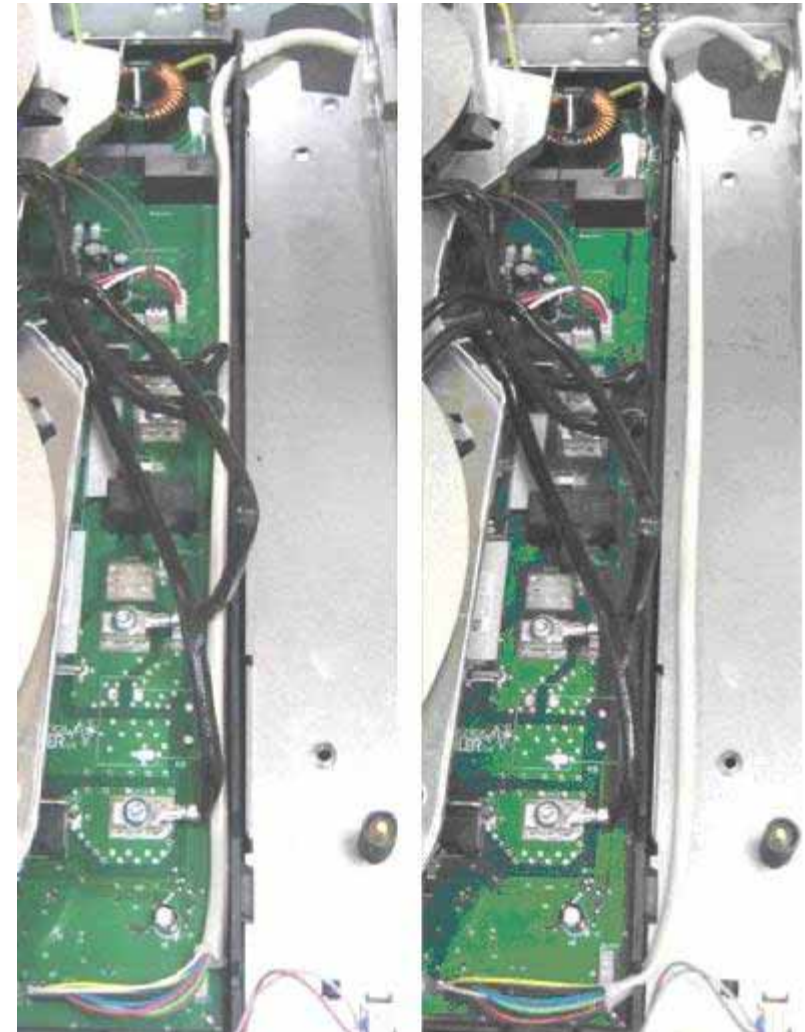

3.10.4.1 90 cm (2 fans)

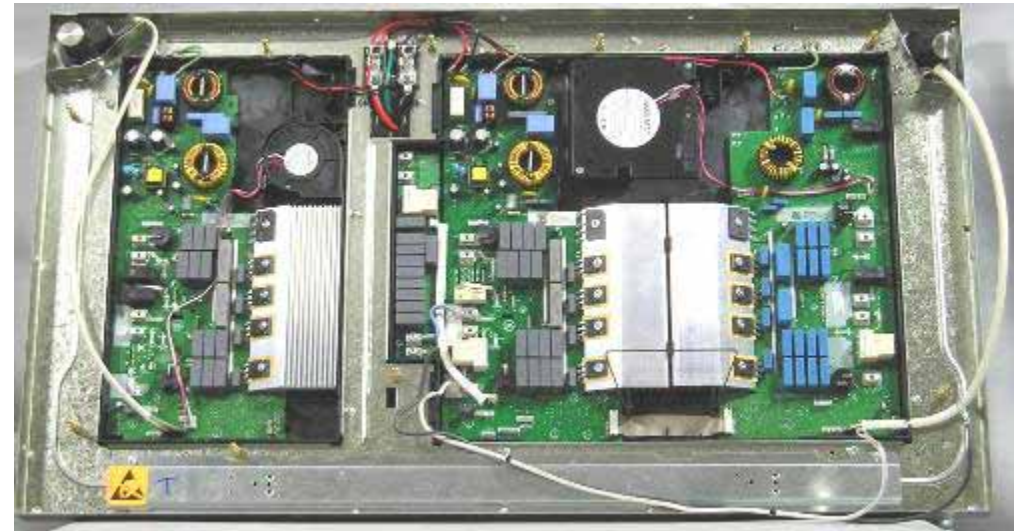

3.10.5 Connection between ELINS

3.10.5.1 5l: 16-way connector

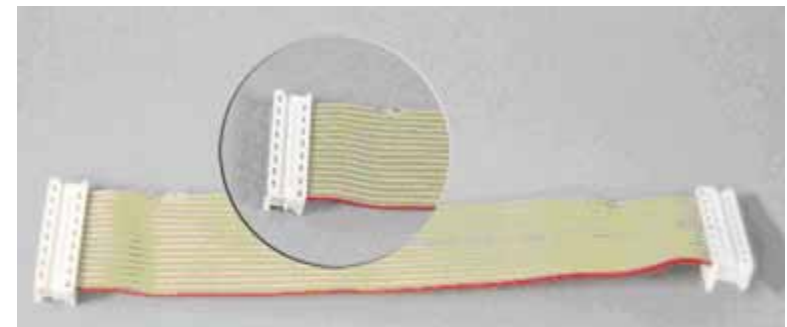

This is a 16-way connector.
Care should be taken upon dismounting it, as it could be damaged.

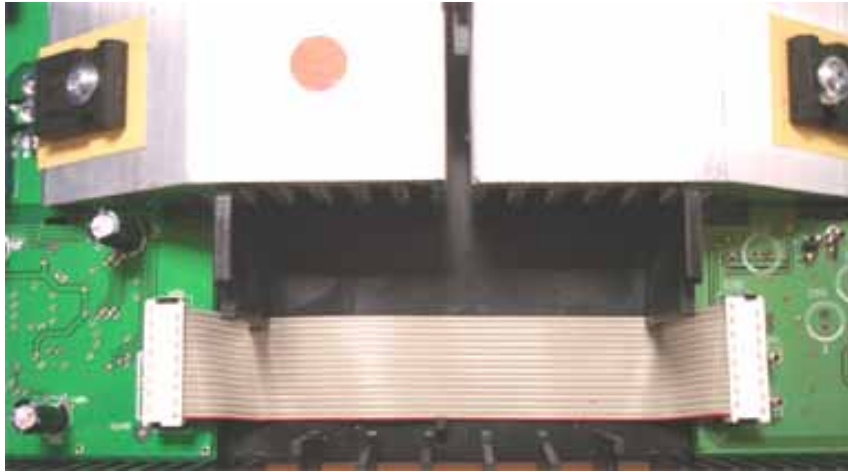

In case of bad connection, check the connector pins; they may be slightly bent.

3.10.6 Superbooster Connection

This is the lower white connector.

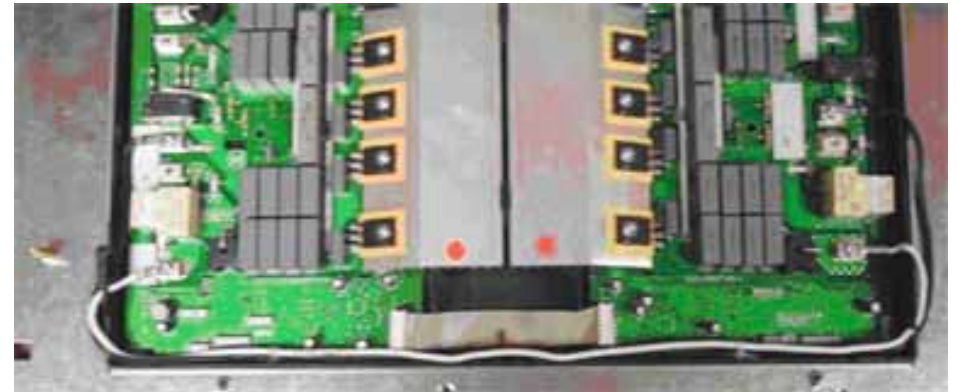

3.10.5.2 Other models: 8-way connector



4 FAULT DIAGNOSTICS

4.1 Mistakes and Service-Program

Mistake codes and service programs are described in own document.

You can find the documents als electric diagram (ASP) in Quickfinder.

Contents are for example

- Mistakes Codes and warnings
- Service-Program
 - Demo mode
 - Basic settings access /exit
 - Service- program access / exit
- Service-Program functions
 - Basic settings functions
 - Service program functions

4.1.1 Before a repair



Warning!

Always before changing a module, it must be checked that all the hob connections are correct and that there does not exist any weak or free cable.

5 CHECK AND INSTALLATION

5.1 NTC sensor checks

5.1.1 Inductor NTC

Each one of the inductors uses an NTC sensor to control operational temperature. The inductor NTC is a replaceable part.



5.1.2 Induction module NTC

The temperature of the semiconductor devices is measured by two NTC sensors that protect the electronics from excessively high temperatures. These sensors are not replaceable parts.

5.1.3 NTC sensor conversion table

Temp (°C)	R (KOhm)	Temp (°C)	R (KOhm)
10	98.264	26	47.788
11	93.229	27	45.794
12	88.632	28	43.873
13	84.404	29	42.019
14	80.489	30	40.228
15	76.845	31	38.496
16	73.435	32	36.819
17	70.233	33	35.193
18	67.213	34	33.616
19	64.357	35	32.085
20	61.647	36	30.597
21	59.070	37	29.150
22	56.613	38	27.741
23	54.264	39	26.369
24	52.016	40	26.065
25	49.860		

5.1.4 Correct position

It is very easy that they could get out of its housing on removing the glass, on raising the inductor set, on changing an ELIN... etc helped by the conductive silicone (white paste).

An incorrectly positioned NTC can cause diverse problems:

- 1- **Power loss.** On having placed the glass the NTC can push down the inductor and the distance between the inductor and cookware increases, giving as a result a power loss.
- 2- **Wrong inductor regulation.** If the NTC is not in direct contact with the glass, the real temperatures are not read.

-
- 3- On having manipulated the inductor set, the aluminium support might lose evenness, provoking again a wrong inductor regulation.

5.1.5 NTC change



Warning!

On changing the NTC or ceran glass, it must be applied again above the NTC the conductive silicone, because the fryingsensor function depends strongly on the quality of the NTC measure.

The spare part number for this conductive silicone is **618647**.



5.2 Fan checks

- ▶ Check that the rotor is not blocked.
- ▶ The operational voltage is 24 V DC.
- ▶ It is possible to check the fan using a suitable direct current.

The fan can not be checked by measuring its resistance because it contains a diode in series within its own electronics.

5.3 Coil checks

The inductor contains no functional parts except for the NTC temperature sensor. Therefore, it is not usually the source of faults. However, the following procedure can be followed:

- ▶ Inductor checks must be performed without voltage.
- ▶ Remove the mica film carefully so as not to damage it and perform a visual inspection. Check that there are no burnt areas.
- ▶ Check continuity of the inductor with a tester (<10hm).
- ▶ Replace the mica film carefully so as not to damage it.

Do not replace the inductor unless burnt areas are found or there is no electrical continuity.

5.4 Induction unit checks (ELIN)

- ▶ Checks must be performed with no voltage.
- ▶ Perform a visual inspection paying particular attention to any burnt components.
- ▶ IGBT checks. The resistance values between

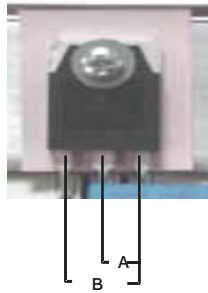

- ▶ the feet of the IGBT's must be:

$A > 10 \text{ Kohm}$

$B > 5 \text{ Kohm}$

- ▶ Check that the thread on the inductor connection screw is not worn. If it is, replace the screw. If the thread problem is with the attachment piece, replace the entire unit.
- ▶ If the induction associated to this coil continues to fail when the above checks provided negative results, replace the coil.
- ▶ Check that the 2 fusible connections (for the power (B) and the mains supply (A)) are intact. If not, the entire coil should be replaced.

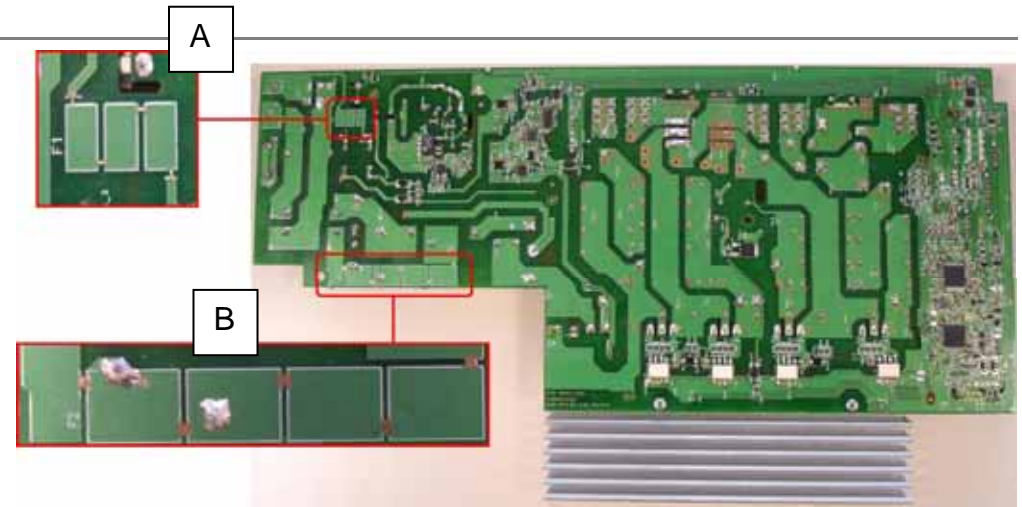

5.5 Radio interference

5.5.1 Problem

The radio cannot be heard properly when operating the inductor.

5.5.2 Cause

Inductor worktops and radios interfere with each other.

Regulations establish certain emission and immunity levels for electronic devices in order to avoid such interference problems. If they occur, they may be caused by one of several reasons:

- The worktop does not comply with the emission limits defined by the regulations governing the product. In our case, the worktops are certified according to European and international regulations EN55011 and CISPR 11. Therefore, they comply with the established emission limits.

See the list of regulations and emission / immunity tests with which all our inductor equipment comply.

- The radio does not comply with the immunity regulations for the product.
- It is possible for interference to occur when the two devices comply with their respective regulations. These regulations are unable to cover the infinite possible number of individual cases (only general situations) and interference may occur.

5.5.3 Solution

Check that the radio receiver complies with the corresponding immunity regulations for the product.

In those cases where the two devices comply with their respective regulations and interference still occurs, it is recommended to separate them sufficiently.

5.5.3.1 List of regulations and emission / immunity tests

EMC - Emission	
Code	Title
EN 55011	Industrial, scientific and medical (ISM) radio-frequency Equipment. Electromagnetic disturbance characteristics. Limits and methods of measurement
EN 61000-3-2	Electromagnetic compatibility (EMC) - Part 3-2: Limits – Section 2: Limits for harmonic current emissions (equipment input current greater than or equal to 16 A per phase)
EN 61000-3-3	Electromagnetic compatibility (EMC) – Part 3-3: Limits – Section 3: Limitation of voltage changes, voltage fluctuations and flicker in public low-voltage supply systems, for equipment with rated current =16 A per phase

EMC – Immunity	
Code	Title
EN 55014-2	Electromagnetic compatibility. Requirements for household appliances, electric tools and similar apparatus. Part 2: Immunity.
EN 61000-4-2	Electromagnetic compatibility (EMC). Part 4: Testing and measurement techniques. Section 2: Electrostatic discharge immunity test.
EN 61000-4-3	Electromagnetic compatibility (EMC). Part 4: Testing and measurement techniques. Section 3: Radiated, radio-frequency, electromagnetic field immunity test
EN 61000-4-4	Electromagnetic compatibility (EMC). Part 4: Testing and measurement techniques. Section 4: Rapid electrical transition immunity test
EN 61000-4-5	Electromagnetic compatibility (EMC). Part 4: Testing and measurement techniques. Section 5: Surge immunity test
EN 61000-4-6	Electromagnetic compatibility (EMC). Part 4: Testing and measurement techniques. Section 6: Immunity to conducted disturbances, induced by radio-frequency fields
EN 61000-4-11	Electromagnetic compatibility (EMC). Part 4: Testing and measurement techniques. Section 11: Immunity tests for voltage gaps, short interruptions and voltage variations.
EN 61000-4-13	Electromagnetic compatibility (EMC). Part 4: Testing and measurement techniques. Section 13: Harmonics, interharmonic including mains signalling at A. C. Power port, Immunity tests.

5.6 Checking the level of supplied power Problem

- Low level of supplied power
- Less power is supplied with the new inductor

5.6.1 Cause

- The pot is not suitable. See list of suitable pots and check the pot detection system.
- The new IH5-I technology supplies less power than the old IH4-I technology (ind IV). See regulations.
- Certain regulations governing power have come into force. See regulations.
- The positioning spring that brings the inductors closer to the glass is not in place.
See position of the spring.

5.6.2 Solution

5.6.2.1 Power regulation

5.6.2.1.1 Booster power regulation

For the first ten minutes, the Booster operates at maximum power, in other words, it supplies 150% of inductor power. Subsequently, the booster is regulated and lowered to power level 9.

If the user wishes to reactivate the booster, this can be done. The booster will supply maximum power for a further 2 minutes and then return to power level 9. After the 12 minutes with the booster at maximum power, if the user tries

to reactive it once more, only 83% of the 150% of inductor power will be supplied and then it will return to power level 9 (100% inductor power).

At this time, if the user wishes to activate the booster again, they must wait for the same period of time as the time they wish it to be activated for, provided that this is less than 10 minutes.

Superbooster (Paella dish)

On these models, it is not possible to reactivate the booster after the initial 10 minutes at maximum power.

If it has been used for 10 minutes, we must wait for 10 minutes in order to try and activate it again.

If we have used it for 5 minutes, we must wait for 5 minutes in order to try and activate it again.

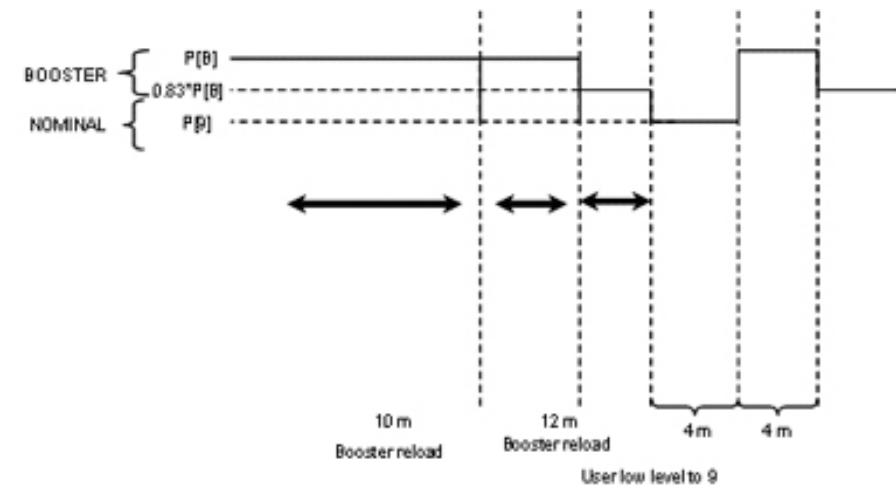

5.6.2.2

Power regulation according to the type and size of the pot



Warning!

The power supplied according to the size of the pot with IH5-I is less than with IH4 (ind IV advanced).

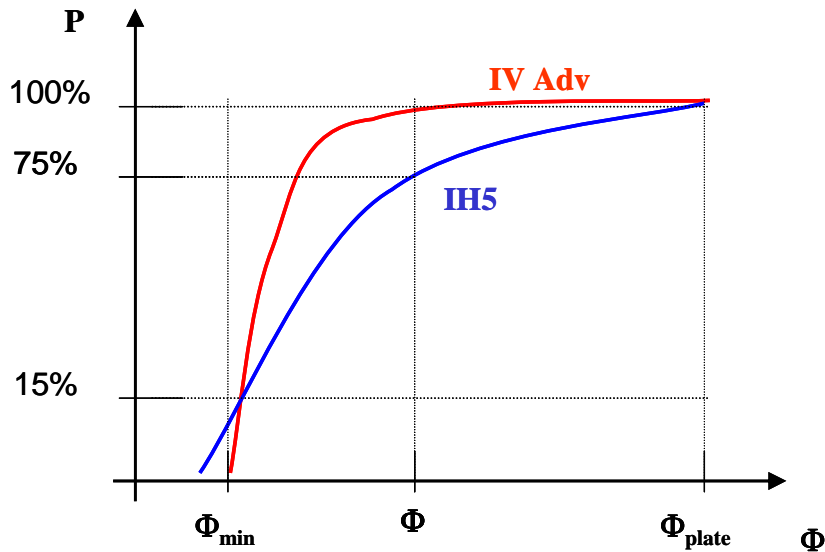

Pot Diameter

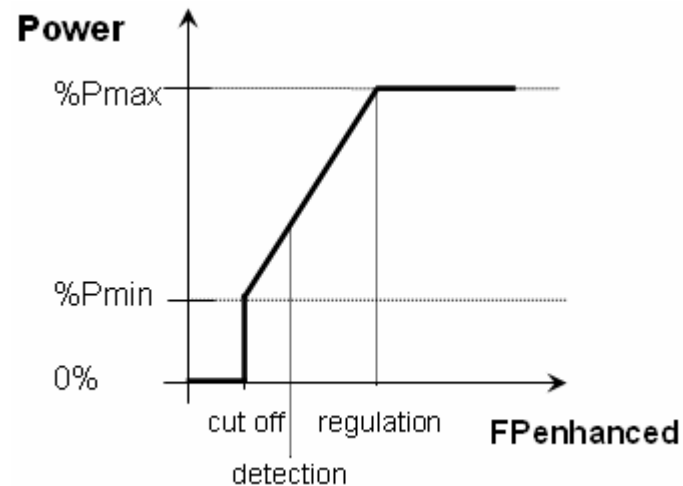
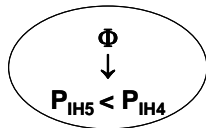

By taking into account the material and size of the pot, the level of power supplied can be reduced and even shut off so as to avoid excessive currents.

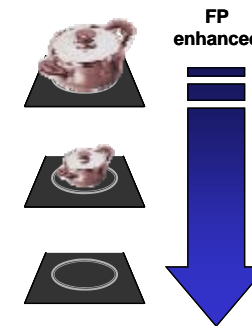

For example, for a pot with a base diameter identical to the size of the inductor coil and of a material with good electro-magnetic properties, the FP enhanced obtained gives us maximum power. If we have no pot, the FP enhanced is nil and the power supplied is nil. The display flashes.

If the pot is not of a suitable diameter and its composition is not suitable for our induction cooker, the FP enhanced calculated by our technology will be so low that the power supplied will be nil.

5.6.2.2.1 Power regulation according to the temperature of the IGBT's

The temperature of the IGBT's is measured using the NTC's located on the rear of the inductor modules. They are marked in red.

See the chapter on error codes and warnings sent via the TouchControl.

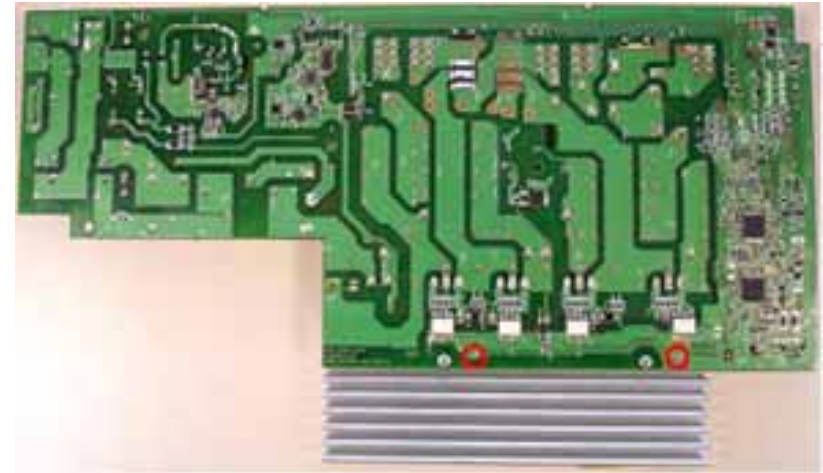
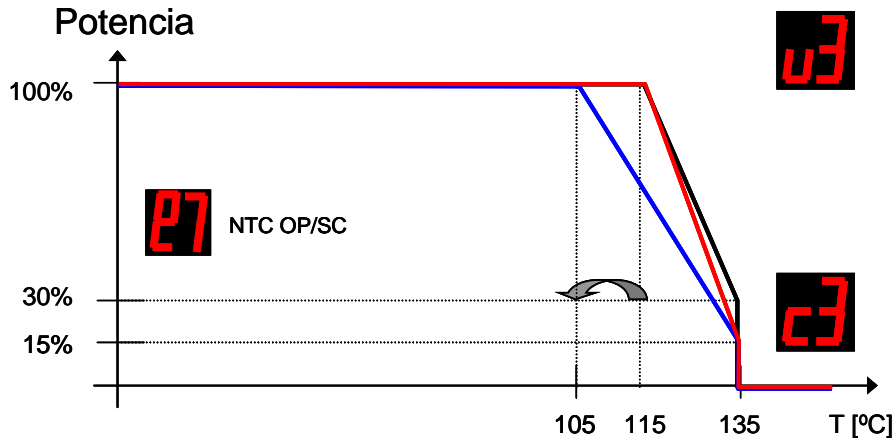

[1] IH4-I.2

[2] IH5-I

[3] IH5-I critical modules

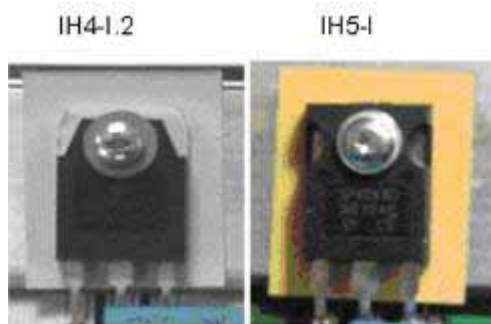

When certain temperature limits are exceeded, a warning is provided via an indication on the TouchControl so as to avoid damage to the IGBT's.

5.6.2.2.2 Power regulation according to the temperature of the NTC's on the inductor

The temperature of the inductors is measured using the NTC's located on the inductors.

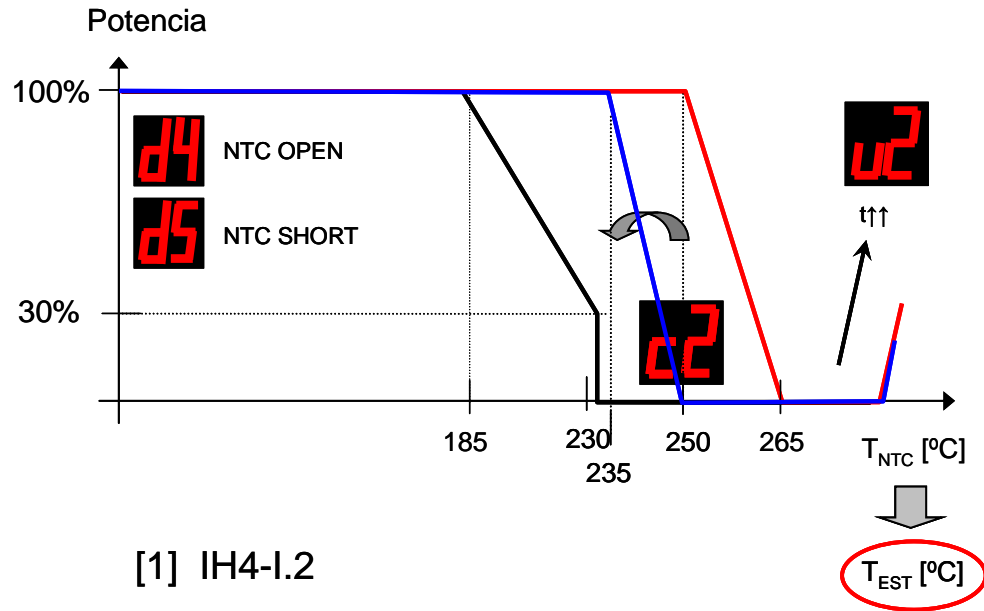

[1] IH4-I.2

[2] IH5-I

[3] IH5-I critical modules

When certain temperature limits are exceeded, a warning is provided via an indication on the TouchControl so as to avoid damage to the inductors.

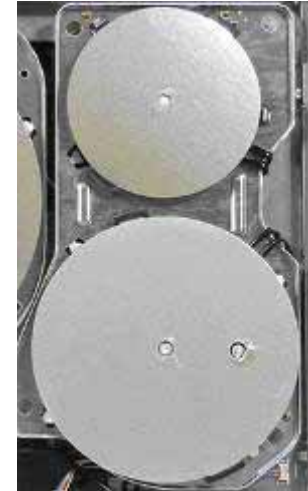

5.6.2.2.3 Power regulation according to the supply voltage

When the supply voltage is less than 215V, an indication is shown on the TouchControl display. See the error codes and warnings sent via the ELIN.

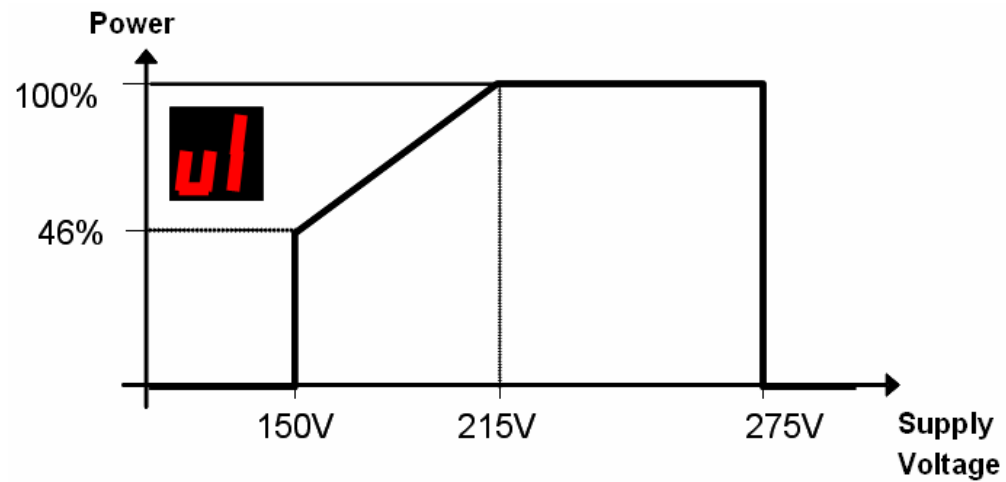

5.6.2.3 Position of the spring

If the spring is not in place, it is possible that the distance between the glass and the inductor is too great and the pot is not being detected correctly and/or the power being supplied may be too low.

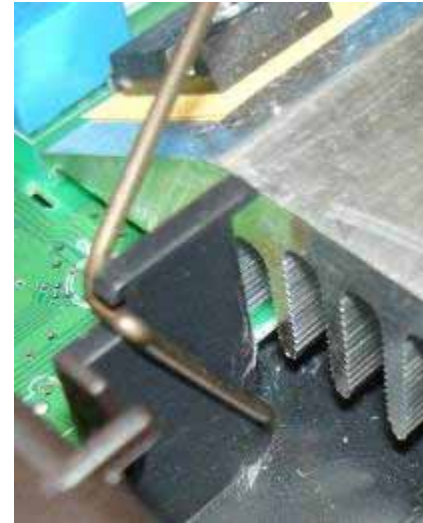

Measurement's conditions

To measure the power supply with the hotplates of an IH5 induction hob, a pot with a bottom diameter matching the tested hotplate is placed centered.

A matching diameter means: bottom-Ø pot = bottom-Ø hotplate +20/-5mm. At table 1 a pot or pan for each IH5 hotplate is recommended for measuring.

The energy consumption is measured with nominal power and afterwards with the boost function like explained in the following:

- The pot is filled with a small amount of water and placed at the hotplate. The pot should never be used empty.
 - The Boost power level is started.
 - Wait 10-15 seconds until the power is supplied constantly.
 - Then measure the energy consumption for a time period of 2 minutes.
-
- The supplied power is calculated: $P(W) = \text{energy consumption (Wh)} \times 30$
 - The calculated supplied power is compared with the nominal power (see table 2) of the tested hotplate1.
 - The same is repeated with the nominal power level.

Important note:

1) Be aware that regarding the supplied power the tolerance rate of produced BSH induction hobs is -10%/+5% of the nominal power (n.p.)

This means with an induction 4-hotplates-hob the nominal power supply should be between 6480W (=90% of n.p.) and 7560W (=105% of n.p.).

The same applies for each hotplate.

2) The "super boost" power is supplied with the 26T, 28D or 32T hotplate until any other hotplate is activated. At this the power is supplied with more than one module.

In case of activating another hotplate, the "boost" power is supplied, because only the module of the hotplate is available. It changes automatically from "super boost" to "boost" when activating a second hotplate.

"Super boost" and "boost" are not indicated different at the Touch control.

Table 1: Pots/Pans for measuring the power supply

hotplate (cm)	15	18	21	26	28	32	Roaster zone
Pot	Hackmann	Hackmann	Hackmann	Demeyere	Kuhn Rikon	Lacor	Demeyere
serie / article nr.	littala	littala	littala	multiline - REF 42632	cater star REF 31134	inox durit REF 60224	HEZ390010
Ø bottom (mm)	156	184	222	260	283	315	285*170
Ø upside (mm)	188	207	242	320	320	400	320*208
Height (mm)	102	130	134	55	62	50	70
	Accessory						Accessory

Table 2: Overview objective power per IH5 hotplate with nominal and boost function

Objective nominal and boost power (W) with IH5 hotplates									
Power levels	15	18	21	28S	28D	26T	32T	18B	
9	17	1400 W	1800 W	2200 W	2400 W	2800	2600	3300	2000
Boost	18	1800 W	2500 W	3300 W	3500	3400	3400	3600	2600
Super Boost ²	18	-	-	-	-	4400	3400	4600	-

B = function booster

SB = Superbooster









((in case of 26T, 28D and 32T: if another hotplate is active, only the Boost function is available.))

S = single hotplate

D = double hotplate

T = triple hotplate

Pictures of the recommended pots and pans

ho tplate (cm)	15	18	21
p lou tre c			
ho tplate (cm)	28	32	Rea cter zo ne
p lou tre c	 	 	 

5.7 Checking the flatness of the hobs

5.7.1 Problem

The hob projects above the worktop.

5.7.2 Cause

- Installation not correct. Cutout guide rails may be missing.
- If FD< 8708, the design of the entire glass frame may be the cause of the flatness problems. There are now 4 profiles in the whole ceramic hob to solve this problem.
- Together with the empty weight of the appliance the inductors have a balloon effect on the glass, as they are pressed forcefully against the glass to ensure correct performance.

5.7.3 Troubleshooting



Attention!

After installing the hob in the cutout of the worktop, measure the flatness.

Send completed checklist (enclosed at the end of the chapter) to the manufacturer, so that the cases which occur in practice can be analysed. E-mail to following addresses:

To facilitate the sending, the checklist is enclosed in a ATI in the affected models.

Sofia.gaspar@bshg.com or Hector.lanuza@bshg.com

Tolerances permitted at the factory:

Diagonal < 1 mm

Area of inductor < 0.5 mm

Observe the following procedure:

- 1- Flow diagram for flush-mounted hobs.
- 2- Flow diagram for hobs with profile frame.

Required materials:

Measuring gauges: [341452](#)

Caliber: [341543](#)

40 cm spirit level [340466](#)

60 cm spirit level [341544](#)

Sealing tape for flush-mounted hobs: Is finally being sold unmounted in a bag together with the appliance. 616479

Clamping claws. Are sold in a bag together with the appliance. 614375



5.7.4 Flow diagram for flush-mounted hobs

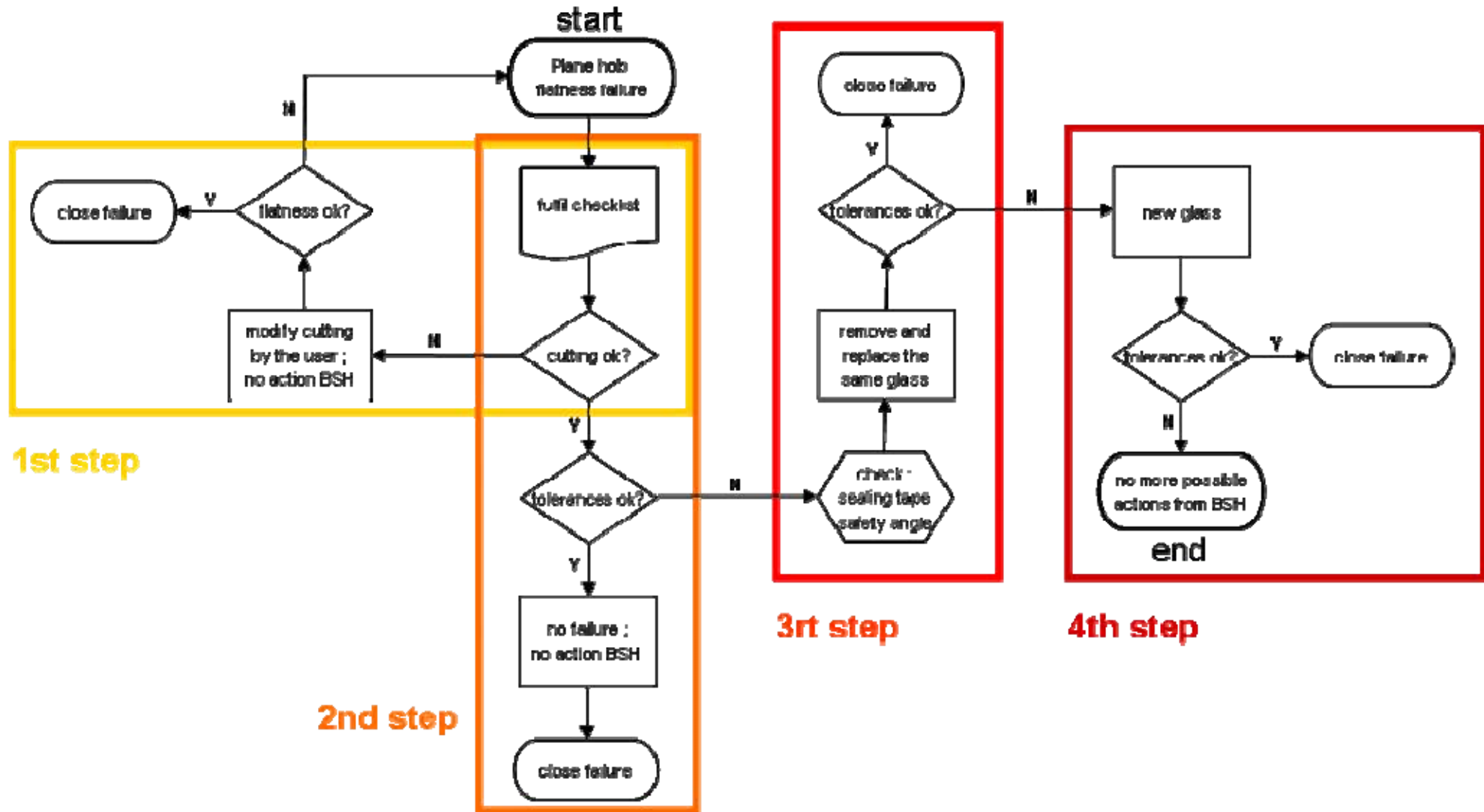

5.7.5 Flow diagram for hobs with profile frame

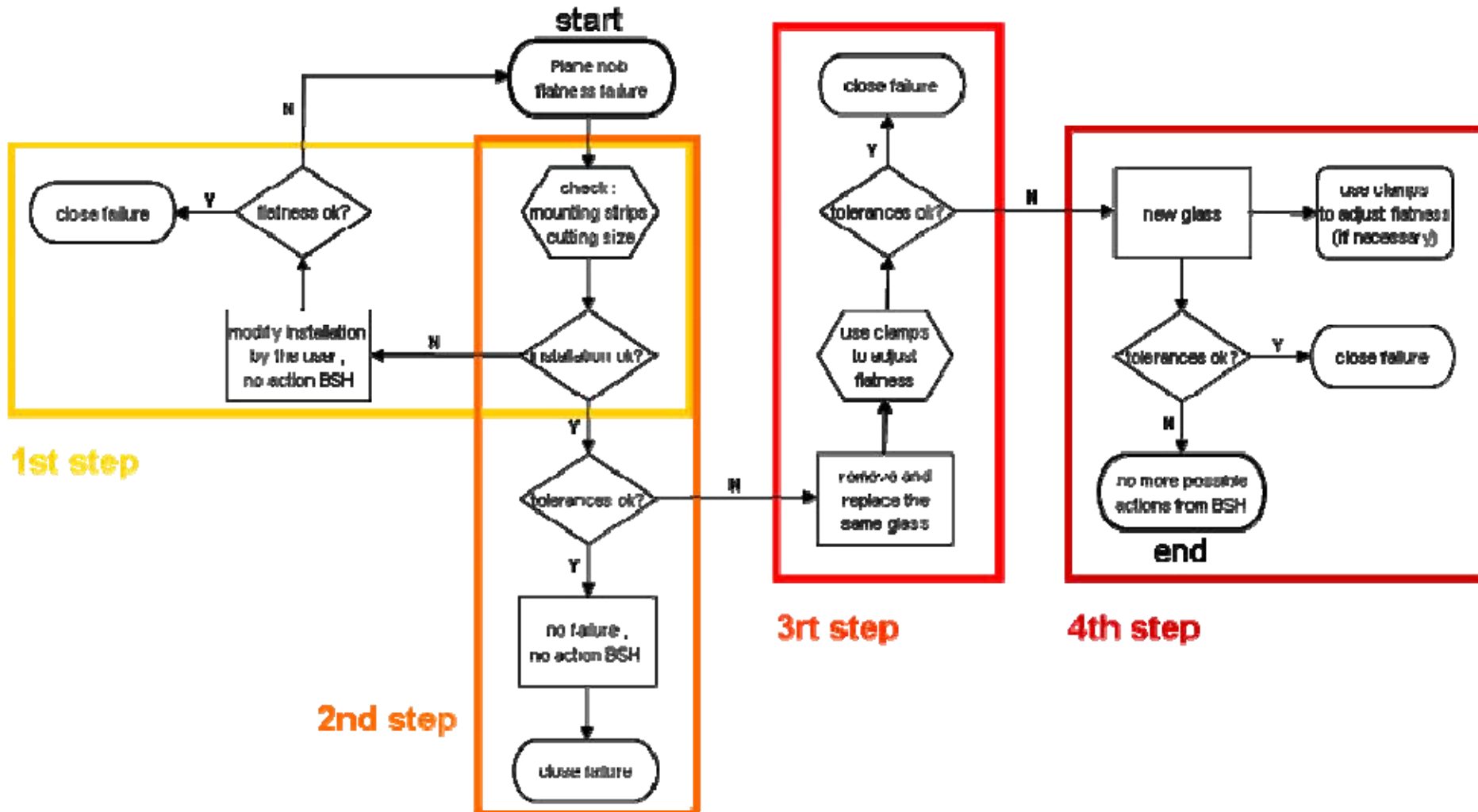

5.7.6 Checklist for induction hobs

INDUCTION CHECKLIST

FLUSH-MOUNTED HOBS

Document number:

Dealer:

1.- Installation

Worktop material	Wood <input type="text"/>	Granite <input type="text"/>	Marble <input type="text"/>	Other <input type="text"/>
Thickness	20 cm <input type="text"/>	30 cm <input type="text"/>	40 cm <input type="text"/>	Other <input type="text"/>
Sealing tape attached	YES (in stone slab) <input type="text"/>	YES (on glass) <input type="text"/>	NO <input type="text"/>	
Clamping claws (clamps) screwed		YES <input type="text"/>	NO <input type="text"/>	

2.- Stone slab cutout

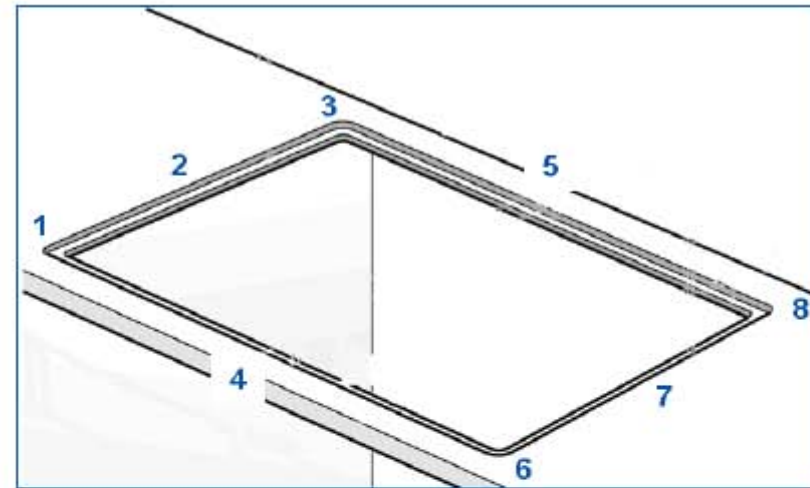
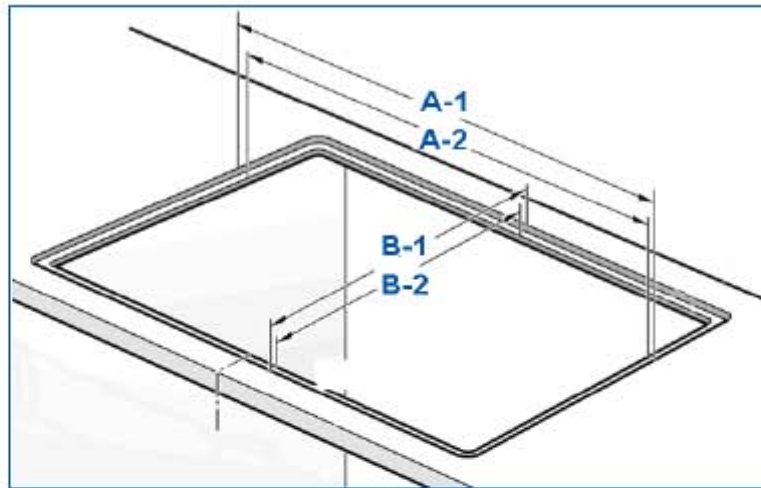

Sides	A-1	A-2	B-1	B-2	
Length					mm.

Points	1	2	3	4	5	6	7	8	
Depth									mm.

In compliance with the installation instructions?

YES

NO

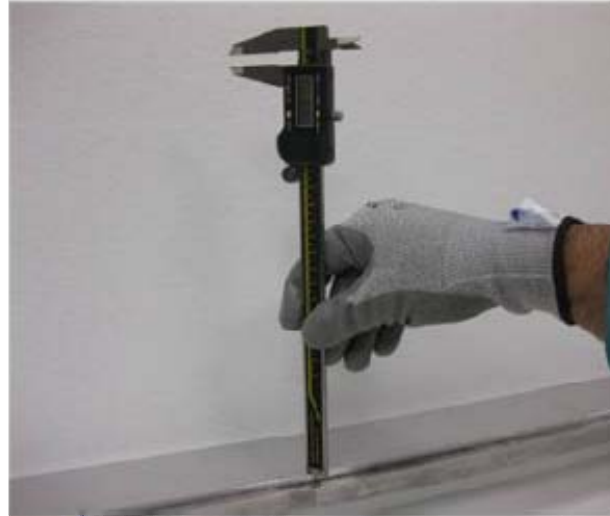
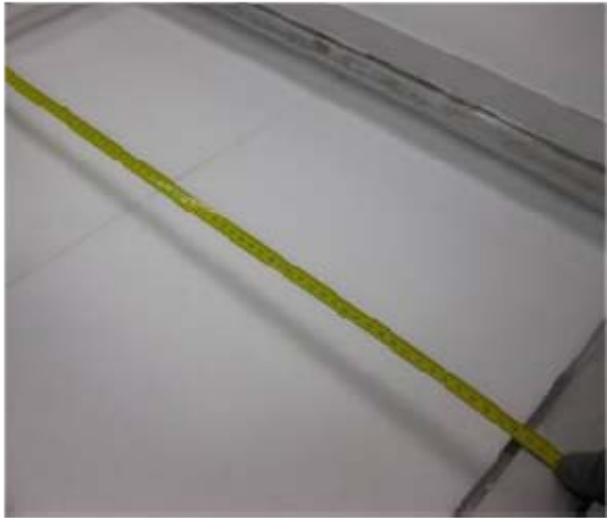

3.- Level of ceramic area with respect to worktop surface

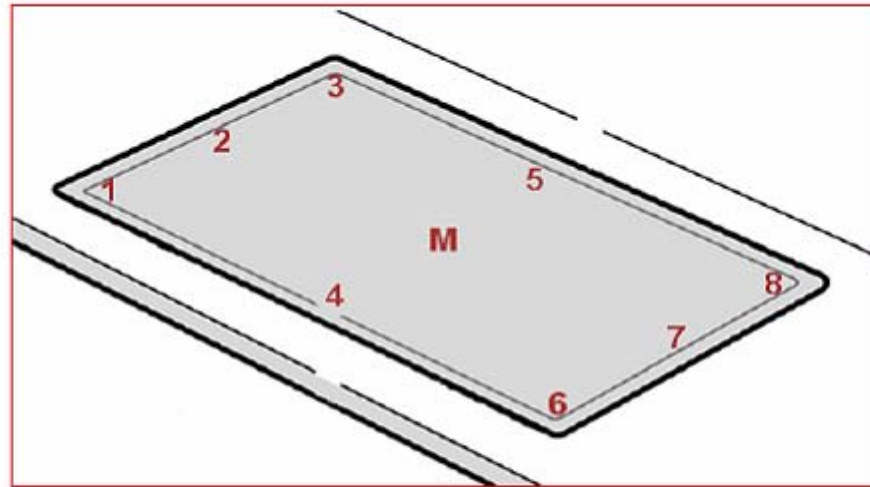

Points	1	2	3	4	5	6	7	8	M	
Step *										mm.

* Explanation of step: + Plus if ceramic is above worktop; – Minus if ceramic is below worktop

4.- Curvature of worktop

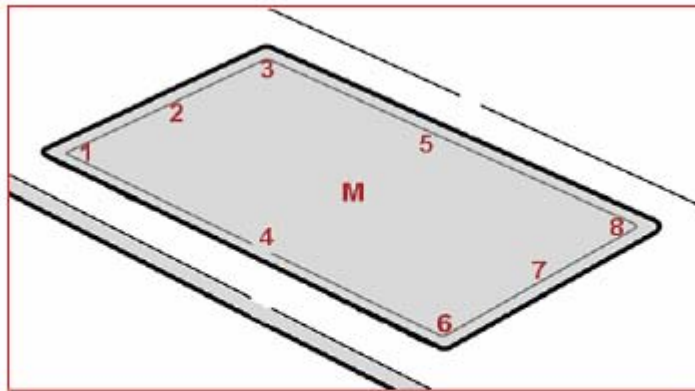

Measurement A: Spirit level from the middle forwards and backwards

	curved upwards	curved downwards
Pos 1-3		
Pos 4-5		
Pos 6-8		

Points	1	2	3	4	5	6	7	8	M	
Step *										mm.

If ceramic is curved upwards: Spirit level as horizontal as possible to measure the gap

Measurement B: Spirit level from the middle to the left and right

	curved upwards	curved downwards
Pos 1-6		
Pos 2-7		
Pos 3-8		

Points	1	2	3	4	5	6	7	8	M	
Step *										mm.

If ceramic is curved downwards: Spirit level as horizontal as possible to measure the gap



5.- Diagrams of problematic points

- Cutout
- Sealing tape
- Safety bracket
- Clamps
- ...

6.- Comment



5.7.7 Attaching the sealing tape.. 616479

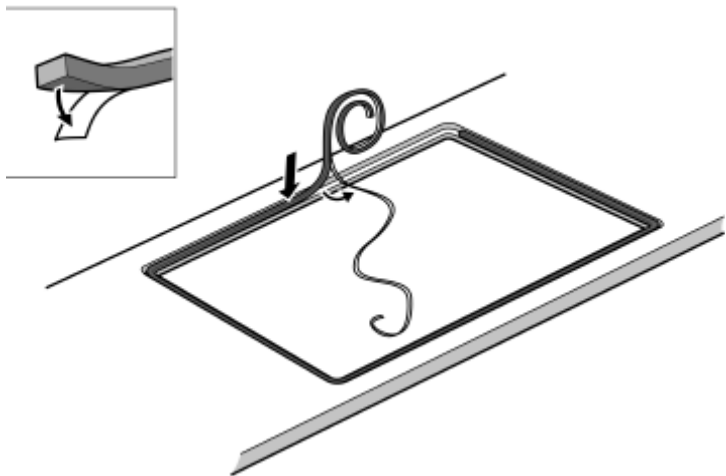

5.7.8 Attaching the clamping claws. 614375

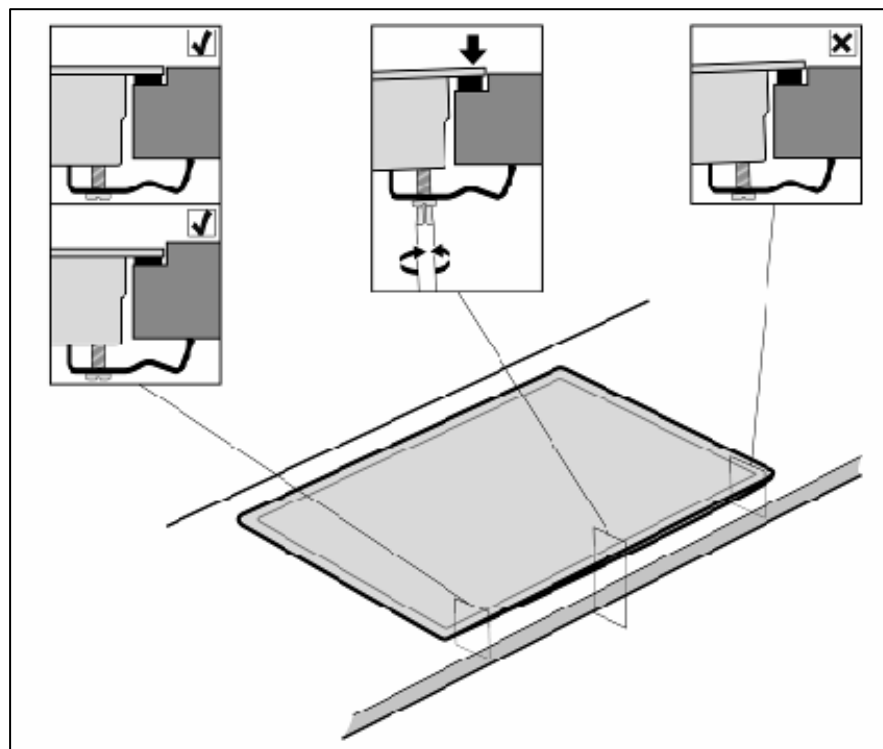
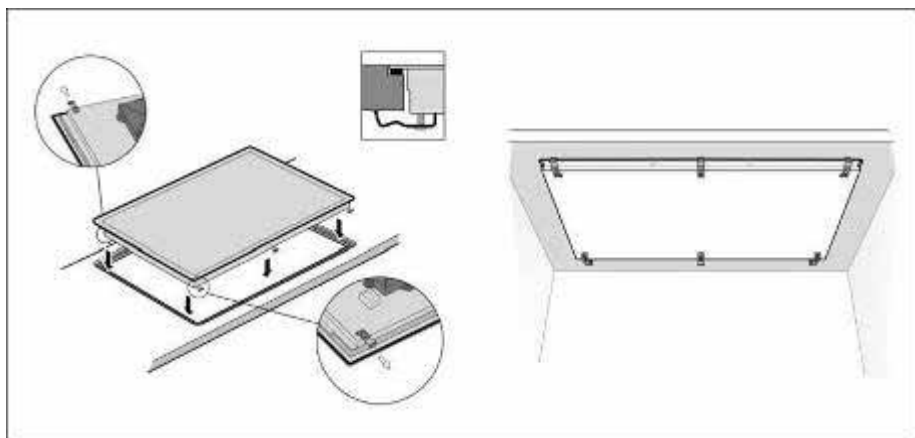

5.8 Checking standard operation noises

5.8.1 Problem

The inductor makes a noise when cooking.

5.8.2 Cause

Induction heating technology is based on the creation of electromagnetic fields that cause heat to be generated directly on the base of the pot. These fields, depending on the construction of the pot, may cause certain noises or vibrations.

5.8.3 Solution

The user should be informed that information about normal operation noises can be found at the back of the instruction booklet and is included below.

These noises form part of the induction technology and do not indicate a fault.

5.8.3.1 Low-pitched buzzing sound coming from the transformer

This noise occurs when cooking with a high level of power. It is caused by the amount of energy being transferred from the hotplate to the pot. This noise will disappear or weaken as the level of power is decreased.

5.8.3.2 A low-pitched whistling sound

This noise occurs when the pot is empty. This noise will disappear as soon as water or food is added to the food.

5.8.3.3 Creaking

This noise occurs with pots that are made of various superimposed materials.

The noise is caused by the vibrations that are created on the joint surfaces between the various superimposed materials.

This noise comes from the pot. The amount and manner of cooking the food may vary.

5.8.3.4 High-pitched whistling sounds

These noises are more common with pots made of different superimposed materials, as soon as they are put on the cooker at high power and in both cooking areas at the same time. These whistling noises disappear or reduce as soon as the power is reduced.

5.8.3.5 Noise from the fan

For optimum use of the electronic system, the hotplate must operate at a controlled temperature. Therefore, the hotplate is fitted with a fan that operates when certain temperature levels are detected via different power levels. The fan may also operate under inertia after the hotplate has been turned off if the detected temperature is still too high.

5.9 Checking pot detection

All inductor areas are fitted with an automatic pot detection system included in the inductor control system. The minimum diameter is approximately 50% of the nominal diameter, although this may vary depending on the material.

When the pot is considered to be of a small size, the inductor control system automatically reduces the supplied power to adapt to the size of the pot.

After activating the cook area, if no pot is placed on it or the pot is made of an unsuitable material, the display showing the level of power will flash. After 90 seconds the TouchControl will emit an acoustic warning and turn off the cook area.

When a pot is recognised as suitable, the power level display will remain constant and the level of power indicated by the display will be supplied.

5.9.1 Problem

- One inductor plate does not detect a pot but another of a smaller diameter does.
- The pot is not detected on any inductor plates.

5.9.2 Cause

- The diameter of the pot is not suitable for that hotplate. See table of recommended minimum diameters.
- The pot is not suitable for our induction technology (the magnet sticks sometimes). Depending on the composition of the pot, our technology may not be programmed to detect it as suitable so as to avoid possible module faults arising from operation in unsuitable conditions. See power supply reduction or cut-off diagram depending on the pot being used.

5.9.3 Solution

See chapter on recommended pots

5.9.3.1 Minimum recommended diameters

This table is provided as a guide only in order to help the understanding of the problems that may arise in the market. These values may vary depending on the composition of each type of pot.

Inductor type	Nominal diameter (cm)	Minimum diameter (cm)
15	14.5	6.5
18	18	11.5
21	21	15
28 Simple	28	15.5
18 Bräter	23	18
28 Double	28	23.5
26 (Triple)	27	25
32 (Triple)	32	29

5.9.3.2 Power supply reduction diagram depending on the pot being used

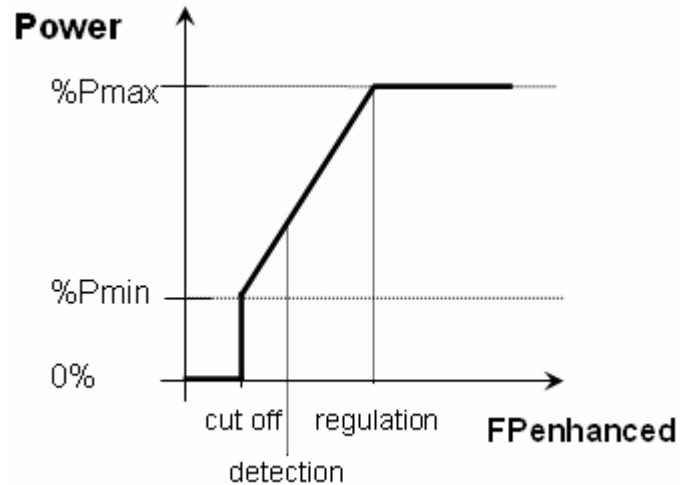

For example, for a pot with a base diameter that is identical to the size of the inductor plate and made from a material with good electromagnetic properties, the enhanced FP obtained gives us maximum power. If there is no pot, the enhanced FP is nil and the level of power supplied is also nil. The display will flash. If the pot is not of a suitable diameter and the composition of the pot is not suitable for our inductor, the enhanced FP calculated by our technology will be so low that the level of power supplied will be nil.

According to the material and size of the pot, the level of power supplied may be reduced or cut off in order to avoid excessive currents.

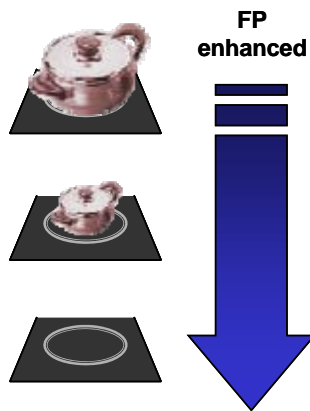

5.10 Checking of broken glass

5.10.1 Problem

The glass has broken. The enamel from the pot has become welded to the vitroceramic glass.

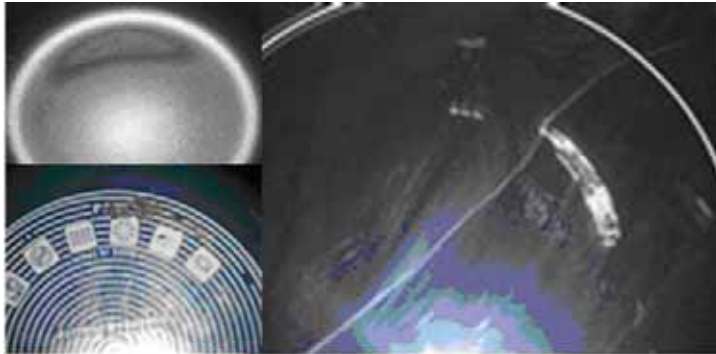

5.10.2 Cause

- Generally-speaking, cases involving the breakage of glass are caused by a strong increase in temperature to the base of the pot (over 400°C). The heat from the pot is transferred to the glass (in fact, it can even weld enamel and glass) and the high temperature causes the glass to break.
- This has been seen to occur when using **pots in bad conditions**, with cracks or scratches: the inducted currents “avoid” these areas and concentrate in specific areas, which generate extremely high temperatures.
- Another possibility is with **thinly enamelled pots** or pots in bad states of disrepair: the flatness of the base is lost in the centre and the defective contact with the plate gives rise to areas with extremely high temperatures.

5.10.3 Solution

- This is more commonly seen with inductors when the user is not used to the shorter heating times compared to radiator plates and insufficient attention is paid when using them. In order to mitigate this problem, it has been thought to include in the user manuals comments such as “If you use thinly enamelled pots, you may cause damage to your hotplate. We recommend that you pay particular attention during the cooking process and do not overheat them”.
- Such thinly enamelled pots, due to the type of material and especially due to the thickness of the base, are very weak and can overheat rapidly. This is even more so when using high levels of power, empty pots or with little oil. If they are left for too long, in other words, when the pot is “abandoned”, firstly the pot covering deteriorates and secondly the base begins to deform, above 250°C. Deformation of the base then results in the average temperature measured by the sensor under the glass (NTC) being less than the actual temperature, the hob is not regulated and the overheating process is accentuated. When reaching some 500°C, the enamelled base begins to melt and degrade (forming bubbles) and may even crack or break the glass.

5.11 Cookware for induction and recommendations

5.11.1 General

All saucepans and frying pans with a ferromagnetic base are suitable for induction.

Only pots whose base is uniformly in contact with the magnet should be used (check the entire base).

When using other types of pots, the inductor does not heat up and the power level display will flash.

The minimum diameter of the pot should also be taken into consideration.

5.11.2 Suitable saucepans and frying pans

Enamelled steel saucepans and frying pans

Cast iron saucepans and frying pans

Iron saucepans

Stainless steel saucepans and frying pans, provided that they have a special ferromagnetic base for induction purposes

5.11.3 Unsuitable saucepans and frying pans

Non-ferromagnetic or non-metallic materials

Aluminium saucepans and frying pans

Copper saucepans and frying pans

Tin saucepans and frying pans

Standard stainless saucepans and frying pans

Glass containers ("Pyrex")

Clay pots

5.11.4 Recommendations

5.11.4.1 ITTALA / DEMEYERE



Pots and pans

444218 pot 16 cm.

444217 pot 18 cm

444210 pot 20 cm

444216 pot 24 cm

444219 pot 22 cm.

464355 frying sensor pan

5.11.4.3 ZENITH MASTER PAELLA PAN



Paella Pans

464338, D 28 cm., D base 23,5 cm.

464339, D 30 cm., D base 25,5 cm.

464340, D 32 cm., D base 28 cm.

464341, D 34 cm., D base 29 cm.

5.11.4.4 28 cm Kuhn-Rikón Paella Pan

The available accessories are:

HZ390260 (Siemens)

HEZ390260 (Bosch)

Z9460X0 (Neff)



5.11.4.5 Bräter

The available accessory is:

HEZ390010

HZ390010



5.11.4.6 Pans for the frying sensor

The available accessories are:

HZ390210 (Siemens); HEZ390210 (Bosch): 15 cm
HZ390220 (Siemens); HEZ390220 (Bosch): 18 cm
HZ390230 (Siemens); HEZ390230 (Bosch): 21 cm

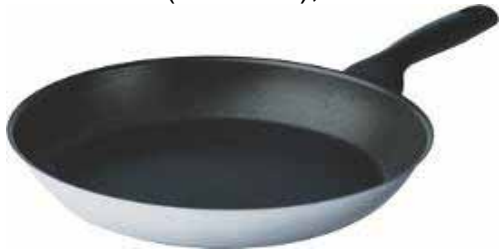

They are available in three sizes: 15 cm, 18 cm and 21 cm
They have a sandwich base.

5.11.4.7 WMF Wok

The available accessories are:

HZ390090(Siemens) ; HEZ390090(Bosch)

Maximum diameter 36 cm and minimum diameter 16 cm.



5.12 Checking the replacement part is correct

5.12.1 Problem

The replacement part does not coincide with the original

5.12.2 Cause

- The supplier has sent the wrong one.
- The warehouse stock has got mixed up.
- The module software is badly saved.

5.12.3 Solution

Inform central office for them to manage the incident.

If the replacement part is an electronic item or module, the supplier code will be located on it. Check to see if this code corresponds to the code on the original part and if not, include this information in the report.

- The label is located on the reverse side of TouchControl units.



- The label is located on the front side of ELIN units.



See table of supplier codes for replacement parts according to model.

The left 1 ELIN is the one located on support ELIN-2.

The left 2 ELIN is the one located on support ELIN-1.

5.12.3.1 Table of replacement parts with supplier code

MODEL	DESCRIPTION	Left 1 ELIN	Right ELIN	Left 2 ELIN	TC
3EB800L	BA.2I.60.SQ.X.X	9000274561	--	--	9000183912
3EB800X	BA.2I.60.SQ.X.X	9000274561	--	--	9000183912
3EB815L	BA.3I.60.SQ.28S.X	9000275522	9000274537	--	9000229599
3EB815X	BA.3I.60.SQ.28S.X	9000275522	9000274537	--	9000229599
3EB820L	BA.4I.60.SQ.X.X	9000274564	9000274537	--	9000183912
3EB820X	BA.4I.60.SQ.X.X	9000274564	9000274537	--	9000183912
3EB900L	BA.2I.60.BAS.X.X	9000274561	--	--	9000237964
3EB900X	BA.2I.60.BAS.X.X	9000274561	--	--	9000237964
3EB9030L	BA.2I.30.BAS.X.X	9000275514	--	--	9000248165
3EB910F	BA.2I.60.BAS.X.FS	9000274561	--	--	9000261599
3EB914L	BA.2I.60P.BAS.28S.X	9000275516	--	--	9000248165
3EB915L	BA.3I.60.BAS.28S.X	9000275522	9000274537	--	9000237965
3EB915X	BA.3I.60.BAS.28S.X	9000275522	9000274537	--	9000237965
3EB917F	BA.3I.60.BAS.28D.FS	9000275523	9000275496	--	9000237967
3EB917L	BA.3I.60.BAS.28D.FS	9000275523	9000275496	--	9000237967
3EB917M	BA.3I.60.BAS.28D.FS	9000275523	9000275496	--	9000283860
3EB917P	BA.3I.60.PZ.28D.FS	9000275523	9000275496	--	9000261070
3EB918L	BA.3I.60.BAS.32T.FS	9000275524	9000275509	--	9000237967
3EB919F	BA.3I.60.LCD.32T.FS	9000275524	9000275509	--	LCD
3EB920L	BA.4I.60.BAS.X.X	9000274564	9000274537	--	9000237964
3EB920X	BA.4I.60.BAS.X.X	9000274564	9000274537	--	9000237964
3EB925F	BA.4I.60.BAS.X.FS	9000274564	9000274537	--	9000237966
3EB925L	BA.4I.60.BAS.X.FS	9000274564	9000274537	--	9000237966
3EB925M	BA.4I.60.BAS.X.FS	9000274564	9000274537	--	9000286371
3EB928L	BA.3I.90P.BAS.28S.X	9000275518	--	9000275521	9000237965
3EB929F	BA.4I.60.LCD.X.FS	9000274564	9000274537	--	LCD
3EB950L	BA.4I.80.BAS.28S.X	9000275526	9000275510	--	9000237964
3EB950M	BA.4I.80.BAS.28S.X	9000275526	9000275510	--	9000283861
3EB957F	BA.4I.80.BAS.28S.FS	9000275526	9000275510	--	9000237966
3EB990F	BA.5I.90.TOP.32T.FS	9000275524	9000275496	9000275520	9000261069
4ET800LT	LY.2I.60.SQ.X.X	9000274561	--	--	9000183912
4ET800XT	LY.2I.60.SQ.X.X	9000274561	--	--	9000183912
4ET813LT	LY.3I.60.SQ.28D.X	9000275523	9000275496	--	9000229599
4ET820LT	LY.4I.60.SQ.X.X	9000274564	9000274537	--	9000183912
CA420350	CN.2I.60.BAS.X.X	9000274561	--	--	9000250933
CA421350	CN.4I.60.BAS.X.X	9000274564	9000274537	--	9000250938
CA422350	CN.4I.60.BAS.BR.X	9000275525	9000274537	--	9000250938
CA428350	CN.4I.80.BAS.BW.X	9000275525	9000275513	--	9000250941
CI261102	GA.4I.60.TOP.BR.FS	9000275525	9000274537	--	9000227509

MODEL	DESCRIPTION	Left 1 ELIN	Right ELIN	Left 2 ELIN	TC
CI261112	GA.4I.60.TOP.BR.FS	9000275525	9000274537	--	9000227509
CI262102	GA.3I.60.TOP.28D.FS	9000275523	9000275496	--	9000216182
CI262112	GA.3I.60.TOP.28D.FS	9000275523	9000275496	--	9000216182
CI263112	GA.4I.60.TOP.BR.FS	9000275525	9000274537	--	9000195219
CI264112	GA.3I.60.TOP.28D.FS	9000275523	9000275496	--	9000196261
CI271112	GA.4I.70.TOP.BR.FS	9000275525	9000274537	--	9000227509
CI273112	GA.4I.70.TOP.BR.FS	9000275525	9000274537	--	9000195219
CI481102	GA.4I.80.TOP.28S.FS	9000275526	9000275510	--	9000216183
CI481112	GA.4I.80.TOP.28S.FS	9000275526	9000275510	--	9000216183
CI481612	GA.4I.80.TOP.28S.FS	9000275526	9000275510	--	9000216183
CI490112	GA.4I.90P.TOP.X.FS	9000275517	--	9000275521	9000227509
CI491102	GA.5I.90.TOP.28D.FS	9000275523	9000275496	9000275520	9000227510
CI491112	GA.5I.90.TOP.28D.FS	9000275523	9000275496	9000275520	9000227510
CI491602	GA.5I.90.TOP.28D.FS	9000275523	9000275496	9000275520	9000227510
CI491612	GA.5I.90.TOP.28D.FS	9000275523	9000275496	9000275520	9000227510
CIS365GB	TH.5I.90.BAS.32T.CS	9000275524	9000275496	9000275520	9000297517
CIT304GB	TH.4I.80.BAS.28S.X	9000275526	9000275510	--	9000242586
CIT304GM	TH.4I.80.BAS.28S.X	9000275526	9000275510	--	9000242586
CIT365GB	TH.5I.90.BAS.32T.X	9000275524	9000275496	9000275520	9000242588
CIT365GM	TH.5I.90.BAS.32T.X	9000275524	9000275496	9000275520	9000242588
EH375CE11E	SE.2I.30.KB.X.X	9000275514	--	--	9000303876
EH375ME11E	SE.2I.30.TOP.X.X	9000275514	--	--	9000248136
EH475ME11E	SE.1I.40.TOP.28D.X	9000275515	--	--	9000248159
EH575ML11E	SE.2I.60P.TOP.28S.X	9000275516	--	--	9000248136
EH601EB11	SE.4I.60.BAS.BR.X	9000275525	9000274537	--	9000250940
EH601MB11	SE.4I.60.TOP.BR.X	9000275525	9000274537	--	9000231127
EH601MD21E	SE.3I.60.TOP.32T.FS	9000275524	9000275509	--	9000231126
EH601ME21E	SE.4I.60.TOP.X.FS	9000274564	9000274537	--	9000231129
EH601TE11E	SE.4I.60.BAS.X.X	9000274564	9000274537	--	9000250938
EH601TK11E	SE.3I.60.BAS.28D.X	9000275523	9000275496	--	9000250937
EH645EB11	SE.4I.60.BAS.BR.X	9000275525	9000274537	--	9000250940
EH645EB11E	SE.4I.60.BAS.BR.X	9000275525	9000274537	--	9000250940
EH645EC11	SE.2I.60.BAS.X.X	9000274561	--	--	9000250933
EH645MB11M	SE.4I.60.TOP.BR.X	9000275525	9000274537	--	9000231127
EH645QE11E	SE.4I.60.SQ.X.X	9000274564	9000274537	--	9000183912
EH645RE11E	SE.4I.60.SQ.X.X	9000274564	9000274537	--	9000229602
EH645RL11E	SE.3I.60.SQ.28S.X	9000275522	9000274537	--	9000229601
EH645TE11E	SE.4I.60.BAS.X.X	9000274564	9000274537	--	9000250938
EH645TE11X	SE.4I.60.BAS.X.X	9000274564	9000274537	--	9000250938

MODEL	DESCRIPTION	Left 1 ELIN	Right ELIN	Left 2 ELIN	TC	MODEL	DESCRIPTION	Left 1 ELIN	Right ELIN	Left 2 ELIN	TC
EH651RE11E	SE.4I.60.SQ.X.X	9000274564	9000274537	--	9000229602	EH875ML21E	SE.4I.80.TOP.28S.FS	9000275526	9000275510	--	9000231129
EH651RF11E	SE.2I.60.SQ.X.X	9000274561	--	--	9000229600	EH875SB11E	SE.4I.80.TOP.BW.X	9000275525	9000275513	--	9000303899
EH651RL11E	SE.3I.60.SQ.28S.X	9000275522	9000274537	--	9000229601	EH875TE11E	SE.4I.80.BAS.WP.X	9000274564	9000275513	--	9000250941
EH651TE11E	SE.4I.60.BAS.X.X	9000274564	9000274537	--	9000250938	EH876ML11U	SE.4I.80.TOP.28S.X	9000275526	9000275510	--	9000231127
EH651TF11E	SE.2I.60.BAS.X.X	9000274561	--	--	9000250934	EH879ML11U	SE.4I.80.TOP.28S.X	9000275526	9000275510	--	9000231127
EH651TK11E	SE.3I.60.BAS.28D.X	9000275523	9000275496	--	9000250937	EH885MB11E	SE.4I.80.PZ.BW.X	9000275525	9000275513	--	9000260115
EH675LD21E	SE.3I.60.LCD.32T.FS	9000275524	9000275509	--	LCD	EH885MB21E	SE.4I.80.PZ.BW.FS	9000275525	9000275513	--	9000242558
EH675LE21E	SE.4I.60.LCD.X.FS	9000274564	9000274537	--	LCD	EH901SK11	SE.5I.90.TOP.28D.X	9000275523	9000275496	9000275520	9000303878
EH675LE31E	SE.4I.60.LCD.X.CS	9000274564	9000274537	--	LCD	EH975LD21E	SE.5I.90.LCD.32T.FS	9000275524	9000275496	9000275520	LCD
EH675MB11E	SE.4I.60.TOP.BR.X	9000275525	9000274537	--	9000231127	EH975LK31E	SE.5I.90.LCD.28D.CS	9000275523	9000275496	9000275520	LCD
EH675MD11E	SE.3I.60.TOP.32T.X	9000275524	9000275509	--	9000231125	EH975MD21E	SE.5I.90.TOP.32T.FS	9000275524	9000275496	9000275520	9000231131
EH675MD21E	SE.3I.60.TOP.32T.FS	9000275524	9000275509	--	9000231126	EH975ME11E	SE.4I.90P.TOP.X.X	9000275517	--	9000275521	9000231127
EH675ME11E	SE.4I.60.TOP.X.X	9000274564	9000274537	--	9000231127	EH975MK11E	SE.5I.90.TOP.28D.X	9000275523	9000275496	9000275520	9000231132
EH675ME21E	SE.4I.60.TOP.X.FS	9000274564	9000274537	--	9000231129	EH975MK21E	SE.5I.90.TOP.28D.FS	9000275523	9000275496	9000275520	9000231131
EH675ME31E	SE.4I.60.TOP.X.CS	9000274564	9000274537	--	9000264650	EH975ML11E	SE.3I.90P.TOP.28S.X	9000275518	--	9000275521	9000231125
EH675MF11E	SE.2I.60.TOP.X.X	9000274561	--	--	9000231124	EH975ML21E	SE.3I.90P.TOP.28S.FS	9000275518	--	9000275521	9000231126
EH675MK21E	SE.3I.60.TOP.28D.FS	9000275523	9000275496	--	9000231126	EH975SK11E	SE.5I.90.TOP.28D.X	9000275523	9000275496	9000275520	9000303878
EH675TE11E	SE.4I.60.BAS.X.X	9000274564	9000274537	--	9000250938	EH975YK11E	SE.5I.90.TOP.28D.X	9000275523	9000275496	9000275520	#N/A
EH675TK11E	SE.3I.60.BAS.28D.X	9000275523	9000275496	--	9000250937	EH976LD21U	SE.5I.90.LCD.32T.FS	9000275524	9000275496	9000275520	LCD
EH679MD21	SE.3I.60.TOP.32T.FS	9000275524	9000275509	--	9000231126	EH979MD11U	SE.5I.90.TOP.32T.X	9000275524	9000275496	9000275520	9000231132
EH685MB21E	SE.4I.60.PZ.BR.FS	9000275525	9000274537	--	9000242579	EH985ME21E	SE.4I.90P.PZ.X.FS	9000275517	--	9000275521	9000242579
EH685MD21E	SE.3I.60.PZ.32T.FS	9000275524	9000275509	--	9000242580	EH985MK21E	SE.5I.90.PZ.28D.FS	9000275523	9000275496	9000275520	#N/A
EH685ME11E	SE.4I.60.PZ.X.X	9000274564	9000274537	--	9000260114	EI601TB11	SE.4I.60.POL.BR.X	9000275525	9000274537	--	9000270673
EH685ME21E	SE.4I.60.PZ.X.FS	9000274564	9000274537	--	9000242579	EI645EB11	SE.4I.60.POL.BR.X	9000275525	9000274537	--	9000270672
EH685MK11E	SE.3I.60.PZ.28D.X	9000275523	9000275496	--	9000259838	EI645EB11E	SE.4I.60.POL.BR.X	9000275525	9000274537	--	9000270672
EH775LD21E	SE.3I.60.LCD.32T.FS	9000275524	9000275509	--	LCD	EI645EB11M	SE.4I.60.POL.BR.X	9000275525	9000274537	--	9000270672
EH775ME21E	SE.4I.60.TOP.X.FS	9000274564	9000274537	--	9000231129	EI675TB11E	SE.4I.60.POL.BR.X	9000275525	9000274537	--	9000270673
EH785ME21E	SE.4I.60.PZ.X.X	9000274564	9000274537	--	9000260114	EI875TB11E	SE.4I.80.POL.BW.X	9000275525	9000275513	--	9000270674
EH801ME21E	SE.4I.80.TOP.WP.FS	9000274564	9000275513	--	9000231130	N44D30N0	NE.2I.30.BAS.X.X	9000275514	--	--	9000257251
EH801SB11	SE.4I.80.TOP.BW.X	9000275525	9000275513	--	9000303899	N44K30N0	NE.2I.30.KB.X.X	9000275514	--	--	9000109346
EH801TB11	SE.4I.80.BAS.BW.X	9000275525	9000275513	--	9000250941	N44K45N0	NE.1I.40.KB.28D.X	9000275515	--	--	9000303875
EH811TL11	SE.4I.80.BAS.28S.X	9000275526	9000275510	--	9000250938	NIB601T14E	BO.4I.60.POL.BR.X	9000275525	9000274537	--	9000270673
EH811TL11E	SE.4I.80.BAS.28S.X	9000275526	9000275510	--	9000250938	NIB645E14E	BO.4I.60.POL.BR.X	9000275525	9000274537	--	9000270672
EH845EB11	SE.4I.80.BAS.BW.X	9000275525	9000275513	--	9000250942	NIB672T14E	BO.4I.60.POL.BR.X	9000275525	9000274537	--	#N/A
EH845EB11E	SE.4I.80.BAS.BW.X	9000275525	9000275513	--	9000250942	NIB675T14E	BO.4I.60.POL.BR.X	9000275525	9000274537	--	9000270673
EH845TE11E	SE.4I.80.BAS.WP.X	9000274564	9000275513	--	9000250941	NIB679T14E	BO.4I.60.POL.BR.X	9000275525	9000274537	--	9000270673
EH845TL11E	SE.4I.80.BAS.28S.X	9000275526	9000275510	--	9000250938	NIB801T14E	BO.4I.80.POL.BW.X	9000275525	9000275513	--	9000270674
EH875LB21E	SE.4I.80.LCD.BW.FS	9000275525	9000275513	--	LCD	NIB872T14E	BO.4I.80.POL.BW.X	9000275525	9000275513	--	#N/A
EH875LB31E	SE.4I.80.LCD.WP.CS	9000274564	9000275513	--	LCD	NIB875T14E	BO.4I.80.POL.BW.X	9000275525	9000275513	--	9000270674
EH875LE21E	SE.4I.80.LCD.WP.FS	9000274564	9000275513	--	LCD	NIC645E14E	BO.2I.60.POL.X.X	9000274561	--	--	9000270670
EH875LL21E	SE.4I.80.LCD.28S.FS	9000275526	9000275510	--	LCD	NIT5065UC	BO.4I.80.TOP.28S.X	9000275526	9000275510	--	9000236088
EH875ME21E	SE.4I.80.TOP.WP.FS	9000274564	9000275513	--	9000231130	NIT5665UC	BO.5I.90.TOP.28D.X	9000275523	9000275496	9000275520	9000236094
EH875ML11E	SE.4I.80.TOP.28S.X	9000275526	9000275510	--	9000231127	NIT8065UC	BO.4I.80.PZ.28S.FS	9000275526	9000275510	--	9000242582

MODEL	DESCRIPTION	Left 1 ELIN	Right ELIN	Left 2 ELIN	TC	MODEL	DESCRIPTION	Left 1 ELIN	Right ELIN	Left 2 ELIN	TC
NIT8665UC	BO.5I.90.PZ.28D.FS	9000275523	9000275496	9000275520	9000296949	PIF651T14E	BO.2I.60.BAS.X.X	9000274561	--	--	9000250934
PIB601N24E	BO.4I.60.TOP.BR.FS	9000275525	9000274537	--	9000236089	PIK601N24E	BO.3I.60.TOP.28D.FS	9000275523	9000275496	--	9000236087
PIB675L24E	BO.4I.60.LCD.BR.FS	9000275525	9000274537	--	LCD	PIK651T14E	BO.3I.60.BAS.28D.X	9000275523	9000275496	--	9000250937
PIB675L34E	BO.4I.60.LCD.BR.CS	9000275525	9000274537	--	LCD	PIK675N24E	BO.3I.60.TOP.28D.FS	9000275523	9000275496	--	9000236087
PIB675M24E	BO.4I.60.TOP.BR.FS	9000275525	9000274537	--	9000249294	PIK675T14E	BO.3I.60.BAS.28D.X	9000275523	9000275496	--	9000250937
PIB675N24E	BO.4I.60.TOP.BR.FS	9000275525	9000274537	--	9000236089	PIK975N24E	BO.5I.90.TOP.28D.FS	9000275523	9000275496	9000275520	9000236091
PIB675T14E	BO.4I.60.BAS.BR.X	9000275525	9000274537	--	9000250938	PIL575N14E	BO.2I.60P.TOP.28S.X	9000275516	--	--	9000248170
PIB685N24E	BO.4I.60.PZ.BR.FS	9000275525	9000274537	--	9000242582	PIL645R14E	BO.3I.60.SQ.28S.X	9000275522	9000274537	--	9000229601
PIB801N24E	BO.4I.80.TOP.BW.FS	9000275525	9000275513	--	9000236090	PIL651R14E	BO.3I.60.SQ.28S.X	9000275522	9000274537	--	9000229601
PIB875L24E	BO.4I.80.LCD.BW.FS	9000275525	9000275513	--	LCD	PIL811T14E	BO.4I.80.BAS.28S.X	9000275526	9000275510	--	9000250940
PIB875L34E	BO.4I.80.LCD.BW.CS	9000275525	9000275513	--	LCD	PIL845T14E	BO.4I.80.BAS.28S.X	9000275526	9000275510	--	9000250938
PIB875N24E	BO.4I.80.TOP.BW.FS	9000275525	9000275513	--	9000236090	PIL875L24E	BO.4I.80.LCD.28S.FS	9000275526	9000275510	--	LCD
PIB875T14E	BO.4I.80.BAS.BW.X	9000275525	9000275513	--	9000250941	PIL875N14E	BO.4I.80.TOP.28S.X	9000275526	9000275510	--	9000236088
PIB885N24E	BO.4I.80.PZ.BW.FS	9000275525	9000275513	--	9000242581	PIL875N24E	BO.4I.80.TOP.28S.FS	9000275526	9000275510	--	9000236089
PIC645E14E	BO.2I.60.BAS.X.X	9000274561	--	--	9000250933	PIL975L34E	BO.5I.90.LCD.28D.CS	9000275523	9000275496	9000275520	LCD
PID675N14E	BO.3I.60.TOP.32T.X	9000275524	9000275509	--	9000236086	PIL975N14E	BO.3I.90P.TOP.28S.X	9000275518	--	9000275521	9000236086
PID675N24E	BO.3I.60.TOP.32T.FS	9000275524	9000275509	--	9000236087	T42D20X0	NE.4I.60.BAS.X.X	9000274564	9000274537	--	9000231118
PID685N24E	BO.3I.60.PZ.32T.FS	9000275524	9000275509	--	9000242583	T42D30X0	NE.3I.60.BAS.28D.X	9000275523	9000275496	--	9000231116
PID775L24E	BO.3I.60.LCD.32T.FS	9000275524	9000275509	--	LCD	T42D85X0	NE.4I.80.BAS.28S.X	9000275526	9000275510	--	9000231118
PID975L24E	BO.5I.90.LCD.32T.FS	9000275524	9000275496	9000275520	LCD	T42P90X0	NE.3I.90P.BAS.28S.X	9000275518	--	9000275521	9000231116
PID975N24E	BO.5I.90.TOP.32T.FS	9000275524	9000275496	9000275520	9000236091	T43D10N0	NE.3I.60.BAS.28S.X	9000275522	9000274537	--	9000231116
PIE375C14E	BO.2I.30.KB.X.X	9000275514	--	--	9000303876	T43D20N0	NE.4I.60.BAS.X.X	9000274564	9000274537	--	9000231119
PIE375N14E	BO.2I.30.TOP.X.X	9000275514	--	--	9000248170	T43D20S0	NE.4I.60.BAS.X.X	9000274564	9000274537	--	9000231119
PIE601N24E	BO.4I.60.TOP.X.FS	9000274564	9000274537	--	9000236089	T43D40N0	NE.4I.60.BAS.BR.X	9000275525	9000274537	--	9000231119
PIE611T14E	BO.4I.60.BAS.X.X	9000274564	9000274537	--	9000250940	T43D80N0	NE.4I.80.BAS.BW.X	9000275525	9000275513	--	9000231121
PIE645Q14E	BO.4I.60.SQ.X.X	9000274564	9000274537	--	9000183912	T43P90N0	NE.4I.90P.BAS.X.X	9000275517	--	9000275521	9000231119
PIE645R14E	BO.4I.60.SQ.X.X	9000274564	9000274537	--	9000229602	T43R10N0	NE.2I.60.BAS.X.X	9000274561	--	--	9000231115
PIE645T14E	BO.4I.60.BAS.X.X	9000274564	9000274537	--	9000250938	T43R20N0	NE.2I.60.BAS.X.X	9000274561	--	--	9000231115
PIE651R14E	BO.4I.60.SQ.X.X	9000274564	9000274537	--	9000229602	T43T20N0	NE.4I.60.TOP.X.X	9000274564	9000274537	--	9000231057
PIE651T14E	BO.4I.60.BAS.X.X	9000274564	9000274537	--	9000250938	T43T40N0	NE.4I.60.TOP.BR.X	9000275525	9000274537	--	9000231057
PIE675L24E	BO.4I.60.LCD.X.FS	9000274564	9000274537	--	LCD	T43T80N0	NE.4I.80.TOP.BW.X	9000275525	9000275513	--	9000231110
PIE675N14E	BO.4I.60.TOP.X.X	9000274564	9000274537	--	9000236088	T43T85N0	NE.4I.80.TOP.28S.X	9000275526	9000275510	--	9000231057
PIE675N24E	BO.4I.60.TOP.X.FS	9000274564	9000274537	--	9000236089	T44C80N0	NE.4I.80.LCD.BW.FS	9000275525	9000275513	--	LCD
PIE685N24E	BO.4I.60.PZ.X.FS	9000274564	9000274537	--	9000242582	T44C90N0	NE.5I.90.LCD.28D.FS	9000275523	9000275496	9000275520	LCD
PIE775N14E	BO.4I.60.TOP.X.X	9000274564	9000274537	--	9000236088	T44D20N0	NE.4I.60.BAS.X.X	9000274564	9000274537	--	9000231119
PIE801N24E	BO.4I.80.TOP.WP.FS	9000274564	9000275513	--	9000236090	T44D30N0	NE.3I.60.BAS.28D.X	9000275523	9000275496	--	9000231116
PIE845T14E	BO.4I.80.BAS.WP.X	9000274564	9000275513	--	9000250941	T44D35N0	NE.3I.60.BAS.32T.FS	9000275524	9000275509	--	9000231117
PIE875N24E	BO.4I.80.TOP.WP.FS	9000274564	9000275513	--	9000236090	T44D85N0	NE.4I.80.BAS.28S.X	9000275526	9000275510	--	9000231119
PIE875T14E	BO.4I.80.BAS.WP.X	9000274564	9000275513	--	9000250941	T44M40N0	NE.4I.60.PZ.BR.X	9000275525	9000274537	--	9000242584
PIE975N14E	BO.4I.90P.TOP.X.X	9000275517	--	9000275521	9000236088	T44M80N0	NE.4I.80.PZ.BW.X	9000275525	9000275513	--	9000242585
PIF645R14E	BO.2I.60.SQ.X.X	9000274561	--	--	9000229600	T44T30N0	NE.3I.60.TOP.28D.X	9000275523	9000275496	--	9000264435
PIF645T14E	BO.2I.60.BAS.X.X	9000274561	--	--	9000250934	EI675ZK11E	SE.3I.60.POL.28D.X	9000275523	9000275496	--	#N/A
PIF651R14E	BO.2I.60.SQ.X.X	9000274561	--	--	9000229600	T44T40N0	NE.4I.60.TOP.BR.X	9000275525	9000274537	--	9000231057

MODEL	DESCRIPTION	Left 1 ELIN	Right ELIN	Left 2 ELIN	TC
T44T70N0	NE.4I.60.TOP.BR.X	9000275525	9000274537	--	9000231057
T44T80N0	NE.4I.80.TOP.BW.X	9000275525	9000275513	--	9000231110
T44T90N0	NE.5I.90.TOP.28D.X	9000275523	9000275496	9000275520	9000231113
T45C80X0	NE.4I.80.LCD.BW.FS	9000275525	9000275513	--	LCD
T45D40X0	NE.4I.60.BAS.BR.X	9000275525	9000274537	--	9000231119
T45D80X0	NE.4I.80.BAS.BW.X	9000275525	9000275513	--	9000231121
T45P90X0	NE.4I.90P.BAS.X.X	9000275517	--	9000275521	9000231119
T45T40X0	NE.4I.60.TOP.BR.X	9000275525	9000274537	--	9000231057
T45T80X0	NE.4I.80.TOP.BW.X	9000275525	9000275513	--	9000231110
T45T90X0	NE.5I.90.TOP.28D.X	9000275523	9000275496	9000275520	9000231113
T83I40N0MC	NE.4I.60.TOP.BR.FS	9000275525	9000274537	--	9000231058
T83I80N0MC	NE.4I.80.TOP.BW.FS	9000275525	9000275513	--	9000231111
NIK675Z14E	BO.3I.60.POL.28D.X	9000275523	9000275496	--	#N/A
NIB645E14M	BO.4I.60.POL.BR.X	9000275525	9000274537	--	9000270672
CA423350	CN.3I.60.BAS.28S.X	9000275522	9000274537	--	9000250937
PIB645M24M	BO.4I.60.TOP.BR.FS	9000275525	9000274537	--	#N/A
EH679ME21	SE.4I.60.TOP.X.FS	9000274564	9000274537	--	#N/A

MODEL	DESCRIPTION	Left 1 ELIN	Right ELIN	Left 2 ELIN	TC
EH679ME11	SE.4I.60.TOP.X.X	9000274564	9000274537	--	#N/A
EH679MB11	SE.4I.60.TOP.BR.X	9000275525	9000274537	--	9000231127
PIE679T14E	BO.4I.60.BAS.X.X	9000274564	9000274537	--	9000250938
PIB679T14E	BO.4I.60.BAS.BR.X	9000275525	9000274537	--	9000250938
EH651RF11E	SE.2I.60.SQ.X.X	9000274561	--	--	9000229600
EH879SB11	SE.4I.80.TOP.BW.X	9000275525	9000275513	--	9000303899
EH679MK11	SE.3I.60.TOP.28D.X	9000275523	9000275496	--	9000231125
EI645EC11	SE.2I.60.POL.X.X	9000274561	--	--	9000270670
PIL879T14E	BO.4I.80.BAS.28S.FS	9000275526	9000275510	--	9000250938
EH679MK21	SE.3I.60.TOP.28D.FS	9000275523	9000275496	--	9000231126
EH879ME21	SE.4I.80.TOP.WP.FS	9000274564	9000275513	--	9000231130
PIK679T14E	BO.3I.60.BAS.28D.FS	9000275523	9000275496	--	9000250937
EH879ML11	SE.4I.80.TOP.28S.X	9000275526	9000275510	--	9000231127
T44T40M0	NE.4I.60.TOP.BR.X	9000275525	9000274537	--	9000242584
T44T80M0	NE.4I.80.TOP.BW.X	9000275525	9000275513	--	9000242585
CI273612	GA.4I.70.TOP.BR.FS	9000275525	9000274537	--	9000227509
CI490612	GA.4I.90P.TOP.X.FS	9000275517	--	9000275521	9000227509

5.13 Stains on glass surface or the inductors

Frequently the stains are actually not stains at all, but stubborn dirt which disappears when cleaned with the glass scraper and a suitable detergent. (Fairy and a BSH product for cleaning ceramic surfaces.)

On the website of the brand manufacturers is a video on the subject of cleaning which may help us explain to the user how to clean ceramic surfaces.

Other stains, which occur when utensils are unintentionally left to stand, also disappear when cleaned properly, however they also cause a brownish discolouration on the inductors and shadows on the back of the glass surface.

5.13.1 Stains caused by leaving utensils to stand

Stains which occur when utensils are left to stand are:

Rear view of the glass surface



Appearance of the inductors

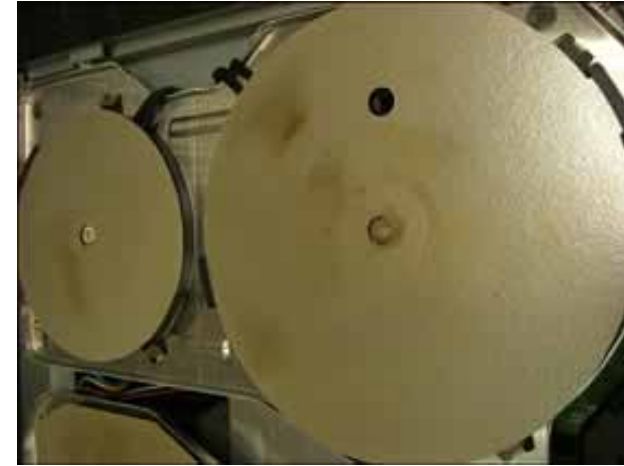

View of the glass surface from above





5.13.2 Repair due to utensils left to stand

First, we clean the glass with Fairy, glass scraper and the BSH detergent for ceramic surfaces.

It is also very important to check whether the inductors are in perfect working order.

Even if they perform correctly, check that the NTC resistors are in perfect working order to avoid subsequent problems.

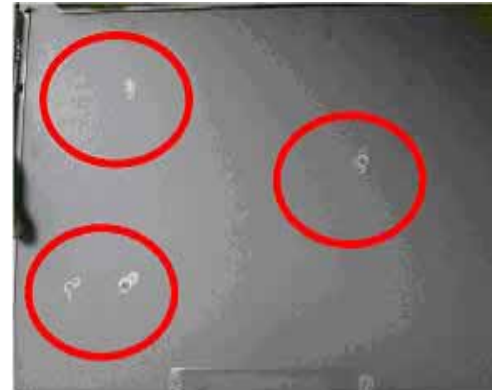

5.13.3 Shimmering metallic stains on the glass surface

Under certain thermal conditions the heat transfer compound of the NTC resistors may react with the coating on the back of the glass surface. This may cause stains on the back of the ceramic which are visible from above.

5.13.3.1 Solution

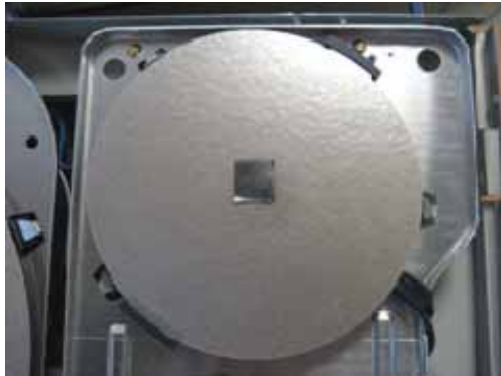

The glass must be replaced with a new one.

Procedure:

1. Remove old glass surface.
2. Apply heat transfer compound to the NTC resistors (618647).
3. Cover heat transfer compound with foil (which comes together with the glass spare part set) to prevent contact with the new glass surface.
4. Attach new glass surface. **Caution with the safety brackets (they may damage the paint).**

5.14 What is to be considered when using induction cookware

- Use **pans** which have a **thick and level base** so that they are in full contact with the cooking surface.
- The diameter of the **pan base** must correspond exactly with the **size of the cooking zone**.
- Remember that the **diameter** to be considered is that of the **ferromagnetic area**.

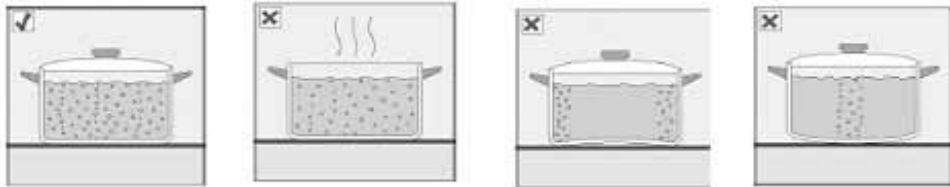

5.14.1 Levelness

If a **thick and level base** is selected, i.e. pans with stainless steel sandwich base, **the heat distribution is much better**, saving time and energy.



5.14.2 Size

The diameter of the **pan base** must correspond exactly with the **size of the cooking zone**.

Opening diameter

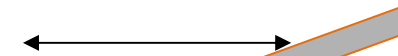

Base diameter

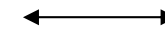

Note that the pan manufacturers usually indicate the opening diameter of the pan.

This is frequently larger than the base diameter.

Each cooking zone has a **pan detection minimum limit**. This value cannot be calculated exactly, as behaviour depends on the material of the pan used. We therefore recommend using the zone which corresponds most closely with the diameter of your pan.

The diameter which is to be considered is that of the **ferromagnetic part**.

Some pans are not ferromagnetic all over. To check this, we must check whether a magnet sticks over the entire pan base.

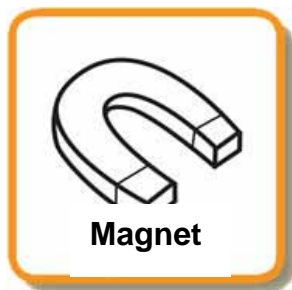

5.14.3 Material

Only **ferromagnetic pans** are suitable for cooking with induction. These can be made of the following materials:

- Enamelled steel
- Cast iron
- Special utensil for stainless steel induction

Never use pans made of:

Normal stainless steel

Glass

Clay/ceramic

Copper

Aluminium

In general the pan manufacturers indicate whether their pans are suitable for induction, you can also check yourself with a magnet and test whether it is attracted by the pan.



5.14.4 Tested or recommended pans

5.14.4.1 Pans with 32 cm diameter for all cooker types



Article number: **570370**.

5.14.4.2 Frying pans for the frying sensor



Brand WMF

Available in three sizes: 15 cm, 18 cm and 21 cm.
With sandwich base.

570364 for 15 cm

570365 for 18 cm

570366 for 21 cm

464355 Frying pan which was supplied together with the appliance,
D21 cm (Demeyere)

5.14.4.3 Coffee pot



463820