

STATE OF NEW HAMPSHIRE
DEPARTMENT OF TRANSPORTATION
**CONSTRUCTION PLANS
FEDERAL AID PROJECT**

X-A000(737)
N.H. PROJECT NO. 13928A
US ROUTE 3

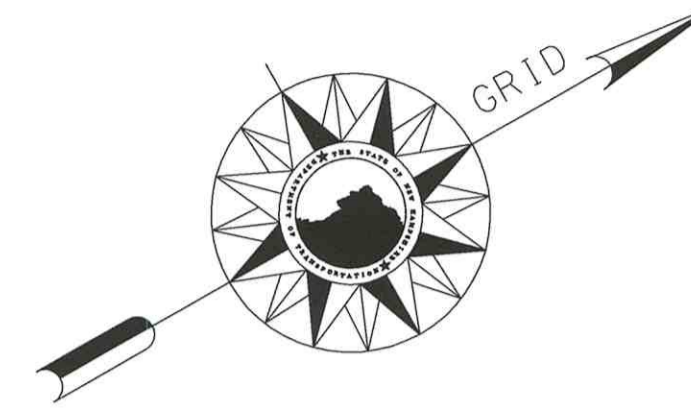

DESIGN DATA	
AVERAGE DAILY TRAFFIC 20_12	4400 vpd
AVERAGE DAILY TRAFFIC 20_32	5400 vpd
PERCENT OF TRUCKS	8.4%
DESIGN SPEED	50 mph
LENGTH OF PROJECT	1.25 mi

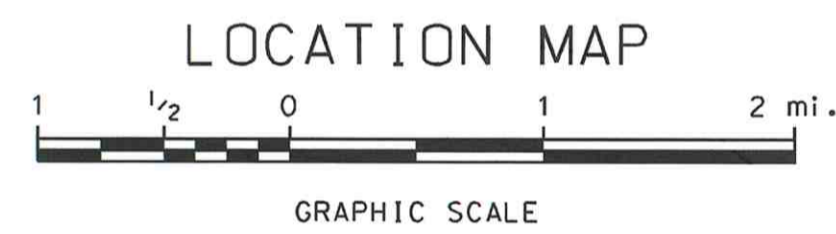
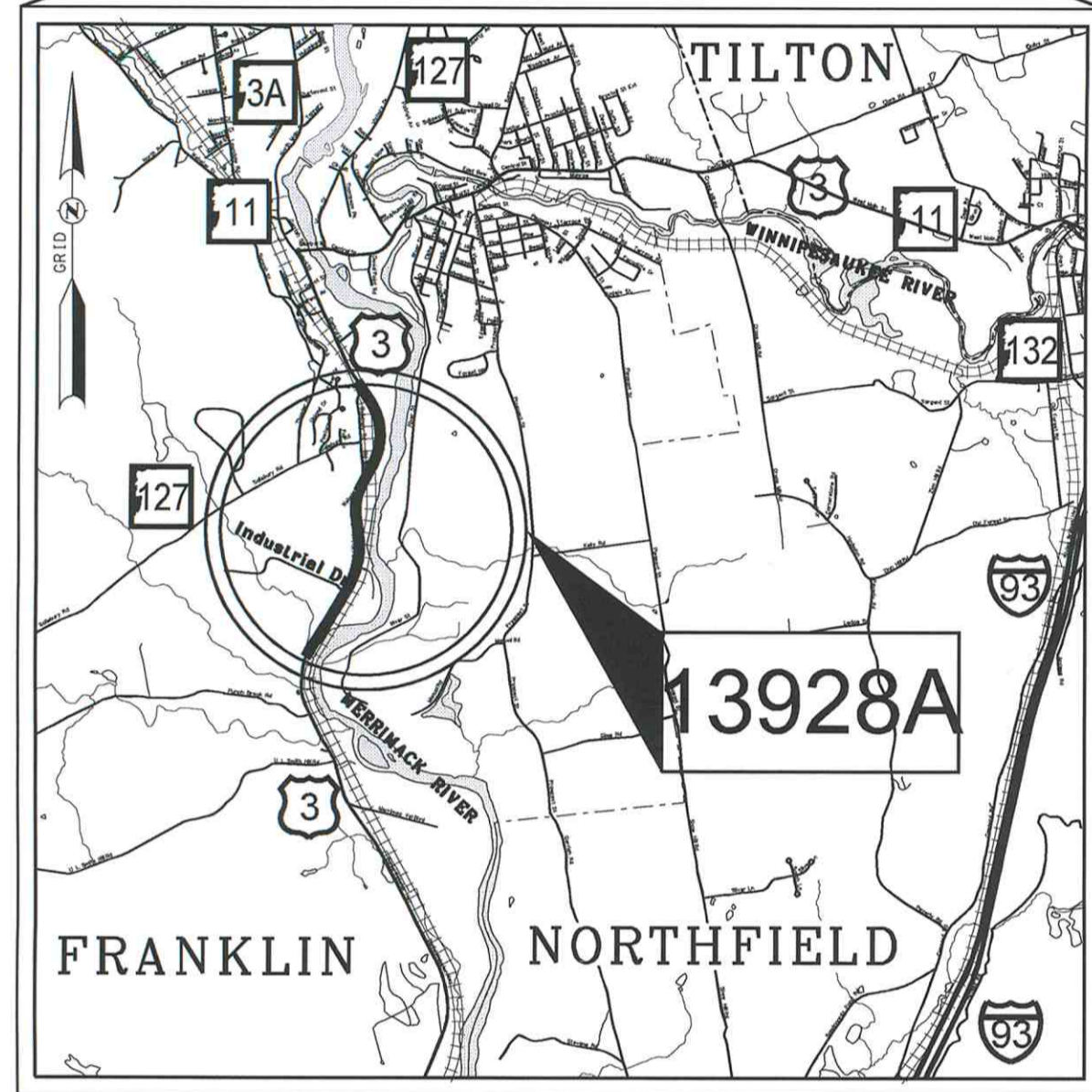

STA. 96+75
BEGIN APPROACH

STA. 97+50
BEGIN FULL BOX
CONSTRUCTION

STA. 24+50
LIMIT OF WORK

STA. 125+50
END FULL BOX CONSTRUCTION
BEGIN RECLAMATION

STA. 162+50
END
RECLAMATION

STA. 163+00
END APPROACH

APPROX 15' BEYOND ISLAND
LIMIT OF WORK

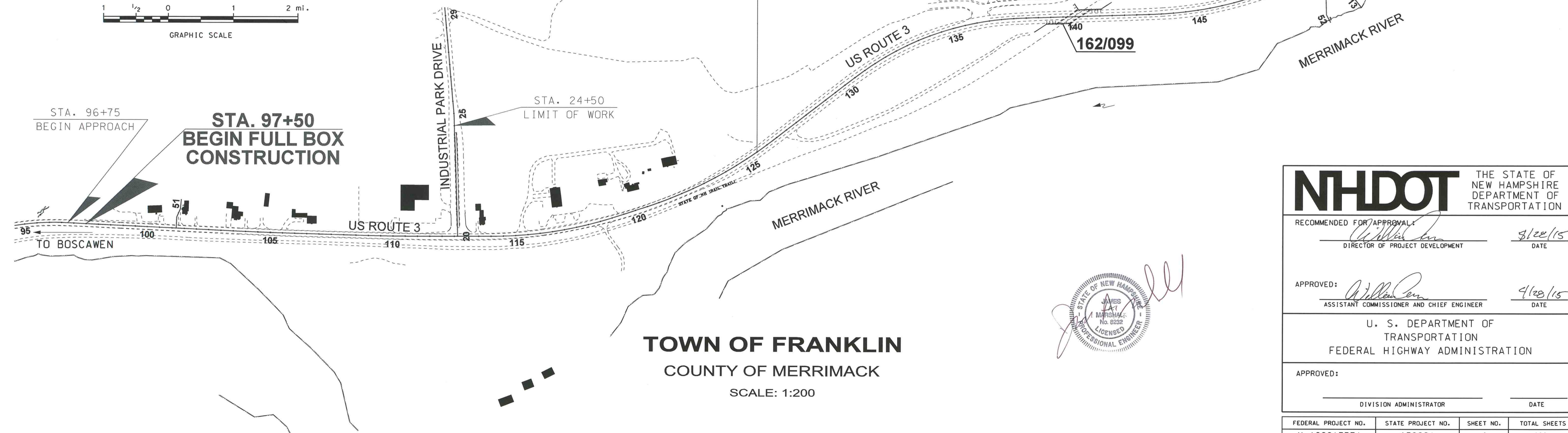

TOWN OF FRANKLIN
COUNTY OF MERRIMACK

SCALE: 1:200



NH DOT THE STATE OF
NEW HAMPSHIRE
DEPARTMENT OF
TRANSPORTATION

RECOMMENDED FOR APPROVAL

 DIRECTOR OF PROJECT DEVELOPMENT 3/22/15
 DATE

APPROVED:

 ASSISTANT COMMISSIONER AND CHIEF ENGINEER 4/28/15
 DATE

U. S. DEPARTMENT OF
TRANSPORTATION
FEDERAL HIGHWAY ADMINISTRATION

APPROVED:
 DIVISION ADMINISTRATOR DATE

FEDERAL PROJECT NO.	STATE PROJECT NO.	SHEET NO.	TOTAL SHEETS
X-A000(737)	13928A	1	160

DRAWN BY L. Schoffeld
 CHECKED BY C. SPETELUNAS
 DATE 06/2014
 DATE 04/2015

GENERAL NOTES

- ① FOR STANDARD PLANS, SEE "STANDARD PLANS FOR ROAD CONSTRUCTION" DATED 2010 (A BOUND BOOK).
- ② HIGH TENSION OVERHEAD TRANSMISSION LINES ARE LOCATED THROUGHOUT THE PROJECT WITH CROSSINGS AT VARIOUS LOCATIONS AND RUNNING ALONG THE ROAD THROUGHOUT THE PROJECT EVEN ON REGULAR POLES. THE CONTRACTOR IS ADVISED THAT EXTREME CAUTION WILL BE REQUIRED IN THE OPERATION OF EQUIPMENT, ESPECIALLY CRANES AND PILE DRIVING EQUIPMENT.
- ③ MODIFY SUPERELEVATION ON EXISTING CURVES BY THE USE OF A LEVELING COURSE TO THE RATES INDICATED ON THE PLANS OR AS ORDERED.
- ④ EXISTING DELINEATORS AND WITNESS MARKERS THAT ARE REMOVED AND DETERMINED BY THE ENGINEER TO BE IN ACCEPTABLE CONDITION SHALL BE RESET (SUBSIDIARY). ADDITIONAL DELINEATORS AND WITNESS MARKERS ORDERED WILL BE PAID UNDER THE APPROPRIATE ITEMS OF THE CONTRACT.
- ⑤ NO EXISTING MONUMENTS, BOUNDS, OR BENCHMARKS SHALL BE DISTURBED WITHOUT FIRST MAKING PROVISIONS FOR RELOCATION.
- ⑥ PERFORM ALL WORK WITHIN THE EXISTING RIGHT-OF-WAY, UNLESS OTHERWISE SHOWN ON THE PLANS OR AS ORDERED BY THE ENGINEER.
- ⑦ REMOVE UNPROTECTED PROJECT MARKERS (SUBSIDIARY).
- ⑧ SURVEY DATA FOR THIS PROJECT WAS COLLECTED BY SDR AND THE FIELD NOTES CAN BE FOUND IN THE FIELD BOOKS 13321 & 13430. COORDINATES ARE NEW HAMPSHIRE STATE PLANE COORDINATES OF NAD83, 1986 ADJUSTMENT AND THE BEARINGS ARE GRID. ELEVATIONS ARE REFERENCED TO NGVD 1929.
- ⑨ QUANTITIES FOR EMBANKMENT AND EXCAVATION FOR SLOPE ROUNDINGS AS SHOWN ON THE TYPICALS HAVE NOT BEEN CALCULATED AND ARE NOT INCLUDED IN THE QUANTITY SUMMARIES, AND ARE CONSIDERED SUBSIDIARY TO THE APPROPRIATE 203 ITEMS.

THE FOLLOWING GENERAL NOTES WILL BE USED ON THIS PROJECT:											
①	○	○	④	⑤	⑥	○	⑧	⑨	○	○	○
○	○	○	○	○	○	○	○	○	○	○	○

SHEET NO.	DESCRIPTION
1	TITLE PAGE
2	INDEX OF SHEETS AND GENERAL NOTES
3,4	STANDARD SYMBOLS
5-10	TYPICAL SECTIONS OF IMPROVEMENT
11-13	SUMMARY OF QUANTITIES
	SPECIAL USE PLANS
14-16	SIGN TEXT LAYOUT
17,18	PAVEMENT MATCH DETAILS
19,20	DRIVE DETAIL @ 101+17
21	DRIVEWAY DETAIL
22,23	DRAINAGE NOTES 6 & 7 SPECIAL DROP INLET DETAILS
24,25	DRAINAGE DETAILS
26,27	SOUTH SLOPE REPAIR @ STA. 150+00 DETAIL
28,29	CONCRETE SWALE DRAINAGE OUTLET DETAIL
30,31	LODGE SLOPE REPAIR @ STA. 153+50 DETAIL
32	31" GUARDRAIL DETAIL
33	PREFERRED OFFSET GUARDRAIL PLATFORM DETAIL
34	CRT DETAIL
35	GUARDRAIL TERMINAL DELINEATION DETAIL
36,37	RETAINING WALL DETAIL
	BRIDGE PLANS
38-41	BRIDGE NUMBER 162/099
	ROADWAY PLANS
42-47	GENERAL PLANS
48-53	PROFILES
54,55	DRAINAGE NOTES
56-61	DRAINAGE & UTILITY PLANS
62-67	PAVEMENT MARKING, PAVEMENT LAYOUT, & CURBING PLANS
68-73	SIGNING & LIGHTING PLANS
	CROSS SECTIONS
74-147	U.S. ROUTE 3
148-154	INDUSTRIAL PARK DRIVE
155-160	CITY WATER MAIN RELOCATION PLANS

STATE OF NEW HAMPSHIRE				
DEPARTMENT OF TRANSPORTATION • BUREAU OF HIGHWAY DESIGN				
<i>INDEX OF SHEETS AND GENERAL NOTES</i>				
REVISION DATE	DGN	STATE PROJECT NO.	SHEET NO.	TOTAL SHEETS
11-21-14	index_sheet	13928A	2	160

GENERAL

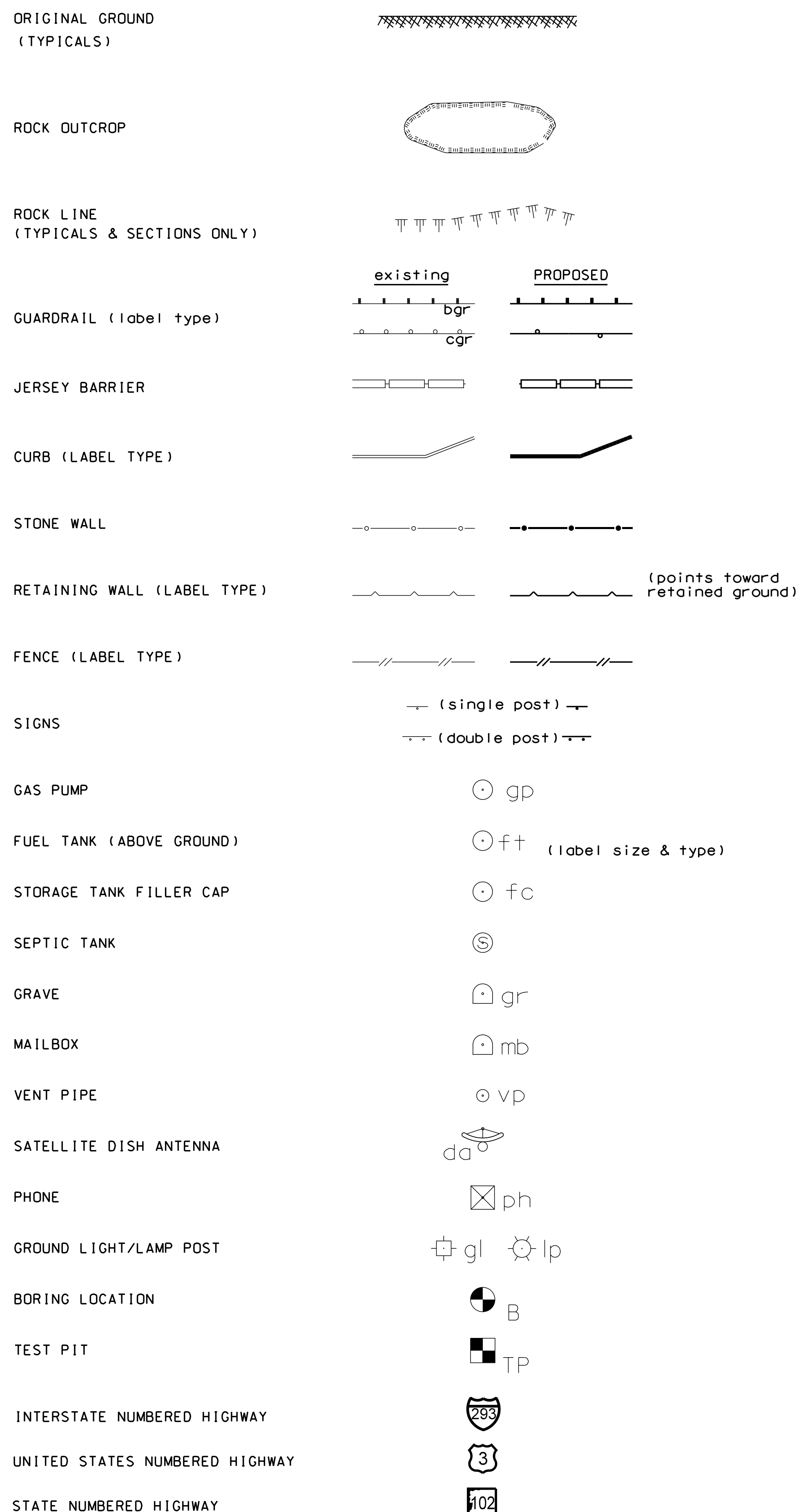
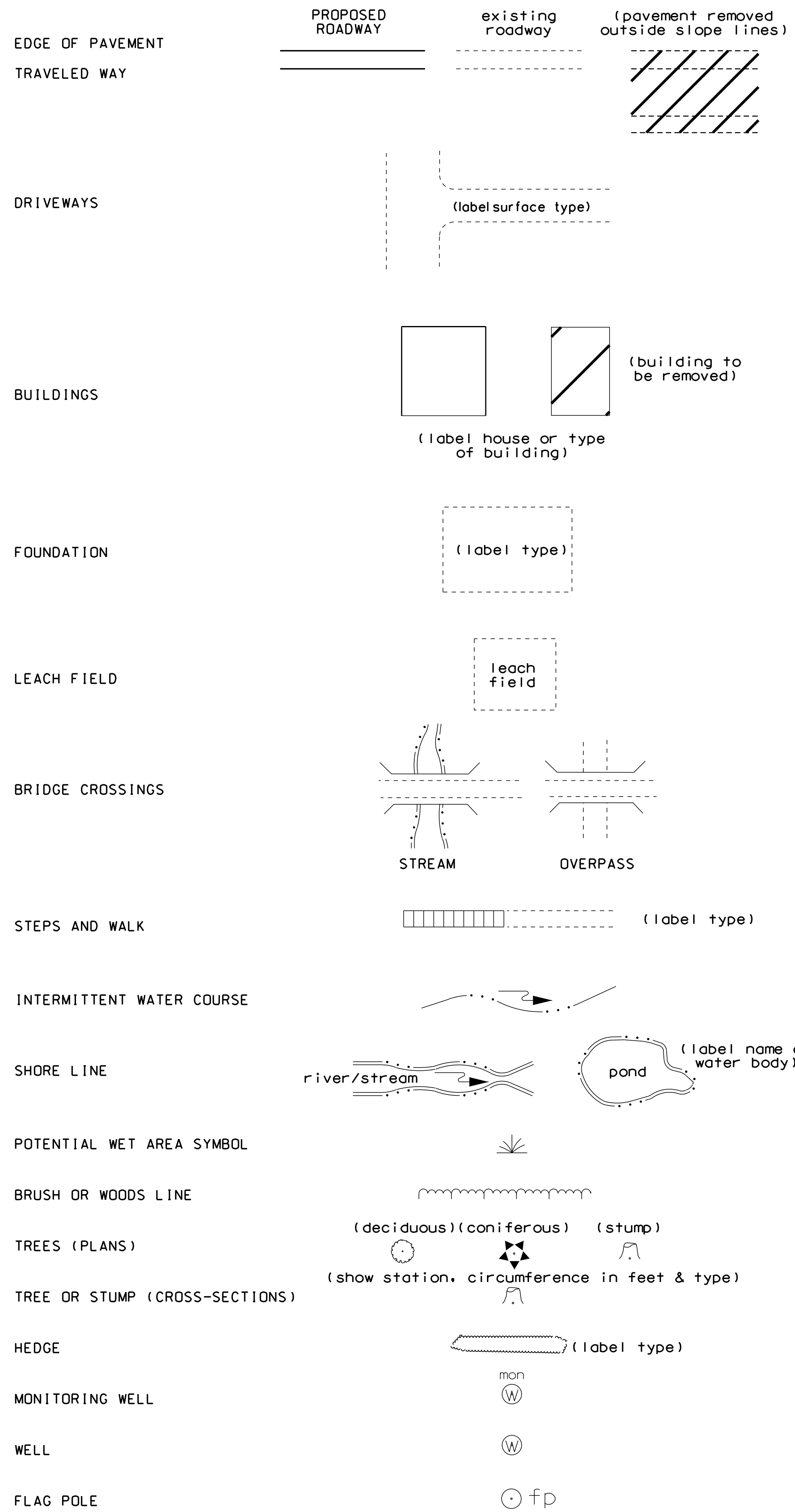

SHORELAND - WETLAND

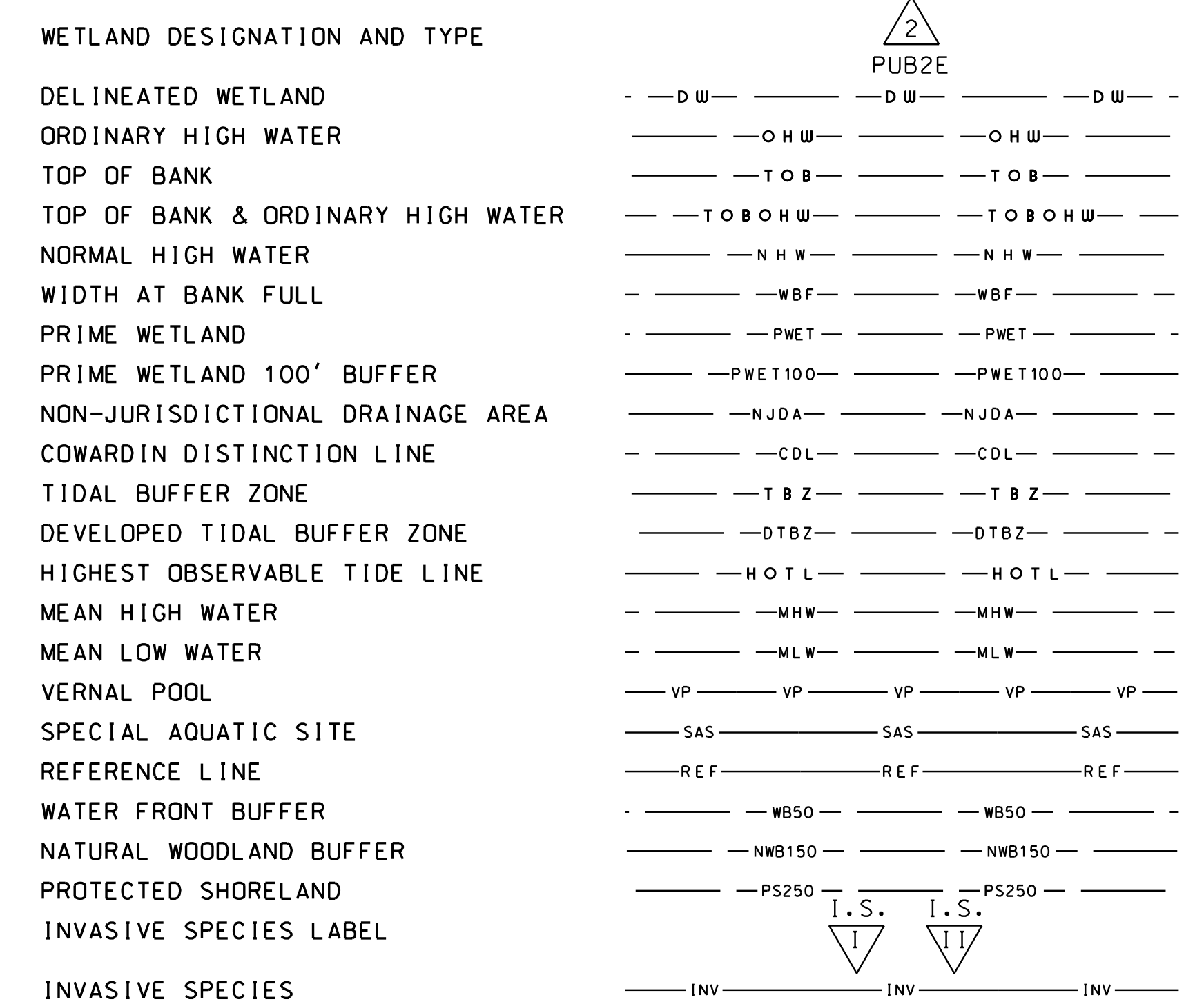

FLOODPLAIN / FLOODWAY

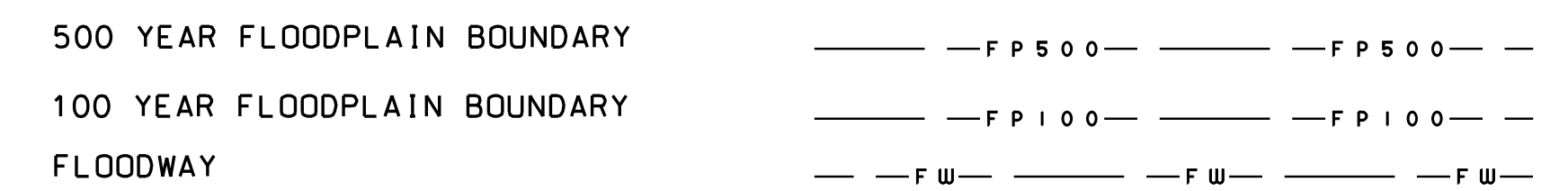

ENGINEERING

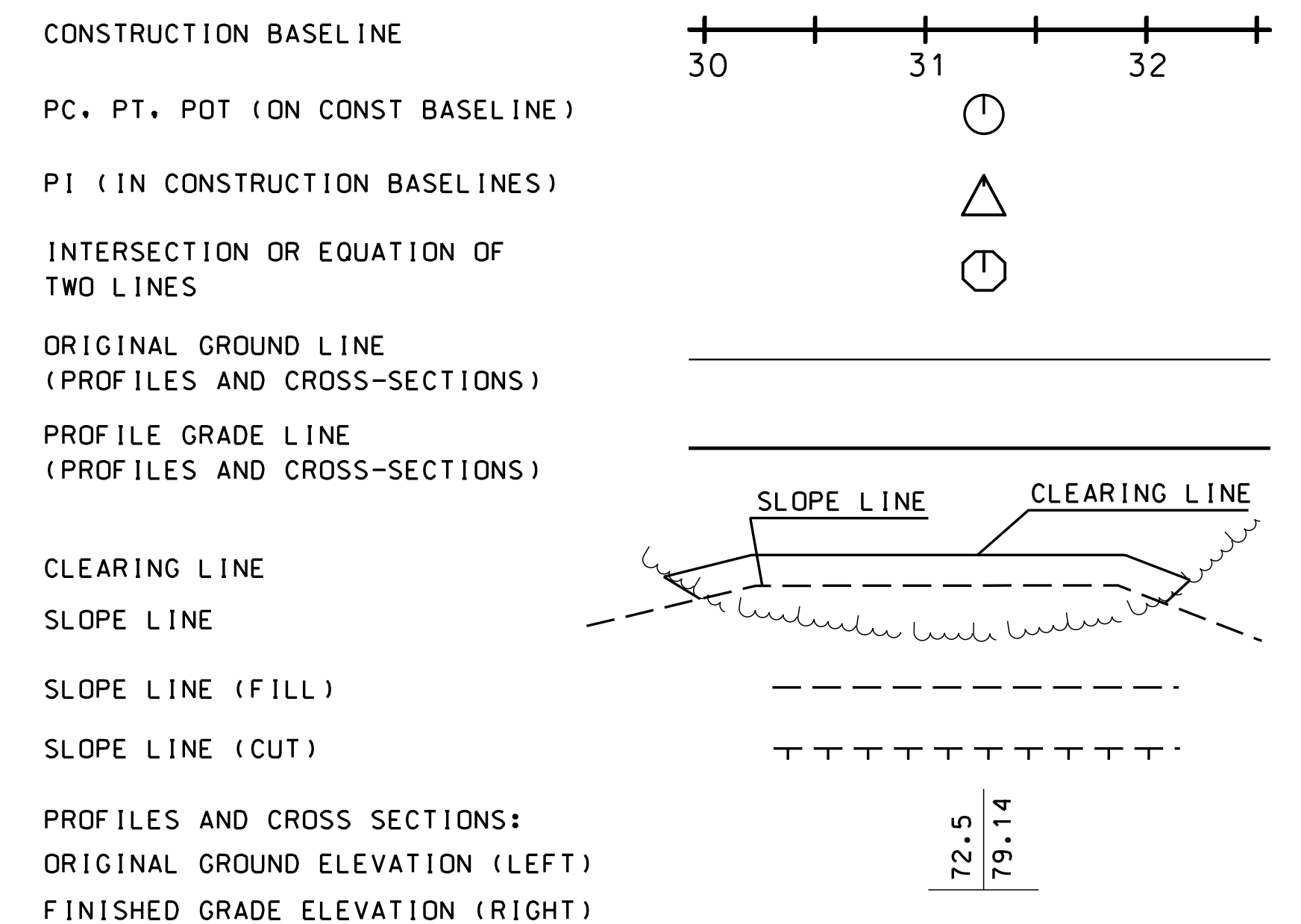

DRAINAGE

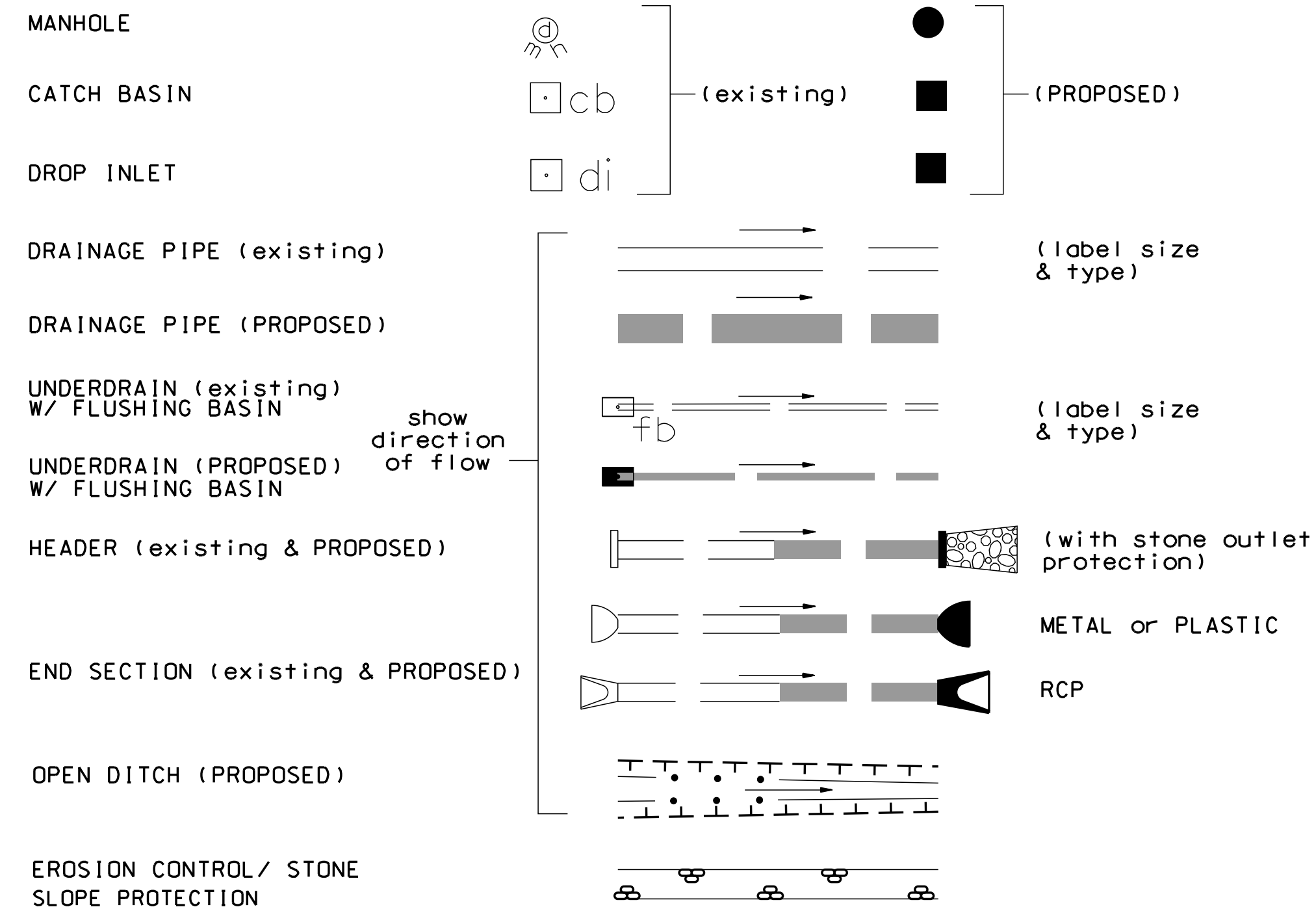

BOUNDARIES / RIGHT-OF-WAY

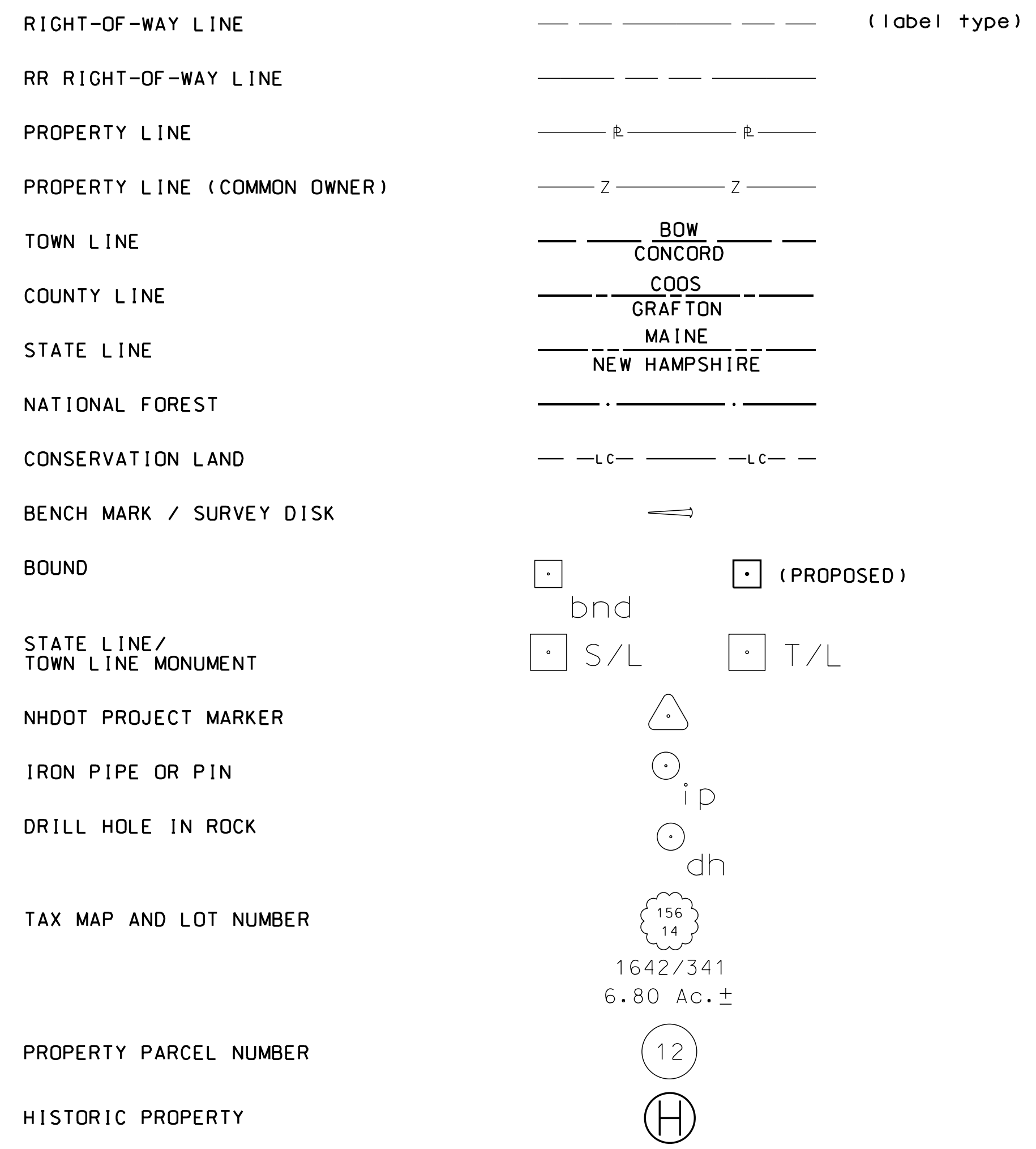

UTILITIES

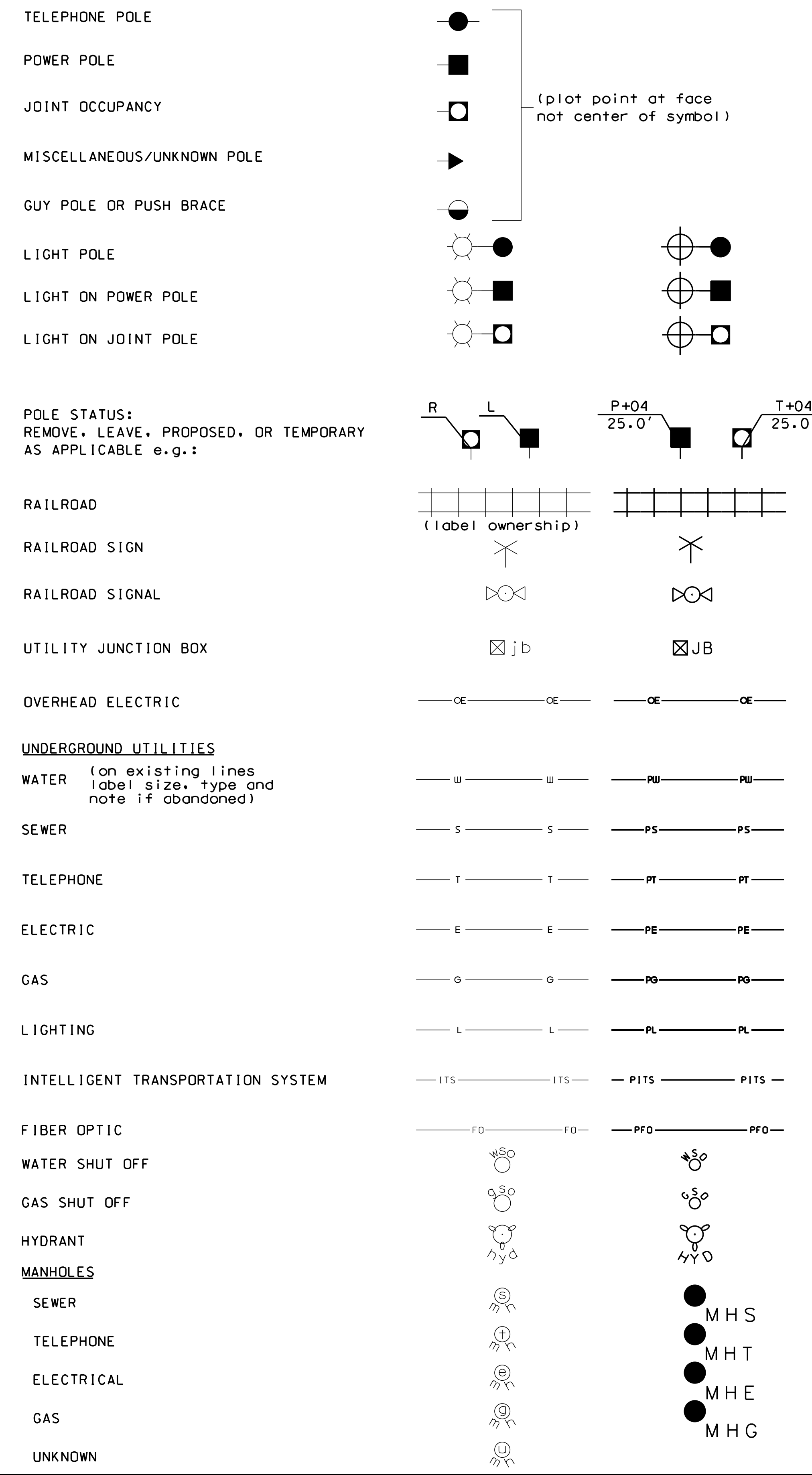

TRAFFIC SIGNALS / ITS

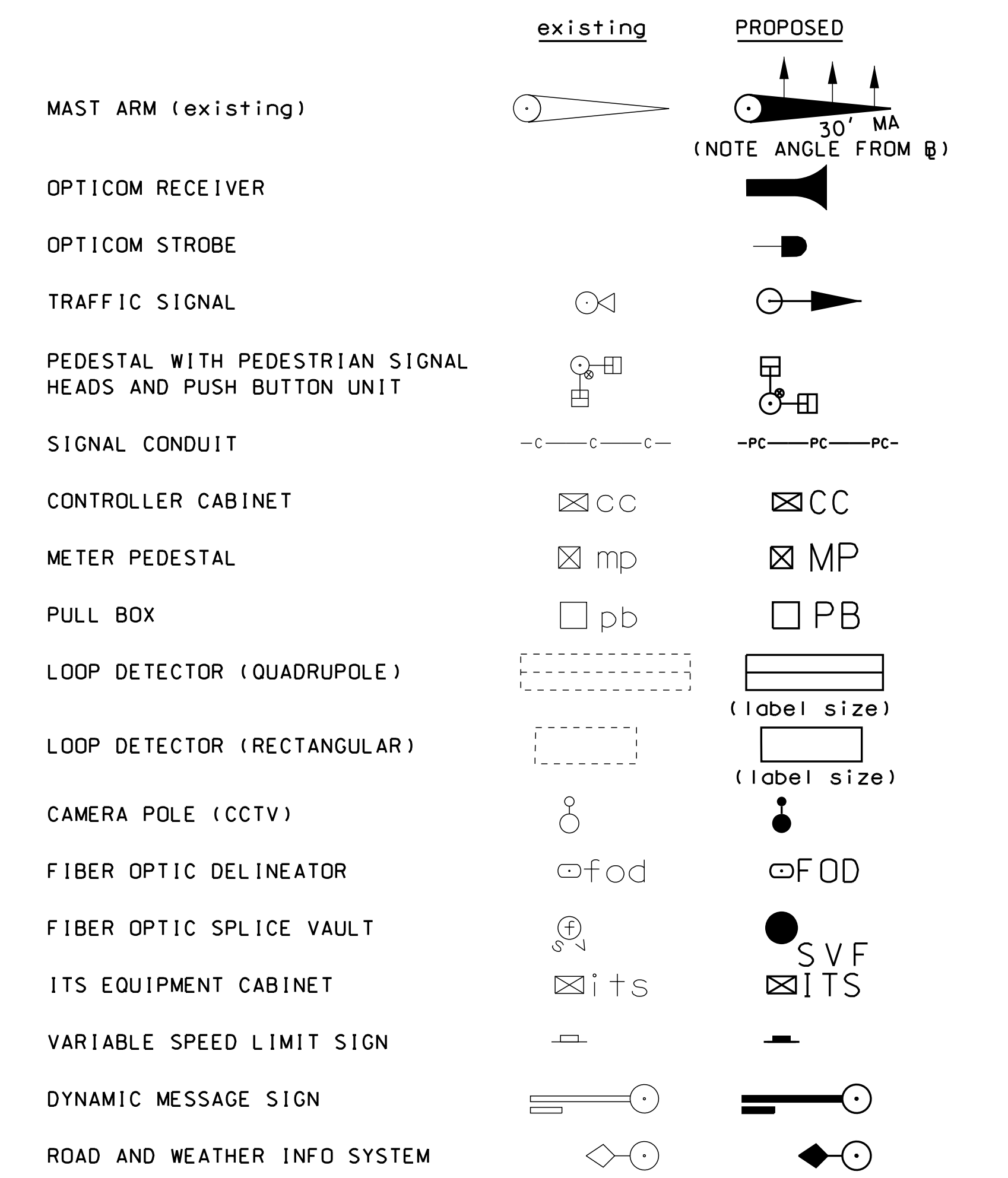

CONSTRUCTION NOTES

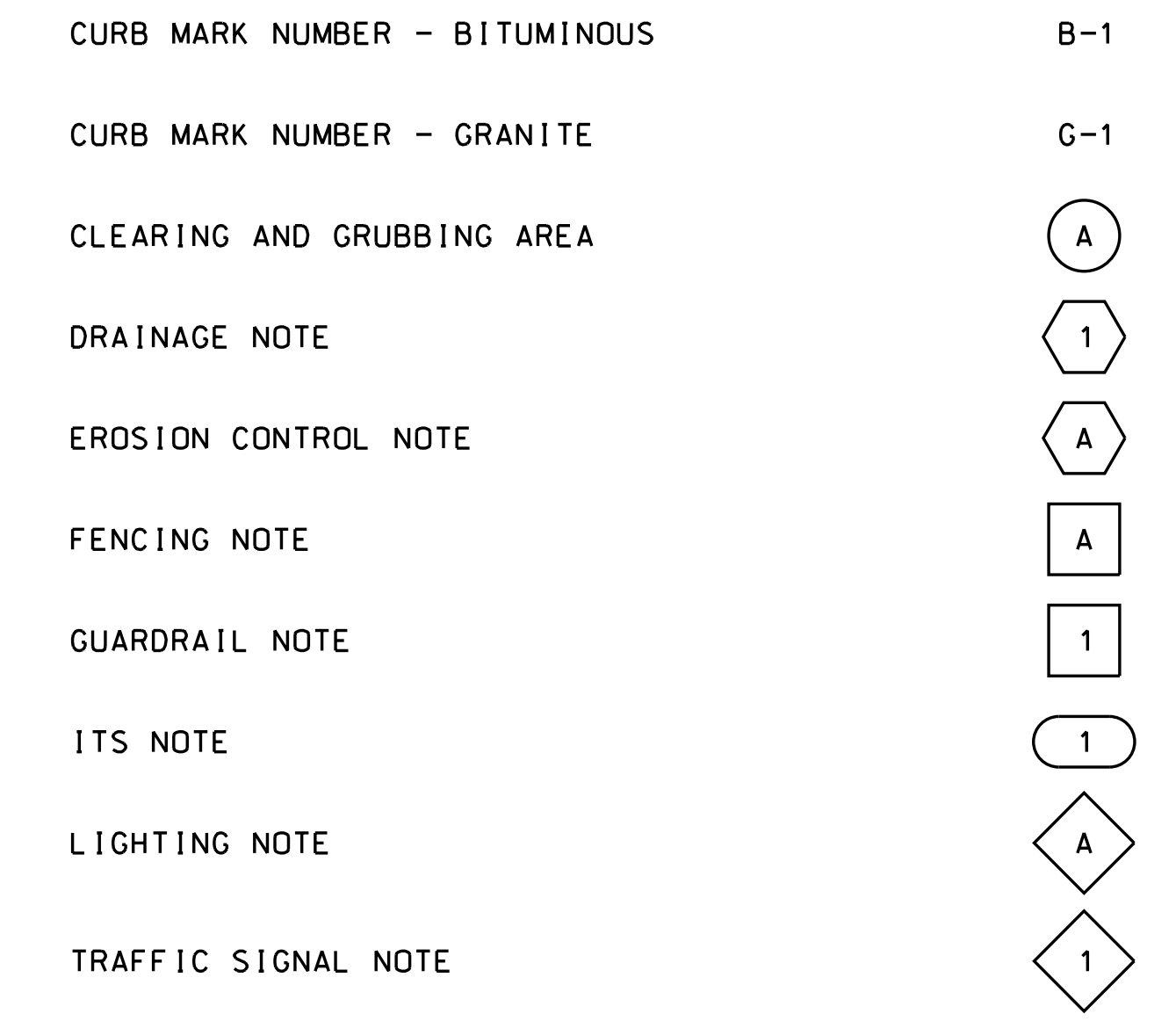

SHEET 2 OF 2

STATE OF NEW HAMPSHIRE				
DEPARTMENT OF TRANSPORTATION • BUREAU OF HIGHWAY DESIGN				
STANDARD SYMBOLS				
REVISION DATE	DGN	STATE PROJECT NO.	SHEET NO.	TOTAL SHEETS
11-21-2014	stdsyms	13928A	4	160

SDR PROCESSED	DATE	08/29/14
NEW DESIGN	DATE	04/22/15
SHEET CHECKED	DATE	
AS BUILT DETAILS	DATE	

REVISIONS AFTER PROPOSAL	DESCRIPTION
STATION	
STATION	
DATE	
NUMBER	

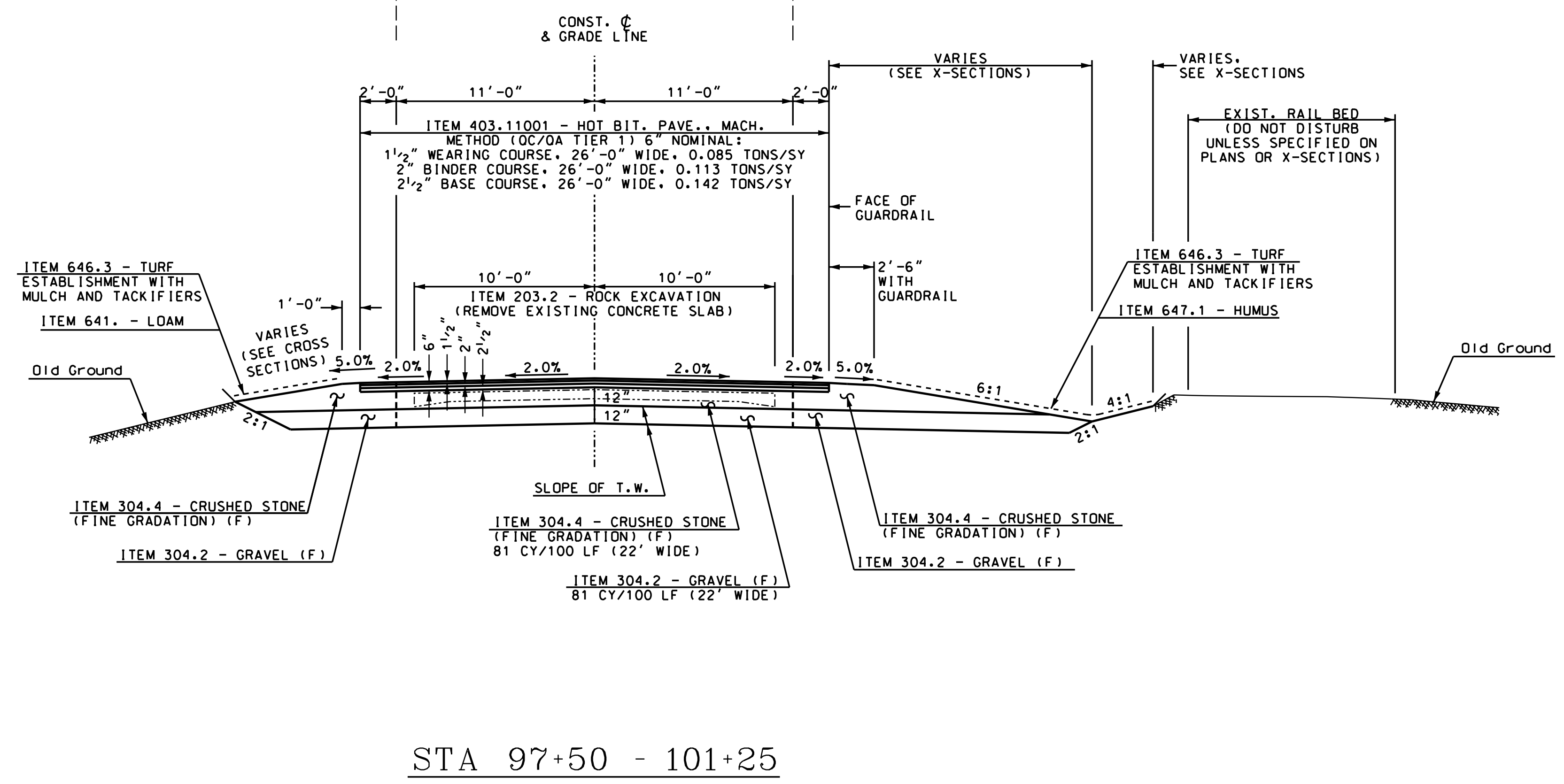
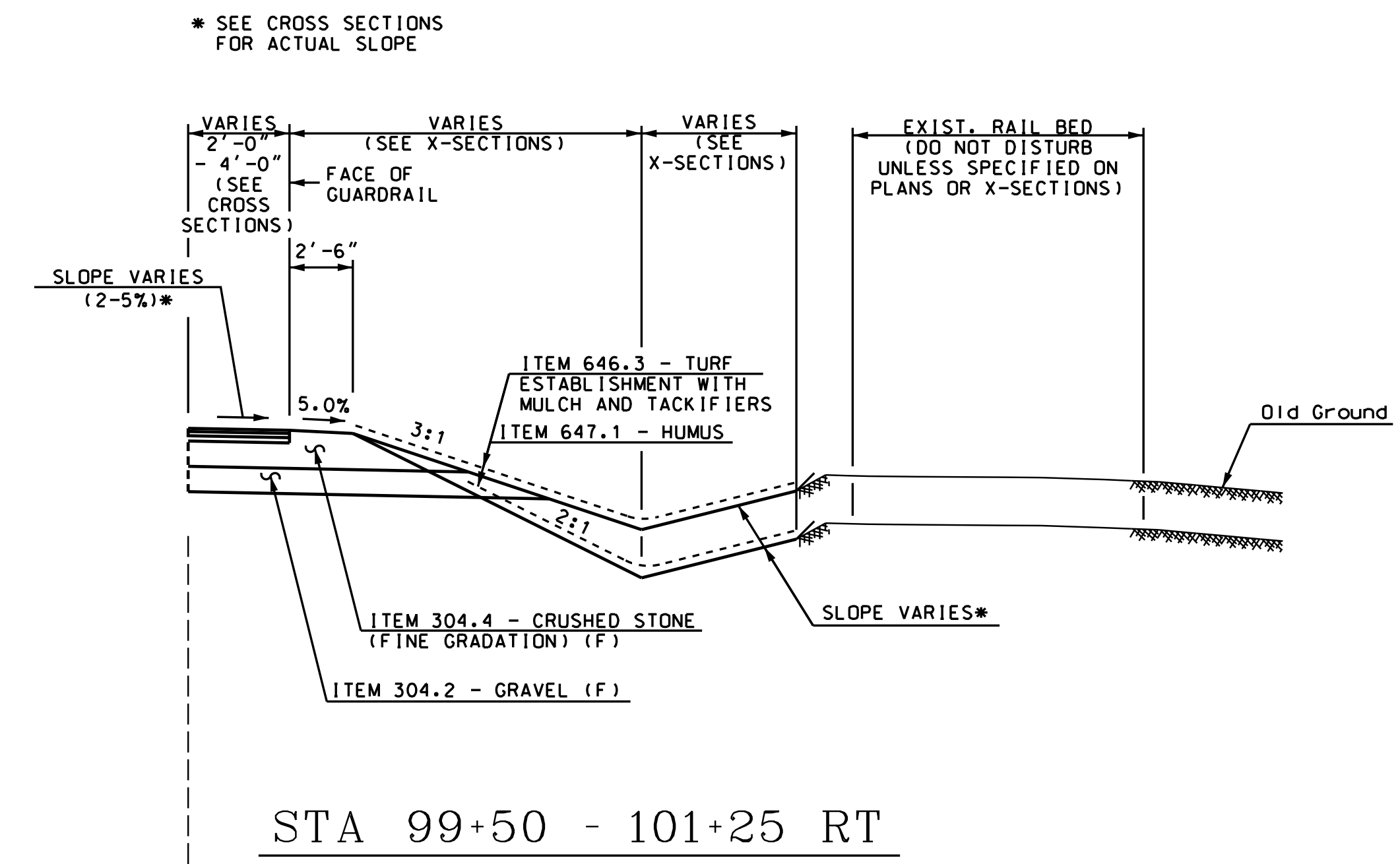
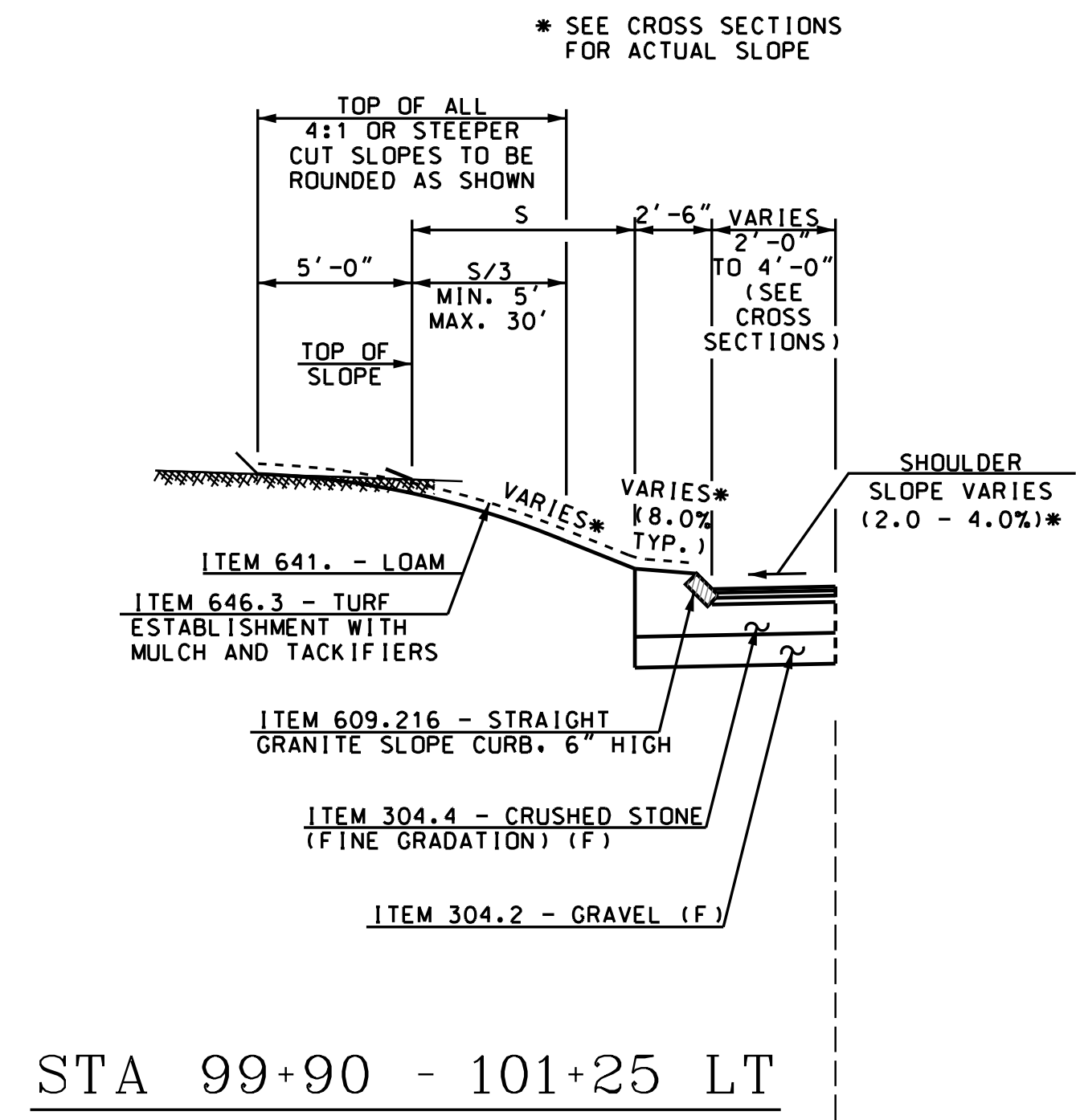

- GENERAL NOTES:
- ITEM 403.6 - PAVEMENT JOINT ADHESIVE IS REQUIRED FOR ALL LONGITUDINAL JOINTS ASSOCIATED WITH ALL BINDER AND WEARING COURSE LIFTS.
 - ITEM 403.4 - MATERIAL TRANSFER VEHICLE (MTV) SHALL BE USED FOR ALL MAINLINE PAVEMENT WORK (ALL LIFTS).
 - A LEVEL 1 RIDE SMOOTHNESS IS SPECIFIED FOR ALL OC/OA TIER 1 PAVEMENT.
 - SEE CROSS SECTIONS FOR ADDITIONAL INFORMATION.

STATE OF NEW HAMPSHIRE			
DEPARTMENT OF TRANSPORTATION • BUREAU OF HIGHWAY DESIGN			
TYPICAL SECTIONS US ROUTE 3			
DGN	STATE PROJECT NO.	SHEET NO.	TOTAL SHEETS
13928atyp	13928A	5	160

SDR PROCESSED	REVISIONS AFTER PROPOSAL	STATION	DATE	DATE	DATE
	DESCRIPTION				
	NUMBER				
	DATE				
NEW DESIGN	08/29/14				
SHEET CHECKED	04/22/15				
AS BUILT DETAILS					

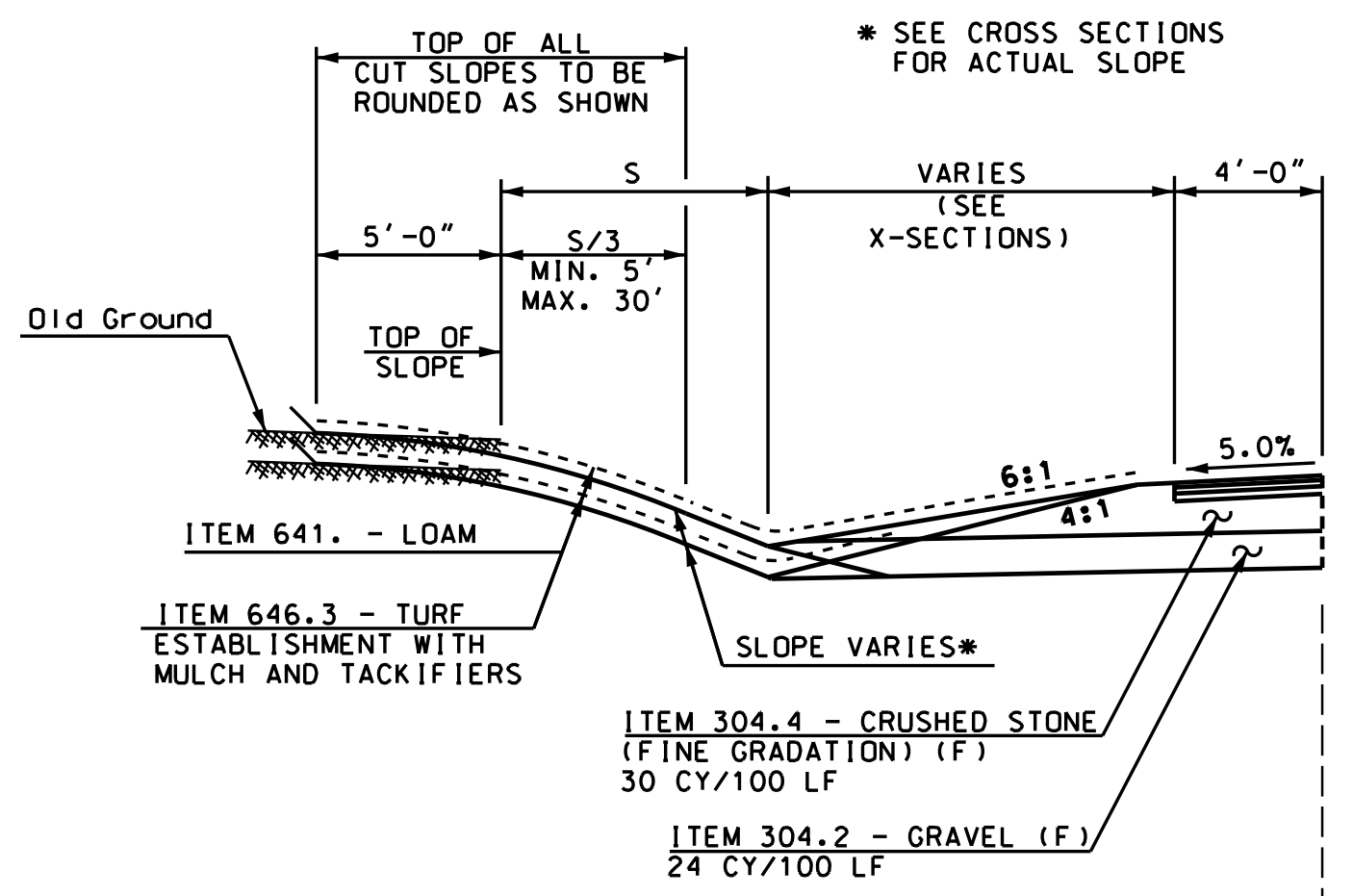

STA. 108+38 - 113+25 LT

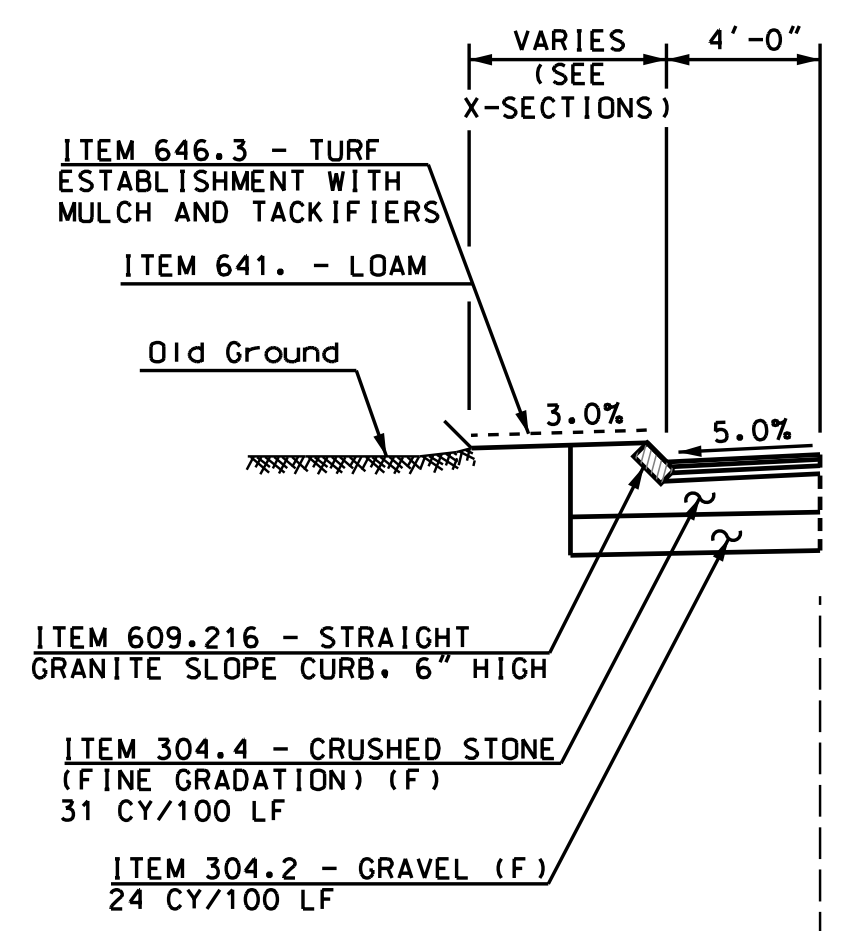

STA. 107+25 - 108+38 LT

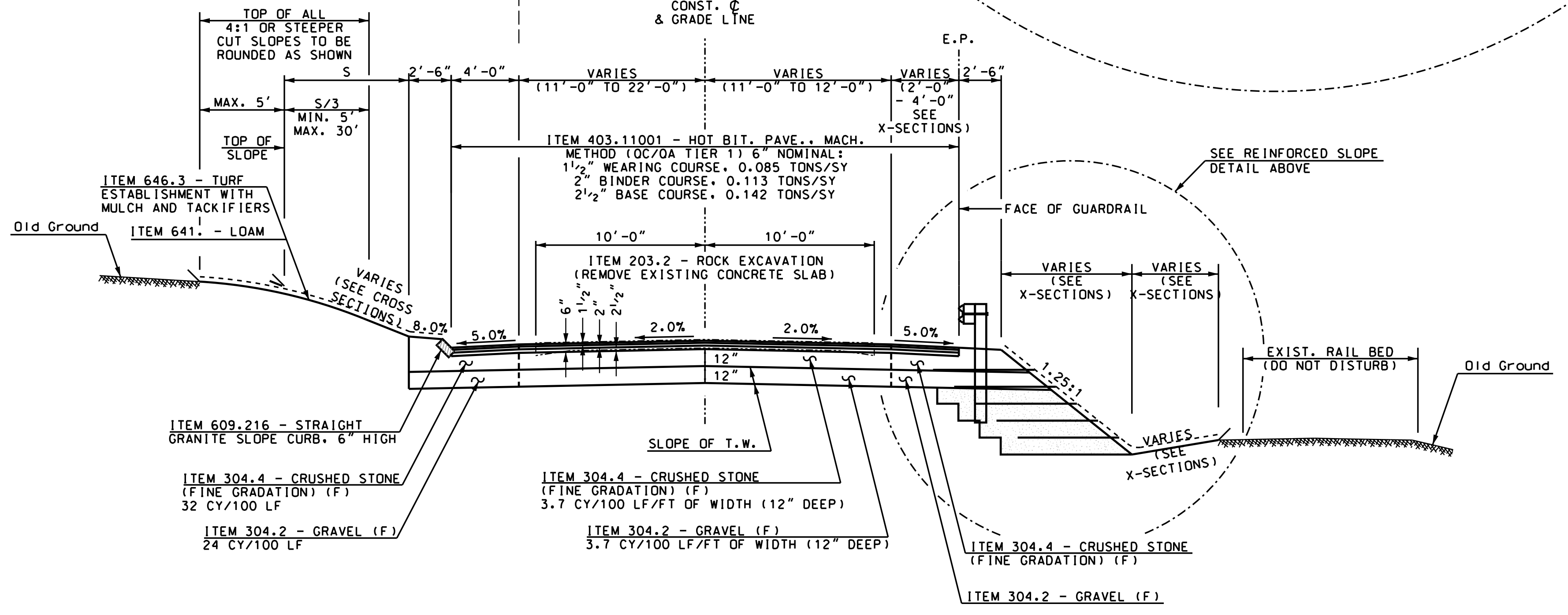

STA 101+25 - 113+25

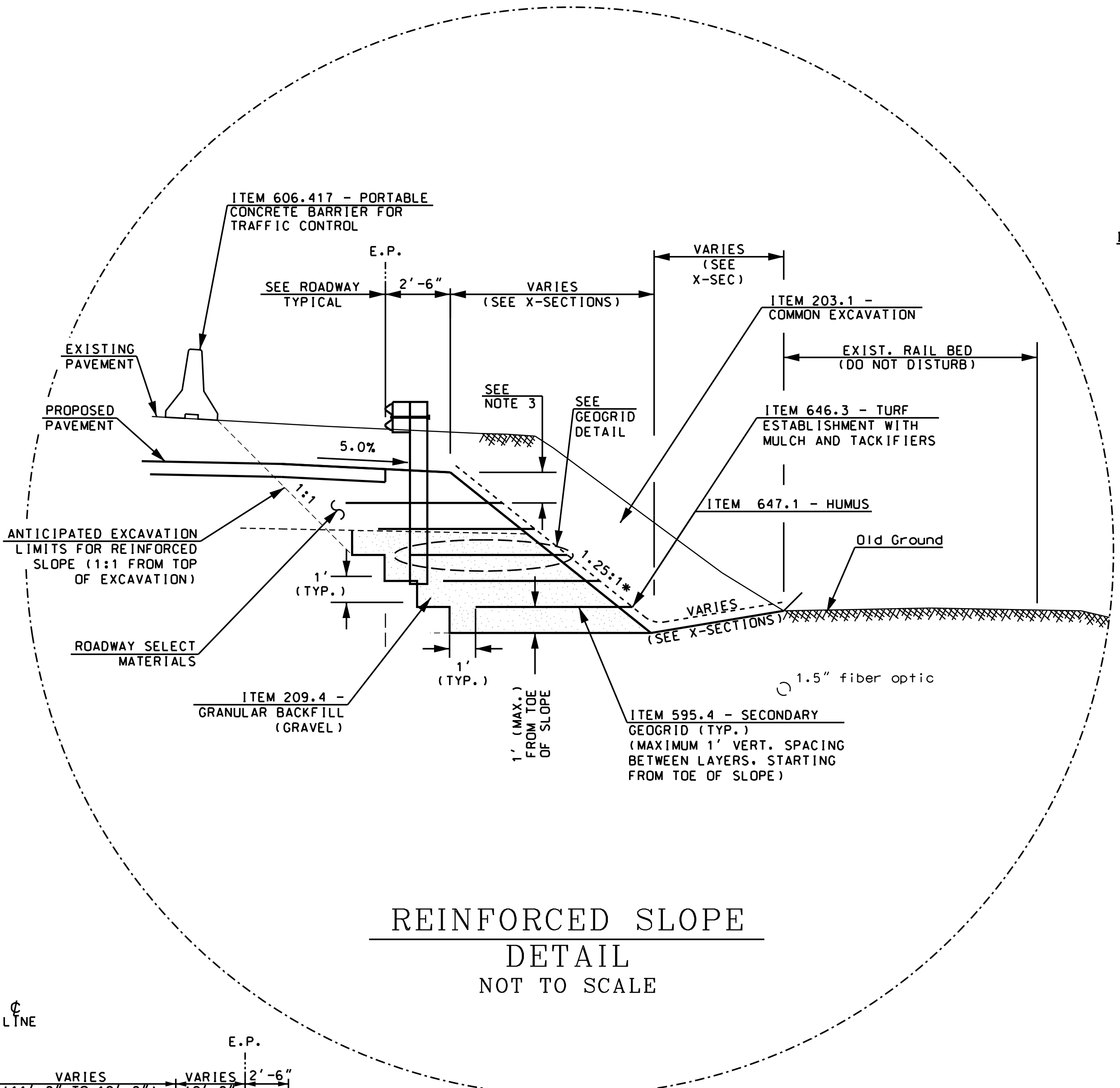

REINFORCED SLOPE
DETAIL
NOT TO SCALE

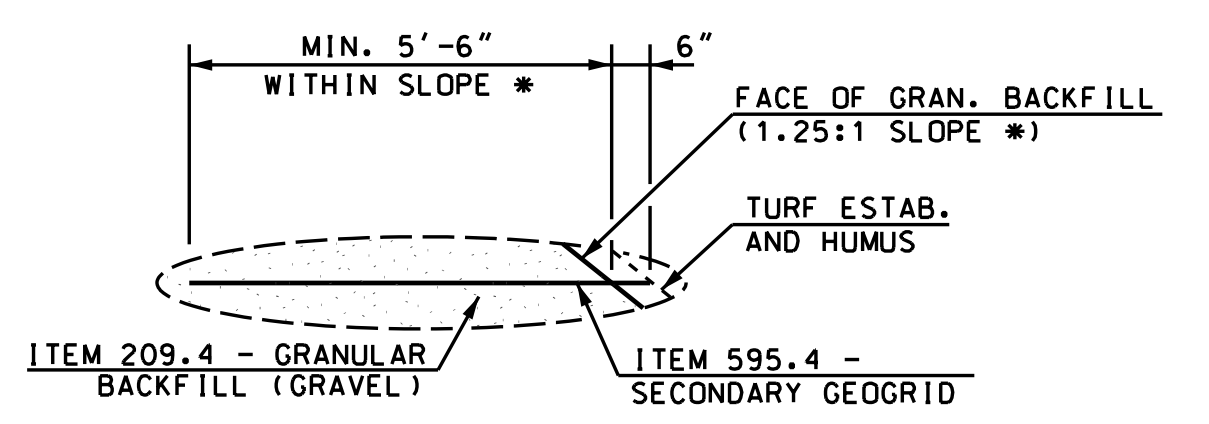

* AT DRAINAGE NOTE 6 (STA. 108+71 RT), DRAINAGE NOTE 7 (STA. 110+25 RT), AND DRAINAGE NOTE 7B (STA. 110+25 RT) WHERE THE PROPOSED REINFORCED SLOPE STEEPENS TO 1:1 (H:V), EXTEND THE SECONDARY GEOGRID TO 9'-6" WITHIN THE SLOPE, FOR A LENGTH OF 25 FEET BEFORE AND AFTER THE DRAINAGE STRUCTURES.

SECONDARY GEOGRID
DETAIL

DETAIL NOTES

1. SLOPE HEIGHT VARIES. SEE CROSS SECTIONS FOR MORE INFORMATION.
2. SECONDARY GEOGRID SHOULD BE INSTALLED WITH A MINIMUM LENGTH OF 5'-6" WITHIN THE SLOPE AND APPROXIMATELY 6" EXTENDING OUT FROM THE FACE OF THE GRANULAR BACKFILL.
3. THE TOPMOST LAYER OF GEOGRID SHOULD BE PLACED AT A MAXIMUM OF 1 FT BELOW THE TOP OF SLOPE WHERE POSSIBLE AND SUCH THAT THE GEOGRID DOES NOT PENETRATE THE NEW PAVEMENT. THE ACTUAL DEPTH OF GEOGRID BELOW THE TOP OF SLOPE VARIES FROM APPROX. 5" TO 1'-4".
4. EXCAVATION FOR PLACEMENT OF ITEM 209.4 - GRANULAR BACKFILL (GRAVEL) SHALL BE PAID FOR UNDER ITEM 203.1 - COMMON EXCAVATION.
5. DO NOT IMPACT EXISTING FIBER OPTIC LINE. REFER TO CROSS SECTIONS AND PROSECUTION OF WORK FOR MORE INFORMATION.

PORTABLE CONCRETE BARRIER NOTES:

1. REFER TO THE CURRENT NHDOT STANDARD PLAN GR-23 FOR BARRIER LAYOUT AND TAPER RATES.
2. MAINTAIN A MINIMUM ROADWAY WIDTH OF 22 FT WHEN PORTABLE BARRIER IS IN USE.

GENERAL NOTES:

1. ITEM 403.6 - PAVEMENT JOINT ADHESIVE IS REQUIRED FOR ALL LONGITUDINAL JOINTS ASSOCIATED WITH ALL BINDER AND WEARING COURSE LIFTS.
2. ITEM 403.4 - MATERIAL TRANSFER VEHICLE (MTV) SHALL BE USED FOR ALL MAINLINE PAVEMENT WORK (ALL LIFTS).
3. A LEVEL 1 RIDE SMOOTHNESS IS SPECIFIED FOR ALL OC/OA TIER 1 PAVEMENT.
4. SEE CROSS SECTIONS FOR ADDITIONAL INFORMATION.

STATE OF NEW HAMPSHIRE			
DEPARTMENT OF TRANSPORTATION • BUREAU OF HIGHWAY DESIGN			
TYPICAL SECTIONS US ROUTE 3			
DGN	STATE PROJECT NO.	SHEET NO.	TOTAL SHEETS
13928atyp	13928A	6	160

SDR PROCESSED	DATE	DATE	DATE	DATE
NEW DESIGN	S. MICOCCI	12/30/14	04/22/15	
SHEET CHECKED	C. SPETELUNAS			
AS BUILT DETAILS				

REVISIONS AFTER PROPOSAL	STATION	STATION	DATE	DESCRIPTION

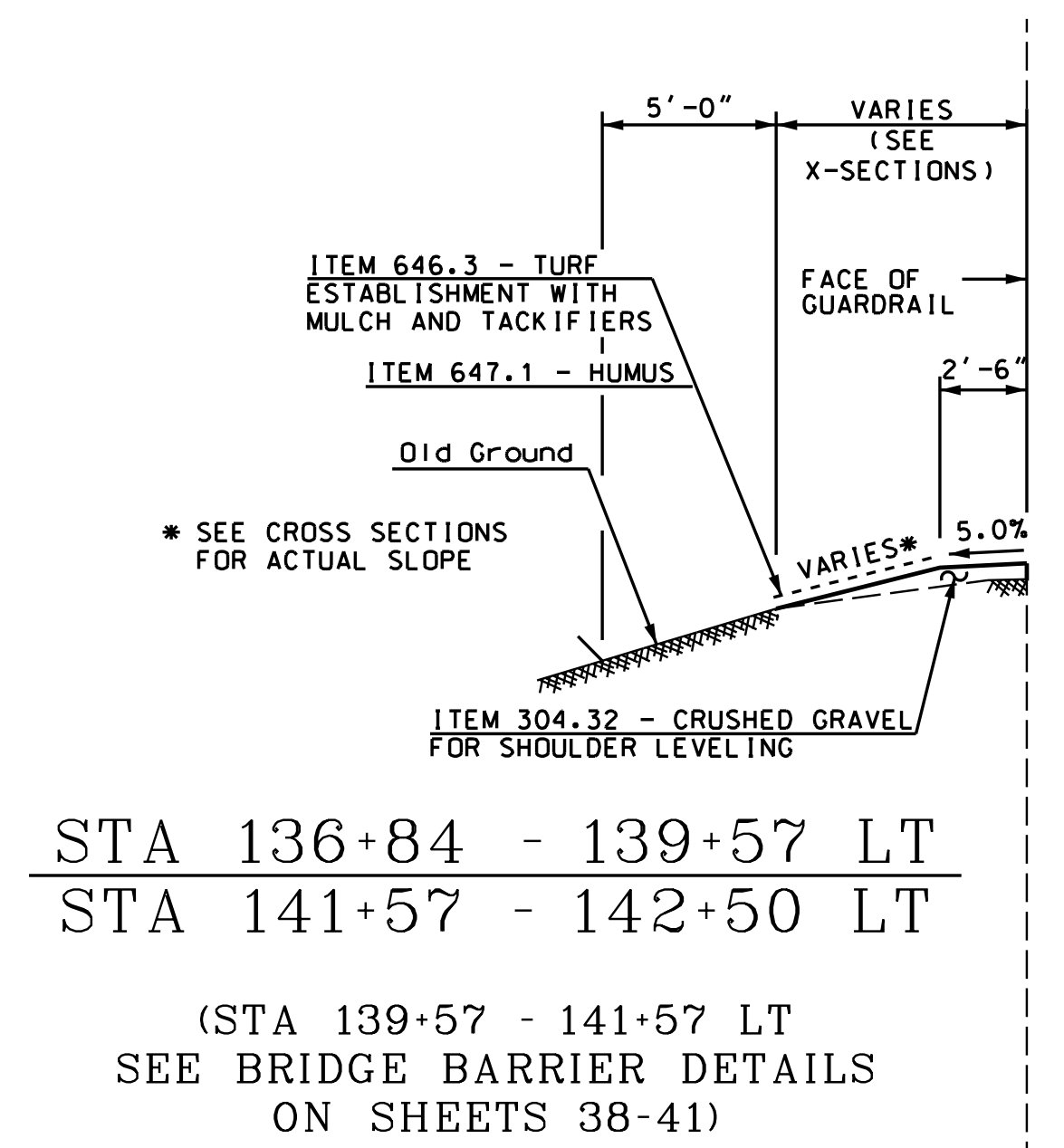

STA 136+84 - 139+57 LT
 STA 141+57 - 142+50 LT

(STA 139+57 - 141+57 LT
 SEE BRIDGE BARRIER DETAILS
 ON SHEETS 38-41)

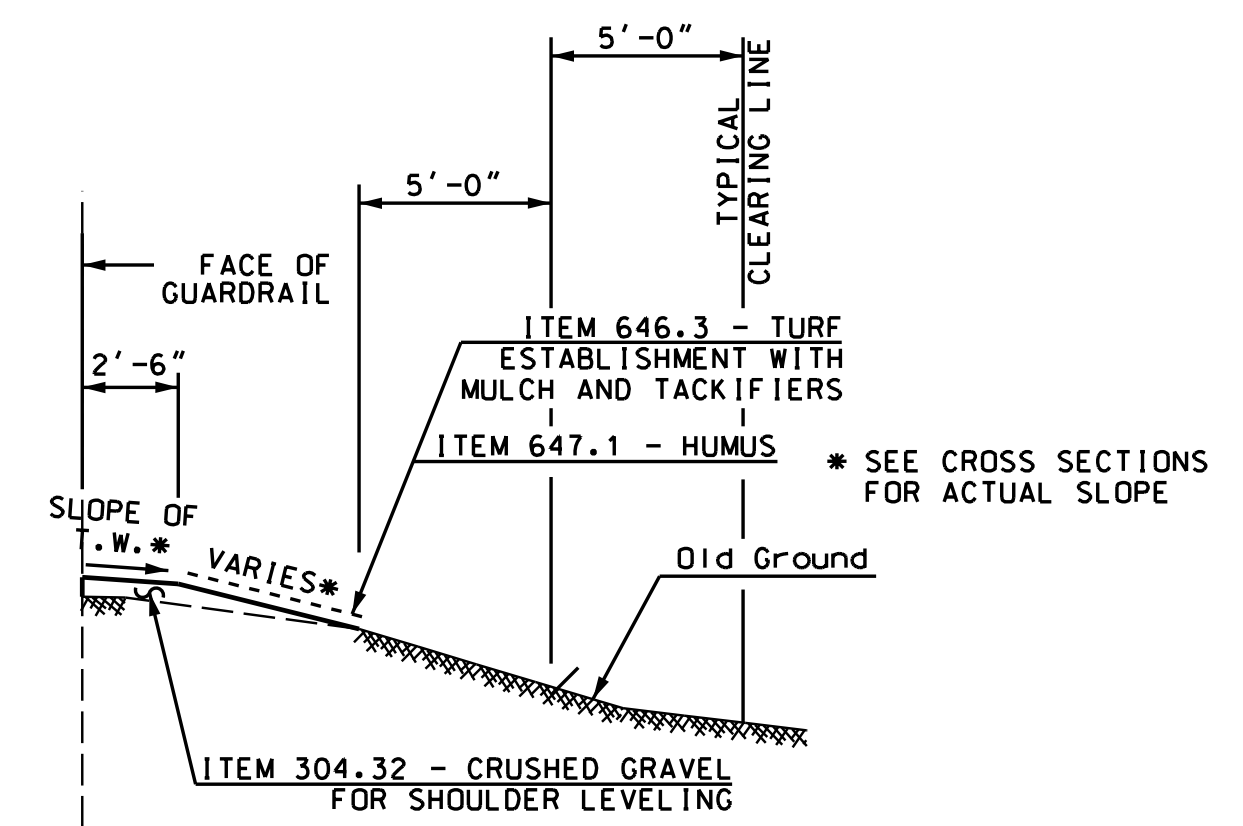

STA 134+60 - 138+30 RT
 STA 140+30 - 142+50 RT

(STA 138+30 - 140+30 RT
 SEE BRIDGE BARRIER DETAILS
 ON SHEETS 38-41)

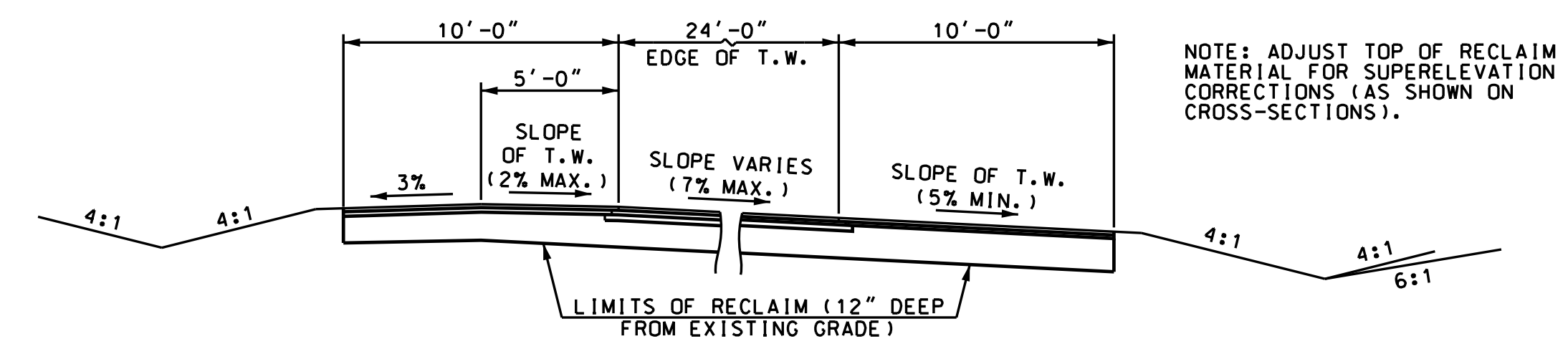

SUPERELEVATED SECTION

CURVE NO. 6 (MAX SUPER = 7.00%)

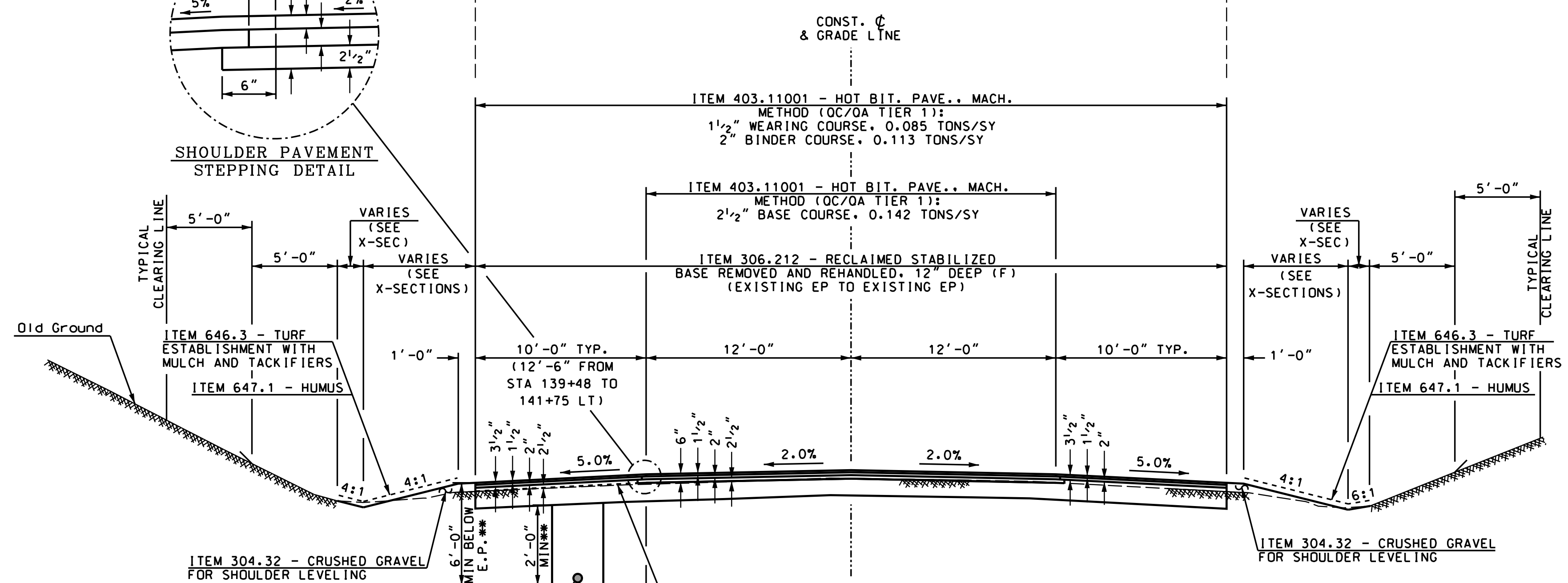
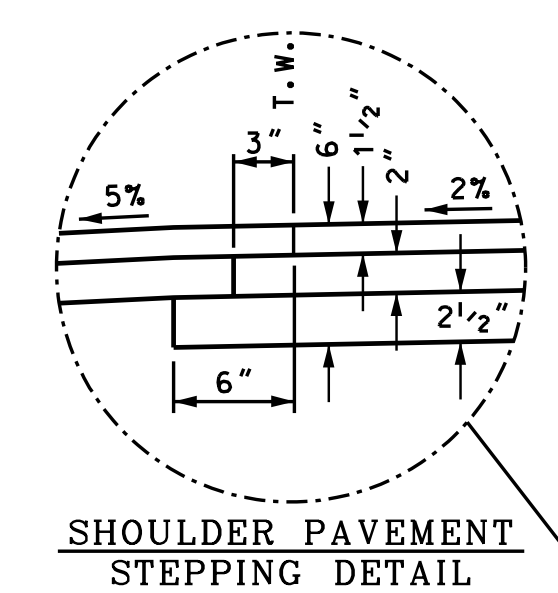

STA 125+50 - 142+50

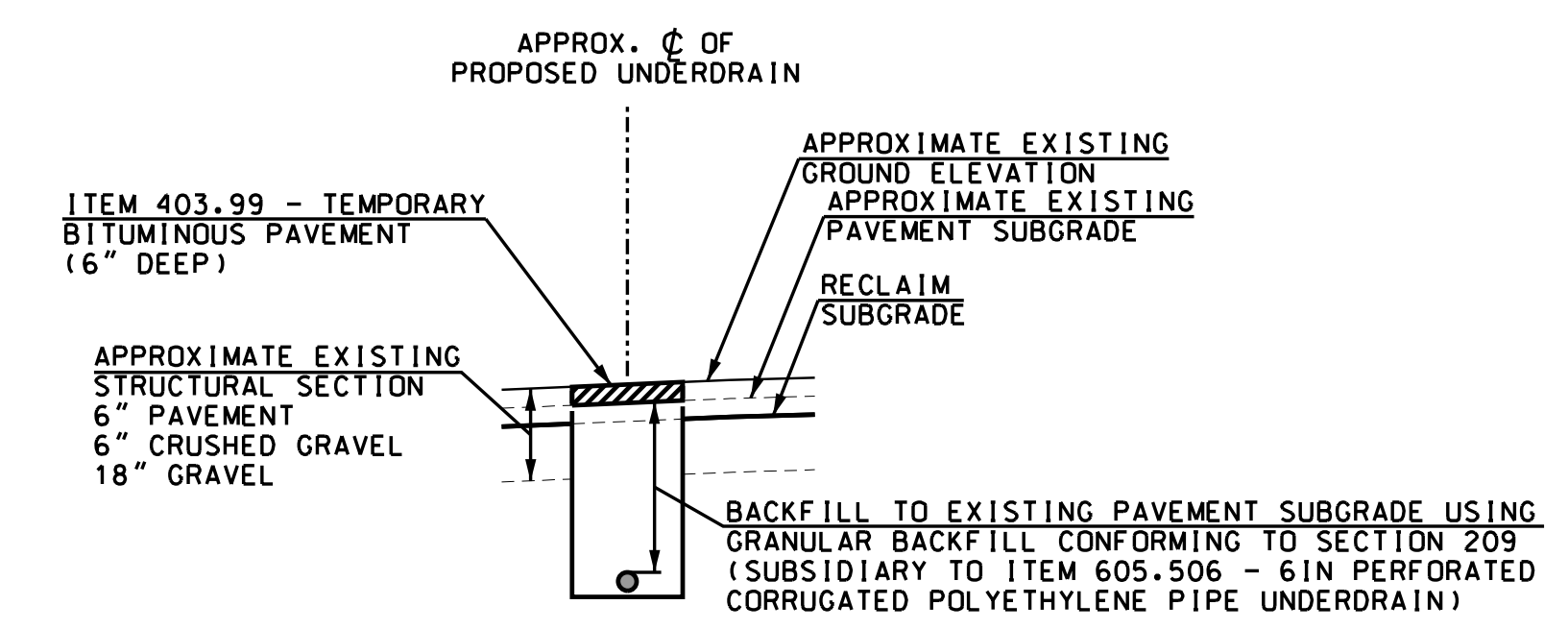

UNDERDRAIN TRENCH DETAIL

1. SEE TYPICAL SECTION FOR AREAS OF INCREASED PAVEMENT SECTIONS WITHIN THE SHOULDER.

- GENERAL NOTES:**
- ITEM 403.6 - PAVEMENT JOINT ADHESIVE IS REQUIRED FOR ALL LONGITUDINAL JOINTS ASSOCIATED WITH ALL BINDER AND WEARING COURSE LIFTS.
 - ITEM 403.4 - MATERIAL TRANSFER VEHICLE (MTV) SHALL BE USED FOR ALL MAINLINE PAVEMENT WORK (ALL LIFTS).
 - A LEVEL 1 RIDE SMOOTHNESS IS SPECIFIED FOR ALL OC/OA TIER 1 PAVEMENT.
 - SEE CROSS SECTIONS FOR ADDITIONAL INFORMATION.

STATE OF NEW HAMPSHIRE			
DEPARTMENT OF TRANSPORTATION • BUREAU OF HIGHWAY DESIGN			
TYPICAL SECTIONS US ROUTE 3			
DGN	STATE PROJECT NO.	SHEET NO.	TOTAL SHEETS
13928atyp	13928A	8	160

SDR PROCESSED	DATE	01/05/15
NEW DESIGN	DATE	04/22/15
SHEET CHECKED	DATE	
AS BUILT DETAILS	DATE	

REVISIONS AFTER PROPOSAL	STATION	DESCRIPTION

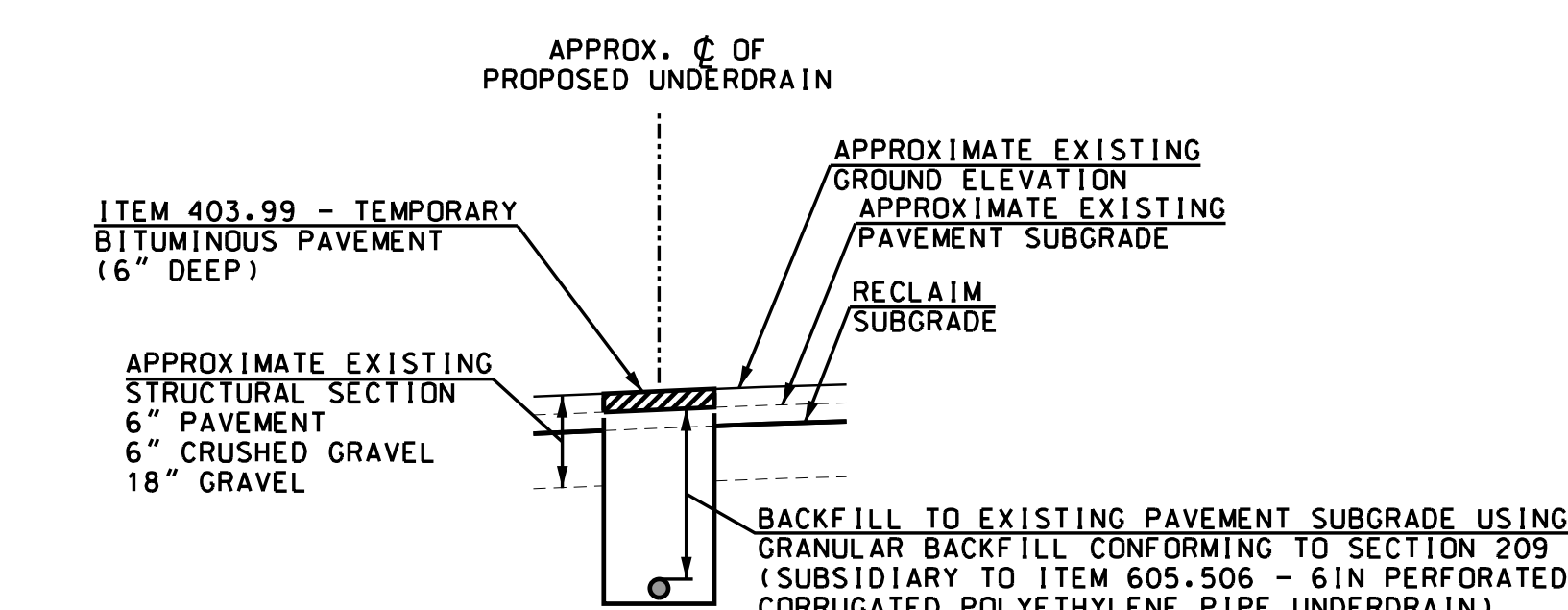
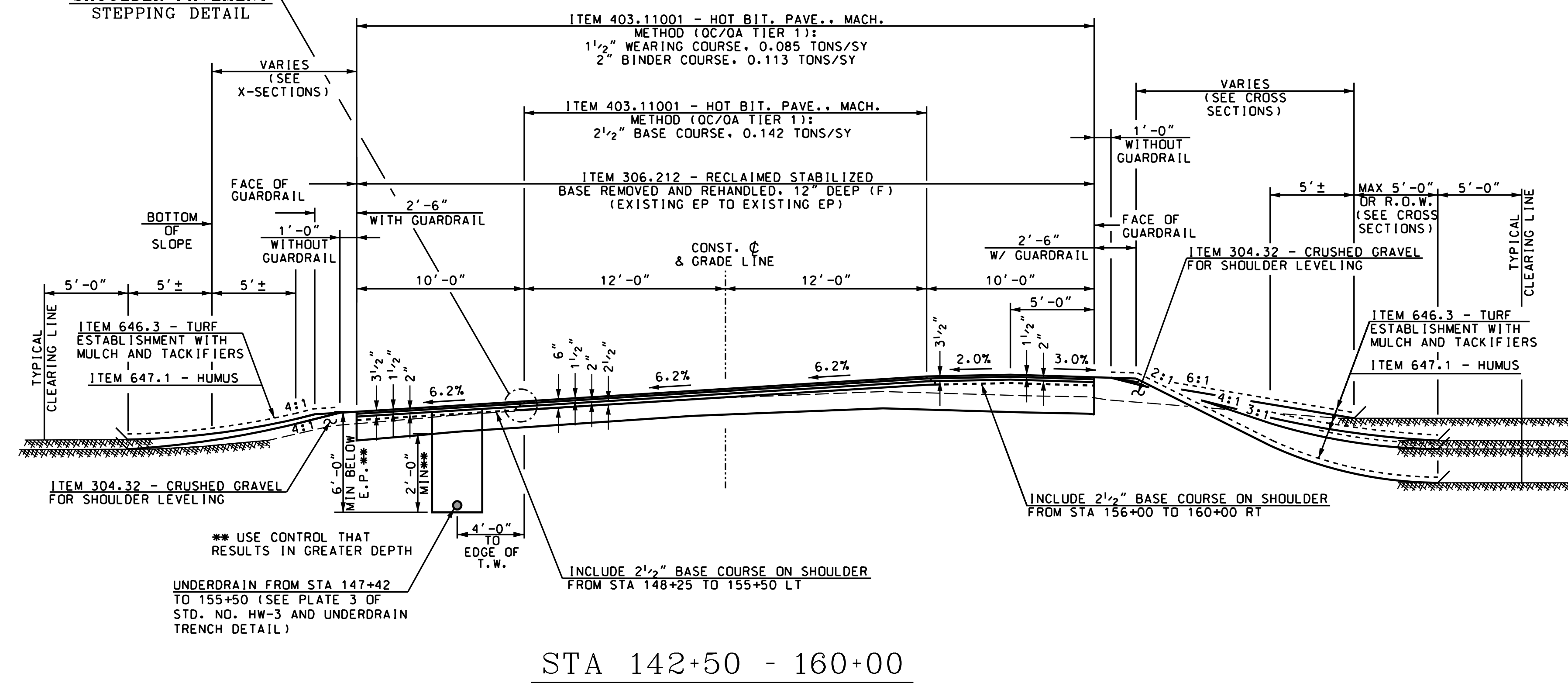
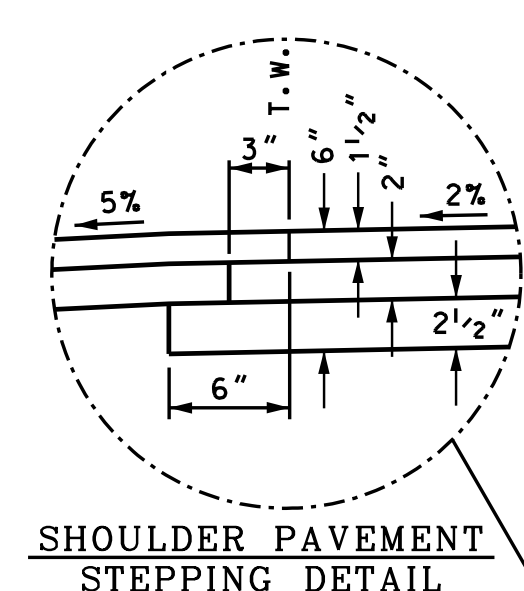
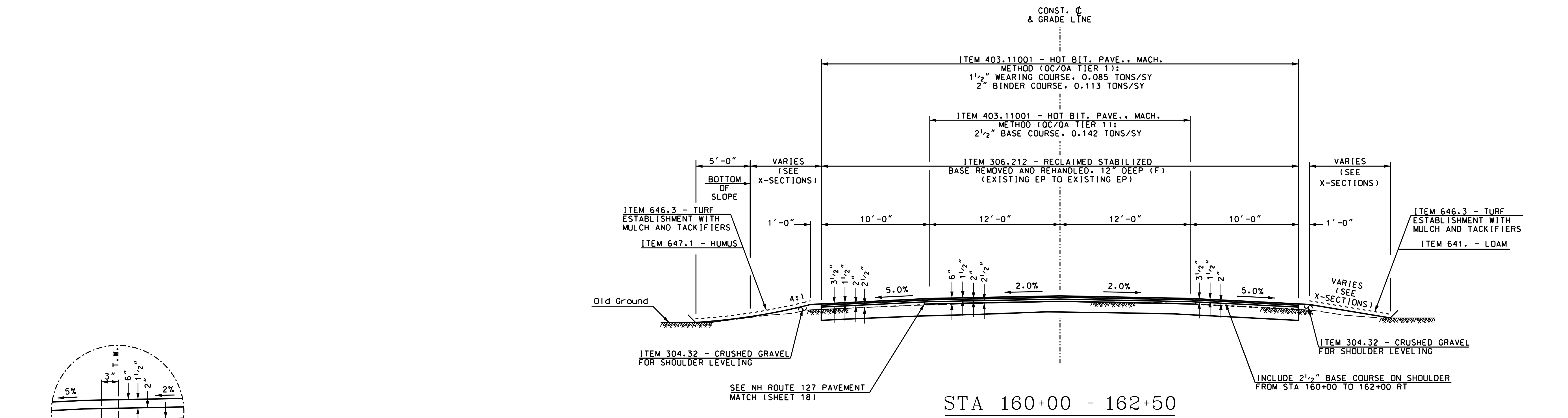

UNDERDRAIN TRENCH DETAIL
 1. SEE TYPICAL SECTION FOR AREAS OF INCREASED PAVEMENT SECTIONS WITHIN THE SHOULDER.

- GENERAL NOTES:**
- ITEM 403.6 - PAVEMENT JOINT ADHESIVE IS REQUIRED FOR ALL LONGITUDINAL JOINTS ASSOCIATED WITH ALL BINDER AND WEARING COURSE LIFTS.
 - ITEM 403.4 - MATERIAL TRANSFER VEHICLE (MTV) SHALL BE USED FOR ALL MAINLINE PAVEMENT WORK (ALL LIFTS).
 - A LEVEL 1 RIDE SMOOTHNESS IS SPECIFIED FOR ALL OC/OA TIER 1 PAVEMENT.
 - SEE CROSS SECTIONS FOR ADDITIONAL INFORMATION.

STATE OF NEW HAMPSHIRE			
DEPARTMENT OF TRANSPORTATION • BUREAU OF HIGHWAY DESIGN			
TYPICAL SECTIONS US ROUTE 3			
DGN	STATE PROJECT NO.	SHEET NO.	TOTAL SHEETS
13928atyp	13928A	9	160

SDR PROCESSED	DATE	AS BUILT DETAILS
NEW DESIGN	S. MICUCCI	
SHEET CHECKED	C. SPETELUNAS	
REVISIONS AFTER PROPOSAL	DESCRIPTION	
STATION		
STATION		
DATE		
NUMBER		
DATE	01/05/15	
DATE	04/22/15	
DATE		

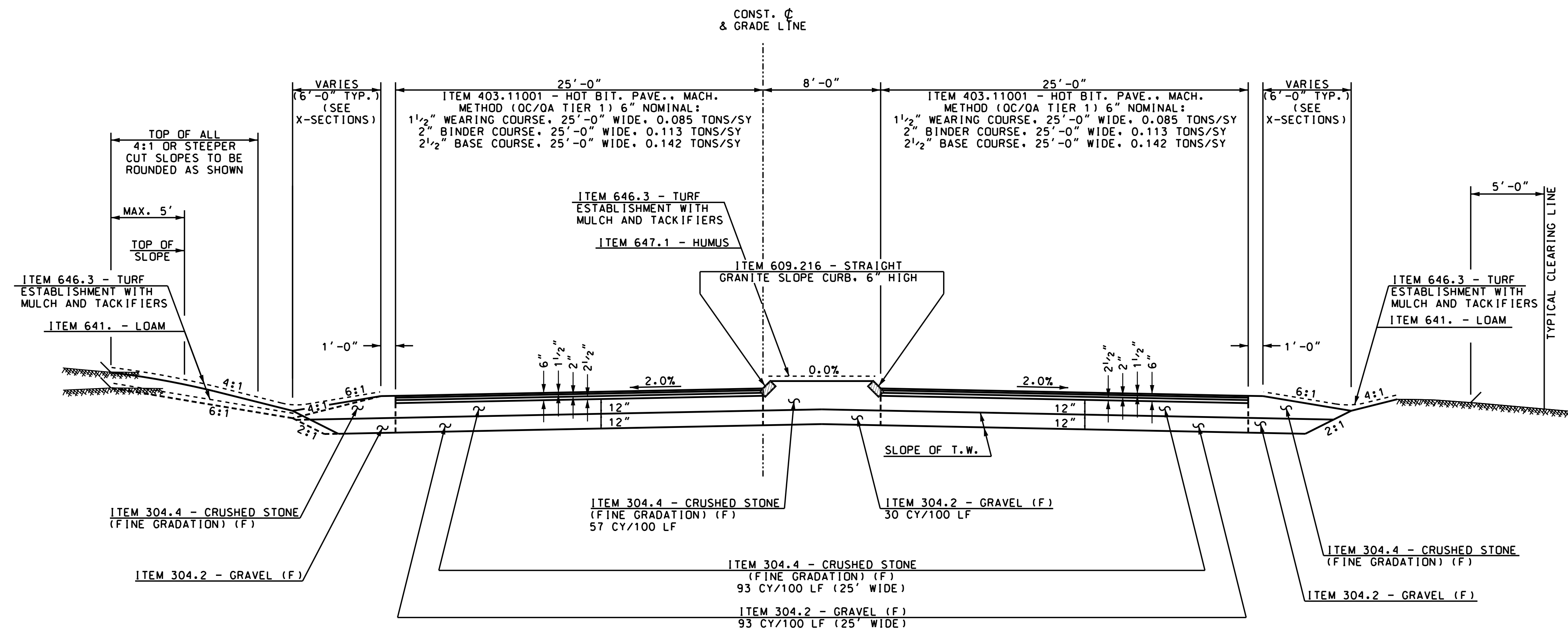

INDUSTRIAL PARK DRIVE
STA. 20+50 TO STA. 21+50

(SEE PAVEMENT MATCH DETAIL ON
 SHEET 18 FOR LIMITS OF PAVEMENT WORK)

- GENERAL NOTES:**
- ITEM 403.6 - PAVEMENT JOINT ADHESIVE IS REQUIRED FOR ALL LONGITUDINAL JOINTS ASSOCIATED WITH ALL BINDER AND WEARING COURSE LIFTS.
 - ITEM 403.4 - MATERIAL TRANSFER VEHICLE (MTV) SHALL BE USED FOR ALL MAINLINE PAVEMENT WORK (ALL LIFTS).
 - A LEVEL 1 RIDE SMOOTHNESS IS SPECIFIED FOR ALL OC/OA TIER 1 PAVEMENT.
 - SEE CROSS SECTIONS FOR ADDITIONAL INFORMATION.
 - SEE PAVEMENT MATCH DETAIL AND CROSS SECTIONS FOR WORK FROM STA. 21+50 TO STA. 24+50.

STATE OF NEW HAMPSHIRE			
DEPARTMENT OF TRANSPORTATION • BUREAU OF HIGHWAY DESIGN			
TYPICAL SECTIONS			
INDUSTRIAL PARK DRIVE			
DGN	STATE PROJECT NO.	SHEET NO.	TOTAL SHEETS
13928atyp	13928A	10	160

DRAINAGE

Table with columns for REF. NO., various material codes (e.g., 202.41, 202.42, 206.1), and REMARKS. Includes subtotals and rounding for the drainage section.

CLEARING AND GRUBBING

Table with columns for ITEM NO., DESCRIPTION, UNIT, SF, and CLEARING AND GRUBBING (F). Includes a subtotal and rounding for the clearing and grubbing section.

LOAM

Table with columns for ITEM NO., ITEM, UNIT, and CY. Includes a list of locations and a subtotal for the loam section.

SUMMARY OF QUANTITIES (ESTIMATED)
THIS INFORMATION IS FOR BIDDING PURPOSES ONLY

CURBING						
ITEM NO.			202.6	609.216	609.226	
ITEM	MARK NUMBER	RADIUS	CURB REMOVAL FOR STORAGE	STRAIGHT GRANITE SLOPE CURB 6" HIGH	STRAIGHT GRANITE SLOPE CURB WITH RADIAL JOINTS 6" HIGH	COMMENTS
UNIT		FT	LF	LF	LF	
US ROUTE 3						
Sta. 99+90 - 100+34 LT	G-1			43.8		
Sta. 100+76 - 100+96 LT	G-2			20.0		
Sta. 101+38 - 101+82 LT	G-3			43.8		
Sta. 102+10 - 103+14 LT	G-4			104.3		
Sta. 103+44 - 103+86 LT	G-5			41.1		
Sta. 104+16 - 104+41 LT	G-6			25.8		
Sta. 104+91 - 105+36 LT	G-7			44.9		
Sta. 105+71 - 108+38 LT	G-8			266.2		
Sta. 113+49 - 115+08 LT	G-17			157.1		
Sta. 115+44 - 116+24 LT	G-18			79.6		
Sta. 116+24 - 116+82 LT	G-19			57.4		
Sta. 116+82 - 116+82 LT	G-20	7		22.0		
Sta. 115+86 - 116+82 LT	G-21			94.4		
Sta. 117+47 - 117+47 LT	G-22	6		18.8		
Sta. 117+47 - 119+19 LT	G-23			169.0		
Sta. 117+47 - 123+12 LT	G-24			561.0		
Sta. 148+26 - 148+50 LT			49			Sloped Granite
Sta. 148+72 - 148+79 LT			24.5			Sloped Granite
Sta. 148+81 - 149+05 LT			28.5			Sloped Granite
Sta. 161+66 - 161+69 LT	G-25	1.5			4.1	
Sta. 161+66 - 161+74 LT	G-26			20.4		
Sta. 161+69 - 161+97 LT	G-27			37.7		
Sta. 161+74 - 161+86 LT	G-28	12		14.6		
Sta. 161+68 - 161+96 LT	G-29			10.6		
Sta. 161+96 - 161+97 LT	G-30	1.5			3.6	
INDUSTRIAL PARK DRIVE						
Sta. 20+38 CL - 20+38 RT	G-9	4		12.6		
Sta. 20+38 - 20+73 CL	G-10			34.8		
Sta. 20+73 CL - 20+73 RT	G-11	4		12.6		
Sta. 20+38 - 20+73 RT	G-12			34.8		
Sta. 20+43 - 20+93 LT			50.8			Sloped Granite
Sta. 20+50 - 20+95 RT			45.3			Sloped Granite
Sta. 20+97 CL - 20+97 RT	G-13	4		12.6		
Sta. 20+97 - 24+20 CL	G-14			323.1		
Sta. 24+20 CL - 24+20 RT	G-15	3.8		11.9		
Sta. 20+97 - 24+20 RT	G-16			323.1		
ROUTE 127 ISLAND						
			90.7			Sloped Granite
SUB-TOTAL			289	2598	8	
ROUNDING			1	2	2	
TOTAL			290	2600	10	

LANDSCAPING AND SLOPE PROTECTION															
ITEM NO.	209.4	503.101	503.102	595.4	644.63	645.12	645.3	645.42	645.44	645.51	645.512	645.531	646.3	647.1	647.16
DESCRIPTION	GRANULAR BACKFILL (GRAVEL)	WATER DIVERSION STRUCTURES	WATER DIVERSION STRUCTURES	SECONDARY GEOGRID	SHADED WETLAND BORDER MIX	TEMPORARY MULCH	EROSION STONE	TEMPORARY SLOPE STABILIZATION TYPE B (WILDLIFE FRIENDLY)	TEMPORARY SLOPE STABILIZATION TYPE D (WILDLIFE FRIENDLY)	HAY BALES FOR TEMPORARY EROSION CONTROL	COMPOST SILT SOCKS	SILT FENCE	TURF ESTABLISHMENT WITH MULCH AND TACKIFIERS	HUMUS	HUMUS, 6" DEEP
UNIT	CY	U	U	SY	LB	A	TON	SY	SY	LF	LF	LF	A	CY	CY
LOCATION															
US ROUTE 3															
INDUSTRIAL PARK DRIVE	1406			4642			35	8932	5262		2368	2368	4.14	1590	
								0					0.20	33	
SLOPE REPAIR @ 150+00															
CONCRETE SWALE @ 152+50															
SLOPE REPAIR @ 153+50															
DRAINAGE		1	1		0.49		39	0					0.01	11	
PROJECT-WIDE						1	125	880	150	100			0.02	4	
SUBTOTAL															
ROUNDING	44	0	0	58	0.51	0	101	5988	30	0	32	32	0.27	11	7
TOTAL															
	1450	1	1	4700	1.00	1	300	15800	7200	100	2400	2400	5.00	1650	300

SURFACING MATERIALS												
ITEM NO.	304.2	304.32	304.4	304.45	306.212	306.36	403.11001	403.12	403.6	403.99	417.	608.74
DESCRIPTION	GRAVEL (F)	CRUSHED GRAVEL FOR SHOULDER LEVELING	CRUSHED STONE (FINE GRADATION) (F)	CRUSHED STONE (FINE GRADATION) FOR DRIVES	RECLAIMED STABILIZED BASE REMOVED AND REHANDLED, 12" DEEP (F)	STONE FOR RECLAIMED STABILIZED BASE	HOT BITUMINOUS PAVEMENT, MACHINE METHOD (QC/QA TIER 1)	HOT BITUMINOUS PAVEMENT, HAND METHOD	PAVEMENT JOINT ADHESIVE	TEMPORARY BITUMINOUS PAVEMENT	COLD PLANING BITUMINOUS SURFACES	4" STONE DUST WEARING SURFACE FOR TRAILS
LOCATION	CY	TON	CY	CY	SY	TON	TON	TON	LF	TON	SY	CY
US ROUTE 3												
INDUSTRIAL PARK DRIVE	4599	1917	4857	623	18090	838	9214	411	60591	467	1636	
NH ROUTE 127	269		456	41			699	36	3153		1343	
RAIL TRAIL SURFACE												
DRAINAGE											14	
CURBING											99	
PROJECT WIDE												
						160						
FROM RETAINING WALL DETAIL												
			30									
SUB-TOTAL												
ROUNDING	4868	1917	5344	664	18090	998	9912	560	64195	467	3431	74
	-	33	-	6	-	2	38	10	5	3	19	1
TOTAL												
	4868	1950	5344	670	18090	1000	9950	570	64200	470	3450	75

INCIDENTAL ITEMS			
ITEM NO.	DESCRIPTION	UNIT	TOTAL
201.881	INVASIVE SPECIES CONTROL TYPE I	SY	340
201.882	INVASIVE SPECIES CONTROL TYPE II	SY	270
211.11	VIBRATION MONITORING SERVICES	HR	60
214.	FINE GRADING	U	1
403.4	MATERIAL TRANSFER VEHICLE (MTV)	T	9,950
606.9523	TEMPORARY IMPACT ATTENUATION DEVICE (NON-REDIRECTIVE), TEST LEVEL 3	U	2
618.61	UNIFORMED OFFICERS WITH VEHICLE	\$	10,000
618.7	FLAGGERS	HR	4,500
619.1	MAINTENANCE OF TRAFFIC	U	1
619.25	PORTABLE CHANGEABLE MESSAGE SIGN	U	4
621.2	RETROREFLECTIVE BEAM GUARDRAIL DELINEATOR	EA	50
622.1	STEEL WITNESS MARKERS	EA	50
628.2	SAWED BITUMINOUS PAVEMENT	LF	170
628.3	SAWED PAVEMENT	LF	25
645.7	STORM WATER POLLUTION PREVENTION PLAN	U	1
645.71	MONITORING SWPPP AND EROSION AND SEDIMENT CONTROLS	HR	190
670.0491	CONSTRUCT & REMOVE TEMPORARY ACCESS ROAD	U	1
670.0492	CONSTRUCT & REMOVE TEMPORARY ACCESS ROAD	U	1
670.066	MAILBOX SUPPORT ASSEMBLIES	EA	10
670.0661	MULTIPLE MAILBOX SUPPORT ASSEMBLIES	EA	3
670.104	TEMPORARY LIGHTING	U	2
670.95	TEMPORARY SAFETY FENCE	LF	1300
692.	MOBILIZATION	U	1
697.11	INVASIVE SPECIES CONTROL AND MANAGEMENT PLAN	U	1
697.41	CRITICAL PATH METHOD (CPM) ELECTRONIC SCHEDULE	U	1
698.13	FIELD OFFICE TYPE C	MON	28
698.2	PHYSICAL TESTING LABORATORY	MON	14
699.	MISCELLANEOUS TEMPORARY EROSION AND SEDIMENT CONTROL	\$	5,000
1010.15	FUEL ADJUSTMENT	\$	40,000
1010.2	ASPHALT CEMENT ADJUSTMENT	\$	20,000
1010.3	QUALITY CONTROL QUALITY ASSURANCE (QC/QA) ASPHALT	\$	38,000

RECLAIM - ITEM 306.36		
LOCATION	AREA (SY)	TON
3" Min. Application Depth (Assumed 2 TONS/CY)		
STA. 125+50 - 127+00 RT	364	61
STA. 132+50 - 136+00 RT	847	141
STA. 134+50 - 136+00 LT	370	62
STA. 143+00 - 156+50 RT	3325	554
STA. 158+50 - 159+00 LT	122	20
PROJECT WIDE (as needed)		160
SUBTOTAL		998
ROUNDING		2
TOTAL		1000

QUANTITIES IN THIS TABLE ARE FOR INFORMATION PURPOSES ONLY

TREE WORK			
ITEM NO.	201.21	201.22	201.4
ITEM	REMOVING SMALL TREES	REMOVING LARGE TREES	REMOVING STUMPS
UNIT	EA	EA	EA
LOCATION			
STA 101+12 LT 55'	1		1
STA 101+42 LT 23'			
STA 102+14 LT 24'	1		
STA 102+36 LT 23'	1		
STA 102+39 LT 22'	1		
STA 104+33 LT 21'		1	
STA 105+30 LT 24'			1
STA 106+22 LT 20'	1		
STA 106+77 LT 22'	1		
STA 106+84 LT 21'	1		
STA 114+23 LT 34'	1		
STA 114+42 LT 35'	1		
STA 116+31 RT 63'	1		
SUBTOTAL			
ROUNDING	0	0	0
TOTAL			
	10	1	2

BOUNDS SUMMARY		
STATION	622.2 CONCRETE BOUNDS EA	REMARKS
US ROUTE 3		
132+37.50 LT 25.00'	1	
137+05.44 RT 25.15'	1	
137+32.51 LT 25.00'	1	
138+00.00 LT 25.00'	1	
138+56.80 RT 30.00'	1	
140+53.61 RT 28.00'	1	
141+15.90 RT 30.00'	1	
141+94.54 LT 39.00'	1	
144+83.63 RT 30.00'	1	
144+83.63 RT 30.00'	1	
146+24.59 LT 37.00'	1	
146+24.67 LT 30.00'	1	
148+53.42 RT 21.00'	1	
150+64.60 RT 21.00'	1	
150+65.10 LT 37.00'	1	
151+87.93 RT 21.00'	1	
249+55.87 RT 25.00'	1	
249+72.23 LT 25.00'	1	
251+26.54 RT 25.00'	1	
SUBTOTAL		
ROUNDING	19	1
TOTAL		
	20	

GUARDRAIL									
REF. NO.	LOCATION	202.7 REMOVAL OF GUARDRAIL (F)	203.55543 GUARDRAIL 50' EAGRT OFFSET PLATFORM	606.01578 FURNISH STEEL POSTS (NU-GUARD 31), 6'-6" WITH HARDWARE	606.1254 BEAM GUARDRAIL (TERMINAL UNIT TYPE EAGRT 50FT), STEEL POST	606.15808 STEEL BEAM GUARDRAIL, STEEL POSTS (NU-GUARD 31)	606.18001 31" W-BEAM GUARDRAIL WITH 8" OFFSET BLOCKS (STEEL POST)	606.417 PORTABLE CONCRETE BARRIER FOR TRAFFIC CONTROL	REMARKS
STATION		LF	U	EA	U	LF	LF	LF	
US ROUTE 3									
1N	97+87 RT 15.7' TO 118+00 RT 18.7'	550.0	2	15	2	1912.5			10% OF TOTAL NU-GUARD POSTS FOR DISTRICT
2N	119+00 RT 16.9' TO 124+62 RT 22.2'	277.9	2		2		462.5		
3N	134+60 RT 25.0' TO 138+29 RT 22.0'	174.2	1		1		312.5		
1S	136+84 LT 25.2' TO 139+57 LT 22.0'	311.4	1		1		225.0		
4N	140+31 RT 22.0' TO 147+99 RT 25.0'	686.1	1		1		725.0		
2S	141+58 LT 22.0' TO 144+61 LT 25.1'	249.8	1		1		250.0		
5N	149+63 RT 25.0' TO 154+99 RT 25.0'	212.2	2		2		337.5		
	99+25.5 RT TO 113+84.5 RT							1460.0	TRAFFIC CONTROL FOR STABILIZED SLOPE
SUBTOTAL									
ROUNDING		2461.6	10.0	15	10.0	1912.5	2312.5	1460.0	
TOTAL									
		2462	10	16	10	1925	2350	1460	

EARTHWORK		
DESCRIPTION	CY	TOTAL
COMMON EXCAVATION IN SECTIONS, INCLUDING BOULDERS AND PAVEMENT		
DRIVE AND APPROACH EXCAVATION, INCLUDING BOULDERS	14,379	870
COMMON EXCAVATION IN SECTIONS, EXCL. BLDRS & CONC. PVMT.		
TOPSOIL REMOVED BENEATH FILL SECTIONS	13,117	2,665
DRIVE AND APPROACH EXCAVATION	861	
COMMON EXCAVATION FOR ESTIMATE	ITEM 203.1	16,643
ROCK EXCAVATION IN SECTIONS (SOLID)		
BOULDERS IN SECTION (1%)	520	144
CONCRETE PAVEMENT IN SECTIONS	1,118	9
DRIVE AND APPROACH EXCAVATION (SOLID ROCK)	9	
DRIVE AND APPROACH EXCAVATION (BOULDERS) (1%)	1	
ROCK EXCAVATION FOR ESTIMATE	ITEM 203.2	1,800
SECTIONS FILL		
TOPSOIL REPLACEMENT	939	2,665
EMBANKMENT-IN-PLACE FOR ESTIMATE (F)	ITEM 203.6	3,604

SUMMARY OF QUANTITIES (ESTIMATED)
THIS INFORMATION IS FOR BIDDING PURPOSES ONLY

STATE OF NEW HAMPSHIRE			
DEPARTMENT OF TRANSPORTATION • BUREAU OF HIGHWAY DESIGN			
<i>QUANTITY SUMMARIES</i>			
DGN	STATE PROJECT NO.	SHEET NO.	TOTAL SHEETS
13928aSummaries	13928A	12	160

WATER LINE RELOCATION (NON-PAR)																	
ITEM NO.	202.31	611.05206	611.05212	611.50107	611.5012	611.51007	611.51020	611.5202	611.70006	611.70012	611.71006	611.770	611.81	611.814	611.951		
DESCRIPTION	FILL ABANDONED PIPE	6" CEMENT LINED DUCTILE IRON WATER PIPE, CL 52	12" CEMENT LINED DUCTILE IRON WATER PIPE, CL 52	3/4" COPPER SERVICE CONNECTION	2" COPPER WATER PIPE	3/4" CORPORATION STOP	2" CORPORATION STOP	2" CURB STOP	6" FITTING	12" FITTING	6" GATE VALVE	CHLORINE INJECTION TAP	HYDRANT	REMOVE HYDRANT	WATER MAIN INSULATION	REMARKS	
UNIT	CY	LF	LF	LF	LF	EA	EA	EA	EA	EA	EA	EA	EA	EA	EA	SY	
US ROUTE 3																	
STA. 94+75, LT						20		1	1							2" water service is to provide temporary water service to the area south of the project	
STA. 100+60, LT. 17' TO 102+65, LT. 17'			205							2					10.67	Sta. 100+60 - 2@ 12x22.5" Bends (H); Construct 2" Water Main Insulation (4' x 12') between the new water main and new CB's at Sta. 100+79 & Sta. 102+12	
STA. 101+50, LT				20		1										Service to House No. 705	
STA. 103+96, LT. 17' TO 106+10, LT. 14'			220							6						12" DI under 15" SPP; Sta. 103+96 - 4@ 12x45" Bends (Vertical & Horizontal); Sta. 106+10 - 2@ 12x22.5" Bends (H)	
STA. 104+75, LT				20		1										Service to House No. 673 & 675	
STA. 108+50, LT. 18' TO 108+90, LT. 19'			40							4						12" DI under 24" SPP; Sta. 108+50 - 2@ 12x45" Bends (V); Sta. 108+90 - 2@ 12x45" Bends (V)	
STA. 109+80, LT. 19' TO 112+76, LT. 16'			300							4						12" DI under 18" SPP; Sta. 109+80 - 2@ 12x45" Bends (Vertical & Horizontal); Sta. 110+33 - 2@ 12x45" Bends (V)	
STA. 110+33, LT		45							2	1	1					12x12x6 TEE; 2@ 6x45" Bends (V); 1@ 6" Gate Valve	
STA. 114+85, LT. 19' TO 116+25, LT. 24'			140							3						Sta. 114+85 - 2@ 12x22.5" Bends (H); Sta. 115+67 - 1@ 11.25" Bend (H)	
STA. 115+67, LT		35							4	1	1					12x12x6 TEE; 1@ 6x45" Bends (V); 1@ 6" Gate Valve; 1@ 6" Cap (Subsidiary)	
STA. 118+16, LT. 22' TO 123+35, LT. 25'	5.8		525							4						Construct 12" DI Water Main over the 15" SPP and 18" SPP Drain Pipes; Sta. 118+16 - 2@ 12x22.5" Bends (H); Sta. 123+35 - 2@ 12x22.5" Bends (H)	
STA. 118+54, LT. 26'		20							1	1			1			New Hydrant; 1@ 12x12x6 TEE; 1@ 6" Gate Valve	
STA. 119+29, LT. 25'														1			
STA. 123+46, LT.															5.33	Construct 2" Water Main Insulation (4' x 12') between existing water main and new DI	
STA. 125+90, LT. 27' TO 126+35, LT. 27'			45							4						12" DI under 12" UND and 24" SPP; Sta. 125+90 - 2@ 12x45" Bends (V); Sta. 126+35 - 2@ 12x45" Bends (V)	
STA. 129+34, LT.																5.33	Construct 2" Water Main Insulation (4' x 12') between existing water main and new CB
STA. 132+31, LT.																5.33	Construct 2" Water Main Insulation (4' x 12') between existing water main and new CB
PROJECT WIDE											3					The number of Chlorine Injection Taps is estimated	
SUBTOTAL	5.8	100	1,475	40	20	2	1	1	6	30	3	3	1	1	26.67		
ROUNDING	1.2	15	50	10	10	0	0	0	2	4	0	0	0	0	3.33		
TOTAL	7	115	1,525	50	30	2	1	1	8	34	3	3	1	1	30		

LIGHTING						
ITEM NO.	614.331	614.522	614.73118	625.2	625.62	
REF. NO.	ITEM	3" STEEL CONDUIT	MOLDED PULL BOX 13"x24"	3" PVC PLASTIC CONDUIT, SCHEDULE 80	CONCRETE LIGHT POLE BASES, TYPE B	RESET/ RELOCATE LIGHT POLES
UNIT	LF	EA	LF	EA	EA	REMARKS
LOCATION						
1-2	Sta. 20+70, RT 48.0' - Sta. 20+64, RT 51.0'	13				POWER SUPPLY TO PULL BOX
2-3	Sta. 20+64, RT 51.0' - Sta. 20+58, RT 4.0'	26	1	20.0		PULL BOX TO PULL BOX
4	Sta. 20+52, 4.3' RT		1		1	LIGHT POLE
SUBTOTAL		39.0	2.0	20.0	1.0	
ROUNDING		1.0	0.0	10.0	0.0	
TOTAL		40.0	2.0	30.0	1.0	

PERMANENT CONSTRUCTION SIGNS (INCLUDED IN ITEM NO. 619.1)								
SIGN NO.	DESCRIPTION	SIZE (ft)		S.F.	NO. REQ.	TOTAL AREA	PORTABLE MOUNTS	LOCATION
		W	H					
G20-2a	"END ROAD WORK"	2	4	8	5	40		US RTE 3 NB & SB, INDUSTRIAL PARK DR, OLD SOUTH MAIN ST AND NH RTE 127 SB.
R50-1	"WORK ZONE SPEED"	4	6	24	3	72		US RTE 3 NB & SB AND NH RTE 127 SB.
W20-1a	"ROAD WORK AHEAD"	4	4	16	5	80		US RTE 3 NB & SB, INDUSTRIAL PARK DR, OLD SOUTH MAIN ST AND NH RTE 127 SB.
W20-1c	"ROAD WORK 1000 FT"	4	4	16	4	64		US RTE 3 NB & SB, OLD SOUTH MAIN ST NB AND NH RTE 127 NB
W20-1e	"ROAD WORK 1/2 MILE"	4	4	16	2	32		US RTE 3 NB & SB
SUBTOTAL								
ROUNDING								
TOTAL								

The estimated quantities of "Permanent Controls" are hereby listed. The Contractor is responsible for all "Operational Controls" required under section 619 of the NHDOT Specifications and the Manual of Uniform Traffic Control Devices (MUTCD), Part VI.

WATER LINE RELOCATION (PAR)								
ITEM NO.	611.05206	611.05212	611.70012	611.71006	611.71012	611.770	611.81	
DESCRIPTION	6" CEMENT LINED DUCTILE IRON WATER PIPE, CL 52	12" CEMENT LINED DUCTILE IRON WATER PIPE, CL 52	12" FITTING	6" GATE VALVE	12" GATE VALVE	CHLORINE INJECTION TAP	HYDRANT	REMARKS
UNIT	LF	LF	EA	EA	EA	EA	EA	
INDUSTRIAL PARK DRIVE								
STA. 20+15, LT. 17' TO 23+35, LT. 33'		323	6		3	1		12" DI under 18" SPP; Sta. 20+44 - 4@ 12x45" Bends (V); Sta. 23+35 - 2@ 12x22.5" Bends (H); 1@ 12x12x12 TEE; 3@ 12" Gate Valves. The number of Chlorine Injection Taps is estimated.
STA. 21+20, RT. 42'	60		1	1			1	1@ 12x12x6 TEE; 1@ 6" Gate Valve; New Hydrant
SUBTOTAL	60	323	7	1	3	1	1	
ROUNDING	5	27	0	0	0	0	0	
TOTAL	65	350	7	1	3	1	1	

FENCE				
ITEM NO.	202.8	607.1	607.4146	
REF. NO.	LOCATION	REMOVAL OF FENCE	WOVEN WIRE FENCE	WOVEN WIRE FENCE POST ASSEMBLIES
STATION	LF	LF	EA	REMARKS
US ROUTE 3				
A	STA 104+96 LT 24' TO 105+29 LT 17'	40.7		
B	STA 106+81 LT 19' TO 107+93 LT 20'	111.9		
C	STA 108+05 LT 20' TO 108+37 LT 36'	48.0		
D	STA 114+04 LT 42' TO 114+92 LT 38'	102.8		
E	STA 115+54 LT 30' TO 115+64 LT 29'	10.2		
F	STA 119+36, LT 33.5' TO 123+12, LT 32.0'		370.6	11.0
				BEHIND RETAINING WALL, ALONG ROW LINE
SUBTOTAL		314	371	11
ROUNDING		6	5	2
TOTAL		320	375	13

PAVEMENT MARKINGS					
ITEM NO.	632.0104	632.3104	632.3108	632.3118	632.32
DESCRIPTION	RETRO- REFLECTIVE PAINT PAVE. MARKING, 4" LINE	RETRO- REFLECTIVE THERMOPLASTIC PAVEMENT MARKING, 4" LINE	RETRO- REFLECTIVE THERMOPLASTIC PAVEMENT MARKING, 8" LINE	RETRO- REFLECTIVE THERMOPLASTIC PAVEMENT MARKING, 18" LINE	RETRO- REFLECTIVE THERMOPLASTIC PAVEMENT MARKING, SYMBOL
UNIT	LF	LF	LF	LF	SF
US ROUTE 3					
INDUSTRIAL PARK DRIVE	106000	136.25		25.3	56.3
NH ROUTE 127	3200			40	
	236	69.7	175		
SUB-TOTAL	109436	206	175	65	56
ROUNDING	564	4	5	5	4
TOTAL	110000	210	180	70	60

SALVAGE OF MATERIALS
DESCRIPTION
TO DISTRICT TWO:
CABLE GUARDRAIL HARDWARE AS SHOWN ON THE ANCHOR POST
SALVAGE DETAIL IN THE PROSECUTION OF WORK
GRANITE CURB

SUBSIDIARY ITEMS
DESCRIPTION
TRAFFIC SIGN REMOVAL
REMOVAL OF EXISTING DRAINAGE (WHERE INDICATED ON PLANS)
SAWCUT PAVEMENT
NOTE: THIS LIST SHOULD NOT BE CONSIDERED TO BE THE COMPLETE LIST OF SUBSIDIARY WORK PRESENT IN THE PROJECT. REFER ALSO TO THE PLANS, PROPOSAL, SPECIAL PROVISIONS, AND TO THE STANDARD SPECIFICATIONS.

SIGNING			
ITEM NO.	DESCRIPTION	UNIT	TOTAL
615.02	TRAFFIC SIGN TYPE B (F)	SF	78.00
615.03	TRAFFIC SIGN TYPE C (F)	SF	169.00
615.06	TRAFFIC SIGN TYPE CC (F)	SF	63.00

FORCE ACCOUNT
DESCRIPTION
PSNH LIGHTING
NHDOT BUREAU OF TRAFFIC - SIGNS AND PAVEMENT MARKINGS

SUMMARY OF QUANTITIES (ESTIMATED)
THIS INFORMATION IS FOR BIDDING PURPOSES ONLY

STATE OF NEW HAMPSHIRE			
DEPARTMENT OF TRANSPORTATION • BUREAU OF HIGHWAY DESIGN			
QUANTITY SUMMARIES			
DGN	STATE PROJECT NO.	SHEET NO.	TOTAL SHEETS
13928aSummary ies	13928A	13	160

SDR PROCESSED	NEW DESIGN	TEAM K IROUAC	DATE	04/2013
	SHEET CHECKED	C. SPETELUNAS	DATE	04/22/15
AS BUILT DETAILS			DATE	

REVISIONS AFTER PROPOSAL	DESCRIPTION
STATION	
STATION	
DATE	
NUMBER	

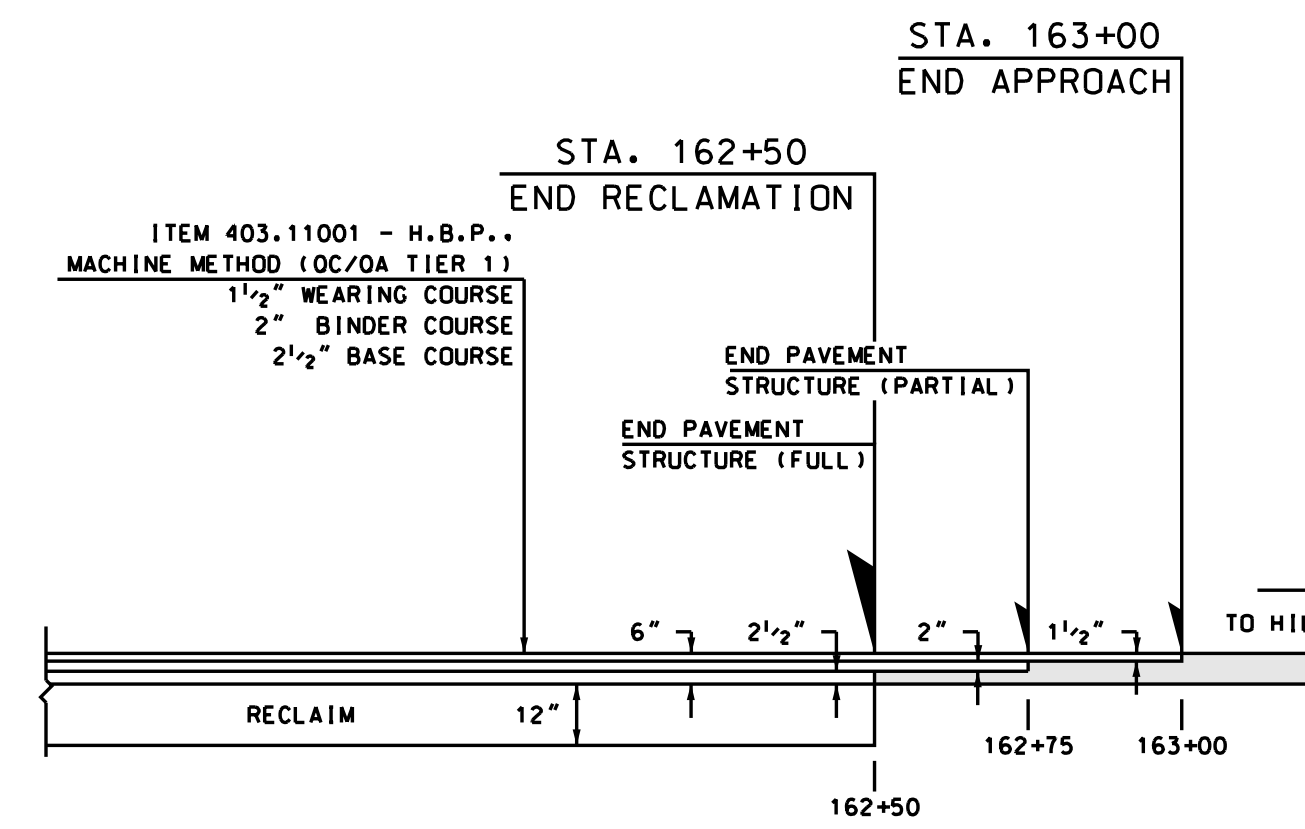
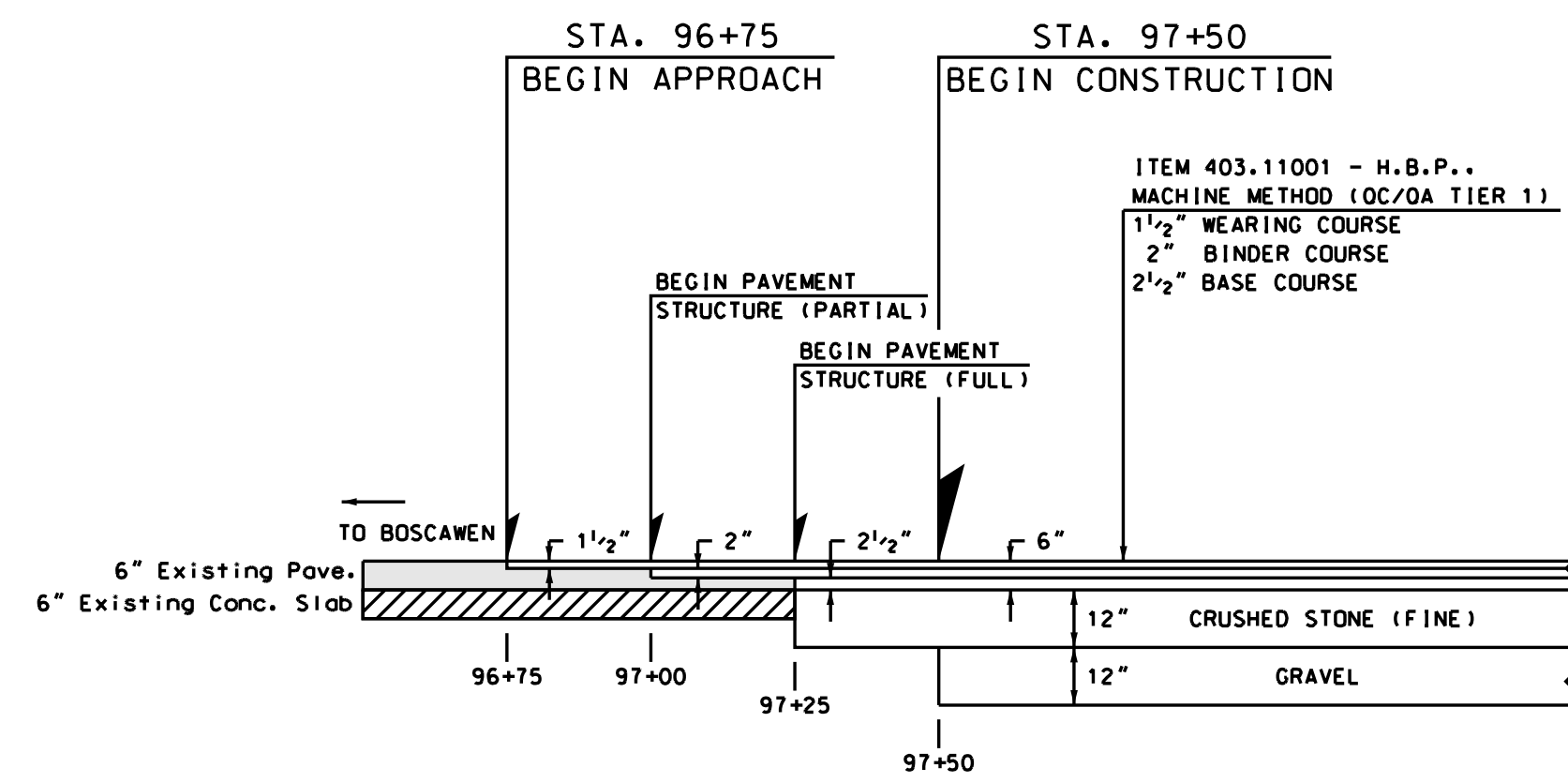

U.S. ROUTE 3

NOT TO SCALE

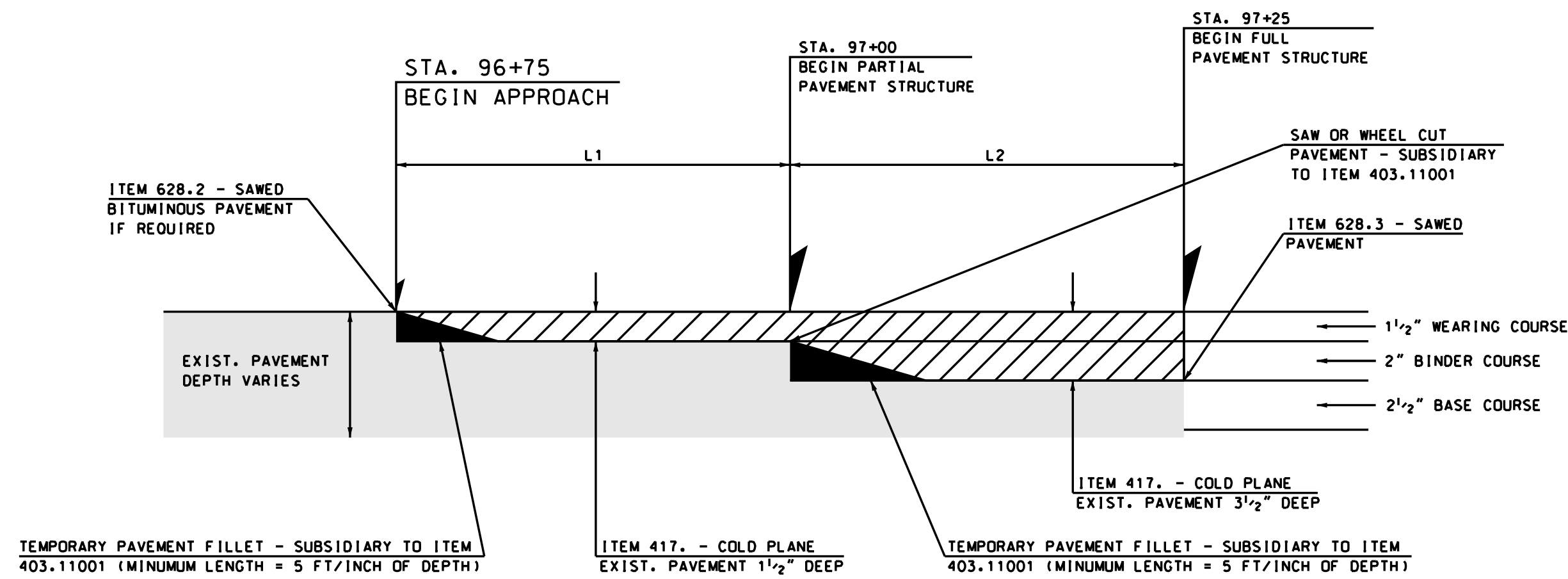

INLAY PAVEMENT MATCH U.S. ROUTE 3 SOUTH

NOT TO SCALE

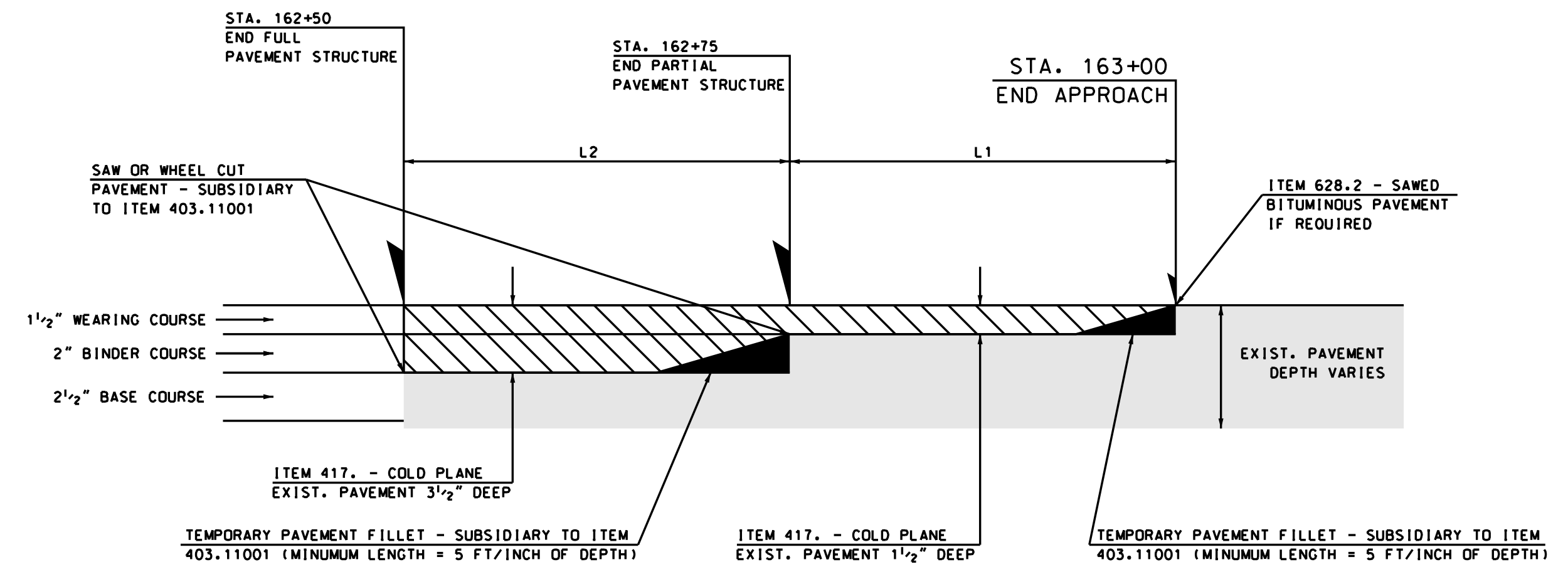

INLAY PAVEMENT MATCH U.S. ROUTE 3 NORTH

NOT TO SCALE

STATE OF NEW HAMPSHIRE			
DEPARTMENT OF TRANSPORTATION • BUREAU OF HIGHWAY DESIGN			
PAVEMENT MATCH DETAILS			
DGN	STATE PROJECT NO.	SHEET NO.	TOTAL SHEETS
13928Apvt-mth	13928A	17	160

SDR PROCESSED	DATE	DATE	DATE	DATE	DATE
NEW DESIGN	TEAM K IROUAC	04/2013	04/22/15		
SHEET CHECKED	C. SPETELUNAS				
AS BUILT DETAILS					

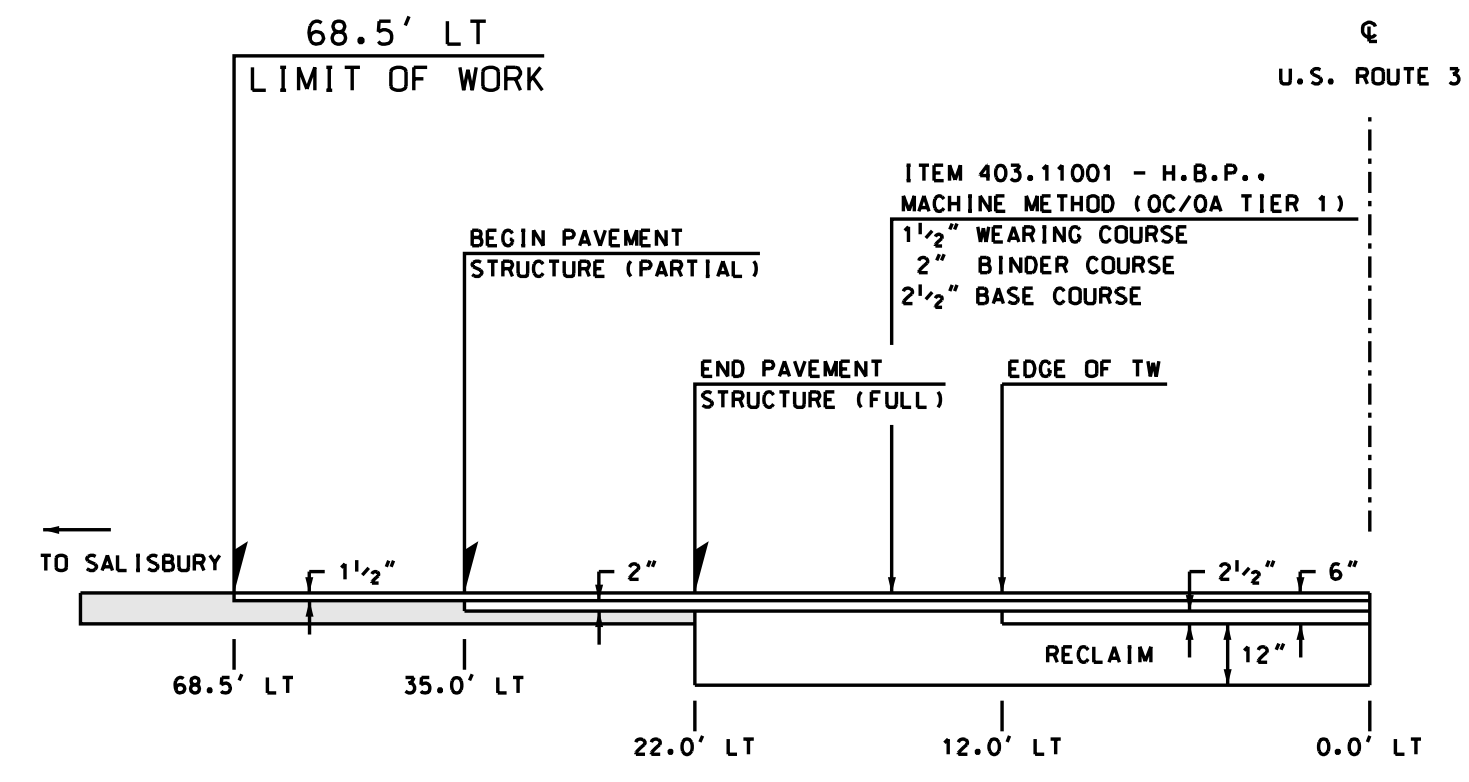

N.H. ROUTE 127 (STA. 161+50 LEFT)
NOT TO SCALE

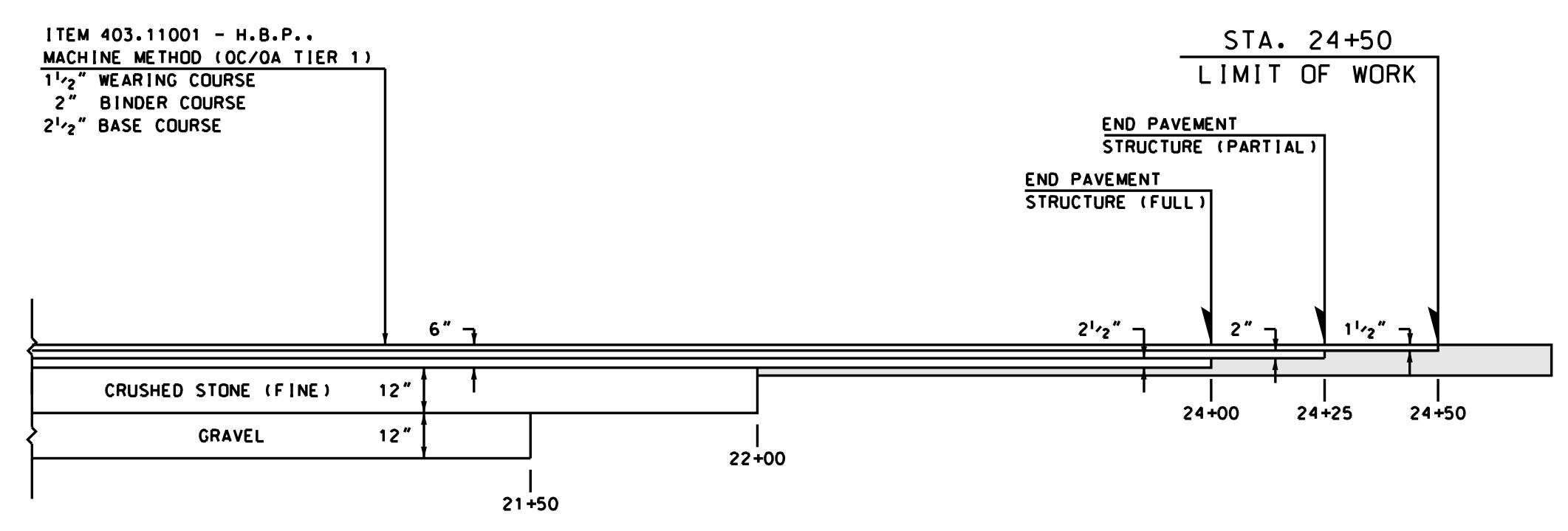

INDUSTRIAL PARK DR.
NOT TO SCALE

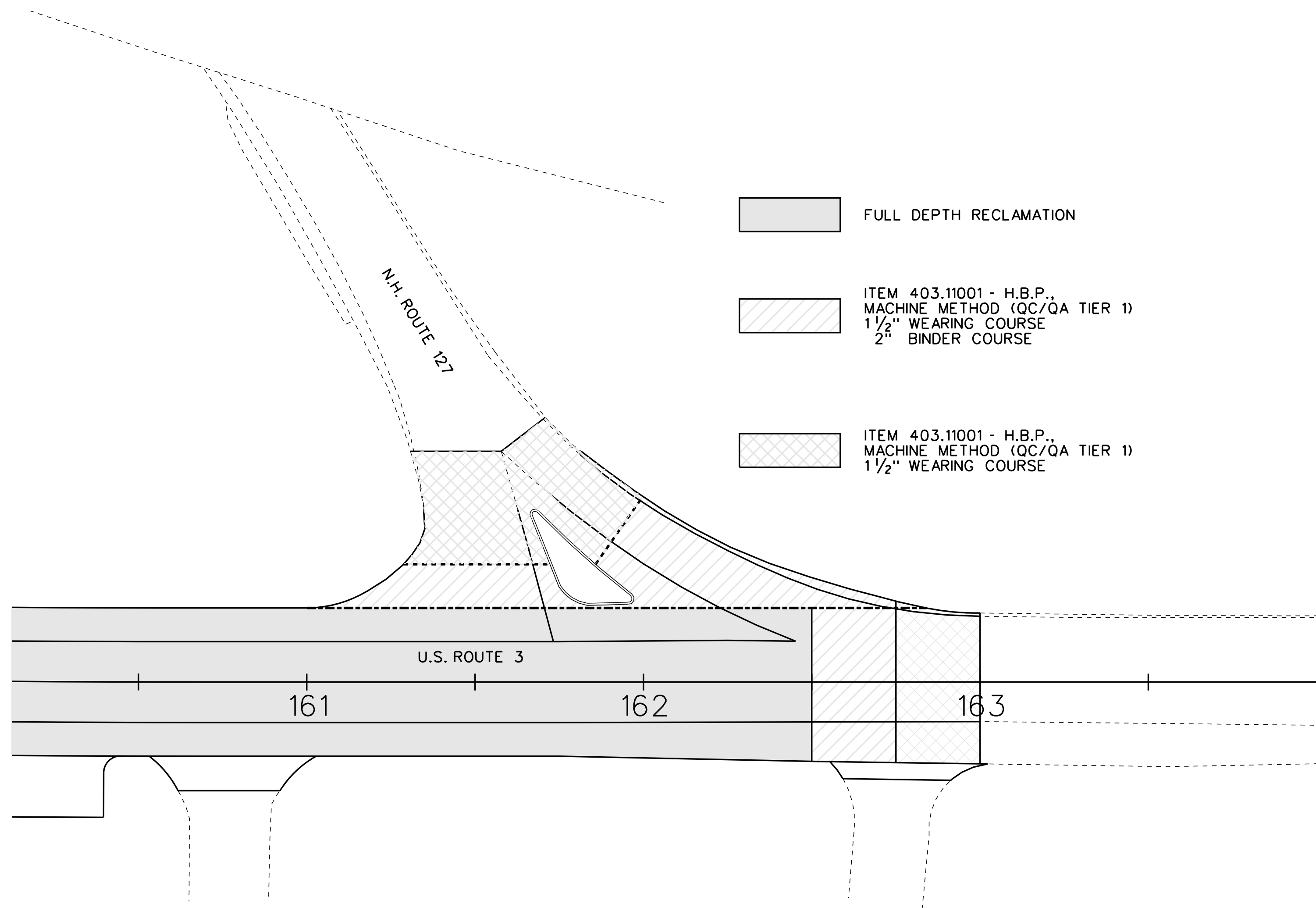

N.H. ROUTE 127 PLAN VIEW
NOT TO SCALE

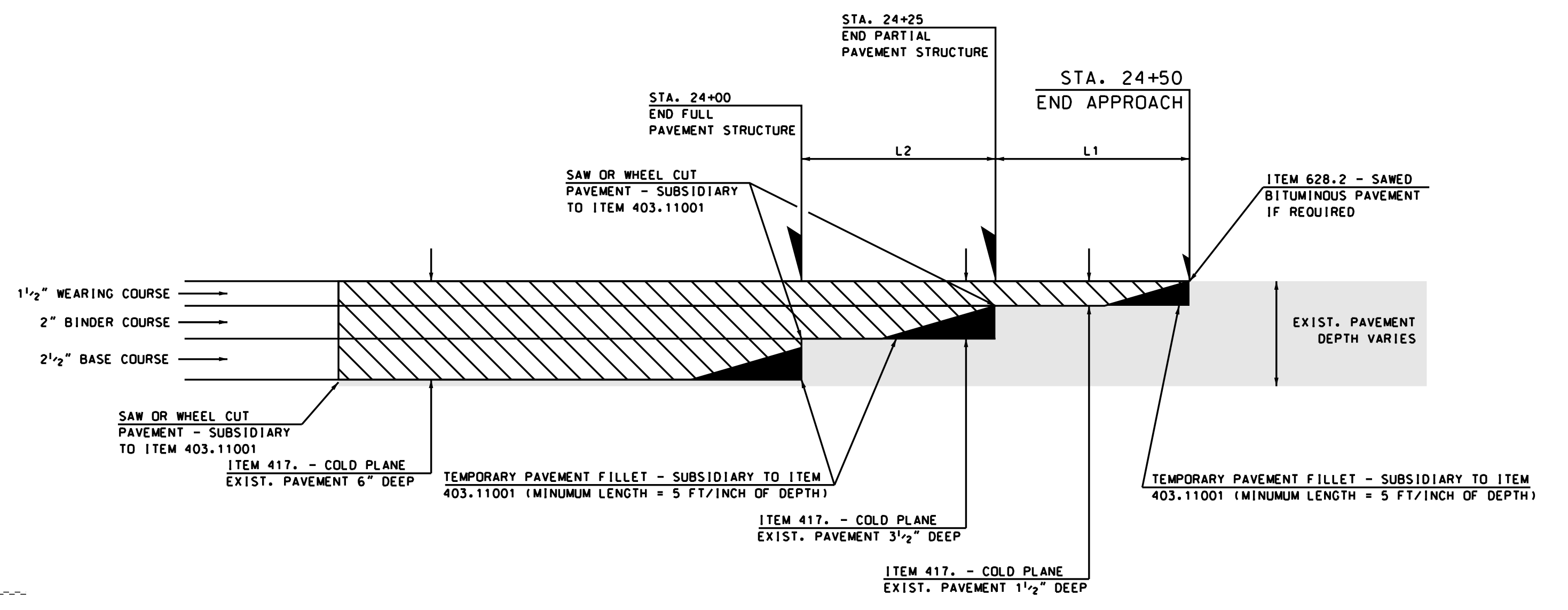

INLAY PAVEMENT MATCH INDUSTRIAL PARK DR.
NOT TO SCALE

STATE OF NEW HAMPSHIRE			
DEPARTMENT OF TRANSPORTATION • BUREAU OF HIGHWAY DESIGN			
PAVEMENT MATCH DETAILS			
DGN	STATE PROJECT NO.	SHEET NO.	TOTAL SHEETS
13928Apvt-mth	13928A	18	160

SDR PROCESSED	DATE	AS BUILT DETAILS
NEW DESIGN	T. RUSSO	DATE
SHEET CHECKED	C. SPETELUNAS	DATE
REVISIONS AFTER PROPOSAL	STATION	DESCRIPTION
NUMBER	DATE	

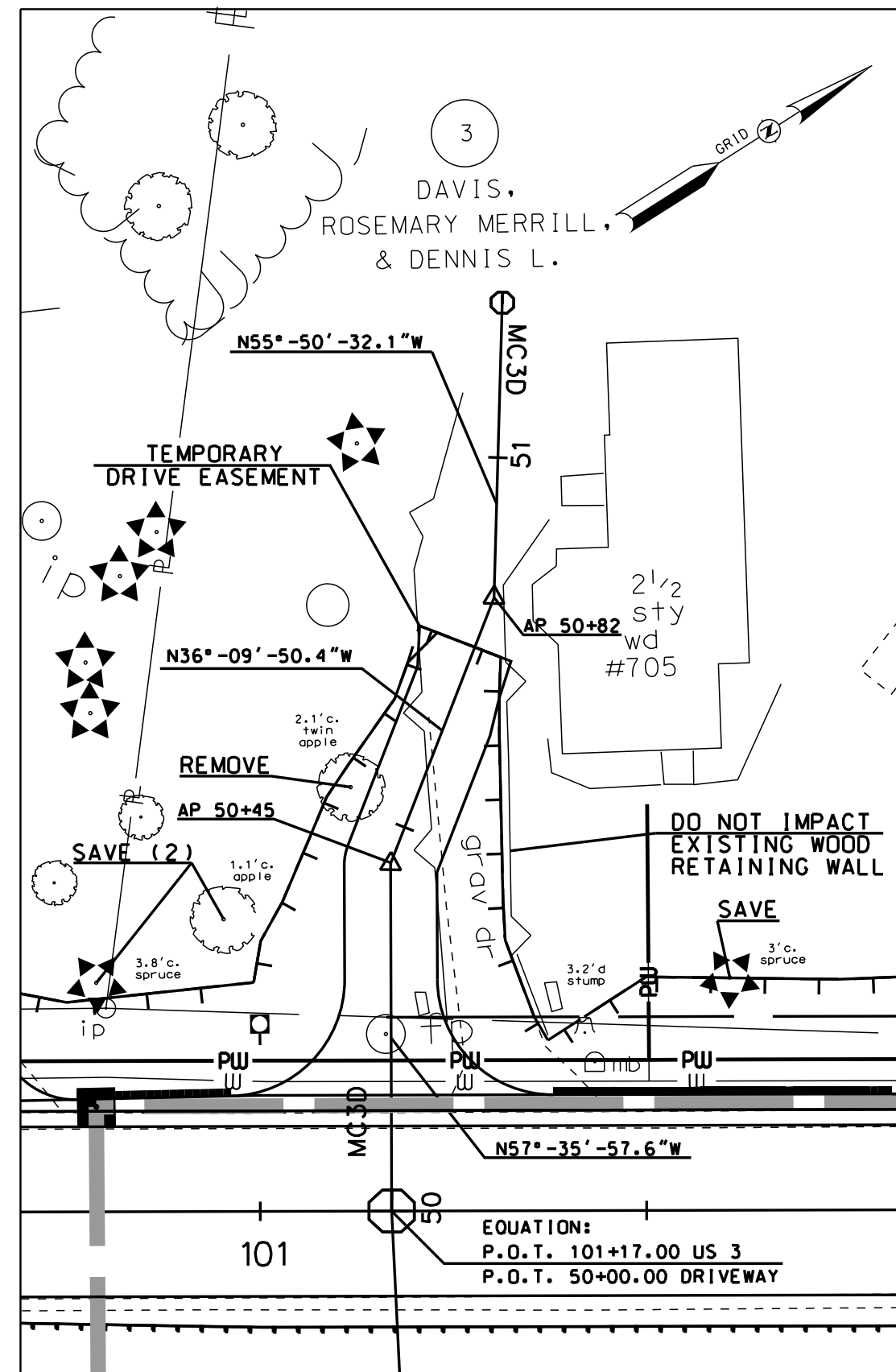

PLAN VIEW
SCALE: 1" = 20'

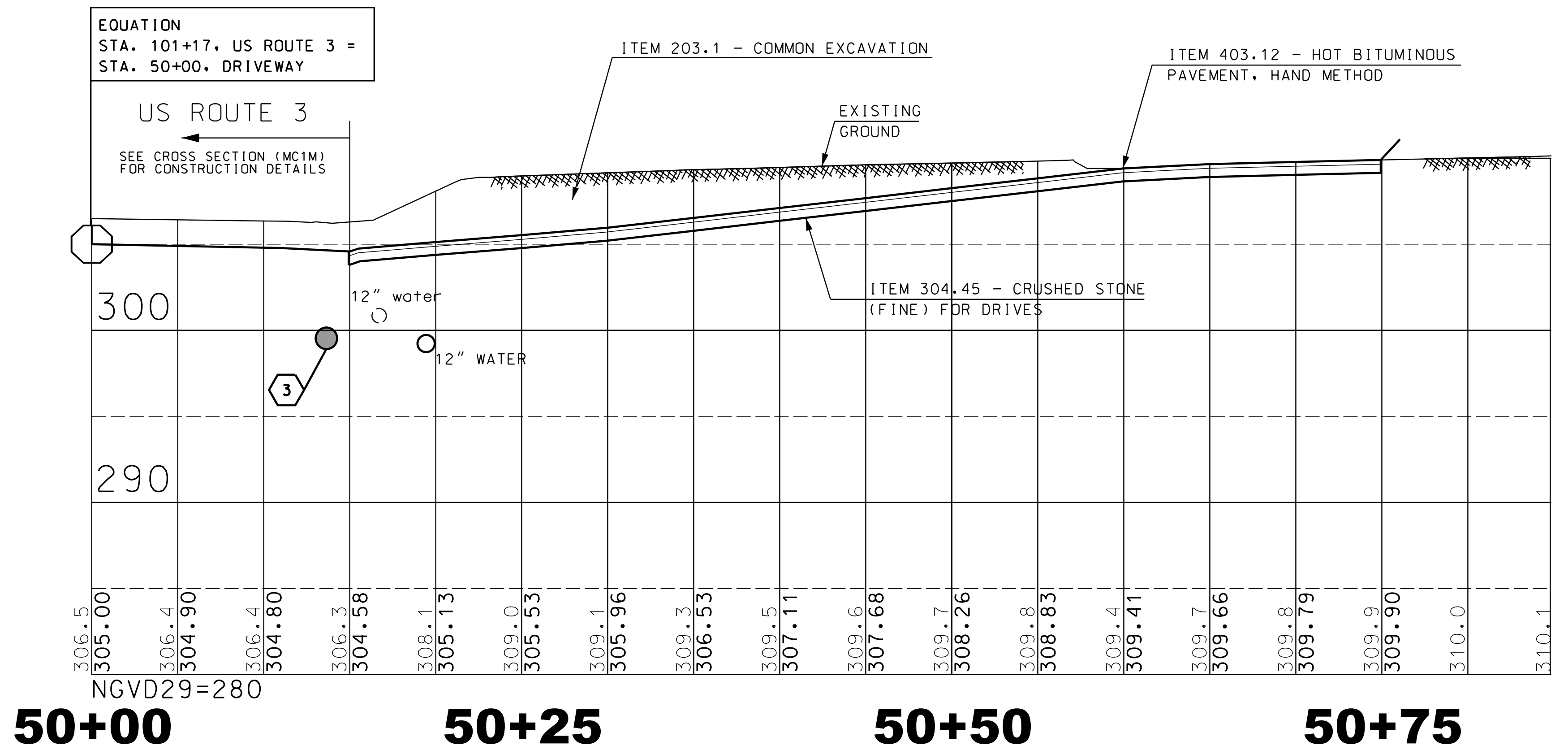

PROFILE ALONG MC3D ALIGNMENT
SCALE: 1" = 5'

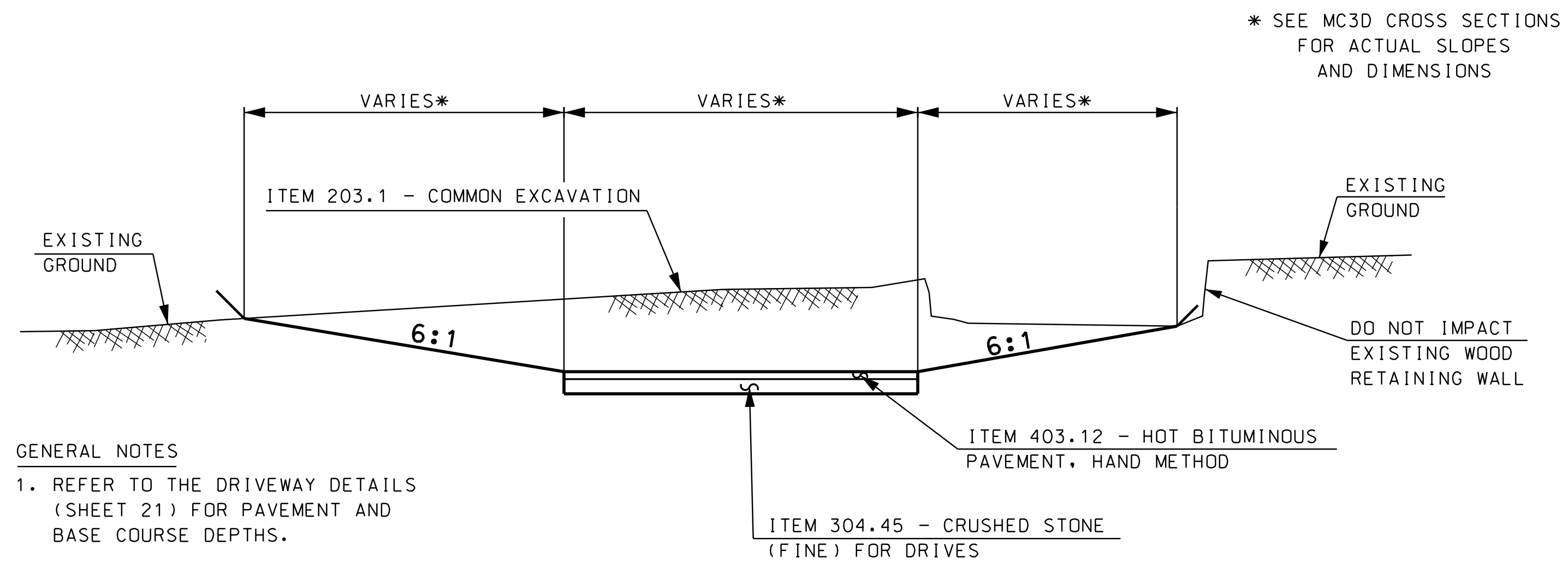

GENERAL NOTES
1. REFER TO THE DRIVEWAY DETAILS (SHEET 21) FOR PAVEMENT AND BASE COURSE DEPTHS.

TYPICAL SECTION
NOT TO SCALE

* SEE MC3D CROSS SECTIONS FOR ACTUAL SLOPES AND DIMENSIONS

STATE OF NEW HAMPSHIRE			
DEPARTMENT OF TRANSPORTATION • BUREAU OF HIGHWAY DESIGN			
DRIVE DETAIL @ STA 101+17			
DGN	STATE PROJECT NO.	SHEET NO.	TOTAL SHEETS
13928A_driveway101+17	13928A	19	160

SDR PROCESSED		DATE		DATE		DATE		DATE		REVISIONS AFTER PROPOSAL	
NEW DESIGN	T. RUSSO	DATE	04/2015	STATION		STATION		NUMBER		DESCRIPTION	
SHEET CHECKED	C. SPETELUNAS	DATE	04/2015								
AS BUILT DETAILS											

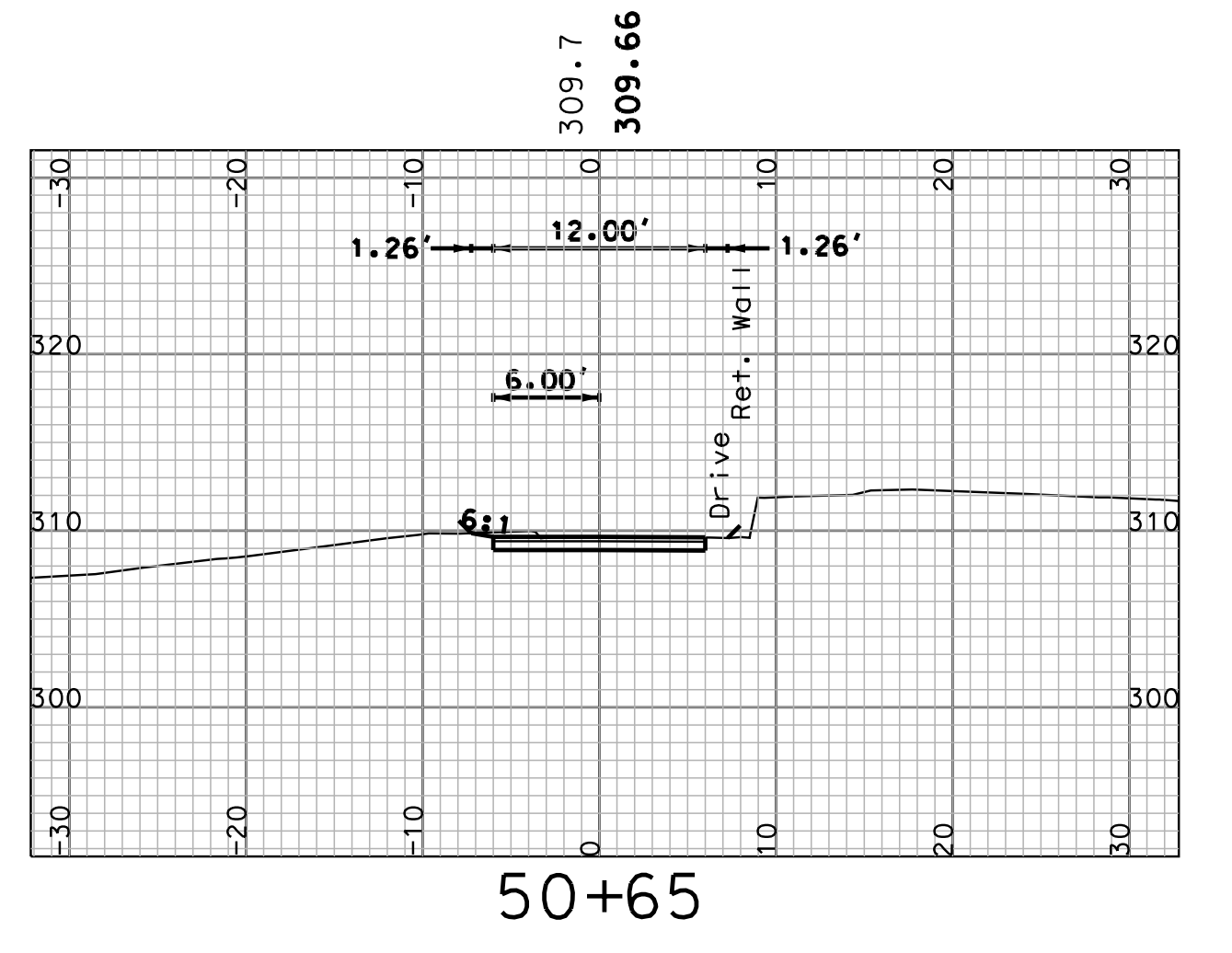
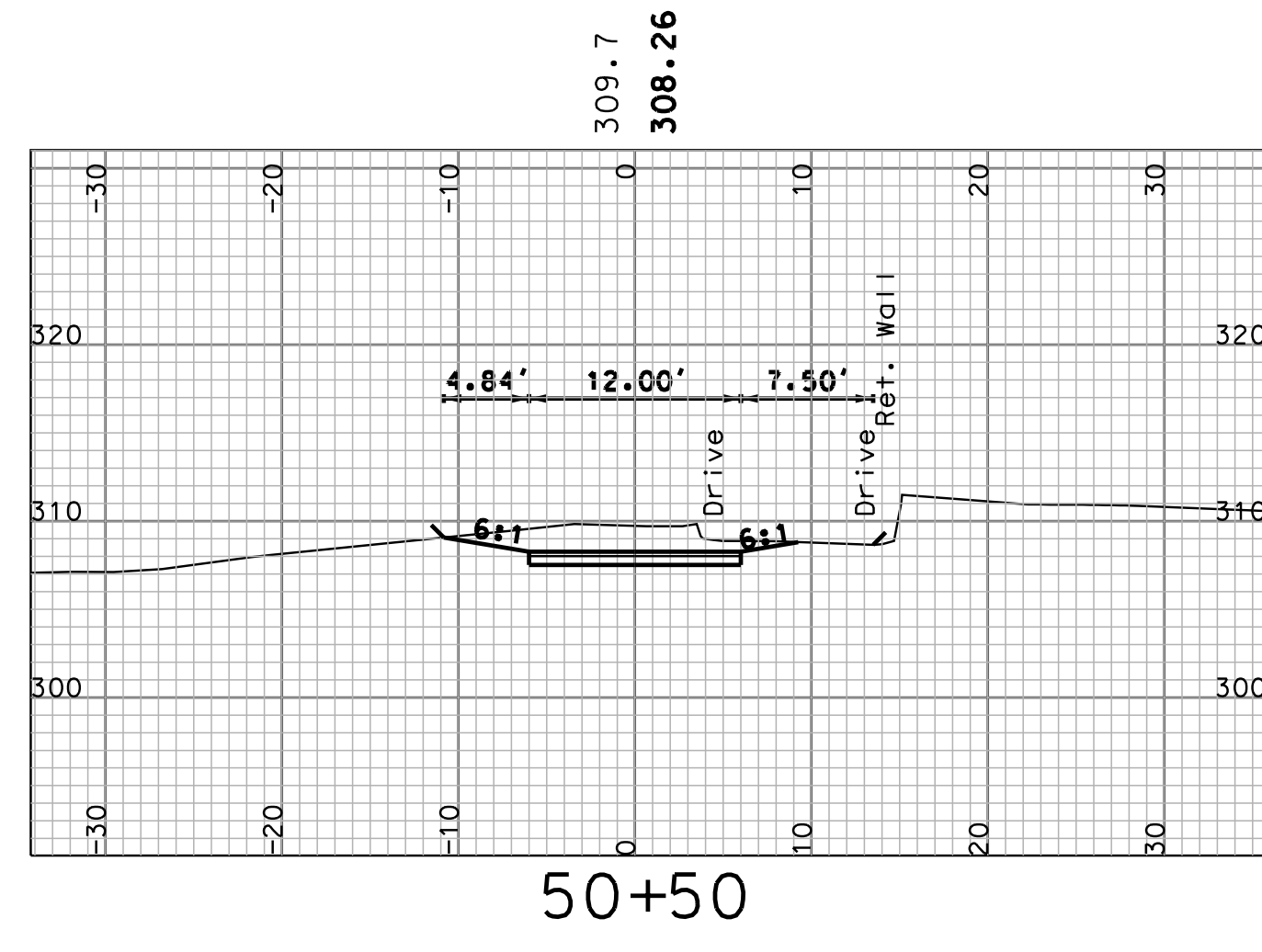
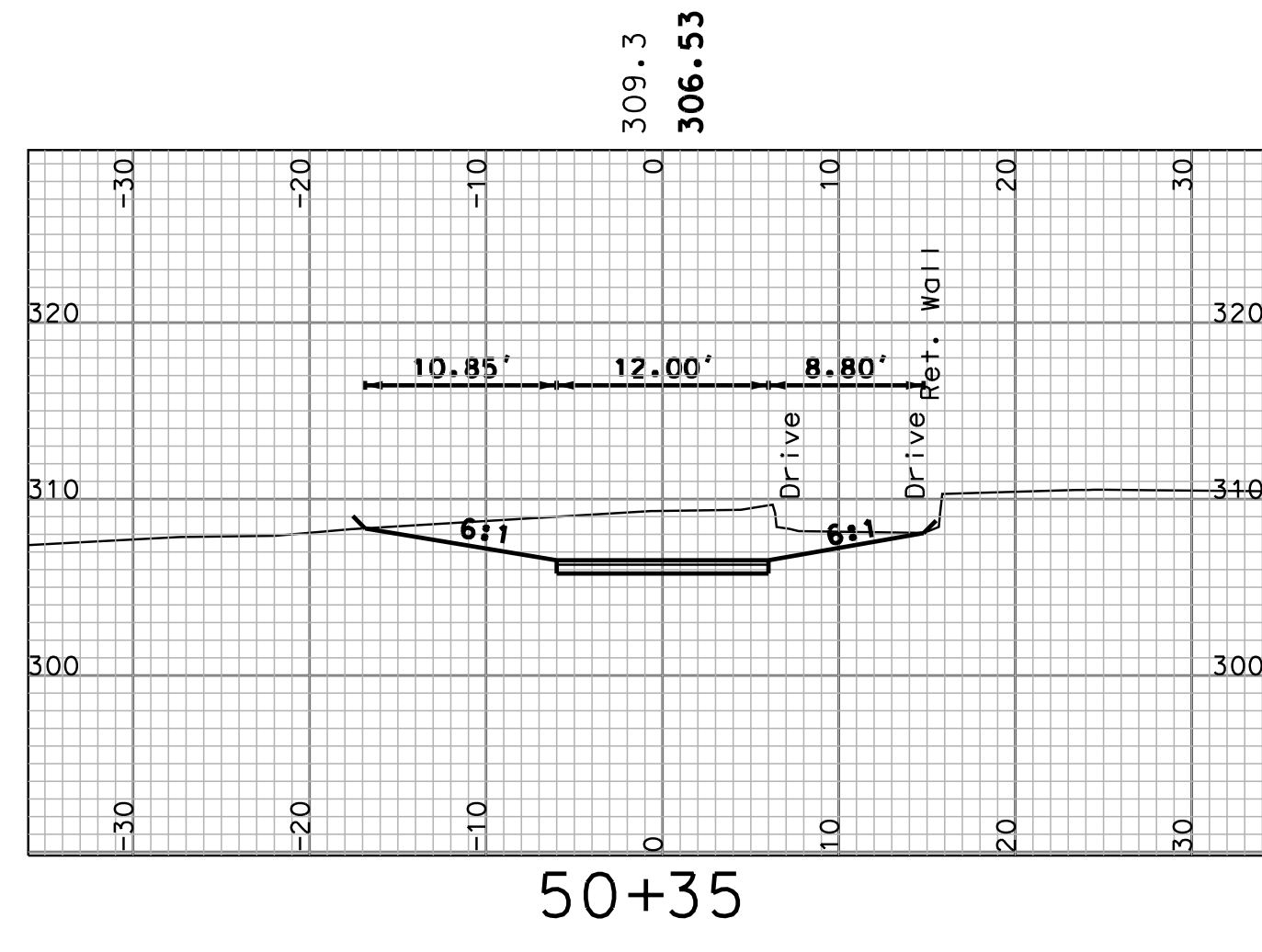
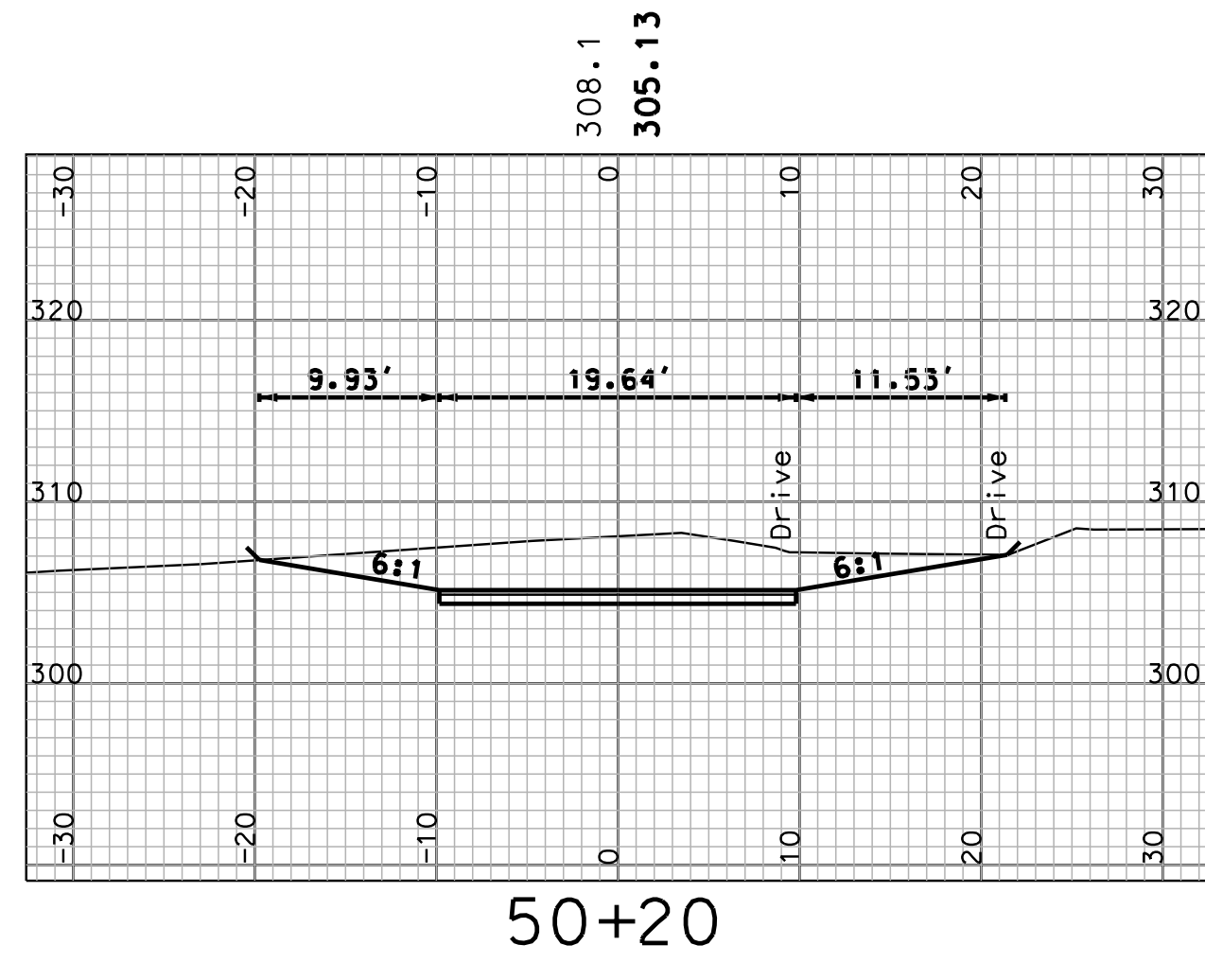
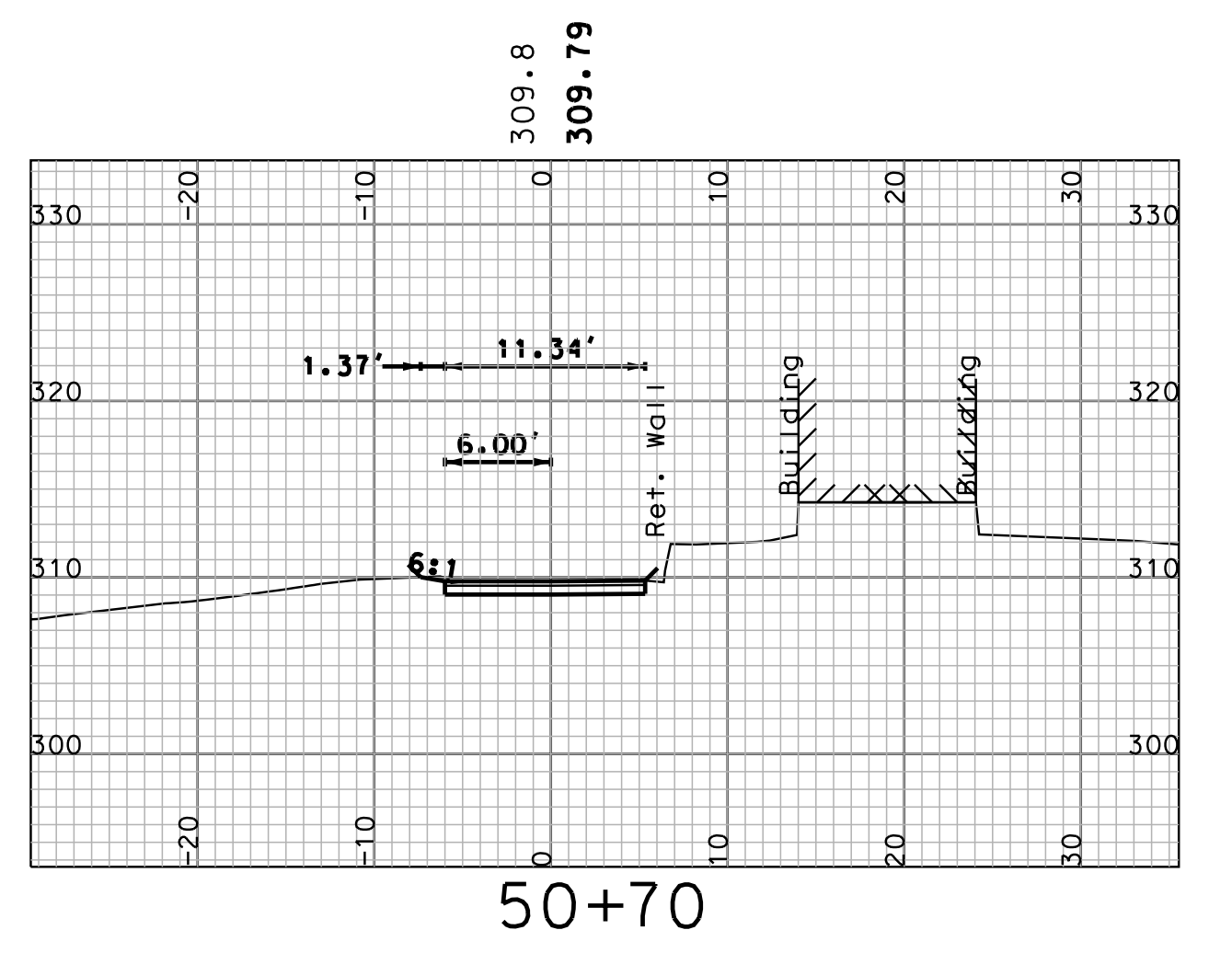
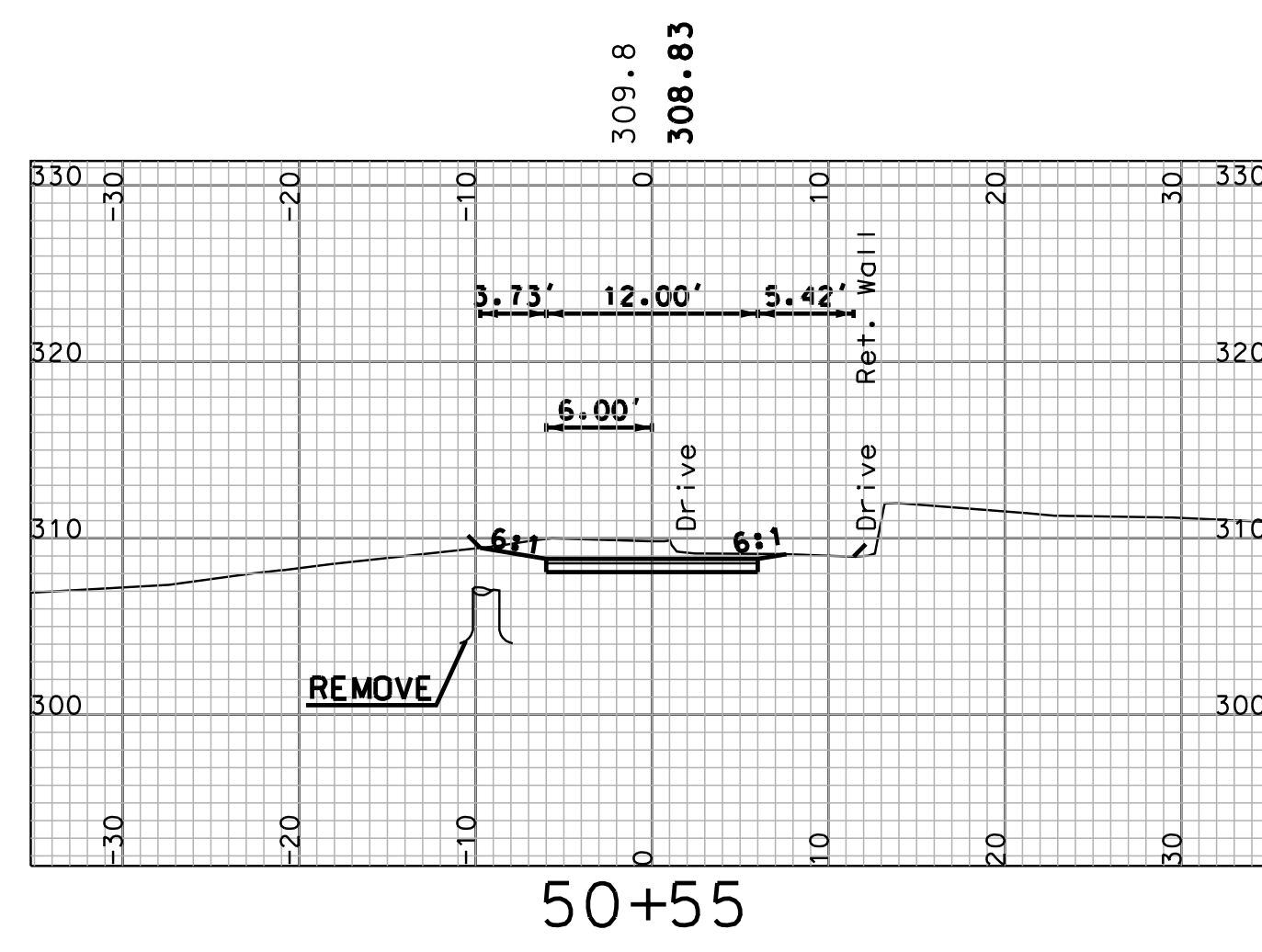
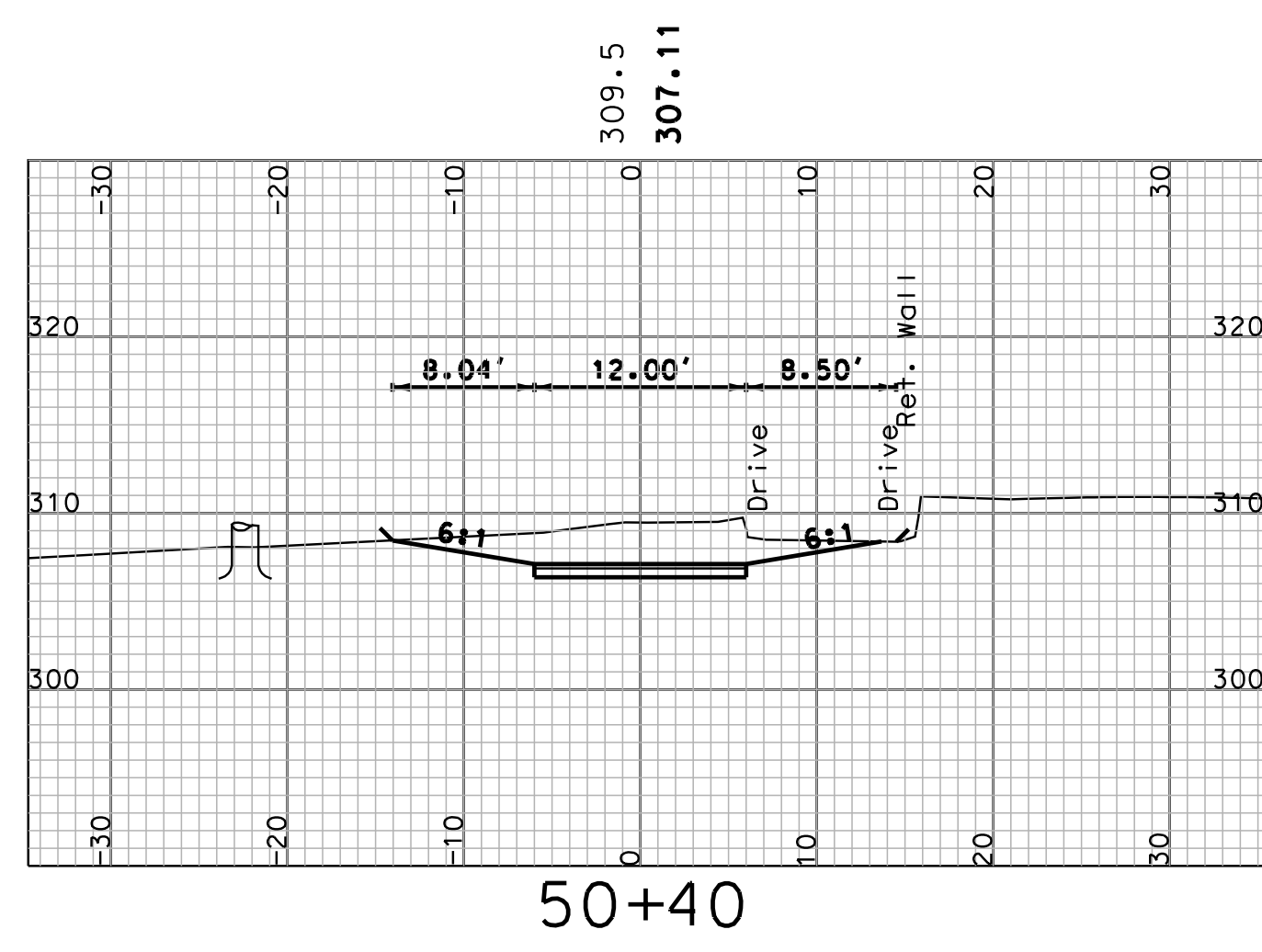
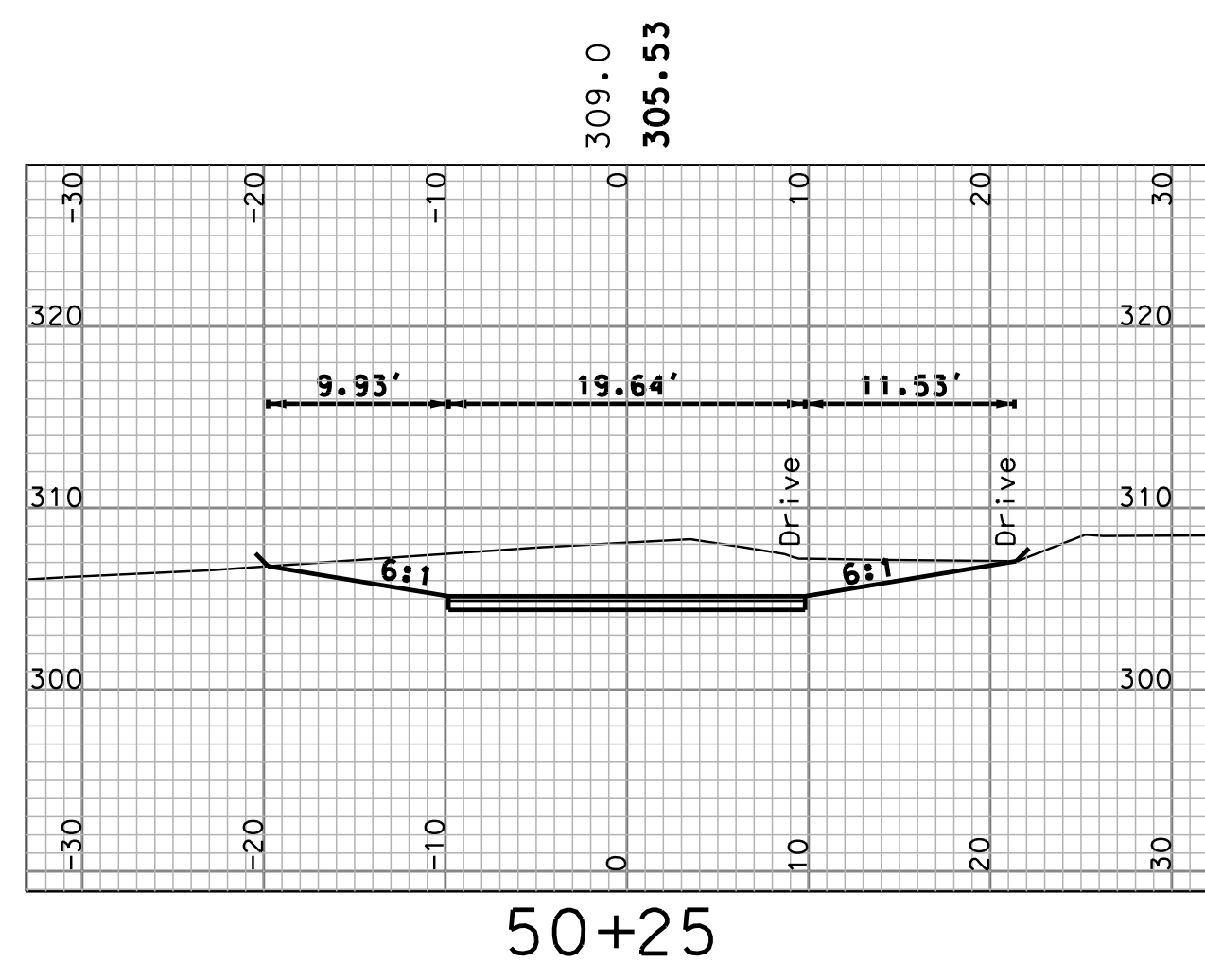
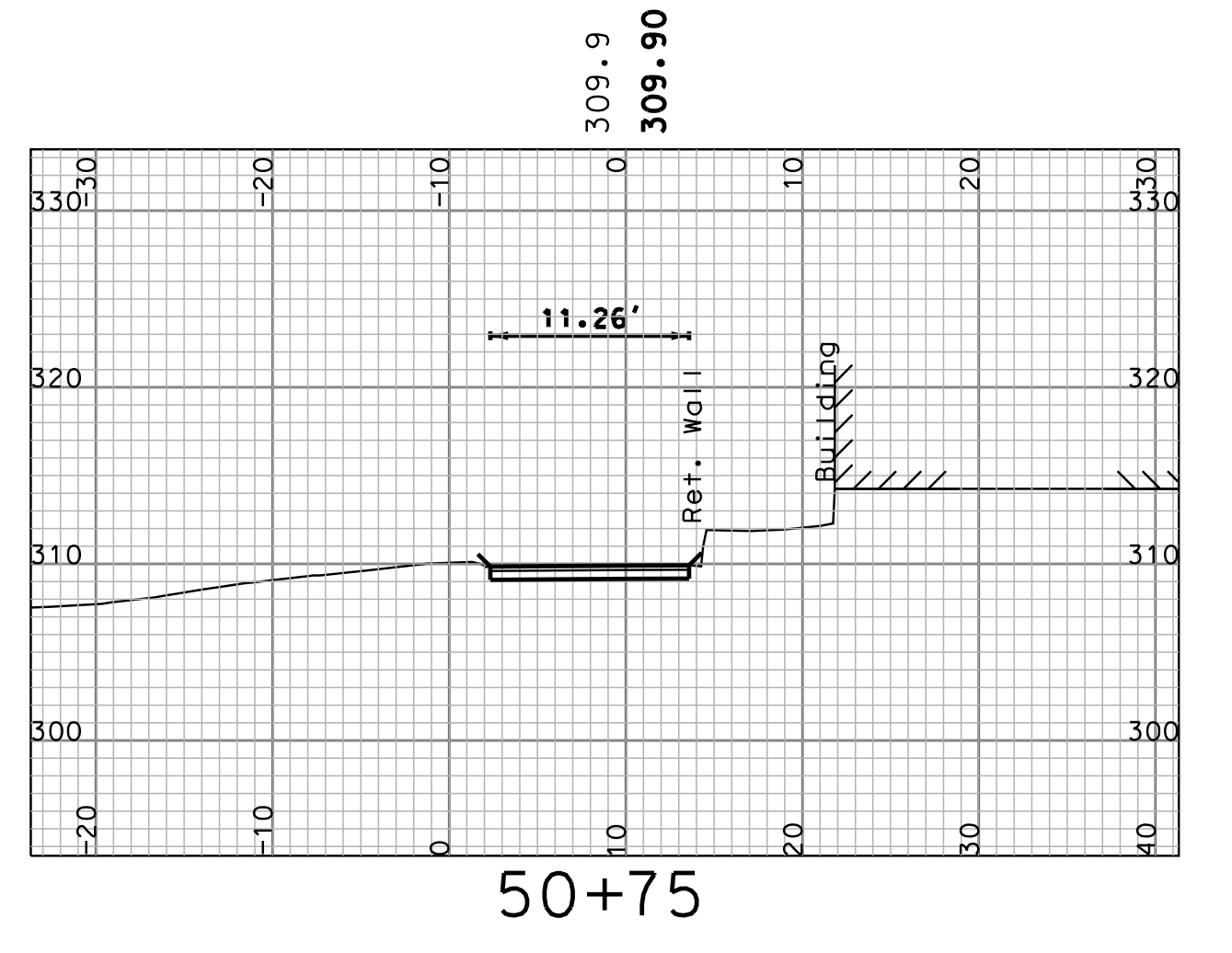
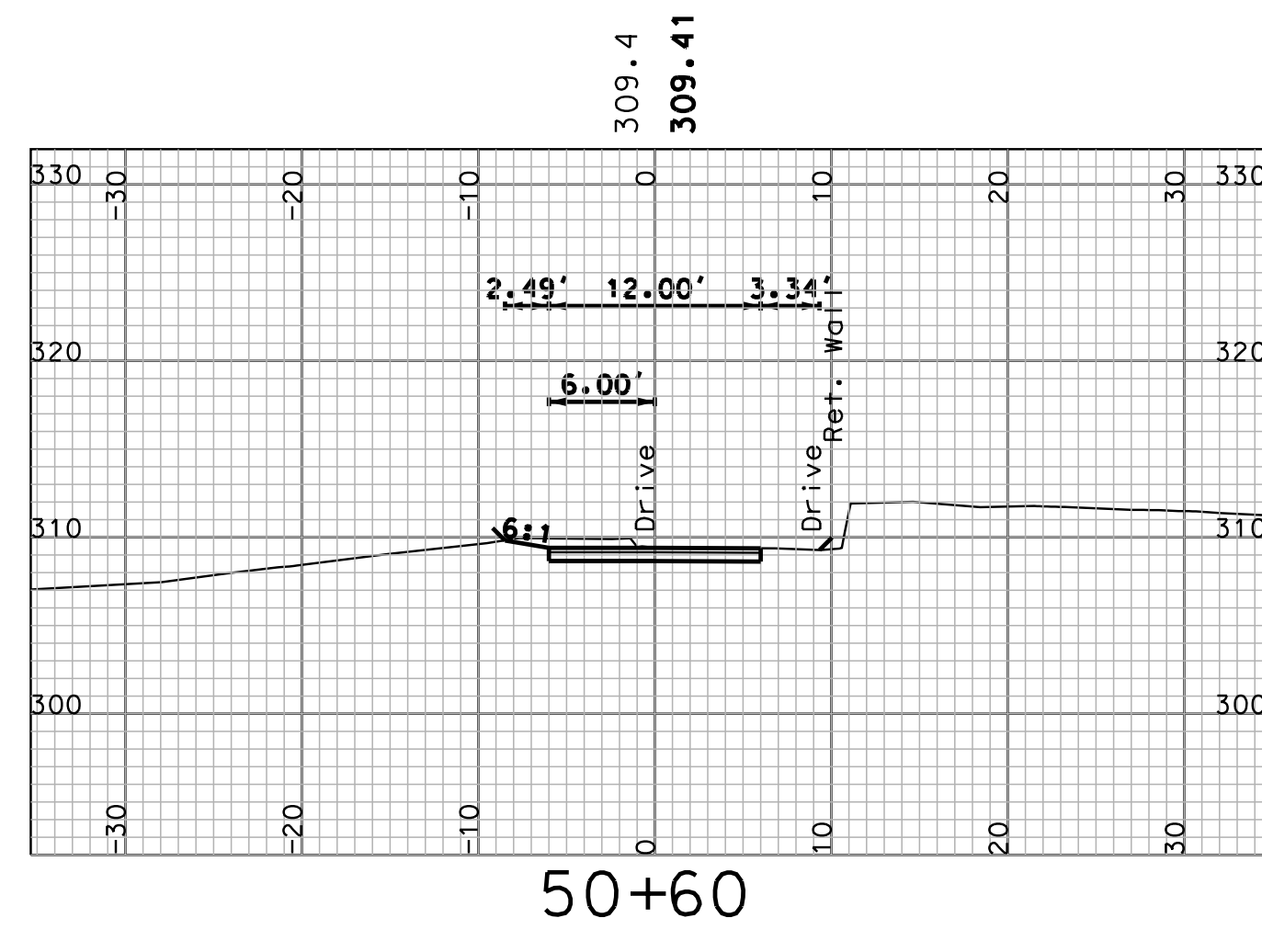
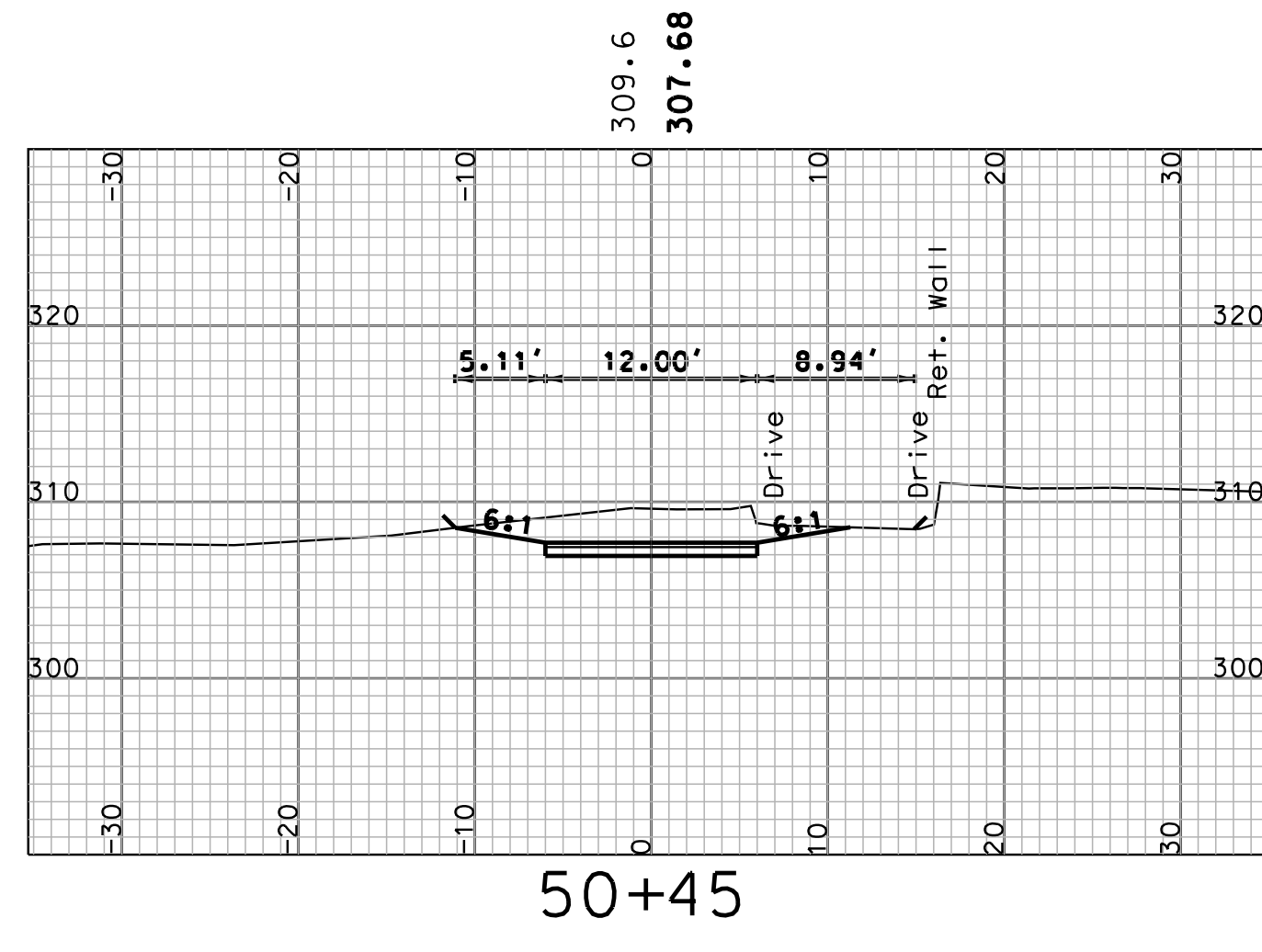
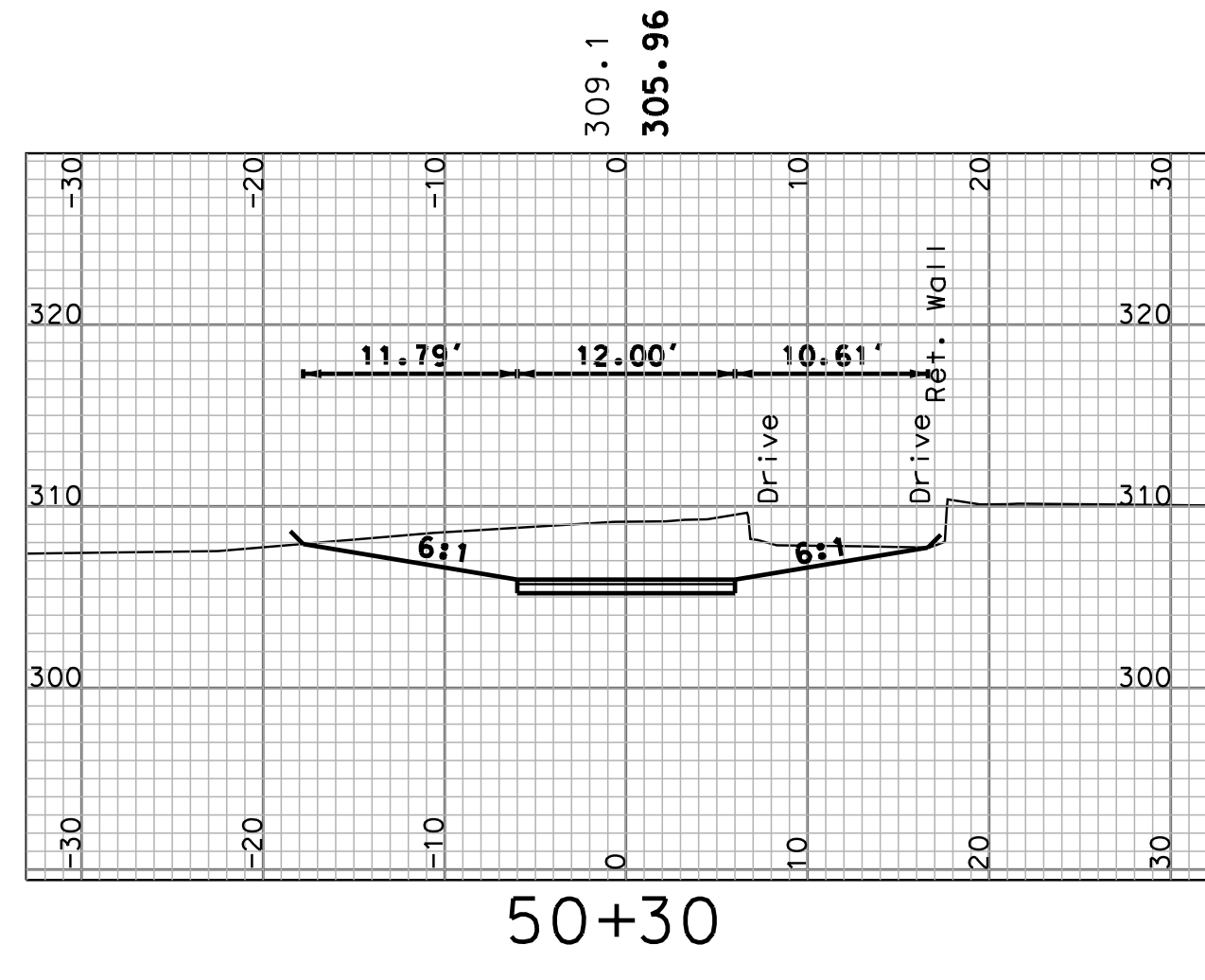

CROSS SECTIONS
SCALE: 1" = 10'

STATE OF NEW HAMPSHIRE			
DEPARTMENT OF TRANSPORTATION • BUREAU OF HIGHWAY DESIGN			
DRIVE DETAIL @ STA 101+17			
DGN	STATE PROJECT NO.	SHEET NO.	TOTAL SHEETS
13928A_driveway101+17	13928A	20	160

NOTE: REFER TO PAVEMENT LAYOUT PLANS AND CROSS-SECTIONS FOR DRIVEWAY LENGTHS, WIDTHS, RADII, CURB CUTS, GRADES AND PAVEMENT & BASE COURSE DEPTHS

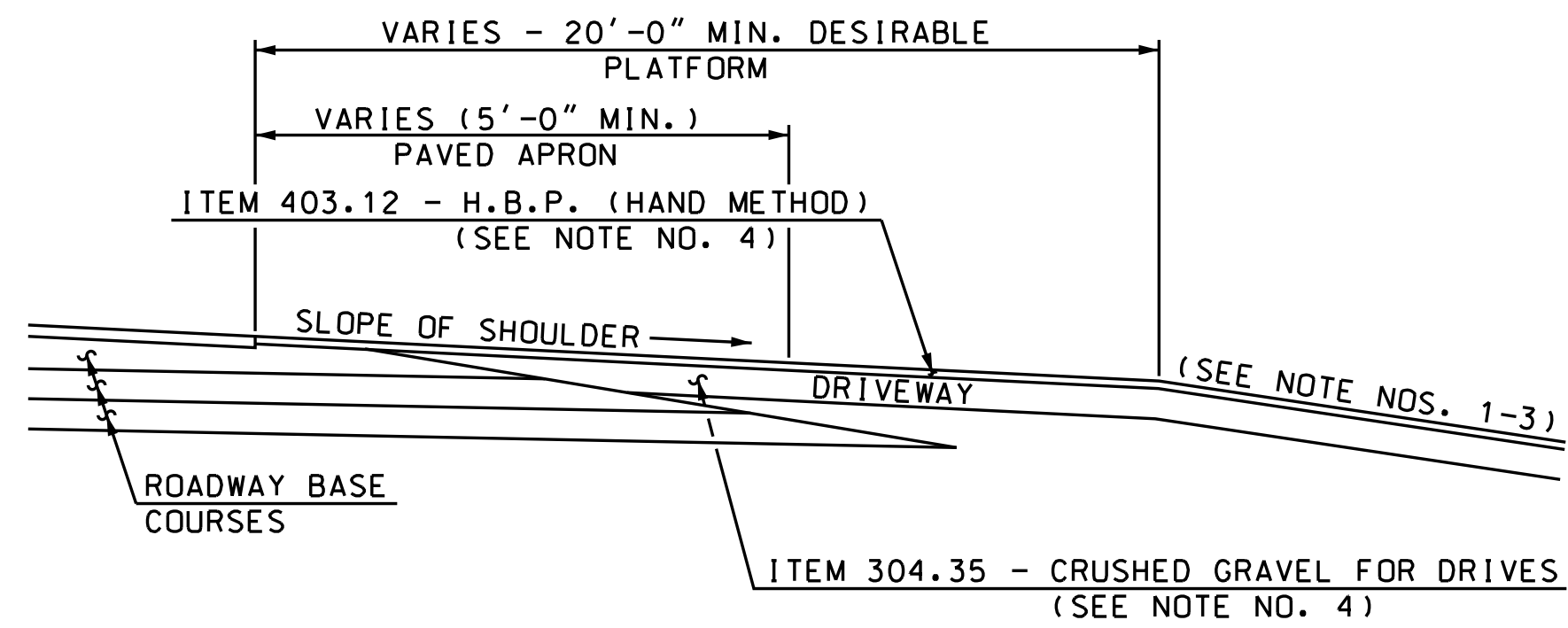

TYPICAL UNCURBED DRIVE IN FILL SECTION

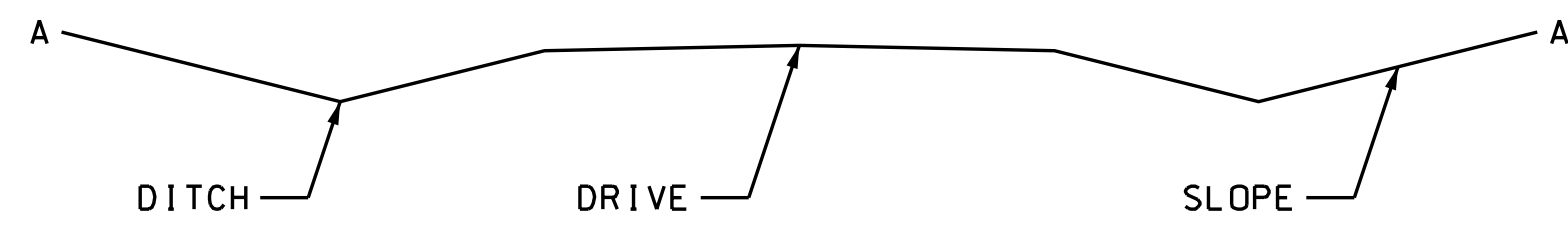
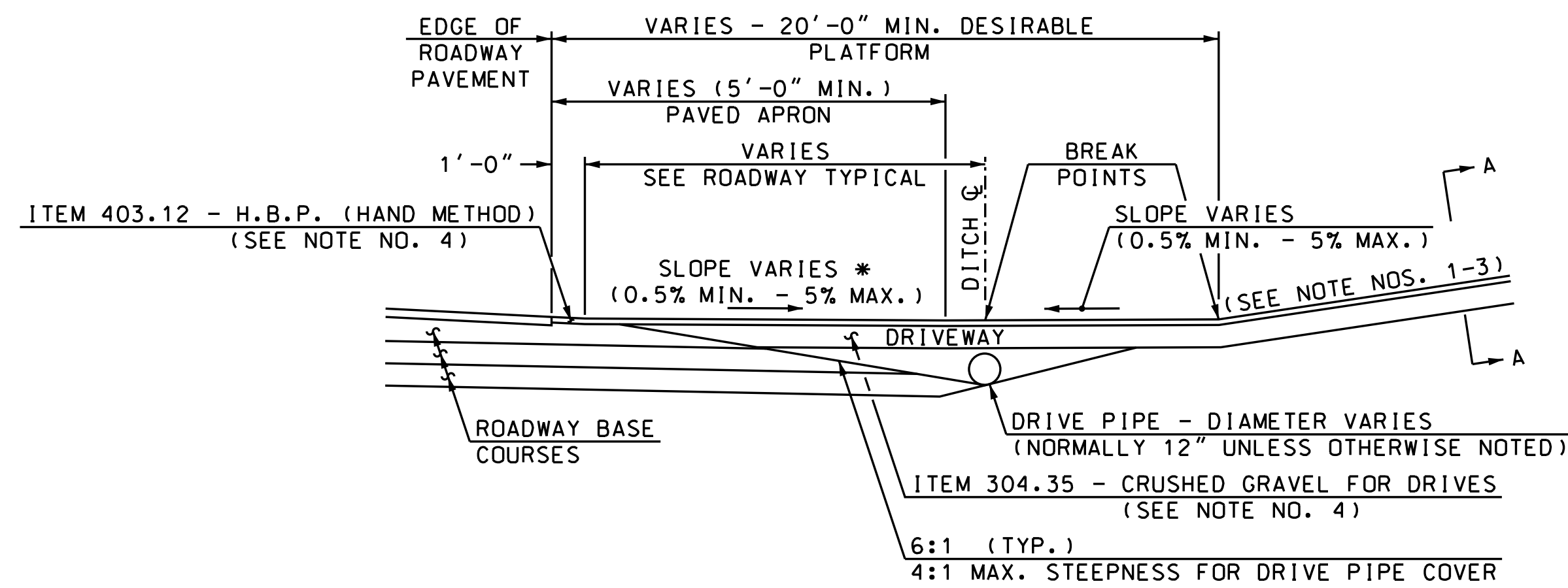

A-A DRIVEWAY CROSS-SECTION

TYPICAL UNCURBED DRIVE IN CUT SECTION

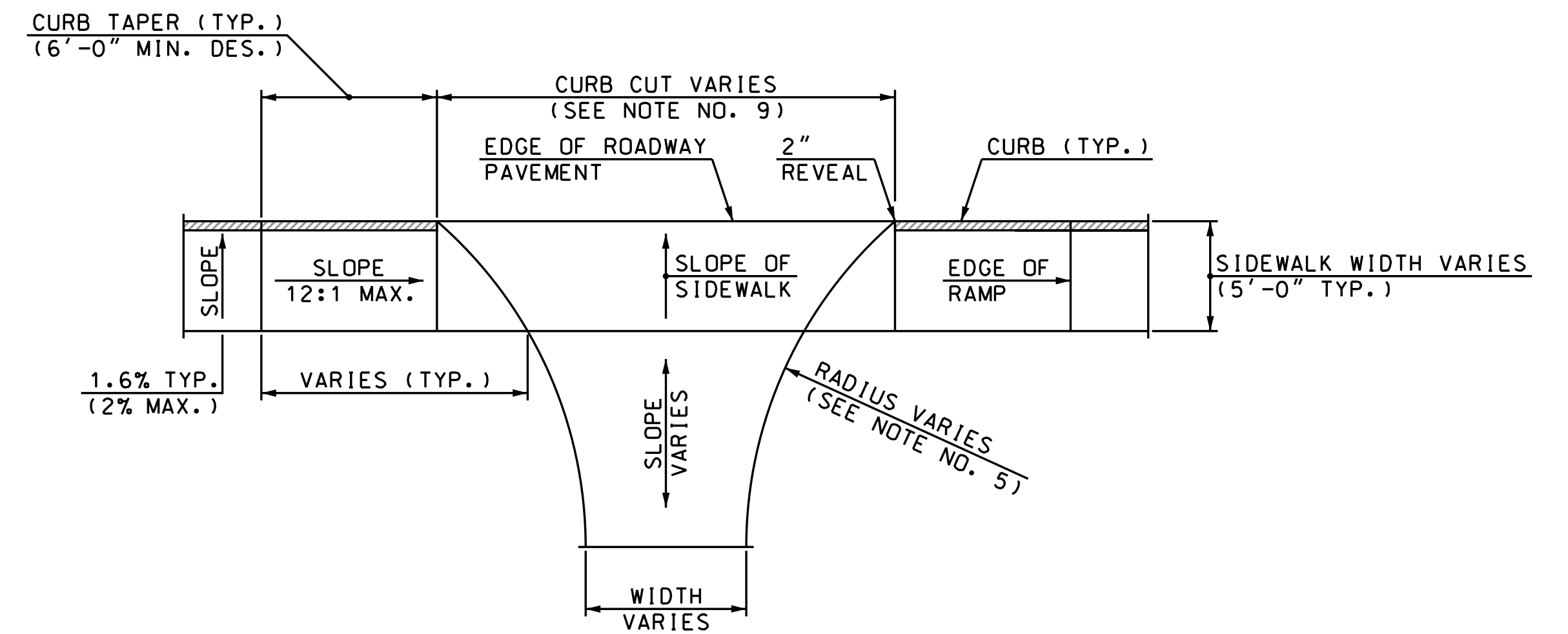

PLAN VIEW WITH SIDEWALK RAMP

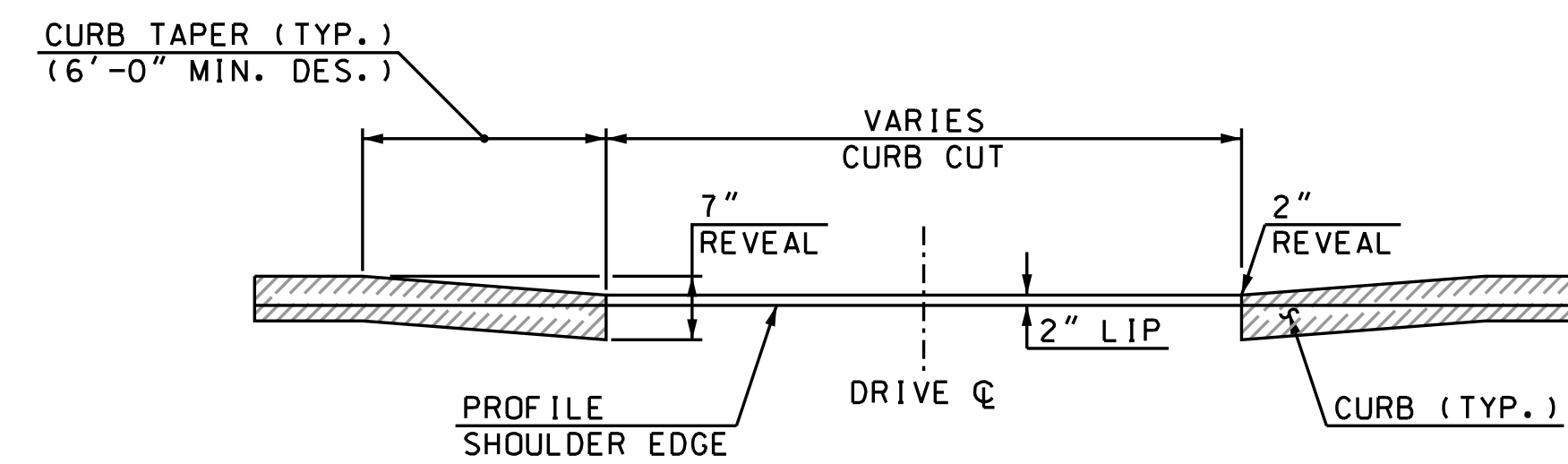

END VIEW

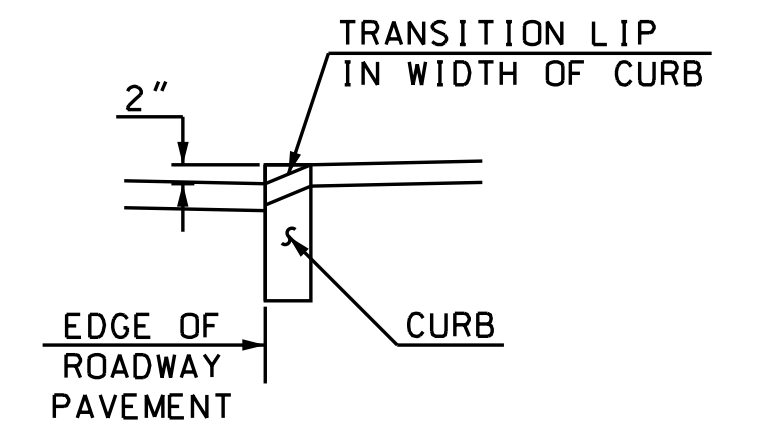

LIP DETAIL

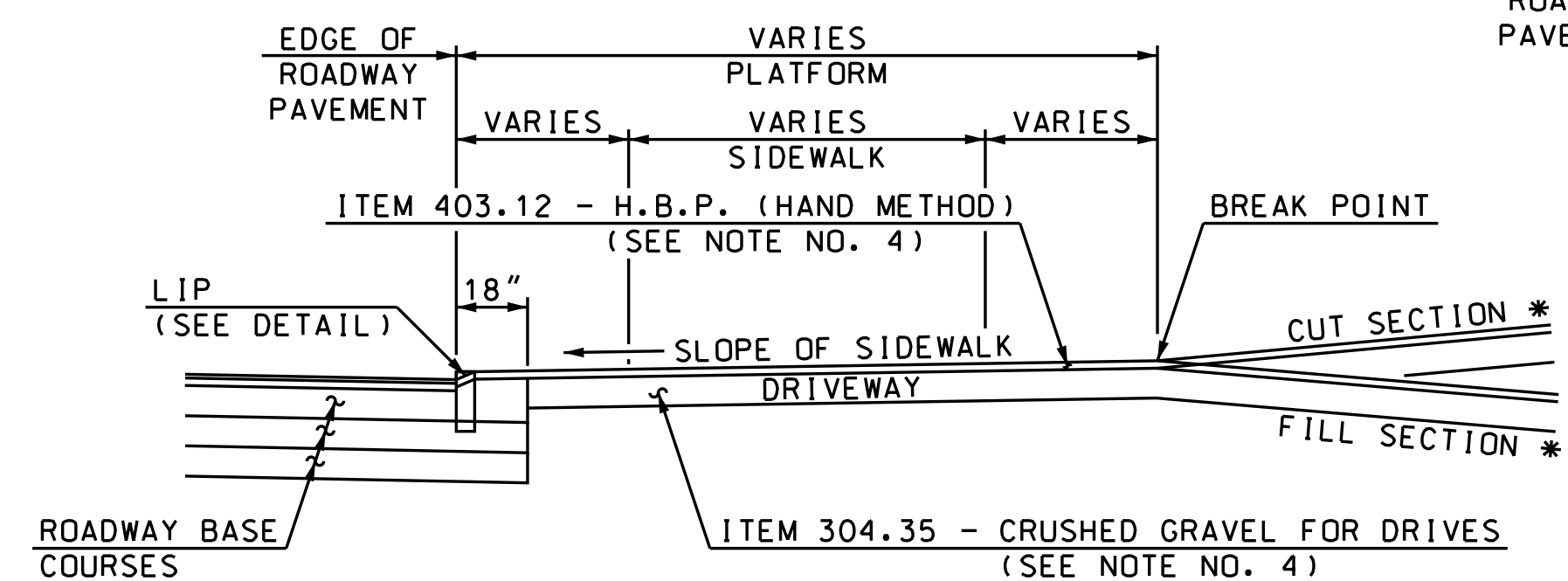

TYPICAL URBAN CURBED DRIVE IN CUT/FILL SECTION

GENERAL NOTES

1. GRADES OF MAJOR ENTRANCES BEYOND THE PLATFORM SHOULD NOT EXCEED 8%.
2. GRADES OF OTHER DRIVES BEYOND THE PLATFORM SHOULD NOT EXCEED 15%.
3. THE ALGEBRAIC DIFFERENCE BETWEEN TWO ADJACENT GRADES SHOULD NOT EXCEED 10%.
4. PAVEMENT AND BASE COURSE DEPTHS ARE:
 - A. TYPICALLY 8" CRUSHED GRAVEL WITH 3" HBP (HAND METHOD, PLACED IN 2 COURSES) FOR RESIDENTIAL DRIVES ADJACENT TO ROADWAYS WITH CONVENTIONAL CRUSHED GRAVEL, GRAVEL, AND SAND STRUCTURAL BOX. IF THE DRIVE IS ADJACENT TO A ROADWAY WITH A CRUSHED STONE STRUCTURAL BOX, 6" OF CRUSHED STONE FINE GRADATION MAY BE SUBSTITUTED FOR THE 8" OF CRUSHED GRAVEL NOTED ABOVE.
 - B. TYPICALLY 12" CRUSHED GRAVEL WITH 3" HBP (HAND METHOD, PLACED IN 2 COURSES) FOR COMMERCIAL DRIVES WITH FREQUENT HEAVY TRUCK TRAFFIC THAT ARE ADJACENT TO ROADWAYS WITH CONVENTIONAL CRUSHED GRAVEL, GRAVEL, AND SAND STRUCTURAL BOX. IF THE DRIVE IS ADJACENT TO A ROADWAY WITH A CRUSHED STONE STRUCTURAL BOX, 9" OF CRUSHED STONE FINE GRADATION MAY BE SUBSTITUTED FOR THE 12" OF CRUSHED GRAVEL NOTED ABOVE.
5. FOR DESIGN CRITERIA AND OTHER ADDITIONAL INFORMATION, REFER TO THE NHDOT DRIVEWAY MANUAL.
6. DITCHES ARE RECOMMENDED FOR UNCURBED DRIVEWAYS IN CUT SLOPES.
7. USE SLOPED END SECTIONS ON DRIVE PIPES FOR UNCURBED DRIVEWAYS.
8. CURBING CAN BE FLARED TO FIT DRIVE RADII IF APPROPRIATE OR ENDED AS DETAILED ABOVE.
9. CURB CUTS FOR RESIDENTIAL DRIVES WITH ANGLES OF ENTRY OF 75°-90° ARE TYPICALLY 25'-0".

STATE OF NEW HAMPSHIRE				
DEPARTMENT OF TRANSPORTATION • BUREAU OF HIGHWAY DESIGN				
DRIVEWAY DETAILS				
REVISION DATE	DGN	STATE PROJECT NO.	SHEET NO.	TOTAL SHEETS
06/04/12	13928adrive	13928A	21	160

SDR PROCESSED	DATE	03/11/15	DATE	04/20/15	DATE	
NEW DESIGN	MAB		CNS			
SHEET CHECKED						
AS BUILT DETAILS						

REVISIONS AFTER PROPOSAL	STATION	DESCRIPTION

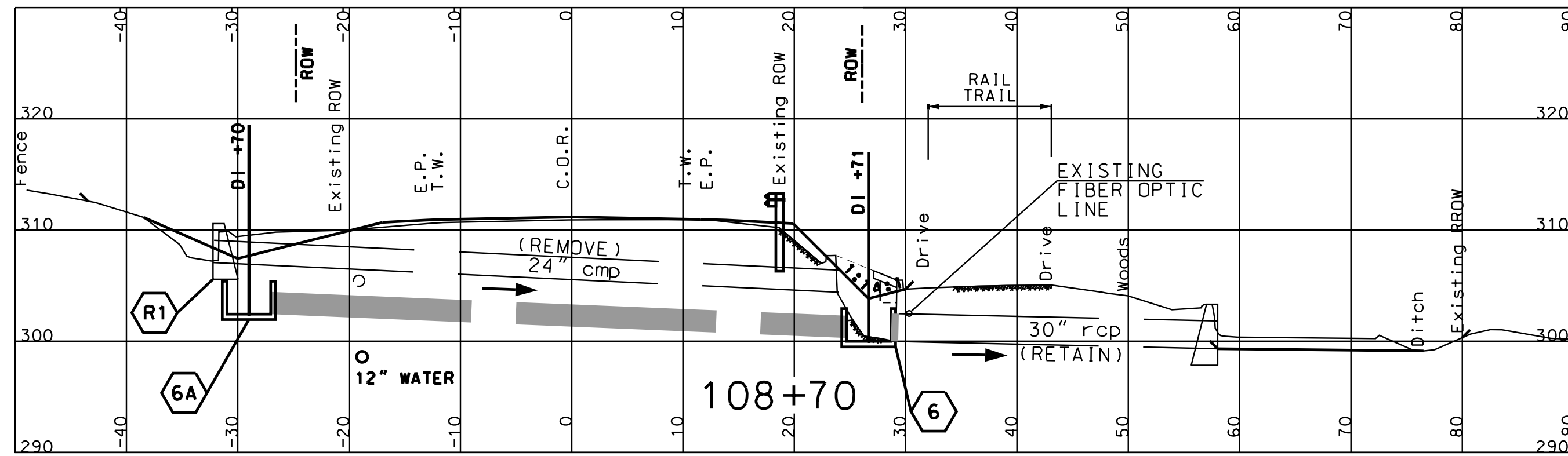

SCALE:
1" = 10' HORIZ.
1" = 10' VERT.

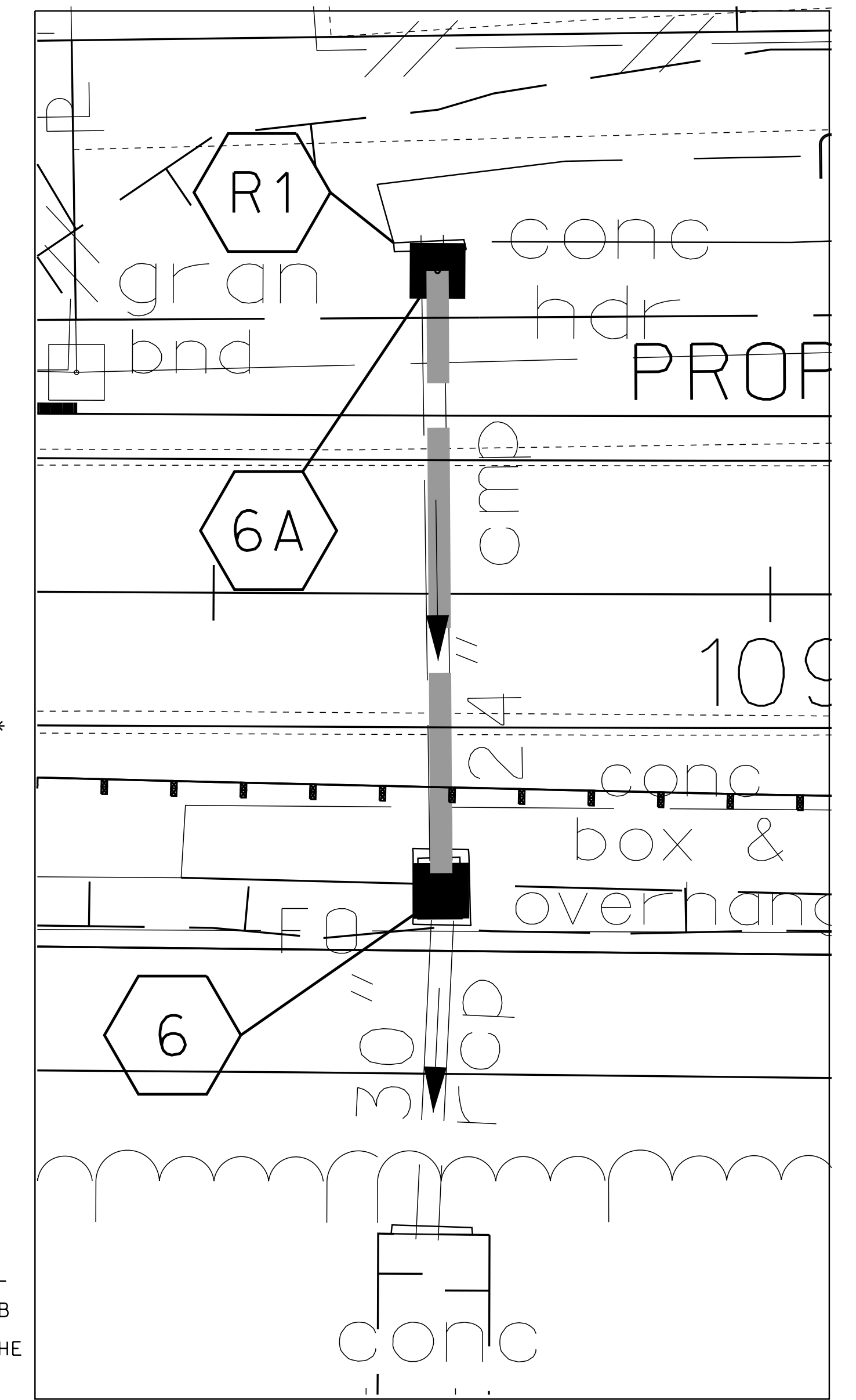
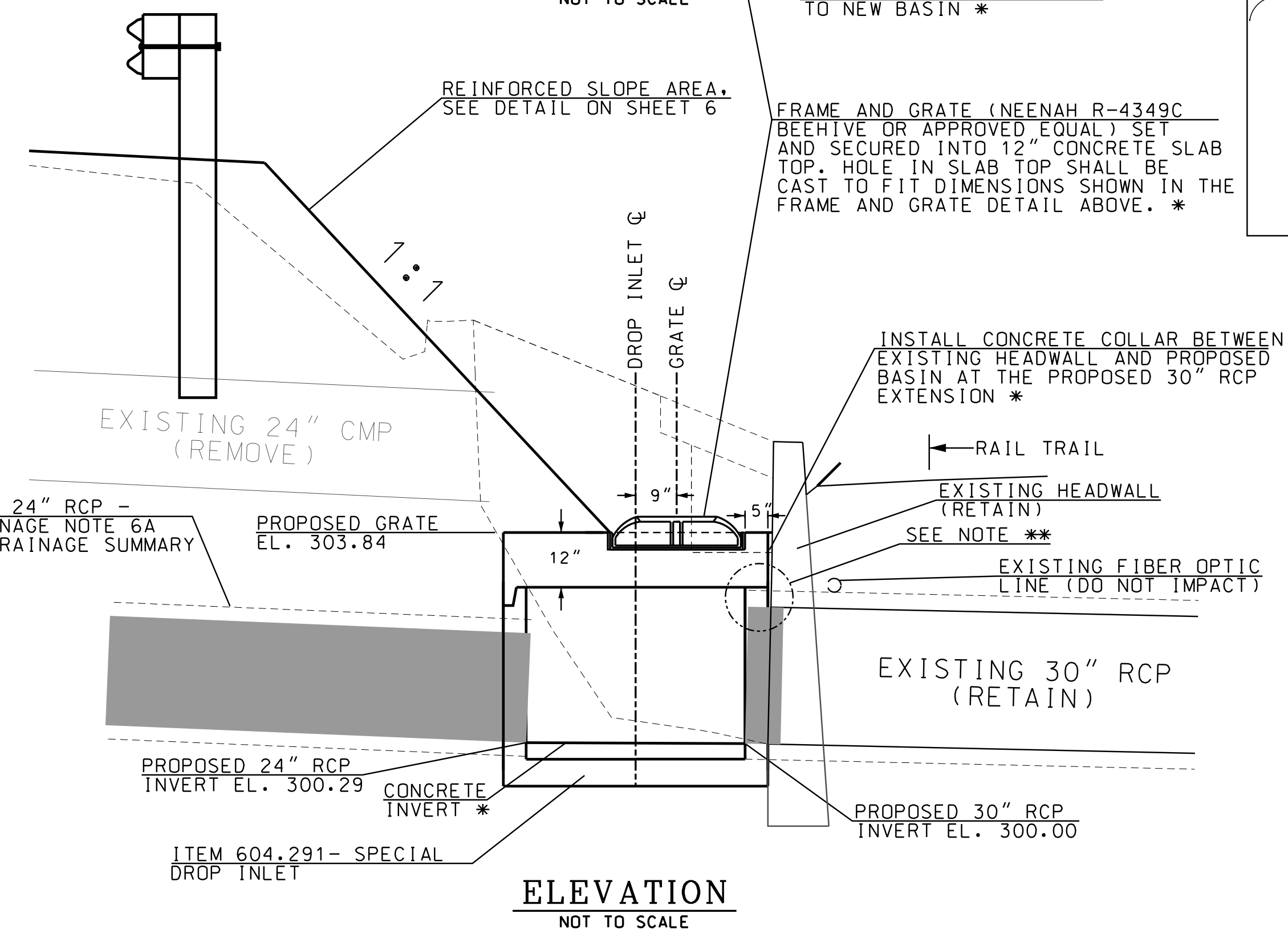
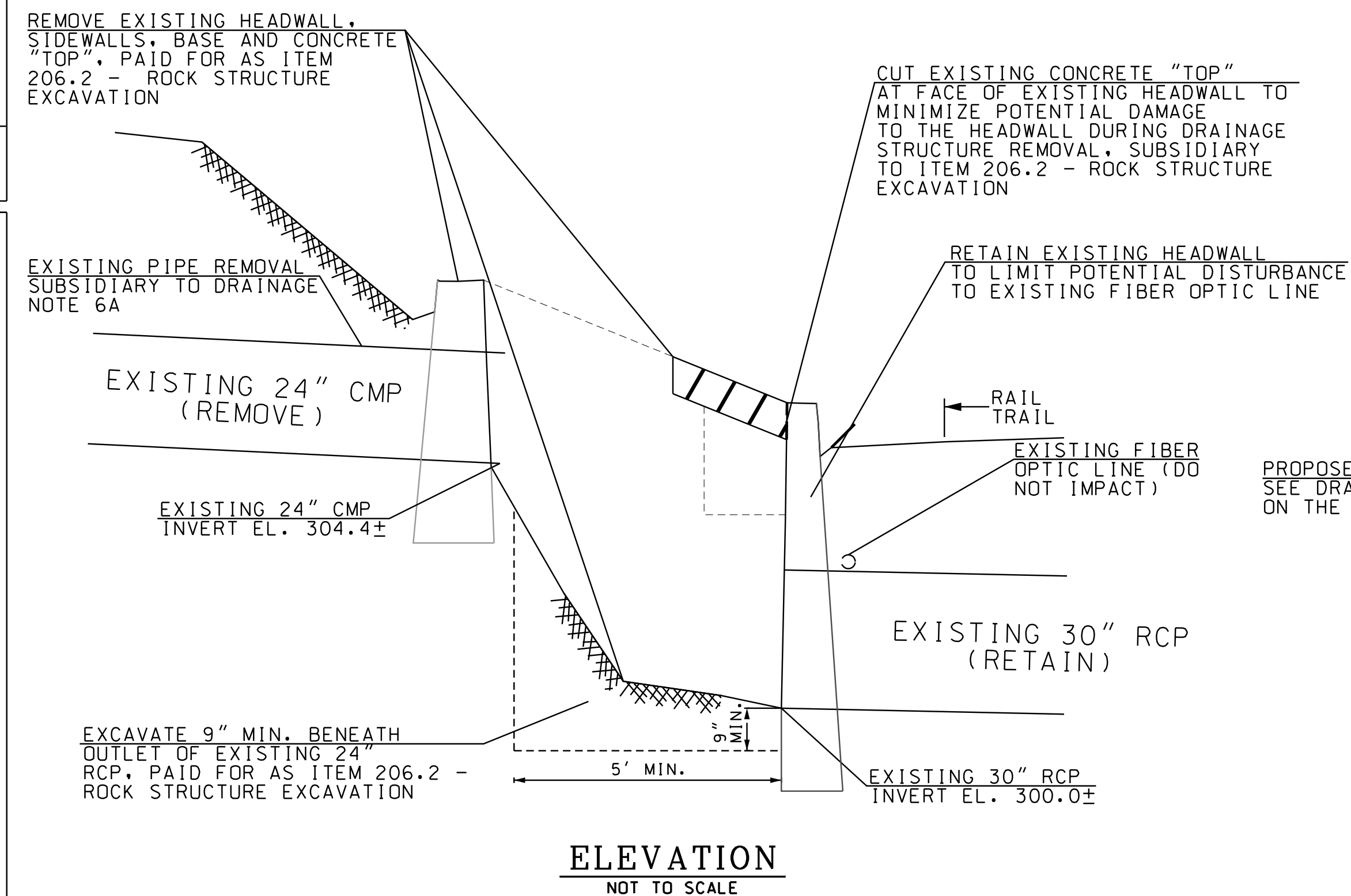
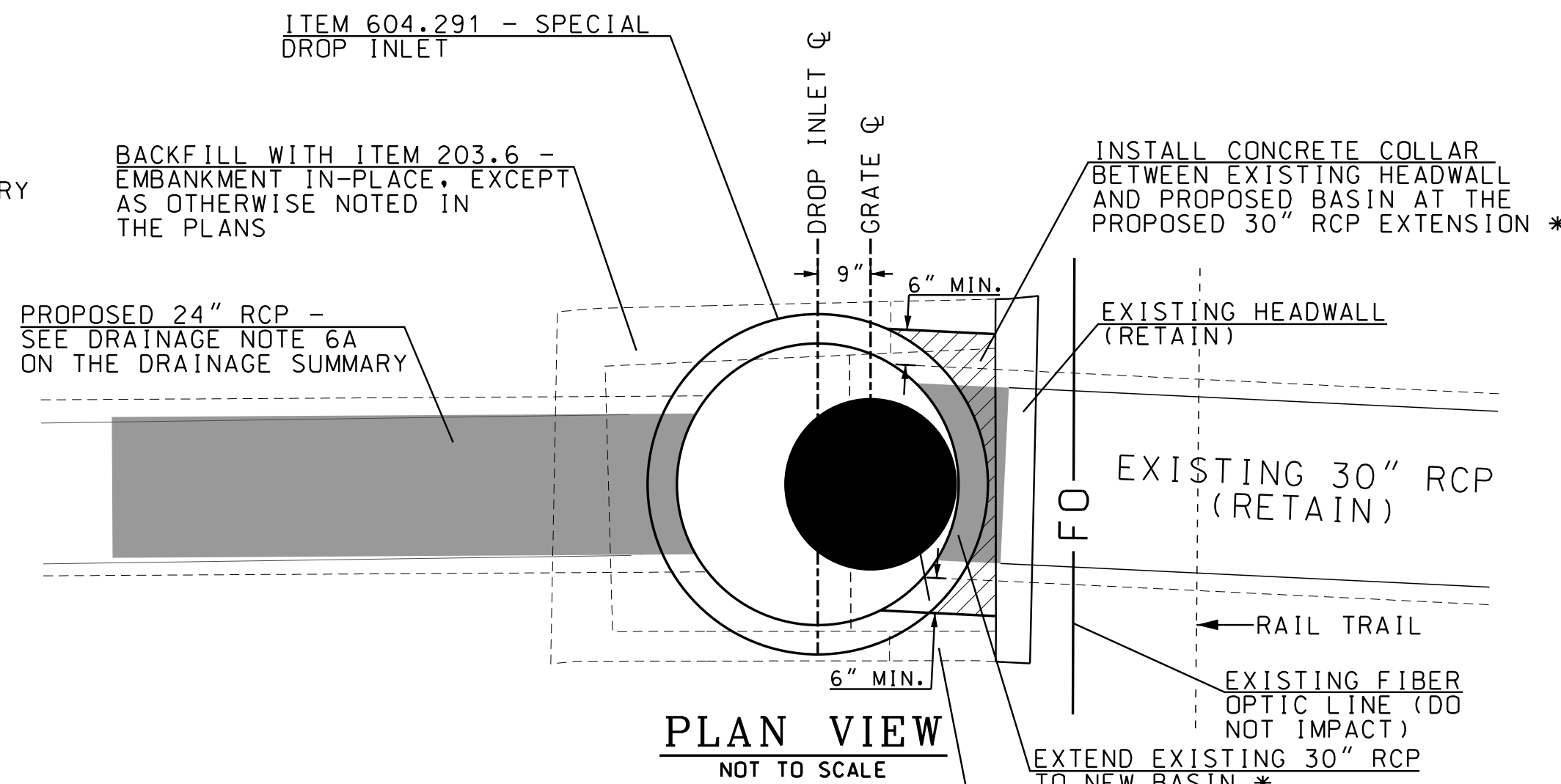
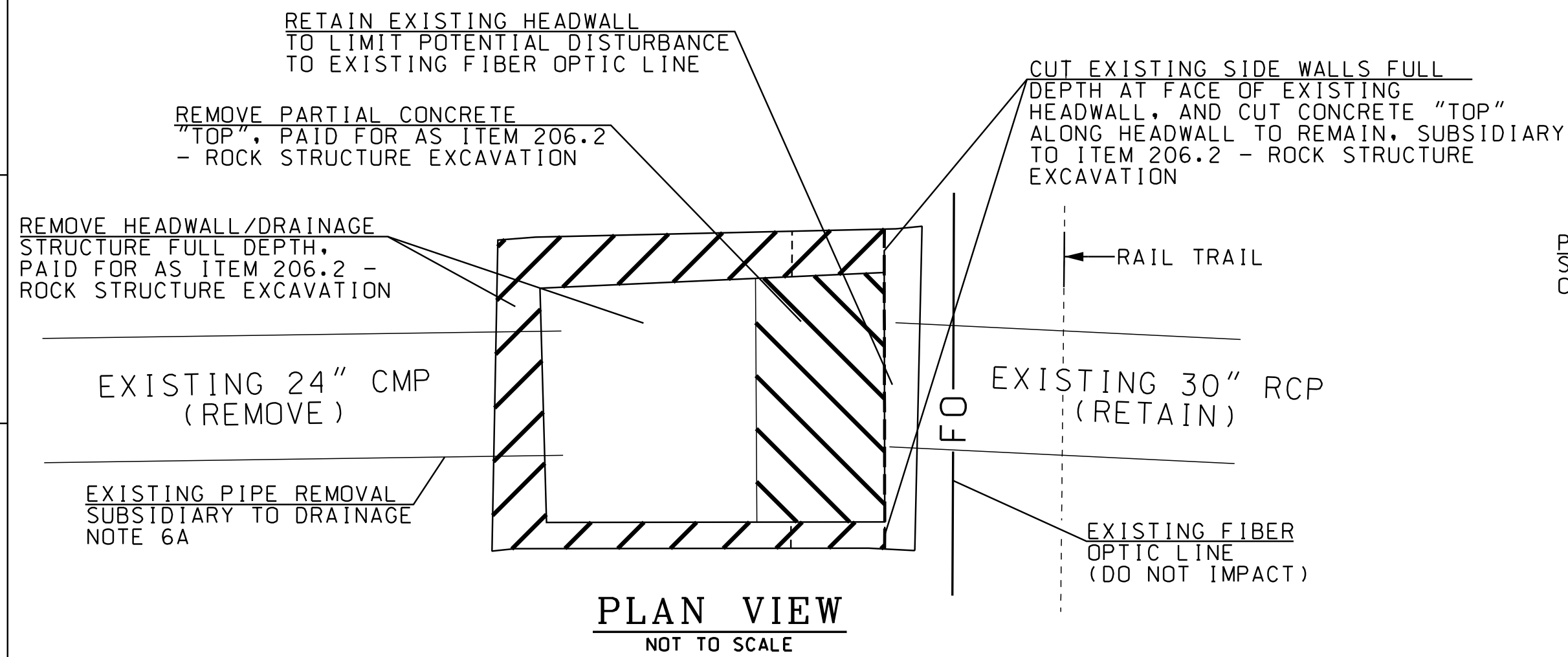
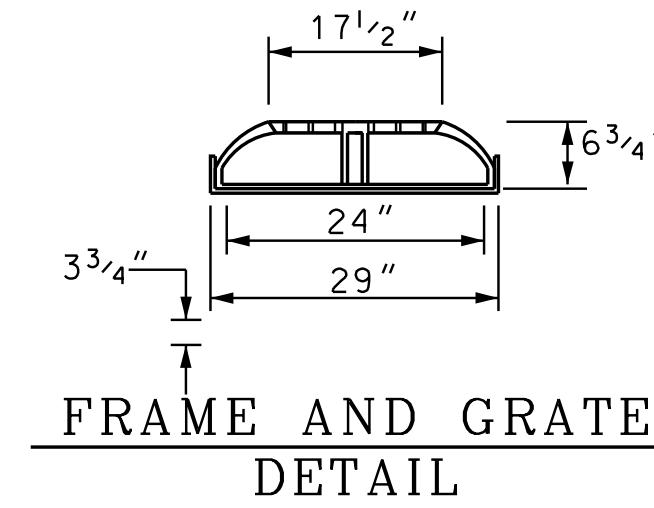

SITE PLAN
DRAINAGE NOTE 6
STA. 108+71

SCALE: 1" = 10' - 0"

** BE AWARE THE OUTLET PIPE CORE HOLE AT THIS LOCATION MAY ENCRANCH WITHIN THE LIP OF THE SLAB TOP AT THE OUTLET PIPE LOCATION. FIELD VERIFY DIMENTIONS PRIOR TO CASTING SLAB TOP.

- NOTES:
- (*) INDICATES WORK IS SUBSIDIARY TO ITEM 604.291 - SPECIAL DROP INLET.
 - PROTECT EXISTING FIBER OPTIC LINE DURING DRAINAGE WORK.
 - FIELD VERIFY ALL DIMENSIONS PRIOR TO ORDERING ANY PRECAST ITEMS.
 - ALL PROPOSED CONCRETE WORK SHALL CONFORM TO ITEM 520.1 - CONCRETE CLASS A, UNLESS OTHERWISE SPECIFIED.

EXISTING CONDITION

PROPOSED CONDITION

STATE OF NEW HAMPSHIRE			
DEPARTMENT OF TRANSPORTATION • BUREAU OF HIGHWAY DESIGN			
DRAINAGE NOTE 6			
SPECIAL DROP INLET DETAIL			
DGN	STATE PROJECT NO.	SHEET NO.	TOTAL SHEETS
13928A_specialCB	13928A	22	160

REVISIONS AFTER PROPOSAL

STATION

STATION

DATE

NUMBER

DATE 03/11/15
DATE 04/20/15

DATE

SDR PROCESSED
NEW DESIGN MAB
SHEET CHECKED CNS
AS BUILT DETAILS

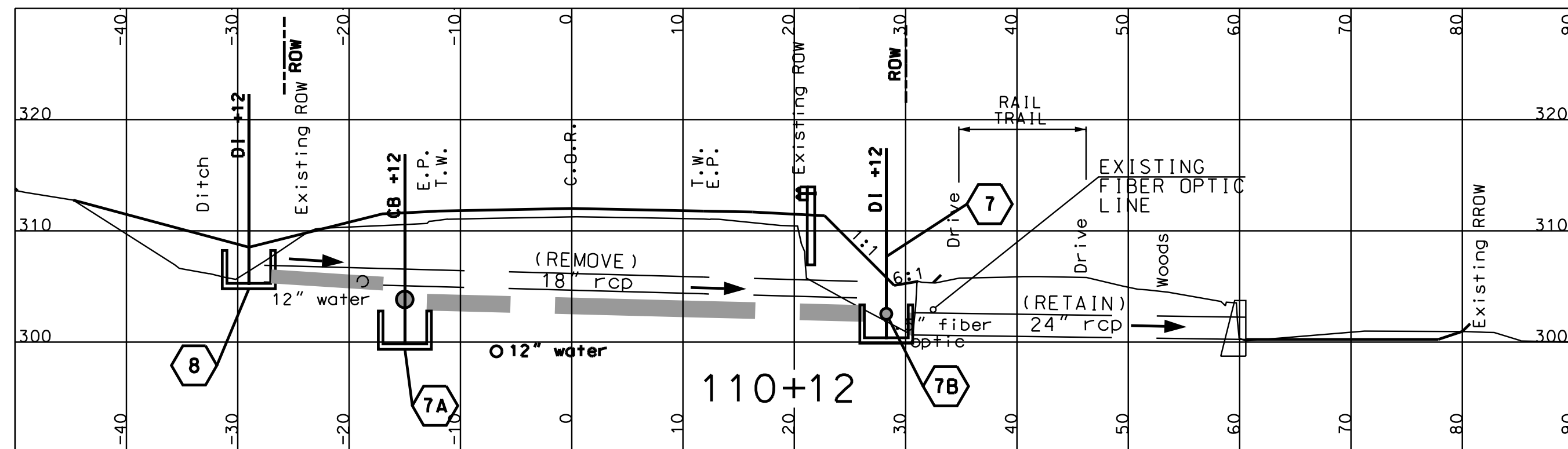

SCALE:
1" = 10' HORIZ.
1" = 10' VERT.

REMOVE HEADWALL/DRAINAGE STRUCTURE FULL DEPTH - PAID FOR AS ITEM 206.2 - ROCK STRUCTURE EXCAVATION

CUT EXISTING SIDE WALLS FULL DEPTH AT FACE OF EXISTING HEADWALL, SUBSIDIARY TO ITEM 206.2 - ROCK STRUCTURE EXCAVATION; RETAIN EXISTING HEADWALL TO LIMIT POTENTIAL DISTURBANCE TO EXISTING FIBER OPTIC LINE

BACKFILL WITH ITEM 203.6 - EMBANKMENT IN-PLACE, EXCEPT AS OTHERWISE NOTED IN THE PLANS

ITEM 604.292 - SPECIAL DROP INLET

EXISTING 18" CMP (REMOVE)

EXISTING 24" RCP (RETAIN)

EXISTING PIPE REMOVAL SUBSIDIARY TO DRAINAGE NOTE 7A

PLAN VIEW
NOT TO SCALE

EXISTING FIBER OPTIC LINE (DO NOT IMPACT)

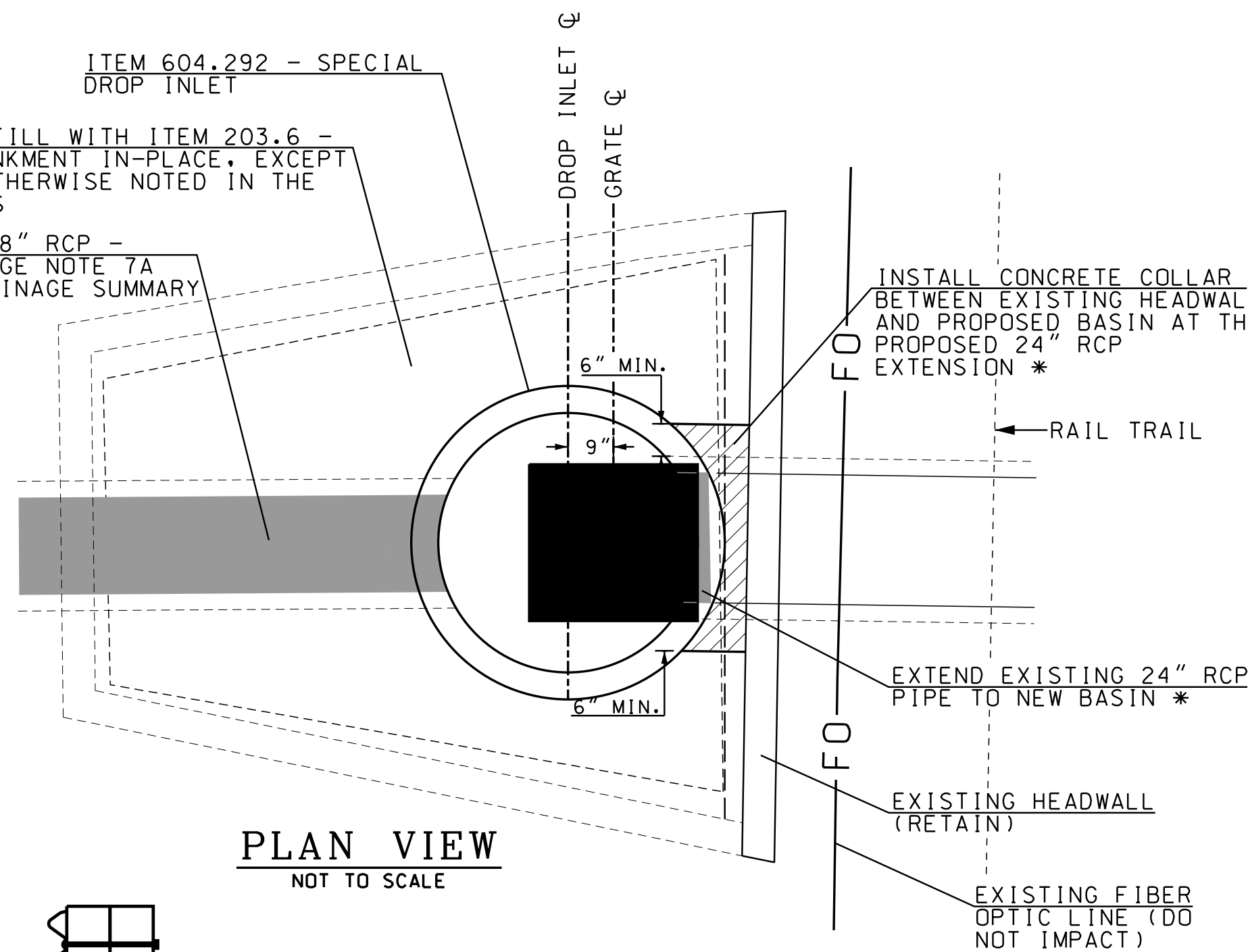

PLAN VIEW
NOT TO SCALE

INSTALL CONCRETE COLLAR BETWEEN EXISTING HEADWALL AND PROPOSED BASIN AT THE PROPOSED 24" RCP EXTENSION *

EXTEND EXISTING 24" RCP PIPE TO NEW BASIN *

EXISTING HEADWALL (RETAIN)

EXISTING FIBER OPTIC LINE (DO NOT IMPACT)

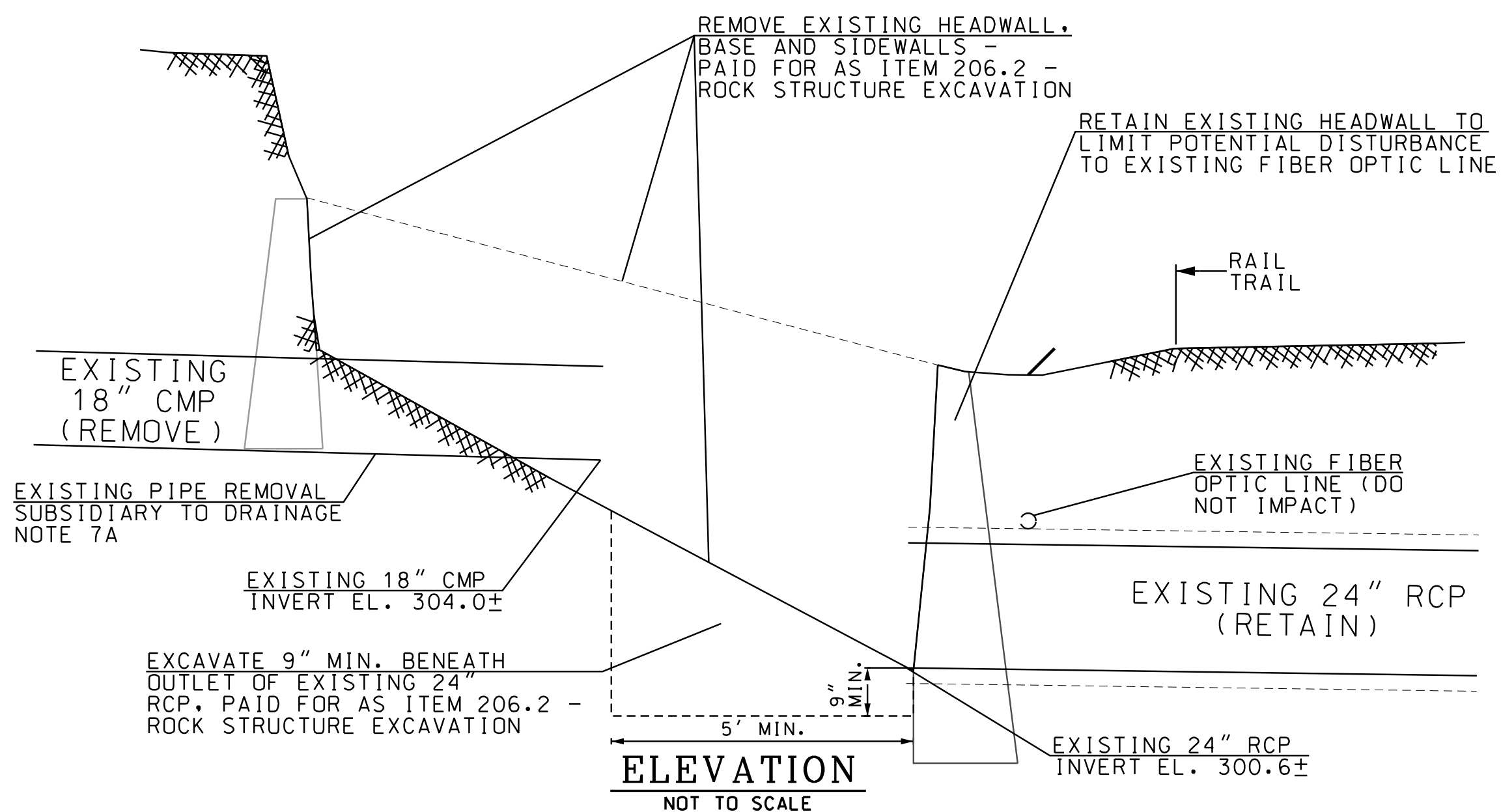

EXISTING CONDITION

ELEVATION
NOT TO SCALE

REMOVE EXISTING HEADWALL, BASE AND SIDEWALLS - PAID FOR AS ITEM 206.2 - ROCK STRUCTURE EXCAVATION

RETAIN EXISTING HEADWALL TO LIMIT POTENTIAL DISTURBANCE TO EXISTING FIBER OPTIC LINE

RAIL TRAIL

EXISTING FIBER OPTIC LINE (DO NOT IMPACT)

EXISTING 24" RCP (RETAIN)

EXISTING 24" RCP INVERT EL. 300.6±

EXISTING 18" CMP (REMOVE)

EXISTING PIPE REMOVAL SUBSIDIARY TO DRAINAGE NOTE 7A

EXISTING 18" CMP INVERT EL. 304.0±

EXCAVATE 9" MIN. BENEATH OUTLET OF EXISTING 24" RCP, PAID FOR AS ITEM 206.2 - ROCK STRUCTURE EXCAVATION

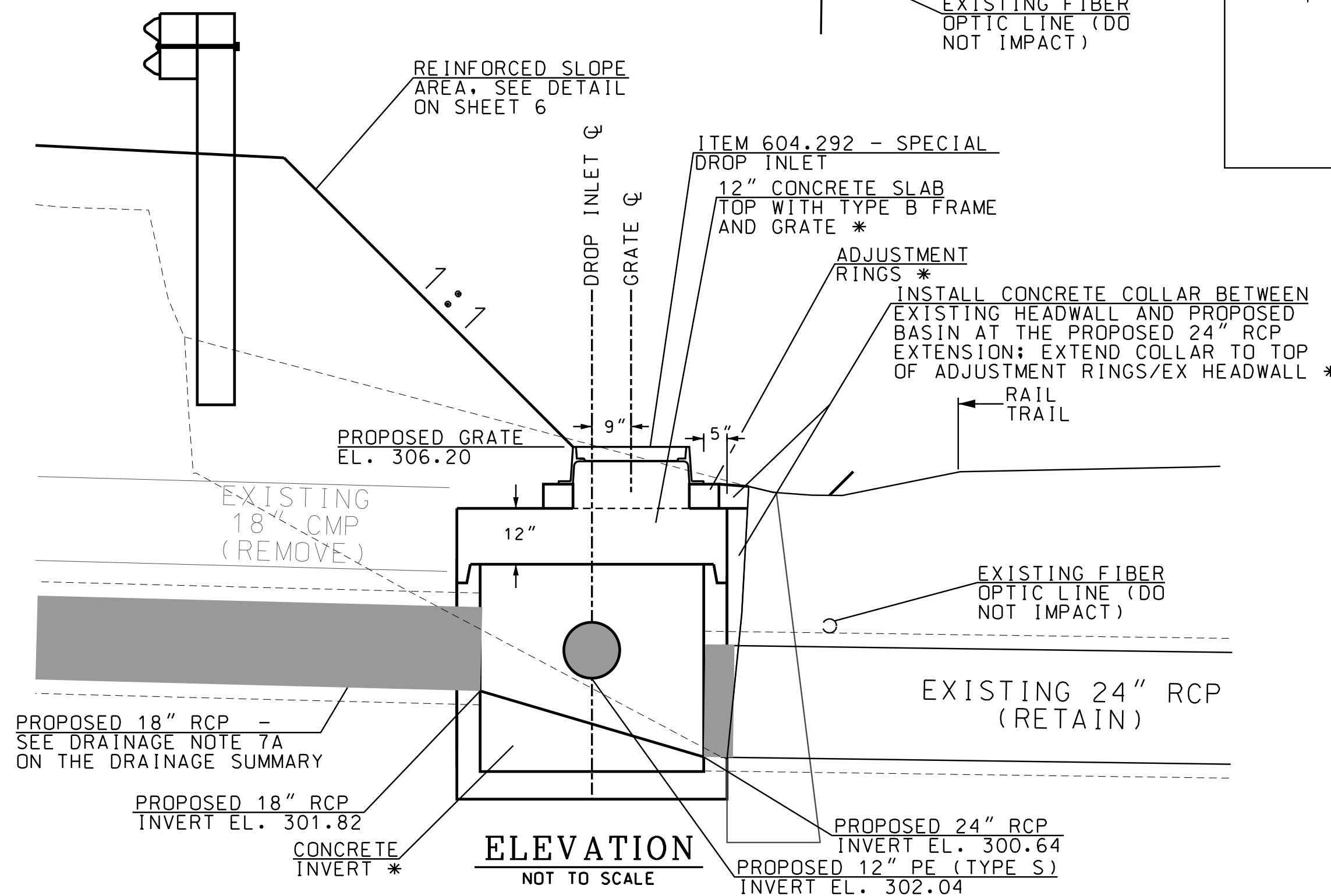

PROPOSED CONDITION

ELEVATION
NOT TO SCALE

PROPOSED 18" RCP - SEE DRAINAGE NOTE 7A ON THE DRAINAGE SUMMARY

PROPOSED 18" RCP INVERT EL. 301.82

CONCRETE INVERT *

ITEM 604.292 - SPECIAL DROP INLET
12" CONCRETE SLAB TOP WITH TYPE B FRAME AND GRATE *

ADJUSTMENT RINGS *

INSTALL CONCRETE COLLAR BETWEEN EXISTING HEADWALL AND PROPOSED BASIN AT THE PROPOSED 24" RCP EXTENSION; EXTEND COLLAR TO TOP OF ADJUSTMENT RINGS/EX HEADWALL *

RAIL TRAIL

EXISTING FIBER OPTIC LINE (DO NOT IMPACT)

EXISTING 24" RCP (RETAIN)

PROPOSED 24" RCP INVERT EL. 300.64

PROPOSED 12" PE (TYPE S) INVERT EL. 302.04

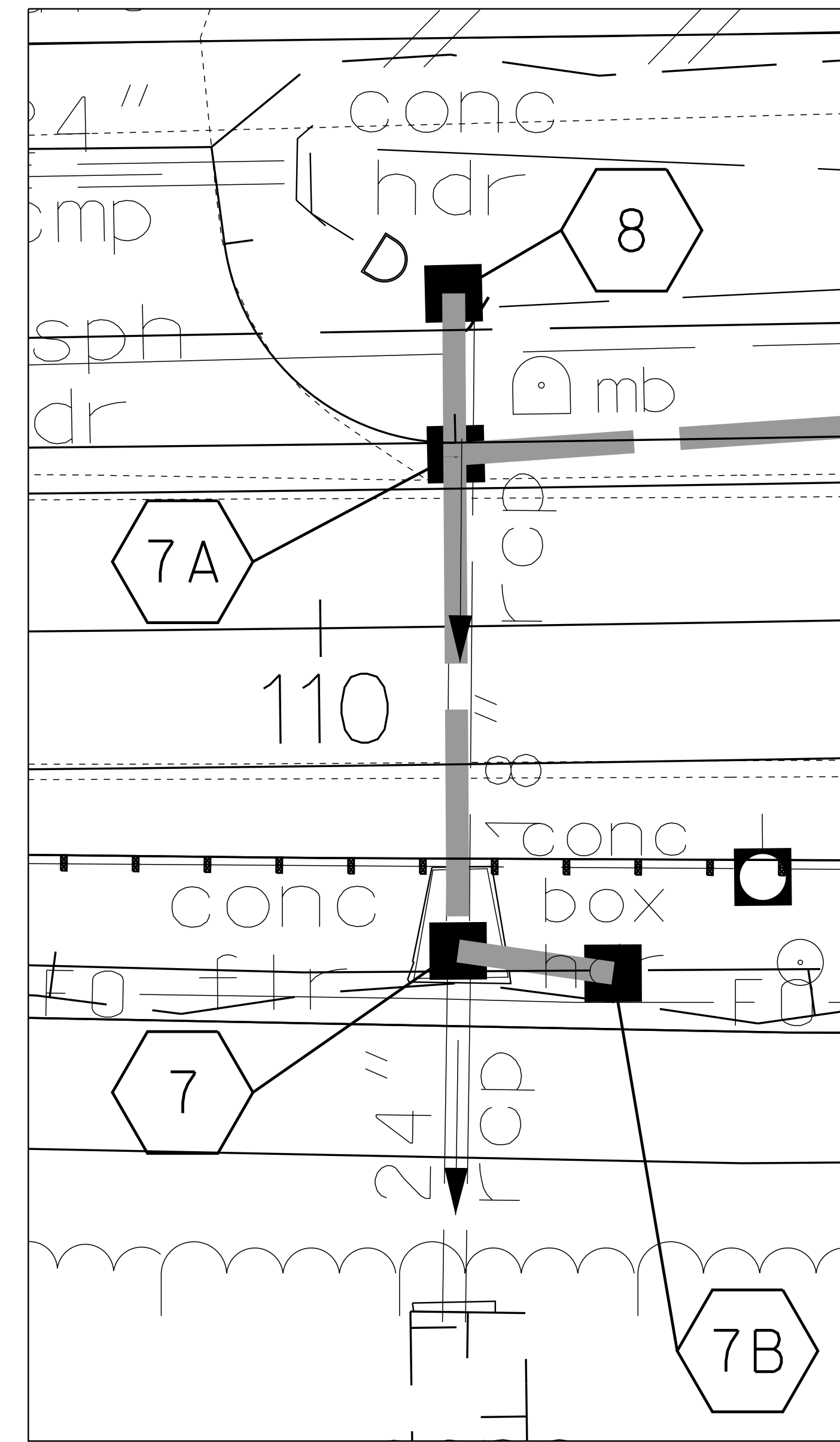

SITE PLAN
DRAINAGE NOTE 7
STA. 110+12

SCALE: 1" = 10' - 0"

- NOTES:
- (*) INDICATES WORK IS SUBSIDIARY TO ITEM 604.292 - SPECIAL DROP INLET.
 - PROTECT EXISTING FIBER OPTIC LINE DURING DRAINAGE WORK.
 - FIELD VERIFY ALL DIMENSIONS PRIOR TO ORDERING ANY PRECAST ITEMS.
 - ALL PROPOSED CONCRETE WORK SHALL CONFORM TO ITEM 520.1 - CONCRETE CLASS A, UNLESS OTHERWISE SPECIFIED.

STATE OF NEW HAMPSHIRE			
DEPARTMENT OF TRANSPORTATION • BUREAU OF HIGHWAY DESIGN			
DRAINAGE NOTE 7 SPECIAL DROP INLET DETAIL			
DGN	STATE PROJECT NO.	SHEET NO.	TOTAL SHEETS
13928A_specialCB	13928A	23	160

SDR PROCESSED	DATE	DATE	DATE	DATE
NEW DESIGN	S. MICOCCI	03/2015		
SHEET CHECKED	C. SPETELUNAS	04/2015		
AS BUILT DETAILS				

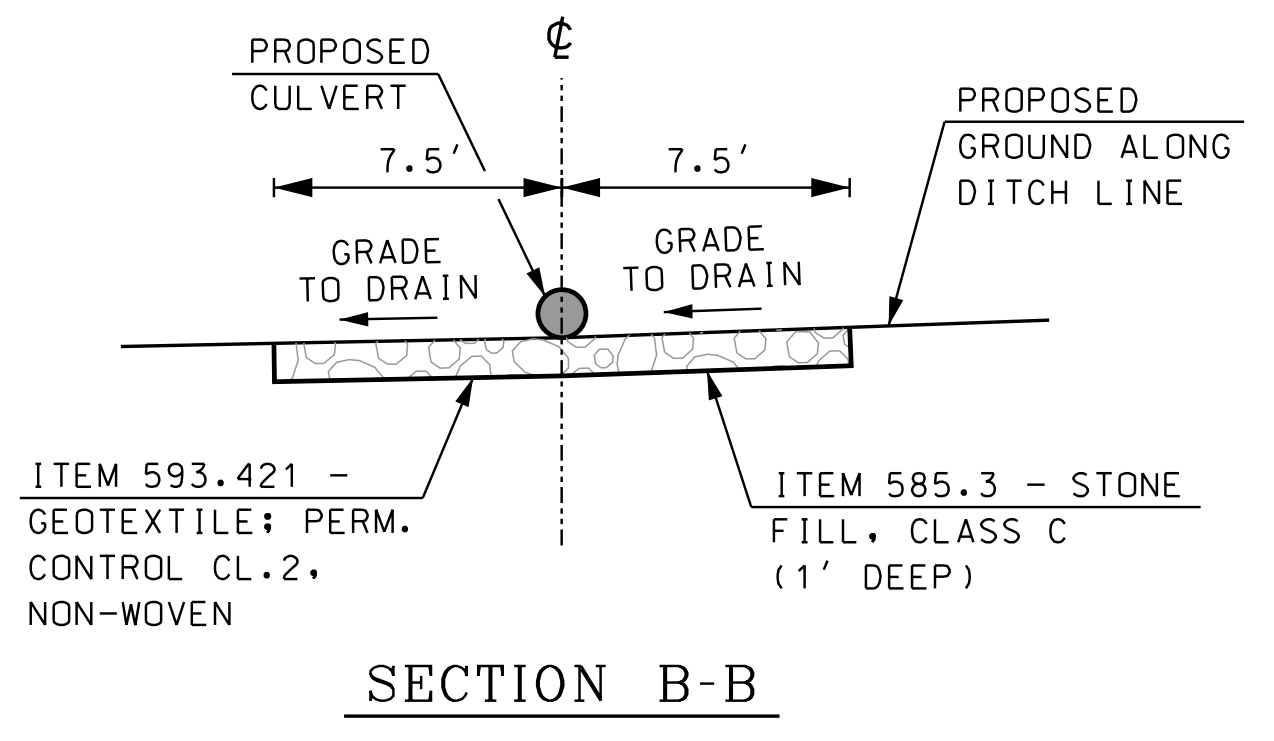
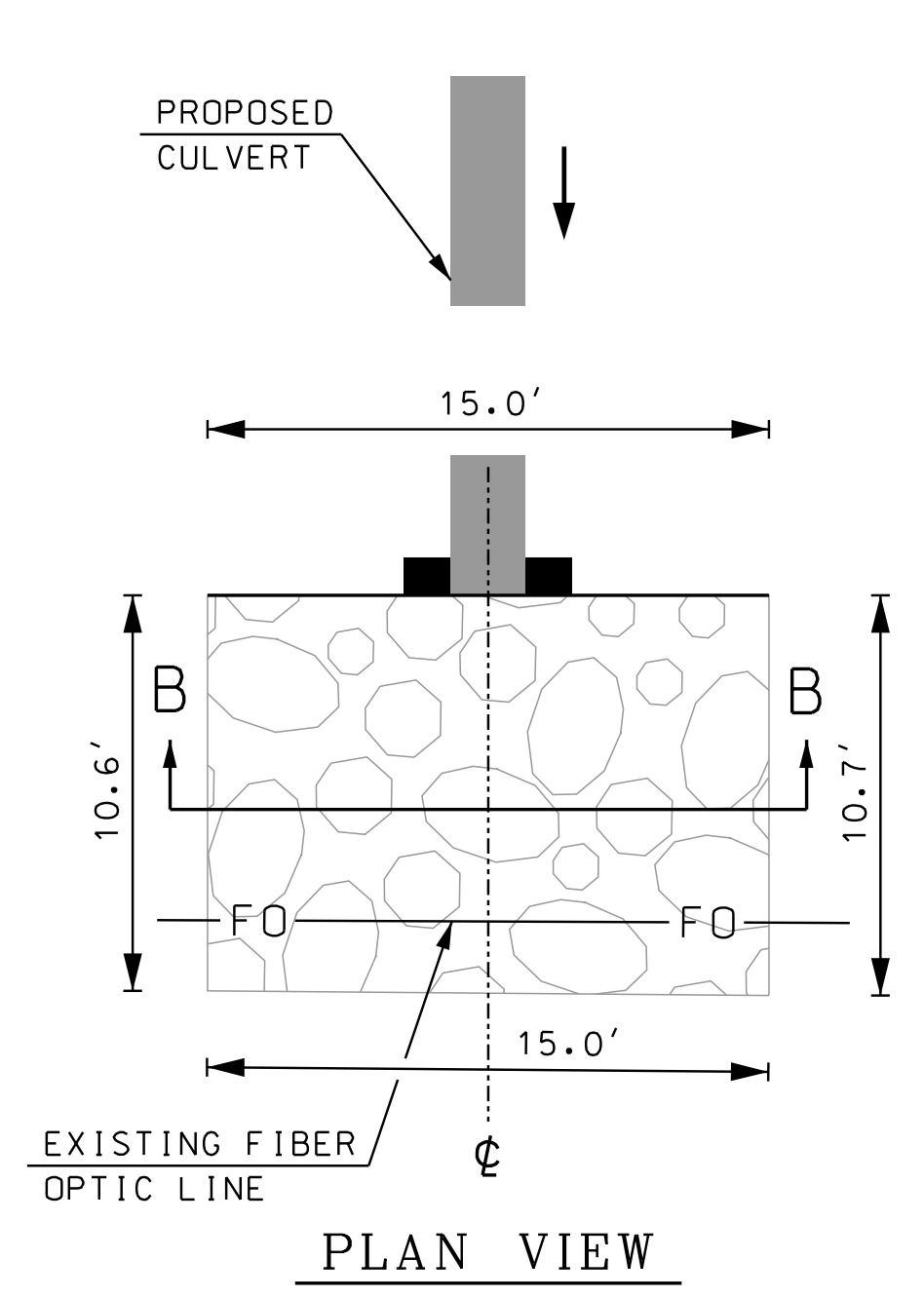

DRAINAGE NOTE 2
OUTLET PROTECTION DETAIL

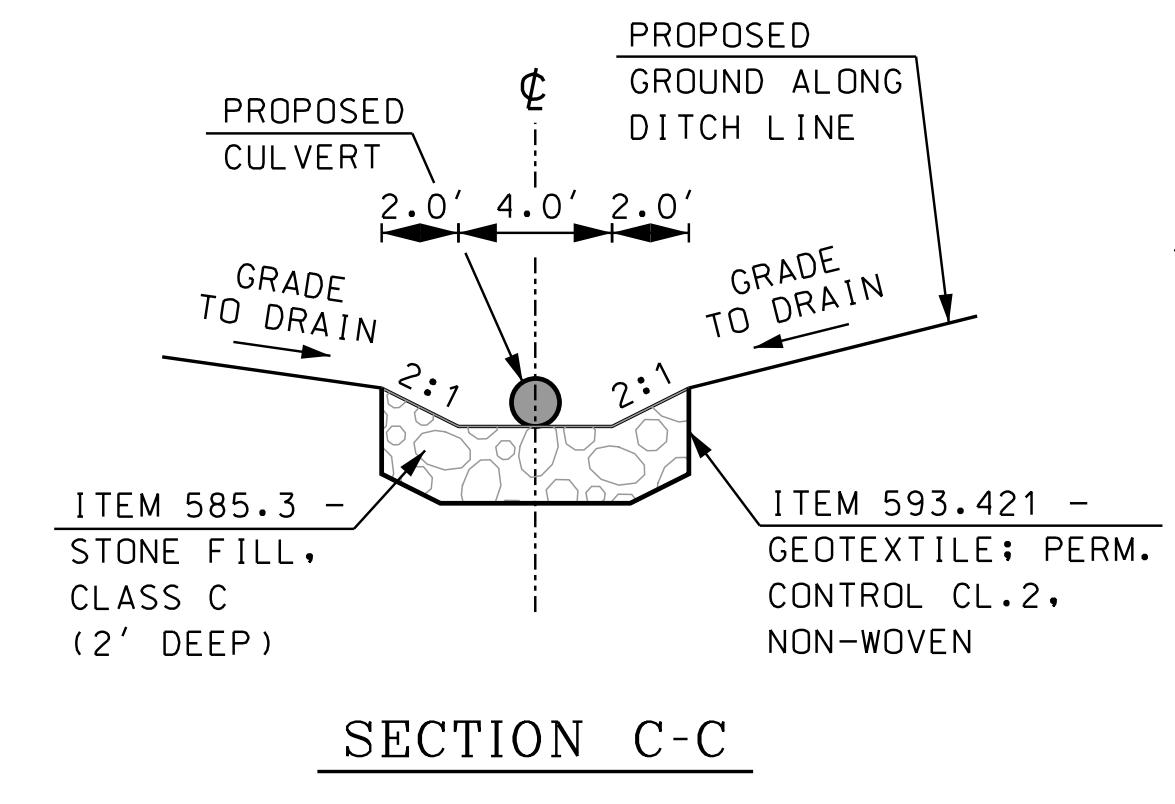
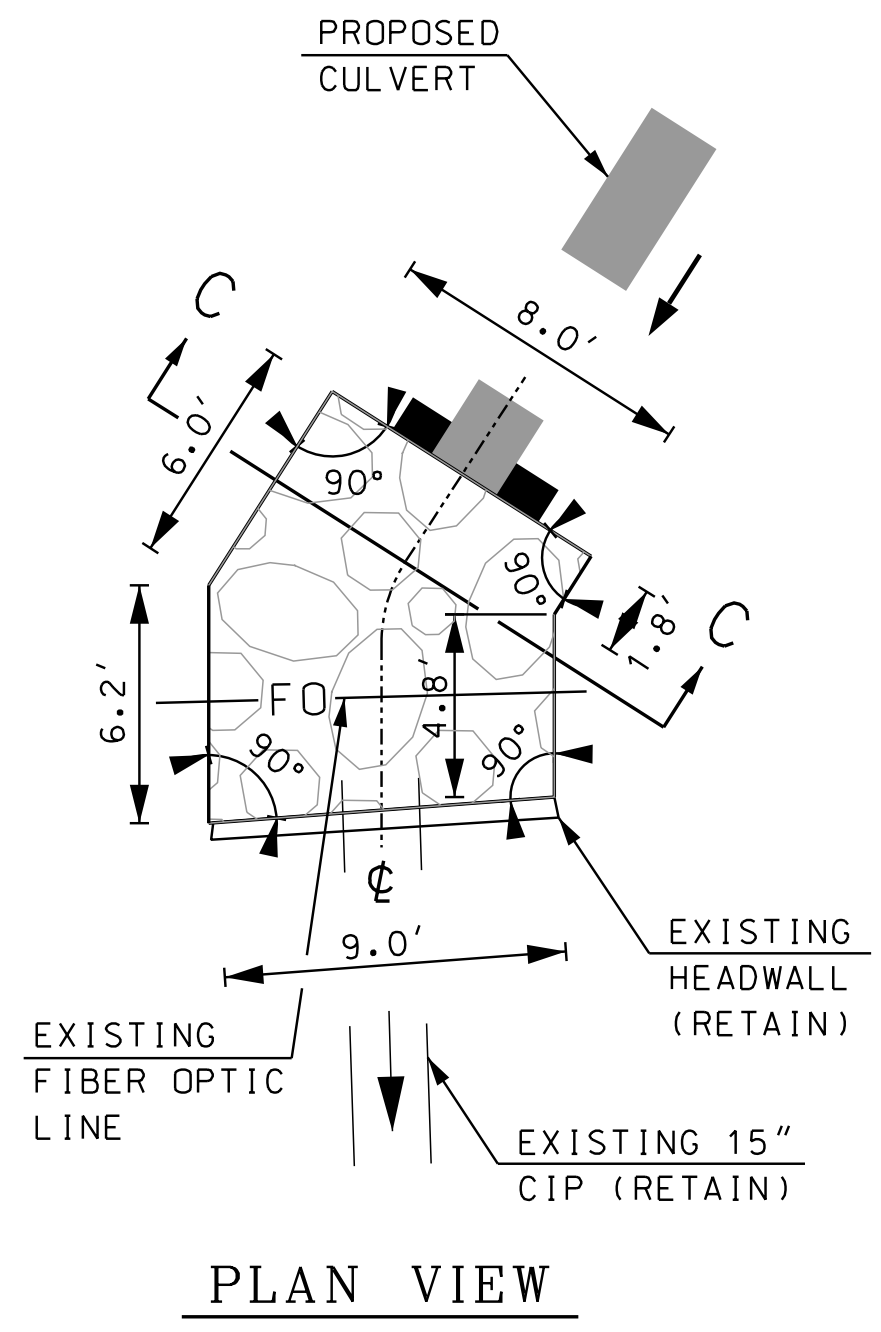

DRAINAGE NOTE 4
OUTLET PROTECTION DETAIL

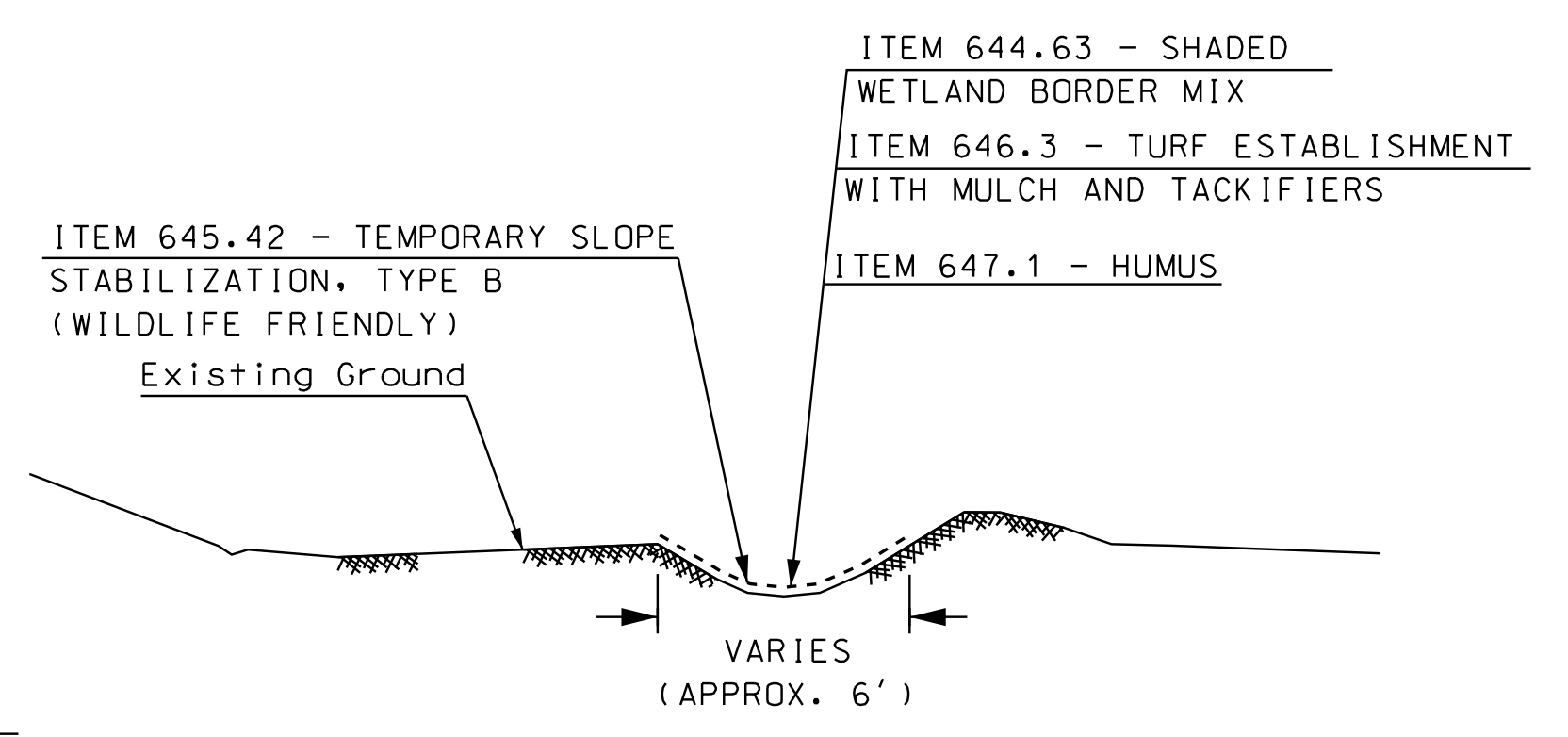

DRAINAGE NOTE 6/7
SWALE VEGETATION DETAIL
STA. 108+50 - 110+12
80' RT

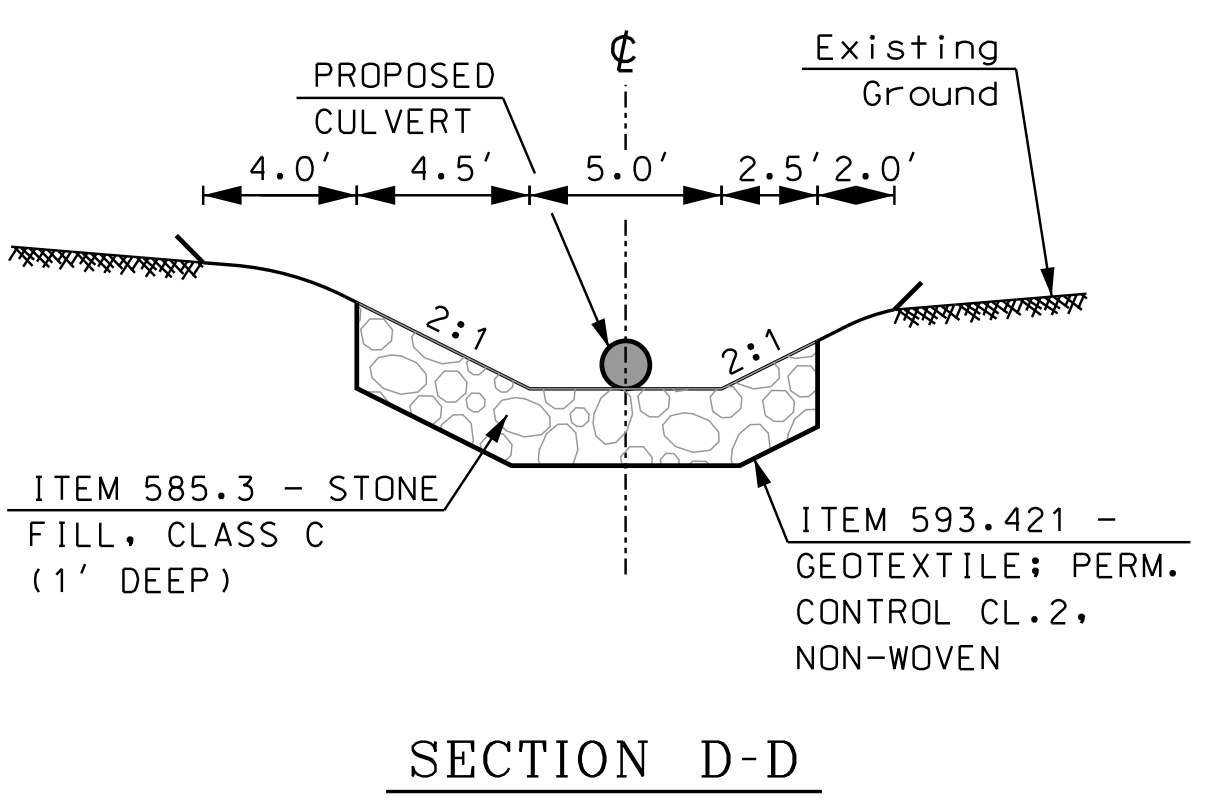
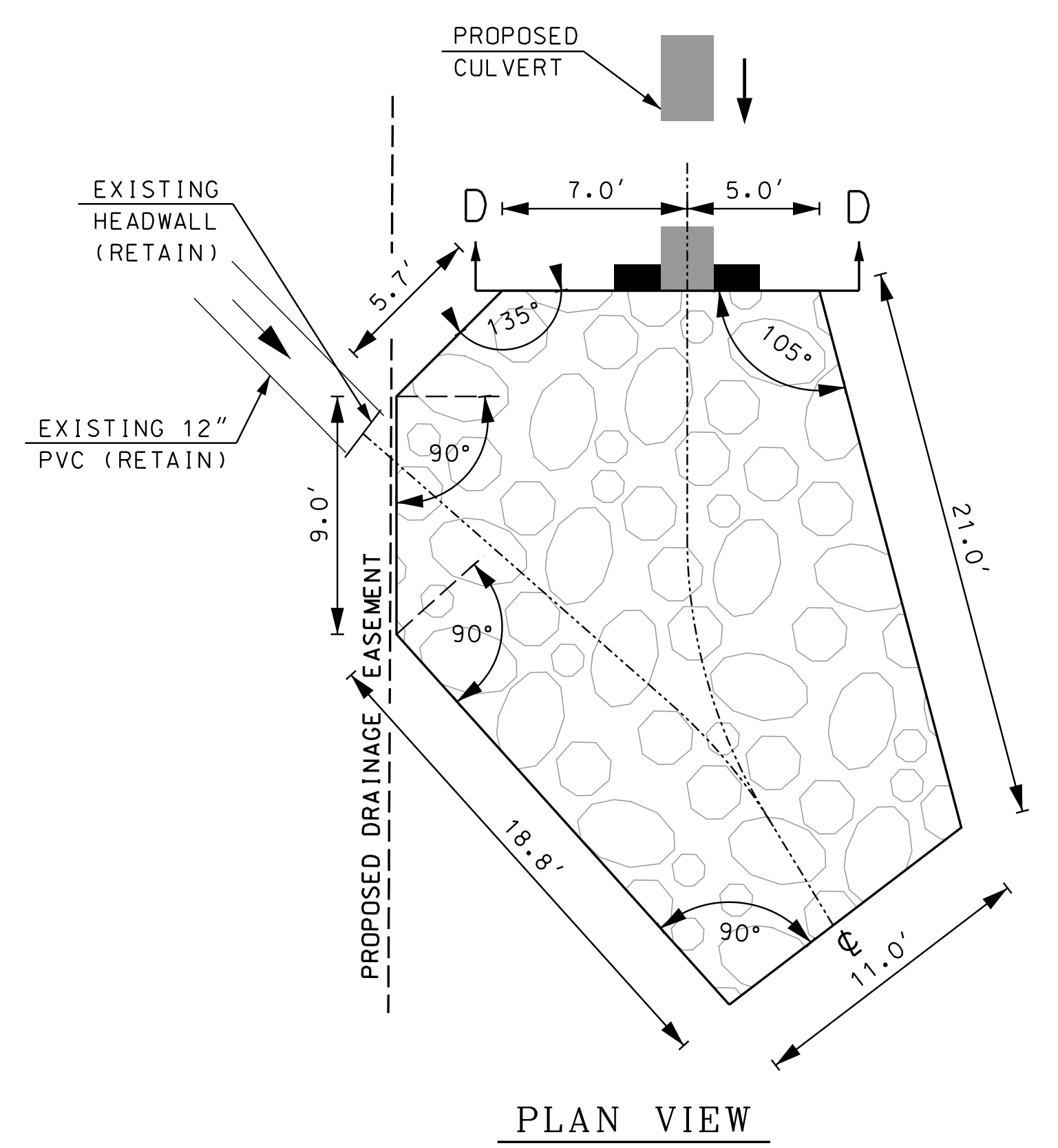

NOTE:
PROPOSED GRADING AND PLACEMENT OF STONE FILL SHALL BE CONFINED TO THE LIMITS OF THE PROPOSED DRAINAGE EASEMENT ONLY.

DRAINAGE NOTE 17
OUTLET PROTECTION DETAIL

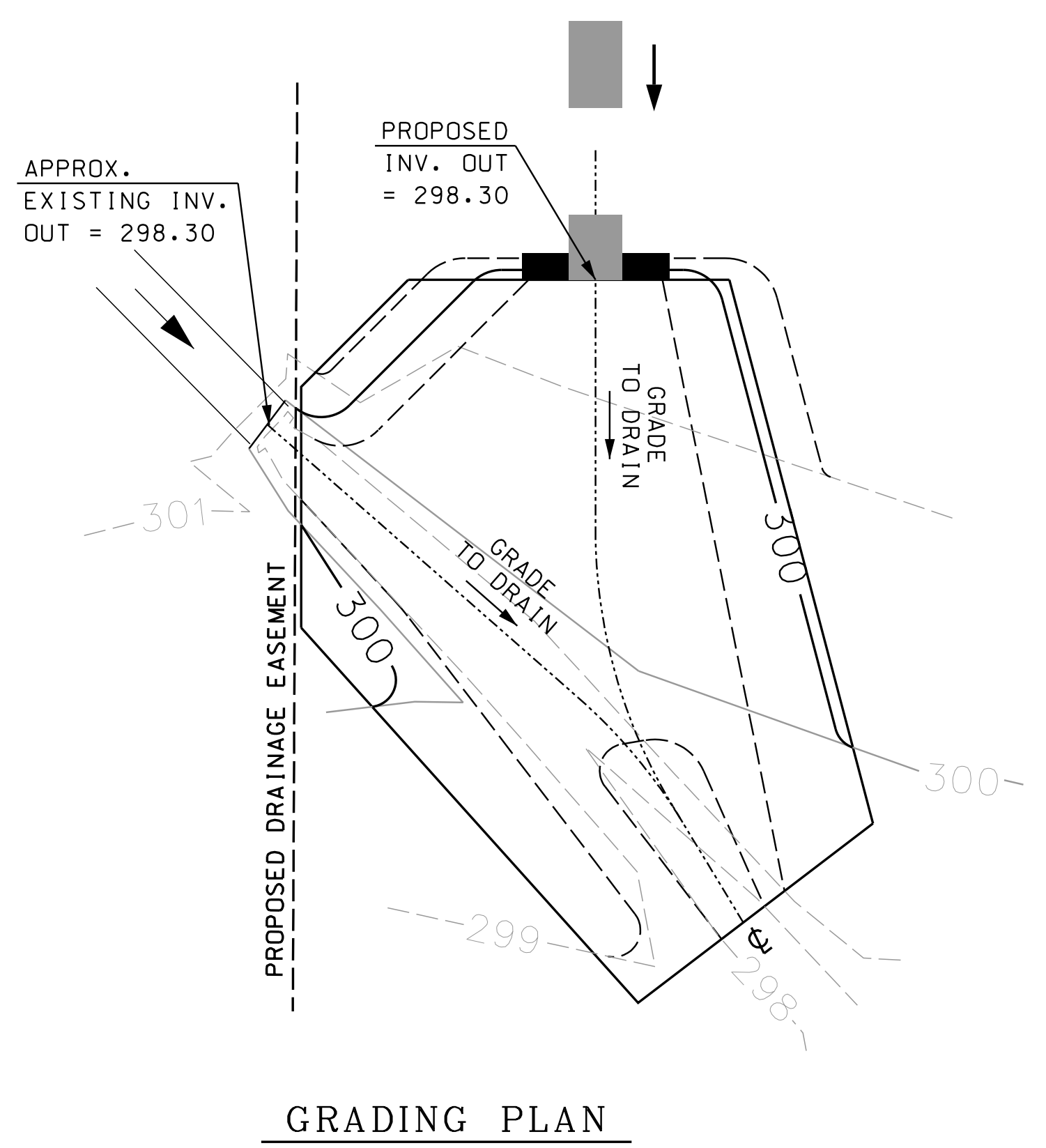

GRADING PLAN

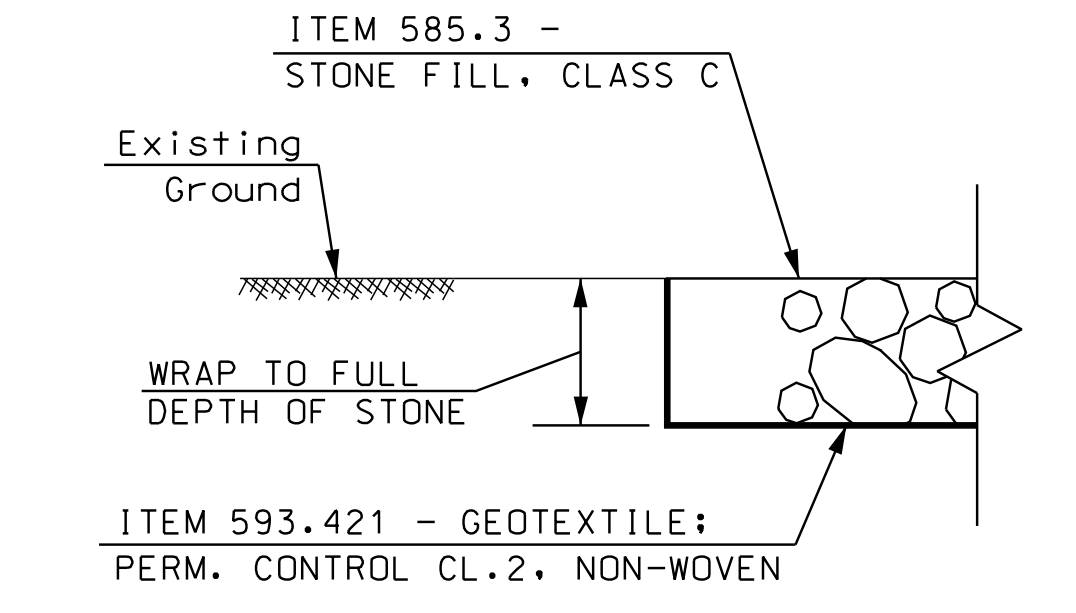

GEOTEXTILE DETAIL
FOR OUTLET PROTECTION

- GENERAL NOTES:**
- SEE DRAINAGE NOTES, CROSS SECTIONS, AND DRAINAGE AND UTILITY PLANS FOR MORE INFORMATION.
 - EXCAVATION FOR PLACEMENT OF STONE FILL OUTLET PROTECTION SHALL BE PAID FOR UNDER ITEM 206.1 - COMMON STRUCTURE EXCAVATION.
 - ANGULAR MEASUREMENTS FOR STONE FILL GEOMETRY ARE APPROXIMATE AND SHOULD BE ADJUSTED TO MATCH FIELD CONDITIONS.
 - WHEN PERFORMING WORK ADJACENT TO THE EXISTING FIBER OPTIC LINE, INCLUDING PLACING STONE FILL, COORDINATE WITH THE UTILITY OWNER AS REQUIRED IN THE CONTRACT PROPOSAL DOCUMENT.

NOT TO SCALE

STATE OF NEW HAMPSHIRE			
DEPARTMENT OF TRANSPORTATION • BUREAU OF HIGHWAY DESIGN			
DRAINAGE DETAILS			
DGN	STATE PROJECT NO.	SHEET NO.	TOTAL SHEETS
13928A_drain_det	13928A	24	160

SDR PROCESSED	DATE	02/2015
NEW DESIGN	S. MIOUCCI	
SHEET CHECKED	C. SPETELUNAS	
AS BUILT DETAILS	DATE	

REVISIONS AFTER PROPOSAL	STATION	DESCRIPTION

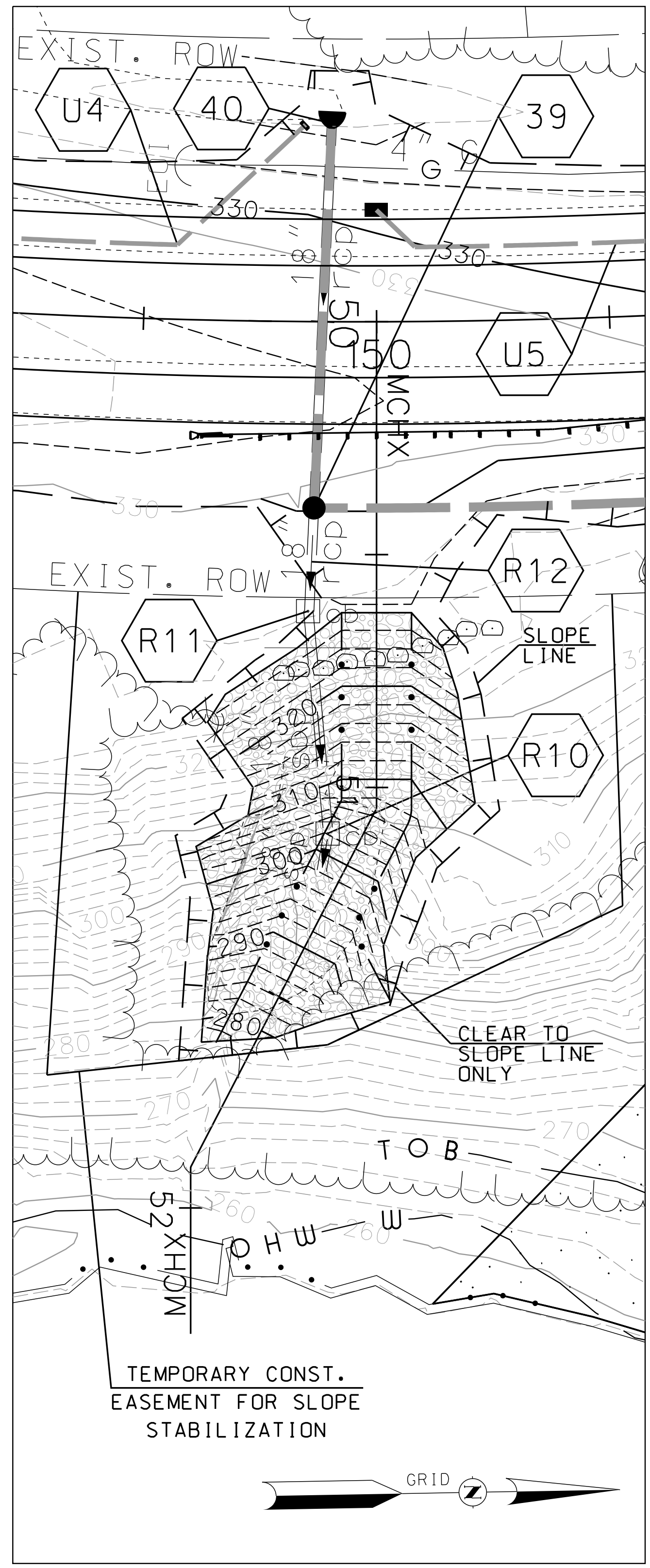

PLAN VIEW
SCALE: 1" = 20'

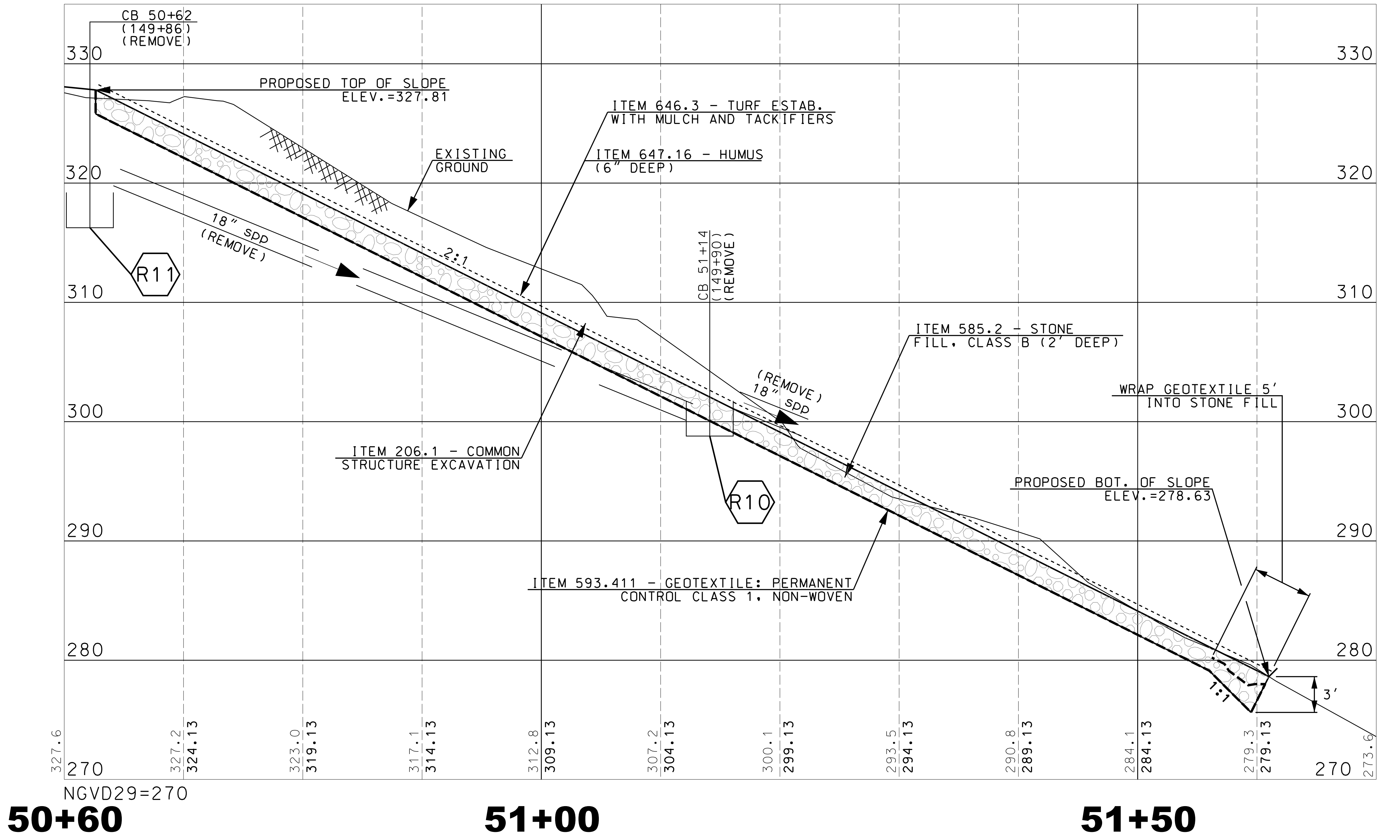

PROFILE ALONG MCHX ALIGNMENT
SCALE: 1" = 5'

STATE OF NEW HAMPSHIRE			
DEPARTMENT OF TRANSPORTATION • BUREAU OF HIGHWAY DESIGN			
SOUTH SLOPE REPAIR			
@ STA 150+00			
DGN	STATE PROJECT NO.	SHEET NO.	TOTAL SHEETS
13928A_southslope	13928A	26	160

SDR PROCESSED	DATE	02/2015
NEW DESIGN	DATE	04/2015
SHEET CHECKED	DATE	
AS BUILT DETAILS	DATE	

REVISIONS AFTER PROPOSAL	STATION	DESCRIPTION

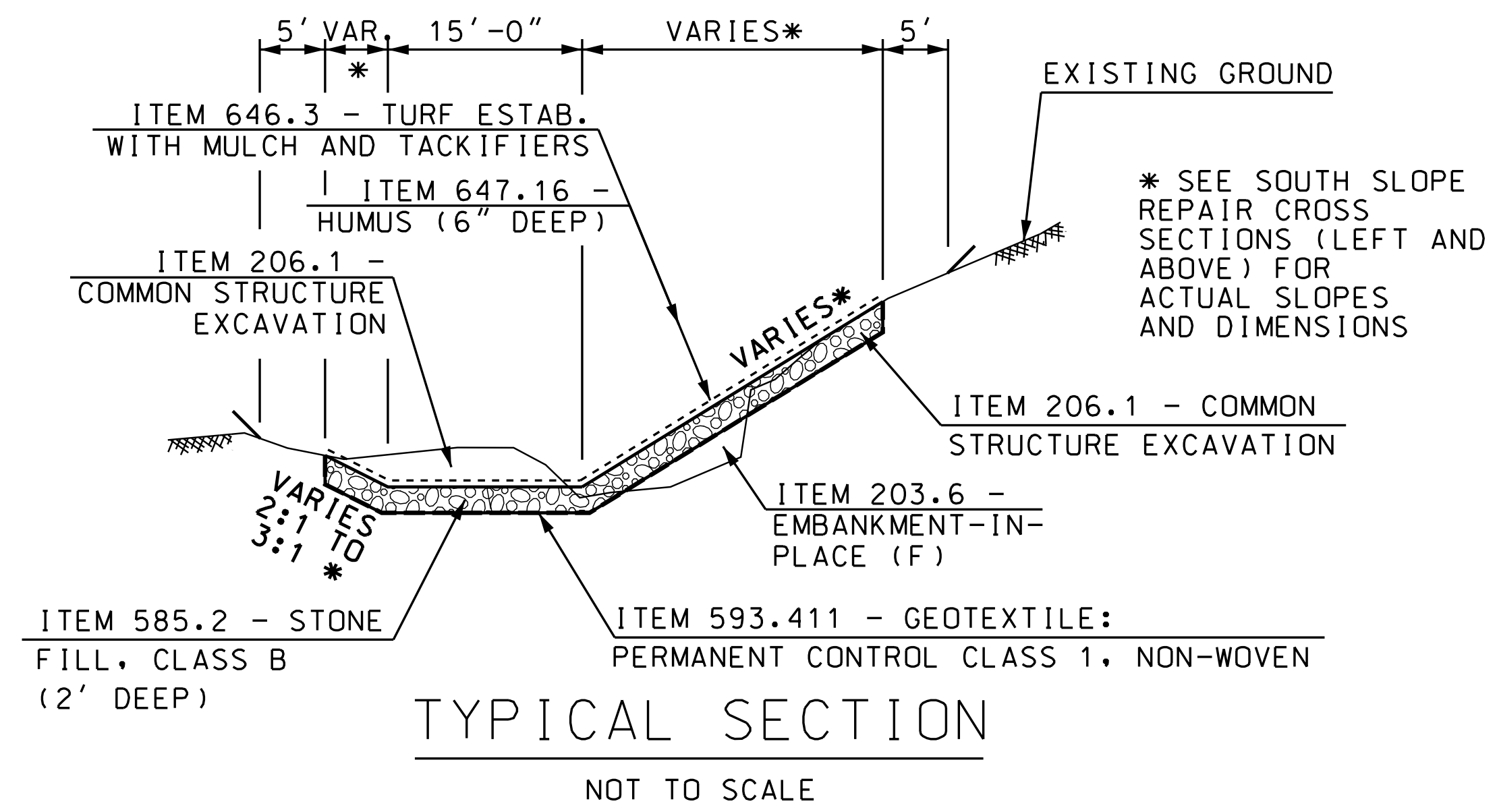
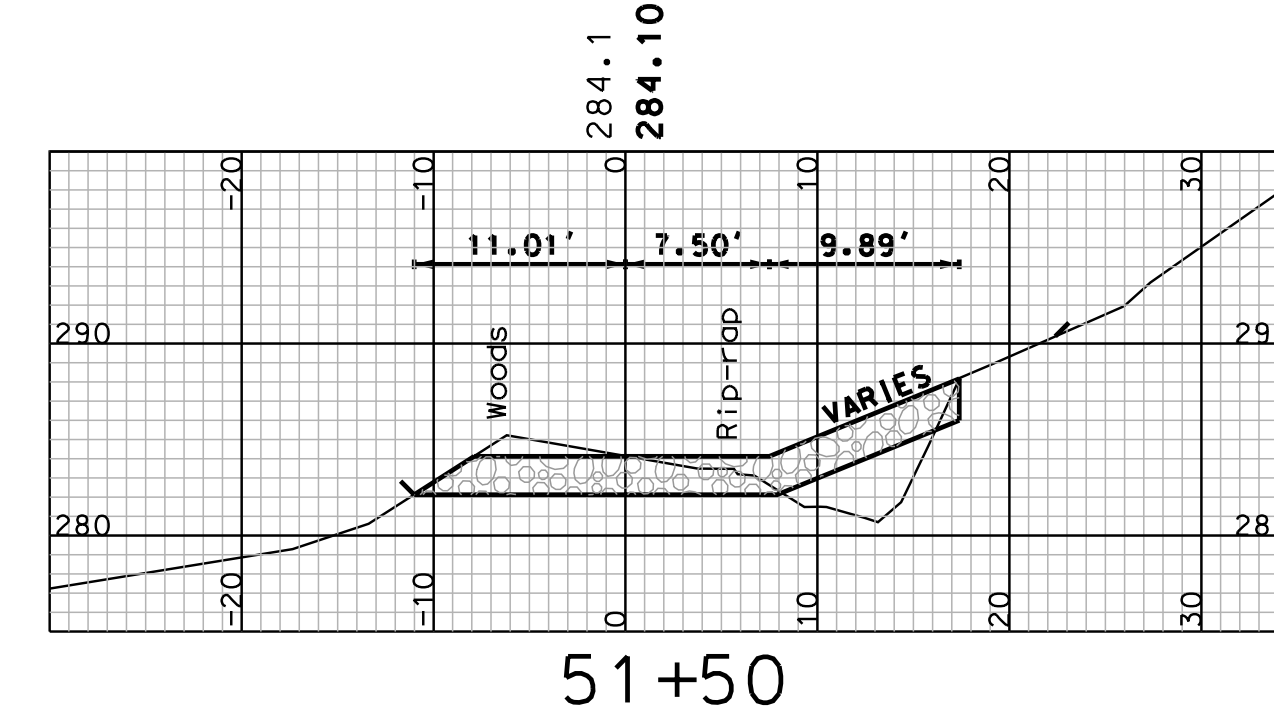
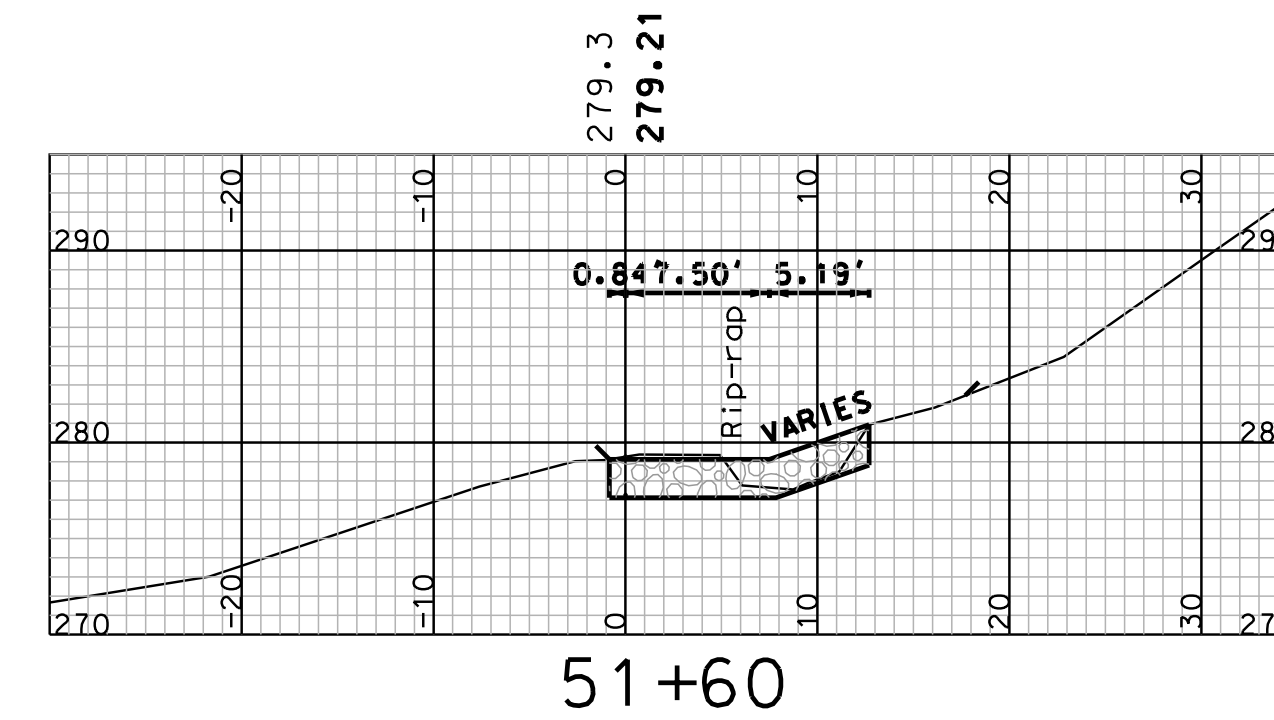
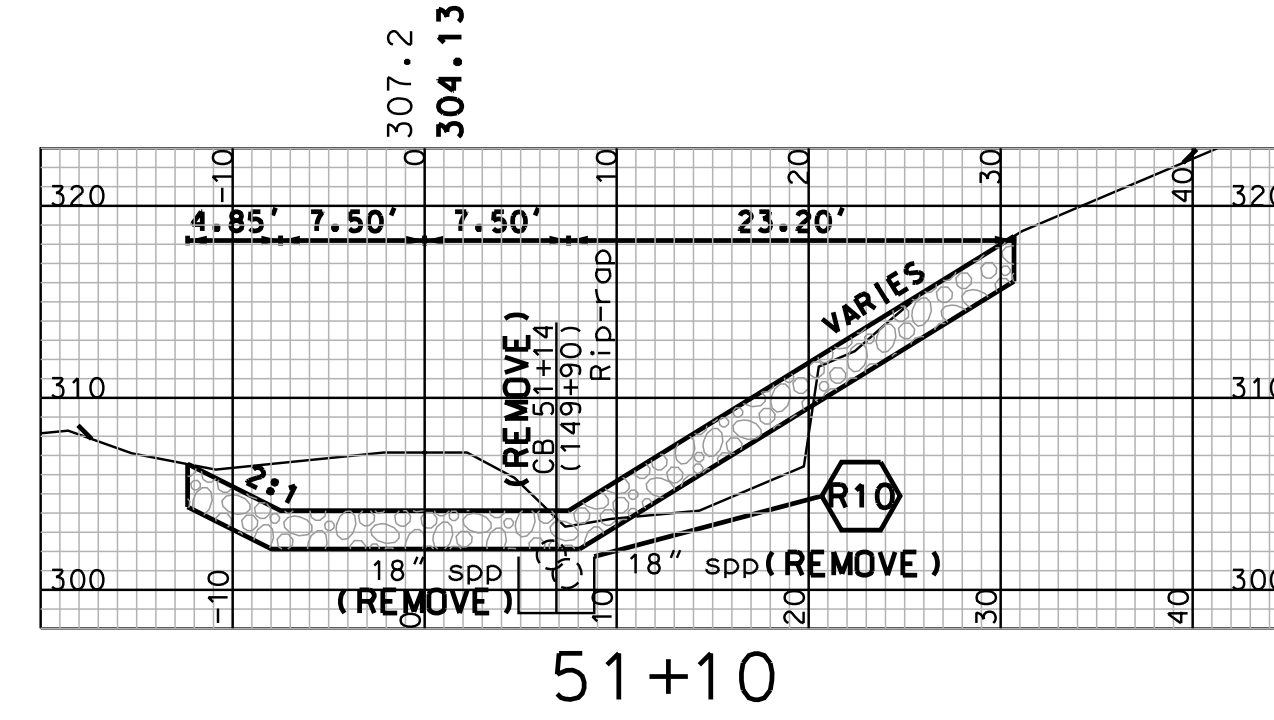
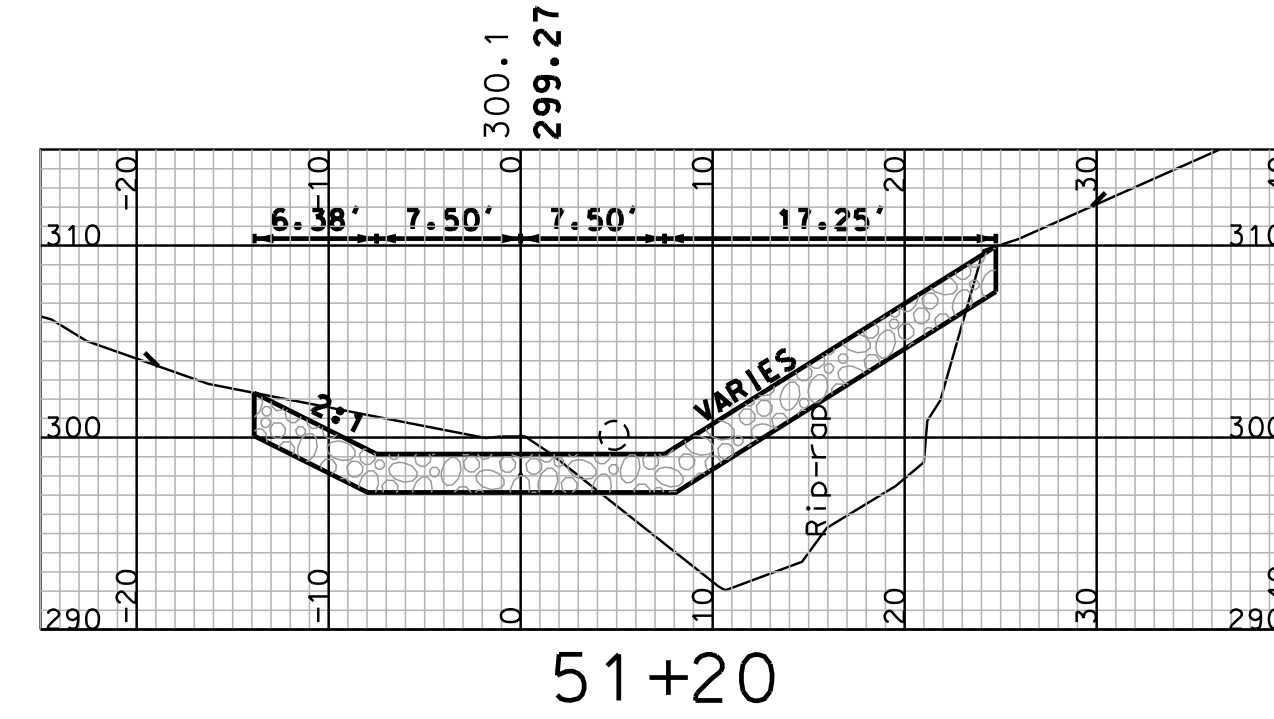
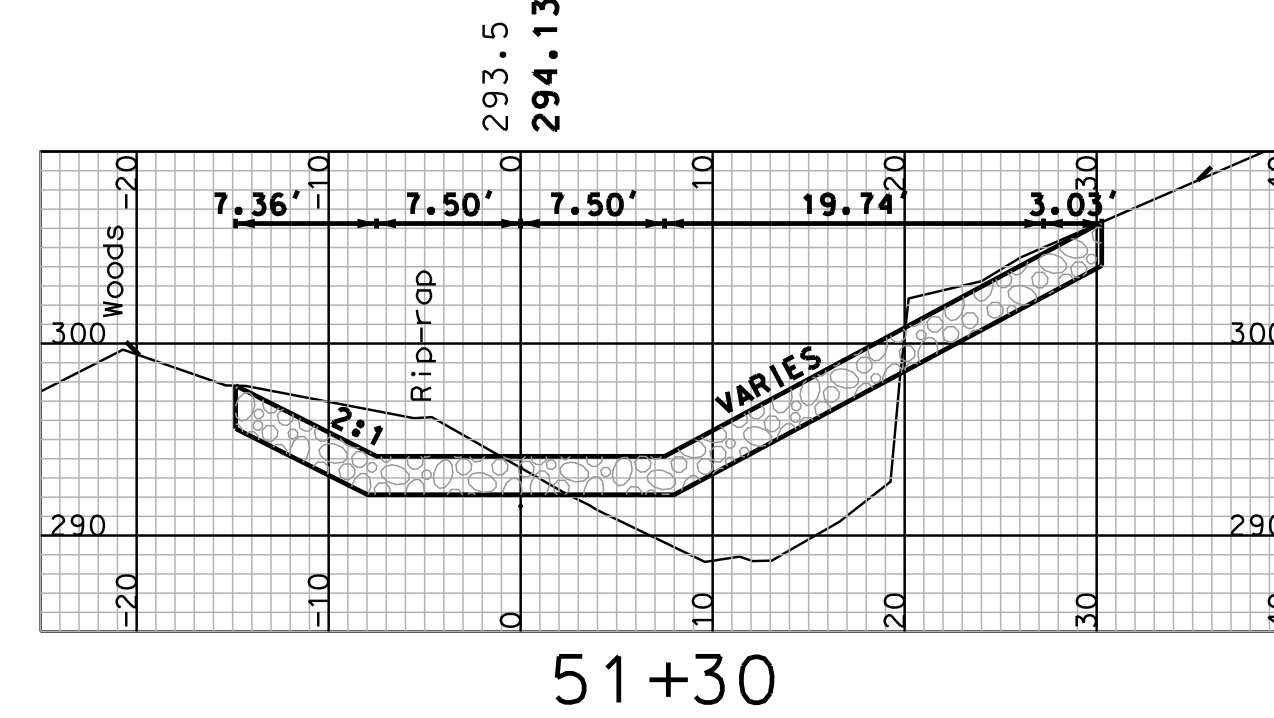
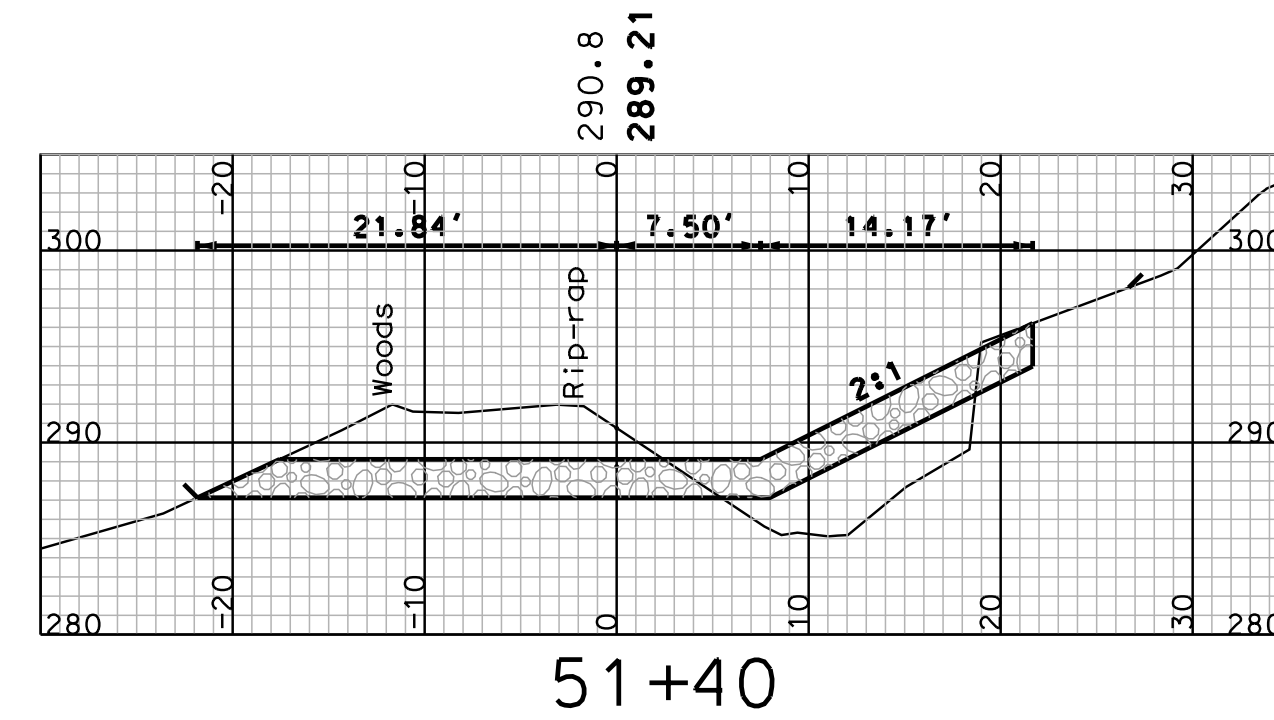
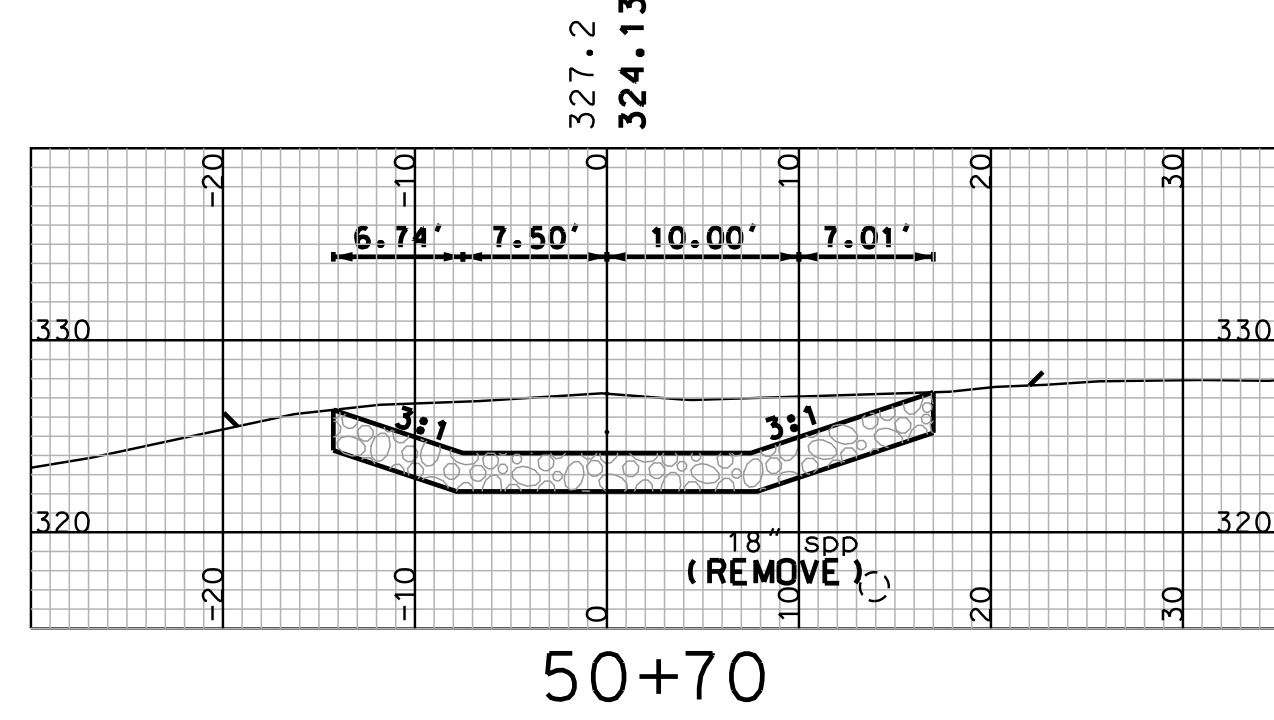
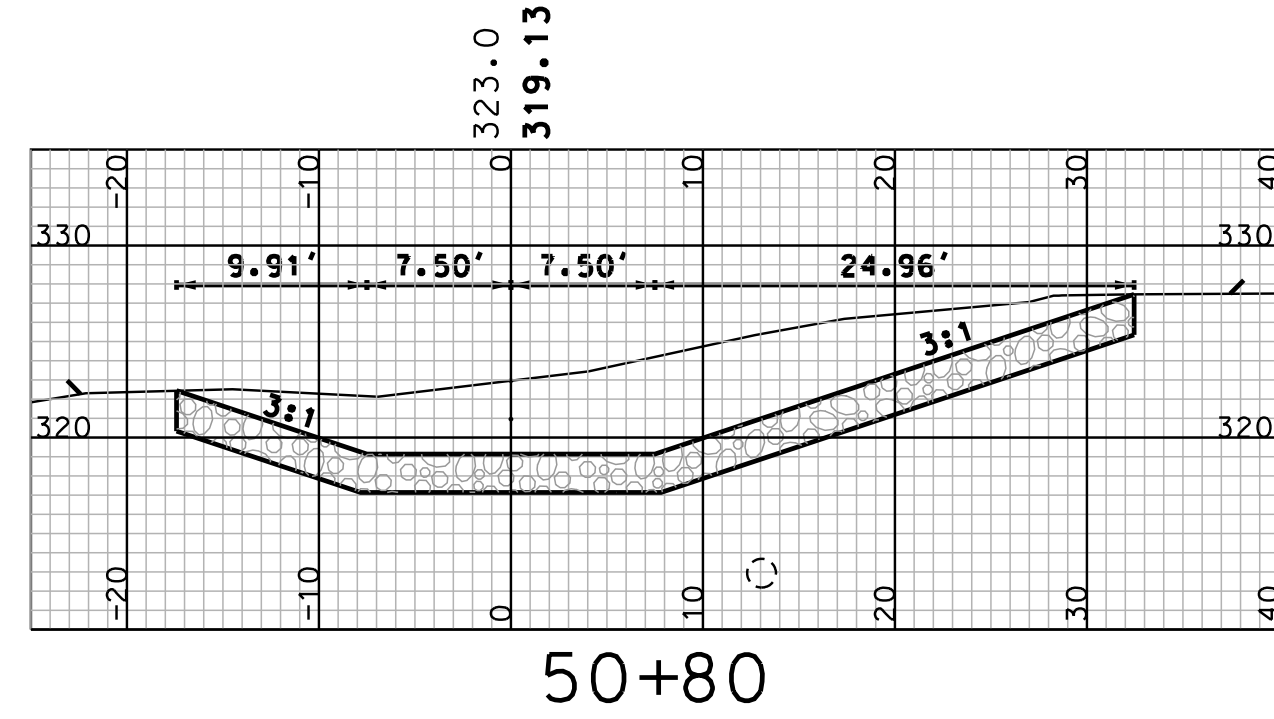
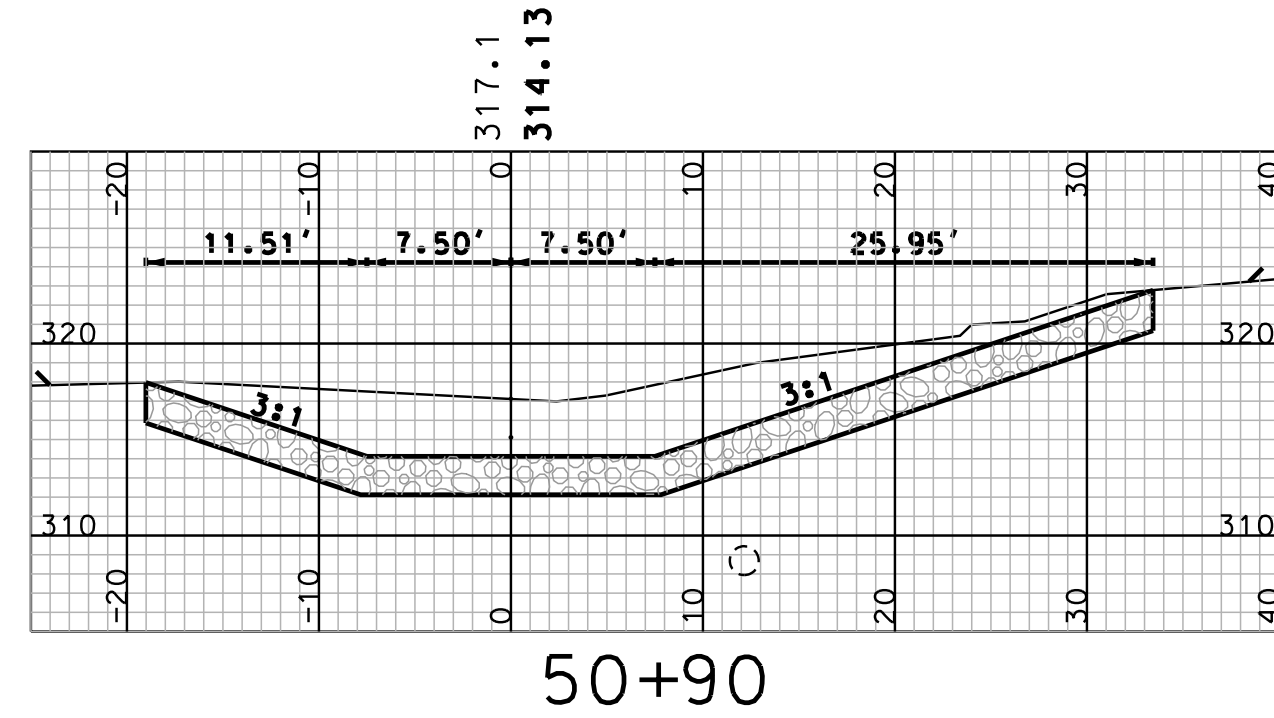
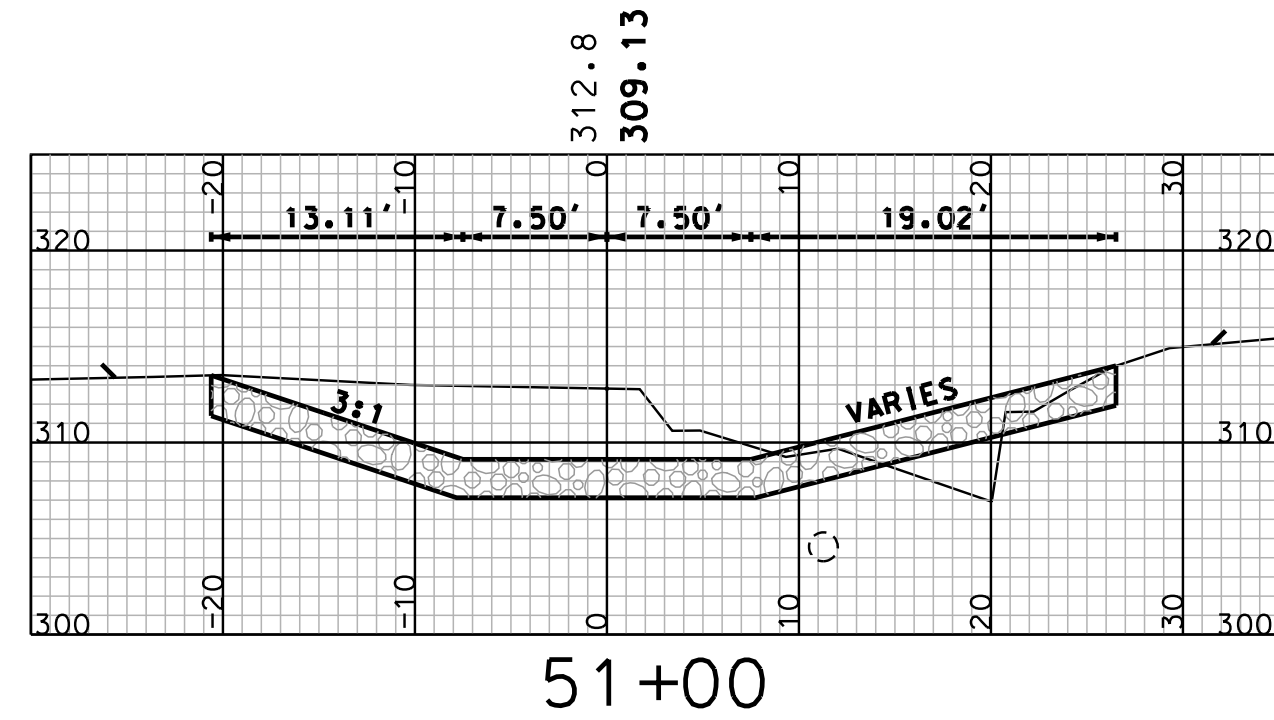

- GENERAL NOTES
- UPON REMOVAL OF EXISTING DEBRIS, VOIDS SHALL BE FILLED WITH EMBANKMENT -IN-PLACE.
 - CHINK STONE FILL SURFACE ACCORDING TO SECTIONS 585.2.1.5 AND 585.3.1 PRIOR TO OVERLAYING WITH HUMUS. MATERIALS AND WORK FOR CHINKING THE STONE FILL SHALL BE SUBSIDIARY TO ITEM 585.2.
 - IF TEMPORARY ACCESS ROAD IS NEEDED FOR SOUTH SLOPE REPAIR, REFER TO TEMPORARY ACCESS ROAD DETAIL ON LODGE SLOPE REPAIR @ STA 153+50 DETAIL (SHEET 30).

CROSS SECTIONS
SCALE: 1" = 10'

STATE OF NEW HAMPSHIRE			
DEPARTMENT OF TRANSPORTATION • BUREAU OF HIGHWAY DESIGN			
SOUTH SLOPE REPAIR @ STA 150+00			
DGN	STATE PROJECT NO.	SHEET NO.	TOTAL SHEETS
13928A_southslope	13928A	27	160

SDR PROCESSED	DATE	02/2015
NEW DESIGN	S. MUCUCCI	DATE
SHEET CHECKED	C. SPETELUNAS	DATE
AS BUILT DETAILS	DATE	

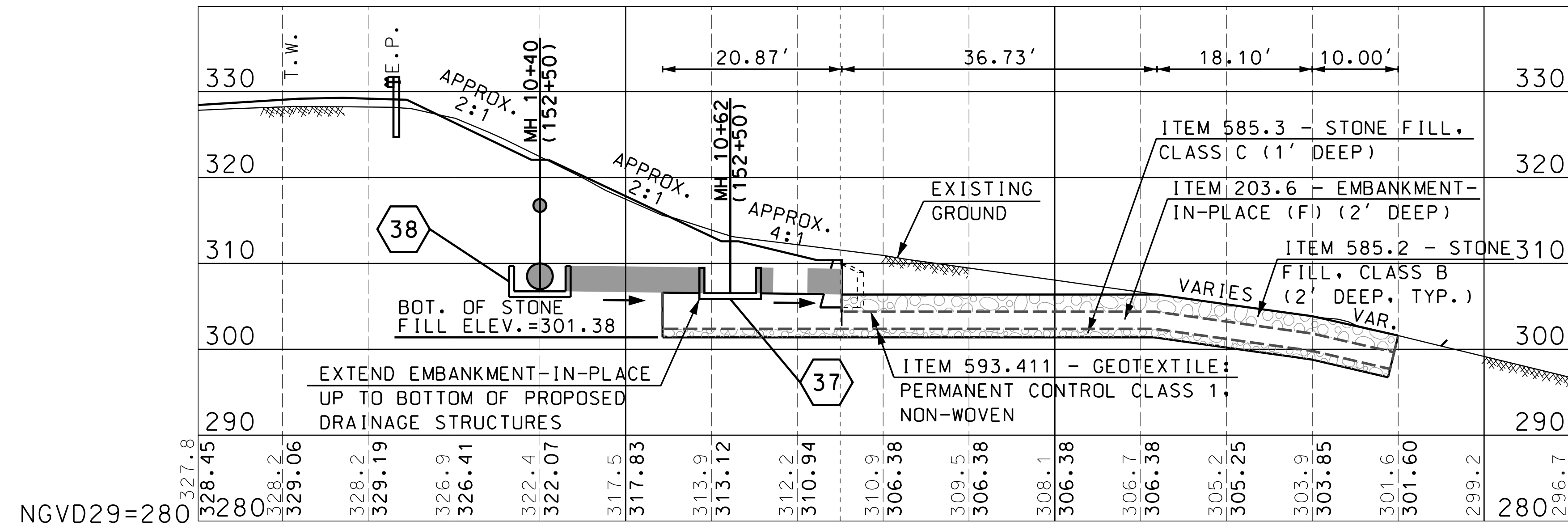

10+00 10+50 11+00 11+50

PROFILE ALONG MCBX ALIGNMENT

SCALE: 1" = 10'

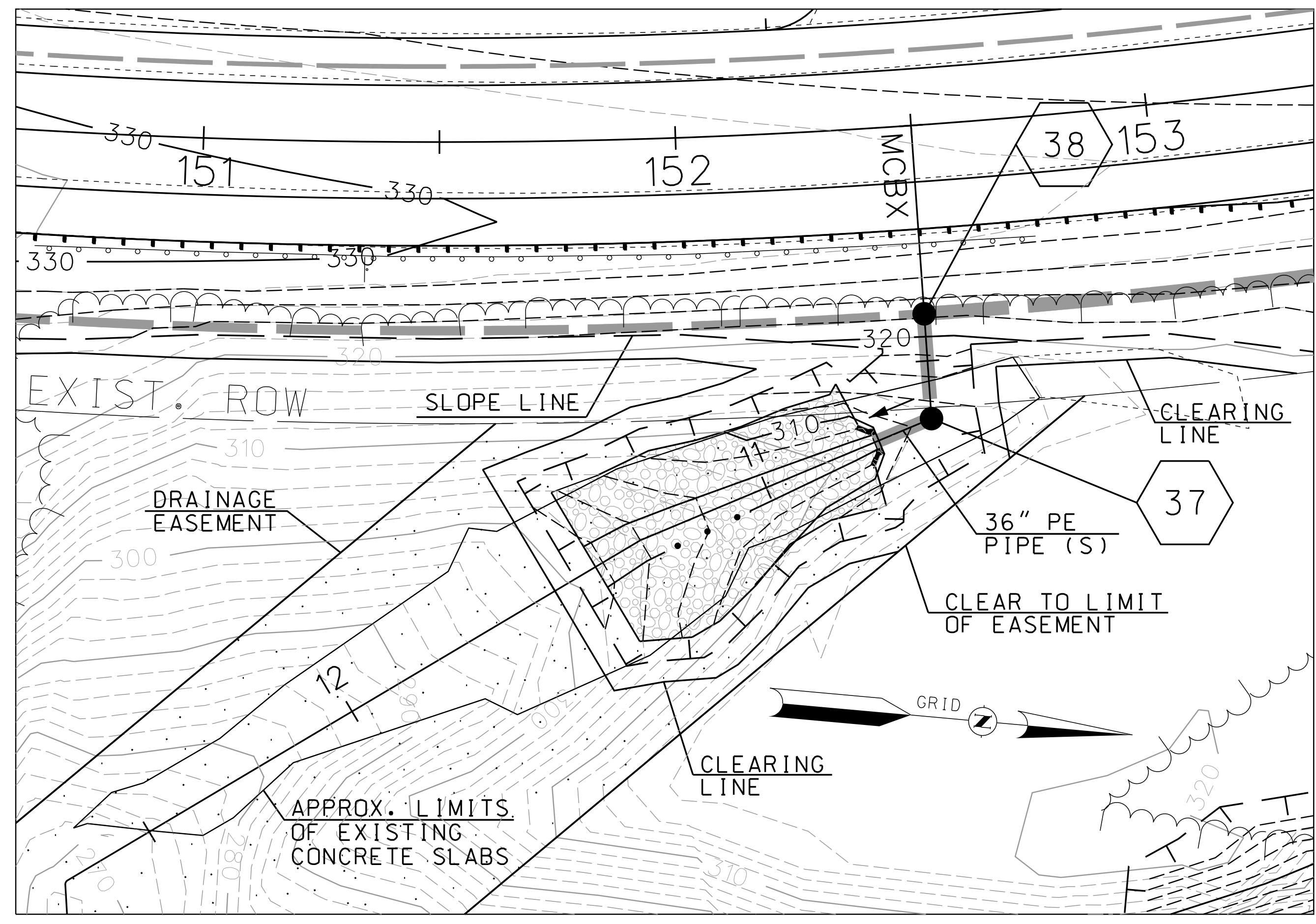

PLAN VIEW

SCALE: 1" = 20'

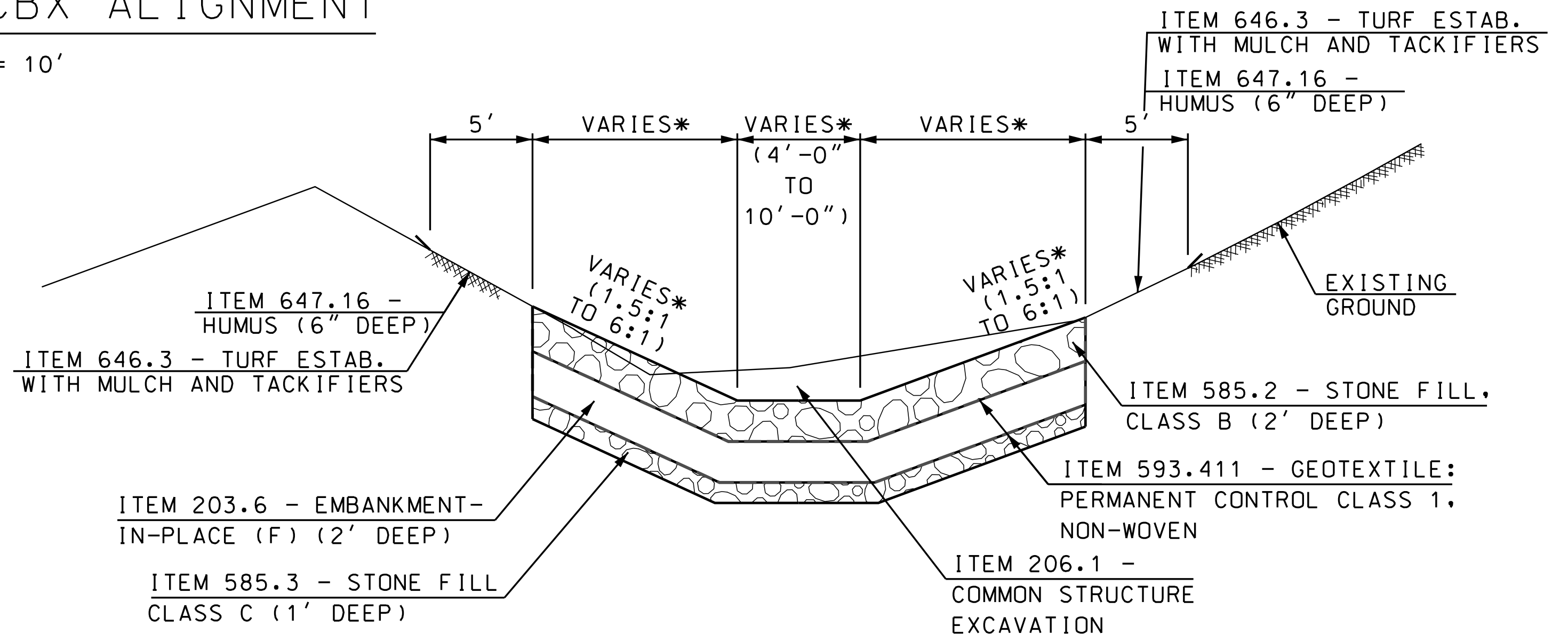

TYPICAL SECTION

NOT TO SCALE

GENERAL NOTES

- UPON REMOVAL OF EXISTING CONCRETE SLABS, VOIDS SHALL BE FILLED AND GRADE OF SWALE ESTABLISHED BEFORE PLACING TYPICAL BOX SHOWN ABOVE. THE CLASS C STONE FILL LAYER SHALL BE MOSTLY FREE OF INTRUSIONS AND CHINKED INTO REMAINING EXISTING CONCRETE SLABS, IF ANY. MINIMAL PROTRUSIONS ARE ACCEPTABLE.
- ITEM 203.6 - EMBANKMENT-IN-PLACE (F) MAY BE SUBSTITUTED WITH EMBANKMENT IN PLACE MIXED WITH CONCRETE PIECES, PROVIDED THE PIECES ARE LESS THAN 12" IN ANY DIRECTION.

* SEE CONCRETE SWALE DRAINAGE OUTLET CROSS SECTIONS ON NEXT SHEET FOR ACTUAL SLOPES AND DIMENSIONS

STATE OF NEW HAMPSHIRE			
DEPARTMENT OF TRANSPORTATION • BUREAU OF HIGHWAY DESIGN			
CONCRETE SWALE DRAINAGE OUTLET DETAIL			
DGN	STATE PROJECT NO.	SHEET NO.	TOTAL SHEETS
13928A_concreteswale	13928A	28	160

REVISIONS AFTER PROPOSAL		STATION	DESCRIPTION
NUMBER	DATE	STATION	DESCRIPTION

SDR PROCESSED	DATE	02/2015
NEW DESIGN	S. MIOUCCI	DATE
SHEET CHECKED	C. SPETELUNAS	DATE
AS BUILT DETAILS	DATE	

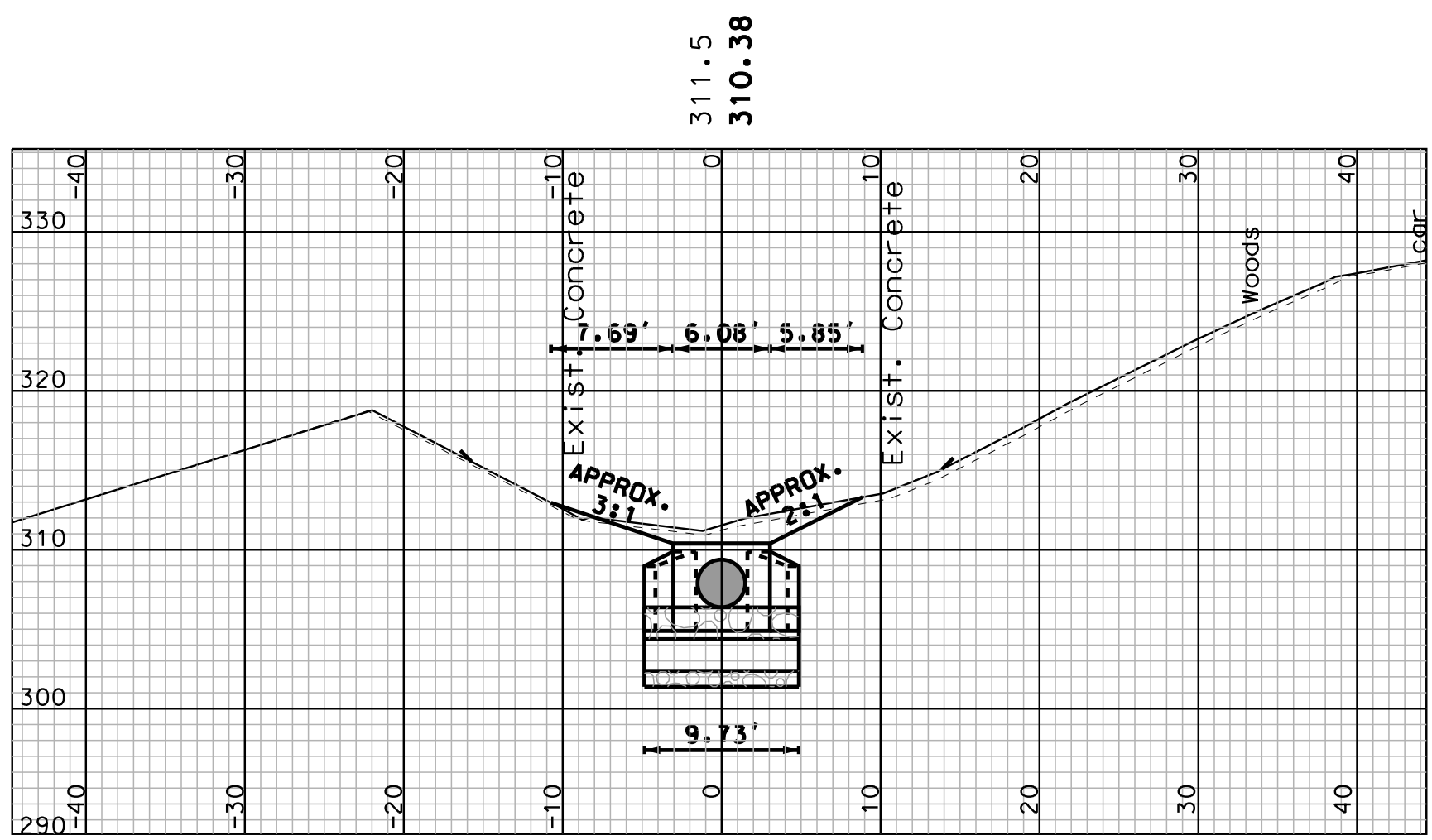

10+75

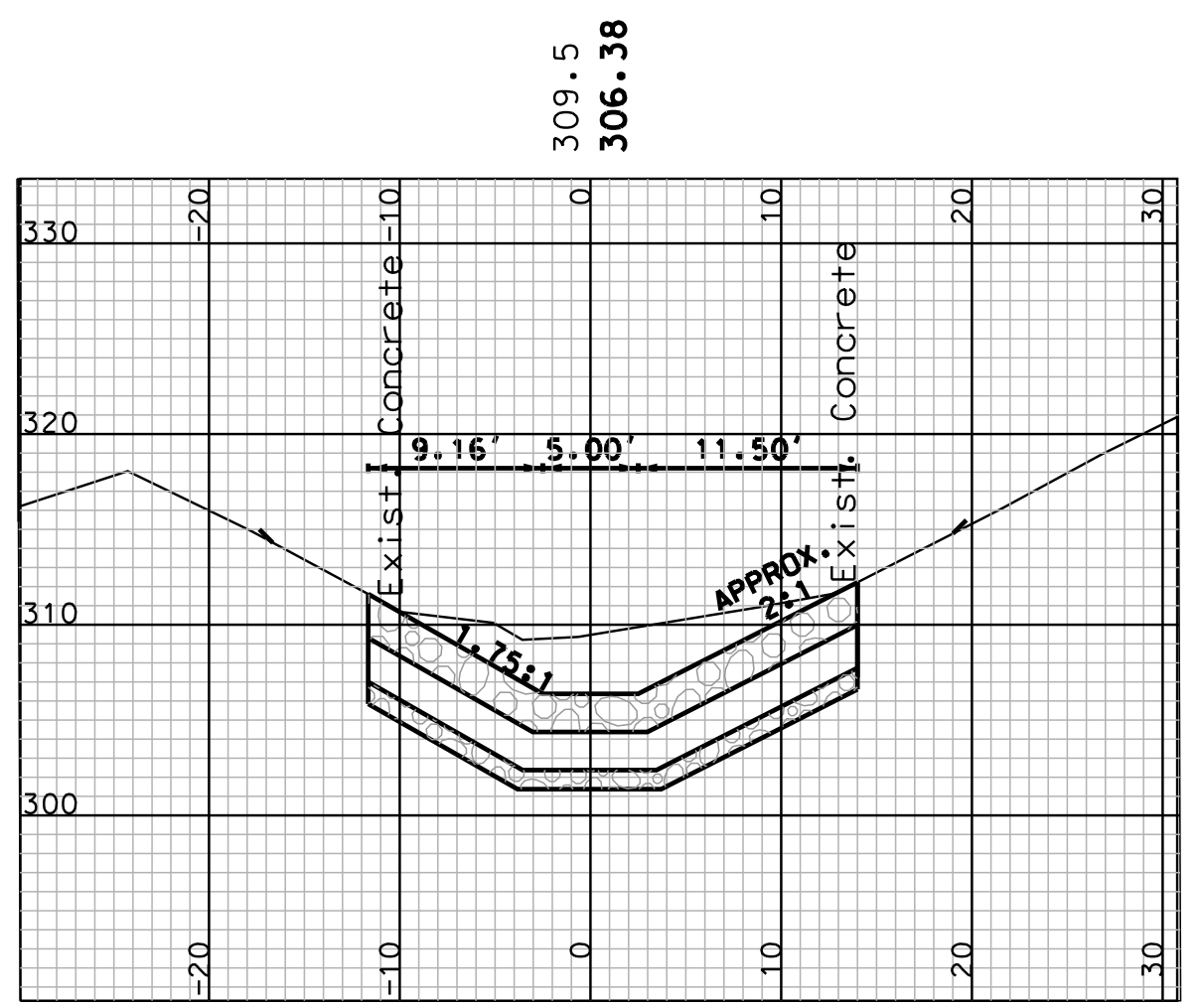

10+90

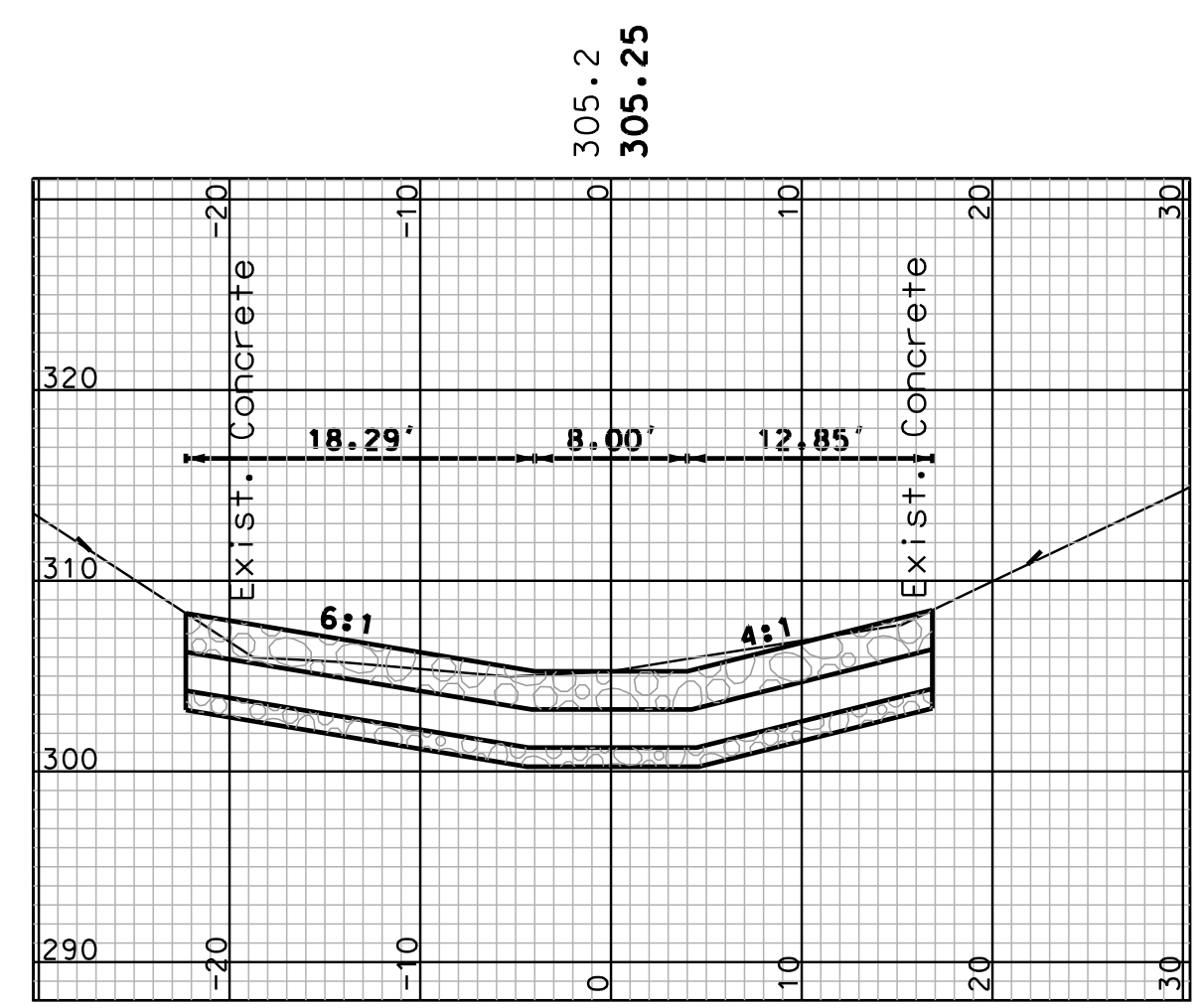

11+20

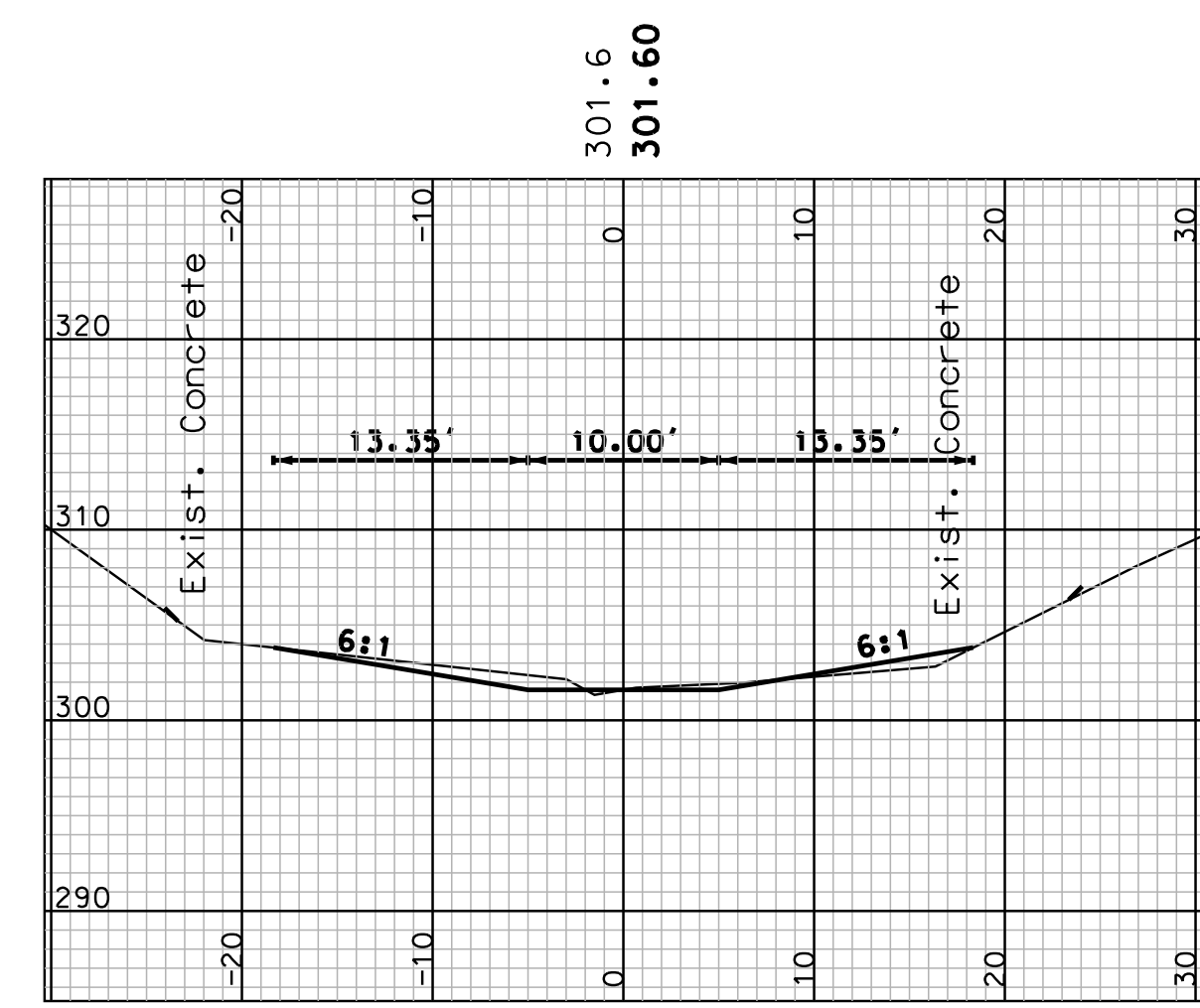

11+40

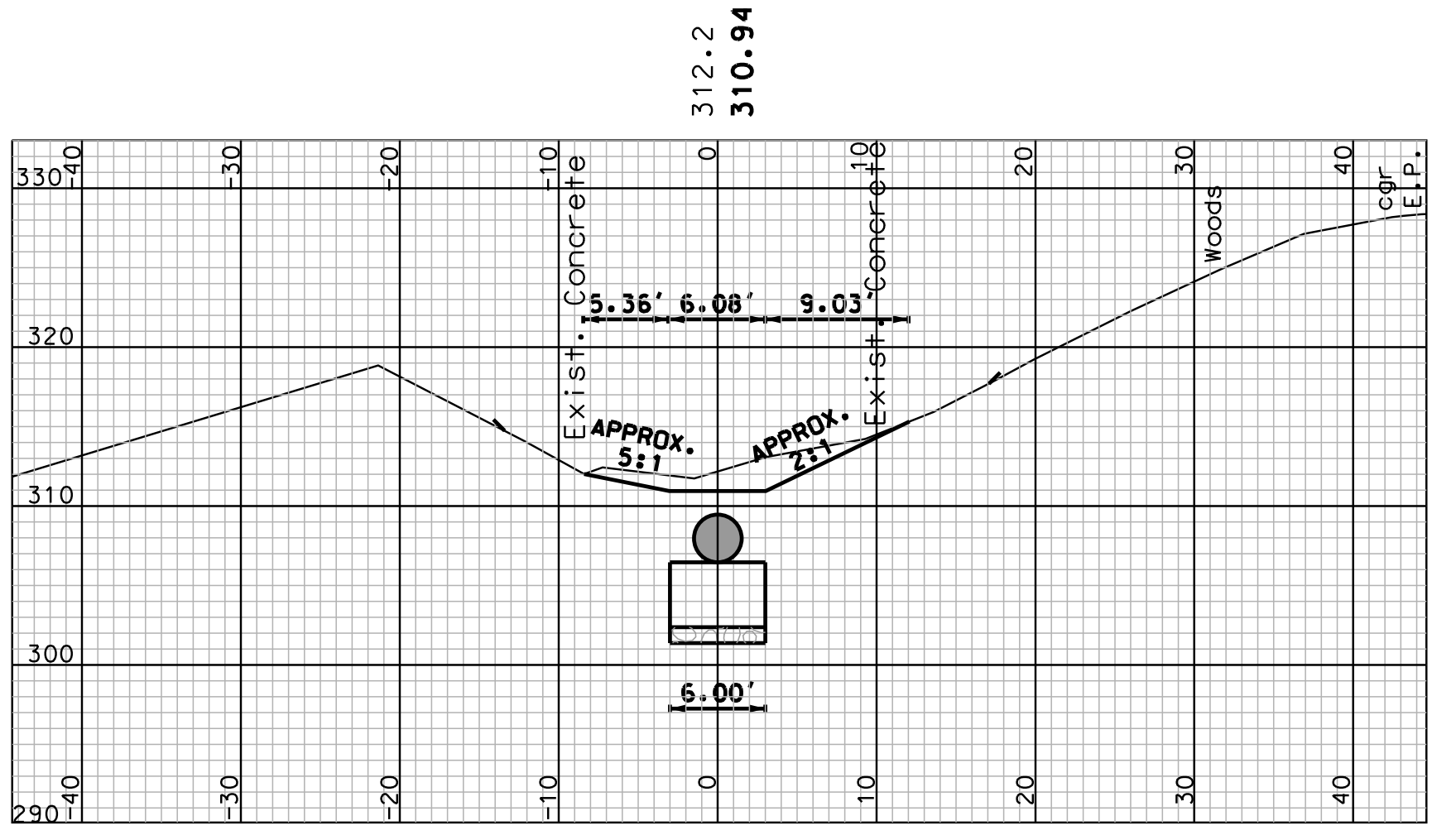

10+70

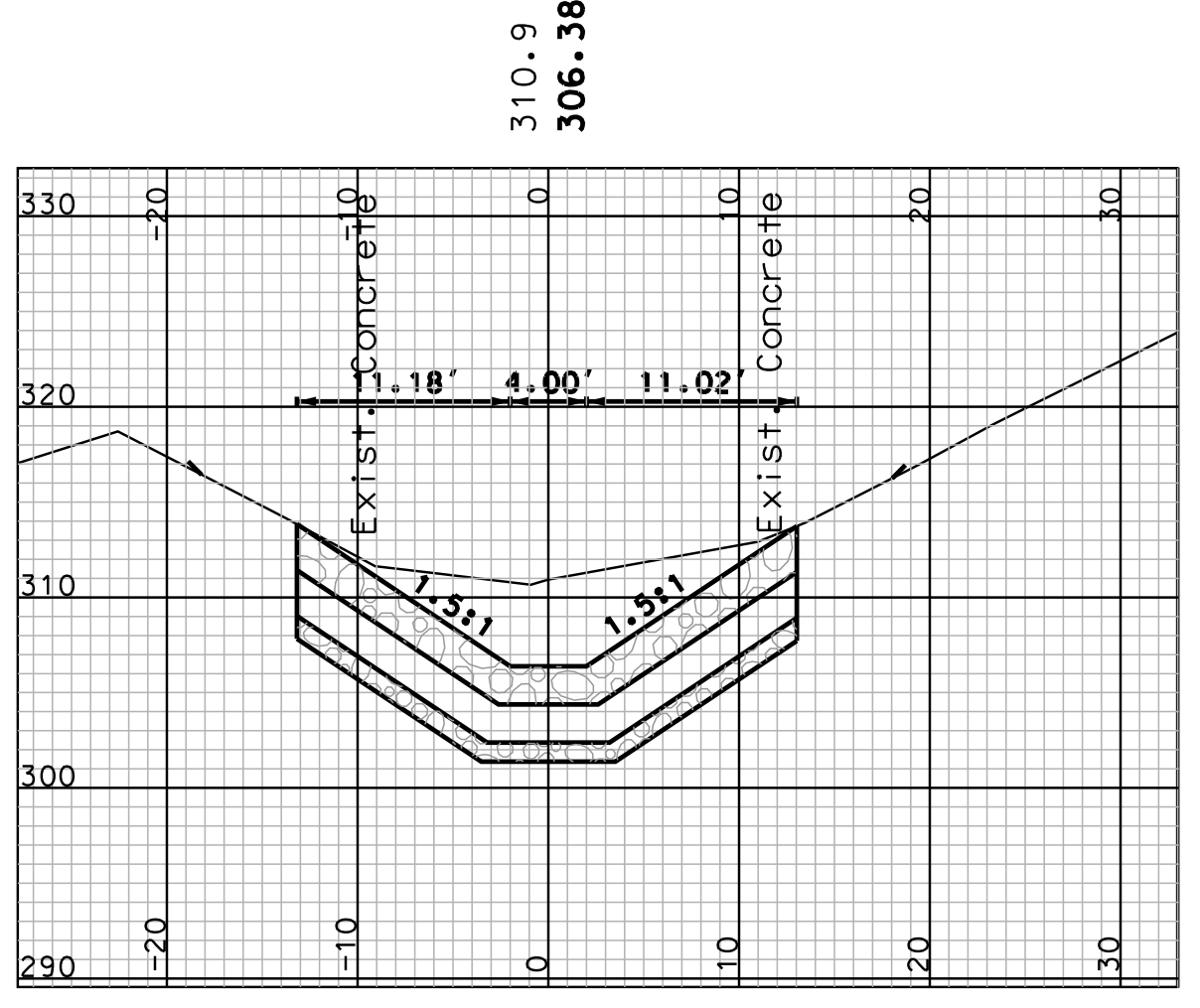

10+80

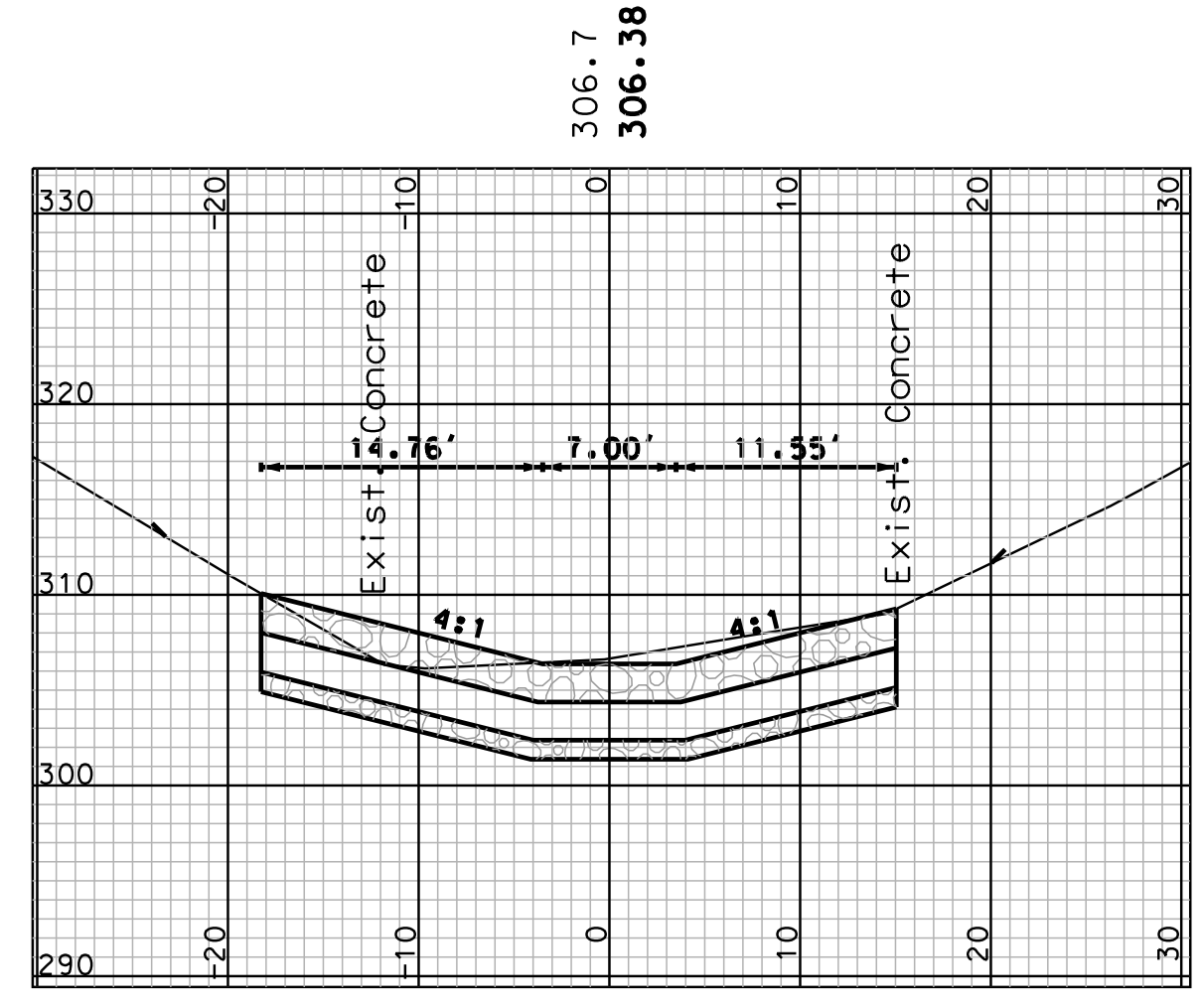

11+10

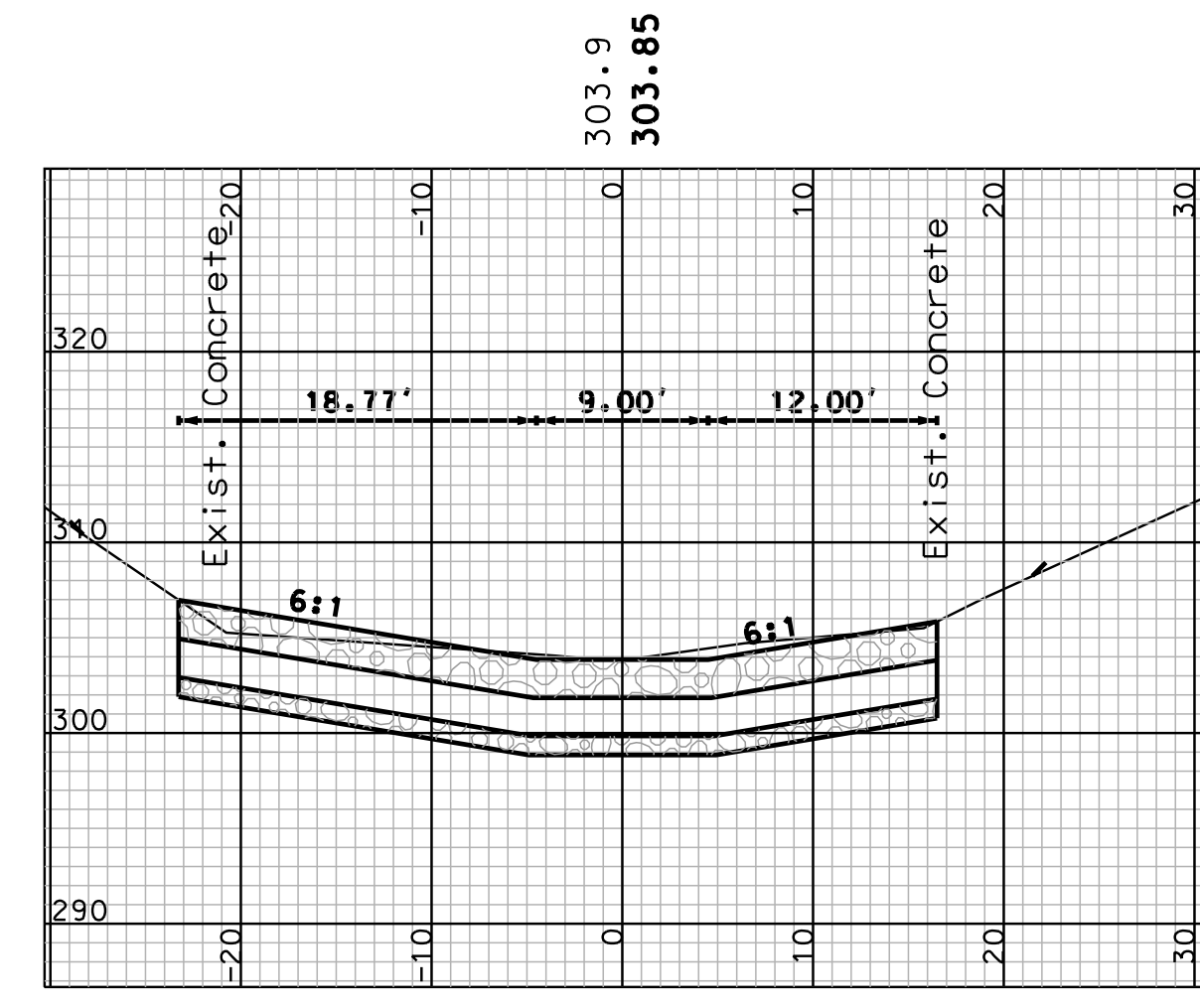

11+30

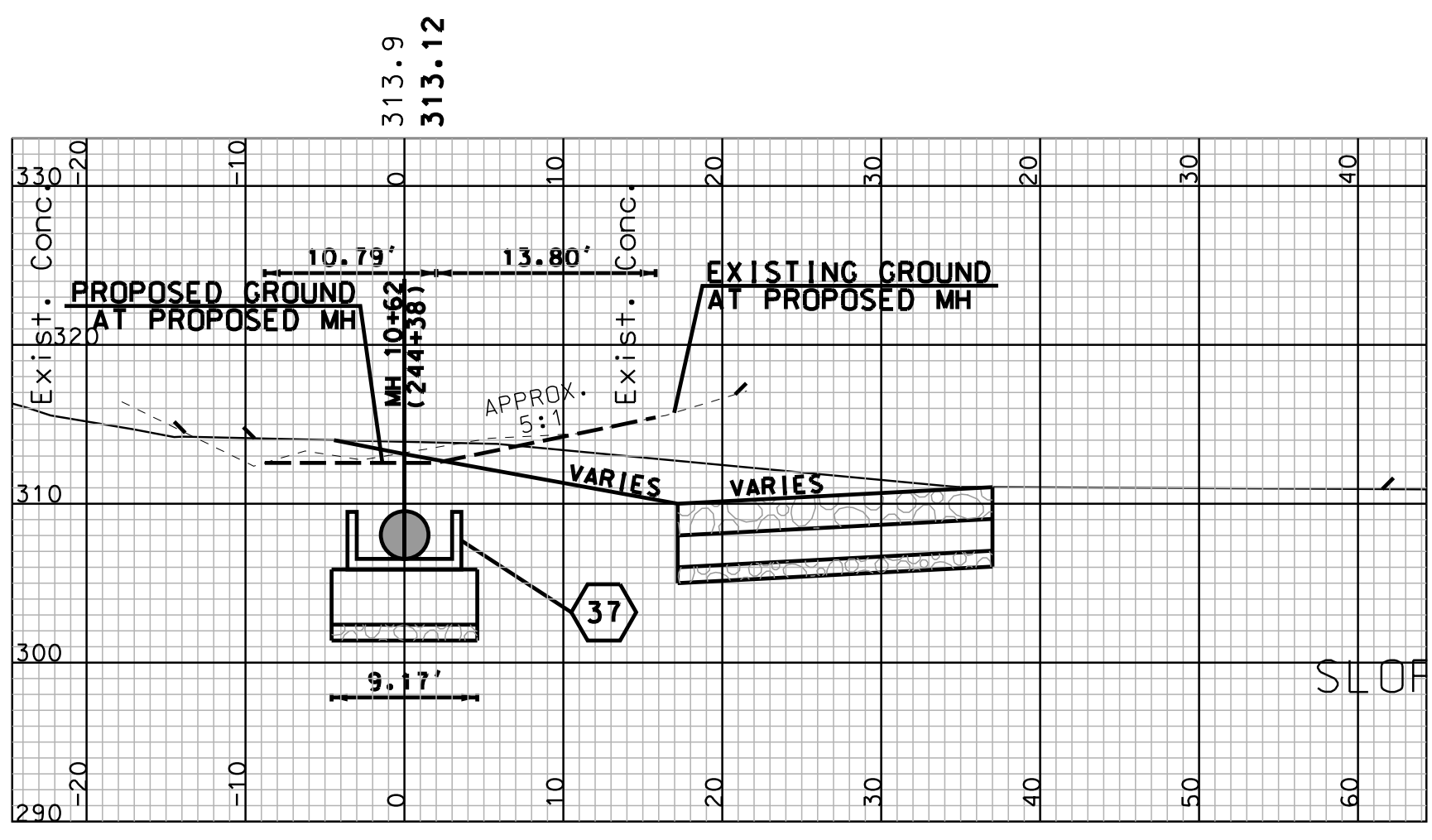

10+60

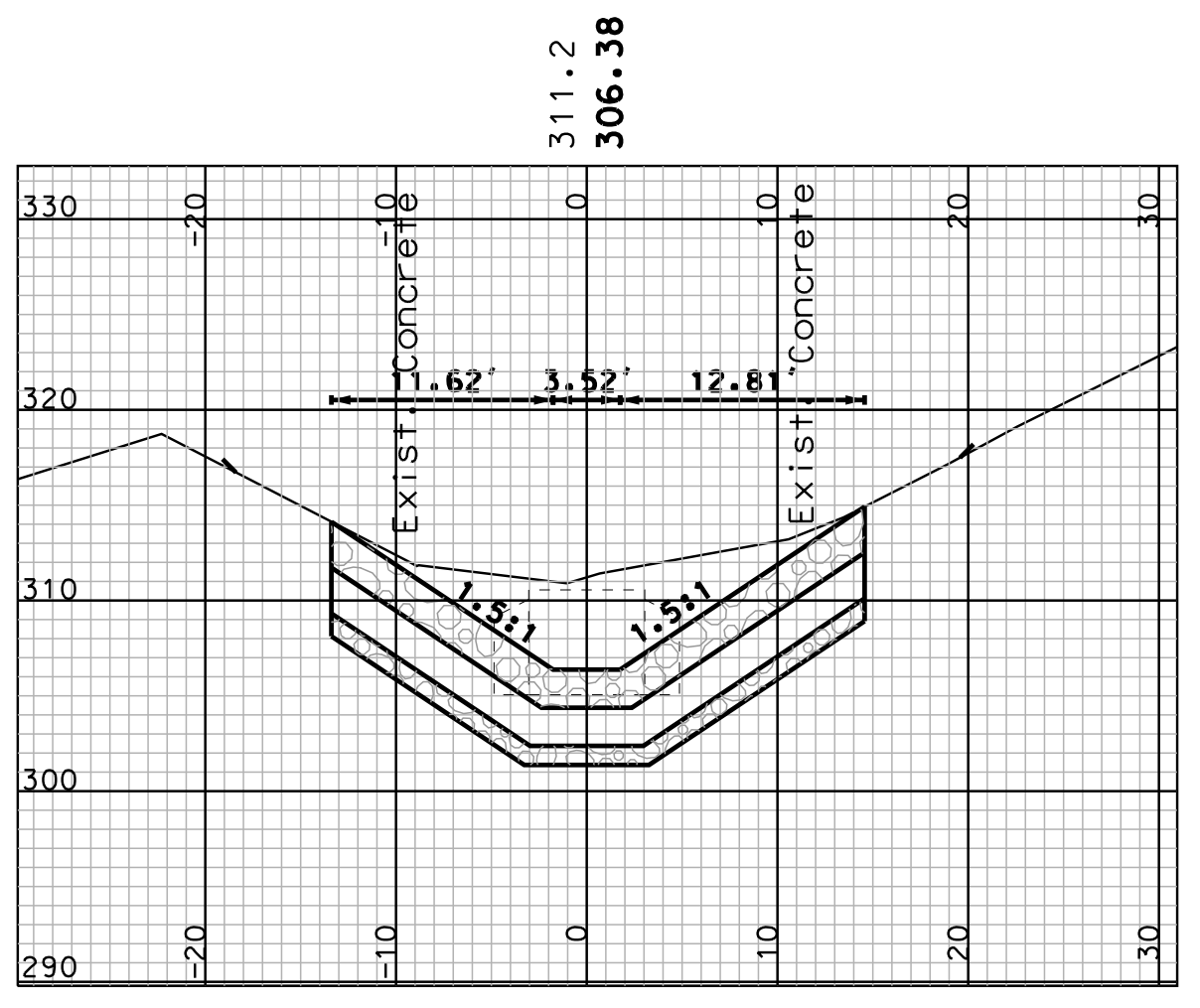

10+78

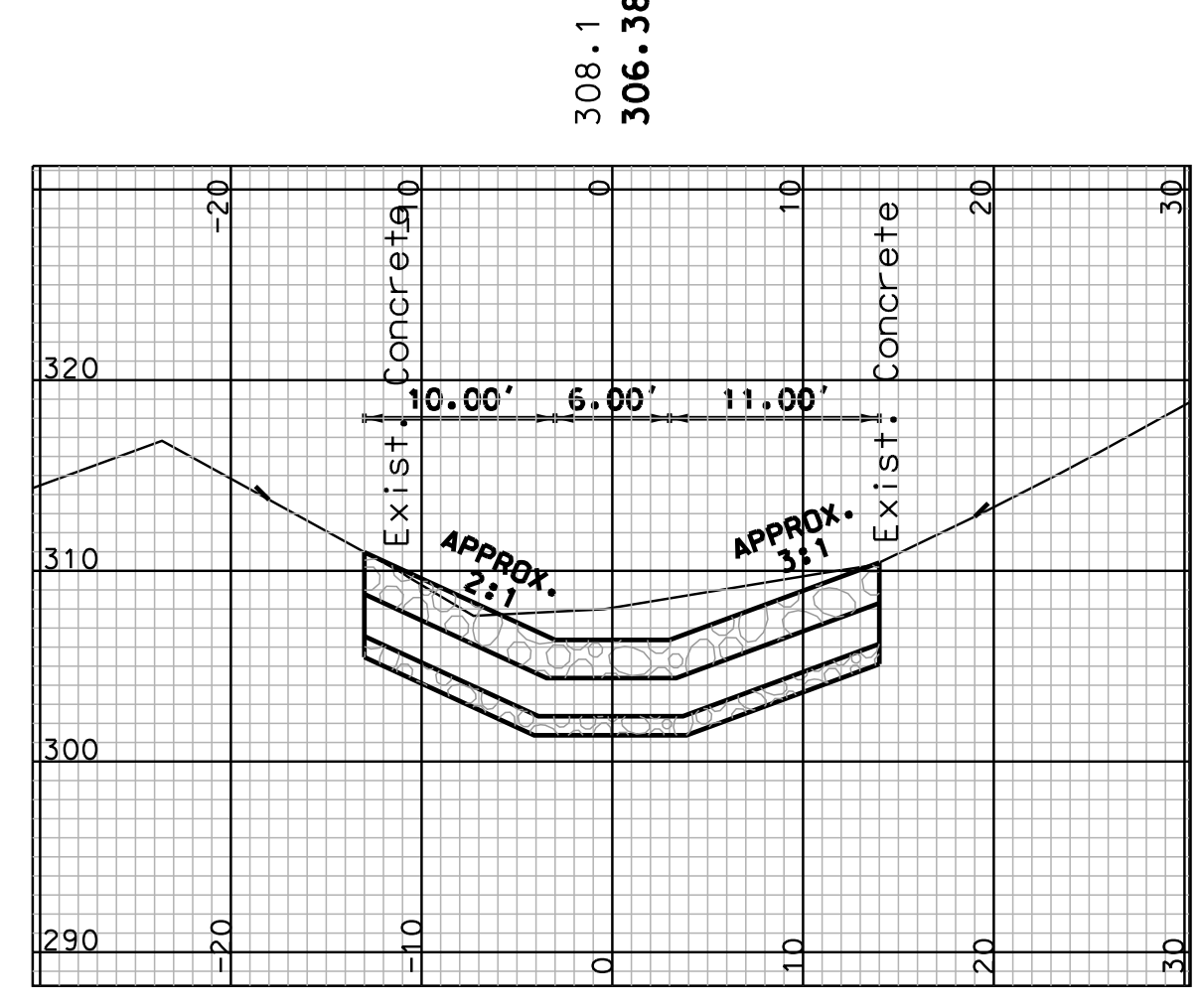

11+00

CROSS SECTIONS
SCALE: 1" = 10'

STATE OF NEW HAMPSHIRE			
DEPARTMENT OF TRANSPORTATION • BUREAU OF HIGHWAY DESIGN			
CONCRETE SWALE DRAINAGE OUTLET DETAIL			
DGN	STATE PROJECT NO.	SHEET NO.	TOTAL SHEETS
13928A_concreteswale	13928A	29	160

SDR PROCESSED	DATE	02/2015
NEW DESIGN	S. MICUCCI	
SHEET CHECKED	C. SPETELUNAS	
AS BUILT DETAILS	DATE	

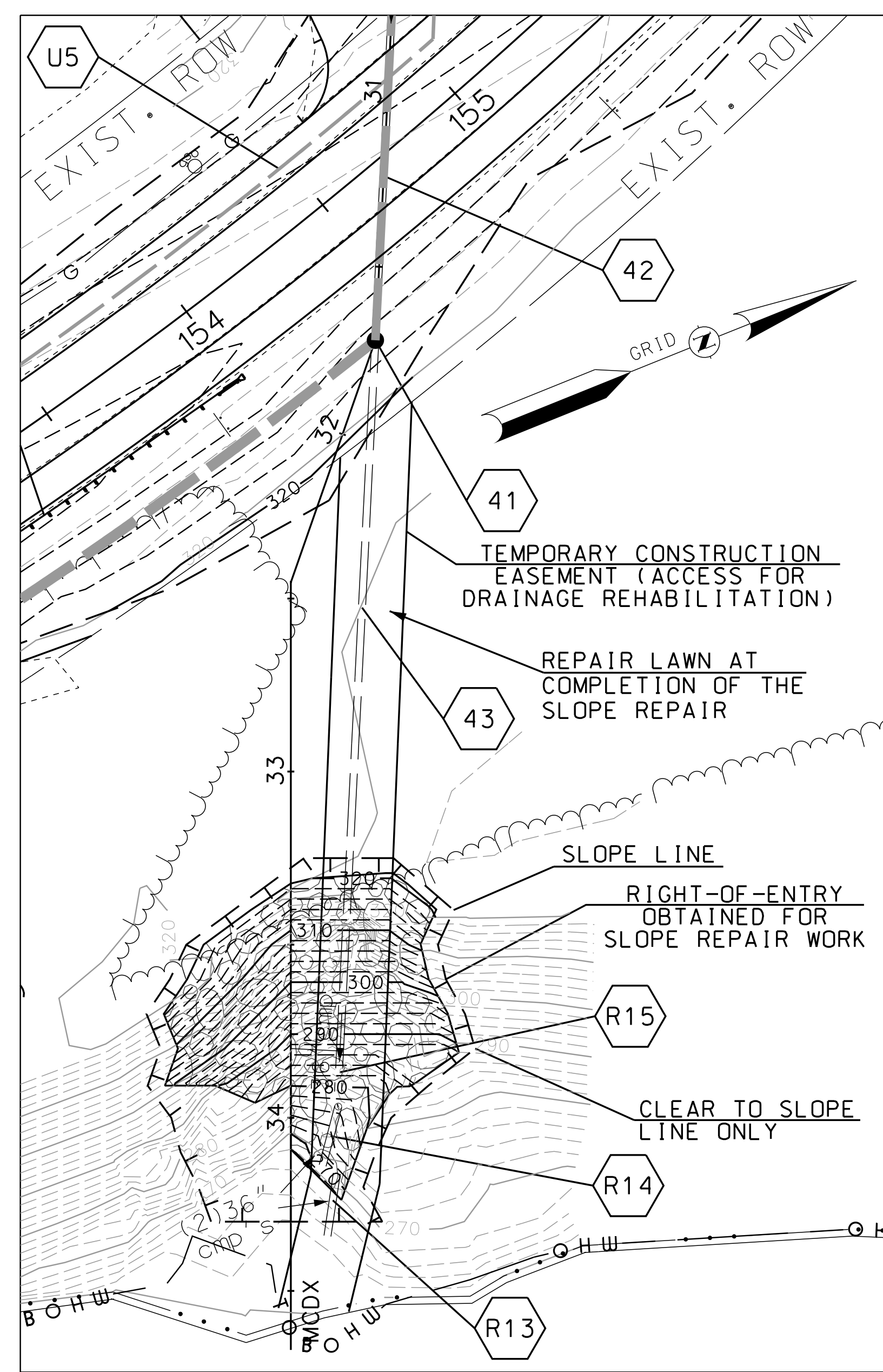

PLAN VIEW

SCALE: 1" = 30'

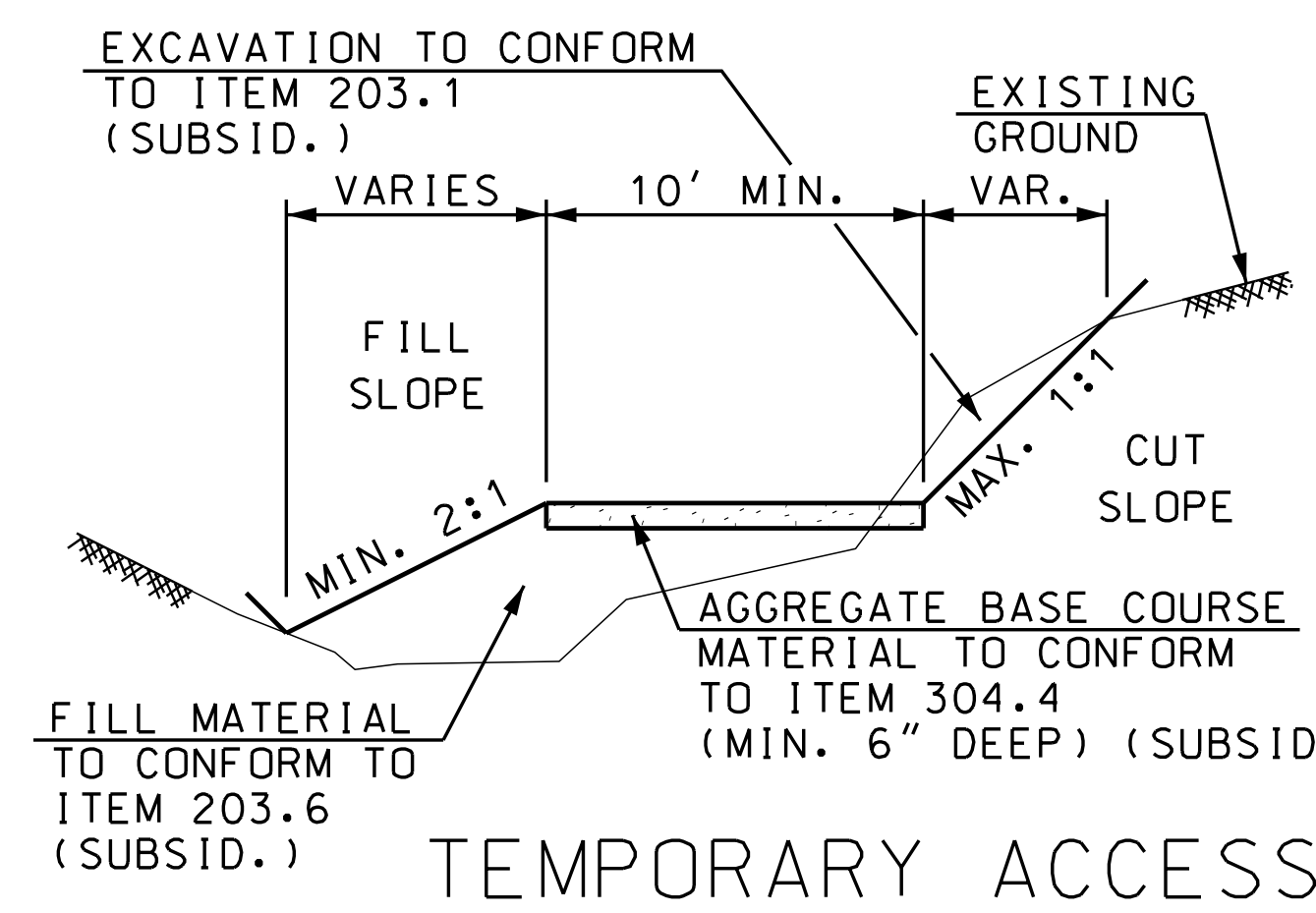

TEMPORARY ACCESS ROAD

NOT TO SCALE

NOTE
CONSTRUCTION AND REMOVAL OF TEMPORARY ACCESS ROADS FOR SOUTH SLOPE REPAIR AT STA 150+00 AND LODGE SLOPE REPAIR AT STA 153+50 TO BE PAID FOR UNDER ITEM 670.0491 AND ITEM 670.0492, RESPECTIVELY.

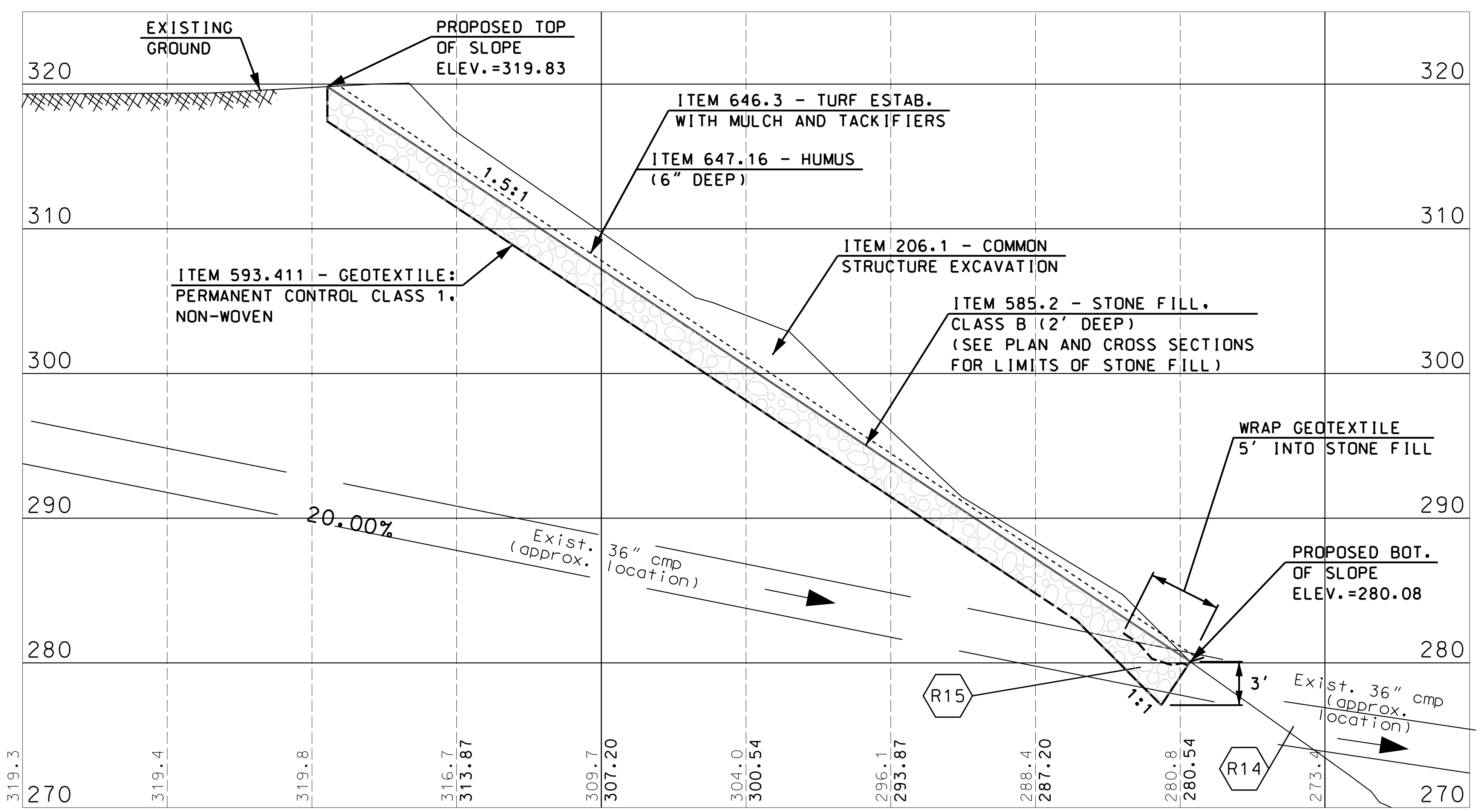

PROFILE ALONG MCDX ALIGNMENT

SCALE: 1" = 5'

* SEE LODGE SLOPE REPAIR CROSS SECTIONS ON NEXT SHEET FOR ACTUAL SLOPES AND DIMENSIONS

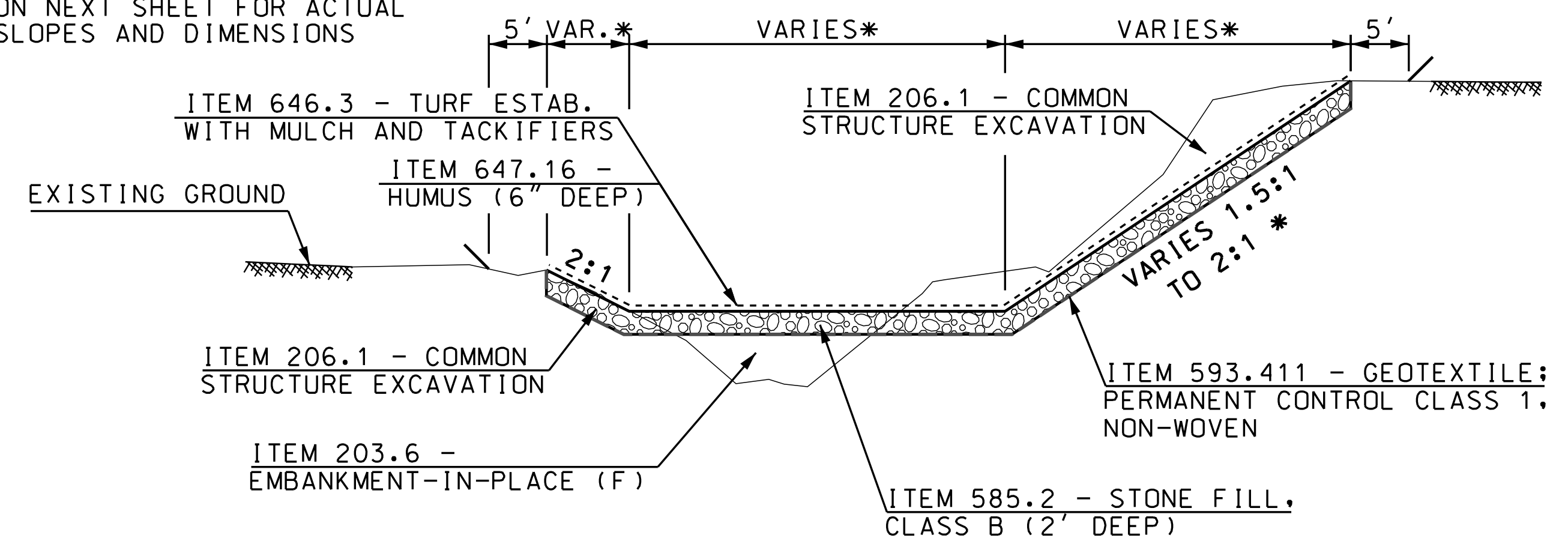

TYPICAL SECTION

NOT TO SCALE

GENERAL NOTES

- UPON REMOVAL OF EXISTING DEBRIS, VOIDS SHALL BE FILLED WITH EMBANKMENT-IN-PLACE.
- CHINK STONE FILL SURFACE ACCORDING TO SECTIONS 585.2.1.5 AND 585.3.1 PRIOR TO OVERLAYING WITH HUMUS. MATERIALS AND WORK FOR CHINKING THE STONE FILL SHALL BE SUBSIDIARY TO ITEM 585.2.
- APPLY SURFACE TREATMENT (HUMUS, TURF ESTABLISHMENT WITH MULCH AND TACKIFIERS) AND EROSION CONTROL MEASURES TO THE ENTIRE AREA WITHIN THE SLOPE LINES.

STATE OF NEW HAMPSHIRE			
DEPARTMENT OF TRANSPORTATION • BUREAU OF HIGHWAY DESIGN			
LODGE SLOPE REPAIR @ STA 153+50			
DGN	STATE PROJECT NO.	SHEET NO.	TOTAL SHEETS
13928A_Lodgeslope	13928A	30	160

SDR PROCESSED		DATE		DATE		DATE		DATE	
NEW DESIGN		S. MICUCCI		02/2015		02/2015		02/2015	
SHEET CHECKED		C. SPETELUNAS		04/2015		04/2015		04/2015	
AS BUILT DETAILS		DATE		DATE		DATE		DATE	

REVISIONS AFTER PROPOSAL	DESCRIPTION
--------------------------	-------------

NUMBER	DATE	STATION	STATION

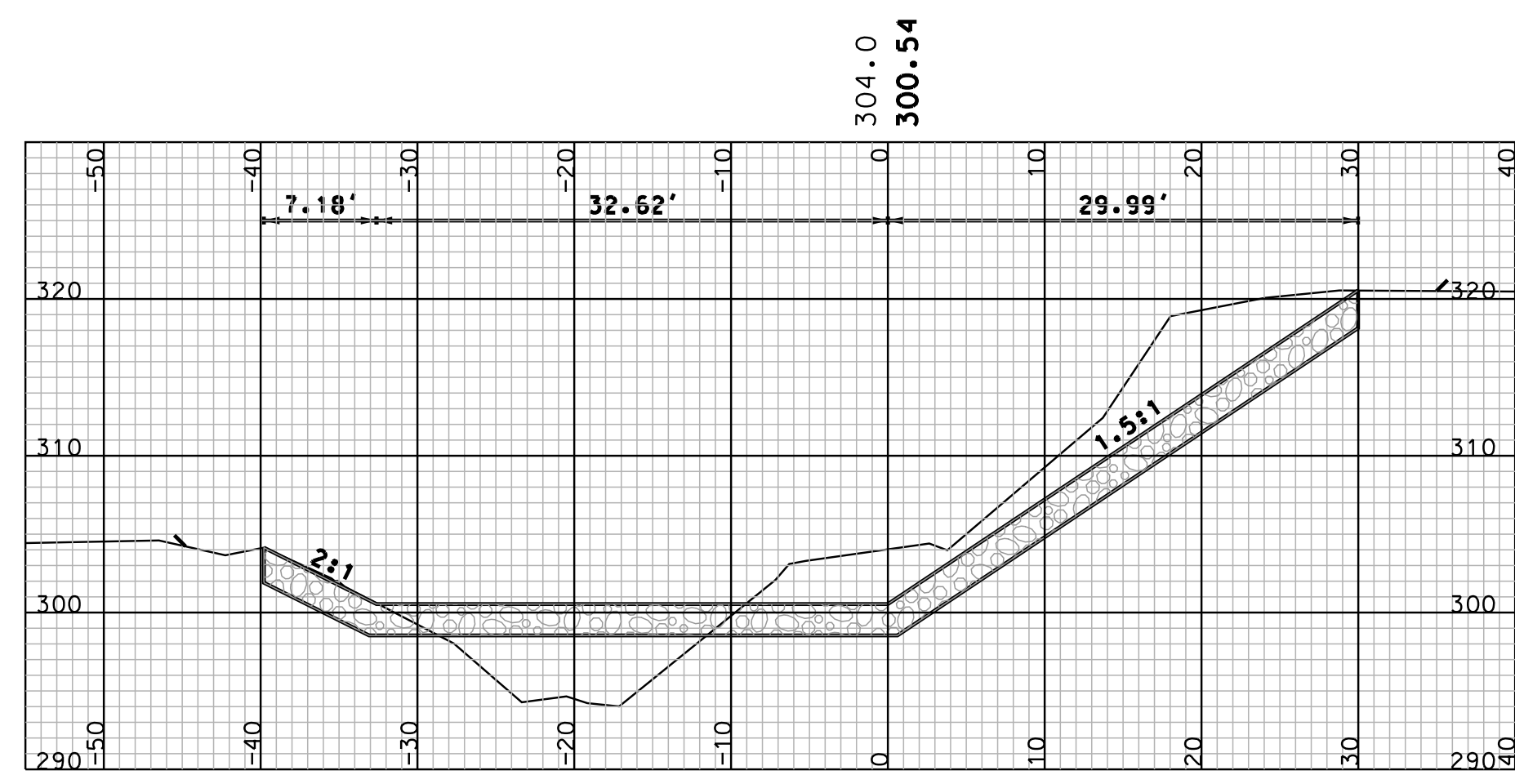

33+60

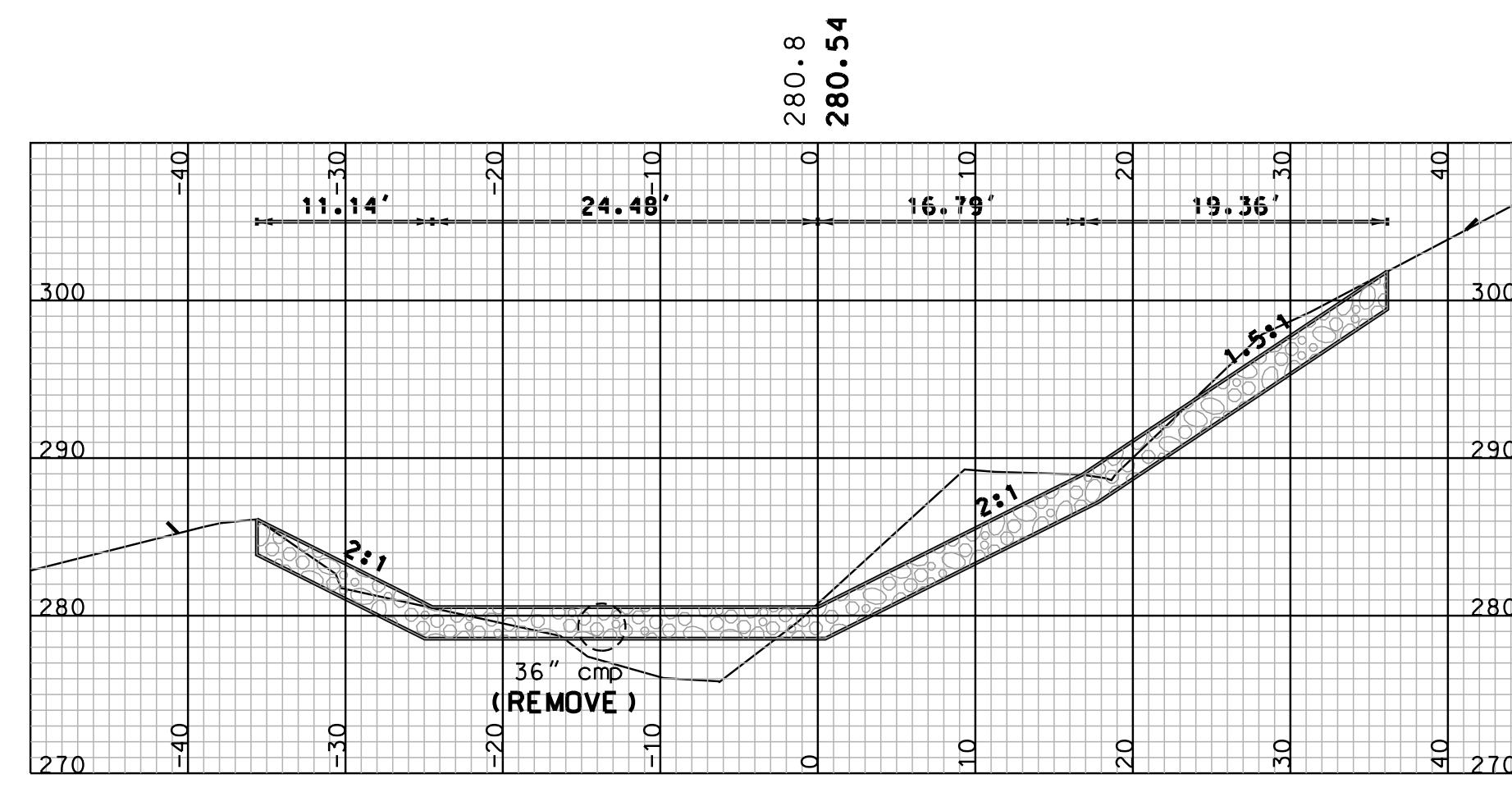

33+90

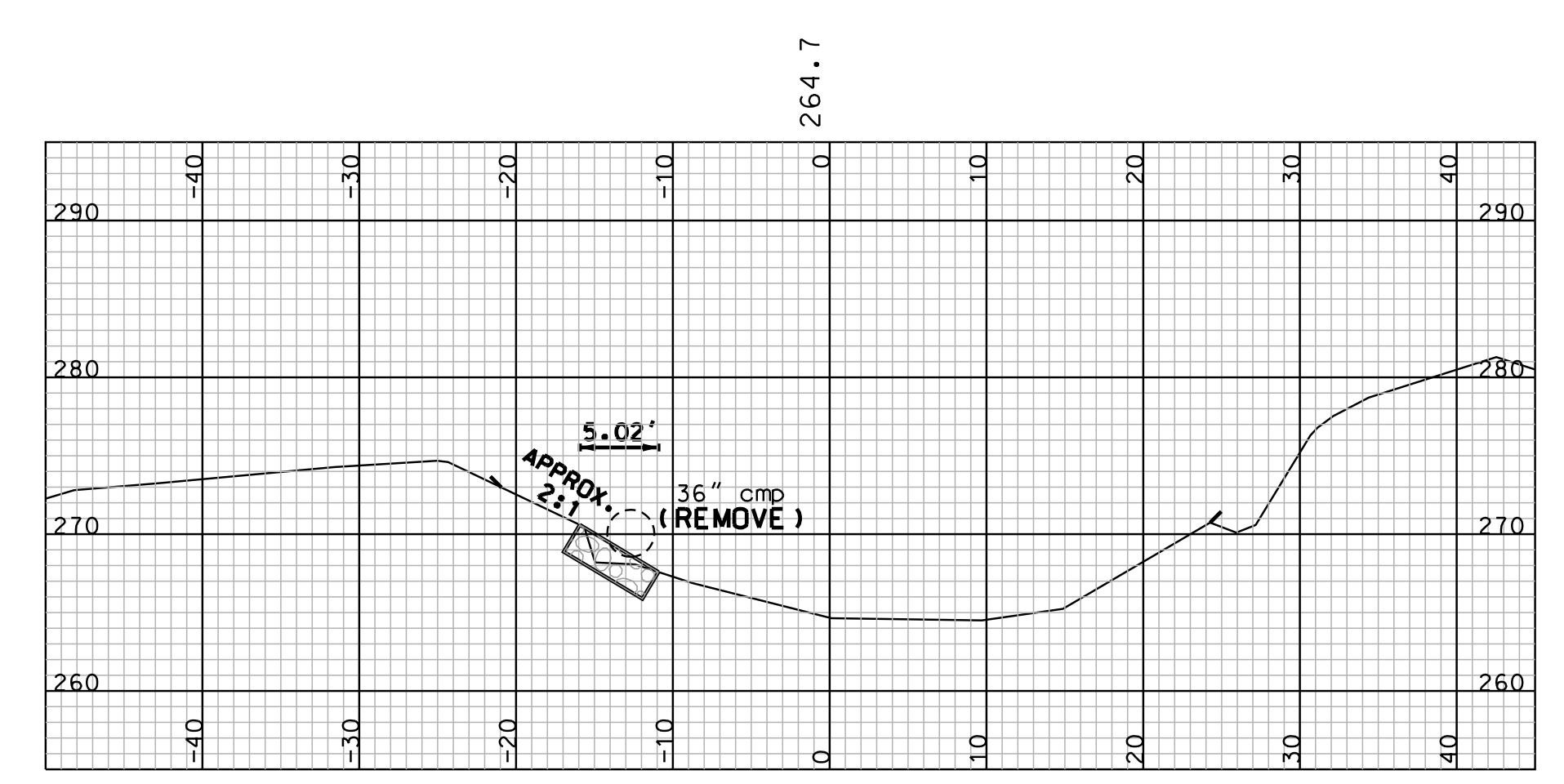

34+20

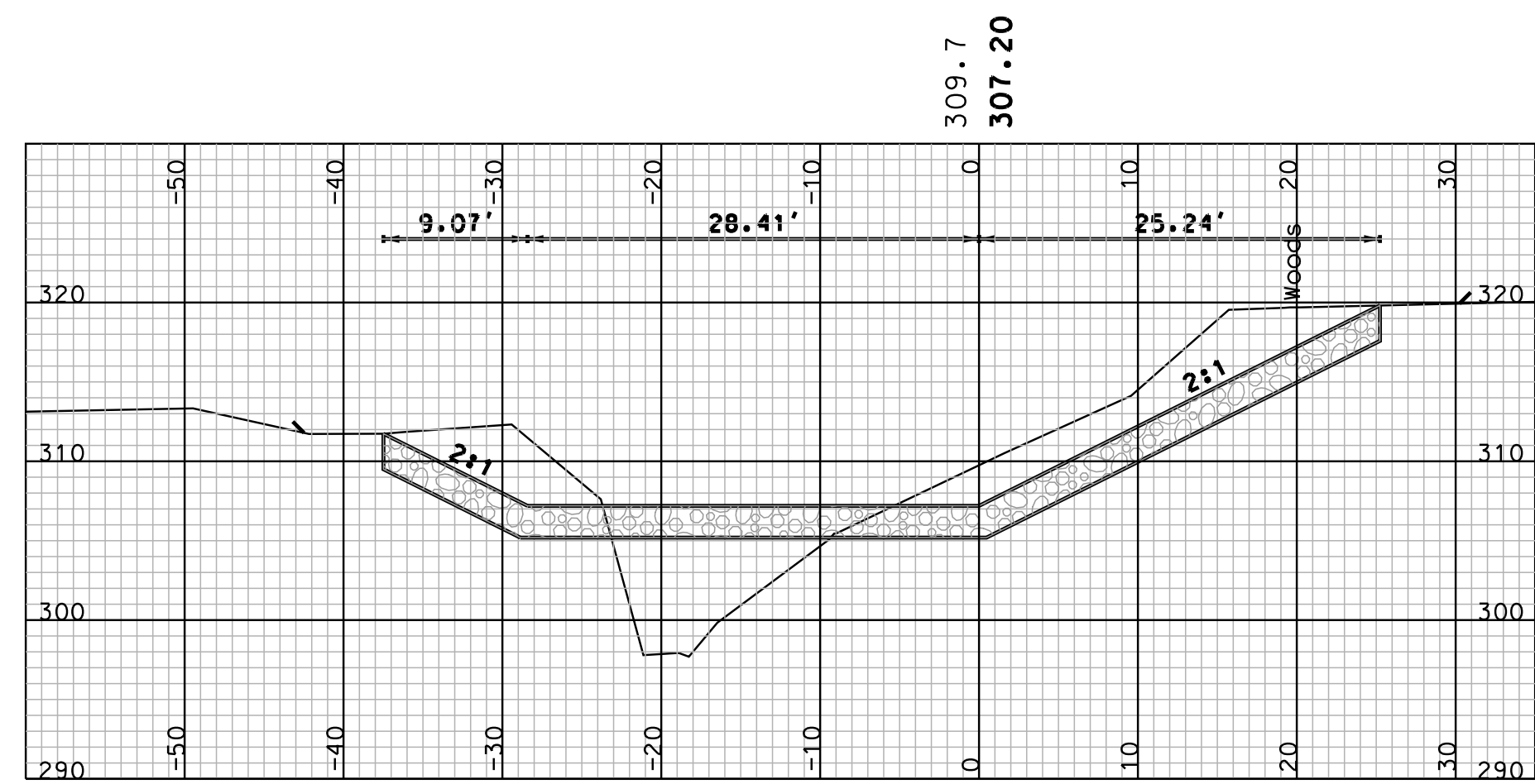

33+50

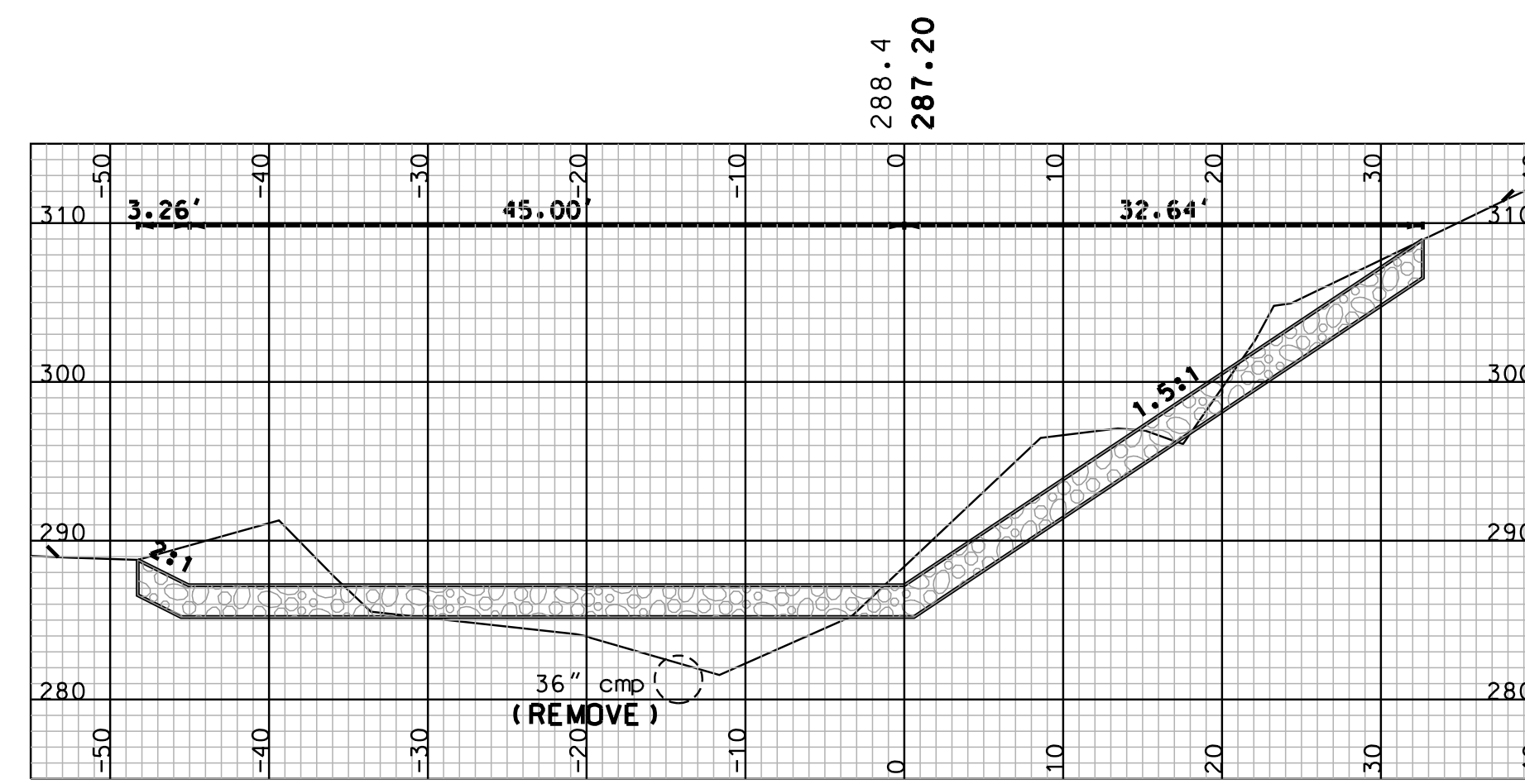

33+80

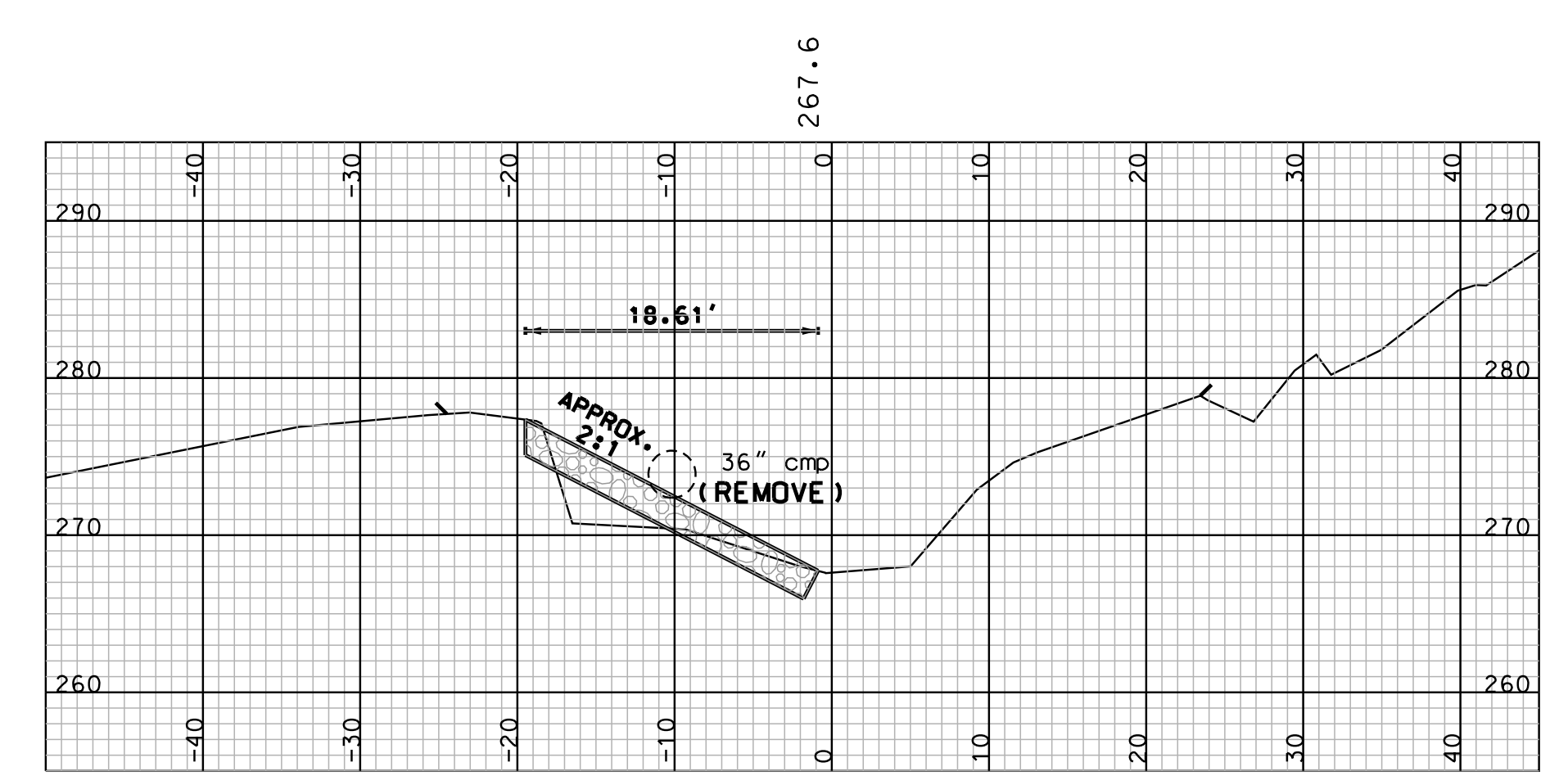

34+10

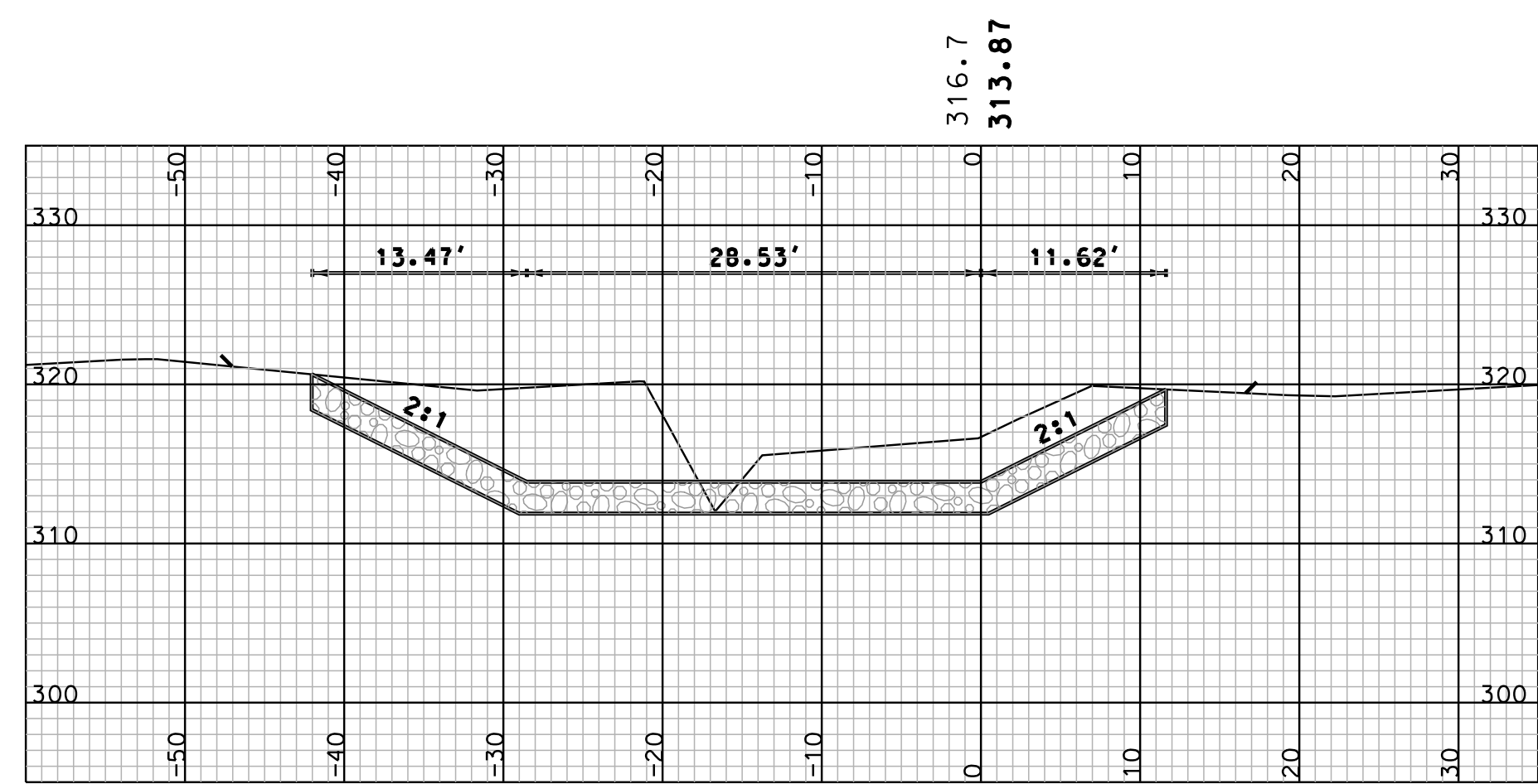

33+40

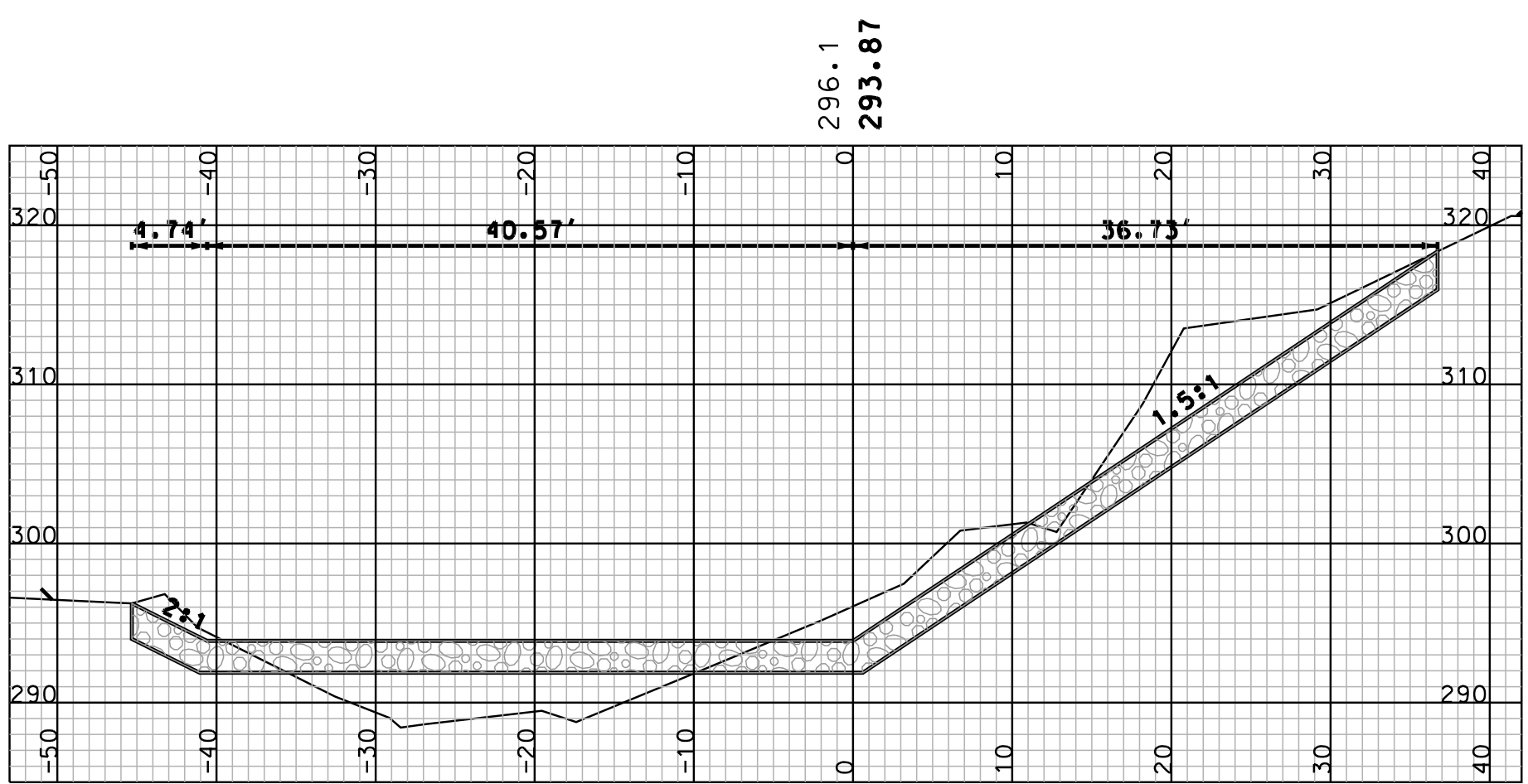

33+70

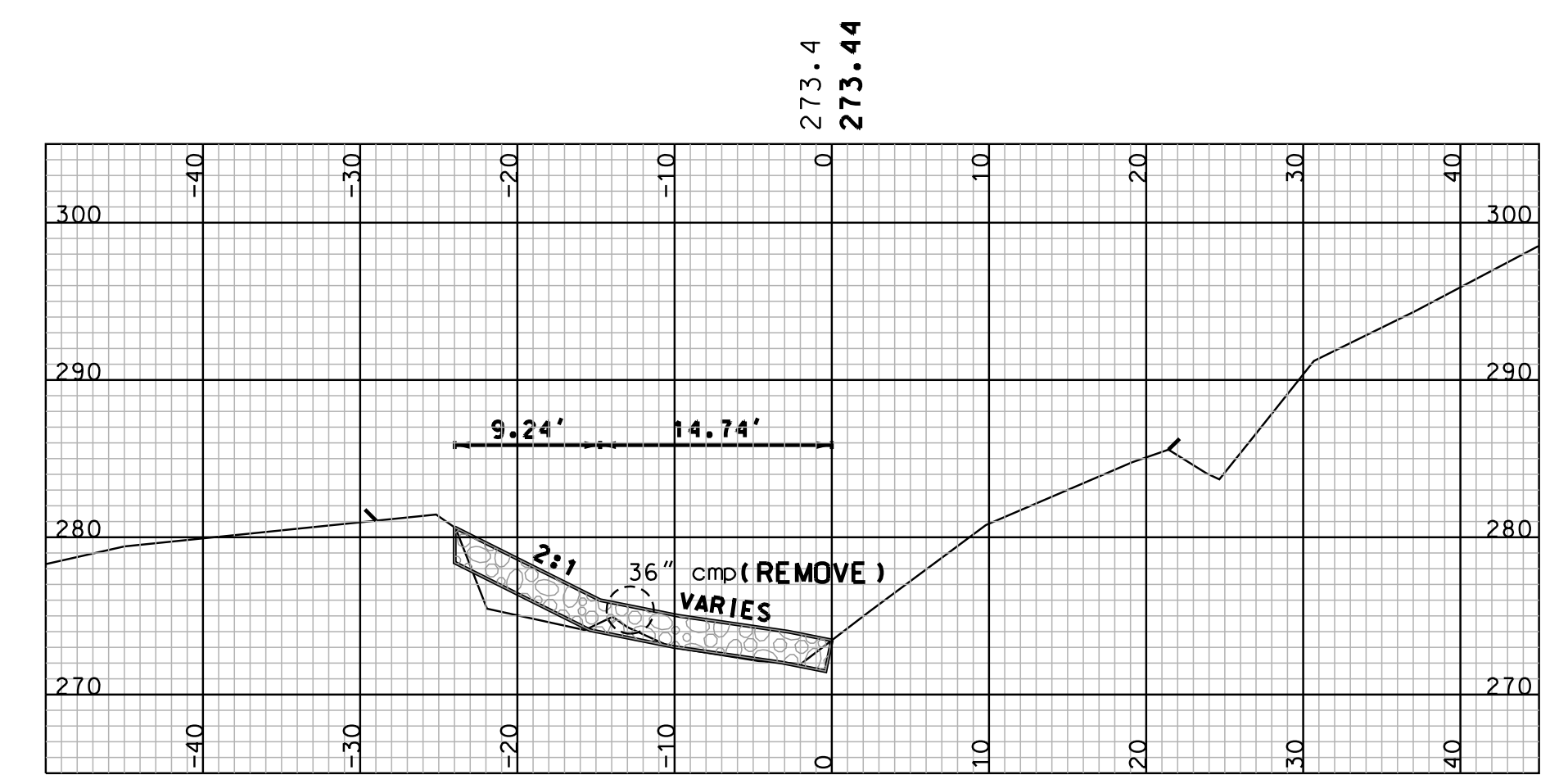

34+00

CROSS SECTIONS

SCALE: 1" = 10'

STATE OF NEW HAMPSHIRE			
DEPARTMENT OF TRANSPORTATION • BUREAU OF HIGHWAY DESIGN			
LODGE SLOPE REPAIR			
@ STA 153+50			
DGN	STATE PROJECT NO.	SHEET NO.	TOTAL SHEETS
13928A_Lodgeslope	13928A	31	160

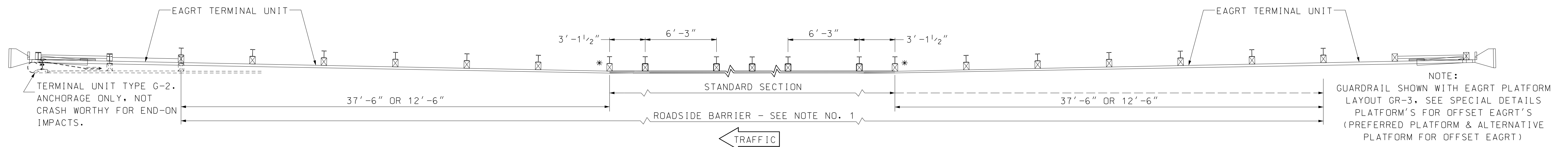

SAMPLE GUARDRAIL INSTALLATION LAYOUT

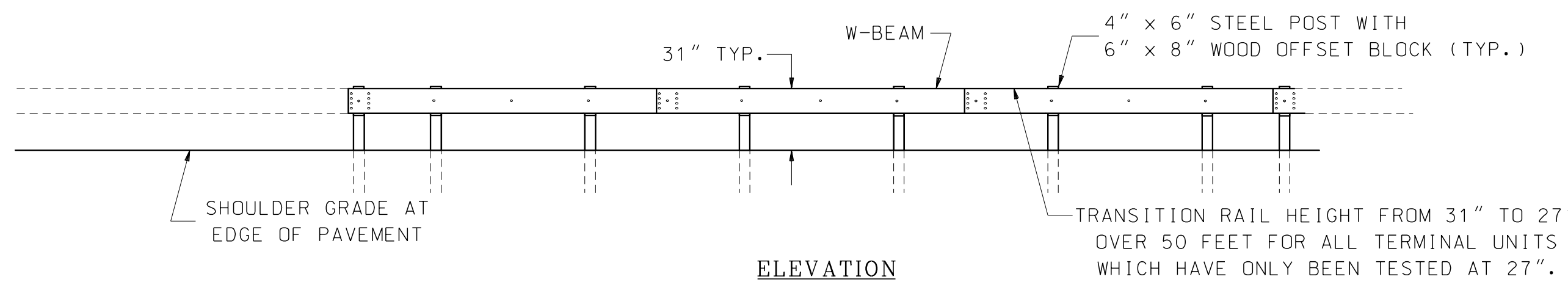
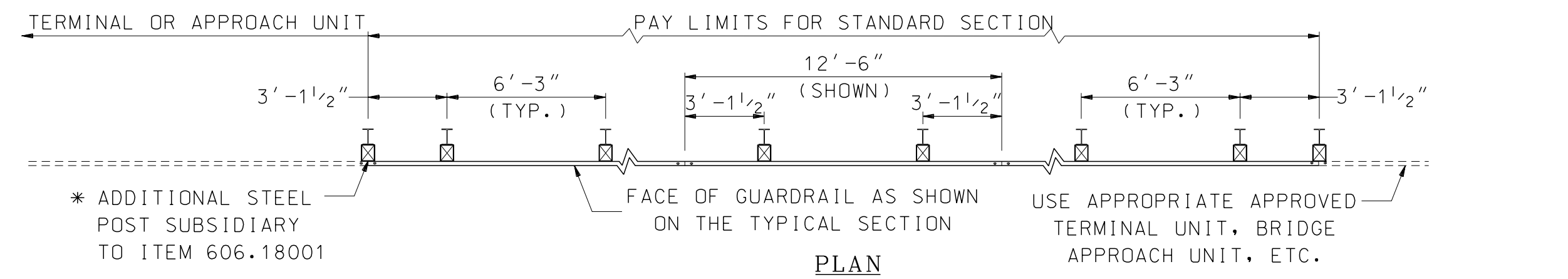

STANDARD SECTION

ITEM 606.18001 - 31" W-BEAM GUARDRAIL WITH 8" OFFSET BLOCK (STEEL POST)
 PAID: LINEAR FOOT
 USE: WHEREVER GUARDRAIL IS REQUIRED

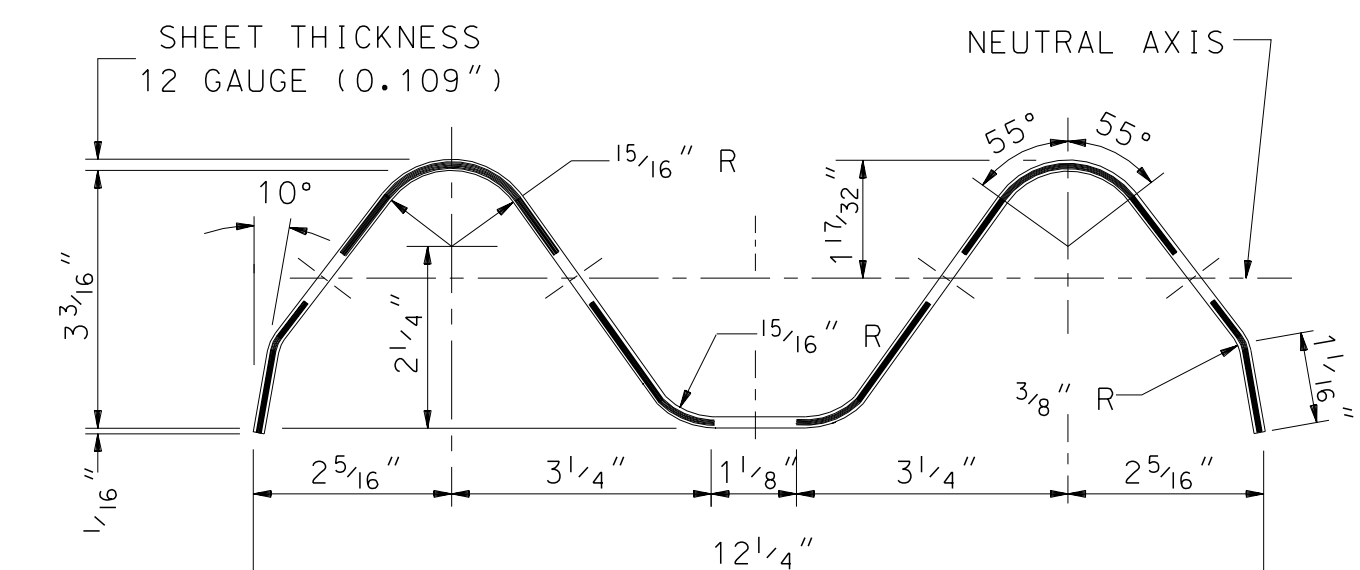

SECTION THRU RAIL ELEMENT

[4 SPACE W-BEAM GUARDRAIL DESIGNATED RWM04a (NOMINALLY 12'-6")]
 [8 SPACE W-BEAM GUARDRAIL UNDESIGNATED AT THIS TIME (NOMINALLY 25'-0")]

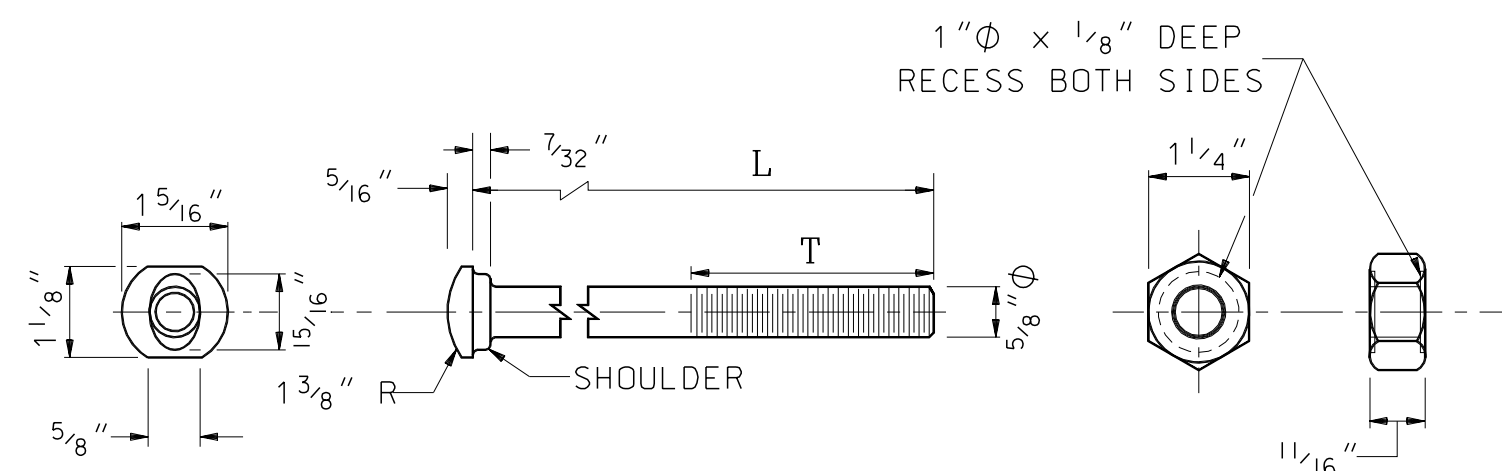

DESIGNATOR	L	T	INTENDED USE
FBB01	1 1/4"	FULL LENGTH THREAD	RAIL SPLICE BOLTS
FBB02	2"	1 3/4" MIN. THREAD LENGTH	POST BOLT (STEEL POSTS)
FBB03	9 1/2"	4" MIN. THREAD LENGTH	POST BOLT

5/8" BUTTON HEAD BOLT AND RECESSED NUT (FBB01-03)

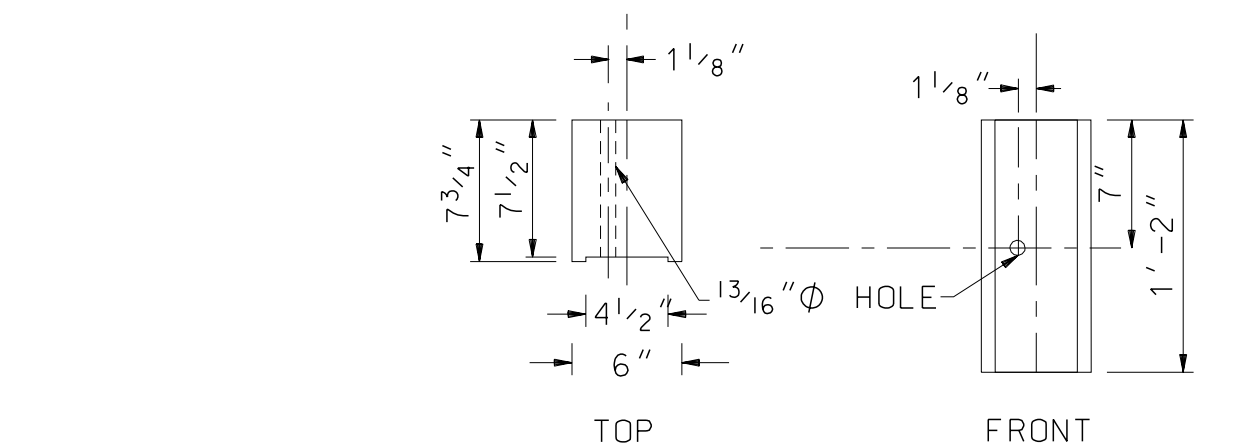

SYNTHETIC OFFSET BLOCK

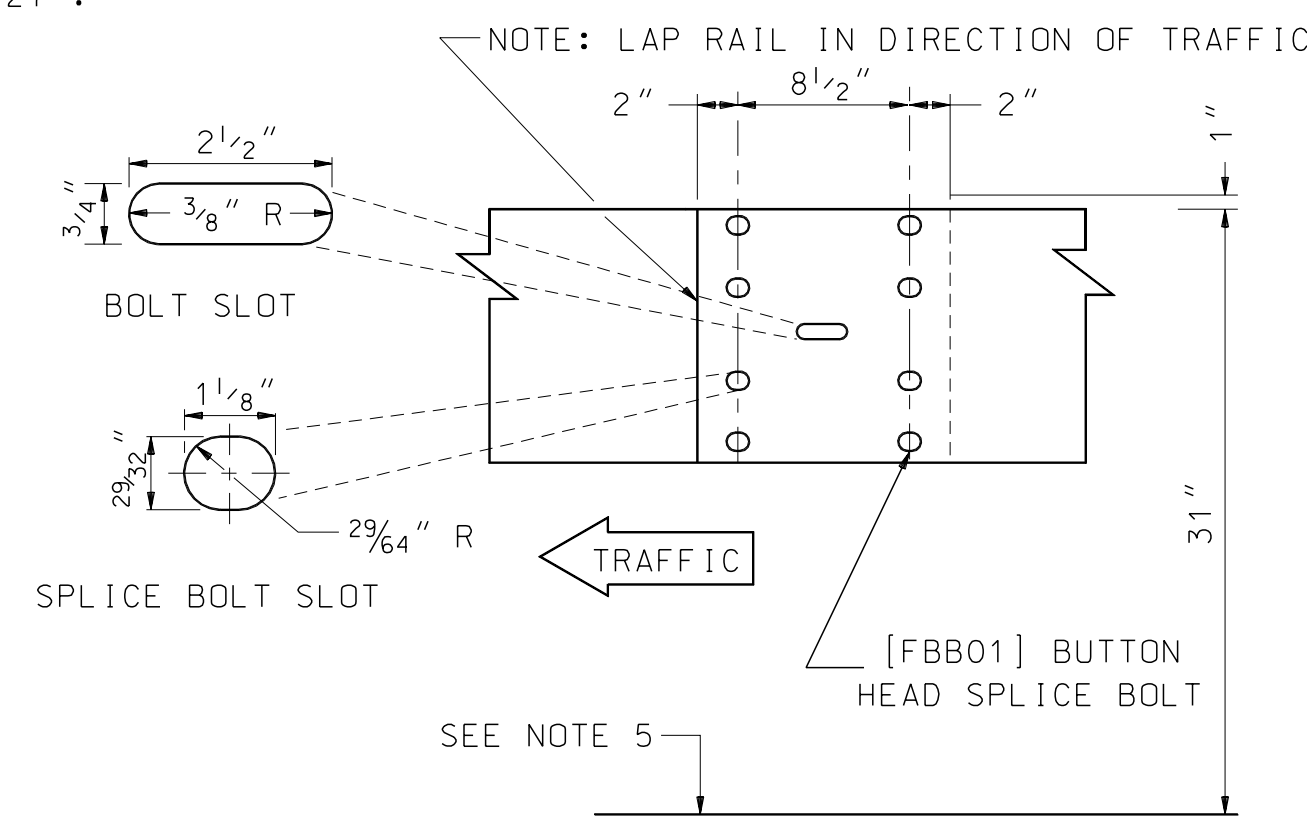

ELEVATION VIEW AT BEAM SPLICE

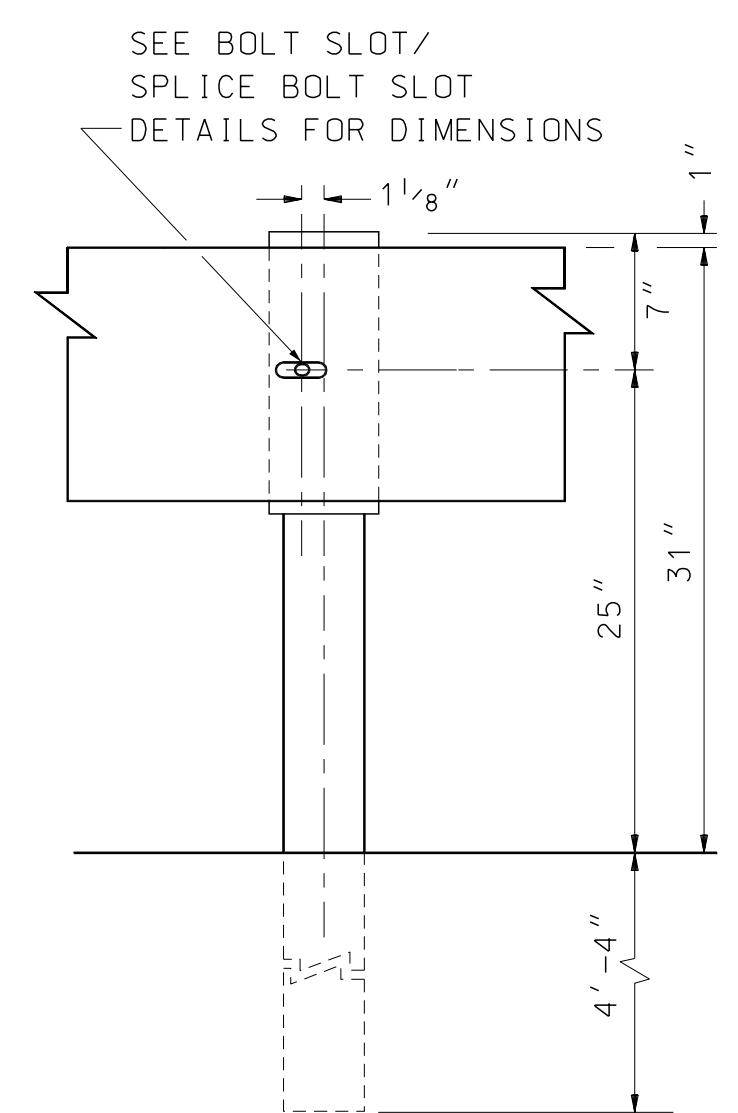

TYPICAL FRONT VIEW (SHOWN WITH FASTENERS)

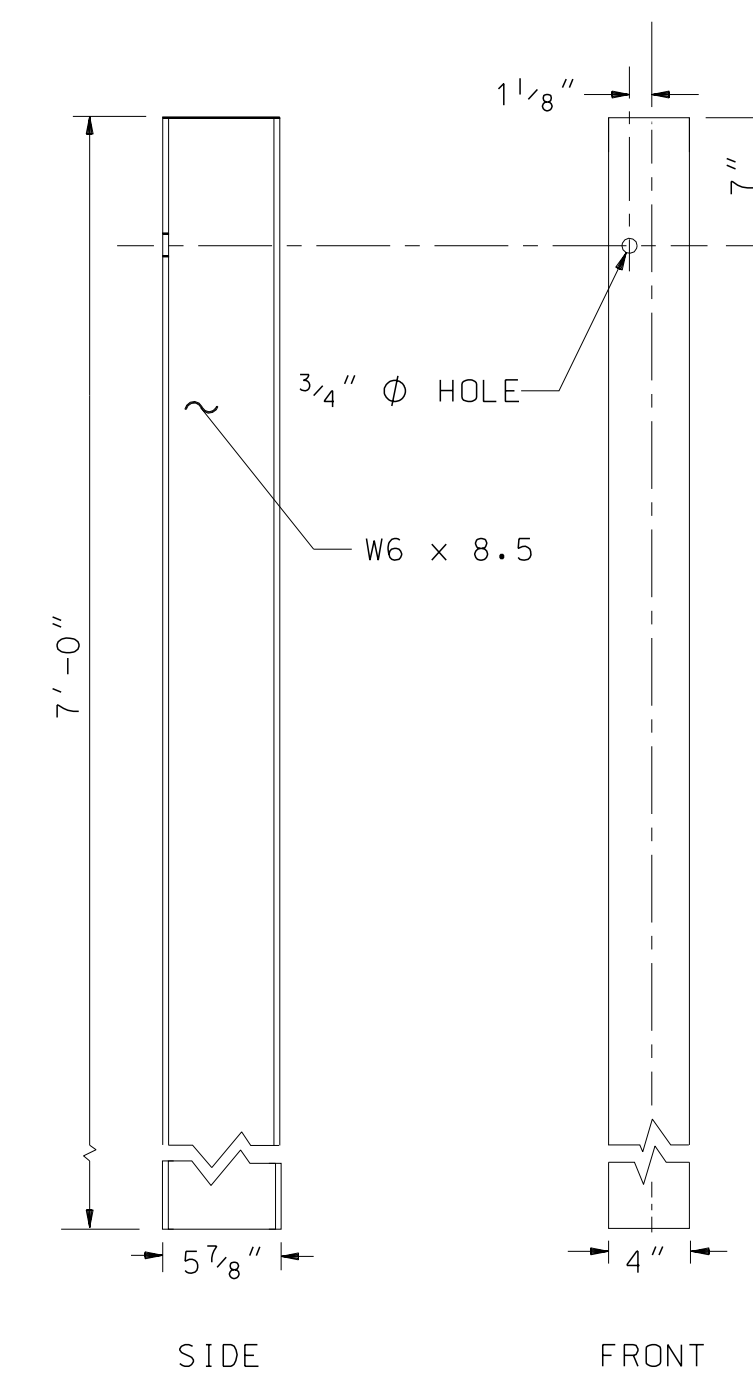

STRUCTURAL SHAPE STEEL POST

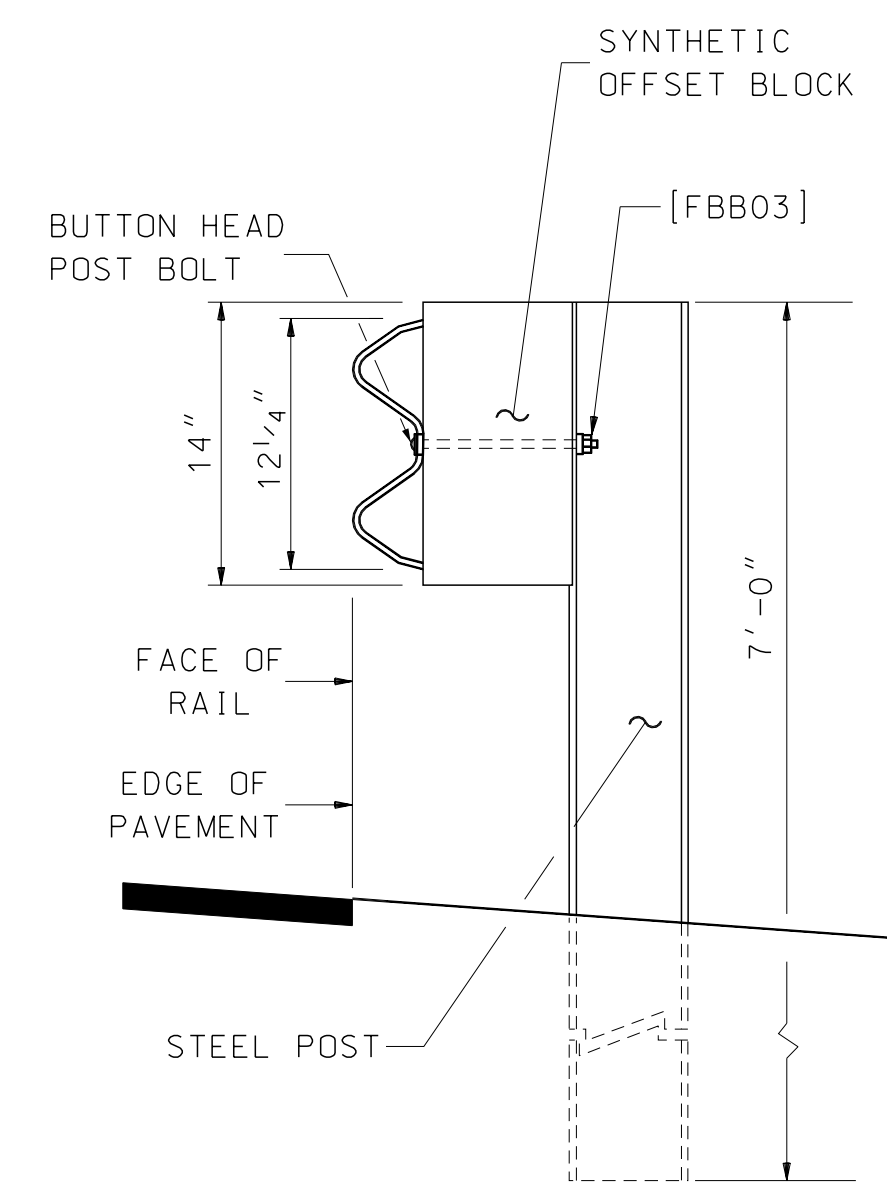

TYPICAL SIDE VIEW (SHOWN WITH FASTENERS)

- GENERAL NOTES**
- THE DEFINITION OF ROADSIDE BARRIER IS PER THE LATEST ADOPTED EDITION OF THE AASHTO ROADSIDE DESIGN GUIDE. EXCLUDED FROM THIS IS THE GATING PORTION OF A GUARDRAIL TERMINAL UNIT OR CRASH CUSHION AS WELL AS THE ENTIRE G-2 TERMINAL UNIT.
 - ITEMS IN BRACKETS [] ARE STANDARD ELEMENTS DESCRIBED IN AASHTO'S "A GUIDE TO STANDARDIZED HIGHWAY BARRIER HARDWARE".
 - ONLY USE RECTANGULAR PLATE WASHERS [FWR03] WHERE SHOWN ON THE OTHER STANDARD SHEETS OR AS REQUIRED BY THE MANUFACTURERS FOR THEIR PROPRIETARY PRODUCTS.
 - USE 12'-6" LENGTH RAIL ELEMENTS IN RAIL CURVES OF LESS THAN 300' RADIUS.
 - ESTABLISH RAIL HEIGHT AS FOLLOWS:
 - SET THE HEIGHT OF RAIL FROM THE EDGE OF PAVEMENT WHEN THE FACE OF RAIL IS AT THE EDGE OF PAVEMENT, WHETHER WITH CURB AT THE EDGE OF PAVEMENT OR WHEN IN AN UN-CURBED SECTION.
 - SET THE HEIGHT FROM THE GROUND AT THE FACE OF RAIL WHEN THE FACE OF RAIL IS OFFSET FROM THE EDGE OF PAVEMENT
 - 6' OR MORE BEHIND THE FACE OF A SLOPE CURB OR
 - IS AT THE BACK EDGE OF SIDEWALK FRONTED BY VERTICAL CURB OR
 - IS NOT BEHIND A CURB BUT IS ON A SLOPE THAT IS 10:1 OR FLATTER REGARDLESS OF OFFSET.
 - IN ORDER TO USE POSTS SHORTER THAN 7', BUT NOT LESS THAN 6', EITHER:
 - THE SLOPE BEHIND GUARDRAIL SHALL BE 4:1 OR FLATTER WITH AT LEAST 1' BEHIND THE POST TO THE SLOPE BREAK OR
 - THE DISTANCE FROM THE BACK OF POST TO THE BREAK IN SLOPE SHALL BE 2' OR GREATER TO ANY STABLE SOIL OR ROCK LINED SLOPE.
 - THE FHWA HAS LISTED OFFSET BLOCKS ON THEIR WEBSITE THAT ARE ELIGIBLE FOR FEDERAL PARTICIPATION PER NCHRP 350 TEST LEVEL 3 CRITERIA. OTHERS MAY BE ADDED UNDER MASH AT TEST LEVEL 3 OR HIGHER IN THE FUTURE. SOME OF THESE OFFSET BLOCKS HAVE OR MAY HAVE DIMENSIONS THAT VARY MORE THAN WOULD BE CONSIDERED WITHIN THE NORMAL CONTEXT OF NOMINAL DIMENSIONS. IN ORDER TO USE ANY OFFSET BLOCKS THAT HAVE OTHER THAN THE NOMINAL DIMENSIONS AS SHOWN ON THE PLANS, THE FOLLOWING APPLIES:
 - THE FACE OF RAIL SHALL REMAIN AT THE EDGE OF PAVEMENT OR AT THE INDICATED LOCATION AS SHOWN ON THE PLANS, AND
 - THE DISTANCE FROM THE BACK OF THE POST TO THE BREAK IN THE SLOPE SHALL NOT BE LESS THAN WHAT IS SHOWN ON THE PLANS BUT IT MAY BE MORE.
 - ALL OTHER REQUIREMENTS OF THE PERTINENT SPECIFICATIONS AND DETAILS REMAIN IN FORCE.
 - THIS GUARDRAIL SYSTEM HAS RECEIVED A FEDERAL ELIGIBILITY LETTER FOR MASH TEST LEVEL 3.

STATE OF NEW HAMPSHIRE
 DEPARTMENT OF TRANSPORTATION • BUREAU OF HIGHWAY DESIGN
**31" BEAM GUARDRAIL
 STANDARD SECTION-STEEL POSTS
 & HARDWARE DETAILS**

REVISION DATE	DGN	STATE PROJECT NO.	SHEET NO.	TOTAL SHEETS
08-15-13	mash_gr_02a	13928A	32	160

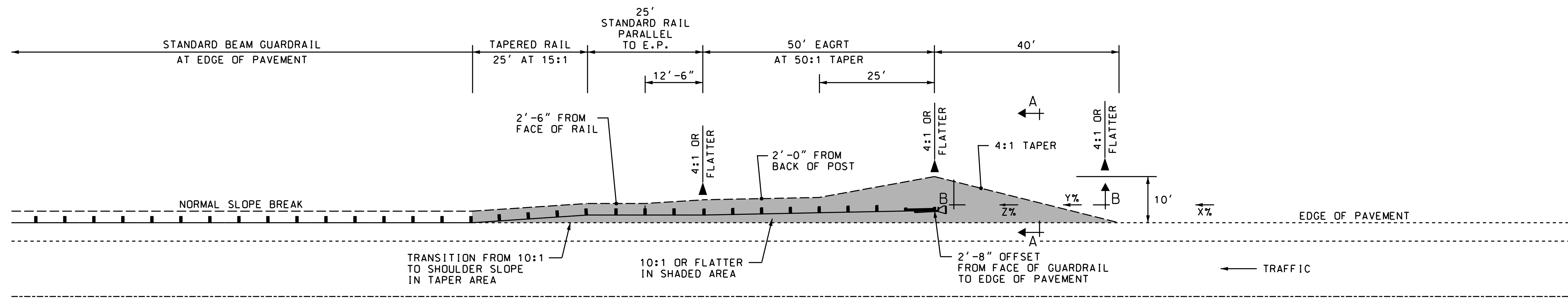

50' EAGRT UNIT

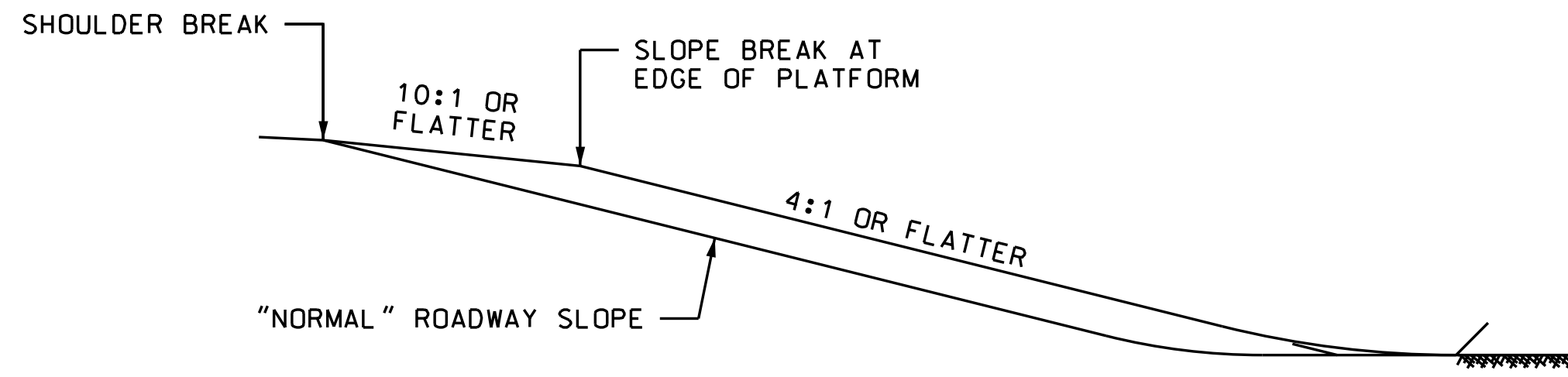

SECTION A-A
PLATFORM SLOPE GRADING

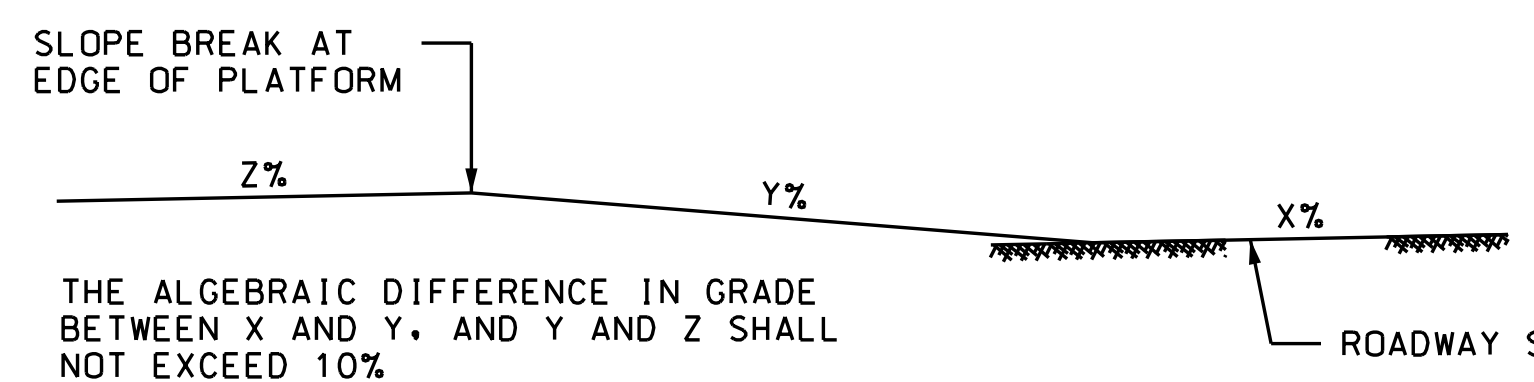

SECTION B-B
PLATFORM APPROACH GRADING

X: LONGITUDINAL GRADE OF ROADWAY SLOPE IN ADVANCE OF PLATFORM
 Y: LONGITUDINAL GRADE OF PLATFORM APPROACH
 Z: LONGITUDINAL GRADE OF PLATFORM

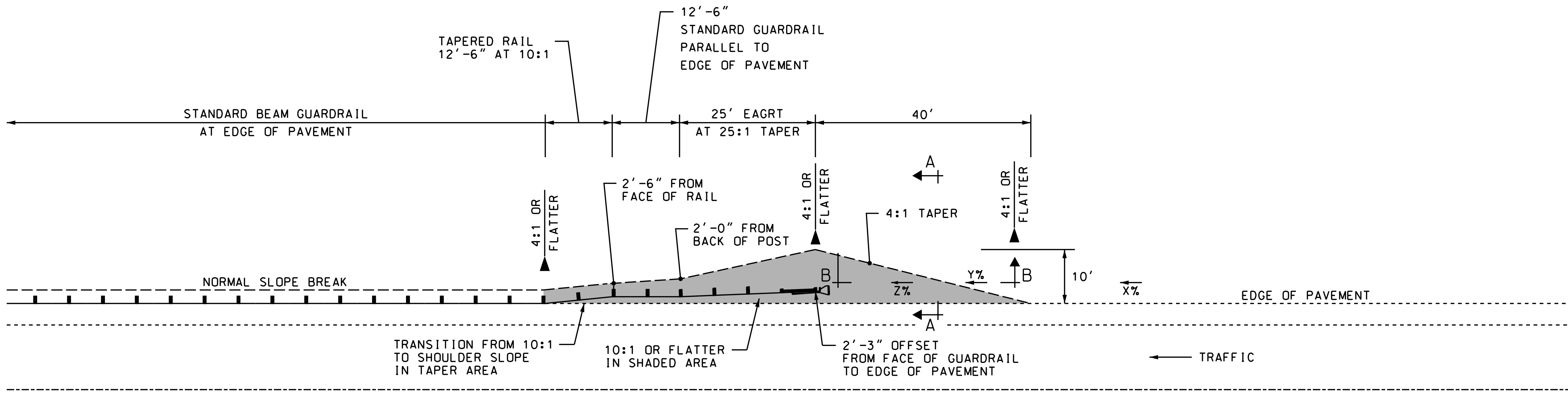

25' EAGRT UNIT

STATE OF NEW HAMPSHIRE
 DEPARTMENT OF TRANSPORTATION • BUREAU OF HIGHWAY DESIGN
**PREFERRED PLATFORM FOR
 OFFSET ENERGY ABSORBING
 GUARDRAIL TERMINAL (EAGRT)**

REVISION DATE	DGN	STATE PROJECT NO.	SHEET NO.	TOTAL SHEETS
11/24/14	prf_pltfrm_offst	13928A	33	160

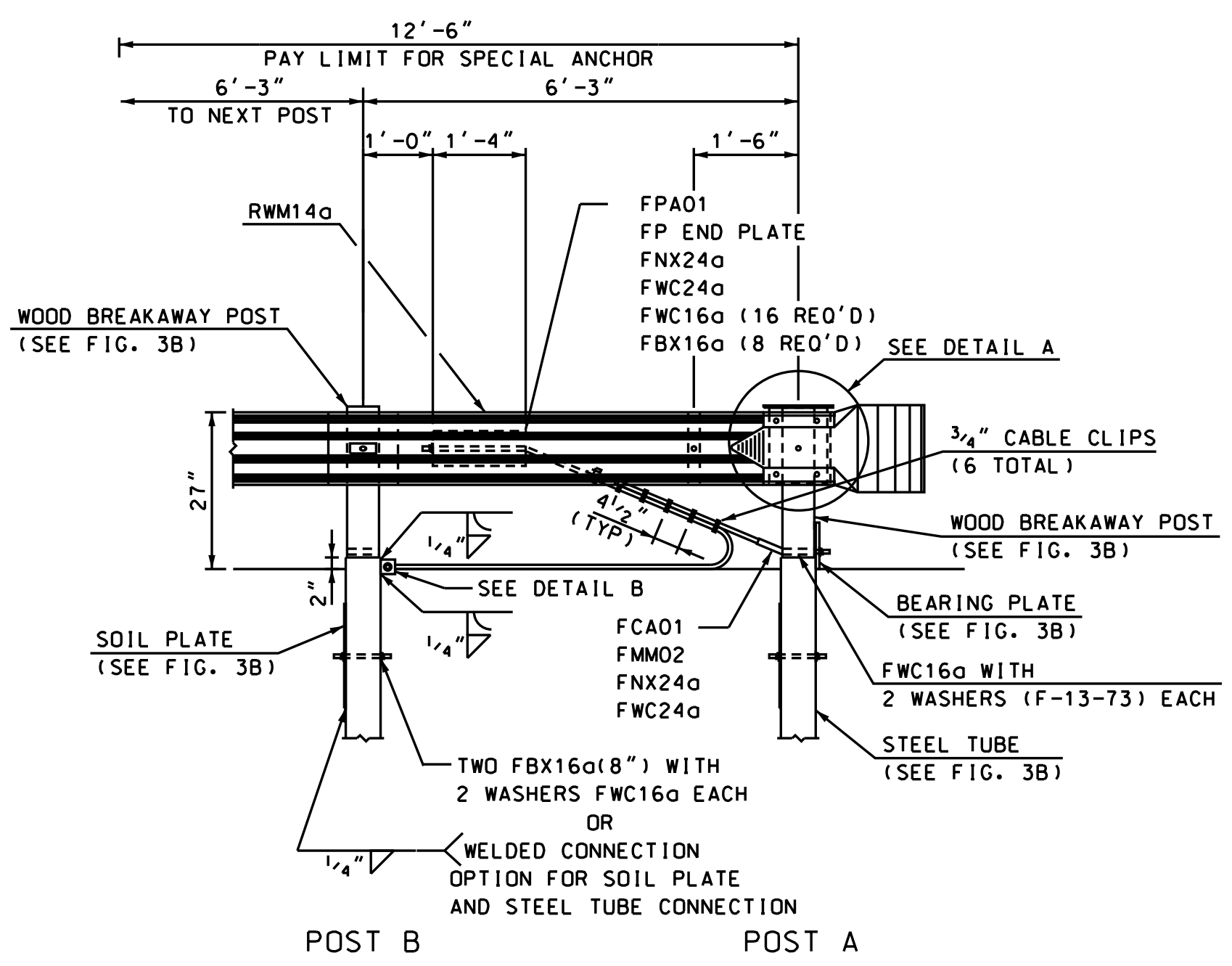
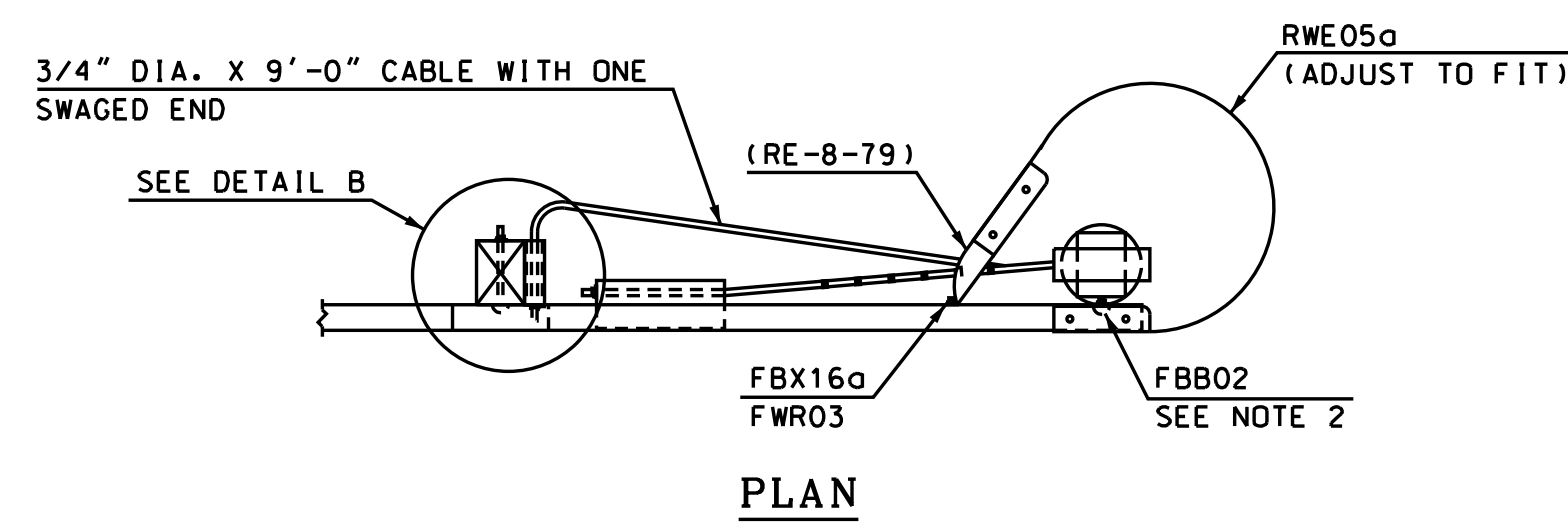

FIGURE 3A (SPECIAL ANCHOR)
SCALE: 1/2" = 1'-0"

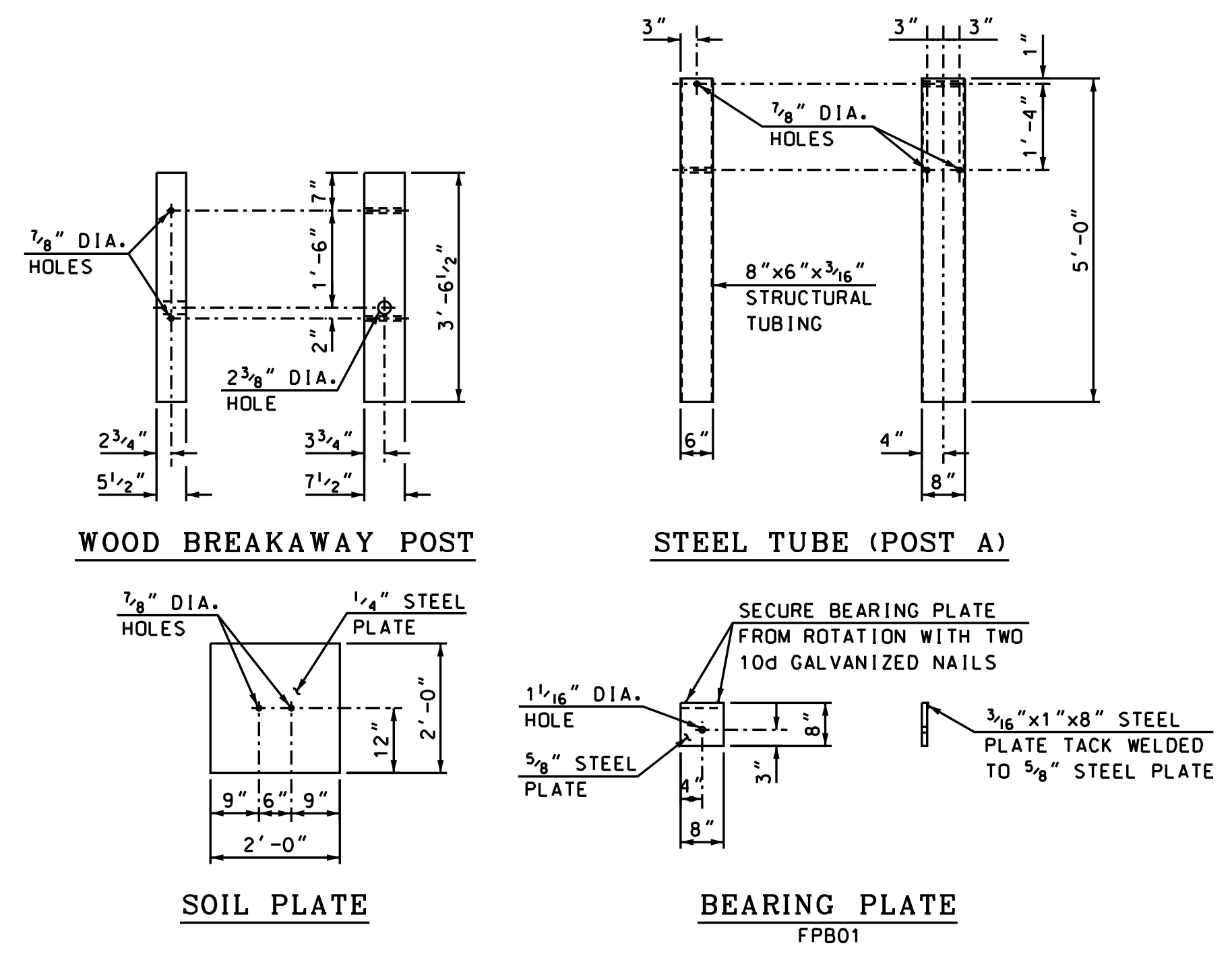
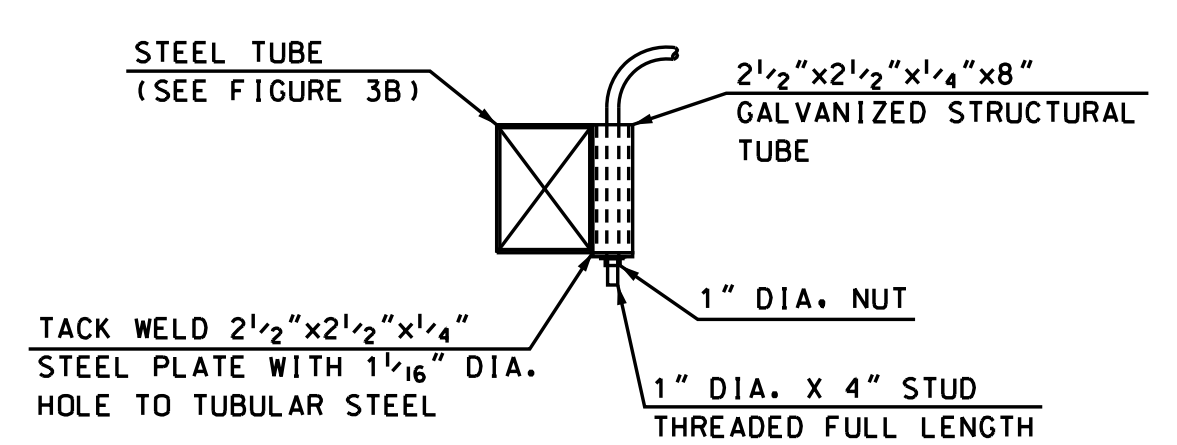
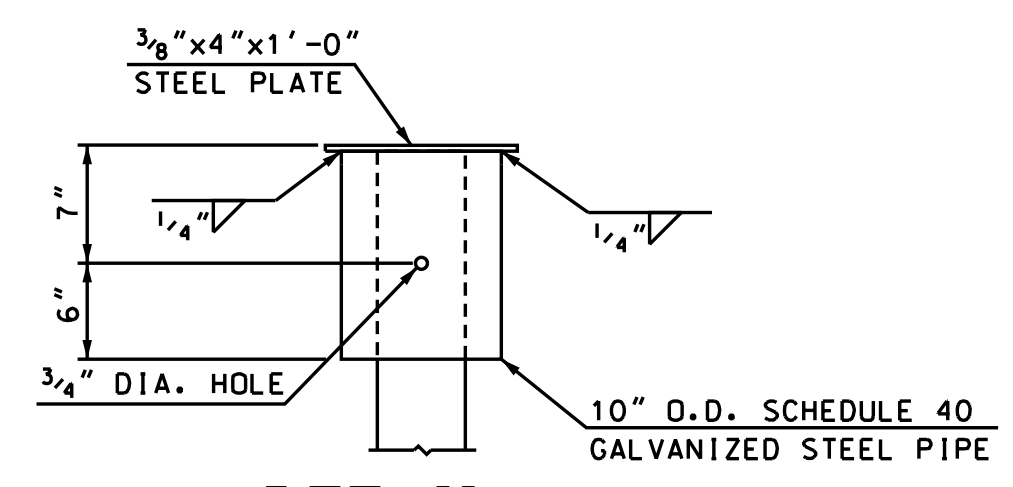

FIGURE 3B
SCALE: 1/2" = 1'-0"



DETAIL B
SCALE: 1" = 1'-0"



DETAIL A
SCALE: 1" = 1'-0"

FIGURE 3A & B NOTES
FBB02

1. ATTACH W-BEAM TO STEEL PIPE WITH F-3[2"]-76 BUTTON HEAD BOLT WITH NO WASHER. NO CONNECTION TO POST IS REQUIRED.
2. THE STEEL TUBE FOR POST B IS FABRICATED FROM POST A BY ADDING THE GALVANIZED STRUCTURAL TUBE (SEE FIGURE 3A, DETAIL B) BEFORE GALVANIZING.

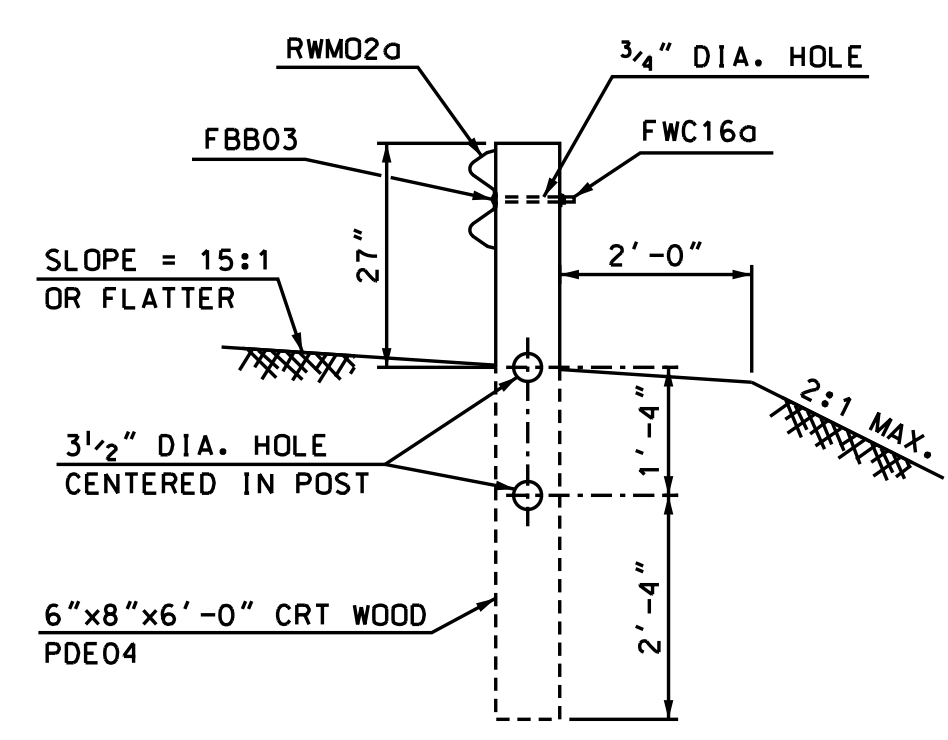

SECTION A-A
SCALE: 1/2" = 1'-0"

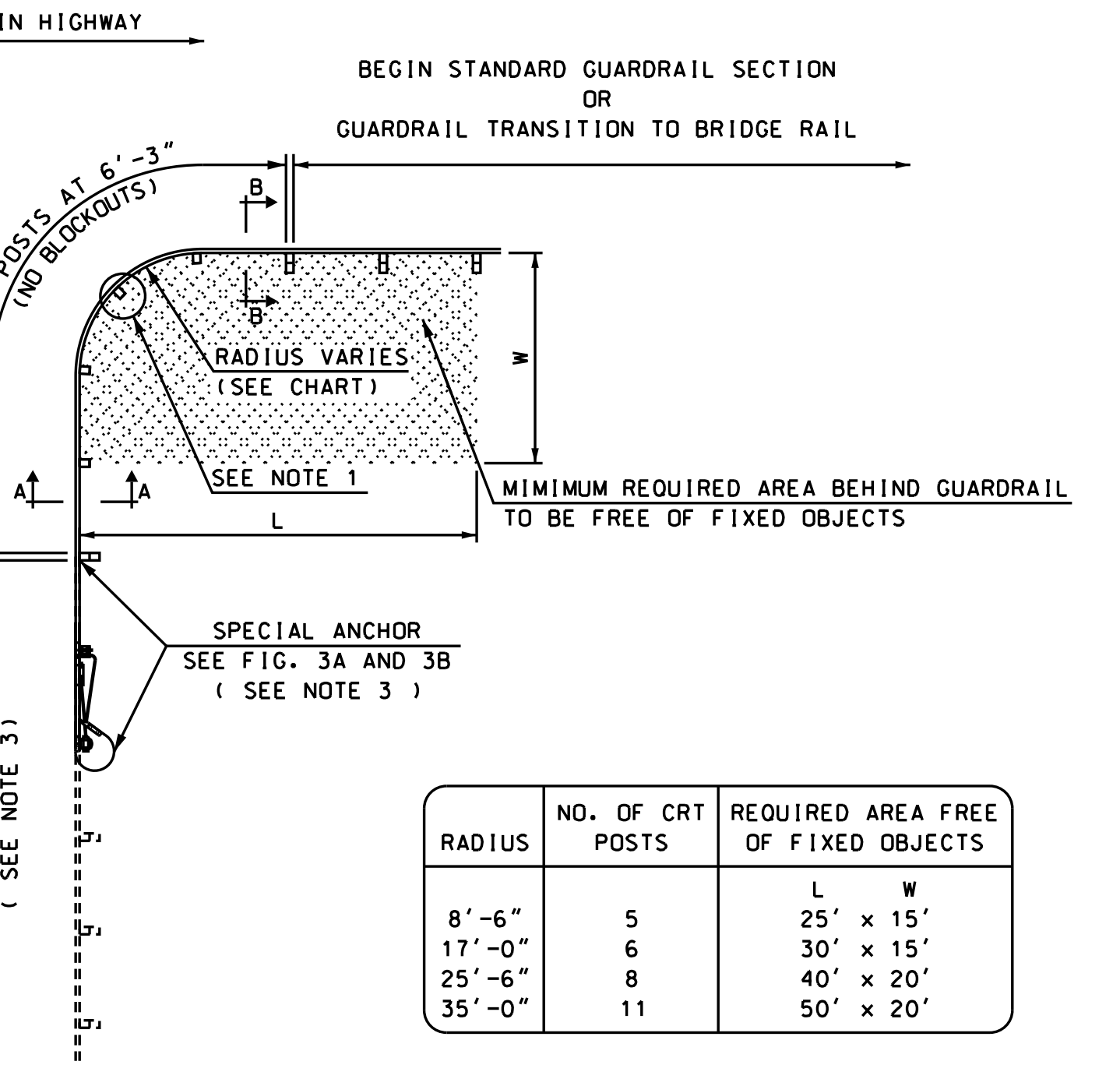

RADIUS	NO. OF CRT POSTS	REQUIRED AREA FREE OF FIXED OBJECTS
8'-6"	5	L W 25' x 15'
17'-0"	6	30' x 15'
25'-6"	8	40' x 20'
35'-0"	11	50' x 20'

CURVED GUARDRAIL DETAIL FOR 8'-6" RADIUS
(ITEMS 606.141 & 606.84)
SCALE: 1" = 10'-0"

CURVED GUARDRAIL NOTES

1. THE RAIL IS NOT BOLTED TO THE CRT POST AT THE CENTER OF THE NOSE AS SHOWN. (8'-6" RADIUS ONLY).
2. THE CURVED GUARDRAIL SECTION SHALL BE SHOP BENT.
3. THE SPECIAL ANCHOR HAS NOT BEEN TESTED AS A CRASHWORTHY END TREATMENT FOR APPROACHING TRAFFIC ON THE INTERSECTING ROADWAY. THEREFORE, IT'S USE SHALL BE LIMITED TO DRIVEWAYS OR LOW SPEED, LOW VOLUME (I.E., 40 MPH MAX., 6000 ADT MAX.) ROADS.

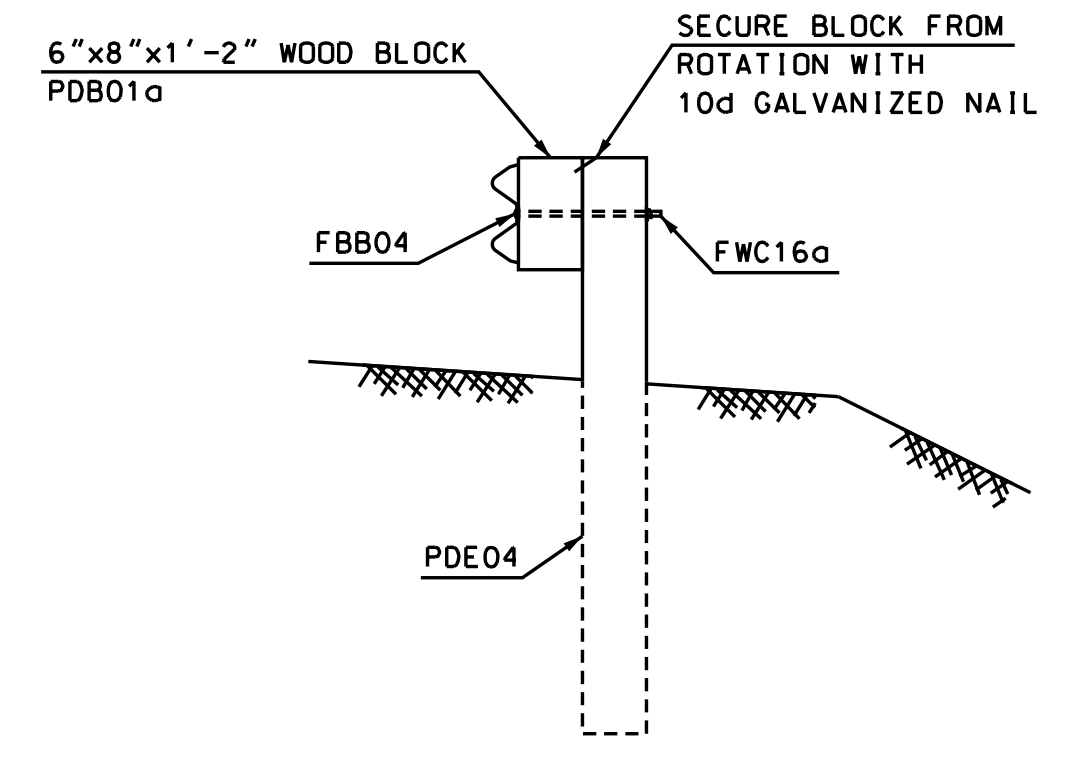

SECTION B-B
SCALE: 1/2" = 1'-0"

GENERAL NOTES

1. ALL DIMENSIONS SUBJECT TO MANUFACTURER'S TOLERANCES.
2. DESIGNATIONS PROVIDED IN PARENTHESIS REFERENCE STANDARD ELEMENTS DETAILED IN "A GUIDE TO STANDARDIZED HIGHWAY BARRIER HARDWARE," 2005, AASHTO-AGC-ARTBA JOINT COOPERATIVE COMMITTEE.

STATE OF NEW HAMPSHIRE				
DEPARTMENT OF TRANSPORTATION • BUREAU OF HIGHWAY DESIGN				
CURVED GUARDRAIL WITH CRT POSTS				
REVISION DATE	DGN	STATE PROJECT NO.	SHEET NO.	TOTAL SHEETS
06/04/12	gr_crt	13928A	34	160

Terminal Unit Delineation

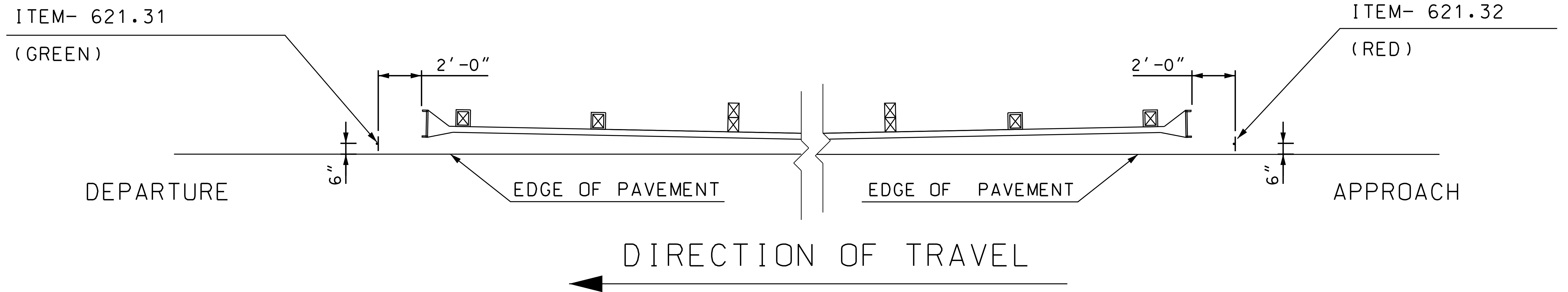

ITEM-621.31
SINGLE DELINEATOR
WITH POST

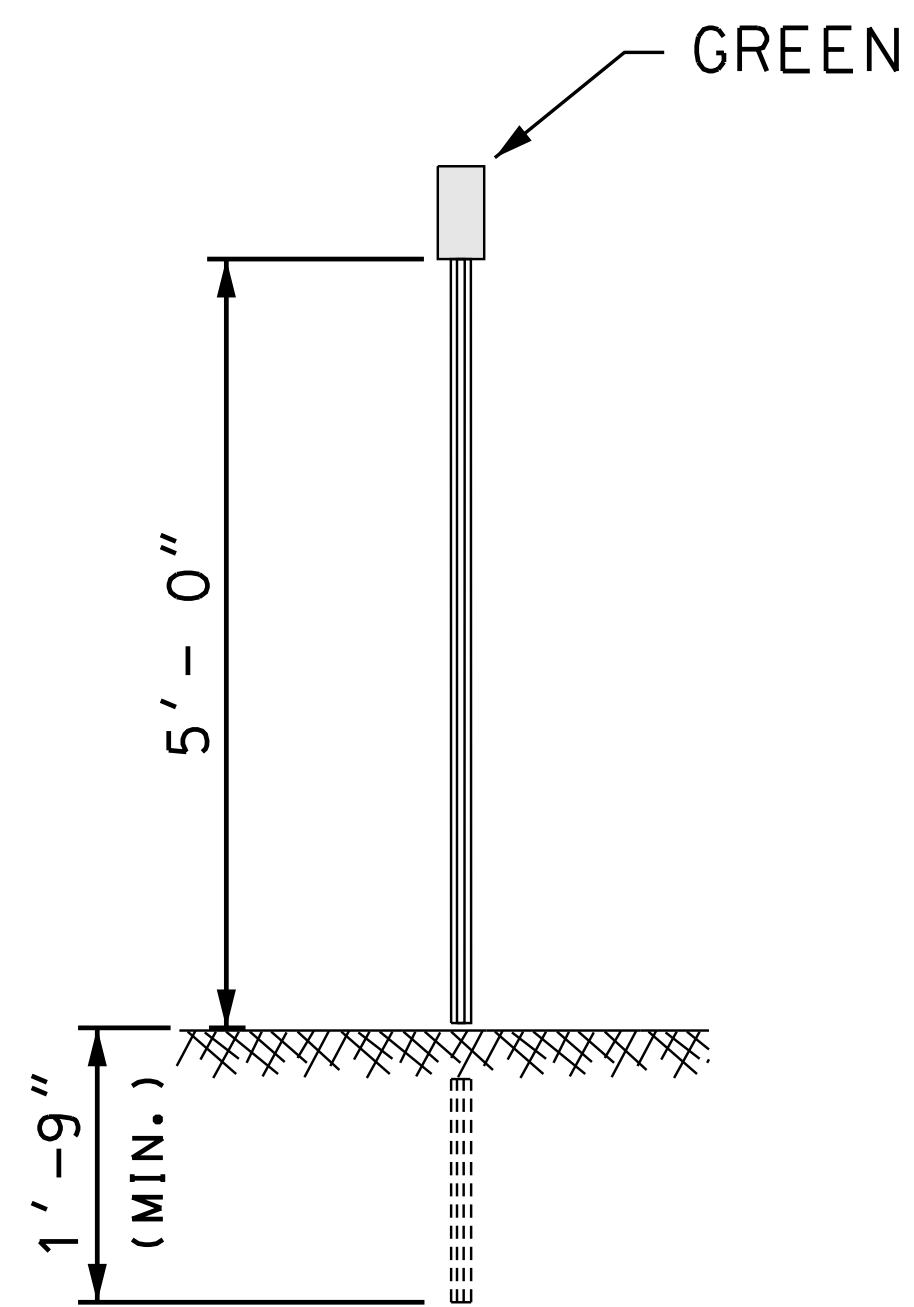

ITEM- 621.32
DOUBLE DELINEATOR
WITH POST

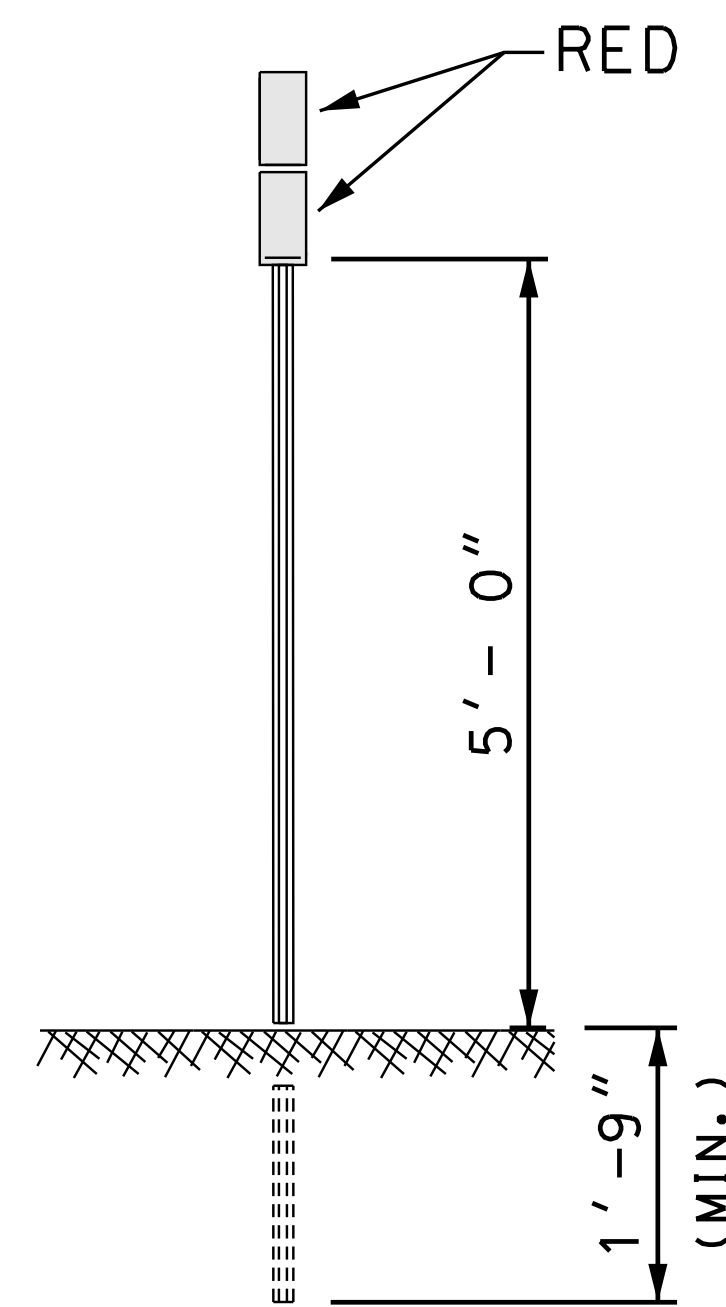

TYPICAL INSTALLATION

STATE OF NEW HAMPSHIRE			
DEPARTMENT OF TRANSPORTATION • BUREAU OF HIGHWAY DESIGN			
<i>Terminal Unit Delineation</i>			
DGN	STATE PROJECT NO.	SHEET NO.	TOTAL SHEETS
termunitdelin	13928A	35	160

SDR PROCESSED	DATE	04/15	DATE	04/15	DATE	
NEW DESIGN	PAB		DATE	04/15	DATE	
SHEET CHECKED	JS		DATE		DATE	
AS BUILT DETAILS						

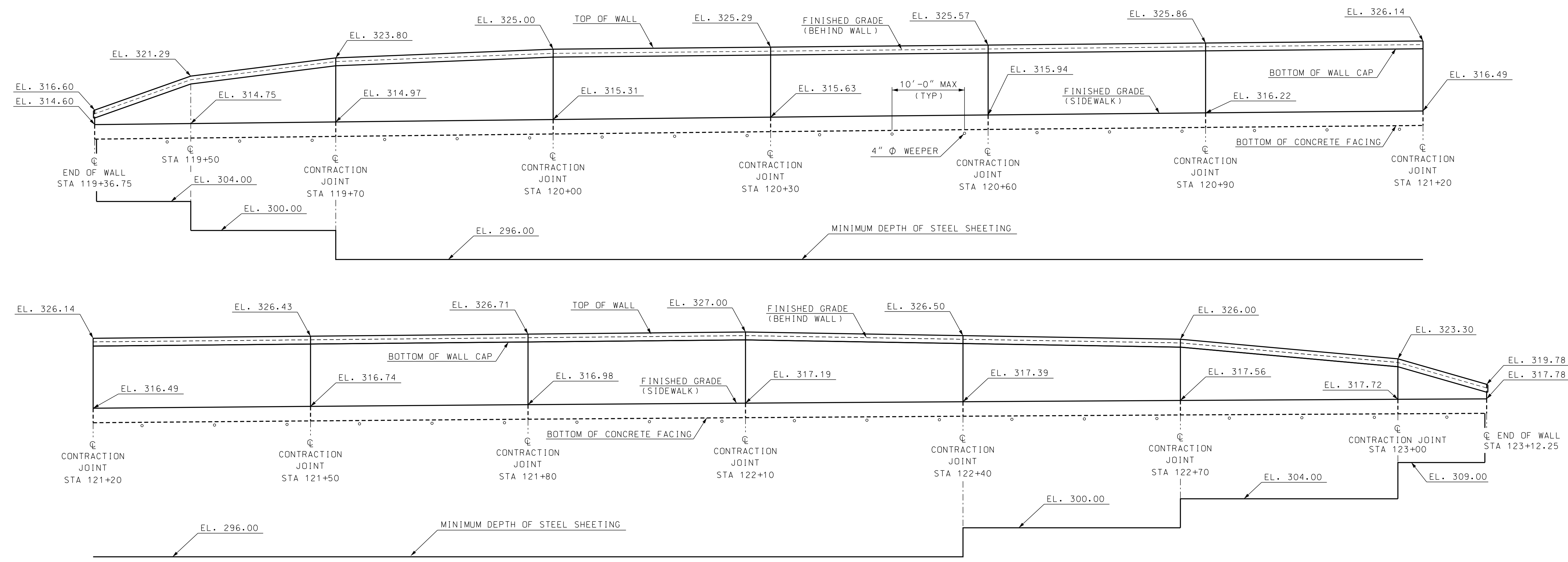

RETAINING WALL ELEVATION

SCALE: 1/8" = 1'-0"

MATERIALS AND SPECIFICATIONS

- ITEM 506.2, STEEL SHEET PILING, SHALL BE AASHTO M223 GR50 (ASTM A572 GR50), PZ 27 OR APPROVED EQUAL (I = 184.2 IN³/FT, S = 30.2 IN³/FT, Z = 36.5 IN³/FT).
- ITEM 520.305, FORM LINER FOR CONCRETE (F), SHALL BE GREENSTREAK, STONE DESIGNS NO. 460 ASHLAR CUT STONE, OR APPROVED EQUAL.
- ITEM 544.2, REINFORCING STEEL - EPOXY COATED, SHALL BE AASHTO M31 (ASTM A615) GRADE 60.
- SPECIFICATIONS: -AASHTO LRFD BRIDGE DESIGN SPECIFICATIONS, 6TH EDITION, 2012 WITH 2013 INTERIM REVISIONS
-LOAD FACTOR OF 1.00 FOR DETERMINING EMBEDMENT DEPTH
-LOAD FACTOR OF 1.50 FOR FLEXURAL DESIGN
-1984 USS STEEL SHEET PILING DESIGN MANUAL

CONSTRUCTION NOTES

- THE CONTRACTOR SHALL PROVIDE SUFFICIENT PILE LENGTH TO CUT THE TOPS OF PILES TO THE PROPER ELEVATION AFTER DRIVING IS COMPLETED, REMOVING ALL DAMAGED SECTIONS OF PILING. NO PILE SPLICES WILL BE ALLOWED.
- WEEPER DRAINS SHALL BE A 4" Ø HOLE IN THE STEEL SHEETING, CENTERED 6" BELOW THE BOTTOM OF CONCRETE FACING. AN EXCAVATION AND BACKFILL NECESSARY TO COMPLETE THE WEEPER DRAIN WORK SHALL BE SUBSIDIARY TO ITEM 506.2.
- THE SHEET PILING SHALL BE BACKFILLED TO THE LEVEL OF THE BOTTOM OF THE CONCRETE CAP PRIOR TO PLACING CONCRETE FORMS. THE FORMS SHALL BE PLACED PLUMB, WITH A MINIMUM CONCRETE THICKNESS OF 8".
- ALL EXPOSED EDGES OF CONCRETE SHALL BE CHAMFERED 3/4".
- THE CONCRETE FORM LINER SHALL EXTEND VERTICALLY FROM 12" BELOW THE BOTTOM OF THE CONCRETE CAP TO A MINIMUM 6" BELOW FINISHED GRADE. THE HORIZONTAL EXTENTS OF THE FORM LINER SHALL BE ESTABLISHED BY A LINE OFFSET 12" FROM THE CENTERLINE OF EACH CONTRACTION JOINT AND EACH END OF THE WALL. A RUSTICATION STRIP SHALL BE INCLUDED AT ALL TOP AND SIDE EDGES OF FORM LINERS ADJACENT TO PLANE CONCRETE IF SO RECOMMENDED BY THE MANUFACTURER. ANY RUSTICATION REQUIRED SHALL BE SUBSIDIARY TO ITEM 520.305.
- ITEM 534.3, WATER REPELLENT (SILANE-SILOXANE), SHALL BE APPLIED TO THE CONCRETE FACING AS SHOWN ON THE PLANS. APPLICATION RATE = 150 SF/GAL.
- ALL REINFORCING STEEL SHALL BE EPOXY COATED. ANY REINFORCING BARS WHICH ARE CUT SHALL BE TOUCHED UP WITH AN APPROVED EPOXY COATING MATERIAL. ALL COSTS SHALL BE INCLUDED IN ITEM 544.2.

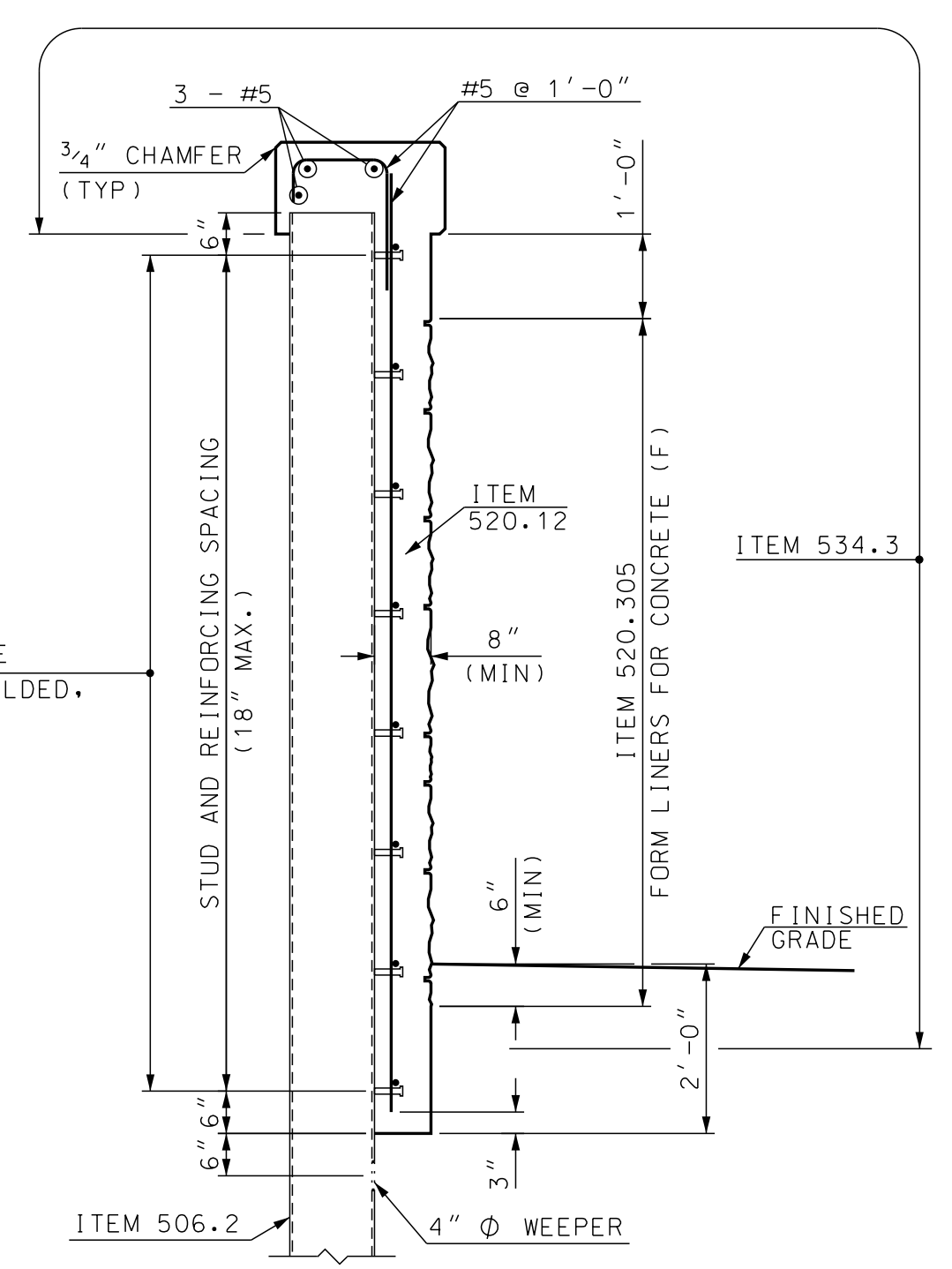

TYPICAL WALL SECTION

SCALE: 1/2" = 1'-0"

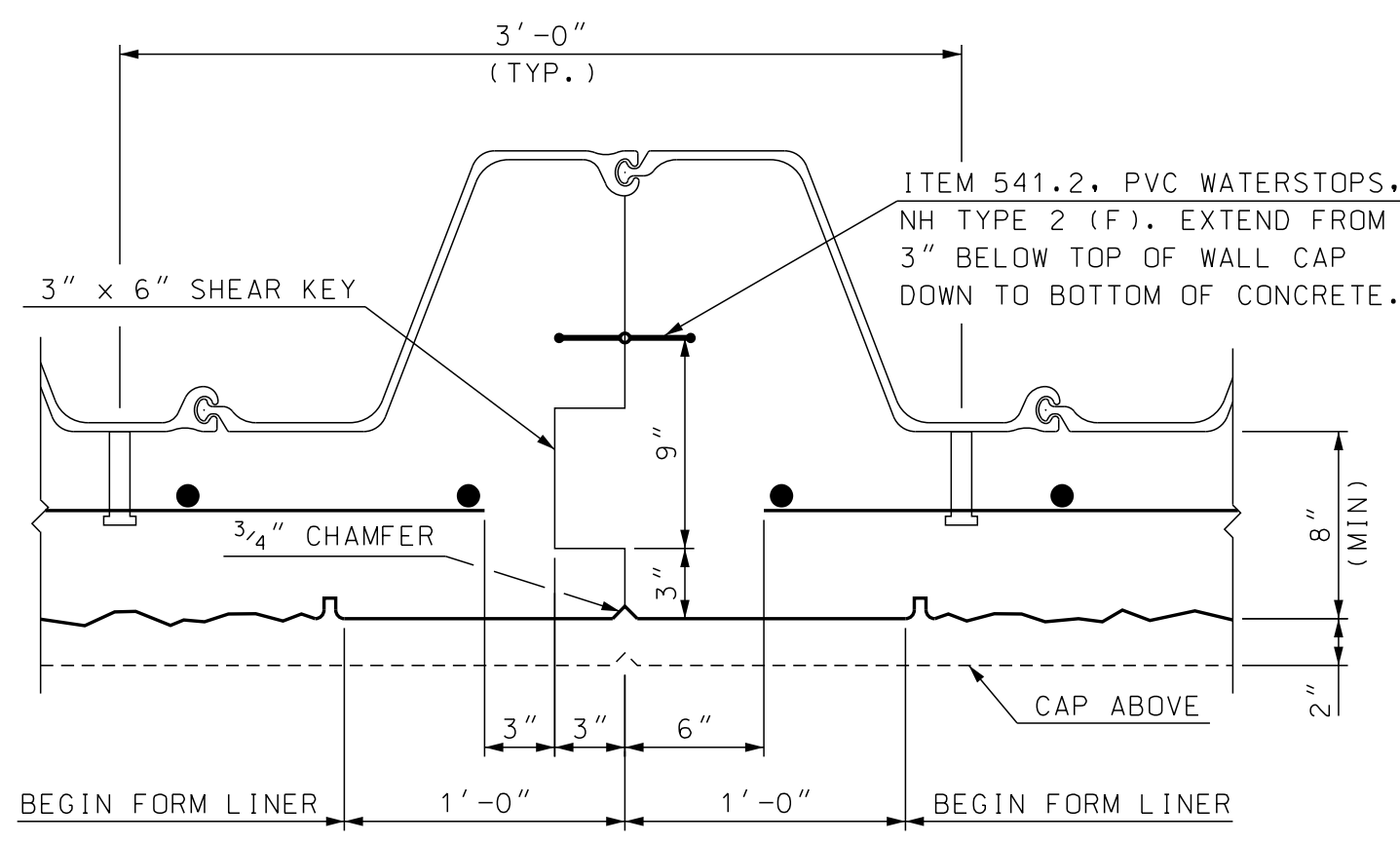

CONTRACTION JOINT DETAIL

SCALE: 1/2" = 1'-0"

RETAINING WALL QUANTITIES

ITEM NO.	ITEM DESCRIPTION	QUANTITY	UNIT
206.1	COMMON STRUCTURE EXCAVATION	190*	CY
304.4	CRUSHED STONE (FINE GRADATION)	30*	CY
506.2	STEEL SHEET PILING	270000	LB
520.12	CONCRETE CLASS A, ABOVE FOOTINGS (F)	185	CY
520.305	FORM LINERS FOR CONCRETE (F)	285	SY
534.3	WATER REPELLENT (SILANE-SILOXANE)	34**	GAL
541.2	PVC WATERSTOPS, NH TYPE 2 (F)	131	LF
544.2	REINFORCING STEEL, EPOXY COATED (F)	9308	LB
547	SHEAR CONNECTORS (F)	950	EA

* NOT AN ITEM TOTAL. REFER TO THE SUMMARY OF QUANTITIES FOR ITEM TOTAL.
** NOT AN ITEM TOTAL. REFER TO THE SUMMARY OF BRIDGE QUANTITIES ON THE BRIDGE GENERAL PLAN FOR ADDITIONAL QUANTITY.

STATE OF NEW HAMPSHIRE			
DEPARTMENT OF TRANSPORTATION • BUREAU OF BRIDGE DESIGN			
RETAINING WALL DETAILS			
DGN	STATE PROJECT NO.	SHEET NO.	TOTAL SHEETS
13928A_RetWall	13928A	36	160

SDR PROCESSED	DATE	04/15	PAB
NEW DESIGN	DATE	04/15	JS
SHEET CHECKED	DATE		
AS BUILT DETAILS	DATE		

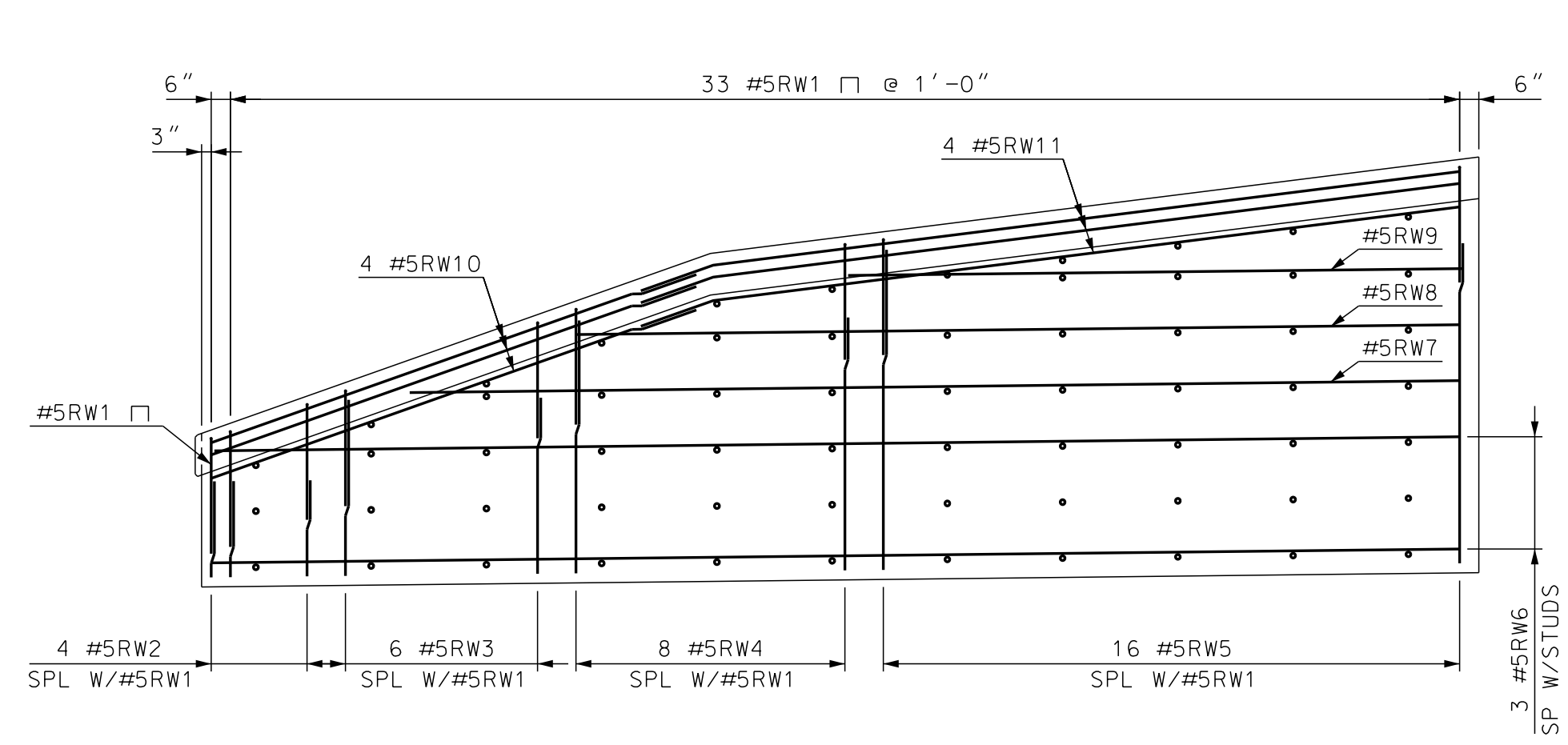

END SECTION - SOUTH
STA 119+36.75 TO STA 119+70

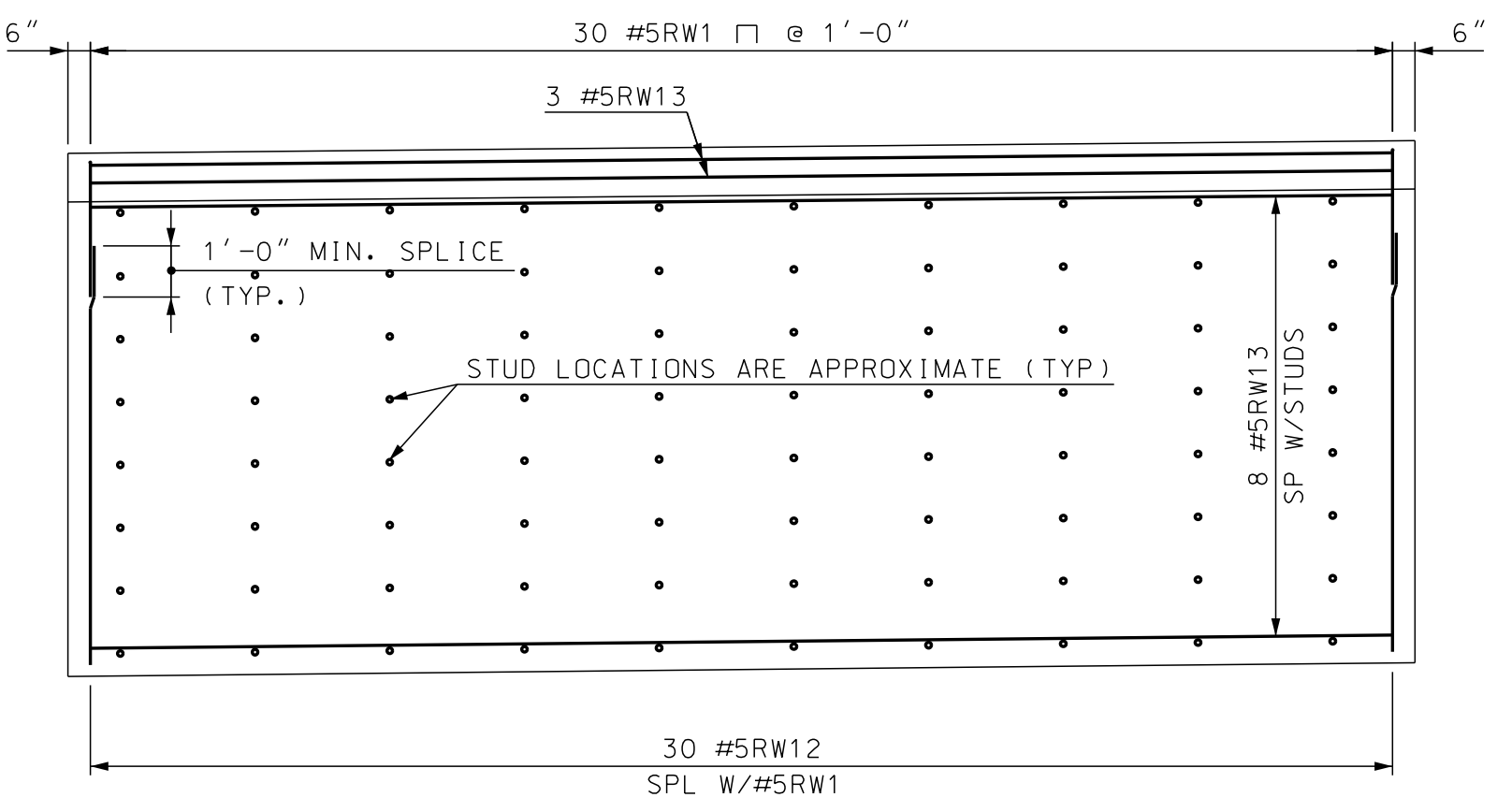

INTERMEDIATE SECTION
TYPICAL FOR 10 SEGMENTS
STA 119+70 TO STA 122+70

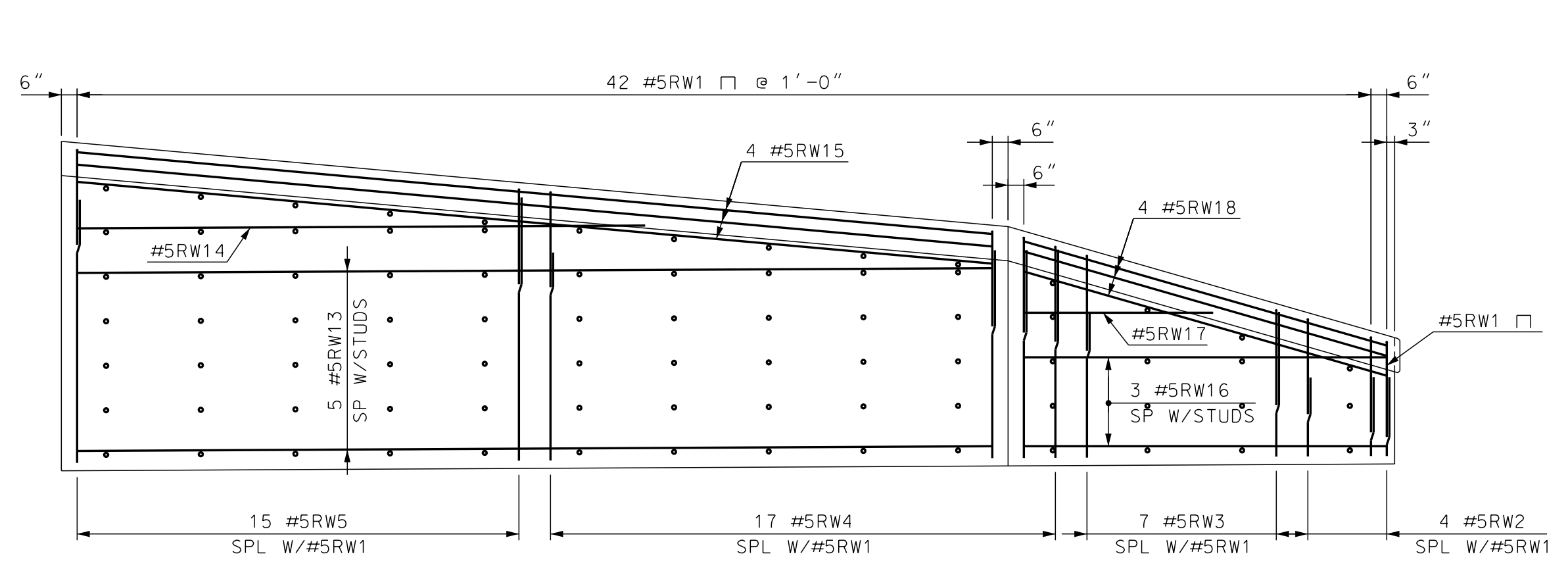

END SECTION - NORTH
STA 122+70 TO STA 123+12.25

RETAINING WALL REINFORCING

SCALE: 1/4" = 1'-0"

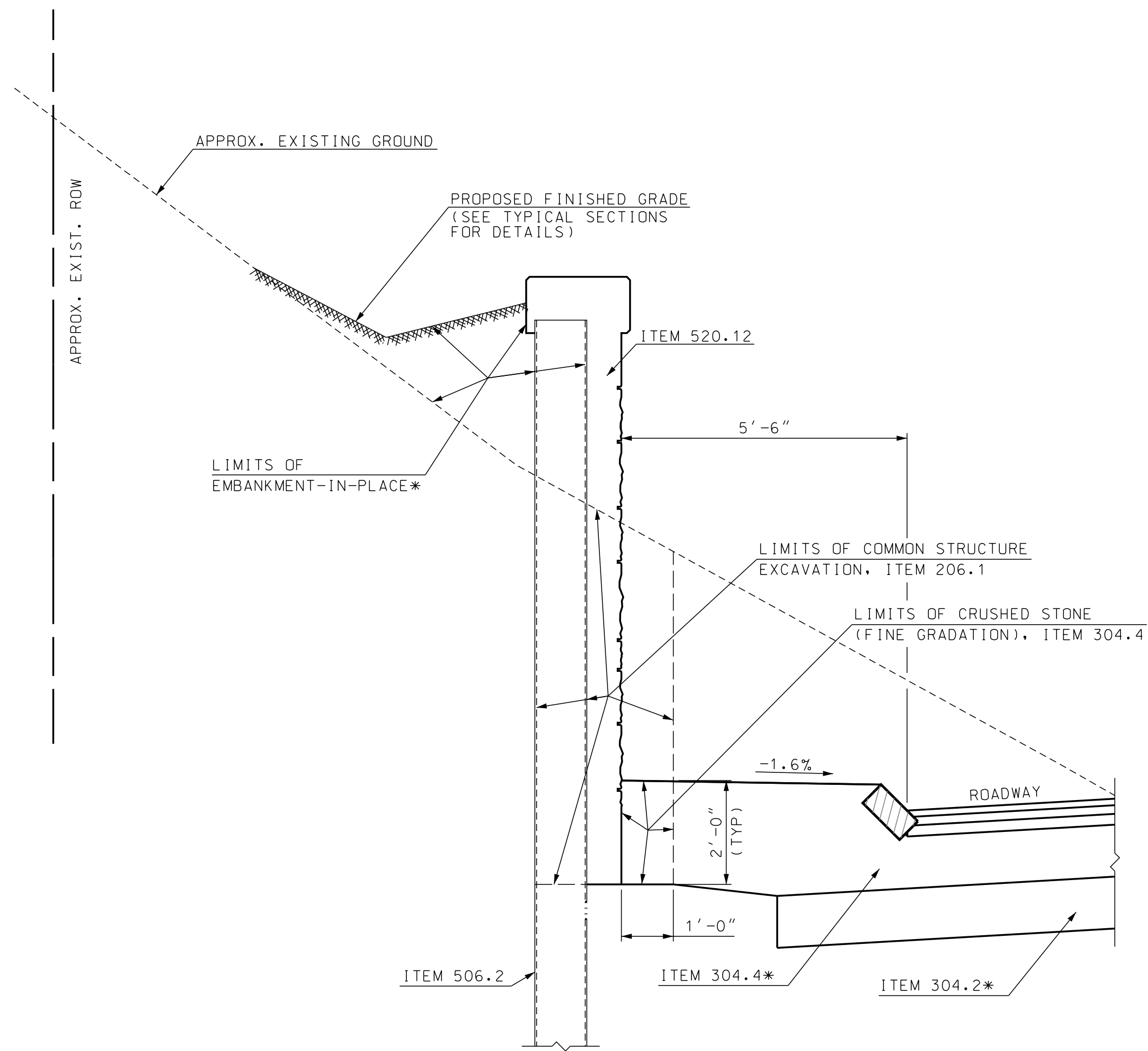

TYPICAL EARTHWORK SECTION
SCALE: 1/2" = 1'-0"

* NOT INCLUDED IN RETAINING WALL QUANTITY

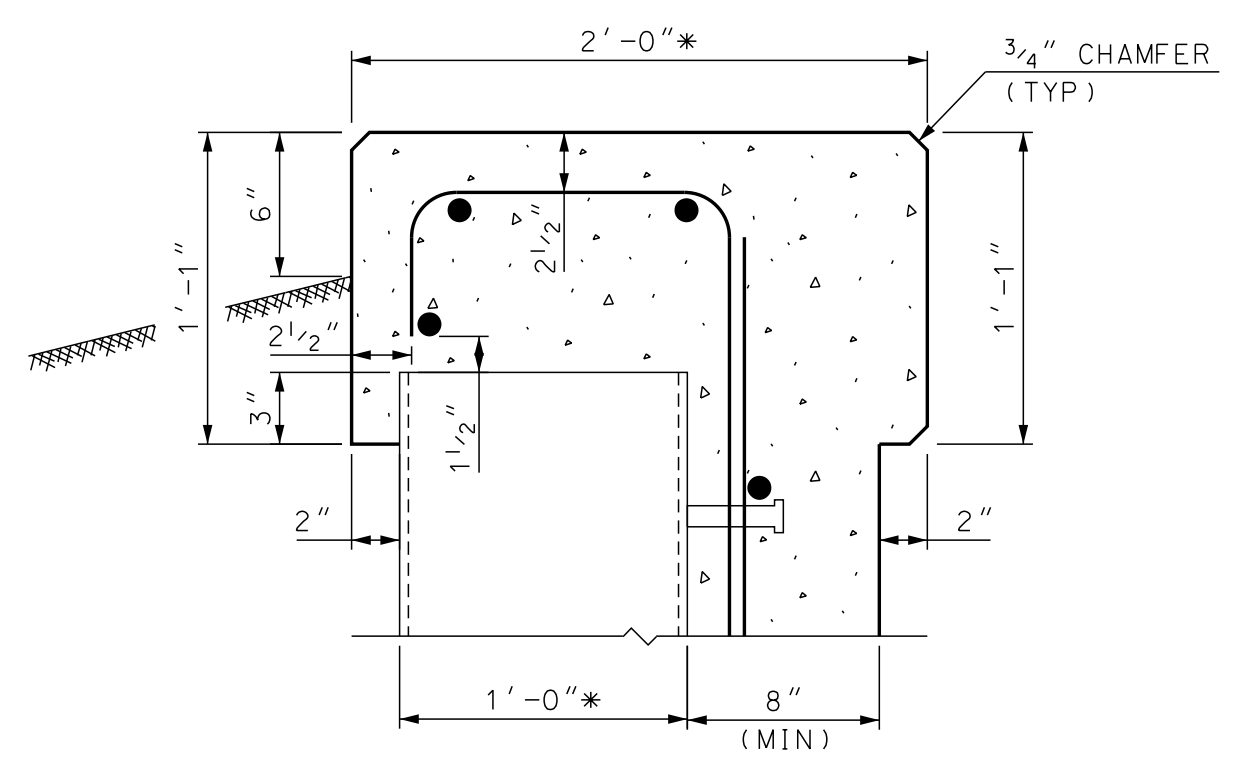

CONCRETE CAP DETAIL

SCALE: 1 1/2" = 1'-0"

* ASSUMES PZ-27 SHEETING IS USED

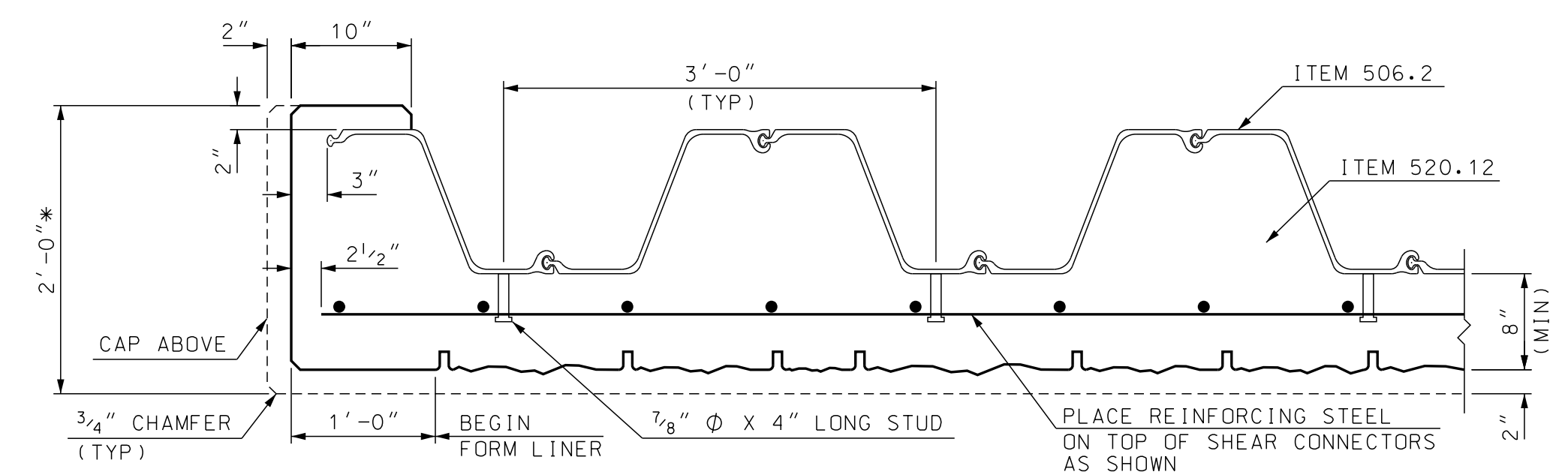

END OF WALL DETAIL

SCALE: 1" = 1'-0"

* ASSUMES PZ 27 SHEETING IS USED

REINFORCING SCHEDULE

MARK	SIZE	LENGTH	# PIECES	TYPE	A	B	C	D	H	J	K	R
RW1	#5	4'-8"	377	17		3'-0"	1'-2"	6"				
RW2	#5	2'-6"	8	-								
RW3	#5	4'-7"	13	-								
RW4	#5	6'-7"	25	-								
RW5	#5	8'-4"	31	-								
RW6	#5	32'-6"	3	-								
RW7	#5	27'-4"	1	-								
RW8	#5	23'-0"	1	-								
RW9	#5	16'-0"	1	-								
RW10	#5	13'-6"	4	-								
RW11	#5	21'-7"	4	N7			2'-0"	19'-7"	5"		1'-11"	
RW12	#5	9'-4"	300	-								
RW13	#5	29'-0"	115	-								
RW14	#5	18'-0"	1	-								
RW15	#5	29'-2"	4	-								
RW16	#5	11'-6"	3	-								
RW17	#5	6'-0"	1	-								
RW18	#5	12'-0"	4	-								

TOTAL WEIGHT (LBS)

ITEM #	DESCRIPTION	#3	#4	#5	#6	#7	#8	#9	#10	TOTAL
544.2	REINFORCING - EPOXY COATED			9308						9308

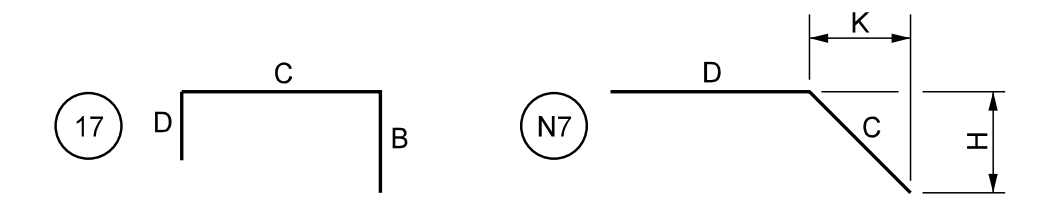

STATE OF NEW HAMPSHIRE
DEPARTMENT OF TRANSPORTATION • BUREAU OF BRIDGE DESIGN

**RETAINING WALL
DETAILS**

DGN	STATE PROJECT NO.	SHEET NO.	TOTAL SHEETS
13928A_RetWall	13928A	37	160

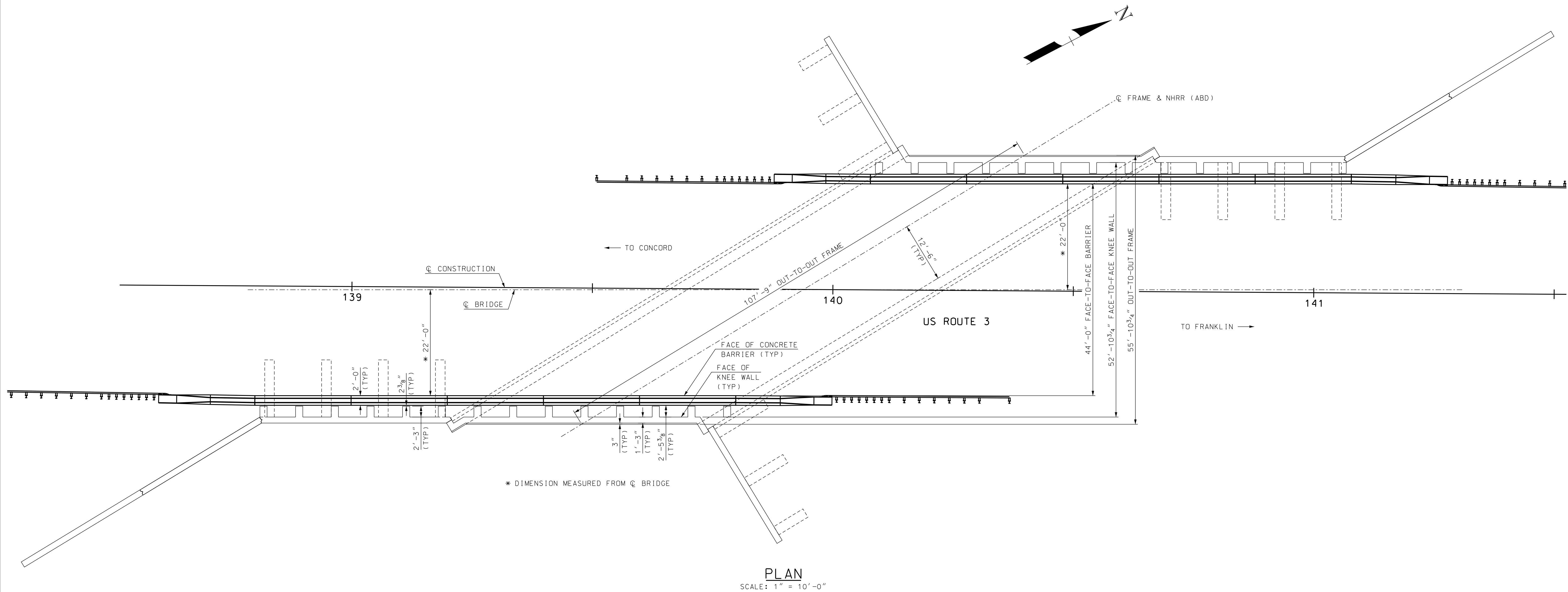

PLAN
SCALE: 1" = 10'-0"

SCOPE OF WORK

BR. NO. 162/099:
- REMOVE AND REPLACE BRIDGE RAIL

MATERIALS AND SPECIFICATIONS

1. SPECIFICATIONS: NHDOT 2010 STANDARD SPECIFICATIONS FOR ROAD AND BRIDGE CONSTRUCTION, AS AMENDED

TO THE CONTRACTOR

THE CONTRACTOR SHOULD BE AWARE THAT EXISTING STRUCTURE DIMENSIONS AND ELEVATIONS SHOWN ON THESE PLANS WERE TAKEN FROM ORIGINAL BRIDGE PLANS AND DO NOT NECESSARILY REPRESENT "AS BUILT" DIMENSIONS AND ELEVATIONS. THE CONTRACTOR SHALL FIELD VERIFY ALL DIMENSIONS AND ELEVATIONS OF THE EXISTING STRUCTURES AND BE PREPARED TO MAKE ANY ADJUSTMENTS REQUIRED TO PROPERLY REHABILITATE THE BRIDGE. ANY DISCREPANCIES IN DIMENSIONS, CHARACTER, OR EXTENT OF THE EXISTING FEATURES SHALL BE BROUGHT TO THE ATTENTION OF THE ENGINEER PRIOR TO ADVANCING THE WORK. THE EXISTING PLANS MAY BE VIEWED AT THE NHDOT, BUREAU OF BRIDGE DESIGN OFFICE DURING THE BIDDING PERIOD. AFTER THE CONTRACT IS AWARDED, A COMPLETE SET OF THE EXISTING PLANS WILL BE FORWARDED TO THE CONTRACTOR UPON REQUEST. THE FILE NUMBER FOR THIS BRIDGE IS 3-3-11.

GENERAL CONSTRUCTION NOTES

- TRAFFIC CONTROL CHANNELIZING DEVICES SHALL BE IN PLACE BEFORE REMOVAL OPERATIONS BEGIN FOR EACH CONSTRUCTION PHASE.
- NO OPERATIONS SHALL BE CONDUCTED IN THE ROADWAY, UNLESS APPROVED BY THE CONTRACT ADMINISTRATOR.
- THE CONTRACTOR SHALL TAKE ALL NECESSARY MEASURES TO INSURE THAT DEBRIS DOES NOT FALL ONTO THE RAILROAD ROW BELOW THE EXISTING STRUCTURE. ALL COSTS SHALL BE PAID UNDER ITEM 502, AND SHALL INCLUDE THE ERECTION, MAINTENANCE, AND REMOVAL OF TEMPORARY STRUCTURES OR OTHER SUCH METHODS AS APPROVED.
- THE EXISTING BRIDGE PLANS INDICATE THAT THE EXISTING BRIDGE RAIL PAINT AND BEARING CAULKING PADS ARE LEAD-BEARING MATERIALS. THE CONTRACTOR'S EXISTING BRIDGE REMOVAL PLAN SHALL INCLUDE DETAILS FOR WORKER AND ENVIRONMENTAL PROTECTION, IN ACCORDANCE WITH 105.02 AND THE SPECIAL ATTENTION FOR ITEM 502, LEAD-BEARING PAINT.
- LEVELING PADS AND APPROPRIATE SHIMMING MATERIAL SHALL BE PLACED UNDER EACH CONCRETE BARRIER SECTION, SUBSIDIARY TO THE APPLICABLE BARRIER ITEM.
- 2" FLOWABLE FILL SHALL BE CONCRETE CLASS F, EXCAVATABLE AND SHALL BE SUBSIDIARY TO THE APPLICABLE BARRIER ITEM.
- PRIOR TO INSTALLATION, COAT ALL SIDES OF CONCRETE BARRIER WITH ITEM 534.3, WATER REPELLENT (SILANE-SILOXANE). APPLICATION RATE = 150 SF/GAL.
- EXISTING EXPOSED BRIDGE RAIL PEDESTALS, KNEE WALLS, FRAME, AND WINGS SHALL BE WASHED, SUBSIDIARY TO ITEM 534.3, IN SUCH A MANNER THAT OVERSPRAY IS KEPT TO A MINIMUM. IF THE WATER BEADS, NO COATING NEEDS TO BE APPLIED. IF THE WATER DOES NOT BEAD, COAT THE SURFACE WITH ITEM 534.3, WATER REPELLENT (SILANE-SILOXANE). APPLICATION RATE = 150 SF/GAL.
- PROVIDE PAVEMENT JOINT ADHESIVE FOR EACH PAVEMENT COURSE ALONG MEDIAN BARRIER, TRANSITION BARRIER, AND BITUMINOUS CURB BENEATH TRANSITION RAIL (ROADWAY ITEM).

SUMMARY OF BRIDGE QUANTITIES

ITEM NO.	ITEM DESCRIPTION	QUANTITY	UNIT
502.	REMOVAL OF EXISTING BRIDGE STRUCTURE	1	U
504.1	COMMON BRIDGE EXCAVATION (F)	80	CY
508.	STRUCTURAL FILL	23	CY
534.3	WATER REPELLENT (SILANE-SILOXANE)	110**	GAL
606.312	SINGLE FACED TRANSITION RAIL, STEEL POST	4	U
606.41292	54" TO BEAM GUARDRAIL TRANSITION SINGLE SLOPE	4	U
	CONCRETE BARRIER, PRECAST, MODIFIED		
606.4135	54" SINGLE SLOPE CONCRETE BARRIER, PRECAST	200	LF
609.811	BITUMINOUS CURB, TYPE B (4" REVEAL)	122	LF
621.1	RETROREFLECTIVE MEDIAN BARRIER DELINEATOR	6	EA

** NOT AN ITEM TOTAL. REFER TO THE SUMMARY OF RETAINING WALL QUANTITIES ON THE RETAINING WALL PLAN FOR ADDITIONAL QUANTITY.

**STATE OF NEW HAMPSHIRE
DEPARTMENT OF TRANSPORTATION * BUREAU OF BRIDGE DESIGN**

TOWN FRANKLIN BRIDGE NO. 162/099 STATE PROJECT 13928A
LOCATION US ROUTE 3 over NHRR (ABD)

GENERAL PLAN

REVISIONS AFTER PROPOSAL				BY	DATE	BY	DATE	BRIDGE SHEET		
				DESIGNED	PAB	2/15	CHECKED	DLS	2/15	1 OF 4
				DRAWN	SMG	2/15	CHECKED	PAB	2/15	FILE NUMBER
				QUANTITIES	SMG	2/15	CHECKED	PAB	2/15	3-3-1-11
				ISSUE DATE			FEDERAL PROJECT NO.		SHEET NO.	TOTAL SHEETS
				REV. DATE			-----		38	160

SUBDIRECTORY	DGN LOCATOR	SHEET SCALE
BRC\	13928A Genplan	AS NOTED

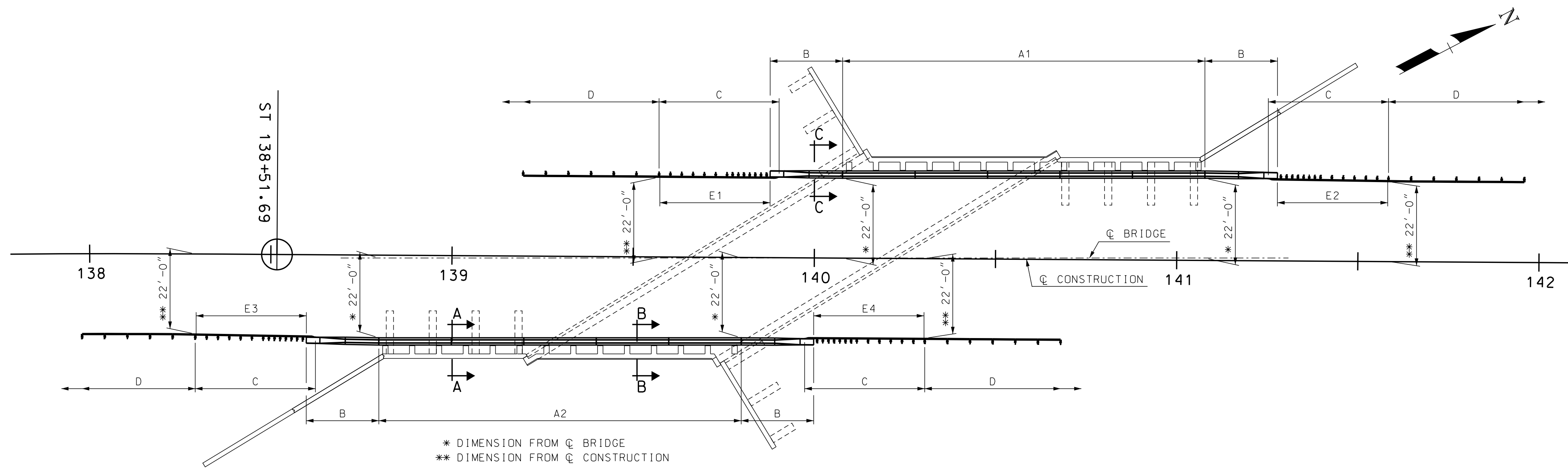

* DIMENSION FROM ϕ BRIDGE
 ** DIMENSION FROM ϕ CONSTRUCTION

RAIL LAYOUT

SCALE: 1" = 20'-0"

RAIL AND CURB NOTES

- A. ITEM 606.4135, 54" SINGLE SLOPE CONCRETE BARRIER, PRECAST
 A1 = 100 LF
 A2 = 100 LF
 ITEM TOTAL = 200 LF
- B. ITEM 606.41292, 54" TO BEAM GUARDRAIL TRANSITION SINGLE SLOPE CONCRETE BARRIER, PRECAST, MODIFIED
 1 UNIT PER CORNER
 ITEM TOTAL = 4 UNITS
- C. ITEM 606.312, SINGLE FACED TRANSITION RAIL, STEEL POST
 1 UNIT PER CORNER
 ITEM TOTAL = 4 UNIT
- D. BEAM GUARDRAIL
 ROADWAY ITEM
- E. ITEM 609.811, BITUMINOUS CURB, TYPE B (4" REVEAL)
 E1 = 30'-6"
 E2 = 30'-6"
 E3 = 30'-6"
 E4 = 30'-6"
 ITEM TOTAL = 122 LF

PORTABLE CONCRETE BARRIER NOTES

1. REFER TO THE CURRENT NHDOT STANDARD PLAN GR-23 FOR BARRIER LAYOUT AND TAPER RATES.
2. MAINTAIN A MINIMUM ROADWAY WIDTH OF 28 FT WHEN PORTABLE BARRIER IS IN USE.
3. PORTABLE CONCRETE BARRIER FOR TRAFFIC CONTROL SHALL REMAIN IN PLACE UNTIL THE PERMANENT CONCRETE RAIL IS IN PLACE.

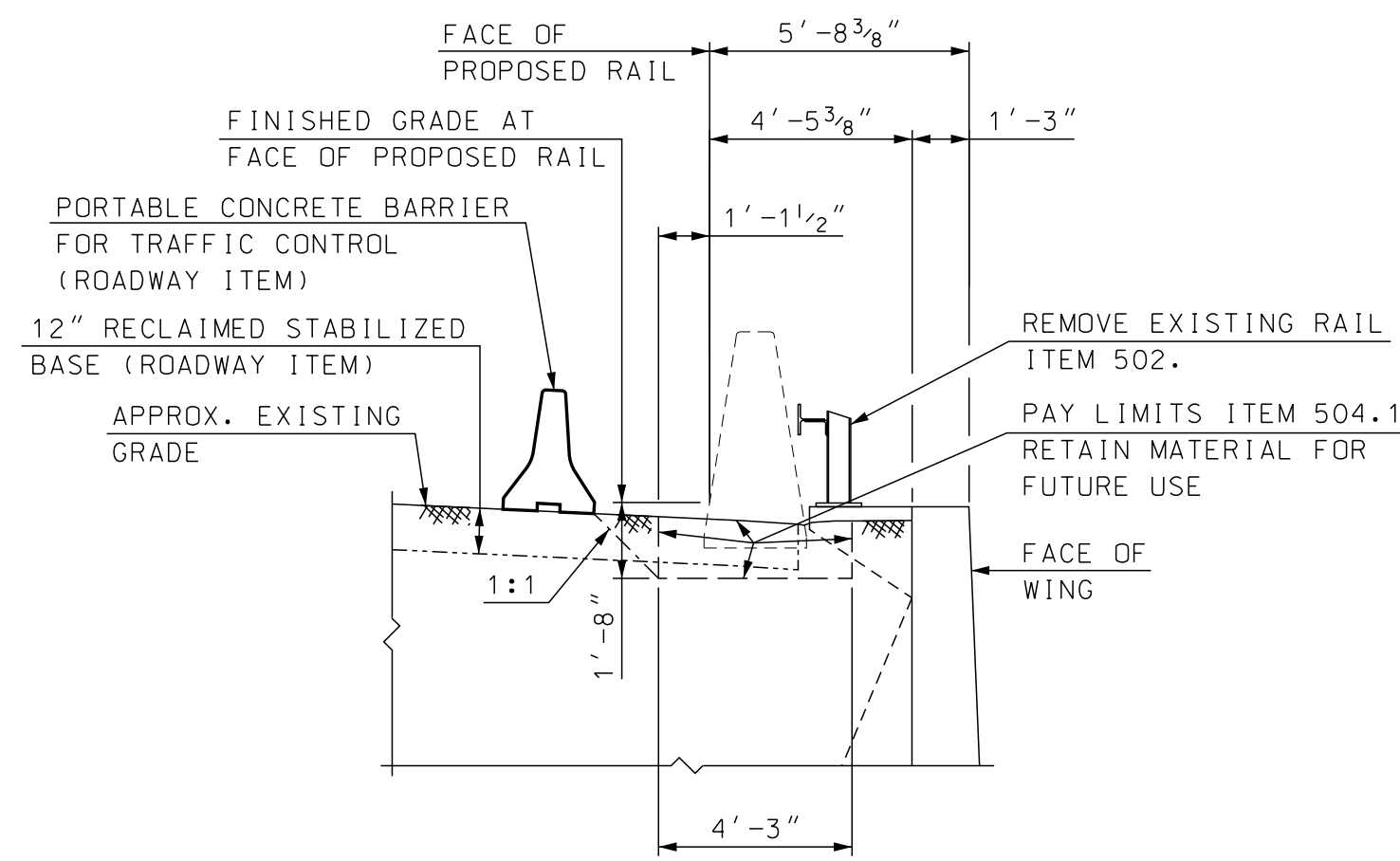

REMOVAL SECTION A-A

SCALE: 1/4" = 1'-0"

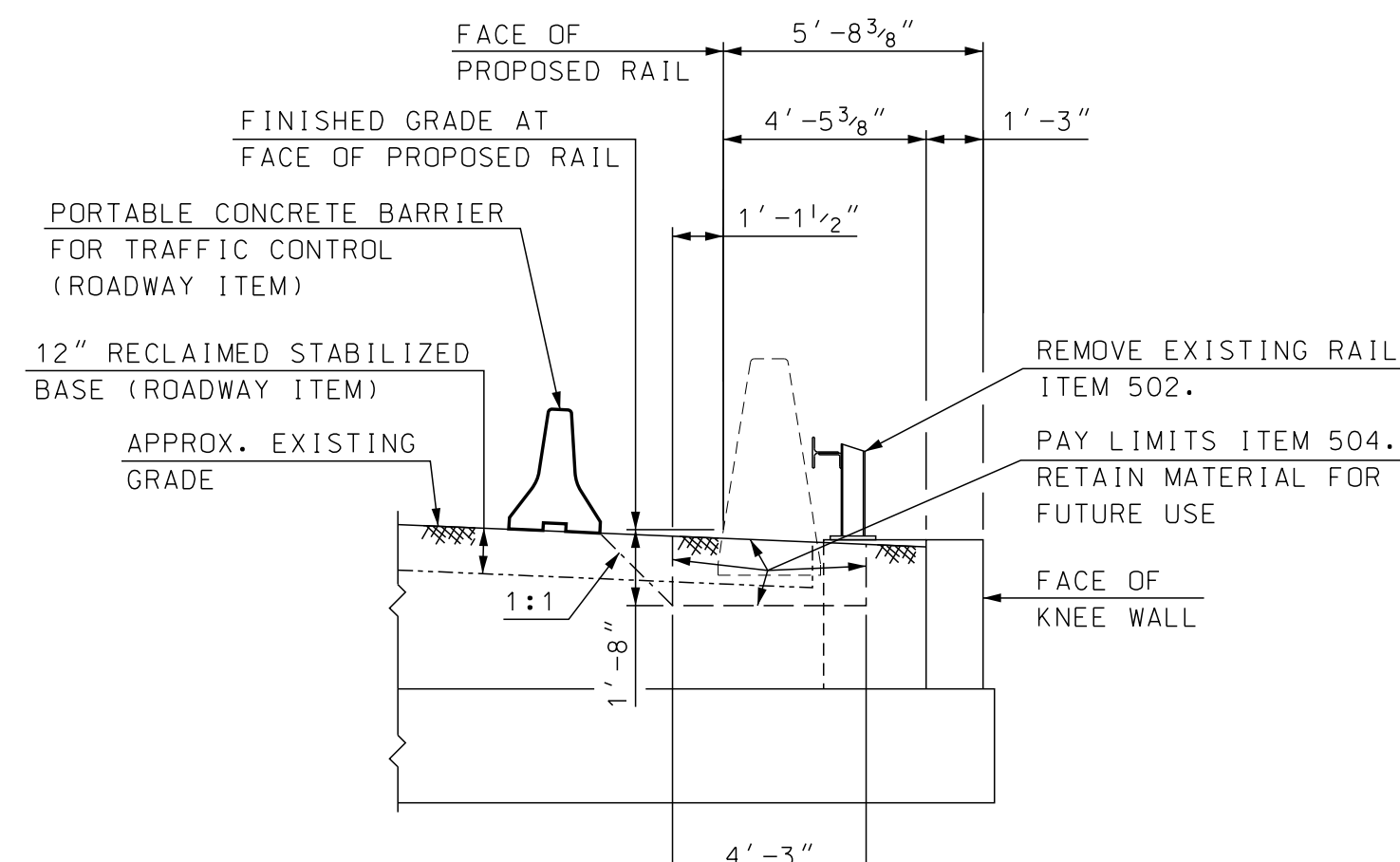

REMOVAL SECTION B-B

SCALE: 1/4" = 1'-0"

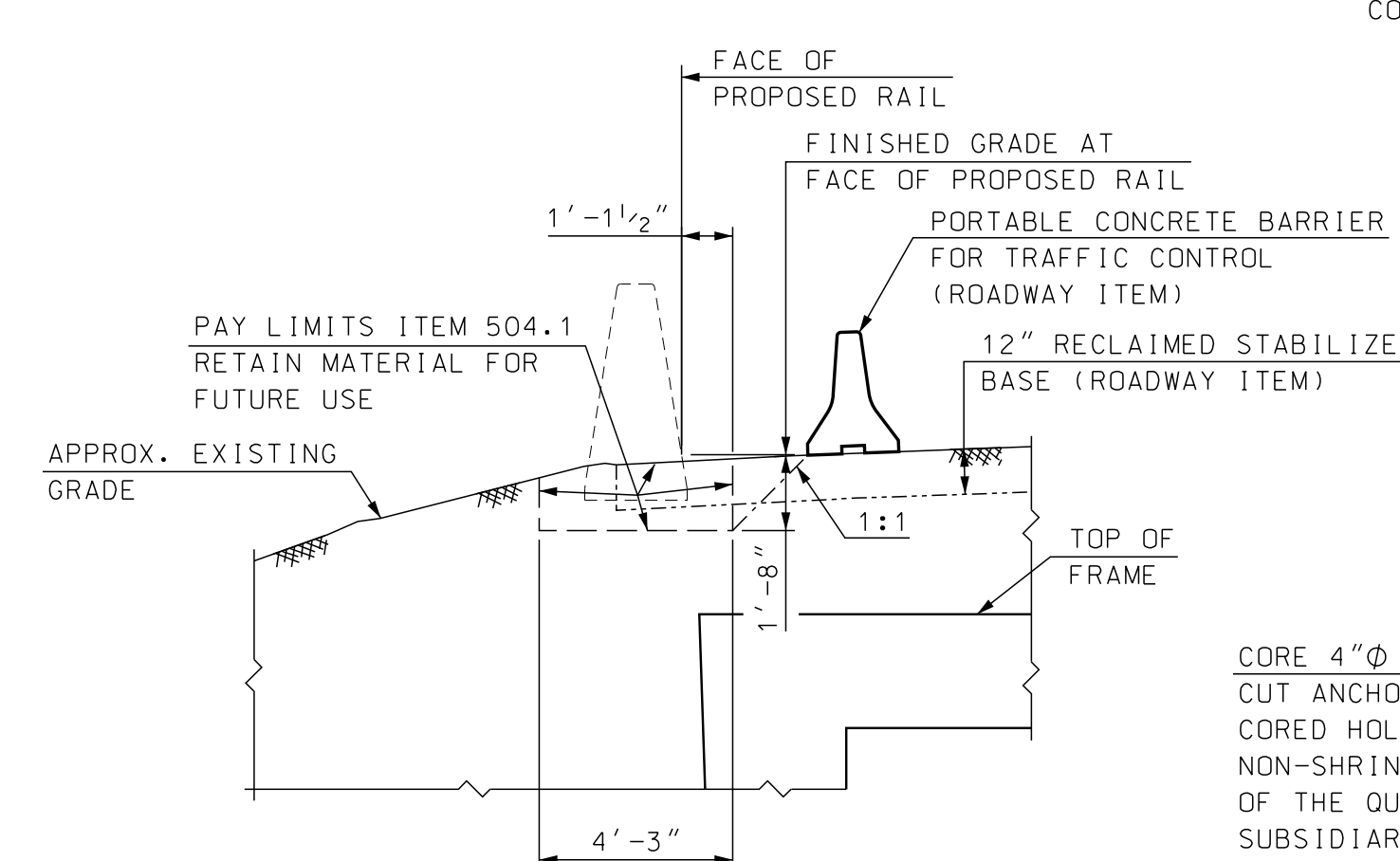

REMOVAL SECTION C-C

SCALE: 1/4" = 1'-0"

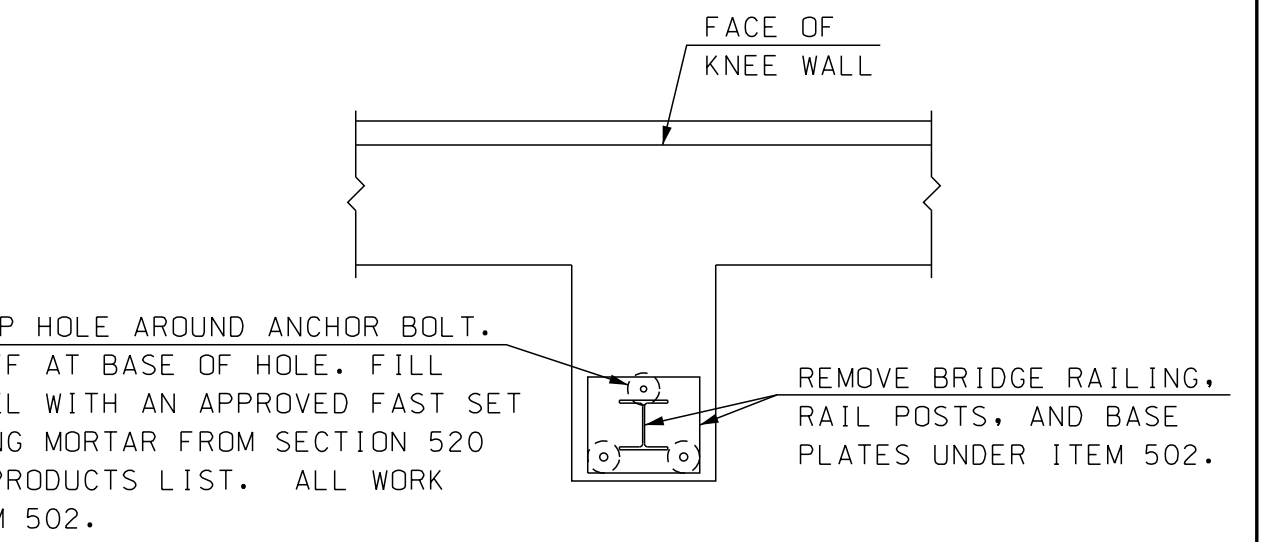

BRIDGE RAIL POST REMOVAL DETAIL

SCALE: 1/2" = 1'-0"

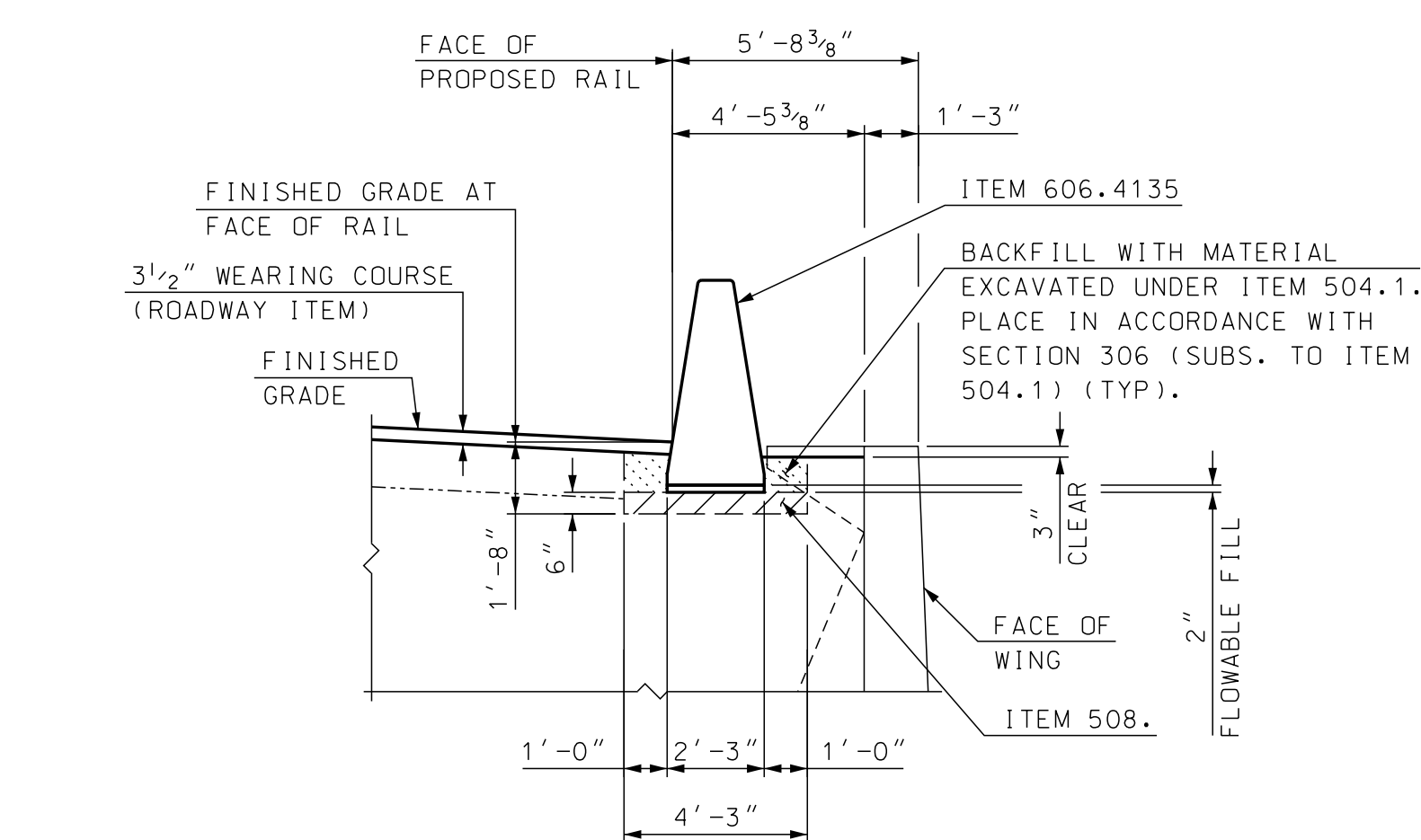

PROPOSED SECTION A-A

SCALE: 1/4" = 1'-0"

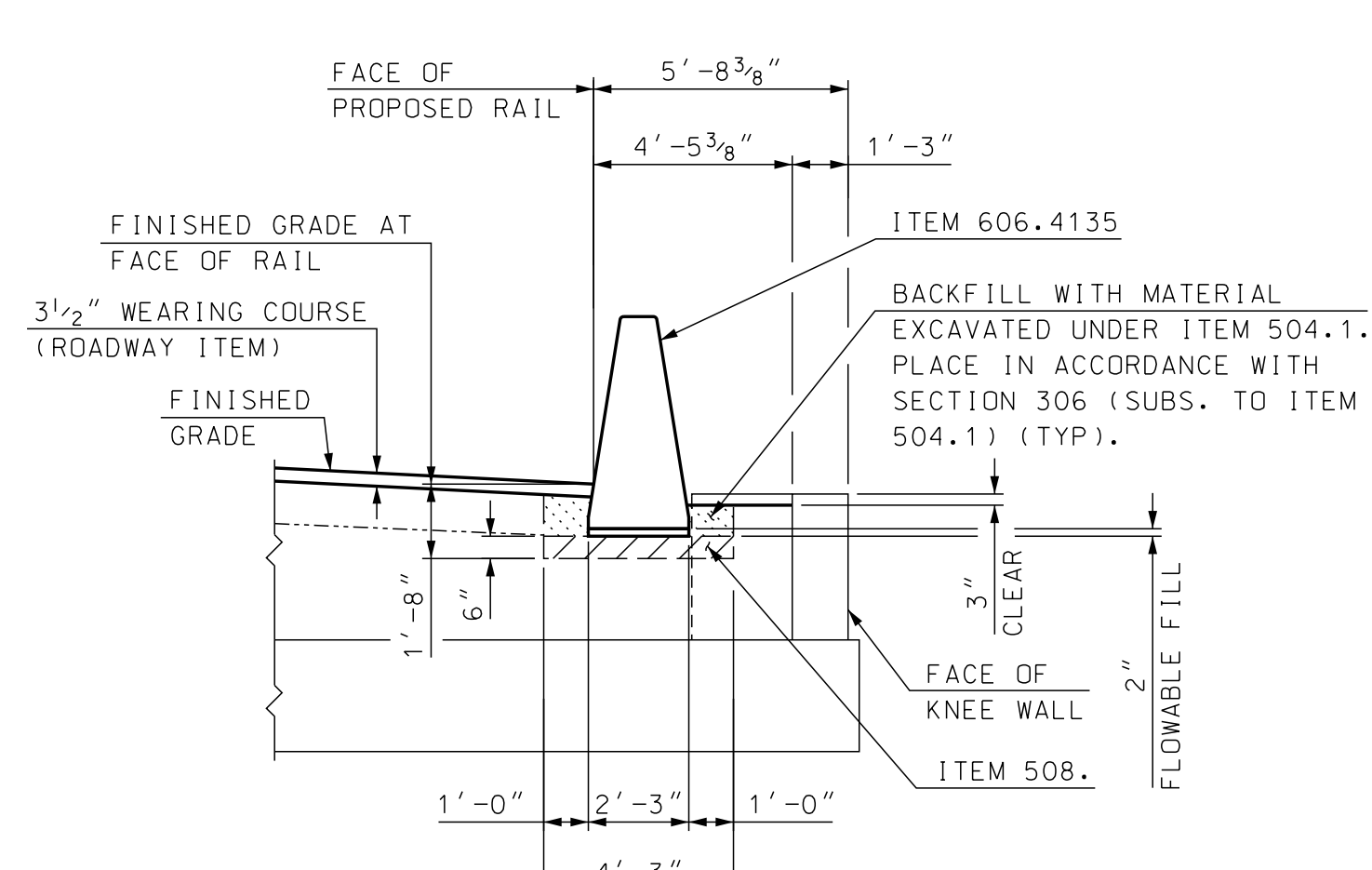

PROPOSED SECTION B-B

SCALE: 1/4" = 1'-0"

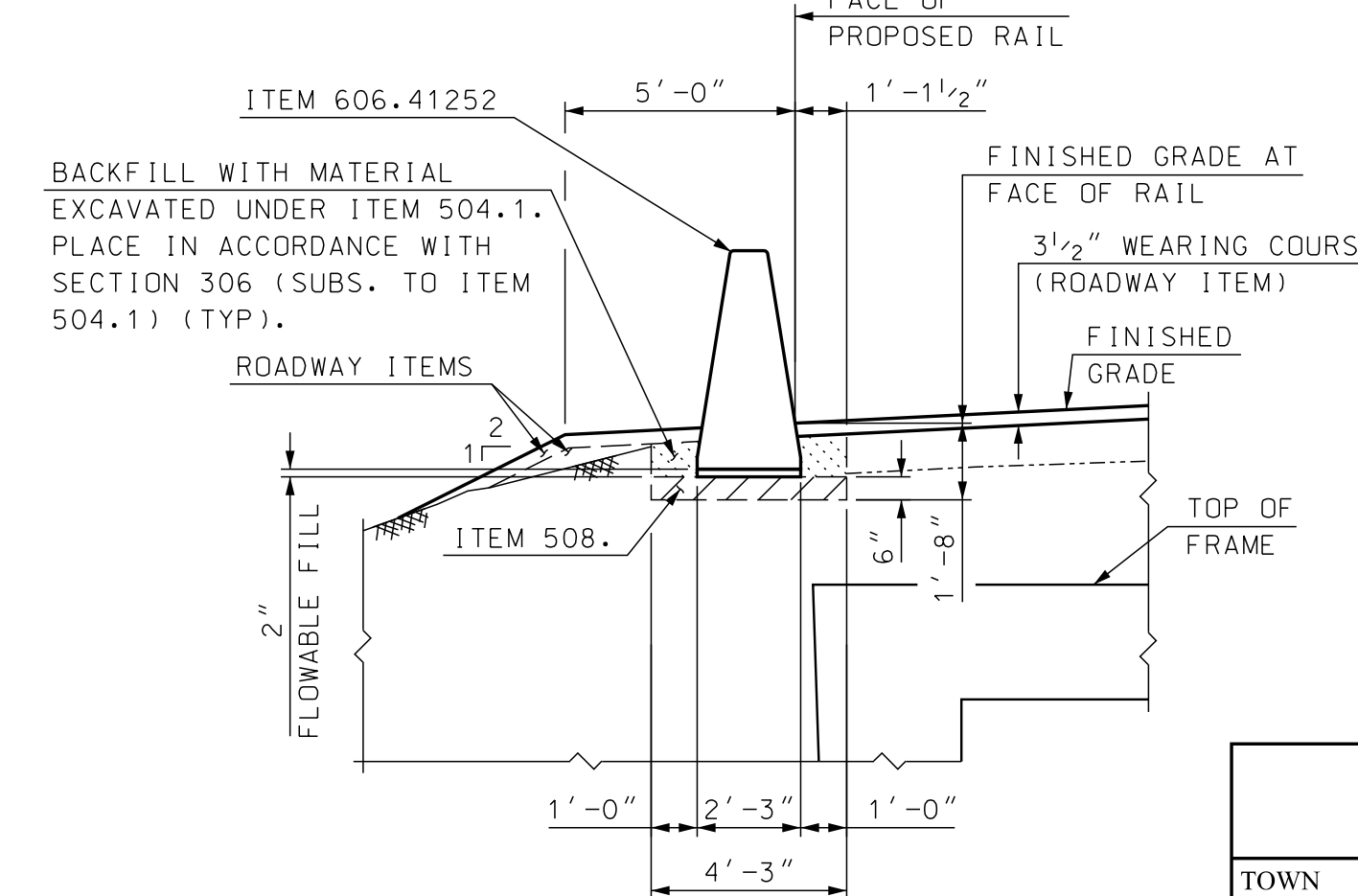

PROPOSED SECTION C-C

SCALE: 1/4" = 1'-0"

STATE OF NEW HAMPSHIRE									
DEPARTMENT OF TRANSPORTATION * BUREAU OF BRIDGE DESIGN									
TOWN	FRANKLIN	BRIDGE NO.	162/099	STATE PROJECT	13928A				
LOCATION	US ROUTE 3 over NHRR (ABD)								
RAIL LAYOUT AND SECTIONS								BRIDGE SHEET	2 OF 4
REVISIONS AFTER PROPOSAL		BY	DATE	CHECKED	DLS	DATE	FILE NUMBER		
		DESIGNED	PAB	2/15	CHECKED	PAB	2/15	3-3-1-11	
		DRAWN	SMG	2/15	CHECKED	PAB	2/15		
		QUANTITIES	SMG	2/15	CHECKED	PAB	2/15		
		ISSUE DATE	FEDERAL PROJECT NO.			SHEET NO.		TOTAL SHEETS	
		REV. DATE	-----			39		160	
SUBDIRECTORY	DGN LOCATOR	SHEET SCALE							
BRC\	13928A Rail	AS NOTED							

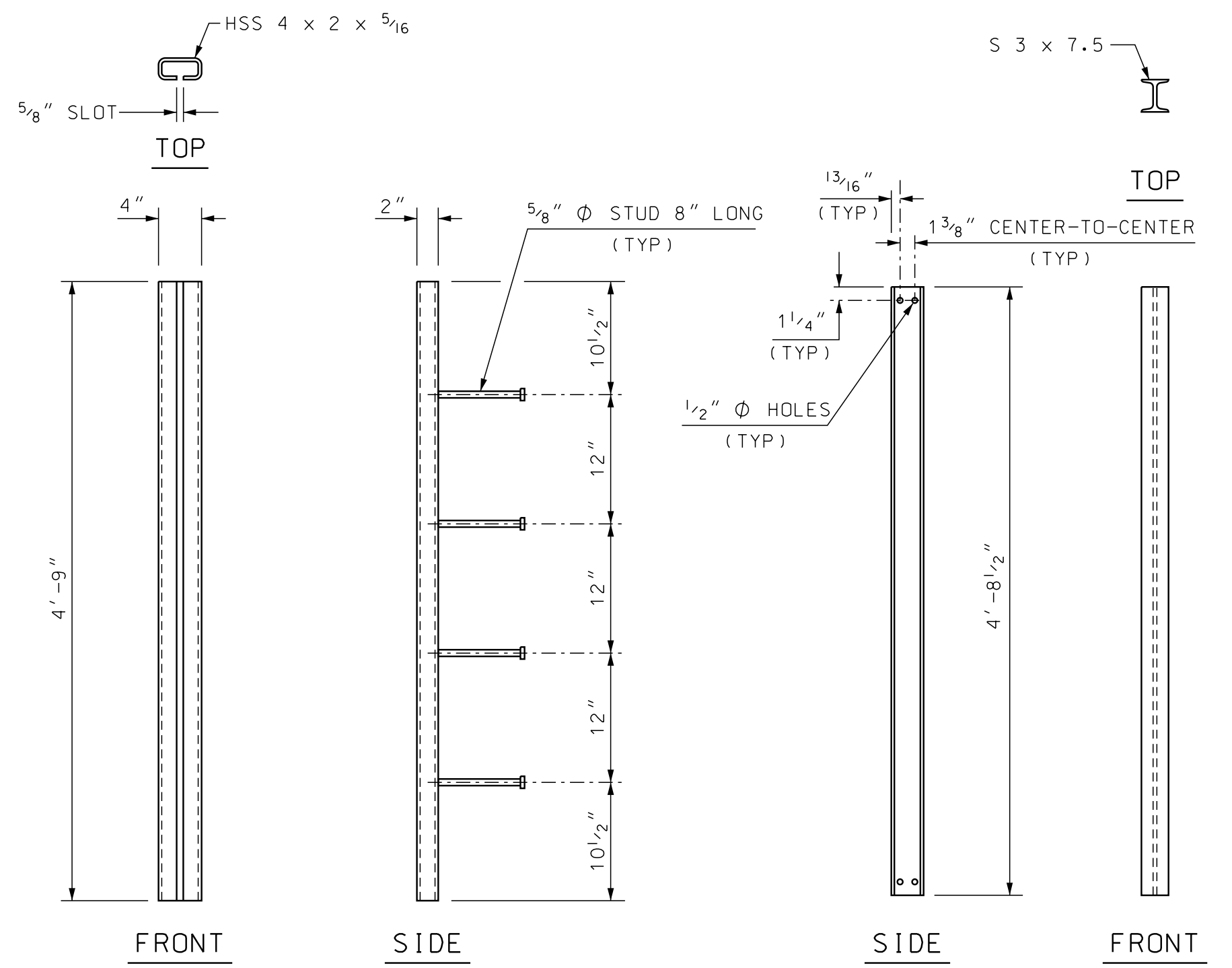

STRUCTURAL SECTION DETAILS
SCALE: 1" = 1'-0"

I-BEAM DETAILS
SCALE: 1" = 1'-0"

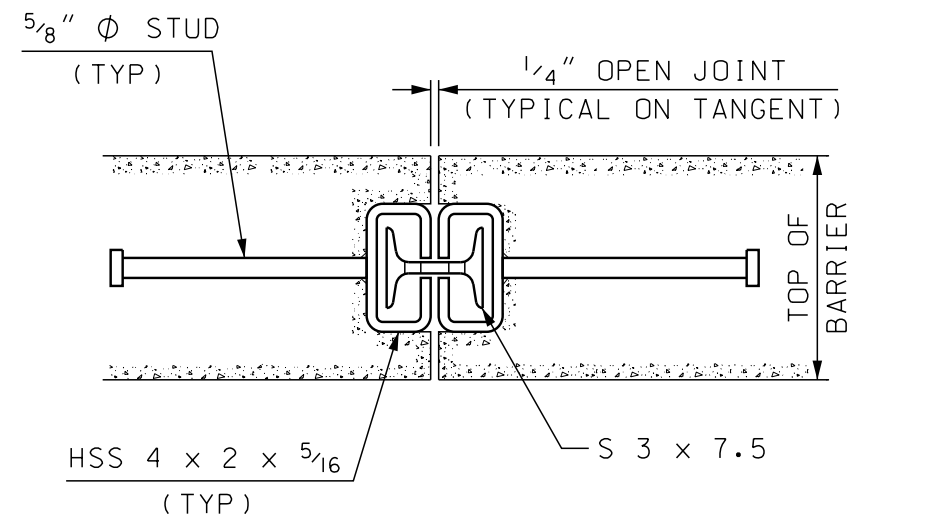

BARRIER CONNECTION DETAIL
SCALE: 2" = 1'-0"

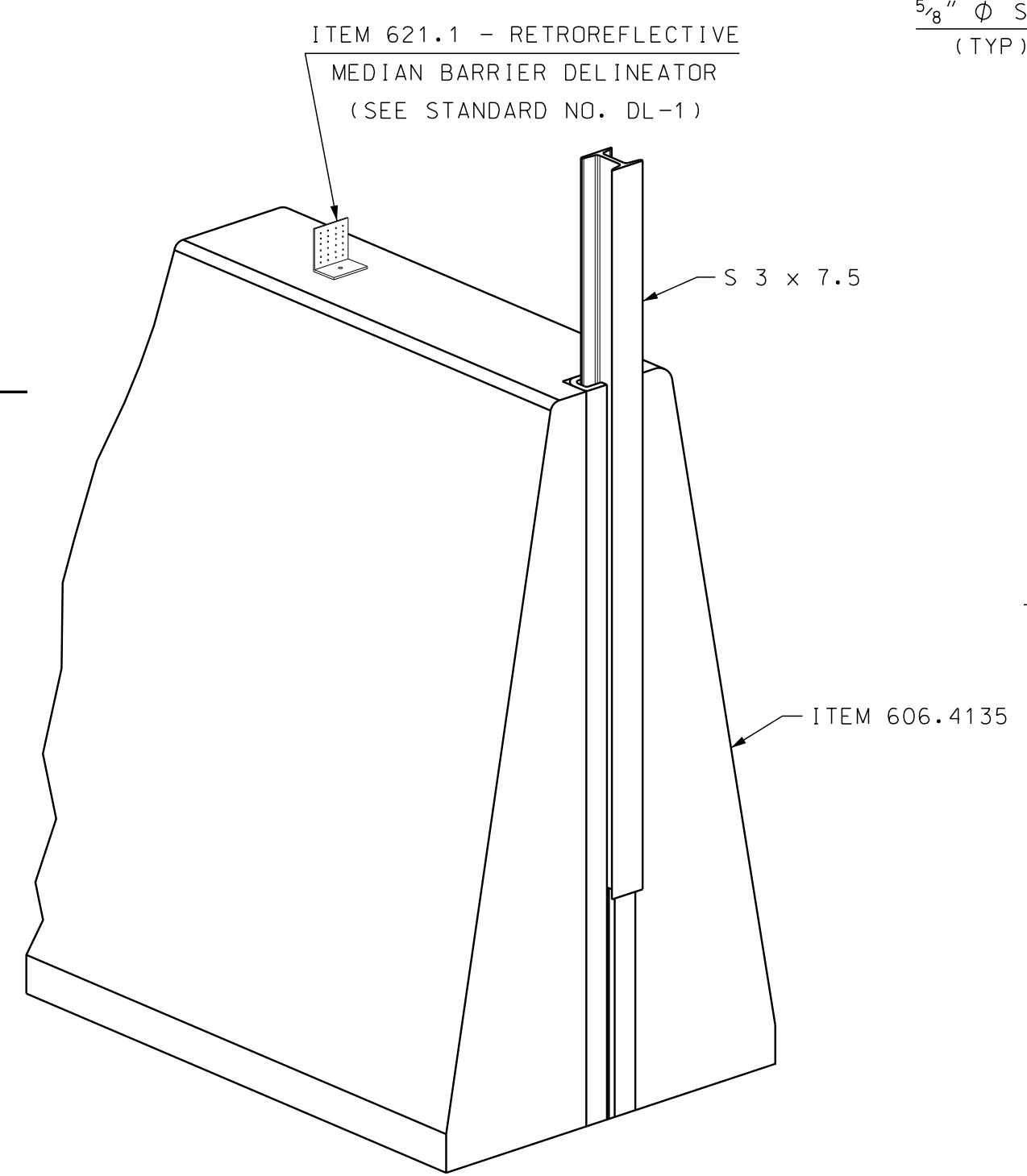

PERSPECTIVE VIEW
SCALE: 1" = 1'-0"

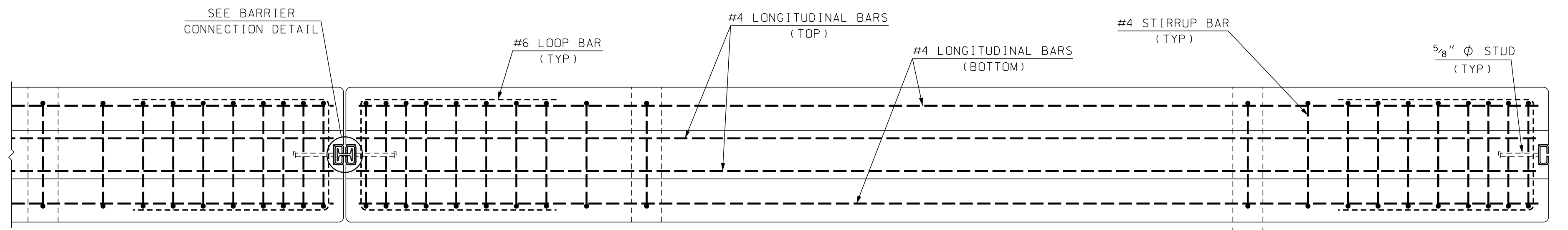

PLAN
SCALE: 3/4" = 1'-0"

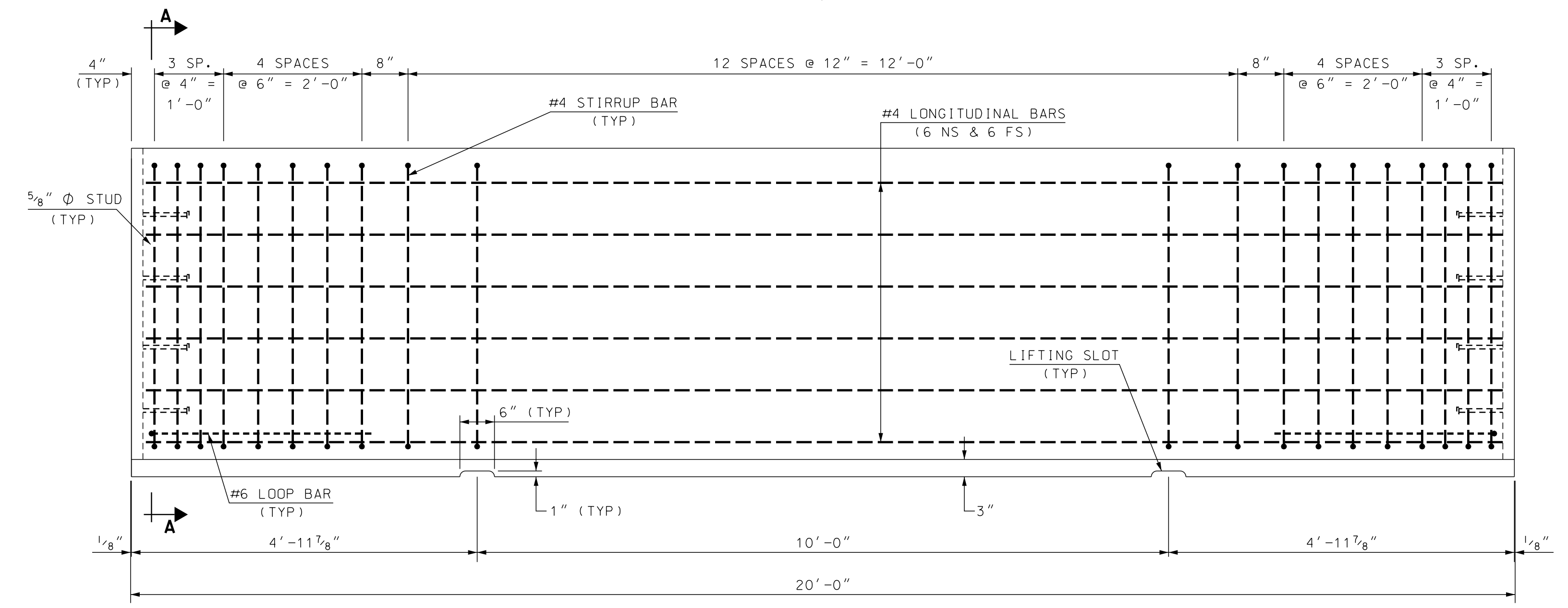

ELEVATION
SCALE: 3/4" = 1'-0"

GENERAL NOTES

1. CONCRETE BARRIER AND ALL ITS COMPONENTS SHALL BE FURNISHED BY THE CONTRACTOR AND PAID AS ITEM 606.4135, 54" SINGLE SLOPE CONCRETE BARRIER, PRECAST.
2. STUD WELDING SHALL BE IN ACCORDANCE WITH SECTION 547.
3. SLOTS IN STRUCTURAL TUBES SHALL BE CUT WITH MECHANICALLY GUIDED MEANS TO A SMOOTH, UNIFORM SURFACE MEETING A SURFACE ROUGHNESS OF 25 μ OR BETTER (ANSI B46.1).
4. CONCRETE BARRIER DETAILS SHOWN ON THIS SHEET ARE IN COMPLIANCE WITH REQUIREMENTS PER UPDATED NCHRP REPORT 350 FOR TEST NO. 5-11 (MASH TL-5), NCHRP 157 VOL. 1.

MATERIAL NOTES

1. THE BARRIERS SHALL BE LIGHT COLORED CLASS AA CONCRETE HAVING A MINIMUM 28 DAY COMPRESSIVE STRENGTH OF 4,000 PSI. BARRIERS SHALL HAVE A SMOOTH UNIFORM SURFACE FREE OF DEFECTS AND IRREGULARITIES. CASTING DATE SHALL BE SHOWN ON BARRIER. ALL EXPOSED EDGES OF CONCRETE SHALL BE CHAMFERED 3/4", UNLESS NOTED OTHERWISE.
2. I-BEAMS AND STRUCTURAL TUBES SHALL BE ASTM A36 OR A572 GALVANIZED AFTER FABRICATION, IN ACCORDANCE WITH SECTION 550.
3. ALL REINFORCING STEEL SHALL BE AASHTO M31 (ASTM-A615) GRADE 60, EPOXY COATED. REINFORCEMENT SHOWN IS THE MINIMUM REQUIRED.
4. EACH BARRIER UNIT SHALL INCLUDE ONE S 3 x 7.5.
5. SHOP DRAWINGS SHALL INCLUDE REINFORCING SCHEDULE.
6. LEVELING PADS, SHIMMING MATERIAL, AND FLOWABLE FILL SHALL BE SUBSIDIARY TO THE CONCRETE BARRIER.

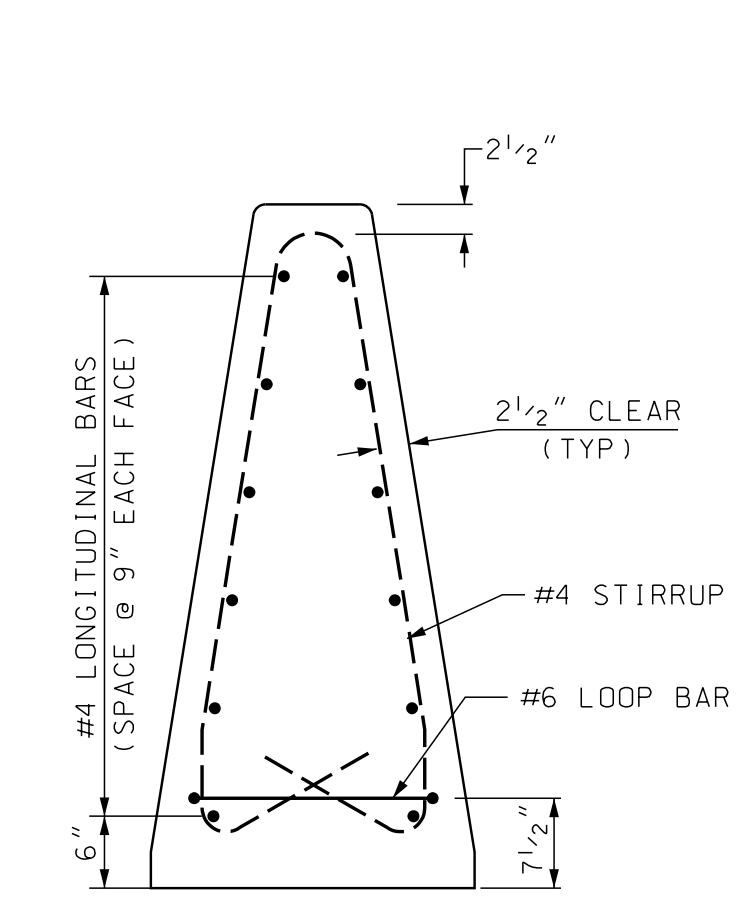

SECTION A-A (REINFORCEMENT)
SCALE: 3/4" = 1'-0"

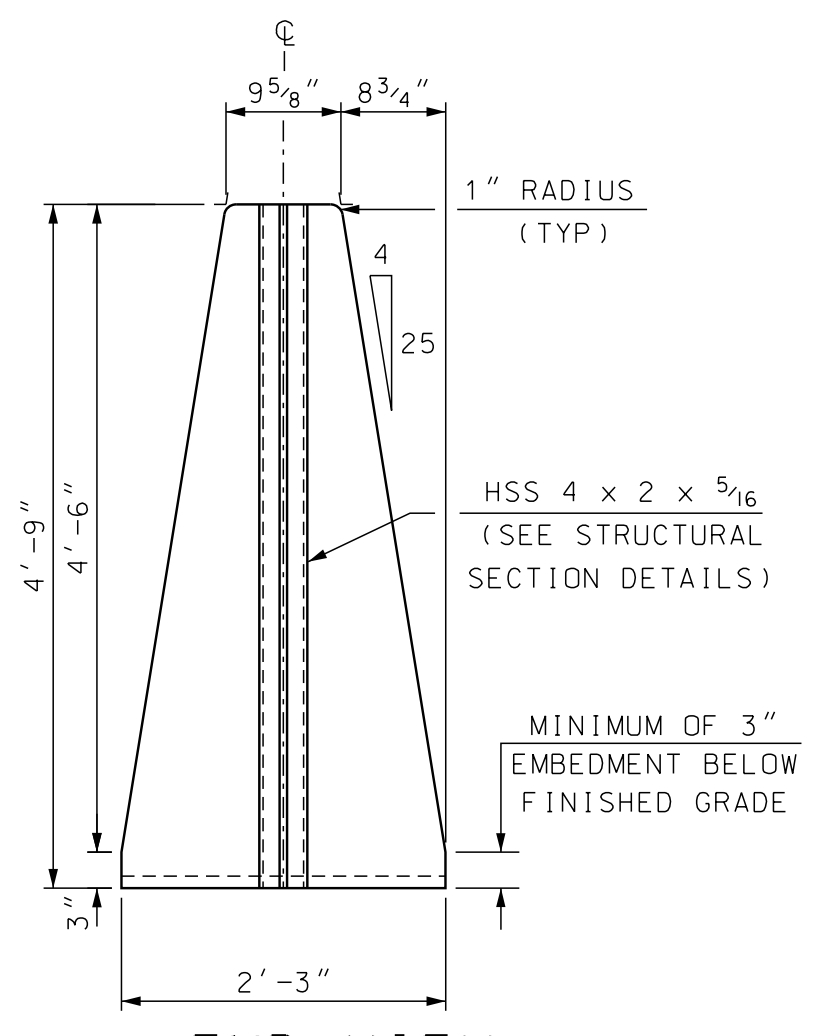

END VIEW (MASONRY)
SCALE: 3/4" = 1'-0"

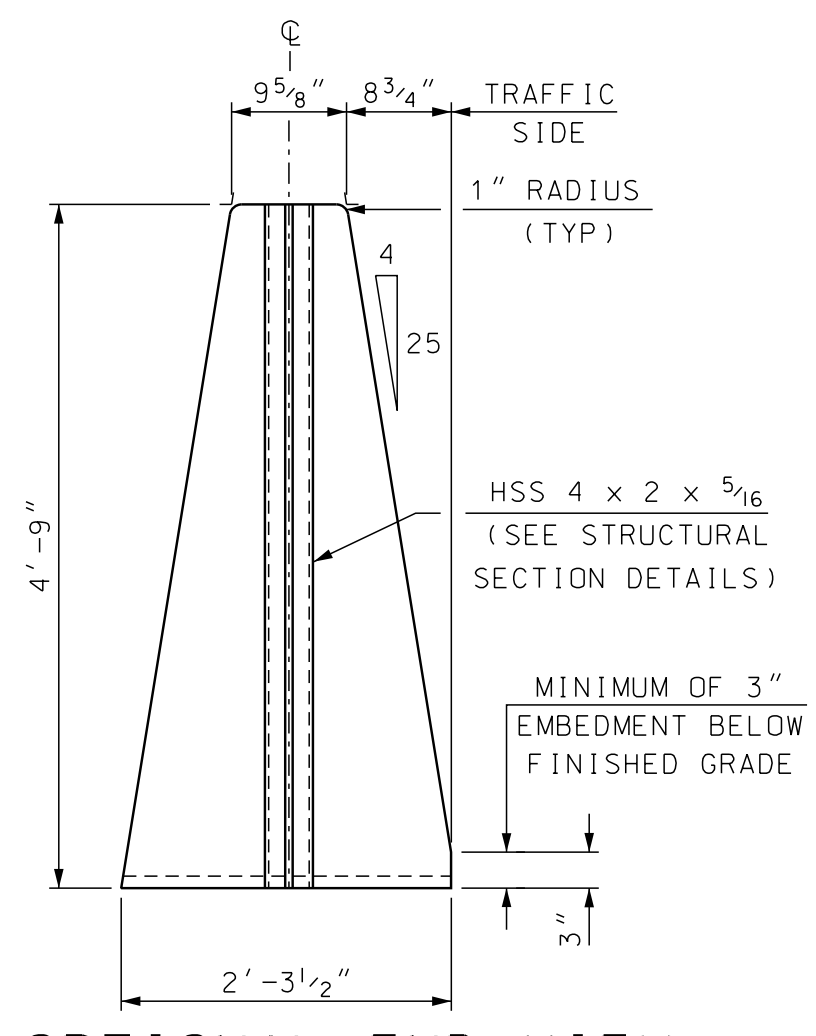

OPTIONAL END VIEW (MASONRY)
SCALE: 3/4" = 1'-0"

CONCRETE BARRIER REINFORCING SCHEDULE				
DESCRIPTION	SIZE	NO.	UNBENT LENGTH	TYPE
LONGITUDINAL (EACH FACE)	#4	12	19'-8"	—
STIRRUPS	#4	29	11'-2"	
LOOP BAR	#6	2	8'-2"	

STATE OF NEW HAMPSHIRE									
DEPARTMENT OF TRANSPORTATION * BUREAU OF BRIDGE DESIGN									
TOWN	FRANKLIN	BRIDGE NO.	162/099	STATE PROJECT	13928A				
LOCATION	US ROUTE 3 over NHRR (ABD)								
54" SINGLE SLOPE CONCRETE BARRIER, PRECAST									BRIDGE SHEET
REVISIONS AFTER PROPOSAL			BY	DATE	BY	DATE	3 OF 4		
			DESIGNED	NHDOT	2/13	CHECKED	NHDOT	2/13	FILE NUMBER
			DRAWN	GMC	2/13	CHECKED	ABH	2/13	3-3-1-11
			QUANTITIES	SMG	2/15	CHECKED	PAB	2/15	
			ISSUE DATE	9/20/13	FEDERAL PROJECT NO.		SHEET NO.		TOTAL SHEETS
			REV. DATE	3/30/14	-----		40		160
SUBDIRECTORY	DGN LOCATOR	SHEET SCALE							
BRC\	54SS-MEDBARRIER	AS NOTED							

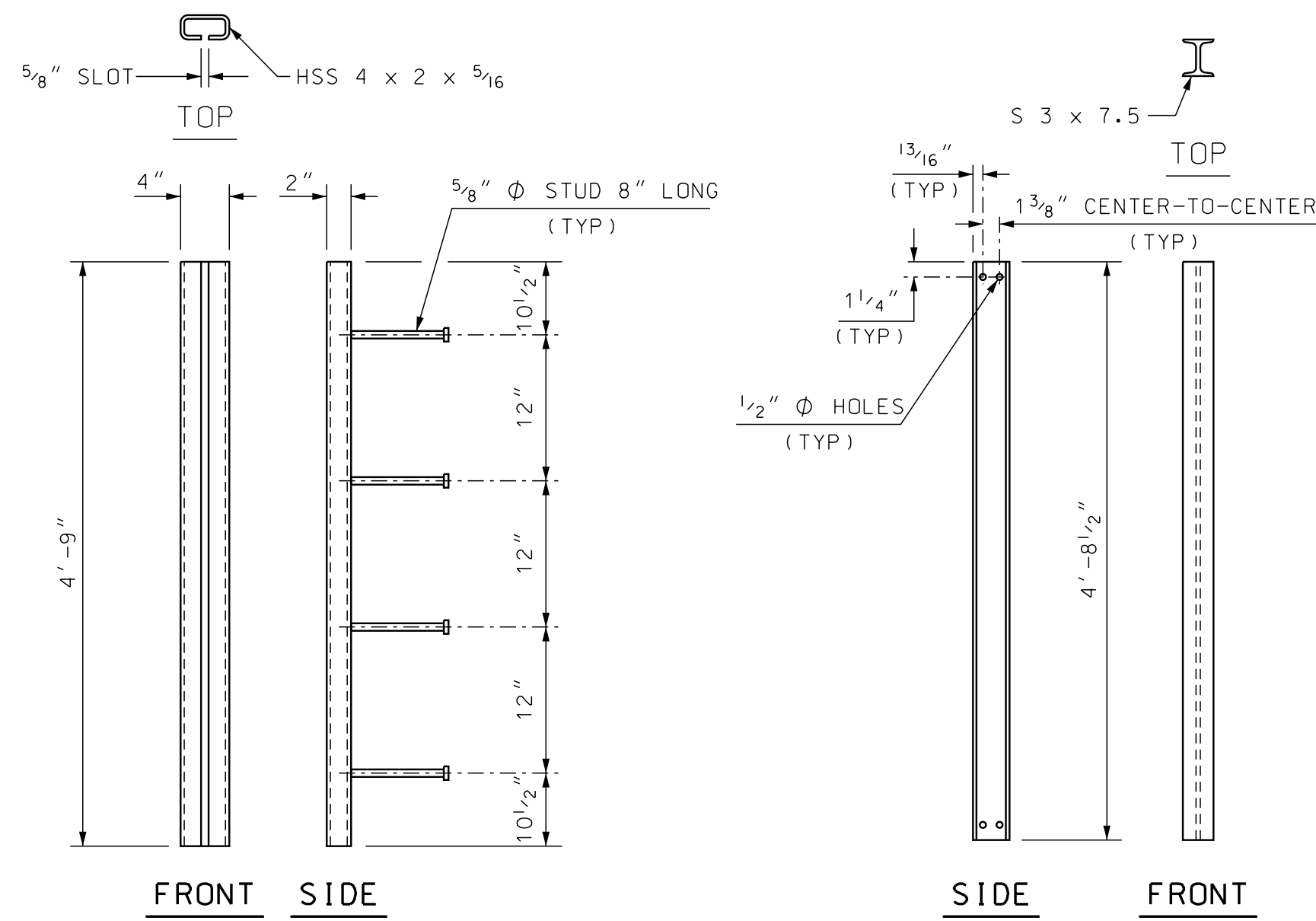

STRUCTURAL SECTION DETAILS
SCALE: 1" = 1'-0"

I-BEAM DETAILS
SCALE: 1" = 1'-0"

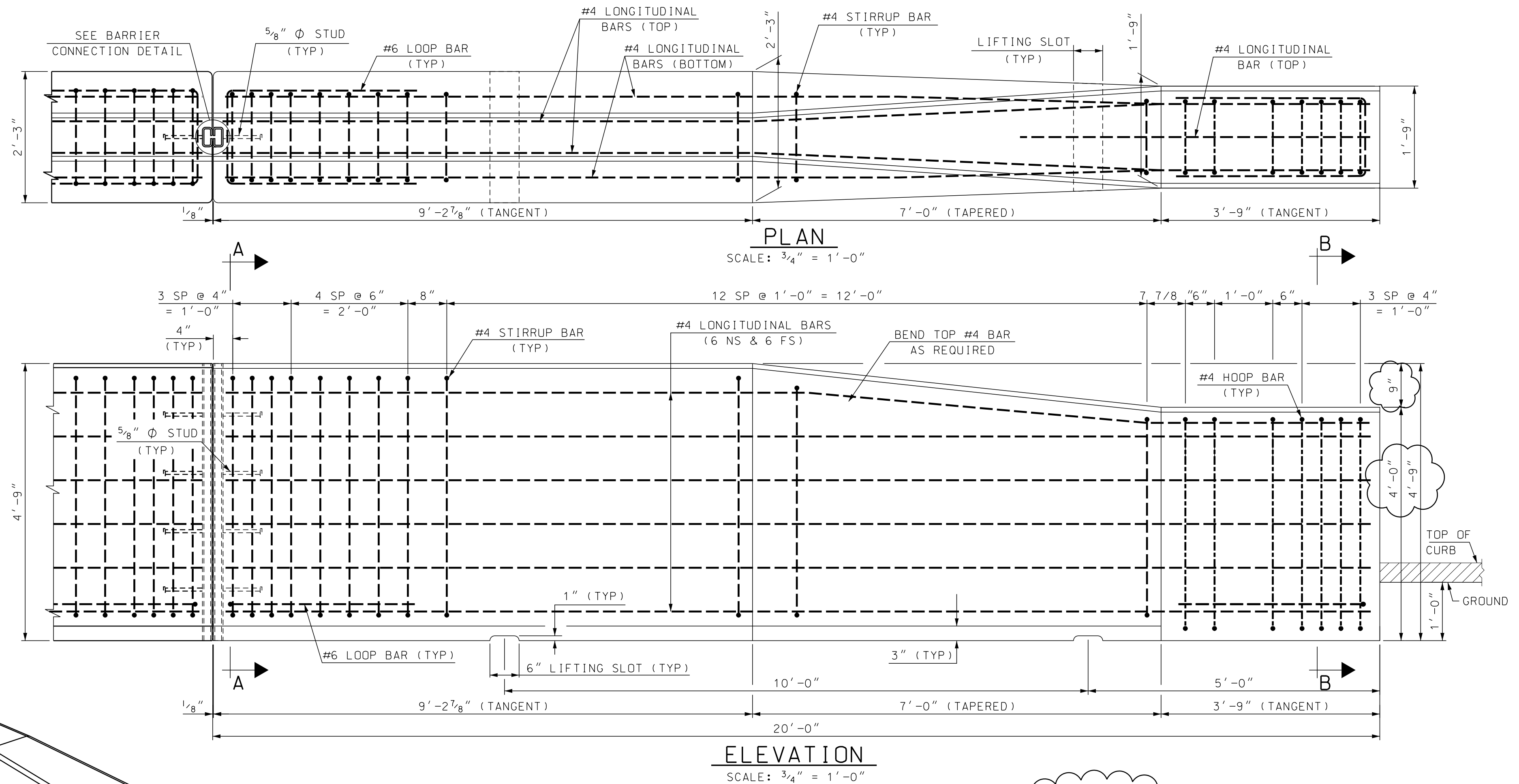

PLAN
SCALE: 3/4" = 1'-0"

ELEVATION
SCALE: 3/4" = 1'-0"

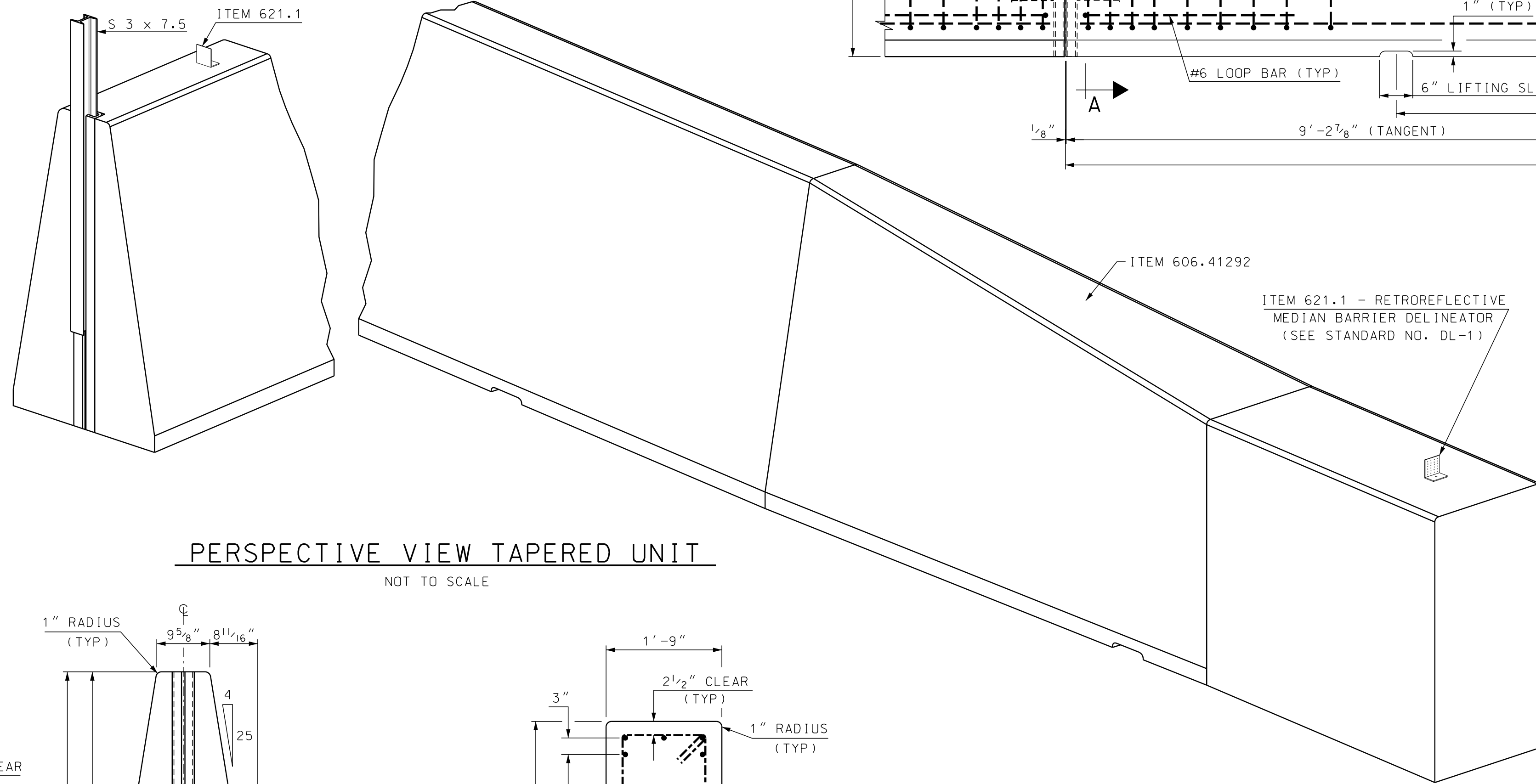

PERSPECTIVE VIEW TAPERED UNIT
NOT TO SCALE

MODIFIED

GENERAL NOTES

1. CONCRETE BARRIER AND ALL ITS COMPONENTS SHALL BE FURNISHED BY THE CONTRACTOR AND PAID AS ITEM 606.41292, 54" TO BEAM GUARDRAIL TRANSITION SINGLE SLOPE CONCRETE BARRIER, PRECAST, MODIFIED.
2. STUD WELDING SHALL BE IN ACCORDANCE WITH SECTION 547.
3. SLOTS IN STRUCTURAL TUBES SHALL BE CUT WITH MECHANICALLY GUIDED MEANS TO A SMOOTH, UNIFORM SURFACE MEETING A SURFACE ROUGHNESS OF 25 μ OR BETTER (ANSI B46.1).
4. CONCRETE BARRIER DETAILS SHOWN ON THIS SHEET ARE IN COMPLIANCE WITH REQUIREMENTS PER UPDATED NCHRP REPORT 350 FOR TEST NO. 5-11 (MASH TL-5), NCHRP 157 VOL. 1.

MATERIAL NOTES

1. THE BARRIERS SHALL BE LIGHT COLORED CLASS AA CONCRETE HAVING A MINIMUM 28 DAY COMPRESSIVE STRENGTH OF 4,000 PSI. BARRIERS SHALL HAVE A SMOOTH UNIFORM SURFACE FREE OF DEFECTS AND IRREGULARITIES. CASTING DATE SHALL BE SHOWN ON BARRIER. ALL EXPOSED EDGES OF CONCRETE SHALL BE CHAMFERED 3/4", UNLESS NOTED OTHERWISE.
2. I-BEAMS AND STRUCTURAL TUBES SHALL BE ASTM A36 OR A572 GALVANIZED AFTER FABRICATION, IN ACCORDANCE WITH SECTION 550.
3. ALL REINFORCING STEEL SHALL BE AASHTO M31 (ASTM-A615) GRADE 60, EPOXY COATED. REINFORCEMENT SHOWN IS THE MINIMUM REQUIRED.
4. EACH BARRIER UNIT SHALL INCLUDE ONE S 3x7.5.
5. SHOP DRAWINGS SHALL INCLUDE REINFORCING SCHEDULE.
6. LEVELING PADS, SHIMMING MATERIAL, AND FLOWABLE FILL SHALL BE SUBSIDIARY TO THE CONCRETE BARRIER.

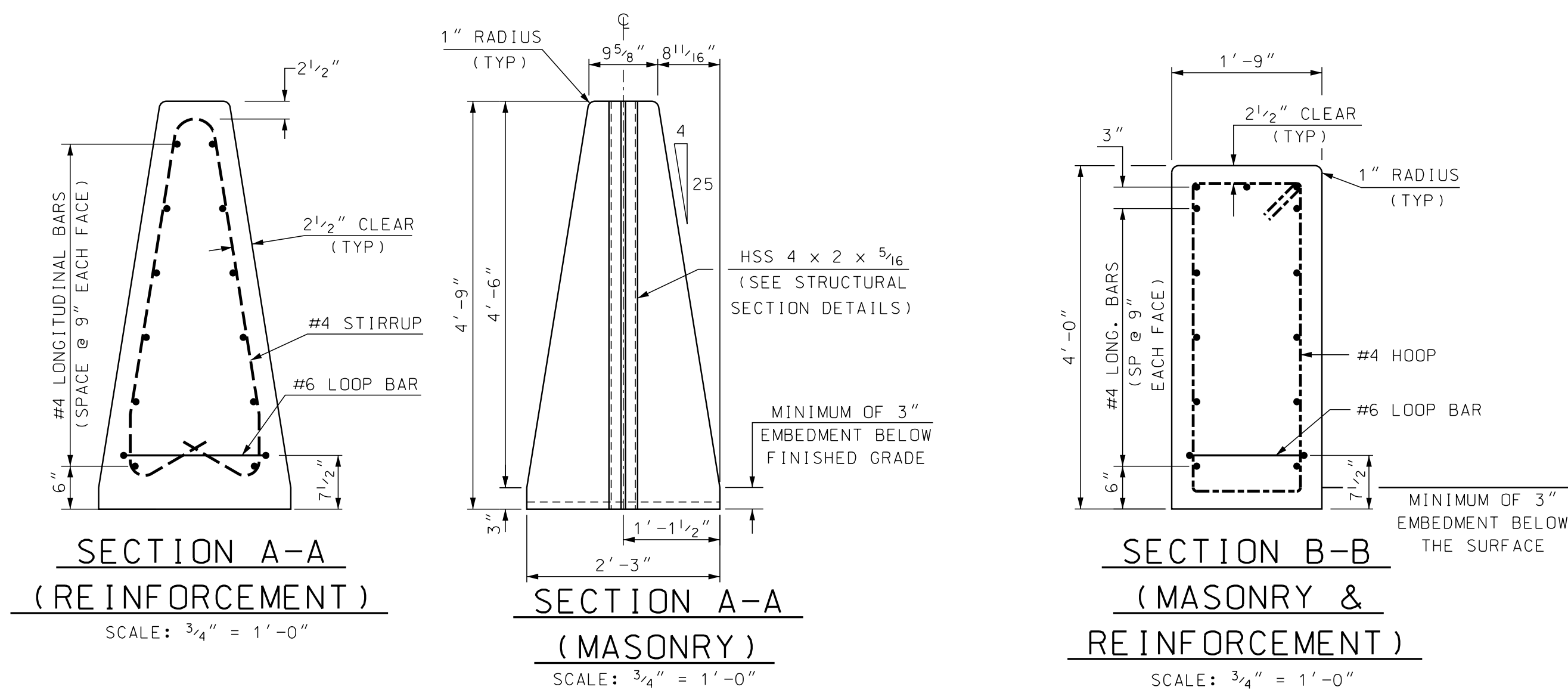

SECTION A-A (REINFORCEMENT)
SCALE: 3/4" = 1'-0"

SECTION A-A (MASONRY)
SCALE: 3/4" = 1'-0"

SECTION B-B (MASONRY & REINFORCEMENT)
SCALE: 3/4" = 1'-0"

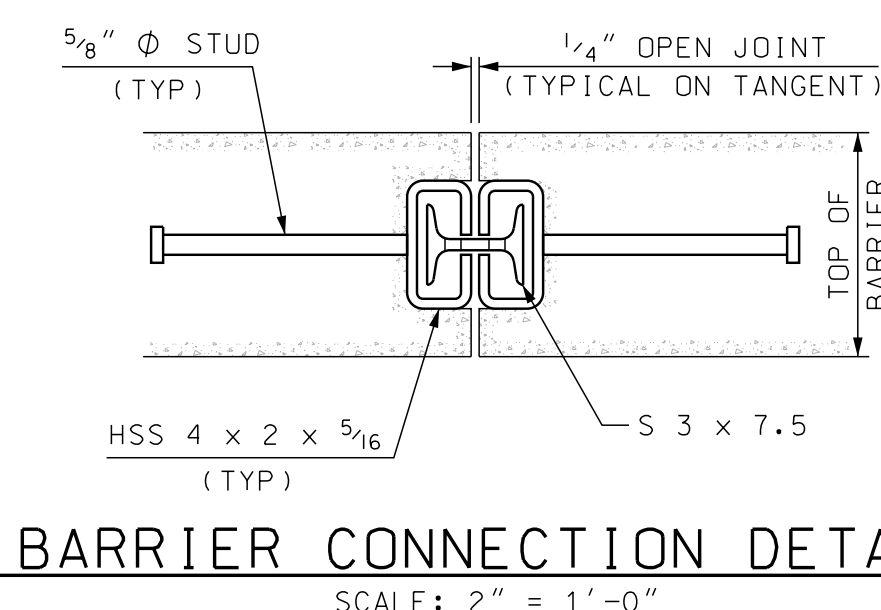

BARRIER CONNECTION DETAIL
SCALE: 2" = 1'-0"

STATE OF NEW HAMPSHIRE									
DEPARTMENT OF TRANSPORTATION * BUREAU OF BRIDGE DESIGN									
TOWN	FRANKLIN	BRIDGE NO.	162/099	STATE PROJECT	13928A				
LOCATION	US ROUTE 3 over NHRR (ABD)					BRIDGE SHEET			
54" TO BEAM GUARDRAIL TRANSITION SINGLE SLOPE CONCRETE BARRIER, PRECAST, MODIFIED						4 OF 4			
DESIGNED		NHDOT	2/14	CHECKED		NHDOT	2/14	FILE NUMBER	
DRAWN		GMC	2/14	CHECKED		ABH	2/14	3-3-1-11	
QUANTITIES		SMG	2/15	CHECKED		PAB	2/15	TOTAL SHEETS	
ISSUE DATE		2/3/14	FEDERAL PROJECT NO.				SHEET NO.		41
REV. DATE		---							160

SUBDIRECTORY	.DGN LOCATOR	SHEET SCALE
BRC\	54SS-TAPEREDSQUARE-MODIFIED	AS NOTED

SDR PROCESSED		PLAN PREP		DATE	09/2013
NEW DESIGN		TEAM KIROUAC		DATE	04/2015
SHEET CHECKED		M. BALDWIN		DATE	
AS BUILT DETAILS				DATE	
REVISIONS AFTER PROPOSAL		STATION	DESCRIPTION	NUMBER	DATE

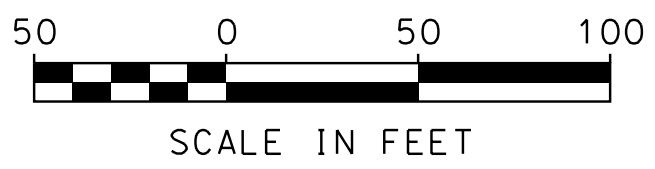
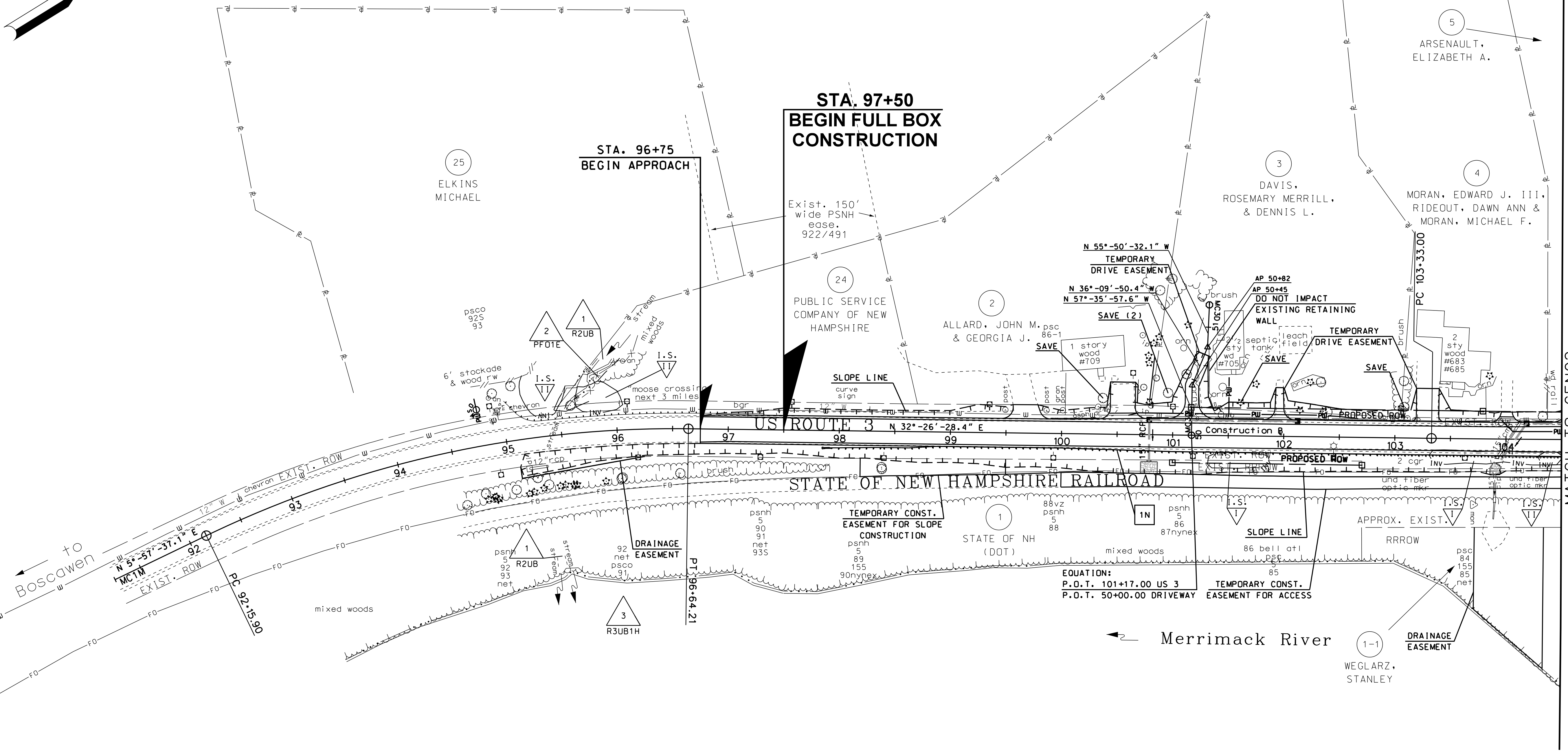
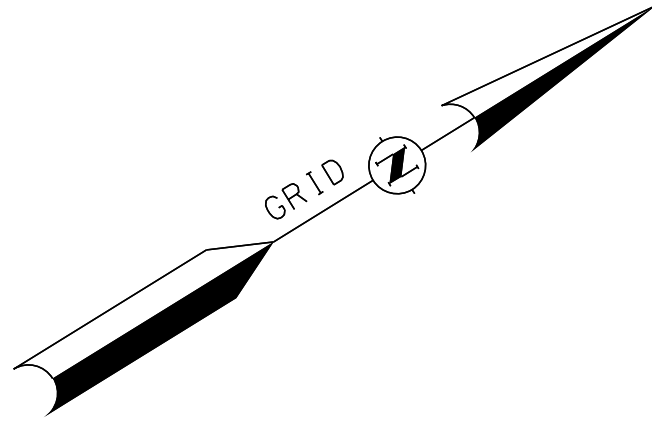

STATE OF NEW HAMPSHIRE				
DEPARTMENT OF TRANSPORTATION • BUREAU OF HIGHWAY DESIGN				
GENERAL PLAN				
MODEL	DGN	STATE PROJECT NO.	SHEET NO.	TOTAL SHEETS
GEN01 Views	13928agenplans	13928A	42	160

MATCH TO GEN02

SDR PROCESSED	PLAN PREP	DATE	09/2013
NEW DESIGN	TEAM KIROUAC	DATE	04/2015
SHEET CHECKED	M. BALDWIN	DATE	
AS BUILT DETAILS		DATE	

REVISIONS AFTER PROPOSAL	STATION	DESCRIPTION

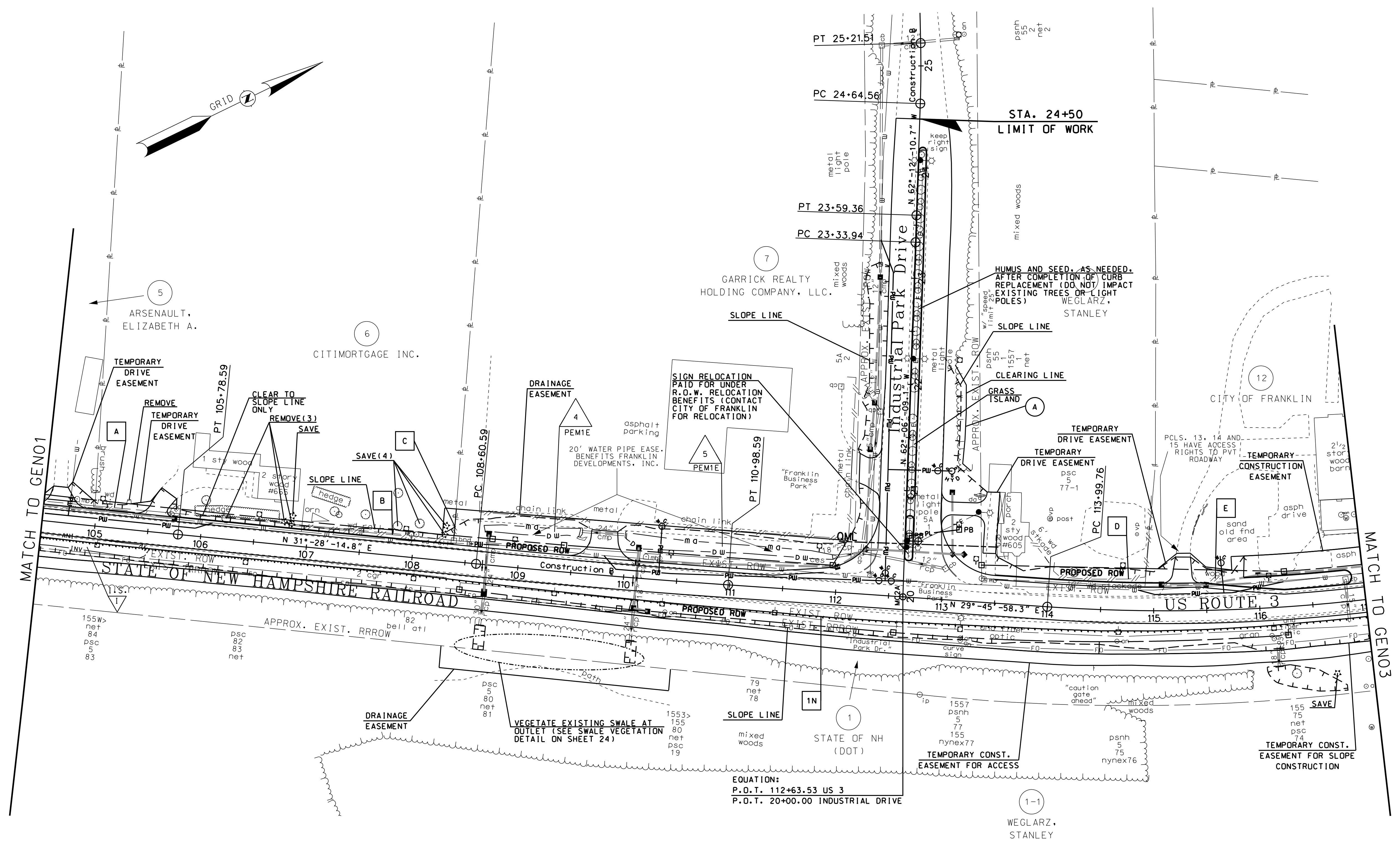

STATE OF NEW HAMPSHIRE				
DEPARTMENT OF TRANSPORTATION • BUREAU OF HIGHWAY DESIGN				
GENERAL PLAN				
MODEL	DGN	STATE PROJECT NO.	SHEET NO.	TOTAL SHEETS
GEN02	13928agenplans	13928A	43	160

SDR PROCESSED	PLAN PREP	DATE	09/2013
NEW DESIGN	TEAM K/TROUAC	DATE	04/2015
SHEET CHECKED	M. BALDWIN	DATE	
AS BUILT DETAILS		DATE	

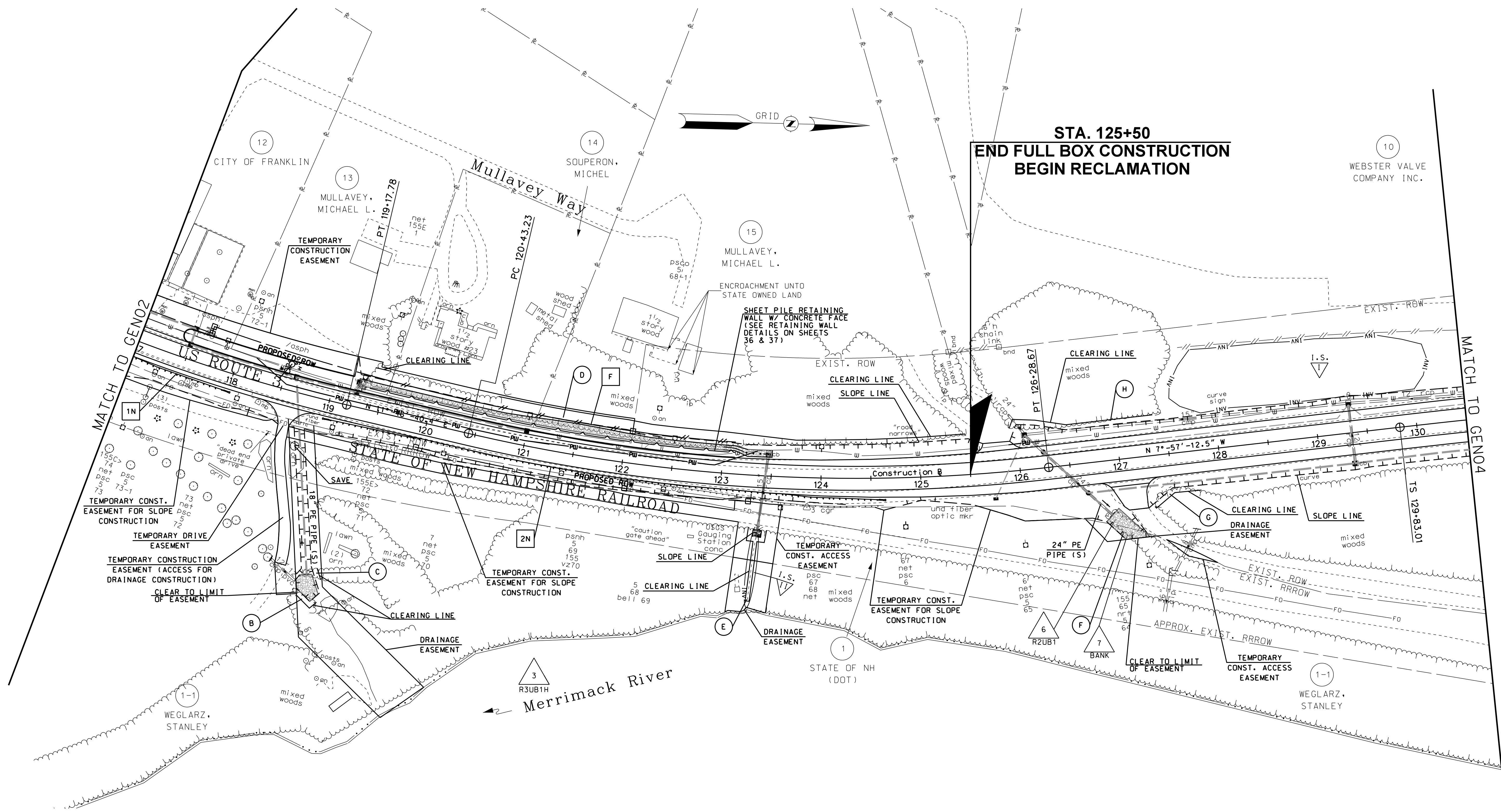

**STA. 125+50
END FULL BOX CONSTRUCTION
BEGIN RECLAMATION**

STATE OF NEW HAMPSHIRE				
DEPARTMENT OF TRANSPORTATION • BUREAU OF HIGHWAY DESIGN				
GENERAL PLAN				
MODEL	DGN	STATE PROJECT NO.	SHEET NO.	TOTAL SHEETS
GEN03	13928agenplans	13928A	44	160

SDR PROCESSED	PLAN PREP	DATE	09/2013
NEW DESIGN	TEAM K IROUAC	DATE	04/2015
SHEET CHECKED	M. BALDWIN	DATE	
AS BUILT DETAILS		DATE	

REVISIONS AFTER PROPOSAL	STATION	DESCRIPTION

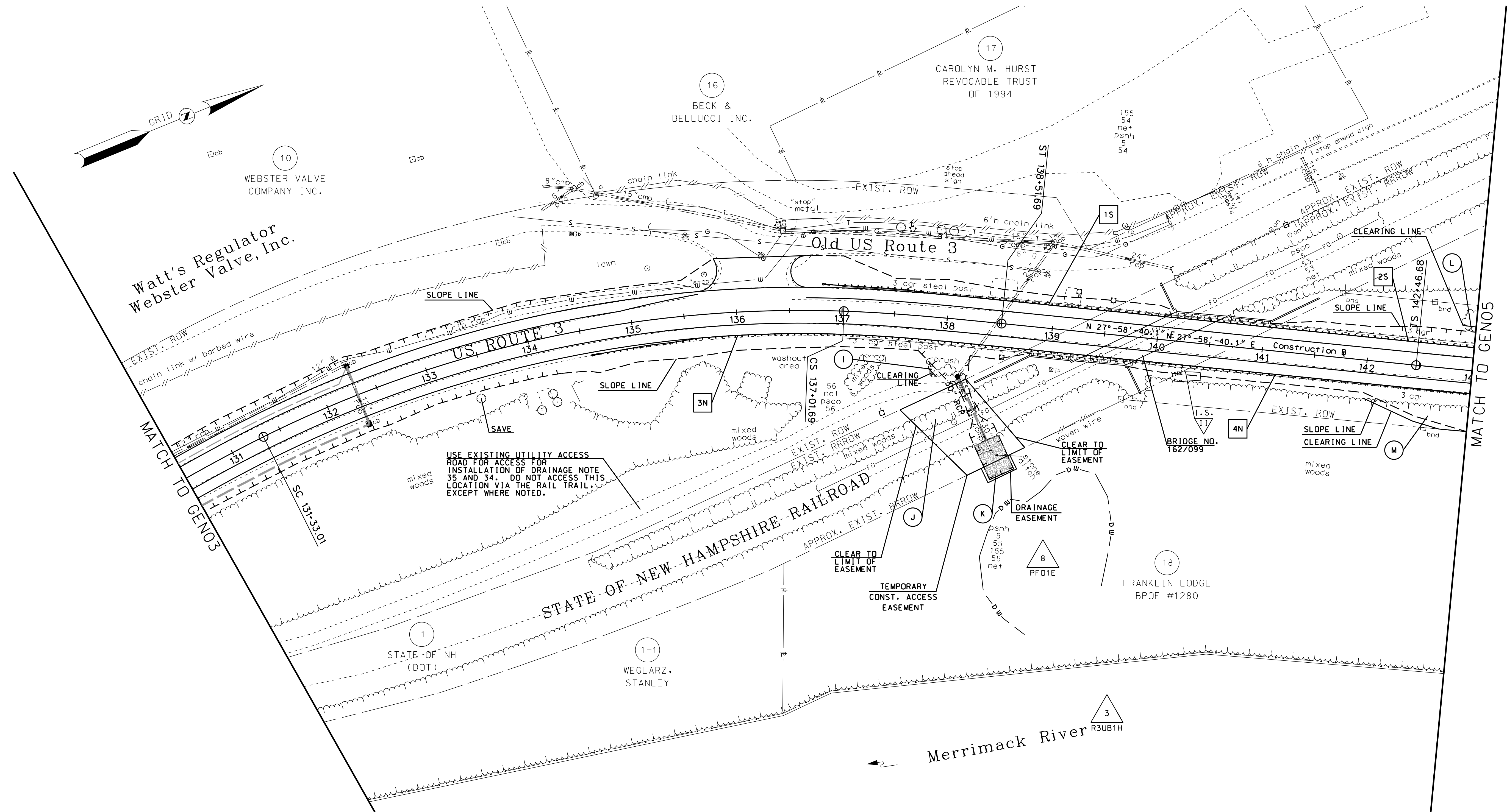
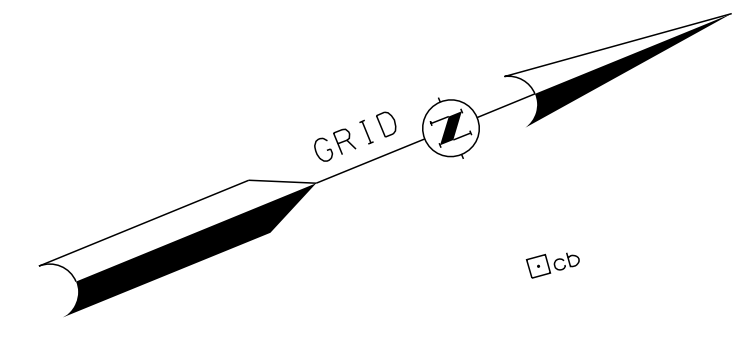

USE EXISTING UTILITY ACCESS ROAD FOR ACCESS FOR INSTALLATION OF DRAINAGE NOTE 35 AND 34. DO NOT ACCESS THIS LOCATION VIA THE RAIL TRAIL, EXCEPT WHERE NOTED.



STATE OF NEW HAMPSHIRE				
DEPARTMENT OF TRANSPORTATION • BUREAU OF HIGHWAY DESIGN				
GENERAL PLAN				
MODEL	DGN	STATE PROJECT NO.	SHEET NO.	TOTAL SHEETS
GEN04	13928agenplans	13928A	45	160

SDR PROCESSED	PLAN PREP	DATE	09/2013
NEW DESIGN	TEAM K/TROJAC	DATE	04/2015
SHEET CHECKED	M. BALDWIN	DATE	
AS BUILT DETAILS		DATE	

REVISIONS AFTER PROPOSAL	STATION	DESCRIPTION

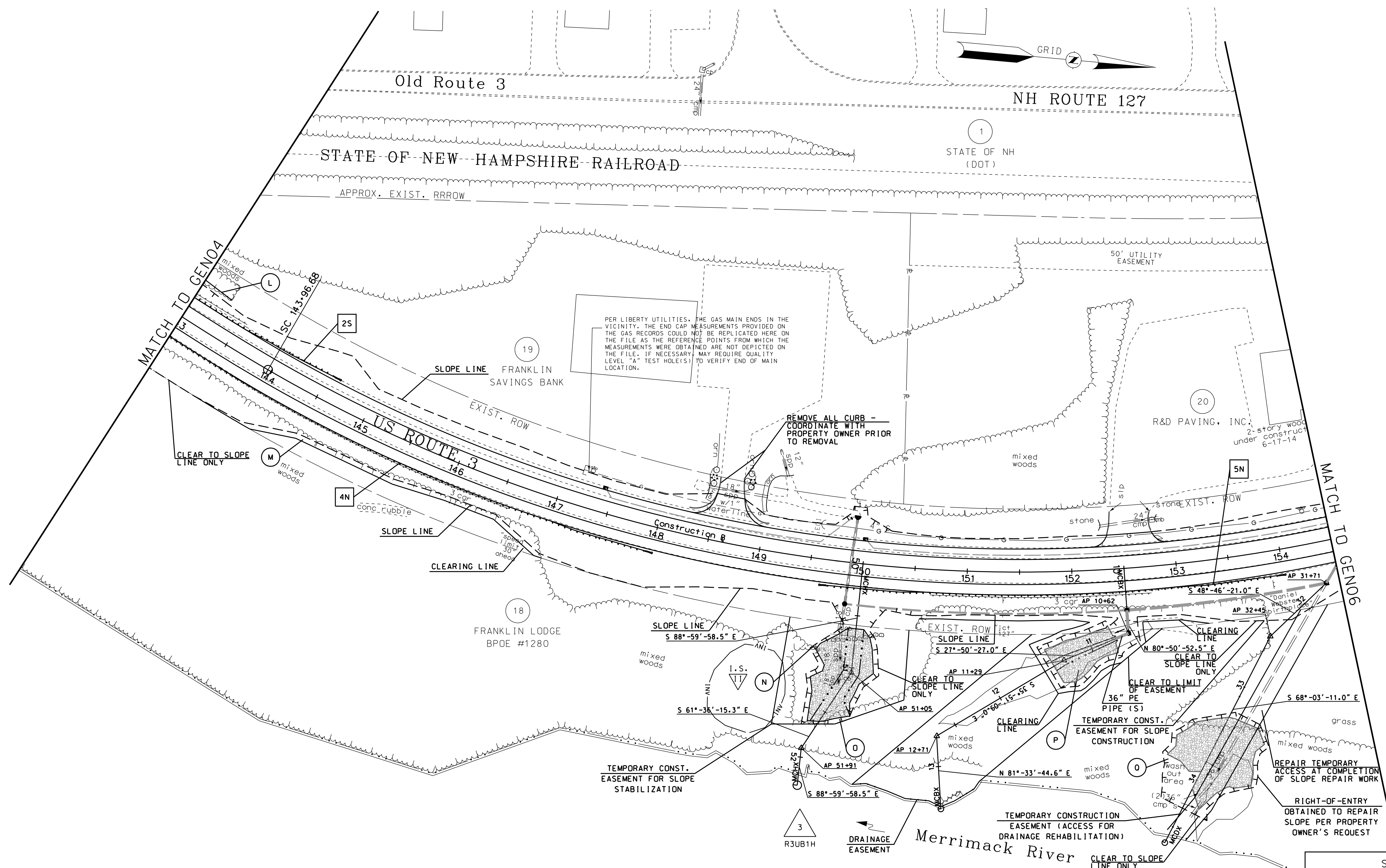

STATE OF NEW HAMPSHIRE				
DEPARTMENT OF TRANSPORTATION • BUREAU OF HIGHWAY DESIGN				
GENERAL PLAN				
MODEL	DGN	STATE PROJECT NO.	SHEET NO.	TOTAL SHEETS
GEN05	13928agenplans	13928A	46	160

SDR PROCESSED	PLAN PREP	DATE	09/2013
NEW DESIGN	TEAM KIROUAC	DATE	04/2015
SHEET CHECKED	M. BALDWIN	DATE	
AS BUILT DETAILS		DATE	

REVISIONS AFTER PROPOSAL	STATION	DESCRIPTION

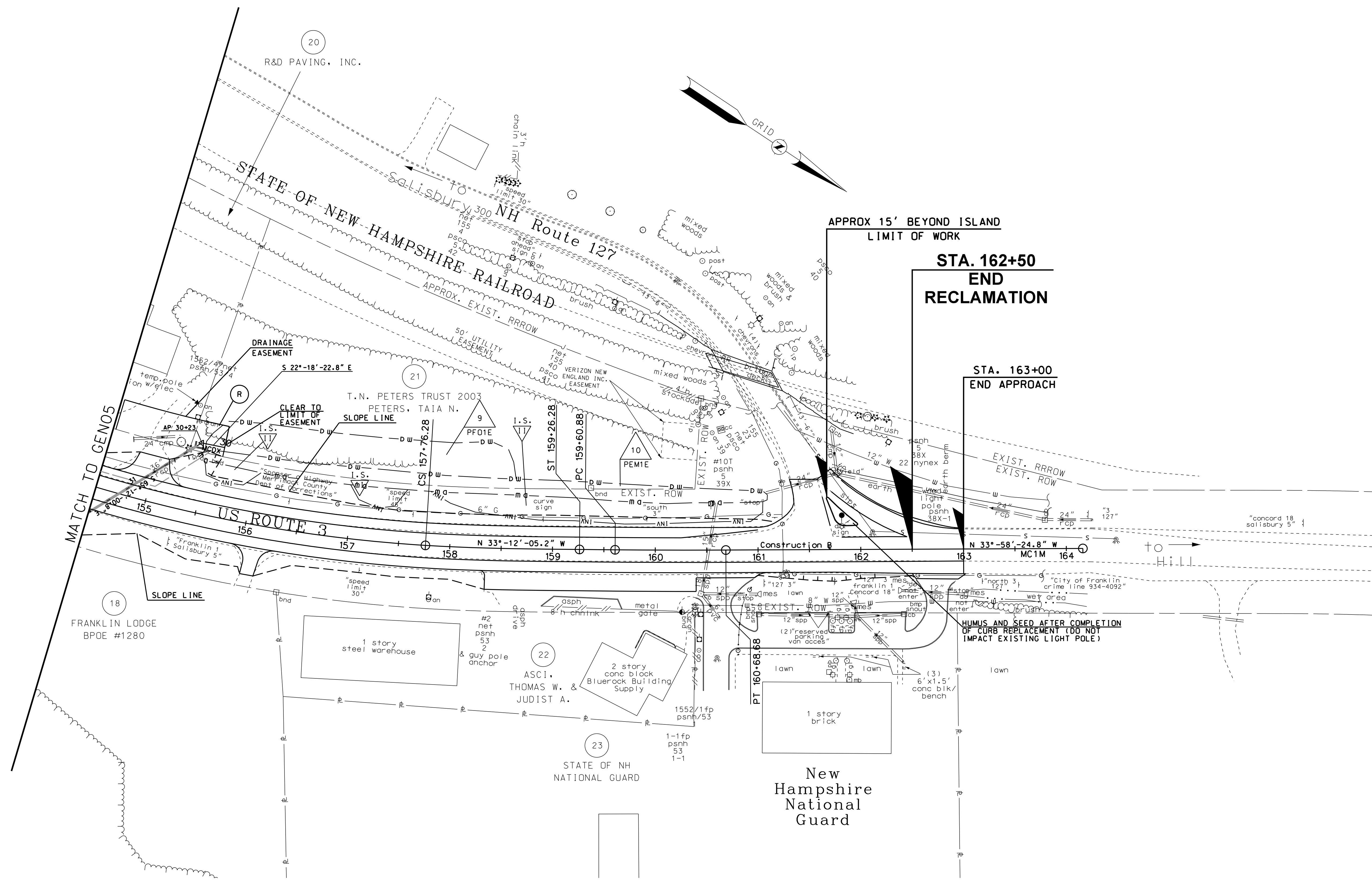

STATE OF NEW HAMPSHIRE				
DEPARTMENT OF TRANSPORTATION • BUREAU OF HIGHWAY DESIGN				
GENERAL PLAN				
MODEL	DGN	STATE PROJECT NO.	SHEET NO.	TOTAL SHEETS
GEN06	13928agenplans	13928A	47	160

SDR PROCESSED	DATE	04/2015	REVISIONS AFTER PROPOSAL
NEW DESIGN	DATE	04/2015	STATION
SHEET CHECKED	DATE	04/2015	STATION
AS BUILT DETAILS	DATE		DESCRIPTION

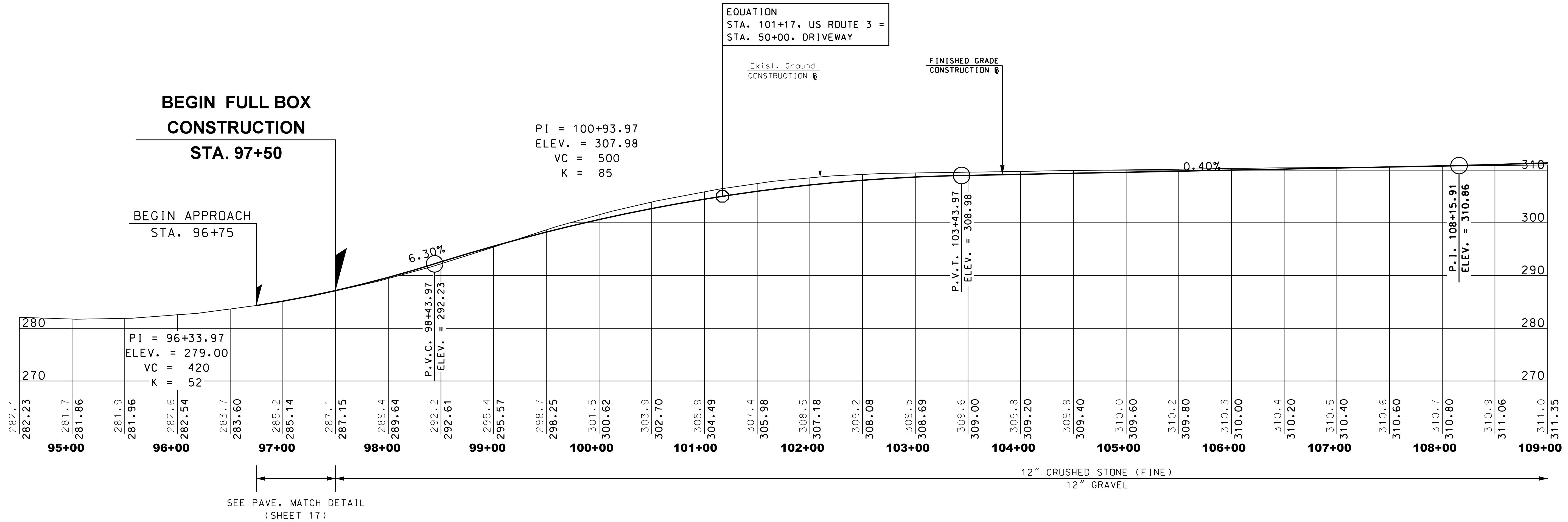

BEGIN FULL BOX CONSTRUCTION
STA. 97+50

BEGIN APPROACH
STA. 96+75

PI = 100+93.97
ELEV. = 307.98
VC = 500
K = 85

PI = 96+33.97
ELEV. = 279.00
VC = 420
K = 52

P.V.C. 98+43.97
ELEV. = 292.23

P.V.T. 103+43.97
ELEV. = 308.98

P.I. 108+15.91
ELEV. = 310.86

SCALE:
1" = 50' HORIZ.
1" = 10' VERT.

STATE OF NEW HAMPSHIRE			
DEPARTMENT OF TRANSPORTATION • BUREAU OF HIGHWAY DESIGN			
US ROUTE 3 PROFILE			
DGN	STATE PROJECT NO.	SHEET NO.	TOTAL SHEETS
13928apro_mc1m	13928A	48	160

1 OF 5

SDR PROCESSED	DATE	04/2015	REVISIONS AFTER PROPOSAL
NEW DESIGN	DATE	04/2015	STATION
SHEET CHECKED	DATE	04/2015	DESCRIPTION
AS BUILT DETAILS	DATE		

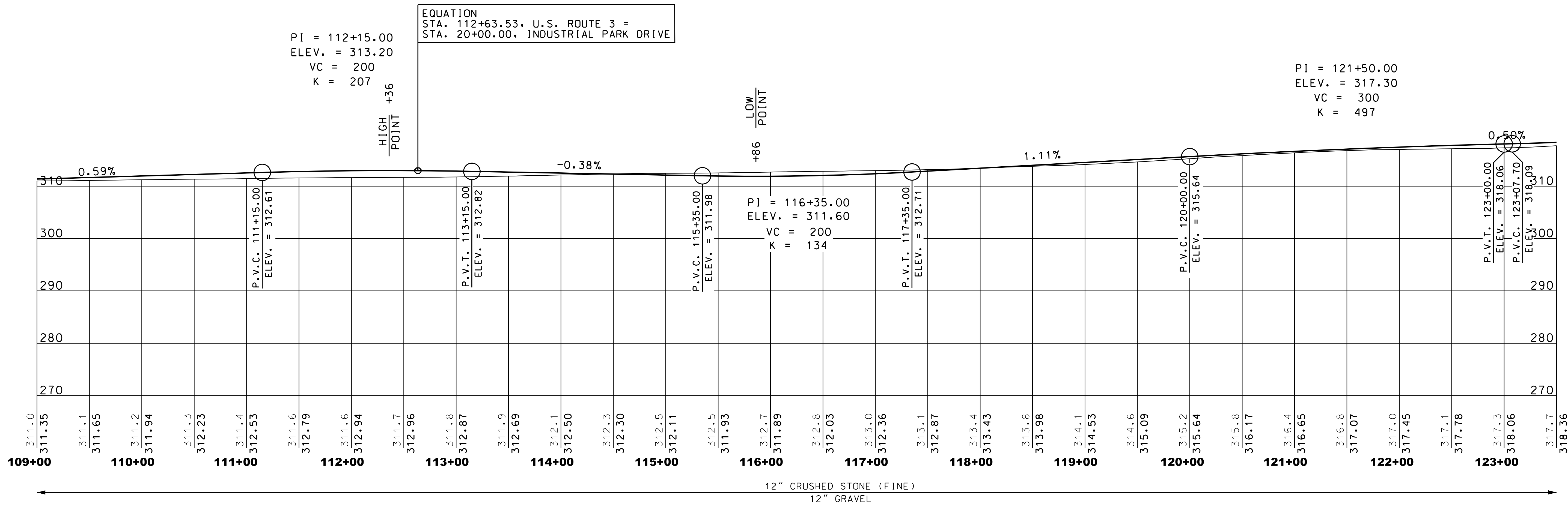

EQUATION
 STA. 112+63.53, U.S. ROUTE 3 =
 STA. 20+00.00, INDUSTRIAL PARK DRIVE

PI = 112+15.00
 ELEV. = 313.20
 VC = 200
 K = 207

PI = 121+50.00
 ELEV. = 317.30
 VC = 300
 K = 497

SCALE:
 1" = 50' HORIZ.
 1" = 10' VERT.

STATE OF NEW HAMPSHIRE
 DEPARTMENT OF TRANSPORTATION • BUREAU OF HIGHWAY DESIGN
**US ROUTE 3
 PROFILE**

DGN	STATE PROJECT NO.	SHEET NO.	TOTAL SHEETS
13928aprc1m	13928A	49	160

SDR PROCESSED		DATE		REVISIONS AFTER PROPOSAL	
NEW DESIGN	C. SPETELUNAS	DATE	04/2015	STATION	
SHEET CHECKED	TEAM BALDWIN	DATE	04/2015	STATION	
AS BUILT DETAILS		DATE		NUMBER	
		DATE		DATE	

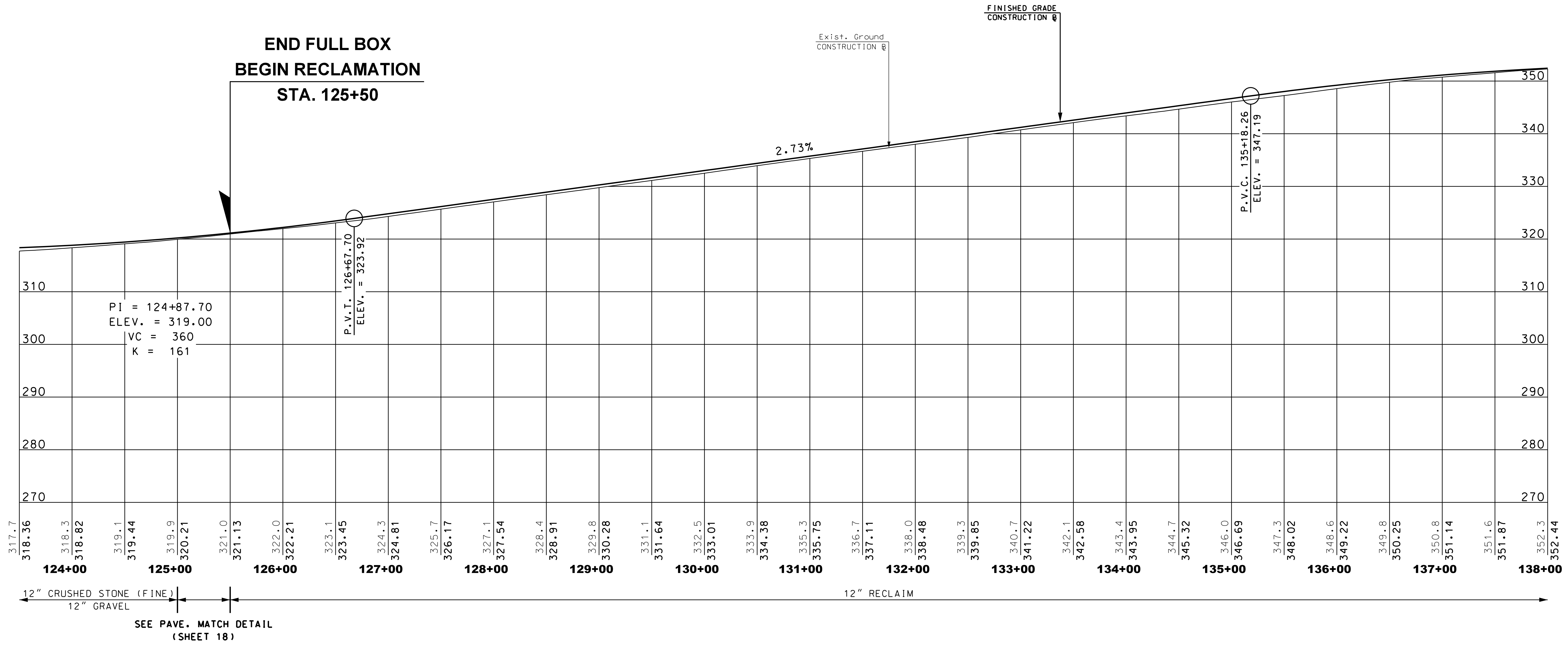

SCALE:
1" = 50' HORIZ.
1" = 10' VERT.

STATE OF NEW HAMPSHIRE			
DEPARTMENT OF TRANSPORTATION • BUREAU OF HIGHWAY DESIGN			
US ROUTE 3 PROFILE			
DGN	STATE PROJECT NO.	SHEET NO.	TOTAL SHEETS
3 OF 5	13928apro_mc1m	13928A	50

SDR PROCESSED		DATE		REVISIONS AFTER PROPOSAL	
NEW DESIGN	C. SPETELUNAS	DATE	04/2015	STATION	DESCRIPTION
SHEET CHECKED	TEAM BALDWIN	DATE	04/2015	NUMBER	
AS BUILT DETAILS		DATE			

Existing Rail Trail Bridge No. 162/099
Sta. 139+70 - 140+18
NOTE: BRIDGE LIMITS ARE TYPICALLY
DEFINED FROM CENTER OF BEARING
FROM ABUTMENT TO ABUTMENT

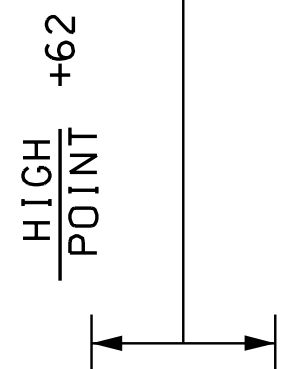

PI = 139+93.26
ELEV. = 360.18
VC = 950
K = 162

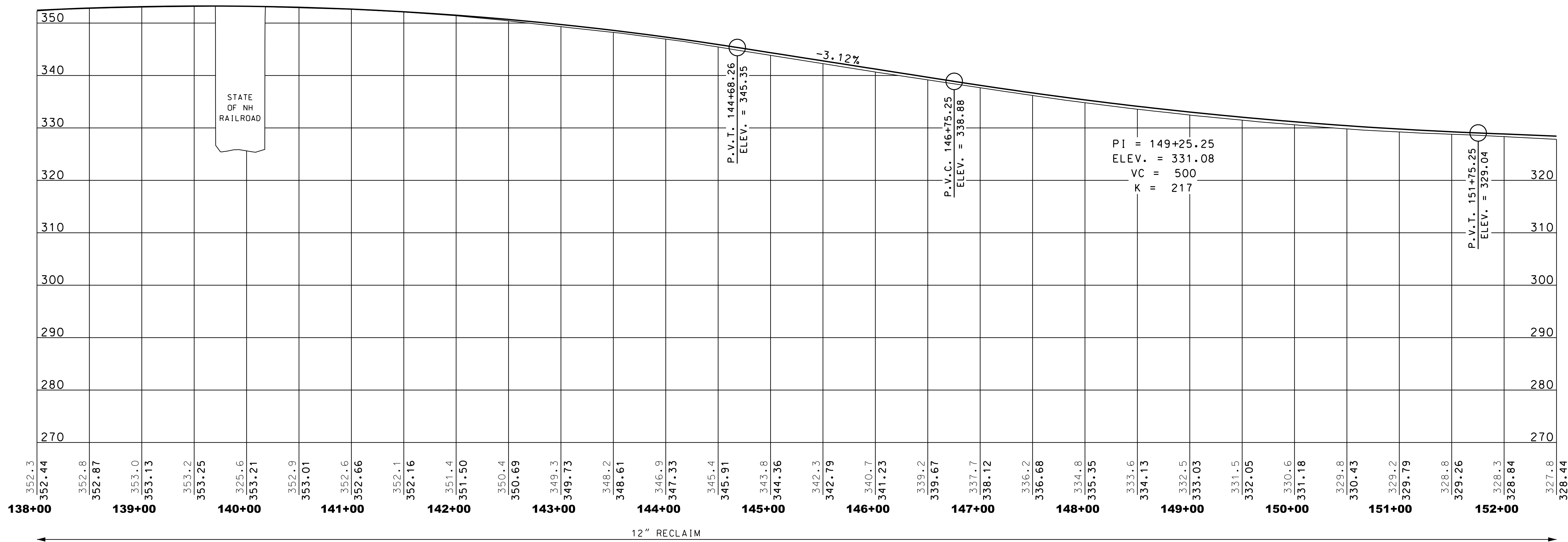

12" RECLAIM

SCALE:
1" = 50' HORIZ.
1" = 10' VERT.

STATE OF NEW HAMPSHIRE			
DEPARTMENT OF TRANSPORTATION • BUREAU OF HIGHWAY DESIGN			
US ROUTE 3 PROFILE			
DGN	STATE PROJECT NO.	SHEET NO.	TOTAL SHEETS
4 OF 5	13928apro_mc1m	13928A	51

SDR PROCESSED	DATE	04/2015	REVISIONS AFTER PROPOSAL
NEW DESIGN	DATE	04/2015	STATION
SHEET CHECKED	DATE	04/2015	STATION
AS BUILT DETAILS	DATE		DESCRIPTION

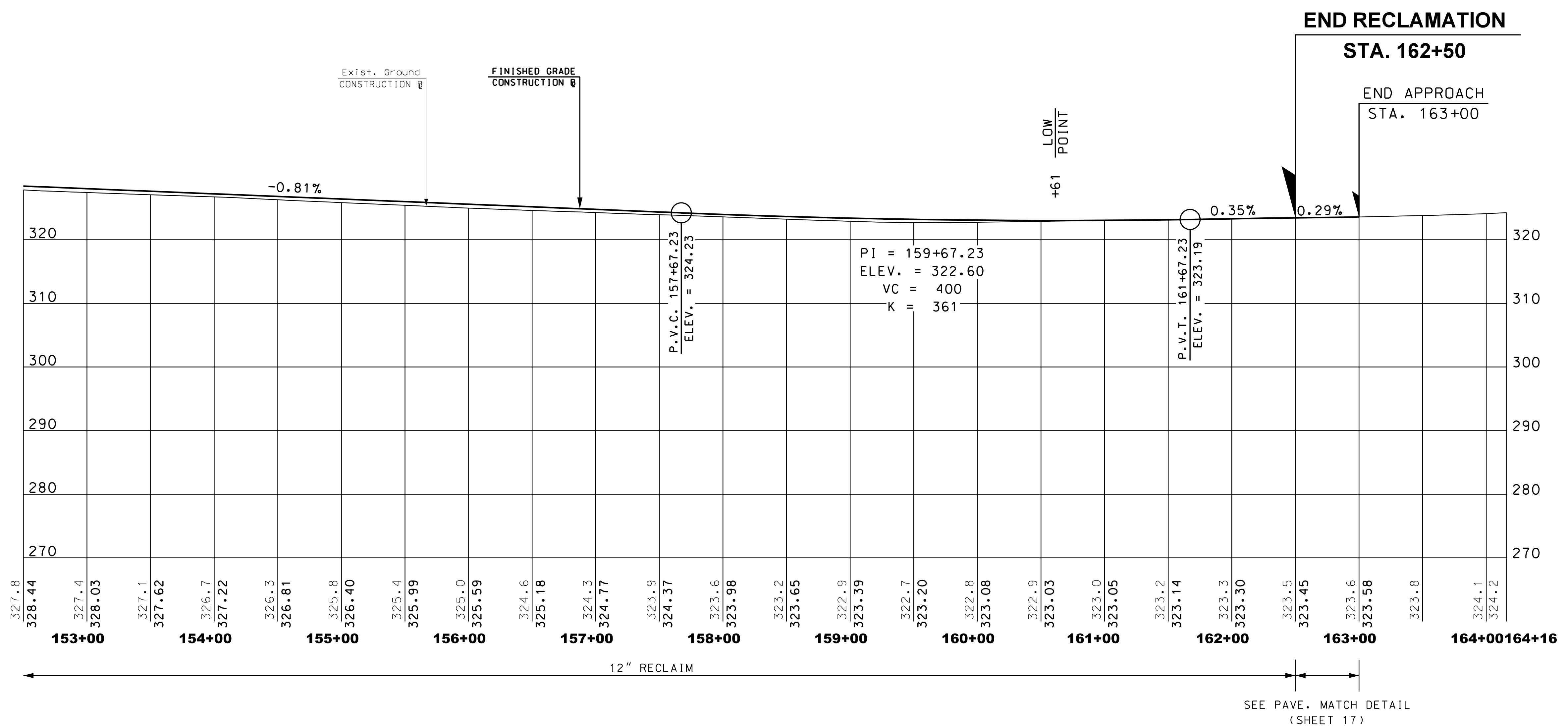

SCALE:
 1" = 50' HORIZ.
 1" = 10' VERT.

STATE OF NEW HAMPSHIRE			
DEPARTMENT OF TRANSPORTATION • BUREAU OF HIGHWAY DESIGN			
US ROUTE 3 PROFILE			
DGN	STATE PROJECT NO.	SHEET NO.	TOTAL SHEETS
5 OF 5	13928apro_mc1m	13928A	52

5 OF 5	13928apro_mc1m	13928A	52	160
--------	----------------	--------	----	-----

SDR PROCESSED		DATE	04/2015	REVISIONS AFTER PROPOSAL	STATION	DESCRIPTION
NEW DESIGN	C. SPETELUNAS	DATE	04/2015			
SHEET CHECKED	TEAM BALDWIN	DATE	04/2015			
AS BUILT DETAILS		DATE				

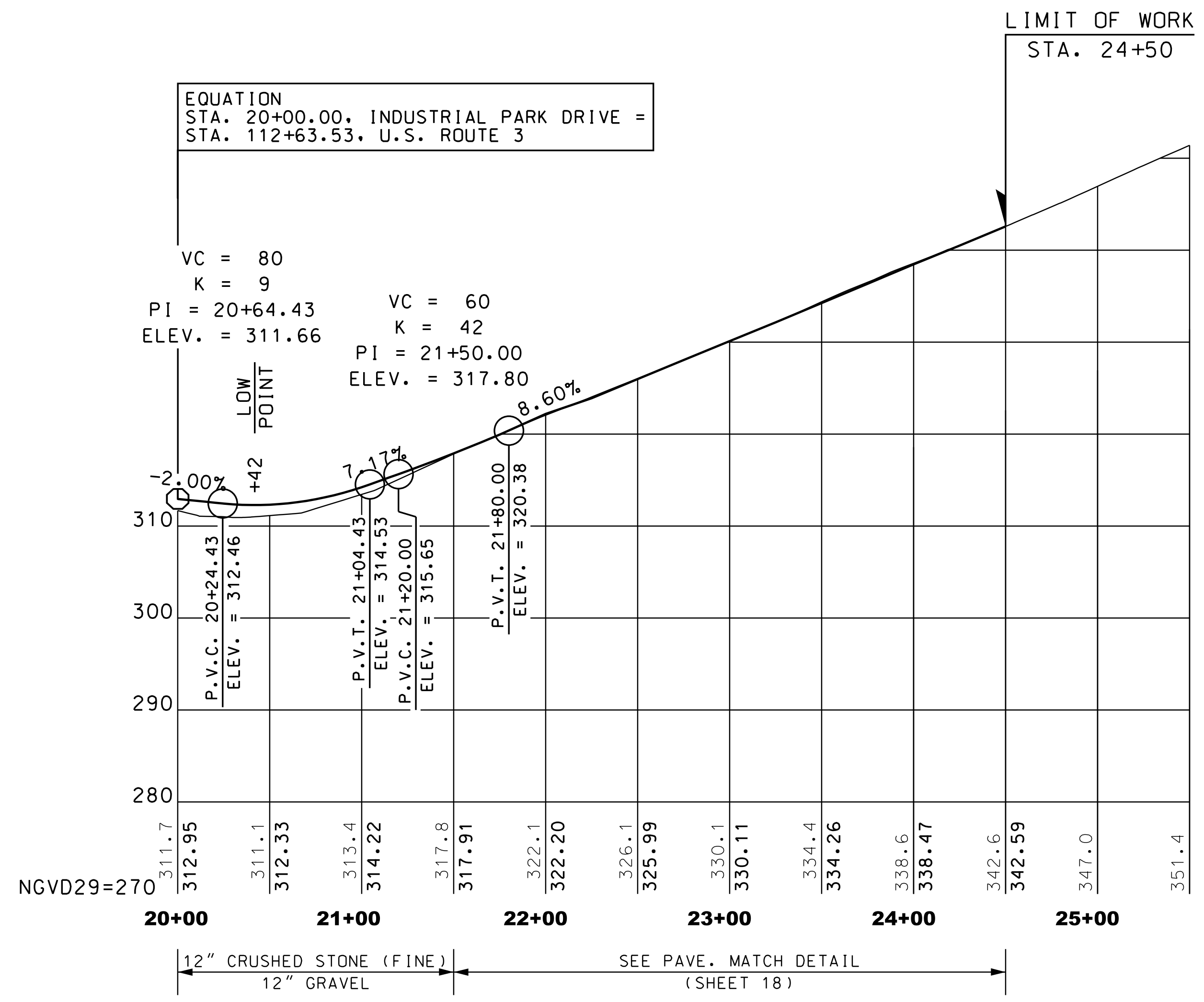

STATE OF NEW HAMPSHIRE			
DEPARTMENT OF TRANSPORTATION • BUREAU OF HIGHWAY DESIGN			
INDUSTRIAL PARK DRIVE PROFILE			
DGN	STATE PROJECT NO.	SHEET NO.	TOTAL SHEETS
13928apr_o_mc2a	13928A	53	160

SDR PROCESSED	DATE	DATE	DATE	DATE	DATE
NEW DESIGN	S. MICUCCI	04/2015	04/2015		
SHEET CHECKED	TEAM BALDWIN				
AS BUILT DETAILS					

REVISIONS AFTER PROPOSAL

DESCRIPTION

STATION

STATION

DATE

NUMBER

- 1 STA 95+17, RT 27.1'
ADJUST EXIST. DI FRAME AND GRATE TO MATCH
ELEVATION OF PROPOSED DITCH LINE
GRADE DITCH TO DRAIN TO EXIST. DI
- 2 STA 100+79, RT 24.3' TO STA 100+79, LT 13.6'
CONST. 35.9 LF X 15" RCP
CONST. PC-1 HEADWALL AT +79, RT 24.3'
15" INV. OUT = 297.50
CONST. CB-F AT +79, LT 13.6'
GRATE = 303.22
15" INV. IN = 297.95
15" INV. OUT = 297.70
CONST. STONE FILL, CLASS C, AT OUTLET
(SEE OUTLET PROTECTION DETAIL ON SHEET 24)
- 3 STA 100+79, LT 13.6' TO STA 102+12, LT 14.0'
CONST. 129.5 LF X 15" PE PIPE (TYPE S)
CONST. CB-B AT +12, LT 14.0'
GRATE = 306.90
15" INV. OUT = 301.30
- 4 STA 103+93, RT 23.2' TO STA 104+18, LT 14.2'
REMOVE EXIST. CONCRETE HEADWALL
AT 103+92, RT 17.5' (SUBSID.)
REMOVE EXIST. CONCRETE HEADWALL
AT 104+14, LT 16.6' (SUBSID.)
REMOVE 40.7 LF X EXIST. 15" CMP (SUBSID.)
CONST. 43.4 LF X 15" RCP
CONST. PC-1 HEADWALL AT +93, RT 23.2'
15" INV. OUT = 302.25
CONST. CB-B AT +18, LT 14.2'
GRATE = 308.80
15" INV. IN = 303.00
15" INV. OUT = 302.67
CONST. STONE FILL, CLASS C, AT OUTLET
(SEE OUTLET PROTECTION DETAIL ON SHEET 24)
- 5 STA 104+18, LT 14.2' TO STA 105+74, LT 15.0'
CONST. 151.4 LF X 15" PE PIPE (TYPE S)
CONST. CB-B AT +74, LT 15.0'
GRATE = 309.40
15" INV. OUT = 303.75
- 6 STA 108+71, RT 26.7'
CONST. SPECIAL DROP INLET
(SEE DRAINAGE NOTE 6 SPECIAL DROP INLET
DETAIL ON SHEET 23)
GRATE = 303.84
24" INV. IN = 300.29
30" INV. OUT = 300.00
VEGETATE OUTLET SWALE (SEE SWALE VEGETATION
DETAIL ON SHEET 24)
- 6A STA 108+71, RT 26.7' TO STA 108+70, LT 29.0'
REMOVE 56.2 LF X EXIST. 24" CMP (SUBSID.)
CONST. 51.7 LF X 24" RCP
CONST. DI-B AT +70, LT 29.0'
GRATE = 307.44
24" INV. OUT = 302.44

- 7 STA 110+12, RT 28.3'
CONST. SPECIAL DROP INLET
(SEE DRAINAGE NOTE 7 SPECIAL DROP INLET
DETAIL ON SHEET 24)
GRATE = 305.10
18" INV. IN = 301.82
12" INV. OUT = 302.04
24" INV. OUT = 300.64
VEGETATE OUTLET SWALE (SEE SWALE VEGETATION
DETAIL ON SHEET 24)
- 7A STA 110+12, RT 28.3' TO STA 110+12, LT 15.0'
REMOVE 40.9 LF X EXIST. 18" RCP (SUBSID.)
CONST. 39.1 LF X 18" RCP
CONST. CB-B AT +12, LT 15.0'
GRATE = 311.62
15" INV. IN = 304.63
18" INV. IN = 303.10
18" INV. OUT = 302.85
- 7B STA 110+25, RT 30.4' TO STA 110+12, RT 28.3'
CONST. 10.6 LF X 12" PE PIPE (TYPE S)
CONST. DI-DB AT +25, RT 30.4'
GRATE = 305.21
12" INV. OUT = 302.05
- 8 STA 110+12, LT 15.0' TO STA 110+12, LT 29.0'
REMOVE 10.0 LF X EXIST. 18" RCP (SUBSID.)
CONST. 10.0 LF X 15" PE Pipe (Type S)
CONST. DI-B AT +12, LT 29.0'
GRATE = 308.52
15" INV. OUT = 305.27
- 9 STA 110+12, LT 15.0' TO STA 112+00, LT 23.9'
CONST. 184.0 LF X 18" PE PIPE (TYPE S)
CONST. CB-B AT +00, LT 23.9'
GRATE = 312.22
18" INV. IN = 305.21
18" INV. OUT = 304.96
- 10 STA 112+00, LT 23.9' TO STA 112+26, LT 42.7' (STA 20+44, LT 35.9')
REMOVE EXIST. CB AT 112+22, LT 40.6' (SUBSID.)
REMOVE 14.0 LF X 12" RCP (SUBSID.)
CONST. 28.2 LF X 18" PE PIPE (TYPE S)
CONST. CB-B AT +26, LT 42.7' (+44, LT 35.9')
GRATE = 311.64
15" INV. IN = 306.53
18" INV. IN = 305.71
18" INV. OUT = 305.46
- 11 STA 112+26, LT 42.7' (STA 20+44, LT 35.9') TO STA 21+38, LT 35.6'
REMOVE 82.8 LF X EXIST. 15" CMP (SUBSID.)
CONST. 89.8 LF X 15" PE PIPE (TYPE S)
CONST. CB-B AT +38, LT 35.6'
GRATE = 314.28
15" INV. IN = 311.03
15" INV. OUT = 310.78
- 12 STA 21+38, LT 35.6' TO STA 21+82, LT 33.0'
CONST. 40.1 LF X 15" PE PIPE (TYPE S)
CONST. CB-B AT +82, LT 33.0'
GRATE = 317.93
12" INV. IN = 314.93
15" INV. OUT = 313.16

- 13 STA 21+82, LT 33.0' TO STA 23+00, LT 32.0'
REMOVE 25.0 LF X EXIST. 12" CMP (SUBSID.)
CONST. 114.5 LF X 12" PE PIPE (TYPE S)
CONST. CB-B AT +00, LT 32.0'
GRATE = 328.86
12" INV. OUT = 322.75
CONNECT EXIST. 12" CMP TO PROPOSED CB
AT +00, LT 32.0' (SUBSID.)
12" INV. IN = 323.01
- 14 STA 112+26, LT 42.7' (STA 20+44, LT 35.9')
TO STA 113+07, LT 43.3' (STA 20+42, RT 45.4')
CONST. 77.3 LF X 18" RCP
CONST. CB-B AT +07, LT 43.3' (+42, RT 45.4')
GRATE = 311.62
15" INV. IN = 306.87
18" INV. IN = 306.37
18" INV. OUT = 306.15
- 15 STA 113+07, LT 43.3' (STA 20+42, RT 45.4')
TO STA 113+18, LT 43.7' (STA 20+42, RT 56.0')
CONST. 6.6 LF X 15" PE PIPE (TYPE S)
CONST. CB-B AT +18, LT 43.7' (+42, RT 56.0')
GRATE = 310.21
15" INV. OUT = 306.96
- 16 STA 113+07, LT 43.3' (STA 20+42, RT 45.4')
TO STA 21+00, RT 43.0'
CONST. 54.2 LF X 15" PE PIPE (TYPE S)
CONST. DI-B AT +00, RT 43.0'
GRATE = 312.06
15" INV. OUT = 307.81
- 17 STA 119+18, RT 174.9' TO STA 118+62, LT 15.0'
CONST. 196.1 LF X 18" PE PIPE (TYPE S)
CONST. PC-1 HEADWALL AT +18, RT 174.9'
18" INV. OUT = 298.30
CONST. 5' DIAM. CB-B AT +62, LT 15.0'
GRATE = 313.20
15" INV. IN = 305.50
15" INV. IN = 300.83
18" INV. OUT = 300.58
CONST. STONE FILL, CLASS C, AT OUTLET
(SEE OUTLET PROTECTION DETAIL ON SHEET 24)
- 18 STA 118+62, LT 15.0' TO STA 117+50, LT 15.0'
CONST. 106.4 LF X 15" PE PIPE (TYPE S)
CONST. CB-B AT +50, LT 15.0'
GRATE = 311.96
15" INV. IN = 302.88
15" INV. OUT = 302.63
- 19 STA 117+50, LT 15.0' TO STA 117+50, LT 31.7'
CONST. 12.5 LF X 15" PE PIPE (TYPE S)
CONST. CB-B AT +50, LT 31.7'
GRATE = 312.21
15" INV. IN = 303.28
15" INV. OUT = 303.03

- 20 STA 117+50, LT 31.7' TO STA 116+00, LT 31.5'
CONST. 143.1 LF X 15" PE PIPE (TYPE S)
CONST. CB-B AT +00, LT 31.5'
GRATE = 310.98
15" INV. IN = 304.67
15" INV. OUT = 304.42
- 21 STA 116+00, LT 31.5' TO STA 115+50, LT 24.3'
CONST. 45.7 LF X 15" PE PIPE (TYPE S)
CONST. CB-B AT +50, LT 24.3'
GRATE = 310.49
15" INV. IN = 305.15
15" INV. OUT = 304.90
- 22 STA 115+50, LT 24.3' TO STA 115+07, LT 25.0'
CONST. 38.0 LF X 15" PE PIPE (TYPE S)
CONST. CB-B AT +07, LT 25.0'
GRATE = 310.66
15" INV. OUT = 305.34
- 23 STA 118+62, LT 15.0' TO STA 119+25, LT 15.0'
CONST. 58.6 LF X 15" PE PIPE (TYPE S)
CONST. CB-B AT +25, LT 15.0'
GRATE = 313.90
15" INV. IN = 308.90
15" INV. IN = 307.94
15" INV. OUT = 307.69
- 24 STA 119+25, LT 15.0' TO STA 119+25, LT 25.0'
CONST. 6.0 LF X 15" PE PIPE (TYPE S)
CONST. DI-B AT +25, LT 25.0'
GRATE = 313.96
15" INV. OUT = 308.96
- 25 STA 119+25, LT 15.0' TO STA 121+00, LT 15.0'
CONST. 170.5 LF X 15" PE PIPE (TYPE S)
CONST. CB-B AT +00, LT 15.0'
GRATE = 315.73
15" INV. OUT = 310.50
- 26 STA 123+34, RT 125.5' TO STA 123+46, LT 21.0'
CONST. DI-B AT +46, LT. 21.0'
GRATE = 316.00
INV OUT (APPROX.) = 311.70
REMOVE EXIST. SEPARATED 15" RCP AT OUTLET (SUBSID.)
REHABILITATE EXIST. 1/2 30" CMP SLUICE FROM
STA 123+34, RT 125.5' TO STA 123+38, RT 62.0'
CONST. PC-1 HEADWALL AT STA 123+39, RT 60.5'
LINE EXIST. 15" RCP WITH 82.3 LF X PE PIPE SOLID WALL
LINER & EXTEND PIPE LINER
(SEE CULVERT OUTLET & SLUICE REHABILITATION
DETAIL ON SHEET 25)
- 26A STA 123+46, LT 21.0' TO STA 119+25, LT 25.0'
CONST. APPROX. 420 LF STONE FILL, CLASS C, DITCH
ABOVE PROPOSED RETAINING WALL (AS SHOWN ON
PLANS, CROSS SECTIONS, AND TYPICAL SECTIONS)

STATE OF NEW HAMPSHIRE			
DEPARTMENT OF TRANSPORTATION • BUREAU OF HIGHWAY DESIGN			
DRAINAGE NOTES			
DGN	STATE PROJECT NO.	SHEET NO.	TOTAL SHEETS
13928aDrainageNotes	13928A	54	160

SDR PROCESSED	DATE	DATE	DATE	DATE	DATE
NEW DESIGN	S. MICUCCI	04/2015	04/2015	04/2015	04/2015
SHEET CHECKED	TEAM BALDWIN				
AS BUILT DETAILS					

27 STA 126+87, RT 54.9' TO STA 126+65, RT 30.0'
 REMOVE 33.1 LF X EXIST. 24" RCP (SUBSID.)
 CONST. 28.1 LF X 24" PE PIPE (TYPE S)
 CONST. PC-1 HEADWALL AT +87, RT 54.9'
 24" INV OUT = 313.32
 CONST. 8' DIAM. DRAINAGE MANHOLE AT +65, RT 30.0'
 COVER = 321.94
 15" INV. IN = 317.09
 24" INV. IN = 313.64
 24" INV. OUT = 313.58
 CONST. STONE FILL, CLASS C, AT OUTLET
 (SEE OUTLET PROTECTION DETAIL ON SHEET 25)

28 STA 126+65, RT 30.0' TO STA 126+25, LT 16.0'
 REMOVE 61.1 LF X EXIST. 24" RCP (SUBSID.)
 CONST. 54.5 LF X 24" RCP
 CONST. 6' DIAM. DRAINAGE MANHOLE AT +25, LT 16.0'
 COVER = 321.94
 6" UND INV. IN = 316.27
 24" INV. IN = 314.28
 24" INV. OUT = 314.23

29 STA 126+25, LT 16.0' TO STA 126+08, LT 34.7'
 REMOVE EXIST. CB AT +08, LT 34.7' (SUBSID.)
 REMOVE 23.2 LF X EXIST. 24" RCP (SUBSID.)
 CONST. 19.0 LF X 24" RCP
 CONST. 6' DIAM. CB-B W/ECCENTRIC CONE AT +08, LT 34.7'
 GRATE = 319.13
 12" UND INV. IN = 316.05
 24" INV. IN (EXIST.) = 314.82
 24" INV. OUT = 314.57

30 STA 126+65, RT 30.0' TO STA 129+34, RT 30.8'
 REMOVE EXIST. CB AT 129+34, RT 30.1' (SUBSID.)
 CONST. 262.2 LF X 15" PE PIPE (TYPE S)
 CONST. CB-B W/ECCENTRIC CONE AT +34, RT 30.8'
 GRATE = 328.46
 15" INV. IN = 324.21
 15" INV. IN = 323.31
 15" INV. OUT = 323.06

31 STA 129+34, RT 30.8' TO STA. 129+34, LT 28.2'
 REMOVE EXIST. CB AT +34, LT 30.0' (SUBSID.)
 REMOVE 57.1 LF X EXIST. 12" RCP (SUBSID.)
 CONST. 55.0 LF X 15" RCP
 CONST. DI-B AT +34, LT 28.2'
 GRATE = 328.86
 6" UND INV. IN = 325.25
 6" UND INV. OUT = 325.87
 15" INV. OUT = 323.86

32 STA 129+34, RT 30.8' TO STA 132+31, RT 30.1'
 REMOVE EXIST. CB AT 132+31, RT 29.1' (SUBSID.)
 CONST. 288.4 LF X 15" PE PIPE (TYPE S)
 CONST. CB-B W/ECCENTRIC GRATE AT +31, RT. 30.1'
 GRATE = 335.69
 15" INV IN = 331.64
 15" INV OUT 331.39

33 STA 132+31, RT 30.1 TO STA 132+31, LT 28.9'
 REMOVE EXIST. CB AT 132+31, LT 29.9' (SUBSID.)
 CONST. 55.0 LF X 15" RCP
 CONST. DI-B AT +31, LT 28.9'
 GRATE = 338.33
 6" UND INV OUT = 336.19
 15" INV OUT = 333.33

34 STA 138+56, RT 124.4' TO STA 138+32, RT 87.0'
 REMOVE 42.8 LF X EXIST. 30" CMP (SUBSID.)
 REMOVE EXIST. STONE HEADWALL AT 138+52, RT 121.4' (SUBSID.)
 CONST. 28.0 LF X 30" RCP (3000D)
 CONST. PC-1 HEADWALL AT 138+49, RT 112.0'
 30" INV OUT = 317.53
 CONST. STONE FILL, CLASS C, AT OUTLET
 (SEE OUTLET PROTECTION DETAIL ON SHEET 25)
 MAINTAIN EXIST. DRAINAGE STRUCTURE AT +32, RT 87.0'
 MATCH NEW PIPES TO EXIST. INVERTS (SUBSID.)
 24" INV. IN = 322.94 (APPROX.)
 30" INV. OUT = 319.86 (APPROX.)

35 STA 138+32, RT 87.0' TO STA 138+15, RT 54.1'
 REMOVE 32.6 LF X EXIST. 24" CMP (SUBSID.)
 REMOVE EXIST. DRAINAGE MH AT +15, RT 54.1' (SUBSID.)
 CONST. 32.6 LF X 24" PE PIPE (TYPE C)
 CONST. DRAINAGE MANHOLE AT +15, RT 54.1'
 COVER = 338.73
 24" INV. IN (EXIST.) = 330.62
 24" INV. OUT = 330.00

36 INTENTIONALLY LEFT BLANK

37 STA 152+38, RT 66.5' TO STA 152+50, RT 62.3'
 CONST. 10.1 LF X 36" PE PIPE (TYPE S)
 CONST. PC-5 HEADWALL AT +38, RT 66.5'
 36" INV. OUT = 306.38
 CONST. 6' DIAM. DRAINAGE MANHOLE AT +50, RT 62.3'
 COVER = 312.54
 36" INV. IN = 306.53
 36" INV. OUT = 306.53

38 STA 152+50, RT 62.3' TO STA. 152+50, RT 40.0'
 CONST. 16.1 LF X 36" PE PIPE (TYPE S)
 CONST. 6' DIAM. DRAINAGE MANHOLE AT +50, RT 40.0'
 COVER = 322.07
 18" INV. IN = 316.00
 36" INV. IN = 307.00
 36" INV. OUT = 306.75

39 STA 152+50, RT 40.0' TO STA. 149+87, RT 40.0'
 CONST. 265.5 LF X 18" PE PIPE (TYPE S)
 CONST. DRAINAGE MANHOLE AT +87, RT 40.0'
 COVER = 330.65
 15" INV. IN = 323.50
 18" INV. OUT = 323.25

40 STA 149+87, RT 40.0' TO STA. 149+90, LT 41.6'
 REMOVE 2.9 LF X EXIST. 18" RCP (SUBSID.)
 CONST. 15" STEEL END SECTION AT 149+90, LT 41.6'
 LINE EXIST. 18" RCP WITH 79.7 LF X PE PIPE SOLID WALL LINER
 INV. IN (APPROX.) = 324.00

41 STA 152+50, RT 40.0' TO STA. 154+38, RT 40.0'
 REMOVE 7.0 LF X EXIST. 36" RCP (SUBSID.)
 CONST. 187.3 LF X 36" PE PIPE (TYPE S)
 CONST. 5' DIAM. DRAINAGE MANHOLE AT +38, RT 40.0'
 COVER = 323.50
 30" INV. IN = 308.45
 36" INV. OUT = 308.20

42 STA 154+38, RT 40.0' TO STA. 155+37, LT 64.0'
 LINE EXIST. 36" RCP WITH 140.5 LF X PE PIPE SOLID WALL LINER
 INV. IN (APPROX.) = 311.25

43 STA 153+12, RT 209.2' TO STA 154+38, RT 40.0'
 FILL AND ABANDON EXIST. 36" CMP

R1 STA 108+69, LT 31.7'
 REMOVE EXIST. CONCRETE HEADWALL

R2 STA 109+57, LT 39.5' TO STA 109+99, LT 39.7'
 REMOVE EXIST. CONCRETE HEADWALL AT +57, LT 39.5'
 REMOVE EXIST. CONCRETE HEADWALL AT +99, LT 39.7'
 REMOVE 41.4 LF X EXIST. 24" CMP

R3 STA 112+01, LT 34.2' (STA 20+36, LT 61.4')
 TO STA 112+22, LT 39.0' (STA 20+40, LT 40.6')
 REMOVE EXIST. CONCRETE END SECTION (SUBSID.)
 REMOVE 19.2 LF X EXIST. 18" RCP

R4 STA 21+25, LT 32.4' TO STA 21+74, LT 27.7'
 REMOVE EXIST. CB AT +74, LT 27.7'
 REMOVE 46.7 LF X EXIST. 15" CMP

R5 STA 21+74, LT 27.7' TO STA 22+75, LT 31.1'
 REMOVE 99.5 LF X EXIST. 12" CMP

R6 STA 20+40, LT 40.6' TO STA 20+28, RT 39.4'
 REMOVE EXIST. CB AT +28, RT 39.4'
 REMOVE 64.8 LF X EXIST. 12" RCP

R7 STA 116+83, RT 20.6' TO STA 116+83, LT 21.0'
 REMOVE EXIST. HEADER AT +83, RT 20.6' (SUBSID.)
 REMOVE EXIST. CB AT +83, LT 21.0'
 REMOVE 39.5 LF X EXIST. 15" CIP

R8 STA 126+08, LT 34.7' TO STA 129+34, LT 30.0'
 REMOVE 322.9 LF X EXIST. 15" CMP

R9 STA 129+34, LT 29.8' TO STA 132+30, LT 31.0'
 REMOVE EXIST. CB AT +30, LT 31.0'
 REMOVE 296.0 LF X EXIST. 12" RCP

R10 STA 149+90, RT 109.9' TO STA 149+89, RT 117.9'
 REMOVE EXIST. CB AT +90, RT 109.9'
 REMOVE 5.7 LF X EXIST. 18" SPP

R11 STA 149+90, RT 109.9' TO STA 149+86, RT 62.2'
 REMOVE EXIST. CB AT +86, RT 62.2'
 REMOVE 43.9 LF X EXIST. 18" SPP

R12 STA 149+86, RT 62.2' TO STA 149+87, RT 40.0'
 REMOVE 22.2 LFX EXIST. 18" RCP

R13 STA 152+90, RT 242.4' TO STA 153+00, RT 228.7'
 REMOVE 20.8 LF X EXIST. 36" CMP

R14 STA 152+98, RT 224.6' TO STA 153+10, RT 212.8'
 REMOVE 17.6 LF X EXIST. 36" CMP

R15 STA 153+12, RT 209.2' TO STA 153+18, RT 199.7'
 REMOVE 11.8 LF X EXIST. 36" CMP

U1 STA 126+08, LT 34.7' TO STA. 125+73, RT 26.3'
 CONST. 68.0 LF X 12" PIPE TRANSVERSE AGGREGATE UNDERDRAIN
 CONNECT TO NEW CB AT +08, LT 34.7' (SEE DRAIN NOTE 29)
 CONST. FLUSHING BASIN AT +73, RT 26.3'

U2 STA 126+25, LT 16.0' TO STA. 129+34, LT 29.2'
 CONST. 310.4 LF X 6" PERF. CORR. POLYETHYL PIPE UND.
 CONNECT TO NEW MH AT +25, LT 16.0' (SEE DRAIN NOTE 28)
 CONNECT TO NEW CB AT +34, LT 29.2' (SEE DRAIN NOTE 31)

U3 STA 129+34, LT 29.2' TO STA. 132+31, LT 29.9'
 CONST. 306.6 LF X 6" PERF. CORR. POLYETHYL PIPE UND.
 CONNECT TO NEW DI AT +34, LT 29.2' (SEE DRAIN NOTE 31)
 CONNECT TO NEW DI AT +31, LT 29.9' (SEE DRAIN NOTE 33)

U4 STA 149+85, LT 42.4' TO STA. 147+42, LT 24.0'
 CONST. 242.4 LF X 6" PERF. CORR. POLYETHYL PIPE UND.
 CONST. UNDERDRAIN HEADWALL AT +85, LT 42.4'
 CONST. FLUSHING BASIN AT +42, LT 24.0'

U5 STA 155+50, LT 60.1' TO STA. 150+00, LT 24.0'
 CONST. 553.5 LF X 6" PERF. CORR. POLYETHYL PIPE UND.
 CONST. FLUSHING BASIN AT +50, LT 60.1'
 CONST. UNDERDRAIN HEADWALL AT +00, LT 24.0'

STATE OF NEW HAMPSHIRE			
DEPARTMENT OF TRANSPORTATION • BUREAU OF HIGHWAY DESIGN			
DRAINAGE NOTES			
DGN	STATE PROJECT NO.	SHEET NO.	TOTAL SHEETS
13928aDrainageNotes	13928A	55	160

SDR PROCESSED	PLAN PREP	DATE	09/2013
NEW DESIGN	TEAM KIROUAC	DATE	04/2015
SHEET CHECKED	M. BALDWIN	DATE	
AS BUILT DETAILS		DATE	

REVISIONS AFTER PROPOSAL	DESCRIPTION
STATION	
STATION	
DATE	
NUMBER	

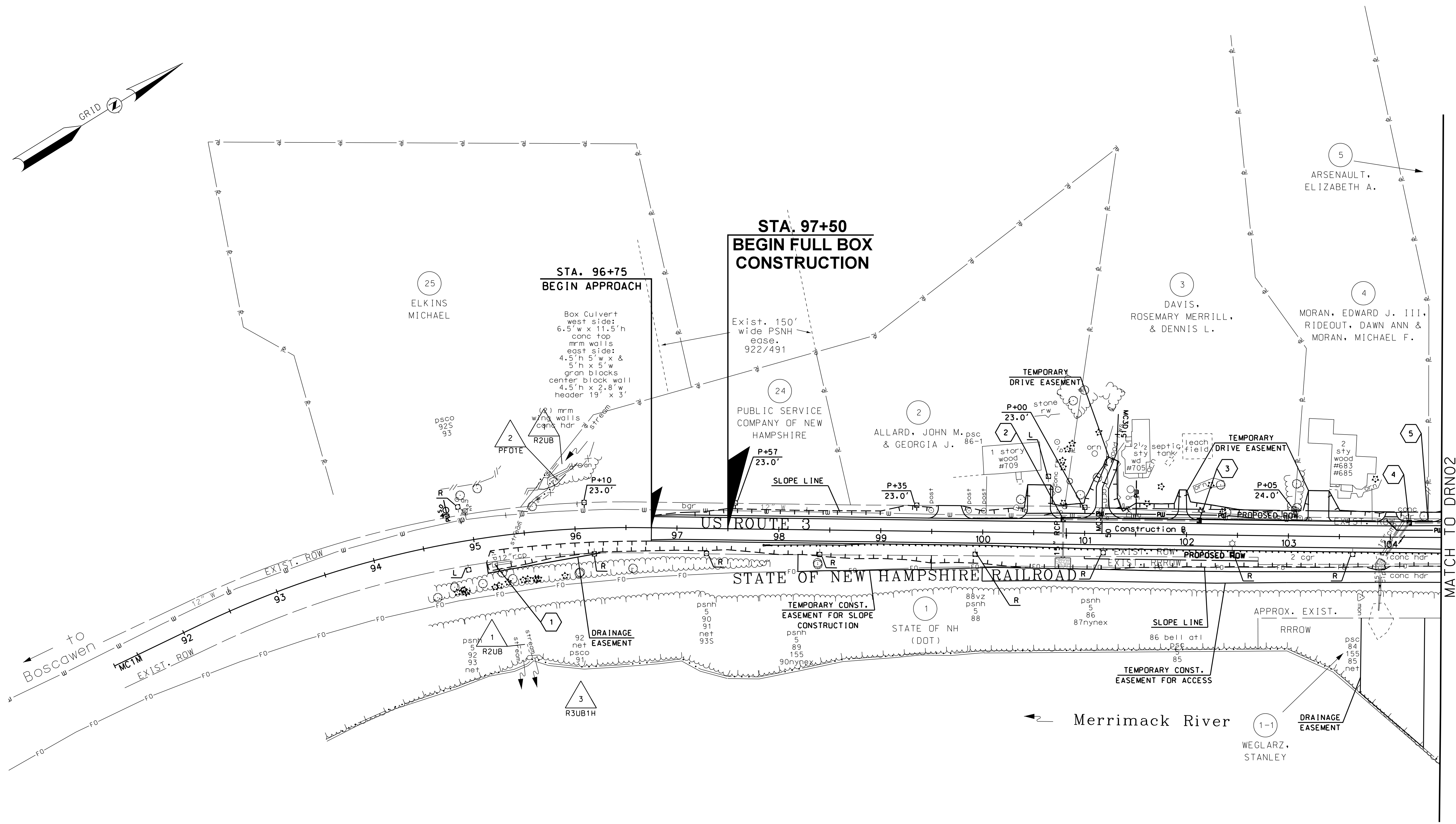
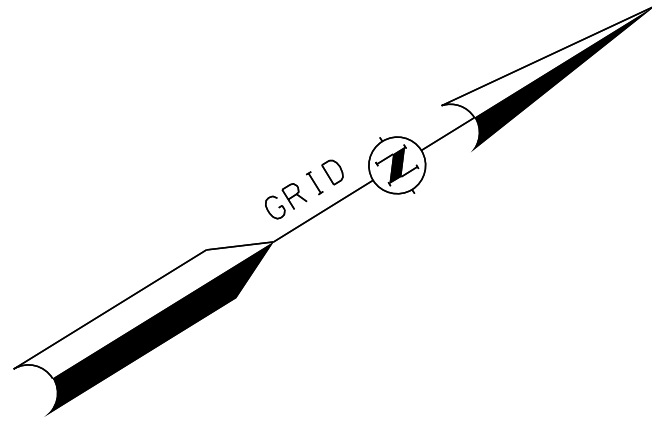

STATE OF NEW HAMPSHIRE				
DEPARTMENT OF TRANSPORTATION • BUREAU OF HIGHWAY DESIGN				
DRAINAGE AND UTILITY PLANS				
MODEL	DGN	STATE PROJECT NO.	SHEET NO.	TOTAL SHEETS
DRN01 Views	13928adrnp1ans	13928A	56	160

SDR PROCESSED	PLAN PREP	DATE	09/2013
NEW DESIGN	TEAM KIROUAC	DATE	04/2015
SHEET CHECKED	M. BALDWIN	DATE	
AS BUILT DETAILS		DATE	

REVISIONS AFTER PROPOSAL	STATION	DESCRIPTION

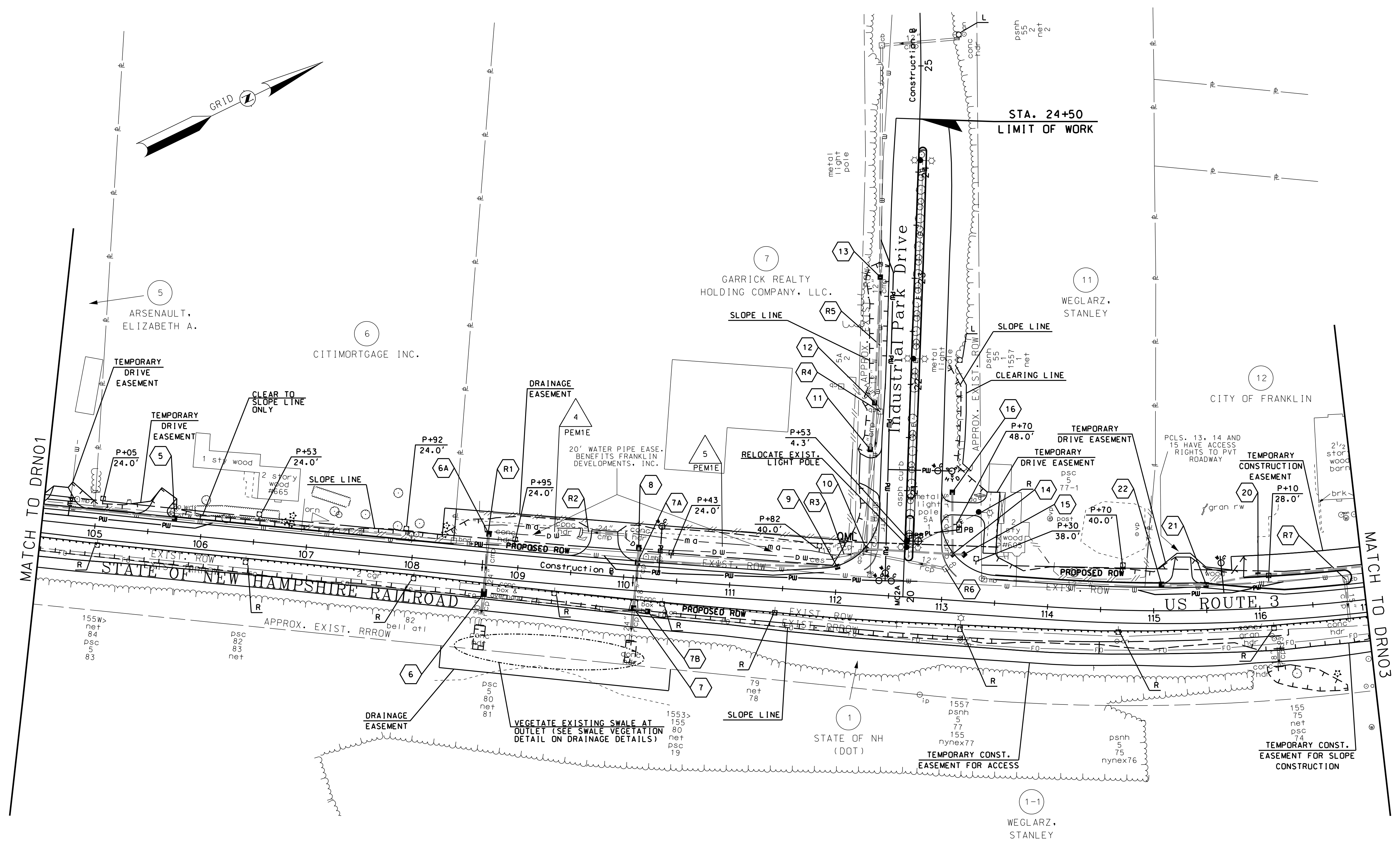

STATE OF NEW HAMPSHIRE				
DEPARTMENT OF TRANSPORTATION • BUREAU OF HIGHWAY DESIGN				
DRAINAGE AND UTILITY PLANS				
MODEL	DGN	STATE PROJECT NO.	SHEET NO.	TOTAL SHEETS
DRN02	13928adrnp1ans	13928A	57	160

SDR PROCESSED	PLAN PREP	DATE	09/2013
NEW DESIGN	TEAM K/TROUAC	DATE	04/2015
SHEET CHECKED	M. BALDWIN	DATE	
AS BUILT DETAILS		DATE	

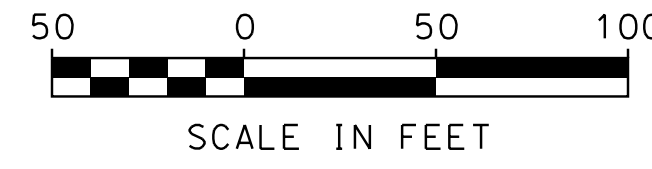
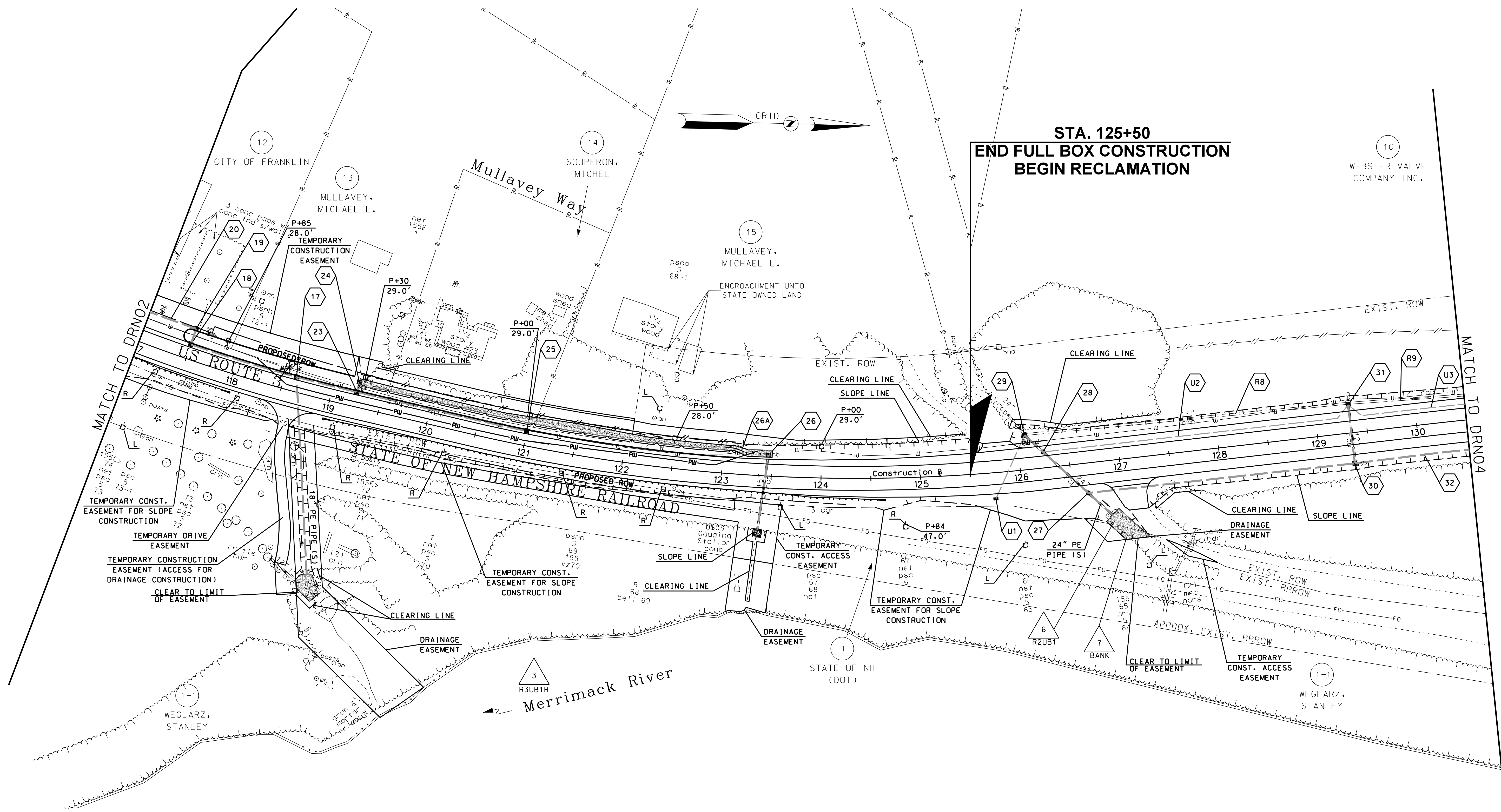

STATE OF NEW HAMPSHIRE				
DEPARTMENT OF TRANSPORTATION • BUREAU OF HIGHWAY DESIGN				
DRAINAGE AND UTILITY PLANS				
MODEL	DGN	STATE PROJECT NO.	SHEET NO.	TOTAL SHEETS
DRN03	13928adrnp1ans	13928A	58	160

SDR PROCESSED	PLAN PREP	DATE	09/2013
NEW DESIGN	TEAM KIROUAC	DATE	04/2015
SHEET CHECKED	TEAM BALDWIN	DATE	
AS BUILT DETAILS		DATE	

REVISIONS AFTER PROPOSAL	STATION	DESCRIPTION

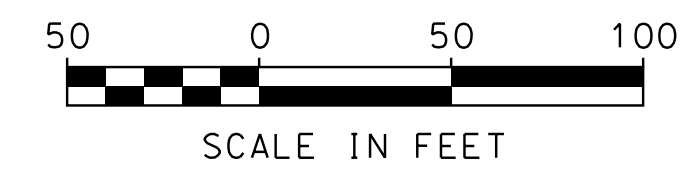
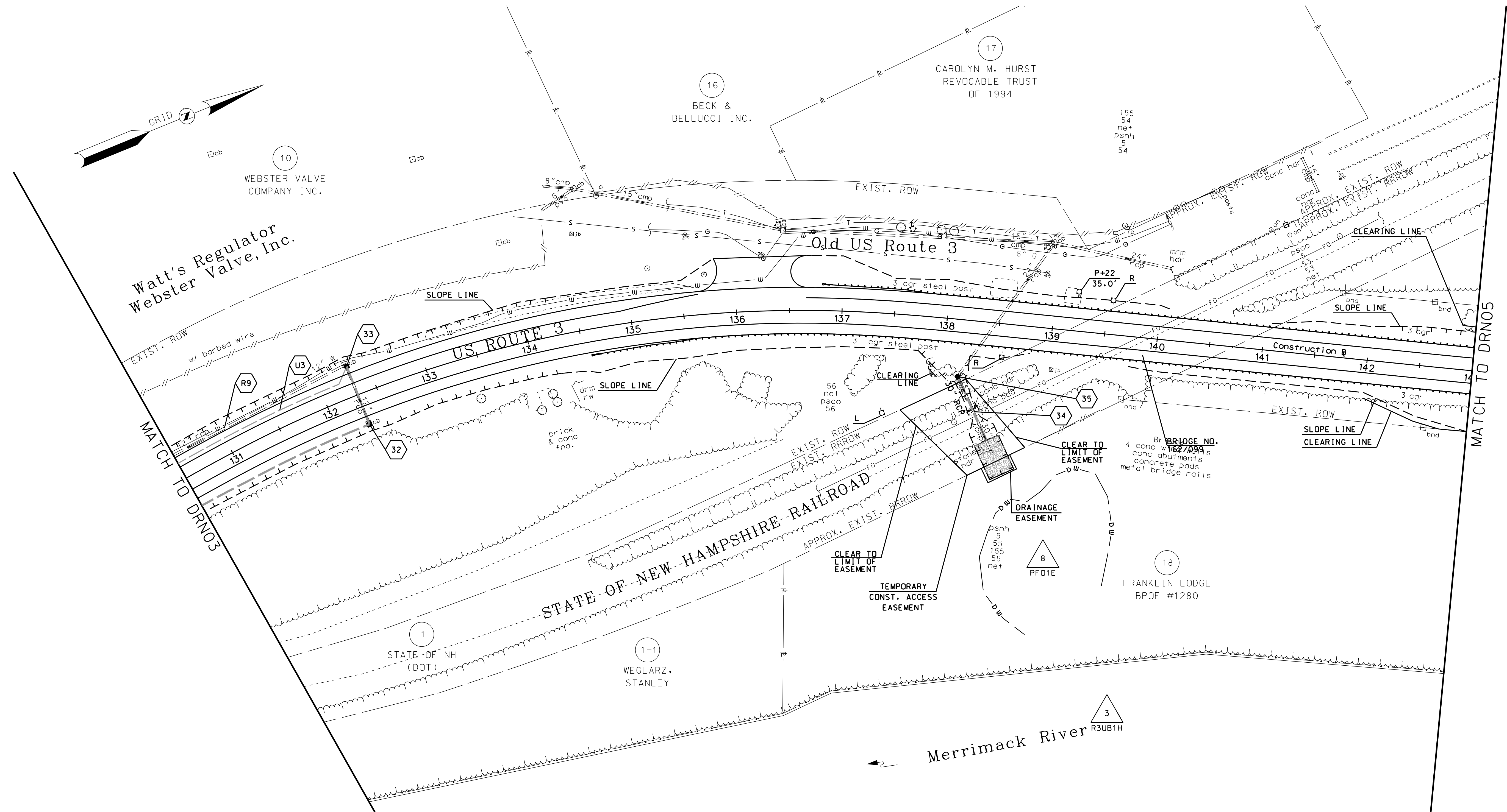
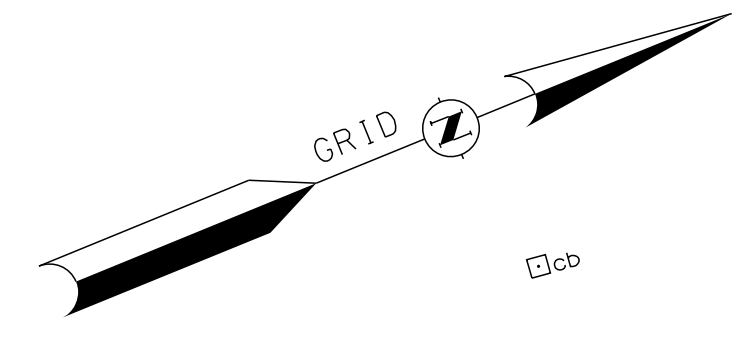

STATE OF NEW HAMPSHIRE				
DEPARTMENT OF TRANSPORTATION • BUREAU OF HIGHWAY DESIGN				
DRAINAGE AND UTILITY PLANS				
MODEL	DGN	STATE PROJECT NO.	SHEET NO.	TOTAL SHEETS
DRN04	13928adrnp1ans	13928A	59	160

SDR PROCESSED	PLAN PREP	DATE	09/2013
NEW DESIGN	TEAM K/TROJAC	DATE	04/2015
SHEET CHECKED	M. BALDWIN	DATE	
AS BUILT DETAILS		DATE	

REVISIONS AFTER PROPOSAL	STATION	DESCRIPTION

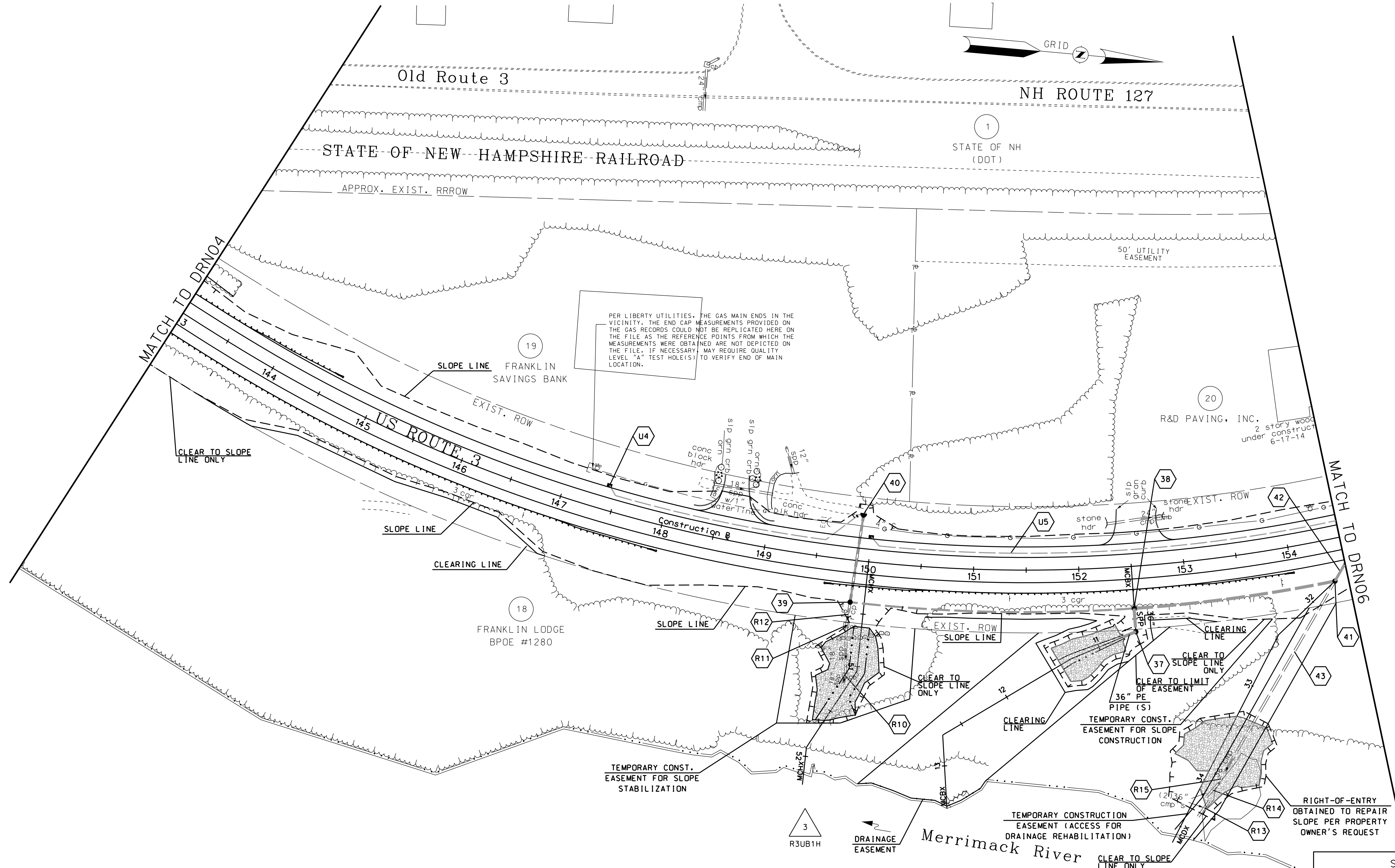

STATE OF NEW HAMPSHIRE				
DEPARTMENT OF TRANSPORTATION • BUREAU OF HIGHWAY DESIGN				
DRAINAGE AND UTILITY PLANS				
MODEL	DGN	STATE PROJECT NO.	SHEET NO.	TOTAL SHEETS
DRN05	13928adrnp1ans	13928A	60	160

PER LIBERTY UTILITIES, THE GAS MAIN ENDS IN THE VICINITY. THE END CAP MEASUREMENTS PROVIDED ON THE FILE AS THE REFERENCE POINTS FROM WHICH THE MEASUREMENTS WERE OBTAINED ARE NOT DEPICTED ON THE FILE. IF NECESSARY, MAY REQUIRE QUALITY LEVEL "A" TEST HOLE(S) TO VERIFY END OF MAIN LOCATION.

R&D PAVING, INC.
2 story wood
construct
6-17-14

FRANKLIN LODGE
BPOE #1280

Merrimack River

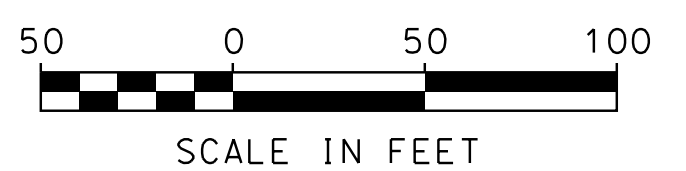

SDR PROCESSED	PLAN PREP	DATE	09/2013
NEW DESIGN	TEAM KIROUAC	DATE	04/2015
SHEET CHECKED	M. BALDWIN	DATE	
AS BUILT DETAILS		DATE	

REVISIONS AFTER PROPOSAL	STATION	DESCRIPTION

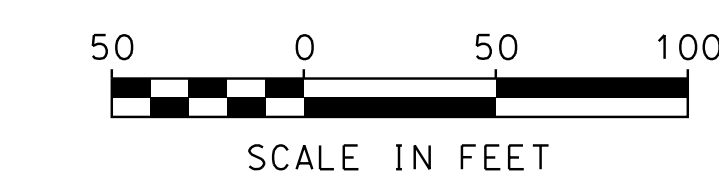
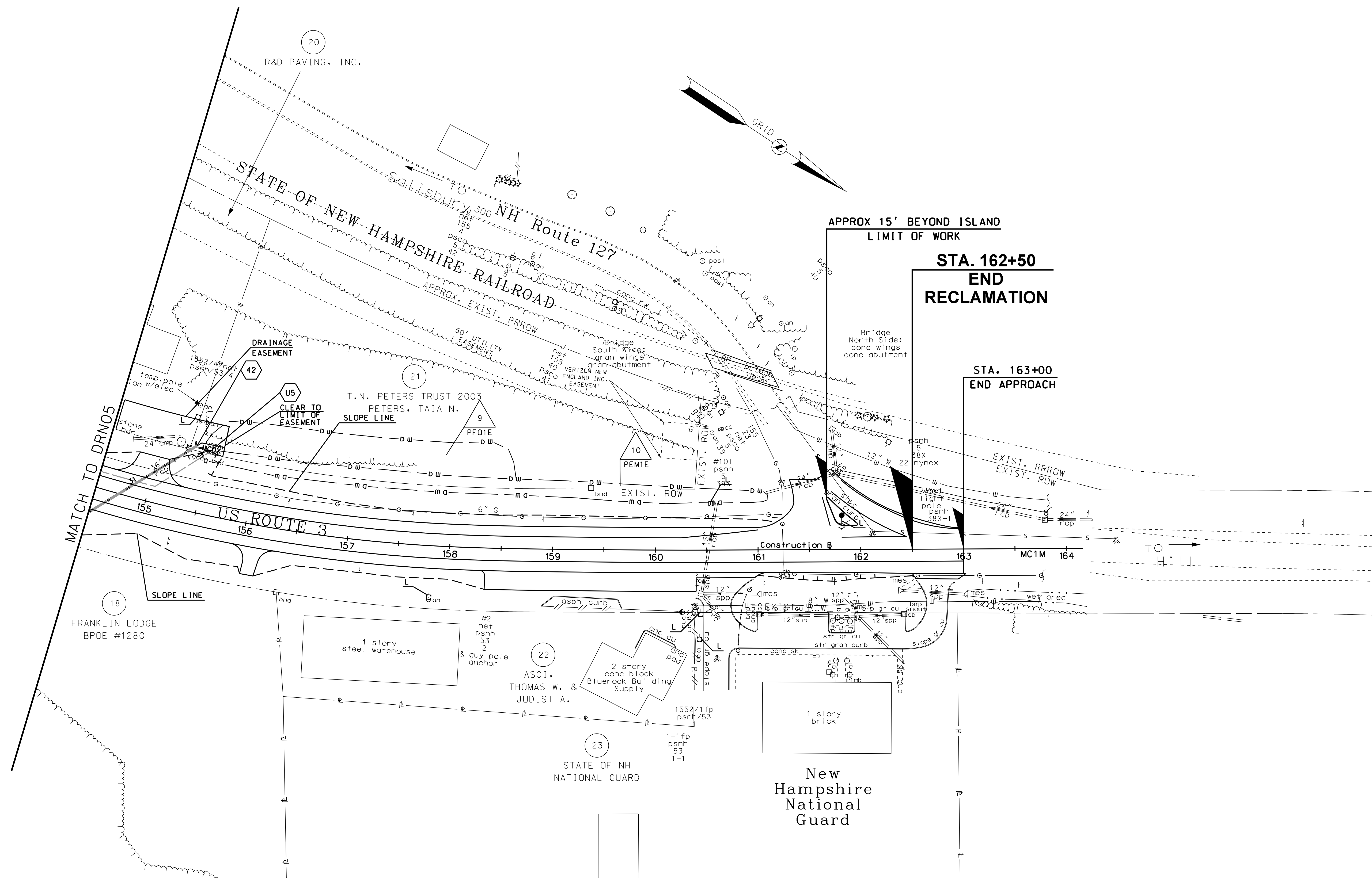

STATE OF NEW HAMPSHIRE				
DEPARTMENT OF TRANSPORTATION • BUREAU OF HIGHWAY DESIGN				
DRAINAGE AND UTILITY PLANS				
MODEL	DGN	STATE PROJECT NO.	SHEET NO.	TOTAL SHEETS
DRN06	13928adrnp1ans	13928A	61	160

SDR PROCESSED	DATE	11/14
NEW DESIGN	DATE	04/2015
SHEET CHECKED	DATE	
AS BUILT DETAILS	DATE	

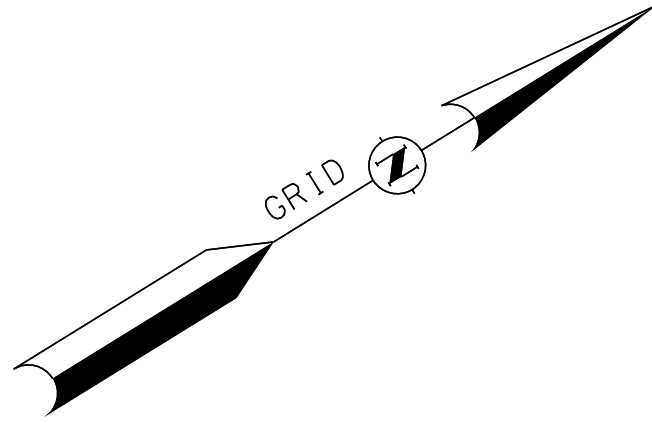

PAVEMENT MARKING NOTE

1. ALL SYMBOLS, WORDS, TRANSVERSE MARKINGS (STOP BARS, CROSSWALK LINES, AND RAILROAD SYMBOLS), LANE LINES AND ALL OTHER MARKINGS NOTED WITH A (T) SHALL BE THERMOPLASTIC.
2. CONTACT BUREAU OF TRAFFIC TO REVIEW ALL PASSING ZONES PRIOR TO STRIPING OR INSTALLING W14-3 SIGNS.
3. THE CONTRACTOR SHALL CONTACT PETER CROUCH AT THE NHDOT BUREAU OF TRAFFIC AT (603) 271-2291 ONE WEEK PRIOR TO PAVEMENT MARKING.
4. REPLACE WORDS/SYMBOLS PER LATEST NHDOT STANDARD PLAN SHEETS.
5. PAVEMENT MARKINGS SHALL EXTEND BEYOND PROJECT PAVING LIMITS TO OVERLAP EXISTING MARKINGS DISTURBED BY CONSTRUCTION.

CURBING NOTES

1. END OF ALL PROPOSED CURB SHALL TAPER FULL REVEAL TO FLUSH IN 8 FT (SEE DETAILS FOR CURB REVEAL TAPER RATES)

MC1M Curve No. 1
 PI = 94+44.13
 N = 333830.32
 E = 986527.00
 $\Delta = 26^\circ - 28' - 51.3''$ RT
 T = 228.23'
 R = 970.00'
 L = 448.31'
 E = 26.49'

+75 BEGIN 23:1 EP TAPER AT EXISTING EP, LT 11.9'
 +75 BEGIN 250:1 TW TAPER AT EXISTING TW, LT 10.9'

STA 104+00 LT
 CONST CR. STONE DRIVE
 WITH 5' PAVED APRON

MC1M Curve No. 2
 PI = 104+55.79
 N = 334690.98
 E = 987074.06
 $\Delta = 0^\circ - 58' - 13.6''$ LT
 T = 122.80'
 R = 14500.00'
 L = 245.59'
 E = 0.52'

**STA. 97+50
 BEGIN FULL BOX
 CONSTRUCTION**

**STA. 96+75
 BEGIN APPROACH**

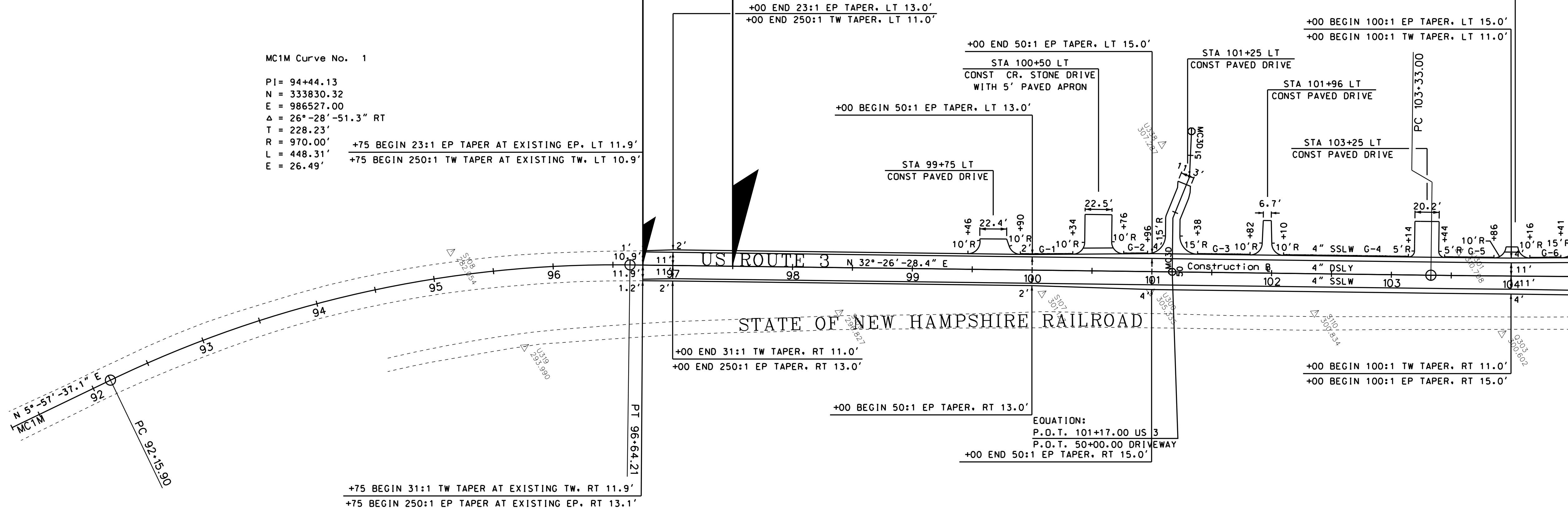

MATCH TO SHEET PVM02

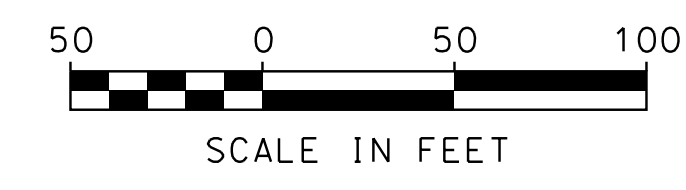

STATE OF NEW HAMPSHIRE				
DEPARTMENT OF TRANSPORTATION • BUREAU OF HIGHWAY DESIGN				
PAVEMENT MARKING, PAVEMENT LAYOUT, & CURBING PLAN				
MODEL	DGN	STATE PROJECT NO.	SHEET NO.	TOTAL SHEETS
PVM01	13928Apvmp1.dgn	13928A	62	160

SDR PROCESSED	DATE	11/14
NEW DESIGN	DATE	04/2015
SHEET CHECKED	DATE	
AS BUILT DETAILS	DATE	

REVISIONS AFTER PROPOSAL	STATION	DESCRIPTION

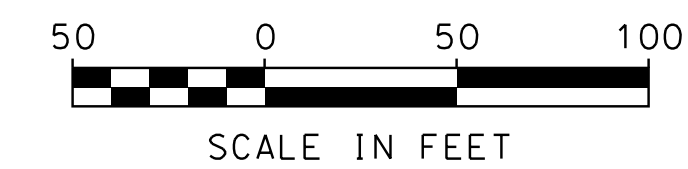
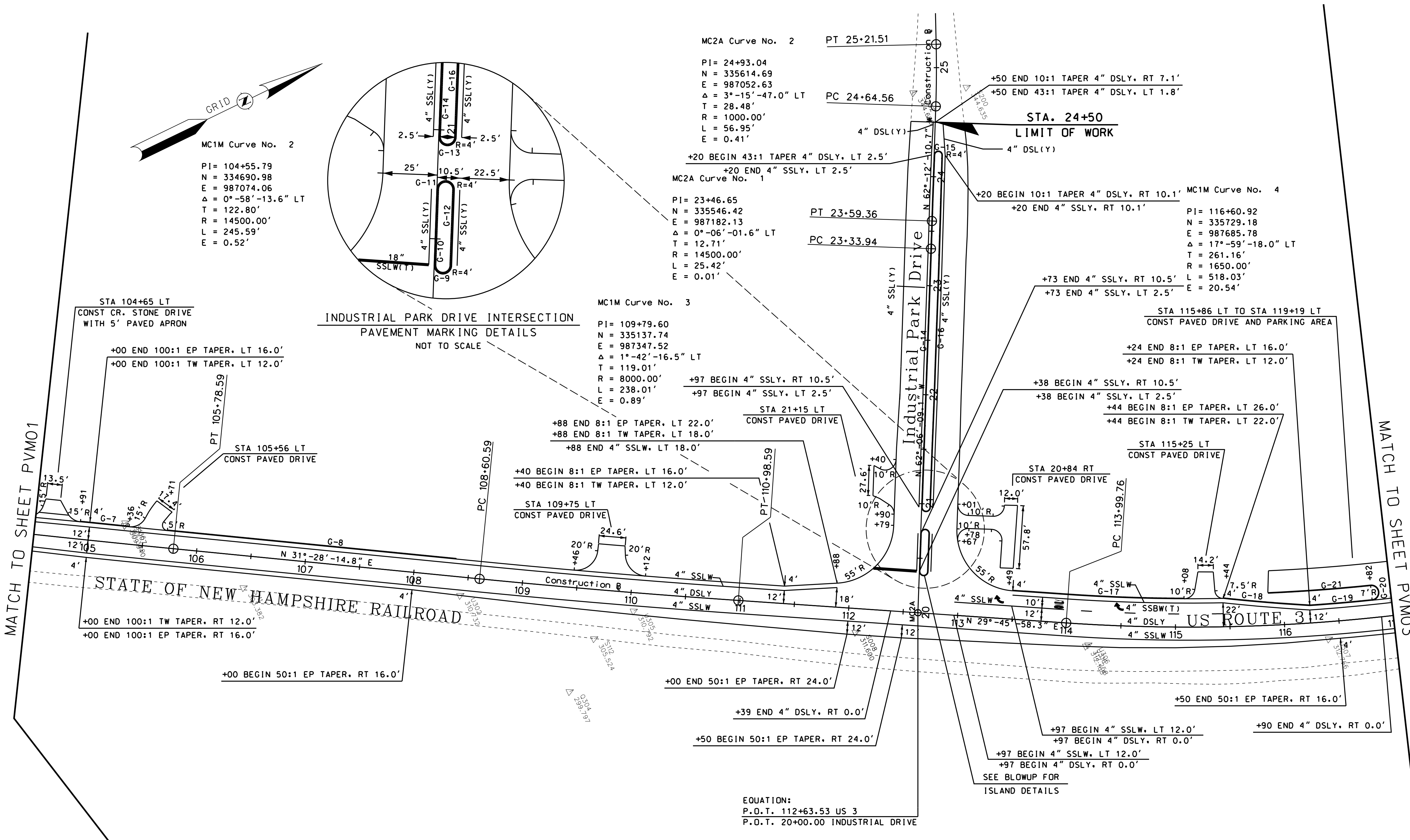

STATE OF NEW HAMPSHIRE				
DEPARTMENT OF TRANSPORTATION • BUREAU OF HIGHWAY DESIGN				
PAVEMENT MARKING, PAVEMENT LAYOUT, & CURBING PLAN				
MODEL	DGN	STATE PROJECT NO.	SHEET NO.	TOTAL SHEETS
PVM02	13928Apvmp1ans	13928A	63	160

SDR PROCESSED	DATE	DATE	DATE	DATE
NEW DESIGN	L. SCHOFFIELD	11/14	DATE	04/2015
SHEET CHECKED	C. SPETELUNAS			
AS BUILT DETAILS				

REVISIONS AFTER PROPOSAL	STATION	DESCRIPTION

MC1M Curve No. 4
 PI = 116+60.92
 N = 335729.18
 E = 987685.78
 $\Delta = 17^{\circ}-59'-18.0''$ LT
 T = 261.16'
 R = 1650.00'
 L = 518.03'
 E = 20.54'

MC1M Curve No. 5
 PI = 123+38.88
 N = 336397.08
 E = 987825.04
 $\Delta = 19^{\circ}-43'-52.9''$ LT
 T = 295.65'
 R = 1700.00'
 L = 585.44'
 E = 25.52'

Curve No. 6
 PI = 134+29.87
 N = 337483.37
 E = 987673.27
 $\Delta = 35^{\circ}-55'-52.6''$ RT
 $\Delta c = 28^{\circ}-25'-54.6''$ RT
 $\Delta d = 4^{\circ}-59'-58.7''$
 Ts = 446.85'
 Es = 59.60'
 Ls = 150.00'
 Lc = 568.68'
 Rc = 1700.00'
 LT = 100.02'
 ST = 50.02'
 $\Delta e = 3^{\circ}-44'-59.0''$
 P = 0.82'
 K = 74.99'
 Xc = 149.94'
 Yc = 3.27'
 LC = 149.97'

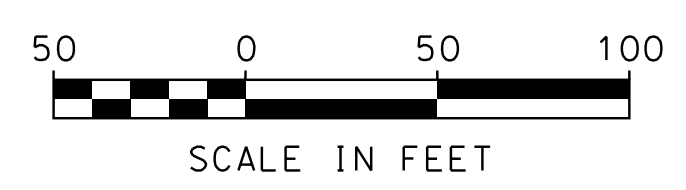
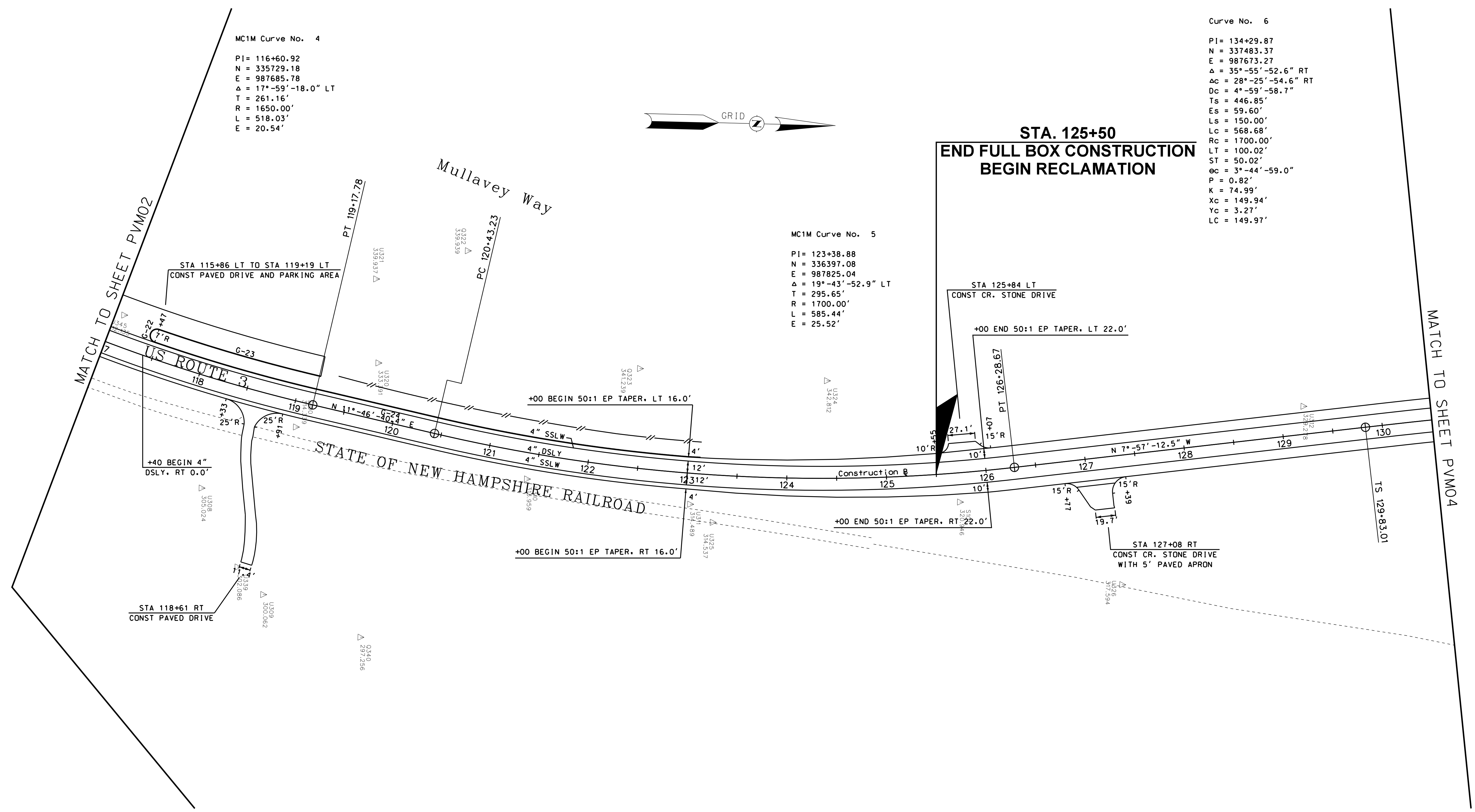
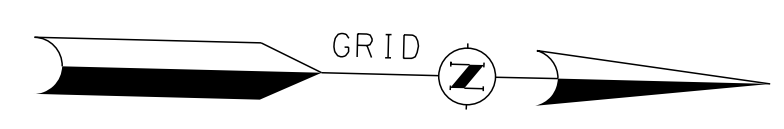

STATE OF NEW HAMPSHIRE				
DEPARTMENT OF TRANSPORTATION • BUREAU OF HIGHWAY DESIGN				
PAVEMENT MARKING, PAVEMENT LAYOUT, & CURBING PLAN				
MODEL	DGN	STATE PROJECT NO.	SHEET NO.	TOTAL SHEETS
PVM03	13928Apvmp1ans	13928A	64	160

SDR PROCESSED	DATE	11/14
NEW DESIGN	L. SCHOFFIELD	DATE
SHEET CHECKED	C. SPETELUNAS	DATE
AS BUILT DETAILS	DATE	

REVISIONS AFTER PROPOSAL	STATION	DESCRIPTION

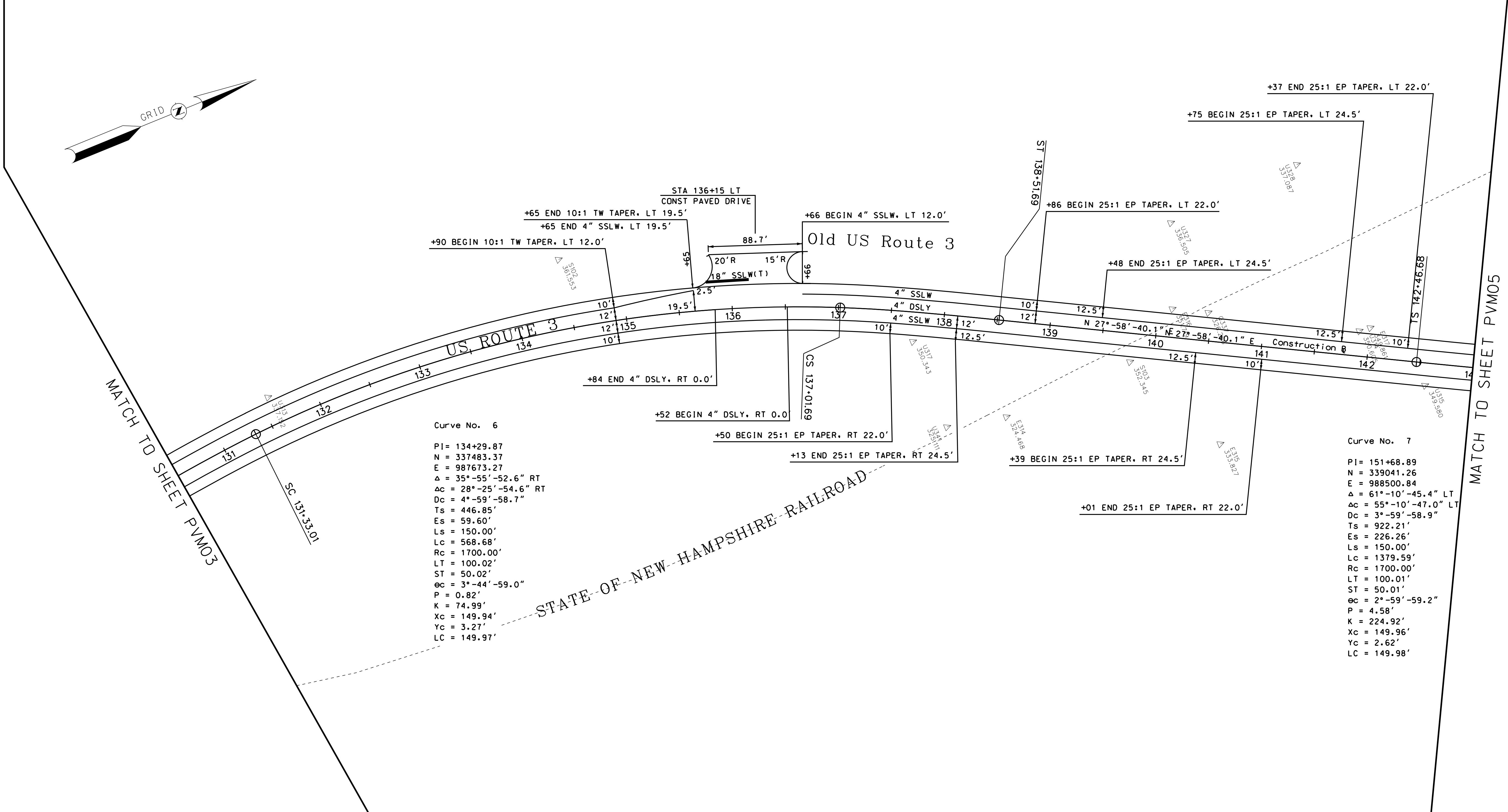
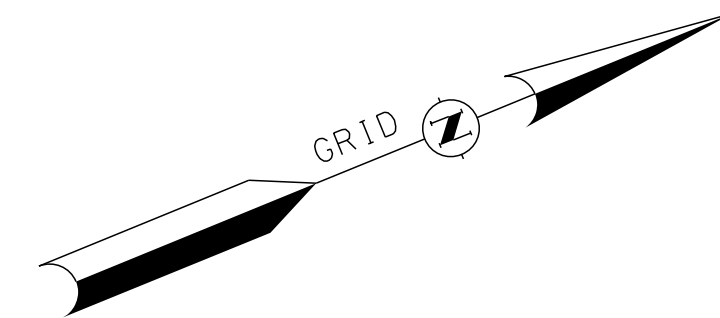

Curve No. 6
 PI = 134+29.87
 N = 337483.37
 E = 987673.27
 $\Delta = 35^\circ-55'-52.6''$ RT
 $\Delta c = 28^\circ-25'-54.6''$ RT
 $Dc = 4^\circ-59'-58.7''$
 Ts = 446.85'
 Es = 59.60'
 Ls = 150.00'
 Lc = 568.68'
 Rc = 1700.00'
 LT = 100.02'
 ST = 50.02'
 $\theta c = 3^\circ-44'-59.0''$
 P = 0.82'
 K = 74.99'
 Xc = 149.94'
 Yc = 3.27'
 LC = 149.97'

Curve No. 7
 PI = 151+68.89
 N = 339041.26
 E = 988500.84
 $\Delta = 61^\circ-10'-45.4''$ LT
 $\Delta c = 55^\circ-10'-47.0''$ LT
 $Dc = 3^\circ-59'-58.9''$
 Ts = 922.21'
 Es = 226.26'
 Ls = 150.00'
 Lc = 1379.59'
 Rc = 1700.00'
 LT = 100.01'
 ST = 50.01'
 $\theta c = 2^\circ-59'-59.2''$
 P = 4.58'
 K = 224.92'
 Xc = 149.96'
 Yc = 2.62'
 LC = 149.98'



STATE OF NEW HAMPSHIRE				
DEPARTMENT OF TRANSPORTATION • BUREAU OF HIGHWAY DESIGN				
PAVEMENT MARKING, PAVEMENT LAYOUT, & CURBING PLAN				
MODEL	DGN	STATE PROJECT NO.	SHEET NO.	TOTAL SHEETS
PVM04	13928Apvmp1ans	13928A	65	160

SDR PROCESSED		REVISIONS AFTER PROPOSAL	
NEW DESIGN	L. SCHOFFIELD	STATION	DESCRIPTION
SHEET CHECKED	C. SPETELUNAS	STATION	DESCRIPTION
AS BUILT DETAILS		DATE	
DATE	11/14	NUMBER	
DATE	04/2015	DATE	
DATE		DATE	

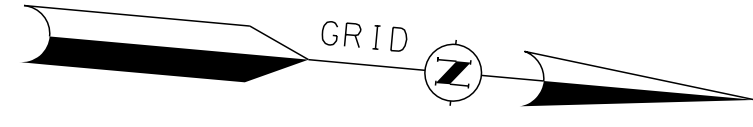
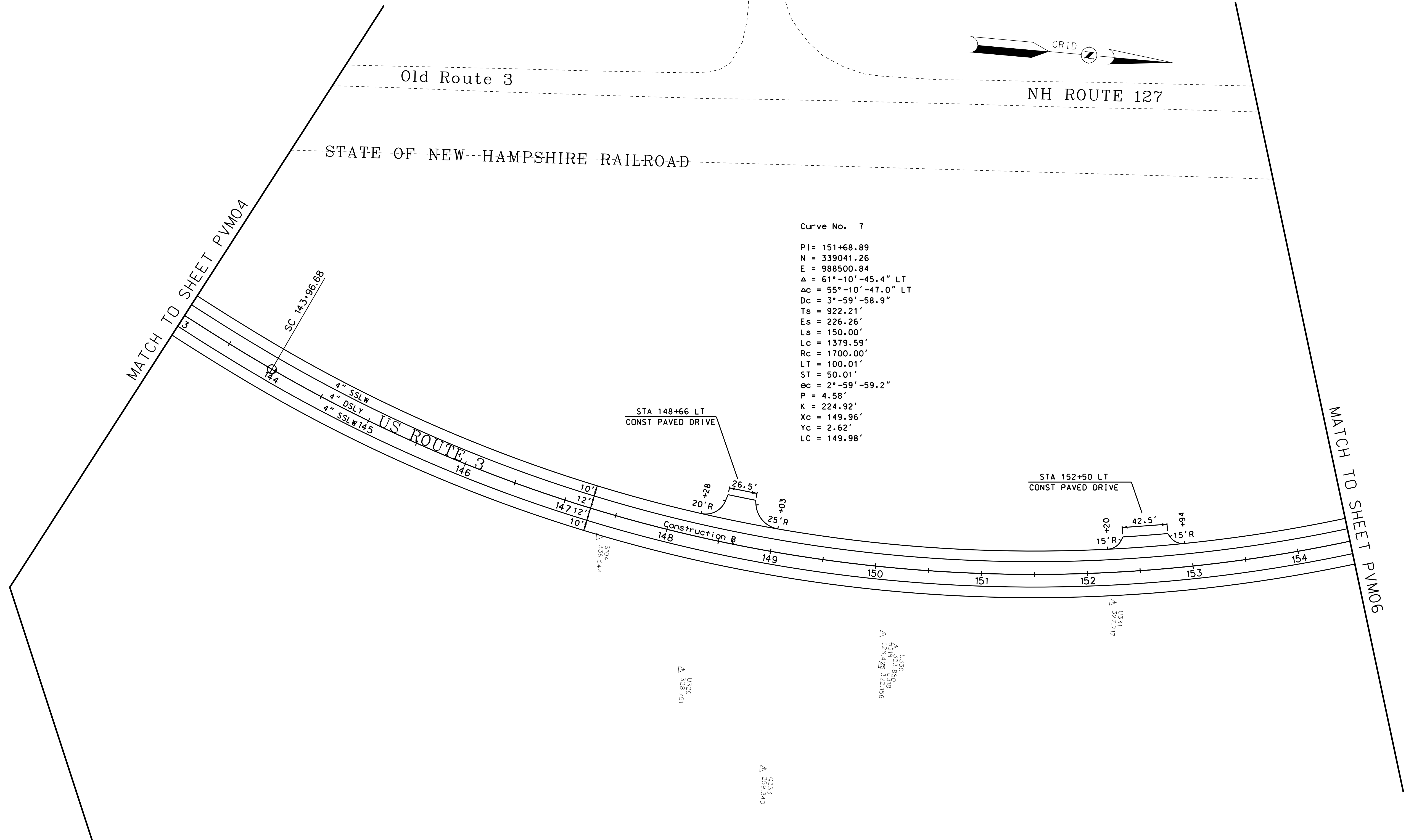

Curve No. 7
 PI = 151+68.89
 N = 339041.26
 E = 988500.84
 $\Delta = 61^\circ - 10' - 45.4''$ LT
 $\Delta c = 55^\circ - 10' - 47.0''$ LT
 $Dc = 3^\circ - 59' - 58.9''$
 Ts = 922.21'
 Es = 226.26'
 Ls = 150.00'
 Lc = 1379.59'
 Rc = 1700.00'
 LT = 100.01'
 ST = 50.01'
 $ec = 2^\circ - 59' - 59.2''$
 P = 4.58'
 K = 224.92'
 Xc = 149.96'
 Yc = 2.62'
 LC = 149.98'



STATE OF NEW HAMPSHIRE				
DEPARTMENT OF TRANSPORTATION • BUREAU OF HIGHWAY DESIGN				
PAVEMENT MARKING, PAVEMENT LAYOUT, & CURBING PLAN				
MODEL	DGN	STATE PROJECT NO.	SHEET NO.	TOTAL SHEETS
PVM05	13928Apvmp1ans	13928A	66	160

SDR PROCESSED	DATE	DATE	DATE	DATE	DATE
NEW DESIGN	L. SCHOFFIELD	11/14			
SHEET CHECKED	C. SPETELUNAS	04/2015			
AS BUILT DETAILS					

REVISIONS AFTER PROPOSAL	STATION	DESCRIPTION

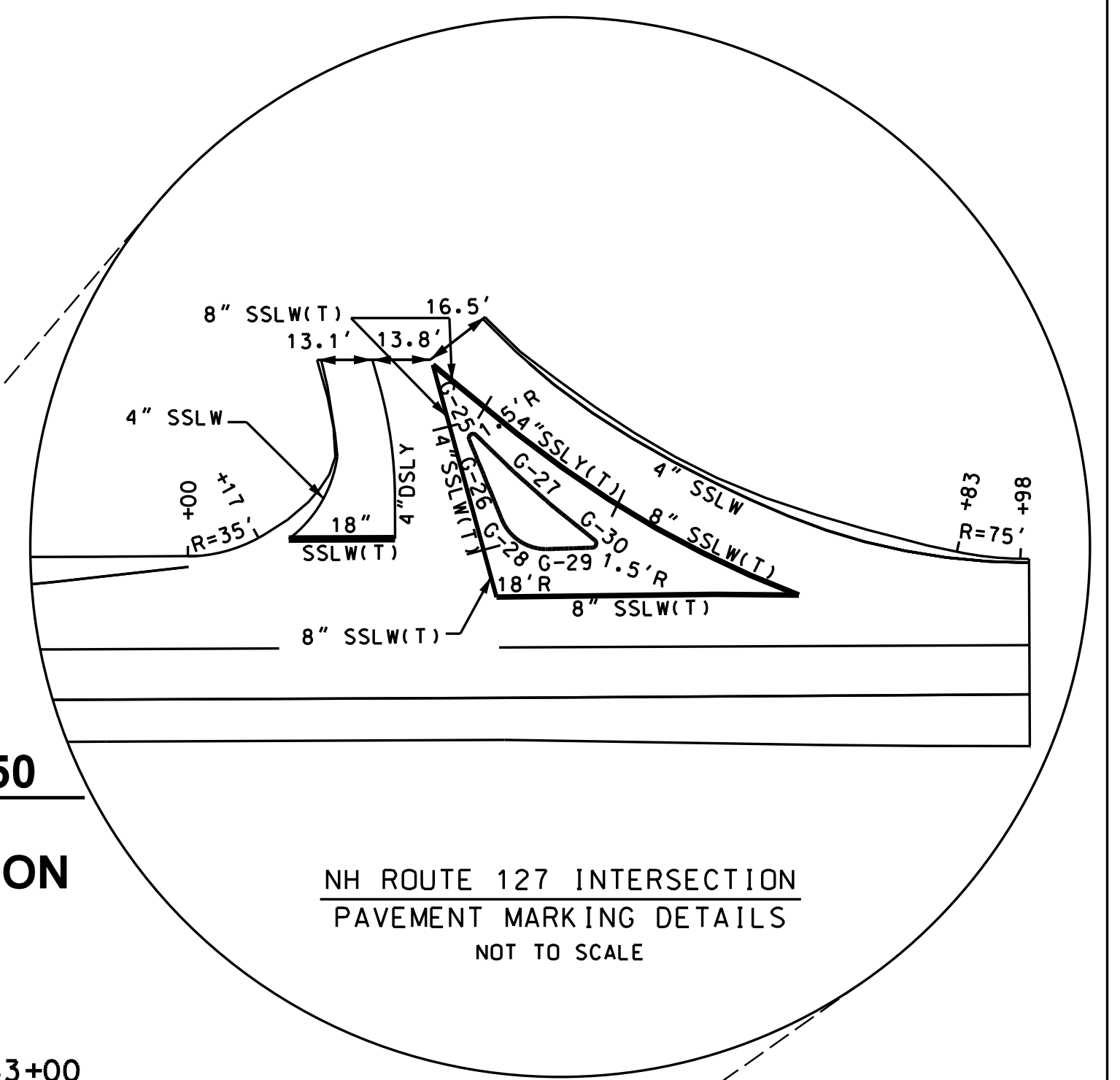
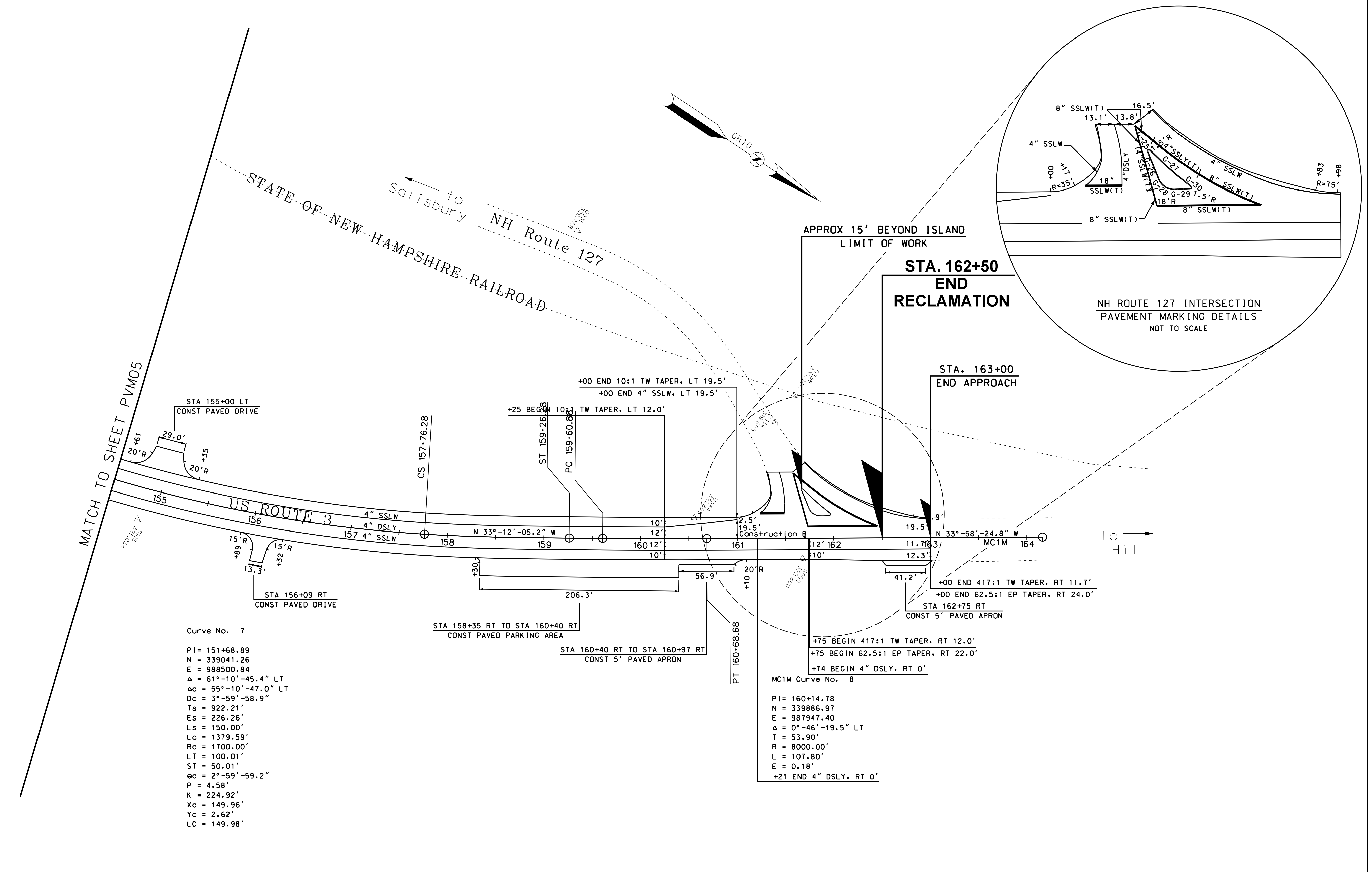

Curve No. 7
 PI = 151+68.89
 N = 339041.26
 E = 988500.84
 Δ = 61°-10'-45.4" LT
 Δc = 55°-10'-47.0" LT
 Dc = 3°-59'-58.9"
 Ts = 922.21'
 Es = 226.26'
 Ls = 150.00'
 Lc = 1379.59'
 Rc = 1700.00'
 LT = 100.01'
 ST = 50.01'
 Δc = 2°-59'-59.2"
 P = 4.58'
 K = 224.92'
 Xc = 149.96'
 Yc = 2.62'
 LC = 149.98'

MC1M Curve No. 8
 PI = 160+14.78
 N = 339886.97
 E = 987947.40
 Δ = 0°-46'-19.5" LT
 T = 53.90'
 R = 8000.00'
 L = 107.80'
 E = 0.18'
 +21 END 4" DSLY, RT 0'

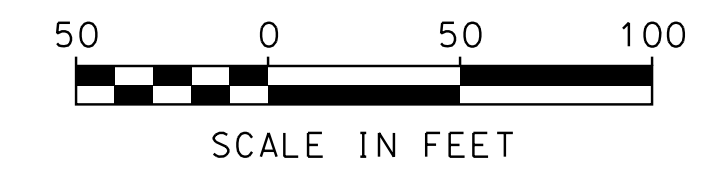

STATE OF NEW HAMPSHIRE				
DEPARTMENT OF TRANSPORTATION • BUREAU OF HIGHWAY DESIGN				
PAVEMENT MARKING, PAVEMENT LAYOUT, & CURBING PLAN				
MODEL	DGN	STATE PROJECT NO.	SHEET NO.	TOTAL SHEETS
PVM06	13928Apvmp1ans	13928A	67	160

SDR PROCESSED	DATE	11/14
NEW DESIGN	DATE	04/15
SHEET CHECKED	DATE	
AS BUILT DETAILS	DATE	

REVISIONS AFTER PROPOSAL	DESCRIPTION
STATION	
STATION	
DATE	
NUMBER	

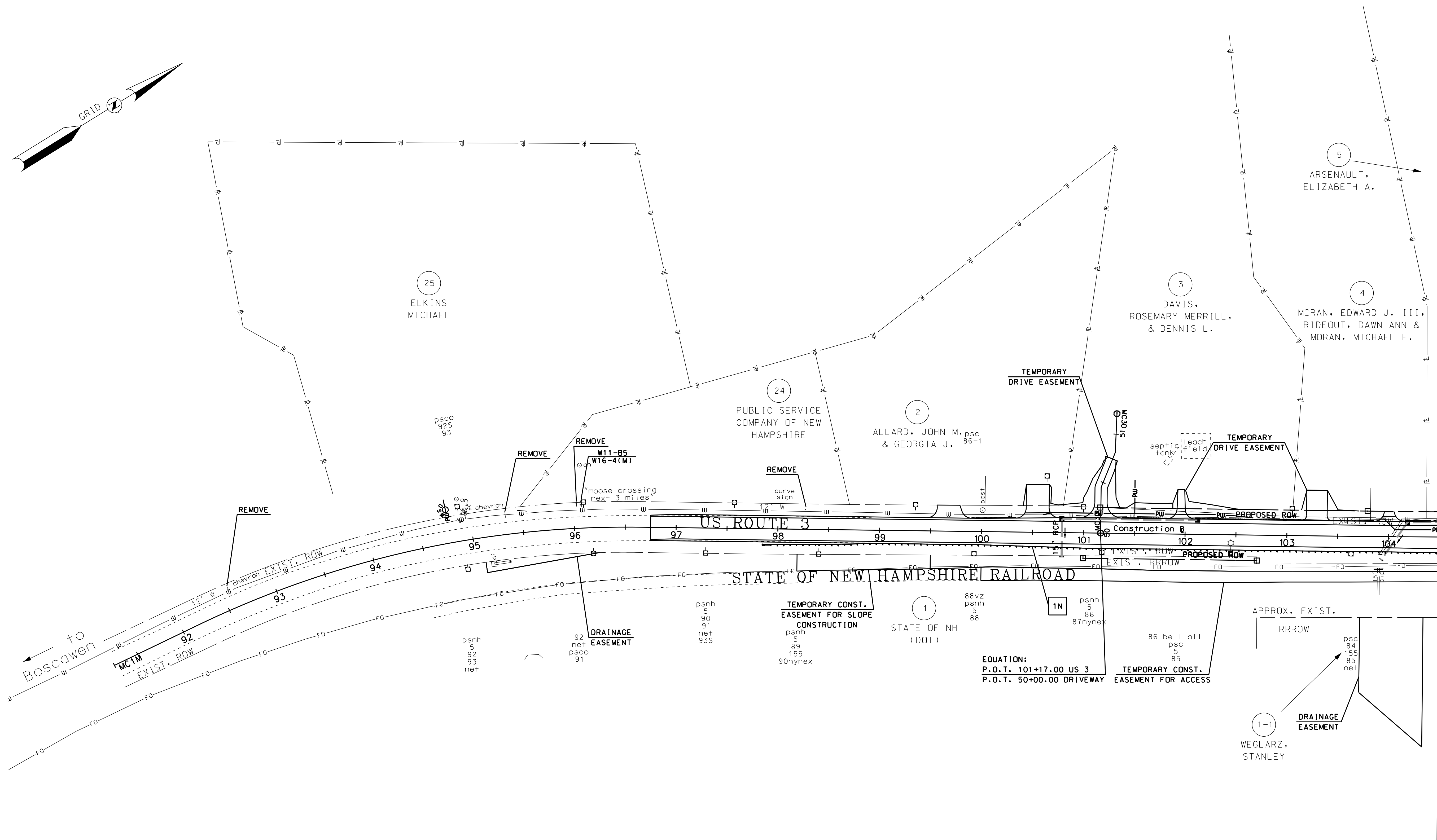
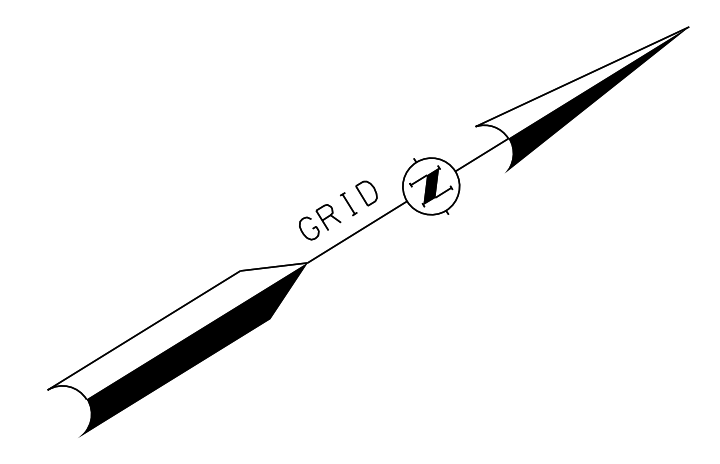

MATCH TO SHEET SCN02

STATE OF NEW HAMPSHIRE				
DEPARTMENT OF TRANSPORTATION • BUREAU OF HIGHWAY DESIGN				
SIGNING & LIGHTING PLAN				
MODEL	DGN	STATE PROJECT NO.	SHEET NO.	TOTAL SHEETS
SCN01	13928Asgnp1ans	13928A	68	160



REVISIONS AFTER PROPOSAL		STATION	DESCRIPTION
NUMBER	DATE	STATION	DESCRIPTION

SDR PROCESSED	DATE	11/14
NEW DESIGN	C. SPETELUNAS	DATE
SHEET CHECKED	M. BALDWIN	DATE
AS BUILT DETAILS	DATE	

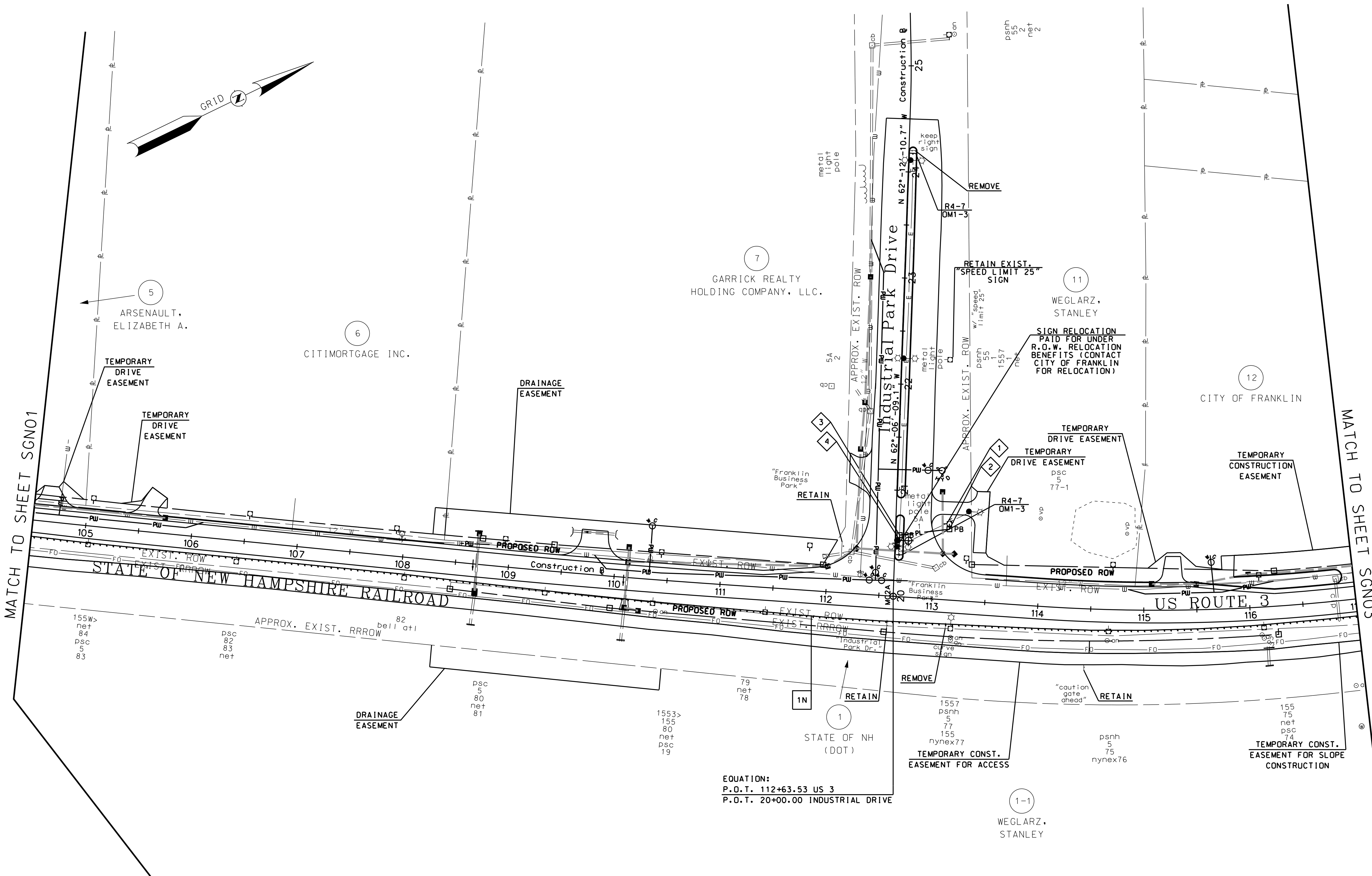

EQUATION:
P.O.T. 112+63.53 US 3
P.O.T. 20+00.00 INDUSTRIAL DRIVE



STATE OF NEW HAMPSHIRE				
DEPARTMENT OF TRANSPORTATION • BUREAU OF HIGHWAY DESIGN				
SIGNING & LIGHTING PLAN				
MODEL	DGN	STATE PROJECT NO.	SHEET NO.	TOTAL SHEETS
SGN02	13928Asgnp1ans	13928A	69	160

SDR PROCESSED	DATE	11/14
NEW DESIGN	C. SPETELUNAS	
SHEET CHECKED	M. BALDWIN	
AS BUILT DETAILS		

REVISIONS AFTER PROPOSAL	STATION	DESCRIPTION

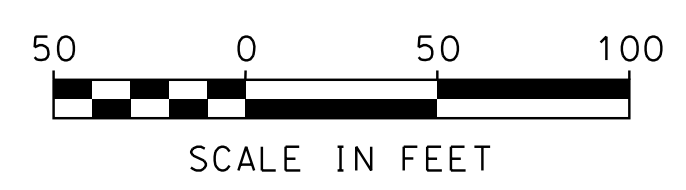
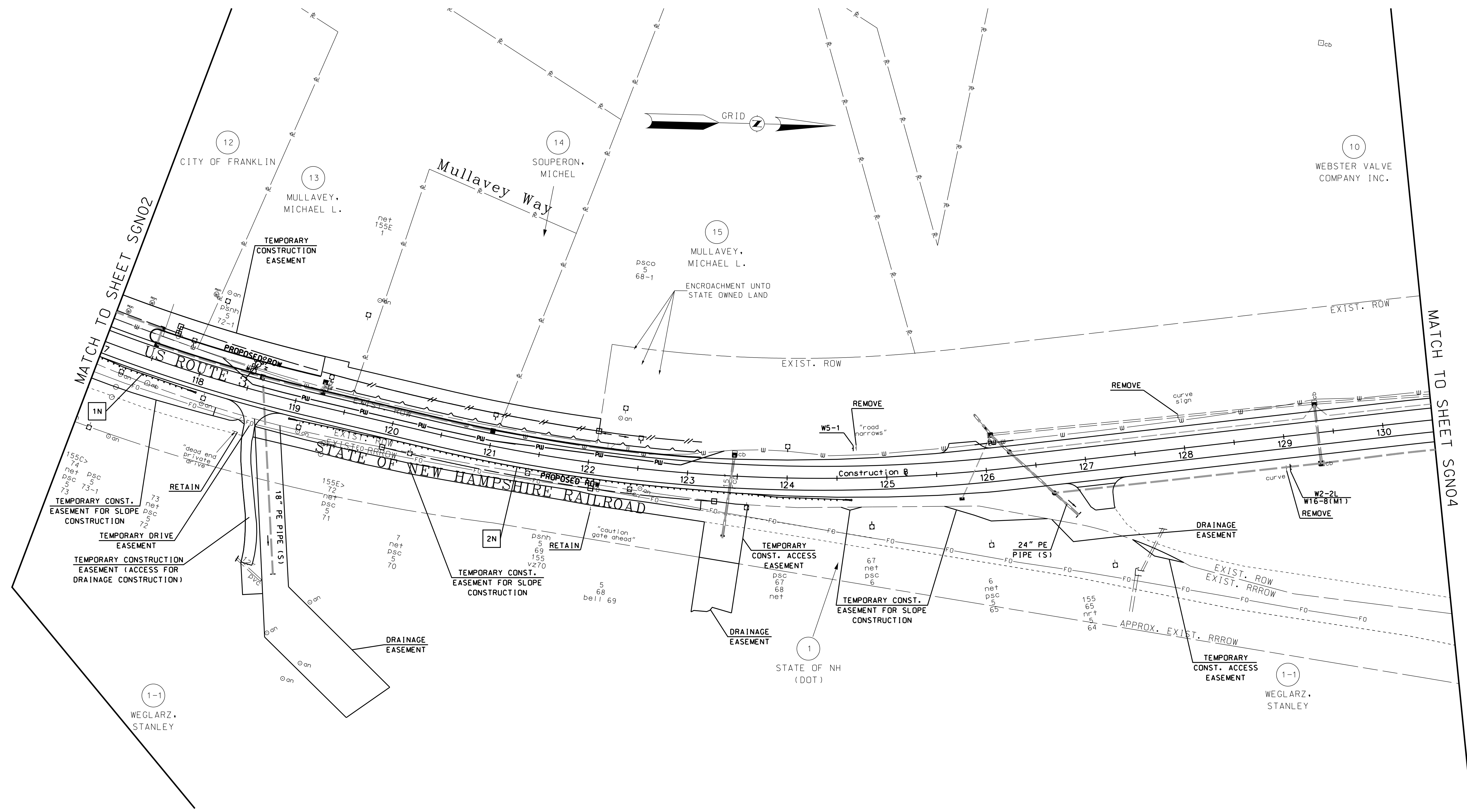

STATE OF NEW HAMPSHIRE				
DEPARTMENT OF TRANSPORTATION • BUREAU OF HIGHWAY DESIGN				
SIGNING & LIGHTING PLAN				
MODEL	DGN	STATE PROJECT NO.	SHEET NO.	TOTAL SHEETS
SGN03	13928Asgnplans	13928A	70	160

SDR PROCESSED	DATE	11/14
NEW DESIGN	DATE	04/15
SHEET CHECKED	DATE	
AS BUILT DETAILS	DATE	

REVISIONS AFTER PROPOSAL	STATION	DESCRIPTION

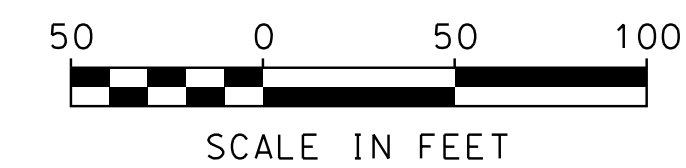
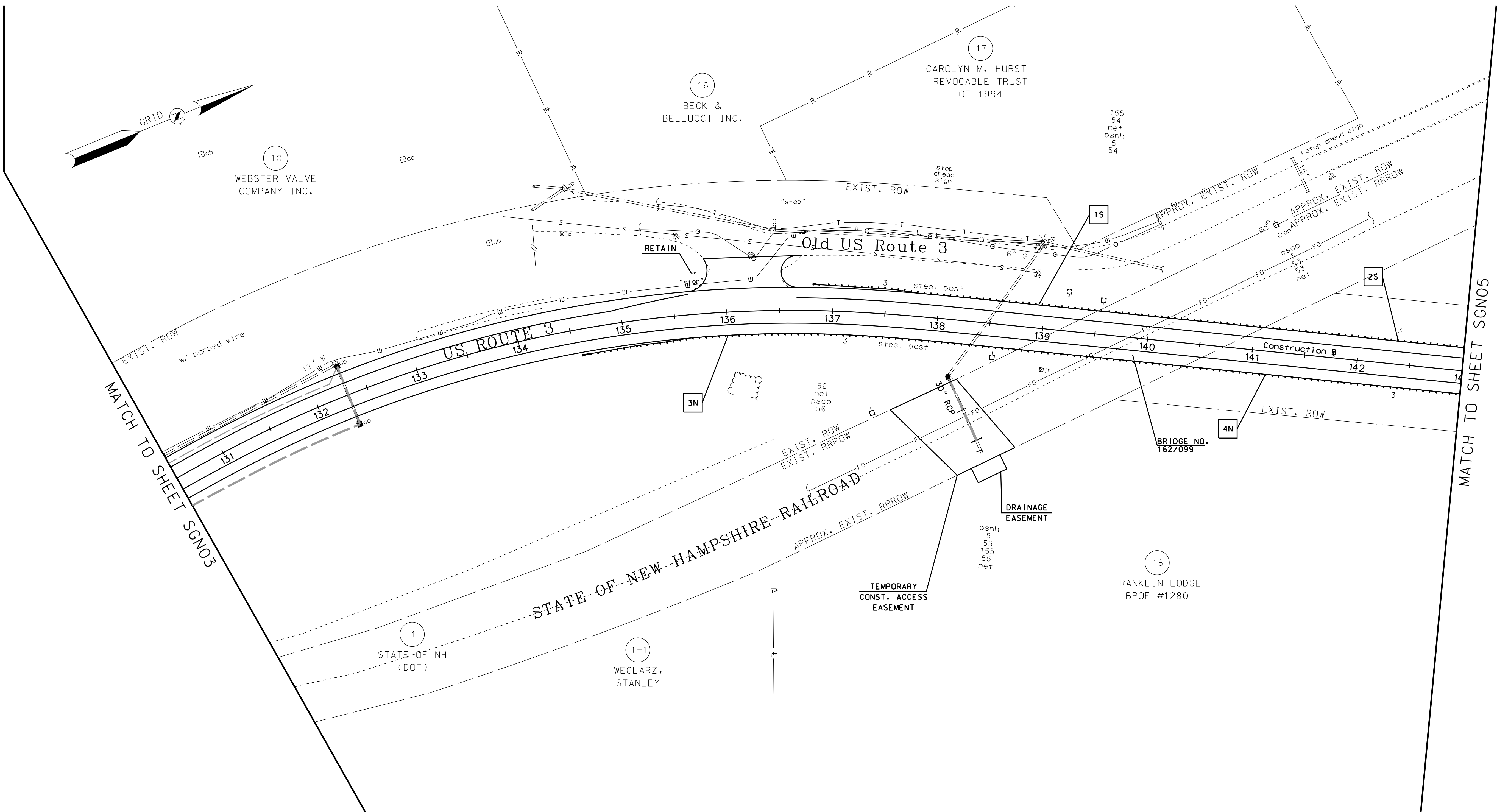

STATE OF NEW HAMPSHIRE				
DEPARTMENT OF TRANSPORTATION • BUREAU OF HIGHWAY DESIGN				
SIGNING & LIGHTING PLAN				
MODEL	DGN	STATE PROJECT NO.	SHEET NO.	TOTAL SHEETS
SGN04	13928Asgnp1ans	13928A	71	160

SDR PROCESSED	DATE	11/14
NEW DESIGN	C. SPETELUNAS	DATE
SHEET CHECKED	M. BALDWIN	DATE
AS BUILT DETAILS		DATE

REVISIONS AFTER PROPOSAL	DESCRIPTION
STATION	
STATION	
DATE	
NUMBER	

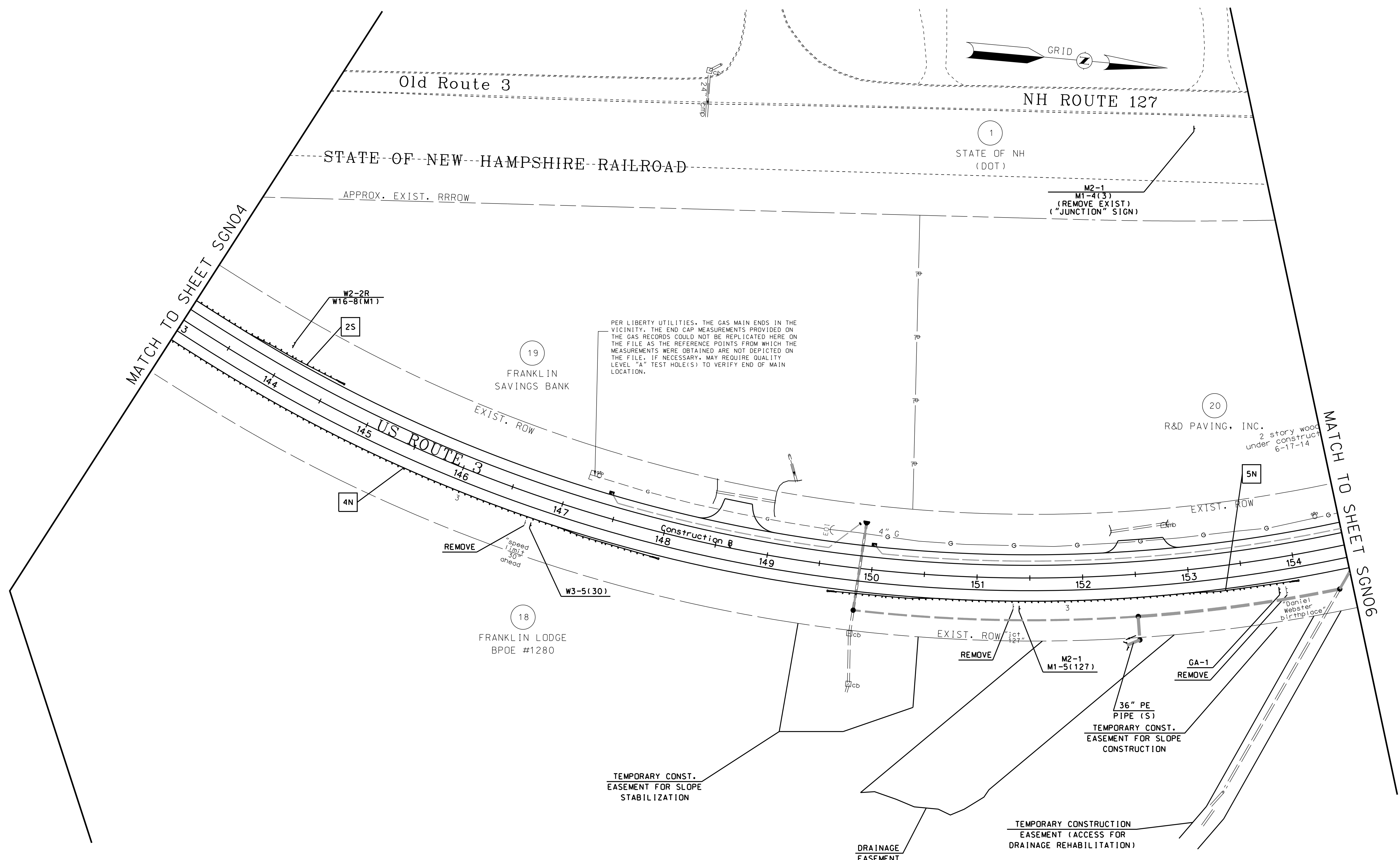

PER LIBERTY UTILITIES, THE GAS MAIN ENDS IN THE VICINITY. THE END CAP MEASUREMENTS PROVIDED ON THE FILE AS THE REFERENCE POINTS FROM WHICH THE MEASUREMENTS WERE OBTAINED ARE NOT DEPICTED ON THE FILE. IF NECESSARY, MAY REQUIRE QUALITY LEVEL "A" TEST HOLE(S) TO VERIFY END OF MAIN LOCATION.

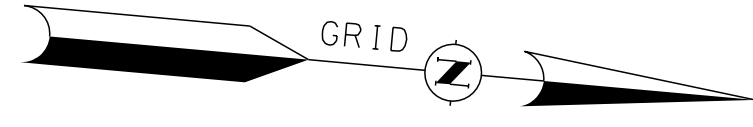

STATE OF NEW HAMPSHIRE				
DEPARTMENT OF TRANSPORTATION • BUREAU OF HIGHWAY DESIGN				
SIGNING & LIGHTING PLAN				
MODEL	DGN	STATE PROJECT NO.	SHEET NO.	TOTAL SHEETS
SGN05	13928AsgnPlans	13928A	72	160

SDR PROCESSED	DATE	11/14
NEW DESIGN	DATE	04/15
SHEET CHECKED	DATE	
AS BUILT DETAILS	DATE	

REVISIONS AFTER PROPOSAL	STATION	DESCRIPTION

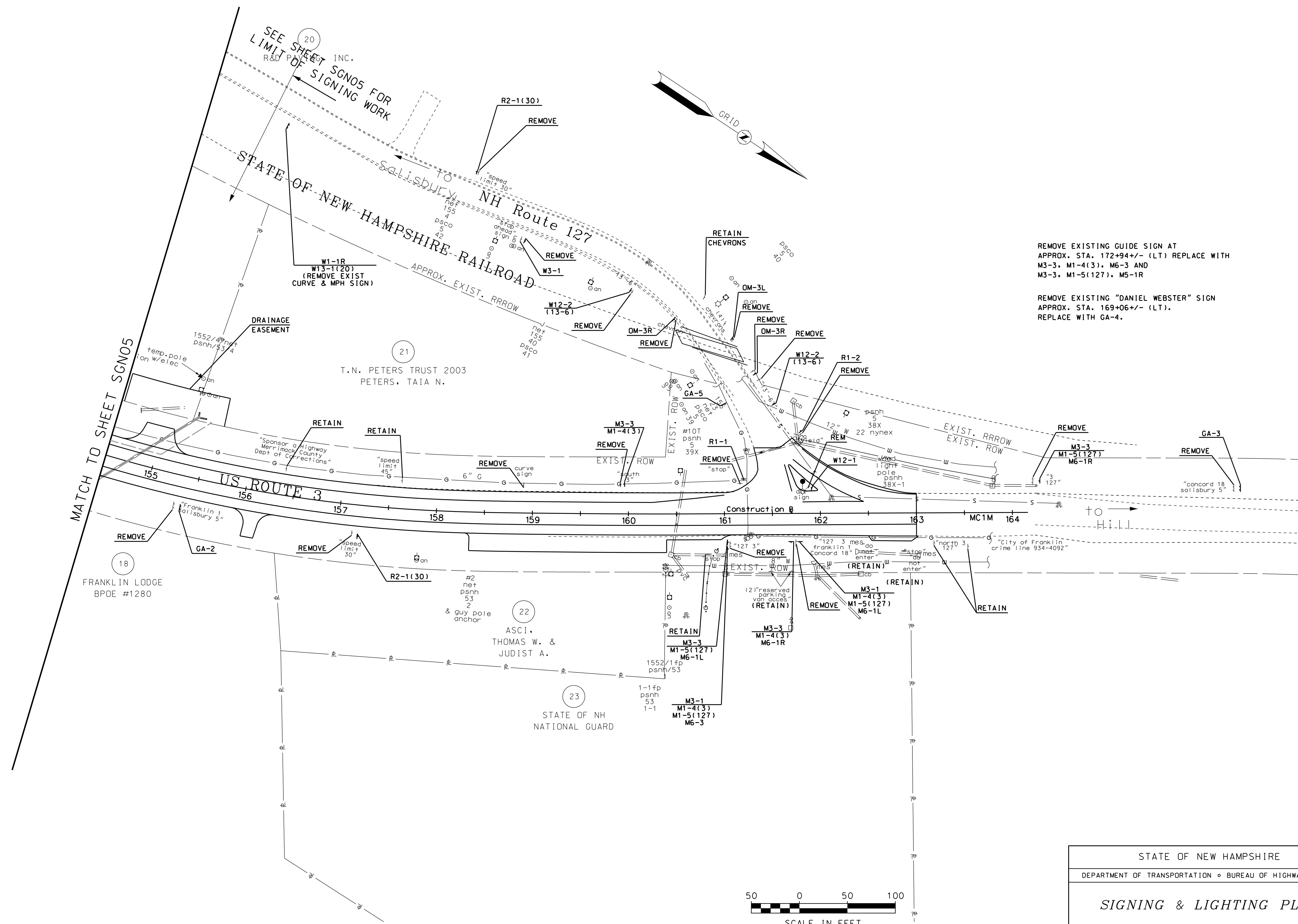

REMOVE EXISTING GUIDE SIGN AT APPROX. STA. 172+94+/- (LT) REPLACE WITH M3-3, M1-4(3), M6-3 AND M3-3, M1-5(127), M5-1R

REMOVE EXISTING "DANIEL WEBSTER" SIGN APPROX. STA. 169+06+/- (LT). REPLACE WITH GA-4.



STATE OF NEW HAMPSHIRE
 DEPARTMENT OF TRANSPORTATION • BUREAU OF HIGHWAY DESIGN
SIGNING & LIGHTING PLAN

MODEL	DGN	STATE PROJECT NO.	SHEET NO.	TOTAL SHEETS
SGN06	13928AsgnPlans	13928A	73	160

SDR PROCESSED	DATE
NEW DESIGN TEAM BALDWIN	DATE 09/2013
SHEET CHECKED TEAM BALDWIN	DATE 04/2015
AS BUILT DETAILS	DATE

REVISIONS AFTER PROPOSAL				
NUMBER	DATE	STATION	STATION	DESCRIPTION

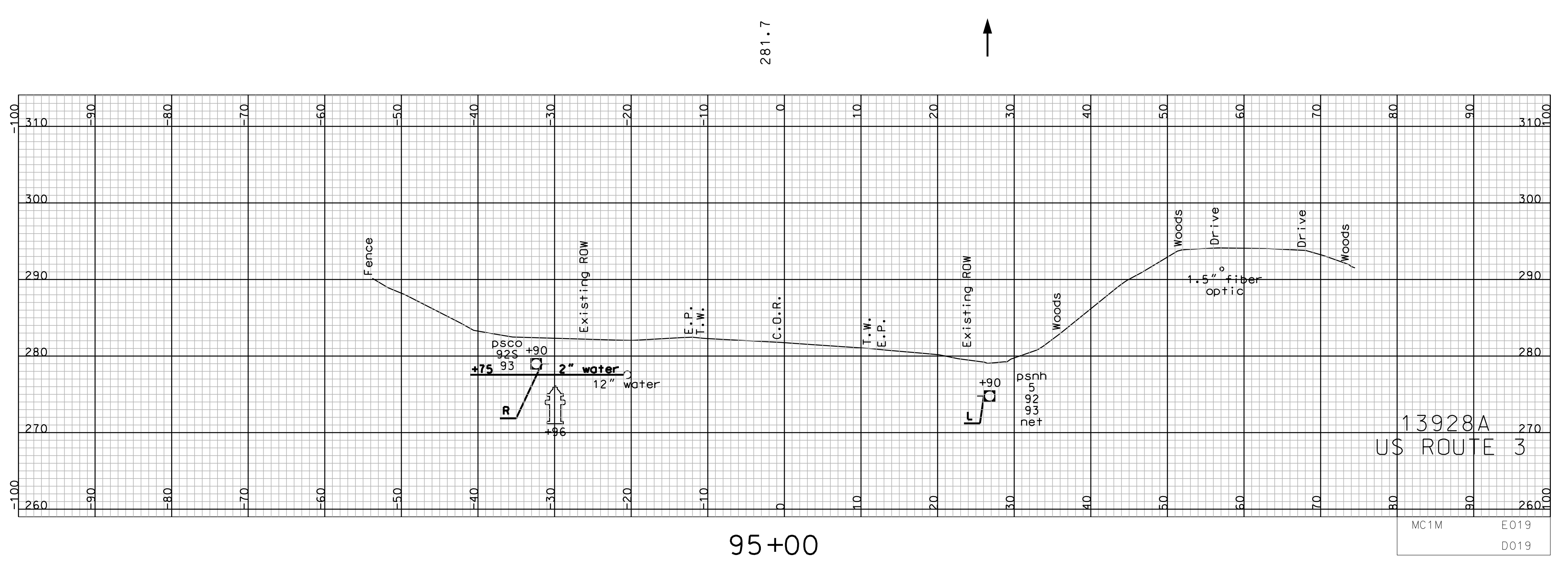
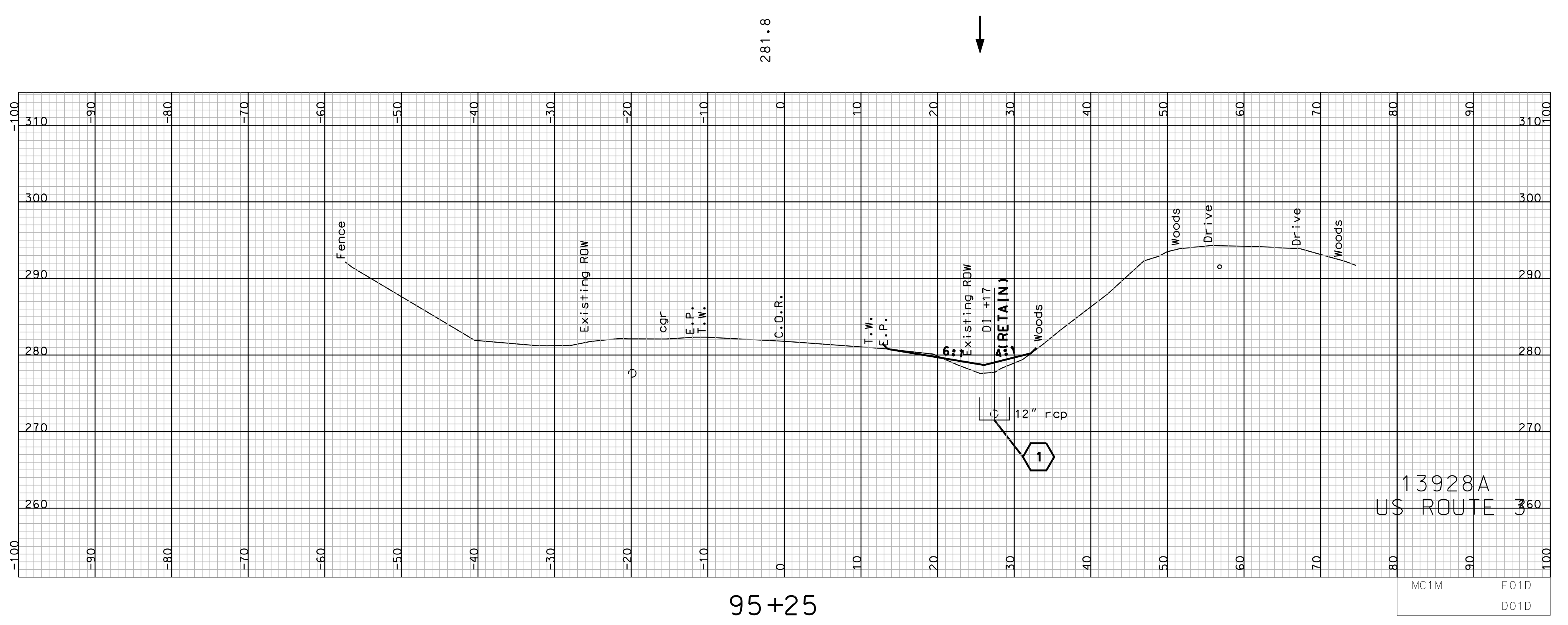
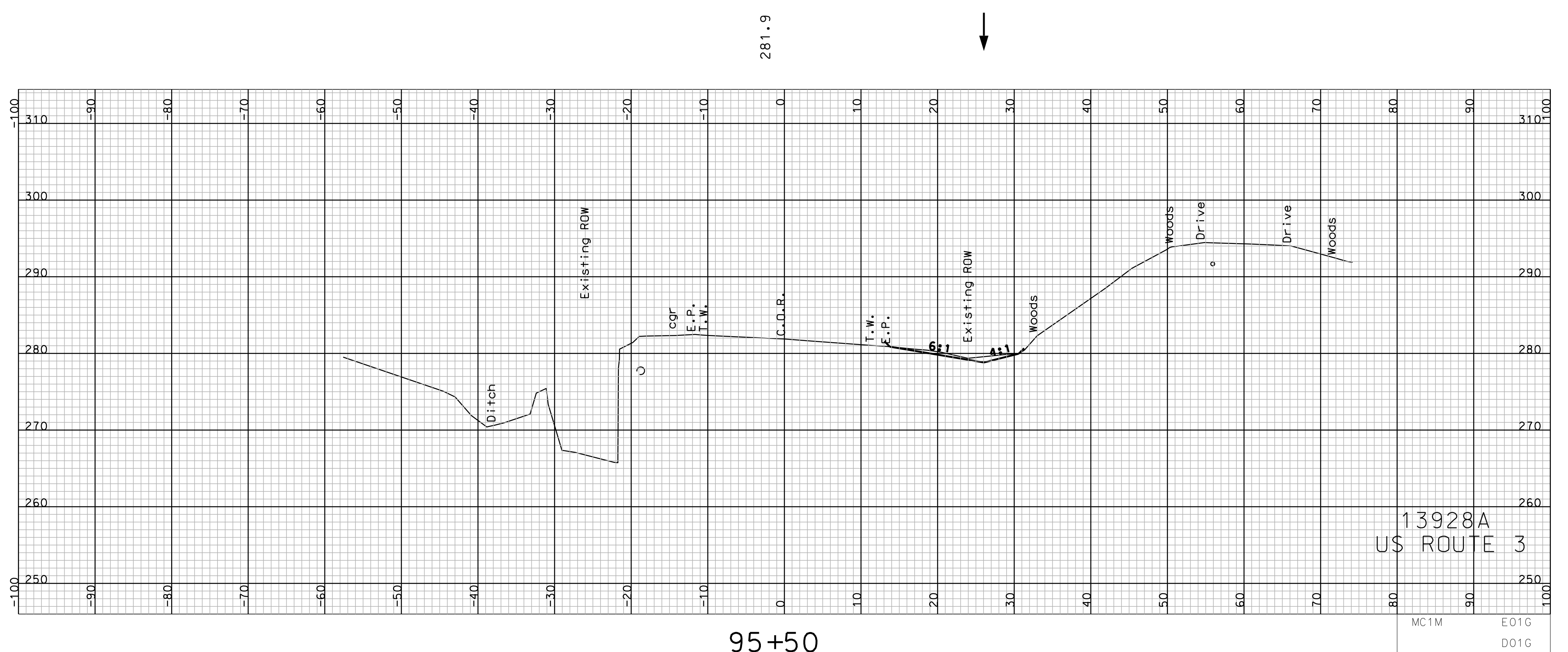

SHEET TOTALS			
COMMON EXCAV.	FILL	ROCK EXCAV.	MUCK EXCAV.
0	8	0	0
C.Y.	C.Y.	C.Y.	C.Y.
DCN	STATE PROJECT NO.	SHEET NO.	TOTAL SHEETS
13928axs-mc1m	13928A	74	160

SDR PROCESSED	DATE
NEW DESIGN TEAM BALDWIN	DATE 09/2013
SHEET CHECKED TEAM BALDWIN	DATE 04/2015
AS BUILT DETAILS	DATE

REVISIONS AFTER PROPOSAL				
NUMBER	DATE	STATION	STATION	DESCRIPTION

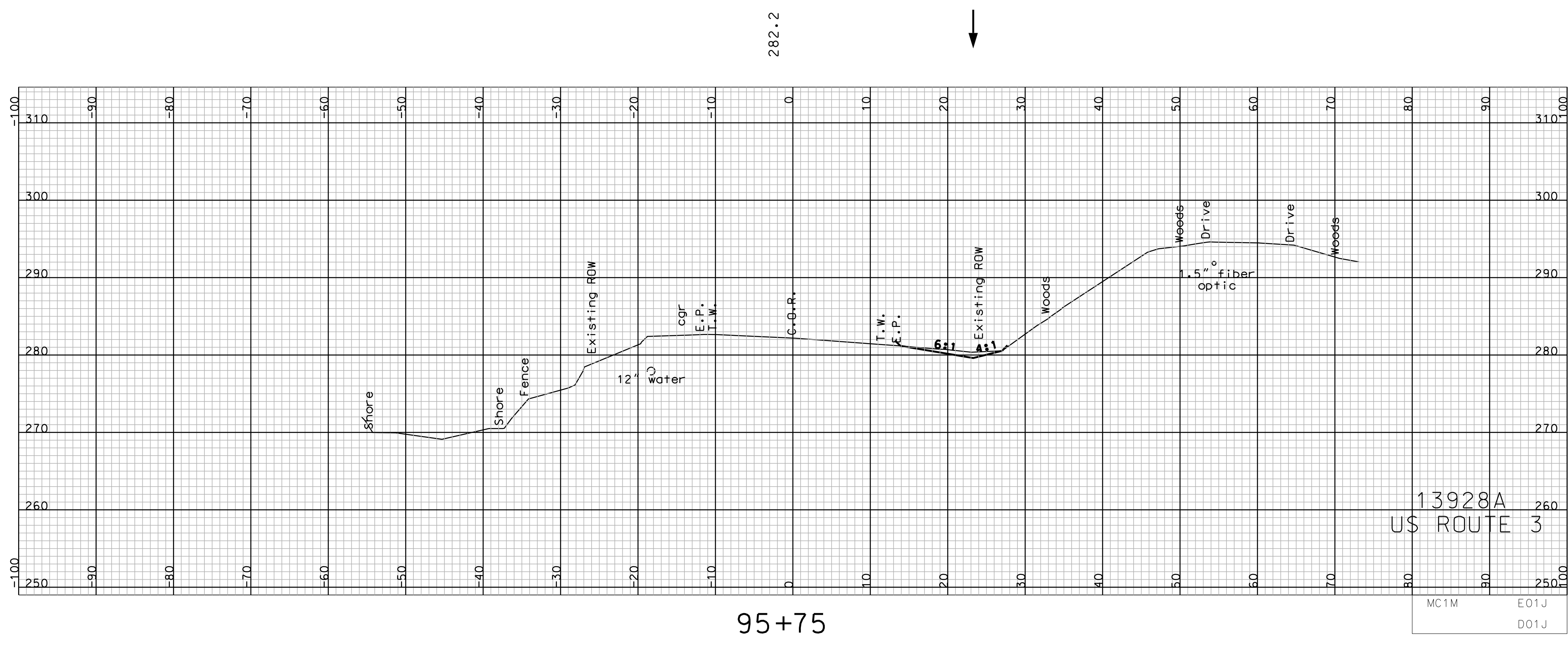
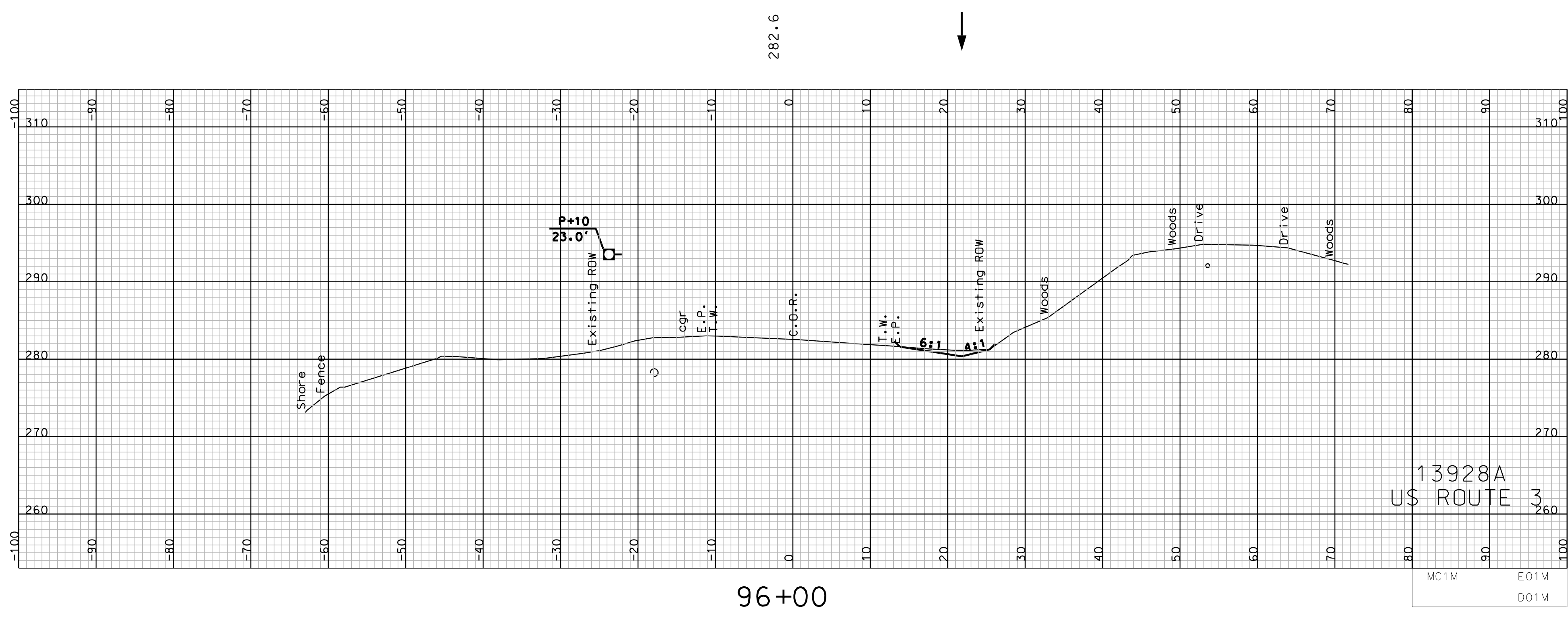
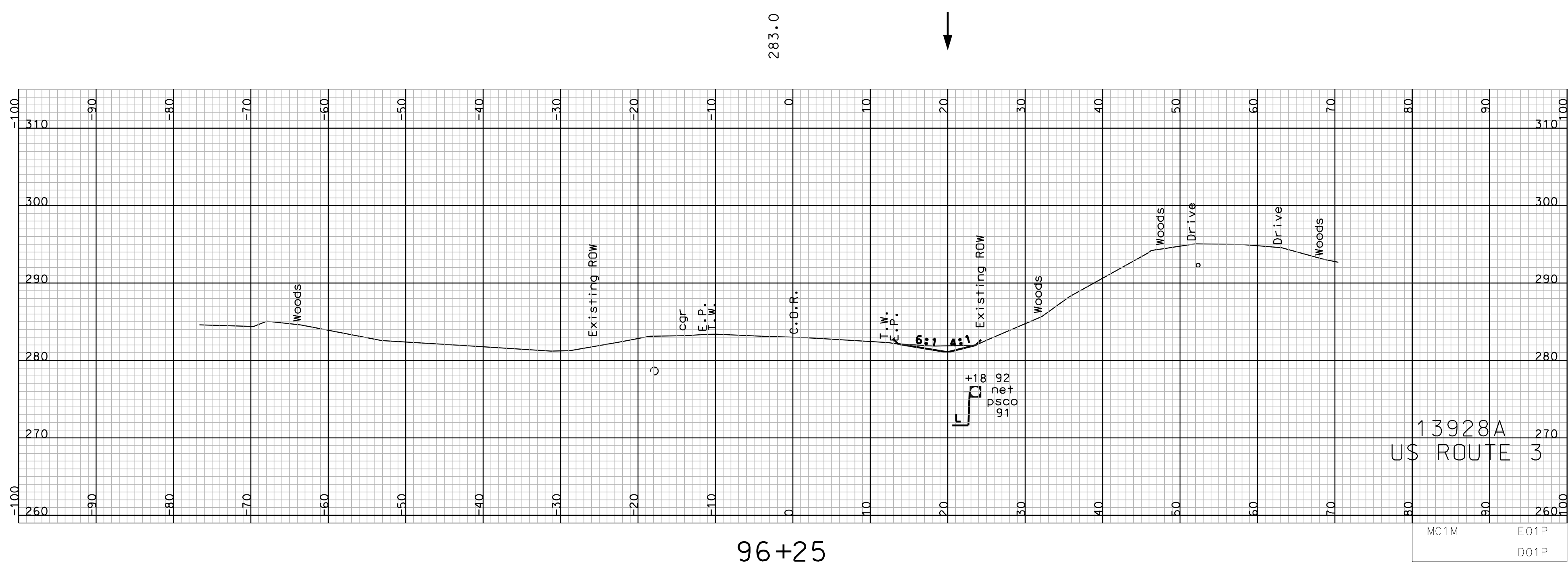

SHEET TOTALS					
COMMON EXCAV.	0	C.Y.	ROCK EXCAV.	0	C.Y.
FILL	0	C.Y.	MUCK EXCAV.	0	C.Y.
DGN	STATE PROJECT NO.	SHEET NO.	TOTAL SHEETS		
13928axs-mc1m	13928A	75	160		

SDR PROCESSED	DATE
NEW DESIGN TEAM BALDWIN	DATE 09/2013
SHEET CHECKED TEAM BALDWIN	DATE 04/2015
AS BUILT DETAILS	DATE

REVISIONS AFTER PROPOSAL				
NUMBER	DATE	STATION	STATION	DESCRIPTION

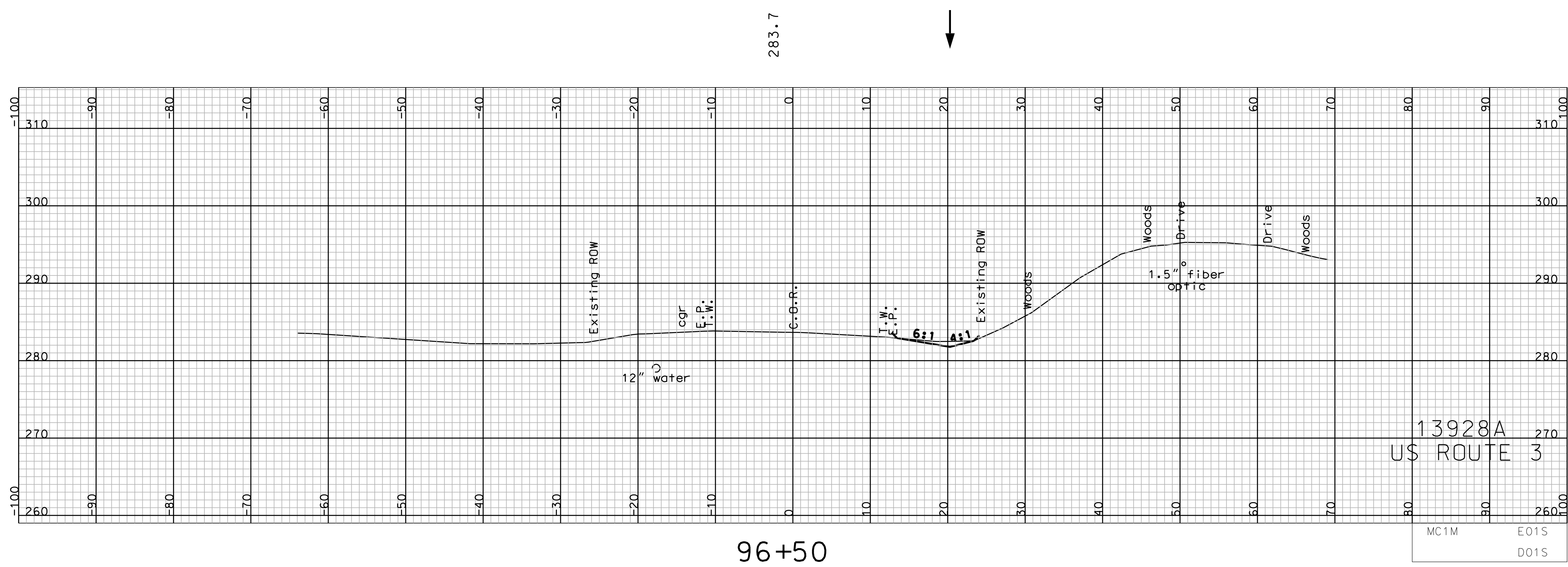
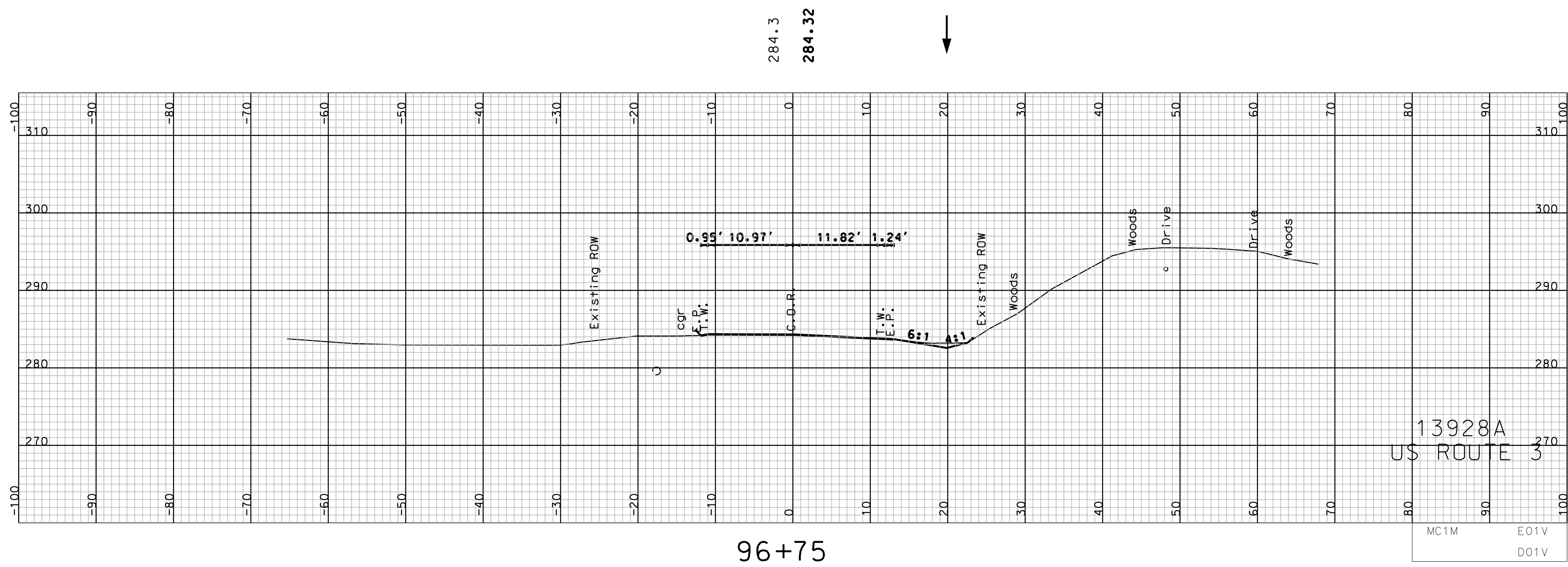
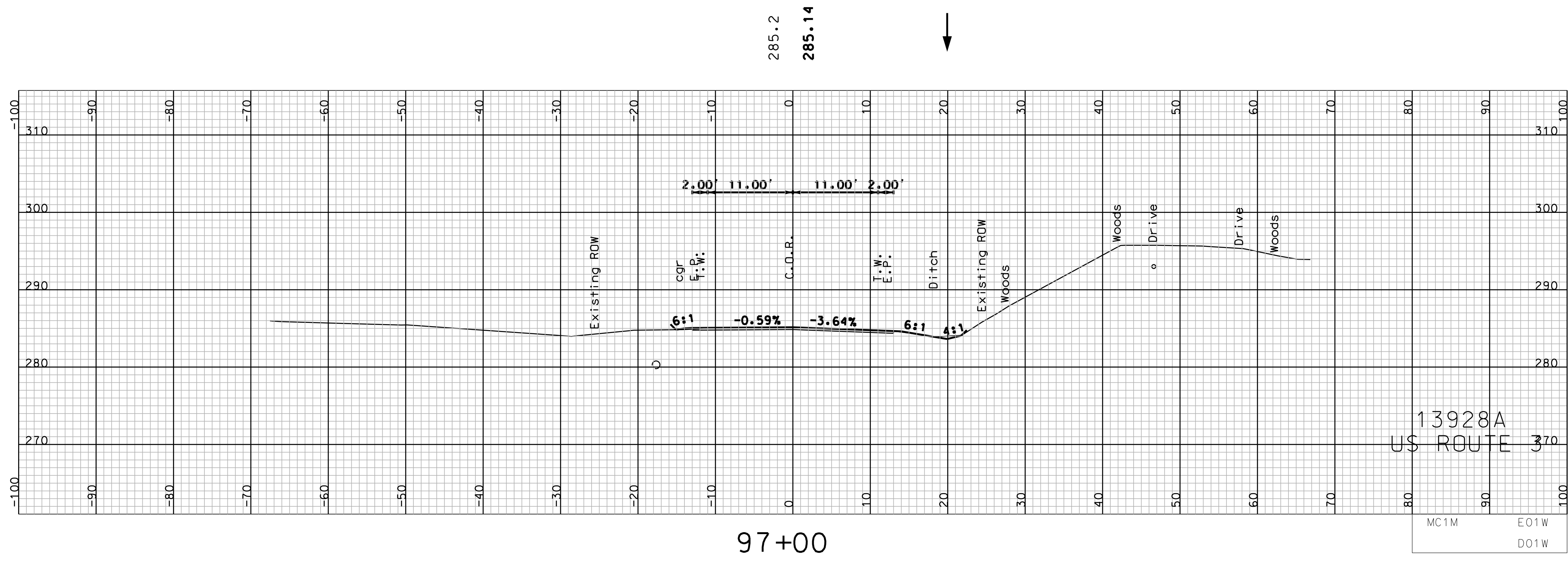

SHEET TOTALS			
COMMON EXCAV.	42 C.Y.	ROCK EXCAV.	19 C.Y.
FILL	0.4 C.Y.	MUCK EXCAV.	0 C.Y.
DGN	STATE PROJECT NO.	SHEET NO.	TOTAL SHEETS
13928axs-mc1m	13928A	76	160

SDR PROCESSED	DATE
NEW DESIGN TEAM BALDWIN	DATE 09/2013
SHEET CHECKED TEAM BALDWIN	DATE 04/2015
AS BUILT DETAILS	DATE

REVISIONS AFTER PROPOSAL				
NUMBER	DATE	STATION	STATION	DESCRIPTION

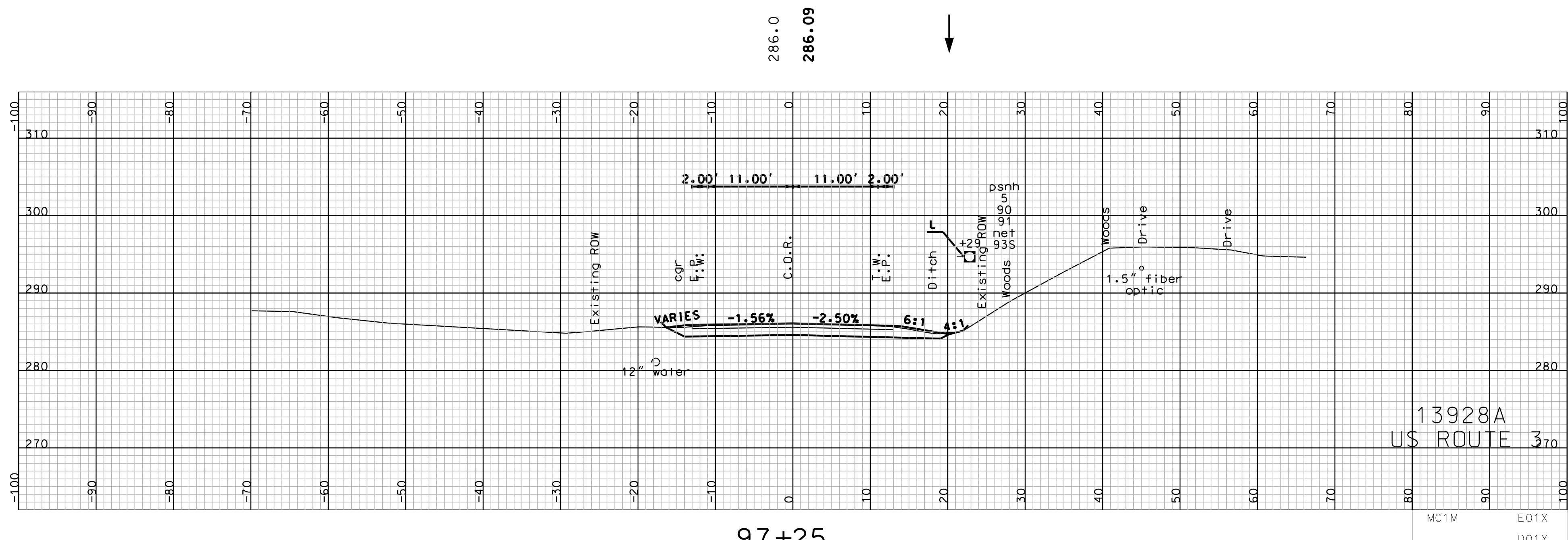
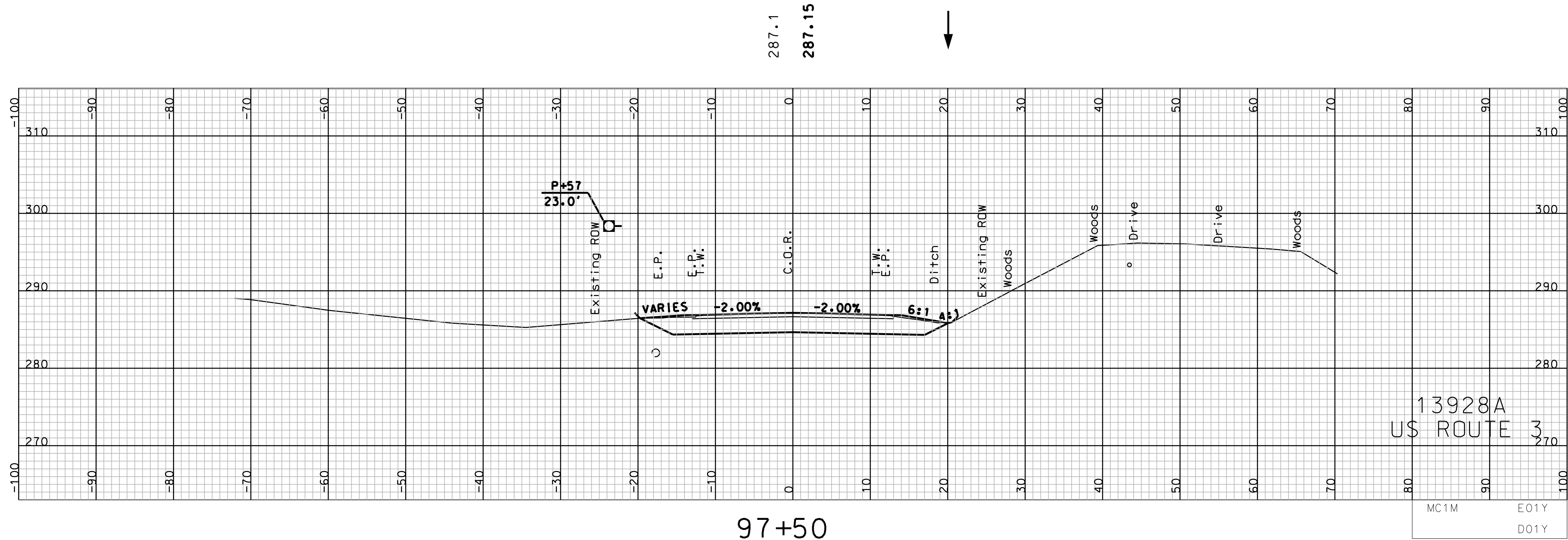
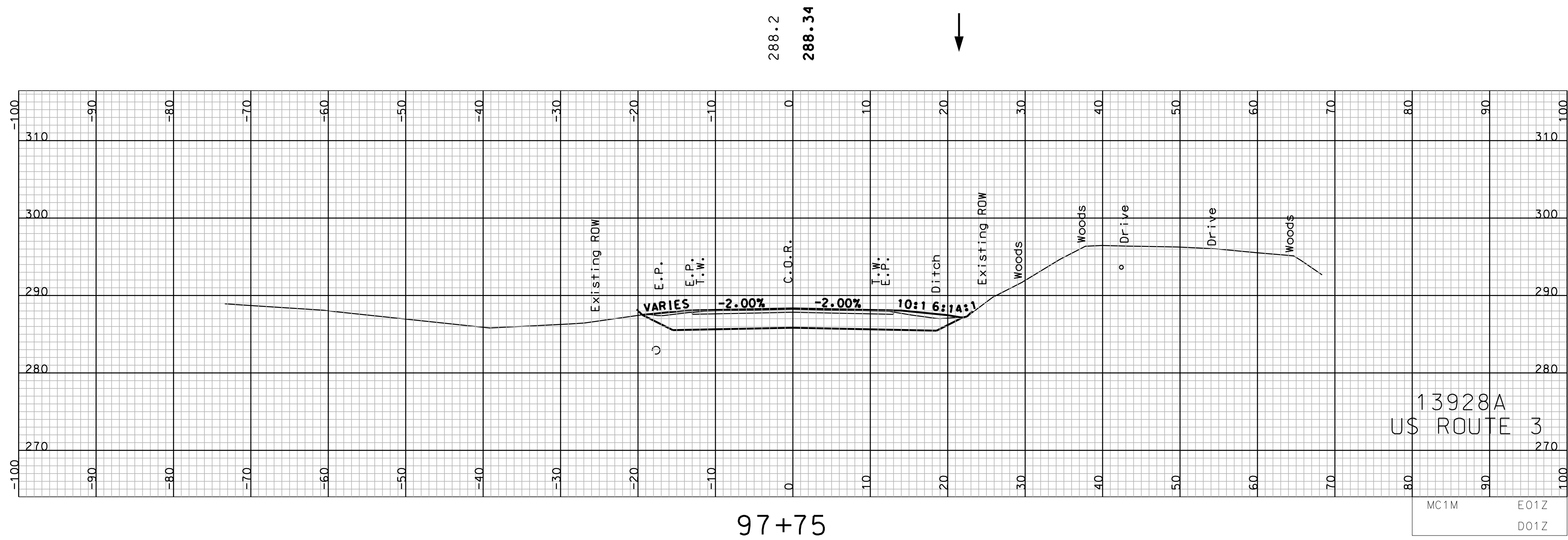

COMMON EXCAV. 216 C.Y.		SHEET TOTALS	
FILL 0 C.Y.		ROCK EXCAV. 29 C.Y.	
		MUCK EXCAV. 0 C.Y.	
DGN	STATE PROJECT NO.	SHEET NO.	TOTAL SHEETS
13928axs-mc1m	13928A	77	160

SDR PROCESSED	DATE
NEW DESIGN TEAM BALDWIN	DATE 12/2013
SHEET CHECKED TEAM BALDWIN	DATE 04/2015
AS BUILT DETAILS	DATE

REVISIONS AFTER PROPOSAL				
NUMBER	DATE	STATION	STATION	DESCRIPTION

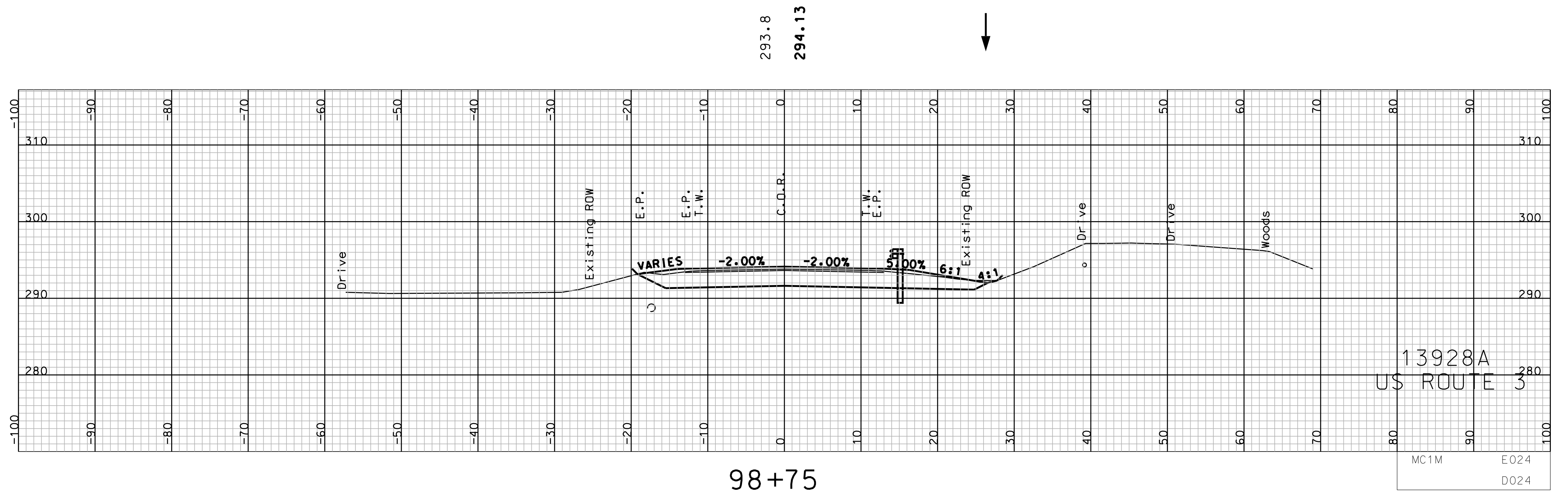

98+75

13928A
US ROUTE 3
MC1M E024
D024

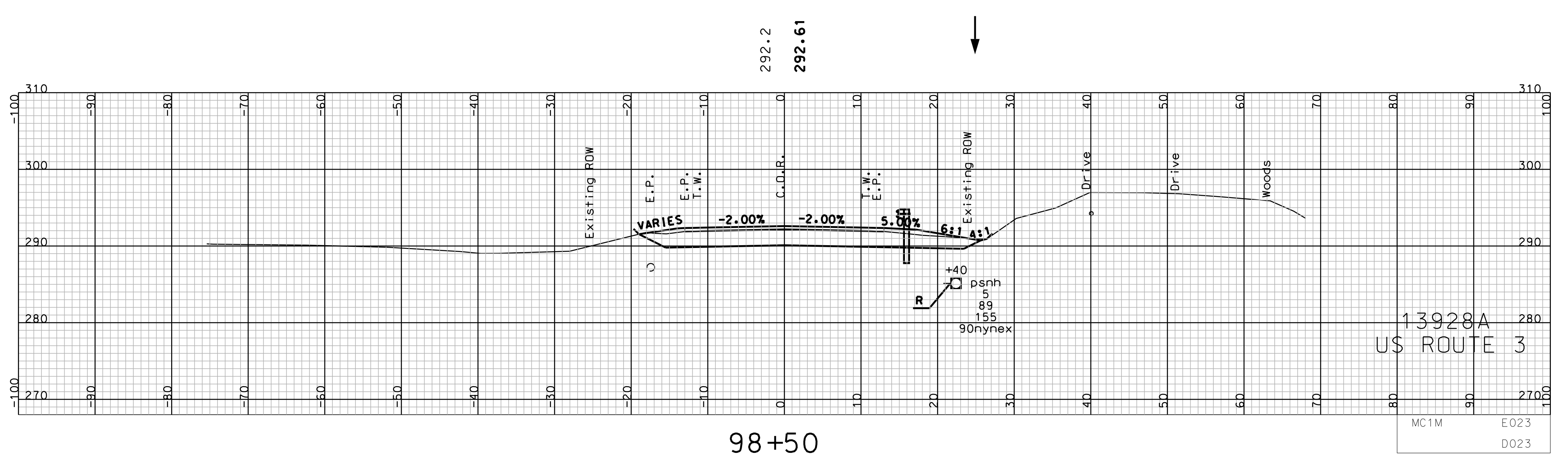

98+50

13928A
US ROUTE 3
MC1M E023
D023

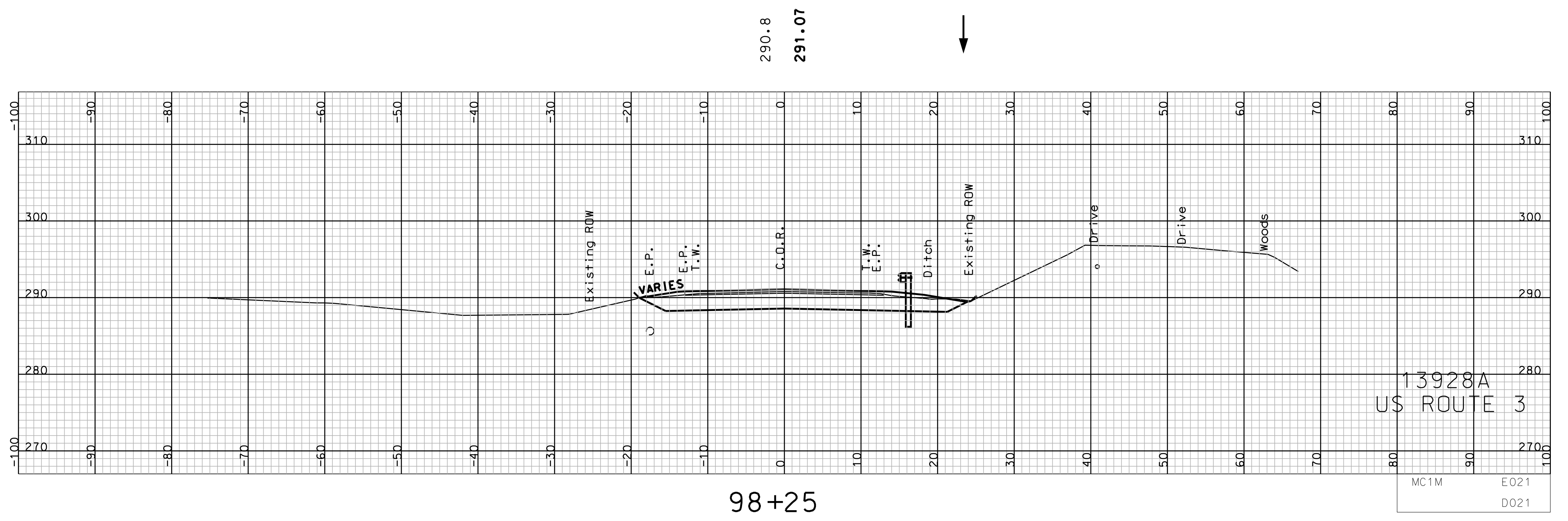

98+25

13928A
US ROUTE 3
MC1M E021
D021

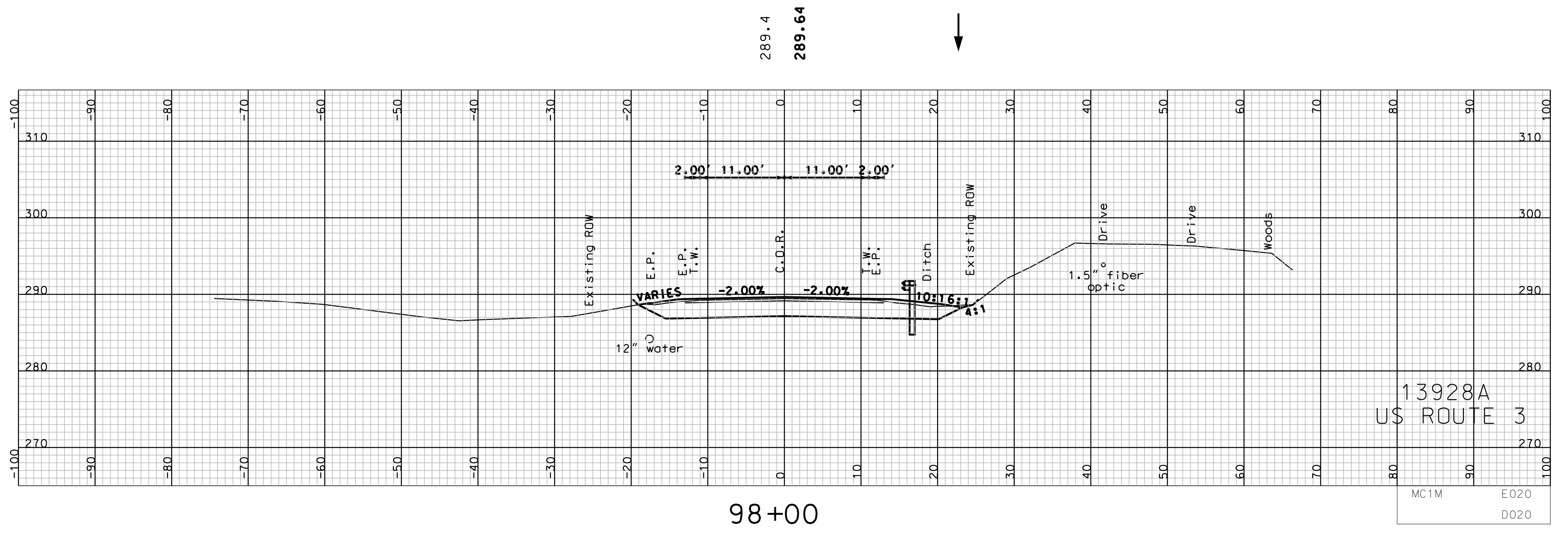

98+00

13928A
US ROUTE 3
MC1M E020
D020

COMMON EXCAV.		SHEET TOTALS		ROCK EXCAV.	
	C.Y.		C.Y.		C.Y.
317				39	
0				0	
FILL		C.Y.		MUCK EXCAV.	
DGN	STATE PROJECT NO.	SHEET NO.	TOTAL SHEETS		
13928axs-mc1m	13928A	78	160		

SDR PROCESSED	DATE
NEW DESIGN TEAM BALDWIN	DATE 09/2013
SHEET CHECKED TEAM BALDWIN	DATE 04/2015
AS BUILT DETAILS	DATE

REVISIONS AFTER PROPOSAL				
NUMBER	DATE	STATION	STATION	DESCRIPTION

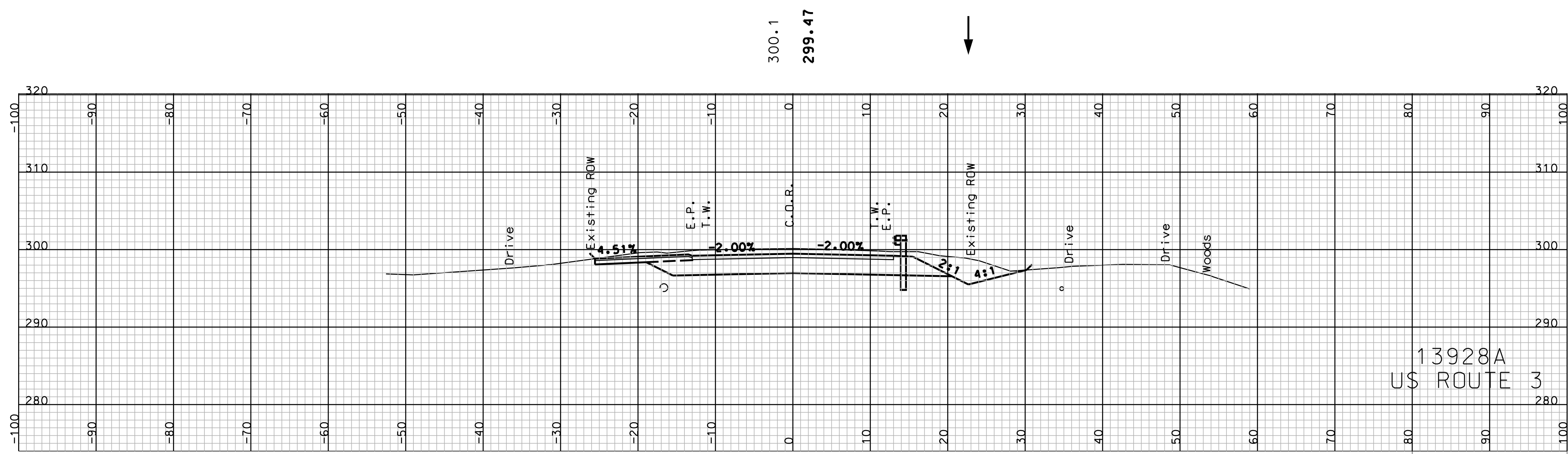

99+75
(DRIVE LT.)

13928A
US ROUTE 3

MC1M E029
D029

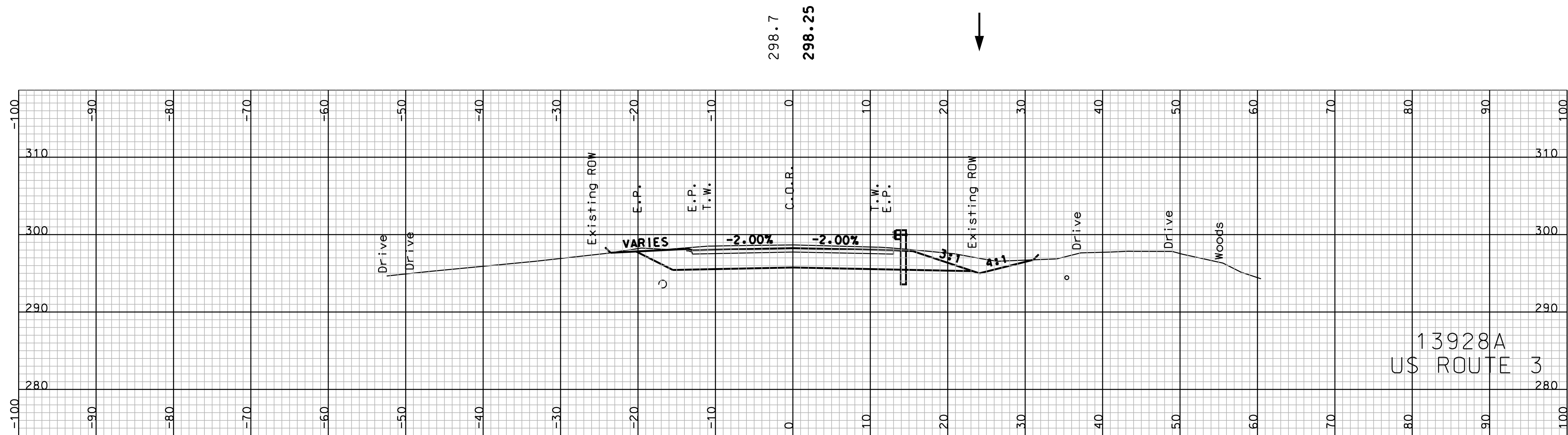

99+50

13928A
US ROUTE 3

MC1M E027
D027

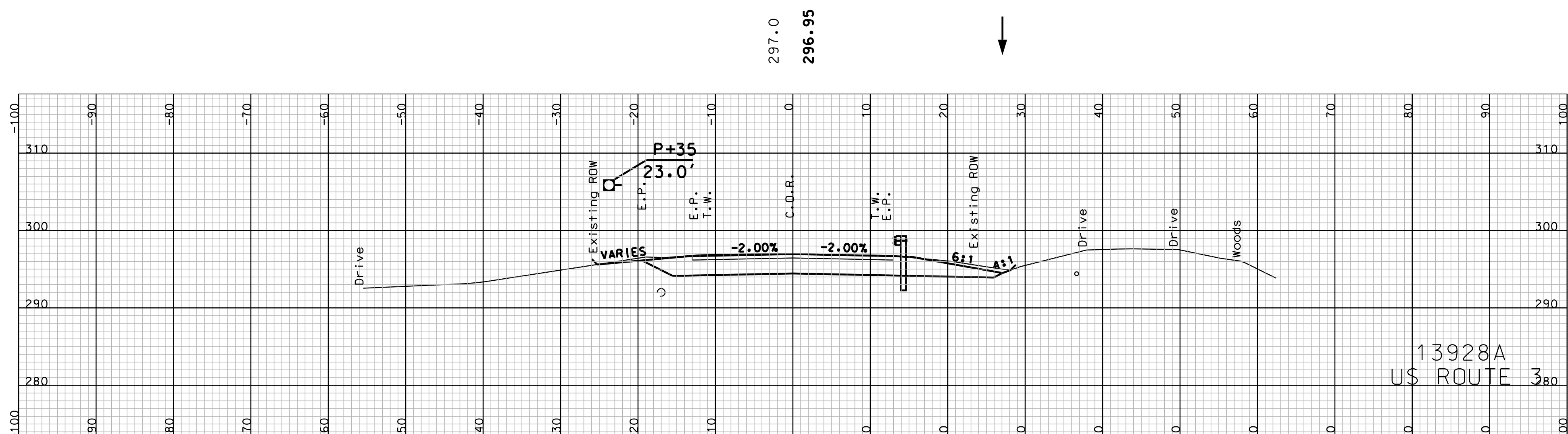

99+25

13928A
US ROUTE 3

MC1M E026
D026

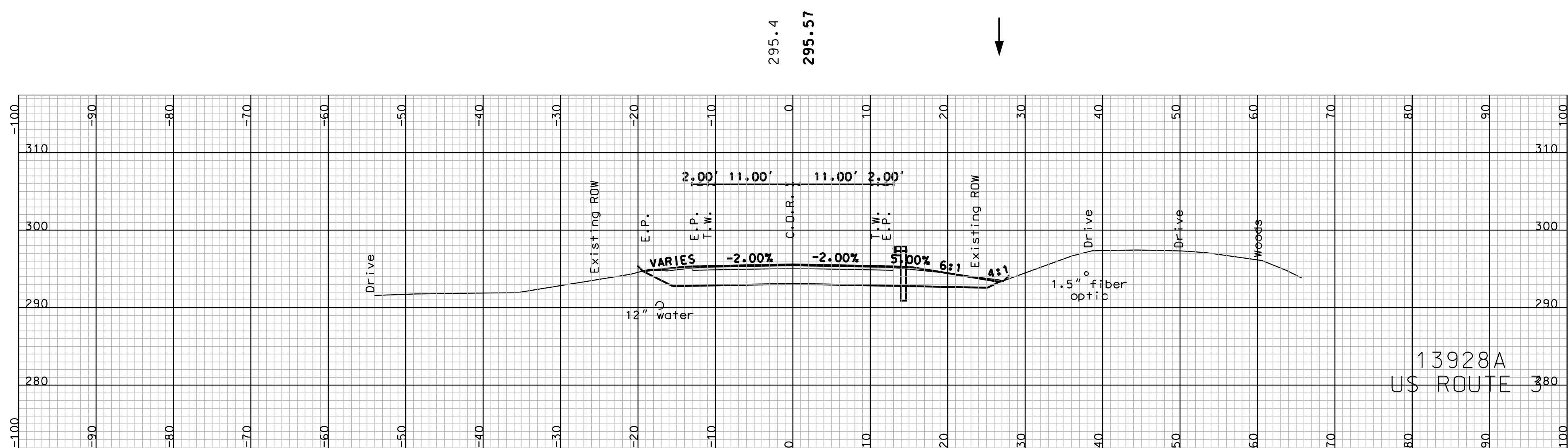

99+00

13928A
US ROUTE 3

MC1M E025
D025

COMMON EXCAV.		SHEET TOTALS		ROCK EXCAV.	
455	C.Y.		C.Y.	39	C.Y.
FILL	0.1	C.Y.	MUCK EXCAV.	0	C.Y.
DGN	13928axs-mc1m	STATE PROJECT NO.	13928A	SHEET NO.	79
TOTAL SHEETS		TOTAL SHEETS		160	

SDR PROCESSED	DATE
NEW DESIGN TEAM BALDWIN	DATE 09/2013
SHEET CHECKED TEAM BALDWIN	DATE 04/2015
AS BUILT DETAILS	DATE

REVISIONS AFTER PROPOSAL				
NUMBER	DATE	STATION	STATION	DESCRIPTION

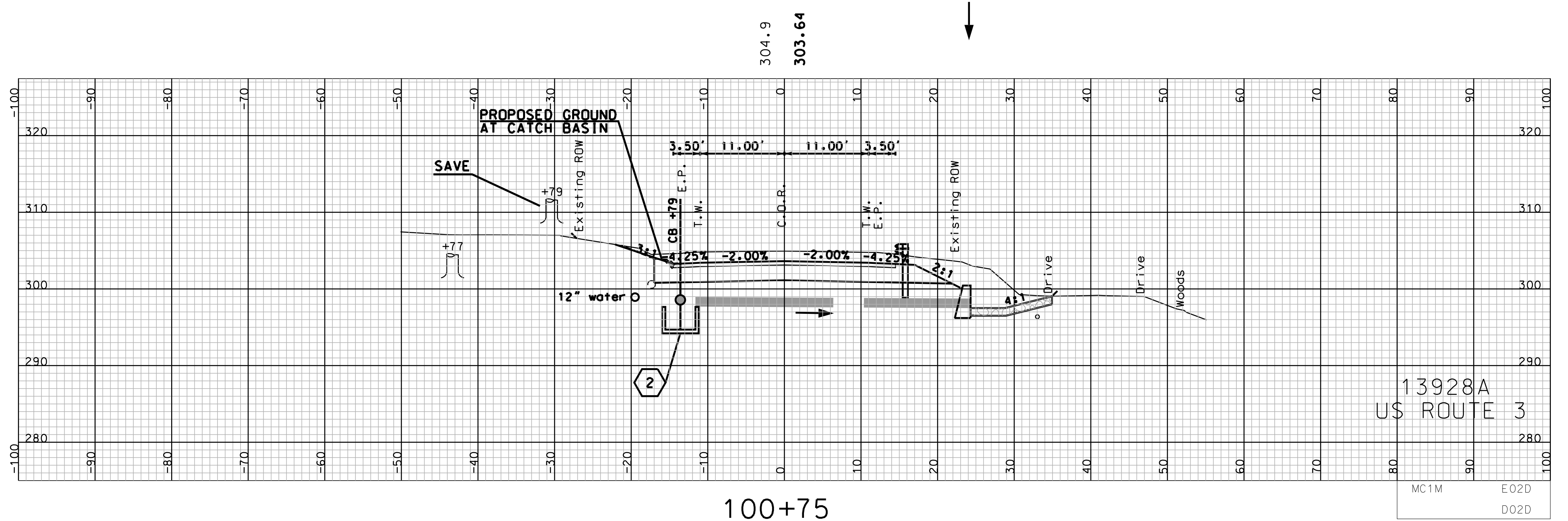

100+75

13928A
US ROUTE 3

MC1M E02D
D02D

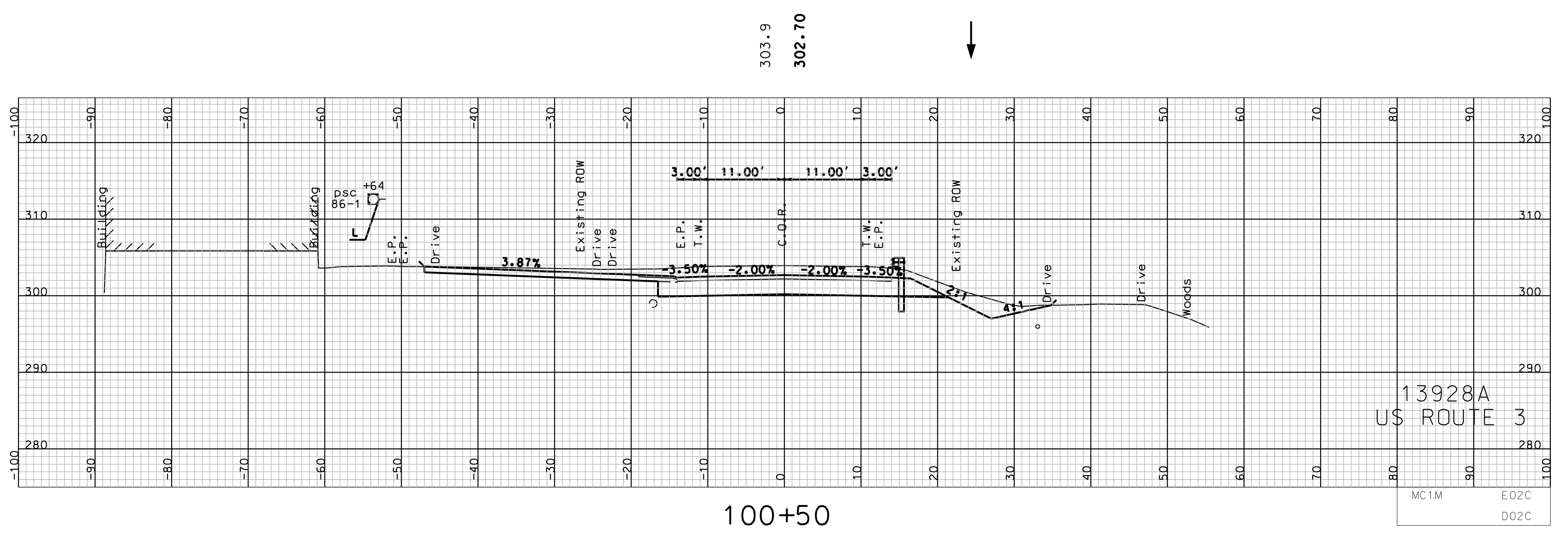

100+50
(DRIVE LT.)

13928A
US ROUTE 3

MC1M E02C
D02C

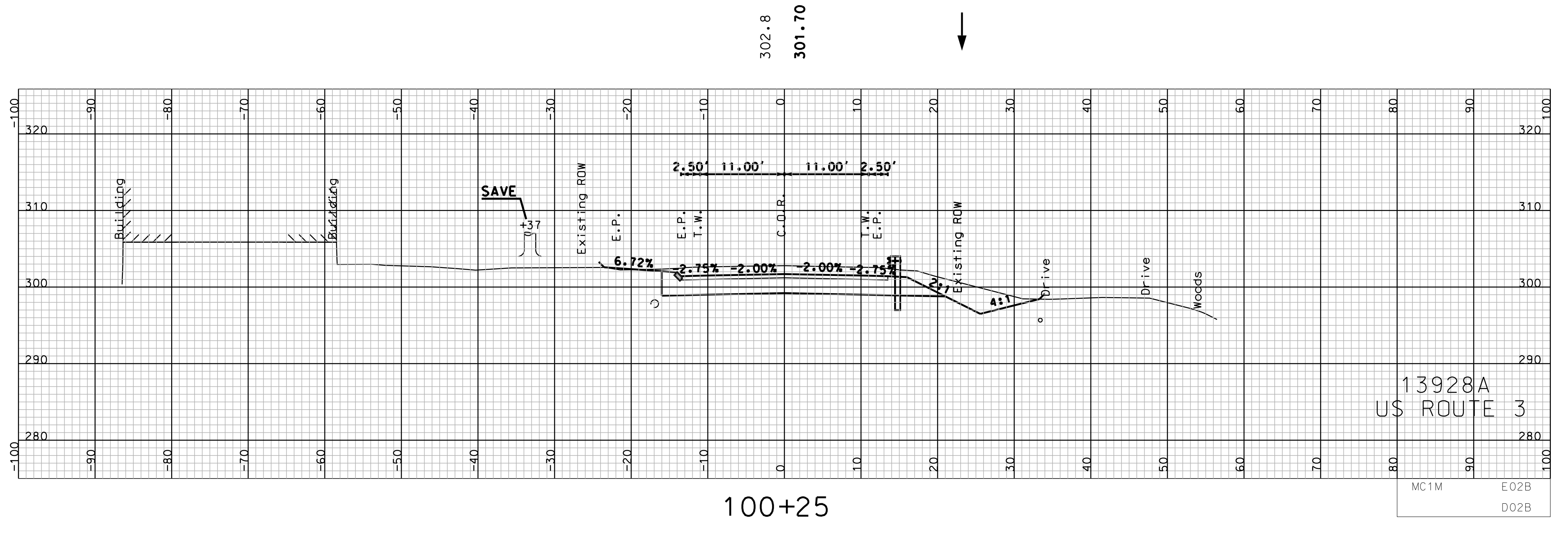

100+25

13928A
US ROUTE 3

MC1M E02B
D02B

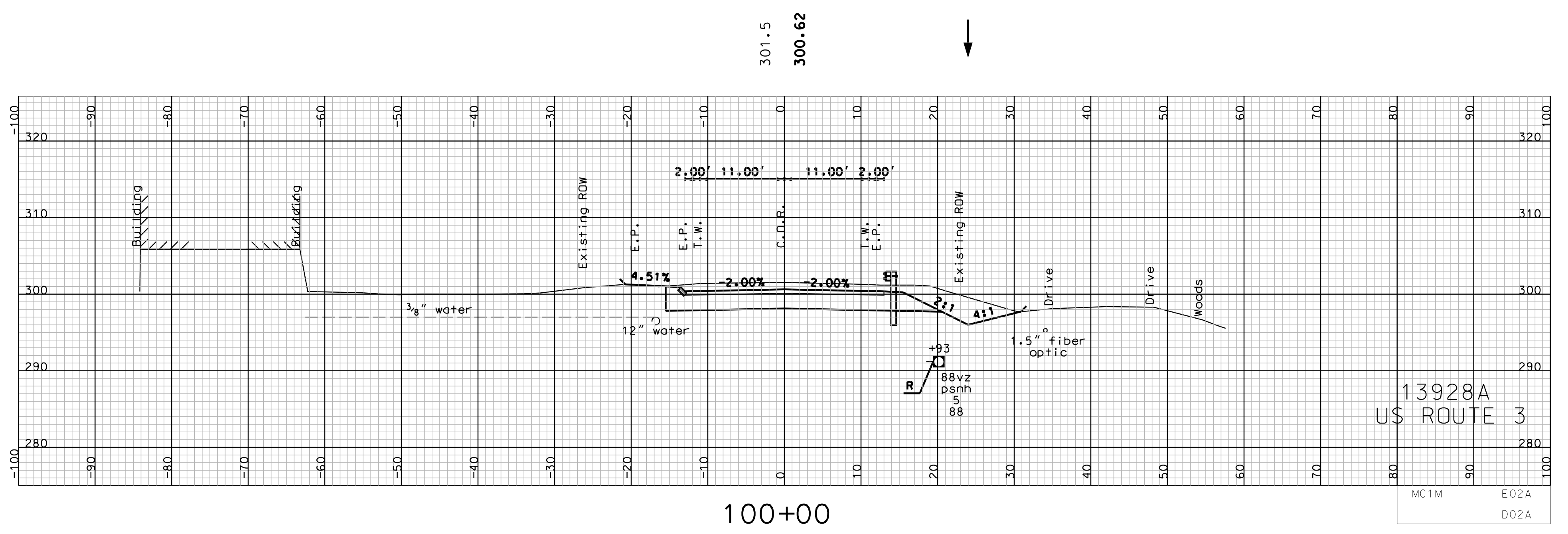

100+00

13928A
US ROUTE 3

MC1M E02A
D02A

COMMON EXCAV.		SHEET TOTALS	
DCN	STATE PROJECT NO.	C.Y.	TOTAL SHEETS
13928axs-mc1m	13928A	642	80
FILL		1	0
ROCK EXCAV.		39	0
MUCK EXCAV.		0	0

SDR PROCESSED	DATE
NEW DESIGN TEAM BALDWIN	DATE 09/2013
SHEET CHECKED TEAM BALDWIN	DATE 04/2015
AS BUILT DETAILS	DATE

REVISIONS AFTER PROPOSAL				
NUMBER	DATE	STATION	STATION	DESCRIPTION

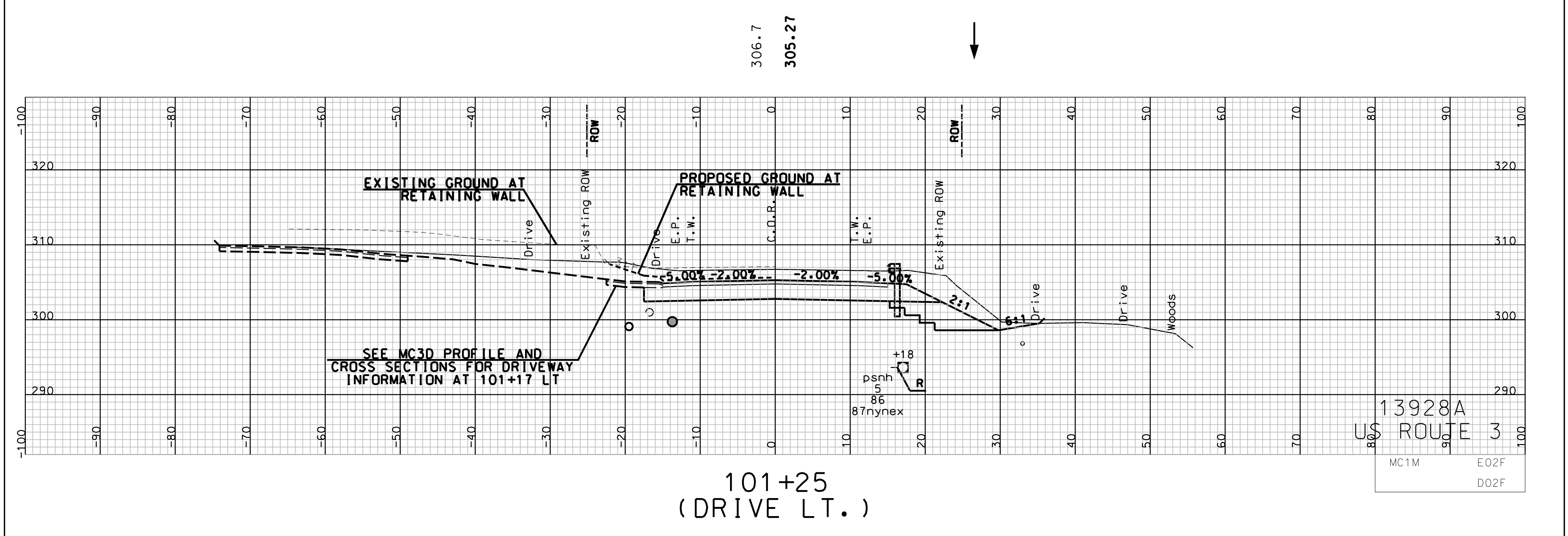
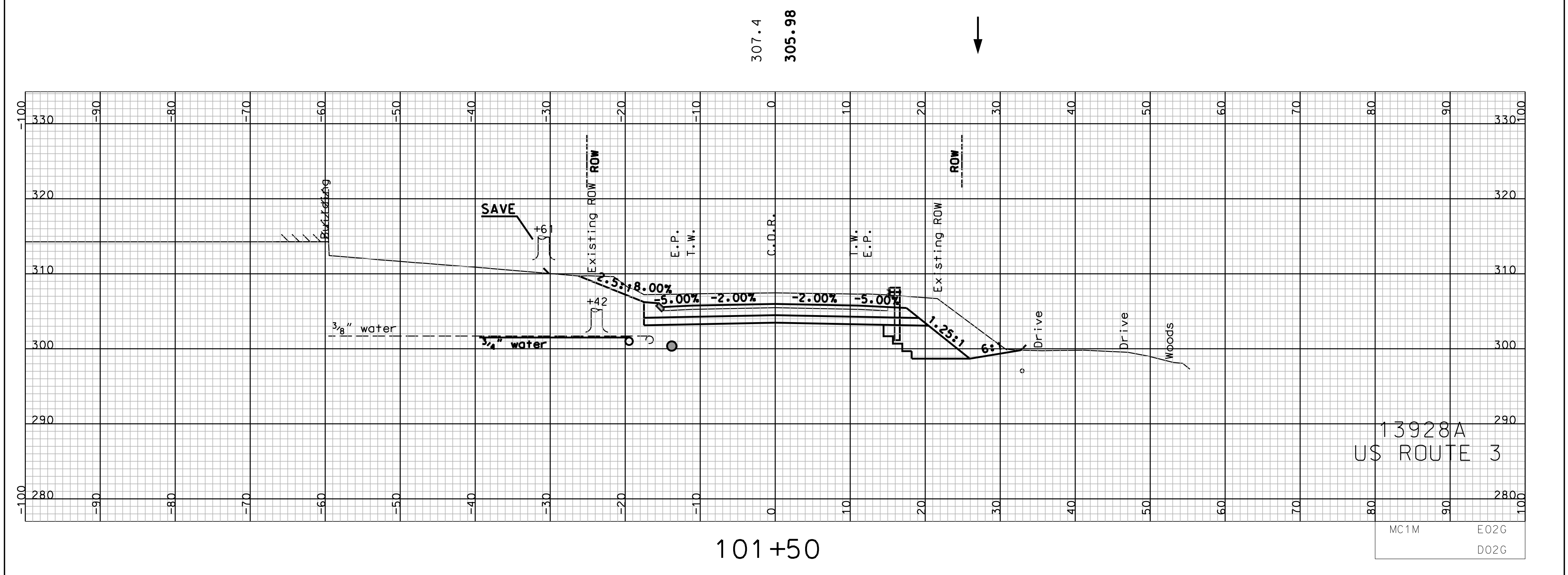

SEE MC3D PROFILE AND
CROSS SECTIONS FOR DRIVEWAY
INFORMATION AT 101+17 LT

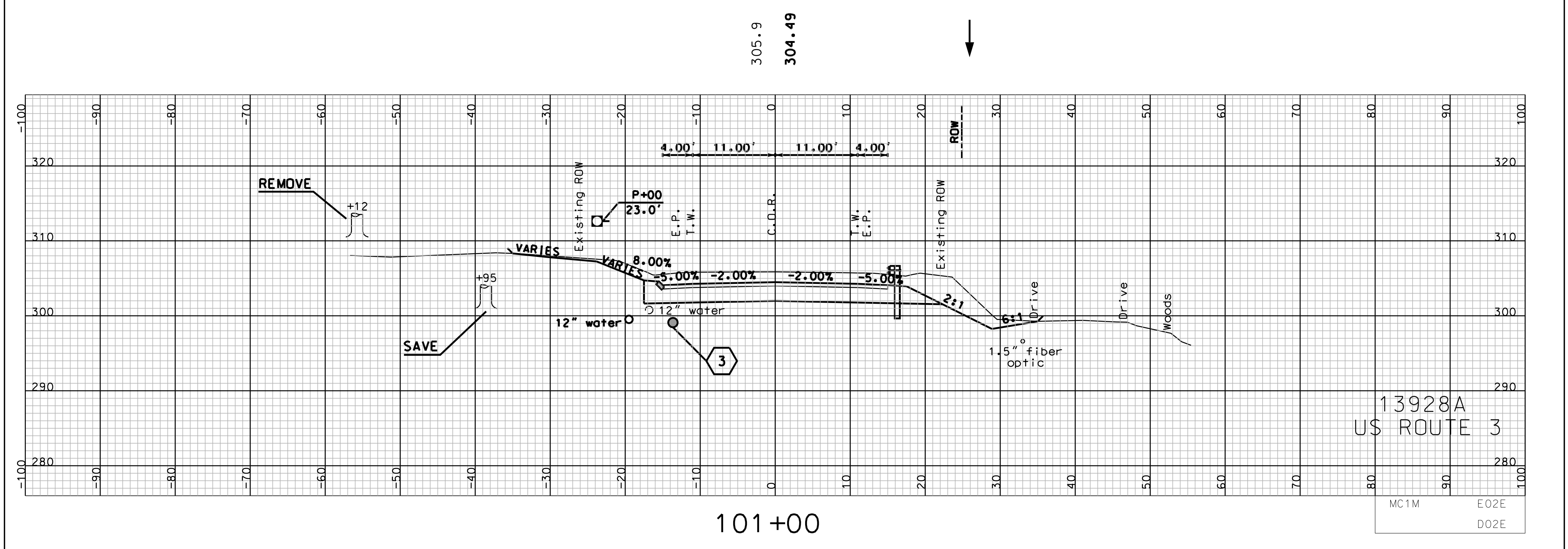

SHEET TOTALS					
COMMON EXCAV.	610	C.Y.	ROCK EXCAV.	29	C.Y.
FILL	0	C.Y.	MUCK EXCAV.	0	C.Y.
DGN	13928axs-mc1m	STATE PROJECT NO.	13928A	SHEET NO.	81
				TOTAL SHEETS	160

SDR PROCESSED	DATE
NEW DESIGN TEAM BALDWIN	DATE 09/2013
SHEET CHECKED TEAM BALDWIN	DATE 04/2015
AS BUILT DETAILS	DATE

REVISIONS AFTER PROPOSAL				
NUMBER	DATE	STATION	STATION	DESCRIPTION

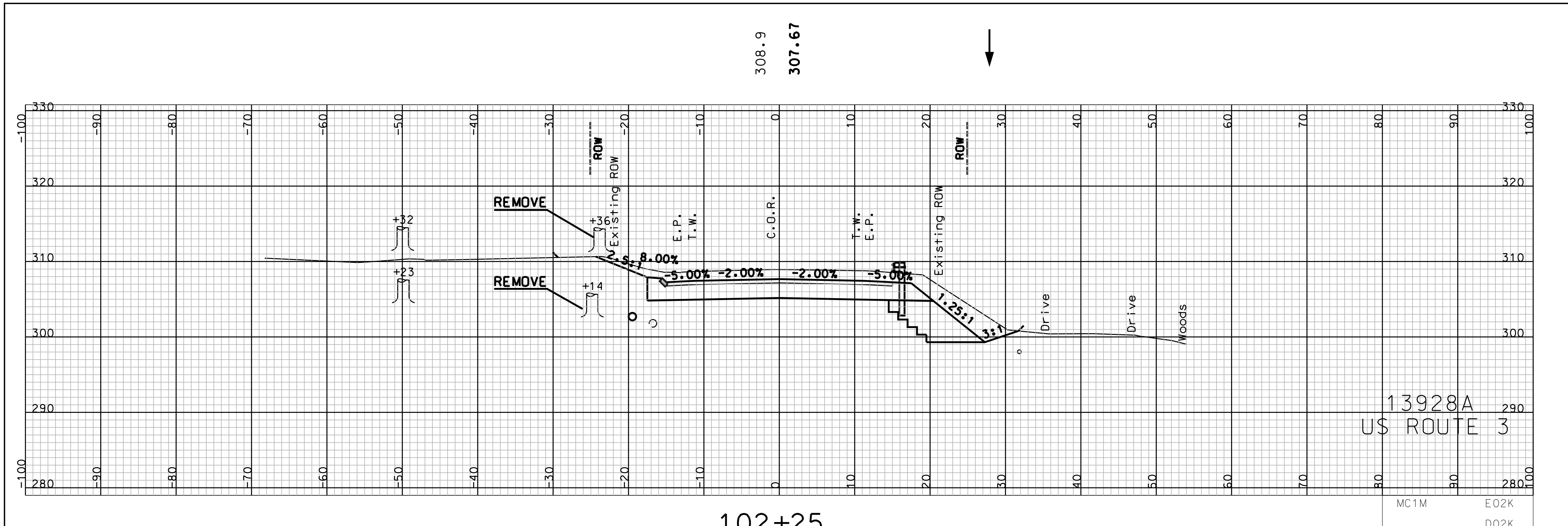

13928A
US ROUTE 3

MC1M	E02K
	D02K

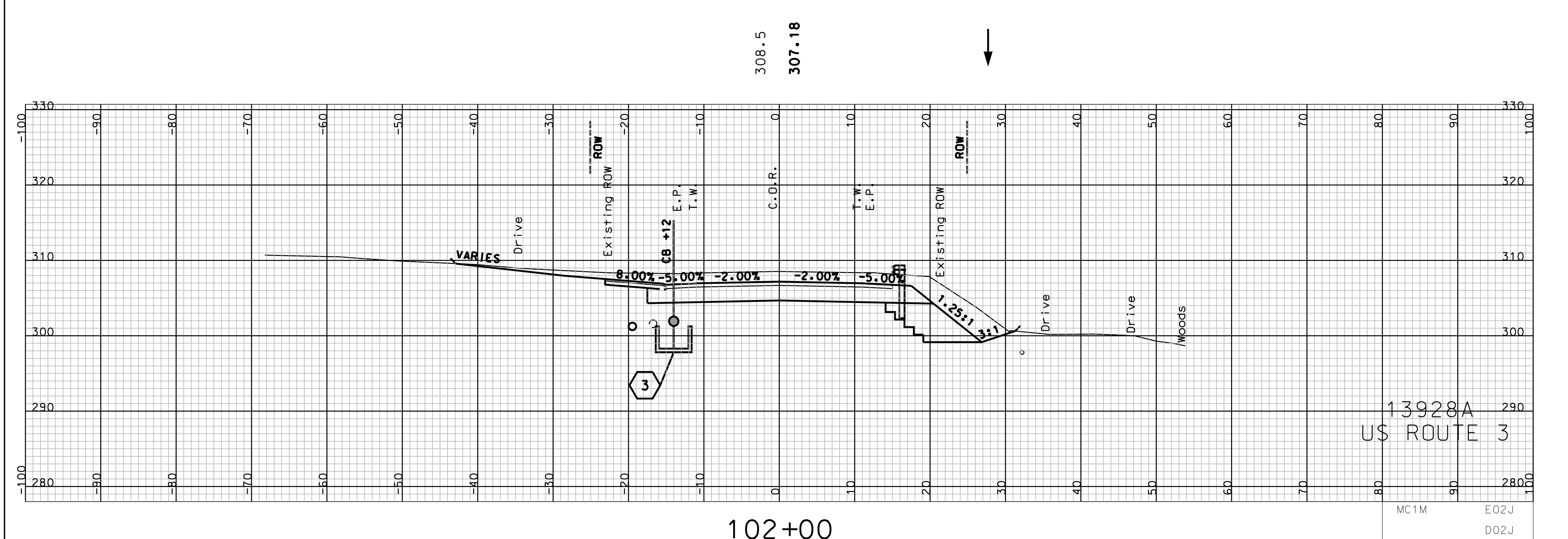

13928A
US ROUTE 3

MC1M	E02J
	D02J

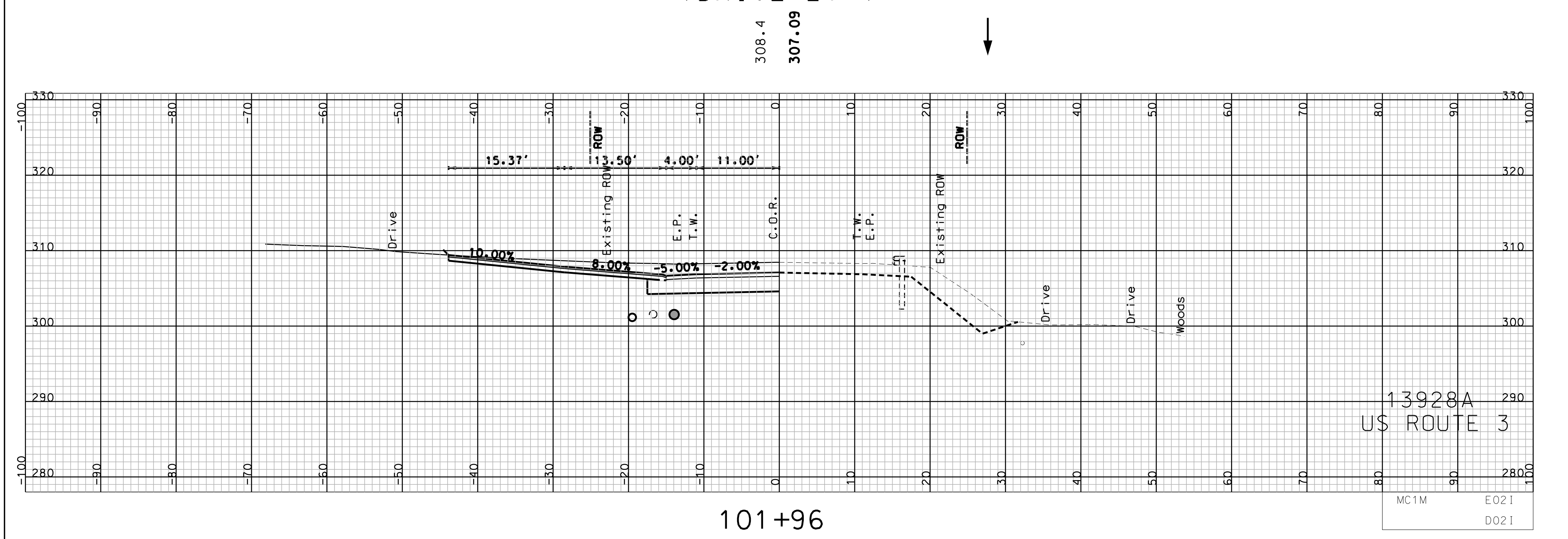

13928A
US ROUTE 3

MC1M	E02I
	D02I

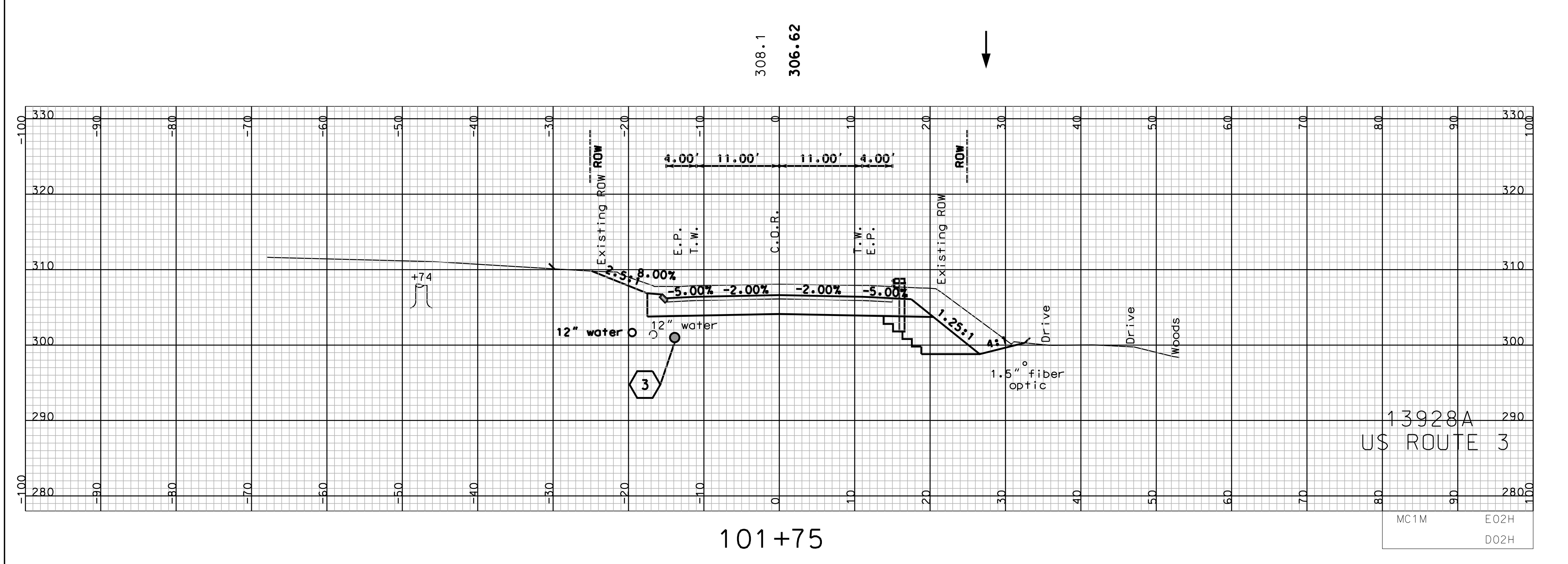

13928A
US ROUTE 3

MC1M	E02H
	D02H

COMMON EXCAV.		SHEET TOTALS	
DCN	STATE PROJECT NO.	C.Y.	TOTAL SHEETS
13928axs-mc1m	13928A	554	82
		0	160

SDR PROCESSED	DATE
NEW DESIGN TEAM BALDWIN	DATE 09/2013
SHEET CHECKED TEAM BALDWIN	DATE 04/2015
AS BUILT DETAILS	DATE

REVISIONS AFTER PROPOSAL				
NUMBER	DATE	STATION	STATION	DESCRIPTION

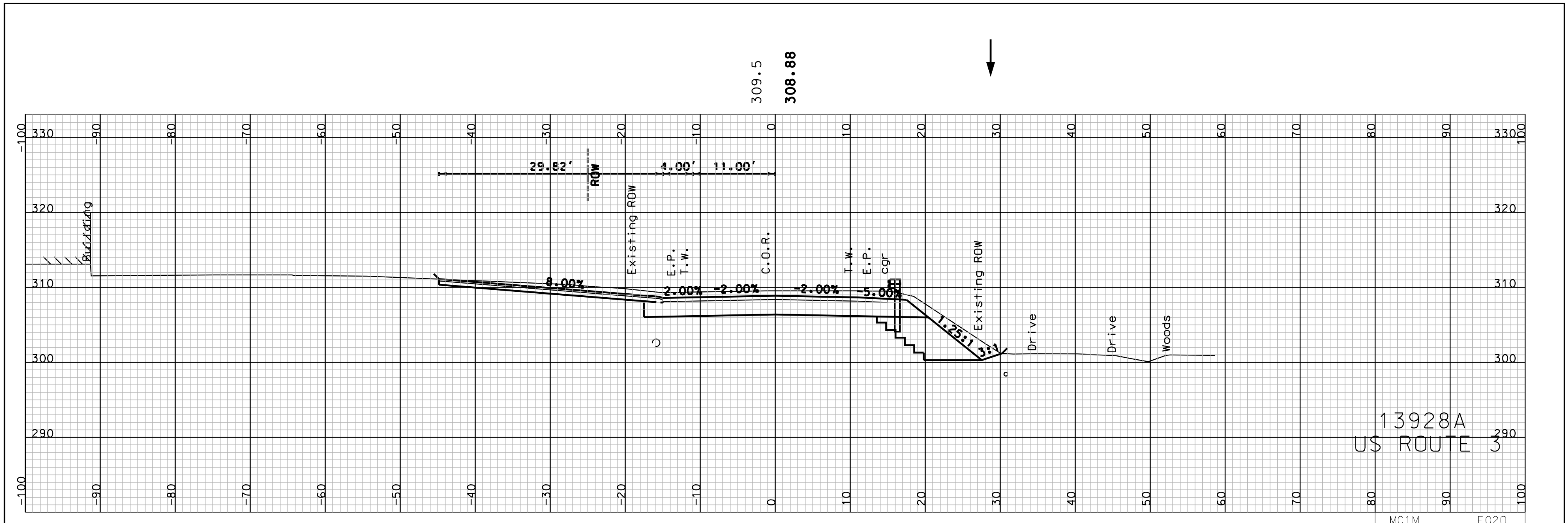

103+25
(DRIVE LT.)

13928A
US ROUTE 3

MC1M E020
D020

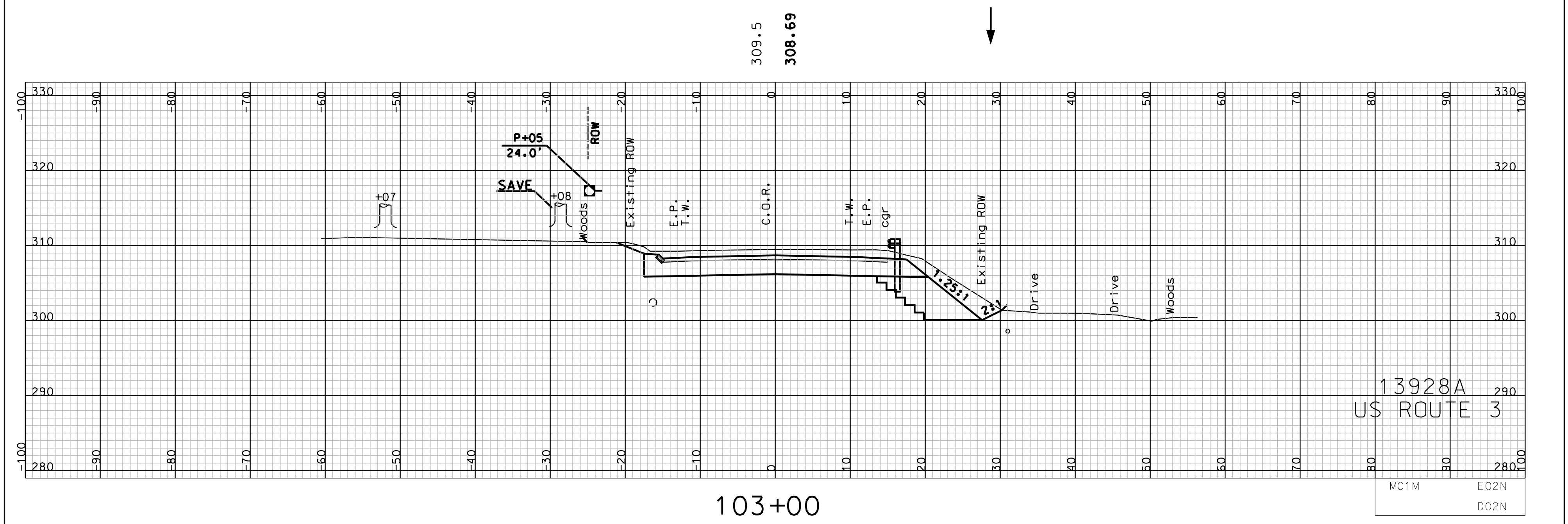

103+00

13928A
US ROUTE 3

MC1M E02N
D02N

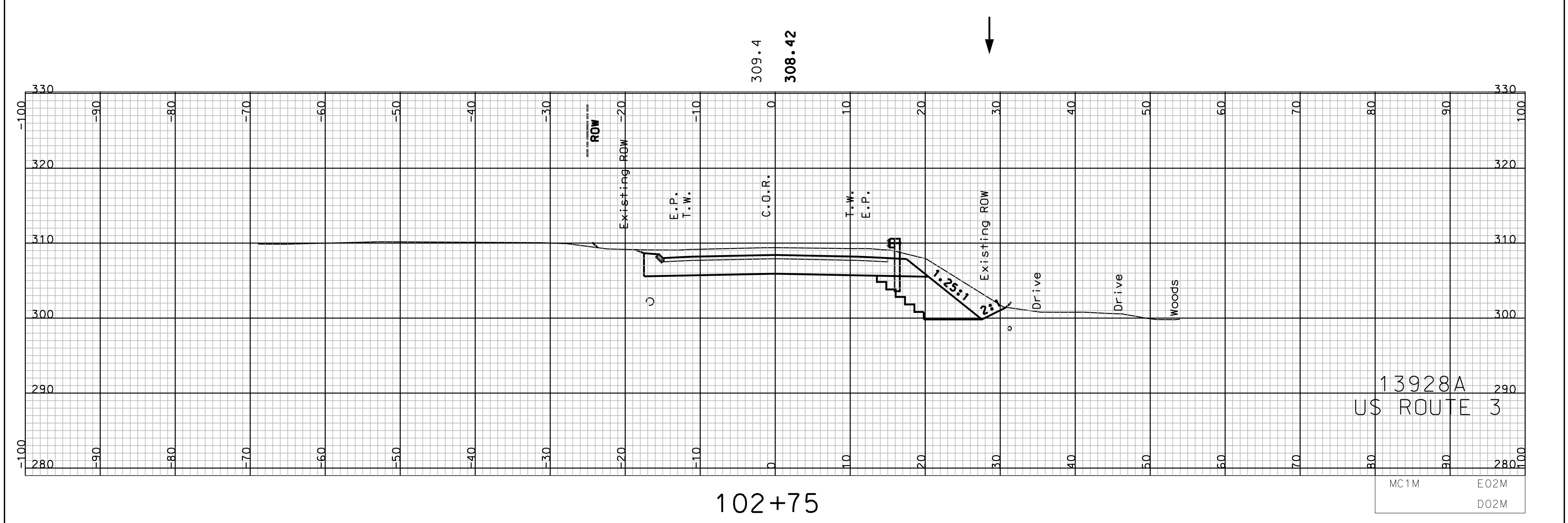

102+75

13928A
US ROUTE 3

MC1M E02M
D02M

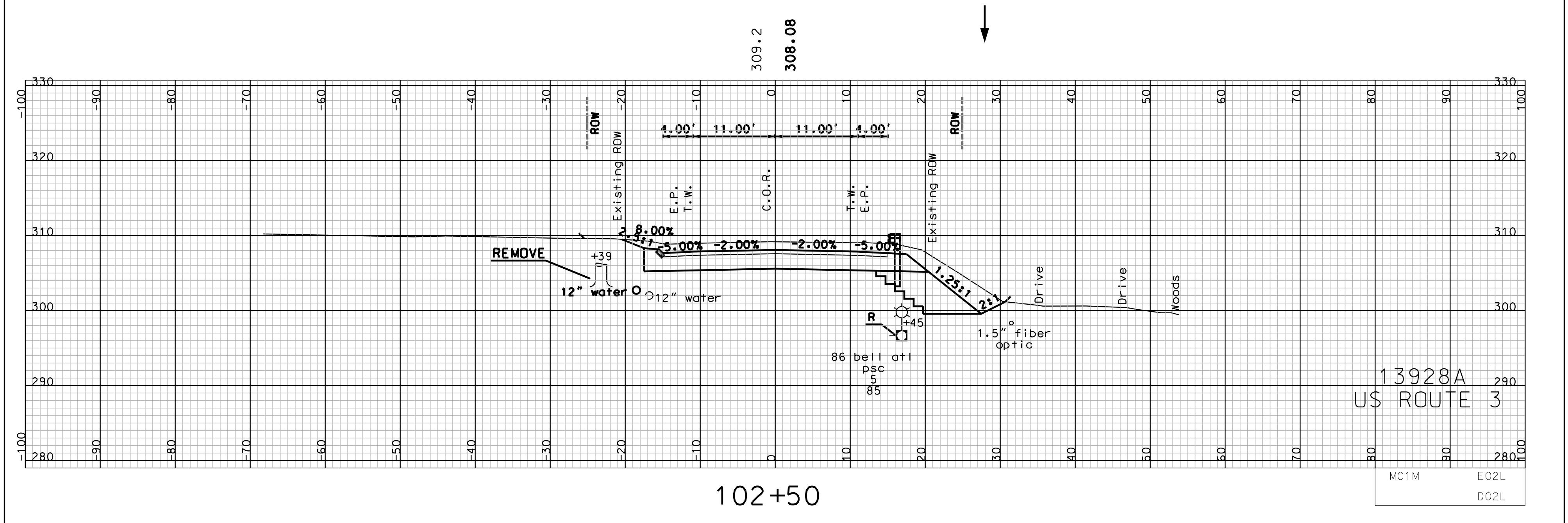

102+50

13928A
US ROUTE 3

MC1M E02L
D02L

COMMON EXCAV.		SHEET TOTALS		ROCK EXCAV.	
731	C.Y.	39	C.Y.	39	C.Y.
FILL 0 C.Y.		MUCK EXCAV. 0 C.Y.			
DGN	STATE PROJECT NO.	SHEET NO.	TOTAL SHEETS		
13928axs-mc1m	13928A	83	160		

SDR PROCESSED	DATE
NEW DESIGN TEAM BALDWIN	DATE 09/2013
SHEET CHECKED TEAM BALDWIN	DATE 04/2015
AS BUILT DETAILS	DATE

REVISIONS AFTER PROPOSAL				
NUMBER	DATE	STATION	STATION	DESCRIPTION

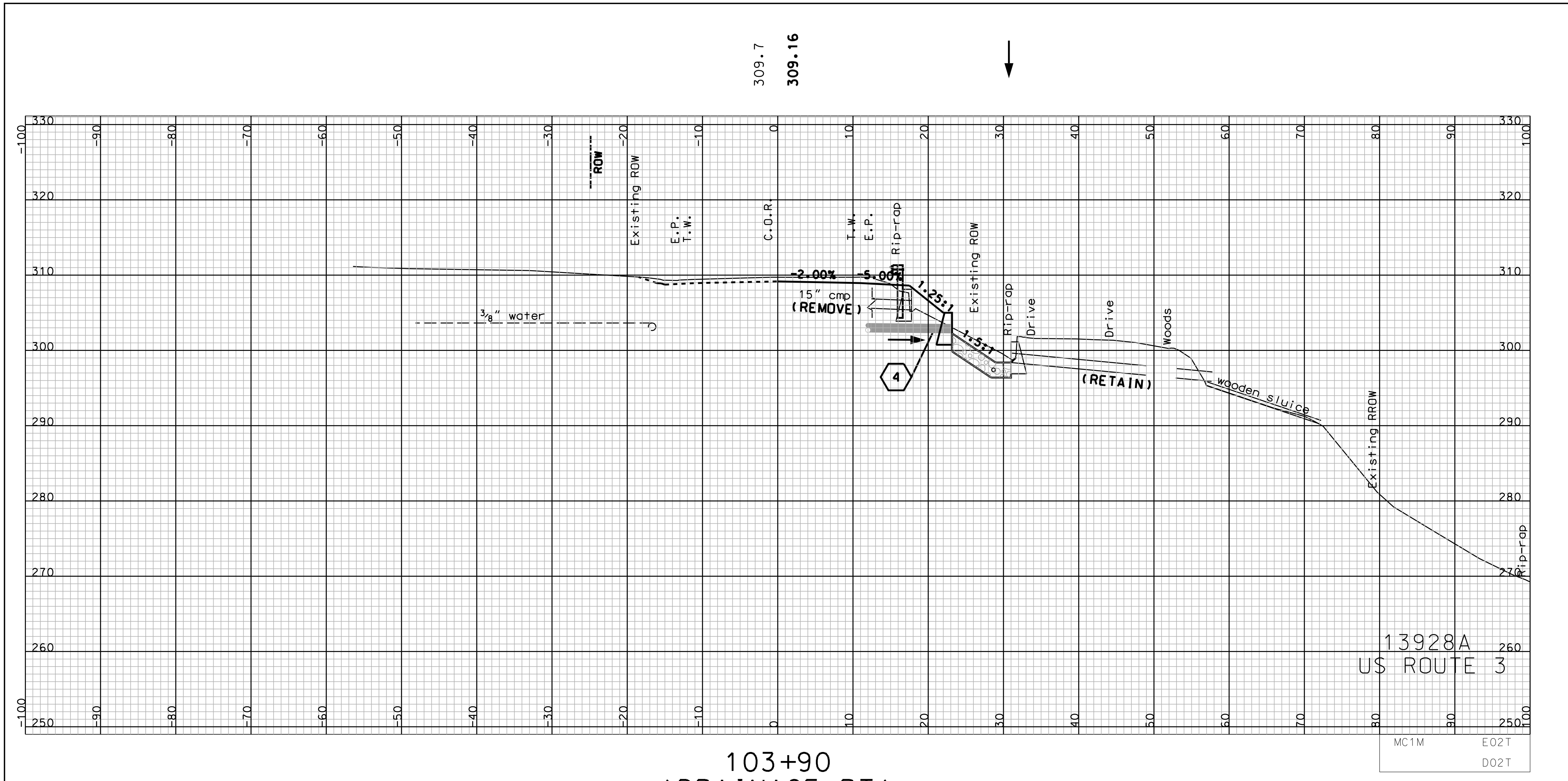

103+90
(DRAINAGE RT)

13928A
US ROUTE 3
MC1M E02T
D02T

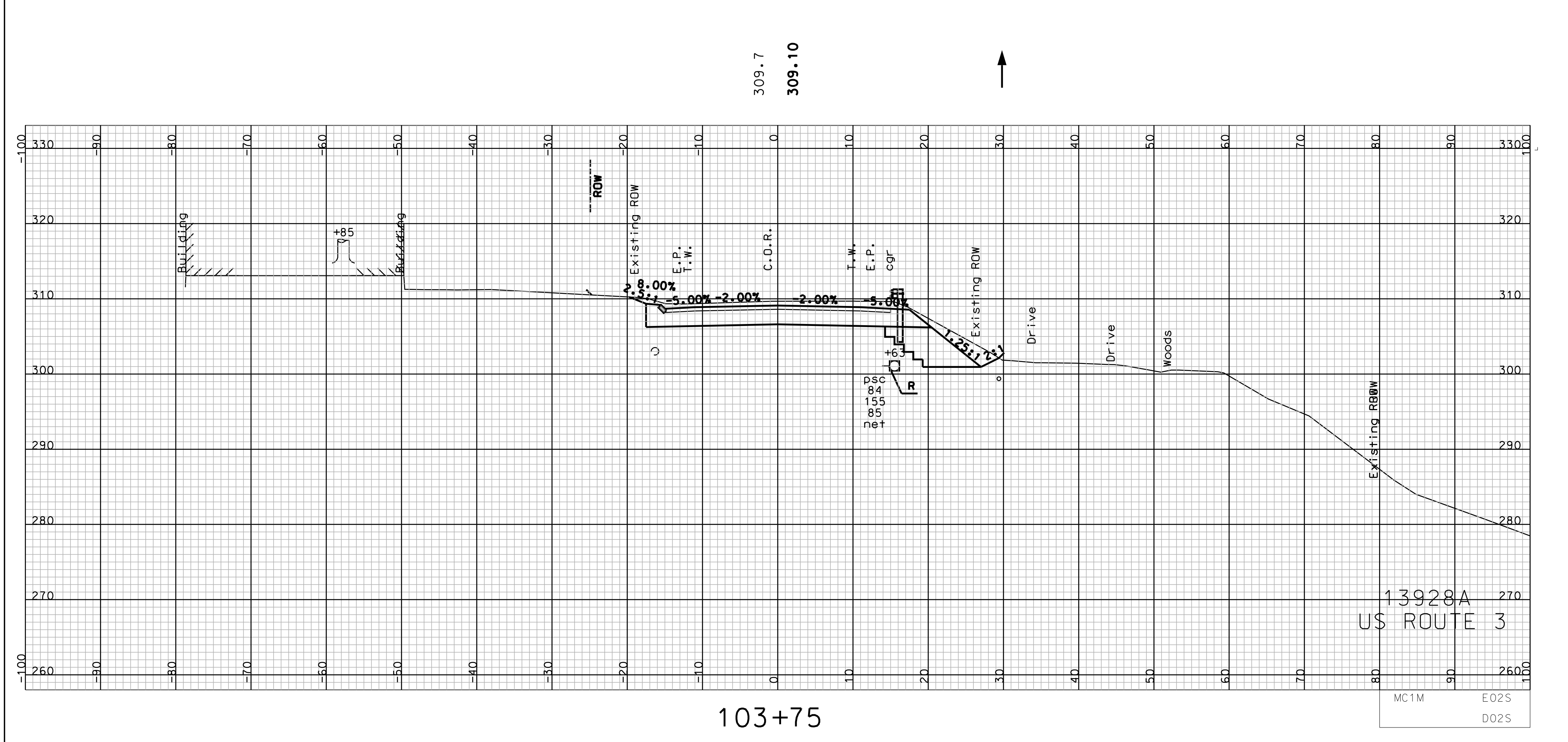

103+75

13928A
US ROUTE 3
MC1M E02S
D02S

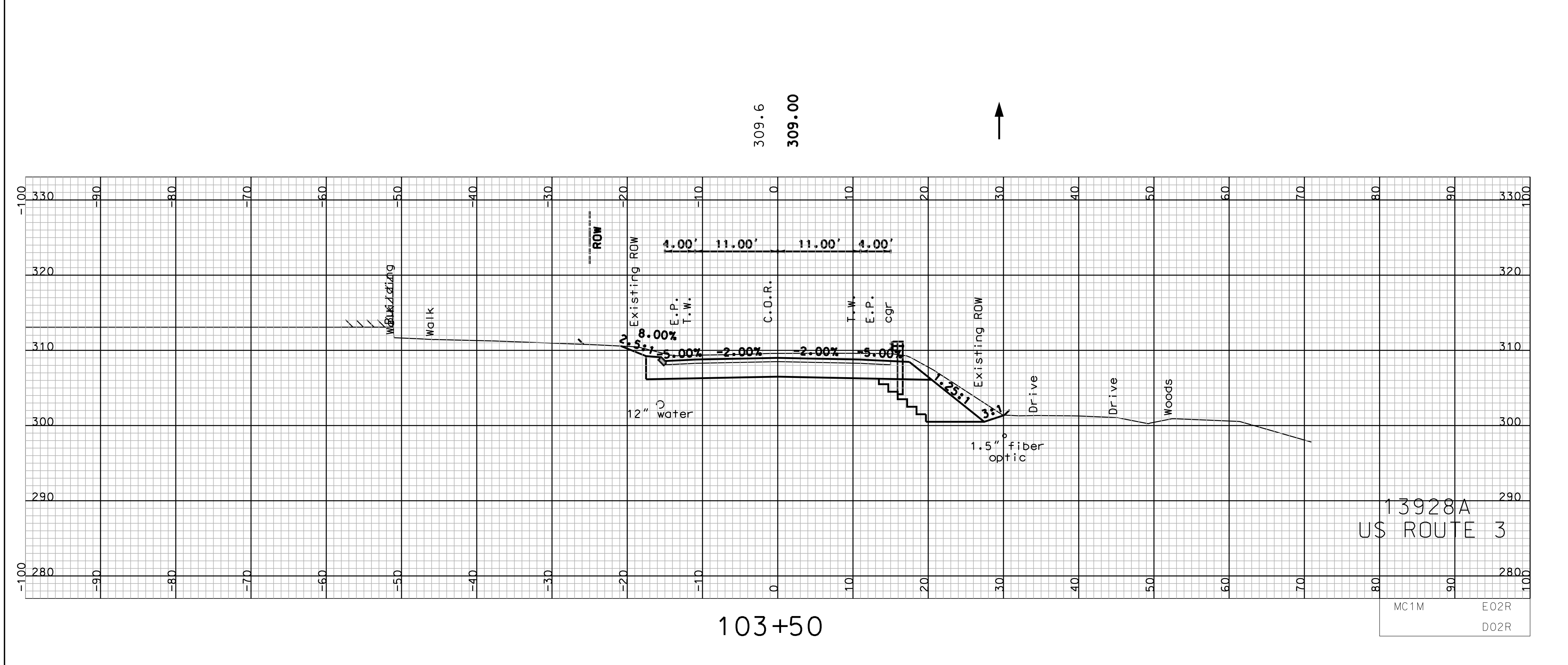

103+50

13928A
US ROUTE 3
MC1M E02R
D02R

COMMON EXCAV.		SHEET TOTALS		ROCK EXCAV.	
DGN	STATE PROJECT NO.	FILL	C.Y.	MUCK EXCAV.	C.Y.
13928axs-mc1m	13928A	313	0	19	0
		TOTAL SHEETS			
		84	160		

SDR PROCESSED	DATE
NEW DESIGN TEAM BALDWIN	DATE 09/2013
SHEET CHECKED TEAM BALDWIN	DATE 04/2015
AS BUILT DETAILS	DATE

REVISIONS AFTER PROPOSAL				
NUMBER	DATE	STATION	STATION	DESCRIPTION

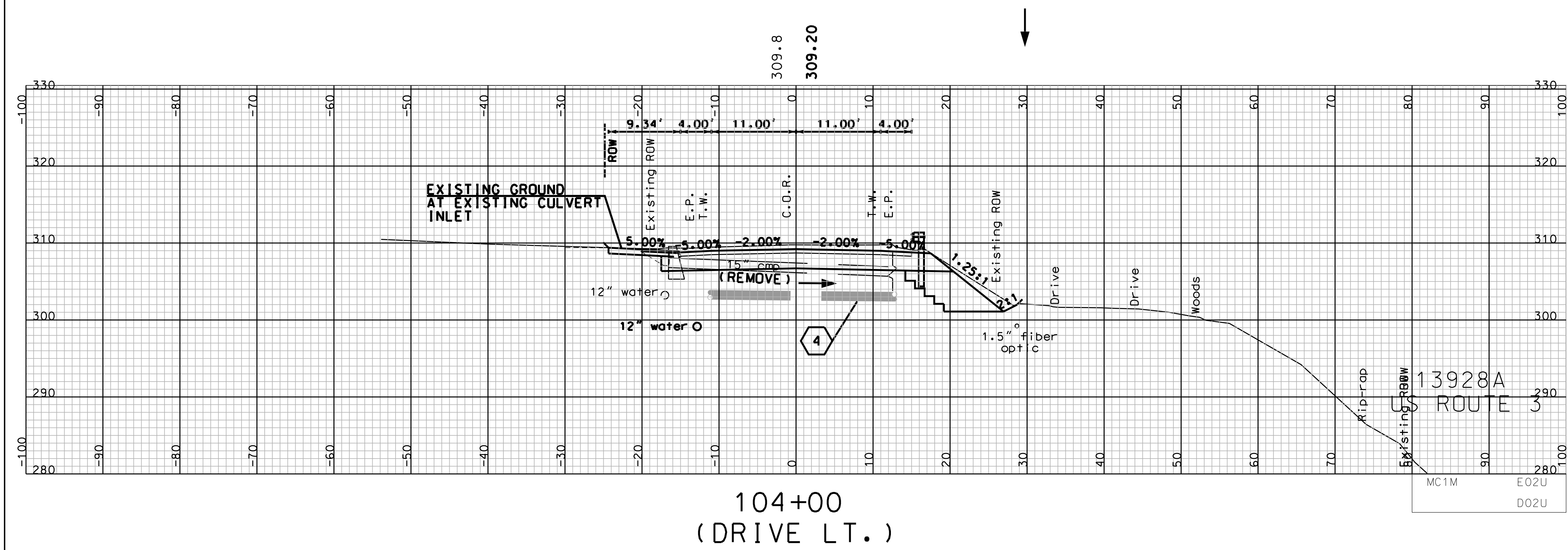
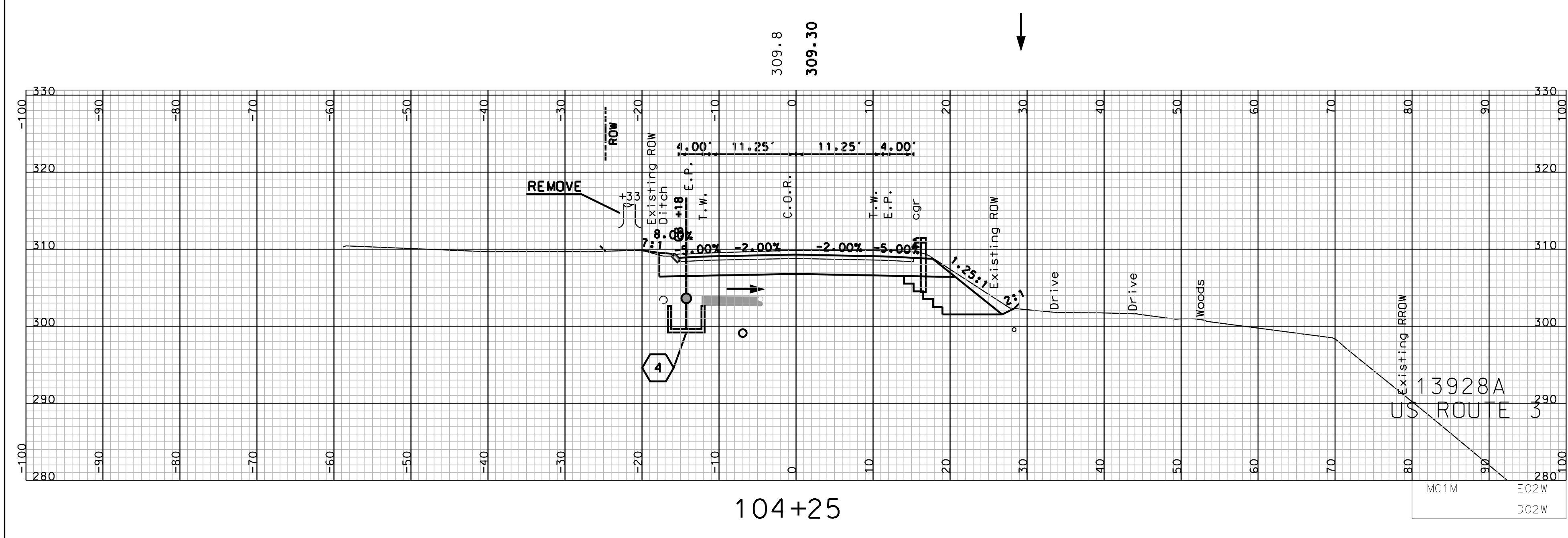
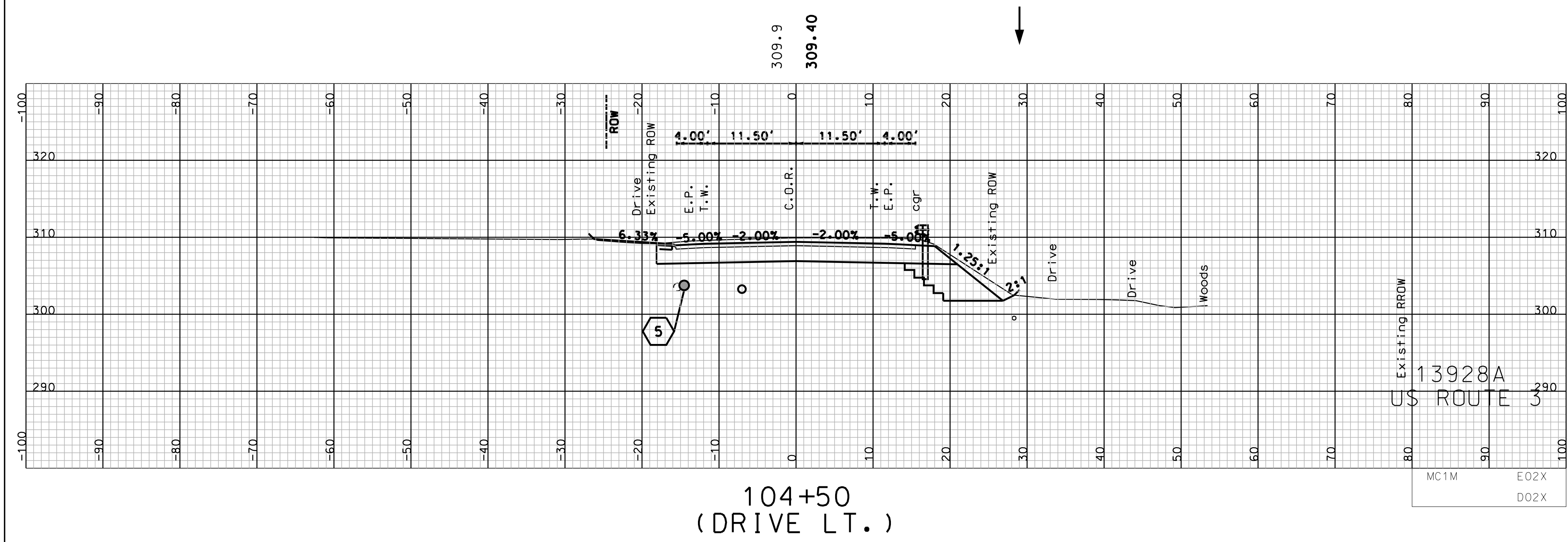

COMMON EXCAV.		SHEET TOTALS		ROCK EXCAV.	
DGN	STATE PROJECT NO.	FILL	C.Y.	SHEET NO.	TOTAL SHEETS
13928axs-mc1m	13928A	351	2	85	160

SDR PROCESSED	DATE
NEW DESIGN TEAM BALDWIN	DATE 09/2013
SHEET CHECKED TEAM BALDWIN	DATE 04/2015
AS BUILT DETAILS	DATE

REVISIONS AFTER PROPOSAL				
NUMBER	DATE	STATION	STATION	DESCRIPTION

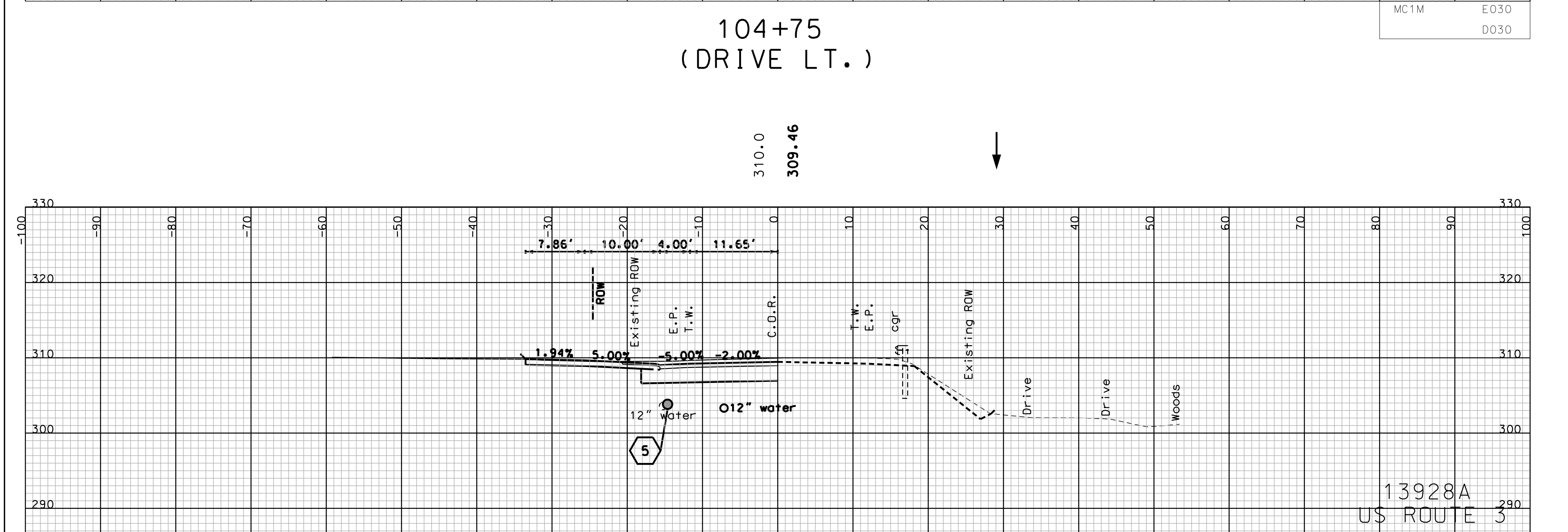
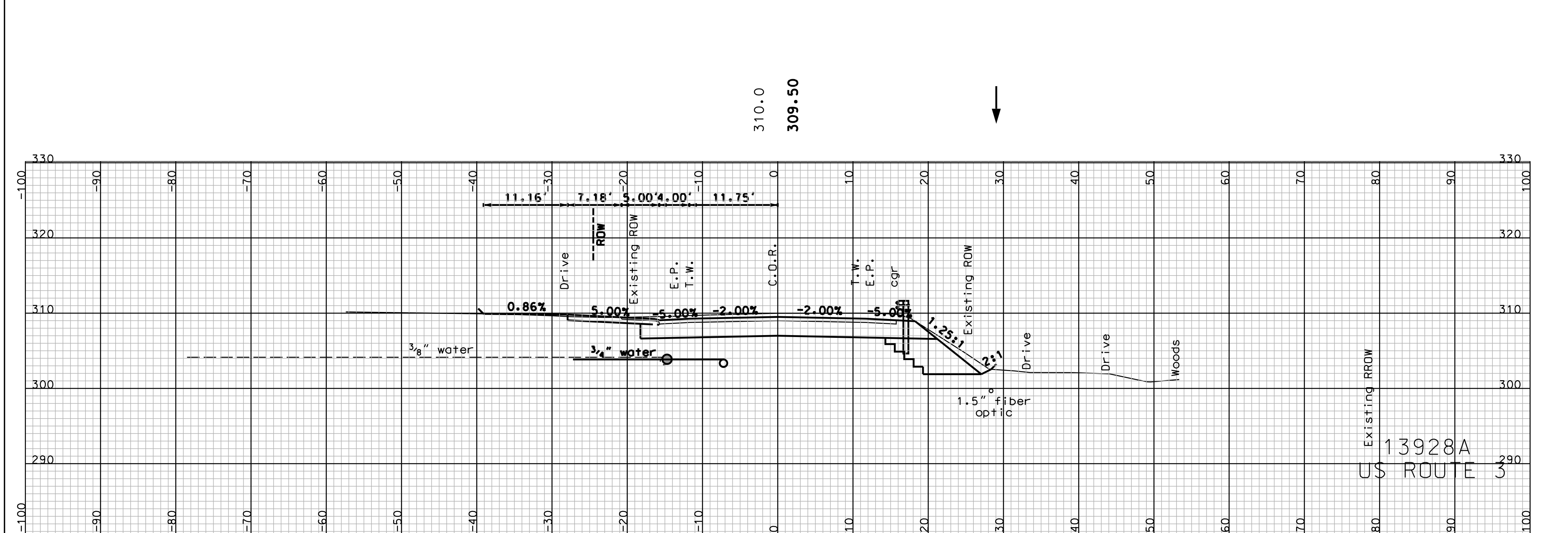
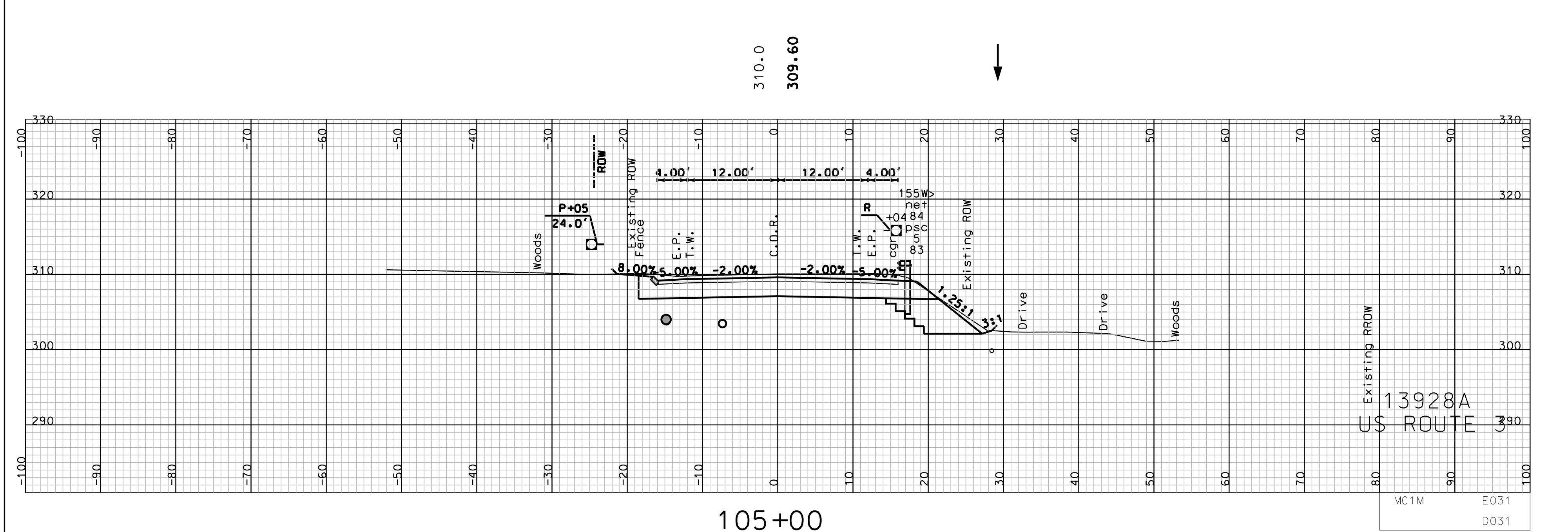
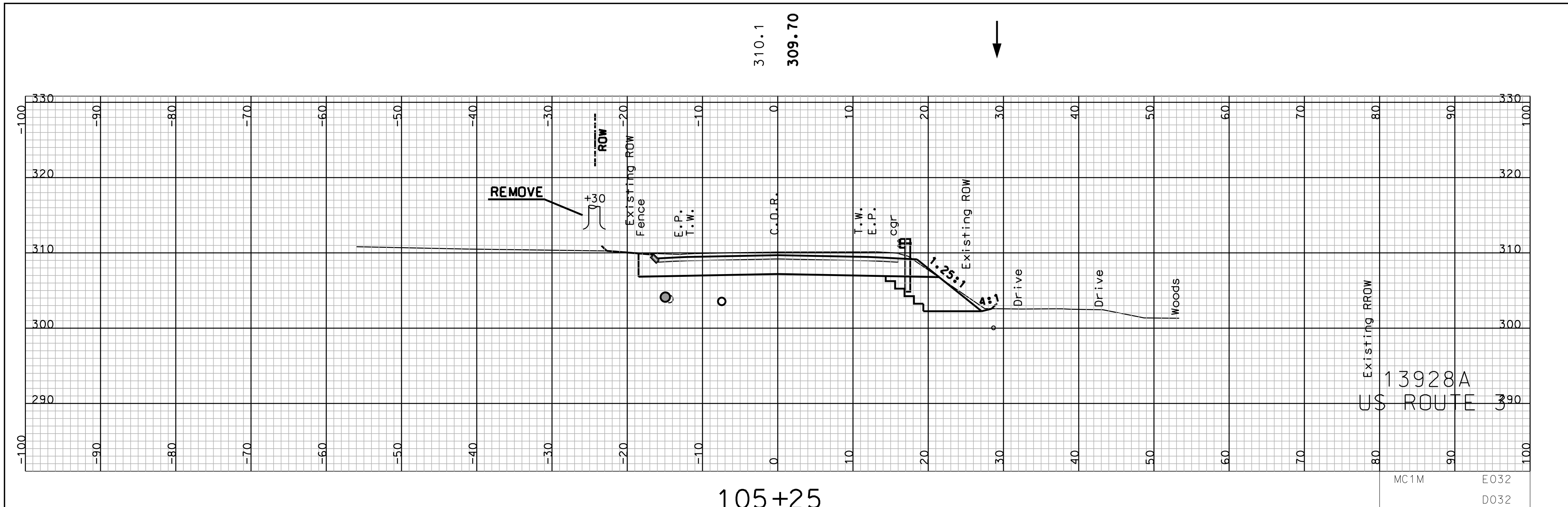

COMMON EXCAV.		SHEET TOTALS	
DCN	STATE PROJECT NO.	C.Y.	TOTAL SHEETS
13928axs-mc1m	13928A	466	86
		ROCK EXCAV. 33	
		MUCK EXCAV. 0	
		FILL 1	

SDR PROCESSED	DATE
NEW DESIGN TEAM BALDWIN	DATE 09/2013
SHEET CHECKED TEAM BALDWIN	DATE 04/2015
AS BUILT DETAILS	DATE

REVISIONS AFTER PROPOSAL				
NUMBER	DATE	STATION	STATION	DESCRIPTION

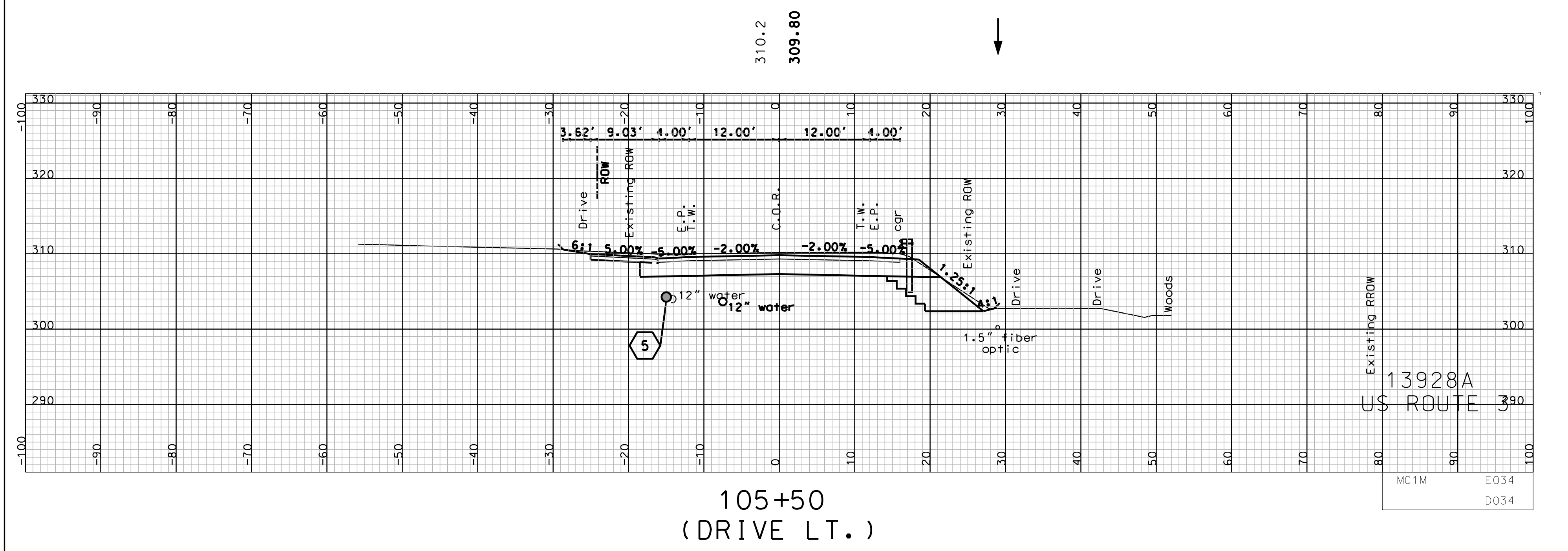
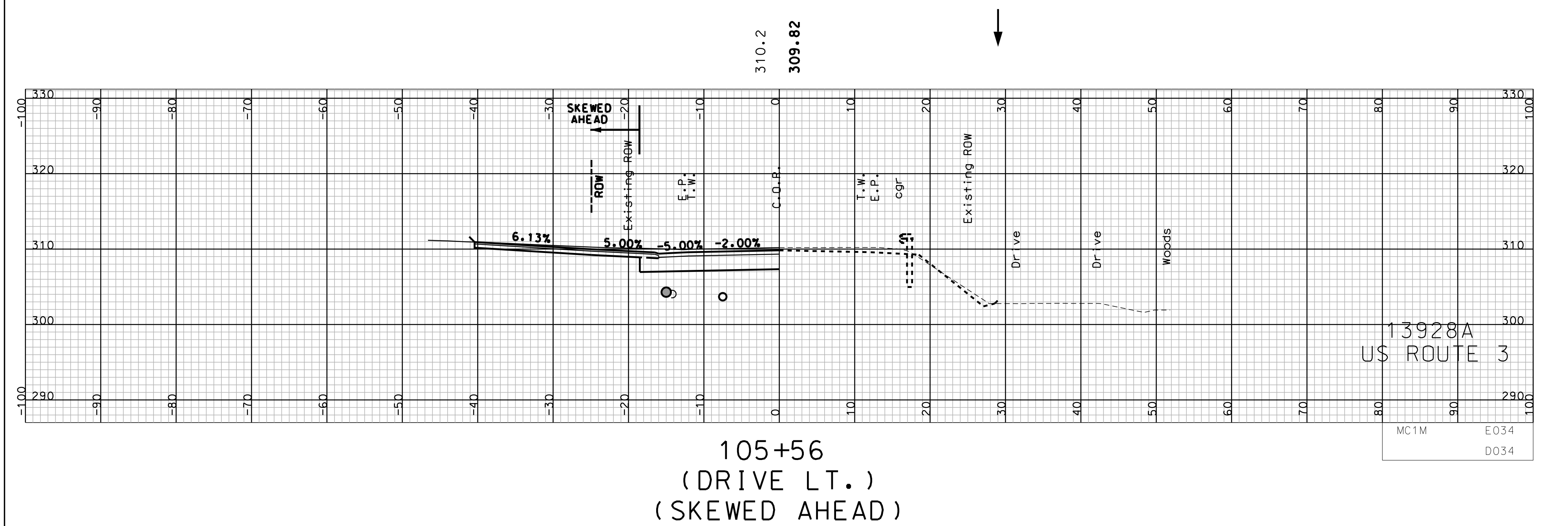
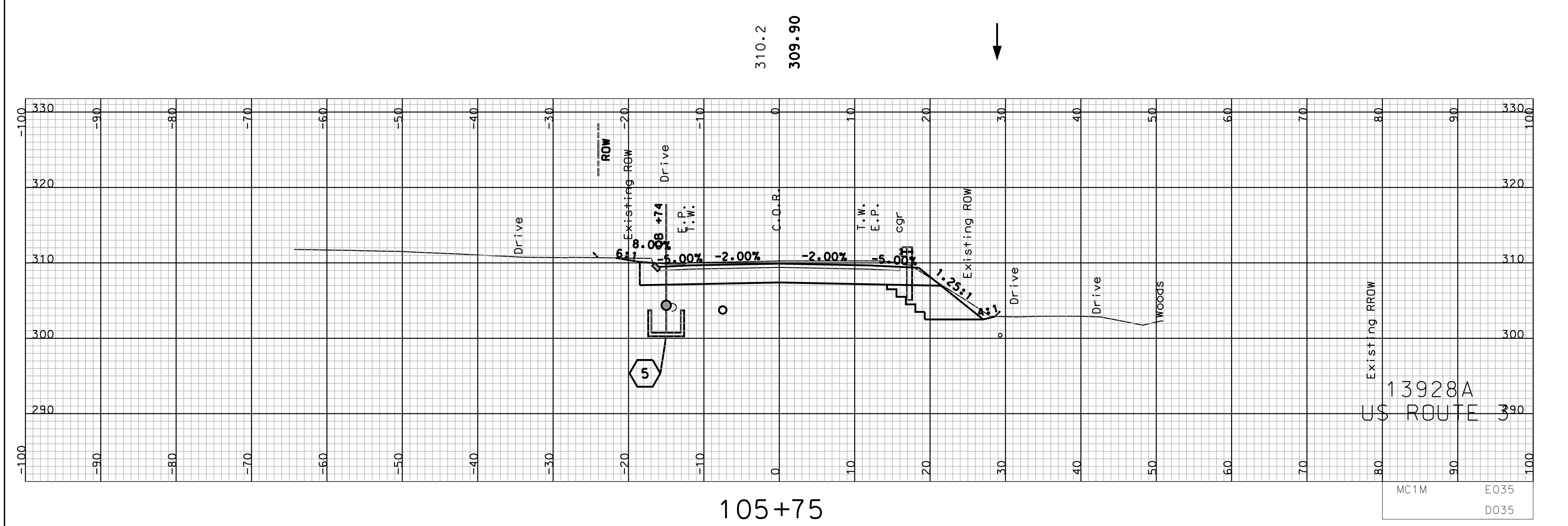
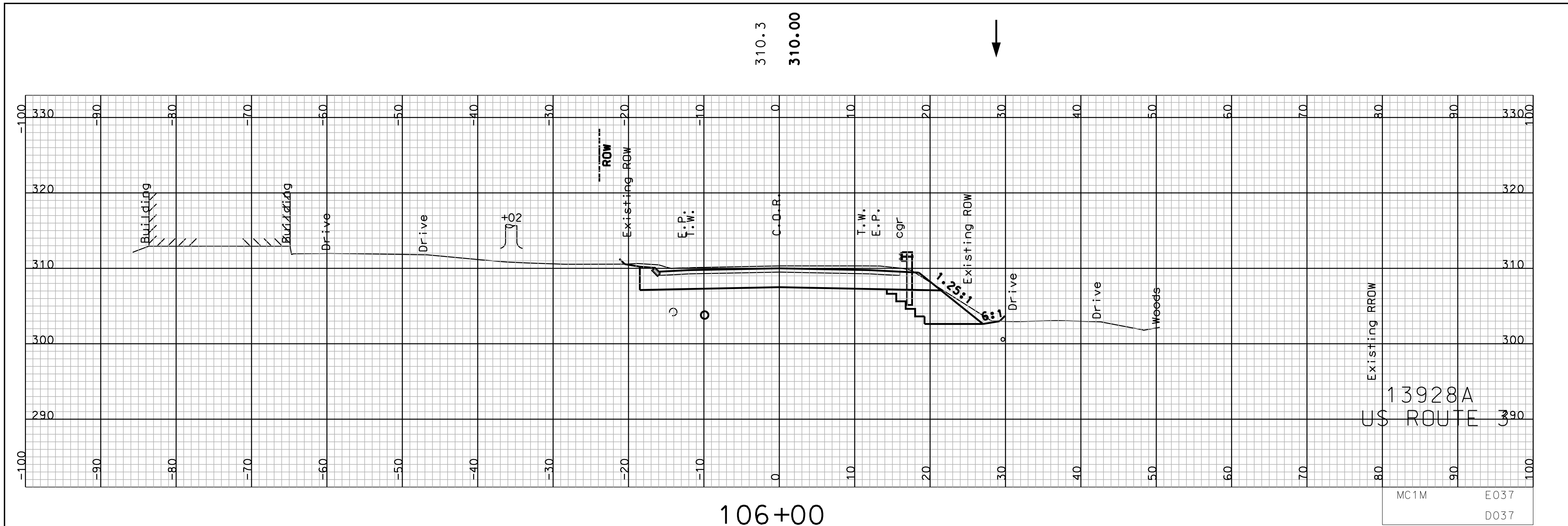

COMMON EXCAV.		SHEET TOTALS	
	C.Y.		C.Y.
378		ROCK EXCAV.	29
0		MUCK EXCAV.	0
DGN		STATE PROJECT NO.	SHEET NO.
13928axs-mc1m		13928A	87
		TOTAL SHEETS	160

SDR PROCESSED	DATE
NEW DESIGN TEAM BALDWIN	DATE 09/2013
SHEET CHECKED TEAM BALDWIN	DATE 04/2015
AS BUILT DETAILS	DATE

REVISIONS AFTER PROPOSAL				
NUMBER	DATE	STATION	STATION	DESCRIPTION

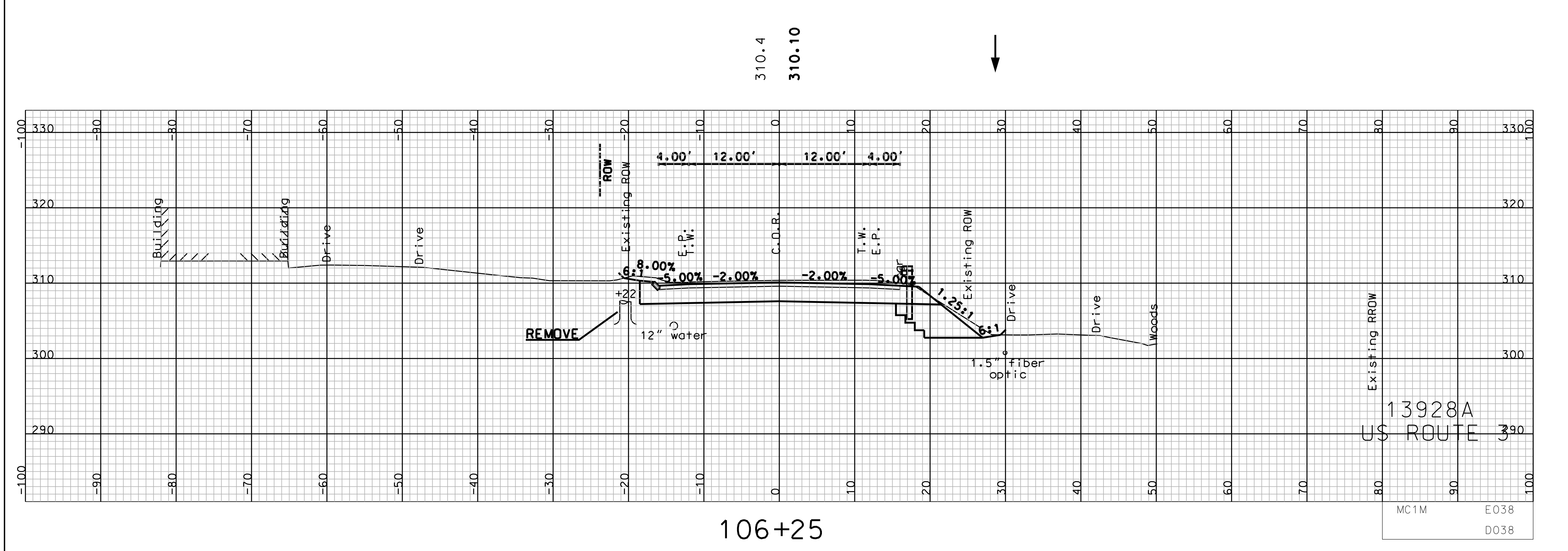
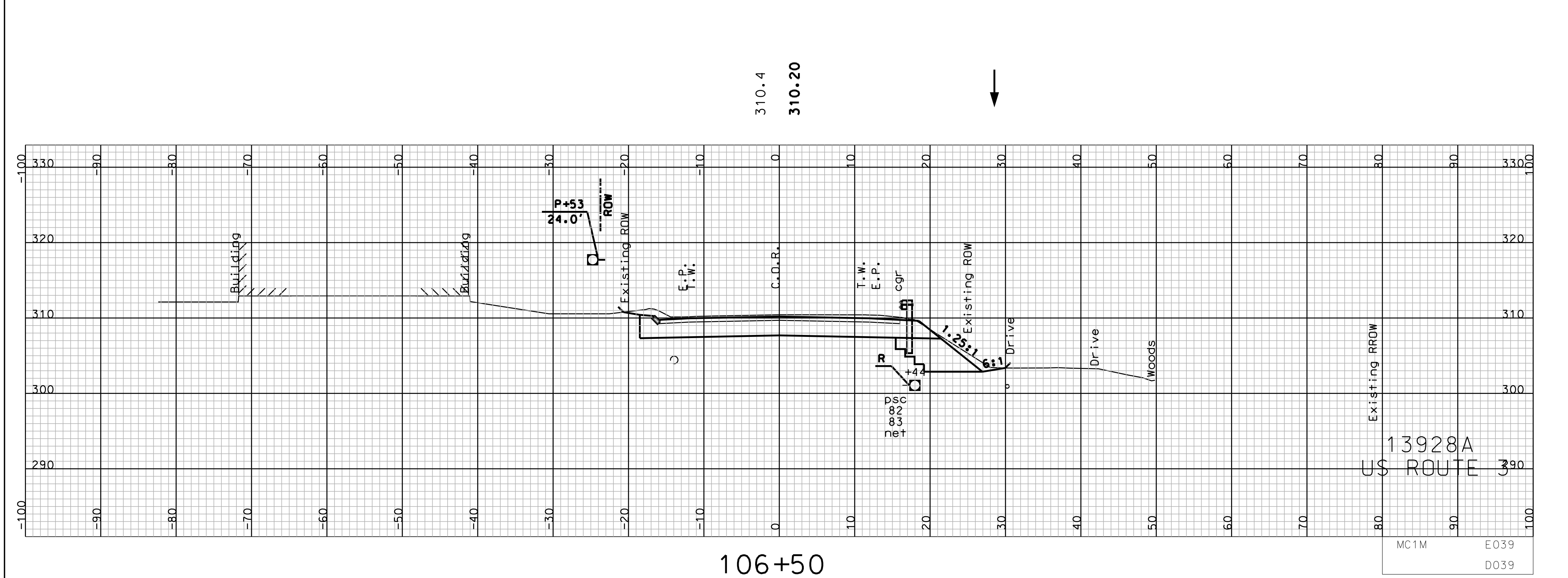
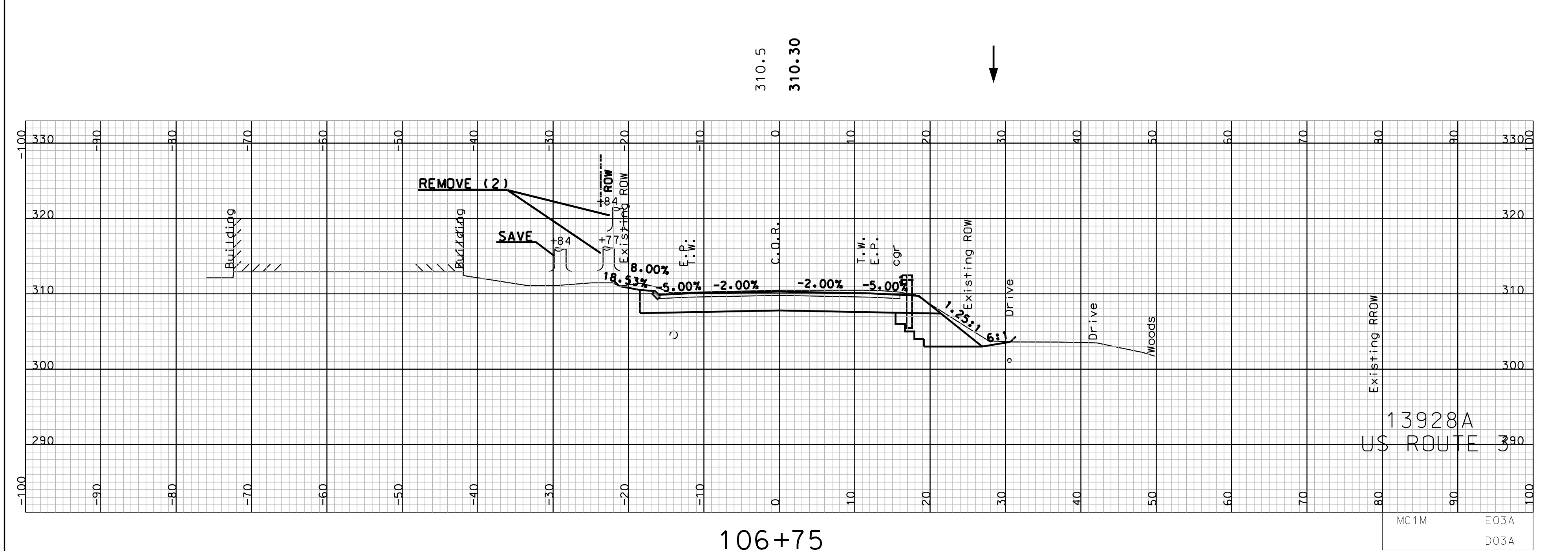
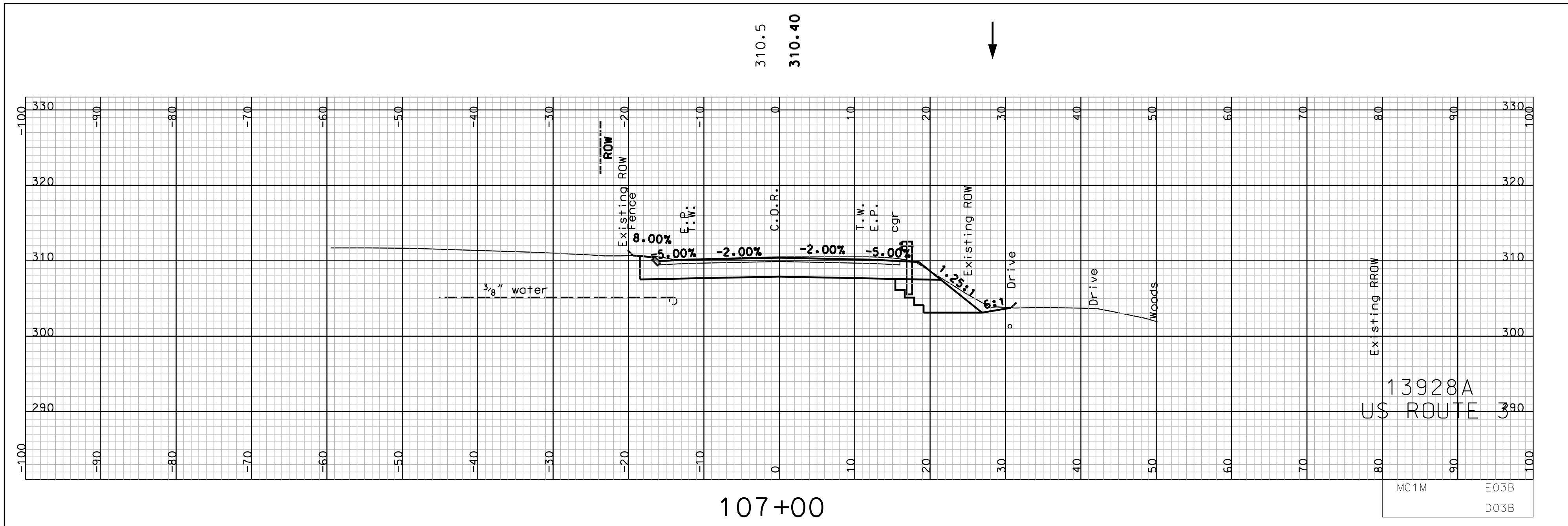

COMMON EXCAV.		SHEET TOTALS	
DGN	STATE PROJECT NO.	SHEET NO.	TOTAL SHEETS
13928axs-mc1m	13928A	88	160

SDR PROCESSED	DATE
NEW DESIGN TEAM BALDWIN	DATE 09/2013
SHEET CHECKED TEAM BALDWIN	DATE 04/2015
AS BUILT DETAILS	DATE

REVISIONS AFTER PROPOSAL				
NUMBER	DATE	STATION	STATION	DESCRIPTION

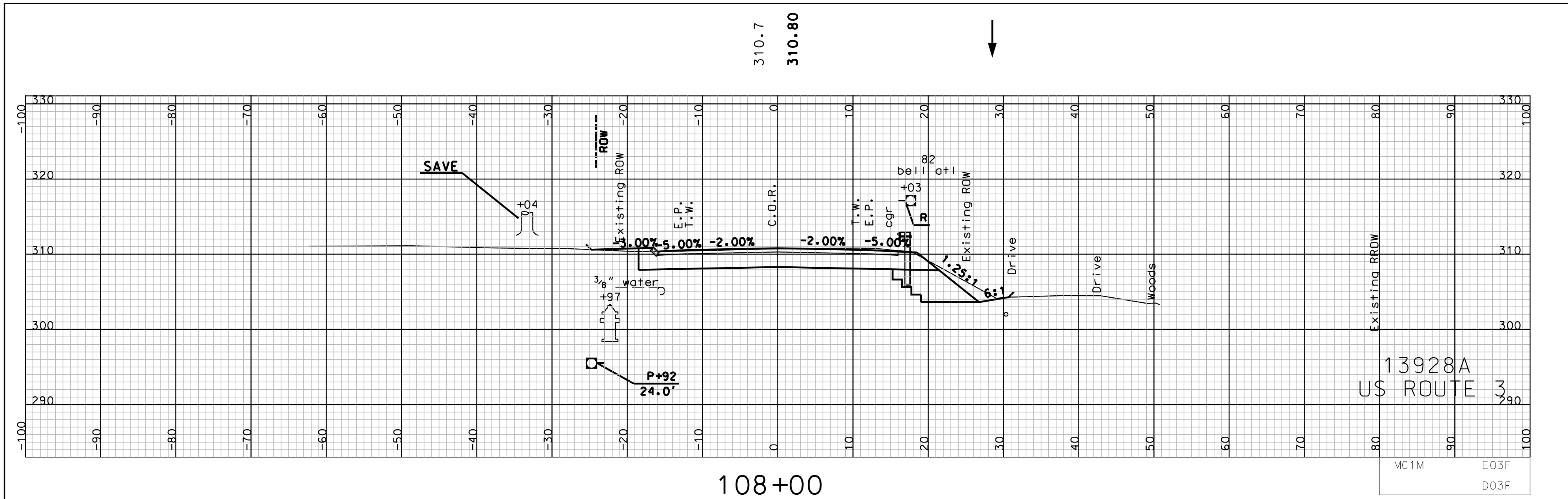

108+00

13928A
US ROUTE 3

MC1M E03F
D03F

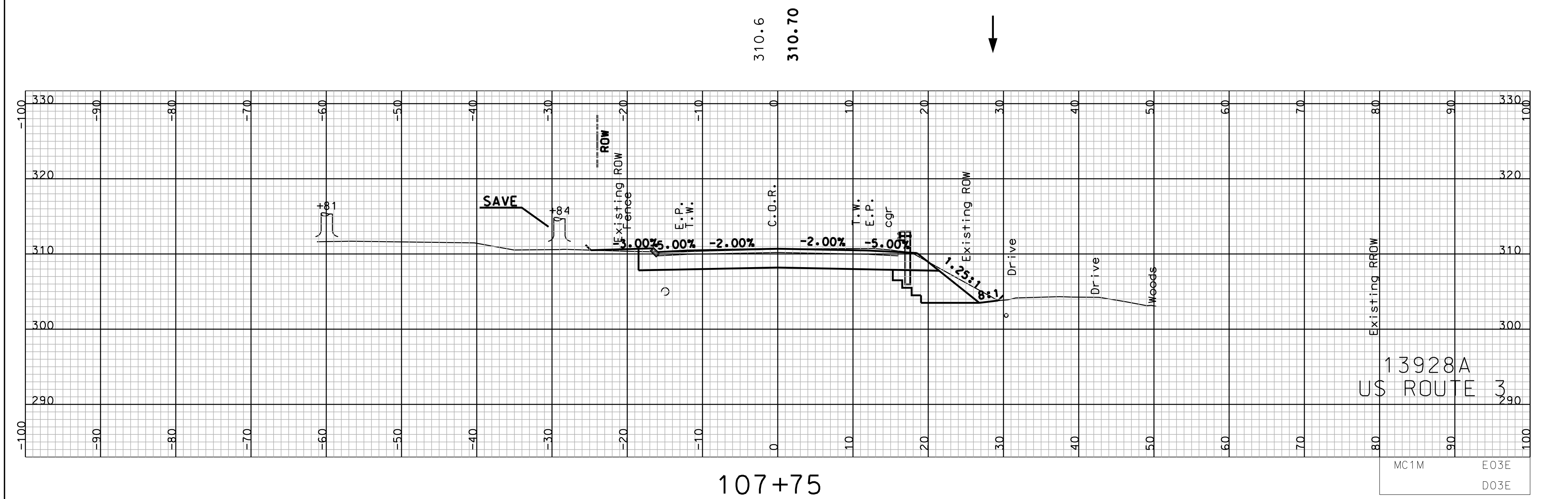

107+75

13928A
US ROUTE 3

MC1M E03E
D03E

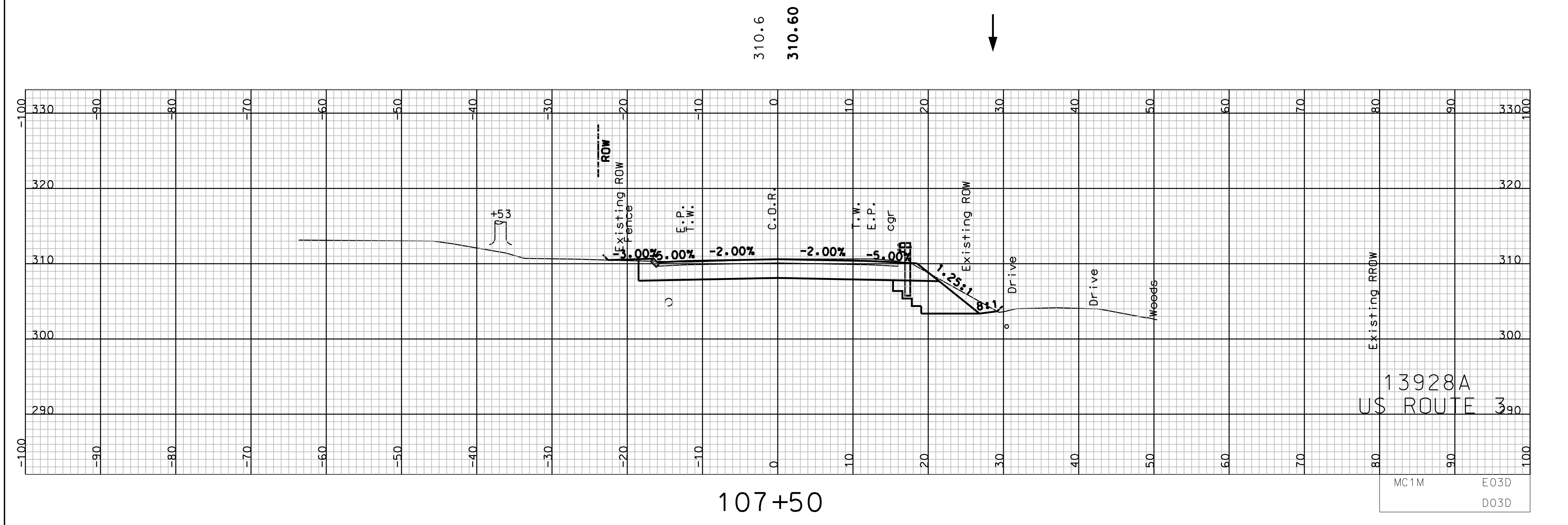

107+50

13928A
US ROUTE 3

MC1M E03D
D03D

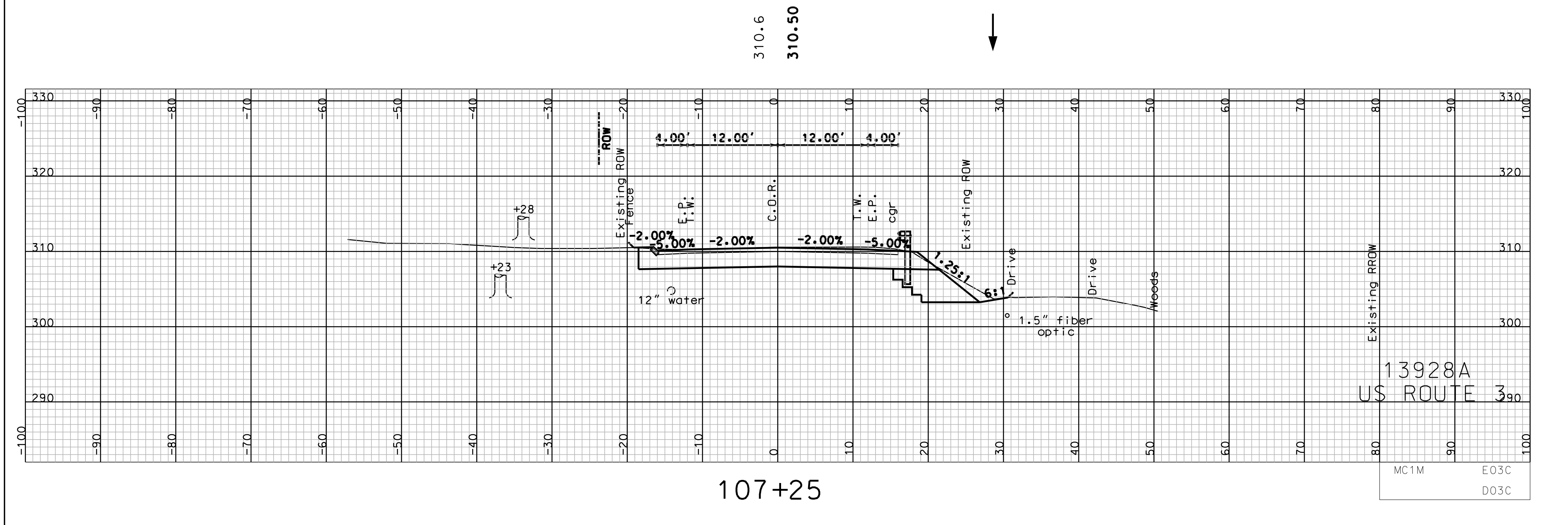

107+25

13928A
US ROUTE 3

MC1M E03C
D03C

COMMON EXCAV.		SHEET TOTALS		ROCK EXCAV.	
496	C.Y.	39	C.Y.	0	C.Y.
FILL 4 C.Y.		MUCK EXCAV. 0 C.Y.			
DGN	STATE PROJECT NO.	SHEET NO.	TOTAL SHEETS		
13928axs-mc1m	13928A	89	160		

SDR PROCESSED	DATE		
NEW DESIGN	TEAM BALDWIN	DATE	09/2013
SHEET CHECKED	TEAM BALDWIN	DATE	04/2015
AS BUILT DETAILS	DATE		

REVISIONS AFTER PROPOSAL				
NUMBER	DATE	STATION	STATION	DESCRIPTION

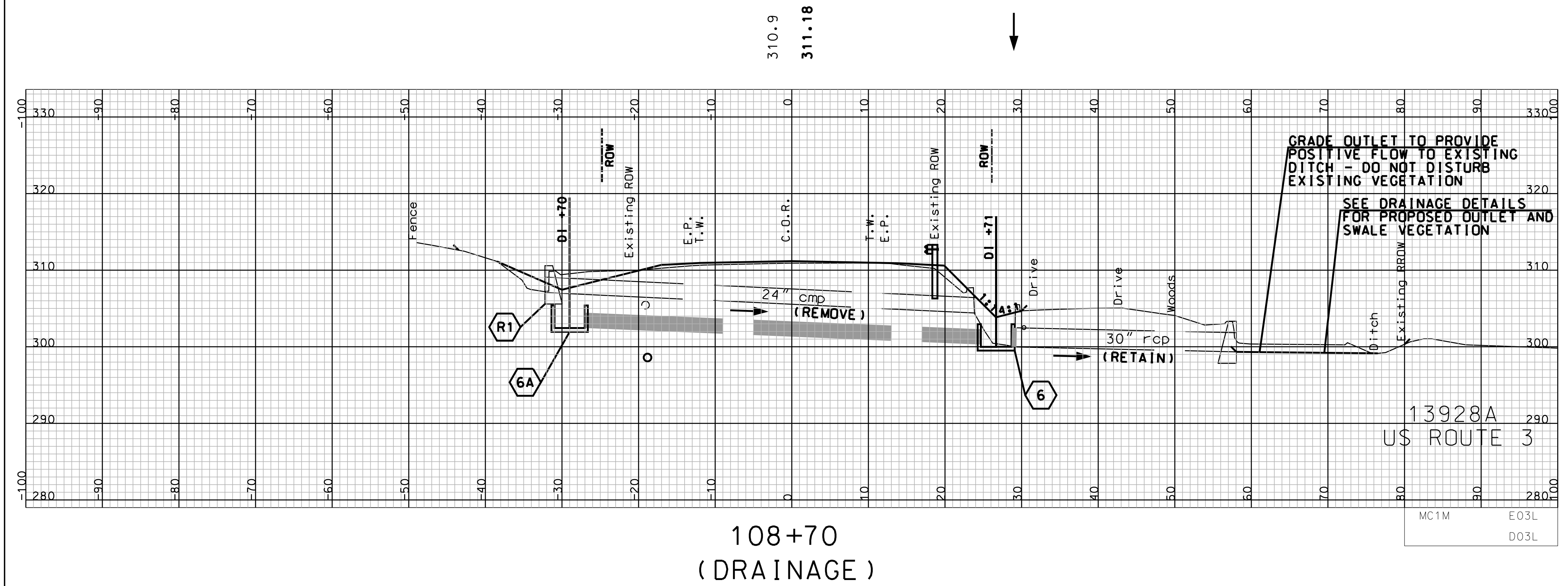

108+70
(DRAINAGE)

MC1M E03L
D03L

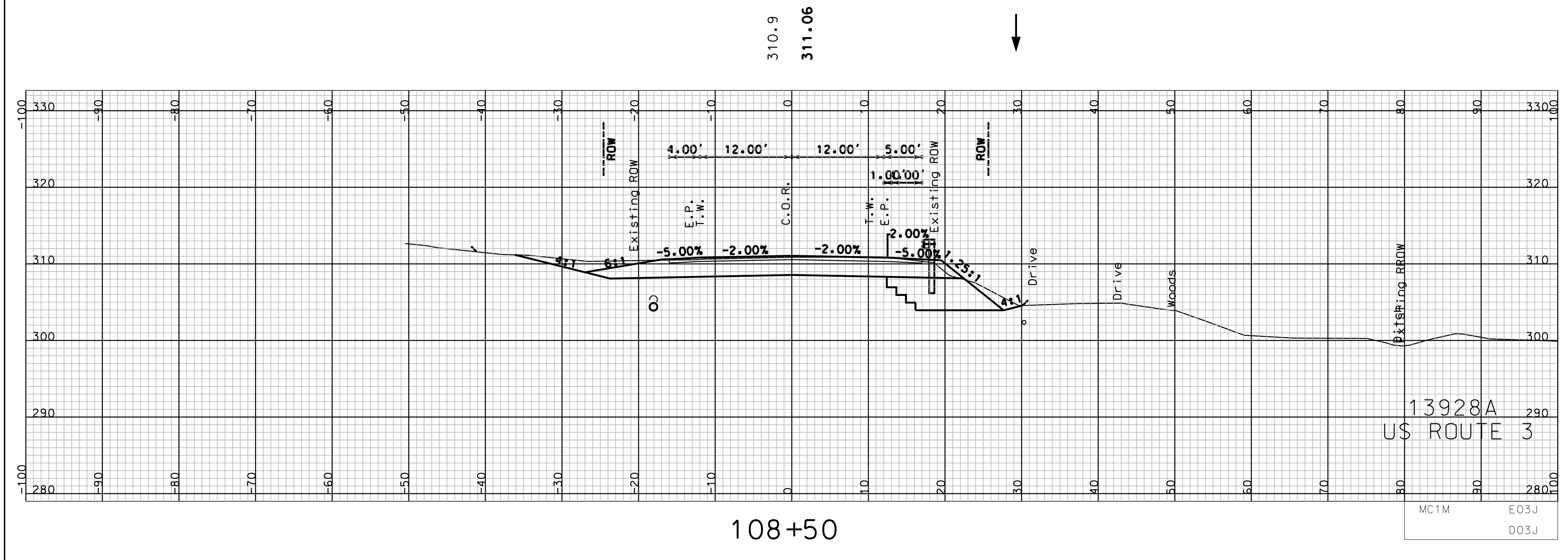

108+50

MC1M E03J
D03J

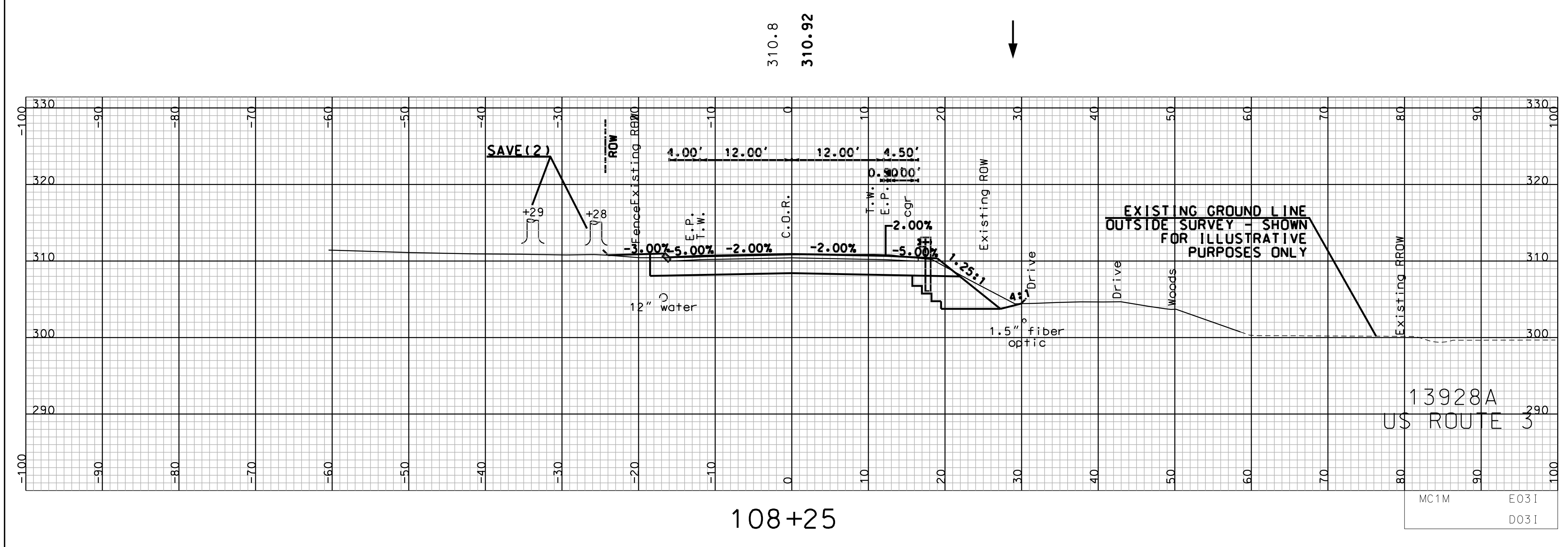

108+25

MC1M E03I
D03I

SHEET TOTALS					
COMMON EXCAV.	258	C.Y.	ROCK EXCAV.	19	C.Y.
FILL	6	C.Y.	MUCK EXCAV.	0	C.Y.
DGN	STATE PROJECT NO.	SHEET NO.	TOTAL SHEETS		
13928axs-mc1m	13928A	90	160		

SDR PROCESSED	DATE
NEW DESIGN TEAM BALDWIN	DATE 09/2013
SHEET CHECKED TEAM BALDWIN	DATE 04/2015
AS BUILT DETAILS	DATE

REVISIONS AFTER PROPOSAL				
NUMBER	DATE	STATION	STATION	DESCRIPTION

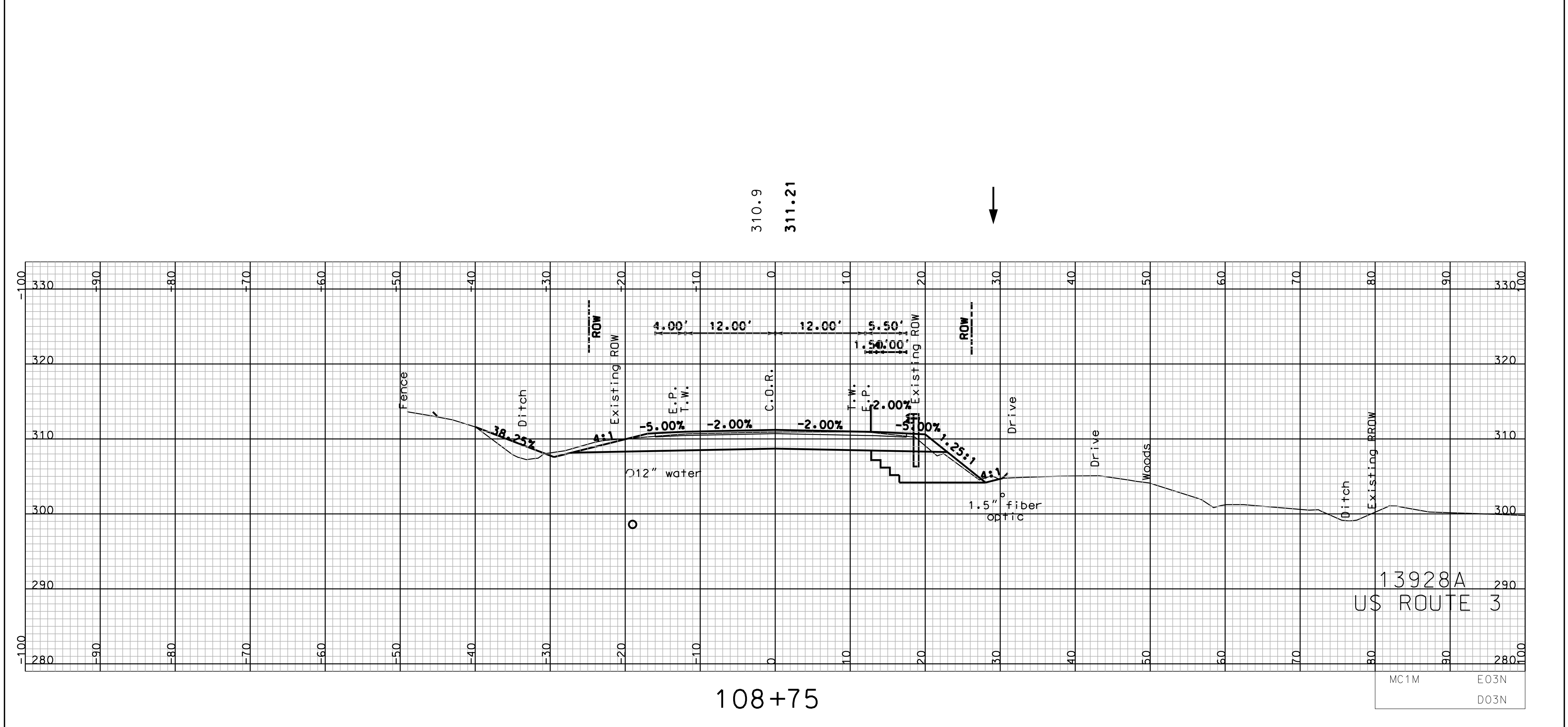
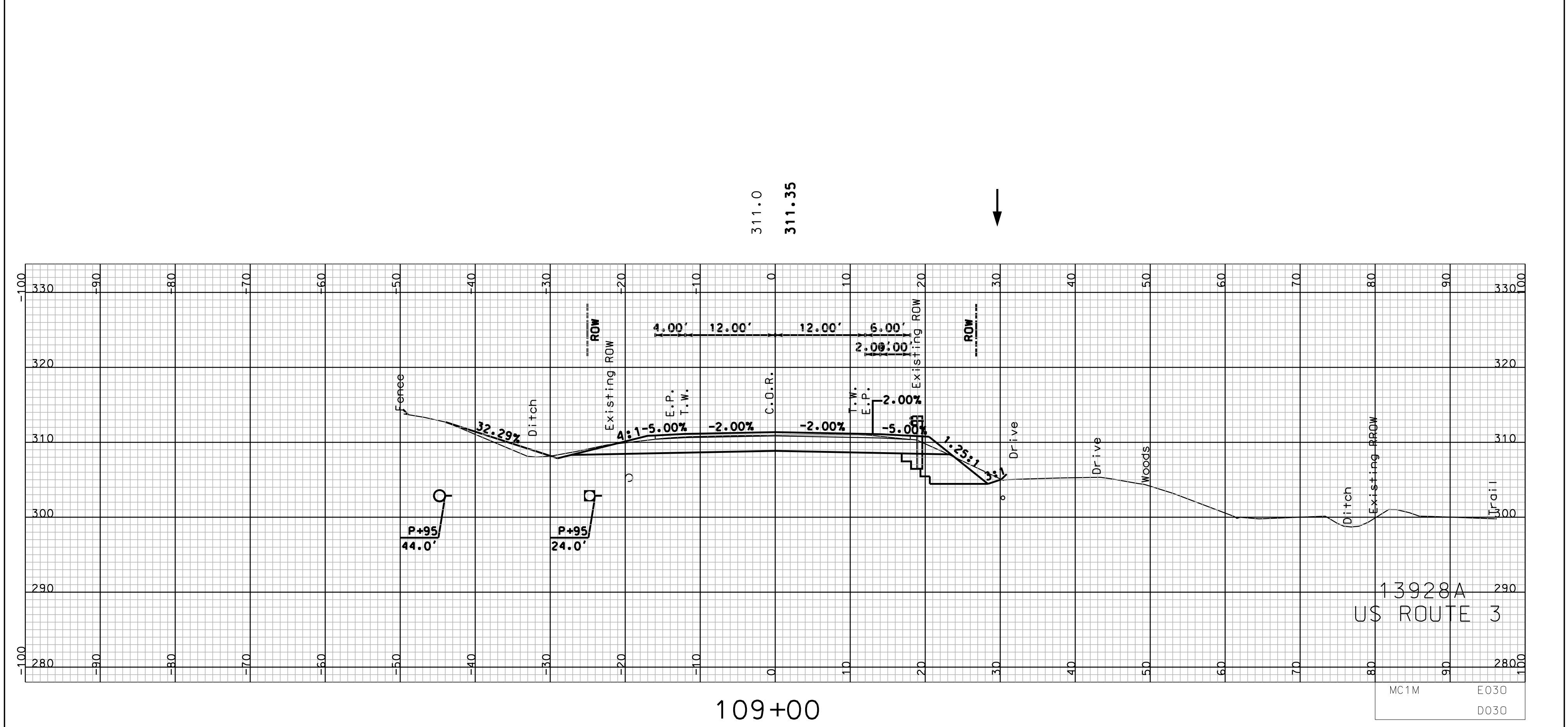
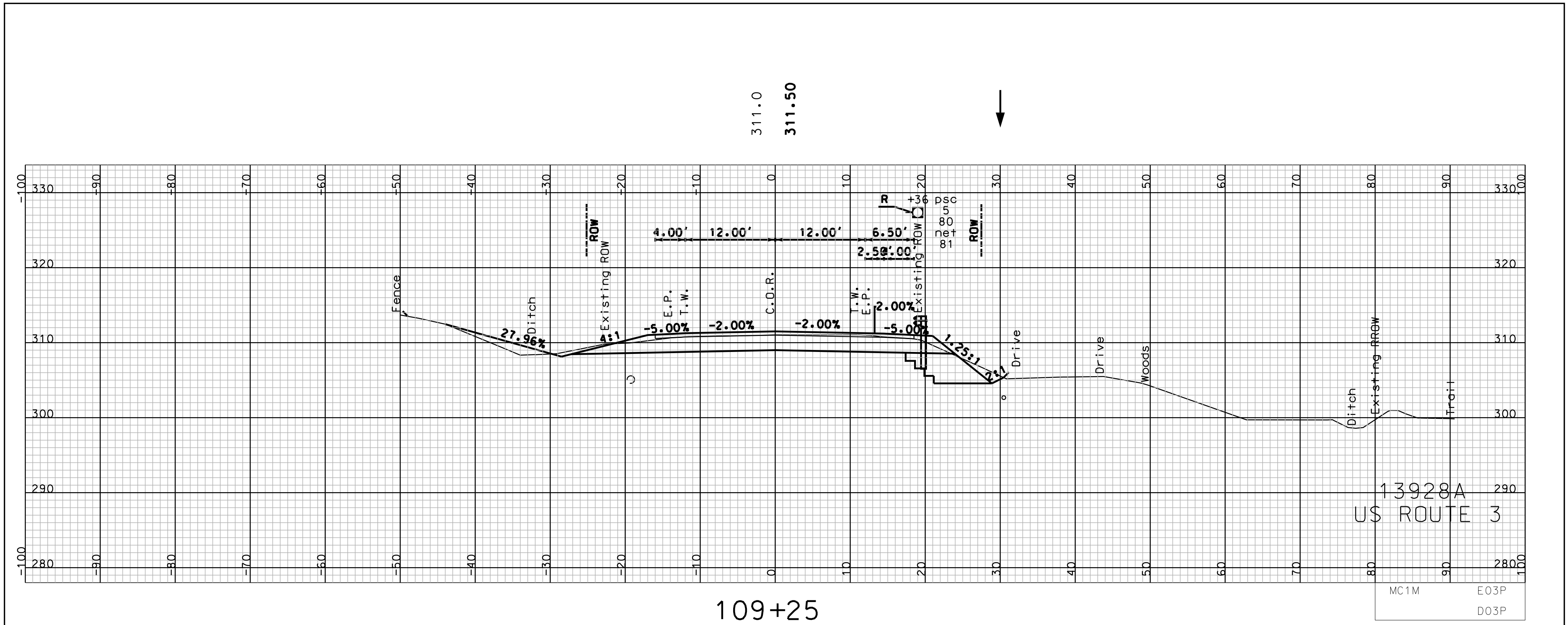

COMMON EXCAV.		SHEET TOTALS		ROCK EXCAV.	
DCN	STATE PROJECT NO.	C.Y.	C.Y.	C.Y.	C.Y.
13928axs-mc1m	13928A	347	29	29	0
TOTAL SHEETS		TOTAL SHEETS		TOTAL SHEETS	
91		160		160	

SDR PROCESSED	DATE
NEW DESIGN TEAM BALDWIN	DATE 09/2013
SHEET CHECKED TEAM BALDWIN	DATE 04/2015
AS BUILT DETAILS	DATE

REVISIONS AFTER PROPOSAL				
NUMBER	DATE	STATION	STATION	DESCRIPTION

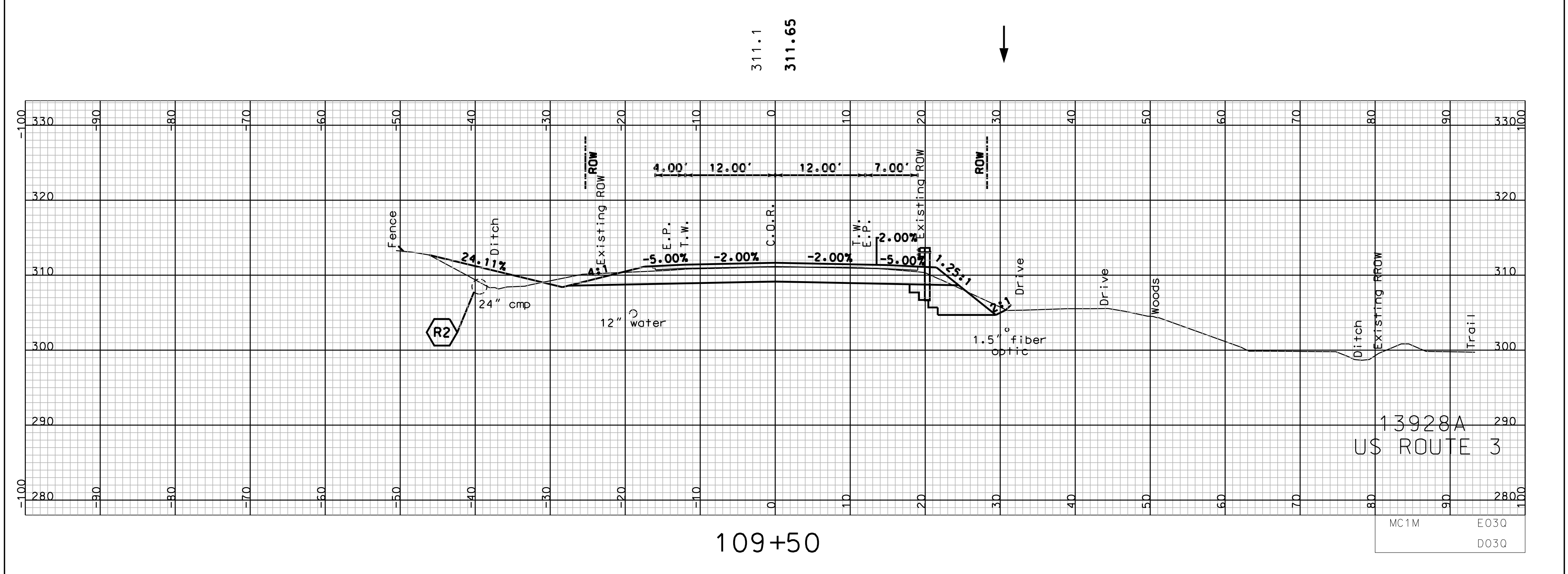
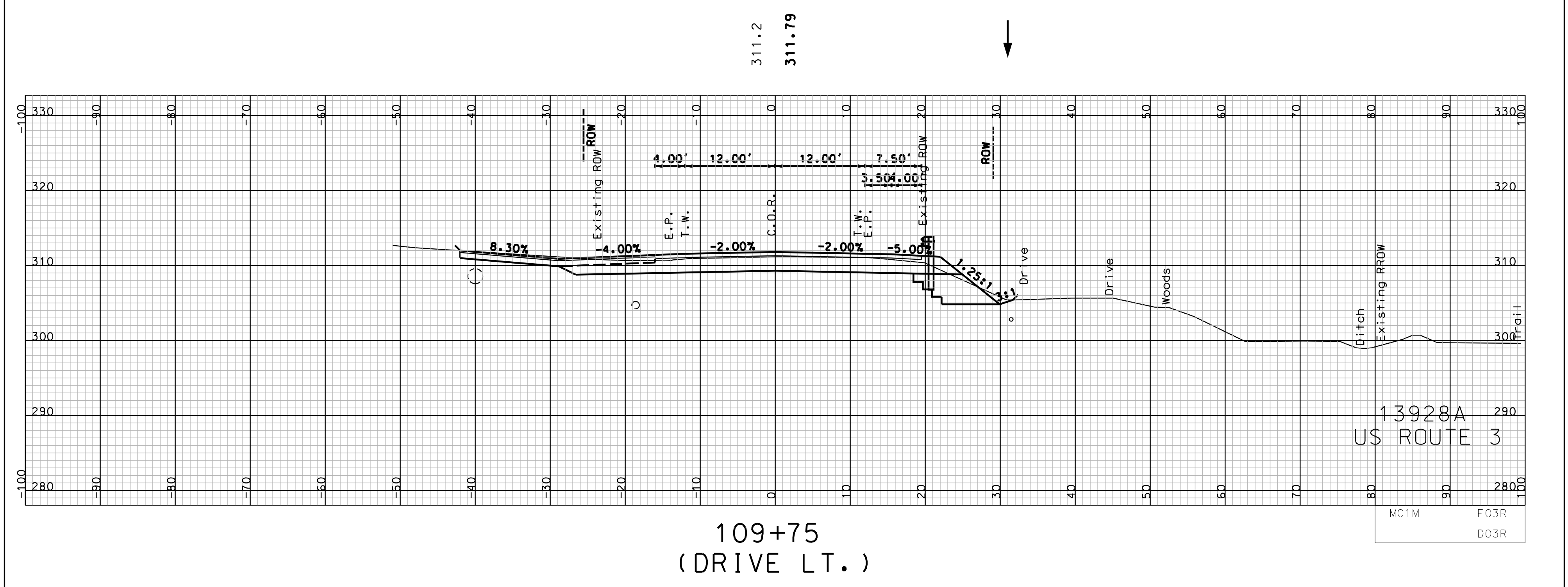
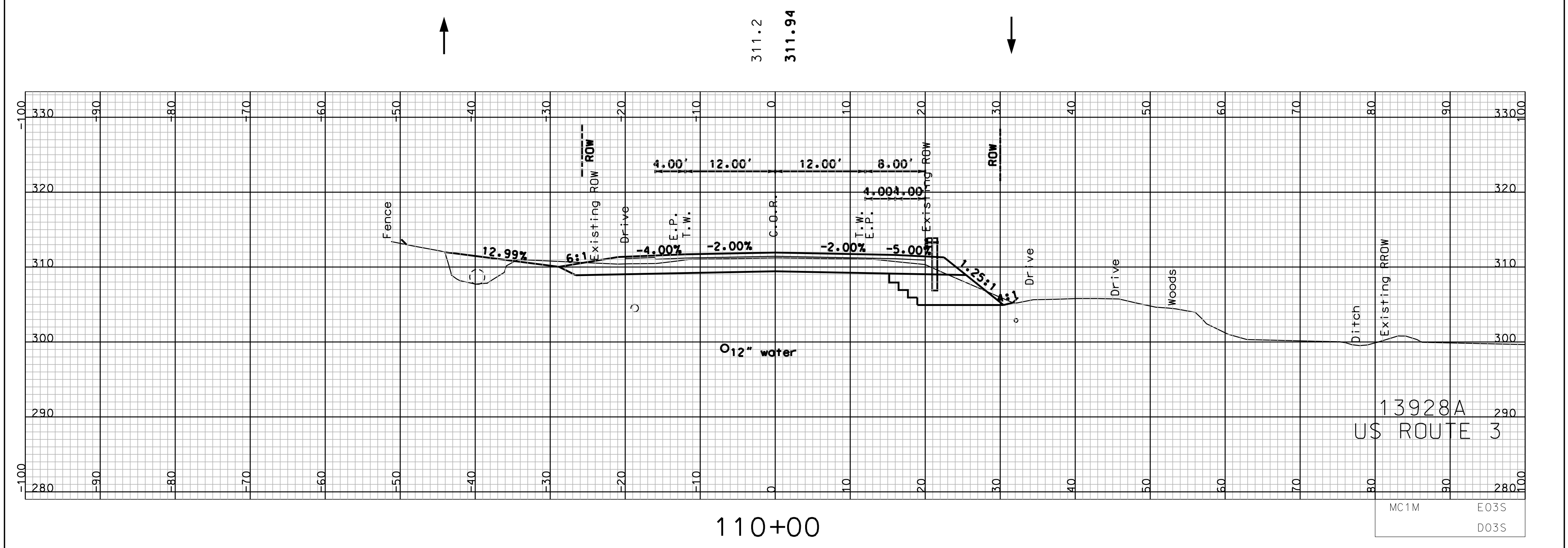

COMMON EXCAV.		SHEET TOTALS	
	C.Y.		C.Y.
COMMON EXCAV.	336	ROCK EXCAV.	29
FILL	48	MUCK EXCAV.	0
DGN	STATE PROJECT NO.	SHEET NO.	TOTAL SHEETS
13928axs-mc1m	13928A	92	160

SDR PROCESSED	DATE
NEW DESIGN TEAM BALDWIN	DATE 09/2013
SHEET CHECKED TEAM BALDWIN	DATE 04/2015
AS BUILT DETAILS	DATE

REVISIONS AFTER PROPOSAL				
NUMBER	DATE	STATION	STATION	DESCRIPTION

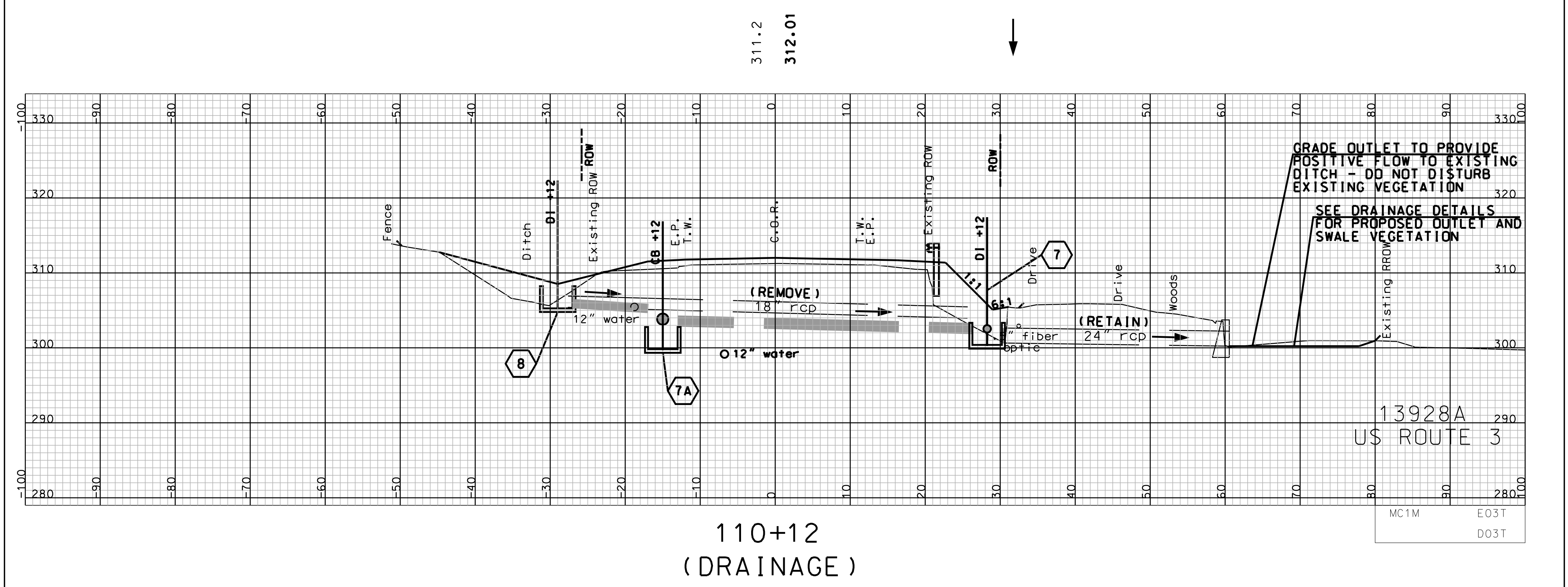
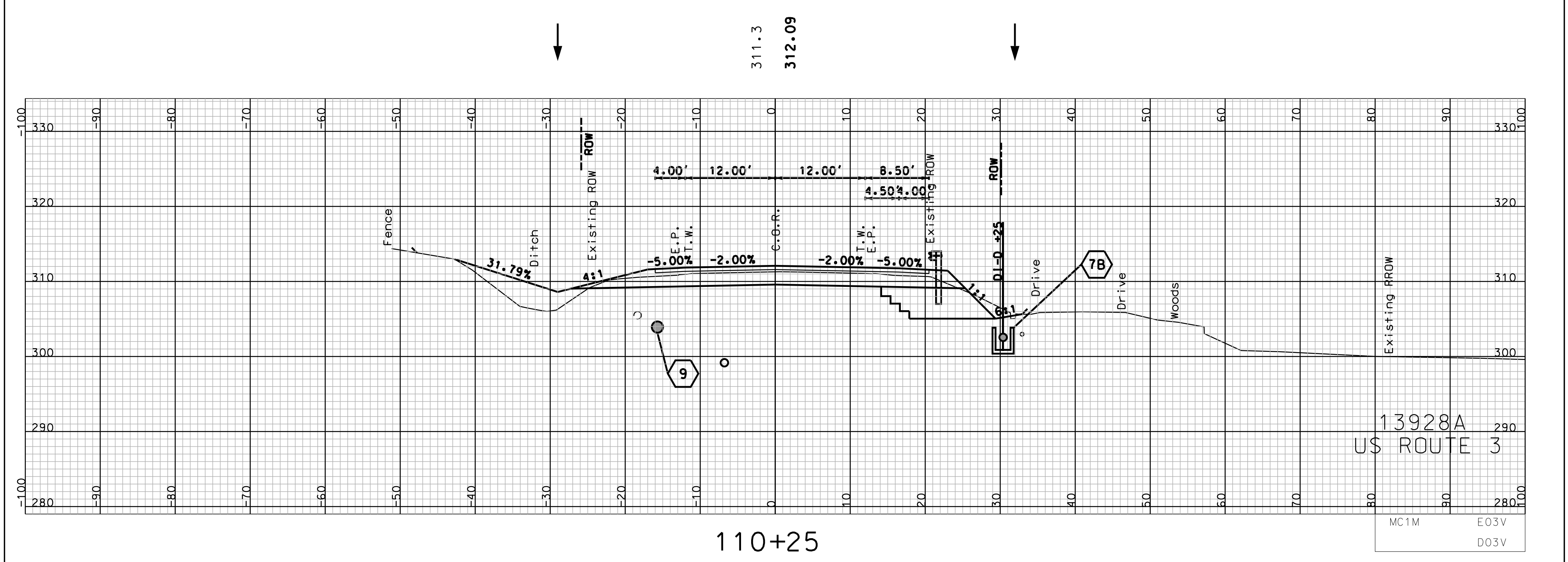
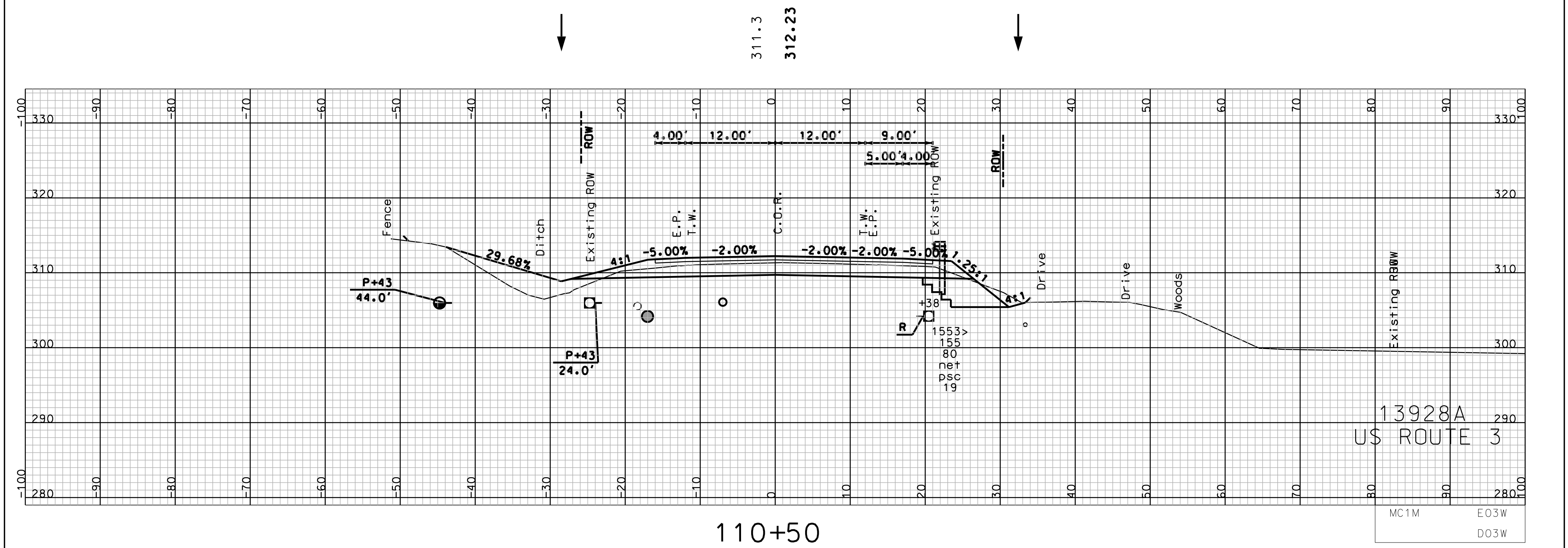

SHEET TOTALS					
COMMON EXCAV.	180	C.Y.	ROCK EXCAV.	19	C.Y.
FILL	68	C.Y.	MUCK EXCAV.	0	C.Y.
DCN	STATE PROJECT NO.	SHEET NO.	TOTAL SHEETS		
13928axs-mc1m	13928A	93	160		

SDR PROCESSED	DATE
NEW DESIGN TEAM BALDWIN	DATE 09/2013
SHEET CHECKED TEAM BALDWIN	DATE 04/2015
AS BUILT DETAILS	DATE

REVISIONS AFTER PROPOSAL				
NUMBER	DATE	STATION	STATION	DESCRIPTION

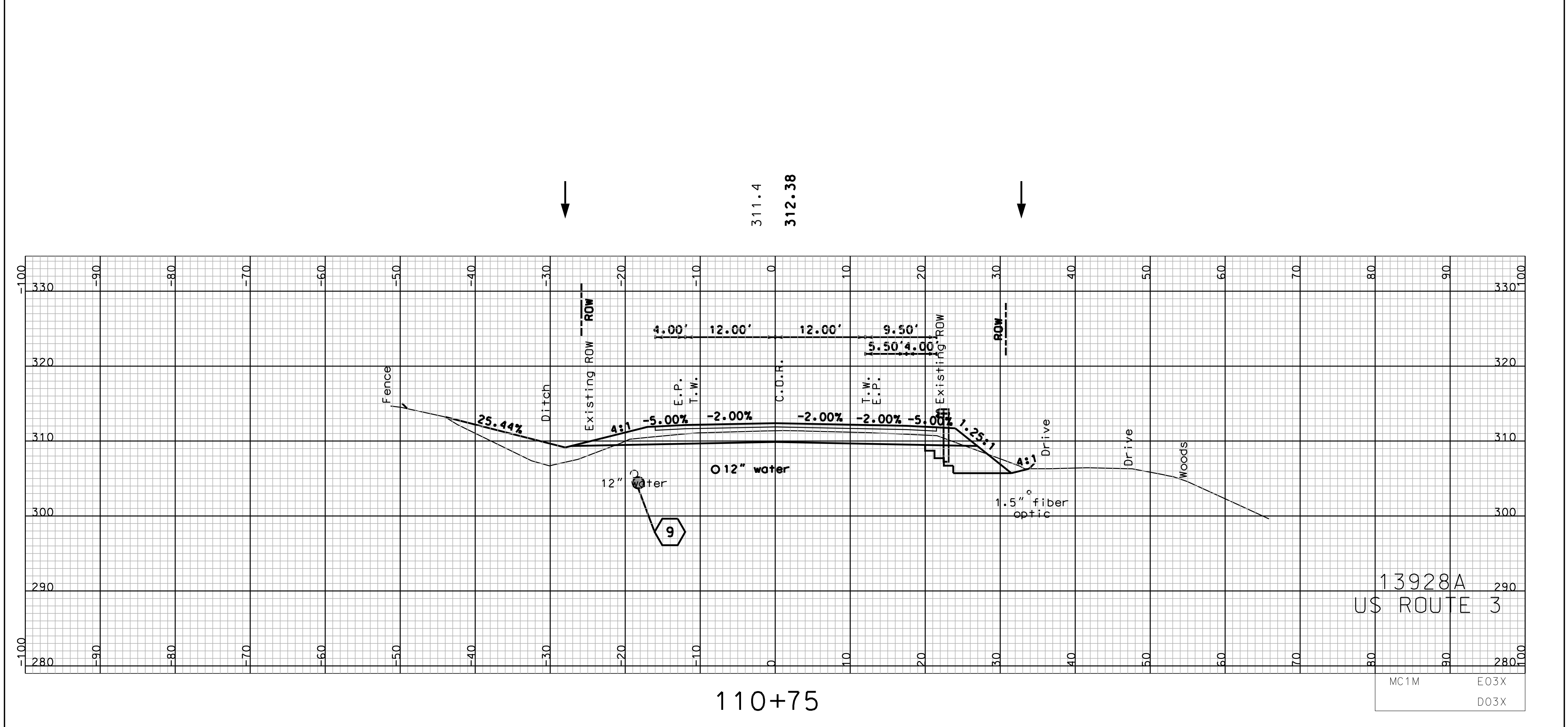
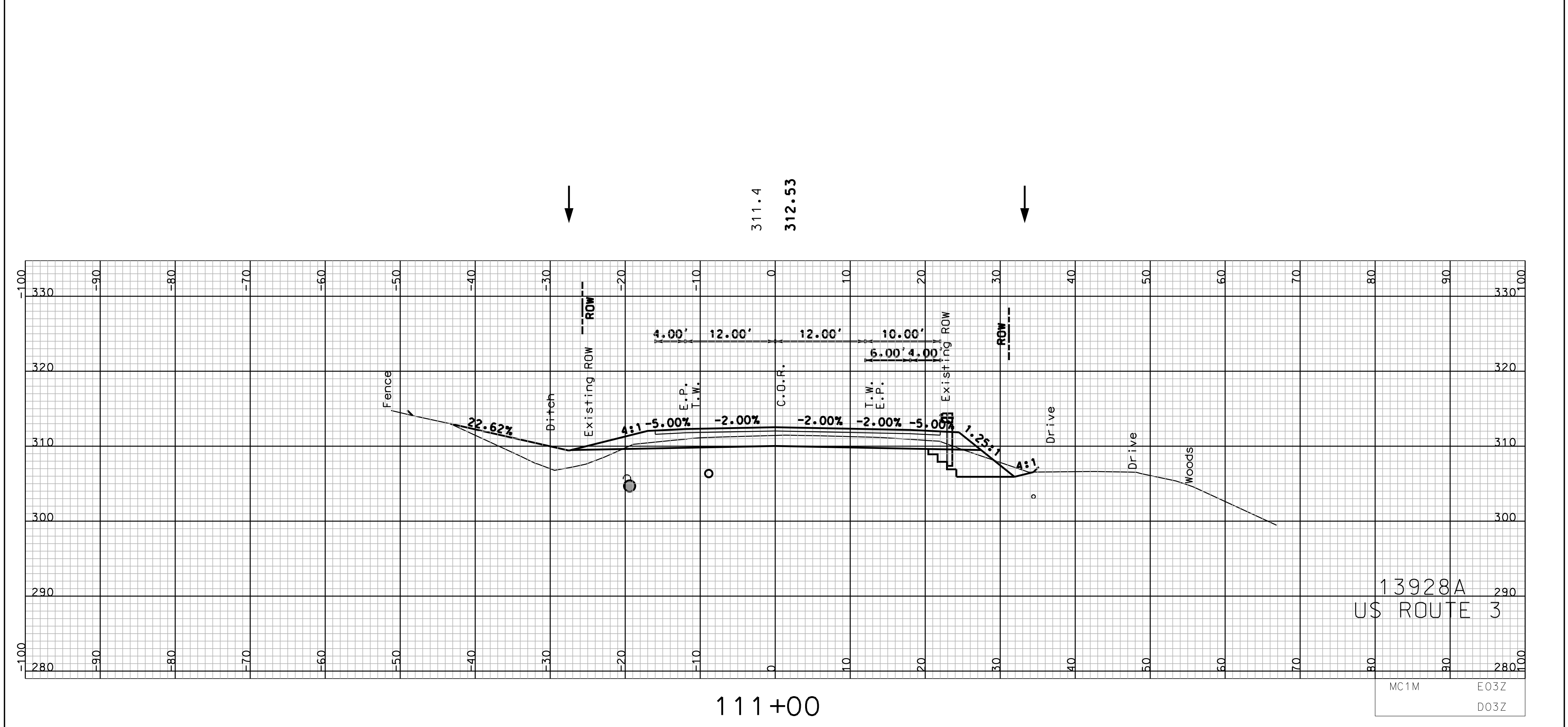
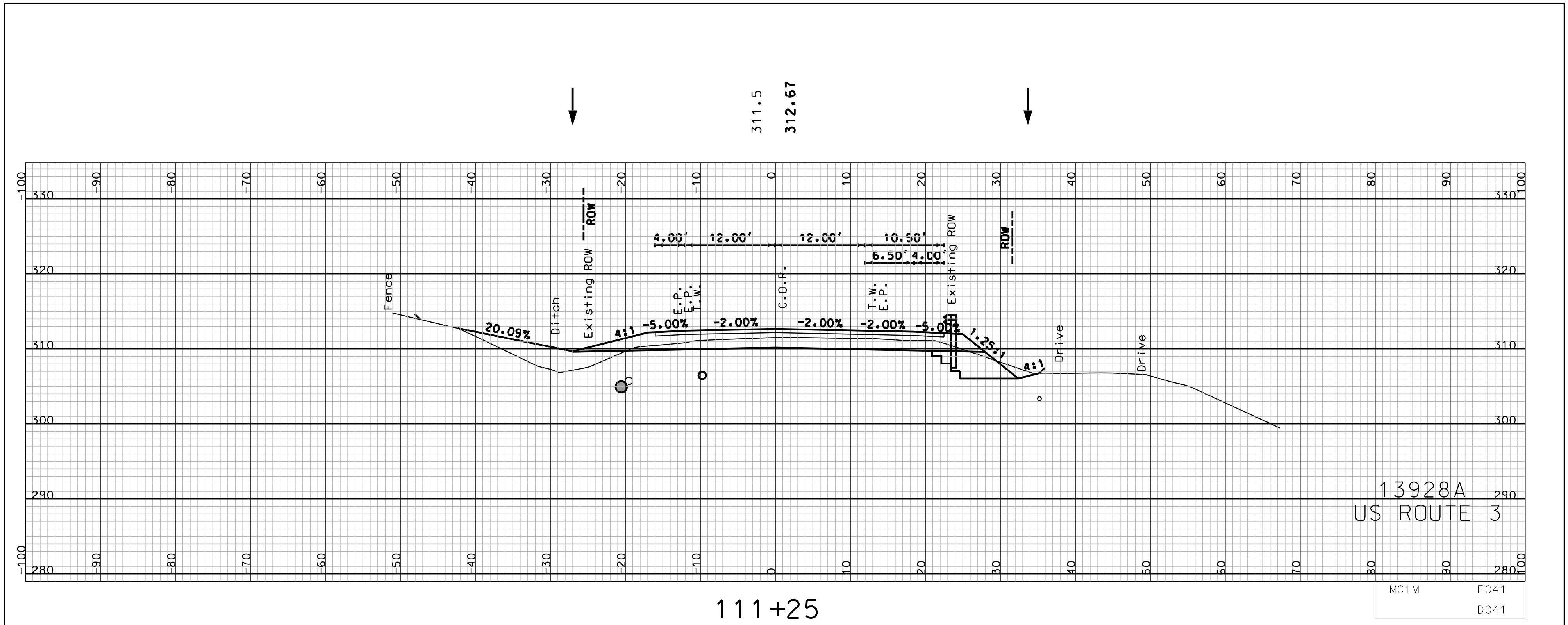

COMMON EXCAV.		SHEET TOTALS	
	C.Y.		C.Y.
229		ROCK EXCAV.	29
107		MUCK EXCAV.	0
DGN	STATE PROJECT NO.	SHEET NO.	TOTAL SHEETS
13928axs-mc1m	13928A	94	160

SDR PROCESSED	DATE		
NEW DESIGN	TEAM BALDWIN	DATE	09/2013
SHEET CHECKED	TEAM BALDWIN	DATE	04/2015
AS BUILT DETAILS	DATE		

REVISIONS AFTER PROPOSAL				
NUMBER	DATE	STATION	STATION	DESCRIPTION

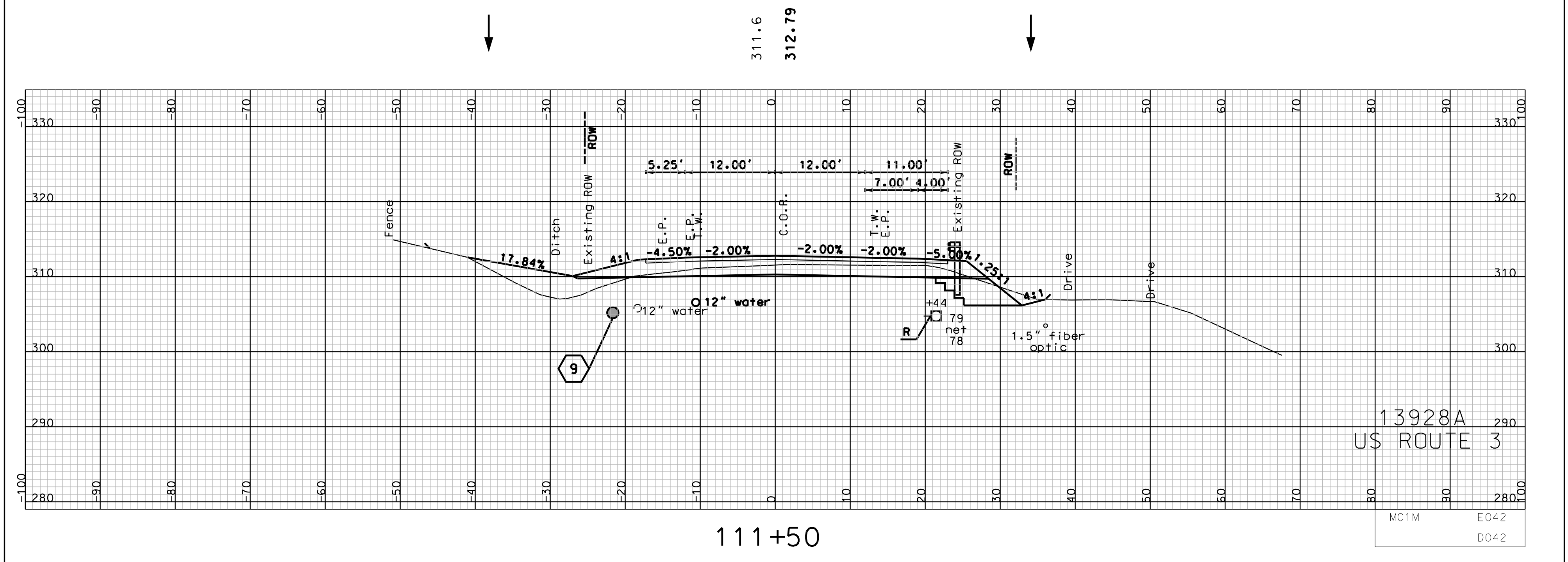
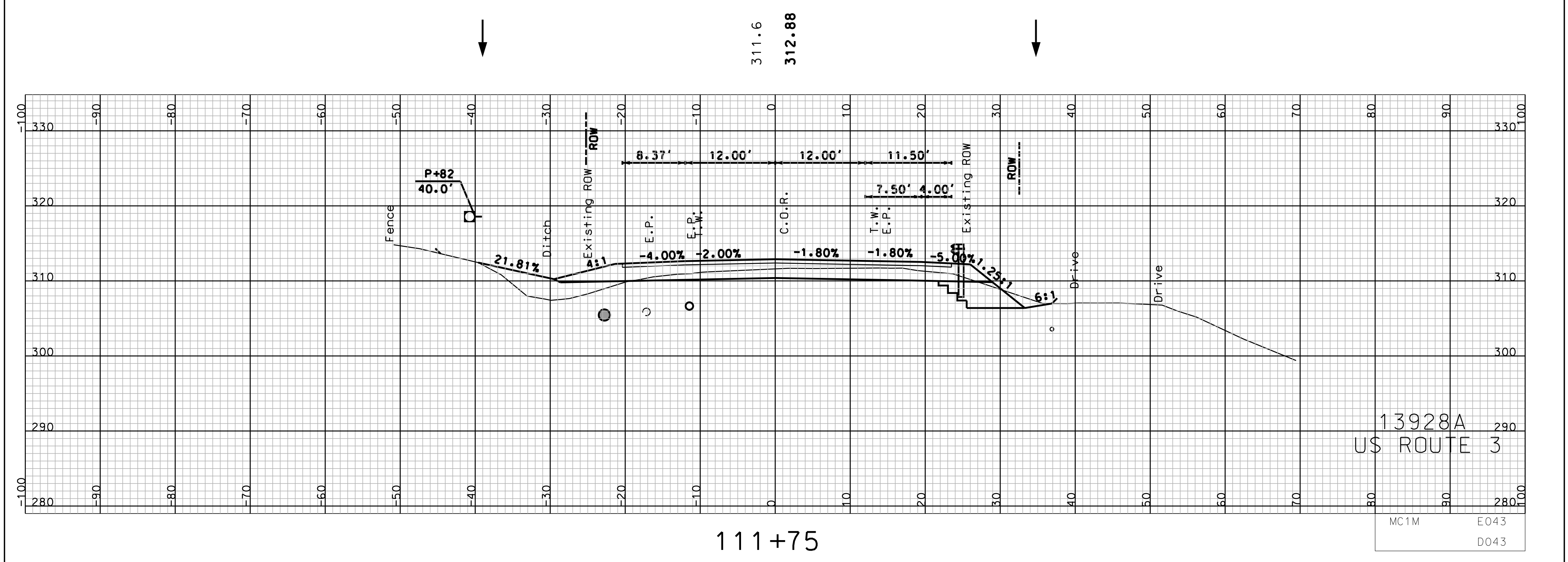
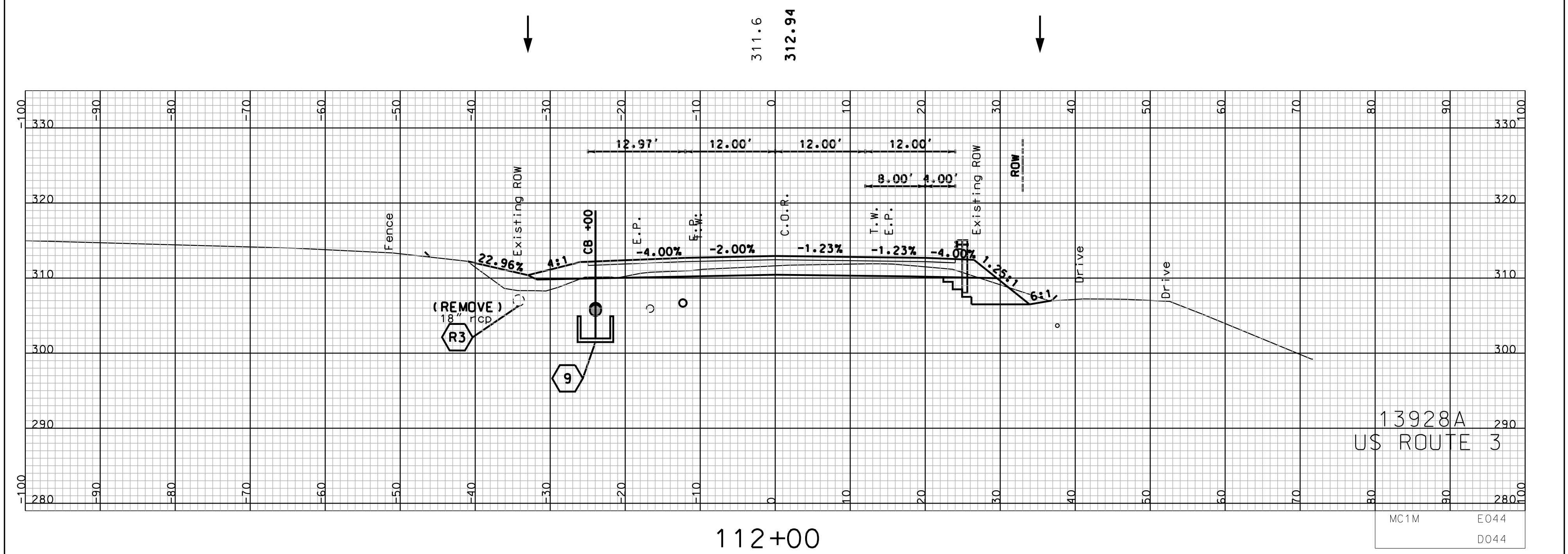

COMMON EXCAV.		SHEET TOTALS		ROCK EXCAV.	
DCN	STATE PROJECT NO.	C.Y.	SHEET NO.	C.Y.	TOTAL SHEETS
13928axs-mc1m	13928A	241	95	29	160
		69		0	

SDR PROCESSED	DATE		
NEW DESIGN	TEAM BALDWIN	DATE	09/2013
SHEET CHECKED	TEAM BALDWIN	DATE	04/2015
AS BUILT DETAILS	DATE		

REVISIONS AFTER PROPOSAL				
NUMBER	DATE	STATION	STATION	DESCRIPTION

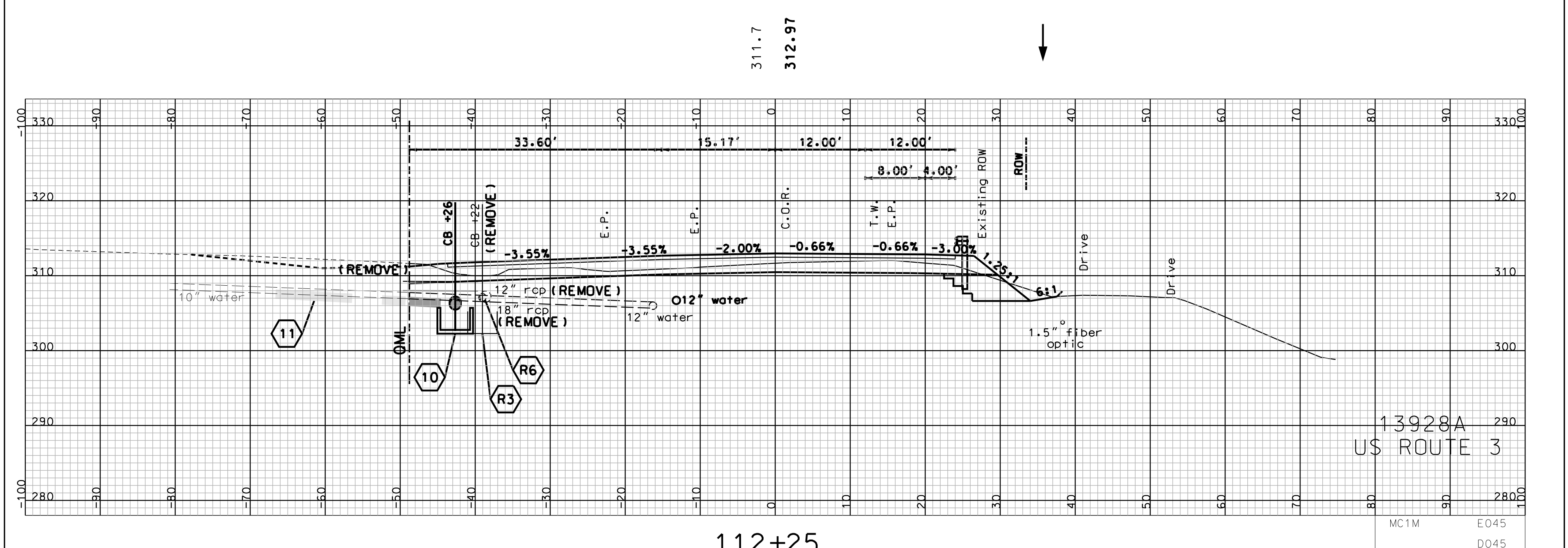
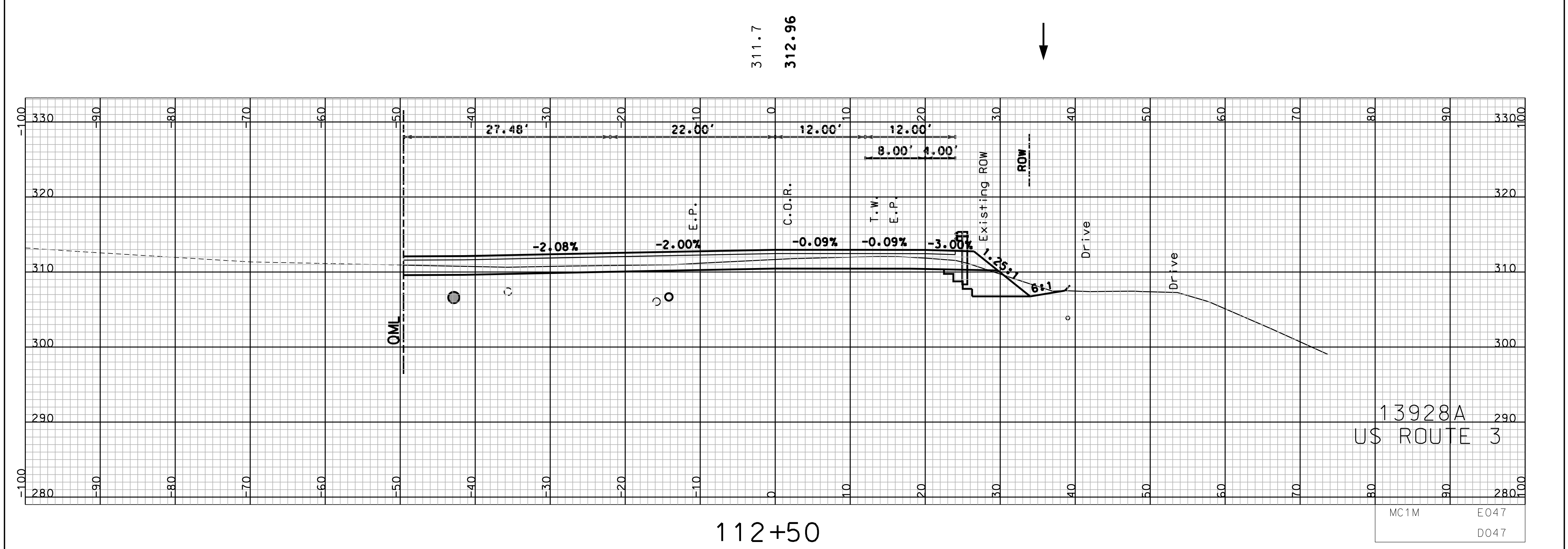
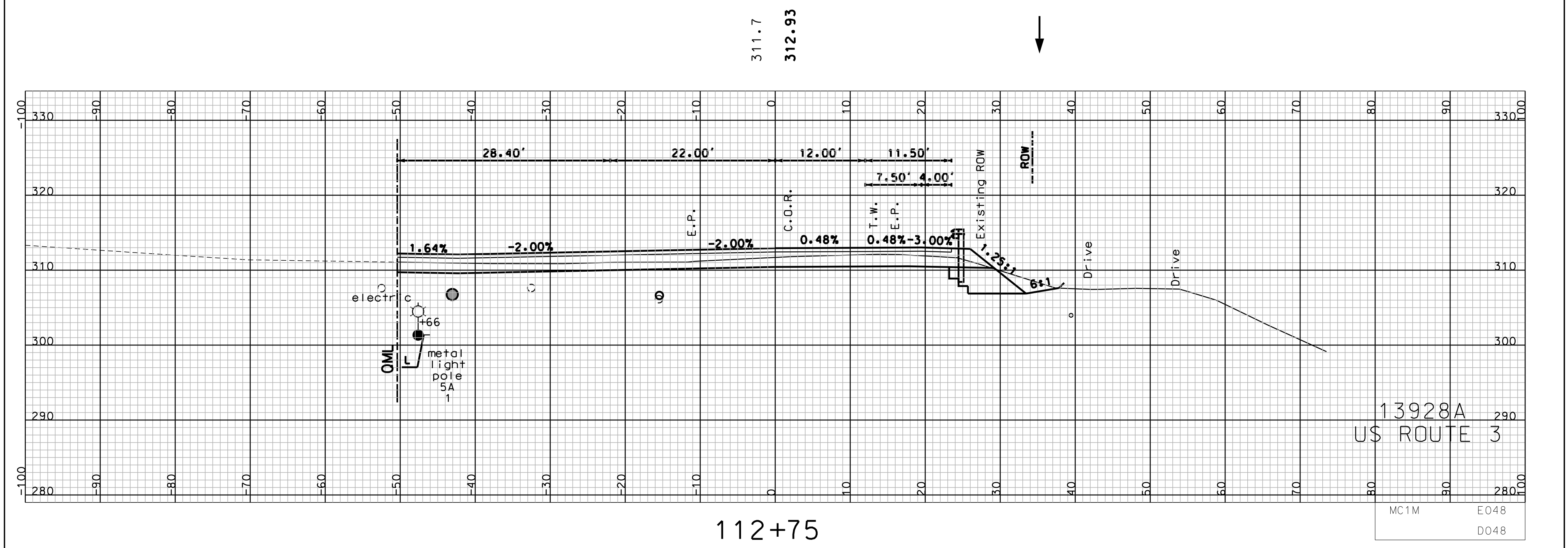

SHEET TOTALS					
COMMON EXCAV.	341	C.Y.	ROCK EXCAV.	29	C.Y.
FILL	0	C.Y.	MUCK EXCAV.	0	C.Y.
DGN	13928axs-mc1m	STATE PROJECT NO.	13928A	SHEET NO.	96
				TOTAL SHEETS	160

SDR PROCESSED	DATE		
NEW DESIGN	TEAM BALDWIN	DATE	09/2013
SHEET CHECKED	TEAM BALDWIN	DATE	04/2015
AS BUILT DETAILS	DATE		

REVISIONS AFTER PROPOSAL				
NUMBER	DATE	STATION	STATION	DESCRIPTION

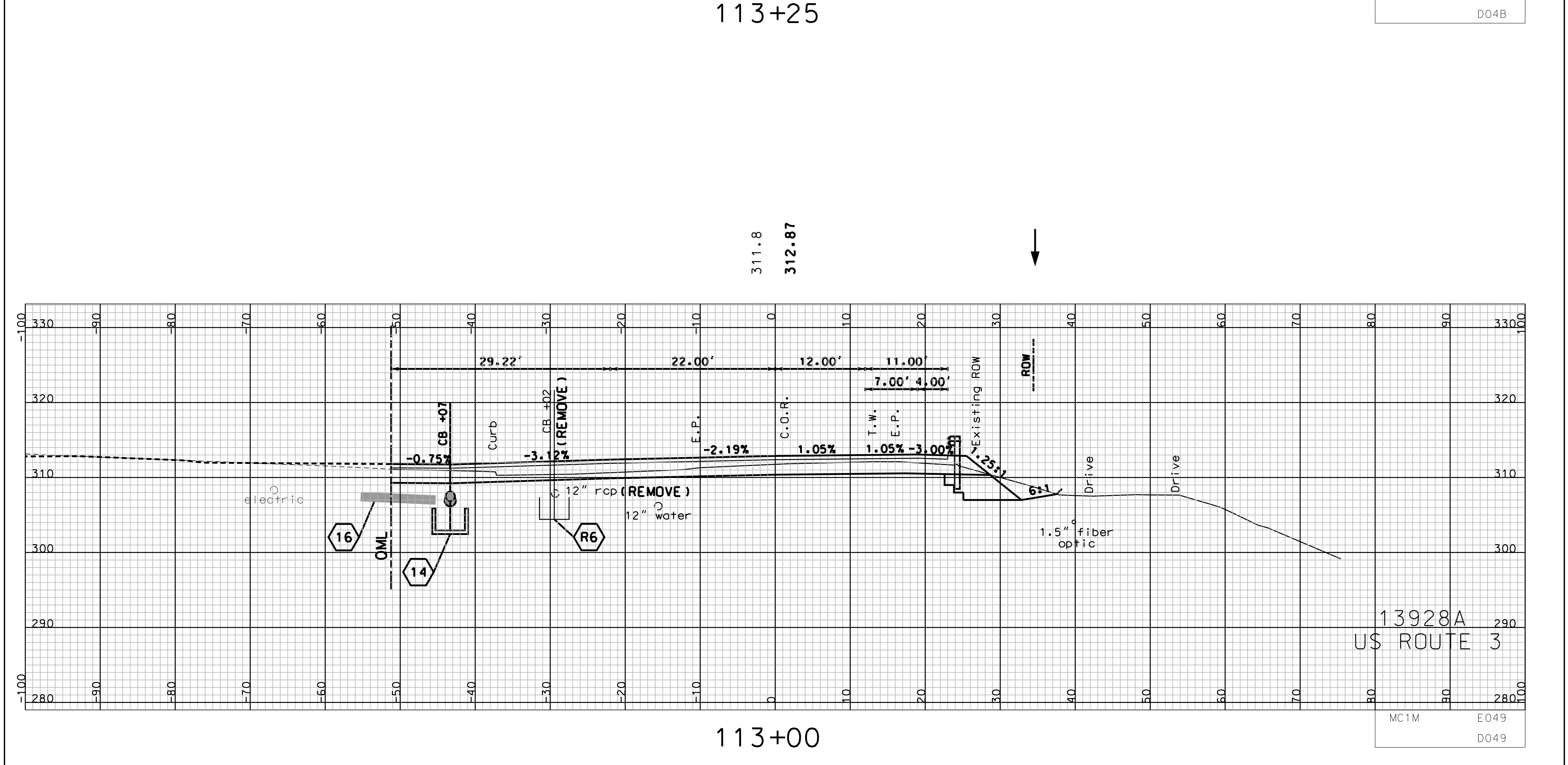
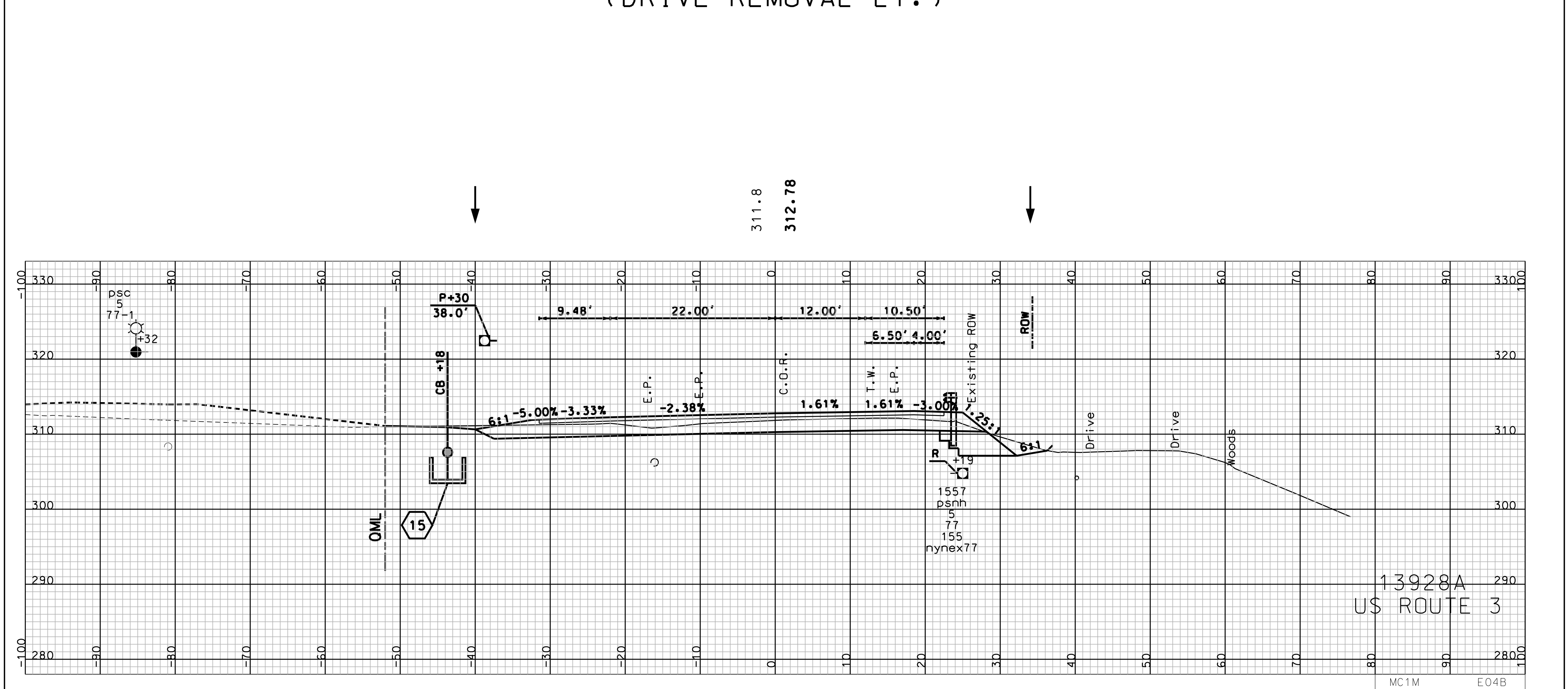
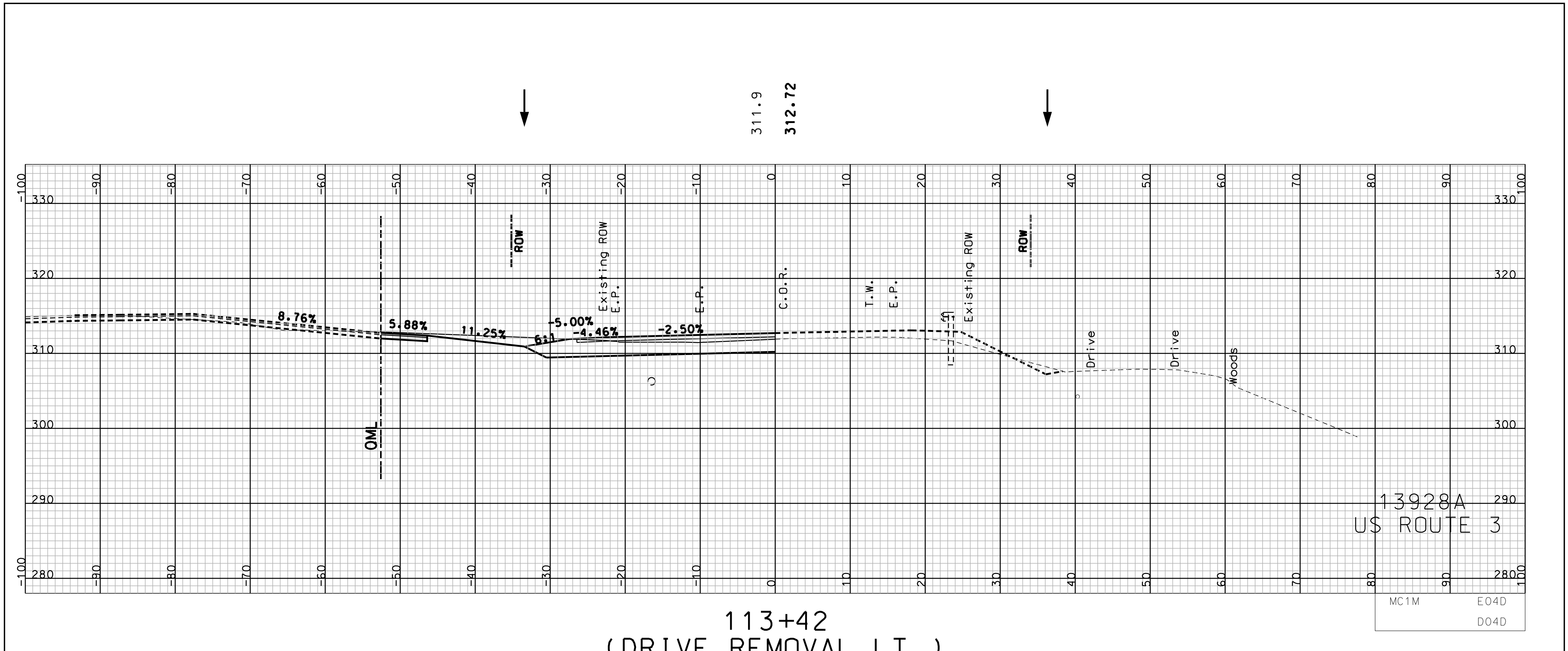

COMMON EXCAV.		SHEET TOTALS		ROCK EXCAV.	
DCN	STATE PROJECT NO.	C.Y.	SHEET NO.	C.Y.	TOTAL SHEETS
13928axs-mc1m	13928A	213	97	19	160

SDR PROCESSED	DATE
NEW DESIGN TEAM BALDWIN	DATE 09/2013
SHEET CHECKED TEAM BALDWIN	DATE 04/2015
AS BUILT DETAILS	DATE

REVISIONS AFTER PROPOSAL				
NUMBER	DATE	STATION	STATION	DESCRIPTION

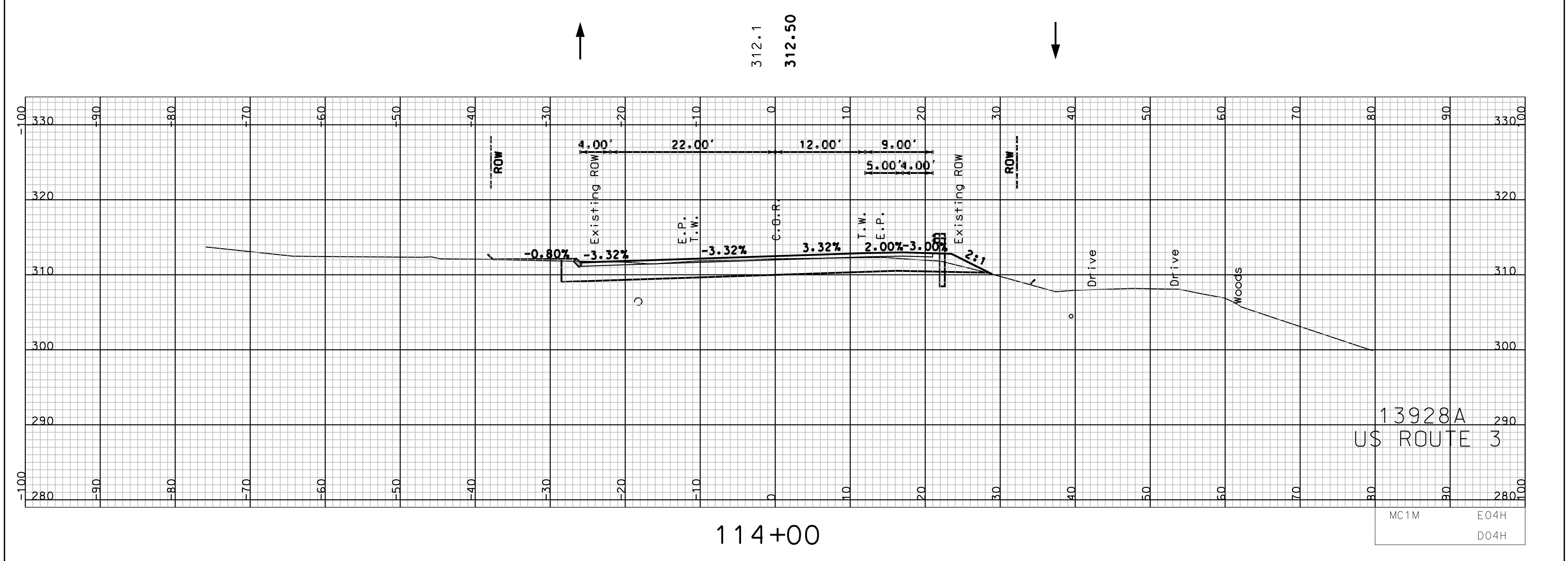

114+00

13928A
US ROUTE 3

MC1M E04H
D04H

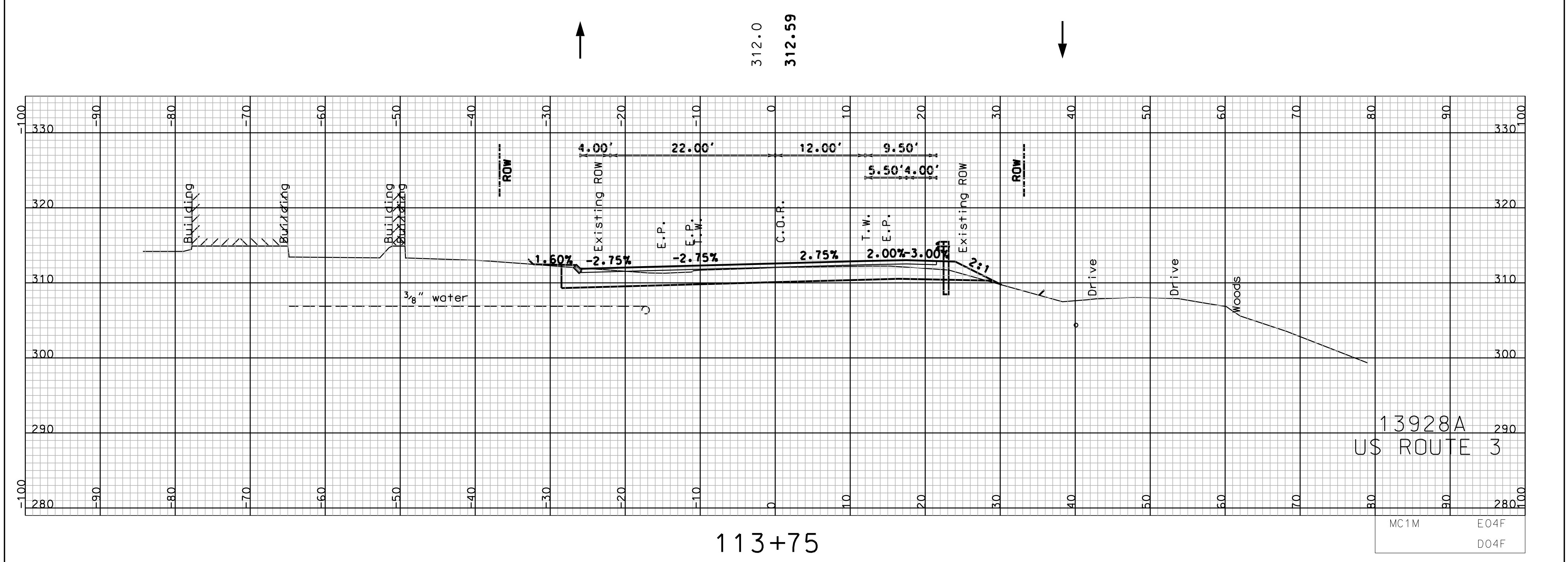

113+75

13928A
US ROUTE 3

MC1M E04F
D04F

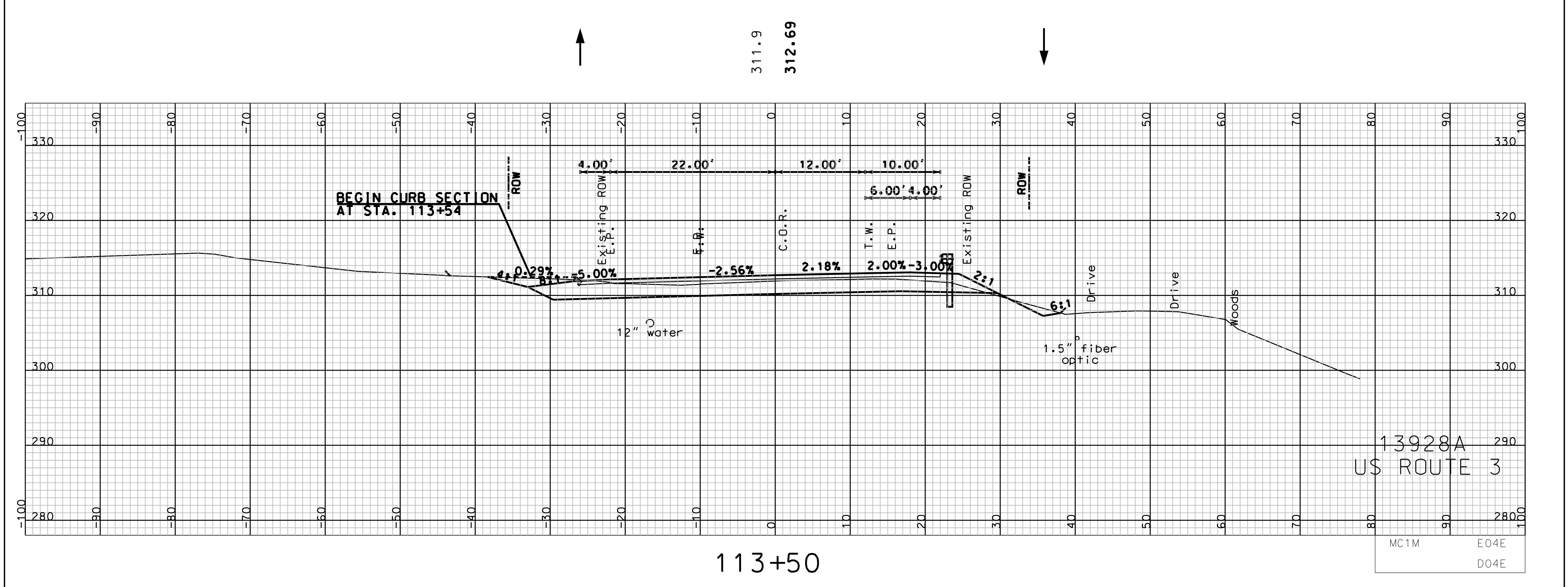

113+50

13928A
US ROUTE 3

MC1M E04E
D04E

COMMON EXCAV.		SHEET TOTALS		ROCK EXCAV.	
DCN	STATE PROJECT NO.	C.Y.	C.Y.	C.Y.	C.Y.
13928axs-mc1m	13928A	300	29	0	0
		FILL	MUCK EXCAV.		
		3	0		
		TOTAL SHEETS			
		98	160		

SDR PROCESSED	DATE
NEW DESIGN TEAM BALDWIN	DATE 09/2013
SHEET CHECKED TEAM BALDWIN	DATE 04/2015
AS BUILT DETAILS	DATE

REVISIONS AFTER PROPOSAL				
NUMBER	DATE	STATION	STATION	DESCRIPTION

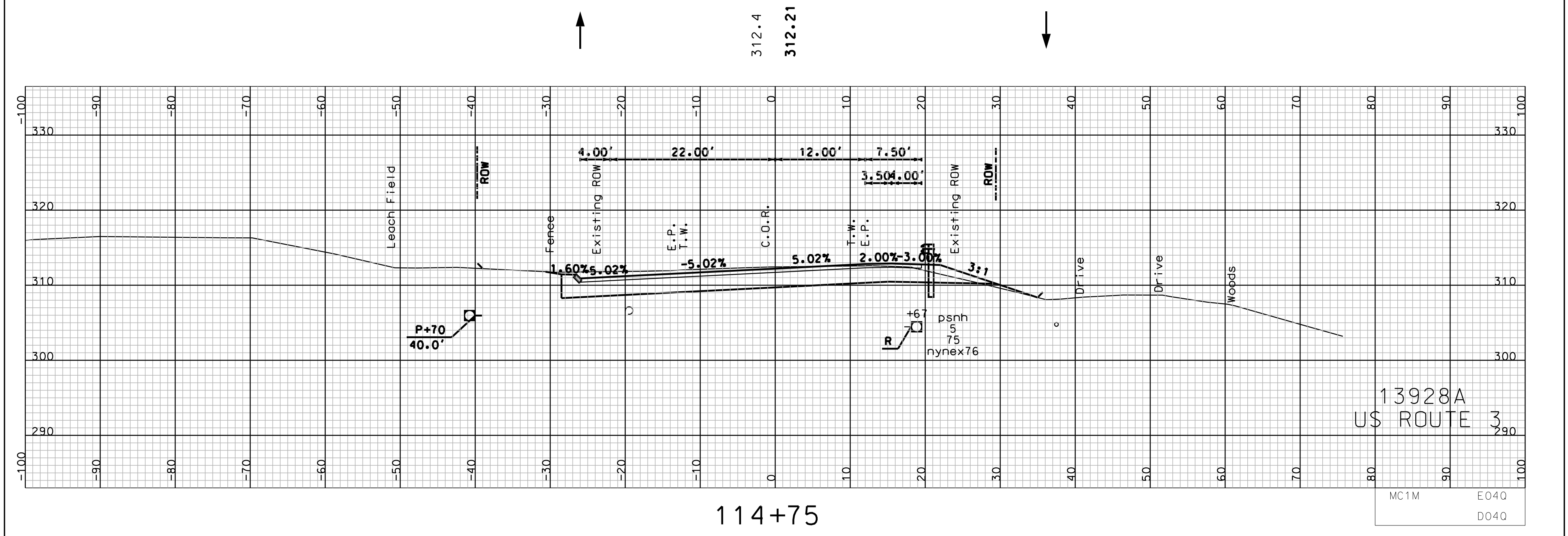

13928A
US ROUTE 3

MC1M E04O
D04O

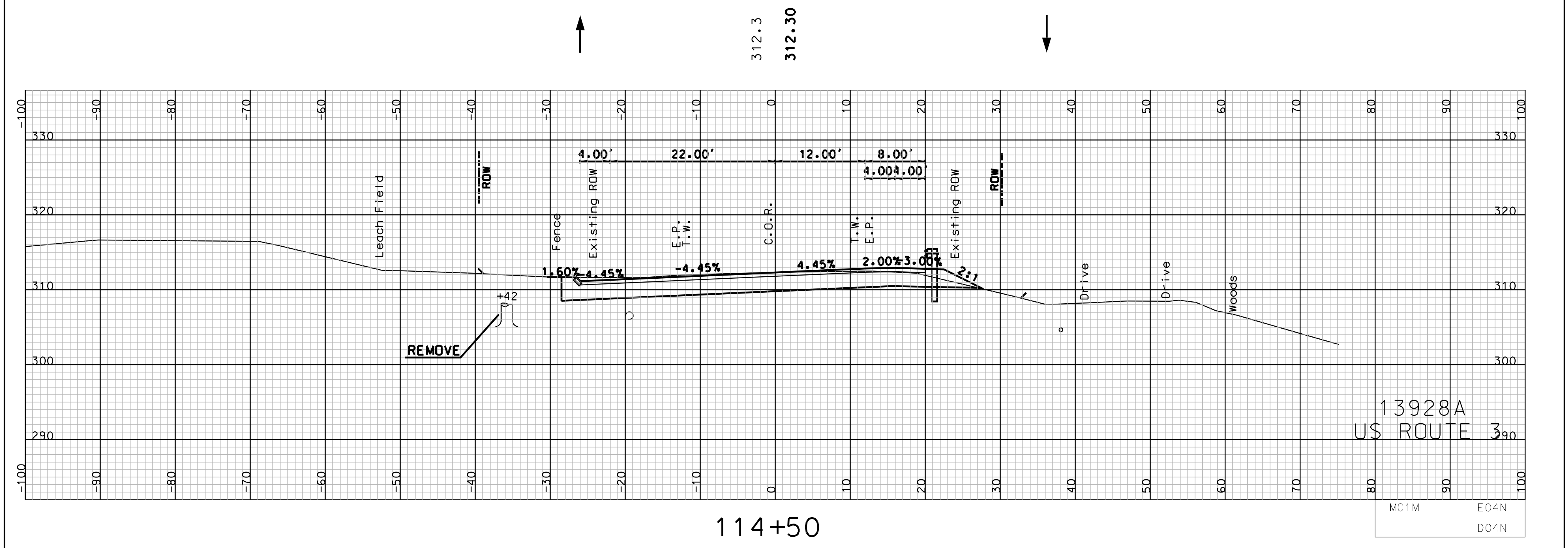

13928A
US ROUTE 3

MC1M E04N
D04N

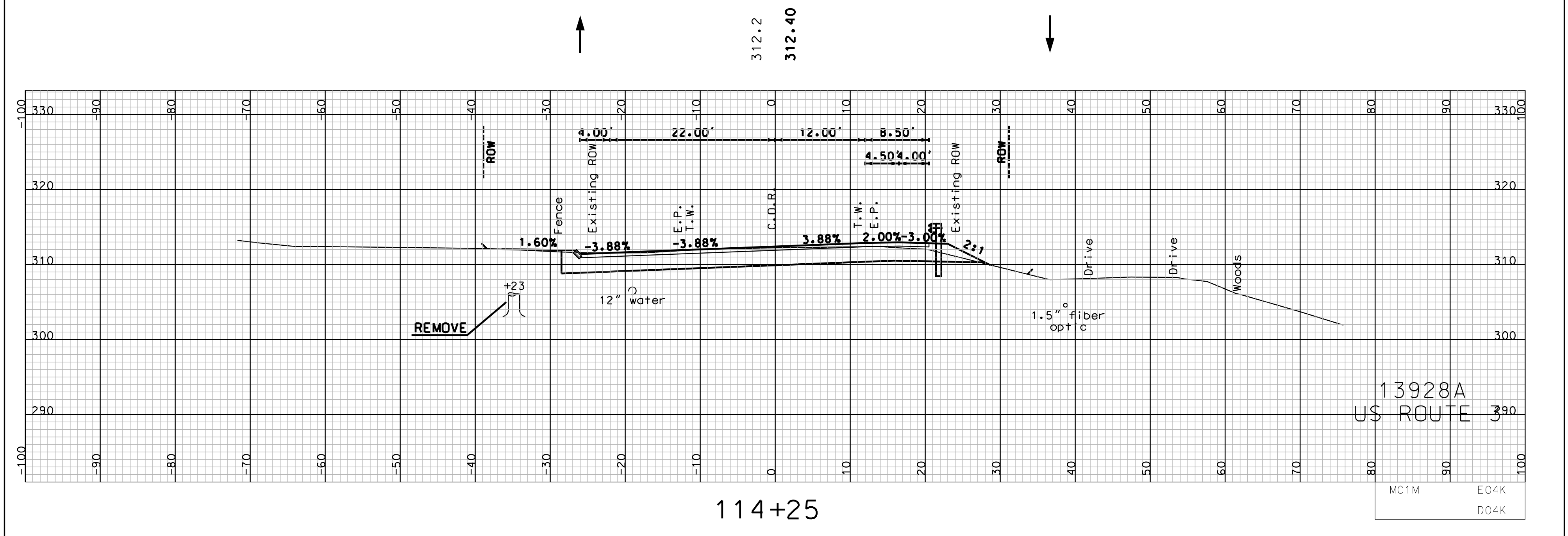

13928A
US ROUTE 3

MC1M E04K
D04K

COMMON EXCAV. 371 C.Y.		SHEET TOTALS	
FILL 2 C.Y.		ROCK EXCAV. 29 C.Y.	
		MUCK EXCAV. 0 C.Y.	
DGN	STATE PROJECT NO.	SHEET NO.	TOTAL SHEETS
13928axs-mc1m	13928A	99	160

SDR PROCESSED	DATE
NEW DESIGN TEAM BALDWIN	DATE 09/2013
SHEET CHECKED TEAM BALDWIN	DATE 04/2015
AS BUILT DETAILS	DATE

REVISIONS AFTER PROPOSAL					
NUMBER	DATE	STATION	STATION	DESCRIPTION	

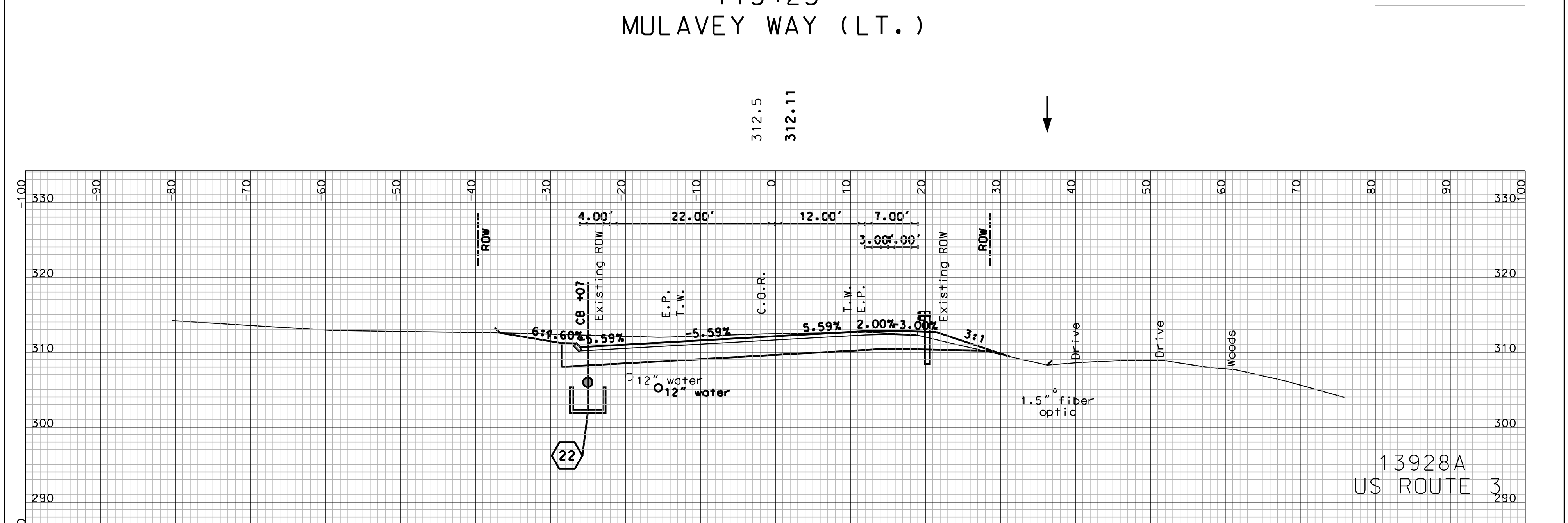
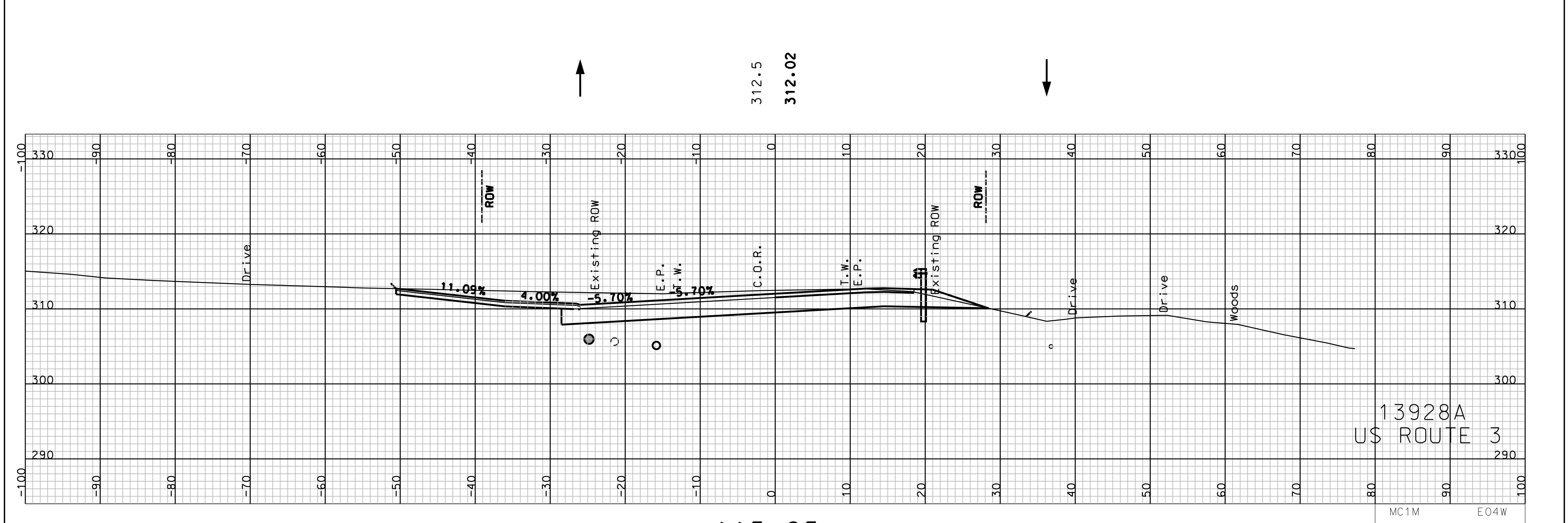
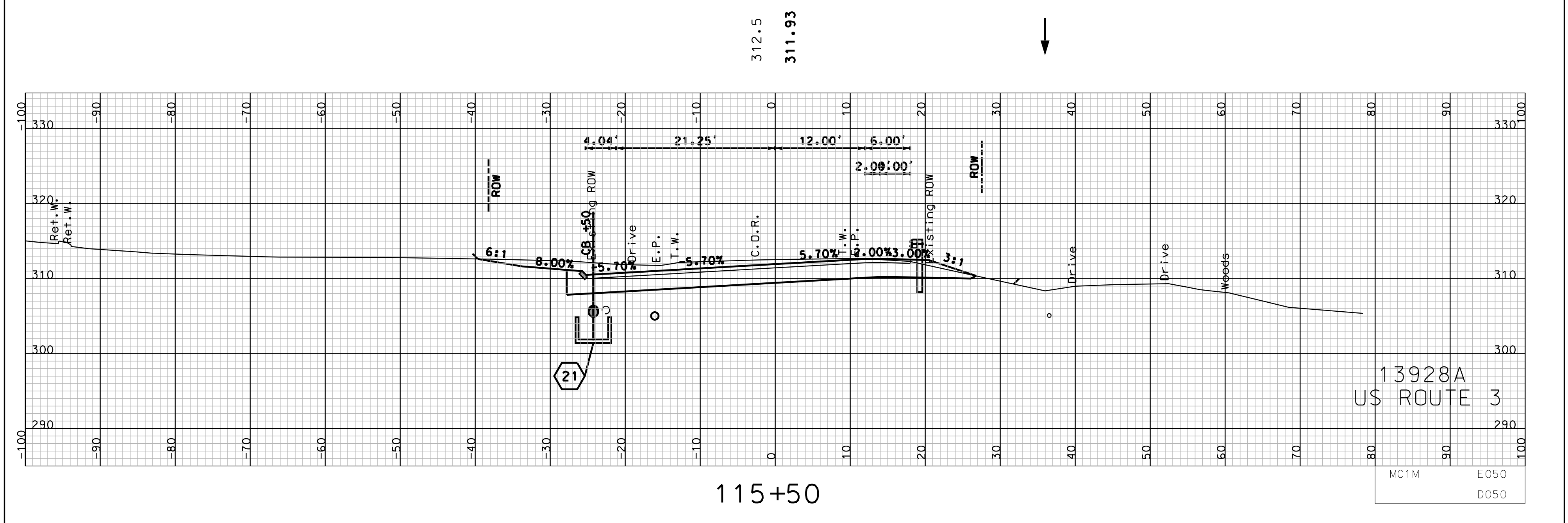
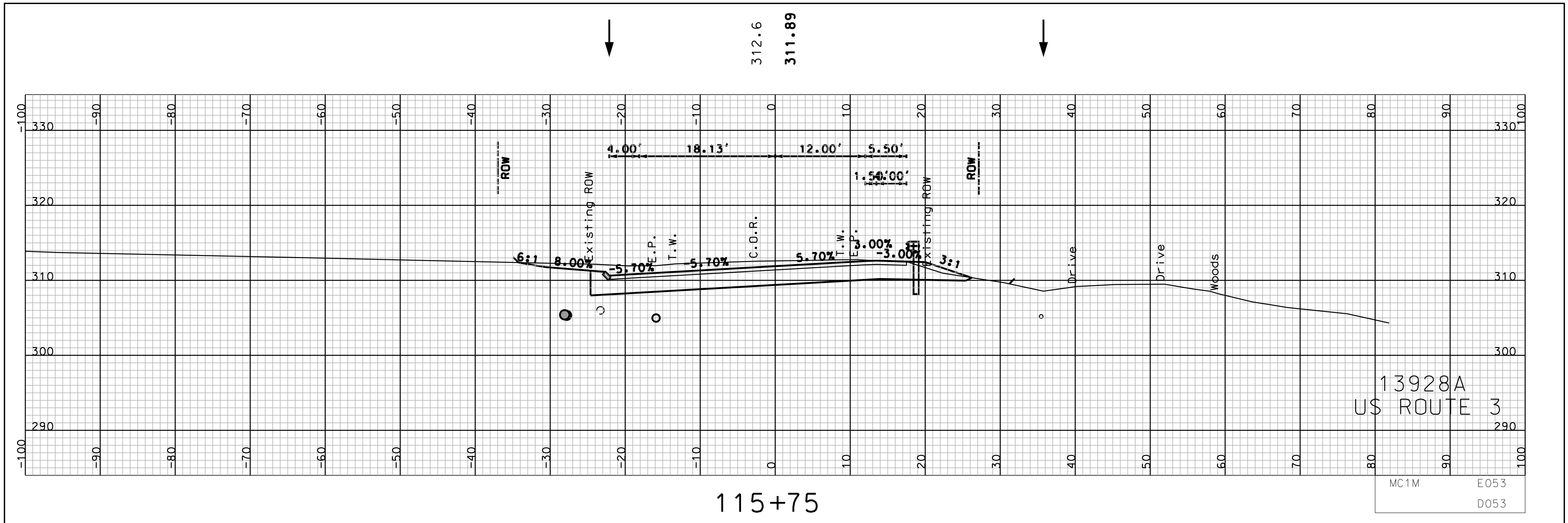

COMMON EXCAV.	634	SHEET TOTALS	ROCK EXCAV.	39
FILL	0.2	C.Y.	MUCK EXCAV.	0
DGN	STATE PROJECT NO.	SHEET NO.	TOTAL SHEETS	
13928axs-mc1m	13928A	100	160	

SDR PROCESSED	DATE
NEW DESIGN TEAM BALDWIN	DATE 09/2013
SHEET CHECKED TEAM BALDWIN	DATE 04/2015
AS BUILT DETAILS	DATE

REVISIONS AFTER PROPOSAL				
NUMBER	DATE	STATION	STATION	DESCRIPTION

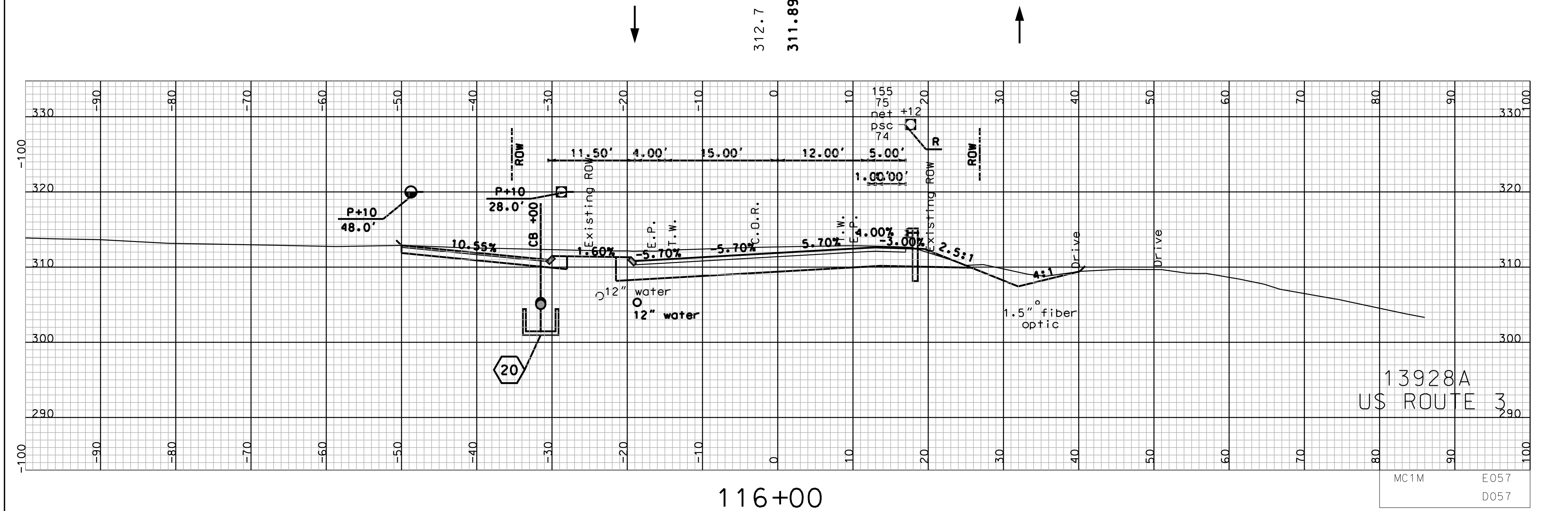
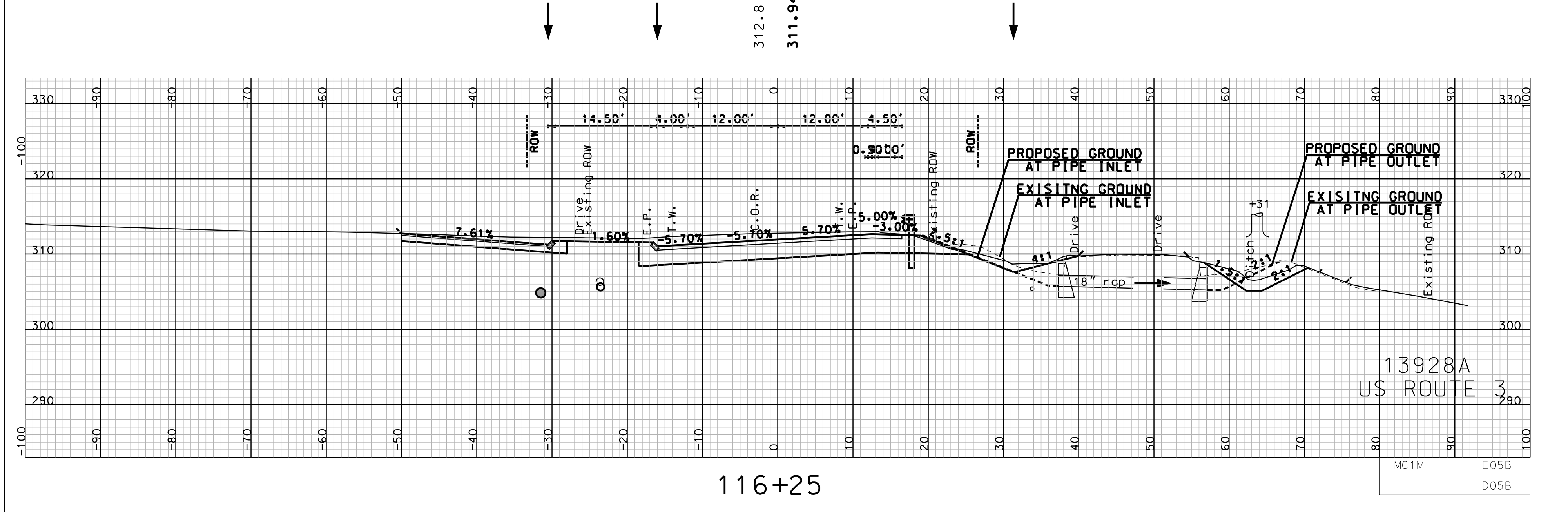
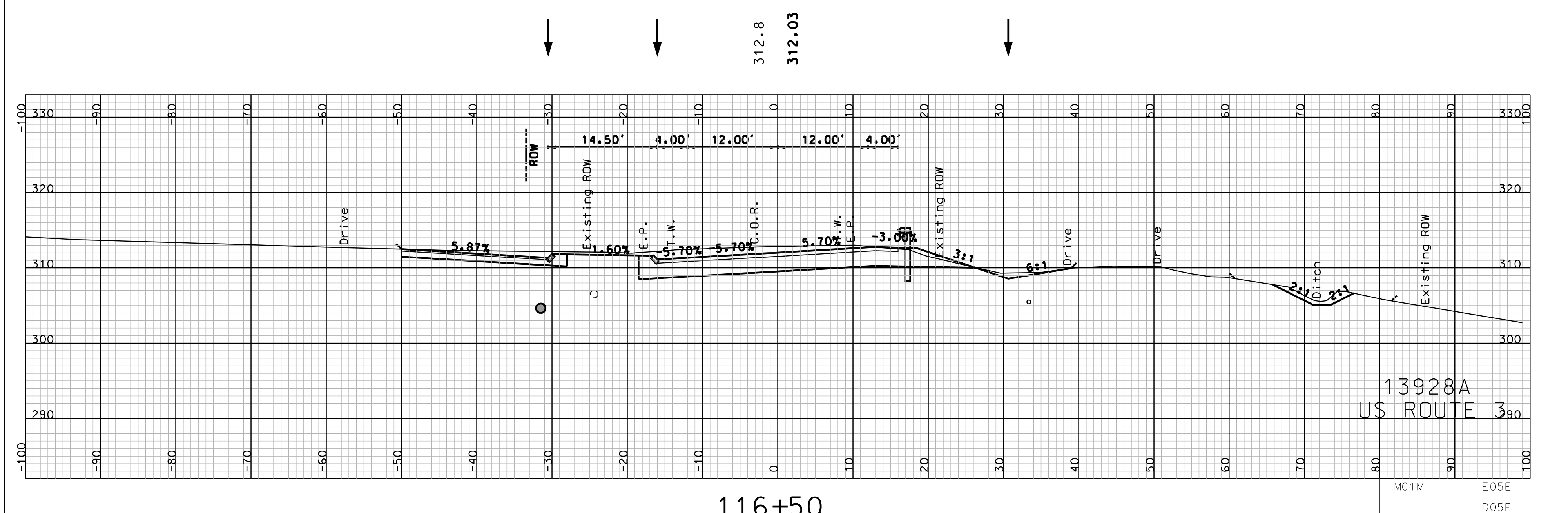
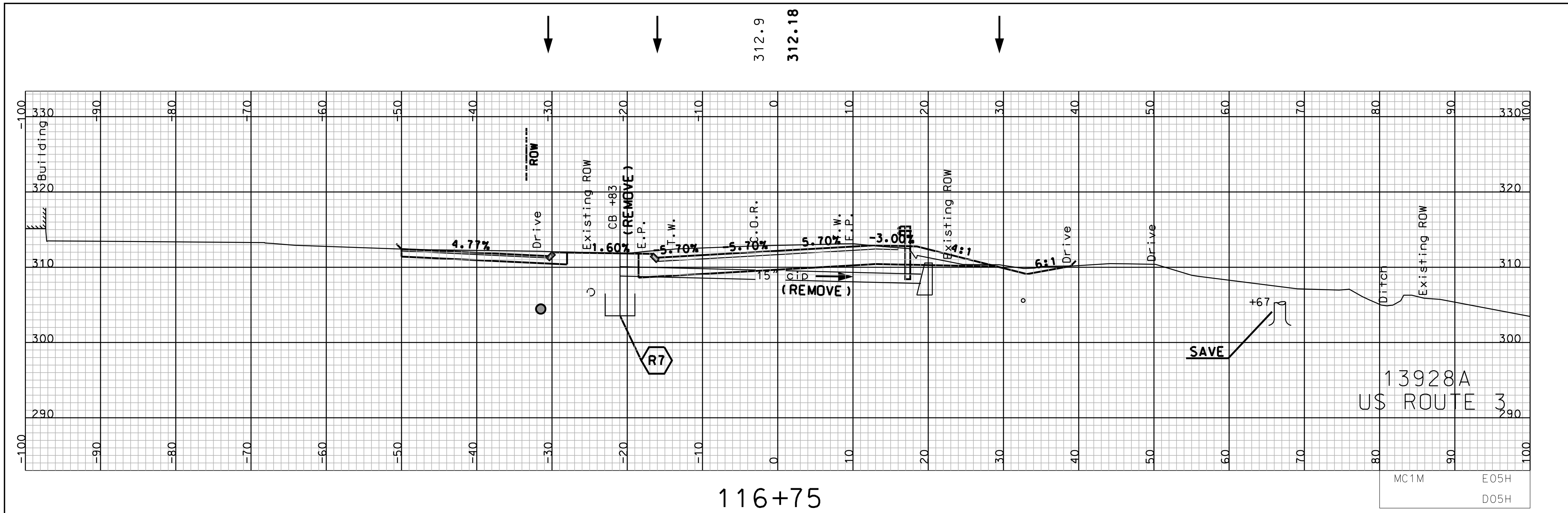

COMMON EXCAV.		SHEET TOTALS		ROCK EXCAV.	
DCN	STATE PROJECT NO.	FILL	C.Y.	MUCK EXCAV.	TOTAL SHEETS
13928axs-mc1m	13928A	616	0	39	160

SDR PROCESSED	DATE
NEW DESIGN TEAM BALDWIN	DATE 09/2013
SHEET CHECKED TEAM BALDWIN	DATE 04/2015
AS BUILT DETAILS	DATE

REVISIONS AFTER PROPOSAL				
NUMBER	DATE	STATION	STATION	DESCRIPTION

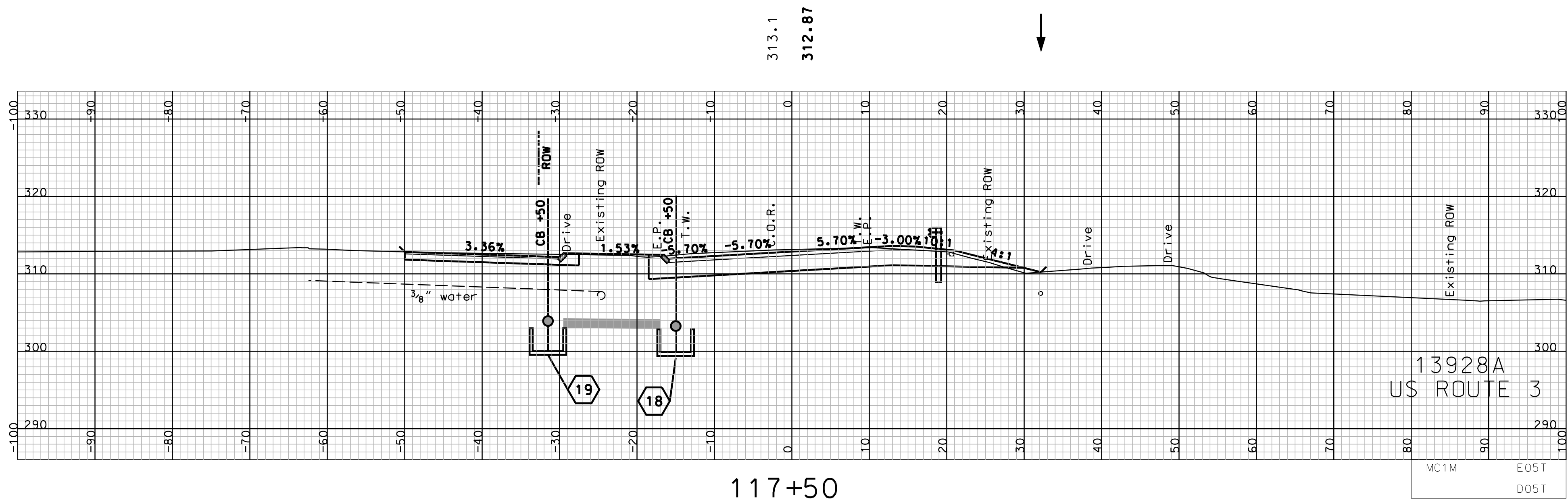

117+50

13928A
US ROUTE 3
MC1M E05T
D05T

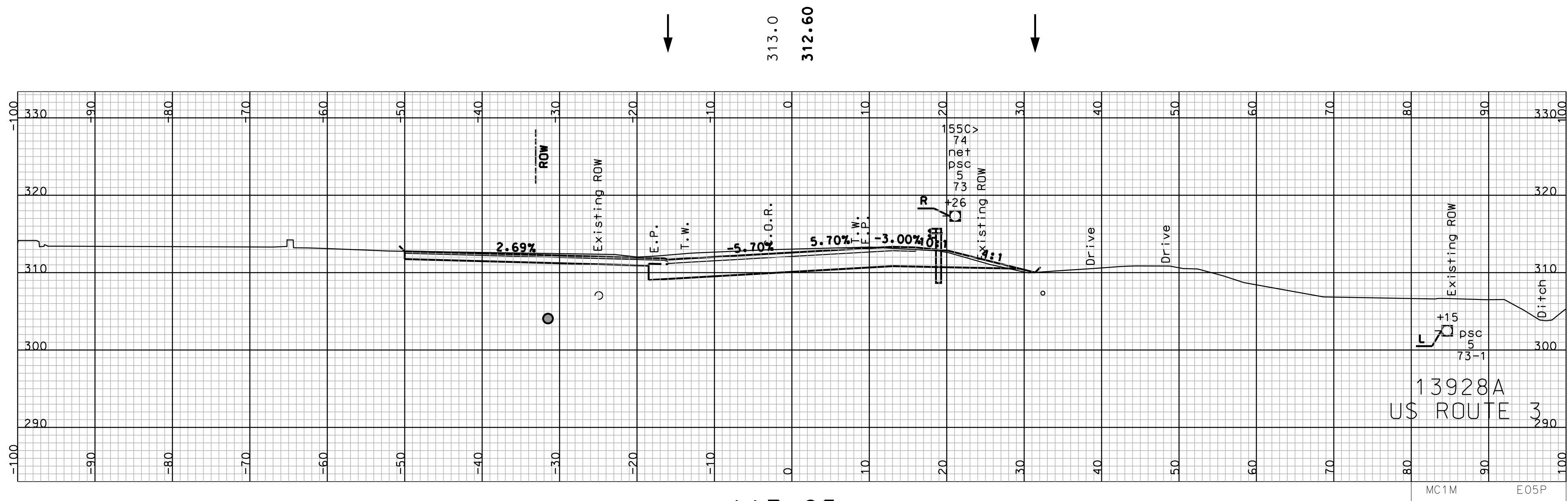

117+25
(DRIVE LT.)

13928A
US ROUTE 3
MC1M E05P
D05P

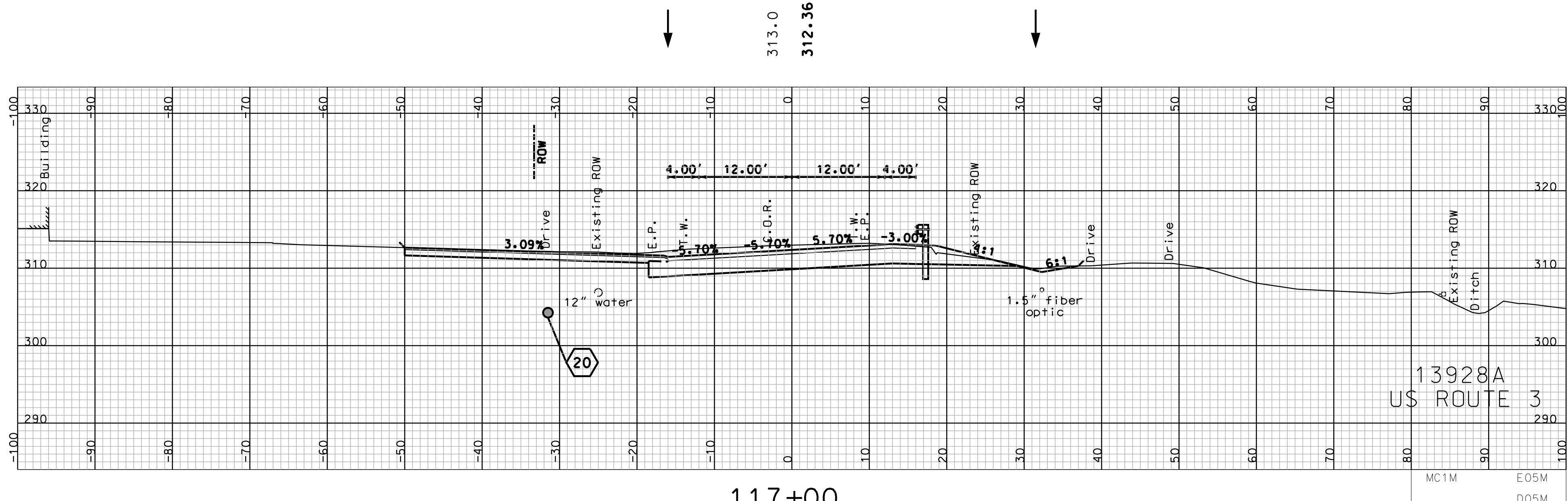

117+00
(DRIVE LT.)

13928A
US ROUTE 3
MC1M E05M
D05M

SHEET TOTALS					
COMMON EXCAV.	395	C.Y.	ROCK EXCAV.	29	C.Y.
FILL	6	C.Y.	MUCK EXCAV.	0	C.Y.
DGN	STATE PROJECT NO.	SHEET NO.	TOTAL SHEETS		
13928axs-mc1m	13928A	102	160		

SDR PROCESSED	DATE
NEW DESIGN TEAM BALDWIN	DATE 09/2013
SHEET CHECKED TEAM BALDWIN	DATE 04/2015
AS BUILT DETAILS	DATE

REVISIONS AFTER PROPOSAL				
NUMBER	DATE	STATION	STATION	DESCRIPTION

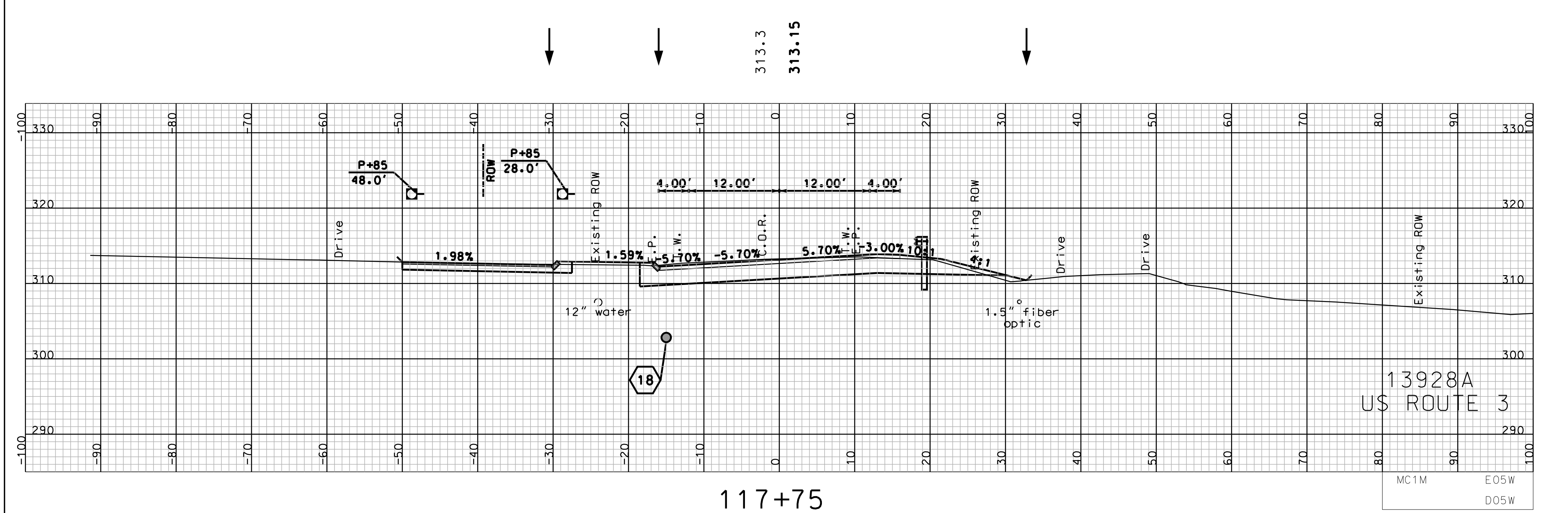
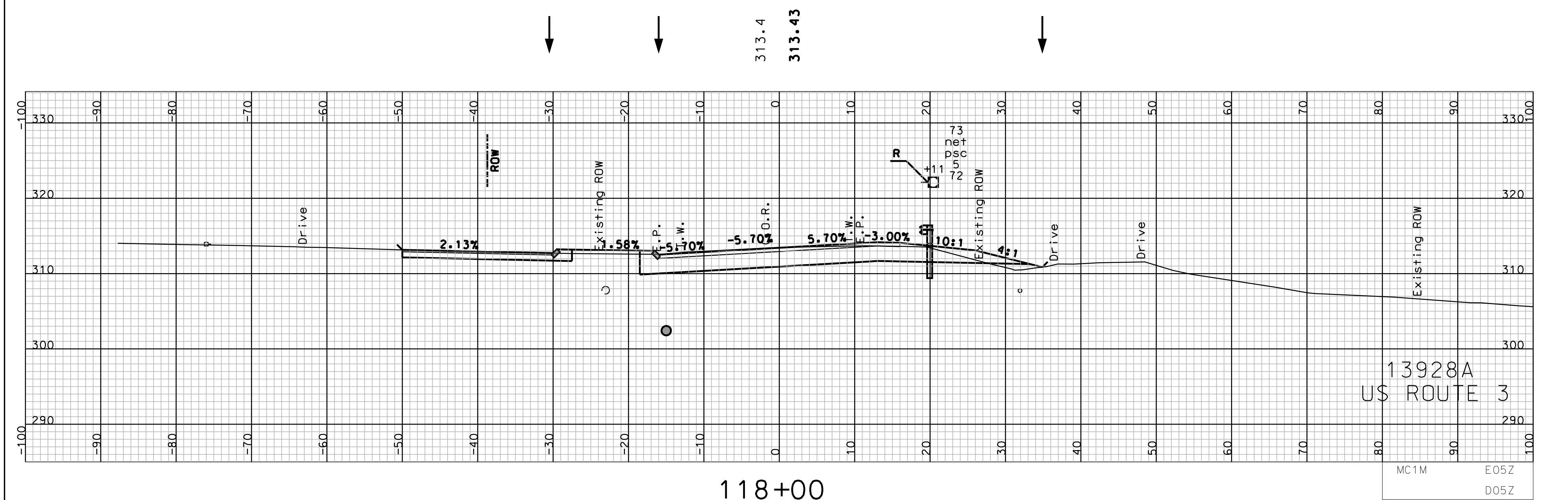
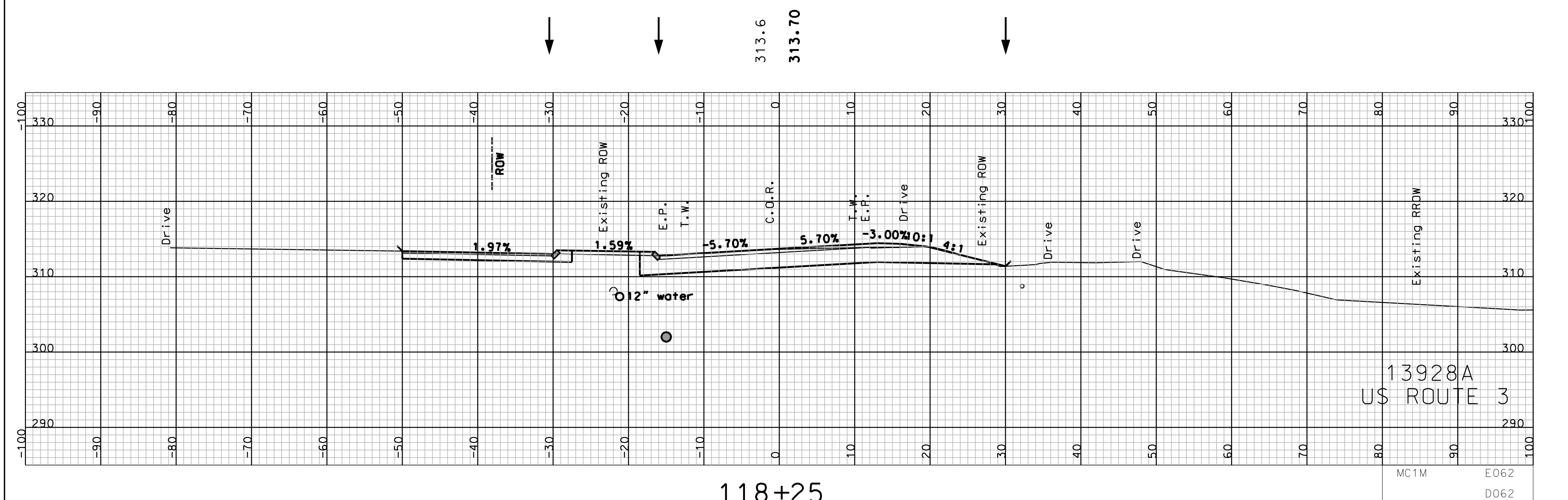
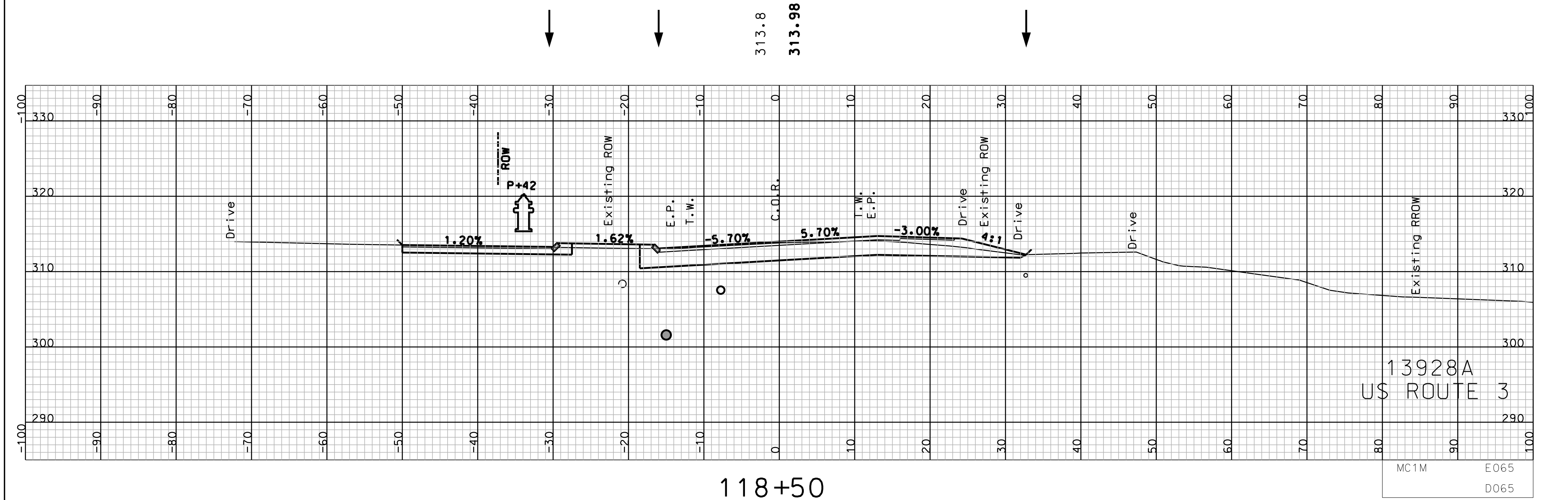

COMMON EXCAV.		SHEET TOTALS		ROCK EXCAV.	
DCN	STATE PROJECT NO.	FILL	C.Y.	MUCK EXCAV.	TOTAL SHEETS
13928axs-mc1m	13928A	371	21	33	103

SDR PROCESSED	DATE
NEW DESIGN TEAM BALDWIN	DATE 09/2013
SHEET CHECKED TEAM BALDWIN	DATE 04/2015
AS BUILT DETAILS	DATE

REVISIONS AFTER PROPOSAL				
NUMBER	DATE	STATION	STATION	DESCRIPTION

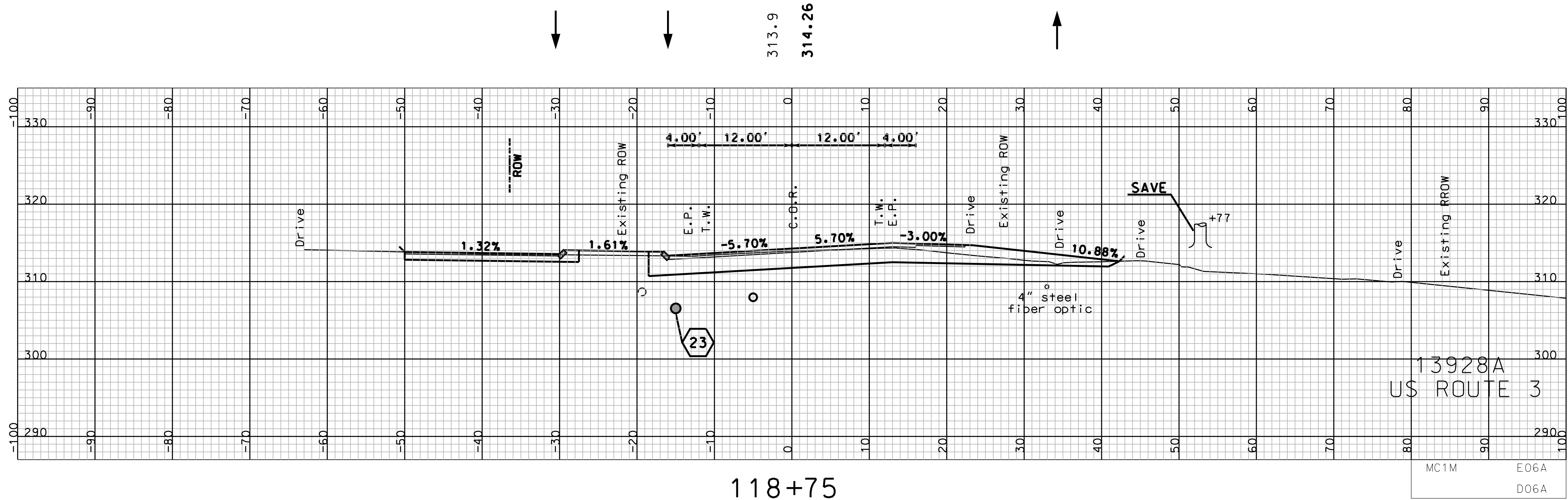

118+75

MC1M E06A D06A

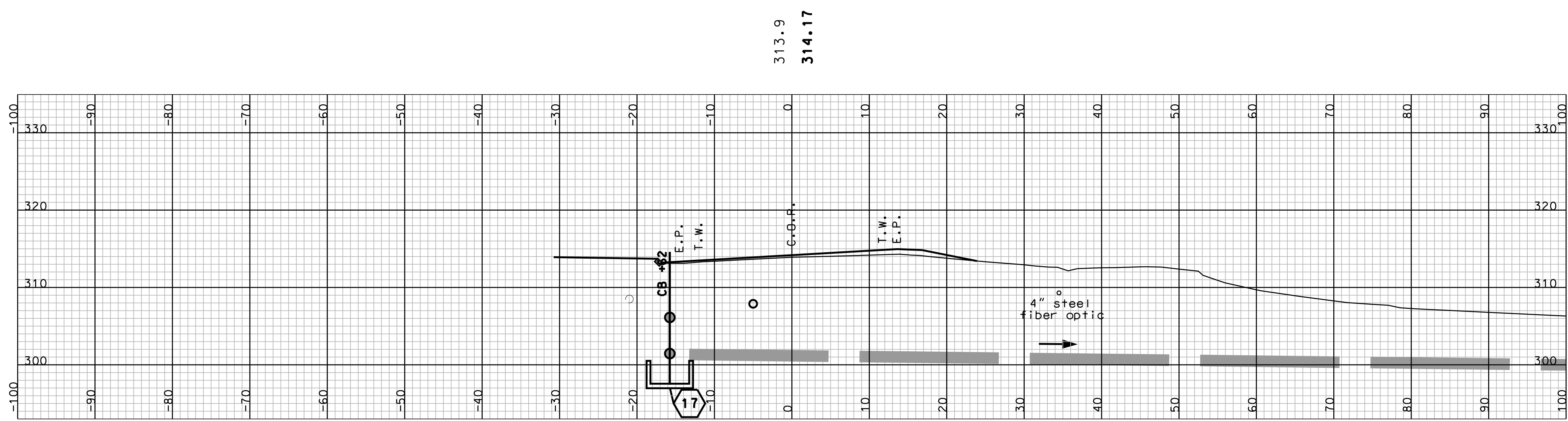

118+67
(DRAINAGE SKEWED)

MC1M E068 D068

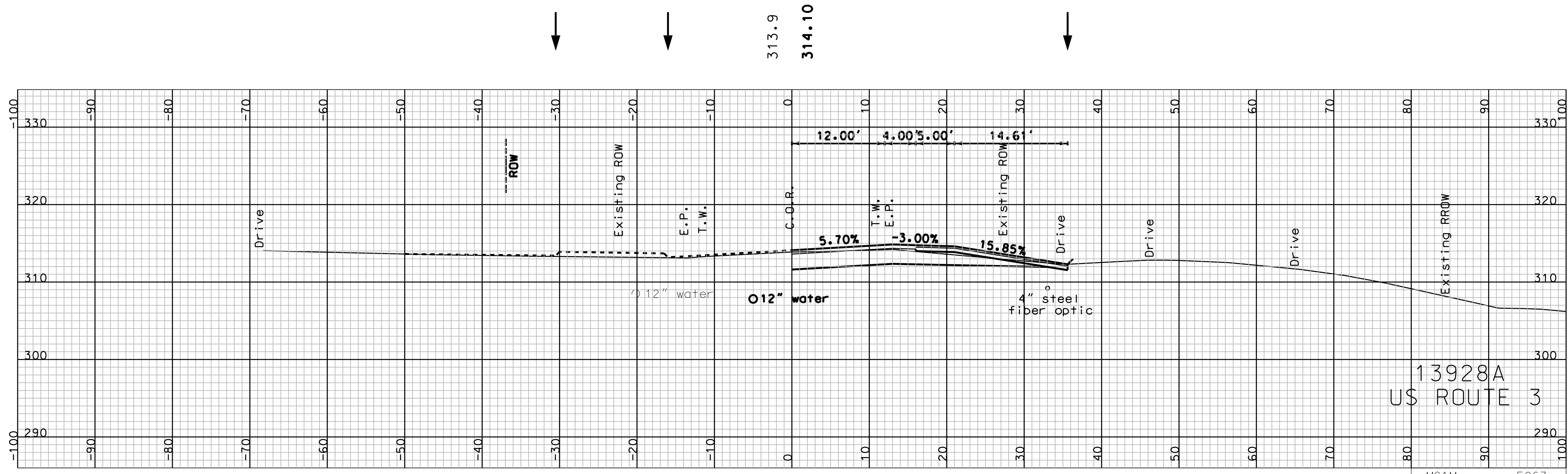

118+61
(DRIVE RT.)

MC1M E067 D067

SHEET TOTALS			
COMMON EXCAV.	150 C.Y.	ROCK EXCAV.	15 C.Y.
FILL	5 C.Y.	MUCK EXCAV.	0 C.Y.
DGN	STATE PROJECT NO.	SHEET NO.	TOTAL SHEETS
13928axs-mc1m	13928A	104	160

SDR PROCESSED	DATE		
NEW DESIGN TEAM BALDWIN	DATE	09/2013	
SHEET CHECKED TEAM BALDWIN	DATE	04/2015	
AS BUILT DETAILS	DATE		

REVISIONS AFTER PROPOSAL				
NUMBER	DATE	STATION	STATION	DESCRIPTION

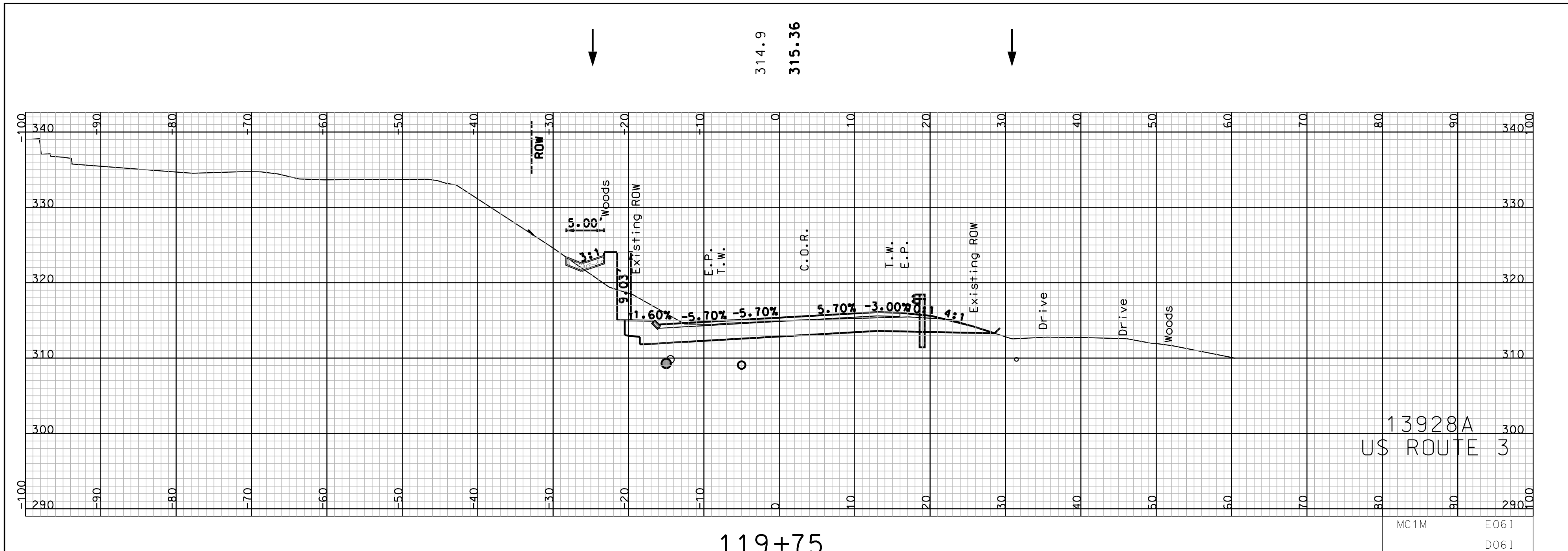

13928A
US ROUTE 3

MC1M E061
D061

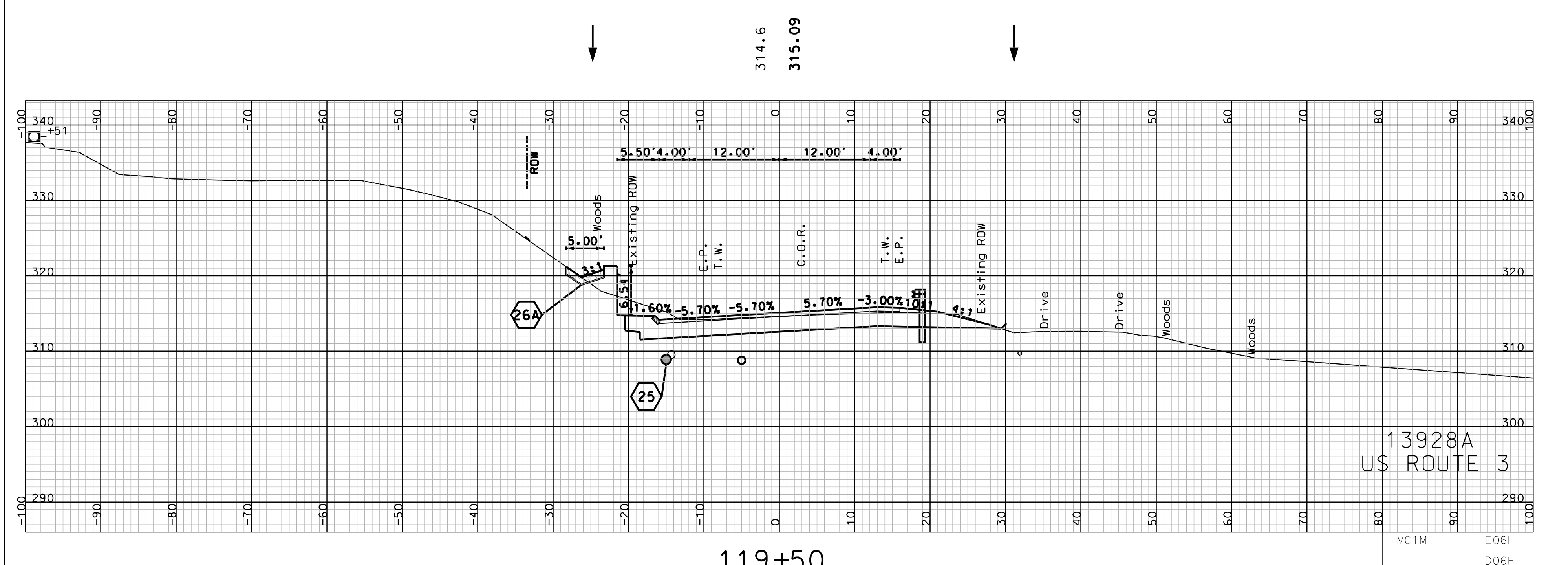

13928A
US ROUTE 3

MC1M E06H
D06H

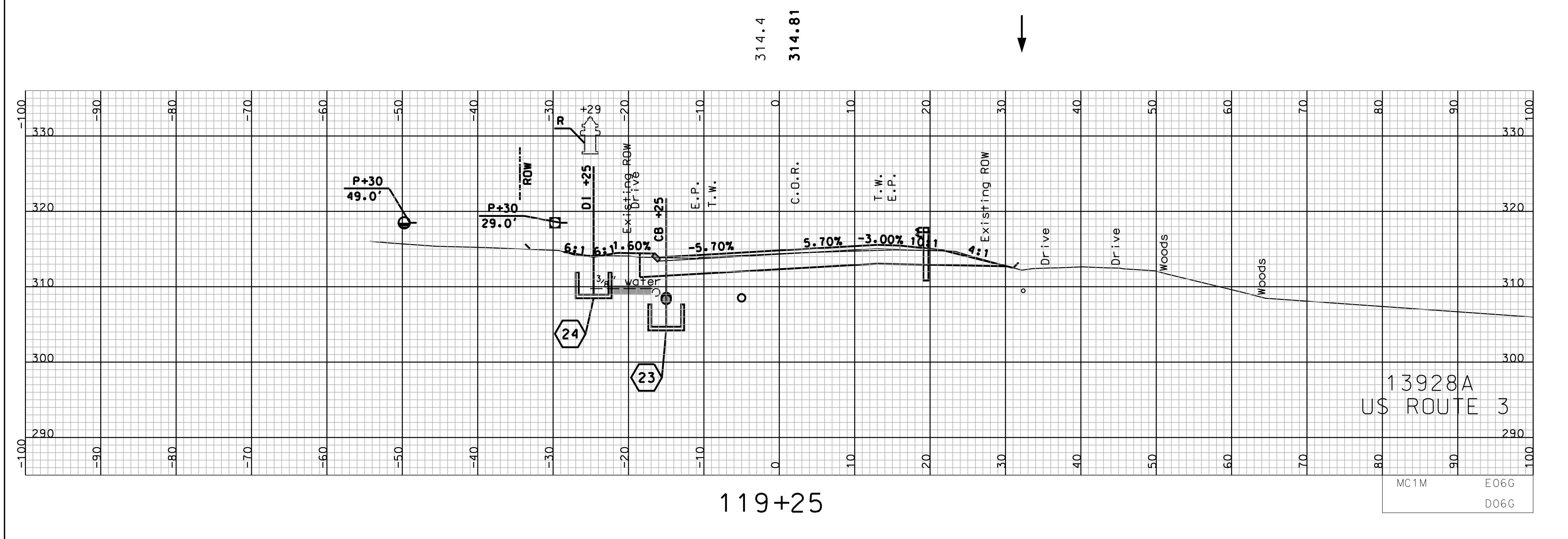

13928A
US ROUTE 3

MC1M E06G
D06G

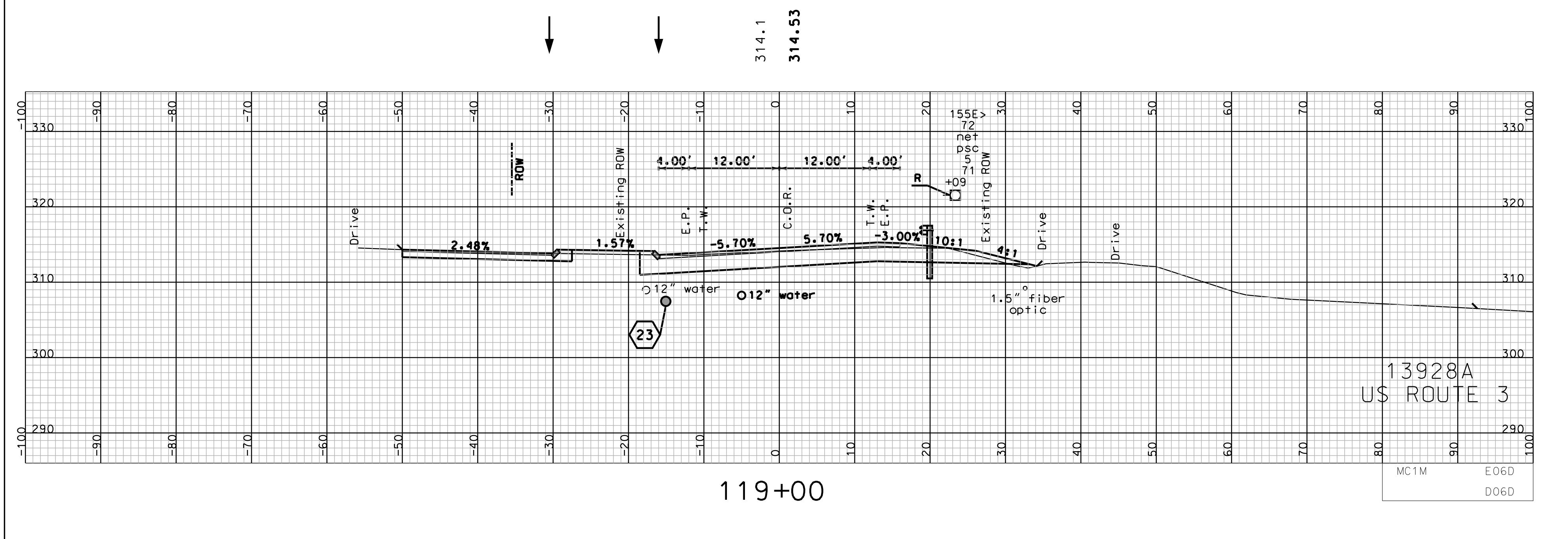

13928A
US ROUTE 3

MC1M E06D
D06D

COMMON EXCAV.		SHEET TOTALS		ROCK EXCAV.	
DCN	STATE PROJECT NO.	C.Y.	C.Y.	C.Y.	C.Y.
13928axs-mc1m	13928A	399	11	39	0
TOTAL SHEETS		105	160		

SDR PROCESSED	DATE
NEW DESIGN TEAM BALDWIN	DATE 09/2013
SHEET CHECKED TEAM BALDWIN	DATE 04/2015
AS BUILT DETAILS	DATE

REVISIONS AFTER PROPOSAL				
NUMBER	DATE	STATION	STATION	DESCRIPTION

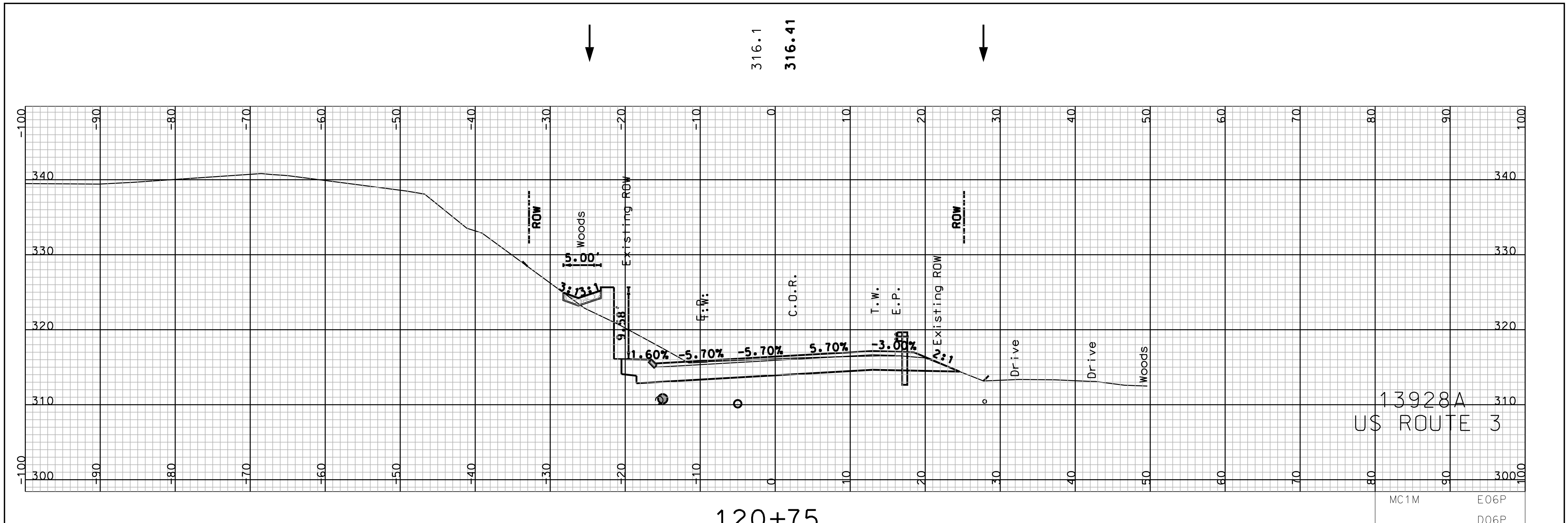

120+75

13928A
US ROUTE 3

MC1M E06P
D06P

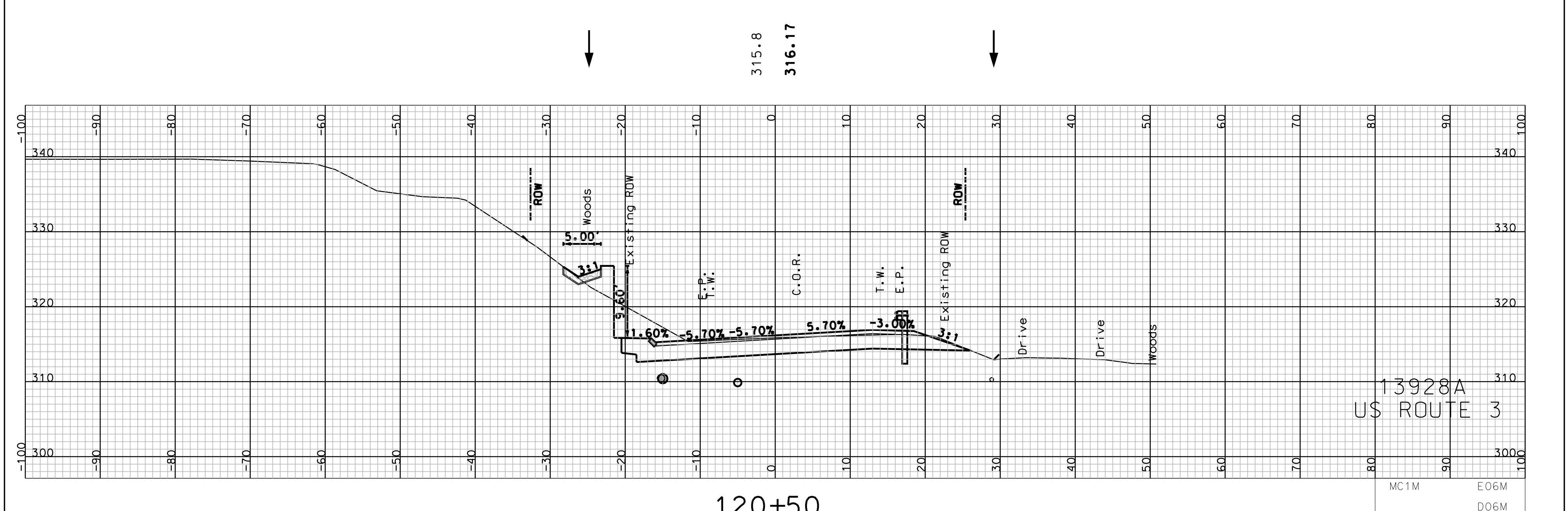

120+50

13928A
US ROUTE 3

MC1M E06M
D06M

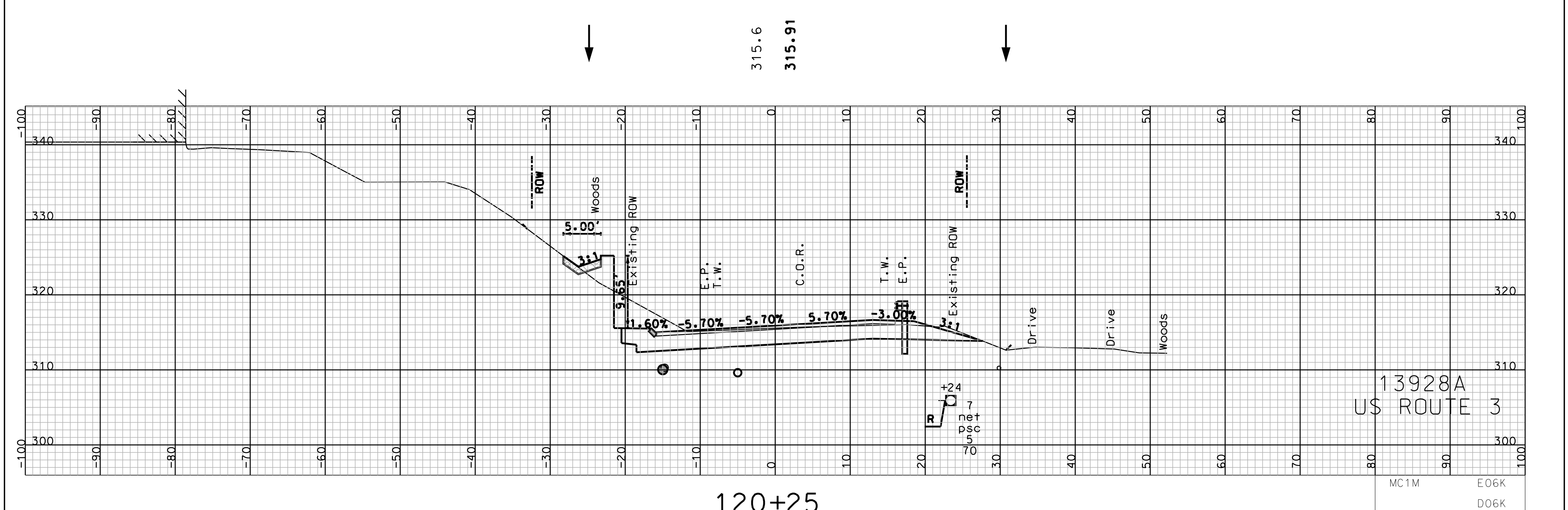

120+25

13928A
US ROUTE 3

MC1M E06K
D06K

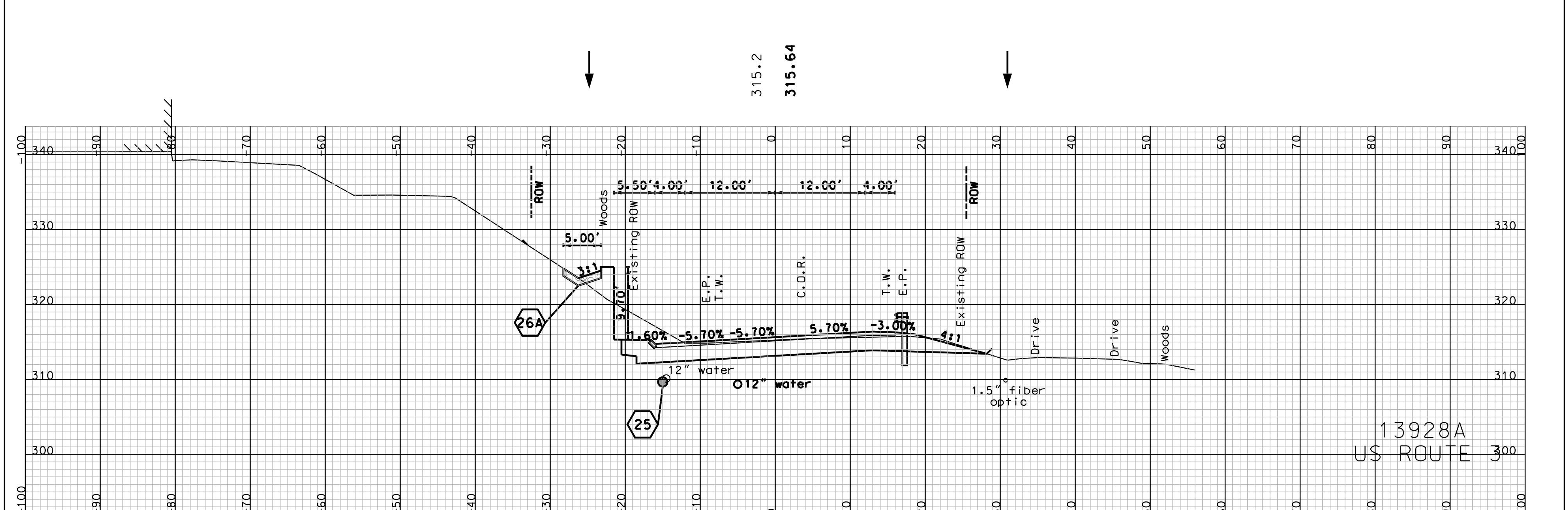

120+00

13928A
US ROUTE 3

MC1M E06J
D06J

COMMON EXCAV.		SHEET TOTALS		ROCK EXCAV.	
439	C.Y.	39	C.Y.	39	C.Y.
FILL 12 C.Y.		MUCK EXCAV. 0 C.Y.			
DGN	STATE PROJECT NO.	SHEET NO.	TOTAL SHEETS		
13928axs-mc1m	13928A	106	160		

SDR PROCESSED	DATE		
NEW DESIGN	TEAM BALDWIN	DATE	09/2013
SHEET CHECKED	TEAM BALDWIN	DATE	04/2015
AS BUILT DETAILS	DATE		

REVISIONS AFTER PROPOSAL				
NUMBER	DATE	STATION	STATION	DESCRIPTION

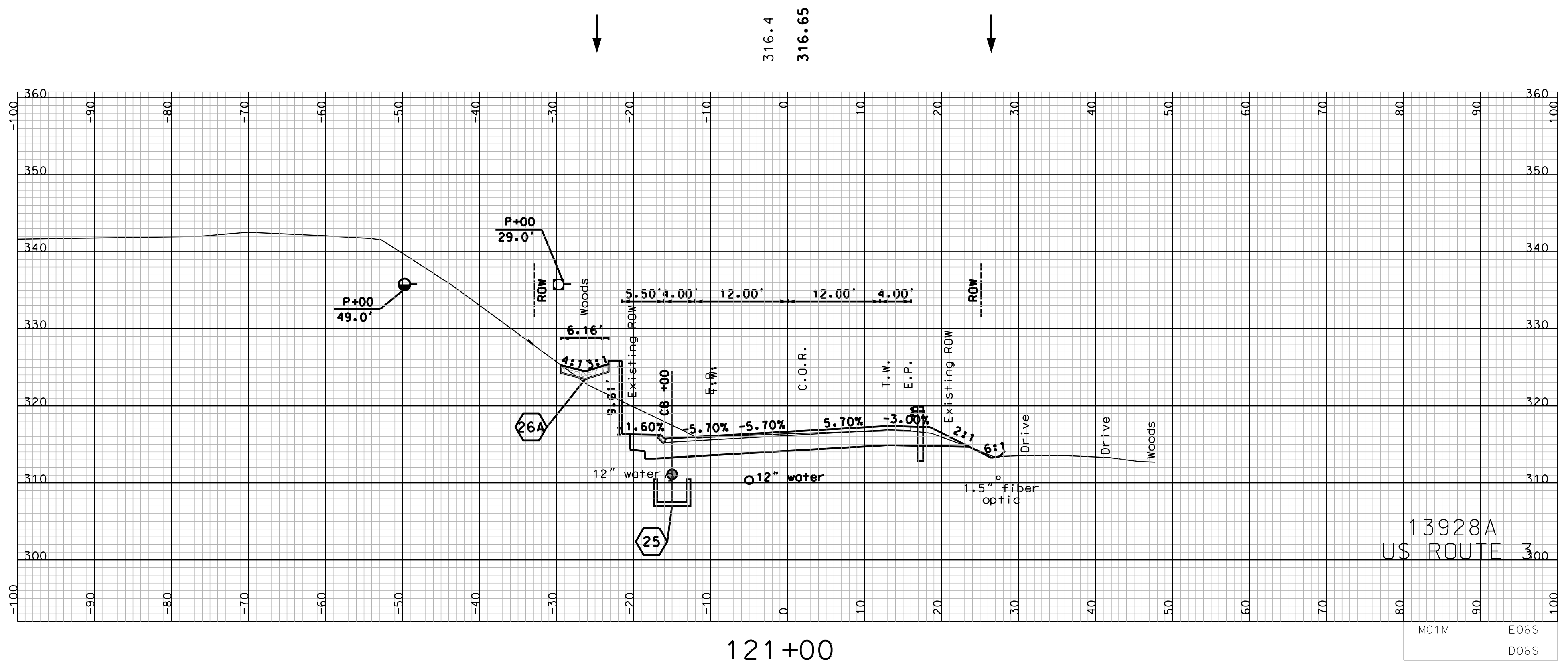
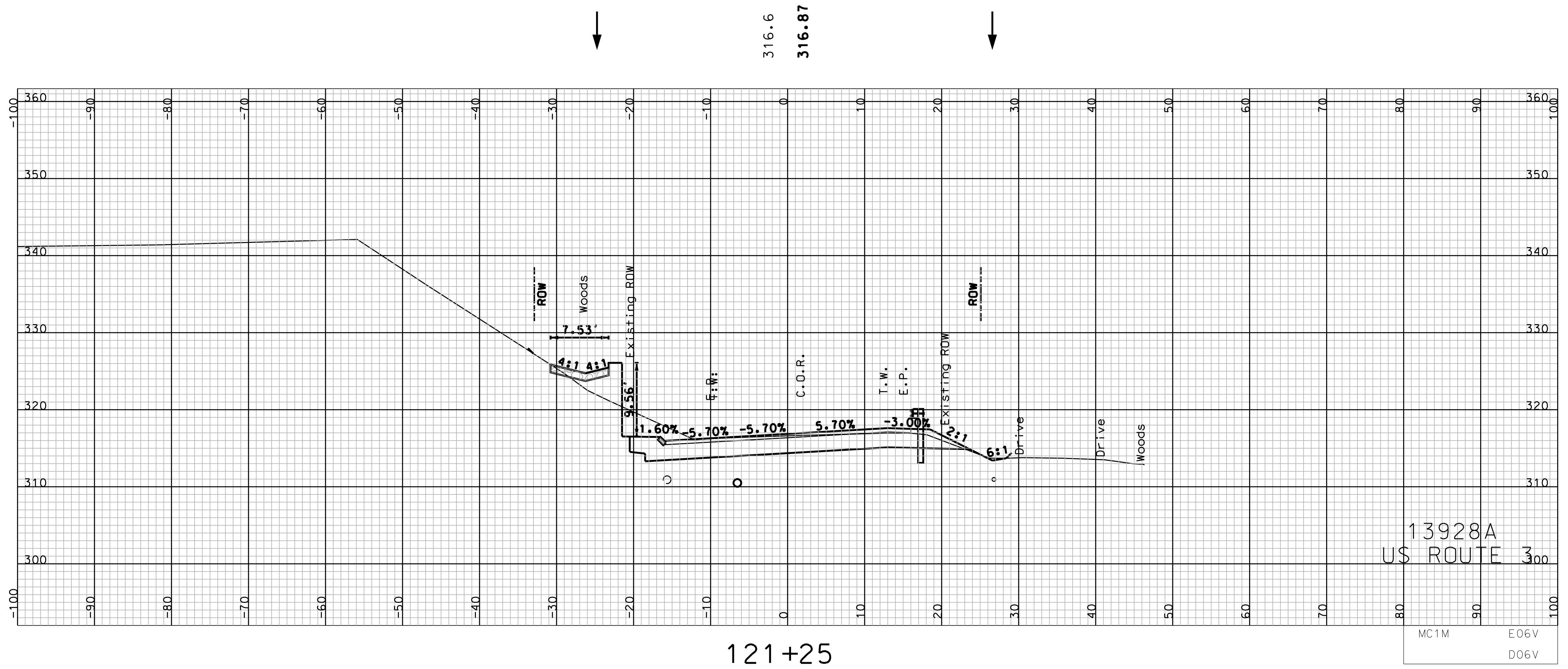
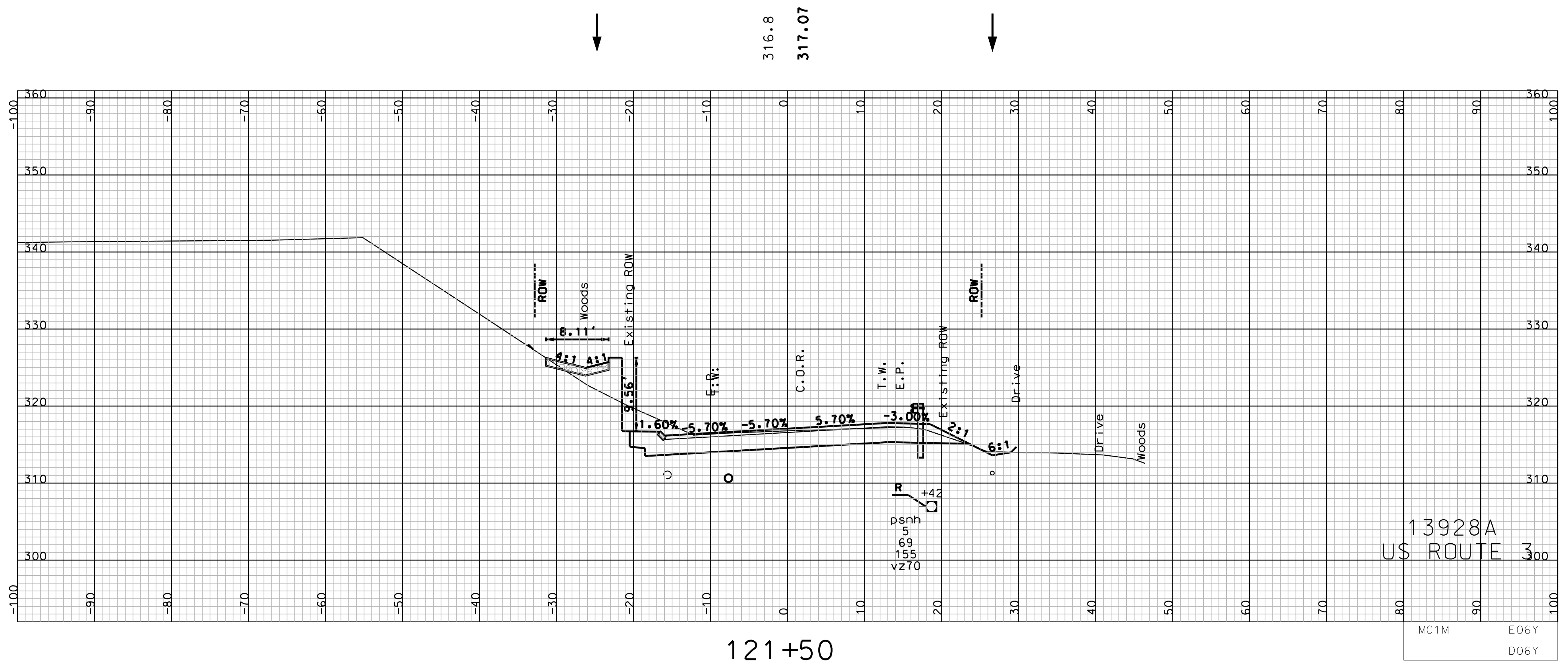

COMMON EXCAV.		SHEET TOTALS		ROCK EXCAV.	
DCN	STATE PROJECT NO.	C.Y.	C.Y.	C.Y.	C.Y.
13928axs-mc1m	13928A	300	21	29	0
TOTAL SHEETS		107		160	

SDR PROCESSED	DATE
NEW DESIGN TEAM BALDWIN	DATE 09/2013
SHEET CHECKED TEAM BALDWIN	DATE 04/2015
AS BUILT DETAILS	DATE

REVISIONS AFTER PROPOSAL				
NUMBER	DATE	STATION	STATION	DESCRIPTION

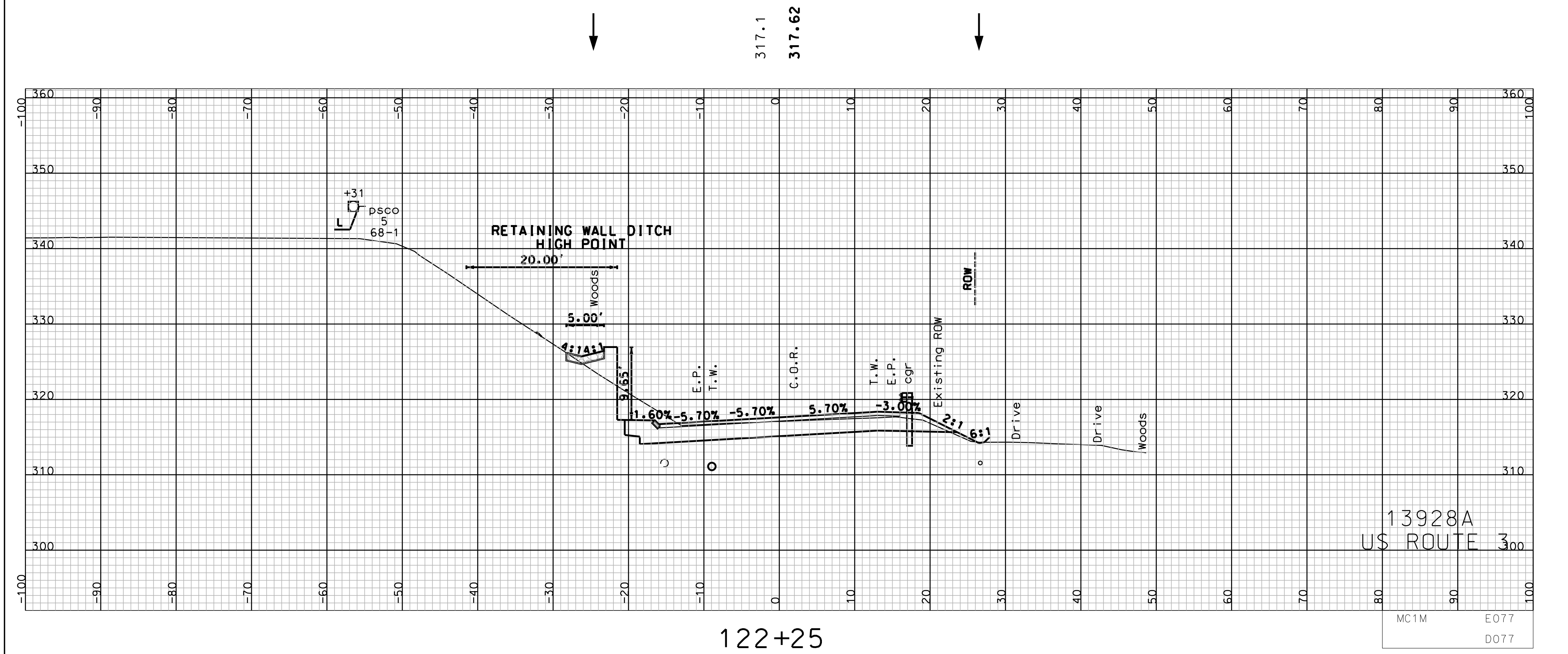

13928A
US ROUTE 300

MC1M	E077
	D077

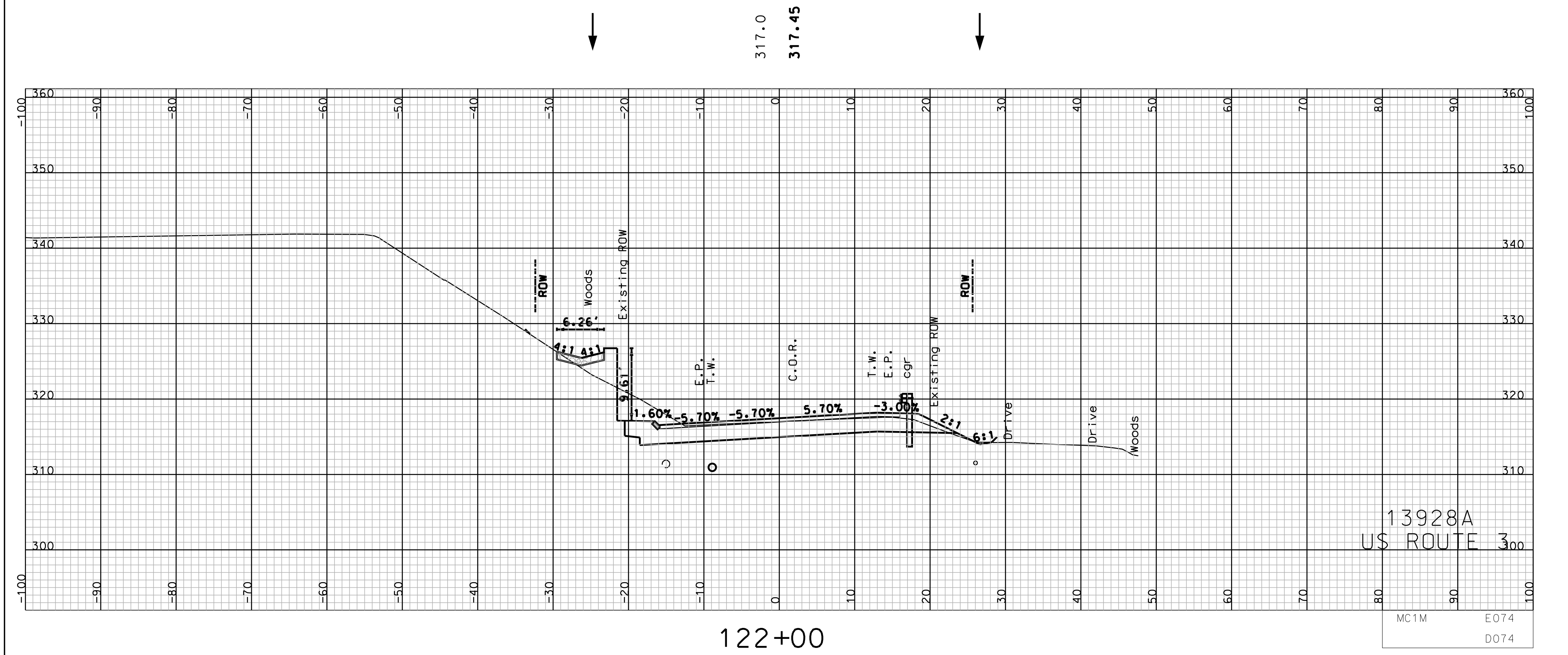

13928A
US ROUTE 300

MC1M	E074
	D074

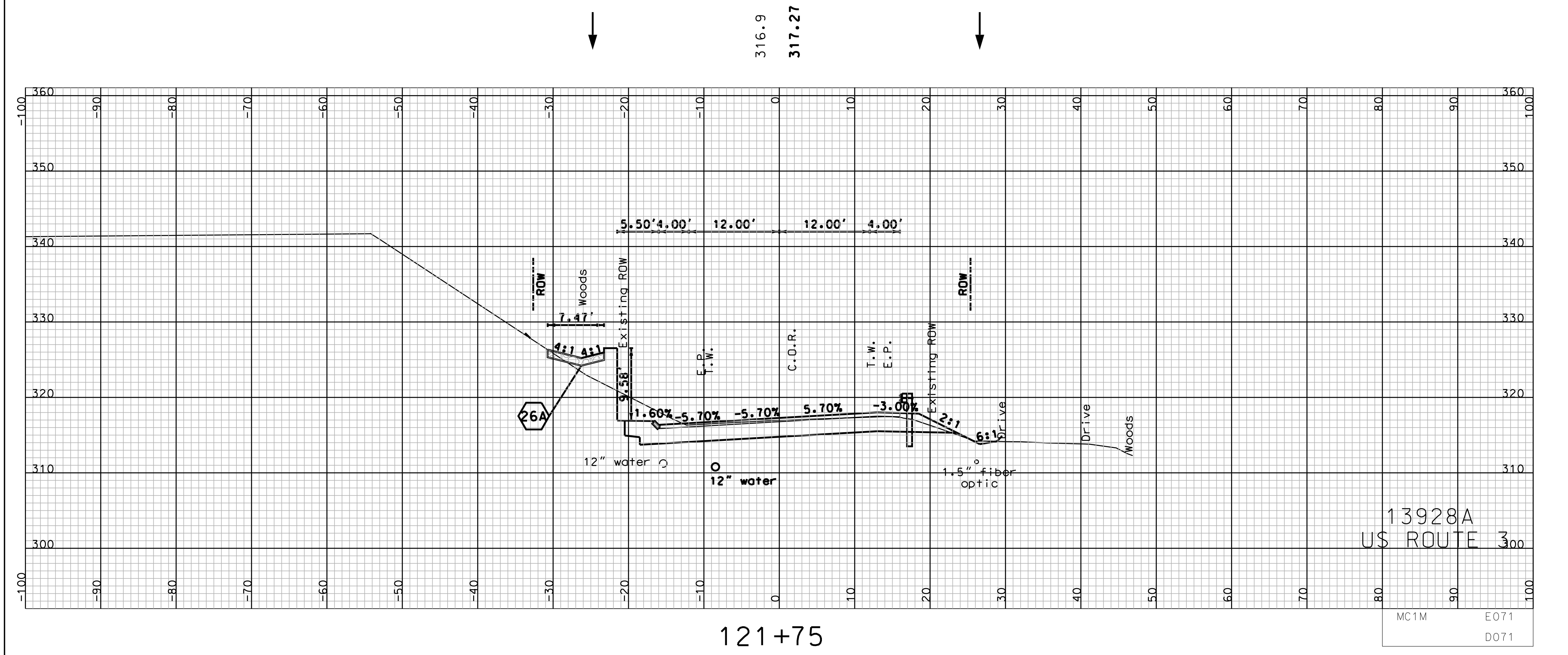

13928A
US ROUTE 300

MC1M	E071
	D071

COMMON EXCAV.		SHEET TOTALS		ROCK EXCAV.	
	C.Y.		C.Y.		C.Y.
282		29			
FILL	14	MUCK EXCAV.	0		
DGN	STATE PROJECT NO.	SHEET NO.	TOTAL SHEETS		
13928axs-mc1m	13928A	108	160		

SDR PROCESSED	DATE
NEW DESIGN TEAM BALDWIN	DATE 09/2013
SHEET CHECKED TEAM BALDWIN	DATE 04/2015
AS BUILT DETAILS	DATE

REVISIONS AFTER PROPOSAL				
NUMBER	DATE	STATION	STATION	DESCRIPTION

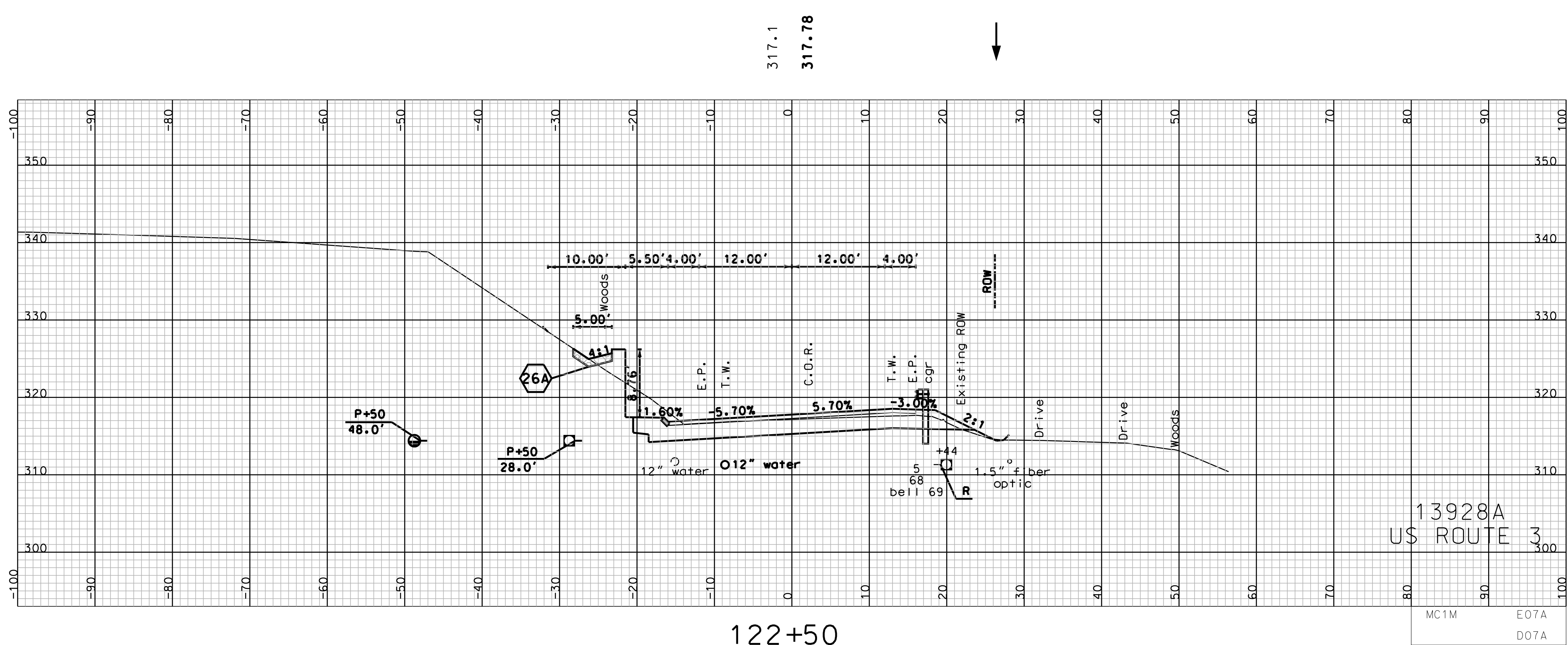
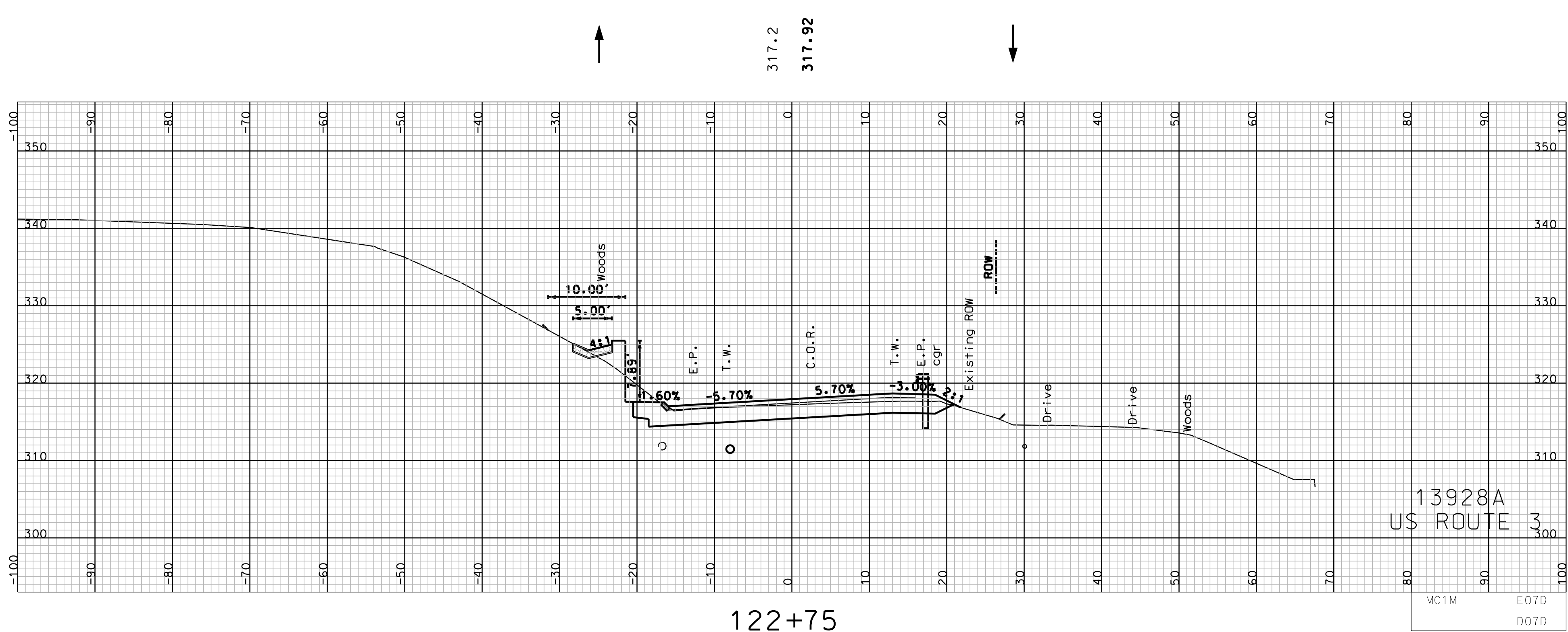
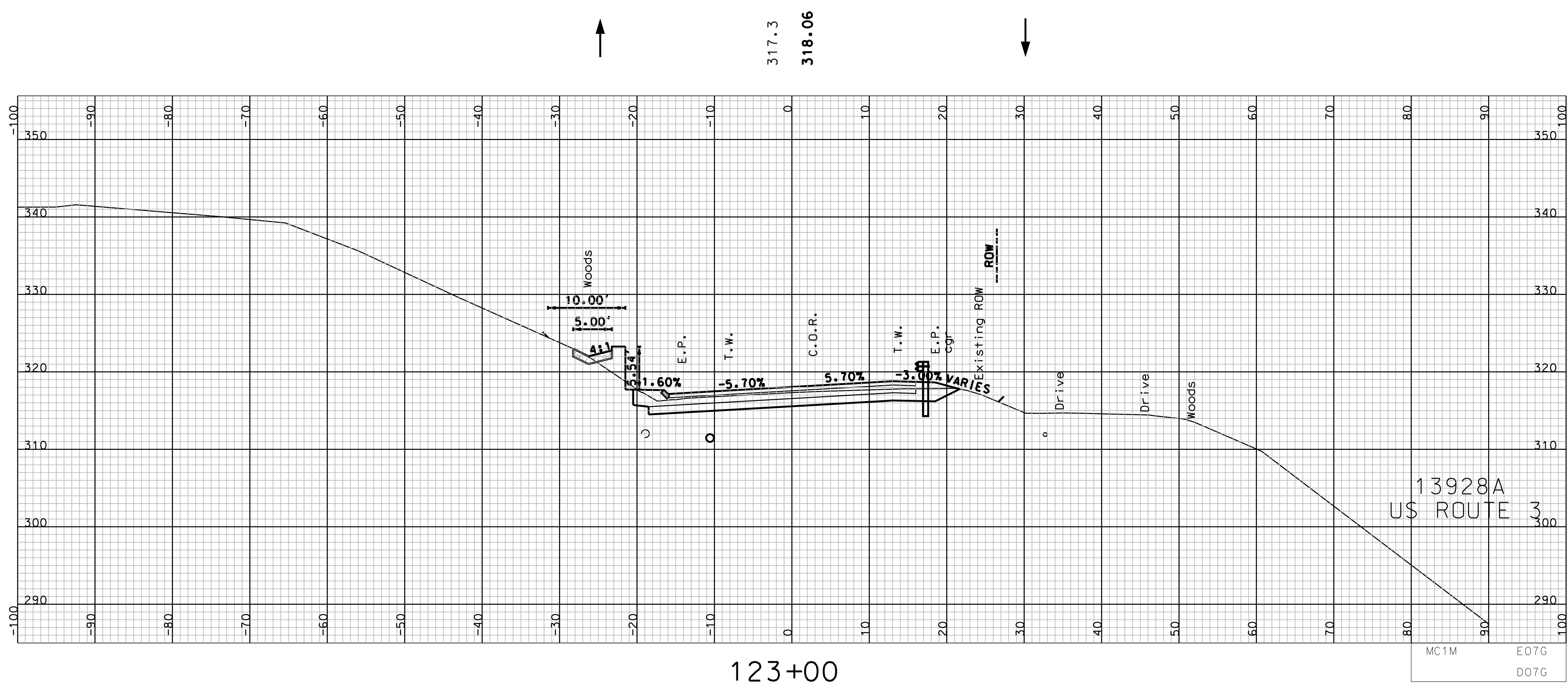

COMMON EXCAV.		SHEET TOTALS		ROCK EXCAV.	
DCN	STATE PROJECT NO.	C.Y.	SHEET NO.	C.Y.	TOTAL SHEETS
13928axs-mc1m	13928A	215	109	29	160
		5		0	

SDR PROCESSED	DATE
NEW DESIGN TEAM BALDWIN	DATE 09/2013
SHEET CHECKED TEAM BALDWIN	DATE 04/2015
AS BUILT DETAILS	DATE

REVISIONS AFTER PROPOSAL				
NUMBER	DATE	STATION	STATION	DESCRIPTION

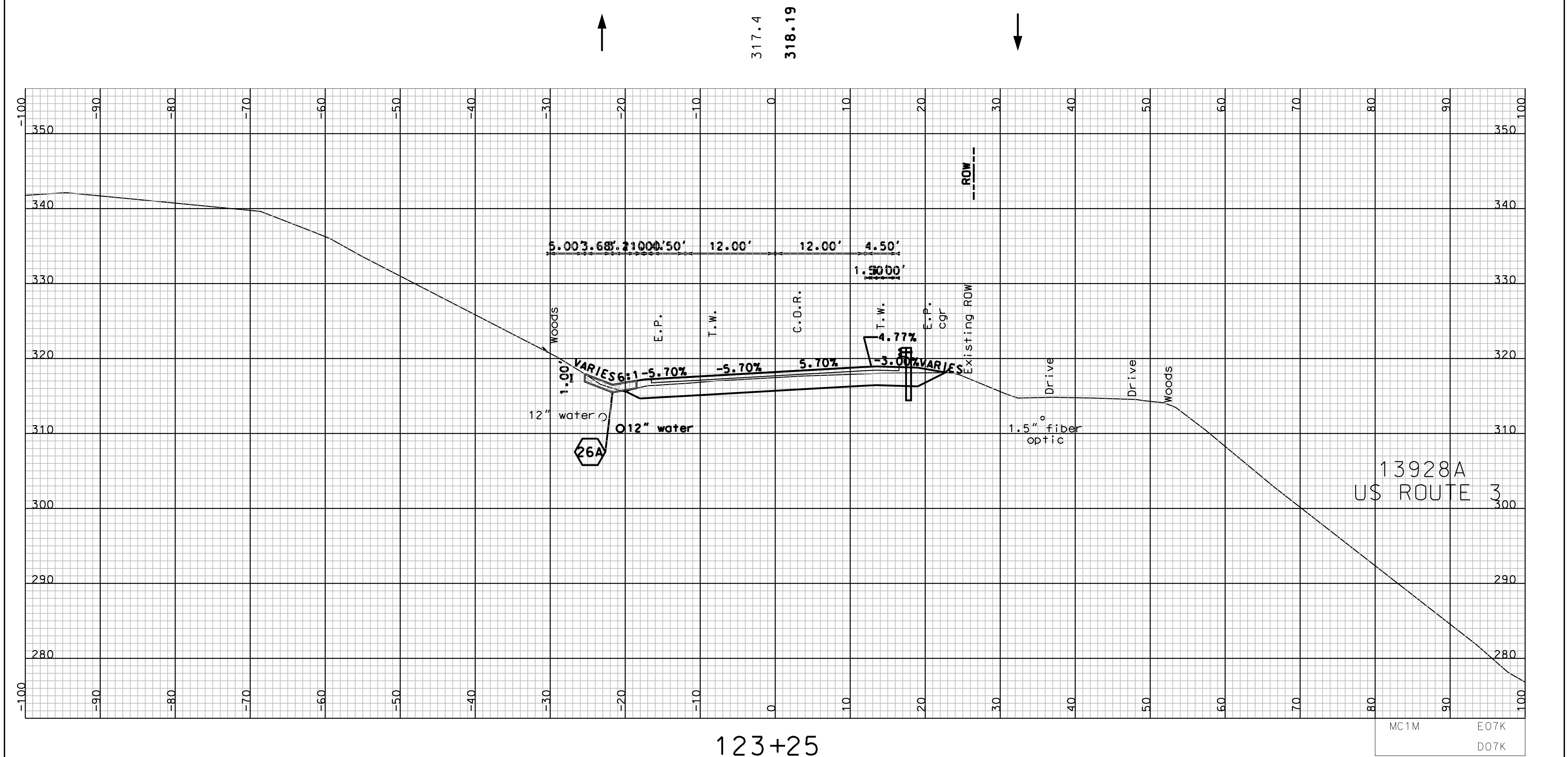
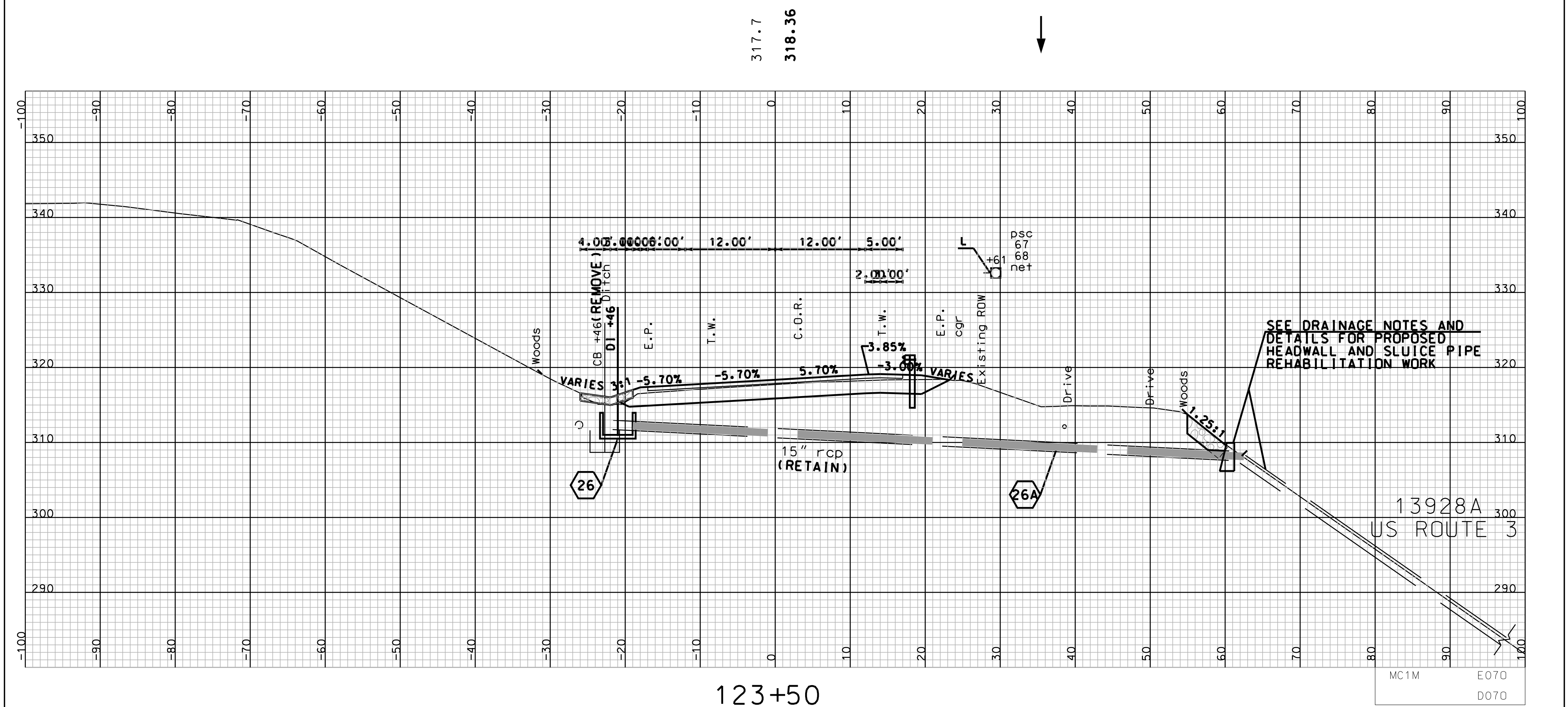

SHEET TOTALS					
COMMON EXCAV.	216	C.Y.	ROCK EXCAV.	29	C.Y.
FILL	1	C.Y.	MUCK EXCAV.	0	C.Y.
DGN	STATE PROJECT NO.	SHEET NO.	TOTAL SHEETS		
13928axs-mc1m	13928A	110	160		

SDR PROCESSED	DATE
NEW DESIGN TEAM BALDWIN	DATE 09/2013
SHEET CHECKED TEAM BALDWIN	DATE 04/2015
AS BUILT DETAILS	DATE

REVISIONS AFTER PROPOSAL				
NUMBER	DATE	STATION	STATION	DESCRIPTION

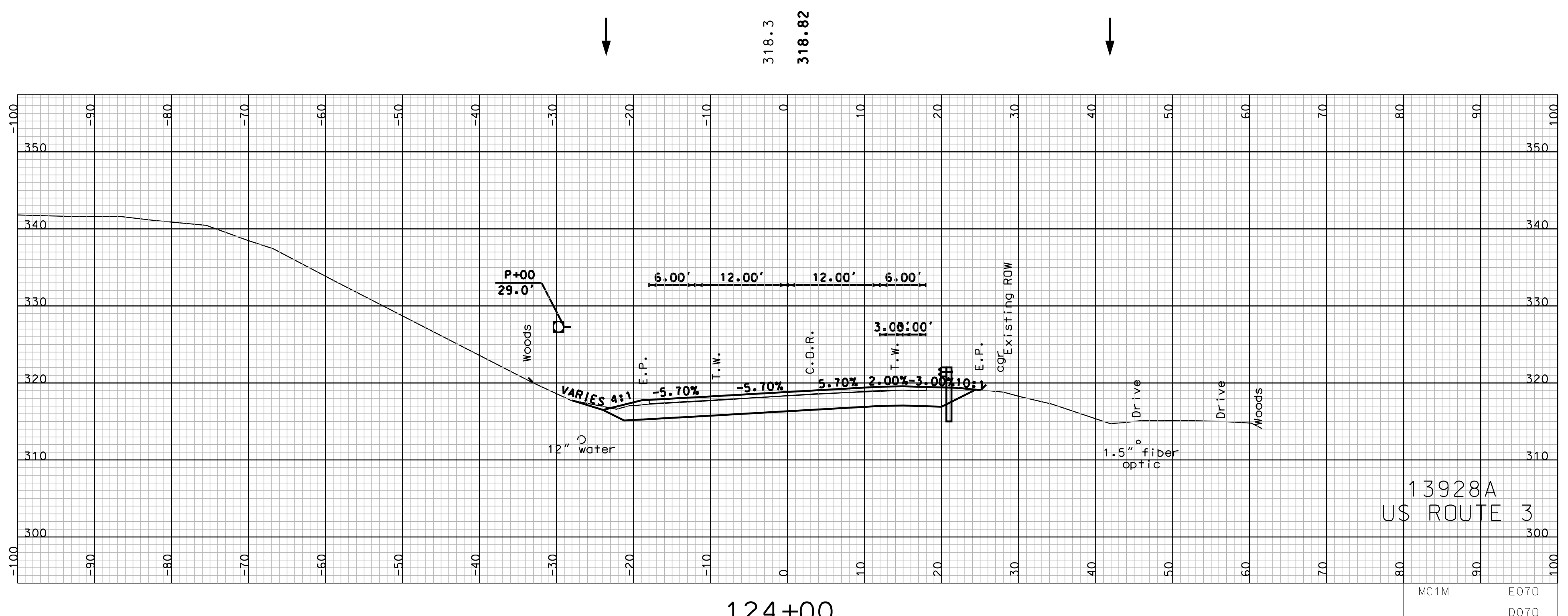
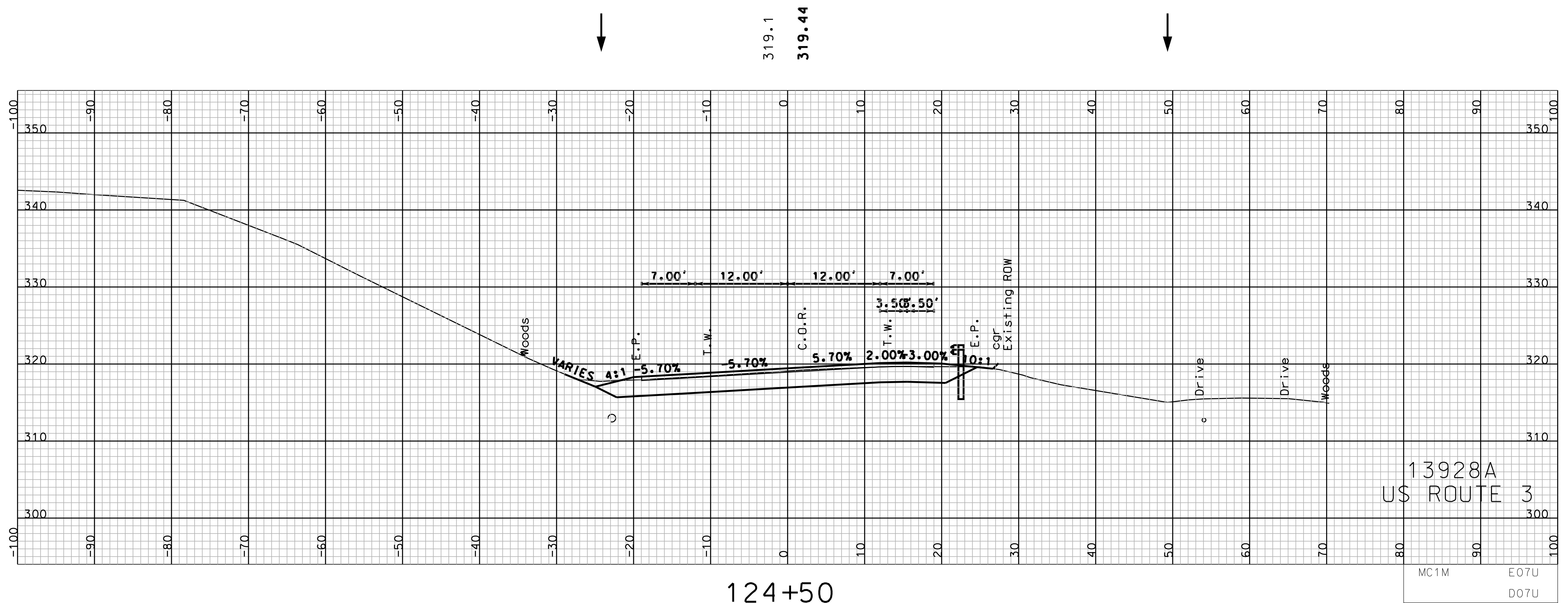
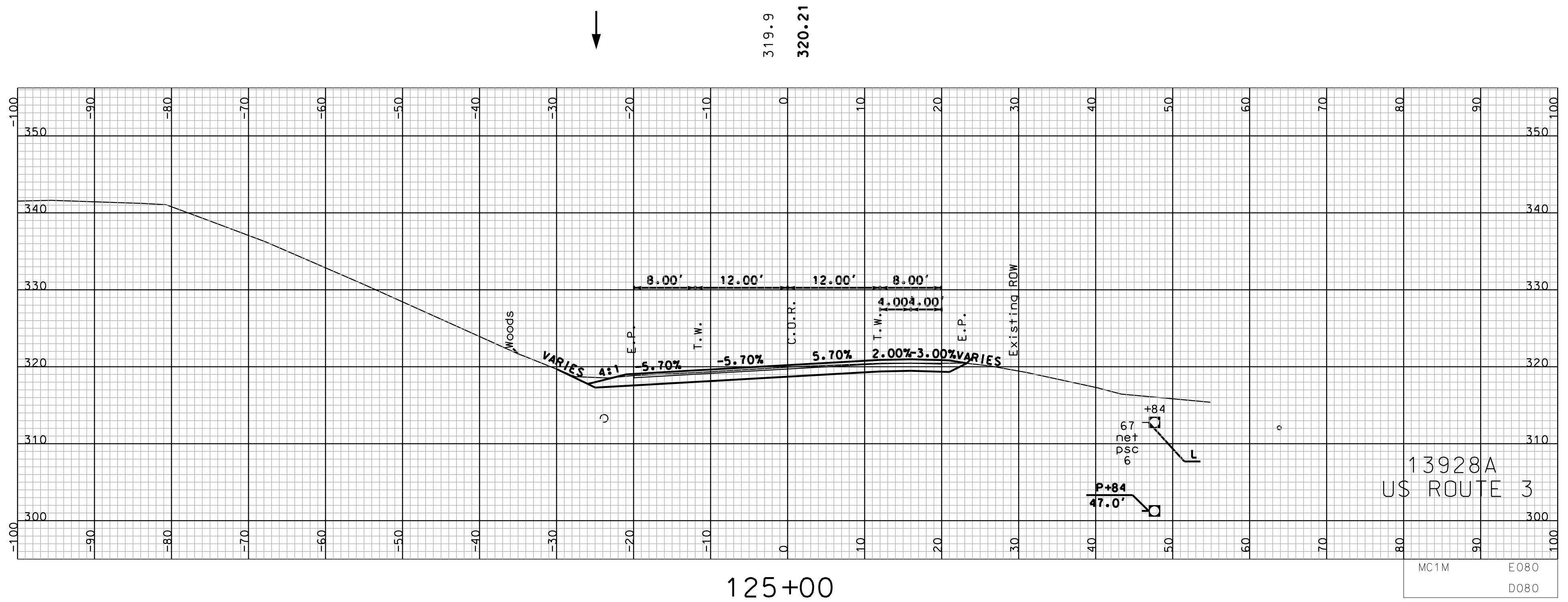

SHEET TOTALS					
COMMON EXCAV.	372	C.Y.	ROCK EXCAV.	58	C.Y.
FILL	0	C.Y.	MUCK EXCAV.	0	C.Y.
DGN	STATE PROJECT NO.	SHEET NO.	TOTAL SHEETS		
13928axs-mc1m	13928A	111	160		

SDR PROCESSED	DATE		
NEW DESIGN TEAM BALDWIN	DATE	09/2013	
SHEET CHECKED TEAM BALDWIN	DATE	04/2015	
AS BUILT DETAILS	DATE		

REVISIONS AFTER PROPOSAL				
NUMBER	DATE	STATION	STATION	DESCRIPTION

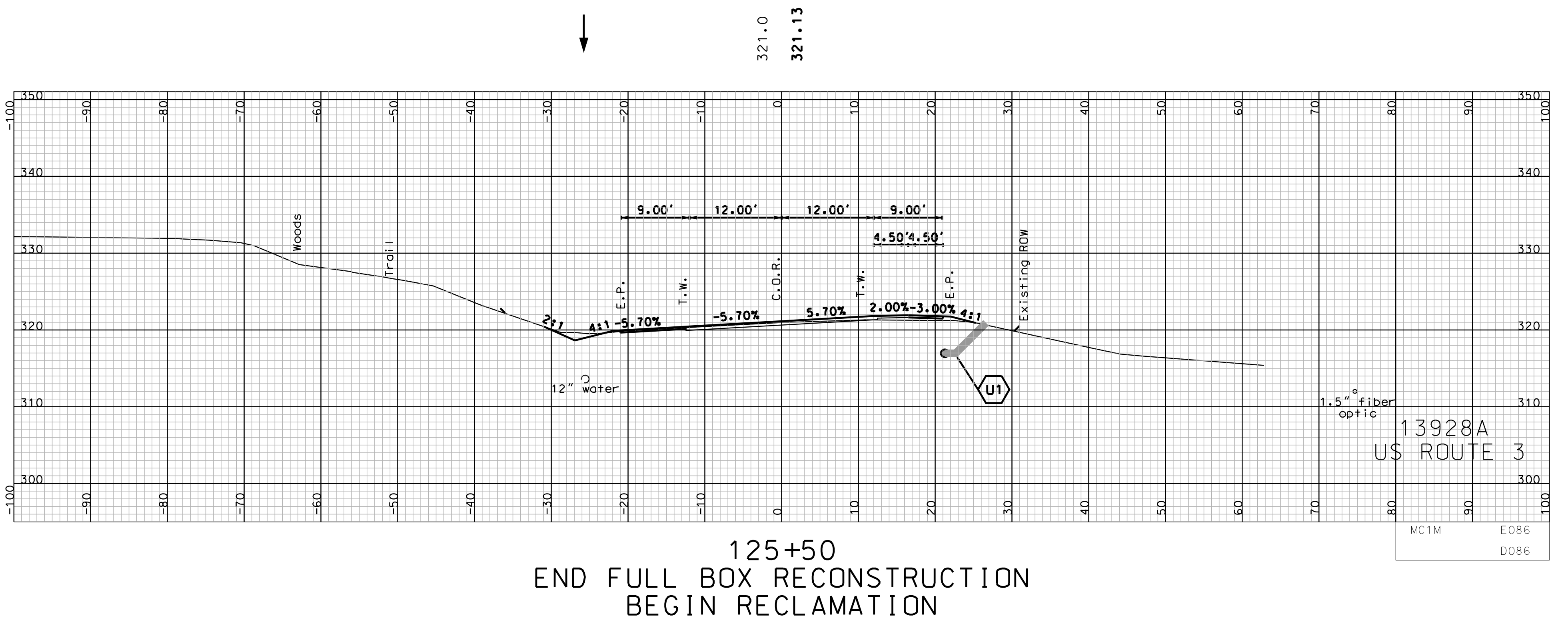
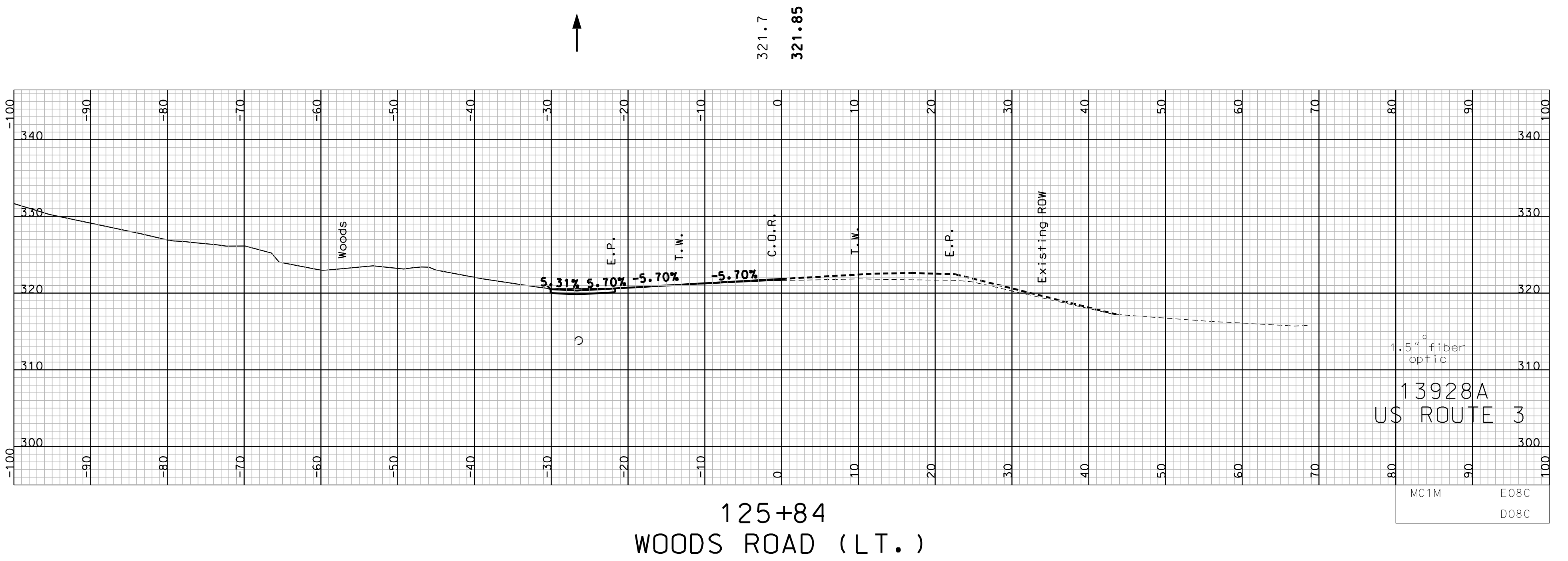
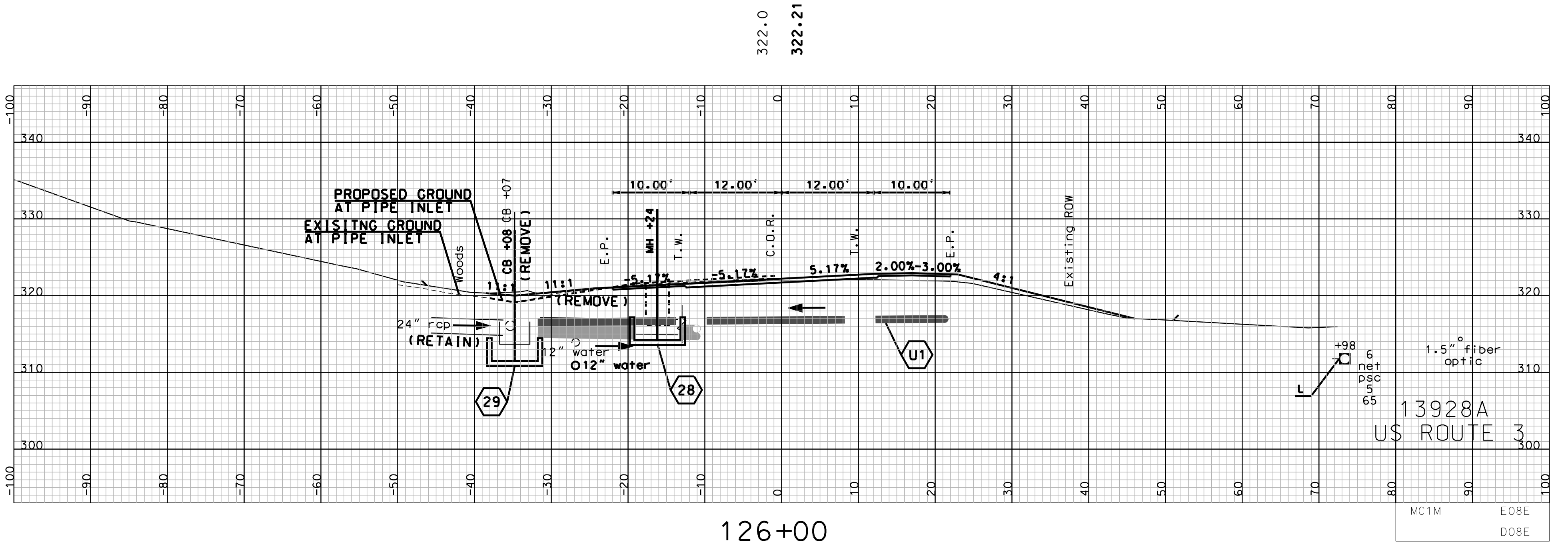

COMMON EXCAV. 5 C.Y.		SHEET TOTALS	
FILL 0 C.Y.		ROCK EXCAV. 0 C.Y.	
		MUCK EXCAV. 0 C.Y.	
DGN	STATE PROJECT NO.	SHEET NO.	TOTAL SHEETS
13928axs-mc1m	13928A	112	160

SDR PROCESSED	DATE
NEW DESIGN TEAM BALDWIN	DATE 09/2013
SHEET CHECKED TEAM BALDWIN	DATE 04/2015
AS BUILT DETAILS	DATE

REVISIONS AFTER PROPOSAL				
NUMBER	DATE	STATION	STATION	DESCRIPTION



324.3
324.81

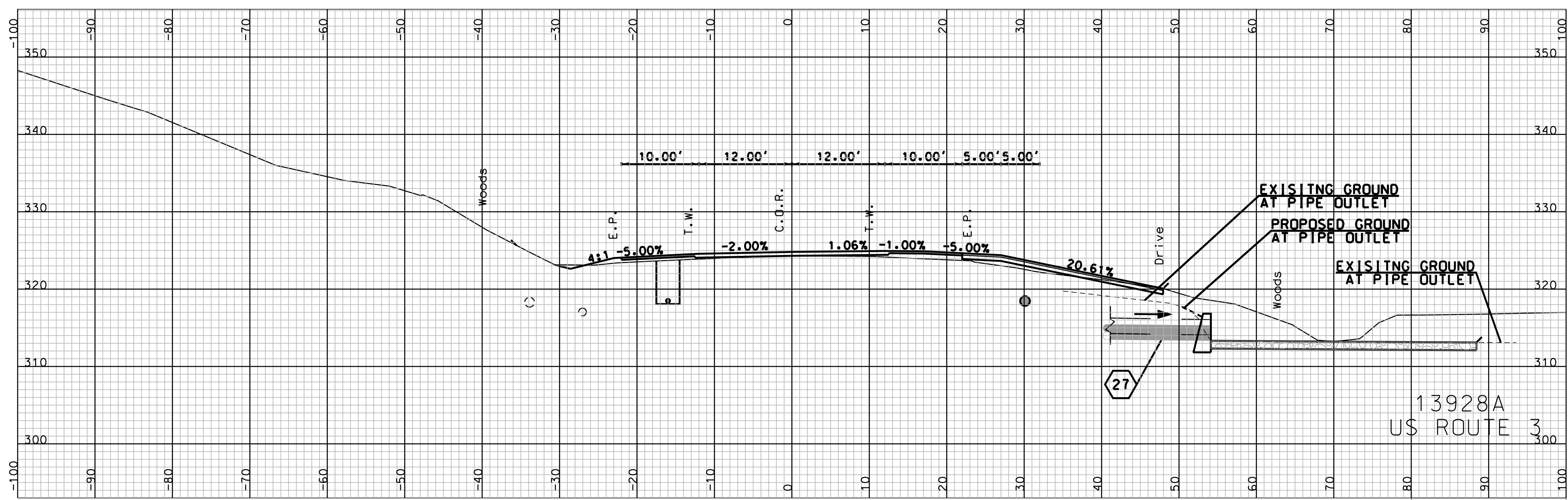

127+00

MC1M	E080
	D080



323.1
323.45

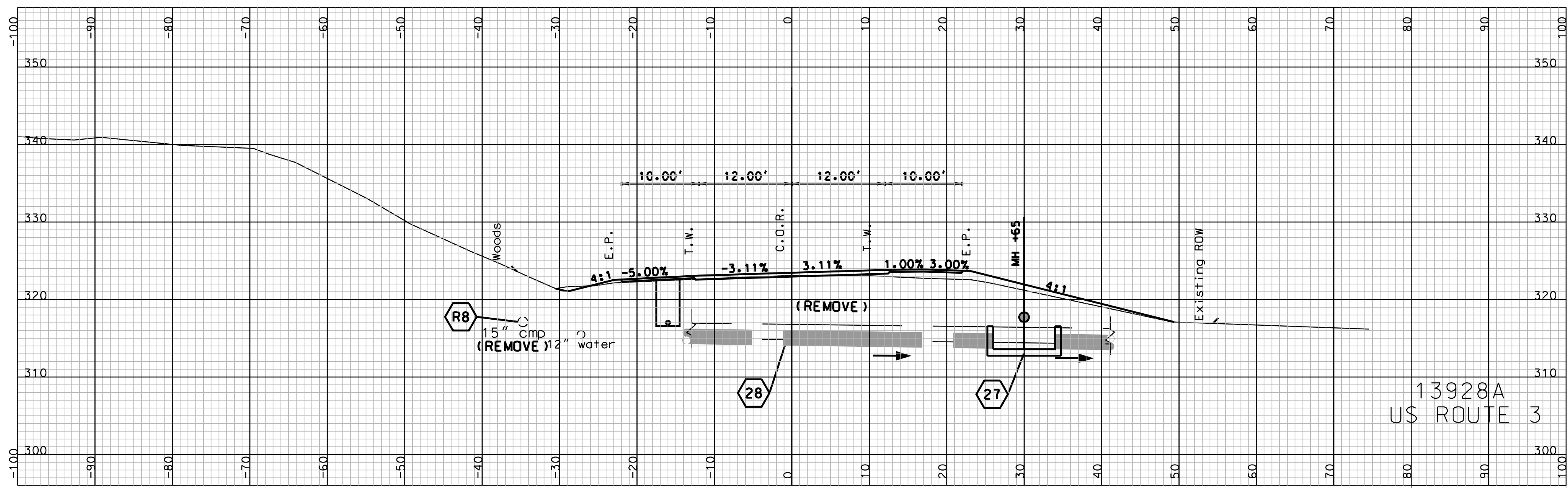

126+50

MC1M	E08L
	D08L

SHEET TOTALS					
COMMON EXCAV.	7	C.Y.	ROCK EXCAV.	0	C.Y.
FILL	9	C.Y.	MUCK EXCAV.	0	C.Y.
DGN	13928axs-mc1m	STATE PROJECT NO.	13928A	SHEET NO.	113
				TOTAL SHEETS	160

SDR PROCESSED	DATE
NEW DESIGN TEAM BALDWIN	DATE 09/2013
SHEET CHECKED TEAM BALDWIN	DATE 04/2015
AS BUILT DETAILS	DATE

REVISIONS AFTER PROPOSAL				
NUMBER	DATE	STATION	STATION	DESCRIPTION

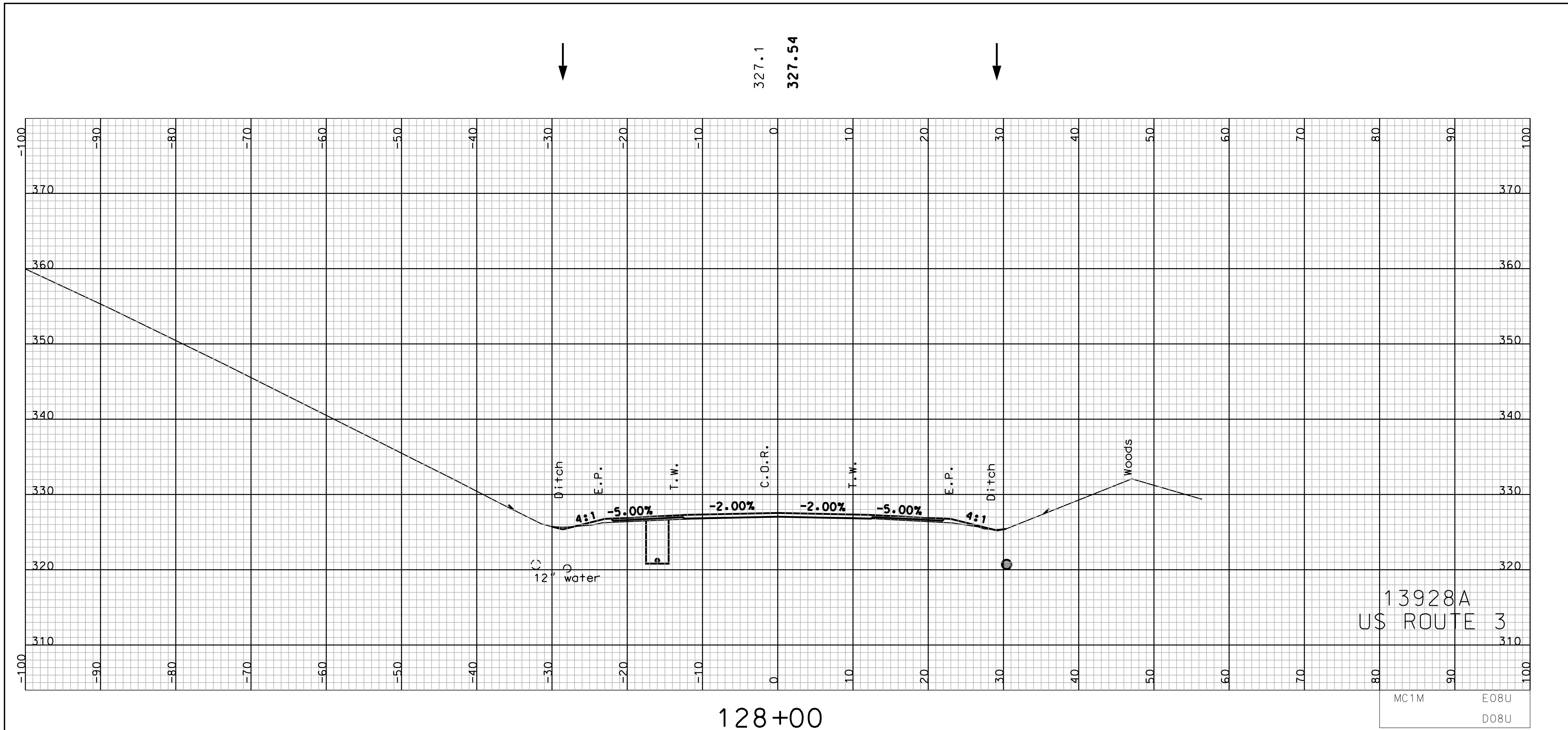

13928A
US ROUTE 3

MC1M E08U
D08U

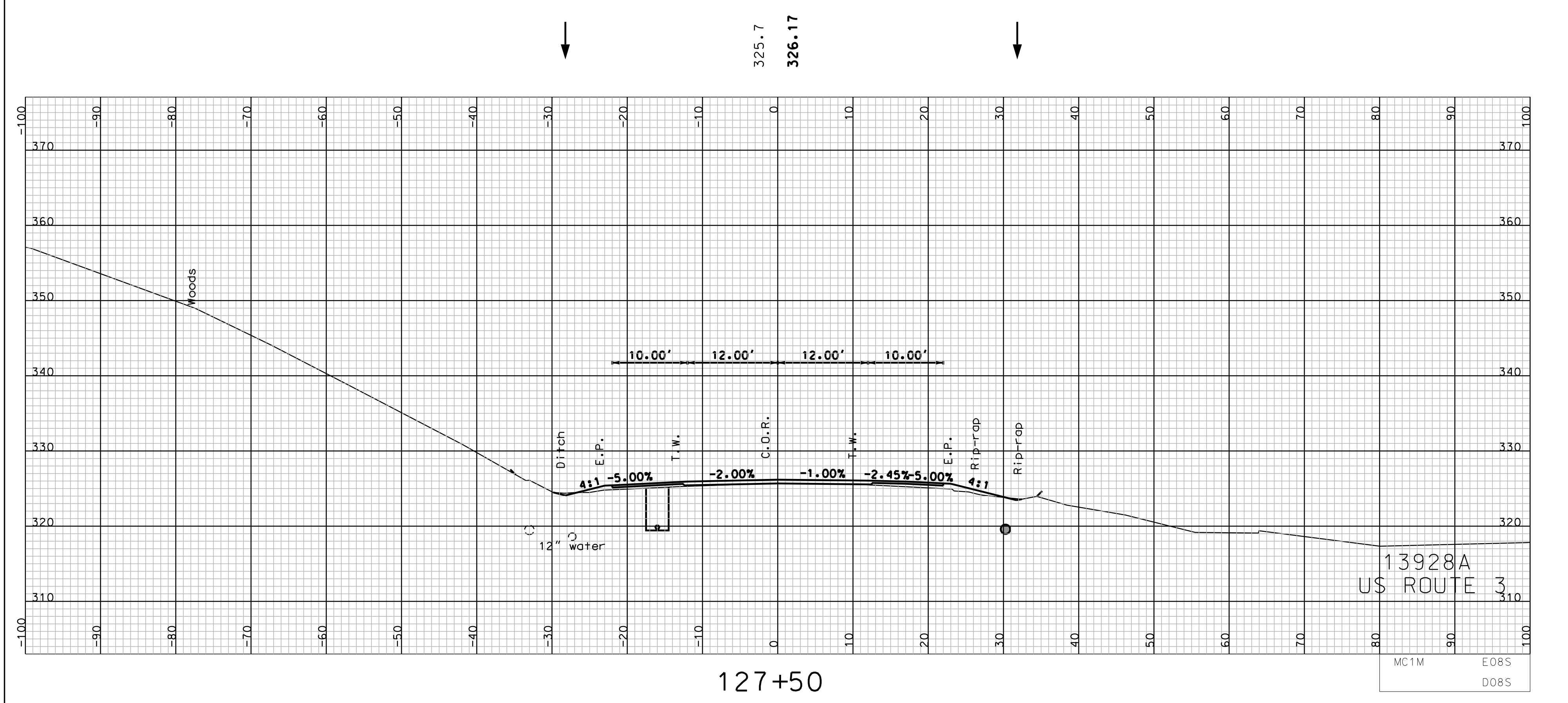

13928A
US ROUTE 3

MC1M E08S
D08S

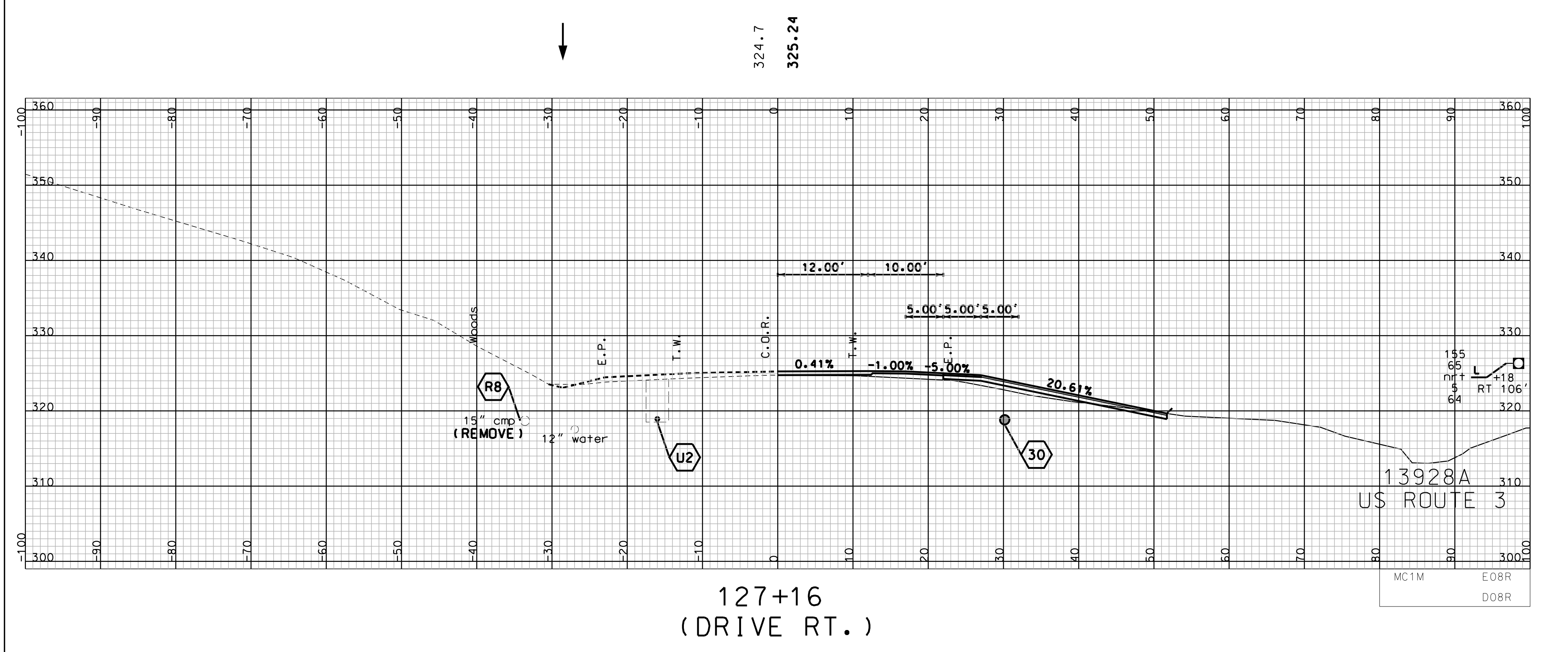

13928A
US ROUTE 3

MC1M E08R
D08R

COMMON EXCAV.		SHEET TOTALS		ROCK EXCAV.	
	C.Y.		C.Y.		C.Y.
2				0	
5				0	
FILL		MUCK EXCAV.			
DGN	STATE PROJECT NO.	SHEET NO.	TOTAL SHEETS		
13928axs-mc1m	13928A	114	160		

SDR PROCESSED	DATE		
NEW DESIGN TEAM BALDWIN	DATE	09/2013	
SHEET CHECKED TEAM BALDWIN	DATE	04/2015	
AS BUILT DETAILS	DATE		

REVISIONS AFTER PROPOSAL				
NUMBER	DATE	STATION	STATION	DESCRIPTION

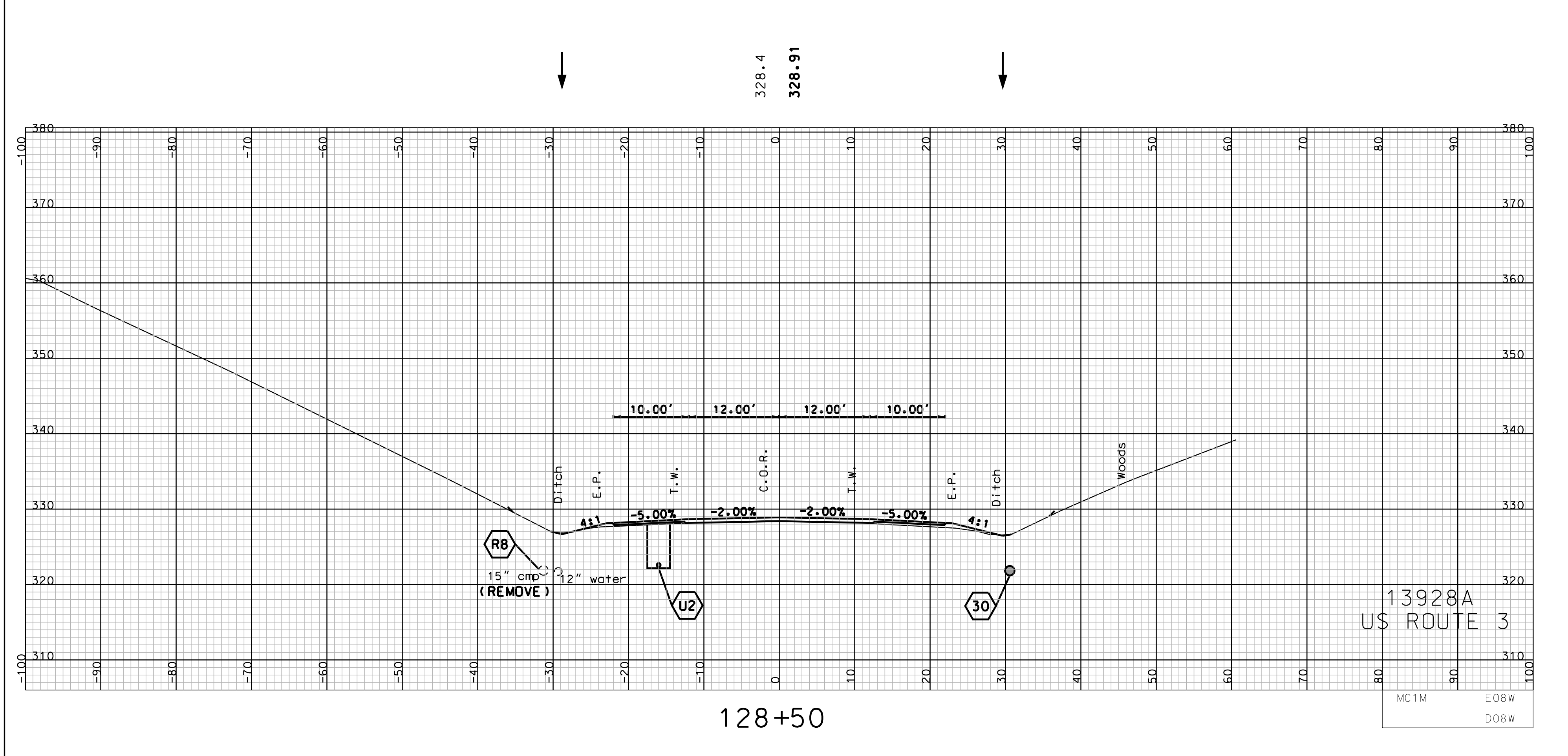
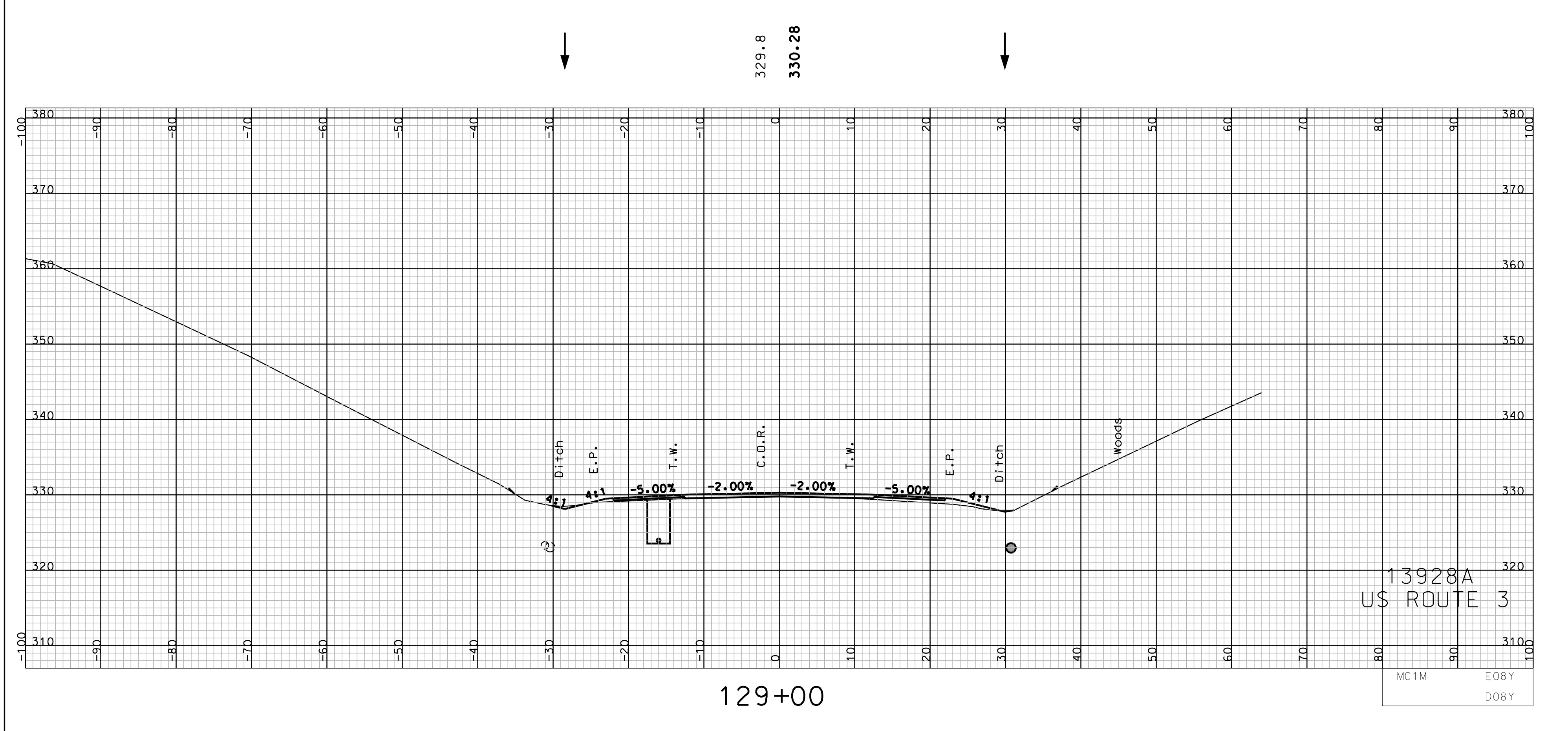
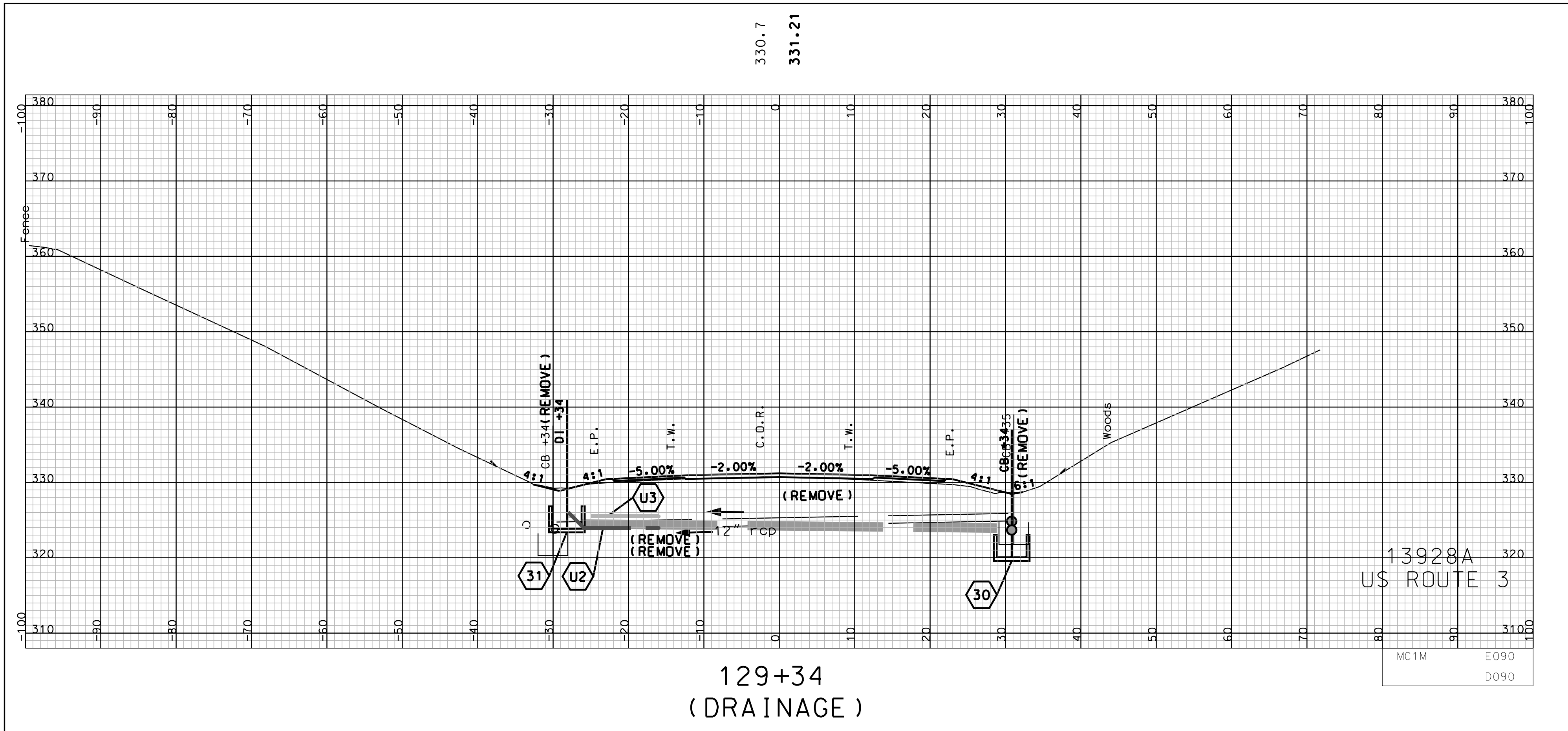

COMMON EXCAV.		SHEET TOTALS		ROCK EXCAV.	
	C.Y.		C.Y.		C.Y.
0	0	0	0	0	0
FILL		MUCK EXCAV.			
0	0	0	0	0	0
DGN	STATE PROJECT NO.	SHEET NO.	TOTAL SHEETS		
13928axs-mc1m	13928A	115	160		

SDR PROCESSED	DATE
NEW DESIGN TEAM BALDWIN	DATE 09/2013
SHEET CHECKED TEAM BALDWIN	DATE 04/2015
AS BUILT DETAILS	DATE

REVISIONS AFTER PROPOSAL				
NUMBER	DATE	STATION	STATION	DESCRIPTION

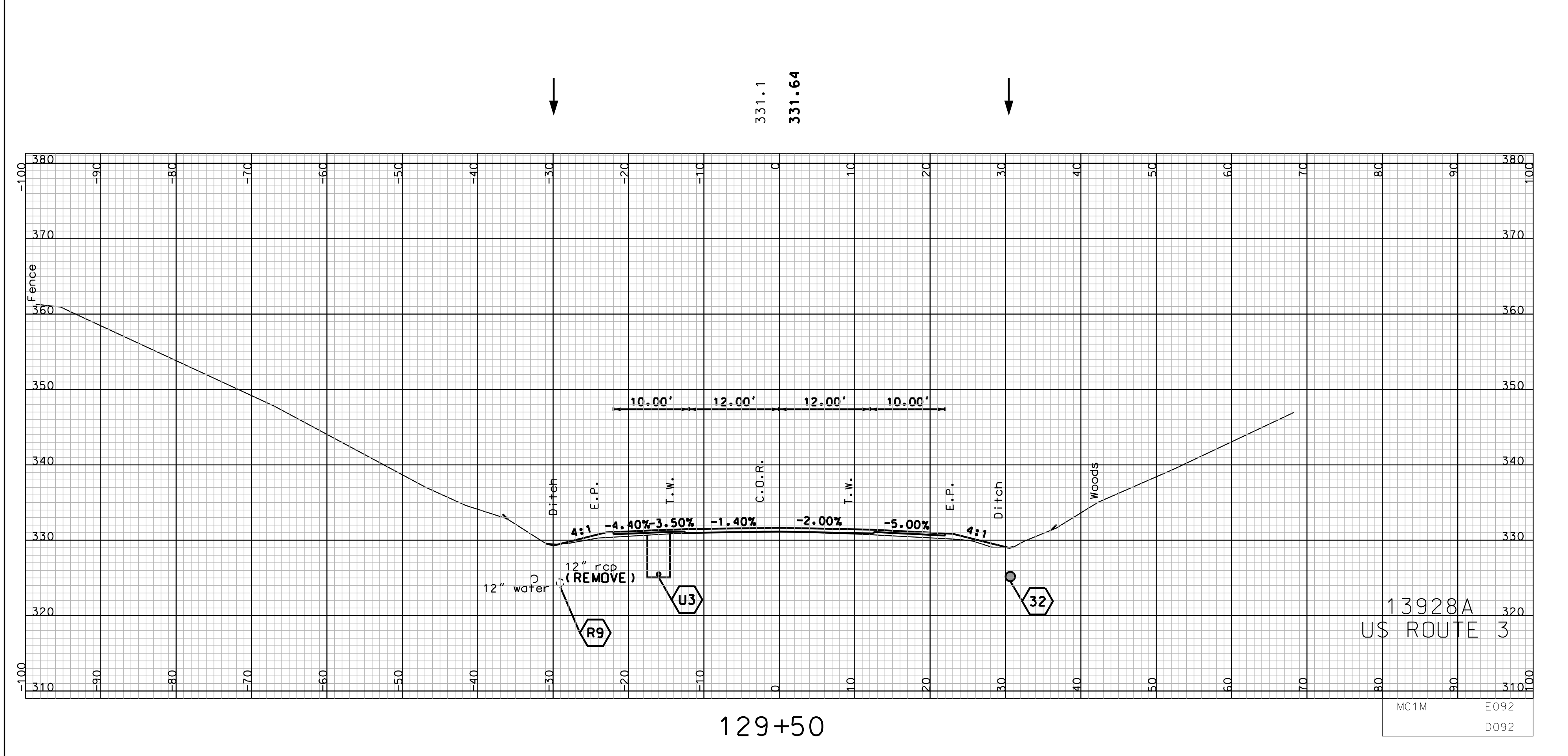
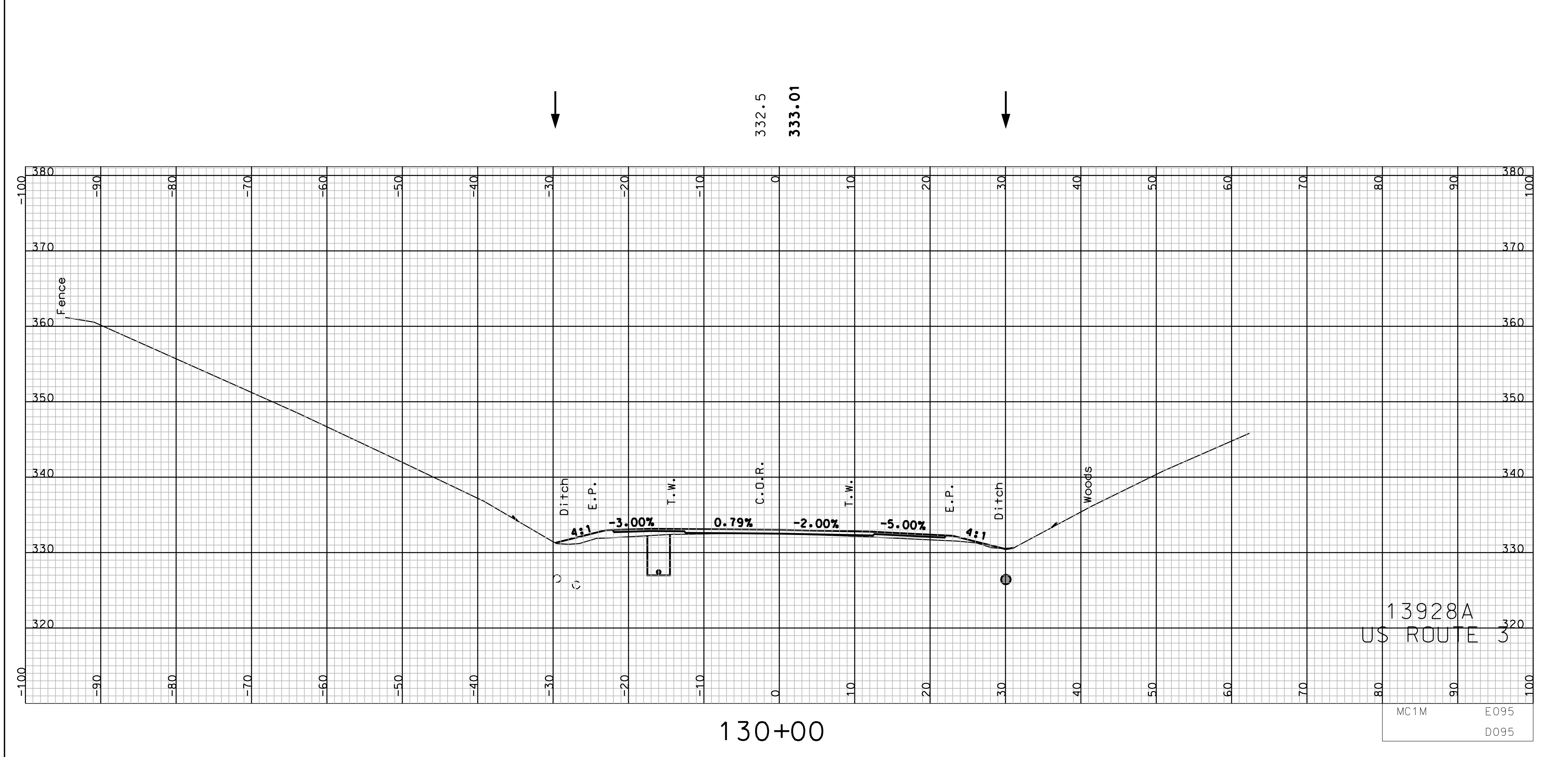
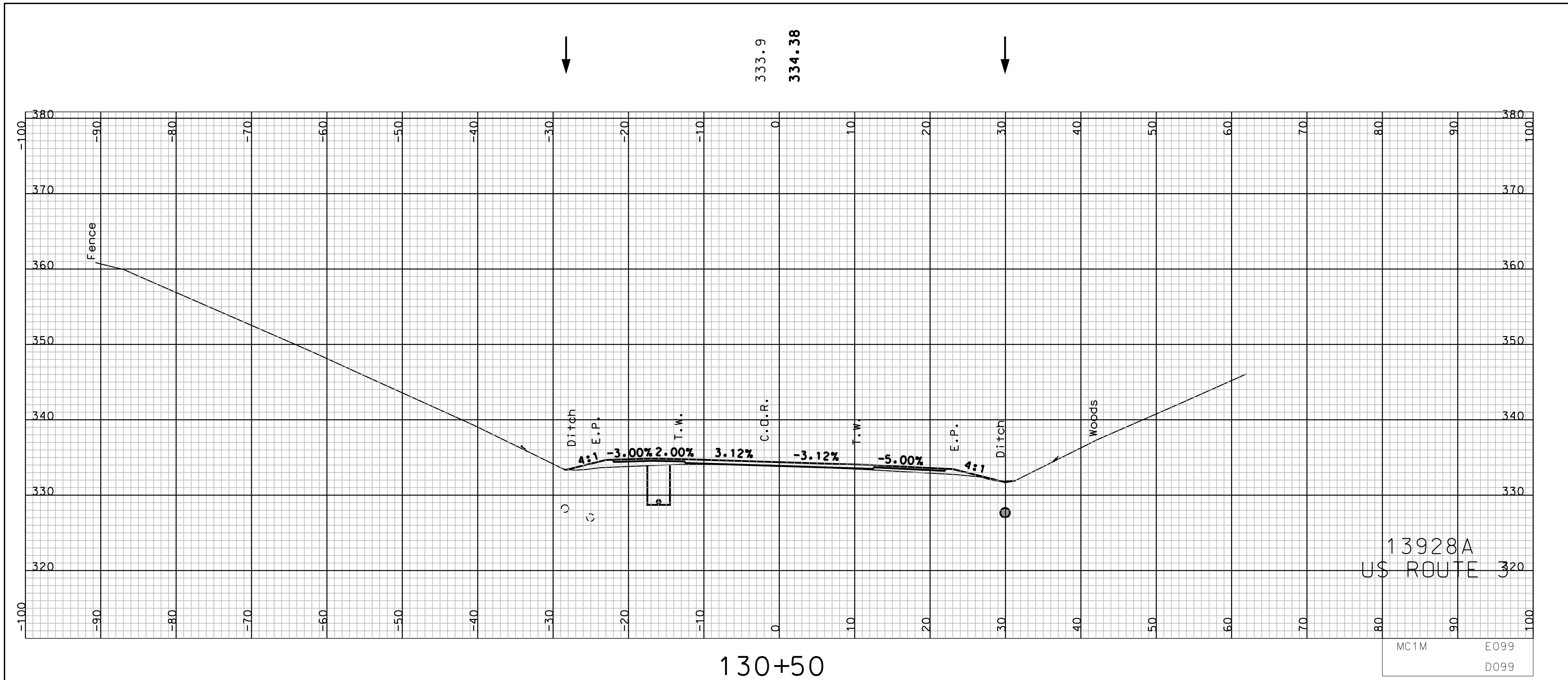

COMMON EXCAV.	0	SHEET TOTALS	ROCK EXCAV.	0
FILL	0	C.Y.	MUCK EXCAV.	0
DGN	STATE PROJECT NO.	SHEET NO.	TOTAL SHEETS	
13928axs-mc1m	13928A	116	160	

SDR PROCESSED	DATE
NEW DESIGN TEAM BALDWIN	DATE 09/2013
SHEET CHECKED TEAM BALDWIN	DATE 04/2015
AS BUILT DETAILS	DATE

REVISIONS AFTER PROPOSAL				
NUMBER	DATE	STATION	STATION	DESCRIPTION

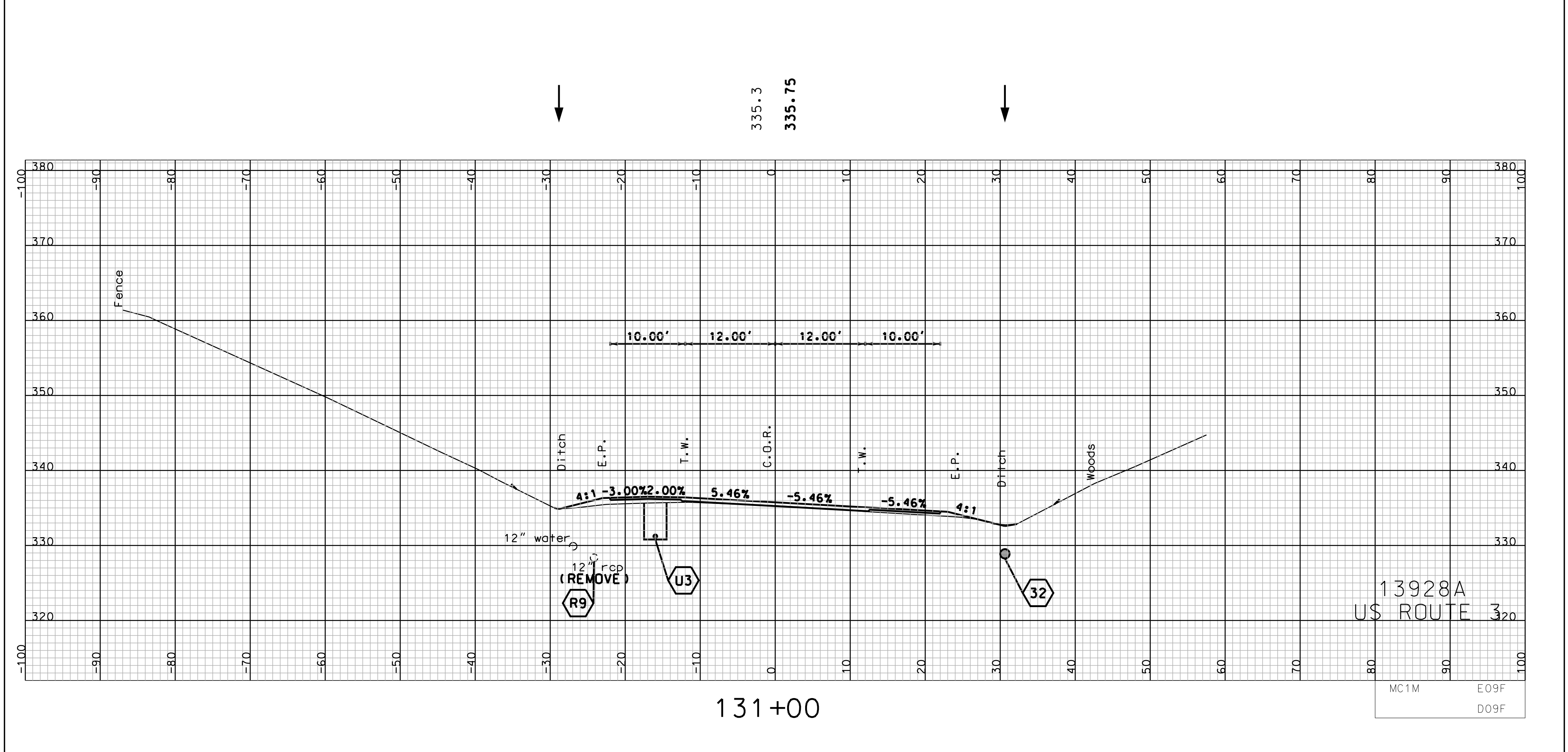
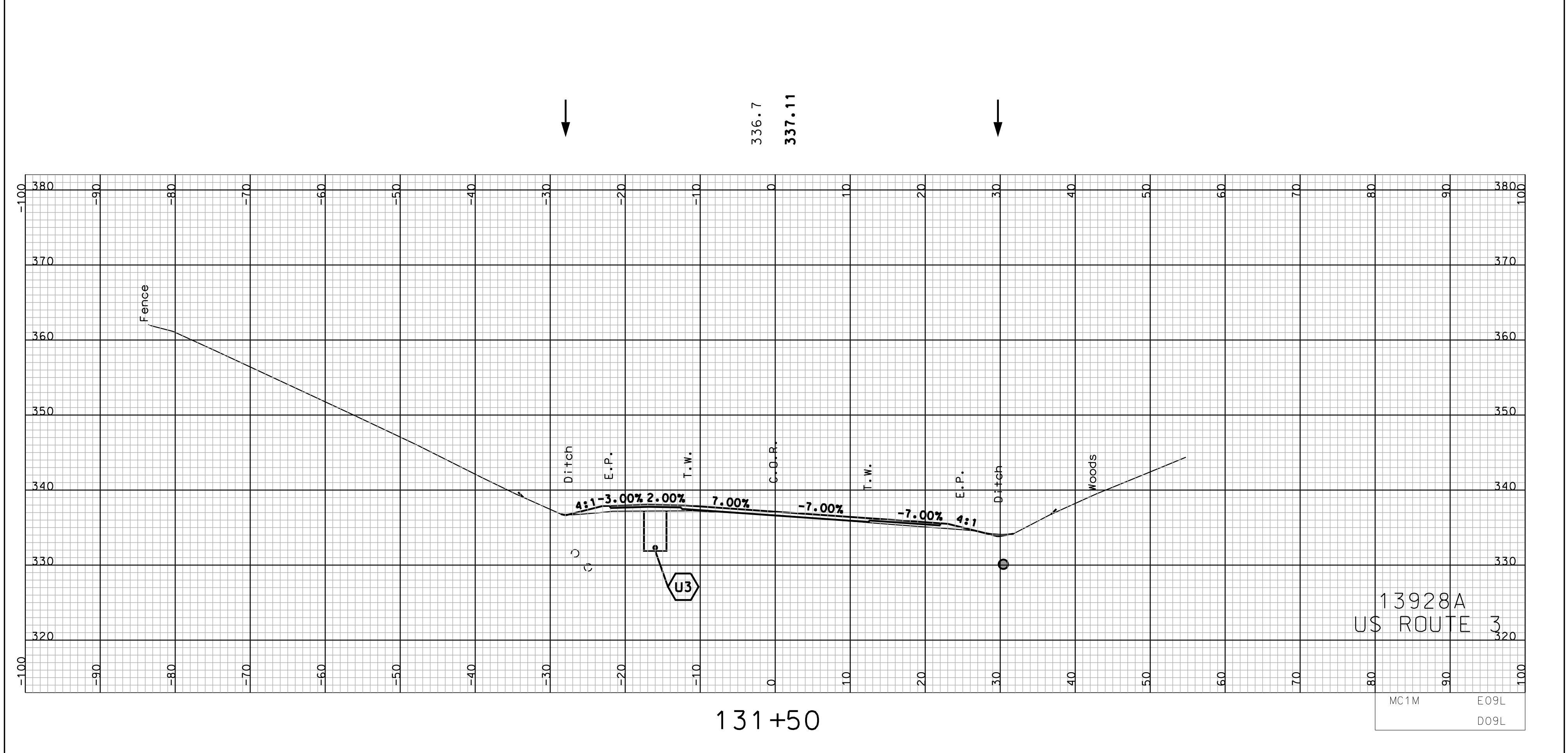
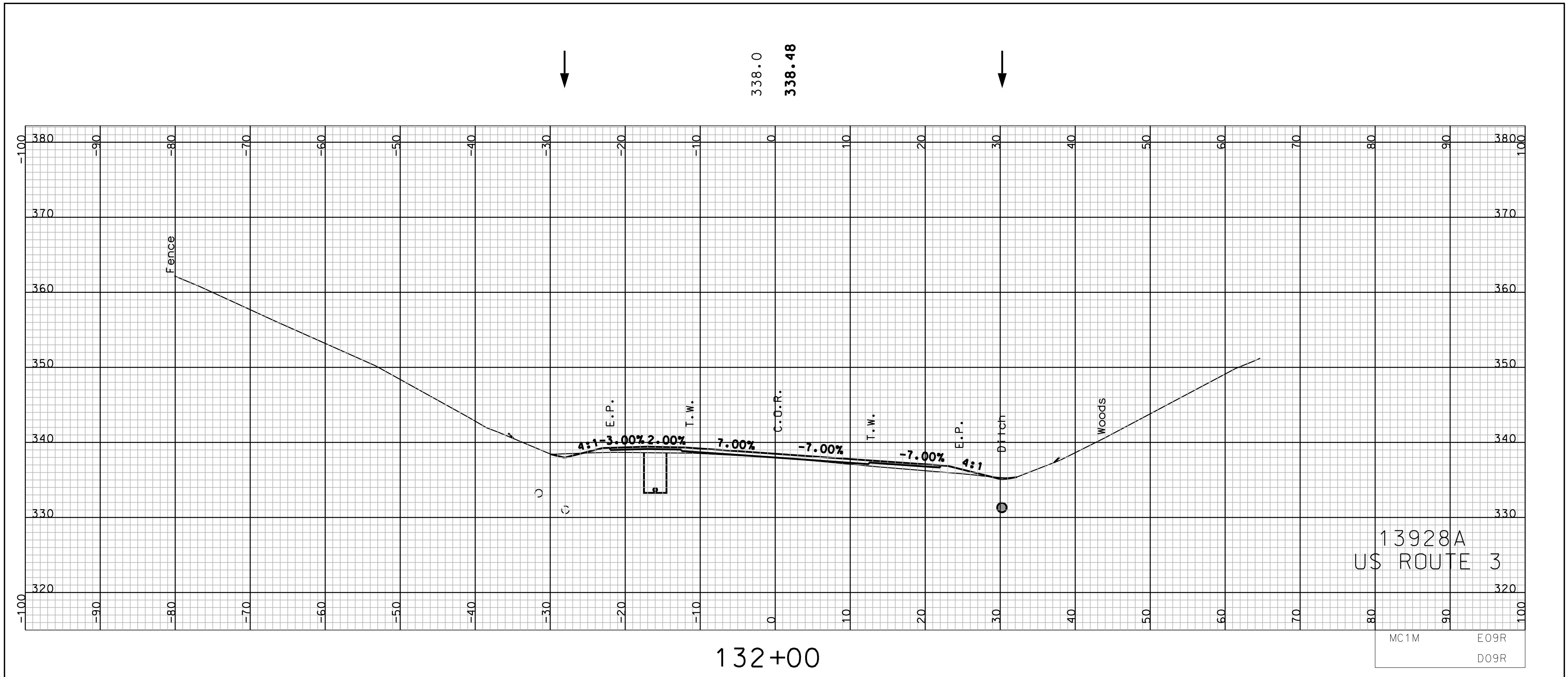

SHEET TOTALS					
COMMON EXCAV.	0	C.Y.	ROCK EXCAV.	0	C.Y.
FILL	0	C.Y.	MUCK EXCAV.	0	C.Y.
DGN	STATE PROJECT NO.	SHEET NO.	TOTAL SHEETS		
13928axs-mc1m	13928A	117	160		

SDR PROCESSED	DATE
NEW DESIGN TEAM BALDWIN	DATE 09/2013
SHEET CHECKED TEAM BALDWIN	DATE 04/2015
AS BUILT DETAILS	DATE

REVISIONS AFTER PROPOSAL				
NUMBER	DATE	STATION	STATION	DESCRIPTION

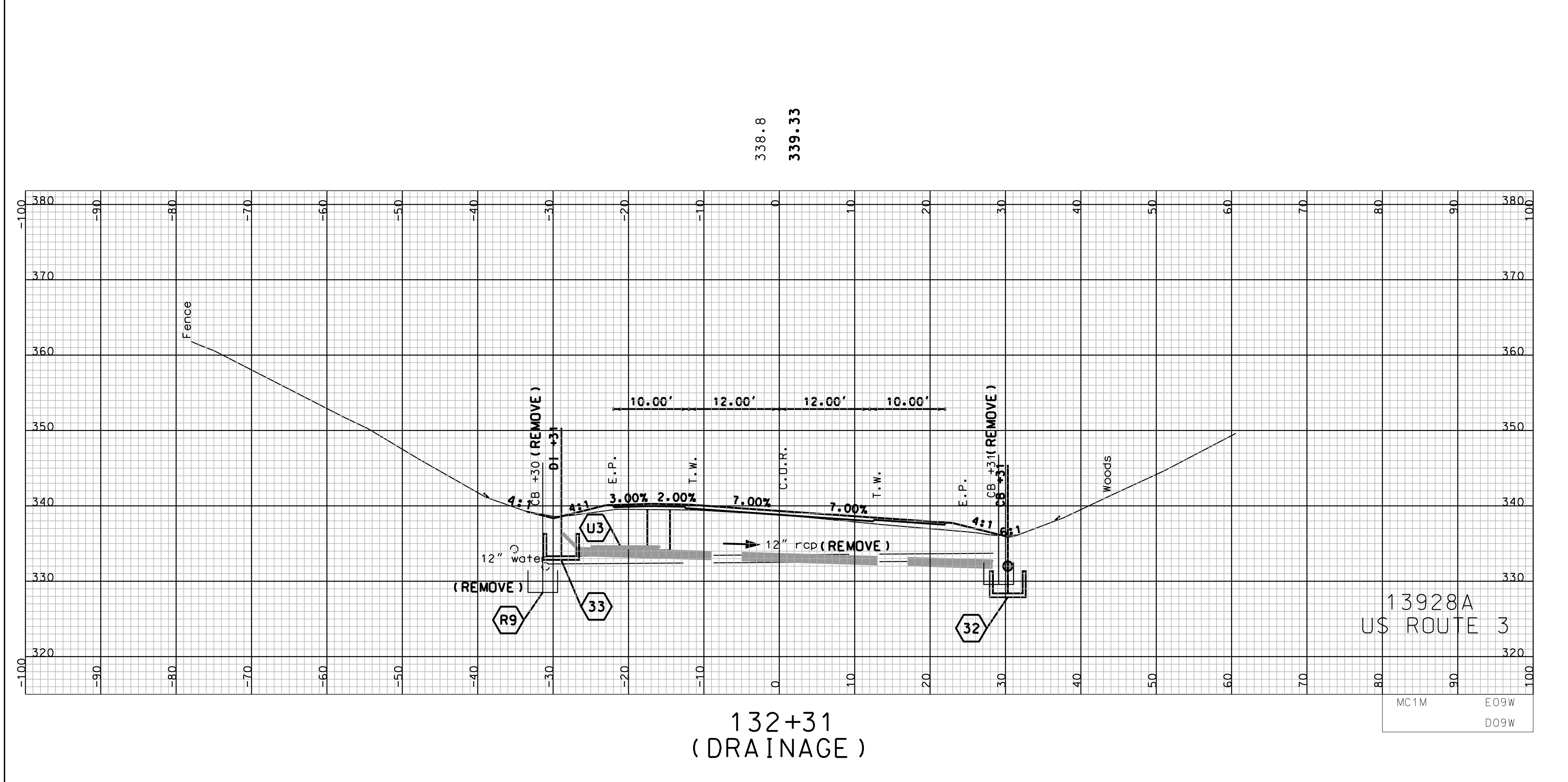
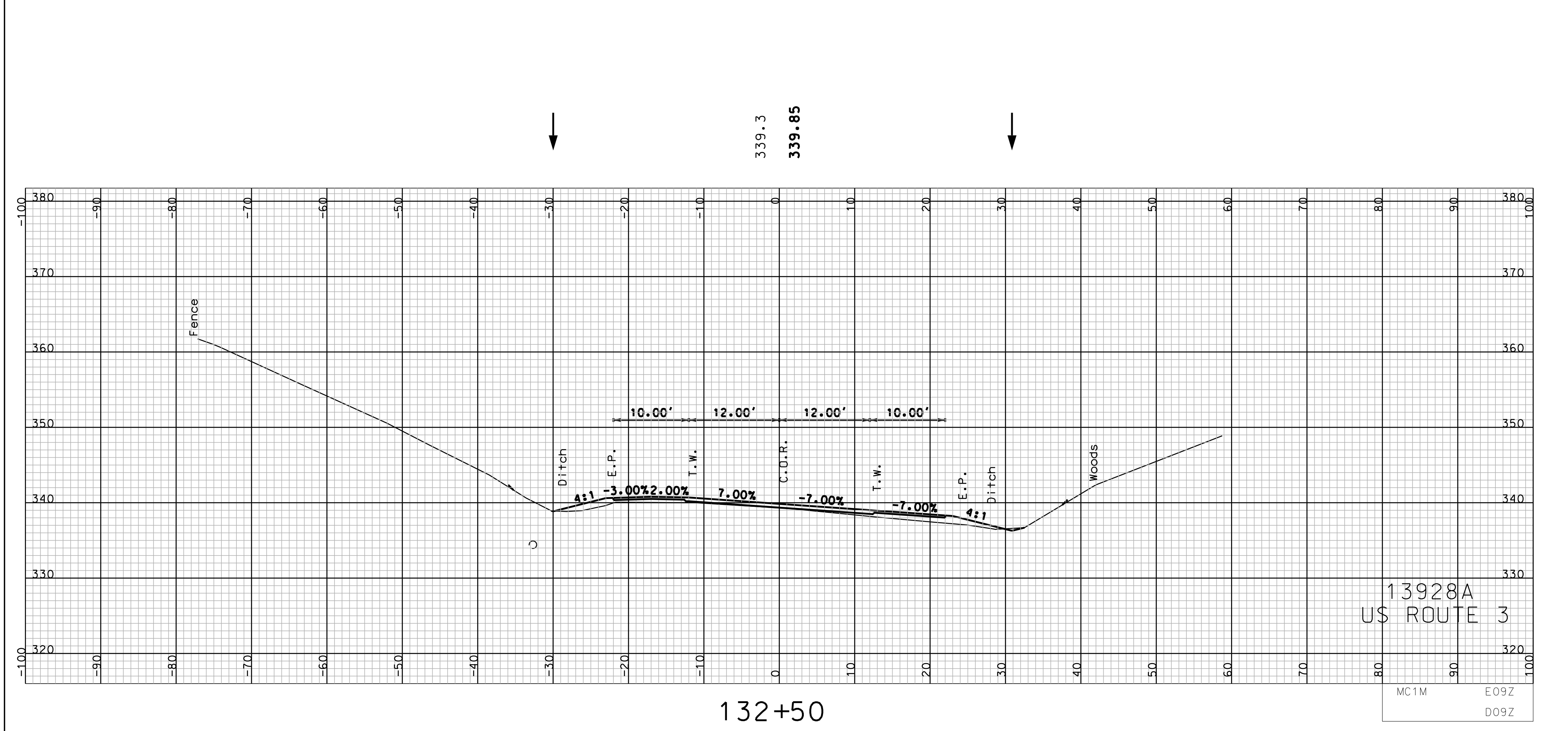
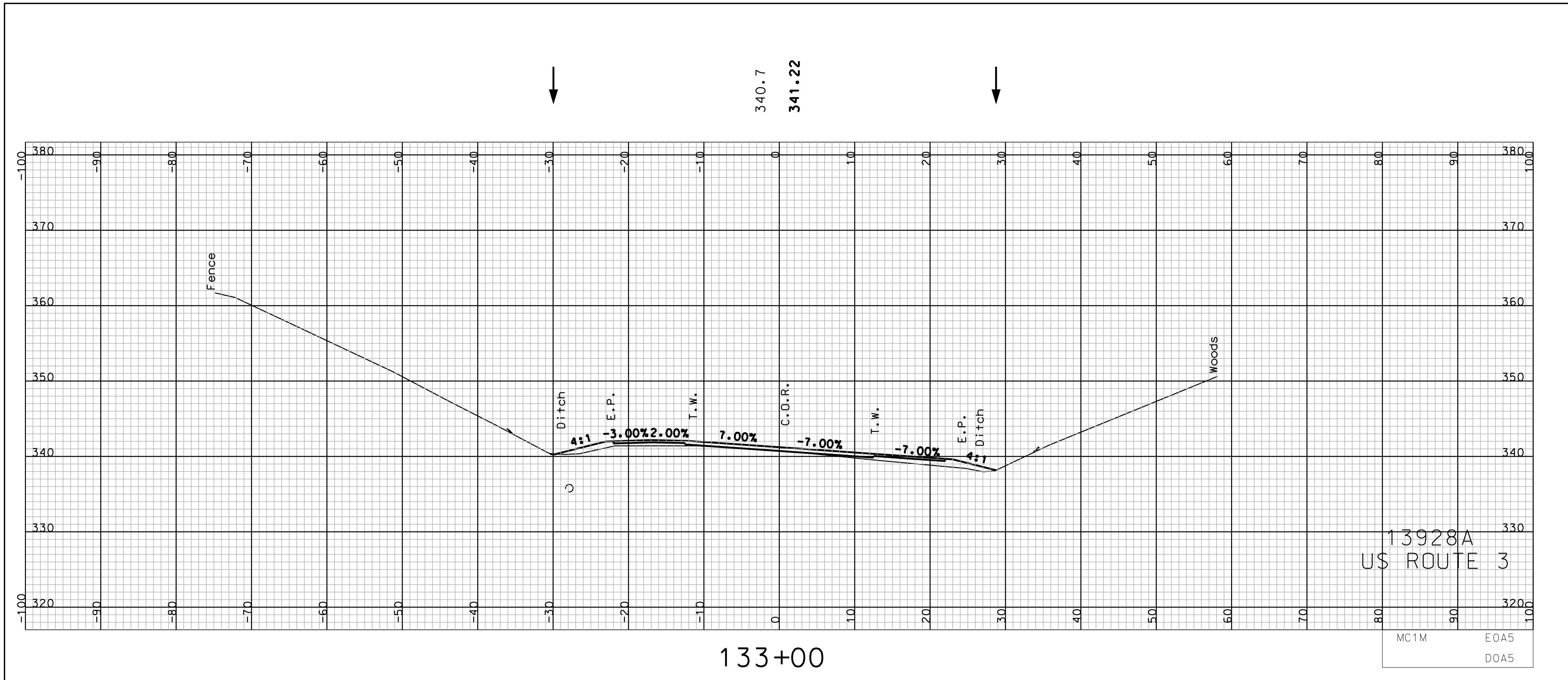

COMMON EXCAV.		SHEET TOTALS		ROCK EXCAV.	
0	C.Y.	0	C.Y.	0	C.Y.
0	C.Y.	0	C.Y.	0	C.Y.
0	C.Y.	0	C.Y.	0	C.Y.
DGN	STATE PROJECT NO.	SHEET NO.	TOTAL SHEETS		
13928axs-mc1m	13928A	118	160		

SDR PROCESSED	DATE
NEW DESIGN TEAM BALDWIN	DATE 09/2013
SHEET CHECKED TEAM BALDWIN	DATE 04/2015
AS BUILT DETAILS	DATE

REVISIONS AFTER PROPOSAL				
NUMBER	DATE	STATION	STATION	DESCRIPTION

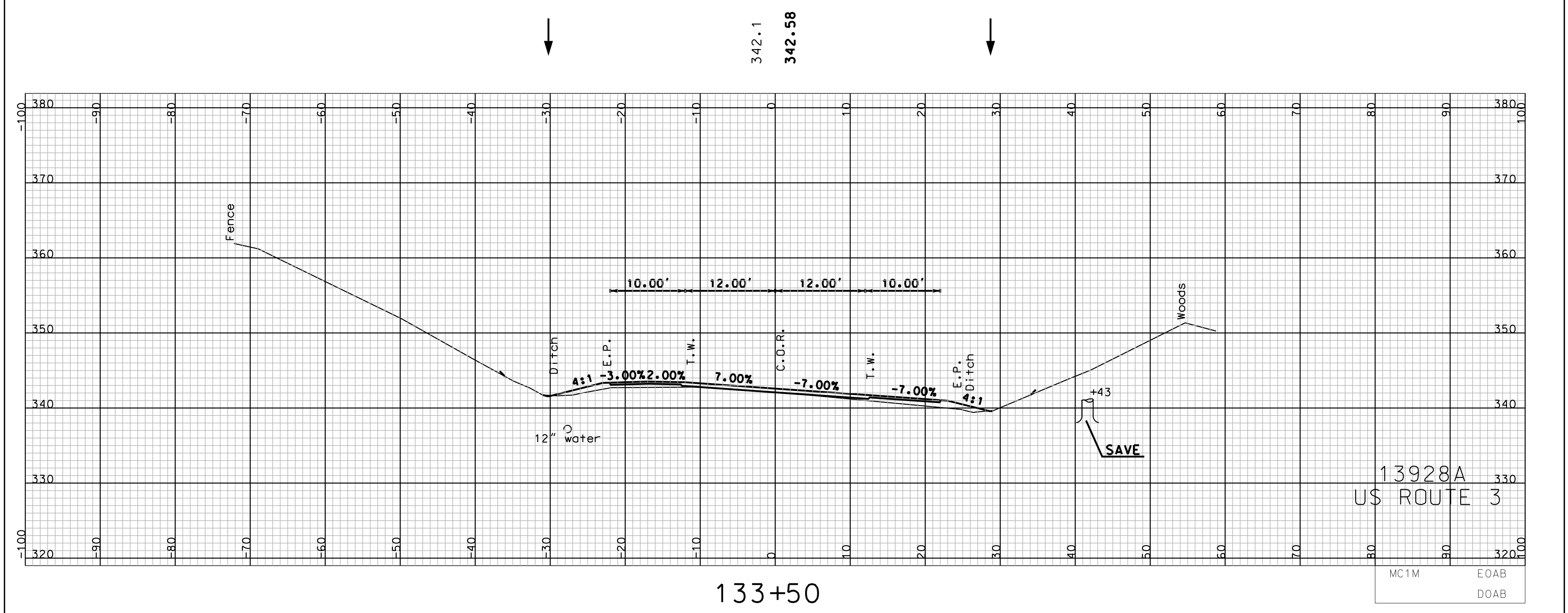
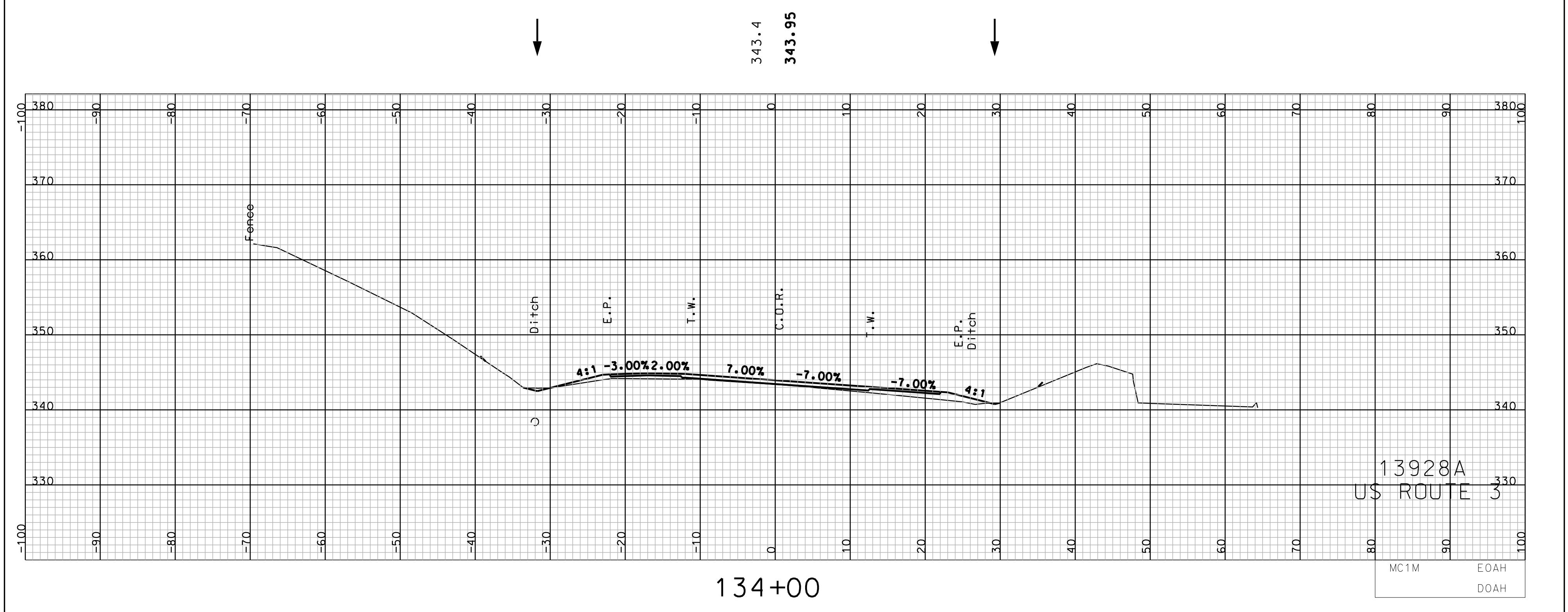
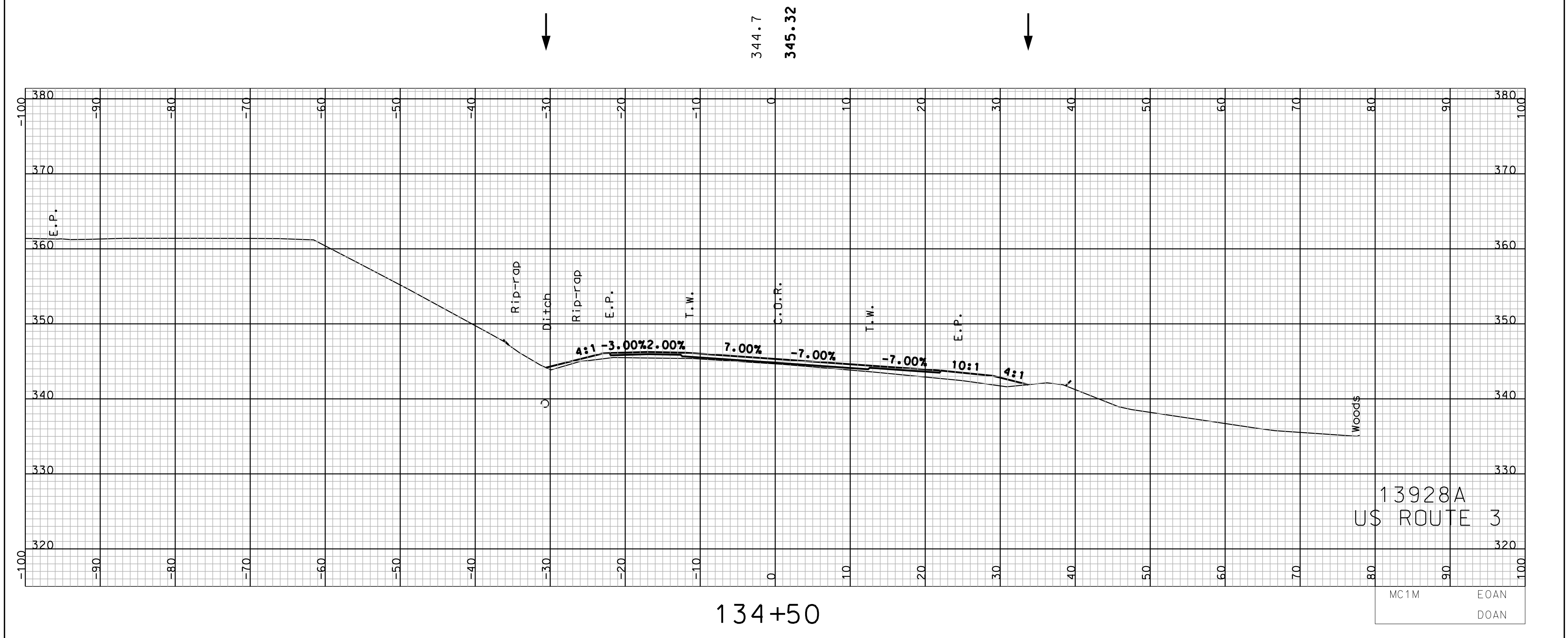

SHEET TOTALS					
COMMON EXCAV.	0	C.Y.	ROCK EXCAV.	0	C.Y.
FILL	0	C.Y.	MUCK EXCAV.	0	C.Y.
DGN	13928axs-mc1m	STATE PROJECT NO.	13928A	SHEET NO.	119
				TOTAL SHEETS	160

SDR PROCESSED	DATE
NEW DESIGN TEAM BALDWIN	DATE 09/2013
SHEET CHECKED TEAM BALDWIN	DATE 04/2015
AS BUILT DETAILS	DATE

REVISIONS AFTER PROPOSAL				
NUMBER	DATE	STATION	STATION	DESCRIPTION

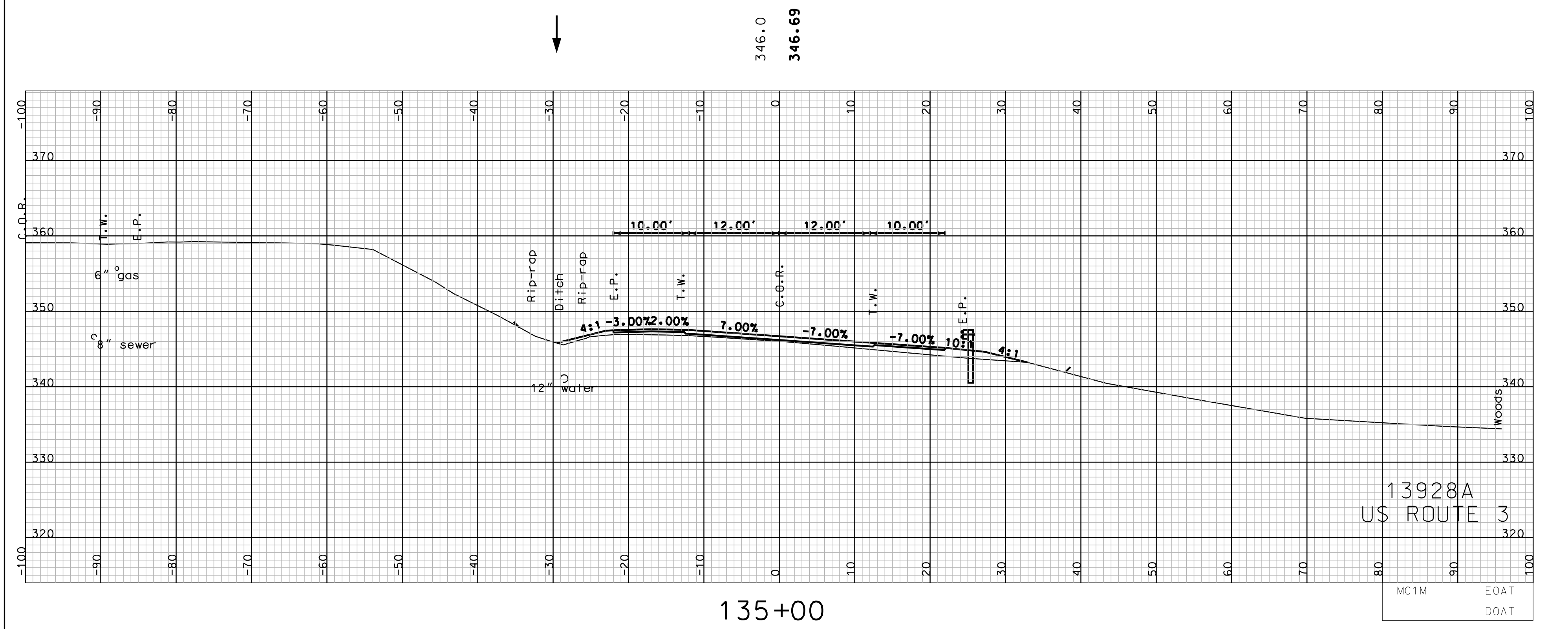
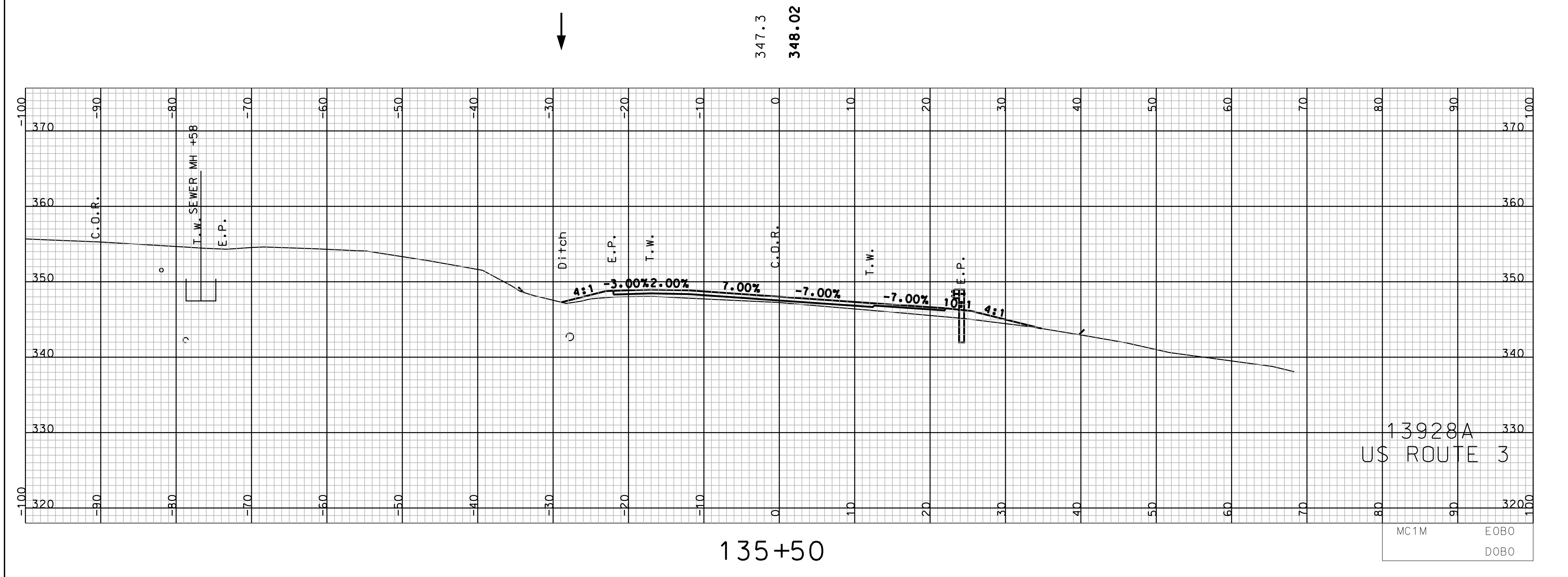
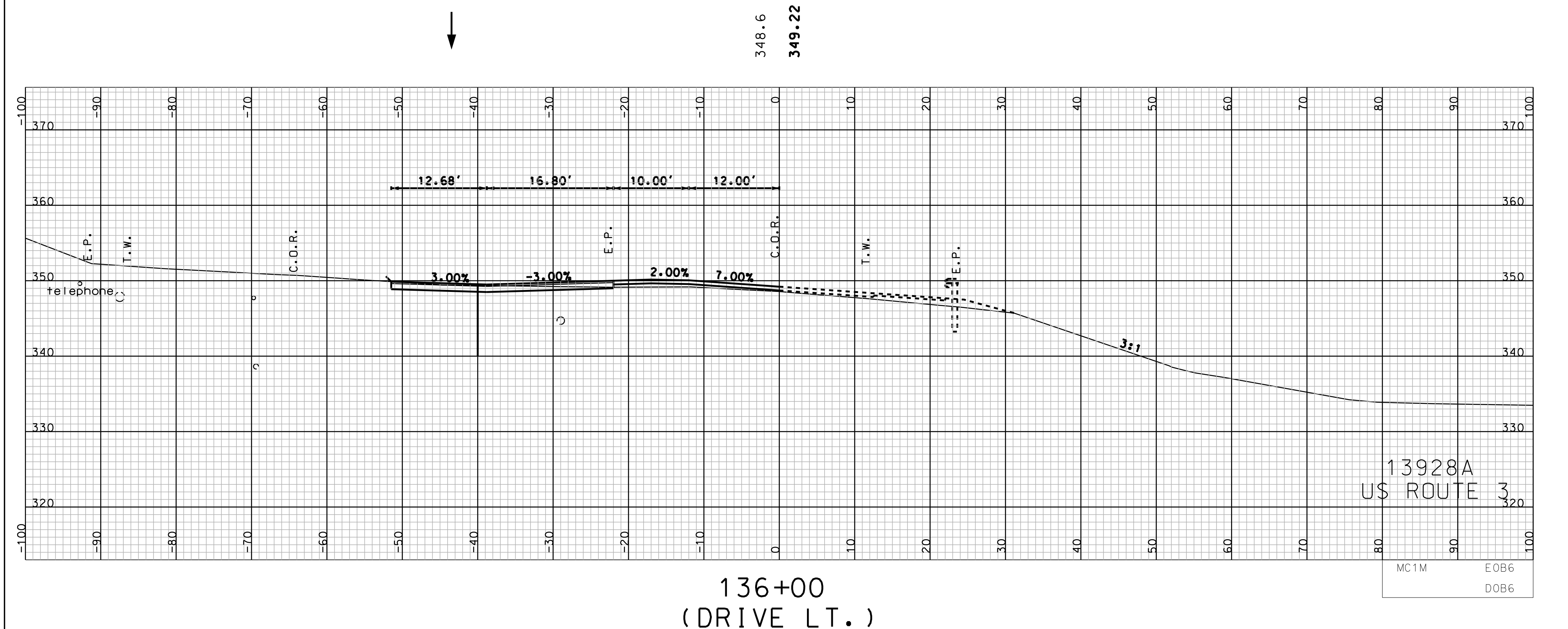

COMMON EXCAV.	46	SHEET TOTALS	ROCK EXCAV.	0
FILL	0	C.Y.	MUCK EXCAV.	0
DGN	13928axs-mc1m	STATE PROJECT NO.	13928A	SHEET NO.
			120	TOTAL SHEETS
			160	

SDR PROCESSED	DATE
NEW DESIGN TEAM BALDWIN	DATE 09/2013
SHEET CHECKED TEAM BALDWIN	DATE 04/2015
AS BUILT DETAILS	DATE

REVISIONS AFTER PROPOSAL				
NUMBER	DATE	STATION	STATION	DESCRIPTION

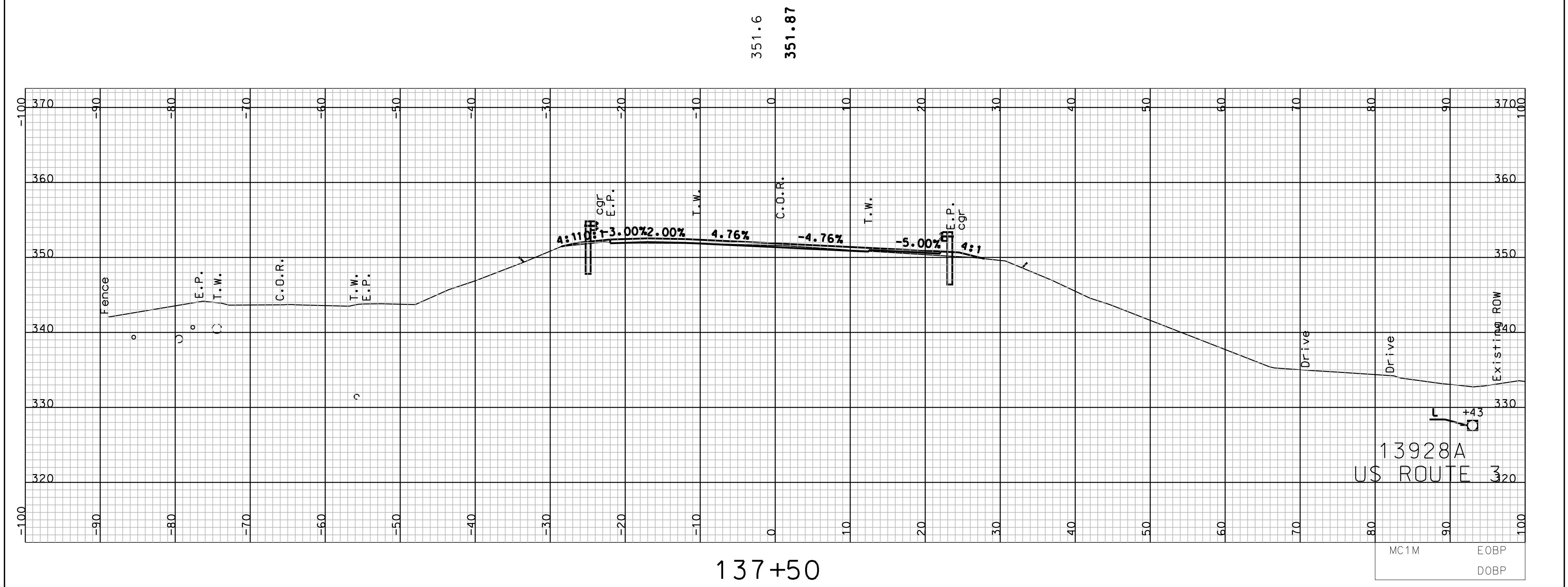

137+50

MC1M EOBP DOBP

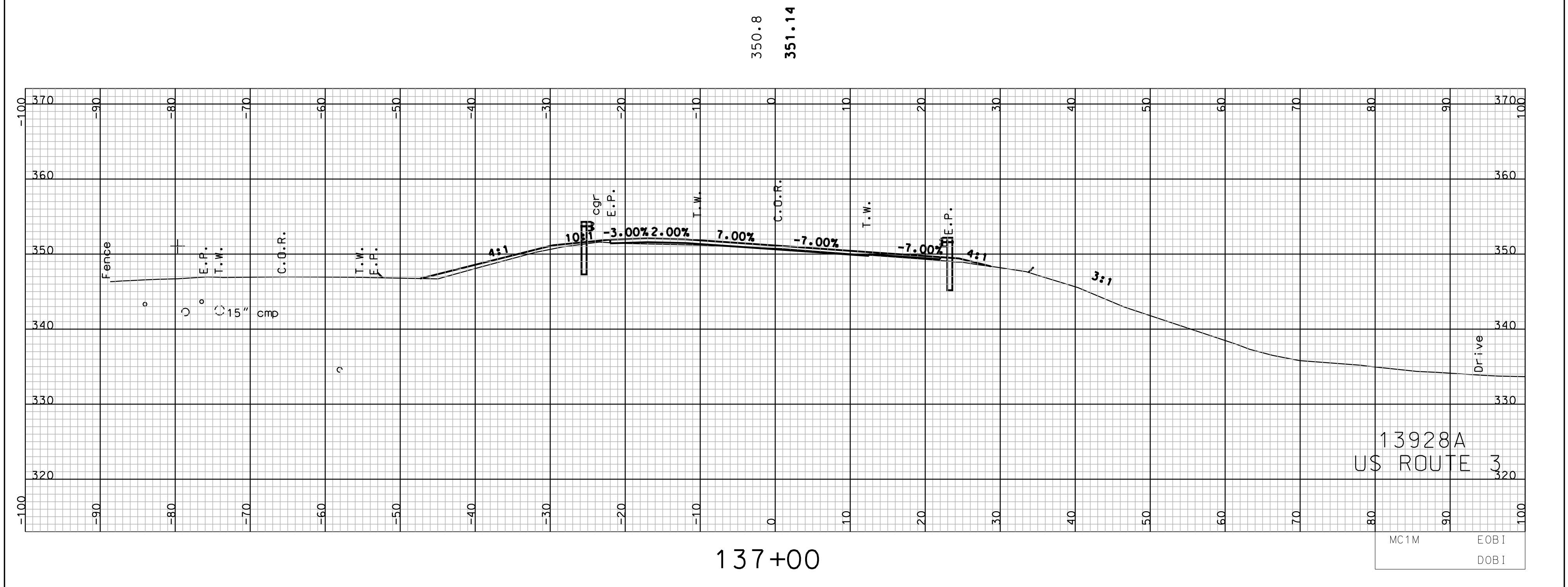

137+00

MC1M EOB1 DOB1

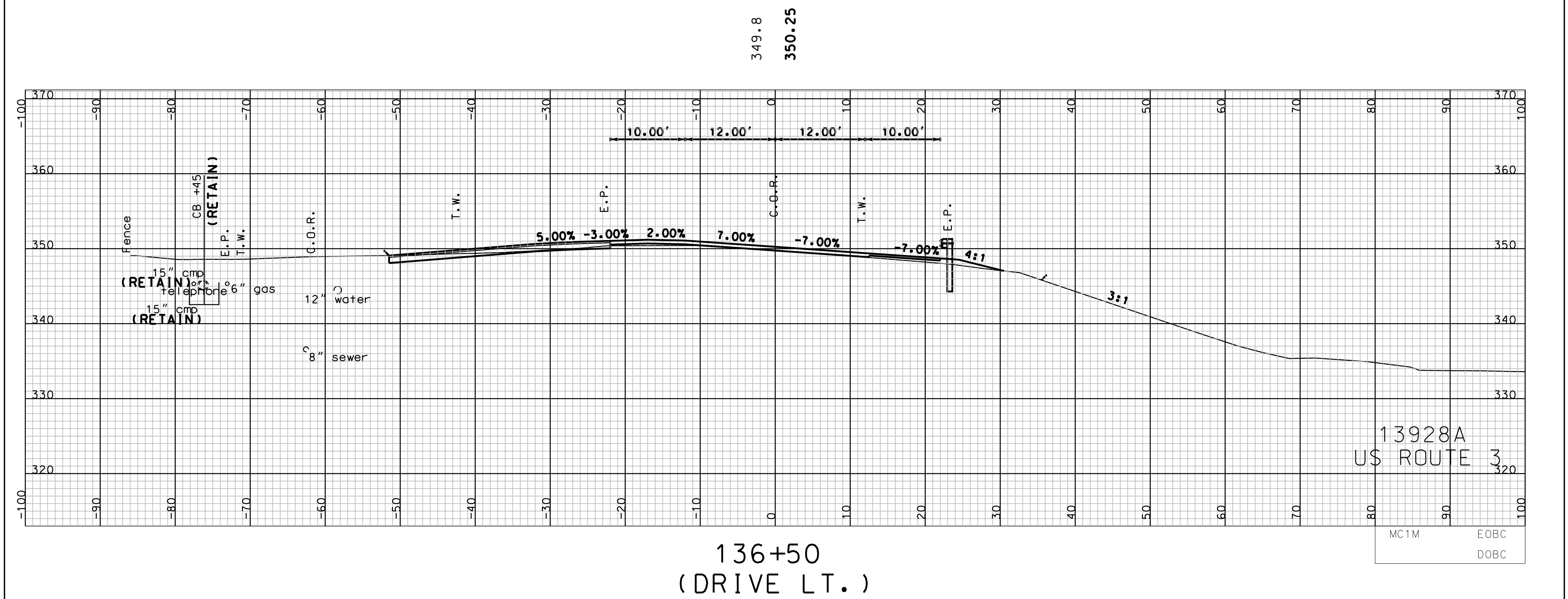

136+50
(DRIVE LT.)

MC1M EOBC DOBC

COMMON EXCAV.		SHEET TOTALS		ROCK EXCAV.	
	C.Y.		C.Y.		C.Y.
24				0	
FILL	18			MUCK EXCAV.	0
					C.Y.
DGN	STATE PROJECT NO.	SHEET NO.	TOTAL SHEETS		
13928axs-mc1m	13928A	121	160		

SDR PROCESSED	DATE
NEW DESIGN TEAM BALDWIN	DATE 09/2013
SHEET CHECKED TEAM BALDWIN	DATE 04/2015
AS BUILT DETAILS	DATE

REVISIONS AFTER PROPOSAL					
NUMBER	DATE	STATION	STATION	DESCRIPTION	

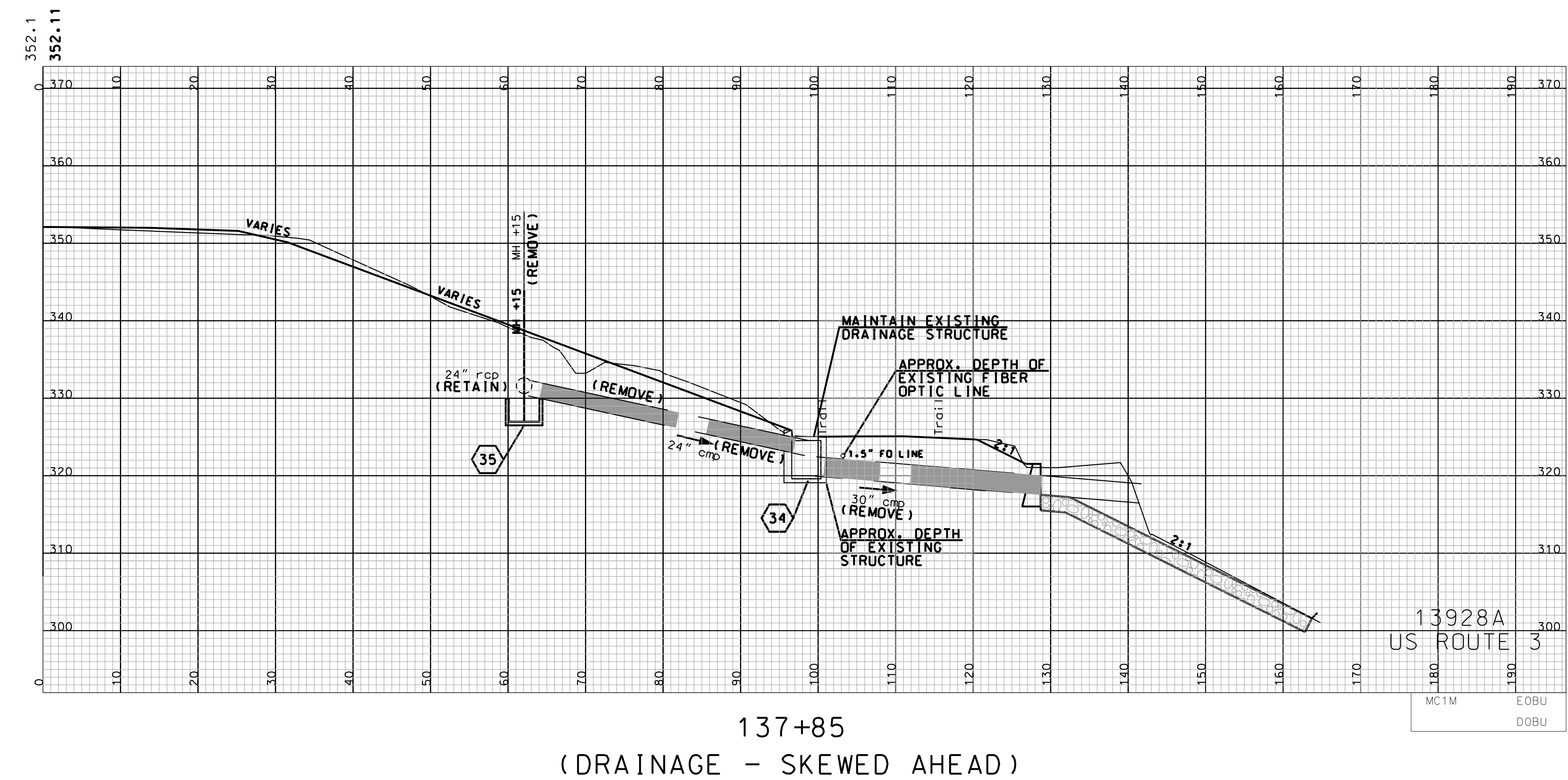
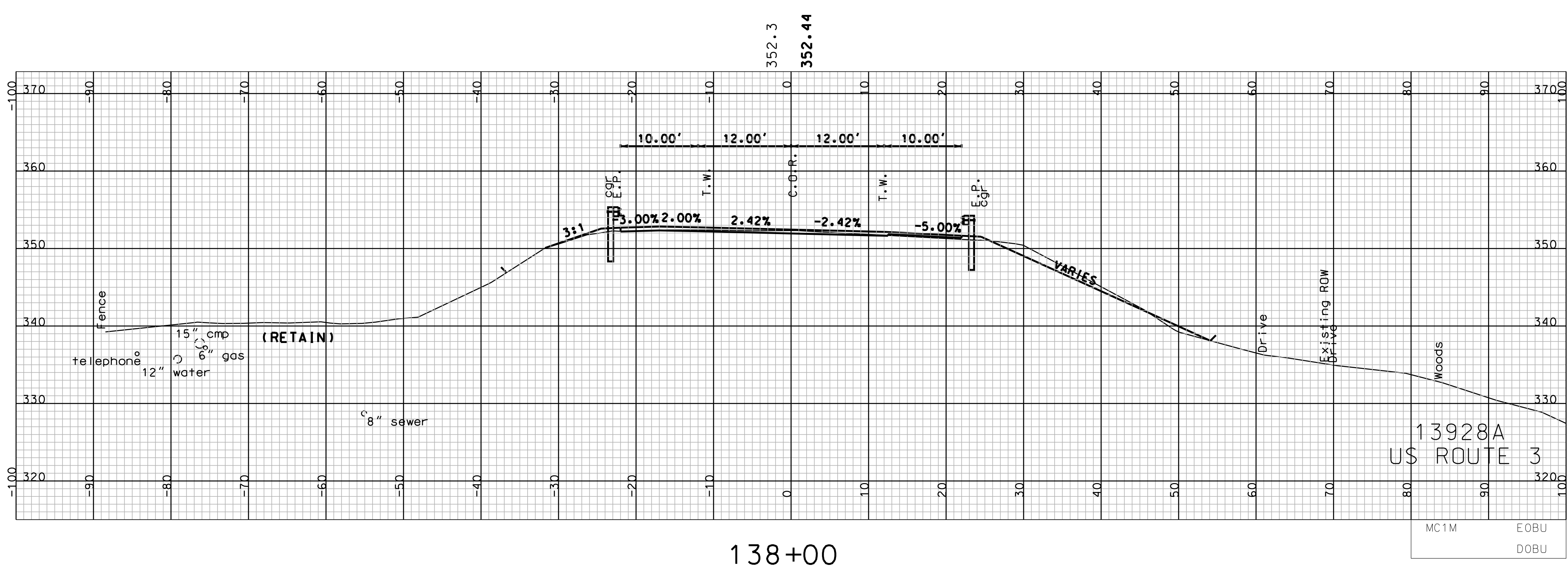
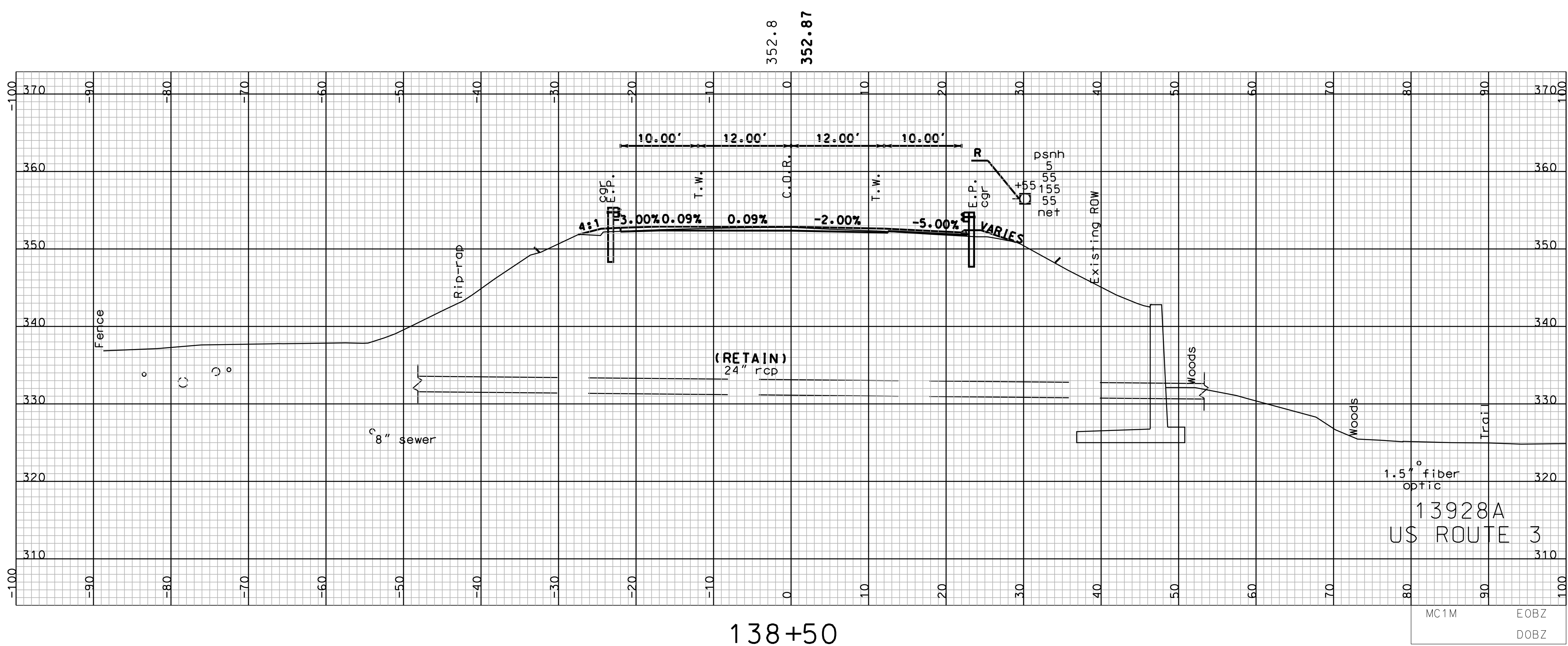

SHEET TOTALS					
COMMON EXCAV.	14	C.Y.	ROCK EXCAV.	0	C.Y.
FILL	12	C.Y.	MUCK EXCAV.	0	C.Y.
DGN	STATE PROJECT NO.	SHEET NO.	TOTAL SHEETS		
13928axs-mc1m	13928A	122	160		

SDR PROCESSED	DATE
NEW DESIGN TEAM BALDWIN	DATE 09/2013
SHEET CHECKED TEAM BALDWIN	DATE 04/2015
AS BUILT DETAILS	DATE

REVISIONS AFTER PROPOSAL				
NUMBER	DATE	STATION	STATION	DESCRIPTION

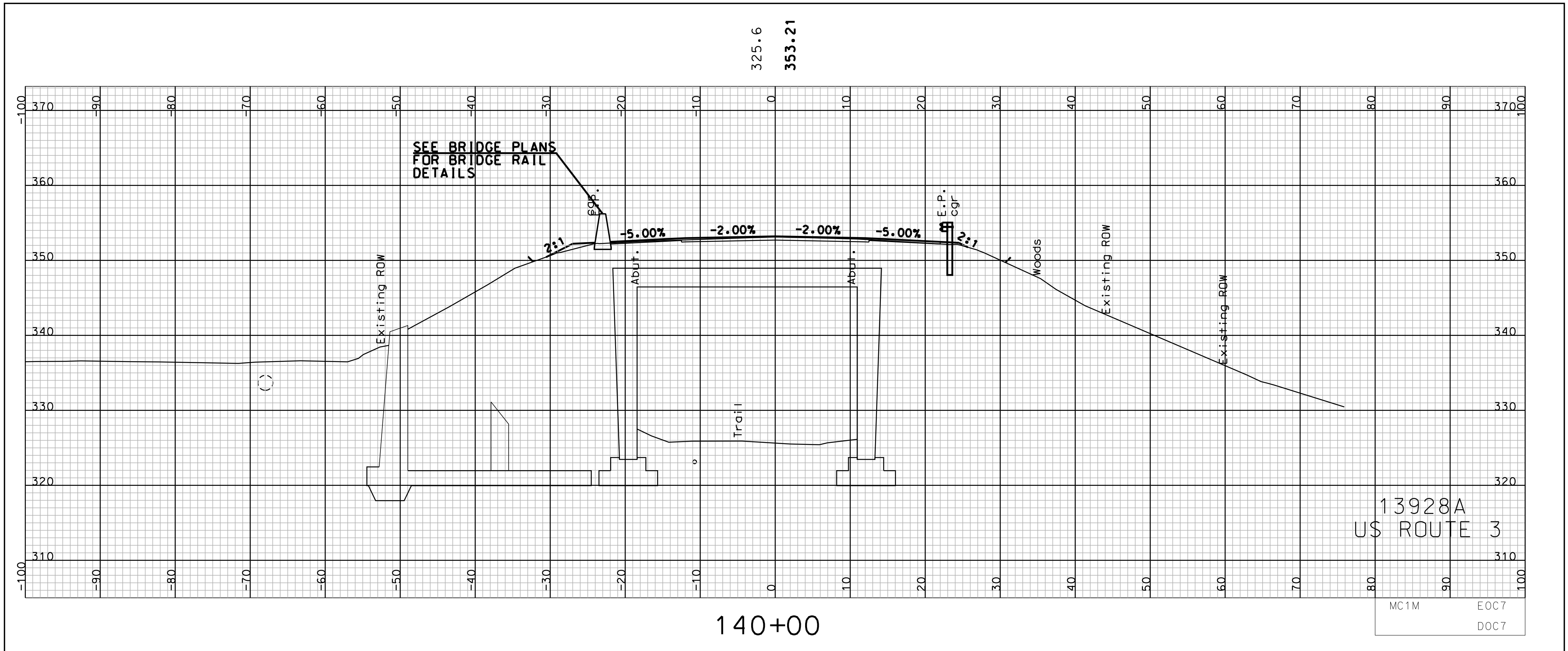

140+00

13928A
US ROUTE 3

MC1M EOC7
DOC7

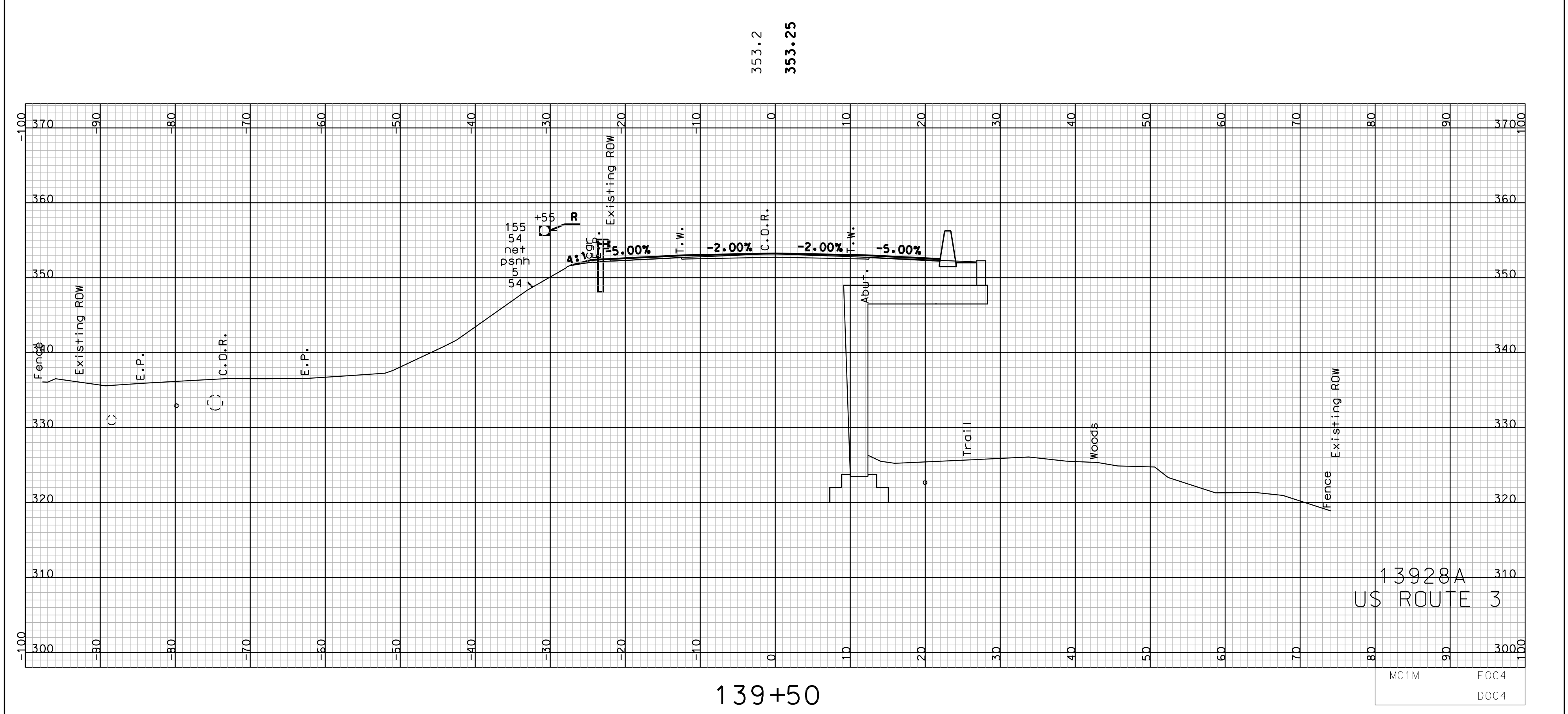

139+50

13928A
US ROUTE 3

MC1M EOC4
DOC4

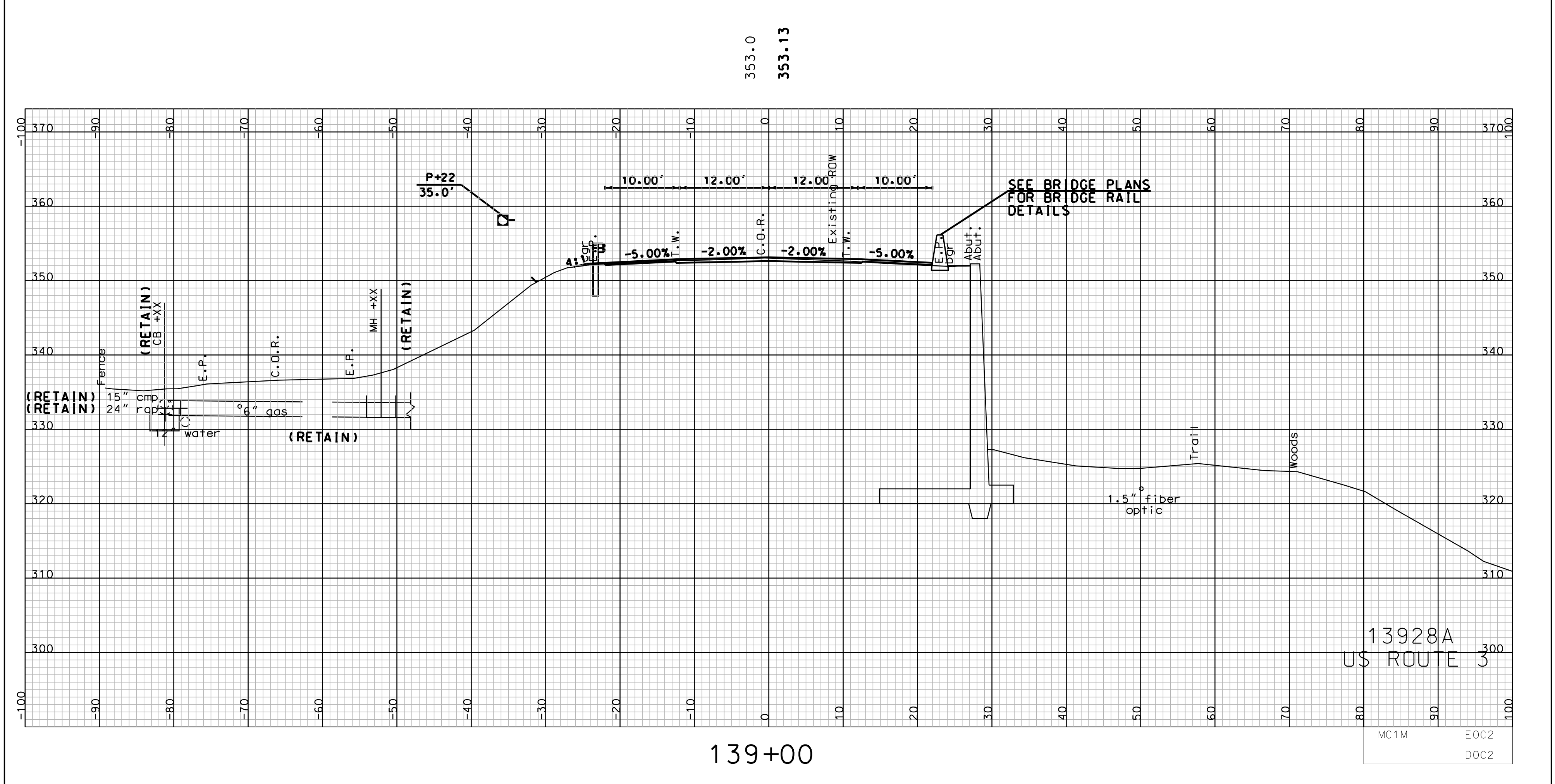

139+00

13928A
US ROUTE 3

MC1M EOC2
DOC2

SHEET TOTALS			
COMMON EXCAV.	C.Y.	ROCK EXCAV.	C.Y.
FILL	C.Y.	MUCK EXCAV.	C.Y.
0	0	0	0
0	0	0	0
DGN	STATE PROJECT NO.	SHEET NO.	TOTAL SHEETS
13928axs-mc1m	13928A	123	160

SDR PROCESSED	DATE
NEW DESIGN TEAM BALDWIN	DATE 09/2013
SHEET CHECKED TEAM BALDWIN	DATE 04/2015
AS BUILT DETAILS	DATE

REVISIONS AFTER PROPOSAL				
NUMBER	DATE	STATION	STATION	DESCRIPTION

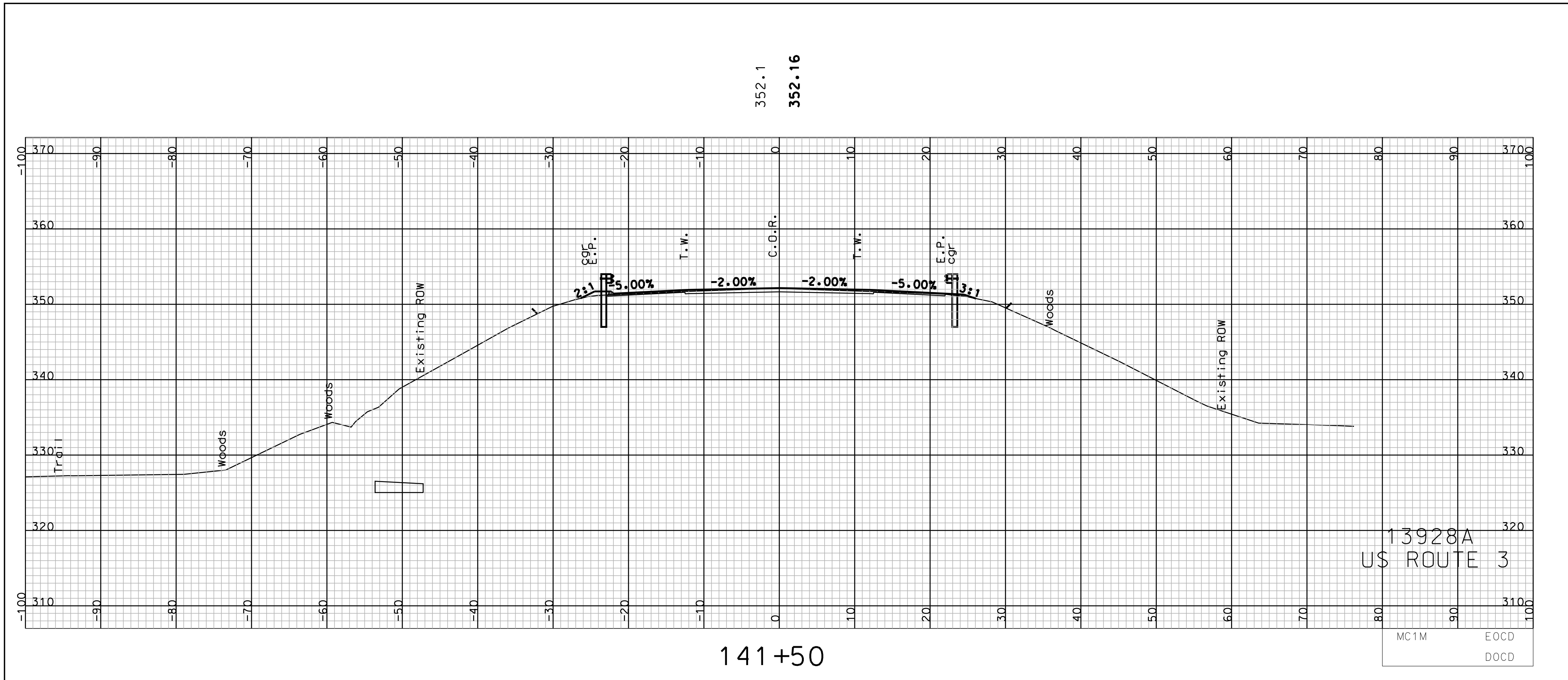

141+50

13928A
US ROUTE 3

MC1M EOC9
DOC9

352.1
352.16

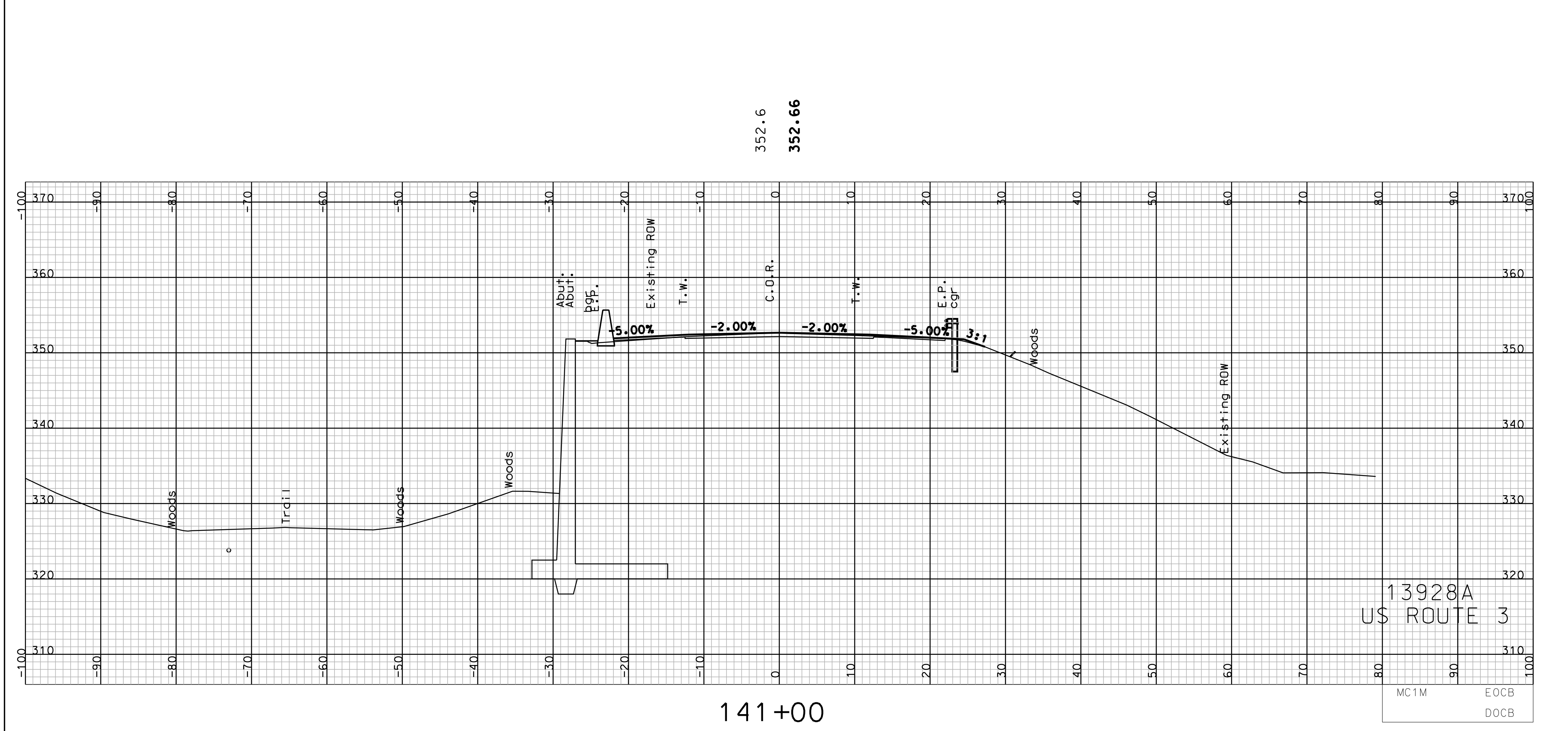

141+00

13928A
US ROUTE 3

MC1M EOCB
DOCB

352.6
352.66

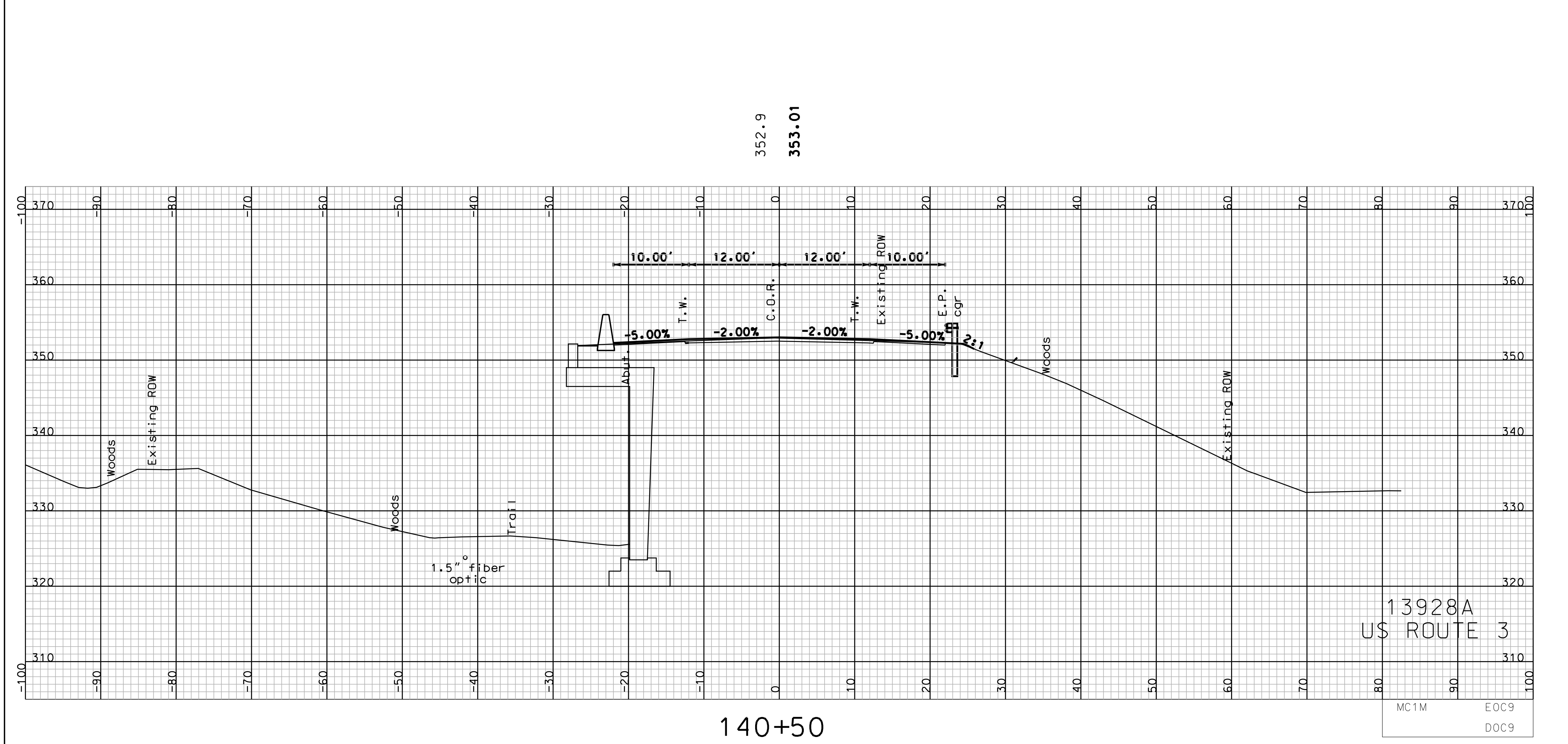

140+50

13928A
US ROUTE 3

MC1M EOC9
DOC9

352.9
353.01

SHEET TOTALS					
COMMON EXCAV.	0	C.Y.	ROCK EXCAV.	0	C.Y.
FILL	0	C.Y.	MUCK EXCAV.	0	C.Y.
DGN	STATE PROJECT NO.	SHEET NO.	TOTAL SHEETS		
13928axs-mc1m	13928A	124	160		

SDR PROCESSED	DATE
NEW DESIGN TEAM BALDWIN	DATE 09/2013
SHEET CHECKED TEAM BALDWIN	DATE 04/2015
AS BUILT DETAILS	DATE

REVISIONS AFTER PROPOSAL				
NUMBER	DATE	STATION	STATION	DESCRIPTION

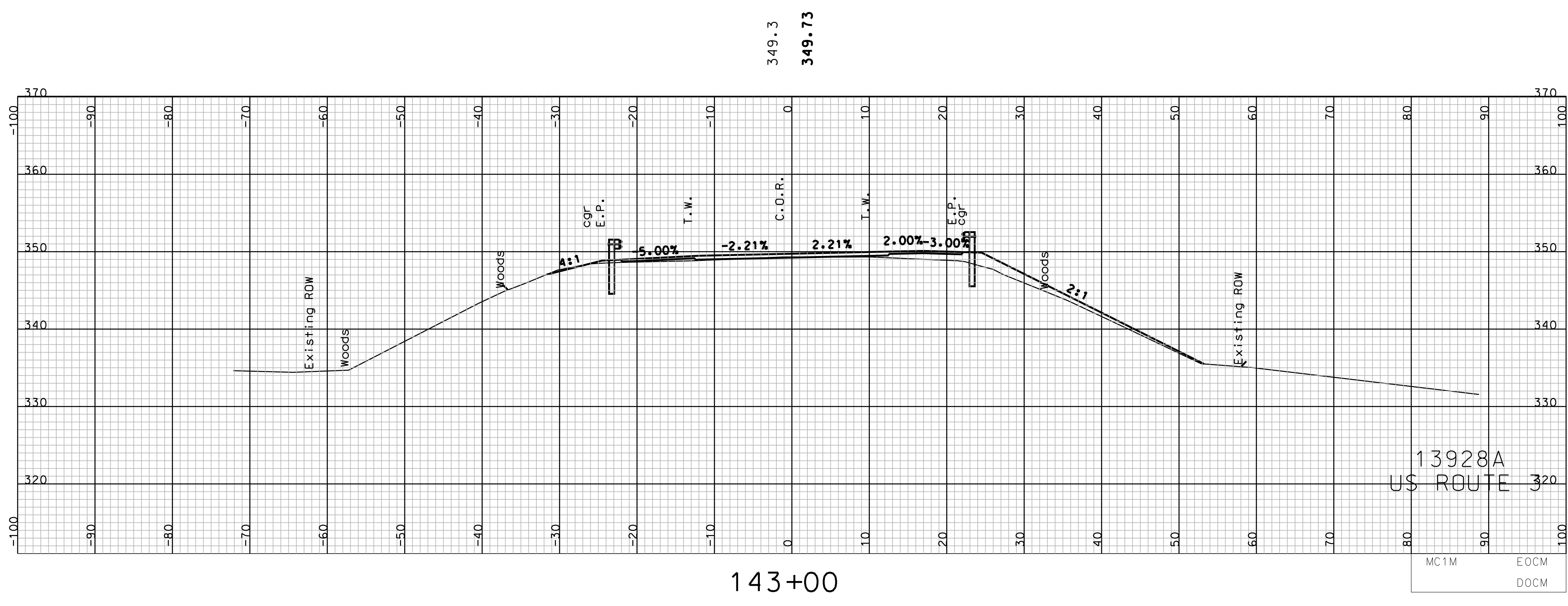

143+00

13928A
US ROUTE 3

MC1M EOCM
DOCM

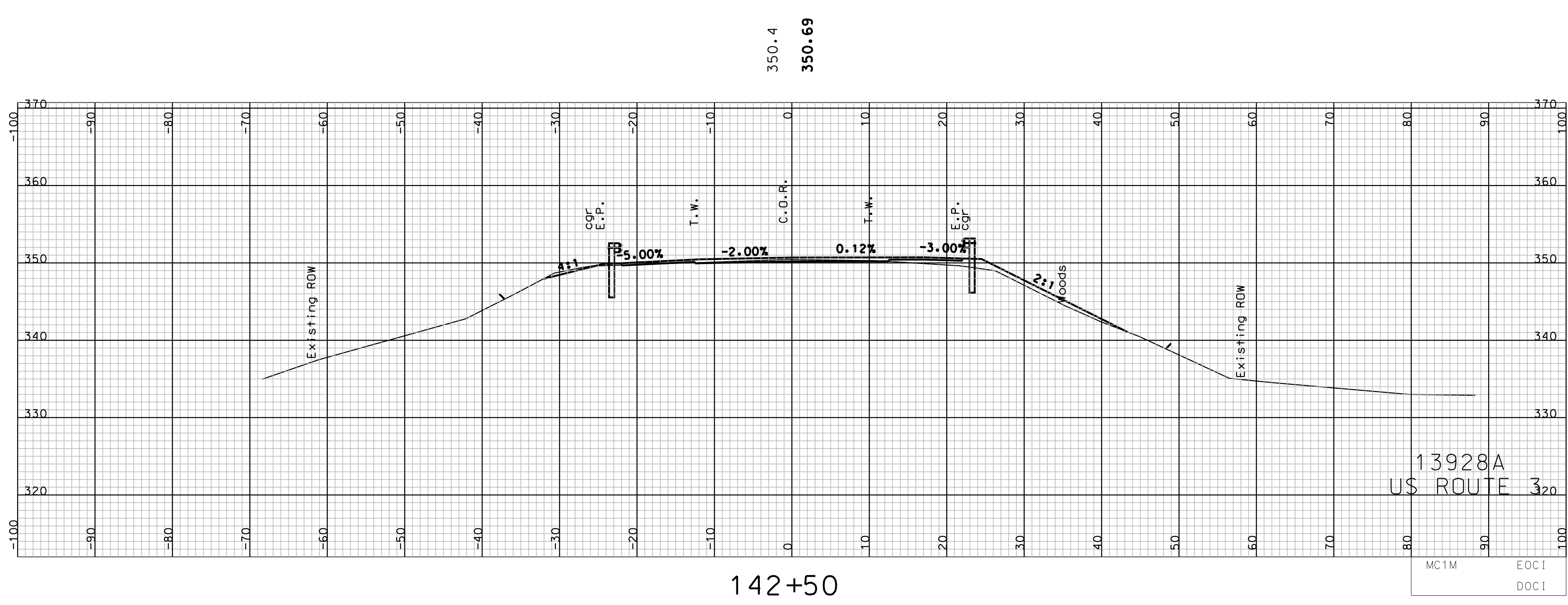

142+50

13928A
US ROUTE 3

MC1M EOC1
DOC1

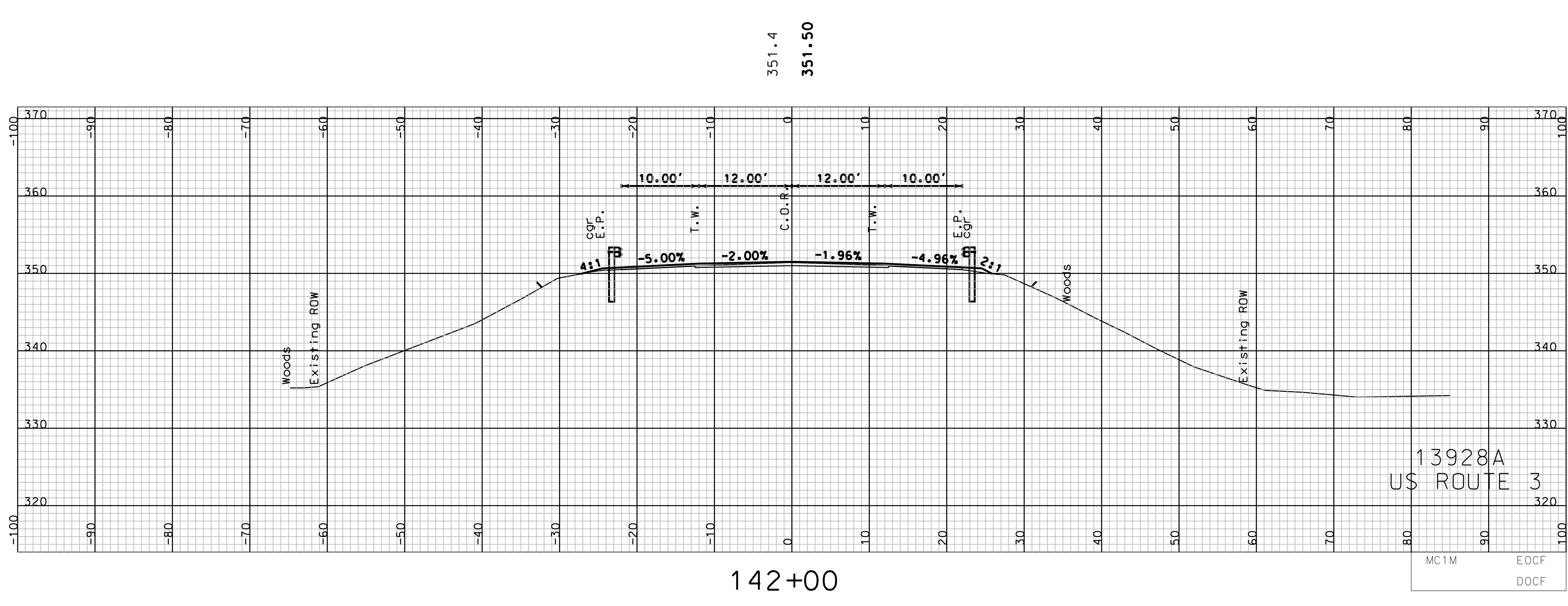

142+00

13928A
US ROUTE 3

MC1M EOCF
DOCF

SHEET TOTALS					
COMMON EXCAV.	4	C.Y.	ROCK EXCAV.	0	C.Y.
FILL	0	C.Y.	MUCK EXCAV.	0	C.Y.
DGN	STATE PROJECT NO.	SHEET NO.	TOTAL SHEETS		
13928axs-mc1m	13928A	125	160		

SDR PROCESSED	DATE
NEW DESIGN TEAM BALDWIN	DATE 09/2013
SHEET CHECKED TEAM BALDWIN	DATE 04/2015
AS BUILT DETAILS	DATE

REVISIONS AFTER PROPOSAL				
NUMBER	DATE	STATION	STATION	DESCRIPTION

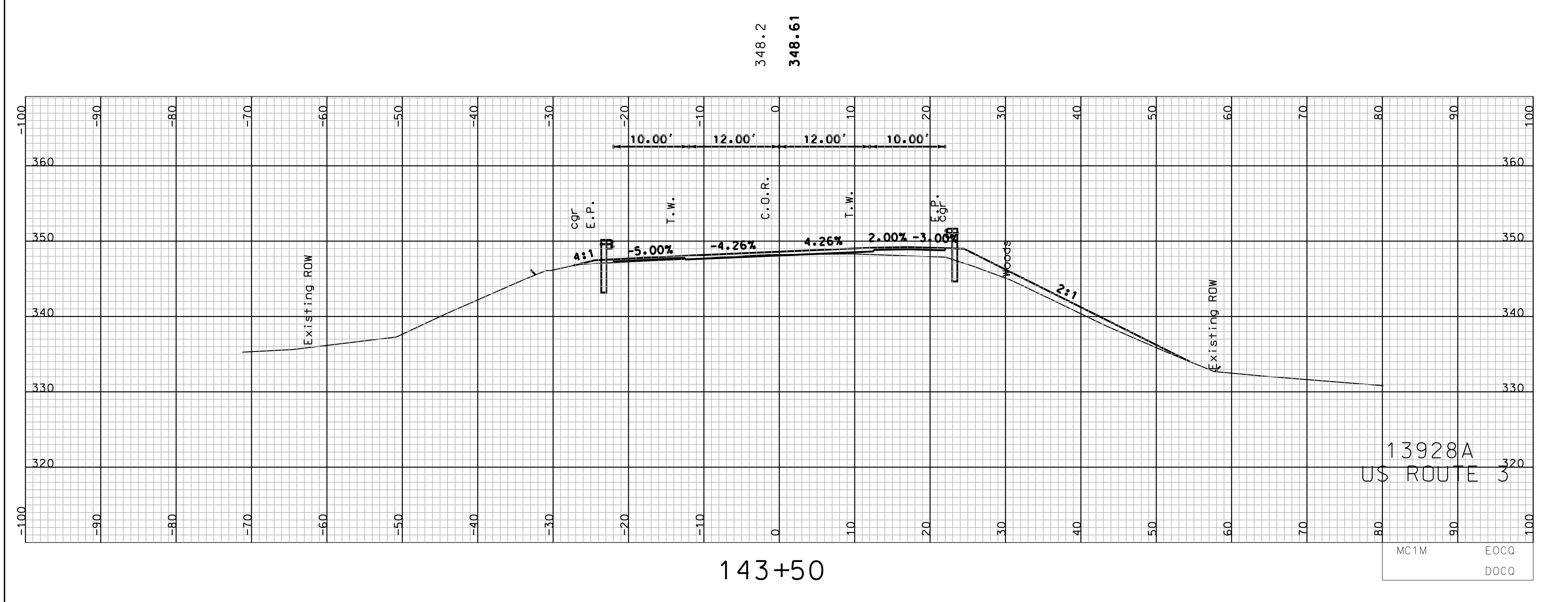
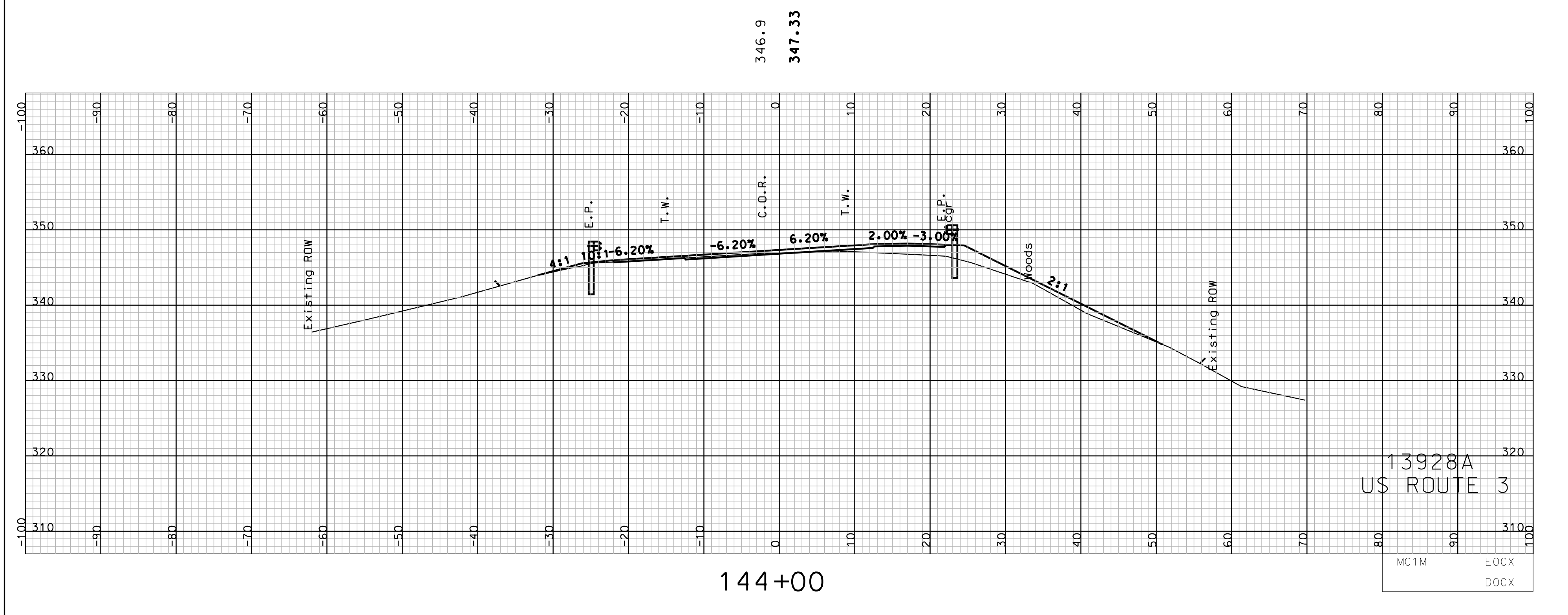
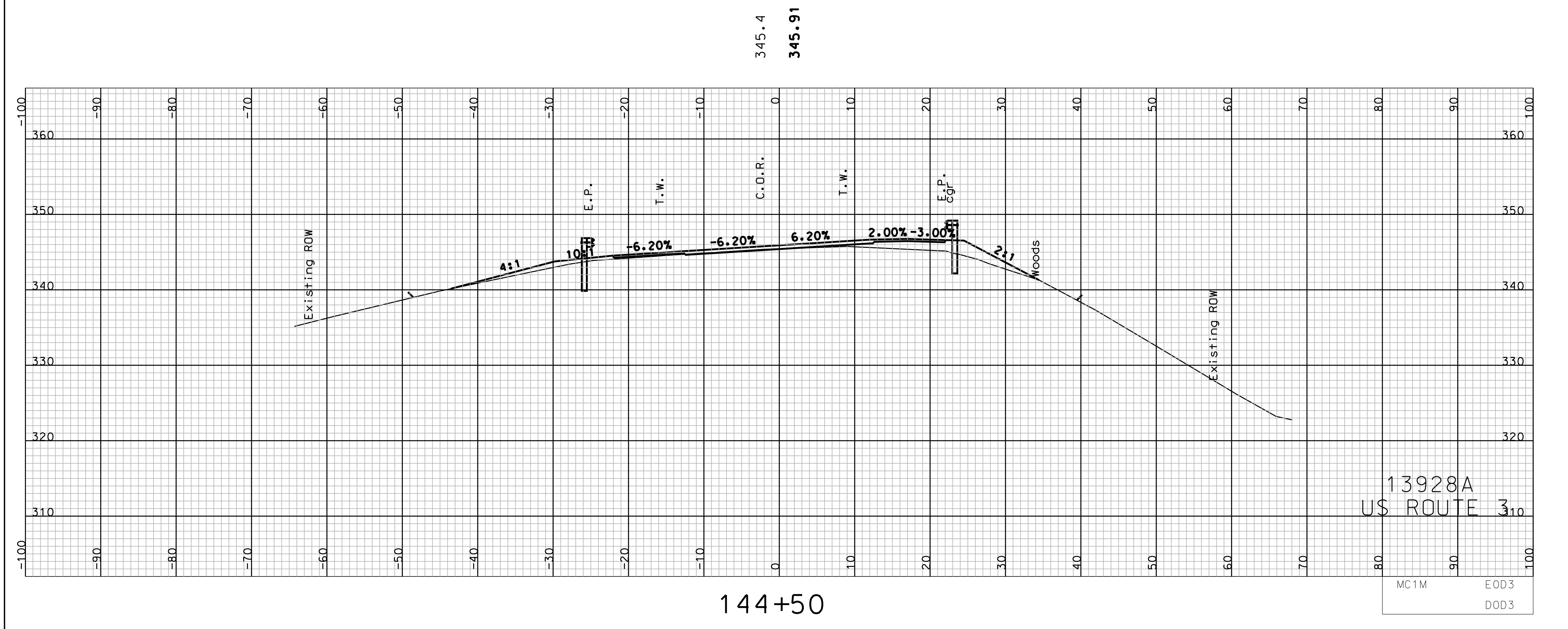

SHEET TOTALS			
COMMON EXCAV.	C.Y.	ROCK EXCAV.	C.Y.
FILL	C.Y.	MUCK EXCAV.	C.Y.
0	0	0	0
0	0	0	0
DGN	STATE PROJECT NO.	SHEET NO.	TOTAL SHEETS
13928axs-mc1m	13928A	126	160

SDR PROCESSED	DATE
NEW DESIGN TEAM BALDWIN	DATE 09/2013
SHEET CHECKED TEAM BALDWIN	DATE 04/2015
AS BUILT DETAILS	DATE

REVISIONS AFTER PROPOSAL				
NUMBER	DATE	STATION	STATION	DESCRIPTION

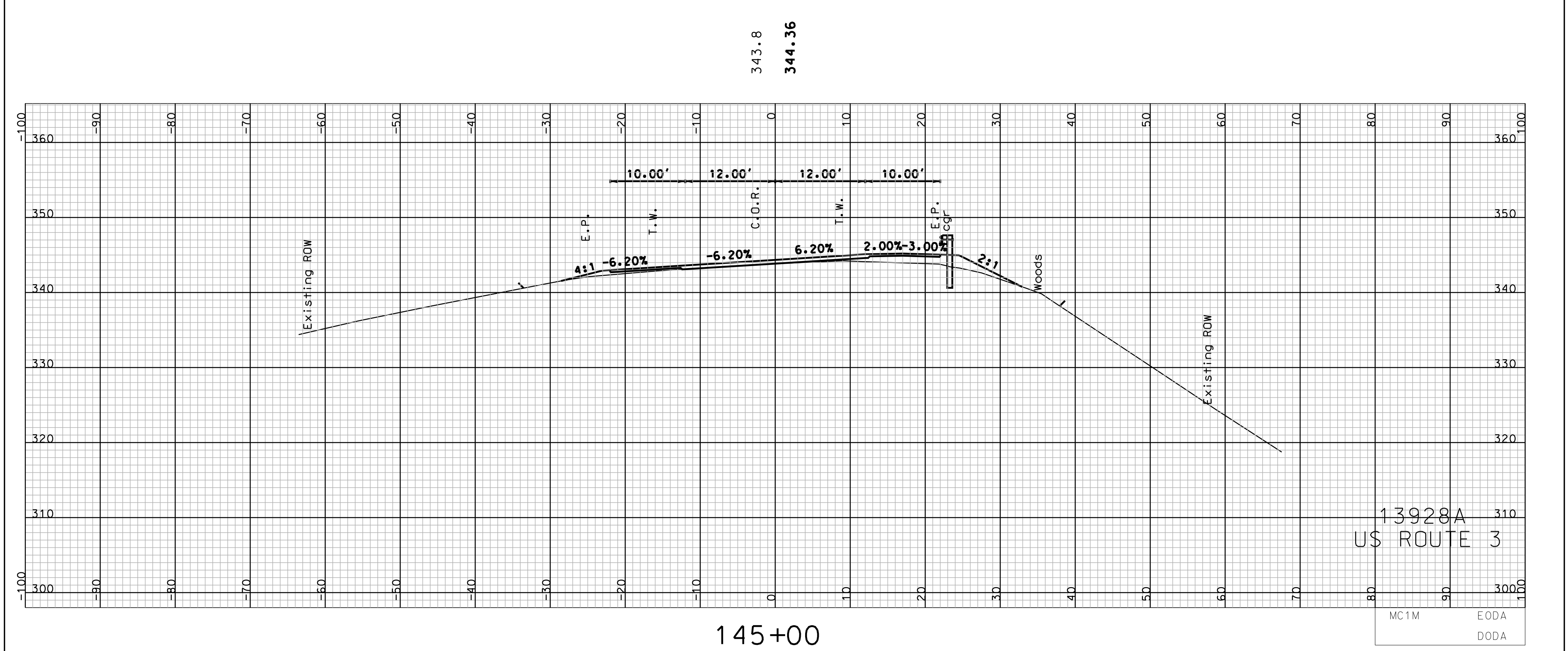
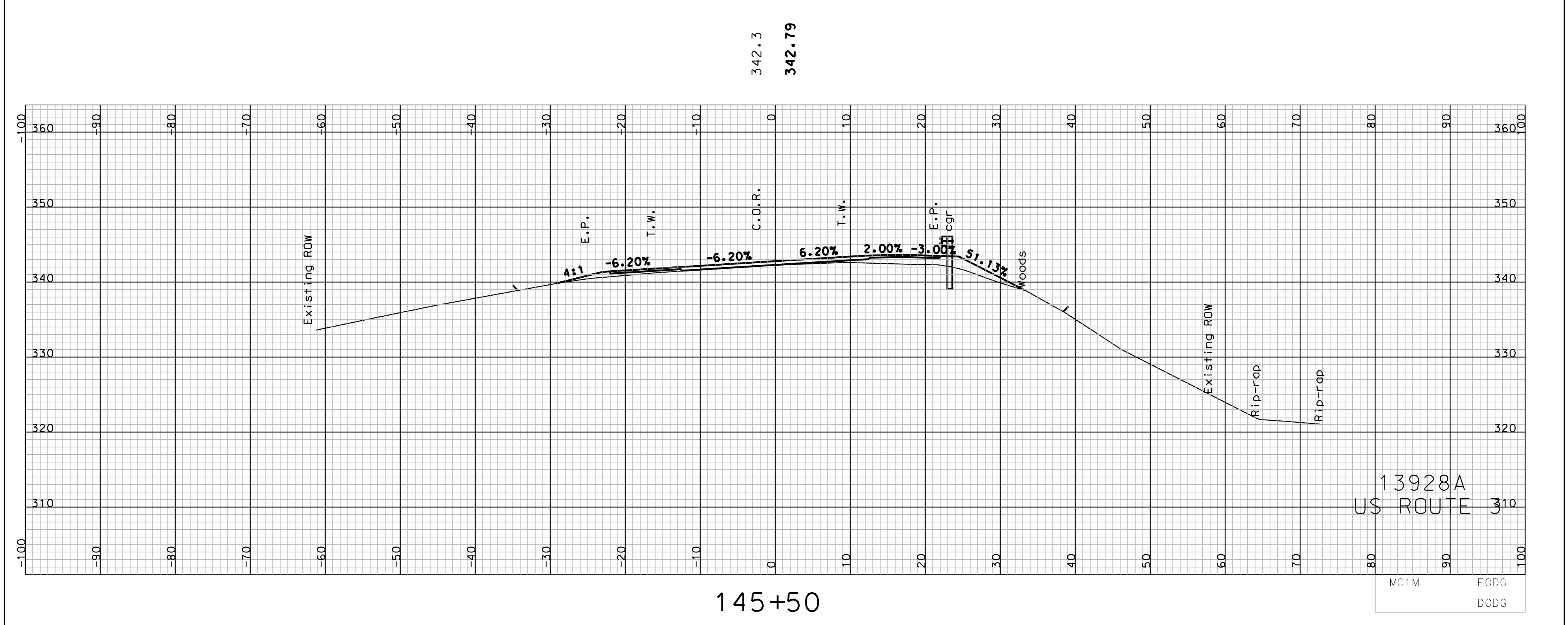
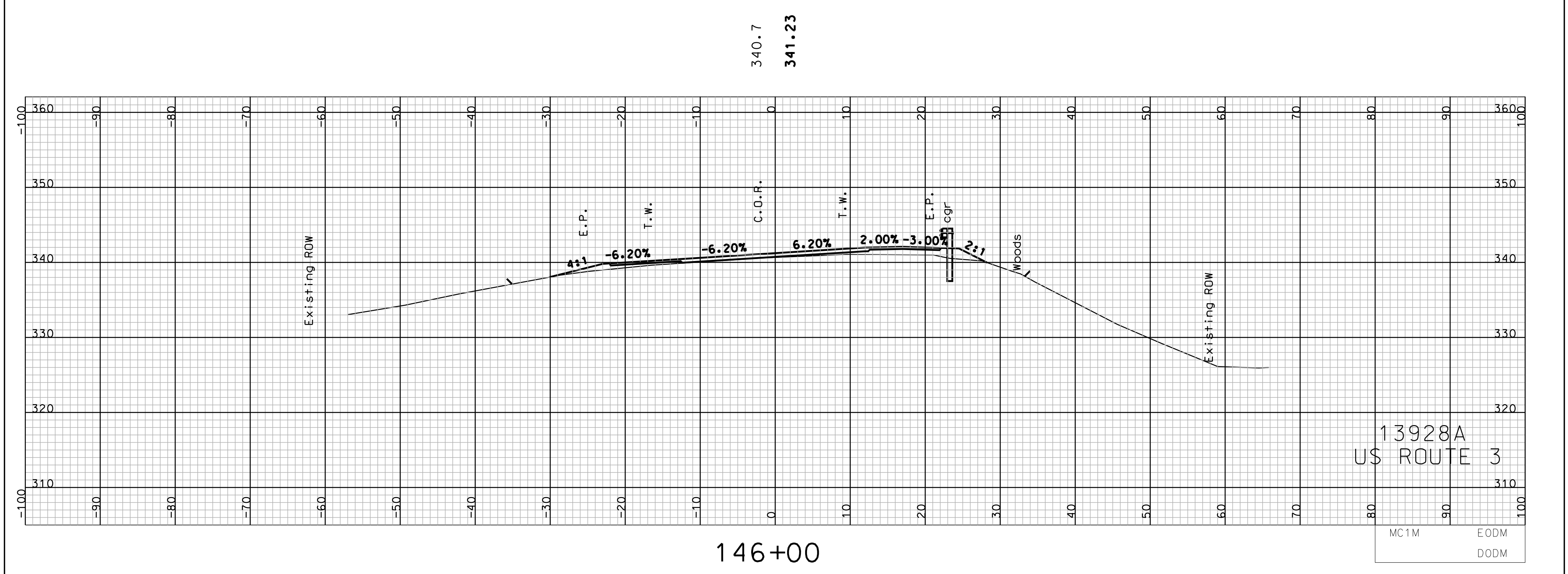

SHEET TOTALS					
COMMON EXCAV.	0	C.Y.	ROCK EXCAV.	0	C.Y.
FILL	0	C.Y.	MUCK EXCAV.	0	C.Y.
DGN	STATE PROJECT NO.	SHEET NO.	TOTAL SHEETS		
13928axs-mc1m	13928A	127	160		

SDR PROCESSED	DATE
NEW DESIGN TEAM BALDWIN	DATE 09/2013
SHEET CHECKED TEAM BALDWIN	DATE 04/2015
AS BUILT DETAILS	DATE

REVISIONS AFTER PROPOSAL				
NUMBER	DATE	STATION	STATION	DESCRIPTION

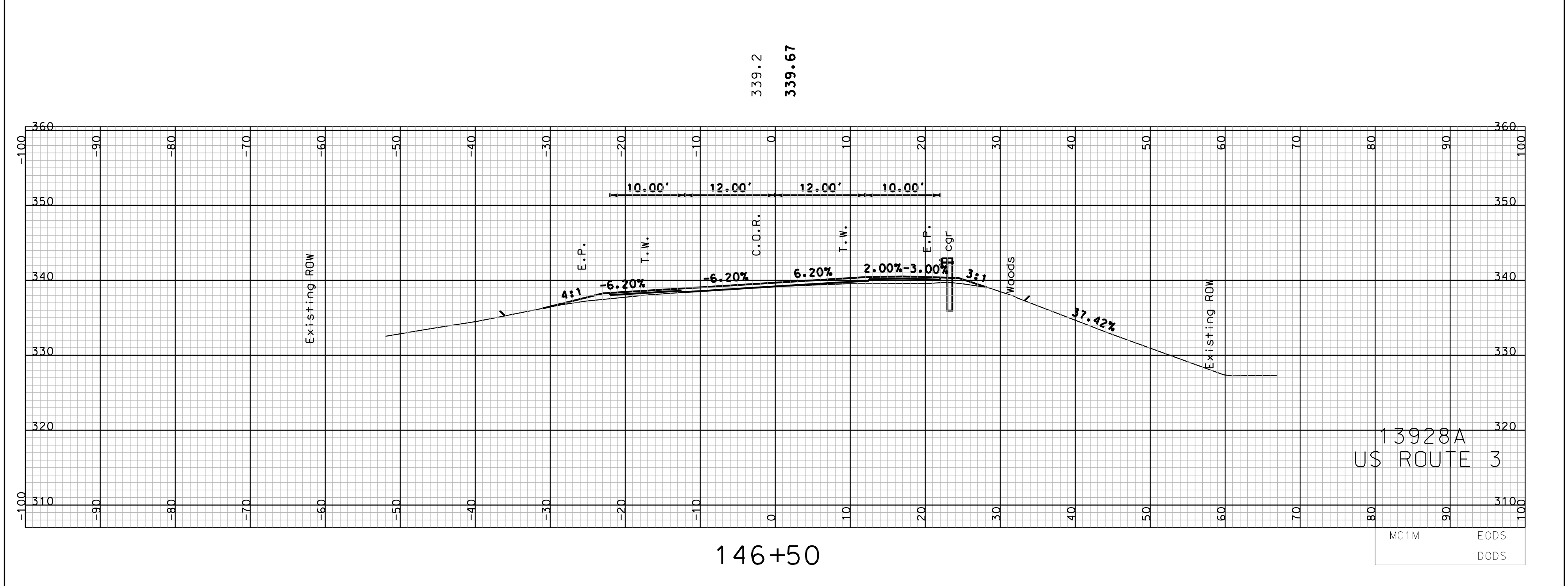
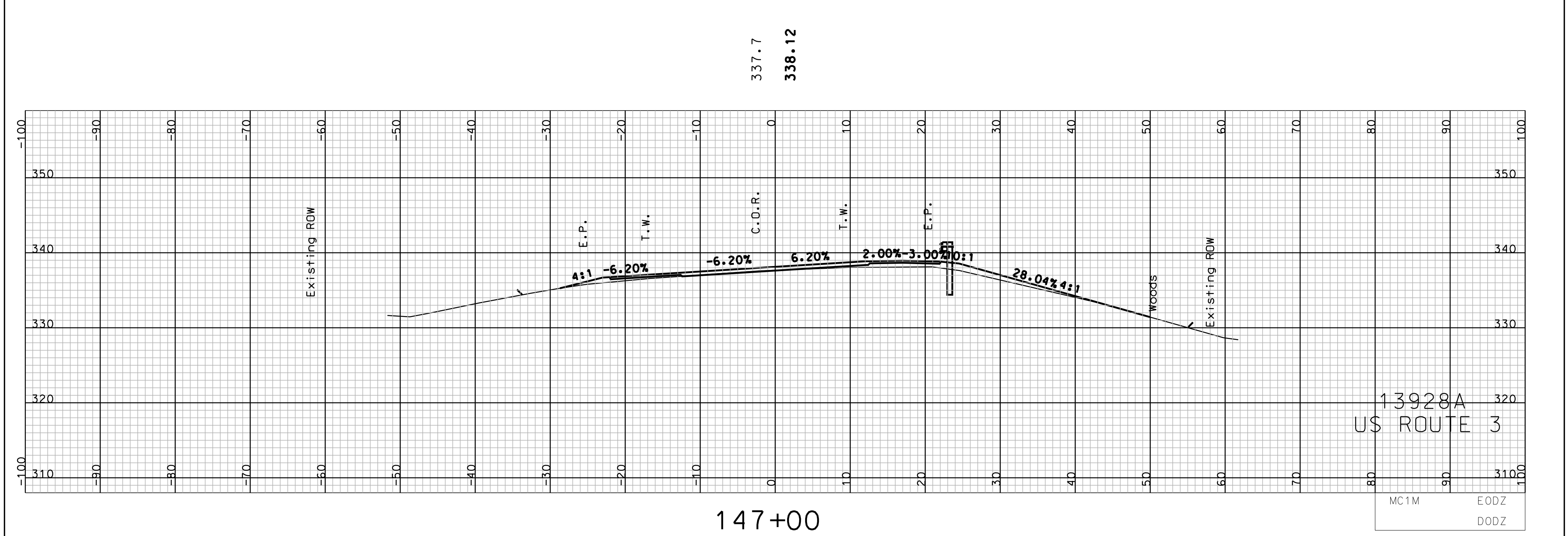
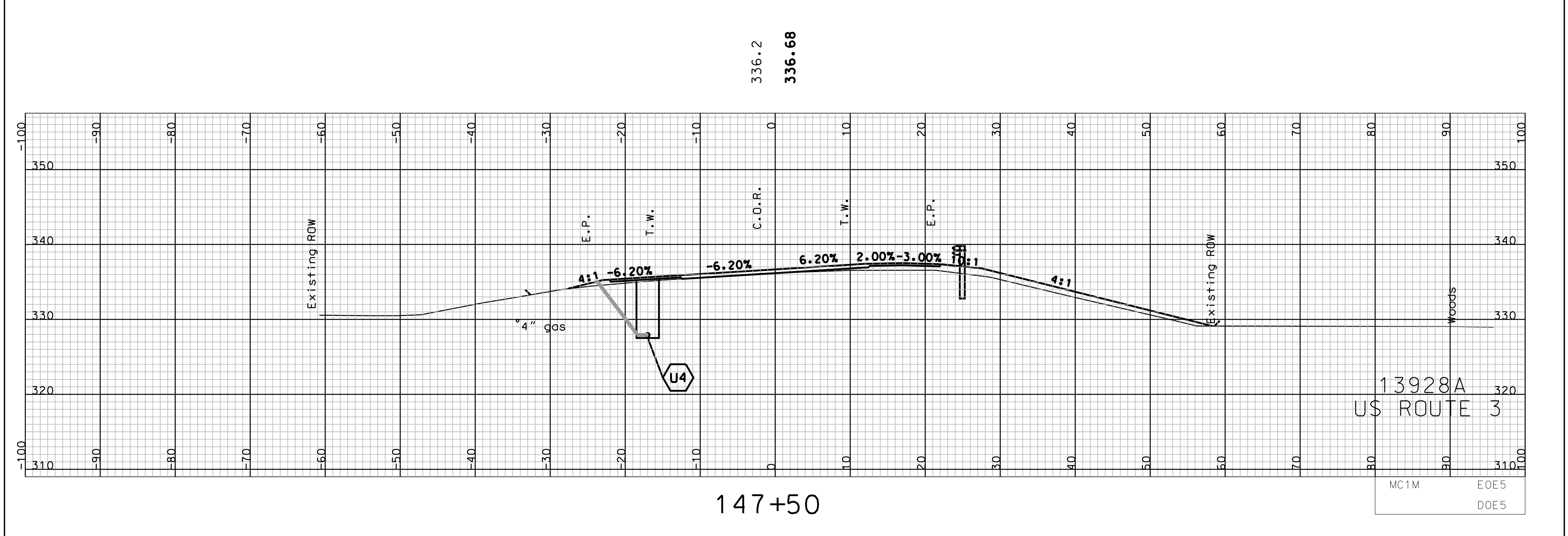
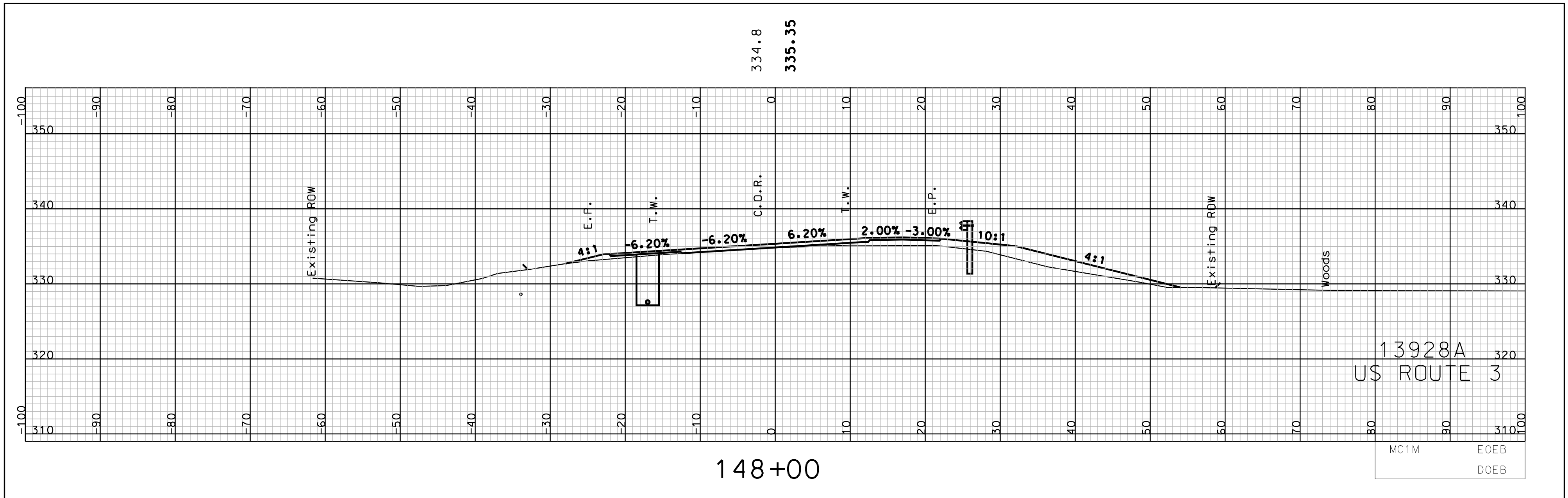

COMMON EXCAV.	12	SHEET TOTALS	ROCK EXCAV.	0	C.Y.
FILL	0	C.Y.	MUCK EXCAV.	0	C.Y.
DGN	13928axs-mc1m	STATE PROJECT NO.	13928A	SHEET NO.	128
				TOTAL SHEETS	160

SDR PROCESSED	DATE
NEW DESIGN TEAM BALDWIN	DATE 09/2013
SHEET CHECKED TEAM BALDWIN	DATE 04/2015
AS BUILT DETAILS	DATE

REVISIONS AFTER PROPOSAL				
NUMBER	DATE	STATION	STATION	DESCRIPTION

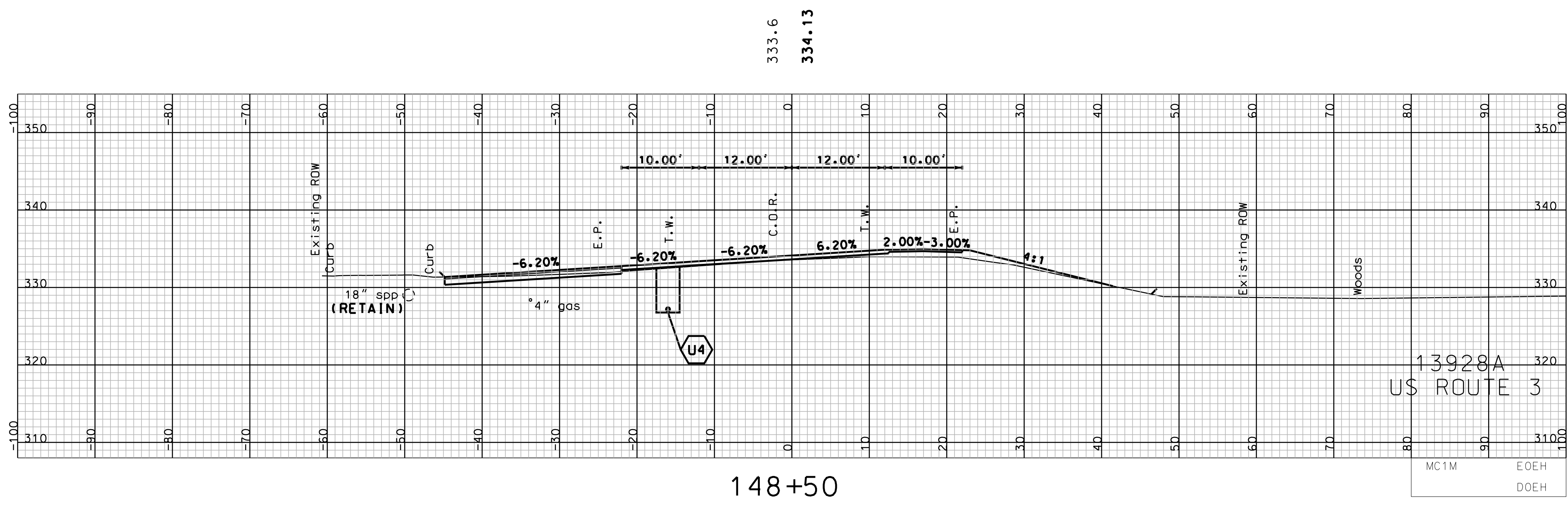
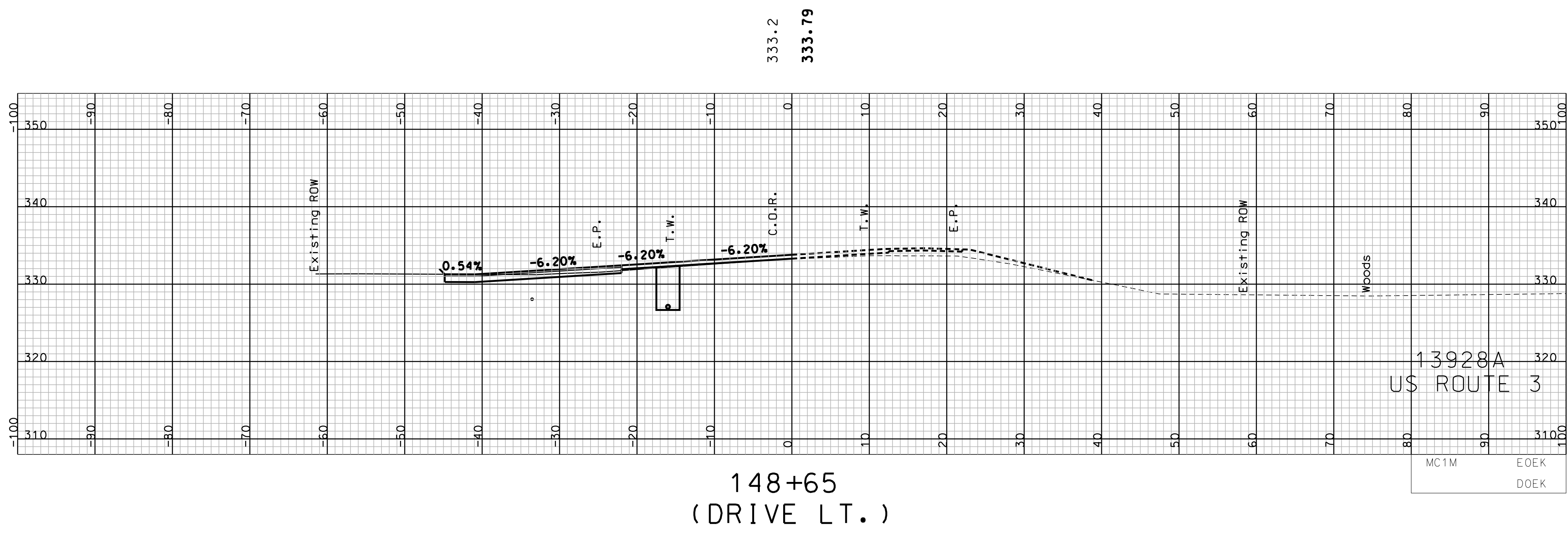

SHEET TOTALS					
COMMON EXCAV.	16	C.Y.	ROCK EXCAV.	0	C.Y.
FILL	0	C.Y.	MUCK EXCAV.	0	C.Y.
DGN	13928axs-mc1m	STATE PROJECT NO.	13928A	SHEET NO.	129
				TOTAL SHEETS	160

REVISIONS AFTER PROPOSAL		STATION	DESCRIPTION
NUMBER	DATE	STATION	DESCRIPTION

SDR PROCESSED	DATE	TEAM
NEW DESIGN	09/2013	TEAM BALDWIN
SHEET CHECKED	DATE	TEAM
AS BUILT DETAILS	04/2015	TEAM BALDWIN
	DATE	

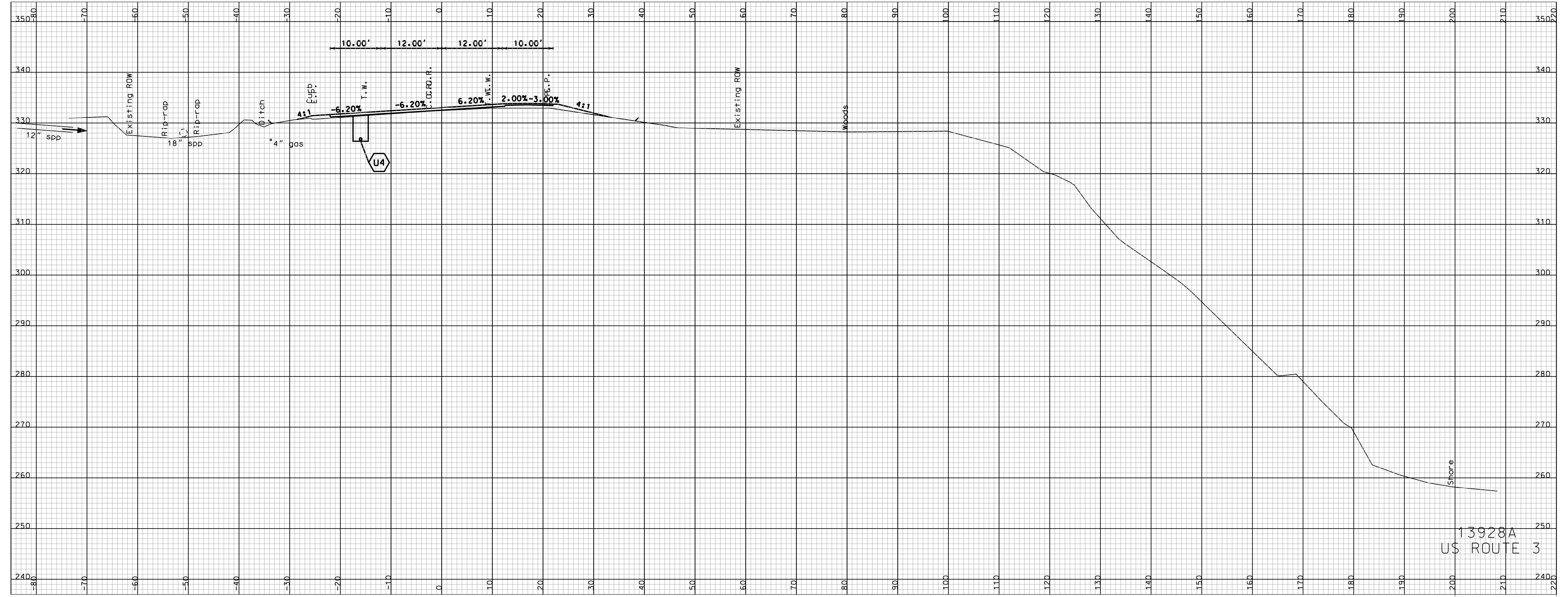

149+00

332.5
333.03

13928A
US ROUTE 3

MC1M E0E0
DOE0

SHEET TOTALS					
COMMON EXCAV.	0	C.Y.	ROCK EXCAV.	0	C.Y.
FILL	0	C.Y.	MUCK EXCAV.	0	C.Y.
DGN	13928axs-mc1m	STATE PROJECT NO.	13928A	SHEET NO.	130
				TOTAL SHEETS	160

REVISIONS AFTER PROPOSAL		STATION	DESCRIPTION
NUMBER	DATE	STATION	DESCRIPTION

SDR PROCESSED	DATE	TEAM
NEW DESIGN	09/2013	TEAM BALDWIN
SHEET CHECKED	DATE	TEAM
AS BUILT DETAILS	04/2015	TEAM BALDWIN

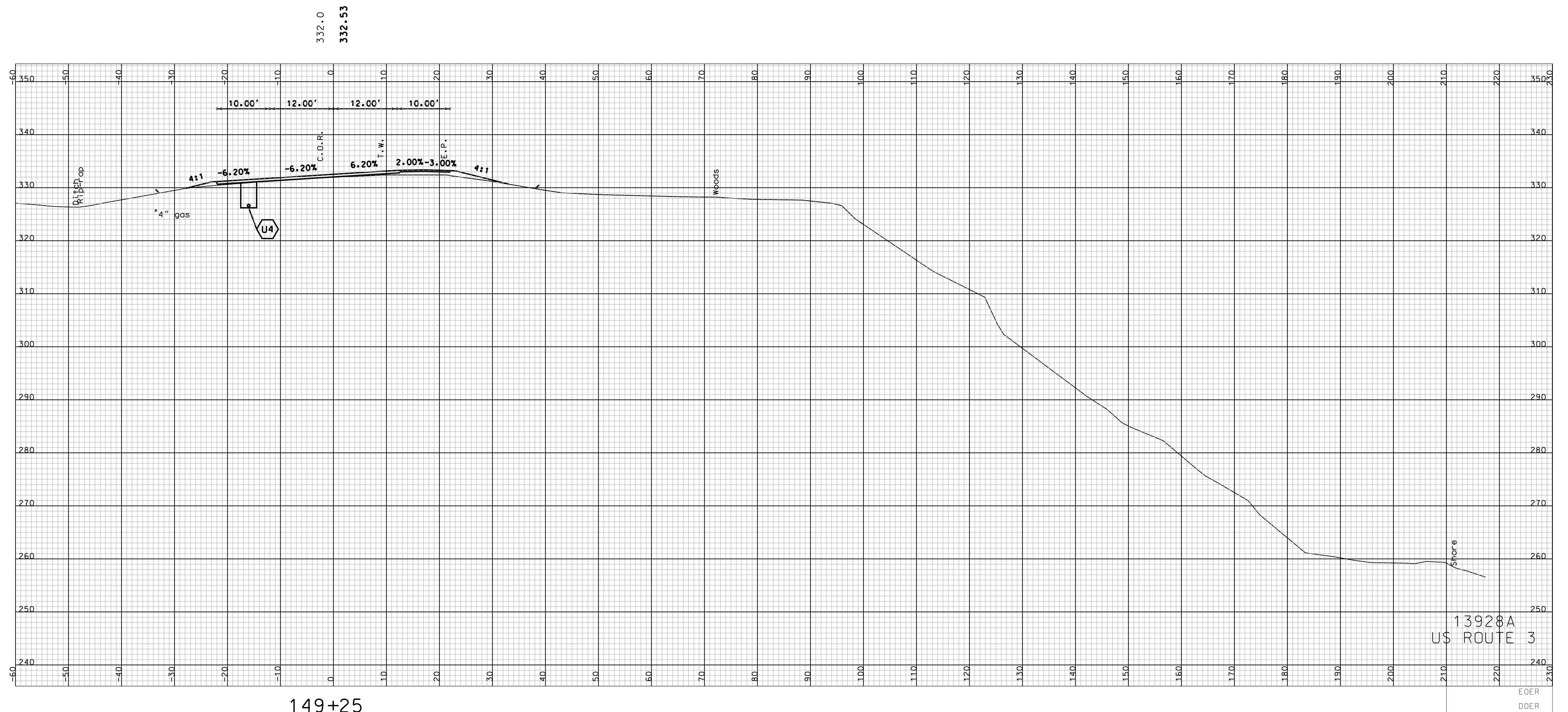

149+25

13928A
US ROUTE 3

EOER
DOER

SHEET TOTALS					
COMMON EXCAV.	0	C.Y.	ROCK EXCAV.	0	C.Y.
FILL	0	C.Y.	MUCK EXCAV.	0	C.Y.
DGN	13928axs-mc1m	STATE PROJECT NO.	13928A	SHEET NO.	131
				TOTAL SHEETS	160

REVISIONS AFTER PROPOSAL		STATION	DESCRIPTION
NUMBER	DATE	STATION	DESCRIPTION

SDR PROCESSED	DATE	TEAM
NEW DESIGN	09/2013	TEAM BALDWIN
SHEET CHECKED	DATE	TEAM
AS BUILT DETAILS	04/2015	TEAM BALDWIN
	DATE	

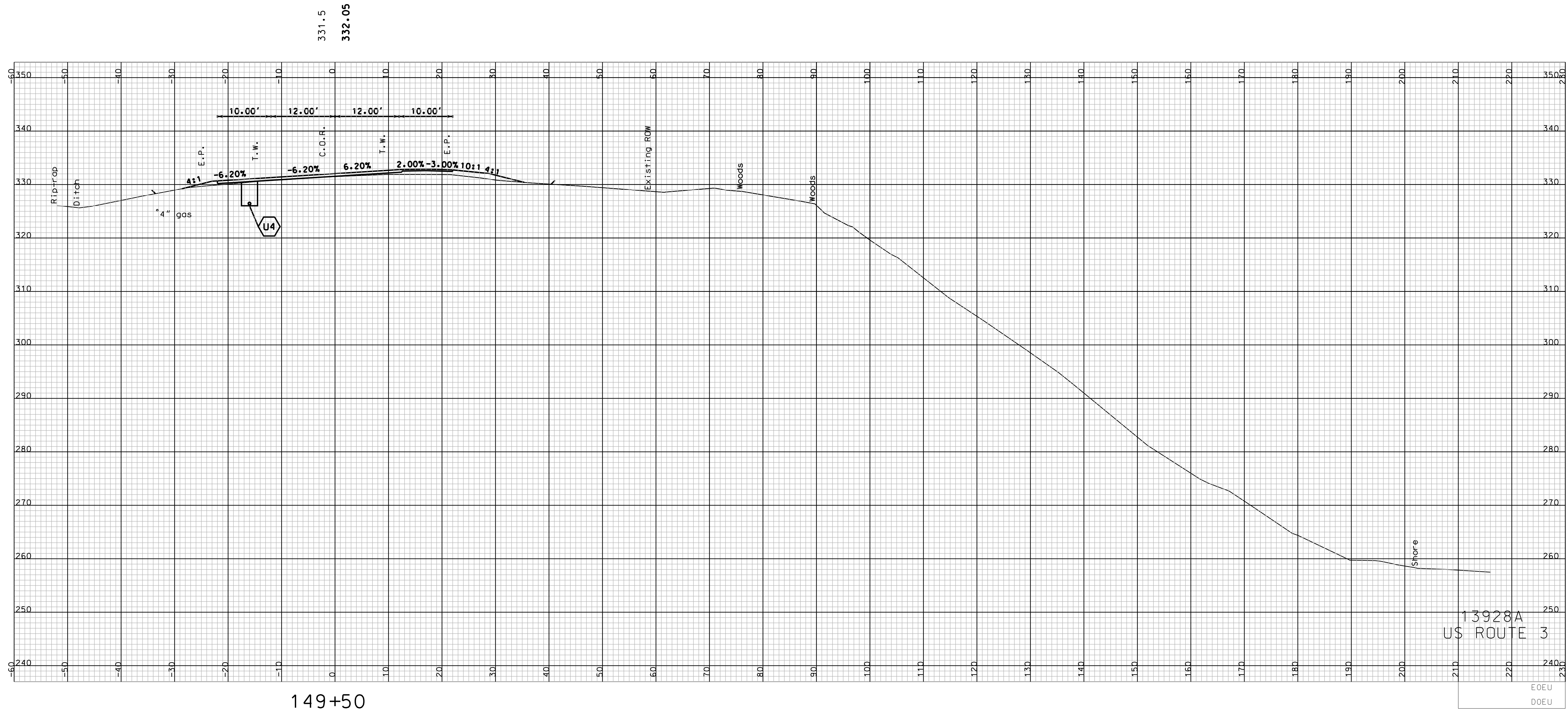

SHEET TOTALS					
COMMON EXCAV.	0	C.Y.	ROCK EXCAV.	0	C.Y.
FILL	0	C.Y.	MUCK EXCAV.	0	C.Y.
DGN	STATE PROJECT NO.	SHEET NO.	TOTAL SHEETS		
13928axs-mc1m	13928A	132	160		

REVISIONS AFTER PROPOSAL		STATION	DESCRIPTION
NUMBER	DATE	STATION	DESCRIPTION

SDR PROCESSED	DATE	TEAM
NEW DESIGN	09/2013	TEAM BALDWIN
SHEET CHECKED	DATE	TEAM BALDWIN
AS BUILT DETAILS	DATE	

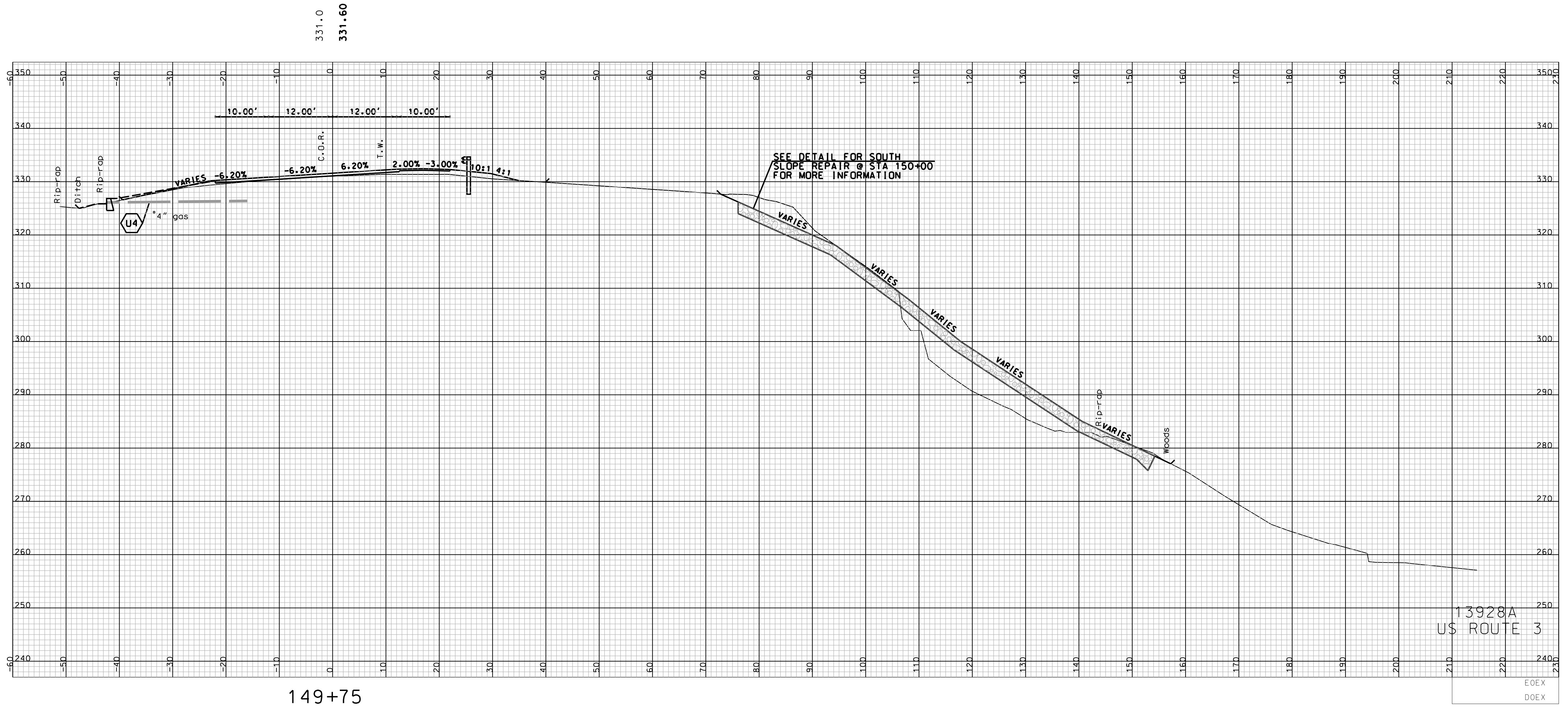

SHEET TOTALS					
COMMON EXCAV.	0	C.Y.	ROCK EXCAV.	0	C.Y.
FILL	0	C.Y.	MUCK EXCAV.	0	C.Y.
DGN	13928axs-mc1m	STATE PROJECT NO.	13928A	SHEET NO.	133
				TOTAL SHEETS	160

REVISIONS AFTER PROPOSAL		STATION	DESCRIPTION
NUMBER	DATE	STATION	DESCRIPTION

SDR PROCESSED	DATE	TEAM
NEW DESIGN	09/2013	TEAM BALDWIN
SHEET CHECKED	04/2015	TEAM BALDWIN
AS BUILT DETAILS	DATE	

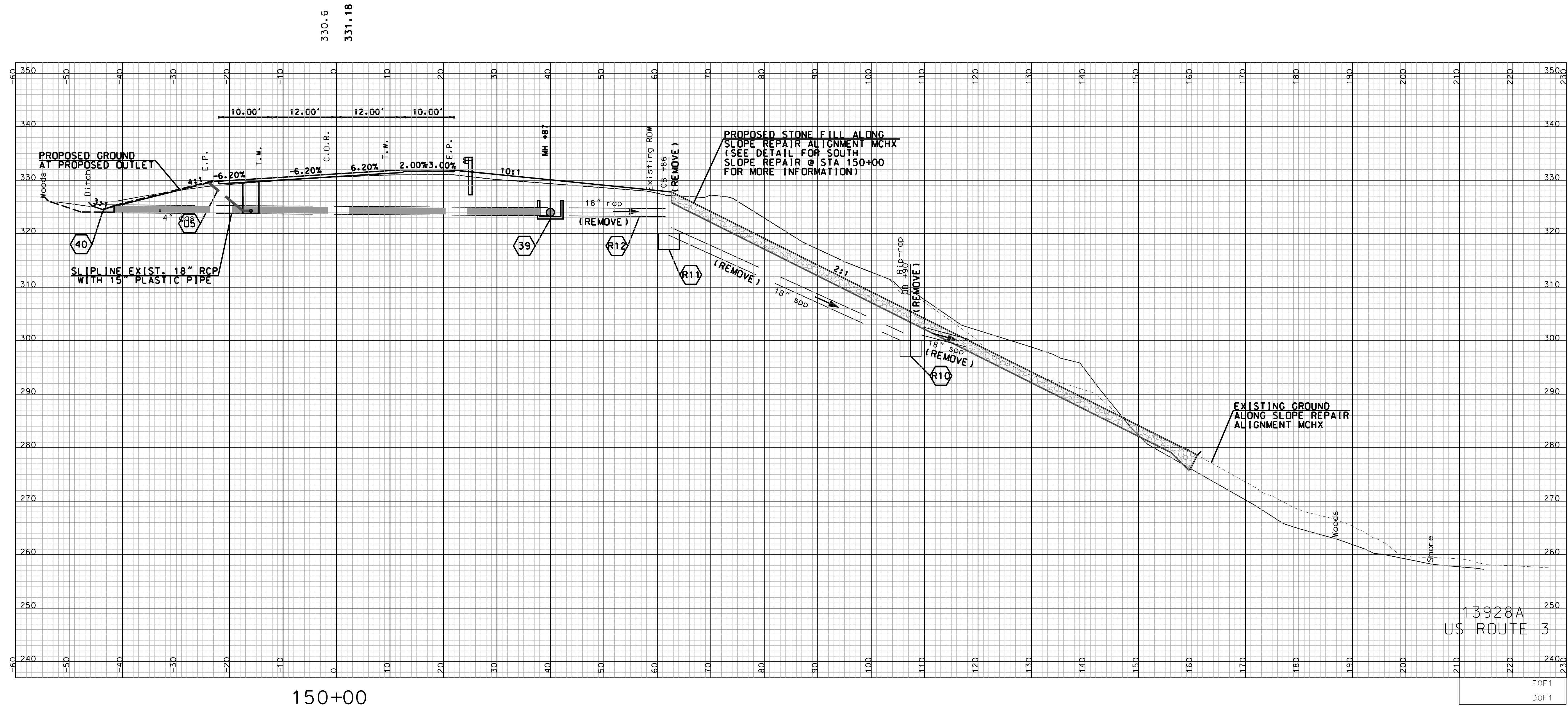

SHEET TOTALS					
COMMON EXCAV.	0	C.Y.	ROCK EXCAV.	0	C.Y.
FILL	0	C.Y.	MUCK EXCAV.	0	C.Y.
DGN	STATE PROJECT NO.	SHEET NO.	TOTAL SHEETS		
13928axs-mc1m	13928A	134	160		

REVISIONS AFTER PROPOSAL			
NUMBER	DATE	STATION	DESCRIPTION

SDR PROCESSED	DATE	TEAM
NEW DESIGN	09/2013	TEAM BALDWIN
SHEET CHECKED	DATE	TEAM BALDWIN
AS BUILT DETAILS	DATE	

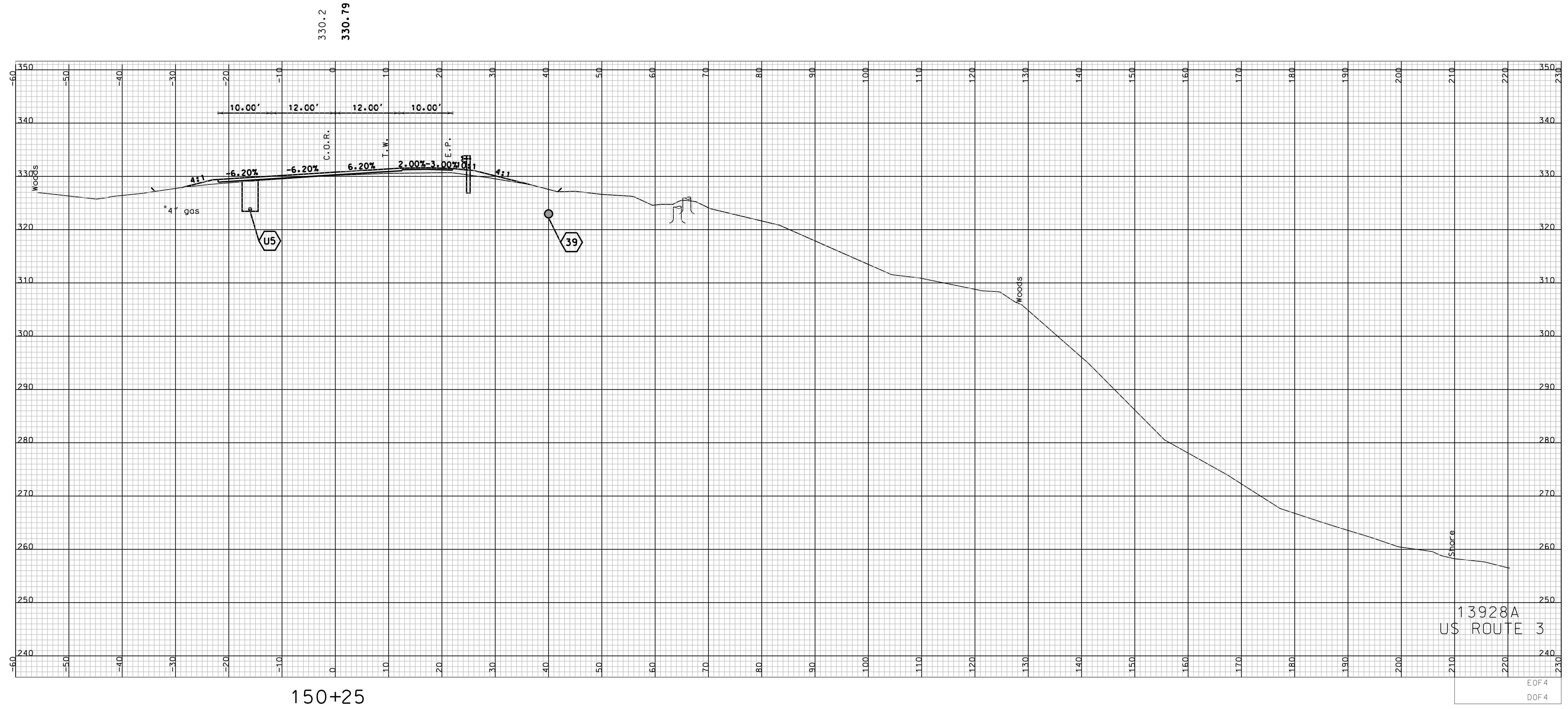

150+25

13928A
US ROUTE 3

EOF 4
DOF 4

SHEET TOTALS			
COMMON EXCAV.	FILL	ROCK EXCAV.	MUCK EXCAV.
0 C.Y.	0 C.Y.	0 C.Y.	0 C.Y.
DGN	STATE PROJECT NO.	SHEET NO.	TOTAL SHEETS
13928axs-mc1m	13928A	135	160

REVISIONS AFTER PROPOSAL		STATION	DESCRIPTION
NUMBER	DATE	STATION	DESCRIPTION

SDR PROCESSED	DATE	TEAM
NEW DESIGN	09/2013	TEAM BALDWIN
SHEET CHECKED	DATE	TEAM
AS BUILT DETAILS	04/2015	TEAM BALDWIN
	DATE	

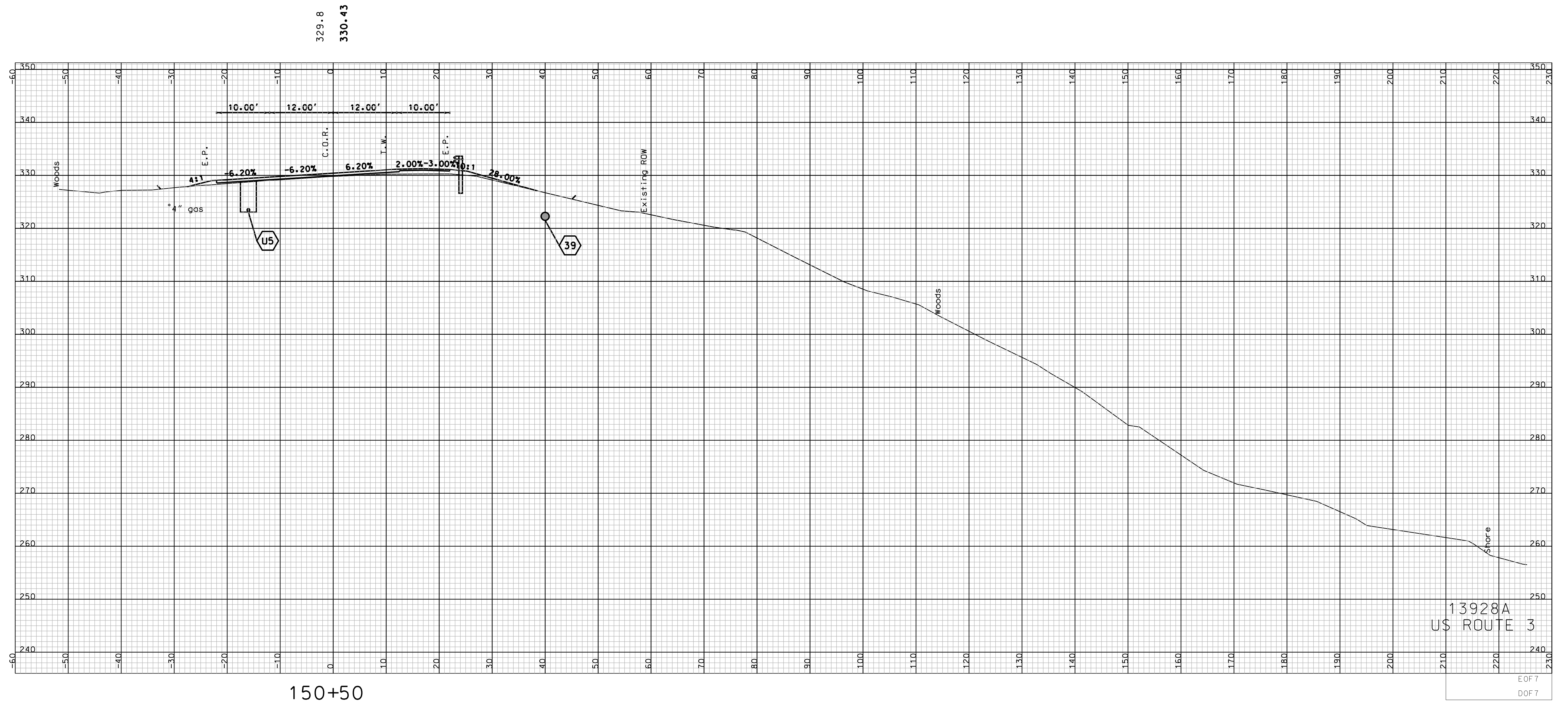

150+50

13928A
US ROUTE 3

EOF 7
DOF 7

SHEET TOTALS					
COMMON EXCAV.	0	C.Y.	ROCK EXCAV.	0	C.Y.
FILL	0	C.Y.	MUCK EXCAV.	0	C.Y.
DGN	STATE PROJECT NO.	SHEET NO.	TOTAL SHEETS		
13928axs-mc1m	13928A	136	160		

REVISIONS AFTER PROPOSAL		STATION	DESCRIPTION
NUMBER	DATE	STATION	DESCRIPTION

SDR PROCESSED	DATE	TEAM
NEW DESIGN	09/2013	TEAM BALDWIN
SHEET CHECKED	04/2015	TEAM BALDWIN
AS BUILT DETAILS	DATE	

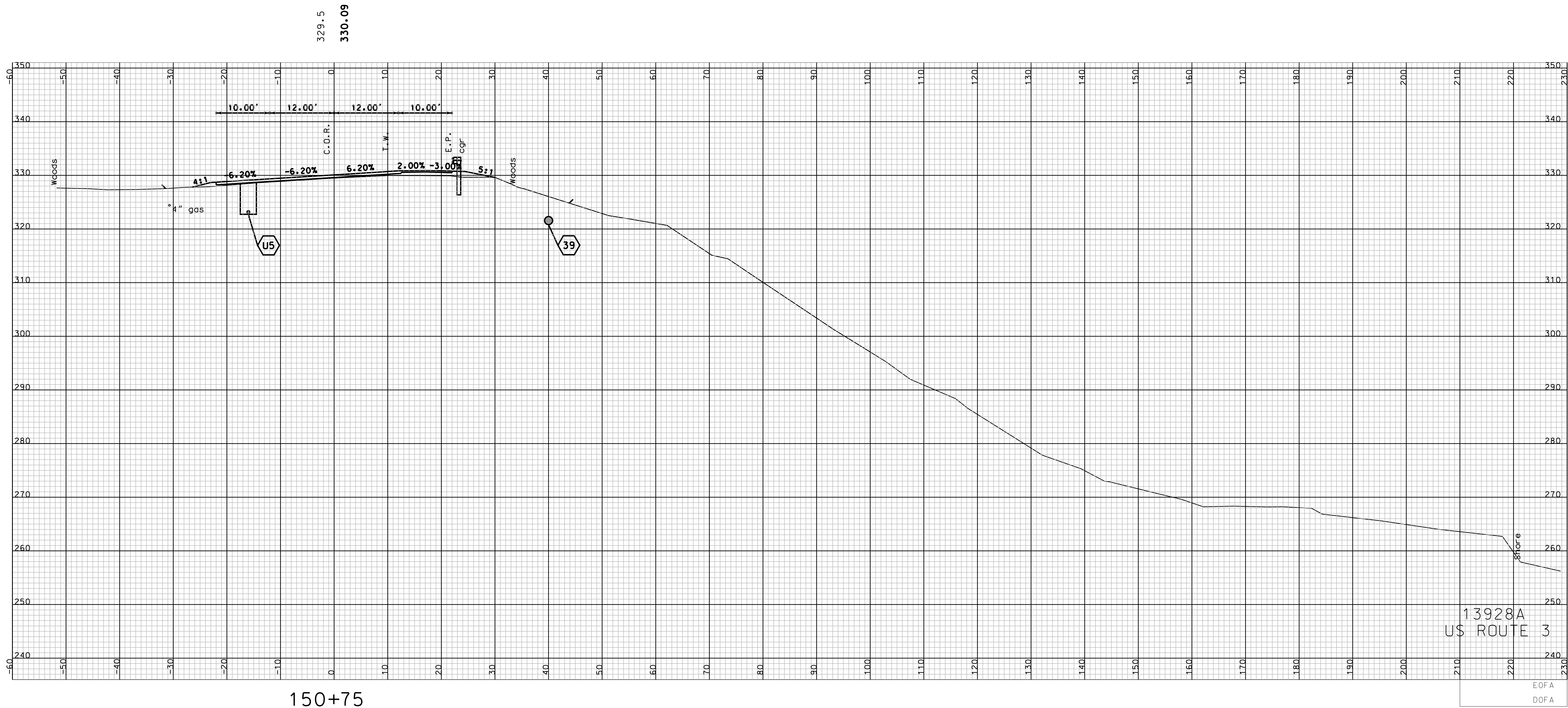

SHEET TOTALS					
COMMON EXCAV.	0	C.Y.	ROCK EXCAV.	0	C.Y.
FILL	0	C.Y.	MUCK EXCAV.	0	C.Y.
DGN	STATE PROJECT NO.	SHEET NO.	TOTAL SHEETS		
13928axs-mc1m	13928A	137	160		

SDR PROCESSED		DATE	REVISIONS AFTER PROPOSAL	
NEW DESIGN	TEAM BALDWIN	DATE 09/2013	STATION	DESCRIPTION
SHEET CHECKED	TEAM BALDWIN	DATE 04/2015	NUMBER	
AS BUILT DETAILS			DATE	

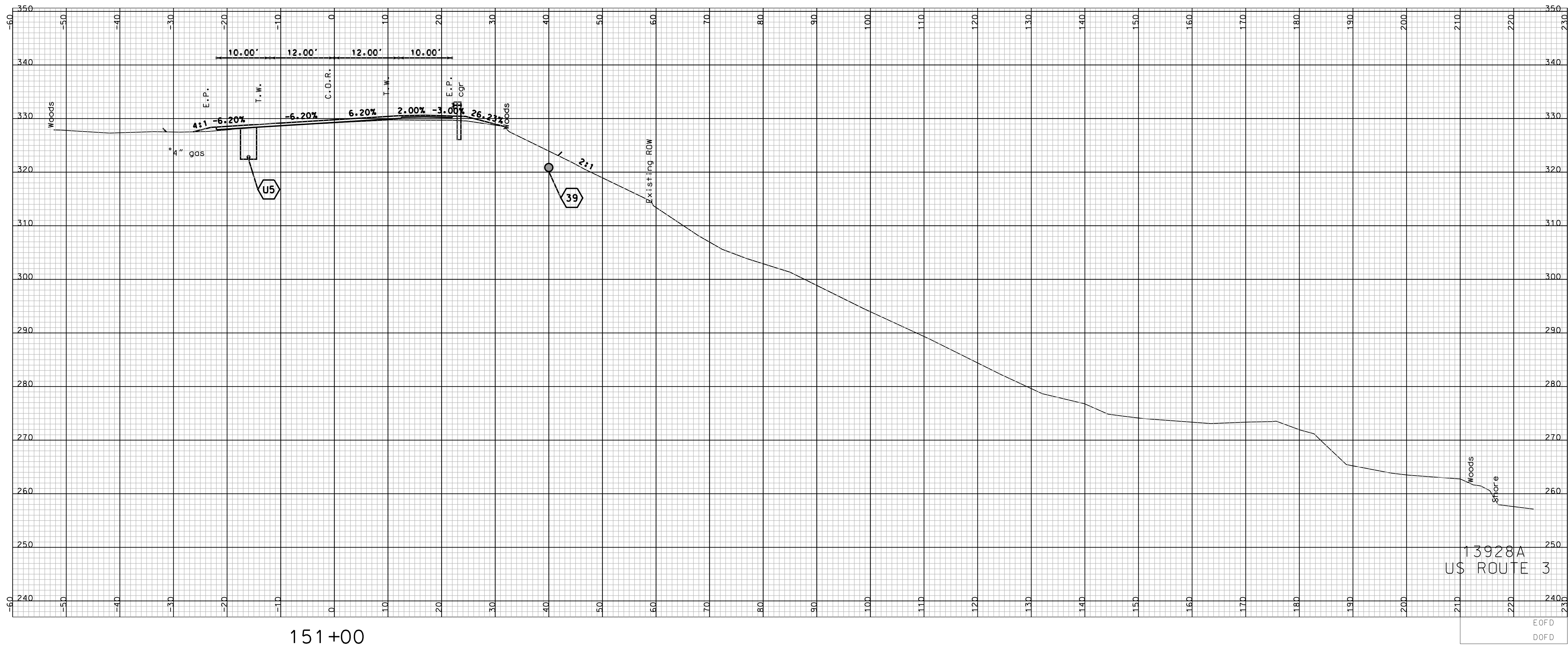

151+00

13928A
US ROUTE 3

EOFD
DOFD

COMMON EXCAV. 0 C.Y.		SHEET TOTALS		ROCK EXCAV. 0 C.Y.	
FILL 0 C.Y.				MUCK EXCAV. 0 C.Y.	
DGN	STATE PROJECT NO.	SHEET NO.	TOTAL SHEETS		
13928axs-mc1m	13928A	138	160		

SDR PROCESSED	DATE
NEW DESIGN TEAM BALDWIN	DATE 09/2013
SHEET CHECKED TEAM BALDWIN	DATE 04/2015
AS BUILT DETAILS	DATE

REVISIONS AFTER PROPOSAL				
NUMBER	DATE	STATION	STATION	DESCRIPTION

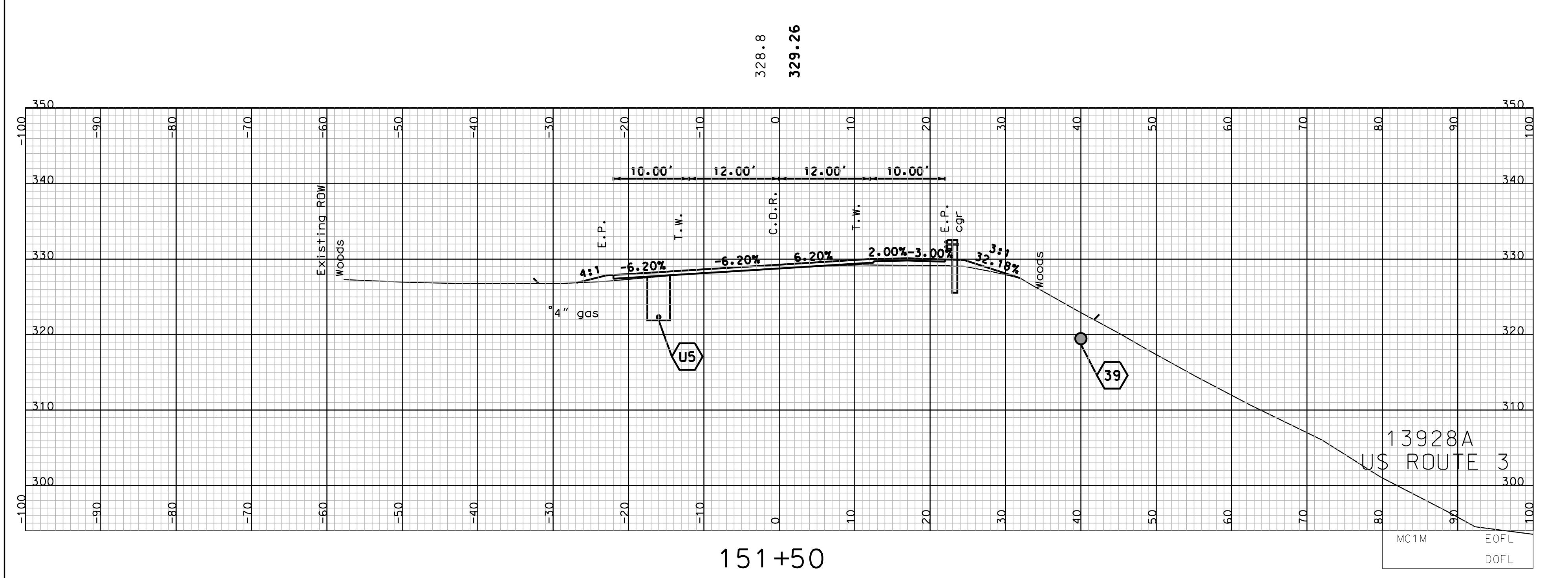
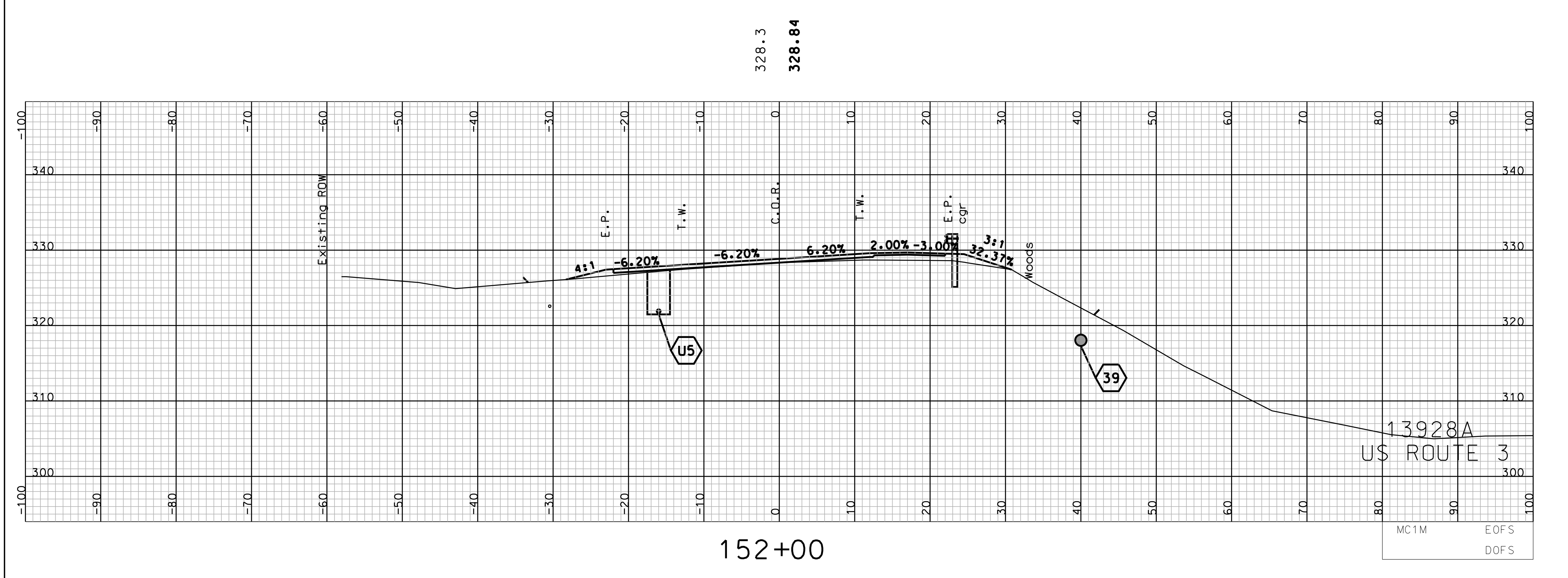
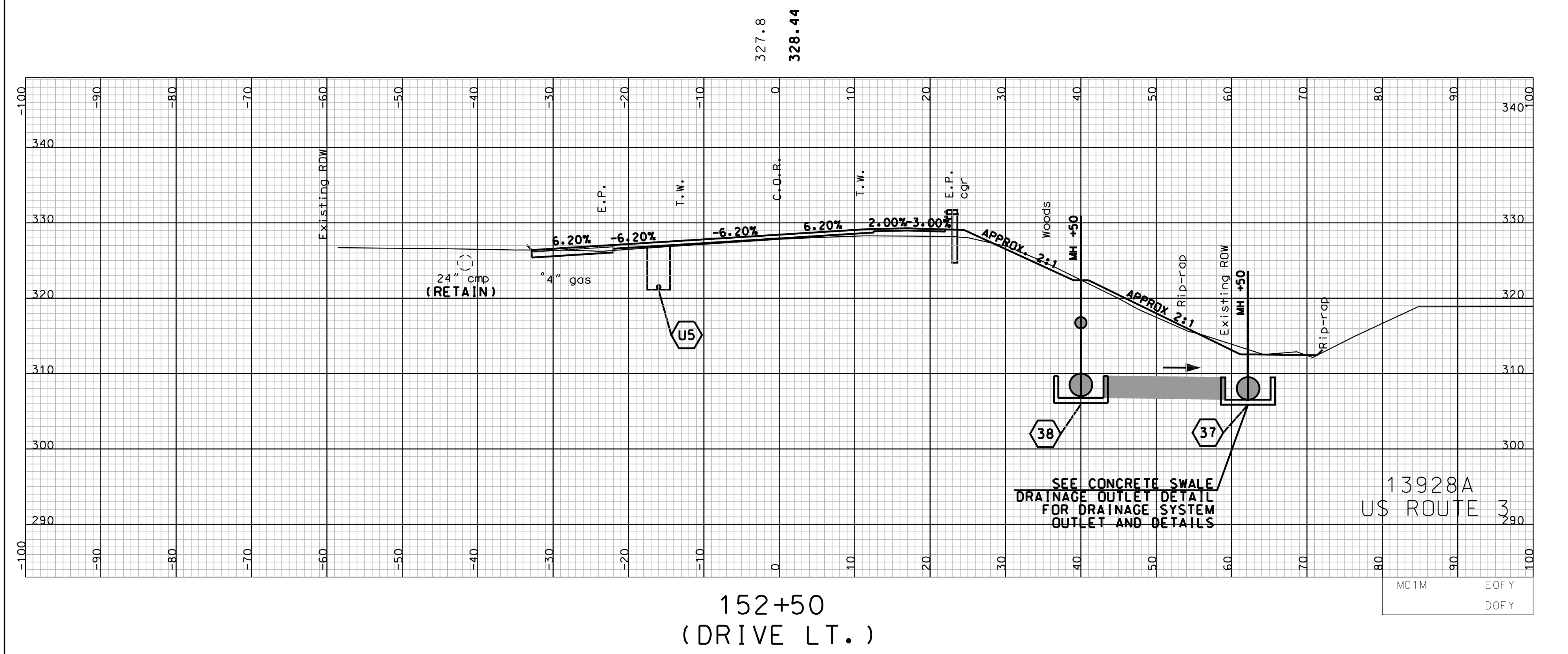

SHEET TOTALS					
COMMON EXCAV.	11	C.Y.	ROCK EXCAV.	0	C.Y.
FILL	0	C.Y.	MUCK EXCAV.	0	C.Y.
DGN	STATE PROJECT NO.	SHEET NO.	TOTAL SHEETS		
13928axs-mc1m	13928A	139	160		

SDR PROCESSED	DATE
NEW DESIGN TEAM BALDWIN	DATE 09/2013
SHEET CHECKED TEAM BALDWIN	DATE 04/2015
AS BUILT DETAILS	DATE

REVISIONS AFTER PROPOSAL				
NUMBER	DATE	STATION	STATION	DESCRIPTION

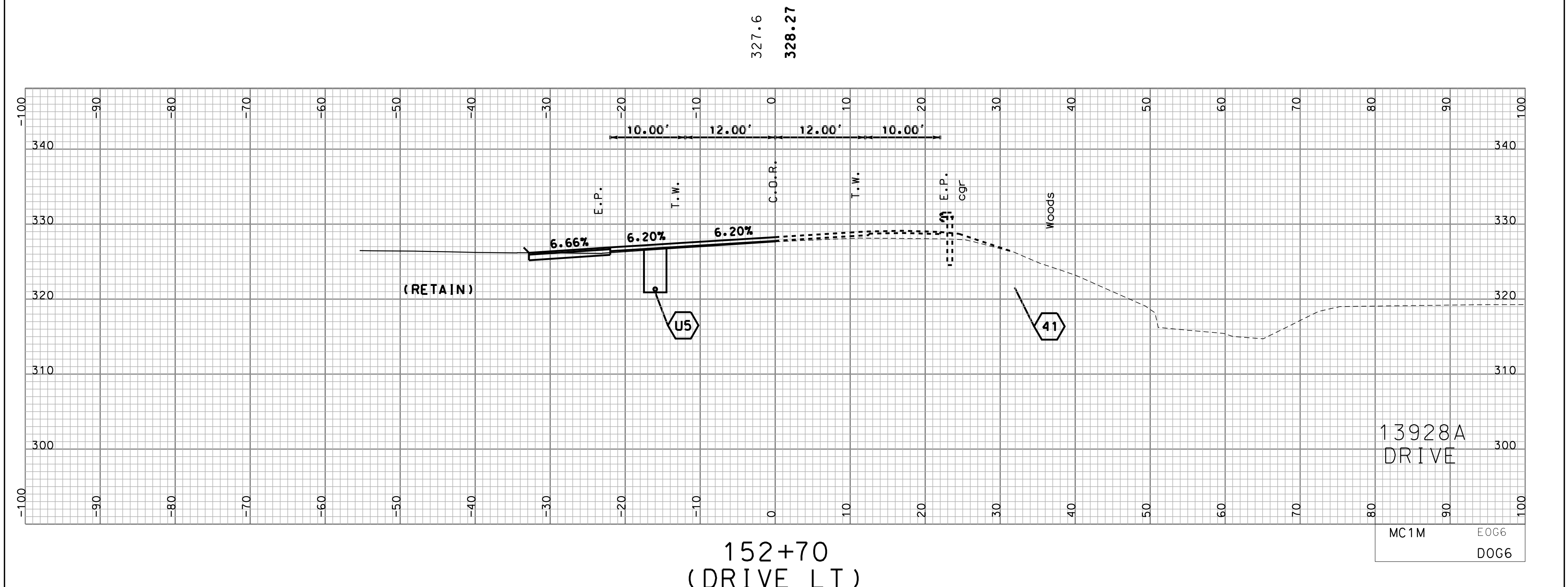
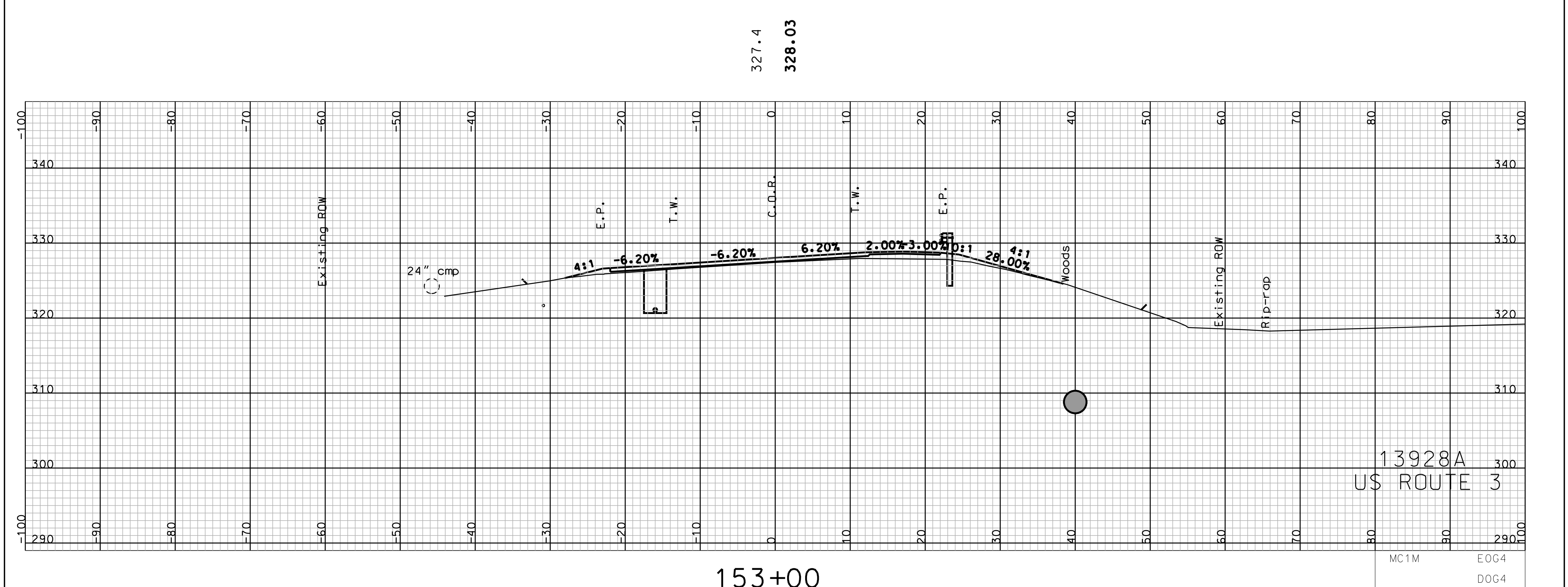
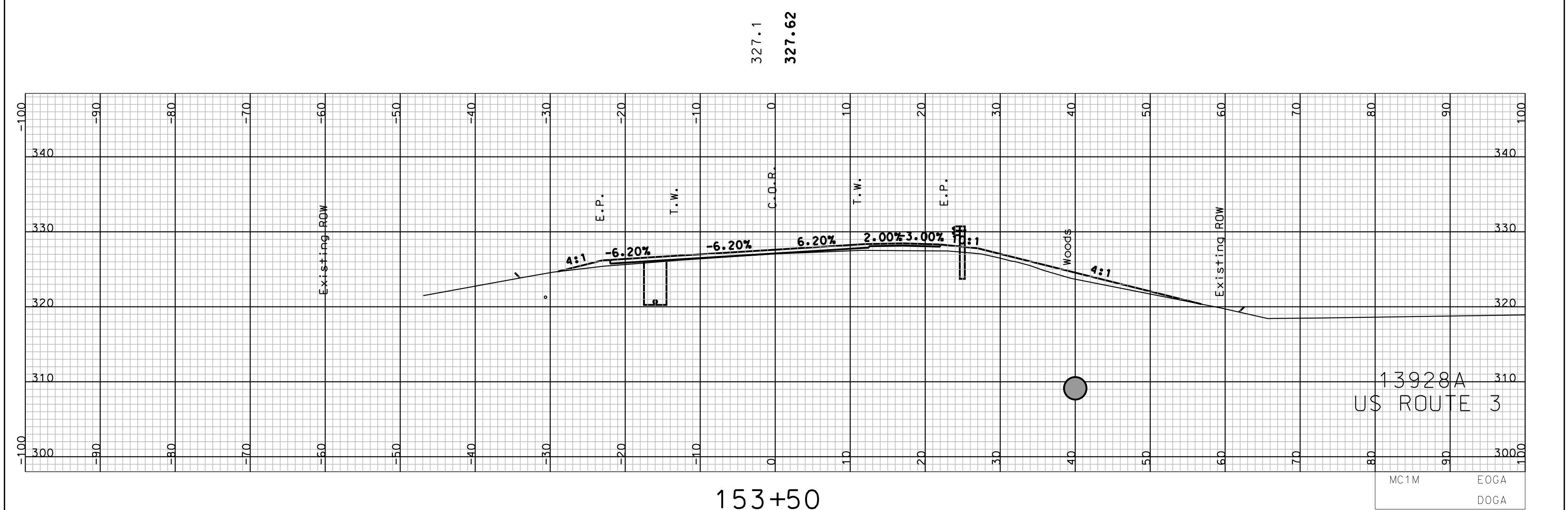

COMMON EXCAV.	10	SHEET TOTALS	ROCK EXCAV.	0
FILL	0	C.Y.	MUCK EXCAV.	0
DGN	13928axs-mc1m	STATE PROJECT NO.	SHEET NO.	TOTAL SHEETS
	13928A		140	160

SDR PROCESSED	DATE
NEW DESIGN TEAM BALDWIN	DATE 09/2013
SHEET CHECKED TEAM BALDWIN	DATE 04/2015
AS BUILT DETAILS	DATE

REVISIONS AFTER PROPOSAL				
NUMBER	DATE	STATION	STATION	DESCRIPTION

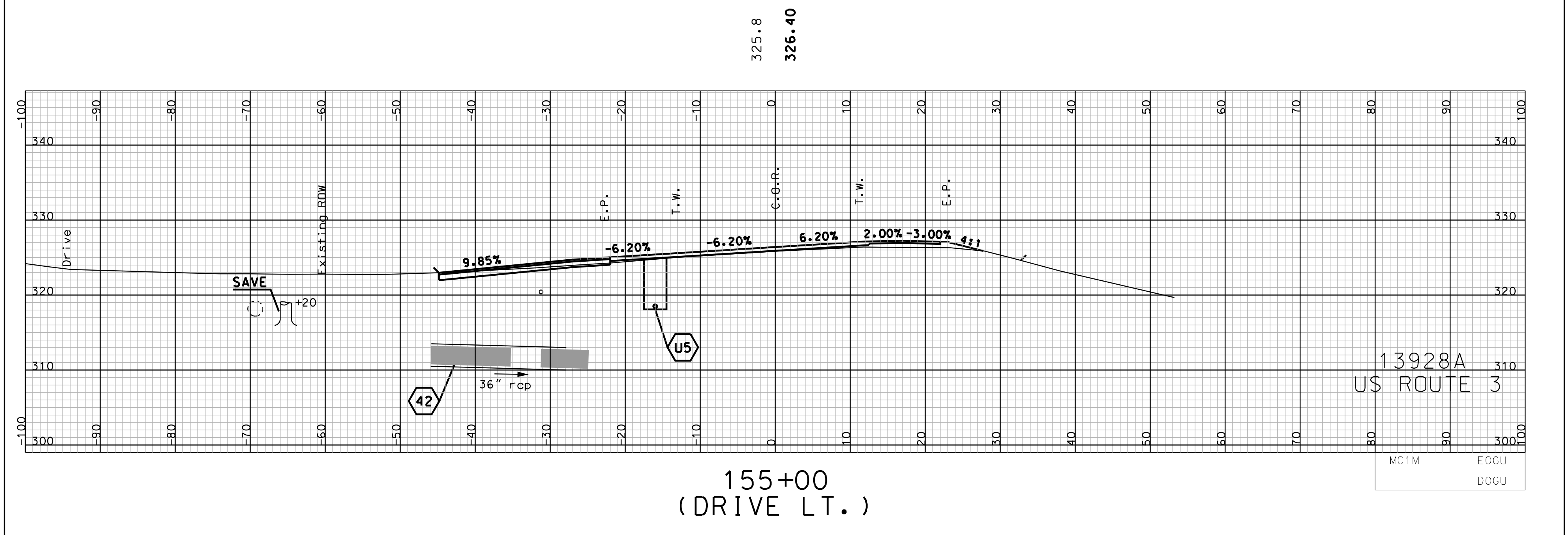

155+00
(DRIVE LT.)

13928A
US ROUTE 3

MC1M EOGU
DOGU

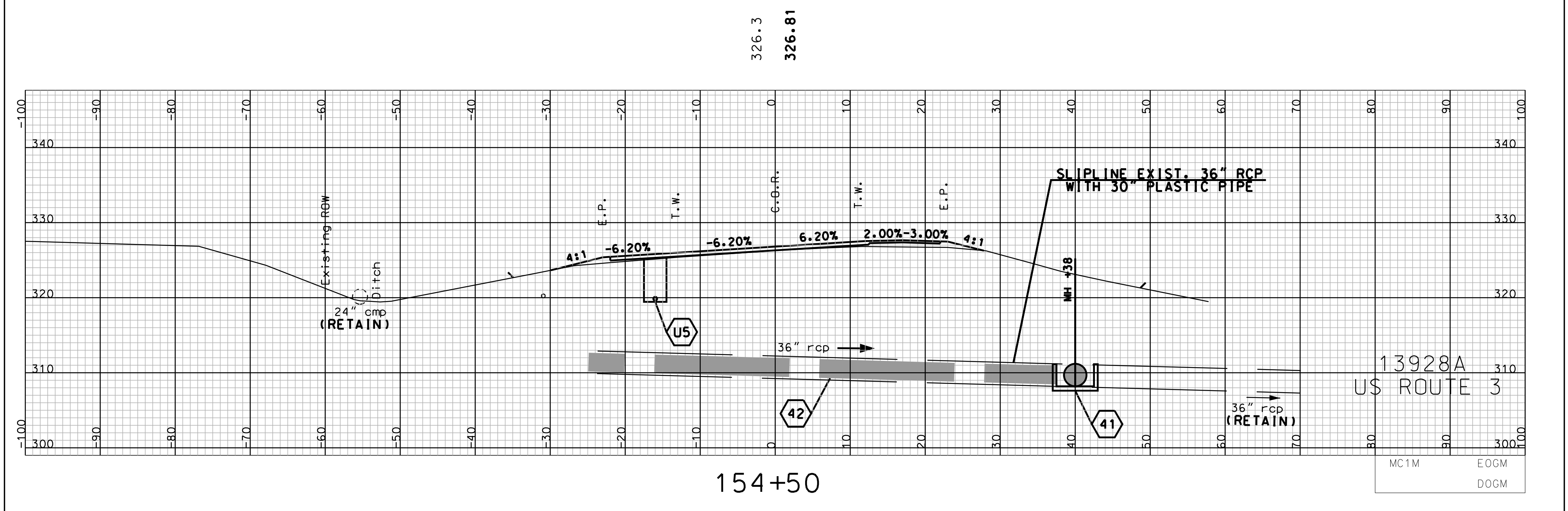

154+50

13928A
US ROUTE 3

MC1M EOGM
DOGM

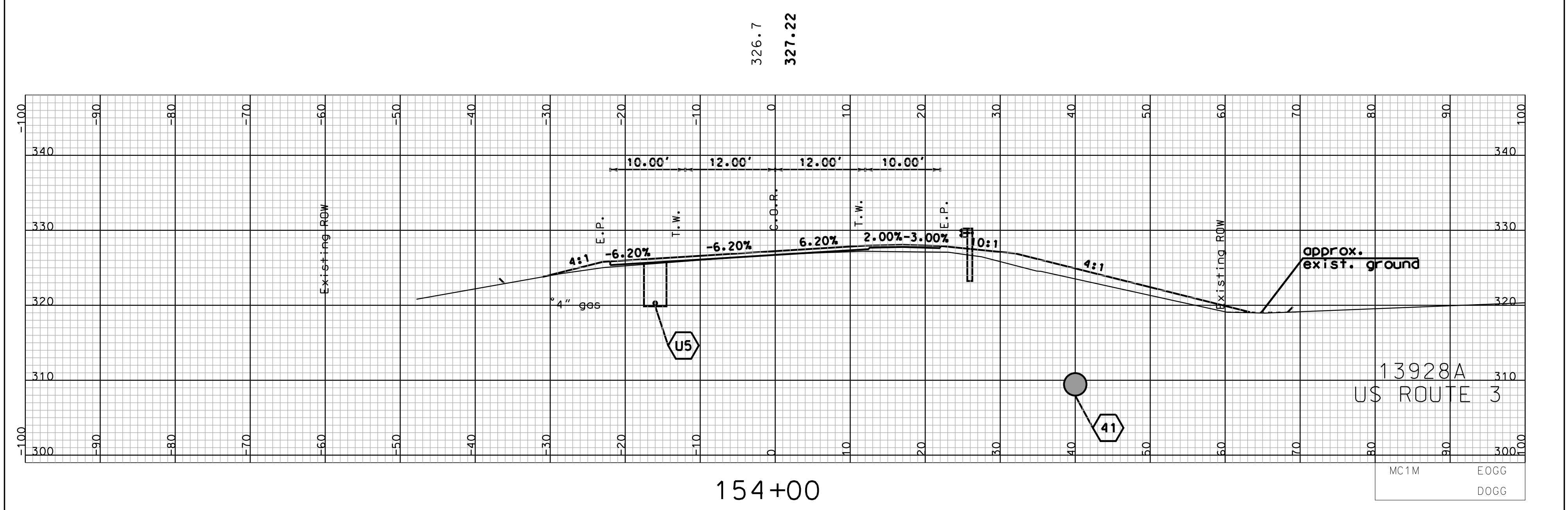

154+00

13928A
US ROUTE 3

MC1M EOGG
DOGG

COMMON EXCAV.		SHEET TOTALS		ROCK EXCAV.	
	C.Y.		C.Y.		C.Y.
32				0	
0				0	
FILL		MUCK EXCAV.			
DGN	STATE PROJECT NO.	SHEET NO.	TOTAL SHEETS		
13928axs-mc1m	13928A	141	160		

SDR PROCESSED	DATE
NEW DESIGN TEAM BALDWIN	DATE 09/2013
SHEET CHECKED TEAM BALDWIN	DATE 04/2015
AS BUILT DETAILS	DATE

REVISIONS AFTER PROPOSAL				
NUMBER	DATE	STATION	STATION	DESCRIPTION

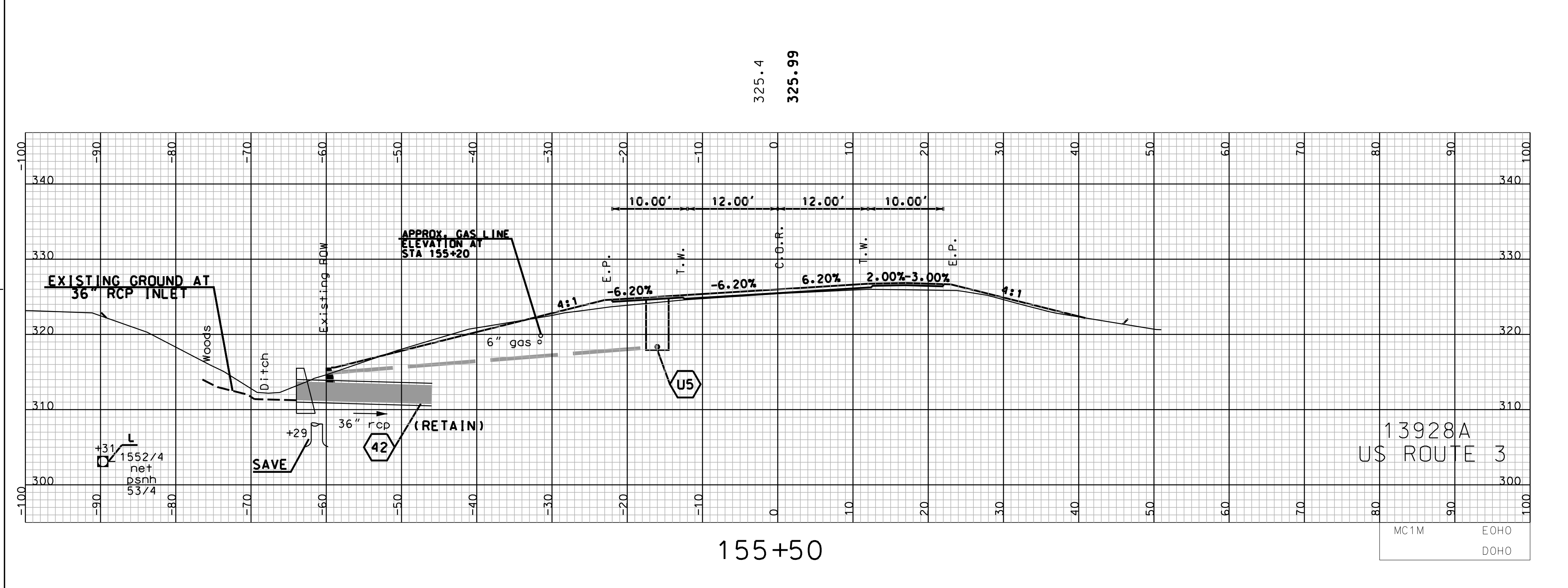
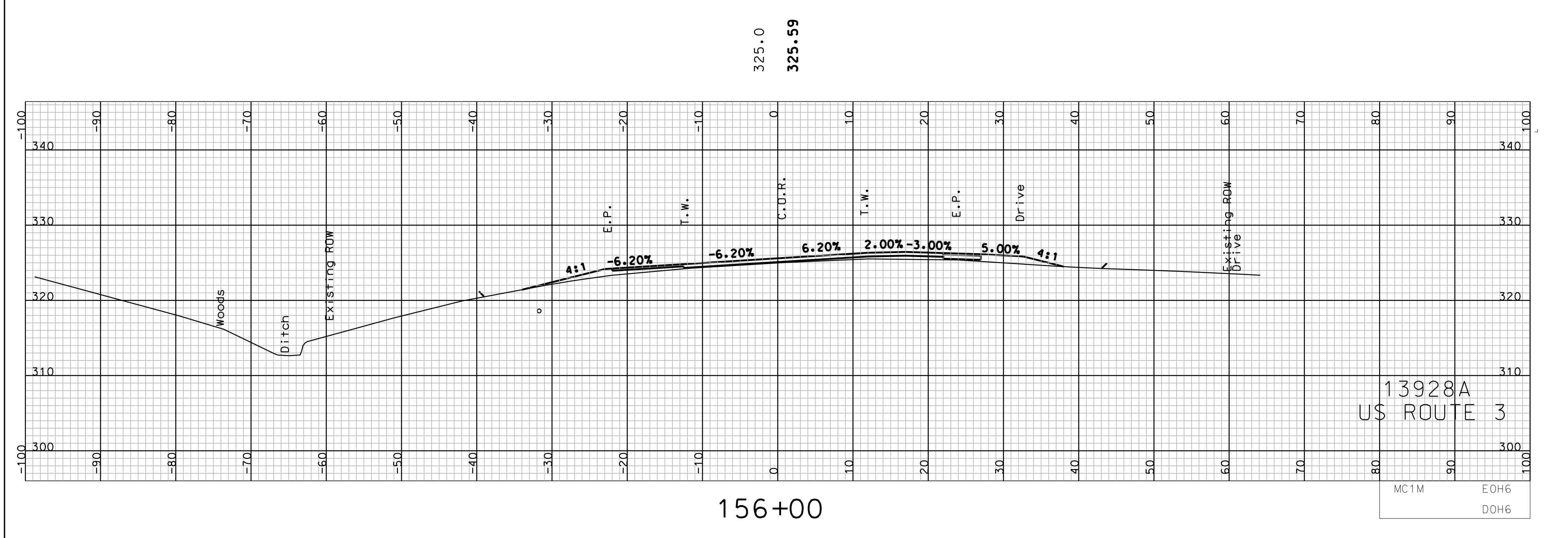
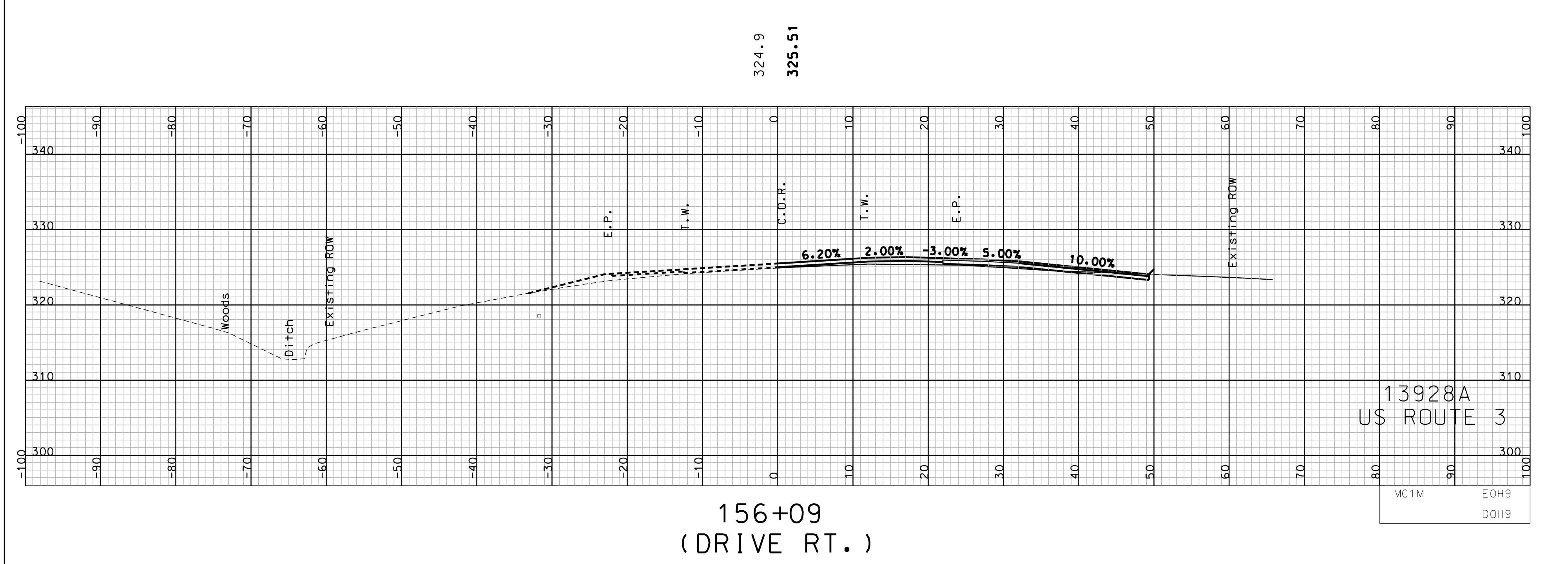
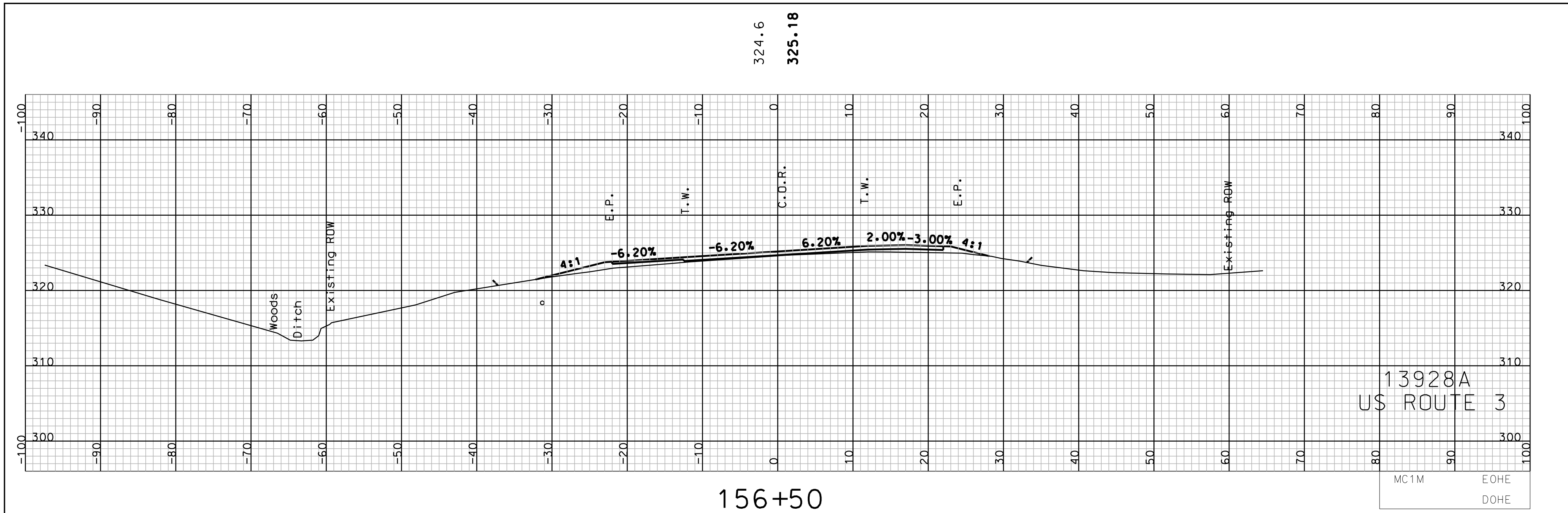

COMMON EXCAV.		SHEET TOTALS		ROCK EXCAV.	
DCN	STATE PROJECT NO.	C.Y.	C.Y.	C.Y.	C.Y.
13928axs-mc1m	13928A	4	3	0	0
TOTAL SHEETS		TOTAL SHEETS		TOTAL SHEETS	
142		160		160	

SDR PROCESSED	DATE
NEW DESIGN TEAM BALDWIN	DATE 09/2013
SHEET CHECKED TEAM BALDWIN	DATE 04/2015
AS BUILT DETAILS	DATE

REVISIONS AFTER PROPOSAL				
NUMBER	DATE	STATION	STATION	DESCRIPTION

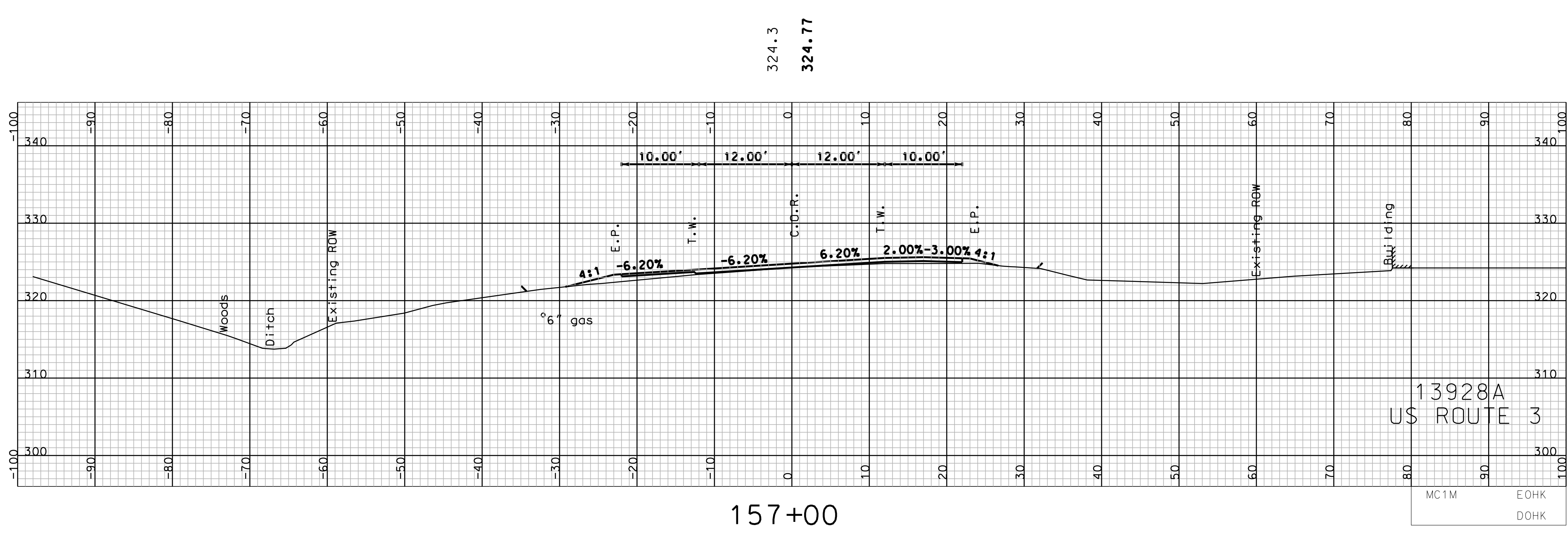
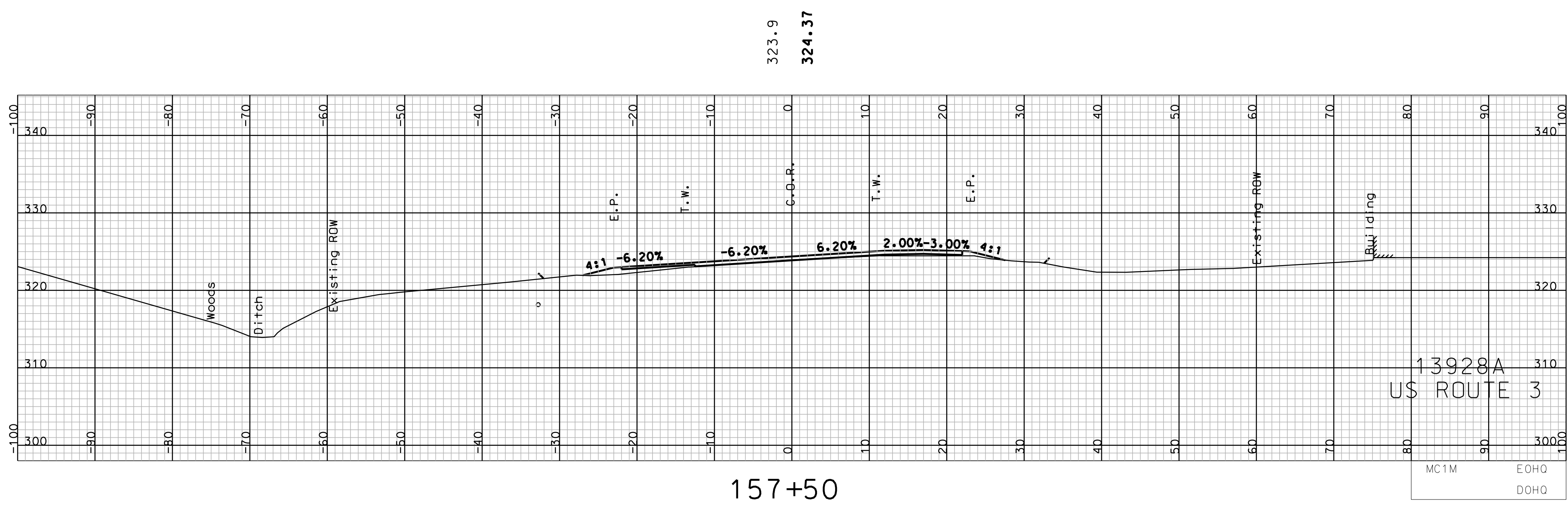
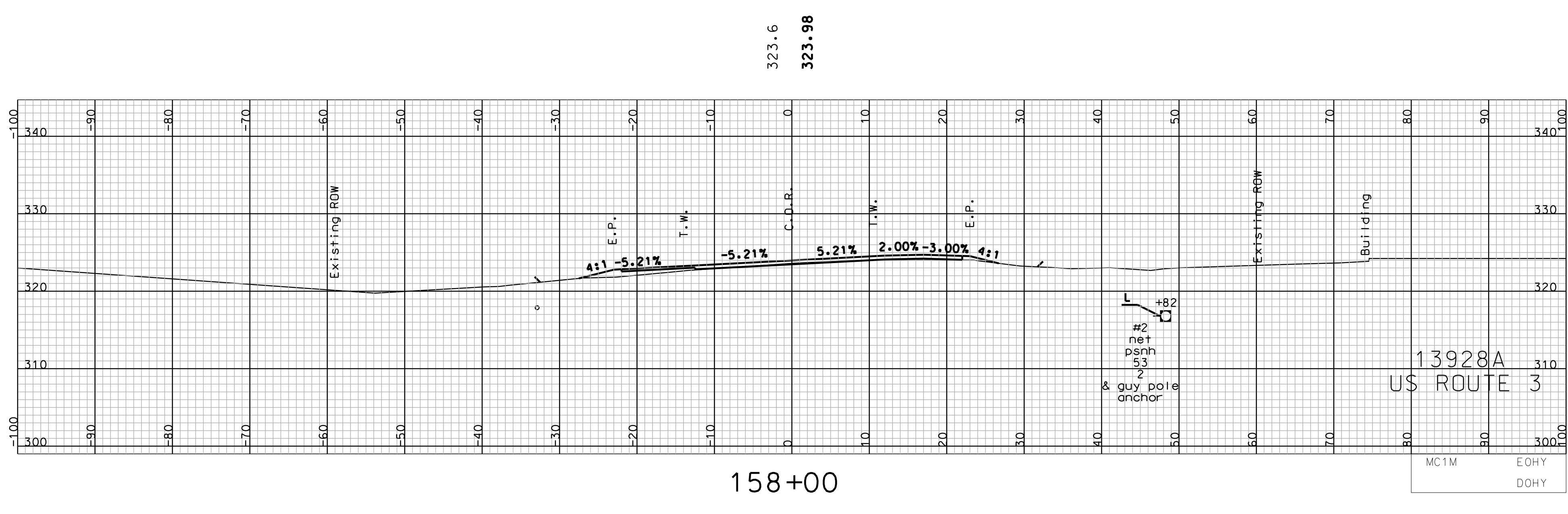
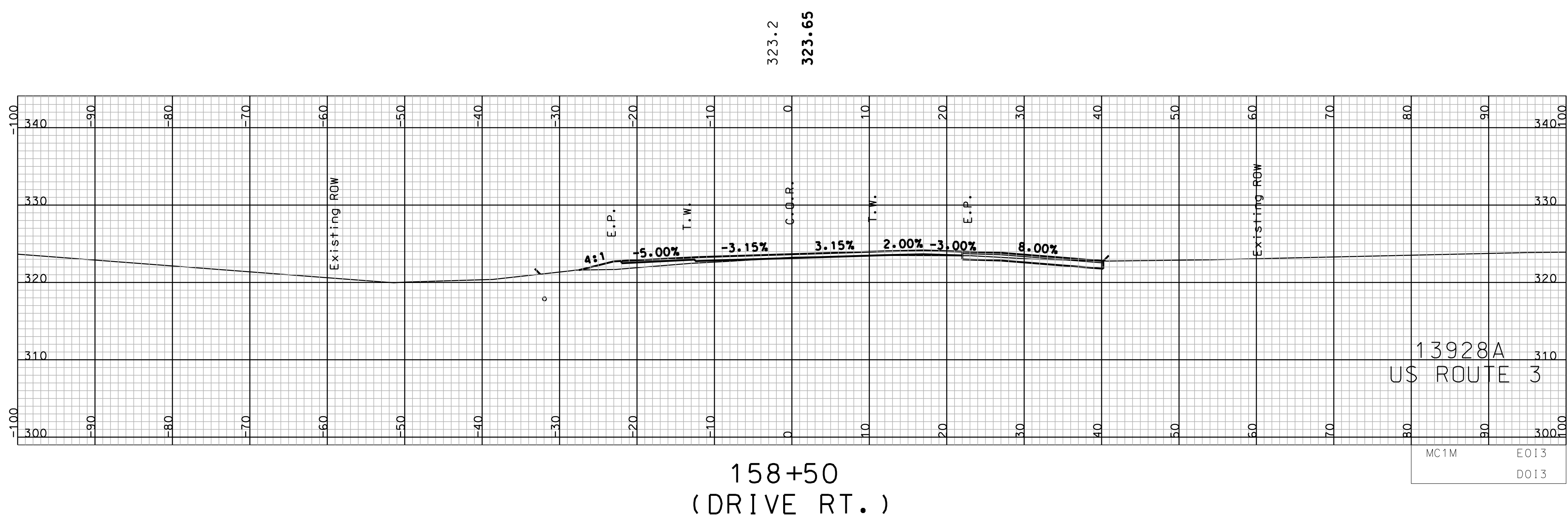

COMMON EXCAV. 31		SHEET TOTALS		ROCK EXCAV. 0	
FILL 0		C.Y.		C.Y.	
MUCK EXCAV. 0		C.Y.		C.Y.	
DGN	STATE PROJECT NO.	SHEET NO.	TOTAL SHEETS		
13928axs-mc1m	13928A	143	160		

SDR PROCESSED	DATE		
NEW DESIGN TEAM BALDWIN	DATE	09/2013	
SHEET CHECKED TEAM BALDWIN	DATE	04/2015	
AS BUILT DETAILS	DATE		

REVISIONS AFTER PROPOSAL					
NUMBER	DATE	STATION	STATION	DESCRIPTION	

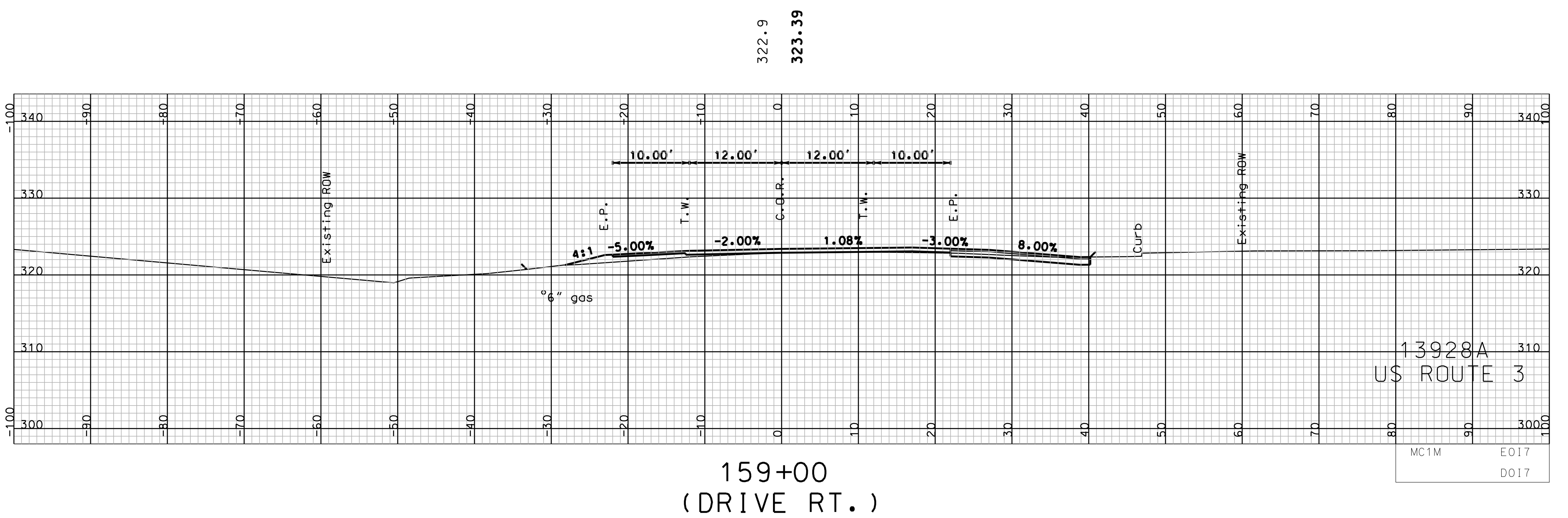
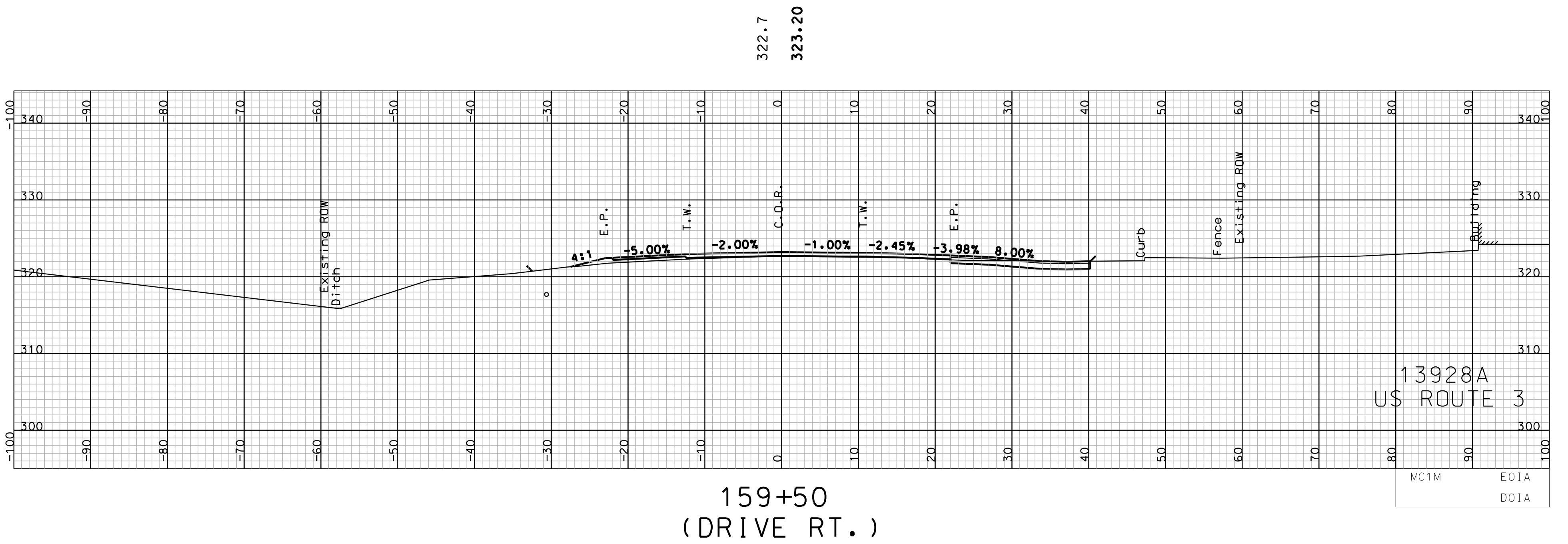
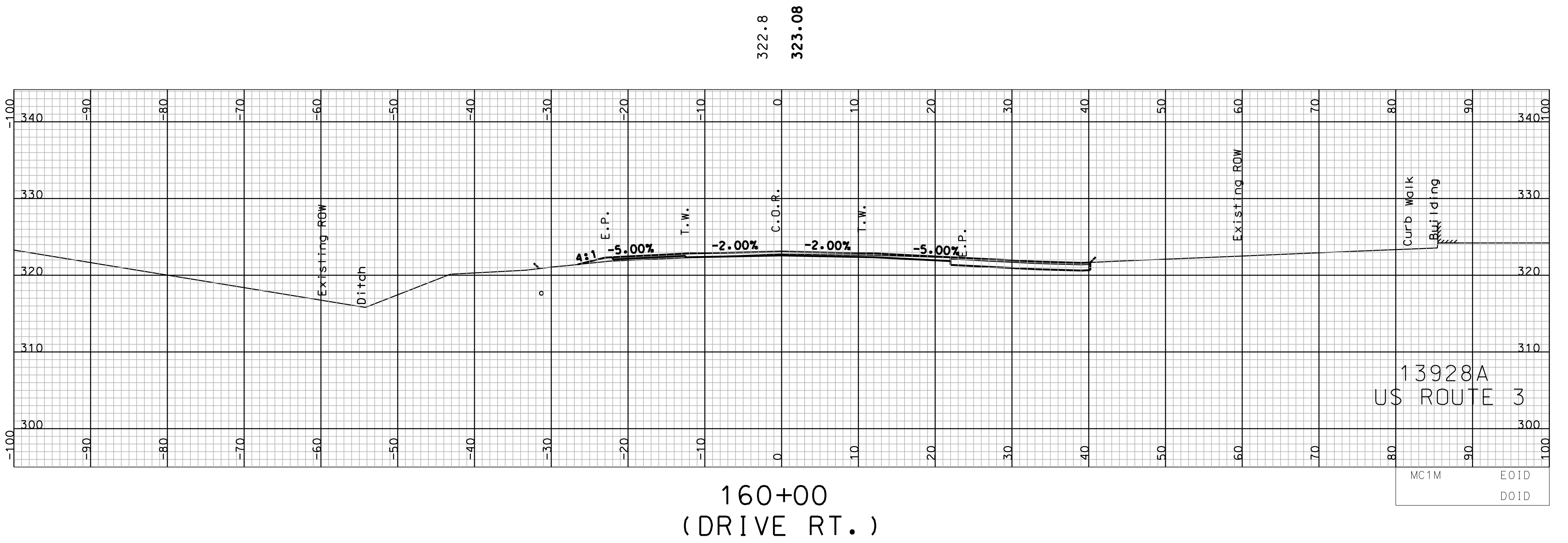
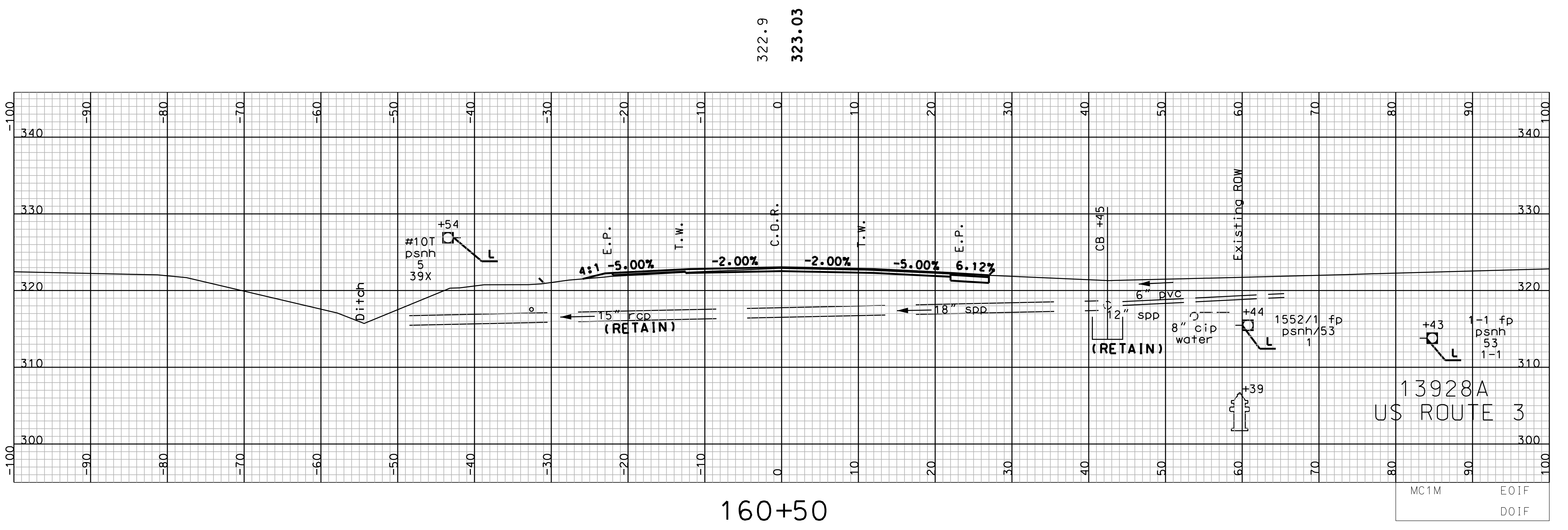

COMMON EXCAV.		SHEET TOTALS		ROCK EXCAV.	
DCN	STATE PROJECT NO.	FILL	C.Y.	MUCK EXCAV.	C.Y.
13928axs-mc1m	13928A	78	0	0	0
TOTAL SHEETS		144		160	

SDR PROCESSED	DATE
NEW DESIGN TEAM BALDWIN	DATE 09/2013
SHEET CHECKED TEAM BALDWIN	DATE 04/2015
AS BUILT DETAILS	DATE

REVISIONS AFTER PROPOSAL				
NUMBER	DATE	STATION	STATION	DESCRIPTION

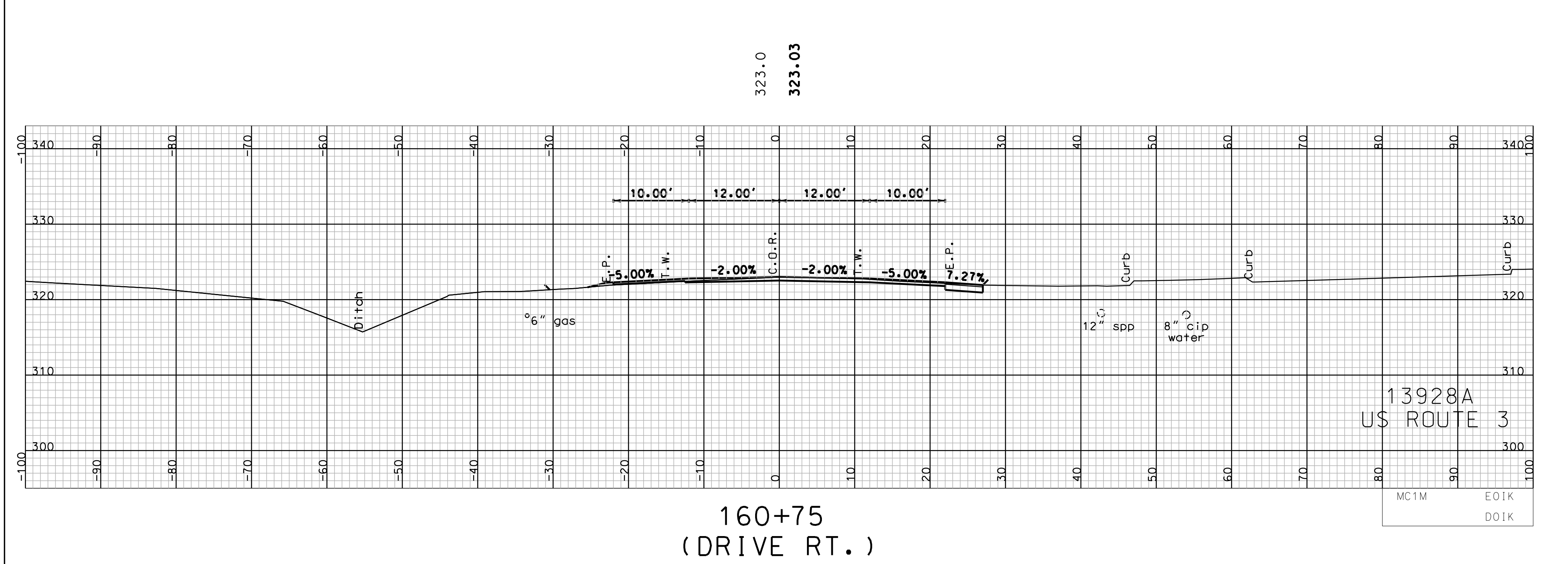
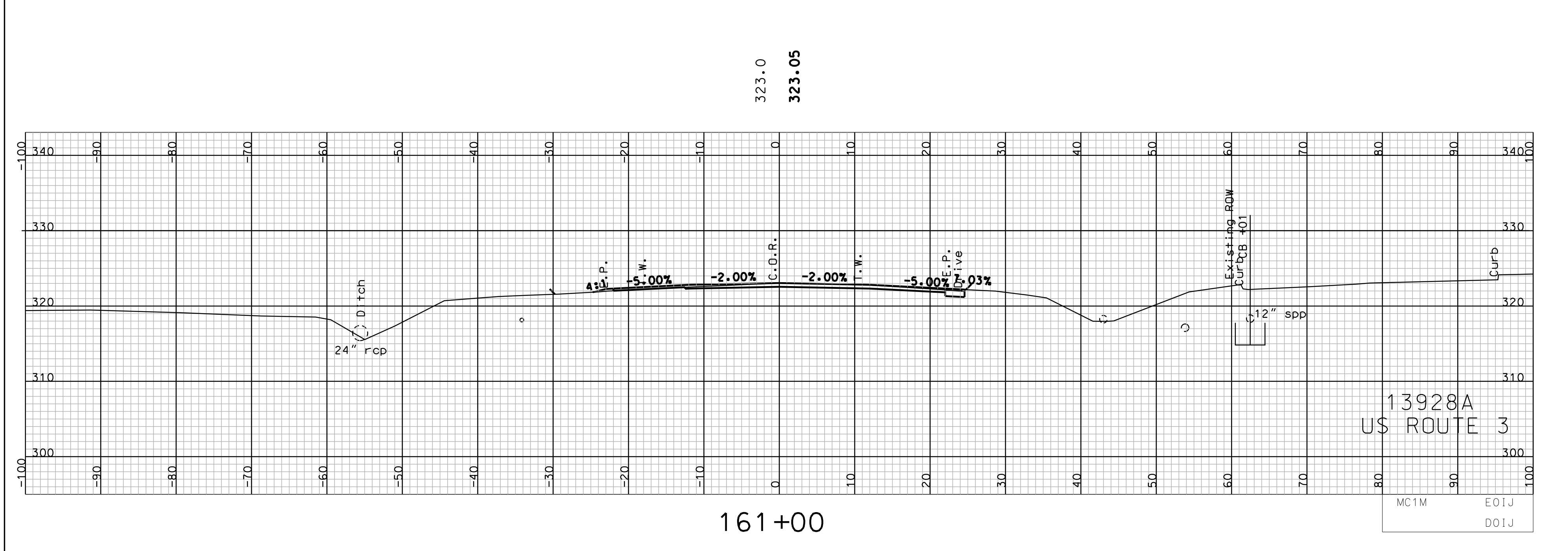
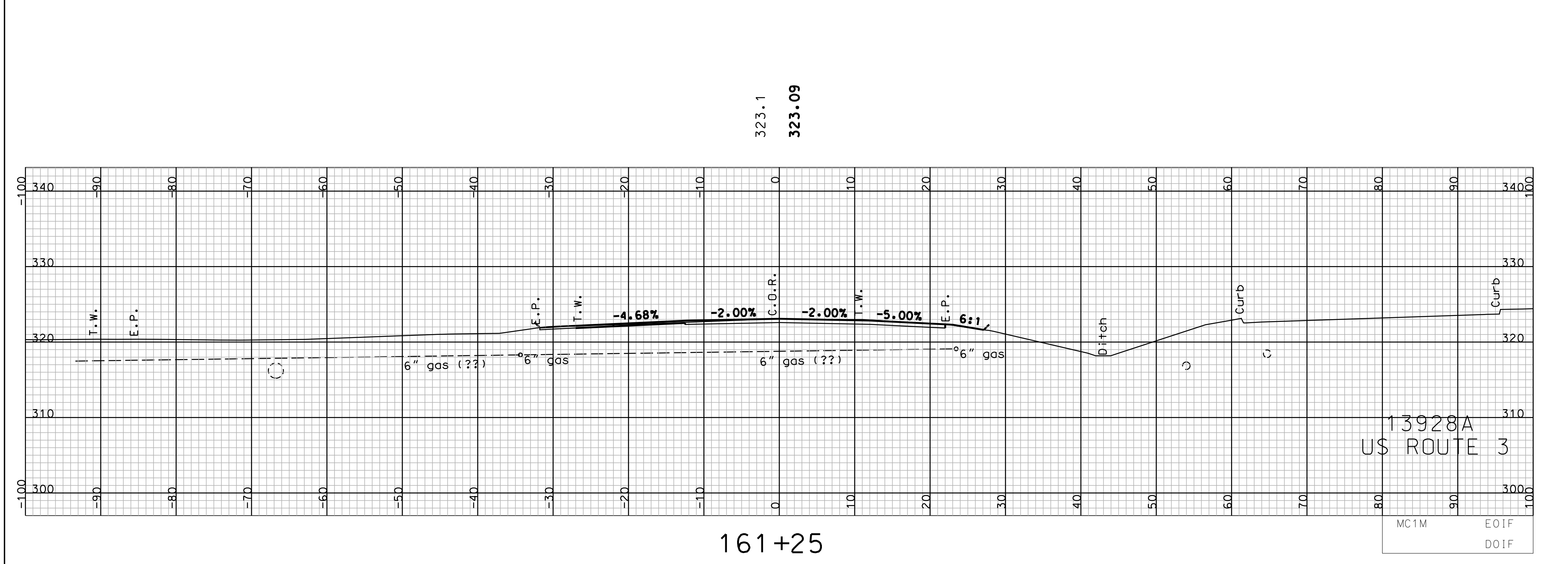
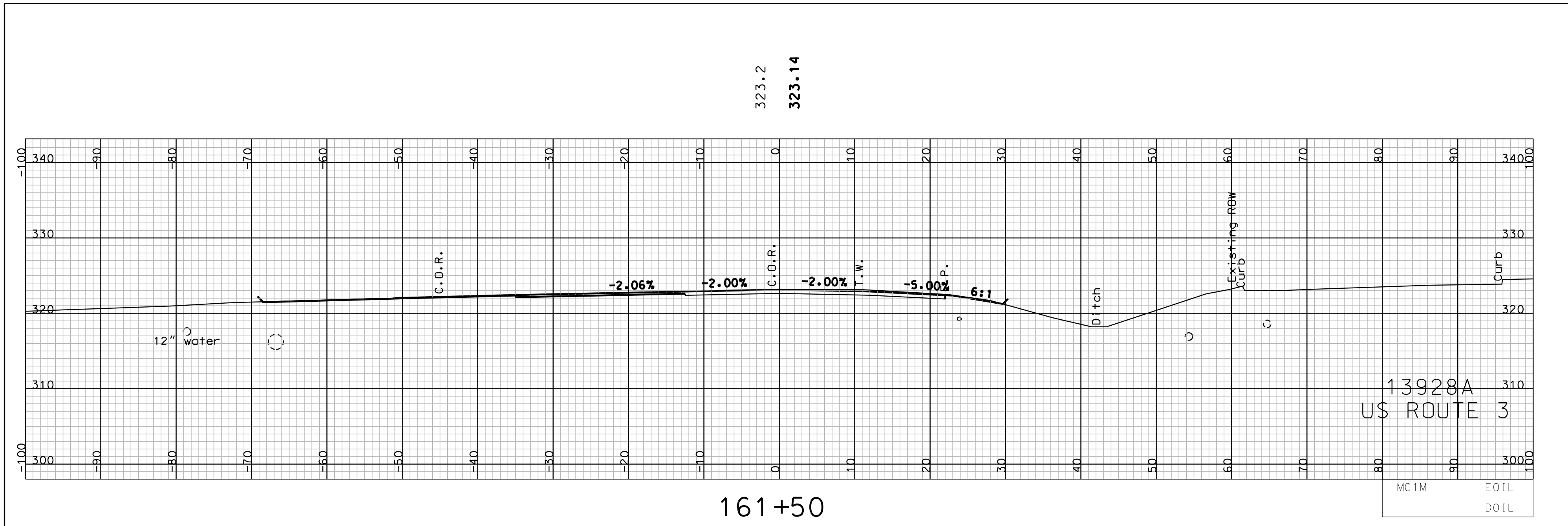

SHEET TOTALS					
COMMON EXCAV.	5	C.Y.	ROCK EXCAV.	0	C.Y.
FILL	0	C.Y.	MUCK EXCAV.	0	C.Y.
DGN	13928axs-mc1m	STATE PROJECT NO.	13928A	SHEET NO.	145
				TOTAL SHEETS	160

SDR PROCESSED	DATE
NEW DESIGN TEAM BALDWIN	DATE 09/2013
SHEET CHECKED TEAM BALDWIN	DATE 04/2015
AS BUILT DETAILS	DATE

REVISIONS AFTER PROPOSAL				
NUMBER	DATE	STATION	STATION	DESCRIPTION

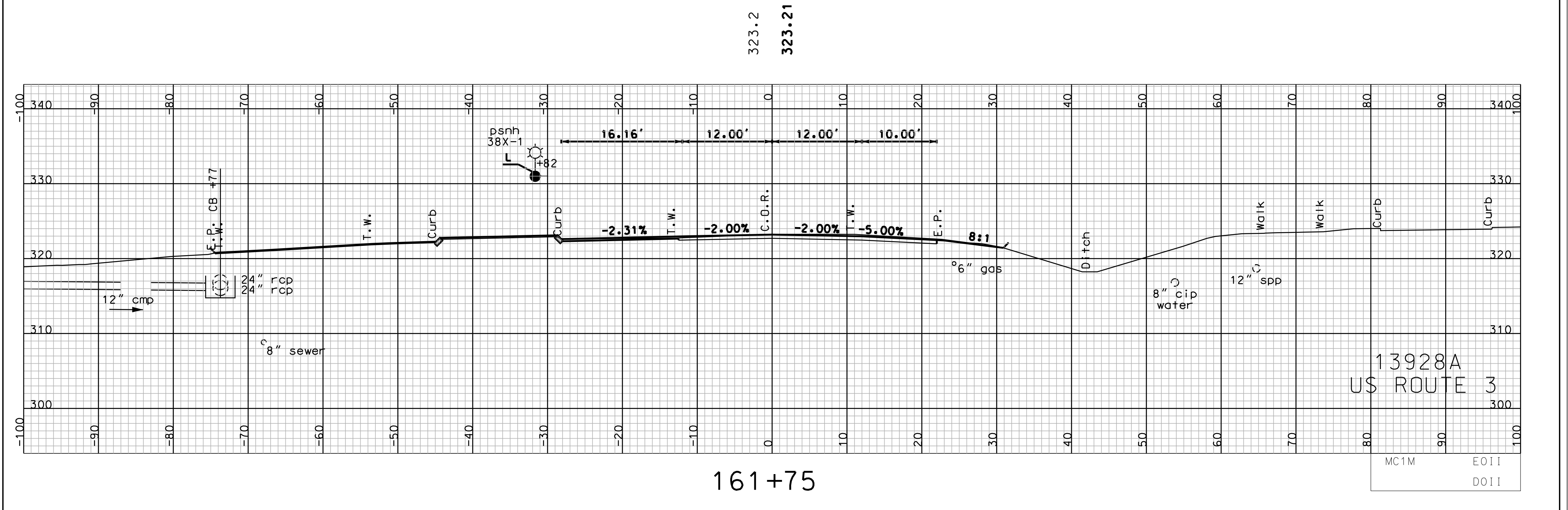
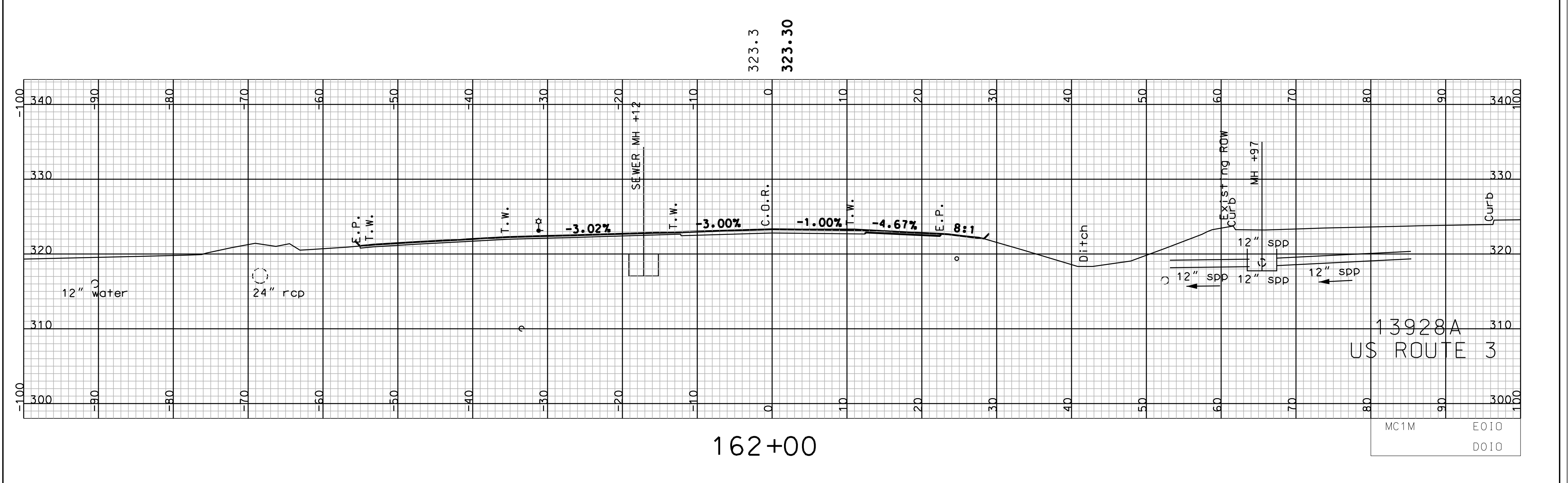
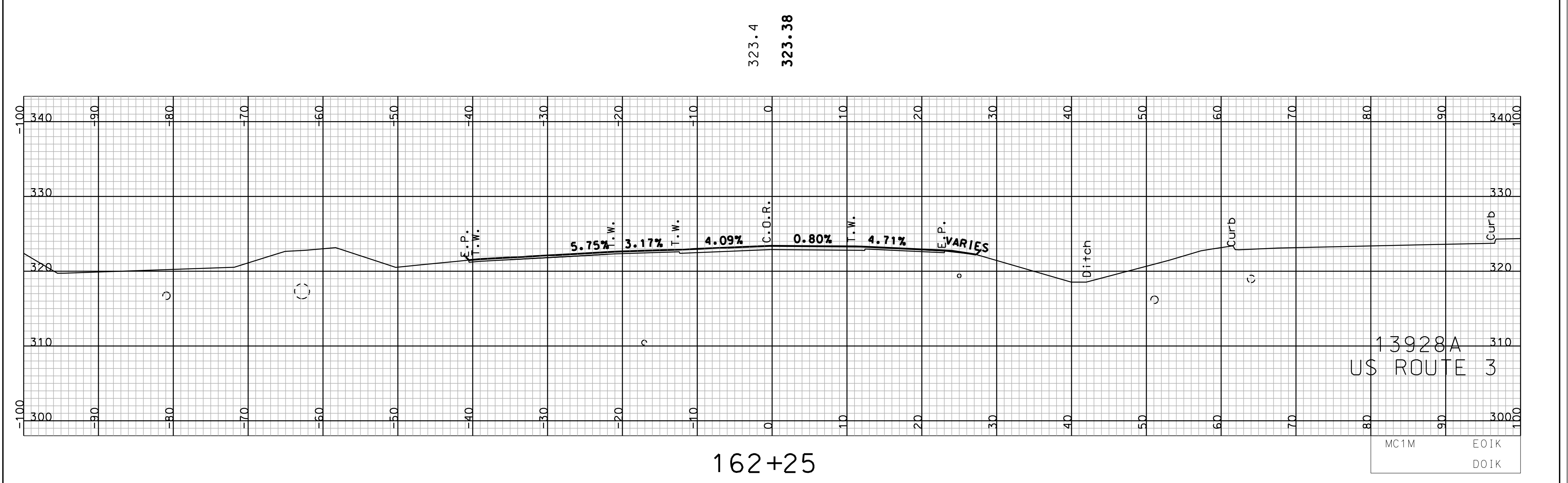
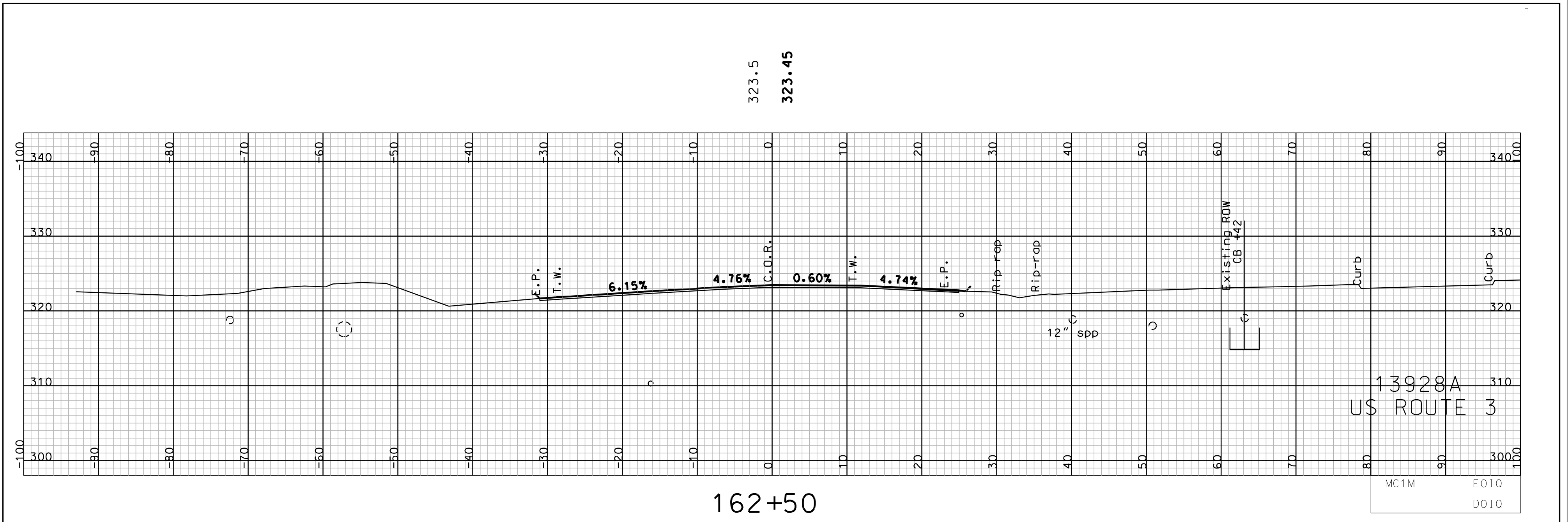

COMMON EXCAV.		3	SHEET TOTALS		ROCK EXCAV.	0	C.Y.
FILL		0	C.Y.		MUCK EXCAV.	0	C.Y.
DGN	STATE PROJECT NO.	13928A	SHEET NO.	146	TOTAL SHEETS	160	

SDR PROCESSED	DATE
NEW DESIGN TEAM BALDWIN	DATE 09/2013
SHEET CHECKED TEAM BALDWIN	DATE 04/2015
AS BUILT DETAILS	DATE

REVISIONS AFTER PROPOSAL				
NUMBER	DATE	STATION	STATION	DESCRIPTION

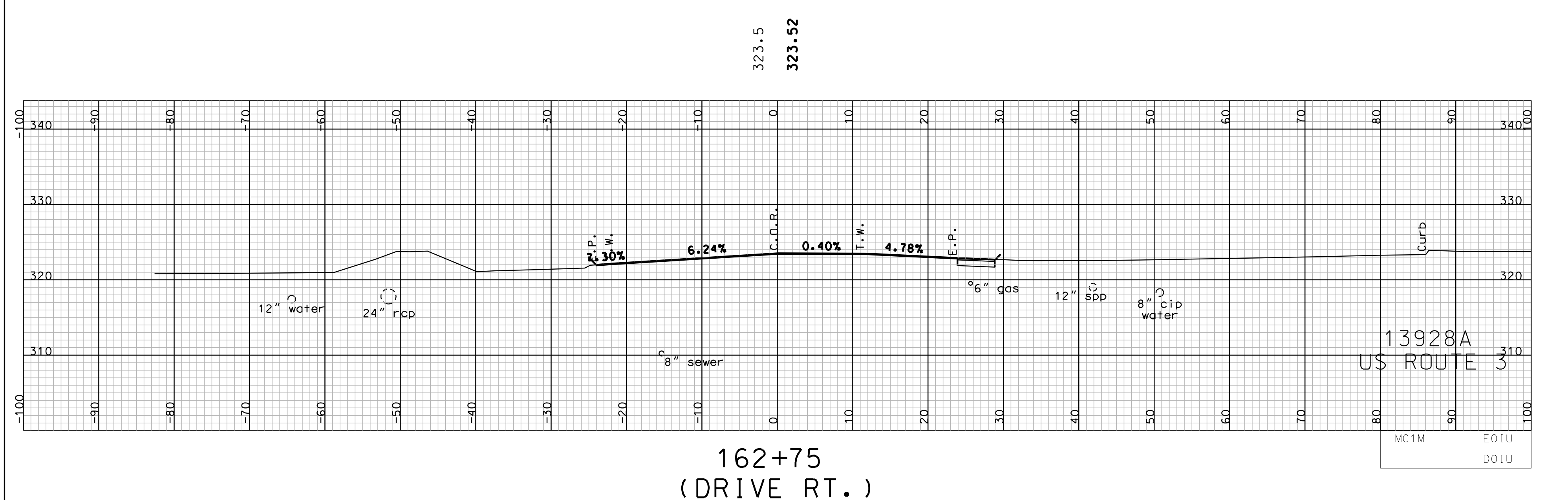
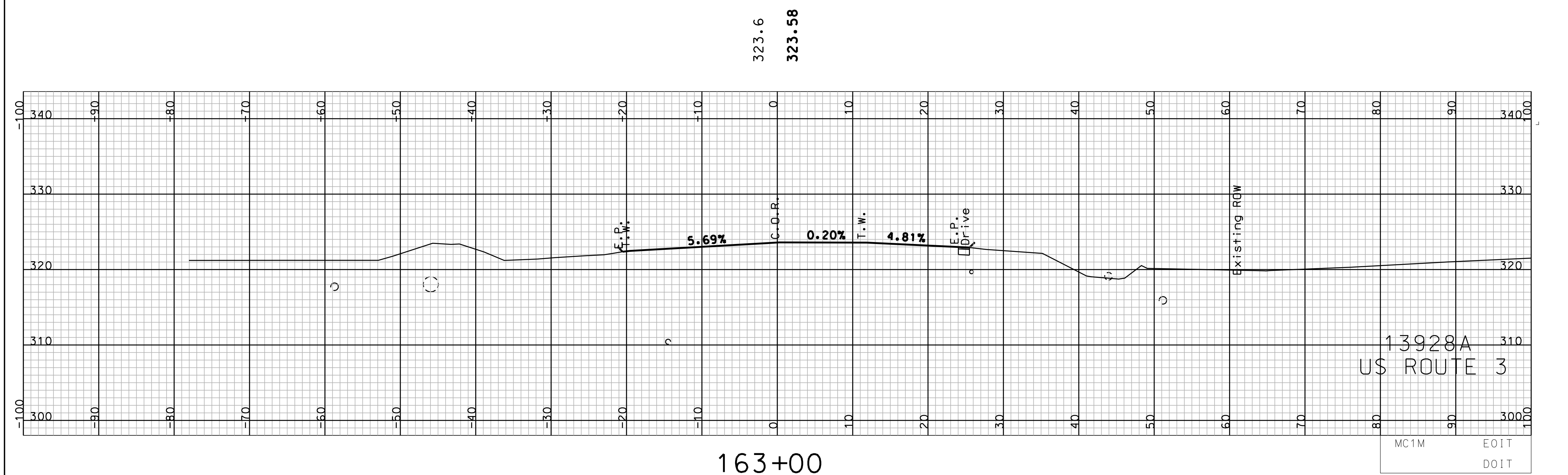
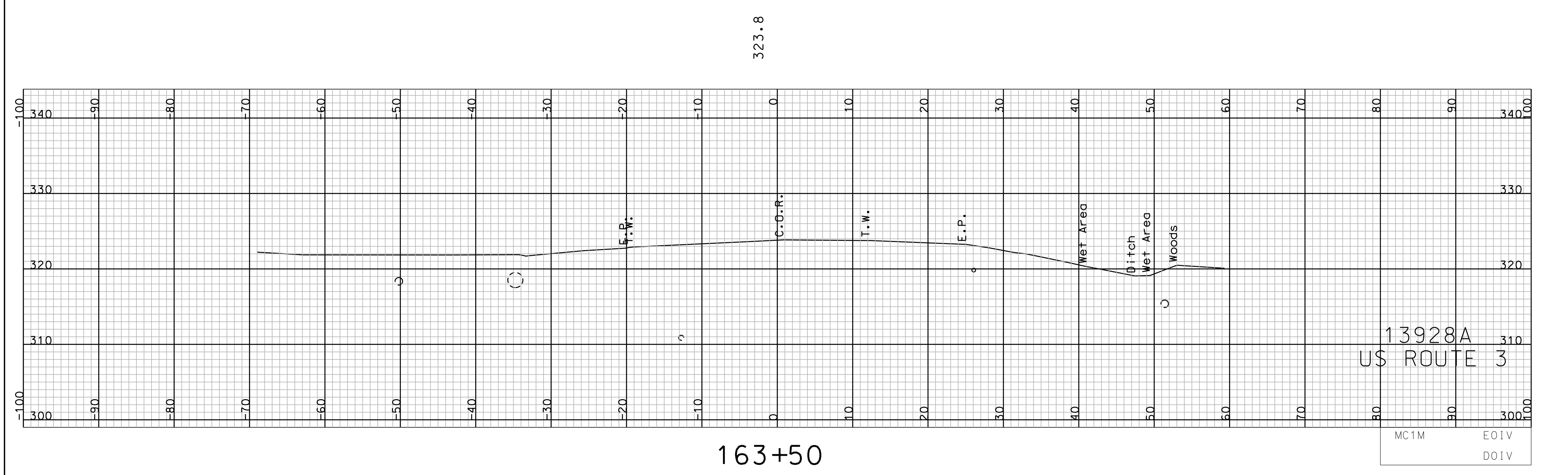
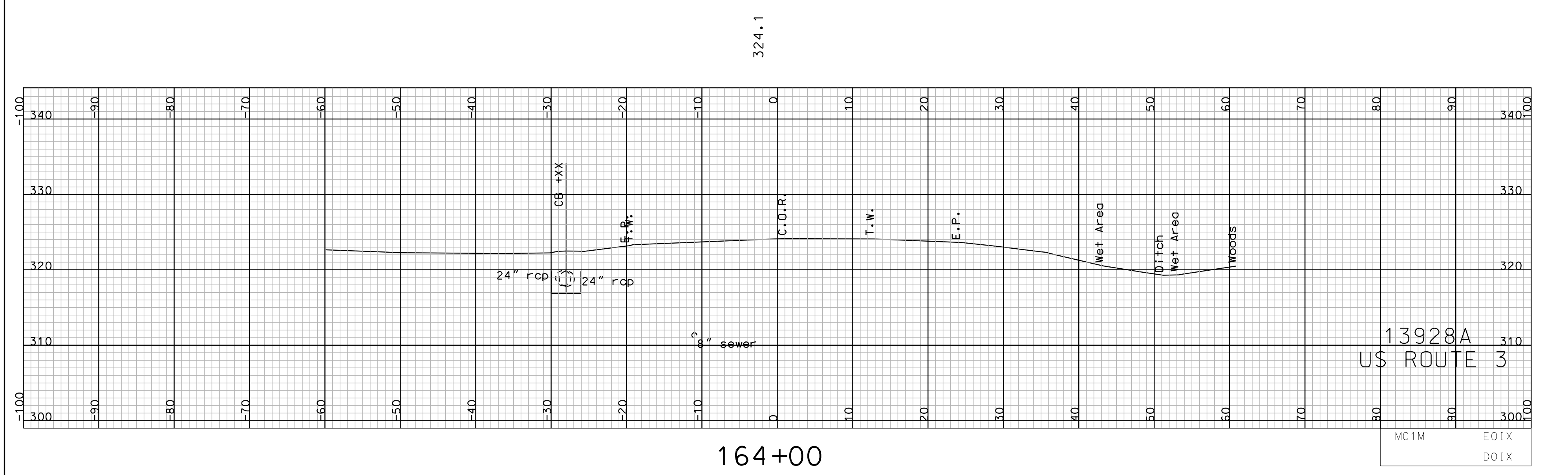

SHEET TOTALS					
COMMON EXCAV.	4	C.Y.	ROCK EXCAV.	0	C.Y.
FILL	0	C.Y.	MUCK EXCAV.	0	C.Y.
DGN	13928axs-mc1m	STATE PROJECT NO.	13928A	SHEET NO.	147
				TOTAL SHEETS	160

SDR PROCESSED	DATE
NEW DESIGN TEAM BALDWIN	DATE 09/2013
SHEET CHECKED TEAM BALDWIN	DATE 04/2015
AS BUILT DETAILS	DATE

REVISIONS AFTER PROPOSAL				
NUMBER	DATE	STATION	STATION	DESCRIPTION

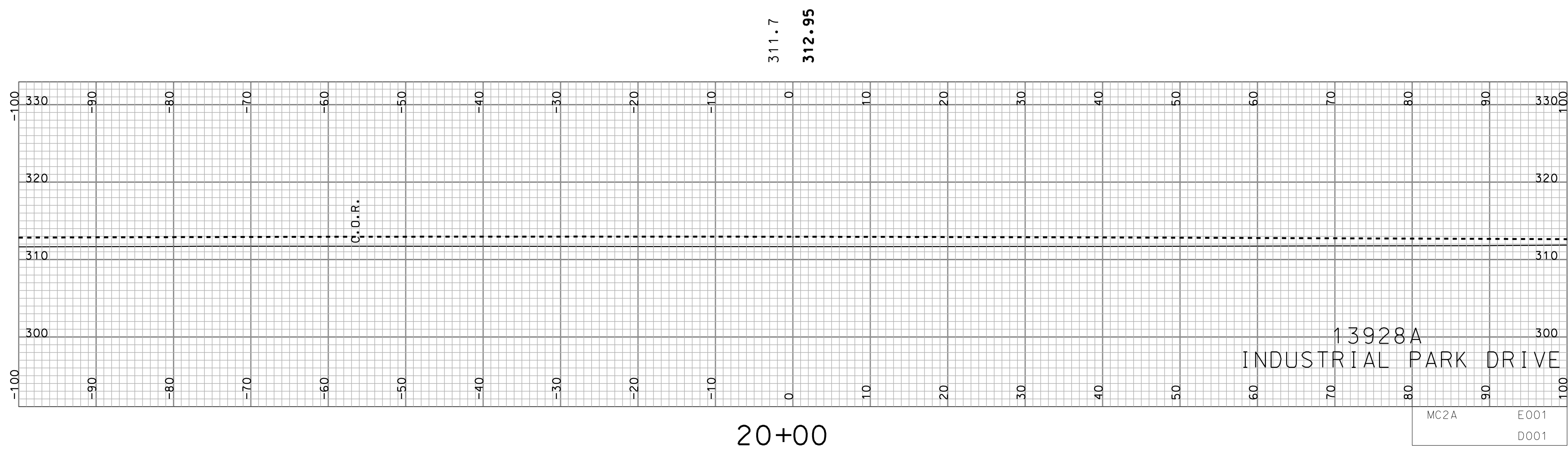
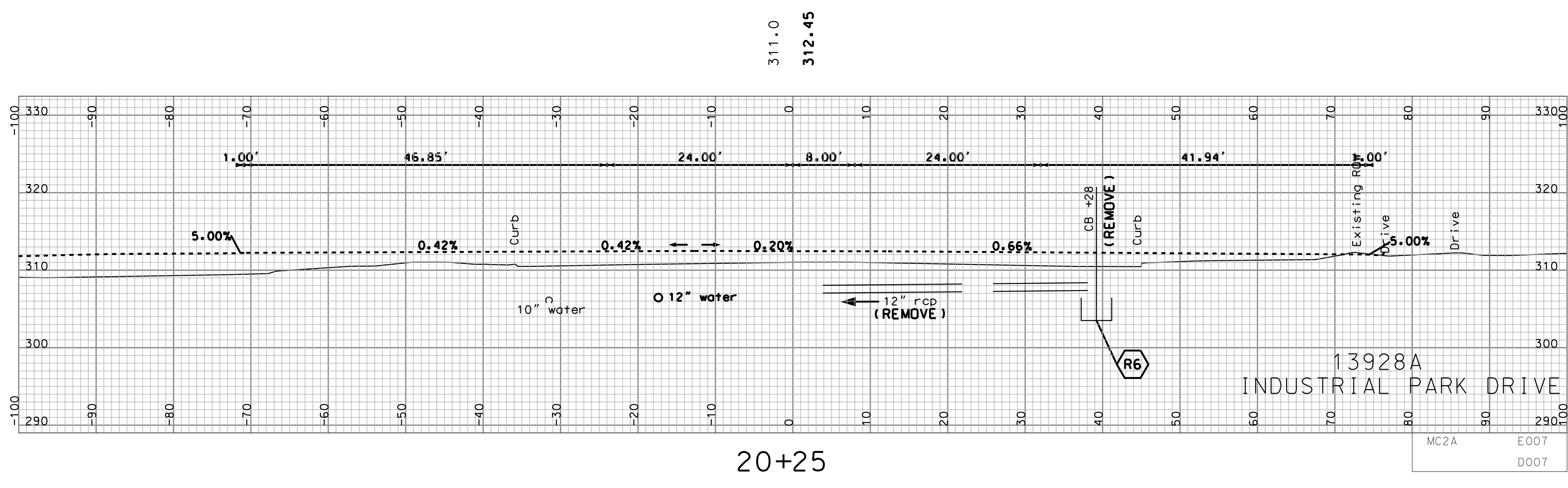
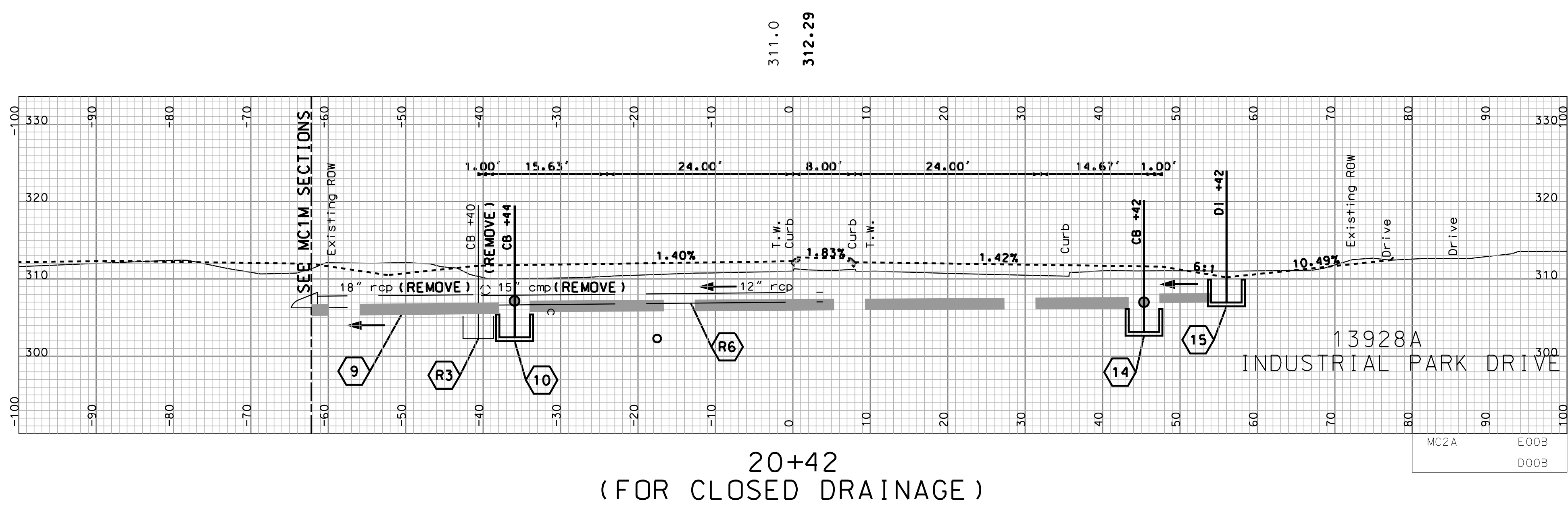

COMMON EXCAV. 70 C.Y.		SHEET TOTALS	
FILL 2 C.Y.		ROCK EXCAV. 0 C.Y.	
		MUCK EXCAV. 0 C.Y.	
DGN	STATE PROJECT NO.	SHEET NO.	TOTAL SHEETS
13928axs-mc2a	13928A	148	160

SDR PROCESSED	DATE
NEW DESIGN TEAM BALDWIN	DATE 09/2013
SHEET CHECKED TEAM BALDWIN	DATE 04/2015
AS BUILT DETAILS	DATE

REVISIONS AFTER PROPOSAL				
NUMBER	DATE	STATION	STATION	DESCRIPTION

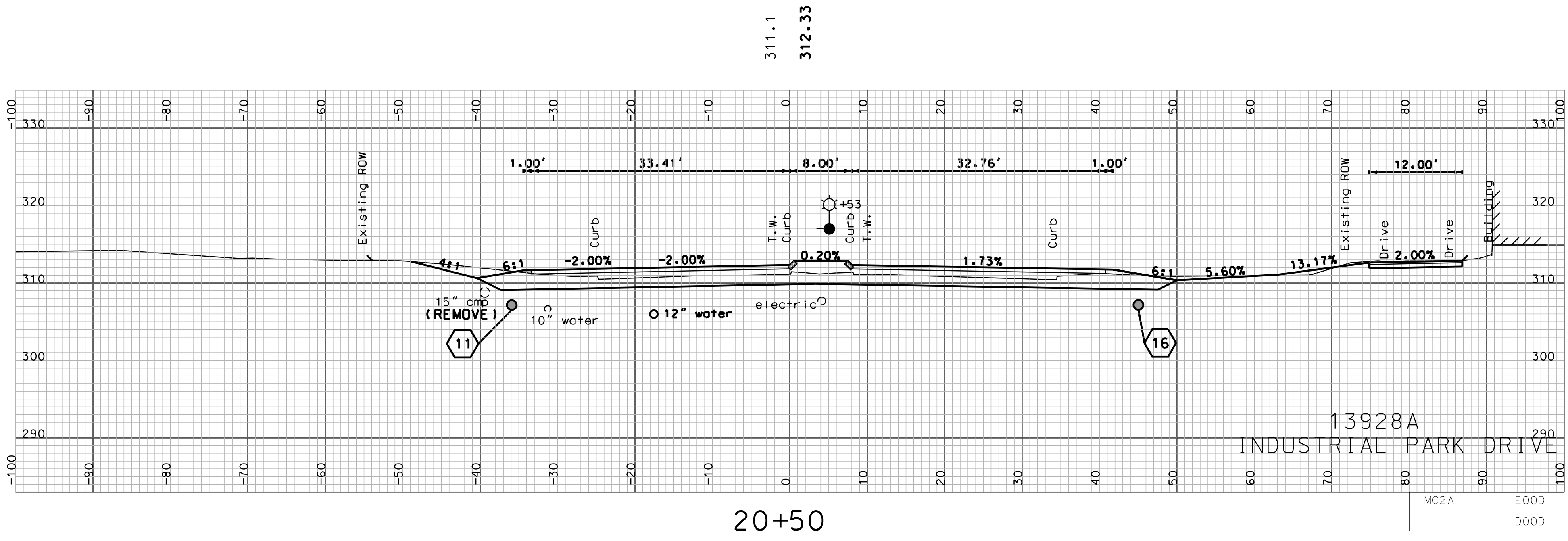
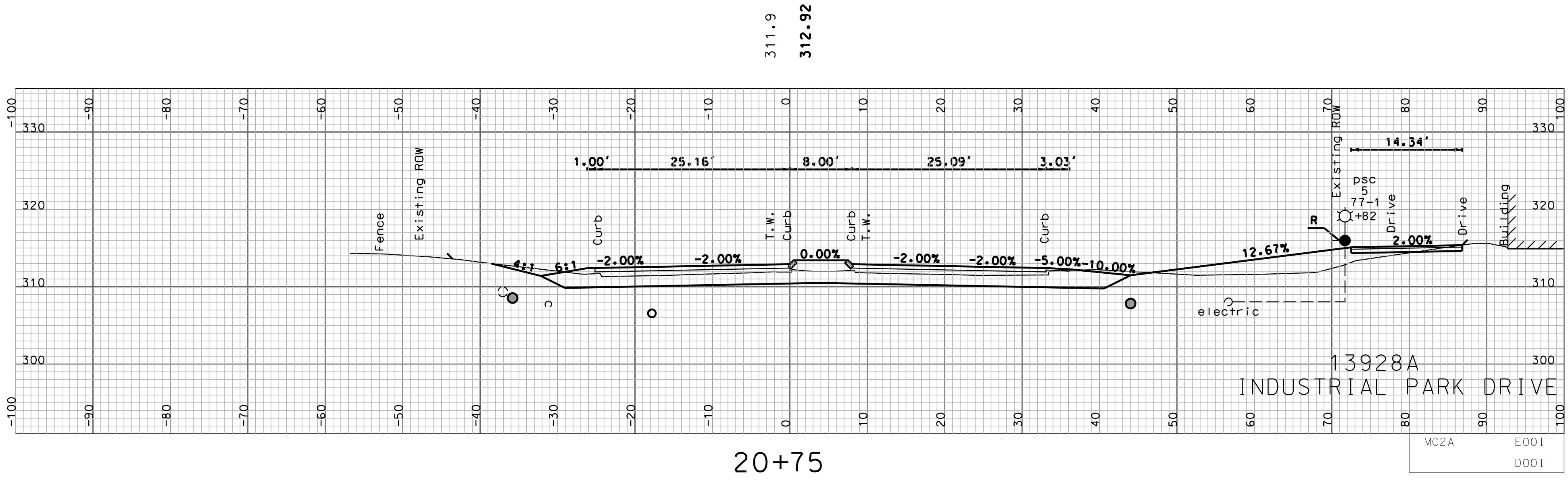
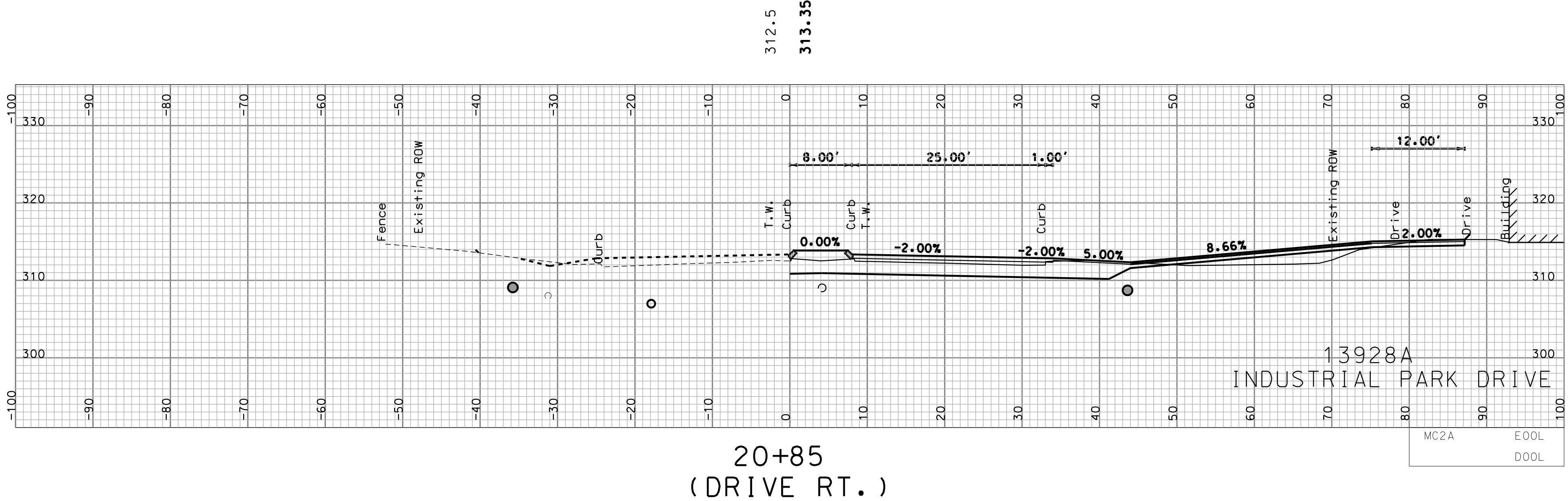

SHEET TOTALS					
COMMON EXCAV.	230	C.Y.	ROCK EXCAV.	0	C.Y.
FILL	47	C.Y.	MUCK EXCAV.	0	C.Y.
DGN	13928axs-mc2a	STATE PROJECT NO.	13928A	SHEET NO.	149
				TOTAL SHEETS	160

SDR PROCESSED	DATE
NEW DESIGN TEAM BALDWIN	DATE 09/2013
SHEET CHECKED TEAM BALDWIN	DATE 04/2015
AS BUILT DETAILS	DATE

REVISIONS AFTER PROPOSAL				
NUMBER	DATE	STATION	STATION	DESCRIPTION

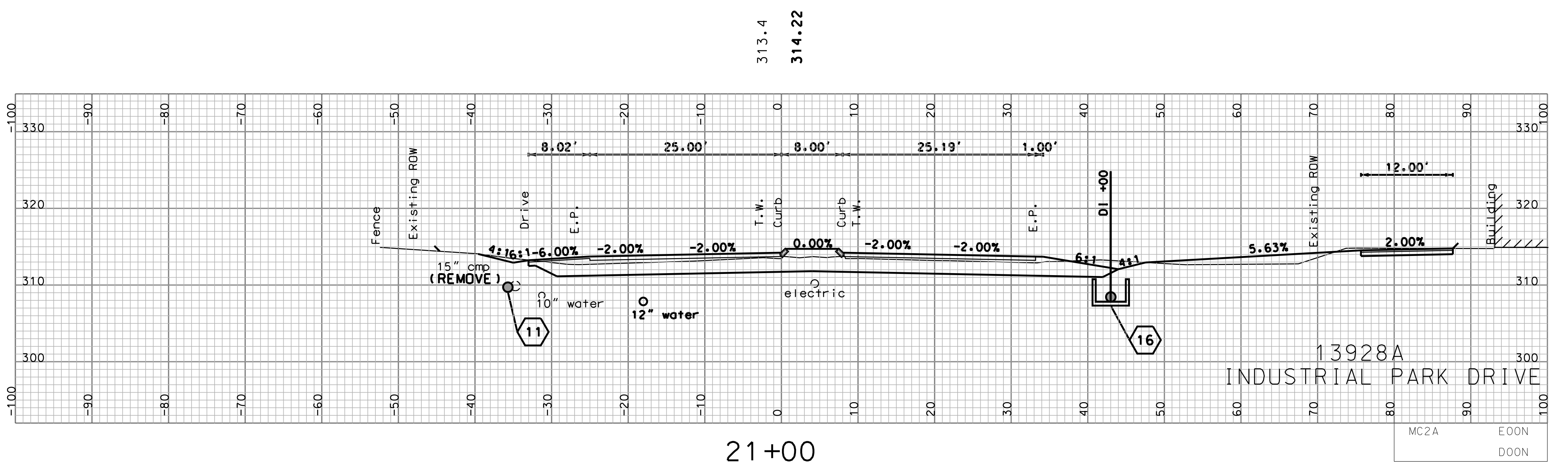
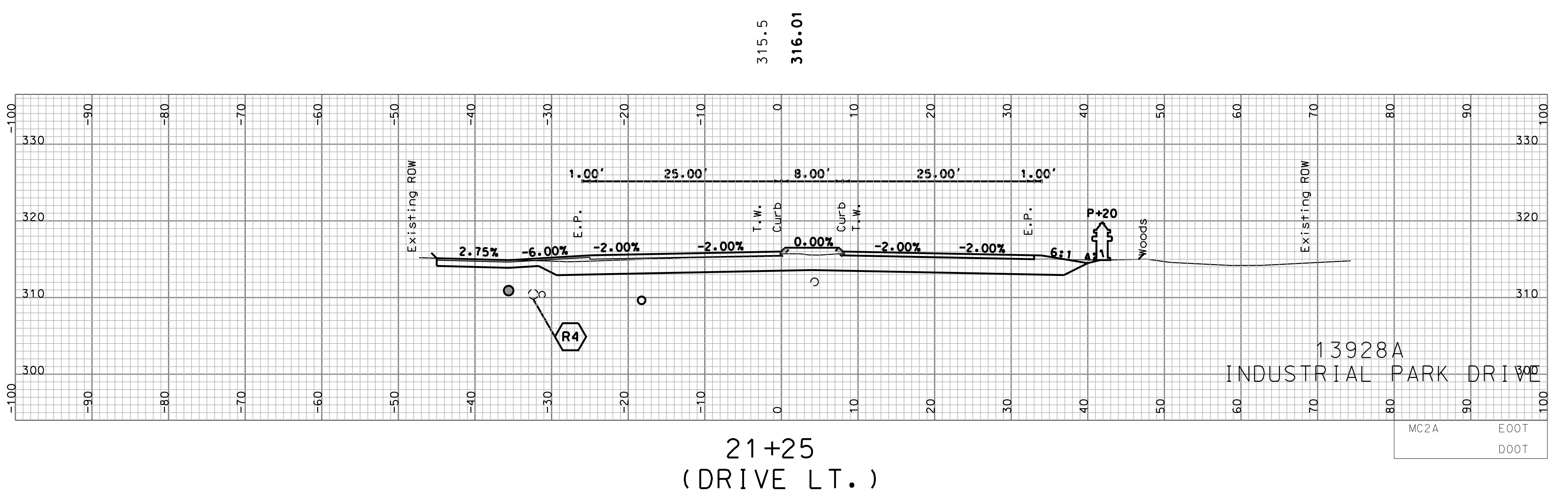
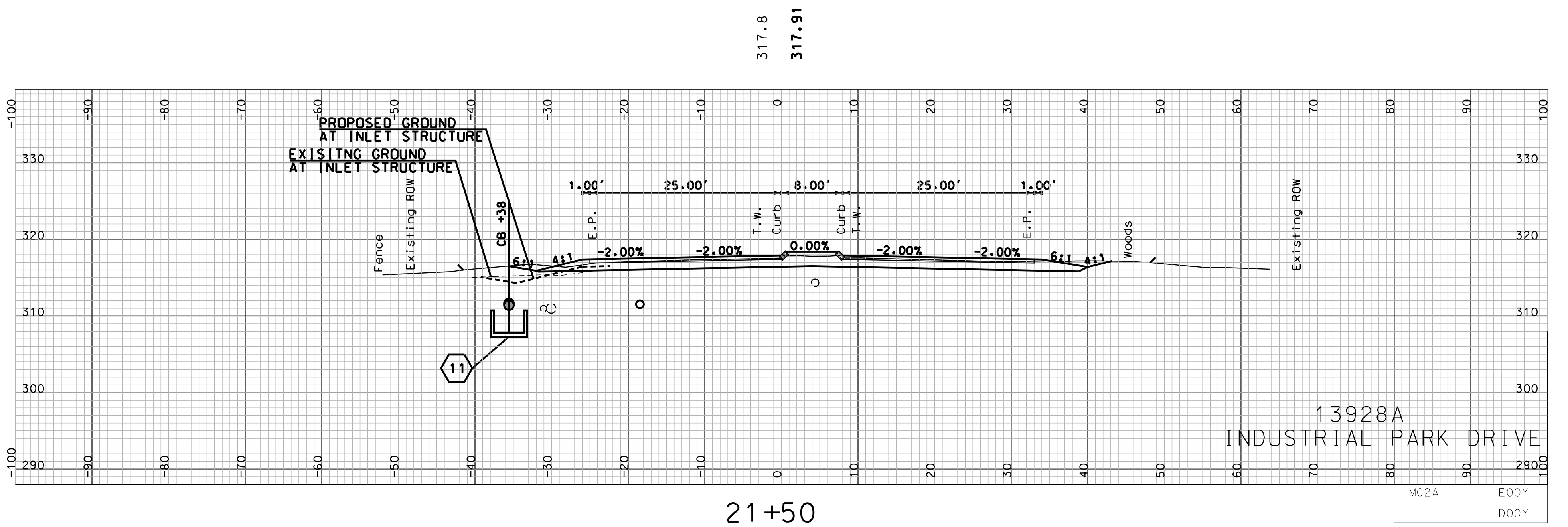

SHEET TOTALS					
COMMON EXCAV.	324	C.Y.	ROCK EXCAV.	0	C.Y.
FILL	9	C.Y.	MUCK EXCAV.	0	C.Y.
DGN	13928axs-mc2a	STATE PROJECT NO.	13928A	SHEET NO.	150
				TOTAL SHEETS	160

SDR PROCESSED	DATE
NEW DESIGN TEAM BALDWIN	DATE 09/2013
SHEET CHECKED TEAM BALDWIN	DATE 04/2015
AS BUILT DETAILS	DATE

REVISIONS AFTER PROPOSAL				
NUMBER	DATE	STATION	STATION	DESCRIPTION

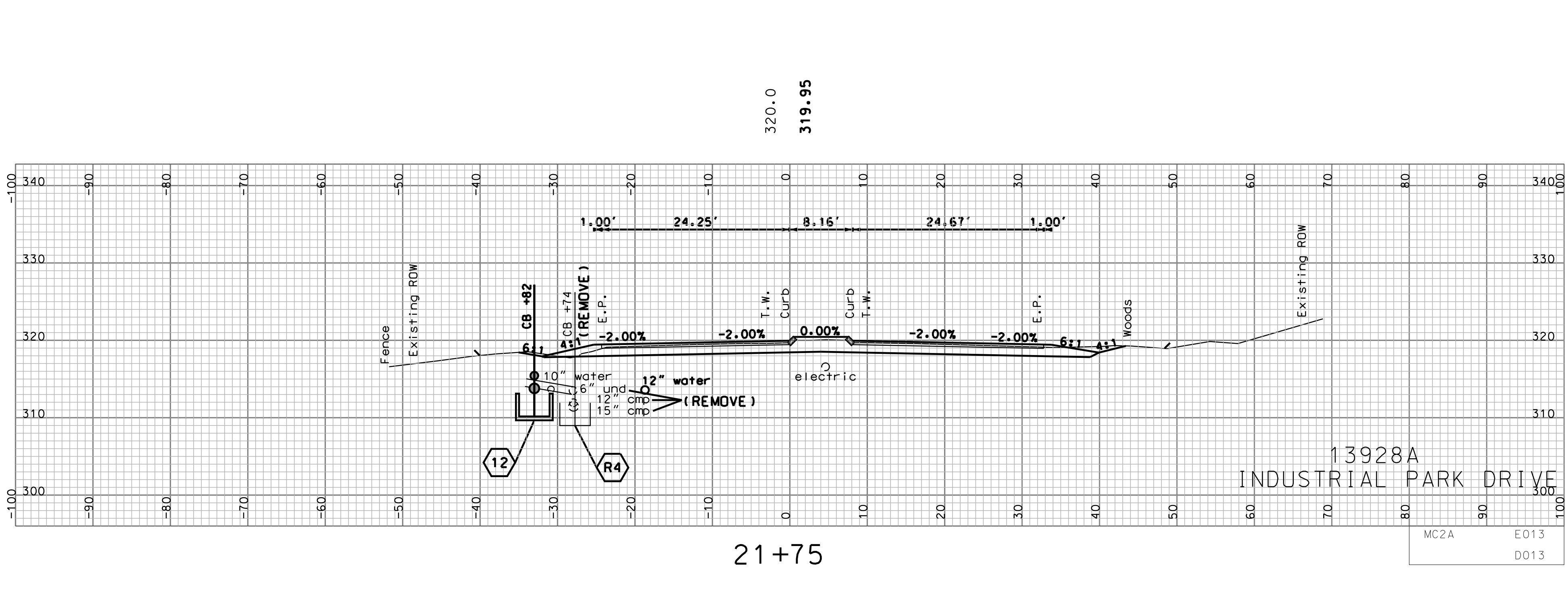
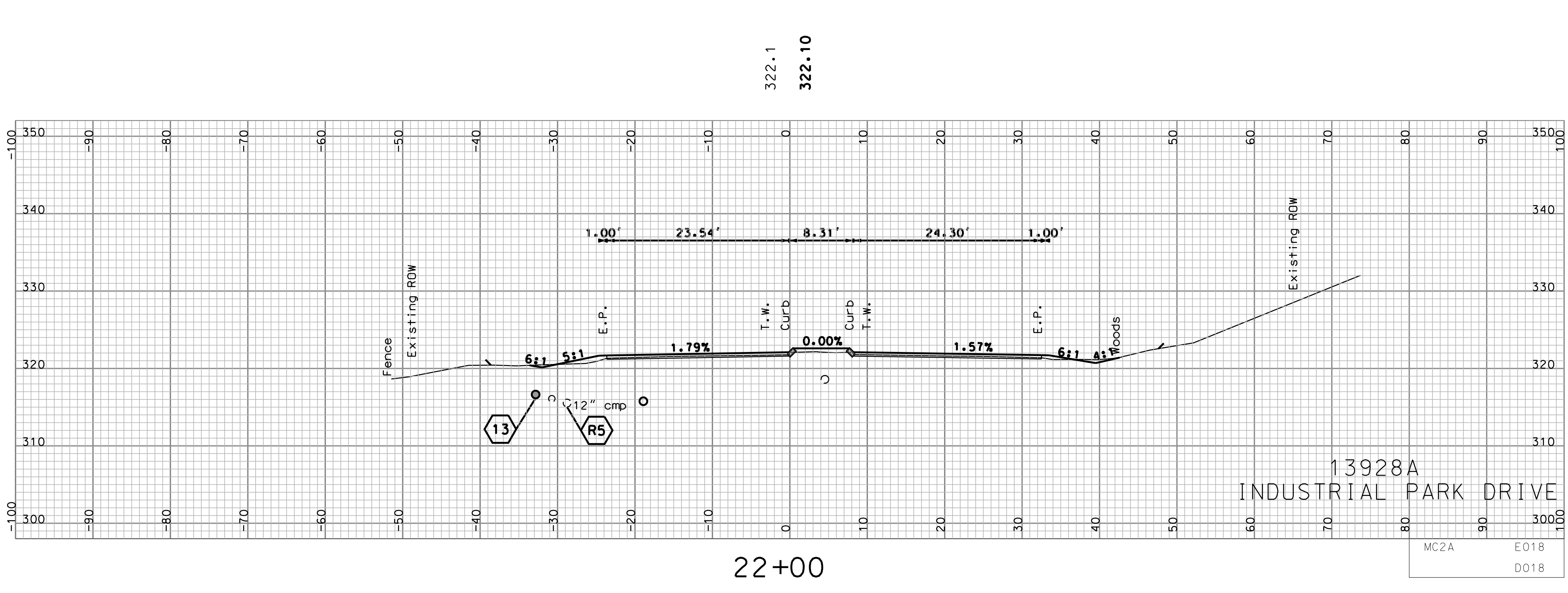
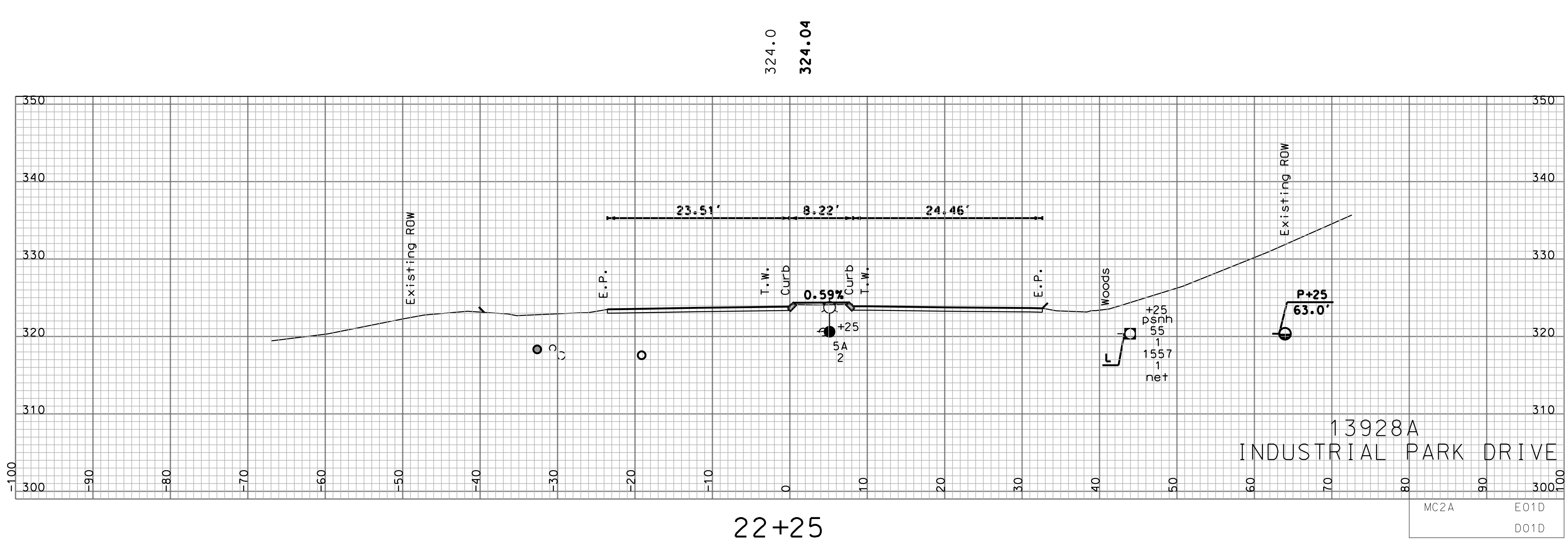
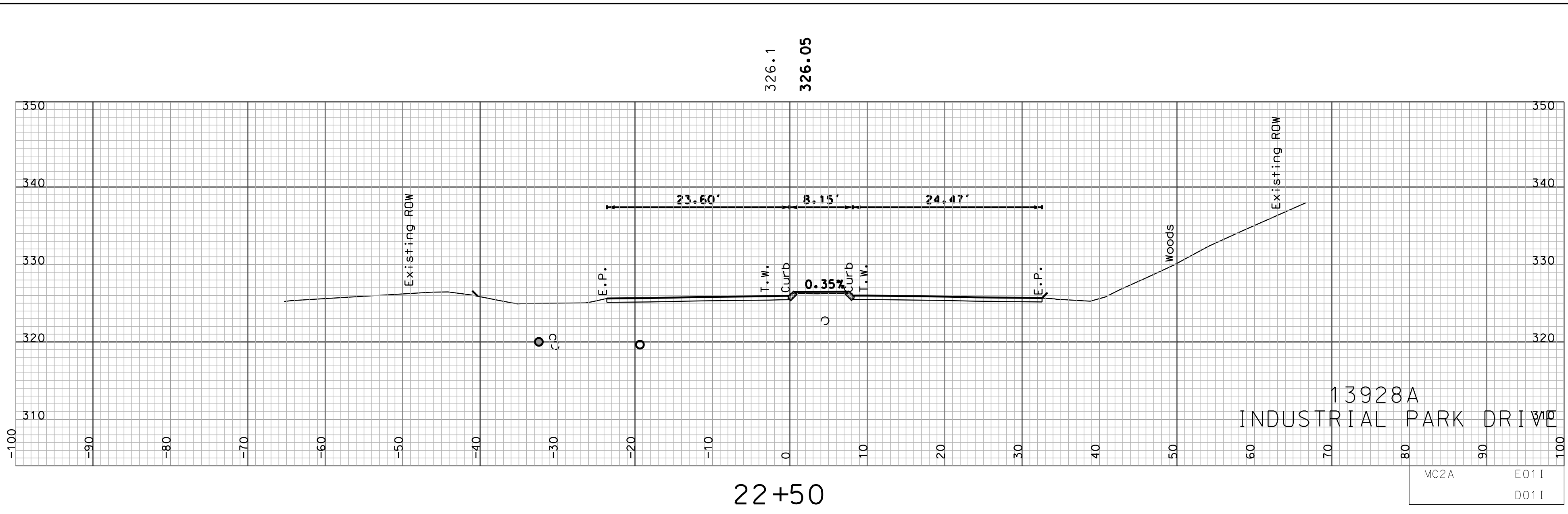

COMMON EXCAV.	48	SHEET TOTALS	ROCK EXCAV.	0
FILL	4	C.Y.	MUCK EXCAV.	0
DGN	13928axs-mc2a	STATE PROJECT NO.	13928A	SHEET NO.
				151
				TOTAL SHEETS
				160

SDR PROCESSED	DATE
NEW DESIGN TEAM BALDWIN	DATE 09/2013
SHEET CHECKED TEAM BALDWIN	DATE 04/2015
AS BUILT DETAILS	DATE

REVISIONS AFTER PROPOSAL				
NUMBER	DATE	STATION	STATION	DESCRIPTION

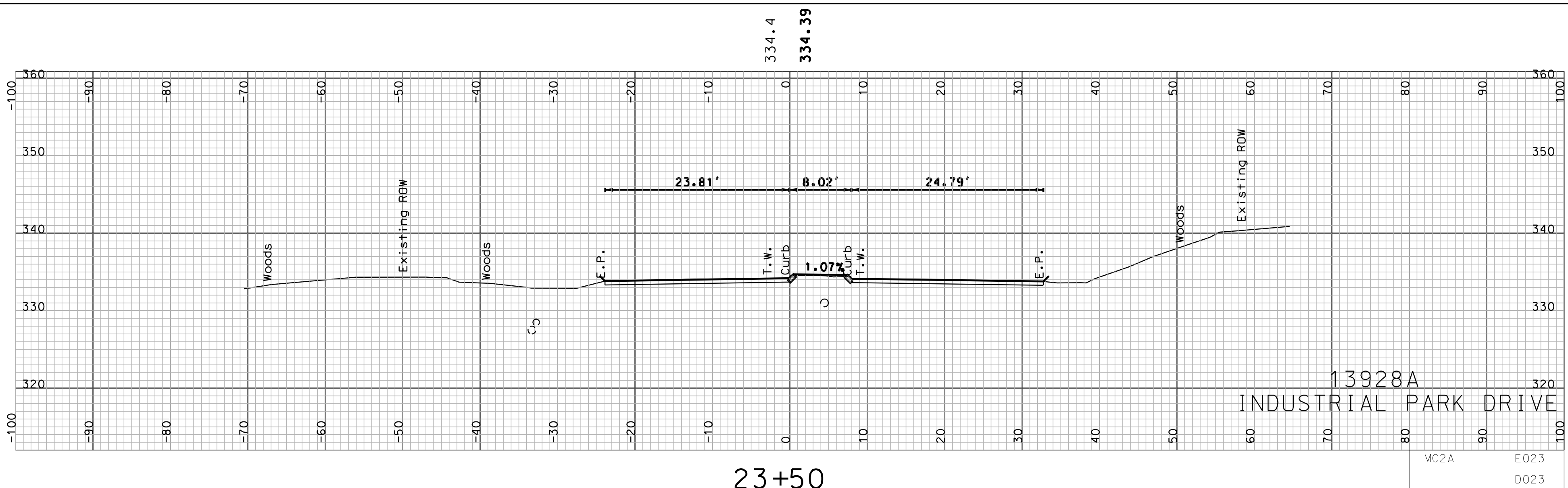

23+50

MC2A E023
D023

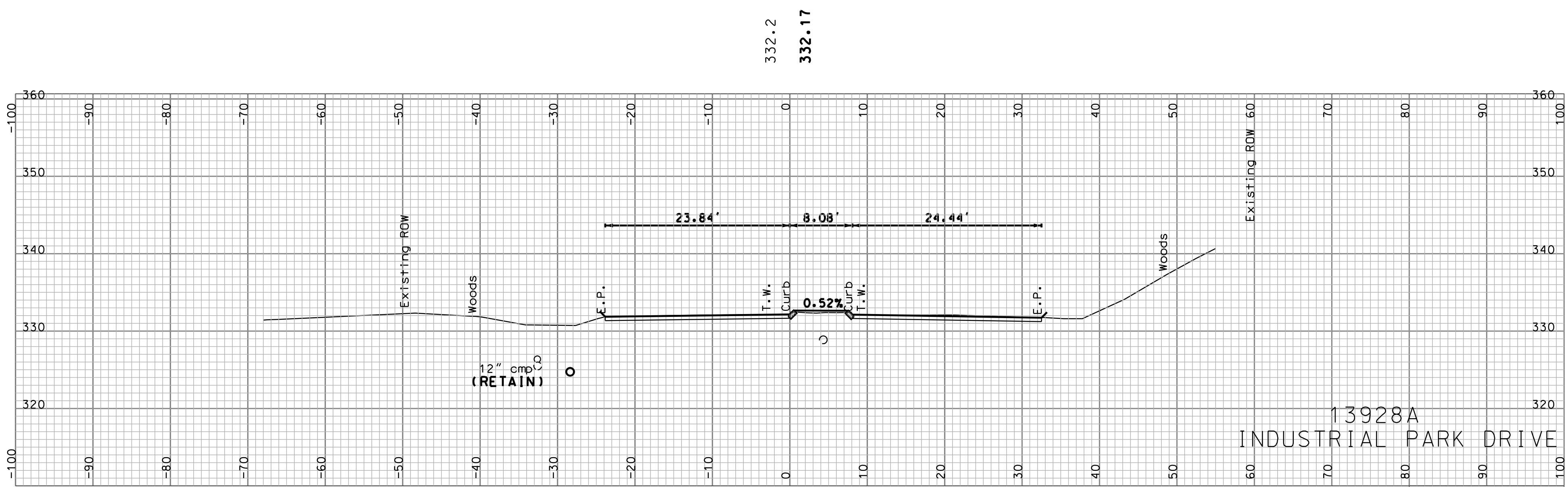

23+25

MC2A E01X
D01X

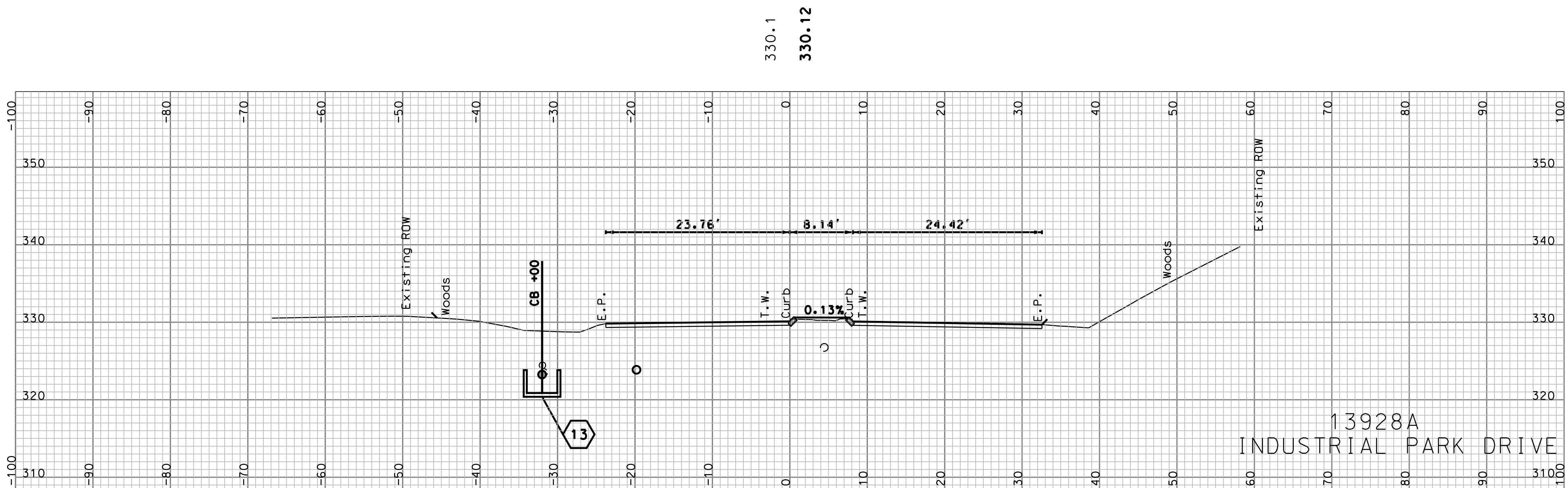

23+00

MC2A E01S
D01S

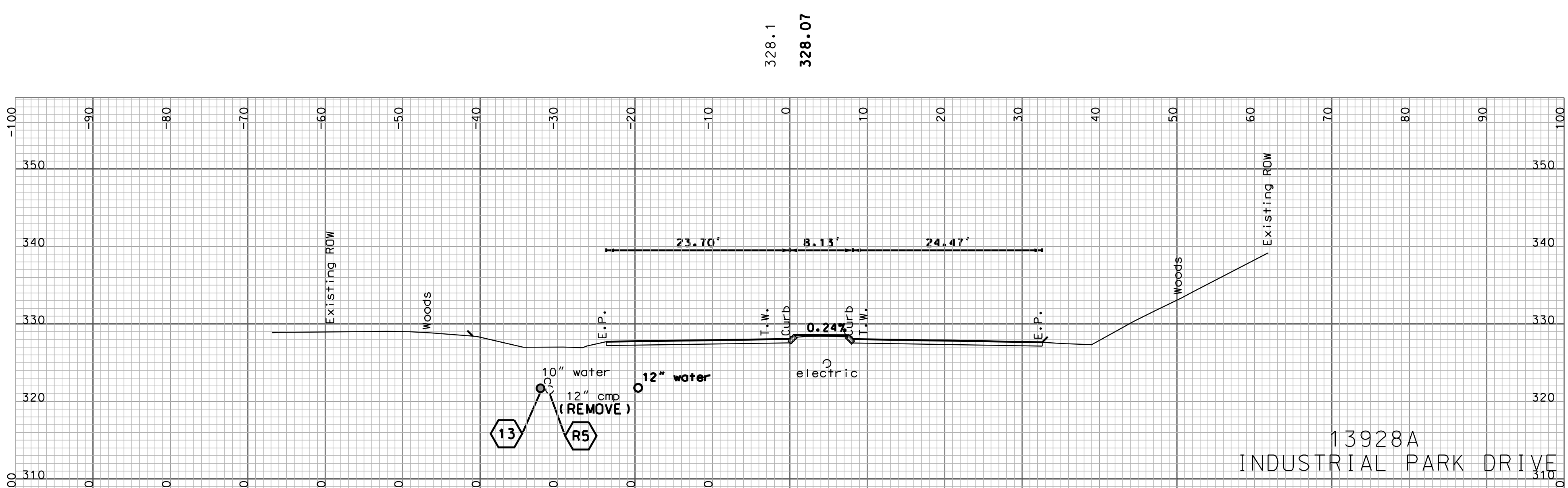

22+75

MC2A E01N
D01N

SHEET TOTALS					
COMMON EXCAV.	0	C.Y.	ROCK EXCAV.	0	C.Y.
FILL	6	C.Y.	MUCK EXCAV.	0	C.Y.
DGN	13928axs-mc2a	STATE PROJECT NO.	13928A	SHEET NO.	152
				TOTAL SHEETS	160

SDR PROCESSED	DATE
NEW DESIGN TEAM BALDWIN	DATE 09/2013
SHEET CHECKED TEAM BALDWIN	DATE 04/2015
AS BUILT DETAILS	DATE

REVISIONS AFTER PROPOSAL				
NUMBER	DATE	STATION	STATION	DESCRIPTION

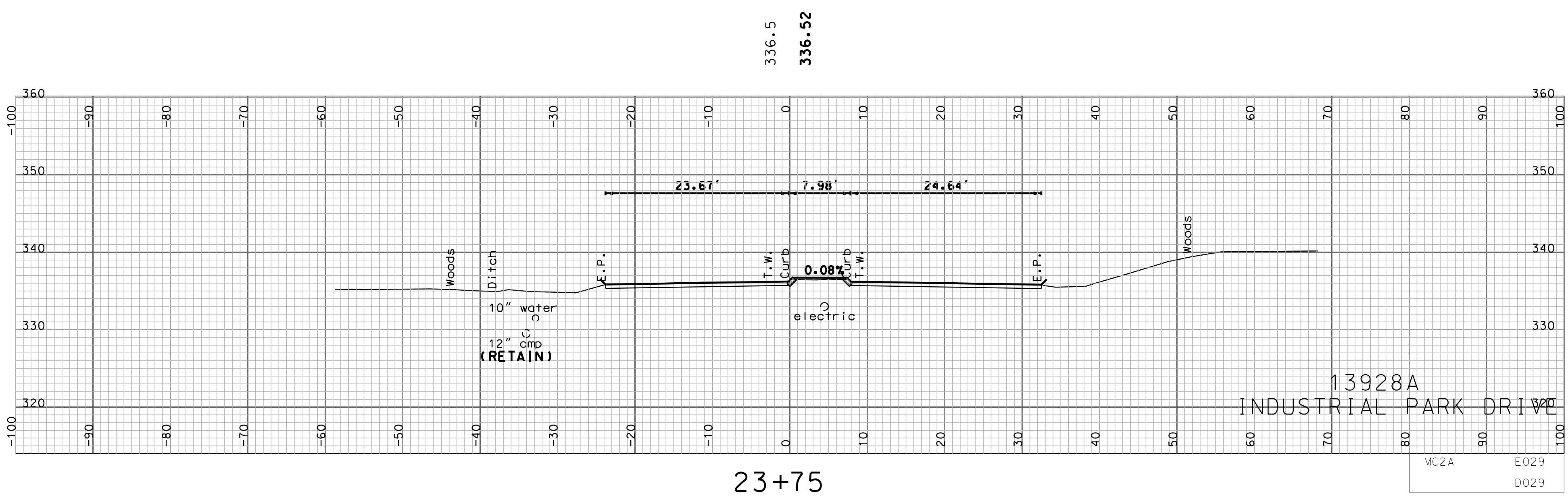
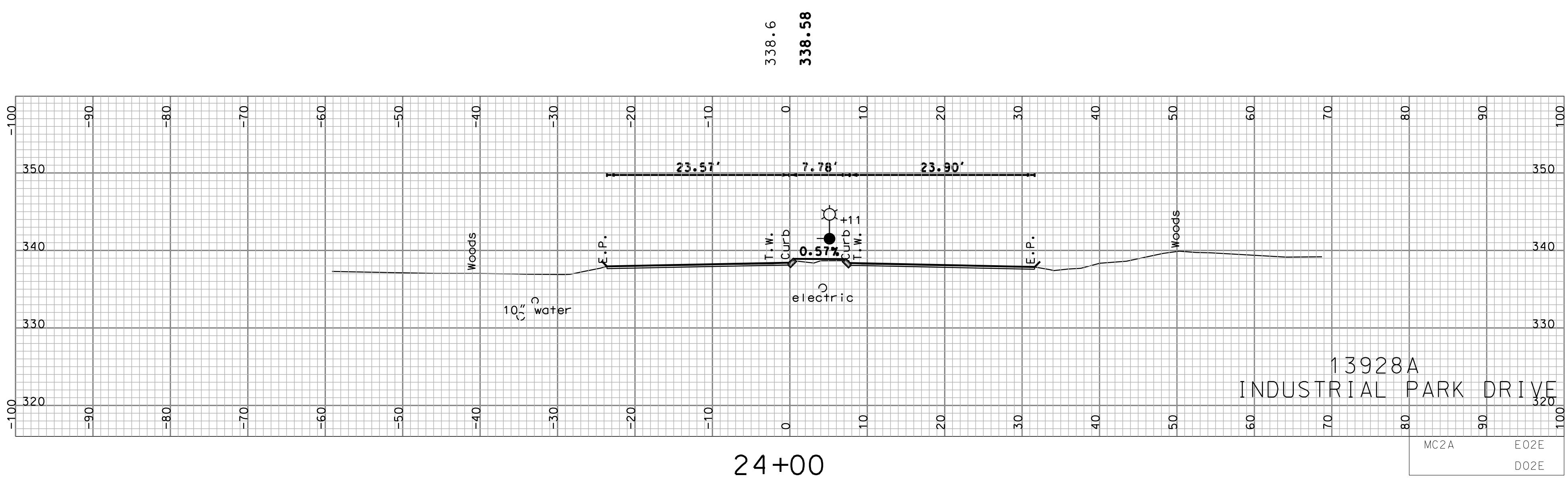
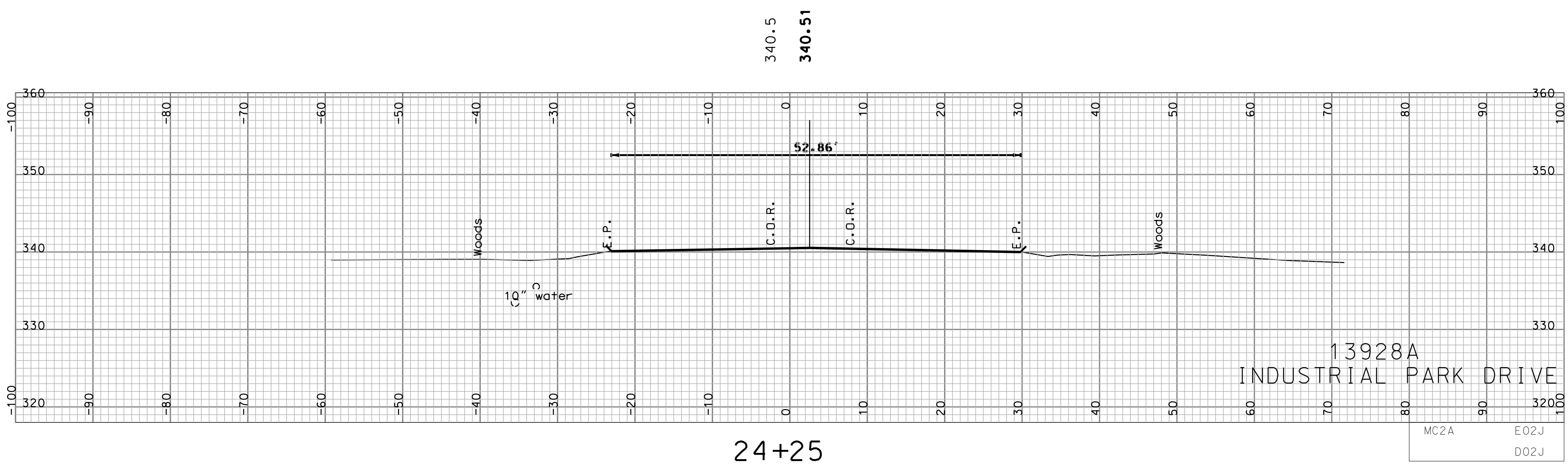
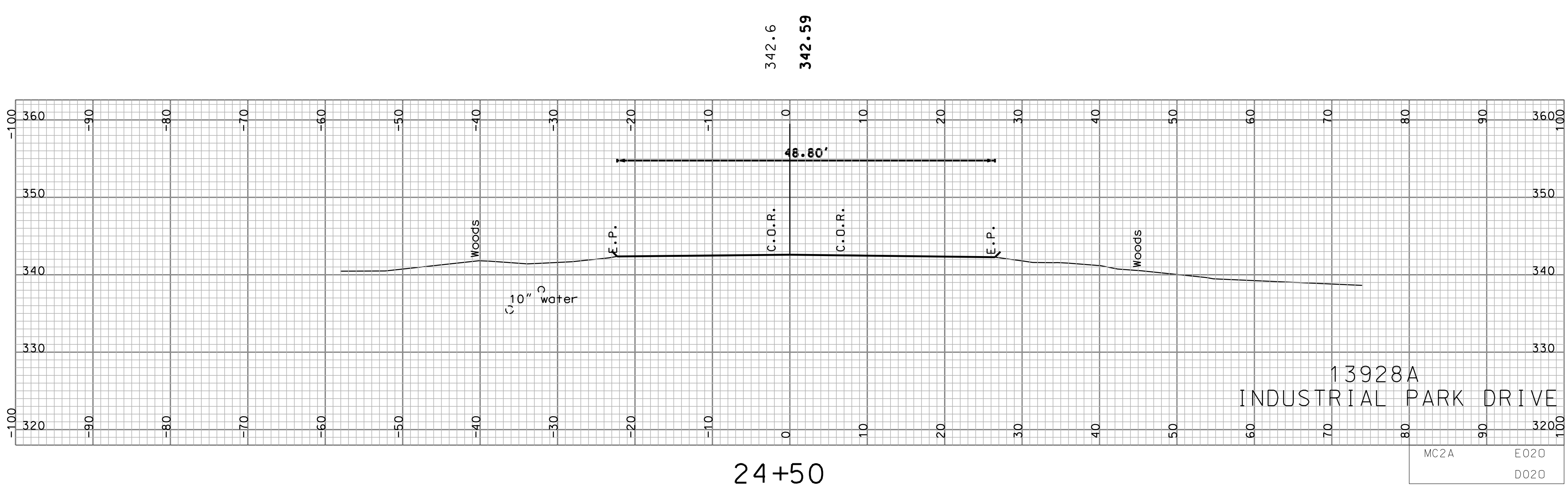

COMMON EXCAV.	0	SHEET TOTALS	ROCK EXCAV.	0
FILL	3	C.Y.	MUCK EXCAV.	0
DGN	13928axs-mc2a	STATE PROJECT NO.	13928A	SHEET NO.
				153
				TOTAL SHEETS
				160

SDR PROCESSED	DATE
NEW DESIGN TEAM BALDWIN	DATE 09/2013
SHEET CHECKED TEAM BALDWIN	DATE 04/2015
AS BUILT DETAILS	DATE

REVISIONS AFTER PROPOSAL				
NUMBER	DATE	STATION	STATION	DESCRIPTION

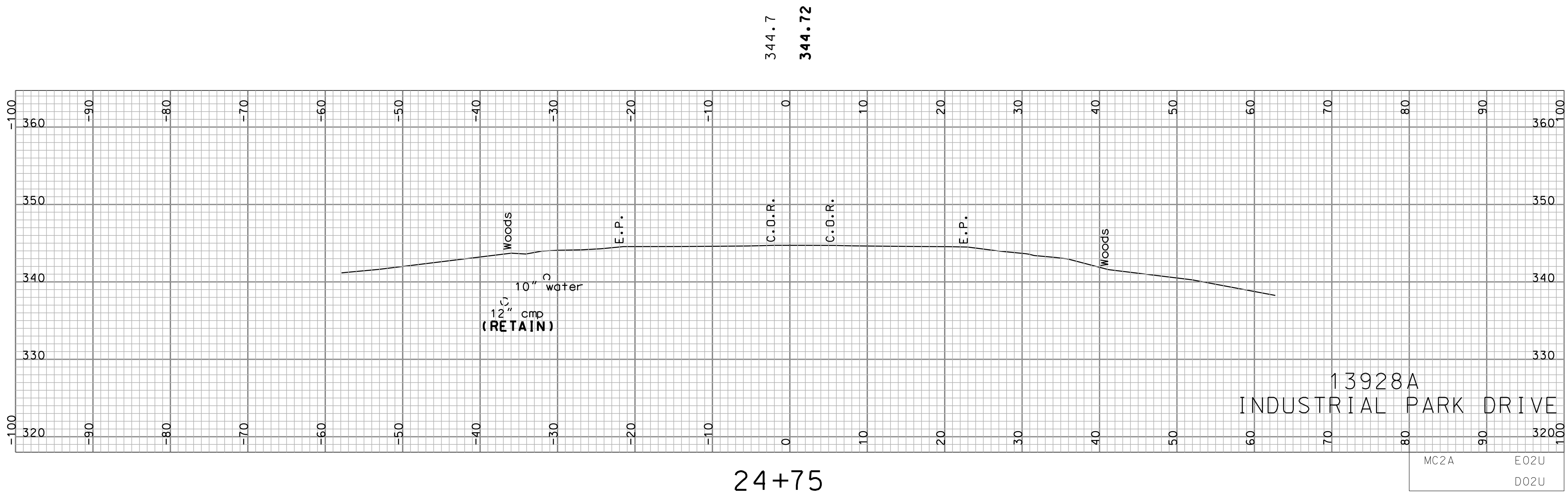
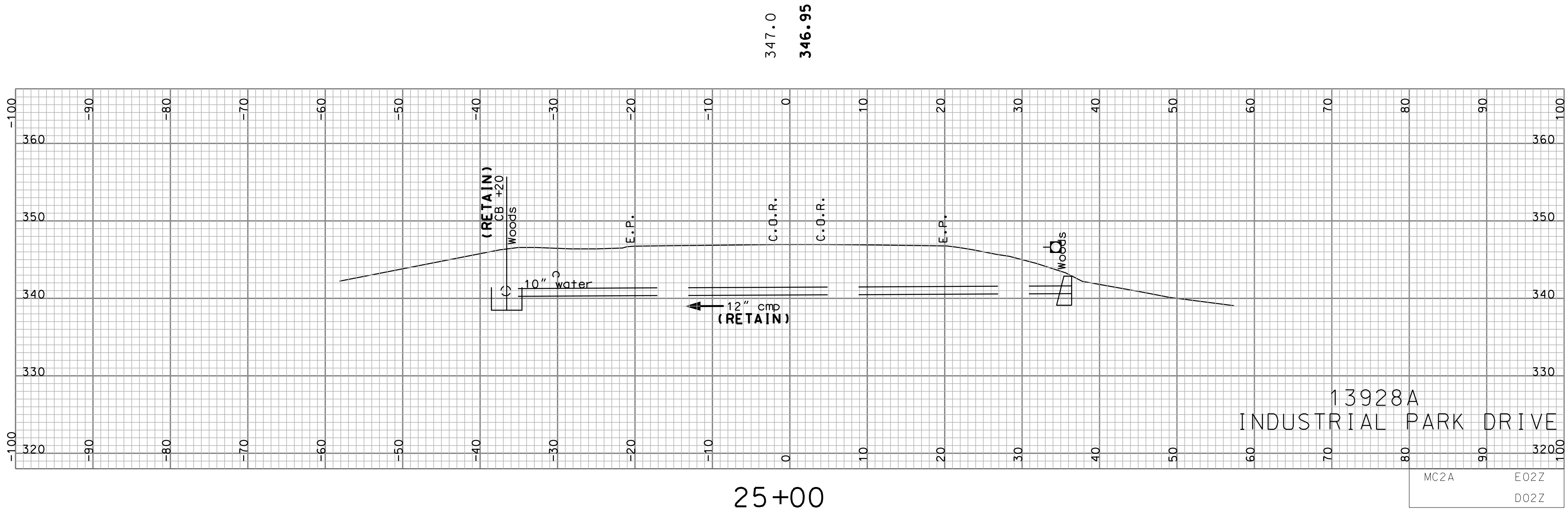

SHEET TOTALS					
COMMON EXCAV.	0	C.Y.	ROCK EXCAV.	0	C.Y.
FILL	0	C.Y.	MUCK EXCAV.	0	C.Y.
DGN	13928axs-mc2a	STATE PROJECT NO.	13928A	SHEET NO.	154
				TOTAL SHEETS	160

SDR PROCESSED	DATE	NUMBER	STATION	REVISIONS AFTER PROPOSAL	DESCRIPTION
NEW DESIGN	DATE				
SHEET CHECKED	DATE				
AS BUILT DETAILS	DATE				

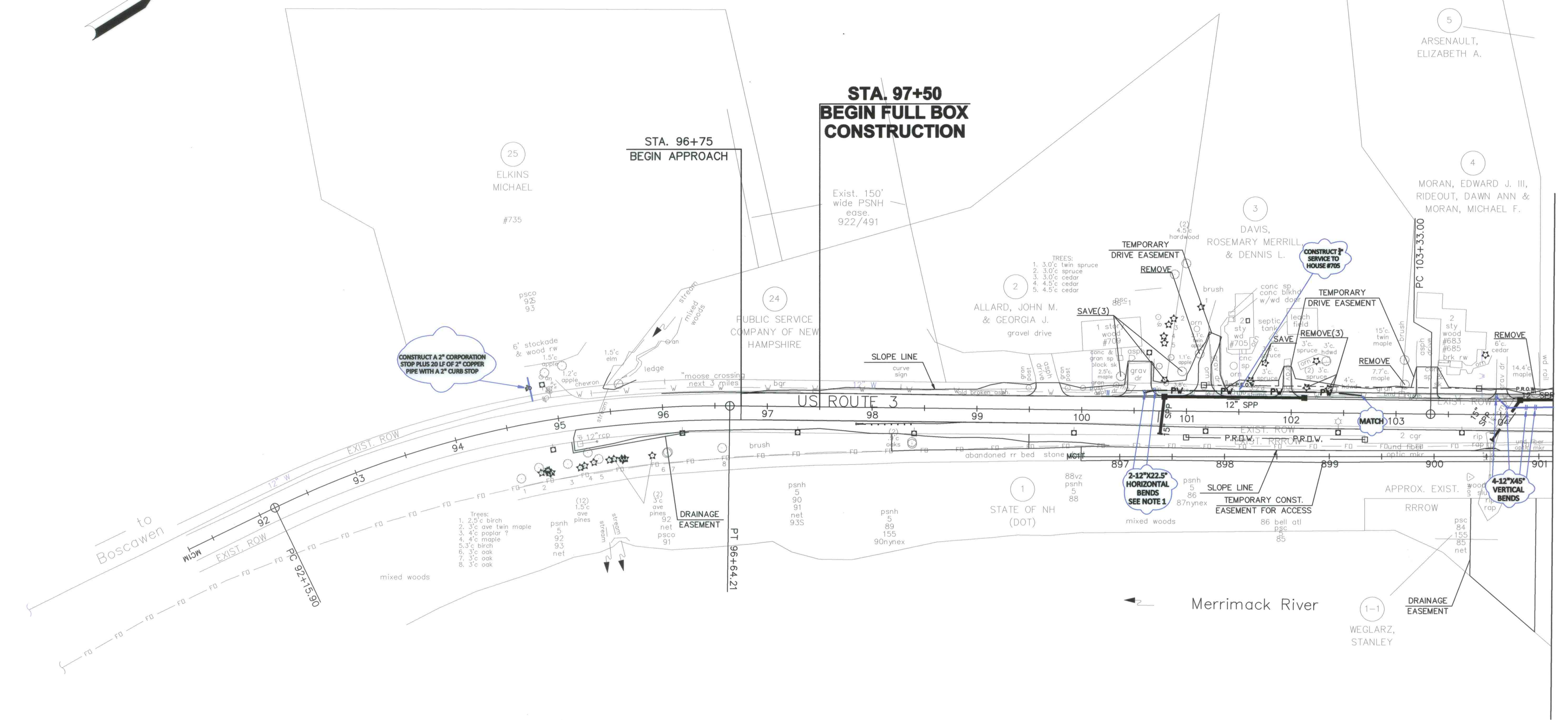
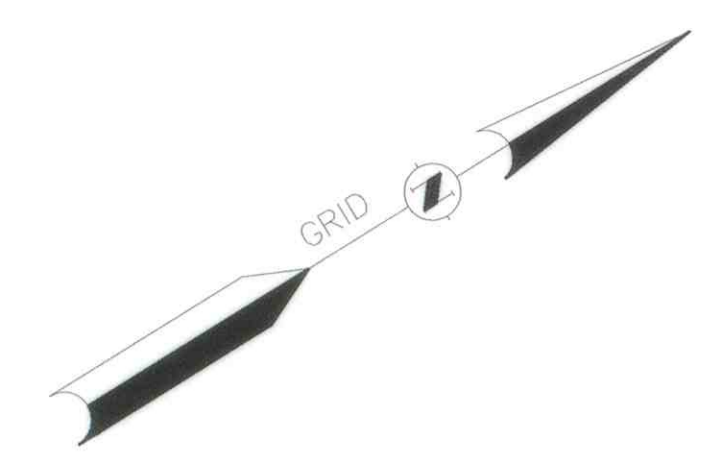

NOTE:
 1. CONSTRUCT INSULATION BETWEEN THE NEW WATER MAIN AND THE NEW CB'S AT STATION 100+79, LEFT, AND 102+12, LEFT.
 2. NEW 12" DI WATER MAIN TO BE CONSTRUCTED UNDER CROSS PIPE AT STATION 104+15±, LEFT.

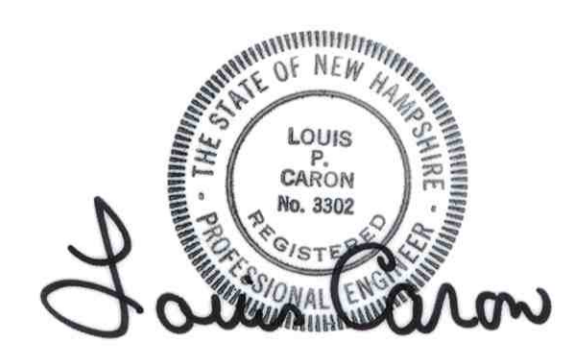
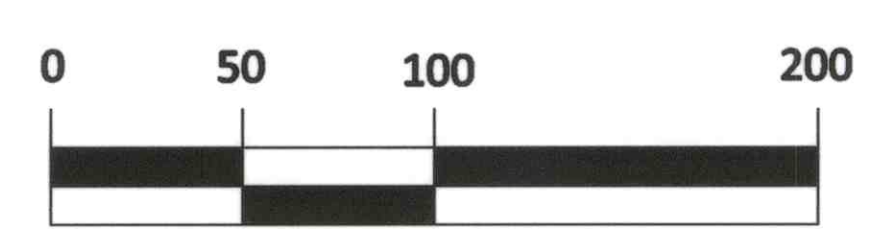

PREPARED BY:
L.C. Engineering Company, LLC
 P.O. Box 903 Phone: (603) 496-2537
 Concord, NH 03301

STATE OF NEW HAMPSHIRE			
DEPARTMENT OF TRANSPORTATION • BUREAU OF HIGHWAY DESIGN			
CITY WATER MAIN RELOCATION PLAN			
DGN	STATE PROJECT NO.	SHEET NO.	TOTAL SHEETS
	13928A	155	160

MATCH TO SHEET

SDR PROCESSED	DATE	REVISIONS AFTER PROPOSAL	STATION	DESCRIPTION
NEW DESIGN	DATE			
SHEET CHECKED	DATE			
AS BUILT DETAILS	DATE			

MATCH TO SHEET

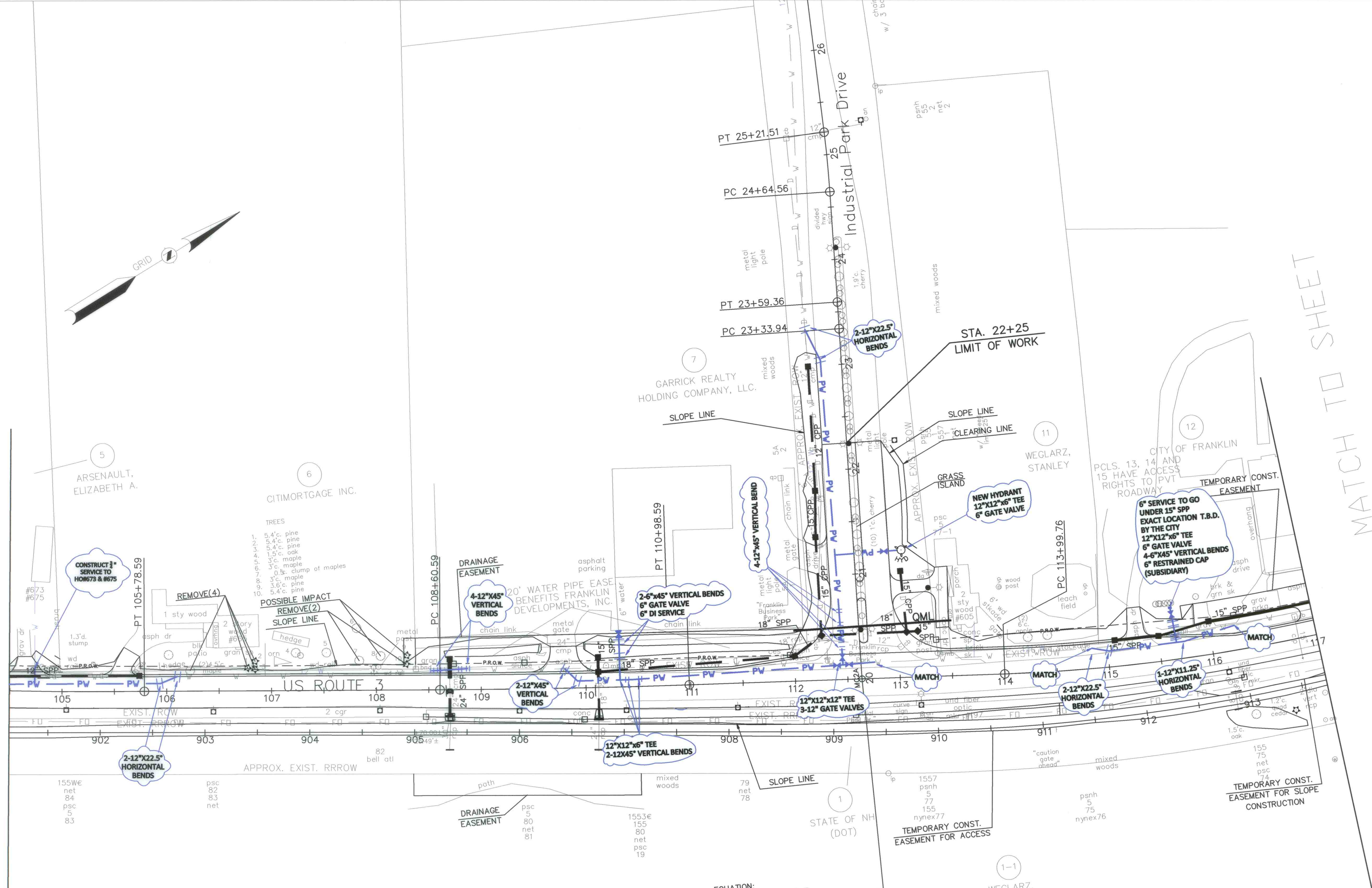

- NOTE:**
1. NEW 12" DI WATER MAIN TO BE CONSTRUCTED UNDER THE CROSS PIPE AT STATION 108+70±, LEFT.
 2. NEW 12" DI WATER MAIN TO BE CONSTRUCTED UNDER THE 18" SPP CROSS PIPE AT STATION 110+12±, LEFT.
 3. NEW 6" DI WATER SERVICE TO GARRICK REALTY TO BE CONSTRUCTED UNDER THE 18" SPP DRAIN PIPE AT STATION 110+33±, LEFT.
 4. NEW 12" DI WATER MAIN TO BE CONSTRUCTED UNDER THE 18" SPP CROSS PIPE AT STATION 20+45±, LEFT.
 5. NEW 12" DI WATER MAIN WITH TEE AND GATE VALVE AT STATION 112+45±, LEFT, TO BE CONSTRUCTED AT A COVER DEPTH OF 6' BELOW FINISH GRADE.
 6. NEW 6" DI SERVICE TO THE CITY PROPERTY TO BE CONSTRUCTED UNDER THE PROPOSED DRAIN PIPE.

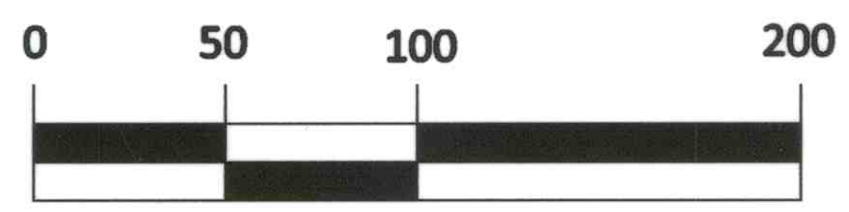

EQUATION:
P.O.T. 112+63.53 US 3
P.O.T. 20+00.00 INDUSTRIAL DRIVE

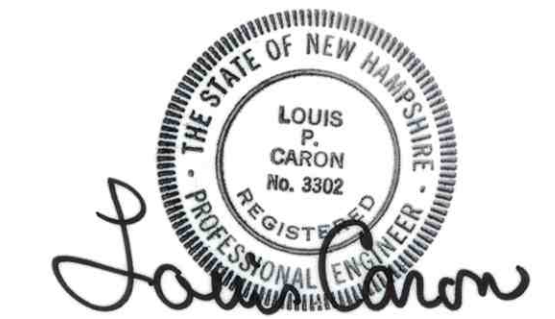

PREPARED BY:
L.C. Engineering Company, LLC
P.O. Box 903 Phone: (603) 496-2537
Concord, NH 03301

STATE OF NEW HAMPSHIRE			
DEPARTMENT OF TRANSPORTATION		BUREAU OF HIGHWAY DESIGN	
CITY WATER MAIN RELOCATION PLAN			
DGN	STATE PROJECT NO.	SHEET NO.	TOTAL SHEETS
	13928A	156	160

MATCH TO SHEET

SDR PROCESSED	DATE	REVISIONS AFTER PROPOSAL	STATION	DESCRIPTION
NEW DESIGN	DATE			
SHEET CHECKED	DATE			
AS BUILT DETAILS	DATE			

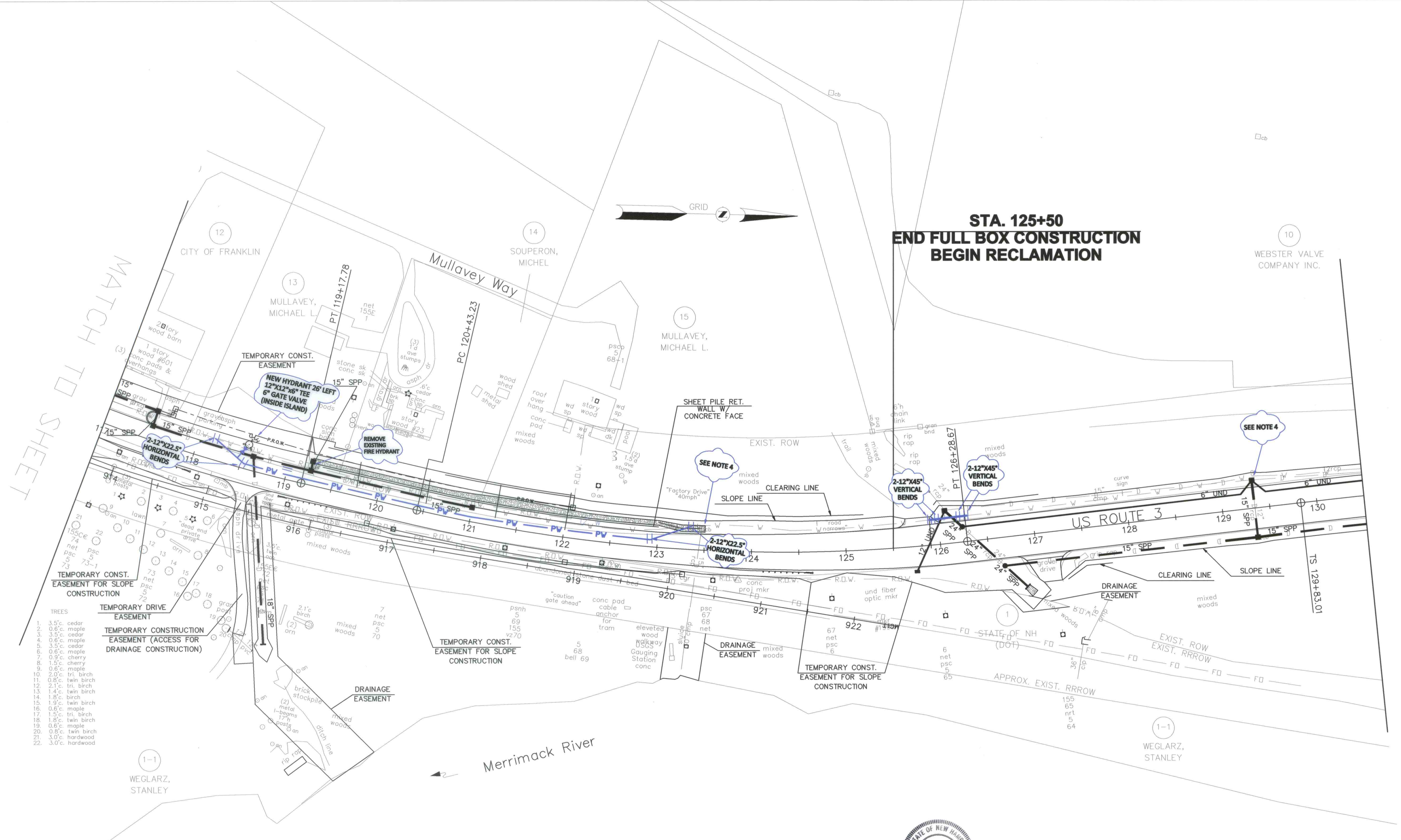

**STA. 125+50
END FULL BOX CONSTRUCTION
BEGIN RECLAMATION**

- NOTE:**
1. NEW 12" DI WATER MAIN TO BE CONSTRUCTED OVER THE DRAIN PIPES AT STATION 118+30±, LEFT AND STATION 118+66±, LEFT.
 2. NEW 6" DI WATER PIPE TO BE CONSTRUCTED OVER THE 15" SPP DRAIN PIPE AT STATION 118+48±, LEFT.
 3. NEW 12" DI WATER MAIN TO BE CONSTRUCTED UNDER THE CROSS PIPES AT STATION 126+00±, LEFT, AND 126+15±, LEFT.
 4. CONSTRUCT INSULATION BETWEEN THE EXISTING WATER MAIN AND THE NEW DI AT STATION 123+46±, LEFT AND CB STATION 129+34±, LEFT.

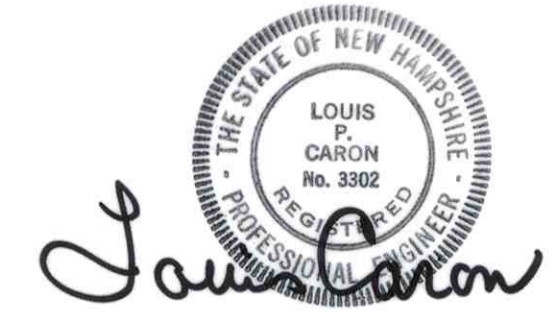
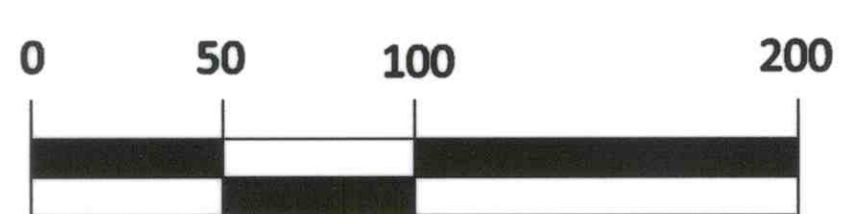

PREPARED BY:
L.C. Engineering Company, LLC
P.O. Box 903 Phone: (603) 496-2537
Concord, NH 03301

STATE OF NEW HAMPSHIRE			
DEPARTMENT OF TRANSPORTATION • BUREAU OF HIGHWAY DESIGN			
CITY WATER MAIN RELOCATION PLAN			
DGN	STATE PROJECT NO.	SHEET NO.	TOTAL SHEETS
	13928A	157	160

SDR PROCESSED	DATE	REVISIONS AFTER PROPOSAL	STATION	DESCRIPTION
NEW DESIGN	DATE			
SHEET CHECKED	DATE			
AS BUILT DETAILS	DATE			

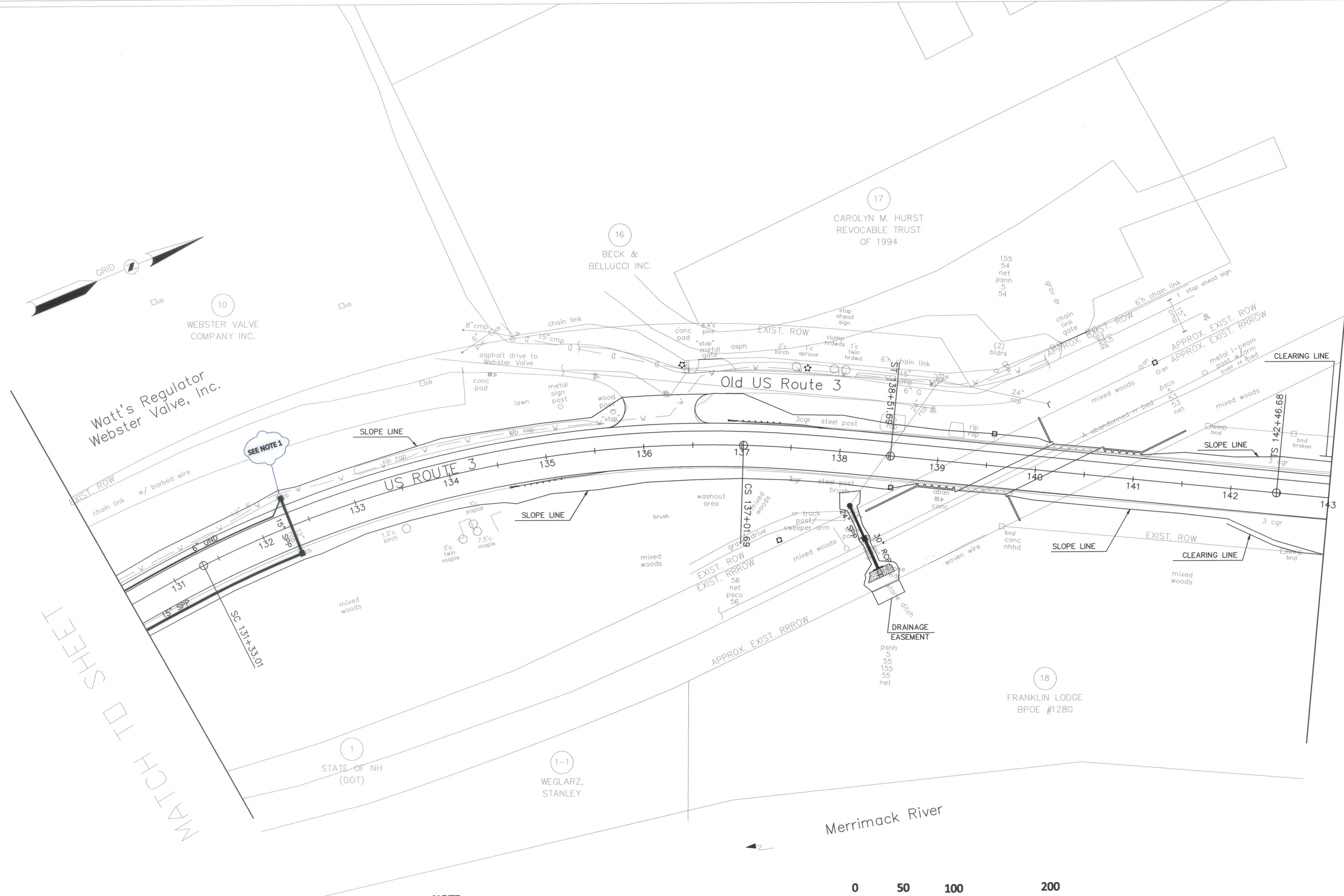
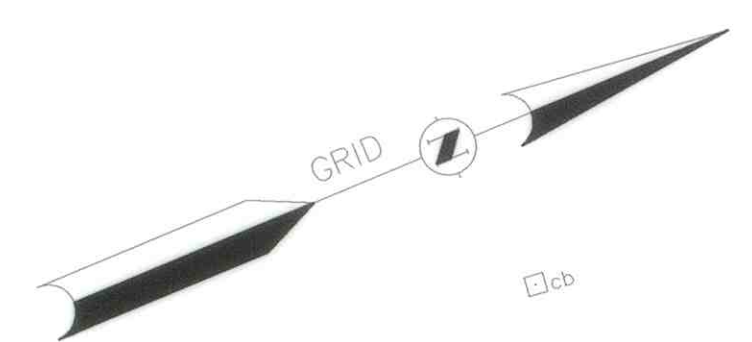

MATCH TO SHEET

MATCH TO SHEET

NOTE:
 1. CONSTRUCT INSULATION BETWEEN THE WATER MAIN AND NEW CB AT STATION 132+31±, LEFT

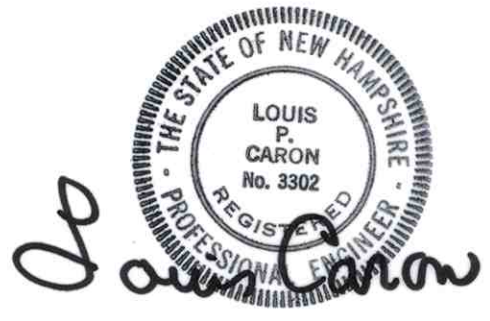
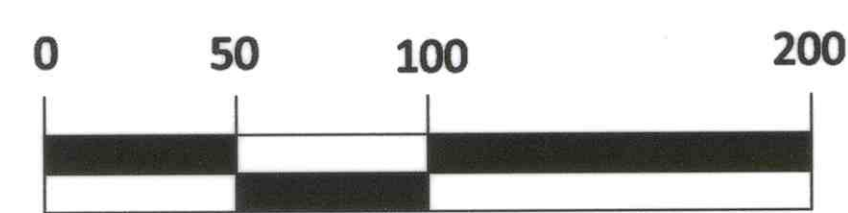

PREPARED BY:
L.C. Engineering Company, LLC
 P.O. Box 903 Phone: (603) 496-2537
 Concord, NH 03301

STATE OF NEW HAMPSHIRE			
DEPARTMENT OF TRANSPORTATION • BUREAU OF HIGHWAY DESIGN			
CITY WATER MAIN RELOCATION PLAN			
DGN	STATE PROJECT NO.	SHEET NO.	TOTAL SHEETS
	13928A	158	160

SDR PROCESSED	REVISIONS AFTER PROPOSAL	STATION	DATE	NUMBER	DATE	NUMBER	DATE	NUMBER	DATE
NEW DESIGN	DESCRIPTION								
SHEET CHECKED									
AS BUILT DETAILS									

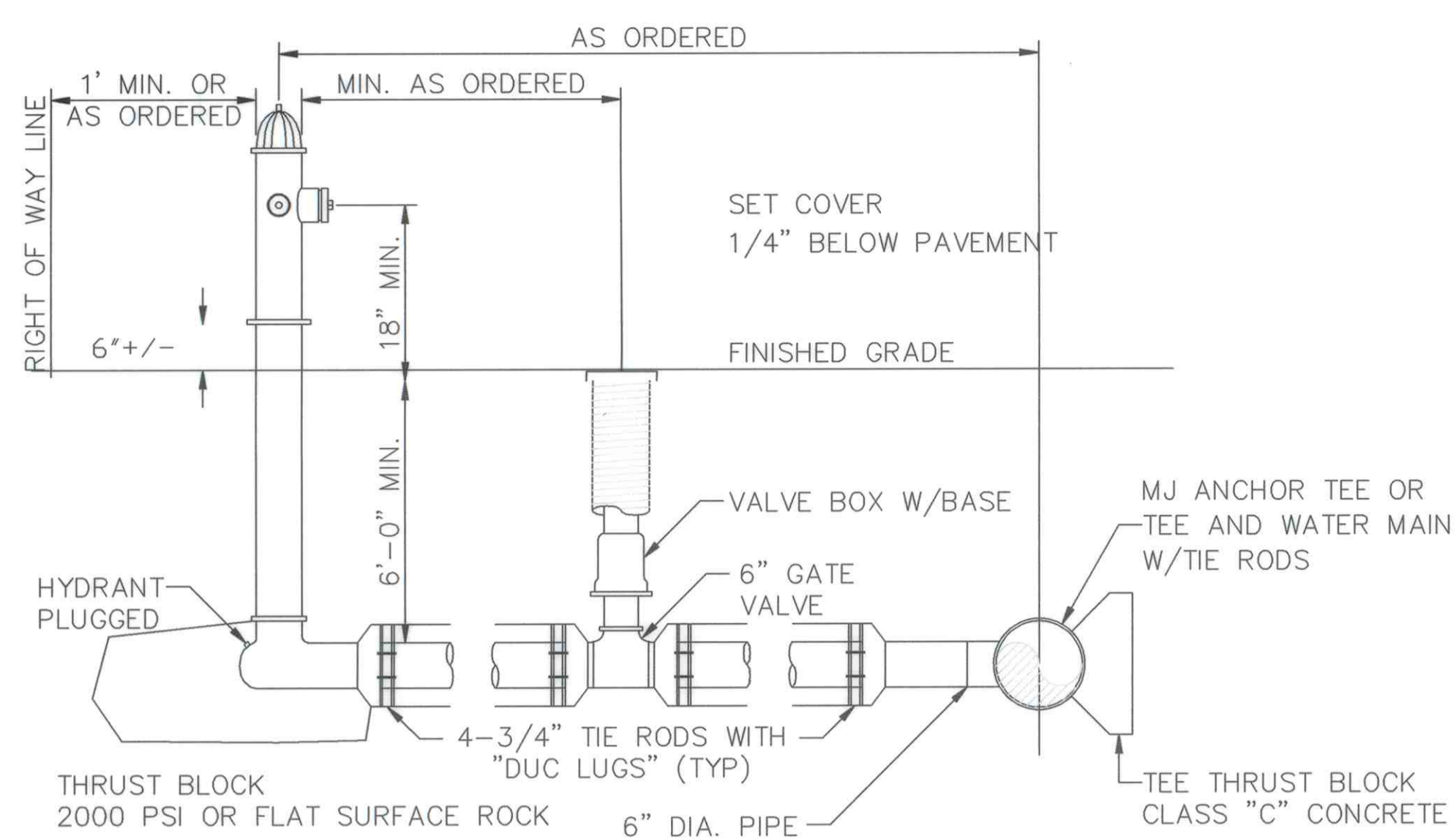

NOTE: HYDRANT DRAIN SHALL BE PLUGGED
THRUST BLOCK SIZED FOR SOIL BEARING CAPACITY

HYDRANT DETAIL
NTS

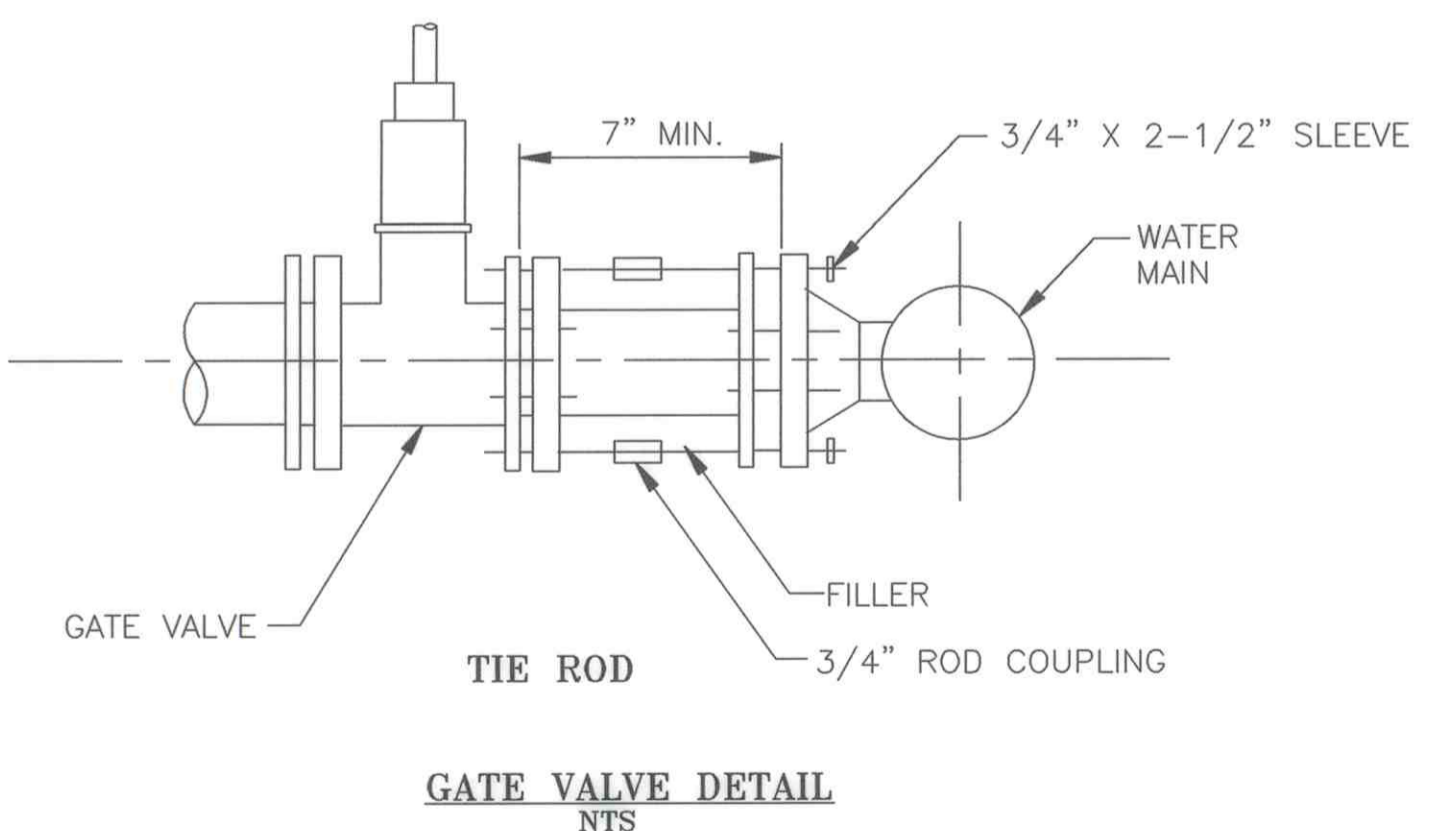
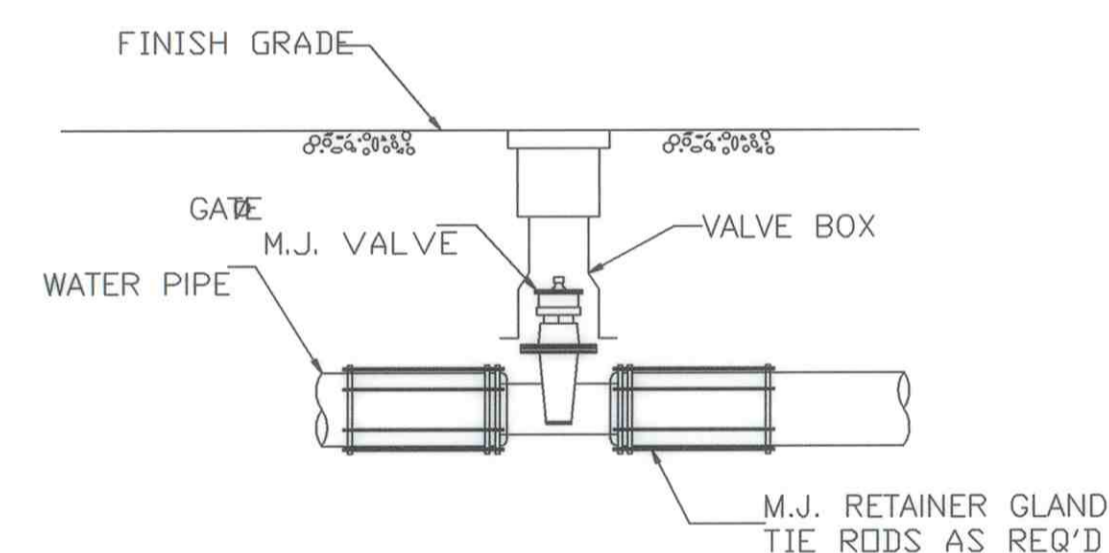

GATE VALVE DETAIL
NTS

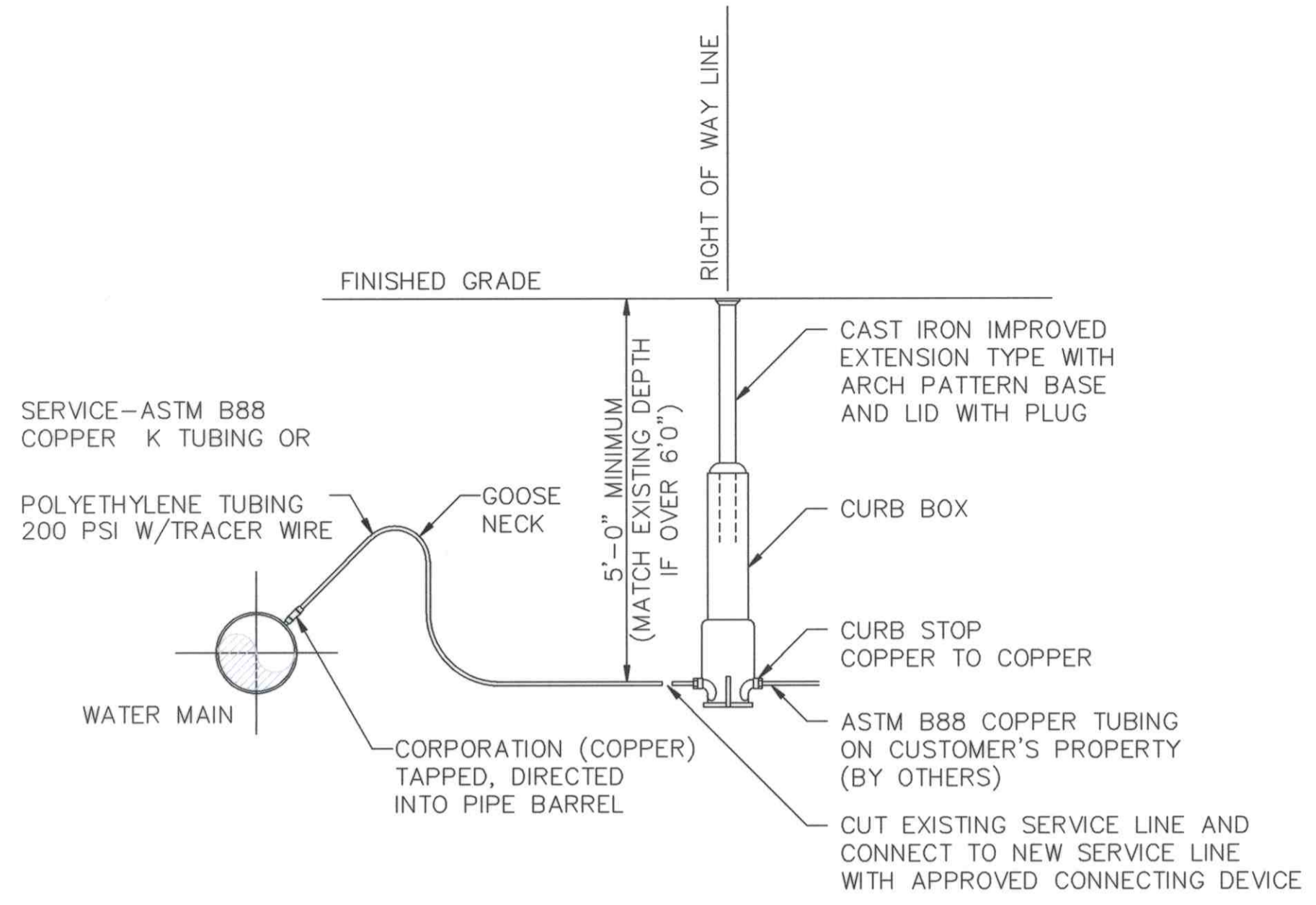

HOUSE SERVICE DETAIL
NTS

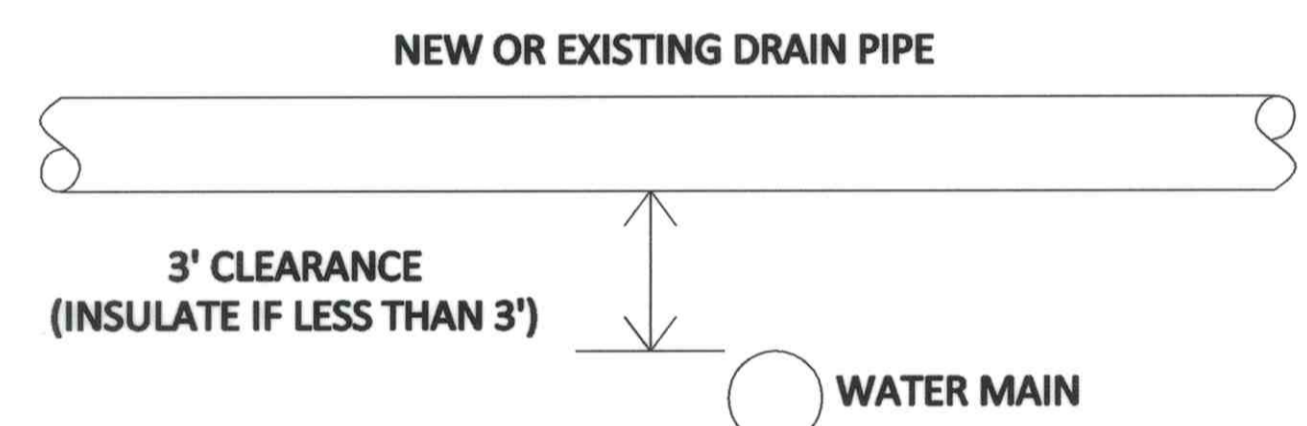

WATER MAIN - DRAIN PIPE SEPARATION DETAIL
NTS

Legend	
	Proposed (New) Water Main
	Insulated Pipe
	Proposed (New) Gate/Insertion Valve
	Proposed (New) Hydrant
	Proposed (New) Vertical/Horizontal bend
	Curb Stop (Water Shut Off)

GENERAL NOTES

- Contact Franklin Municipal Services prior to beginning any work on the water main portion of the project. Phone 603-934-4103.
- Confirm with Franklin Municipal Services which existing gate valves are considered to be operational. Field test where necessary.
- Where possible, existing water main, fittings, and valves removed are to be salvaged to the City of Franklin. Stock pile salvaged material on City lot, station 117+00, Left. Coordinate with the City Municipal Services staff.
- All new water pipes are class 52, Ductile Iron (DI) and shall be constructed with a minimum 5' 6" of cover.
- New water mains shall be constructed with a minimum 3' separation with existing or new drain pipes. Install insulation at locations with less than 3' separation.
- All horizontal bends on this project shall be 22.5 degrees (except as noted) and all vertical bends shall be 45 degrees. Alternative bends must be specifically authorized by Franklin Municipal Services.
- All house services are 3/4 inch.
- Existing 12" water main abandoned in-place is to be filled with Concrete Class F, Flowable Fill, Excavatable (NHDOT Item 520.421).
- Service pipe couplings shall be made of brass. Both ends of the coupling shall be compression type with a grip joint (subsidiary).
- Restrained plugs are subsidiary.
- Existing services: property owners shall be given a minimum 7 days notice as to the date and time water service to their building will be shut off while being moved from existing water main to the new one.
- Water service to existing businesses on Industrial Park Drive may be impacted by this project. (see note 10).
- Water service to Webster Place on Holy Cross Road (south of the project) must be maintained at all times.
- The location and method of providing service for the temporary by-pass piping system shall be the responsibility of the contractor. The contractor shall submit a by-pass piping plan for engineer review prior to installation, which at a minimum shows the pipe size, locations of recessed crossings & temporary hydrant locations. The depiction on the contract drawings indicates the limit of the work only. Payment for this item will be incidental to the water main payment items. No additional payment shall be made for cross trenches or additional piping.



PREPARED BY:

L.C. Engineering Company, LLC

P.O. Box 903 Phone: (603) 496-2537
Concord, NH 03301

STATE OF NEW HAMPSHIRE

DEPARTMENT OF TRANSPORTATION • BUREAU OF HIGHWAY DESIGN

CITY WATER MAIN RELOCATION PLAN

DGN	STATE PROJECT NO.	SHEET NO.	TOTAL SHEETS
	13928A	159	160

DESCRIPTION

REVISIONS AFTER PROPOSAL

STATION

STATION

DATE

NUMBER

DATE

DATE

DATE

DATE

DATE

DATE

DATE

DATE

DATE

DATE

DATE

DATE

DATE

DATE

**City of Franklin
Municipal Services Department
43 West Bow Street
Franklin, NH
Vertical Thrust Block**

VERTICAL ANCHOR DIMENSIONS												
UP TO 150 P.S.I. WORKING PRESSURE												
PIPE SIZE	45° BEND			ROD DIA.	22 1/2° BEND			ROD DIA.	11 1/4° BEND			
	a	b	c		a	b	c		a	b	c	
4"	3'-0"	3'-0"	2'-0"	3/4"	2'-6"	2'-3"	1'-6"	3/4"	2'-0"	2'-0"	1'-6"	3/4"
6"	3'-0"	3'-0"	2'-0"	3/4"	2'-6"	2'-3"	1'-6"	3/4"	2'-0"	2'-0"	1'-6"	3/4"
8"	3'-6"	3'-6"	2'-6"	3/4"	3'-0"	3'-0"	1'-9"	3/4"	2'-6"	2'-6"	1'-3"	3/4"
10"	4'-3"	4'-0"	3'-0"	3/4"	3'-6"	3'-3"	2'-0"	3/4"	2'-9"	2'-9"	1'-6"	3/4"
12"	4'-9"	4'-6"	3'-3"	3/4"	4'-0"	3'-9"	2'-6"	3/4"	3'-3"	3'-3"	1'-9"	3/4"

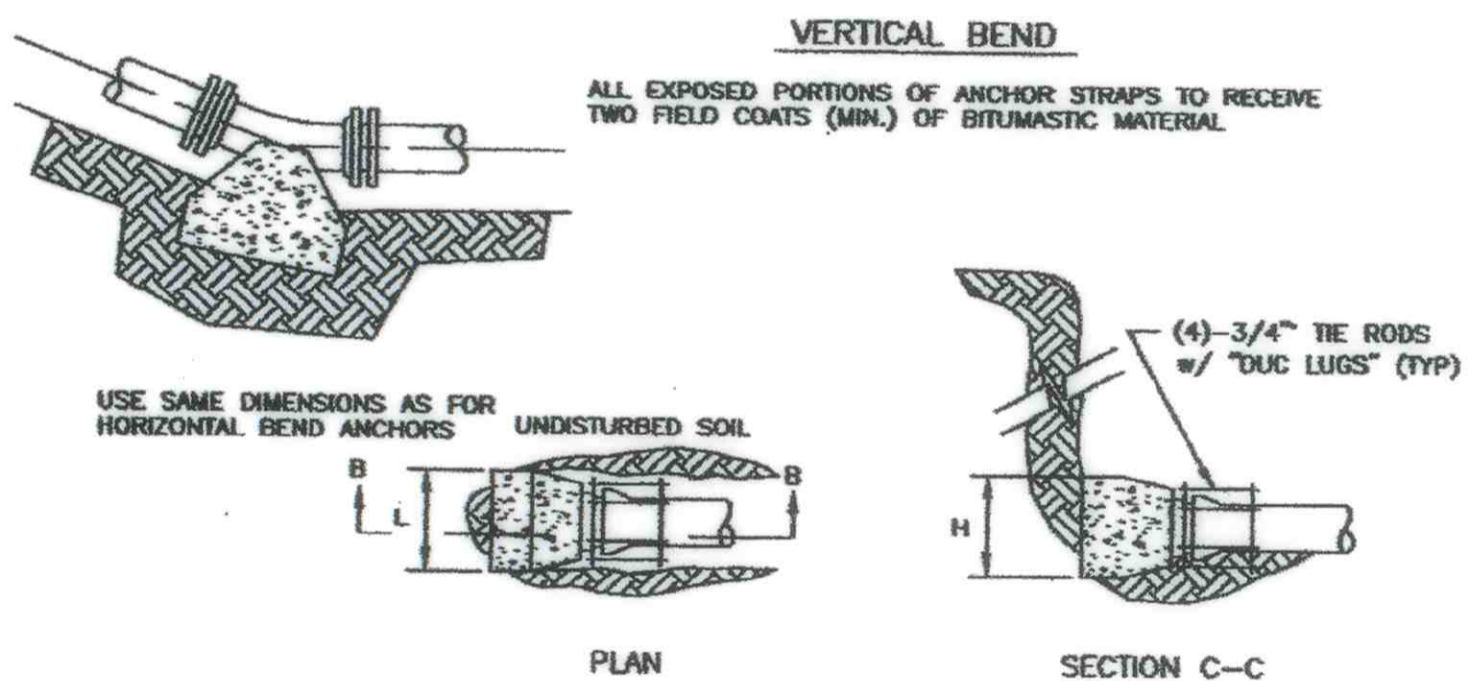
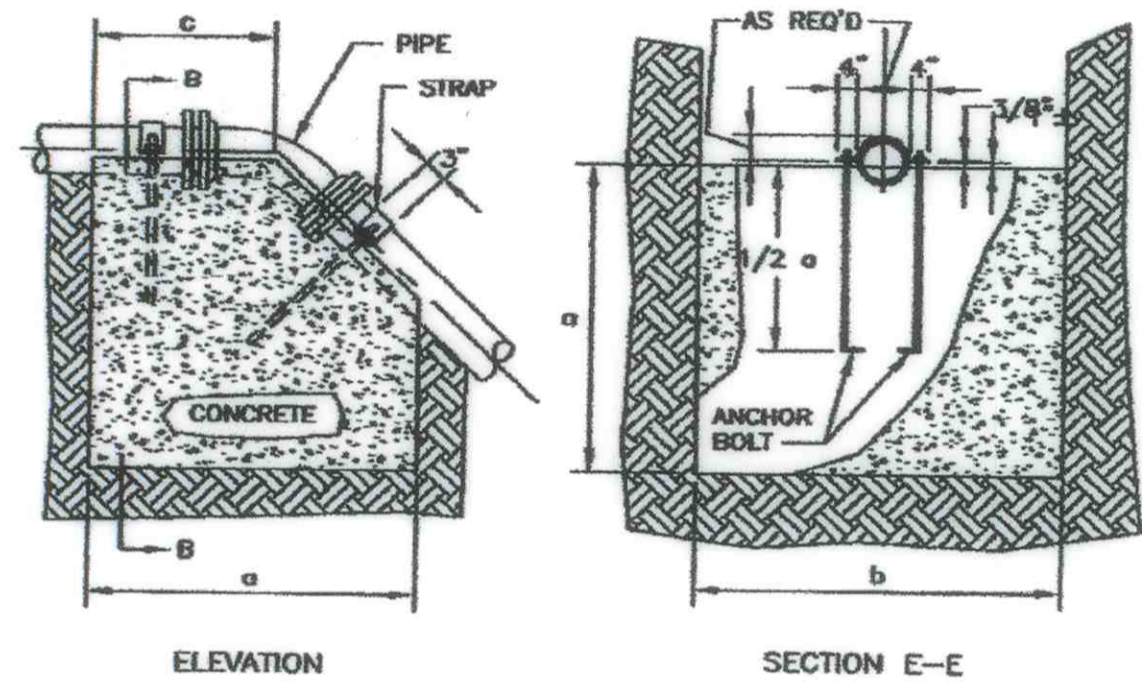

MECHANICAL RESTRAINT SHALL BE USED ON ALL FITTINGS, THRUST BLOCKS SHALL ONLY BE USED WITH SPECIAL PERMISSION FROM CITY OF FRANKLIN

**Franklin, NH
Horizontal Thrust Block**

HORIZONTAL ANCHOR DIMENSIONS FOR PIPE INSTALLATION IN ROCK										
UP TO 150 P.S.I. WORKING PRESSURE										
PIPE SIZE	TEE OR TAP SLEEVE		90° BEND		45° BEND		22 1/2° BEND		11 1/4° BEND	
	H	L	H	L	H	L	H	L	H	L
4"	0'-0"	1'-0"	0'-0"	1'-0"	0'-0"	1'-0"	0'-0"	1'-0"	0'-0"	1'-0"
6"	0'-0"	1'-0"	0'-0"	1'-0"	0'-0"	1'-0"	0'-0"	1'-0"	0'-0"	1'-0"
8"	1'-2"	1'-2"	1'-2"	1'-2"	1'-2"	1'-2"	1'-2"	1'-2"	1'-2"	1'-2"
10"	1'-4"	1'-4"	1'-4"	1'-4"	1'-4"	1'-4"	1'-4"	1'-4"	1'-4"	1'-4"
12"	1'-8"	1'-8"	1'-8"	1'-8"	1'-8"	1'-8"	1'-8"	1'-8"	1'-8"	1'-8"

HORIZONTAL ANCHOR DIMENSIONS FOR AVERAGE SOIL CONDITIONS										
UP TO 150 P.S.I. WORKING PRESSURE										
PIPE SIZE	TEE OR TAP SLEEVE		90° BEND		45° BEND		22 1/2° BEND		11 1/4° BEND	
	H	L	H	L	H	L	H	L	H	L
4"	1'-0"	2'-0"	1'-0"	2'-0"	1'-0"	2'-0"	1'-0"	2'-0"	1'-0"	2'-0"
6"	1'-0"	2'-0"	1'-0"	2'-0"	1'-0"	2'-0"	1'-0"	2'-0"	1'-0"	2'-0"
8"	1'-4"	2'-8"	1'-4"	2'-8"	1'-4"	2'-8"	1'-4"	2'-8"	1'-4"	2'-8"
10"	1'-8"	3'-2"	1'-8"	3'-2"	1'-8"	3'-2"	1'-8"	3'-2"	1'-8"	3'-2"
12"	2'-0"	4'-0"	2'-0"	4'-0"	2'-0"	4'-0"	2'-0"	4'-0"	2'-0"	4'-0"

- NOTES:
- TABLES ARE BASED ON AN ALLOWABLE SOIL PRESSURE OF 3000 PSF ON UNDISTURBED EARTH BEHIND THE ANCHOR BLOCK. WHERE SOIL HAS BEEN DISTURBED BY ADJACENT EXCAVATIONS OR WHERE SOIL CANNOT WITHSTAND SUCH A PRESSURE, THE TABLE DOES NOT APPLY.
 - WHERE ENTIRE DEPTH OF PIPE IS BELOW THE TOP SURFACE OF SOUND ROCK, USE "HORIZONTAL ANCHOR DIMENSIONS FOR PIPE INSTALLATION IN ROCK" TABLE.

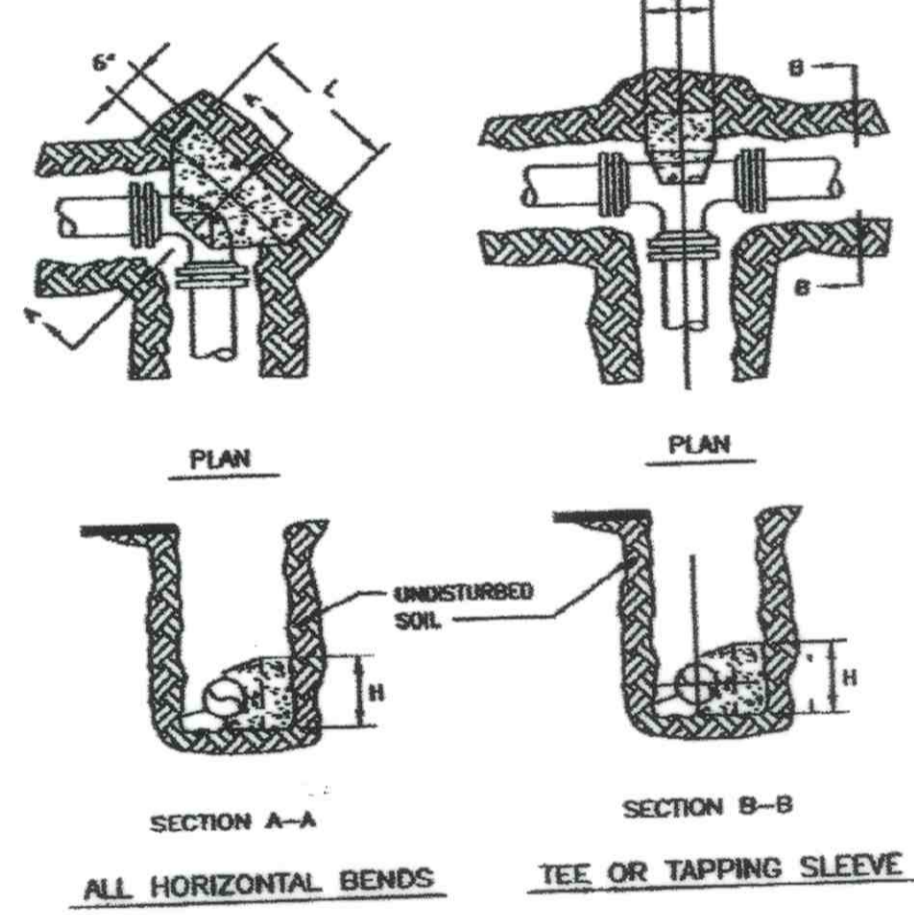

MECHANICAL RESTRAINT SHALL BE USED ON ALL FITTINGS, THRUST BLOCKS SHALL ONLY BE USED WITH SPECIAL PERMISSION FROM CITY OF FRANKLIN

Water Trench Construction Detail

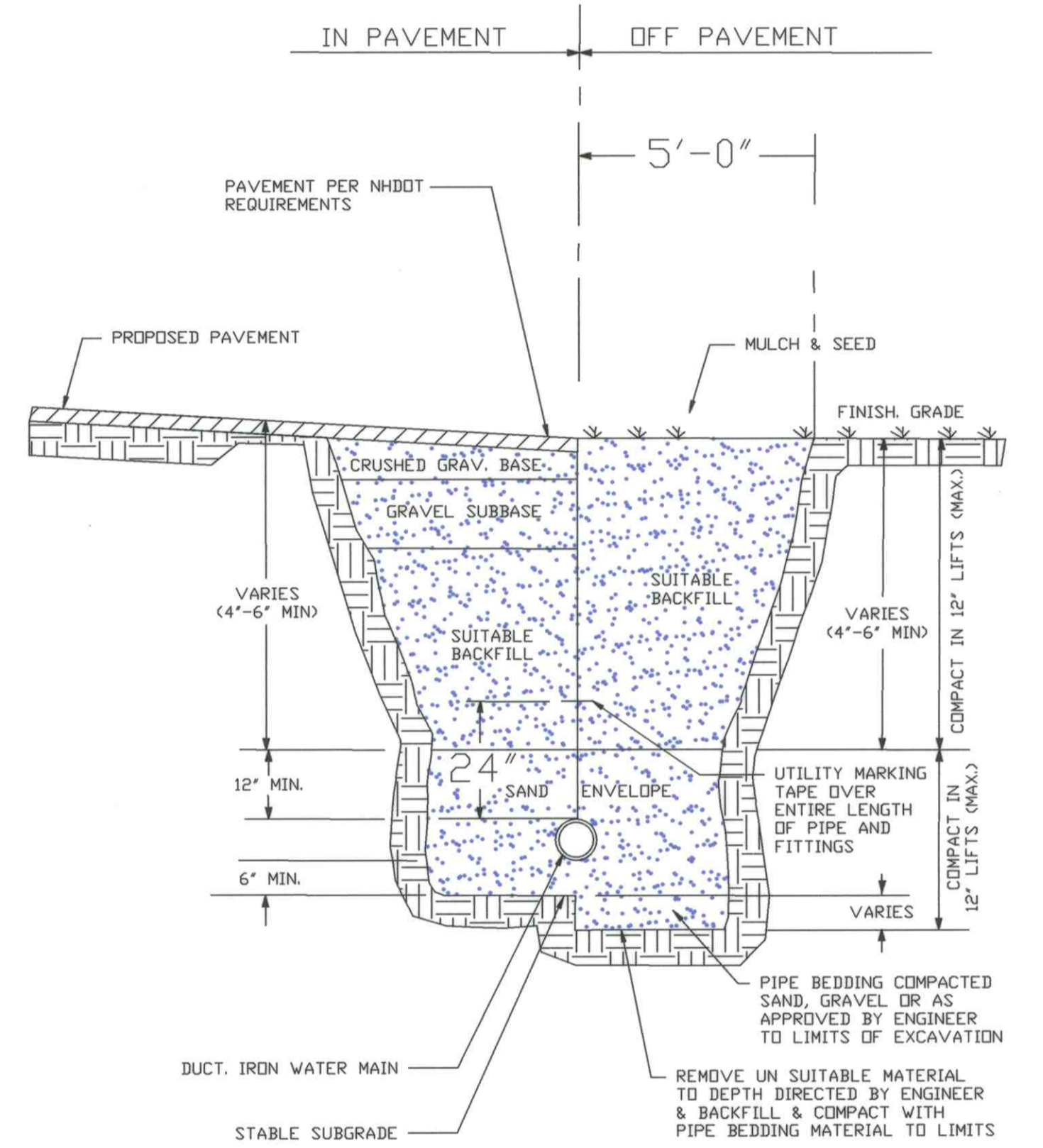

NOTE: ALL NEW WATER PIPES SHALL BE CONSTRUCTED WITH A MINIMUM 5'-6" OF COVER.

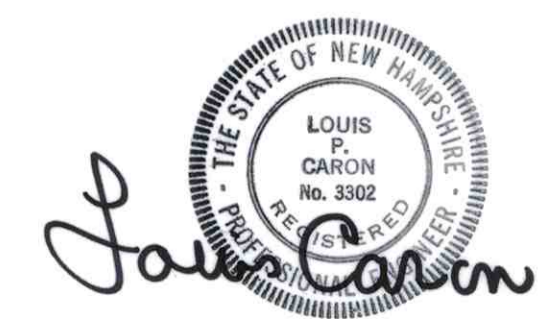

PREPARED BY:
L.C. Engineering Company, LLC
P.O. Box 903 Phone: (603) 496-2537
Concord, NH 03301

STATE OF NEW HAMPSHIRE			
DEPARTMENT OF TRANSPORTATION • BUREAU OF HIGHWAY DESIGN			
CITY WATER MAIN RELOCATION PLAN			
DGN	STATE PROJECT NO.	SHEET NO.	TOTAL SHEETS
	13928A	160	160