

Environmental Report

2005

Committed to Keeping the Trust of Society



T. Ohashi

Tadaharu Ohashi
President

Working together to achieve a prosperous future that is friendly to the global environment

—Contributing to society by creating technologies and products from a broad perspective.—

The Earth gives us life, but we have reached the stage where we must become aware of its limits. We, humankind, need to immediately address global environmental issues including global warming and desertification. Given this situation, Kawasaki's mission in the 21st century is to help resolve global environmental issues.

I believe that the main cause of global environmental deterioration is the overconsumption of precious fossil fuels in the pursuit of convenience that has occurred in the modernization process of industrialized nations including Japan. At present, Japan imports most of its food from foreign countries and the exporting countries consume large quantities of valuable water resources to produce these foods for Japan. In spite of this, the food wasted in Japan almost equals Japan's total domestic agricultural and fishery production. The waste that occurs in the economic activities and overconsumption of the industrialized nations needs to be considered carefully.

When the Kyoto Protocol was concluded in 1997, the industrialized member nations agreed to reduce their greenhouse gas emissions. The signatory nations were motivated to conclude this convention because of their shared wish to reduce and undo environmental impacts. The Protocol mainly affects developed nations, but we must not forget people in developing nations when considering global environmental issues in the future.

The pursuit of comfortable lives and convenience is a primal human urge that has propelled the development of humankind. As such, we cannot deny this urge, nor can we turn back the clock. For the same reasons, we must not deny the aspirations of developing nations to reach the level of the industrialized world.

The developed nations must set aside their egos and work together with the developing world to resolve global environmental issues and aim to realize a prosperous life for all, including those in developing nations.

We must use our wisdom and effort to solve the problems that humans have caused. Fortunately, Japan and other industrialized

nations are now beginning to find new economic development paths while remaining conscious of the global environment. I believe that bringing out this wisdom will be our greatest contribution to the future.

For a company like Kawasaki, whose main businesses involve building social infrastructure, it is vital to offer environmentally friendly products and technologies to developing countries, maintain a broad perspective, and contribute on a global scale by developing technologies to resolve environmental issues.

Developing Trust in the Kawasaki Brand

—Commitment to Environmental Management—

We have been making steady steps toward fulfillment of the goals of our 2010 Environmental Vision. Though certain challenges remain to be overcome, the strong commitment of my predecessor, Mr. Tazaki, has laid a solid foundation for us as a company that contributes to the creation of a sustainable society.

Now, I would like to describe two core points of environmental management.

◆Contribution to society through the speedy provision of products and technologies

Kawasaki is dedicated to offering environmentally conscious products and technologies. Examples include power generation systems using natural energy sources such as wind power and biomass, highly efficient and clean gas turbine cogeneration systems, plants that use energy derived from wastes, and LNG storage tanks and tankers for efficient utilization of natural gas, a cleaner energy source. Using our accumulated expertise, we want to provide customer satisfaction by developing and providing these products. By responding to the fear of resource depletion, our products and technologies will greatly contribute to society.

At the same time, we are also contributing to the prevention of global warming by providing highly energy efficient transportation equipment, including rolling stock, ships and aircraft.

Furthermore, to contribute to developing countries where the supply of electricity is insufficient and logistic systems for people and resources are poorly organized, we are making efforts to encourage these countries to adopt environmentally conscious Kawasaki products and technologies. These include clean gas turbine power generation systems, instead of conventional power generation systems that consume much fossil fuel and are less efficient, and railway trains as environmentally conscious mass transportation systems. Through these efforts, we can both attain business success and contribute to the global environment, thereby **establishing Kawasaki as a trusted global enterprise brand** in the 21st century.

◆"Clean, Honest and Fast"

—Promoting compliance as part of the corporate culture—

Corporate social responsibility and environmental awareness have become essential for companies. Antisocial conduct such as environmental pollution in the local community around the site of an enterprise and improper waste disposal will be severely criticized and the value of the enterprise will be heavily jeopardized. I will promote **compliance** not just for environmental issues, but also in

every part of our corporate culture.

By **compliance**, I do not mean a simple, superficial compliance with the letter of the law. Rather, I believe that it is vital for everyone, from senior management to line managers and general employees, to have a strong sense of right and wrong grounded in their individual understanding of social norms. Having this sense of right and wrong will enable employees to achieve compliance themselves, while also increasing the value of the **Kawasaki brand** by fostering corporate contribution to society.

My motto is **Clean, Honest and Fast**, and I believe that these virtues are also important aspects of environmental protection efforts that are transparent, sincere and prompt in responding to needs.

Contributing to the Global Environment

–Don't make unneeded products, create lasting value–

I believe that fostering a culture that makes only excellent things and uses them for a long time is necessary in reconsidering the overconsumption of the modern age. From the manufacturer's viewpoint, we must not produce things that are not valued, but offer things that truly satisfy customers. We must be completely committed to producing high-quality, high-performance products with the minimum consumption of resources and energy. This is in line with my management philosophy of **"Quality Followed by Quantity Management."** I am actively committed to these goals and am working to establish even stronger environmental management.

Our employees are the driving force of our business activities, and I am making efforts to improve their environmental awareness. What actions create environmental awareness? I believe they are actions that give employees a broad and deep environmental mindset and the ability to understand how the current situation affects the global environment. Constantly remaining aware that "Kawasaki is an enterprise that contributes to the global environment," they should commit themselves to environmental protection with a sense of duty.

My lucky color is green. Since my younger days, I have chosen green neckties for important occasions. Green is also a color that symbolizes environmental consciousness. I will continue to wear a green tie and remain committed to Kawasaki's mission as an enterprise for the 21st century that contributes to the global environment and the realization of a sustainable society.



Message from the President	1
----------------------------	---

Corporate Profile	3
-------------------	---

Internal Companies and Affiliates	3
-----------------------------------	---

Editorial Policy	4
------------------	---

Highlights of FY2004	5
----------------------	---

Environmental Management

Environmental Charter	7
-----------------------	---

Action Plan for our 2010 Environmental Vision	7
---	---

Message from the Chief Environmental Officer / Organization for Environmental Management	8
--	---

Key Measures and Evaluations for FY2004	9
---	---

Environmental Accounting	10
--------------------------	----

Environmental Management System (EMS)	11
---------------------------------------	----

Environmentally Conscious Products

Product Assessment / Life Cycle Assessment (LCA) / Green Procurement	13
--	----

Examples of Products that Contribute to Environmental Impact Reduction	13
--	----

Environmentally Conscious Products	15
------------------------------------	----

Environmental Protection Products	17
-----------------------------------	----

Feature Report—Environmental Business

Kawasaki is Committed to Contributing to the Realization of a "Hydrogen Energy Society" that is Friendly to the Environment

Environmentally Conscious Production

Energy Conservation	21
---------------------	----

Prevention of Global Warming	21
------------------------------	----

Waste Reduction	22
-----------------	----

Chemical Substance Reduction	22
------------------------------	----

Coexistence with Communities

Contributions to Communities	23
------------------------------	----

Compliance Management	24
-----------------------	----

Information Disclosure and Environmental Communications	24
---	----

Relations with Employees	25
--------------------------	----

Environmental Data

Internal Companies / Affiliates	27
---------------------------------	----

Production Base	29
-----------------	----

Corporate Profile

Name: Kawasaki Heavy Industries, Ltd.
Incorporated: October 15, 1896 (Founded: April, 1878)
Capital: 81.4 billion yen
Kobe Head Office: 1-3 Higashikawasaki-cho 1-chome, Chuo-ku, Kobe, Hyogo 650-8680 Japan
Tokyo Head Office: 4-1 Hamamatsu-cho 2-chome, Minato-ku, Tokyo 105-6116 Japan
Representative: Tadaharu Ohashi, President
Kawasaki Network: Domestic: 24 (including 12 Works) Overseas: 7
Affiliates: 133 (As of March 31, 2005)

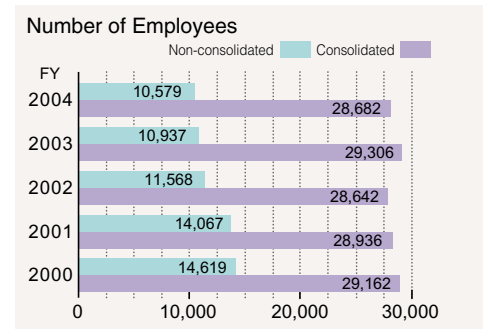
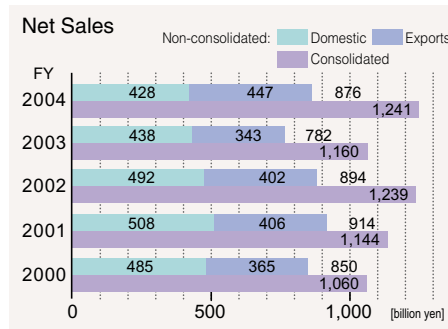
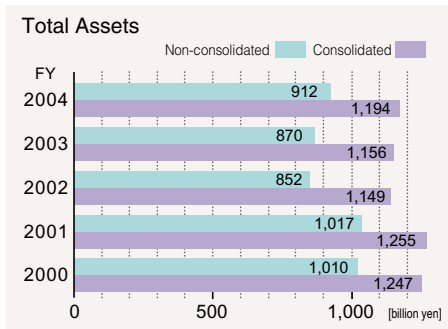
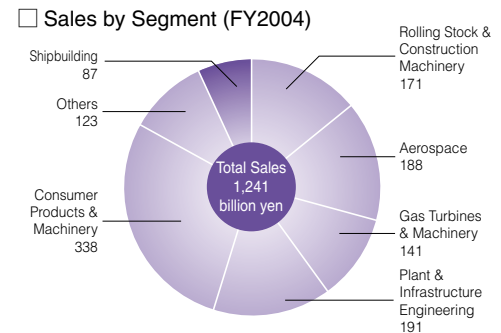

Internal Companies and Affiliates

Business Fields, Major Products and Domestic Works

Rolling Stock & Construction Machinery Company

Major Products

Rolling Stock, Construction Machinery



The rolling stock that we have been making for shinkansen high-speed train systems, subways and monorails is leaving its mark on railway history. Recently, we have been delivering rolling stock to overseas markets. We exported the first batch of shinkansen trains that we have been contracted to manufacture to Taiwan where test-runs began in January 2005. We have become more deeply committed to research and development programs for high-speed trains, including magnetic levitation trains, as well as the development of environmentally conscious vehicles that feature low noise and low vibration.

In the field of construction machinery, we are manufacturing equipment that contributes to land development and delivering it to domestic and international markets. Our efforts are centered on wheel loaders utilized for earth-moving and snow removal.

Hyogo Works, Banshu Works

Aerospace Company

Major Products

Aircraft, Space Development Equipment



We are taking part in the joint development and distributed production of passenger aircraft with Boeing in the USA and Embraer in Brazil. In addition, we are committed to a wide range of aircraft production businesses, including production of training craft, maritime surveillance planes and transports for the Japan Defense Agency (JDA). A transport helicopter we prepared for the JDA is one of the largest models in the world. We are working to develop this model, the BK117 with a German partner for civilian use as well. In Japan, we manufacture the greatest overall variety of aircraft models.

In the space development sector, we have been put in charge of construction of the launch facility for the H-IIA rocket, which is entirely Japanese made. We also develop and fabricate fairings for satellite bearing rockets. In addition, we are contributing to the development of the Japanese version of the space shuttle and the lab module of the international space station.

Gifu Works, Nagoya Works 1, Nagoya Works 2

Gas Turbines & Machinery Company

Major Products

General-purpose Gas Turbines, Jet Engines, Prime Movers, Equipment



We develop and manufacture jet engines for fixed wing aircraft and helicopters. We often cooperate with domestic and international partners, and the scope of our activities continues to expand. For example, we are taking part in national projects to develop supersonic transport and spacecraft.

We also independently developed and marketed gas turbine-driven emergency power generation equipment. Our share of the compact and medium-sized emergency power generation equipment market is now the largest in Japan.

The machinery business began as a maker of ship engines, but has firmly established its position among manufacturers of land-based power generation equipment as well by producing, for example, power generation steam turbines and compressors.

Akashi Works, Seishin Works, Kobe Works

- *With this Report, we intend to inform you about the current status of progress relative to our 2010 Environmental Vision—What Kawasaki Should Be in the Year 2010, as well as the 4th Environmental Management Activities Plan (FY2003-FY2005) that was developed in accordance with the 2010 Environmental Vision. Environmental Report 2005 describes planned and actual environmental protection activities for FY2004, and our self-evaluation of the achievements of these activities.
- *Kawasaki is a manufacturer that produces a variety of heavy industrial equipment that is utilized for the infrastructure of modern society. This Report provides information about how our products contribute to society in terms of environmental protection by summarizing specific data about improvements in product performance (energy conservations, air quality improvements, reduction of hazardous materials use, recycling, etc.) as well as the development of environmental protection-related technologies.
- *We disclose environmental impact data for each of our internal companies, major affiliates and production bases (works).
- *Regarding "Coexistence with Communities," this Report summarizes our contributions to communities not only for environmental aspects, but also for efforts related to employment and labor safety and health.

We hope that this Report helps you understand our commitment to environmental management for realization of a sustainable society as well as our environmental protection activities.

To develop this Report, we have referred to the Environmental Reporting Guidelines (Fiscal Year 2003 Version) issued by the Ministry of the Environment, Government of Japan.

Reporting Scope

This Report covers information on environmental aspects of Kawasaki Head Offices, Technical Institute, branch offices, and works in Japan, and major affiliates Kawasaki Shipbuilding Corporation and Kawasaki Precision Machinery Corporation (KPM), but does not cover overseas offices.

Reporting Period

In principle, the information contained herein is reported for the period of April 1, 2004 to March 31, 2005, which is our FY2004.

Schedule for Future Issues

This Report will be issued annually.

Promise to the Earth



地球が微笑むモノづくり

[Environmental symbol]

This symbol identifies our environmentally conscious products and manufacturing processes, and reflects our dedication to solving global environmental problems.

Consumer Products & Machinery Company

Major Products

Motorcycles, ATVs, Jet Ski Watercraft, Industrial Robots



The Kawasaki brand is highly valued around the world in the general consumer products field. Our motorcycles and Jet Ski® personal watercraft are loved by riders everywhere because of their uniqueness and performance.

In 1970, our robot division developed the first industrial robot in Japan. Since then, we have been leading the robot industry with sophisticated technology and high reliability. Our business motto is "simple and friendly" and, with this in mind, we manufacture high speed, high performance, compact state-of-the-art industrial robots, and offer engineering support for complete production systems that are designed with robots as key hardware.

Akashi Works

Environmental Control Plant Division Steel Structure & Industrial Equipment Division

Major Products

Environmental Protection Facilities, all types of Steel Structures



We are developing pollution control equipment as part of our dedication to the safe treatment of wastes and wastewater. The broad scope of our environmental protection equipment includes incineration plants and gasifying-melting furnace for processing city wastes and industrial wastes, as well as sewage treatment and sludge incineration plants.

Utilizing long years of experience in steel structure technology, we are building steel structures for key pieces of social infrastructure. Examples of such products include steel bridges and steel building frames such as those used in the Tokyo Metropolitan Government Office Building, airports and multipurpose domes. Furthermore, our steel structure technology is employed in the construction of energy-related facilities such as LNG tanks and wind power generation plants.

Kobe Works, Harima Works

Kawasaki Shipbuilding Corporation

Major Products

Marine Vessels, Offshore Structures



At Kawasaki Shipbuilding Corporation, we make full use of extensive experience accumulated through a "century of making ships" to engage in shipbuilding and ship repair. As a pioneer in the field, we have superb engineering know-how and advanced technologies. Throughout our history, the company has produced many "first" ships in Japan, including the first submarine and the first LNG carrier. Our engineering ability remains at the top level in the world.

We build virtually every type of ship at our two shipyards in Japan and one shipyard abroad, including LNG carriers, LPG carriers, container ships, oil tankers, oceanographic vessels and Japan Coast Guard patrol vessels. We believe that our ships and our efforts to develop technologies that make them more efficient and reduce environmental impacts contribute to the lives of people around the world.

Kobe Works, Sakaide Works

Highlights of FY2004

Following the slogan, "Think Globally, Act Locally," the Kawasaki Group remains actively committed to the realization of a sustainable society.

Environmental Management

(p7 to p11)

EMS development is in progress at offices and affiliates

Major affiliates in Japan are developing an environmental management system (EMS) to fulfill our 2010 Environmental Vision of "establishing and implementing EMS by the Kawasaki Group."

In March 2005, the Kobe Head Office acquired Kobe Environmental Management System (KEMS) certification.



KEMS certification mark

Kobe Head Office

Kawasaki Environmental Handbook is published

As part of our in-house environmental education, we published our Environmental Handbook in March 2005.



Kawasaki Environmental Handbook

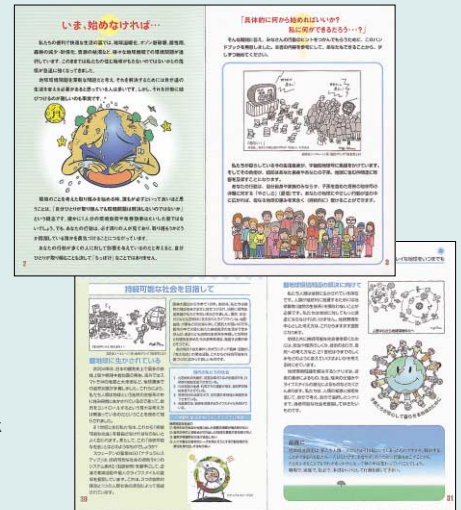

Environmentally Conscious Products

(p13 to p20)

Kawasaki is committed to contributing to the realization of a "hydrogen energy society" that is friendly to the environment

Hydrogen is a clean energy source that generates only water when burned. Utilizing our comprehensive knowledge of cryogenic technology such as that used in the liquid hydrogen storage-supply station for Japan's H-II rockets, we are working to develop and construct liquid hydrogen containers and tankers.



Liquid hydrogen container

New aluminum alloy joining technology is developed that can reduce electricity consumption by 95% or more

We have developed a unique friction spot joining (FSJ) technology for aluminum and other light metal components in which the joining spots of components are softened with frictional heat, and then the components are joined together to make a permanent joint. We have also created a robot product designed for this purpose.

Compared with conventional resistance spot welding techniques, the power consumption with this new technology is reduced by 95% or more.



Typical system configuration that combines the special gun and an articulated robot

Environmentally Conscious Production

(p21 to p22)

Gas turbine cogeneration system started at Gifu Works

In August 2004, the Gifu Works introduced a gas turbine cogeneration system. This system will improve the total energy efficiency for electricity and steam and reduce CO₂ emissions by 14%.



Cogeneration system



Commissioning ceremony

All Kawasaki works achieve zero emissions

The Gifu Works and Yachiyo Works achieved zero emissions, meaning that all Kawasaki works have achieved zero emissions.



Gifu Works



Yachiyo Works

Coexistence with Communities

(p23 to p26)

BULL DOG humanitarian de-mining system makes a great step toward practical use

Our BULL DOG system, which detects, excavates and detonates antipersonnel mines, underwent a demonstration test in real mine fields in Afghanistan from June 2004 to February 2005.



MINE DOG mine detection vehicle



MINE BULL mine clearance vehicle

Preparing for large-scale disasters

In order to begin relief activities promptly in the event of a large-scale disaster, the safety of our employees and their family members needs to be verified quickly. For this purpose, we have developed a Safety Confirmation System that uses the Internet and the telephone network.

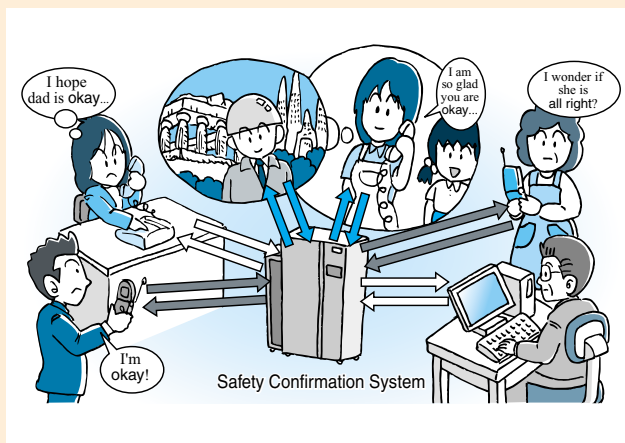

Environmental Management

To realize our intentions to contribute to a sustainable society, we have an "Environmental Charter." Furthermore, we are promoting environmental management activities to fulfill our 2010 Environmental Vision—What Kawasaki Should Be in the Year 2010.

Environmental Charter

Environmental Philosophy

As a company in key industries related to land, sea and air, Kawasaki is deploying its business activities globally in pursuit of reducing environmental impact and creating a sustainable society. This makes us to commit ourselves to contribute to the sustainable development of society through our environmentally conscious business activities, technologies and products that preserve the global environment.

Conduct Guidelines

1. Recognizing that global environmental protection is a common and serious issue for humankind, Kawasaki will positively volunteer to engage itself in harmonizing with the environment globally. We shall regard this as one of the most important strategies when we deploy our business activities.
2. During its production stages, Kawasaki will endeavor to conserve resources, to save energy, to recycle resources and to reduce industrial waste and will promote the reduction of environmental impacts.
3. In the new product planning (i.e. research and development) and designing stages, Kawasaki will render careful attention throughout the procurement, production, distribution, utilization and material disposal stages in order to minimize the environmental impacts.
4. In seeking solutions to global environmental issues, Kawasaki will do its best to develop and provide new technologies and new products that contribute to environmental protection, energy saving and resource conservation.
5. Notwithstanding its compliance with environmentally related institutional laws, regulations and agreements and voluntary action plans of each industry concerned, Kawasaki will voluntarily institute its own environmental control standards as an appropriate and necessary action in order to strive to improve environmental control levels.
6. Through environmental training and public awareness activities, Kawasaki will strive to enlighten all its employees on global environmental issues and will support individual views, lifestyles and will encourage their participation in the social activities and services.
7. Kawasaki will implement an environmental management system to promote environmental preservation and conservation, and hold regular conferences to review management systems and maintain continual improvement.

Action Plan for our 2010 Environmental Vision

In 2003, we established "What Kawasaki Should Be in the Year 2010" as the 2010 Environmental Vision of the Kawasaki Group. This vision defines how we should be in the year 2010, and consists of five aspects — environmental philosophy, environmental management, environmentally conscious products, environmentally conscious production, and

environmental communication.

In practice, we have been working to realize this vision through a series of three-year Environmental Management Activities Plans, the first of which began in FY1994.

Item	2010 Environmental Vision (What Kawasaki Should Be in the Year 2010)		4th Environmental Management Activities Plan (FY2003-FY2005)
Environmental Philosophy	<ul style="list-style-type: none"> • Actions by all employees are taken with concern for the environment, not only at work, but also in their local communities and homes, in accord with our Environmental Philosophy, which declares our commitments to the realization of a sustainable society. 	Development into 3-year Environmental Management Activities Plan	Provision of comprehensive education and training programs for promoting environmental consciousness <ul style="list-style-type: none"> • Publication of the Environmental Handbook in FY2004 • Use of IT to promote the environmental consciousness of all employees • Continued education activities about environmental issues for employees
Environmental Management	<ul style="list-style-type: none"> • Implementation of an Environmental Management System (EMS) and actions are taken based on this EMS by all employees. • Incorporation of environmental considerations into the business management of each internal company enhances their environmental management levels. • An environmental management information system is created. 		Environmental management to increase social trust <ul style="list-style-type: none"> • Support for promotion and creation of EMS for affiliates • Establishment of techniques for analyzing environmental management activities • Provision of management-related environmental information to management • Utilization of Information Technology for acquiring and managing environmental data
Environmentally Conscious Products	<ul style="list-style-type: none"> • Design for Environment (DfE) is used for all products to enhance their environmental efficiency. • Products are offered that help protect the environment, thus contributing to the environment, society and businesses. 		Contribution to the sustainable development of society through technologies and products that help protect the environment <ul style="list-style-type: none"> • Application of DfE (product assessment, LCA, etc.) for major products • Promotion of green procurement systems in order to expand the use of green goods • Enhancement of supply of products that promote environmental protection and reduce environmental impact
Environmentally Conscious Production	<ul style="list-style-type: none"> • Administrative penalties and administrative provisions are avoided, and voluntary control standards based on the needs of society are established to improve environmental control levels. • Every production activity is free of irrationality and waste to enhance the efficient utilization of resources and energies. • Total greenhouse gas emissions in FY2010 is reduced by 6% relative to the FY1990 level. • Total waste production in FY2010 is reduced by 10% relative to the FY2000 level. • Maintenance of zero emissions (recycling rate 100%) is realized in all works. • The use of hazardous chemical substances is reduced. 		Compliance with environmental laws, regulations and agreements <ul style="list-style-type: none"> • No administrative penalty, administrative provision, resident complaint, etc. • Setup of voluntary control standards that addresses social needs Promotion of environmental impact alleviation in production activities <ul style="list-style-type: none"> • Examination of programs for measuring and reducing the amounts of resources and energy input in production processes • Reduction in total emissions of greenhouse gases to the FY1990 level • Reduction in total waste emissions by 5% relative to the FY2000 level • Realization of zero emissions in all works by the end of FY2004 • Implementation of hazardous chemical substances reduction program
Environmental Communication	<ul style="list-style-type: none"> • Kawasaki Environmental Reports that comply with the needs of society are published. • Communication with stakeholders is promoted. • The entire corporation and all employees are committed to environmental improvement in local communities. 		Improvement of social trust in Kawasaki for sustainable development <ul style="list-style-type: none"> • Information disclosure of environmental data • Promotion of communications with stakeholders • Positive cooperation in environmental activities of national and local governments

Message from the Chief Environmental Officer



Masatoshi Terasaki

Senior Executive Vice President

Dedicated to Earning the Trust of Society

Five years into the 21st century, it has become common knowledge that commitment to the environment is the key to enabling sustainable growth for future generations.

As a member of society, this is truly one of the most important challenges for Kawasaki.

Considering this, the following efforts are fundamental for a company such as Kawasaki, whose business deals with products and technologies.

- **Contributing to the environment through products and technologies**
At Kawasaki, we supply transportation equipment and social infrastructure that contribute to the progress of human society. We help solve environmental issues in the following ways.
 - Developing and offering environmentally conscious products and technologies that reflect consideration of potential environmental impacts, including total energy costs, over their entire lifecycles
 - Developing and offering products and technologies that help protect the environment
- **Ensuring energy and resource conservation in production activities**
We are improving production efficiency and minimizing global environmental impacts in order to be environmentally friendly.

In 2003, we released our 2010 Environmental Vision—What Kawasaki Should Be in the Year 2010—and launched our 4th

three-year Environmental Management Activities Plan to achieve this vision. FY2004 marked the second year of the plan, and our accomplishments included the following.

- Published Kawasaki Environmental Handbook to promote employee environmental consciousness
- Drafted an EMS development plan for affiliates
- Achieved zero emissions (no landfill waste disposal) in two divisions bringing the total to 10 out of 12 divisions
- Developed voluntary reduction targets for chemical substances in each division, and based on them established key targets for the entire company

FY2005 is the final year of our 4th Environmental Management Activities Plan, and the preparation year for our 5th, which will start in FY2006. We will focus on the following efforts in FY2005.

- Enlarge and improve EMS development in Japanese affiliates and establish action policies for overseas affiliates to raise the level of environmental management throughout the Kawasaki Group
- Plan to review our environmental risks to ensure comprehensive environmental protection
- Promote reduction of hazardous chemical substances
- Introduce and implement an environmental data management system that will help management grasp environmental impacts

A company is a group of individuals and everything it does is based on their acts.

We must continue to ensure that each employee understands the importance of the global environment and feels a sense of duty to contribute to it through Kawasaki products and technologies in his or her work. Additionally, we must act so that every employee maintains an awareness of and makes a positive impact on the environment, not only at work but in the community and at home as well. When every employee has achieved this, I believe that we will have earned the trust of society as a company that contributes to the environment.

We, at Kawasaki, remain committed to achieving this goal.

Organization for Environmental Management

The organizational structure for the environmental management of the entire Kawasaki Group is illustrated to the right. Internal company systems are applied to environmental management activities so that environmental protection programs suitable to the products manufactured by each internal company are promoted. An Environmental Management Officer, an Environmental Protection Officer and a manager responsible for environmental protection are assigned to every internal company, every affiliate and the Corporate Technology Division.

Environmental Management System

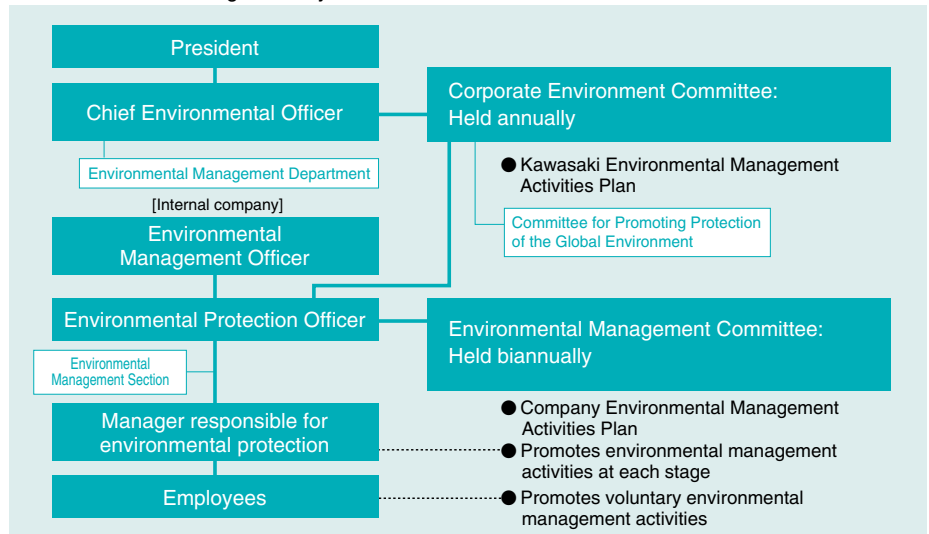

Key Measures and Evaluations for FY2004

FY2004 Plans and Achievements and FY2005 Plans

FY2004 marked the second year of our 4th Environmental Management Activities Plan (FY2003–FY2005), which is a three-year basic plan. In this year, to fulfill our 2010 Environmental Vision—What Kawasaki Should Be in the Year 2010, measures were developed and executed along five themes. The achievements in this year are summarized below.

Items for which we failed to fully achieve our goals in FY2004, including complaints from residents and increases in waste emissions, are included in our FY2005 key measures. We will execute environmental management activities aimed at fulfilling our 2010 Environmental Vision.

*Evaluation criteria: ◎···Target was fully achieved. ○···Target was almost fully achieved. △···Target was not achieved.

Item	FY2004 Plan	Evaluation Result	FY2004 Achievements	FY2005 Plan
Environmental Philosophy	① Publication of the Environmental Handbook for the environmental consciousness of all employees	◎	① Distributed the Environmental Handbook to all employees in March 2005	• Review and examine the contents of the Environmental Handbook
	② Consideration of environmental education utilizing Information Technology	○	② Provided expenses for FY2005 environmental e-learning courses	• Implement environmental education system through e-learning
	③ Education for all Kawasaki employees about environmental issues	○	③ Environmental News, in-house magazine, "Kawasaki" (see page 12)	• Continue publication of environment-related articles
Environmental Management	① Support of EMS at affiliates	○	① Established EMS achievement plan for domestic affiliates	• Develop action guidelines for EMS at overseas affiliates
	② Establish methods for analyzing environmental management activities	○	② Introduced a method for evaluating greenhouse gas emissions reduction activities	• Begin reappraisal of environmental risks for our 5th Environmental Management Activities Plan
	③ Disseminate environmental information associated with business management	△	③ Introduction after investigating VOC emission control information	• Continue publications related to environmental management
	④ Consider online environmental data collection	◎	④ Investigated data input and output forms at each site in preparation of system introduction	• Develop structure for practical utilization of environmental data management system
Environmentally Conscious Products	① Apply Design for Environment (DfE) to major products	○	① Product assessment and LCA (see page 13)	• Continue and expand application of DfE
	② Formulate green procurement rules for subcontractors	○	② Developed procurement rules by each division (aircraft, construction machinery, etc.)	• Develop green procurement rules by each division and expand the scope of green materials procured
	③ Expand scope of environmental protection products	○	③ Examples of products (see pages 13 through 20)	• Continue supply of products that decrease environmental impacts
Environmentally Conscious Production	① No administrative penalty/provision, resident complaint, etc.	△	① Received three resident complaints (see page 12)	• No administrative penalty/provision, resident complaint, etc.
	② Establish voluntary control standards that meet social needs	○	② Established atmosphere-related voluntary control standards	• Establish voluntary control standards that meet social needs
	③ Implement trial of energy flow control method for major processes	○	③ Initiated energy flow control (machinery division, construction machinery division)	• Continue activities for appropriate use of resources and energies
	④ Decrease greenhouse gas emissions by 1.9% (265,800 t-CO ₂) or more relative to the FY2003 level	△	④ Increased emissions by 5.1% (285,000 t-CO ₂) relative to the FY2003 level	• Decrease greenhouse gas emissions to the FY1990 level (258,700 t-CO ₂)
	⑤ Decrease waste emissions by 3.5% (66,300 tons) or more relative to the FY2000 level	△	⑤ Decreased waste emissions by 2.6% (66,900 tons) relative to the FY2000 level	• Decrease waste emissions by 5% or more relative to the FY2000 level
	⑥ Achieve zero emissions at all Kawasaki works	◎	⑥ Achieved by Gifu Works and Yachiyo Works in March 2005, completing achievement of zero emissions by all KHI and KPM works	• Establish zero emission maintenance system
	⑦ Develop hazardous chemical substance reduction plan	○	⑦ Developed reduction plan for VOC, hazardous heavy metals and dichloromethane	• Reduce hazardous chemical substances in accordance with both corporate-wide targets and voluntary targets of individual divisions
	⑧ Promote program to achieve total elimination of PCB-containing equipment use	○	⑧ Developed replacement program for PCB-containing equipment	• Develop disposal program for stored PCBs and promote replacement of PCB-containing equipment
Environmental Communication	① Include data by site and affiliates in the Environmental Report for social trust	○	① Environmental data information (see pages 27 through 30) Status of chemical substance control (see page 22)	• Continue providing information for social trust
	② Establishment of system for risk communication with stakeholders	○	② Risk communication system (see page 11)	• Establish risk communication system
	③ Promotion of environmental volunteer activities in local communities	○	③ Actual activities (see pages 23 through 24)	• Continued activities for contribution to communities

Evaluation of Kawasaki's Environmental Level

In order to evaluate our FY2004 environmental protection activities, we used the results of self-evaluations prepared by all divisions to calculate corporate-wide averages. As summarized in the results shown to the right, there are 12 indexes stipulated by our Environmental Activities Evaluation Guide that was created in FY2002. These indexes are subcategorized into 37 items.

As a result of self-evaluation for FY2004, there were improvements in some items, including green procurement (5) and environmental considerations in overseas businesses (12) over the FY2003 level. However, the marks are still low and additional efforts are needed to make further improvements.

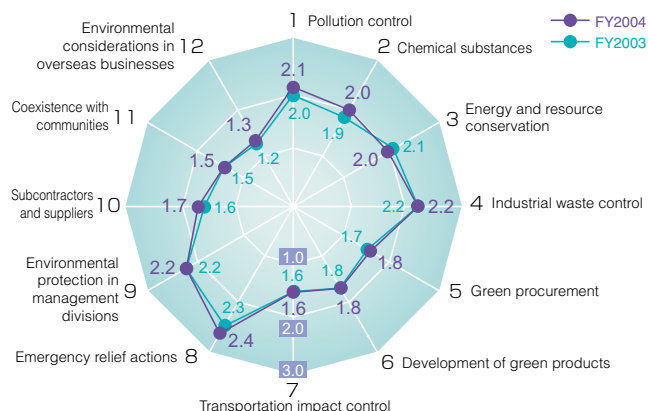

Environmental Accounting

In accordance with the "Environmental Accounting Guidebook" issued by the Japanese Ministry of the Environment, we have attempted to provide an easy-to-understand presentation of our environmental accounting calculations for FY2004, focusing on the formulation of indexes for use by internal management. Based on the calculation results, we evaluated the environmental investments and costs for maintaining environment-related

equipment, economic effects, and the amounts of substances decreased. We analyzed and assessed the contributions of various investments and costs to actual decreases in substance amounts in order to develop more cost-efficient and effective environmental protection measures.

○Coverage: Domestic works and offices of Kawasaki Heavy Industries, Ltd., Kawasaki Shipbuilding Corporation and Kawasaki Precision Machinery Ltd. (KPM) ○Period: April 1, 2004 to March 31, 2005

Calculation Results for FY2004 Environmental Accounting

Unit: million yen

Category	Item	Environmental investments	Environmental costs	Economic effect	Amount of decrease relative to the previous fiscal year	
Category	Sub-category	Details			★Indicates increase	
Business area cost	Global warming prevention (energy conservation, decrease in greenhouse gas emissions, ozone layer protection, etc.)		927.2	691.1	Reduction of energy costs by saving 539.7	Total energy consumption 6,060 TJ Reduction in energy consumption ★91 TJ
	Efficient use of resources (raw materials, water, etc.)		17.8	156.4	Reduction of materials costs by resource conservation 161.9	Total greenhouse gas emissions 284,842 t-CO ₂ Targeted emissions reduction 5,200 t-CO ₂ Actual emissions reduction ★13,865 t-CO ₂
	Resource recycling activities	●Resource recycling activities	32.2	721.1	Income from recycling 820.2	Total material input 493,696 t Reduction in material input ★27,261 t
		●Waste disposal cost	16.3	522.7	Reduction of waste disposal costs 70.6	Total water consumption 7,616,000 m ³ Reduction in water consumption ★460,000 m ³
	Risk control (pollution control, compliance management)		654.0	756.4	—	Total waste emissions 66,929 t Targeted emissions reduction 100 t Reduction in emissions ★534 t
	Subtotal		1,647.4	2,847.7	1,592.5	Amount of waste recycled 63,406 t Recycling rate 95 %
Comparison with previous FY		337%	84%	87%		
Upstream/downstream costs	Assessment, improvement for eco-products and green procurement		250.2	3,192.0	0.0	
	Recovery, recycling, reuse and adequate disposal of products		0.0	0.1	0.0	
	Reduction of environmental impacts from containers and packing materials		0.0	0.0	0.0	
	Subtotal		250.2	3,192.0	0.0	
Management activity cost	Management activities	●Environmental education	0.0	86.0	—	
		●Environmental Management Systems	0.0	315.4	—	
		●Environmental impact monitoring	9.0	45.2	—	
	Subtotal		9.0	446.6	—	
R&D activity cost	Research & development		12.7	2,739.7*1	—	
Social activity cost	Social activities	●Improvement of environment, contribution to communities	3.7	171.0	—	
		●Information disclosure	0.0	20.7	—	
Subtotal		3.7	191.7	—		
Environmental damage cost	Countermeasures against pollution, etc.		187.2	26.2	—	
Total		2,110.1*2	9,443.9	1,592.5		
Comparison with previous FY		267%	98%	85%		

Item	Sum
Total investments in the applicable period*3	22,127.3
Total R&D costs in the applicable period*4	12,267.8

Item	Proportion
Percentage of environmental investment (Sum of environmental investments*2 / Total investments*3)	10%
Percentage of R&D costs (Total environmental R&D costs*1 / Total R&D costs*4)	22%

Environmental Management System (EMS)

Risk Management

While environment-related laws and regulations are being enhanced or newly enacted, each internal company is fully involved in risk management so that its established EMS functions satisfactorily and environment-related trouble is avoided.

The risk communication system for information disclosure is illustrated below. A request or inquiry from local residents or environmental NPOs is received by the environmental management section of each internal company or division involved, which then determines and provides an appropriate response. A critical consideration or fact that should be known by all of Kawasaki is reported to Head Office and at that time, instructions are sought as necessary.

□ Risk Communication System

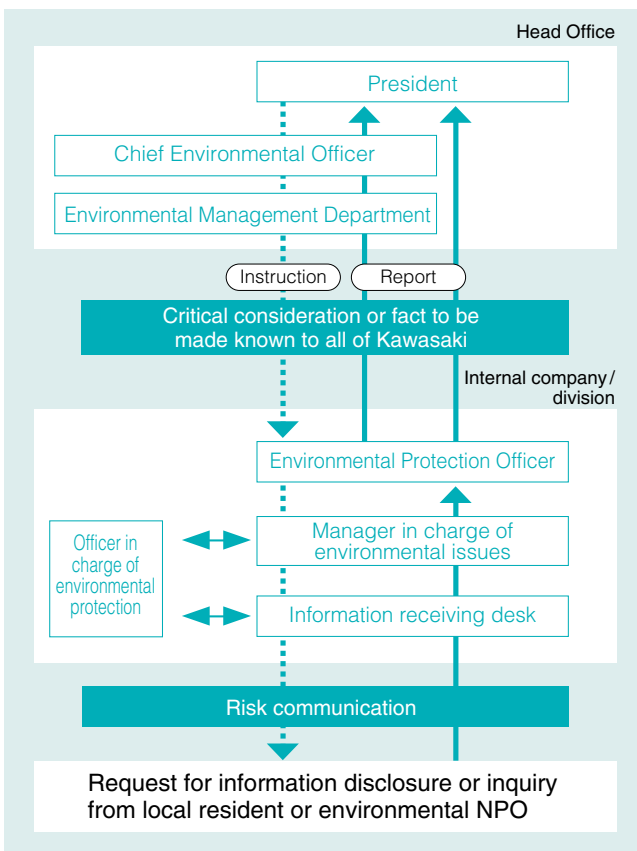

EMS in Offices and Affiliates

With the goal of establishing an environmental management system in the Kawasaki Group, we are promoting EMS at affiliates in Japan. We have set up three levels – acquisition of ISO 14001 certification, acquisition of certification for a simplified EMS, and EMS self-declaration. We are also setting policies for domestic affiliates to establish EMS with consideration of the natures of their businesses, including whether or not they have factories.

In FY2004, Kawajyu Shoji Co., Ltd. acquired ISO 14001 certification, the Kobe Head Office acquired Kobe Environmental Management System (KEMS) certification and Kawaju Techno Service Corp. (KTS) declared the

□ Kawasaki Environmental Auditing System

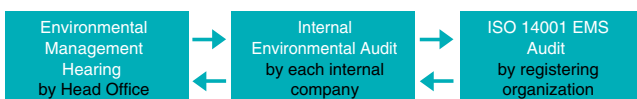

ISO 14001 Certification

All our works in Japan have already acquired ISO 14001 certification, and established EMS.

The year and month of certification and the reviewing & registering organization for each internal company and affiliate are summarized below.

		Date acquired	Registration
Rolling Stock & Construction Machinery Company	Rolling Stock Division	2002.2	LRQA
	Construction Machinery Division	2000.5	JICQA
Aerospace Company	Aerospace Company	2002.2	BSK
Gas Turbines & Machinery Company	Gas Turbine Division	2000.3	LRQA
	Machinery Division	2000.12	NK
Consumer Products & Machinery Company	Consumer Products & Machinery Company	2000.2	DNV
(Under direct control of Head Office)			
	Environmental Control Plant Division	1999.3	NK
	Steel Structure & Industrial Equipment Division	1999.11	JICQA
Affiliates	Kawasaki Shipbuilding Corporation		
	Kobe Works	2002.8	NK
	Sakaide Works	2000.8	DNV
	Kawasaki Precision Machinery Ltd.	1998.2	DNV
	Kawasaki Plant Systems, Ltd.*	2001.2	NK

* Former Power Plant & Industrial Plant Engineering Division became a separate company in April 2005.

Registering organization: LRQA: Lloyd's Register Quality Assurance
 JICQA: JIC Quality Assurance
 NK: Nippon Kaiji Kyokai (ClassNK)
 BSK: Bouei Choutatsu Kiban Seibi Kyoukai (Defense Procurement Framework Establishment Association of Japan)
 DNV: Det Norske Veritas

As of April 1, 2005

development of EMS. We have been steadily achieving EMS development at affiliates in Japan. We are also planning to examine EMS levels at major overseas affiliates.

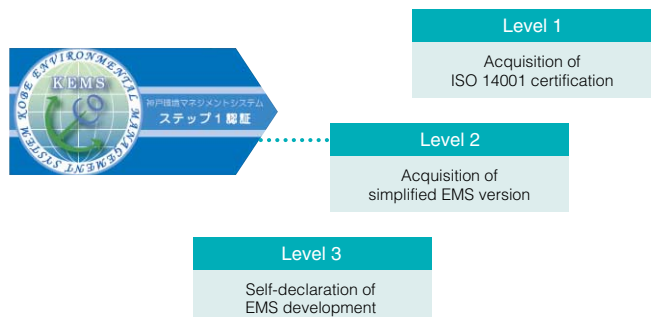

Compliance with Laws and Regulations

In FY2004, there were three resident complaints – an oily water leak at the Banshu Works due to a typhoon, and separate noise and odor complaints at the Akashi Works. We have already implemented measures to prevent recurrence of these problems.

No problems were subject to administrative warning or more serious government action.

Environmental Education

In addition to an environmental education program at each internal company and division, Kawasaki holds corporate-wide internal environmental auditor training courses for ISO 14001 at regular intervals.

The internal environmental auditors trained and qualified in FY2004, including those at affiliates, amounted to 169 persons. The number of people legally qualified for environmental protection is summarized in the tables to the right.

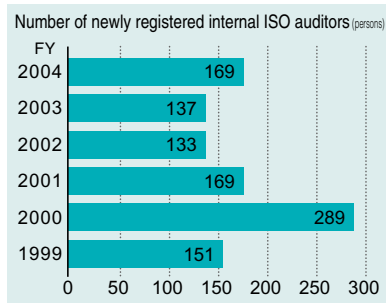

Environmental Month and Environmental Slogans

During Environmental Month held in June every year, we encourage employees to make individual proactive efforts that promote energy conservation and resource conservation in addition to usual environmental protection activities.

Employees submit slogans for Environmental Month and the number of submissions has steadily increased. In FY2004, 447 employees submitted 613 slogans. Most works, including the one that won the grand prize, "Create the environment that is friendly to people with gratitude expressed by every person" (Seiichi Fujii, Kawasaki Shipbuilding Corporation), show a desire to address environmental issues through our manufacturing work.

Publication of the Kawasaki Environmental Handbook

The Kawasaki Environmental Handbook was issued to all group employees in March 2004. This handbook consists of four chapters titled after the syllables in the name Kawasaki. Chapter "Ka" covers topics about the present-day environment, chapter "Wa" is about the energy that we need and use, chapter "Sa" deals with participation in a sustainable society, and chapter "Ki" provides information about conservation of the earth.

The handbook is edited so readers can understand the current status of global environmental issues and become familiar with ways for individual employees to address environmental protection. It also includes articles about our global environmental efforts and achievements. We believe that this handbook will help every employee act with consciousness of the environment at all times in their work, homes and local communities.

Promotion of Environmental Awareness

To promote the environmental awareness of our employees, we publish Environmental News four times a year. The quarterly in-house magazine "Kawasaki" also has an environmental column called Eco-mind.

Violations, Accidents and Complaints in the Past 5 Years

FY	2000	2001	2002	2003	2004
Judicial or administrative penalty	0	0	0	0	0
Administrative provision	0	0	0	0	0
Administrative warning	1	1	3	0	0
Resident complaints	0	4	2	1	3

Judicial or administrative penalty: Punishment by judicial or administrative authorities
 Administrative provision: Instructions imparted in writing (e.g. improvement order, etc.)
 Administrative warning: Verbal warning

Number of Qualified Pollution Control Managers

Air	81
Water	92
Noise	36
Vibration	23
Others (Dust, Senior Managers)	17
Total	249

Number of Qualified Energy Managers

Heat	36
Electricity	22
Total	58

FY2005 Environmental Month Slogan Prize Winners

Grand Prize slogan

"Create the environment that is friendly to people with gratitude expressed by every person"

Second place slogans

"A little energy conservation by every person creates great conservation"

"Manufacture products friendly to humankind and the earth through our efforts"

"Every Kawasaki employee's efforts help us save the green earth for future generations"

"Eco-life: affluence from another perspective"



Kawasaki Environmental Handbook



Environmental News



Eco-mind page in in-house magazine "Kawasaki"

Environmentally Conscious Products

With our 2010 Environmental Vision goals of "application of Design for Environment to products" and "provision of products that contribute to environmental protection," we intend to contribute to the formation of a sustainable society by offering products and technologies that help protect the environment.

Product Assessment

Every division in the entire Kawasaki Group actively executed product assessment, which is a key technique for Design for Environment.

The Rolling Stock & Construction Machinery Company Decreases Multi Rotor MINI Power Consumption

The Crushing Plant Business Division (now renamed Earth Technica Co., Ltd.) of the Rolling Stock & Construction Machinery Company conducted a product assessment for crushers used for recovering useful resources from waste. We have achieved dramatic energy conservation and resource conservation improvements with our crusher products.

The equipment that underwent the assessments were Multi Rotor products, which are single shaft crushers used for crushing soft materials including plastic, vinyl sheets, fabric, wood and rubber. This assessment led to the development of Multi Rotor MINI products for small-scale crusher plants that do not have material force-feeding systems. Compared with previous crushers, this line of crusher products requires approximately 17% less power.



Multi Rotor MINI

Implementation of Product Assessments in Past Years

FY	2000	2001	2002	2003	2004
Divisions with regulation/ Total divisions	10/14	11/14	10/13*	10/12*	10/12
Cases of product assessment	69	138	123	98	95

*The total has decreased from the previous year due to the integration of two divisions.

Life Cycle Assessment (LCA)

Every division of the Kawasaki Group is attempting to apply LCA as a technique to assess the environmental impacts of its products.

Environmental Control Plant Division Commitment to LCA

The Environmental Control Plant Division is actively involved in LCA research efforts in the environmental business field, taking part in various outside committees that make environmental assessments for waste disposal and perform LCA study activities. In particular, we are involved and cooperating in the development of a software tool that allows efficient implementation of Waste Life Cycle Assessment (WLCA), which we believe will provide an effective means for developing products that are better for the environment.

Examples of Products that Contribute to Environmental Impact Reduction

New Energy-Saving Joining Technique for Aluminum Alloy Components

● Friction Spot Joining (FSJ)

The Corporate Technology Division has been playing a key role in researching the friction stir welding (FSW) technique for joining aluminum alloy components in the manufacture of rolling stock and ships. This technique has already been put into use. Recently, the Consumer Products & Machinery Company has developed and marketed a unique robot that is designed to perform friction spot joining (FSJ), which operates on principles similar to those of FSW. The power consumption of this new technique is at least 95% lower than conventional aluminum welding techniques.

A very common joining technique for light metal used in the bodies and skins of automobiles and rolling stock is resistance spot welding. This technique, however, has several drawbacks including high power consumption because light metal components are joined together using a strong electric current.

With our friction spot joining technique, frictional heat is utilized to soften the joining spots, allowing the components to be joined together. While a cylindrical joining tool having a threaded projection on its end is rotated, the tool is forced into the material, thereby the material is softened with frictional heat and the components are joined together. The only electricity needed is for running the motor that drives the tool. As a result, the electric power needed for our FSJ technique is at least 95% less than conventional resistance spot welding techniques.

Our FSJ system comprising an articulated robot and a special gun has been put in use by some automakers for



Typical system configuration that combines the special gun and an articulated robot

assembling hoods and doors. Since the ordinary automobile assembly process incorporates scores of industrial robots, adoption of our FSJ system in increasing numbers will lead to decreased power consumption, greatly contributing to CO₂ emissions reduction.

* Suppose that one robot unit performs joining sequences for 1,000,000 joints per year, which is the average for this type of robot, the reduction in CO₂ emissions will amount to approximately 12.3 tons of CO₂ per robot unit every year.

FSJ system: approx. 0.7 t-CO₂/year/system

Resistance spot welding system: approx. 13 t-CO₂/year/system

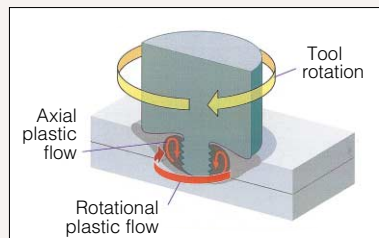

Friction spot joining overview

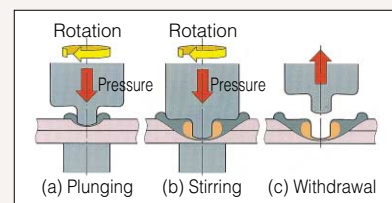

Joining process

Green Procurement

To increase our ratio of green products, green procurement should be regarded as one part of Design for Environment practice. Given this, the Kawasaki Group is promoting green procurement in accordance with our Basic Policy of Green Procurement.

The Consumer Products & Machinery Company developed Green Procurement Guidelines that define practices for procuring products and materials and has already begun application of managing, checking and restricting the materials used, beginning with new motorcycle models. It is also verifying the environmental management system of its subcontractors and suppliers.

The degree of progress in conversion to green products varies depending on the type of business of each industry and specific product requirements, but positive efforts are increasingly apparent throughout the Kawasaki Group. Organizations that are actively committed to developing Green Procurement Guidelines include the Aerospace Company, the Rolling

Basic Policy of Green Procurement Implemented in 1999

- ① Environmental impact must be considered across the entire lifecycle of all products from resource mining to waste.
- ② In the selection of a supplier, if multiple suppliers are equal in terms of quality, price and delivery, a supplier who is most seriously committed in environmental conservation is given priority over other suppliers.
- ③ Environmental product information must be obtained from suppliers.

Stock & Construction Machinery Company, and Kawasaki Precision Machinery Ltd.

To rationalize procurement of indirect materials including office equipment, we are introducing an electronic procurement system called "e-bazar" that displays the environmental considerations for each product. This system will allow the Kawasaki Group to realize better management and expansion of green procurement efforts.



Screen from e-bazar

Commitment to Decreasing the Use of Environmentally Hazardous Substances in Motorcycles

● Efforts to Decrease the Use of Four Environmentally Hazardous Substances

In accordance with our Green Procurement Guidelines, the Consumer Products & Machinery Company is committed to decreasing the use of four environmentally hazardous substances (lead, mercury, hexavalent chromium, cadmium).

All newly developed motorcycle models produced from FY2004 onwards are equipped with lead-free wheel balancers. An increasing number of lead-free components are also being incorporated into previous models that are still in production. Furthermore, lead-free coatings are now used on all motorcycles currently being manufactured.

We have virtually completed eliminating the use of mercury except for minute amounts used in components that are absolutely necessary for ensuring traffic safety. In cooperation with component manufacturers, we are also committed to decreasing the amounts of cadmium and hexavalent chromium used in products and developing alternative technologies that enable the production of cadmium-free electronic and electrical components.



Lead-free wheel balancer

Hexavalent chromium has been used in rustproofing for metal components and parts including bolts and nuts. We have been developing an alternative technology for critical motorcycle components and parts such as brakes and engines. For other components and parts, we have been switching to those whose surfaces are treated without hexavalent chromium and will continue to expand our use of hexavalent chromium-free elements. Furthermore, we are developing a new technology to phase out the use of hexavalent chromium for rustproofing aluminum components and parts and for surface preparation before coating aluminum components and parts.



2005 Model Ninja ZX-6R

Environmentally Conscious Products

When developing and designing new products, we always evaluate them from an environmental perspective. We handle a diverse spectrum of products and the nature of the environmental impacts of these products varies greatly. For every product, however, we intend to find and execute

possible improvements for protecting the environment, beginning with the easiest to achieve.

★...Corporate Technology Division, Head Office ●...Rolling Stock & Construction Machinery Company ●...Aerospace Company ●...Gas Turbines & Machinery Company ●...Consumer Products & Machinery Company
 ●...Environmental Control Plant Division / Steel Structure & Industrial Equipment Division ●...Kawasaki Shipbuilding Corporation ●...Kawasaki Precision Machinery Ltd. ●...Kawasaki Plant Systems, Ltd.

Energy Efficiency Improvement and Control of Greenhouse Gas Emissions

Fuel-Efficient Large Wheel Loader

The new AUTHENT 135ZV model of large wheel loader is our largest product of this kind, boasting a bucket capacity of 9.3 m³ and a vehicle weight of 80 tons. It features better operability and lower fuel consumption due to its three operation modes, unique hydraulic system and tire spin control function. The engine satisfies currently effective exhaust gas regulations and has longer oil replacement intervals, thus contributing to reducing waste emissions. After starting sales in the USA, we released this product in Japan in FY2004.



Energy Saving Rudder Device

The Kawasaki Rudder Bulb System with Fins (RBS-F) is an energy conservation device, consisting of a streamlined bulb and a pair of fins, that is installed on the rudder behind the propeller. By smoothing both the inflow to the propeller and the rotational flow behind the propeller, this system converts otherwise wasted energy into positive propulsion, thereby reducing energy loss and cutting the propulsive horsepower required by 2 to 7%. Capable of improving energy efficiency a great degree, this system has been installed on more than 80 Kawasaki ships during the past 30 years. Since it can be easily retrofitted on already operating ships, we are designing and supplying an RBS-F design for ships constructed by other shipbuilders. The expected results of incorporation of this device, assuming that all vessels with it remain operative for 20 years, are very impressive – a decrease in fuel consumption of 1,000,000 tons and a reduction in CO₂ emissions of 3,000,000 tons.

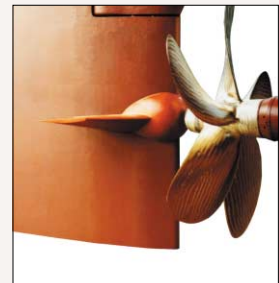

Energy Efficiency Improvement

Example

● Development of electronically controlled marine diesel engines: realization of low fuel consumption, and reduction in NO_x and dust emissions ● Steam turbine for CCPP: Steam consumption rate has been improved by 2% compared to conventional designs ● Fuel efficiency improvement for motorcycles has been evaluated as a percentage through the product assessment ● Energy-efficient spot joining method for light metal components:

friction spot joining (FSJ) ● A novel bow form "Sharp Entrance Angle bow as an Arrow" (SEA-Arrow) was introduced that, by reducing wave-making resistance, improves the propulsion performance of vessels ● Improved hull form design realizes an efficient LNG carrier able to carry 10,000 m³ (about 7%) more LNG with almost the same fuel consumption as conventional LNG carriers

Control of Greenhouse Gas Emissions

Example

● Wheel loaders: reduced use of air conditioner refrigerant (HFC)
 ● Wheel loaders and road rollers: Instruction manuals and labels specify that recovery of air conditioner refrigerant (HFC) is mandatory

Resource Utilization Efficiency

Lightweight Marine Diesel Engine Designs

Recently, the need for marine diesel engines with higher outputs, compact designs, and improved reliability and maintainability have been increasing. In response to these needs, a new MC-C model based on the conventional MC engine has been proposed. We have completed the world's first machine for one class of this model. We are now expanding production of this and other classes. Compared with the MC model, the MC-C model is approximately 10% lighter while having a 10% greater output. In other words, the MC-C is a compact, resource conserving, environmentally conscious product. Since 1921, we have manufactured 2,500 marine and land diesel engines. We are currently producing marine diesel engines on a licensed production basis, but our Technical Institute and specialists perform design reviews to verify and improve licensor designs.



Product Weight

Example

● Back-up gas turbine generators: Compact designs with greatly reduced weight have been adopted for all 19 models
 ● Weight reduction percentage for motorcycles is evaluated through product assessment
 ● Industrial robots: decreased robot product weight relative to its load-bearing capacity
 ● Adoption of the hovering stage has enabled designs for unique multi-purpose domes (with baseball fields, soccer fields, etc.) to help promote resource conservation

Containers and Packaging

Example

● The wooden crates for tugboat propellers were replaced with steel racks to eliminate the use of wood materials
 ● The packing of Jet Ski engines for export has been converted to a returnable steel pallet
 ● The packing for hydraulic components for export has been converted to a returnable type

Product Service Life

Example

● Model change intervals for motorcycles have been evaluated through product assessment
 ● Composite slab with a truss-type shear connector has realized a highly durable slab for road bridges

Hazardous Substances and Environmental Pollutants Control

● Environmental Protection Measures for Taiwan's High Speed Railway Trains

The 700T train for Taiwan's High Speed Rail Corporation is a low power consumption, low noise, high speed train design based on the technologies of the JR 700 series shinkansen train. To cope with the customer's need to protect the local environment, the outer surface of the train is painted with a coating that does not contain heavy metal (chromium). In addition, a decorated aluminum panel material and an olefin-based material are used instead of PVC for the interior and floor covering of the train to alleviate possible environmental impacts when the train is eventually decommissioned. Furthermore, the drive system on the train utilizes a flexible plate joint that is free from meshing between gears to improve the quietness in the cars.



● Application of Low-Polluting Paints for Aircraft

Introduction of coatings (paints) with reduced environmental impacts is in progress in various industrial fields. In aircraft painting, use of high-solid coatings containing a low level of organic solvents, which have harmful environmental impacts, is increasing. For the small commercial aircraft that we cooperate in producing, approximately 1/3 of the coating materials used are high-solid coatings. We have developed and acquired certification for a high-solid coating that is produced in Japan according to our specifications and have begun its use on applicable aircraft.



Example

- Cleaner exhaust gas from wheel loaders and road rollers
- Motorcycles: promotion of decrease in use of four environmentally hazardous substances (lead, mercury, hexavalent chromium, cadmium)
- Adoption of oil-free hydraulic actuation system for sluice gates: elimination of environmental pollution including oil leakage
- Development of heat insulating polyurethane foam for cargo tanks of LNG and LPG carriers that uses non-ozone depleting fluorocarbon as a foaming agent
- Adoption of chlorine-free coating instead of chlorinated rubber coating for LNG

- carriers, LPG carriers and oil tankers to reduce use of chlorine-based coating
- Ships: In order to decrease use of thinner, a solvent-free coating has been used on the inner surface of fresh water tanks
- Realization of mono-block design of combination control valves for compressed natural gas vehicles
- Study of possible improvements for hydraulic pumps in order to use bio-degradable hydraulic fluid

Waste Disposal and Recycling

● Motorcycle Recycling System Starts

Prior to the enforcement of the Car Recycling Law in Japan, the four domestic motorcycle manufacturers as well as importers jointly and voluntarily created a recycling system for used motorcycles that was put into operation on October 1, 2004. In this system, recycling costs are included in the prices of motorcycles and thus collected from users when they purchase new ones with motorcycle recycling labels. After a used motorcycle is delivered to the system by a user for disposal, the manufacturer or importer is responsible for recycling the used motorcycle. If a motorcycle lacking a recycling label is brought in for disposal, the user is charged for the recycling costs.

Motorcycle recycling label



Ratio of Use for Reusable and Recyclable Parts

Example

- Shield tunneling machines: Reuse system has been implemented

Recovery of Used Products, Containers & Packaging

Example

- Tire rollers: Engine hood material changed from FRP to sheet metal
- Material type is indicated by a symbol on resin components (● wheel loaders, road rollers ● back-up gas turbine generators ● motorcycles ■ hydraulic components)

Disassembly times for products

Example

- Wheel loaders, road rollers: decreased use of FRP components that have embedded metal parts
- Decreased numbers of parts in motorcycles

Vibration and Noise Control

● Soundproof Equipment attached to Noise Barriers (Silent Edge)

We have developed unique soundproof equipment with a hybrid structure composed of resonance and noise absorption devices. This equipment has been adopted as a noise countermeasure at the Komazawa Viaduct in the Tokyo Metropolis and at other locations. When tested in accordance with the performance evaluation method of the Ministry of Land, Infrastructure and Transport, this equipment exhibited noise reduction performance of the highest level compared with other products of the same type. Installation of this equipment allows the use of noise barriers with lower profiles on roads, avoiding influences on the surrounding area such as a sunlight blocking and radio wave interference.



Silent edge

Example

- Helicopters: Rotor blade geometry and rotor wingtip form have been optimized to decrease helicopter noise in flight
- Back-up gas turbine generator: New package features an equipment noise level of 55 dB
- Noise prediction and reduction of steel viaduct for railway
- Development of an electro-hydraulic hybrid system (inverter motor-driven pump unit) featuring reduced noise and power consumption

Environmental Protection Products

We are dedicated to continuing to make a wide range of products that help protect the environment by realizing efficient energy utilization, pollution control, waste treatment and recycling. In FY2004, we remained committed to environmental protection by keeping pace with the current legal and

regulatory trends in environmental protection and better understanding social needs by providing a diverse variety of new and proven products.

★...Corporate Technology Division, Head Office ●...Rolling Stock & Construction Machinery Company ●...Aerospace Company ●...Gas Turbines & Machinery Company ●...Consumer Products & Machinery Company
 ●...Environmental Control Plant Division / Steel Structure & Industrial Equipment Division ●...Kawasaki Shipbuilding Corporation ●...Kawasaki Precision Machinery Ltd. ●...Kawasaki Plant Systems, Ltd.

Energy

● Combined Cycle Power Plant (CCPP)

A CCPP system is a combined power generation system in which a gas turbine generates electricity and, using the waste heat from the gas turbine, a steam turbine creates electricity. We use the L20A, one of the world's most efficient gas turbines, as the core of its CCPP system. With this system, we are expanding our power generation plant business to achieve comprehensive energy efficiency improvement and CO₂ emissions reduction. In July 2004, we delivered a CCPP system rated with a total output of 50 MW to the Chiba Mihama Power Generation Project.* This system, designed for total optimization, consists of the L20A and other main equipment produced by Kawasaki.

*Heat-electricity supply project undertaken by Sumitomo Corporation in which heat and electricity are supplied to multiple factories and surplus electric power is sold to consumers.



● Wind Turbine Generation System

We actively participate in the field of wind turbine generation. For example, we are an investor in the Japanese representative of Vestas, the company that boasts the largest share in the global wind turbine generation market, and has already completed a total of 32 wind turbine generation systems throughout Japan. In June 2004, we, together with Penta-Ocean Construction, won a contract to construct a wind turbine generation system for a large-scale wind turbine generation plant. This system boasts six 2,000 kW-class wind turbines, which are among the largest generators of their kind in Japan, with a total output of 12,000 kW. This system will be constructed in FY2005 at the seaside of Setana-cho, Hokkaido, where we have already delivered Japan's first offshore wind turbine generation system.



★ New Type of Battery (Gigacell)

We are developing a new Ni-H battery that does not contain hazardous heavy metals such as lead and cadmium. This new battery features a greater output and higher power storage efficiency since its scale can be increased for larger capacities and higher voltages, but its structure is simple, so it can be disassembled and recycled simply. This battery will find applications in wind power, solar power and other natural energy-based power generation systems where power outputs tend to fluctuate, as well as in factories whose power requirement can vary greatly.



Conservation and Effective Utilization of Energy

Product

- Gas turbine cogeneration system
- Waste heat recovery boiler
- Cement plant waste heat power generation system
- Top-pressure recovery plant for blast furnace
- Stirling engine power generator
- Ice storage cooling system
- District heating and cooling system
- Optimization and diagnosis of industrial energy system

Research & Development

- Ceramic gas turbine
- Fuel cell power system

Renewable Energy System

Product

- Photovoltaic system
- Geothermal generation system
- ★ ■ Woody biomass power generation system

Research & Development

- ★ Black liquor gasification technology

New Energy System

Product

- Liquid hydrogen container

Air Pollution Control

■ Reaction Analysis for Flue Gas Desulfurization System

There have been few studies with detailed models for very complex and unique reactions such as those in flue gas desulfurization system where chemical substances are dissociated into ions in aqueous solution. We are aiming to establish a reaction simulation technique that eliminates empirical approximations for these types of electrolyte ion reaction problems. Through research on this technique, we will be able to design and develop optimized flue gas desulfurization system that satisfies varying needs including equipment for the Chinese market where design requirements greatly differ from those of the Japanese market.



SOx/NOx Reduction, Dust Collection

Product

- De-NOx plant and dust collector for flue gas
- Low-NOx gas turbine generation system
- Low NOx coal burning boiler
- Low NOx heavy oil burning boiler
- NO₂ removal system for road tunnel
- Ventilation filter for road tunnel
- Electrostatic precipitator for road tunnel

Research & Development

- ★ Motorcycle exhaust gas purifying catalyst

Air Pollution Control

Product

- ★ Photocatalyst

Waste Treatment and Recycling

● Fluidized Bed Type Gasifying-Melting Furnace

This system, which gasifies refuse in a fluidized bed type gasifying furnace and then melts ash in the melting furnace, has the advantage of melting ash by using the energy of the refuse itself and is intended to reduce the impact on the environment and operate economically. In FY2004, we won a contract for constructing a gasifying-melting furnace with a daily capacity of 300 tons, which is the first of its kind in the Tokyo Metropolis.

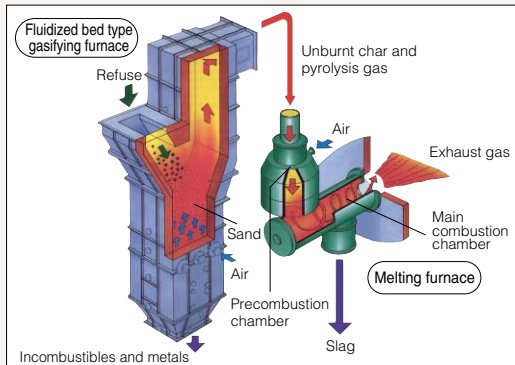

■ Melt State Polymerization System for Chemical Recycling of PET Bottles

The PET bottle recycle process consists of the units including crushing, foreign material removal, rinsing, depolymerization to monomer, purification (so-called thin-film evaporation), and repolymerization of PET material via Melt State and Solid State Polymerization System, and so on. We provided the Melt State Polymerization System for the recycle plant constructed in Kawasaki City, Japan, in 2004. This plant can first regenerate PET resin from recycled bottles with the same quality of PET resin from virgin raw material. We will remain committed to recycling efforts to conserve precious resources with our accumulated expertise.



Waste Incineration

Product

- High-performance refuse incineration system (Stoker-type furnace, Internal circulation fluidized bed type furnace)
- Refuse gasifying-melting system (Shaft-type gasifying-melting furnace)
- High-efficiency refuse power generation system (Power generation from refuse combined with gas turbine)
- Waste-to-energy system (RDF power generation, Kraft recovery boiler, etc.)
- Flue gas treatment system for dioxin removal
- Dioxin thermal decomposition system for fly ash

Research & Development

- Monitoring technology for dioxin surrogates

Crushing and Sorting

Product

- Bulky waste crushing and recycling system
- Waste automobile/electrical appliance crushing and recycling system
- Construction waste crushing and recycling system

Recycling, Pollution Control

Product

- Refuse incineration ash treatment system (Melting)
- Refuse derived fuel (RDF) production system
- Refuse paper and plastic fuel (RPF) production system
- Refuse melting slag utilization system
- Food waste treatment system (Methane fermentation, Compost, Feed, etc.)
- Livestock waste treatment system (Methane fermentation, Compost, etc.)
- Coal fired boiler's ash recycling system (Road base material, etc.)
- Ultrasonic air filter cleaning system (Reuse of air filter)

Research & Development

- Refuse incineration ash utilization technology
- Organic wastes treatment technology (Gasification, etc.)
- ★ Refuse gasification power generation technology
- PCB decomposition technology

Radioactive Waste Treatment

Product

- Radioactive waste treatment system

Research & Development

- Nuclear reactor decommissioning technology

Water and Soil Pollution Control

● On-Vehicle Sludge Drying System

This unique system accepts sludge from sewage treatment facilities and dries, deodorizes and forms the sludge on site to convert it into useful resources such as fertilizer and solid fuel. This on-vehicle system contributes to cost reduction for sludge disposal at small and medium sewage treatment facilities and decreases the amount of sludge disposed of as landfill.

Drying is achieved with the exhaust gas from the compact gas turbine generator within the system, and the electricity generated by the generator is used to drive the whole system. As a result, greater thermal efficiency is achieved and the CO₂ emissions from the system are decreased.



Sewage/Sludge Treatment

Product

- Sewage/sludge treatment system
- Membrane type water treatment system
- Sewage sludge processing system (Transformation of sludge into activated charcoal, fuel, fertilizer, etc.)

Decontamination of Contaminated Soil

Research & Development

- Cleaning technology for dioxin polluted soil

Kawasaki is Committed to Contributing to the Realization of a "Hydrogen Energy Society" that is Friendly to the Environment

When fired (oxidized), hydrogen produces just water, making it one of the most friendly energy sources for humankind and nature. A great dream for the 21st century is to realize a clean "hydrogen energy society" that uses hydrogen instead of fossil fuels that unavoidably lead to emissions of substances that are harmful to the environment.

Our cryogenic technology, which has helped achieve successes in various projects including a liquid hydrogen storage-supply station for Japan's H-II rockets, will help us provide infrastructure for the hydrogen energy society. In this section, our efforts to develop hydrogen-related technologies are described.

Liquid hydrogen storage-supply station for Japan's H-II rockets



Development of Japan's First Liquid Hydrogen Container

In a liquid state, the volume of hydrogen is 1/800 as small as when in a gaseous state, meaning that liquid hydrogen can be more easily stored and transported. With an increasing number of fuel cell cars being used, a network of hydrogen stations will be needed so that hydrogen can be made available throughout Japan like gasoline. As a means of supplying hydrogen to these stations, the liquid hydrogen container we have developed will come into the spotlight.

In January 2005, we successfully completed a long-distance public road test with this liquid hydrogen container, transporting it from Amagasaki City to the Tokyo Metropolis. We will continue to study how to improve the performance of liquid hydrogen containers so that they can be used commercially in the near future.

Utilization of Experience with Cryogenic Technology Accumulated Through Space Development and Other Efforts

A liquid hydrogen container can be defined as a transportation and storage container that is specifically designed for handling liquid hydrogen and satisfies the unique requirements to do so. Currently, mainly tanker trucks are used for transporting liquid hydrogen. Use of liquid hydrogen containers, however, will increase the range of flexibility for transportation methods and result in decreased transportation expenses. The higher insulation performance of liquid hydrogen containers will also allow transportation for longer times and distances. A liquid hydrogen container will also serve for liquid hydrogen storage. We have been committed to the development of a liquid hydrogen container and have been commissioned to do this by the New Energy and Industrial Technology Development Organization (NEDO). NEDO is committed to research on advanced elements for liquid hydrogen containers as part of Japan's National Development for Safe Utilization and Infrastructure of Hydrogen project.

The volume of hydrogen when liquefied is as small as 1/800 that of hydrogen in a gaseous state, so, hydrogen in a liquid state can be conveniently stored or transported. However, since the temperature of liquid hydrogen is as low as -253°C, design and fabrication of a container requires much advanced technology. We have so far gained experience in developing and fabricating storage tanks for LPG (-45°C), LNG (-162°C) and liquid helium (-269°C). The fuel for Japan's H-series space rockets is liquid hydrogen, and we had the responsibility for construction and maintenance of the liquid hydrogen storage tanks at the rocket launch facility. Our liquid hydrogen container design reflects the accumulation of knowledge and expertise that we gained from experience with cryogenic technologies.

Preparing for the commercial use of hydrogen fuel cells

Hydrogen is sometimes referred to as a "post-LNG" energy source. However, hydrogen manufacture, storage, transportation and utilization on a large scale have still not been achieved, making it an underdeveloped energy source. Manufacturing costs, efficiency and costs associated with transportation of hydrogen need to be improved greatly. Ten or more years of effort will be necessary before hydrogen can be utilized like petroleum or LNG. However, considering ever worsening environmental problems and the rapid depletion of oil resources, overcoming the various obstacles to realize the commercial utilization of hydrogen is imperative.

A gradual increase in the utilization of hydrogen will help accelerate research and development, possibly leading to an earlier-than-expected commercialization of hydrogen energy. The scheme, which consists of use of surplus electricity for manufacture and liquefaction, storage and transportation in the form of liquid hydrogen that features higher volume efficiency, and utilization in stationary fuel cells, may be commercialized in the near future. Liquid hydrogen containers are a key technology for realizing this possibility.



Yoshifumi Kimura
Assistant Manager, Engineering Office, Steel Structure & Industrial Equipment Division

Devising Arrangements for Support and Insulation Materials in Limited Vacuum Space

The structure of a liquid hydrogen container is shown schematically below. The container itself is a double-cylinder vacuum structure like a thermos bottle designed to maintain a cryogenic temperature. The major challenge in realizing this container was assuring the ability to transport a much larger amount of liquid hydrogen while achieving heat insulation efficiency that is better than that of existing liquid hydrogen vessels such as tanker trucks in spite of the size limitations of the container. To address these challenges, we designed the inner tank to be as large as possible and kept the vacuum space between the inner tank and outer tank as small as possible. This vacuum space includes aluminum-deposited film for preventing radiant heat, pipes for transferring liquid hydrogen and supports for retaining the inner tank. In order to arrange these components in the limited space while ensuring heat insulation efficiency, we adopted novel arrangements in addition to conventional techniques. For example, though the inner tank is supported with a suspension structure similar to the one used for the liquid hydrogen storage tanks situated at Japan's H-II rocket launch site, we have incorporated measures to prevent the inner tank from shaking during transport and to allow shrinkage of the inner tank when it is subjected to very low temperatures.

Incidentally, a law stipulates that baffle plates must be incorporated to minimize the vibration of liquid hydrogen during transport. Through a fluid vibration simulation, we have optimized the size and locations of the baffle plates and the intervals between them.

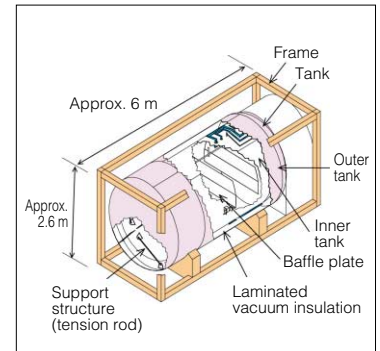

Structure of liquid hydrogen container



Installation of insulation

Demonstrating High Performance in Amagasaki-Tokyo Public Road Test

We subjected a liquid hydrogen container to various tests. In August 2003, a liquid nitrogen (-196°C) filling test was performed with the container in a stationary state. In January 2004, a liquid hydrogen filling test was conducted and then the container filled with liquid hydrogen was subjected to a traveling test on the site of the works to investigate the amount of hydrogen lost by evaporation. Since January 2005, several public road tests have also been performed.

The first public road test took place in January 2005 with a container carrying approximately 6 kL of liquid hydrogen – only half of the container's capacity. The liquid hydrogen container was transported along a 600-km route from the hydrogen liquefaction station in Amagasaki City, Hyogo Prefecture, to the hydrogen station for fuel cell cars in Koto-ku, Tokyo. The amount of liquid hydrogen

lost to evaporation was limited to only 0.7% per day, demonstrating the container's high performance.

We will further pursue lighter weight, higher insulation efficiency and lower costs and also hope to develop a large-sized liquid hydrogen container for rolling stock and ships.



Liquid hydrogen container

Identifying Technological Challenges for Liquid Hydrogen Tankers

Manufacture and liquefaction of hydrogen requires an enormous amount of electricity. Possible sources for providing such electricity are hydroelectric power in Canada, which has abundant water resources, solar power in deserts and wind power. To transport hydrogen to consumer locations, liquid hydrogen tankers need to be realized. Since taking an active role in WE-NET, we have been pursuing technological development to overcome the obstacles to the realization of liquid hydrogen tankers.

WE-NET: World Energy Network

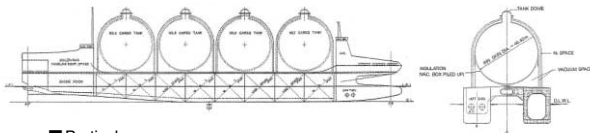

Particulars

Tank type	Double skin spherical tank
Ship type	Wave piercing semi-SWATH
Cargo capacity	200,000 m ³ ($\sim 253 \text{ t}$; 0.071 t/m ³)
Length (o.a.)	About 345.00 m
Breadth (mld.)	64.00 m
Depth (mld.)	26.00 m
Draft (mld.)	14.00 m
Main engine	Hydrogen burning boiler + Steam turbine
MCR	2 x About 40,000 PS (29,400 kW)
Propulsion system	4 x About 20,000 PS (14,700 kW) Waterjet pump
Service speed	About 25 knots
Boil-off rate	About 0.4%/day

Technically Feasible

WE-NET was a Japanese national project for development and verification of hydrogen-related technology at all phases from manufacture to utilization, and included construction of a liquid hydrogen tanker. We executed technical studies for liquid hydrogen tankers from 1993 to 1998.

A great challenge for the realization of a liquid hydrogen tanker is the provision of an insulation method capable of keeping the liquid hydrogen below its boiling point of -253°C . According to calculations, when using the same insulation materials as those for LNG tankers, the thickness needed will be approximately 1,000 mm. Currently, no technique exists that can either produce or install insulation of such thickness. One possibility is to design a double-shell tank, with a vacuum maintained in the space between the inner and outer shells. However, to provide sufficient strength for a double-shell tank to withstand pitching and rolling on the ocean, it is impossible to adopt the conventional "suspension structure" that supports the tank with thin supports of lower heat conduction. New tank support methods and materials that satisfy both strength and heat conduction requirements need to be developed.

Furthermore, hydrogen molecules are very small and can pass through very fine pores that would block LNG molecules. Therefore, extremely cautious welding work, which has hitherto been unnecessary, must be performed when assembling the liquid hydrogen tank.

Notwithstanding, through concentrated studies, we have learned that construction of a liquid hydrogen tanker is technically feasible.

At Least 10 Years of Development Is Necessary before Commercialization

Having designed and constructed the liquid hydrogen storage tanks for Japan's H-II rockets as an application on land and built Japan's first LNG tanker as an application at sea, we have learned that the realization of a liquid hydrogen tanker will take a considerable development period. Since hydrogen molecules are very small, it is very light, and the temperature of liquid hydrogen is extremely low, time consuming efforts and very advanced technologies will be needed to optimize the tank, heat insulation, cargo outfitting, propulsion system and ship type and structure. The next challenge is to develop design and implementation techniques that can reduce construction costs while ensuring safety.

I believe Japan should lead international cooperation projects for research and development of liquid hydrogen tankers as well as other hydrogen-related technologies. Our comprehensive experience with cryogenic technology and large-scale high-speed ship technology will greatly contribute to the realization of a hydrogen energy society.

Recently, hydrogen utilization technologies, including fuel cells, have been developing rapidly while the price of petroleum has been soaring. For these reasons, I believe that in the near future, liquid hydrogen tankers will be traveling the oceans between hydrogen production sites and the locations of hydrogen consumption.



Masato Nakamura
Senior Manager, Initial Design Department, Engineering Division, Kawasaki Shipbuilding Corporation

Environmentally Conscious Production

In FY2004, a cogeneration system was commissioned at the Gifu Works, and all Kawasaki works achieved zero emissions. We are making sincere efforts to decrease greenhouse gas emissions and reduce use of hazardous chemical substances through energy and resource conservation activities.

Energy Conservation

All internal companies and major affiliates grasp the statuses of their utilization of electricity, fuels and water in their business activities and have energy management indicators (basic units) for these activities. Their energy conservation activities include the promotion of employee energy conservation awareness, operation with lower energy consumption in conjunction with ISO 14001 environmental management programs (EMP) and improvement of production lines through understanding energy flows in their major processes.

We are actively investing in energy conservation plants and equipment

including a cogeneration system at the Akashi Works (commissioned in 2001) and a variable heat-electricity ratio cogeneration system at the Gifu Works (commissioned in 2004).

In spite of an increase in production, our total energy consumption in FY2004 remained the same as in FY2003 and an improvement was achieved in terms of management indicators.

(NOTE) For management of energy conservation efforts, we use total quantity of heat (TJ: terajoules), which represents the sum of electricity and thermal energy, as the measurement unit.

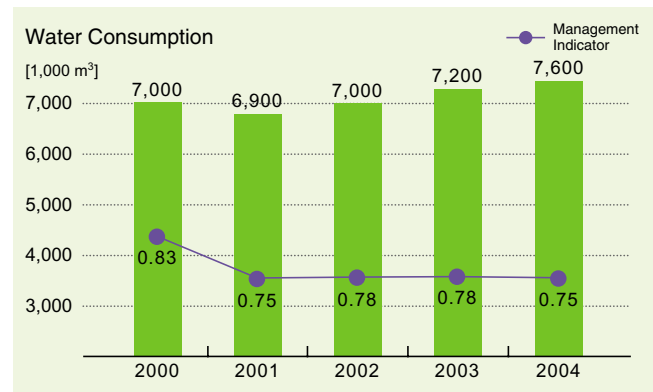
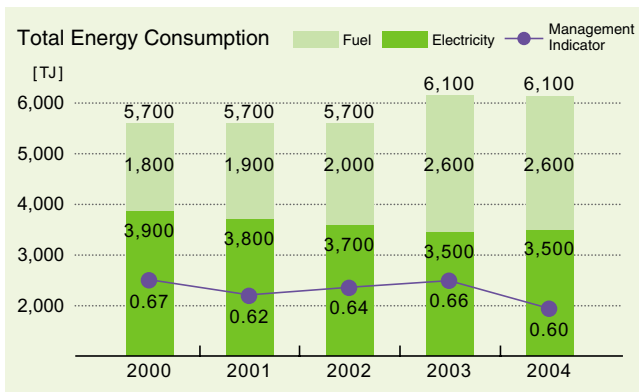

*Management Indicator: Total energy consumption, water consumption, and CO₂ emissions each divided by sales volume (including Kawasaki Shipbuilding Corporation and KPM).

Prevention of Global Warming

Through energy conservation, resource conservation and waste reduction efforts, our business divisions are performing effective activities and making investments in plants and equipment to decrease greenhouse gas emissions. These efforts improved our management indicator, but our overall CO₂ emissions increased by 14,000 tons due to electricity conversion factor increase by power utility companies in FY2004.

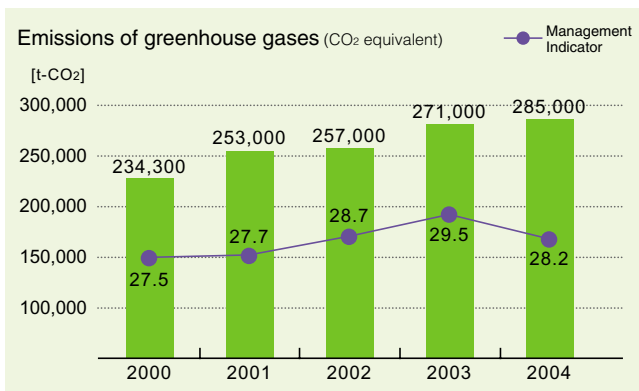

- Calculation of sulfur hexafluoride (SF₆) has been included since FY2001.
- Waste disposal subcontracted to outside agents has been excluded since FY2002.
- The electricity conversion factors employed are those specified by the power utility companies.
- Each fuel conversion factor is as specified in the Kawasaki guidelines.

Breakdown of Greenhouse Gas Emissions

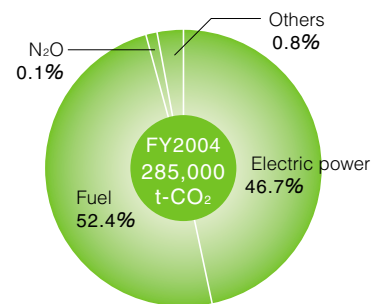

Steps toward Reducing Greenhouse Gas Emissions

1st step (2002 - 2004)

[Promotion of Cost-Effective Emission Reduction]

- Energy conservation and data analysis
- Review of reduction effects and cost effectiveness resulting from investments in plants and equipment
- Research on international trading

2nd step (2005 - 2007)

[Review of Possible Reductions, Costs, Effects, and Barriers]

- Determination of final reduction allotment
- Planning of credit trading system
- Determination of in-house standard for emission credit purchase cost

3rd step (2008 - 2012)

[Realization of 6% Reduction in Greenhouse Gases Relative to 1990 Level]

- Construction of in-house emission credit trading system

Waste Reduction

In March 2005, the Gifu Works, Nagoya Works 1, Nagoya Works 2 and Yachiyo Works declared the achievement of zero emissions. This means that all the works and offices of Kawasaki Heavy Industries (non-consolidated basis) achieved zero emissions.

The Zero Emissions Working Group, consisting of the representatives from works in the Kansai region, around Osaka and Kobe, was organized, in 2000, marking the beginning of our efforts to achieve zero emissions. Since then the group has investigated the statuses of waste occurrence, sorting methods, recycling methods and technologies, defined the problems to be solved and selected reliable recycling agents. By expanding development of these activities to the Kanto (around Tokyo) and Chubu (around Nagoya) regions, achievement of zero emissions was fulfilled during FY2004.

We will further enhance activities for alleviating environmental impacts by reducing amounts of wastes and improving recycling rates and product recyclability.

The two works of Kawasaki Shipbuilding Corporation have been making efforts to achieve zero emissions.

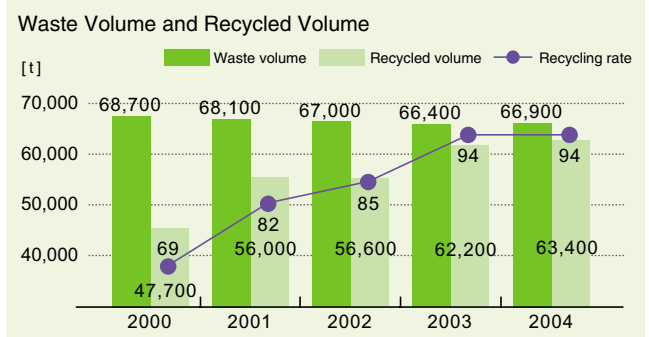

□ Achievement of Zero Emissions by Fiscal Year

2001	2002	2003	2004
Harima Works	Hyogo Works	Akashi Works	Gifu Works
Banshu Works	Kobe Head Office	Seishin Works	Nagoya Works 1
Nishi-Kobe Works		Kobe Works (Machinery Division)	Nagoya Works 2
			Yachiyo Works
		Tokyo Head Office	
		Tokyo Design Office	

Chemical Substance Reduction

Aiming to decrease the amounts of hazardous chemical substances handled and emitted by 2010, each Kawasaki works determined critical items and reduction targets and started activities necessary to achieve them. The Kawasaki Group will make efforts to fulfill the following targets:

- ① Decrease emissions of main volatile organic compounds (toluene, xylene, ethyl benzene) by 30%
- ② Decrease emissions of dichloromethane by 50%
- ③ Decrease the amounts of hazardous heavy metals (lead, hexavalent chromium, cadmium) handled (30% reduction targets for hexavalent chromium and cadmium)

□ Total of Chemical Substances Handled in FY2004

Unit of measurement: ton (unless otherwise indicated)

Gov. no.	Substance	Release into air	Release into public water area	Release into ground	Release subtotal	Transfer to public sewerage	Transfer as waste
[Type 1 Designated Chemical Substances]: 1,000 kg or more handled annually							
30	Bisphenol A	0	0	0	0	0	6.4
40	Ethyl benzene	235.4	0	0	235.4	0	6.0
43	Ethylene glycol	0	0	0	0	0	0.3
63	Xylene	640.9	0	0	640.9	0	52.5
67	Cresol	0	0.1	0	0.1	0	1.0
68	Chromium and its trivalent compounds	0.08	0.02	0	0.1	0	54.3
100	Cobalt and its compounds	0.001	0	0	0.001	0	0.5
101	2-ethoxyethyl acetate	1.3	0	0	1.3	0	0.7
108	Inorganic cyan compounds	0	0.006	0	0.006	0	0.3
145	Dichloromethane (Also known methylene chloride)	70.0	0.02	0	70.1	0.0001	5.2
177	Styrene	8.1	0	0	8.1	0	2.7
207	Water-soluble copper salts (other than complex salts)	0	0.04	0	0.04	0	0.3
224	1,3,5-trimethyl benzene	0.77	0	0	0.77	0	0.04
227	Toluene	231.4	0	0	231.4	0	55.8
230	Lead and its compounds	0	0	0	0	0	0.5
231	Nickel	0.002	0	0	0.002	0	0.7
266	Phenol	0	0.004	0	0.004	0	5.9
283	Hydrogen fluoride and its water-soluble salts	0.29	1.1	0	1.4	0	6.7
309	Poly (oxyethylene) = nonylphenyl ether	0	0.001	0	0.001	0	2.5
311	Manganese and its compounds	0.32	0	0	0.32	0	56.7
346	Molybdenum and its compounds	0.001	0	0	0.001	0	0.3
[Special Type 1 Designated Chemical Substances]: 500 kg or more handled annually							
69	Hexavalent chromium compounds	0	0.009	0	0.009	0	3.5
179	Dioxins (mg-TEQ)	4.8	0.1	0	4.9	0	0
232	Nickel compounds	0	1.0	0	1.0	0	4.1
299	Benzene	0.005	0	0	0.005	0	0

Coexistence with Communities

Firmly adhering to the belief that "enterprises must be members of their communities," we encourage all employees not only to abide by community rules but to also maintain firm commitments to information disclosure and to making positive contributions to their communities.

Contributions to Communities

BULL DOG Humanitarian De-mining System Takes a Great Step Toward Practical Use

More than 100,000,000 antipersonnel mines in minefields around the world cause over 20,000 casualties annually, including noncombatant citizens. This makes the prompt development of a safe and efficient de-mining system imperative.

We have been developing a reliable de-mining system and recently performed mine detection and removal by detonating and crushing them on real minefields in the demanding natural environment of Afghanistan. These tests showed this de-mining system's extremely high detection efficiency, de-mining performance and safety.

Our de-mining system consists of the MINE DOG, which is equipped with a mine detection sensor, the MINE BULL, which detonates and crushes antipersonnel mines and collects iron fragments, and the remote controllers for operating them. While traveling at a speed of 2 km/h, the MINE DOG detects and marks mines, efficiently performing mine detection over a wide area. The MINE BULL, traveling at a speed of 1.5 km/h, excavates mines with its digging drum, detonates and crushes them.

Based on the data obtained from the demonstration test in Afghanistan, and responding to requests from the UN and local NGOs that are committed to de-mining activities, we will improve our de-mining system so that it can be put to practical use in real minefields in the near future.



MINE BULL antipersonnel mine clearance vehicle



MINE DOG mine detection vehicle

Cooperation in Cleanup Activities Around the Canal at the Port of Kobe

Kobe, where many of our business bases are centered, is a clean and beautiful city. This condition is maintained by the volunteer activities of many citizens and volunteer groups including the Hyogo Canal Association, an organization of Kobe enterprises and citizens who want to maintain the pleasant environment of the canal. This canal was constructed at the end of the 19th century and has played an important role in the development of the Port of Kobe. We have also been using this canal for transportation of rolling stock, and other products.

As a company based in Kobe, the Hyogo Works has been an active participant in the cleanup activities of this association.



Cleanup on the Kiyomori Bridge that spans the Hyogo Canal



Cleanup campaign banner raised along the canal

Personal Watercraft Users Clean Toné River Flood Plain

Several hundred personal watercraft (PWC) users who enjoy recreation at the Great Toné Weir in Gunma Prefecture have been committed to cleanup activities for the past several years in cooperation with local people who had been annoyed by illegally discarded refuse. They not only participate in the river cleanup program held twice a year by local authorities but also voluntarily gather refuse from the flood plain. In the early days of this activity, the number of volunteers was about 60, but now, more than 100 volunteers participate in the program, including users of Kawasaki Jet Skis.

To honor these activities, Letters of Appreciation were issued by the Ministry of Land, Infrastructure and Transportation of Japan and the Upper Toné River Users Association.



PWC users gathering on the flood plain



Letter of appreciation presentation ceremony

Gifu Works Supports Reforestation Efforts

In 2002, there was a large-scale forest fire outbreak in Kakamigahara City where the Gifu Works is located, and many trees and plants over an area of 160 hectares were destroyed. The Kakamigahara City Government has been proceeding with a reforestation project to restore the trees and plants in the fire-ravaged area. More than a hundred of the Gifu Works employees participated in a tree planting ceremony held in February 2005.

On this occasion, our employees, worked together with several thousand people to plant approximately 15,300 saplings of 25 species, including oaks, selected to suit the vegetation of the original forest to help restore the natural landscape. These employees are planning to foster the healthy growth of these saplings.



Happy atmosphere during reforestation efforts

Employees Volunteer in Beach Cleanup Activities

Since Kawasaki was founded as a shipbuilder, the sea is very special for us. For this reason, our employees have been voluntarily taking part in beach cleanup activities.

In 2004, the largest number of typhoons ever recorded in Japanese meteorological history struck the Japanese archipelago. As a result, a surprisingly large amount of refuse from rivers drifted ashore. The scale of beach cleanup activities this year became large, but we also enjoyed a sense of great achievement afterwards.



Seto Inland Sea (Suma Beach)



Japan Sea (Oura Beach)

Fully Committed to Providing Disaster Relief

We are fully prepared to do our utmost as a corporate citizen in local communities for relief work in the event of large-scale disasters. If a corporation is to remain reliable as an organization after the occurrence of a disaster, it must be capable of verifying the safety of its employees and their family members so that it can mobilize them for volunteer activities. For this reason, the Kawasaki Group developed a Safety Confirmation System that uses the Internet and telephone networks. We also performed disaster relief trainings in January 2005 with domestic group companies on the 10th anniversary of the 1995 Kobe Earthquake.

The Kawasaki Group produces a variety of products including helicopters, construction machinery and motorcycles. Immediately after that great earthquake 10 years ago, we offered four Kawasaki manufactured helicopters along with pilots for use by Hyogo Prefecture and Kobe City. We also offered our heliports and the grounds of our works and actively transported relief materials. In addition, we offered 10 motorcycles with riders to the Hyogo Prefectural Government and 40 motorcycles to the Hyogo Prefectural Police. These motorcycles greatly contributed to personnel transportation and liaison purposes when the roads and streets were impassable to ordinary 4-wheeled cars. Furthermore, we provided three

wheel loaders and various crushing equipment to the Kobe City Government for rubble clearance. These pieces of equipment were also very useful for the restoration efforts that followed.

Learning from these experiences with disaster and restoration activities, we, members of the Kawasaki Group, want to contribute to the creation of a society that is resilient against disasters by utilizing the comprehensive technology and expertise that we have cultivated through development of products for land, sea and air.



Wheel loader Model 60ZV



On-road/off-road model Super SHERPA

Compliance Management

We recognize that antisocial conduct can endanger the very existence of a corporation, so we are vigorously pursuing compliance management. Kawasaki's corporate policy has always been that no employee shall ever be involved in any unlawful activities.

As one concrete implementation of this policy, in June 2003, we established the Compliance Reporting and Consultation Program. This program enables employees who become aware of any potential compliance violation within the company to report such violation to an outside counsel. The outside counsel then forwards this information to the in-house Compliance Committee, which, if deemed necessary, will form an in-house investigation team to investigate the reported issues. If the Compliance Committee determines that there was a compliance violation, then it will take appropriate action to deal with it.

The Compliance Guidebook, which outlines the system and introduces examples of violations, has been developed and distributed to all employees.



In this day and age, it is critical that employees of every level within the company have a strong ethical standard. To achieve this goal, we are always striving to create an open and frank working environment where employees can speak out and openly discuss matters related to work which trouble them with their superiors. To further this effort, we have established this Compliance Reporting and Consultation Program.

Flowchart for Reporting and Consultation

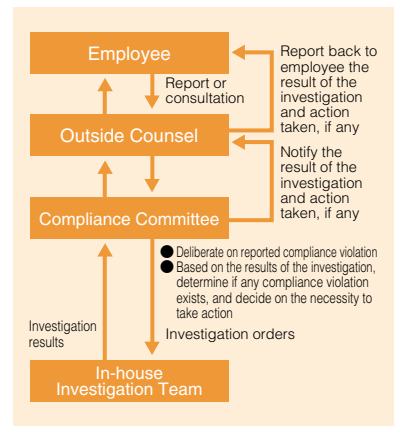

Information Disclosure and Environmental Communications

We have been disclosing information about our environmental management activities and environmental protection activities through our Environmental Reports, which have been issued since 1999, as well as our

web page and various other media.

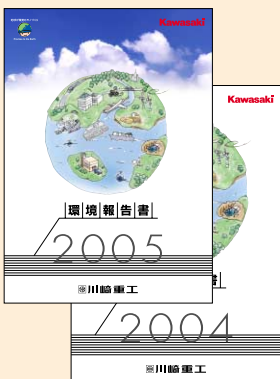

Environmental Report



Annual Report

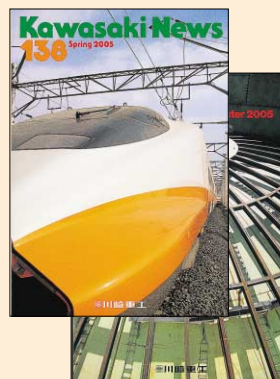

Kawasaki News



Kawasaki Scope

Relations with Employees

Fundamental Principles of Personnel Management

We think that the purpose of our existence is to create value for a better society. We believe that employees are the driving force to create such value and that the company is a place both to earn a living and to achieve self-realization for them. For this reason, giving employees "a sense of both the value of life and the value of work" is a guiding principle for our personnel management.

In order to create high value and provide it to society, all employees must fully utilize and further develop their abilities, and fulfill their individual roles so that the whole organization can make full use of our strengths.

To realize this in practice, we have established various personnel management systems, adopting "maximize use of personal abilities," "develop individual abilities," and "bring everyone's power together" as key phrases that express our personnel management principles.

Personnel management framework

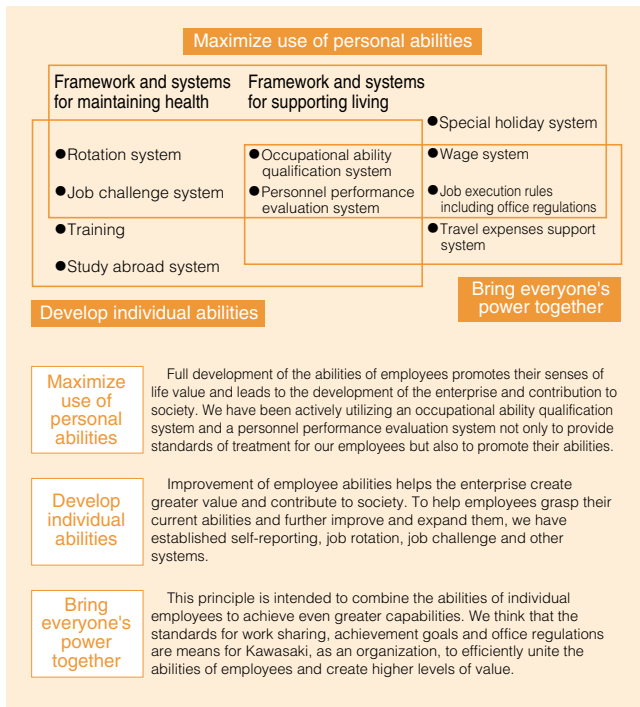

Personnel affairs system

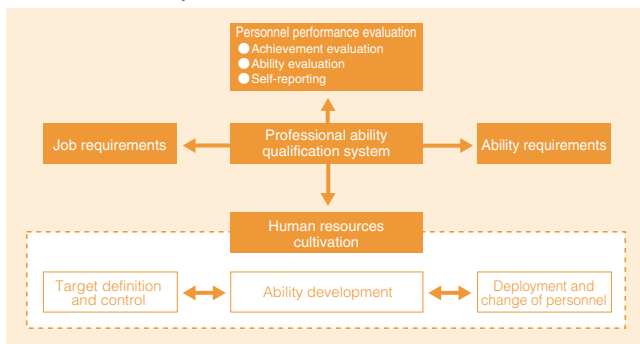

Policy for Human Resources Cultivation

In order for any enterprise to be able to grow and develop, it must cultivate and activate people who can develop concrete ideas to achieve objectives and act appropriately. We believe that the basis of development of an enterprise lies in its human resources and that human resources are cultivated through job execution. We have established human resources policies according to the following guidelines.

1. Human resources are cultivated in order to help corporate performance develop and contribute to employee ability improvement and "sense of life value."
2. The basic means for human resource cultivation are on-the-job-training, self-education and rotation.
3. Line managers are responsible for the cultivation of human resources on their lines.
4. Human resource cultivation needs to be tailored and conducted continuously in a planned manner for each individual employee.
5. Opportunities for ability development are provided to every employee from the time of joining Kawasaki to retirement.

Career design concept

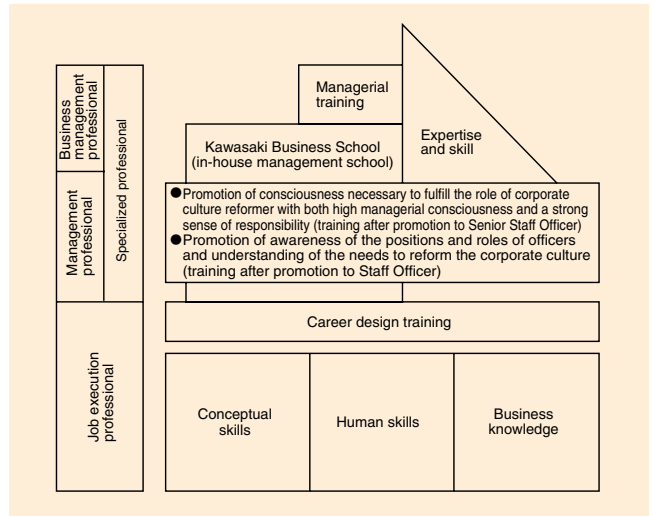

Major Efforts

Job challenge system

Our job challenge system is a scheme for reassigning employees through internal job postings. This system allows aggressive employees to be reassigned promptly to an important or newly launched division, and allows each employee to select favorite tasks, thereby improving their motivation.

Specifically, after a division that wants new personnel makes an application, the job announcements for that division are posted in the house magazine and on our intranet. In FY2004, a total of 14 employees were transferred to new divisions through the job challenge system.

Freedom from sexual harassment

In order to create environments where all employees enjoy working, it is vital to prevent the occurrence of sexual harassment and to provide an atmosphere where every employee respects the unique characters of other employees.

Kawasaki has a strict ban on sexual harassment in its office regulations. We also attempt to prevent occurrence of sexual harassment by providing basic knowledge about prevention and presenting case studies about sexual harassment through various means, including our intranet and house magazine. Furthermore, to cope with possible sexual harassment cases, we have designated a special division where any employee can seek advice while remaining anonymous.

Industrial Safety and Hygiene

In order to ensure the safety and health of our employees and subcontractor employees and provide a comfortable work environment, we are committed to safety and hygiene promotion activities based on our philosophy of respect for people, which includes respect not just for human life but also for the humanity of each individual.



Implementation of Labor Safety, Health and Hygiene Management Based on our New First Corporate-Wide Safety and Hygiene Three-Year Plan

We developed our New First-Phase Corporate-Wide Safety and Hygiene Three-Year Plan in order to convert from conventional safety and hygiene management that emphasizes following and enforcing rules to one in which every person is intentionally committed to safety and hygiene activities.

This year marks the first fiscal year of a three-year plan. We have therefore set up important corporate-wide policies about safety and hygiene management as summarized below. All our offices and works are executing relevant safety and hygiene management activities in accord with these important policies.

Safety Management

To promote safety, we are committed to safety management activities for the following four important corporate-wide management policies.

1. Returning to the starting point, we review the status of observation of labor safety and hygiene related laws and regulations, as well as in-house rules.
2. All workers assess the possible risks in the execution of their tasks and make corrections and improvements for items where safety scores are low, so that the safety of all workers in task execution is improved.
3. In order to improve the working environments of entire job sites and eliminate unsafe conditions, risks are assessed for all the machines and equipment at the job sites in a manner identical to risk assessments associated with task execution.
4. Accident prevention measures are enhanced for employees of affiliates and subcontractors.

Health Management

On the issue of employee health, an important factor is that employees are getting older on average, which is the general trend in Japanese society, and the frequency and severity of lifestyle-related diseases are increasing. At the same time, mental health issues are posing greater problems for our employees, their family members and even the company.

To address this situation, we are performing health management activities with the following three items as important corporate-wide management policies.

1. Enhance countermeasures against lifestyle-related diseases
2. Enhance measures for promotion of mental health
3. Enhance countermeasures against occupational illnesses

We are going to promote activities for these policies based on the following basic policies and specific measures.

Accident Occurrence Trend

Since the introduction of our Labor Safety and Hygiene Management System in FY2002, we have been committed to improving safety and hygiene levels and preventing labor accidents.

We have also been continuing our KSKY Campaign to prevent the occurrence of accidents.

K: "Kihon rule," basic rule observation activities; S: "Shisa-kosho," pointing out and identifying sources of danger activities; KY: "Kiken-yochi," hazard prediction activities

Accident Occurrence Rate Trend (only accidents that led to suspension of operation)

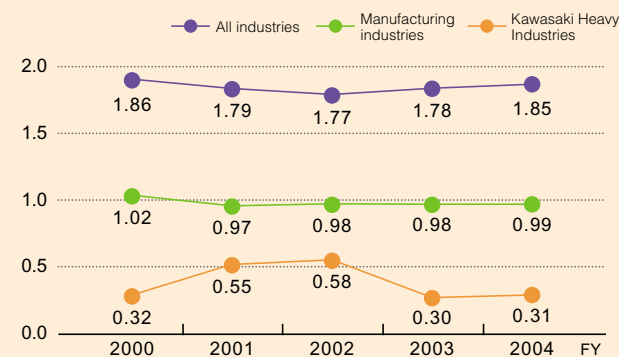

* Per 1,000,000 hours

Countermeasures against Lifestyle-Related Diseases

《Concrete measures》

- Execution of periodic medical examinations and efficient post-medical examination health guidance and follow-up
 - Implementation of THP programs, including Lifestyle Improvement Classes, run by three parties – Kawasaki Heavy Industries, *Kawaju Kenko Hoken Kumiai* (KHI health insurance cooperative), and the *Kawaju Rodo Kumiai* (KHI labor union).
- THP: Total Health Promotion

Mental Health Promotion

《Basic policies》

- Early detection and efficient treatment
- Thorough support for returning to work
- Promotion of healthy job environments

Occupational Illness Prevention

《Basic policies》

- Prevention of occurrence of new cases
- Prevention of worsening of existing patient conditions

We have developed the Health KY Card that provides useful tips for improving health on job sites and at homes, and have distributed it to all Kawasaki Group employees.



Environmental Data

In our work to reduce environmental impacts, we are promoting energy conservation, the prevention of global warming, waste reduction, and chemical substance reduction. The table below summarizes the energy and resource inputs and outputs associated with our FY2004 business activities by internal companies and major affiliates. Information about the environmental impacts and products of our major production works is given on pages 29 and 30.

Internal Companies/Affiliates

- * 1. Performance items in the table below were taken from State of Activities for Reduction of Environmental Impact contained in the Environmental Reporting Guidelines of the Ministry of the Environment in Japan. Environmental data is given in the horizontal direction for internal companies as well as for a single group consisting of the Head Offices, branch offices and the Corporate Technology Division.
- * 2. The discharge concentration of regulated substances and the generation of noise, vibrations and odors are listed as "Compliant" or "Not Compliant."
- * 3. "-" shows that data was unavailable. "0" means the measured data was zero.
- * 4. "Not applicable" means there were no regulated facilities that caused environmental impacts of this type.
- * 5. Data in [] is the percentage of increase/decrease from the performance data of the previous year and is provided only where last year's data was available.

Performance Items *1		Units	Rolling Stock & Construction Machinery Company	Aerospace Company	Gas Turbines & Machinery Company	
Environmental Impacts from Material/Energy Input	Total material input: Metals (steel, aluminum, copper, etc.)	ton	58,043	8,783	21,961	
	Recycled material amount	ton	5,130	0	0	
	Total energy consumption	Electricity	TJ	491	647	518
		Fuel	TJ	147	584	531
		Total	TJ	637	1,231	1,048
	Renewable energy consumption	TJ	0	0	0	
	Water consumption	m ³	602,487	4,018,757	526,162	
	Recycled water amount	m ³	0	88,530	0	
	Recycled resource and recycled parts input	ton	0	0	0	
	Amount of hazardous material handled	ton	1,997.5	115.7	27.0	
Upstream Environmental Impacts						
Environmental Impacts from Output of Refuse	Green purchasing	1 million yen	18	276	18	
	Greenhouse gas emissions	t-CO ₂	27,149	65,341	51,305	
	Ozone depleting substance emissions	ODP ton	0	0	0	
	SOx emissions	ton	5.1	4.2	4.2	
	NOx emissions	ton	5.1	34.6	75.3	
	Soot and dust emissions	ton	0.87	0.39	0.65	
	VOCs emissions	ton	169.6	152.0	19.2	
	PRTR regulated substance emissions	ton	169.9	64.2	19.2	
	Concentration of restraint substances when emitted	SOx	PPM	Compliant *2	Compliant *2	Compliant *2
		NOx	PPM	Compliant *2	Compliant *2	Compliant *2
		Dust	g/m ³ N	Compliant *2	Compliant *2	Compliant *2
		Dioxins	ng/m ³ N	Not applicable *4	Not applicable *4	Not applicable *4
		Benzene	mg/m ³ N	Not applicable *4	Not applicable *4	Not applicable *4
	Noise and vibration	dB	Compliant *2	Compliant *2	Compliant *2	
	Odor	m ³ /min	Compliant *2	Compliant *2	Compliant *2	
	Emissions to "Water and Soil"	Total amount of drainage	m ³	276,483	2,239,580	127,884
		PRTR regulated substance discharge	ton	0	0.3	0
		COD discharge	ton	0.5	8.6	0.05
		Nitrogen discharge	ton	0.8	15.1	0.03
		Phosphorus discharge	ton	0.04	0.18	0.002
Density of emissions of substances under drainage control		mg/L	Compliant *2	Compliant *2	Compliant *2	
Emissions of Wastes	Total amount of wastes	ton	12,380	3,726	4,909	
	Reused resources	ton	5,176	2,052	1,078	
	Recycled resources	ton	6,745	1,056	3,522	
	Resources subject to thermal energy recovery	ton	423	388	279	
	Amount of wastes incinerated	ton	0	0	0	
	Final disposal wastes	ton	35	5	24	
	Waste reduction by intermediate treatment	ton	0	225	6	
	Specially controlled industrial waste	ton	96.4	184.4	0.2	
	PRTR substance transfer	ton	140.8	37.1	2.7	
Downstream Environmental Impacts						
Environmental impact caused by product characteristics			P13—20	P13—20	P13—20	
Production and sale of environmental impact reducing products			— *3	— *3	— *3	
Environmental Impacts from Transportation	CO ₂ emissions during transport	t-CO ₂	9	339	51	
	NOx emissions during transport	ton	0.07	1.67	0.59	
	Number of eco-vehicles introduced	unit	0	6	6	

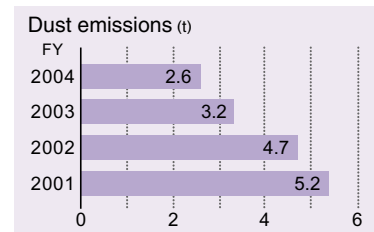
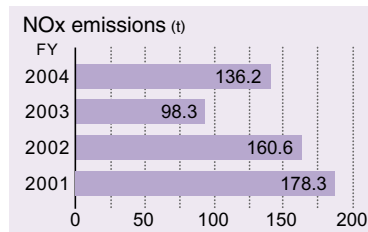
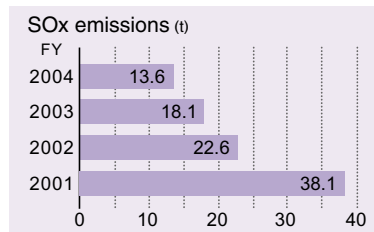

Plant & Infrastructure ★ Engineering Company	Consumer Products & Machinery Company	Head Offices, Branch Offices & Corporate Technology Division	Kawasaki Shipbuilding Corporation	Kawasaki Precision Machinery Ltd. (KPM)	Total	Comparison with Previous Year *5
31,216	172,610	98	171,676	29,309	493,696	[+5.8%]
0	725	0	1,497	0	7,352	
131	760	88	557	300	3,490	[0%]
26	681	45	354	202	2,570	[+3.5%]
157	1,441	133	911	502	6,060	[+1.5%]
0	0	0	0	0	0	
92,291	1,208,437	69,883	872,384	225,586	7,615,987	[+6.4%]
30,222	30,234	0	34,425	22,831	206,242	[−42.2%]
25	0	0	0	0	25	[+150%]
26.7	614.9	0	927.8	41.7	3,751.3	[+25.3%]
461	189	17	9	32	1,021	[−13.8%]
6,270	63,180	5,494	44,712	21,391	284,842	[+4.4%]
0	0	0	0	0	0	
0	0.1	— *3	0.03	0.02	13.6	[−25.2%]
0.3	10.2	— *3	0.2	10.5	136.2	[+38.5%]
0	0.54	— *3	0.03	0.09	2.57	[−19.3%]
25.5	138.1	— *3	1,113.1	34.1	1,651.6	
24.9	138.1	0	738.1	34.1	1,188.6	[+8.5%]
Compliant *2	Compliant *2	Not applicable *4	Compliant *2	Compliant *2	Compliant *2	
Compliant *2	Compliant *2	Not applicable *4	Compliant *2	Compliant *2	Compliant *2	
Compliant *2	Compliant *2	Not applicable *4	Compliant *2	Compliant *2	Compliant *2	
Not applicable *4	Compliant *2	Not applicable *4	Not applicable *4	Not applicable *4	Compliant *2	
Not applicable *4	Not applicable *4	Not applicable *4	Not applicable *4	Not applicable *4	Not applicable *4	
Compliant *2	Compliant *2	Not applicable *4	Compliant *2	Compliant *2	Compliant *2	
Compliant *2	Compliant *2	Not applicable *4	Compliant *2	Compliant *2	Compliant *2	
26,145	639,288	0	114,939	68,457	3,492,776	
0	2.0	— *3	0	0	2.4	[−20.9%]
0.09	5.3	0	1.3	0.5	16.3	[−1.4%]
0.3	10.7	— *3	1.0	0.8	28.7	
0.05	0.34	— *3	0.32	0.11	1.04	
Compliant *2	Compliant *2	Compliant *2	Compliant *2	Compliant *2	Compliant *2	
4,178	14,992	361	22,582	3,803	66,929	[+0.8%]
3,275	4,418	154	16,733	522	33,408	
504	9,355	115	2,542	3,070	26,909	[+1.9%]
399	1,184	83	123	210	3,089	
0	0	0	2,023	0	2,023	[−3.8%]
0	36	10	1,160	0	1,270	[−39.6%]
0	0	0	0	0	231	
0	606.8	22.6	89.2	25.2	1,024.9	[−1.2%]
1.8	40.2	0	36.8	7.6	267.0	[+8.7%]
P13—20	P13—20	P13—20	P13—20	P13—20	P13—20	
— *3	— *3	— *3	— *3	— *3	— *3	
388	20	2	0	0	810	
2.44	0.14	0	0	0	4.91	
8	10	0	0	0	30	[−44.4%]

★ Plant & Infrastructure Engineering Company: The Environmental Division and Steel Structure Division are under direct control of the Head Office, while the Power Plant Division became an independent company, Kawasaki Plant Systems, in April 2005.

Production Base

Gifu Works
(including Nagoya Works 1 and Nagoya Works 2)

Major products: aircraft (including helicopters), spacecraft, aviation-related facilities and equipment
Address: 1 Kawasaki-cho, Kakamigahara, Gifu 504-8710 Japan



BK117 C-2 helicopter

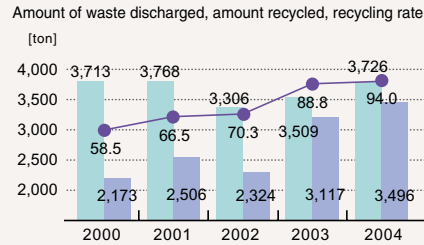
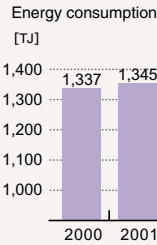

Amount released into the atmosphere (ton)

SOx	4.2
NOx	34.6
Dust	0.39

Amount released into public water (ton)

COD	8.6
Nitrogen	15.1
Phosphorus	0.18

Kobe Works
(including Kawasaki Shipbuilding Corporation)

Major products: marine vessels, offshore structures, submarines, land and marine turbines, diesel engines
Address: 3-1-1 Higashikawasaki-cho, Chuo-ku, Kobe, Hyogo 650-8670 Japan



Two-cycle marine diesel engine

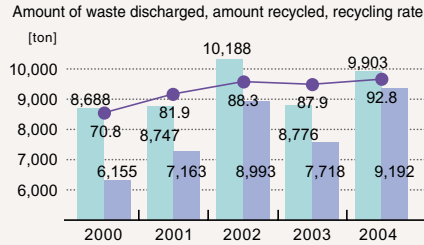
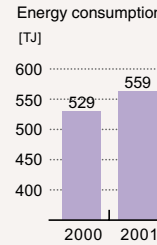

Amount released into the atmosphere (ton)

SOx	4.2
NOx	75.3
Dust	0.7

Amount released into public water (ton)

COD	0.05
Nitrogen	0.03
Phosphorus	0.002

Hyogo Works

Major products: rolling stock, automated guideway transport, platform doors
Address: 2-1-18 Wadayamadori, Hyogo-ku, Kobe, Hyogo 652-0884 Japan



Magnetically levitated linear motor-driven high-speed train (for JR)

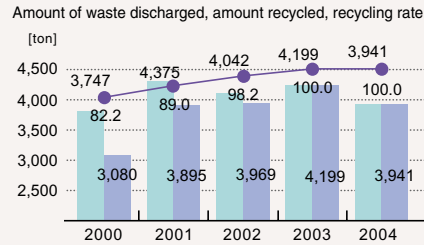
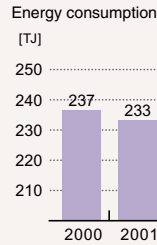

Amount released into the atmosphere (ton)

SOx	0.004
NOx	0.8
Dust	0.02

Amount released into public water (ton)

COD	0.07
Nitrogen	0.03
Phosphorus	0.004

Akashi Works
(including Seishin Works)

Major products: motorcycles, robots, jet engines, general-purpose gas turbines
Address: 1-1 Kawasaki-cho, Akashi, Hyogo 673-8666 Japan



Ninja ZX-10R

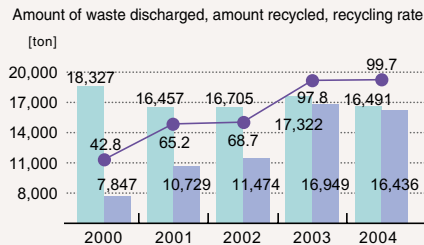
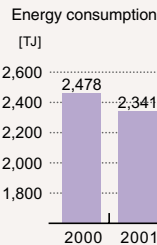

Amount released into the atmosphere (ton)

SOx	0.1
NOx	10.2
Dust	0.5

Amount released into public water (ton)

COD	5.3
Nitrogen	10.7
Phosphorus	0.34

Banshu Works

Major products: construction machinery, cargo handling machinery
Address: 2680 Oka, Inami-cho, Kako, Hyogo 675-1113 Japan



Wheel loader

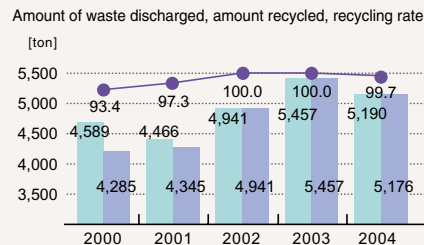
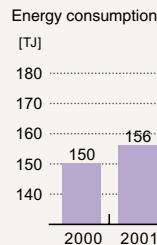

Amount released into the atmosphere (ton)

SOx	0
NOx	0
Dust	0

Amount released into public water (ton)

COD	0.4
Nitrogen	0.5
Phosphorus	0.005

Harima Works

Major products: plants, environmental protection facilities, boilers, construction machinery, steel structures
Address: 8 Nijima, Harima, Kako, Hyogo, 675-0155 Japan



Detachableslurry triple station shield machine

Energy consumption

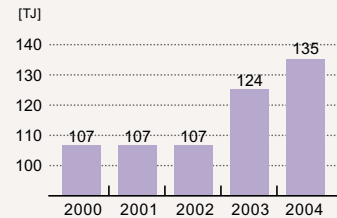

Amount of waste discharged, amount recycled, recycling rate

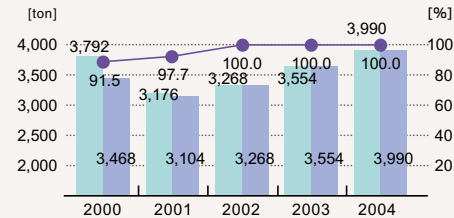

Amount released into the atmosphere (ton)

SOx	0
NOx	0.3
Dust	0

Amount released into public water (ton)

COD	0.09
Nitrogen	0.3
Phosphorus	0.05

Sakaide Works (Kawasaki Shipbuilding Corporation)

Major products: marine vessels, marine equipment (LNG/LPG carriers, container ships, oil drilling rigs, etc.)
Address: 1 Kawasaki-cho, Sakaide, Kagawa 762-8507 Japan



LNG carrier

Energy consumption

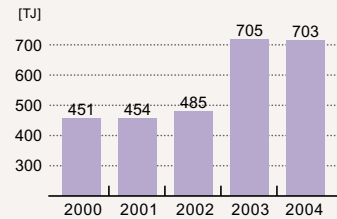

Amount of waste discharged, amount recycled, recycling rate

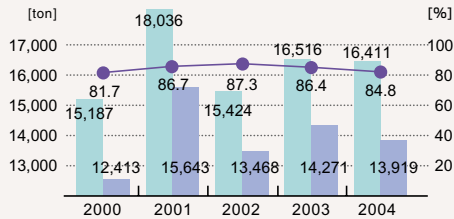

Amount released into the atmosphere (ton)

SOx	0.03
NOx	0.2
Dust	0.03

Amount released into public water (ton)

COD	1.3
Nitrogen	1.0
Phosphorus	0.32

Nishi-Kobe Works (Kawasaki Precision Machinery Ltd.)

Major products: industrial hydraulic devices, marine machinery, precision equipment/devices
Address: 234 Matsumoto, Hasetani-cho, Nishi-ku, Kobe, Hyogo 651-2239 Japan



Hydraulic equipment

Energy consumption

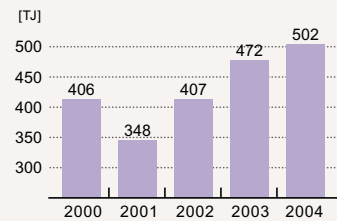

Amount of waste discharged, amount recycled, recycling rate

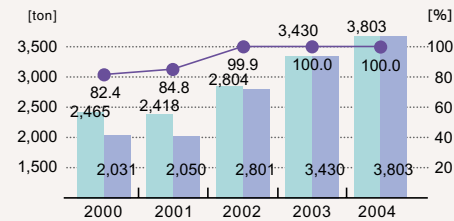

Amount released into the atmosphere (ton)

SOx	0.02
NOx	10.5
Dust	0.09

Amount released into public water (ton)

COD	0.5
Nitrogen	0.8
Phosphorus	0.11

Yachiyo Works

(became Earth Technica Co., Ltd., an independent company, in April 2005.)

Major products: RPF production facilities, crushers, pulverizers, cast steel products, cast iron products
Address: 1780 Kamikoya, Yachiyo, Chiba 276-0022 Japan



RPF (fuel derived from solidified waste paper and plastic) production facilities

Energy consumption

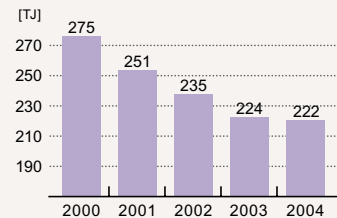

Amount of waste discharged, amount recycled, recycling rate

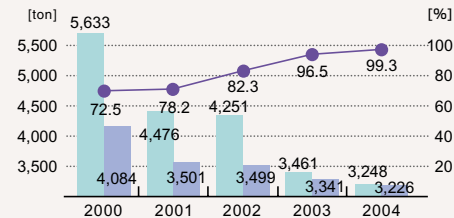

Amount released into the atmosphere (ton)

SOx	5.1
NOx	4.3
Dust	0.9

Amount released into public water (ton)

COD	0.07
Nitrogen	0.3
Phosphorus	0.04

Editor's Note: Kawasaki joined Team Minus 6%, an environmental movement supported by the Japanese government, in June 2005.



Stop global warming together

Team Minus 6%

About Team Minus 6%

HOME > About Team Minus 6% > I am Team Minus 6% > List > Details

I am Team Minus 6%.

Team member No. [213]

Kawasaki Heavy Industries, Ltd. Chairman **Masamoto Tazaki**



Through developing technologies to protect the global environment and supply environmentally conscious products, Kawasaki will contribute to the sustainable development of society. At the same time, with the "think globally, act locally" spirit, we will continue to maintain environmentally conscious business activities and routine activities with a global viewpoint.

http://www.team-6.jp/about/people_detail_09.html#213

This is an abridged translation. The original is in Japanese only.

Global Network

● Overseas office ● Overseas affiliate (sales) ● Overseas affiliate (production)

- 1 Seoul Office
- 2 Beijing Office
- 3 Shanghai Office
- 4 Taipei Office
- 5 Bangkok Office
- 6 Kuala Lumpur Office
- 7 Jakarta Office
- 8 Kawasaki do Brasil Indústria é Comércio Ltda.
- 9 Kawasaki Heavy Industries (Europe) B.V.
- 10 Kawasaki Heavy Industries (H.K.) Ltd.
- 11 Kawasaki Heavy Industries (Singapore) Pte. Ltd.
- 12 Kawasaki Heavy Industries (U.S.A.), Inc.
- 13 Kawasaki Heavy Industries (U.S.A.), Inc. (Houston Branch)
- 14 Kawasaki Heavy Industries (UK) Ltd.
- 15 KHI Europe Finance B.V.
- 16 KHI (Dalian) Computer Technology Co., Ltd.

- 17 Kawasaki Gas Turbine Europe G.m.b.H.
- 18 KHI Design & Technical Service Inc.
- 19 Canadian Kawasaki Motors Inc.
- 20 Kawasaki Machine Systems Korea, Ltd.
- 21 Kawasaki Motors Germany Branch
- 22 Kawasaki Motors (Phils.) Corporation
- 23 Kawasaki Motors Corp., U.S.A.
- 24 Kawasaki Motors Europe N.V.
- 25 Kawasaki Motors France Branch
- 26 Kawasaki Motors Italy Branch
- 27 Kawasaki Motors Sweden Branch
- 28 Kawasaki Motors Pty. Ltd.
- 29 Kawasaki Motors U.K. Branch
- 30 Kawasaki Robotics (U.S.A.), Inc.
- 31 Kawasaki Robotics (UK) Ltd.
- 32 Kawasaki Robotics G.m.b.H.

- 33 P.T. Kawasaki Motor Indonesia
- 34 Kawasaki Motors Enterprise (Thailand) Co., Ltd.
- 35 Kawasaki Rail Car, Inc.
- 36 Kawasaki Construction Machinery Corp. of America
- 37 Nantong Cosco KHI Ship Engineering Co., Ltd.
- 38 Wuhan Kawasaki Marine Machinery Co., Ltd.
- 39 Kawasaki Precision Machinery (UK) Ltd.
- 40 Kawasaki Motors Manufacturing Corp., U.S.A. (Maryville Plant)
- 41 Kawasaki Motors Manufacturing Corp., U.S.A. (Lincoln Plant)
- 42 Kawasaki Motors (Phils.) Corporation
- 43 P.T. Kawasaki Motor Indonesia
- 44 Kawasaki Motors Enterprise (Thailand) Co., Ltd.
- 45 Kawasaki Aeronáutica do Brasil Indústria Ltda.

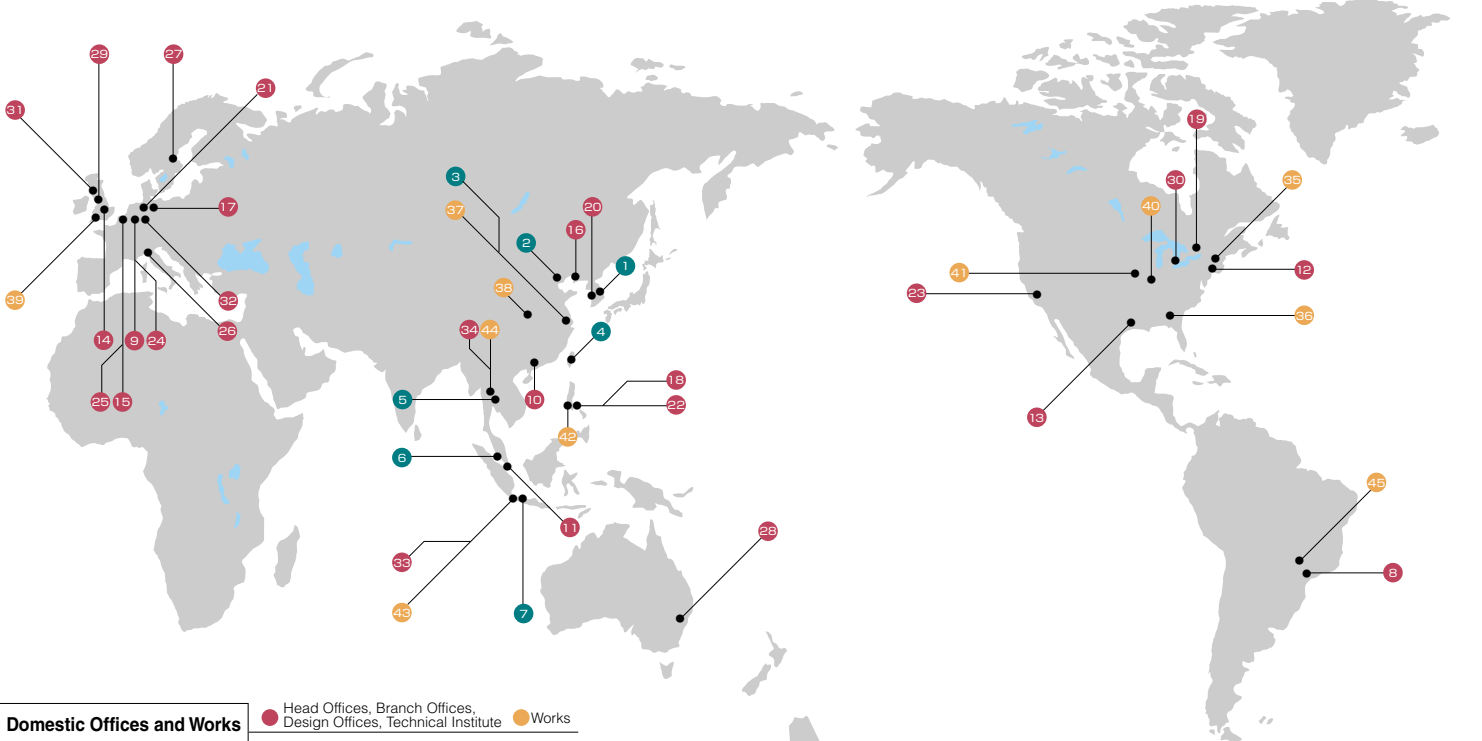

Domestic Offices and Works

● Head Offices, Branch Offices, Design Offices, Technical Institute ● Works

- 1 Kobe Head Office
- 2 Tokyo Head Office
- 3 Tokyo Design Office
- 4 Akashi Technical Institute
- 5 Sapporo Office
- 6 Sendai Office
- 7 Nagoya Office
- 8 Osaka Office
- 9 Hiroshima Office
- 10 Shikoku Office
- 11 Fukuoka Office
- 12 Okinawa Office
- 13 Yachiyo Works
- 14 Gifu Works
- 15 Nagoya Works 1
- 16 Nagoya Works 2
- 17 Kobe Works
- 18 Hyogo Works
- 19 Nishi-Kobe Works
- 20 Seishin Works
- 21 Akashi Works
- 22 Banshu Works
- 23 Harima Works
- 24 Sakaide Works

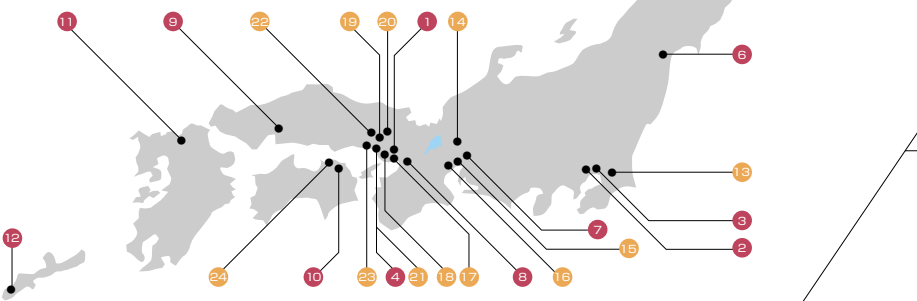

Kawasaki Heavy Industries, Ltd.

Environmental Management Dept.

- Kobe Crystal Tower, 1-3 Higashikawasaki-cho 1-chome, Chuo-ku, Kobe 650-8680 Japan
- Phone: 81-78-371-9542 ● Fax: 81-78-360-8700
- Kawasaki Web Site <http://www.khi.co.jp/earth/english/index.html>
- E-mail: webecocenter@khi.co.jp



Printed on 100% recycled paper



Printed with aroma-free soy ink.