



**TURISMO**

Mercedes-Benz Sprinter

**OWNER'S MANUAL**

**[WWW.GRECHRV.COM](http://WWW.GRECHRV.COM)**

# INTRODUCTION

## Dear Grech RV Owner,

Thank you for purchasing a Grech RV product. Your decision to own a true luxury vehicle is what drives our efforts every day and we appreciate your vote of confidence. A substantial investment has been made and we want to insure that your experience is priceless.

Welcome to the exciting world of RV travel and camping, with all the comforts of home with you, while you travel and enjoy the outdoors. We want the experience with your new RV to be enjoyable.

It is important to carefully read and understand this manual to assure yourself and your loved ones one of the best possible experiences. To accomplish this, we recommend to take the time to become fully acquainted with the vehicle before ever taking it on the open road.

Your RV has been designed and manufactured to enhance your travel and camping experience and to provide you with safe, efficient and trouble-free operation.

### OWNER'S MANUAL

An RV is a unique specialty vehicle which requires several new skills in order to maintain safe driving conditions at all times. Motor Homes include systems that can be dangerous if not completely understood and mastered.

In this Owner's Manual you will find several suggestions and information that will make your ownership a long and enjoyable one! This manual's main objective is to serve as a reference document for the operations and maintenance procedures that will be required throughout the life of your vehicle.

It contains vital information used to identify your specific vehicle and the safety features that must be understood and followed in order to operate this vehicle safely. This manual is not intended to serve as a maintenance manual. It provides the basic procedures, along with a comprehensive overview of your new motor home's operating systems.

There are many safety notices that appear throughout the manual that alert you to items that require your attention and/or understanding to assure the safety of you and your passengers as well as other drivers on the road. We urge you to take the time to completely understand your RV, so you can drive with confidence as you explore new places with family and friends.

The information contained in this document is intended to reflect standard and optional equipment included in a typically equipped model at the time of delivery to the initial retail owner. In the case that you are not the initial retail owner of the unit, this document will not reflect modifications that may have been performed by previous owners.

It is the policy of **GRECH RV**, to incorporate product improvements whenever possible or practical to do so. We reserve the right to make changes and or improvements at any time without incurring any obligation to make such changes on previously sold products. The information and specifications contained in this manual are subject to change at any time, without notice.

If there is any question or doubts regarding what is written and disclosed in this handbook for your RV feel free to call Grech RV at **(855)-994-GRECH (7324)**.

In the event that you require any type of service concerning any difficulty with the RV be sure to have your Vehicle Identification Number (VIN) and mileage available before you call.

©Copyright GRECH RV. All rights reserved. All other trademarks or registered trademarks are property of their respective holders. Brand name products of other companies mentioned in this manual are not endorsed by the manufacturer of the RV.



# NOTICES & DISCLAIMERS

The information and specifications contained in this manual are current at time of printing. Subsequently, **all information contained in this manual is subject to change at any time, without notice.** Please note that this manual applies to the **RV TURISMO 144"** and explains standard equipment as well as many options and may include equipment not presently installed on your vehicle.

## NOTICE

For your safety and the safety of others, we ask that you completely familiarize yourself with this manual, and all other operators manuals before you operate this vehicle for the first time.

**PLEASE NOTE:** Updates to all manuals are online at [www.grechrv.com](http://www.grechrv.com)

## WARNING

- Breathing diesel engine exhaust exposes you to chemicals (engine exhaust, carbon monoxide, phthalates, and lead) known to the State of California to cause cancer and birth defects or other reproductive harm.
- Wear gloves or wash your hands frequently when servicing your vehicle.
- Always start and operate the engine in a well-ventilated area.
- If in an enclosed area, vent the exhaust to the outside.
- Do not modify or tamper with the exhaust system.
- Do not idle the engine except as necessary.

For more information visit:

[www.P65warnings.ca.gov/diesel](http://www.P65warnings.ca.gov/diesel)

**FAILURE TO COMPLY COULD RESULT IN DEATH OR INJURY.**

## NOTICE

Product information and specifications are shown herein as of the time of printing. The motorhome manufacturer reserves the right to change product specifications, designs and standard equipment without notice and without incurring obligation.

**PLEASE NOTE:** Updates to all manuals are online at [www.grechrv.com](http://www.grechrv.com)

## DANGER

**DO NOT FILL PROPANE CONTAINER TO MORE THAN 80% OF CAPACITY.**

**FAILURE TO COMPLY COULD RESULT IN DEATH OR INJURY.**

Overfilling the propane containers can result in uncontrolled propane flow, which can cause fire or explosion. A properly filled container holds 80% of its volume as liquid propane.

## DANGER

### IN CASE YOU SMELL PROPANE:

- Extinguish any open flames, pilot lights and smoking materials.
- Do not touch electrical switches.
- Shut off the propane supply at the container valve(s) or propane supply connection.
- Open doors and other ventilating openings.
- Leave the area until the odor clears.
- Have the propane system checked and leakage source corrected before using again.

**FAILURE TO COMPLY COULD RESULT IN DEATH OR INJURY.**

## WARNING

Propane cylinders shall not be placed or stored inside the vehicle. Propane cylinders are equipped with safety devices that relieve excessive pressure by discharging propane to the atmosphere.

**FAILURE TO COMPLY COULD RESULT IN DEATH OR INJURY.**

## WARNING

### IT IS NOT SAFE TO USE COOKING APPLIANCES FOR COMFORT HEATING.

Cooking appliances need fresh air for safe operation

**FAILURE TO COMPLY COULD RESULT IN DEATH OR SERIOUS INJURY.**

Due to the limited size an RV offers unlike a home the amount of oxygen supply is restricted. Proper ventilation is important and necessary when using cooking appliances, ventilating the RV reduces the chances of asphyxiation.

# INSURANCE INFORMATION

## SERIAL NUMBERS

This section below provides a convenient place to identify and record component information that may be needed if in a situation a problem should arise with a product. Serial numbers are important for both the manufacturer and the vehicle's owner to know. They are unique and individual numbers found on each component or only to one camper, and it allows an owner or insurance company to look up the history of the RV.

- › **MOTOR HOME**- Serial Number: \_\_\_\_\_
- › **MOTOR HOME**- Federal Vehicle ID Number: \_\_\_\_\_
- › **ENTRY DOOR**- Key Number: \_\_\_\_\_
- › **COOKTOP/ RANGE**- Model: \_\_\_\_\_
  - **Serial Number:** \_\_\_\_\_
- › **MICROWAVE**- Model: \_\_\_\_\_
  - **Serial Number:** \_\_\_\_\_
- › **REFRIGERATOR**- Model: \_\_\_\_\_
  - **Serial Number:** \_\_\_\_\_
- › **GENERATOR**- Model: \_\_\_\_\_
  - **Serial Number:** \_\_\_\_\_
- › **ROOF AIR CONDITIONER (s)**- Model: \_\_\_\_\_
  - **Serial Number:** \_\_\_\_\_
- › **INVERTER**- Model: \_\_\_\_\_
  - **Serial Number:** \_\_\_\_\_





## RV DIMENSIONS

### TURISMO FRONT AND REAR VIEW

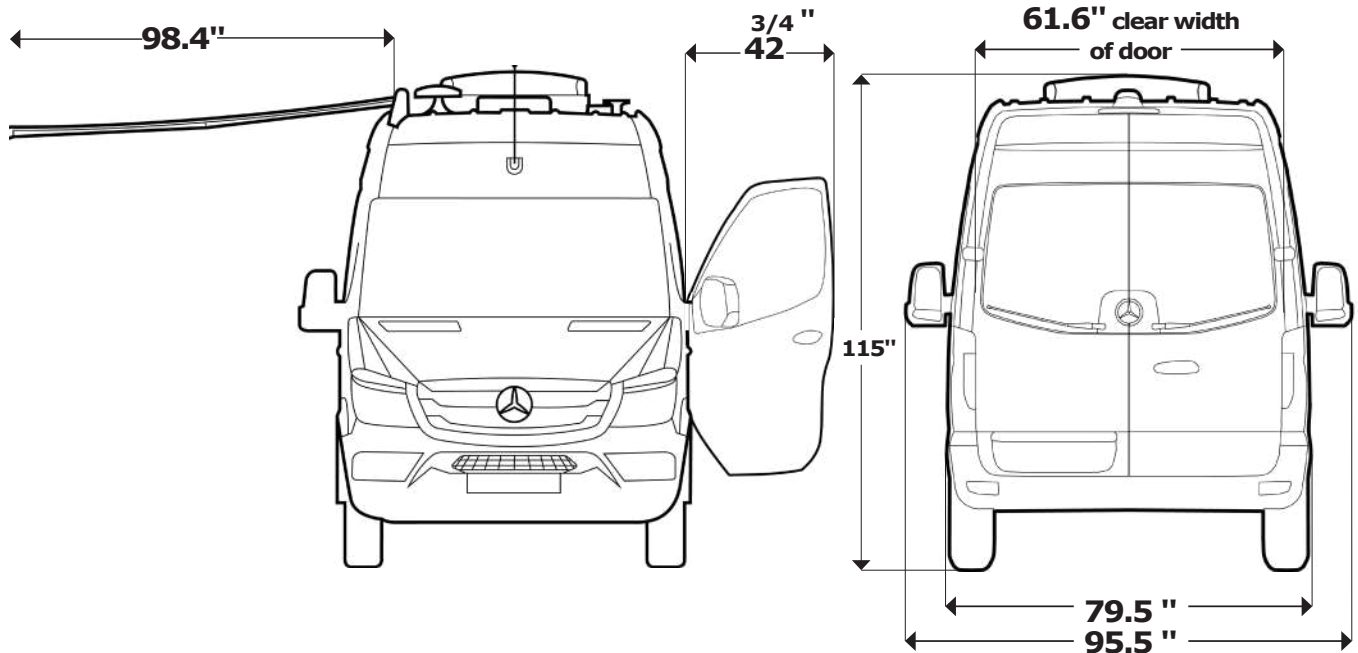

### TURISMO SIDE VIEW (PASSENGER SIDE)

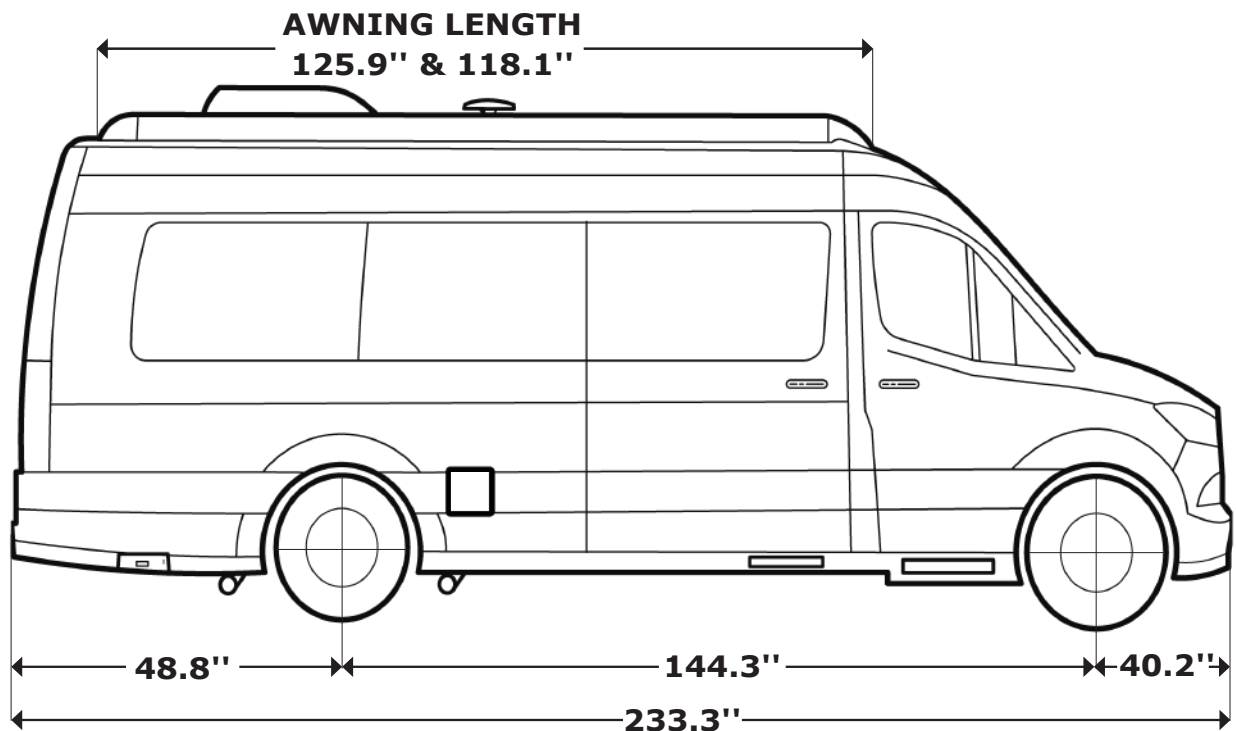

## RV DIMENSIONS

### TURISMO 4x4 FRONT AND REAR VIEW

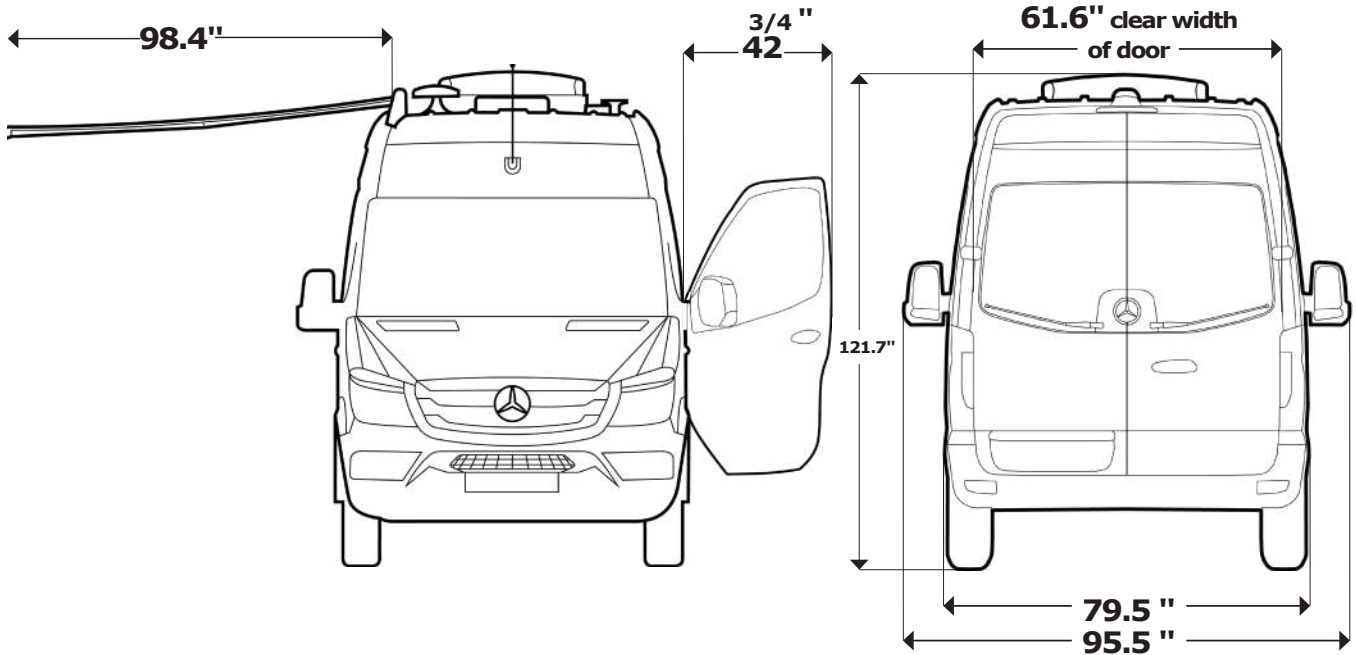

### TURISMO 4x4 SIDE VIEW (PASSENGER SIDE)

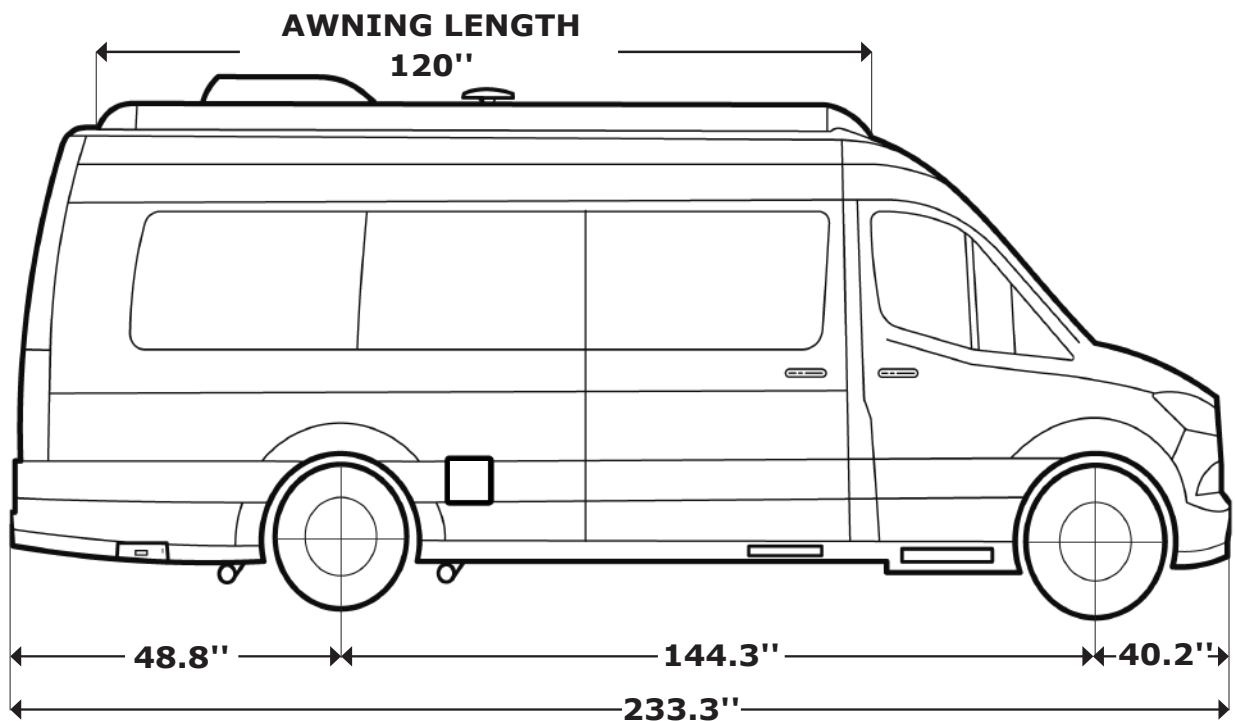

# FLOOR PLANS

## ABOUT THE TURISMO

**Turismo**, offers refined luxury in a **smaller** more agile package with the same renowned craftsmanship and attention to detail found in our flagship Strada Mercedes Class B RV.

The Turismo sets a new standard of quality with unparalleled fit and finish. The **luxurious** amenities and functional features elevate your RV experience. It exemplifies what a luxury Class B RV should be with remarkable **quality, craftsmanship** and **attention** to detail never before seen in the Class B RV world. Turismo has the **highest level** of standard equipment in its class. Built on the Mercedes-Benz Sprinter **2500XD 144" High Roof** with a **6 Cylinder Diesel engine**.

The Grech RV Turismo RV 144" Class B has 4 types of RV's: **Turismo, Turismo-ion, Turismo 4x4** and the **Turismo-ion 4x4**.

Turismo-ion RV's are **Lithium-ion battery system** powered which replaces the Cummins Onan Propane Generator on LPG powered RV's and provides **clean** and **quiet** Lithium-ion Based Energy which will power your entire RV.

The **Turismo 4x4** RV is a model which is intended for adventures both on-road and off-road with the same refined craftsmanship found on other models.

## TURISMO AND TURISMO 4X4 FLOOR PLAN

**Length**  
19'

**Seats up to**  
4

**Sleeps up to**  
2



# SPECIFICATIONS CHART

## MERCEDES-BENZ SPRINTER 2500 144" EXT RV CLASS B TURISMO RV

NAME	TURISMO 2500XD 144" HIGH ROOF SPECS	TURISMO-ion 2500XD 144" HIGH ROOF SPECS
<b>CHASSIS</b>	Mercedes-Benz Sprinter 2500 144" High Roof	Mercedes-Benz Sprinter 2500 144" High Roof
<b>ENGINE MODEL</b>	3.0L V6 Blue TEC w/50 State EPA/CARB Standards 6 Cylinder Diesel Engine	3.0L V6 Blue TEC w/50 State EPA/CARB Standards 6 Cylinder Diesel Engine
<b>STEERING WHEEL LOCATION</b>	Left Side	Left Side
<b>TIRES</b>	<b>TURISMO:</b> LT245/70R17 <b>TURISMO 4X4:</b> LT245/70R17	<b>TURISMO:</b> LT245/70R17 <b>TURISMO 4X4:</b> LT245/70R17
<b>HORSEPOWER</b>	188HP	188HP
<b>SUSPENSION</b>	Default from Mercedes-Benz	Default from Mercedes-Benz
<b>TORQUE</b>	325 ft-lb	325 ft-lb
<b>TRANSMISSION</b>	7 Speed Automatic	7 Speed Automatic
<b>AXLE RATIO</b>	3.923	3.923
<b>WHEEL BASE</b>	144"	144"
<b>DISTANCE BETWEEN AXIS</b>	366.52 cm	366.52 cm
<b>EXTERIOR OVERALL LENGTH</b>	19.44 ft / 233.3 in / 5925.82 mm	19.44 ft / 233.3 in / 5925.82 mm
<b>EXTERIOR OVERALL HEIGHT</b>	<b>TURISMO:</b> 9.59 ft / 115 in / 2923.54 mm <b>TURISMO 4X4:</b> 10.14 ft / 121.7 in / 3091.18 mm	<b>TURISMO:</b> 9.59 ft / 115.1 in / 2923.54 mm <b>TURISMO 4X4:</b> 10.14 ft / 121.7 in / 3091.18 mm
<b>EXTERIOR OVERALL WIDTH</b>	6.64 ft / 79.7 in / 2024.38 mm	6.64 ft / 79.7 in / 2024.38 mm
<b>INTERIOR HEIGHT</b>	6 ft 2 in / 74 in / 1879.6 mm	6 ft 2 in / 74 in / 1879.6 mm
<b>HITCH WEIGHT</b>	5000 lbs	5000 lbs
<b>GROSS VEHICLE WEIGHT RATING</b>	9,050 lbs	9,050 lbs
<b>GROSS COMBINED WEIGHT RATING</b>	13,930 lbs	13,930 lbs
<b>DRY WEIGHT</b>	4,993 lbs	4,993 lbs
<b>CARGO WEIGHT</b>	4,057 lbs	4,057 lbs
<b>TOW CAPACITY</b>	Up to 5,000 lbs.	Up to 5,000 lbs.
<b>FUEL TANK &amp; TYPE</b>	Diesel 24.5 Gal Tank	Diesel 24.5 Gal Tank
<b>FRESH WATER CAPACITY</b>	16 gal (12V Heated)	16 gal (12V Heated)
<b>GRAY WATER TANK</b>	26 gal (12V Heated)	26 gal (12V Heated)
<b>BLACK WATER TANK</b>	13 Gallon (12V Heated)	13 Gallon (12V Heated)
<b>LIQUIFIED PETROLEUM GAS (LPG)</b>	7.7 gal	7.7 gal
<b>WATER HEATER AND FURNACE TYPE</b>	Timberline Diesel Powered System	Timberline Diesel Powered System
<b>REFRIGERATOR/FREEZER</b>	Vitrifrigo C90IbD4-F 12/24VDC – 115/230VAC Total volume of 3.1 Cu. Ft.	Vitrifrigo C90IbD4-F 12/24VDC – 115/230VAC Total volume of 3.1 Cu. Ft.
<b>MICROWAVE</b>	Contoure 1.1 Cu.Ft. Combo Convection/Air Fryer	Contoure 1.1 Cu.Ft. Combo Convection/Air Fryer
<b>COOKTOP</b>	Dometic 2 Burner Induction w/ Integrated Cover Propane cooktop (Optional)	Dometic 2 Burner Induction w/ Integrated Cover Propane cooktop (Optional)
<b>TELEVISION</b>	24" LED Smart TV's	24" LED Smart TV's
<b>SPEAKERS</b>	Bose Soundbar w/ Premium Sound System	Bose Soundbar w/ Premium Sound System
<b>CHARGING PORTS</b>	USB and 110V	USB and 110V
<b>MEDIA PLAYERS</b>	Blu-Ray/DVD Player	Blu-Ray/DVD Player
<b>GENERATOR (LPG) W/ AUTOGEN START</b>	Onan 2.5 kW (LPG)	N/A
<b>BATTERIES (HOUSE)</b>	(2) 100 Amp Hour Lithium Batteries	(2) 100 Amp Hour Lithium Batteries
<b>ENERGY</b>	N/A	Lithium Based Energy
<b>POWER OUTLET</b>	110/120V	110/120V

# SPECIFICATIONS CHART

MERCEDES-BENZ SPRINTER 2500 144" EXT RV CLASS B TURISMO RV		
NAME	TURISMO 2500XD 144" HIGH ROOF SPECS	TURISMO-ion 2500XD 144" HIGH ROOF SPECS
<b>LIGHTING</b>	Dimmable LED Accent Lighting Throughout	Dimmable LED Accent Lighting Throughout
<b>INVERTER</b>	Xantrex 2,000 Watt True Sine w/ 100 Amp Inverter Charger	Xantrex 3,000 Watt True Sine w/ 100 Amp Inverter Charger
<b>SHORE POWER</b>	30 amp/110V Service	30 amp/110V Service
<b>SOLAR POWER</b>	Zamp Solar 200 Watt	Zamp Solar 200 Watt
<b>AIR CONDITIONER</b>	Dometic Low Profile 13,500 BTU Air Conditioning	Dometic Low Profile 13,500 BTU Air Conditioning
<b>REAR PARKING SENSORS</b>	Standard	Standard
<b>BED SIZE (REAR LOUNGE)</b>	Seats up to 3, sleeps up to 2 <b>Bed width:</b> 5.5 ft / 66 in / 1676.4 mm	Seats up to 3, sleeps up to 2 <b>Bed width:</b> 5.5 ft / 66 in / 1676.4 mm
<b>ALARMS</b>	Gas Detector/Smoke/Co2 Alarm	Gas Detector/Smoke/Co2 Alarm
<b>AWNING</b>	Automatic and powered with LED Lights <b>Awning Length:</b> <b>Turismo:</b> 320 cm / 300 cm <b>Turismo 4x4:</b> 304.8 cm <b>Min Canva Length:</b> 285 cm / 250 cm <b>Shadow Surface:</b> 7.2 m <sup>2</sup> / 8 m <sup>2</sup>	Automatic and powered with LED Lights <b>Awning Length:</b> 320 cm / 300 cm <b>Min Canva Length:</b> 285 cm / 250 cm <b>Shadow Surface:</b> 7.2 m <sup>2</sup> / 8 m <sup>2</sup>
<b>GRECH RV WARRANTY</b>	<b>Limited Warranty:</b> 3 years / 36,000 miles. <b>Firefly Integrations:</b> 3 years Unlimited Miles.	<b>Limited Warranty:</b> 3 years / 36,000 miles. <b>Firefly Integrations:</b> 3 years Unlimited Miles.
<b>MERCEDEZ-BENZ WARRANTY</b>	<b>24/7-365 Roadside Assistance:</b> 3 years / 36,000 miles. <b>Basic Limited Warranty:</b> 3 years / 36,000 miles. <b>Engine Limited Warranty:</b> 5 years / 100,000 miles.	<b>24/7-365 Roadside Assistance:</b> 3 years / 36,000 miles. <b>Basic Limited Warranty:</b> 3 years / 36,000 miles. <b>Engine Limited Warranty:</b> 5 years / 100,000 miles.
<b>WINDOW SHADES</b>	Automotion Power Window Shades	Automotion Power Window Shades
<b>CONTROL SYSTEM</b>	Firefly Control System	Firefly Control System
<b>UTILITY CENTER</b>	LP, Cable, 30 amp Outlet, Water Connection	LP, Cable, 30 amp Outlet, Water Connection
<b>HOSE (In compartment) (No hose reel)</b>	<b>Length:</b> 20 ft	<b>Length:</b> 20 ft
<b>WASTE FLUSH</b>	Valterra Bladex Waste Valve 3"w/ handles	Valterra Bladex Waste Valve 3"w/ handles
<b>SOFA/BED</b>	Memory Foam. 66"W x 73"L	Memory Foam. 66"W x 73"L
<b>CABINET DOORS</b>	Italian Hardwood	Italian Hardwood
<b>FLOORING</b>	Chilewich Woven Flooring w/ 3/4" Composite Honeycomb Subfloor	Chilewich Woven Flooring w/ 3/4" Composite Honeycomb Subfloor
<b>SUBFLOOR</b>	Insulated 3/4" Composite Honeycomb	Insulated 3/4" Composite Honeycomb
<b>INSULATION</b>	Full Insulation Throughout Foil-Faced Fiberglass (Roof & Sidewalls)	Full Insulation Throughout Foil-Faced Fiberglass (Roof & Sidewalls)

1. The **height** of the RV is measured from the **ground** to the top of the **highest component**.
2. **Load capacity** of your RV is designated by **weight**, not by volume, so you cannot necessarily use all available space when loading your RV.
3. **Tank capacities** are based on measurements **prior** to installation. Slight **variations** may occur due to tank **shrinkage** or **expansion**.
4. Actual filled **propane tank** capacity is filled at **80%** due to **overfilling** prevention device on tank.



# UNDERSTANDING THE WARRANTY'S POLICY



## GRECH RV'S WARRANTY

**Grech RV** is the **final stage** manufacturer of a previously incomplete vehicle which is manufactured and separately warranted by a vehicle manufacturer; Grech RV's Sprinter manufacturer is **Mercedes-Benz**.

Should your RV require services related to the converted areas of the vehicle, read this section **first** before taking any action.

By doing so, you will clearly understand the **Grech RV Service Process** and avoid possible **delays**. Never initiate or attempt to diagnose a warranty repair without **prior approval** of the **Grech RV Service Department**.

A **R.A.N** (Repair Authorization Number) must be obtained before each warranty repair is **honored**. Not following this procedure could **void** your warranty reimbursement for that particular repair.

## CUSTOMER RESPONSIBILITY

It is important you **read** and **understand** the information provided to you in the package containing all manuals pertaining to your Grech RV.

Familiarize yourself with the applicable warranties. You are **responsible** and **obligated** to return your motorhome to an authorized Grech RV dealership for **warranty service repairs**.

As the owner of the motorhome, you are responsible for **regular** and **proper** performed in accordance with the Grech RV and OEM Manuals provided. Maintenance will help **prevent** conditions arising from neglect that are **not** covered under warranty.

## WHAT IS MY WARRANTY PERIOD?

Grech RV, warrants the specified new motorhome to be **free from defects** in material and craftsmanship on portions manufactured by Grech RV, Inc. under normal use and service.

If you use your RV only for recreational travel and family camping purposes, the **Limited Warranty** provided by Grech RV ("Warrantor") covers your new motor home when sold by an authorized dealer:

- It shall be limited to **36 months/ 36, 000 miles** (whichever comes first) after the date of purchase by the first retail purchaser from an authorized Grech RV Dealer.
- Warranty shall be fulfilled by an authorized Grech RV dealer or authorized Grech RV service facility.

Grech RV, guarantees the motorhome to be **free** from manufacturing **defects** in materials and craftsmanship on portions manufactured by Grech RV under normal wear and tear. Individual components may carry their **own** respective warranty.

Mercedes-Benz has warranty conditions and options such as:

- **Basic Limited Warranty:**
  - Coverage 3 years or 36,000 miles.
- **Diesel Engine Limited Warranty:**
  - Coverage for 5 years or 100,000 miles.
- **Mercedes-Benz Roadside Assistance:**
  - Coverage for 3 years or 36,000 miles.

## WHAT THE WARRANTY COVERS

Warrantor's Limited Warranty (L.W) covers defects in the **manufacture** of your RV and defects in **materials**. Provided the prior authorization that was obtained from the **Warranty Department of Grech RV**, all labor costs associated with the repair or replacement of defective parts will be **paid** by Grech RV.

The L.W **doesn't** extend to any part or portion of the incomplete vehicle except as specifically required by any applicable **federal law** or **regulation**.

**Original Equipment Manufacturer** (OEM) chassis may have been modified by Grech RV from the original configuration.

### NOTICE

Grech RV reserves the right to make a physical inspection of the vehicle by authorized factory personnel following any complaint prior to any repair.

## LIMITATIONS OF IMPLIED WARRANTY

There is **no warranty** of any nature made by the Warrantor beyond that contained in this **Limited Warranty**. No person has the authority to **enlarge, amend** or **modify** the terms and conditions of the above stated Limited Warranty.

The **dealer** is not the Warrantors agent, it is an **independent entity**. The Warrantor is **not** responsible for any undertaking, representation or warranty made by any dealer or other persons beyond those set forth in this **Limited Warranty**.

## WHAT THE WARRANTY DOES NOT COVER

- An RV that has been **altered** outside our factory in any way so as, in our sole opinion and discretion, may affect its **stability, operation** or **reliability**.
- Damage caused by the failure to seek repairs on **time**.
- Damage caused by the **failure** to use **reasonable efforts** to **mitigate damage** caused by defects.
- Damage caused by the **failure** to **comply** with the **instructions set** forth in the Owner's Manual.
- RV damaged while stored in exterior storage compartments. Exterior storage compartments may not be moisture free due to weather and humidity conditions.



# UNDERSTANDING THE WARRANTY'S POLICY



- › **Condensation** and the results of condensation including, but not limited to, **water damage** and the growth of **mildew** or **mold**. Mold and mildew are **natural growths** given certain environmental conditions and are **not covered** by the terms of this warranty.
- › Items which are **added** or **changed** after the motor home leaves warrantor's possession.
- › Items that are **working as designed**, but which you are **unhappy** with because of the design.
- › An RV that, in our sole opinion and discretion, has been subject to **misuse, negligence, or accidents**.
- › **Deterioration** due to normal **wear** and **usage** or **exposure**, such as **fading** or **discoloration**, including but not limited to **rust, corrosion, oxidation** and **cosmetic blemishes**.
- › **Flaking, peeling** and **chips** or damage in or on the exterior caused by rocks or other road hazards, the environment including airborne pollutants, salt, tree sap and hail.
- › **Defacing, scratching, dents** and **chips** on any surface or fabric of the RV, not caused by warrantor.
- › An RV that has been declared a **total loss** by an insurance company, or by Grech RV indicates it is designated as "salvage", "junk", "rebuilt" or a word of similar impact.
- › **Routine maintenance**, including wheel alignments.
- › Unauthorized changes made on the RV, such as **repairs, alterations, variations** or **modifications**.
- › The **automotive chassis** and **power train** is covered by its own manufacturer's warranty, including but not limited to: **power train, engine, steering** and **handling, tires, batteries, gauges** and **muffler**.
- › The appliances and components that are covered by their own manufacturer's warranty: **microwave, refrigerator, stove, water heater, televisions, stereo, DVD player, lithium batteries, heating surface, Firefly Control System, generator** and **roof, air conditioners** and **all other electronic devices**.
- › Damages caused by, but not limited to: **hail, tornadoes, lighting, floods, earthquakes, hurricanes, fire, rain**, and other environmental conditions, which include but are not limited to, **tree sap, tar, chemicals, oils, salts, road hazards, stone chips, infestations, rodents**.
- › Failure of the coach and/or chassis resulting in **incidental** damages, such as but not limited to: **goods** stored both **inside** and **outside** the coach; **loss of use** and **equipment** of RV; inconvenience; cost of **rental** vehicle; cost of **accommodations**; travel expenses; towing; meals; and other miscellaneous **incidental** expenses.
- › Some states do not allow **exclusions** or **limitations** of **incidental** or **consequential** damages, for this reason, the above limitations or exclusion may or may not apply to you.
- › The conditions of this limited warranty shall not apply to **degeneration** due to **wear, tear** and **exposure** after these limitations.
- › **For ninety (90) days** from the original retail purchase date:
  - **Adjustments** to compartment door latches, light bulbs/LEDs, fuses, remote and smoke detector batteries.
- › **For one (1) year** from the original retail date purchase date or **12,000 miles** (whichever comes first), by the original retail purchaser from an Authorized Grech RV Dealer:
  - All seat, curtain, door panel, wall and ceiling fabrics used in RV
  - Window seals and caulking
  - Exterior TV outlets
  - Floor coverings
  - Patio Screen Door
  - Exterior striping
  - Painted plastic exterior body molding and bumpers
    - » Painting exterior moldings magnifies the original equipment manufacturer condition of the plastic molding
    - » Some conditions of the plastic, such as but not limited to, body attachment points and texture may be more visible when painted (considered normal).
- › **For three (3) years or 36,000 miles** (whichever comes first) by the original retail purchaser from an authorized Grech RV Dealer:
  - Exterior painted surfaces

## OWNER'S WARRANTY

Grech RV neither **assumes** nor **authorizes** any other person to assume for us any liability in connection with the sale of our RV's other than expressed **above**.

All correspondence should be directed to the **authorized** Grech RV dealer from whom the RV was purchased and must give the **serial number** and **date of purchase** of the RV.

The **original retail customer** of the RV prior to performing any work in case of wanting to make any change or alteration on the RV, must obtain a **Repair Authorization Number (RAN)** of the RV and should contact the **Warranty Department** of Grech RV.

Grech RV reserves the right to make **changes** in RVs already **built** and/or **sold** at any time without incurring any obligations to make the **same** or **similar** changes on RVs previously built and/or sold by Grech RV.



# UNDERSTANDING THE WARRANTY'S POLICY



## EMERGENCY REPAIRS

For **emergency repairs** while traveling, you may choose to deal with **non-authorized** RV service facilities; however, **all warranty repairs** must be **pre-authorized** by Grech RV. Grech RV will, at its option, replace or repair **free of charge** any defective part, including **labor**. The purchaser shall notify their authorized Grech RV dealer within the warranty period.

If you obtain warranty repairs from a **non-authorized** RV service facility without Grech RV pre-authorization, it is at Grech RV sole discretion whether or not to **reimburse the claim**.

In the event that this RV is used for **commercial** or **rental** purposes, Grech RV's warranty coverage shall be limited to **one (1) year 12,000 miles** (whichever comes first) from the date of original purchase.

The above Limited Warranty applies to **all owners**, including **subsequent owners**, of the RV. However, a subsequent owner must submit a **warranty transfer form** by filing the form through an authorized Grech RV dealer. A subsequent owner's warranty period shall be the **remaining balance** of the warranty coverage period that the prior owner was entitled to under this Limited Warranty. Warranty transfer forms can be obtained by contacting the **Grech RV's service department**. There is **no charge** for the transfer.

## WHAT WE'LL DO TO CORRECT PROBLEMS

Warrantor will **repair** and/or **replace**, at its option, any covered defect if:

1. You **notify** the Warrantor or one of its authorized servicing dealers of the defect during the warranty coverage period time and within **five (5) days** of discovering the defect.
2. You **deliver** your RV to Warrantor or Warrantor's authorized servicing dealer **at your cost** and **expense**.

For the repair of your RV, warrantor may use **new** and/or **remanufactured parts** and/or **components** of substantially equal **quality** to complete any repair.

**Defects** and/or **damage** to interior and exterior surfaces, trim, upholstery and other appearance items **may occur** at the factory during manufacture, during delivery of the RV to the selling dealer or on the selling dealer's lot. Normally any defect or damage is **detected** and **corrected** at Grech RV or by the selling dealer during the inspection process performed by the warrantor and/or the selling dealer.

If, however, you **discover** any defect or damage when you take delivery of the RV, you must **notify** your dealer or Warrantor within **five (5) days** of the date of purchase to have repairs performed at **no cost** to you as provided by this Limited Warranty.

In case that two or more **unsuccessful** repair attempts have been made to correct any covered defect that you believe substantially **impairs the value** and/or use of safety of your RV, you must, to the extent permitted by law, **notify** warrantor directly in **writing** of the failure to successfully repair the defect so that Warrantor can become involved in performing a **successful** repair to the identified defect.

## WARRANTY SERVICE FORMS

The **Warranty Registration form** must be returned to Warrantor promptly upon purchase to assure **proper part replacement** or **repair** of your RV. Failure to return the warranty registration form **will not** affect your rights under the Limited Warranty so long as you can provide **proof of purchase**.

For warranty service simply contact one of warrantor's **authorized service centers** for an appointment, and then deliver your RV (at your expense) to the **service center**.

If you need help or assistance in locating an authorized warranty service facility, contact **Grech RV Warranty Department's** number **(1-855 994-7324)** or at:

Grech RV  
Attn: Service Department Manager  
6915 Arlington Avenue  
Riverside, California 92504

In the event the RV roadside assistance is needed refer to Mercedes Benz Road Side Assistance. The warrantor **will not** have control and is not responsible of the authorized servicing dealers **scheduling** of **service work**

Some **delay** in scheduling and/or in the **completion** of the **repairs** may or may not happen when trying to repair your RV at the nearest **authorized repair facility**.

### ⚠ CAUTION

In the event that it becomes necessary and/or required to tow your RV, refer to Mercedes-Benz guidelines.

## OBTAINING WARRANTY REPAIRS

To obtain warranty repairs, you must contact your **authorized Grech RV dealer** and schedule an **appointment**. It is best if you have a written **list of defects** or items in need of repair. As the owner, you are solely **responsible** for the maintenance of the RV as required or recommended by this owner's manual and **associated costs** by failure to maintain the RV as required or recommended are **not** covered by warranty.

# UNDERSTANDING THE WARRANTY'S POLICY



## WARRANTY REPAIRS PERFORMED

There are **three (3) methods**:

1. Repair is done at the **Grech RV Service Department**, in Riverside, California.
2. Repair is done at a **Grech RV authorized service facility** near you.
3. Repair is done at a **shop of your choice**, with prior approval of the Grech RV Service Department.

### NOTICE

Grech RV does not control the scheduling of service work at authorized or independent dealerships. You may encounter some delay in scheduling or completion of work.

If either method **2** or **3** are to be used, you must obtain **pre-authorization** and a **Repair Authorization Number (R.A.N)**, Grech RV Service Department in advance of performing any **repairs**.

Both requirements may be accomplished from a single phone call to the Grech RV Service Department, at **(1-855-994-7324)**.

## WARRANTY SERVICE PROCEDURES

**Warranty repairs** must be within **three years** or **36,000 miles** (whichever comes first) limited warranty. Grech RV warranty registration cards must be **on file** before any claims will be processed. Claims made without **warranty registration cards** will be rejected until proof of **ownership** can be established.

Grech RV will not **reimburse** any claims for work done on any components or appliances that are covered under their **respective** manufacturer's warranties. These warranties must be claimed through the **manufacturer** of the **appliance** or **component**. Examples include but are not limited to: refrigerator, microwave, roof air-conditioning, water pump, furnace, TV etc.

All warranty work required to be done on the chassis must be taken to an **authorized Mercedes-Benz dealer** and processed through their warranty procedures.

Grech RV **will not reimburse** any claims regarding the **chassis**. Grech RV will pay for the **removal** and **reinstallation** of RV components only if it is absolutely **necessary** to perform chassis warranty **repairs**. Grech RV **will not reimburse** any costs in the **removal** and **re-installation** of these components if it is: out of the warranty period; non-warranty repairs; and/or routine maintenance or service.

## WARRANTY VERSUS NON-WARRANTY

Whether a particular problem is **covered** under the Grech RV Warranty depends, in some cases, on several **factors**. The **Grech RV Service Department**, determines coverages **ahead of time** on a case-by-case basis, either over the phone or at our Riverside, California facility.

## NON-WARRANTY REPAIRS PERFORMED

If the **service manager** has determined that the repair is **not covered**, or you are sure that it is not covered, we would be pleased to recommend a service shop in your area, or schedule an appointment with the **Grech RV Service Department**, whichever is more convenient.

Other non-warranty parts and/or components needs may be handled by contacting the **Grech RV Parts Department**, directly at **(1-855-994-7324)**. In order to expedite your parts order, have your Grech RV **serial number**, which starts with **G-#####**, it is located on the driver's door jamb of the RV.

## EVENTS DISCHARGING WARRANTOR FROM OBLIGATION UNDER WARRANTY

Grech RV shall have no liability for any **defect** or **damage** caused by the original owner's use of parts or services which are **not authorized** by Grech RV or for any parts or paint which have been subject to **misuse**, **neglect** or **accidents**, or have been subject to external **mechanical** or **chemical influences**, especially stone chips, airborne rust or industrial fall-out.

Additionally, Grech RV **will not have accountability** for: misuse or neglect, accidents, unauthorized alterations, failure to provide reasonable and necessary maintenance, damage caused by off-road use, collision, fire, theft, vandalism, explosions, overloading, and odometer tampering shall **discharge** warrantor from any **expressed** or **implied** warranty obligation to repair any resulting defect.

### NOTICE

It is the policy of Grech RV, to incorporate product improvements to our products whenever possible or practical to do so. We reserve the right to make changes and/or improvements at any time without incurring any obligation to make changes on previously sold products.

The **information** and **specifications** specified in this manual are current at time of publishing. Subsequently, all information contained in this manual is subject to **change** at any time, **without notice**.

If there is any doubt as to whether or not a repair is related to the Grech RV Warranty, call the **Grech RV Service Department** at **(1-855-994-7324)**, this may save you time wasted at a **chassis dealer** or another **service shop** for a problem appropriately solved by contacting Grech RV Service Department.

# UNDERSTANDING THE WARRANTY'S POLICY



## CUSTOMER ASSISTANCE

Warranty repairs to your vehicle must be performed by an **authorized dealer**. While any authorized dealer handling your vehicle line will provide **warranty service**, we recommend to return to your selling authorized dealer who will want to ensure your continued **satisfaction**.

Some warranty repairs require **special training** and **equipment**, so not all authorized dealers are authorized to perform all warranty **repairs**. This means that, depending on the warranty repair needed, you may have to take your vehicle to another authorized dealer.

**Time** must be allowed to **perform** a **repair** after taking your vehicle to the authorized dealer. Repairs shall be made using **new** or **remanufactured** Grech RV **components** or other elements or components that are previously authorized by Grech RV.

## AWAY FROM HOME

If you are away from home when your vehicle needs **service**, contact the **Grech RV Customer Relations** or use the online resources listed below:

Grech RV  
Customer Relationship  
6915 Arlington Avenue  
Riverside, California 92504  
Telephone: **(1-855-994-7324)**.

## ADDITIONAL ASSISTANCE

If any **questions** or **concerns** arise or you are **unsatisfied** with the service you are receiving follow these steps:

1. Contact your **Sales Representative** or **Service Advisor** at your selling/servicing authorized dealer.
2. If the defect or concern remains **unresolved**, contact the sales manager, service manager or customer relations manager.
3. If you require **assistance** or **clarification** on Grech RV policies, please contact the **Grech RV Customer Relationship Center**.

For an easier and faster process please have the following information available when contacting **Customer Relationship Center**:

- **VIN** (Vehicle Identification Number)
- Your **telephone number** (home and business)
- The **name** of the **authorized dealer** and **city** where it is located.
- The **vehicle's current odometer reading**.

In some states, you must directly notify **Grech RV** in writing before pursuing remedies under your state's warranty laws. Grech RV is also allowed a **final repair attempt** in some states.

In the United States, a **warranty dispute** must be submitted to the **BBB AUTO LINE** before taking action under the **Magnuson-Moss Warranty Act**, or to the extent allowed by state law, before pursuing **replacement** or **repurchase** remedies provided by certain state laws.

To learn more about the **specific automotive chassis** not covered under the Grech RV Warranty or any other component in your RV, please contact your **authorized selling dealer**, Grech RV or review your **Mercedes-Benz warranty package information**.

## REPORTING SAFETY DEFECTS (U.S ONLY)

If you believe that your vehicle has a **defect** which could cause a **crash** or could cause **injury** or **death**, you should immediately inform the **National Highway Traffic Safety Administration** (NHTSA) in addition to notifying **Grech RV**.

If **NHTSA** received **similar complaints**, it may open an investigation, and if it finds that a safety defect exists in group of vehicles, it may order a **recall** and **remedy campaign**. However, **NHTSA** cannot become involved in individual problems between you, your dealer or Grech RV.

To contact **NHTSA**, you may call the **Vehicle Safety**

**Hotline** toll-free at:

**1-888-327-4236**

**(TTY: 1-800- 424-9153)**

Or visit, <http://www.safercar.gov> to obtain other information regarding **RV safety** or write to:

Administrator

1200 New Jersey Avenue, Southeast

Washington, D.C. 20590

# INSPECTION

Any item not passing inspection, must be reported immediately, before operating vehicle. Failure of highlighted item(s) to pass inspection will cause vehicle to be grounded.

## INSPECTION PROCEDURE CHECKLIST

ITEM	INSPECTION PROCEDURE	PASS	FAIL
1	Check preventative maintenance schedule for services due at present mileage		
2	Calculate Load Carrying/Payload Capacity		
3	Check operation of drivers seat and seat belt		
4	Check operation of steering wheel and shift levers		
5	Check operation of turn indicators		
6	Check operation of foot pedals and parking brake		
7	Check operation of all gauges, for normal reading with engine running		
8	Check operation of dash indicator lights with key on, engine not started, then again with engine started		
9	Check operation of ventilation system: heating, defrosters, fans and air conditioning		
10	Check: horn, wipers, washers, and mirrors for cleanliness, adjustment, operation and damage		
11	Check conditions of fire extinguisher and first aid kit		
12	Check all doors, glass and windows for operation, cleanliness, and damage.		
13	Check all emergency exits for operation, warning devices, markings, to be free and clear		
14	Check interior lighting: for operation and damage		
15	Check exterior lighting for operation and damage		
16	Check exterior for cleanliness, markings and damage		

# INSPECTION

ITEM	INSPECTION PROCEDURE	PASS	FAIL
17	Check fuel cap in place and secure		
18	Check all tires and wheels for tread depth, cracks & bulges, missing lug nuts, and air pressure		
19	Check engine coolant level		
20	Check power steering fluid level		
21	Check brake fluid level		
22	Check DEF (Diesel Exhaust Fluid)		
23	Check belts for tension and wear		
24	Check operation of cameras, if applicable		
25	Check operation of audio and video system, if applicable		

## GENERAL VEHICLE SAFETY WARNINGS

### ⚠ CAUTION

No standing while vehicle is in motion. It could cause bad injuries.

### ⚠ WARNING

Discontinue operation of the vehicle, if any critical item on the pre-trip inspection list fails to pass, or until all problems have been resolved.

### ⚠ CAUTION

If a door ajar warning light is lit, check all doors for proper closure.

### ⚠ NOTICE

Never operate this vehicle until the problem has been resolved.

### ⚠ WARNING

Discontinue operation of the vehicle, if a door or awning opens while the vehicle is in motion.

# SAFETY AND DRIVING

Before beginning any trip with an **extended** duration, ensure you are thoroughly familiar with the **operation** and **conditions** of your RV. Make sure you know all about the **components, features, appliances** and **limitations**.

It is the **responsibility** of the owner and operator to read, understand and follow all considerations and instructions in this manual, the **chassis manual**, all **appliances/equipment system manuals** located in the Grech RV information kit provided to you when you buy from Grech RV.

Adequate preparation is **essential** for an enjoyable, successful and safe trip. The **time** you spend getting to know all about your RV will **enhance** the enjoyment of you and the passengers, will maximize the experience and contribute to a more **prosperous, rewarding** and **fortunate** trip.

Safety, comfort and easy of operation of your RV are key **considerations** during the **design** and **manufacture** of all Grech RV's.

In this manual you will find boxes with **safety labels** with key words such as: **Danger, Warning, Caution** and **Notice** which will emphasize areas of special concern in your RV. The meaning of these **key words** are:

## ⚠ DANGER

Indicates a hazardous situation which, if not avoided, WILL result in death or serious injury.

## ⚠ WARNING

Indicates a hazardous situation which, if not avoided, COULD result in death or serious personal injury and/or damage to the RV.

## ⚠ CAUTION

Indicates a hazardous situation which, if not avoided, COULD result in minor or moderate personal injury and/or damage to the RV.

## ⓘ NOTICE

Identifies hazards not related to personal injury.

## CHECKLISTS

### SAFETY CHECKLIST

The following checklists highlights items that need to be checked on the RV **before traveling**. Prior to departing several items will need to be prepared.

Regular use of this **checklist** will provide a **safe operation** and **long life span** of your RV. It will also help to find a **malfunction** in an equipment or component before there is a bigger problem. By doing so, there is a better chance of not facing problems in the future.

### EXTERIOR CHECK LIST

These tips must be followed **before entering** the RV:

1. Check condition of **tires**. Keep **cold inflation pressure** as recommended per tire.
2. Turn **off** remote **LPG** valve switch.
3. Check the **exterior components** such as: hose, city water hookup, TV cable/satellite, shore power station, awning and all the exterior components are **unhooked** and **stored**.
4. Check compartments and water filling openings are **closed** or **locked**.
5. Check that items **hooked** or **tied** on the RV are **secured**.
6. Follow all tips and recommendations on **checking** and **filling fluid levels**.
7. Check exterior **lights** and the general **condition** of vehicle.
8. Make sure there are **no objects** in the way of the RV that may cause accidents or any **damage** to the RV.
9. Confirm that all belongings are **safely stored** inside the RV and none are left behind on the exterior.
10. Ensure that the hitch cover is **on** and secured from the **bottom**. (If it's not in use)

### INTERIOR CHECK LIST

These tips must be followed **before driving** the RV:

1. Check that refrigerator door is **closed** and **latched** to avoid **spillings** or **injuries**.
2. Check **small** and potentially **dangerous** objects found on counter tops or shelves. Doing this could prevent **injuries** or **lost items** in case of a **crash** or a **sudden braking**.
3. Check that nothing **heavy** is stored in **high cabinets** but in low cabinets.
4. Do not cook until RV is **off** and **parked**. Hot food or liquids can be a potential **hazard** in case of a **crash** or **sudden braking**.
5. Put away **galley's** table or **pedestal** table. Store table's base in the **upper rear storage**.
6. Make sure all **LPG controls** on the appliances are turned **off**.
7. All doors must be **closed** and **locked** during traveling.

## ⚠ CAUTION

Failure to follow these checklists may cause damage to the vehicle or personal injury for you or the passengers.



## SAFETY AND DRIVING

8. Check internal **stowage** is securely held in place.
9. **Switches** and **lights** must be set in **safe positions** for travel.
10. Driver's seat should be in a **comfortable** position to be in **reach** of all controls. Seats must only be **modified** if the RV is **parked** and turned **off** to avoid any accidents by **losing control** while driving.
11. All passengers must be **secured** with seat belts.
12. **Mirror adjustment** should be checked and modified if necessary to **maximum visibility**.
13. Small children should be in a **federally-approved** child restraint chair or device to **avoid accidents** in case of a **crash** or sudden **braking**.

### PRE ROAD TRIP TIPS

#### TRAVELING

Refer to the chassis manual in the RV Information Kit for the engine starting, operation and stopping instructions.

#### INSPECTION

Be aware of passenger automobiles and RVs **differences** when traveling. The **key** to safely operate a motorhome is **inspection**. Any defect found could result in problems on the road that may cause **loss of time** and **money**. Several states require that the motorhome is inspected prior to **registration**. Know and observe the **laws of the state** in which you will be traveling and remember that laws may vary from state to state. A **systematic inspection** conducted prior to moving the motor home will ensure nothing is overlooked and will assist in **familiarizing** the owner with the RV.

#### GET ACQUAINTED

The **location** and **height** of the driver's seat in the RV is **higher** and **further** to the left than in most vehicles. This creates a different **perspective** of the roadway. Rely on the **outside mirrors** to line up with the center of the road and to check conditions behind the motor home. The **dashboard** may contain more **gauges** and **controls** than what is normally found in passenger car. Become familiar with these gauges and their indications before ever starting out.

#### CONTROLS

Your RV driver controls are similar to those of an automobile. Steering and braking controls are power assisted to help make driving as comfortable as possible. Your RV is much higher, wider and heavier than any automobile so the operator must anticipate and account for the differences.

#### SEAT BELT SAFETY

All occupants must be furnished with and use **seat belts** while motor home is moving. The driver's seat and all other seats which are designed to carry passengers while the motor home is in **motion** are equipped with **safety seat belts**. Do not occupy beds or any seats that are not equipped with a safety belt while the motor home is in motion.

The driver and passenger's seat should **always** be locked in the **forward facing position** when the vehicle is in motion. To fasten a seat belt, pull belt from the retractor and insert it into the buckle until it clicks.

#### SEAT BELT CARE

Keep the seat belts **clean** and **dry**; to clean, use mild soap and lukewarm water. Never use bleach, lye or abrasive cleaners as they may weaken the belt. Inspect the belts periodically. Check for cuts, frays or loose parts; replace the belt(s) assembly if involved in a severe impact, even if visual damage is not apparent.

#### ⚠ WARNING

Seats must be pointed in a forward position and seatbelts fastened while the motor home is in motion. Avoid seat rotation while in transit. Children must never be transported unrestrained. Infants must be placed in an approved safety seat. Small children must be restrained in approved child safety seats. Failure to comply with these rules can lead to injury or death.

#### ⚠ CAUTION

Seat belts must only be used on permanently mounted seats. Do not use a single seat belt on more than one person.

### DRIVING TIPS

#### MOUNTAIN DRIVING

When driving in hilly or mountainous terrain, exercise safe driving techniques that match terrain conditions. It is important to check the area and become familiar with it to avoid any complications in the moment.

#### CLIMBING A HILL

The **key** to traversing a steep incline is to use lower gears. Using the **lower gear** on your RV helps you to get more **torque** and that's the force that can help **pull** all of the weight uphill. **Transmission** of your RV is designed to automatically **down-shift** when required during long uphill climbs. If the transmission frequently **shifts** up and down, select the lower gear for the duration of the climb to prevent **repeated** shifting. This will prevent **unnecessary** wear and tear on the transmission.

## SAFETY AND DRIVING

## DESCENDING A HILL

Select a **lower transmission gear** when descending a hill to avoid prolonged **brake** applications. Under extreme conditions, prolonged brake applications could lead to excessive brake **wear**, **overheating** and **failure** causing you to lose control of the RV.

When descending a long hill, use the **braking** force of the engine to maintain a safe, **slow speed**. Do not rely entirely on the service brakes to slow the RV when descending **long grades**.

"**Pumping**" and riding the service brakes is not recommended when descending a grade, as the brakes can **overheat**. Over-use can result in loss of **break effectiveness**.

To use the service brakes for **additional** braking, use moderately **heavy pressure** on the brake pedal to reduce the RV's speed to the **desired** speed of travel, and then **release** it.

Before descending a grade, **downshift** the transmission to a lower gear and use the engine to slow the vehicle. Monitor the motor home speed while **descending the grade**.

If the RV begins to **accelerate** while proceeding down the grade, or it becomes necessary to slow the RV, activate the **auxiliary** braking device.

## NOTICE

A safe driving practice is to use the same lower gear position when descending a hill that you used while climbing the hill.

## CAUTION

Extended brake applications can cause excessive wear, overheating and under extreme conditions, brake failure that could cause you to lose control of the RV.

## BACKING UP

Whether you are a **long time** owner of an RV or just **starting out**, backing up is always a **challenge**. The driver must always use the help of **mirrors**, **back-up camera** and the **co-pilot's directions** for **assistance**. It is recommended to practice in a parking lot before going on the road, and always remember that backing up is a **team effort**.

First of all, backing up should begin when the RV is in a **forward** motion. Maneuvering the RV to **align** with the chosen sign will allow **straight alignment** with the site. When the RV is properly **aligned** with the site, the parking area will be visible in **both** mirrors. With the help of straight lines, such as **road markings** will be used as **reference points**.

## NOTICE

If the destination does not have a "pull through" site, try to pick a solid, level site. If possible pick a site located on the left/drivers side of the RV.

In case, there is **no spot** on the left side, the driver will have to use **right side mirrors** which gives **less road vision** and **blind spots**.

Before starting the backing up process, it is important to **stop** the RV and get out and **observe** the area. This will give you input on what is **around** the area (rocks, low hanging limbs, sign posts, etc).

Remember, the **co-pilot** will have a just as important role as the driver. When backing up, have the co-pilot safely **stand** at the **roadside corner** so the co-pilot remains **visible** in the roadside mirror at all times. The co-pilot can watch for any **obstacles** and give **hand signals** during the backing up process.

If the driver **loses sight** of the co-pilot, the backing up process will **stop** until the co-pilot is **visible** again. If required or if the driver is **unsure**, it will be necessary to stop the process and inspect all **angles** and **areas** of concern. The use of **walkie-talkies** might be very helpful for great and efficient **communication** between the **co-pilot** and **driver**.

## ON THE ROAD

The RV is built to travel safely and comfortably at **normal highway speeds**. However, because it takes more time to get up to normal highway speeds, you will need to allow **more time** when attempting to pass another vehicle. This is especially true if you are trying to pass while going **uphill**.

When you are **descending a hill**, you need to be aware that the added weight of the RV, magnifies the **need** for increased attention to speed, road conditions and distance from other vehicles. Before ever venturing into traffic, practice **stopping** so you become familiar with it and the distance it requires to stop.

## DRIVING SAFETY TIPS

1. When backing the RV, have a person stand to the rear on the driver's side to guide you.
2. Before departing on a trip, check your routes for height restrictions. Remember, some tunnels prohibit RV with LP gas systems.
3. While traveling, make sure all occupants correctly use their seatbelts.
4. While traveling, make sure all doors are closed and that cabinets, drawers and loose objects are secure.
5. Instruct your family about what to do in case of fire.
6. Maintain a properly charged fired extinguisher.



## SAFETY AND DRIVING

7. Ensure LP Gas and smoke detectors are unobstructed and in proper working order at all times.
8. Keep a well-stocked first aid kit on board.
9. Check tires often while traveling. Make it a habit to check tire pressures before each trip and each time you refuel.
10. If you have a cell phone, carry it with you for emergencies.
  - **Do not** drink and drive. Do not allow others to do so.
  - **Do not** text and drive.
  - **Do not** use a cell phone while driving. Always use a hands-free system while driving.
11. **Defense driving:** An RV **cannot** stop quickly, it cannot accelerate quickly and it cannot turn or swerve quickly. When someone pulls into the **large gap** between you and the vehicle ahead slow down to once more **increase** the distance. Watch **further** ahead that you are used to.
12. **Minor usage:** Learn to use them and use them **constantly**. RV's have very large **blind spots**, where other vehicles can't be seen. Watch for traffic coming from behind that gets **too close** to be seen and then holds that position. When changing lanes, use the **mirrors**, turn on the turn **signals** early, and slowly change **lanes**.

 NOTICE

On vehicles, it is suggested that you stay at least 2 seconds behind on a regular vehicle, so in an RV, you might want to make that a 5-10 second rule. Tip: When the car in front of you passes a fixed object on the side of the road (electric pole or bridge), begin to count to ten and that's as far back as you should drive.

13. **Braking:** Stopping an RV requires time and space, so keep a safe distance between your vehicle and others on the road.
14. **Steep hills:** These vehicles are not known for **power** or **hill climbing** ability. They will **overheat** on long steep hills; the solution is to slow down, change to a **lower gear** and watch the temperature **gauge**. Downhill slope presents another challenge to the **brakes**, which can easily **overheat** and **fail**, slow down and change to a **lower** gear. Watch for trucks or other RV's, if they are slow going downhill, you should be, too.
15. **Road placement:** Keep your RV in the **center** of your lane. The RV is wider than a normal vehicle, you may want to keep to the **right**, but keeping it in the **center** of the lane is ideal.
16. **Turning:** A long, wide vehicle requires extended, wide turns. Right turns are particularly tricky because they put you next to the curb and does require **extra space** to turn. Go further before starting the **turn**, leaving room for the **rear** of the vehicle to turn and stay on the road. Keep an eye on the rear, use the **mirrors** and stay close to the center lane and avoid accidents.

**17. Parking:** Having a person to **help** direct you and the RV into parking **spots** is a very good system to use if you're not comfortable. If you're **towing**, remember that backing up turns the trailer in the **opposite** direction of the steering wheel. Find the **easier** and most **comfortable** spot to park to **avoid** accidents.

## TRAVEL TIPS

As you travel with your RV, you will **learn** a lot from your own **experiences**. It is important to share your experiences with other RV owners and learn from their experiences too.

Read RV, outdoor and camping **magazines** for camping and travel tips. The following are some basic **suggestions** which may also make your **travel** and **camping** experience easier and more enjoyable:

1. Make sure refrigerator and cabinets doors are closed **securely**. Carefully open these doors after traveling. Contents may have **shifted** while traveling and may **fall** when you open the door.
2. It is important to know the **height** and **width** of your RV, to take into consideration when passing through bridges and tunnels.
3. Use your **mirrors** while driving to determine whether you are crowding the **center** line or the **outside** edge of the highway. Remember, your RV requires a much different driving **style** than normal vehicles.
4. When **towing** a vehicle, make sure the **combined weight** of the towed vehicle does not exceed the **GCWR** as stated on the vehicle certification label located on the passenger door frame.
5. Check the **routes** that you will travel in carefully before you travel. Some jurisdictions prohibit vehicles with **LP Gas** containers to drive through highway **tunnels**.
6. Fill your **water tank** with clean, fresh potable water only. Do not use a new **hose** to fill the tank- it may leave a taste of rubber or vinyl.
7. Conserve water, especially when **showering**. The holding tanks have a **limited** capacity.
8. Dump sewage only at **approved** dumping sites.
9. Store all **liquids** in plastic containers with light **seals**.
10. Watch the **levels** in your holding tanks at all times. Dump **regularly** to avoid unnecessary buildup and potential odor. After dumping, add water to the **black** water tank to prevent solids from **settling** in the tank. Without **adequate** liquid in the black water tank, dumping can be difficult or impossible. It is important to dump the black tank **first** then the gray tank to wash away all **waste** and **impurities** left.

## SAFETY AND DRIVING

**11.** Be careful not to leave odor-causing food or materials in your RV for extended periods of time. Make sure wet clothing and towels are fully dried before storing.

**12.** Make sure your fire extinguisher is ready for use and that you and all passengers know how to fully operate it.

### DRIVING CAUTIONS

- **Avoid** getting too close to the **edge of the road**; a soft shoulder may not support the weight of the RV.
- **Side spacing** is best maintained by keeping the RV **centered** in the driving lane.
- Driving lanes in work zones can be **uneven, congested** and **narrower** than usual.
- Be cautious of road debris which can damage the undercarriage of the RV or become **lodged** in the dual tires causing **damage** to **tires** or **wheel rims**.
- Posted speed signs are passenger **automobile rated**. An extra **awareness** of the driving conditions and appropriate speed for an RV is **necessary**, especially on corners and mountain roads.
- **Downgrade** speed should be at least **5mph** less than upgrade speed, or downgrade speed should be attainable within **three seconds** of a brake application.
- Use a **four second rule** when following other vehicles at speeds **under 40mph**.
- Use a **five second rule** when following at speeds **over 40mph**.

### NIGHT DRIVING

- As always be **well rested** and **alert** when driving. If necessary, find a safe stopping place to rest until ready to continue.
- Avoid using any **interior lights** while driving. They can create a **glare** on the windshield, decreasing **visibility**.
- **Dim** the dash lights to a comfortable level to reduce the **level of glare**.

### LEFT TURNS

**Do not** start the turn until the **center** of the **intersection** is reached with your **hips**. If there are two lanes available, take the **right hand lane**. A car or driver on the left hand side is **easier** to be seen.

#### ⓘ CAUTION

Adjust the convex wing mirrors on the vehicle, so both you and your co-pilot can see down the sides of your unit. These mirrors increase the field of vision, particularly in the blind spot area, and help to better see passing vehicles and tires in motion. Remember that things are closer than they appear, so don't use convex mirrors to judge distance

### RIGHT TURNS

Negotiating a **right hand turn** in an RV can be difficult. Many drivers **fear** they can't make the turn without entering into the other lane or jumping the curb. Here are a few **tips** to make a right hand turn **easier**:

- As the turn approaches, look into the mirror to **ensure** the lane to the left is **clear**, then move wide over to the **left**.
- When you are about to make the **turn**; the **left rear** wheel should touch the **center line** of the road and your hips should be **parallel** to the roadside curb of the corner being turned. This will **aid** in **avoiding** a premature turn.
- Make them turn **slowly**.
- **Check mirrors** frequently, being aware of necessary clearance and space management of the RV, while negotiating the turn.

#### ⓘ DANGER

Avoid the risk of fire or explosion. Turn off all pilot lights and appliances before entering the refueling station.

### WEATHER CONDITIONS

As an RV traveler and driver, you may want to **explore** new and out of the way places. These recreational areas can be vulnerable to **unusual** and **severe** weather conditions. You may find yourself more aware of the weather than when you lived in a house. The following **suggestions** and **safety precautions** may help you in case you find yourself in severe weather situations:

- 1. Be alert.** Thunderstorms and heavy rains can occur **suddenly** and **unexpectedly**. Frequently check weather **reports** for the area in which you are camping or travelling so you will not be caught unaware of **sudden** weather changes.
- 2. Remember the following terms:**
  - **Weather Watch:** Severe weather may develop in your area. Be prepared for an emergency.
  - **Weather Warning:** Severe weather is occurring or is imminent. Immediately find a safe location.
- 3. When camping near** a body of water, leave plenty of **space** and **elevation** between your RV and the water.
- 4. If you get caught in a flood,** do not attempt to **move** your vehicle. Abandon it, and return only after the water level has **subsided**. Never attempt to drive through any **flooded area**.
- 5. Comply with all warnings and instructions provided by local authorities.**
- 6. Stock enough survival supplies** for several days. (Food, water, first aid supplies and necessary medications).
- 7. When you leave home, inform** someone of your **destination** and your schedule. Notify the same person if your plans change.

# SAFETY AND DRIVING

## WET CONDITIONS

- The risk of **hydroplaning** is increased if tires are worn or improperly inflated.
- Be aware that **heavy** rain or **deep standing** water can affect brake application causing them to apply **unevenly** or **grab**.

## EXTREME HOT WEATHER

- Observe all **gauges** frequently. Any **variations** from the **normal** conditions should be evaluated promptly.
- Check **tire pressure** frequently, when traveling in hot conditions. Tire air pressure increases with heat. It is **not advisable** to let air out of a hot tire. When the tires cool down they will return to the **correct/previous** tire pressure.
- Pay extra attention to **hoses** and **belts** which are more susceptible to **fatigue** in extreme heat.

## COLD CLIMATE CONDITIONS

- The RV should be prepared for **Cold Weather Use**.
- Keep speeds **slow** and **steady**. Make moves **gradually** and increase **visual distance** for a gain in reaction time.
- If road or weather conditions are **treacherous** find a safe stopping place and wait for conditions to **improve**.
- **Wipers** should be in good conditions and the washer reservoir should have sufficient **window washer fluid** that has **antifreeze** included within it.
- Use the mirror heat to keep the mirrors **clear**.
- Remove any **ice build-up** from the entry step to avoid accidental slipping.

## GENERAL HANDLING

The RV power-to-weight ratio is lower than that of the average automobile. It is essential to compensate for slower acceleration when moving into traffic or when passing another vehicle. Allow extra room to corner and to change lanes. When going underneath a bridge or similar overhang, you must be aware of your maximum height.

## HIGH WIND HANDLING

High winds or strong wind gusts may lead to unpredictable handling and RV control. When encountering high winds or strong wind gusts, proceed as follows:

- Slow down significantly so you can maintain control of your RV.
- Find a safe place to pull off the road and take shelter.
- Park your RV facing directly into the wind to minimize high wind buffeting.

### ⓘ CAUTION

Be aware of your location and surroundings. In the event of an emergency, you'll want to be able to report the address of your location to authorities.

### ⓘ NOTICE

All RV occupants must be familiar with the safety precautions and tips written in this manual and should be alert to changing weather.

### ⓘ NOTICE

Always know the weather forecast for your area, along with your destination and your route on travel days.

### ⓘ CAUTION

Choose campsites with an eye toward potential hazards if a sudden storm were to sneak up on you. Trees with low-hanging branches, nearby bodies of water, and other natural or man made objects can quickly become dangerous in an extreme weather situation.

## REFUELING

### REFUELING TIPS

- **Truck stops** are good refueling points for RV's.
- Know which **side** the **fuel port** is on.
- Be aware of the **concrete/steel posts** installed around the fuel island.
- Avoid running over the fuel station, as it can get hung up on the RV, causing **body damage**.
- Use of **gloves** is advised for **refueling**.
- To prevent **grease** and **fuel deposits** from being tracked into the motorhome when refueling, change shoes before entering the RV. **Store** the extra pair near the entry door.

## FUEL ECONOMY

Many factors contribute to the amount of fuel **consumed** during **driving**. Driving styles, wind resistance, terrain, vehicle weight, and engine-driven accessories are some of the factors that affect the fuel economy. Use the following **guidelines** to help increase fuel efficiency:

- When starting out, apply the **throttle** lightly and accelerate gradually, avoid using excessive throttle and **accelerating** quickly.
- Check the **tire pressure**. A low tire is not only a **safety hazard**, it also increases rolling resistance which increases **fuel consumption**.
- While operating the RV keep the engine at a **low** to **mid** operating range of **1,100** or **1,500 RPM**. This will use less fuel than operating at higher RPM.

Avoid using full throttle when ascending a **long hill**. This **wastes** fuel and increases engine operating temperature from incomplete **combustion**. Manually downshift to a lower gear and use fewer throttles. Fuel will burn more **efficiently**.

## SAFETY AND DRIVING

RV PREPARATION  
SAFETY PRECAUTIONS

If you are **careless** with **dangerous materials** such as, cigarettes, matches, flammable material, or any hazardous material, the potential for accidents is **substantially elevated**.

## WEIGHT DISTRIBUTION

It is **highly critical** that you organize a great distribution as to your **additional cargo** plus the **weight** of fresh water and waste water tanks, water heater and storage areas within the RV. Remember, with **great** and **equipped** storage comes major responsibility.

If in a situation where you want to travel, you occupy **all** of the **storage compartments**, the **volume of fluids** may have to **decrease**. It is preferable to **hook up** to a city water supply (if the place has one) and with that the water load on route is **reduced** and storage **increases**.

## TIRES

Properly **maintained** tires with suitable **inflation pressure** is significant for proper **tire load carrying capacity** steering, stopping, traction, load-carrying and wear.

**Unsuitable pressure** will lead to unusual wear and sudden tire **failure**. Weigh the RV fully **loaded** for travel to establish the **appropriate** tire inflation pressure. If one tire position on the axle is **heavier** than the other one, inflate **both** sides according to the heaviest side.

## NOTICE

For more information please refer to the Tires section on this manual.

## GENERATOR SAFETY

Please **do not** operate the generator in an **enclosed** building or in a partly enclosed area, like a **garage**.

## APPLIANCES AND EQUIPMENT

An appliance, like a stove and equipment like, generator, etc typically operate on **liquefied petroleum (LP) gas**. LP is very **flammable** and is contained under **high pressure**. Improper handling or misuse of it may cause **fire** or an **explosion**.

It is of high importance to read all instructions and warnings in this manual as those in the specific owner's manual of the **appliances** and **equipment**.

## NOTICE

Not all RV's have LP gas, some operate with battery.

## MOLD

Mold and mold spores exist throughout **indoor** and **outdoor environments**. There is no practical way to **eliminate** all mold and mold spores in the indoor environment; however, the way to **control indoor mold growth** is to control **moisture**.

## CHEMICAL SENSITIVITY

When your RV is in your possession, right away as you walk in for the first time you may notice a **strong odor** and/or experience a **chemical sensitivity**. This is not a defect or flaw in your new RV, the reason is because it may have been **closed** for a prolonged period of time.

A new car or a new home has many products, such as carpet, linoleum, plywood, insulation, upholstery. Unlike a new home or a new car, an RV is **smaller** in space and the interior equipment and hardware are very **different** however, the **exchange** of air inside the RV is much reduced therefore the **odor** too.

**Formaldehyde** is also a chemical present in **combustion** and numerous household products (paint, coatings, and cosmetics). These products when exposed to **elevated temperatures** and/or **humidity** may **off-gas**, in combination with the **air exchange**. This could cause **irritation** of the eyes, nose, and throat, as well as headache, nausea and a variety of asthma-like symptoms.

## VENTILATION

**Ventilation** of the unit normally **reduces** the exposure to a comfortable level. **Formaldehyde** may be present **inside** the RV; it is released from **smoking, cooking, use of detergents** or **soaps** and other household product. it is something you need to do **regularly**.

We strongly recommend **ventilation** of the RV after purchase and on a **regular basis**. When the climate is **humid** and **hot** it is important to open windows, exhaust vents, and doors. Operate ceiling and/or fans, turning on the AC can also help to force **stale air out** and bring brand new **fresh air** inside the RV.

## SMOKING

A very important suggestion is that you **do not smoke inside** the RV. It can **damage** your RV but it can also **release** chemicals that may be present on your RV and without **proper ventilation** it may be harmful **healthwise**.

## SMOKE DETECTOR/ALARM

Most fire **casualties** in RVs or house are caused by direct fire but less visible smoke (**combustion**). Smoke alarms can help **alert** you or the other passengers if there is a **fire** present in the RV. The sound of smoke alarms is very **distinguishable**.

## NOTICE

There is no way to ensure against injury or loss of life in a fire: however, the smoke detector is intended to help reduce the risk of tragedy. Additional smoke detectors may help to reduce the risk. Proper use and care of the smoke detector could save lives.



# EMERGENCIES

## EMERGENCIES WHILE DRIVING

Your RV is designed with **features** that allows the driver and occupants to resolve some emergencies or failures while **traveling**. Review this section to become familiar with the recommended procedures to **resolve** these **conditions** or **situations**.

When traveling with your RV there would be certain **situations**, **emergencies** or **failures** that the driver and passengers should know how to handle and resolve. Review this section to **familiarize** yourself with the recommended procedures to resolve any particular emergencies or problems you may **encounter**.

## HAZARD WARNING LIGHTS

Your RV is equipped with a hazard warning light system. Front and rear turn signals flash in unison when the system is turned on. It is located on the cockpit.



- ▶ **To switch on/off:** Press the **Hazard Warning Lamp Switch**. If you have indicated a turn while the hazard warning lamps are switched **on**, only the turn signal lamps on the side of the vehicle selected will **light up**.
- ▶ The hazard warning lamps will switch **on automatically** if:
  - An air bag is **deployed**.
  - You brake **sharply** and bring the vehicle to a **halt** from a **speed** of more than **45 mph** (70 km/h).

If the **hazard** warning lamps have been switched **on** automatically, press the Hazard Warning Lamp Switch to switch them **off**.

### NOTICE

Hazard warning lamps work even when the ignition is switched off.

Activate the **hazard warning lights** whenever the RV is stopped on the **side** of the road or near moving **traffic**. The hazard warning lights **alerts** other drivers of a potential hazard and to take extra **precautions**. The Hazard Warning Lights will continue **flashing** when the switch is on, even when the key is in the **off** position or **removed** from the ignition.

## FLAT TIRE

If you have a flat tire while **operating** your RV, **slow down** gradually to **prevent** loss of control and pull to the side of the road. Whether it **blows** when you are driving down the road or you wake up in the morning to a **flat** tire, it is unfortunate. Either way, stop on a **level paved** surface and **engage** the parking **brake**.

This RV doesn't come with an **extra** tire, let alone with a jack that will be **able** to lift the **weight** of your RV. Even if you did have the **proper** equipment, it would take up **space** that you may not have for your RV. The safest and most reliable option is to contact a **mechanic** or a **qualified** roadside repair service specialist.

Refer to the following steps in case you need to change a tire or have the **opportunity** and **equipment** to do it:

1. Turn on the **hazard warning lights**.
2. Place wheel **chocks** in front and rear of the tires located on the opposite side of the flat tire.
3. Immediately contact a qualified **roadside repair service specialist** because your RV is not equipped with a spare tire.
4. If a roadside service is **unavailable**, inspect the flat tire to determine whether you can give service or repair it.
5. If you can give **service** or **repair** the flat tire, you must **raise** the RV using the jack.
6. Consult the chassis **manual** in the RV Information Kit provided to you with the RV to locate the **appropriate** jack placement locations on the chassis.
7. If the ground is **soft** or **unstable**, carefully move the RV to a **safe** location before attempting to **lift** with the jack.
8. Use a **jacking board** for **stability** on loose or soft ground.
9. **Raise** the RV with the jack according to the **instructions** in the chassis manual.
10. Never allow for a person to be **under** the vehicle at any time while **raising** or **supporting** the RV with the jack.
11. Before resuming travel with a **new** or **repaired** tire, ensure the **lug nuts** are tightened in the proper sequence and to the torque **specified** in the chassis manual. Use a torque **wrench** to ensure the specified torque is achieved. **Recheck** and **re-torque** the wheel lug nuts after **25** and **100** miles (40 miles and 160 km) of operation.

### NOTICE

It is important to take a regular account of each tire's pressure. You should check your tire pressure every morning before you drive. Ensuring that they're at the right pressure will not only save you from possible blowout, but it'll also keep you driving with better fuel efficiency.

## EMERGENCIES

### HYDRAULIC JACK

A hydraulic jack is a device that is used to **lift** heavy loads by applying a **force** via a hydraulic cylinder. Hydraulic jacks lift **loads** using the force created by the **pressure** in the **cylinder chamber**. In case of an emergency you can find the Hydraulic Jack under the passenger's seat.



#### NOTICE

Do not push or tow the RV in an attempt to start it. The powertrain is not designed to transmit torque to turn the engine over to start.

#### NOTICE

Attempting to pull or tow the RV to start may result in major drivetrain component failure or damage.

### DEAD BATTERY

If the vehicle won't **start**, often a dead battery is the **problem**. When the engine doesn't even try to turn **on** and no **dashboard lights** come on, it is likely the **battery**.

From time to time, it's not the battery itself but the **terminal connection**. **Corrosion** can build upon and around these connections preventing power from getting through.

A **battery terminal cleaner** is a handy product to have on hand. It clears away the **corrosion** and **rust** so that the leads can reconnect cleanly and easily. If this doesn't fix the problem, you may have an **actual** dead battery. Another RV owner may be able to offer you a **jump start** so that you can go get a new battery. Otherwise, please call a **roadside repair service specialist**.

If the RV **breaks down** on the roadway, please pull off the road and **stop**, engage the parking **brake**, turn on the **hazard warning lights** and **chock** the wheels if you are on **uneven** or **unstable** ground. Call an approved **towing service** and provide it with all the vehicle general information, **weight**, **length**, **width** and **height** to ensure they dispatch an appropriately sized truck to tow your RV to a **qualified repair facility**.

In case that, you are **still** having **engine trouble** that is unrelated to the battery or temperature, there may be a **mechanical issue**. Unless you're an RV mechanic or you have a lot of **experience** working on RV engines, seeking a **professional** RV service is probably your best option here. If it won't run at all, you may have to call for a **tow service** to the nearest **RV service center**.

#### WARNING

For more jump starting instructions and tips for starting your engine please refer to the Chassis Manual in the Owner's Manual provided in the RV Information Kit. Please contact Grech RV for assistance with approved repair centers.

### OVERHEATING

Another common problem is **engine overheating**, which can happen in **extremely hot weather**. When the needle in the engine temperature gauge shows a significant **rightward shift** or a **red light** starts frantically on the dash panel, your RV is trying to convey some **danger** signals to you that the engine is **overheating**.

If you see the gauge **rising** or the light **blinking**, move to the side of the road and stop. It's time to call a **towing service company** and take your rig to the nearest repairing **facility**. Before you find a **safe** spot to pull over, take few necessary steps to minimize danger.

### CHECK FOR STEAM

**Steam** coming out of your RV is always bad sign and should always be **supervised** and **checked**. The hood will be very hot, so be as careful as you can, and give the engine a few minutes to **cool** down.

Checking your **coolant** will inform you the **condition** in which the coolant is, as well as the levels it has. If the levels look **normal**, you probably have a **faulty** temperature gauge, which can be easily replaced. If that seems to be the **issue**, please safely make it to the nearest **service center**, as long as you pay attention for any other **signs** of overheating.

If the coolant levels are **low** or the reservoir is **empty**, more problems may appear such as a leak somewhere in the **coolant** or **radiator systems**.

Cooling system **leaks**, blocked **passageways**, or the wrong coolant concentration can often contribute to the **problem**. If you find that this seems to be the **issue**, having extra hoses, clamps and the **correct** coolant for your particular RV's engine on hand can be imperative to keeping your engine for irreparable damage.

A related **issue** may be in the **radiator system**; if the radiator is **faulty** in any way, such as **leaking** or experiencing **clogs**, or the radiator fan is **broken** then it may cause your engine to **overheat**.

Leaks in the coolant or radiator systems are often the result of **worn out** hoses. As mentioned, keeping these on hand can be very helpful in such cases.

Other possible **causes** of an **overheating** engine include:

- A loose or broken belt
- A faulty thermostat
- An incorrectly working water pump

# EMERGENCIES

If any of these **issues** appear on your RV, it is recommended that you call a **mechanic** or a specialist. If you think your engine is **overheating**, you should **not** continue driving until you have assessed or resolved the situation. If you ignore any potential dangerous issue, it may result in **permanent damage** to your RV's **engine** or can even cause an **accident**.

A well-maintained engine can **reduce** the risk of **overheating**, but even the **cleanest** engine may at times face problems. Knowing what to look for and how to **mitigate** the issue when it emerges can help you save your engine from **permanent** damage.

## OVERHEATING SOLUTION

Driving up the side of a mountain on a hot summer day or even driving for many **miles** can **overwork** even the most **well-maintained** RV. These are some main things to look out for if you suspect your RV's engine may be overheating:

1. Pull to the side of the road and **stop** immediately.
2. Shut **off** the engine.
3. Check the **coolant level** in the **coolant recovery tank**. The coolant level should be between the "**full**" and "**add**" marks on the tank.
4. If the coolant level is **low**, proceed as followed:
  - Check for visible **leaks** from the hose connections, radiator and water pump.
  - Make sure the **water pump belt** is tight and the **cooling fan** is turning.
  - If **coolant level** is low, add **coolant** to the **recovery** tank as soon as possible.
  - If the coolant is **leaking**, the water pump belt is **loose** or **broken**, or the red warning light stays **on**, do NOT start the engine until the problem is **corrected**.
5. Once the **temperature gauge** returns to normal, resume **driving** and keep an eye on the **gauge**. Do NOT resume driving until the problem has been corrected and the temperature as returned to **normal**.
6. Also check your **oil levels** and refill, if the problem exists.
7. If either problem **persists**, have your RV **serviced**.

Deal with the issue as quickly as possible before it becomes a large and more costly issue.

### ⚠ WARNING

To avoid burns or other injury, allow coolant to cool before removing any cap from a radiator or coolant recovery tank.

### ⓘ NOTICE

The hazard warning lamps work even when the ignition is switched off.

### ⓘ NOTICE

When freeze plugs wear out, or when a hose rusts, coolant can leak slowly from your car's system. Leaks can also be caused by increased water pressure from overloading the system with coolant. Regardless of the culprit, leaks should be addressed immediately, to avoid serious damage to your engine.

### ⓘ NOTICE

Coolant, also known as anti-freeze, protects your cooling system while aiding the water in absorbing heat from the engine. With the addition of coolant, water doesn't corrode the system as much. In general, you should use a coolant to water ratio of 1:1.

In case you can't pull over at the moment while traveling or you are stuck in traffic please follow these tips:

- **Turn off the AC:** Your RV's air conditioning system consumes a huge amount of energy. You can lower the load on the engine significantly by turning off the AC.
- **Switch on the Cabin Heater:** Switch on the cabin heater to increase the cabin temperature, set it to the highest. Heating the cabin will help transfer some of the engine's heat from the engine into the passenger's compartment. Forget discomfort, because this way it will keep engine damage at the minimum as long as the ignition is on.
- **If trapped in traffic, rev up the engine:** If you can't pull over due to high traffic, shift into the neutral gear and rev the engine. This will increase the engine's fan speed, and will also activate the water pump. This will supply an extra gush of air and fluid through the radiator and will cool down the engine.
- **Pull over:** Shutting down the engine as early as possible is important, but don't pull over until you spot a safe parking place. Next, call up an emergency roadside service.

### ⚠ DANGER

Overheating is a serious mechanical issue and ignoring the issue and problem to your rig's overheating signals can result in serious injury or death.

# EMERGENCIES

## JUMP-STARTING

Do not use a **rapid** charging device to start the vehicle. If your vehicle's battery is **discharged** the engine can be jump-started from another vehicle or from a donor battery using **jumper cables**. For this purpose, the vehicle has a jump-starting connection **point** in the engine compartment.

If your vehicle requires jump-starting, or if you use it to jump-start another vehicle, use the jump-starting **connection point** in the engine compartment.

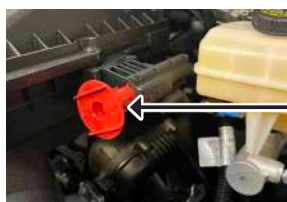

**Jump-Starting Connection Point**

When **jump-starting**, observe the following **points**:

- The battery is not **accessible** in all vehicles. If other vehicle's battery is not accessible, jump-start the vehicle using a **donor** battery or a jump-starting **device**.
- Do not start the engine if the battery is **frozen**. Let the battery **thaw** first.
- Jump-starting may only be performed from **batteries** with a nominal voltage of **12V**.
- Only use **jumper cables** that have a sufficient cross-section and insulated terminal clamps.
- If the battery is fully **discharged**, attach the battery of another vehicle for a few minutes before attempting to **start**. This charges the empty battery a little.
- Make sure that the two vehicles **do not touch**.

**NOTICE**  
Bare parts of the terminal clamps do not come into contact with other metal parts while the jumper cables are connected to the battery.

**NOTICE**  
Make sure the jumper cables are not damaged.

**NOTICE**  
The jumper cables cannot come into contact with parts such as the V-belt pulley or the fan. These parts move when the engine is started while it is running.

**NOTICE**  
Jumper cables and further information regarding jump starting can be obtained at any qualified specialist workshop.

## TOWING

In some cases, you may want to travel with more stuff than originally planned and may want to tow a trailer with your RV. Towing a trailer can affect the **handling, durability, performance** and **fuel economy** of your RV. The factory-installed towing hitch is rated with a **5,000 lb** towing package so you can bring everything you need for your travels.

The **combined weight** of the RV and any towed vehicle must not exceed the **Gross Combined Weight Rating (GCWR)**. Also, the combined weight of the RV and any towed vehicle hitch weight must not exceed the RV's **Gross Vehicle Weight Rating (GVWR)** or its rear **Gross Axle Weight Rating (GAWR)** as listed on the vehicle certification label.

**NOTICE**  
For more information please refer to the "RV Preparation: Labels" section in this Owner's Manual.

The towing **capacity** of a vehicle is **how much** weight it can tow. The towing capacity is determined mainly by which **axles** the truck has and their **ratings**. Because no two vehicles are the same, it is important to know your **specific vehicle ratings**. This can be found on the **doorframe** on the driver's side. These numbers may be easy to **overlook**, but they determine what **type** of trailer you can tow **safely**.



**Towing Compartment Closed**



**Remove Screws with Cross Screwdriver**



**Towing Compartment Ready to be Used**



# EMERGENCIES

## IMPORTANT SAFETY NOTES ABOUT TOWING

### NOTICE

Information on the Gross Vehicle Weight can be found on the Vehicle Identification Plate.

When towing away, you must observe the **legal** requirements for the country in which you are currently **driving**. It is preferable to have the vehicle **transported** or trailer instead of towing it.

The battery must be **connected** and **charged** otherwise you may not **turn** the key in the ignition lock.

Before the vehicle is towed, switch off the automatic locking feature, you could otherwise lock yourself out of the vehicle when pushing or towing away the vehicle.

## TOWING AWAY IN THE EVENT OF MALFUNCTIONS

### NOTICE

For more information, please refer to the Mercedes-Benz Interactive Operator's Manual provided in the RV Information Kit.

#### Front or rear axle damage on RV:

- If the vehicle has front or rear axle damage, have it transferred on a transporter or trailer.

#### With transmission damage:

- Always use new bolts when installing the propeller shafts.
- Only have the propeller shafts fitted or removed by qualified skilled personnel.
- If the vehicle has transmission damage, have the propeller shaft removed before towing away.

#### Towing with the front or rear axle raised:

- The ignition must be switched off if the vehicle is being towed with the front or rear axle raised.
- Always use new bolts when installing the propeller shafts.
- Only have the propeller shafts fitted or removed by qualified skilled personnel.

#### Towing the vehicle with both axles on the ground:

### NOTICE

If the front axle is damaged, raise the vehicle at the front axle and if the rear axle is damaged, raise the vehicle at the rear axle.

### WARNING

You can no longer steer the vehicle if the steering wheel lock has been engaged. There is a risk of an accident. Always switch off the ignition when towing the vehicle with a tow cable or a tow bar.

### NOTICE

Do not exceed the towing speed of 30 mph (50 km/h). You could otherwise damage the transmission.

#### Recovering a vehicle that is stuck:

- If the tires get trapped on loose or muddy ground, recover the vehicle with the utmost care.
- Never attempt to recover a vehicle with a trailer attached.
- Pull out the vehicle backwards, if possible, using the tracks it made when it became stuck.

## HITCH COVER

A hitch is the primary **connector** between a **tow vehicle** and **trailer**. It is a **structural** component that bolts onto the vehicle and provides an **anchor** point to hook up a trailer.

This RV has a **Rear Receiver Trailer Hitch**, which is by far the most **common** type of truck hitch, in addition it has a classic rear receiver hitch **square** shaped that you may insert a wide variety of things into.

**Covering** your hitch can extend the life of your hitch and protect it from **outside elements**, like rain, dew, frost and sunlight which can lead to rust or water damage. If the RV is **not** used every day and it is left outside. A **hitch cover** is highly recommended to be used and it will also help to keep the hitch compartment in good conditions.

To **remove** the hitch cover you will need to kneel down behind the rear bumper. There will be **two screws** on each corner of the cover at the **bottom**. After removing the hitch cover, place it in a **safe place** inside the RV.

Hitch Cover



Hitch

# EMERGENCIES

## FIVE DIRECTIONAL SIGNALS

When the co-pilot is **guiding** the driver the use of five **previously** defined and discussed **signals** should be used, one at a time. Signals should be used and given with **purpose** and **confidence**, otherwise the driver will probably make mistakes.

These **signals** are made to be easily comprehended by the driver's **mirror**. No more **signals/movements** will be made until the driver moves the RV to the **desired** motion.

When traveling, make sure **bridges** being crossed can support the **weight** of the RV. Check the **tonnage** limit of the bridges before crossing them. Signs should be posted at **bridge entrances**.

Check the **posted height** of all overpasses or situations where overhead clearance is **limited**. Keep in mind, road surfaces may have been **repaved** or become **packed** with snow therefore the actual posted clearance **height** would not apply in such conditions.

## MEANING OF THE DIRECTIONAL SIGNALS

The signals should be practiced and previously read and understood by both, the **driver** and **co-pilot**.

- 1. GO RIGHT:** Co-pilot will use left hand and arm and will be held horizontal, with forefinger pointing right, to direct rear of RV to the right.
- 2. GO LEFT:** Co-pilot will use right hand and arm and will be held horizontal, with forefinger pointing left, to direct rear of RV to the left.
- 3. STRAIGHT BACK:** Co-pilot will use both arms and hands parallel with thumbs pointing up and to rear in a waving vertical motion. This will signal the driver to maintain a straight back direction.
- 4. DISTANCE FORM STOPPING POINT:** Co-pilot will hold arms horizontally, hands open with palms facing one another. Start with a wide separation, gradually closing distance of hands, in a rate appropriate to vehicle speed, to indicate amount of distance to the stop point.
- 5. STOP:** Closed fists and crossed arms will indicate the driver to immediately stop the RV.

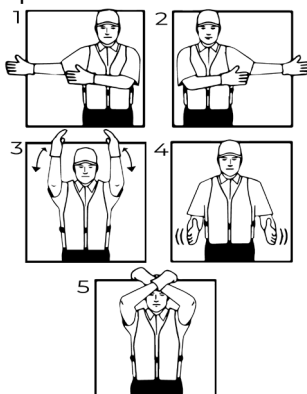

### ⚠ WARNING

Risk of injury from adjusting the vehicle settings, such as mirrors, while the vehicle is in motion.

### ⓘ NOTICE

These movements will indicate the desired direction of travel/movement of the rear of the RV.

## MIRRORS

### MIRROR ADJUST

Utilize your driving **mirrors** to observe **traffic conditions** as well as the RV's exterior **proximity** to its surroundings. Never use your mirrors in place of **physically** observing your surroundings, but do become acquainted with how they can **assist** you in driving **safely**.

### ⓘ NOTICE

Before starting the engine: Adjust the driver's seat, head restraint, steering wheel or the mirror and fasten your seat belt.

### ⚠ CAUTION

Risk of accident due to misjudgement of distances when using the passenger mirror.

## OPERATING THE OUTSIDE MIRRORS

Please note, that you could **lose control** of the vehicle in the following situations:

- ▶ If you **adjust** the **driver's seat, head restraint**, the **steering wheel** or the **mirror** while the vehicle is in motion.
- ▶ If you **fasten** your seat belt while the vehicle is in motion.

The **outside mirror** on the **front-passenger side** reflects objects on a **smaller** scale. You may **misjudge** the **distance** between you and the road user driving behind you, for example, when **changing lanes**.

### ⚠ CAUTION

Always look over your shoulder in order to ensure that you are aware of the actual distance between you and the road users driving behind you.

### ⓘ NOTICE

Please refer to Mirrors section in this Owner's Manual to know more about the operation of the mirrors in your RV.



## LABELS

### PACK YOUR TRAILER PROPERLY

One common **mistake** people often make when packing their RV is not **distributing** the weight properly. You should distribute weight **equally** side-to-side and emphasize it **upfront**. By placing the weight towards the RV front, you increase the amount of weight placed on the **hitch**, granting a **steadier** tow. If you are experiencing **less control** or your RV is **swaying**, it probably means there is **too much** weight on the back of the RV.

Traveling with **full tanks** can also cause weight distribution issues. A gallon of water weighs approximately **8 pounds**, your RV has fresh, gray and black water tanks which could easily add up to **500+ pounds**.

Keeping your vehicle's weight in mind is **integral** as well. If your vehicle weighs **too much** for your tow vehicle, it increases the **stopping distance** and **likelihood** of damage to your tow vehicle or RV.

Towing an RV can **affect** the handling, durability, performance and fuel economy of your RV. The towing package in your vehicle is a total of **5,000 lbs**.

The **combined weight** of the RV and any towed vehicle must now exceed the **Gross Combined Weight Rating (GCWR)**. Also the combined weight of the RV and any towed vehicle hitch weight must not exceed the RV's Gross Vehicle Weight Rating (GVWR) or its **rear Gross Axle Weight Rating (GAWR)** as listed on the **vehicle certification label**.

To ensure the correct **weight balance**, take your loaded RV to a weigh **scale** to determine the actual weight distribution. After you've done this once, you will have a better understanding about how to **load** your vehicle in the future.

Remember, your RV will handle differently when towing a trailer, and stopping distances will be longer. Make sure your trailer is equipped with a **braking system** and is properly connected to your RV.

#### NOTICE

It is the responsibility of the driver to ensure that the RV's loading specifications and limits are not exceeded. Always weigh and reload if required. Be familiar with and comply with all applicable laws and regulations.

#### CAUTION

For safe towing and vehicle handling, maintain proper RV and trailer weight distribution. The total weight of the RV and the towed vehicle must not exceed the GCWR rating as stated on the vehicle certification label.

### LOADING AND WEIGHTS

This section will guide you with the **proper** loading of your RV to keep your loaded vehicle weight within its design rating **capability**, with or without a trailer. Properly loading your vehicle will provide **maximum** return of vehicle design performance.

The components of your RV are designed to perform if the RV is not loaded in **excess** of the **Gross Vehicle Weight Rating (GVWR)**, the maximum front and rear **Gross Axle Weight Rating (GAWR)** or the **Gross Combined Weight Rating (GCWR)**. These terms are ratings listed on labels located on the driver's door.

- ▶ The **Gross Vehicle Weight Rating (GVWR)** is the maximum permissible weight of the RV when it's **fully** loaded and ready for travelling.
- ▶ The **Unloaded Vehicle Weight (UWV)** is the weight of your RV as manufactured at the factory with full fuel, engine oil and coolants.
- ▶ The **Cargo Carrying Capacity (CCC)** (Canada) is equal to the GVWR minus each of the following: UWV, full fresh (potable) water weight (including water heater), full LP gas weight, and Sleeping Capacity Weight Rating (SCWR).
- ▶ The **Occupant and Cargo Carrying Capacity (OCCC)** is equal to the GVWR, minus UWV, plus full LP gas weight. In other words, OCCC is the amount of weight in occupants, cargo, water, and trailer tongue weight that can be added to the RV, without exceeding the GVWR.
- ▶ The **Gross Axle Weight Rating (GAWR)** is the value specified as the load carrying capacity of a single axle system (front or rear), as measured at the tire-ground interface. These numbers are shown on the Safety Compliance Certification Label.
- ▶ The **Base Curb Weight** is the weight of the vehicle including a **full tank** of fuel and all standard equipment. It does not include passengers, cargo, or optional equipment.
- ▶ The **Vehicle Curb Weight** is the weight of your new vehicle when you picked it up from your authorized dealer plus any aftermarket equipment.

# LABELS

## DETERMINING WEIGHTS

To determine that your RV is properly loaded, drive the fully loaded vehicle to a scale and weight as follows to obtain the specified weights:

- 1. Front Gross Axle Weight:** Drive only the front wheels onto the scale.
- 2. Gross Vehicle Weight (GVW):** Place the entire vehicle (both axles) onto the scale.
- 3. Rear Gross Axle Weight:** Drive forward until only the rear wheels are on the scale.
- 4. Corner Weight:** Drive each tire individually onto the scale and record the weight.

Compare the **GVW** with the **GVWR** on the label:

- If the **GVW** exceeds the **GVWR**, you must reduce the total vehicle load.
- If the **GVW** is less than the **GVWR** on the label, check the front and rear gross axle weights against the front and rear GAWR on the label.
- If either axle weight **exceeds** the GAWR for that axle, redistribute the load to ensure that loads on front and rear axle are within the required limits.

**NOTICE**

Load heavier items as centrally and as low as possible. Store lighter items in cabinets, closets and drawers. Secure luggage or similar cargo inside your RV to prevent it from shifting and causing damage or injury.

**CAUTION**

Total vehicle load must NOT exceed the max. GVWR/GAWR/GCWR of the chassis. The total load on each axle must never exceed its Gross Axle Weight Rating.

**NOTICE**

If you install any aftermarket or authorized-dealer installed equipment on the vehicle, you must subtract the weight of the equipment from the payload listed on the Payload Information Label in order to determine the new payload.

**WARNING**

The appropriate loading capacity of your vehicle can be limited either by volume capacity (how much space is available) or by payload of your vehicle, do not add more cargo, even if there is space available. Overloading or improperly loading your vehicle can contribute to loss of vehicle control & vehicle rollover.

**NOTICE**

The weight of cargo of your RV should never exceed numbers shown on the tag.

## TIRE AND LOADING INFORMATION

You will find information on tire pressure for the vehicle's factory-mounted tires on the labels described here. The recommended tire pressure can be found on the Tire and Loading information placard or label or the tire pressure table. The Tire and Loading information tag lists all the information regarding the **size** and **cold inflation pressure** of the **tires** on your vehicle, the **weight** of your RV just as it was manufactured, and the **GVWR**. (Gross Vehicular Rating). It can be found on the **B-Pillar** or the edge of the driver door.

### TIRE SIZE: MAXIMUM INFLATION PRESSURE

A tire's maximum inflation pressure is the **highest "cold"** inflation pressure that the tire is **designed** to contain. However the tire's maximum inflation pressure should only be used when called for on the **vehicle's tire placard** or in the **vehicle's owners manual**.

The vehicle's **recommended** tire inflation pressure should always be measured and set when the tire is **"cold"**. Cold conditions are defined as **early** in the morning before the day's **ambient temperature**, sun's radiant heat or the heat generated while driving can cause the tire pressure to temporarily **increase**.

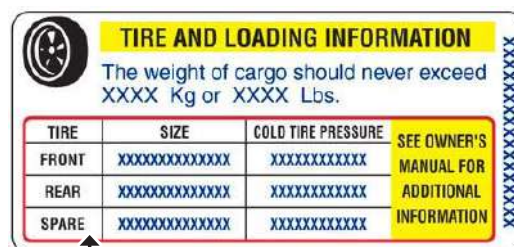

**NOTICE**

Information shown in the label above is not information for this model. Please check your RV for these same labels for the information of your unit in specific.

**NOTICE**

Inflation pressures recommended (while cold) for the tires originally installed on your RV. These tire pressure levels must be maintained to ensure proper handling, safety and fuel economy.



# LABELS

## COMBINED WEIGHT OF OCCUPANTS AND CARGO

- These numbers show the **maximum** weight of cargo the RV can load and carry when travelling as built by Grech RV.
- Is the **combined** weight of **cargo** and **passengers** that the vehicle is carrying.
- The **maximum payload** for your vehicle appears on the **Tire and Loading label**.
- The maximum payload for your vehicle can be found on the **Payload Information Label** on the **B-Pillar** or the edge of the driver door.
- The **payload** listed on the **Tire and Loading Information** label is the **maximum** payload for your vehicle as built by Grech RV.
- When towing, trailer tongue weight or king pin weight is also part of payload.



**NOTICE**  
Vehicles exported outside the US and Canada may not have the Payload Information Label.

**WARNING**  
Exceeding this information about the vehicle weight rating limits could result in substandard vehicle handling or performance, engine, transmission and/or structural damage, serious damage to the vehicle, loss of control and/or personal injury.

**NOTICE**  
If you install any additional equipment on your vehicle, you must determine the new payload. Subtract the weight of the equipment from the payload listed on the Tire and Loading label.

**NOTICE**  
When towing, trailer tongue weight or king pin weight is also part of payload.

**WARNING**  
The appropriate loading capacity of your vehicle can be limited either by volume capacity (how much space is available) or by payload capacity (how much weight the vehicle should carry). Once you have reached the maximum payload of your vehicle, do not add more cargo, even if there is space available. Overloading or improperly loading your vehicle can contribute to loss of vehicle control and vehicle rollover.

## VEHICLE'S MANUFACTURERS ID LABEL

The label below is an example of the label on your vehicle which specifies the proper **tire loading limits** which must be followed to insure the operation of your vehicle.

This label is located on the door in driver's side of the RV.

- **GM #:** This is your permanent Grech Vehicle Identification #.
- **Vin #:** This is your OEM Vehicle Identification Number.
- **GVWR:** Gross rated weight capacity of your vehicle.

**NOTICE**  
Gross Vehicle Weight Rating (GVWR) is the max permissible weight of this RV when fully loaded, it includes all weight at the RV's axles(s).

- **GAWR Front:** Rated weight capacity of the front axle.
- **GAWR Rear:** Rated weight capacity of the rear axle.
- **Incomplete Vehicle Manufactured:** Date the chassis was produced by the OEM manufacturer.
- **Date of manufacture by Grech:** Date the vehicle was completed by Grech RV.
- **Paint Code:** Master number for the paint specification and color used on your vehicle.

**NOTICE**  
Gross Axle Weight Rating (GAWR) is the value specified as the load carrying capacity of a single axle system, as measured at the tire-ground interfaces.

**NOTICE**  
Do not exceed GVWR or the GAWR specified on the labels.

- **Tires, Rims:** Required tire and rim sizes, and air capacities for your specific vehicle, for your maximum payload.

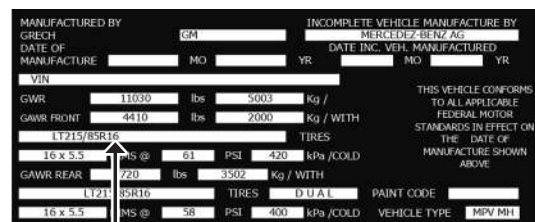

**NOTICE**  
Information shown in the label above is not information for this model. Please check your RV for these same labels for the information of your unit in specific.

# LABELS

## NOTICE

Inflation pressures recommended (while cold) for the tires originally installed on your RV. These tire pressure levels must be maintained to ensure proper handling, safety and fuel economy.

## LT- METRIC

The **Tire and Load Information** label are based on standards including The Tire and Rim Association, Inc. (TRA) which is how this label is written. A brief explanation of the sizing system is explained below:

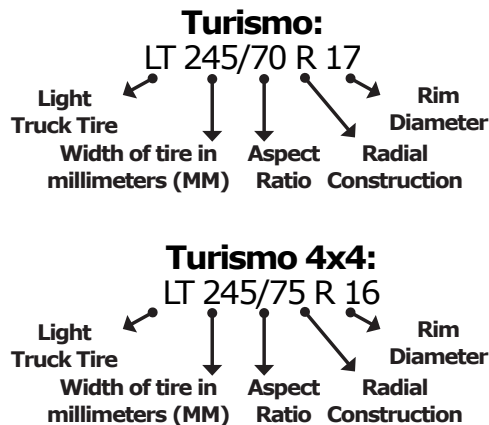

## WARNING

Do not overload the tires by exceeding the specified load limit as indicated on the Tire and Loading Information placard on the driver's door B-pillar. Overloading the tires can overheat them, possibly causing a blowout. Overloading the tires can also result in handling or steering problems, or brake failure.

## WARNING

Exceeding the maximum speed for which tires are rated can lead to sudden tire failure, causing loss of vehicle control and possibly resulting in an accident and/or serious personal injury and possible death, for you and for others.

## NOTICE

Do not use replacement tires with lower carrying capacities than the original tires because they may lower the vehicle's GVWR and GAWR limitations. Replacement tires with a higher limit than the original tires do not increase the GVWR and GAWR limitations.

## WARNING

For you and all your passenger's safety the wheel tightening must be checked after changing a tire and after approximately 30 miles, to avoid wheels becoming loose therefore causing a possible accident. It is important to adjust the wheel's torque at 133 ft lbs on 144" models.

## FIRE EXTINGUISHER'S LABELS

The **testing** and **maintenance** of fire extinguishers is essential and required by law to ensure they **work** if and when they're ever needed. Following these activities the extinguisher must be **labelled** appropriately to confirm their fitness for purpose.

The **tag** is where you will find everything you need to know about your extinguisher, including the **serial number**, **model number** or other **identifying** information.

All recorded information is **essential** for maintaining the **efficacy** of your fire extinguisher, never **remove** or **mark** on the tag unless authorized to do so.



# LABELS

## RV VEHICLE INFORMATION

There are other two labels at the bottom of the driver side which has all the information you will need to know how to load your RV safely within its recommended limits.



**Vehicle Noise Emission Control Information**  
**MFD BY MERCEDES-BENZ AG**      **Make Mercedes-Benz**      **10/2021**

This Vehicle Conforms to U.S. EPA Regulations for Noise Emission Applicable to Medium and Heavy Trucks. The following acts or the causing thereof by any person are prohibited by the Noise Control Act of 1972: (A) The removal or rendering inoperative, other than for purposes of maintenance, repair, or replacement, of any noise control device or element of design (listed in the owner's manual) incorporated into this vehicle in compliance with the Noise Control Act; (B) The use of this vehicle after such device or element of design has been removed or rendered inoperative.

A 907 584 24 05

**INCOMPLETE VEHICLE**  
**MFD BY MERCEDES-BENZ AG**

VIN W1X8ED3Y0MT076691

GVWR	5003/11030	KG/LB
GCWR	6917/15250	KG/LB
GAWR FRONT	2000/4410	KG/LB
GAWR REAR	3502/7720	KG/LB
DATE OF MFD	10/2021	

PAINT CODE  
**9136**

A 907 584 34 05



## HOW TO CALCULATE WEIGHTS

- ▶ **For your Gross Vehicle Weight (GVW):**
  - Curb Weight + Cargo Weight + Water Weight + LP Weight + Passenger Weight + Tongue Weight

**REMEMBER:** GVW must not exceed GVWR.
- ▶ **To figure out your Gross Combination Weight (GCW):**
  - GVW + Trailer Weight or Toad Weight

**REMEMBER:** GCW must not exceed GCWR.
- ▶ **To get your towing capacity:**
  - GCWR - GVW

**NOTICE**

Knowing the actual weight will also tell you how much margin is left before the RV is overloaded, which may come in handy on a long trip where you may want to travel with more gear or supplies.

# ALARMS

All models are equipped with a **LP gas** and **carbon monoxide** alarm and a **smoke** alarm as standard equipment.

## ⚠ CAUTION

Alarms indicate the slow accumulation of LP gas, CO or smoke and may warn low battery levels. In case the alarm goes off please have an authorized service center to check the system and identify the source of the alarm. Correct the problem before using the RV.

## CARBON MONOXIDE / LP GAS ALARM

**Carbon Monoxide (CO)** gases and propane, or liquified petroleum (LP) can be **dangerous**. Propane is commonly used in recreational vehicles, and early detection of propane **leaks** can help prevent dangerous conditions. CO can also accumulate with **improper ventilation** or with **malfunctioning appliances**.

This alarm can be found on the passenger side of the RV under the sofa bed on the rear side of the RV.



Carbon Monoxide is a **colorless, odorless, and tasteless** gas. The CO detector is designed to **detect** the toxic CO gas resulting from **incomplete combustion** of any fuel, for example (gasoline, propane, natural gas, oil, charcoal or wood). Anything that **burns fuel** such as engines, generators, furnaces, stoves or water heaters produce **CO gas**.

When there is a **high** carbon monoxide level, your alarm will beep/chirp **4 times** in a loud constant pattern. Just like the smoke alarm the industry-standard alarm setting **ensures** that even people who are asleep will be **alerted** to emergencies. When there is a **high level** of propane the alarm will sound with **constant** beeps. The smoke/carbon monoxide detector will make a noise **once** for about a **minute** for at least **30 days** when the battery is weak. The battery must immediately be replaced.

## ⚠ WARNING

This alarm has not been designed to detect smoke, fire, or gases other than carbon monoxide and propane.

## ⓘ NOTICE

Test alarm operation after vehicle has been in storage, before each trip and once per week during use.

CO is a gas that binds with **hemoglobin** reducing the body's ability to **absorb** and carry oxygen to vital organs. When removed from exposure, the symptoms dissipate as CO is expelled through the lungs.

## POTENTIAL PROBLEM SOURCES OF CO GAS

The **sources** of carbon monoxide gas can be very difficult to locate due to the odorless, colorless nature of the gas, especially after the RV has been aired-out prior to the investigator's arrival. Look closely at the following:

1. **RV's nearby**
2. **Camp fires**
3. **Engine or generator exhaust entering RV.**
4. **Excessive spillage or reverse venting of fuel-burning appliances:**
  - Outdoor ambient conditions such as wind direction and/or velocity, including high gusts of wind; heavy air in the vent pipes.
  - Negative pressure differential resulting from the use of exhaust fans.
  - Simultaneous operation of several fuel burning appliances competing for limited internal air.
  - Vent pipe connection vibrating loose from clothes, dryer, furnace, or water heater.
  - Obstructions or unconventional vent pipe designs which amplify the above situations.
5. **Extended operation of unvented fuel-burning devices** (range, oven, fireplace, etc.)
6. **Temperature inversions which can trap exhaust gases near the ground.**
7. **Poorly designed or maintained vents.**

## ⚠ DANGER

Do not breathe heating or cooking fumes or engine exhaust to prevent asphyxiation.



# ALARMS

## THE DANGERS OF CO GAS POISONING

The following are the symptoms of carbon monoxide poisoning and need to be discussed with all occupants of the RV:

- **Mild Exposure:**
  - Slight headache, nausea, vomiting, fatigue ("flu-like" symptoms")
- **Medium Exposure:**
  - Severe throbbing headache, drowsiness, confusion, fast heart rate.
- **Extreme Exposure:**
  - Unconsciousness, convulsions, cardiorespiratory failure, brain damage, and death.

Many cases of reported carbon monoxide **poisoning** indicate that while victims are aware they are not well, they become so **disoriented** they are unable to save themselves by either exiting the RV or calling for assistance.

### ⚠ CAUTION

Children and pets may be the first affected. Other highly sensitive people may include the elderly and those with lung or anemia.

## ALARM STATES MEANING

- **Normal Operation State:** The green power Led is **ON** when the alarm is functioning and no CO or propane gas is present. Press the **Silence/Test button** to perform a self test.
- **Power Off State:** If no LEDs are **ON** then the alarm is powered **OFF**. Apply power to the alarm to resume normal operation.
- **Self Test State:** If the **Silence/Test** button is pressed while in normal operation, the alarm will perform a **self test** of the CO sensor, propane sensor and battery voltage. It is recommended to perform a self test **weekly**, after power up from storage (**4 rapid beeps** followed by a **4-5 sec. pause**), followed by **2 cycles** of the propane horn pattern (**constant beeping**).
- **CO Alarm State:** If CO gas reaches **unsafe** levels, the alarm will enter CO alarm state. The horn will sound with **4 rapid beeps** followed by a **4 second pause** and the **red** led will flash rapidly. Open windows and doors and turn off appliances. Move to fresh air and **call 911**.
- **Propane Alarm State:** If propane gas exceeds **10%** of the **lower-explosive-limit** for more than **30 seconds**, the alarm will enter propane alarm state. The horn will sound with **constant** beeps and the **red** LED will be on. Immediately **turn off** all propane appliances and gas valve at the propane tanks. Open doors and windows to properly ventilate the RV. Check for any gas **leaks** and contact a qualified RV technician.

- **Alarm Silenced State:** A CO alarm or propane alarm can be silenced for up to **5 mins.** by pressing the Silence/Test button. The **red** LED will flash each second while the alarm is silenced. The original alarm state will **resume** after **5 mins** if the CO or propane levels still exceed safe levels.
- **Low Battery State:** If the supply voltage drops below **8VDC**, the alarm will enter Low Battery State. The horn will beep **every minute** and **both** LEDs will flash every min. Alarm performance cannot be guaranteed as the supply voltage drops below the low battery threshold. **Charge or replace the RV battery immediately.** Do not disconnect the alarm.
- **End-of Life or other Failure State:** If the OC or propane alarm fails a self test, or if the End-of-Life is reached (**after 5 years of operation**), the alarm will enter the Failure State. The horn will beep **every minute** and **both** LEDs will do a **double** flash every min. Replace alarm **immediately**.

ALARM STATES			
State	Green LED	Red LED	Audible Horn
Normal Operation	On	Off	Off
Power Off	Off	Off	Off
CO Alarm (RVCOLP models only)	Off	Flashing	4 constant beeps
Self Test	Off	On/Flashing	4 constant beeps
Propane Alarm	Off	On	Constant beeps
Alarm Silenced (5 mins. Max.)	Off	Flash each sec.	Off
Low Battery	Flash each min.	Flash each min.	Chirp each min.
End-of-Life or other Failure	Off	Double flash each min.	Chirp each min.

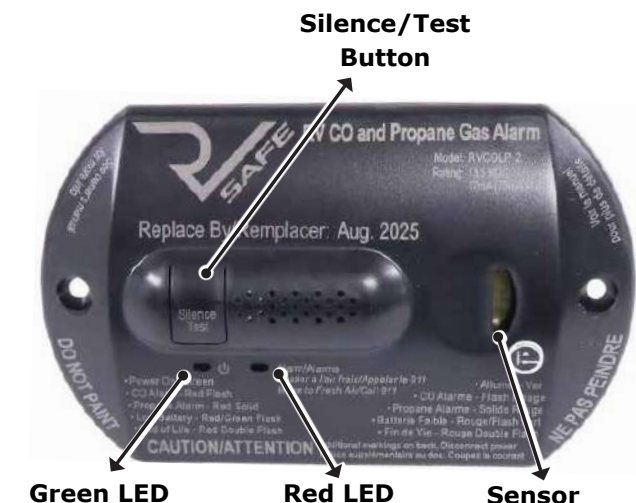

### ⚠ NOTICE

For more information please refer to the CO and Smoke Safe Alarm Owner's Manual provided in the RV information kit.

# ALARMS

## DETECTOR TEST

If the Silence/Test button is pressed while in normal operation, the alarm will perform a self test of the **CO sensor**, **LP sensor** and **battery voltage**. It is recommended to perform a self test weekly, after power up from storage, and before each trip.

If the self test passes, the alarm will perform **2 cycles of the CO horn pattern** (4 rapid beeps followed by a 4 second pause), followed by **2 cycles of the Propane horn pattern** (constantly beeping).

This CO and Propane detector is **not** designed to detect **smoke**. Neither to be seen as a substitute for the proper servicing of **fuel-burning** appliances and finally it is not used on an **intermittent** basis, or as a portable alarm for **spillage** of combustion products from fuel-burning appliances.

### ⚠ DANGER

Activation of your CO alarm indicates the presence of Carbon Monoxide (CO) which can kill you.

### ⓘ NOTICE

Carbon Monoxide and LP detector must be replaced every five years.

### ⚠ CAUTION

It is not recommended that the detector be disconnected from the battery during periods of storage. There is a small heater on the sensor of the device that burns away impurities in the air during periods of normal use. During periods when power is interrupted, impurities can build up on the sensor. When power is returned to the detector, the alarm may activate until the impurities are burned off. This could take a number of hours, and the alarm will be constantly on during this time.

## DANGERS OF LP GAS

Liquified petroleum (LP) gas is commonly called **propane** and it is used as fuel for **heating** and cooking appliances in RV's in particular. Propane gas is denser than air, and will usually accumulate close to the floor. Therefore, the alarm must be placed near the floor in order to quickly detect propane gas leaks.

If your alarm detects CO it will sound with a **4-chirp pattern** and if your alarm detects LP gas it will sound with a **constant beeps** and these are some **tips** if an **emergency** happens:

### ⚠ WARNING

Activation of this device indicates the presence of Propane Gas, which can cause an explosion and/or fire. This normally indicates a leak in the propane gas pipes or a propane gas appliance.

### ⚠ DANGER

Propane gas is denser than air, and will usually accumulate close to the floor. Therefore, Grech RV made sure to place it near the floor in order to quickly detect gas leaks.

### ⚠ WARNING

**If you smell gas or CO**, immediately follow these steps:

1. Extinguish open flames, pilot lights and all smoking materials.
2. Do not touch any electrical switches in or near the RV.
3. Do not start vehicle's engine or generator.
4. Shut off the propane gas supply at propane tanks or supply.
5. Open doors, windows and roof vents after making sure the roof vent fans are "OFF".
6. Leave the motorhome and its immediate vicinity until odor is gone.
7. Have a qualified service technician check the system for leaks and make any necessary corrections and repairs.
8. If you cannot reach a gas supplier or qualified service technician, contact the local fire department.
9. Do not turn on gas supply until the leak has been repaired.

## IMPORTANT SAFETY PRECAUTIONS

- ▶ The location of the LP and CO detector is in a perfect spot to detect any **leaks**, near the heater, kitchen and grills.
- ▶ **Ensure** that the alarm horn can be **heard** by all passengers with hearing capabilities.
- ▶ Seek **medical help** if you or other passengers in the RV are suffering from Carbon Monoxide poisoning.
- ▶ Remember, Carbon Monoxide is an **odorless, colorless and tasteless** gas, the alarm sounds will make sure to alert you from any leaks.
- ▶ **Never** ignore the problem as it may cause **sickness, injury or death** in some or all passengers in the RV.
- ▶ When using kitchen appliances, **ventilation** in the RV is required due to the fact that this may trigger the CO alarm and cause a **false alarm**.

### ⚠ WARNING

Do not use cooking appliances for comfort heating. Cooking appliances need fresh air for safe operation.

### ⚠ CAUTION

Have a qualified technician check your LP gas system annually or if you have any signs of leaks or malfunctions.

### ⚠ CAUTION

Check alarm vent each time LP tank is filled to make sure it is clear of obstructions.

### ⓘ NOTICE

CO and propane alarms will not work without a source of power. The alarm will not operate nor sound if the power source is low or disconnected.

### ⓘ NOTICE

When contacting the dealer for more information or replacements, service or product information, the model and serial numbers must be handy for an easier and faster assistance.

# ALARMS

## REGULAR MAINTENANCE OF CO ALARM

Both Smoke and CO/LP gas alarms need to be **cleaned** for better performance. Clean the alarm at least **once a month**, this will **ensure** that smoke, LP gas or CO can reach the alarm's sensing chamber with no trouble.

Here are some tips to give your CO and LP gas detector a proper maintenance

1. **Wipe down** the outside of the detector with a dry, soft cloth around the **sensor**.
2. Attach the **soft brush** attachment to the vacuum hose, **gently** vacuum the CO detector, focusing on the area **around the sensor**. Try not to touch the sensor with the hard plastic of the vacuum attachment. The sensor is **sensitive** and can be easily **damaged**.
3. Spray the area around the sensor with **canned air** or a **gas duster**.



### NOTICE

Some components that could affect your alarm are:

- Water
- Excessive dust or grease
- Cleaning supplies, chemical sprays and perfume products.
- Do not paint the alarm. Paint can block the air flow to the sensor.
- Silicon adhesives (ex. hairsprays)
- Corrosive liquids (ex. acids)
- Alkaline base metals (ex. salt spray)

### WARNING

CO and propane alarms have been proven to be both effective and reliable, but they may not be effective under all conditions. No alarm/sensor design can offer total protection of life and property. A CO and/or propane alarm is not a substitute for an adequate homeowner's property insurance or life insurance policy.

### WARNING

The installation of CO alarms should not be used as a substitute for proper installation, use, and maintenance of fuel-burning appliances, including appropriate ventilation and exhaust systems.

### NOTICE

CO and LP gas sensors may not always activate and provide early enough warning. A CO sensor will only activate when its maintained in working order and sufficient amounts of CO gas reaches the unit.

## SMOKE ALARM

Your RV is also equipped with a smoke alarm that will sound whenever there is an **unsafe** amount of smoke in the RV. Always have any type of ventilation inside the RV before and after cooking by opening roof vent, entrance, rear door or windows.

This alarm can be found on the driver side, above the TV that is located on the rear side besides the bathroom.



## OPERATION ON ALKALINE SMOKE ALARMS

This smoke alarm is equipped with a feature that **automatically activates** the alarm when the alarm is mounted to the mounting bracket for the first time.

It is armed with **9 Volt Alkaline** batteries and will not operate without a battery installed. Proper battery must be installed immediately when **low battery** signal is given or the unit will fail.

When products of **combustion** are sensed, the unit sounds a **loud** alarm which continues until the air is **cleared**. This alarm incorporates the internationally recognized horn signal for **evacuation**. During **alarm mode**, the horn produces **3 short beeps** followed by a **2 second pause** and then **repeats**.

## FALSE ALARMS FEATURE: MUTE FEATURE

The "mute" feature has the capability of **temporarily** reducing the **sensitivity** of the alarm circuit for approximately **8 minutes**. This feature is to be used only when a known alarm condition such as **smoke** from **cooking** activates the smoke alarm.

The smoke alarm is deactivated by pushing the **test button** on the smoke alarm cover for at least **three seconds**. The smoke alarm will automatically reduce **sensitivity** and "beep" every **30-40 seconds** for approximately **8 minutes** to indicate the alarm is in the **temporary** silent condition. The smoke alarm will gradually reactivate during the **8 minutes** and sound the alarm if particles of **combustion** are still present. The "mute" feature may be used **repeatedly** until the air has **cleared**.

### CAUTION

Before using the "Alarm Mute" feature, identify the source of smoke and be certain that safe conditions exist.

# ALARMS

## TESTING THE SMOKE ALARM

Test by pushing the **test button** on the smoke alarm cover until the alarm sounds, then release. The alarm sounds if all **electronic circuitry, horn** and **battery** are working. The alarm may continue to sound for up to **10 seconds** after the button is released. If there are no alarm sounds, the unit may have a **defective battery** or other failure. Test the smoke alarm **weekly** to assure proper operation.

### ⚠ DANGER

Never use an open flame of any kind to test this unit. You might accidentally damage or set fire to the unit or to your home.

### ⚠ WARNING

Test smoke alarm operation after vehicle has been in storage, before each trip, and at least once per week during use. An identical marking provided and permanently located, visibly at 24 inches (610 mm) of the smoke alarm.

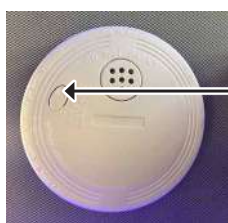

Test/  
Silence  
Button

## BATTERY REPLACEMENT

The smoke alarm comes with a **9 Volt battery**. The battery should last for at least **one year** under normal operating conditions. The smoke alarm has a **low battery indicator**, an audible "beep". It will operate at **30-40 second** intervals for a minimum of **7 days**. When this indication occurs, replace battery with an **Alkaline type** (Eveready Energizer #522, Duracell #MN1604).

## WHAT TO DO IN CASE OF SMOKE ALARM

Open doors, windows and roof vents to **air out** the RV and silence the alarm. Identify and eliminate the source of smoke. If smoke is detected you will be alerted by **3 beeps, pause, 3 beeps, pause** in a repeating pattern and the detectors **LED** will flash **red** as the alarm is sounding. The industry-standard alarm setting **ensures** that even people who are asleep will be **alerted** to emergencies.

If smoke is detected you will be alerted by **3 beeps, pause, 3 beeps, pause** in a repeating pattern and the detectors **LED** will flash **red** as the alarm is sounding. The industry-standard alarm setting **ensures** that even people who are asleep will be **alerted** to emergencies.

When vacationing in an isolated area, keep in mind that help from emergency services may be some distance away.

It's vitally important that you eliminate your risk from fire and have a fire escape plan in place that everyone is familiar with and has previously practiced.

### ⚠ WARNING

It is crucial yo know your location when an accident with fire happens so the emergency responders can find you. Be aware of your locations and surroundings.

### ⚠ WARNING

In case of a smoke alarm emergency immediately follow these steps:

1. Dont panic; stay calm.
2. Get out of the RV as quick as possible. Don't stop to get dressed or collect anything.
3. Cover your nose and mouth with a cloth (preferly damp). Take short, shallow breaths.
4. Meet outside in a safe distance from the RV and do a head count to make sure everybody got out safely.
5. Call the fire department as soon as possible from outside. Give location and name.
6. Don't go back inside the RV when it's still burning. Wait until firefighters tell you it's safe to go in.

### ⚠ WARNING

Make sure all travellers in the RV know what the sound of each type of alarm indicates and what to do when they hear it.

### ⚠ DANGER

Remember, DON'T FIGHT A FIRE. A fire extinguisher is no substitute for the fire department.

## SMOKE ALARM MAINTENANCE

- **ONCE A MONTH:** By pressing and holding the test button for at least 5 seconds until you hear the beeps.
- **EVERY 6 MONTHS:** Vacuum dust off the smoke alarm. Keeping it free of particles helps reduce false alarms and ensure smoke can easily reach the internal sensor.
- **EVERY YEAR:** Replace alkaline batteries every 12 months.

### ⚠ CAUTION

Gas cylinders, pipes, fittings and connections should be checked regularly, particularly after driving on bumpy roads, which may loosen connections. Maintain the RV's mechanical systems, such as radiator hoses, fuel lines, brake systems, transmission, etc., in good working order to eliminate the risk of any leaks or malfunctions that may result in a fire.

### ⚠ CAUTION

Maintain the RV's mechanical systems, such as radiator hoses, fuel lines, brake systems, transmission, etc., in good working order to eliminate the risk of any leaks or malfunctions that may result in a fire. Check all electrical appliances for frayed cords and any other visible damages in components.

### ⓘ NOTICE

For more information please refer to the Smoke & Fire Alarm manual provided in the RV information kit.



# EMERGENCIES

**Portable** fire extinguishers save lives, RV fires are not an uncommon occurrence, so **preparation** and **prevention** are key.

In all RV models, the fire extinguisher is **located** behind the **passenger's seat** on the **right** side of the RV near the entrance.

## LOCATION



### NOTICE

In reference to the U.S Fire Administration reports, the top causes for fires in RV's are unintentional actions and failure of equipment or heat source. It is very rare that the fire is caused by an act of nature. Leading areas of origin inside RV's are typically in the engine area, running gear, wheel area, cooking area and heater area of the vehicle. Because there can be diverse sources of ignition on an RV, the NFPA requires that all RV's must have a B:C rated fire extinguisher.

## TYPES OF FIRE EXTINGUISHERS

Portable fire extinguishers are rated by **classes**, these classes demonstrate the **type of fires** the extinguisher can handle. NFPA requires that RV's have a **Class 1-A:10-B:C extinguisher** because of the possibility of an engine fire, propane spill or gas spill. These are all **flammable liquids** that are commonly handled in and around an RV.

- **Class A:** For ordinary combustibles like wood, paper, plastics.
- **Class B:** For flammable liquids and gases.
- **Class C:** For fires involving live electrical equipment.
- **Class D and K:** For metals or cooking fires involving oils.

### WARNING

Stay a safe distance from a fire and near an exit. Stay close to the floor to avoid heat and fumes. The chemical from the fire extinguisher will shoot at least 10 feet (3m).

### WARNING

Use of RV is not recommended without a working fire extinguisher installed.

## OPERATION

An easy way to remember the **proper** and **correct** way to use a fire extinguisher is the acronym **P.A.S.S**, this stands for:

- **P-Pull:** Pull the pin that is located at the top of the extinguisher and hold the extinguisher upright.
- **A-Aim:** Aim the nozzle at the base (bottom) of the fire and stand six feet away
- **S-Squeeze:** Squeeze the handle/lever to discharge the agent.
- **S-Sweep:** Sweep from side to side until the fire is extinguished.

Make sure to stand about **8 to 10 feet away** from the fire, this gives you enough space for you to be **safe** from burning and to put out the fire. If the fire is not able to be **controlled quickly**, it'll be time to **evacuate** the RV and **call 911**. Do not try to extinguish fires that are **large** or **out of control**.



### WARNING

After the fire is out, beware of flashback. Flashback occurs when flammable vapors from combustible liquids spread back to the ignition source and reignite the fire.

Once the fire is **out** is completely extinguished, **discharge** the fire extinguisher entirely and get it **recharged** or **replaced immediately**.

### CAUTION

The first rule of RV firefighting is to save lives first and property second. Get yourself and the passengers to safety before attempting to extinguish any fire. Only if you can do so without endangering yourself or others should you use firefighting aids on hand. Re-emphasize to everyone aboard that objects can be replaced, people can't. NEVER re-enter a burning RV to retrieve anything. **Get out and stay out.**

### WARNING

Remember to not fight a fire, unless you call the fire department first. A fire extinguisher is no substitute for the fire department.

### NOTICE

Ensure family members know how to use the extinguishers.



# EMERGENCIES

## FIRE EXTINGUISHER'S MAINTENANCE

It is not required to have **professional inspections** for the portable fire extinguishers in the RV but it is important to have **visual inspections** on regular basis. Look for signs of **damage** and check to see that the **gauge** is still set to **green**, if the fire extinguisher has been used in a previous occasions it is necessary to **replace** it.

It is recommended that the fire extinguisher is inspected at least **once a month**. It will need to be inspected more frequently if the extinguisher is exposed to **high temperatures** or possible **tampering**. Do not test the extinguisher by **partially discharging** since this will cause that the **internal pressure** escapes and the fire extinguisher will need to be replaced.

The **powder** in some extinguishers can **compress**, that over course of time will **settle** and **harden** at the bottom almost like concrete, making them **unusable**. A good and effective way to solve this is by **inverting** and/or **shaking** the fire extinguisher. Sometimes you will not listen the powder **fall**, if this happens you can **slightly** hit the fire extinguisher so the powder moves and **loosen up** you will know when the powder **falls** because you will feel it and listen.



### NOTICE

Extinguishers need an annual check-up to make sure fire extinguishers still work properly when there is a need to be used. You want to check that the pin and tamper seal are intact and that the pressure is still in the green. In reference to Home Renovation site "Make it Right", they suggest: "Tip is upside down. The agent inside the extinguisher can settle at the bottom—it has the consistency of flour and can easily get packed over time. Turn the fire extinguisher upside down a few times to break up the agent inside."

**Periodically** check the **pressure gauge** on your fire extinguisher. If it loses pressure, the dry chemical will not **effectively discharge**. Do not operate or occupy the RV without a **fully charged** fire extinguisher.



### NOTICE

If the pointer on the pressure gauge is not in the operating range (pointer in the green portion of the gauge), immediately replace the extinguisher. Record the inspection date on the tag provided.

### WARNING

#### TIPS TO AVOID FIRE ACCIDENTS

Before hitting the road, it is crucial that all passengers know about **safety tips** when travelling.

- ▶ Show everyone where the fire extinguisher is **located** and **how** and **when** to use it.
- ▶ When there is a fire emergency you have to **act fast** and be **prepared** because time is **limited** depending on what started the fire and what components are near.
- ▶ Ensure that your fire extinguisher is **working properly**.
- ▶ Immediately clean up any **fuel spills**. Gasoline and propane can **combust quickly**. While diesel, although less flammable, it will evaporate more **slow** and pose a **risk** for longer.
- ▶ Make sure all small batteries are **kept secure** in a plastic container so that they cannot roll or bounce around the RV. Loose batteries that can move or fall can **split** or **combine** in a way that induces **fire**.
- ▶ Your stove will continue to **emit propane** even with the flame extinguished. To **avoid** the risk of an explosion, double check that it is turned off properly when you're finished and **never** heat your rv with the stove.
- ▶ Have your fuel-burning appliances **checked** at the beginning of each camping season to ensure they are properly **vented, working well** and **free** of any obstructions such as cobwebs, bitds, nests, etc.
- ▶ Maintain the RV's **mechanical systems**, such as radiators hoses, fuel lines, brake systems, transmissions, etc., in **good working order** to eliminate the risk of any **leaks** or **malfunctions** that may result in fire.
- ▶ Never leave cooking **unattended**.
- ▶ Store all **linens** and other **combustibles** well away from the **kitchen area**. In RVs compact kitchens components such as paper towels and curtains are likely to be closer to the stove, exercise even greater **caution** than you do at home when cooking in your RV.
- ▶ Keep all lighters and matches safely out of reach of children.

### NOTICE

For detailed information, refer to the Fire Extinguisher manual provided in the RV Information Kit.

# RV OPERATION

## REFUELING THE VEHICLE

### ⚠ WARNING

Make sure all LP Gas tanks and appliances are shut off before refueling. Do not smoke when refueling. Keep flames, sparks and smoking materials away from fuel or flammable fumes.

### ⚠ CAUTION

Modern fuel systems may allow pressure to build up in the fuel tank during hot weather. Under certain conditions, small amounts of fuel may spray from the fuel filler tube when the fuel cap is removed quickly, creating a potential hazard.

### ⚠ DANGER

Fuel is highly flammable. Improper handling of fuel creates a risk and explosion. Avoid fires, open flames, smoking and creating sparks under all circumstances. Switch off the engine and, if applicable, the auxiliary heating before refueling.

### ⚠ WARNING

Fuel is poisonous and hazardous to health. There is a risk of inkury. You must make sure that fuel does not come into contact with your skin, eyes or clothing and that it is not swallowed. Do not inhale fuel vapors. Keep fuel away from children.

### ⓘ NOTICE

If you or others come into contact with fuel, observe the following:

- ▶ Wash away fuel from skin immediately using soap and water.
- ▶ If fuel comes into contact with your eyes, immediately rinse them thoroughly with clean water. Seek medical assistance without delay.
- ▶ If fuel is swallowed, seek medical assistance without delay. Do not induce vomiting.
- ▶ Immediately change out of clothing which has come into contact with fuel.

### ⚠ WARNING

If you mix fuel with gasoline, the flash point is lower than that of pure pure diesel fuel. When the engine is running, exhaust system components could overhead without being noticed. There is a risk of fire. Never refuel with gasoline. Never mix gasoline with diesel fuel.

### ⓘ NOTICE

Environmental note: If fuels are handled improperly, they pose a danger to persons and environment. Do not allow fuels to run into the sewage system, the surface waters, the ground water or into the ground.

### ⚠ WARNING

Use Ultra Low Sulfur Highway Diesel Fuel only. Max. B5 (Max. 5 percent biodiesel allowed). Otherwise the emission control system will be damaged.

## FUEL CAP

The fuel tank filler cap is located adjacent to the driver's door. on the exterior. Slowly remove the fuel cap to release any built up pressure. If you hear a hissing sound, wait for hissing to stop before fully removing the cap.



The fuel filler flap is beside the driver's side door. It is only possible to open the fuel filler flap when the front door is open.

## REFUELING PROCEDURE

- ▶ Remove the key from the ignition lock.
- ▶ Switch off the auxiliary heating system.
- ▶ Open the driver's side door first, and then the fuel filler cap.
- ▶ Close all vehicle doors to prevent fuel vapors from entering the vehicle interior.
- ▶ Turn fuel filler cap counter-clockwise, remove it and let it hang from strap.
- ▶ Completely insert the filler neck of the fuel pump nozzle into the tank and refuel.
- ▶ Only fill the tank until the pump nozzle switches off. Fuel may otherwise leak out.
- ▶ Replace tank filler cap on tank and turn clockwise. You will hear a click when the fuel filler cap is closed fully.
- ▶ Open the front left-hand door first, and then close the filler flap.

### ⓘ NOTICE

Overfilling the fuel tank may cause damage to the fuel evaporative emission system.

## PROBLEMS WITH THE FUEL AND FUEL TANK

**If your vehicle is losing fuel, the fuel lines or the fuel tank are defective:**

- ▶ Turn the key immediately to position 0 in the ignition lock and remove it.
- ▶ Do not restart the engine under any circumstances.
- ▶ Consult a qualified specialist workshop.

# RV OPERATION

If the fuel tank has been run dry, after refueling carry out the following steps:

- **Before starting the engine:** Switch on the ignition three or four times.
- Turn the key to position **2** in the ignition lock. The **preglow indicator lamp** in the instrument cluster lights up briefly.
- Once the **preglow indicator lamp** goes out, turn the key to position **3** in the ignition lock and release it as soon as the engine is **running**.

You can start the diesel engine without preglow when the engine is warm.



**Preglow Indicator Lamp**

## DIESEL EXHAUST FLUID (DEF)

The **Diesel Exhaust fluid (DEF)** is an emissions control liquid required by **modern** diesel engines. It is injected into the **exhaust stream**. DEF is **never** added to diesel fuel, it is a non-hazardous solution of **32.5%** urea in **67.5%** de-ionized water. DEF is **clear** and **colorless**, looks exactly like water, it has a slight smell of ammonia, similar to some home cleaning agents.

### NOTICE

Urea is a compound of nitrogen that turns to ammonia when heated. It is used in a variety of industries, including as a fertilizer in agriculture.

DEF consists of **deionized water** in a 1:2 solution and is contained in a **reservoir** separate from the fuel tank and is metered into the engine's exhaust stream to **control** certain emissions. Inside the **exhaust pipe**, the DEF vaporizes and decomposes into **ammonia** and **carbon dioxide**.

## RUNNING OUT OF DIESEL EXHAUST FLUID

Diesel exhaust fluid is used to **reduce** Nitrogen Oxigen emissions (NOx). You will get a lot of **warnings** to refill the DEF tank before you **run out**. If you decide to ignore the warnings to refill the DEF tank before you run out, the engine is designed to **limit** its power and fueling **dramatically**.

### WARNING

The 32.5% urea concentration is the ideal solution as it provides the lowest freeze point, for this reason it is critical.

### NOTICE

A 32.5% solution of DEF will begin to crystallize and freeze at 12 deg F (-11 deg C). At 32.5%, both the urea and water will freeze at the same rate, ensuring that as it thaws, the fluid does not become diluted, or over concentrated. The freezing and untawing of DEF will not cause degradation of the product.

### NOTICE

DEF residue can be easily cleaned up by washing the area with warm water.

### NOTICE

DEF fluid is corrosive to most metals used in automotive applications. Carbon steels, iron, zinc, nickel, copper, aluminum and magnesium are some of them. If it comes into contact with any metals, you should clean the area with plenty of warm water to eliminate accelerated corrosion.

### NOTICE

The fluid typically has life of 18 months. It technically does not expire, but it can lose its water content and the ratio of urea/water could change.



**DEF Filler Cap**

## OPERATION

- DEF filler cap is located on the **left** side of the engine compartment.
- **To open:** Switch off the ignition.
- Open the hood.
- Turn filler cap counter-clockwise and remove it.
- **To close:** Replace cap on the filler neck and turn it clockwise. You will hear a click when cap is fully closed.
- Close the hood.

### WARNING

Drinking it must be voided at all costs. If that happens, contact a doctor immediately.

### CAUTION

If it gets into your eyes, flush with large amounts of water immediately for at least 15 minutes. Consult a doctor if you have any doubts or symptoms that are concerning.

### NOTICE

The DEF you purchase should state and display the certification of the American Petroleum Institute (API), German Institute of Standardization DIN 70700, the International Organization for Standardization ISO 22241-1, and meet AUS-32 specifications. This will ensure the proper purity and concentration (32.5%) of urea. For more information of these specifications, visit [www.iso.org](http://www.iso.org)

# RV OPERATION

## POWERED REAR SCREEN

The **Powered Rear Screens** come down automatically by pressing the button down on the **Firefly Multiplex System** once. In case you need to stop it at a certain **length** press the rear screen button **again**. The powered rear screens will stop eventually when it reaches its **set limit**. In the event that you want the power rear screen **back up**, press the button on the Multiplex Control Panel **again**.

There are **two** different powered screens as you can see from the pictures. The **white** one is a powered shade screen that stops **sunlight** from entering the RV. The **black** one is a powered **mesh** screen that stops insects from entering the RV and also allows the **driver** and **passengers** to look outside.



Both rear screens can be powered by **Firefly Multiplex System** touch screens inside your RV, you may find them in the "**Shades**" category. The Powered Shade Screen can be controlled by pressing the **arrow icons** in the "**Rear Doors**" category and the Powered Mesh Screen is named "**Power Screen**".

## BACK-UP CAMERA

The camera is located on the **rear** of the vehicle. The camera's system operation consists of two major components:

- **Indash LCD Monitor:** Located inside the RV on the **cockpit** of the RV which will be a **tool** on the road for the driver.
- **Sensors:** They are located on the front and rear part of the RV. They detect near objects that could interfere with the driving and backing up process of the driver.



### ⚠ CAUTION

Do not take your eyes off the road for extended periods of time or a crash could result causing injury or death. Do not give extended attention to the in-dash entertainment system while driving.

## EXTERIOR SLIDING STEP

The curbside sliding door has a sliding step with **auto retract** that **extends** and **withdraws**. There is a **switch** located at the **entrance** of the RV, **above** passenger seat.

It is important that all passengers in the RV know about all the **components** of the RV, particularly the exterior **sliding** step.

The step will **extend** and **retract** when pushing the exterior sliding step button. It should only be extended and retracted when the RV is not in **movement**.

The step has an **undercarriage light**, to locate the step in the dark and avoid accidents or injuries. It can be turned **on/off** or **dimmed** using the multiplex panel.

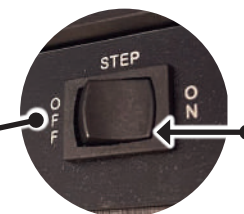

**Exterior Sliding Step Button**

### ⚠ WARNING

The exterior sliding step switch disables and enables step operation. When the switch is in the OFF position and the ignition is off, the step will not extend or retract.

### ⚠ CAUTION

Ensure the entry door step has fully extended before stepping out of the RV.



# RV OPERATION

## DOORS

### SLIDING DOOR: MANUAL OPERATION

#### 1. To open from the inside:

- Pull door handle. The sliding door opens.
- Push back the sliding door using door handle until it engages.
- Check the sliding door detent.

#### 2. To close from the inside:

- Slide the sliding door firmly forwards by the handle until it closes.

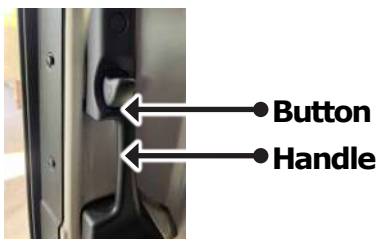

#### NOTICE

The sliding door has two locking knobs which besides the handle which will help lock and unlock the sliding door.

#### 1. To unlock:

- Pull locking knob upwards. Only this sliding door unlocks, the other doors remain locked.

#### 2. To open:

- Press button
- Slide the sliding door by handle back to the stop.
- Check the sliding door detent. The sliding door must be engaged.

#### 3. To close:

- Slide the sliding door firmly forwards by door handle until it engages.

#### 4. To lock:

- Press locking knob down.
- Only the sliding door is locked. All the other doors that were previously unlocked remain unlocked.

### ELECTRICAL CLOSING ASSIST

Your RV is equipped with **two electrical closing assist**, you will require less force to close the sliding door. The red button is located above the passenger seat just beside the sliding door and the black button is located in the middle of the cockpit.



## REAR DOORS

#### 1. To open from the inside:

- Pull door handle. The sliding door opens.
- Push back the sliding door using door handle until it engages.
- Check the sliding door detent.

#### 2. To close from the inside:

- Slide the sliding door firmly forwards by the handle until it closes.

#### Rear Door Left-Handle



#### Rear Door Locks

#### Door Retainer



#### 1. To operate rear door left-handle:

- Make sure that the right-hand rear door is open and engaged.
- Pull release handle.
- Swing the rear door to the side until it engages.

#### 2. Opening or closing rear doors from the inside:

- Release lever on the inside of the right rear door. Slide the rear door locks to lock or unlock the rear doors.

#### 2. Opening rear doors to an angle of 180° or 270°:

- Open the rear door to about 45°.
- Pull and hold door retainer in the direction of the arrow.
- Open the rear door more than 90°, so that the door retainer cannot engage.
- Release the door retainer and open the door to an angle of 180° or 270°.

#### WARNING

You can only open the locked rear doors from the inside if the child-proof locks have not been activated.

#### WARNING

Only open rear doors when traffic conditions permit. Always make sure that the rear doors are properly locked while on road.



# RV OPERATION

## DOOR LOCKS

The usage of separate and different keys are required for opening the **latches** on the exterior of your RV and RV **door locks**. Just like in common vehicles, there is **two** buttons on the driver and passenger doors which locks and unlocks all doors on vehicles.

**Lock    Unlock**



## KEY FOB

The **latches** on the outside of your RV and the driver **door lock** require the use of **different** keys, both can be used with the Mercedes Sprinter key fob provided to you.

The key fob has a **remote controller** which gives you the opportunity to **lock** and **unlock** all doors. It has **two** keys: **main key** which opens all compartments/latches on the outside of your RV and a key **inside** the controller which opens the drivers side door.

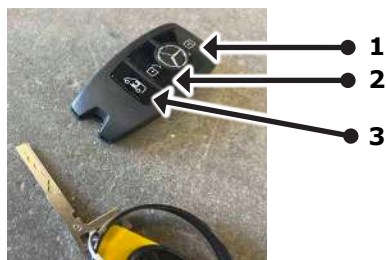

## KEY FOB REMOTE CONTROL

- 1. To lock all doors:** Press the lock button.
- 2. To unlock drivers side door:** Press once the unlock button.
- 2. To unlock all doors:** Pressing unlock button twice within 2 seconds.
- 3. To open and close entrance door:** Pressing once will open or close the door.

### ⚠ WARNING

Do not keep the key with remote control with electronic devices (mobile phone or another key with remote control) with metallic objects (coins or metal foil) or inside metallic objects such as metal cases. This can affect the key's functionality.

### ⓘ NOTICE

The remote control key has a range of up to 32 ft (10 m). Use the remote control of the key only when in immediate proximity of the vehicle. This will prevent theft.

### ⚠ WARNING

Batteries on your remote control on your key fob contain toxic and corrosive substances. If batteries are swallowed, it can result in severe health problems. There is a risk of fatal injury. Keep batteries out of reach of children. If a battery is swallowed, seek medical attention immediately.

## LOCKING OR UNLOCKING DRIVERS DOOR

There is an **anti theft alarm system** (ATA) on your RV that is triggered if you unlock and open the driver's door or the rear door with the key.

The **alarm** can be stopped in the following **two** ways:

- By pressing the lock or unlock **button** on your remote controller in your key fob.

## ENGINE IGNITION BUTTON

### ⓘ NOTICE

Remember, there is no key to start the ignition on your RV. You may start the ignition on your RV by pressing the ignition button on the center of the cockpit in your RV.



## USB PORTS

Your RV is equipped with multiple 110 V dual USB ports.



### ⓘ NOTICE

Check the USB Ports and Outlet Connectors Location diagram at the end of this Owners Manual for more information

# RV OPERATION

## AWNING

The awning presented in the RV, is **100% automatic** and can be used with the **Multiplex Firefly Control System** screens, located in the RV it controls the **extend/retract** feature of the awning with a simple touch that activates the **12V** battery and motor.



## WIND DETECTIVE SAFETY SYSTEM

The awning comes with an intelligent **Wind Sensor System** that automatically activates the **12V** motor and closes if the wind picks up beyond a certain **threshold**. This **auto-close** mechanism protects your awning and offers it complete safety from any sort of **damage** that it could otherwise experience from bad weather.

Additionally, it is equipped with a **sensor** that detects the **oscillatory** movements of the front bar and when the movement exceeds the set threshold just when there is wind, it will also **automatically** close. The awning can also be **manually** closed in case of an emergency or if you need to get going quickly.

## SELF SUPPORTING ARMS

The awning in your RV has **self-supporting** arms that are reinforced thanks to the innovative and solid **duralumin double block**, which is why it doesn't require vertical supports.



### NOTICE

During the automatic closing of the awning, don't stop the movement. Once it stops with the lead bar closed you can reopen it.

## CHARACTERISTICS

Arms are fixed at a **10°** angle, it can be modified from 5° to 17°, to allow the correct flow of water.

TURISMO" RV AWNING CHARACTERISTICS	MODEL #1	MODEL #2
Power Supply	12 V	12 V
Absorption	12 A	14 A
Awning Length	320 cm	400 cm
Min. Canva Length	285 cm	250 cm
Shadow Surface	7.5 m2	8 m2

TURISMO 4X4" RV AWNING CHARACTERISTICS	MODEL #1
Awning Length	304.8

### NOTICE

The power awning will not operate with the RV ignition on. It is equipped with a safety feature preventing the awning from extending while the RV ignition is on (driving).

### CAUTION

Awnings are designed to provide shade and protection from the sun. Retract awning if experiencing rain or wind conditions and when leaving unit unattended. Always secure awning in travel position when not in use.

### CAUTION

Auto-retract systems provide protection against adverse elements; but no auto-retract system is a guarantee against severe or destructive weather; the effects of wind and rain on an awning are unpredictable and may cause severe damage to the awning and/or vehicle. If wind or extended periods of rain are expected, retract the awning.

### CAUTION

Keep all sources of heat and flame away from the awning canopy. Fabric is not fire-proof and can burn if left in contact with any flame or heat source.

# RV OPERATION

## MAINTENANCE

The awning's fabric does not **rot** or **mildew** however due to the construction of the fabric, most dirt will be only on the **surface**, and can be easily removed with luke warm water and a cloth and/or brush.

Heavy **marks** or **stains** can be removed using a mild dish washing detergent. Do not use **aggressive** cleaners, detergents and do not use **high-pressure** washers on your fabric.

A cleaning option for **stubborn** and **intense** stains is:

1. Soak the fabric for approximately **20 minutes** in a solution of no more than 1/2 cups (4 oz.) of bleach and 1/4 cup (2 oz.) natural soap per gallon of water at approximately 100 degrees fahrenheit.
2. Rinse **thoroughly** in **cold** water to remove all soap.
3. Allow to **soak** it for a prolonged time and when it's finally **dry** roll it back in.

### NOTICE

Make sure your awning is completely dry and clean before closing it, as the remaining humidity could stain the fabric. However, if you must close the awning when it is still wet, make sure to open it again within 12 hours or less for drying.

### CAUTION

Excessive use of bleach can deteriorate sewing threads of your awning. It can remove part of the water repellency and the fabric will need a water repellent treatment later on.

## WEATHER

If the awning has been **open** in hot sunny weather for a long time, the fabric may **stretch** slightly or **shrink** and wrinkles could appear when closing the awning. Simply open the awning again, leave in the **sun** for a few hours, and the wrinkles will disappear, letting you close the awning **smoothly**. Do not steam press or dry in electric or gas dryers, instead allow the awning to air dry.

It is not recommended that the awning is used in **freezing** temperatures, since the fabric may become **less** flexible or **elastic** which may result in the risk of **cracks** appearing and potentially a tear in the fabric.

### NOTICE

Please note, that with each day and use of the awning, the color of the fabric may change. This is a natural process to the exposure of your awning to different temperatures and weathers.

## INCLINATION ADJUSTMENT

The inclination of the awning may be **modified**, it is previously fixed at a **10°** angle. Adjust it according to your needs and demands, following the instructions on this page and the diagram on the next page:

1. Open your awning completely.
2. Lightly loosen screw A.
3. Completely unscrew the stop screw C.
4. **Operate on screw B:** rotating clockwise, the arm rises and the inclination decreases; always checking that the lead bar moves in a horizontal position. Rotating anticlockwise the effect is the opposite.
5. Check the **degrees indicator D** to verify the correspondance of the inclination of the two arms. You may repeat the same operation on the other side.
6. Operate inside the lead bar, unscrew the **two** screws **T** and **rotate** the stop plate in the position of the desired angle.

### NOTICE

For more information on the awning please refer to the Owner's Operator Manual of the awning provided in the RV Information Kit.

### DIAGRAM OF INCLINATION ADJUSTMENT OF AWNING

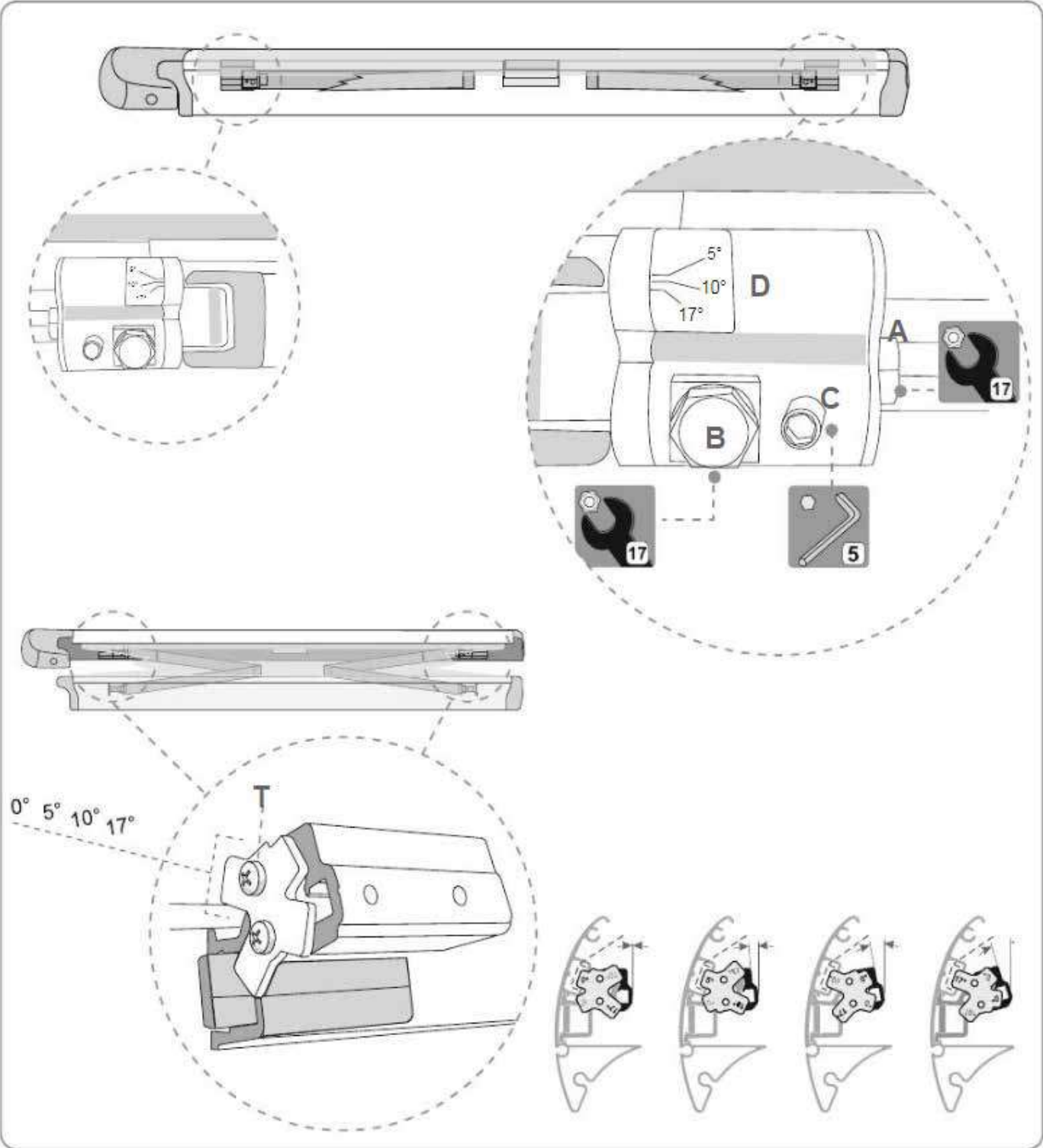

For more information please check the awning's manual or call for assistance.

# RV OPERATION

## SEATS

Your seat must be **adjusted** in such a way that you can wear a **seat belt** correctly.

Observe the following points:

- Position the **backrest** in an almost **vertical** position so that you are virtually **upright**. Do not drive with the backrest reclined **too far back**.
- Your arms should be slightly **bent** when you are holding the steering wheel.
- Avoid seat positions that **prevent** the seat belt from being **routed** correctly. The shoulder section of the **belt** must be routed over the **middle** of your shoulder and be pulled tight against your upper body. The **lap belt** must always pass across your lap as low down as possible, over your **hip joints**.
- Adjust the **head restraint** so that it supports the back of the head at eye level.
- The **distance** from the **pedals** should be such that you can depress them fully.

### ⚠ WARNING

You could lose control of your vehicle if you do the following while driving:

- Adjust the driver's seat, head restraint, steering wheel or mirrors.
- Fasten the seat belt.

There is a risk of an accident. Adjust the driver's seat, head restraint, steering wheel and mirror and fasten your seat belt before starting the engine.

### ⚠ WARNING

When you adjust a seat, you or other vehicle occupants could become trapped. For example, on the seat guide rail. There is a risk of injury. Make sure when adjusting a seat that no one has any body parts in the sweep of the seat.

### ⚠ WARNING

The seat belt does not offer the intended level of protection if you have not moved the backrest to an almost vertical position. When braking or in the event of an accident, you could slide underneath the seat belt and sustain abdomen or neck injuries. This poses an increased risk of injury or even fatal injury.

### ⓘ NOTICE

Adjust the seat properly before beginning your journey. Always ensure that the backrest is in an almost vertical position and that the shoulder section of your seat belt is routed across the center of your shoulder.

### ⚠ WARNING

If head restraints are not installed and adjusted correctly, they cannot provide protection as intended. There is an increased risk of injury in the head and neck area in the event of an accident or when braking.

### ⓘ NOTICE

Always drive with the head restraints installed. Before driving off, make sure for every vehicle occupant that the center of the head restraint supports the back of the head at about eye level.

Use the head restraint **button** to adjust the head restraint so that it is as close as **possible** to the back of your head.

### ⓘ NOTICE

Before the journey, make sure the head restraints have been correctly set for each of the vehicle's passengers.



## HEAD RESTRAINTS

The primary **function** of head restraints/headrests in vehicles is safety. They are not made to reduce **whiplash**, an unpleasant side effect of the **rearward** movement of the head and neck that occurs during a rear impact.

Head restraints prevent "**whiplash**" injuries by stopping your head and neck from **over extending** in the event of a crash. A properly adjusted headrest combined with a **correctly** positioned seat can **reduce** whiplash injury to a minimum.

**Do not** change over the head restraints for the front and rear seats. Otherwise, it will not be possible to correctly **adjust** the **height** and **angle** of the head restraints. Adjust the head restraint so that it is as **close** as possible to your head.



### ⓘ NOTICE

A properly placed head restraint has been shown to lower the chances of neck injury by up to 43% during a rear-end collision.

### ⚠ WARNING

If the head restraints are not installed or not adjusted correctly, they cannot provide protection as intended. In the event of braking, there is an increased risk of injury in the head and neck area.

### ⚠ WARNING

Always drive with the head restraints installed. Before driving off, make sure for every vehicle occupant that the center of the head restraint supports the back of the head at about eye level.



# RV OPERATION

## OPERATION

1. Head restraint angle button
2. Head restraint angle position
3. Release button

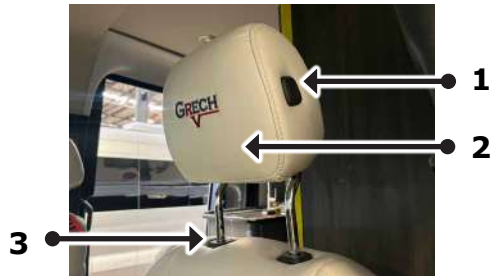

- **To raise:** Pull the head restraint up to the desired position.
- **To lower:** Press release button and slide the head restraint down to the desired position.
- **To adjust the angle:** Hold the front part of the luxury head restraint by the lower edge and tilt it to the desired position.
- **To remove:** Pull the head restraint up to the stop.
- Press release button and pull out the head restraint.
- **To insert:** Insert the head restraint so that the rod with the detents is on the left when viewed in the direction of travel.
- Press and hold release button.
- Push the head restraint down until it engages.

## SEATBELTS

In case of **collision**, a seatbelt keeps you in your seat. The **pre-tensioners** in the belt tighten upon sensing a **hit** and distribute the force over your shoulders, chest and hips, areas where the body can best handle an **impact**. When worn correctly, seatbelts **reduces** the chances of death in a collision by **47%** and the chances of serious injury by **52%**.

To be **effective**, your seatbelt must:

- Be snug over the shoulder and across the hips.
- Be flat and not twisted.
- Be kept over the shoulder and not under the arm, as this can cause serious injury in a collision.



## DRIVER AND PASSENGER'S SEATS

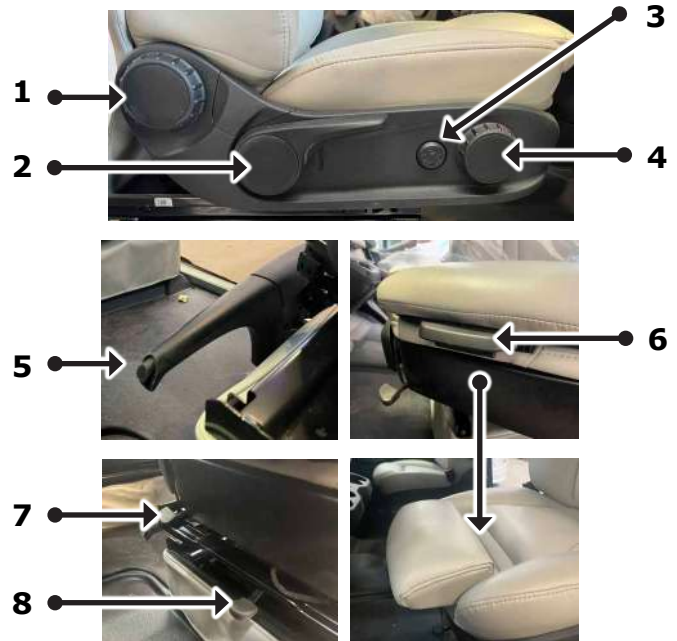

### 1. To adjust seat backrest:

- Turn handwheel towards the front: The seat backrest moves to a vertical position.
- Turn handwheel towards the rear: The seat backrest tilts towards the rear.

### 2. To adjust seat height:

- Press or pull lever repeatedly until you have reached the desired seat height.

### 3. To operate lumbar support controls:

- Use these controls to adjust the support to suit your comfort needs.

### 4. To adjust seat cushion angle adjustment:

- Press or pull lever repeatedly until you have reached the desired seat height.

### 5. Handbrake:

- Press button and pull or push lever. Remember that the handbrake should be un the down position while driving.

### 6. To adjust seat extension:

- Pull component to extend the seat for more comfort.

### 7. To adjust seat position:

- Pull lever and adjust seat to the front or to the back .

### 8. To swivel/rotate the seat:

- Pull the swivel lock lever (located near the base of the seat) to the left, and swivel the seat slowly toward the center line of the RV to prevent damage to the seat, door panel and post.

# RV OPERATION

## ELECTRIC SEAT ADJUSTMENTS

Some RV's may have the back rest adjustment buttons and components on the passenger's and driver's side door instead of in the bottom of each seat.



- 1. Adjust the angle of the seat:** Slide the back rest adjustment button forward or backwards.
- 2. To raise the seat height:** Push the button upwards until the desired height is reached.
- 2. To lower the seat height:** Push the button downwards until the desired height is reached.
- 3. To raise seat cushion:** Push the seat cushion height adjustment button up or down to adjust the height of the seat cushion. This will raise only the seat cushion without raising the entire seat.

## ROTATING SEATS

When rotating the seats, make sure that there is **sufficient** space to do so. Move the seat **forward** or **backward** first. This will help to avoid contact with other parts of the interior. Push the **handbrake lever** down to the stop.

The driver's and front passenger seat can be rotated **50°** and **180°**. The seats **engage** when facing in the direction of travel as well as when facing in the **opposite** direction and also engage at an angle of **50°** to the door.

- Make sure that the parking brake has been engaged and that the handbrake lever has been pushed down to the stop.
- Adjust the steering wheel to provide the necessary space to rotate and adjust the driver's seat.
- Before rotating, push the front-passenger seat forwards.
- **To rotate the seat:** Push lever on the rear of the seat towards the center of the vehicle and rotate the seat slightly inwards. The rotation device is released.
- Release lever.
- Turn the seat about 50° towards the outside or inside to the desired position.

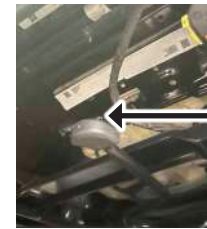

**Swivel/  
Rotate  
Seat  
Lever**

### ⚠ WARNING

If the driver's and front-passenger seats are not engaged facing the direction of travel while driving, the restraint systems may not be able to provide the intended protection. There is an increased risk of injury, possibly even fatal.

### ⓘ NOTICE

Engage the driver's and front-passenger seats so they are facing the direction of travel before starting the engine.

## REAR SEATS / SOFA BED

- **To fold a seat cushion forwards:** Go to your Firefly Multiplex Control Panel and click on the home page. The actions permitted are **EXT** (Extended), **RET** (Retract), **DOWN**, **UP**. Select the options needed:

- **D/S Ottoman:** Driver's Side Ottoman
- **P/S Ottoman:** Passenger's Side Ottoman
- **Sofa:** Rear three passenger Sofa Bed.

With the opportunity to use the Firefly Multiplex Control Panel there is no need to move the seats and ottomans manually



### ⚠ WARNING

Please make sure there is no objects or passengers on the seats to avoid injuries. Do not leave food or beverages on the seats to avoid spillages.

### ⓘ NOTICE

Use the armrests on the sofa bed as an extension of the bed on the rear side of the bed in between of the headrests.

## ARMRESTS

- **To set the armrest angle:** Fold the armrest upwards by more than 45°. The armrest is released.
- Fold armrest forwards to the stop.
- Slowly fold the armrest upwards to the desired position.
- **To fold the armrest up:** If necessary, fold the arm rest upwards by more than 90°.

## RV OPERATION

### ULTRALEATHER SEATING SURFACES

Ultra-leather fabric has a **100% polyurethane** surface on a **rayon** backing. It's a PVC-free faux leather.

The fabric can easily be cleaned with **soap** and **water**. For most soils and stains, the fabric manufacturer recommends **spot treatment** with a solution of water and detergent or an equivalent.

**Stubborn** stains may be treated with a water-based multipurpose **cleaner/degreaser**. Solvent cleaners such as nail polish remover or other aromatic solvents are **not recommended**.

To **dry** the ultra-leather seating surfaces you may let them **air dry** or **dry quickly** with a warm setting of a hair dryer.

Removes most stains with **alcohol-based** solutions and it also **disinfects** with **5:1** bleach solution.

#### ⚠ WARNING

Do not use hot temperature if you dry the ultra-leather seating surfaces.



### STAINS CHART FOR ULTRA LEATHER

Type of Stain	Detergent/Water	Cleaner/Degreaser
Coffee / Tea	●	
Red Wine	●	
Cola / Soft Drinks	●	
Milk	●	
Ketchup	●	
Steak / Soy Sauce	●	
Mayo / Butter	●	●
Salad Oil	●	●
Chocolate	●	●
Cosmetic Makeup	●	●
Lipstick	●	●
Face Cream	●	●
Suntan Oil / Lotion	●	●
Shoe Polish	●	●
Urine	●	●
Machine Oil	●	●

These are some type of stains that are very common to taint or mark your RV.

### FOLDING TABLES

Turismo RV comes with three folding tables in three different locations, as shown in the following images:

#### Folding Table on the Rear Side of the RV



#### Folding Table on the Passenger Side of the RV



#### Folding Table on the Driver Side of the RV



Folding Shelf Brackets



Safety Lock

#### ⚠ CAUTION

Beware of your fingers when folding the table back to its place as you may injure yourself if not done properly and with caution. Don't let kids perform this action.



# RV OPERATION

## NOTICE

Appliances and equipment may vary according to your RV model, specifications and floor plan. Refer to your RV Information Kit for operation and maintenance details of each appliance and equipment installed on your RV.

## FIREFLY MULTIPLEX SYSTEM

All models that Grech RV offers come with a **Multiplex System** which controls and operates many different features in your RV.

## NOTICE

For more information on using your Firefly Multiplex System Screens refer to the Vegatouch Grech Motors Sprinter V3 Owner's Manual in your RV information kit.

## REFRIGERATOR

Your RV is equipped with a small refrigerator above your driver's side ottoman:

- Small Vitriego Fridge model **C90IBD4-F-1** with freezer compartment with a **12/24 Vdc** and **100-240 Vac 50/60 Hz.** (AC and DC).



## NOTICE

The RV must be completely leveled for the refrigerator to operate properly and safely.

## CAUTION

Operating the refrigerator with the RV parked on an unlevel ground could result in permanent damage to the appliance.

## NOTICE

If the refrigerator will be unused for an extended period of time, make sure it is emptied, switched off, defrosted, cleaned and left with the door ajar. Leaving the door slightly ajar allows air to circulate and prevents the build-up of odor and mold.

## OPERATING TIPS

- Ensure the refrigerator is **cold** before placing items in it.
- Allow items to **cool** before loading the refrigerator.
- Do not add **warm** or **hot** items.
- Do not pack the refrigerator **too full**. To operate efficiently, the refrigerator needs **air** to circulate.
- Use **smaller** containers to store items and containers that seal **tightly**.
- Place **crumpled paper** between items in the refrigerator to prevent them from **rattling** while driving.

The refrigerator in your RV is an ergonomic, silent and safe unit. It is **supplied** with:

- An integral **compressor** and **cooling** unit fitted behind the ice box at the top of the cabinet.
- Magnet closure** with a **locking hatch**.
- Internal light** and a **mechanical thermostat** to control the temperature.
- A 9.8 L** ice box, single **shelf** with bottle holder.
- 12/24v.**

## AIRLOCK SYSTEM

The **airlock closure system** has been designed to allow an **easier** access for the end user and integrate different features in order to offer an innovative product, extremely user-friendly.

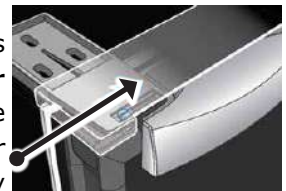

### "Vent position" system:

- To keep the fridge door ajar, preventing the formation of unpleasant odors and mold when not in use.

# RV OPERATION

## ELECTRIC UNITS ONLY

### COOKTOP

Electric and LP RV's have different components for each model and of them is the cooktop. There are two models for each type of RV unit: **electric** and LP **gas** cooktop.

### ELECTRIC COOKTOP

Electric RV's operates on an induction cooktop with **2 burners** with a smooth tempered glass surface that allows for effortless cleanup and withstands **intense heat** without cracking or chipping.

**NOTICE**  
Most stainless steel and cast-iron cookware are induction compatible.

### HEAT LEVEL SETTINGS

It provides **9 temperature level settings** (120°F to 460°F), **8 power level settings** from 300W to 1800W on left burner, **6 power level settings** from 300W to 1300W on right burner power-sharing.

It has a heating level from as low as **300w**, **fast** boiling, accurate and easy temperature **changes** at the touch of a button, boil, stew, fry, stir fry, switch from one mode to another as needed, making cooking easy and enjoyable.

### HOT SURFACE INDICATOR

An "H" will appear in the surface cooking **area** display to let you know when **elements** are hot to the touch with just a glance. Pan size **sensor** heats the element to the size of your cookware and turns off when no pan is present for **safety** and more **efficient** cooking. With induction cooking, heat is generated directly in the cookware, so the cooktop stays **cooler** to the touch, with child control **lock** feature prevents unintended activation for added safety.

1. Left cooking zone
2. Right cooking zone
3. Ceramic glass
4. Left touch control panel
5. Right touch control panel
6. Child safety lock
7. Timer control key
8. Lower power or temp key
9. Power or temp option display
10. Raise power or temp key
11. Function selection
12. ON/OFF

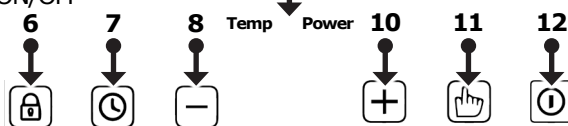
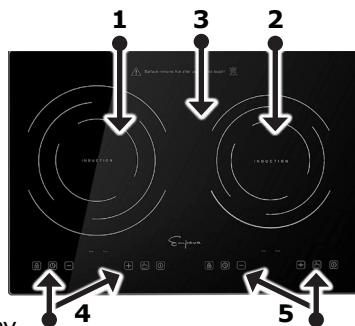

## CONTROLS

### Standby mode:

- Upon inserting the power plug into an electric socket, induction cooktop will make a "beep" sound once, and all the digital lights on the cooktop will blink once.

### Controls lock:

- **It will be activated when the cooktop is off:** Controls lock prevents activation of any sensor key, except for the Lock key pad, so you must deactivate the control lock firstly, then touch the main power key pad to turn on the cooktop.
- **It will be activated during the cooktop use:** Controls lock prevents activation of any sensor key, except for the on/off, power and lock key pad.

### To lock:

- Touch and hold lock key pad for 3 seconds, a "beep" will sound and the indicator light above the lock key pad will be lit up.

### To unlock:

- Touch and hold lock key pad for 3 seconds, a beep will sound, the indicator light will turn off.



**NOTICE**  
Touch and hold for 3 seconds.

### Readiness mode:

- While in the standby mode, press the "on/off" key, it will make a "beep" sound once and "on/off" indicator light will blink, indicating that the induction cooktop functions are ready to use. The unit will automatically return to standby mode if function is not turned on within 60 seconds.

### Turning off unit:

- When you stop using the cooktop, press the "on/off" key and "on/off" light will turn off, indicating the unit is now on the standby mode.

**NOTICE**  
Please do not pull the power plug until the cooling fan has stopped.

**NOTICE**  
For more information please refer to the Empara Appliances Induction Cooktop "Use and Care Guide".



# RV OPERATION

## MAINTENANCE

Please follow these directions along with important **safety** tips and steps for cleaning advised in this manual and on the "**Use and Care Guide**" for this induction cooktop.

- Use a ceramic glass cleaner on the glass cooktop.
- **To maintain and protect the surface of your glass cooktop, follow these steps:**

- Before using the cooktop for the first time, clean it to protect the top and makes cleanup easier.

**1.** Daily use of ceramic glass cleaner when the cooktop is **cool** will keep the cooktop looking new.

**2.** Shake the cleaning solution well. Apply a few drops of ceramic glass cleaner directly to the cooktop.

**3.** Use a paper towel or a soft cleaning pad for ceramic surface to clean the entire cooktop surface.

**4.** Use a dry cloth or paper towel to remove all cleaning residue. No need to rinse. **Never run the cooktop under water.**

- **Cleaning burned residue area:**

- 1.** Allow the cooktop to cool.
- 2.** Spread a few drops of the ceramic glass cleaner on the burned residue area.
- 3.** Using the ceramic glass cleaning pad, rub the residue area, applying pressure as needed.
- 4.** If any residue remains, repeat the steps listed above.
- 5.** For additional protection, after all residue has been removed, polish the entire surface with the ceramic glass cleaner and a paper towel.

### NOTICE

It is very important that you do not use the cooktop until it has been thoroughly cleaned.

### WARNING

Damage to the glass surface may occur if you use scrub pads or any other type of abrasive cleaning materials.

- **Cleaning heavy burned residue area:**

- 1.** Allow the cooktop to cool.
- 2.** Use a single-edge razor blade scraper approximately at a 45° angle against the glass surface, and scrape off the residue.
- 3.** After scraping off the residue, apply a few drops of the ceramic glass cleaner on the entire burned residue area. Use the cleaning pad to remove any remaining residue.
- 4.** For additional protection, after all residue has been removed, polish the entire surface with the ceramic glass cleaner and a paper towel.

- **Metal marks and scratches:**

Be careful not to slide pots or pans across the cooktop surface, it will leave behind metal markings. These marks are removable using the ceramic glass cleaner along with the cleaning pad for induction cooktop.

If pots with a thin overlay of aluminum or copper boil dry, the overlay may leave a black discoloration on the cooktop. This should be removed immediately before using the cooktop again or the discoloration will become permanent.

### NOTICE

If cracks or indentations in the glass surface occurs, the cooktop glass will have to be replaced.

## LP COOKTOP SPECIFICATIONS

Overall Dimensions	EMPV-IDC12B2
Product dimension (wxdxh)	20 1/2" x 14 1/8" x 2 1/8"
Voltage (Volts)	120
Frequency (Hz)	60
Total power (Watts)	1800
Min. Circuit Breaker Amperage	20
Elements	2
Front	N/A
Rear	N/A
Left	1800W
Right	1300W

# RV OPERATION

## ELECTRIC COOKTOP WARNINGS

### ⚠ CAUTION

When the unit is on, do not touch outside the control panel as the surface may contain residual heat.

### ⚠ WARNING

To protect against electric shock, do not immerse cord plugs or cooktop in water (or other liquid substances).

### ⚠ DANGER

While cooking fat or oil on the cooktop may ignite. There is a risk of burning and fire; therefore, never leave the cooktop unattended at anytime.

### ⚠ CAUTION

When using any electric appliance around children, close supervision is required.

### ⚠ WARNING

Do not operate any appliance with a damaged cord or plug, after a malfunction of it has been damaged in any manner. Please replace the component.

### ⚠ WARNING

Do not cook on a broken or damaged cooktop as spillovers may penetrate surface and create a risk of electric shock.

### ⚠ WARNING

Avoid preparing food in aluminum foil or plastic containers over the hot cooking zones.

### ⚠ NOTICE

Do not store temperature sensitive objects, material or substances underneath the cooktop, such as: detergents, sprays, etc.

### ⚠ NOTICE

To prevent accidents and achieve optimal fan ventilation, allow for sufficient space around the cooking area.

### ⚠ NOTICE

Items with a magnetic field such as, radios, television, credit cards, cassette tape etc., can affect the unit.

### ⚠ WARNING

Wear proper apparel, loose fitting or hanging garments should never be worn while using the appliance.

### ⚠ CAUTION

In case of appliance failure, immediately disconnect the appliance from the main power source and contact the manufacturer.

### ⚠ NOTICE

Do not place metallic objects such as knives, forks, spoons, lids, cans or aluminum foil on the cooktop.

### ⚠ NOTICE

Clean cooktop with caution. Do not clean while unit is still hot, some cleaners product steam or fumes if applied to a heated surface.

### ⚠ DANGER

Do not store items of interest to children in cabinets above the range or on the backguard of a range- children climbing on the range to reach items should get seriously injured.

### ⚠ NOTICE

Do not repair or replace any part of the appliance unless specifically recommended in the manual of the component. All other services should be referred to a qualified technician.

### ⚠ CAUTION

Use only dry potholders- Moist or damp potholders on hot surfaces may result in burns from steam. Do not use a towel or other bulking cloth.

### ⚠ WARNING

Use proper cookware size. Choose cookware with a flat bottom large enough to cover the unit heating surface. The use of undersized cookware will expose a portion of the heating surface where direct contact may be made and cause serious injury. Compatible cookware is necessary to operate properly.

### ⚠ WARNING

Protective liners. Do not use aluminum foil to line cooking zone, drip bowls or even bottoms; except as suggested in the component's manual. Improper use of these liners may result in a risk of electric shock or fire.

### ⚠ DANGER

To reduce risk of burns, ignition of flammable materials, and spillage due to unintentional contact with cookware, the cookware handles should be turned inward and not extend over adjacent heating surface.

### ⚠ DANGER

Do not use steam cleaners or high pressure cleaners to clean the cooktop, as this may result in electric shock.

### ⚠ DANGER

Do not touch cooking zones or areas near units. Cooking zones may be hot even though they are dark in color. Areas near cooking zones may become hot enough to cause burns. During and after use, do not touch, or let clothing or other materials have contact with the cooking zones or areas near the unit until they have had sufficient time to cool.

# RV OPERATION

## LP UNITS ONLY

### COOKTOP

Electric and LP RV's have different components for each model and of them is the cooktop. There are two models for each type of RV unit: **electric** and LP **gas** cooktop.

### LP COOKTOP

LP RV's have a **2 burner propane** cooktop with a tempered glass lid which hides the cooktop when not in use. In addition, it has a **cast iron gate** that distributes and holds heat evenly. It has sealed burners with a **5,200** and **7,200 BTU** rating. This cooktop has an **LP Gas** (Propane) power source and an ignition of a **12V DC** electric power source.

It must be lit **manually** using the **integrated igniter**. Make sure the **LP shut-off switch**, (located in the roadside utility center) is turned to the "on" position.

#### NOTICE

Please refer to the "Liquid Propane Gas System" section for more details and information.

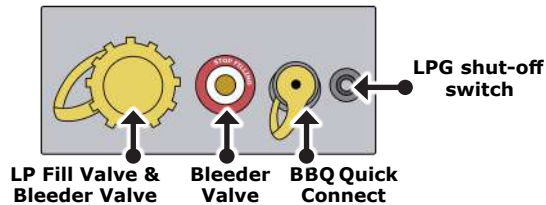

#### WARNING

If the information in this manual (section Safety: Alarms) and on the component's manual provided to you with the RV information kit is not followed exactly, a fire or explosion may result, causing property damage, personal injury, or death.

#### NOTICE

Please refer to section "Safety: Alarms" on this manual for more information on what to do if you smell gas or in case of fire.

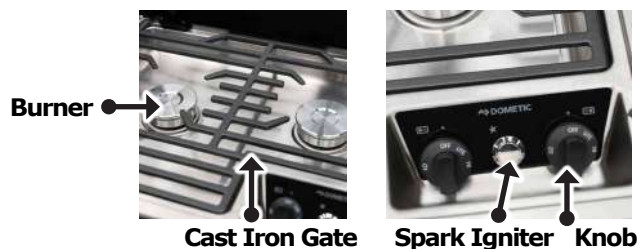

## OPERATION OF COOKTOP COVER

This section will describe how to open and close the glass and metal covers on this cooktop.

### Opening the glass cover:

- Lift the cover from the corner slot. Raise it completely, then gently lower the cover down to rest on the cooktop.

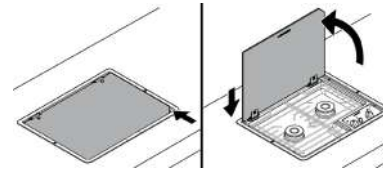

### Closing the glass cover:

- Lift the cover up, then gently lower it down onto the cooktop.

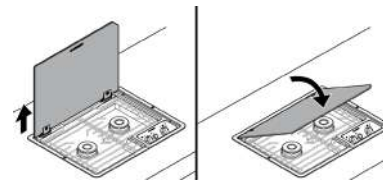

#### NOTICE

Glass can be easily scratched. Use care when setting items on the top of the cover. Avoid sliding items across the cover. Do not drop objects onto the cover, as this may cause breakage.

## WHAT TO DO IF YOU SMELL GAS

- Do not try to **light** any appliance or **touch** electrical switches.
- **Clear** the RV of all occupants.
- Turn off the **gas supply tank valve(s)** or **main gas supply**.
- Immediately call your **gas supplier** for instructions.
- If you cannot reach your gas supplier, call the **fire department**.
- Have the gas system **checked** and a **possible leakage** source **corrected** by a qualified installer, service agency, or the gas supplier, manufacturer or dealer.

#### WARNING

To prevent accidents and achieve optimal ventilation, allow for sufficient space around the cooking area.

#### DANGER

Be aware that the unit's surface will remain hot for a period of time after use.

#### WARNING

To reduce risk of burns, ignition of flammable materials, and spillage due to unintentional contact with cookware. Cookware handles should be turned inward and not extend over adjacent heating surface.

# RV OPERATION

## LIGHTING THE BURNER

All burner controls operate counterclockwise and must be pressed inward when turning to light. Do not attempt to light more than one burner at a time.

- **To light the cooktop with a match:**
  - Turn the **knob** counterclockwise and immediately hold a **lit match** near the burner.
- **To light the cooktop using a spark igniter:**
  - Turn the **knob** counterclockwise and press the **spark igniter** button until it clicks and the burner ignites.
- **To light the cooktop using the electronic ignition:**
  - Turn the **knob** counterclockwise then press and hold the **electronic ignition** button until the burner lights.
- **To extinguish the burner:**
  - Turn the **knob** to the "off" position (to the right) to stop the flow of gas to the burner.

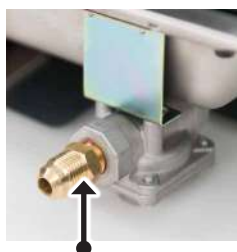

Gas hose connector

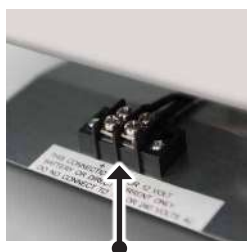

12V Battery Connector

### NOTICE

Do not operate the cooktop or the igniter while traveling refueling your RV. The burners may ignite fumes present during fueling.

### NOTICE

Do not allow stove top burners to remain lit for an extended period of time without placing cookware above the flame. **Overheating the burner grates may cause damage.**

### NOTICE

Turn on the roof vent and open a window to ensure proper ventilation when operating the cooktop.

### NOTICE

Do not operate burners with glass top lid closed.

### WARNING

**BURN HAZARD, FIRE, EXPLOSION, AND/OR CARBON MONOXIDE HAZARD.**

Keep cooktop area clear of combustible cleaning materials, gasoline, and other flammable vapors and liquids. Failure to obey this warning could result in damage, a burn hazard, possible explosion, carbon monoxide buildup, serious injury, or death.

## LP COOKTOP MAINTENANCE

- All cooktop surfaces, burner grates, and burners must be **cool** before **cleaning** or **disassembling** the cooktop.
- Clean all surfaces **quickly** after spills.
- Use **warm soapy water** only to clean the burner grates, burner box, painted surfaces, porcelain surfaces, stainless steel surfaces, and plastic items on your cooktop.
- Do not use **gritty** or **acid-type** cleaners.
- Do not use **steel wool** or **abrasive cleaners**, as they will damage your cooktop.
- Use only **non-abrasive** plastic scrubbing pads.
- Do not allow foods containing **acids** (such as lemon juice, tomato juice or vinegar) to remain on porcelain or painted surfaces. Acids may remove the **glossy** finish.
- **Pitting** and **discoloration** will result if spills are allowed to remain for any length of time on stainless steel.
- Do not allow spills to remain on **burner caps**. Caps could be permanently stained if spills are not cleaned up **promptly**.
- Remove the **grill** from the cooktop.
- Dry all **surfaces** and the **burner box** then spray surfaces with **vegetable oil** or a similar product to help prevent the surface from **rusting** during storage.

## ELECTRIC COOKTOP SPECIFICATIONS

Overall Dimensions	19"W x 12-5/8"D
Cabinet Depth	4-5/8"
Cut-Out Dimensions	17-7/8" x 13-3/4"
Power Source	LP Gas (Propane)
Ignition	12V DC Electric
Gas Pressure Requirement	11"W.C. (Low Pressure)
BTU's	5,200 & 7,200
Safety Shut-Off (Thermocouple)	No
Finish	Stainless Steel
Grate Style	Cast Iron

# RV OPERATION

## LP COOKTOP WARNINGS

Burn hazard, fire, explosion, and/or carbon monoxide hazard. Failure to obey the following warnings could result in damage, a burn hazard, possible explosion, carbon monoxide buildup, serious injury, or death:

### ⚠ DANGER

Avoid negative draft or positive draft situations or the operation of this cooktop during excessively windy conditions. Negative draft caused by air moving across the cooktop may blow out the burner flame or move the flame into the cooktop, resulting in damage a burn hazard, possible explosion, carbon monoxide buildup, injury, or death.

### ⚠ WARNING

Do not use the cooktop for space heating. Doing so may cause overheating of the cooktop and/or could cause carbon monoxide poisoning, resulting in serious injury or death.

### ⚠ WARNING

While operating the cooktop, frequently check the temperature of contents within cabinet areas above the cooktop (cabinets). Do not store flammable or combustible materials inside, or above and/or besides the cooktop. Failure to follow these instructions could result in a fire, serious injury or death.

### ⚠ CAUTION

Do not heat unopened containers. They could explode. The hot contents may cause burns and container particles may cause injury.

### ⚠ CAUTION

Verify sufficient gas supply before attempting to light any burner. Air in the gas supply line will significantly delay burner ignition, and a burner may light unexpectedly as the air in the line clears out and is replaced by LP gas; this unexpected ignition may burn you. Air may be introduced into the supply line when the vehicle gas bottle is replaced, during servicing of other gas appliances, etc.

### ⓘ NOTICE

If any burner should extinguish (after initially lighting or due to accidental blowout), turn all burner knobs clockwise to OFF and wait 5 minutes before attempting to re-light the burner.

### ⚠ CAUTION

Do not touch burners, burner grates, or areas near burners during and after use. Do not let clothing or other flammable materials contact burners or areas near burners until these areas have had sufficient time to cool.

### ⓘ NOTICE

Use large enough pans to cover the burner area and contain the cooked food. This will reduce or eliminate heavy splattering or spills that can ignite and burn you.

### ⓘ NOTICE

Make sure the glass cooking utensils you use are safe for use on the cooktop. Only certain kinds of glass utensils are suitable for surface or burner use without breaking due to sudden changes in temperature.

### ⚠ WARNING

Never leave burners unattended when in use, as pan contents may boil over, resulting in smoke or a grease spill that may ignite.

### ⚠ WARNING

Turn pan handles inward, but not over the top burners. This reduces the chances of burns due to bumping.

### ⚠ WARNING

Because grease is flammable, never allow grease to collect around top burners or on the cooktop surface. Wipe up any grease spills immediately.

### ⓘ NOTICE

Never use water on grease fires, and never pick up a flaming pan. Smother a flaming pan with a right-fitting lid or cookie sheet. Flaming grease outside of the pan can be extinguished with baking soda or a multipurpose dry chemical or foam-type fire extinguisher.

### ⚠ CAUTION

Use care when lighting a burner by hand. If the burner lights unexpectedly, or your hand is close to the burner, you may be burned.

### ⚠ CAUTION

Burner flame should not extend beyond the edge of the cooking utensil. The flame could burn you and cause poor cooking result.

### ⚠ DANGER

Control knobs must be turned OFF when not cooking. Someone could be burned or a fire may start if a burner is accidentally left ON.

### ⚠ WARNING

Do not operate cooktop if its damaged or not working properly.

### ⚠ WARNING

Make sure you have adequate ventilation when operating the burners. Light the burner immediately after turning on the burner control knob to prevent a gas build-up. Excess gas can cause a flare-up when lit.



# RV OPERATION

## MICROWAVE

Your microwave oven operates off of **110 volt AC** power only it is a microwave, convection and air fryer. To use your microwave you must be plugged into **shore power**, have the generator operating, or use the **3,000 watt inverter** on electric units only.



## LOCATIONS



### ⚠ WARNING

**To reduce the risk of fire in the oven interior:** Do not overcook food. Carefully attend appliance when paper, plastic or other combustible materials are placed inside the oven to facilitate cooking.

### ⚠ WARNING

If materials inside the oven ignite, keep oven door closed, turn oven off, and disconnect the power cord, or shut off power at the fuse or circuit breaker panel.

### ⚠ WARNING

It is important to not use the interior for storage purpose.

## UNDERSTANDING YOUR OVEN

- Do not use the oven without the **turntable** and **support** or turn the turntable over so that a large dish can be placed in the oven.
- The turntable will turn both **clockwise** and **counterclockwise**.
- Always have food in the oven when it is on to absorb the **microwave energy**.
- When using the oven at power levels **below 100%** you might hear the **magnetron** cycling on and off.
- This model of microwave includes a smart **air-fry convection** which will give you the opportunity to bake, brown or crisp foods.

### 📌 NOTICE

Please refer to the manufacturer's operating manual before running this component for more important safety information and operation of this microwave.

### ⚠ WARNING

Do not attempt to operate the oven with the door open. This may result in harmful exposure to microwave energy.

### ⚠ WARNING

Do not place any objects between the oven front face and the door or allow cleaner residue to accumulate on sealing surfaces.

### ⚠ WARNING

Do not operate the oven if its damaged. Do not operate the oven if there is damage to the door, hinges, latches, seals or sealing surfaces. Do not operate the oven if the door does not close properly or is bent.

### ⚠ WARNING

Do not adjust or repair the oven door. Have the unit serviced by qualified service personnel if necessary. Do not operate the oven when empty.

## KITCHEN FAUCET

The kitchen faucet is a streamline **pull-down** handle brushed satin **nickel** with a toggle that allows you to move your faucet's head, right where you need it.

The **finish** on your product is designed to retain the sheen on your faucet for years. Little care and caution with **mild soap** and **water** to clean the product will maintain it for years. The use of abrasive cleaners may **scratch** the finish or cause other damage.

### Pull-down handle



## TELEVISION

The Turismo RV is equipped with only **one** television located on the rear side of your RV.



# RV OPERATION

## CABINETS

Furniture in your Turismo RV is manufactured from a high-pressure laminate of Birch Hardwood. The **Hardwood Upper Cabinets** can be opened by pushing the lock and the radius doors will open automatically.



## ROOF AIR VENT

The roof vent on your RV will keep your RV **cool** by extracting **heat** as it rises to the top of your RV. It will suck up any **steam** and **scents** while you cook, helping to remove excess **moisture** that can otherwise lead to issues like **mold** or **rust**.

### ► Knob Vent Lid Open/Close:

**Manual Opening Models:** Pull to unlock prior to turning. Rotate knob clockwise to Close Vent Lid; Rotate Knob counter-clockwise to Open Vent Lid. Push "IN" to lock when Vent Lid is open or closed.

### ► Insect Screen Retainer Knob:

Rotate all 4 knobs 1/2 turn to remove screen.

### ⚠ CAUTION

Never operate fan with screen removed. When removing screen for cleaning, turn the Roof Air Vent off and when cleaning your fan use only a mild detergent solution.

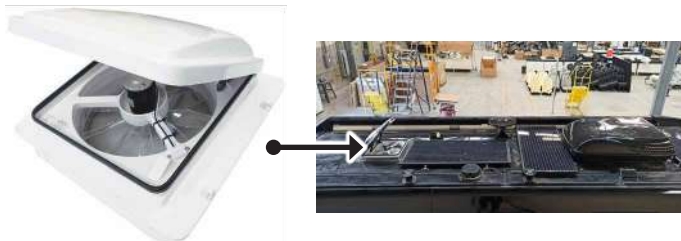

Knob Vent Lid  
Open/Close



Rain  
Sensor

Insect Screen  
Retainer Knob

Thermostat  
Temperature  
Sensor

### ⚠ NOTICE

The roof air vent is designed to be fully opened or fully closed when the vehicle is in motion.

## ROOF AIR CONDITIONER

The roof air conditioner located on the **interior rear side** of the RV is controlled by the Firefly Multiplex System screens.

**Air flow** into the RV can be **controlled** and **directed** by adjusting the **RV vents** and the temperature may be controlled and changed with the **arrows** in the **Climate** section of your Firefly Multiplex System Screen.

## TEMPERATURE ON THE AC

The ability of the air conditioner to **maintain** the desired **temperature** depends on the **heat gain** inside the RV.

Some **preventative** measures taken by the occupants of the RV can **reduce** the heat gain and **improve** the performance of the A.C. During extremely **high** outdoor temperatures, the **heat gain** of the vehicle may be reduced by:

- Parking the RV in a shaded area
- Using window shades (blinds and/or curtains)
- Keeping windows and doors shut or minimizing usage
- Avoiding the use of heat producing appliances
- 

### ⚠ NOTICE

Refer to the Firefly Multiplex System User Manual for more information on the operation of the screens.



## COLLAPSING CLOTHES ROD

Two Collapsing Clothes Rod are located on the rear side of the RV above the sofa bed.

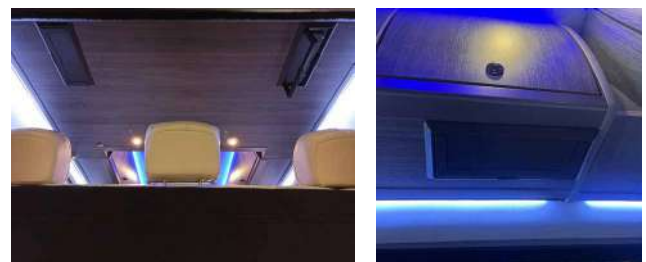

# RV OPERATION

## WATER FIXTURES

### TOILET

The toilet in your RV has a **pedal flush** mechanism which allows you to easily flush without having contact with the component.



### TROUBLESHOOTING

#### 1. LEAKS:

- **Back of toilet:**
  - Check water supply line connection at **water valve**
  - **Resecure** or **retighten** as necessary. If leaks persists from water valve, replace.
- **Vacuum breaker leaks while flushing:**
  - Replace vacuum **breaker** or water **module**, depending on model.
- **Between closet flange and toilet:**
  - Check **flange nuts** for tightness.
  - If leak continues, remove toilet and check **flange height**.
  - Use spacers to adjust, if necessary, to **7/16"** above floor.
  - Replace **flange seal**.

#### 2. TOILET WON'T HOLD WATER:

- Check for and remove any **debris** from blade seal track.
- Check blade seal **compression** with mechanism.
- If blade seal is worn, **replace**.

#### 3. PEDAL IS HARDER THAN NORMAL:

- Apply light film of toilet seal **lubricant** and **conditioner** to the blade/ball.

#### 4. POOR FLUSH:

- Pedal must be held fully open during flush. A good flush should be obtained within **2 to 3 seconds**.
- If problem persists, remove the **water supply line** and check **flow rate**.
- The flow rate should be at least **ten** quarts (9.5 L) per min.

#### NOTICE

To avoid damage do not use spray lubricants other than silicone.

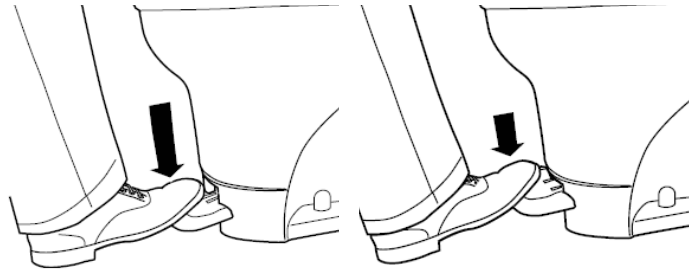

**To flush water:**  
Press all the way.

**To add water:**  
Press halfway.

#### TIPS

- RV toilets are not like the toilets you find at home because there is no toilet tank.
- Everytime the toilet is used a **two-step flush** will be to be done.
  - Push the handle or pedal **halfway** down to fill the toilet bowl with water, then push it down all the way to **flush** into the holding tank.
  - It is very important to do **both steps**, letting the toilet fill with water, so that there is enough water in the holding tank to **break down** the solid waste.
  - Rushing the flush will prevent **breakdown**, thorough dumping and lead to waste **buildup** in your holding tank.
- **Do not throw trash into your toilet.** It won't completely break down in the holding tank and will clog the sewer drain creating debris.
- Be sure to use toilet paper **specifically** for RV's, it will break down much **quicker**. Remember, the **less solid** waste that needs to dissolve inside the tanks, the better.

#### NOTICE

Anything other than RV toilet paper and body waste will damage system.

#### CAUTION

**Flush only RV toilet paper and body waste!**

# RV OPERATION

## SPRAY NOZZLE

Your bathroom sink is equipped with bathroom sink **faucet** that is also a **hand held shower head** which you can attach to the wall just like the images show.

### NOTICE

Please refer to the operating instructions in the RV Information Kit for more information on how to operate your hand held spray nozzle.



## SHOWERS

### INTERIOR SHOWER

The standard bathroom faucet installed in your sink can control the **water temperature** while you shower. Remember to return the **shower nozzle** back to its place to avoid incidents while the RV is moving.

### EXTERIOR SHOWER

Your RV is equipped with an exterior shower unit, it is located on the **Roadside Utility Compartment**. It has a water inlet to attach a water hose or a shower head and you may control **hot** and **cold** temperatures. It can be used with the **Water Pump** or with the **City Water Inlet**.



## DOME FAN AND LIGHT OPERATION

- **To open the dome fan lid:** Push the button on the handle to dis-engage the clip and slide the handle away from you until the clip engages the upper opening.
- **To close lid:** Push the button on the handle to dis-engage the clip and pull the handle toward you until the clip engages the lower opening.
- **Operation of your Dome Fan** simply entails pushing the **on/off** button on the fan to activate the exhaust fan.
- The optional **LED lighting** on the garnish ring is operated by the push button on the garnish ring. The LED lighting and fan operate independently.
- Close the lid to impede **infiltration** of air when exhaust fan is not in use.

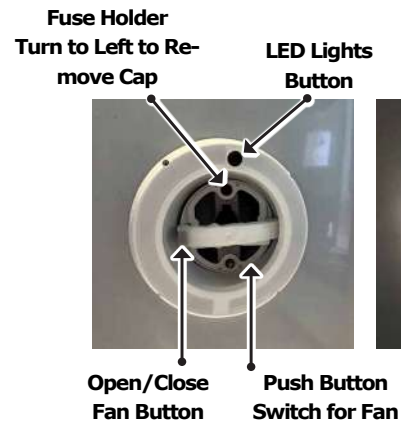

### NOTICE

The dome fan should not be operated with the lid closed.

## DOME FAN MAINTENANCE

Cleaning of your Dome Fan may be achieved with mild soap and water only. The screen can be removed for cleaning by removing the four screws.

Before removing the screen cleaning, ensure the fan is turned to the OFF position.

### NOTICE

Do not operate the fan with the screen removed.

### CAUTION

For general ventilation use only. Do not use to exhaust hazardous or explosive materials and vapors.

### NOTICE

For more information on the Dome Fan and Light please refer to the Installation Instructions, Information and Operating Guide on your RV Information Kit.



# RV OPERATION

## 144"- UPPER VIEW DIAGRAM

This section includes a general explanation of the location and usages of the exterior features found on the upper side of your RV.

1. **High Powered Ceiling Fan** with 10 speed intake and exhaust fan. It is waterproof and includes a rain sensor that closes automatically.
2. Wifi Antenna.
3. Power boosted omnidirectional **Digital HDTV Over-the-Air Antenna**. It is wired to outlets on the inside and the exterior of the RV.
4. **Air Conditioner**.
5. **Two RV Holding Tank Vent Cap** removes odors from the inside of the RV. Odors are exhausted through the roof vent before they have a chance to invade the RV.
6. **Exhaust Fan** for rooftop ventilation and moisture control in small areas (bathroom and shower). It has a locking lid with a single hand push button operation.
7. **Three Solar Panels** with 300 Watt Solar System.

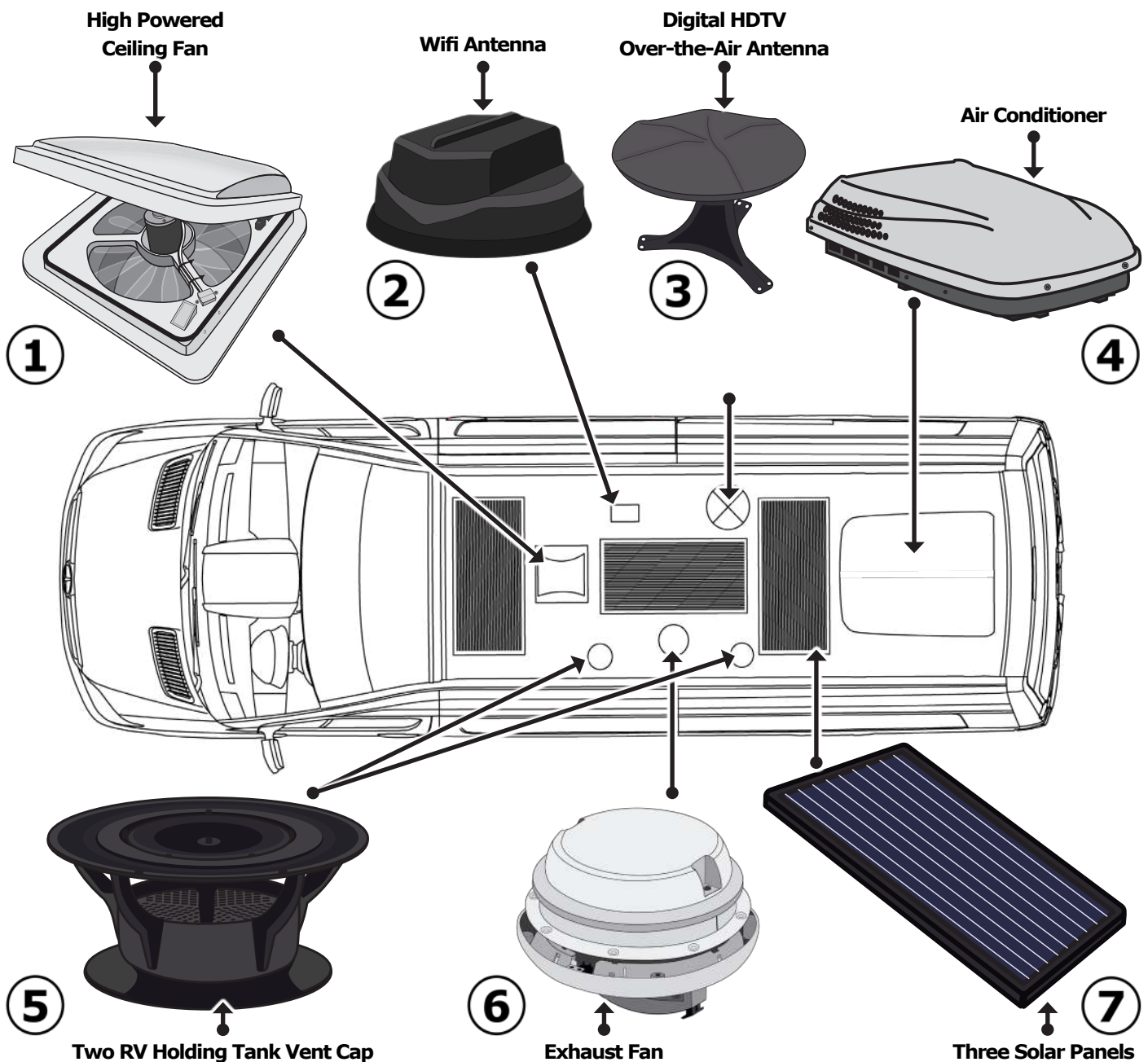



## RV OPERATION

### 144": DRIVER'S SIDE DIAGRAM

This section includes a general explanation of the location and usages of the exterior features found on the passenger side of your RV.

#### 1. ROADSIDE UTILITY COMPARTMENT

This compartment provides:

(In order from left to right)

- City Water Inlet Water inlet
- Exterior Shower
- TV/ Antenna Hookup
- Shore Power Cord Hookup Station with a 30amp/110 service.

#### 2. WASTE CONTROL SYSTEM

This compartment provides:

- **Water Inlet:** Works as a Black Tank Flush, it power washes the inside of the Black Tank.
- **Sewer Outlet Connection/ Pressure Hose Reel:** Retractable Water Hose to dump tank residues.

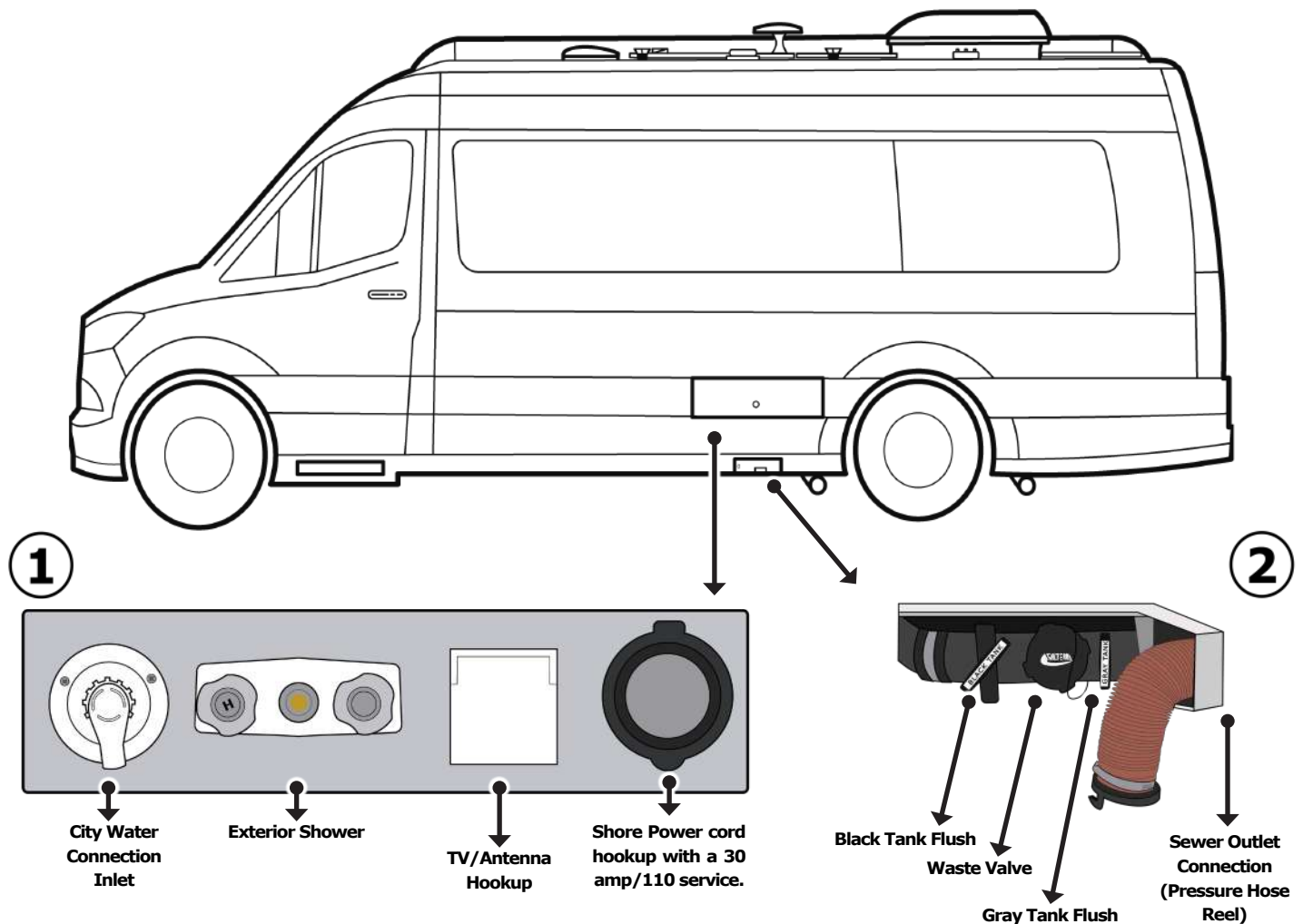

## RV OPERATION

### 144": PASSENGER'S SIDE DIAGRAM

This section includes a general explanation of the location and usages of the exterior features found on the passenger side of your RV.

#### 1. AWNING

- Automatic awning controlled with Multiplex Firefly Control System screens.

#### 2. LP & POWER GENERATOR STATION

(In order from left to right)

##### ➤ On LP units:

- Propane Tank filler
- Bleeder Valve
- LPG Switch
- External BBQ Point
- TV/Antenna Hookup
- Two 110V power Outlets.

##### ➤ On Electrical units:

- Two 110V power outlets and a TV/Antenna Hookup.

#### 3. FRESH WATER HOLDING TANK FILL.

#### 4. EXTERIOR SLIDING STEP

- Sliding step with auto retract, it has a step out warning buzzer and a lock extended switch for easy entry into the RV.
- It is controlled with switch on the inside of the RV, on the main entrance on the passenger side of the RV, under the Firefly Multiplex System screen.

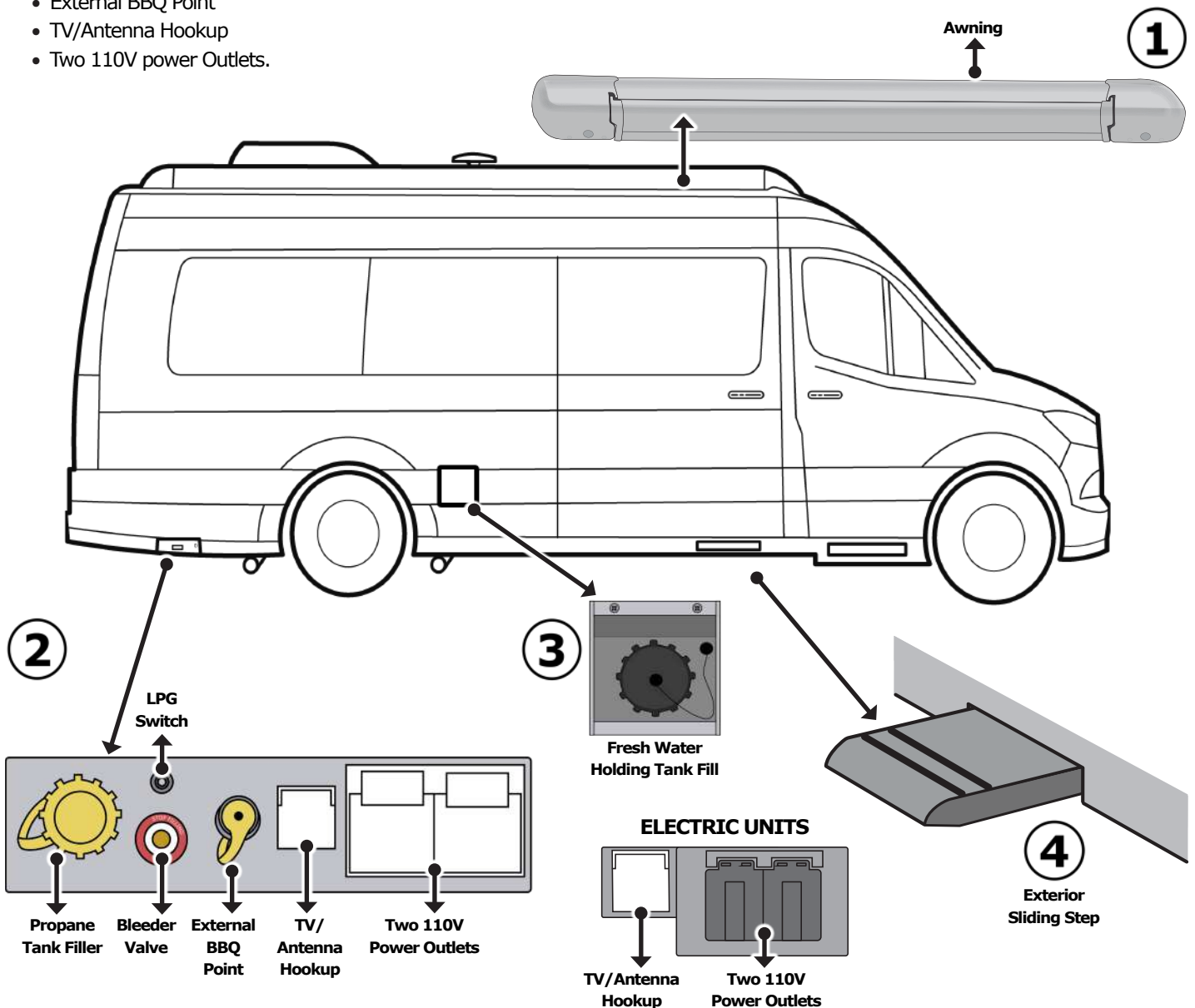

# WATER SYSTEM

## RV WINTERIZATION

Winterizing means getting your RV ready for the **freezing temperatures** that come along with **winter** in most places. It happens when you want to **store** your RV for a few months while it's too **cold** to travel. Winterizing's **objective** is to prevent the **freezing damage** to Fresh Water Lines, Waste Drain Lines, Waste Holding Tanks, Water Heater and batteries.

You will want to winterize your RV in **two different scenarios**: When storing your RV for the winter and very cold weather camping.

When **storing** your RV, use the same precautions as you would in your home in regard to **perisables, ventilation, winterizing** and **rain protection**. If you are leaving your RV unattended for a prolonged time you should **flush** out all **drain lines** and **waste holding tanks**.

It is crucial to know the importance of **winterization** and how it will **affect** your RV if you don't do it. If you don't winterize your RV, you could end up with a **burst pipe** because water will **freeze**, expand in your **hoses** and potentially **explode**. Winterizing will protect your **water pump** and avoid a **malfunction** and **damages** within your water/holding tank systems.

Using a **Non-Toxic Antifreeze** approved for drinking to water lines would do the job for winterizing protection for your RV.

### › System Coolant

- The system coolant does not require winterization
- The system coolant can be tested for its freeze protection value.

### › Domestic Water System:

- The domestic water circuit needs to be drained or protected using RV winterizing fluid.
- Draining is accomplished by opening the low point drains and blowing air through the water system.
- Propylene-glycol can be pumped through the system using the domestic water pump and opening both hot and cold valves. Using this procedure does not require draining the Demand Hot Water exchanger.
- **Propylene-glycol** can be pumped through the system using the domestic water pump and opening both hot and cold valves at a plumbing fixture. Using this procedure does not require draining the Demand Hot Water exchanger.

### 📌 NOTICE

Grech RV recommends that approximately twice a year or after a long period of time of storing your RV to give a check-up and cleaning of the gas-operated appliances.

### 📌 NOTICE

Please disconnect the current to all chassis electric consumers using the battery isolator switch if the vehicle sits for long periods or for more than 2 months. The battery isolator is located on the right of the accelerator pedal in the driver's foot well. Slide the red release down and pull it off the post. This will save jump starts, battery charge ups, and possible battery damage and replacement. The Mercedes-Benz Sprinter Operator's Manual describes its location, operation and cautions in detail.

### 📌 NOTICE

Drain valves are located on the driver side of the unit in front of the rear tires.

## STEPS FOR WINTERIZING

1. **Drain** all holding tanks (Fresh, Grey, and Black)
  2. Pour a **non-toxic** RV water system **antifreeze** into the fresh water tank (4 gal).
  3. Turn **on** water pump and run the water pump until the non-toxic antifreeze solution fills the water lines.
  4. Run each **sink faucet** in the **cold** and **hot** position **until steady** stream of **antifreeze** is flowing out for **10 seconds**. Run **anti-freeze** down the **shower drain** for **10 seconds** as well.
  5. **Flush** toilet and **hold** pedal down until **steady** steam of **antifreeze** is coming out.
  6. Open **exterior shower faucet** until the non-toxic antifreeze emerges from the hose, **shut off** the valve and remove the drain valve/hose **assembly**.
- While the water is draining from all of the faucets and system.**
- › You may remove, drain and store the exterior components that you've previously attached to your RV (such as hoses and/or shower heads).
7. Shut off the **pump** when the non-toxic antifreeze has been **distributed** throughout the system.

# WATER SYSTEM

## 8. Water Pump:

- Turn the pump **on** briefly to pump out any remaining water from the pump head and lines from the tank.
- Check water pump **strainer**, check if no water is **remaining**.

9. Open each **Holding Tank Valves** (Gray and Black) until antifreeze starts to come out the end off the tank **drainage hose**.

## 10. Close Holding Tank Valves.

### NOTICE

Grech RV water systems are designed that the average owner can winterize their RV without having to deal with the time inconvenience or cost of dealer assistance.



### NOTICE

It is important to winterize your RV in a plain surface, so the winterize fluid can spread on all surfaces correctly.

### DANGER

Do not use automotive antifreeze to winterize potable water systems. Such solutions are highly toxic. Ingestion may cause serious injury or death.

## HOUSE BATTERIES

- If you store the RV for 30 days or less, turn off the **battery disconnect** switch. Never stop checking your batteries, at least weekly in **severe** weather.
- It is important that there is a **periodic** check of the batteries to make sure they are **fully** charged to prevent their **optimum** life to decrease. (Make sure to do this step when there is freezing or below freezing temperatures).

## PUMP WINTERIZING

**Planning** the winterizing process and **how** much time and where the RV is going to be stored is essential.

Always keep in mind that the holding tanks are **drained** and **flushed** properly and thoroughly, due to the fact that water can damage the **system**.

1. Dump and drain the **tanks**.
2. Add a quart or two of **Non-Toxic Antifreeze** special for RV's to one of the holding tanks.
3. Press the Pump **switch**.
4. Pull both grey and black **drain Valves** until the **Non-Toxic Antifreeze** emerges at the end of the **Pump Hose**.
5. Add a quart of **Non-Toxic Antifreeze** to the **Black Water Tank**.
6. Pour a quart of **Non-Toxic Antifreeze** into a sink drain to protect the Holding Tanks, Valves and Pump from **residual freezing**.

# WATER SYSTEM

## TOILET REMOVAL

1. Shut off main water supply and flush toilet.
2. Disconnect water supply line from toilet. You will probably find a small mirror very useful.
3. Remove mounting nuts.
4. Cover riser or tank inlet with cardboard to prevent debris from falling into tank.

### NOTICE

If water is frozen inside the toilet, do not attempt to flush until the ice thaws- Never use automotive type antifreeze.

### NOTICE

Always replace flange seal when toilet has been removed to prevent outside components to enter.

## TOILET MAINTENANCE

If the bowl-sealing **blade** does not operate freely after extended use, it may be restored to its original, **smooth** operating condition by applying a **light film** of silicone spray to the blade.

**To clean the toilet use:** Use any high grade, non-abrasive cleaner. Do not use highly concentrated or high acid content household cleaners since they may damage the rubber seals.

## TOILET TROUBLESHOOTING

### 1. Leaks:

- **Back of toilet:**
  - If water keeps running in the bowl check if foot lever is all the way up.
  - Check water supply line connection at water valve.
  - Check if there is any foreign material on the waste valve blade seal at the bottom of the toilet bowl.
  - Secure or tighten if necessary.
  - If leak persists from water valve, replace component.

### 2. Vacuum breaker leaks while flushing:

- Replace component or water module, depending on model.
- Between closet flange and toilet: Check flange nuts for tightness. If leak continues, remove toilet and check flange height. Use Thetford spacers to adjust, if necessary, to 7/16-in. above floor. Replace flange seal.

### 3. Toilet won't hold water:

- Check for debris and remove if found from bladeball seal track.
- Check blade/ball seal compression mechanism. If blade/ball seal is worn, replace component.

### 4. Harder than normal pedal or hand lever operation:

- Apply light film of Thetford Toilet Seal Lubricant & Conditioner or silicon spray to blade/ball. (To avoid damage, do not use spray lubricants other than silicone.)

### 5. Poor flush:

- Pedals or hand levers must be held fully open during flush. A good flush should be obtained within 2 to 3 seconds. If problem persists, remove the water supply line and check flow rate. The flow rate should be at least 10 qt (9.5 L) per minute.

## STORING YOUR RV

When storing the vehicle, do the following:

- Clean and defrost the refrigerator, leave the door open and put an open box of baking soda inside.
- Empty the holding tank, leaving a bit of water and deodorizer in the tanks to keep the seals moist. Add 2 gallons of RV antifreeze when you're storing the vehicle where temperatures fall below 40°F, one surprise hard freeze can do a lot of damage.
- Close the propane tank valve.
- Shut all shades to keep the interior cooler.

### NOTICE

When the storage period is over, the water system must be filled again with water and all air must be removed from lines before using the RV again.

## RESTORING SERVICE

When it's time to use the RV again after the **storage period**. It's important to follow these steps so the RV works properly without **no failures**.

### STEPS

1. Re-install the fully charged **house batteries**.
2. Close **Low Point Drain Valves, Holding Tank Waste Valves, Water Faucets, and Fresh Water Tank Drain**.
3. Reconnect **Water Pump Line**.
4. Add fresh water to the **Fresh Water Tank**.
5. Turn the **Water Pump** on.
6. Open and close faucet one at a time until water runs **clear** at all faucets signaling that the RV non-toxic antifreeze is flushed out of lines. Go back and recheck **water clarity** at all faucets.
7. Turn off **Water Pump**.
8. Hook up **City Water**, open **Faucet Valves** and recheck **water clarity**.



# WATER SYSTEM

## WATER SUPPLY

Your RV is equipped with a **water system** containing of a Fresh Water Tank, Gray Tank and Black Water Tank and the associated **plumbing equipment** and **components** to handle all of the water and waste demands. This section will provide all information of how all elements operate together.

## DRAIN AND WASTE SYSTEM

The drain and waste system includes **waste holding tanks** made from **corrosion-free**, molded plastic and they are supported with trouble-free dump valves.

There are three water tanks included in this RV: **fresh, gray, and black water tanks**.

The differences between each tank are:

- **Fresh Water Tank:** Potable water, it is water that will come out from faucets, showers and toilets.
- **Gray Water Tank:** Used water from faucets and showers.
- **Black Water Tank:** Holds human waste/sewage directly from the toilet.

The three tanks are monotorized with **Firefly Integrations Control System**, which displays when are the tanks are **empty** or **full**. Monitors are pretty **accurate** as long the tanks are free of debris. If toilet or other **debris** are introduced into the tanks it could **interfere** with how the monitors **display** the tank's information.

## TANKS CAPACITIES

- **Fresh Water Tank:** 16 gal (Heated 12V)
  - **Location:** Under the cooktop and the kitchen zink. (Passenger's side).
- **Gray Water Tank:** 26 gal (Heated 12V)
  - **Location:** Undemeath the RV, under the toilet and shower. (Driver's side).
- **Black Water Tank:** 13 gal
  - **Location:** On the interior of the RV, under the toiletlet. (Driver's side).

### NOTICE

Please check the diagram "Tanks Location: Fresh, Gray and Black Water Tanks" for an accurate visualization of the tanks locations in each floor plan.

## GRAY TANK

Gray water tanks contains **all water** used in your RV, except what goes to flush the toilet. All activities that require **water** such as: cooking, washing dishes and showering, goes into this tank. This tank has its own dump valve "**Gray Valve Switch**" which connects to the same termination outlet as the Black Water Tank.



Gray Water Tank



Gray Water Tank Valve

## BLACK TANK

An RV black tank is a holding container **attached** to the RV under the toilet. Properly maintaining your RV black water tank is one of the **simplest** and most **important** ways to have an enjoyable RV experience. There is nothing worse than **sewer odors** in an RV, but if you maintain your black tank, you should never have that experience. **Emptying** your black tank on a **regular basis**, and especially before putting the RV in **storage** (long or short term) is a great solution to avoid **stinks**.

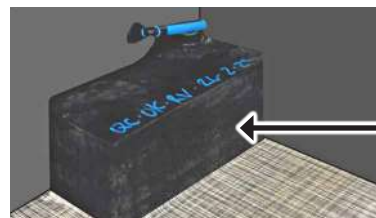

Black Water Tank

### NOTICE

The picture above of the black water tank it is not a complete picture of the tank. There is more tank space under the toilet and it is not visible.

## FRESH WATER SYSTEM

The **water system** built into your RV provides a system service very comparable to what you are **familiar** with in your home. With help of a **12-Volt self-priming pump**, it will provide **pressurized** water from the fresh water tank to all **cold water faucets** and the **water heater**.

To **fill** the fresh water tank, use the **water fill** located on the driver's side of the RV on the **Roadside Utility Compartment**.

You'll now when the fresh water tank is **full** by checking in the Firefly Multiplex Control System where it will show how much the tank is **filled** or **emptied**. Water will **overflow** from the vent when **full**.

# WATER SYSTEM

## HOW TO HAVE ACCESS TO WATER

This RV has **two** options to get water coming through your RV plumbing system:

➤ **By attaching a hose to your RV from the outside (City Water Connection):**

- When using a **City Water Connection**, you don't have to fill your holding tank, water pump or fresh water tank.
- The water goes from the **hose** directly into and through the **pipes** that leads to the RV's toilet, faucet(s) and shower head.
- The **water spigot** can stay on/connected all the time, the water pressure from the spigot will **push** the water through your RV water system.

**⚠ WARNING**

If you are using a water inlet/spigot from a campground, a good alternative is to have a water pressure regulator to attach to your RV water hose. Pressure may burst the water pipes inside your rig or even cause leaks at plumbing fittings.

➤ **By using the RV's pump to use water stored in your Fresh Water Tank.**

- The Fresh Water Tank may be **filled before** hitting road or some campgrounds may have a designated area to fill the Fresh Water Tank.
- If your **GVWR** (Gross Vehicle Weight Rating), it's best to not drive with your Fresh Water Tank **full** the entire way, depending on how far you have to go.
- Driving with your tank full may also **affect** your **gas mileage** to a certain **degree** (depending on how much water you will need to feel your tank).
- Keep in mind that each **gallon** of water weighs approximately **8.3 lbs** and the Fresh Water Tank capacity on your RV is of **26 gal.**
- To fill your tank, simply locate the outside **Fresh Water Holding Tank Fill** port/inlet.

The fresh water system consists of the **fresh** water tank, water pump, **water filler** and a **city/fresh** water connection. Use a **water** hose that is marked for **potable** water only.

## USING THE FRESH WATER HOLDING TANK

Every RV with a sink, faucet or shower in it has a **Fresh Water Holding tank**. You may either fill your fresh water tank at home before you hit the road, or you can **fill** it just before you arrive at your campsite at any **station** or convenience store. Some campgrounds will have a **designated** area where you can fill your **fresh** water tank before driving off.

The city water connection and water fill inlet are located on the **passenger side** of the unit.

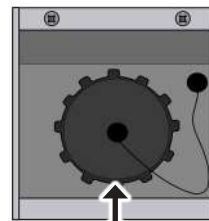

**Fresh Water Holding Tank Fill**



**Fresh Water Tank**

**ⓘ NOTICE**

This compartment is located on the driver's side of the RV. It is a power and water hook up station.

**ⓘ NOTICE**

Overfilling the fresh, gray and black water tank could cause overflow to back up through the toilet.

# WATER SYSTEM

## WATER PUMP AND STRAINER

The water pump is located **below** the sink **beside** the water heater and the black waste tank. It is controlled by the **Firefly Multiplex System** control panels.

The water pump will deliver **smooth, consistent** flow at all ranges of operation, while drawing low current.



**Water Pump Button**

This water pump has sealed switches and are finished with an **Electro Coating** to inhibit **corrosion**. They are enclosed to prevent incidental moisture from entering and when installed correctly.

It operates normally up to **40-psi**, where a spring-loaded by-pass valve opens, allowing flow back from the **output side** to the **input side**, providing smooth, steady flow with no cycling. When the faucet is opened back up, the pressure will **drop**, the by-pass will close and full flow is again obtained.

## OPERATION

The pump operates normally up to about **40-psi**, where a **spring-loaded** by-pass valve opens, allowing flow back from the output side to the input side, providing smooth and steady flow.

As a faucet is opened back up, the pressure will **drop**, the by-pass will **close** and full flow is again **obtained**. It will allow **good flow**, even with restrictive showers and pullout sprayer faucets.

The by-pass is a spring loaded diaphragm that opens up allowing water from the discharge side back to the inlet side. It is set to begin opening at about 40psi and increasing full by-pass at about 62-psi. The pressure switch is set to shut off at 55psi.

## HOW TO OPERATE WATER PUMP

1. Make sure drain valves are closed.
2. Turn off the water pump.
3. Fill the water tank.
4. Open the hot and cold faucets.
5. Turn on the water pump switch.
6. Close hot and cold faucets when water flows normal and steadily through the faucet.
7. Verify that the water pump stops after closing all faucets.
8. The water pump is now ready for automatic operation.

### ⚠ WARNING

It is better to shut off the water pump when leaving the RV unattended.

### ℹ NOTICE

You should not run the RV's Fresh water pump when hooked up to city water. The city water system should provide sufficient water pressure for your RV's fresh water system.

### ℹ NOTICE

Don't forget to always turn off the water pump switch when leaving the RV unattended for an extended period of time and when driving. This will prevent excessive damage and battery discharge in the event of a leak.

### ⚠ WARNING

An unattended water pump can cause an engine to overheat. Make sure you periodically check for leaks or any other signs that your water pump is not working as it should.

## CITY WATER CONNECTION

The City Water connection is located in the **Roadside Utility Compartment** and is an easier way to have access to water **inside** your RV without using the Fresh Water Tank. It travels directly to **all pipes** via **line pressure**

### ℹ NOTICE

It is advisable to use a water pressure regulator because excessive pressure may result in line damage.

## STEPS TO USE CITY WATER CONNECTION

1. Open the Roadside Utility Compartment.
2. Remove insert from the City Water Connection.
3. Attach a potable water hose of the same size using a rubber washer to ensure fitting is tight.
4. Turn on the City Water Supply/water source on a medium pressure.
5. Turn on the water pump
6. Slowly open the cold water tap until water runs smoothly. Repeat with hot water tap.
7. Check for leaks in the city water connection and re-tighten the hose if necessary.

### ℹ NOTICE

After connecting to an external water supply open the faucets in your RV slowly and cautiously. Air trapped in the line can cause the water to splash into the sink. Drape a washcloth over the faucet to prevent excessive splashing.

# WATER SYSTEM

## DISCONNECTING CITY WATER CONNECTION

1. Turn off the water source/city water supply.
2. Open a faucet inside the RV to relieve some of the pressure in the lines.
3. Unhook/disconnect the hose from the City Water Connection Inlet.

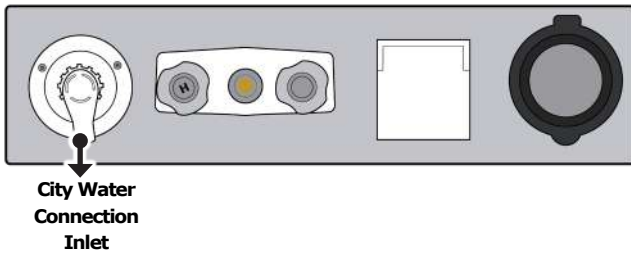

## USING CITY WATER

When attaching a **hose** to your RV and using the **city water** method you don't have to fill your **holding** tank or "fresh water tank" and use your **water pump**. With the **city water** method, the water goes from the **hose** directly into and through the **pipes** that lead to your **toilet, faucets** and **shower head**.

### NOTICE

When using city water, it is important to get a water pressure regulator to attach to your RV water hose. Some RV parks have pressure that is too high for RV plumbing systems. It can burst water pipes inside your RV or cause leaks at plumbing fittings.

## DRAINING THE FRESH WATER SYSTEM

To drain the fresh water tank, open the **Low Point Drain Valves** which are connected directly to your fresh water system and will allow you to **drain** the fresh water system when the vehicle is not in use.

1. Turn off the hot water heater before you drain the fresh water system.
2. Wait for the water in both the Fresh Water System and the heater holding tank to cool down to room temperature.
3. Open all faucets, including the outside shower.
4. Set the water heater to a bypass position to prevent water from entering the heater tank.
5. Open the Low Point Drain Valve, both hot and cold water.
6. Flush the toilet until water stops flowing.
7. Turn the water pump on as needed, removing any remaining water from the fresh water lines.

### WARNING

If you notice that water is running out from underneath the RV, check if the valves located on the driver side of the unit in front of the rear tires are closed. These drains usually are closed just and they will be opened when there is the need to drain the fresh water tank.



Drain Valves



### NOTICE

If you plan on winterizing or storing your RV for an extended period of time, you should drain your fresh water tank. If not, the water in your freshwater tank will become contaminated and unhealthy to use.

### NOTICE

Even when traveling, it is wise to drain both the fresh water tank and the waste tanks beforehand (or keep the tanks nearly empty). Traveling with full tanks will add weight to your RV, causing wear and tear increasing fuel consumption.

### NOTICE

You should only keep fresh water in your fresh water tank for about two weeks. However, many factors can affect how long your potable water will remain fresh.

## DUMPING WASTE TANKS

Below the Roadside Utility Compartment there is the **Sewer Outlet Connector**, it is located on the driver's bottom side of the RV. This section includes a **Water Inlet** for flushing black tank and a **Sewer Outlet Connection** as a **3" dump hose** which can be used with the switch found in the **Waste Control Panel**.

The RV **sewer house outlet connection** is an essential element of the RV. The sewer outlet connection's goal is to be a connection consisting of all **pipes, fittings** and **equipment** from the **drain outlet** of the RV to the inlet of the sewer riser pipe.

The **sewage** of the RV is held in a tank until it is ready to be **dumped** using the sewer outlet connection. To get rid of the waste from the **gray** and **black** tank, you'll need to take your RV to an appropriate **dumping** station, which are typically found in most **campgrounds, state parks, and national parks**.

# WATER SYSTEM

## WASTE CONTROL SYSTEM

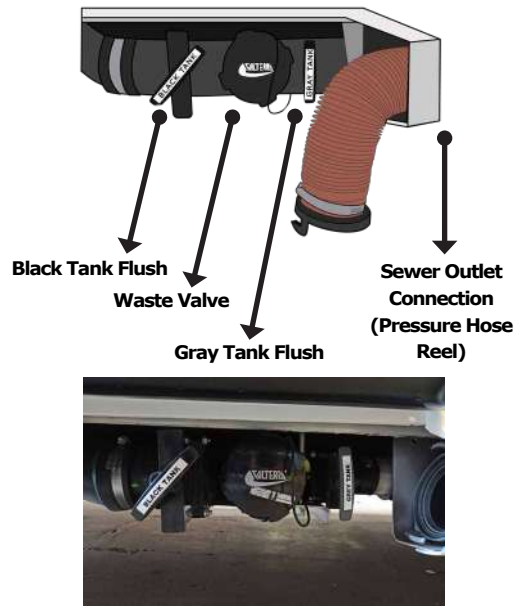

### NOTICE

Never attempt to dump sewage down drain pipes or in the wilderness.

### CAUTION

When working on the sewer outlet connection it is important to wear polyethylene or surgical latex gloves and wash your hands or use antibacterial immediately.

### NOTICE

When draining the waste tanks make sure to drain the black tank first and gray tank second. This will help clean the fittings and tanks if there is any waste or debris stuck from the black tank.

## WASTE WATER HOLDING TANKS

### NOTICE

Keep your holding tank clean using a cleaning agent approved for recreational vehicle sanitation systems.

### WARNING

Be aware of not scratching or hitting your holding tanks on the exterior as this may damage the plastic component and would probably need to be replaced.

### NOTICE

Use soft, single-ply, non-dyed, biodegradable toilet tissue, this type will desintegrate a lot easier and will not cause damage to your waste water system.

### CAUTION

If water is allowed to freeze in the system, serious damage to the plumbing may occur. Failures of this type will void the warranty. The best guarantee against damage is to completely drain the water system.



# WATER SYSTEM

## DRAINING TANKS OPERATION

1. Open the **Waste Control System Center**.
2. Pull the **Water Hose** that will help you empty the waste tanks.  
(Hose Length: 20 ft).
3. Connect the opening of the **Waste Hose** to the **Sewer Outlet** where the waste will be emptied/dumped and to the opening of the **Waste Valve**.
3. Pull the **Black Tank Flush**. (This will open up the Black Water Tank pipelines).
4. While the Black Water Tank is being emptied, pull the **Gray Tank Flush**. (This will open up the Black Water Tank pipelines).
5. When both tanks are empty **close** both Black and Gray Tank **Flushes**.
7. Flush your tanks by **refilling** them, and **draining** them again with **Fresh Clean Water**.
8. Disconnect the **hose** from the **hole**, and **rinse** the area around it, in case some **spillage** happened.
9. Cover the **hole** on the ground.
10. Rinse the **Waste Hose** and return the hose to the **Waste Control System** compartment.
11. You may add RV Water Tank **Treatment** to your tanks.

Open valves only when the tanks are **full**, when there is **enough** waste to drain or when you are **ready** to leave the campground. This will allow solid waste to **deconstruct** and/or stay in **suspension** allowing the waste to be drained with liquids.

### NOTICE

As we previously mentioned, always drain the Black Water Tank first and then the Grey Water Tank, as this may help to drain the tank from any debris or residues left in the tank.

### WARNING

Before the black or grey tank water starts flowing through the retractable sewer hose, make sure it is tight and firmly secured into the sewer drain.



### WARNING

If the valves stay open, the liquid waste will drain, leaving solid waste accumulate at the bottom of the tank. In case you are in this situation, fill the tank with water and drive a few miles. The movements of the vehicle accompanied by the water, will help the solid waste to move and break down.

## BEST PRACTICES FOR DUMPING

Wait until the tanks are **full** or **nearly full**, the black tanks must be dumped **first**. Dumping the gray tank **last** helps flush out **both** black and gray residues directly to the sewer hose. It also helps flush out any remaining **residues** from the black tank.



### NOTICE

A general rule is to wait until your tanks are about two-thirds full before emptying them. It creates a much better "flow" when dumping, making the process much more efficient. If possible, don't dump more than once every few days to a week. Longer intervals means more time to break down solids.

### NOTICE

Keep both dump valves closed and the drain valves closed and in place while traveling and to enable the tanks to fill before emptying.

### WARNING

Do not dump black tank's water when camping off the road or boondocking. Black water waste is filled with dangerous bacteria that can spread diseases and be a serious hazard for passengers and hurtful for the earth.

After you dump **both** tanks, thoroughly **flush out** the tanks. When you're connected to a **sewer** at a campground, always keep the tank valves **closed** until you need to drain. Otherwise, you won't get the **buildup** you need for a thorough dumping.

It is very normal to think that you should empty the **Black Tank** often to avoid **odors** in the RV. The black tank on your RV is **odorless**, no odor from the **residues** will go to the RV.

Emptying your tank too **often** or when it is still pretty **low** means that the solid waste will still be **sturdy** and **firm**. The fuller the tank, the more the **solid waste** will break down. The more **water** or **liquid state** the sewage is the easier emptying and flushing out the waste will be. If you are **constantly** dumping, solid waste will stay behind inside the tank and will maybe **interfere** with the tank **sensors**.

## WATER SYSTEM

### SEWER STATIONS

When staying at a campground where there is **sewer station** available, your RV sewer hose may be **attached** and left in place for as long as you are staying. When you arrive to a sewer station, the **length** of your retractable sewer hose will determine how close you need to park.

#### NOTICE

When using the sewer hookup at an RV park, you should keep the valve closed until the holding tank is at least partially full, then begin to drain.

#### NOTICE

Before dumping, make sure the area is a designated City Sewer Connection Spot destined for dumping waste.

#### NOTICE

Always wear gloves when using an RV sewer station and disinfect with wipes or spray and paper towels everything you touch after you use the RV dump station.

#### NOTICE

Gray water may be less toxic than black water but it's always a good practice to dump your tanks into the actual sewer where the water can be treated and reused.

### SANITIZING

#### WATER PUMP AND STRAINER

Potable water systems require **periodic** and **regular** maintenance to deliver a consistent flow of fresh water. Depending on use and the environment the system is subject to, **sanitizing** is recommended prior to **storing** and before using the water system after a long period of storage.

#### SANITIZING METHODS

1. Use one of the following methods to determine the amount of **common household bleach** needed to sanitize the tank:
  - Multiply "gallons" of tank capacity by 0.13, the result will be in ounces (oz.) of how much bleach is needed to sanitize the tank.
  - Multiply "liters" of tank capacity by 1.0, the result will be the milliliters of how much bleach is needed to sanitize the tank.
2. Mix into **solution** the proper amount of **bleach** within a container of water.
3. Pour the **solution** (water/bleach) into the tank and fill the tank with potable **water**.
4. Open **all** faucets (hot & cold) allowing the water to run until the distinct odor of **chlorine** is **detected**.

# HEATING SYSTEM

The Timberline Heating System operates the **water heater** and **furnace** of your RV. To initiate the system you first need to select your **heater type**.

There are **2 heat source types** on this Timberline Heater System, the first heat source is the **heater element** located on the bottom right corner of the screen and the second is the **fuel fire burner** and it is positioned on the bottom left corner of the screen.

## ICONS MEANINGS

### 1. Heater Element:

- It will initiate the **control of the heater** through the heater element. The heater element is only going to be getting power source via **generator** or **shore power**, it is operated by **110v** source only.

### 2. Fuel Fire Diesel Burner:

- It enables the diesel fueled **fire burner** by initiating that icon it will **turn on** the fuel fire burner in the system. If the electrical element can't keep up with the **demand** of the heating system, the fuel fire heater will **initiate**.

### 3. Water Heater:

- Tapping this icon will be useful if you are going to be controlling the **water heater**. It allows the heater system to **monitor** the **heat exchanger** for the water heater part of the system for **30 minutes**.

### 4. Settings:

- When tapping the wrench and screwdriver icon, it will open multiple screens with **information** and **preferences** regarding the Timberline Heating System which you can select and modify **at any time**.



## TURNING THE FURNACE ON

- To **turn on** the furnace to a **lower** or **higher** temperature on cabin, press and hold your finger on the control panel.
- Scroll through the temperatures up to the desired temperature.
- Turn clockwise** to increase temperature and **counterclockwise** to reduce it. This will **initiate** the **furnace** part of the heating system and the fans on the heat exchangers will warm the cabin to the **desired temperature**.
- When the options are **activated** the icons will turn from **white to red**, to deactivate them **tap** again.
- The temperature at the **bottom** is the **cabin's** temperature and the temperature at the **top** is the **desired** temperature for cabin.

### NOTICE

A suggestion is to have this system initiated from 5 to 10 minutes prior to wanting any hot water or any furnace on in the system.

**Heat and hot water present** in this Heating System is generated by the Autoterm Binar Compact, a strong and potent but silent **diesel** or **gasoline** heating component. A heated **glycol solution** is circulated in the interior of the unit and it goes through air handlers that provides gentle **heat**.

You can **operate** the heating system without actually having **contact** with the heater itself. This system allows you to control and handle with the help of a **touch screen** with a digital panel located inside the RV.

It gives you full control of your **interior temperature**, the controls are easy to understand and to use. It allows to **adjust** how **hard** or **soft** you want the heat to **distribute** in the RV and whether you want to utilize your **fuel** or **electric** source.

One of the **advantages** of this system is that when the RV reaches a **cold** temperature, the fans automatically run on **high** until the **interior** temperature starts to reach the **target**. Once it get closer the fans will **slow down** and remain on **low**.



### NOTICE

Please check Timberline Heating Systems screens locations diagram for more information or where the screens are located.

# HEATING SYSTEM

## HEATING LOOPS: WINTER & SUMMER LOOP

This section will explain how the **Timberline Heating System** works on your RV. For this purpose we decided to include diagrams that show both: **Winter Loop** and **Summer Loop** (shown on previous page) any RV owner might be involved while **traveling**.

### WINTER LOOP

Winter Loop means **how the heater will work** in winter season where you will need both **water heater** and the **cabin fans** for warm sensation in the RV.

1. The **glycol** starts in the **expansion tank**, this is where the **electric element** sits.
2. The **glycol** then goes to the **circulation pump**, where is pumped into the **diesel heater**. The diesel heater is the **primary heat source** at **17,000 BTU's**.
3. Next the **glycol** travels to the heat exchanger; place where the **cold domestic water** comes in and **hot domestic water** comes out. This hot and cold domestic water is where water from the **shower** and **sink** is created.
4. Now the **hot glycol** proceeds to the **solenoid**. Visualize the solenoid as a **closed** gate, reason being that you want **heat** in your RV to whichever **temperature** you set in the thermostat.

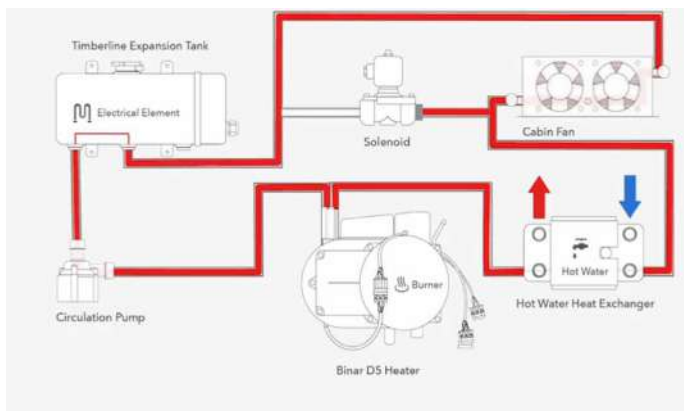

### SUMMER LOOP

For the Summer Loop, it is basically the same thing as in the Winter Loop, except when the **glycol** gets to the **solenoid**. This time the **solenoid** will "**open** up the gate" and let the glycol **flow** through it, **avoiding** the cabin fans and letting the RV to a **cool temperature**.

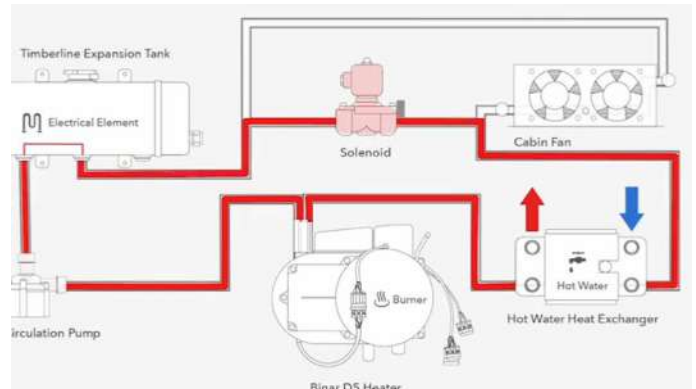

### CREATING CONTINUOUS HOT WATER

If you are looking to create **continuous hot water** using the Timberline Heating System you need to select the **Fuel Fire Diesel Burner** and the **electrical element**. The **diesel burner** is capable of putting out **17, 000 BTU's** of heat while the **electrical element** is capable of **1,500 BTU's** of heat, not enough to create continuous hot water.

When **both** icons are selected the system automatically prioritizes using **heat** from the **electrical element** so it will minimize the usage of **diesel** by the **burner**.

If there is a **greater** heating demand on the system, the diesel burner will **automatically** engage picking up where the **element** left off.

#### NOTICE

If you are trying to create hot water without heating the RV make sure only the Water Element Icon and Diesel Icon are selected.

# HEATING SYSTEM

## HEATING LOOP OVERVIEW DIAGRAM

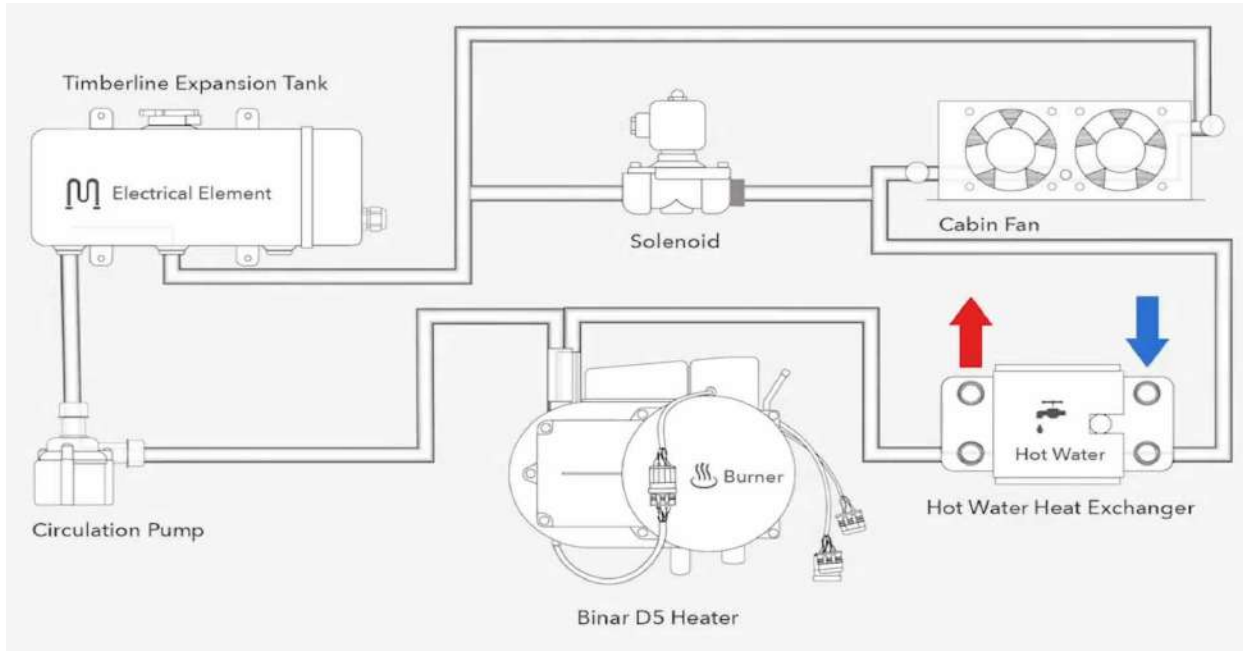

Once it's near the **desired temperature** the fans will **slow** down and they will remain on **low levels** with the objective to maintain the **comfort** levels inside the RV.

The Timberline Heating System operates the **water heater** and **furnace** of your RV. To **initiate** the system you first need to select your **heater type**.

There are **2 heat source types** on the Timberline Heater system the first one is the **electrical element** located on the bottom right corner of the screen and the second is the **fuel fire burner** and it is positioned on the bottom left corner of the screen.

**NOTICE**  
When using the diesel system, run it with a 3/8 full fuel tank. If there is not enough diesel fuel in the tank you will get an error code 29 on the Elwell panel.

**NOTICE**  
If you want to heat the coach with hot air, you could use the electric portion of the system but need to be plugged to shore power. However, heating the coach with electric only, has limitations. It can only be used in moderate temperatures, if it's cold outside your electric heater won't be enough to keep the coach warm.

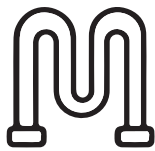

Electrical Element



Fuel Burner



Hot Water Element



Settings



# HEATING SYSTEM

## HEATER SCREENS

### SERVICE INFORMATION SCREEN

This screen will show information in regards to the heating system.

- **Air Temperature:**
  - Reads the cabin temperature **at the moment** in the living space.
- **Tank Temperature:**
  - It's the temperature that the tank is **holding** for the heating system to **work**. This temperature will come up as long as there is some type of **heat source** in there.
- **Heater Temperature:**
  - It shows the temperature of the **diesel fueled fire heater** which if it's initializing at the moment, the temperature will be moving.
- **Heat Exchange:**
  - It demonstrates the heat exchange for the water **heater** side of the heating system. This temperature will be coming up when it's **running**.
- **Circulation Pump:**
  - Displays the **circulating water** in the system that is being **heated** by the heat temperature and the **heater element** that it's in the tank **assembly**.
- **Solenoid:**
  - Is the one that controls the **furnace** part of the system. If the option is **on**, it indicates the heating loop solenoid is **activated**.
- **Fuel Pump:**
  - It shows that the **fuel fire burner** is heating the whole **entire** system. It indicates if the fuel pump for the Timberline heater is **activated**.
- **Element Relay:**
  - Indicates if the 110V element is activated in the Timberline Tank.

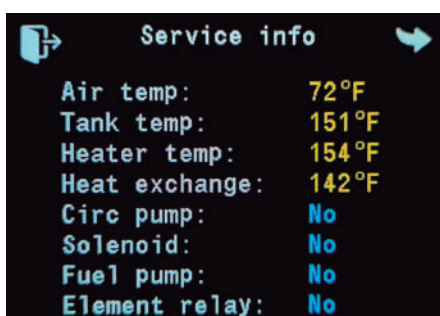

### SYSTEM INFORMATION SCREEN

In the event of an **issue** with the system and you need to contact the serving facility this information about the system may be of use.

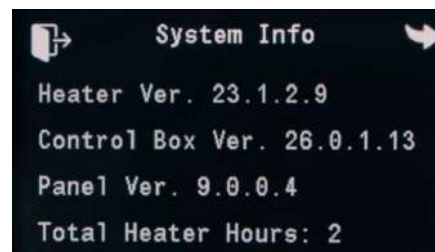

### LIMITATION OF HEATING DURATION SCREEN

Domestic water bar option shows you how to **limit** the time the **domestic hot water** will be **activated**. It can be with a maximum of **30 minutes**.

**System option** allows you to choose the length of time the system will be **activated** from **1 hour** to **maximum**. The amount of **time** you decide will be the time that the **heater** will be **on** if you leave the RV and when the time is up it will automatically **shut down**.

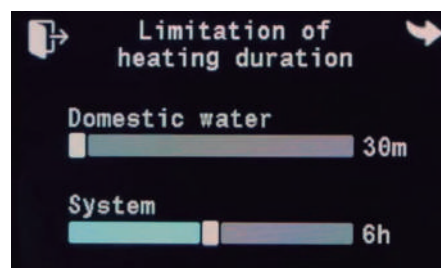

### DISPLAY SCREEN

Like all screens on mobile devices, brightness is always an option. This feature will come in handy at **night** when the RV is dark, you might want to **lower** the brightness so it doesn't hurt your eyes. The **timeout** option is how long you want to screen to **stay on** before it automatically **turns off**.



# HEATING SYSTEM

## FAN AUTO MODE

When auto mode is selected, it will automatically have the fans **regulate air flow** based on the needs of the RV's temperature at that moment. The fans will operate on **high mode** depending on how much **heat** is needed and **slower** if you select a **specific** temperature. When the temperature of the cabin comes down closer to the **cabin's set** temperature the fans will automatically **slow down**.

- > **Fan manual mode:** Manually move the speed of the fans.
- > **Pump override(10 min):** This is mainly for technician use. The coolant pump will run for 10 minutes and will purge air from the coolant system.

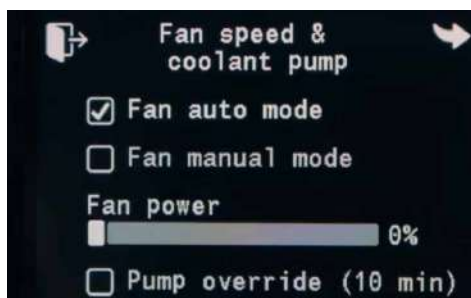

## CLOCK

If you check the "Show Clock in Sleep" the clock will show up when the heater is in **time out mode**. The set up time option means that you can change the **hours, minutes** and even the **day of the week**. To change the day of the week keep rotating clockwise until the day that you are looking for appears.

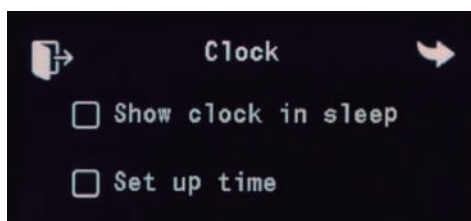

## MAINTENANCE

- > **Hydronic System:**
  - Glycol system **does not** require **annual** maintenance.
  - It is recommended to test the alkalinity in the system coolant annually.
- > **Domestic Water:**
  - Domestic water loop **does not** require **annual** maintenance.
  - **Calcium** build-up over time will act as an **insulator**.
  - The exchanger unit can be back-flushed with a lime removal cleanser.
- > **Fan Unit (s):**
  - The fan unit **does not** require **annual** maintenance.
- > **Furnace:**
  - The Timberline system is equipped with the efficient Autoterm Binar **Compact Diesel** or **Gasoline burner**.
  - This burner is designed for **optimal** use in **all climates** including **high altitude** up to **10,000 ft**.
  - **Limited** required **maintenance** for the Autoterm burner.
  - It is recommended to **exercise** the burner **every month** letting the burner run for **15-20 minutes**.
  - If the burner is utilized **monthly** there is no **annual** or **hour based** maintenance required.
- > **Exhaust System:**
  - The exhaust system should be inspected **annually** for **damage**.

# ELECTRICAL

## POWER DISTRIBUTION PANELS

The **Power Distribution Panels**, are located under the driver's side ottoman, it contains **120 Volt Breakers** for the **120 Volt AC System** and **12 Volt Fuses** for the **12V DC system**.

The **Upper Breaker Panel** contains 120 volt AC breakers and the **Side Breaker Panel** contains 12 volt DC fuses.

### NOTICE

Check the panel decals on the Breaker Panels for more information on identifying the function of each breaker.



## 120V AC CIRCUIT BREAKERS

A **Circuit Breaker** contains electrical switches which are designed to protect **electrical circuits** from damage caused by **overcurrent/overload** or **short** circuit. Its basic function is to interrupt current flow after protective relays detect a **fault** in the electrical system. It is basically a safety device to prevent damage to motors and wiring when the current flowing through the electrical circuit supersedes its design limits. It does this by removing the current from a circuit when an unsafe condition arises.

### WARNING

In the event of an overload, the circuit breaker cuts off the flow of electricity in the particular affected circuit of the system and helps prevents damage or fire.

It protects all **120 Volts AC** equipment and components in the RV. If the circuit breaker **stops** working correctly, allow a brief cool down period of 30-90 seconds, then **reset** the breaker by turning it "**OFF**" and then "**ON**".

If the Circuit Breaker continues to fail, the circuit may be **overloaded**, or there may be something wrong in the wiring or in the equipment.

### NOTICE

An overcurrent is any current in excess of the rated current of equipment or the ampacity of a conductor. An overcurrent is the result of an overload, short circuit, arc or ground fault. Effects of overcurrent includes fires, conductor insulation damage and equipment damage.

### NOTICE

Overload on the electrical system is the operation of equipment in excess of normal, full-load rating or of a conductor in excess of rated ampacity. When it persists for a sufficient length of time it could cause damage or dangerous overheating. An overload is NOT a short circuit, ground or arc fault.

### NOTICE

A short circuit is an overcurrent which greatly exceeds the normal full load current of the circuit. Also, as the name infers, a short circuit leaves the normal current carrying path of the circuit and takes a "shortcut" around the load and back to the power source. A short circuit is an overcurrent but not an overload.

### NOTICE

Ampacity is defined as the maximum current, in amperes, that a conductor can carry continuously under the conditions of use without exceeding its temperature rating. Also described as current-carrying capacity.

## 12V DC FUSES

Each 12V DC system circuit is protected by a **dedicated fuse**. Fuses are critical in any electrical system and are used to protect a circuit's cabling from excessive current that could lead to damage and very often an electrical fire.

### Excessive current is most likely to be caused by:

- **Incorrect Wiring:** Wrong connections as a result of human error.
- **Damage to the Circuit:** A wire working loose or insulation wearing through and causing a wire to short to ground.
- **Overloading the Circuit:** Connecting one or more pieces of equipment that draw more current than the circuit is designed to carry or, conversely, using cable of insufficient size for the current draw of the intended equipment.

When a fuse **stops** working shut off all appliances or lights on the affected circuit and **replace** the fuse with a new one of the same **amperage**.

### NOTICE

Please have in mind that the best option to repair any problem on your RV if you have no experience in the electric field is to contact Grech RV, take your RV to a qualified service personnel or check the equipment's manual for more assistance on this problem.

# ELECTRICAL

## MAIN CAUSES OF ELECTRICAL CABLE FAILURE

There are multiple reasons why a cable may fail in service, with the failure at its most serious resulting in fire or other serious fault.

### Some of the main causes of cable failure include:

- The service life of a cable can be significantly **reduced** if it has been **expected** to operate outside of the optimal operating conditions it was designed for.
  - The ageing process usually results in **embrittlement**, **cracking** and eventual **failure** of the insulating and sheathing materials, exposing the **conductor** and risking a potential **short circuit**, a likely cause of electrical fire.
- **Application:**
- If the cable is not appropriate for the application it is more likely to fail in service.
  - A cable which is not robust enough for the environment, either mechanically or chemically resistant to the ambient conditions, it is more likely to fail than one whose construction is suitable for the installation environment.
- **Mechanical Failure:**
- If the cable is damaged either during installation or in subsequent use, the integrity of the cable will be affected and reduce its service life and suitability.
- **Degradation of the cable sheath:**
- There are several reasons why the sheathing material may degrade, including excessive heat or cold, chemical, weather conditions, and abrasion of the sheath.
  - All of these factors can ultimately cause electrical failure as the insulated cores are no longer protected by the sheathing as originally designed.
- **Moisture in the Insulation:**
- Moisture ingress can cause significant problems including short circuits and corrosion of the copper conductors.
- **Heating of Cable:**
- Excessive heating of the cable will cause degradation of the insulation and sheathing material and premature failure. The heat may come from an external source or may be generated by the resistance to current flow in the conductor- a particular problem if the cable is overloaded and/or underrated for the application.
- **Electrical Overloading:**
- It normally occurs when the cable is underrated for the application or when too much load is being placed on the cable. In domestic applications this is often a result of plugging too many appliances into the one socket and overloading the wiring to that individual socket, extension adaptor or gang socket.

## GFI RECEPTACLE OUTLET

Your RV is equipped with GFI receptacles, all passenger's side receptacles are GFI outlets. **GFI** stands for **Ground Fault Interrupter**, it is a fast-acting breaker designed to shut off electrical power in the event of a ground fault.

It provides reliable **overload** and **short-circuit** protection, plus protection from ground faults that might result from contact with a **hot wire** and **ground**. A **Ground Fault** occurs when there is a grounding path from an appliance, tool or electrical system.

These devices **electronically monitor** the amount of current going **out** in the circuit and should match with the amount of current coming **back** to the circuit. **Both** values should always be the same, if there is a difference it means that the **current** is taking another pathway to **ground** (ground fault).

**⚠ DANGER**

If the current takes another pathway or there is a fault, the most dangerous situation is that your body could be the source of the current "leakage", otherwise known as electrocution. If your body comes in contact with electricity, the current will flow become an electrical conductor. GFCI receptor will prevent electrocution because it will react and open the circuit within milliseconds, therefore preventing electrocution.

GFI receptacles are required anytime electricity is **used** around **water sources**, therefore the GFI receptacles on your RV are located on the passenger side of the RV.

A single GFI receptacle may protect **numerous** outlets down circuit. **Power** from the Circuit Breakers panel goes to the **GFI** device and from there **all** outlets down circuit from the device, are **protected**. If the device **trips**, numerous outlets can be **affected**.

GFI devices should be **tested** once a month. It's a simple procedure, just press the "**test**" button on the Power Distribution Panel and it will also reset the system if there is any failure.

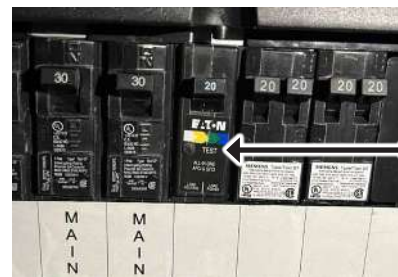

**⚠ CAUTION**

The GFI will not completely eliminate the risk of electrical shock. Small children or persons with heart conditions should be extra cautious because electrical shock could cause burns or cause the heart to stop even when a GFI is present.



# ELECTRICAL

## G12 CONTROL PANEL

There is a compartment with a G12 Control Panel, Battery Switches and a See Level II Monitor Panel.

### ELECTRIC UNIT



### LP UNITS



## SEE LEVEL II MONITOR PANEL

The See Level II Monitor Panel is located below the passenger's side ottoman on the rear side of the RV. All user input to this display is done by using the four buttons along the bottom of the display.

### NOTICE

It is important to know that it is not completely necessary to use this display panel to check this information, the same information can be consulted on the Multiplex Firefly System screens.

## DISPLAY

### To read a Water or Sewer Tank Level:

1. Press the **button** corresponding to the tank to be **checked** and **release** it, the display will show the **level** in percent on the **LED** display. If no other button is pressed, then the display will shut off after about **5 seconds**.
2. If another button (including **BATT**) is pressed before the **5 second** time is up for the first button, the display will immediately **switch** to show the new **level** or **voltage**. The 5 second **timeout** is restarted every time a button is pressed.
3. To continuously display a **reading**, press and release the **desired** button, and then press the same button a **second** time. When the button is released, the display will be in **hold mode**, which is indicated by the **decimal** point on the right hand side turning **on**. While the display is in the hold mode it will **recheck** the level once per second so the user can watch the level change while the tank is being **filled** or **drained**. The display will automatically **shut off** after 5 minutes in hold mode. To **end** the hold mode before the 5 minutes is up, press any tank button, and the **display** will shut off.

### To read the battery voltage:

1. Press the **BATT** button and release it, the display will show the **battery voltage** on the LED display.
2. If another button is pressed then the display will shut down after about **5 seconds**. If the **BATT** button is held down, the display will continuously **recheck** the voltage and show the **updated** value. The reading may **flicker** back and forth between **two** values, for example, 12.6 and 12.7 volts. This is **normal** behavior for a digital voltage display.
3. If **another** button is pressed before the 5 second time is up for the **BATT** button, the display will immediately switch to showing the **value** for the **new** button. The 5 second timeout is **restarted** every time a button is pressed.
4. There is **no hold mode** for the battery voltage.



### NOTICE

For more information, check the See Level II RV Tank Monitor Manual provided to you in your RV Information Kit.



# ELECTRICAL

## ELECTRICAL POWER

RV's require **power** to run any of the electrical devices installed within the RV, either from **shore power** or **batteries** or a combination of **both** depending on your RV's electrical system.

## 12V SYSTEM

Your RV is powered by either a **12-volt system batteries** or by being plugged into a **120-volt power source** through a **power cord**, also known as **shore power**. It is equipped with a **25ft, 30 amp power cord**. Your RV is powered by batteries also has a **Shore Power Station**, so you can **alternate** both Shore Power and Battery as **alternatives** to obtain power.

The major portion of electrical power in your RV is **12 volt**, this **current power** is almost in everything except roof A/C, 120-volt receptacles, and microwave oven. However some of these appliances have **12-volt electronic boards**.

The power is **routed** from the **battery disconnect switch** to the **12-volt distribution panel** and through its branch circuits to the rest of the RV.

The **12 volt RV batteries** supplies power to the interior components (except the roof air conditioner and fridge while set on AC) for **short-term use**. The **12 volt** or **DC power** supplies an **AC 110-120 volt** current to the interior plug outlets, the entertainment centers and the microwave through the **2,000 Watt True Sine w/100 Amp Inverter Charger**.

## OPERATION

As a responsible owner of an RV you should make sure that the **house battery** does not **run down**. In normal usage this shouldn't be a problem since you would normally be plugged into an **external AC power source** at night or when camping.

When you're plugged into **shore power** or running the **generator**, the **inverter/charger** charges the battery and carries much of the load.

The **battery bank** is charged when the **engine** is running. In addition to when you are connected to a **110-120V** power source such as **shore power** or a **generator**. The RV is also equipped with **solar panels** that will help charge the RV's batteries.

### NOTICE

This section references pages in your Lithionics Battery User Guide. Thoroughly read the user guide to understand before operating electrical components and potentially damaging them.

### DANGER

It is important to know that when working around electricity, it may carry dangerous amperage that could cause sparks or combustion which can lead to accidents.

## LITHIONICS BATTERY

The Grech RV Turismo is equipped with four **12V Lithionics Lithium Batteries** with an integrated battery management system, an auxiliary **280 Amp Alternator** with Wakespeed Regulator and a **2,000 Watt Xantrex Inverter**. The house batteries are located under the sofa bed in the rear side of the RV.



## LITHIUM-ION BASED ENERGY

Turismo RV's have a **Lithium-ion battery system** which will replace the Propane Generator, will provide a clean and quiet lithium-ion **based energy** that will power your entire RV. This is the most **advanced energy storage system** available in the camper van world. The lithionics batteries are the only **UL Listed** and **UL Tested** lithium-ion batteries in the market.

This system provides a total of **1,260AH** (Amp Hours)/ **16,128WH** (Watt Hours), it will run the RV's AC for up to **10 hrs** on battery power alone.

The **integrated battery management software** pairs perfectly with the Firefly Integrations Control System with a **280AMP** high output auxiliary alternator and Wakespeed Regulator the Lithium-ion Batteries will recharge from **idle** whenever your RV is **running**. The **2,000 Watt Xantrex Inverter** and **300 Watt Zamp Solar System**, you will have peace of mind knowing that your lithium-ion batteries will stay charged.

### NOTICE

The batteries should be fully charged to 14.4V at least once every 2 weeks.

## OPERATION OF BATTERIES

Batteries need to be fully charged to **14.4V** to condition the battery for use. **Fully** charging the battery **calibrates** the **state-of-charge** percentage to be the most accurate and allows the cells to **balance** if necessary.

Before powering **on**, ensure the battery **terminals** are **insulated** and any connected **devices** are properly **fused**. Due to shipping laws and regulations, your battery may be received at a partial state-of-charge of typically **50%**. The battery needs to be **fully charged** before use, to calibrate the **state-of-charge** meter as previously mentioned.

# ELECTRICAL

## SHORE POWER

For a long term use, your RV may be powered by plugging into a **110-120V** external power source with the supplied **25 foot power cable**. This cable must be connected from the **Shore Power Station** in your **Roadside Utility Compartment** to a **110-120 volt / 30 amp** outlet power source. The power will distribute throughout the RV with a **110-120 volt power**.

**Shore power service** is the most efficient source of electrical power and it is recommended to use this as the **primary** power source. It is an **alternating current (AC)** power from the **electrical grid** that goes directly through a campground pedestal. It connects to the pedestal using power that will convert the energy to **usable electricity**.

The **30 AMP Shore Power Supply** hookup station is situated in the **Roadside Utility Center**. This will give the RV the **power** to run any of the **electrical** devices installed within the camper.

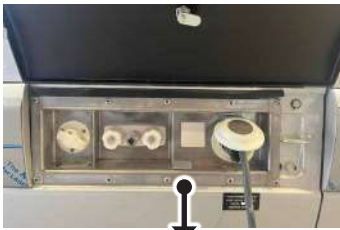

**Roadside Utility Compartment**

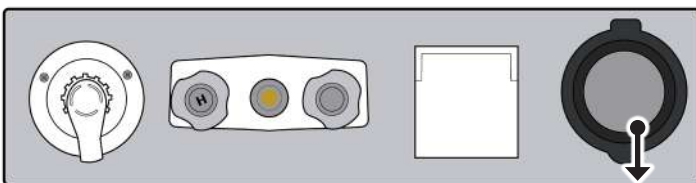

**Shore Power Cord Hookup**

This **connection** will provide a **120-volt** power hookup when connected to an **electrical** pedestal in a campground.

The **120 Volt AC power** source supplies electricity and power to these **components** on the RV: TV, microwave, roof air conditioner, refrigerator in the electric mode and the 120 Volt electrical outlets. For the most part everything else in the RV works off of the **12-volt DC power**.

When the RV is connected to the **campground**, a portion of the 120 volt **AC current** is **converted** to 12-volt **DC power** for items that specifically work only with a 12-volt power. Some of the **items** are: overhead lights, vent fan, water pump, LP gas leak detector, stereo and the refrigerator if it's in LP gas mode.

## ACTIVATE ALL POWER CIRCUITS

- Connect and lock the **power cord** to your RV in the Roadside Utility Center and to an adequate **110-120 volt** power source.
- The power cord connections are rated **30 amp outlets**.

The shore power connection is the last component at the right of the **Roadside Utility Compartment**.

Electricity comes in **two** forms: **alternating current (AC)** and **direct current (DC)**. Both are essential to enable the functioning of the RV. There are differences between both of them and it is important to know the difference between them.

### ➤ Alternating Current (AC) power:

- Is the standard electricity that comes out of power outlets and is defined as a flow of charge that exhibits a periodic change in direction.

### ➤ Direct Current (DC) power:

- It is a direct and linear electrical current that moves in a straight line.
- It can come from batteries, solar cells, fuel cells, and some modified alternators.

### ⓘ NOTICE

Understanding the basic concepts of power is helpful in knowing the differences in power in your RV. A basic formula, Watts: Amps x Volts (W: A x V) which will tell you how many different electrical appliances you can have running at one time, or how much power you need to run them.

### ⓘ NOTICE

A watt is the measurement of electrical power usage. It is the amount of energy an item needs to function; the rate at which energy is consumed. The best way to determine power usage is to get it from the device nameplate of each component. If the manufacturer of each component doesn't specify it, it may be calculated with the formula.

### ⓘ NOTICE

It is important to remember to always attach the power cord to your RV first and then to the power source of choice.

### ⚠ WARNING

The electrical system is engineered and tested for complete safety. Circuit breakers and fuses protect the electrical circuits from overloading. If you plan on modifications or additions to the electrical system, we strongly recommend consulting your dealer for assistance to ensure integrity and safety of the electrical system.

### ⓘ NOTICE

Please note that any modifications to your electrical systems may void the warranty.

# ELECTRICAL

## INVERTER CHARGER

RV inverters are **electrical modules** that change incoming **DC** current from the battery into usable **AC** current for various appliances and other devices plugged into outlets. **Inverters** allow people using an RV off-grid to access **power** without using a **generator** or **shore power**.



Your Electrical RV is equipped with the **Xantrex 2,000 Watt True Sine w/ 100 Amp Inverter Charger**. It provides **12 volt DC** power inverted to **110-120 volt AC** power for the microwave, entertainment center and all AC outlets in and outside the RV.

The Inverter Charger is set to charge the **batteries** and it also converts **110 volts** into **12 volt** to operate **12 volt appliances** when plugged into **110/120 volt power** or when running the **generator**.

It will be limited by the **state of charge** of the RV batteries and **amperage** that was drawn from the appliances/components.

The **inverter** is power-driven by the one large **red wire** and **one large black wire** that are marked as "inverter" with yellow tape in the battery section located in the rear side of the RV. In addition it is powered by a **Class T Fuse Cover with 300 Amps**.

The Inverter Charger is located on the rear side of the RV under the sofa/bed on both battery and gas powered RV's.



### NOTICE

The Inverter/Charger charges the batteries and converts 12-VDC to 120-VAC current for distribution to the entertainment devices. To operate your entertainment circuit the inverter must be ON, unless connected to generator or shoreline power.

### NOTICE

The inverter will draw .6 amps of DC power if it is turned on and no load is being drawn from the inverter. Remember, if no load is on the inverter, it will shut down itself after 25 hours of continual operation.

### WARNING

Vents in the inverter should be clear from blockage or obstruction as this may affect the performance of this component.

### KEEP YOUR INVERTER ON IF:

- If you want to use the AC appliances while traveling.
- If you are expecting to lose power and you want to keep using the appliances.
- If you are using a refrigerator that you don't want to lose power.
- If you have items that you don't want to lose the settings for.
- If you are planning on charging your devices.

### LPG INVERTER CHARGER

Your LPG is equipped with the Xantrex 3,000 Watt True Sine w/ 150 Amp Inverter Charger.

### NOTICE

For more information, regarding the arrangement and organization of the wires please refer to the Electrical Diagrams section of this manual.

# ELECTRICAL

## DISPLAY PANEL

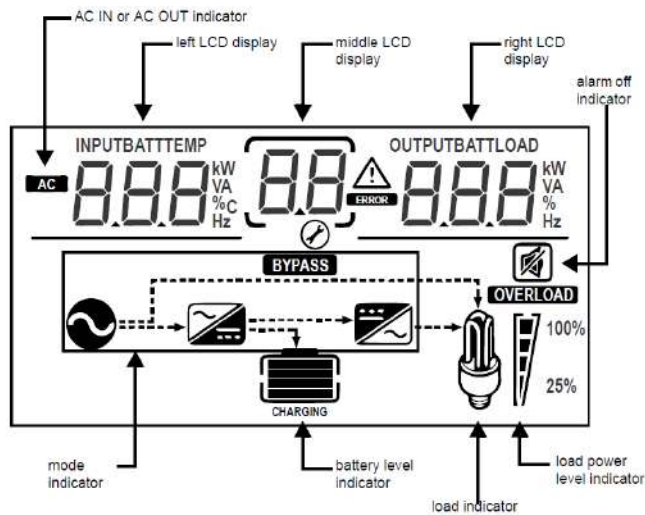
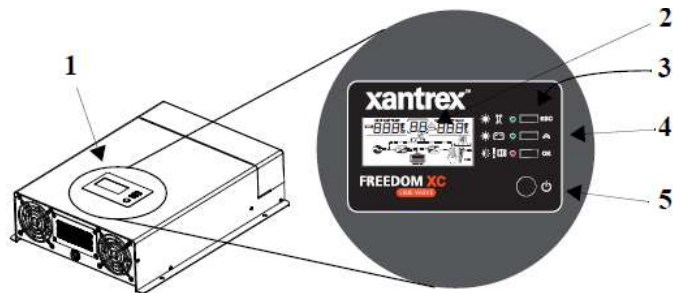

FEATURE	DESCRIPTION
1	Display panel displays status information on the screen. It is comprised of a display screen, LEDs, select and power buttons.
2	Multi-function LCD screen shows status information and error codes.
3	Status LEDs indicate the mode of operation.
4	Three function buttons change status information displayed on the screen. Also, changes inverter/charger settings.
5	Power button is pressed for turning on the unit. The inverter turns on for the loads and when applicable, the charger turns on automatically.

ICON	DESCRIPTION
<b>ESC</b>	Return to default screen or exit setting mode.
<b>SCROLL</b>	Next screen or next selection/option.
<b>OK</b>	Enter the setting mode or to confirm the setting/option.
<b>POWER</b>	Turns on inverter/charger operation or to standby mode.

INDICATOR	DEFINITION
1	<b>solid green</b> Indicates grid mode in which shore power is available and passing through to the loads and charging the battery.
2	<b>solid green</b> Indicates Battery Mode (Inverter mode) in which the inverter is running and supplying power to the loads from the battery.
3	<b>solid red</b> Indicates error or fault mode and is accompanied by an error code displayed on the LCD screen. For a list of error codes see "Warning Messages" on the Inverter Charger's Owner's Guide.
4	<b>flashing red</b> Indicates a Warning condition and is accompanied by an error code and a sounding alarm. For a list of error codes, see "Warning messages" on the Inverter Charger's Owner's Guide.

**NOTICE**

You may find the Xantrex screen display right on the Inverter Charger Box but you may easily check it on the Firefly Multiplex Control System Screens found on inside your RV. In the screens you may check the status and any current I/C faults as well as adjusting individual settings or reset to default.

**NOTICE**

Please refer to Firefly Integrations Owner's Guide for more information on how to manage the I/C settings on the Firefly Multiplex Control System Screens.

**NOTICE**

To turn the inverter ON or OFF you must press and hold the power button on the inverter control panel for at least 1 second.

**NOTICE**

This control panel will turn the inverter ON or OFF. The 12 volt battery disconnect switch or charge line disconnect switch does not turn the inverter ON or OFF. Always make sure the inverter is in the OFF position when not in use. The inverter can draw .6 amps from your coach batteries if left in the ON position while not in use.



# ELECTRICAL

## MOTORISED BATTERY SWITCH

The RV is equipped with a motorised battery switch that will serve a variety of functions that will help you **preserve power**, keep your battery **healthy**, and make the most of your time on the road. The RV battery switch provides a simple way to **cut off** the **main RV circuit** from your battery.

This switch is located in the **rear** side of the RV in the compartment **below** the drivers side **ottoman**.

## IMPORTANCE OF BATTERY SWITCH

The motorised battery switch can **protect** you against **shock** while performing **maintenance** and allow you to conduct troubleshooting without **interfering** with your work. Most important the battery switch helps to avoid the batteries **discharging** or **draining** fast.

When the batteries are connected to a circuit they tend to drain a lot faster even if turned **off**. Appliances draw some **amount** of power in anticipation of the startup.

The **loss** of power can lead you to having a **dead battery** and when it's necessary for you to use the RV you might find a dead battery as a **surprise**. This process usually happens in a week or so to occur and it by having a Battery Switch this can be **avoided**. The switch will be in charge of having a **slow battery discharge**.

When you are using shore power from a campground, the batteries can be **recharged** when you arrive. Knowing the **accurate** state of charge of the batteries is very beneficial for an RV user, check them rigorously on the Multiplex Control Panel.



## AUTOMATIC TRANSFER SWITCH (ATS)

The main objective of the Automatic Transfer Switch, is that it will allow your RV to get **power** from **one source**; either the **generator** or the **shore power cord** it will **bypass** the inverter.

The automatic transfer switch is located on the **rear side** of the RV under the sofa bed. To **access** the the transfer switch open the **small door** of the rear side of vehicle under the sofa-bed.

The Automatic Transfer Switch has many different **protective features** to keep your RV from receiving **low quality power**

This RV includes protection against **high voltage**, **low voltage**, and an incorrectly **connected** chassis ground. If one of these **fault** conditions is encountered, the ATS will open both contactors in order to protect the RV.

Once the fault condition goes away, the ATS will **delay** for approximately **2.5 minutes** before trying to close the appropriate contactor again.

## ATS: TROUBLESHOOTING

► **If the ATS fails to close the contactor or fails to transfer when expected:**

- Check the level of the **input voltage** to ensure it is within the proper operating limits.
- Check if **Open Ground LED** status is **ON**, indicating open ground.
- Check that the ATS is correctly connected to **chassis ground** and that the **neutral conductor** is correctly connected to ground at the power pedestal.
- Wait **2.5 minutes** to check if the fault condition was **temporary** and has cleared.

Occasionally check the display to see if an **error message** is displayed when trouble with your ATS is present. The screen will flash error messages such as "**Loss of Ground**", "**High Volt**" or "**Reverse Polarity**".

### NOTICE

For more information, refer to the Automatic Transfer Switch Model 40430 RVC Surge Guard from Southwire Troubleshooting Guide. You will find a sections that will present solutions for problems and troubleshooting as steps to fix the errors presented.

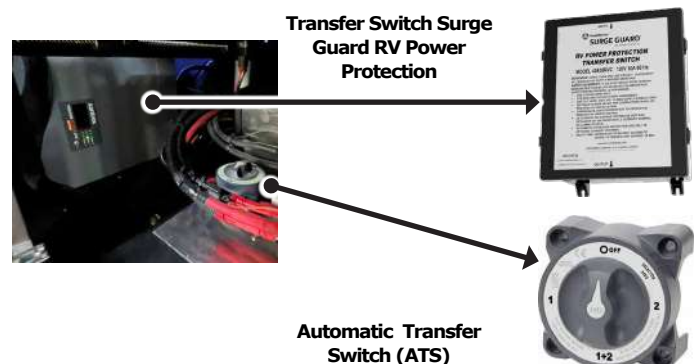



# ELECTRICAL

## SOLAR POWER

The Grech RV Turismo 144" has **three** solar panels on the top that helps power appliances inside the RV. Solar panels are devices that convert **light** (sunlight) into **power** (electricity). It is important to know that solar panels will **not** power **100%** your RV, their **primary** purpose is to **recharge** the battery bank when not connected to **shore power** or **generator**.

Solar charging system requires no **gas**, makes no sound and can charge your batteries for **hours** and hours unattended as long as the sun is shining.

Without solar power, you'll need to **resort** to using a generator or an **alternator**.

- **Generator:** Your RV on-board or portable generator is the most **common** recharging method, but generators require a steady supply of **gasoline** to run.
- **Alternator:** The alternator can charge both the **chassis** and **house batteries** while driving.



## BATTERY CHARGER / SOLAR CONTROLLER

A solar charge controller is a **solar-powered voltage** and current **regulator**. They are used in **off-grid** and hybrid **off-grid** applications to regulate power input from Photovoltaics (PV).

A **Photovoltaic System** is the conversion of light into electricity using **semiconducting** materials which can be solar cells from solar panels. In other words, photovoltaics gets its name from the process of **converting** light (photons) to electricity (voltage).

Solar charge controllers maintain **batteries** at their **highest** state of charge without **overcharging** them to avoid gassing and battery damage.

The solar charger controller in your RV has a built in **generator** to prevent your battery from being **overcharged**. Overcharging occurs when the charge voltage is unregulated. This can result in premature battery failure. It also has a **regulator** to prevent your battery from being **undercharged**, in the solar energy field, battery undercharge may happen.

It is connected to the battery **permanently** to keep the battery **fully charged** by using a process called "**floating**". Floating means that the controller will stop charging when the battery is **full** and will automatically **start** charging the battery as required. This process will also reduce water **loss** and help the battery from "**drying out**" from power.

A solar controller will protect your battery from **discharge** at night. Under **low** light or no light conditions the solar panel voltage could be less than the battery voltage. The unit contains a special **circuit** which prevents current flowing back from the **battery** and into the **solar panel**.



**Battery Charger Solar Controller**

The battery charger has **colored** LED's to easily indicate the operational status and battery conditions. It contains a digital **LCD** screen to display battery voltage, charging current, charging capacity (Amp hour), battery types and faulty codes. It provides a digital display meter.

## GENERATOR

This RV contains a Generator that can be selected for use when **AC shore power** or **solar power** is not available. A generator maintains all comforts of home when camping unplugged or on the go. Generators also charge **RV's batteries**, so when it gets shut down, the 12-volt system of the RV keeps operating.

It is recommended to run the generator for a **few hours** each day to **charge** batteries and run larger appliances, then shut them down for the night when they are not needed.

There will be times when you'll want to run a generator. When there is no way to charge the batteries, an alternative is the use of the solar power panels. **Solar power** can also power bigger appliances such as the air conditioner, heater or other "power hungry" appliances when your battery bank is low and can't provide energy. Batteries will provide power for the lights, water pump, and appliances. They will keep the essentials running even without a generator running.

# ELECTRICAL

## BASIC GENERATOR SAFETY INFORMATION

1. Don't sleep in the vehicle with the generator **running** without ensuring the **CO detector** is **working**. Inspection of possible exhaust system **leaks** need to be done to assure safety and protection against **CO poisoning**.
2. Don't operate the generator in an **enclosed** building or in a **closed area** such as a garage.
3. It is important to review the **safety precautions** for **fuel** and **exhaust** fumes in the generator manual.
4. Keep the **generator** and its **compartment** clean. **Excess** oil and oily rags can catch fire. Dirt and gear stowed in the compartment can **restrict** cooling air.
5. Do not operate the generator when the RV is **parked** in grass or near vegetation. **Heat** from the exhaust could cause **fire** in dry conditions.
6. Do not operate simultaneously the **generator** and **ventilator**, it may result in the entry of **exhaust gas**. It is recommended that if exhaust ventilators are used, to open a **window** on the opposite side of the unit to provide **cross ventilation**.
7. When parked, orient the RV so that the wind carries the **exhaust away** from the vehicle. Do not open **nearby** windows or doors.
8. Do not operate the generator when parked in **close proximity** to vegetation, snow, buildings or other vehicles that could **deflect** the **exhaust** under or into the vehicle.
9. Do not touch the generator when **running** the RV or **immediately** after shutting off. Heat from the generator can cause **burns**.
10. Allow the generator to **cool off** before attempting maintenance.
11. Used **engine oil** has been identified by some state and federal agencies as causing cancer or reproductive toxicity. **Do not ingest, inhale or make contact with used oils or its vapors**.
12. Do not work on the generator when **mentally** or **physically** fatigued or after consuming alcohol or drugs.

### ⚠ DANGER

- Learn the **symptoms** of **CO poisoning** in this manual and never sleep in the vehicle while the generator is **running**.
- Engine cooling air must not be used for **heating** the **working, living space** or **compartment**.
- Inspect for **exhaust leaks** at every startup and after every **8 hours** of running.
- Make sure there is **fresh air** when operating the generator in a **confined** area.
- Alarms should be tested **once a week** to ensure that they are **working**.

## TIMBERLINE HEATING SYSTEM

Timberline heat and hot water is generated by the **Autoterm Binar Compact**, a powerful but quiet diesel or gasoline heating unit made for the most adverse conditions. A **heated glycol solution** is circulated through the interior of the living space through quiet air handlers that provide soft radiant **heat**.

The **glycol** is also circulated through an instantaneous water **heat exchanger** which produces hot water for showers and kitchen use. By using the **diesel** or **gasoline burner** coupled with **110V Electric Element Support**, it provides efficient comfort whether dry camping or plugged into shore power.

The Timberline touchscreen digital panel located inside the RV gives you **full control** of the interior temperature. The controls are intuitive and will easily allow you to **adjust** the desired temperature and will give you the choice of whether you want to use your **fuel source** or **electric only**.



## FURNACE AND WATER HEATER

Your RV is equipped with an **auto-ignite 13,500 BTU** suburban furnace. An RV furnace is a main source of **heat** that uses both **propane** and **electricity**. Propane heats the furnace system while electricity enables the fan to move.

When the **thermostat temperature** is set higher than what the RV's temperature is in, the blower motor gets **activated**. Slowly, the heater begins to warm the RV, as propane burns to create hot air, and the ducts in the system blows the hot air.

An RV **furnace** will require: propane and electricity. Propane for creating hot air, and electricity to turn on the heating system as well as to run the fans.

Please refer to the manufacturer's operating manual before running this component for more important safety information and operation of this cooktop.

### ⚠ NOTICE

For more information on the Timberline Heating System, Furnace and Water Heater please check the Heating System Section on this manual for more information on how to use the Firefly Control System screens.

# LIQUID PROPANE GAS SYSTEM

## LIQUID PROPANE GAS SYSTEM LP UNITS

**LP gas** is a main source of **energy** to power **generators** and fuel **appliances** necessary for comfort heating, cooking and refrigeration. LP gas is produced by **processing** natural gas and refining **crude** oil. When LP gas is placed under modest pressure, it liquifies, don't forget that LP gas is **odorless** and **colorless**.

LP (**Liquid Petroleum**) Gas is a **colorless** gas compressed into liquid form for easy **transportation** and **storage**. It is the **energy source** for your cooktop, furnace, hot water heater, LP generator, and an alternate energy source for your refrigerator.

**Propane** stored in **cylinders** is in a **liquid state**. Once the cylinder is **connected** to the RV's LP gas system and the **service valve** on top is opened, the liquid propane **boils** and **exits** the cylinder as a **vapor** in much the same way that boiling water converts to **steam** (water vapor).

Your RV is equipped with a **Liquid Propane Gas System** that its main **objective** is to provide a fuel source to the appliances, which are meant to be used with **gas**.

### LPG AND POWER GENERATOR STATION

The LP & Power Generator station is located in the **passenger's bottom side** of the RV. It includes a propane tank filler, bleeder valve, LPG shut-off switch, BBQ quick connect, TV/Antenna hookup and two 110V power outlets.

This station will only be found on **LP RV's** and will be located on the **passenger's bottom side** of the RV. It includes a propane tank filler, bleeder valve, LPG shut-off switch, BBQ quick connect, TV/Antenna hookup and two 110V power outlets.

**NOTICE**  
Electrical RV's will have only the two power outlets and TV/Antenna Hookup since there is no gas integrated in this model.

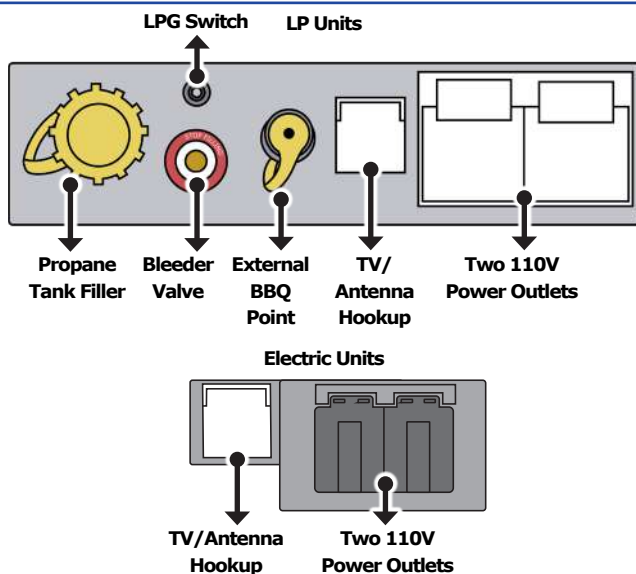

### NOTICE

The LPG system is designed and built to adhere to federal government and industry regulatory requirements.

Many safety devices and backup systems have been installed in your RV to improve safety and reliability. These devices include the following: LPG gas detectors, and Carbon Monoxide (CO) detectors. In addition, although LPG is naturally odorless, it contains an odor additive so it can be more easily detected.

### PRECAUTIONS FOR THE SAFE USE OF LP GAS

LPG may leak as a **gas** or a **liquid**, it will quickly evaporate and form a relatively large cloud of gas which will **drop** to the ground, as it is **heavier** than air. LPG vapors can run for long distances along the ground and can collect in drains or basements.

### DANGER

When the gas meets a source of ignition it can burn or explode. Gas cylinder can explode if involved in a fire. LPG can cause burns to the skin and it can act as an asphyxiant at high concentrations.

#### 1. Familiarize yourself with the odor of LPG.

- The smell of propane isn't pleasant it is naturally odorless, but a chemical is added to make it smell like rotten eggs, making leak detection much easier.
- If you smell gas, get everyone out of the RV. If you suspect a leak, immediately turn off the LPG supply and have qualified service center determine the source of leak, don't return to the RV until it is safe to do so.

2. Check the **entire system for leaks** every time the tank is filled. Take time to regularly inspect the system for leaks.

3. Always ensure **adequate ventilation** and never use indoors or in confined spaces.

4. Do not use **LPG systems** and appliances in **windy** conditions.

5. Only use **approved** or **certified** hoses and connections designed for gas.

6. **Turn off the LP Gas Supply Switch** when the LPG system is not used.

7. **Do not fill the LPG tank about 80%** of its maximum capacity. LPG required room to expand within the tank.

8. **Make sure all appliance vents are open** and free of obstruction when using the LPG system.

9. Check for cracks or damage on the hose or a damaged gas regulator.

# LIQUID PROPANE GAS SYSTEM

## PROPANE TANK FILLER

1. Shut off the LPG shut off switch in the LPG and Power Generator Station before filling up the LPG tank or traveling.
2. Connect the LPG supply connector to the Propane Tank Filler.

### NOTICE

Be careful of not overfilling your LPG tank. Stop filling when liquid appears to overflow the Propane Tank Filler.

3. Check the LPG level on the Firefly Multiplex System after refilling. Make sure it is at an 80% filled to give a 20% for expansion.

### WARNING

Only certified LPG suppliers should fill the LPG tank. Turn remote gas supply switch off before filling or refilling LPG tank

### WARNING

Shut off the LPG gas when refueling the RV.

### WARNING

All LP gas appliances must be turned off during refueling your RV's fuel tank and the LPG tank.

### NOTICE

To prevent overfilling, have the tank filled only by an authorized filling station.

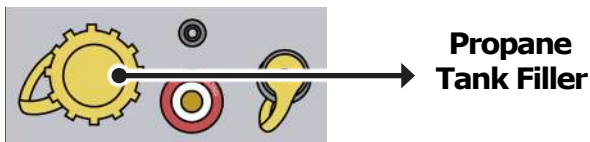

### DANGER

**IT IS IMPORTANT TO NOT FILL LP CONTAINER TO MORE THAN THE 80% CAPACITY RECOMMENDED.** Over filling the LP gas container may cause uncontrolled gas flow, which can cause a fire or explosion.

The Firefly Multiplex System offers you the opportunity to check your LP gas current state.

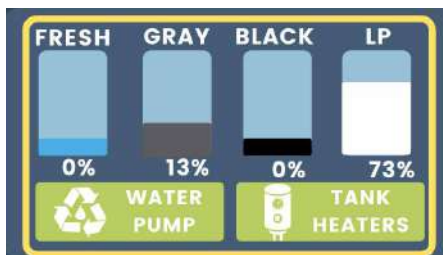

## LPG BLEEDER VALVE

The bleeder valve allows **pressure** to **vacate** the LPG tank when the tank is **80% full**. Make sure the fill is **free** of dirt, it may help to remind your LPG supplier to only use a **clean** fill hose to **fill** your tank. Turn off the **LPG Shut-off Switch** when the LPG system is not in use, as it draws **12V** current from the batteries.

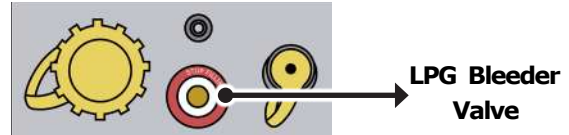

## BBQ QUICK CONNECT

It is directly connected to the RV **LP system** and equipped with its own **shut-off valve** (black handle).

The quick connect is a **regulated** (low pressure) LP line that is supplied from the on board **LP tank**. It works with the **standard**, full-flow male quick connect fitting. You will need a BBQ that is set-up for a **low pressure** LP source.

### NOTICE

For you and your passenger's security, propane will only flow from the BBQ quick connect when the hose is connected. The black handle will function as a security handle that may only be able to release the hose from the quick connect when its in the OFF position.

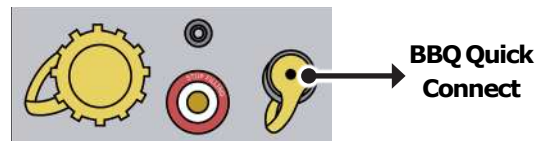

## HOW TO USE THE BBQ QUICK CONNECT

1. Make sure that the **black valve** is in **OFF** position.
2. Remove **yellow cap** that is covering the **nozzle**.
3. Make sure the opening is **clean** and without **debris**.
4. Insert the **male quick connect fitting**, it should be a snug fit.
5. Push the **fitting** until the **sleeve** snaps forward, until it locks into the **socket**.
6. Connect your **BBQ**.
7. Turn the **black handle valve** to the **ON** position to allow **propane** to enter and flow through the connected **BBQ**.
8. Make sure that the main **LPG switch** is **ON** to allow the passing of **gas**.

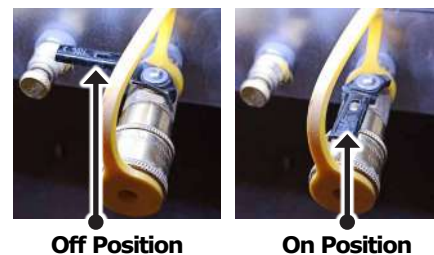



# LIQUID PROPANE GAS SYSTEM

## WHAT TO DO IF YOU FIND AN LPG LEAK

1. Turn the **black handle off** until the valve is in the **OFF** position. If for any particular reason the handle is **stuck** or you can't move it, step away from the area immediately.
2. Once you're a **safe** distance away from the RV, **call 911** or a specialist in LPG tanks.
3. Make sure there are **no** flames, sparks or any potential **fire hazards** near. Immediately put **out** all smoking material and other open flames.
4. Do not **operate** lights, appliances, telephones or cell phones near the section. **Flames** or **sparks** from these sources can trigger an explosion or a fire.
5. Open **doors** and **windows**.
6. If you have campground neighbors, make sure to **warn** them too so they can take **precautions**.
7. Get both your **grill** and **propane** tank and valves **checked**. Do not try to use any of those components until the problem and solution has been **determined**.
8. Make sure a **qualified service technician** takes a look at the situation and get your LPG tank inspected.

## SIGNS THAT SOMETHING ISN'T RIGHT

- **Sniff test:**
  - A smell like rotten eggs or skunk spray indicates you have a propane leak.
- **Yellow or irregular flames:**
  - Propane should always burn with a blue flame in your appliances. Yellow or irregular flames indicate that the propane isn't burning properly, which could be a sign that carbon monoxide is being released.
- **Soot buildup:**
  - Propane burns clean, so there should be no soot, dust or ashes in or around your appliances. If there is, it's an incentive of a potential fire or damage in your LP lines and tanks. Inspect appliances and clear any dirt before attempting to use them. Use compressed air or a long duster for any hard to reach places. Make sure all dirt has been cleared before turning appliances back on.

### ⚠ WARNING

Be careful when working around electricity, as it can carry dangerous amperage and cause sparks or combustion.

### ⚠ WARNING

The electric gas shut-off solenoid closes automatically when 12-volt power is disconnected. It will reopen when power is restored.

## LPG SHUT-OFF SWITCH

The LPG Switch is located in the passenger's bottom side on the **LP and Power Generation Station**. Its main objective is to open and close the LPG valve, it will shut off all **gas appliances**. The switch activates an **electric solenoid** which opens and closes, shutting the gas off at the tank. This switch should be turned off during the filling of the LPG tank.



### ⚠ WARNING

If any type of failure or error appears to occur in under no circumstance use open flame to search for the possible error or solution. If you smell gas or any appliance pilots fail to stay on, use the LP shut-off switch to turn off the tank valve immediately and call a qualified LPG service or contact us.

## HOW TO DETECT A PROPANE GAS LEAK

For you and your passenger's **safety** it is important to inspect your **propane** tank and **outdoor propane appliances** for any leaks that may occur.

Propane leaks are **flammable** and can be very **dangerous**. Leak test should be made before the first use of every season or if it hasn't been used in a while.

### Signs that your LPG tank may have a leak:

- **You smell gas:**
  - One of the **fastest** and **easiest** ways to identify a **leak**.
  - A smell like rotten eggs or skunk spray will indicate that you may have a **propane leak**.
- **Usage Spikes:**
  - On the event that you notice that your LPG tank is running **out of gas** so much faster than normal, a leak may be culprit.
- **Poor performance:**
  - If you notice that your propane grill, space heater, or fire pit have a smaller, **weaker flame** than usual, or it's not working the way it usually does, it may have a propane leak.

### ⚠ WARNING

Remind the service attendant to use the 80% overflow valve when refueling. Space on LPG tank must be left for vaporization and expansion to occur.

### ⚠ WARNING

Check for leaks. Your tank should be securely connected to the grill's gas line. To make sure the connection is secure and there are no leaks, conduct a simple "bubble" leak test. You should perform leak tests regularly, but especially before you use your grill for the first time in a while.



# LIQUID PROPANE GAS SYSTEM

## HOW TO CONDUCT A LEAK CHECK: USING THE "BUBBLE TEST"

The "bubble test" or "soapy water test" allows to indicate if there is a **gas leak**. You just need to coat all gas transmission gears (pipes, hoses and valves) with soapy water or leak detector solution and then pressurise the system.

### NOTICE

It is important to regularly test for any gas leaks in your BBQ quick connect, regulator and hose to know when it needs maintenance or a replacement. Not giving a proper maintenance may cause fires or accidents.

### 1. Turn the propane tank off:

- ▶ Make sure the **black handle** is all the way to your left in the **OFF** position.

### 2. Apply propane leak detector solution or soapy water:

- ▶ Use either special leak detector solution or a pinch of thick soapy water. Spray the entire valve, regulator and hose assembly.
- ▶ The soapy water or leak detector solution may be applied with a sponge, paint brush or basting brush.

### 3. Turn on the LPG and watch for bubbles:

- ▶ If bubbles do appear at the connection points, close the black handle, tighten the connection, and repeat the process.
- ▶ Test again for other possible leaks on the entire assembly, from the gas bottle valve to where the gas hose attaches to the BBQ.
- ▶ If bubbles continue to appear, close the gas valve immediately and contact a LPG tank specialist or contact us.
- ▶ Rinse with clean water to remove the soap solution.

### WARNING

Do not turn back on or attempt to use the BBQ quick connect until the problem is rectified or components are replaced.

### DANGER

Never use an open flame to test for leaks. Never fill the LPG tank. Never fill the LPG tank when either the engine or the generator is running. Keep all protective covers and caps in place.

### NOTICE

Gas lines should be checked periodically for leaks with ammonia-free soapy water.

### DANGER

Never carry flammable liquid containers inside the RV or driving areas of your RV. Gases may inadvertently be discharged into the confined space which could result in fire, asphyxiation or explosion.

## IF AN LPG ALARM SOUNDS

An RV LPG alarm senses and indicates the **presence** of **LPG** in the air. When a certain **concentration** of gas is detected, your RV will detect and indicate the presence of LPG, alerting people in the area of the **danger**.

Your RV LPG alarm is mounted **low** down on a wall of the interior of your RV. That's because propane is **heavier** than air, so in the event of a **leak**, it tends to accumulate **low** down near the floor.

### If the propane alarm goes off:

- ▶ Extinguish all open flames on RV.
- ▶ Do not operate lights, appliances or cellphones, which can produce a spark.
- ▶ Exit the RV immediately.
- ▶ If possible and safe, turn off the LPG shut off switch.
- ▶ Leave area and call 911.
- ▶ Before you turn on any propane equipment, have it inspected by a qualified propane technician.

### At campgrounds:

- ▶ Open a window, turn on the roof vent and turn on your exhaust fan when cooking.
- ▶ Never use your stove for space heat.
- ▶ Never use outdoor fuel-burning equipment inside the RV.

### In storage:

- ▶ Turn off all propane supply valves and appliances.
- ▶ Keep vents open.
- ▶ If you store your vehicle in an enclosed area, store your RV in a well ventilated area.
- ▶ Have your RV's propane system inspected before using your RV after storing your RV for a long period of time.



### NOTICE

The instructions previously provided are a general guideline only. To ensure proper service and safety, it is important to always take your RV to a qualified service center.

### NOTICE

Please refer to the Smoke section on this Owner's Manual for more information on the CO, LPG and Smoke Alarm and to each components User Guide provided to you on the RV Information Kit.

# LIQUID PROPANE GAS SYSTEM

## LPG TANK SYSTEM

The LPG storage tank is mounted on the undercarriage of your RV and can be operated from the LPG and Power Generation Station.

### NOTICE

Before turning on the LPG shut off switch located on the LPG and Power Generation Stations and make sure all LPG powered appliances are in the off position to prevent the LPG system to leak.

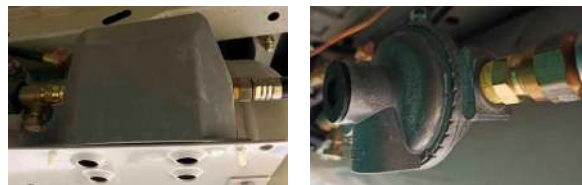

## LP TANK GAUGE

The propane gauge is located on the left of the LPG tank where it indicates how full or empty the tank is. There is also the opportunity to check the LPG tank status in the Multiplex Firefly Control System screens inside the RV.

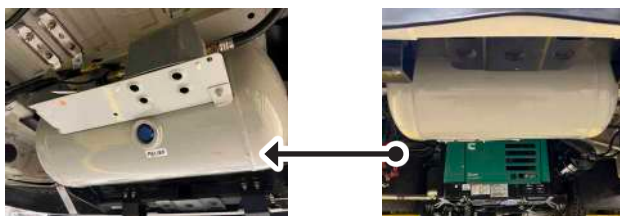

## MANUALLY OPERATED LPG TANK COMPONENTS

The LPG storage tank it is equipped with manually operated components located on the exterior of the LPG tank.

Gauge



LPG Relief



Regulator Valve

## LPG REGULATOR VALVE

The regulator on your LPG tank controls the **flow** of **gas** from the propane tank to the **appliance** that is using the propane. It reduces the **high** gas pressure from the propane cylinder to the much **lower** gas pressure that the propane appliance **needs**.

The regulator also acts as a **safety device** and it is often referred to as the **heart** of the LPG system. Inside the LPG tank, propane exists as a **liquid** under very **high** pressure. It is consumed by your appliances, however, as a **gas**. When the liquid transforms into a gas, it **expands** creating even more **pressure**. If not controlled by the regulator, you may run into problems like **ruptured hoses** or even an **explosion**.

### CAUTION

Do not use open flame to search for problems. If gas can be smelled, appliance pilots fail to stay on, or any other abnormal situation occurs, use the remote supply switch to shut off the tank valve immediately and call a qualified LPG service center or Grech RV.

### NOTICE

Gas lines should be checked periodically for leaks with ammonia-free soapy water.

### CAUTION

Moisture in the LPG tank will cause a malfunction of the regulator in controlling proper pressure. This may result in the flame lifting off the burner or going out frequently.

# LIQUID PROPANE GAS SYSTEM

## GENERATOR

Your RV has a **2,500 watt generator** that provides the electricity to equipment and appliances within your RV. It feeds the **electricity** via the **circuit breaker panel** to these equipment and appliances. It also provides the power to operate your **inverter/charger**, which charges your RV house batteries.

The **internal combustion** engine converts the **chemical** energy stored in the fuel to **mechanical** energy. The alternator, coupled to the engine, converts this **mechanical** energy to **electrical** energy. This electrical energy then flows to your RV's circuit breaker panel to feed the **loads, equipment and appliances** within your RV.

Your RV's **house batteries** and **shore power**, when connected, are other sources of electrical energy for the appliances within your RV.

The generator on your RV is located on the **undercarriage** of your RV in front of your LPG tank.



## ENERGY AND POWER TERMS

There are **three key elements** associated with RV generators that will help you understand more about your generator:

### › Amperage (Amps):

- The amount of current flowing in a wire or conductor. The size of the wires and internal breakers determines the RV's amp capacity. Turismo model has a 30amp shore power.

### › Voltage (Volts):

- The amount of electrical potential present, in this RV there is a 120 VAC or 120/240 VAC when running from shore power, generator or on board inverter.
- The voltage will be 12 VDC when operating from batteries.
- Many interior lights, absorption refrigerators, liquid propane furnaces and other appliances operate on 12 VDC.
- Inverters take 12 VDC and convert it to 120 or 240 AC to operate appliances when shore power or a generator is not present.

### › Wattage (Watts):

- It is the multiplication of voltage and amps.  
(voltage x amps= watts)

### ⚠ CAUTION

Before operating the generator, refer to the LPG generator operator's manual located in the RV Information Kit.

## SAFETY PRECAUTIONS

- Keep fire extinguishers handy.
- Make sure all fasteners are secure and torqued properly.
- Keep the genset and its compartment clean. Excess oil and oily rags can catch fire.
- Be caution when making adjustments while the genset is running hot, moving or electrical parts can cause severe personal injury or death.
- Used engine oil, benzene and lead in some gas stations have been identified by some state and federal agencies as causing cancer or reproductive toxicity. Do not ingest, inhale or contact used oil or its vapors.
- Do not work on the genset when mentally or physically fatigued or after consuming alcohol or drugs.
- Use personal protective equipment when performing maintenance operations such as glasses, gloves, etc.

### ⚠ DANGER

Generator output connections must be made by a qualified electrician in accordance with applicable codes.

**GENERATOR VOLTAGE IS DEADLY!**

### ⚠ DANGER

Use caution when working on live electrical equipment. Remove jewelry, make sure clothing and shoes are dry and stand on a dry wooden platform.

### ⚠ WARNING

Watch constantly for people near the exhaust of the generator set while its running.

### ⚠ DANGER

Do not smoke or turn electrical switches ON or OFF where fuel fumes are present or in areas sharing ventilation with fuel tanks or equipment. Keep flame, sparks, pilot lights and switches and all other sources of ignition well away.

# LIQUID PROPANE GAS SYSTEM

## SIGNS TO LOOK FOR

It is a crucial component of every RV gas system and if it is not working properly you will notice problems with the LP appliances. There are several signs to look out for:

### ▶ Yellow flames:

- The **flame** on your LP appliances should be a strong **blue**, if you have **yellow** flames after lighting one of the burners on your RV stove, it indicates **lack** of pressure in your LPG system.
- If the flame is **blue** but makes a **roaring** sound and it is a **tall** flame, then it has **too much** pressure.

### ▶ Dark Soot Deposits:

- Propane is a **clean** gas and it doesn't normally have **dark smoke** when it burns.
- A **healthy** LP flame shouldn't should leave **hardly** any soot. If you have started noticing **dark black** marks forming around your **water heater** or even in your cooktop, you either have something in the **burner** causing the soot or the flame is **weak** and isn't burning **cleanly**.

#### ⓘ NOTICE

Dark soot can best be described as a product of the incomplete combustion of fueled carbon. When carbon burns all the way through, very little residue is left. When it doesn't, it leaves behind a black, flaky substance called soot.

### ▶ Popping noises:

- If you hear popping noises when you turn **off** the flames on your cooktop, then your LP regulator could be having **issues**.
- It can also be a result of a **damaged** burner. If you hear the popping noises on one burner but not on the others, check the **problematic** burner; it may be **dirty** or **askew**.

### ▶ Leaking:

- If there is a **propane smell** coming from your propane regulator it may be **damaged** or not **sealing** properly.
- Propane regulators have a **vent** located on the side to help the regulator **breathe** while being used. Make sure it is open and not obstructed in any way.

#### ⓘ NOTICE

If there is propane coming out from the vent, check to make sure your propane tank is not overfilled. If the tank is not the problem, then the regulator has gone bad and needs to be replaced.

## TIPS TO PREVENT ASPHYXIATION

1. Inspect the RV's **chassis** and **generator exhaust system** regularly, at least before each discarding any other incidents that could potentially cause more damage.
2. Inspect the RV for **openings** in the floor or sidewalls. If you locate a hole, have it **repaired** before using your **generator**.
3. Inspect windows, door seals, and weather strips to ensure that they are **sealed** properly.
4. Yellow flames in **propane**-burning appliances such as, cooktop, oven and water heater usually indicate a **lack** of **oxygen**. Determine the cause of this **condition** and **correct** it immediately.
5. Do not operate your **generator** if the **exhaust system** is **damaged** in any way or if an **unusual noise** is present.
6. Park your RV so that the **exhaust** may easily **dissipate away** from the vehicle. Do not park next to high grass, weeds, snowbanks, buildings or other obstructions that might prevent exhaust gases from dissipating as they should.
7. Keep in mind that **shifting winds** may cause exhaust to **blow away** from the RV and may come back under the RV.
8. Do not sleep with the generator **operating**.
9. Leave a roof **vent** open anytime the generator is **running**, even during winter. Ensure there is always proper ventilation to prevent **asphyxiation**. Long term use of LP appliances or equipment increases the chances of **possible** asphyxiation.
10. If you or any passenger doesn't feel good, do not rule out the possibility of symptoms of **asphyxiation**. Shut **off** generator, step out of the RV and get some fresh air.

#### ⓘ DANGER

Do not carry possible flammable materials such as wood or charcoal grills, heaters or stoves inside the RV that are not previously installed by Grech RV. The addition and use of this equipment may cause a deadly carbon monoxide gas or cause fires.

#### ⓘ DANGER

Avoid breathing exhaust fumes from gas or diesel engines and LPG appliances. Poisonous exhaust fumes are generated from operating the RV or generator engine, stove, oven, refrigerator, furnace and hot water heater.

#### ⓘ WARNING

Make sure all alarms are in proper working condition and with battery life, to prevent accidents and possible set backs.

#### ⓘ NOTICE

Do not run the RV or generator engine in a confined or constricted area. If your RV was on storage in a confined area you can run the engine to move the RV from one place to another.



# MAINTENANCE

## EXTERIOR CARE

**Regular** care of your vehicle is a condition for **retaining** the **quality** in the long term. Use **care** products and **cleaning** agents recommended and approved for **sprinter** vehicles.

You can wash the vehicle in an **automatic car wash** from the very start. Wash off excess **dirt** before cleaning the vehicle in an automatic car wash. After putting the vehicle through an automatic car wash, **wipe off wax** from:

- Rear view camera lens
- Windshield
- Windshield wiper blades

This will prevent **smears** and reduce **wiping noises** caused by **residue** on the windshield.

### NOTICE

For cleaning your vehicle, do not use any of the following: dry rough or hard cloths, abrasive cleaning agents, solvents and cleaning agents containing solvents.

## WASHING BY HAND

- Do not use **hot water** and do not wash the **vehicle** in **direct sunlight**.
- Use a **soft** car sponge.
- Use a **mild** cleaning agent, a car shampoo **approved** for use with Sprinter vehicles.
- Thoroughly hose down the vehicle with a **gentle** jet of water.
- Rinse out the sponge **frequently**.
- Rinse the vehicle with **clean** water and **dry** thoroughly with a chamois.
- Do not let the cleaning agents **dry** on the paintwork.
- When using the vehicle in **winter**, remove all traces of **road salt** deposits carefully and as soon as possible.

### NOTICE

Do not park your vehicle for a long period of time directly after cleaning, particularly after cleaning the wheel rim with wheel cleaner. Wheel cleaner can lead to the increased corrosion of the brake discs and pads. Therefore, drive for a few minutes after cleaning. By heating up the brakes, the brake discs and pads dry. The vehicle can then be parked for a long period of time.

Even when using **power pressure** as a washing option for your RV, it may not result in the way you want and **hand washing** may become a great alternative.

It is important to verify **before** starting to hand wash your RV that every **tool** you use (brushes, mitts, solutions, etc) will not **damage** your vehicle. Even **scrubbing** in an intense way and for a long time can affect the finish of the RV. Cleaning the tires may also affect, **damage** and create **scratches**, if the **appropriate** brush is not used.

## Before cleaning the windshield:

- Turn the key to position **0** in the ignition **lock** or **remove** it.
- Fold the **windshield wiper arms** away from the windshield until you feel them **engage**.
- Before switching the ignition **on** again, fold the windshield wipers back into **position**.

## Cleaning the windows:

- Clean the **inside** and **outside** of the windows with a **damp** cloth and a **cleaning agent** that is recommended and approved for RV's.



### CAUTION

There is a risk of injury when cleaning the windshield or wiper blades if they start moving. Always switch off the windshield wipers and the ignition before cleaning the windshield or wiper blades.

### CAUTION

The water jet from a circular jet nozzle (dirt blasters) can cause invisible exterior damage to the tires or chassis components. Do not use power washers with circular jet nozzles to clean the vehicle. Have damaged tires or chassis components replaced immediately.

### CAUTION

Under no circumstances use power washers in the vehicle interior. The pressurized water and associated spray produced by the power washer could cause extensive damage to the vehicle.

## POWER WASHERS

You should **never** pressure wash or power wash your RV because of the **high-pressure** of the water will **damage** your RV's exterior surfaces and components. As well, pressure washing injects water into **crevices** that may seep into your RV's interior.

Most importantly though, if not used correctly, a pressure wash tool can also cause **injuries**.



# MAINTENANCE

## USING PRESSURE WASHING

**Pressure Washing** and **Power Washing** are two different things. A jet wash in a power washing machine uses **heated** water, where as the water in a pressure water is **not heated**.

When using a pressure washer, you may want to ensure that the right **Pounds per Square Inch** (PSI) range is used in addition of the right nozzle tips. High-pressure water can **sneak** behind overlapping **layers** and **gaskets** and cause **damage**.

Light- duty pressure washers are perfect, anything up to **1,500 PSI** will do the job, it is recommended to use less than **1,500 PSI** just to be safe.

### ⚠ CAUTION

Observe the minimum distance to be maintained between the nozzle of the high-pressure cleaner and the object to be cleaned and beware that water must not enter ventilation openings.

When using a round-jet nozzle keep **distance** of **2.2 ft** (70 cm) and **1 ft** (30 cm) when using a **25°** flat-spray jets and concentrated-power jets.

Keep the water jet **moving** while cleaning. To avoid causing **damage**, do not point the water jet **directly** at: Door joints, brake hoses, electrical components, electrical connections, seals, drive train, especially not at the intermediate bearing of the propeller shaft, and rear view camera. Keeping a **minimum** distance of **1.6 ft** (50 cm).

### ⚠ WARNING

When cleaning with high pressure water or steam cleaners, the spray must not be aimed directly at electrical components or the terminals of electrical lines.

## PSI

**Water pressure** is a really important factor when using a pressure washer to knock off **dirt** from RV's surface. When it has **too much** pressure it could **damage** the vehicle.

### ⚠ WARNING

Do not park your vehicle for a long period of time directly after cleaning, particularly after cleaning the wheel rim with wheel cleaner. Wheel cleaners can lead to the increased corrosion of the brake discs and pads/linings. Therefore, drive for a few minutes after cleaning. By heating up the brakes, the brake discs and pads dry. Then the vehicle can then be parked for a long period of time.

## RV'S BODY MATERIALS

RV's are usually made from one of three **main exteriors**: Metal, painted metal or fiberglass. Each material requires a **special** cleaning **solution** or **brush**. Any finish will deteriorate **over time** and because of **exposure** to extreme sunlight, pollutants and excessive moisture can cause **dulling**, **fading** and **yellowing**.

### > **Plastic / Moulded Parts:**

- This RV has plastic somewhere on the **exterior** such as light covers, roof vents headlight and AC covers are all made of **plastic**.
- It is pretty **easy** to clean, all you need is a bucket of **soapy** water and a **soft** bristel brush. It is essential that this brush is not a **hard heavy** duty brush because it will harm and **damage** the component that has been cleaned.

### > **Fiberglass:**

- Nowadays, RV's with **fiberglass body** is what is commonly found, for the reason that fiberglass is **light** which means more **fuel efficiency**.
- When cleaning an RV made with **fiberglass**, stick to a **low** pressure washer. It is preferable to use a **cleaner** that not only washes but also applies a layer of **wax** at the same time.

It is certainly **suggested** the use of an **extension wand** for the pressure washing, it may come helpful when cleaning your RV.

RV's have **layers** or **gaskets** that overlap as well as areas that are sealed or other **pliable** material that will not withstand the **pressured** water that is forced out by a power wash.

### ⚠ NOTICE

Areas that have been sealed with products such as silicon and other malleable materials can be loosened when using a high-pressure washer. This can lead to serious damage to sealed areas unless a good brush attached to a light-duty pressure washer is used.

### ⚠ WARNING

Giving your vehicle a look-over before spraying will help you avoid any potential mishaps of getting water into places you don't want it. Pressure washing without studying your vehicle could easily lead to more damage than the dirt you want to get rid of. This step is crucial to avoid any mistakes that could cost you time and money to repair.

## CLEANING THE PAINTWORK

**Scratches**, **corrosive deposits**, areas affected by **corrosion** and **damage** caused by inadequate care cannot always be completely **repaired**. In such cases, visit a specialist workshop.

- > Remove **impurities** immediately and avoid **rubbing** too hard.
- > **Soak** insect remains with insect **remover** and **rinse off** the treated **areas** afterwards.
- > **Soak** bird droppings with **water** and **rinse off** the treated **areas** afterwards.
- > **Remove** coolant, brake fluid, tree resin, oils, fuels and greases by rubbing **gently** with a cloth soaked in **petroleum ether** or **lighter fluid**.
- > Use **tar remover** to remove tar **stains**.
- > Use **silicone remover** to remove **wax**.

# MAINTENANCE

## PRESSURE WASHER NOZZLE GUIDE

Pressure washers spray water in a **V shape** from the end of the wand. Each nozzle **added** to the end of the wand will spray water in a **wider** or **narrower** form, depending on what **degree angle** the nozzle is set in. Example: **15°** is **narrow** and **stronger** compared to a 40° which is significantly wider.

The **less degree** the nozzle has the **narrower** the spray is, as well as **more pressure** in the spray however just in a restricted small area. In contrast, the **wider** spray, which are the **higher-degree** nozzles, provides less pressure but it covers **more** area. For RV's, it is recommended to use a **white nozzle** when cleaning your RV. Refer to this handy pressure washer nozzle **chart** for **guidance** when choosing a **nozzle** for when cleaning your RV or another pressure washer **project**.

## SAFETY GUIDELINES FOR PERSONAL USE

- Always read the **manufacturer's instructions** before using a pressure washer or any other component. Pay close **attention** to **safety** instructions.
- Wear **safety gear** including safety goggles, boots, gloves, long-sleeved shirts and long pants.
- Note any **tripping hazards** in your path when using the pressure washer, to **avoid** falling down while using it. **Remove** tripping hazards whenever possible.
- Never use the **tool** for anything that it was not designed to do. For example, **never clean** something that it was not **designed** to clean, as it could cause **damage**.
- Do not turn the **spray nozzle** on yourself (like to clean your shoes), and never **aim** at anyone else.
- Never spray **bare skin** and keep it **away** from yourself.

Nozzle Color	Spray Pattern	Uses	Surfaces
Red	0° 	powerful pinpoint for spot cleaning of hard, unpainted surfaces or for high reach areas	unpainted metal or concrete; DO NOT use on wood
Yellow	15° 	intense cleaning of unpainted hard surfaces	grills, driveways, concrete or brick walkways, unpainted brick or stucco
Green	25° 	standard cleaning nozzle for most applications	yard tools, sidewalks, lawn furniture, unpainted siding, stucco, gutters and eaves, concrete, brick surfaces
White	40° 	cleaning of painted or delicate surfaces	auto/RV, marine, wood, painted brick and stucco, vinyl, painted siding
Black	low pressure 	applies cleaning solutions	Low pressure spray is safe on all surfaces. Always verify compatibility of cleaning solution prior to use.

# MAINTENANCE

## NOTICE

Do not affix stickers, films, magnetic planes or similar items to painted surfaces you could otherwise damage the paintwork.

## CLEANING PRODUCTS

It is **easy** to have access to **commercial** products to wash your RV on websites such as Amazon or at your local RV dealer.

There is a more accessible and DIY alternatives such as using **baby shampoo** with a small amount of **distilled white vinegar** added to a bucket of water, it is a great DIY basic solution and most important it is a **non-toxic** soap. You may clean the RV with a **hand mitt**, the type used for **washing vehicles**, or a **soft-bristled** hand brush will work for lower areas of the RV.

It is suggested, to **change** the water often while washing an RV. The last thing you want to do is swirl **dirt particles** around the RV's surface that may cause **abrasion**, **streaks** or **additional dirt** while trying to remove it.

When cleaning the **body** of the RV with the pressure washing it is best done performing it in a **horizontal** swiping motion beginning from the **top** to **bottom**.

## NOTICE

Dish soap should never be used because it leaves a film that baby shampoo doesn't leave. Overtime it deteriorates and affects your RV even if the it is regularly waxed.

## NOTICE

Preferably aim the pressure wash nozzle to the desired zone of the RV that needs to be cleaned to avoid unwanted damage in the RV.

## TIRE CARE

It is really important that **inspection** is made before driving your RV, even if the RV has been in **storage** for a long time. It is necessary to inspect the **condition** or possible **damages** made in tires.

A really complete **wheel inspection** must include interior and exterior **examination** of sidewalls, thread area and the condition os valve stems, valve caps and wheels. **Thorough** inspection of **wheel threads** should be made, and unusual **wear**, **cracking**, **penetrations**, **cuts** or **scratches** are some of the things you should be looking for. Since many RV's are used only for only a season, many others are used all year round, tires will **wear out** and should be checked **daily** or at least **once** a month.

If there is a damage in the tires **detected**, tires will need to be replaced as **soon** as possible. It is important that if the RV is not in use, to store it in a **cool** and **dry** area away from heavy and strong **heat** sources and extreme **cold**. Remember that if the RV needs to be outside, to cover the **rims** from direct sunlight.

It is important to **maintain** the wheels to provide **traction** while **moving** and **grip** when **steering** or **stopping**.

## TIRE CARE TIPS

To decrease the risk of tire failure:

### 1. Check the pressure of the tires:

- The tires should be checked at least **once a month**.
- It is important that tires are not **hot** when checking the pressure. Tires should be **cool** (vehicle has to previously be stopped for 3 hrs and driven less than 1 mi) to be checked.

### 2. Use a tire gauge:

- To check **pressure** and maintain it at the recommended level.

### 3. Do not overload the tires:

- Take notice of the **maximum load-carrying** capability of your tires.

### 4. Check tires frequently:

- You may find **scrapes**, **cuts**, **damages** or **rasps**, if you find any of these it is important to find help from a tire dealer for assistance.

### 5. Do not operate your vehicle in high speeds:

- It is advisable to check what **type of speeds** the tires can **handle** for a better performance and operation.

### 6. Be caution of running over objects:

- Objects may **damage** the tire through **impact** or **cutting**, such as chuck holes, glass, metal, etc.

### 7. Never drive on smooth tires:

- Tires need to be **removed** when there's remaining a **2/32 in** of tread depth.

### 8. Warm climate:

- You may want to park your RV when there's **warm climate**.
- If UV sunrays are too **strong** use tire covers to prevent **deterioration** or **damage** to the rims.

Rims are easily cleaned with **soap** and **water**, it is important to avoid using **caustic** cleaning products, to protect the environment and reduce **maintenance**. This will keep the wheels looking their best with a lot less effort saving you **time** and **money**.

**Aluminum alloy** wheels rims offer a number of **advantages** over **steel** rims and are a popular choice on many RV's. **Aluminum** wheels are bound to **lighten** the weight and **efficiency** of your vehicle. These rims offer the opportunity of penetrating the **aluminum**, these wheels keep their **shine**, even after hundreds of washes and thousands of miles without **polishing**.

Aluminum wheel **covers** should be checked **once** or **twice** a year for any signs of **rust**. Dealing with rust as **soon** as it is noticed implies that it won't **spread**.

# MAINTENANCE

## DURA-BRIGHT WHEELS:

### ➤ Cool down:

- Allow wheels to cool below **95°F (35°C)** before cleaning.

#### ⓘ NOTICE

Do not use any acidic or alkalin cleaning agents. They can cause corrosion on the wheel bolts (wheel nuts) or the retainer springs for the wheel-balancing weights.

### ➤ Pre-rinse:

- Rinse with water for at least **30 seconds**. To prevent scratching and abrasion, **rinse** wheels thoroughly with a water **hose** or **power washer** to remove any loose and visible dirt.

### ➤ Prepare cleaning solution:

- Add a **mild detergent**, like common liquid dish soap, to the water at the specified **dilution ratio** before applying to vehicle.
- The **pH level** should be **3-11** for Dura-Bright EVO and **5-9** for Dura Bright XBR.
- If using **multiple solutions**, each solutions must fall within the pH range of **3-11** for Dura-Bright EVO and **5-9** for Dura-Bright XBR.
- Do not use **Hydrofluoric Acid (HF)**, **Hydrochloric Acid (HCl)** or **sulfuric Acid (H2 SO4)** on Dura-Bright Wheels.

### ➤ Clean the wheel:

- Apply **soap** or **detergent** generously on wheel surface with either a spray applicator, a clean, **soft** bristled brush or **soft** sponge.

### ➤ Rinse the wheel:

- Rinse the wheel thoroughly with **clean** water to remove all remaining **soap** and **dirt**. Dry your wheels with a soft cloth that is free of debris.

### CONVENTIONAL COATING

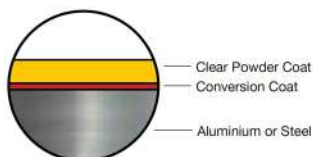

### DURA-BRIGHT® EVO

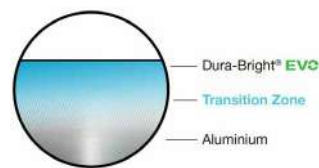

## COMPARTMENT SEALS

Windows and doors have **flexible rubber seals** that are designed to **protect** the RV from wind, rain and bugs. It is necessary to preserve them and keep them **soft** and **flexible**.

**Silicon** based cleaners can help keep the rubber seals from drying out. A recommendation is to spray it into a piece of **cloth** and carefully **wipe** it onto rubber seals.

## CLEANING THE SENSORS

These sensors may be found in the **front** and **rear bumper**. These sensors (1) should be cleaned with water, shampoo and a soft cloth with special careful.



## CLEANING CONTRACTORS

Many campgrounds recommend **cleaning contractors** since many people don't carry cleaning products such as **extensible brushes** or **power washers**. The contractors will come to the campgrounds with their own **supplies** and **provisions**. It is important that if you have doubts or questions of the services that the cleaning contractors will provide, ask them before they start.

### Questions to ask before the service:

- Are the brushes soft-bristle brushes?
- What detergents will be utilized?
- Will any pressure washing be used?

#### ⓘ WARNING

Be careful and avoid applying any cleaners intentional or by accident to windows glass or in the RV's body finish, it can damage it and may need replacement.

#### ⓘ NOTICE

Make sure that cleaning contractors use a white 40° pressure nozzle.

## WAXING YOUR RV

Waxing an RV is really similar as waxing a car. When wax is **used**, it adds up a **layer of protection** to your RV from the sun's UV rays.

It can be a really **challenging** and in many occasions people tend to **hire** a service that does it **professionally**. If it's decided that you want to do this task, make sure to select a wax designed for RV's and test it in an **unnoticed** and **discreet** area in case of any **malfunction** or **bad** reaction.

For **fiberglass** body and **glossy gel coat** finishes, it is essential to use a conventional wax. **Spray-on** is a great option too, however the wax finish doesn't **last** like the conventional wax finish does.



# MAINTENANCE

## INTERIOR CARE

It is extremely important to know that with the **ownership** of an RV comes great **responsibility** of keeping it clean and offer it a **maintenance** from time to time. Grech RV's motorhomes are design with the **highest quality** components and products to guarantee **comfort, convenience, longevity** and **endurance** while providing a luxury and good appearance.

## COUNTERTOP AREA

The Grech RV Turismo has quartz **countertops** which are a very durable and attractive looking compared to laminate based products.

This solid surface countertop requires a **basic** maintenance with **common** household cleaners:

- **For most dirt and stains:** Soapy water or ammonia-based cleaners will remove most dirt and stains from all types of finishes.
- **For tough stains:** It is recommended to use Deep Cleaner from Stone Care International which is a pH neutral destined for stone cleaning. Cleaner with an ammonia-base (avoid window cleaner) works well on tough stains.
- **For an occasional disinfectant:** Wipe surface with dilute household bleach – 1:100 (5 Tbsp. of bleach to 1 gallon of water. After the surface is washed with soap and water, make sure all excess moisture is wiped away.



**⚠ WARNING**  
Do not place hot pots, pans, etc. directly on the countertop surface use a protective pad.

**⚠ DANGER**  
Avoid getting the bleach solution in your eyes or on bare skin.

**ⓘ NOTICE**  
To prevent a soap film or residue, make sure to dry the surface thoroughly after cleaning. Residue streaks can leave behind what looks like light scratches. Scratches can be removed by using a damp cloth with mild abrasive cleaner and rubbing it in small circles onto the surfaces and wipe dry.

## HOUSEHOLD SUBSTANCES

Some common **household substances** like milk, whiskey, distilled water, vegetable oil, citric acid (10%), lye, household ammonia, iodine uid (10%), vinegar, pine oil, ketchup, naphtha, hydrogen peroxide (3%), household bleach, trisodium phosphate (5%), and isopropyl alcohol (90%) can be removed with water and a general kitchen cleaner. Crayon, lipstick, #2 pencil, coffee, mustard, and ethyl alcohol (90%) can be cleaned with a cleanser.

Most **common cleaners**, including **oxalic acid solutions**, **dilute hydrochloric acid** solutions, and dilute **trisodium phosphate** solutions, won't harm the **finish** of your solid surface. Powdered abrasive cleansers, ammonia, and strong detergents are all safe.

Although **liquids** cannot penetrate this **quartz solid surface**, it is best to wipe up spills as they occur. Generally, a damp **microfiber cloth** used with a standard household kitchen spray should remove most stains.

**⚠ CAUTION**  
Avoid acidic drain cleaner, toilet cleaner, and oven cleaner; these can cause whitening which is difficult to remove.

**ⓘ NOTICE**  
Some colors of Corian® may require more frequent cleaning to maintain a uniform finish. Darker colors require more attention than lighter colors.

## SINK AREA

It is recommended that **once** or **twice** a week, the sink receives **maintenance**. Remove all the **fat** and **oil** residues of **normal food preparation** from the sink, using a **detergent** or a **hard-surface cleaner**.

You may use a **spray** with **3/4** of **liquid household bleach** and **1/4** **water** to spray the sink and leave it for a few hours or overnight (less than 16 hours). When time has passed, it should be **rinsed** or **cleaned** with a **damp cloth** in a circular motion.





# MAINTENANCE

## HOW OFTEN SHOULD I WAX MY RV?

The **right time** to wax your RV will be determined after you asked yourself this **questions** about the usage of your RV.

- How **often** do you use the RV?
- Is the RV stored **inside** or **outside**?
- Is the RV constantly exposed to the **sun**?
- If it is stored outside, is it **covered**?

### NOTICE

It is important to not attempt to wax an older RV with oxidized fiberglass siding. (Type of damage caused by exposure to the sun, it will leave a chalky film on the fiberglass). Remove all oxidation before waxing the surface or applying a layer of wax.

If the RV is outside **exposed** to other elements, your RV's exterior should be waxed **frequently** or if it is stored outside, waxing it **every season** is a great choice. In the event that the RV is stored inside, waxing only **once a year** may be sufficient.

## CLEANING YOUR RV ROOF

It is important to **start** from the **top** when cleaning your RV. This is because if any dirt or dirty water drains from the roof to the RV's body it is **easier** and **better** to clean it off.

Here are some **tips** for cleaning your RV's roof:

- Sometimes if the RV is parked for a long period of time, **dirt** and **dust** from the RV can **accumulate** and **sweeping** with a broom may become an alternative.

## RV'S LONGEVITY

For longevity of your RV it is important **constant** maintenance for the **preservation** and **sustenance** of your RV's life span.

Storing your RV will help **extend** the durability of the RV. If **storing** the RV indoor is not an option, it is recommended to use an RV **cover**, **routine cleaning**, **inspections** and **maintenance**.

## RV'S MAINTENANCE TIPS

These are **6 tips** to extend your RV's lifespan and to stay on **top** of maintenance so you can enjoy your RV for many **years**:

1. Wash your RV exterior after each trip.
2. Wax or apply a protectant to your RV exterior.
3. Clean your awning and keep it dry for storage.
4. Inspect any sealed areas thoroughly to prevent water damage.
5. Lubricate all hinges, locks and moving parts.
6. Cover your RV if it's on the exterior to avoid contact with the sun's dangerous UV rays that may deteriorate your RV.

## PREVENTATIVE MAINTENANCE TIPS

The tips provided on the next page, will be given as a **convenient reference** for certain **systems** and **components** found in Turismo RV.

These intervals are given recommended by GRECH RV and must be considered as **maximum intervals**. Keep in mind that because of different **types of operations** the RV is subjected to, the **severity** of service must be considered when establishing maintenance **intervals**.

### NOTICE

Maintenance general inspection and service operations of shorter intervals are always preferable to longer intervals.

## CABINETS AND OVERHEAD LOCKERS

Furniture found in Grech RV's are **fabricated** and **constructed** from a high pressure laminate. These surfaces can be cleaned with **soapy water** or with a **common solvent** on tough spots.

Here's what you need to do:

- **Soap and water:** Use a clean, soft cloth and mild detergent. Soak and wring out the cloth, then wipe down all surfaces, paying particular attention to corners, handles and hinges.
- **Rinse:** Clean doors and sideboards promptly with a soft cloth and warm water, then wipe the remaining moisture with another dry, soft cloth.
- **Tough stains or marks:** Use a solution of white vinegar and hot water for an inexpensive and natural solution that produces very good results. Mix up a solution of one cup of vinegar to two cups of hot water.



# MAINTENANCE

## MAINTENANCE REQUIREMENTS

The following tips specify at how many miles and hours with a list of the minimum requirements that are necessary to maintain your RV's systems and components for a longer life span.

### CHECK EVERYDAY:

- › Side Driver and Passenger Door Release Operation and Rear back door correct operation.
- › Side Passenger entry door operation.
- › Side Step Operation (Sound and retract and extend operation)
- › Function of all interior and exterior lights
- › Tire Pressure
- › Fluid Leaks: Transmission, engine, power steering, engine coolant, gear oil, fuel.
- › Check all seatbelts for proper function and/or possible damage.
- › Retract and extend operation of the awning.
- › Fresh, Black, and Gray water tank for possible leaks.

### CHECK EVERY MONTH:

- › Passenger, Driver and Rear back door door leakage.

### AT 5,000 MILES/600 HOURS:

- › Inspect tires for wear and inspect tread depth.
- › Lube door seals with silicon spray, check for proper sealing
- › Rotate tires.

### AT 15,000 MILES/1800 HOURS:

- › Lube door seals with silicon spray, check for proper sealing
- › Rotate tires.
- › Inspect engine air filter

### AT 20,000 MILES/2,400 HOURS:

- › Inspect tires for wear and inspect tread depth.
- › Rotate tires.
- › Inspect engine air filter.
- › Clean battery terminals/ check for proper torque.

### AT 25,000 MILES/3,000 HOURS:

- › Inspect tires for wear and inspect tread depth.
- › Rotate tires.
- › Inspect engine air filter.
- › Clean condenser coils.

### AT 30,000 MILES/3,600 HOURS:

- › Lube door seals with silicon spray, check for proper sealing.
- › Inspect tires for wear and thread depth.
- › Rotate tires.

### AT 45,000 MILES/5,400 HOURS:

- › Lube door seals with silicon spray, check for proper sealing.
- › Inspect tires for wear and tread depth.
- › Rotate tires.

### AT 60,000 MILES/7,200 HOURS:

- › Lube door seals with silicon spray, check for proper sealing.
- › Inspect tires for wear and tread depth.
- › Clean condenser coils.

### AT 75,000 MILES/9,000 HOURS:

- › Lube door seals with silicon spray, check for proper sealing.
- › Inspect tires for wear and tread depth.

### AT 90,000 MILES/10,800 HOURS:

- › Lube door seals with silicon spray, check for proper sealing.
- › Inspect tires for wear and tread depth.
- › Clean condenser coils.

#### NOTICE

Check each component's manual for specific maintenance tips and intervals.

## EXTENDED OCCUPANCY

Your RV is designed for **recreational** and **short-term** occupancy. In case of **extended** occupancy, there are a few things to keep in mind regarding **humid** conditions and **condensation** that may be encountered. The relatively **small** space and tight compact construction of this RV means that the normal living activities of even a **few** occupants could lead to rapid **moisture** saturation of the **air** contained inside, especially in **cold** weather.

Just as moisture **collects** on the outside of a **glass** of cold water during **humid weather**, moisture can condense on the inside surfaces of the recreational vehicle. This condition is **increased** because the **insulated** walls of an RV are much **thinner** than house walls. Estimates indicate that four passengers can vaporize up to three gallons of water daily through **breathing, cooking** and **bathing**.

Excessive moisture released inside the RV can cause water **stains** and **mildew** on the upholstery, wall materials and woodwork. Moisture **condensing** on the windows is an indication that the **humidity** inside your RV is too **high**.

The following **procedures** will help to **reduce** the moisture level inside your RV:

- 1. Open** windows and vents. This will allow **fresh** air to flow through your RV and reduce **moisture** levels.
- 2. Reduce** the amount of moisture **released** inside the RV. Run the bathroom **fan** when using the bathroom and turn on the roof vent fan while **cooking** to help remove excessive moisture from your RV. Do not hang wet towels or swimwear **inside** the RV to dry.

# VEHICLE ELECTRICAL WIRING DIAGRAMS

---

## TURISMO Mercedez-Benz Sprinter

THE INFORMATION DISCLOSED ON THIS DRAWING IS PROPRIETARY. IT IS ISSUED FOR ENGINEERING USE ONLY AND MAY NOT BE REPRODUCED OR DISCLOSED, IN WHOLE OR IN PART, TO ANYONE WITHOUT THE DIRECT WRITTEN PERMISSION OF GRECH MOTORS LLC. PARTS OR TOOLS MANUFACTURED TO MEET THE REQUIREMENTS OF THIS DRAWING MAY NOT BE USED BY OR SOLD TO ANYONE WITHOUT THE DIRECT WRITTEN PERMISSION OF GRECH MOTORS LLC.

REVISION HISTORY			
REV	DESCRIPTION	DATE	APPROVED
B	Updated wiring routing afted elimination of shunt and reubication of Negative Distribution Block in the Passenger Side of the RV	17/02/2022	

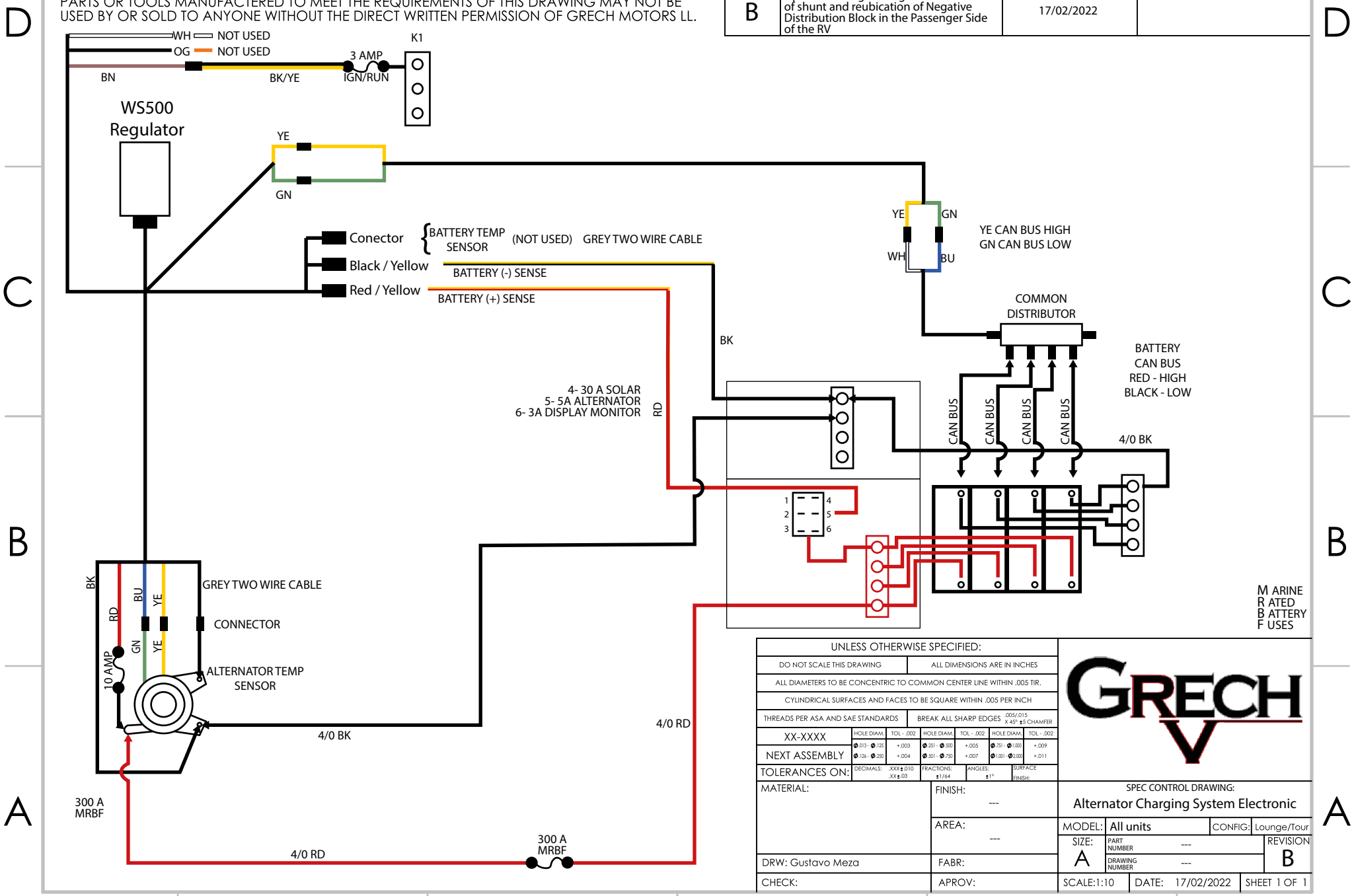

UNLESS OTHERWISE SPECIFIED:							
DO NOT SCALE THIS DRAWING				ALL DIMENSIONS ARE IN INCHES			
ALL DIAMETERS TO BE CONCENTRIC TO COMMON CENTER LINE WITHIN .005 TIR.							
CYLINDRICAL SURFACES AND FACES TO BE SQUARE WITHIN .005 PER INCH							
THREADS PER ASA AND SAE STANDARDS				BREAK ALL SHARP EDGES .005/.015 X.45° ±5° CHAMFER			
XX-XXXX	HOLE DIAM.	TOL -.002	HOLE DIAM.	TOL -.002	HOLE DIAM.	TOL -.002	
NEXT ASSEMBLY	Ø.013 - Ø.125	+0.003	Ø.251 - Ø.500	+0.005	Ø.751 - Ø.100	+0.009	
TOLERANCES ON:	Ø.126 - Ø.250	+0.004	Ø.501 - Ø.750	+0.007	Ø.101 - Ø.100	+0.011	
	DECIMALS: .XXX ±0.10 XX ±0.03		FRACTIONS: XX ±0.03		ANGLES: ±1°	SURFACE FINISH:	
MATERIAL:				FINISH: ---			
AREA: ---				SPEC CONTROL DRAWING:			
DRW: Gustavo Meza				FABR: ---			
CHECK: ---				APROV: ---			
MODEL: All units		CONFIG: Lounge/Tour		SIZE: PART NUMBER ---		REVISION NUMBER ---	
DRAWING NUMBER ---		REVISION NUMBER ---		SCALE: 1:10		DATE: 17/02/2022	
SHEET 1 OF 1		SHEET 1 OF 1		SHEET 1 OF 1		SHEET 1 OF 1	



SPEC CONTROL DRAWING:			
Alternator Charging System Electronic			
MODEL: All units	CONFIG: Lounge/Tour	SIZE: PART NUMBER ---	REVISION NUMBER ---
DRAWING NUMBER ---	REVISION NUMBER ---	SCALE: 1:10	DATE: 17/02/2022
SHEET 1 OF 1	SHEET 1 OF 1	SHEET 1 OF 1	SHEET 1 OF 1

M ARINE  
R ATED  
B ATTERY  
F USES

THE INFORMATION DISCLOSED ON THIS DRAWING IS PROPRIETARY. IT IS ISSUED FOR ENGINEERING USE ONLY AND MAY NOT BE REPRODUCED OR DISCLOSED, IN WHOLE OR IN PART, TO ANYONE WITHOUT THE DIRECT WRITTEN PERMISSION OF GRECH MOTORS LLC. PARTS OR TOOLS MANUFACTURED TO MEET THE REQUIREMENTS OF THIS DRAWING MAY NOT BE USED BY OR SOLD TO ANYONE WITHOUT THE DIRECT WRITTEN PERMISSION OF GRECH MOTORS LLC.

REVISION HISTORY			
REV	DESCRIPTION	DATE	APPROVED
A	Creation of piece and Part #	05/08/2021	

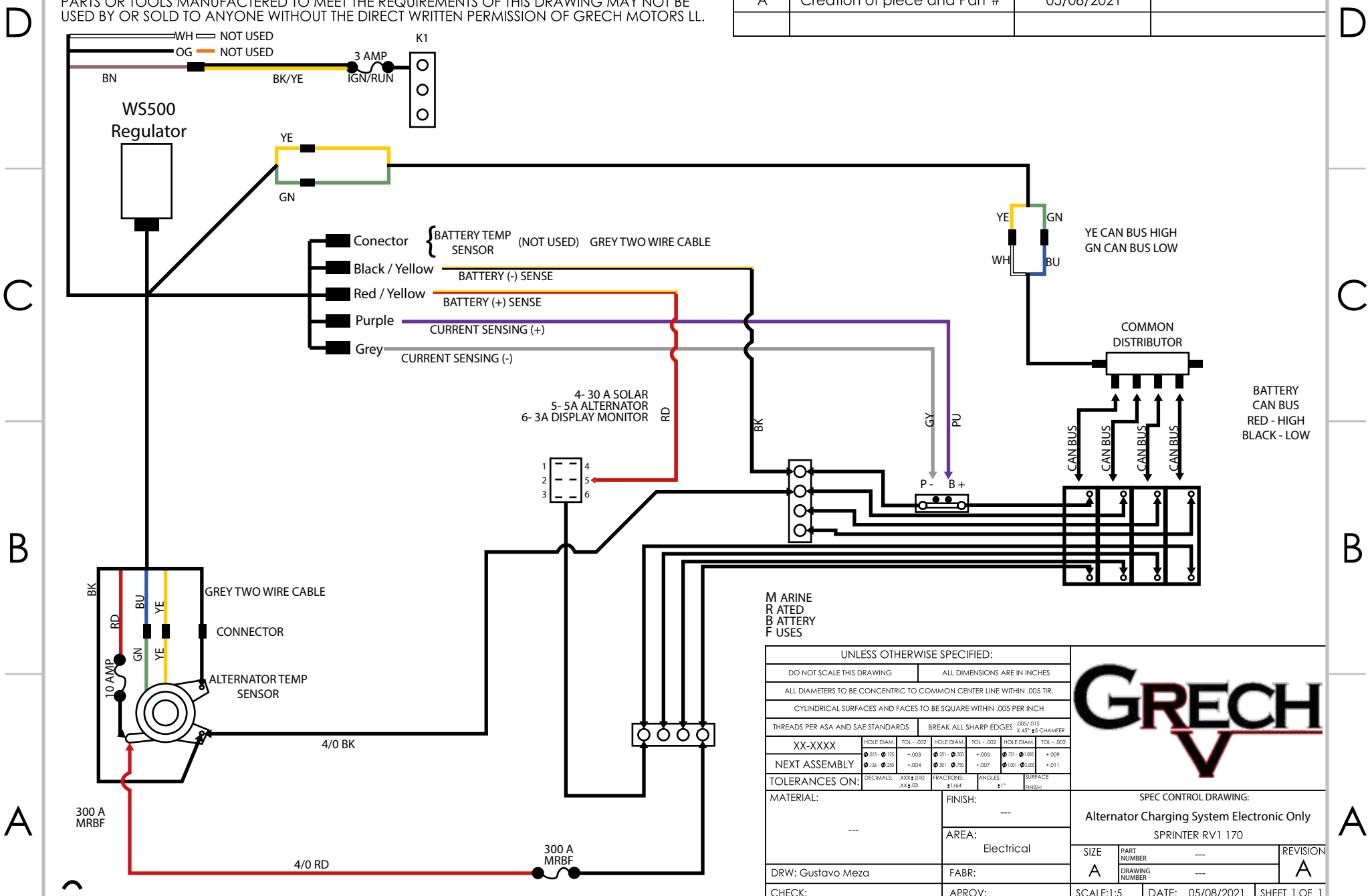

MARINE RATED BATTERY USES

UNLESS OTHERWISE SPECIFIED:							
DO NOT SCALE THIS DRAWING				ALL DIMENSIONS ARE IN INCHES			
ALL DIAMETERS TO BE CONCENTRIC TO COMMON CENTER LINE WITHIN .005 TIR.							
CYLINDRICAL SURFACES AND FACES TO BE SQUARE WITHIN .005 PER INCH							
THREADS PER ASA AND SAE STANDARDS				BREAK ALL SHARP EDGES .005/.015 1/4" & 5/8" CHAMFER			
XX-XXXX	HOLE DIAM.	TOL - .002	HOLE DIAM.	TOL - .002	HOLE DIAM.	TOL - .002	
NEXT ASSEMBLY	Ø.013 - Ø.175	+ .003	Ø.201 - Ø.300	+ .005	Ø.751 - Ø.100	+ .009	
TOLERANCES ON:	Ø.126 - Ø.200	+ .004	Ø.301 - Ø.750	+ .007	Ø.1001 - Ø.100	+ .011	
MATERIAL:	DECIMALS: .XXX ± 0.10 XX ± 0.03	FRACTIONS: ± 1/64	ANGLES: ± 1°	SURFACE FINISH:			
FINISH:	---						
AREA:	Electrical						
DRW: Gustavo Meza	FABR:		SPEC CONTROL DRAWING:				
CHECK:	APROV:		Alternator Charging System Electronic Only				
			SPRINTER RV1 170				
	SIZE	PART NUMBER	REVISION				
	A	---	A				
	DRAWING NUMBER	---					
		SCALE: 1:5	DATE: 05/08/2021	SHEET 1 OF 1			



Alternator Charging System Electronic Only  
SPRINTER RV1 170



THE INFORMATION DISCLOSED ON THIS DRAWING IS PROPRIETARY. IT IS ISSUED FOR ENGINEERING USE ONLY AND MAY NOT REPRODUCED OR DISCLOSED, IN WHOLE OR IN PART, TO ANYONE WITHOUT THE DIRECT WRITTEN PERMISSION OF GRECH MOTORS LLC. PARTS OR TOOLS MANUFACTURED TO MEET THE REQUIREMENTS OF THIS DRAWING MAY NOT BE USED BY OR SOLD TO ANYONE WITHOUT THE DIRECT WRITTEN PERMISSION OF GRECH MOTORS LL.

REVISION HISTORY

REV	DESCRIPTION	DATE	APPROVED
A	CREATION OF DRAWING	17/08/21	

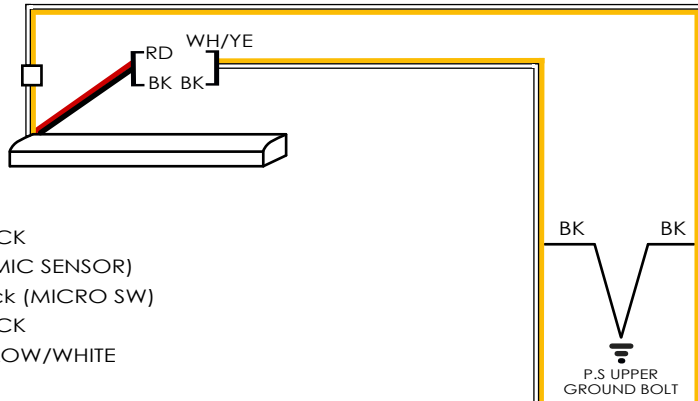

- (B)
- 1 BLACK
  - 4 (SISMIC SENSOR)
  - 5 black (MICRO SW)
  - 6 BLACK
  - 7 YELLOW/WHITE

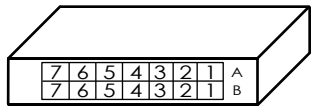

- (A)
- 1 PURPLE/WHITE ↔ BLUE } MOTOR
  - 2 PURPLE ↔ RED }
  - 3 RED (+)
  - 4 RED (SISMIC SENSOR)
  - 5 BLUE/BLACK ↔ RED (MICRO SW) = LIGHT BLUE (-)
  - 6 ORANGE/WHITE RETRACT SIGNAL
  - 7 ORANGE EXTEND SIGNAL

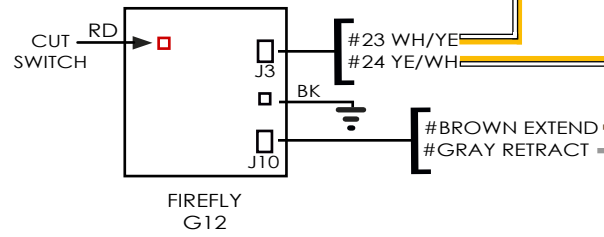

CONNECTOR FROM HARNESS SIDE

RD 1	8 BK
VT 2	7 VT/WH
BU/BK 3	6 BK
YE/WH 4	5 BU

CONNECTOR FROM AWNING SIDE

RD 1	8 BK
VT 2	7 VT/WH
BU/BK 3	6 BK
RD 4	5 BU

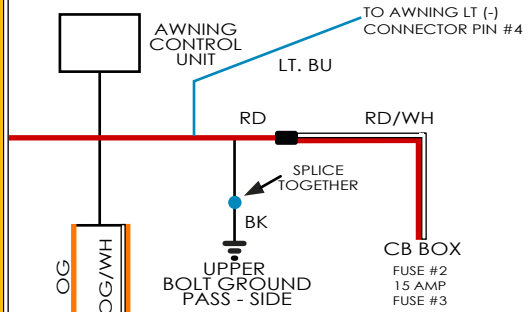

UNLESS OTHERWISE SPECIFIED:

DO NOT SCALE THIS DRAWING	ALL DIMENSIONS ARE IN INCHES		
ALL DIAMETERS TO BE CONCENTRIC TO COMMON CENTER LINE WITHIN .005 TIR.			
CYLINDRICAL SURFACES AND FACES TO BE SQUARE WITHIN .005 PER INCH			
THREADS PER ASA AND SAE STANDARDS	BREAK ALL SHARP EDGES .005/.015 1/4" & 5/8" CHAMFER		
XX-XXXX	HOLE DIAM. TOL -.002	HOLE DIAM. TOL -.002	HOLE DIAM. TOL -.002
NEXT ASSEMBLY	Ø.013 - Ø.125 +.003	Ø.251 - Ø.500 +.005	Ø.751 - Ø.100 +.009
	Ø.126 - Ø.250 +.004	Ø.501 - Ø.750 +.007	Ø.1001 - Ø.100 +.011
TOLERANCES ON:	DECIMALS: .XXX ± 0.10 XX ± 0.03	FRACTIONS: ± 1/64	ANGLES: ± 1° SURFACE FINISH:
MATERIAL:	FINISH: ---		
	AREA: Electrical		
DRW: Gustavo Meza	FABR:		
CHECK:	APROV:		



SPEC CONTROL DRAWING  
AWNING FIAMMA  
TOUR LOUNGE  
SPRINTER RV1 170

SIZE	PART NUMBER	REVISION
A	---	A
DRAWING NUMBER	---	

SCALE: 1:5    DATE: 05/08/2021    SHEET 1 OF 1

THE INFORMATION DISCLOSED ON THIS DRAWING IS PROPRIETARY. IT IS ISSUED FOR ENGINEERING USE ONLY AND MAY NOT REPRODUCED OR DISCLOSED, IN WHOLE OR IN PART, TO ANYONE WITHOUT THE DIRECT WRITTEN PERMISSION OF GRECH MOTORS LLC. PARTS OR TOOLS MANUFACTURED TO MEET THE REQUIREMENTS OF THIS DRAWING MAY NOT BE USED BY OR SOLD TO ANYONE WITHOUT THE DIRECT WRITTEN PERMISSION OF GRECH MOTORS LL.

REVISION HISTORY

REV	DESCRIPTION	DATE	APPROVED
A	CREATION OF DRAWING	05/10/21	

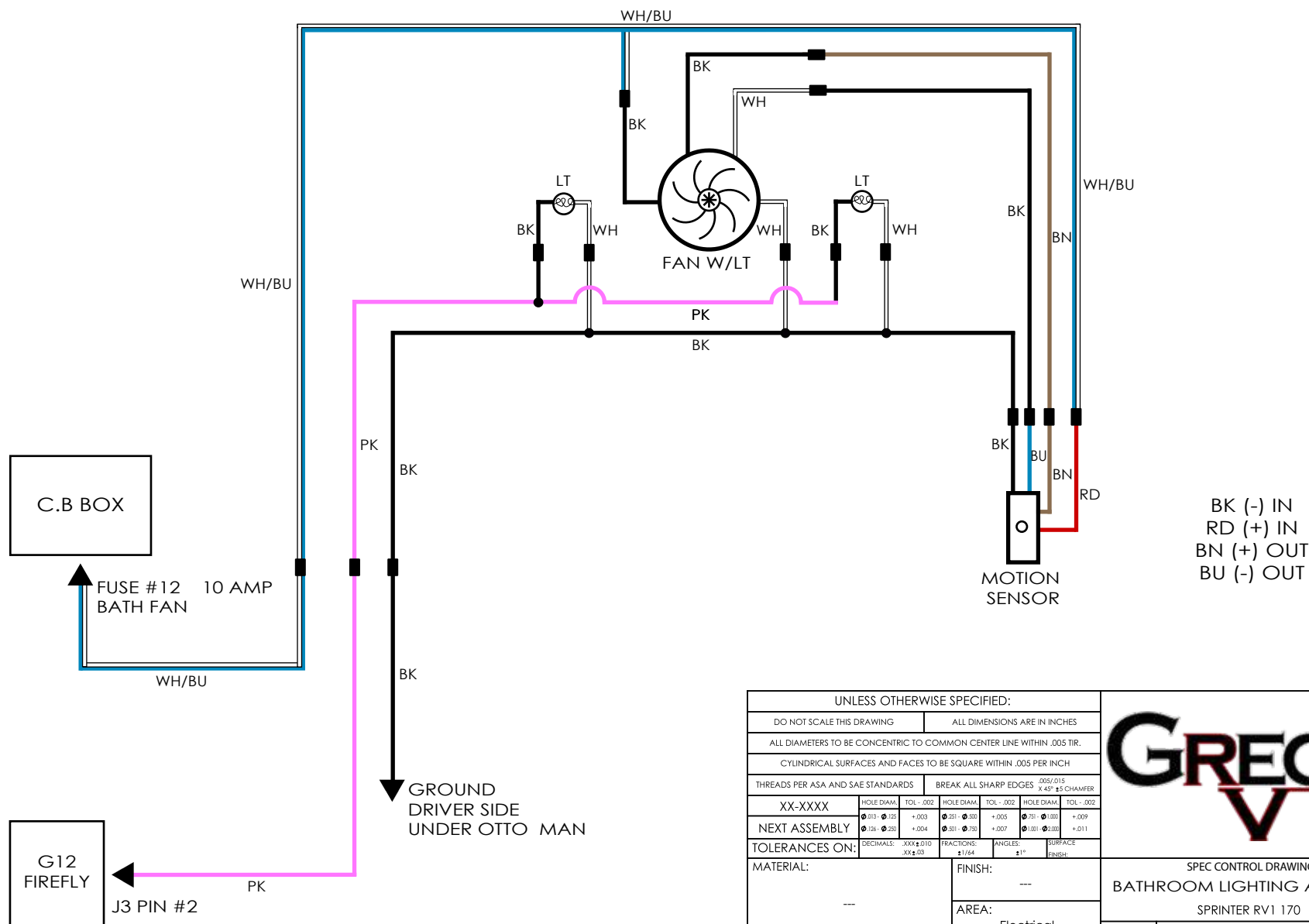

BK (-) IN  
RD (+) IN  
BN (+) OUT  
BU (-) OUT

UNLESS OTHERWISE SPECIFIED:			
DO NOT SCALE THIS DRAWING		ALL DIMENSIONS ARE IN INCHES	
ALL DIAMETERS TO BE CONCENTRIC TO COMMON CENTER LINE WITHIN .005 TIR.			
CYLINDRICAL SURFACES AND FACES TO BE SQUARE WITHIN .005 PER INCH			
THREADS PER ASA AND SAE STANDARDS		BREAK ALL SHARP EDGES .005/.015 R.45° ±5° CHAMFER	
XX-XXXX	HOLE DIAM. TOL - .002	HOLE DIAM. TOL - .002	HOLE DIAM. TOL - .002
NEXT ASSEMBLY	Ø.013 - Ø.125 +0.003	Ø.251 - Ø.500 +0.005	Ø.751 - Ø.100 +0.009
TOLERANCES ON:	DECIMALS: .XXX ±.010 XX ±.03	FRACTIONS: ±1/64	ANGLES: ±1° SURFACE FINISH:
MATERIAL:	FINISH: ---		SPEC CONTROL DRAWING
---	AREA: Electrical		
DRW: Gustavo Meza	FABR:		BATHROOM LIGHTING AND FAN SPRINTER RV1 170
CHECK:	APROV:		SIZE A PART NUMBER --- DRAWING NUMBER ---
			REVISION A



SCALE: 1:5	DATE: 05/08/2021	SHEET 1 OF 1
------------	------------------	--------------

THE INFORMATION DISCLOSED ON THIS DRAWING IS PROPRIETARY. IT IS ISSUED FOR ENGINEERING USE ONLY AND MAY NOT BE REPRODUCED OR DISCLOSED, IN WHOLE OR IN PART, TO ANYONE WITHOUT THE DIRECT WRITTEN PERMISSION OF GRECH MOTORS LLC. PARTS OR TOOLS MANUFACTURED TO MEET THE REQUIREMENTS OF THIS DRAWING MAY NOT BE USED BY OR SOLD TO ANYONE WITHOUT THE DIRECT WRITTEN PERMISSION OF GRECH MOTORS LL.

REVISION HISTORY			
REV	DESCRIPTION	DATE	APPROVED
A	CREATION OF DRAWING	03/09/21	

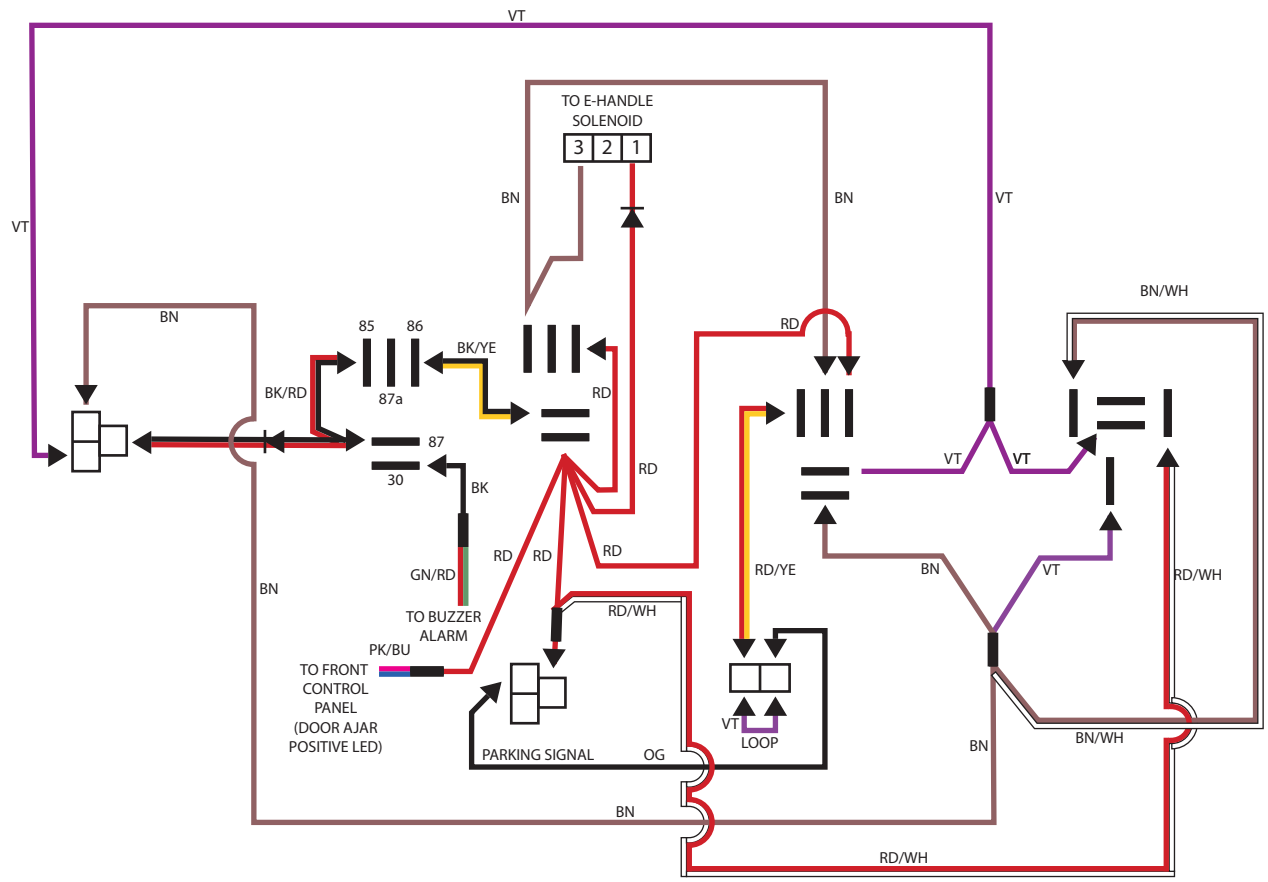

UNLESS OTHERWISE SPECIFIED:

DO NOT SCALE THIS DRAWING		ALL DIMENSIONS ARE IN INCHES	
ALL DIAMETERS TO BE CONCENTRIC TO COMMON CENTER LINE WITHIN .005 TIR.			
CYLINDRICAL SURFACES AND FACES TO BE SQUARE WITHIN .005 PER INCH			
THREADS PER ASA AND SAE STANDARDS		BREAK ALL SHARP EDGES $\frac{.005}{.015}$ X 45° ±5 CHAMFER	
XX-XXXX	HOLE DIAM. TOL. -.002	HOLE DIAM. TOL. -.002	HOLE DIAM. TOL. -.002
NEXT ASSEMBLY	+.003 +.004	+.005 +.007	+.009 +.011
TOLERANCES ON:	DECIMALS: .XXX ±0.0 XX ±0.03	FRACTIONS: $\frac{1}{64}$	ANGLES: ±1° SURFACE FINISH:
MATERIAL:	FINISH: ---		
	AREA: Electrical		
DRW: Gustavo Meza	FABR:		
CHECK:	APROV:		



SPEC CONTROL DRAWING			
BCE DOOR RELAYS			
GRECH MOTOR BUSES			
SIZE	PART NUMBER	---	REVISION
A	DRAWING NUMBER	---	A
SCALE: 1:5	DATE: 05/08/2021	SHEET 1 OF 1	

THE INFORMATION DISCLOSED ON THIS DRAWING IS PROPRIETARY. IT IS ISSUED FOR ENGINEERING USE ONLY AND MAY NOT REPRODUCED OR DISCLOSED, IN WHOLE OR IN PART, TO ANYONE WITHOUT THE DIRECT WRITTEN PERMISSION OF GRECH MOTORS LLC. PARTS OR TOOLS MANUFACTURED TO MEET THE REQUIREMENTS OF THIS DRAWING MAY NOT BE USED BY OR SOLD TO ANYONE WITHOUT THE DIRECT WRITTEN PERMISSION OF GRECH MOTORS LL.

REVISION HISTORY

REV	DESCRIPTION	DATE	APPROVED
A	CREATION OF DRAWING	13/08/21	

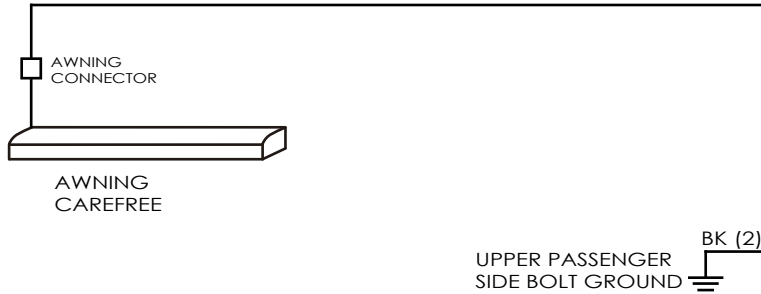

FROM FIREFLY SIGNAL	GY 18 ga	8	1	BK	14 ga
	BN 18 ga	7	2	BK	18 ga
FROM FIREFLY J3-23	YE 18 ga	6	3	RD	14 ga
	WH/YE 16 ga	5	4	YE/WH	16 ga

FACE CONNECTOR

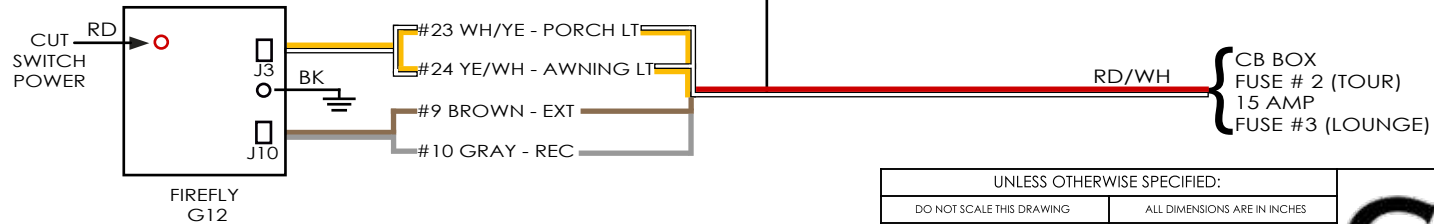

UNLESS OTHERWISE SPECIFIED:			
DO NOT SCALE THIS DRAWING		ALL DIMENSIONS ARE IN INCHES	
ALL DIAMETERS TO BE CONCENTRIC TO COMMON CENTER LINE WITHIN .005 TIR.			
CYLINDRICAL SURFACES AND FACES TO BE SQUARE WITHIN .005 PER INCH			
THREADS PER ASA AND SAE STANDARDS		BREAK ALL SHARP EDGES .005/.015 X.45° ±5° CHAMFER	
XX-XXXX	HOLE DIAM. TOL - .002	HOLE DIAM. TOL - .002	HOLE DIAM. TOL - .002
NEXT ASSEMBLY	Ø.013 - Ø.125 +0.003	Ø.251 - Ø.500 +0.005	Ø.751 - Ø.100 +0.009
TOLERANCES ON:	DECIMALS: .XXX ± 0.10 XX ± 0.03	FRACTIONS: ± 1/64	ANGLES: ± 1° SURFACE FINISH: ---
MATERIAL: ---	FINISH: ---		SPEC CONTROL DRAWING <b>CAREFREE AWNING</b> SPRINTER RV1 170
AREA: Electrical	SIZE PART NUMBER --- DRAWING NUMBER ---		
DRW: Gustavo Meza	FABR: ---		REVISION <b>A</b>
CHECK: ---	APROV: ---		SCALE: 1:5 DATE: 05/08/2021 SHEET 1 OF 1



D  
C  
B  
A

D  
C  
B  
A

6

5

4

3

2

1

6

5

4

3

2

1

THE INFORMATION DISCLOSED ON THIS DRAWING IS PROPRIETARY. IT IS ISSUED FOR ENGINEERING USE ONLY AND MAY NOT BE REPRODUCED OR DISCLOSED, IN WHOLE OR IN PART, TO ANYONE WITHOUT THE DIRECT WRITTEN PERMISSION OF GRECH MOTORS LLC. PARTS OR TOOLS MANUFACTURED TO MEET THE REQUIREMENTS OF THIS DRAWING MAY NOT BE USED BY OR SOLD TO ANYONE WITHOUT THE DIRECT WRITTEN PERMISSION OF GRECH MOTORS LL.

REVISION HISTORY			
REV	DESCRIPTION	DATE	APPROVED

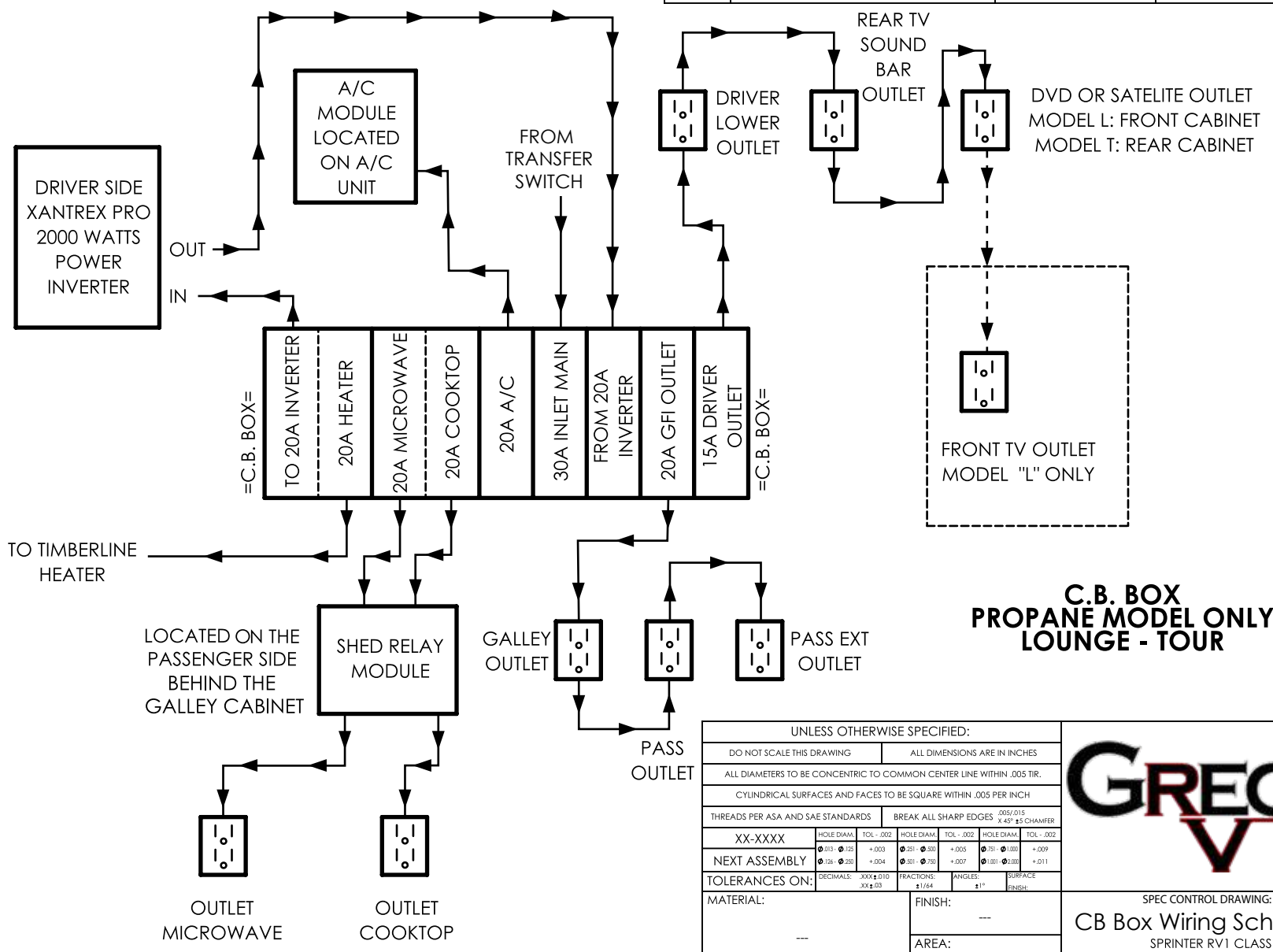

**C.B. BOX  
PROPANE MODEL ONLY  
LOUNGE - TOUR**

UNLESS OTHERWISE SPECIFIED:					
DO NOT SCALE THIS DRAWING			ALL DIMENSIONS ARE IN INCHES		
ALL DIAMETERS TO BE CONCENTRIC TO COMMON CENTER LINE WITHIN .005 TIR.					
CYLINDRICAL SURFACES AND FACES TO BE SQUARE WITHIN .005 PER INCH					
THREADS PER ASA AND SAE STANDARDS		BREAK ALL SHARP EDGES .005/.015 1/4" & 5/8" CHAMFER			
XX-XXXX	HOLE DIAM.	TOL -.002	HOLE DIAM.	TOL -.002	HOLE DIAM.
NEXT ASSEMBLY	Ø.013 - Ø.175	+ .003	Ø.201 - Ø.300	+ .005	Ø.751 - Ø.100
TOLERANCES ON:	Ø.126 - Ø.200	+ .004	Ø.301 - Ø.750	+ .007	Ø.1001 - Ø.100
	DECIMALS: XXXX ± 0.10 XX ± 0.03	FRACTIONS: ± 1/64	ANGLES: ± 1°	SURFACE FINISH:	
MATERIAL:	---		FINISH: ---		
DRW:	---		AREA: Electrical		
CHECK:	---		FABR: ---		
	---		APROV: ---		



SPEC CONTROL DRAWING:			
CB Box Wiring Schematic			
SPRINTER RV1 CLASS B			
SIDE	PART NUMBER	---	REVISION
A	DRAWING NUMBER	---	A
SCALE: 1:20	DATE: 19/07/2021	SHEET 1 OF 1	



THE INFORMATION DISCLOSED ON THIS DRAWING IS PROPRIETARY. IT IS ISSUED FOR ENGINEERING USE ONLY AND MAY NOT REPRODUCED OR DISCLOSED, IN WHOLE OR IN PART, TO ANYONE WITHOUT THE DIRECT WRITTEN PERMISSION OF GRECH MOTORS LLC.  
PARTS OR TOOLS MANUFACTURED TO MEET THE REQUIREMENTS OF THIS DRAWING MAY NOT BE USED BY OR SOLD TO ANYONE WITHOUT THE DIRECT WRITTEN PERMISSION OF GRECH MOTORS LL.

REVISION HISTORY

REV	DESCRIPTION	DATE	APPROVED
A	CREATION OF DRAWING	16/08/21	

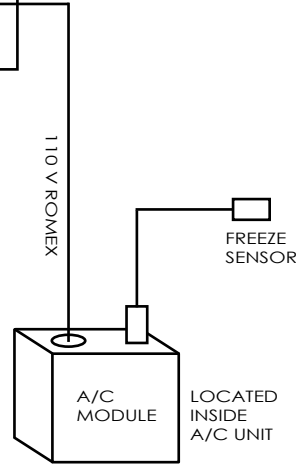
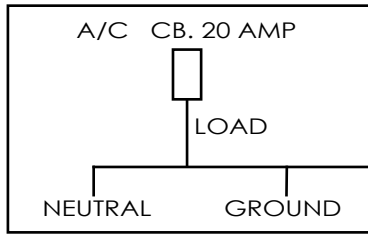

A/C DATA CONNECTOR

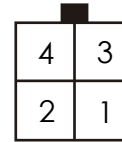
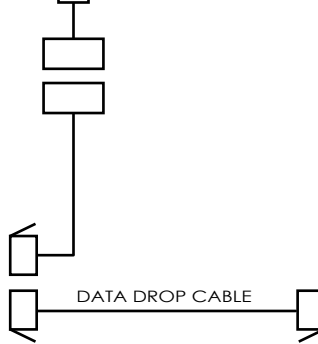

- 1 CAN H WHITE
- 2 CAN L BLUE
- 3 NEGATIVE BLACK
- 4 POSITIVE RED



- 1 POSITIVE RED
- 2 CAN H WHITE
- 3 CAN L BLUE
- 4 NEGATIVE BLACK

UNLESS OTHERWISE SPECIFIED:						
DO NOT SCALE THIS DRAWING			ALL DIMENSIONS ARE IN INCHES			
ALL DIAMETERS TO BE CONCENTRIC TO COMMON CENTER LINE WITHIN .005 TIR.						
CYLINDRICAL SURFACES AND FACES TO BE SQUARE WITHIN .005 PER INCH						
THREADS PER ASA AND SAE STANDARDS		BREAK ALL SHARP EDGES .005/.015 X.45° ±5° CHAMFER				
XX-XXXX	HOLE DIAM.	TOL -.002	HOLE DIAM.	TOL -.002	HOLE DIAM.	TOL -.002
NEXT ASSEMBLY	Ø.013 - Ø.125	+ .003	Ø.251 - Ø.500	+ .005	Ø.751 - Ø.100	+ .009
	Ø.126 - Ø.250	+ .004	Ø.501 - Ø.750	+ .007	Ø.101 - Ø.100	+ .011
TOLERANCES ON:	DECIMALS: .XXX ±0.10 XX ±.03	FRACTIONS: ±1/64	ANGLES: ±1°	SURFACE FINISH:		
MATERIAL:	---		FINISH: ---		<p>SPEC CONTROL DRAWING</p> <p><b>DOMETIC A/C</b></p> <p>SPRINTER RV1 170</p>	
DRW: Gustavo Meza	FABR:		AREA: Electrical			
CHECK:	APROV:		SIZE A			
PART NUMBER ---		DRAWING NUMBER ---		REVISION A		
SCALE: 1:5		DATE: 05/08/2021		SHEET 1 OF 1		



SIZE	PART NUMBER	---	REVISION	A
	DRAWING NUMBER	---		

THE INFORMATION DISCLOSED ON THIS DRAWING IS PROPRIETARY. IT IS ISSUED FOR ENGINEERING USE ONLY AND MAY NOT REPRODUCED OR DISCLOSED, IN WHOLE OR IN PART, TO ANYONE WITHOUT THE DIRECT WRITTEN PERMISSION OF GRECH MOTORS LLC. PARTS OR TOOLS MANUFACTURED TO MEET THE REQUIREMENTS OF THIS DRAWING MAY NOT BE USED BY OR SOLD TO ANYONE WITHOUT THE DIRECT WRITTEN PERMISSION OF GRECH MOTORS LL.

REVISION HISTORY			
REV	DESCRIPTION	DATE	APPROVED
A	CREATION OF DRAWING	06/08/21	

# ELIXIR FURRIOR

15	Spare
14	10AMP AMP Antenna
13	10AMP ACC/COOK
12	10AMP Bath Fan
11	10AMP Heater Mod
10	15AMP Seelevel
9	3AMP CO Alarm
8	5AMP USB
7	20ACB Hose Reel
6	20AMP Macerator
5	10AMP Ext. Fan
4	15AMP Fridge
3	15AMP Awning
2	25AMP Heater Pump
1	Spare

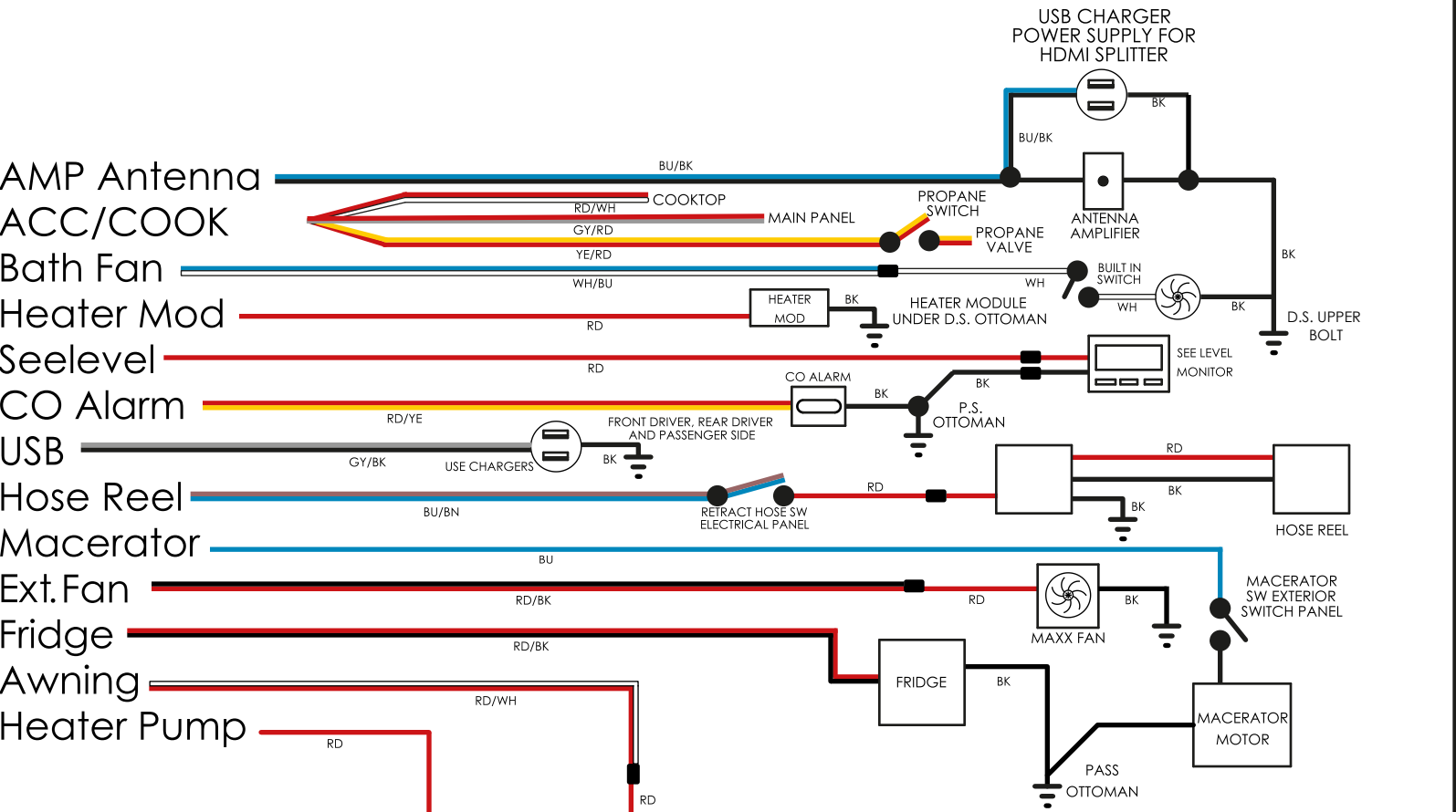

UNLESS OTHERWISE SPECIFIED:						
DO NOT SCALE THIS DRAWING			ALL DIMENSIONS ARE IN INCHES			
ALL DIAMETERS TO BE CONCENTRIC TO COMMON CENTER LINE WITHIN .005 TIR.						
CYLINDRICAL SURFACES AND FACES TO BE SQUARE WITHIN .005 PER INCH						
THREADS PER ASA AND SAE STANDARDS			BREAK ALL SHARP EDGES .005/.015 1/4" & 5/8" CHAMFER			
XX-XXXX	HOLE DIAM.	TOL - .002	HOLE DIAM.	TOL - .002	HOLE DIAM.	TOL - .002
NEXT ASSEMBLY	⌀.013 - ⌀.125	+ .003	⌀.251 - ⌀.500	+ .005	⌀.751 - ⌀.100	+ .009
TOLERANCES ON:	⌀.126 - ⌀.250	+ .004	⌀.501 - ⌀.750	+ .007	⌀.101 - ⌀.100	+ .011
MATERIAL:	DECIMALS: .XXX & .010	FRACTIONS: ± 1/64	ANGLES: ± 1°	SURFACE FINISH:		
---	XX & .03					
DRW: Gustavo Meza	FINISH: ---		SPEC CONTROL DRAWING:			
CHECK:	AREA: Electrical		Fuses Distribution Center Model Lounge			
	FABR:		SPRINTER RV1 170			
	APROV:		SIDE: A	PART NUMBER: ---	REVISION: A	
			DRAWING NUMBER: ---			
	SCALE: 1:5		DATE: 05/08/2021	SHEET 1 OF 1		



SPEC CONTROL DRAWING:		
Fuses Distribution Center Model Lounge		
SPRINTER RV1 170		
SIDE: A	PART NUMBER: ---	REVISION: A
DRAWING NUMBER: ---		
SCALE: 1:5	DATE: 05/08/2021	SHEET 1 OF 1

THE INFORMATION DISCLOSED ON THIS DRAWING IS PROPRIETARY. IT IS ISSUED FOR ENGINEERING USE ONLY AND MAY NOT BE REPRODUCED OR DISCLOSED, IN WHOLE OR IN PART, TO ANYONE WITHOUT THE DIRECT WRITTEN PERMISSION OF GRECH MOTORS LLC. PARTS OR TOOLS MANUFACTURED TO MEET THE REQUIREMENTS OF THIS DRAWING MAY NOT BE USED BY OR SOLD TO ANYONE WITHOUT THE DIRECT WRITTEN PERMISSION OF GRECH MOTORS LL.

REVISION HISTORY			
REV	DESCRIPTION	DATE	APPROVED
A	CREATION OF DRAWING	06/08/21	

# ELIXIR FURRIOR

15	Spare	
14	10AMP	AMP Antenna
13	10AMP	ACC/COOK
12	10AMP	Bath Fan
11	10AMP	Heater Mod
10	15AMP	Seelevel
9	3AMP	CO Alarm
8	5AMP	USB
7	20ACB	Hose Reel
6	20AMP	Macerator
5	10AMP	Ext. Fan
4	15AMP	Fridge
3	15AMP	Freezer
2	15AMP	Awning
1	25AMP	Heater Pump

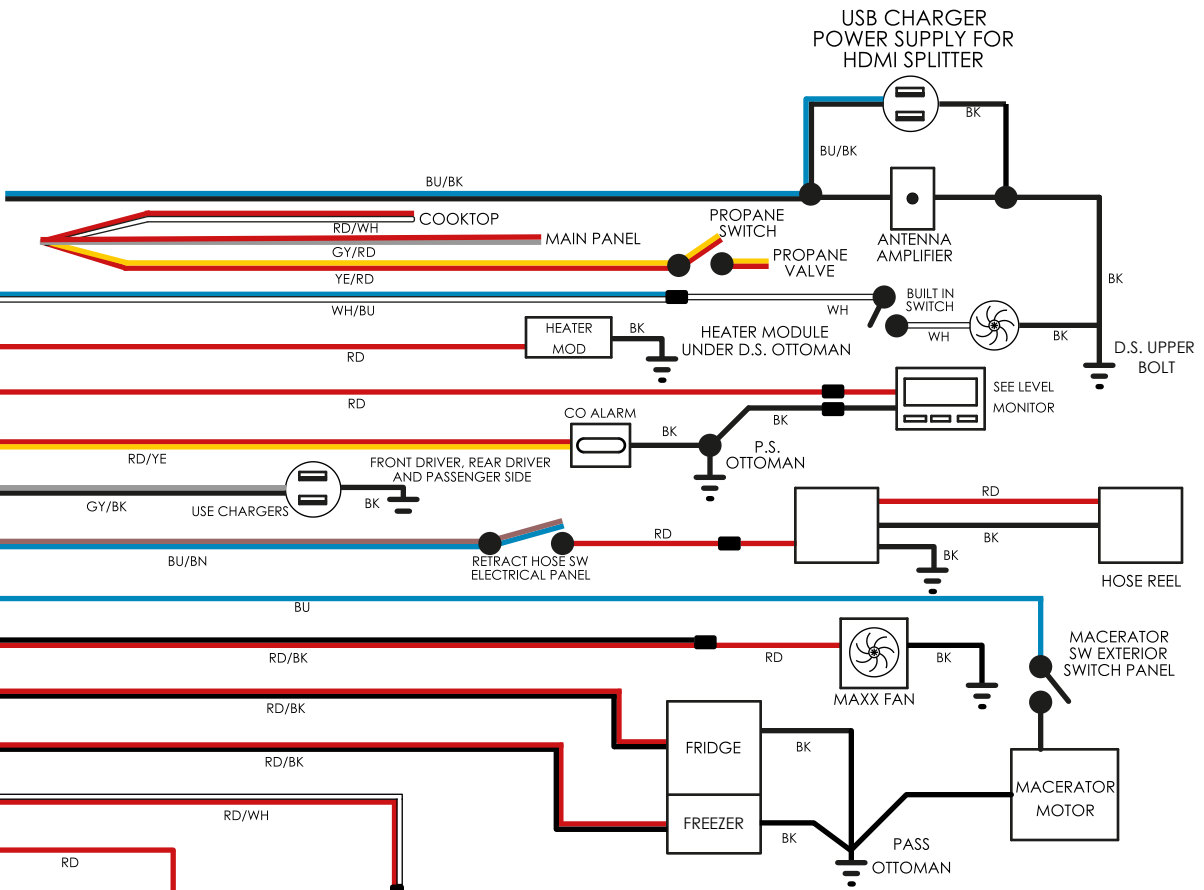

UNLESS OTHERWISE SPECIFIED:							
DO NOT SCALE THIS DRAWING				ALL DIMENSIONS ARE IN INCHES			
ALL DIAMETERS TO BE CONCENTRIC TO COMMON CENTER LINE WITHIN .005 TIR.							
CYLINDRICAL SURFACES AND FACES TO BE SQUARE WITHIN .005 PER INCH							
THREADS PER ASA AND SAE STANDARDS				BREAK ALL SHARP EDGES .005/.015 1/4" & 5/8" CHAMFER			
XX-XXXX	HOLE DIAM.	TOL - .002	HOLE DIAM.	TOL - .002	HOLE DIAM.	TOL - .002	
NEXT ASSEMBLY	Ø.013 - Ø.125	+ .003	Ø.251 - Ø.500	+ .005	Ø.751 - Ø.100	+ .009	
TOLERANCES ON:	DECIMALS: .XXX ± 0.10 XX ± 0.03	FRACTIONS: ± 1/64	ANGLES: ± 1°	SURFACE FINISH:			
MATERIAL:				FINISH: ---			
AREA:				Electrical			
DRW: Gustavo Meza				FABR:			
CHECK:				APROV:			



SPEC CONTROL DRAWING:			
Fuses Distribution Center Model Tour			
SPRINTER RV1 170			
SIDE	PART NUMBER	REVISION	
A	---	A	
DRAWING NUMBER	---		

THE INFORMATION DISCLOSED ON THIS DRAWING IS PROPRIETARY. IT IS ISSUED FOR ENGINEERING USE ONLY AND MAY NOT BE REPRODUCED OR DISCLOSED, IN WHOLE OR IN PART, TO ANYONE WITHOUT THE DIRECT WRITTEN PERMISSION OF GRECH MOTORS LLC. PARTS OR TOOLS MANUFACTURED TO MEET THE REQUIREMENTS OF THIS DRAWING MAY NOT BE USED BY OR SOLD TO ANYONE WITHOUT THE DIRECT WRITTEN PERMISSION OF GRECH MOTORS LLC.

REVISION HISTORY			
REV	DESCRIPTION	DATE	APPROVED
A	Creation of piece and Part #	05/08/2021	

D  
C  
B  
A

D  
C  
B  
A

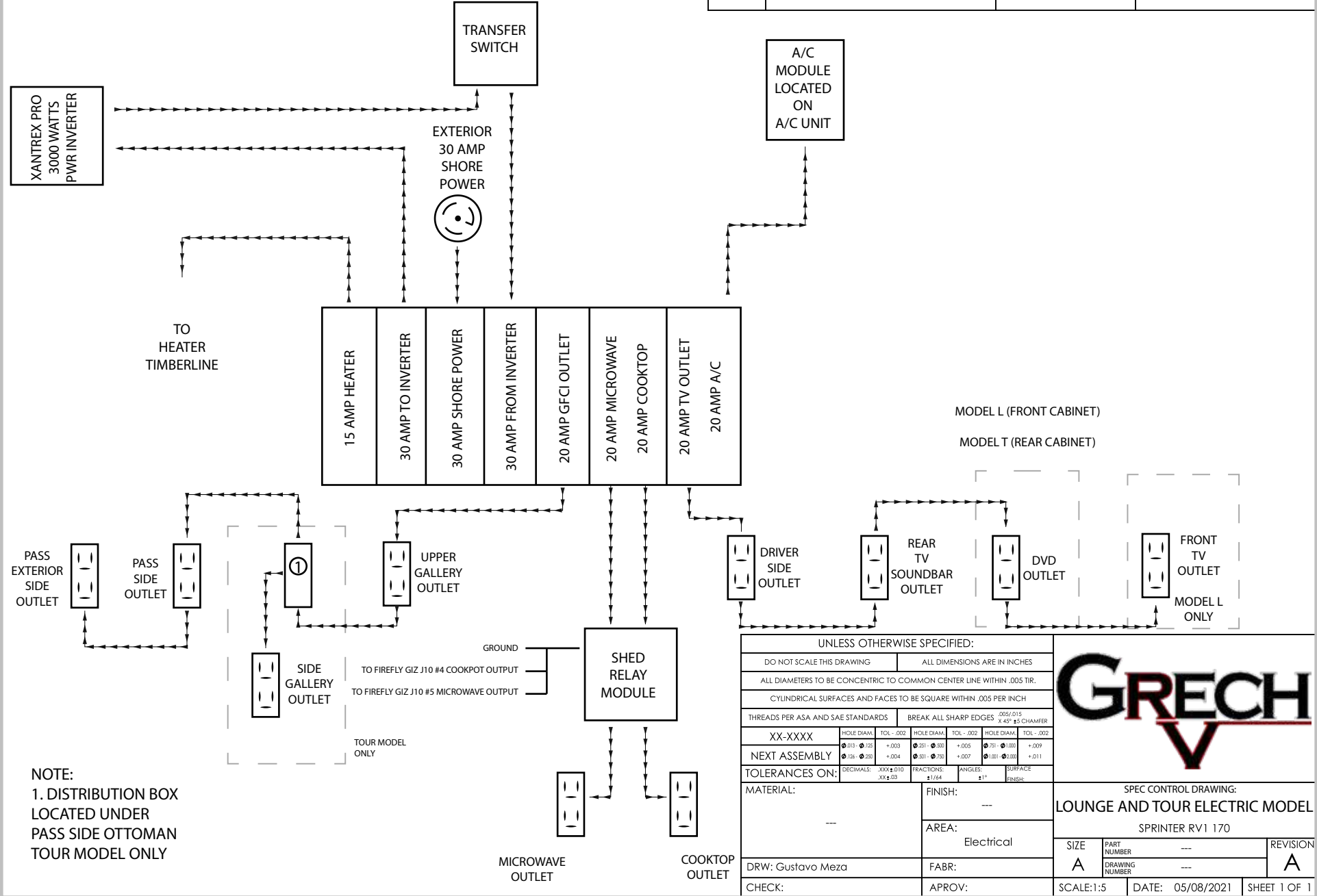

NOTE:  
1. DISTRIBUTION BOX LOCATED UNDER PASS SIDE OTTOMAN TOUR MODEL ONLY

MODEL L (FRONT CABINET)  
MODEL T (REAR CABINET)

UNLESS OTHERWISE SPECIFIED:							
DO NOT SCALE THIS DRAWING				ALL DIMENSIONS ARE IN INCHES			
ALL DIAMETERS TO BE CONCENTRIC TO COMMON CENTER LINE WITHIN .005 TIR.							
CYLINDRICAL SURFACES AND FACES TO BE SQUARE WITHIN .005 PER INCH							
THREADS PER ASA AND SAE STANDARDS				BREAK ALL SHARP EDGES .005/.015 R.45° ±.5° CHAMFER			
XX-XXXX	HOLE DIAM.	TOL -.002	HOLE DIAM.	TOL -.002	HOLE DIAM.	TOL -.002	
NEXT ASSEMBLY	∅.013 - ∅.125	+0.003	∅.251 - ∅.500	+0.005	∅.751 - ∅.100	+0.009	
TOLERANCES ON:	∅.126 - ∅.250	+0.004	∅.501 - ∅.750	+0.007	∅.1001 - ∅.100	+0.011	
MATERIAL:	DECIMALS: XXX ±.010 XX ±.03		FRACTIONS: ±1/64		ANGLES: ±1°		SURFACE FINISH:
FINISH:	---						
AREA:	Electrical						
DRW: Gustavo Meza	FABR:		APROV:		SCALE: 1:5		
CHECK:	DATE: 05/08/2021		SHEET 1 OF 1				



SPEC CONTROL DRAWING:			
LOUNGE AND TOUR ELECTRIC MODEL			
SPRINTER RV1 170			
SIZE	PART NUMBER	REVISION	
A	---	A	

6 5 4 3 2 1

THE INFORMATION DISCLOSED ON THIS DRAWING IS PROPRIETARY. IT IS ISSUED FOR ENGINEERING USE ONLY AND MAY NOT REPRODUCED OR DISCLOSED, IN WHOLE OR IN PART, TO ANYONE WITHOUT THE DIRECT WRITTEN PERMISSION OF GRECH MOTORS LLC. PARTS OR TOOLS MANUFACTURED TO MEET THE REQUIREMENTS OF THIS DRAWING MAY NOT BE USED BY OR SOLD TO ANYONE WITHOUT THE DIRECT WRITTEN PERMISSION OF GRECH MOTORS LL.

REVISION HISTORY

REV	DESCRIPTION	DATE	APPROVED
A	CREATION OF DRAWING	16/08/21	

CB. BOX

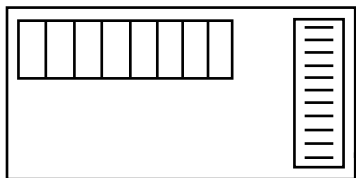

EXT. FAN FUSE #5 FURRIOR ELIXIR

GROUND DRIVER SIDE UPPER CABINET BK



RD/BK

4 PIN DATA CABLE

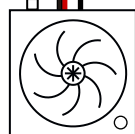

MAXXFAN EXTRACTOR FAN

MINI MOLEX FAN CONNECTOR DATA

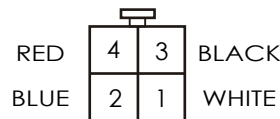

BLUE CAN L  
WHITE CAN H  
RED (+)  
BLACK (-)

MINI MOLEX FAN POWER CONNECTOR

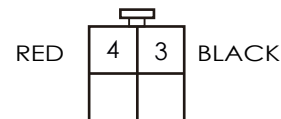

RED (+)  
BLACK (-)

DROP PLUG TO FIREFLY

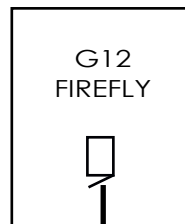
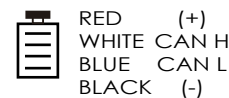

DATA CABLE



G4 COMMON DROP TAP

UNLESS OTHERWISE SPECIFIED:			
DO NOT SCALE THIS DRAWING		ALL DIMENSIONS ARE IN INCHES	
ALL DIAMETERS TO BE CONCENTRIC TO COMMON CENTER LINE WITHIN .005 TIR.			
CYLINDRICAL SURFACES AND FACES TO BE SQUARE WITHIN .005 PER INCH			
THREADS PER ASA AND SAE STANDARDS		BREAK ALL SHARP EDGES .005/.015 1/4" R5 CHAMFER	
XX-XXXX	HOLE DIAM. TOL - .002	HOLE DIAM. TOL - .002	HOLE DIAM. TOL - .002
NEXT ASSEMBLY	Ø.013 - Ø.125 +.003	Ø.251 - Ø.500 +.005	Ø.751 - Ø.100 +.009
	Ø.126 - Ø.250 +.004	Ø.501 - Ø.750 +.007	Ø.101 - Ø.100 +.011
TOLERANCES ON:	DECIMALS: .XXX ±.010 XX ±.03	FRACTIONS: ±1/64	ANGLES: ±1° SURFACE FINISH:
MATERIAL:	FINISH: ---		SPEC CONTROL DRAWING
---	AREA: Electrical		
DRW: Gustavo Meza	FABR:		MAXXFAN: EXTRACTOR FAN SPRINTER RV1 170
CHECK:	APROV:		SIZE PART NUMBER --- DRAWING NUMBER ---
			REVISION A



SCALE: 1:5	DATE: 05/08/2021	SHEET 1 OF 1
------------	------------------	--------------



THE INFORMATION DISCLOSED ON THIS DRAWING IS PROPRIETARY. IT IS ISSUED FOR ENGINEERING USE ONLY AND MAY NOT REPRODUCED OR DISCLOSED, IN WHOLE OR IN PART, TO ANYONE WITHOUT THE DIRECT WRITTEN PERMISSION OF GRECH MOTORS LLC. PARTS OR TOOLS MANUFACTURED TO MEET THE REQUIREMENTS OF THIS DRAWING MAY NOT BE USED BY OR SOLD TO ANYONE WITHOUT THE DIRECT WRITTEN PERMISSION OF GRECH MOTORS LL.

REVISION HISTORY

REV	DESCRIPTION	DATE	APPROVED
A	Creation of piece and Part #	05/08/2021	

D

D

C

C

B

B

A

A

CONNECT THIS CABLE TO NEGATIVE OF THE FIREFLY SYSTEM

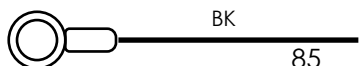

SHED RELAY

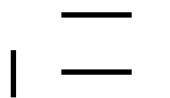

SPLICE THIS CABLE WITH THE RD/BK WIRE AND CONNECTED TO PIN#12 - PLUG#10 FROM G12 FIREFLY

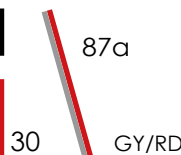

3AMP FUSE



CONNECT THIS CABLE TO POSITIVE OF THE FIREFLY SYSTEM

UNLESS OTHERWISE SPECIFIED:															
DO NOT SCALE THIS DRAWING		ALL DIMENSIONS ARE IN INCHES													
ALL DIAMETERS TO BE CONCENTRIC TO COMMON CENTER LINE WITHIN .005 TIR.															
CYLINDRICAL SURFACES AND FACES TO BE SQUARE WITHIN .005 PER INCH															
THREADS PER ASA AND SAE STANDARDS		BREAK ALL SHARP EDGES .005/.015 X.45° ±5° CHAMFER													
XX-XXXX	HOLE DIAM. TOL - .002	HOLE DIAM. TOL - .002	HOLE DIAM. TOL - .002												
NEXT ASSEMBLY	Ø.013 - Ø.125 +.003	Ø.251 - Ø.500 +.005	Ø.751 - Ø.100 +.009												
	Ø.126 - Ø.250 +.004	Ø.501 - Ø.750 +.007	Ø.101 - Ø.100 +.011												
TOLERANCES ON:	DECIMALS: .XXX ±.010 XX ±.03	FRACTIONS: ±1/64	ANGLES: ±1° SURFACE FINISH: ---												
MATERIAL: ---	FINISH: ---		<p>SPEC CONTROL DRAWING: Retrofit Power Inverter SPRINTER RV1 170</p> <table border="1"> <tr> <td>SIZE</td> <td>PART NUMBER</td> <td>REVISION</td> </tr> <tr> <td>A</td> <td>---</td> <td>A</td> </tr> <tr> <td>DRW: Gustavo Meza</td> <td>FABR:</td> <td></td> </tr> <tr> <td>CHECK:</td> <td>APROV:</td> <td></td> </tr> </table>	SIZE	PART NUMBER	REVISION	A	---	A	DRW: Gustavo Meza	FABR:		CHECK:	APROV:	
SIZE	PART NUMBER	REVISION													
A	---	A													
DRW: Gustavo Meza	FABR:														
CHECK:	APROV:														
AREA: Electrical															
DRW: Gustavo Meza	FABR:														
CHECK:	APROV:														
SCALE: 1:5	DATE: 05/08/2021	SHEET 1 OF 1													



6

5

4

3

2

1

THE INFORMATION DISCLOSED ON THIS DRAWING IS PROPRIETARY. IT IS ISSUED FOR ENGINEERING USE ONLY AND MAY NOT REPRODUCED OR DISCLOSED, IN WHOLE OR IN PART, TO ANYONE WITHOUT THE DIRECT WRITTEN PERMISSION OF GRECH MOTORS LLC. PARTS OR TOOLS MANUFACTURED TO MEET THE REQUIREMENTS OF THIS DRAWING MAY NOT BE USED BY OR SOLD TO ANYONE WITHOUT THE DIRECT WRITTEN PERMISSION OF GRECH MOTORS LL.

REVISION HISTORY

REV	DESCRIPTION	DATE	APPROVED
A	CREATION OF DRAWING	05/09/21	

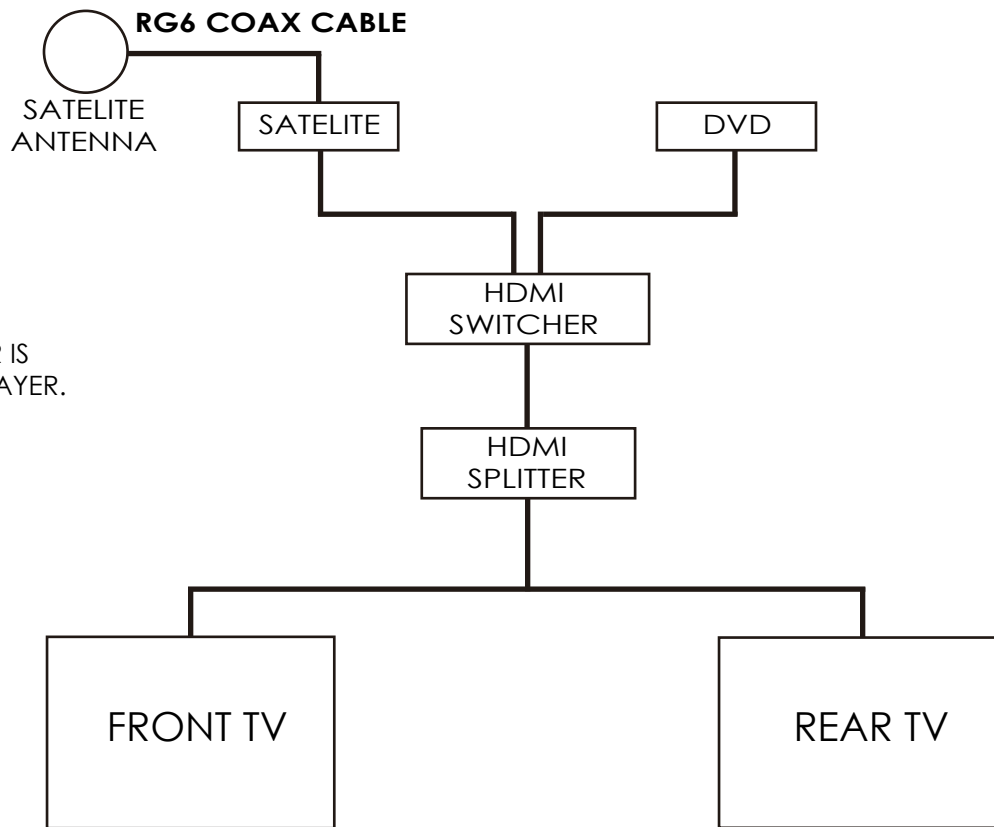

**COX CABLE:**  
ONE END IS LOCATED BEHIND THE FRONT RV AND THE OTHER IS LOCATED BEHIND THE DVD PLAYER.

UNLESS OTHERWISE SPECIFIED:			
DO NOT SCALE THIS DRAWING		ALL DIMENSIONS ARE IN INCHES	
ALL DIAMETERS TO BE CONCENTRIC TO COMMON CENTER LINE WITHIN .005 TIR.			
CYLINDRICAL SURFACES AND FACES TO BE SQUARE WITHIN .005 PER INCH			
THREADS PER ASA AND SAE STANDARDS		BREAK ALL SHARP EDGES .005/.015 X.45° ±5° CHAMFER	
XX-XXXX	HOLE DIAM. TOL - .002	HOLE DIAM. TOL - .002	HOLE DIAM. TOL - .002
NEXT ASSEMBLY	Ø.013 - Ø.125 +0.003	Ø.251 - Ø.500 +0.005	Ø.751 - Ø.100 +0.009
TOLERANCES ON:	DECIMALS: .XXX ±.010 XX ±.03	FRACTIONS: ±1/64	ANGLES: ±1° SURFACE FINISH:
MATERIAL:	FINISH: ---		SPEC CONTROL DRAWING
---	AREA: Electrical		
DRW: Gustavo Meza	FABR:		SATELITE OPTION W/ DVD SPRINTER RV1 170
CHECK:	APROV:		SIZE PART NUMBER --- DRAWING NUMBER ---
			REVISION A



SCALE: 1:5	DATE: 05/08/2021	SHEET 1 OF 1
------------	------------------	--------------

THE INFORMATION DISCLOSED ON THIS DRAWING IS PROPRIETARY. IT IS ISSUED FOR ENGINEERING USE ONLY AND MAY NOT REPRODUCED OR DISCLOSED, IN WHOLE OR IN PART, TO ANYONE WITHOUT THE DIRECT WRITTEN PERMISSION OF GRECH MOTORS LLC.  
PARTS OR TOOLS MANUFACTURED TO MEET THE REQUIREMENTS OF THIS DRAWING MAY NOT BE USED BY OR SOLD TO ANYONE WITHOUT THE DIRECT WRITTEN PERMISSION OF GRECH MOTORS LL.

REVISION HISTORY

REV	DESCRIPTION	DATE	APPROVED
A	CREATION OF DRAWING	17 /08/21	

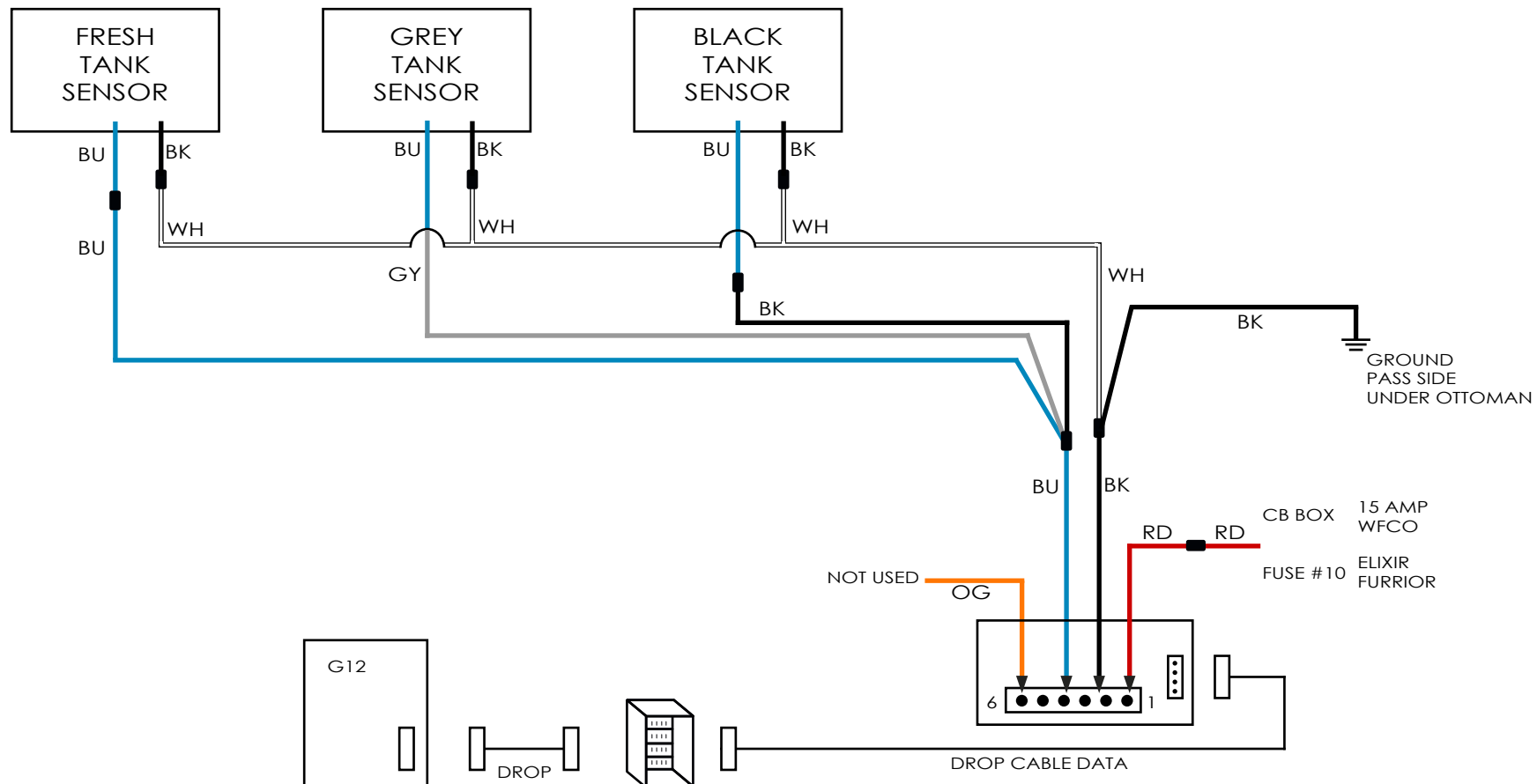

UNLESS OTHERWISE SPECIFIED:

DO NOT SCALE THIS DRAWING	ALL DIMENSIONS ARE IN INCHES		
ALL DIAMETERS TO BE CONCENTRIC TO COMMON CENTER LINE WITHIN .005 TIR.			
CYLINDRICAL SURFACES AND FACES TO BE SQUARE WITHIN .005 PER INCH			
THREADS PER ASA AND SAE STANDARDS	BREAK ALL SHARP EDGES .005/.015 1/4" ±5° CHAMFER		
XX-XXXX	HOLE DIAM.	TOL - .002	HOLE DIAM.
NEXT ASSEMBLY	±.013 - .012	+ .003	±.011 - .010
TOLERANCES ON:	DECIMALS: XXX ±.010 XX ±.03	FRACTIONS: ±1/64	ANGLES: ±1°
MATERIAL:	FINISH: ---		
	AREA: Electrical		
DRW: Gustavo Meza	FABR:		
CHECK:	APROV:		



SPEC CONTROL DRAWING			
SEELEVEL TANK MONITOR			
SPRINTER RV1 170			
SIZE	PART NUMBER	---	REVISION
A	DRAWING NUMBER	---	A
SCALE: 1:5	DATE: 05/08/2021	SHEET 1 OF 1	

THE INFORMATION DISCLOSED ON THIS DRAWING IS PROPRIETARY. IT IS ISSUED FOR ENGINEERING USE ONLY AND MAY NOT REPRODUCED OR DISCLOSED, IN WHOLE OR IN PART, TO ANYONE WITHOUT THE DIRECT WRITTEN PERMISSION OF GRECH MOTORS LLC. PARTS OR TOOLS MANUFACTURED TO MEET THE REQUIREMENTS OF THIS DRAWING MAY NOT BE USED BY OR SOLD TO ANYONE WITHOUT THE DIRECT WRITTEN PERMISSION OF GRECH MOTORS LL.

REVISION HISTORY			
REV	DESCRIPTION	DATE	APPROVED
A	Creation of piece and Part #	05/08/2021	

D  
C  
B  
A

D  
C  
B  
A

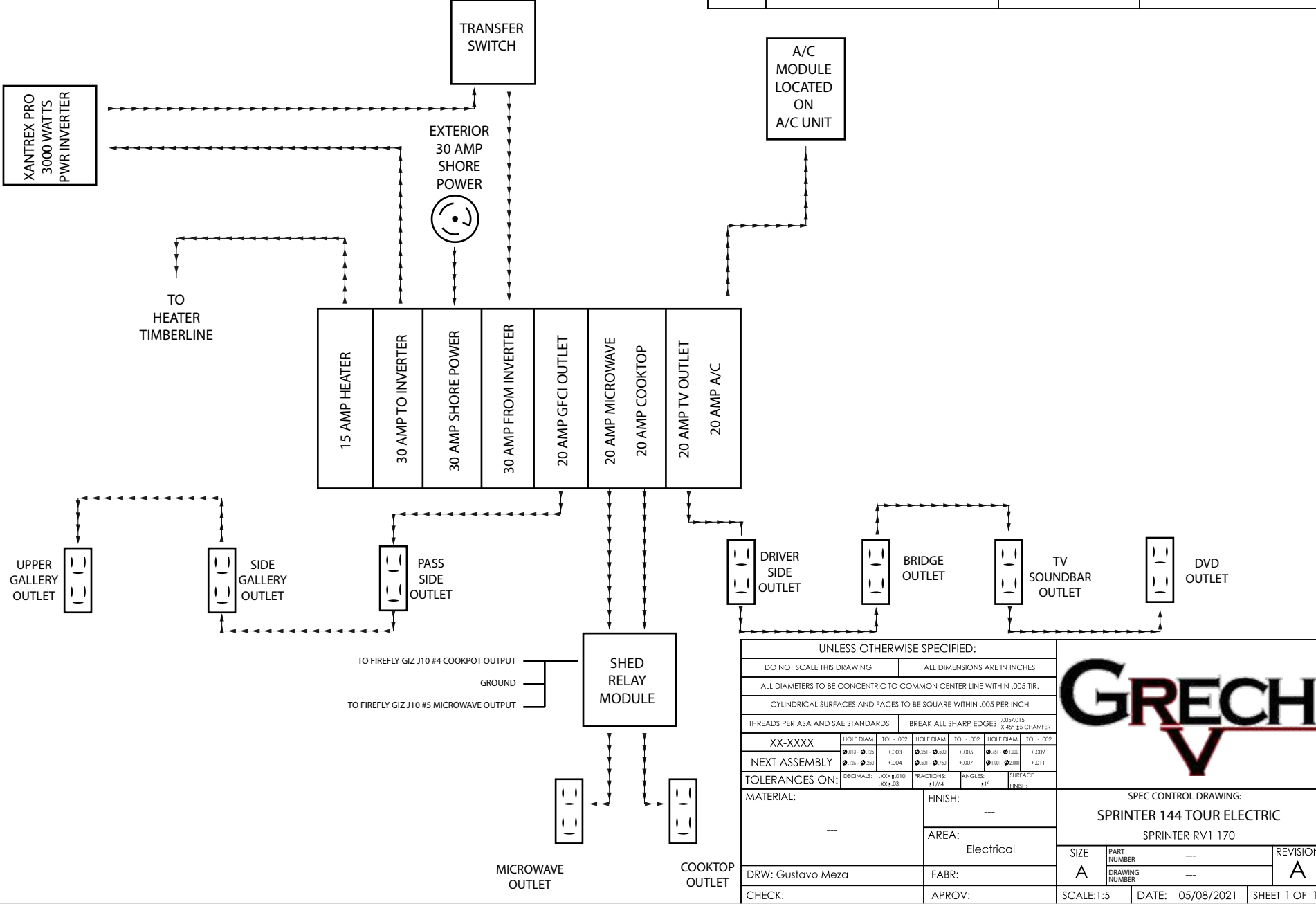

UNLESS OTHERWISE SPECIFIED:

DO NOT SCALE THIS DRAWING	ALL DIMENSIONS ARE IN INCHES		
ALL DIAMETERS TO BE CONCENTRIC TO COMMON CENTER LINE WITHIN .005 TIR.			
CYLINDRICAL SURFACES AND FACES TO BE SQUARE WITHIN .005 PER INCH			
THREADS PER ASA AND SAE STANDARDS	BREAK ALL SHARP EDGES .005/.015 1/4" & 5/8" CHAMFER		
XX-XXXX	HOLE DIAM. TOL -.002	HOLE DIAM. TOL -.002	HOLE DIAM. TOL -.002
NEXT ASSEMBLY	Ø.013 - Ø.125 +0.003	Ø.251 - Ø.500 +0.005	Ø.751 - Ø.100 +0.009
TOLERANCES ON:	DECIMALS: .XXX ± 0.10 XX ± 0.03	FRACTIONS: ± 1/64	ANGLES: ± 1° SURFACE FINISH:
MATERIAL:	FINISH: ---		SPEC CONTROL DRAWING: SPRINTER 144 TOUR ELECTRIC SPRINTER RV1 170
AREA: Electrical	FABR:		
DRW: Gustavo Meza	APROV:		SIZE: A PART NUMBER: --- DRAWING NUMBER: ---
CHECK:	SCALE: 1:5		REVISION: A
	DATE: 05/08/2021	SHEET 1 OF 1	

6 5 4 3 2 1

THE INFORMATION DISCLOSED ON THIS DRAWING IS PROPRIETARY. IT IS ISSUED FOR ENGINEERING USE ONLY AND MAY NOT REPRODUCED OR DISCLOSED, IN WHOLE OR IN PART, TO ANYONE WITHOUT THE DIRECT WRITTEN PERMISSION OF GRECH MOTORS LLC. PARTS OR TOOLS MANUFACTURED TO MEET THE REQUIREMENTS OF THIS DRAWING MAY NOT BE USED BY OR SOLD TO ANYONE WITHOUT THE DIRECT WRITTEN PERMISSION OF GRECH MOTORS LL.

REVISION HISTORY

REV	DESCRIPTION	DATE	APPROVED
A	CREATION OF DRAWING	16/08/21	

D  
C  
B  
A

D  
C  
B  
A

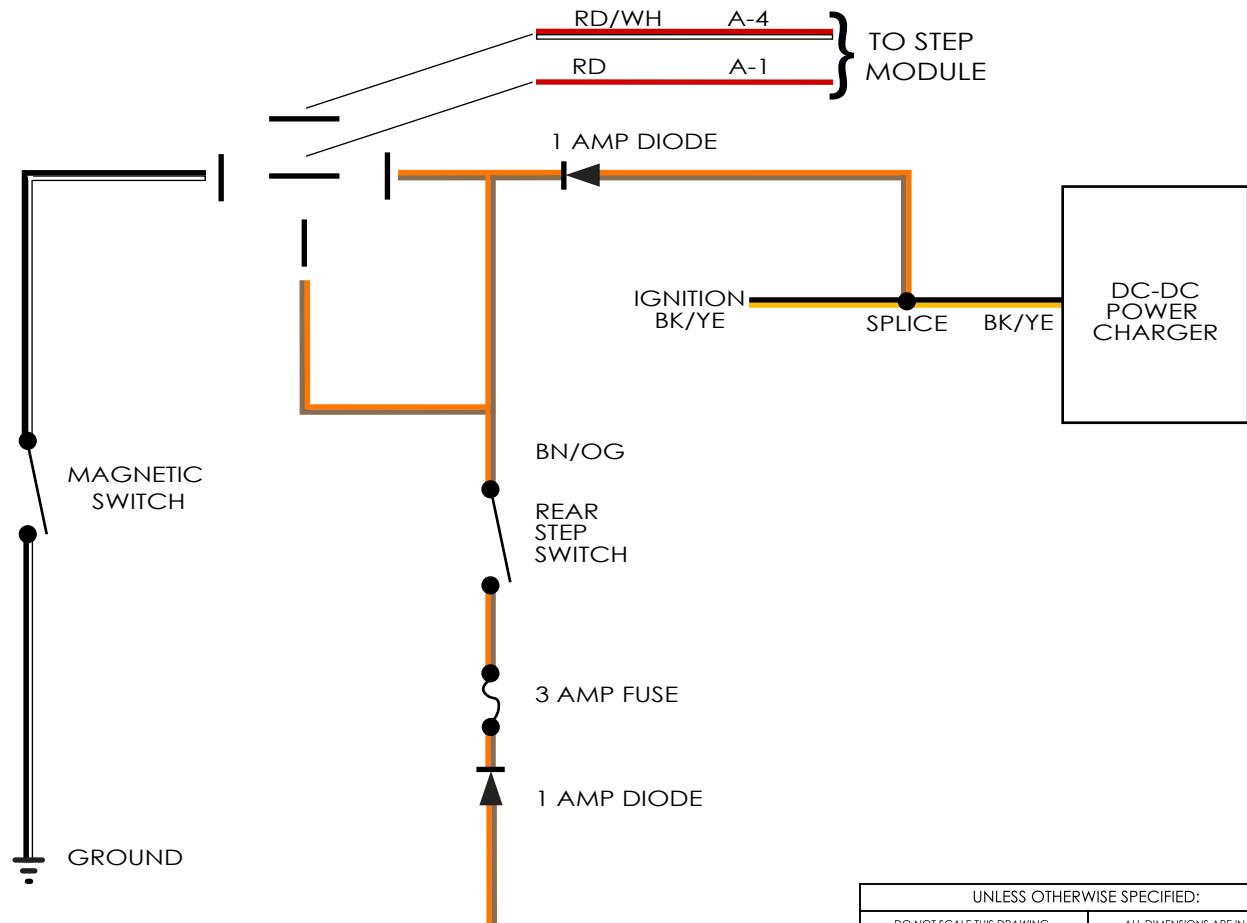

CONNECT THIS TO THE RED WIRE FROM THE SOFA SWITCH (12 V # 10ga)

UNLESS OTHERWISE SPECIFIED:															
DO NOT SCALE THIS DRAWING	ALL DIMENSIONS ARE IN INCHES														
ALL DIAMETERS TO BE CONCENTRIC TO COMMON CENTER LINE WITHIN .005 TIR.															
CYLINDRICAL SURFACES AND FACES TO BE SQUARE WITHIN .005 PER INCH															
THREADS PER ASA AND SAE STANDARDS	BREAK ALL SHARP EDGES .005/.015 R.45° ±5° CHAMFER	<p>SPEC CONTROL DRAWING STEP RETROFIT SPRINTER RV1 170</p>													
XX-XXXX	HOLE DIAM. TOL - .002 HOLE DIAM. TOL - .002 HOLE DIAM. TOL - .002														
NEXT ASSEMBLY	<table border="1"> <tr> <td>Ø.013 - Ø.175</td> <td>+ .003</td> <td>Ø.251 - Ø.300</td> <td>+ .005</td> <td>Ø.751 - Ø.100</td> <td>+ .009</td> </tr> <tr> <td>Ø.156 - Ø.200</td> <td>+ .004</td> <td>Ø.301 - Ø.750</td> <td>+ .007</td> <td>Ø.101 - Ø.100</td> <td>+ .011</td> </tr> </table>			Ø.013 - Ø.175	+ .003	Ø.251 - Ø.300	+ .005	Ø.751 - Ø.100	+ .009	Ø.156 - Ø.200	+ .004	Ø.301 - Ø.750	+ .007	Ø.101 - Ø.100	+ .011
Ø.013 - Ø.175	+ .003			Ø.251 - Ø.300	+ .005	Ø.751 - Ø.100	+ .009								
Ø.156 - Ø.200	+ .004	Ø.301 - Ø.750	+ .007	Ø.101 - Ø.100	+ .011										
TOLERANCES ON:	DECIMALS: .XXX ± 0.10 XX ± .03 FRACTIONS: ± 1/64 ANGLES: ± 1° SURFACE FINISH:														
MATERIAL:	FINISH: ---	<table border="1"> <tr> <td>SIZE</td> <td>PART NUMBER</td> <td>REVISION</td> </tr> <tr> <td>A</td> <td>---</td> <td>A</td> </tr> </table>		SIZE	PART NUMBER	REVISION	A	---	A						
SIZE	PART NUMBER			REVISION											
A	---	A													
AREA: Electrical	FABR:														
DRW: Gustavo Meza	APROV:	SCALE: 1:5	DATE: 05/08/2021	SHEET 1 OF 1											

6 5 4 3 2 1



THE INFORMATION DISCLOSED ON THIS DRAWING IS PROPRIETARY. IT IS ISSUED FOR ENGINEERING USE ONLY AND MAY NOT REPRODUCED OR DISCLOSED, IN WHOLE OR IN PART, TO ANYONE WITHOUT THE DIRECT WRITTEN PERMISSION OF GRECH MOTORS LLC. PARTS OR TOOLS MANUFACTURED TO MEET THE REQUIREMENTS OF THIS DRAWING MAY NOT BE USED BY OR SOLD TO ANYONE WITHOUT THE DIRECT WRITTEN PERMISSION OF GRECH MOTORS LL.

REVISION HISTORY			
REV	DESCRIPTION	DATE	APPROVED
A	Creation of piece and Part #	05/08/2021	

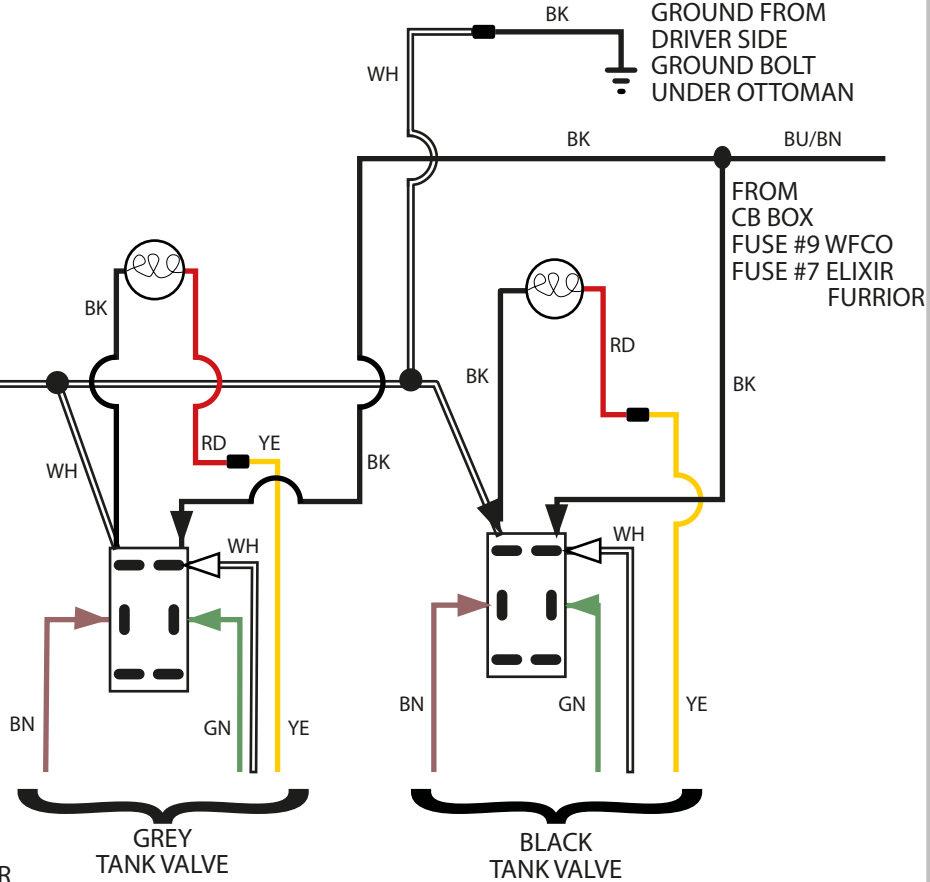
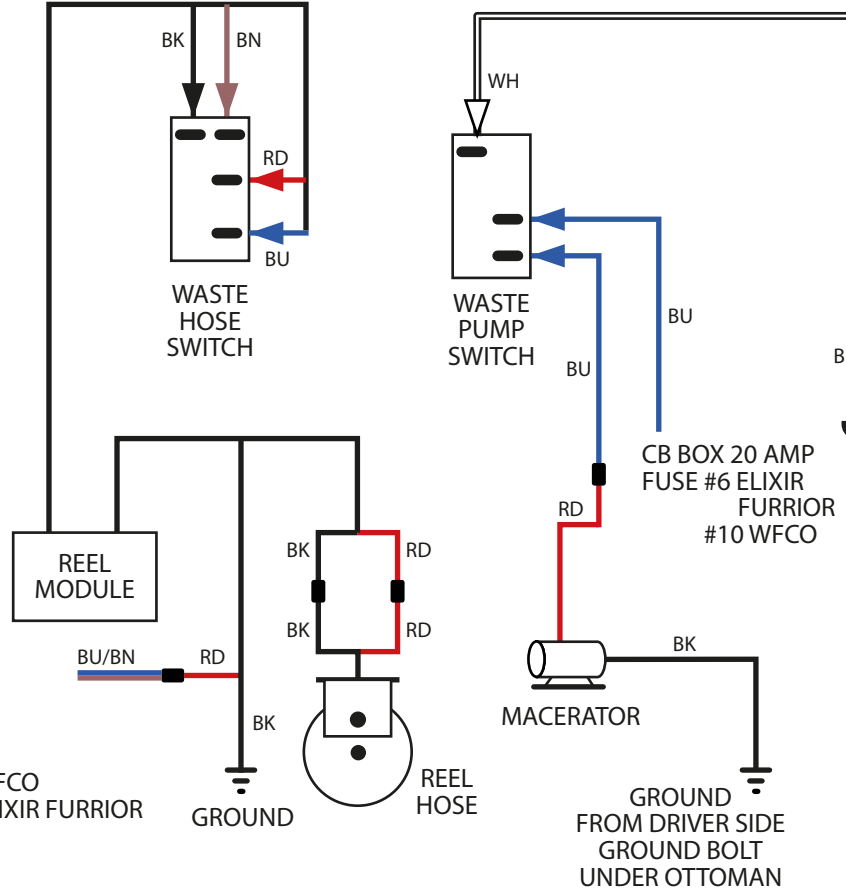
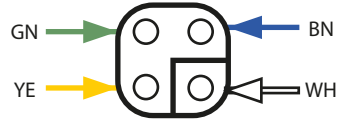
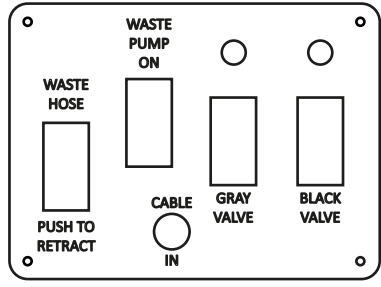

UNLESS OTHERWISE SPECIFIED:

DO NOT SCALE THIS DRAWING		ALL DIMENSIONS ARE IN INCHES	
ALL DIAMETERS TO BE CONCENTRIC TO COMMON CENTER LINE WITHIN .005 TIR.			
CYLINDRICAL SURFACES AND FACES TO BE SQUARE WITHIN .005 PER INCH			
THREADS PER ASA AND SAE STANDARDS	BREAK ALL SHARP EDGES .005/.015 1/4" ±.5 CHAMFER		
XX-XXXX	HOLE DIAM. TOL -.002	HOLE DIAM. TOL -.002	HOLE DIAM. TOL -.002
NEXT ASSEMBLY	Ø.013 - Ø.125 +.003	Ø.251 - Ø.500 +.005	Ø.751 - Ø.100 +.009
TOLERANCES ON:	DECIMALS: .XXX ±.010 XX ±.03	FRACTIONS: ±1/64	ANGLES: ±1° SURFACE FINISH:
MATERIAL:	FINISH: ---		SPEC CONTROL DRAWING: <b>System Plumbing Diagram</b> SPRINTER RV1 170
AREA:	Electrical		
DRW: Gustavo Meza	FABR:		SIZE: A
CHECK:	APROV:		SCALE: 1:5



SIZE: A	PART NUMBER: ---	REVISION: A
DRWING NUMBER: ---	DATE: 05/08/2021	
SHEET 1 OF 1		

THE INFORMATION DISCLOSED ON THIS DRAWING IS PROPRIETARY. IT IS ISSUED FOR ENGINEERING USE ONLY AND MAY NOT REPRODUCED OR DISCLOSED, IN WHOLE OR IN PART, TO ANYONE WITHOUT THE DIRECT WRITTEN PERMISSION OF GRECH MOTORS LLC.  
PARTS OR TOOLS MANUFACTURED TO MEET THE REQUIREMENTS OF THIS DRAWING MAY NOT BE USED BY OR SOLD TO ANYONE WITHOUT THE DIRECT WRITTEN PERMISSION OF GRECH MOTORS LL.

REVISION HISTORY

REV	DESCRIPTION	DATE	APPROVED
A	Creation of piece and Part #	05/08/2021	

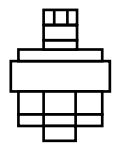
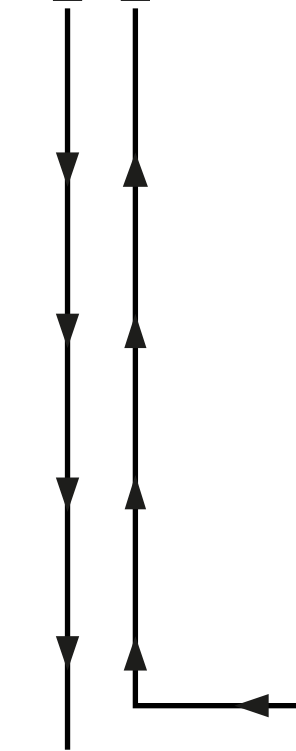

CIRCULATION PUMP

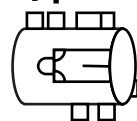

HEATER EXCHANGER

NORMALLY OPEN SOLENOID

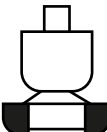

NORMALLY CLOSE SOLENOID

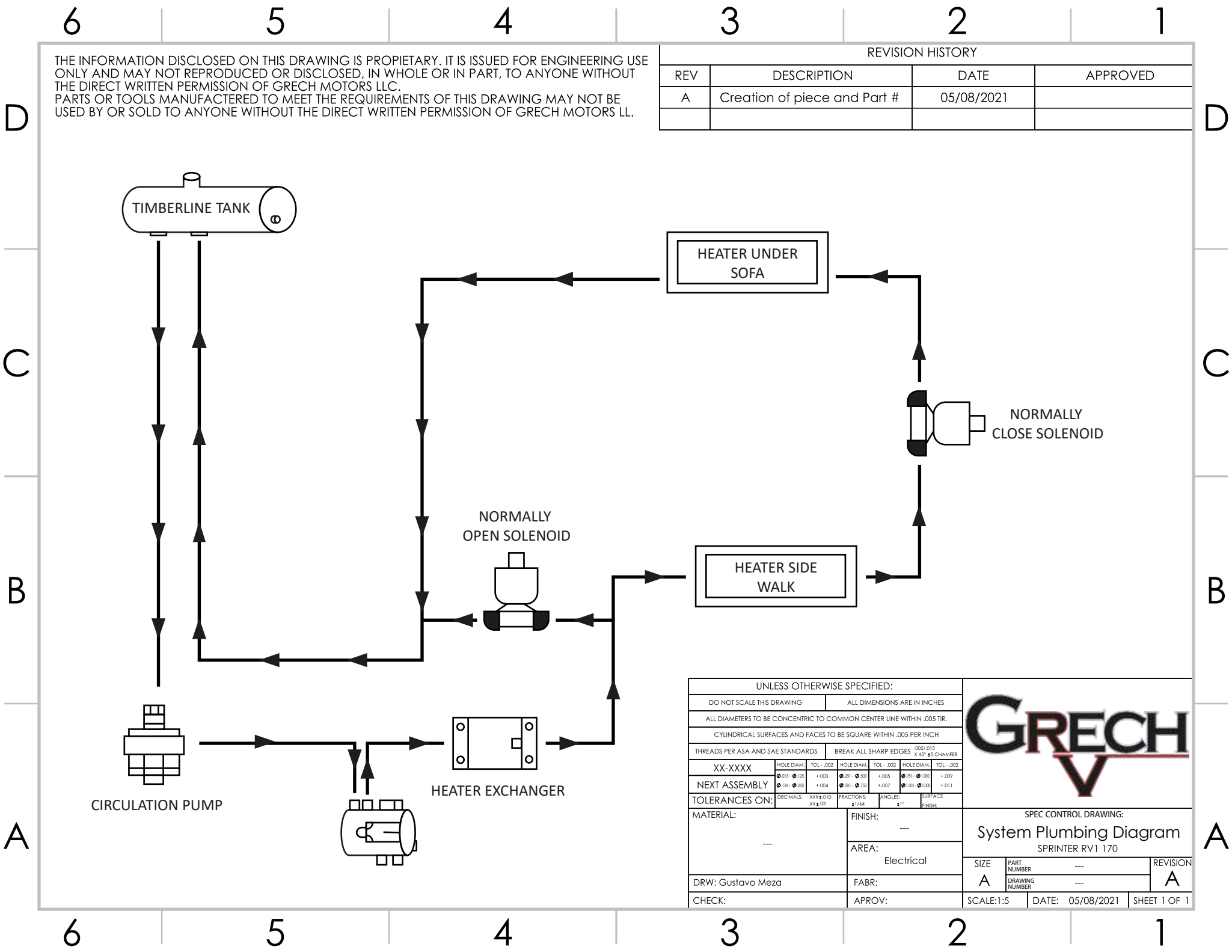
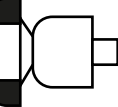

UNLESS OTHERWISE SPECIFIED:							
DO NOT SCALE THIS DRAWING				ALL DIMENSIONS ARE IN INCHES			
ALL DIAMETERS TO BE CONCENTRIC TO COMMON CENTER LINE WITHIN .005 TIR.							
CYLINDRICAL SURFACES AND FACES TO BE SQUARE WITHIN .005 PER INCH							
THREADS PER ASA AND SAE STANDARDS				BREAK ALL SHARP EDGES .005/.015 1/4" & 5/8" CHAMFER			
XX-XXXX	HOLE DIAM.	TOL -.002	HOLE DIAM.	TOL -.002	HOLE DIAM.	TOL -.002	
NEXT ASSEMBLY	Ø.013 - Ø.125	+0.003	Ø.251 - Ø.500	+0.005	Ø.751 - Ø.100	+0.009	
	Ø.126 - Ø.250	+0.004	Ø.501 - Ø.750	+0.007	Ø.101 - Ø.100	+0.011	
TOLERANCES ON:	DECIMALS: XXX ±.010 XX ±.03	FRACTIONS: ±1/64	ANGLES: ±1°	SURFACE FINISH:			
MATERIAL:	---			FINISH: ---			
	---			AREA: Electrical			
DRW: Gustavo Meza	FABR:			APROV:			
CHECK:	---			---			



SPEC CONTROL DRAWING:			
System Plumbing Diagram			
SPRINTER RV1 170			
SIZE	PART NUMBER	---	REVISION
A	DRAWING NUMBER	---	A
SCALE: 1:5	DATE: 05/08/2021	SHEET 1 OF 1	

THE INFORMATION DISCLOSED ON THIS DRAWING IS PROPRIETARY. IT IS ISSUED FOR ENGINEERING USE ONLY AND MAY NOT REPRODUCED OR DISCLOSED, IN WHOLE OR IN PART, TO ANYONE WITHOUT THE DIRECT WRITTEN PERMISSION OF GRECH MOTORS LLC.  
PARTS OR TOOLS MANUFACTURED TO MEET THE REQUIREMENTS OF THIS DRAWING MAY NOT BE USED BY OR SOLD TO ANYONE WITHOUT THE DIRECT WRITTEN PERMISSION OF GRECH MOTORS LL.

REVISION HISTORY

REV	DESCRIPTION	DATE	APPROVED
A	Creation of piece and Part #	05/08/2021	

D

D

C

C

B

B

A

A

6

5

4

3

2

1

6

5

4

3

2

1

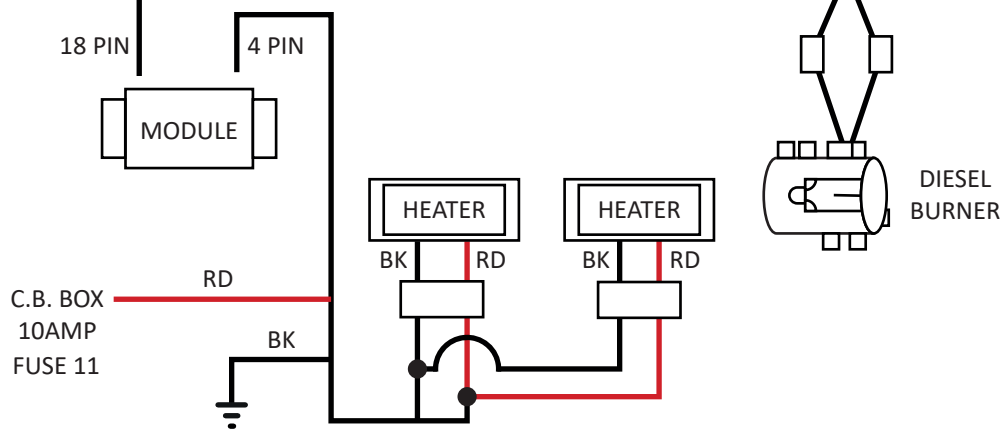
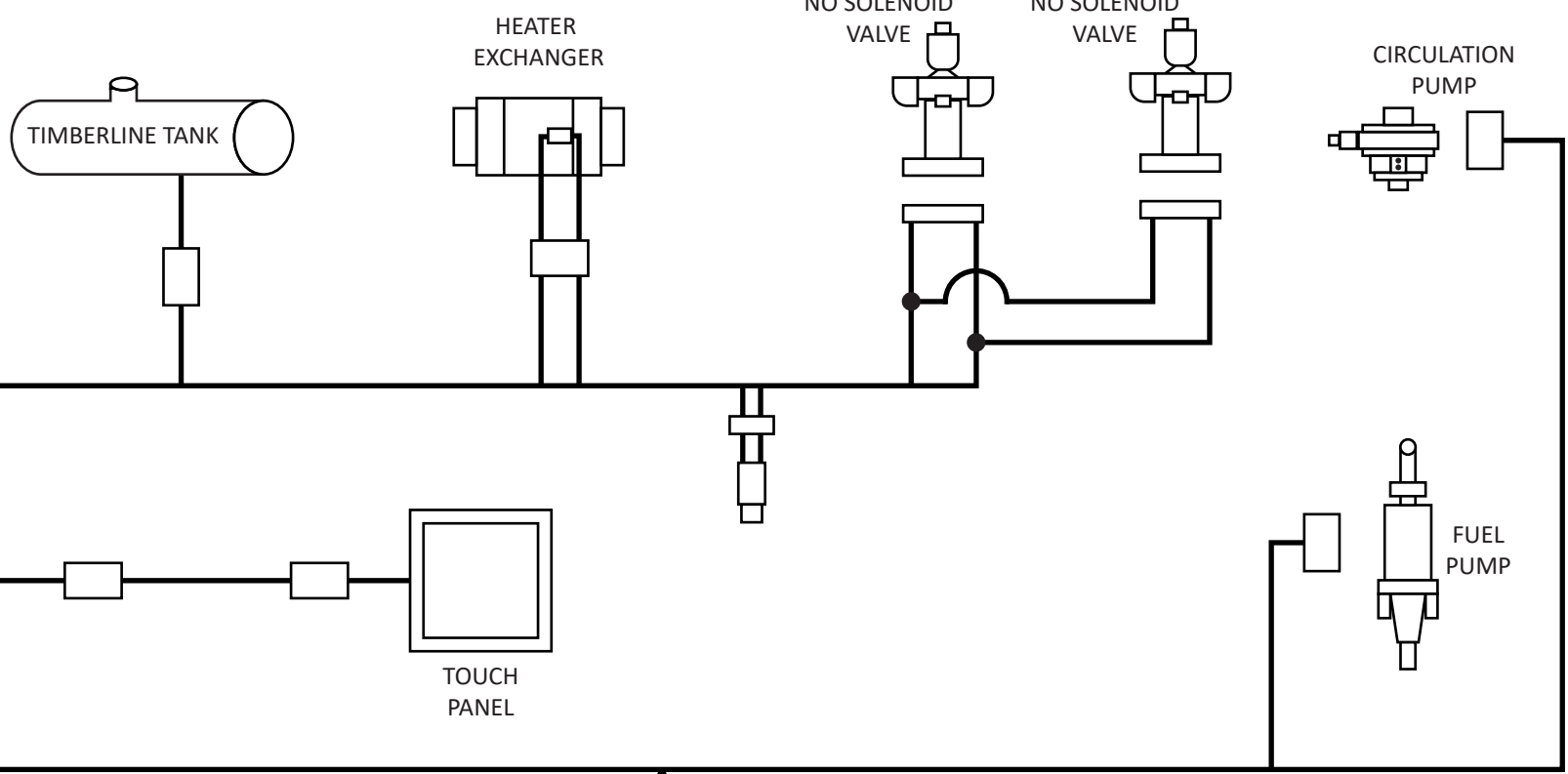

UNLESS OTHERWISE SPECIFIED:

DO NOT SCALE THIS DRAWING	ALL DIMENSIONS ARE IN INCHES					
ALL DIAMETERS TO BE CONCENTRIC TO COMMON CENTER LINE WITHIN .005 TIR.						
CYLINDRICAL SURFACES AND FACES TO BE SQUARE WITHIN .005 PER INCH						
THREADS PER ASA AND SAE STANDARDS	BREAK ALL SHARP EDGES .005/.015 1/64" R5 CHAMFER					
XX-XXXX	HOLE DIAM.	TOL -.002	HOLE DIAM.	TOL -.002	HOLE DIAM.	TOL -.002
NEXT ASSEMBLY	Ø.013 - Ø.125	+0.003	Ø.251 - Ø.500	+0.005	Ø.751 - Ø.100	+0.009
TOLERANCES ON:	Ø.126 - Ø.250	+0.004	Ø.501 - Ø.750	+0.007	Ø.101 - Ø.100	+0.011
	DECIMALS: .XXX ± 0.10 XX ± 0.03		FRACTIONS: ± 1/64	ANGLES: ± 1°	SURFACE FINISH:	
MATERIAL:	FINISH: ---					
	AREA: Electrical					
DRW: Gustavo Meza	FABR:					
CHECK:	APROV:					



SPEC CONTROL DRAWING:  
Timberline Tank  
SPRINTER RV1 170

SIZE	PART NUMBER	REVISION
A	---	A
DRW NUMBER	---	

SCALE: 1:5    DATE: 05/08/2021    SHEET 1 OF 1

THE INFORMATION DISCLOSED ON THIS DRAWING IS PROPRIETARY. IT IS ISSUED FOR ENGINEERING USE ONLY AND MAY NOT REPRODUCED OR DISCLOSED, IN WHOLE OR IN PART, TO ANYONE WITHOUT THE DIRECT WRITTEN PERMISSION OF GRECH MOTORS LLC. PARTS OR TOOLS MANUFACTURED TO MEET THE REQUIREMENTS OF THIS DRAWING MAY NOT BE USED BY OR SOLD TO ANYONE WITHOUT THE DIRECT WRITTEN PERMISSION OF GRECH MOTORS LL.

REVISION HISTORY

REV	DESCRIPTION	DATE	APPROVED
A	CREATION OF DRAWING	05/08/21	

18 PIN CONNECTOR	DESCRIPTION	COLOR CODE
	1 NOT USED	-
	2 HEATER WIRE GROUND	BLUE
	3 TOUCH SCREEN GROUND	BLUE
	4 HEATER EXCHANGER SENSOR (-)	BK/WH
	5 TANK SENSOR (-)	BK/WH
	6 AIR SENSOR (-)	BU
	7 HEATER DATA RX	GREEN
	8 ELEMENT RELAY (-)	BLACK
	9 SOLENOID VALVE (-)	BLACK
	10 TOUCH SCREEN DATA (RX)	GREEN
	11 HEATER DATA (TX)	WHITE
	12 TOUCH SCREEN DATA (RX)	WHITE
	13 HEATER EXCHANGER SENSOR (+)	WHITE
	14 TANK SENSOR (+)	WHITE
	15 AIR SENSOR (+)	WHITE
	16 TOUCH SCREEN (+)	RED
	17 ELEMENT RELAY (+)	RED
	18 SOLENOID VALVE (+)	RED

TIMBERLINE TANK SENSOR	DESCRIPTION	COLOR CODE
	1 SENSOR (-) TANK SENSOR	BK/WH
	2 SENSOR (+) TANK SENSOR	WH
	3 ELEMENT RELAY (-)	BK
	4 ELEMENT RELAY (+)	RD

AMBIENT SENSOR	DESCRIPTION	COLOR CODE
	1 SENSOR (-)	BU
	2 SENSOR (+)	WH

SOLENOID VALVE	DESCRIPTION	COLOR CODE
	1 SOLENOID (-)	BLACK
	2 SOLENOID (+)	RED

CIRCULATION PUMP	DESCRIPTION	COLOR CODE
	1 PUMP (-)	BLACK
	2 PUMP (+)	YELLOW

4 PIN CONNECTOR	DESCRIPTION	COLOR CODE
	1 GROUND	BLACK
	2 ACC (+)	RED
	3 FAN (-)	BLACK
	4 FAN (+)	RED

TOUCH SCREEN CONNECTOR	DESCRIPTION	COLOR CODE
	1 GND	BU
	2 (+)	RD
	3 DATA TX	GN
	4 DATA RX	WHITE

FAN CONNECTOR	DESCRIPTION	COLOR CODE
	1 FAN (-)	BLACK
	2 FAN	RED

UNLESS OTHERWISE SPECIFIED:

DO NOT SCALE THIS DRAWING	ALL DIMENSIONS ARE IN INCHES			
ALL DIAMETERS TO BE CONCENTRIC TO COMMON CENTER LINE WITHIN .005 TIR.				
CYLINDRICAL SURFACES AND FACES TO BE SQUARE WITHIN .005 PER INCH				
THREADS PER ASA AND SAE STANDARDS	BREAK ALL SHARP EDGES .005/.015 R.45° ±5° CHAMFER			
XX-XXXX	HOLE DIAM. TOL - .002	HOLE DIAM. TOL - .002		
NEXT ASSEMBLY	$\begin{matrix} \text{HOLE DIAM.} & \text{TOL} \\ \text{.013} & \text{.012} & +.003 \\ \text{.026} & \text{.020} & +.004 \end{matrix}$	$\begin{matrix} \text{HOLE DIAM.} & \text{TOL} & \text{HOLE DIAM.} & \text{TOL} \\ \text{.051} & \text{.050} & +.005 & \text{.071} & \text{.060} & +.009 \\ \text{.101} & \text{.090} & +.007 & \text{.101} & \text{.090} & +.011 \end{matrix}$		
TOLERANCES ON:	DECIMALS: XXX ±.010 XX ±.03	FRACTIONS: ±1/64	ANGLES: ±1°	SURFACE FINISH:
MATERIAL: ---	FINISH: ---			
AREA: Electrical				
DRW: Gustavo Meza	FABR:			
CHECK:	APROV:			



SPEC CONTROL DRAWING  
TIMBERLINE DIAGRAM  
SPRINTER RV1 170

SIZE A	PART NUMBER ---	REVISION A
	DRAWING NUMBER ---	
SCALE: 1:5	DATE: 05/08/2021	SHEET 1 OF 1

THE INFORMATION DISCLOSED ON THIS DRAWING IS PROPRIETARY. IT IS ISSUED FOR ENGINEERING USE ONLY AND MAY NOT REPRODUCED OR DISCLOSED, IN WHOLE OR IN PART, TO ANYONE WITHOUT THE DIRECT WRITTEN PERMISSION OF GRECH MOTORS LLC. PARTS OR TOOLS MANUFACTURED TO MEET THE REQUIREMENTS OF THIS DRAWING MAY NOT BE USED BY OR SOLD TO ANYONE WITHOUT THE DIRECT WRITTEN PERMISSION OF GRECH MOTORS LL.

REVISION HISTORY

REV	DESCRIPTION	DATE	APPROVED
A	CREATION OF DRAWING	05/08/21	

HE AT EXCHANGER SENSOR	DESCRIPTION	COLOR CODE
	1 EXCHANGER SENSOR (-)	BK / WH
	2 EXCHANGER SENSOR (+)	WH

FUE L PUMP	DESCRIPTION	COLOR CODE
	1 POSITIVE	RD/BK
	2 NEGATIVE	BK

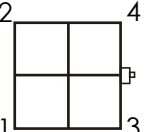
HEATER DATA	DESCRIPTION	COLOR CODE
	1 HEATER GND	BU
	2	
	3 HEATER DATA RX	GN
	4 HEATER DATA TX	WHITE

HARNES SIDE HEATER BURNER - MALE	DESCRIPTION	COLOR CODE
	1 FUEL PUMP OUT	RD /BK
	2 HEATER GND DATA	BU
	3 HEATER DATA RX	GN
	4 HEATER DATA TX	WHITE

HARNES SIDE HEATER BURNER - FEMALE	DESCRIPTION	COLOR CODE
	1 POWER INN	RD /WH
	2 GROUND	BK
	3 CIRCULATION PUMP DATA	YE
	4	BN

UNLESS OTHERWISE SPECIFIED:													
DO NOT SCALE THIS DRAWING	ALL DIMENSIONS ARE IN INCHES												
ALL DIAMETERS TO BE CONCENTRIC TO COMMON CENTER LINE WITHIN .005 TIR.													
CYLINDRICAL SURFACES AND FACES TO BE SQUARE WITHIN .005 PER INCH													
THREADS PER ASA AND SAE STANDARDS	BREAK ALL SHARP EDGES .005/.015 R.45° ±5° CHAMFER												
XX-XXXX	HOLE DIAM. TOL - .002 HOLE DIAM. TOL - .002 HOLE DIAM. TOL - .002												
NEXT ASSEMBLY	<table border="1"> <tr> <td>Ø.013 - Ø.125</td> <td>+ .003</td> <td>Ø.251 - Ø.500</td> <td>+ .005</td> <td>Ø.751 - Ø.100</td> <td>+ .009</td> </tr> <tr> <td>Ø.126 - Ø.250</td> <td>+ .004</td> <td>Ø.501 - Ø.750</td> <td>+ .007</td> <td>Ø.1001 - Ø.100</td> <td>+ .011</td> </tr> </table>	Ø.013 - Ø.125	+ .003	Ø.251 - Ø.500	+ .005	Ø.751 - Ø.100	+ .009	Ø.126 - Ø.250	+ .004	Ø.501 - Ø.750	+ .007	Ø.1001 - Ø.100	+ .011
Ø.013 - Ø.125	+ .003	Ø.251 - Ø.500	+ .005	Ø.751 - Ø.100	+ .009								
Ø.126 - Ø.250	+ .004	Ø.501 - Ø.750	+ .007	Ø.1001 - Ø.100	+ .011								
TOLERANCES ON:	DECIMALS: .XXX ±.010 XX ±.03 FRACTIONS: ±1/64 ANGLES: ±1° SURFACE FINISH:												
MATERIAL:	FINISH: ---												
	AREA: Electrical												
DRW: Gustavo Meza	FABR:												
CHECK:	APROV:												



SPEC CONTROL DRAWING	
HEATER DIAGRAM	
SPRINTER RV1 170	
SIZE A	PART NUMBER ---
	DRAWING NUMBER ---
	REVISION A
SCALE: 1:5	05/08/2021 SHEET 1 OF 1



THE INFORMATION DISCLOSED ON THIS DRAWING IS PROPRIETARY. IT IS ISSUED FOR ENGINEERING USE ONLY AND MAY NOT REPRODUCED OR DISCLOSED, IN WHOLE OR IN PART, TO ANYONE WITHOUT THE DIRECT WRITTEN PERMISSION OF GRECH MOTORS LLC. PARTS OR TOOLS MANUFACTURED TO MEET THE REQUIREMENTS OF THIS DRAWING MAY NOT BE USED BY OR SOLD TO ANYONE WITHOUT THE DIRECT WRITTEN PERMISSION OF GRECH MOTORS LL.

REVISION HISTORY

REV	DESCRIPTION	DATE	APPROVED
A	Creation of piece and Part #	05/08/2021	

D  
C  
B  
A

D  
C  
B  
A

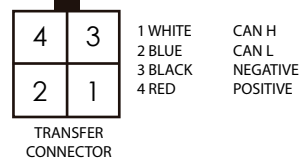
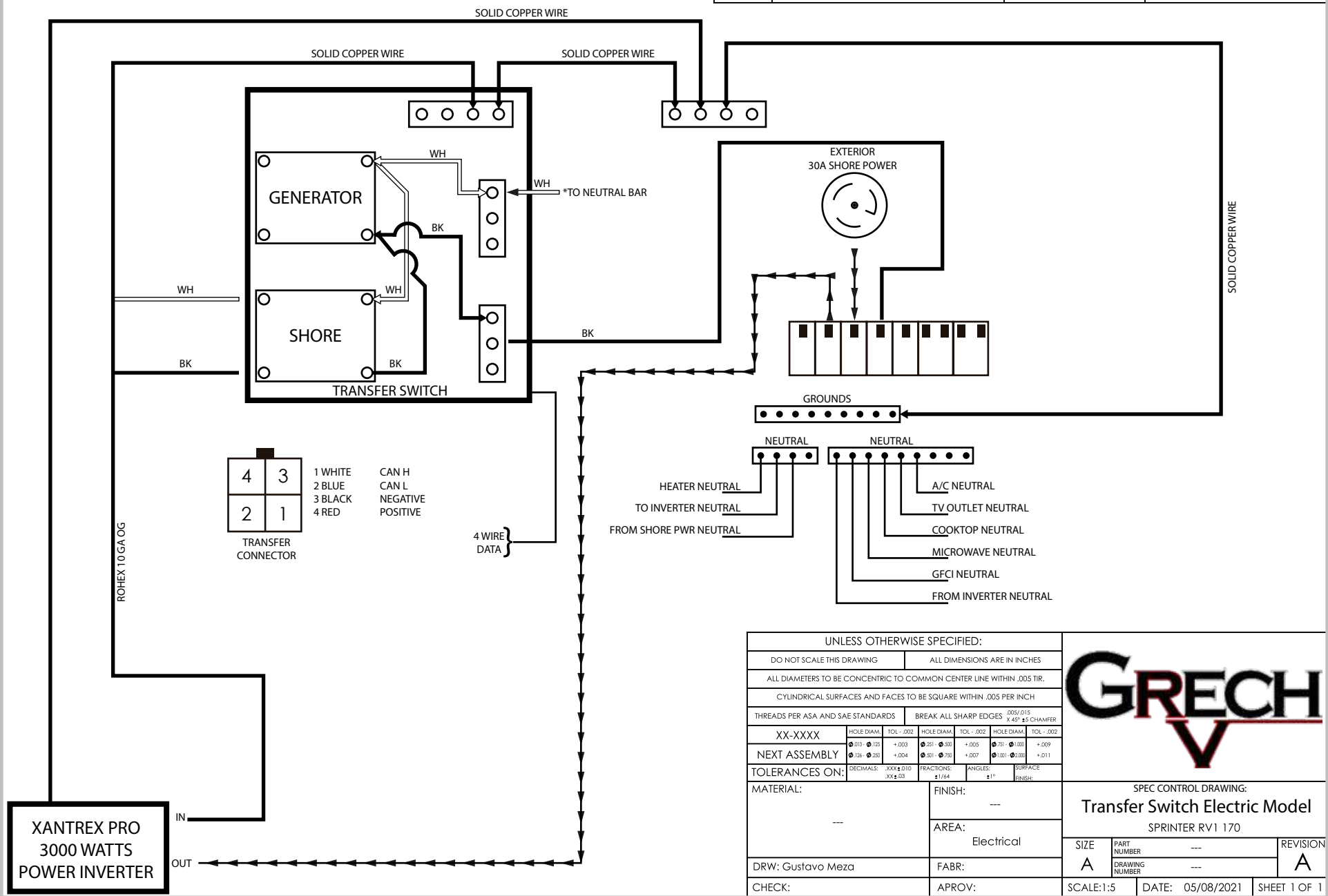

**XANTREX PRO  
3000 WATTS  
POWER INVERTER**

UNLESS OTHERWISE SPECIFIED:							
DO NOT SCALE THIS DRAWING				ALL DIMENSIONS ARE IN INCHES			
ALL DIAMETERS TO BE CONCENTRIC TO COMMON CENTER LINE WITHIN .005 TIR.							
CYLINDRICAL SURFACES AND FACES TO BE SQUARE WITHIN .005 PER INCH							
THREADS PER ASA AND SAE STANDARDS				BREAK ALL SHARP EDGES .005/.015 1/4" & 5/8" CHAMFER			
XX-XXXX		HOLE DIAM.	TOL -.002	HOLE DIAM.	TOL -.002	HOLE DIAM.	TOL -.002
NEXT ASSEMBLY		Ø.013 - Ø.175	+0.003	Ø.201 - Ø.300	+0.005	Ø.751 - Ø.100	+0.009
TOLERANCES ON:		Ø.126 - Ø.200	+0.004	Ø.301 - Ø.750	+0.007	Ø.1001 - Ø.100	+0.011
		DECIMALS: .XXX ± 0.10 XX ± 0.03	FRACTIONS: ± 1/64	ANGLES: ± 1°	SURFACE FINISH:		
MATERIAL: ---				FINISH: ---			
				AREA: Electrical			
DRW: Gustavo Meza				FABR: ---			
CHECK: ---				APROV: ---			



SPEC CONTROL DRAWING:			
<b>Transfer Switch Electric Model</b>			
SPRINTER RV1 170			
SIZE	PART NUMBER	REVISION	
A	---	A	
SCALE: 1:5	DATE: 05/08/2021	SHEET 1 OF 1	

6 5 4 3 2 1

THE INFORMATION DISCLOSED ON THIS DRAWING IS PROPRIETARY. IT IS ISSUED FOR ENGINEERING USE ONLY AND MAY NOT REPRODUCED OR DISCLOSED, IN WHOLE OR IN PART, TO ANYONE WITHOUT THE DIRECT WRITTEN PERMISSION OF GRECH MOTORS LLC. PARTS OR TOOLS MANUFACTURED TO MEET THE REQUIREMENTS OF THIS DRAWING MAY NOT BE USED BY OR SOLD TO ANYONE WITHOUT THE DIRECT WRITTEN PERMISSION OF GRECH MOTORS LL.

REVISION HISTORY			
REV	DESCRIPTION	DATE	APPROVED

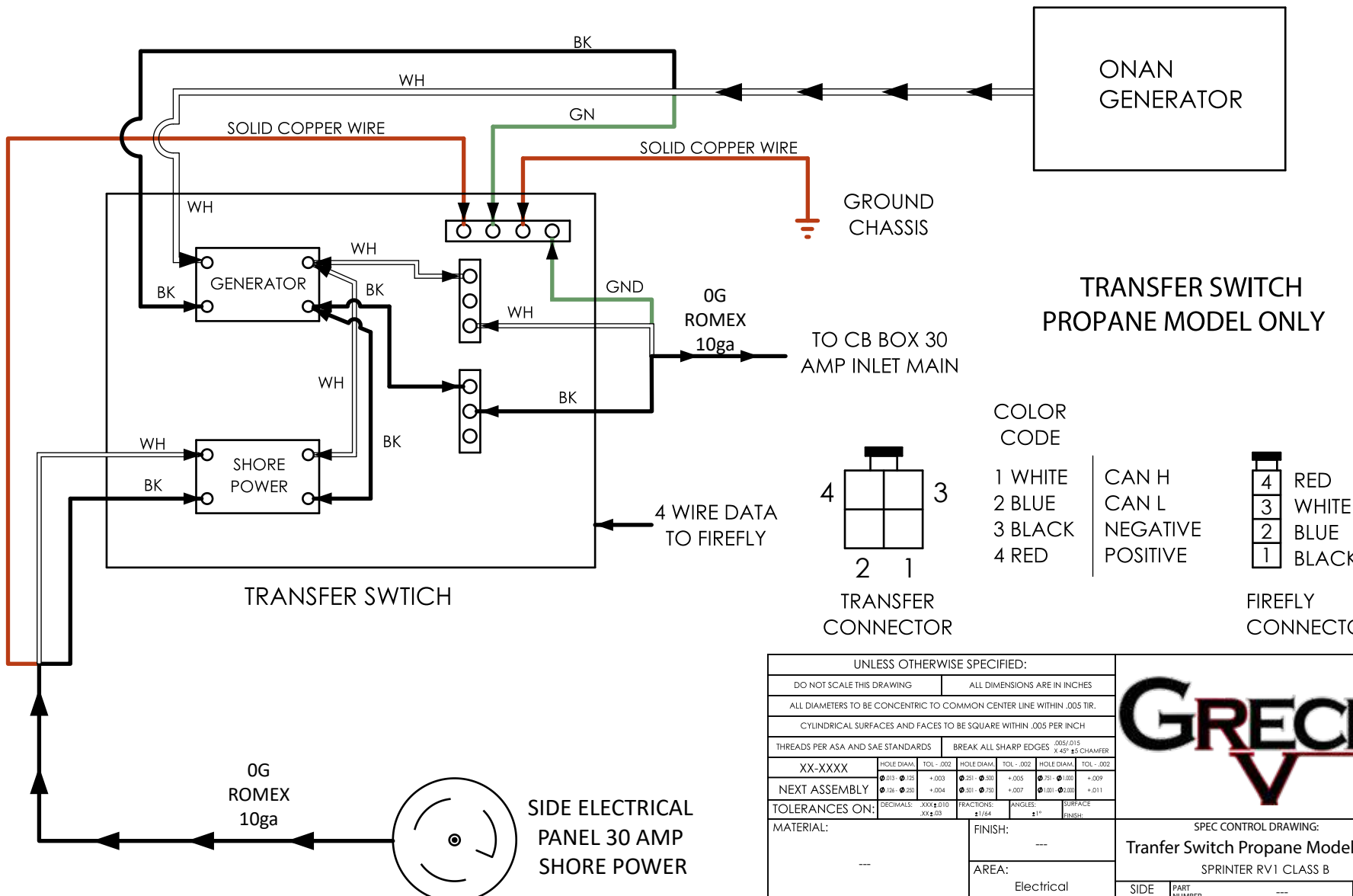

**TRANSFER SWITCH PROPANE MODEL ONLY**

COLOR CODE

1 WHITE	CAN H	4 RED
2 BLUE	CAN L	3 WHITE
3 BLACK	NEGATIVE	2 BLUE
4 RED	POSITIVE	1 BLACK

TRANSFER CONNECTOR

FIREFLY CONNECTOR

UNLESS OTHERWISE SPECIFIED:										
DO NOT SCALE THIS DRAWING	ALL DIMENSIONS ARE IN INCHES									
ALL DIAMETERS TO BE CONCENTRIC TO COMMON CENTER LINE WITHIN .005 TIR.										
CYLINDRICAL SURFACES AND FACES TO BE SQUARE WITHIN .005 PER INCH										
THREADS PER ASA AND SAE STANDARDS	BREAK ALL SHARP EDGES .005/.015 R.49° ±.5° CHAMFER	<p>SPEC CONTROL DRAWING: Transfer Switch Propane Model Only SPRINTER RV1 CLASS B</p> <table border="1"> <tr> <td>SIDE</td> <td>PART NUMBER</td> <td>---</td> <td rowspan="2">REVISION</td> </tr> <tr> <td>DRW:</td> <td>DRAWING NUMBER</td> <td>---</td> </tr> </table>		SIDE	PART NUMBER	---	REVISION	DRW:	DRAWING NUMBER	---
SIDE	PART NUMBER			---	REVISION					
DRW:	DRAWING NUMBER			---						
XX-XXXX	HOLE DIAM. TOL - .002			HOLE DIAM. TOL - .002	HOLE DIAM. TOL - .002					
NEXT ASSEMBLY	Ø.013 - Ø.125 +.003	Ø.251 - Ø.500 +.005	Ø.751 - Ø.100 +.009							
TOLERANCES ON:	DECIMALS: .XXX ±.010 XX ±.03	FRACTIONS: ±1/64	ANGLES: ±1° SURFACE FINISH: ---							
MATERIAL:	FINISH: ---		<table border="1"> <tr> <td>APROV:</td> <td>SCALE: 1:20</td> <td>DATE: 19/07/2021</td> <td>SHEET 1 OF 1</td> </tr> </table>	APROV:	SCALE: 1:20	DATE: 19/07/2021	SHEET 1 OF 1			
APROV:	SCALE: 1:20	DATE: 19/07/2021		SHEET 1 OF 1						
---	AREA: Electrical									
FABR:	FABR:									
CHECK:	APROV:									

THE INFORMATION DISCLOSED ON THIS DRAWING IS PROPRIETARY. IT IS ISSUED FOR ENGINEERING USE ONLY AND MAY NOT REPRODUCED OR DISCLOSED, IN WHOLE OR IN PART, TO ANYONE WITHOUT THE DIRECT WRITTEN PERMISSION OF GRECH MOTORS LLC. PARTS OR TOOLS MANUFACTURED TO MEET THE REQUIREMENTS OF THIS DRAWING MAY NOT BE USED BY OR SOLD TO ANYONE WITHOUT THE DIRECT WRITTEN PERMISSION OF GRECH MOTORS LL.

REVISION HISTORY

REV	DESCRIPTION	DATE	APPROVED
A	CREATION OF DRAWING	16/08/21	

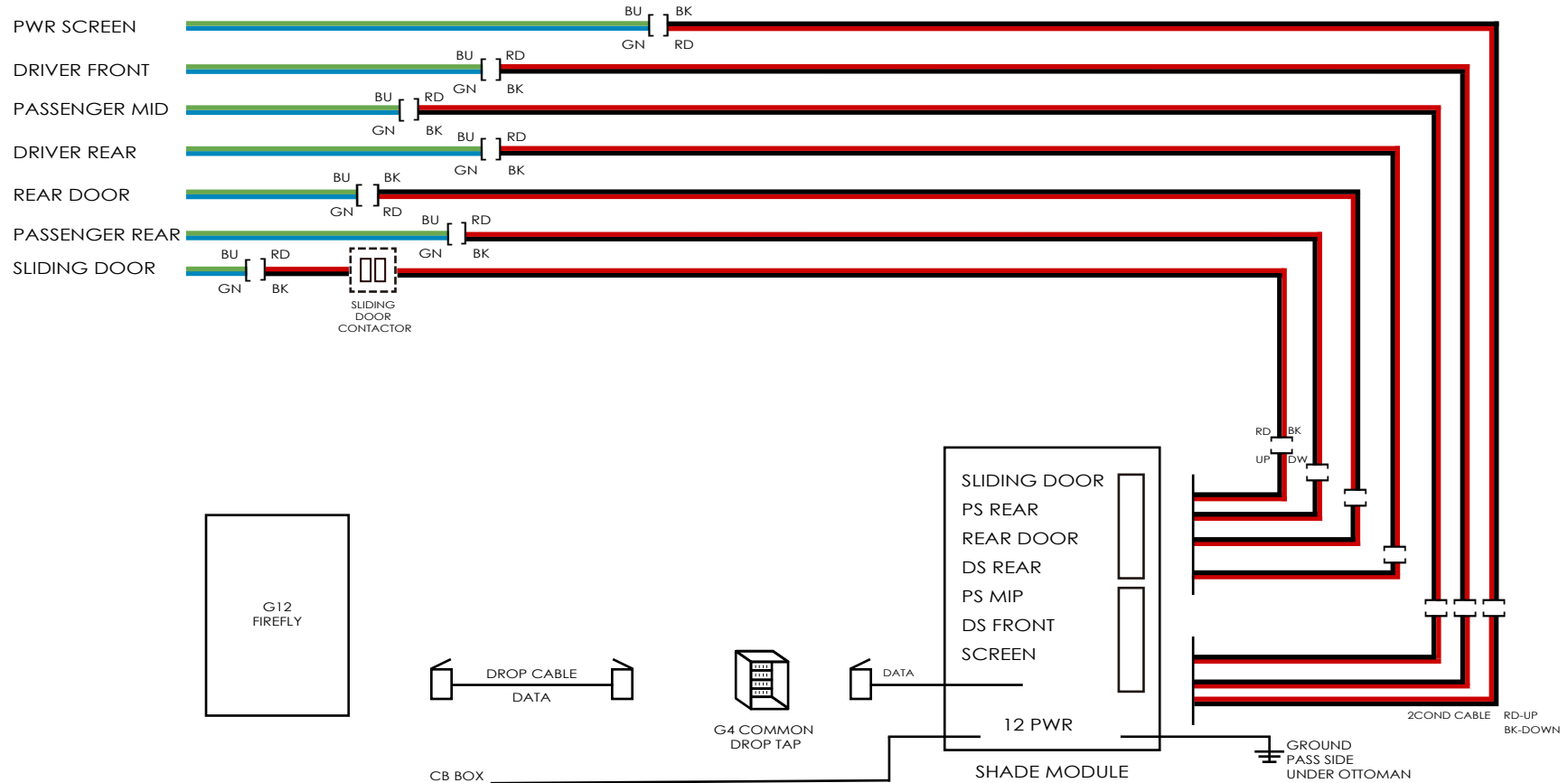

CB BOX FUSE #10  
15 AMP / SHADE MODULE / SEELEVEL

UNLESS OTHERWISE SPECIFIED:						
DO NOT SCALE THIS DRAWING			ALL DIMENSIONS ARE IN INCHES			
ALL DIAMETERS TO BE CONCENTRIC TO COMMON CENTER LINE WITHIN .005 TIR.						
CYLINDRICAL SURFACES AND FACES TO BE SQUARE WITHIN .005 PER INCH						
THREADS PER ASA AND SAE STANDARDS			BREAK ALL SHARP EDGES .005/.015 R.49° ±5° CHAMFER			
XX-XXXX	HOLE DIAM.	TOL - .002	HOLE DIAM.	TOL - .002	HOLE DIAM.	TOL - .002
NEXT ASSEMBLY	Ø.013 - Ø.175	+ .003	Ø.201 - Ø.300	+ .005	Ø.751 - Ø.100	+ .009
	Ø.126 - Ø.200	+ .004	Ø.301 - Ø.750	+ .007	Ø.1001 - Ø.100	+ .011
TOLERANCES ON:	DECIMALS: XXX ± 0.10 XX ± 0.03	FRACTIONS: ± 1/64	ANGLES: ± 1°	SURFACE FINISH:		
MATERIAL:	---		FINISH: ---			
	---		AREA: Electrical			
DRW: Gustavo Meza	FABR:		---			
CHECK:	APROV:		---			



SPEC CONTROL DRAWING			
Window Shade Module			
SPRINTER RV1 170			
SIZE	PART NUMBER	---	REVISION
A	DRAWING NUMBER	---	A
SCALE: 1:5	DATE: 05/08/2021	SHEET 1 OF 1	

FIREFLY  
INTEGRATIONS



# VEGATOUCH

Grech Motors Sprinter V3



**Imagination ~ Innovation ~ Integration**

1013 Elroy Drive, Middlebury, Indiana 46540 (574) 825-4600

# Grech Motors Sprinter V3 Manual

All information contained in this document is subject to change without notice.

2	Table of Contents
3	Screen Navigation
4	Home
6	Lights
7	Electrical Settings
8	Auto Gen Start (AGS)
9	Inverter/Charger
10	Climate
12	Shades
13	Settings
14	Settings/Network Diagnostics
16	Overcurrent Detection
17	Settings/Mobile App
18	Vegatouch Mira Setup
22	G12 Control Panel
23	Networking
24	Network Status Indicators
25	Mira NET LED Status Key
26	System Diagrams





---

## Screen Navigation

---

This system utilizes a 7" Lyra and a 5" Lynx touchscreens. Although they share much of the same functionality, please note that the Lyra screen should be considered the primary touchscreen.

Tap any icon from the navigation menu to select your desired page. The currently selected page will always be listed in the top corner of the screen.



A red triangle will appear in the screen header whenever a fault condition is present. Tap the triangle to navigate to the Network Diagnostics screen for specific fault information.

The screenshot displays the GRECH control interface. At the top, a green header bar contains the word "HOME" on the left, a red triangle warning icon in the center, and the time "3:05PM" on the right. Below the header, the interface is divided into several sections. On the left, a vertical navigation menu lists "Home", "Lights", "AGS", "Climate", "Shades", and "Settings", each with a corresponding icon. The main area features the "GRECH" logo in large green letters. To the right of the logo, there are four water level indicators labeled "FRESH", "GREY", "BLACK", and "LP", each with a blue bar and a percentage sign. Below these are two buttons: "Water Pump" (blue) and "Tank Heaters" (green). In the center, there are two rows of controls: "ON" and "OFF" buttons for "Light Master", and "EXT" and "RET" buttons for "Awning". On the right side, there are "Start" and "Stop" buttons for "GEN Stopped 12.6Hrs House", a "12.2V" voltage indicator, and a "DISABLED" button for "AGS".

Follow the link to watch a short system overview video:

<https://youtu.be/mMFdN-suRkQ>

---

## Home

---

1

The Light Master controls all interior lights at once. When Light Master Off is pressed, it will remember which lights were on. Then, when Light Master On is pressed, it will only turn on the lights that are in memory. To turn on all lights again, press and hold Light Master On for at least one second.

\*Troubleshooting – Memory is rewritten each time Light Master Off is pressed. In the case that it is pressed twice in a row, it will remember that no lights were on and just touching Light Master On won't turn on any lights. Press and hold Light Master On to turn the lights back on. Note: Light Master On/Off buttons will always appear green and will not show feedback at any time.

2

Awning – Press and Hold EXT or RET to operate the Awning (Fiama Awning option enabled). If the Fiama option is disabled, Awning Stop will activate both the Extend and Retract circuits. If the Ignition Input is active, only Awning Retract will be functional no matter which options are selected.

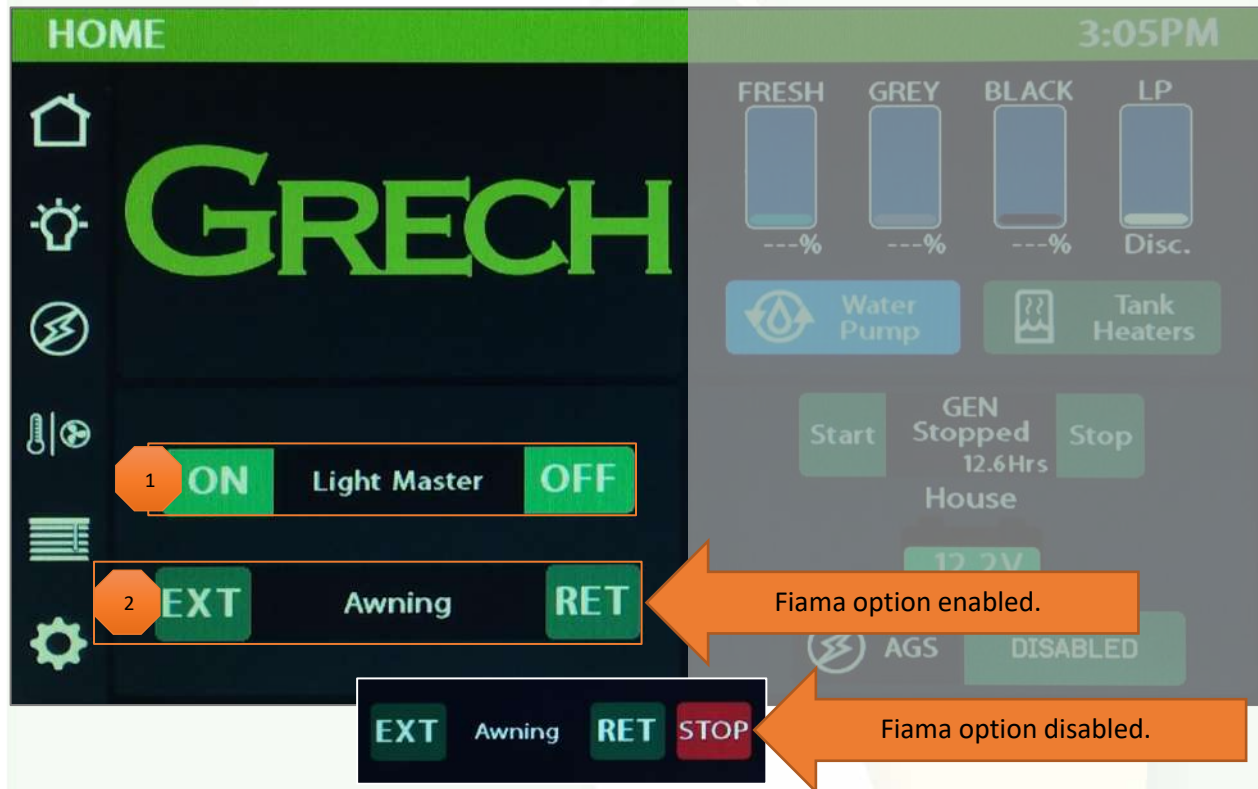

Note: The Grech logo above (7-inch screen) will disappear if the D/S Ottoman, P/S Ottoman or Sofa Ext/Ret options are selected.

These graphics represent the percentage filled for holding tanks and LP (currently disconnected).

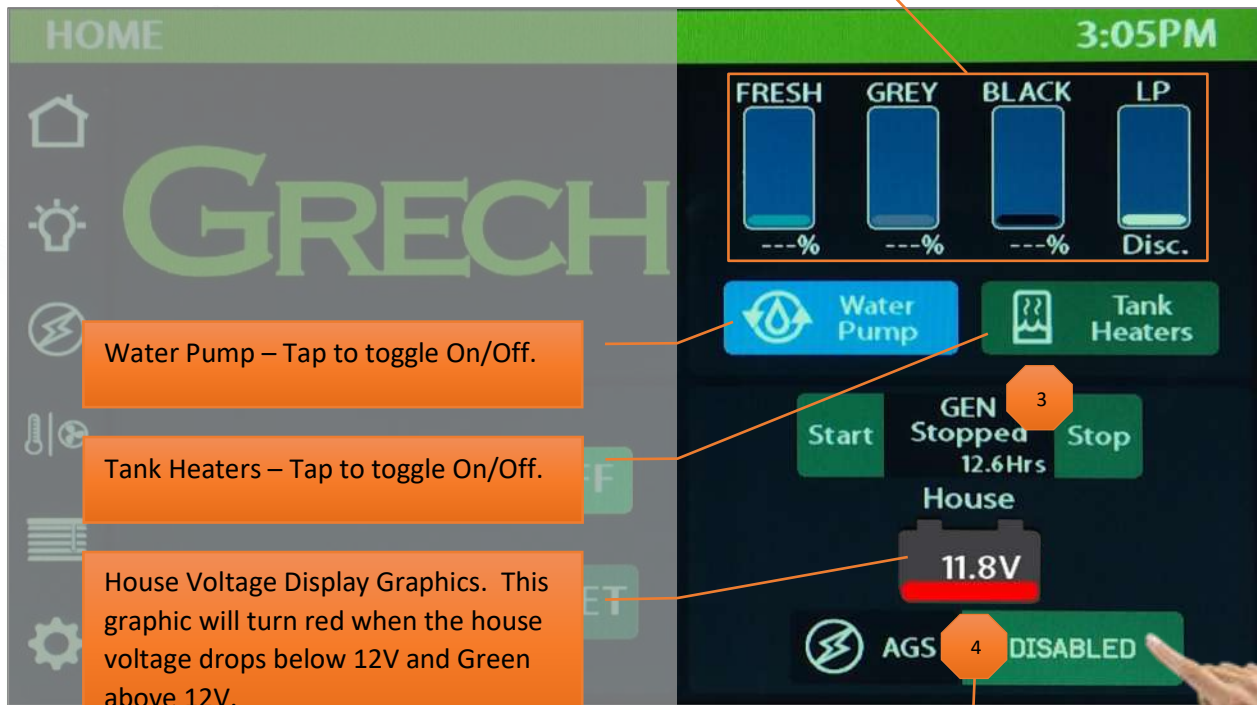

Water Pump – Tap to toggle On/Off.

Tank Heaters – Tap to toggle On/Off.

House Voltage Display Graphics. This graphic will turn red when the house voltage drops below 12V and Green above 12V.

### 3 Generator Controls

Gen Start – Press and Hold to Start to start the generator.

Gen Stop – Tap Stop to stop the generator.

The Generator display will show the total number of generator hours accumulated as well as the current operating status (running or stopped). Generator hours are saved to the system, not to the generator itself. Press and Hold the generator display hours for 5 seconds to access the Set Gen Hours screen. Use the keypad to enter your desired gen hours then press Yes to save and exit.

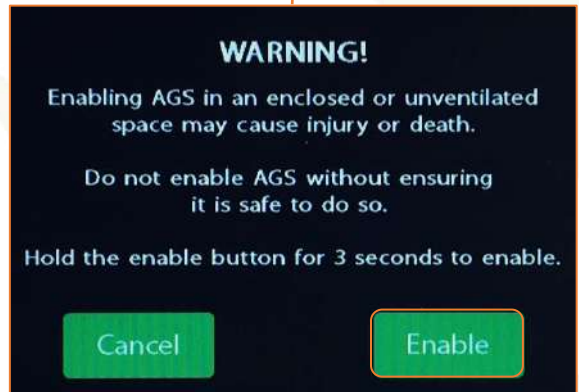
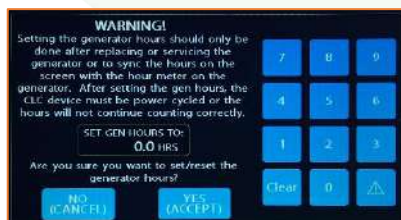

### 4 AGS

Tap to enable AGS. A warning screen will require action to enable (3 second hold).

AGS will be disabled:

- by any change of the state of the ignition.
- if there is any non-AGS (Manual) start or stop detected.
- If the set number of retries is reached without starting the generator.

---

## Lights

---

The Light Master controls all interior lights at once. When Light Master Off is pressed, it will remember which lights were on. Then, when Light Master On is pressed, it will only turn on the lights that are in memory. To turn on all lights again, press and hold Light Master On for at least one second.

\*Troubleshooting – Memory is rewritten each time Light Master Off is pressed. In the case that it is pressed twice in a row, it will remember that no lights were on and just touching Light Master On won't turn on any lights. Press and hold Light Master On to turn the lights back on and bring them to 100% brightness. Note: Light Master On/Off buttons will always appear green and will not show feedback at any time.



Lights with up/down arrows are dimmable. Press and hold these buttons to adjust the brightness up or down. Tap the buttons to toggle On/Off.



## Electrical Settings

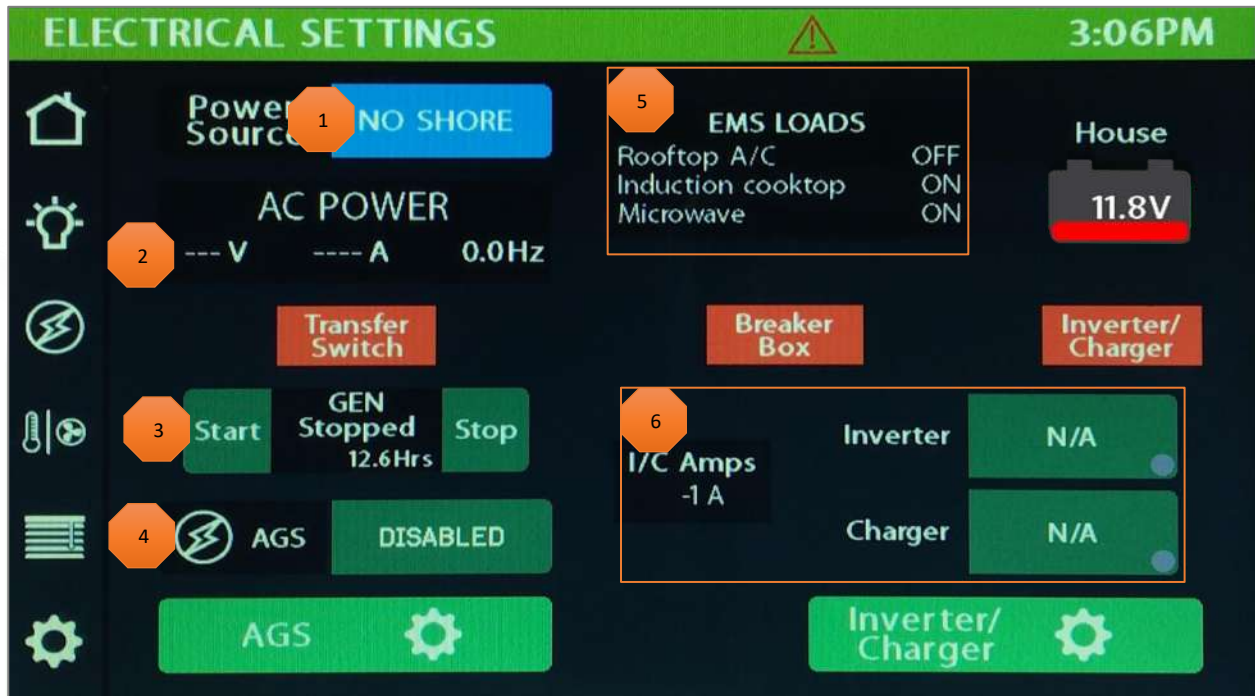

- 1 Power Source – Shore power display. Tap to select your required AC amps (30, 20 or 15).
- 2 Shore Line Display – AC power displays the voltage, amperage draw and frequency information.
- 3 Generator – Creates electrical energy.
- 4 AGS – Auto Gen Start is a system that will start the generator automatically based on your customized trigger settings. Press to Enable/Disable AGS. Only enable AGS if your coach is in a well-ventilated area.
- 5 Energy Management System (EMS) – EMS will ensure that power is available before allowing certain systems to run (excludes Premier 48V A/C). If power is not available, it will not allow particular systems to run (shed the load). The loads will shed in the following order:
  - Rooftop A/C
  - Cooktop
  - Microwave
- 6 Inverter/Charger Status – Status and controls to toggle the Inverter and Charger On/Off.



---

## Auto Gen Start Settings (AGS)

---



Tap to Enable/Disable AGS. A warning message will require action to Enable.

Trigger Options – Automatically start the generator using specified voltage settings (Low Volts) or based on climate energy needs (HVAC Load). At least one trigger must be selected or AGS will not operate (excludes Premier 48V A/C system).

Gen Hours - The number of hours that the generator has been used. These are saved to the system, not the generator itself. Press and Hold (5 sec) to adjust hours.

Quiet Time Start - Use the +/- buttons to select the starting point for Quiet Time, the hours that your generator will not run in an effort to reduce noise.

Quiet Time Stop - Use the +/- buttons to select the stopping point for Quiet Time. AGS will work normally at this point.

Start at Volts - The generator will start when the voltage drops to this set point depending on “Time at Start Volts” setting below. (Range 10.5v – 12.5v)

Time at Start Volts - The generator will start when the voltage drops to the Start at Voltage for this specific amount of time. (Range 5 seconds – 1 minute)

Stop at Volts - The generator will shut off when the voltage reaches this set point depending on “Time at Stop Volts” setting below. (Range 13.2v – 14.5v)

Time at Stop Volts - The amount of time required for the voltage to remain at “Stop at Volts” level before the generator shuts off. (Range 5min – 120min)

Maximum Gen Run Time - Use the +/- buttons to set the maximum amount of time that your generator will run once it has started. (Range 120min – 240min)

Gen Start Retries - Use the +/- buttons to set the number of tries that your generator will retry to start. (Range 1-5 retries)

## Inverter/Charger Settings

The Inverter/Charger settings screen pages will show the status of the Inverter/Charger and will list any current I/C faults. Individual settings can be adjusted by tapping on the Xantrex Controls button and adjusting each setting as desired. Tap Reset to Defaults to reset all settings back to factory default. Please see your inverter's user manual for operating instructions.



1 Xantrex Controls – Navigate to this page to set your specific inverter values. Tap Reset to Defaults to return all inverter settings back to Grech default settings. Please see your inverter's user manual for operating instructions.

---

## Climate

---

- 1 Set Temp – Tap the arrows to select your desired temperature.
- 2 Current Temp – The current temperature in the coach.
- 3 Mode Display – The currently selected climate control mode will be represented by a graphic (Blue Snowflake, Red Flame or a White Fan). The climate graphic will also show a White Letter (H or L) to represent the current fan speed (high or low).
- 4 Mode Selector – Tap a climate button to select your desired climate mode. Note: The Set Temp must be higher than the current temp for Furnace to work, and lower than the current temp for Air Conditioning to work. Auto mode will run whichever mode is necessary to keep the temperature consistent. When the set point reaches 3 degrees difference from the current temp, the heat or cool circuits will turn on. At that point, the fan speed will increase automatically for every additional 2 degrees of difference.
- 5 Fan Speeds – Tap to select a fan speed. The fan speed (Auto Fan Mode) will increase as the difference between the Set Temp and the Current Temp increases. Auto Fan Mode will be disabled if a specific fan speed is chosen. Note – If Premier 48V A/C is enabled, a Medium fan speed button will be displayed as well.

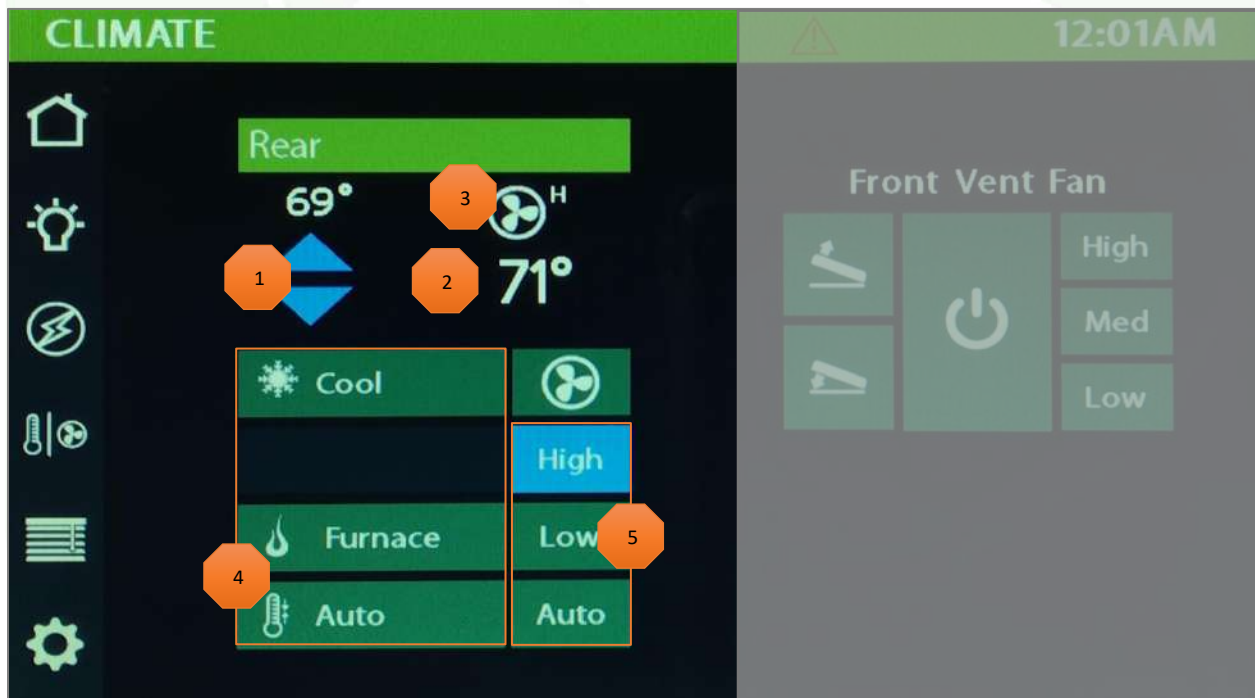

Tap the buttons below to operate a Vent fan.

Tapping the Lid Up button will open the fan without powering up the fan.

Tapping Power (ON) will raise the lid, power up the fan and bring it to medium speed. Tapping Power again (OFF) will power down the fan but will not lower the lid.

Tapping the Lid Down button will close the lid and power down the fan.

Tap the speed buttons to manually select your desired fan speed.

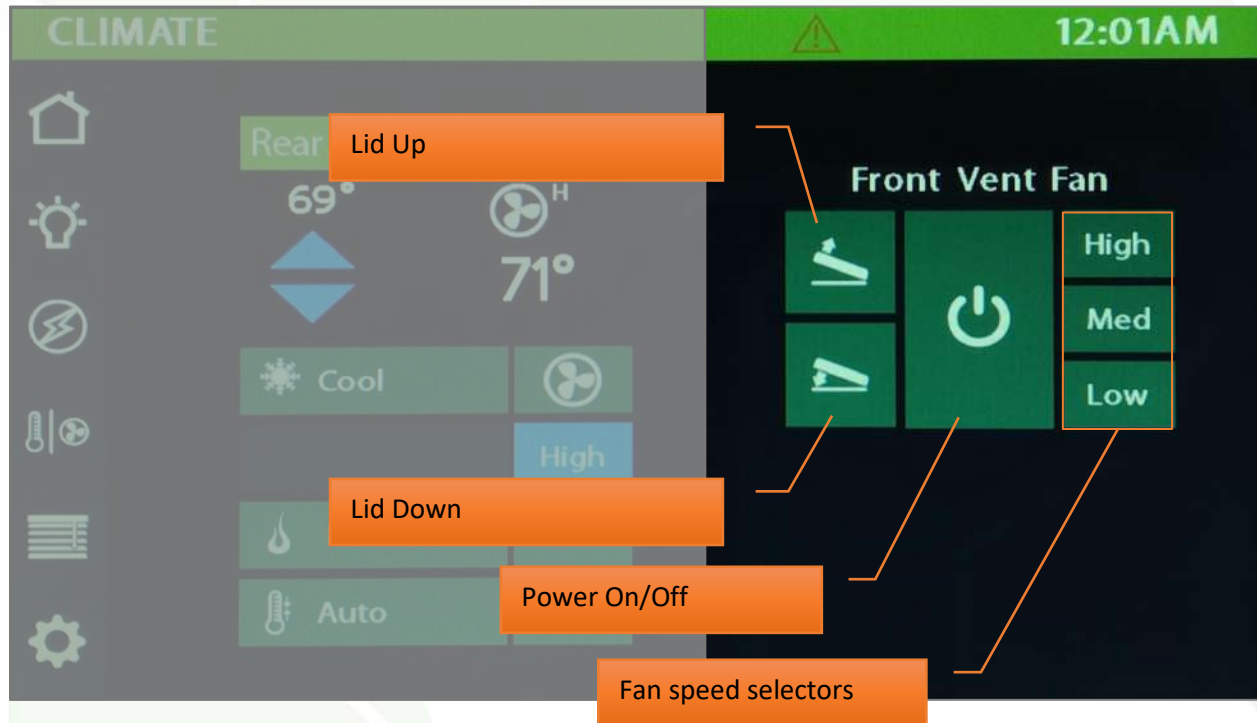

---

## Shades

---

Tap the arrows to operate a single shade or tap shade master to run all associated shades up or down. Tap the arrows a second time if you prefer not to fully raise/lower the shades, but instead want to stop their travel immediately.

Power Screen – Tap the arrows to raise or lower the power screen.

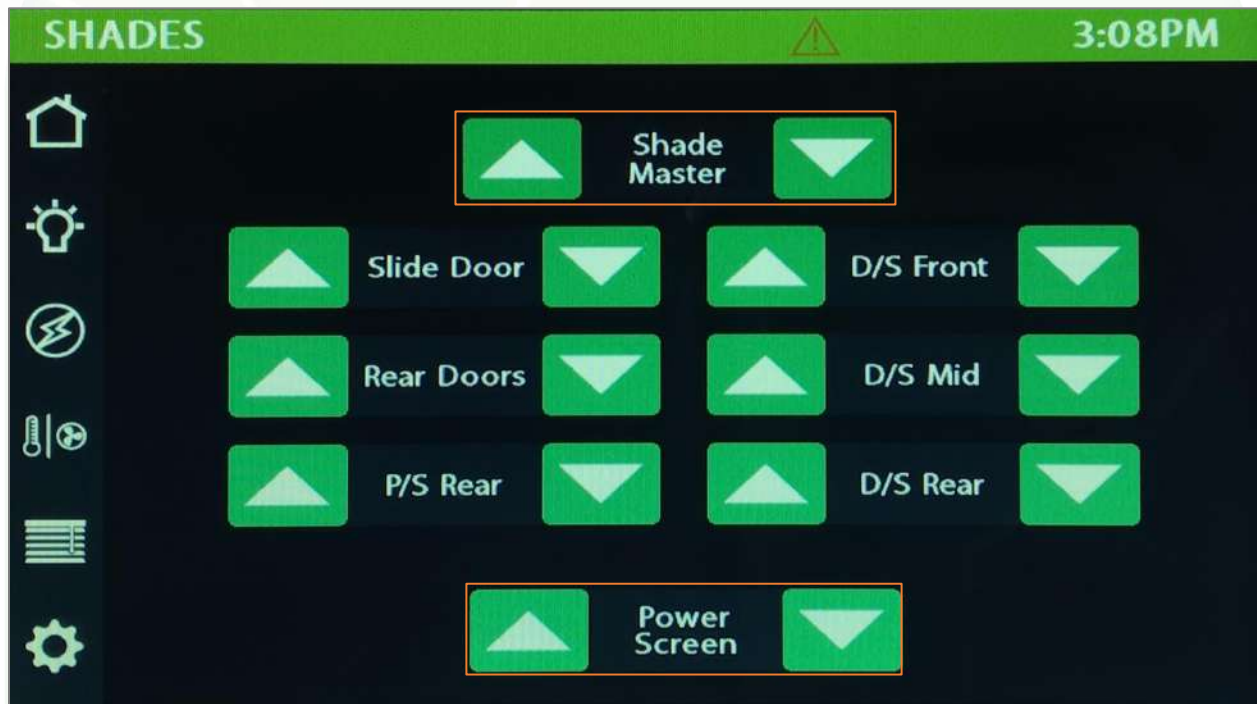



---

## Settings

---



1 Drag the slider to select screen brightness.

2 When Auto Dimming is enabled, the screen will enter sleep mode after 60 seconds of inactivity. Tap anywhere on the screen to wake it up. Please note that even if Auto Dimming has been disabled, the screen will still enter sleep mode after 15 minutes of inactivity.

3 Tap to disable the touchscreen for 15 seconds for the purpose of disinfecting.

4 Floorplan display.

5 Tap to change the temperature units display between Fahrenheit and Celsius.

6 Tap to navigate to the Mobile App connection screen.

7 Tap to navigate to the Network Diagnostics screen.

8 Tap to set the time or select 24-hour mode.

**Please note the technical information at the bottom of the screen before calling Technical Support.**

## Settings/Network Diagnostics

**NETWORK DIAGNOSTICS** 3:09PM

**G12**

STATUS ●  
FIRMWARE: 1.2g  
CONFIG: 3.15

**FAULTS**

AirCon 1 coil temperature invalid (no thermistor).

**G12 INPUTS**

IN 6 - IGNITION (12V) ●  
Generator (12V) ●

Faults G12 Outputs Roof

*Note: An orange arrow labeled 'Current Faults' points to the fault message.*

**NETWORK DIAGNOSTICS** 3:09PM

**G12**

STATUS ● **Online**  
FIRMWARE: 1.2g  
CONFIG: 3.15

**G6 INPUTS**

IN 6 - IGNITION (12V) ● **Active Input**  
Generator (12V) ●

**G6 OUTPUTS**

01 - OTTOMAN EXT ●  
02 - D/S OTTOMAN RET ●  
03 - P/S OTTOMAN EXT ●  
04 - P/S OTTOMAN RET ●  
05 - SOFA DOWN ●  
06 - SOFA UP ●  
07 - AWNING EXT ●  
08 - AWNING RET ●  
09 - AWNING EXT ●  
10 - AWNING RET ●  
11 - COOK TOP SHED ●  
12 - MICROWAVE SHED ●  
13 - FIAMA AWNING EXT ●  
14 - FIAMA AWNING RET ●  
15 - OTTOMAN EXT ●  
16 - OTTOMAN RET ●  
17 - P/S OTTOMAN EXT ●  
18 - P/S OTTOMAN RET ●  
19 - GENERATOR START ●  
20 - GENERATOR STOP ●  
21 - CEILING LTS ●  
22 - BATHROOM LTS ●  
23 - PORCH LTS ●  
24 - AWNING LTS ●  
25 - CEILING ACCENT LTS ●  
26 - COMPARTMENT LTS ●  
27 - GALLEY LTS ●  
28 - READING LTS ●  
29 - FLOOR LTS ●  
30 - FURNACE ●  
31 - COMPARTMENT LTS ●  
32 - GALLEY LTS ●  
33 - READING LTS ●  
34 - FLOOR LTS ●  
35 - FURNACE ●  
36 - GALLEY LTS ●  
37 - READING LTS ●  
38 - FLOOR LTS ●  
42 - FURNACE ●

Faults G12 Outputs Roof

*Note: An orange arrow labeled 'Active Output' points to the 'Active Output' label.*

# NETWORK DIAGNOSTICS

3:10PM

**Aircon** →

AIRCON 1	
STATUS	●
FW Version	6.11
Config Revision	1.15
COMPRESSOR	●
FAN HIGH	●
FAN LOW	●
COIL TEMP STATUS	●
COIL FREEZE ACTIVE	●

← **Vent Fan**

VENT FAN 1	
STATUS	●
FW Version	6.11
Config Revision	1.13
OPENING	●
CLOSING	●
FAN HIGH	●
FAN MED	●
FAN LOW	●
RAIN SENSOR	●

Faults   G12 Outputs   Roof



## Overcurrent Detection



If an output on the G12 experiences an overcurrent fault, a lightning bolt graphic will appear at the top of the screen. Tapping the Lightning Bolt graphic will result in a Warning screen with a brief set of instructions. From this screen, tap Continue to navigate to the Diagnostics screen.

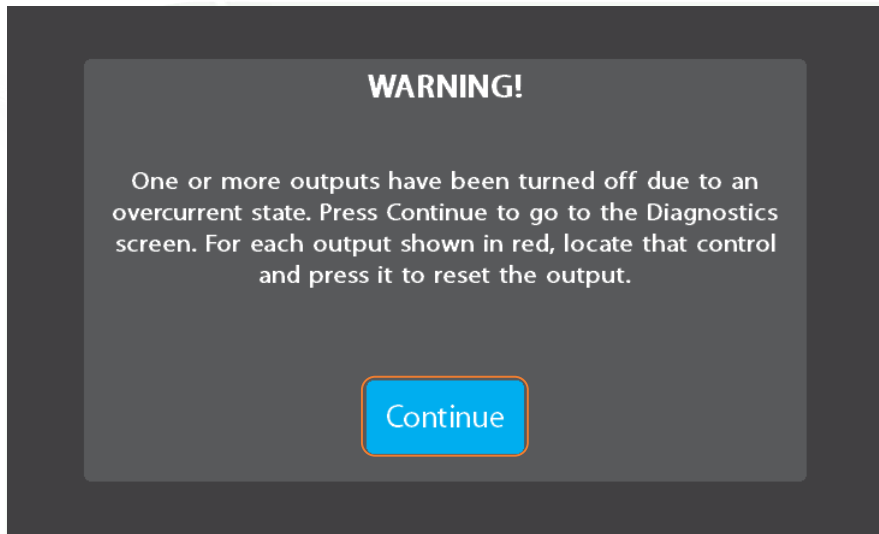

The Diagnostics screen will use red lights to alert you of overcurrent detections. To clear the faults, navigate to each faulted control and tap them to reset. Note – you'll notice that their buttons have turned red and will remain that way until cleared.

If the fault persists, there is likely a fault in the wiring or load on the circuit that must be resolved.

**NETWORK DIAGNOSTICS** 3:09PM

G12	G6 OUTPUTS
STATUS ●	01 - D/S OTTOMAN EXT ●
FIRMWARE: 1.2g	02 - D/S OTTOMAN RET ●
CONFIG: 3.15	03 - P/S OTTOMAN EXT ●
	04 - P/S OTTOMAN RET ●
	05 - SOFA DOWN ●
	06 - SOFA UP ●
	07 - TANK HEATERS ●
	08 - WATER PUMP ●
	09 - AWNING EXT ●
	10 - AWNING RET ●
	12 - COOK TOP SHED ●
	13 - MICROWAVE SHED ●
	14 - FIAMA AWNING EXT ●
	15 - FIAMA AWNING RET ●
	19 - GENERATOR START ●
	20 - GENERATOR STOP ●
	21 - CEILING LTS ●
	22 - BATHROOM LTS ●
	23 - PORCH LTS ●
	24 - AWNING LTS ●
	25 - OUTSIDE STEP LTS ●
	26 - ACCENT LTS ●
	27 - CEILING ACCENT LTS ●
	31 - COMPARTMENT LTS ●
	36 - GALLEY LTS ●
	37 - REA ●
	38 - FLO ●
	42 - FUR ●

**G6 INPUTS**

- IN 6 - IGNITION (12V) ●
- Generator (12V) ●

**LIGHTS**

- Home
- Lightbulb
- Lightbulb (Red) - Ceiling

RED = Overcurrent Fault

Tap to reset

---

## Settings/Mobile App

---

Vegatouch Mira is a wireless control module that easily connects to any Android or iOS device to give total control to many electrical, electronic and mechanical systems in your coach. Pair any device with the coach's built-in interface to monitor and control many coach components.

**MOBILE APP** 1:39AM

Download the Vegatouch Mira app from Google Play Store or the App Store.

Mira ID:  
**Mira: 180427**

Mira PIN:  
**777777**

[Reset PIN to Default](#)



---

## Vegatouch Mira Setup

---

**Notice: Make sure that Bluetooth is turned ON in your smart device settings before proceeding.**

### Locate the Login Information:

The login information can be found by clicking on the Mobile App button on the settings page of the front touchscreen or the Mira module's label.



### Download:

Download Vegatouch Mira from the Google Play store or the App Store. Once the download has finished, install the app and open it.

### Setup:

Tap SCAN to find the Mira Module's signal. After scanning, any Mira Module in your area will appear on the screen. Tap the ID # that matches the one on your Mira label. Enter the PIN number from the Mira label and press AUTHENTICATE to connect to the system.

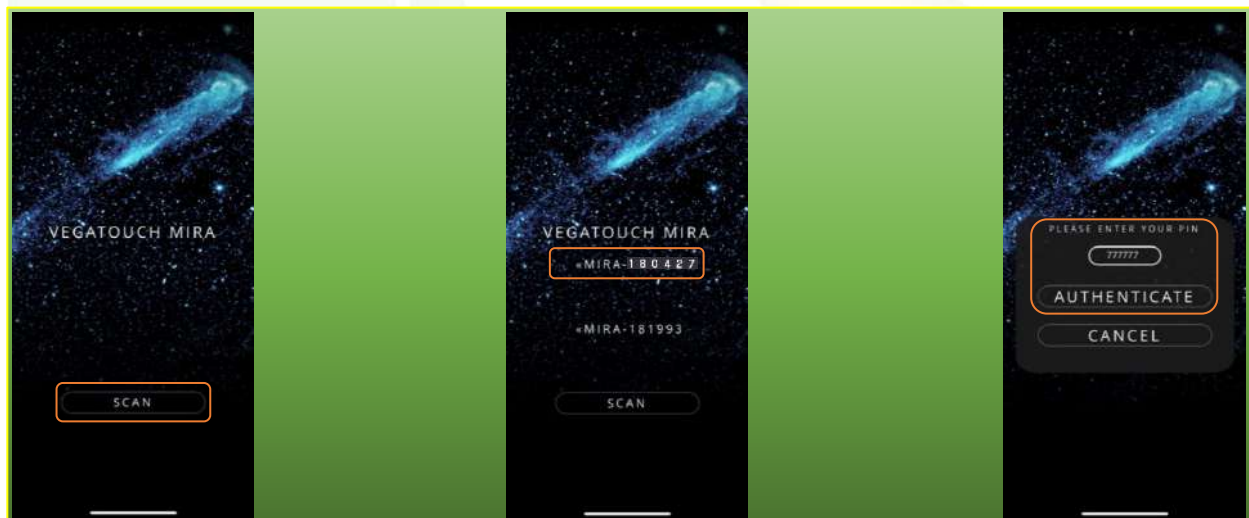

## Notice: iOS Setup Tips

Turn on Bluetooth to allow Vegatouch Mira to connect to Accessories.

If you do not have Bluetooth turned ON in your iOS settings you will see this screen. Do not click OK, you must click SETTINGS. Your Bluetooth Settings page will now appear and you should turn Bluetooth ON.

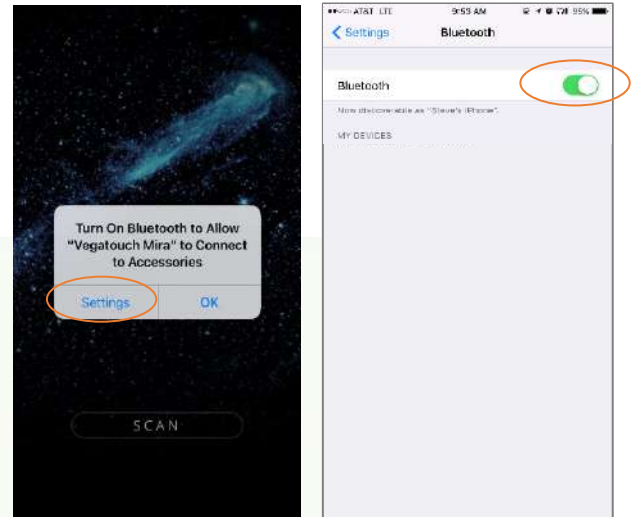

## Location Services Required

To enable Location Services on your Apple device:

1. Go to settings/Privacy/Location Services.
2. Make sure that Location Services is ON.
3. Scroll down to find your app.
4. Tap the app and select "Always allow access to your location".

## Notice: Android Setup Tips

Allow Vegatouch Mira to access this device's location.

Mira will need to be allowed access to your location. Click ALLOW when you see this screen.

To enable Location Services on your Android device:

1. Open your phone's Settings app.
2. Tap Location/App Permission  
-If you don't see "Location" tap Security & Location/Location.  
-If you have a work profile, tap Advanced/Location.
3. Under "Allowed all the time" and "Allowed only while in use" view the apps that can use your phone's location, tap it, then choose the location access for the app.
4. To change the App's permissions, tap it, then choose the location access for the app.

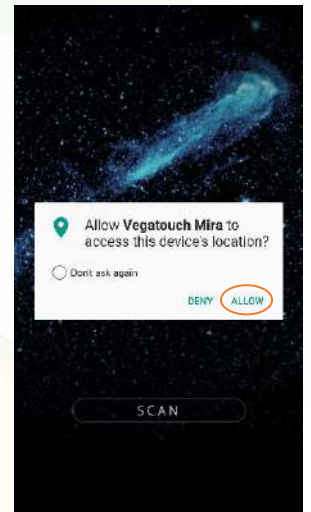

## App Settings:

Access the App Settings page by tapping the triangle (at the bottom of the screen) to expose the Settings button. Tap the gear to visit the settings page.

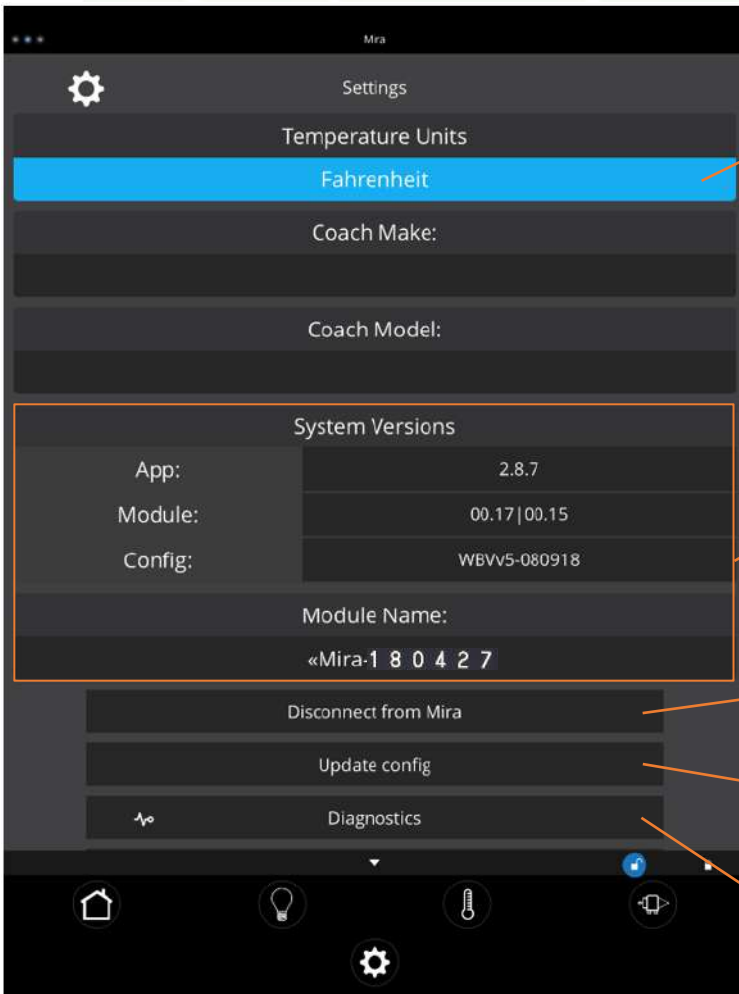
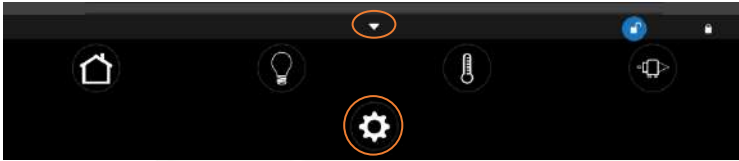

Tap the Temperature Units selection to choose between Fahrenheit and Celsius.

System Information and Mira Name.

Tap to disconnect your device from Mira.

Tapping Update Config will force a download of the config from the cloud.

Tap to enter the Diagnostic Tools screen.

## Diagnostic Tools:

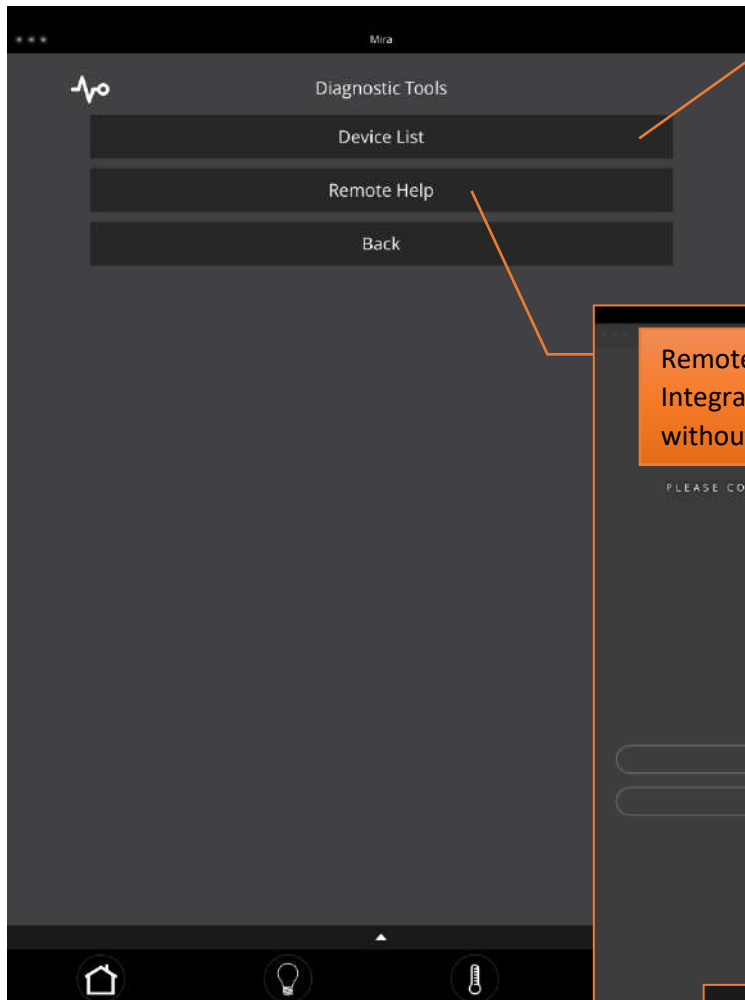

Tap to display a list of currently connected devices.

Remote Help is available by calling Firefly Integrations. Do not enable remote help without consultation.

PLEASE CONTACT TECH SUPPORT BEFORE ENABLING REMOTE HELP  
EMAIL: SUPPORT@FIREFLYINT.COM  
PHONE: 374-825-4600

VEGATOUCH MIRA  
REMOTE HELP

SESSION: 729-033-021

ENABLE REMOTE HELP

CANCEL

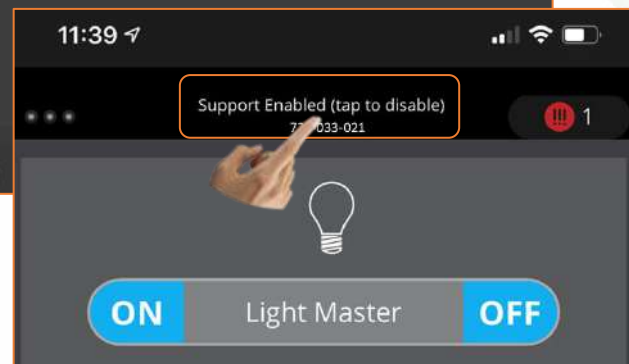

### Remote Help:

If instructed by Firefly, tap Enable Remote Help for advanced technical support. Once enabled, provide the Session ID to allow Firefly to remotely connect to your Mira app (internet connection required). To disable Remote Help, simply tap the Session ID number from the Home page of your Mira app.

## G12 DC Panel

Your G12 control panel is the power distribution center for the coach. This panel receives the signals sent from your switch panels and performs the actions that have been requested by activating and deactivating the required circuits.

Every circuit controlled by the G12 is numbered and listed on a black label (load list) which is usually mounted next to the G12 panel. Troubleshooting Example - If you press the Ceiling Accent lights button on your touchscreen screen and the lights don't come on, check the Network Diagnostics Page to see if the light for Output 27 shows status. If it does, you will want to check output voltage on that pin to make sure that the G12 is sending power to the lights (Fig 1).

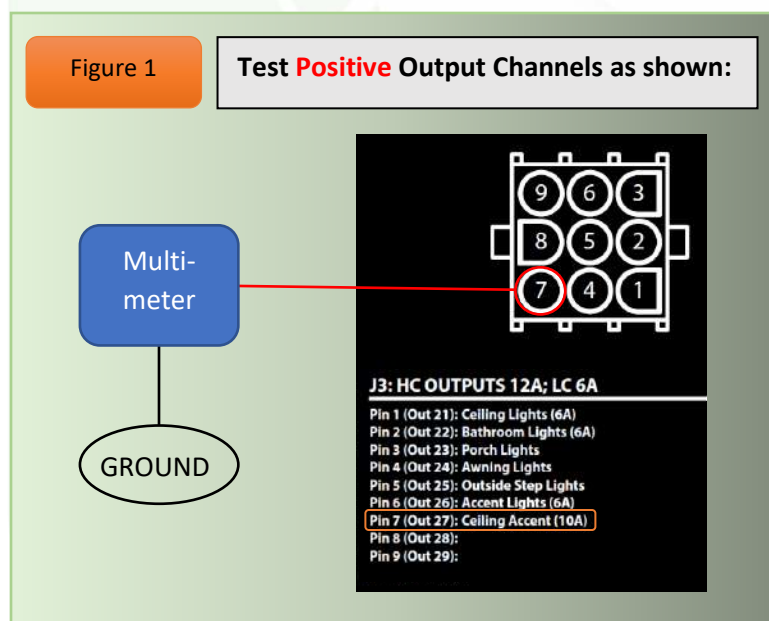
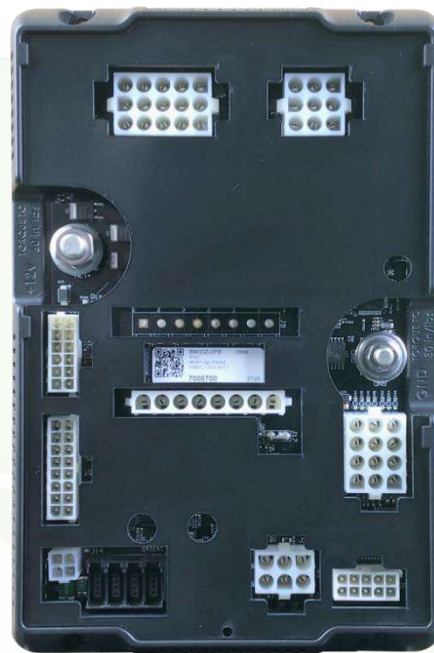



---

## Networking

---

Your distribution panel and touchscreens are connected via your coach's RV-C network. Each component will have a NET LED that is used to show network status. If a NET LED is displaying anything other than solid green and some of the panel's functions are not working, please contact your manufacturer for Technical Support.

### Net LED Locations:













---

## Network Status Indicators

---

Every component of the Firefly system uses an LED to communicate network status. Use the key below to determine the network status of your hardware. \*

### Panel Network Status Indicator – Applies to any device with a network indicator:

-  /  Fast flashing Green Light (4 times/sec) – Device is attempting to make initial connection.
-  /  Slow flashing Green Light (1 time/sec) – Device was online but has been offline for at least 5 sec.
-  Solid Green – Device is connected to network and is communicating properly.
-  Solid Red – Device has gone offline and is not connected to a network.
-  /  Alternating Red & Orange – Device has gone offline and is trying to re-connect (within 30 sec).
-  /  Alternating Green & Orange – Device is currently online but has gone offline 2 or more times.

\*Note: Mira modules use a different networking key. Please see the next page.

## Mira NET LED Status Key

The NET LED on your Mira module can change color in different situations. Use the following key to determine the operational status of your module.

	Off	Device has no power or has completely failed
	Fast flashing green (4 times/sec)	Device is attempting to make initial connection to the CAN network and good files
	Solid green	Device is operating correctly and has seen a CAN message in the past 5 seconds and good files
	Slow flashing green (1 time/sec)	Device was active on the CAN bus but has not seen a valid message in 5 seconds and good files
	Alternating red and yellow	Device has not seen CAN messages in 30 seconds and good files
	Alternating yellow and green	Device is currently active on the CAN bus but has not seen a CAN message within a 30s interval 2 for more times since the last power cycle and good files
	Solid red	Device has not seen a CAN message in the past 60 seconds and good files
	Fast alternating green and blue (4 times/sec)	Device is attempting to make initial connection to the CAN network and corrupted files
	Solid blue	Device is operating correctly and has seen a CAN message in the past 5 seconds and corrupted files
	Slow alternating green and blue (1 time/sec)	Device was active on the CAN bus but has not seen a valid message in 5 seconds and corrupted files
	Alternating red and blue	Device has not seen CAN messages in 30 seconds and corrupted files
	Alternating yellow and blue	Device is currently active on the CAN bus but has not seen a CAN message within a 30s interval 2 or more times during a power cycle and corrupted files
	Solid purple	Device has not seen a CAN message in the past 60 seconds and corrupted files
	Flashing white	Device pin is being reset
	Solid yellow	Device pin has been reset
	Flashing blue	Device does not have a valid application
	Flashing red (2 seconds)	Factory test: Red LED
	Flashing green (2 seconds)	Factory test: Green LED
	Flashing blue (2 seconds)	Factory test: Blue LED

# G12 Master

Log In:

Customer: GRECH Model: RV/SPRINTER Revision: 3V5  
 Raw Part: 7000700 G12 w/Probe Custom Part: Date: 02/17/2021 AG  
 Outputs: 1-44 Program Version: \_\_\_\_\_

J4: HIGH CURRENT OUTPUTS 12A; LOW CURRENT 6A				
Pin	Out	Load	AMP	O/C
1	30		4A	27s
2	31	COMPARTMENT LIGHTS(OPTION)	6A	27s
3	32		4A	27s
4	33		4A	27s
5	34		4A	27s
6	35		4A	27s
7	36	GALLEY LIGHTS(OPTION)	6A	27s
8	37	READING LIGHTS(OPTION)	4A	27s
9	38	FLOORLIGHTS(OPTION)	4A	27s
10	39		4A	27s
11	40		4A	27s
12	41		4A	27s
13	42	FURNACE(OPTION)	5A	27s
14	43		4A	27s
15	44		4A	27s

J3: HIGH CURRENT OUTPUTS 12A; LOW CURRENT 6A				
Pin	Out	Load	AMP	O/C
1	21	CEILING LIGHTS(DIM)(OPTION)	6A	27s
2	22	BATHROOM LIGHTS(DIM)(OPTION)	6A	27s
3	23	PORCH LIGHTS(DIM)(OPTION)	4A	27s
4	24	AWNING LIGHTS(DIM)(OPTION)	4A	27s
5	25	OUTSIDE STEP LIGHTS(DIM)(OPTI	4A	27s
6	26	ACCENT LIGHTS(DIM)(OPTION)	6A	27s
7	27	CEILING ACCENT(DIM)(OPTION)	10A	27s
8	28		4A	27s
9	29		4A	27s

J12: THERMISTORS	
Pin	Load
1	THERMISTOR1
2	
3	
4	
5	
6	
7	THERMISTOR1 GND
8	
9	
10	
11	
12	

J11: TANKS	
Pin	Load
1	(SEE LEVEL: FRESH TANK)
2	(SEE LEVEL: GREY TANK)
3	(SEE LEVEL: BLACK TANK)
4	
5	
6	
7	
8	
9	
10	
11	
12	
13	
14	
15	
16	

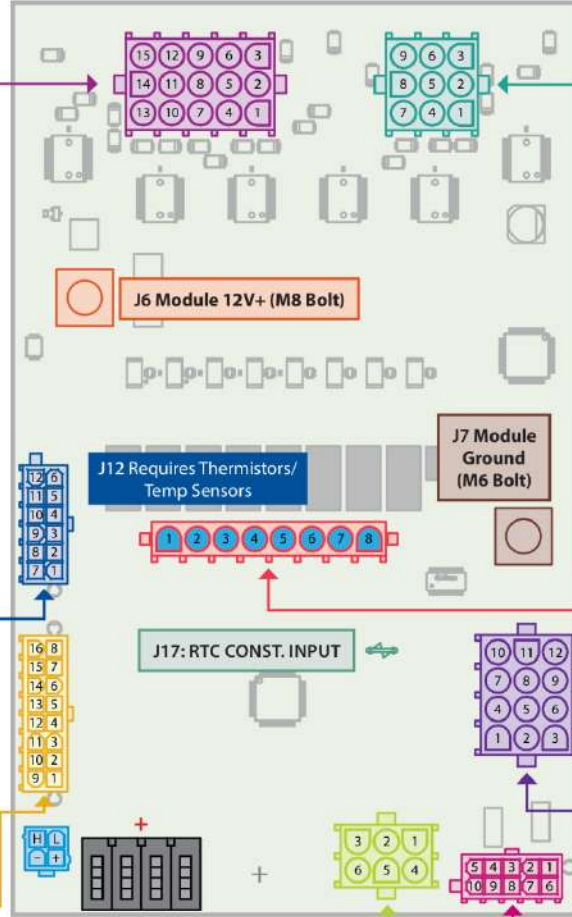

J8: HIGH CURRENT RELAYS (20A MAX)				
Pin	Out	Load	AMP	O/C
1	1	D/SOTTOMAN EXT (FP)(OPTION)	20A	1.0s
2	2	D/SOTTOMAN RET (FP)(OPTION)	20A	1.0s
3	3	P/SOTTOMAN EXT (FP)(OPTION)	20A	1.0s
4	4	P/SOTTOMAN RET (FP)(OPTION)	20A	1.0s
5	5	SOFA DOWN (FP)(OPTION)	20A	1.0s
6	6	SOFA UP (FP)(OPTION)	20A	1.0s
7	7	TANK HEATERS	20A	2.0s
8	8	WATERPUMP	20A	2.0s

J13: LPG	
Pin	Load
1	LP GAS SIG
2	
3	
4	LP GAS GND
5	
6	GEN RUN (12V)(OPTION)

J10: HALF BRIDGES 1A (PROGRAMMABLE POLARITY)				
Pin	Out	Load		+/-
1	9	AWNING EXT (1 SEC PULSE)(OPTION)		+
2	10	AWNING RET (1 SEC PULSE)(OPTION)		+
3	11	PREMIER COMPRESSOR (OPTION)		+
4	12	INDUCTION COOKTOP		+
5	13	MICROWAVE SHED RELAY		+
6	14	FIAMA AWNING EXT (MOM)(OPTION)		-
7	15	FIAMA AWNING RET (MOM)(OPTION)		-
8	16	PREMIER FAN LOW (OPTION)		+
9	17	PREMIER FAN MEDIUM (OPTION)		+
10	18	PREMIER FAN HIGH (OPTION)		+
11	19	GENERATOR START (30 SEC PULSE)(OPTION)		-
12	20	GENERATOR STOP (30 SEC PULSE)(OPTION)		-

J5: INPUTS		
Pin	Load	+/-
1		-
2		-
3		-
4		-
5		-
6	IGNITION	+
7		+
8		+
9		+
10		+

Add Placeholders

Pin Legend: ■ Reverse Polarity

**Shed Priority 1**  
Rooftop A/C  
(Logic Only)

**Shed Priority 2**  
Relay 2:  
Induction  
Cook Top

**Shed Priority 3**  
Relay 1:  
Microwave

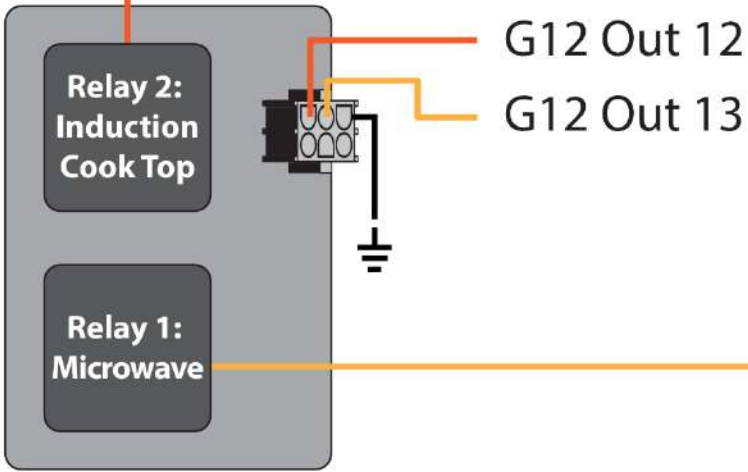

- 3 Relay 2: G12 Out 12
- 2 Relay 1: G12 Out 13
- 1 Relay 1 & 2 Ground

<b>Grech: Sprinter</b>		DI: MD
Relay Box Diagram		PI: **
Revision: 3v0	10/27/20	



## Dipswitch Setting

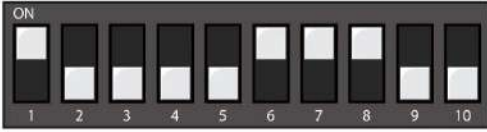

<b>1A:</b>	Slide Door UP
<b>1B:</b>	Slide Door DOWN
<b>2A:</b>	P/S Rear UP
<b>2B:</b>	P/S Rear DOWN
<b>3A:</b>	Rear Doors UP
<b>3B:</b>	Rear Doors DOWN
<b>4A:</b>	D/S Rear UP
<b>4B:</b>	D/S Rear DOWN
<b>5A:</b>	D/S or P/S Mid UP
<b>5B:</b>	D/S or P/S Mid DOWN
<b>6A:</b>	D/S Front UP
<b>6B:</b>	D/S Front DOWN
<b>7A:</b>	Power Screen UP
<b>7B:</b>	Power Screen DOWN
<b>8A:</b>	
<b>8B:</b>	

**\*\*\*PRELIMINARY PINOUT FOR REVIEW AND APPROVAL ONLY\*\*\***

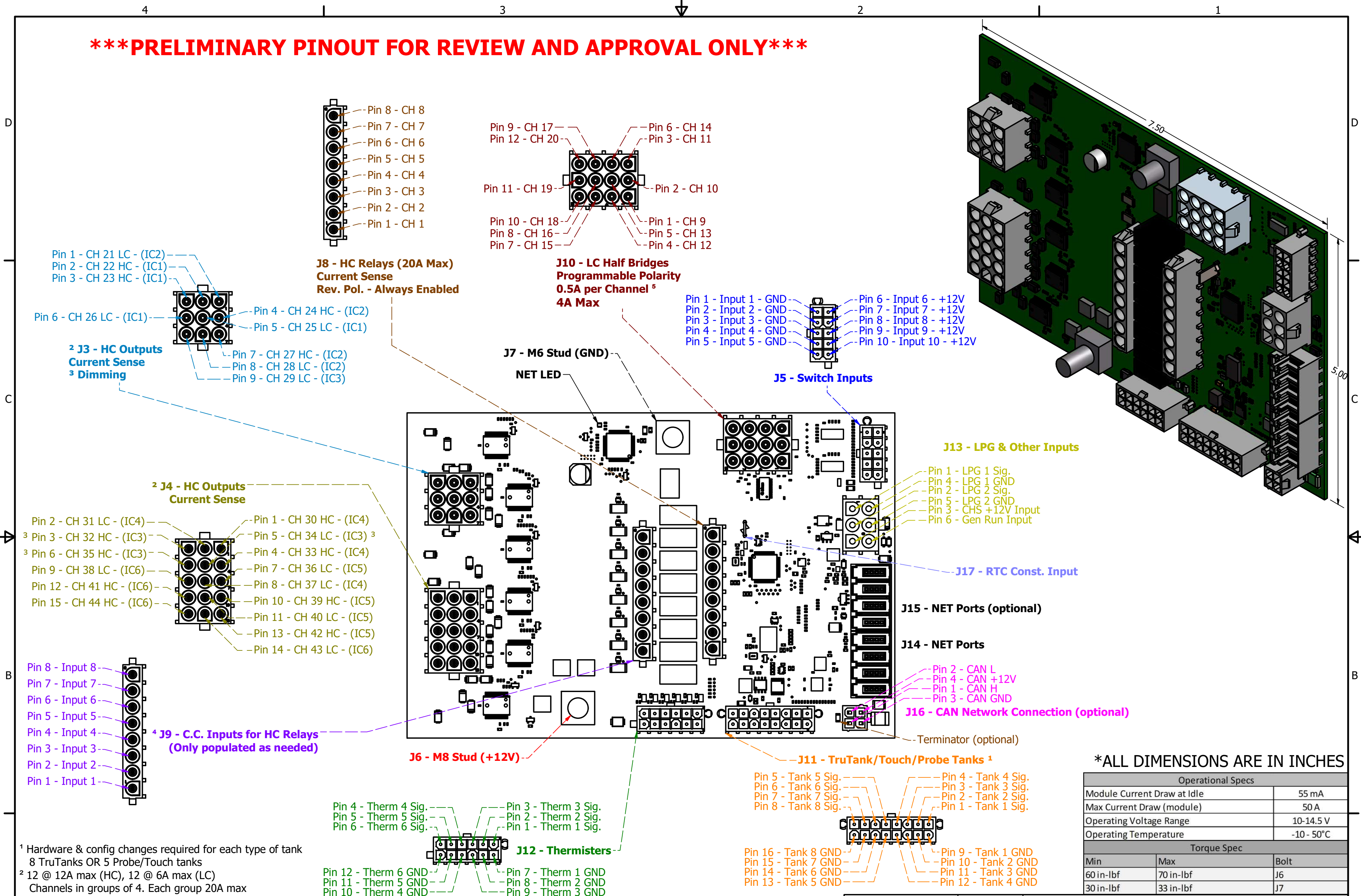

\*ALL DIMENSIONS ARE IN INCHES

Operational Specs	
Module Current Draw at Idle	55 mA
Max Current Draw (module)	50 A
Operating Voltage Range	10-14.5 V
Operating Temperature	-10 - 50°C
Torque Spec	
Min	Max
60 in-lbf	70 in-lbf
30 in-lbf	33 in-lbf
	Bolt
	J6
	J7

<sup>1</sup> Hardware & config changes required for each type of tank  
8 TruTanks OR 5 Probe/Touch tanks  
<sup>2</sup> 12 @ 12A max (HC), 12 @ 6A max (LC)  
Channels in groups of 4. Each group 20A max  
<sup>3</sup> Dimming  
<sup>4</sup> Can be 2, 4, 6, 8 position, depending on requirements  
<sup>5</sup> 4A Max for Header. Individual channels may exceed 500mA,  
but this will decrease useable amperage across header

Mating Connectors				
Manufacturer	Part Number	Pin P/N	Description	Mate
MATE-N-LOK	350720-1	350551-6	09P UMNL PLUG	J3
MATE-N-LOK	350736-1	350551-6	15P UMNL PLUG	J4
MATE-N-LOK	770580-1	1-770988-1 or Similar	10 Position Mini-Molex Connector	J5
MATE-N-LOK	640582-1	350551-6	08P UMNL PLUG	J8, J9
MATE-N-LOK	770022-1	350551-6	12P UMNL PLUG	J10
MATE-N-LOK	770583-1	1-770988-1 or Similar	16 Position Mini-Molex Connector	J11
MATE-N-LOK	770581-1	1-770988-1 or Similar	12 Position Mini-Molex Connector	J12
MATE-N-LOK	1-480704-0	350551-6	06P UMNL PLUG	J13
3M	37104-2165-000 FL 100 or Similar	N/A	4 Position Mini-Clamp Connector	J14, J15
Molex	39-01-2040	39-00-0038 or Similar	4 Position Mini-Molex Connector	J16

DRAWN	Joshua Graça	2019-04-26
CHECKED		
QA		
MFG		
APPROVED		

Spyder Controls Corp			
TITLE			
G12 Pinout			
SIZE	DWG NO	REV	
C	G12 0vA - Pinout - 2018.12.19	00	
SCALE	SHEET 1 OF 1		

NET LED Status	
LED Activity	Status
	Device is connected to network and communicating properly
	Device has no power or has completely failed
	Device has gone offline and is not connected to network
	Device is attempting to make initial connection to network
	Device was online but has not seen a valid network message for 5 seconds
	Device has gone offline and is attempting to re-connect (within 30 seconds)
	Device is currently online but has gone offline 2 or more times



# G12 Master

Log In:

Customer: \_\_\_\_\_ Model: \_\_\_\_\_ Revision: \_\_\_\_\_

Raw Part: \_\_\_\_\_ Custom Part: \_\_\_\_\_ Date: \_\_\_\_\_

Outputs: \_\_\_\_\_ Program Version: \_\_\_\_\_

**J4: HIGH CURRENT OUTPUTS 12A; LOW CURRENT 6A**

Pin	Out	Load	AMP	O/C
1				
2				
3				
4				
5				
6				
7				
8				
9				
10				
11				
12				
13				
14				
15				

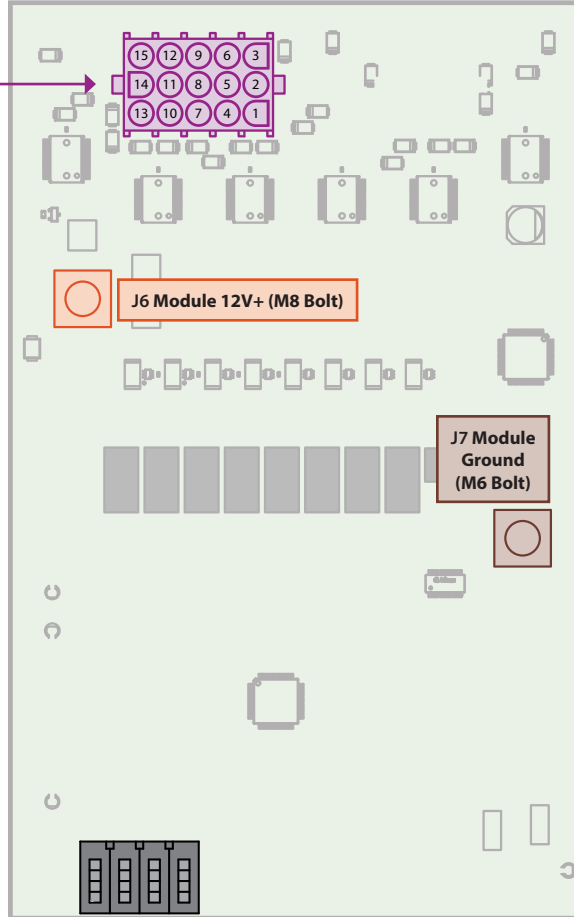

Pin Legend: ■ Reverse Polarity



Lithionics Battery®

Rev.B 2021 © Lithionics Battery®

# Lithionics Battery® Monitor: Bluetooth® App



Bluetooth® Telemetry Available for NeverDie® Compact Series, Standard Series & Advanced Series Battery Management Systems.

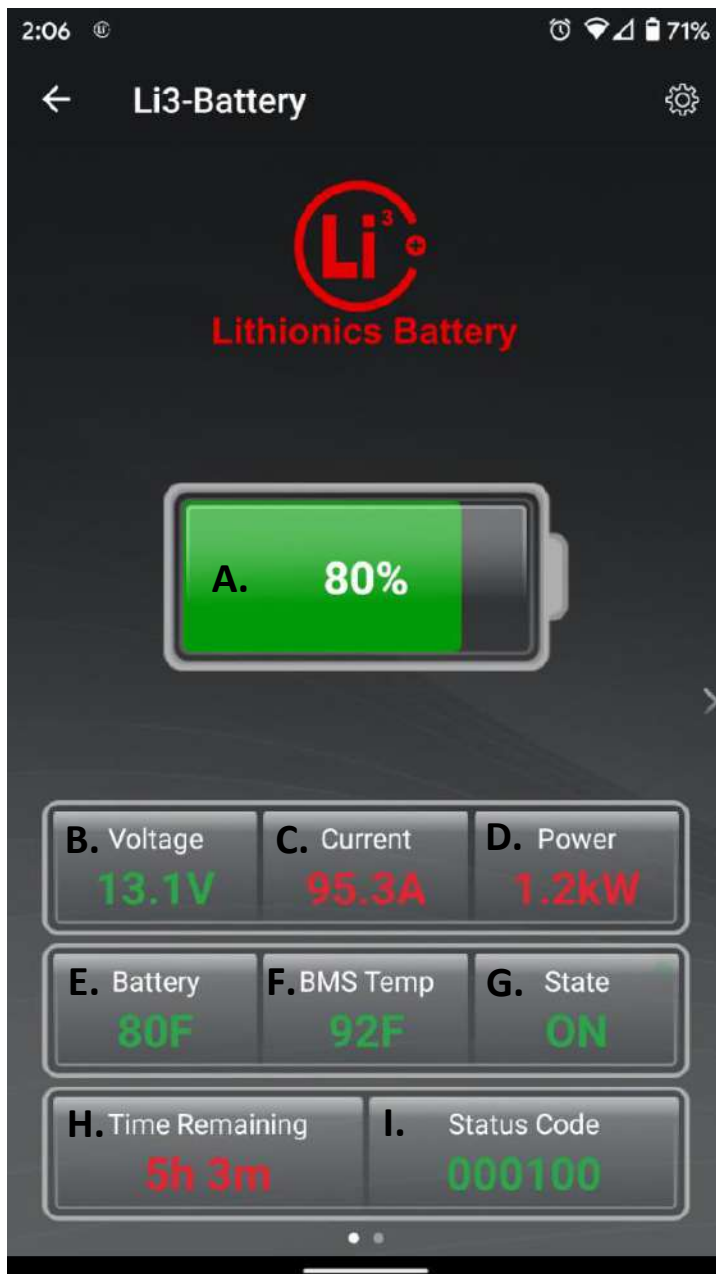

Swipe left/right on the battery main screen to view more battery details.

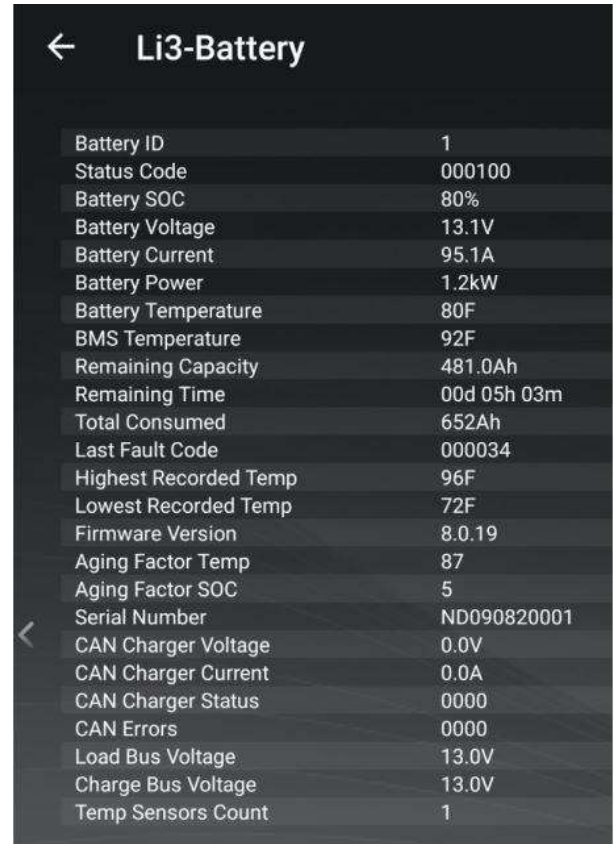

### Main Screen:

- A. SoC Percentage
- B. Voltage
- C. Current
- D. Power
- E. Battery Temp
- F. BMS Temp
- G. Power State
- H. Time Remaining
- I. Status Code

Depending on your battery model, some screens may look slightly different.

To connect to Bluetooth® telemetry:

- 1) The battery must be in the ON position.
- 2) Bluetooth® must be enabled on your smart device and support BLE 4.0 and higher.
- 3) Open the Lithionics Battery® Monitor App.
- 4) Under the Device List, select the battery device you would like to monitor.

A. Battery State of Charge Percentage



B. Battery Voltage

Reading:

GREEN = normal voltage

RED = voltage too low or too high



C. Net Current Draw in Amps. RED Indicates Discharging Current. GREEN indicates Charging Current.



D. Net Power Draw in Watts. RED Indicates Discharging Power. GREEN indicates Charging Power.



E. Internal Battery Temperature: GREEN = normal temp RED = temp too low or too high



F. Battery Management System Temperature: GREEN = normal temp RED = temp too high



G. Power State: Flashing green dot (heartbeat signal) indicates a healthy connection.



I. Status Code:  
Tap status code from the main screen to view codes...

Idle State			
Cell 4 Balancing	Cell 3 Balancing	Cell 2 Balancing	Cell 1 Balancing
		BMS Fault	
Cell Under-Voltage	Cell Over-Voltage	Short Circuit Protection	Overcurrent State
Power Off State	Battery Overload	Low Voltage State	Reserve Range
BMS Temp High	NeverDie Reserve	Cell Temp High/Low	High Voltage State

Compact Series Battery Type Interface

		Overcurrent State	Charge Disable State
Aux Input State	Low Temp State	High Temp State	AGSR State
Temp Sensor Error	TSM Charger Error	TSM Charger Present	AC Power Present
Contactor Flutter	Pre-Charge Error	Aux Contact Error	Aux Contact State
Power Off State	Battery Protection	Low Voltage State	Reserve Range
OptoLoop Open	NeverDie Reserve	Charge Detected	High Voltage State

Advanced Battery Type Interface

Normal operational states will be highlighted in GREEN, while fault or protection events will be highlighted in RED.

NOTE: A Status Code can be manually entered within the app by pressing the Status Code Reader button available at the bottom of the Settings screen, and selecting the BMS type.



## Data Logging

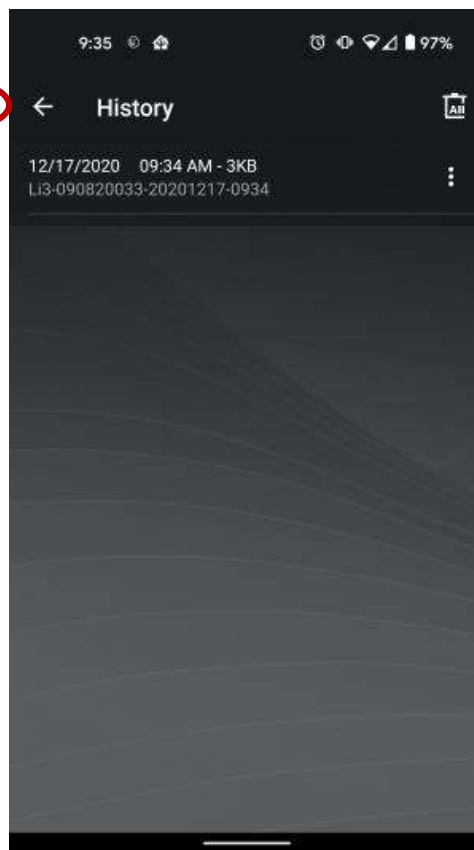

The app automatically data logs when connected to a battery. The log files can be found under the settings menu “LOG” button. From here you can view, share and delete logs as needed.

Terminal Console can be used to access live battery data stream and send bi-directional commands.

**NOTE: Commands should only be used to adjust BMS settings if directed by Lithionics Battery®.**

## Firmware Updates

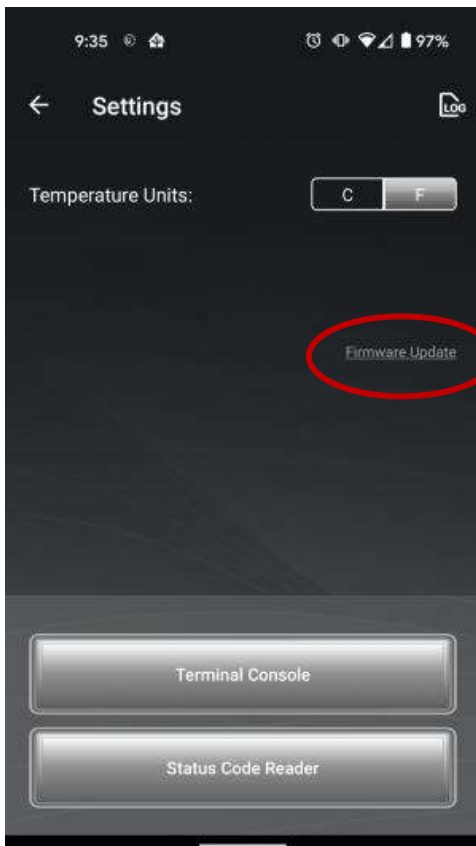

The “Firmware Update” feature is also located in the Settings menu. Firmware update option is not available on older battery models.

**NOTE: The firmware update should only be performed if necessary.**

For additional support on the Lithionics Battery® BlueTooth® App, click on the following YouTube Link here:

[Lithionics Battery Monitor App Demo](#)



# Storage Procedure

Storing your battery at the correct specifications is important as it keeps the battery in the healthiest state possible for the fastest deployment when needed. Consult the table below for proper storage conditions.

<b>Storage</b>		
<b>Storage Temperature</b>	<b>&lt; 1 Month</b>	<b>-4F ~ 95F (-20 ~ 35C), 45 ~ 75% RH</b>
<b>&amp; Humidity Range</b>	<b>&lt; 3 Months</b>	<b>14F ~ 86F (-10 ~ 30C), 45 ~ 75% RH</b>
	<b>&gt;3 Months or 6 Months MAX.</b>	<b>&gt;32F (&gt;0C) Above Freezing, &lt;86F (30C)</b>

## Short Term Storage: Up to 3 months:

1. Fully charge the battery. Record and maintain the storage VOLTAGE reading (not SoC%) for your warranty.
2. Turn the battery **OFF** by the On/Off/Storage switch. If you have an external BMS, it is preferred to fully disconnect the BMS from the MODULE by pulling apart the Anderson EURO DIN connector.
3. Keep the battery in an environment according to the specifications shown above.
- 4.

## Long Term Storage: >3 Months and 6 Months Maximum

1. Reduce the battery SOC to 3.3V/cell which is 50% ±10% SOC. **Note:** See chart below for cell voltage calculation. In order to maintain your warranty, please RECORD the voltage reading at the 3-month date you reduced the state of charge. **Please keep a record of this value for warranty validation purposes.** (NOTE: for some it may be inconvenient to access the battery system at the 3-month mark to perform a charge-discharge cycle. You may choose to keep the battery at full charge voltage for the entire 6-month time period. Studies show that a small loss of capacity may occur with all lithium ion batteries.
2. Turn the battery **OFF** via the On/Off/Storage switch. If you have an EXTERNAL BMS, we suggest you disconnect the BMS from the module or modules by pulling apart the large Anderson EURO DIN connector.
3. **Storage Temperature: the battery must be maintained ABOVE freezing temperatures (>32F/0C)**
4. Every 6 months, you must charge the battery to 100% SOC, then discharge the battery to RVC, then charge it back to 50% ±10% SOC. This cycle from full to reserve then up to the storage VOLTAGE is important for long life.

Battery Voltage	Number of Cells	~50% SOC Voltage
12V	4	13.2
16V	5	16.5
24V	8	26.4
36V	12	39.6
48V	15	49.5
51V	16	52.8
64V	20	66
76V	24	79.2
96V	30	99
102V	32	105.6
201V	63	207.9