



# HP E2620 Switches

Installation and Getting Started Guide



Power over Ethernet



---

# HP E2620 Switches

---

Installation and Getting Started Guide

## Publication Number

5998-0902  
January 2013

## Applicable Products

HP E2620-24 Switch	(J9623A)
HP E2620-24-PPoE+ Switch	(J9624A)
HP E2620-24-PoE+ Switch	(J9625A)
HP E2620-48 Switch	(J9626A)
HP E2620-48-PoE+ Switch	(J9627A)
HP 600 Redundant and External Power Supply	(J8168A)
HP 620 Redundant and External Power Supply	(J8696A)
HP 630 Redundant and/or External Power Supply	(J9443A)

## Disclaimer

HEWLETT-PACKARD COMPANY MAKES NO WARRANTY OF ANY KIND WITH REGARD TO THIS MATERIAL, INCLUDING, BUT NOT LIMITED TO, THE IMPLIED WARRANTIES OF MERCHANTABILITY AND FITNESS FOR A PARTICULAR PURPOSE. Hewlett-Packard shall not be liable for errors contained herein or for incidental or consequential damages in connection with the furnishing, performance, or use of this material.

The information contained herein is subject to change without notice. The only warranties for HP products and services are set forth in the express warranty statements accompanying such products and services. Nothing herein should be construed as constituting an additional warranty. HP shall not be liable for technical or editorial errors or omissions contained herein.

Hewlett-Packard assumes no responsibility for the use or reliability of its software on equipment that is not furnished by Hewlett-Packard.

## Warranty

See the Customer Support/Warranty booklet included with the product.

A copy of the specific warranty terms applicable to your Hewlett-Packard products and replacement parts can be obtained from your HP Sales and Service Office or authorized dealer.

---

## Safety

Before installing and operating these products, please read the "Installation Precautions" in chapter 2, "Installing the E2620 Switches", and the safety statements in appendix C, "Safety and EMC Regulatory Statements".

---

---

# Contents

## 1 Introducing the Switch

Front of the Switch .....	1-5
Network Ports .....	1-6
LEDs .....	1-6
Port LEDs .....	1-9
LED Mode Select Button and Indicator LEDs .....	1-10
Reset Button .....	1-11
Clear Button .....	1-11
Console Port .....	1-12
Back of the Switch .....	1-12
RPS and EPS Input Port .....	1-13
Power Connector .....	1-13
Switch Features .....	1-13

## 2 Installing the Switch

Included Parts .....	2-1
Installation Precautions .....	2-3
Installation Procedures .....	2-4
1. Prepare the Installation Site .....	2-6
2. Verify the Switch Passes Self Test .....	2-6
LED Behavior .....	2-8
3. Mount the Switch .....	2-9
Rack or Cabinet Mounting .....	2-9
Rack Mounting the E2620-PoE+ switches .....	2-10
Rack Mounting the Non-PoE+ Switches .....	2-12
Flat Wall Mounting (non-PoE+ models only) .....	2-14
Horizontal Surface Mounting .....	2-15
4. Connect the Switch to a Power Source .....	2-15
5. Connect the Network Cables .....	2-15
Using the RJ-45 Connectors .....	2-16

6. Installing or removing SFP transceivers (mini-GBICs) . . . . .	2-17
Installing the SFP transceivers: . . . . .	2-17
Removing the SFP transceiver . . . . .	2-18
Connecting Cables to SFP transceivers . . . . .	2-18
7. (Optional) Connect an External Power Supply to the Switch . . . . .	2-19
RPS/EPS Operation . . . . .	2-20
Operating Characteristics of the external power supplies . . . . .	2-20
External Power Supply LEDs . . . . .	2-21
External Power Supply Connectivity . . . . .	2-23
8. (Optional) Connect a Console to the Switch . . . . .	2-25
Terminal Configuration . . . . .	2-25
Direct Console Access . . . . .	2-26
Sample Network Topologies for	
Non-PoE+ Switches . . . . .	2-27
As a Desktop Switch . . . . .	2-27
As a Segment Switch . . . . .	2-28
Connecting to a Backbone Switch . . . . .	2-29
Sample Network Topologies for PoE+ Switches . . . . .	2-31
As a Desktop Switch Implementing PoE+ . . . . .	2-31
As a Segment Switch Implementing PoE . . . . .	2-32
Stacking the Switch . . . . .	2-34

### **3 Configuring the Switch**

Recommended Minimal Configuration . . . . .	3-1
Using the Console Setup Screen . . . . .	3-2
Where to Go From Here . . . . .	3-3
Using the IP Address for Remote Switch Management . . . . .	3-5
Starting a Telnet Session . . . . .	3-5
Starting a Web Browser Session . . . . .	3-5

## 4 Troubleshooting

Basic Troubleshooting Tips .....	4-1
Diagnosing with the LEDs .....	4-4
LED patterns for General Switch Troubleshooting .....	4-4
LED Patterns for PoE Troubleshooting .....	4-8
Proactive Networking .....	4-9
Hardware Diagnostic Tests .....	4-10
Testing the Switch by Resetting It .....	4-10
Checking the Switch LEDs .....	4-10
Checking Console Messages .....	4-10
Testing Twisted-Pair Cabling .....	4-11
Testing Switch-to-Device Network Communications .....	4-11
Testing End-to-End Network Communications .....	4-11
Restoring the Factory Default Configuration .....	4-12
Downloading New Switch Software .....	4-13
HP Customer Support Services .....	4-13
Before Calling Support .....	4-13

## A Switch Specifications

Physical .....	A-1
Electrical .....	A-1
RPS/EPS Electrical Input .....	A-2
Environmental .....	A-2
BTU Ratings .....	A-2
Acoustics .....	A-3
RPS/EPS Connectors .....	A-3
Cable Length .....	A-3
Safety .....	A-4
Standards .....	A-4

## **B Cabling and Technology Information**

Cabling specifications .....	B-1
Technology distance specifications .....	B-2
Mode Conditioning Patch Cord .....	B-3
Installing the Patch Cord .....	B-3
Twisted-Pair Cable/Connector Pin-Outs .....	B-4
Straight-through Twisted-Pair Cable for 10 Mbps or 100 Mbps Network Connections .....	B-6
Cable Diagram .....	B-6
Pin Assignments .....	B-6
Crossover Twisted-Pair Cable for 10 Mbps or 100 Mbps Network Connection .....	B-7
Cable Diagram .....	B-7
Pin Assignments .....	B-7
Straight-Through Twisted-Pair Cable for 1000 Mbps Network Connections .....	B-8
Cable Diagram .....	B-8
Pin Assignments .....	B-8

## **C Safety and EMC Regulatory Statements**

Safety Information .....	C-1
Informations concernant la sécurité .....	C-2
Hinweise zur Sicherheit .....	C-3
Considerazioni sulla sicurezza .....	C-4
Consideraciones sobre seguridad .....	C-5
Informações de Segurança .....	C-6
Safety Information (Japan) .....	C-7
Safety Information (China) .....	C-8
EMC Regulatory Statements .....	C-9
U.S.A. .....	C-9
Canada .....	C-9
Australia/New Zealand .....	C-9
Japan .....	C-9
Korea .....	C-10
Taiwan .....	C-10
European Community .....	C-11



## **D Recycle Statements**

Waste Electrical and Electronic Equipment (WEEE) Statements . . . . . D-1

## **Index**



# Introducing the Switch

---

The HP E2620 Switches are multiport switches that can be used to build high-performance switched workgroup networks. These switches are store-and-forward devices that offer low latency for high-speed networking. The non-PoE and PPOE+ switches support Redundant power supply (HP 600 RPS/ EPS). The E2620-PoE+ Switches also support Redundant and External Power Supply, and Power over Ethernet (PoE/PoE+) technologies.

**HP E2620-24 Switch (J9623A)**



**HP E2620-48 Switch (J9626A)**



**HP E2620-24-PPoE+ Switch (J9624A)**



**HP E2620-24-PoE+ Switch (J9625A)**



**HP E2620-48-PoE+ Switch (J9627A)**



Throughout this manual, these switches will be referred to as the E2620 Switches and the E2620-PoE+ Switches.

- The E2620 Switches, have either 24 or 48 auto-sensing 10/100Base-TX RJ-45 ports with four Gigabit Uplink ports, two RJ-45 and two mini-GBIC (Small Form Factor Pluggable (SFP)) slots.

The RJ-45 Gigabit Uplink ports are auto-sensing 10/100/1000Base-T. These ports operate independently, they are not dual-personality and do not support PoE+ power.

**Table 1-1. Optional Network Connectivity, Speeds and Technologies**

			Transceiver Form-Factor and Connector <sup>1</sup>
Speed	Technology	Cabling	SFP ("mini-GBIC") Connector
<b>100 Mbps</b>	100-FX	Fiber (multimode)	LC
	100-BX	Fiber (single mode)	LC
<b>1 Gbps</b>	1000-T	Copper (twisted-pair)	RJ-45
	1000-SX	Fiber (multimode)	LC
	1000-LX	Fiber (multimode or single mode)	LC
	1000-LH	Fiber (single mode)	LC
	1000-BX	Fiber (single mode)	LC
<p><sup>1</sup> For supported transceivers, visit <a href="http://www.hp.com/networking/support">www.hp.com/networking/support</a>.</p> <ul style="list-style-type: none"> <li>– In the first textbox, type <b>J4858</b> (for 100-Mb and Gigabit information).</li> <li>– Select any of the products that display in the dropdown list.</li> <li>– Select <b>Product support information</b>. Then click on <b>Manuals</b> and find the <b>Transceiver Support Matrix</b>.</li> </ul> <p>For technical details of cabling and technologies see "Cabling and Technology Information" in the appendices.</p>			

The E2620-PoE+ Switches incorporate two additional features. These switches offer two types of power, one for switch AC operating power, and the other for Power over Ethernet (PoE+) power:

- **Power-over-Ethernet or PoE+ power** - PoE+ technology allows IP telephones, wireless LAN Access Points and other appliances to receive power as well as data over existing LAN cabling, without needing to modify the existing Ethernet infrastructure. The E2620-PoE+ Switches are designed with an internal PoE+ power supply capable of providing 364 watts of PoE power (126 watts on the E2620-24-PPoE+. The PPoE+ (Partial PoE+) switch provides 24 Ethernet ports, 12 of which can supply PoE+ power).

All of the Switch E2620-PoE+ ports can provide up to 30 watts (or 4 ports at 30 watts, or 8 ports at 15.4 watts on the E2620-24-PPoE+) of PoE+ power to connected devices. For further information regarding PoE/PoE+ power, see the *HP Power over Ethernet (PoE/PoE+) Planning and Implementation Guide*, which is on the HP Web site at [www.hp.com/networking/support](http://www.hp.com/networking/support).

- **Redundant and External Power Supply Support** - The E2620 non-PoE+ and PPoE+ switches can be connected to an HP 600 Redundant and External Power Supply (J8168A), hereafter referred to as the 600 RPS/ EPS, for RPS power only. As an RPS unit, the 600 RPS/EPS will provide all the AC power necessary to keep the switch running should the switch internal AC power supply fail. The 600 RPS/EPS can not be used for EPS (PoE+) power for the E2620-PoE+ switches.
- The E2620 PoE+ switches can be connected to an HP 620 Redundant and External Power Supply (J8696A), hereafter referred to as the 620 RPS/ EPS, for RPS only. As an RPS unit, the 620 RPS/EPS will provide all the AC power necessary to keep the switch running should the switch internal AC power supply fail. The 620 RPS/EPS can not be used for EPS (PoE+) power for the E2620-PoE+ switches.
- Also, the E2620 PoE+ switches can be connected to an HP 630 Redundant and/or External Power Supply (J9443A), hereafter referred to as the 630 RPS/EPS, and receive redundant power from that unit. As an EPS unit, the 630 RPS/EPS can supply up to 398 watts of PoE power to the switch if the internal PoE power supply of the switch should fail. When used with the Switch E2620-48-PoE+, the additional EPS power can provide up to 30 watts per port for 48 ports. For further information regarding the RPS/ EPS PoE+ capabilities, see the *HP Power over Ethernet (PoE/PoE+) Planning and Implementation Guide*, or the *HP Redundant and/or External Power Supplies Installation and Getting Started Guide* which is on the HP Web site at [www.hp.com/networking/support](http://www.hp.com/networking/support).

**Table 1-1. RPS/EPS Compatibility Matrix**

Switch	RPS Support	EPS Support
HP E2620-24 (J9623A)	600	N/A
HP E2620-48 (J9626A)	600	N/A
HP E2620-24-PPoE+ (J9624A)	600	N/A
HP E2620-24-PoE+ (J9625A)	620/630	630
HP E2620-48-PoE+ (J9627A)	620/630	630

These switches can be directly connected to computers, printers, and servers to provide dedicated bandwidth to those devices, and you can build a switched network infrastructure by connecting the switch to hubs, other switches, or routers. In addition, the E2620 Switches offer full network management capabilities.

# Front of the Switch

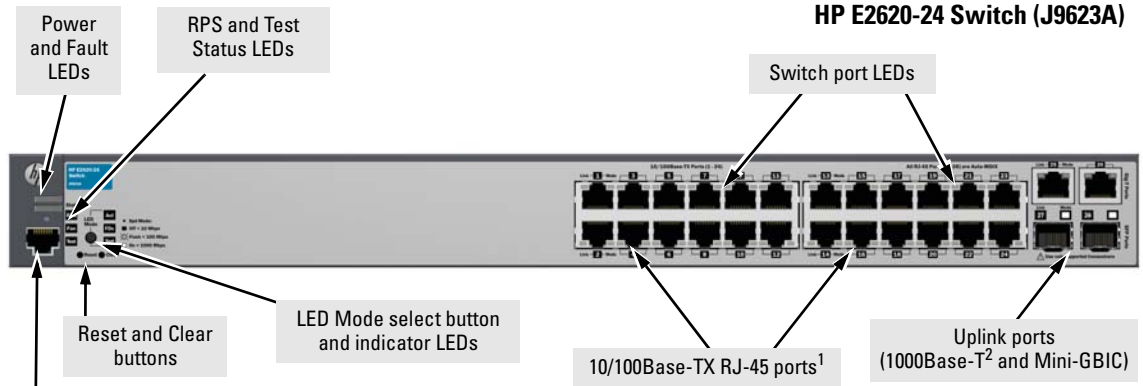
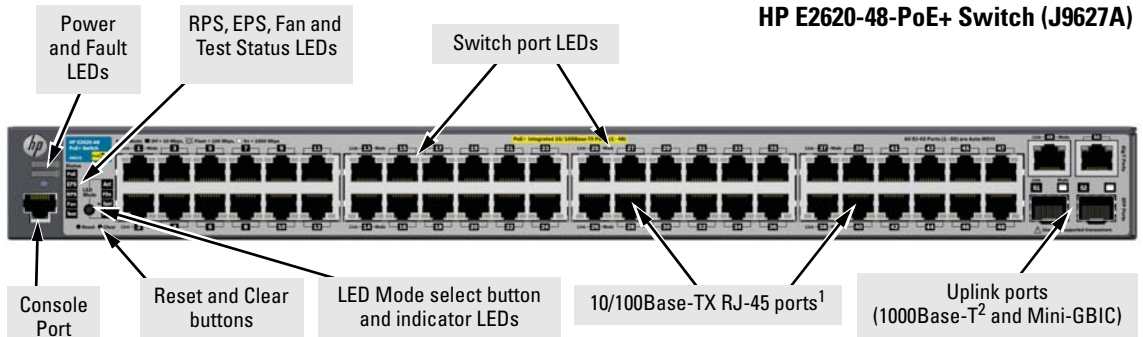
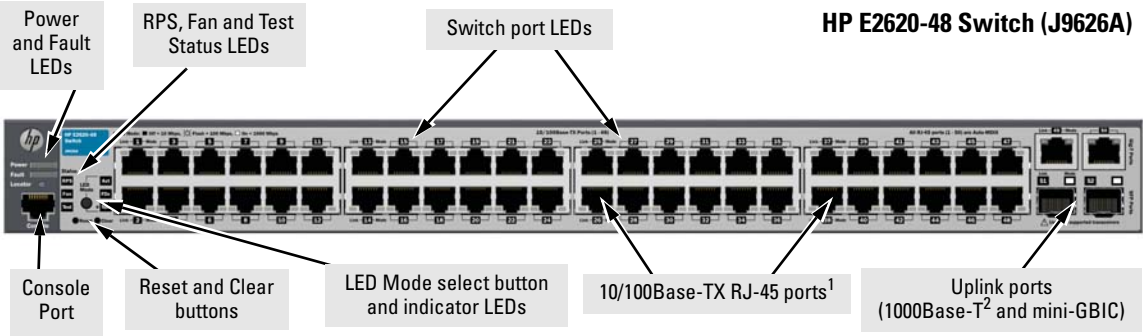

<sup>1</sup> All 10/100Base-TX RJ-45 ports have the Auto-MDIX feature.  
<sup>2</sup> Two RJ-45 10/100/1000Base-T ports and two Mini-GBIC (SFP) slots.

## Network Ports

- 24, or 48 auto-sensing 10/100Base-TX ports.  
All these ports have the “Auto-MDIX” feature, which means that you can use either straight-through or crossover twisted-pair cables to connect any network devices to the switch.
- Two RJ-45 10/100/1000Base-T ports for high speed uplink.
- Two mini-GBIC (SFP) slots for fiber uplinks.

## LEDs

On the E2620 Switches, there are three groupings of LEDs:

- switch status LEDs (Table 1-2)
- port LEDs (Table 1-3)
- Port LED Mode indicator LEDs (near the selector button) (Table 1-4)

**Table 1-2. Switch Status LEDs**

Switch LEDs	State	Meaning
Power (green)	On	The internal power supply is working properly.
	Off	No power connection. The switch is NOT receiving power.
	Flashing <sup>2</sup>	A failure of the internal power supply. It should be flashing simultaneously with the Fault LED. (If an RPS is connected to the switch, the RPS is actively powering the switch, the RPS LED will be on.)
Fault (orange)	Off	The normal state; indicates there are no fault conditions on the switch.
	Flashing <sup>2</sup>	A fault has occurred with a component on the switch. The Status LED for the component with the fault will flash simultaneously.
	On	On briefly after the switch is powered on or reset, at the beginning of switch self test. If this LED is on for a prolonged time, the switch has encountered a fatal hardware failure, or has failed its self test. See chapter 4, “ <b>Troubleshooting</b> ” for more information.



Switch LEDs	State	Meaning
Locator (blue)	On Flashing Off	The Locator LED is used to locate a specific switch in an area full of switches. The LED can be set to be on solid or flash for a specified number of minutes (1-1440). The default is 30 minutes. Use the command "chassislocate".
PoE (green/ orange) <sup>3</sup>	On Flashing/ orange <sup>2</sup> Flashing/ orange <sup>1</sup>	Normal operation. The switch is ready to supply PoE power  One or more ports has experienced a fault condition for PoE delivery. The Fault LED will be flashing simultaneously. If it is a self test failure, the Test LED will be flashing simultaneously. When the switch is put in PoE LED Mode, The Mode LED for the port with the problem will also be flashing simultaneously.  One or more ports has an alert condition for PoE delivery, for example, an oversubscription condition (not enough PoE power available). Only this LED will be flashing, the Fault LED is off. When the switch is put in PoE LED Mode, The Mode LEDs for the ports with the alert condition will also be flashing.
RPS Status (green/ orange)	On Flashing orange <sup>1</sup> Off	Normal operation. An external power supply is connected and operating correctly. The external power supply could be powering the unit.  An external power supply is connected but may be powering another switch or the external power supply has experienced a fault. Only this LED flashes, the Fault LED is off.  An external power supply is not connected.
EPS Status <sup>3</sup> (green)	On Flashing orange <sup>1</sup> Off	The switch is connected to an external power supply and operating correctly.  The external power supply has experienced a fault: <ul style="list-style-type: none"> <li>• There is a fan, overcurrent, power supply, or temp fault on the EPS.</li> <li>• The Switch detects the EPS is present but cannot communicate with it.</li> </ul> Check the Error Log on the switch for more information.  The switch is not connected to an external power supply or the EPS cable is connected but the external power supply is not powered up.
Fan (green/ orange)	On Flashing orange <sup>2</sup>	The cooling fan is operating normally.  The cooling fan has failed. The switch Fault LED will be flashing simultaneously.

**Introducing the Switch**  
Front of the Switch

Switch LEDs	State	Meaning
Test (green/ orange)	Off	The normal operational state; the switch is not undergoing self test.
	On	The switch self test and initialization are in progress after the switch has been power cycled or reset. The switch is not operational until this LED goes off. The Test LED also comes on briefly when you “hot swap” a mini-GBIC into the switch; the mini-GBIC is tested when it is hot swapped.
	Flashing orange <sup>2</sup>	A component of the switch has failed its self test. The switch Fault LED, Test LED, and the failed component LED will flash simultaneously.
<sup>1</sup> The flashing behavior is an on/off cycle once every 0.8 seconds approximately, a fast flash.		
<sup>2</sup> The flashing behavior is an on/off cycle once every 1.6 seconds approximately, a slow flash.		
<sup>3</sup> HP E2620-24-PoE+ (J9625A) and HP E2620-48-PoE+ Switch (J9627A) Switches only.		

See the *HP Redundant and/or External Power Supply Installation and Getting Started Guide* for information on the LED behavior of the external power supplies.

## Port LEDs

The port LEDs provide information about the individual switch ports.

**Table 1-3. Port LEDs**

Switch LEDs	State	Meaning
<b><i>E2620 non-PoE Switches</i></b>		
Port LEDs		Displays port link information, network activity information, whether the port is configured for full-duplex operation, or the speed of the connection depending on the LED Mode selected. See “LED Mode Select Button and Indicator LEDs” on the next page for more information.
Mini-GBIC LEDs: Link	Flashing orange	One of the following conditions exist: <ul style="list-style-type: none"> <li>the mini-GBIC is not supported by the current software</li> <li>the mini-GBIC is not a genuine HP Mini-GBIC and is not supported</li> <li>the mini-GBIC is an “A” version in a switch that requires a “B” version or later.</li> </ul>
Link and Mode (green)	On for 2 seconds	Both the Link and Mode LED turn on solid for 2 seconds and then go to normal operation. This indicates the mini-GBIC has been recognized by the switch.
<b><i>Switch E2620-PoE Switches</i></b>		
Link (green)	On	The port is enabled and receiving a link indication from the connected device. In PoE+ mode, indicates that the port is configured to enable PoE power delivery to the connected device.
	Off	One of these condition exists: <ul style="list-style-type: none"> <li>no active network cable is connected to the port</li> <li>the port is not receiving link beat or sufficient light</li> <li>the port has been disabled through the switch console, the web browser interface, ProCurve Manager, or other network management tool.</li> <li>In PoE+ mode, indicates that the port is configured such that PoE+ power delivery is disabled.</li> </ul>
	Flashing <sup>1</sup>	The port has failed self test. The switch Fault, and Self Test LEDs will flash simultaneously.
Mode (green)		Depending on the mode selected, displays the following: <ul style="list-style-type: none"> <li>Connection speed information</li> <li>network activity information</li> <li>PoE+ power delivery status</li> </ul> See “LED Mode Select Button and Indicator LEDs:” below for more information.
<sup>1</sup> The flashing behavior is an on/off cycle once every 1.6 seconds, approximately.		

## LED Mode Select Button and Indicator LEDs

To optimize the amount of information that can be displayed for each of the switch ports in the limited space available, the E2620 Switches use multiple-display LEDs for each port.

The non-PoE+ switches, have two LEDs per port. The Link status is always shown by the Link LED. The operation of the Mode LED is controlled by the LED Mode select button, and the current setting is indicated by the LED Mode indicator LEDs near the button. Press the button to step from one view mode to the next. The default view is Activity (Act).

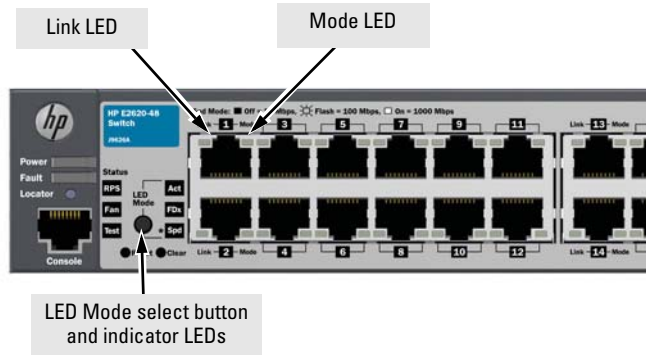

Figure 1-2. E2620 non-PoE Switches

The PoE+ switches also have two LEDs per port. The Link status is always shown by the Link LED as with the non-PoE switches. The operation of the Mode LED is the same as the non-PoE switches. The difference is the PoE+ switches have an additional mode, and that is PoE+. In PoE+ mode, the Link LED indicates the PoE+ configuration for the port: On if PoE+ is enabled on the port; Off if PoE+ is disabled on the port. The default view is Activity (Act).

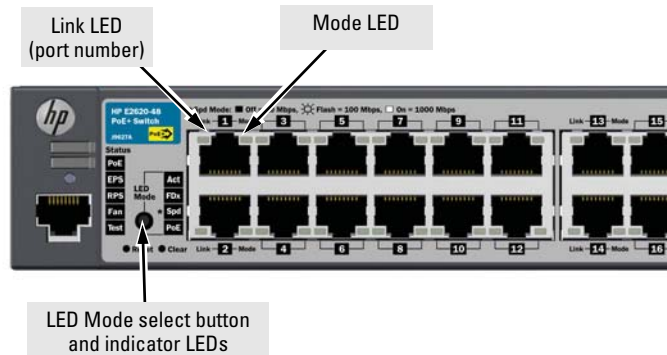

Figure 1-3. E2620-PoE+ Switches

**Table 1-4. Multiple-Display Port LEDs**

Switch LEDs	State	Meaning
<i>All E2620 Switches</i>		
Port LED View indicator LEDs (3 green LEDs)	Act	Indicates the Port LEDs are displaying network activity information.
	FDx	Indicates the Port LEDs are lit for ports that are in full-duplex mode.
	Spd	Indicates the Port LEDs are displaying the connection speed at which each port is operating: <ul style="list-style-type: none"> <li>• if the Port LED is off, the port is operating at 10 Mbps.</li> <li>• if the Port LED is flashing, the port is operating at 100 Mbps.</li> <li>• if the Port LED is on continuously, the port is operating at 1000 Mbps.</li> </ul>
<i>Switch E2620-PoE+ Series</i>		
LED Mode indicator LEDs (PoE+ is the additional LED, green)	PoE+	Indicates the Port LEDs are lit for ports that are providing PoE+ power to the connected device.

## Reset Button

This button is for:

- **Resetting the switch** - When the switch is powered on. This action clears any temporary error conditions that may have occurred and executes the switch self test.
- **Restoring Factory Default Configuration** - When pressed with the Clear button in a specific pattern, any configuration changes you may have made through the switch console, the web browser interface, and SNMP management are removed, and the factory default configuration is restored to the switch. For the specific method to restore the factory default configuration, see [“Restoring the Factory Default Configuration” on page 12](#), “Troubleshooting” of this manual.

## Clear Button

This button is used for:

- **Deleting Passwords** - When pressed by itself for at least one second, the button deletes any switch console access passwords that you may have configured. Use this feature if you have misplaced the password and need console access. This button is provided as a convenience, however if you are concerned with the security of the switch configuration and operation, you should make sure the switch is installed in a secure location. This button can be disabled by a CLI command.
- **Restoring Factory Default Configuration** - See Reset Button above.

## Console Port

This port is used to connect a console to a E2620 Switches by using the RJ-45 to DB9 cable, supplied with the switch. This connection is described under “8. (Optional) Connect a Console to the Switch” on page 25 in chapter 2, “Installing the Switch.” The console can be a PC or workstation running a VT-100 terminal emulator, or a VT-100 terminal.

---

## Back of the Switch



Figure 1-4. HP Switch E2620-24 and E2620-48 non-PoE+



Figure 1-5. HP Switch E2620-24-PoE+ and E2620-48-PoE+



Figure 1-6. HP Switch 2620-24-PPoE+

## RPS and EPS Input Port

The E2620 Switches support connectivity to three external power supplies depending on the switch to be supported.

- The HP 600 Redundant and External Power Supply (J8168A) can be connected to:
  - E2620-24 (J9623A)
  - E2620-48 (J9626A)
  - E2620-24-PPoE+ (J9624A)

For RPS power only. EPS power is not supported on these switches.

- The HP 620 Redundant and External Power Supply (J8696A) and the HP 630 Redundant and/or External Power Supply (J9443A) can be connected to:
  - E2620-24-PoE+ (J9625A)
  - E2620-48-PoE+ (J9627A)

The RPS functionality of these external power supplies provide redundant system power in case the switch's internal power supply fails. The EPS functionality of the 630 provides additional PoE+ power. The E2620 Switches do not support EPS power from the 620 RPS/EPS. Also refer to the RPS/EPS Compatibility Matrix on [page 1-4](#).

## Power Connector

The E2620 Switches and E2620-PoE+ Switches do not have a power switch; they are powered on when connected to an active AC power source. The switches automatically adjust to any voltage between 100-127 and 200-240 volts and either 50 or 60 Hz. There are no voltage range settings required.

---

## Switch Features

The features of the E2620 Switches and E2620-PoE+ Switches include:

- 24, or 48 auto-sensing 10/100Base-TX RJ-45 ports with Auto-MDIX.
- 4 Uplink ports—two are 1000Base-T RJ-45 and two are mini-GBIC (SFP) slots.

- Power over Ethernet (PoE/PoE+) operation—the E2620-PoE+ Switches are IEEE 802.3at compliant and provide up to 30W per port to power IP phones, wireless access points, web cameras, and more. For more information, see the *HP Power over Ethernet (PoE/PoE+) Planning and Implementation Guide*, which is on the HP Web site at [www.hp.com/networking/support](http://www.hp.com/networking/support).
- The E2620-PoE+ Switches support some pre-standard PoE devices. However, the use of a cross-over cable may be required. For a current list see the FAQ page for the E2620-PoE+ Switch, which can be found on the HP Web site, [www.hp.com/networking/support](http://www.hp.com/networking/support).
- Plug-and-play networking—all ports are enabled—just connect the network cables to active network devices and your switched network is operational.
- Auto-MDIX on all twisted-pair ports, 10/100 and 10/100/1000, meaning that all twisted-pair connections can be made using straight-through cables. Cross-over cables are not required, although they will also work.
- Automatic learning of the hardware addresses in each switch's 8000-address forwarding table, (with configurable address aging value).
- Automatically negotiated full-duplex operation for the 10/100 and 10/100/1000 RJ-45 ports when connected to other auto-negotiating devices—the mini-GBIC ports always operate at full duplex, unless a 100-FX SFP transceiver is installed. The 100-FX SFP transceiver can operate at half duplex.
- Easy management of the switches through several available interfaces:
  - **console interface**—a full featured, easy to use, VT-100 terminal interface that is especially good for out-of-band switch management or for Telnet access to the switch.
  - **web browser interface**—an easy to use built-in graphical interface that can be accessed from common web browsers.
  - **ProCurve Manager**—an SNMP-based, graphical network management tool that you can use to manage your entire network.
- Support for the Spanning Tree Protocol to eliminate network loops
- Support for up to 512 IEEE 802.1Q-compliant VLANs so you can divide the attached end nodes into logical groupings that fit your business needs.
- Download of new switch software for product enhancements or bug fixes.
- Variable-speed fans to maintain cooling.
- Support for many advanced features to enhance network performance—for a description, see the *Management and Configuration Guide*, which is on the HP Web site at [www.hp.com/networking/support](http://www.hp.com/networking/support).



---

# Installing the Switch

---

The HP E2620 Switches come with an accessory kit that includes the brackets for mounting the switch in a standard 19-inch telco rack, or in an equipment cabinet. The brackets for the **non-PoE+** 2620 models also allow them to be mounted on a wall. The brackets are designed to allow mounting the switch in a variety of locations and orientations. Rubber feet are provided that can be attached so the switch can be securely located on a horizontal surface. This chapter shows how to install the E2620 Switches.

---

## Included Parts

The E2620 Switches have the following components:

- *HP Switch Quick Setup Sheet*
- *Read Me First*
- *HP Switches General Safety and Regulatory Information* booklet
- *E2620 Switch Specific Safety and Regulatory Information* sheet
- Console cable
- Customer Support/Warranty booklet
- Accessory kits:

---

**E2620 Non-PoE+ switches and the J9624A 24-port P-PoE+ switch****Kit number 5069-6535**

Contains:

- two mounting brackets
- eight 8-mm M4 screws to attach the mounting brackets to the switch
- four 5/8-inch number 12-24 screws to attach the switch to a rack
- four rubber feet

---

**E2620-PoE+ switches, J9625A and J9627A****Kit number 5069-5705**

Contains:

- two mounting brackets <sup>1</sup>
- eight 8-mm M4 screws to attach the mounting brackets to the switch
- four 5/8-inch number 12-24 screws to attach the switch to a rack
- four rubber feet

<sup>1</sup> The mounting brackets in this kit are longer to support the increased depth of the E2620-PoE+ products. They **cannot** be used to wall mount the PoE+ switches.

AC power cord, one of the following:

Country/Region	Non-PoE+ and PPOE+ Switches	PoE+ Switches <sup>1</sup>
Australia/New Zealand	8121-0834	8121-0857
China	8120-8377	8121-1034
Continental Europe	8120-6802	8120-5336
Denmark	8120-6806	8120-5340
Japan	8120-6804	8120-5342
Switzerland	8120-6807	8120-5339
United Kingdom/Hong Kong/Singapore	8120-6809	8120-5334
South Africa	8121-0919	8120-5341
Thailand	8121-0673	8121-0671
Taiwan	8121-0964	8121-0967
United States/Canada/Mexico	8120-6805	8121-0973
Israel	8121-1035	8121-1009
Chile	8120-6980	8120-8389
Brazil	8121-1069	8121-1132
Argentina	8120-6869	8120-8375

<sup>1</sup> The cords for the PoE+ Switches support a higher amperage and a C15 connector.

---

**Japan Power  
Cord Warning**

---

製品には、同梱された電源コードをお使い下さい。  
同梱された電源コードは、他の製品では使用出来ません。

## Installation Precautions

---

### WARNINGS

- **The rack or cabinet should be adequately secured to prevent it from becoming unstable and/or falling over.**

**Devices installed in a rack or cabinet should be mounted as low as possible, with the heaviest devices at the bottom and progressively lighter devices installed above.**

- **For safe operation do not install the switch with the side of the switch (with the fan vents) facing either downward or upward.**
- 

### Cautions

- If one of the following switches is to be mounted in a rack, you can use a rack kit, J9583A - HP X410 1U Universal 4-Post Rack Mounting Kit **for the following switches only:**
    - J9085A HP Switch E2620-24
    - J9088A HP Switch E2620-48
    - J9086A HP Switch E2620-24-PPoE+
  - Ensure the power source circuits are properly grounded, then use the power cord supplied with the switch to connect it to the power source.
  - If your installation requires a different power cord than the one supplied with the switch, ensure the cord is adequately sized for the switch's current requirements. In addition, be sure to use a power cord displaying the mark of the safety agency that defines the regulations for power cords in your country. The mark is your assurance that the power cord can be used safely with the switch. If the PoE+ device's supplied power cord does not fit, contact HP networking support.
  - When installing the switch, the AC outlet should be near the switch and should be easily accessible in case the switch must be powered off.
  - Ensure the switch does not overload the power circuits, wiring, and over-current protection. To determine the possibility of overloading the supply circuits, add together the ampere ratings of all devices installed on the same circuit as the switch and compare the total with the rating limit for the circuit. Maximum ampere ratings are usually printed on the devices near the AC power connectors.
  - Do not install the switch in an environment where the operating ambient temperature might exceed 55°C (131°F). This includes a fully-enclosed rack. Ensure the air flow around the sides and back of the switch is not restricted. Leave at least 7.6 cm (3 inches) for cooling.
  - Ensure all port covers are installed when the port is not in use.
-

## Installation Procedures

These steps summarize your switch installation. The rest of this chapter provides details on these steps.

1. **Prepare the installation site** ([page 2-6](#)). Make sure the physical environment into which you will be installing the switch is properly prepared, including having the correct network cabling ready to connect to the switch and having an appropriate location for the switch. See [page 2-3](#) for some installation precautions.
2. **Verify the switch passes self test** ([page 2-6](#)). Plug the switch into a power source and observe that the LEDs on the switch's front panel indicate correct switch operation.
3. **Mount the switch** ([page 2-9](#)). The E2620 Switches can be mounted in a 19-inch telco rack, in an equipment cabinet, or on a horizontal surface.

The **non-PoE+** E2620 Switches can also be wall mounted. See [page 2-14](#) for wall mounting instructions.

The following switches can be rack mounted with rack kit, J9583A - HP X410 1U Universal 4-Post Rack Mounting Kit.

- J9623A HP Switch E2620-24
  - J9626A HP Switch E2620-48
  - J9624A HP Switch E2620-24-PPoE+
4. **Connect power to the switch** ([page 2-15](#)). Once the switch is mounted, plug it into the main power source.
  5. **Connect the network devices** ([page 2-15](#)). Using the appropriate network cables, connect the network devices to the switch ports.
  6. **(Optional) Install mini-GBICs** ([page 2-17](#)). The switch has two slots for installing mini-GBICs. Depending on where you install the switch, it may be easier to install the mini-GBICs first. Mini-GBICs can be hot swapped—they can be installed or removed while the switch is powered on.
  7. **(Optional) Connect an External Power Supply to the Switch** ([page 2-19](#)). You may wish to use a 600 RPS/EPS, 620 RPS/EPS, or 630 RPS/EPS with your E2620-PoE+ Switches. To do so you must connect these external power supplies using the RPS or EPS cables supplied with these devices.

8. **(Optional) Connect a console to the switch** ([page 2-25](#)). You may wish to modify the switch's configuration, for example, to configure an IP address so it can be managed using a web browser, from an SNMP network management station, or through a Telnet session. Configuration changes can be made by using the included console cable to connect a PC to the switch's console port.

At this point, your switch is fully installed. See the rest of this chapter if you need more detailed information on any of these installation steps.



**Figure 2-1. Air flow direction of the E2620 switches**

## 1. Prepare the Installation Site

**Cabling Infrastructure** - Ensure the cabling infrastructure meets the necessary network specifications. See the following table for cable types and lengths, and see appendix B, “[Cabling and Technology Information](#)” for more information:

- **Installation Location** - Before installing the switch, plan its location and orientation relative to other devices and equipment:
  - In the front of the switch, leave at least 7.6 cm (3 inches) of space for the twisted-pair and fiber-optic cabling.
  - In the back of the switch, leave at least 3.8 cm (1 1/2 inches) of space for the power cord.
  - On the sides of the switch, leave at least 7.6 cm (3 inches) for cooling.

## 2. Verify the Switch Passes Self Test

Before mounting the switch in its network location, you should first verify it is working properly by plugging it into a power source and verifying it passes its self test.

1. Connect the power cord supplied with the switch to the power connector on the back of the switch, and then into a properly grounded electrical outlet.

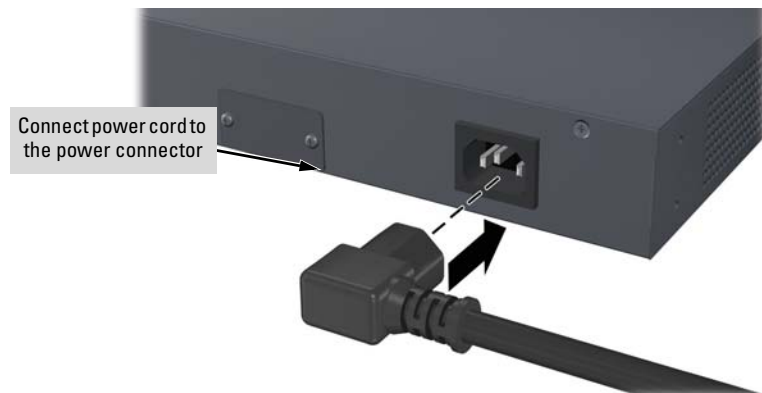

**Figure 2-2. Example of connecting the power cord**

---

**Note**

The E2620 Switches do not have a power switch. They are powered on when the power cord is connected to the switch and to a power source. For safety, the power outlet should be located near the switch installation.

The switch automatically adjusts to any voltage between 100-127 or 200-240 volts and either 50 or 60 Hz. There are no voltage range settings required.

If your installation requires a different power cord than the one supplied with the switch, be sure the cord is adequately sized for the switch's current requirements. In addition, be sure to use a power cord displaying the mark of the safety agency that defines the regulations for power cords in your country. The mark is your assurance that the power cord can be used safely with the switch. If the PoE+ device's supplied power cord does not fit, contact HP networking support.

---

2. Check the LEDs on the switch as described below.

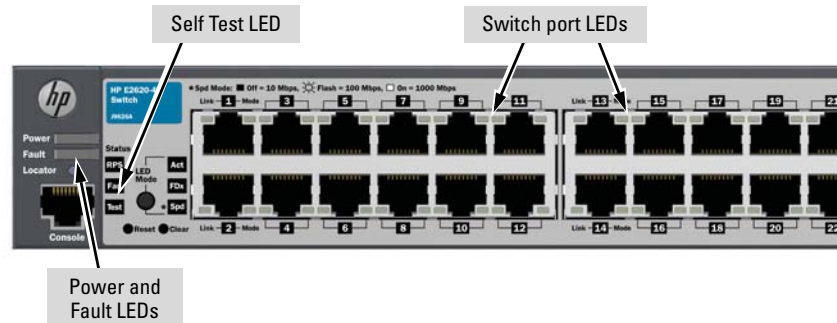

**Figure 2-3. Checking the LEDs on the E2620 non-PoE+ switches**

When the switch is powered on, it performs its diagnostic self test. Self test takes approximately 50 seconds to complete.

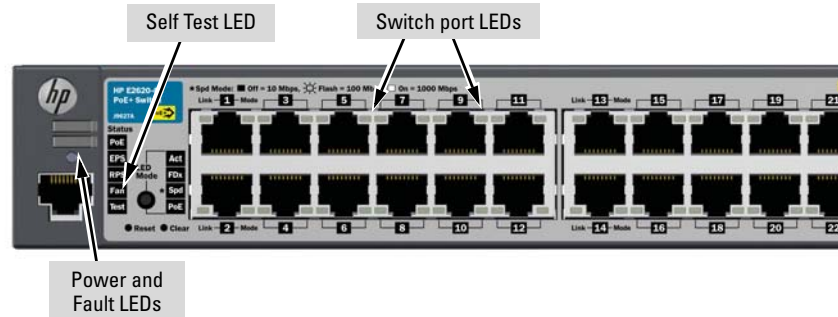

Figure 2-4. Checking the LEDs on the E2620-PoE+ switches

## LED Behavior

### During the self test:

- Initially, all the switch and port LEDs are on. Most of the LEDs go off and then may come on again during phases of the self test.
- For the duration of the self test, the Self Test LED stays on.

### When the self test completes successfully:

- The **Power** and **Fan** LEDs remain on.
- The **Fault** and **Test** LEDs go off.
- The port LEDs on the front of the switch go into their normal operational mode:
  - If the ports are connected to active network devices, the LEDs behave according to the Port LED View or LED Mode selected. The default view mode (Link), the LEDs should be on and the Mode LEDs will flicker if there is network activity.
  - If the ports are not connected to active network devices, the Link and **Act** LEDs will stay off.

If the LED display is different than what is described above, especially if the **Fault** and **Test** LEDs stay on for more than 60 seconds or they start flashing, the self test has not completed correctly. Refer to chapter 4, “[Troubleshooting](#)” for diagnostic help.



### 3. Mount the Switch

After the switch passes self test, it is ready to be mounted in a stable location. The E2620 Switches can be mounted in these ways:

Mounting Location	Non-PoE+ Switches	PoE+ Switches
In a rack or cabinet	Yes	Yes
On a horizontal surface	Yes	Yes
On a wall	Yes <sup>1,2</sup>	No
Under a desk	Yes <sup>1</sup>	No

<sup>1</sup> This also includes the E2620-24-PPoE+ Switch (J9624A).

<sup>2</sup> RJ-45 ports facing up only.

#### Rack or Cabinet Mounting

The E2620 Switches are designed to be mounted in any EIA-standard 19-inch telco rack or communication equipment cabinet. Note that the mounting brackets have multiple mounting holes and can be rotated allowing for a wide variety of mounting options. Secure the rack in accordance with the manufacture's safety guidelines.

---

#### WARNING

---

**For safe operation, please read the mounting precautions on [page 2-3](#), before mounting a switch.**

---

#### Equipment Cabinet Note

---

The 12-24 screws supplied with the switch are the correct threading for standard EIA/TIA open 19-inch racks. If installing the switch in an equipment cabinet such as a server cabinet, use the clips and screws that came with the cabinet in place of the 12-24 screws that are supplied with the switch.

## Rack Mounting the E2620-PoE+ switches

1. Use a #1 Phillips (cross-head) screwdriver and attach the mounting brackets to the switch with the included 8-mm M4 screws.



**Figure 2-5. Attaching large mounting brackets**

---

### **WARNING**

---

**For safe reliable installation, only use the screws provided in the accessory kit to attach the mounting brackets to the switch.**

---

### **Note**

---

The mounting brackets have multiple mounting holes and can be rotated allowing for a wide variety of mounting options. These include mounting the switch so that its front face is flush with the face of the rack, or mounting it in a more balanced position as shown in the illustration above.

2. Hold the switch with attached brackets up to the rack and move it vertically until rack holes line up with the bracket holes, then insert and tighten the four number 12-24 screws holding the brackets to the rack.

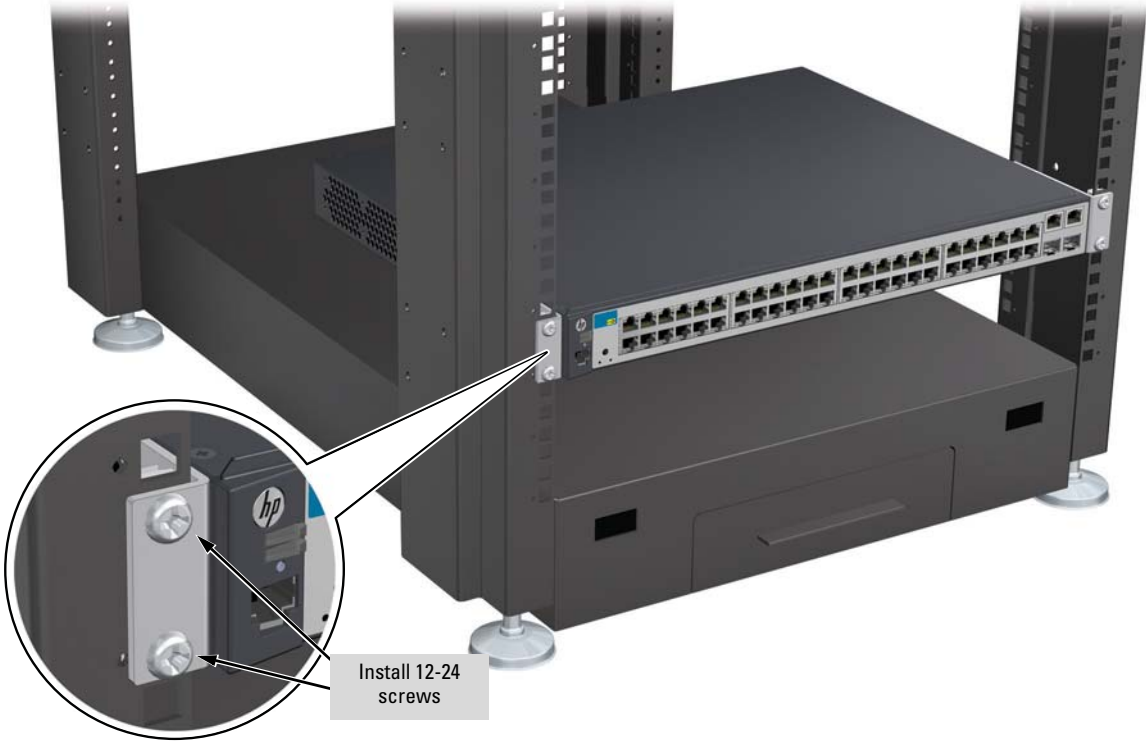

**Figure 2-6. Mounting in a rack**

## Rack Mounting the Non-PoE+ Switches

1. Use a #1 Phillips (cross-head) screwdriver and attach the mounting brackets to the switch with the included 8-mm M4 screws.



**Figure 2-7. Attaching small mounting brackets**

---

**Note**

The mounting brackets have multiple mounting holes and can be rotated allowing for a wide variety of mounting options. These include mounting the switch so that its front face is flush with the face of the rack, or mounting it in a more balanced position as shown in the illustration.

---

**WARNING**

**For safe reliable installation, only use the screws provided in the accessory kit to attach the mounting brackets to the switch.**

2. Hold the switch with attached brackets up to the rack and move it vertically until rack holes line up with the bracket holes, then insert and tighten the four number 12-24 screws holding the brackets to the rack.



**Figure 2-8. Mounting in a rack**

### Flat Wall Mounting (non-PoE+ models only)

You can mount the **non-PoE+** 2620 models on a wall. They should be mounted with the RJ-45 ports facing up as shown in Figure 2-9.

---

#### WARNING

---

**For safe operation do not install the switch with either side vent holes facing downward.**

---

#### Caution

---

The switch should be mounted only to a wall or wood surface that is at least 1/2-inch (12.7 mm) plywood or its equivalent.

1. Use a #1 Phillips (cross-head) screwdriver and attach the mounting brackets to the switch with the included 8-mm M4 screws.
2. Attach the switch to the wall or wood surface with two 5/8-inch number 12 wood screws (not included).

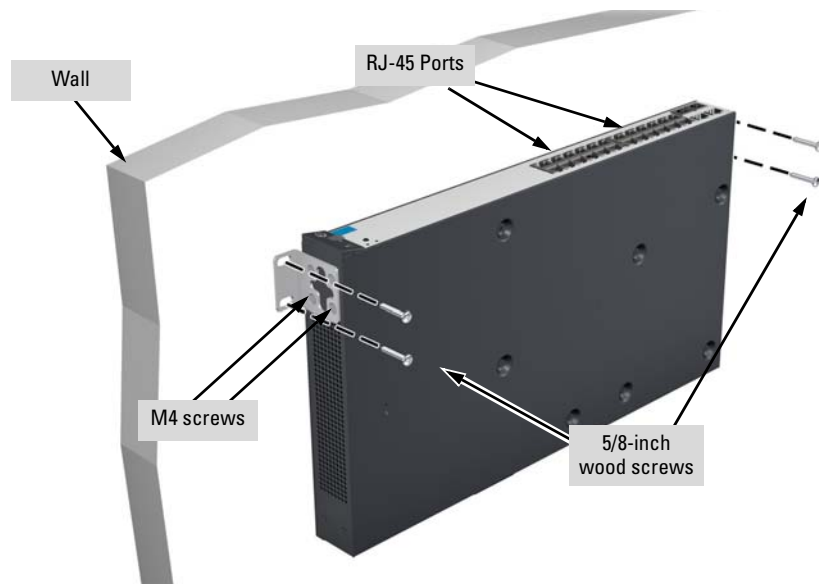

**Figure 2-9. Wall mounting RJ-45 ports facing up**

## Horizontal Surface Mounting

Place the switch on a table or other horizontal surface. The switch comes with rubber feet in the accessory kit that can be used to help keep the switch from sliding on the surface.

Attach the rubber feet to the four corners on the bottom of the switch within the embossed angled lines. Use a sturdy surface in an uncluttered area. You may want to secure the networking cables and switch power cord to the table leg or other part of the surface structure to help prevent tripping over the cords.

---

**Caution**

---

Ensure the air flow is not restricted around the sides and back of the switch.

## 4. Connect the Switch to a Power Source

1. Plug the included power cord into the switch's power connector and into a nearby AC power source. See [page 2-6](#).
2. Re-check the LEDs during self test. See "LED Behavior" on [page 2-8](#).

## 5. Connect the Network Cables

Connect the network cables, described under "Cabling Infrastructure" ([page 2-6](#)), from the network devices or your patch panels to the fixed RJ-45 ports on the switch or to any mini-GBICs you have installed in the switch.

## Using the RJ-45 Connectors

### To connect:

Push the RJ-45 plug into the RJ-45 port until the tab on the plug clicks into place. When power is on for the switch and for the connected device, the Link LED for the port should light to confirm a powered-on device (for example, an end node) is at the other end of the cable.

If the Link LED does *not* go on when the network cable is connected to the port, see “Diagnosing With the LEDs” in chapter 4, “Troubleshooting”.

### To disconnect:

Press the small tab on the plug and pull the plug out of the port.

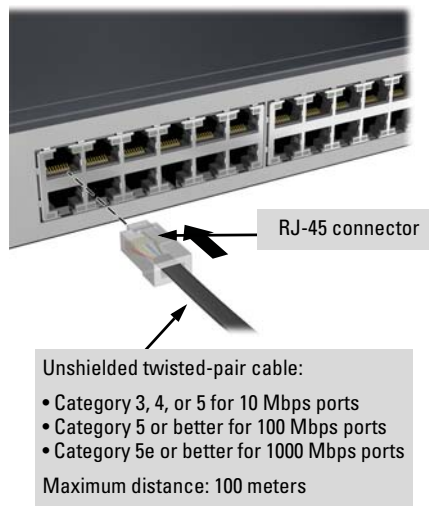

**Figure 2-10. Connecting network cables**



## 6. Installing or removing SFP transceivers (mini-GBICs)

You can install or remove an SFP (mini-GBIC) from an SFP slot without having to power off the switch. Use only HP SFP transceivers.

---

### Notes

- The SFP slots are not shared with the two 10/100/1000Base-T RJ-45 ports. When an SFP is installed in a slot, it operates independently of the RJ-45 ports.
  - The SFP ports operate only at full duplex. Half duplex operation is not supported, unless a 100-FX SFP transceiver is installed. The 100-FX SFP transceiver can operate at half duplex.
  - Ensure the network cable is NOT connected when you install or remove an SFP.
- 

---

### Caution

Use only supported genuine HP SFP transceivers with your switch. Non-HP SFP transceivers are not supported, and their use may result in product malfunction. Should you require additional HP SFP transceivers, contact your HP networking Sales and Service Office or authorized dealer.

---

#### Installing the SFP transceivers:

Remove the protective plastic cover and retain it for later use. Hold the SFP transceiver by its sides and gently insert it into either of the slots on the switch until the transceiver clicks into place.

---

### WARNING

**The HP SFP transceivers are Class 1 laser devices. Avoid direct eye exposure to the beam coming from the transmit port.**

---

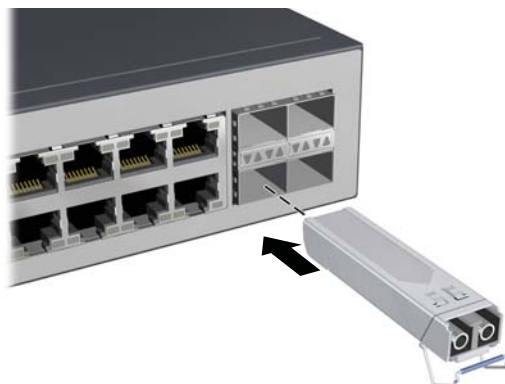

**Figure 2-11. Installing an SFP transceiver**

### Removing the SFP transceiver

---

**Note**

---

You should disconnect the network cable from the SFP transceiver before removing it from the switch.

Depending on when you purchased your HP SFP transceiver, it may have either of three different release mechanisms: a plastic tab on the bottom of the transceiver, a plastic collar around the transceiver, or a wire bail.

To remove the transceivers that have the plastic tab or plastic collar, push the tab or collar toward the switch until you see the transceiver release from the switch (you can see it move outward slightly), and then pull it from the slot.

To remove the transceivers that have the wire bail, lower the bail until it is approximately horizontal, and then using the bail, pull the transceiver from the slot.

Replace the protective plastic cover on the transceiver.

### Connecting Cables to SFP transceivers

If you have any SFP transceivers installed in the switch, the type of network connections you will need to use depends on the type of transceivers you have installed. See appendix B, “[Cabling and Technology Information](#)”, for cabling information.

For SFP transceiver ports, and in general for all the switch ports, when a network cable from an active network device is connected to the port, the port LED for that port should go on. If the port LED does *not* go on when the

network cable is connected to the port, see “[Diagnosing with the LEDs](#)” in chapter 4, “Troubleshooting”.

## 7. (Optional) Connect an External Power Supply to the Switch

There are three external power supplies available for these switches:

- HP 600 Redundant and External Power Supply, J8168A, is an accessory product for the E2620 switches and specific other HP switches.
- HP 620 Redundant and External Power Supply, J8696A, is an accessory product for the E2620 switches and specific other HP switches.
- HP 630 Redundant and/or External Power Supply, J9443A, is an accessory product for the E2620-PoE+ switches and specific other HP PoE+ switches.

The external power supplies provide two types of power to the switches:

- Redundant power, to back up the internal switch power supply in case of AC power loss, or a fault condition. Should the internal switch power supply fail, power will be supplied from the external power supply.
- External Power-over-Ethernet (PoE/PoE+) power. The external power supplies can supply PoE/PoE+ power to the switch if the internal PoE/PoE+ power supply fails. For the 48 port switch, the external PoE/PoE+ power is additional power made available to the switch's ports.

For further information regarding the external power supply PoE/PoE+ capabilities, see the following manuals:

- *HP Power over Ethernet (PoE/PoE+) Planning and Implementation Guide*
- *HP Redundant and/or External Power Supply Installation and Getting Started Guide*

These manuals are on the HP Web site at [www.hp.com/networking/support](http://www.hp.com/networking/support).

These external power supplies are unmanaged power supplies that only provide information by way of LEDs.

## RPS/EPS Operation

The RPS/EPS monitors the power signal from the switch by detecting that the RPS/EPS is connected to a switch with an RPS/EPS cable. When the power from the switch is no longer detected, the RPS/EPS will provide power to the switch within 1 millisecond.

The RPS/EPS supports hot plugging of the RPS/EPS cable without causing a reboot of the switch or causing the power supply in either the RPS/EPS or switch to shut down temporarily or permanently. For more information refer to the documentation that came with the RPS/EPS.

## Operating Characteristics of the external power supplies

The 600 external power supply has six RPS ports, the 620 RPS has two RPS ports, and the 630 external power supply has one RPS port, each of which can provide redundant +12V power to a connected switch. If a switch with no AC power is connected to an operating external power supply, it will not receive power. The switch must be initially powered on using AC power before external power supply will provide RPS power.

The 600 and 620 external power supplies can not be used by the E2620 switches for PoE/PoE+ (EPS) power. The 630 external power supply has one EPS port and can provide a maximum of 388 watts of PoE/PoE+ power. PoE power is provided at 50 volts and PoE+ power is provided at 54 Volts.

- It is important to understand the PoE/PoE+ power requirements of the switches because if the PoE/PoE+ power is not planned and implemented correctly the end devices connected to the switch ports may not receive power if an internal switch PoE/PoE+ power supply should fail. For further information regarding the external power supply PoE/PoE+ capabilities, see the following manuals:
  - *HP Power over Ethernet (PoE/PoE+) Planning and Implementation Guide*
  - *HP Redundant and/or External Power Supply Installation and Getting Started Guide*

These manuals are on the HP Web site at [www.hp.com/networking/support](http://www.hp.com/networking/support).

For redundant AC power, connect the external power supply to the switch using one of the supplied RPS cables. For redundant or additional PoE/PoE+ power, connect the external power supply to the switch using one of the supplied EPS cables. The RPS and EPS cables are 2.00 meters (6.56 feet) in length. These cables are identical. If accidentally cross connected, nothing will happen. No power will flow until properly connected.

## External Power Supply LEDs

The external power supply LEDs are duplicated on the front and back of the units. The following graphics show examples of the back of the 600 EPS/RPS and the front and back of the 630 RPS/EPS. There are dual colored (green/orange) LEDs for each RPS and EPS port:

- Device Connected
- Power Status

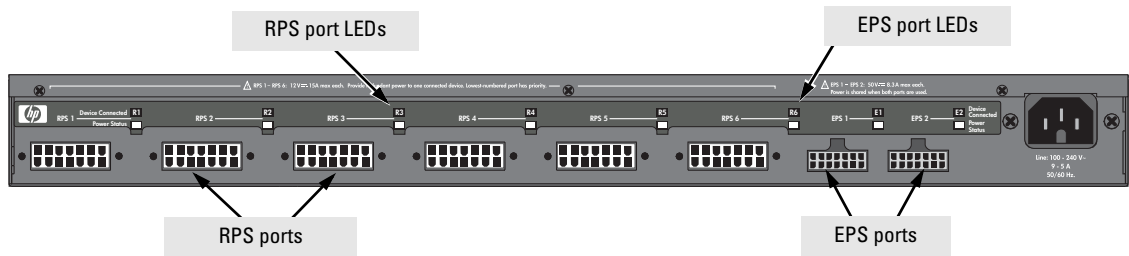

**Figure 2-12. Back of the 600 RPS/EPS**

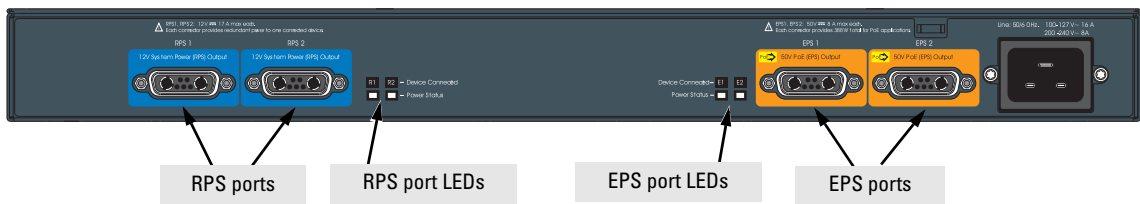

**Figure 2-13. Back of the 620 RPS/EPS**

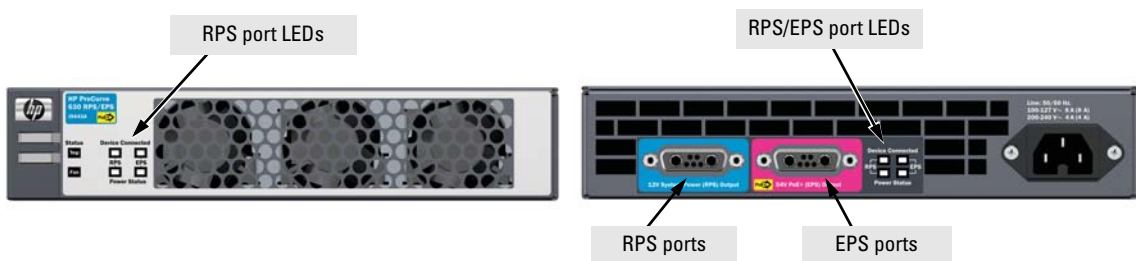

**Figure 2-14. Front and back of the 630 RPS/EPS**

**Table 2-1. RPS/EPS LEDs**

LED	State	Meaning
Power (green)	On	The unit is powered on.
	Off	The unit is NOT powered on.
Fault (orange)	Off	The normal state; indicates that there are no fault conditions on the unit.
	Blink orange <sup>1,3</sup>	A fault has occurred on the unit, one of the ports, or the fan. The Status LED for the component with the fault will blink simultaneously.
	On	On briefly after the unit is powered on or reset, at the beginning of unit self test. If this LED is on for a prolonged time, the unit has encountered a fatal hardware failure, or has failed its self test. See chapter 3, “ <a href="#">Troubleshooting</a> ” for more information.
Temp Status (green and orange)	On	The temperature of the unit is within specification.
	Blink orange <sup>2</sup>	One of these conditions exists: <ul style="list-style-type: none"> <li>• A cooling fan has failed. The unit Fault LED and Fan Status LED will be blinking simultaneously.</li> <li>• There is an over temperature condition in the unit. The unit Fault LED is off.</li> </ul>
Fan Status (green and orange)	On	The cooling fans are operating normally.
	Blink orange <sup>1</sup>	A cooling fan has failed. The unit Fault LED will be blinking simultaneously.
Port Status (also on back panel of the external power supplies)		
Device Connected (green – over-laid with the port number)	On	There is a valid connection to a device.
	Off	There is no valid device connected to the port.
Power Status (green and orange)	On	The unit is supplying power to a connected device.
	Off	One of these conditions exists: <ul style="list-style-type: none"> <li>• There is no connected device.</li> <li>• A connected RPS device does not require power.</li> <li>• A connected EPS device has not successfully communicated for EPS power.</li> </ul>
	Blink orange <sup>1</sup>	One of these conditions exists: <ul style="list-style-type: none"> <li>• On the external power supply, RPS power is not available to the connected device because there is a hardware or power supply failure in the external power supply.</li> <li>• When the LED is blinking simultaneously with the Fault LED, there is a fault condition on the port.</li> </ul>
<sup>1</sup> The blinking behavior is an on/off cycle once every 1.6 seconds, approximately. <sup>2</sup> The blinking behavior is an on/off cycle once every 0.8 seconds, approximately. <sup>3</sup> Specific fault conditions can be viewed by checking switch log files.		

## External Power Supply Connectivity

This section shows some recommended connection topologies using the external power supplies.

### 600 RPS/EPS

The 600 RPS/EPS can provide backup power support for up to six HP switches. In the illustration below, one HP E2620-24-PoE+ switch is connected to an RPS port on a 600 RPS/EPS.



Figure 2-15. Connecting RPS to one switch

### 620 RPS/EPS

The 620 RPS/EPS can provide backup power support for two HP switches. In Figure 2-16, two HP E2620 PoE+ switches are connected to the RPS ports on a 620 RPS/EPS.

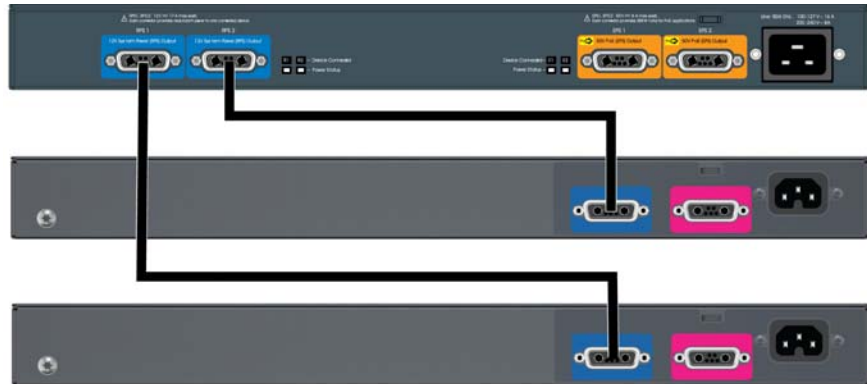

Figure 2-16. Connecting RPS to two switches

### 630 RPS/EPS

The 630 RPS/EPS can provide backup power support for one HP switch. In Figure 2-17, one HP E2620-48-PoE+ switch is connected to the RPS port on a 630 RPS/EPS.



**Figure 2-17. Connecting the 630 RPS to a switch**

The 630 RPS/EPS is designed to provide primary or backup PoE+ power to one HP PoE+ switch. In the following illustration, one HP E2620-48-PoE+ switch is being supplied with external PoE+ power from a 630 RPS/EPS. The switch provides PoE+ power to Ethernet devices connected to the ports.



**Figure 2-18. Connecting the 630 EPS to a switch**

- For further information regarding the external power supply PoE/PoE+ capabilities, see the following manuals:
  - *HP Power over Ethernet (PoE/PoE+) Planning and Implementation Guide*
  - *HP Redundant and/or External Power Supply Installation and Getting Started Guide*

These manuals are on the HP Web site at [www.hp.com/networking/support](http://www.hp.com/networking/support).



## 8. (Optional) Connect a Console to the Switch

The E2620 Switches have a full-featured, easy to use console interface for performing switch management tasks including the following:

- monitor switch and port status and observe network activity statistics
- modify the switch's configuration to optimize switch performance, enhance network traffic control, and improve network security
- read the event log and access diagnostic tools to help in troubleshooting
- download new software to the switch
- add passwords to control access to the switch from the console, web browser interface, and network management stations

The console can be accessed through these methods:

- **Out-of-band:** The E2620 Switches come with a serial cable for connecting a PC or VT-100 terminal, to be used as a console, directly to the switch.
- **In-Band:** Access the console using Telnet from a PC or UNIX station on the network, and a VT-100 terminal emulator. This method requires that you first configure the switch with an IP address and subnet mask by using either out-of-band console access or through DHCP/Bootp. For more information on IP addressing and on starting a Telnet session, see chapter 3, “[Configuring the Switch](#)”, in the Management and Configuration Guide, which is on the HP Web site at [www.hp.com/networking/support](http://www.hp.com/networking/support), (See [page 1-14](#)).

The E2620 Switches can simultaneously support one out-of-band console session through the Console Port and in-band Telnet console sessions.

### Terminal Configuration

To connect a console to the switch, configure the PC terminal emulator as a DEC VT-100 (ANSI) terminal or use a VT-100 terminal, and configure either one to operate with these settings:

- any baud rate from 1200 to 115200 (the switch senses the speed)
- 8 data bits, 1 stop bit, no parity, and flow control set to Xon/Xoff
- for the Windows Terminal program, also disable (uncheck) the “Use Function, Arrow, and Ctrl Keys for Windows” option
- for the Hilgraeve HyperTerminal program, select the “Terminal keys” option for the “Function, arrow, and ctrl keys act as” parameter

If you want to operate the console using a different configuration, make sure you change the settings on both the terminal and on the switch so they are compatible. Change the switch settings first, then change the terminal settings, then reboot the switch and reestablish the console session.

## Direct Console Access

To connect a console to the switch, follow these steps:

1. Connect the PC or terminal to the switch's Console Port using the console cable included with the switch. (If your PC or terminal has a 25-pin serial connector, first attach a 9-pin to 25-pin straight-through adapter at one end of the console cable.)
2. Turn on the terminal or PC's power and, if using a PC, start the PC terminal program.
3. Press **[Enter]** two or three times and you will see the copyright page and the message "Press any key to continue". Press a key, and you will then see the switch console command (CLI) prompt, for example:

**ProCurve Switch #**

If you want to continue with console management of the switch at this time, see chapter 3, "Getting Started With Switch Configuration" for some basic configuration steps. For more detailed information, refer to the *Management and Configuration Guide*, which is on the HP Web site at [www.hp.com/networking/support](http://www.hp.com/networking/support), (See page 1-14).

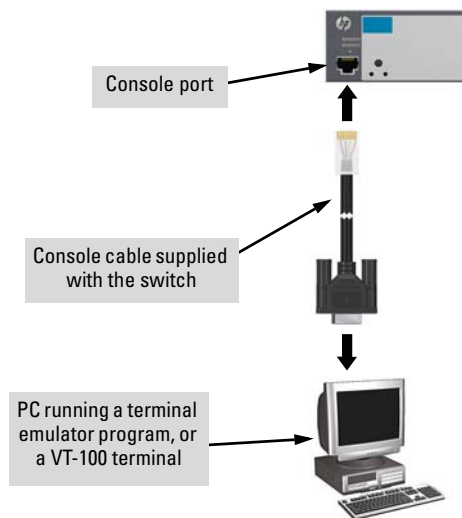
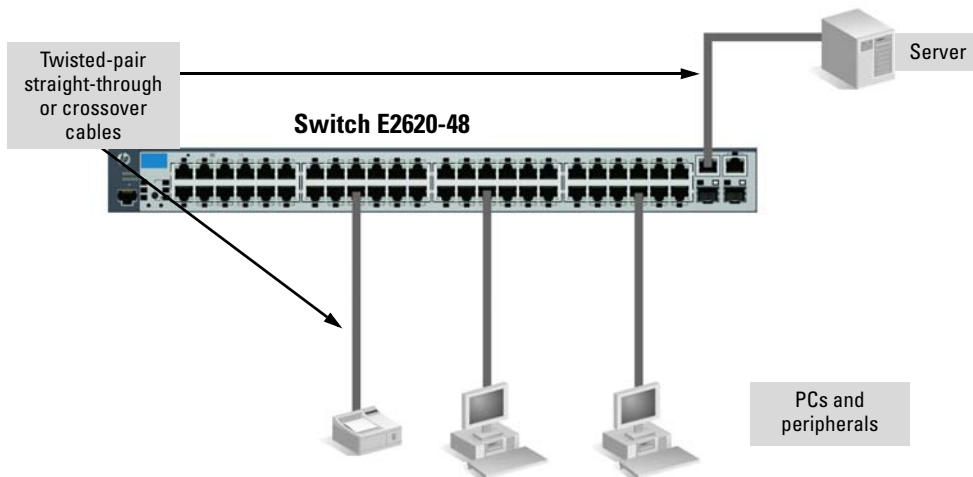

**Figure 2-19. Connecting the console cable**

## Sample Network Topologies for Non-PoE+ Switches

This section shows a few sample network topologies in which the Switch E2620 is implemented. For more topology information, see the HP networking products Web site, [www.hp.com/networking/support](http://www.hp.com/networking/support).

### As a Desktop Switch



**Figure 2-20. Basic desktop configuration**

The E2620 Switches are designed to be used primarily as desktop switches to which end nodes, printers, other peripherals, and servers are directly connected, as shown in the above illustration. The end node devices are connected to the switch by straight-through or crossover twisted-pair cables. Either cable type can be used because of the Auto-MDIX feature on the E2620 Switches ports.

## As a Segment Switch

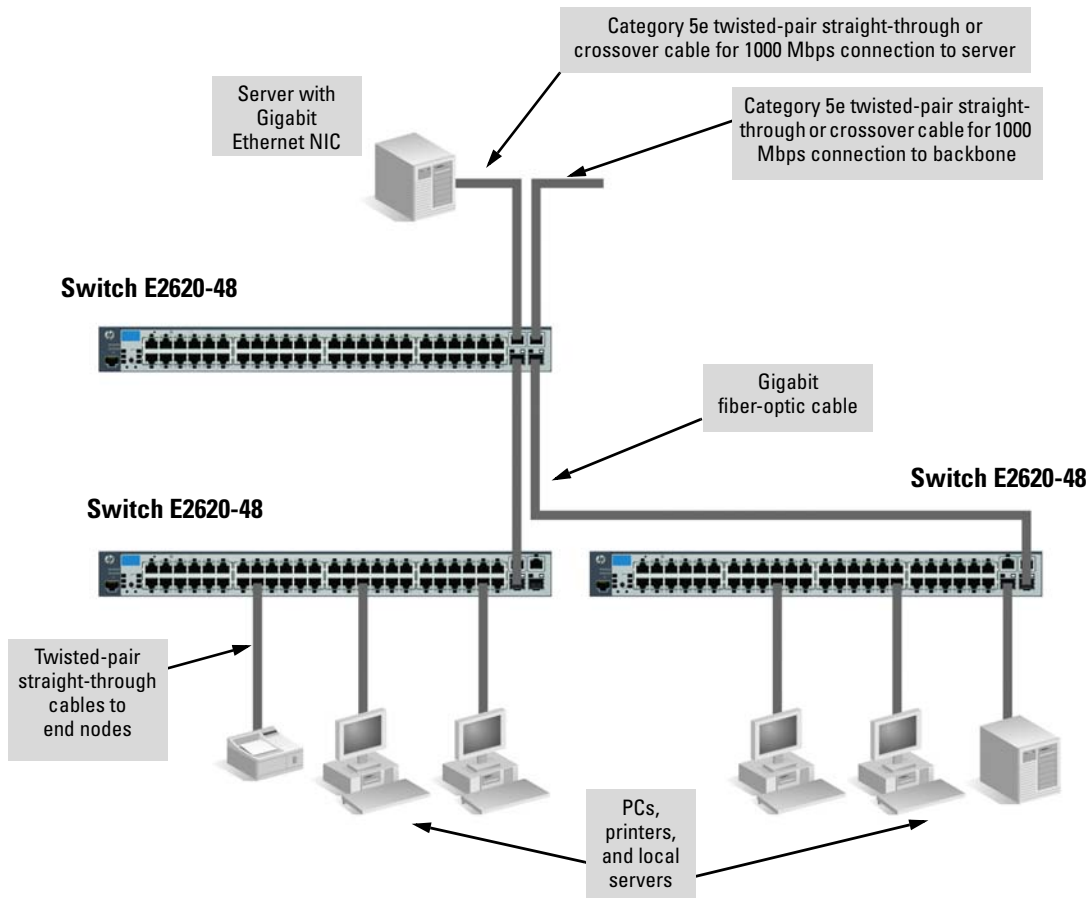

**Figure 2-21. Segment network configuration**

The E2620 Switches also work well as segment switches. That is, with their high performance, they can be used for interconnecting network segments—simply connect the network devices that form those segments to the E2620 Switches.

In the illustration above, two “Fast Ethernet” switches with PCs, printers, and local servers attached, are both connected to a Switch E2620-48. The devices attached to the two desktop switches can now communicate with each other through the switch. They can also all communicate with the server that is connected to a 1000Base-T port on the switch.

Because the E2620 Switches have the Auto-MDIX feature, the connections between the switches, and between the switch and end nodes or servers can be through category 5 straight-through or crossover twisted-pair cable. Category 3 or 4 cable can also be used if the connection is 10 Mbps only. In all cases, the device ports must be configured to auto negotiate the link characteristics for this feature to work.

The switch, in turn, can be connected to a network backbone through fiber-optic cabling connected to a Gigabit-SX, -LX, or -LH mini-GBIC. Now, all the devices on these network segments can access other network resources that are connected elsewhere on the network backbone. Always remember when connecting fiber-optics that all components match in specification.

## Connecting to a Backbone Switch

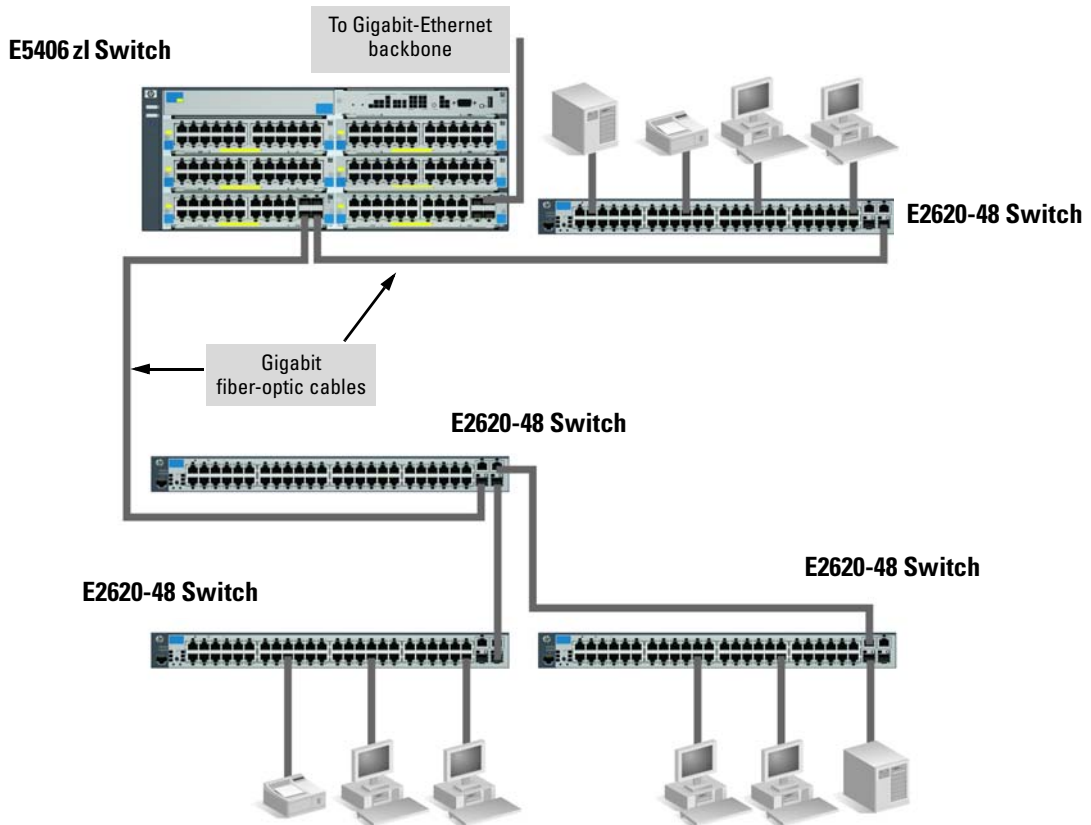

Figure 2-22. Networking to a gigabit ethernet backbone

## Installing the Switch

### Sample Network Topologies for Non-PoE+ Switches

The simpler desktop and segment networks shown in the previous two examples can easily be combined and expanded. For example, you could use a HP E5406 zl Switch to interconnect each of your smaller switched workgroups to form a larger switched network. All the devices in this network can communicate with each other. For example, with Gigabit-SX Mini-GBICs installed in a Mini-GBIC Module, in the E5406 zl Switch, the entire switched topology could be connected to a campus backbone, as shown in the illustration above.

---

#### **Note**

In the Figure 2-22, the 1000 Mbps fiber-optic connection between the E2620 Switches and the 5406 zl Switch is by way of a Gigabit-SX mini-GBIC installed in the E2620 Switches connected to a Gigabit SX mini-GBIC installed in the mini-GBIC Module in the 5406 zl Switch.

---

## Sample Network Topologies for PoE+ Switches

This section shows a few sample network topologies for implementing the Switch E2620-PoE+ Series. For more topology information, see the HP networking products Web site, [www.hp.com/networking/support](http://www.hp.com/networking/support).

### As a Desktop Switch Implementing PoE+

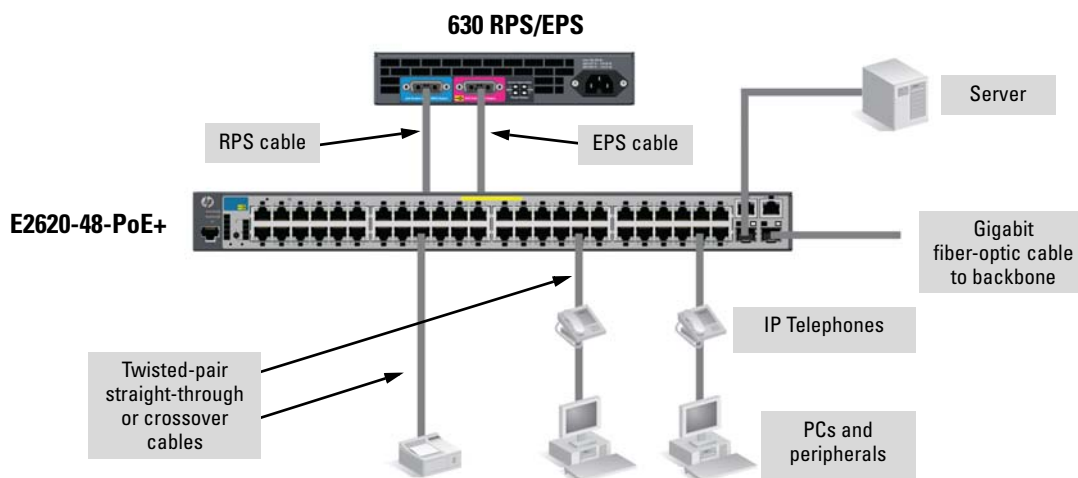

**Figure 2-23. Basic desktop configuration with external power**

The Switch E2620-PoE+ Series are also designed to be used as desktop switches to which end nodes, printers and other peripherals, and servers are directly connected, as shown in the above illustration. Except now these switches can supply PoE power to end devices such as IP telephones.

As shown in the above illustration the IP telephones can be connected in line, that is, between the switch and the end device, in this case a PC. The IP telephones have two ports, one in and one out. Therefore the phone receives voice and power from the switch and the PC can send and receive data through the phone to the switch.

The end node devices are connected to the switch by straight-through or crossover twisted-pair cables. Either cable type can be used because of the Auto-MDIX feature on the E2620-PoE+ Switches.

## As a Segment Switch Implementing PoE

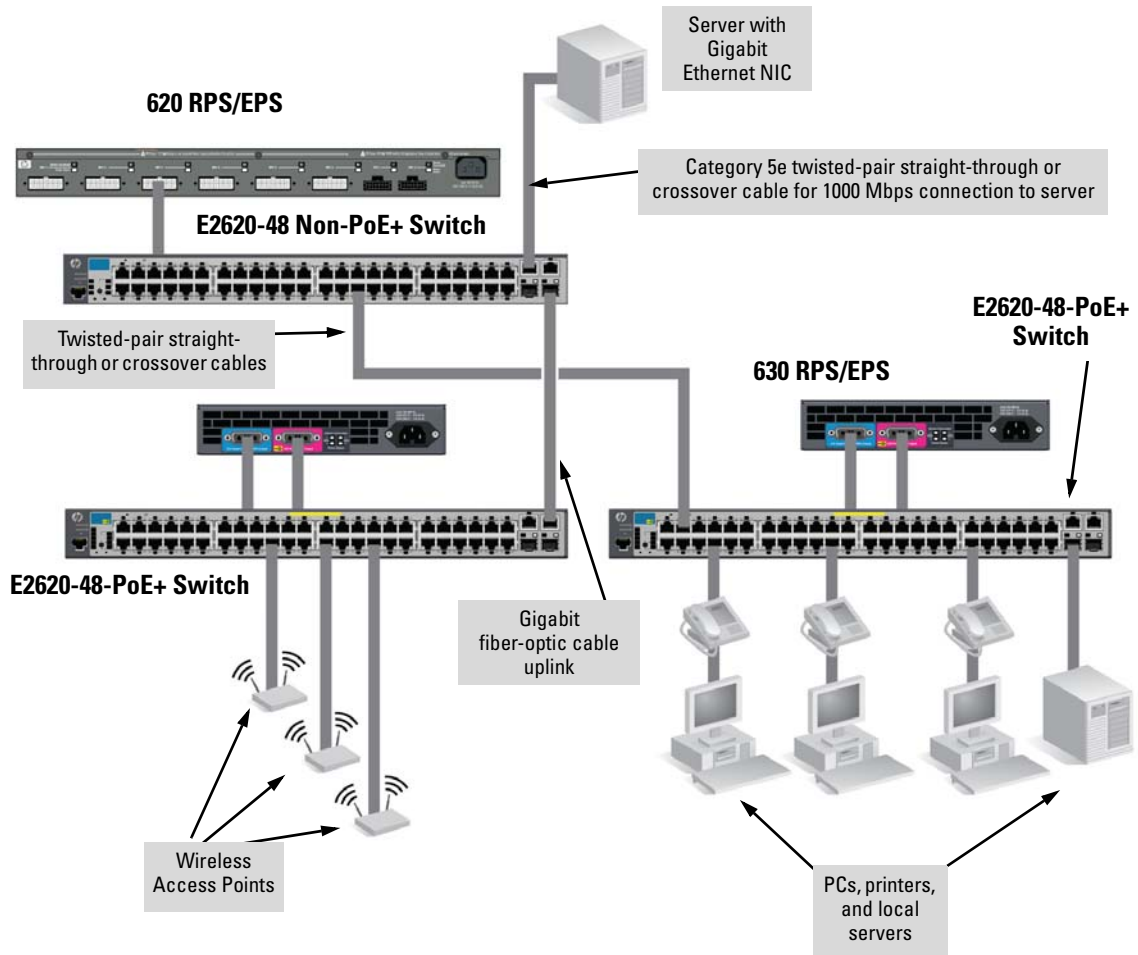

**Figure 2-24. Segment network configuration with PoE+ switches**

As shown in the illustration above, the IP telephones have been inserted in between the E2620-48-PoE+ Switch and the PCs, and wireless access points (WAPs) have been connected to another E2620-48-PoE+ Switch. Both the telephones and WAPs will receive PoE+ power from each of the switches. Only devices directly connected to the PoE+ switches can receive PoE+ power. Devices connected to a non-PoE+ segment switch cannot receive PoE+ power.



## Connecting to a Backbone Switch Implementing PoE

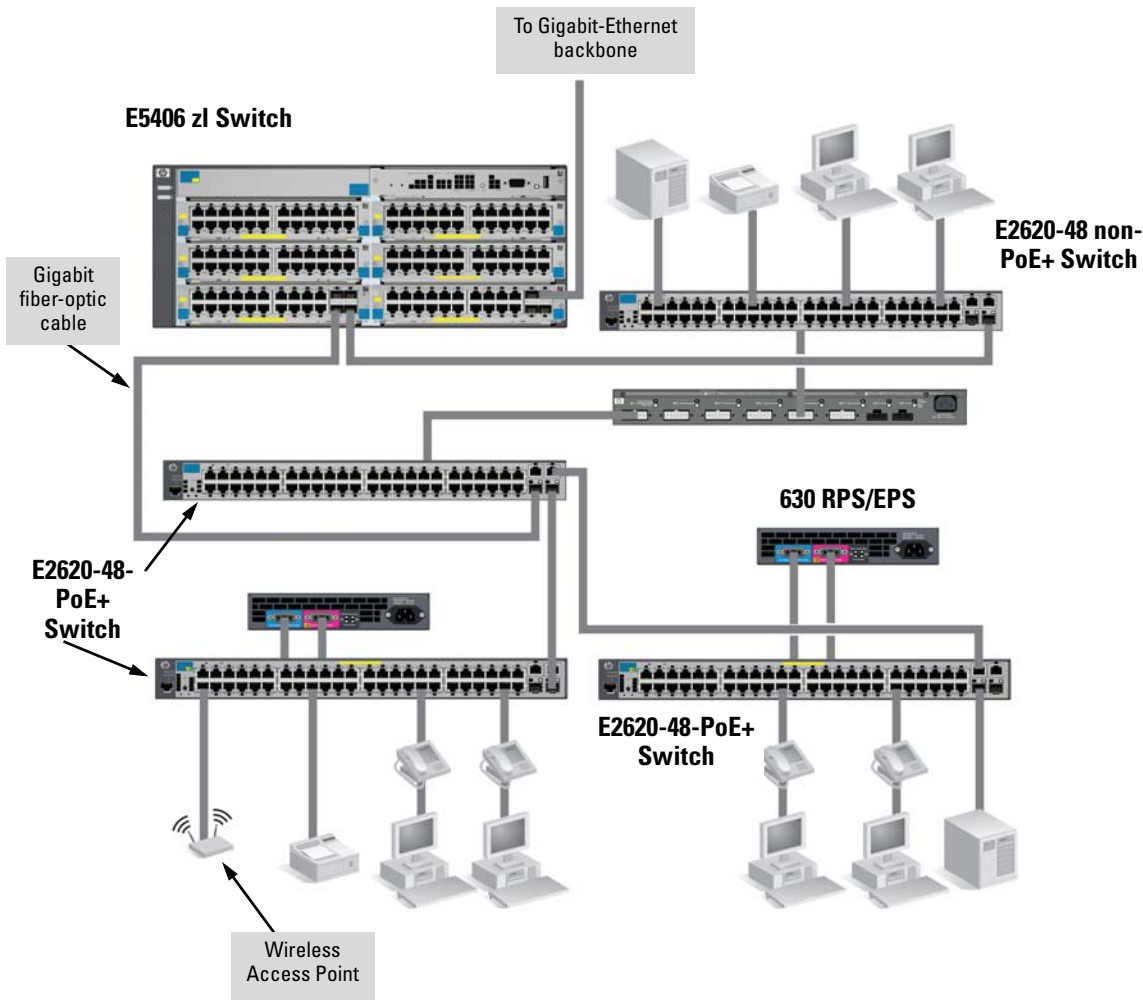

Figure 2-25. Networking PoE+ switches to a gigabit ethernet backbone

## Stacking the Switch

The E2620 and E2620-PoE+ Switches can be connected together, through standard network connections, and managed through a single IP address. Up to 16 switches can be connected together in such a “virtual stack”.

You identify an E2620 or E2620-PoE+ Switch as the “Commander” and give that switch an IP address. Up to 15 other switches in the network can then easily be configured as Members of the stack and managed through the Commander’s IP address. The management includes Telnet access and web browser interface access to the Commander and to each Member switch through the Commander.

For more information on stacking your switch, see the *Management and Configuration Guide*, which is on the HP Web site at [www.hp.com/networking/support](http://www.hp.com/networking/support), (see [page 1-14](#)).

# Configuring the Switch

---

This chapter is a guide for using the console Switch Setup screen to quickly assign an IP (Internet Protocol) address and subnet mask to the switch, set a Manager password, and, optionally, configure other basic features.

For more information on using the switch console and the web browser interface, please see the *Management and Configuration Guide*, which is on the HP Web site at [www.hp.com/networking/support](http://www.hp.com/networking/support), (see page 1-14).

## Recommended Minimal Configuration

In the factory default configuration, the switch has no IP (Internet Protocol) address and subnet mask, and no passwords. In this state, it can be managed only through a direct console connection. To manage the switch through in-band (networked) access, you should configure the switch with an IP address and subnet mask compatible with your network. Also, you should configure a Manager password to control access privileges from the console and web browser interface. Other parameters in the Switch Setup screen can be left at their default settings or you can configure them with values you enter.

Many other features can be configured through the switch's console interface, to optimize the switch's performance, to enhance your control of the network traffic, and to improve network security. Once an IP address has been configured on the switch, these features can be accessed more conveniently through a remote Telnet session, through the switch's web browser interface, and from an SNMP network management station running a network management program. For a listing of switch features available with and without an IP address, refer to "How IP Addressing Affects Switch Operation" in the *Management and Configuration Guide*, which is on the HP Web site at [www.hp.com/networking/support](http://www.hp.com/networking/support), (see page 1-14).

For more information on IP addressing, refer to "IP Configuration" in the *Management and Configuration Guide*.

---

**Note**

By default, the switch is configured to acquire an IP address configuration from a DHCP or Bootp server. To use DHCP/Bootp instead of the manual method described in this chapter, see "DHCP/Bootp Operation" in the *Management and Configuration Guide*, which is on the HP Web site at [www.hp.com/networking/support](http://www.hp.com/networking/support), (see page 1-14).

---

## Using the Console Setup Screen

The quickest and easiest way to minimally configure the switch for management and password protection in your network is to use a direct console connection to the switch, start a console session, and access the Switch Setup screen.

1. Using the method described in the preceding section, connect a terminal device to the switch and display the switch console command line interface (CLI) prompt (the default display).

The CLI prompt appears, for example:

**HP#**

2. At the prompt, enter the **setup** command to display the Switch Setup screen. The following illustration shows the Setup screen with the default settings.

```
E2620 Switch                               1-Jan-1990  0:29:20
----- CONSOLE - MANAGER MODE -----
Switch Setup

System Name : E2620 Switch
System Contact :
Manager Password :
Confirm Password :
Login Default : CLI                Time Zone [0] : 0
Community Name : public           Spanning Tree Enabled [No] : No
Default Gateway :
Time Sync Method [None] : TIMEP
TimeP Mode [Disabled] : Disabled

IP Config [Manual] : DHCP/Bootp
IP Address : 10.10.131.148
Subnet Mask : 255.255.255.0
Actions->  Cancel      Edit      Save      Help

Enter System Name - up to 32 characters.
Use arrow keys to change field selection, <Space> to toggle field choices,
and <Enter> to go to Actions.
```

**Figure 3-1. Example console setup screen**

3. Use the **[Tab]** key to select the **Manager Password** field and enter a manager password of up to 16 printable ASCII characters.
4. **[Tab]** to the **IP Config (DHCP/Bootp)** field and use the Space bar to select the **Manual** option.
5. **[Tab]** to the **IP Address** field and enter the IP address that is compatible with your network.
6. **[Tab]** to the **Subnet Mask** field and enter the subnet mask used for your network.
7. Press **[Enter]**, then **[S]** (for **Save**).

Here is some information on the fields in the Setup screen. For more information on these fields, see the *Management and Configuration Guide*, which is on the HP Web site at [www.hp.com/networking/support](http://www.hp.com/networking/support), (see [page 1-14](#)):

---

<b>Parameter</b>	<b>Default</b>	
System Name	blank	Optional; up to 25 characters, including spaces
System Contact	blank	Optional; up to 48 characters, including spaces
Manager Password	blank	Recommended; up to 16 characters (no blank spaces)
Logon Default	CLI	The default setting selects the command line interface for console access. The alternative is the menu interface.
Time Zone	0 (none)	Optional; 1440 to -1440. The number of minutes your location is to the West (-) or East (+) of GMT.
Community Name	public	Default setting recommended.
Spanning Tree Enabled	No	Default setting recommended unless STP is already running on your network or the switch will be used in complex network topologies.
Default Gateway	blank	Optional; Enter the IP address of the next-hop gateway node if network traffic needs to be able to reach off-subnet destinations.
Time Sync Method	None	Optional; The protocol the switch uses to acquire a time signal. The options are SNTP and TimeP.
TimeP Mode	Disabled	Optional; The method the switch uses to acquire the TimeP server address.
IP Config (DHCP/Bootp)	DHCP/Bootp	Set to Manual unless a DHCP/Bootp server is used on your network to configure IP addressing.
IP Address	xxx.xxx.xxx.xxx	Recommended; If you set IP Config to Manual, then enter an IP address compatible with your network.
<b>Note:</b> The IP address and subnet mask assigned for the switch must be compatible with the IP addressing used in your network. For more information on IP addressing, see the <i>Management and Configuration Guide</i> , which is on the HP Web site at <a href="http://www.hp.com/networking/support">www.hp.com/networking/support</a> , (see <a href="#">page 1-14</a> ).		
Subnet Mask	xxx.xxx.xxx.xxx	Recommended; If you entered an IP address, then enter a subnet mask compatible with your network.

---

## Where to Go From Here

The above procedure configures your switch with a Manager password, IP address, and subnet mask. As a result, with the proper network connections, you can now manage the switch from a PC equipped with Telnet, and/or a web browser interface.

## Configuring the Switch

### Recommended Minimal Configuration

Some basic information on managing your switch is included in the next section. For more information on the console, web browser, and SNMP management interfaces and all the features that can be configured on the E2620 Switches, see the *Management and Configuration Guide*, which is on the HP Web site at [www.hp.com/networking/support](http://www.hp.com/networking/support), (see page 1-14).

#### **To Recover from a Lost Manager Password:**

If you cannot start a console session at the manager level because of a lost Manager password, you can clear all passwords and user names by getting physical access to the switch and pressing and holding the Clear button for a full second.

# Using the IP Address for Remote Switch Management

With your switch, you can use the switch's IP address to manage the switch from any PC that is on the same subnet as the switch. You can use either a Telnet session or a standard web browser to manage the switch.

## Starting a Telnet Session

To access the switch through a Telnet session, follow these steps:

1. Make sure the switch is configured with an IP address and that the switch is reachable from the PC that is running the Telnet session (for example, by using a Ping command to the switch's IP address).
2. Start the Telnet program on a PC that is on the same subnet as the switch and connect to the switch's IP address.
3. You will see the copyright page and the message "Press any key to continue". Press a key, and you will then see the switch console command (CLI) prompt, for example:

**HP#**

Enter **help** or **?** to see a list of commands that can be executed at the prompt. Entering any command followed by **help** provides more detailed context help information about the command. Entering any command followed by **?** displays a list of options that are available at that point in the command entry.

## Starting a Web Browser Session

The E2620 Switches can be managed through a graphical interface that you can access from any PC or workstation on the network by running your web browser and typing in the switch's IP address as the URL. No additional software installation is required to make this interface available; it is included in the switch's onboard software.

A typical web browser interface screen is shown in the next illustration.

## Configuring the Switch

### Using the IP Address for Remote Switch Management

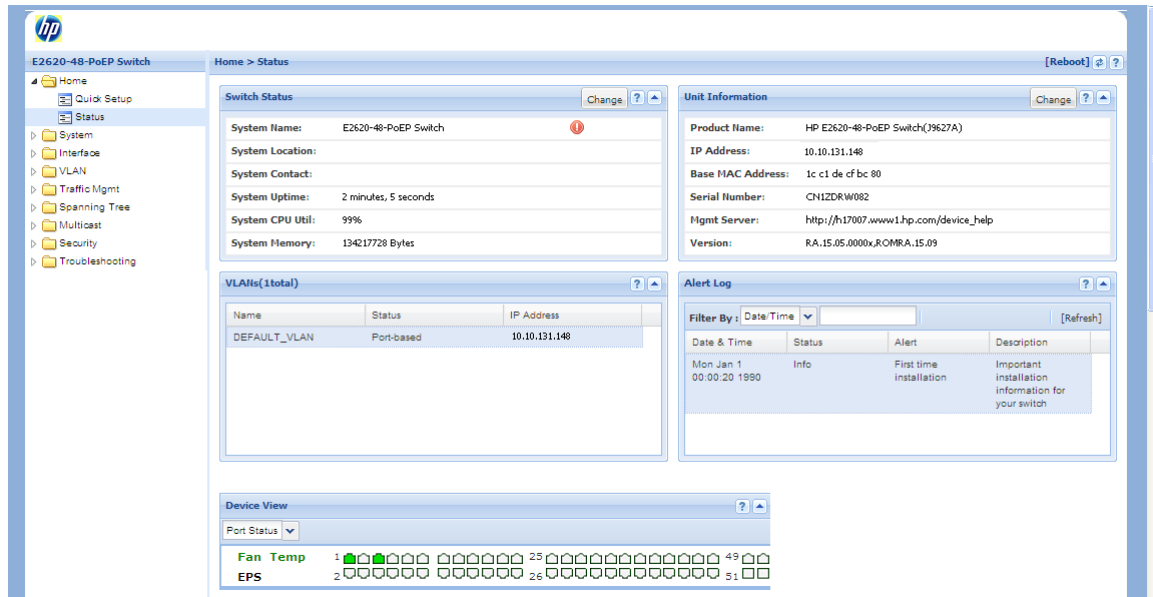

**Figure 3-2. Example web browser session**

For more information on using the web browser interface, please see the *Management and Configuration Guide*, which is on the HP Web site at [www.hp.com/networking/support](http://www.hp.com/networking/support), (see page 1-14).

An extensive help system is also available for the web browser interface. To access the help system though, the subnet on which the switch is installed must have access to the internet.



# Troubleshooting

---

This chapter describes how to troubleshoot your HP E2620 Switches. This document describes troubleshooting mostly from a hardware perspective. You can perform more in-depth troubleshooting on these devices using the software tools available with the switches, including the full-featured console interface, the built-in web browser interface, and ProCurve Manager, the SNMP-based network management tool. For more information, see the chapter “Troubleshooting” in the *Management and Configuration Guide*, which is on the HP Web site at [www.hp.com/networking/support](http://www.hp.com/networking/support), (see [page 1-14](#)).

This chapter describes the following:

- basic troubleshooting tips ([page 4-1](#))
  - diagnosing with the LEDs ([page 4-4](#))
  - proactive networking tools ([page 4-9](#))
  - hardware diagnostic tests ([page 4-10](#))
  - restoring the factory default configuration ([page 4-12](#))
  - downloading new software to the E2620 Switches ([page 4-13](#))
  - HP Customer Support Services ([page 4-13](#))
- 

## Basic Troubleshooting Tips

Most problems are caused by the following situations. Check for these items first when starting your troubleshooting:

- **Connecting to devices that have a fixed full-duplex configuration.** The RJ-45 ports are configured as “Auto”. That is, when connecting to attached devices, the switch operates in one of two ways to determine the link speed and the communication mode (half duplex or full duplex):
    - If the connected device is also configured to Auto, the switch will automatically negotiate both link speed and communication mode.
    - If the connected device has a fixed configuration, for example 100 Mbps, at half or full duplex, the switch will automatically sense the link speed, but will default to a communication mode of half duplex.
-

## Caution

---

Because the E2620 Switches behave in this way (*in compliance with the IEEE 802.3 standard*), if a device connected to the switch has a fixed configuration at full duplex, the device will not connect correctly to the switch. The result will be high error rates and very inefficient communications between the switch and the device.

Ensure all devices connected to the E2620 Switches are configured to auto negotiate, or are configured to connect at half duplex (all hubs are configured this way, for example).

- **Faulty or loose cables.** Look for loose or obviously faulty connections. If the cables appear to be OK, make sure the connections are snug. If that does not correct the problem, try a different cable.
- **Non-standard cables.** Non-standard and miswired cables may cause network collisions and other network problems, and can seriously impair network performance. Use a new correctly-wired cable or compare your cable to the cable in appendix B, “Switch Ports and Network Cables” for pinouts and correct cable wiring. A category 5 cable tester is a recommended tool for every 100Base-TX and 1000Base-T network installation.
- **Improper Network Topologies.** It is important to make sure you have a valid network topology. Common topology faults include excessive cable length and excessive repeater delays between end nodes. If you have network problems after recent changes to the network, change back to the previous topology. If you no longer experience the problems, the new topology is probably at fault. Sample topologies are shown at the end of chapter 2 in this book, and some topology configuration guidelines can be found online at the HP Web site, [www.hp.com/networking/support](http://www.hp.com/networking/support).

In addition, you should make sure your network topology contains *no data path loops*. Between any two end nodes, there should be only one active cabling path at any time. Data path loops will cause broadcast storms that will severely impact your network performance.

For your Switch, if you wish to build redundant paths between important nodes in your network to provide some fault tolerance, you should enable **Spanning Tree Protocol** support on the switch. This ensures that only one of the redundant paths is active at any time, thus avoiding data path loops. Spanning Tree can be enabled through the switch console or the web browser interface.

The E2620 Switches also support **Trunking**, which allows multiple network cables to be used for a single network connection without causing a data path loop. For more information on Spanning Tree and Trunking, see the *Management and Configuration Guide*, which is on the HP Web site at [www.hp.com/networking/support](http://www.hp.com/networking/support), (see [page 1-14](#)).

- **Check the port configuration.** A port on your switch may not be operating as you expect because it has been put into a “blocking” state by Spanning Tree, GVRP (automatic VLANs), or LACP (automatic trunking). (Note that the normal operation of the Spanning Tree, GVRP, and LACP features may put the port in a blocking state.) Or, the port just may have been configured as disabled through software.

Use the switch console to determine the port’s configuration and verify that there is not an improper or undesired configuration of any of the switch features that may be affecting the port. For more information, see the *Management and Configuration Guide*, which is on the HP Web site at [www.hp.com/networking/support](http://www.hp.com/networking/support), (see [page 1-14](#)).

For more information on possible network problems and their solutions, refer to the technical note “Troubleshooting LAN Performance and Intermittent Connectivity Problems”, which can be found on the HP Web site, [www.hp.com/networking/support](http://www.hp.com/networking/support), in the Reference Library section, A-Z Index.

## Diagnosing with the LEDs

Table 4-1 shows LED patterns on the switch that indicate problem conditions for general switch operation troubleshooting.

Table 4-2 shows LED patterns that indicate problem conditions for PoE troubleshooting.

### LED patterns for General Switch Troubleshooting

1. Check in the table for the LED pattern you see on your switch.
2. Refer to the corresponding diagnostic tip on the next few pages.

**Table 4-1. LED Error Indicators**

LED Pattern Indicating Problems							Diagnostic Tips
Power	Fault	RPS	EPS	Test	Fan	Port Link LED	
Off with power cord plugged in	1	1	1	1	1	1	❶
On	Prolonged On	1	1	Prolonged On	1	1	❷
On	Flashing <sup>2</sup>	1	1	Flashing <sup>2</sup>	1	1	❸
On	Flashing <sup>2</sup>	1	1	Off	Flashing <sup>2</sup>	1	❹
On	Flashing <sup>2</sup>	1	1	Flashing <sup>2</sup>	1	Flashing <sup>2</sup>	❺
On	Off	1	1	Off	1	Off with cable connected	❻
On	Off	1	1	Off	1	On, but the port is not communicating	❼
On	Flashing	Flashing	Flashing		1	1	❽

<sup>1</sup> This LED is not important for the diagnosis.  
<sup>2</sup> The flashing behavior is an on/off cycle once every 1.6 seconds, approximately.

## Diagnostic Tips:

Tip	Problem	Solution
<b>1</b>	The switch is not plugged into an active AC power source, or the switch's power supply may have failed.	<ol style="list-style-type: none"> <li>1. Verify the power cord is plugged into an active power source and to the switch. Make sure these connections are snug.</li> <li>2. Try power cycling the switch by unplugging and plugging the power cord back in.</li> <li>3. If the Power LED is still not on, verify the AC power source works by plugging another device into the outlet. Or try plugging the switch into a different outlet or try a different power cord.</li> </ol> <p>If the power source and power cord are OK and this condition persists, the switch power supply may have failed. Call your HP-authorized LAN dealer, or use the electronic support services from HP to get assistance. See the Customer Support/Warranty booklet for more information.</p>
<b>2</b>	A switch hardware failure has occurred. All the LEDs will stay on indefinitely.	Try power cycling the switch. If the fault indication reoccurs, the switch may have failed. Call your HP-authorized LAN dealer, or use the electronic support services from HP to get assistance. See the Customer Support/Warranty booklet for more information.
<b>3</b>	The switch has experienced a software failure during self test.	<ol style="list-style-type: none"> <li>1. Try resetting the switch by pressing the Reset button on the front of the switch, or by power cycling the switch.</li> <li>2. If the fault indication reoccurs, attach a console to the switch (as indicated in chapter 2) and configure it to operate at 9600 baud. Then, reset the switch. Messages should appear on the console screen and in the console log identifying the error condition. You can view the console log at that point by selecting it from the console Main Menu or by typing "Show log" at the Manager command prompt (#).</li> </ol> <p>If necessary to resolve the problem, contact your HP-authorized LAN dealer, or use the electronic support services from HP to get assistance. See the Customer Support/Warranty booklet for more information.</p>
<b>4</b>	One of the switch cooling fans may have failed.	Try disconnecting power from the switch and wait a few moments. Then reconnect the power to the switch and check the LEDs again. If the error indication reoccurs, one of the fans has failed. In switches with multiple fans the switch may continue to operate under this condition if the ambient temperature does not exceed normal room temperature, but for best operation, the switch should be replaced. Contact your HP-authorized LAN dealer, or use the electronic support services from HP to get assistance. See the Customer Support/Warranty booklet for more information.
<b>5</b>	The network port for which the LED is flashing has experienced a self test or initialization failure.	<p>Try power cycling the switch. If the fault indication reoccurs, the switch port may have failed. Call your HP-authorized LAN dealer, or use the electronic support services from HP to get assistance. See the Customer Support/Warranty booklet for more information.</p> <p>If the port is a mini-GBIC, verify that it is one of the mini-GBICs supported by the switch. Unsupported mini-GBICs will be identified with this fault condition. The supported mini-GBICs are listed in Chapter 2, "Installing the Switch" on <a href="#">page 2-17</a>. The mini-GBICs are also tested when they are "hot-swapped"—installed or changed while the switch is powered on.</p> <p>To verify the port has failed, remove and reinstall the mini-GBIC without powering off the switch. If the port fault indication reoccurs, you will have to replace the mini-GBIC. Check the event log to see why the mini-GBIC failed.</p>

*continued on the next page*

Tip	Problem	Solution
⑥	The network connection is not working properly.	<p>Try the following procedures:</p> <ul style="list-style-type: none"><li>• For the indicated port, verify that both ends of the cabling, at the switch and the connected device, are connected properly.</li><li>• Verify the connected device and switch are both powered <i>on</i> and operating correctly.</li><li>• Verify you have used the correct cable type for the connection:<ul style="list-style-type: none"><li>– For twisted-pair connections to the fixed 10/100 or 10/100/1000 ports, if the port is configured to “Auto” (auto negotiate), either straight-through or crossover cables can be used because of the switch’s “Auto-MDIX” feature and the Auto MDI/MDI-X feature of the 10/100/1000-T port.</li></ul></li></ul> <hr/> <p><b>Note:</b> If the switch port configuration is changed to one of the <b>fixed configuration</b> options (for example, 100 Mbps/Full Duplex), then the port operates as <b>MDI-X only</b> and you must use the correct type of cable for the connection. In general, for connecting an end node (MDI port) to the switch, use straight-through cable; for connecting to MDI-X ports on hubs, other switches, and routers, use crossover cable.</p> <hr/> <ul style="list-style-type: none"><li>– For fiber-optic connections, verify the transmit port on the switch is connected to the receive port on the connected device, and the switch receive port is connected to the transmit port on the connected device.</li><li>• For the dual-personality 10/100/1000-T ports, be sure a mini-GBIC is not installed in the associated slot.</li><li>• For 1000Base-T connections, verify the network cabling complies with the IEEE 802.3ab standard. The cable should be installed according to the ANSI/TIA/EIA-568-A-5 specifications. Cable testing should comply with the stated limitations for Attenuation, Near-End Crosstalk, Far-End Crosstalk, Equal-Level Far-End Crosstalk (ELFEXT), Multiple Disturber ELFEXT, and Return Loss. The cable verification process must include all patch cables from any end devices, including the switch, to any patch panels in the cabling path.</li><li>• Verify the port has not been disabled through a switch configuration change. You can use the console interface, or, if you have configured an IP address on the switch, use the web browser interface to determine the state of the port and re-enable the port if necessary.</li><li>• Verify the switch port configuration matches the configuration of the attached device. For example, if the switch port is configured as “Auto”, the port on the attached device also <b>MUST</b> be configured as “Auto”. Depending on the port type, twisted-pair or fiber-optic, if the configurations don’t match, the results could be a very unreliable connection, or no link at all.</li><li>• If the other procedures don’t resolve the problem, try using a different port or a different cable.</li></ul>

Tip	Problem	Solution
7	The port may be improperly configured, or the port may be in a “blocking” state by the normal operation of the Spanning Tree, LACP, or IGMP features.	<p>Use the switch console to see if the port is part of a dynamic trunk (through the LACP feature) or to see if Spanning Tree is enabled on the switch, and to see if the port may have been put into a “blocking” state by those features. The <b>show lacp</b> command displays the port status for the LACP feature; the <b>show spanning-tree</b> command displays the port status for Spanning Tree.</p> <p>Also check the Port Status screen using the <b>show interfaces</b> command to see if the port has been configured as “disabled”.</p> <p>Other switch features that may affect the port operation include VLANs and IGMP. Use the switch console to see how the port is configured for these features.</p> <p>For software troubleshooting tips, see the chapter “Troubleshooting” in the <i>Management and Configuration Guide</i>, which is on the HP Web site at <a href="http://www.hp.com/networking/support">www.hp.com/networking/support</a>, (see page 1-14).</p> <p>Ensure also, that the device at the other end of the connection is indicating a good link to the switch. If it is not, the problem may be with the cabling between the devices or the connectors on the cable.</p>
8	RPS or EPS is connected but has experienced a fault.	Refer to the HP Redundant and or External Power Supplies documentation.

## LED Patterns for PoE Troubleshooting

If the PoE Status LED is flashing, that indicates a problem with the delivery of PoE power out one or more switch ports. Press the LED Mode button to put the switch into PoE mode and the port LEDs will show which ports are experiencing the problem. The following tables identify the specific problems that are shown by the LEDs.

1. Check in the table for the LED pattern you see on your switch.
2. Refer to the corresponding diagnostic tip.

**Table 4-2. LED Error Indicators**

LED Pattern Indicating Problems				Diagnostic Tips
Fault	PoE Status	Port Link	Port Mode	
Off	Fast Flash Orange	Slow Flash Green	Off	❶
Slow Flash	Slow Flash Orange	Slow Flash Green	Off	❷

### Diagnostic Tips:

Tip	Problem	Solution
❶	PoE oversubscription condition. All available PoE power is already taken by higher-priority ports.	If possible add additional PoE power, or redefine port priorities.
❷	PoE hardware fault. A switch hardware component that is involved with PoE power delivery has failed.	The switch must be replaced.



## Proactive Networking

The HP E2620 Switches have built-in management capabilities that proactively help you manage your network including:

- finding and helping you fix the most common network error conditions (for example, faulty network cabling, and non-standard network topologies)
- informing you of the problem with clear, easy-to-understand messages
- recommending network configuration changes to enhance the performance of your network

The following interfaces provide tests, indicators, and an event log that can be used to monitor the switch and its network connections and to help you take advantage of these proactive networking features:

- A graphical web browser interface you can use to manage your switch from a PC running a supported web browser, for example Microsoft Internet Explorer, and Netscape Communicator.
- A full-featured easy-to-use console interface you can access by connecting a standard terminal or PC running a terminal emulator to the switch's console port. The cable to make that connection is provided with your switch. The console interface is also accessible through a Telnet connection.

For more information on using these software tools to diagnose and manage your switch, see the “Troubleshooting” chapter in the *Management and Configuration Guide*, which is on the HP Web site at [www.hp.com/networking/support](http://www.hp.com/networking/support), (see [page 1-14](#)).

## Hardware Diagnostic Tests

### Testing the Switch by Resetting It

If you believe the switch is not operating correctly, you can reset the switch to test its circuitry and operating code. To reset a switch, either:

- unplug and plug in the power cord (power cycling)
- press the Reset button on the front of the switch

Power cycling the switch and pressing the Reset button both cause the switch to perform its power-on self test, which almost always will resolve any temporary operational problems. These reset processes also cause any network traffic counters to be reset to zero, and cause the System Up Time timer to reset to zero.

### Checking the Switch LEDs

The self test passes if the Fault and Self Test LEDs on the front of the switch go off after approximately 50 seconds. If these LEDs stay on longer than 60 seconds or begin flashing, there may be a problem with the switch.

See “Diagnosing With the LEDs” on [page 4-4](#) for information on interpreting the LED patterns.

### Checking Console Messages

Useful diagnostic messages may be displayed on the console screen when the switch is reset. As described in chapter 2 under step 7, Connect a Console to the Switch connect a PC running a VT-100 terminal emulator program or a standard VT-100 terminal to the switch’s Console Port and configure it to run at 9600 baud, and with the other terminal communication settings shown on “[Configuring the Switch](#)”. Then, when you reset the switch, note the messages that are displayed. Additionally, you can check the switch event log, which can be accessed from the console using the **show log** command, or from the console Main Menu after entering the **Menu** command.

## Testing Twisted-Pair Cabling

Network cables that fail to provide a link or provide an unreliable link between the switch and the connected network device may not be compatible with the IEEE 802.3 Type 10Base-T, 100Base-TX, or 1000Base-T standards. The twisted-pair cables attached to the switch must be compatible with the appropriate standards. To verify your cable is compatible with these standards, use a qualified cable test device.

## Testing Switch-to-Device Network Communications

You can perform the following communication tests to verify the network is operating correctly between the switch and any connected device that can respond correctly to the communication test.

- **Link Test**—a physical layer test that sends IEEE 802.2 test packets to any device identified by its MAC address
- **Ping Test**—a network layer test used on IP networks that sends test packets to any device identified by its IP address

These tests can be performed through the switch console interface from a terminal connected to the switch or through a Telnet connection, or from the switch's web browser interface. For more information, see the *Management and Configuration Guide*, which is on the HP Web site at [www.hp.com/networking/support](http://www.hp.com/networking/support), (see [page 1-14](#)).

## Testing End-to-End Network Communications

Both the switch and the cabling can be tested by running an end-to-end communications test—a test that sends known data from one network device to another through the switch. For example, if you have two PCs on the network that have LAN adapters between which you can run a link-level test or Ping test through the switch, you can use this test to verify that the entire communication path between the two PCs is functioning correctly. See your LAN adapter documentation for more information on running a link test or Ping test.

## Restoring the Factory Default Configuration

As part of your troubleshooting process on the Switch, it may become necessary to return the switch configuration to the factory default settings. This clears any passwords, clears the console event log, resets the network counters to zero, performs a complete self test, and reboots the switch into its factory default configuration including deleting the IP address, if one is configured.

---

### Note

This process removes all switch configuration changes that you have made from the factory default settings. This includes, for example, configuration of VLANs, Spanning Tree, trunks, and stacking. Returning the configuration of these features to their factory default settings (usually disabling them) may result in network connectivity issues.

If the switch has a valid configuration, and you are restoring the factory default settings for a reason other than configuration problems, you should save the switch configuration prior to performing the factory default reset. Then, after the reset and resolution of the original problem, you can restore the saved configuration to the switch. For both the save and restore processes, you can use the console **copy** command. For more information on this command, see the *Management and Configuration Guide*, which is on the HP Web site at [www.hp.com/networking/support](http://www.hp.com/networking/support), (see [page 1-14](#)).

---

You can restore the factory default configuration either on the switch itself, or through the switch console.

To execute the factory default reset on the switch, perform these steps:

1. Using pointed objects, simultaneously press both the Reset and Clear buttons on the front of the switch. The power and fault lights come on.
2. Continue to press the Clear button while releasing the Reset button.
3. When the Self Test LED begins to flash, release the Clear button.

The switch will then complete its self test and begin operating with its configuration restored to the factory default settings.

To restore the factory default configuration using the console, execute the **erase startup-config** command from the console command prompt.

---

## Downloading New Switch Software

When product enhancements occur for the E2620 Switches, new software can be downloaded to the switch through several methods, for product enhancements and new features. For more information, see the *Management and Configuration Guide*, which is on the HP Web site at [www.hp.com/networking/support](http://www.hp.com/networking/support), (see page 1-14).

The new switch software would be available on the HP Web site, [www.hp.com/networking/support](http://www.hp.com/networking/support).

---

## HP Customer Support Services

If you are still having trouble with your switch, Hewlett-Packard offers support 24 hours a day, seven days a week through the use of a number of automated electronic services. The HP Web site, [www.hp.com/networking/support](http://www.hp.com/networking/support) also provides up-to-date support information.

Additionally, your HP-authorized network reseller can provide you with assistance, both with services that they offer and with services offered by HP.

### Before Calling Support

Before calling your networking dealer or HP Support, to make the support process most efficient, you first should retrieve the following information:

Information Item	Information Location
• product identification, including mini-GBICs	the front of the switch and on labels on the mini-GBICs
• details about the switch's status including the software (OS) version, a copy of the switch configuration, a copy of the switch Event Log, and a copy of the switch status and counters information	switch console: <b>show tech</b> command
• copy of your network topology map, including network addresses assigned to the relevant devices	your network records



# Switch Specifications

---

## Physical

<b>E2620 Non-PoE Switches</b>	<b>Width</b>	<b>Depth</b>	<b>Height</b>	<b>Weight</b>
E2620-24 (J9623A)	44.3 cm (17.4 in)	25.4 cm (10.0 in)	4.4 cm (1.73 in)	2.58 kg (5.70 lbs)
E2620-48 (J9626A)	44.3 cm (17.4 in)	25.4 cm (10.0 in)	4.4 cm (1.73 in)	4.94 kg (6.48 lbs)
<b>E2620-PoE+ Switches</b>				
E2620-24-PPoE+ (J9624A)	44.3 cm (17.4 in)	25.4 cm (10.0 in)	4.4 cm (1.73 in)	3.2 kg (7.04 lbs)
E2620-24-PoE+ (J9625A)	44.3 cm (17.4 in)	36.6 cm (14.4 in)	4.4 cm (1.73 in)	4.83 kg (10.67 lbs)
E2620-48-PoE+ (J9627A)	44.3 cm (17.4 in)	36.6 cm (14.4 in)	4.4 cm (1.73 in)	5.22 kg (11.53 lbs)

## Electrical

<b>E2620 Non-PoE Switches</b>	<b>AC voltage</b>	<b>Maximum current</b>	<b>Frequency range</b>
E2620-24 (J9623A)	100-127 volts	0.43A	50/60 Hz
	200-240 volts	0.27A	50/60 Hz
E2620-48 (J9626A)	100-127 volts	0.68A	50/60 Hz
	200-240 volts	0.39A	50/60 Hz
<b>E2620-PoE+ Switches</b>			
E2620-24-PPoE+ (J9624A)	100-127 volts	1.8A	50/60 Hz
	200-240 volts	0.97A	50/60 Hz
E2620-24-PoE+ (J9625A)	100-127 volts	4.9A	50/60 Hz
	200-240 volts	2.5A	50/60 Hz
E2620-48-PoE+ (J9627A)	100-127 volts	5.6A	50/60 Hz
	200-240 volts	2.8A	50/60 Hz

The switch automatically adjusts to any voltage between 100-127 or 200-240 volts and either 50 or 60 Hz.

## RPS/EPS Electrical Input

<b>E2620 Non-PoE Switches</b>	<b>AC voltage</b>	<b>Input voltage</b>	<b>Maximum current</b>
E2620-24 (J9623A)	RPS Input EPS Input	+12 VDC N/A	2.5A N/A
E2620-48 (J9626A)	RPS Input EPS Input	+12 VDC N/A	5.0A N/A
<b>E2620-PoE+ Switches</b>			
E2620-24-PPoE+ (J9624A)	RPS Input EPS Input	+12 VDC N/A	3.0A N/A
E2620-24-PoE+ (J9625A)	RPS Input EPS Input	+12 VDC +54 VDC	4.0A 8.0A
E2620-48-PoE+ (J9627A)	RPS Input EPS Input	+12 VDC +54 VDC	4.0A 8.0A

## Environmental

<b>E2620 Switches</b>	<b>Operating</b>	<b>Non-Operating</b>
<b>Temperature</b>	0°C to 55°C (32°F to 131°F)	-40°C to 70°C (-40°F to 158°F)
<b>Relative humidity (non-condensing)</b>	15% to 95% at 40°C (104°F)	15% to 90% at 65°C (149°F)
<b>Maximum altitude</b>	3.0 Km (10,000 ft)*	4.6 Km (15,000 ft)

\* The operating maximum altitude should not exceed that of any accessory being connected to any switch in the E2620 series.

## BTU Ratings

<b>Switch Model</b>	<b>Combined BTU<sup>1</sup></b>	<b>Switch only BTU</b>
E2620-24-PPoE+	827	181
E2620-24-PoE+	2281	410
E2620-48-PoE+	2281	410
E2620-24	Non-PoE	142
E2620-48	Non-PoE	285

<sup>1</sup> Includes switch and maximum number of PoE powered devices connected to the switch at 30 watts.



## Acoustics

### Non-PoE+ Switches

Switch E2620-24 (J9623A) No fans.

Switch E2620-48 (J9626A)

Geraeuschemission LwA=24.5 dB am fiktiven Arbeitsplatz nach DIN 45635 T.19

Noise Emission LpA=36.5 dB at virtual work space according to DIN 45635 T.19

### PoE+ switches

Switch E2620-24-PPoE+ (J9624A)

Geraeuschemission LwA=25.9 dB am fiktiven Arbeitsplatz nach DIN 45635 T.19

Noise Emission LpA=37.1 dB at virtual work space according to DIN 45635 T.19

Switch E2620-24-PoE+ (J9625A)

Geraeuschemission LwA=29.7 dB am fiktiven Arbeitsplatz nach DIN 45635 T.19

Noise Emission LpA=34.0 dB at virtual work space according to DIN 45635 T.19

Switch E2620-48-PoE+ (J9627A)

Geraeuschemission LwA=25.3 dB am fiktiven Arbeitsplatz nach DIN 45635 T.19

Noise Emission LpA=34.0 dB at virtual work space according to DIN 45635 T.19

## RPS/EPS Connectors

- EPS connector: A 2x7 Molex Micro-Fit connector should be used for EPS connection.
- RPS connector: A 2x7 connector is provided for external RPS connection on the power supply module.

## Cable Length

- EPS cables are 2.0 meters (6.56 feet) in length
- RPS cables are 1.25 meters (4.10 feet) in length

## Safety

Complies with:

- EN60950-1/IEC60950-1
- CSA 22.2 No. 60950-1
- UL 60950-1

## Standards

**Table A-1. Technology Standards and Safety Compliance**

		Laser safety information	
Technology	Compatible with these IEEE standards	EN/IEC standard compliance	SFP ("mini-GBIC") Lasers
<b>10-T</b>	IEEE 802.3 10BASE-T		
<b>100-TX</b>	IEEE 802.3u 100BASE-TX		
<b>1000-T</b>	IEEE 802.3ab 1000BASE-T		
<b>100-FX</b>	IEEE 802.3u 100BASE-FX	EN/IEC 60825	Class 1 Laser Product Laser Klasse 1
<b>100-BX</b>	IEEE 802.3ah 100BASE-BX10	EN/IEC 60825	Class 1 Laser Product Laser Klasse 1
<b>1000-SX</b>	IEEE 802.3z 1000BASE-SX	EN/IEC 60825	Class 1 Laser Product Laser Klasse 1
<b>1000-LX</b>	IEEE 802.3z 1000BASE-LX	EN/IEC 60825	Class 1 Laser Product Laser Klasse 1
<b>1000-LH</b>	(not an IEEE standard)	EN/IEC 60825	Class 1 Laser Product Laser Klasse 1
<b>1000-BX</b>	IEEE 802.3ah 1000BASE-BX10	EN/IEC 60825	Class 1 Laser Product Laser Klasse 1

# Cabling and Technology Information

This appendix includes network cable information for cables that should be used with the Switch E2620, including minimum pin-out information and specifications for twisted-pair cables.

## Note

Incorrectly wired cabling is the most common cause of problems for LAN communications. HP recommends that you work with a qualified LAN cable installer for assistance with your cabling requirements.

## Cabling specifications

**Table B-2. Cabling Specifications**

<b>Twisted-pair copper</b>	10 Mbps Operation	Category 3, 4 or 5, 100-ohm unshielded twisted-pair (UTP) or shielded twisted-pair (STP) cable, complying with IEEE 802.3 10BASE-T specifications.
	100 Mbps Operation	Category 5, 100-ohm UTP or STP cable, complying with IEEE 802.3u 100BASE-TX specifications.
	1000 Mbps Operation	Category 5, 100-ohm 4-pair UTP or STP cable, complying with IEEE 802.3ab 1000BASE-T specifications—Category 5e or better is recommended. See note on 1000BASE-T Cable Requirements below.
<b>Multimode fiber</b>		62.5/125 $\mu\text{m}$ or 50/125 $\mu\text{m}$ (core/cladding) diameter, low metal content, graded index fiber-optic cables, complying with the ITU-T G.651 and ISO/IEC 793-2 Type A1b or A1a standards respectively. <sup>1</sup>
<b>Single mode fiber</b>		9/125 $\mu\text{m}$ (core/cladding) diameter, low metal content fiber-optic cables, complying with the ITU-T G.652 and ISO/IEC 793-2 Type B1 standards.
<sup>1</sup> A mode conditioning patch cord may be needed for some Gigabit-LX installations. See <b>"Mode Conditioning Patch Cord"</b> on page B-3 for more information.		

### Note on 1000Base-T Cable Requirements

The Category 5 networking cables that work for 100Base-TX connections should also work for 1000Base-T, as long as all four-pairs are connected. But, for the most robust connections you should use cabling that complies with the Category 5e specifications, as described in Addendum 5 to the TIA-568-A standard (ANSI/TIA/EIA-568-A-5).

## Cabling and Technology Information

Because of the increased speed provided by 1000Base-T (Gigabit-T), network cable quality is more important than for either 10Base-T or 100Base-TX. Cabling plants being used to carry 1000Base-T networking must comply with the IEEE 802.3ab standards. In particular, the cabling must pass tests for Attenuation, Near-End Crosstalk (NEXT), and Far-End Crosstalk (FEXT). Additionally, unlike the cables for 100Base-TX, the 1000Base-T cables must pass tests for Equal-Level Far-End Crosstalk (ELFEXT) and Return Loss.

When testing your cabling, be sure to include the patch cables that connect the switch and other end devices to the patch panels on your site. The patch cables are frequently overlooked when testing cable and they must also comply with the cabling standards.

### Technology distance specifications

**Table B-3. Technology Distance Specifications**

Technology	Supported cable type	Multimode fiber modal bandwidth	Supported distances
100-FX	multimode fiber	any	up to 2,000 meters
100-BX	single mode fiber	N/A	0.5 - 10,000 meters
1000-T	twisted-pair copper	N/A	up to 100 meters
1000-SX	multimode fiber	160 MHz*km 200 MHz*km 400 MHz*km 500 MHz*km	2 - 220 meters 2 - 275 meters 2 - 500 meters 2 - 550 meters
1000-LX	multimode fiber single mode fiber	400 MHz*km 500 MHz*km N/A	2 - 550 meters 2 - 550 meters 2 - 10,000 meters
1000-LH	single mode fiber	N/A	10 - 70,000 meters <sup>1</sup>
1000-BX	single mode fiber	N/A	0.5 - 10,000 meters

<sup>1</sup> For distances less than 20km, a 10dB attenuator must be used. For distances between 20km and 40km, a 5dB attenuator must be used. Attenuators can be purchased from most cable vendors.

## Mode Conditioning Patch Cord

The following information applies to installations in which multimode fiber-optic cables are connected to a Gigabit-LX port. Multimode cable has a design characteristic called “Differential Mode Delay”, which requires the transmission signals be “conditioned” to compensate for the cable design and thus prevent resulting transmission errors.

Under certain circumstances, depending on the cable used and the lengths of the cable runs, an external Mode Conditioning Patch Cord may need to be installed between the Gigabit-LX transmitting device and the multimode network cable to provide the transmission conditioning. If you experience a high number of transmission errors on those ports, usually CRC or FCS errors, you may need to install one of these patch cords between the fiber-optic port in your switch and your multimode fiber-optic network cabling, at both ends of the network link.

The patch cord consists of a short length of single mode fiber cable coupled to graded-index multimode fiber cable on the transmit side, and only multimode cable on the receive side. The section of single mode fiber is connected in such a way that it minimizes the effects of the differential mode delay in the multimode cable.

---

**Note**

---

Most of the time, if you are using good quality graded-index multimode fiber cable that adheres to the standards listed in Appendix B, there should not be a need to use mode conditioning patch cords in your network. This is especially true if the fiber runs in your network are relatively short.

## Installing the Patch Cord

As shown in the illustration below, connect the patch cord to the ProCurve transceiver with the section of single mode fiber plugged in to the Tx (transmit) port. Then, connect the other end of the patch cord to your network cabling patch panel, or directly to the network multimode fiber.

If you connect the patch cord directly to the network cabling, you may need to install a female-to-female adapter to allow the cables to be connected together.

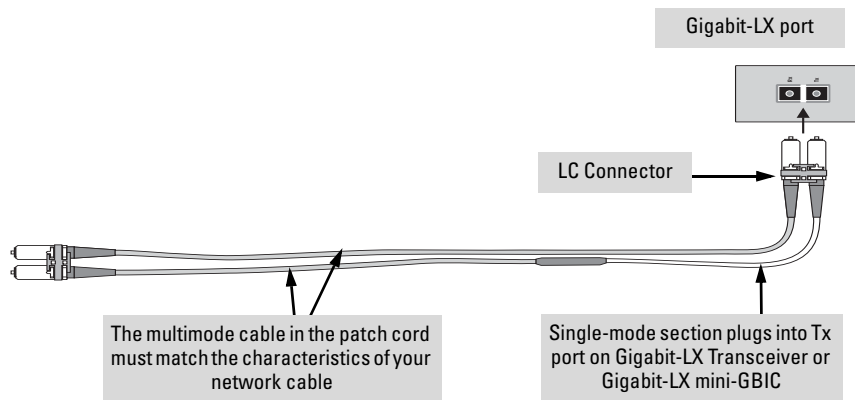

**Figure B-1. Connecting a patch cord**

Make sure you purchase a patch cord that has appropriate connectors on each end, and has multimode fibers that match the characteristics of the multimode fiber in your network. Most important, the core diameter of the multimode patch cord must match the core diameter of the multimode cable infrastructure (either 50 or 62.5 microns).

---

## Twisted-Pair Cable/Connector Pin-Outs

### The Auto-MDIX Feature:

In the default configuration, “Auto”, the fixed 10/100Base-TX ports on the E2620 Switches all automatically detect the type of port on the connected device and operate as either an MDI or MDI-X port, whichever is appropriate. So for any connection, a straight-through twisted-pair cable can be used—you *no longer have to use crossover cables*, although crossover cables can also be used for any of the connections. (The 10/100/1000-T ports support the IEEE 802.3ab standard, which includes the “Auto MDI/MDI-X” feature, which operates the same way.)

If you connect a E2620 or E2620-PoE+ Switch twisted-pair port to another switch or hub, which typically have MDI-X ports, the E2620 Switch port automatically operates as an MDI port. If you connect it to an end node, such as a server or PC, which typically have MDI ports, the E2620 Switch port operates as an MDI-X port. In all cases, you can use standard straight-through cables or crossover cables.

If you happen to use a correctly wired crossover cable, though, the switch will still be able to automatically detect the MDI/MDI-X operation and link correctly to the connected device.

**Other Wiring Rules:**

- All twisted-pair wires used for 10 Mbps, and 100 Mbps operation must be twisted through the entire length of the cable. The wiring sequence must conform to EIA/TIA 568-B (not USOC). See “Twisted-Pair Cable Pin Assignments” later in this appendix for a listing of the signals used on each pin.
- For 1000Base-T connections, all four pairs of wires in the cable must be available for data transmission. See [“Note on 1000Base-T Cable Requirements” on page B-1](#) for more information on 1000Base-T cabling.
- For 10 Mbps connections to the ports, you can use Category 3, 4, or 5 unshielded twisted-pair cable, as supported by the IEEE 802.3 Type 10Base-T standard.
- For 100 Mbps connections to the ports, use 100-ohm Category 5 UTP or STP cable only, as supported by the IEEE 802.3u Type 100Base-TX standard.
- For 1000 Mbps connections, 100-ohm Category 5e or better cabling is recommended.
- To provide Power over Ethernet to the access point, all 4 pairs must be connected for any network cable attached to this port; the cable must meet ISO/DIS 11801 Class D requirements and IEEE 802.3af requirements.

## Straight-through Twisted-Pair Cable for 10 Mbps or 100 Mbps Network Connections

Because of the Auto-MDIX operation of the 10/100 ports on the switch, for all network connections, to PCs, servers or other end nodes, or to hubs or other switches, you can use straight-through cables.

If any of these ports are given a fixed configuration, for example 100 Mbps/ Full Duplex, the ports operate as MDI-X ports, and straight-through cables must be then used for connections to PC NICs and other MDI ports.

### Cable Diagram

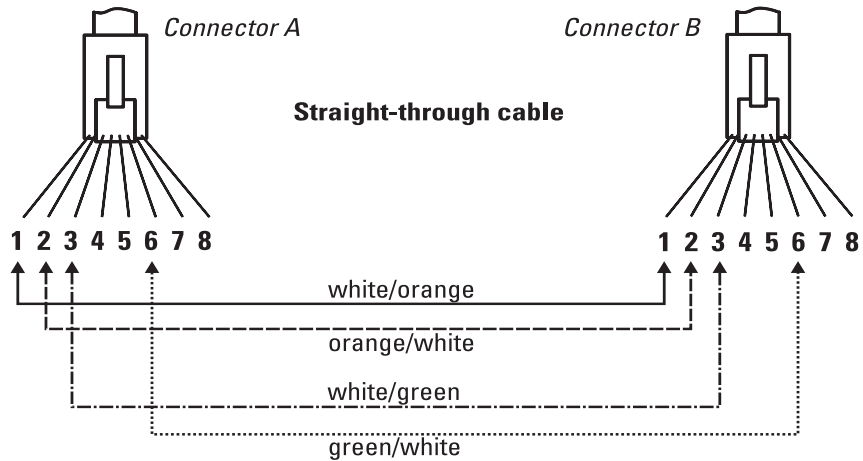

### Note

Pins 1 and 2 on connector “A” *must* be wired as a twisted pair to pins 1 and 2 on connector “B”.

Pins 3 and 6 on connector “A” *must* be wired as a twisted pair to pins 3 and 6 on connector “B”.

Pins 4, 5, 7, and 8 are not used in this application, although they may be wired in the cable.

### Pin Assignments

Switch End (MDI-X)		Computer, Transceiver, or Other End		
Signal	Pins	Pins	Signal	
receive +	1	←————→	1	transmit +
receive -	2	←————→	2	transmit -
transmit +	3	————→	3	receive +
transmit -	6	————→	6	receive -



## Crossover Twisted-Pair Cable for 10 Mbps or 100 Mbps Network Connection

The Auto-MDIX operation of the 10/100 ports on the switch also allows you to use crossover cables for all network connections, to PCs, servers or other end nodes, or to hubs or other switches.

If any of these ports are given a fixed configuration, for example 100 Mbps/ Full Duplex, the ports operate as MDI-X ports, and crossover cables *must* be then used for connections to hubs or switches or other MDI-X network devices.

### Cable Diagram

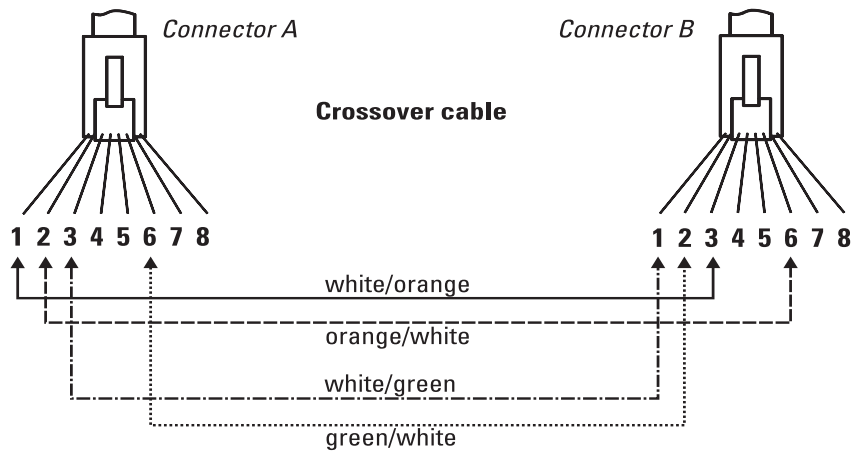

### Note

Pins 1 and 2 on connector “A” *must* be wired as a twisted pair to pins 3 and 6 on connector “B”.

Pins 3 and 6 on connector “A” *must* be wired as a twisted pair to pins 1 and 2 on connector “B”.

Pins 4, 5, 7, and 8 are not used in this application, although they may be wired in the cable.

### Pin Assignments

Switch End (MDI-X)		Hub or Switch Port, or Other MDI-X Port End	
Signal	Pins	Pins	Signal
receive +	1	6	transmit -
receive -	2	3	transmit +
transmit +	3	2	receive -
transmit -	6	1	receive +

## Straight-Through Twisted-Pair Cable for 1000 Mbps Network Connections

1000Base-T connections require that all four pairs of wires be connected.

### Cable Diagram

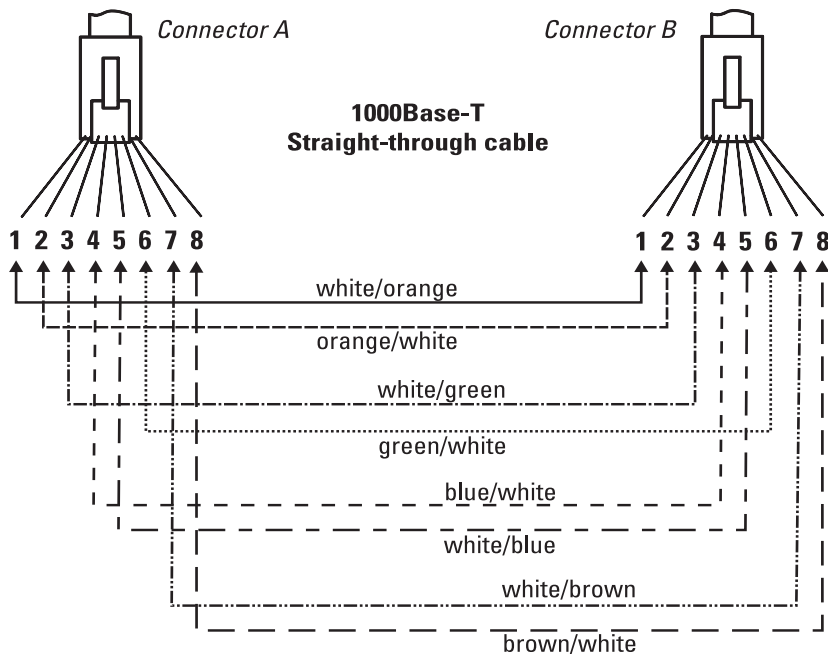

---

### Note

Pins 1 and 2 on connector "A" *must* be wired as a twisted pair to pins 1 and 2 on connector "B".  
Pins 3 and 6 on connector "A" *must* be wired as a twisted pair to pins 3 and 6 on connector "B".  
Pins 4 and 5 on connector "A" *must* be wired as a twisted pair to pins 4 and 5 on connector "B".  
Pins 7 and 8 on connector "A" *must* be wired as a twisted pair to pins 7 and 8 on connector "B".

---

### Pin Assignments

For 1000Base-T operation, all four pairs of wires are used for both transmit and receive.

# Safety and EMC Regulatory Statements

---

## Safety Information



Documentation reference symbol. If the product is marked with this symbol, refer to the product documentation to get more information about the product.

### WARNING

A WARNING in the manual denotes a hazard that can cause injury or death.

### Caution

A Caution in the manual denotes a hazard that can damage equipment.

Do not proceed beyond a WARNING or Caution notice until you have understood the hazardous conditions and have taken appropriate steps.

### Grounding

These are safety class I products and have protective earthing terminals. There must be an uninterruptible safety earth ground from the main power source to the product's input wiring terminals, power cord, or supplied power cord set. Whenever it is likely that the protection has been impaired, disconnect the power cord until the ground has been restored.

For LAN cable grounding:

- If your LAN covers an area served by more than one power distribution system, be sure their safety grounds are securely interconnected.
- LAN cables may occasionally be subject to hazardous transient voltages (such as lightning or disturbances in the electrical utilities power grid). Handle exposed metal components of the network with caution.

### Servicing

There are no user-serviceable parts inside these products. Any servicing, adjustment, maintenance, or repair must be performed only by service-trained personnel.

These products do not have a power switch; they are powered on when the power cord is plugged in.

## Informations concernant la sécurité



Symbole de référence à la documentation. Si le produit est marqué de ce symbole, reportez-vous à la documentation du produit afin d'obtenir des informations plus détaillées.

### WARNING

Dans la documentation, un WARNING indique un danger susceptible d'entraîner des dommages corporels ou la mort.

### Caution

Un texte de mise en garde intitulé Caution indique un danger susceptible de causer des dommages à l'équipement.

Ne continuez pas au-delà d'une rubrique WARNING ou Caution avant d'avoir bien compris les conditions présentant un danger et pris les mesures appropriées.

Cet appareil est un produit de classe I et possède une borne de mise à la terre. La source d'alimentation principale doit être munie d'une prise de terre de sécurité installée aux bornes du câblage d'entrée, sur le cordon d'alimentation ou le cordon de raccordement fourni avec le produit. Lorsque cette protection semble avoir été endommagée, débrancher le cordon d'alimentation jusqu'à ce que la mise à la terre ait été réparée.

Mise à la terre du câble de réseau local:

- si votre réseau local s'étend sur une zone desservie par plus d'un système de distribution de puissance, assurez-vous que les prises de terre de sécurité soient convenablement interconnectées.
- Les câbles de réseaux locaux peuvent occasionnellement être soumis à des surtensions transitoires dangereuses (telles que la foudre ou des perturbations dans le réseau d'alimentation public). Manipulez les composants métalliques du réseau avec précautions.

Aucune pièce contenue à l'intérieur de ce produit ne peut être réparée par l'utilisateur. Tout dépannage, réglage, entretien ou réparation devra être confié exclusivement à un personnel qualifié.

Cet appareil ne comporte pas de commutateur principal; la mise sous tension est effectuée par branchement du cordon d'alimentation.

---

## Hinweise zur Sicherheit



Symbol für Dokumentationsverweis. Wenn das Produkt mit diesem Symbol markiert ist, schlagen Sie bitte in der Produktdokumentation nach, um mehr Informationen über das Produkt zu erhalten.

### WARNING

Eine WARNING in der Dokumentation symbolisiert eine Gefahr, die Verletzungen oder sogar Todesfälle verursachen kann.

### Caution

Caution in der Dokumentation symbolisiert eine Gefahr, die das Gerät beschädigen kann.

Fahren Sie nach dem Hinweis WARNING oder Caution erst fort, nachdem Sie den Gefahrenzustand verstanden und die entsprechenden Maßnahmen ergriffen haben.

Dies ist ein Gerät der Sicherheitsklasse I und verfügt über einen schützenden Erdungsterminal. Der Betrieb des Geräts erfordert eine ununterbrochene Sicherheitserdung von der Hauptstromquelle zu den Geräteingabeterminals, den Netzkabeln oder dem mit Strom belieferten Netzkabelsatz voraus. Sobald Grund zur Annahme besteht, daß der Schutz beeinträchtigt worden ist, das Netzkabel aus der Wandsteckdose herausziehen, bis die Erdung wiederhergestellt ist.

Für LAN-Kabelerdung:

- Wenn Ihr LAN ein Gebiet umfaßt, das von mehr als einem Stromverteilungssystem beliefert wird, müssen Sie sich vergewissern, daß die Sicherheitserdungen fest untereinander verbunden sind.
- LAN-Kabel können gelegentlich gefährlichen Übergangsspannungen ausgesetzt werden (beispielsweise durch Blitz oder Störungen in dem Starkstromnetz des Elektrizitätswerks). Bei der Handhabung exponierter Metallbestandteile des Netzwerkes Vorsicht walten lassen.

Dieses Gerät enthält innen keine durch den Benutzer zu wartenden Teile. Wartungs-, Anpassungs-, Instandhaltungs- oder Reparaturarbeiten dürfen nur von geschultem Bedienungspersonal durchgeführt werden.

Dieses Gerät hat keinen Netzschalter; es wird beim Anschließen des Netzkabels eingeschaltet.

## Considerazioni sulla sicurezza



Simbolo di riferimento alla documentazione. Se il prodotto è contrassegnato da questo simbolo, fare riferimento alla documentazione sul prodotto per ulteriori informazioni su di esso.

### WARNING

La dicitura WARNING denota un pericolo che può causare lesioni o morte.

### Caution

La dicitura Caution denota un pericolo che può danneggiare le attrezzature.

Non procedere oltre un avviso di WARNING o di Caution prima di aver compreso le condizioni di rischio e aver provveduto alle misure del caso.

Questo prodotto è omologato nella classe di sicurezza I ed ha un terminale protettivo di collegamento a terra. Dev'essere installato un collegamento a terra di sicurezza, non interrompibile che vada dalla fonte d'alimentazione principale ai terminali d'entrata, al cavo d'alimentazione oppure al set cavo d'alimentazione fornito con il prodotto. Ogniqualvolta vi sia probabilità di danneggiamento della protezione, disinserite il cavo d'alimentazione fino a quando il collegaento a terra non sia stato ripristinato.

Per la messa a terra dei cavi LAN:

- se la vostra LAN copre un'area servita da più di un sistema di distribuzione elettrica, accertatevi che i collegamenti a terra di sicurezza siano ben collegati fra loro;
- i cavi LAN possono occasionalmente andare soggetti a pericolose tensioni transitorie (ad esempio, provocate da lampi o disturbi nella griglia d'alimentazione della società elettrica); siate cauti nel toccare parti esposte in metallo della rete.

Nessun componente di questo prodotto può essere riparato dall'utente. Qualsiasi lavoro di riparazione, messa a punto, manutenzione o assistenza va effettuato esclusivamente da personale specializzato.

Questo apparato non possiede un commutatore principale; si mette scotto tensione all'inserirsi il cavo d'alimentazione.

---

## Consideraciones sobre seguridad



Símbolo de referencia a la documentación. Si el producto va marcado con este símbolo, consultar la documentación del producto a fin de obtener mayor información sobre el producto.

### WARNING

Una WARNING en la documentación señala un riesgo que podría resultar en lesiones o la muerte.

### Caution

Una Caution en la documentación señala un riesgo que podría resultar en averías al equipo.

No proseguir después de un símbolo de WARNING o Caution hasta no haber entendido las condiciones peligrosas y haber tomado las medidas apropiadas.

Este aparato se enmarca dentro de la clase I de seguridad y se encuentra protegido por una borna de puesta a tierra. Es preciso que exista una puesta a tierra continua desde la toma de alimentación eléctrica hasta las bornas de los cables de entrada del aparato, el cable de alimentación o el juego de cable de alimentación suministrado. Si existe la probabilidad de que la protección a tierra haya sufrido desperfectos, desenchufar el cable de alimentación hasta haberse subsanado el problema.

Puesta a tierra del cable de la red local (LAN):

- Si la LAN abarca un área cuyo suministro eléctrico proviene de más de una red de distribución de electricidad, cerciorarse de que las puestas a tierra estén conectadas entre sí de modo seguro.
- Es posible que los cables de la LAN se vean sometidos de vez en cuando a voltajes momentáneos que entrañen peligro (rayos o alteraciones en la red de energía eléctrica). Manejar con precaución los componentes de metal de la LAN que estén al descubierto.

Este aparato no contiene pieza alguna susceptible de reparación por parte del usuario. Todas las reparaciones, ajustes o servicio de mantenimiento debe realizarlos solamente el técnico.

Este producto no tiene interruptor de potencia; se activa cuando se enchufa el cable de alimentación.

## Informações de Segurança



Símbolo de referência à documentação. Se o produto estiver marcado com este símbolo, consulte a documentação do produto para obter mais informações sobre ele.

### **AVISO**

Um **AVISO** no manual indica um perigo que possa causar ferimentos ou morte.

### Cuidado

Um Cuidado no manual indica um perigo que possa danificar o equipamento.

Não passe por um **AVISO** ou uma indicação de Cuidado sem entender as condições de perigo e tomar as atitudes apropriadas.

### **Aterramento**

Estes são produtos de classe de segurança I, e contam com terminais de aterramento protetores. É preciso haver um aterramento de segurança ininterrupto da principal fonte de energia até os terminais de ligação de entrada, o cabo de alimentação ou o conjunto de cabo de alimentação do produto. Sempre que parecer provável que a proteção tenha sido danificada, desconecte o cabo de alimentação até que o aterramento seja restaurado.

Para aterramento de cabo de LAN:

- Caso sua LAN cubra uma área servida por mais de um sistema de distribuição de energia, certifique-se de que os aterramentos de segurança deles estejam interconectados com segurança.
- Os cabos de LAN podem ocasionalmente estar sujeitos a tensões transitórias perigosas (como raios ou perturbações na rede de energia). Tenha cuidado ao manipular componentes metálicos da rede.

### **Manutenção**

Não há peças internas que possam sofrer manutenção pelo usuário nestes produtos. Qualquer manutenção, ajuste ou reparo deve ser realizado apenas por pessoal treinado.

Estes produtos não têm um botão liga/desliga; eles são ativados quando o cabo de alimentação é conectado.



---

## Safety Information (Japan)

安全性の考慮

安全記号



マニュアル参照記号。製品にこの記号がついている場合はマニュアルを参照し、注意事項等をご確認ください。

WARNING マニュアル中の「WARNING」は人身事故の原因となる危険を示します。

CAUTION マニュアル中の「CAUTION」は装置破損の原因となる危険を示します。

「WARNING」や「CAUTION」の項は飛ばさないで必ずお読みください。危険性に関する記載事項をよく読み、正しい手順に従った上で次の事項に進んでください。

これは安全性クラス1の製品で保護用接地端子を備えています。主電源から製品の入力配線端子、電源コード、または添付の電源コード・セットまでの間、切れ目のない安全接地が存在することが必要です。もしこの保護回路が損なわれたことが推測されるときは、接地が修復されるまで電源コードを外しておいてください。

LAN ケーブルの接地に関して:

- もし貴社の LAN が複数の配電システムにより電力を受けている領域をカバーしている場合には、それらのシステムの安全接地が確実に相互に結合されていることを確認してください。
- LAN ケーブルは時として危険な過度電圧（例えば雷や、配電設備の電力網での障害）にさらされることがあります。露出した金属部分の取扱いには十分な注意をはらってください。

本製品の内部にはユーザーが修理できる部品はありません。サービス、調整、保守および修理はサービス訓練を受けた専門家におまかせください。

本製品には電源スイッチがありません。電源コードを接続したとき電源入となります。

---

**Japan Power  
Cord Warning**

---

製品には、同梱された電源コードをお使い下さい。  
同梱された電源コードは、他の製品では使用出来ません。

## Safety Information (China)

### HP 网络产品使用安全手册

#### 使用须知

欢迎使用惠普网络产品，为了您及仪器的安全，请您务必注意如下事项：

1. 仪器要和地线相接，要使用有正确接地插头的电源线，使用中国国家规定的220V电源。
2. 避免高温和尘土多的地方，否则易引起仪器内部部件的损坏。
3. 避免接近高温，避免接近直接热源，如直射太阳光、暖气等其它发热体。
4. 不要有异物或液体落入机内，以免部件短路。
5. 不要将磁体放置于仪器附近。

#### 警告

为防止火灾或触电事故，请不要将该机放置于淋雨或潮湿处。

#### 安装

安装辅助管理模块，请参看安装指南。

#### 保修及技术支持

如果您按照以上步骤操作时遇到了困难，或想了解其它产品性能，请按以下方式与我们联系。

如是硬件故障：

1. 与售出单位或当地维修机构联系。
2. 中国惠普有限公司维修中心地址：  
北京市海淀区知春路49号希格玛大厦  
联系电话：010-62623888 转 6101  
邮政编码：100080

如是软件问题：

1. 惠普用户响应中心热线电话：010-65645959
2. 传真自动回复系统：010-65645735

---

# EMC Regulatory Statements

## U.S.A.

### FCC Class A

This equipment has been tested and found to comply with the limits for a Class A digital device, pursuant to Part 15 of the FCC Rules. These limits are designed to provide reasonable protection against interference when the equipment is operated in a commercial environment. This equipment generates, uses, and can radiate radio frequency energy and, if not installed and used in accordance with the instruction manual, may cause interference to radio communications. Operation of this equipment in a residential area may cause interference in which case the user will be required to correct the interference at his own expense.

## Canada

This product complies with Class A Canadian EMC requirements.

## Australia/New Zealand



This product complies with Australia/New Zealand EMC Class A requirements.

## Japan

### VCCI Class A

この装置は、情報処理装置等電波障害自主規制協議会（VCCI）の基準に基づくクラスA情報技術装置です。この装置を家庭環境で使用すると電波妨害を引き起こすことがあります。この場合には使用者が適切な対策を講ずるよう要求されることがあります。

## Korea

사용자 안내문 : A 급기기

이기는 업무용으로 전자파 적합등록을 받은 기기 이오니, 판매자 또는 사용자는 이점을 주의하시기 바라며, 만약 잘못 구입하셨을 때에는 구입한 곳에서 비업무용으로 교환하시기 바랍니다.

## Taiwan

警告使用者：這是甲類的資訊產品，在居住的環境中使用時，可能會造成射頻干擾，在這種情況下，使用者會被要求採取某些適當的對策。

## European Community



### DECLARATION OF CONFORMITY

according to ISO/IEC 17050-1 and EN17050-1

**Supplier's Name:** Hewlett-Packard Company      DOC#: RSVLC-1004B\_03182011

**Supplier's Address:** 8000 Foothills Blvd.  
Roseville, CA 95747-5502  
U.S.A.

**declares, that the product**  
**Product Name<sup>2</sup>:** HP E2620-48 Switch

**Product Model(s):** J9626A

**Regulatory Model Number<sup>1</sup>:** RSVLC-1004B

**Product Options:** None

#### conforms to the following Product Specifications and Regulations:

**EMC:** Class A  
EN 55022:2006 +A1 :2007  
EN 55024:1998 +A1:2001 +A2:2003  
EN 61000-3-2:2006  
EN 61000-3-3:1995 +A1:2001 +A2 :2005  
FCC CFR 47 Part 15 2008

**Safety:**  
EN 60950-1:2006 +A11:2009  
IEC 60950-1:2005

This device complies with part 15 of the FCC Rules. Operation is subject to the following two conditions: (1) this device may not cause harmful interference; and, (2) this device must accept any interference received, including interference that may cause undesired operation.

The product herewith complies with the requirements of the Low Voltage Directive 2006/95/EC, the EMC Directive 2004/108/EC, and carries the CE-marking accordingly.

#### Additional Information:

- 1) This product is assigned a Regulatory Model Number which stays with the regulatory aspects of the design. The Regulatory Model Number is the main product identifier in the regulatory documentation and test reports. This number should not be confused with the marketing name or the product numbers.
- 2) This product was tested with HP branded products only.

Roseville, 18-March-2011

  
Michael E. Avery, Regulatory Eng. Manager

European Contact: Your local Hewlett-Packard Sales and Service Office or Hewlett-Packard GmbH, Department HQ-TRE, Herrenberger Straße 140, D-71034 Böblingen (FAX: + 49-7031-14-3143)



## DECLARATION OF CONFORMITY

according to ISO/IEC 17050-1 and EN17050-1

**Supplier's Name:** Hewlett-Packard Company      DOC#: RSVLC-1005\_03182011

**Supplier's Address:** 8000 Foothills Blvd.  
Roseville, CA 95747-5502  
U.S.A.

**declares, that the product**  
**Product Name<sup>2</sup>:** HP E2620-24-PPoE+ Switch

**Product Model(s):** J9624A

**Regulatory Model Number<sup>1</sup>:** RSVLC-1004

**Product Options:** None

### conforms to the following Product Specifications and Regulations:

**EMC:** Class A  
EN 55022:2006 +A1 :2007  
EN 55024:1998 +A1:2001 +A2:2003  
EN 61000-3-2:2006  
EN 61000-3-3:2008  
FCC CFR 47 Part 15 2008

**Safety:**  
EN 60950-1:2006 +A11:2009  
IEC 60950-1:2005

This device complies with part 15 of the FCC Rules. Operation is subject to the following two conditions: (1) this device may not cause harmful interference; and, (2) this device must accept any interference received, including interference that may cause undesired operation.

The product herewith complies with the requirements of the Low Voltage Directive 2006/95/EC, the EMC Directive 2004/108/EC, and carries the CE-marking accordingly.

### Additional Information:

- 1) This product is assigned a Regulatory Model Number which stays with the regulatory aspects of the design. The Regulatory Model Number is the main product identifier in the regulatory documentation and test reports. This number should not be confused with the marketing name or the product numbers.
- 2) This product was tested with HP branded products only.

Roseville, 18-March-2011

  
Michael E. Avery, Regulatory Eng. Manager

European Contact: Your local Hewlett-Packard Sales and Service Office or Hewlett-Packard GmbH, Department HQ-TRE, Herrenberger Straße 140, D-71034 Böblingen (FAX: + 49-7031-14-3143)



## DECLARATION OF CONFORMITY

according to ISO/IEC 17050-1 and EN17050-1

**Supplier's Name:** Hewlett-Packard Company      DOC#: RSVLC-1006\_03182011

**Supplier's Address:** 8000 Foothills Blvd.  
Roseville, CA 95747-5502  
U.S.A.

**declares, that the product**

**Product Name<sup>2</sup>:** HP E2620-24-PoE+ Switch, HP E2620-48-PoE+ Switch

**Product Model(s):** J9625A, J9627A

**Regulatory Model Number<sup>1</sup>:** RSVLC-1006

**Product Options:** None

### conforms to the following Product Specifications and Regulations:

**EMC:** Class A  
EN 55022:2006 +A1 :2007  
EN 55024:1998 +A1:2001 +A2:2003  
EN 61000-3-2:2006  
EN 61000-3-3:1995 +A1:2001 +A2 :2005  
FCC CFR 47 Part 15 2008

### Safety:

EN 60950-1:2006 +A11:2009  
IEC 60950-1:2005

This device complies with part 15 of the FCC Rules. Operation is subject to the following two conditions: (1) this device may not cause harmful interference; and, (2) this device must accept any interference received, including interference that may cause undesired operation.

The product herewith complies with the requirements of the Low Voltage Directive 2006/95/EC, the EMC Directive 2004/108/EC, and carries the CE-marking accordingly.

### Additional Information:

- 1) This product is assigned a Regulatory Model Number which stays with the regulatory aspects of the design. The Regulatory Model Number is the main product identifier in the regulatory documentation and test reports. This number should not be confused with the marketing name or the product numbers.
- 2) This product was tested with HP branded products only.

Roseville, 18-March-2011

  
Michael E. Avery, Regulatory Eng. Manager

European Contact: Your local Hewlett-Packard Sales and Service Office or Hewlett-Packard GmbH, Department HQ-TRE, Herrenberger Straße 140, D-71034 Böblingen (FAX: + 49-7031-14-3143)

**Safety and EMC Regulatory Statements**  
EMC Regulatory Statements



# Recycle Statements

## Waste Electrical and Electronic Equipment (WEEE) Statements



### Disposal of Waste Equipment by Users in Private Household in the European Union

This symbol on the product or on its packaging indicates that this product must not be disposed of with your other household waste. Instead, it is your responsibility to dispose of your waste equipment by handing it over to a designated collection point for the recycling of waste electrical and electronic equipment. The separate collection and recycling of your waste equipment at the time of disposal will help to conserve natural resources and ensure that it is recycled in a manner that protects human health and the environment. For more information about where you can drop off your waste equipment for recycling, please contact your local city office, your household waste disposal service or the shop where you purchased the product.



### Likvidace zařízení soukromými domácími uživateli v Evropské unii

Tento symbol na produktu nebo balení označuje výrobek, který nesmí být vyhozen spolu s ostatním domácím odpadem. Povinností uživatele je předat takto označený odpad na předem určené sběrné místo pro recyklaci elektrických a elektronických zařízení. Okamžité třídění a recyklace odpadu pomůže uchovat přírodní prostředí a zajistí takový způsob recyklace, který ochrání zdraví a životní prostředí člověka. Další informace o možnostech odevzdání odpadu k recyklaci získáte na příslušném obecním nebo městském úřadě, od firmy zabývající se sběrem a svozem odpadu nebo v obchodě, kde jste produkt zakoupili.



### Bortskaffelse af affald fra husstande i den Europæiske Union

Hvis produktet eller dets emballage er forsynet med dette symbol, angiver det, at produktet ikke må bortskaffes med andet almindeligt husholdningsaffald. I stedet er det dit ansvar at bortskaffe kasseret udstyr ved at aflevere det på den kommunale genbrugsstation, der forestår genvinding af kasseret elektrisk og elektronisk udstyr. Den centrale modtagelse og genvinding af kasseret udstyr i forbindelse med bortskaffelsen bidrager til bevarelse af naturlige ressourcer og sikrer, at udstyret genvindes på en måde, der beskytter både mennesker og miljø. Yderligere oplysninger om, hvor du kan aflevere kasseret udstyr til genvinding, kan du få hos kommunen, den lokale genbrugsstation eller i den butik, hvor du købte produktet.



### Seadmete jäätmete kõrvaldamine eramajapidamistes Euroopa Liidus

See tootel või selle pakendil olev sümbol näitab, et kõnealust toodet ei tohi koos teiste majapidamisjäätmetega kõrvaldada. Teie kohus on oma seadmete jäätmed kõrvaldada, viies need elektri- ja elektroonikaseadmete jäätmete ringlussevõtmiseks selleks ettenähtud kogumispunkti. Seadmete jäätmete eraldi kogumine ja ringlussevõtmise kõrvaldamise ajal aitab kaitsta loodusvarasid ning tagada, et ringlussevõtmise toimub viisil, mis kaitseb inimeste tervist ning keskkonda. Lisateabe saamiseks selle kohta, kuhu oma seadmete jäätmed ringlussevõtmiseks viia, võtke palun ühendust oma kohaliku linnakantselise, majapidamisjäätmete kõrvaldamise teenistuse või kauplusega, kust Te toote ostsite.

## Recycle Statements

### Waste Electrical and Electronic Equipment (WEEE) Statements



#### Laitteiden hävittäminen kotitalouksissa Euroopan unionin alueella

Jos tuotteessa tai sen pakkauksessa on tämä merkki, tuotetta ei saa hävittää kotitalousjätteiden mukana. Tällöin hävitettävä laite on toimitettava sähkölaitteiden ja elektronisten laitteiden kierrätyspisteeseen. Hävitettävien laitteiden erillinen käsittely ja kierrätys auttavat säästämään luonnonvaroja ja varmistamaan, että laite kierrätetään tavalla, joka estää terveyshaitat ja suojelee luontoa. Lisätietoja paikoista, joihin hävitettävät laitteet voi toimittaa kierrätettäväksi, saa ottamalla yhteyttä jätehuoltoon tai liikkeeseen, josta tuote on ostettu.



#### Élimination des appareils mis au rebut par les ménages dans l'Union européenne

Le symbole apposé sur ce produit ou sur son emballage indique que ce produit ne doit pas être jeté avec les déchets ménagers ordinaires. Il est de votre responsabilité de mettre au rebut vos appareils en les déposant dans les centres de collecte publique désignés pour le recyclage des équipements électriques et électroniques. La collecte et le recyclage de vos appareils mis au rebut indépendamment du reste des déchets contribue à la préservation des ressources naturelles et garantit que ces appareils seront recyclés dans le respect de la santé humaine et de l'environnement. Pour obtenir plus d'informations sur les centres de collecte et de recyclage des appareils mis au rebut, veuillez contacter les autorités locales de votre région, les services de collecte des ordures ménagères ou le magasin dans lequel vous avez acheté ce produit.



#### Entsorgung von Altgeräten aus privaten Haushalten in der EU

Das Symbol auf dem Produkt oder seiner Verpackung weist darauf hin, dass das Produkt nicht über den normalen Hausmüll entsorgt werden darf. Benutzer sind verpflichtet, die Altgeräte an einer Rücknahmestelle für Elektro- und Elektronik-Altgeräte abzugeben. Die getrennte Sammlung und ordnungsgemäße Entsorgung Ihrer Altgeräte trägt zur Erhaltung der natürlichen Ressourcen bei und garantiert eine Wiederverwertung, die die Gesundheit des Menschen und die Umwelt schützt. Informationen dazu, wo Sie Rücknahmestellen für Ihre Altgeräte finden, erhalten Sie bei Ihrer Stadtverwaltung, den örtlichen Müllentsorgungsbetrieben oder im Geschäft, in dem Sie das Gerät erworben haben



#### Απορριψη άχρηστου εξοπλισμού από χρήστες σε ιδιωτικά νοικοκυριά στην Ευρωπαϊκή Ένωση

Το σύμβολο αυτό στο προϊόν ή τη συσκευασία του υποδεικνύει ότι το συγκεκριμένο προϊόν δεν πρέπει να διατίθεται μαζί με τα άλλα οικιακά σας απορρίμματα. Αντίθετα, είναι δική σας ευθύνη να απορρίψετε τον άχρηστο εξοπλισμό σας παραδίδοντάς τον σε καθορισμένο σημείο συλλογής για την ανακύκλωση άχρηστου ηλεκτρικού και ηλεκτρονικού εξοπλισμού. Η ξεχωριστή συλλογή και ανακύκλωση του άχρηστου εξοπλισμού σας κατά την απόρριψη θα συμβάλει στη διατήρηση των φυσικών πόρων και θα διασφαλίσει ότι η ανακύκλωση γίνεται με τρόπο που προστατεύει την ανθρώπινη υγεία και το περιβάλλον. Για περισσότερες πληροφορίες σχετικά με το πού μπορείτε να παραδώσετε τον άχρηστο εξοπλισμό σας για ανακύκλωση, επικοινωνήστε με το αρμόδιο τοπικό γραφείο, την τοπική υπηρεσία διάθεσης οικιακών απορριμμάτων ή το κατάστημα όπου αγοράσατε το προϊόν.



#### Készülékek magánháztartásban történő selejtezése az Európai Unió területén

A készüléken, illetve a készülék csomagolásán látható azonos szimbólum annak jelzésére szolgál, hogy a készülék a selejtezés során az egyéb háztartási hulladéktól eltérő módon kezelendő. A vásárló a hulladékká vált készüléket köteles a kijelölt gyűjtőhelyre szállítani az elektromos és elektronikai készülékek újrahasznosítása céljából. A hulladékká vált készülékek selejtezés kori begyűjtése és újrahasznosítása hozzájárul a természeti erőforrások megőrzéséhez, valamint biztosítja a selejtezett termékek környezetre és emberi egészségre nézve biztonságos feldolgozását. A begyűjtés pontos helyéről bővebb tájékoztatást a lakhelye szerint illetékes önkormányzattól, az illetékes személtakarító vállalattól, illetve a terméket eláruló helyen kaphat.



### **Smaltimento delle apparecchiature da parte di privati nel territorio dell'Unione Europea**

Questo simbolo presente sul prodotto o sulla sua confezione indica che il prodotto non può essere smaltito insieme ai rifiuti domestici. È responsabilità dell'utente smaltire le apparecchiature consegnandole presso un punto di raccolta designato al riciclo e allo smaltimento di apparecchiature elettriche ed elettroniche. La raccolta differenziata e il corretto riciclo delle apparecchiature da smaltire permette di proteggere la salute degli individui e l'ecosistema. Per ulteriori informazioni relative ai punti di raccolta delle apparecchiature, contattare l'ente locale per lo smaltimento dei rifiuti, oppure il negozio presso il quale è stato acquistato il prodotto.



### **Nolietotu iekārtu iznīcināšanas noteikumi lietotājiem Eiropas Savienības privātajās mājāsaimniecībās**

Šāds simbols uz izstrādājuma vai uz tā iesaiņojuma norāda, ka šo izstrādājumu nedrīkst izmest kopā ar citiem sadzīves atkritumiem. Jūs atbildat par to, lai nolietotās iekārtas tiktu nodotas speciāli iekārtotos punktos, kas paredzēti izmantoto elektrisko un elektronisko iekārtu savākšanai otrreizējai pārstrādei. Atsevišķa nolietoto iekārtu savākšana un otrreizējā pārstrāde palīdzēs saglabāt dabas resursus un garantēs, ka šīs iekārtas tiks otrreizēji pārstrādātas tādā veidā, lai pasargātu vidi un cilvēku veselību. Lai uzzinātu, kur nolietotās iekārtas var izmest otrreizējai pārstrādei, jāvērsas savas dzīves vietas pašvaldībā, sadzīves atkritumu savākšanas dienestā vai veikalā, kurā izstrādājums tika nopirkts.



### **Vartotoju iš privačių namų ūkių įrangos atliekų šalinimas Europos Sąjungoje**

Šis simbolis ant gaminio arba jo pakuotės rodo, kad šio gaminio šalinti kartu su kitomis namų ūkio atliekomis negalima. Šalintinas įrangos atliekas privalote pristatyti į specialią surinkimo vietą elektros ir elektroninės įrangos atliekoms perdirbti. Atskirai surenkamos ir perdirbamos šalintinos įrangos atliekos padės saugoti gamtinius išteklius ir užtikrinti, kad jos bus perdirbtos tokiu būdu, kuris nekenkia žmonių sveikatai ir aplinkai. Jeigu norite sužinoti daugiau apie tai, kur galima pristatyti perdirbtinas įrangos atliekas, kreipkitės į savo seniūniją, namų ūkio atliekų šalinimo tarnybą arba parduotuvę, kurioje įsigijote gaminį.



### **Verwijdering van afgedankte apparatuur door privé-gebruikers in de Europese Unie**

Dit symbool op het product of de verpakking geeft aan dat dit product niet mag worden gedeponeerd bij het normale huishoudelijke afval. U bent zelf verantwoordelijk voor het inleveren van uw afgedankte apparatuur bij een inzamelingspunt voor het recyclen van oude elektrische en elektronische apparatuur. Door uw oude apparatuur apart aan te bieden en te recyclen, kunnen natuurlijke bronnen worden behouden en kan het materiaal worden hergebruikt op een manier waarmee de volksgezondheid en het milieu worden beschermd. Neem contact op met uw gemeente, het afvalinzamelingsbedrijf of de winkel waar u het product hebt gekocht voor meer informatie over inzamelingspunten waar u oude apparatuur kunt aanbieden voor recycling.



### **Pozbywanie się zużytego sprzętu przez użytkowników w prywatnych gospodarstwach domowych w Unii Europejskiej**

Ten symbol na produkcie lub jego opakowaniu oznacza, że produktu nie wolno wyrzucać do zwykłych pojemników na śmieci. Obowiązkiem użytkownika jest przekazanie zużytego sprzętu do wyznaczonego punktu zbiórki w celu recyklingu odpadów powstałych ze sprzętu elektrycznego i elektronicznego. Osobna zbiórka oraz recykling zużytego sprzętu pomogą w ochronie zasobów naturalnych i zapewnią ponowne wprowadzenie go do obiegu w sposób chroniący zdrowie człowieka i środowisko. Aby uzyskać więcej informacji o tym, gdzie można przekazać zużyty sprzęt do recyklingu, należy się skontaktować z urzędem miasta, zakładem gospodarki odpadami lub sklepem, w którym zakupiono produkt.



#### Descarte de Lixo Elétrico na Comunidade Européia

Este símbolo encontrado no produto ou na embalagem indica que o produto não deve ser descartado no lixo doméstico comum. É responsabilidade do cliente descartar o material usado (lixo elétrico), encaminhando-o para um ponto de coleta para reciclagem. A coleta e a reciclagem seletivas desse tipo de lixo ajudarão a conservar as reservas naturais; sendo assim, a reciclagem será feita de uma forma segura, protegendo o ambiente e a saúde das pessoas. Para obter mais informações sobre locais que reciclam esse tipo de material, entre em contato com o escritório da HP em sua cidade, com o serviço de coleta de lixo ou com a loja em que o produto foi adquirido.

---



#### Likvidácia vyradených zariadení v domácnostiach v Európskej únii

Symbol na výrobku alebo jeho balení označuje, že daný výrobok sa nesmie likvidovať s domovým odpadom. Povinnosťou spotrebiteľa je odovzdať vyradené zariadenie v zbernom mieste, ktoré je určené na recykláciu vyradených elektrických a elektronických zariadení. Separovaný zber a recyklácia vyradených zariadení prispieva k ochrane prírodných zdrojov a zabezpečuje, že recyklácia sa vykonáva spôsobom chrániacim ľudské zdravie a životné prostredie. Informácie o zberných miestach na recykláciu vyradených zariadení vám poskytnú miestne zastupiteľstvo, spoločnosť zabezpečujúca odvoz domového odpadu alebo obchod, v ktorom ste si výrobok zakúpili.

---



#### Odstranjevanje odslužene opreme uporabnikov v zasebnih gospodinjstvih v Evropski uniji

Ta znak na izdelku ali njegovi embalaži pomeni, da izdelka ne smete odvreči med gospodinjске odpadke. Nasprotno, odsluženo opremo morate predati na zbirališče, pooblaščno za recikliranje odslužene električne in elektronske opreme. Ločeno zbiranje in recikliranje odslužene opreme prispeva k ohranjanju naravnih virov in zagotavlja recikliranje te opreme na zdravju in okolju neškodljiv način. Za podrobnejše informacije o tem, kam lahko odpeljete odsluženo opremo na recikliranje, se obrnite na pristojni organ, komunalno službo ali trgovino, kjer ste izdelek kupili.

---



#### Eliminación de residuos de equipos eléctricos y electrónicos por parte de usuarios particulares en la Unión Europea

Este símbolo en el producto o en su envase indica que no debe eliminarse junto con los desperdicios generales de la casa. Es responsabilidad del usuario eliminar los residuos de este tipo depositándolos en un "punto limpio" para el reciclado de residuos eléctricos y electrónicos. La recogida y el reciclado selectivos de los residuos de aparatos eléctricos en el momento de su eliminación contribuirá a conservar los recursos naturales y a garantizar el reciclado de estos residuos de forma que se proteja el medio ambiente y la salud. Para obtener más información sobre los puntos de recogida de residuos eléctricos y electrónicos para reciclado, póngase en contacto con su ayuntamiento, con el servicio de eliminación de residuos domésticos o con el establecimiento en el que adquirió el producto.

---



#### Bortskaffande av avfallsprodukter från användare i privathushåll inom Europeiska Unionen

Om den här symbolen visas på produkten eller förpackningen betyder det att produkten inte får slängas på samma ställe som hushållssopor. I stället är det ditt ansvar att bortskaffa avfallet genom att överlämna det till ett uppsamlingsställe avsett för återvinning av avfall från elektriska och elektroniska produkter. Separat insamling och återvinning av avfallet hjälper till att spara på våra naturresurser och gör att avfallet återvinns på ett sätt som skyddar människors hälsa och miljön. Kontakta ditt lokala kommunkontor, din närmsta återvinningsstation för hushållsavfall eller affären där du köpte produkten för att få mer information om var du kan lämna ditt avfall för återvinning.

---



#### Изхвърляне на отпадъчно оборудване от потребители в частни домакинства в Европейския съюз

Този символ върху продукта или опаковката му показва, че продуктът не трябва да се изхвърля заедно с другите битови отпадъци. Вместо това, трябва да предпазите човешкото здраве и околната среда, като предадете отпадъчното оборудване в предназначен за събирането му пункт за рециклиране на неизползваемо електрическо и електронно борудване. За допълнителна информация се свържете с фирмата по чистота, чиито услуги използвате.

---

# Index

---

## Numerics

- 10/100Base-TX ports
  - location on switch ... 1-5
- 1000Base-BX ... B-2
  - fiber-optic cable specifications ... B-2
- 1000Base-LH ... B-2
  - fiber-optic cable specifications ... B-2
- 1000Base-T
  - 1000Base-T
    - fiber-optic cable specifications ... B-2
- 600 RPS/EPS
  - LEDs ... 2-21

## A

- AC power connector
  - location on back of switch ... 1-12
- acoustic specifications ... A-3
- air flow ... 2-5
- auto MDI/MDI-X operation ... B-6, B-8
  - HP Auto-MDIX feature ... B-4

## B

- back of switch
  - description ... 1-12
  - power connector ... 1-13
  - RPS input port ... 1-13
- backbone switch
  - topology with ... 2-29, 2-33–2-34
- basic switch configuration
  - IP address ... 3-2
  - manager password ... 3-2
  - subnet mask ... 3-2
  - Switch Setup screen ... 3-2
- basic troubleshooting tips ... 4-1
- Bootp
  - automatic switch configuration ... 3-1
  - for in-band access ... 2-25
- BTU ratings ... A-2
- buttons
  - Clear button ... 1-11
  - Reset button ... 1-11

## C

- cabinet
  - mounting the switch in ... 2-9
- cable
  - RPS/EPS cable length ... 2-20
- cable length specifications ... A-3
- cables
  - connecting cables to switch ports ... 2-15
  - effects of non-standard cables ... 4-2
  - infrastructure requirements ... 2-6
  - serial, for direct console connection ... 2-26
- cables, twisted pair
  - category 3, 4, 5 ... B-5
  - cross-over cable pin-out ... B-7
  - MDI-X to MDI connections ... B-6, B-8
  - MDI-X to MDI-X connections ... B-7
  - pin-outs ... B-6, B-8
  - straight-through cable pin-out ... B-6, B-8
  - switch-to-computer connection ... B-6, B-8
  - switch-to-switch or hub connection ... B-7
- cables, twisted-pair
  - HP Auto-MDIX feature ... B-4
  - wiring rules ... B-5
- cables, twisted-pair connector pin-outs ... B-4
- cabling infrastructure ... 2-6
- Clear button
  - deleting passwords ... 1-11
  - description ... 1-11
  - location on switch ... 1-5, 1-11
  - restoring factory default configuration ... 1-11, 4-12
  - to delete password protection ... 3-4
- CLI prompt, console
  - displaying ... 2-26
- configuration ... 2-17
  - checking when troubleshooting ... 4-3
  - DHCP/Bootp ... 3-1
  - IP address ... 3-2
  - IP address, manually ... 3-2
  - manager password ... 3-2
  - restoring factory defaults ... 1-11, 4-12
  - subnet mask ... 3-2
  - Switch Setup screen ... 3-2

- connecting the switch to a power source ... 2-15
- connector specifications ... A-3
- console
  - checking messages during troubleshooting ... 4-10
  - displaying the CLI prompt ... 2-26
  - features ... 2-25
  - how to connect in-band ... 2-25
  - how to connect out-of-band ... 2-25
  - serial cable connection ... 2-26
  - Switch Setup screen ... 3-2
  - Telnet access ... 3-5
  - terminal configuration ... 2-25
- console port
  - definition ... 1-12
  - location on switch ... 1-5
- cross-over cable
  - pin-out ... B-7

## D

- deleting passwords ... 1-11
- description
  - back of switch ... 1-12
  - front of switch ... 1-5
  - LEDs ... 1-6
  - switch ... 1-1
- desktop switch
  - sample topology ... 2-27, 2-31
- DHCP
  - automatic switch configuration ... 3-1
  - for in-band access ... 2-25
- diagnostic tests ... 4-10
  - checking the console messages ... 4-10
  - checking the LEDs ... 4-10
  - end-to-end connectivity ... 4-11
  - testing the switch only ... 4-10
  - testing twisted-pair cabling ... 4-11
- downloading new switch software ... 4-13

## E

- electrical specifications, switch ... A-1
- EMC regulatory statements ... C-9
- environmental specifications
  - BTU ratings ... A-2
- environmental specifications, switch ... A-2
- EPS input port ... 1-13

- external power supply
  - cables ... 2-20
  - operating characteristics ... 2-20
- External power supply connections
  - sample topology ... 2-23

## F

- factory default configuration, restoring ... 1-11, 4-12
- Fan Status LED ... 1-7, 2-22
- Fault LED ... 1-6, 2-22
  - behavior during self test ... 2-8
  - behaviors ... 1-6, 2-22
  - blinking definition ... 2-22
  - flashing definition ... 1-8–1-9
  - location on switch ... 1-5
  - showing error conditions ... 4-4
- features
  - console ... 2-25
  - switch ... 1-13
- fiber-optic cables
  - 1000Base-BX ... B-2
  - 1000Base-LH ... B-2
  - 1000Base-T ... B-2
- flashing LEDs
  - error indications ... 4-4
- front of switch ... 1-5
  - 10/100Base-TX ports ... 1-5
  - Clear button ... 1-11
  - description ... 1-5
  - LEDs ... 1-6
  - network ports ... 1-6
  - Reset button ... 1-11
- full-duplex fixed configuration
  - effects on network connections ... 4-1

## H

- horizontal surface
  - mounting switch on ... 2-15
- HP 600 Redundant and External Power Supply ... 1-3
- HP 610 External Power Supply ... 1-3
- HP Auto-MDIX
  - feature description ... B-4

## I

- in-band ... 3-1

- in-band console access
  - types of ... 2-25
- included parts ... 2-1
- installation
  - connecting the switch to a power source ... 2-15
  - horizontal surface mounting ... 2-15
  - location considerations ... 2-6
  - network cable requirements ... 2-6
  - precautions ... 2-3
  - rack or cabinet mounting ... 2-9
  - site preparation ... 2-6
  - wall mounting ... 2-14

- IP address
  - configuring ... 3-2
- IP telephones ... 2-31

## L

- LEDs
  - behavior during self test ... 2-8
  - blinking definition ... 2-22
  - checking during troubleshooting ... 4-10
  - descriptions of ... 1-6
  - error indications ... 4-4
  - Fan Status ... 1-7, 2-22
  - Fault ... 1-6, 2-22
    - behavior during self test ... 2-8
    - showing error conditions ... 4-4
  - flashing definition ... 1-8–1-9
  - location on switch ... 1-5
  - on switch ... 1-6
  - port
    - description ... 1-9
  - port description ... 2-22
  - Power ... 1-6, 2-22
    - behavior during self test ... 2-8
  - Self Test ... 1-8
    - behavior during self test ... 2-8
  - Temp Status ... 2-22
- link test ... 4-11
- location for the switch, considerations ... 2-6

## M

- MDI-X to MDI network cable ... B-6, B-8
- MDI-X to MDI-X network cable ... B-7
- mini-GBICs
  - full-duplex operation

- half-duplex operation ... 2-17
- slot, location on switch ... 1-5
- mounting the switch
  - in a rack or cabinet ... 2-9
    - precautions ... 2-3
  - on a horizontal surface ... 2-15
  - on a wall ... 2-14
    - precautions ... 2-14
- Multiple-Display Port LEDs ... 1-10

## N

- network cables
  - HP Auto-MDIX feature ... B-4
  - required types ... 2-6
  - twisted-pair connector pin-outs ... B-4
  - twisted-pair, wiring rules ... B-5
- network devices
  - connecting to the switch ... 2-15
- network ports
  - connecting to ... 2-15
  - location on switch ... 1-6
  - standards compliance ... A-3
  - types of ... 1-6
- non-standard network cables, effects ... 4-2

## O

- out-of-band console access ... 3-5

## P

- parts, included with the switch ... 2-1
- password
  - configuring ... 3-2
- passwords
  - deleting with the Clear button ... 3-4
  - if you lose the password ... 3-4
- passwords, deleting ... 1-11
- physical specifications, switch ... A-1
- Ping test ... 4-11
- pin-outs
  - twisted-pair cables ... B-4
- PoE LED patterns ... 4-8
- PoE troubleshooting ... 4-8
- port configuration
  - checking when troubleshooting ... 4-3

- port LEDs
  - description ... 1-9, 2-22
  - normal operation ... 2-8
- ports
  - 10/100Base-TX, location on switch ... 1-5
  - connecting to ... 2-15
  - console ... 2-25
  - HP Auto-MDIX feature ... B-4
  - location on unit ... 2-21
  - network connections ... 2-15
  - RPS, location on unit ... 2-21
- power connector ... 1-13
- Power LED ... 1-6, 2-22
  - behavior during self test ... 2-8
  - behaviors ... 1-6, 2-22
  - location on switch ... 1-5
- power source
  - connecting the switch to ... 2-15
- Power-over-Ethernet
  - PoE ... 2-19
  - PoE power ... 1-3
- precautions
  - mounting the switch ... 2-3
  - power requirements ... 2-3
- preparing the installation site ... 2-6
- Proactive Network tools
  - diagnostics with ... 4-9

**R**

- rack
  - mounting precautions ... 2-3
  - mounting the switch in ... 2-9
- recycle statements ... D-1
- Redundant and External Power Supply ... 1-3
- Redundant Power Supply ... 2-19
- regulatory statements ... C-9
- Reset button
  - description ... 1-11
  - location on switch ... 1-5, 1-11
  - restoring factory default configuration ... 4-12
- resetting the switch
  - factory default reset ... 4-12
  - location of Reset button ... 1-11
  - troubleshooting procedure ... 4-10
- RPS/EPS ... 2-19
  - operation ... 2-20

**S**

- safety and regulatory statements ... C-1
- safety specifications ... A-4
- segment switch
  - sample topology ... 2-28, 2-32
- self test
  - Fault LED behavior ... 2-8
  - LED behavior during ... 2-8
  - Power LED behavior ... 2-8
- Self Test LED ... 1-8
  - behavior during factory default reset ... 4-12
  - behavior during self test ... 2-8
- serial cable
  - for direct console connection ... 2-26
- SFP ports ... 1-2
- slots for mini-GBICs
  - location on switch ... 1-5
- specifications
  - acoustic ... A-3
  - cable length ... A-3
  - cablings ... B-1
  - connectors ... A-3
  - distance ... B-2
  - electrical ... A-1
  - environmental ... A-2
  - physical ... A-1
  - safety ... A-4
- straight-through cable
  - pin-out ... B-6, B-8
- subnet mask
  - configuring ... 3-2
- switch
  - connecting to a power source ... 2-15
  - description ... 1-1
  - downloading new software ... 4-13
  - electrical specifications ... A-1
  - environmental specifications ... A-2
  - features ... 1-13
  - front panel description ... 1-5
  - included parts ... 2-1
  - LED descriptions ... 1-6
  - mounting in a rack or cabinet ... 2-9
  - mounting on a wall ... 2-14
  - mounting on horizontal surface ... 2-15
  - physical specifications ... A-1
- switch operation
  - verifying after installation ... 2-6



- Switch Setup screen ... 3-2
  - configuring a subnet mask ... 3-2
  - configuring an IP address ... 3-2
  - field descriptions ... 3-3
- switch specifications ... A-1

## T

- technology distance specifications ... B-2
- Telnet access to the console ... 3-5
- Temp Status LED ... 2-22
- terminal configuration ... 2-25
- testing
  - checking the console messages ... 4-10
  - checking the LEDs ... 4-10
  - diagnostic tests ... 4-10
  - end-to-end communications ... 4-11
  - link test ... 4-11
  - Ping test ... 4-11
  - switch operation ... 4-10
  - switch-to-device communications ... 4-11
  - twisted-pair cabling ... 4-11
- tips for troubleshooting ... 4-1
- topologies
  - effects of improper topology ... 4-2
  - samples of ... 2-27, 2-31
- troubleshooting ... 4-1
  - basic tips ... 4-1
  - checking port configuration ... 4-3
  - checking the console messages ... 4-10
  - checking the LEDs ... 4-10
  - common network problems ... 4-1
  - connecting to fixed full-duplex devices ... 4-1
  - diagnostic tests ... 4-10
  - effects of improper topology ... 4-2
  - effects of non-standard cables ... 4-2
  - link test ... 4-11
  - Ping test ... 4-11
  - Proactive Network tools ... 4-9
  - restoring factory default configuration ... 4-12
  - testing connections to other devices ... 4-11
  - testing end-to-end communications ... 4-11
  - testing the switch ... 4-10
  - testing the twisted-pair cables ... 4-11

- twisted-pair cable
  - cross-over cable pin-out ... B-7
  - pin-outs ... B-4, B-6, B-8
  - straight-through cable pin-out ... B-6, B-8
  - switch-to-computer connection ... B-6, B-8
  - switch-to-switch or hub connection ... B-7
  - testing ... 4-11
- twisted-pair ports
  - HP Auto-MDIX feature ... B-4

## V

- VT-100 terminal
  - serial cable connection for ... 2-26

## W

- wall
  - mounting switch on ... 2-14
- wiring rules for twisted-pair cables ... B-5





---

Technology for better business outcomes

To learn more, visit [www.hp.com/networking](http://www.hp.com/networking)

© Copyright 2011, 2012, 2013 Hewlett-Packard Development Company, L.P.  
The information contained herein is subject to change without notice. The only warranties for HP products and services are set forth in the express warranty statements accompanying such products and services. Nothing herein should be construed as constituting an additional warranty. HP will not be liable for technical or editorial errors or omissions contained herein.



January 2013

Manual Part Number  
5998-0902