



Installation Guide

SAP® NetWeaver BW Accelerator 7.20

Components

- SAP® NetWeaver Business Warehouse Accelerator 7.20 Revision 1 or later

Target Audience

- System Administrators
- Technology Consultants
- SAP Hardware Partners

Document Version 1.2 – 12/10/2009

© Copyright 2009 SAP AG. All rights reserved.

No part of this publication may be reproduced or transmitted in any form or for any purpose without the express permission of SAP AG. The information contained herein may be changed without prior notice.

Some software products marketed by SAP AG and its distributors contain proprietary software components of other software vendors.

Microsoft, Windows, Excel, Outlook, and PowerPoint are registered trademarks of Microsoft Corporation.

IBM, DB2, DB2 Universal Database, System i, System i5, System p, System p5, System x, System z, System z10, System z9, z10, z9, iSeries, pSeries, xSeries, zSeries, eServer, z/VM, z/OS, i5/OS, S/390, OS/390, OS/400, AS/400, S/390 Parallel Enterprise Server, PowerVM, Power Architecture, POWER6+, POWER6, POWER5+, POWER5, POWER, OpenPower, PowerPC, BatchPipes, BladeCenter, System Storage, GPFS, HACMP, RETAIN, DB2 Connect, RACF, Redbooks, OS/2, Parallel Sysplex, MVS/ESA, AIX, Intelligent Miner, WebSphere, Netfinity, Tivoli and Informix are trademarks or registered trademarks of IBM Corporation.

Linux is the registered trademark of Linus Torvalds in the U.S. and other countries.

Adobe, the Adobe logo, Acrobat, PostScript, and Reader are either trademarks or registered trademarks of Adobe Systems Incorporated in the United States and/or other countries.

Oracle is a registered trademark of Oracle Corporation.

UNIX, X/Open, OSF/1, and Motif are registered trademarks of the Open Group.

Citrix, ICA, Program Neighborhood, MetaFrame, WinFrame, VideoFrame, and MultiWin are trademarks or registered trademarks of Citrix Systems, Inc.

HTML, XML, XHTML and W3C are trademarks or registered trademarks of W3C®, World Wide Web Consortium, Massachusetts Institute of Technology.

Java is a registered trademark of Sun Microsystems, Inc

JavaScript is a registered trademark of Sun Microsystems, Inc., used under license for technology invented and implemented by Netscape.

SAP, R/3, xApps, xApp, SAP NetWeaver, Duet, PartnerEdge, ByDesign, SAP Business ByDesign, and other SAP products and services mentioned herein as well as their respective logos are trademarks or registered trademarks of SAP AG in Germany and in several other countries all over the world. All other product and service names mentioned are the trademarks of their respective companies. Data contained in this document serves informational purposes only. National product specifications may vary.

These materials are subject to change without notice. These materials are provided by SAP AG and its affiliated companies ("SAP Group") for informational purposes only, without representation or warranty of any kind, and SAP Group shall not be liable for errors or omissions with respect to the materials. The only warranties for SAP Group products and services are those that are set forth in the express warranty statements accompanying such products and services, if any. Nothing herein should be construed as constituting an additional warranty.

Disclaimer

Some components of this product are based on Java™. Any code change in these components may cause unpredictable and severe malfunctions and is therefore expressly prohibited, as is any decompilation of these components.

Any Java™ Source Code delivered with this product is only to be used by SAP's Support Services and may not be modified or altered in any way.

Documentation in the SAP Service Marketplace





You can find this documentation at the following Internet address:

service.sap.com/instguides

Typographic Conventions

Type Style	Represents
<i>Example Text</i>	Words or characters that appear on the screen. These include field names, screen titles, pushbuttons as well as menu names, paths and options. Cross-references to other documentation
Example text	Emphasized words or phrases in body text, titles of graphics and tables
EXAMPLE TEXT	Names of elements in the system. These include report names, program names, transaction codes, table names, and individual key words of a programming language, when surrounded by body text, for example, SELECT and INCLUDE.
Example text	Screen output. This includes file and directory names and their paths, messages, names of variables and parameters, source code as well as names of installation, upgrade and database tools.
Example text	Exact user entry. These are words or characters that you enter in the system exactly as they appear in the documentation.
<Example text>	Variable user entry. Pointed brackets indicate that you replace these words and characters with appropriate entries.
EXAMPLE TEXT	Keys on the keyboard, for example, function keys (such as F2) or the ENTER key.

Icons

Icon	Meaning
	Caution
	Example
	Note
	Recommendation
	Syntax

Contents

Installing SAP NetWeaver 7.20 BW Accelerator.....	2
Naming Conventions.....	3
BW Accelerator Concepts, Architecture and Usage.....	3
Documentation and SAP Notes for BW Accelerator.....	6
Checklist.....	7
Installation Planning.....	8
Hardware and Software Requirements	8
BW Accelerator System Check	10
BW Accelerator Local Area Network Landscape.....	11
BW Accelerator for BW Environment.....	13
Documentation and SAP Notes for BW Accelerator	16
Installation Preparation	17
Creating a SAP System User for the TREX Admin Tool (Stand-Alone).....	17
Installation	19
Step 2: Getting Parameters for BWA Instance Installation.....	22
Step 3: Installing the BW Accelerator Instance.....	24
Step 4: Clone Installed BW Accelerator Instance	24
Step 5: Configure RFC Connection to the BW System	26
Check RFC Connection BW System to BW Accelerator Box	27
Final Steps.....	28
Appendix	28
BW Accelerator System Check Messages	28
Configuring RFC Connection by Script.....	44



Installing SAP NetWeaver 7.20 BW Accelerator

Purpose

This guide describes how you install a *SAP NetWeaver BW accelerator 7.20* system with the installation script. The installation script installs the BW accelerator instance, clones it to all blades and configures the RFC connection to the *SAP NetWeaver Business Warehouse (BW)* system. The target audience for the guide is the hardware partner that provides the BW accelerator system.

The guide is structured as follows:

- The section [BW Accelerator Concepts and Architecture \[Page 3\]](#) describes the concept of BW accelerator and the connection to the BW system.
- The section [Naming Conventions \[Page 3\]](#) contains information on special naming conventions for this guide.
- The section [Documentation and SAP Notes for BW Accelerator \[Page 16\]](#) lists the documentation that you need for the installation.
- The section [Installation Planning \[Page 8\]](#) describes the steps that have to be done before the installation.
- The section [Installation \[Page 19\]](#) describes the installation steps in detail.

Introduction

TREX is the underlying engine for the BW accelerator. BW accelerator is part of the scenario variant *Running a Data Warehouse, Process Performance Optimization* which belongs to the IT scenario Enterprise Data Warehousing.

For details, see:

- *SAP NetWeaver 7.0 Master Guide* on SAP Service Marketplace
<https://service.sap.com/instguidesNW70>
- SAP NetWeaver BW Accelerator Knowledge Center on SAP Service Marketplace
<https://service.sap.com/bwa>

A TREX aggregation engine for processing structured business data is powering these capabilities. The data of the BW InfoCubes are replicated to the TREX engine and are stored as TREX indices. The BW accelerator clearly reduces the response time, especially for large data volumes.



You can use BW accelerator only in connection with the *SAP NetWeaver 7.0 BW* starting with *SAP NetWeaver 7.0 Enhancement Package 1 Support Package Stack (SPS) 5*. BW accelerator is a special Linux 64 bit version of *SAP NetWeaver Search and Classification (TREX)* which is delivered on preconfigured hardware.

You can **not** use BW accelerator for the regular TREX search and classification functionality.



Naming Conventions

The following naming conventions are valid for this documentation:

Terminology

Term	Meaning
AS ABAP	SAP NetWeaver 7.0 usage type Application Server ABAP.

Variables

Variable	Meaning
<SAPSID>	SAP System ID in uppercase letters
<sapsid>	SAP System ID in lowercase letters
<TREX_DIR>	Installation directory for the BW accelerator system on the file server.
<DVD_DIR>	Directory under which you mount the DVD.
<OS>	Name of the operating system in a path.
User <sapsid>adm	Operating system user that you log on with to administrate the BW accelerator system.

Commands

A command line that is separated into several lines in this documentation has to be entered as one line when you execute the command.



BW Accelerator Concepts, Architecture and Usage

SAP NetWeaver BW Accelerator can be used in the following scenarios:

- SAP NetWeaver BW Accelerator used by SAP NetWeaver Business Warehouse
 In this case the BWA loads data from a BW system and provides high performance analytical functions based on that BW data.
 For more information, see SAP NetWeaver BW Accelerator Knowledge Center on SAP Service Marketplace <http://service.sap.com/bwa> and on SAP Community Network/SDN <http://www.sdn.sap.com/irj/sdn/bwa>.
- SAP NetWeaver BW Accelerator used as part of SAP BusinessObjects Explorer, accelerated version
 SAP BusinessObjects Explorer, accelerated version provides intuitive information exploration by SAP BusinessObjects Explorer and high performance analytics by BWA for loading any source data via SAP BusinessObjects Data Services and - in addition - for loading BW data as in the classical BWA usage.

The following picture shows the way the BWA is used by Data Services

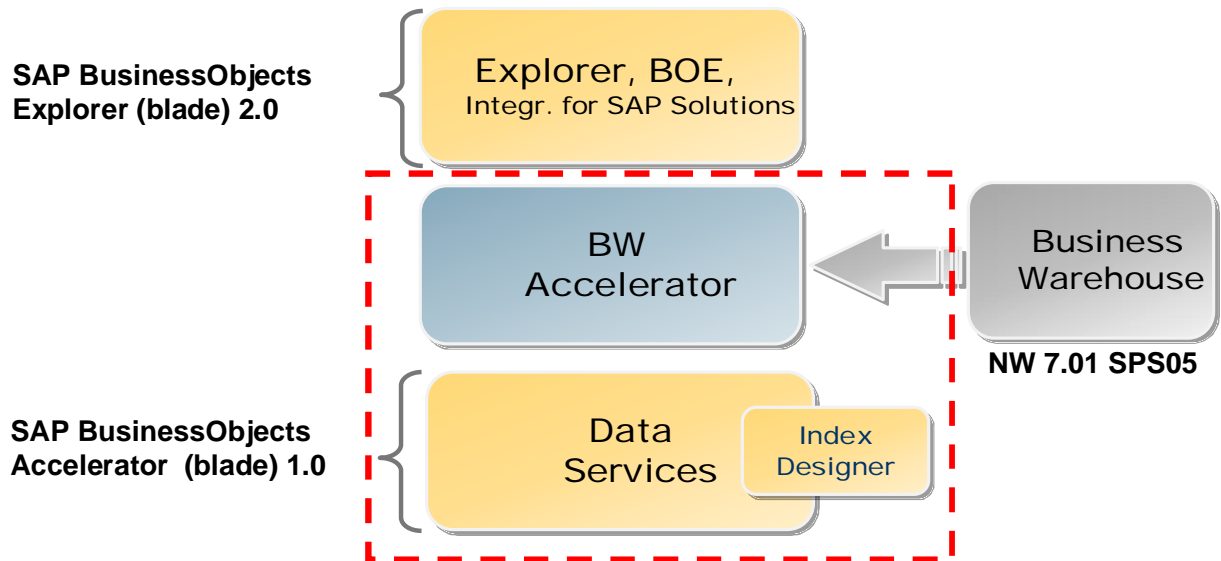

For more information about this BWA usage, see the SAP BusinessObjects Explorer Knowledge Center on SAP Service Marketplace <https://service.sap.com/bosap-explorer> and on SAP Help Portal <http://help.sap.com/bosap-explorer>.

BW Accelerator used by BW

The BW Accelerator enhances SAP NetWeaver BW performance based on SAP's search and classification engine TREX, and on preconfigured hardware delivered by SAP hardware partners. It is packaged as an appliance for use with SAP NetWeaver Business Warehouse (BW) and provides enhanced performance for online analytical processing in an Enterprise Data Warehousing IT scenario.

A TREX aggregation engine for processing structured business data provides enhanced performance. The data from the BW InfoCubes is indexed in the BW Accelerator and stored as TREX indexes in its storage subsystem. The BWA indexes are loaded into memory and used to answer OLAP queries entirely in memory. The BW Accelerator clearly reduces the response time, especially for large data volumes. SAP NetWeaver BW customers adopting the BW Accelerator can expect significant improvements in query performance through in-memory data compression and horizontal and vertical data partitioning, with near zero administrative overhead. Since the BW Accelerator is delivered to the customer as a preinstalled and preconfigured system on dedicated hardware as BW Accelerator box the installation and initial configuration has been done by the hardware partner and no additional administrative tasks needed to be done by the customer for the first usage of the BW Accelerator. This documentation describes additional administrative tasks that are possible for optimizing and monitoring the BW Accelerator.

Architecture – BW Accelerator used by BW System

The following graphic depicts the BW Accelerator architecture and its relationship with the BW system:

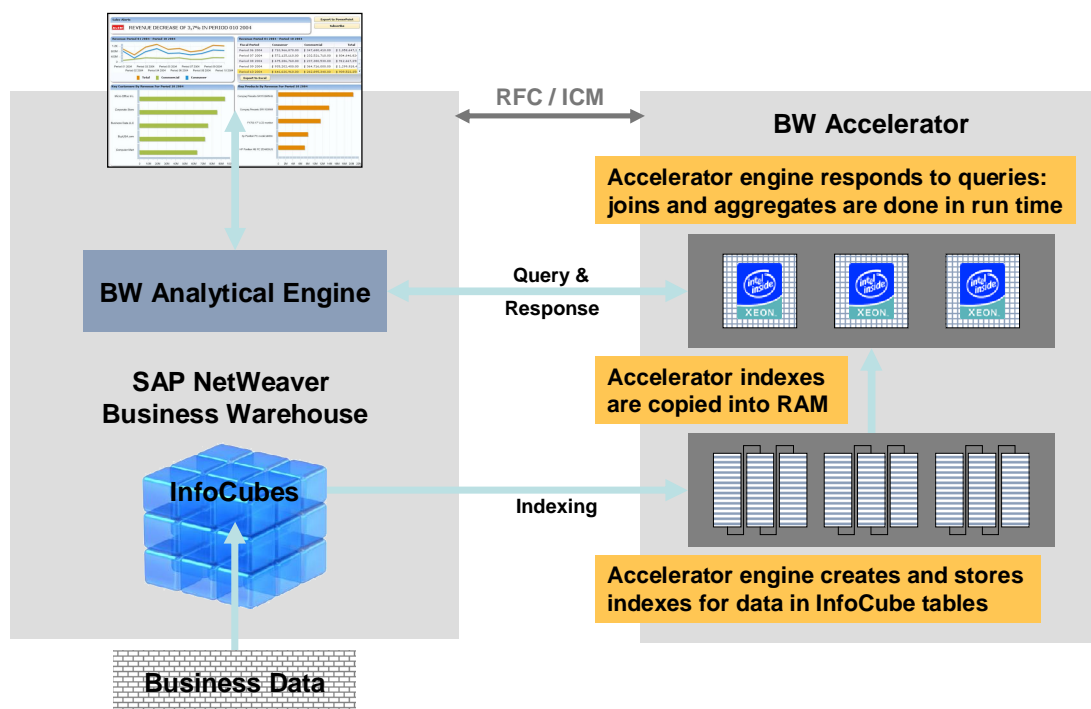

For more information about BW systems and BW Accelerator landscapes, see [BW Accelerator Local Area Network Landscape \[Page 11\]](#) and [BW Accelerator Environment \[Page 13\]](#).

The BW Accelerator is installed on a preconfigured blade system. A blade system consists of hosts in the form of server blades. The server blades are connected to central disk storage. This is referred to here as a file server, regardless of the underlying hardware.

The special feature of a BW Accelerator installation on a blade system is that the BW Accelerator software can be stored centrally as well as the BW Accelerator data. This means that the software will be installed only once on the file server. Maintaining the system is efficient because you only have to implement software updates once.

All server blades on which BW Accelerator is running access the same program files. However, each server blade has its own configuration files. The configuration files in the directory <TREX_DIR> are only used as templates. A script creates a separate subdirectory for each server blade and copies the configuration files to this subdirectory.



Documentation and SAP Notes for BW Accelerator

To keep the BW Accelerator up-to-date, you have to check the SAP Service Marketplace for the latest Support Package. The SAP Notes contain the most up-to-date information and corrections for the documentation.

Documentation

Latest Documentation for SAP NetWeaver BW Accelerator	<ul style="list-style-type: none"> - http://service.sap.com/bwa Knowledge Center on SAP Service Marketplace - https://www.sdn.sap.com/irj/sdn/bwa Knowledge Center on SAP Community Network
Latest documentation for SAP BusinessObjects Explorer, accelerated version	<ul style="list-style-type: none"> - http://service.sap.com/bosap-explorer Knowledge Center on SAP Service Marketplace - http://help.sap.com/bosap-explorer Knowledge Center on SAP Help Portal

SAP Notes for BW Accelerator

Make sure that you use the current version of the SAP Notes. The SAP Notes can be found in the SAP Service Marketplace at service.sap.com/notes.



Note that you need a SAP Service Marketplace (SMP) user to access the links in the SAP note list below.

SAP Note	Title
SAP BusinessObjects Explorer, accelerated version	
1380736	Central Note: SAP BO Explorer, accelerated version
1384526	SAP BusinessObjects Explorer, acceler. version: New Features
1397539	SAP BusinessObjects Explorer, acceler. version: Known Issues
1398242	SIZING SAP BusinessObjects Explorer, accelerated version
1398303	Performance & Reliability SAP BO Explorer, acceler. version
SAP NetWeaver BWA 7.20	
1393505	BWA 7.20: Central Note
1392570	BWA 7.20: Installation
1392526	BWA 7.20: Update
1392524	BWA 7.20: Upgrade/Migration BIA 7.0 to BWA 7.20
SAP NetWeaver BW 7.0.1	
1370156	Composite note for BO Explorer accelerated 7.01 SP06



Checklist

Purpose

The BW accelerator installation has three installation steps, one RFC configuration step and final steps. Refer to the following section as follows:

- **Installation**
Starting an installation or resuming a BW accelerator installation that has been paused after step 1 or 2.
- **RFC Configuration**
Resuming a BW acceleration installation that has been paused after step 3.

Installation

Installation Planning

✓	Action
	Check the hardware and software requirements [Page 8] .
	Check the required documentation [Page 16] .

BW Accelerator Installation

✓	Action
	Installation preparation [Page 17]
	Start Installation [Page 19]
	BW accelerator installation: Step 1 [Page 22]
	BW accelerator installation: Step 2 [Page 24]
	BW accelerator installation: Step 3 [Page 24]
	RFC configuration: Step 4 [Page 26]
	Final Steps [Page 28]

RFC Configuration

Configure RFC Connection to the BW System

✓	Action
	Start RFC Configuration
	RFC configuration: Step 4 [Page 26]
	Final Steps [Page 28]



Installation Planning

Purpose

The following sections contain information that is relevant for the installation planning.



Hardware and Software Requirements

The tables below contain the hardware, network and software requirements for the BW accelerator box.

BW Accelerator

Hardware Requirements



Requirement Type	Requirement
Memory size of RAM	For details, see the PAM entry for BW Accelerator: http://service.sap.com/pam
File server	The file server has to be configured as follows: BW accelerator all box sizes: HP system: OCFS IBM system: GPFS
BW accelerator box	Use <code>mount</code> to mount the directory <code>myGlobalFileShare</code> on all blade systems.

Network Requirements

Requirement Type	Requirement
Network speed	The network speed between the BW system and the BW accelerator box is to be a dedicated 1 GBit or faster.
Network configuration	It is mandatory to have the BW accelerator and the BW Application Server in a private subnet. Otherwise the full BW accelerator performance can not be guaranteed. For more information see, BW Accelerator Local Area Network Landscape [Page 11]

Software Requirements

Requirement Type	Requirement
Operating System	SUSE SLES10 64Bit (HP) – latest SP

Host name	<p>The host name must be specified in lower case characters, start with a letter and end with a numeric character.</p>  <p>Valid host names:</p> <pre>bwaccelerator1 bwaccelerator100</pre> <p>Invalid host names:</p> <pre>bwaccelerator Bwaccelerator100 bwa0001.wdf.sap.corp</pre>
Operating system settings	<p>SAP provides the <code>sysctl.conf</code> configuration file to set the property <code>kernel.shmmax</code> to value 2147483648.</p>  <p>Line in configuration file <code>/etc/sysctl.conf</code>:</p> <pre>kernel.shmmax = 2147483648</pre> <p>Copy the <code>sysctl.conf</code> configuration file to folder <code>/etc</code>.</p>
Open Files	<p>Use command <code>ulimit -a</code> to get a list of the user limits. The parameter <code>open files</code> must have a value not less than 8000.</p>  <p>Result of command <code>ulimit -a</code> with valid parameters:</p> <pre>core file size (blocks, -c) 0 data seg size (kbytes, -d) unlimited file size (blocks, -f) unlimited max locked memory (kbytes, -l) 3403008 max memory size (kbytes, -m) 6887040 open files (-n) 8192 pipe size (512 bytes, -p) 8 stack size (kbytes, -s) 8192 cpu time (seconds, -t) unlimited max user processes (-u) 69119 virtual memory (kbytes, -v) 23259120</pre> <p>If the value for <code>open files</code> is smaller than 8000, add the following lines in the file <code>/etc/security/limits.conf</code>:</p> <pre>* soft nofile 8000 * hard nofile 8000</pre> <p>Copy the modified file <code>/etc/security/limits.conf</code> to the other blades of the BWA system.</p>
Other packages	<p>SAP provides packages that have to be installed on the BW accelerator system and a description how to configure <code>ssh</code>.</p>

For more information about usage of BW Accelerator as part of *SAP NetWeaver BusinessObjects Explorer, accelerated version*, see the Master Guide SAP NetWeaver BusinessObjects Explorer, accelerated version on SAP Service Marketplace at : <https://service.sap.com/bosap-explorer>



BW Accelerator System Check

Use

The `checkBIA` script executes a BW accelerator system check which evaluates the general settings of the BW accelerator and gives a detailed status report. The `checkBWA` script can be used before the installation of the BW accelerator as well as during operation of the BW accelerator. It checks the BW accelerator hardware and the BW accelerator software when it is installed. The script checks the following features:

- Hardware vendor, processor type and memory size
- Hardware name and operating system
- Filer size and usage
- System settings, like open files limit and currently open files
- Network throughput and filer performance
- RFC connection and BW application server availability
- Basic functionality of BWA

Starting BW Accelerator System Check

The start of the BW accelerator system check depends on the installation state of the BW accelerator.

Start BWA System Check if BW Accelerator not Installed

1. Open a shell on a blade.
2. Go in the folder of the installation script (`install.sh`) and enter the following command and finish the input with the `<Enter>` key.

```
checkBIA.sh
```

Start BWA System Check if BW Accelerator already Installed

1. Open a shell on a blade.
2. Go to the python support folder with the following commands. Finish the input of a line with the `<Enter>` key.

```
./TREXSettings.sh
```

```
cd /usr/sap/<sapsid>/TRX<instance>/exe/python_support
```

3. Start the script with the following command and finish the input with the `<Enter>` key.

```
python checkBIA.py
```

Start BW Accelerator system check on BW system side

The BW Accelerator system check can also be started from the BW system by starting the transaction `RSDDBIAMON2` (*BW Accelerator Monitor*) from the BW system:

1. Start the transaction `RSDDBIAMON2` (BW Accelerator Monitor) in the BW system which uses the BW accelerator.
2. Press the button *System Check* or choose *BWA Checks* → *System Check* in the navigation pane to start the BWA system check.

The BWA system check will be executed as part of the *simple functionality test for BWA index*.

Both BWA system check results are display in the *Log Display* screen.

Result

The *checkBWA* script generates a list of the checked features with a result of the check and log file. The status of a check can be:

- INFO
Only displays information about feature, setting, parameters, and values.
- OK
Feature or setting check is OK. No action necessary.
- Warning
Feature or setting needs attention. You can continue with the installation or operation but must take care of the feature as soon as possible.
- Error
Feature or setting does not meet the requirements and needs immediate attention.

For a detailed description of all BW accelerator system check messages see [BW Accelerator System Check Messages \[Page 28\]](#).

Log File

In addition to the screen output the *checkBWA* script creates a log file and stores the log file in an archive. The location and the name of the log file and the archive is displayed at the end of the screen output.



...

```
OK: Stored report: /tmp/checkBWA_report.txt
```

```
OK: Archived: /tmp/checkBWA_report.gz
```



Attach the log file to any support message you send to SAP or your hardware partner.



BWA Local Area Network Landscape for BW Usage

The BW system and the BW Accelerator are both part of several networks on the customer side. However, it is mandatory to have the BW Accelerator and the BW system in a dedicated subnet of their own. Otherwise, full BWA performance cannot be guaranteed.



The number of hops between the BW system and the BW Accelerator should be as low as possible. SAP strongly recommends a maximum of one network hop between the BW system and the BW Accelerator. Note that every hop bears a potential performance risk, since it can be accessed from other systems quite

heavily at certain times, and this access is not covered by the BWA system check or other BWA tests.

The following graphic depicts the different local area networks in a productive BW and BW Accelerator landscape:

BWA Local Area Network Landscape for BW

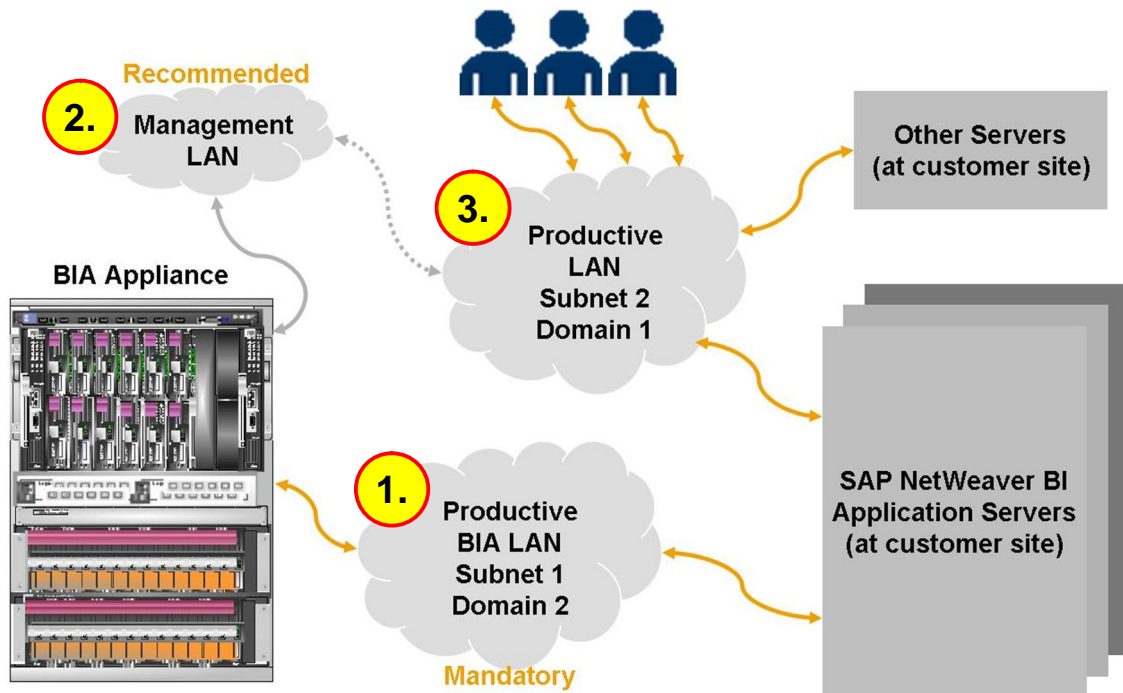

1. Productive BWA LAN

This LAN must be used exclusively for the connection between the BW system and the BW Accelerator. It is mandatory to have the BW Accelerator and the BW system together in a dedicated subnet of their own. Otherwise, full BWA performance cannot be guaranteed.

There has to be a dedicated LAN connection between the BW system as logical unit on the one hand and the BW Accelerator as a logical unit on the other hand. The network reachability between every BW application and every BW Accelerator blade must be guaranteed. This connection should **not** be established between each BW application server and the BW Accelerator, since a local gateway should be used.

2. Management LAN

This LAN is recommended for support purposes, so that the BW Accelerator can be accessed using this network exclusively for administration purposes and for monitoring problems.

3. Productive LAN

This LAN represents the productive main network of which the productive BW system is part and that can be connected to other servers of the customer landscape as well. All BW users can access the BW system using the LAN.



The network speed between the BW system and the BW Accelerator box must be 1 Gbit (dedicated) or faster.



BW Accelerator for BW Environment

Purpose

This section describes the recommendations, constraints, and technical possibilities for using several BW Accelerator landscapes in one or more physical racks. It describes the recommended and supported BWA landscapes for a development, testing, and productive scenario.

Terminology

Term	Definition
BWA landscape/ BWA installation (Software)	<p>A BWA landscape is a BWA installation on a shared storage (e.g. file server) that is used by server blades. The server blades are connected to the shared storage and each server blade uses its own configuration files that are stored in a specific subdirectory on the shared storage. The BWA installation is a logical unit which has a SAPSID and a directory named <code>/usr/sap/<SAPSID>/TRX<instance_number></code></p> <p>All server blades, on which the BW Accelerator is running, access the same program files. During the BWA installation the configuration files of the initial installation are used as templates. A script creates a separate subdirectory for each server blade and copies the configuration files to this subdirectory.</p>
Rack (Hardware)	A rack consists of several blades. Blades are technically aggregated in groups of blade enclosures (HP), blade centers (IBM), and the BladeFrames solution PRIMERGY BX620 (Fujitsu-Siemens). In this document, the description of BWA landscapes is independent of the aggregation of blades.
SAN (Hardware)	Storage area network

Constraints and Recommendations

Constraints

- Only one BWA installation on one blade system

You can deploy only one BWA installation (landscape) on the blades of a blade system (blade rack). You are not allowed to implement more than one BWA installation per blade system.



This is the most important constraint for using BWA installations in an effective and high-performance manner.

- Only one BW system for one BWA installation

You can only connect one BWA installation (landscape) to one BW system. You are not allowed to connect more than one BW system to a BWA installation. There is a 1:1 relationship between the BW system and the BWA installation.

- Maximum number of blades in a BWA landscape.

The number of blades in a BWA landscape is restricted to a specific number (for example, 28 or 32). For the specific number of blades of the hardware you are using, please contact your hardware partner. Exceptions are possible with the permission of SAP Active Global Support (AGS).
- Installation of new BW Accelerator instances
 - Productive BWA system

On a productive BW Accelerator system the customer should not deploy additional BW Accelerator installations. Note that only one BW Accelerator installation is allowed for each blade system. It is not allowed to implement several BWA installations on a blade system (blade rack).
 - BWA test system

On a BW Accelerator test system the customer is allowed to deploy additional BW Accelerator installations .
- No customer-specific SAN storages may be used.

Currently the usage of a customer-specific SAN storage for a BWA customer is not supported. Exceptions are possible with the permission of SAP Active Global Support (AGS).

Recommendations (Best Practice)

- BWA test and productive system

Customers should not run development and testing landscapes on the same racks as the productive landscape, since this may cause severe performance problems.
- BWA test system
 - On the hardware of a BWA test system several disjunctive BWA software installations (not BWA instances) can be deployed. Each of these disjunctive BWA installations differ regarding their SAPSID and are allowed to be connected only to one and only one BW system.
 - The minimal configuration for a BW Accelerator test landscape can consist of only one blade for testing purposes. You can use several BW systems with one BW Accelerator in a test landscape. However, this is not recommended for a productive scenario.
- Productive BWA system

In a productive scenario, a one-to-one relationship is needed between the BW system and the BWA. On the hardware of a productive BWA system one and only one BWA software installation is allowed to be deployed. This BWA software installation is allowed to be connected only to one and only one BW system. In addition, the use of more than one BW system with one BW Accelerator was not part of the original BWA concept (performance, distribution of data, possibility of restarting the BWA), since it does not allow the synchronization of data across several BW systems.

Productive BWA System (Planned/Future)

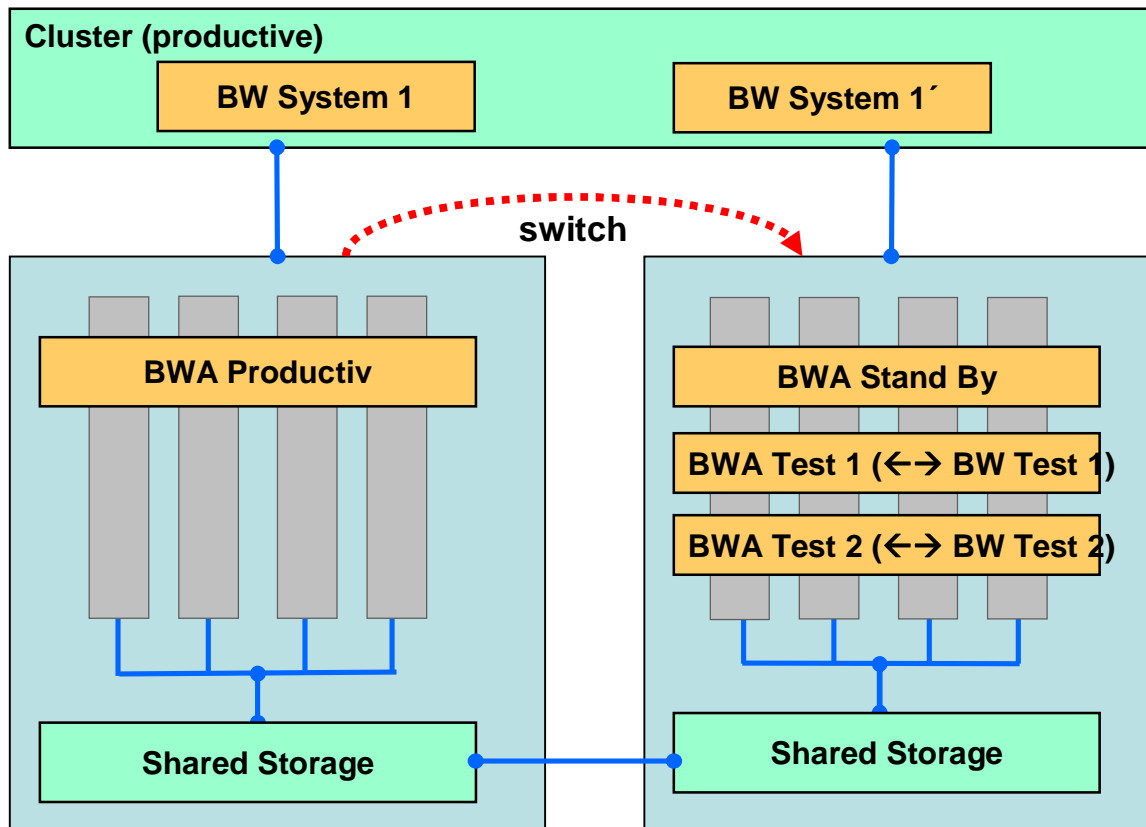

After the switch over the test system must be shut down.

Supported BWA Environments

- The usage of different CPU type (*Irwindale*, *Woodcrest*, and *Clovertown*) based blades is supported.
- The BWA sizing remains unchanged. The initial hardware sizing of the BW Accelerator to be implemented is carried out by the SAP hardware partner based on the input provided by the BW customer. The values and parameters needed to estimate the hardware sizing are requested from the customer by means of the SAP sizing report for the BW Accelerator.



For more information, see [SAP Note 917803 Estimating the memory consumption of a BWA index](#).



Documentation and SAP Notes for BW Accelerator

To keep the BW Accelerator up-to-date, you have to check the SAP Service Marketplace for the latest Support Package. The SAP Notes contain the most up-to-date information and corrections for the documentation.

Documentation

Latest Documentation for SAP NetWeaver BW Accelerator	<ul style="list-style-type: none"> - http://service.sap.com/bwa Knowledge Center on SAP Service Marketplace - https://www.sdn.sap.com/irj/sdn/bwa Knowledge Center on SAP Community Network
Latest documentation for SAP BusinessObjects Explorer, accelerated version	<ul style="list-style-type: none"> - http://service.sap.com/bosap-explorer Knowledge Center on SAP Service Marketplace - http://help.sap.com/bosap-explorer Knowledge Center on SAP Help Portal

SAP Notes for BW Accelerator

Make sure that you use the current version of the SAP Notes. The SAP Notes can be found in the SAP Service Marketplace at service.sap.com/notes.



Note that you need a SAP Service Marketplace (SMP) user to access the links in the SAP note list below.

SAP Note	Title
SAP BusinessObjects Explorer, accelerated version	
1380736	Central Note: SAP BO Explorer, accelerated version
1384526	SAP BusinessObjects Explorer, acceler. version: New Features
1397539	SAP BusinessObjects Explorer, acceler. version: Known Issues
1398242	SIZING SAP BusinessObjects Explorer, accelerated version
1398303	Performance & Reliability SAP BO Explorer, acceler. version
BWA 7.20	
1393505	BWA 7.20: Central Note
1392570	BWA 7.20: Installation
1392526	BWA 7.20: Update
1392524	BWA 7.20: Upgrade/Migration BIA 7.0 to BWA 7.20
BW 7.0.1	
1370156	Composite note for BO Explorer accelerated 7.01 SP06

- You can check the current SAP notes for BWA and the respective BWA usages.

You do this by searching for one of the following CSS/CSN components:

BWA/TREX: BC-TRX-BIA, BC-TRX-EXP, BC-TRX-INS, BC-TRX

BW for BWA: BW-BEX-OT-BIA

SBOP Explorer: BOJ-ERQ-EXP-ACC, BOJ-ERQ-EXP

SBOP Data Services: BOJ-EIM-DEP, BOJ-EIM-DI

CSS/CSN search also supports */asterisk search, so you can, for example, also search for BC-TRX*, BOJ-ERQ-EXP*, BOJ-EIM* or similar and you will get results for all subordinated components.



Installation Preparation

Purpose

The following sections describe the steps you carry out before the BW accelerator installation



Creating a SAP System User for the TREX Admin Tool (Stand-Alone)

Use

You must create an SAP user that the TREX admin tool (stand-alone) can use to log on to the SAP system. In addition, the SAP user is required so that the TREX alert server has permission to regularly test and check the RFC configuration. When doing this, the user can have been created in the default client or in another client. In this case, make sure that you enter the associated client for the user during the configuration of the RFC connection in the TREX admin tool.

The TREX admin tool (stand-alone) is used to configure and monitor TREX. You also use this admin tool to configure the RFC connection between TREX and the ABAP application that is using TREX. To use the TREX admin tool (stand-alone) to create the RFC destination, the admin tool requires an SAP system user that you create based on the predefined role `SAP_BC_TREX_ADMIN`. This user then has the authorization required to configure the RFC connection.



For more information on the `SAP_BC_TREX_ADMIN` role, see SAP Note 766516.

Overview of the Permissions Assigned by the `SAP_BC_TREX_ADMIN` Role

Type and Scope of the Permission	Activity	Explanation
Permission check for RFC access	Execute	Name of the RFC object to be protected: SYST, TREX_ARW_ADMINISTRATION
Administration for the RFC destination	Add or generate, change, display, delete, extended maintenance	Type of entry in RFCDES: Start of an external program using TCP/IP
Check on the transaction code at transaction launch		Transaction code: SM59, TREXADMIN, TREXADMIN_AUTH
Administering TREX	Change, display, execute	

ABAP: Program flow checks	Schedule programs for background processing, execute ABAP program, maintain variants and execute ABAP program	
ALV standard layout	Maintain	
Application log	Display, delete	

Procedure

Create an SAP system user for the TREX admin tool (stand-alone) and assign the `SAP_BC_TREX_ADMIN` role to this user.

4. Launch transaction `SU01` (user maintenance) or choose *Administration* → *System Administration* → *User Maintenance* → *User* in the SAP menu. The *User Maintenance: Initial Screen* appears.
5. Enter a new user name and choose *Create*.
6. On the *Address* tab page, enter the personal data for the user.
7. On the *Roles* tab page, assign the `SAP_BC_TREX_ADMIN` role and thus the permission to access the SAP system to the SAP system user for the TREX admin tool (stand-alone).

Result

This user for the TREX admin tool (stand-alone) now has the authorization required to configure the RFC connection.



Installation

Purpose

This section describes the steps of the BW accelerator installation. For the SAP BWA hardware partners the following BWA installation options are possible:

1. Starting installation from downloaded BWA Revision
2. Starting installation from BWA installation DVD

1. Starting Installation from Downloaded BWA Revision

You start the BWA installation from the BWA software package that you have downloaded from the SAP Service Marketplace. SAP BWA hardware partner can use the most current BWA software package on SAP Service Marketplace <https://service.sap.com/swdc> not only for updating older versions of BWA but also for an initial full installation of BWA.

You do this by executing the following steps:

1. Download the BWA Revision
2. Unpack the BWA Revision archive file
3. Start the BWA installation.

1.1 Download the BWA Revision

1. Access the SAP Software Distribution Center on SAP Service Marketplace at service.sap.com/swdc
2. Navigate to the respective download area on SAP Service Marketplace. Depending on the scenario you are using the BW Accelerator with (BWA used by BW and BWA used as part of SBOP Explorer, accelerated version), the navigation paths differ, but the BWA binaries are the same:
 - BWA used by BW (**SAP NetWeaver**)
<https://service.sap.com/swdc>
 Download
 - Support Packages and Patches
 - Support Packages and Patches - Entry by Application Group
 - SAP NetWeaver
 - SAP NETWEAVER
 - SAP BW ACCLERATOR 7.2
 - BIA 7.20
 - Linux SUSE on x86_64 64bit
 - BWA as part of SBOP Explorer, accelerated version (**SAP BusinessObjects**)
<https://service.sap.com/swdc>
 Download
 - Support Packages and Patches
 - Support Packages and Patches - Entry by Application Group
 - SAP BusinessObjects packages and products
 - SBOP EXPLORER ACCELERATED VERSION
 - SAP BI ACCELERATOR → SAP BW ACCLERATOR 7.2
 - BIA 7.20
 - Linux SUSE on x86_64 64bit

File Type	Download Object	Title	Info File	File Size	Last Changed
SAR	BWA72_<revision_number>-	BWA 7.20 REV	Info	<file_size>	<date>

	<archive_file_number>.SAR	<revision_number>			
For example:					
SAR	BWA72_2-2005013.SAR	BWA 7.20 REV 02	Info	321150	4.12.09

3. Choose *Add to Download Basket*.
4. Download your download basket with the newest BWA Revision to a folder **<BWA_REVISION>** on your host.

1.2 Unpack BWA Revisions Archive File

The tool SAPCAR is used to unpack a BWA Revision and to extract the SAR archives. You can find SAPCAR on the SAP Service Marketplace at:

<http://service.sap.com/patches> → *Technology Components* → *SAPCAR*.

For further information on the use of SAPCAR, see **SAP Note 212876**.

Procedure

1. Change to the directory in which you have downloaded or copied the archive file:
`cd /<BWA_REVISION>`
2. Start SAPCAR as superuser to extract the archive to the current directory **<BWA_REVISION>**.
`<path to SAPCAR>/SAPCAR -xvf <file name>.SAR`

The directory structure of the archive is maintained. Directories in the archive will be created as subdirectories of directory **<BWA_REVISION>**.

Example for unpacking a BWA Revision by SAPCAR:

(Note that SAPCAR and the support package are in the **<BWA_REVISION>** folder)

```
cd /<BWA_REVISION>
SAPCAR -xvf BWA72_2-2005013.SAR
```

The result of the unpackaging process by SAPCAR will be shown like the following after executing the Linux `ls` command:

```
. .. BIA BWA72_01.SAR PRODLABEL SAPCAR checkBIA.sh install.sh
```

1.3 Start the BWA Installation

Start the installation script `install.sh`.



```
sh install.sh
```

The installation starts and displays some information how the installation works and how to use it. The installation procedure is now asking for various parameters.

2. Starting Installation from BWA Installation DVD

You start the BWA installation from the BWA software DVD.

1. Log on to the installation host as root.
2. Mount the DVD with the installation files.



Mount the DVD locally. We do not recommend using Network File System (NFS).

3. Start the installation script.



```
sh install.sh
```

The installation starts and displays some information how the installation works and how to use it. The installation procedure is now asking for various parameters.



Every input has to be ended with the <Enter> key.

To remove a character left of the cursor press the <Backspace> key. If the <Backspace> key does not delete the character left of the cursor but generates characters like ^?, you can try the following key combinations:

```
<Shift><Backspace>, <Ctrl><Backspace>, <del>, <Shift><del>, <Ctrl>< del>.
```

When you made a type error and none of the key combinations mentioned above is working, press the <Enter> key. Some questions validate the input immediately, for example, if an expected numeric value is in the allowed range. In this case the question will be repeated and you can type in the correct value.

If the value cannot be checked, the question will not be repeated. In this case continue with the script until you can select the option to repeat the data entry for the current step.

Options for Executing the BWA Installation Script

After starting the BWA installation script, the following options will be shown:

```
1 - install a new TREX instance
2 - clone an existing TREX instance to a new blade host
3 - update an existing TREX instance
4 - configure RFC connection of an existing TREX instance
5 - deinstall an existing TREX instance
6 - quit without any system change
```

Enter one of the options: 1, 2, 3, 4, 5, 6

1. Choose option 1 to start a new BWA installation. A screen with a disclaimer text appears.
2. Continue with the command `c`.

Step 1: BWA System Check before BWA Installation

The script now automatically performs the *BWA system check* before the BWA installation itself has started. Parameters like hardware vendor, processor type and memory size, hardware name, operating system, filer size and usage will be checked in advance.

For more information, see [BW Accelerator System Check \[Page 10\]](#).

- If the system the BWA is to be installed on meets the predefined requirements, the BWA system check will display an OK.
- If the system the BWA is to be installed on does not meet the predefined Requirements, BWA system check message will be displayed. For more information, see [BW Accelerator System Check Messages \[Page 28\]](#).



•

Continue with [Step 2: Getting Parameters for BWA Instance Installation \[Page 22\]](#).



Step 2: Getting Parameters for BWA Instance Installation

To install the BW accelerator instance, the script shows you the following messages and asks for the following parameters:

Prompt	User Input / Procedure Steps
Instance definition	
Enter the System Id (SAPSID, like T11) of your new TREX system	<p><SAPSID> of the new BW accelerator system specified by three characters. The first character of the has to be a letter (A-Z). The following characters can be alphanumeric characters (A-Z and 0-9).</p> <p>For example: T11</p> <p>It is recommended to give the new BW accelerator system a different <SAPSID> than the SAP BW system.</p> <p> The <SAPSID> is added to the user name. When the SAP BW system and BW accelerator have the same <SAPSID> and the Yellowpages/NIS is installed on the BW accelerator box you have to check if the admin user name used for the BW accelerator box is listed in NIS. If the user exists you have to enter the BW <SAPSID>adm password when the password is required.</p>
Enter the Instance Number (two digits) [default: 00]	<p>Instance number of the BW accelerator system. The instance number must be entered as a two digit number and the range is 00 – 98.</p> <p>For example: 00</p>
Do you want to define the user id of user <user_name>, otherwise it gets computed? (y/n) [default: y]	You can manually define a specific user ID in case the automatically created use ID had been already allocated to a host.
Enter the user id of user <user_name>	Enter the user ID.
Password of the new TREX admin user <SAPSID>adm (min 5 chars, input is hidden).	<p>TREX or BW (see security advice in first row/action) admin password for the system.</p> <p> The characters typed in will not be echoed. If you enter a wrong password, you have to repeat the data entry for step I by selecting the option Repeat data entry later in the script and enter the correct password.</p>
Confirm password	To confirm, enter the password again.

<p>The central instance and the TREX instance will be installed on a shared filer directory. In this directory, a subdirectory '<SAPSID>' will be created later on.</p> <p>Enter the shared filer directory</p>	<p>Enter the shared filer directory myGlobalFileShare where the BW accelerator instance should be installed. The directory must exist. A warning will be displayed if the directory does not exist and you have to correct the entry.</p>
<p>Parameters used for instance cloning</p>	
<p>Enter the number of blade hosts including the local host [default:1]</p>	<p>Enter the number of blades in your system including the blade you are currently working on.</p>
<p>By default the instance of local host <nameOfLocalHostnnn> will be cloned to blade <nameOfLocalHostnnn+1>.</p> <p>Do you want to use this blade? (y/n) [default: y]</p>	<p>To clone the installed BW accelerator instance to the other blades (performed in step 3), the name of the local host, for example bs11004, is incremented by one for every blade in the system.</p> <p>Example: 4 blades, local host bs11004</p> <p style="padding-left: 40px;">Cloned to blades bs11005 through bs11007</p> <p>If you want to use other names for the blades, you have to enter n (=No) and you will be prompted for the host name of every blade in the system, except the blade you are currently working on.</p>
<p>Optional:</p> <p style="padding-left: 40px;">Enter host name of blade #x</p>	<p>If you entered n before, you will be prompted for the host name for every blade in the system, except the blade you are currently working on.</p>
<p>Enter the root user to be used for ssh remote access to all blades [default: root]</p>	<p>Enter the name of the root user that will have access to all blades via ssh remote.</p>
<p>...</p>	<p>An overview of the entered parameters will be shown and some BWA checks will be executed by the system.</p>

The dialog for step 1 is finished. The specified parameters are displayed and the installation script gives you following options:

- **c**
Continue with the installation. Make sure that the displayed parameters are correct before you continue.
- **e**
Exit the installation script. When you select this option, the installation script is terminated without any changes on your system.
- **r**
Repeat the questions for the first step to change or correct the parameters.
- **3**
Skip the installation of BW accelerator (step3) and continue with the cloning of the installed instance (see [Step 4: Clone Installed BW Accelerator Instance \[Page 24\]](#)).



Select this option only when you already have installed BW accelerator in a previous installation process.

- 4

Skip the installation of BW accelerator (step 3) and the cloning (step 4) and continue with the RFC configuration [Step 5: Configure RFC Connection to the BW System \[Page 26\]](#).



Select this option only when you already have installed BW accelerator and cloned it in a previous installation process.

When you have entered `c` to continue, [Step 4: Clone Installed BW Accelerator Instance \[Page 24\]](#) is performed.



Step 3: Installing the BW Accelerator Instance

This step installs the BW accelerator instance with the parameters provided in [Step 2: Getting Parameters for BWA Instance Installation \[Page 22\]](#) on the first blade.

Except from the master password, this step requires no user input. This step will take a while.

The system also performs remote login preparations and access checks to facilitate the remote access to the other blades via `ssh` utility by distributing key files.



Due to the `ssh` remote connection a question for a password may appear. Enter then the root password.

The system is performing the following actions:

- Extracting the installation archives
- Syncing binaries
- Saving installation files
- Creating host configuration
- Creating cloning preparation file

Result

When the installation is finished a BW accelerator instance is installed on the blade. Next installation step is to clone the BW accelerator instance to the other blades: [Step 4: Clone Installed BW Accelerator Instance \[Page 24\]](#)



Step 4: Clone Installed BW Accelerator Instance

Prerequisites

A BW accelerator instance must exist on the local host. See [Step 2: Getting Parameters for BWA Instance Installation \[Page 22\]](#) for details.

Procedure

To clone the installed BW accelerator instance, the script asks for the following parameters:

Prompt	Input
You can start cloning now or exit the script and clone later. Enter 'c' to continue or 'e' to exit [default: c]	You can exit the installation at this point by entering the character e . To resume the installation you start the installation script <code>install.sh</code> again and skip installation step 3. (see Step 2: Getting Parameters for BWA Instance Installation [Page 22] for details). We recommend to continue the installation.
Do you want to be prompted before each cloning step? (y/n) [default: n]	You can decide if you want the system to clone to all blades in one process or ask you before cloning to each blade.
When you continue the installation:	
Password	The password for the super user (e.g. <code>root</code>) is required to clone the BW accelerator instance. The password may be necessary for every blade.  You have three (3) attempts to enter the correct password.

When you entered the correct password cloning for this blade is started. This step is repeated until all blades are processed.

Result

The installation of BW accelerator is now completed. When you have entered `c` to continue, the RFC configuration is started (see [Step 5: Configure RFC Connection to the BW System \[Page 26\]](#)).



TREX data and program files are stored only once on the file server. After the cloning process every blade contains symbolic links (*symlinks*) in the `<TREX_DIR>` to the TREX data and program files on the file server.

Error Handling

When an error message is displayed while the installation script is executing this step, please check the `shmmax` setting of the BW accelerator system. See [Hardware and Software Requirements \[Page 8\]](#) for details.



Part of the error message that indicates that the `shmmax` setting is too low.

```
invoking TREX_CONFIG_HOOK euclidConfig.cloneConfig(...)
error!
```



Step 5: Configure RFC Connection to the BW System

Prerequisites

The BW accelerator instance must be installed and cloned:

- See [Step 2: Getting Parameters for BWA Instance Installation \[Page 22\]](#) for details.
- See [Step 3: Installing the BW Accelerator Instance \[Page 24\]](#)

You have to know the following parameters:

- <SAPSID> of the BW system
- System number
- Application server host name of the BW system and the username and password for this system.
- Client number

Procedure

The script prompts you for data to establish a connection between the BWA engine and the specified BW system. To configure the RFC connection, the script asks for the following parameters:

Prompt	Input
SAP System Name	<SAPSID> of the BW system. For example: BCI
System Number	System number of the BW system. For example: 26
Application Server Host	Application Server host name of the BW system. For example: 1x0297
Client	Client number: For example: 000
User	User name for application server. See also, SAP Note 766516.
Password	Password
Should a new RFC destination be created in the SAP system <SAPSID>? (y/n)	You have the choice to use an existing RFC destination from the BW system or create a new one. This option has the following affect: <ul style="list-style-type: none"> • n (=No) Use this answer, when your BW system already has a RFC destination that you want to use for the BW accelerator connection. No new RFC destination is created in the BW system.

	<ul style="list-style-type: none"> • y (=Yes) Use this answer, to create an new RFC destination in the BW system.
Name of new RFC destination [default: TREX_BWA]	<p>Enter the name of the new RFC destination.</p> <p>If you answered the previous question with n (=No) the settings are made on the BW accelerator host but no new RFC destination is created in the BW system.</p> <p>If you answered the previous question with y (=Yes) the settings are made on the BW accelerator host and a new RFC destination is created in the BW system.</p>

The dialog for step 4 is finished. The specified parameters are displayed and the installation script gives you following options:

- **c**
Continue with the installation. Make sure that the displayed parameters are correct before you continue.
- **e**
Exit the installation script. When you select this option, the installation script is terminated without creating a RFC destination.
- **r**
Repeat the questions for the RFC destination to change or correct the parameters.

Step 6: BWA System Check after BWA Installation

After finishing the creation of the RFC destination the BWA system check will be executed again, but now with a full check of all relevant BWA system parameters and settings. For more information, see [BW Accelerator System Check \[Page 10\]](#).

- If the system the BWA is to be installed on meets the predefined requirements, the BWA system check will display an OK.
- If the system the BWA is to be installed on does not meet the predefined Requirements, BWA system check message will be displayed. For more information, see [BW Accelerator System Check Messages \[Page 28\]](#).

Result

When you entered c (=continue), the BW accelerator system is now ready to use.

See [Final Steps \[Page 28\]](#) for details about settings on the BW system.



Check RFC Connection BW System to BW Accelerator Box

Procedure

The RFC connection has to be registered on the BW system.

✓	Action
---	---------------

	Log on to the BW system as administrator.
	Start the transaction sm59 .
	Select the BW accelerator RFC connection. Default name for the RFC connection: TREX_HPA
	Choose Connection Test button.

Result

A result of the test is displayed. The list must not contain red entries.



Final Steps

Check BWA Installation Log Files

Installation steps 1 through 4 have to be successfully finished.

Steps to check if the installation was successful.

✓	Action
	Check the log files of the BWA installation. The log files can be found at: <code>/tmp/bia_install_<year-month-day>_<timestamp>/_install.log</code>

Check RFC Connection BW System to BW Accelerator Box

The RFC connection has to be registered on the BW system.

✓	Action
	Log on to the BW system as administrator.
	Start the transaction sm59 .
	Select the BW accelerator RFC connection. Default name for the RFC connection: TREX_HPA
	Choose Connection Test button.



Appendix



BW Accelerator System Check Messages

The BWA Accelerator system check messages comprise the following sections:

- BWA System Check Report
- Common Parameters
- Nodes
- Parameter Deviation
- Performance
- Functionality Test
- BWA Connectivity

The tables below describe the messages that the BW Accelerator system check displays in detail.

***** BWA SYSTEM CHECK REPORT *****

This section displays information about the BWA `checkBIA.py` script, such as version, user, and the start time for the script.

Info Type	Parameter	Description and Values
OK	Version: <version_nr>/ <Perforce_branch> <change_list>/<date> Example: Version: #13/ BWA_COR 109174 2006/12/20	Version of the <code>checkBIA.py</code> script.
Info	user: <SAPSID>adm (<user_ID>) Example: user b71adm (1111)	<SAPSID>adm user that started the <code>checkBWA.py</code> script. The user ID can be specified separately during the BWA installation.
Info	started on: <name_of_BWA_server> Example: started on: loantrxh001	Name of the server/blade on which the BWA system check was first started.
Info	Time: <date_and_time> Example: Time: 2007-01-30 09:49:13 UTC	Start time of the check.
Info	check of <BWA_install_directory> (<number_of_hosts>) Example:	<ul style="list-style-type: none"> • BWA installation directory that is checked by the script. This path is identical for all BWA nodes of the BWA landscape. • Number of TREX hosts/blade installations to be checked

	check of /usr/sap/B71/TRX71 (8 hosts)	
--	---	--

***** COMMON PARAMETERS *****

This section displays information about common parameters for the BWA installation such as the following:

- Hardware vendor, processor type, memory size, CPU speed and so on.
- Hardware name and operating system
- System settings such as maximum shared memory, core file limit, and shared storage.

Info Type	Parameter	Description and Values
OK	Hardware vendor: <vendor_name> Source: <protocol> Example: Hardware vendor: HP Source: Inet6	Name of hardware vendor. Possible values: HP, IBM, Fujitsu Siemens, Dell, Sun The <code>source</code> parameter signifies the source from which the information about the hardware vendor is retrieved (Inet6 = Internet protocol version 6 family).
WARNING	Hardware vendor not available	
ERROR	Hardware vendor not supported	
OK	CPU vendor: Intel	Name of CPU manufacturer. Mandatory value: Intel
ERROR	CPU vendor not supported	All other CPU vendors. This message appears if the CPU vendor does not match the mandatory value.
INFO	CPU speed: <value> Example: CPU speed 3600.000	CPU clock rate measured in MHz. <ul style="list-style-type: none"> • For single-core CPUs: 3.6 GHz Note: Intel CPUs switch to sleep mode with a clock rate of 2.8 GHz when not used. <ul style="list-style-type: none"> • For dual-core CPUs: 3.0 GHz
OK	CPU count: <value>	Number of CPUs. A CPU is a physical package of one (single-core) or several (dual/quad-core) cores. A single-core CPU comprises only one processor or core. A dual-core CPU comprises two cores, a quad-core CPU four cores.
ERROR		A CPU count of less than 2 is not allowed.

INFO	CPU cores: <value>	Number of cores for each CPU (single-core: 1, dual-core: 2, quad-core: 4).
INFO	Logical CPU count: <value>	Total number of logical processors. Logical CPU count = CPU count * CPU cores (* 2 if hyper-threading is enabled)
INFO	CPU siblings <value>	Number of logical processors for each CPU.
INFO	Hyper-threading: yes/no	Tells you whether or not hyper-threading is enabled. Hyper-threading doubles the number of logical processors.
OK	CPU cache size: <value> Example: CPU cache size: 2048 KB	Size of CPU cache measured in KB. Threshold <ul style="list-style-type: none"> • For single-core CPUs: 2048 KB • For dual-core CPUs: 4096 KB
WARNING		Less than 2048 KB.
INFO	CPU name: Intel(R) Xeon(TM) CPU 3.60 GHz	CPU brand name/CPU clock rate.
OK	CPU type: x86_64	CPU type. Mandatory value: x86_64
ERROR		Occurs if the CPU type is not a mandatory value.
OK	Total OS memory: <value> Example: Total OS memory 8 GB	Total size of computer memory (RAM) measured in GB. Threshold values for all CPU types: <ul style="list-style-type: none"> • ERROR: Less than 8 GB For single-core CPUs: <ul style="list-style-type: none"> • OK: 8 GB For dual-core CPUs: <ul style="list-style-type: none"> • OK: 16 GB • WARNING: Less than 16 GB • ERROR: More than 48 GB For quad-core CPUs: <ul style="list-style-type: none"> • OK: 16 GB • WARNING: Less or more than 16 GB

WARNING/ ERROR	Total OS memory is <value>, needed <value>GB	
-------------------	---	--

OK	Kernel: Linux	Kernel of operating system.
ERROR	Kernel not supported	Mandatory value: Linux
OK	Kernel release: <version> Example: Kernel release 2.6.5-7.252-smp	Release version of Linux kernel Note: All BWA nodes must have the same Linux kernel release.
Error		Minimum requirement: SLES 10 SP2
OK	Operating system SUSE Linux <release_nr> Example: Operating system SUSE Linux 10	Name and release number of operating system.
WARNING	Operating system is SUSE Linux <OS_version>, needed 10 at least	Minimum operating system requirement for all hardware vendors: SUSE Linux 10
ERROR	Operating system too old/Operating system not supported	
OK	Max shared memory: <value> Example: Max shared memory: 2 GB	Maximum shared memory (kernel parameter: Large block of RAM that can be accessed by different processes for fast data exchange).
WARNING	Max shared memory<value>, needed <value>GB	Default value: 2 GB This value is set to 2 GB during the BWA installation.
ERROR		Less than 1 GB
OK	Net: Channel bonding is OK	Checks whether or not the bond interface is available. Channel bonding in computer networking is an arrangement in which two or more network interfaces on a host computer are combined for

		redundancy or increased throughput.
ERROR		Occurs if the bond interface has the status 'down'.
OK	Open files limit: <value> Example: Open files limit: 8000	Maximum number of open files. On UNIX platforms, each process may only have a certain number of files open at once. If you create a large number of BWA indexes, a large number of files are opened. The open files limit parameter shows you the value of the open files limit. The open files limit parameter must have a value that is not less than 8000.
ERROR		Occurs if the Open files limit is less than 8000.
OK	Actual open files limit<SAPSID>adm_user) Example: Actual open files (ABCadm): 8000	Actual open files limit for the <SAPSID>adm user. The actual open files limit parameter shows the current value for the number of open files. The actual open files limit parameter must have a value that is not less than 8000.
ERROR		Occurs if the Actual open files limit is less than 8000
OK	Core file limit: <value>/unlimited	If the core file limit is set to unlimited core, files of any size can be written. Core files can be used to check the core for errors. A core dump is the recorded state of the working memory of a computer program at a specific time, generally when the program has terminated. Mandatory value: unlimited
ERROR	Core file limit is <value>, needed unlimited	If core file limit is set to a value other than unlimited, a WARNING/ERROR message appears.
OK	GDB is installed	GNU Debugger (GDB) is a command line-based debugger tool that can be used for checking core files. Mandatory value: installed
ERROR	GDB is missing	
OK	DDD is installed	Data Display Debugger (DDD) is a graphical user interface for the GDB command line debugger.

INFO	DDD is missing	DDD is not mandatory.
OK	<p>Shared storage: <mount_point></p> <p>Example: Shared storage: /export</p>	<p>Mount point for central data storage device specified as a path. All BWA nodes must be able to access the central storage device using this mount point. There is only one central mount point for each BWA installation/system. It points to the central storage device acting as one logical volume.</p> <p>From the <code>../../usr/sap</code> directory, a symbolic link points to the <code>/export</code> directory so that the paths <code>../../usr/sap</code> and <code>export/</code> can be used synonymously.</p>
ERROR		<p>An error message appears if the following requirements are not met for the central storage device:</p> <ul style="list-style-type: none"> • Device for hardware vendor IBM: GPFS (General Parallel File System). • Device for hardware vendor HP: <ul style="list-style-type: none"> ○ OCFS (Oracle Cluster File System). ○ NFS (Network File System) • Device for Fujitsu: NFS • Device for Sun: OCFS • Device for Dell: OCFS
OK	size: <value> T/GB	Size of central storage device available for BWA, measured in terabytes or GB.
WARNING		Less than 500 GB
ERROR		Less than 200 GB
OK	usage: <percentage>	<p>Proportion of usage of the central storage device by BWA as a percentage value,</p> <p>Threshold values:</p> <ul style="list-style-type: none"> • With BWA installed: Usage of less than 80% • Otherwise: Usage of less than 10%
WARNING		<p>Threshold values:</p> <ul style="list-style-type: none"> • With BWA installed: Usage of 80 to 95 % • Otherwise: Usage of 10 to 25%
ERROR		<p>Threshold values:</p> <ul style="list-style-type: none"> • With BWA installed: Usage of more than 95 % • Otherwise: More than 25%

OK	BWA shared memory free space <percentage>	Proportion of BWA shared memory. 64 MB are allocated for the BWA shared memory. The percentage value refers to this absolute value.
WARNING	BWA shared memory free space not checked	
ERROR	BWA shared memory is full, free space <percentage>	Tells you that the proportion of usage is less than 5%.
OK		The BWA check has found one BWA instance on the node where the BWA script was executed. Only one BWA instance should be installed on each node.
WARNING	More than one instance found (<number_of_instances> Example: More than one instance found (5)	The BWA check has found more than one BWA instance on the node where the BWA script was executed. It is highly recommended that you install only one BWA instance on each node.

***** NODES *****

This section displays information about the different server blades (nodes) of your BWA installation.

Info Type	Parameter	Description and Values
INFO	<FQDN> (IP address)	Fully qualified domain name (FQDN) and IP address of the server/blade where the BW Accelerator is installed.
INFO	loantrhx001.wdf.sap.corp (10.17.65.139)	Example
INFO	loantrhx002.wdf.sap.corp (10.17.65.140)	Example
INFO	loantrhx003.wdf.sap.corp (10.17.65.141)	Example
INFO	...	The BW Accelerator is installed on several server blades/nodes, and the messages belonging to the BWA installation occur several times depending on the number of BWA server blades/nodes.

***** PARAMETER DEVIATION *****

This section describes how the parameters of specific nodes deviate from the common parameters in the *Common Parameters* section. The name of the specific node is listed together with the deviating parameter and the expected parameter.

Info Type	Parameter	Description and Values
-----------	-----------	------------------------

ERROR/ WARNING	<name_of_BWA_server>: <parameter> differs: <deviating_value>, exp <expected_value>	<ul style="list-style-type: none"> Name server/blade where the BW Accelerator is installed. Value of the deviating parameter and the value that was expected for comparison purposes.
ERROR	loantrhx001: Kernel release differs: 2.6.5- 7.282-smp, exp: 2.6.5- 7.252-smp	Example
WARNING	loantrhx001: CPU speed differs: 2800, exp: 3600	Example
ERROR/ WARNING	...	Example
OK	No IP address duplications found	IP addresses must be unique in the BWA landscape.
ERROR	Duplicated IP address <IP_address> for <specific_host>	If there is a duplicated IP address for a specific host, an error is shown.
ERROR	BWA shared memory not used on all nodes	BWA shared memory should be used on all BWA nodes. Otherwise, an error is shown.
ERROR	BWA shared memory not used (<specific_host>)	If a specific host does not use shared memory, an error is shown.
WARNING	BWA shared memory availability not checked	
OK	BWA shared memory used on all nodes	
INFO	===== BWA Instances =====	
	This section lists the specific BWA nodes and the corresponding instances that are installed on them. For each instance, characteristic parameters describe the BWA node.	
WARNING	<name_of_BWA_server>: more than one instance found (<number_of_ instances>) Example: loantrhx001: More than one instance found (6)	<p>The BWA check has found more than one BWA instance on the node specified by the <name_of_BWA_server>.</p> <p>It is highly recommended that you install only one BWA instance on each node.</p>
INFO	----- Instances <name> -----	
INFO	Version: <BWA_build_nr> Example: 700.47.122347 <release>: 700 <revision>: 47 <internal_version _number >: 122347	BWA build number, comprising number of BWA release, BWA revision, and internal version number.

INFO	Storage: <mount_point> Example: storage /sapmnt/test/	Mount point for central data storage device, specified as a path.
INFO	state active/inactive	Status of BWA instance.

***** PERFORMANCE *****

This section displays parameters and issues related to BWA performance.

Info Type	Message	Description and Values
INFO	Current network load <state> Example: Current network load low	Overall network load. Possible values: very high/high/low
INFO	===== Network =====	
OK	Net throughput <value> avg Example: Net throughput 64.9 MB/s avg	Network throughput between BWA nodes, measured in MB per second. Threshold value: 50 MB/s Expected values: 75 to 90 MB/s Note: These values refer to a BWA system that runs in no-load mode.
ERROR		Network throughput is less than 50 MB/s.
OK	Local network throughput <value> avg Example: Local network throughput 160.9 MB/s avg	Local network throughput measured in MB/second between different services communicating by TCPIP (local network interface/loop back interface) and not by shared memory. This value is relevant since BWA uses this type of communication frequently. Threshold value: 133 MB/s Expected value: 150 to 266 MB/s Note: These values refer to a BWA system that runs in no-load mode.
ERROR		Local network throughput is less than 133 MB/s.
INFO	===== Shared Storage =====	
	The performance test in the Shared Storage section checks the throughput of the central storage device (filer) that is connected to the BWA nodes. All BWA nodes read and write on the same central storage device. The performance test checks whether or not this device meets the necessary BWA requirements.	
INFO	----- Local Parallel Test -----	
INFO	Shared storage: <usr/sap/<SAPSID>/ TRX<instance_number>	Mount point for the central storage device (filer). All BWA nodes must be able to access the central storage using this mount point. There is only one central mount point for each BWA installation/system. The central storage device

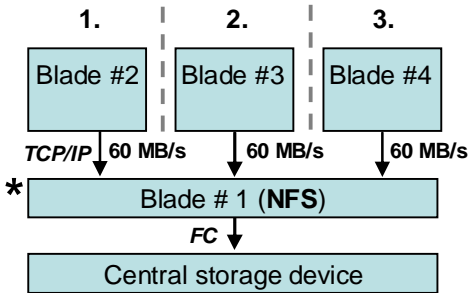
	<p>Example:</p> <p>Shared storage:</p> <pre>/usr/sap/B71/TRX71/ index.checkbia</pre>	<p>acts as one logical volume.</p> <p>From the <code>/.../usr/sap</code> directory, a symbolic link points to the <code>/export</code> directory so that the paths <code>usr/sap/<SAPSID>/TRX<instance_number></code> and <code>/export/<SAPSID>/TRX<instance_number></code> can be used synonymously. <code>Index.checkbia</code> is the file that is used for testing the central storage device.</p>
INFO	<p>1 thread: <value></p> <p>Example:</p> <pre>1 thread 143.39 MB/s</pre>	<p>Throughput result measured in MB/second: Writing one file with one thread on one BWA node.</p>
INFO	<p>10 thread: <value></p> <p>Example:</p> <pre>10 thread: 179.01 MB/s</pre>	<p>Throughput result measured in MB/second: Writing 10 files with 10 threads in parallel on one BWA node.</p>
INFO	<p>20 thread</p> <p>Example: 191.82 MB/s</p>	<p>Throughput result measured in MB/second: Writing 20 files with 20 threads in parallel on one BWA node.</p>
INFO	<p>----- Distributed Serial Test -----</p>	
OK	<p>Average write <value> (<number_of_BWA_host> hosts)</p> <p>Example:</p> <pre>Average write 60 MB/s (3 hosts) 4 blades in total</pre>	<p>Throughput for each BWA node (except the BWA node with NFS): Sequentially writing files on the central storage device measured in MB/second.</p> <p>This value shows the maximum throughput one single blade can write in ideal circumstances.</p> <p>Example:</p> <ol style="list-style-type: none"> Blade # 2 writes files and stops. Blade # 3 writes files and stops. Blade # 4 writes files and stops.  <pre> 1. 2. 3. [Blade #2] [Blade #3] [Blade #4] TCP/IP 60 MB/s * [Blade # 1 (NFS)] FC [Central storage device] </pre> <p>* Note: If a file system other than NFS is used (for example, GPFS, OCFS), the blades of the BWA installation are connected directly to the central storage device. In this case, no blade is needed exclusively for the NFS.</p>
WARNING		<p>Value is less than 50 MB (only valid if there is no network traffic from other applications).</p>
ERROR		<p>Value is less than 40 MB (only valid if there is no</p>

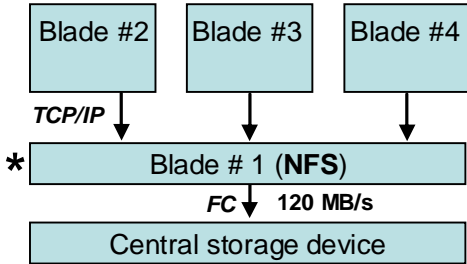
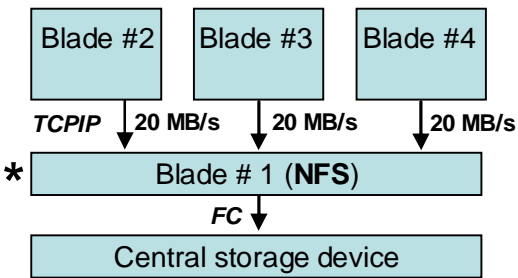
		network traffic from other applications).
INFO	----- Distributed Parallel Test -----	
INFO	<p>Write throughput <code><name_of_BWA_server></code> <code><value></code></p> <p>Example: Write throughput loantrxh001 120 MB/s</p>	<p>Throughput for one BWA node only, accessing the central storage device as the NFS (Network File System), measured in MB/second.</p> <p>This value shows the largest possible throughput from a BWA node to the central storage device.</p> <p>Example:</p>  <pre> graph TD B2[Blade #2] -- TCP/IP --> B1[Blade #1 (NFS)] B3[Blade #3] -- TCP/IP --> B1 B4[Blade #4] -- TCP/IP --> B1 B1 -- FC --> CS[Central storage device] </pre> <p>* Note: If a file system other than NFS is used (for example, GPFS, OCFS), the blades of the BWA installation are connected directly to the central storage device. In this case, no blade is needed exclusively for the NFS and the test of the <code>write throughput</code> parameter is superfluous.</p>
INFO	<p>Average write <code><value></code> (<code><number_of_BWA_host></code> hosts)</p> <p>Example: Average write 20 MB/s (3 hosts) In brackets: Number of BWA nodes writing in parallel</p>	<p>Average throughput result for each BWA node (without the BWA node with NFS), measured in MB/second. All BWA nodes (except the BWA node with NFS) write files in parallel on the central storage device.</p> <p><code><average_write>/<number_of_BWA_hosts></code></p> <p>Example:</p>  <pre> graph TD B2[Blade #2] -- TCP/IP --> B1[Blade #1 (NFS)] B3[Blade #3] -- TCP/IP --> B1 B4[Blade #4] -- TCP/IP --> B1 B1 -- FC --> CS[Central storage device] </pre> <p>* Note: If a file system other than NFS is used (for example, GPFS, OCFS), the blades of the BWA installation are connected directly to the central storage device. In this case, no blade is needed exclusively for the NFS.</p>
INFO	<p>Shared storage write channel <code><value></code></p>	<p>Throughput result for all BWA nodes (without the BWA node with NFS) measured in MB/second:</p> <p><code><average_write> *</code></p>

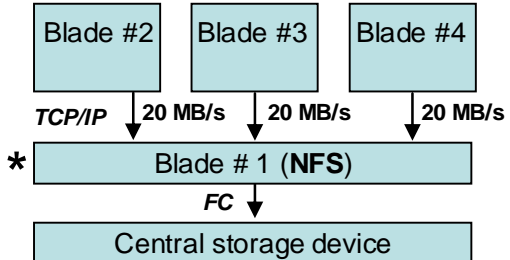
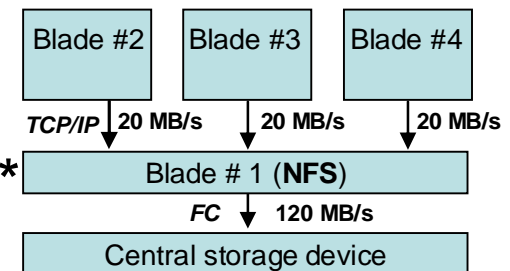
	<p>Example: Shared storage write channel 60 MB/s</p>	<p><number_of_BWA_hosts></p> <p>Example: 20 MB/s * 3 hosts = 60 MB/s</p>  <p>* Note: If a file system other than NFS is used (for example, GPFS, OCFS), the blades of the BWA installation are connected directly to the central storage device. In this case, no blade is needed exclusively for the NFS.</p>
<p>INFO</p>	<p>Average write <value></p> <p>Example: 45 MB/s (all 4 hosts)</p>	<p>Average throughput result for each BWA node (including the BWA node with the NFS) measured in MB/second:</p> <p><write_throughput> + <shared_storage_write_channel> / <number_of_BWA_hosts></p> <p>Example: 120 MB/s + 60 MB/s / 4 host = 45 MB/s</p>  <p>* Note: If a file system other than NFS is used (for example, GPFS, OCFS), the blades of the BWA installation are connected directly to the central storage device. In this case, no blade is needed exclusively for the NFS.</p>
<p>INFO</p>	<p>Write channel <value></p>	<p>Summed up throughput result for all BWA nodes (including the BWA node with NFS), measured in MB/second:</p> <p><write_throughput> + <shared_storage_write_channel></p> <p>Example 120 MB/s + 60 MB/s = 180 MB/s</p>

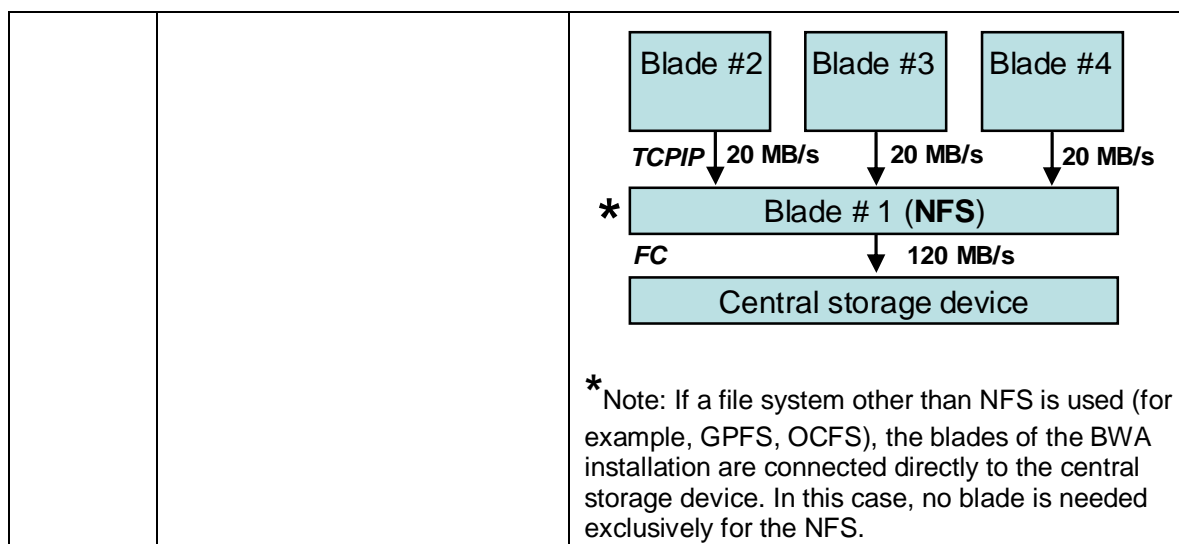

***** FUNCTIONALITY TEST *****

This section displays information about testing basic BWA functions such as index creation, indexing, and searching.

Info Type	Message	Description and Values
OK	Creating	The creation of the BWA test index was successful.
ERROR	Creating failed	The creation of the BWA test index failed.
OK	Indexing	The BWA indexing test was successful.
ERROR	BWA indexing/ searching not functioning	The BWA indexing/searching test failed.
OK	Searching	The BWA searching test was successful.
ERROR	BWA indexing/searching not functioning	The BWA indexing/searching test failed.
OK	Deleting	The deletion of the BWA test index was successful.
ERROR	Deleting failed	The deletion of the BWA test index failed
OK	BWA searching functioning	All BWA function tests work correctly.

***** BWA CONNECTIVITY *****

This section displays information on the following:

- RFC connection that the BW Accelerator uses to communicate with the application servers of the BW system
- Availability and performance of the BW application servers

Info Type	Message	Description and Values
INFO	===== RFC Configurationm =====	

OK	RFC configuration	RFC configuration test. BWA is connected to the BW system by means of RFC.
ERROR	RFC check failed	The RFC configuration test failed.
OK	Rfc Servers and threads	For the BWA scenario, the multi-threaded mode is mandatory. An RFC server runs on every BWA node/blade. As many RFC server threads are automatically started as dialog and batch processes are initiated on the BW application server side. The BWA system automatically starts the corresponding number of RFC server and server threads.
ERROR		Single-threaded mode is being used.
OK	RFC server mode: single threaded/ multi threaded	The RFC server can run in single threaded and multi-threaded mode. For the BWA scenario, the multi threaded mode is mandatory.
OK	Number of RfcServer Threads/Processes. Data found: Example: Number of RfcServer Threads/Processes. Data found: BCE:TREX_B2 numRfcServers=120 (numInstances=3 numTrexHosts=8 numAppServers=5) totalWPs=102 (totalDiaWPs=84 totalBgdWPs=18)	Detailed information about the RFC connection between the BWA and the BW system, especially about the total number of RFC server threads on the BWA side and the total number of work (dialog and batch) processes on the BW application side. The total number of work processes on the BW application side should not exceed the number of RFC server threads on the BWA side: <number_of_RFC_server_threads> ≥ <total_number_of_work_processes> Syntax: <SAPSID_of_BW_system> <name of RFC connection> <number_of_RFC_server_threads>= <number_of_RFC_server_instances> * <number_of_TREX/BWA_hosts> * <number_of_BW_application_servers> <number_of_work_processes>= <number_of_dialog_work_processes> + <number_of_background_work_processes>
WARNING		A WARNING message appears if <number_of_RFC_server_threads> is not greater than <total_number_of_work_processes>.
ERROR		An ERROR message appears if the RFC connection is not configured.

INFO	System <SAPSID_of_BW_system> connection: <RFC_connection_type>: <BW_system_ID> Example: System BCE A:bcmmain:26	SAPSID and system ID of the BW system to which the BWA is connected. <RFC_connection_type>: <ul style="list-style-type: none">• A = Connect to a specific SAP application server• B = Connect to an SAP message server using load balancing
INFO	RFC destination <SAPSID_of_BW_system>: <name_of_rfc_destination>: <number_of_RFC_server_instances>: <automatic_changes: on/ff> Example: RFC destination BCE:TREX_B2: 3:1	Information about the RFC destination.
	AppServer <SAPSID_of_BW_system> <name_of_BW_application_server> <BW_system_ID> -><BW_host_name> Examples BCE:bsl8015 26 -> bsl8015 AppServer BCE:bcmmain 26 -> bcmmain AppServer BCE:bsl8010 26 -> bsl8010	Information about the BW application server that is connected to the BWA. If the BWA is connected to several BW application servers, a list of connected application server is displayed.
INFO	==== Application Server Ping ====	
INFO	host(ip) min/avg/max/mdev	This section displays information about the availability of the application server of the BW system to which the BW Accelerator is connected.
INFO	----- System <name> -----	
INFO	<BW_host_name>(IP address) response time: minimal/average/maximal/ mediumdeviation	The availability of the application server is checked by the ping command, which sends a request to the server. The minimum, average, and maximum response times are displayed.
INFO	bsl8015(10.66.64.26) 0.324/0.324/0.324/ 0.000 ms	Example
INFO	bcmmain(10.21.80.255) 0.376/0.376/0.376/ 0.000 ms	Example
INFO	bsl8010(10.66.64.21) 0.330/0.330/0.330/ 0.000 ms	Example
INFO	...	Note: A list of messages is displayed

		depending on the number of BW application servers.
INFO	===== Application Servers traceroute =====	
INFO	Route hops to <BW_system>	This section displays information about the hop count from the BWA to the BW system. The hop count describes how many intermediate points the data needs to pass through on its way from the BWA to the specified BW system. Ideally this value should be 0. In an ideal scenario, the BW systems and the BWA should be connected directly and should use the same switch/router/hop to avoid transmission delays.
INFO	----- System <name> -----	
INFO	route hops to bsl8015: 6 route hops to bcemain: 6 route hops to bsl8010: 6	
OK	All 5 AppServers(BCE) are connected directly	Ideally, the BW systems and the BWA should be connected directly and should use the same switch/router/hop to avoid transmission delays.
WARNING	All 5 AppServers(BCE) are not connected directly	Signals that the BW systems using the BWA are not connected directly to the BWA.



Configuring RFC Connection by Script

Use

You configure the RFC connection by a script individually, when the BW accelerator installation script has been ended before the RFC configuration step.

Prerequisites

The BW accelerator installation step 1, 2, 3, and 4 have to be successfully finished.

Configuring RFC Connection by Python Script

Starting the RFC configuration script:

1. Log on to the BW accelerator system with the user <sapsid>adm.
2. Set the environment variables required by TREX:
 - o Bourne shell `sh`, Bourne-again shell `bash`, Korn shell `ksh`:
 - `TREXSettings.sh`
 - o C shell `csh/tcsh`:

```
source TREXSettings.csh
```

3. Go to the `python_support` directory in the TREX installation directory `<TREX_DIR>`.
4. Start Python script:

```
python initialRfcConfiguration.py
```



When the Python directory is not included in the search path you have to enter a full qualified file name:

```
/usr/bin/python initialRfcConfiguration.py
```

Configuring RFC Connection by BWA Installation Script

You can also use the BWA installation script for configuring the RFC connection individually.

After starting the script, choose the option 4 - configure RFC connection of an existing TREX instance. Enter the requested input as described in [Step 5: Configure RFC Connection to the BW System \[Page 26\]](#).

Result

The RFC configuration dialog is started. See [Step 5: Configure RFC Connection to the BW System \[Page 26\]](#) for details.