

Integration Guide

Document Version: 1.0 – 08-Feb-2016

CUSTOMER

SAP Complex Assembly Manufacturing 7.2 SPS 5



Typographic Conventions

Type Style	Description
<i>Example</i>	Words or characters quoted from the screen. These include field names, screen titles, pushbuttons labels, menu names, menu paths, and menu options. Textual cross-references to other documents.
Example	Emphasized words or expressions.
EXAMPLE	Technical names of system objects. These include report names, program names, transaction codes, table names, and key concepts of a programming language when they are surrounded by body text, for example, SELECT and INCLUDE.
Example	Output on the screen. This includes file and directory names and their paths, messages, names of variables and parameters, source text, and names of installation, upgrade and database tools.
Example	Exact user entry. These are words or characters that you enter in the system exactly as they appear in the documentation.
<Example>	Variable user entry. Angle brackets indicate that you replace these words and characters with appropriate entries to make entries in the system.
EXAMPLE	Keys on the keyboard, for example, F2 or ENTER.

Document History

Version	Date	Change
1.0	8-Feb-2016	Initial release

Table of Contents

1	Introduction.....	6
1.1	Before You Start.....	6
1.2	Assumptions.....	7
1.3	Scalability/Availability.....	8
1.4	Variables.....	8
1.5	Useful Links.....	9
1.6	SAP Notes.....	9
2	Configure Environment Variables for the Server.....	10
3	Modify File Permissions.....	12
4	Configure Database Connection to the SAP Complex Assembly Manufacturing Database.....	13
5	Configure Users and Roles within SAP NetWeaver.....	17
6	Deploy CAMS-INTws to SAP NetWeaver.....	21
7	Allocate CAMS-INTws Actions to Roles.....	22
8	Deploy CAMS-INT to SAP MII.....	24
9	Configure SAP MII Connectivity to SAP.....	26
10	Configure SAP to Send Messages to SAP MII.....	28
10.1	Create an RFC Destination in SAP.....	28
10.2	Creating an IDoc Listener in SAP MII.....	30
10.3	Testing the IDoc Listener Connection.....	32
10.4	Defining a Logical Port.....	33
10.5	Defining a Partner for the RFC Destination.....	34
10.6	Creating a Partner Profile.....	35
10.7	Creating a Distribution Model.....	37
10.8	Placing a Document on a Queue.....	38
10.9	Standard Service Transactions.....	40
10.10	MessageValidationService (SAP/ Manufacturing/CAMS/framework/test).....	42
11	Configure SAP MII Connection to the SAP Complex Assembly Manufacturing Database.....	43
12	Configure SAP MII Message Listeners for the Message Types.....	44
12.1	Enable Message Cleanup Rules.....	49

13	Configure SAP MII Credentials to Be Used by CAMS-INT	51
14	Configure Schedule Tasks Used by CAMS-INT	53
15	Configure CAMS-INT	59
15.1	Menu Creation	59
15.2	Global Configuration	62
15.3	Email Notifications	63
15.4	Supported Plants.....	64
15.5	Workflow Configuration	65
15.6	Configuration Import/Export	68
15.7	Defining Integration Server Configuration	70
15.8	SAP Complex Assembly Manufacturing ERP Interface Configuration	72
16	Post Installation Tests	75
16.1	Integration Server Tests	75
16.2	SAP to SAP MII Interface Test.....	76
16.3	SAP MII to SAP Interface Test.....	78
17	Monitoring Capabilities.....	79
17.1	Queue Monitor	79
17.2	Archive Queue Monitor	81
17.3	Message Statistics	82
17.4	BOM Holding Queue.....	82
17.5	Change Masters	83
	Appendix A: High Availability (HA) Options	85
	Appendix B: Planning Hold Interface	95
	Appendix C: Configuration Tips	100

1 Introduction

This document describes the procedures for the installation and configuration of the components to allow SAP Complex Assembly Manufacturing 7.2 Support Package Stack 5 (SPS 5) to interface to external systems or applications. Throughout this document, CAMS-INT is used to refer to these capabilities.

It defines and explains how to do the following:

- Configure environment variables for the server
- Modify the file permissions to allow CAMS-INTs to work
- Configure the database connection to the SAP Complex Assembly Manufacturing database
- Configure users and roles in SAP NetWeaver
- Deploy CAMS-INTs to SAP NetWeaver
- Allocate CAMS-INTs actions to roles
- Deploy CAMS-INT to SAP Manufacturing Integration and Intelligence (SAP MII)
- Configure SAP MII connectivity to SAP
- Configure SAP to be able to send messages to SAP MII
- Configure SAP MII connectivity to the SAP Complex Assembly Manufacturing database
- Configure SAP MII Message Listeners for the message types
- Configure SAP MII credentials to be used by CAMS-INT
- Configure schedule tasks used by CAMS-INT
- Configure CAMS-INT
- Run post-installation tests
- Use the monitoring capabilities

1.1 Before You Start

Before you start the integration and installation, you should do the following:

1. Complete the steps for installation or upgrade of the SAP Complex Assembly Manufacturing software components as described in the [Installation Guide](#), which is included in the SAP Complex Assembly Manufacturing delivery or is available on the SAP Support Portal (see section 1.5, Useful Links).
2. Refer to the [Master Guide](#) for a technical overview of SAP Complex Assembly Manufacturing. This guide is included in the SAP Complex Assembly Manufacturing delivery or is available on the SAP Support (see section 1.5, Useful Links).

3. Ensure that you have downloaded the 64-bit package for SAP Complex Assembly Manufacturing 7.2 SPS 5 (titled `CAMSINT 7.2`) from the SAP Support Portal at <http://support.sap.com/swdc>. This package includes the `SAPTCLIntegration_CAMS_7.2.5.##.zip` file, which includes three files:
 - o `CAMS-INT-7.2.5.zip`
 - o `CAMS-INT-Actions-7.2.5.jar`
 - o `CAMSINTws725_##.sca` (with `##` representing a build number; see the Variables section for details)
4. Extract the `SAPTCLIntegration_CAMS_7.2.5.##.zip` to install all the files to the `<SAP_CAMS_7.2_PI\CAMS-INT>` directory for your SAP Complex Assembly Manufacturing installation.
5. As the 64-bit version of SAP Complex Assembly Manufacturing used to support CAMS-INT needs to use the same database configuration as the 32-bit version, copy the `camsDBInfo` file that is created when completing the steps in the *Installation Guide* into the same location for the 64-bit `<SAP_CAMS_7.2_PI>` directory for it to use. The `RunCAMS.bat` file can also be configured on the CAMS-INT server as a way to ensure the SAP Complex Assembly Manufacturing installation is running and connecting to the database.
6. Java is required to view the forms in CAMS-INT. Please ensure that you have the Java version specified in the SAP MII documentation.

1.2 Assumptions

This document assumes the following:

- If a `CustomerDiscriminator` in SAP MII is used, the expanded functionality from the base 7.2 version of the `SimpleDocumentDiscriminator` will have to be merged with the existing custom code.
- That, at a minimum, SAP NetWeaver 7.3 including EHP 1, SPS 14 (Java) and SAP MII 14.0 SP 05, Patch 6 are installed on the server to be used by CAMS-INT. While the minimum patch levels are stated, SAP encourages using the latest available patch version.

Note

The instructions in this document assume use of the SAP NetWeaver and SAP MII versions noted above. If you are using a version other than those stated, you may see a slightly different user interface than that described here. Please refer to the SAP NetWeaver and SAP MII documentation for your version as needed.

- o Both the SAP MII and SAP MII administration modules must have been deployed. Refer to the SAP MII documentation for instructions.
- That, at a minimum, the SAP ECC system being connected to is ECC 6.0 EHP4. While a minimum value is stated, SAP encourages using the latest versions.
- That an Oracle Client installation has been done:
 - o SAP Complex Assembly Manufacturing supports Oracle 11g Release 2 or Oracle Database 12c. For client installations of SAP Complex Assembly Manufacturing 7.2 SPS 5, the Oracle client must be the 32-bit Windows release. For CAMS-INT on Microsoft Windows Server 2008, the Oracle client must be the 64-bit Windows release.

- The following must be set:

```
NLS_NCHAR_CHARACTERSET    UTF8 (the default is AL16UTF16 so be sure to change it)
NLS_CHARACTERSET          AL32UTF8
```

- That the Oracle Transparent Network Substrate (TNS) names are defined on the server to allow connection to the main SAP Complex Assembly Manufacturing database.
- That the x64 VC++ redistribution file (vcredist_x64.exe) has been downloaded from Microsoft® and installed, which is available from Microsoft.com at: <http://www.microsoft.com/downloads/en/details.aspx?familyid=ba9257ca-337f-4b40-8c14-157cfdffee4e&displaylang=en>. (This link was valid as of November 2015.) Note: if this redistributable is installed after SAP NetWeaver is installed, it may be necessary to re-install SAP NetWeaver's version of this redistributable after installing the version downloaded from Microsoft.
- This guide assumes that both a basis and SAP Complex Assembly Manufacturing administrator will be available as this document covers requirements handled by these roles. Communication between the two roles needs to be active to allow a successful install. By way of a guide, the following parts of the document may be applicable to these roles:
 - Basis role:
 - Installation of SAP MII (not covered in this document)
 - Sections 2 – 10 as a general guide, though there are some SAP Complex Assembly Manufacturing administrator functions in these sections; however, for the most part they are more for a basis person.
 - SAP Complex Assembly Manufacturing administrator role:
 - Section 11 and up

1.3 Scalability/Availability

CAMS-INT can be installed on an installation of SAP NetWeaver that has been installed in any of the supported installation configurations whether it is for High Availability (<https://cw.sdn.sap.com/cw/docs/DOC-115886>) or Cluster Failover (<https://cw.sdn.sap.com/cw/docs/DOC-115730>).

Ensure that the installation of SAP NetWeaver and SAP MII are completed before the installation of CAMS-INT. As all SAP MII instances will be sharing the same database, configuration at the SAP MII layer is only required to be performed on a single server as all servers will get the same data.

See Appendix A for options available for installing CAMS-INT in a high availability environment rather than the traditional standalone instance installation.

1.4 Variables

Variable	Description
<SAP_CAMS_7.2>	For purposes of this documentation, indicates the high-level directory structure in which the SAP Complex Assembly Manufacturing commercial off-the-shelf (COTS) application files are installed

Variable	Description
<SAP_CAMS_7.2_PI>	For purposes of this documentation, indicates the high-level directory structure in which the SAP Complex Assembly Manufacturing configuration files are installed
##	This designation in file names represents a build number for the package being delivered. When the files described in this document are ready for download, an integer will replace the ## in the file names. For example, if the SAPTCLIntegration_CAMS_7.2.5 zip file had to be built four times during the test and validation cycle prior to release, then the file posted on the SAP Service Marketplace would be SAPTCLIntegration_CAMS_7.2.5.4.zip.

1.5 Useful Links

Content	Location on the SAP Support Portal
Information about creating customer incidents	http://support.sap.com/message
SAP Notes search	http://support.sap.com/notes
SAP Software Download Center (software download and ordering of software)	http://support.sap.com/swdc
SAP Complex Assembly Manufacturing documentation	http://support.sap.com/documentation . Choose ► C ► <i>SAP Complex Assembly Manufacturing solution</i> ►.

1.6 SAP Notes

Please read the following note before starting the integration.

Make sure that you have up-to-date versions of the SAP Note, which you can find in the SAP Support Portal at <http://support.sap.com/notes>.

SAP Note Number	Title	Description
2110441	Enable adding custom properties for 2.0 DataSources with object factory available in <i>Application Resources</i>	Information on resolving an error when adding a custom JDBC 2.0 DataSource.

2 Configure Environment Variables for the Server

In order to prepare SAP NetWeaver to have access to the SAP Complex Assembly Manufacturing software for CAMS-INTws, you must define some environment variables so that SAP NetWeaver knows where to locate it.

From the *Environment Variables* dialog box in Windows, you need to define two new variables. The first determines where the SAP Complex Assembly Manufacturing root software is located and the second is a required to enable a specific element of SAP Complex Assembly Manufacturing to be located. You also need to add some folders to the system path.

To define the first variable, the SAP Complex Assembly Manufacturing software location:

1. Choose the *Start* button and choose *Control Panel*.
2. In the *Control Panel*, double-click on *System*.
3. Choose *Advanced System Settings* to open the *System Properties* dialog box.
4. Choose the *Advanced* tab and then choose the *Environment Variables* button.
5. In the *Environment Variables* dialog box, choose the *New* button in the *System variables* area.
6. In the *New System Variable* dialog box, enter **CAMS_ROOT** for the *Variable name* and set the *Variable value* to the name of the folder where the SAP Complex Assembly Manufacturing 64-bit software is installed (this folder should contain *bin*, *capp*, *shop*, *lib*, *publiclib*, etc.). Make sure the variable name and variable value are entered correctly and completely.
7. Choose *OK*.

To define the second variable, a specific location in the SAP Complex Assembly Manufacturing software distribution:

1. In the *Environment Variables* dialog box, choose the *New* button in the *System variables* area.
2. In the *New System Variable* dialog box, enter **TCL_LIBRARY** for the *Variable name* and enter **%CAMS_ROOT%\lib\tcl18.5** for the *Variable value*.
3. Choose *OK*.

Next, you need to update the system path variable to add several paths:

1. In the *Environment Variables* dialog box, choose the *Path* variable in the *System variables* area.
2. Choose the *Edit* button. The *Edit System Variable* dialog box appears.
3. In the *Variable value* field, add each of the items below to the path using a semicolon to delineate the items:

%CAMS_ROOT%\bin

%CAMS_ROOT%\lib

%CAMS_ROOT%\lib\tcl18.5

%CAMS_ROOT%\lib\tclblend

`%CAMS_ROOT%\publiclib`

4. Choose *OK*.
5. **You must now reboot the server where SAP NetWeaver is installed for these changes to take effect.**

3 Modify File Permissions

SAP NetWeaver runs the Microsoft Windows service modules as the internal LocalSystem user or a service specific user to ensure that the server is not running with elevated permissions. Since CAMS-INTws needs access to the Oracle Client area to interact with the OCI libraries and the SAP Complex Assembly Manufacturing software, you need to either change this user to a new service user that has similar permissions but has read/execute access to the Oracle and SAP Complex Assembly Manufacturing folders, or you need to add the user that is running the services to these folders and files. This permission should be on the root and all sub-folders to allow access to the required libraries by the SAP Service user.

To locate the services look in the Services application in Windows for services that start with SAP and are followed by the instance ID, e.g., _00 and _01:

1. Choose the *Start* button and choose *Control Panel*.
2. In the Control Panel, double-click on *Administrative Tools*.
3. In the *Administrative Tools* window, double-click on *Services*.

OR

1. Choose the *Start* button and choose *Run*.
2. In the *Run* dialog box, type `services.msc` in the *Open* field.
3. Choose *OK*.

4 Configure Database Connection to the SAP Complex Assembly Manufacturing Database

A database connection must be established from the SAP NetWeaver installation to the SAP Complex Assembly Manufacturing database. This is used both by SAP MII and the CAMS-INT Integration server to interact with the database.

Before you do this task, it is important that you have the `ojdbcXX.jar` file for Oracle available to you (it is located in the `<Oracle Home>/jdbc/lib` folder of the Oracle installation and is not provided as part of the SAP Complex Assembly Manufacturing distribution). You will need to use either `ojdbc5.jar` or `ojdbc6.jar`—`ojdbc5.jar` is specifically for the jdk 1.5 jvm, `ojdbc6.jar` for 1.6 jvm. Use the highest version available—SAP recommends using `ojdbc6.jar`.

The first thing you need to do is to deploy this `ojdbcXX.jar` file so that SAP NetWeaver is aware of the library and will allow the database connection process to occur. To do this:

1. Log onto the SAP NetWeaver Administration console.
2. Navigate to the [Application Resources](#) screen by selecting the [Configuration](#) tab, then the [Infrastructure](#) tab, and then choosing the [Application Resources](#) link as shown below.

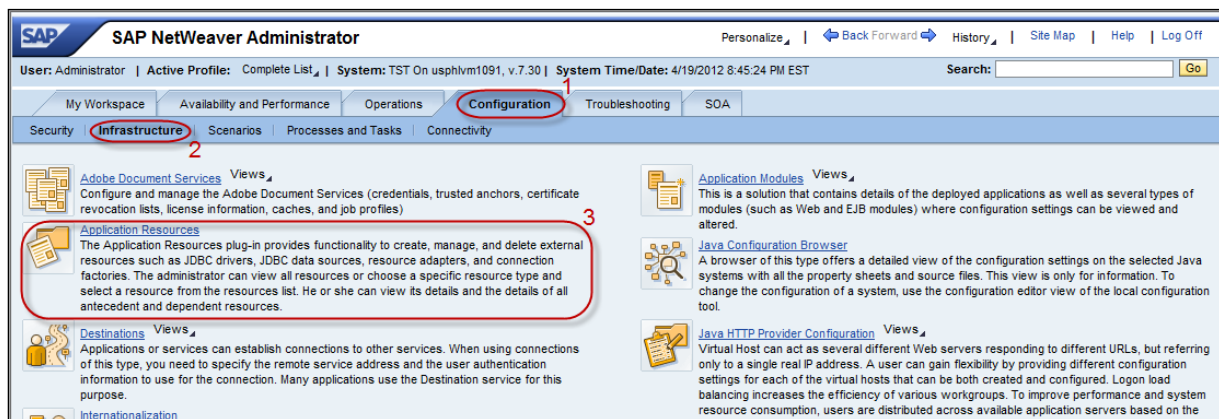

3. Once you are on the [Application Resources: Overview](#) screen, choose the [Create New Resource](#) button and choose the [Deploy New JDBC Driver](#) option.
4. In the screen that appears, provide a [JDBC Driver Name](#) and then choose the [Add New Driver File](#) button.
5. A file upload dialog box appears. Browse and choose the `ojdbcXX.jar` file and choose the [OK](#) button to upload the file. The name provided is not important, but will be required in the next steps; for our example, we use Oracle JDBC as the driver name.

1 Note

If one is already deployed then there is no need to perform this step.

- Choose the [Save](#) button.

Once the driver has been installed, you need to create a new JDBC Custom DataSource. To do this:

- On the [Application Resources: Overview](#) screen, choose the [Create New Resource](#) button and choose the [New JDBC Custom DataSource](#) option. The following screen appears.

- The following table lists the required data for the fields on this screen. These items are case sensitive, so please ensure that the case is correct.

Property	Value
Application Name	CAMS-INT
DataSource Name	CAMSINTBaseDataSource
Driver Name	As named when the JDBC driver was deployed. For our example, this is Oracle JDBC (selection is from a dropdown list; if it is not visible, recheck the deployment of the jar).
SQL Engine	Vendor SQL
Isolation Level	Default
JDBC Version	2.0 (with XA support)
Object Factory	oracle.jdbc.pool.OracleDataSourceFactory
DataSource Type	XA DataSource
XADS Class Name	oracle.jdbc.xa.client.OracleXADataSource
Description	Description of JDBC data source

- Optional: The connection pooling can be adjusted as required by choosing the [Connection Pooling](#) tab. You can configure the initial, maximum, and wait times as required. The defaults are suitable for the installation, however, so changes to the connection pooling are not required.

- You will also need to specify the username, password, and URL for the data source. To do so, choose the *Additional Properties* tab.
- Choose the *Add New Property* button to create three new entries as follows (depending on the version of Oracle, you may need to use the uppercase version rather than the lowercase version. Unfortunately, the only way to know is if the database connection does not work):

Property	Value
<i>user</i> or <i>User</i>	The HMS schema user for SAP Complex Assembly Manufacturing
<i>password</i> or <i>Password</i>	The HMS schema user's password
<i>url</i>	<p>The URL takes the form:</p> <pre>jdbc:oracle:thin:@<host>:<port>:<sid></pre> <p>where:</p> <ul style="list-style-type: none"> <host> is the server where the Oracle database is running; <port> is the listener port number (usually 1521 though it may be different); and <sid> is the Oracle service, or SID, name for the database instance where the SAP Complex Assembly Manufacturing schemas reside. <p>If you are running an Oracle Real Application Clusters (RAC) database, see the Oracle documentation for differences in the URL definition.</p> <p>If you are using SAP NetWeaver 7.3 including EHP1 Support Package (SP) 13 or higher, you make selections from a dropdown list.</p> <p>Note</p> <p>Please see SAP Note 2110441 for information on resolving an error when adding a custom JDBC 2.0 DataSource.</p>

- Once all the information is defined, choose the *Save* button.

Finally, you need to create a JDBC DataSource Alias so that this JDBC connection will be available for CAMS-INT to use:

- From the *Application Resources: Overview* screen, choose the *Create New Resource* button and choose *New JDBC DataSource Alias* from the list. The following screen appears.

The screenshot shows the 'Application Resources: Overview' page with a search bar and navigation links. Below, the 'New JDBC DataSource Alias Creation' dialog is open, displaying a 'Settings' tab with the following fields:

- DataSource Alias Name: *
- DataSource Name: *
- Isolation Level:
- Maximum Connections: -1

-
2. The following table lists the required data for the fields on this screen.

Property	Value
<i>DataSource Alias Name</i>	CAMSINTDataSource
<i>DataSource Name</i>	Choose CAMSINTBaseDataSource from the dropdown list. If this is not visible in the list, please validate that the creation of the DataSource as described above was completed successfully.
<i>Isolation Level</i>	Leave blank
<i>Maximum Connections</i>	-1

3. Choose the *Save* button.

5 Configure Users and Roles within SAP NetWeaver

In order to support running CAMS-INT under SAP NetWeaver, you need to establish a minimum of two new users:

- To provide visibility to the general CAMS-INT menus (no administrator access) requires `CAMS_INT_USER`
- To include or provide only the Administration section of CAMS-INT in the visible menus requires `CAMS_INT_ADMIN`

Each user requires that certain roles be assigned to it to provide the correct permissions to access the various aspects of CAMS-INT.

To configure the roles:

1. Log onto the SAP NetWeaver Administration console.
2. Navigate to the *Identity Management* screen by choosing the *Configuration* tab, then the *Security* tab, and then choosing the *Identity Management* link as shown below.



3. The *Identity Management: Overview* screen appears. In the *Search Criteria* dropdown, choose *Role*.

- The screen refreshes. Choose the *Create Role* button to expand the screen and see the *Details* area as shown below.

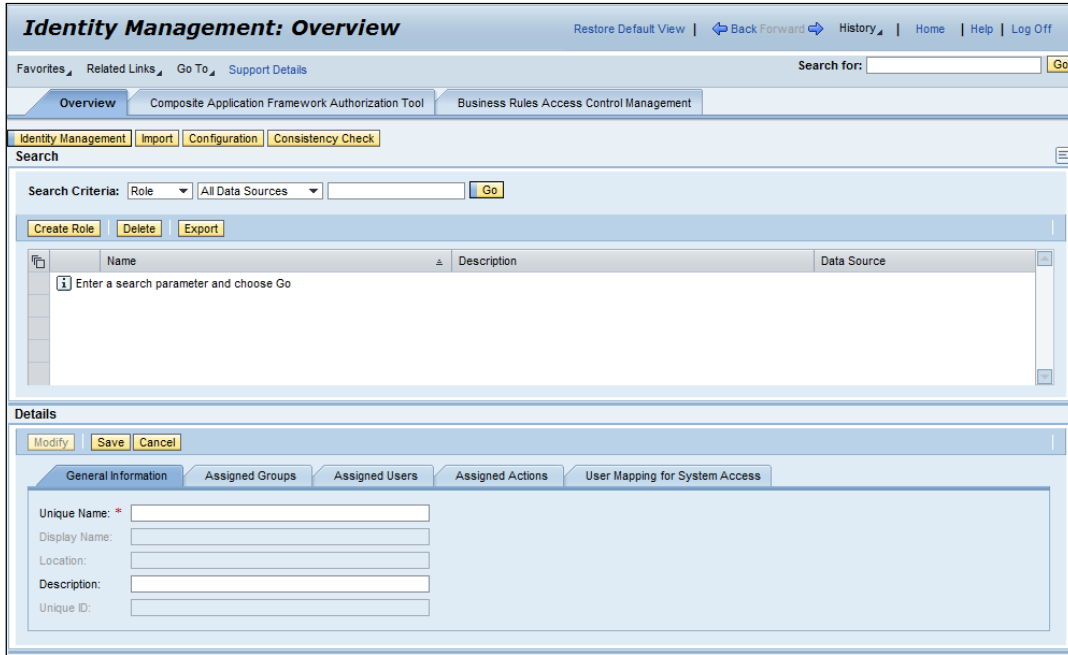

- To create the first role, enter the data listed in the first row of the table below for the *Unique Name* and the *Description*. Choose the *Save* button.
- To create the second role, choose the *Create Role* button. Enter the data listed in the second role of the table below for the *Unique Name* and the *Description*. Choose the *Save* button.

Unique Name	Description
CAMS_INT_ADMIN	Admin Role for the CAMS-INT application
CAMS_INT_USER	User for the CAMS-INT application

Next, you must verify that the SAP_XMII_Administrator has the XMII_PersonalizationService action. Without this, the user cannot login to SAP MII. To assign the action:

- Choose the SAP_XMII_Administrator role.
- Choose the *Assigned Actions* tab and choose the *Modify* button.
- In the *Get* field, enter **XMII** and choose the *Go* button.
- Choose *XMII_PersonalizationService* in the *Available Actions* table and choose the *Add* button.
- Choose the *Save* button.

Now you need to create the required users, which you can also do from the *Identity Management: Overview* screen:

➔ Recommendation

This integration guide recommends creating individual users. To minimize the system impact in the event there is a problem with a user, such as password expiration, SAP suggests creating a second user.

1. In the *Search Criteria* dropdown, select *User*.
2. The screen refreshes. Choose the *Create User* button to expand the screen and see the *General Information* tab with the fields shown below.

The screenshot displays the SAP Identity Management user creation interface. The top section is titled "Search" and includes a dropdown for "Search Criteria" set to "User", a search input field, and buttons for "Go" and "Advanced Search". Below this are buttons for "Create User", "Copy to New User", "Delete", "Unlock", "Lock", "Generate New Password", and "Export". A table with columns for "Status", "Logon ID", "Name", "Department", and "Data Source" is shown, with a search prompt "Enter a search parameter and choose Go". The bottom section is titled "Details" and contains tabs for "General Information", "Account Information", "Contact Information", "Additional Information", "Assigned Roles", and "Assigned Groups". The "General Information" tab is active, showing fields for "Logon ID", password options ("Define Initial Password", "Generate Password", "Disable Password"), "Define Password", "Confirm Password", "Last Name", "First Name", "E-Mail Address", "Form of Address", "Language", "Activate Accessibility Feature", "Security Policy", and "Unique ID".

3. On the *General Information* tab enter the information for the first user:
 - Enter the *Logon ID* as noted in the first row of the table below.
 - Make sure to choose the *Define Initial Password* option. Enter the required password in the *Define Password* field and confirm it as required in the *Confirm Password* field.
 - Complete the *Last Name* and *First Name* fields as noted in the first row of the table below.
4. Choose the *Assigned Roles* tab and assign the applicable roles to this user as defined in the table below.
5. Once the data is entered, choose the *Save* button.
6. Create the second user: Choose the *Create User* button. Repeat steps 3–5 for the second user, using the data from the second row of the table below.
7. Create the third user: Choose the *Create User* button. Repeat steps 3–5 for the second user, using the data from the second row of the table below.

Logon ID	Last Name	First Name	Assigned Roles
tcl_outbound_user	User	Inbound	CAMS_INT_USER Roles defined by SAP MII to run transactions – refer to SAP MII documentation for the specifics. SAP_XMII_User
cams_int_runner	User	Schedule	SAP_XMII_User
camsadm	User	CAMSAdmin	CAMS_INT_ADMIN CAMS_INT_USER Roles defined by SAP MII for full Admin access – refer to SAP MII documentation for the specifics.

To allow admin access to CAMS-INT, you will need to assign the CAMS_INT_ADMIN role as well as CAMS_INT_USER role to all applicable users. These roles control what is displayed within CAMS-INT and what features the end user will have access to. The CAMS_INT_ADMIN role is required to make any configuration change items visible to the user. For general access, the CAMS_INT_USER is all that is required.

To provide user access to CAMS-INT, the SAP NetWeaver user also needs the SAP_XMII_User permission.

6 Deploy CAMS-INTws to SAP NetWeaver

CAMS-INTws, the SAP Complex Assembly Manufacturing integration server side of CAMS-INT, needs to be deployed in SAP NetWeaver using SAP Solution Manager.

Please download the latest version of SAP Solution Manager from the SAP Support Portal at <http://support.sap.com/swdc>:

For new installations of SAP Solution Manager, choose ► *Installations & Upgrades* ► *A – Z Alphabetical List of my Products* ► *S* ► *SAP Solution Manager* ↘.

For customers who already have SAP Solution Manager, choose ► *Support Packages and Patches* ► *A – Z Alphabetical List of Products* ► *S* ► *SAP Solution Manager* ↘.

For installation or upgrade information or for details on using this tool, refer to the SAP Solution Manager documentation and online help at help.sap.com/solutionmanager.

7 Allocate CAMS-INTws Actions to Roles

The roles created in section 5 now need to have the CAMS-INTws actions assigned to them. These actions were created as the result of the deployment of `CAMSINTws725_#.#.sca` and so you cannot do the steps in this section until the `sca` file has successfully been deployed.

To allocate actions to roles:

1. Log onto the SAP NetWeaver Administration console.
2. Navigate to the *Identity Management* screen by choosing the *Configuration* tab, then the *Security* tab, and then choosing the *Identity Management* link as shown below.



3. The *Identity Management: Overview* screen appears. In the *Search Criteria* dropdown, choose *Role*.
4. The screen refreshes. Enter `CAMS*` in the search field and choose the *Go* button to retrieve all the roles starting with CAMS defined in the system.
5. In the results table, choose the `CAMS_INT_ADMIN` record. The screen expands to show the *Details of the Role* section.
6. Choose the *Assigned Actions* tab and choose the *Modify* button.
7. In the *Get* field, enter `CAMS*` and choose the *Go* button. The screen should look as follows:

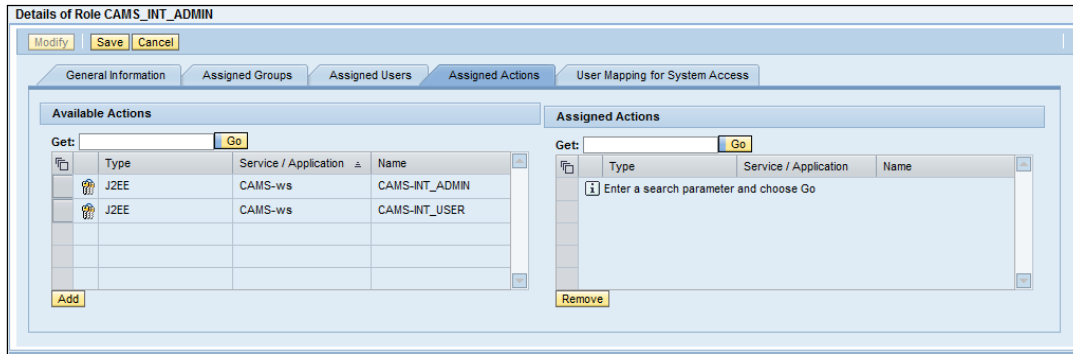

8. Choose both the *CAMS-INT_ADMIN* and *CAMS-INT_USER* actions in the *Available Actions* table by selecting the grey square to choose the row and pressing and holding the **SHIFT** key to multi-select.
9. Choose the *Add* button to assign these actions to the *CAMS_INT_ADMIN* role.
10. Choose the *Save* button.
11. In the results table, choose the *CAMS_INT_USER* and repeat steps 6–10 for this role. This time however, only choose the *CAMS-INT_USER* action in step 8 as this is the only one needed for this role.

8 Deploy CAMS-INT to SAP MII

You now need to deploy CAMS-INT to SAP MII. This involves installing a custom action file and a single SAP MII project. To do this:

1. Log onto SAP MII with an Administration account and navigate to the *System Resources* menu area.
2. Choose the *Custom Actions* menu.
3. Choose the *Upload* dropdown and choose *Upload Assembly*.
4. In the *Custom Actions Archive for Upload* dialog box, choose the browse button to navigate to `<SAP_CAMS_7.2_PI\CAMS-INT>` and choose the `CAMS-INT-Actions-7.2.4.jar` file.
5. Choose the *OK* button to upload the file.
6. Choose the box in the first column next to the `CAMS-INT-Actions-7.2.4.jar` file and then choose the *DeployAll* button to deploy the file.

Next, you need to deploy the CAMS-INT project:

1. From the main *System Management* menu area, choose *Projects*.
2. Choose the *Import* button. The *Import Project* dialog box appears.

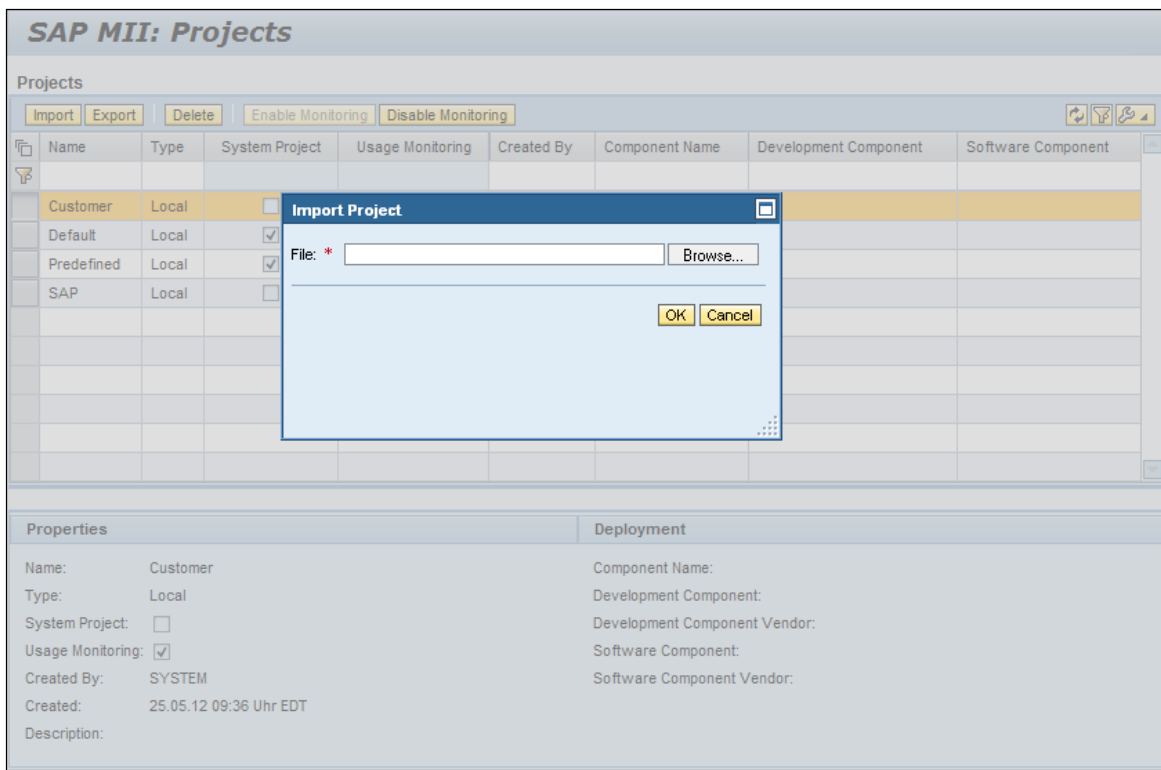

-
3. Choose the *Browse* button. Navigate to `<SAP_CAMS_7.2_PI\CAMS-INT>` and choose the `CAMS-INT-7.2.5.zip` file.
 4. Choose the *OK* button to upload the project.

Finally, you must modify the SAP MII system properties:

1. From the main *System Management* menu area, choose *System Properties*.
2. On the *SAP MII: System Properties* screen, choose the *Edit* button.
3. There is a default value in the *Default File Path* field. Remove the default value and leave the field blank. This allows the SAP MII files to be read.
4. Choose the *Save* button.

9 Configure SAP MII Connectivity to SAP

This section explains the procedures for configuring SAP MII to be able to connect to SAP ERP.

Before you start, you need the following information about the SAP system:

SAP System Number	_____	Use the SAP Logon application to locate this information
SAP Client Number	_____	Use the SAP Logon application to locate this information
SAP Server	_____	Use Transaction SMGW to locate this information

You also need to define the following information for use within these configuration steps:



SAP ERP User	_____	Valid SAP ERP User
SAP ERP Password	_____	Applicable password for the SAP User

1. Logon to the XMII main application as Administrator or as a user with Administration access.
2. Under the *Data Services* menu, choose *Connections*. The *SAP MII: Connections* screen appears.
3. Choose *Create*. The *Connections – Create* dialog box appears. Create a new connection named **xMII_SAP_JCO** (case is important) and define the *Connection Type* as *JCO*. Choose *OK*.
4. In the *Settings* tab (lower part of the screen), enter the ECC information as required.
5. Once done, choose the *Save* button.

While in this configuration area of SAP MII, create the connection alias for the mail server to support e-mail notification of failed messages.

1. Choose *Create*. The *Connections – Create* dialog box appears. Create a new connection named **CAMSINTMail** (case is important) and enter in the specific mail server name. Change the *Connection Type* to *Mail* and choose the *OK* button.
2. In the *Settings* tab, ensure that that the port is updated from *-1* to the applicable port for your mail server (the default would normally be *25*).
3. As we will be using SMTP to send mail, ensure the *Protocol* is changed to *smtp*.
4. Once done, choose the *Save* button. The screen should now look as shown below.

SAP MII: Connections

Connection Type: Any **Create** **Delete** | **Edit** **Save** **Cancel**  

Connection Name	Connection Type
xMI_SAP_JCO	JCO
CAMSINTMail	MAIL

Details for xMI_SAP_JCO

Settings **Usage**

Name: xMI_SAP_JCO

Description: xMI_SAP_JCO Desc (lscibu2.pal.sap.corp)

Server: lscibu2.pal.sap.corp

Client: 200

System: 56

Pool Size: 10

SSO:

Language: EN

Use Logon Group:

R/3 Name:

Logon Group:

10 Configure SAP to Send Messages to SAP MII

10.1 Create an RFC Destination in SAP

This section explains the procedure for configuring the SAP MII IDoc Listener as a registered RFC Destination on the SAP server.

Note

These steps assume that you have the correct authorizations for SAP to add RFC Destinations. If not, you will need to have the SAP administrator perform this procedure.

Before you start, you need the following information about the SAP system:

SAP System Number	_____	Use the SAP Logon application to locate this information
SAP Message Server Name	_____	Use the SAP Logon application to locate this information
SAP Client Number	_____	Use the SAP Logon application to locate this information
SAP Gateway Host	_____	Use Transaction SMGW to locate this information
SAP Gateway Service	_____	Use Transaction SMGW to locate this information

You will also need to define the following information for use within these configuration steps:

RFC Destination Name	_____	Used when creating the RFC Destination
Logical Port Name	_____	Used when creating the Logical Port. The recommendation is that it is the same as the RFC Destination
Partner Profile Name	_____	Used when creating the Partner Profile. The recommendation is that it is the same as the RFC Destination

To configure:

1. Log into SAP and enter transaction SM59 or use the following path: choose [Tools](#) > [Administration](#) > [Administration](#) > [Network](#) > [SM59 RFC Destinations](#).

2. Choose *TCP/IP Connections*.
3. Choose *Create* (📄). A screen similar to the following appears.

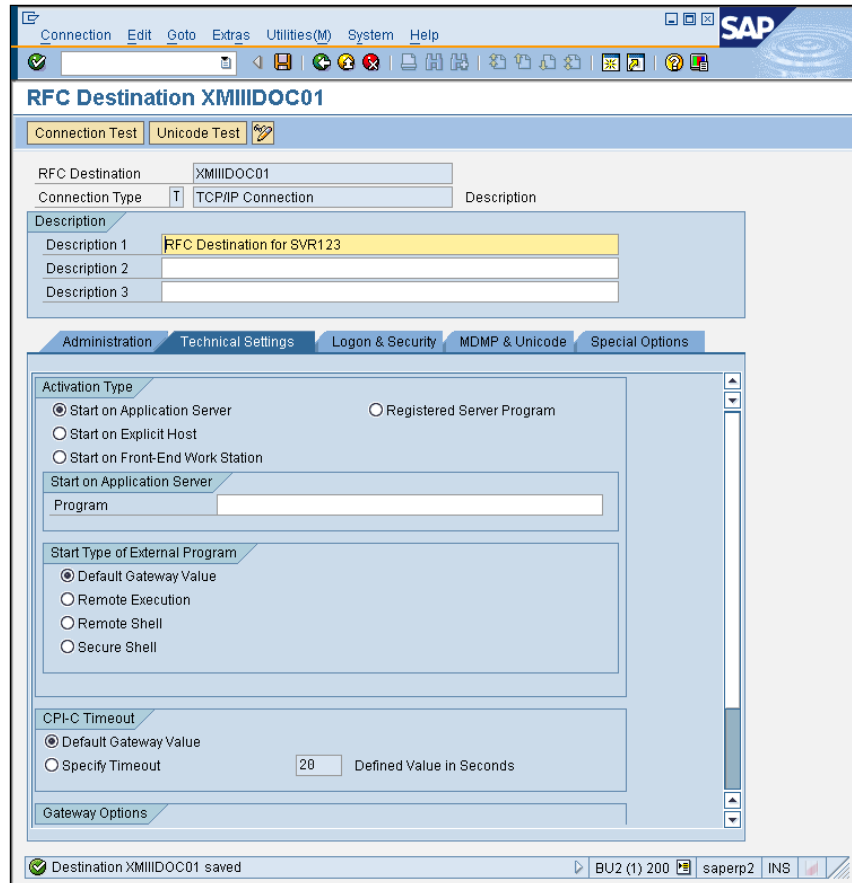

4. In the *RFC Destination* field, enter a meaningful name that identifies the SAP MII Listener you are establishing. This name will be entered several times through this process and so it is prudent to keep it simple and memorable. As case is important, we recommend that it is entered in all capital letters.
5. Ensure that the *Connection Type* field contains a *T* (for TCP/IP).
6. Choose the *Save* icon (📄) in the toolbar or choose **Connection > Save**.
7. Choose the *Technical Settings* tab:
 - a. Choose the *Registered Server Program* option.
 - b. In the *Program ID* field (which appears when *Registered Server Program* is enabled) enter the name of your RFC Destination exactly as you entered it before.

i Note

Your program ID can only be used for a single RFC Destination. Using the same Program ID for multiple destinations will cause errors.

- c. Choose the *Save* icon in the toolbar or choose **► Connection ► Save**..
8. Scroll down to the *Gateway Options* section and enter the *SAP Gateway Host* and *SAP Gateway Service* values.
9. Choose the *Save* icon in the toolbar or choose **► Connection ► Save**..
10. Choose the *MDMP & Unicode* tab and select (check) the *Unicode* option. When this is selected, you will be asked to run a Unicode test. Choose the *Close* button (✕) in the message window to skip the test as more configuration steps must be done before this will work.
11. Choose the *Save* icon in the toolbar or choose **► Connection ► Save**..

10.2 Creating an IDoc Listener in SAP MII

To enable IDocs to be sent to SAP MII, the IDoc listener needs to be defined. This is performed within the SAP NetWeaver web-based administration. SAP MII is shipped with 10 predefined IDoc resources that can be used to connect to multiple SAP instances. The configuration process is the same for them all, but CAMS-INT requires only one be defined. To configure one of these, do the following:

1. Log into the SAP NetWeaver system where SAP MII is installed. The account used for this must have the permissions to modify the default SAP MII listeners in SAP NetWeaver and start the Resource.
2. Choose the *Configuration* tab and then the *Infrastructure* tab.
3. Choose the *Application Resources* link on the *Infrastructure* page. A screen similar to the following appears.

The screenshot shows the 'Application Resources: Overview' page in the SAP NetWeaver Administration console. The page has a navigation bar with 'Home', 'History', 'Back', 'Forward', 'Help', and 'Log Off'. Below the navigation bar, there is a 'Show' dropdown menu set to 'All Resources' and a 'Related Links' link. The main content area is titled 'Resource List' and contains a table with columns: State, Resource Name, Resource Type, Owner Name, and Owner Type. The table lists 10 resources, with 'SAPCE1DB' highlighted in yellow. Below the table, there is a 'Possible States' legend and a 'Resource Details' section for 'SAPCE1DB'. The 'Resource Details' section has tabs for 'Settings', 'Connection Pooling', 'Antecedent JDBC Driver', and 'Dependent JDBC DataSource Aliases'. The 'Settings' tab is active, showing fields for Driver Name (SYSTEM_DRIVER), SQL Engine (Open SQL), Isolation Level (Default), and Deployer (DefaultDataSource).

State	Resource Name	Resource Type	Owner Name	Owner Type
Fully available	SAPCE1DB	JDBC System DataSource	JDBCResourceManager	JDBC Resource
Fully available	SYSTEM_DRIVER	JDBC Driver	JDBCResourceManager	JDBC Resource
Unknown	OracleJDBCdriver	JDBC Driver	JDBCResourceManager	JDBC Resource
Fully available	CAMSINDataSource	JDBC Custom DataSource	sap.com/CAMS-Integration	Java EE Application
Fully available	SAPBC_SDIC_SS	JDBC DataSource Alias	tc-di-sdic-srv Service	Java EE Application
Fully available	SAPBC_XIB	JDBC DataSource Alias	sap.com/com.sap.xi.lib.resources	Java EE Application
Partly available	SAPBC_ADM	JDBC DataSource Alias	sap.com/tc-monitoring-systeminfo	Java EE Application
Fully available	XMIDATASOURCE	JDBC DataSource Alias	sap.com/xapps-xmi-ear	Java EE Application
Fully available	SAPWS_MON_COLLECTOR	JDBC DataSource Alias	tc-esi-esap-lib Library	Java EE Application
Fully available	SAPVER_CLASSIFICATION	JDBC DataSource Alias	sap.com/tc-esi-uddi-sr-cs-ear	Java EE Application

4. In the blank line at the top of the table:
 - a. Enter the IDoc Listener you wish to use in the *Resource Name* column (the example in the figure below shows XMIIIDOC01, but it can be any unused one).
 - b. Enter *Resource Adapter* in the *Resource Type* column.
 - c. Press .
5. Choose the XMIIIDOCxx item you wish to configure. The screen updates to show the IDoc Listeners that can be used for configuration as shown below.

Application Resources: Overview

Show: All Resources

Resource List

State	Resource Name	Resource Type	Owner Name	Owner Type
	XMIIIDOC	Resource Adapter		
■	XMIIIDOC01	Resource Adapter	sap.com/sappra-xmiiidoc01	Java EE Application
■	XMIIIDOC02	Resource Adapter	sap.com/sappra-xmiiidoc02	Java EE Application
■	XMIIIDOC03	Resource Adapter	sap.com/sappra-xmiiidoc03	Java EE Application
■	XMIIIDOC04	Resource Adapter	sap.com/sappra-xmiiidoc04	Java EE Application
■	XMIIIDOC05	Resource Adapter	sap.com/sappra-xmiiidoc05	Java EE Application
■	XMIIIDOC06	Resource Adapter	sap.com/sappra-xmiiidoc06	Java EE Application
■	XMIIIDOC07	Resource Adapter	sap.com/sappra-xmiiidoc07	Java EE Application
■	XMIIIDOC08	Resource Adapter	sap.com/sappra-xmiiidoc08	Java EE Application
■	XMIIIDOC09	Resource Adapter	sap.com/sappra-xmiiidoc09	Java EE Application
■	XMIIIDOC10	Resource Adapter	sap.com/sappra-xmiiidoc10	Java EE Application

Possible States: ■ Fully available ▲ Partly available ❌ Not Available ◇ Unknown

Resource Details

XMIIIDOC01

Resource Adapter

Save

Settings Properties Loader References Message Listeners Administration Objects Security Permissions Dependent JCA Resource

JNDI Name: XMIIIDOC01

Class Name: com.sap.mw.jco.jra.JRASResourceAdapterImpl

Description:

Work Manager Max Thread Count: -1

Work Manager Start Thread Count: -1

6. In the *Resource Details* section in the lower part of the page, choose the *Properties* tab.
 - a. In the *Value* column, enter the following specific information for the SAP system (these are the SAP ECC login credentials; you can find the values from the RFC connection transaction SM59):

- A unique *Program ID*

i Note

Your Program ID can only be used for a single Listener. Using the same Program ID in multiple Listeners or for multiple SAP MII Instances will cause errors.

- *SAPClient*
- *UserName*
- *Password*
- *Language*

- *ServerName* (fully qualified)
 - *PortNumber* (System Number)
 - *BindingKey*
- b. Ensure that the *MaxReaderThreadCount* property is set to a minimum value of 1 from the default value of 0.
 - c. Enter any notes or comments in the *Description* column.
 - d. Choose the *Save* button.

The screenshot displays the 'Application Resources: Overview' interface. It features a 'Resource List' table with columns for State, Resource Name, Resource Type, Owner Name, and Owner Type. The resource 'XMIIIDOC01' is highlighted. Below the list, the 'Resource Details' section shows the configuration for 'XMIIIDOC01' as a 'Resource Adapter'. A 'Properties' tab is active, showing a table of configuration parameters:

Name	Type	Value	Description
ProgramID	Class java.lang.String	XMIIIDOC01	servers Program ID as defined in sm59
MaxReaderThreadCount	Class java.lang.Integer	1	Maximum count of listening servers
SAPClient	Class java.lang.String	200	Client, e.g. 001
Username	Class java.lang.String	ssmith	User able to assess configured SAP system
Password	Class java.lang.String	*****	Password
Language	Class java.lang.String	EN	Language, e.g. DE or EN
ServerName	Class java.lang.String	saperp2.pal.sap.corp	SAP Applicatio Server, e.g. us7400
PortNumber	Class java.lang.String	00	SAP System number, e.g. 01
BindingKey	Class java.lang.String	XMIIIDOC	Binding Key Specific for XML (Do not change)

10.3 Testing the IDoc Listener Connection

Once the configuration above has been defined, the RFC Destination can be tested to make sure the connectivity is correct:

1. Log into SAP and go to transaction SM59 (RFC Destination).
2. Expand the *TCP/IP* folder and double-click on the row for the RFC Destination you created earlier.
3. Choose the *Connection Test* button to perform a test to make sure the connectivity is verified.



A process runs and then the screen updates to show the results of the transfer tests. If any errors are listed, then you will need to review all the previous steps to make sure that there are no mistakes in the configuration. You can run the test as many times as needed, and if other errors are found, repeat the steps until the test is successful. A successful result looks something like the following (the result times will vary).

Action	Result
Logon	160 msec
Transfer of 0 kB	205 msec
Transfer of 10 kB	425 msec
Transfer of 20 kB	454 msec
Transfer of 30 kB	335 msec

10.4 Defining a Logical Port

Now that an RFC Destination has been established, a system port number needs to be associated with it to ensure the low-level networking requirements are met. This logical port will be used to send the IDocs to CAMS-INT from within SAP. This step can only be done once the RFC Destination is complete as it makes use of it.

To create a Logical port:

1. Log into SAP and go to transaction WE21 or use the following path: **Tools > ALE > ALE Administration > Runtime Settings > Port Maintenance**.
2. Choose **Transactional RFC** and choose the **Create** icon () or choose **Port > Create**.
3. Choose the **own port name** option.
4. Enter the RFC Destination name you created earlier in the **Port** field and provide a **Description** for it.
5. Choose the IDoc version required—for CAMS-INT this should be **IDoc record types SAP Release 4.x**.
6. Enter the **RFC destination** value as previously defined.
7. Choose the **Save** icon () in the toolbar or choose **Port > Save**.

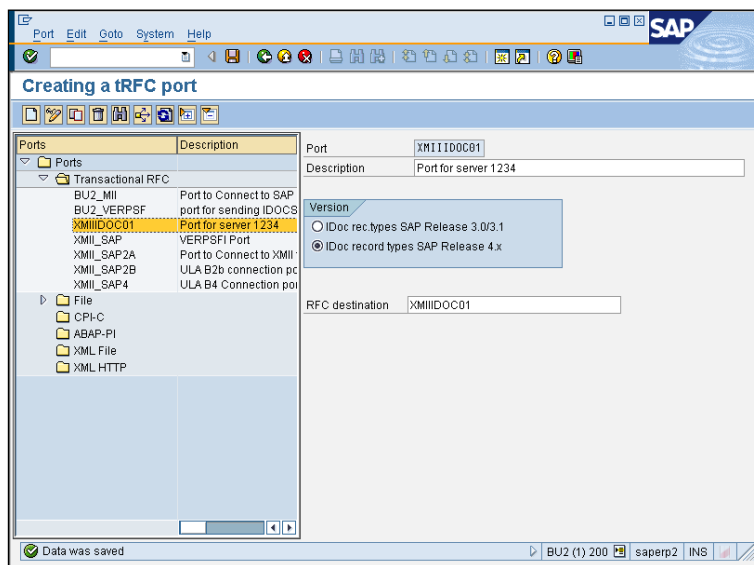

10.5 Defining a Partner for the RFC Destination

A partner (logical system) manages one or more RFC destinations:

1. Log into SAP and enter transaction SPRO_ADMIN or use the following path: **Tools** > **Customizing** > **IMG** > **Project Administration**.
2. Choose **Go** > **SAP Reference IMG** or choose the **SAP Reference IMG** button.
3. Expand the following nodes using the gray arrows as shown in the following figure:
 - **SAP NetWeaver** > **Application Server** > **IDoc Interface/Application Link Enabling (ALE)** > **Basic Settings** > **Logical Systems** > **Define Logical System**. Choose the clock icon  to use the Define Logical System item.

Note

You can also use transaction **SALE** and follow the path above starting at **IDoc Interface/Application Link Enabling (ALE)**.

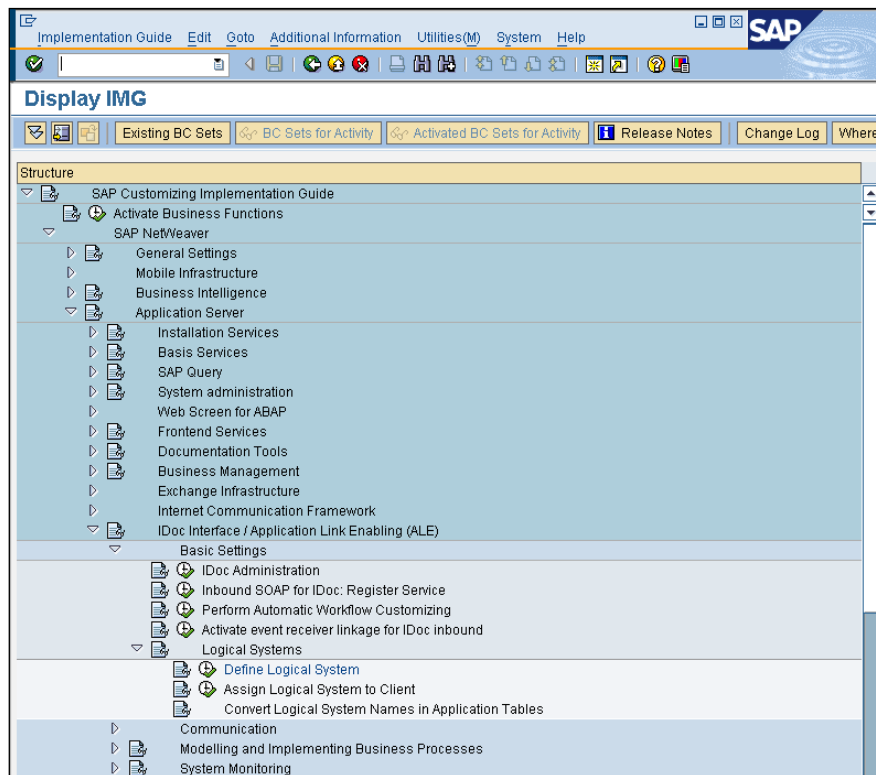

4. View the list and select a receiving logical system. The receiving logical system cannot be the same as the transmitting logical system (the current system + client you are logged into). For example, if you are logged into QEG (003), then choose the logical system QEGCLNT004 and not QEGCLNT003. You will also need to make sure that the selected system does not already have a partner profile assigned. You can check partner profiles following the instructions under Creating a Partner Profile just below.

Note

It is assumed that you do not have rights to create a logical system. Just view the list and make a note for use in the next step.

If you have the rights to create a logical system, you can create one for this purpose. SAP recommends that you make the name consistent with the Listener. For our example, we are using `XMIIIDOC01`, so the name we would choose for our logical system (partner) would also either be `XMIIIDOC01` or something similar that identifies which of the 10 IDoc Listeners we are using.



10.6 Creating a Partner Profile

To create a partner profile:



1. Log into SAP and enter transaction WE20 or use the following path: [Tools](#) > [ALE](#) > [ALE Administration](#) > [Runtime Settings](#) > [Partner Profiles](#) .

Note

If a change is made to the partner profile good practice would be to log into SAP MII and re-save the listener configuration. This ensures that the configuration is propagated correctly. This can be done in the same screen as the listener was defined (see section 9 of this document).

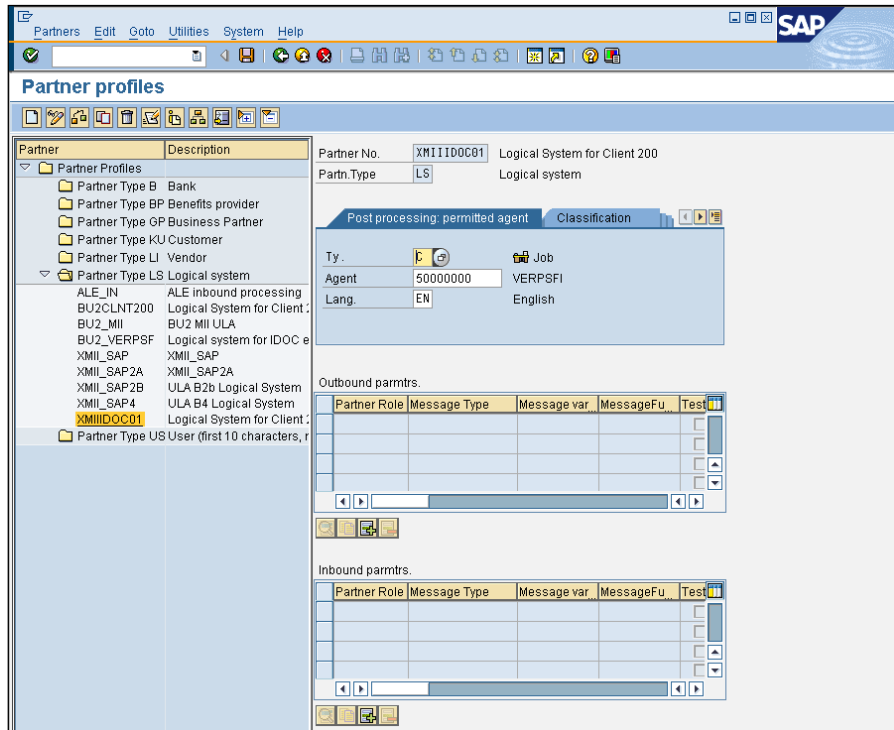
2. Choose [Partner Type LS](#) (just choose it, do not expand it).
3. Choose the [Create](#) icon () or choose [Partners](#) > [Create](#) .
4. In the [Partn. No.](#) field, enter the logical system recorded earlier.
5. In the [Partn. Type](#) field, enter `LS`.
6. On the [Post processing: permitted agent](#) tab:
 - a. In the [Ty.](#) field, enter `C`.
 - b. In the [Agent](#) field, enter the required job identifier or search for the required entry. If a job identifier does not exist then please create one using the tcode PPOME and then use this here.
 - c. In the [Lang.](#) field, enter `EN`.



7. Choose the *Save* icon () in the toolbar or **Partners > Save**.
8. Just below the *Outbound parmtrs.* (parameters) table, choose the *Add Row* icon () to add a row. The *Partner profiles: Outbound parameters* screen appears.
9. Enter the *Message Type* as **MATMAS**.
10. On the *Outbound Options* tab:
 - a. In the *Receiver port* field, enter the name of the logical port you created earlier.
 - b. Choose the *Transfer IDoc Immed.* option.
 - c. Enter **MATMAS04** in the *Basic type* field.
11. Choose the *Save* icon in the toolbar.

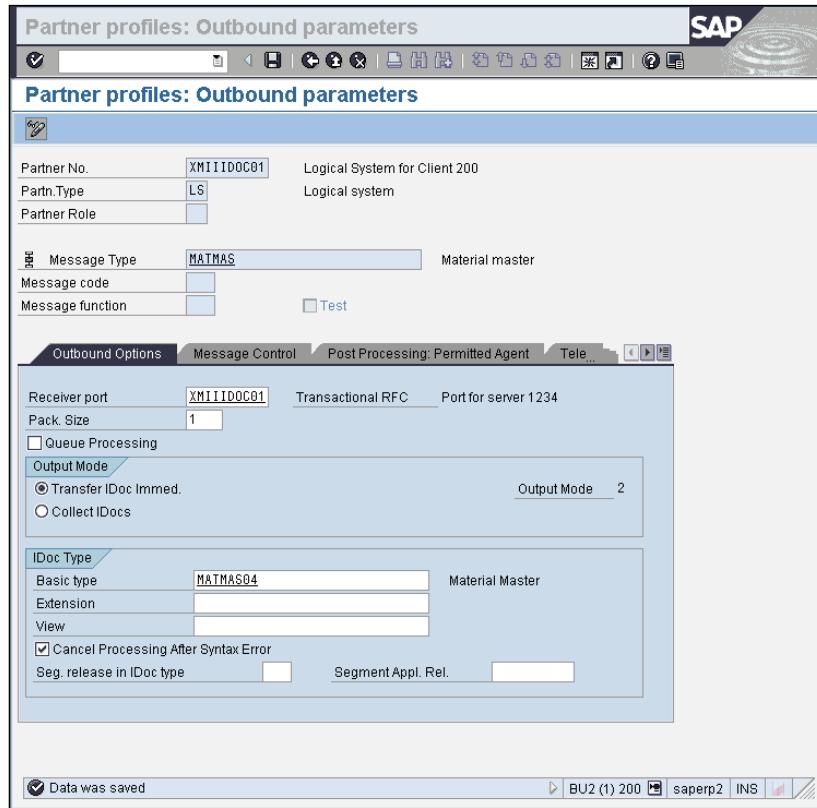

12. Repeat steps 9 – 11 for the following IDoc types:

IDoc Message Type	IDoc Basic Type
HRMD_A	HRMD_A06
INVCON	INVCON01
LOIPRO	LOIPRO01
SYNCH	SYNCHRON
LOIWCS	LOIWCS02

10.7 Creating a Distribution Model

Once you have defined a Partner and a Partner Profile, you need to create a distribution model that triggers the creation of a communication IDocs:

1. Log into SAP and enter transaction BD64 or use the following path: [Tools](#) > [Customizing](#) > [IMG](#) > [Execute Project](#) > [SAP Reference IMG](#) > [SAP NetWeaver](#) > [Application Server](#) > [IDoc Interface/Application Link](#) > [Enabling \(ALE\)](#) > [Modeling and Implementing Business Processes](#) > [Maintain Distribution Model and Distribute Views](#).

2. Choose the *Edit* icon ()

3. Choose the *Create model view* button.
4. Enter a *Short text* string and a *Technical name* for your new model view.

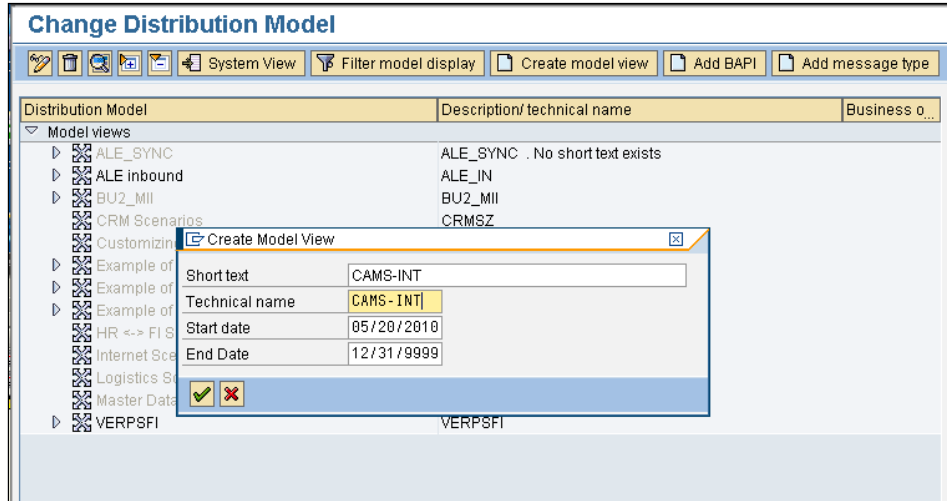

5. Save your Distribution Model by choosing .
6. Choose your new model view in the Distribution Model tree and choose the *Add message type* button.
7. In the dialog box that appears, enter the *Sender* (for example, the logical system you are currently logged onto – QPTCLNT004). Enter the *Receiver* (for example, the logical system you previously created). Enter the *Message Type* (for example, LOIPRO or MATMAS).

You must do an *Add message type* for each of the message types you recorded previously (with the exception of SYNCH).

10.8 Placing a Document on a Queue

Messages can be placed into the CAMS-INT queue through three different mechanisms. The first is via a message listener configured in SAP MII to route messages from SAP-ERP (specifically IDocs) into the queue by configuring a message listener for each message root node, setting the Message Type options buttons to IDoc for this mode, and then configuring SAP MII to call the following transaction (note another of the three methods, the last one documented here, calls this transaction directly):

```
SAP/Manufacturing/CAMS/services/RegisterDocumentService
```

This service has the following parameter requirements (not shown in any particular order):

Parameter Name	Comments
<i>ProcessKeyData</i>	This must be set to 1 or 0. A setting of 1 causes CAMS-INT to parse the XML message with the KeyData XSLT to obtain a data string which is intended to identify the key information in the XML data. For example, if this is an order create request, the Key Data XSLT could return "Order No: 0123456789," which would then show on the queue to help locate a specific message more easily. It is dependent on there being an applicable template in the Key Data XSLT otherwise an undesirable result will occur.
<i>QueueName</i>	This is the queue where this message should be recorded. These queues are user definable (by entering a different value here) and can be controlled via a Scheduled event to process the messages in the queue.
<i>ParentMessageID</i>	This is used if multiple messages need to be related to a single message. Normally, however, this would be left blank and this value handled by CAMS-INT
<i>XMLMessage</i>	The actual XML message to be processed.

The second mechanism would be to use the Web Service interface of SAP MII to get the message into the queue. In this mode you still create a message listener within SAP MII but this time setting the *Message Type* option to *Web Service* and registering the transaction in the same manner as with the IDoc one above. To send messages to this configuration, the XML is sent to SAP MII via the URL:

```
http://<server>:<port>/XMII/Illuminator?service=WSMessageListener&mode=WSMessageListenerServer&NAME=<xml_root_node>
```

The call requires at least basic authentication defined in the HTTP header along with defining the Content-Type to include `application/soap+xml`, and the XML message should be the content of the http message. SAP MII takes this and submits it to the message listener defined and this causes the XML message to be registered as required.

The third and final approach is to send the message directly to the transaction in SAP MII using the `TransactionRunner` servlet in SAP MII. This method differs from the other two because no message listener needs to be defined for the XML message. Due to there being no listener defined, the parameters specified in the table above have to be defined as part of the URL. The URL needed is as follows:

```
http://<server>:<port>/XMII/Runner?Transaction=SAP/Manufacturing/CAMS/services/RegisterDocumentService&ProcessKeyData=<key_data>&QueueName=<queue_name>&OutputParameter=*&XMLMessage=<xml_message>
```

The result of calling the transaction in this manner will result in an XML message being returned to the caller. This XML message contains information about the registered message including the internal message ID so that this message status can be programmatically monitored (as can any transaction) using another service within SAP MII. The result XML is as follows:

```
<?xml version="1.0" encoding="UTF-8" ?>
<Rowsets DateCreated="2010-07-16T16:24:16" EndDate="2010-07-16T16:24:16"
StartDate="2010-07-16T16:24:16" Version="12.1.5 Build(92)" TransactionID="2177">
  <Rowset TrxID="2177">
    <Columns>
      <Column Description="" MaxRange="0.0" MinRange="0.0" Name="Status"
SQLDataType="1" SourceColumn="Status" />
      <Column Description="" MaxRange="0.0" MinRange="0.0" Name="MessageID"
SQLDataType="1" SourceColumn="MessageID" />
    </Columns>
  </Rowset>
</Rowsets>
```

```

        <Column Description="" MaxRange="0.0" MinRange="0.0" Name="MessageKeyData"
SQLDataType="1" SourceColumn="MessageKeyData" />
    </Columns>
    <Row>
        <Status>PASSED</Status>
        <MessageID>40970bb0-9131-11df-ae44-fede0a042d5c</MessageID>
        <MessageKeyData>Order/Oper: 00121221 / 0020</MessageKeyData>
    </Row>
</Rowset>
</Rowsets>

```

The main information is the `Status` and `MessageID`, and if `Key Data` had been requested, this is shown in the `MessageKeyData` field. The `MessageID` can be used to query the system programmatically by using the method detailed next.

To query the status of a message, the transaction is called `GetMessageStateById`, and can be called as follows:

```

http://<server>:<port>/XML/Runner?Transaction=SAP/Manufacturing/CAMS/services/GetMessageState
ById&RecordId=<record_id>&OutputParameter=result

```

Again, this call requires that basic authentication is added into the header of the request with an applicable SAP NetWeaver user to access this resource.

The following XML message is returned:

```

<?xml version="1.0" encoding="UTF-8" ?>
<CAMSINT_MESSAGE>
  <ID>0a9f70b0-7f1b-11df-9bc7-d4600a042d5c</ID>
  <MESSAGE_SEQUENCE>1</MESSAGE_SEQUENCE>
  <MESSAGE_NAME>Z_MATMAS04</MESSAGE_NAME>
  <CATEGORY>GeneralInbound</CATEGORY>
  <MESSAGE_TYPE>Initial</MESSAGE_TYPE>
  <STATUS>Passed With Message</STATUS>
  <RECEIVED_DATE_TIME>2010-06-23T18:59:56</RECEIVED_DATE_TIME>
  <START_DATE_TIME>2010-06-23T19:29:45</START_DATE_TIME>
  <END_DATE_TIME>2010-06-23T19:29:47</END_DATE_TIME>
  <RETRY_COUNT>0</RETRY_COUNT>
  <PARENT_ID>---</PARENT_ID>
  <CORRELATION_KEY>---</CORRELATION_KEY>
  <KEY_DATA>---</KEY_DATA>
  <RESPONSE_MESSAGE>TEST</RESPONSE_MESSAGE>
  <HISTORY>
    <RECORD seq="1" type="request">Request Successful</RECORD>
    <RECORD seq="2" type="response">TEST</RECORD>
  </HISTORY>
</CAMSINT_MESSAGE>

```

10.9 Standard Service Transactions

CAMS-INT comes with three main out-of-the-box services for the workflows. These services allow for a Web Service call and two variants for BAPI calls – one that supports transactional capability for multiple calls and one that is a single BAPI call. Each one of these transactions requires a set of parameters to be provided in the form `Param1=Value1;Param2=Value2` – named value pairs, delimited with a semicolon.

10.9.1 StandardWebService (SAP/Manufacturing/CAMS/framework/helpers)

This transaction takes an XML message and wraps it with a SOAP envelope and then makes the HTTP call to the endpoint. The XML message sent to this transaction must be the actual payload for the SOAP envelope's body element. The parameters supported by this transaction are as follows:

Parameter Name	Comments
serviceURL	This is the URL for the web service endpoint, without the server part specified. This value is concatenated with the MES Server value defined in the Supported Plants configuration screen as it is configurable by Plant code.
credentials	The credential alias name associated with the username and password requirements to connect to this server. Credential aliases are defined within the SAP MII administration console under the Security Services > Credential Editor page.

10.9.2 StandardBAPIService (SAP/Manufacturing/CAMS/framework/helpers)

This transaction takes an XML message and handles sending it into SAP ERP via the RFC connection. The expectation for this transaction is that the actual XML message sent into the transaction can be sent directly to SAP ERP without modification. The parameters supported by this transaction are as follows:

Parameter Name	Comments
bapiName	This property is the root node of the BAPI being called by this event.
credentials	The credential alias name associated with the username and password requirements to connect to this server. Credential aliases are defined within the SAP MII administration console under the Security Services > Credential Editor page.

10.9.3 TransactionBAPIService (SAP/Manufacturing/CAMS/framework/helpers)

This transaction takes an XML message and handles sending it into SAP ERP via the RFC connection. The expectation for this transaction is that the actual XML message sent into the transaction will be broken up into separate messages and sent into SAP ERP one at a time within a single transaction. This ensures that any one item failing will cause all updates within this transaction to fail. There is an assumption that the split messages are all for the same BAPI call and that the structure of the XML message is such that a single XSLT can convert the message segment into the required BAPI message. The parameters supported by this transaction are as follows:

Parameter Name	Comments
<i>bapiName</i>	This property is the root node of the BAPI being called by this event.
<i>transformXSLT</i>	This is the name of the registered XSLT document to break the provided XML message in to submessages to be sent to SAP ERP.
<i>credentials</i>	The credential alias name associated with the username and password requirements to connect to this server. Credential aliases are defined within the SAP MII administration console under the Security Services > Credential Editor page.

10.10 MessageValidationService (SAP/ Manufacturing/CAMS/framework/test)

This transaction provides a single test transaction for cases where interfaces are being developed or where the end system is not currently available. The service performs a validation process on the message and returns a standard generic response message indicating whether the validation was successful or not. There is also a corresponding UI page (see section 15.1, item 16) which allows for XML messages to be posted into CAMS-INT which is detailed here. The parameters supported by this transaction are as follows:

Parameter Name	Comments
<i>schemaURL</i>	This is the URL for the schema to load to ensure that the XML provided validates against it. This URL should be fully qualified and the CAMS-INT integration server can be used to store these Schema files.
<i>credentials</i>	The credential alias name associated with the username and password requirements to connect to this server. Credential aliases are defined within the SAP MII administration console under the Security Services > Credential Editor page.

11 Configure SAP MII Connection to the SAP Complex Assembly Manufacturing Database

To enable CAMS-INT to connect to the SAP Complex Assembly Manufacturing database, a data server needs to be defined. To create this connection:

1. Logon to the XMII main application as Administrator or as a user with Administration access.
2. Navigate to *Data Services* menu and choose *Data Servers*.
3. In the *Connector Type* dropdown, choose *DataSource*.
4. Choose the *Create* button.
5. This will change the UI to show a data collection screen where you enter the name, connector type, and description. Complete the fields on this screen using the values from the following table. You may need to use the right scroll bar to see all these fields:

Property Name	Value
<i>Server Name</i>	CAMS-INT
<i>Connector Type</i>	DataSource
<i>Description</i>	CAMS Database Connection

6. Choose the *Finish* button.
7. To complete the configuration, you will need to enter the following information into the *Connection* tab.

Property Name	Value
<i>Data Source</i>	jdbc/CAMSINTDataSource
<i>Date Prefix</i>	TO_DATE '
<i>Date Suffix</i>	', 'MM/DD/YYYY HH24:MI:SS')
<i>Retention Days</i>	7
<i>Internal Date Format</i>	yyyy-MM-dd HH:mm:ss
<i>Max Retry Count</i>	5
<i>Retry Interval</i>	60000

8. Go back to the *Settings* tab:
 - a. Enable the connection by choosing the *Enabled* field.
 - b. Enable dynamic queries by selecting the *Allow Dynamic Query* checkbox.
9. Choose the *Save* button.

12 Configure SAP MII Message Listeners for the Message Types

To enable messages to be sent and processed by CAMS-INT, message listeners need to be created to enable the hand off to CAMS-INT from SAP MII:

1. Logon to the XMII main application as Administrator or as a user with Administration access.
2. Navigate to *Message Services* menu and then choose *Message Processing Rules*.
3. Choose the *Create* button. The screen shown appears.

SAP MII: Message Processing Rules

Processing Rules

Listener: All Processing Type:

Name	Message Listener	Message Name	Message Type	Processing Type
BOM_DATA	XMIMESSEAGELISTENER	BOM_DATA	Web Service	Transaction
CHANGE_MASTER_REQUEST	XMIMESSEAGELISTENER	CHANGE_MASTER_REQUEST	Web Service	Transaction
CLFMAS02	XMIIIDOC01	CLFMAS	IDOC	Transaction
CREATE_FABPLAN_001	XMIMESSEAGELISTENER	CREATE_FABPLAN_001	Web Service	Transaction
CREATE_INSTLPLAN_001	XMIMESSEAGELISTENER	CREATE_INSTLPLAN_001	Web Service	Transaction
ECMREV01	XMIIIDOC01	ECMREV	IDOC	Transaction
HRMD_A06	XMIIIDOC01	HRMD_A	IDOC	Transaction
INVCON01	XMIIIDOC01	INVCON	IDOC	Transaction
LOIPRO01	XMIIIDOC01	LOIPRO	IDOC	Transaction
LOWCS02	XMIIIDOC01	LOWCS	IDOC	Transaction

Details for

Settings

Name: *

Description:

Message Listener: * XMIIIDOC01

Message Type: * IDOC

Message Name: *

Processing Type: transaction

Processing

Transaction: ...

Persist Transaction:

Log Level:

Parameters

Name	Value

- You need to generate a message processing rule for the following XML documents (see step 5). You also will need to know the Message Listener value used in the previous section when connecting SAP NetWeaver to SAP for some of the configuration steps.

i Note

Comments must not exceed 100 characters. If you enter more than that, an error appears and the message processing rule is not saved.

NAME	Message Name	Type	Key Data	Queue Name	Comments
BOM_DATA	BOM_DATA	Web Service	1	GeneralQueue	Supports the Manufacturing Bill of Material (MBOM) message being sent to SAP ERP
CHANGE_MASTER_REQUEST	CHANGE_MASTER_REQUEST	Web Service	1	GeneralQueue	Supports the creation of the Model/Unit effectivity change master in SAP (used in conjunction with the BOM_DATA message)
CREATE_INSTLSTEPPLAN_001	CREATE_INSTLSTEPPLAN_001	Web Service	1	GeneralQueue	Supports the Routing message being sent to SAP ERP (only if using installation documents with steps). This message in the <i>CAMS INT Queue</i> is CREATE_SAPROUTING RELEASE_001.
CREATE_FABPLAN_001	CREATE_FABPLAN_001	Web Service	1	GeneralQueue	Supports the Routing message being sent to SAP ERP (only if using fabrication documents without steps). This message in the <i>CAMS INT Queue</i> is CREATE_SAPROUTING RELEASE_001.
CREATE_FABSTEPPLAN_001	CREATE_FABSTEPPLAN_001	Web Service	1	General Queue	Supports the Routing message being sent to SAP ERP (only if using fabrication documents with steps). This message in the <i>CAMS INT Queue</i> is

NAME	Message Name	Type	Key Data	Queue Name	Comments
					CREATE_SAPROUTING RELEASE_001.
CREATE_INSTLPLAN_001	CREATE_INSTLPLAN_001	<i>Web Service</i>	1	<i>GeneralQueue</i>	Supports the Routing message being sent to SAP ERP (only if using installation documents without steps). This message in the <i>CAMS INT Queue</i> is CREATE_SAPROUTING RELEASE_001.
CREATE_SAPROUTINGRELEASE_001	CREATE_SAPROUTINGRELEASE_001	<i>Web Service</i>	1	<i>GeneralQueue</i>	Supports the Routing message being sent to SAP ERP
HRMD_A06	HRMD_A	<i>IDoc</i>	1	<i>GeneralQueue</i>	Supports User Certifications being sent from SAP ERP to SAP Complex Assembly Manufacturing
INVCON01	INVCON	<i>IDoc</i>	1	<i>CompPartQueue</i>	Supports Goods Movements being sent from SAP ERP to SAP Complex Assembly Manufacturing to support component Lot/Serial number assignment
LOIPRO01	LOIPRO	<i>IDoc</i>	1	<i>GeneralQueue</i>	Supports Order Creation requests from SAP ERP to SAP Complex Assembly Manufacturing
LOIWCS02	LOIWCS	<i>IDoc</i>	1	<i>GeneralQueue</i>	Supports Work Center creation or updates sent from SAP ERP to SAP Complex Assembly Manufacturing
MATMAS04	MATMAS	<i>IDoc</i>	1	<i>GeneralQueue</i>	Supports Material Records being sent from SAP ERP to SAP Complex Assembly Manufacturing

NAME	Message Name	Type	Key Data	Queue Name	Comments
PLAN_HOLD  Note See the Appendix B for some SAP ECC tasks that also must be done for the plan hold interface.	PLAN_HOLD	Web Service		GeneralQueue	Supports Holding/Releasing via Task List
WIP_ORDER	WIP_ORDER	Web Service	1	GeneralQueue	Supports the operation confirmation message being sent to SAP ERP
WIP_ORDER_UNDO	WIP_ORDER_UNDO	Web Service	1	GeneralQueue	Supports the operation confirmation reversal message being sent to SAP ERP

5. For each of the XML documents listed above, create a message rule as follows:
 - a. In the *Name* field, enter the XML document name using the table above.
 - b. Enter a *Description*.
 - c. For XML documents where the *Type* is:
 - *Web Service*, set the *Server Name* field to *XMIIMESSAGELISTENER*.
 - *IDoc*, set the *Server Name* field to the Message Listener value used previously (*XMIIDOC01* for example).

 **Note**

When configuring for an IDoc, you will need to set the Message Name to be the XML Document name without the trailing numbers – for example, **MATMAS** not **MATMAS04**.

- d. For *Message Type*, choose the option that matches the Type column above, i.e., *Webservice* or *IDoc*.
- e. Choose the *Transaction* option for the *Processing Type*.
- f. For the *Transaction* value, choose the ... button and navigate to **SAP > Manufacturing > CAMS > Services** and choose *RegisterDocumentService* as shown below. Choose *OK*.

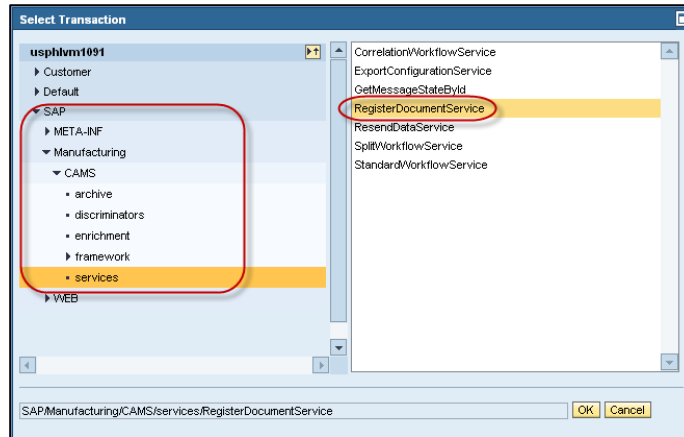

- g. Choose *Never* in the *Persist Transaction* dropdown. To aid in debugging issues, you may want to temporarily set this to *Always* to see the issues generated in SAP MII. Once resolved, however, it is strongly recommended that you reset this to *Never*.
- h. Choose *None* in the *Log Level* dropdown or choose *Info* for the plan hold rule.
- i. In the *Parameters* table:
 - i. Select (check) the *XMLMessage* checkbox. This will set the value to *ReceivedMessageXML* meaning the actual XML message is being sent in with this message.

 **Caution**

Do not select (check) any field other than *XML Message* as doing so will cause configuration and data issues.

- ii. Leave *ParentMessageID* blank.
- iii. Set the *QueueName* to the value in the Queue Name column in the table above.
- iv. Set *ProcessKeyData* to the value in the Key Data column in the table above.

Parameters	Name	Value
<input checked="" type="checkbox"/>	XMLMessage	ReceivedMessageXML
<input type="checkbox"/>	ParentMessageID	
<input type="checkbox"/>	QueueName	
<input type="checkbox"/>	ProcessKeyData	

- 6. Choose the *Save* button.

12.1 Enable Message Cleanup Rules

For every message processing rule, you also need to define a message cleanup rule. These cleanup rules ensure that records are kept for as long as necessary and are then deleted. You will need to know many of the same values used for the message processing rule to create the cleanup rule.

To create a message cleanup rule:

1. Logon to the XMII main application as Administrator or as a user with Administration access.
2. Navigate to *Message Services* and then choose *Message Cleanup Rules*. The screen shown appears.
3. Choose the *Create* button.

4. Complete the fields in the *Details for* area as noted in the table below.

Property	Value
<i>Name</i>	A unique name for the entry. It should be the same as the <i>Name</i> field for the processing rule.
<i>Description</i>	A descriptive name for the entry.
<i>Message Listener</i>	The message listener value. It should be the same as the <i>Message Listener</i> field for the processing rule.
<i>Message Type</i>	<i>WebService</i> or <i>IDOC</i> . It should be the same as the <i>Message Type</i> field for the processing rule.
<i>Message Name</i>	This is the XML message name. It should be the same as the <i>Message Name</i> field for the processing rule.
<i>Messages Older Than</i>	Enter the number of hours to keep the message in the <code>MIID_MESSAGE</code> table before deleting it. This can be set to any value – SAP suggests 24 or 48 hours.
<i>Processing Status</i>	Choose <i>Success</i> . This means only messages successfully pushed through into CAMS-INT are cleaned up. These records are not needed unless something

Property	Value
	catastrophic occurs and you need to resend the messages from the Message Monitor . Any other messages will stay in the <code>MI_I_MESSAGE</code> table.
Enabled	Select the checkbox to make the rule active.

5. Choose the [Save](#) button.
6. Repeat these steps for every message defined in the processing rules.

Once a rule is created, you can invoke it manually by choosing the rule in the table and choosing the [Run](#) button. Otherwise, the rules are triggered by SAP MII based on the setting in the [XLBL_MESSAGE_CLEANUP_INTERVAL \[Hours\]](#) field on the [System Properties](#) screen. The default value is `1`, which means the rule is run every hour. You can adjust this value as needed by choosing [System Management > System Properties](#). This is an interval value; you cannot define when it actually runs so this needs to be considered when changing this value.

With the configuration done as noted above, all messages that are successfully passed into CAMS-INT will be removed from SAP MII after they have been stored for longer than the interval specified. This will exclude any messages that failed to be passed from SAP MII to CAMS-INT or were in some status other than [Success](#).

Choose [Message Services > Message Monitor](#) to go to the [Message Monitor](#) screen where you can view failed messages or messages in a status other than [Success](#) and disposition them as needed. You will also see successful messages in the [Message Monitor](#), but only up to the current time interval.

13 Configure SAP MII Credentials to Be Used by CAMS-INT

Credentials need to be created for the JCO connector (xMII_SAP_JCO), the Mail connection, and CAMS-INTs to support all the capabilities of CAMS-INT.

To configure these credentials:

1. Logon to the XMI main application as Administrator or as a user with Administration access.
2. Navigate to *Security Services* menu and choose *Credential Stores*. The screen shown appears.

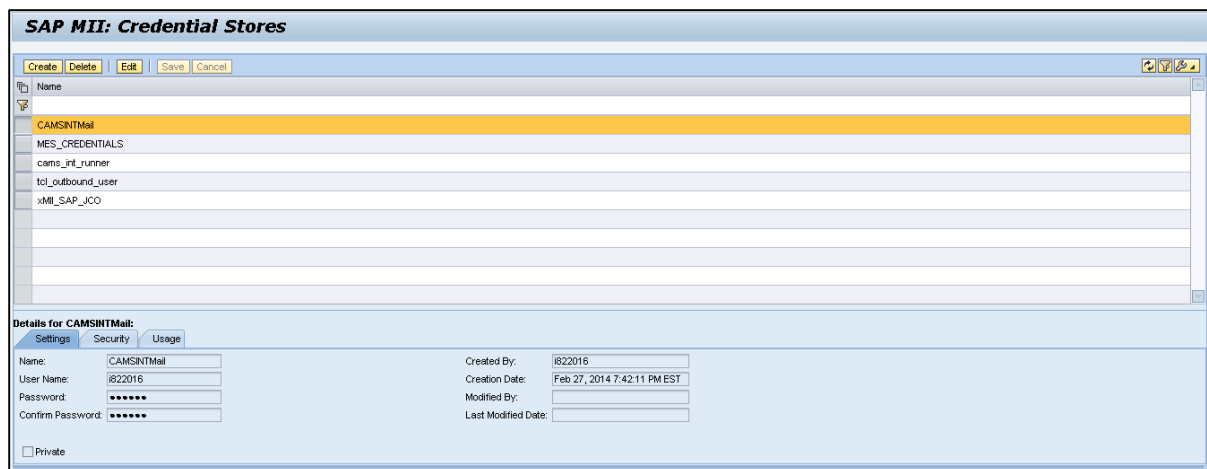

3. First, create the required entry for JCO connector:
 - a. Choose the *Create* button
 - b. In the *Name* field, enter **xMII_SAP_JCO**.
 - c. Enter the *User Name* and *Password* needed for the ECC server to allow the required connectivity to occur.
 - d. Re-enter the password in the *Confirm Password* field.
 - e. Choose the *Save* button.
4. Next, create the required entry for email notification:
 - a. Choose the *Create* button
 - b. In the *Name* field, enter **CAMSINTMail**.
 - c. Enter the *User Name* and *Password* needed for the SMTP server to allow sending of mail from the internal mail server.
 - d. Re-enter the password in the *Confirm Password* field.
 - e. Choose the *Save* button.

-
5. Next, create the required entry to allow connectivity between SAP Complex Assembly Manufacturing and CAMS-INTws:
 - a. Choose the *Create* button.
 - b. In the *Name* field, enter `tcl_outbound_user` (defined in section 5).
 - c. Enter the *User Name* and *Password* you created for that user.
 - d. Re-enter the password in the *Confirm Password* field.
 - e. Choose the *Save* button.
 6. Next, create the required entry to allow connectivity between CAMS-INT and CAMS-ws:
 - a. Choose the *Create* button.
 - b. In the *Name* field, enter `MES_CREDENTIALS`.
 - c. Enter the *User Name* and *Password* you created for the `tcl_outbound_user` user in section 5 above.
 - d. Re-enter the password in the *Confirm Password* field.
 - e. Choose the *Save* button.
 7. Next, create the required entry `cams_int_runner`:
 - a. Choose the *Create* button.
 - b. In the *Name* field, enter `cams_int_runner`.
 - c. Enter the *User Name* and *Password* you created for the `tcl_outbound_user` user in section 5 above.
 - d. Re-enter the password in the *Confirm Password* field.
 - e. Choose the *Save* button.

If additional credentials are required during the implementation because of connectivity requirements to other systems, these should be defined in this area within SAP MII and referenced in the CAMS-INT workflow.

14 Configure Schedule Tasks Used by CAMS-INT

➔ Recommendation

SAP recommends that you regularly examine your message loads and the average processing time and use that information to adjust the pattern intervals and the count settings discussed below to maximize the number of records per scheduler. Also be sure to capture your settings for reference.

CAMS-INT makes use of the scheduler in SAP MII to perform tasks for processing data. To create these schedule tasks:

1. Logon to the XMI main application as Administrator or as a user with Administration access.
2. Navigate to *System Management* and choose *Scheduler*. The *SAP MII: Scheduler* screen appears.

The screenshot displays the 'SAP MII: Scheduler' interface. At the top, there are buttons for 'Run Job', 'Stop Scheduler', 'Create', 'Delete', 'Edit', 'Save', and 'Cancel'. Below this is a table listing scheduled tasks:

ID	Name	Next Run Time	File	Description	Job Type	Status
1,001	ComponentSerialNumberService	Dec 10, 2015 2:38:40 PM PST	SAPManufacturing/CAMS/services/SpillWorkflowService	Component Serial Number Processor	Transaction	Scheduled
1,002	GeneralQueueMessageDispatcher	Dec 10, 2015 2:38:50 PM PST	SAPManufacturing/CAMS/services/StandardWorkflowSe...	General Queue Message Processor	Transaction	Pending
1,004	MaterialCorrelation	Dec 10, 2015 2:38:50 PM PST	SAPManufacturing/CAMS/services/CorrelationWorkflowS...	Correlation process for Material Records	Transaction	Pending
1,005	ResendDataService	Dec 10, 2015 2:38:50 PM PST	SAPManufacturing/CAMS/services/ResendDataService	Resend Data From CAMS to CAMS-INT ...	Transaction	Pending

Below the table, the 'Details for ComponentSerialNumberService' are shown. The 'Transaction Scheduler' tab is active, displaying the following configuration:

- Name: ComponentSerialNumberS
- Description: Component Serial Number Processor
- Enabled:
- Transaction: SAPManufacturing/CAMS/services/SpillWorkfl...
- Credential Store: cams_int_runner
- User Name: [Empty]
- Password: [Empty]
- Pattern: */10 * * * * * (at every 10 Seconds at every Minute)
- Persist Transaction: Never
- Log Level: None

The 'Parameters' section shows the following settings:

Name	Value
Category	CompPartQueue
Count	1
DestinationCategory	GeneralQueue
EnrichmentParameters	
EnrichmentTransaction	SAPManufacturing/CAMS/enrichment/Comp...
PlantXPath	/INVCOND1/IDOC/E11CSLOWMERKS
SplitXSLT	SerialNumberSplit

3. Choose the *Create* button. The *Create Scheduler* dialog box appears:
 - a. Enter `GeneralQueueMessageDispatcher` in the *Name* field.
 - b. Leave the *Scheduler Type* as *Transaction*.
 - c. Choose *OK*.
4. Choose the job in the table.

5. To create a general message dispatcher, complete the fields on the *Transaction Scheduler* tab in the lower part of the screen using the values from the following table:

Property Name	Value						
<i>Description</i>	General Queue Message Processor						
<i>Enabled</i>	Selected (checked)						
<i>Transaction</i>	Choose <input type="button" value="..."/> and choose the transaction - <i>SAP/Manufacturing/CAMS/services/StandardWorkflowService</i> . Choose <i>OK</i> .						
<i>User Name</i>	cams_int_runner (as defined in Section 13)						
<i>Password</i>	Password for cams_int_runner (as defined in Section 5)						
<i>Pattern</i>	Choose <input type="button" value="..."/> and choose the desired run interval. It is advised that the duration be set to every 10 seconds within the hour – or (* / 10 * * * * *). The format of this entry is as per the UNIX Cron Pattern.						
<i>Persist Transaction</i>	<i>Never</i>						
<i>Log Level</i>	<i>Error</i>						
<i>Parameters</i>	<table border="0"> <tr> <td><i>Category</i></td> <td>GeneralQueue</td> </tr> <tr> <td><i>Count</i></td> <td>20</td> </tr> <tr> <td><i>RetryLimit</i></td> <td>2</td> </tr> </table>	<i>Category</i>	GeneralQueue	<i>Count</i>	20	<i>RetryLimit</i>	2
<i>Category</i>	GeneralQueue						
<i>Count</i>	20						
<i>RetryLimit</i>	2						

6. Choose the *Save* button.
7. To enable the Data Resend service (this is used to pull failed and stored data from SAP Complex Assembly Manufacturing into CAMS-INT), choose the *Create* button. The *Create Scheduler* dialog box appears:
 - a. Enter **ResendDataService** in the *Name* field.
 - b. Leave the *Scheduler Type* as *Transaction*.
 - c. Choose *OK*.
8. Choose the job in the table.
9. Complete the fields on the *Transaction Scheduler* tab in the lower part of the screen using the values from the following table:

Property Name	Value
<i>Description</i>	Resend Data From CAMS to CAMS-INT Processor
<i>Enabled</i>	Selected (checked)
<i>Transaction</i>	Choose <input type="button" value="..."/> and choose the transaction - <i>SAP/Manufacturing/CAMS/services/ResendDataService</i> . Choose <i>OK</i> .
<i>User Name</i>	cams_int_runner (as defined in Section 13)
<i>Password</i>	Password for cams_int_runner (as defined in Section 5)

Property Name	Value								
<i>Pattern</i>	Choose <input type="text"/> and choose the desired run interval. It is advised that the duration be set to every 5 minutes within the hour – or (0 5 * * * *). The format of this entry is as per the Unix Cron Pattern.								
<i>Persist Transaction</i>	<i>Never</i>								
<i>Log Level</i>	<i>Error</i>								
<i>Parameters</i>	<table> <tr> <td><i>CredentialAlias</i></td> <td>MES_CREDENTIALS</td> </tr> <tr> <td><i>ResendDataType</i></td> <td>CHANGEMASTER;BOM;ROUTING</td> </tr> <tr> <td><i>Server</i></td> <td>http://<server>:<port>/</td> </tr> <tr> <td><i>URI</i></td> <td>CAMS-ws/ResendDataService</td> </tr> </table>	<i>CredentialAlias</i>	MES_CREDENTIALS	<i>ResendDataType</i>	CHANGEMASTER;BOM;ROUTING	<i>Server</i>	http://<server>:<port>/	<i>URI</i>	CAMS-ws/ResendDataService
<i>CredentialAlias</i>	MES_CREDENTIALS								
<i>ResendDataType</i>	CHANGEMASTER;BOM;ROUTING								
<i>Server</i>	http://<server>:<port>/								
<i>URI</i>	CAMS-ws/ResendDataService								

10. Choose the *Save* button.
11. To enable the Material Correlation service, choose the *Create* button. The *Create Scheduler* dialog box appears:
 - a. Enter **Material Correlation** in the *Name* field.
 - b. Leave the *Scheduler Type* as *Transaction*.
 - c. Choose *OK*.
12. Choose the service in the table.
13. Complete the fields on the *Transaction Scheduler* tab in the lower part of the screen using the values from the following table:

Property Name	Value										
<i>Description</i>	Correlation process for Material Records										
<i>Enabled</i>	Selected (checked)										
<i>Transaction</i>	Choose <input type="text"/> and choose the transaction - <i>SAP/Manufacturing/CAMS/services/CorrelationWorkflowService</i> . Choose <i>OK</i> .										
<i>User Name</i>	cams_int_runner (as defined in Section 13)										
<i>Password</i>	Password for cams_int_runner (as defined in Section 5)										
<i>Pattern</i>	Choose <input type="text"/> and choose the desired run interval. It is advised that the duration be set to every 10 seconds within the hour – or (* / 10 * * * *). The format of this entry is as per the UNIX Cron Pattern.										
<i>Persist Transaction</i>	<i>Never</i>										
<i>Log Level</i>	<i>Error</i>										
<i>Parameters</i>	<table> <tr> <td><i>Category</i></td> <td>MaterialQueue</td> </tr> <tr> <td><i>CorrelationXSLT</i></td> <td>MaterialMasterCorrelation</td> </tr> <tr> <td><i>Count</i></td> <td>How many messages to process with each run</td> </tr> <tr> <td><i>DestinationCategory</i></td> <td>GeneralQueue</td> </tr> <tr> <td><i>MergeTransaction</i></td> <td></td> </tr> </table>	<i>Category</i>	MaterialQueue	<i>CorrelationXSLT</i>	MaterialMasterCorrelation	<i>Count</i>	How many messages to process with each run	<i>DestinationCategory</i>	GeneralQueue	<i>MergeTransaction</i>	
<i>Category</i>	MaterialQueue										
<i>CorrelationXSLT</i>	MaterialMasterCorrelation										
<i>Count</i>	How many messages to process with each run										
<i>DestinationCategory</i>	GeneralQueue										
<i>MergeTransaction</i>											

Property Name	Value
<i>NewDocumentName</i>	Z_MATMAS04
<i>NumberOfDocuments</i>	3
<i>WaitTimeLimit</i>	10

14. Choose the *Save* button.
15. To enable the Component Serial/Lot service, choose the *Create* button. The *Create Scheduler* dialog box appears:
 - a. Enter **ComponentSerialNumberService** in the *Name* field.
 - b. Leave the *Scheduler Type* as *Transaction*.
 - c. Choose *OK*.
16. Choose the service in the table.
17. Complete the fields on the *Transaction Scheduler* tab in the lower part of the screen using the values from the following table:

Property Name	Value														
<i>Description</i>	Component Serial Number Processor														
<i>Enabled</i>	Selected (checked)														
<i>Transaction</i>	Choose <input type="button" value="..."/> and choose the transaction - <i>SAP/Manufacturing/CAMS/services/SplitWorkflowService</i> . Choose <i>OK</i> .														
<i>User</i>	cams_int_runner (as defined in Section 13)														
<i>Password</i>	Password for cams_int_runner (as defined in Section 5)														
<i>Pattern</i>	Choose <input type="button" value="..."/> and choose the desired run interval. It is advised that the duration is set to every 10 seconds within the hour – or <i>(* / 10 * * * * *)</i> . The format of this entry is as per the UNIX Cron Pattern.														
<i>Persist Transaction</i>	<i>Never</i>														
<i>Log Level</i>	<i>Error</i>														
<i>Parameters</i>	<table border="0"> <tr> <td><i>Category</i></td> <td>CompPartQueue</td> </tr> <tr> <td><i>Count</i></td> <td>How many messages to process with each run</td> </tr> <tr> <td><i>DestinationCategory</i></td> <td>GeneralQueue</td> </tr> <tr> <td><i>EnrichmentParameters</i></td> <td>RemoveOrderLeadingZeros=1</td> </tr> <tr> <td><i>EnrichmentTransaction</i></td> <td>SAP/Manufacturing/CAMS/enrichment/ComponentSerialNumberRetriever</td> </tr> <tr> <td><i>PlantXPath</i></td> <td>/INVCN01/IDOC/E1ICHD0/E1ICIT0/WERKS</td> </tr> <tr> <td><i>SplitXSLT</i></td> <td>SerialNumberSplit</td> </tr> </table>	<i>Category</i>	CompPartQueue	<i>Count</i>	How many messages to process with each run	<i>DestinationCategory</i>	GeneralQueue	<i>EnrichmentParameters</i>	RemoveOrderLeadingZeros=1	<i>EnrichmentTransaction</i>	SAP/Manufacturing/CAMS/enrichment/ComponentSerialNumberRetriever	<i>PlantXPath</i>	/INVCN01/IDOC/E1ICHD0/E1ICIT0/WERKS	<i>SplitXSLT</i>	SerialNumberSplit
<i>Category</i>	CompPartQueue														
<i>Count</i>	How many messages to process with each run														
<i>DestinationCategory</i>	GeneralQueue														
<i>EnrichmentParameters</i>	RemoveOrderLeadingZeros=1														
<i>EnrichmentTransaction</i>	SAP/Manufacturing/CAMS/enrichment/ComponentSerialNumberRetriever														
<i>PlantXPath</i>	/INVCN01/IDOC/E1ICHD0/E1ICIT0/WERKS														
<i>SplitXSLT</i>	SerialNumberSplit														

18. Choose the *Save* button.
19. To enable archiving (mandatory) to archive messages out of the main CAMS-INT table and into an archive table for reference, choose the *Create* button. The *Create Scheduler* dialog box appears:
 - a. Enter **ArchiveData** in the *Name* field.
 - b. Leave the *Scheduler Type* as *Transaction*.
 - c. Choose *OK*.

i Note

The archive process is based on days in the active queue as an indicator as to whether the record should be archived or not. The archive process moves all record types and is not configured to a specific record type.

20. Choose the service in the table.
21. Complete the fields on the *Transaction Scheduler* tab in the lower part of the screen using the values from the following table:

Property Name	Value
<i>Description</i>	Archive Data , for example
<i>Enabled</i>	Selected (checked)
<i>Transaction</i>	Choose <input type="button" value="..."/> and choose the transaction - <i>SAP/Manufacturing/CAMS/archive/ArchiveDataProcess</i> . Choose <i>OK</i> .
<i>User</i>	Tcl_outbound_user (or equivalent; as defined in Section)
<i>Password</i>	Password for Tcl_outbound_user (as defined in Section 5)
<i>Pattern</i>	Choose <input type="button" value="..."/> and choose the desired run interval. SAP recommends that this be set to run during down times as it uses resources and will impact any live interface currently running. It should also be set to run daily.
<i>Persist Transaction</i>	<i>Never</i>
<i>Log Level</i>	<i>Error</i>

Property Name	Value	
<i>Parameters</i>	<i>NoOfDaysFromToday</i>	Defaults to 150, but should be set to the number of days a message should stay in the queue. As the transaction transfers all messages, this needs to be large enough to allow issue resolution but low enough to maintain a reasonable number of records in the active table.
	<i>NoOfRecords</i>	How many records to process when triggered. This value should be set to a low number when you are bringing the number of records in the live queue down to the desired level and then increased to pull more records when it is in a maintenance state (this would typically be aligned with a change in run duration. Shorter time interval with a lower number, higher number with a longer time frame.)
	 Caution Care should be taken when initially setting up the archive process as running this transaction with live data passing through the interface will cause a slowdown. SAP recommends that the archive process is put into the system with a more frequent runtime and lower message count until the records are transferred and then move into a larger record count with a lower frequency to maintain a normal run condition. These numbers can be altered at any time and will take effect the next time the task is run.	

i Note

To remove from this archive table, you will need to create a database script to clean out the records as needed. SAP does not provide a task for doing this.

22. Choose the *Save* button.

15 Configure CAMS-INT

Before CAMS-INT can be used, some configuration is required. Initially, the CAMS-INT functionality needs to be exposed through a series of menus that appear on the left hand side of the screen. Once the menu is defined, additional configuration needs to be done as explained in this section.

15.1 Menu Creation

CAMS-INT functionality can be broken into two distinct categories: Administration and Monitoring/Configuration. The Administration items relate to configuration that, if changed, could cause functional issues to occur. Monitoring/Configuration relates to day-to-day monitoring tasks and notification configuration—things that will not prevent process issues.

To provide this separation, the menu items will be split between the two roles created earlier: CAMS_INT_ADMIN and CAMS_INT_USER.

For the *CAMS_INT_ADMIN* menu structure, do the following:

1. Logon to XMII and navigate to the following: **Content Development** > **Workbench**. This will start a Java Web Start application. If a dialog appears asking whether to block potentially unsafe components from being run, select *No* otherwise the application will not run.
2. When the application starts, choose **Tools** > **Navigation Editor**. The following screen appears:

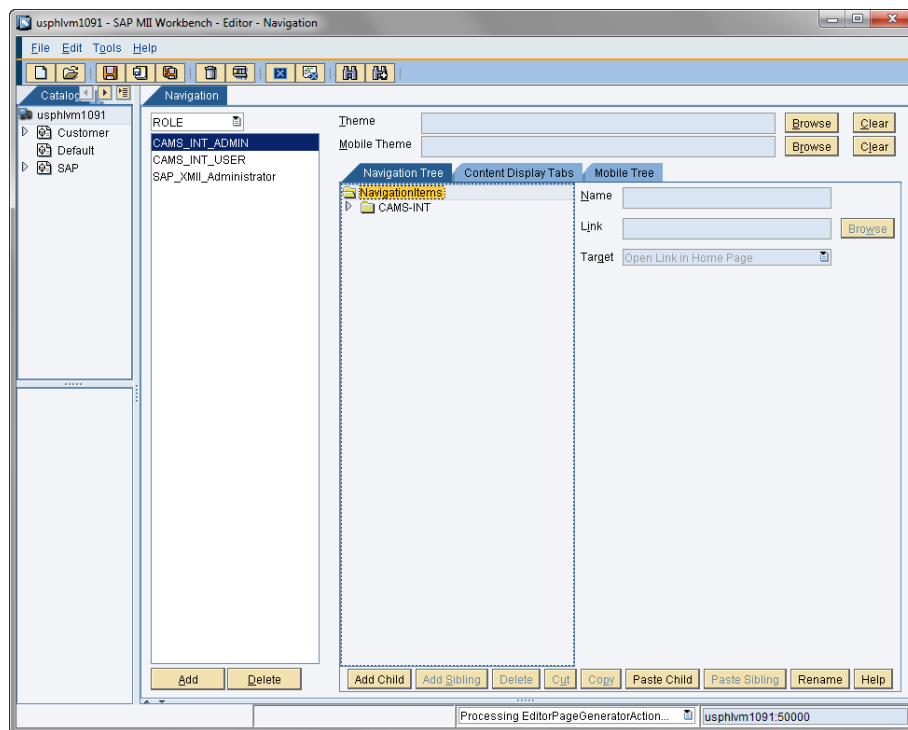

3. First, we need to add the roles we want to assign access rights to. Choose the *Add* button (lower left of the screen) and enter **CAMS_INT*** in the search field. Choose the *Search* button. Choose both the *CAMS_INT_ADMIN* and *CAMS_INT_USER* items returned.
4. In the *ROLE* data list, choose *CAMS_INT_ADMIN*.
5. With the *NavigationItems* folder chosen, choose the *Add Child* button.
6. In the *Name* field, enter **CAMS-INT**.
7. Choose *OK*, and then on the main screen choose the *Save* button.
8. With *CAMS-INT* chosen, choose the *Add Child* button.
9. In the *Name* field, enter **Administration**.
10. Choose *OK*, and then on the main screen choose the *Save* button.
11. With *CAMS-INT* chosen, choose the *Add Child* button.
12. In the *Name* field, enter **Configuration**.
13. Choose *OK*, and then on the main screen choose the *Save* button.

You now have the first level menu structure defined.

14. With *Configuration* chosen, choose the *Add Child* button:
 - Using the table data below, enter the corresponding data in the appropriate screen. Leave the *Target* value (as defaulted by the application) as *Open Link in Home Page*. Once entered, choose *OK*, and then on the main screen choose the *Save* button. Repeat this step until all items are defined.

Name	Link
<i>Workflow Configuration</i>	/XMII/CM/SAP/Manufacturing/CAMS/framework/ui/Workflow/Workflow ConfigurationView.irpt
<i>Supported Plants</i>	/XMII/CM/SAP/Manufacturing/CAMS/framework/ui/Configuration/SupportedPlantsView.irpt
<i>E-Mail Notifications</i>	/XMII/CM/SAP/Manufacturing/CAMS/framework/ui/Notification/NotificationConfigurationView.irpt
<i>Global Configuration</i>	/XMII/CM/SAP/Manufacturing/CAMS/framework/ui/Configuration/GlobalConfigurationView.irpt
<i>Integration Server</i>	/XMII/CM/SAP/Manufacturing/CAMS/framework/ui/Configuration/ServerPropertiesView.irpt

15. With *Administration* chosen, choose the *Add Child* button:
 - Using the table data below, enter the corresponding data in the appropriate screen (as defaulted by the application) as *Open Link in Home Page*. Once entered, choose *OK*, and then on the main screen choose the *Save* button.

Name	Link
<i>Configuration Import Export</i>	/XMII/CM/SAP/Manufacturing/CAMS/framework/ui/Configuration/ConfigurationImportExportView.irpt

16. This next step is only required if you wish to expose the test UI page to allow posting of XML messages to the CAMS-INT queue (as discussed in section 10.10) – effectively bypassing either the RFC or web service connections used by SAP ECC and SAP Complex Assembly Manufacturing. This allows for unit testing of CAMS-INT to ensure connectivity between the required systems. If this is required, then you need to add an additional item to the *Administration* menu, so with *Administration* chosen, choose the *Add* button:
 - Using the table data below, enter the corresponding data in the appropriate screen (as defaulted by the application) as *Open Link in Home Page*. Once entered, choose *OK*, and then on the main screen choose the *Save* button.

Name	Link
<i>Post Test XML</i>	/XMII/CM/SAP/Manufacturing/CAMS/framework/ui/Test/PostXMLtoQueue.irpt

For the *CAMS_INT_USER* menu structure:

1. In the *ROLE* data list, select *CAMS_INT_USER*.
2. With the *NavigationItems* folder chosen, choose the *Add Child* button.
3. In the *Name* field, enter *CAMS-INT*.
4. Choose *OK*, and then on the main screen choose the *Save* button.
5. With *CAMS-INT* chosen, choose the *Add Child* button.
6. In the *Name* field, enter *Queues*.
7. Choose *OK*, and then on the main screen choose the *Save* button.
8. With *CAMS-INT* chosen, choose the *Add Child* button.
9. In the *Name* field, enter *Reports*.
10. Choose *OK*, and then on the main screen choose the *Save* button.

You now have the first level menu structure defined.

11. With *Queues* chosen, choose the *Add Child* button:
 - Using the table data below, enter the corresponding data in the appropriate screen. Leave the *Target* value (as defaulted by the application) as *Open Link in Home Page*. Once entered, choose *OK*, and then on the main screen choose the *Save* button. Repeat this step until all items are defined.

Name	Link
<i>Queue Monitor</i>	/XMII/CM/SAP/Manufacturing/CAMS/framework/ui/Queues/QueueMonitorView.irpt
<i>Archive Queue Monitor</i>	/XMII/CM/SAP/Manufacturing/CAMS/framework/ui/Queues/ArchiveQueueMonitorView.irpt

12. With *Reports* chosen, choose the *Add Child* button:
 - Using the table data below, enter the corresponding data in the appropriate screen. Leave the *Target* value (as defaulted by the application) as *Open Link in Home Page*. Once entered, choose *OK*, and then on the main screen choose the *Save* button. Repeat this step until all items are defined.

Name	Link
Message Statistics	/XMII/CM/SAP/Manufacturing/CAMS/framework/ui/statistics/MessageStatisticsView.irpt
BOM Holding Queue	/XMII/CM/SAP/Manufacturing/CAMS/framework/ui/BomHoldingQueue/BomHoldingQueueView.irpt
Routing Holding Queue	/XMII/CM/SAP/Manufacturing/CAMS/framework/ui/PlanHoldingQueue/PlanHoldingQueueView.irpt
Change Masters	/XMII/CM/SAP/Manufacturing/CAMS/framework/ui/ChangeMaster/ChangeMasterView.irpt

To enable the menu items for the active user, log out and back in to XMII. To enable the menus for users, please ensure that the applicable role is defined for them. Apply the role or roles to each required user as needed through the SAP NetWeaver administration module as per section 5, Configure Users and Roles within SAP NetWeaver.

15.2 Global Configuration

CAMS-INT has a set of global properties that allow the underlying application to function. These items need to be checked and updated as required for the implementation.

To go to the [CAMS-INT Global Configuration](#) screen shown below, under the [CAMS-INT](#) menu item, navigate to [Configuration](#) > [Global Configuration](#). If you do not see this menu item, please ensure that your user account has been assigned the CAMS_INT_ADMIN role.



The Discriminator_TX value shown is an example only. The value will vary by customer.

CAMS-INT GLOBAL CONFIGURATION

Parameter Name:

Parameter Value:

Parameter Name	Parameter Value	Description
DATABASE_TYPE	ORACLE	The underlying database (Oracle/MaxDB/etc)
DATE_TIME_FORMAT	MM/dd/yyyy HH24:mi:ss	The date time format required.
DISCRIMINATOR_TX	SAP/Manufacturing/CAMS/discriminators/SimpleDocumentDiscriminator	The fully qualified discriminator transaction.
SMTP_FROM_ADDRESS	donotreply@someplace.com	The from address to use in the notification e-mail.
RESEND_DATA_URL	CAMS-ws/ResendDataService	The resend data URL for CAMS-INT

The main customer configurable item is the [SMTP_FROM_ADDRESS](#), which is the from address used in all email notifications. The other properties should only be changed after consultation with SAP. To change the value:

1. Choose [SMTP_FROM_ADDRESS](#) in the table. The data is copied to the [Parameter Name](#) and [Parameter Value](#) fields at the top of the window.
2. Make the change to the [Parameter Value](#) field.
3. Choose [Save](#).

15.3 Email Notifications

To support sending notification messages upon a failed message, CAMS-INT needs to know which email address or addresses to send the email to. The configuration is made based upon the message name (the XML root node) and can only be set when this message name has been made known to CAMS-INT through the workflow configuration.

To go to the [CAMS-INT Notification Configuration](#) screen shown below, under the [CAMS-INT](#) menu, navigate to [Configuration](#) > [E-Mail Notifications](#). If you do not see this menu item, please ensure that your user account has been assigned the CAMS_INT_ADMIN role.

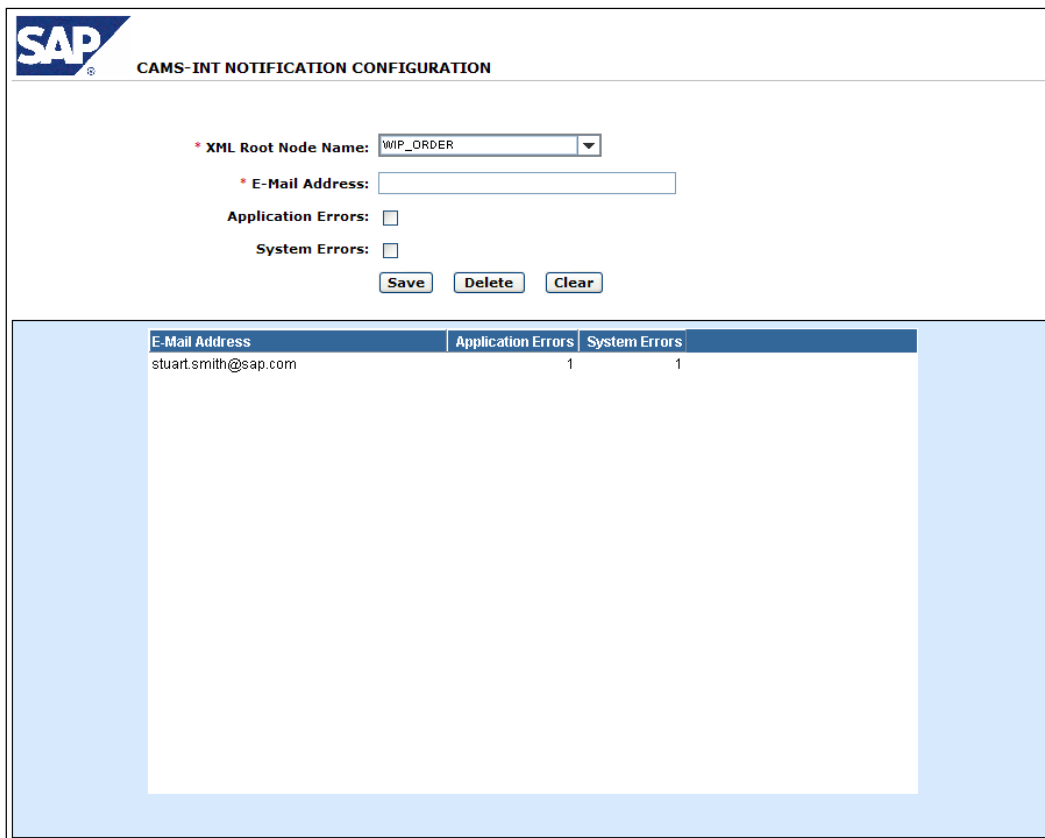

The screenshot displays the 'CAMS-INT NOTIFICATION CONFIGURATION' interface. At the top left is the SAP logo. The main form area includes the following elements:

- * XML Root Node Name:** A dropdown menu currently showing 'WIP_ORDER'.
- * E-Mail Address:** An empty text input field.
- Application Errors:** A checkbox that is currently unchecked.
- System Errors:** A checkbox that is currently unchecked.
- Three buttons: 'Save', 'Delete', and 'Clear'.

Below the form is a table with the following data:

E-Mail Address	Application Errors	System Errors
stuart.smith@sap.com	1	1

All message names made available to CAMS-INT through the Workflow Configuration are selectable from the [XML Root Node Name](#) dropdown.

To configure the notification:

1. Choose an [XML Root Node Name](#) value.
2. In the [E-Mail Address](#) field, enter the email address of the recipient for this message type. This can be a group email address or a single account. You can also have multiple emails assigned to one [XML Root Node Name](#)—repeat these steps for each address.
3. Choose whether this notification is for [Application Errors](#) or [System Errors](#) by selecting the appropriate checkbox. Application errors are hard errors for which a retry cannot be performed; system errors are subject to retry.
4. Choose the [Save](#) button.

15.4 Supported Plants

i Note

This section assumes that plants have already been created in SAP ERP.

CAMS-INT supports routing of messages between multiple CAMS-ws and SAP ERP based upon a plant or site code. You can define the mapping in the *Supported Plants* screen. Even if the configuration is one-to-one, all applicable plants have to be configured to allow the messages to be sent through CAMS-INT.

To go the *Supported Plants* screen shown below, under the *CAMS-INT* menu navigate to **Configuration** *Supported Plants*. If you do not see this menu item, please ensure that your user account has been assigned the CAMS_INT_ADMIN role.

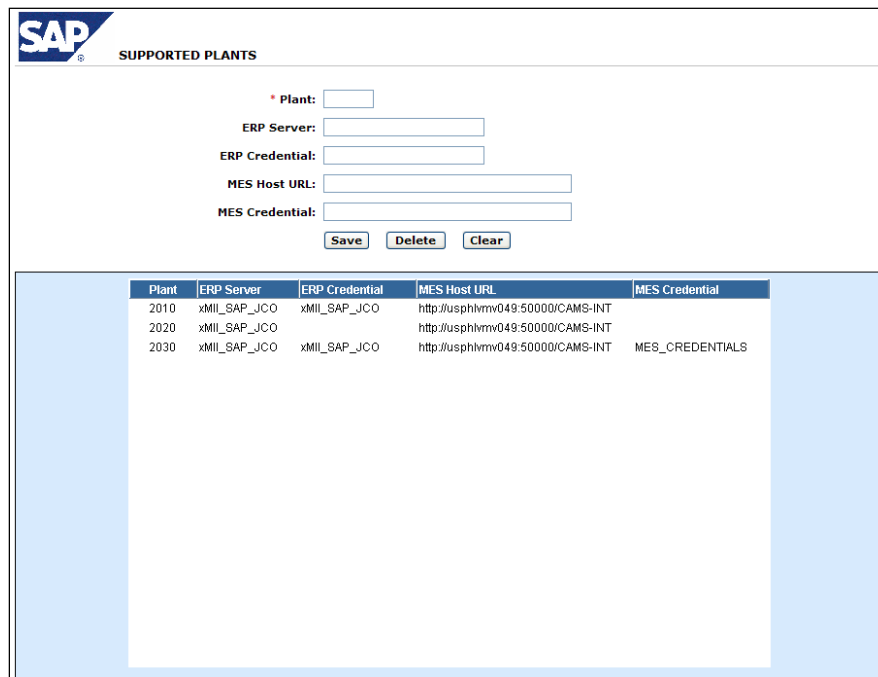

Plant	ERP Server	ERP Credential	MES Host URL	MES Credential
2010	xMIL_SAP_JCO	xMIL_SAP_JCO	http://usphlrmv049:50000/CAMS-INT	
2020	xMIL_SAP_JCO		http://usphlrmv049:50000/CAMS-INT	
2030	xMIL_SAP_JCO	xMIL_SAP_JCO	http://usphlrmv049:50000/CAMS-INT	MES_CREDENTIALS

To configure a new plant:

1. Enter the *Plant* value
2. Enter the *ERP Server*—for SAP this will be the JCo connection; for other ERP entries this can be the HTTP address for the endpoint.
3. Enter the *ERP Credential* (if needed). This is the name of the credentials defined in the Credential Store within SAP MII as defined in section 13.
4. Enter the *MES Host URL*.
5. Enter the *MES Credential* (if needed). This is the name of the credential defined in the Credential Store within SAP MII as defined in section 13.
6. Choose *Save*.

To change a value of an existing record:

1. Choose the plant record in the table. The plant data is copied into the fields at the top of the screen.
2. Make the required changes.
3. Choose [Save](#).

15.5 Workflow Configuration

There are three types of workflows that can be used to process inbound messages:

- Standard Workflow
- Correlation Workflow
- Split Workflow

15.5.1 Standard Workflow

The standard workflow is the main processing workflow of CAMS-INT. You can have multiple processes scheduled to run the standard workflow processing where each task is for a different category. You should not create multiple tasks running against the same category. If this occurs, the potential exists that duplicate data will occur as the queue is not multiprocessing safe.

The standard workflow requires the configuration of three parameters as detailed in the table below. The parameters tell the workflow to look for messages in the category defined, to process a number of records defined by the *Count* value, and if an error occurs that supports retries, then retry the message the number of times specified by the *RetryLimit* value.

Parameter Name	Description
<i>Category</i>	The category from which the messages should be read
<i>Count</i>	The number of records to process when run from the scheduler
<i>RetryLimit</i>	The maximum number of times to reprocess this message before failing

15.5.2 Correlation Workflow

The correlation workflow allows for multiple discrete messages to be merged into a single document and then be passed into a category being processed by a standard workflow. The correlation workflow will be triggered as a scheduled task, and it looks for records registered with the *Category* specified. It is required that all messages for a specific correlation process use the same *Category* to ensure that process occurs as expected.

The correlation process will take any new messages, up to the *Count* value, and use the XSLT specified in the *CorrelationXSLT* parameter to determine a unique key that will be specific to all the messages that need to be merged together. Once the process detects that there are the number of documents specified in the *NumberOfDocuments* value, it uses the *MergeTransaction* parameter to create a new message of the name specified in the *NewDocumentName* parameter. (If the *MergeTransaction* value is blank, the standard merge process will be

used.) This new message will then be placed into the category defined by the *DestinationCategory* parameter. If for some reason not enough messages are received, the system processes the merge once the *WaitTimeLimit* has been exceeded so as not to leave them in the queue.

Parameter Name	Description
<i>Category</i>	The category from which the messages should be read
<i>CorrelationXSLT</i>	The transformation to handle creating the correlation ID from the message
<i>Count</i>	How many messages to process with each run
<i>DestinationCategory</i>	The category to place the correlated message into for further processing
<i>MergeTransaction</i>	(Optional) Custom merge transaction name (fully qualified)
<i>NewDocumentName</i>	The name of the merged document that will result from a correlation process
<i>NumberOfDocuments</i>	The maximum number of documents to wait for
<i>WaitTimeLimit</i>	The number of seconds to wait before processing regardless of whether the number of documents has been reached

15.5.3 Split Workflow

The split workflow allows for a single message received into the system to be broken up into smaller messages and then posted into a category being processed by a standard workflow. The split process is performed by the *SplitXSLT* parameter and it is its responsibility to generate a new XML document with a root node of DOCS and then merge all the new messages as children under it. Each child element under DOCS will become a new message placed into the *DestinationCategory*. The process will process a number of records defined by the *Count* parameter.

You also have the ability to enrich the incoming message before the split takes place. If this is needed, then a transaction is specified in the *EnrichmentTransaction* parameter and it will be run before the split takes place. If this transaction needs any configuration parameters, then these should be set in *EnrichmentParameters*.

Parameter Name	Description
<i>Category</i>	The category to read the messages from
<i>Count</i>	How many messages to process with each run
<i>DestinationCategory</i>	The category to place the correlated message into for further processing
<i>SplitXSLT</i>	The transformation to handle the split
<i>EnrichmentTransaction</i>	An SAP MII transaction to enrich the XML message before performing the split
<i>EnrichmentParameters</i>	The parameters needed for the enrichment process
<i>PlantXPath</i>	The XPath statement to determine the plant data for this XML message

15.5.4 Creating a Workflow

CAMS-INT processes messages based upon a workflow definition for that message name. The workflow for the preconfigured interfaces will be delivered and so you do not need to manually configure them.

If new message types are required, you need to create a new workflow:

1. To go to the *CAMS-INT Workflow Configuration* screen shown below, under the *CAMS-INT* menu navigate to *Configuration* > *Workflow Configuration*. If you do not see this menu item, please ensure that your user account has been assigned the CAMS_INT_ADMIN role.

2. Specify the *XML Root Node* value. This is the root node of the XML message that will be processed with this workflow.
3. Specify the *Plant* XPath statement. This value is the path into the XML document where the plant data is located. This will be used as a lookup into the supported plants configuration to determine the ERP and MES server location and any credentials to support connectivity. The ERP and MES servers will be used in the Main Transaction (see step 7) as needed.
4. Specify the *Enrichment* transaction (choose  to browse for it) for this workflow if required. The Enrichment transaction is a custom transaction used to add in additional information to the XML message to support processing.
5. Specify the *Enrichment Params* (Parameters). These will be any external configuration for the Enrichment transaction and whether there is any, or what they are, will be specific to the Enrichment transaction.
6. Specify the *Pre Transform XSL*. This XSLT file is required if and when the XML message needs to be converted before being sent to the Main Transaction (see step 7). If the XML being sent into CAMS-INT is as needed by the Main Transaction, then this field is not required.
7. Specify the *Main Transaction*. This is the SAP MII transaction that will be doing the actual reason for this workflow. CAMS-INT comes with three basic Main Transactions to support sending web service requests and communication to SAP. Custom Main Transactions can be created to perform other tasks.
8. Specify the *Main Transaction Params*. The parameters and definition of the parameters will be dependent upon the Main Transaction requirements.

9. Specify the *Post Transform XSL*. This XSLT is used to interpret the response from the Main Transaction—which should be an XML message—to report back to the CAMS-INT framework whether the call was successful or not, and if not whether a retry is required.
10. Specify the *Pass Handler*. If additional work needs to be done after the Main Transaction has successfully completed, then the SAP MII transaction performing this task would be defined here.
11. Specify the *Pass Handler Params*. These will be any external configuration for the Pass Handler transaction and whether there is any, or what they are, will be specific to this Pass Handler.
12. Specify the *Fail Handler*. If additional work needs to be done after the Main Transaction has unsuccessfully completed, then the SAP MII transaction performing this task would be defined here.
13. Specify the *Fail Handler Params*. These will be any external configuration for the Fail Handler transaction and whether there is any, or what they are, will be specific to this Fail Handler.
14. Choose *Save*.

If modifications need to be made to the workflow:

1. Choose the required *XML Root Node* in the dropdown. The existing data appears in the fields.
2. Make the required changes.
3. Choose *Save*.

15.6 Configuration Import/Export

Once the configuration is complete or a change has been made, it is advisable to export the settings so that you can use them to recover an instance or provide a baseline for another instance of CAMS-INT. All configuration settings will be lost if the CAMS-INT SAP MII project is deleted or updated, so it is imperative that you export the configuration before performing such a task.

To export the configuration:

1. Go the *CAMS-INT Import/Export Configuration* screen shown below. Under *CAMS-INT* menu navigate to *Administration* > *Configuration Import Export*. If you do not see this menu item, please ensure that your user account has been assigned the CAMS_INT_ADMIN role.

2. Ensure you are running the configuration directly on the SAP MII server.
3. Choose the items you want to export by selecting the checkbox next to the item. You must select at least one item to export.
4. In the *Filename* field, specify the file you want to export the data to. You can create an empty file in the location required and the configuration data will be written to this file. The file can also be on a shared folder that is visible from the SAP MII server.
5. Choose the *Export* button. The data is extracted to this file.
6. If you are not able to get to the SAP MII machine, choose the *View* button and the XML will be displayed in the browser. Use the browser *Save-As* function to write this file to the client machine.

To import the configuration, which will overwrite existing values:

1. At the end of the *Filename* field, choose the *Browse* button and choose the configuration file `WorkflowConfiguration.xml` from the `<SAP_CAMS_7.2>\CAMS-INT-Config\` directory. Please note the trailing backslash is required.
2. Choose the *Import* button.
3. The data is imported and overwrites the existing values.

The *CAMS-INT Import/Export Configuration* screen can also be used to update the Key Data XSLT. This XSLT is used by CAMS-INT to allow human-readable text from the XML message and have it displayed in the queue. This is to aid in locating the actual message of interest rather than checking all messages of a given type for a given timeframe. To use this feature:

1. At the end of the *Key Data Filename* field, choose the *Browse* button to locate the XSLT file for the Key Data process.
2. Once the file is chosen, choose the *Upload Key Data* button to load the XSLT into CAMS-INT.

Finally, the *CAMS-INT Import/Export Configuration* screen supports uploading the main XSLT files needed by CAMS-INT. A configuration file is provided as part of the CAMS-INT distribution called `InterfaceXSLTConfiguration.xml`. This file should be used as the entry to the Main XSLT Filename:

1. At the end of the *Main XSLT Filename* field, choose the *Browse* button to locate the `InterfaceXSLTConfiguration.xml` file.
2. In the *Main XSLT directory path*, enter the directory where the XSLT files are located, `<SAP_CAMS_7.2>\CAMS-INT\XSLT\`. Please note the trailing backslash is required. This needs to be a folder that is visible on the SAP MII server as the server will try to read from this location.
3. Once the data is entered, choose the *Update XSLT* button to upload and populate CAMS-INT with the data.

15.7 Defining Integration Server Configuration

The web service part of CAMS-INT requires configuration in a similar manner to the main SAP Complex Assembly Manufacturing application.

To go the *Server Configuration* screen shown below, under the *CAMS-INT* menu navigate to *Configuration > Integration Server*. If you do not see this menu item, please ensure that your user account has been assigned the CAMS_INT_ADMIN role.

Environment	Parameter	Description
DEV	args.cfile	Location of the Select configuration file
DEV	args.application	The default application to start
DEV	args.userid	Optional user id to log in with
DEV	args.password	Optional password to log in with
DEV	args.document	Optional CAPP document type to load on startup. Do
DEV	args.keylist	List of document keys, ie part_key, plan_key, etc. to
DEV	args.keyvalues	Optional document key values.
DEV	args.cust	Customer
DEV	args.dbInstance	Database Instance Environment
DEV	env.DBINFOFILENAME	Identifies the filename for the username/password
DEV	env.TNSNAME	Identifies the Tnsname of the database to which the
DEV	env.TNS_ADMIN	1
DEV	env.CAMSRoot	1
DEV	env.HMS_LOC_UNIX	1
DEV	env.HMS_LOC_WIN32	1
DEV	env.HMS_HOME	File Path to CAMS Core Software Installation
DEV	env.CLIENTCODE	File Path to CAMS Select Software Installation
DEV	env.ENVIRONMENT	Application environment

This screen allows for the configuration of the environment variables required by the application. These configurations are very close to the requirements for running SAP Complex Assembly Manufacturing and should match. The properties to match are related to the parameters that start with *env*. These represent the environment parameters and the environment variables defined in the batch file. The simplest way to obtain these values is to look at the batch file that starts SAP Complex Assembly Manufacturing—*RunCAMS.bat*. For each active parameter in the batch file, there should be an *env.xxx* equivalent. The user ID and modified data are added automatically.

For a SAP Complex Assembly Manufacturing preconfigured implementation (PI), the following items will need to be modified but a complete check between the *RunCAMS.bat* and the configuration here needs to be performed once SAP Complex Assembly Manufacturing is up and running.

Parameter Name	Comments
<i>args.cfile</i>	Replace the <ENTER LOCATION> with the path to the PI code installation. Please use the forward slash (/) character as a file delimiter.

Parameter Name	Comments
<i>env.DBINFOFILENAME</i>	This needs to be set to the name of the DB authentication file as created when SAP Complex Assembly Manufacturing was installed.
<i>env.TNSNAME</i>	This is the TNS Name entry for the connection to the SAP Complex Assembly Manufacturing database.
<i>env.HMS_HOME</i>	Replace <ENTER_LOCATION> with the path to the SAP_CAMS_7.2 installation.

If the SAP NetWeaver installation to be used with CAMS-INT uses an Oracle database, it is possible that the Oracle installation supporting SAP NetWeaver and the Oracle client providing the connection to the SAP Complex Assembly Manufacturing Oracle database will each have their own set of sqlnet and tnsname files. If the server does not have the environment variable `ORACLE_HOME` set by default, then it will be necessary to add a new property called *env.ORACLE_HOME* to force the Oracle installation used to connect to the SAP Complex Assembly Manufacturing database to use the correct sqlnet and tnsname files. In order to determine if this additional environment variable is required, attempt to connect to the SAP Complex Assembly Manufacturing database from the server using the Oracle SQL Plus application. If you are sure that the connection information for the SAP Complex Assembly Manufacturing database is correct and you still receive a TNS error, then attempt to connect to the SAP Complex Assembly Manufacturing database using SQL Plus from the `ORACLE_HOME/Network/Admin` directory. If that connection is successful, then you will need to set the *env.ORACLE_HOME* property.

After the configuration is complete, if the interpreters are not starting correctly (the smoke test cannot be successfully performed) an additional parameter called *args.errorlog* can be added to the configuration. The value for this property should be a fully qualified filename (for example, `C:/Temp/CAMS_INT_ErrorLog.log`), which will be used to write out logging information to aid in obtaining the solution to the problem. Any error reported during startup of the interpreter will be written to this file. It is not advised to keep this property present once the issue(s) have been resolved.

To create a new property:

1. Enter the *Environment* value.
2. Enter the *Parameter* value. This is basically the environment property from the batch file prefixed with *env*. So if the property was TEMP, the parameter would be *env.TEMP*.
3. Enter a *Description* for this property.
4. Enter the *Value* required.
5. Choose *Save*.

To edit an existing property:

1. Choose the required record in the table. The values are added to the fields at the top of the screen.
2. Modify the required items. If you change the *Environment* or *Parameter*, a new item is written to the database.
3. Choose *Save*.

When a change has occurred:

1. Open a web browser and go to `http://<server>:<port>/CAMS-ws`.
2. At the login prompt enter the username and password of a user with the `CAMS_INT_ADMIN` role.

- From the main menu screen, choose the **Purge Interpreter Pools** link (used for SAP Complex Assembly Manufacturing patch installations). This will clear out any existing interpreters and restart them with the new configurations.

15.8 SAP Complex Assembly Manufacturing ERP Interface Configuration

For the interfaces to be functional, you must enable them in the Shop Floor Management (SFM) *Control Parameters* dialog box. If the interfaces are disabled, calls into CAMS-INT will not be processed completely and each call will result in a warning message in the Queue Monitor saying that the applicable interface is not enabled.

To enable the interfaces:

- Log into SFM using an account with administrator privileges.
- Choose **System** > **Configuration Parameter**.
- The *Control Parameters* dialog box appears. Choose the **ERP Interface** bar to expand the section as shown.

ERP Interface		
ERP Interface Active	<input checked="" type="radio"/> Yes	<input type="radio"/> No
Operation Confirmation Enabled	<input checked="" type="radio"/> Yes	<input type="radio"/> No
Use Max Rev for Order Create	<input type="radio"/> Yes	<input checked="" type="radio"/> No
Exclude Part Type For Order	EI CP MA	
Create Certs as needed	<input type="radio"/> Yes	<input checked="" type="radio"/> No
Export Plan to SAP Step ERP	<input checked="" type="radio"/> Yes	<input type="radio"/> No
Generate SAP Task List and Group Counter	<input checked="" type="radio"/> Yes	<input type="radio"/> No
SAP BOM Effectivity Definition	MODEL_UNIT	
Add Items to SAP Change Master	<input type="radio"/> Yes	<input checked="" type="radio"/> No
BOM Release Enabled	<input checked="" type="radio"/> Yes	<input type="radio"/> No
URL for SAP CAMS-INT	http:// :50000/XMII/Illuminator	
SAP CAMS-INT Authentication File name	// /CAMS-INT/CamsAuth.ini	
SAP Change Master Number Format	09999999999	
SAP Change Master Number Prefix	E	
Disable Sending Messages to MII	<input type="radio"/> Yes	<input checked="" type="radio"/> No
Change Number for given BOM usage	VF01/01/1901	
Value to increment the line item by	2	
List of cols to exc from BOM Imp		
Order Create Interface Enabled	<input checked="" type="radio"/> Yes	<input type="radio"/> No
Certifications Import Interface Enabled	<input checked="" type="radio"/> Yes	<input type="radio"/> No
Part master Interface Enabled	<input checked="" type="radio"/> Yes	<input type="radio"/> No
Resend Data Interface Enabled	<input checked="" type="radio"/> Yes	<input type="radio"/> No
Enforce SAP Data Rules	<input checked="" type="radio"/> Yes	<input type="radio"/> No
Use Plant as ERP site	<input checked="" type="radio"/> Yes	<input type="radio"/> No
Order Split Interface Enabled	<input checked="" type="radio"/> Yes	<input type="radio"/> No
Order Cancel Interface Enabled	<input checked="" type="radio"/> Yes	<input type="radio"/> No
W/C Create/Update Interface Enabled	<input checked="" type="radio"/> Yes	<input type="radio"/> No
Enforce Serial No. Change Prevention	<input checked="" type="radio"/> Yes	<input type="radio"/> No
Generic Message Interface Enabled	<input checked="" type="radio"/> Yes	<input type="radio"/> No
Plan Hold Interface Enabled	<input checked="" type="radio"/> Yes	<input type="radio"/> No
Plan Hold: Hold Status		
Plan Hold: Release Status		
Plan Hold: Work Area		
Plan Hold: Change Master		

- To enable the configuration parameters, set **ERP Interface Active** to **Yes**.

5. Next, ensure that SAP Complex Assembly Manufacturing knows where CAMS-INT is located by entering the CAMS-INT URL in the *URL for SAP CAMS-INT* field using the format:
`http://<server>:<port>/XMII/Illuminator.`
6. Ensure that the user access account authentication file is defined in the *SAP CAMS-INT Authentication File* name field. This should be both specified with a fully qualified path and be visible to both the desktop clients and the CAMS-INT installation. For a shared location this file needs to have the applicable permissions assigned to it so both the desktop and the SAP NetWeaver service accounts can access it. The authentication file will use the Logon ID `tcl_outbound_user` created in section 5 of this document. To create the authentication file, use the following command:
 - a. From the `CAMS/bin` directory, issue the command: `RunCreateCAMSINTAuthFile.bat`
 - b. The *CAMS-INT License* dialog box appears. Enter the username and password defined in section 5 of this document, and enter the path and filename where you want to write the authentication file. For example, this may be `<SAP_CAMS_7.2_PI>/CAMS-INT/CamsAuth.ini`. Please ensure that you use a forward slash (/) as a path separator and not a backslash (\).

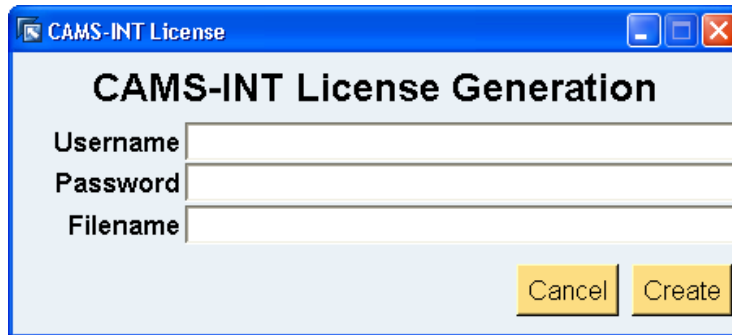

- c. Choose the *Create* button to write the file and close the dialog box.
7. Next, enable the interfaces specific to CAMS-INT:
 - a. Set *Order Create Interface Enabled* to *Yes*.
 - b. Set *Certifications Import Interface Enabled* to *Yes*.
 - c. Set *Part master Interface Enabled* to *Yes*.
 - d. Set *Resend Data Interface Enabled* to *Yes*.
8. Once the interfaces are enabled, the order create and certification imports can be further configured.

For order create, set the following configuration parameters as noted:

Parameter Name	Comments
<i>Use Max Rev for Order Create</i>	This property should be set to <i>No</i> to force the SAP Group and Group counter values to be used. Setting this to <i>Yes</i> will stop the code using these items and the order created will be based on the highest released revision of the plan.

Parameter Name	Comments
Exclude Part Type For Order	This is a space delineated list of BOM Part Types for which orders will not be created. This allows for all orders to be sent from SAP and allows SAP Complex Assembly Manufacturing to filter as required.
List of Cols to Exc from BOM Imp	This is a space delineated list of columns in the Part Master XML to exclude from the import process.

For the certifications import, set the following configuration parameters as noted:

Parameter Name	Comments
Create Certs as needed	This property should be set to Yes only if the desire of the certification import is to generate unknown certifications as needed. If set to No , the interface will skip any certifications assigned to a user that SAP Complex Assembly Manufacturing SFM does not know about.

For explanations of the remaining ERP Interface configuration parameters, right-click on a parameter and choose [What's This](#) to see the parameter description. You can also refer to the [ERP Interface Parameters](#) section in the [Configuration Guide](#) or in the System Maintenance online help.

16 Post Installation Tests

Once the entire configuration is complete, there are some basic checks that you can do to ensure that all the connections and the configuration are correct. These checks will ensure that SAP can send IDocs successfully to SAP MII and that SAP MII can talk back to SAP and that the integration server is operating correctly.

16.1 Integration Server Tests

The easiest way to verify that the integration server is configured and working correctly is to perform the following steps:

1. Open a web browser and navigate to the URL <http://<server>:<port>/CAMS-ws> (replacing <server>:<port> with your server and port).
2. At the login prompt enter a username and password for a user with the CAMS_INT_ADMIN role.
3. The main menu screen shown appears.

Integration Server Configuration

[View the Purge Interpreter Pools \(used for CAMS patch installations\).](#)

[View the Integration Server configuration data.](#)

[View the Integration Server log file.](#)

[View the interpreter.properties file.](#)

[List Deployed Services.](#)

[Run TCL Command \(Test Page\).](#)

Schema Configuration

[List Schema Interface Definitions.](#)

[Define Schema Interface.](#)

[Delete Schema Interface Definition.](#)

[Configure Web Service Validation.](#)

XSLT Configuration

[List XSLT Interface Definitions.](#)

[Define XSLT Interface.](#)

[Delete XSLT Interface Definition.](#)

- Choose the [Run TCL Command \(Test Page\)](#) link. The following screen appears.

Integration server test page.

Interpreter

Command

Arguments

- In the *Command* field, enter `info`.
- In the *Arguments* field, enter `commands`.
- Choose the [Execute Command](#) button. If all is configured correctly, a *Command Result* screen appears. If this screen does not appear, double-check that the integration server properties are correctly defined.

Command Result.

Command issued : info
 using arguments : commands
 Within the Interpreter pool : pool

```
Returned data is : subst pwd listBox nextRecord unknown lrange hmsCappLogin_Version hmsProjectConfig_Version oracols auto_import case break
closeTab hmsinformation auto_execok linsert pkg_mkIndex ellipses catch lastRecord tkPostOverPoint if join auto_mkindex hmsUtilities_Version
orastmList toplevel auto_reset hmsSecurity_Version hmsTextPopup focus label scale oramsgr_whatThisPopup format image DisplayMessage
hmsBomTools_Version package .hmsTablePopupNoEdit hmsStdLibrary_Version binary hmsTableMaint_Version trace oraconfig tk_textPaste
hmsInfo_Version hmsTextPopup.print after flush orafetch grab continue . hmswarning oraclose foreach loadtblblend hmsGui_Version lempy
orabindex tk_getSaveFile unset hmsWinOSUtilities_Version interp customerLogo lindex tk_messageBox bell hmsBomEvents_Version eof hmserror
oraopen list oraexec .hmsTablePopupNoRowCmds.howmany auto_load_index lsearch fblocked TestCleanupSerialAuxFlags proc lappend scrollId
hmsCallboardEvents_Version graphics_Version orabind firstRecord TestCleanupShopDisplay hmsCapp_Version hmsGraphics
foconfigure .hmsStdTextTablePlannerReset switch auto_qualify RedLight tktable_version hmsCallboardUtilities_Version tclPkgUnknown close
hmsGraphics_Version table .hmsTablePopup.howmany radiobutton set read hmsStdText_Version oraldalist seek while hmsEvents_Version
hmsDBClient_Version hmsUserMaint_Version selection hmsXMLevents_Version console .hmsStepRollupPopup hms_Version grid load tk_tableCut
puts hmsTools_Version tk socket tell menubutton open gdi pid exec hmsSignoffPopup hmsCappEvents_Version pack checkbutton bind place
hmsMQEvents_Version return tk_tablePasteHandler openTab error oracommit hmsDBTools_Version split raise tkwait
orainfo .hmsTablePopupNoRowCmds array tk_textCut lreplace concat fcopy option hmsConfig_Version update wm previousRecord AddYears
openETab for hmsNcmEvents_Version append auto_load hmsquestion hmsReport_Version hmsXMLConfig_Version button hmsCappInit_Version
scan oralob lower registry hmsBom_Version winfo printer tk_chooseDirectory menu pullDown oralong
oraautocom .hmsStdTextTablePopup .hmsTablePopup fileevent regexp frame EncryptString upvar hmsCappConfig_Version encoding tcl_findLibrary
hmsBack tkTextInsert tk_tableCopy logo .busylock exit oraroll hmsBomInterface_Version incr tclLog tk_textCopy hmsPrepImageForPrint
panedwindow oralong oraexec glob bindtags HMSBackImage hmsCappMassUpdateEvents_Version time eval clipboard lassign graphics tk_popup
```

16.2 SAP to SAP MII Interface Test

The simplest way to check the connectivity between SAP and SAP MII is to push an IDoc from SAP to SAP MII. You can use the Material Master (MATMAS) as a test case as it can easily be sent to SAP MII from the SAP-ERP transaction BD10. You will need a valid material number with an applicable plant value.



To run the interface test:

- Log into SAP-ERP and go to transaction BD10.
- In the *Material* field, enter a valid material number.











3. In the *Logical System* field, enter the Logical System value defined in section 10.5.
4. Select the *Send material in full* checkbox.
5. Choose  (*Execute*) to send the IDoc. Pop-up messages will notify you that the IDoc was setup and generated.
6. Log into SAP MII and navigate to ► *Message Services* ► *Message Monitor* ►.
7. Enter **MATMAS** in the *Find* field and then choose the *Go* button to query the recent messages received from SAP-ERP. A screen similar to the following should appear showing the MATMAS message as received.
 - There may be more than the one MATMAS record if the material specified has classifications or revisions as these come through as separate IDoc messages.
 - If there is no message, check the configuration of SAP MII for that Logical System.

SAP MII: Message Monitor

Messages

Listener: All Delete Reprocess   

Find: MATMAS With Status: Any From: Last Week Go [Advanced](#)

Received	Status	Name	Type	Server	Category	Processed
28. Mai 2012 07:43:58 EDT	 Success	MATMAS	IDOC	XMIIDOC01		28. Mai 2012 07:43:59 EDT
28. Mai 2012 07:43:59 EDT	 Success	MATMAS	IDOC	XMIIDOC01		28. Mai 2012 07:43:59 EDT
28. Mai 2012 07:43:59 EDT	 Success	MATMAS	IDOC	XMIIDOC01		28. Mai 2012 07:43:59 EDT
28. Mai 2012 07:43:59 EDT	 Success	MATMAS	IDOC	XMIIDOC01		28. Mai 2012 07:43:59 EDT
28. Mai 2012 07:44:00 EDT	 Success	MATMAS	IDOC	XMIIDOC01		28. Mai 2012 07:44:00 EDT
28. Mai 2012 07:50:45 EDT	 Success	MATMAS	IDOC	XMIIDOC01		28. Mai 2012 07:50:45 EDT
28. Mai 2012 07:50:48 EDT	 Success	MATMAS	IDOC	XMIIDOC01		28. Mai 2012 07:50:48 EDT
28. Mai 2012 07:50:48 EDT	 Success	MATMAS	IDOC	XMIIDOC01		28. Mai 2012 07:50:48 EDT
28. Mai 2012 07:53:00 EDT	 Success	MATMAS	IDOC	XMIIDOC01		28. Mai 2012 07:53:00 EDT
28. Mai 2012 07:53:16 EDT	 Success	MATMAS	IDOC	XMIIDOC01		28. Mai 2012 07:53:16 EDT

16.3 SAP MII to SAP Interface Test

To check that SAP MII is connected to SAP:

1. Choose **Message Services** > **Message Listeners**. The following screen appears.

SAP MII: Message Listeners

Message Listeners

Update Edit Save Cancel

Name	Description
XMIIIDOC01	IDOC Listener
XMIIIDOC02	IDOC Listener
XMIIIDOC03	IDOC Listener
XMIIIDOC04	IDOC Listener
XMIIIDOC05	IDOC Listener
XMIIIDOC06	IDOC Listener
XMIIIDOC07	IDOC Listener
XMIIIDOC08	IDOC Listener
XMIIIDOC09	IDOC Listener
XMIIIDOC10	IDOC Listener

Details for XMIIIDOC01:

Configuration Status

Name: XMIIIDOC01

Description: IDOC Listener

SAP Server: BU2

SAP Client: 200

Message Name: IDOC Name

2. Choose the entry used to connect to SAP (the above example shows it was *XMIIIDOC01*). The data fields to the right list the SAP Server and Client information.
3. Choose the *Status* tab to see if the connection is present.
4. The system will open a dialog box with either *Server Connected* or *Server Not Connected*.
 - o If you see *Server Not Connected*, check the SAP MII settings to ensure they are correct.

17 Monitoring Capabilities

CAMS-INT provides a number of forms to allow messages and data to be monitored. This section outlines these capabilities.

17.1 Queue Monitor

To enable visibility into the messages being processed by CAMS-INT, there is a *Queue Monitor* screen where you can search for, examine, and manipulate messages.



To get to the *CAMS-INT Queue Monitor* screen shown below, under the *CAMS-INT* menu item, choose *Queues* *Queue Monitor*. If you do not see this menu item, please ensure that your user account has been assigned the CAMS_INT_USER role.

Status	Message Name	Received	Finished	Category	Key Data	Attempts	Response Message
<input type="radio"/>	ORDER_STATUS	07/08/2010 17:47:40	---	GeneralInbound	No data requested.	NA	---
<input type="radio"/>	ORDER_STATUS	07/08/2010 15:04:57	---	GeneralInbound	No data requested.	NA	---
<input checked="" type="radio"/>	Z_MATMAS04	06/23/2010 18:59:56	06/23/2010 19:29:47	GeneralInbound	---	0	TEST - 358274e0-7ff1f-11df-bf8e-d4
<input type="radio"/>	SPLIT_DATA	06/23/2010 18:59:47	---	GeneralQueue	No data requested.	NA	---
<input type="radio"/>	SPLIT_DATA	06/23/2010 18:59:46	---	GeneralQueue	No data requested.	NA	---
<input type="radio"/>	SPLIT_DATA	06/23/2010 18:59:46	---	GeneralQueue	No data requested.	NA	---
<input checked="" type="radio"/>	SPLIT_DATA_TEST	06/23/2010 18:53:44	06/23/2010 18:59:47	SplitQueue	---	NA	---
<input checked="" type="radio"/>	MATMAS04	06/23/2010 12:23:03	06/23/2010 18:59:56	MaterialCorrelation	MM04: F2505T-PA-2	NA	---

The upper area of the screen (the area with the blue background) includes the filter controls, which you can use to filter the data that appears by status, category, key data, etc. It is important to note that regardless of the filter settings, the table will only show the top 100 records. Once you define your filter criteria, choose the *Search* button to see records that match your criteria.

On the screen, the first column is static so as the table is scrolled left to right this is always visible. The remaining columns contain specific information about the record. The column name and the purpose are as follows (not all columns are shown in the figure above):

Column Name	Description
<i>Status</i>	Visual indicator showing the status of the message. The colors are as follows: <ul style="list-style-type: none"> • White: Queued. Message received and waiting to be processed. • Black: Correlation has occurred on the message. • Green: Message has been successfully processed with no response message. • Cyan: Message has been successfully processed and has a response message. • Red: Message has failed.
<i>Message Name</i>	The root node of the message.
<i>Received</i>	The date/time when the message was received into CAMS-INT.
<i>Finished</i>	The date/time when the message processing was completed.
<i>Category</i>	The queue name where this message was posted.
<i>Key Data</i>	If a key data transformation was defined for a message type then it is shown in this column.
<i>Attempts</i>	Number of attempts to process the message.
<i>Response Message</i>	Any response message returned from the service. This could be an error or informational text depending upon whether the message was successful or failed.
<i>Parent ID</i>	If the message was posted from a correlation or split workflow process, this contains the ID of the resulting message.
<i>Correlation Key</i>	For correlation messages, this shows the key generated for this message.
<i>ID</i>	The unique ID generated for the message when inserted into the CAMS-INT queue.

The icon in the lower left corner of the table () can also be used to refresh the data currently listed in the table. The icon to the right of it () can be used to enable auto refresh of the data.

Function buttons available on the *Queue Monitor* screen are:

Button Name	Description
<i>Search</i>	Used to refresh the table data based on the filter criteria specified.
<i>Retry</i>	Used to resend a failed message. Choose one or more failed messages in the queue list and choose this button. The status of the selected items is set back to <i>Queued</i> .
<i>Remove</i>	Used to remove a specific message from the queue. Choose one or more messages then choose this button to delete the data. Once deleted, the message data is not recoverable.
<i>Trace</i>	Used to see the processing stages of the selected message. See the Tracing section on the next page for details.
<i>Clear Dates</i>	Used to remove the data from the filter date fields.
<i>Clear Form</i>	Used to reset all the filter data fields.

17.1.1 Tracing

The *Queue Monitor* provides the ability to view the XML message through the workflow. If a message fails and you want to know how this message changed through the workflow:

1. Choose that failed message and choose the *Trace* button. The *Document Trace* screen appears.

The content of this screen is dependent upon the number of retries that have occurred with the message. In this example, no retries occurred; therefore, it shows the three stages, which are the initial message, the request message (shown as *[2] Message*), and the response message (shown as *[3] Message*). The request message is the XML provided to the Main Transaction and consequently used in the process; the response message is the XML provided by the Main Transaction once the applicable process took place.

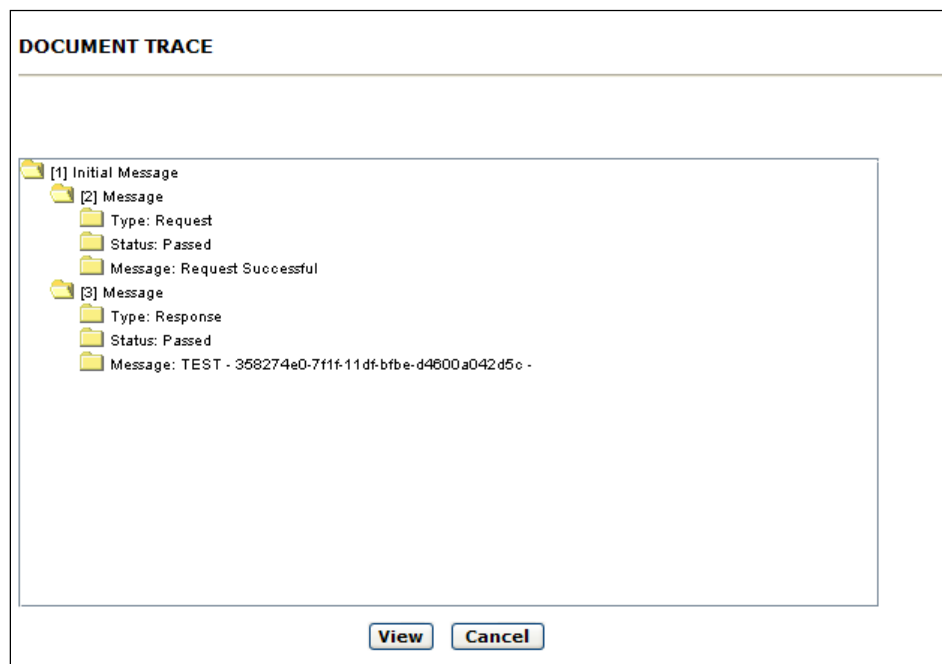

2. To view the XML message, either the initial message or one of the request/response messages, select the applicable node in the tree where the text starts with *[..]* and choose the *View* button.
3. A new window appears showing the XML recorded for this message. Choose *Cancel* to close the *Document Trace* screen.

17.2 Archive Queue Monitor

CAMS-INT has a mechanism to archive messages from the main queue into an archive queue after a certain number of days. Once archived, the messages are no longer visible in the main *Queue Monitor* and they must be viewed from the *Archive Queue Monitor*.

To go to the [Archive Queue Monitor](#) screen, under the *CAMS-INT* menu item, choose [Queues](#) [Archive Queue Monitor](#). If you do not see this menu item, please ensure that your user account has been assigned the CAMS_INT_USER role.

The functionality of the [Archive Queue Monitor](#) is exactly the same as the [Queue Monitor](#). The only difference is that you cannot retry a message so there is no [Retry](#) button.

17.3 Message Statistics

You can view some basic statistics on the messages being processed by CAMS-INT in the [CAMS-INT Message Statistics](#) screen. For each message in the CAMS-INT queue, this screen shows the number of messages, the maximum and minimum queue time, and the minimum and maximum processing time. The time is quoted in seconds.

To go to [CAMS-INT Message Statistics](#) screen shown below, under the *CAMS-INT* menu item, choose [Reports](#) [Message Statistics](#). If you do not see this menu item, please ensure that your user account has been assigned the CAMS_INT_USER role.

Warning: The values shown in the table below are basic averages from the known records. It will not take into account any archived messages. All times shown in Seconds.

Last Update: Sep 7, 2010 3:49:31 PM

Message Name	No of Messages	Max. Queue Time	Min. Queue Time	Max. Process Time	Min. Process Time
ORDER_STATUS	5	NA	NA	NA	NA
SPLIT_DATA	3	NA	NA	NA	NA
IS22013_TEST	13	3,211	144	2	2,207
MATMAS04	1	2,538	2,538	35	35
Z_MATMAS04	3	1,789	1,789	2	2
SPLIT_DATA_TEST	1	362	362	1	1
MF_ROOT	3	2,080	2,080	2	2
WIP_ORDER_TEST	1	2,080	2,080	2	2

17.4 BOM Holding Queue

The [CAMS-INT BOM Holding Queue Enquire](#) screen is a view screen for the Bill of Material Management (BOMM) SAP-ERP interface. When a message cannot be sent to CAMS-INT it is placed into a holding queue where a resend process from CAMS-INT ensures that it gets processed.

To view the contents of this queue you can either use the SAP Complex Assembly Manufacturing application or CAMS-INT. Both provide the same capabilities. To go to this screen in CAMS-INT, under the *CAMS-INT* menu item, choose [Reports](#) [BOM Holding Queue](#). If you do not see this menu item, please ensure that your user account has been assigned the CAMS_INT_USER role.

The upper table shows all the records in this queue; the lower table shows the change masters for the message, which allows you to investigate any change master issue that is holding up sending the message.

Not all messages will have change master issues. Some may be present because of communication issues or simply because a previous revision is present in the queue as well. To see if there are change masters outstanding, select the row in the upper table and the lower table will be populated with any change master items. Change masters will have one of the following statuses:

- *Rejected* indicates a failed change master request.
- *Pending* indicates the change master has not made it through to SAP yet.
- *Passed* means there is no issue with the change master.

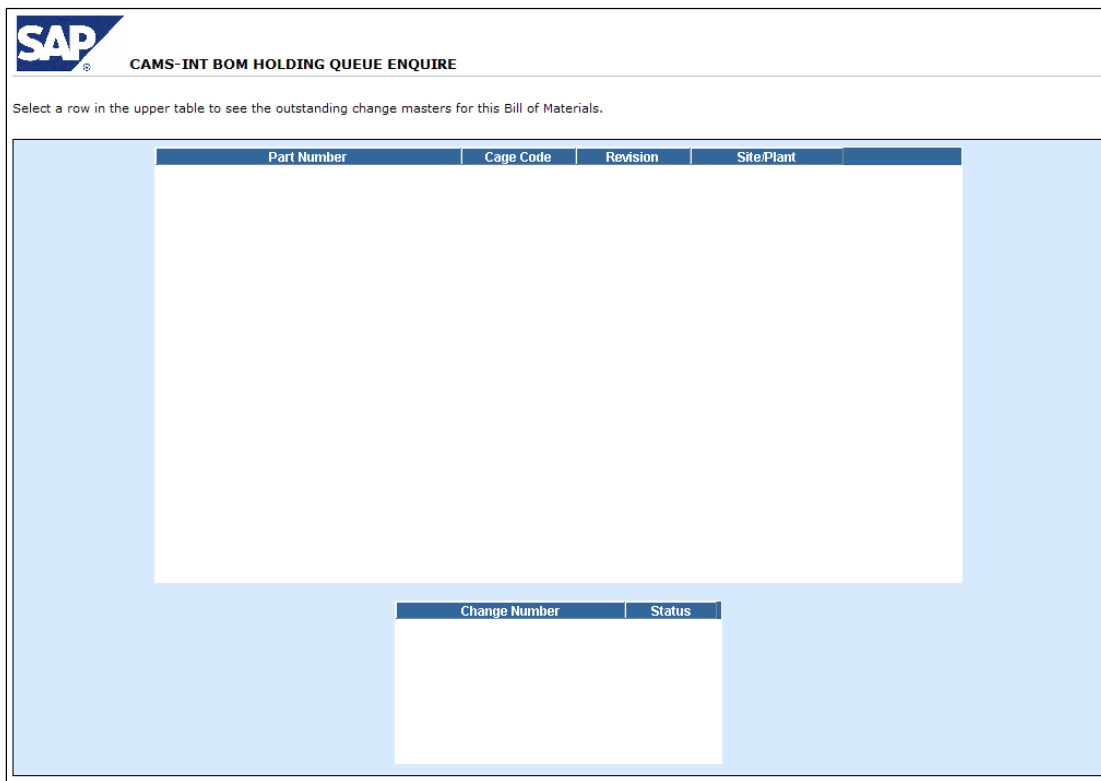

17.5 Change Masters

The *CAMS-INT Change Master Enquire* screen allows an SAP MII user to query the status of any given change master in the system generated in SAP Complex Assembly Manufacturing. It provides visibility into the change masters that have been requested by SAP Complex Assembly Manufacturing. The status of the change master is also included to allow visibility into whether the change master has been processed and is available in SAP.

To view the contents of this queue, you can either use the SAP Complex Assembly Manufacturing application or CAMS-INT. Both provide the same capabilities. To go to this screen in CAMS-INT, under the *CAMS-INT* menu item, choose **Reports > Change Masters**. If you do not see this menu item, please ensure that your user account has been assigned the `CAMS_INT_USER` role.

To query a change master, enter the required value in the *Change Number* field and choose the *Search* button. The percent sign (%) can be used as a wildcard character to return multiple records that match your query.

The screenshot displays the SAP interface for 'CAMS-INT CHANGE MASTER ENQUIRE'. At the top left is the SAP logo. Below it, the title 'CAMS-INT CHANGE MASTER ENQUIRE' is centered. A search form contains a label '* Change Number:' followed by a text input field and a 'Search' button. Below the search area is a table with two columns: 'Change Number' and 'Status'. The table is currently empty, and the background of the interface is light blue.

Appendix A: High Availability (HA) Options

Caution

The approach of multiple servers behind a load balancer is meant to be used when SAP MII is being used for CAMS-INT only. If other applications are running on SAP MII, you need to evaluate them to ensure no issue will be generated from the configuration described here.

High availability is a set of techniques and design practices for business continuity. It is achieved by eliminating the single point of failure and providing the ability to rapidly resume operations after a system outage with minimal business loss.

This section describes options available to install CAMS-INT in a high availability environment rather than the more traditional standalone instance installation.

The options provided are based on standard installations of SAP NetWeaver and SAP MII. Please refer to the installation guide for your SAP NetWeaver and SAP MII versions and your underlying database for more information.

The options here provide the cleanest representation of the proposal; however, the actual implementation may be different as long as the principle behind the option—that is, removing a single point of failure for an important element of the system—is maintained.

1 Requirements

The base requirements for the system are as follows. These requirements assume the need for the event to occur with minimal or no disruption to the business processes unless otherwise outlined in the specific requirement.

1.1 Unplanned Outages

Unplanned outages are defined as occurrences where the event was unexpected and potentially catastrophic:

- **Hardware Failure:**

The system shall support the ability to address hardware failures that may occur on the servers with minimal disruption to the system availability.
- **Operating System (OS) Failure:**

The server OS fails for some reason or some underlying software fails that would otherwise impact a single server installation.
- **Java Virtual Maching (JVM) Crash:**

If for some reason an event occurs within the native code, then the system needs to restart and become available once more.
- **Software Failure:**

These relate to specific SAP NetWeaver or supporting applications running on the system.

1.2 Planned Outages

Planned outages are assumed to be expected and under control of some planned activity. Some examples are hardware maintenance, OS patching, and SAP and database software upgrades:

- **Operating System Updates:**

The system shall support the ability to perform regular updates to the underlying Windows operating system. The frequency of these updates is projected to be once a month, but this could change depending on issues located and addressed by Microsoft.

- **SAP NetWeaver Updates**

The system shall support the ability to perform updates to SAP NetWeaver as needed. These updates cover items such as new support package stacks (SPS) or patches to an SPS. The need to support major updates to SAP NetWeaver is not part of this consideration and will be handled through alternative processes.

- **SAP MII Updates:**

The system shall support the ability to perform updates to SAP MII as needed. These updates cover items such as a new SPS or patches to an SPS. The need to support major updates to SAP MII is not part of this consideration and will be handled through alternative processes.

- **SAP Complex Assembly Manufacturing Updates/CAMS-INT:**

The system does not need to support SAP Complex Assembly Manufacturing updates without a scheduled downtime to apply the code change due to the interdependency between the desktop, CAMS-INT, and the database. It is accepted that any updates required for SAP Complex Assembly Manufacturing will be performed during a scheduled system downtime.

2 Option 1 – Multiple Standalone Instances of CAMS-INT

This section outlines options for using a standalone instance or instances to drive SAP NetWeaver, SAP MII, and CAMS-INT in an HA environment fronted with a HTTP load balancer. It also includes an assessment as to how these options relate to the initial requirements and additional pertinent information.

This approach is not a standard HA configuration for SAP NetWeaver and SAP MII but does make use of standard delivered components and installation options of SAP NetWeaver. Also, in the two diagrams, the SAP Complex Assembly Manufacturing database is shown as a single database. This is done for clarity as it is not the direct topic of this document. It can, and should, be made highly available as well. The load balancer is depicted as a single item but it is assumed this will be redundant as well, as is traditional with these devices.

2.1 Non-Clustered Environment – Multiple Databases

The following installation diagram consists of one or more standalone instances of SAP NetWeaver, SAP MII, and CAMS-INT running on separate virtual or physical machines. To ensure that the collection of CAMS-INT will be seen as a single entry point from the SAP Complex Assembly Manufacturing desktop sessions, a hardware load balancer

will need to be installed. The installation process with this option will be the same as for any standalone install of SAP NetWeaver; each server will require its own instance name; and changes will have to be added to each server independently. In this approach, each server runs independently of each other, and so any scheduled tasks or code being run would need to be aware of this and manage record locking as needed.

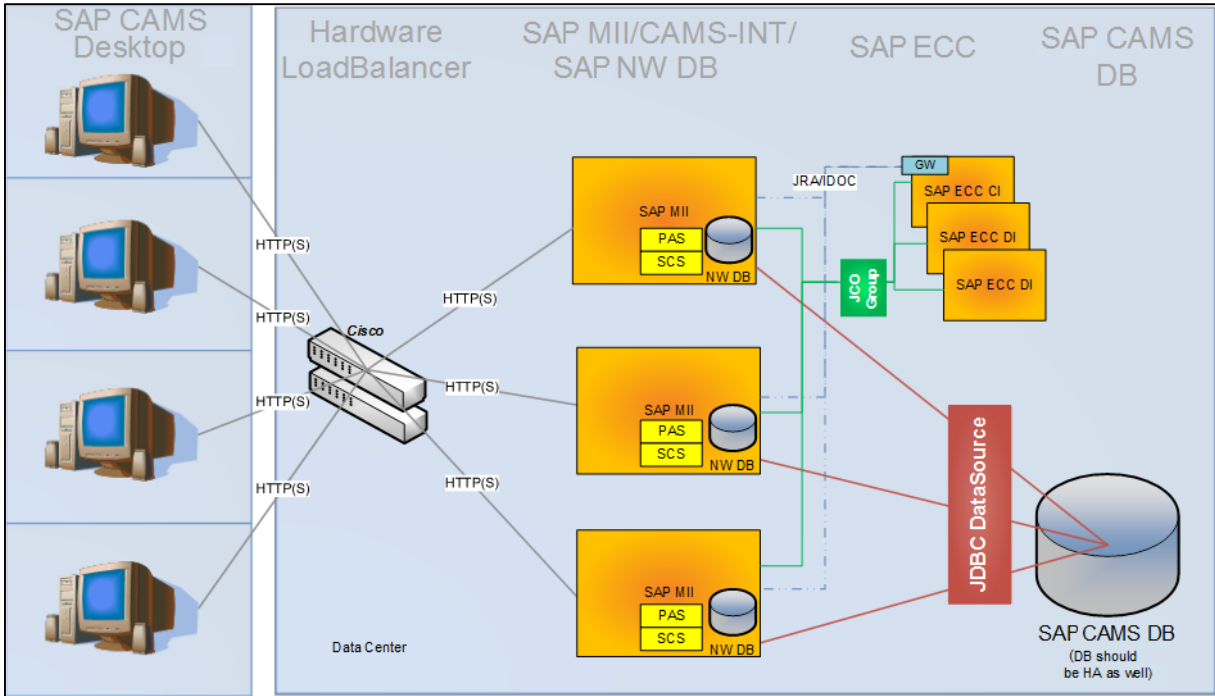

2.2 Non-Clustered Environment – Single Database

The following variation is principally the same as the one outlined above but it makes use of a single database for the multiple SAP NetWeaver installations. This installation is referred to as multiple components on a single database (MCOD) and is a fully supported alternative installation approach. Since this approach presents the MCOD database as a single point of failure, the MCOD database needs to be protected with high availability solutions, e.g., database replication to a standby MCOD database or cluster is required.

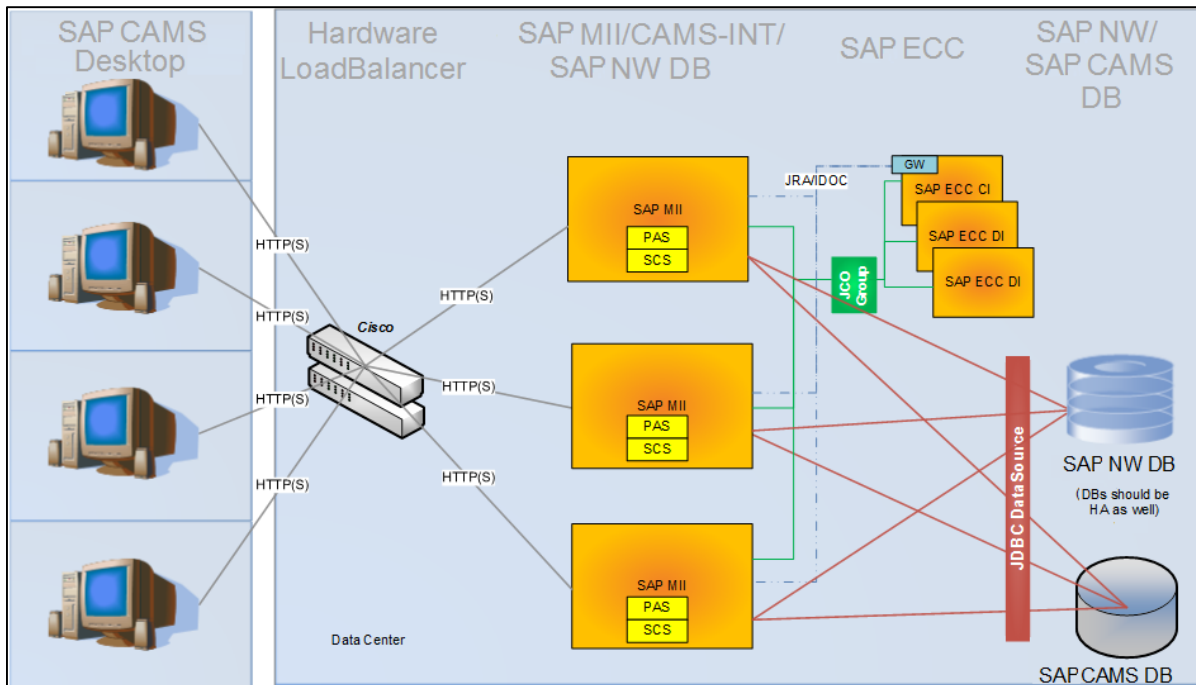

2.3 Configuration Requirements

Regardless of whether one or multiple databases are used, the configuration requirements for these systems are basically the same. The main difference relates to the management of the underlying database system.

In this approach, each server is behaving as though it is the only server present and no work will be shared from one server to the next. Sharing of requests is handled by the load balancer and not the individual servers. As a result, certain conditions apply to the work being performed as any data not stored in a centrally accessible location will cause issues if that server is lost. Due to the nature of how CAMS-INT functions, no processing data is stored in the local SAP NetWeaver database but is instead all stored within the SAP Complex Assembly Manufacturing database. Consequently, all message data will be available to all server nodes for processing. Care must be taken on any new processes to ensure they are compatible with these limitations.

To ensure JCo connections are not linked to a specific SAP ECC node, the JCo connections should also be configured to use the logon group option, and an applicable logon group should be established across the SAP ECC cluster with a minimum of two SAP ECC application servers.

As the hardware load balancer has no direct knowledge of the current condition of the CAMS-INT application, suitable heartbeat rules need to be established within the load balancer to ensure it is made aware of the condition. These rules should look at more than a simple response from the server; they should look specifically at the HTTP code returned and act accordingly. This will ensure any issue with CAMS-INT or SAP MII will be detected and the server marked as offline. If multiple server nodes are to be configured (recommended) for each instance, the load balancer can also be configured to send heartbeats to individual server nodes. [SAP Note 1440724](#) details the steps to direct connect to each server node within the same instance.

With this approach, every server needs to be configured separately and so the risk of a small issue being introduced may be possible. The use of the configuration import/export feature of CAMS-INT and SAP MII will be able to minimize this.

Another concern with this approach is in the resolution of configuration issues. Currently, there is nothing in the message processing mechanism that identifies which server was being used to process this message – whether from the SAP MII or CAMS-ws side of things. Consequently, if a message fails with an error pointing to a configuration issue, the logs on all servers will need to be reviewed until the actual server is identified.

2.4 Assessment of this Approach vs. the Requirements

This approach, regardless of the database option, covers the requirements as follows:

Outage Type	Requirement	Comments
Unplanned	Hardware Failure	As each server is separate and operated independently, any one (or more) of the servers can fail or drop offline, and the system will still function. The impacts to the processing time, etc., will depend on the number of servers left to handle the processing.
Unplanned	OS Failure	As each server is separate and operated independently, any one (or more) of the servers can fail or drop offline, and the system will still function. The impacts to the processing time, etc., will depend on the number of servers left to handle the processing.
Unplanned	JVM Crash	If the VM were to crash for some reason, the down time for this instance before it restarts will not impact the overall system availability because the other servers will pick up the work. So long as the load balancer heartbeat mechanism is configured to detect this condition, the data will be routed around this server until it is back online. Any transactions being processed by this server may have to be retried./assessed as the impact to where the crash occurred will be unknown.
Unplanned	Software Failure	If a software failure occurred for some reason, the down time for this instance before it restarts will not impact the overall system availability because the other servers will pick up the work. So long as the load balancer heartbeat mechanism is configured to detect this condition, the data will be routed around this server until it is back online. Any transactions being processed by this server may have to be retried./assessed as the impact to where the crash occurred will be unknown.
Planned	OS Updates	As the infrastructure is split over multiple physical servers, OS patches can be applied on a rolling schedule where updates can be made to a percentage of the environments allowing others to run as-is to handle the current processing removing the outage from impacting processing though adding load to the remaining servers in the interim. However, the load balancer needs to be modified to put the patching server in maintenance mode so no traffic will be directed to it.

Outage Type	Requirement	Comments
Planned	SAP NetWeaver or SAP MII Updates	As with the OS level changes, the roll out of patches to SAP NetWeaver and SAP MII can occur in a similar manner, allowing no interruption in service during this time. However, the load balancer needs to be modified to put the patching server in maintenance mode so no traffic will be directed to it.
Planned	SAP Complex Assembly Manufacturing/CAMS-INT Updates	As a change to CAMS-INT, or CAMS-ws, could introduce new processing requirements or business rules it is recommended that these updates occur on all servers at once or within a short time frame to ensure changes in data requirements are not impacted. There will be changes where this will have minimal impact and so taking the rolling update approach would be acceptable. With this type of update, the scheduler could be stopped on all servers to support inbound messages making it through and then starting the tasks on different servers as the change is applied. This will cause some disruption to the end user (some messages may not get processed immediately) but it will be minimal. However, the load balancer needs to be modified to put the patching server in maintenance mode so no traffic is directed to it.

3 Option 2 – SAP NetWeaver Instance Using Traditional SAP NetWeaver Clustering Options

In this option, a more traditional high availability configuration is covered, and it pertains to the standard installation options provided by SAP NetWeaver (Microsoft Clustering, Veritas, etc). To keep things as simple as possible, the key elements of SAP NetWeaver have been highlighted in yellow and need to be part of the failover configuration. Without this, some aspect of the environment will be lost to a point where the system will not work as intended.

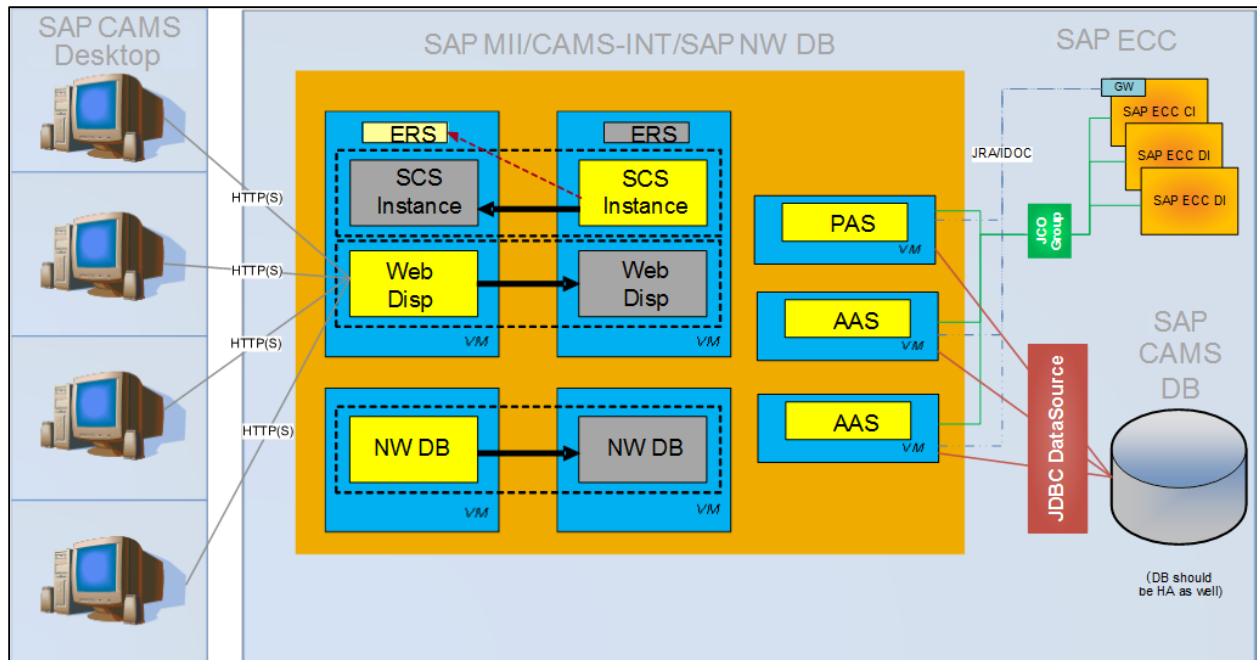

To ensure SAP NetWeaver is able to run and operate through hardware failure, it is important to protect the single points of failures. From this, the elements of SAP NetWeaver that need to have redundancy are the SCS (central services), the Web Dispatcher, and the database where the SAP NetWeaver database is installed (this is not the CAMS database). This will ensure that a failure in one of the servers will cause the cluster controller to switch it over to the backup server to continue processing. A small time-out may be detected during the failover. To ensure the system is able to continue to process, the Enqueue Replication Server must be installed (shown in the diagram as ERS). Without this component, the SAP NetWeaver instance will force a restart of the server node(s) on failover to ensure all locks, etc., are released.

The Primary Application Server (PAS) and the Additional Application Server (AAS) can be installed on standard virtual machines or on an HA-aware virtual machine known as VMware HA. If they are all placed on a single server, then redundancy will be lost; therefore, they need to ideally be on their own server (as shown).

While this diagram shows seven separate servers, there is nothing stopping the Web Dispatcher from being placed on its own cluster if required, though it is not a requirement due to the low hardware requirements to run the Web Dispatcher and the SCS. Another possible option here, if the workload is able to fit within a single vCPU VM configuration, is to use VMware Fault Tolerance for provisioning the SCS or Web Dispatcher VM for continuous availability.

All connections from SAP Complex Assembly Manufacturing and CAMS-INT are made through the Web Dispatcher port, and it will be responsible for pushing the request to one of the servers in the cluster. Because the Web Dispatcher is an integral part of SAP NetWeaver, it will be notified of any issue with the PAS or AAS and consequently remove it from the list of available servers until it is resolved. As most cluster controllers monitor hardware issues, it will not trigger on a software-level event. There are additional software providers that provide software triggering of the failover so this will need to be considered, or correct heartbeat rules need to be established to make this determination.

3.1 Assessment of this Approach vs. the Requirements

This approach, regardless of the database option, covers the requirements as follows:

Outage Type	Requirement	Comments
Unplanned	Hardware Failure	If a server fails, the system will trigger a failover to the other server to come into use. For the PAS and AAS, depending on whether they are in a VMWare HA configuration, will either go off-line or failover as needed. The Web Dispatcher will know about this event if it is a PAS or AAS and routing messages accordingly.
Unplanned	OS Failure	As the Microsoft clustering software is detecting hardware failures, issues at the OS level may not result in a failover event occurring..
Unplanned	JVM Crash	If the PAS or AAS server were to crash then this node would be taken out of the list of available servers until it has restarted and is ready for use. Impacts will be minimal as the load will be taken by the other AAS or PAS servers while this occurs.
Unplanned	Software Failure	If a software failure occurred this wouldn't trigger a failover if outside of the PAS or AAS as MSCS will not be monitoring the software. Plugins for MSCS exist which will support this to handle a software failure in the same manner as a hardware failure. An example of such software is Symantec Application HA used with VMware to monitor the failure of the application layer of the SAP software.
Planned	OS Updates	The underlying OS can be updated by forcing the cluster to failover and installing the updates while off-line. Once installed, the cluster can be failed back allowing that machine to be updated. Each PAS and AAS instance can be taken off-line and updated separately to allow minimal distribution of system availability.
Planned	SAP NetWeaver/SAP MII updates	As this is configuration is handled and seen as a single SAP NetWeaver install then any updates to SAP NetWeaver and SAP MII will require a planned outage to do.
Planned	SAP Complex Assembly Manufacturing/CAMS-INT Updates	A change to CAMS-INT or CAMS-ws will need a planned outage to update. Because each server will get the update as the update is performed on a server, they cannot be done separately. While a planned outage is required for this as all the servers use the same configuration, changes to support the update are needed in only one place and will be propagated to the others.

4 Enabling HA on the Gateway

In addition to configuring an HA environment for SAP NetWeaver and CAMS-INT, it is equally important to ensure the corresponding SAP ECC environment is similarly configured to make the gateway highly available. This will ensure connectivity between CAMS-INT and SAP ECC is maintained so the JRA and IDoc registration will not be impacted. The next two diagrams outline possible ways to achieve this. While these diagrams build on the single instance HA environment, they are equally as applicable with the option 1 approach.

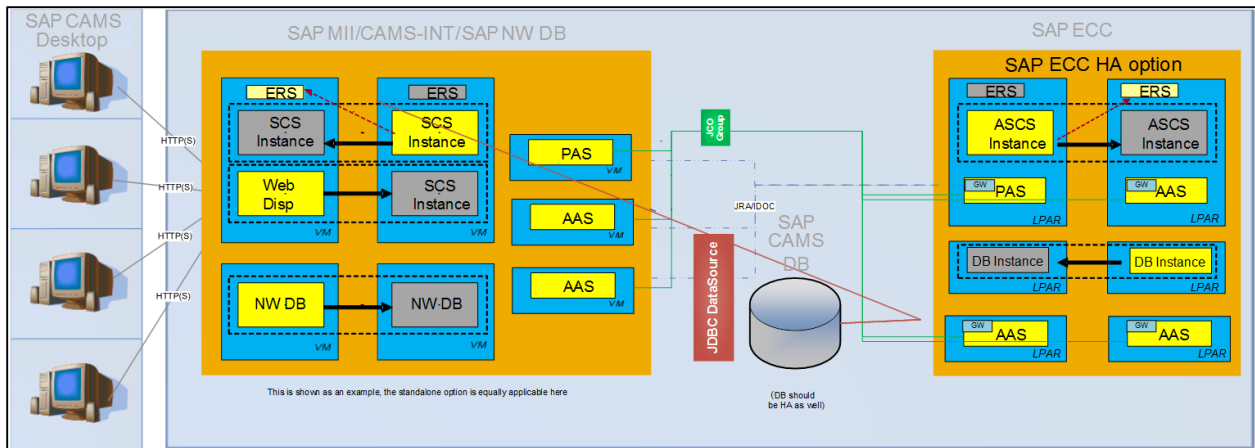

This diagram builds on the HA approach for SAP NetWeaver but also expands the SAP ECC side of things to show the requirements there to ensure the gateway is highly available. Here we have a PAS and AAS installed across the HA cluster but both active and sharing a common instance number. If failover occurs, the ASCS instance will switch and the AAS will step in and support the required gateway functionality, keeping things alive and working.

As SAP ECC runs on top of SAP NetWeaver, the requirements for fault tolerant for the specific elements of the system remain the same and mirror the requirements of SAP NetWeaver where SAP MII is installed.

The installation option outlined below differs from the above option by the installation of a standalone gateway module on the ABAP Central Services ASCS servers.

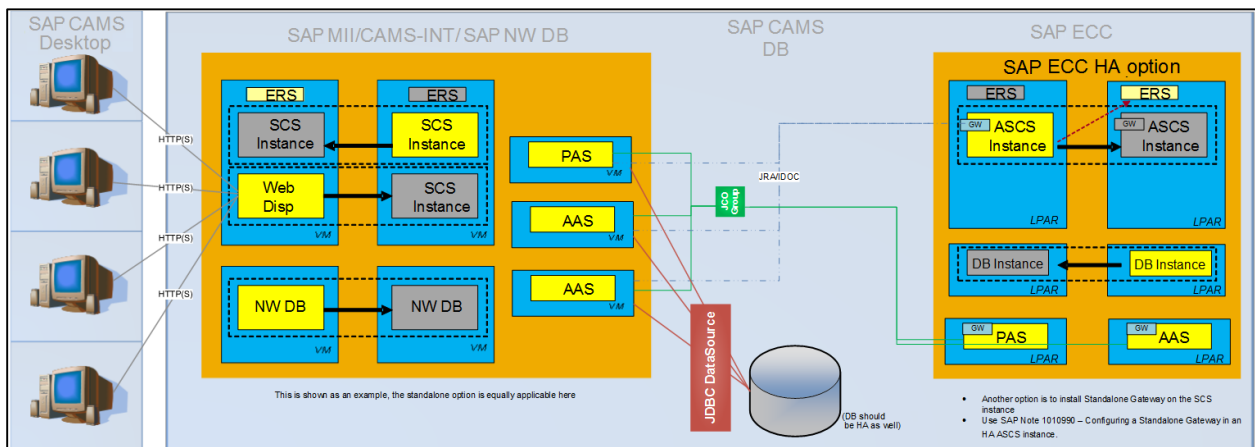

The main difference between this option and the previous option relates to what is being installed on the server, and hence the hardware requirements. Installing the gateway as a separate module requires smaller hardware than including the primary or application server requirements.

5 Further Considerations

This section defines additional things to consider.

5.1 Multiple Instances of SAP NetWeaver

The current SAP Complex Assembly Manufacturing configuration will need to be modified so the URL specified in the SFM *URL for SAP CAMS-INT* configuration parameter uses the load balancer as the URL and not a given server. In addition to this, some software updates could be required to ensure concurrency of transactions and the message processing order.

With this configuration, messages will be received from SAP ECC. It needs to be understood that the supported plant configuration should be set based on the server and not the load balancer. This will ensure once a message is picked up for processing it will be handled by that server and not sent out and into another server in the cluster to handle the request. While this will remove extra time in processing the message due to sending it out of the machine, there is nothing in the message data that indicates which server the message was actually processed on so any configuration issues with CAMS-INT (old code, missed updates, etc.) will not be immediately known. To fully understand which environment processed the message, the SAP NetWeaver log files will have to be scanned to locate it. If this is seen as an issue, it can be mitigated by adding the server name processing the request to the response message provided by CAMS-INT. It would then be available in the *Trace* screen.

From the current transaction list, the messages that have call backs will potentially have this message routed back through a different server as the URL defined for the call back will be obtained from the SAP Complex Assembly Manufacturing database – which would be the load balancer. Due to the way the software works, this would be difficult to change.

There is one scheduled task, the resend data service, that should only be running on one of the nodes.

5.2 Conventional High Availability Configuration

While this approach will work with SAP Complex Assembly Manufacturing and CAMS-INT as it is delivered today, changes required to support multiple instances of SAP NetWeaver would still be of benefit as it will support multiple scheduler tasks running against a single queue.

The issues related to locating a configuration imbalance will not exist because this whole system works as a single SAP NetWeaver instance and so configuration is done only once. Knowing which server something was processed by is not as important and is certainly not required to locate and troubleshoot an issue.

Appendix B: Planning Hold Interface

In addition to creating the processing rule for the plan hold interface as explained in section 12, you must do the following tasks in SAP ECC and you must set up some configuration parameters in SAP Complex Assembly Manufacturing.

i Note

There is also a `PLAN_HOLD` workflow (see section 15.5) that is delivered as part of core SAP Complex Assembly Manufacturing.

1 Create Task List Status

In order to create a new *Task List Status*, you must go to transaction code `OP46`. Create a **CAMS Hold** status that will only be used by the SAP Complex Assembly Manufacturing application. In the case below, a *Task List Status* of **6** has been created. This is the value you will use for the *Plan Hold: Hold Status* configuration parameter described later in this section.

Stat	Description of the status	Relind	Cstng	Cons.chk.
1	Created	<input type="checkbox"/>	<input type="checkbox"/>	<input type="checkbox"/>
2	Released for order	<input checked="" type="checkbox"/>	<input type="checkbox"/>	<input checked="" type="checkbox"/>
3	Released for costing	<input type="checkbox"/>	<input checked="" type="checkbox"/>	<input checked="" type="checkbox"/>
4	Released (general)	<input checked="" type="checkbox"/>	<input checked="" type="checkbox"/>	<input checked="" type="checkbox"/>
5	Archived Status	<input type="checkbox"/>	<input type="checkbox"/>	<input type="checkbox"/>
6	CAMS Hold	<input type="checkbox"/>	<input type="checkbox"/>	<input type="checkbox"/>
7	A TEST	<input type="checkbox"/>	<input type="checkbox"/>	<input type="checkbox"/>

2 Verify Task List Status – Released

When a *Task List* is first created in SAP ECC (via SAP Complex Assembly Manufacturing), it is typically created with a *Task List Status* of **4 – Released (general)**. This is the value you will use for the *Plan Hold: Released Status* configuration parameter described later in this section. To verify the *Task List Status*:

1. Save a plan complete in SAP Complex Assembly Manufacturing.
2. In SAP MII, look at the Routing Release XML (message 1) for that saved plan. Use the `<TASK_LIST_GROUP>` and `<GROUP_COUNTER>` tag values.
3. In SAP ECC, go to transaction code `SE16N`. In the *Table* field, enter `PLKO`. For the group, enter the `<TASK_LIST_GROUP>` value from above into both the *Fr. Value* and *To Value* fields.
4. Execute the query by choosing .

You should now see a screen similar to the one shown below. As you can see, the *Stat* (Status) is **4**.

Display of Entries Found																						
Table to be searched: PLS0 Task list - header																						
Number of hits: 1																						
Runtime: 00:00:05 Maximum no. of hits: 500																						
Type	Group	GrC	Counter	Valid From	T st from	Change No.	DelID	Ina	Created on	By	Chngd By	Usage Plant	Stat	Unit	FrmLotSize	To LotSize	PlGrp	Ch.no.	Task list description	Language	Last call	
H	48915	1	1	01/01/1901					01/15/2013	SAPMII		1	2010	4	EA	0.000	9,999,999.000					

3 Create Change Master

In order to create a new change master, you must go to transaction code `CC01`. Create an SAP Complex Assembly Manufacturing change master that will only be used by the SAP Complex Assembly Manufacturing application. In the example below, `CAMS_CM1` has been created. This is the value you will use for the *Plan Hold: Change Master* configuration parameter described later in this section.

On the *Create Change Master: Initial Screen*:

1. Enter the desired *Change Number*.
2. Choose (*Enter*) to continue to the next screen.
3. Enter change number description.
4. Enter a *Valid From* date of `1/1/1901`.
5. Ensure *Change no. status* is `01` (i.e., active).
6. Choose to continue to the next screen.

Create Change Master: Change Header

Change number: CAMS_CM1 | CAMS - Plan Hold Change Master
Change Master Without Release Key

Description

Valid From: 1/1/1901

Authorization group: []

Reason for Change: []

Status Information

Change no. status: 01

Usage

Deletion Flag

Administrative Data

Created On: [] Created by: []

Changed On: [] Changed by: []

7. For the *Task List* item, ensure the *Actv.*, *Object*, and *MgtRec* boxes are selected as below.
8. Choose (Save). The change master is now created.

Create Change Master: Object Types

Change number: CAMS_CM1 | CAMS - Plan Hold Change Master
Change Master Without Release Key

Object types

Description	Actv.	Object	MgtRec	Gen new	GenDial	Lock	Created	Created by	Chngd On	Changed by
Bill of Material	<input type="checkbox"/>	<input type="checkbox"/>	<input type="checkbox"/>	<input type="checkbox"/>	<input type="checkbox"/>	<input type="checkbox"/>				
Task List	<input checked="" type="checkbox"/>	<input checked="" type="checkbox"/>	<input checked="" type="checkbox"/>	<input type="checkbox"/>	<input type="checkbox"/>	<input type="checkbox"/>				
Document	<input type="checkbox"/>	<input type="checkbox"/>	<input type="checkbox"/>	<input type="checkbox"/>	<input type="checkbox"/>	<input type="checkbox"/>				
Material	<input type="checkbox"/>	<input type="checkbox"/>	<input type="checkbox"/>	<input type="checkbox"/>	<input type="checkbox"/>	<input type="checkbox"/>				
Characteristic	<input type="checkbox"/>					<input type="checkbox"/>				
Characteristics of Class	<input type="checkbox"/>					<input type="checkbox"/>				
Classification	<input type="checkbox"/>					<input type="checkbox"/>				
Object Dependencies	<input type="checkbox"/>					<input type="checkbox"/>				
Configuration Profile	<input type="checkbox"/>					<input type="checkbox"/>				
Variant Table	<input type="checkbox"/>					<input type="checkbox"/>				
Validity of Material Version	<input type="checkbox"/>					<input type="checkbox"/>				
PVS Variant	<input type="checkbox"/>	<input type="checkbox"/>	<input type="checkbox"/>	<input type="checkbox"/>	<input type="checkbox"/>	<input type="checkbox"/>				
PPPE Process Structure Mode	<input type="checkbox"/>					<input type="checkbox"/>				
PVS Dependency	<input type="checkbox"/>					<input type="checkbox"/>				

4 Create Work Area

In order to create a new work area, you must go to transaction code `OP77`. Create an SAP Complex Assembly Manufacturing work area that will only be used by the SAP Complex Assembly Manufacturing application. In the example below, `CAMS_WA1` has been created. This is the value you will use for the *Plan Hold: Work Area* configuration parameter described later in this document.

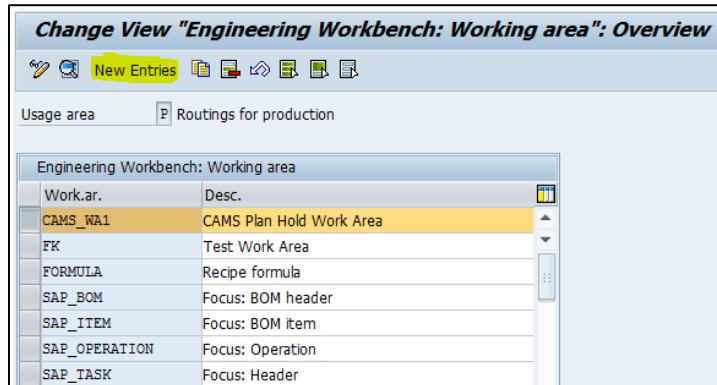

1. In the *Change View "Engineering Workbench: Working area": Overview* screen, select *New Entries*.
2. On the *New Entries: Details of Added Entries* screen, enter a *Working Area* name and a description. This working area should only be used by SAP Complex Assembly Manufacturing.
3. Ensure all the checkboxes that are selected in the figure below are selected for your new work area.
4. Choose .

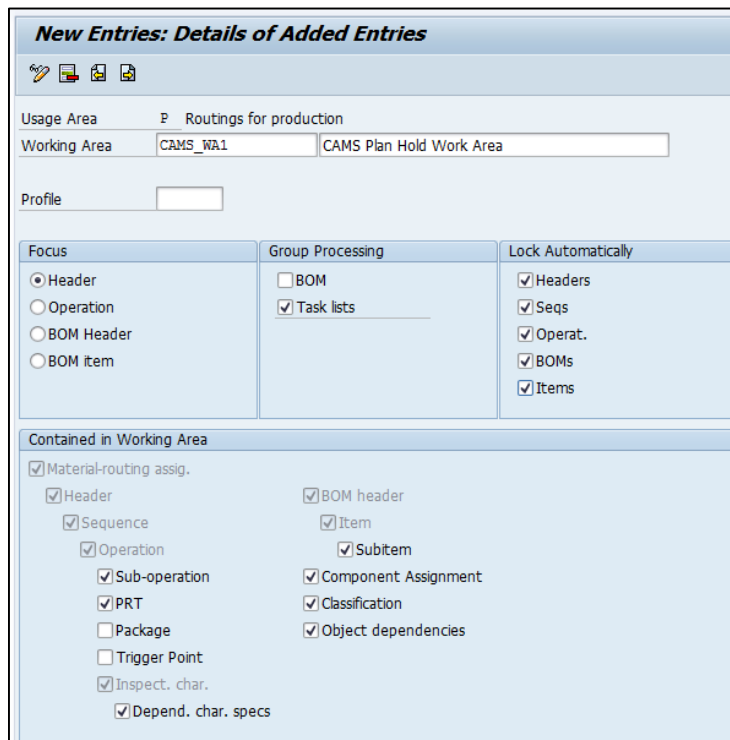

5 Configuration Parameters

A new set of *ERP Interface* configuration parameters were created to support plan holds. These plan hold configuration parameters must be configured on site after all of the steps above have been successfully performed.

The *Plan Hold Interface Enabled* configuration parameter must be set to *Yes*. Based on the examples used above, the other plan hold configuration parameters would look as shown. To set these configuration parameters, in SFM select *System > Configuration Parameters* and choose the *ERP Interface* bar.

	<input checked="" type="radio"/> Yes	<input type="radio"/> No
Plan Hold Interface Enabled		
Plan Hold: Hold Status	E	
Plan Hold: Release Status	4	
Plan Hold: Work Area	CAMS_WA1	
Plan Hold: Change Master	CAMS_CM1	

Appendix C: Configuration Tips

If you intend to use operation precedence in SAP Complex Assembly Manufacturing, then control keys defined and used in routings should not be defined as milestone types or have settings where SAP ECC could prevent confirmations being sent out of order. This is due to the precedence in SAP Complex Assembly Manufacturing not being passed to SAP ECC during the routing transfer.



www.sap.com/contactsap