

© 2000 by the  
University of  
Chicago Press  
All rights reserved.  
Printed in the  
United States of  
America

Lab.  
XJ  
.0843

V. 6  
1921

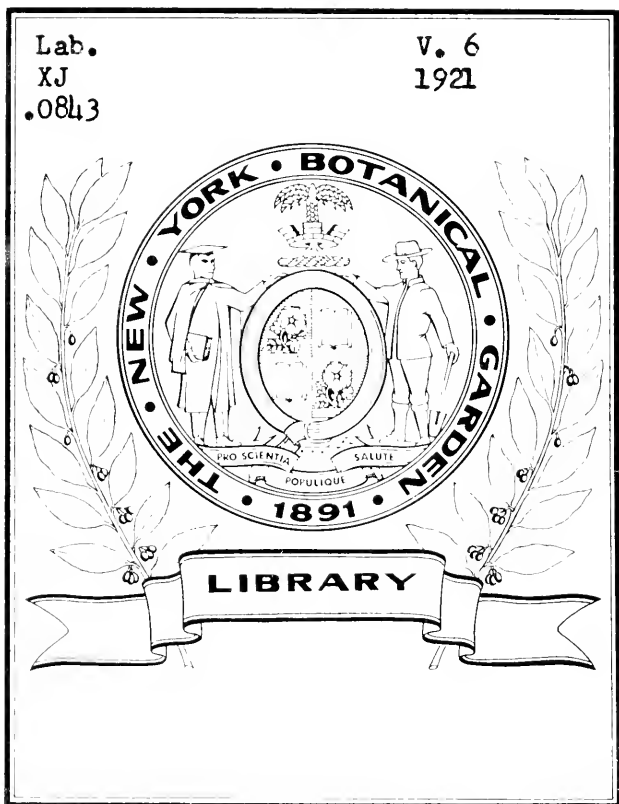







JOURNAL  
OF  
BACTERIOLOGY

VOLUME VI

W. B. KILPATRICK,  
Editor  
W. H. WELCH,  
Editor  
W. H. WELCH,  
Editor

BALTIMORE, MD.  
1921

Lab.

XJ

.0343

Vol. 6

1931

## CONTENTS

### No. 1, JANUARY, 1921

Chemical Criteria of Anaerobiosis with Special Reference to Methylene Blue. Ivan C. Hall.....	1
Powdered Litmus Milk. A Product of Constant Quality and Color which Can be Made in Any Laboratory. Herbert W. Hamilton.....	43
Bacteria Concerned in the Ripening of Corn Silage. P. G. Heineman and Charles R. Hixson.....	45
Some Atypical Colon-Aerogenes Forms Isolated from Natural Waters. Margaret C. Perry and W. F. Monfort.....	53
Botulism in Cattle. Robert Graham and Herman R. Schwarze.....	69
Note on the Indol Test in Tryptophane Solution. Chr. Barthel.....	85
The Nature of Hemolysins. J. T. Connell and L. E. Holly.....	89
The Nature of Toxin. The Antigens of <i>Corynebacterium diphtheriae</i> and <i>Bacillus megatherium</i> and their Relation to Toxin. C. C. Warden, J. T. Connell and L. E. Holly.....	103
The Gas Production of <i>Streptococcus Kefir</i> . James M. Sherman.....	127
The Importance of Preserving the Original Types of Newly Described Species of Bacteria. C.-E. A. Winslow.....	133

### No. 2, MARCH, 1921

Progress Report for 1920 Committee on Bacteriological Technic. H. J. Conn, Chairman, K. N. Atkins, I. J. Kligler, J. F. Norton, and G. E. Harmon.	135
A Study of the Variations in Hydrogen-Ion Concentration of Broth Media. Laurence F. Foster and Samuel B. Randall.....	143
The Relation of Hydrogen-Ion Concentration to the Growth, Viability and Fermentative Activity of <i>Streptococcus hemolyticus</i> . Laurence F. Foster.....	161
The Biochemistry of <i>Streptococcus hemolyticus</i> . Laurence F. Foster....	211
Notes on the Flagellation of the Nodule Bacteria of Leguminosae. Ivan V. Shunk.....	239
Method for the Intravenous Injection of Guinea-Pigs. George B. Roth...	249
Rose Bengal as a General Bacterial Stain. H. J. Conn.....	253

### No. 3, MAY, 1921

William Thompson Sedgwick, 1855-1921.....	255
The Main Lines of the Natural Bacterial System. S. Orla-Jensen.....	263
Variations in Typhoid Bacilli. Kan-Ichiro Morishima.....	275
Solid Culture Media with a Wide Range of Hydrogen or Hydroxyl Ion Concentration. Frederick A. Wolf and I. V. Shunk.....	325
Studies on <i>Azotobacter Chroococcum</i> Beij. Augusto Bonazzi.....	331

## No. 4, JULY, 1921

Spiral Bodies in Bacterial Cultures. Laura Florence.....	371
The Cause of Eyes and Characteristic Flavor in Emmental or Swiss Cheese. James M. Sherman.....	379
A New Modification and Application of the Gram Stain. G. J. Hucker....	395
Color Standards for the Colorimetric Measurement of H-Ion Concentration. Louis J. Gillespie.....	399
The Effect of Pepton upon the Production of Tetanus Toxin. Harriet Leslie Wilcox.....	407
On the Growth and the Proteolytic Enzymes of Certain Anaerobes. K. G. Dernby and J. Blanc.....	419

## No. 5, SEPTEMBER, 1921

The Mannitol-Producing Organisms in Silage. G. P. Plaisance and B. W. Hammer.....	431
Principles Concerning the Isolation of Anaerobes. Studies in Pathogenic Anaerobes II. Hilda Hempl Heller.....	445
Indol Production by Bacteria. John F. Norton and Mary V. Sawyer.....	471
On Nitrification. IV. The Carbon and Nitrogen Relations of the Nitrite Ferment. Augusto Bonazzi.....	479
Toxins of Bact. Dysenteriae, Group III. Th. Thjøtta.....	501

## No. 6, NOVEMBER, 1921

Salt Effects in Bacterial Growth. I. Preliminary Paper. George E. Holm and James M. Sherman.....	511
Suggestions concerning a Rational Basis for the Classification of the Anaero- bic Bacteria. Studies in Pathogenic Anaerobes IV. Hilda Hempl Heller.....	521
Hydrogen Ions, Titration and the Buffer Index of Bacteriological Media. J. Howard Brown.....	555
On Decreasing the Exposure Necessary for the Gelatin Determination. J. E. Rush and G. A. Palmer.....	571
Chart of the Families and Genera of the Bacteria. Harold Macy.....	575

VOLUME VI

NUMBER 1

# JOURNAL OF BACTERIOLOGY

OFFICIAL ORGAN OF THE SOCIETY OF AMERICAN  
BACTERIOLOGISTS

JANUARY, 1921

EDITOR-IN-CHIEF

C.-E. A. WINSLOW



*It is characteristic of Science and Progress that they continually  
open new fields to our vision.—PASTEUR.*

PUBLISHED BI-MONTHLY  
WILLIAMS & WILKINS COMPANY  
BALTIMORE, U. S. A.

Entered as second-class matter April 17, 1916, at the postoffice at Baltimore, Maryland, under the act of March 3, 1879. Acceptance for mailing at special rate of postage provided for in Section 1103, Act of October 3, 1917. Authorised on July 16, 1918.

Copyrighted, 1921, Williams and Wilkins Company

Price, net { \$5.00 per volume, United States, Mexico, Cuba  
postpaid { \$5.25 per volume, Canada  
          { \$5.50 per volume, other countries

# Holadin and Bile Salts

Holadin - - 2½ grs.

Bile Salts - - ½ gr.

(enteric capsules)

“Investigations begun originally by Professor ‘Nencki in his Berne laboratory and carried ‘on by Heidehain, Rachford, Williams and ‘Martin, have shown that the bile has a ‘favouring action on the ferments of the pan- ‘creatic juice.

“The Bile, indeed, proved itself to be a ‘constant and powerful auxiliary of the pan- ‘creatic juice, a fluid which is of such impor- ‘tance for digestion and in itself already so ‘complicated.”

—Prof. J. P. Pawlow.

“*Holadin and Bile Salts*”, a combination of the most potent pancreas extract with the isolated glycocholate and taurocholate of sodium, in their native association—

is a therapeutic resource of distinct service in pancreatic (intestinal) disorders dependent upon, or associated with, deficient bile action.

FAIRCHILD BROS. & FOSTER  
New York

## LaMotte Standards GUARANTEED

Section 1.—Standardized Indicator dyes. Covering a wide range of H-ion concentration. Supplied in dry form and in sterile stock solutions. Each Indicator is standardized in strict accordance with the specifications of Clark & Lubs. (Jr. Bact., Vol. II, Nos. 1, 2, 3, 1917.)

Common Name	Color Change	PH Value
Thymol Blue (acid range)	red-yellow	1.2-2.8
Methyl Orange	red-yellow	2.9-4.0
Bromphenol Blue	yellow-blue	3.0-4.6
Resorcin Blue	pink-blue	4.0-7.2
Methyl Red	red-yellow	4.4-6.0
Bromcresol Purple	yellow-purple	5.2-6.8
Litmus (special)	red-blue	5.5-8.9
Bromthymol Blue	yellow-blue	6.0-7.6
Phenol-Red	yellow-red	6.8-8.4
Cresol Red	yellow-red	7.2-8.8
Thymol Blue (alkaline range)	yellow-blue	8.0-9.6
Cresol-phthalein	colorless-red	8.2-9.8
Phenol-phthalein	colorless-red	8.4-9.2

Section 2-B.—Specially prepared and standardized Buffer salts and solutions. Buffer mixtures may be obtained in series covering any particular range of H-ion concentration from PH 1.0 to 10.0.

### Standardized Buffer Solutions (M/5)

Potassium Phosphate	Potassium Phthalate	Sodium Hydroxide (CO <sub>2</sub> free)
Potassium Chloride	Hydrochloric Acid	Di-Sodium Phosphate, 2H <sub>2</sub> O

A large number of general synthetic and purified compounds are manufactured by us and information concerning them may be obtained by addressing

**LA MOTTE CHEMICAL PRODUCTS CO.**  
“Standards Department”

13 W. Saratoga St.

Baltimore, Md.

# JOURNAL OF BACTERIOLOGY

OFFICIAL ORGAN OF THE SOCIETY OF AMERICAN BACTERIOLOGISTS

DEVOTED TO THE ADVANCEMENT AND DISSEMINATION OF KNOWLEDGE IN REGARD TO THE BACTERIA AND OTHER MICRO-ORGANISMS

## *Editorial Board*

### *Editor-in-Chief*

C.-E. A. WINSLOW

Yale Medical School, New Haven, Conn.

A. PARKER HITCHENS

DR. CHARLES KRUMWIEDE, JR., Ex officio

## *Advisory Editors*

C. C. BASS

R. E. BUCHANAN

P. F. CLARK

F. P. GAY

F. P. GORHAM

P. C. HARRISON

H. W. HILL

E. O. JORDAN

A. I. KENDALL

C. B. LIPMAN

C. E. MARSHALL

V. A. MOORE

M. E. PENINGTON

F. B. PHELPS

L. F. RETTGER

L. A. ROGERS

M. J. ROSENAU

W. T. SEDGWICK

F. L. STEVENS

A. W. WILLIAMS

H. ZINSSER

## CONTENTS

IVAN C. HALL. Chemical Criteria of Anaerobiosis with Special Reference to Methylene Blue.....	1
HERBERT W. HAMILTON. Powdered Litmus Milk. A Product of Constant Quality and Color which Can be Made in Any Laboratory .....	43
P. G. HEINEMAN AND CHARLES R. HIXSON. Bacteria Concerned in the Ripening of Corn Silage .....	45
MARGARET C. PERRY AND W. F. MONFORT. Some Atypical Colon-Aerogenes Forms Isolated from Natural Waters.....	53
ROBERT GRABAM AND HERMAN R. SCHWARZE. Botulism in Cattle .....	69
CHR. BARTHEL. Note on the Indol Test in Tryptophane Solution .....	85
J. T. CONNELL AND L. E. HOLLY. The Nature of Hemolysins .....	89
C. C. WARDEN, J. T. CONNELL AND L. E. HOLLY. The Nature of Toxin. The Antigens of <i>Corynebacterium diphtheriae</i> and <i>Bacillus megatherium</i> and their Relation to Toxin.....	103
JAMES M. SHERMAN. The Gas Production of <i>Streptococcus kefir</i> .....	127
C.-E. A. WINSLOW. The Importance of Preserving the Original Types of Newly Described Species of Bacteria.....	133

Abstracts of American and foreign bacteriological literature appear in a separate journal, *Abstracts of Bacteriology*, published bi-monthly by the Williams & Wilkins Company, under the editorial direction of the Society of American Bacteriologists. Back volumes can be furnished in sets consisting of Volumes I, II and III. Price per set, net, postpaid, \$18.00, United States, Mexico, Cuba; \$18.75, Canada; \$19.50, other countries. Subscriptions are in order for Volume IV, 1920. Price, per volume, \$5.00, United States, Mexico, Cuba; \$5.25, Canada; \$5.50, other countries.

# ELECTRIC STOVES

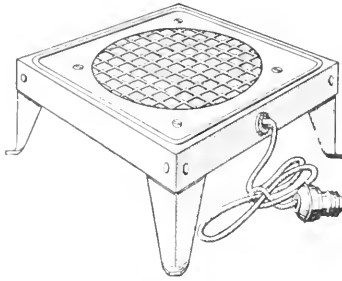

Efficient, durably constructed of sheet metal. For both A.C. and D.C. Complete with plug and cord

Black finish - - - - \$5.00 Each  
 Nickel and Oxidized - - 6.00 "

**The Will Corporation**

Laboratory Apparatus - Chemicals  
 Glassware

ROCHESTER, N. Y.



# INTERNATIONAL CENTRIFUGES

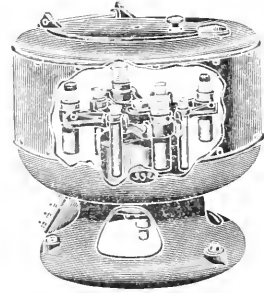

**INTERNATIONAL  
EQUIPMENT COMPANY**

352 Western Ave., (Brighton)

BOSTON, MASS.

Catalog Cy. on request

# JOURNAL OF IMMUNOLOGY

OFFICIAL PUBLICATION OF

THE SOCIETY FOR SEROLOGY AND HEMATOLOGY AND  
 THE AMERICAN ASSOCIATION OF IMMUNOLOGISTS

Edited by ARTHUR F. COCA

Vol. V. No. 6

CONTENTS

NOVEMBER, 1920

JAMES D. SMITH AND M. A. WILSON. Comparison of Smear, Culture and Complement Fixation in Chronic Gonorrhoea in Women. A Preliminary Report.....	499
MOTOMATSU MATSUMOTO. Experiments upon the Production of Anti-Human Hemolysin with Special Reference to Immunization with Erythrocytes Sensitized with Heated Serum.....	507
MOTOMATSU MATSUMOTO. A Note on the Non-Specific production of Antibodies.....	517
THOMAS G. HULL AND EVA E. FAUGHT. The Sachs-Georgi Precipitation Test for Syphilis.....	521
HERBERT L. KOECKERT. A Study of the Mechanism of Human Isohemagglutination.....	529
THOMAS P. HASLAM. Immunization with Blackleg Aggressin.....	539
CHARLES KRUMWIEDE AND GEORGIA M. COOPER. A Study of the Specificity of the Absorption of Anti-Bacterial Precipitates.....	547

Current Volume: Vol. V, 1920—Price, \$5.00 Domestic; \$5.50 Foreign

Back volumes can be furnished: Vols. I-IV incl. Price per set: \$24.00, United States, Mexico, Cuba; \$25.00, Canada; \$26.00, other countries. Prices are net postpaid

**Subscription Order for the Journal of Immunology**

WILLIAMS & WILKINS' COMPANY, MOUNT ROYAL AND GUILFORD AVENUES, BALTIMORE, MD., U. S. A.

I } enclose { \$ \_\_\_\_\_ } for subscription to the current volume of JOURNAL OF IMMUNOLOGY.  
 We }

Please send Back Volumes

Name.....

(Please state whether Dr., Prof., etc.)

Address.....



LIBRARY  
NEW YORK  
BOTANICAL  
GARDEN

# CHEMICAL CRITERIA OF ANAEROBIOSIS WITH SPECIAL REFERENCE TO METHYLENE BLUE<sup>1</sup>

IVAN C. HALL

*From the Department of Hygiene and Bacteriology, University of Chicago*

Received for publication June 4, 1920

The literature of anaerobic technology contains frequent references to various criteria of anaerobiosis aside from growth of organisms. To be sure, the successful cultivation of a known anaerobic micro-organism under given conditions, in contrast with the failure of growth of the same organism on the surface of solid media of similar composition in free contact with air, constitutes a satisfactory *biological* criterion of anaerobiosis for the particular organism used in the test and under the special conditions thereof. But there are circumstances in which it is desirable to correlate other means of determining oxygen tension reduction. An obviously useful *physical* means is the vacuum manometer, but most helpful of all are *chemical* criteria, which are usually based upon coloration changes.

One of the earliest indicators used, and a notable exception to the rule of indicators with coloration changes, was phosphorus, whose failure to ignite was employed by Gratama, a student of Gunning's (1877).

A mixture of alkali with pyrogallic acid, as used in reducing oxygen tension for the cultivation of anaerobic organisms, is also frequently mentioned as affording a criterion of successful anaerobiosis since in the absence of oxygen the solution remains nearly or quite colorless. But it is scarcely possible for this

<sup>1</sup>This essay is based upon an investigation completed during the writer's tenure of the Logan Fellowship at the University of Chicago and is one of a series awarded the Howard Taylor Ricketts Memorial Prize for 1920.

JAN 29 1927

reagent to serve both as a means of removing oxygen and as a criterion of removal at the same time, so that the latter purpose can be achieved only when combined with other means of oxygen tension reduction.

Fermi and Bassu (1904), using alkaline pyrogallol as a criterion, encountered extreme difficulty in demonstrating complete anaerobiosis. For example, they found that boiling media under paraffine oil for over one hour does not prevent the darkening of an alkali-pyrogallol mixture placed therein and a similar statement was made respecting the passage of hydrogen and carbon dioxide through media. It appears from my own experiments that the colored compounds formed by the action of oxygen upon alkali-pyrogallol mixtures are quite stable and the reactions irreversible, for neither very weakly alkaline-solutions which show only a trace of color with pyrogallic acid nor strongly alkaline deep colored solutions can be decolorized by prolonged boiling. Therefore the difficulty of making the mixture without obtaining some coloration and the further impossibility of removing it previous to actual test distinctly limit the practicability of alkaline pyrogallol as a criterion of anaerobiosis, notwithstanding its great value as a means of oxygen tension reduction.

More extensive use has been made of substances which in the absence of free oxygen are reduced to leucobases. Some of these can be used, not only in media during the active growth of organisms, but separately as well, for estimating the suitability of special apparatus. Among such indicators may be mentioned potassium ferro-ferro cyanid, litmus, indigo (sodium indigo sulphonate) and methylene blue.

Potassium ferro-ferro cyanid [ $(K_2Fe (Fe Cy_6))$ ] is of slight historical, but no practical, importance. It was used by Gunning (1877) (1878) (1879) and is said to become colorless [ $Fe_2Fe Cy_6$ ] when air is eliminated.

The earliest authentic reference to the bacteriological use of litmus appears to be that of Würtz (1892) who introduced litmus lactose agar as a differential medium for *Bact. coli* and *Bact. typhosum*. It was impossible to confirm Novy's (1893) allusion [copied by Hunziker (1902)] to Buchner (1885) and Cohen (?)

as first to use litmus to indicate acid and reduction changes respectively, the last reference apparently being altogether erroneous. The decolorization of indigo and methylene blue in culture media were studied by Spina (1887) whose interest in these dyes hinged rather upon their reduction by bacterial growth though he recognized the phenomenon as occurring most vigorously in the depths and noted the return of color on exposure to the air. Kitasato and Weyl (1890) confirmed this observation so far as regards sodium indigo sulphate. The decolorization of all three dyes by sterile culture media under anaerobic conditions, as well as by living aerobic and anaerobic cultures, was especially investigated by Smith (1893) (1896) who noted the necessity of some organic substance such as glucose or peptone and an alkaline reaction in the case of sterile media decolorized by heat.

I found neutral litmus solutions unaffected in color by heating for twenty minutes in a boiling water bath, and the same is true of litmus with 1 per cent glucose. Litmus solutions with 1 per cent glucose and HCl stronger than  $N/8$  were precipitated by heating and the precipitate was not redissolved on cooling; weaker acid solutions were unaffected except for reddening. Strong alkali  $N/2$  to  $N/32$  caramelized the sugar and decolorized the dye permanently; weaker solutions decolorized on boiling for a few minutes and regained their original blue color only on exposure to air.

The recoloration of such decolorized solution of litmus, indigo and methylene blue by exposure to air indicates reversible reactions and constitutes the key to the use of such dyes as criteria of anaerobiosis.

McLeod (1913) cleverly utilized the blue laboratory pencil mark as a criterion of anaerobiosis upon the basis of its decolorization in the absence of air. Some pencils fail to respond, however, according to my experience.

#### METHYLENE BLUE AS A CRITERION OF ANAEROBIOSIS

The most valuable and most extensively advocated chemical criterion of anaerobiosis is methylene blue. Introduced as an ingredient of culture media by Spina (1887), studied as an indi-

cator of anaerobiosis by Smith (1893) and others, it has been used to a certain extent by almost every serious investigator of anaerobiosis since. Smith (1893) (1896) noted its decolorization in the closed arm of the fermentation tube. Sanfelice (1893) and Liefmann (1908) defended the use of glass slips on the basis of the decolorization of methylene blue in the underlying agar. Trenkmann (1898) and Rivas (1902) used it in their culture tests with  $\text{Na}_2\text{S}$  as a reducing agent. Kabrhel (1899) used it in his bell jar device for plates and thereby showed the necessity of removing the covers for efficacious absorption of oxygen by alkaline pyrogallol; he also showed its value as an indicator of the anaerobiosis of deep culture media, liquid and solid. It was used by Petri (1900) in connection with oxygen tension reduction by hydrogen and alkaline pyrogallol, by Sellards (1904) with phosphorus, by Fremlin (1903) (1904), Stüler (1904), Berner (1904), Lentz (1910) with various plating devices, by Wrzosek (1907) (1909), Liefmann (1907), Hata (1908), Guillemot and Szczawinska (1908), Zinsser, Hopkins and Gilbert (1915) with plant and animal tissues, by Laidlaw (1915), and McIntosh and Fildes (1916) in the use of spongy platinum and palladium black as hydrogen-oxygen catalysers, by Wilson (1917) in the use of coal gas, by Douglas, Fleming, and Colebrook (1917) in connection with many porous substances and by a great many others.

#### CHEMISTRY OF METHYLENE BLUE

Discovered by Caro in 1876 and used empirically for many years in the arts, methylene blue, as a chemical compound, was studied most authoritatively by Bernthsen. He showed (1883) that  $\text{Na}_2\text{S}_2\text{O}_4$  reduces it to its colorless leuco base, methylene white, which may be crystallized out of ether and whose aqueous solution becomes dark blue again in acid solution with iron chloride. Möhlau (1883) expressed the rule that methylene white is changed to methylene blue by oxidizing agents in acid solution. Bernthsen (1883) engaged in a brief polemic with Möhlau (1883) and Erlenmeyer (1883) as to the structural formulae of these compounds and finally (1884) set down methylene blue chloride as

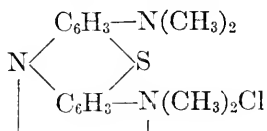

which is reduced (Bernthsen 1885) by the action of zinc or zinc chloride with HCl or H<sub>2</sub>SO<sub>4</sub> and in alkaline solution with ammonium sulfate to leuco-methylene blue

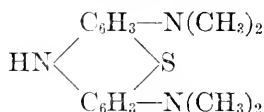

These formulae are generally accepted now, practically the only disagreement being as to the direct bond between two of the nitrogen atoms.

Landauer and Weil (1910) also obtained leuco-methylene blue by treating a solution of the blue salt in alcohol, with phenylhydrazine, warming and cooling under CO<sub>2</sub>. It has a melting point of 185°C. and is not oxidized even by pure oxygen in an atmosphere free from acid and in strongly alkaline solutions is not acted upon by permanganate or hydrogen peroxide. The following equation represents the reaction

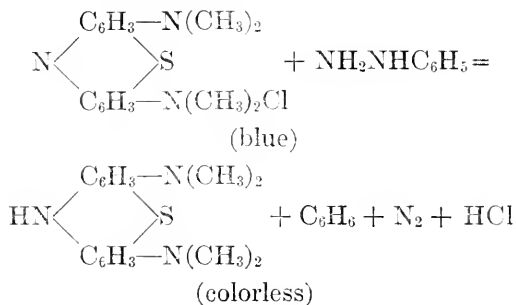

Excepting Landauer and Weil (1910) chemists have studied methylene blue largely from the standpoint of action of inorganic compounds upon it. We turn now to a consideration of its behavior in the presence of those factors which enter into bacteriological culture media, since the custom, not altogether defensible,

as I shall show, has grown up of adding a trace of this dye to the culture medium—either with or without inoculation—as a criterion of anaerobiosis.

We have already referred to the fundamental observations of Smith (1893) (1896) on the decolorization of methylene blue in alkaline solutions containing glucose or peptone under anaerobic conditions induced by heating. Kabrhel (1899) and Hammerl (1901) used such a solution along with their cultures as an indication of the successful exclusion of oxygen and the latter showed that the sugar might be replaced with sodium formate. Fremlin (1904) found an alkalinized methyl alcohol solution of methylene blue more delicate than an aqueous solution but recognized the possible inhibitory action of the volatile spirit upon bacterial growth.

As Bernthsen has shown, commercial methylene blue is likely to be a mixture with methylene azure, the latter being formed by the action of alkalis. Underhill and Closson (1905) have given methods for the purification of both, which however is not necessary in using methylene blue as a criterion of anaerobiosis since both compounds yield colorless leuco-bases under similar conditions; furthermore methylene azure is formed from methylene blue under conditions of alkalinity such as obtain in the test.

#### EXPERIMENTAL WORK

##### *Decolorization—Preliminary discussion*

The writer's interest in methylene blue as a criterion of anaerobiosis dates from the invention of the constricted tube and marble device (Hall, 1915). It was possible to show by its use that certain shipments of tubes contained 4 per cent with defective bore so that they could not be used. A properly made tube containing a methylene blue solution of certain composition, with a good marble seal will not permit the return of color below the marble for several days after decolorization by heating. One must not fall into the error of assuming, however, that decolorization of methylene blue necessarily indicates suitability for anaerobic growth; there are many factors, aside from the reduc-

tion of oxygen tension, in the cultivation of anaerobes. However, the failure of a *properly balanced* solution to remain decolorized indicates a defect in the method of air exclusion proposed. Decolorization of methylene blue probably occurs at a definite point during the abstraction of oxygen—a point yet to be determined. So decolorization may indicate suitability for some organisms and not for others. Methylene blue tests with McLeod's (1913) plate were satisfactory yet the bacteriological use of this plate in our hands was never satisfactory. Therefore, while we must admit that the decolorization of methylene blue solution, delicately adjusted, frequently correlates with successful anaerobic cultures, it is more important to recognize the limits and conditions of this test and to appreciate that the factors which enter into the successful decolorization of methylene blue are not necessarily common to the growth of all obligative anaerobes. It should be emphasized especially that acidification, probably through absorption of carbon dioxide from the air, may account for a return of color to decolorized methylene blue solutions and that in this case the dye cannot be bleached again without re-alkalinization.

#### *Essential factors in decolorization*

Preliminary experiments had to do with tests of Grüber's methylene blau für Bacillen in two culture media commonly used for the cultivation of anaerobes—magnesium carbonate glucose broth (Hall, 1915) and neutral (phenolphthalein) glucose agar. A trace of methylene blue in either of these media is easily decolorized by heating in a boiling water bath. In the open air such decolorized solutions quickly recover their original blue color but protected from air remain decolorized indefinitely. Thus in the constricted tube filled with glucose broth the color returns above but not below the marble seal; in deep glucose agar the color returns to the upper layers first and gradually descends. But it was noticed in certain cases of methylene blue glucose broth allowed to stand for several days that heating failed to decolorize the dye although it had done so originally. The outcome was a series of experiments to determine the

principal factors of decolorization and return of color in methylene blue solution.

Considering each of the ingredients of magnesium carbonate glucose broth as possible single factors in the decolorization of the dye, it was first shown that only those solutions slightly alkalized, as by means of magnesium carbonate or sodium or potassium hydroxide, lose color on boiling. The use of magnesium carbonate referred to involves addition of an excess and the removal of the undissolved residue by filtration after boiling: only a trace of magnesium goes into solution and the reaction is made faintly alkaline ( $\text{pH} =$  about 8). With such adjustment it was found possible to dispense with the salt and any two of the other three factors (meat infusion, peptone, and glucose) without interfering with decolorization. But the clearest cut results were obtained with glucose present. Furthermore, rather prolonged boiling is required for decolorization if the glucose be added to the filtrate from a heated  $\text{MgCO}_3$  suspension in water, i.e., is not heated in the presence of an excess of  $\text{MgCO}_3$ ; a slightly alkaline solution of 2 per cent agar was also decolorized easily. Further experiments were then undertaken to determine the effect of variation in reaction upon methylene blue solutions in the presence of these various organic substances.

The following facts stand out as a result of many experiments.

Neutral aqueous solutions of Grüber's Methylene blau für Bacillen containing 0.0001 gram or more per cubic centimeter are not decolorized in a water bath boiling hard for twenty minutes. Neither the inorganic acids,  $\text{HCl}$ ,  $\text{H}_2\text{SO}_4$ ,  $\text{HNO}_3$ , nor the organic acids, oxalic, acetic, lactic, citric, butyric, succinic, formic, and propionic, in a concentration of  $\text{N}/10$ , have any visible effect when heated in weak solutions of methylene blue. Yet methylene blue is decolorized slowly in a solution of  $\text{HCl}$  acting on zinc in the presence of platinum.  $\text{N}/10$   $\text{NH}_4\text{OH}$  has no visible effect while the equivalent concentrations of  $\text{BaOH}$ ,  $\text{NaOH}$  and  $\text{KOH}$  produce a violet lavender color only—indicating, no doubt, the formation of methylene azure.

Neutral glucose solutions ranging from 1 to 10 per cent and faintly or deeply colored with methylene blue are not decolorized



during thirty minutes in a boiling water bath. The same is true of 2 per cent Witte's peptone solutions and of 2 per cent agar solutions. Neither does the addition of 0.5 per cent glucose to any of the acid solutions mentioned above result in decolorization on heating; likewise 2 per cent agar and 2 per cent Witte's peptone in graded hydrochloric acid solutions up to  $N/10$  for agar (which fails to solidify), and up to  $N/2$  for peptone, refuse to decolorize on heating. The neutral sodium salts of the above acids formed by adding equivalent amounts of standardized NaOH do not alter the result; none decolorize on heating.

On the other hand an extremely small excess of alkali causes the heated glucose, agar or peptone solution of methylene blue to lose its color completely. Even such traces of alkali as may be dissolved from the glassware may cause the decolorization of methylene blue in glucose solutions on heating. Incidentally we recall that Laird (1913) found the reaction time for Fehling's solution reduced by boiling glucose, laevulose, galactose, maltose and lactose in various makes of German glassware, owing to the abstraction of calcium hydroxide from the glass. All experiments reported herein were made with glassware carefully cleaned with chromic acid cleaning fluid and rinsed in distilled water. The use of such weak concentrations of alkali, which were approximated only by dilutions of standardized  $N/1$  solutions, involves the possibility of other factors of error, as for example, atmospheric  $CO_2$  and non-neutral distilled water, which do not enter so fully with higher concentrations. Repeated tests of the distilled water by colorimetric tests with phenolsulphonaphthalein showed the limits of pH value to be 6.8 and 7.0; thus this possible factor of error was excluded. The  $CO_2$  factor of error was reduced as far as possible by the use of freshly boiled distilled water for the preparation of solutions and checked as a disturbing factor in the interpretation of results. The great difficulty in adequately and exactly controlling the very slight alkalinity of the solutions in different experiments without the use of buffer substances may account for some nonsignificant discrepancies between the results with high dilutions of alkali in different tests. It should be made quite clear that decolorization of

alkaline methylene blue solutions in the presence of these certain organic ingredients of culture media is quite independent of the presence or absence of the acid ions mentioned.

Neutral and  $N/20$  HCl solutions of 1 per cent levulose, glucose, lactose, maltose, sucrose, raffinose, inulin, dextrin, mannitol and, dulcitol, (all Merck's highest purity), with 0.00005 gram methylene blue were tested also for decolorization by heating in a boiling water bath for ten minutes, with negative results. Glucose,

TABLE 1

*Correlation of Fehling's test and decolorization of methylene blue by alkalinized sugar solution*

	$N/3NaOH$	$N/100NaOH$	$N/1000NaOH$	NEUTRAL	$N/20HCl$	REDUCTION N FEHLING'S TEST*
Levulose.....		+	+	-	-	+
Glucose.....		+	+	-	-	+
Lactose.....		+	+	-	-	+
Maltose.....		+	+	-	-	+
Sucrose.....	-	-	-	-	-	-
Raffinose.....		+	-	-	-	-
Inulin.....		+	-	-	-	?
Dextrin.....		+	-	-	-	?
Mannitol.....	-	-	-	-	-	-
Dulcitol.....	-	-	-	-	-	-

\* Quoted from Hawk-Practical Physiological Chemistry. Blakiston, Philadelphia, 1907.

Reduction indicated by +.

No reduction during ten minutes in boiling water bath indicated by -.

levulose, lactose, and maltose solutions decolorized methylene blue, however, in one or two minutes in  $N/1000$  NaOH, but raffinose, inulin and dextrin solution required  $N/100$  NaOH while sucrose, mannitol, and dulcitol, failed to decolorize methylene blue in even  $N/3$  NaOH.

These results with ten representative carbohydrates of reputable purity suggested the following attempt to correlate methylene blue reduction with that of copper sulphate in Fehling's test as in table 1.

There is apparently a well defined correspondence between those carbohydrates whose reducing action is shown in Fehling's

test and those which reduce methylene blue in  $N/1000$  NaOH. These carbohydrates are also most susceptible to alkaline-hydrolysis. The trisaccharid raffinose and the poly-saccharids inulin and dextrin are generally considered not to give Fehling's test; they are less easily hydrolysed by alkalis, and they require therefore a stronger concentration of alkali to reduce methylene blue. The disaccharide, sucrose, and the alcohols, dulcitol and mannitol, are especially resistant to alkalis: they respond therefore to neither Fehling's nor the methylene blue test. But preliminary treatment of sucrose with  $N/100$  HCl readily hydrolyses it and the overneutralization of such a mixture to  $N/100$  alkalinity causes it to decolorize methylene blue quickly on heating.

*Quantitative relations*

In many of the experiments up to this point the importance of quantitative relations was recognized.

We have just seen that a minute quantity of alkali ( $N/1000$  NaOH) suffices to insure decolorization of certain carbohydrates in 1 per cent solution with 0.00005 gram methylene blue per cubic centimeter. The rapidity of decolorization of glucose solution varies according to the concentration of alkali, which, if sufficiently strong, effects the destruction of color without heating: furthermore, less alkali is required to effect the loss of color under anaerobic conditions than in the presence of the air. The following is abstracted from a protocol covering an experiment with 1 per cent glucose, 1:10,000 methylene blue, of varying degrees of alkalinity as indicated, placed in constricted tubes with marble seals and read after twenty-four hours incubation at  $37^{\circ}\text{C}$ . without preliminary heating.

TUBE NUMBER	NaOH	ABOVE MARBLE	BELOW MARBLE
1	$N/60$	Nearly colorless	Slightly yellow
2	$N/120$	Blue	Colorless
3	$N/240$	Blue	Nearly colorless
4	$N/480$	Blue	Blue

On boiling five minutes all were decolorized above and below except tube 4. This experiment thus illustrates not only the point just mentioned but also our frequent observation that very weakly alkaline solutions are likely to fail to decolorize if allowed to stand exposed to the air long before use, probably owing to neutralization by  $\text{CO}_2$ . This is a point to which we shall return.

As to variations in dye content with  $N/1000$  NaOH and 1 per cent glucose, 1:1000 and 1:10,000 methylene blue failed to decolorize in this particular experiment while solutions containing 1:100,000 did so. The weaker the concentration of dye, the less alkali is required.

With  $N/1000$  NaOH and 1:10,000 methylene blue variations in glucose from 0.15 to 20 per cent appeared to make little or no difference in decolorization, yet further dilution and variations in alkalinity and dye content showed distinct effects, to which reference will now be made for it is apparent that the three reagents necessary in a test for the decolorization of methylene blue by heating bear a definite quantitative relation, one to another. Briefly, the amount of alkali required bears an inverse relation to that of glucose but the necessary amounts of these two reagents bear a direct relation to that of methylene blue. The more alkali the less glucose is required and vice versa, but the more methylene blue the more glucose or alkali is required. Those relations are best displayed in the following experiment:

For the purpose of this and several similar experiments a copper water bath with a support providing for 10 rows of 10 perforations each to hold test tubes was used. The tubes were of uniform size as to length and bore; they were carefully cleaned and placed in the support in rows corresponding to the record marks of table 2, one tube for each mark. To each were first added 7 cc. neutral distilled water and 1 cc. of an aqueous methylene blue solution 10 times the strength required in that particular section of the experiment. Solutions 10 times the strength of glucose required in each of the vertical rows and of sodium hydroxide in each of the horizontal rows were prepared and of these 1 cc. each was added to each tube in the test. In such

an experiment it is always important to add the alkali last to avoid any considerable action of a concentration greater than that indicated by the recorded data. The total volume of liquid in each tube was 10 cc.

The support with the tubes was then placed in the bath filled with boiling water and the boiling continued for ten minutes, when the support with the tubes was removed and the color or lack of color in the solutions recorded. The reading was repeated five and fifteen minutes after removal from the bath.

To facilitate the manipulation and observation of so many tubes when an important time element is involved it was necessary to divide the experiment in point of time into three sections corresponding to the different quantities of methylene blue used; conditions were duplicated as far as possible in each section with the exception of the quantity of dye, even to the use of dilutions from identical solutions of the three reagents. Also while the data submitted were secured during the space of one afternoon, the tests were repeated several times on other occasions with essentially similar results.

The lines drawn in table 2 indicate the division at each reading between those tubes showing definite color and those not showing color. Next the line on the colored side there were always tubes partially decolorized. As the tests were exposed to room temperature and the air the division line had to be moved in the direction of stronger alkali and stronger glucose, in short, those solutions containing least sugar and least alkali were last to decolorize and first to regain their color.

Table 2 shows also that larger quantities of glucose and alkali are required for the decolorization of a larger quantity of methylene blue and, further, that a decrease in alkali is compensated for by an increase in glucose. Roughly, within certain limits a five-fold increase in glucose permits halving the alkali and vice versa. It is not difficult to understand the direct correspondence between the amount of dye decolorized and the amounts of glucose and alkali required upon the theory that a definite quantity of some substance or substances produced by the action of alkali on glucose and other susceptible carbohydrates is necessary

as a matter of chemical equivalence but an attempt to apply the Guldberg-Waage mass law was not successful.

The present status of our knowledge of the changes which monosaccharids undergo in the presence of alkalis, so well sum-

TABLE 2

*Decolorization and recoloration of varying concentrations of methylene blue in relation to varying concentrations of glucose and alkali*

NaOH	METHYLENE BLUE 1:1000						REMARKS
N/100	-	-	+	+	+	+	After 5 minutes
N/200	-	-	-	+	+	+	At once
N/400	-	-	-	-	-	-	
N/800	-	-	-	-	-	-	
N/1600	-	-	-	-	-	-	
N/3200	-	-	-	-	-	-	
	0.004	0.02	0.1	0.5	1.0	2.0	Per cent glucose
	METHYLENE BLUE 1:10,000						
N/100	-	-	+	+	+	+	After 15 minutes
N/200	-	-	+	+	+	+	After 5 minutes
N/400	-	-	-	+	+	+	At once
N/800	-	-	-	-	+	-	
N/1600	-	-	-	-	-	-	
N/3200	-	-	-	-	-	-	
	0.004	0.02	0.1	0.5	1.0	2.0	Per cent glucose
	METHYLENE BLUE 1:100,000						
N/100	-	+	+	+	+	+	
N/200	-	+	+	+	+	+	After 15 minutes
N/400	-	+	+	+	+	+	
N/800	-	-	+	+	+	+	After 5 minutes
N/1600	-	-	-	+	+	+	
N/3200	-	-	-	-	+	+	At once
	0.004	0.02	0.1	0.5	1.0	2.0	Per cent glucose

- indicates no reduction—a blue solution.

+ indicates reduction—a colorless solution.

marized by Woodyatt (1915, 1918), indicates a tremendous variety of reactions according to the sugars concerned, the concentration of hydroxyl ions, degree and time of heating, presence

and absence of air, etc. In general, the basis laid by Lobry de Bruyn (1895), Lobry de Bruyn and Van Ekenstein (1895, 1896, 1897) Nef (1907), Mathews (1909), Henderson (1911), Glattfeld (1913), and others, indicates two groups of products resulting from alkali treatment, first, isomers as a result of the action of weak concentrations, low temperature, etc., and second, split products as a result of stronger concentration and higher temperature. Weak alkalis are transformative, strong alkalis destructive. The literature indicates clearly that glucose ionizes in the presence of alkali as a weak acid, which can be readily shown by colorimetric determination of the change in  $H^+$  ion concentration of alkaline buffer solutions to which glucose is added. Alkali upsets the stability of the molecule causing the formation not only of all the possible isomers, but of metallic glucosates, and sugars of one, two, three, four, and five carbon atoms as well as oxy-acids.

The fact that decolorization occurs in the presence of minute quantities of alkalis might seem to speak strongly for some isomer as responsible for decolorization. But since isomers as well as the original sugar are destroyed by higher concentrations of alkali and these decolorize more readily than low concentrations we cannot entertain this idea seriously. Also the decolorization of methylene blue in similar concentrations of glucose and levulose depends upon identical concentrations of alkali; thus 0.1 per cent solutions of these sugars were decolorized in  $N/800$  NaOH but not in  $N/1600$  NaOH during ten minutes boiling.

Similarly the temptation to explain the possible reduction of alkalinity in the test almost to the vanishing point, by increasing the glucose content, as a result of the adulteration of glucose with effective isomers or split products is checked by the observation that even 20 per cent solutions of glucose without alkali fail to decolorize methylene blue on prolonged boiling.

On the other hand we are unable to exclude split products as the effective agency when alkali is present. Methylene blue solutions caramelized by boiling a few minutes in  $N/10$  or stronger NaOH, and, when neutralized or even slightly acidified, and allowed to regain their color (yellow + blue = green), can be

decolorized (yellow) in this condition by further boiling; furthermore, *prolonged* boiling of glucose, levulose, and lactose in strongly acid solutions also results ultimately in more or less complete decolorization of methylene blue.

Some of the organic acids were noted above as failing to furnish conditions necessary for the decolorization of heated methylene blue solutions even in the presence of glucose. Alone in  $N/10$  concentration, neutralized with equivalent amounts of  $N/10$  NaOH, and alkalized to  $N/10$  NaOH, they also fail. Neither formaldehyde, a building stone of glucose, nor ethyl alcohol, one of the most frequent fermentation products of glucolysis, in 5 per cent solution, acidified with HCl to  $N/10$ , neutral, or alkalized to  $N/10$  NaOH, causes the decolorization of methylene blue solutions containing 1 part per 100,000 on boiling. Other products of alkali glucolysis must be tested if we are to fasten the responsibility for the decolorization of methylene blue upon a definite single substance. Our present speculations lead us to suspect that decolorization of methylene blue depends upon those conditions which liberate nascent hydrogen and, that the formation of metallic glucosates by alkalis is somewhat analogous in this respect to the action of HCl on zinc. Or, it may be that the hydrogen required for the reduction of methylene blue to its leuco-base is derived from the dissociation of water and corresponds to the equivalent oxygen uniting with the residue of the sugar molecule, according to Nef's theory.

Two per cent Witte's peptone solutions and 2 per cent agar solutions with 1:100,000 methylene blue are decolorized by heating with alkali. But with peptone, at least 1 part  $N/1$  NaOH in 128 had to be present, owing possibly to the considerable buffer action of peptone. With agar solutions ( $pH = 7$ ) decolorization occurred with 1 part  $N/1$  NaOH per 200 agar but not with 1 part per 250, although agar is supposed to have little or no buffer action according to Clark and Lubs (1917). Addition of 0.5 per cent glucose did not permit decolorization in less alkali than in controls without glucose, in fact the presence of agar inhibits decolorization in concentrations of alkaline glucose solution which will readily decolorize without the agar.



In the decolorization of methylene blue temperature is a factor; heat plays a double rôle, driving out oxygen by lowering the solubility point and accelerating the chemical reaction between alkali and organic matter.

Sunlight also effects the decolorization of methylene blue but this factor is mentioned here only as a disturbing influence which has been avoided in the experimental work. Lasareff (1912) and Gebhard (1912) have shown that the bleaching effect of light is most intense in the absence of oxygen; the color returns in the dark in the presence of oxygen providing exposure was to wave lengths less than  $620 \mu\mu$  but otherwise does not.

Table 3 displays the results of an experiment showing that the return of color to decolorized methylene blue agar in bright sunlight is considerably less rapid than in diffuse light or in the dark.

TABLE 3

*Depth of colored band at top of 2 per cent agar with N/100 NaOH at different time intervals after decolorization, in varying light intensities*

	AFTER FOLLOWING NUMBER OF MINUTES REMOVAL FROM BATH:							
	15	30	45	60	120	180	240	300
	<i>mm.</i>	<i>mm.</i>	<i>mm.</i>	<i>mm.</i>	<i>mm.</i>	<i>mm.</i>	<i>mm.</i>	<i>mm.</i>
Sunlight.....	0.5	0.6	1.0	1.5	2.6	3.4	4.1	4.9
Diffuse-light.....	0.5	1.1	2.0	2.5	3.8	5.0	5.5	6.0
Dark.....	0.8	1.5	2.1	3.0	4.1	5.2	5.6	6.2

As to the decolorization of methylene blue by living cells this discussion does not particularly concern itself further than to note with Jordan that "anaerobes will grow in media where . . . reduced methylene blue shows no trace of reoxidation." They will grow also in undecolorized methylene blue but observations of many tests have shown no instance where such growth was unaccompanied by decolorization. While, as Ricketts (1904) has mentioned, we cannot regard the reduction of methylene blue as a definite test for living cells, as Ehrlich and others have suggested, since methylene blue becomes leucomethylene blue when its affinities for hydrogen have been satisfied, whether through reduction by living or non living matter,

yet in the known absence of non living reducing agents, the decolorization of methylene blue in culture media may be taken as a fair indication of anaerobic growth where the conditions of anaerobiosis are such as not in themselves to decolorize the dye. The failure of certain streptococci to decolorize methylene blue in milk as sherman and Albus (1918) found, appears to be a matter of inhibition; it is interesting to note Brown's (1920) observation that some of these forms will develop in the depths of agar containing decolorized methylene blue but not in the colored band near the surface; contrary-wise it is possible for many organisms to grow aerobically upon media colored with methylene blue without decolorization. The possible rôle of adsorption of methylene blue by bacterial bodies in its relation to true reducing processes still remains to be investigated.

#### *Recoloration of methylene blue*

Whereas we are able only to speculate as to the basic explanation of these various phenomena a knowledge of them enables us to gauge correctly the concentration of ingredients in the use of methylene blue as a criterion of anaerobiosis. Such use depends, as already noted, upon the recoloration of decolorized methylene blue in the presence of air, and the failure of recoloration when air is excluded. But recoloration does not occur in glucose solutions in alkali stronger than  $N/32$  in which marked caramelization has occurred, nor in peptone more strongly alkaline than  $N/16$ , nor in agar sufficiently alkalinized to prevent solidification; neutralization of such glucose solutions permits recoloration, however (Yellow + blue = green).

As a general rule, the delicacy of methylene blue as a criterion of anaerobiosis varies directly as the kind and amount of reducing agent employed, and the temperature used to effect decolorization, and inversely as the alkalinity of the solution. As shown in table 2 those decolorized solutions last to lose their color were first to regain it. In general a moderate concentration of glucose, e.g., 0.5 to 2 per cent with a low concentration of alkali ( $N/500$  to  $N/1000$  NaOH) gives the best results for tests involving

liquids; 2 per cent neutral agar, plus 1 part N:1 NaOH per 100 is satisfactory for tests involving solid media.

There is a possible fallacy in the use of too weakly alkaline solutions, namely, that on standing they cannot be decolorized by boiling. By exposing all the seven possible combinations of one, two, or all, of the three factors, glucose, alkali, and dye, for forty-eight hours, and then adding those lacking in each of six of these, it can be shown readily that only those originally containing alkali deteriorate; that is, deterioration consists in loss of alkalinity. The test solution must be freshly alkalized, though the glucose methylene blue or agar methylene blue may be kept as stock solutions. Loss of ability to decolorize might conceivably be attributable to acid in the glassware though I have never encountered this factor knowingly. The change of reaction is most reasonably attributed to absorption of atmospheric carbon dioxide. An easy proof of change in reaction of faintly alkaline solutions on exposure to air is afforded if one heats N/1000 NaOH colored with phenolphthalein in a constricted tube with marble seal in a bath of boiling water; this dye is not affected by such heating. But on cooling for several hours the color above the marble fades while that below remains. Or, drawing air through such a colored solution causes it to fade, through change of reaction, but if the air be washed by bubbling through several tubes of strong lye to remove CO<sub>2</sub>, with the efficacy of such removal tested by passage through clear lime water, the phenolphthalein test solution remains alkaline. A repetition of this last experiment with a decolorized methylene blue solution gives the same result, i.e., recoloration, with air containing CO<sub>2</sub> and air freed therefrom, except that the solution recolorized with the latter continues susceptible to repeated decolorization longer than with the former. This proves that CO<sub>2</sub> is not the only factor in recolorization of methylene blue as it is in the change of reaction in the phenolphthalein experiment. If the air be carefully washed in several successive mixtures of alkaline pyrogallol so as to remove both carbon dioxide and oxygen its passage through a decolorized methylene blue solution does not cause the return of color. In short, there

are two possible factors in the recoloration of methylene blue by exposure to air, oxygen and carbon dioxide—two processes, oxidation and acidification.

Since the reaction rests unquestionably upon a quantitative basis, even though we know nothing of the absolute values in oxygen and carbon dioxide concerned, the volumes of test solution in relation to surface exposure, where time marks the progress of recoloration, is of great importance in comparative tests. With equal surface exposure large volumes regain their color more slowly than small volumes. In all cases care has been taken to use the same size tubes and identical volumes in a given experiment unless otherwise stated. Differences in volume between experiments account readily for certain apparent discrepancies in actual observations of time required for recoloration.

#### *Application to methods of culture*

With these data at hand tests have been made of a great many methods of cultivation, in which connections I gladly acknowledge the aid of my student, Miss Margaret Eakin. Here, as in the culture of anaerobic microorganisms, we have to distinguish between the factors of oxygen tension reduction and of reduced oxygen tension maintenance.

We have referred already to the literature on biological reduction of methylene blue; to this we may add that our experiments show the general possession by living cells of the property of reduction. This property is common to many aerobes and anaerobes, so in symbiotic mixtures, methylene blue is reduced as a matter of course. With a broth culture of hay bacillus in an external rubber stoppered tube and a smaller internal tube containing slanted 2 per cent agar with 1:100,000 methylene blue and  $n/100$  NaOH analogous to the method of Salomonson (1889), only partial reduction was obtained in twenty-four hours at 37°C. and similar tubes of nutrient agar inoculated with *B. botulinus*, *B. tetani*, *B. welchii* and other obligative anaerobes failed to yield satisfactory surface growth. Failure of complete decolorization here is correlated with refusal of strict anaerobes

to multiply. This method is well known to be adapted to the culture of microphilic aerobes, however.

Plant and animal tissues also reduce methylene blue in the depths of liquid media. In one instance a piece of sterile guinea pig kidney under mineral oil kept methylene blue decolorized in its immediate neighborhood at 37°C. for 196 hours whereas the control without tissue but with an equivalent depth of oil was completely recolored in thirty minutes.

Many investigators, as already noted, have referred to the decolorization of methylene blue by animal and plant tissues as well as by various inert substances in culture media as indicating anaerobic conditions therein. Of these, Zinsser, Hopkins and Gilbert (1915) recognized most clearly that we have to deal here with another process in addition to reduction, namely adsorption. They were unable, by extraction of animal organs, to secure any reducing substance whatever apart from the tissues and concluded that adsorption is mainly responsible for the loss of color in media containing methylene blue in the presence of such agents. This conclusion was strengthened by their observation that heated tissues are nearly, if not quite, equal to unheated tissues for this purpose. Similar observations were previously made by Wrzosek (1907), Liefmann (1907), Guillemot and Szczawinska (1908), and Hata (1908) but it is doubtful if any of these workers appreciated the important rôle of adsorption.

It is possible, as I shall show presently, to extract reducing substances from both plant and animal tissues, and in this important respect their action upon methylene blue differs from that of inert particulate substances such as sand.

When a small piece of potato was placed in an aqueous solution of methylene blue (1:100,000) at room temperature, the solution adjacent to the tissue lost its color within two to three hours and within a few more hours the test tube showed a lightly colored bluish liquid in which the potato fragment was slightly tinged with blue, most prominently at its uppermost end. No recoloration occurred in such a partially decolorized solution on exposure in a Petri dish nor could it be decolorized by boiling except on alkalinization. In contrast, the potato fragment became mark-

edly bluer on exposure, and if cut into displayed a decreasing intensity of dye in the interior, the color deepening rapidly in contact with the air. Such an experiment may be interpreted as indicating adsorption plus reduction, the latter occurring mainly, if not exclusively, within the plant tissue.

Acid ( $N/100$  HCl) and alkaline ( $N/100$  NaOH) solutions gave similar results. Heating such a series immediately in the boiling water bath resulted in decolorization of the alkaline solution only. Exposed to the air in the tube the color returned to this solution on cooling in an intensity practically equal to that of the neutral and acid solutions. Adsorption proceeded in all three and did not seem to be notably accelerated by the heating. Previous boiling of the potato fragment seemed to have no influence on the result.

Extraction by boiling a 1 gram fragment of potato in 1.0 cc. of  $N/10$  HCl, neutral water, or  $N/10$  NaOH for ten minutes and decanting the supernatant fluid yielded a solution containing a reducing substance for methylene blue which could be demonstrated by its decolorization on boiling in  $N/20$  alkaline solution. The color readily returned to such solutions on exposure to the air in a Petri dish. The method of extraction suggested that the substance extracted was probably starch which assumption was substantiated by the iodine test. Starch reduces methylene blue on boiling in alkaline solutions.

Experiments with animal tissues, such as rabbit and guinea pig liver, in aqueous solutions of methylene blue gave results apparently identical with those recorded for plant, i.e., potato tissues. The solutions, acid, neutral and alkaline, became decolorized in the immediate neighborhood of the tissues within a few hours and almost completely, throughout, in twenty-four hours. The nearly colorless solutions separated from their tissues did not regain their color on exposure to the air nor could they be completely decolorized by heating except in the case of the alkaline solution. Alkalinization of the neutral and acid solutions, however, facilitated their rapid decolorization by heat. The tissues became slightly tinged with blue during contact with the dye solution and quickly colored on exposure to the air,

both on the surface and in the exposed depths. These phenomena coincide exactly with those observed for the plant tissue and point to the same two processes, adsorption and reduction.

But when it came to extraction of the reducing substance from the animal tissues it was found that the solutions from freshly boiled liver, whether acid ( $N/10$  HCl), neutral, or alkaline ( $N/10$  NaOH), failed to decolorize methylene blue added to them, even when strongly alkalinized and heated further. Immediate decolorization upon the addition of a trace of glucose proved the suitability of the general conditions of the test for the proof of a reducing agent. But kept in the ice chest overnight either with or without previous boiling, and in acid, neutral or alkaline solutions and then further boiled immediately previous to separation of the clear supernatant fluids, guinea-pig liver yielded a reducing substance to the fluid capable of decolorizing methylene blue under the influence of heat in alkaline solutions. Guinea pig kidney also gave a similar result in neutral distilled water; acid and alkaline extractions of kidney were not tried.

The results with these animal tissues differ from those with potato, both in respect to the relative ease of extraction of the reducing agent in the latter case, and probably in regard to its chemical nature. There is little reason to doubt that the reducing substance extracted from potato is starch; the chemical nature of that from the animal tissues is only conjectural. We may say definitely that it belongs to the non-heat-coagulable extractives, that it is not materially affected by relatively strong acids and alkalis, and that it escapes from the tissue into the solution during sixteen hours maceration in the ice chest or at room temperature, with or without previous boiling. Furthermore, and this may be the point overlooked by Zinsser, Hopkins and Gilbert (1915), a necessary condition for decolorization of methylene blue by heat in the presence of either the reducing substance from potato or that from rabbit and guinea pig liver and kidney is an alkaline reaction. Solutions so decolorized regain their color on exposure to air.

Thus in considering the action of such plant and animal tissues in anaerobic culture media from the standpoint of their effect

on methylene blue we have to recognize that both adsorption and reduction are concerned.

To complete a representative study of porous substances used in the cultivation of anaerobic organisms I have selected white sea sand. There has been a strong suggestion in such recent work as that of Douglas, Fleming and Colebrook (1917) that the principal value in plant and animal tissues added to culture media for the cultivation of obligative anaerobes lies in their provision of interstices which by their minute size serve to prevent diffusion of oxygen as well as to afford secluded foci for the initiation of growth, and this view has much to commend it. They have shown, indeed, and others as well as ourselves have confirmed, the value of various inert insoluble substances added to media in place of animal and plant tissue.

When I attempted the treatment of simple methylene blue solutions with sand, results startlingly like those with tissues were secured except that there was no reduction in the depths of the sand. In brief, adsorption is the sole process concerned here, and it occurs aerobically as well as anaerobically. In a Smith fermentation tube filled with an aqueous methylene blue solution and shaken up with sand which settled into the neck, marked decolorization occurred in both the open and the closed arms.

Of course it was impossible to "extract" a reducing agent from sand. But so far as the solution itself was concerned it behaved exactly like that treated with tissue; with this exception, that some reducing agent such as glucose, as well as an alkaline reaction had to be provided in order to secure complete decolorization by heating.

Whereas sand of itself has no true reducing action, there is no doubt of its efficacy as a means of maintaining reduced oxygen pressure, as we may judge from the persistence for many days of decolorization in the closed arm of a fermentation tube provided with a slightly alkaline glucose solution of methylene blue and a sand seal in the neck of the tube. The sand seal with suitable culture media in the fermentation tube is also quite satisfactory from the cultural standpoint.



In summary, the difference between plant and animal tissues and inert substances such as sand are the differences between more or less soluble organic substances and insoluble inorganic substances. No doubt, plant and animal tissues may serve the same mechanical purposes as sand; in addition they may supply nutrients to the medium, buffer substances and possibly even "vitamins." With plant and animal tissues in media, otherwise lacking in reducing substances, these may be of supplementary importance in the cultivation of obligate anaerobes. Finally, unless we are willing to concede some importance to adsorption as a factor in anaerobiosis, sand and other inert porous substances may serve only as a means of maintenance of reduced oxygen tension, i.e., as seals, whereas tissues may serve not only this purpose but may actually aid in the reduction of oxygen tension in addition to the nutritive functions they fulfill. We may emphasize the importance of heat in this connection since the existence of a true self active reducing agent as distinguished from the phenomenon of adsorption seems as yet unproved.

As to physical reduction, i.e., ebullition, the data already presented bear testimony to the efficacy of boiling. In these tests, as in the actual culture of anaerobes, boiling is often an essential preliminary procedure in the test. The use of both liquid and solid deep media so decolorized shows the first return of color at the top and proves the importance in the case of liquid solutions, of such factors as narrowness of bore in the tube volume of solution, the effect of diffusion currents, etc. With solid media these are not so important.

In 1, 2 and 3 per cent agar, with  $N/100$  NaOH and 1:100,000 methylene blue, decolorized by boiling in standard culture tubes of 1.5 cm. bore, the depth of the blue band at the top of the agar at various intervals appeared as in table 4.

Apparently variation of agar content, within the limits of 1 to 3 per cent makes only a little difference in the rate or depth of recoloration. We may point out that the depth of blue color at the top of the agar column corresponds roughly to that in a deep glucose agar stab or shake culture which is free from growth though there are doubtless variations according to species, and

perhaps nutrient conditions, as Burke (1919) has mentioned. On standing longer the blue band thickens, and it is suggested that the distance from the surface at which anaerobic growth commences is determined partly by the rapidity of multiplication permitted by the nutritional conditions of the culture.

Deep tubes of agar, in which recoloration of decolorized methylene blue is occurring, present the phenomenon of rhythmic banding, i.e., Liesegang's rings. This subject has been studied recently by Holmes (1918) in other cases, but no one, so far as I am aware, has investigated the phenomenon in the case of methylene blue, for which no really satisfactory explanation is available.

TABLE 4

*Depth of returning blue band in decolorized methylene blue agar of varying densities*

AGAR	MINUTES					
	5	10	20	30	40	50
<i>per cent</i>	<i>mm.</i>	<i>mm.</i>	<i>mm.</i>	<i>mm.</i>	<i>mm.</i>	<i>mm.</i>
1	0.4	0.5	0.6	1.8	2.6	3.3
2	0.4	0.5	0.7	1.8	2.5	2.8
3	0.6	0.8	0.8	2.5	3.5	4.5

AGAR	HOURS				
	1	2	4	10	21
<i>per cent</i>	<i>mm.</i>	<i>mm.</i>	<i>mm.</i>	<i>mm.</i>	<i>mm.</i>
1	3.6	5.5	7.5	11.2	16.5
2	3.2	5.3	7.2	11.0	16.0
3	5.0	7.5	10.0	14.0	19.8

Other methods of deep culture involving solid or semi-solid media present phenomena analogous to those observed with deep agar tubes. Thus gelatin and deep brain media with methylene blue remain decolorized in the depths for several days after heating but the immediate coloration in the uppermost layer gradually extends downward as oxygen and carbon dioxide are absorbed. Corresponding to the usual failure of cultural tests with unprotected liquid media, alkaline glucose solutions of methylene blue regain their color on exposure to

air soon after boiling. But large flasks of solution or very slender deep tubes of such decolorized solutions remain decolorized for some hours—sufficiently long, indeed, for anaerobic growth to be initiated in suitable media heavily inoculated under similar circumstances. In the Smith fermentation tube efficacy for anaerobic culture, or maintenance of decolorization of methylene blue, depends largely upon the bore at the bend and satisfactory results for either cannot be secured without the use of a special seal, such as sand, tissues, etc. In some unprotected tubes the color returned to the solution in the closed arm in fifteen minutes, in others in sixty minutes and in still others after several hours; with sand seals the dye color returned only in the open arm and then gradually faded even here through adsorption.

The method of deep colony culture between the nested halves of a Petri dish when tested with methylene blue showed a progressive recoloration of the decolorized dye from the periphery inward, except when protected by a paraffine or vaseline seal.

There is no phase of the methylene blue problem to which we have given more careful attention than its use in connection with insoluble liquid seals, i.e., hydrocarbon oil, wax and grease. The widespread use of these substances as a means of excluding oxygen together with the theoretical and practical objections to their use, especially in the case of oil, have justified a searching examination of this matter. The results with methylene blue only serve to support the conclusion that liquid hydrocarbons are to a degree superfluous and inefficacious means of maintaining anaerobiosis; on the other hand the waxes and semisolid grease seals are more satisfactory for certain purposes, from the standpoint of air exclusion, though inferior to mechanical seals in the matter of convenience and cleanliness.

In the first place an alkaline glucose solution of methylene blue does not decolorize at 37°C. under 2.5 cm. depth of mineral oil, although it may be mentioned here that it does so readily in a few hours under the marble seal in a constricted tube, or under a cover slip in a plain tube, or under a thin layer of paraffine.

I have shown repeatedly with different samples of mineral

oil that the color returns to alkaline glucose methylene blue solution decolorized under varying depths of oil by heating in a boiling water bath almost as soon as without the oil. The following instance illustrates this point. Two per cent glucose (Pfanstiehl) with  $N/500$  NaOH and 1:100,000 methylene blue (Grübler) in aqueous solution was placed in equal depth (3 cm.) in similar culture tubes of  $\frac{1}{2}$  inch diameter and covered to the depths noted with "Fulmor" oil, a white neutral mineral oil prepared by the Fuller Morrison Company of Chicago; a constricted tube with the same dye solution and marble seal was included for a control. It should be noted that the diameter of this tube was about twice, and the surface exposure of liquid therefore 4 times, that of the other, thus offering even greater opportunities for rapid recoloration, which was observed above the seal. All were decolorized throughout by heating two minutes in the boiling water bath and readings made as follows on the removal therefrom.

DEPTH OF OIL	ONE-QUARTER HOUR	ONE HOUR	TWO HOURS	SIXTEEN HOURS— (BOILED TEN MINUTES)
<i>cm.</i>				
5	Colorless	Slightly blue	Blue	Nearly colorless
3	Colorless	Slightly blue	Blue	Nearly colorless
1	Colorless	Slightly blue	Blue	Slightly blue
0	Slightly blue	Blue	Blue	Blue
Constricted tube	Above—Blue	Blue	Blue	*
	Below—Colorless	Colorless	Colorless	*

\* Not boiled with other tubes—still colorless below after six days.

This representative experiment indicates that oil is much less efficacious than sometimes assumed as a means of oxygen exclusion. The progressive ease of repeated decolorization in relation to depth of oil suggests that carbon dioxide is excluded somewhat better but one must not lose sight of the fact that the maximum depth of oil in this experiment is much greater than ordinarily used.

I have noted elsewhere (1915) that, culturally, the growth of obligative anaerobes is delayed under oil except where relatively large inocula are used. In certain experiments, comparing the efficacy of the marble and oil (2.5 cm.) seals in constricted tubes with identical media, growth has been negative with the oil seal in twenty-four to forty-eight hours at a million times the dosage showing definite growth under the marble. Continued observation of the oil tubes has usually decreased the disproportion, however. Although these experiments suggest an inhibitive action of the oil this was not substantiated by comparing progressively diluted cultures under both the oil and marble with a similar set under the marble only; in this case equivalent dilutions developed in parallel order.

In this connection it was interesting to study the effect of filling a constricted tube with alkaline methylene blue solution and oil in such a way that the marble seal lay in the oil. The results of a carefully controlled experiment are summarized herewith, the solutions having been decolorized first in the usual way by heating and removed for observation.

	<i>Ten minutes</i>	
Tube 1—No seal.....	Solution blue	} Blue above Colorless below—remained so for over two weeks.
Tube 2—Marble in solution.....		
Tube 3—Marble in oil.....	Solution blue	
Tube 4—Oil alone .....	Solution blue	

Tube 3 in addition to showing this remarkable result also shows regularly, in such an experiment, a striking and fairly permanent emulsification of water in oil which has been made the subject of a special monograph by the writer (1917).

But it was most disconcerting to find that the marble placed in the oil fails to protect the decolorized solution from recoloration on cooling and suggests that the effect of heating a solution in contact with oil is to drive the oxygen from the solution in which it is less soluble, into and possibly to some extent through the oil, in which it is more soluble, and that on cooling there is a return of some of the oxygen from the oil to the solution.

A duplication of this experiment using phenolphthalein instead of methylene blue showed that  $\text{CO}_2$  also is probably similarly concerned: for with the marble seal in the solution the alkalinity of that portion below the seal was protected for over twenty-one hours as against a failure above the marble but below the oil within 1 hour, while with the marble in the oil the solution was only faintly alkaline at one hour and frankly acid at three and one-half hours.

It is impossible to attribute any change in reaction directly to contact with the oil in view of an experiment with oil layered on standard buffer solutions of known acidity ( $\text{pH} = 5, 6, 7, 8,$  and  $9$ ) and colored with brom-cresol purple and cresol-red in their respective ranges for comparison with identical solutions with out oil; there was not the slightest evidence of changed reaction either after shaking together cold, or during, or immediately after heating.

An attempt to make a better showing for the oil by heating the mixture of alkaline glucose methylene blue solution in the autoclave for twenty minutes at 25 pounds pressure ( $267^\circ\text{C}.$ ) gave no better results. Neither was separate heating of solution and oil either in the boiling water bath or in the autoclave, followed by immediate layering, as efficacious in preventing the return of color as heating together in the water bath.

Vigorous boiling of the solution under the oil by the cautious use of a  $110^\circ\text{C}.$  saturated salt solution while accelerating the rate of decolorization failed to show any material advantage in excluding the air as judged by the time in which the color returned.

Several attempts to layer oil at or near its own boiling point (about  $300^\circ\text{C}.$ ) upon decolorized solution at  $100^\circ\text{C}.$  resulted disastrously in breakage of glassware and almost explosive scattering of hot oil. Cooled rapidly to about  $120^\circ\text{C}.$  in a few experiments I had the gratification of seeing the solution under the oil, even without the marble seal, remain completely decolorized for nearly twenty-four hours; with the marble seal in the oil it remained so for much longer. In still other experiments where the oil was heated to boiling and allowed to cool even for a few minutes, to as low as  $60^\circ\text{C}.$  and then immediately brought

up to 100°C. and layered upon the hot solution the color returned to the latter in about half an hour as in the case of oil heated with the solution in a boiling water bath.

If one increases the depth of solution in a tube without oil, several times over that of a similar tube with oil, both being equally decolorized by boiling, the former may be seen to regain its color even before the latter.

These experiments lend little support to the use of oil as a means of anaerobiosis and limit the technic where it is used to layering on of freshly boiled oil quickly cooled nearly to 100°C., but even in this case it is less efficacious than the marble seal.

In none of the experiments with alkaline glucose methylene blue solution has there been any evidence of absorption of the dye by the oil. Methylene blue is insoluble in oil. A bluish tinge sometimes observed in the oil layer is really due to the dye dissolved in a film of water which separates the oil from the glass wall as I have mentioned elsewhere (1917) or, in the case of oil-dye solutions actively boiled over the free flame or in a strong salt solution bath, to emulsified water holding the dye in suspension. A suggestion that the dye might be absorbed in the form of the colorless leuco-base was proven erroneous by pipetting off the oil from the tube of decolorized dye solution into a tube of distilled water; on exposure to air the color returned at once to the original dye solution whereas the water and the oil overlying it remained quite colorless.

Experiments analogous to some of those with the liquid solution have been performed with 2 per cent neutral agar made alkaline by the addition of 1 cc.  $N/1$  NaOH per 100 and colored with 1 part methylene blue per 100,000 as offering a roughly quantitative measure of the rate of air absorption which is indicated by the thickness of the blue band that appears at the top and deepens as exposure continues. Another advantage of this means of test is that disproportionate volumes do not introduce time differences into the observations of recoloration as they do with a liquid test solution, yet in both cases the volumes and areas exposed in different tubes have been kept identical for comparative purposes except where otherwise noted.

The importance in such observations of having a sufficient quantity of test solution is shown in the following experiment which offers a comparison of the results with equal ratios but differing absolute quantities of test solution and seal.

The liquid test solution was the usual 2 per cent glucose, with  $N/500$  NaOH, and 1:100,000 methylene blue; the agar test solution was 2 per cent agar with  $N/1$  NaOH and 1:100,000 methylene blue; the seal was vaseline. The mixtures were made in tubes of 10 cm. diameter and heated in a boiling water bath for a few minutes to decolorize. They were allowed to stand overnight at room temperature and then examined for recoloration. The results appear in table 5.

TABLE 5  
*Relation between absolute and proportional quantities of test solution and seal*

VASELINE	SOLUTION	RESULT	VASELINE	SOLUTION	RESULT
Liquid test solution					
cc.	cc.		cc.	cc.	
1	10	Colorless	1	10	Colorless
1	5	Colorless	2	10	Colorless
1	2	Blue	5	10	Colorless
1	1	Blue	10	10	Colorless
Agar test solution					
1	10	Blue, 1 mm.	1	10	Blue, 1 mm.
1	5	Blue, 1 mm.	2	10	Blue, 1 mm.
1	2	Blue, 1 mm.	5	10	Blue, 1 mm.
1	1	Blue	10	10	Blue, 1 mm.

The logical explanation of this result appears to lie in the assumption that sufficient oxygen or carbon dioxide is retained in the seal to recolor a small amount of test fluid previous to setting of the seal but not sufficient to recolor a larger amount.

Boiling an agar solution under 3 cm. of oil, in a water bath, heating to 25 pounds steam pressure (267°C.) in the autoclave for twenty minutes, or layering the separately heated oil and agar solutions, made only a slight difference in the rate of return of color at the oil-agar surface, which is almost as rapid as without the oil.



Neither heating the oil in the boiling water bath nor boiling (about 300°C.) over the free flame appeared to affect the density of color in the superficial colored layers of alkaline, 2 per cent agar containing methylene blue 1:100,000. This experiment negatives the suggestion that de-aerated oil is able to abstract oxygen and carbon dioxide from media containing them. Also, whereas melted alkaline agar colored with methylene blue and poured without further heating to decolorize into tubes, loses its color to within 1 to 2 cm. of the surface in a few hours, the immediate layering of such a solution with mineral oil makes only a barely measurable difference in the thickness of the band of color at the top.

TABLE 6

*A comparison of mineral oil and paraffine as seals against the recoloration of alkaline methylene blue agar*

	HOURS						
	0.25	2	6	24	45	70	96
	<i>cm.</i>	<i>cm.</i>	<i>cm.</i>	<i>cm.</i>	<i>cm.</i>	<i>cm.</i>	<i>cm.</i>
No seal.....	0.5	0.7	0.8	1.5	1.7	2.0	2.5
Mineral-oil.....	0.3	0.5	0.6	1.0	1.5	1.9	2.5
Paraffine.....	0.2	0.3	0.4	0.6	1.1	1.1	0.9

Depth of agar, 7 cm.

Depth of paraffine and oil, 2.5 cm.

An equal amount of paraffine in a similar tube, however, reduced the band of undecolorized medium to 1 cm. in sixteen hours. In a comparison of these three conditions where boiling was used as a means of immediate decolorization followed by rapid cooling and incubation at 37°C., the measurements of the blue band indicated (in centimeters) in table 6 were made.

An analogous comparison of paraffine and vaseline of approximately equal melting points (50°C.) and boiling points (about 300°C.) showed vaseline to be superior even to paraffine. Table 7 shows the actual measurements in centimeters (alkaline methylene blue agar 7 cm. deep).

The recession of the band under paraffine and vaseline was not peculiar to this particular experiment; it has frequently been

seen, but never with oil nor in media without covering except under the influence of light. It has a logical explanation, I believe in the assumption that a certain limited amount of oxygen and carbon dioxide are absorbed from the seal, thus accounting for the band observed, but failure or reduction in the supply coming through when the seal hardens permits the loss by diffusion from the lower surface of the blue band of these gases into the deeper layers of medium and their dilution thereby to a concentration insufficient to recolor the dye.

TABLE 7

*A comparison of paraffine and vaseline as seals against the recoloration of alkaline methylene blue agar*

	HOURS			
	1.5	4	24	50
	<i>cm.</i>	<i>cm.</i>	<i>cm.</i>	<i>cm.</i>
No seal.....	0.7	1.1	2.0	2.3
Paraffine.....	0.6	0.7	1.3	0.7
Vaseline.....	0.2	0.2	0.3	0.0

Tests with the liquid solution also indicate the great superiority of paraffine wax and especially vaseline over mineral oil as a means of protecting decolorized methylene blue solutions from recoloration. These compare favorably with the mechanical seals such as the marble in a constricted tube, or the cover glass in either plain or constricted tube, or sand in a Smith fermentation tube, under all of which the dye may remain water clear for days.

The efficacy of these seals is not a matter of boiling points since mineral oil has approximately the same boiling point as paraffine. Furthermore, the lower boiling hydrocarbons such as xylol (137° to 140°C.) and heptane (95° to 100°C.) are even less efficacious than mineral oil. Viscosity and consistency seem to be the essential elements; perhaps the ease with which vaseline clings to the glass on hardening explains its superiority over paraffine. The liquid oils probably permit the return of absorbed gases but more particularly operate through convection currents

which transfer gases absorbed at the air surface to the oil-medium surface. Such convection currents are absent, of course, in the solid waxes and semisolid greases.

These researches would be barren were we not able to affirm the parallelism of cultural studies. As a matter of fact, dilution experiments with such organisms as *B. tetani*, *B. Welchii*, *B. sporogenes* and others confirm the great value of paraffine and vaseline as compared with liquid mineral oil. *B. tetani* absolutely failed to grow under either xylol or heptane, gave only delayed turbidity under mineral oil and vigorous early gas production under paraffine. Yet none of these is germicidal for *B. tetani* as shown by successful growth under the marble in a constricted tube of glucose broth covered with them.

The great objections to vaseline and paraffine are their messiness and the fact that they do not provide sufficient variety of oxygen pressures in the medium to meet the possible requirements of different organisms.

Boiling as a means of oxygen tension reduction is sometimes used in methods where the air chamber is sealed either by fusion of the glass outlet or by mechanical devices such as valves, cocks, etc. Either method is satisfactory from the standpoint of the persistence of the decolorized state of methylene blue but is obviously superfluous for deep cultures and is inapplicable to surface cultures for reasons easily apparent.

Evacuation by water pump to 58 cm. mercurial pressure with immediate sealing of a constricted portion of the tube has never sufficed to decolorize methylene blue 1:100,000 either with 2 per cent glucose and N/500 NaOH or 2 per cent agar and N/100 NaOH at ordinary room temperature in our hands. Nor have we ever been able to secure surface growths of such obligate anaerobes as *B. Welchii*, *B. tetani*, *B. oedematis* and *B. botulinus* on the surface of solidified glucose agar by this means alone. We are therefore forced to conclude that evacuation by water pumps of such efficiency is of relatively little value alone as a method of securing anaerobiosis. Higher evacuation might yield more successful results.

The literature is notably deficient in accurate data on the oxygen tension limits of anaerobic bacteria determined by vacuumetric methods. The limit of 35 cm. Hg pressure for the *vibrion septique* set by Rosenthal (1906) in liquid media is of doubtful value when viewed in the light of the recent observations of Harris (1919) on the apparently high tolerance of *B. sporogenes* for oxygen in liquid cultures as compared with agar slopes.

While we have tested the effect of inert gases in the case of hydrogen and carbon dioxide, it is scarcely fair to consider the results as necessarily corresponding to those obtained by cultural methods where we conceive the action to be primarily physical, since with methylene blue solutions we may also have chemical reactions. Hydrogen, indeed, did decolorize cold solutions of 0.5 per cent glucose with  $N/500$  NaOH and 1:100,000 methylene blue slowly, and hot solutions already decolorized remained so during fifteen minutes of active ebullition by hydrogen from a Kipp generator loaded with zinc and sulfuric acid and purified by passage through 10 per cent  $\text{PhNO}_3$  and alkaline pyrogallol. Furthermore when sealed the hot solution remained decolorized till opened on the fourth day while the cold solution showed only a trace of color while sealed.

Passage of commercial carbon dioxide through similar solutions of the dye for one hour failed to decolorize the cold solution although the hot solution remained decolorized during this part of the experiment but soon regained the blue color after sealing. Reheating these solutions failed to decolorize either of them, without further addition of alkali. Here is a situation, which, barring the known inhibitive action due to improper acidity for certain organisms, might yield satisfactory results in the case of certain others, as Pasteur found, without permitting a satisfactory degree of alkalinity for the decolorization of methylene blue.

Coming now to the matter of chemical reduction of oxygen tension, we conceive that in so far as regards reducing agents *in the medium*, they have been sufficiently dealt with already, and the necessity of recognizing limitations of time and space

reduces this discussion, in so far as it relates to chemical reduction by means of an agent *in the air* chamber, to the most valuable agent with which we have to deal, i.e., alkaline-pyrogallol.

Inasmuch as this reagent finds a legitimate use only in connection with attempts to secure surface colonies on solid media, it is to this that we have limited our attention. Buchner's (1888) original technic involving the use of a small tube containing slanted culture medium (2 per cent agar, methylene blue 1:100,000, N/100 NaOH) in a longer one containing the usual alkaline pyrogallol mixture gave satisfactory results when the cotton stopper was left out of the inner tube, but otherwise did not, unless the tube were inverted. Decolorization begins, as does growth of obligate anaerobes on suitable media, in the thinnest portion of the slant. In Wright's (1901) modification, which involves the saturation of the plug with the mixture, sealing by rubber stopper, and inversion, even better results were obtained. In either case partial decolorization appeared at the surface in less than twenty-four hours at 37°C. and continued to completion within two to three days. Both these methods, but notably the last, have given quite satisfactory results in the surface cultivation of *B. tetani*, *B. welchii*, *B. sporogenes*, *B. chauveauii*, *B. botulinus*, and many unidentified anaerobes. Wright's method has been relied upon largely for repeated surface colony isolation of the writer's cultures.

Two plating methods for surface culture have been studied in connection with the methylene blue test, namely Lentz's (1910) pyrogallic acid saturated cardboard, and McLeod's (1913) divided plate. Both showed the dye-agar decolorized at 37°C. within eighteen hours. The latter method has refused consistently however to yield us surface colonies of well known anaerobes on either blood or glucose agar identical with that used in controls by Wright's method. Dr. Oskar Klotz at the University of Pittsburg has stated his belief that aromatic substances in the clay are sufficiently germicidal to explain the failure of bacterial growth and has overcome the difficulty through the use of a special cement containing paraffine and some other substances. At any rate, McCleod's device seems constructed

according to our best conceptions of the requirements. In contrast, the method of Lentz is open to the technical objection that considerable absorption may occur before the seal is completed. We have not tested the latter sufficiently from a bacteriological standpoint to justify any conclusion as to its real worth. The dye test points to its suitability.

In conclusion it is suggested that further studies are required to show exactly to what degree of oxygen tension reduction the decolorization of methylene blue under stated conditions corresponds. Harvey's (1919) recent demonstration of the direct relation between oxygen content and time of decolorization of methylene blue in Schardinger's test and the interesting parallelism between methylene blue reduction and luciferin formation (1920) is significant in this regard, but one must not overlook the great importance of the hydrogen ion concentration of the test solution, and the effect upon this of atmospheric carbon dioxide.

Similar studies are equally needed in the investigation of the oxygen relations of obligate anaerobic bacteria.

#### SUMMARY

This paper reviews the literature on chemical criteria of anaerobiosis, and undertakes a critical experimental survey of the subject in so far as it relates to the use of methylene blue for this purpose. The mechanism of the decolorization of methylene blue is studied in detail and shown to depend upon the interaction of alkali and certain organic substances, notably carbohydrates. A correspondence between Fehling's test and the decolorization of methylene blue in alkaline solutions of various carbohydrates is pointed out.

It is shown that while there is a direct relation between the amount of dye decolorized by heating and the amounts of alkali and glucose, there is an inverse relation between the last two factors in the test, so that an increase in one permits a decrease in the other for the same result.

Carbon dioxide, as well as oxygen, is shown to be an effective factor in the recoloration of decolorized methylene blue.

Various methods of anaerobiosis are viewed critically in the light of experimental tests with carefully balanced solutions of alkaline glucose methylene blue in comparison with cultural tests with *B. Welchii*, *B. tetani*, *B. botulinus*, and other obligate anaerobes.

A detailed study of the decolorization of methylene blue by plant and animal tissues is described, showing the important role of adsorption as a means of decolorization by these and other porous substances. The extraction from plant and animal tissues of reducing substances for methylene blue, active in alkaline solution, is described.

The efficacy of deep culture methods for anaerobes is shown while the inefficacy of insoluble liquid (i.e., oil) seals is contrasted with the reliability of semi-solid waxes and greases, and that of mechanical seals.

The short-comings of certain methods of surface culture of obligative anaerobes are exposed and the value of a modification of Wright's method upheld by these studies.

Finally, the desirability is indicated of determining exactly to what degree of oxygen tension reduction the decolorization of methylene blue corresponds, and whether decolorization occurs at a definite hydrogen ion concentration irrespective of the sugar content of the solution.

#### REFERENCES

- BERNER 1904 On a vial for the culture of anaerobic bacteria on plates. Centralbl. f. Bakteriol., 1 Abt. Orig., **37**, 478.
- BERNTSEN 1883 Ueber das Methylenblau. Berichte d. deutschen Chem. Gesellsch., **16**, 1025.  
1883 Zur Kenntniss des Methylenblau u. verwandter Farbstoffe. Ibid., **16**, 2896.  
1884 Ibid., **17**, 611.  
1885 Studien in der Methylenblaugruppe. Liebig's Annalen der Chemie, **230**, 73, 137.
- BROWN 1920 Cultural differentiation of beta hemolytic streptococci of human and bovine origin. Jour. Exp. Med., **31**, 35.
- BUCHNER, E. 1885 Ueber den Einfluss des Sauerstoffs auf Gährungen. Ztschr. f. Phys. Chem., **9**, 380.
- BUCHNER, H. 1884 Eine neue Methode zur Kultur anaerober Mikroorganismen. Centr. f. Bakt., 1 Abt. Orig. **4**, 149.

- BURKE 1919 Notes on *B. botulinus*. Jour. Bact., **4**, 555.
- CLARKE AND LUBS 1917 The colorimetric determination of hydrogen ion concentration and its applications in bacteriology. Jour. Bact., **2**, 109, 191.
- DOUGLASS, FLEMING, AND COLEBROOK 1917 On the growth of anaerobic bacilli in fluid media under apparently aerobic conditions. Lancet, **2**, 530.
- ERLENMEYER 1883 Zur Constitution des Methylenblau. Berichte d. deutschen chem. Gesellsch., **16**, 2857.
- FREMLIN 1903 A note on the cultivation of anaerobic bacteria. Lancet, **1**, 518.
- 1904 The plate cultivation of anaerobic bacteria. Ibid., **2**, 824.
- FERMI AND BASSU 1904 Untersuchungen über die Anaerobiosis. Centr. f. Bakt., 1 Abt. Orig., **35**, 563, 714.
- GEBHARDT 1912 Ueber das Ausbleichen von Methylenblau im sichtbaren Spectrum. Ztschr. physik. Chem., **79**, 639.
- GLATTFELD 1913 On the oxidation of glucose in alkaline solution by air as well as by hydrogen peroxide. Dissertation, Univ. of Chicago.
- GUILLEMOT AND SZCZAWINSKA 1908 Rôle des substances réductrices dans la culture des anaérobies en présence de l'air. Comptes rend. Soc. biol., **64**, 171.
- GUNNING 1877 Ueber Sauerstoffgasfreie Medien. Jour. f. prakt. Chemie., **16**, 314.
- 1878 Experimental Untersuchungen über Anaërobie bei den Fäulnisbakterien. Ibid., **17**, 266.
- 1879 Ueber die Lebensfähigkeit der Spaltpilze bei fehlenden Sauerstoff. Ibid., **20**, 434.
- HALL 1915 A new aerobic-anaerobic culture tube. Univ. of Calif. Pub. in Pathology, **2**, 147.
- 1917 The stability of emulsions in the constricted tube and marble device for anaerobiosis. Jour. of Physical Chemistry **21**, 609.
- HAMMERL 1901 Ein Beitrag zur Züchtung der Anäroben. Centr. f. Bakt. 1 Abt. Orig., **30**, 658.
- HARVEY 1920 The action of acid and light in the reduction of cypridina oxyluciferin. Jour. Gen. Physiol., **2**, 207.
- 1919 Relation between the oxygen concentration and rate of reduction of methylene blue by milk. Jour. Gen. Physiol., **1**, 415.
- HATA 1908 Ueber eine einfache Methode zur aërobische Kultivierung der Anäroben. mit besondrer Berücksichtigung ihrer Toxin Produktion. Centr. f. Bakt. 1 Abt. Orig., **46**, 539.
- HENDERSON 1911 The instability of glucose at the temperature and alkalinity of the body. Jour. Biol. Chem., **10**, 3.
- HOLMES 1917 Rhythmic banding. Science, **46**, 442.
- 1918 Experiments in rhythmic banding. Jour. Am. Chem. Soc., **40**, 1187.
- HUNZIKER 1902 Review of existing methods for cultivating anaerobic bacteria. Jour. Applied Microscopy, **5**, 1694, 1741. 1800, 1854.
- JORDAN 1918 General Bacteriology, 6th ed., Saunders. Phila., p. 84.



- KABRHEL 1899 Zur Frage der Zucht anaërober Bakterien. *Centr. f. Bakt.* 1 Abt. Orig., 25, 555.
- KITASATO AND WEIL 1890 Zur Kenntniss der Anaëroben, 8, 41.
- LAIDLAW 1915 Some simple anaerobic methods. *Brit. Med. Jour.*, 1, 497.
- LAIRD 1913 Action of sugar solutions on glass. *Jour. Path. and Bact.*, 18, 32.
- LANDAUER AND WEIL 1910 Studien über das Methylenblau. *Berichte d. deutsche chem. Gesellsch.*, 43, 198.
- LASAREFF 1912 Ueber das Ausblühen von Methylenblau im Sichtbaren Spektrum. *Ztschr. physik. Chem.*, 78, 661.
- LENTZ 1910 Ein neues Verfahren für die Anaeroben Züchtung. *Centr. f. Bakt.* 1 Abt. Orig., 53, 358.
- LIEFMAN 1907 Ueber das scheinbar aerobe Wachstum anaërober Bakterien. *Münc. med. Wehnschr.*, 54, 823.  
1908 Ein einfaches verfahren zur Züchtung und Isolierung anaerober Keime. *Centr. f. Bakt.* 1 Abt. Orig., 46, 377.
- LOBRY DE BRUYN 1895 Action des alcalis dilués sur les hydrates de carbone. I. *Rec. trav. Chim.*, 14, 156.
- LOBRY DE BRUYN ET VAN EKENSTEIN 1895 Action des alcalis sur les sucres. II. *Rec. trav. Chim.*, 14, 203.  
1896 *Ibid.* III, 15, 92.  
1897 *Ibid.*, IV, 16, 257.
- MATHEWS 1909 Spontaneous oxidation of the sugars. *Jour. Biol. Chem.*, 6, 1.
- MCINTOSH AND FILDES 1916 A new apparatus for the isolation and cultivation of anaerobic microorganisms. *Lancet*, 1, 768.  
1916 Nouvelle méthode d'isolement et de culture pour les microbes anaerobies. *Comptes rend. Soc. biol.*, 79, 768.
- MCLEOD 1913 A method for the plate culture of anaerobic bacteria. *Jour. of Path. and Bact.*, 17, 454.
- MÖHLAU 1883 Synthese des Methelenblau. *Berichte d. deutsche chem. Gesellsch.*, 16, 2728.
- NEF 1907 Dissociationsvorgänge in der Zuckergruppe. *Liebig's Annalen der Chemie*, 357, 214.
- NOVY 1893 Die Kulture anaërober Bakterien. *Centr. f. Bakt.*, 1 Abt. Orig., 14, 581.
- PETRI 1900 Neue anaërober Gelatine-Schälenskultur. *Centr. f. Bakt.* 1 Abt. Orig., 28, 196.
- RICKETTS 1904 Reduction of methylene blue by nervous tissue. *Jour. Inf. Dis.*, 1, 590.
- ROSENTHAL 1906 Culture aërobie du vibron septique; Mensuration de l'anaerobiose. *Comptes rend. Soc. biol.*, 60, 874.
- SANFELICE 1893 Untersuchungen über anaërober Mikro-organism. *Ztschr. f. Hyg.*, 14, 339.
- SELLARDS 1904 Some researches on anaerobic cultures with phosphorus. *Centr. f. Bakt.*, 1 Abt. Orig., 37, 632.
- SHERMAN AND ALBUS 1918 Some characters which differentiate the lactic acid streptococcus from streptococci of the pyogenes type in milk. *Jour. Bact.*, 3, 153.

- SMITH The fermentation tube with special reference to anaerobiosis and gas production among bacteria. Wilder Quarter Century Book, p. 187. Comstock Pub. Co., Ithaca, N. Y.
- SMITH 1896 Reductionserscheinungen bei Bakterien. Centr. f. Bakt., 1 Abt. Orig., **19**, 181.
- SPINA 1887 Bakteriologische Versuche mit gefärbten Nährsubstanzen. Centr. f. Bakt., 1 Abt. Orig., **11**, 71.
- STÜLER 1904 Neue Methode zur Anäerobenkultur und Anäerokultur. Centr. f. Bakt., 1 Abt., Orig., **37**, 298.
- TRENKMANN 1898 Das Wachstum der anäeroben Bakterien. Centr. f. Bakt., 1 Abt. Orig., **23**, 1038.
- UNDERHILL AND CLOSSEN 1905 The physiological behavior of methylene blue and methylene azure. Am. Jour. Physiol., **13**, 358.
- WILSON 1917 An easily improvised and effective method of obtaining plate cultures of anaerobes. Lancet, **1**, 724.
- WOODYATT 1915 Studies on the theory of diabetes. Jour. Biol. Chem., **20**, 129.  
1918 Diabetes, Chap. 22, in Wells' Chemical Pathology. Saunders, Phila.
- WRIGHT 1901 A method for the cultivation of anaerobic bacteria. Centr. f. Bakt., 1 Abt. Orig., **29**, 61.
- WRZOSEK 1909 Bemerkungen zur Abhandlung von Calderini, Untersuchungen über Anäeroben Zuchtung nach dem Tarozzischen Verfahren. Centr. f. Bakt., **53**, 476.  
1907 Weitere Untersuchungen über die Zuchtung von obligatorischen Anäeroben in aerober Weise. Centr. f. Bakt. 1 Abt. Orig., **44**, 607.
- WÜRTZ 1892 Note sur deux caracteres differentiels entre le bacille d'Eberth et le B. coli commune. Arch. de med. exper., **4**, 85.
- ZINSSER, HOPKINS AND GILBERT 1915 Notes on the cultivation of *Treponema pallidum*. Jour. Exp. Med., **21**, 213.

## POWDERED LITMUS MILK

A PRODUCT OF CONSTANT QUALITY AND COLOR WHICH CAN  
BE MADE IN ANY LABORATORY

HERBERT W. HAMILTON

*Sanitary Research Laboratories, Massachusetts Institute of Technology*

Received for publication June 7, 1920

The wide use of litmus milk as a culture medium, due to its great value in the differentiation of bacteria, has led to the development of various casein media as substitutes. Canned milk has also been used with varying degrees of success. This paper presents a formula which insures a standard product.

Present practice requires the purchase of milk, whole or skimmed. In the former case the fat has to be removed. When the milk is finally prepared it is often found to be too acid and readjustment is required. After such a readjustment is made the effect of sterilization of the milk is often detrimental. But what is more important is the varying color of the milk with every batch. It was with this fact in view that the present formula was developed.

### PREPARATION OF THE INDICATOR

1. The dye should be a blue azolitmin, as free as possible from the red dye. This may be prepared by extracting litmus cubes with boiling distilled water and decanting off the clear solution. The liquid is evaporated to a thin paste over a free flame and treated with an excess of glacial acetic acid. The evaporation is now carried to dryness on a water bath. A quantity of 95 per cent alcohol is added and the whole transferred to a filter. The residue is washed several times with alcohol. The filtrate is discarded. Should the residue be left reddish a drop or two of sodium hydroxide solution will restore

its color. The residue is dissolved in water. This is evaporated to dryness, first over a free flame and finally on the water bath. The yield is about one twenty-fifth of the original weight of the cubes. (Azolitmin may be purchased from certain dealers.)

2. A satisfactory powder may be prepared by extracting the cubes with hot water, filtering and evaporating the filtrate to dryness. The residue is treated with 95 per cent alcohol overnight. In the morning the alcohol is decanted off and the residue dried on the water bath.

#### THE MILK

*Skimmed* milk powder is purchased from a bakers' supply company or grocer. Care should be taken to see that it is clean. Quantities in small containers are more satisfactory than bulk purchases.

The litmus powder so prepared is mixed with the milk powder. In the case of the litmus powder prepared by the first method (or purchased azolitmin powder) one part of the dye is added to 52.7 parts of the skimmed milk powder. When the dye is prepared by the second method one part of the dye powder is added to 49.6 parts of the milk powder.

The resulting mixture is dissolved in distilled water in the proportion of one part of the litmus milk powder to 9.5 parts of water.

Care should be taken in the mixing that the litmus powder is well ground and well dispersed in the milk powder.

All media made in this way have been sterilized perfectly in the Arnold Sterilizer. When autoclaved at 15 pounds for five minutes the medium resumes its true color on cooling. The mixed powder has kept perfectly in a glass stoppered bottle for two years.

Cultures of *Bact. coli*, *B. Welchii*, *Bact. acidi-lactici*, *Bact. alcaligenes*, *Pseudomonas fluorescens*, *B. mesentericus-vulgatus*, *Staph. pyogenes-albus*, and *Proteus vulgaris* all grew well and gave typical reactions in the normal time.

# BACTERIA CONCERNED IN THE RIPENING OF CORN SILAGE

P. G. HEINEMAN AND CHARLES R. HIXSON

*From the Laboratories of the United States Standard Products Company*

Received for publication July 2, 1920

The production of silage on the farm may be regarded as a means of conserving valuable food material. During the process of fermentation which takes place in the silo the fresh fodder is so altered as to prevent spoilage and to conserve its food value. Experience as well as experiment has shown that a highly nutritious and palatable food is thus made available during the winter months, when fresh fodder cannot be obtained.

The authors make no claim to have solved all the problems connected with the fermentation of silage. Many details must remain for future investigation and all that can be claimed is progress. Hunter and Bushnell and Sherman lay stress on the activity of lactobacilli in the ripening of silage and the present work confirms the findings of these authors, namely that lactobacilli are important factors, but that they probably reach the maximum of their activity during late stages of fermentation.

Opportunity presented itself to investigate silage from three silos. Two of these are constructed of wood with concrete foundation, while the third is concrete throughout. The investigation, as might be anticipated, shows that although the fermentative process in general is similar in different silos, it is by no means identical. That is to say, after a definite lapse of time the silage of one silo may be fermented in larger measure than that in another silo. Furthermore, the same stage of fermentation does not necessarily obtain throughout the same silo. No relation to the difference in construction could however be detected.

The silage in the three silos was removed from the top as it was required as food for cattle. Therefore the samples obtained for investigation had not only fermented during progressively longer periods of time, but since the surface layers were periodically removed samples had to be procured from increasing depths. It is conceivable, therefore that anaerobic fermentation becomes more pronounced as silage ripens.

#### METHODS

Samples were taken from the silos in November, January, February, March, April, May and June. A few days elapsed between sampling the different silos in order not to crowd the work but this short interval probably made no material difference in the relative stage of fermentation. Ten grams of each sample were infused with 50 cc. of cold physiologic salt solution. From this infusion stains were prepared and inoculations made in milk with addition of brom-cresol-purple as indicator, into flasks and fermentation tubes containing 2 per cent glucose broth, and on agar. The last medium was used for surface and stab cultures. The infusion of silage was titrated with  $N/20$  NaOH with phenolphthalein as indicator and then together with the inoculated media was incubated at  $37^{\circ}\text{C}$ .

#### RESULTS

Stains from the silage infusion showed enormous numbers of microorganisms. No attempt was made to enumerate them or separate the types, but the predominating types were noted and cultivated. Yeast cells were invariably present and frequently formed a solid film on the surface of the incubated infusion. The acidity of this infusion was never more than 3 per cent normal, but it is probable that the salt solution did not dissolve all the acid contained in the silage. If the juice had been pressed from the silage and then diluted five times its volume with salt solution the acidity would probably have proved higher than the values obtained. After 24 hours incubation of the silage infusion the acidity rose to about three

times the original amount, but after forty-eight hours a marked decrease of acidity was observed coincident with the development of a heavy film consisting of yeast cells:

A bacillus of the colon-aerogenes group was present in large numbers, but only in smears prepared from silage during early stages of fermentation. During late stages the bacillus may still have been present, but if so was numerically insignificant. Streptococci and lactobacilli were always present in early as well as in late samples. The streptococci were readily isolated by plating, but the lactobacilli did not grow readily on ordinary media and were isolated by the method employed by Heineman and Hefferan, namely by repeated transfers through milk and final plating on whey agar.

The streptococci isolated varied somewhat morphologically. In some cases the diplococcus form was predominant, while in others chain formation was observed. However, the diplococcus form was found chiefly in early samples of silage, while chain formation was abundant in later samples. Chains were prominent also in stock cultures prepared from the isolated streptococci, but the short form reappeared when fresh subcultures were prepared. The fact has been repeatedly recorded, that during the most active period of growth, streptococci, especially saprophytic ones, appear chiefly in diplococcus form, while after the maximum growth has passed chain formation becomes more evident. The size of individual cells of streptococci confirms the assumption that they are more active in early silage than in the ripened product. From early samples the cells were uniformly small and in later samples they were large and frequently appeared swollen. These abnormal forms disappeared when young generations grew on inoculated media.

The amount of acid formed in glucose broth by the streptococci was determined by titration with  $N/20$  NaOH. The quantity thus determined never exceeded 5 per cent normal acid in five days. Milk was readily coagulated by most strains of streptococci isolated, in some cases within twenty-four hours.

The lactobacilli observed occurred singly, showed granular staining with methylene-blue in many instances and were rather difficult to isolate. They grew slowly on media containing 2

per cent glucose and the colonies formed on whey agar were always very small. However, from the latest samples a streptobacillus was isolated which grew with relative abundance on glucose media and produced up to 11.5 per cent acid in glucose broth in six to seven days. This bacillus appeared in long filaments composed of rather short bacilli. The acid produced consisted chiefly of lactic acid. It should be emphasized that this strepto-bacillus was never observed in early samples, although it probably was present in small numbers.

Milk inoculated with two loopfuls of silage infusion coagulated promptly, usually within twenty-four hours and when inoculated with the infusion of early samples considerable amounts of gas were produced. In some instances the gas formation was so vigorous as to break up the coagulum. As ripening of the silage progressed the amount of gas formed in milk decreased and finally in the last stages of fermentation no gas appeared. Stains from the coagulated milk, prepared after twenty-four hours incubation, showed that in early stages organisms of the colon-aerogenes group were present in abundance, accompanied by large numbers of streptococci, but as the ripening process proceeded streptococci became more prominent and finally were present practically in pure culture. The milk cultures were not incubated for a sufficient length of time to permit lactobacilli to supersede streptococci, excepting when lactobacilli were searched for.

In a recent paper Gorini calls attention to the presence of butyric acid bacilli in silage and warns of the possibility of their influence on the product. Since anaerobic conditions obtain, at least in deep layers of silage, and since the temperature may be relatively high, conditions for the growth of butyric acid bacilli are not unfavorable. Gorini suggests that the temperature be not permitted to go beyond 50°C. nor below 30°C. in order to favor the growth of lactic ferments (lactobacilli and streptococci) and thus antagonize butyric acid bacilli. In our limited investigation no evidence of the presence of butyric acid bacilli was observed, although they may have been present in small numbers. Several anaerobic cultures prepared from the silage infusion invariably gave a growth of streptococci, practically in pure culture.



## DISCUSSION

As stated before the investigation reported in this paper does not warrant very definite conclusions and the following suggestions are offered tentatively. It is a well known fact that the groups of colon-aerogenes bacilli, of streptococci and of lactobacilli are widely distributed in nature and especially on fodder. Lacto-bacilli were found by Heineman and Hefferan in cornmeal and by Sherman on fresh corn leaves. The presence of these groups in silage may therefore be considered as established. This condition recalls observations on the so-called normal souring of milk and the activity of streptococci and lactobacilli during cheese ripening. Assuming that the colon-aerogenes group is present in fresh silage a limited growth of these organisms would produce an initial fermentation with acid and gas as the chief products. This assumption is supported by the fact that considerable pressure is developed during the ripening of silage and by our observation that gas is formed in abundance in milk cultures prepared from samples of silage in early stages of ripening. The colon-aerogenes group is soon suppressed by the streptococci. Acid is the chief product of this group. Milk cultures showed a progressive decrease of gas formation a fact which indicates the gradual suppression of the colon-aerogenes group. Streptococci are then crowded out by lactobacilli, but probably never disappear entirely as they could be isolated readily from silage in its last stages of fermentation. It is suggested that at least two groups of lactobacilli are active. The first group is of the slow-growing type, the bacilli occurring singly and showing granular staining with methylene-blue. The second group of lactobacilli is of the more rapid-growing order and is readily isolated from later stages of fermenting silage.

Wyant inoculated corn silage experimentally with cultures of *Streptococcus lacticus* and *Lactobacillus bulgaricus* and obtained a product which according to the author's description resembled normal silage. However, after a period of four to five weeks lactobacilli were not isolated, while streptococci were recovered without difficulty. This shows that the silage had not passed

beyond the second phase of fermentation. According to the investigation reported in this paper the third phase of fermentation, when lactobacilli are active, does not occur during the first weeks of the ripening process.

The investigation came to a conclusion because the silage was practically exhausted in the silos whose product was available. The remaining silage contained considerable quantity of acid and the owners of the silos hesitated to use this remnant for fodder. It does not seem, however, that the acidity was great enough to cause injury to the cattle. Fair samples could not be obtained from these remnants.

It has been stated that stains from early samples of silage showed the presence of large numbers of microorganisms of various types. During the progress of the work the number of types was gradually reduced and the microscopic picture of stains from the last stages of ripening differed materially from that obtained from early stages, inasmuch as streptococci and lactobacilli were clearly predominant and other forms had disappeared in very large measure. No doubt the result is explained by the accumulation of acid in the final product. The disappearing bacteria may influence the ripening process by consuming oxygen and thus create favorable conditions for facultative anaerobes, such as streptococci and lactobacilli.

#### CONCLUSION

The authors as a result of this investigation offer as a tentative hypothesis of the ripening process of corn silage the following: The fermentation consists of three phases brought about by three groups of bacteria. The initial phase is of short duration and is caused by members of the colon-aerogenes group of bacteria. It is accompanied by acid and gas formation. The second phase is carried on by streptococci and is accompanied by moderate acid formation. The third phase is the result of the activity of lactobacilli. The third phase may possibly be subdivided into minor phases owing to the presence of different strains of lactobacilli. It should be added that the assumption

of some investigators that the first process of silage ripening is a respiratory process (Babcock and Russell) is not excluded by the hypothesis advanced and does not interfere with it. Furthermore, mention should be made of the fact that at no time was growth of yeasts in the silage observed, although yeast cells were invariably present. Growth of yeast was observed only when an extract of silage was incubated at 37°C. There is therefore in this investigation no indication of an alcoholic or acetic acid fermentation as suggested by Esten and Mason.

It should be emphasized that the assumption of different phases of silage fermentation does not mean that the phases are distinctly separated, or that a period of rest occurs when one phase passes into the next one, or finally that the same phase is operative throughout the whole quantity of silage. The authors are inclined to the opinion that conditions of ripening are not the same in different parts of the silage and that unless samples are taken from definite regions, if this were possible, the progress of ripening would appear somewhat obscured. It is suggested further that the process of ripening may differ in kind and in degree in different silos, owing to variations in construction, in moisture content, and to climatic conditions. However, the fundamental principles and the groups of organisms active in the fermentation of silage are similar under a variety of conditions.

## REFERENCES

- BABCOCK, S. M., AND RUSSELL, H. L. 1900 Causes operative in the production of silage. Ann. Rep. Wis. Agri. Exp. Sta., 123-141.
- ESTEN, W. M., AND MASON, C. J. 1912 Silage fermentation. Conn. Agri. Exp. Sta., Bull. 70.
- GORINI, CONSTANTINE 1919 Studi sui silo lattici in base alla fisiologia microbica. Reale istituto Lombardo di scienze lettere, **52**, 192-205.
- HEINEMAN, P. G., AND HEFFERAN, M. 1909 A study of *B. bulgaricus*. Jour. Inf. Dis., **6**, 304-318.
- HUNTER, O. W., AND BUSHNELL, L. D. 1916 The importance of *Bacterium bulgaricum* group in ensilage. Science, N.S., **43**, 318-320.
- SHERMAN, JAMES M. 1916 A contribution to the bacteriology of silage. Jour. Bact., **1**, 445.
- WYANT, ZAE NORTHROP 1920 Experiments in silage inoculation. Abstr. Bact., **4**, 6.



# SOME ATYPICAL COLON-AEROGENES FORMS ISOLATED FROM NATURAL WATERS

MARGARET C. PERRY AND W. F. MONFORT

Received for publication July 6, 1920

Attempts to bring cultures isolated from routine water samples in the laboratory of the Illinois State Water Survey within the tentative classification of the committee of the American Public Health Association (1917) reveal certain inadequacies of the scheme, some of which have been previously noted in the literature without emphasis.

## ANOMALOUS METHYL RED-VOGES-PROSKAUER REACTIONS

Correlation of the methyl red reaction with the Voges-Proskauer reaction has been adjudged almost complete for low ratio organisms; but for high ratio types, a very considerable number of exceptions have been noted.

Berrier, McCrady and Lafreniere (1916), applying these tests to 450 organisms isolated from feces, city sewage and grains, found the Voges-Proskauer and methyl red tests to agree completely with the generally accepted standard tests for *Bact. coli* organisms when applied to 197 strains from human feces, except in one instance. Applied to grain and sewage cultures the correlation was found in 80 per cent of the cases.

Levine (1916) cites a small group of organisms isolated from soil, resembling *Bact. aerogenes* with respect to gas formation from various carbohydrates, etc., which did not give the Voges-Proskauer reaction and were neutral to methyl red after three days' incubation at body temperature. Some did not give the Voges-Proskauer reaction and were not alkaline to methyl red until the fifth or seventh day of incubation. These resemble closely a form described by MacConkey, who records the Voges-Proskauer reaction as positive or negative.

The strains described by Johnson and Levine (1917) from soil include four methyl red neutral, Voges-Proskauer positive; 13 methyl red neutral, Voges-Proskauer negative; and 2 methyl red negative, Voges-Proskauer negative. The temperature and period of incubation differ from those now current, but concordant results recorded in the same paper are cited by Rogers, Clark and Lubs (1918) and by Winslow, Kligler and Rothberg (1919).

Burton and Rettger (1917) report the biometric method inapplicable to the colon-aerogenes group on account of the marked variability of organisms of the high ratio type with respect to the methyl red test in Clark and Lubs medium (1915) as well as in others employed. While variability with regard to the Voges-Proskauer reaction was noticeable, it was less frequent than in the methyl red test. They refer to two cases found by Rogers, Clark and Davis (1914) and Rogers, Clark and Evans (1915) where an organism had apparently altered its gas ratio profoundly, explained by the authors as possibly due to an error in lettering apparatus, remarking that this is undoubtedly the safer explanation, but that in view of the results of themselves and others in this field variability must also be reckoned with. In explaining variability of high ratio organisms they suggest that metabolism may take two courses, not necessarily parallel or of equal rate: the fermentations may proceed irregularly and yield equivocal results even when the Witte peptone broth of Clark and Lubs is used. With the same strain there may be rapid exhaustion of sugar, heavy growth, large gas volume, high gas ratio and low acidity; or incomplete sugar utilization, small gas volume, low gas ratio, and high acidity. If neither factor predominates it would be possible to have an organism capable of giving the Voges-Proskauer reaction and an acid reaction with methyl red. The authors cite one strain which became persistently methyl red positive and Voges-Proskauer positive.

Burton (1916) in his thesis, of which Burton and Rettger present the summary, instances 50 strains from sources, mostly unpolluted, which gave conflicting or variable methyl red and Voges-Proskauer reactions.

Miss Bixby (1918) reports 6 strains from waters which are methyl red and Voges-Proskauer positive; and 1 which is negative in both reactions.

Levine (1918) included in the aerogenes-cloacae group all strains which gave the Voges-Proskauer reaction, "practically always alkaline to methyl red," and 10 cultures which fermented starch with gas formation but did not react typically for the Voges-Proskauer nor the methyl red tests. Of the 151 organisms 142 were from soil, 9 from sewage.

Winslow and Cohen (1918) report perfect correlation between the methyl red and Voges-Proskauer reactions for 53 strains in a total of 54 isolated from polluted, unpolluted and stored water. Winslow, Kligler and Rothberg (1919) speak of their series of high ratio cultures as including 8 of the *Bact. cloacae* and 23 of the *Bact. aerogenes* type, all but 1 alkaline to methyl red and all but 8 Voges-Proskauer positive.

Rettger and Chen (1919) report an "almost perfect correlation between the two types" in the synthetic as well as in the Witte's peptone medium (not in Difco) when the incubation period was prolonged to five days. We have seen only the authors' abstract of this paper.

#### INTERPRETATION OF ADONITOL REACTIONS

The adonitol positive reaction has been considered discriminative of *Bact. aerogenes* of fecal origin, and is so rated in the rather diagrammatic scheme of the committee of the American Public Health Association (1917). But Rogers (1918) considers that while *Bact. aerogenes* isolated from feces is adonitol positive, it does not necessarily follow that all waterborne *Bact. aerogenes* with this character are therefore derived from immediate fecal sources.

Rogers, Clark and Lubs (1918) isolated aerogenes strains from stools of but three out of eighteen persons; all of the 46 strains were adonitol positive; but of the low ratio cultures from similar sources 17 were likewise adonitol positive (12.98 per cent).

Darling (1919) cites numerous references in confirmation of his findings: of 113 coli-like cultures isolated from feces of man

and of animals none were *Bact. aerogenes*. To his references may be added Hulton (1916), Stokes (1919) and Rettger and Chen (1919) who encountered no organisms of the *Bact. aerogenes* type in 173 cultures isolated from feces.

Far from being a specific reagent for members of the aerogenes-cloacae group, adonitol probably deserves a place not much superior to dulcitol as a reagent of rather dubious import in discriminating members of the low ratio group. Winslow, Kligler and Rothberg (1919) summarize the earlier work of Kligler (1914) and Levine (1918) in tabular form, to which we add in parentheses the less usual reactions of these and the high ratio types:

	SUCROSE	SALICIN	DUCITOL	ADONITOL
<i>Bact. aerogenes</i> .....	+	+	+ -	+ -
<i>Bact. cloacae</i> .....	+	+	+ -	+ -
<i>Bact. neapolitanus</i> .....	+	-	- (+)	- (+)
<i>Bact. communior</i> .....	+	-	+ (-)	-
<i>Bact. coli</i> .....	-	+	+ (-)	-
<i>Bact. acidi-lactici</i> .....	*	*	-	+ (-)

Adonitol is important as being sometimes included in the list of sugars, etc., fermented by *Bact. aerogenes*, which Winslow and his co-workers consider as perhaps the most primitive of the colon-typhoid group, and of the highest fermentative power. As such it is least significant as an indicator of fecal pollution. The significance of the so-called "fecal aerogenes type" in waters is probably slight.

#### DEPARTURES FROM STANDARD METHODS

Because of the shortage of Witte's peptone and the impossibility of obtaining material for the synthetic medium of Clark and Lubs (1917) for testing the methyl red reaction, Difco peptone was substituted in the initial determinations. Preliminary tests on pure cultures with 0.75 per cent Difco, properly buffered, and incubated at 30°C. for two days, gave results identical with those of the same cultures in the standard Witte broth. As the number of strains isolated increased, tests were repeated with



newly found cultures, using 0.5 per cent, 0.75 per cent and 1 per cent Difco in comparison with the standard methyl red broth. While the Difco medium, with whatever concentration used, is not equivalent to the standard broth; the reversion of acid reaction with definite concentrations of the substituted peptone with a definite buffer reaction presents phenomena affording a basis for division of cultures into provisional groups. From the strains thus segregated some were selected for study with standard media.

Koser (1918) proposed the use of a medium containing no nitrogen except in the form of uric acid for the discrimination of colon and aerogenes forms, reporting the results with 74 strains of *Bact. coli* and 50 of *Bact. aerogenes*: the former showed no growth; the latter grew well. Rettger and Chen found that, with few exceptions, among the colon strains from soils the uric acid test gave very satisfactory correlation with the other reactions when necessary precautions were taken. Their culture comprised 447 strains of the cloacae-aerogenes group and 20 of the colon type from unpolluted soils, and 173 strains from feces of men and of animals.

To test the validity of this reaction as a criterion of high and low ratio organisms, we have arranged our cultures isolated from waters with reference to their uric acid reactions, for later comparison with the arrangement of specially studied strains grouped according to their methyl red and Voges-Proskauer reactions.

#### STUDY OF CULTURES ISOLATED FROM WATERS

In the course of this work 392 cultures were isolated which gave gas in lactose broth, more or less characteristic colonies on Endo's medium, and usually gas in lactose broth after transfer from the endo medium. They were tested as to their reaction in Difco methyl red broths after two days; with adonitol and with uric acid broth. The first series comprised 233, the second, 159 strains. The results are summarized in table 1. Arranged according to lactose fermentation, adonitol and uric acid reactions, they fall into 19 provisional groups to which are assigned reference numbers of purely temporary value.

The first six groups of strains (uric acid positive adonitol negative) may be regarded as varying about the third, which is typical "non-fecal aerogenes." Those grouped under numbers seven to ten inclusive may be thought of as variants of the so-called "fecal aerogenes type" (number eight uric acid positive, adonitol positive). Those grouped under numbers eleven to

TABLE I  
*Provisional arrangement of strains isolated from water*

REFER- ENCE NUMBER	LAC- TOSE BROTH	ENDO'S MEDIUM	LAC- TOSE BROTH	METHYL RED DIFCO		ADONI- TOL	URIC ACID	SPORES	NUMBER OF SERIES		STRAINS TOTAL
				6.5 percent	0.75 percent				1	2	
1	+	+	-	-	-	-	+	-	16		16
2	+	+	-	+	-	-	+	-	2		2
3	+	+	+	-	-	-	+	-	19	6	25
4	+	+	+	-	-	-	+	+	1		1
5	+	+	+	+	-	-	+	-	4	4	8
6	+	+	+	+	+	-	+	-	6	3	9
7	+	+	-	-	-	+	+	-	4		4
8	+	+	+	-	-	+	+	-	27	6	33
9	+	+	+	+	-	+	+	-	11	5	16
10	+	+	+	+	+	+	+	-	16	14	30
11	+	+	+	+	+	+	-	-	15	5	20
12	+	+	+	+	-	+	-	-	3		3
13	+	+	+	+	+	-	-	-	84	113	197
14	+	+	+	+	-	-	-	-	5		5
15	+	+	+	+	+	-	-	+	1		1
16	+	+	+	-	-	-	-	-	2		2
16a	+	+	+	-	-	-	-	+		1	1
17	+	+	-	+	+	-	-	-	8	2	10
18	+	+	?	+	+	-	-	+	2		2
19	+	+	-	-	-	-	-	-	7		7
									233	159	392

sixteen inclusive (uric acid negative, adonitol positive or negative) may be variants of number 13—typical *Bact. coli*.

From numbers 1 to 6 and from 7 to 10 there is progressive increase in net acidity to the limit of pH 5.8; from 11 to 16 there is a decrease in acid formation, and from 17 to 19 there is irregularity in acidity and in gas formation in lactose. Five spore-bearing forms were isolated, which are fully described in a forthcoming paper.

The second series represents strains which passed through enrichment processes whenever they showed delayed reaction with media. Perhaps this may have somewhat diminished the number of forms varying about the three types. In the course of this treatment the purity of our strains was assured.

There are differences in reactions of strains from a single source or from one sample of water. Nine of the samples were from 75-foot tubular wells in the same stratum: two were from a group of wells furnishing a city supply, and the remaining seven were from a single nearby well. Table 2 shows the numbers of strains

TABLE 2  
*Strains isolated from one source*

REFERENCE NUMBER	NUMBER OF STRAINS	REACTIONS WITH	
		Uric acid	Adonitol
3	6	+	-
6	2	+	+
8	9	+	+
9	3	+	+
10	2	+	+
11	7	-	+
13	12	-	-
17	2	-	-
19	1	-	-
	44		

assigned to each provisional group. As many as 7 strains, distributed among 6 groups, were found in a single sample. Of the 44 strains assigned to 9 groups, 22 are uric acid positive: 14 uric acid positive, adonitol positive; and 14 fall into the transition groups 5, 9, 10, and 11. Eight vary about "non-fecal," and 14 about "fecal aerogenes;" 19 about the *Bact. coli* type, and 3 give slow lactose fermentation. Other instances of varying strains from a single sample can be found in table 3.

#### SPECIAL STUDY OF STRAINS IN TRANSITION GROUPS

Thirty-five strains, mostly from the second series, were tested with a number of sugars, alcohols, etc. (In these tests both a

TABLE 3  
*Reactions of strains in transition groups*

REFERENCE NUMBER	SOCIETY NUMBER	URIC ACID	METHYL RED	VOGEN-PROSKAUER	SALICIN	DULCITOL	ADONITOL	
4	121.1112033	+	var.	+	-	-	-	
5a	222.1112031	+	+	+	-	-	-	
5b	222.1132031	+	+	-	-	-	-	Raffinose +
6a	222.1132031	+	+	-	+	+	-	<i>Bact. coli</i>
6a	222.113 031	+	+	-	-	+	-	<i>Bact. coli</i>
6b	222.1112031	+	+	-	+	+	-	<i>Bact. aerogenes</i>
9a	222.1112031	+	-	+	+	+	+	<i>Bact. aerogenes</i>
9b	222.111 031	+	-	-	-	+	+	<i>Bact. aerogenes</i> ?
9c	222.1112031	+	+	-	-	+	+	<i>Bact. communior</i> ?
9c	222.111 031	+	+	-	-	+	+	<i>Bact. communior</i> ?
9c	222.1112031	+	+	+	+	+	+	<i>Bact. aerogenes</i>
10a	222.1112031	+	+	-	+	-	+	<i>Bact. aerogenes</i> ? Raff.—
10b	222.1112031	+	+	+	+	-	+	<i>Bact. aerogenes</i>
10b	222.1112031	+	+	+	-	-	+	<i>Bact. aerogenes</i> ?
10b	222.1112031	+	+	+	+	-	+	<i>Bact. aerogenes</i>
10b	222.1112031	+	+	+	+	-	+	<i>Bact. aerogenes</i>
10b	222.1112031	+	+	var.	+	-	+	<i>Bact. aerogenes</i>
10b	222.1112031	+	+	+	+	-	+	<i>Bact. aerogenes</i>
10b	222.1112031	+	-	-	-	-	+	<i>Bact. aerogenes</i> ?
10c	221.1112031	+	+	-	+	-	+	<i>Bact. aerogenes</i> ?
10d	222.1112033	+	+	-	+	+	+	<i>Bact. aerogenes</i>
10d	222.1112033	+	+	-	+	+	+	<i>Bact. aerogenes</i>
10d	222.1112033	+	+	-	+	+	+	<i>Bact. aerogenes</i>
10d	222.1112033	+	+	-	+	+	+	<i>Bact. aerogenes</i>
10d	222.1112033	+	var.	-	-	+	+	<i>Bact. communior</i> ?
11a	222.1112031	-	+	-	-	-	+	<i>Bact. communior</i> ?
11c	222.1112033	-	+	-	+	+	+	?
11c	222.1112033	-	+	-	+	+	+	?
11b	222.1132031	-	+	-	+	-	+	<i>B. coli</i> ?
11b	222.1132031	-	+	-	+	-	+	<i>B. coli</i> ?
15	121.1112011	-	var.	-	-	-	-	
16a	121.1113011	-	-	+	-	-	-	
17	222.333 033	-	+	-	-	-	-	
18a	121.1332032	-	var.	+	-	-	-	
18b	121.1332033	-	-	+	-	-	-	

0.2 per cent and the standard 1 per cent sugar, alcohol and starch broths were used with identical results.) Some of the strains were lost before the series of tests was complete. It will

be noted that members of the same provisional group show considerable divergence in their ability to react with sugars, etc., and with gelatine. If these variations are made the basis of subdivision, the number of provisional groups is increased, as indicated by literal suffixes to the reference numbers in table 3. The cultures are arranged as before, primarily with regard to their lactose, uric acid and adonitol reactions, then with reference to sucrose, dulcitol and glycerol.

For the sake of conciseness the reactions of strains are represented so far as is possible by the numerical scheme of the Society's chart, with the addition of methyl red and Voges-Proskauer reactions in standard media and a few other reactions. Maltose and mannitol were fermented with gas formation by all strains except 17, 18a and 18b. Starch was attacked with gas formation by but 2 strains, and those were sporeformers. Gelatine was liquefied by 10c and by 5 sporeformers. Raffinose and sucrose reactions were of like signs for all save 5b and 10a.

The inclusion of sporebearing forms in this table is anticipated by the work of Loehnis and Smith (1916), who state that a single species (particularly *Azotobacter*) may pass through as many as 12 to 14 distinct morphological forms in its life cycle, including spores. Kellermann and Scales (1916), in a preliminary report on the life cycle of *Bact. coli*, studied 12 strains from widely different sources which were found to produce all the types described by Loehnis and Smith except spores. Burton and Rettger report 9 occurrences of a form differing chiefly from our No. 15 in that theirs is Gram positive. Meyer (1918) and Ewing (1919) isolated from waters a spore-bearing, lactose-fermenting, acid-forming bacillus which seems identical with our 16b. Itano and Neill (1919) found sporeformation by *B. subtilis* to be a function of temperature and hydrogen ion concentration: it is possible that unfavorable environment may lead to sporeformation by members of the colon-aerogenes group.

Methyl red reactions in different concentrations of Difco peptone varied upon repetition. The strains grouped under numbers 4 to 9 inclusive gave slightly more methyl red positive reactions with the 0.5 per cent Witte peptone broth incubated for 5

days than with the substituted 0.75 per cent Difco incubated for 2 days, while with those grouped under reference numbers 10 and 11 agreement between the original reactions in Difco and in the standard broth was complete. The number of anomalies discovered would probably have been even greater had we been able to use the standard medium throughout this work; but our purpose of segregating atypical forms was served in a measure by the provisional grouping based upon the reaction in Difco peptone broth.

The methyl red reaction was tested after 2 days' and after five days' incubation in standard Witte broth: but 1 strain (9c) was acid after two days and alkaline after five days; all the rest gave concordant results for the two incubation periods at that time.

Of the 25 uric acid positive strains, two (9a and 9b) are methyl red negative and have the general characters of *Bact. aerogenes*.

Ten strains give anomalous results with the methyl red and the Voges-Proskauer reactions: Nos. 4 and 5a fail to ferment salicin, dulcitol, adonitol, starch and glycerol. The last of the 9c strains and the first seven of the 10b strains are positive to both methyl red and the Voges-Proskauer reaction; and the last listed, 10b, is negative in both these reactions; two of these strains were lost before salicin tests were made; but the characters of these eight strains are predominantly those of the aerogenes type.

Thirteen strains are uric acid positive, methyl red positive with the Voges-Proskauer reaction negative or not recorded: 5b fails to ferment salicin, dulcitol and adonitol and can not be assigned a place; the two strains 6a resemble *Bact. coli* in most respects; 6b is sucrose, salicin, dulcitol positive, and is probably *Bact. aerogenes*; the first two 9c strains resemble *Bact. communior*; 10a is perhaps more like *Bact. aerogenes* than *Bact. communior*; 10c liquefies gelatine and ferments all carbohydrates, etc., save starch and dulcitol: the first four strains numbered 10d ferment actively all the carbohydrates, etc., except starch and glycerol; the last 10d fails to ferment salicin, starch and glycerol. Whether these 13 strains, departing more or less from type forms, are to be regarded as colon forms from soil or as

intermediate between the colon and aerogenes types, their positive uric acid reaction seems to mark them as without significance as indicators of pollution. There is a tendency of strains grouped under 9 and 10 to approach the maximum of fermentative power ascribed by Winslow and his co-workers to *Bact. aerogenes* as the most primitive type of the entire colon-typhoid group.

Five uric acid negative strains are acid to methyl red and Voges-Proskauer negative: the two 11c strains ferment all carbohydrates, etc., tested except starch; 11a resembles *Bact. communior* in that it is salicin and dulcitol negative; the two strains marked 11b approach *Bact. coli*.

The strains 11c and 10d were isolated from apparently unpolluted wells, respectively 1300 and 2000 feet deep.

The remaining strains are spore bearers, excepting No. 17, which lost most of its original characters under laboratory cultivation. They resemble the strains 4, 5a and 5b in their failure to ferment salicin, dulcitol and adonitol.

The relative value of the three criteria for discrimination of high and low ratio groups with these strains appears from the following considerations: 15 uric acid positive strains ferment mannitol, maltose, glucose, lactose, sucrose, salicin, dulcitol, adonitol, and glycerol, or all save one of the last three and are considered as probable *Bact. aerogenes* forms; 2 are methyl red negative; 7 give the Voges-Proskauer reaction, and 1 is variable. There are 13 discrepancies in the methyl red and uric acid tests, and 7 or 8 in the uric acid and Voges-Proskauer tests. Two uric acid positive strains which failed only in fermenting dulcitol were not tested with salicin: 1 was acid to methyl red and was Voges-Proskauer positive; 1 was negative in both reactions. The uric acid test was confirmed by one of these reactions and negated by the other in each instance.

Two strains (11b) fermented all the above listed sugars, etc., save glycerol, but were uric acid negative, methyl red positive, Voges-Proskauer negative in repeated tests. These are the only instances which raise a question as to the validity of the Uric acid reaction, which in all other cases cited appears preferable in discriminating high ratio members in waters.

## DISCUSSION OF RESULTS

It is apparent that in our results, as in instances earlier cited, the methyl red and Voges-Proskauer reactions of the same strain are not always of opposite signs. Variation in each, but principally in the former, has been observed in the standard broth. Ayers and Rupp (1918) have shown that reversion of acid reaction exhibited by *Bact. aerogenes* cultures is due to the secondary decomposition of organic acids and is accompanied by rapid destruction of formic, acetic and other acids. With *Bact. coli* they noted that acid formation does not run parallel with the destruction of glucose, formic acid remaining constant or being slightly reduced during the later stages of fermentation. The distinction between *Bact. coli* and *Bact. aerogenes* is considered as lying chiefly in the difference in rate between the preliminary decomposition of sugars into acids and the secondary decomposition of the acids themselves. The suggestion was made by Burton and Rettger that there may be a difference in the rate of the secondary decomposition even in strains of *Bact. aerogenes* which would explain divergence in the atypical strains such as we are considering. They found the Voges-Proskauer reaction more reliable than the methyl red reaction, as cited above. The simpler uric acid reaction may prove even more dependable than the complex Voges-Proskauer reaction, being accomplished in briefer period and permitting less modification of the strain under cultivation. It is true that Rettger and Chen found it possible to shorten the incubation period from five days to twenty-four hours (even ten to fourteen hours) without altering the Voges-Proskauer reaction; they also report the successful use of Difco peptone in this test. But even with this reduction in the time element the possibility of variation in the complex reaction is not removed.

The positive uric acid reaction overlaps the acid methyl red and the negative Voges-Proskauer reactions in many strains. If the observation is confirmed, that the Koser reaction gives satisfactory correlation with the other reactions except among colon strains from soils, this may prove of value in clearing up



such anomalies as have been emphasized in this work and mentioned in the earlier cited references.

A considerable number of methyl red positive strains gave deferred fermentation of lactose (after three days) which is in line with the observations of Bronfenbrenner and Davis (1918) on *Bact. coli* from foods. Similar behavior of colon forms in gentian violet broth has been ascribed by Hall and Ellefsen (1919) to the inhibitive effect of the dye: it may have been in part attributable to the inhibitory effect of lactose itself, noted by Smith (1893), confirmed by Burling and Levine (1916), and recognized in the latest recommendation of the committee of the American Public Health Association (1920), which reduces the percentage of lactose in broth to 0.5 per cent. If our observation holds, that 0.2 per cent of lactose and other sugars and alcohols suffices in culture broths, some relief might be expected from delayed development of gas; but our strains reacted similarly in both 1 per cent and 0.2 per cent sugar broths throughout. In the most striking instances of erratic behavior studied there was no marked difference in the time of beginning gas production by typical and atypical forms.

The list of anomalous strains is undoubtedly incomplete: Levine, Burton and Rettger, and Burton in his thesis, to which we have had access through the courtesy of the author, Bronfenbrenner and Davis, and Rettger and Chen suggest abundant material not yet reducible to the fixed categories of any classification. This may be said also of the sporebearing forms: although some of them can hardly be confused with typical *Bact. coli*, several are likely to lead to misapprehension as to the safety of a water supply.

#### INTERPRETATION OF LABORATORY RESULTS

If the atypical strains, sporebearers and vegetative forms herein listed and cited, are considered as intermediate or transition forms from accepted colon or aerogenes types, the question of sanitary interpretation is unavoidable. Any of the lactose fermenting organisms (29 of the 31 especially studied) would lead to the condemnation of a water supply according to the

United States Treasury Department (1914) standard if more than two organisms were found in 100 cc.; of these 29, 3 are sporebearers, 1 is typical *Bact. aerogenes* not necessarily of fecal origin (Rogers 1918), 9 are anomalous with respect to those reactions accepted as indicative of high and low gas ratio; 16 are within the class of low ratio organisms on the basis of the methyl red and Voges-Proskauer reactions, and of these but 3 uric acid negative strains conform to recognized types.

An organism which requires prolonged invigoration to be restored to, or to acquire, conventional reactions with sugar broths and other media is far removed from the organism typical of fecal pollution. Considering the opportunity thus afforded for change in the original characters, a conclusion as to what must be regarded as essential indicators of pollution must take into account the undoubtedly wide variation of bacilli of the general colon-aerogenes group occurring in waters. Invigoration might lead an organism, long away from, or originating quite outside, the alimentary tract, to acquire the characters of typical fecal inhabitants. While it is important to ascertain the ultimate genetic relation between members of the group, it is one thing to say that these forms are of common, remote origin, and a very different one to say that the existent, feebly reacting, yet convertible forms are identical with, and of equal diagnostic importance with, organisms freshly isolated from feces under laboratory conditions: that is, to attribute to them as originally present in a water supply all the newly acquired characters. The uric acid reaction, however, admits of repetition without change so far as we have found with the limited number of strains isolated.

It is important that the laboratory procedure be as quickly completed as is reasonably possible, and that characters be neither lost nor acquired. Water seriously polluted shows gas production within much less than 24 hours. The readiness of strains to react is perhaps of greater diagnostic significance than the appearance of gas at twenty-four hours and at forty-eight hours as now observed. Levine (1920) considers the rate of gas production more significant than the total volume of gas formed. Burton suggested shortening preliminary enrichment

to avoid development of *Bact. cloacae*. The committee's recommendation (1912) for enrichment with transfer "as soon as gas is formed (usually in sixteen to twenty-four hours)" has persisted in many laboratories and is perhaps worth reviving officially, not so much to avoid overgrowth as to prevent undue modification. For the same reason the Voges-Proskauer reaction tested at the end of ten to fourteen hours' incubation in available American peptone broth is preferable to reliance upon the methyl red reaction, which requires 5-day incubation in a broth for which materials are not generally at hand. The uric acid test seems worthy of at least provisional acceptance because of the simplicity of the reaction and the facility afforded for confirming or correcting the somewhat erratic results observed in the Voges-Proskauer reactions of soil and water borne strains.

#### SUMMARY

Strains isolated from natural waters are grouped by their lactose, uric acid, adonitol, and methyl red reactions in Difco peptone broth (0.5 per cent and 0.75 per cent), and 35 strains especially studied are so arranged as to make evident the conflict between the Voges-Proskauer reaction and the methyl red reaction of strains in standard Witte peptone broth. There is lack of agreement in the discrimination of high and low ratio types. The uric acid positive reaction correlates best with the characters of the aerogenes type in carbohydrates, etc.

Upon the assumption that the uric acid reaction of colon forms from soils sufficiently characterizes them, this reaction may prove useful in checking and correcting the assignment of strains to the low ratio type indicative of possible fecal pollution.

Five sporebearers were isolated. It is probable that the number of these and of other anomalous forms is far less than would have been discovered had we been able to use Witte peptone in all methyl red tests.

The sugar reactions of members of the larger group seem to be as well tested in 0.2 per cent sugars as in the 1 per cent broths of the old standard procedure.

For the purpose of sanitary examination of waters it is desirable that the laboratory procedure be completed as early as con-

sistent with fairness to avoid change in characters, and to this end those methods are preferable which involve the simplest reactions and the briefest incubation periods.

## REFERENCES

- American Public Health Association 1912 Standard methods for the examination of water and sewage
- American Public Health Association 1917 Standard methods for the examination of water and sewage.
- American Public Health Association 1920 Standard methods for the examination of water and sewage.
- AYERS, S. H., AND RUPP, P. 1918 *Jour. Inf. Dis.*, **23**, 188.
- BERRIER, McCRADY AND LAFRENIERE 1916 *Bull. San.*, Quebec, **16**, 93.
- BIXBY, MADELINE 1918 *Bull. Ill. State Water Survey*, **15**, 100.
- BRONFENBRENNER, J., AND DAVIS, C. R. 1918 *Jour. Med. Res.*, **39**, 33.
- BURLING, H. A., AND LEVINE, M. 1918 *Amer. Jour. Pub. Health*, **8**, 306.
- BURTON, L. V. 1916 (Thesis) Correlation studies of gas-producing bacteria, with special reference to members of the colon-aerogenes group found in soils.
- BURTON, L. V., AND RETTGER, L. F. 1917 *Jour. Inf. Dis.*, **21**, 162.
- CHEN, C. C., AND RETTGER, L. F. 1920 *Jour. Bact.*, **5**, 253.
- CLARK, W. M., AND LUBS, H. A. 1915 *Jour. Inf. Dis.*, **17**, 160.
- CLARK, W. M., AND LUBS, H. A. 1917 *Jour. Biol. Chem.*, **30**, 209.
- DARLING, C. A. 1919 *Amer. Jour. Pub. Health*, **9**, 844.
- EWING, C. L. 1919 *Amer. Jour. Pub. Health*, **9**, 257.
- HALL, I. C., AND ELLEFSEN, L. J. 1919 *Jour. Amer. Water Works Assoc.*, **6**, 67.
- HULTON, FLORENCE 1916 *Jour. Inf. Dis.*, **19**, 606.
- ITANO, A., AND NEILL, J. 1919 *Abst. Bact.*, **3**, 2.
- JOHNSON, B. R., AND LEVINE, M. 1917 *Jour. Bact.*, **2**, 379.
- KELLERMANN, K. F., AND SCALES, F. M. 1916 *Abst. Bact.*, **1**, 27.
- KLIGLER, I. J. 1914 *Jour. Inf. Dis.*, **15**, 187.
- KOSER, S. A. 1918 *Jour. Inf. Dis.*, **23**, 377.
- LEVINE, M. 1916 *Jour. Bact.*, **1**, 619.
- LEVINE, M. 1918 *Jour. Bact.*, **3**, 253.
- LEVINE, M. 1920 *Jour. Amer. Water Works Assoc.*, **7**, 188.
- LOEHNIS, F., AND SMITH, N. R. 1916 *Jour. Agr. Res.*, **6**, 675.
- MEYER, E. M. 1918 *Jour. Bact.*, **3**, 9.
- RETTGER, L. F., AND CHEN, C. C. 1919 *Abst. Bact.*, **3**, 1.
- ROGERS, L. A. 1918 *Jour. Bact.*, **3**, 313.
- ROGERS, L. A., CLARK, W. M., AND DAVIS, B. J. 1914 *Jour. Inf. Dis.*, **14**, 411.
- ROGERS, L. A., CLARK, W. M., AND EVANS, A. C. 1915 *Jour. Inf. Dis.*, **17**, 137.
- ROGERS, L. A., CLARK, W. M., AND LUBS, H. A. 1918 *Jour. Bact.*, **3**, 23.
- SMITH, T. 1893 *The Wilder Quarter Century Book*, 187.
- STOKES, W. R. 1919 *Amer. Jour. Pub. Health*, **9**, 571.
- UNITED STATES TREASURY DEPARTMENT. 1914 *Pub. Health Repts.*, **29**, 2959.
- WINSLOW, C.-E. A., AND COHEN, B. 1918 *Jour. Inf. Dis.*, **23**, 82.
- WINSLOW, C.-E. A., KLIGLER, I. J., AND ROTHBERG, W. 1919 *Jour. Bact.*, **4**, 429.

## BOTULISM IN CATTLE

ROBERT GRAHAM AND HERMAN R. SCHWARZE

*Department of Animal Husbandry, Laboratory of Animal Pathology, University of Illinois*

Received for publication July 11, 1920

The etiologic factor, or factors, in a sporadic toxemic-like disease in cattle sometimes designated as forage poisoning have been the subject of many experimental studies in the last decade. During this time the disease has occurred sporadically with varying severity throughout the middle western states, and more recently our attention has been repeatedly invited to these losses. It may be significant to mention that corn silage of some character was being fed to many of the herds developing the disease that came under our observation during the winter months of 1919-1920, yet this feed was definitely incriminated in but three instances. The primary relation of *B. botulinus*-like organisms to one type of forage poisoning in horses and mules, together with the occasional occurrence of this anaerobe in different animal feeds, has suggested the importance of determining the relation, if any, of certain toxic anaerobes to so-called forage poisoning in cattle, and our investigations of the disease in these animals have been devoted primarily to the pathogenic and toxic characters of spore bearing anaerobes in suspicious feeds, and of like organisms encountered in the intestinal content and spleen of animals fatally afflicted.

### CLINICAL SYMPTOMS

In view of the fact that so-called forage poisoning in cattle may apparently be confused with hemorrhagic septicemia or enteric bacterial infections of the colon-typhoid group, or other rapidly fatal diseases of a toxemic character, a brief description

of the symptomatology of the disease under investigation is given. A differential diagnosis based upon clinical symptoms and gross anatomical findings at death may perplex the clinician and autopsist in many outbreaks. As noted to date in several affected animals, an acute and chronic symptom-complex of food or forage poisoning may be recognized in cattle. In the latter, weakness, local paresis, emaciation, muscular stiffness and decumbency are noted in varying degrees. Clonism developing without premonitory symptoms, terminating in sudden death, or followed by complete relaxation and recovery, marks the acute form of the disease. The nervous manifestations may be of a vicious character resulting in violence to feeding troughs, mangers or fences. Noticeable symptoms are not observed in the peracute disease preceding the agonal clonic spasm. Animals may remain decumbent for two or more days before death, during which time dyspnea, opisthotonus, coryza, lacrymation and catarrhal conjunctivitis often develop. One fatal spontaneous case delivered to our laboratory suffered from a secondary bronchial pneumonia, disclosed at autopsy. Several unsuccessful attempts to administer medicine by the mouth to the animal before death were probably associated with the development of the pneumonia, which was clearly of medicinal or mechanical origin.

In the more chronic cases animals may display visual disturbances. An estranged or frightened attitude on being approached, or a staring expression of the eyes, is noted. Emaciation and weakness contribute to an ill nourished cachectic appearance. Contraction of the flexor tendons in the posterior limbs, resulting in an extension of the metatarsalphalangeal articulation ("cock ankle"), with incoördination of movement, is not an uncommon complication, and animals may appear stiff, with a noticeable nervous attitude, and even loss of control in the anterior limbs, on being suddenly approached. Restraint or excitement of animals suffering from the chronic disease, accompanied by running or violent exertion, may terminate fatally from cardiac failure. In the acute type of bovine botulism partial or complete pharyngeal paresis is not uncommon,

yet in the chronic disease the appetite as well as organs of deglutition appear quite normal. The body temperature remains essentially unchanged, with slight fluctuations upward which are of short duration unless associated with secondary infection. Subnormal temperature and obstinate constipation are invariably present.

#### SUSCEPTIBILITY

Preliminary observations indicate that cattle between the ages of six months and two years are most susceptible, while older animals may also be affected. The mortality varies between 2 and 10 per cent though in extreme outbreaks a loss of 30 to 70 per cent or higher may occur. From observations it would appear that some cattle have, or acquire, an immunity to certain types of poisonous substances in feed, yet the natural resistance possessed by cattle of all ages to the type of intoxication under consideration is not always sufficient to protect against more or less serious constitutional disturbances. In more resistant animals death is not induced, yet the growth and development of the affected animal may be temporarily or permanently impaired. The mortality of the disease in many outbreaks may thus be secondary to the loss sustained by failure of the animals to increase in weight, by the decrease in milk flow in dairy cattle, or the loss of the feed in case the contaminated ration can be detected. Moreover it is believed that symptoms of *B. botulinus* intoxication in resistant cattle may thus be transitory and of an indefinite character, and that bovine forage poisoning may even prevail unrecognized as a distinct disease, manifested only by unthrift and malnutrition. In the light of recent observations the writers have probably failed to recognize the disease in cattle as a clinical entity in several outbreaks during the period of 1912-1917.

#### CAUSATIVE FACTOR RELATED TO RATIONS

In clinical outbreaks of the above character, bacteriological evidence has seldom been obtained to sustain or refute a presumptive diagnosis of a food or forage poisoning. As a matter

of fact the cause of the disease as it occurs throughout the Mississippi Valley has been satisfactorily established in but few outbreaks. Notwithstanding negative findings relative to the cause or causes involved, the recurrence of a clinical toxemic-like disease in cattle in the feed lots and pastures of Illinois and other middle western states lends evidence to the possibility of a distinct entity of forage poisoning, based upon our clinical conception of food poisoning in other domestic animals, i.e., in horses and mules (Graham, Brueckner and Pontius (1917) ). In these animals the cause of death in several sporadic outbreaks has apparently been definitely associated with certain types of *B. botulinus* intoxication, as demonstrated by bacteriological findings in the feed and confirmed by the apparent protective value of specific antitoxin in susceptible animals receiving contaminated rations.

Feeding experiments (Rusk and Grindley (1918)) have been conducted by different investigators in an attempt to reproduce the disease in cattle. An accomplishment of this character would obviously afford an opportunity to inaugurate more definite and extended bacteriological studies, looking to the establishment of an etiologic factor. Experimental results in cattle feeding projects, together with the natural resistance of some animals accompanied by the abrupt or irregular termination of the spontaneous fatal disease in natural outbreaks, have in a broad sense failed to incriminate the rations specifically. However, in many outbreaks it appeared that the causative factor or factors were related to, if not incorporated in the feed. With this conception of the etiological relation of the feed to the disease, bacteriological studies have been extended to numerous samples of feed from suspicious outbreaks of this disease. The possibility of the disease or diseases encountered being associated with *Pasteurella bovisseptica*, or toxic aerobes of the colon-typhoid group prompted animal inoculation and cultural methods to eliminate these microorganisms in tissue specimens.

Moulds have been mentioned in a more or less definite way in connection with forage poisoning in cattle and horses. A variety of these organisms have been encountered upon animal feeds



and it is suggested that these organisms may apparently be associated with the disease or may serve as causal agents in a secondary etiologic capacity, since experimental evidence in animals, to demonstrate the primary toxic character of certain organisms of this class per se, is unconvincing. If deductions are to be drawn at this time from a review of the literature and experimental evidence at hand in our studies, it appears that the moulds encountered are probably not of widespread primary importance in the toxemic-like disease of animals in question, as it occurs throughout the Mississippi Valley.

The writers have observed outbreaks of so-called forage poisoning in equines which were quite definitely related to the consumption of feed containing *B. botulinus* toxin. Susceptible animals (horses and mules) could be protected against the toxin in the feed by a prophylactic injection of botulinus antitoxin (Graham and Brueckner (1919)). The relation of *B. botulinus* of human origin (type B), was also noted by immunologic tests, while Burke of California has more recently incriminated *B. botulinus* (type A) in forage poisoning in horses (Burke, 1919). This strain has not been encountered to date in outbreaks of equine botulism coming under our observation.

#### RESISTANCE OF BOVINES TO BOTULINUS TOXIN

Following preliminary field observations of bovine forage poisoning in Illinois, Rusk and Grindley state

The results of these investigations seem to indicate that most cattle are not so susceptible to forage poisoning as are horses and mules, and that contaminated corn silage, and possibly other animal feeds which are unsafe or fatal to horses, may be fed with less danger to cattle . . . however, the evidence from many outbreaks leads the authors to suspect that some cattle are more susceptible than others and that damaged or otherwise contaminated corn silage, or possibly other feeds, may in some instances produce fatal results in cattle following ingestion.

Cattle have been fed rations spontaneously contaminated with botulinus toxin (type B) without manifest symptoms of illness other than loss of body weight, and mature cattle have con-

sumed ten to twenty lethal equine doses of botulinus toxin (type B) at one time in wholesome feed without inducing noticeable symptoms. In fact our observations indicate that a mature ruminant may possess marked resistance to botulinus toxin (type B) in the feed.

Information relative to *B. botulinus*-like organisms and their relation to forage poisoning in cattle, if any, has been eagerly sought in natural outbreaks, yet the degree of tolerance experimentally observed in mature, healthy experimental cattle to botulinus toxin (type B) suggested the possibility of an independent factor in this disease of bovines, and until recently the spontaneous occurrence of forage poisoning in cattle, wherein the rations proved to be contaminated with *B. botulinus*-like organisms, was in our observations without convincing bacteriological and immunological evidence.

#### SILAGE CONTAMINATED WITH *B. BOTULINUS*

In January, 1920, a sample of silage (Laboratory index 126), was received from Mr. L. W. Wise of Iroquois County, Illinois. It was stated that the sample in question was representative of feed which had apparently proven injurious to a herd of forty-seven pure bred cattle of all ages. Upon physical examination the silage did not show noticeable indications of spoilage. There were scant circumscribed colonies of wild yeast (*Monilia candida* Bon) on some of the leaves, which was identified in pure cultures by Professor H. W. Anderson, Assistant Professor of Pomology, University of Illinois. The colonies of yeast were visible only on close examination and the specimen could not be regarded as mouldy in the general sense that some feeds harbor organisms of this class. Indefinite evidence which pointed to the disease producing properties of the silage consisted of symptoms of illness observed in several (18) cattle, and as described by the owner, included inappetance, marked emaciation, constipation and general unthrift, with some transitory nervous manifestations (see fig. 1). Four animals chronically affected died. The younger animals of the herd were apparently not as susceptible as the mature full grown animals, or it may be pre-

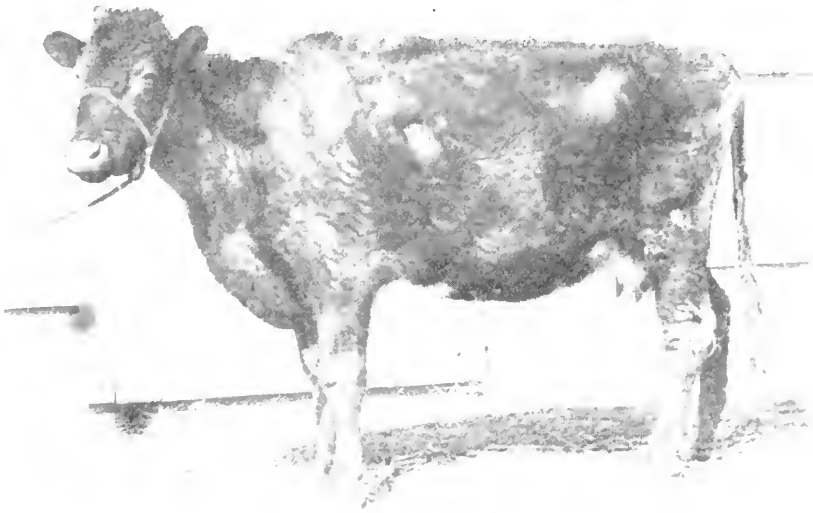

FIG. 1. A COW SUFFERING FROM A CHRONIC FORM OF BOTULISM AS A RESULT OF CONSUMING CONTAMINATED CORN SILAGE NO. 126

sumed that the older animals consumed more of the silage. The owner noted that trough space prevented the small animals from getting as liberal a portion of the feed as the older animals secured. Simultaneously with the marked illness and death of the animals, feeding of silage was discontinued and the herd improved. After an interval of three weeks the cattle were again allowed to eat of the silage in small quantities and illness again appeared in some animals of the herd. The symptoms were analogous to the manifestations noted in the original outbreak, but the silage was promptly eliminated from the daily ration and the affected animals improved and made a complete recovery. This experience suggested to the owner that the silage could not be safely used for feeding purposes, and opportunity to observe the effect of the continuous feeding of the silage in this herd or to other cattle or horses was not provided.

The clinical illness in these cattle on two separate occasions was at marked variance with experiments in feeding rations spontaneously contaminated with botulinus toxin to horses and mules, in that the character of the disease in cattle was chronic and slowly fatal. Furthermore, the manifest symptoms reported in this herd had not been noted in feeding *B. botulinus* contaminated silage to cattle, yet the anamnesis appeared somewhat in keeping with other spontaneous outbreaks of a disease of unknown etiology occurring in cattle throughout the corn belt states.

While clinical deductions might have suggested the presence of a poisonous substance in the silage, there appeared two important possibilities for consideration in this assumption. (a) The poisonous substance in the silage was not overcome by the natural resistance of the animals, or (b) the illness was induced by bacterial agents, chemicals, et cetera, unassociated with the silage and not mentioned by the owner. No feeding experiments were conducted to incriminate the silage further, but a bacteriologic examination of this feed was made.

#### BACTERIOLOGICAL FINDINGS

A sample of silage (50 grams) received for examination was immersed in sterile water and allowed to macerate in a dark place twenty-four hours at a temperature of 22°C. The sample

was then gently shaken and the liquid content removed to a sterile flask. Small particles of visible silage were removed by filtering through four layers of sterile gauze. The filtrate was then seeded in shake agar culture and heated fifteen minutes to 80°C. to destroy vegetative bacteria. The inoculated tubes were quickly placed in a cold water bath and allowed to solidify. On the surface of the agar to a depth of 2 to 6 cm., equal parts of agar and glycerol containing 1 per cent phenol were added to insure anaerobiosis. Ten days later the cultures, after incubating at 22°C., were examined and in one of the fifteen dilutions planted there was gas formation in the base of the tube, though distinct colonies were not visible. Anaerobes encountered in animal feeds, in our observations, are favored by the addition of glucose to the media, yet the numerous saprophytes encountered may outgrow and even disguise the presence of *B. botulinus*-like organisms. It is true that *B. botulinus* does not thrive on agar, yet it seems to develop slowly in plain agar shake cultures at 22°C. to 25°C. with limited gas production. Subculturing in glucose pork agar and transferring colonies to glucose pork broth (faintly alkaline) was employed to determine the toxic character of anaerobes cultivated in agar after ten days incubation in vacuum or hydrogen atmosphere. The normal toxicity of newly isolated *B. botulinus*-like organisms in broth cultures may not be characteristic or fully acquired until the second or third transfer at intervals of seven to ten days. The cultural characters and toxic quality of *B. botulinus* from silage as observed in guinea pigs, is illustrated in table 1; and in figures 2 and 3. All animals succumbed with the symptoms characteristic of *B. botulinus* intoxication.

TABLE 1

NUMBER	WEIGHT	DATE	TOXIN 126	RESULT
1	250	1/20/20	0.1 per os	Died 1/22/20
2	250	1/20/20	0.1 per os	Died 1/23/20
3	250	1/20/20	0.1 per os	Died 1/22/20
4	250	1/20/20	0.1 per os	Died 1/21/20
5	250	1/20/20	0.1 per os	Died 1/21/20
6	250	1/20/20	0.1 per os	Died 1/21/20
7	250	1/20/20	0.1 per os	Died 1/21/20

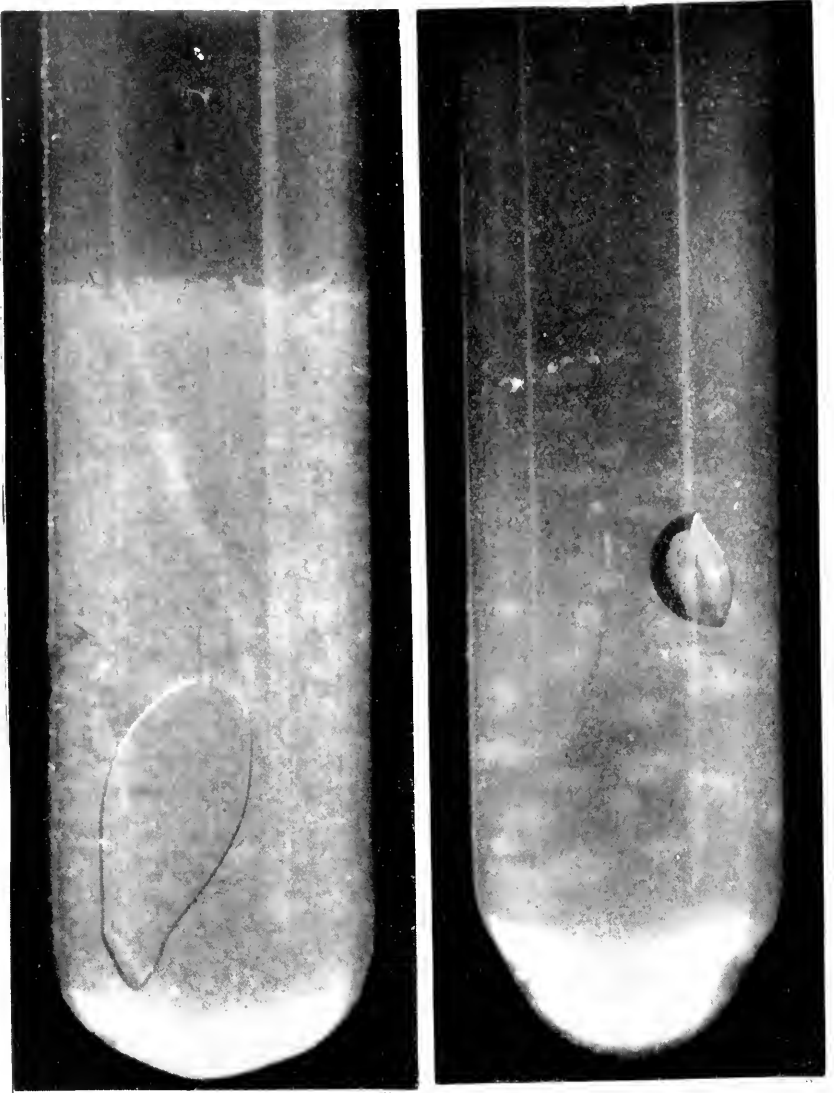

FIG. 2. GLUCOSE SHAKE AGAR CULTURES OF *B. BOTULINUS* ISOLATED FROM SILAGE No. 126

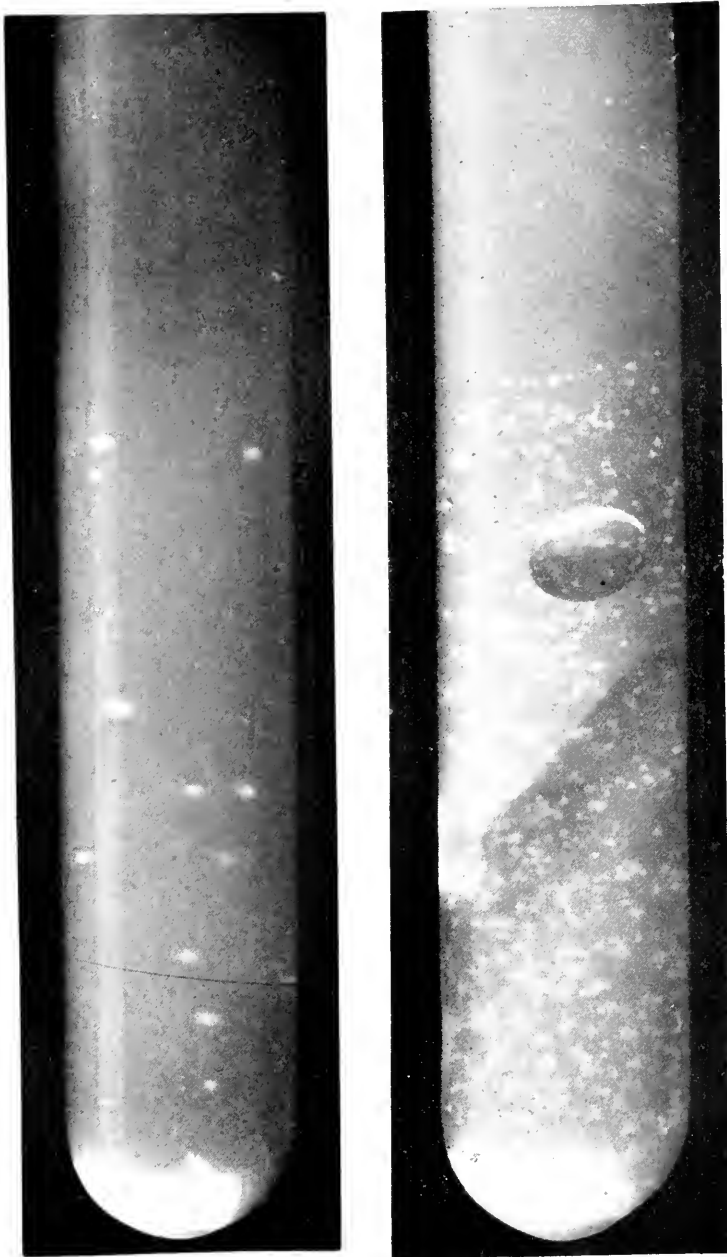

FIG. 3. GLUCOSE SHAKE AGAR CULTURES OF *B. BOTULINUS* ISOLATED FROM SILAGE No. 126

## IMMUNOLOGICAL FINDINGS

Immunological tests upon guinea-pigs using unfiltered broth cultures of the toxic anaerobe isolated from corn silage (126) and botulinus antitoxin prepared from a heterologous strain of *B. botulinus*, gave evidence of the identity of the toxin and according to Burke's classification (1919) proved to be of type B variety. The strain possesses the usual pathogenic characters for small laboratory animals and is culturally analagous to

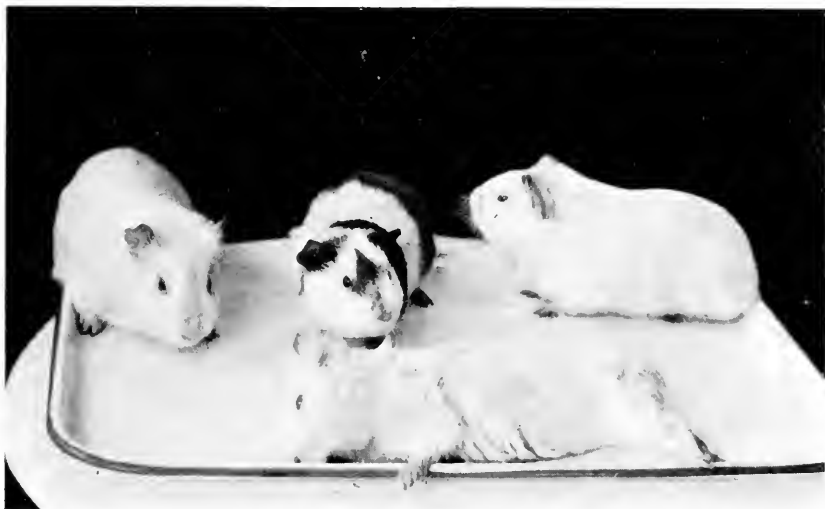

FIG. 4. IMMUNOLOGIC TEST SHOWING RELATION OF STRAIN OF TOXIN FROM SILAGE No. 126, *B. BOTULINUS* ANTITOXIN (TYPE B)

The three pigs in the rear received the serum and toxin. The control pig received the toxin only.

other strains of *B. botulinus*. Botulinus antitoxin (type B) proved efficacious in small animals against many lethal doses (c. f. 100) of toxin per os. An arbitrary toxic unit of 0.001 cc., which represents the minimum lethal dose, when given per os to guinea pigs of a given weight, has been tentatively used in determining the relative potency of antitoxic serum. This toxic unit per os in guinea-pigs weighing 250 grams may produce symptoms in twenty-four to forty-eight hours and is invariably



followed by death on the ninth or tenth day. Results of immunologic tests in guinea-pigs as in table 2 illustrate the specific relation of the *B. botulinus* strain from the corn silage sample 126 to type B variety (see fig. 4). One to two cubic centimeters of antitoxic serum of the desired potency has repeatedly proven efficacious against 100 minimum lethal toxic units given separately by the mouth at the time or a few hours after the anti-

TABLE 2

NUMBER	WEIGHT	DATE	SERUM TYPE B	TOXIN 126	RESULT
1	780	1 21 20	2 cc. subcutaneously	0.1 per os	Healthy
2	785	1 21 20	2 cc. subcutaneously	0.1 per os	Healthy
3	800	1 21 20	2 cc. subcutaneously	0.1 per os	Healthy
4	775	1/21/20	0	0.1 per os	Died 1/23/20

serum, while 0.001 cc. of antitoxin of sufficient strength per gram weight suffices to protect a guinea-pig against 100 minimum lethal doses of toxin given by the mouth. Guinea-pigs varying in weight from 200 to 800 grams, owing to shortage of pigs of uniform weight, have been employed to note the specific relations of the toxin to the antitoxin of types A and B. In table 2 the relation of strain 126 to type B immune serum is tabulated.

#### SERUM TREATMENT OF CATTLE

The preliminary bacteriologic and immunologic studies herein enumerated suggested that the losses in cattle consuming the silage was probably associated with *B. botulinus* intoxication. This conclusion was practically established in the laboratory when it was learned that several tons of the silage in question were to be condemned and discarded as unfit for feeding purposes. In view of the preliminary findings the advisability of recommending that this silage be fed to the cattle seemed logical to us, providing the animals in the herd might first be injected with botulinus antitoxin. It was believed that the practical value of specific antitoxic serum in cattle for the prevention of botulism might be observed and possibly definitely demon-

strated under natural conditions comparable to field tests with horses (Rusk and Grindley) wherein the value of antitoxin was apparently observed.

Dr. I. B. Boughton of the Animal Pathology Division, University of Illinois, with the consent of the owner treated 43 cattle of the original herd with antitoxin, type B. Amounts varying from 30 to 50 cc. were injected subcutaneously into each animal. A control or untreated animal was placed in the herd with the 43 treated cattle. Following the injection of serum the silage which had previously proven injurious to cattle, and which upon examination proved to be contaminated with *B. botulinus* (type B) was fed in liberal amounts for sixty consecutive days, until the supply of silage was exhausted. No symptoms of illness were noted in the treated animals and the one untreated animal.

The protective value of type B serum in these animals must be discounted, in the opinion of the writers, for the reason that a degree of immunity might have been developed by a previous illness which had occurred in approximately one-half of the animals of this herd and which in all probability was induced by botulinus toxin in the silage. The control animal did not succumb or even display clinical symptoms of illness, and therefore no precise and definite deductions can be drawn, yet the protective value of botulinus antitoxin in laboratory tests suggests the possible value of this antitoxin in combating *B. botulinus* intoxication in cattle, as well as the advisability of further tests of this character in the control of natural outbreaks of this disease in bovines.<sup>1</sup>

<sup>1</sup> As this manuscript is being prepared the importance of a polyvalent serum in further trials is suggested by the results of bacteriologic and immunologic findings in two separate and distinct outbreaks of botulism in cattle occurring near Paxton, Illinois, wherein A and B types of *B. botulinus* respectively were encountered.

During the feeding test, the owner advised that the silage in question had been fed independently to an untreated cow not included in the experimental group, with the result that the animal developed symptoms indistinguishable from the illness originally observed in the herd. This animal had not previously received the silage and the owner's observations seem worthy of record.

## SUMMARY

1. An anaerobic bacillus biologically resembling *B. botulinus* (type B) was isolated from a corn silage (126).

2. Several (18) cattle of the herd consuming the silage in question developed symptoms of forage poisoning on two different occasions and four animals died. It is possible that botulinus toxin in the ensilage was primarily related to the disease in question.

3. The silage was regarded as unsafe for cattle and after discontinuing its use in the daily rations, the animals remained healthy.

4. Botulinus antitoxin (type B) proved efficacious in protecting guinea-pigs against lethal doses of toxin in unfiltered broth cultures produced by the anaerobic bacillus isolated from the corn silage (126).

5. An opportunity was afforded to inject forty-three cattle on this farm with botulinus antitoxin, and subsequently to feed them with the silage. The animals remained apparently healthy. One control or untreated animal did not show visible illness and the value of the antitoxin in the feeding operations is therefore not conclusive. It is worthy of record that the treatment did not injure the animals and encouragement is offered for more extensive field trials in determining the value of the antitoxin in cattle against the ill effects of otherwise nourishing rations containing *B. botulinus* toxin which heretofore has advisedly been discarded. The latter item is of importance considering the increased cost of producing grain and forage.

## REFERENCES

- BURKE, G. S. 1919 Notes on *Bacillus botulinus*. Jour. Bact., 4, 555.  
1919 The occurrence of *Bacillus botulinus* in nature. Jour. Bact., 4, 541.
- GRAHAM, ROBERT, BRUECKNER, A. L., AND PONTIUS, R. L. 1917 Studies in forage poisoning, V and VI. Bulletin 207-208, Kentucky Agricultural Experiment Station.
- GRAHAM, ROBERT, AND BRUECKNER, A. L. 1919 Studies in forage poisoning. Jour. Bact., 4, 1.
- RUSK, H. P., AND GRINDLEY, H. S. 1918 Field investigations of forage poisoning in cattle and horses. Bulletin 210, Illinois Agricultural Experiment Station.



# NOTE ON THE INDOL TEST IN TRYPTOPHANE SOLUTION

CHR. BARTHEL

*Department of Bacteriology, Central Agricultural Experiment Station, Experimentalfältet, Stockholm*

Received for publication, July 22, 1920

The application of the indol test to tryptophane solutions by H. Zipfel was, without doubt a great advance. The theoretical basis of this reaction is so generally<sup>1</sup> known that it is superfluous to give an explanation here.

In applying the method of Zipfel it has happened on different occasions, that I have failed to obtain growth (turbidity) in the tryptophane solution even with bacteria, which are known as strong indol liberators,<sup>2</sup> as for example *Bact. vulgare*. Of course in this case there is also no indol reaction with the reagent of Ehrlich (p-dimethylamidobenzaldehyde). It occurred to me that this failure might be due to the hydrogen ion concentration in the solution in question.

Zipfel says nothing about the neutralization of the solution in either of his two publications on this subject and so far as I know, this fact has never been pointed out by any other worker. In an electrical determination of the hydrogen ion concentration, which I undertook on a tryptophane solution of the composition prescribed by Zipfel<sup>3</sup> I found the value of the pH = 5.41.

<sup>1</sup> Centralbl. für Bakteriöl., Abt. I., Orig., **64**, 1912, 65; Centralbl. für Bakteriöl. Abt. I., Orig., **67**, 1913, 572.

<sup>2</sup> The term "liberation" is better than "formation," as the action is merely a splitting up of the tryptophane molecule, with liberation of the indol group.

	<i>per cent</i>
Asparagin.....	0.5
Ammonium lactate.....	0.5
Potassium diphosphate.....	0.2
Magnesium sulfate.....	0.02
Tryptophane.....	0.03

As is obvious, this is a manifestly acid solution. The possibility that here was the explanation of the failure to obtain growth with *Bact. vulgare* now seemed very probable to me. An investigation of this question was therefore undertaken, which I wish to present in this paper. I have also attempted to answer another question, namely, whether or not it is necessary to have both asparagine and ammonium lactate present in the solution.

The researches, after a series of orientation experiments, which need not to be given here, were carried out in the following manner: 500 cc. of the tryptophane solution, but without

TABLE I

COMPOSITION OF THE SOLUTION	pH	
	Before sterilization	After sterilization
With ammonium lactate, neutral.....	6.81	6.29
With ammonium lactate, neutral, Jena glass.....		5.97
With ammonium lactate, acid.....	5.21	4.83
With ammonium lactate, acid, Jena glass.....		4.69
Without ammonium lactate, neutral.....	6.81	6.23
Without ammonium lactate, neutral, Jena glass.....		6.03
Without ammonium lactate, acid.....	4.86	4.83
Without ammonium lactate, acid, Jena glass.....		4.67

ammonium lactate, was divided into two portions of 250 cc. each. To one of these was added 1.25 grams (0.5 per cent) ammonium lactate. Each one of these solutions was divided into two parts, of which one was left as it was, while the other was neutralized with *N* NaOH to litmus. All of these four solutions were then transferred to test tubes (10 cc. per tube). From each of these four solutions, Jena glass tubes were also made up for comparison. The pH was determined in all the solutions before and after sterilization, which was carried out in the autoclave at 118°C. momentarily. The results of these series are shown in table I.

From the table it is seen that the solution itself is very acid, where it is not neutralized, and almost without exception the

hydrogen ion concentration increases during the sterilization. Furthermore, it follows from this that some alkali has been leached from the glass of the ordinary tubes, because the values of the pH of the Jena glass tubes are, consistently, lower (from 0.14 to 0.32) than for the others.

With these four sterilized solutions, indol tests were carried out with eight different species of bacteria, of which three are known to be strong indol liberators, namely *Bact. coli*, *Bact. vulgare* and *Vibrio cholerae*.<sup>4</sup> The other five are not indole liberators. These species were *Bact. aerogenes*, a variety of *Bact. Zopfii*, isolated from soil of the northern coast of Greenland, a motile non-sporeforming rod, isolated from the faeces of a crow and finally a yellow, non-motile non-sporeforming short rod isolated from the faeces of the musk ox. The two last were also obtained from Northern Greenland.

Of all these strains, one platinum loop from a twenty-four hour broth culture was inoculated in each of the above mentioned solutions. After incubation for twenty-four hours at 37°C., they were examined for growth (turbidity), as well as for the setting free of indol, by adding 5 cc. of the p-dimethylamidobenzaldehyde. According to Zipfel's work, which I can confirm in this point, it is quite unnecessary to let the tryptophane cultures stand longer than twenty-four hours at 37°C. If there is no growth in this time, it is of no use to continue the observation.

The results of these series are given in table 2.

If we consider at first only the influence of the hydrogen ion concentration, we find our suspicions confirmed that the non-neutralized solution is too acid always to permit the growth of the organism which is to be examined for indol liberation. *Bact. vulgare* and *Vibrio cholerae* do not grow and therefore naturally cannot give the indol reaction in the solutions which are not neutralized.

If we consider the results from the solutions with and without ammonium lactate, we may conclude from these experiments

<sup>4</sup> I wish to thank Prof. C. Kling, director of Statens Bakteriologiska Laboratorium, for his kindness in supplying me with the cultures of *V. cholerae* and *Bact. typhi*.

that it is of no consequence whether this compound is present or not. To be sure, in some cases the growth (turbidity) was stronger in the tubes which also contain ammonium lactate, but examples to the contrary are also to be noted, and in no

TABLE 2

CULTURE	+AMMONIUM LACTATE NEUTRAL pH=6.29	+AMMONIUM LACTATE ACID pH=4.83	WITHOUT AMMONIUM LACTATE NEUTRAL pH=6.23	WITHOUT AMMONIUM LACTATE ACID pH=4.83
<i>Bact. coli:</i>				
Growth.....	+++	-	++	+
Indole reaction.....	+	-	+	+
<i>Bact. vulgare:</i>				
Growth.....	++	-	(+)	-
Indole reaction.....	+	-	+	-
<i>V. cholerae:</i>				
Growth.....	+	-	++	-
Indole reaction.....	+	-	+	-
<i>Bact. typhi:</i>				
Growth.....	+	+	+	+
Indole reaction.....	-	-	-	-
<i>Bact. aerogenes:</i>				
Growth.....	+++	++	++	++
Indole reaction.....	-	-	-	-
<i>Bact. Zopfii:</i>				
Growth.....	++	-	++	+
Indole reaction.....	-	-	-	-
<i>Bacteria from crow:</i>				
Growth.....	(+)	-	(+)	-
Indole reaction.....	-	-	-	-
<i>Bacteria from musk ox:</i>				
Growth.....	-	-	+	-
Indole reaction.....	-	-	-	-

cases has the indol reaction given different results in the tubes with and without ammonium lactate.

The results of the experiments here related are that the solution of Zipfel is equally satisfactory even without ammonium lactate, but that under all conditions it must be neutralized.<sup>5</sup>

<sup>5</sup> It may happen occasionally that the tryptophane solution gives satisfactory results without neutralization, but this probably generally depends upon an especially strong leaching of the alkali from the glass during the sterilisation.



## THE NATURE OF HEMOLYSINS

J. T. CONNELL AND L. E. HOLLY

*Ann Arbor, Michigan*

Received for publication July 20, 1920

Attention was first called to the fact that some bacteria produce hemolysins when Ehrlich (1898) showed that the bacillus of tetanus produced a substance which he called tetanolysin. The discovery of the existence of this lysin was rapidly followed by the announcement of other bacterial hemolysins, such as pyocyanolysin (Bulloch and Hunter, 1900; Weingeroff, 1901), staphylolysin by Neisser and Wechsburg (1901), streptolysin by Besredka (1901), typholysin by E. and P. Levy (1901), megath-eriolysin by Todd (1901), etc.

It was soon shown that these lysins were characteristic of the organisms that produced them. For instance the staphylolysin, according to Neisser and Wechsburg, is injured by heating to 48°C. for twenty minutes, and destroyed at 56°C. for twenty minutes. Pyocyanin is destroyed by heating to 100°C. for fifteen minutes if it is free in the filtrate, but if the organisms are present it requires a higher temperature, and typholysin is not destroyed by boiling. Streptolysin requires 70°C. for two hours.

The majority of the lysins give rise to antilysins which are specific, though streptolysin is an exception. In fact the ability of a lysin to call forth an antilysin seems to run parallel with the ability of the microorganism producing the lysin to call forth antibodies to itself.

Lubenau (1901) considered the possibility that some substances which are known to be present in the medium may at times be responsible for the hemolysis. He tested the hemolytic power of sodium carbonate, ammonia, glucose and lactic acid, and showed that the strengths of these substances required to hemolyze are rarely ever present at the time the hemolysin is

active. Bulloch and Hunter showed that while a culture of *Ps. pyocyanea* is highly alkaline yet when the pH is brought back to near the neutral point it is still hemolytic though less so. This statement has been denied by Jordan who maintains that the hemolysis in this case is due to alkali.

In view of the light that has been thrown by Warden's work upon the composition of organisms, particularly in respect to their fatty complexes, it seemed logical to us that these fat antigens should be investigated as to the possibility of their playing a part in hemolysin production. This idea seemed particularly attractive because those organisms such as *Streptococcus* and *B. megatherium* which produce hemolysin early in their growth, and which also yield the most powerful hemolysins, are Gram positive, and the Gram positiveness of an organism is known to depend upon the presence of unsaturated fats. It is also well known that the unsaturated fatty acids and their salts are much better hemolytic agents than the non-volatile, saturated acids. We are aware, also, of the fact that if the fatty acid complexes should play a part in hemolysis the action would not be that following their simple suspension in salt solution because of the factors of a colloid nature introduced by the broth menstruum.

With these ideas in mind we decided to see if it were possible to produce an artificial hemolysin, using the fat complexes which were characteristic of the organism whose lysin we were trying to imitate. In order to do this ideally we realized that we must copy as closely as possible the condition existing in the medium at the time the hemolysin is at its height. The hemolysin first studied was that of the *Streptococcus*. The medium used throughout this work, called the standard medium, consisted of a veal infusion broth containing 2 per cent bactopecton and 0.5 per cent NaCl. The pH was varied from 7.1 to 7.9. In growing the *Streptococcus* organisms 10 per cent rabbit serum was added before inoculation. The cells used in the hemolytic experiments were fresh rabbit cells washed four times with 0.85 per cent salt solution, and made up in a 2 per cent salt solution suspension.

Figure 1 is typical of a number of curves derived when two different kinds of media were used, each having an original pH of 7.2, one being the standard medium, the other the standard plus 0.2 per cent glucose. All tubes were heated to 37°C. before

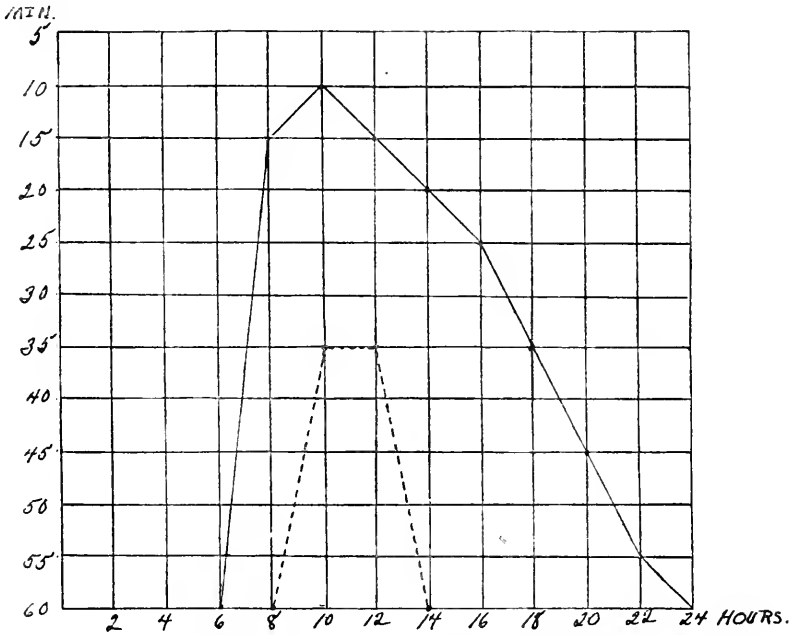

FIG. 1. SOLID LINE, PLAIN BROTH STANDARD MEDIUM  
BROKEN LINE, GLUCOSE BROTH STANDARD MEDIUM

inoculating, and then inoculated with a 4 mm. loopful from a twelve hour 10 per cent serum-broth culture of *Streptococcus hemolyticus*. The tubes were incubated at 37°C. and every two hours one tube of each kind of medium was removed, a part being centrifugated for one-half hour at 1800 revolutions per minute, and the pH of the remaining portion determined. Then 0.1 cc. of the supernatant fluid was added to 1 cc. of cell suspension and placed in a water bath at 37°C. for one hour. The abscissae of the chart represent minutes required for complete hemolysis, the ordinates showing the age of the culture.

The pH of the standard medium was found to change to 7.0 at eight hours returning to about the original reaction at from eighteen to twenty hours. The pH of the medium containing glucose rose to 5.58 at twelve hours and returned to 6.10 at twenty hours.

The striking feature in the chart is seen to be the disadvantage of even small amounts of glucose for the production of hemol-

TABLE 1

	A. Broth containing 40 mgm. per liter of K salts antigen.	
	B. Broth containing 40 mgm. per liter of Na salts antigen	
	C. Broth containing 40 mgm. per liter of fatty acid antigen	
1 cc. of A plus 1 cc. of 2 per cent rabbit cell suspension.....		++ 20 minutes
1 cc. of B plus 1 cc. of 2 per cent rabbit cell suspension.....		++ 20 minutes
1 cc. of C plus 1 cc. of 2 per cent rabbit cell suspension.....		++ 25 minutes

++ indicates complete hemolysis.

- indicates no hemolysis.

The above mixtures remained perfectly clear. They were completely inactivated upon heating at 65°C. for thirty minutes.

ysin. Not only was the hemolysin weaker but of much shorter duration, though the specimens were centrifugated in the same centrifuge for the same length of time.

We also determined the strength and duration of hemolysin, starting with a pH of 7.8 in the standard broth, but found no striking difference from that of the 7.2. In growing these cultures and in testing the strength of the hemolysin and the time in which it appeared, two points were impressed upon us, first, that noted by other workers, that the hemolysin occurs earlier and is much stronger if the culture from which the transplant is taken is young, preferably not over twelve hours old, second, that using 0.1 cc. of culture for the transplant instead of a loopful caused the hemolysin to appear earlier in the incubation.

In attempting to produce an artificial hemolysin the standard medium was used. We omitted the serum because it was found that it distinctly interfered with hemolysin production, just as it also interfered with the lytic power of natural hemolysin if added after the lysin appears. We believe that the function of the serum in growing *Streptococcus* is to insure rapid and abundant growth, which is apparently essential for the production of

lysin, and that the colloidal property of the serum which interferes with the action of the streptolysin is undoubtedly destroyed by the growth of the organism. We shall show further on that serum added to a medium in which an organism (*B. megatherium*) produces strong lysin without it, interferes markedly with lysin production.

The antigen used was the fat complex, in the form of the fatty acids and their salts, found by Warden to be characteristic for the *Streptococcus*. The sodium and the potassium salts of the complex were made up in alcoholic solutions of such strengths that 1 cc. contained respectively 10 mgm. and the solution of the fatty acids such that 1 cc. contained 20 mgm. and consequently the amounts of alcohol necessary to add to secure the concentration of antigen desired was never sufficient to cause a change in the appearance of the broth or to have any hemolyzing effect on the red cells. The antigens were added by means of 1 cc. pipettes graduated in hundredths and thoroughly mixed with the broth, taking care to avoid foam. The amounts used varied between 32 mgm. and 120 mgm. per liter, these quantities apparently having no appreciable effect on the pH. We noted in some of the broth that clouding appeared after about 45 mgm. per liter had been added, whereas other broths remained clear with 60 mgm. per liter. One factor in this regard appeared to be the color of the broth—the darker the color the more antigen it would take up without clouding. Another important observation was the variation in the amount of antigen per liter required to make the broth hemolytic, in some instances 30 mgm. sufficing, in others 50 mgm. These differences were found to be due to slight variations in the manner of emulsifying and in the time the mixtures were allowed to stand. Table 1 is a specimen protocol of the hemolytic power of the artificial emulsions.

Table 2 gives an example of the effect of pH upon the hemolyzing power and the temperature of inactivation of artificial emulsions made with the K salt and fatty acid antigens.

We realized that the broth containing the natural hemolysins must be quite different from the artificial emulsions we were

working with because of the action (digestive and otherwise) upon it of the microorganisms. What probably is more important is that it contained emulsifying substances which were

TABLE 2

- A. pH of broth 7.1 with 60 mgm. K salt antigen per liter  
 B. pH of broth 7.1 with 60 mgm. acid antigen per liter  
 C. pH of broth 7.4 with 60 mgm. K salt antigen per liter  
 D. pH of broth 7.4 with 60 mgm. acid antigen per liter  
 E. pH of broth 7.9 with 60 mgm. K salt antigen per liter  
 F. pH of broth 7.9 with 60 mgm. acid antigen per liter

	AT ONCE	ONE HOUR	TWO HOURS	AFTER 65°C FOR THIRTY MINUTES
1 cc. of A plus 1 cc. rabbit cell emulsion....	++12'	++9'	++9'	++23'
1 cc. of B plus 1 cc. rabbit cell emulsion....	++17'	++15'	++12'	++28'
1 cc. of C plus 1 cc. rabbit cell emulsion....	++11'	++10'	++12'	-1 hr.
1 cc. of D plus 1 cc. rabbit cell emulsion....	++26'	++15'	++15'	-1 hr.
1 cc. of E plus 1 cc. rabbit cell emulsion....	++19'	++12'	++15'	++40'
1 cc. of F plus 1 cc. rabbit cell emulsion....	++30'	++16'	++14'	++45'

From the above experiment it will be seen that the artificial hemolysin is inactivated at 65°C. for thirty minutes at a pH of 7.4, but at concentrations of 7.1 and 7.9 the inactivation is only partial.

delivered into it with the disintegration of the bacteria. With this idea in mind we tried the effects of some emulsifying substances to see if we could imitate the natural process more closely, and to determine whether the broth would not hold more of the fats without clouding. The substances chosen were such proteins as hemoglobin, casein, and typhoid protein, with which the fat antigen was emulsified,—imitating the conditions we believe to exist in the germ bodies—prior to adding to the broth. The following table is an example of the results.

TABLE 3

- A. 35 cc. of broth to which was added slowly in fractions 5 cc. of a solution containing 10 mgm. of typhoid protein and 2.4 mgm. of K salt antigen.  
 B. 35 cc. of broth to which was added in the same manner 5 cc. of a solution of 10 mgm. of casein with 2.4 mgm. of K salt antigen.  
 C. 35 cc. of broth to which was added in the same manner 5 cc. of a solution of hemoglobin with 2.4 mgm. of K salt antigen.

The proteins were dissolved in 5 cc. of salt solution and the solution of antigen mixed drop by drop with continual gentle shaking.

1 cc. of A plus 1 cc. of cell suspension.....	++ in 20 minutes
1 cc. of B plus 1 cc. of cell suspension.....	++ in 10 minutes
1 cc. of C plus 1 cc. of cell suspension.....	++ in 10 minutes

Control emulsions of like amounts of solutions of broth with the proteins alone showed no hemolytic power.

All the above mixtures remained perfectly clear, and were inactivated at 65°C. for thirty minutes. Other combinations were tried with amounts of fat antigen varying from 40 mgm. to 120 mgm. per liter, and with quantities of protein varying from 5 mgm. to 20 mgm. per 40 cc. These mixtures also remained perfectly clear.

The influence of the colloidal nature of the broth on these artificial hemolysins was so apparent that we were desirous of seeing whether alterations in the broth would affect any particular changes. To this end the ordinary standard broth was passed through a Berkefeld filter before emulsification with the antigens. A control unfiltered broth of pH 7.1 containing 32 mgm. per liter of K salt antigen in amounts of 1 cc. produced total hemolysis of 1 cc. of cell suspension in sixty minutes, whereas the filtered broth containing the same amount of the antigen gave no hemolysis whatever. By doubling the amount of antigen added to the filtered broth the hemolysis appeared and was complete in one hour. This experiment, repeated with the Na salt and with the fatty acid antigen, gave similar results, and appeared to indicate that filtration removed from the broth particles of some material instrumental in hemolysin production.

After it had been found that inactivation of the *B. megatherium* lysin could be brought about by various adsorbents, to be mentioned later, we attempted the same procedure with both the natural and artificial streptolysin. The results appear in table 4.

The results of inactivation by means of the surface of defatted colon bodies were the same as from starch. Also inactivation by the same adsorbents in the ice box over night instead of at 45°C. gave identical results. In short, the artificial antigen was readily inactivated by these methods but the natural lysin was not. We then tested out the inactivation of the artificial lysin when produced in 10 per cent serum broth. As stated pre-

viously it is difficult to produce artificial lysin in the presence of serum, but it is merely a question, of adding larger amounts of antigen to serum-broth than are required to render standard

TABLE 4

A. Twelve hour centrifugated Streptococcus culture	
B. Artificial lysin with 60 mgm. K salts Strep. antigen	
C. Artificial lysin with 60 mgm. Na salts Strep. antigen	
D. Artificial lysin with 60 mgm. acids Strep. antigen	
1 cc. of A plus 1 cc. cell suspension.....	++ in 10 minutes
1 cc. of B plus 1 cc. cell suspension.....	++ in 12 minutes
1 cc. of C plus 1 cc. cell suspension.....	++ in 14 minutes
1 cc. of D plus 1 cc. cell suspension.....	++ in 15 minutes

To 5 cc. of A, B, C, and D there was added a definite quantity of starch suspension and the tubes were placed in the water bath at 45°C. for 1 hour, together with control tubes without the starch suspension. After centrifugation of the starch the lysins were tested as follows:

A1, B1, C1, D1, represent the lysins treated with starch	
A2, B2, C2, D2, represent the lysins untreated	
1 cc. of A1 plus 1 cc. cell suspension.....	++ 40 minutes
1 cc. of B1 plus 1 cc. cell suspension.....	-
1 cc. of C1 plus 1 cc. cell suspension.....	-
1 cc. of D1 plus 1 cc. cell suspension.....	-
1 cc. of A2 plus 1 cc. cell suspension.....	++ 18 minutes
1 cc. of B2 plus 1 cc. cell suspension.....	++ 20 minutes
1 cc. of C2 plus 1 cc. cell suspension.....	++ 20 minutes
1 cc. of D2 plus 1 cc. cell suspension.....	++ 20 minutes

broth hemolytic. Much larger quantities of antigen can be added to serum-broth, if added in small amounts at a time, without clouding, than to standard broth. As a result of this experiment it was shown that with a Streptococcus serum-broth culture fourteen hours old, centrifugated, 1 cc. of which hemolyzed 1 cc. of cell suspension in twenty minutes and with an artificial K salts hemolysin containing 300 mg. antigen per liter, 1 cc. of which hemolyzed 1 cc. of cell suspension in five minutes attempted inactivation with the adsorbing substances in the ice box and at 45°C. produced no such effect, i.e., neither natural or artificial hemolysin was inactivated. This seemed to justify the conclusion that the reason we were unable to inactivate the



natural streptolysin was because of the presence of the serum and not because of any peculiarity of the lysin itself.

Several attempts were made to produce antilysin by injections into animals of the natural streptolysin, the artificial lysin and streptococci themselves, but the results were unsatisfactory. This work is being continued and it is hoped we may report on it later. This difficulty has been commonly encountered by other workers (Besredka, 1903).

The second microörganism selected for observation was *B. megatherium*. We chose this bacterium because from the work of Todd (1901) it was known to produce strong hemolysin in a comparatively simple medium, and give rise to good antilysin. The hemolysin of this organism is also very stable which is an advantage over streptolysin. The standard medium was used in all the experiments. We found that the lysin appeared as early as the tenth hour and lasted for weeks. The pH of the cultures, determined at two hour intervals was found to change to 7.2 or 7.3 when the original pH of the medium was 7.8. The addition of 10 per cent of rabbit serum to the standard medium before inoculation gave very much weaker hemolysin than when the standard broth was used alone.

The antigen used for the production of the artificial hemolysin was the fat complex found by Warden, Connell and Holly to be characteristic for the *B. megatherium*. The various solutions of the antigen were made in the same manner as those used in the work on the streptococcus, and the emulsification of the antigen with the broth was carried out similarly. Tests showed that artificial hemolysin containing 40 mgm. K salt antigen per liter gave complete hemolysis, in 1 cc. doses, of 1 cc. of red cell suspension in thirty minutes, that of Na. salt antigen of equal strength gave complete hemolysis in the same length of time; and that containing the acid antigen produced, in the same dose, complete hemolysis in twenty-five minutes. These artificial lysins were inactivated at 65°C. for thirty minutes.

The following table is an example of the effect of pH upon the hemolytic power, and upon the inactivation of the K salt and acid antigen of the *megatherium*.

TABLE 5

- A. Broth pH 7.1 plus 60 mgm. K salts antigen per liter  
 B. Broth pH 7.4 plus 60 mgm. K salts antigen per liter  
 C. Broth pH 7.9 plus 60 mgm. K salts antigen per liter  
 D. Broth pH 7.1 plus 60 mgm. acids antigen per liter  
 E. Broth pH 7.4 plus 60 mgm. acids antigen per liter  
 F. Broth pH 7.9 plus 60 mgm. acids antigen per liter

	AT ONCE	ONE HOUR	TWO HOURS	INACTI- VATION AFTER ONE HOUR AT 65°C
1 cc. of A plus 1 cc. cell suspension.....	++28'	++17'	++17'	++50'
1 cc. of B plus 1 cc. cell suspension.....	++35'	++19'	++20'	-1 hr.
1 cc. of C plus 1 cc. cell suspension.....	++36'	++25'	++25'	-1 hr.
1 cc. of D plus 1 cc. cell suspension.....	++20'	++13'	++15'	++38'
1 cc. of E plus 1 cc. cell suspension.....	++30'	++13'	++16'	-1 hr.
1 cc. of F plus 1 cc. cell suspension.....	++30'	++18'	++19'	-1 hr.

These emulsions remained perfectly clear.

The question of partial digestion of the broth on the part of the microorganisms during growth led us to attempt a similar procedure in the effort to copy as closely as might be the germ action in the production of our artificial lysin. We added a small quantity of pancreatin powder to the broth containing the antigen and digested the mixtures in the water bath at 45°C. for one hour. The result of this experiment was complete inactivation of the lysin, rather than one favorable to lysin production. The question then arose as to whether the loss of hemolytic power was not due to simple adsorption of the antigen rather than to digestion, and the following experiment showed such to be the case.

One cubic centimeter of artificial *B. megatherium* hemolysin containing 100 mgm. of the K salts per liter hemolyzed 1 cc. of cell suspension in ten minutes. Five cubic centimeter quantities of this hemolysin were treated with a definite amount of starch, and the same quantities with defatted colon bodies. These mixtures, together with 5 cc. controls of untreated hemolysin were placed in the water bath at 45°C. for one hour, and identical specimens were placed in the ice box over night. After

centrifugation at 1800 revolutions per minute to remove the adsorbent the fluids were tested for hemolytic power. Those that had been treated with adsorbent were completely inactive while the controls hemolyzed promptly in fifteen and in ten minutes.

We then tested the natural hemolysin of the *B. megatherium* to see if it could also be inactivated in the same manner. The culture used was an eighteen hour standard broth growth centrifuged at 1800 revolutions per minute and the clear supernatant fluid pipetted off. 0.25 cc. of this hemolysin hemolyzed 1 cc. of cell suspension in twenty minutes. The procedure with the previous adsorbents was then repeated with this natural lysin, with the result that the treated portions were found to be completely inactivated while the untreated controls gave complete hemolysis in fifteen minutes. In other words we found it possible to inactivate the artificial and the natural lysin by adsorption upon surfaces. Inactivation in this manner can be rapidly effected by heating to 45°C. for one hour, a temperature at which ordinary organisms do not grow, or more slowly by allowing the mixtures to stand in the ice box over night. Apparently the pancreatin powder acts, not by breaking up the fats but rather by simple adsorption. Attention has been previously called by others to the fact that pepsin and trypsin destroy the lysin of *Ps. pyocyanea*.

It was also found that previous emulsification of the *B. megatherium* antigen mixtures with hemoglobin, casein and typhoid protein before their addition to the broth gave results quite in accord with those obtained with the *Streptococcus* antigen.

Todd showed, as mentioned previously, that the lysin produced by *B. megatherium* when injected into animals gave rise to antilysin. We injected several groups of rabbits, some with natural lysin, others with the artificial hemolysin. These animals were given six injections subcutaneously, three at daily intervals and then, after an interval of four days, three more at daily intervals. On the seventh day after the last injection the animals were bled from the heart and the serums allowed to separate in the ice box over night. The serums were inacti-

vated at 56°C. for thirty minutes following which they were tested for antilytic power. Table 6 shows a typical protocol of several experiments.

TABLE 6

HS. Serum of rabbit immune to natural hemolysin.  
 AS. Serum of rabbit immune to artificial lysin.  
 NS. Serum of normal rabbit.  
 A. Supernatant fluid from a centrifugated eighteen-hour culture of *B. megatherium*.

0.5 cc. A plus 1 cc. cell suspension .....	++	in 8 minutes
0.5 cc. A plus 1 cc. cell suspension .....	++	in 8 minutes
0.5 cc. A plus 0.2 cc. HS plus 1 cc. cell suspension.....	-	in 1½ hours
0.5 cc. A plus 0.2 cc. HS plus 1 cc. cell suspension.....	-	in 1½ hours
0.5 cc. A plus 0.2 cc. AS plus 1 cc. cell suspension.....	-	in 1½ hours
0.5 cc. A plus 0.2 cc. AS plus 1 cc. cell suspension.....	-	in 1½ hours
0.5 cc. A plus 0.2 cc. NS plus 1 cc. cell suspension.....	++	in 60 minutes
0.5 cc. A plus 0.2 cc. NS plus 1 cc. cell suspension.....	++	in 60 minutes

Further experiments on the immune bodies resulting from immunization of animals with the artificial hemolysin of *B. megatherium* are given in the paper on the Nature of Toxin by Warden and ourselves.

## DISCUSSION

We have dealt merely with the hemolysins of two organisms streptolysin and megatheriolysin, both of which are very powerful and occur early in the growth of the organisms. The former is only produced under special conditions and disappears in twenty-four hours. The latter is elaborated readily upon very simple media and remains active for weeks. The difference in the ease with which these hemolysins are produced appears to bear a direct relation to the rapid and abundant growth of the bacteria, the hemolysin not being present in quantities sufficient to detect until the growth is quite abundant. We are aware that with the artificial antigens we have not obtained hemolysins as active as those formed by the germs, but a discrepancy of the sort was to be expected. The microorganism delivers its antigen into the broth in a state of emulsification difficult to imitate with only the colloid properties of the broth itself, and those of the few proteins used as adjuvants to aid us in our attempts to

bring about an optimum surface for the adsorption of the antigen. The variations in the quantity of antigen necessary to produce hemolysin in the various broths used bear out the importance of the colloidal properties of the menstruum to which the artificial antigen was added, and the fact that broth that has been passed through a Berkefeld filter requires the addition of more antigen than the unfiltered broth to make it hemolytic seems also to emphasize the importance of surface in the production of artificial hemolysin.

Another point that seems at first sight to afford a distinction between the natural and artificial hemolysin is the clouding that occurs with certain doses of the antigen. This variation is however only apparent and can be avoided by emulsification of the antigen before its addition to the broth, or by the presence in the broth of just the proper surface at the time of the addition of the antigen. Clouding depends in part on the rate at which the antigen is added and upon the manner of adding it—a considerably larger amount can be introduced without formation of a cloud if the emulsification be made drop by drop slowly and with constant gentle motion.

The points in which the natural and artificial antigens resemble each other are as follows (a) both are comparably hemolytic; (b) both are inactivated by heat at approximately the same temperatures. The natural lysin of *B. megatherium* is usually inactivated by heating to 56°C. for thirty minutes, though in some specimens it was found to require 60°C. for the same length of time, while the artificial hemolysin when containing 40 to 60 mgm. of antigen per liter is inactivated at from 60° to 65°C. for one-half hour. These temperatures are sufficiently close together for the discrepancy to be accounted for by the crudeness of the artificial methods. Streptolysin was found to inactivate at 70°C. for two hours by Besredka and by Ruediger when serum medium was used and then diluted with salt solution before being passed through a Berkefeld filter. In our serum-broth medium the streptolysin was inactivated at 65°C. for one-half hour. We are forced to believe that the colloidal state of the medium has considerable effect on the temperature

at which inactivation occurs. (c) The natural and artificial lysin of the *B. megatherium* is inactivated by adsorbents under the same conditions. The natural streptolysin is not inactivated by these agents, nor is the artificial lysin in the presence of serum. (d) Analysis of the broth in which *B. megatherium* had been grown for twenty-four hours showed the presence of approximately 60 mgm. per liter of the fat complex of the organism. No analysis of the Streptococcus broth was made because of the serum present. (e) Neither natural or artificial streptolysin has thus far yielded satisfactory antilysin. Both natural and artificial lysins of the *B. megatherium* gave rise to strong specific antilymins.

We have shown that certain artificial specific fat complexes exhibit all the reactions characteristic of the bacteria examined.

We believe that the hemolysins of the organisms studied consist of the respective fat antigens of the bacteria existing in definite colloid states.

#### REFERENCES

- BESREDKA 1901 Ann. de l'Ins. Past., p. 880.  
BULLOCH AND HUNTER 1900 Centbl. f. Bakt., Bd. 28, p. 866.  
EHRlich 1898 Berl. klin. Woch., p. 273.  
LEVY, E., AND P. 1901 Centbl. f. Bakt., Bd. 30, p. 405.  
LUBENAU 1901 Centbl. f. Bakt., Bd. 30, p. 402.  
NEISSER AND WECHSBURG 1901 Zeitsch. f. Hyg., Bd. 36.  
RUEDIGER 1903 J. A. M. A., **41**, 962.  
TODD 1901 Lancet, **2**, 1663.  
WEINGEROFF 1901 Centbl. f. Bakt., Bd. 29.

## THE NATURE OF TOXIN

### THE ANTIGENS OF CORYNEBACTERIUM DIPHTHERIAE AND BACILLUS MEGATHERIUM AND THEIR RELATION TO TOXIN

C. C. WARDEN, J. T. CONNELL AND L. E. HOLLY

*Ann Arbor, Michigan*

Received for publication July 20, 1920

Previous work upon a considerable number of bacteria and other types of living cells having demonstrated that each variety of cell possesses a fat complex which is specifically antigenic,<sup>1</sup> it was determined to ascertain whether toxin-producing bacteria might not also yield fat antigen complexes, and whether such antigens bear any relationship to the toxins.

For this purpose we selected *C. diphtheriae* and the *B. megatherium*, both of which yield heavy growths as well as produce abundant toxin in suitable media. It has seemed advisable for purposes of explanation and comparison to include the observations upon both of these bacteria in one paper. The toxin of *C. diphtheriae* induces strong antitoxin, but the antigen of the organisms themselves is not conspicuous in the production of other immune substances such as agglutinins, precipitins and complement fixing bodies, while on the other hand the *B. megatherium* gives rise to abundant antibodies of such nature together with antihemolysins and antitoxins. Where the reactions of these two organisms have characters in common they tend to confirm one another, and the deficiencies of one may be explained by the data obtained from the other. Moreover, the work on these bacteria was carried on at the same time, together with that of Connell and Holly on the "Nature of Hemolysins."

<sup>1</sup> Warden, Jour. Infect. Dis., 1918, **22**, 133; *ibid.*, 1918, **23**, 504; *ibid.*, 1919, **24**, 285; Warden and Connell, *ibid.*, 1919, **25**, 399.

## C. DIPHTHERIAE. THE ANTIGEN

The strain of organism used was the Park no. 8. The cultures were prepared in a manner calculated to produce the greatest luxuriance of growth and the maximum of toxin. For these purposes there was used veal infusion to which were added 2 per cent pepton and 0.5 per cent NaCl. The pepton was for the most part a "proteose" pepton prepared by the Digestive Ferments Company which was found to yield toxin of high grade. The proteose broth was adjusted to a pH of 7.9 with NaOH prior to autoclaving. The organisms were trained to rapid pellicle formation by frequent transplantations before the final inoculations upon large surfaces of the nutrient broth as recommended by Bunker<sup>2</sup> which were made upon shallow depths of broth in Roux flasks laid on the flat and slightly inclined, giving an area of 40 square inches per flask and a depth varying from  $\frac{3}{4}$  to  $1\frac{1}{2}$  inches. Good pellicles covered the surfaces in twelve hours, and the growths were maintained at 35°C. for five to six days. It was essential that the medium should be as nearly fat-free as possible, and accordingly every precaution was taken in that regard. Careful siphonage and filtration while the broth was strongly acid, that is before the addition of alkali, with strict attention to cleanliness of vessels and glassware insured a medium containing a negligible amount of fat.

At the conclusion of the incubation period the toxic broth was separated from the germ mass by filtration through paper. The germ residues were then examined for fat content by methods described in earlier articles. The total moist residue, a portion of which was kindly supplied by Dr. Clark of the laboratory of Parke, Davis and Company, used in the examination weighed over 1 kgm. The fatty acid complex obtained therefrom was found to consist of approximately 80 per cent of unsaturated acids, and 20 per cent of saturated, nonvolatile acids.

The toxin broth filtrates to the amount of 50 liters were also examined and found to contain the same fat complex in quantities averaging 60 to 80 mgm. per liter, an amount equal to about two-thirds of that obtained from the germ residue from

<sup>2</sup> Jour. Bact., 1919, 4, 4.



1 liter. The addition of cresols or other similar preservatives to the cultures renders the toxin filtrates unfit for examination, and the germ residues must be freed from it before accurate examination of the fats can be made. The cresols pass unchanged into the solvents along with the fatty acids, making their purification difficult and wasteful. A trace of cresol renders an iodine determination fallacious because of the formation of additive compounds with the halogen in Hübl's solution.

Having determined approximately the composition of the fatty acid complex derived from the germ bodies and toxin broth, this complex was then tested against the serums of immunized animals—it being the custom to check the tentative analysis in this manner. Knowing the complex to contain about 80 per cent of unsaturated fatty acid corresponding closely in its various values to an oleic acid, and about 20 per cent of lower, non-volatile saturated acids having a calculated M.W. of 250, and melting point of 58°C., several trial artificial antigen complexes were prepared, having approximately the same values, from the purest obtainable fatty acids procured from sources other than the germ bodies. These artificial antigens were: No. 1, oleic acid 80 per cent, palmitic acid 16 per cent, myristic acid 4 per cent. No. 2, oleic acid 83.3 per cent, palmitic acid 16.7 per cent. No. 3, oleic acid 84 per cent, stearic acid 16 per cent. (The specimen of oleic acid used was the normal acid, having an I. V. of 87.5). They were prepared for testing by combining the Na salts of the acids in the above proportions in alcoholic solution in such weights that 1 cc. contained 2 mgm. of the complex, and to each 5 parts of the solution there was added 4 parts of a 1 per cent alcoholic solution of cholesterol, the latter being employed to furnish an adsorption surface for the antigen proper.

Experiments in complement fixation were then made with the serums of rabbits that had been immunized, some with washed *C. diphtheriae* germ bodies, others with toxin. Three separate tests were made with the serums of two groups of animals, using the sheep-rabbit hemolytic system, fresh guinea-pig complement, and a control antigen suspension in salt solution of thoroughly washed diphtheria bacilli from a twenty-four hour broth

culture. The antigenic titer of the control antigen was 0.04 cc. and that of the artificial antigens 0.1 cc. of emulsions made by mixing 1 cc. of the alcoholic antigen solutions with 16.5 cc. of salt solution. Two units of amboceptor and 2 units of complement were used, and 0.5 cc. of a 2 per cent washed sheep cell suspension, all tubes being brought to a volume of 1 cc. with salt solution. The first incubation was for thirty minutes at 37°C., the second for one hour followed by standing at 20°C. for several hours. The serums of control and immunized rabbits were inactivated at 56°C. for thirty minutes. The results of the tests are shown in tables 1, 2 and 3.

TABLE 1  
*First group of rabbits*

SERUMS	ANTIGENS				
	Control germ suspension	No. 1	No. 2	No. 3	Control anthrax antigen
1. Rabbit injected organisms.....	++	++	++	++	±
2. Rabbit injected organisms.....	++	++	++	++	+
3. Rabbit injected toxin.....	++	++	++	++	++
4. Rabbit injected toxin.....	++	++	++	++	±
5. Normal horse.....	-	-	-	++	-
6. Normal rabbit.....	-	+	-	++	++
7. Normal horse.....	+	+	±	++	-
8. Control, no serum.....	-	-	-	-	-

TABLE 2  
*Second test of first group, following fresh bleeding two days later*

SERUMS	ANTIGENS				
	Control germ suspension	No. 1	No. 2	No. 3	Control Streptococcus antigen
1	++	+	++	-	+
2	++	+	++	±	-
3	++	+	++	++	-
4	++	+	++	++	-
5	-	±	-	-	+
6	-	-	-	+	+
7	++	-	++	++	++
Control, no serum.....	-	-	-	-	-

TABLE 3  
*Second group of rabbits, sixty days later*

SERUMS	ANTIGENS			
	Control germ suspension	No. 1	No. 2	No. 3
1. Rabbit injected organisms.....	+	++	+	+
2. Rabbit injected organisms.....	+	+	+	+
3. Rabbit injected organisms.....	++	++	++	+
4. Rabbit injected toxin.....	-	-	-	-
5. Rabbit injected toxin.....	+	±	+	++
6. Normal rabbit.....	-	-	-	-
7. Control, no serum.....	-	-	-	-

In tables 1, 2, and 3, ++ = no hemolysis, complete inhibition; + = partial hemolysis; - = complete hemolysis, no inhibition.

From these tests it appeared that artificial antigen no. 2 gave results in closest agreement with the control diphtheria germ suspension antigen. It was accordingly employed in the succeeding work. We do not agree with the statement of A. Besson<sup>3</sup> to the effect that animals immunized with toxin show no immune bodies in their serums.

Agglutination and precipitation experiments were not made with these serums or this antigen, nor was any attempt made, for reasons mentioned earlier, to immunize animals with the artificial antigen, such reactions being shown better with the *B. megatherium*.

#### THE NATURE OF DIPHTHERIA TOXIN

The toxic broth as it comes from the filters is alkaline, having a pH varying from 8.0 to 8.33. An experiment of Connell's showed that the increased alkalinity might be due to the ammonia, of which there was found 34 mgm. against 14 mgm. in fresh broth. We had also shown that, among other changes, the broth had become richer in fats, or salts of fatty acids, and that these corresponded with those obtained from the bodies of the germs themselves.

<sup>3</sup> Pract. Bact., 1913, p. 269.

We assume there can be no question that diphtheria toxin is diphtheria antigen since its injection into animals produces a specific antitoxin which unites with no other known antigen. The concensus of opinion is that toxin is not a protein and does not require protein for its development.<sup>4</sup> If we accept, then, as one postulate the statement that toxin is specific antigen, and as another that the specific fat complexes of cells constitute their antigens, it follows that diphtheria toxin must be composed of the diphtheria fat complex in one form or another, and it should be possible to demonstrate the correctness or falsity of our assumption by means of the artificial fat antigen in a certain colloidal state.

In taking up this work we planned to commence with a broth menstruum known to yield good toxin, and to combine with it varying proportions of the fat antigen in various forms. Accordingly a standard broth identical with that used for actual toxin production was adopted. Artificial antigen no. 2 was prepared in proper proportions in the forms of the fatty acids, the alkali salts, Na and K, the ethyl esters, and the glyceryl and cholesterol esters. The ammonium salts were too unstable for use since in presence of Na ions in excess the  $\text{NH}_4$  ions are replaced. Cholesterol was omitted from these antigens.

We regarded the broth as a highly complex colloidal fluid containing proteoses existing as particles of varying colloidal dimensions, as shown by ultrafiltration<sup>5</sup> unknown organic matter from the veal infusion, coloring matter, and various electrolytes in addition to NaCl, all under the influence of a primary pH of 7.9. We assumed that the diphtheria bacilli, trained to the most rapid reproduction on the most favorable medium must also die and disintegrate rapidly according to a general principle of life and death,<sup>6</sup> liberating their fat complex in an emulsified or

<sup>4</sup> Jordan, *Genl. Bact.*, 1918, p. 266; Guinochet, *Arch. de Med. exp.*, 1892, **4**, 487; Hadley, *Jour. Infec. Dis.*, 1907, Suppl. 3, p. 95.

<sup>5</sup> Bechhold-Bullowa, *Colloids in Biol. and Med.*, 1919, p. 99.

<sup>6</sup> Vesilova, *Russk. Vrach.*, 1915, **9**, 205; Park and Williams, *Pathol. Microorg.*, 1920, p. 343. As an adjunct to the "life and death" principle in accounting for the death of microorganisms, in fluid cultures at a time when the quantity of lysin or toxin is at a maximum, is the fact of the existence in the fluid of the

colloidal form, which then, by reason of the necessity for such surface-tension-lowering substances to collect at the interfaces between dispersed and watery phases, become adsorbed upon colloidal particles of a certain size in the broth, forming, with electrolyte, an adsorption entity constituting toxin. We do not believe there is any evidence whatever to show that toxin exists preformed within the bodies of the bacilli and passes through their membranes into the culture medium. The particles of the toxic adsorption aggregate must be very small as we know from the ultrafiltration experiments of Bechhold<sup>7</sup> being slightly larger than protalbumoses and smaller than the particles in 1 per cent hemoglobin solution. We realized the impossibility of reproducing artificially all the changes undergone by medium and bacteria during the life of the culture, but we tried to imitate as closely as might be the processes of colloidal nature which we assumed on good evidence to take place.

The various methods used may be mentioned here: (a) The fatty acid antigen in varying doses, in ether solution, was overlaid on the surface of 100 cc. of broth in Erlenmeyer flasks of 250 cc. capacity. This was soon abandoned. (b) The fatty acids were floated in bulk on the broth surface. This method was also unavailable. (c) The fatty acids in alcoholic solution were pipetted upon the surface of the medium, and also emulsified by mixing at once. (d) The same methods were used with the K and Na salts, and with the ethylic, glyceryl and cholesteryl esters. Several flasks of each description were always made so as to permit of daily examination. All the operations were carried out in a sterile manner. Departures were made from the standard medium to include veal infusion without peptone, peptone solutions alone, and, finally, to eliminate all protein, colloids of mastic-fat in water and salt solution.

fatty acids, or their salts, derived from the bacteria, in just such amounts as inhibit the growth of the germs, and at the same time cause the lysis of cells. It is significant that the dose of the Na salts of the anthrax antigen just sufficient to prevent the development in broth of the bacilli from spores, 60 mgm. per liter, is that which toxic and lytic broths were found to contain, and approximately that which was added of the alkali salts to the artificial lysins and toxins, as will be shown later.

<sup>7</sup> Loc. cit.

The alcoholic solutions of the antigen fatty acids, salts and esters were sterile and of convenient strengths for the pipetting of small amounts to the broth with the minimum of alcohol. Control experiments showed that the addition of corresponding quantities of alcohol alone gave rise to no precipitation or other appreciable change. The antigens were added in weights varying from 1 mgm. per 100 cc. to 20 mgm. per 100 cc. in a maximum of 1 cc. of alcohol, without material change in the pH either at once or with the passage of time. After inoculation the flasks were placed, without stirring, save where emulsification was done at once, in the incubator at 35° to 37°C. where they remained undisturbed until examined. The pH of the broth was also made to vary from the standard so as to try the effects of such concentrations as 7.38, 8.0, 8.1 and 8.33. Some of the flasks were made alkaline to the lower figures by ammonia added in a sterile manner after autoclaving and cooling. Several flasks were incubated under lowered oxygen tension. When a flask was removed from the incubator the pH of the contents was taken, and the degree of clearness noted, as well as the presence or absence of sediment and of faint scum of unemulsified fat upon the surface. As a rule 2 cc. quantities taken from the center of the fluid were then injected subcutaneously into guinea pigs averaging 275 grams weight.

The results of these experiments are shown in tables 4 and 5.

TABLE 4

FATTY ACIDS	TOTAL GUINEA PIGS INJECTED	DIED
8 mg. artificial diphtheria antigen added to broth surface. Incubation at 37°C., five to six days .....	82	79
Same dosage K or Na salts of fatty acids added to broth surface. Incubation 37°C. five to six days.....	15	11
Mastic emulsions; alkali salts; no incubation.....	25	20
Number of pigs dying in 1 to 4 days.....		21
Number of pigs dying in 5 to 14 days.....		50
Number of pigs dying in 14 to 30 days.....		29

TABLE 5  
*Showing a specimen portion of the death record in greater detail*

pH.....	7.3	7.6	7.8	7.9	8.04	8.3
Deaths.....	0	2	1	9	4	1
Alcoholic solution fatty acids:						
Incubation (days).....	2	3	4	5	6	8-12
Deaths.....	1	3	1	8	2	4
Days to kill.....	1	2	3	4	5-10	10-14
Deaths.....	3	3	2	4	4	4

There were included in these tables only those animals dying without infection which presented at autopsy a definite picture of the macroscopic lesions characteristic of death from diphtheria toxin, viz., great emaciation, hemorrhages into the capsules of the adrenals and kidneys, enlarged and hemorrhagic kidneys, injection and hemorrhage of the lungs. Free fluid in the pleural sacs and intestinal injection were variable signs. The best results were obtained from dark colored broth inoculated on the surface with 8 mgm. of the fatty acid antigen and allowed to remain at 37°C. for five to six days, and which, at the time of injection was clear, or with a fine colloidal haze, had a pH of 7.9 to 8.1, a very slight or no surface pellicle and a slight sediment consisting for the most part of crystalline phosphates. Nearly all animals injected with such broth died. Filtration through a Berkefeld filter greatly diminished the toxicity. Distinctly cloudy fluids did not give good results. The antigen in the form of the K salts gave good results, while no deaths at all were obtained from the broth containing the ethyl, glyceryl or cholesteryl esters. We found that with the same broth inoculated with the same dose of antigen, in the same manner so far as control was possible, there were obtained fluids of many degrees of emulsification from clearness to dense cloudiness. The reason for this in the absence of contamination was not apparent. We had difficulty also in making different lots of broth alike, particularly in color, some being pale, others dark, depending somewhat on the quality of the veal used for making the infusion.

A notable feature of the results was the irregularity in killing time. Not infrequently a toxic broth which killed one guinea-pig in two days did not kill the other of the pair until much later. We attempted to account for this peculiar result by recognizing the extreme instability of such colloids, the slightly different conditions encountered in the tissues of the various guinea-pigs sufficing to alter the physical state of the injected fluid.

Control guinea-pigs that died following injection of *Streptococcus* and of *Pneumococcus* artificial antigen broth showed pulmonary congestion and hemorrhages without particular damage to kidneys or adrenals.

The most serviceable colloids of mastic were found, after many trials, to be those prepared by adding to an alcoholic solution of mastic of known concentration the desired amount of alcoholic solution of fat antigen, and then emulsifying in sterile water or salt solution by adding the alcoholic mixture to the fluid kept in constant whirling motion. The emulsions were pale white with orange colors by reflected light, and the particles were beyond the limits of microscopic vision. The clearest results were obtained with colloids containing 5 mgm. of mastic and 5 to 8 mgm. of the K salt antigen in 100 cc. of diluent, and brought to a pH of 7.9–8.0 with NaOH. On standing the pH shifts to the acid side. The injections were made with freshly prepared sterile emulsions.

The pathological picture exhibited in guinea-pigs dying from diphtheria and artificial toxin, while characteristic, presents certain features which in the long run do not appear to be distinctive of that poison alone. Out of the control animals in number at least equal to the determinants and kept under the same conditions, there were found two pigs dead following injections of supposedly tuberculous urine showing hemorrhages into the adrenals, and one apparently normal pig, without infection, showing the same lesion. The kidneys of these animals were not noticeably affected. These three control guinea-pigs were the only examples however, in this and in previous work upon fat antigens, in which lesions in any way similar to those of diphtheria toxin were observed.



The diphtheria fatty acid-colloidal fluids used for injection were not hemolytic for rabbit cells in the test tube, whereas those prepared with the K salts were strongly so. Vesilloff<sup>8</sup> showed that the bacilli from very young broth cultures removed by centrifugation and suspended in salt solution were hemolytic. Lubenau<sup>9</sup> states that broth cultures are hemolytic between the second and fourteenth days, varying with different strains.

In seeking an explanation for the instability of our artificial toxic colloids we were reminded of the fact that the methods of emulsification so far employed must be of the crudest nature compared with those which accompany the disintegration of the bacilli. We regard the cells, bacterial or other, as consisting of emulsion colloids of water, protein, fat, salts, etc., having at their surfaces or limiting layers an excess of those substances which lower surface tension and aid in regulating permeability, and which, according to the principle of Willard Gibbs must exist at the surfaces, namely emulsified fats, their acids and salts, and protein. The colloidal state of the limiting surfaces is probably different from that within the cells—a reversed type of colloid like a water-in-oil emulsion, in contrast to an oil-in-water emulsion to which one may compare the state of the interior of the cells.<sup>10</sup> Cells disintegrating or autolyzing in a watery colloidal menstruum such as broth possess dispersion means of remarkable power owing to the highly emulsified state of the fats which, liberated under such conditions, must pass to interfaces in the fluid in a manner far more delicate than we can readily approach in an artificial way. With these ideas in mind we believed we should be able to obtain greater stability in the artificial toxins if we emulsified the fat antigen prior to adding it to the broth. Accordingly we combined the antigen with solutions of the commoner proteins at hand such as hemoglobin, casein, egg albumen, gelatin, and a protein derived from the *Bact. typhosum*, substituting the alkali salts of the antigen for the fatty acids because of their somewhat greater emulsifying

<sup>8</sup> Russk. Vrach., 1913, October 13, p. 235.

<sup>9</sup> Centr. f. Bakt., 1901, 30, 365.

<sup>10</sup> Clowes, Science, 1916, 43, 750-757.

properties. The colloids formed in this manner were of great interest. If to a solution of 10 mgm. of hemoglobin in 5 cc. of salt solution there was added drop by drop the alcoholic antigen solution a somewhat opalescent colloid resulted. When this mixture was added to the standard broth in constant motion drop by drop there resulted beautifully clear, stable liquids even when the amount of fat antigen exceeded 200 mgm. per 1 liter. When, however, the hemoglobin solution alone, or the hemoglobin-antigen solution was added to the broth all at once, instead of gradually, the resulting fluids became cloudy. The same results were noted with fat-free casein-antigen and the typhoid protein-antigen mixtures. The emulsions made with fresh egg white and with gelatin were never perfectly clear.

Of particular interest were the colloids made with the typhoid protein-antigen emulsions. The typhoid protein itself, of which mention has been made in an earlier paper, is soluble in salt solution, non coagulable by heat, contains but traces of amino nitrogen and is highly toxic for laboratory animals in small doses. It is toxic also when its solution is mixed with broth by the drop method, 1 cc. of the fluid containing 0.25 mgm. injected intraperitoneally into guinea-pigs being fatal in twenty-four hours. On the other hand twice the dose produces no symptoms at all if the protein solution be added to the broth all at one time. The addition of the fat antigen to the colloid increases the toxicity, and gives to the autopsy picture its distinctive character. Guinea-pigs dying from the effects of the protein alone present no signs beyond slight injection of the visceral and parietal peritoneum whereas those dying from the protein antigen emulsions show characteristic signs of diphtheria toxin poisoning. We do not believe that the typhoid protein, derived as it is from the germ bodies that have undergone prolonged defatting extractions with alcohol and with ether, represents the proper protein of the bacteria during life, but this view does not militate against the conception that the proteins of some microorganisms liberated by autolysis in fluids may also be somewhat toxic if emulsion in a proper colloidal state occurs. We are inclined to the belief that the potentialities for toxin

production are always present when bacteria are permitted to undergo lysis in fluid culture media, and that actual toxin production depends first on the characters of the emulsified fat antigen complex and second upon its colloidal arrangement.

The mixtures of hemoglobin and broth, and of casein and broth did not show toxicity whereas these emulsions containing the fat antigen were toxic.

Still another factor instrumental in the making of suitable protein-antigen broth colloids is that of the color of the broth. The pigment of broth appears to be a distinct aid to emulsification. Very light colored broth is a much poorer colloidal medium than one which is dark. Besredka<sup>11</sup> noted that the filtrates of his streptococcus lysin which had lost some of the color during the filtration were impaired in hemolytic power. Connell and Holly showed that a broth which had been passed through a Berkefeld filter prior to the addition of artificial megatherium antigen had practically lost its hemolytic power as compared with the unfiltered broth containing the antigen. Very slight alterations in broth lead to great colloidal changes.

A very important factor also is the maturation of the protein-fat antigen-broth colloids. A period of time of at least one hour at 20°C. after the mixing of the ingredients is essential to the development of maximum hemolytic and toxic power, after which time, at 4°C. the activity remains stationary for a considerable period and then gradually declines. Heat inactivates these mixtures in a manner similar to true hemolysin and toxins.

The toxicity of the artificial fat-protein colloids is shown in the specimen protocol given in table 6. All the injections were

TABLE 6

*Artificial colloid no. 1:* 35 cc. of standard broth to which was added in divided doses 10 mgm. of typhoid protein dissolved in 5 cc. salt solution.

*Artificial colloid no. 2:* The same, to which the protein solution was added in a single dose.

*Artificial colloid no. 3:* The same, to which was added in divided doses 5 cc. of a salt solution emulsion of 10 mgm. of typhoid protein with 4.8 mgm. of K salt diphtheria antigen.

*Artificial colloid No. 3A:* The same, with 5 mgm. of typhoid protein.

---

<sup>11</sup> Ann. de l'Inst. Past., 1901, 15, 880.

TABLE 6—Continued

*Artificial colloid no. 4:* 35 cc. of standard broth to which was added divided doses 5 cc. of a salt solution emulsion containing 10 mgm. of fat-free casein and 4.8 mgm. of K salt antigen.

*Artificial colloid no. 5:* The same, with 10 mgm. of hemoglobin substituted for the casein.

*Artificial colloid no. 6:* The same, with 10 mgm. of gelatin substituted for the hemoglobin.

*Artificial colloid no. 7:* The same, using 100 mgm. of fresh egg white as protein.

GUINEA PIG NUMBER	AMOUNT INJECTED INTRA- PERITONE- ALLY	RESULTS
Guinea-pigs injected with colloid no. 1		
1	2.0	Died in 12 hours, intestines hemorrhagic
2	2.0	Died in 4 hours, intestines hemorrhagic
3	1.0	Died in 4 hours, intestines hemorrhagic
4	0.5	Lived
5	0.25	Lived
Guinea-pigs injected with colloid no. 2		
6	2.0	No symptoms
7	1.0	No symptoms
8	0.5	No symptoms
Guinea-pigs injected with colloid no. 3		
9	2.0	Died 4½ hours; typical lesions
10	2.0	Died 5 hours; typical lesions
11	2.0	Died 3½ hours; typical lesions
12	2.0	Died 7 hours; typical lesions
13	2.0	Died 6 hours; typical lesions
14	1.0	Died 7 hours; typical lesions
15	0.5	Died 15 days
16	0.5	Lived
17	1.0*	Lived
18	1.0*	Lived
19	2.0†	Lived
20	2.0†	Lived
21	2.0†	Lived

\* Plus 250 units antitoxin.

† Plus 500 units antitoxin.

TABLE 6—*Concluded*

GUINEA PIG NUMBER	AMOUNT INJECTED INTRA- PERITONE- ALLY	RESULTS
Guinea-pigs injected with colloid 3a		
22	2.0	Died second day; typical lesions
23	2.0	Died third day; typical lesions
Guinea-pigs injected with colloid 4		
24	2.0	Died third day; typical lesions
25	2.0	Died fourth day; typical lesions
26	1.00*	Died seventh day; fair lesions
27	1.00*	Died seventh day; fair lesions
Guinea-pigs injected with colloid 5		
28	2.0	Died third day; typical lesions
29	2.0	Died first day; typical lesions
30	2.0	Died fifth day; fair lesions
31	2.0	Died tenth day; typical lesions
Guinea-pigs injected with colloid 6		
33	2.0	Died second day; good lesions
33	2.0	Lived
Guinea-pigs injected with colloid 7		
34	2.0	Lived
35	2.0	Lived

made intraperitoneally into guinea-pigs of 250 grams average weight. The autopsies showed the characteristic lesions. All the colloidal fluids were matured for one and one-half hours at 20°C.

The neutralizing action of antitoxin upon artificial toxin is indicated in the foregoing table. The dose of toxin used was one always fatal to guinea-pigs in six to eight hours. It would have occasioned no surprise had antitoxin failed to protect, since at best we had only hoped to approximate the toxic colloid in our artificial mixtures, but the experiments while they have not been

carried on to the extent one would desire seem clearly to indicate a protective influence, specific or otherwise, but proportionate to dosage, on the part of the antitoxin.

Further observations upon the production of artificial toxin mixtures have suggested the availability of emulsifying substances other than proteins, such, for instance, as the dyes, of which Congo red has thus far alone been tried. This question is of interest in connection with the coloring matter of broths noted earlier.

#### B. MEGATHERIUM. THE ANTIGEN

The strains of *B. megatherium* were two in number, one of our own, and that known as No. 7 kindly sent us from the Museum of Natural History, the latter having been used and commended by Rous, Robertson and Oliver.<sup>12</sup>

Heavy cultures of the organism were grown for twenty-four to thirty-six hours at 35°C. in Roux flasks on beef-peptone 1 per cent agar, the mass removed in small amounts of water and saponified in the manner previously described. The collected fatty acid complex was then examined and found to consist of approximately 56 per cent of insoluble unsaturated fatty acid and 44 per cent of volatile fatty acid. The saturated fraction obtained by steam distillation had a melting point of 30°C. a neutralization value of 233 mgm. NaOH, and a calculated M.W. of 175, showing that it probably consisted wholly of capric acid. The insoluble residue from the distillation, after conversion into the Pb salts and extraction with ether, showed the absence of further saturated acids, and the fluid acid obtained by conversion of the Pb salts gave an I.V. of 90, a neutralization value of 142 mgm. NaOH and a calculated M.W. of 283, data quite in agreement with an oleic acid. The tentative formula for the Megatherium antigen, then, consisted of oleic acid 56 per cent and capric acid 44 per cent. This was different from any previous complex studied but resembled in physical characters most closely that for *B. anthracis*.

<sup>12</sup> Jour. Exp. Med., 1919, 29, 283.

The antigen in the form of the Na salts with cholesterol was then tested for complement fixing power with the serums of rabbits immunized with washed *Megatherium* organisms, and with *Megatherium* hemotoxin. The procedure in this experiment was identical with that used in testing the Diphtheria antigen. The results appear in table 7.

TABLE 7

SERUMS	ANTIGENS	
	Control germ suspension	Artificial fat antigen
1. Rabbit injected, organisms.....	++	++
2. Rabbit injected, organisms.....	++	++
3. Rabbit injected, toxin.....	++	++
4. Rabbit injected, toxin.....	++	++
5. Rabbit injected, toxin.....	++	++
6. Normal rabbit.....	+	+
7. Normal.....	-	-
8. Normal.....	++	++
9. Normal.....	-	-
Control, no serum.....	-	-

++ = no hemolysis, complete inhibition; + = partial hemolysis; - = complete hemolysis, no inhibition.

Table 8 shows the results of the agglutination-precipitation tests of the same serums with the artificial fat antigen.

TABLE 8

Each tube contained: Antigen solution 0.08 cc., serum 0.2 cc. and salt solution 1 cc. The tubes after mixing and shaking were placed in the ice box over night and read the following morning.

SERUM NUMBER	ACTIVE SERUM	INACTIVATED SERUM
1	+	+
2	+	+
3	+	+
4	+	+
5	+	+
6	-	-
7	+	+
8	-	-
Control, no serum	-	-

+ = precipitation; - = cloudy, no precipitation.

Table 9 shows the results of the precipitation test with the same serums.

TABLE 9

*Antigen No. 1.* True Megatherium toxin broth.

*Antigen No. 2.* Artificial toxin broth, composed of 40 cc. broth containing 5 mgm. of Typhoid protein and 2.4 mgm. of the K salts of the Megatherium antigen.

Each tube contained 0.5 cc. of antigen and 0.04 cc. of diluted serum. Readings taken as in table 7.

SERUM NUMBER	SERUMS DILUTED 1:60		SERUMS DILUTED 1:120	
	(1) Toxin	(2) Artificial toxin	(1) Toxin	(2) Artificial toxin
1	++	+	++	+
2	++	+	++	+
3	++	+	++	+
4	++	+	++	+
5	++	+	++	+
6	-	-	-	-
7	-	-	-	-
8	-	-	-	-
Antigen only	-	-	-	-

These experiments showed that in all probability the artificial antigen was approximately correct. We observed in these and in later tests that many normal rabbits have natural antibodies against the *B. megatherium* and its toxin. This fact was noted by Todd.<sup>13</sup>

In order to test further the antigenic action of the artificial fat complex, rabbits were immunized by divided S.Q. injections of 0.5 mgm. doses emulsified both in broth and in salt solution. Eight days after the sixth and last injection the rabbits were bled and the serums separated and inactivated at 56°C. for thirty minutes. The following table shows the results of complement fixation carried out in the manner previously described.

From these experiments it appeared that the serums of rabbits immunized with the artificial antigen of *B. megatherium* contained agglutinating and complement fixing antibodies in fair amount together with strong antilynsins. Connell had pre-

<sup>13</sup> Lancet, 1901, 2, 1663; Trans. Path. Soc. Lond., 1902, 53, 196.



TABLE 10

SERUMS	ANTIGENS	
	Megatherium suspension in salt solution	Artificial antigen
1. Rabbit injected, salt solution emulsion.....	++	++
2. Rabbit injected, salt solution emulsion.....	++	++
3. Rabbit injected, broth emulsion.....	+	+
4. Rabbit injected, broth emulsion.....	+	+
5. Normal rabbit.....	±	-
6. Normal rabbit.....	±	-
Control, no serum.....	-	-

TABLE 11

*The same serum agglutinated a suspension of washed Megatherium in salt solution*

Each tube contained: Salt solution suspension 1 cc. and 0.04 cc. serum. Temperature 4°C. for two hours.

SERUMS	SUSPENSION
1	+
2	+
3	+++
4	++
5	-
6	-
Control, no serum	-

+++ = complete agglutination and precipitation; ++ = almost complete agglutination; + = partial agglutination; - = no agglutination.

TABLE 12

*Showing the presence of antihemolysis in the same serums which were tested against the clear centrifugated lysin of a twenty-four hour veal-Bacto peptone 1 per cent broth culture of which 0.5 cc. caused complete hemolysis of 1 cc. of a 2 per cent suspension of rabbit red cells in salt solution in eight minutes at 37°C.*

Each tube contained: 0.5 cc. of fresh hemolysin, 1 cc. of cell suspension and 0.04 cc. of serum. The tubes were shaken and placed in a water bath at 37°C. for two hours, and then allowed to stand at 20°C. over night.

SERUMS	0.04 CC. OF ACTIVE SERUM	0.04 CC. OF INACTIVE SERUM DILUTED 1/5 WITH SALT SOLUTION
1	-	-
2	-	-
3	-	-
4	-	-
5	++	++
6	++	++
No serum	++	++

- = no hemolysis; ++ = complete hemolysis.

viously shown that the serums of rabbits immunized with Megatherium organisms and with toxin contained strong agglutinins and precipitins. The Megatherium antibodies diminish fairly rapidly in the serums of rabbits after having reached their maximum. This fact was shown by repeated experiments upon the antihemolytic power of the serums from both the series of animals immunized with germ bodies and toxin, and with the artificial antigen, they having been bled two days and again four days after the first drawing. The subsidence in antibody titer was shown to be parallel in the two series.

TABLE 13

*Shows the hemolytic and toxic power of our strain of B. megatherium*

*Toxin no. 1:* Twenty-four hour broth culture (composition given above) centrifugated clear at high speed, of which 0.04 cc. hemolyzed 1 cc. of 2 per cent red cell suspension in twenty minutes.

*Toxin no. 2:* Six day broth culture, centrifugated clear. 1 cc. hemolyzed 1 cc. of red cell suspension in thirty minutes.

GUINEA PIG NUM- BER	AMOUNT IN- JECTED IN- TROPERI- TONEALLY	TOXIN NUMBER	RESULTS
1	2	1	Died in less than 12 hours
2	2	1	Died in less than 12 hours
3	2	2	Died in less than 12 hours
4	2	2	Died in less than 12 hours

Autopsies showed: Abdomen distended; peritoneum bright red, cavity containing hemolyzed blood; small intestines hemorrhagic with hemorrhages into the lumen; lungs slightly injected; bloody fluid in pleural sacs; heart muscle injected; bloody transudate over thighs.

Guinea-pigs nos. 1 and 2 showed much more intense signs than nos. 3 and 4.

This experiment indicated that both the hemolytic and toxic powers of twenty-four hour cultures of the strain were greater than those of the six day cultures and that, hemolysin and toxin were probably the same substance.

## DISCUSSION

We believe with Bordet,<sup>14</sup> Todd,<sup>15</sup> Craw,<sup>16</sup> and many others whose work our observations tend to confirm that hemolysins are true toxins. Some toxins may not be hemolytic for the reason that the toxic particle may be of a size which does not readily form adsorption aggregates with red cells, or because of the protective action of proteins or other emulsifying substances. All antigens so far examined are hemolytic in certain colloidal states.

We have brought considerable evidence to show that the toxins of *C. diphtheriae* and of *B. megatherium* probably consist of the respective fat antigens of the organisms existing in definite colloidal states, the particulate nature of the complexes being an indispensable factor. As will be stated in greater detail in another paper the particulate character of all antigens is necessary to the colloidal concept of immune processes. Just as bacteria, parasitic in the blood and tissues of an animal, are colloidal particles having specific and characteristic surface chemistry, so also are the artificial fat antigens which have been used as substitutes for the germ bodies. The mode of action of such colloids is twofold, the primary one being that of "surface," or particles, alone, the secondary one that of the specific chemistry of the particles regulating the specificity of the immune response. The injection of unorganized particulate surface (kaolin, charcoal) leads to adsorptions and induced toxicity of the plasma of the animal (anaphylaxis); injections of, or infection by, bacteria or other cells also produce adsorptions, but the character of the substances adsorbed must be different for each species of cell, depending on the chemical complex constituting its surface.

The result of such adsorptions on the body fluids is a deprivation of some of their constituents, followed by the fluids compensating, or making good their loss by an attack upon certain

<sup>14</sup> Bordet-Gay, *Studies in Immunity*, 1909, p. 186. et seq.

<sup>15</sup> *Loc. cit.*

<sup>16</sup> *Proc. Roy. Soc. Lond., Ser. B.*, 1905, **76**, 179.

groups of body cells which may contain the missing substances upon their surfaces. There is considerable evidence pointing to the fact that toxins and antigens need not act directly on the cells but through the medium of the fluids bathing them. The substances primarily adsorbed, when regained gradually and in excess from the cells we regard as specific antibody.

The specific fat antigen complex of a cell may be one which in its particulate character may produce poor or ready response on the part of the body fluids, the result being inferior or strong antibody, as for instance *Streptococcus* and *V. cholerae*; while on the other hand the definite colloidal size of the antigen particle may be necessary to powerful antibody production, for example the *C. diphtheriae*; and again the colloidal dispersion of the antigen may be variable and still yield all antibodies from the agglutinins at one extreme to antitoxin at the other, as with the *B. megatherium*. It is conceivable also that the fluids and cells of the body respond better to some fat complexes than to others, irrespective of colloidal arrangement. At best poor antibodies result from attempted immunizations of laboratory animals with the bodies of streptococci, and the same is true with the artificial antigen and with the true streptococcus hemolysin, but considering the extraordinary colloidal richness of mammalian fluids and cells this idea does not seem so tangible as another which is, briefly, that the antigenic complexes of these microorganisms have not up to the present been employed in a proper colloidal form, and we are inclined to think that further study on the fluid media in which the bacteria are grown will throw light on the obscure problem.

A necessary corollary to these principles is that all antigen-antibody reactions, from agglutination and precipitation through complement fixation to toxin-antitoxin aggregates, are but phases of the same phenomenon acting from one extreme of the colloidal realm to the other, and that all phases must be possible with all cell antigens if only the proper colloidal state can be found. Dean<sup>17</sup> showed that complement fixation and precipi-

<sup>17</sup> Lancet, 1918, 1, 45.

tation are phases of the same reaction, and J. Alexander<sup>18</sup> has seen the diphtheria toxin-antitoxin union by ultramicroscopic methods.

It will be observed that no mention has been made of the so-called "lipoids." These substances play no part in the phenomenon whatever. The term "fat" has been given a somewhat elastic use to include the fatty acids and their salts and esters. Cholesterol is not a lipid but an alcohol. The writers are of opinion that the evidence for the existence of hard and fast lipid substances such as lecithin and kindred bodies, as such, in the fluids and cells of the body is very unsatisfactory and doubtful. The mere fact that they may be extracted from dried tissues by certain solvents does not signify at all that they existed as entities therein. There are as many kinds of lecithin as there are kinds of tissue, and, on the other hand, Barbieri and his pupils<sup>19</sup> failed to find a trace of lecithin in 3000 eggs. The availability of, if not the necessity for, delicate, easily shifted, labile adsorption compounds of electrolyte-fat-protein within the body fluids is, however, undisputed, and it is probable that the whole mechanism of immunity occurs in just such emulsion colloids. The proper emulsification of bacterial and their artificial antigens with emulsifying agents is regarded as the *sine qua non* of toxin production. The rôle of cellular protein aside from some such action does not appear to be paramount and is not otherwise essential to antibody formation. The "type" antibody response to protein and the "specific" antibody response to cells are but phases of the same process. Fat-free protein, having no fat at its surface, has nevertheless chemical configuration and particulate size, factors assuring adsorptions and antibody production, and the antibodies respond clearly to the antigen "type" only, lacking the sharp specificity of cellular antibody for the very reason of the fat-free character of the antigen.

The similar behavior of true and artificial lysins and toxins in relation to heat, pH, reagents, adsorbents, effects on animals, etc.,

<sup>18</sup> Bechhold-Bullawa, footnote, p. 195.

<sup>19</sup> Gazzetta, 1917, 47, 1.

has been brought out in the paper of Connell and Holly "On the Nature of Hemolysin."

We believe there has been adduced fair evidence warranting the following tentative conclusions:

1. The *C. diphtheriae* and *B. megatherium* possess characteristic fat complexes which are, under proper colloidal conditions, the true antigens of these microorganisms. Artificial fat antigens have replaced the antigens of the germ bodies in the various immune reactions.

2. The lysins and toxins of the *C. diphtheriae* and the *B. megatherium* are the same substances, being, respectively, the specific fat antigens of the microorganisms existing in definite and particular colloidal states.

3. Aside from colloidal or emulsifying activity cellular protein appears to have no place in the immune reactions studied.

# THE GAS PRODUCTION OF STREPTOCOCCUS KEFIR<sup>1</sup>

JAMES M. SHERMAN

*From the Research Laboratories of the Dairy Division, United States Department of Agriculture, Washington, D. C.*

Received for publication August 7, 1920

In her work on cheese streptococci, Miss Evans (1918) has noted the presence in Cheddar cheese of gas-forming streptococci apparently similar to a streptococcus first isolated by von Freudenreich from kefir. It was observed also that the gas, which consisted entirely of carbon dioxid, was produced much more abundantly in some media than in others. For example, in trypsin-digested milk a relatively large amount of gas was formed while in lactose broth a much smaller volume was obtained, notwithstanding the fact that the latter medium underwent a vigorous acid fermentation. This indicated that the source of the carbon dioxid might be something other than the sugar.

Aside from its purely physiological interest, knowledge of the source of the carbon dioxid produced by this organism is of scientific and practical importance in connection with the curing of Cheddar cheese. Van Slyke and Hart (1903) showed that carbon dioxid is given off from Cheddar cheese throughout the curing process. The lactose of cheese, however, is entirely consumed during the first few days; hence the source of the carbon dioxid is not the sugar. The discovery by Miss Evans of the occurrence of a gas-producing streptococcus in Cheddar cheese naturally suggested that this organism might account for the evolution of carbon dioxid from cheese of this type. In an effort to throw some light on this subject the work reported in this paper was undertaken.

<sup>1</sup> Published with the permission of the Secretary of Agriculture.

The two cultures employed in this work were obtained from Miss Evans and belonged to the collection used in her studies of cheese. For the determination of carbon-dioxid production the special tube designed by Eldredge and Rogers (1914) has been used. The cultures were grown in 30 cc. of broth and the carbon dioxid absorbed with barium hydroxid. Titrations were expressed in cubic centimeters of  $\frac{N}{10}$  barium hydroxid neutralized.

Following the hypothesis that the carbon dioxid formed by this organism might be derived from some source other than the sugar, a number of experiments were run with various sugar-free media but in no instance was a significant amount of this gas

TABLE 1  
*Relation of peptone concentration to carbon-dioxid production*

CULTURE	MEDIUM NO. 1: 1.0 per cent peptone 1.0 per cent yeast 1.0 per cent $\text{Na}_2\text{HPO}_4$ 0.3 per cent $\text{KH}_2\text{PO}_4$ 0.2 per cent lactose	MEDIUM NO. 2: Same as medium 1 except 2.0 per cent peptone	MEDIUM NO. 3: Same as medium 1 except 4.0 per cent peptone
2 ar	5.9*	5.9	5.8
2 ar	5.7	6.0	5.7
96 gq	5.8	6.0	6.0
96 gq	5.8	6.2	5.8

\* Cubic centimeters of  $\frac{N}{10}$   $\text{Ba}(\text{OH})_2$  neutralized.

obtained. Other experiments were conducted in an effort to show the relation between the amount of carbon dioxid produced and the concentration of nitrogenous constituents of the culture medium. For example the evolution of carbon dioxid was measured from media consisting of 0.2 per cent lactose, 1 per cent dried yeast and varying amounts of peptone. The results of such an experiment are shown in table 1. It may be seen from this table that there was just as much carbon dioxid formed in the broth containing only 1 per cent of peptone as there was in those containing a greater concentration. The results of experiments of this type and of numerous tests with various sugar-free media of various compositions would not indicate that the gas produced by this organism is derived from the nitrogenous portion of the medium.



Organic acids naturally suggested themselves as a possible source of carbon dioxide. These were therefore tested in a broth consisting of 2 per cent of peptone, 1 per cent of dried yeast and 0.5 per cent dibasic sodium phosphate. The sodium salts of formic, acetic, propionic, butyric, caproic, lactic, malic, valeric, oxalic, tartaric, citric, and succinic acids were subjected to this test but in no case was there an increase in carbon dioxide over that obtained from the same medium without the addition of an acid.

The sugar content of the medium, of course, was considered as a possible source of carbon dioxide and experiments were con-

TABLE 2  
*Relation of lactose concentration to carbon-dioxide production*

CULTURE	MEDIUM NO. 1 4.0 per cent peptone 1.0 per cent yeast 1.0 per cent Na <sub>2</sub> HPO <sub>4</sub> 0.3 per cent KH <sub>2</sub> PO <sub>4</sub>	MEDIUM NO. 2 Same as medium 1 plus 0.2 per cent lactose	MEDIUM NO. 3 Same as medium 1 plus 0.1 per cent lactose	MEDIUM NO. 4 Same as medium 1 plus 0.8 per cent lactose
2 ar	0.5*	7.5	13.5	22.9
2 ar	0.4	7.4	13.6	22.5
96 gq	0.4	5.8	11.7	18.8
96 gq	0.4	5.6	11.9	19.6

\* Cubic centimeters of  $\frac{N}{10}$  Ba(OH)<sub>2</sub> neutralized.

ducted in order to throw some light on this question. The observation of Miss Evans, that a small amount of gas is obtained in ordinary lactose broth whereas a greatly increased volume is given off by the organisms when grown in digested milk, was confirmed. Experiments conducted on this point, using a well-buffered broth and varying the lactose content showed, however, that the carbon dioxide produced increases with the increased concentration of sugar. This is true up to the point where the lactose content results in acid production beyond the amount cared for by the buffer. In table 2 are given the results of an experiment which shows the increase of carbon dioxide evolved with the increase in lactose concentration. This experiment was verified on several occasions.

From observations on this point no hesitation is felt in concluding that the source of the carbon dioxide produced in these experiments was the lactose contained in the medium and not any of the other possible sources.

It was thought, since the gas produced by this organism is apparently derived from the sugar, that the greater production of carbon dioxide in digested milk over lactose broth might be explained by the greater buffer content of the milk medium. In fact it was noted early in the work that the amount of gas obtained from lactose broth was increased with the addition of phosphate. We therefore compared in other experiments the carbon-dioxide production of these cultures in digested milk

TABLE 3  
*Carbon-dioxide production in digested milk and in highly buffered lactose broth*

CULTURE	TRYPSIN-DIGESTED MILK	MEDIUM: Beef infusion 3.0 per cent peptone 1.0 per cent Na <sub>2</sub> HPO <sub>4</sub> 0.5 per cent KH <sub>2</sub> PO <sub>4</sub> 2.0 per cent lactose
2 ar	27.0*	23.6
2 ar	27.7	23.2
96 gq	26.5	31.1
96 gq	26.3	30.1

\* Cubic centimeters of  $\frac{N}{10}$  Ba(OH)<sub>2</sub> neutralized.

and in highly buffered lactose broths. The data obtained from one of these tests are given in table 3. It will be seen that the carbon-dioxide production in lactose broth may be so increased by an increase in the buffer content of the medium as to give results comparable to those obtained from digested milk.

The conclusion to be drawn from the experiments reported in this paper is that the carbon dioxide produced by organisms of the *Streptococcus kefir* type, when grown in ordinary lactose broths, is derived from the carbohydrate portion of the media. With reference to the carbon dioxide produced in the ripening of Cheddar cheese, after the original lactose content of the cheese is exhausted, it would not be safe to draw definite conclusions from these observations. However, from tests with this organ-

ism in various sugar-free media, and in media containing a variety of organic acids, it would appear doubtful whether it could be held responsible for the normal carbon-dioxid production of Cheddar cheese. With the cheese-ripening problem in view, other tests were run in which glycerol was used as a possible source of carbon dioxid. These experiments also gave negative results.

## REFERENCES

- ELDREDGE, E. E., AND ROGERS, L. A. 1914 The bacteriology of cheese of the Emmental type. *Centbl. Bakt. (etc.)*, 2 Abt., **40**, 5-21.
- EVANS, ALICE C. 1918 A study of the streptococci concerned in cheese ripening. *Jour. Agr. Research*, **13**, 235-252.
- VAN SLYKE, L. L., AND HART, E. B. 1903 The relation of carbon dioxid to proteolysis in the ripening of Cheddar cheese. *N. Y. Agr. Expt. Sta.*, Bul. no. 231.



# THE IMPORTANCE OF PRESERVING THE ORIGINAL TYPES OF NEWLY DESCRIBED SPECIES OF BACTERIA

C.-E. A. WINSLOW

*American Museum of Natural History, New York City*

Received for publication July 10, 1920

One of the most serious difficulties with which systematic bacteriology must contend is the incompleteness of the published descriptions of new species and varieties. More care is now exercised than was formerly the case but even the most exhaustive descriptions must become incomplete as new diagnostic tests are introduced in the future. The systematists who deal with the higher plants have established the custom of preserving in museum collections the actual type specimen on which a specific description is established so that a later worker with new ideas in regard to specific characters can always examine the original plant and determine its actual characteristics.

In dealing with bacteria we cannot derive information of any special value from the study of stained slides which would correspond to the dead herbarium specimens of the botanist. The only alternative is the preservation of living cultures and this is a less satisfactory procedure in view of the fact that certain characteristics may, and sometimes do, alter as a result of long-continued cultivation on artificial media. Nevertheless the preservation of such living types of cultures offers the only possibility of stabilizing bacteriological nomenclature.

There are now at least three institutions in existence which aim to preserve type cultures for the systematic bacteriologist. Kral's Museum at Vienna (now under the direction of Dr. Pribram) has survived the war and the revolution and has just issued a new catalogue. The Museum of Living Bacteria at the American Museum of Natural History in New York has now been in operation for nearly ten years; and during the past year

a third institution, the National Collection of Type Cultures, has been established by the Medical Research Council of Great Britain at the Lister Institute under the direction of Dr. J. C. G. Ledingham.

Dr. Ledingham has asked for American assistance in his work and it is obviously most desirable that the closest coöperation should exist. He will furnish the American Museum with any new cultures he receives and we will send him all of ours that he may desire. Such an arrangement will not only make for the convenience of British and American bacteriologists, but will offer a double insurance against the loss of strains of delicate constitution.

The present note is presented to call the attention of the bacteriologists of America to the facilities offered at the Lister Institute and the American Museum and to urge upon all who may describe new bacterial species the great importance of promptly depositing with us the original type strain so that it may be available for the comparative study of systematists in future years.

## INFORMATION FOR CONTRIBUTORS

Although there are numerous journals in the United States that deal with various special phases of bacteriology (as applied to Medicine, Sanitary Science, Agriculture and the like), there has been no journal in the English language to represent the science as a whole.

The Society of American Bacteriologists has established the *JOURNAL OF BACTERIOLOGY* as its official organ and as a medium for the discussion of the more general problems of the science—the structure and physiology of the microbes, the inter-relationships of microbial types, the effects of physical and chemical agents upon microbial life, the mutual interactions of microbes growing together in various media, the nutritional needs and products of metabolic activity of various microbes, and new methods of laboratory technique—and similar advances in knowledge which are so fundamental as to be of vital interest to workers in all parts of this great field. The *JOURNAL OF BACTERIOLOGY* includes in its scope not only the bacteria but other related micro-organisms, yeasts, molds, protozoa, etc. While it is planned to make the *JOURNAL* in particular an organ for the more fundamental and general aspects of bacteriology, it will necessarily include many papers whose interest is mainly technical, particularly in those fields of bacteriology which have now no satisfactory organ of publication at their disposal.

Manuscripts should be sent to Prof. C.-E. A. Winslow, Yale Medical School, New Haven, Conn.

All other communications pertaining to editorial work should be addressed to Major A. Parker Hitchens, M. C., Army Medical School, Washington, D. C.

Twenty-five reprints, without covers, of articles will be furnished gratis to contributors when ordered in advance. A table showing cost, with an order slip, is sent with proof.

## INFORMATION FOR SUBSCRIBERS

THE *JOURNAL OF BACTERIOLOGY* is issued bi-monthly, in January, March, May, July, September, and November. A volume consists of approximately 600 pages. Subscriptions to the *Journal* are taken for the volume only. Under the present plans, one volume is issued a year.

**Subscription Price:** 1921 volume, Vol. VI, \$5.00, United States, Mexico, Cuba; \$5.25, Canada; \$5.50, elsewhere, net postpaid.

**Back Volumes** are supplied on orders for Vols. I to V, inclusive. Price, \$30.00, United States, Mexico, Cuba; \$31.25, Canada; \$32.50, elsewhere. Extra single volumes will be supplied on request when in stock at \$5.00, United States, Mexico, Cuba; \$5.25, Canada; \$5.50, elsewhere. Prices are net postpaid. Single numbers can be furnished, in many instances, at \$1.00 a copy.

Correspondence concerning business matters should be addressed to the Williams & Wilkins Company, Mount Royal and Guilford Avenues, Baltimore, U. S. A.

Subscriptions are received:

For Argentina and Uruguay: Beutelspacher & Cia., Sarmiento 815, Buenos Aires, Argentina.

For Australia: Stirling & Co., 317 Collins Street, Melbourne.

For Belgium: Henri Lamertin, 58 Rue Coudenberg, Bruxelles.

For the British Empire, except Australia and Canada: Address any British bookseller or send your orders direct to the publishers.

For Canada: Wm. Dawson & Sons, Ltd., 87 Queen Street East, Toronto, Canada.

For Denmark: H. Hagerup's Boghandel, Gothersgade 30, Kobenhavn.

For France: Emile Bougault, 48 Rue des Ecoles, Paris.

For Germany: R. Friedländer & Sohn, Buchhandlung, Carlstrasse 11, Berlin NW. 6.

For Holland: Scheltema & Holkema, Boekhandel, Rokin 74-76, Amsterdam

For Italy: Ulrico Hoepli, Milan, Italy.

For Japan and Korea: Maruzen Company, Ltd. (Maruzen-Kabushiki-Kaisha), 11 to 15 Nihonbashi Tori-Sanchome, Tokyo; Fukuoka, Osaka, Kyoto, and Sendai, Japan.

For Spain: Ruiz Hermanos, Plaza de Santa Ana, 13, Madrid.

For Switzerland: George & Cie, Freiestrasse 10, Basel, Switzerland.

For the United States and other countries except as above: WILLIAMS & WILKINS COMPANY, MOUNT ROYAL AND GUILFORD AVENUES, BALTIMORE, U. S. A.

Claims for copies lost in the mails will not be allowed unless such claims are received within 30 days (90 days, foreign) of the date of issue. Claimants must state that the publication was not delivered at their recorded address. The publishers will not be responsible for loss due to change of address unless notification is received at least two weeks in advance of issue.

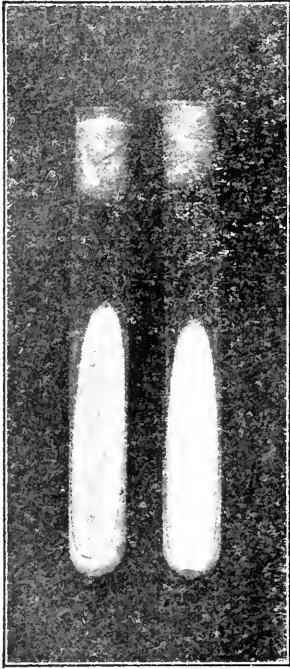

**DIFCO**

**BACTO  
LOEFFLER'S  
BLOOD SERUM,  
DEHYDRATED,  
FOR THE DIAGNOSIS OF  
DIPHTHERIA**

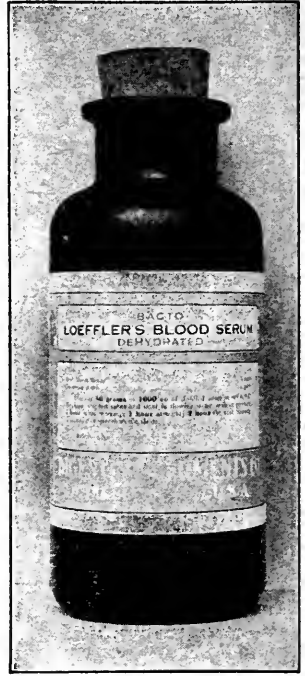

*In times of emergency every hour counts*

If you have a bottle of LOEFFLER'S BLOOD SERUM, DEHYDRATED, on your laboratory shelf, you can yourself prepare within one hour 1000 fresh moist slants ready to culture.

Simply weigh out the powder, restore the necessary moisture, with distilled water, dispense into tubes, coagulate and sterilize, according to our directions.

This gives a finished medium ready to use.

No time-consuming waits for the separation of serum from clot.

No spoilage. Dehydrated media keep at all temperatures. They are dry.

---

*Also* NUTRIENT AGAR :: NUTRIENT BROTH :: CARBOHYDRATE BROTHS, *Etc.*

---

— COMPLETE LIST ON APPLICATION —  
Carried in stock by principal dealers in scientific supplies

**DIGESTIVE FERMENTS COMPANY**  
DETROIT, MICHIGAN, U. S. A.



VOLUME VI

NUMBER 2

# JOURNAL OF BACTERIOLOGY

OFFICIAL ORGAN OF THE SOCIETY OF AMERICAN  
BACTERIOLOGISTS

MARCH, 1921

EDITOR-IN-CHIEF

C.-E. A. WINSLOW



*It is characteristic of Science and Progress that they continually  
open new fields to our vision.—PASTEUR.*

PUBLISHED BI-MONTHLY  
WILLIAMS & WILKINS COMPANY  
BALTIMORE, U. S. A.

Entered as second-class matter April 17, 1916, at the postoffice at Baltimore, Maryland, under the act of March 3, 1879. Acceptance for mailing at special rate of postage provided for in Section 1103, Act of October 3, 1917. Authorized on July 16, 1918.

Copyright 1921, Williams and Wilkins Company

Price, net { \$5.00 per volume, United States, Mexico, Cuba  
postpaid { \$5.25 per volume, Canada  
          { \$5.50 per volume, other countries

# Holadin and Bile Salts

Holadin - - 2½ grs.  
Bile Salts - - ½ gr.  
(enteric capsules)

“Investigations begun originally by Professor Næncki in his Berne laboratory and carried on by Heidehain, Rachford, Williams and Martin, have shown that the bile has a favouring action on the ferments of the pancreatic juice.

“The Bile, indeed, proved itself to be a constant and powerful auxiliary of the pancreatic juice, a fluid which is of such importance for digestion and in itself already so complicated.”

—Prof. J. P. Pawlow.

“*Holadin and Bile Salts*”, a combination of the most potent pancreas extract with the isolated glycocholate and taurocholate of sodium, in their native association—

is a therapeutic resource of distinct service in pancreatic (intestinal) disorders dependent upon, or associated with, deficient bile action.

FAIRCHILD BROS. & FOSTER  
New York

## LaMotte Standards GUARANTEED

Section 1.—Standardized Indicator dyes. Covering a wide range of H-ion concentration. Supplied in dry form and in sterile stock solutions. Each Indicator is standardized in strict accordance with the specifications of Clark & Lubs. (Jr. Bact., Vol. II, Nos. 1, 2, 3, 1917.)

Common Name	Color Change	pH Value
Thymol Blue (acid range)	red-yellow	1.2-2.8
Methyl Orange	red-yellow	2.9-4.0
Bromphenol Blue	yellow-blue	3.0-4.6
Resorcin Blue	pink-blue	4.0-7.2
Methyl Red	red-yellow	4.4-6.0
Bromcresol Purple	yellow-purple	5.2-6.8
Litmus (special)	red-blue	5.5-8.9
Bromthymol Blue	yellow-blue	6.0-7.6
Phenol-Red	yellow-red	6.8-8.4
Cresol Red	yellow-red	7.2-8.8
Thymol Blue (alkaline range)	yellow-blue	8.0-9.6
Cresol-phthalein	colorless-red	8.2-9.8
Phenol-phthalein	colorless-red	8.4-9.2

Section 2-B.—Specially prepared and standardized Buffer salts and solutions. Buffer mixtures may be obtained in series covering any particular range of H-ion concentration from pH 1.0 to 10.0.

### Standardized Buffer Solutions (M/5)

Potassium Phosphate	Potassium Phthalate	Sodium Hydroxide (CO <sub>2</sub> free)
Potassium Chloride	Hydrochloric Acid	Di-Sodium Phosphate, 2H <sub>2</sub> O

A large number of general synthetic and purified compounds are manufactured by us and information concerning them may be obtained by addressing

**LA MOTTE CHEMICAL PRODUCTS CO.**  
“Standards Department”

13 W. Saratoga St.

Baltimore, Md.

# JOURNAL OF BACTERIOLOGY

OFFICIAL ORGAN OF THE SOCIETY OF AMERICAN BACTERIOLOGISTS

DEVOTED TO THE ADVANCEMENT AND DISSEMINATION OF KNOWLEDGE IN REGARD TO THE BACTERIA AND OTHER MICRO-ORGANISMS

## *Editorial Board*

### *Editor-in-Chief*

C.-E. A. WINSLOW  
Yale Medical School, New Haven, Conn.

A. PARKER HITCHENS

DR. CHARLES KRUMWIEDE, JR., *Ex officio*

## *Advisory Editors*

C. C. BASS  
R. E. BUCHANAN  
P. F. CLARK  
F. P. GAY  
F. P. GORHAM  
P. C. HARRISON

H. W. HILL  
E. O. JORDAN  
A. I. KENDALL  
C. B. LIPMAN  
C. E. MARSHALL

V. A. MOORE  
M. E. PENINGTON  
F. B. PHELPS  
L. F. RETTGER  
L. A. ROGERS

M. J. ROSENAU  
W. T. SEDGWICK  
F. L. STEVENS  
A. W. WILLIAMS  
H. ZINSSER

## CONTENTS

H. J. CONN, <i>Chairman</i> , K. N. ATKINS, I. J. KLIGLER, J. F. NORTON, AND G. E. HARMON. Progress Report for 1920 Committee on Bacteriological Technic. . . . .	135
LAURENCE F. FOSTER AND SAMUEL B. RANDALL. A Study of the Variations in Hydrogen-Ion Concentration of Broth Media . . . . .	143
LAURENCE F. FOSTER. The Relation of Hydrogen-Ion Concentration to the Growth, Viability, and Fermentative Activity of <i>Streptococcus hemolyticus</i> . . . . .	161
LAURENCE F. FOSTER. The Biochemistry of <i>Streptococcus hemolyticus</i> . . . . .	211
IVAN V. SHUNK. Notes on the Flagellation of the Nodule Bacteria of Leguminosae. . . . .	239
GEORGE B. ROTH. Method for the Intravenous Injection of Guinea-Pigs . . . . .	249
H. J. CONN. Rose Bengal as a General Bacterial Stain. . . . .	253

Abstracts of American and foreign bacteriological literature appear in a separate journal, *Abstracts of Bacteriology*, published bi-monthly by the Williams & Wilkins Company, under the editorial direction of the Society of American Bacteriologists. Back volumes can be furnished in sets consisting of Volumes I, II and III. Price per set, net, postpaid, \$18.00, United States, Mexico, Cuba; \$18.75, Canada; \$19.50, other countries. Subscriptions are in order for Volume IV, 1920. Price, per volume, \$5.00, United States, Mexico, Cuba; \$5.25, Canada; \$5.50, other countries.

## What a scientific worker says of our Bacteriological Catalog

*"I am hastening to thank you for the receipt by this morning's mail of your catalogue of Bacteriological Apparatus. Its completeness and attractiveness would incline me to turn first to it for help in making out my orders even if I did not know by experience that your service is the most satisfactory which I have thus far received from any concern."*

Owing to cost of production of this catalogue and in order to obtain for it the best possible distribution, copies are limited to institutions and laboratories having need for this particular publication.



The Will Corporation  
Laboratory Apparatus - Chemicals  
Glassware  
ROCHESTER, N. Y.

## INTERNATIONAL CENTRIFUGES

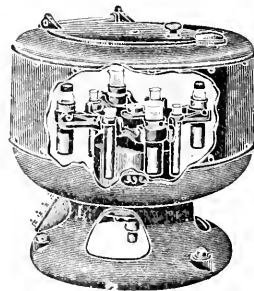

### INTERNATIONAL EQUIPMENT COMPANY

352 Western Ave. (Brighton)  
BOSTON, MASS.

Catalog Cy. on request

## COLORIMETRIC DETERMINATIONS

We are offering

### INDICATORS

Covering a Continuous Range from  $P_H$  1.2 to  $P_H$  9.8

Also

### COLOR COMPARISON TUBES

From  $P_H$  6.6 to  $P_H$  8.6

*Literature Upon Request*

**HYNSON, WESTCOTT & DUNNING**  
BALTIMORE

LIBRARY  
NEW YORK  
BOTANICAL  
GARDEN

## PROGRESS REPORT FOR 1920 COMMITTEE ON BACTERIOLOGICAL TECHNIC

H. J. CONN, *Chairman*, K. N. ATKINS, I. J. KLIGLER, J. F. NORTON, AND  
G. E. HARMON

Received for publication December 10, 1920

Committees dealing with various matters of bacteriological technic have been appointed in the past by this Society and by other organizations interested in bacteriology. There have been, for example, the committees on standard methods of water analysis and on standard methods of milk analysis of the American Public Health Association, also our committee on methods of milk analysis to coöperate with the latter, and our committee on the descriptive chart. With the exception of the committee on the descriptive chart, all these committees have had for their chief function the standardization of technic and the establishment of official methods. Even the committee on the descriptive chart at first entertained the plan of establishing official methods for pure culture study; but as the work of the committee progressed, it proved that it might have a wider usefulness as an agency through which different procedures might be compared and their relative merits for different purposes established without giving official standing to any one technic. So important did this particular function of the committee appear, and so many similar problems along other lines were called to its attention, that finally the committee on the chart resigned and a new committee was appointed in December 1919 to take up in the same manner various points of technic of interest to bacteriologists. A continuation of the work on the chart was assigned to this committee as part of its function.

The logic of such a committee as a part of our Society is evident. The other bodies with committees on bacteriological technic are in general interested in official control work and

MAR 25 1921

desire methods that give uniform and reasonably reliable results with as little labor as possible, rather than methods giving the most accurate scientific data. As a society of bacteriologists, however, we should be interested in the accuracy of technic rather than in simple and inexpensive methods.

#### WORK ON THE DESCRIPTIVE CHART

The use of the descriptive chart has lately come to be mainly for instruction purposes. Hence the recent committee on the chart drew up a folder especially designed for instruction. There has been considerable demand for this chart, but two modifications have been quite generally called for: its condensation into smaller space, and the omission of the old and illogical group number. To see how generally this opinion is held among bacteriologists, an enquiry was addressed to each instructor who has ordered the Society charts during the last two years. The replies received have almost unanimously been in favor of a single sheet chart without the group number. These two modifications, it was pointed out, would make the chart more useful not only to instructors but to investigators as well. Accordingly both modifications have been adopted in the new chart which the committee is proposing to the Society this year, together with various minor changes which it is hoped will be found to be improvements.

The new chart is like the instruction folder in the omission of the detail which made the old card poorly adapted to the instruction laboratory, but a few of the more commonly used tests, omitted from the instruction chart, such as that for indol, are included on the new form. By the use of finer type and the reduction of the space left for sketches, all this material has been condensed on two sides of an 8½ by 11 inch sheet. Nevertheless, some blank space is still retained for sketches and for recording the results of special tests. The group number, as such, is omitted entirely; but all the useful purposes of the group number are retained by adopting a new form of marginal characterization. In place of the group number, an "Index number" has been

substituted, the object of which is merely to assist the student in filing a large number of the completed charts according to the salient characteristics of the organisms described on them. Its use, however, is optional; it is plainly stated to be intended for index purposes only; and as it does not contain the generic symbol, there is no danger of its suggesting to the novice that it is intended to supplant the specific name of an organism.

If this chart meets the approval of the Society, it will be printed and will be ready for distribution at about the time that this report appears in the Journal. The old charts will still be kept on sale as long as there is any demand for them. All the charts may be obtained from the chairman of this committee (address Geneva, N. Y.). A sample copy of the new chart will be sent to anyone on request.

#### METHODS OF PURE CULTURE STUDY

The committee on the descriptive chart prepared two or three reports on methods of pure culture study (1918, 1919, 1920), which the present committee plans to keep up to date. To do this, new methods are being investigated that they may be published in future reports. The methods at present under investigation are: methods of determining acid production from sugars and other carbon compounds; methods of determining diastatic action on starch; modifications of the Gram stain. A preliminary publication on the first of these problems has already been made this year by Conn and Hucker (1920). There is nothing yet ready for publication on the other problems, further than the material which appeared in the 1919 report of the committee on the descriptive chart.

#### METHODS OF COUNTING BACTERIA

There is no phase of bacteriological technic that has been given more attention by scientific organizations than methods of counting bacteria. The reason for this is the importance from the public health standpoint of knowing the number of bacteria in any food or drink for human consumption. It must not be

forgotten, however, that there is one other equally important object in counting bacteria, for it is only by this means that we can determine the abundance of the organisms in any particular habitat—a problem of value from the standpoint of pure science. This latter aspect of the matter especially concerns this Society rather than organizations interested in disease or public health. The very fact that the subject is being so thoroughly investigated from the standpoint of the sanitarian makes it all the more important that it be studied by this Society also. Standardization of methods—which has been the chief aim of other organizations taking up the matter—tends to prevent progress by fixing the technic. To counteract this tendency, the committee on technic plans to compare the various methods of counting bacteria, laying chief stress upon their accuracy, rather than upon their adaptability to routine use.

There are three criteria by which methods of counting bacteria can be judged: (1) agreement of duplicate determinations; (2) size of the counts obtained; and (3) actual accuracy of the counts. The first of these, agreement of duplicate determinations, is the object desired in control work, where incomplete counts are entirely suitable, provided a uniform fraction of the total number of bacteria is counted. Size of the counts is the most commonly used criterion as to the relative merits of different methods of counting, because it is generally recognized that ordinary counts are but partial ones and the presumption is that the higher count is the more nearly correct. Actual accuracy, however, although a far better criterion, is the hardest of all to apply, because counts may be too high instead of too low, and there is no absolute standard of comparison with which to check up results. Even the best bacterial counts are but estimates because the total numbers are too high to count with absolute accuracy, and high magnification is necessary to see the individuals; so the only way the accuracy of any one method may be determined is by comparing it with other methods and discounting the probable sources of error in each method.

There are three general types of methods by which bacteria may be counted: the dilution method, the plate method, and the



microscopic method. The dilution method (whereby a medium is inoculated with progressively decreasing quantities of the material under investigation until a dilution is reached too great to contain any bacteria) is cumbersome and is not applicable to many types of bacterial flora. The plate method and the microscopic method, each with various modifications, are in common use and can be applied to a great variety of bacterial habitats. Each method has its advantages and each its disadvantages; but by using both methods and properly comparing the results, it is possible to obtain very good information as to the actual number of bacteria in the material under investigation. An admirable investigation of this sort, of the methods of counting bacteria in milk, has recently been made by Breed and Stocking (1920).

Although milk has been investigated in this way more than any other material, there are other natural habitats of bacteria where it may be fully as important to know the best methods of determining the actual numbers of organisms present as well as to have official methods for routine use. There are, for example: water, soil, sewage, vaccines, and various foodstuffs, such as cheese, ketchup, butter, ice-cream, hamburg steak, dried egg powder, and so forth. The field is too broad to cover at once; but by attacking one problem at a time and by the eventual establishment of various sub-committees, it is hoped to round up the matter in time.

Shortly after the appointment of the committee, the problem of microorganisms in ketchup was referred to it. In this case the work is practically limited to the microscopic method, as the processing of the material kills the greater part of the organisms originally present. Counting is difficult, and yet results are important because they have already been used in the control of this food industry. It was pointed out to the committee that the industry would be glad to finance an investigation, but wanted it entirely free from their influence. (The name of the person or firm offering the money is not known to us.) The matter was turned over to the New York Agricultural Experiment Station, and it was found that they would gladly furnish the

facilities for the work, but did not wish to accept money from a commercial source. The Experiment Station, therefore, took it up with the National Research Council. Upon receiving the endorsement of the Research Council of our Society, the National Research Council agreed to act as an intermediary and to become responsible for the supervision of the investigation. In this way a responsible, scientific, and disinterested supervision of the work has been secured.

Although this work is no longer in the hands of the committee on bacteriological technic, and when completed will be published as an independent piece of investigation, it is given its place in this report because the problem was originally submitted to the committee and the investigation was planned as a part of the general committee program. It is regarded as merely a beginning. Other similar problems are to be investigated in the future. One that has already been referred to the committee is the counting of bacteria in vaccines and other similar preparations. Anyone interested in this matter is hereby urged to correspond with the chairman of this committee on the subject.

#### STANDARDIZATION OF STAINS

As this committee is primarily interested in the accuracy of technic, one of the first points that has been called to its attention is the inaccuracy of certain procedures (e.g., Gram stain) due to the present unreliability of dyes used in staining. It was suggested that the committee might undertake to test the various stains on the market and to certify the reliable products, also that it might do what it could to stimulate the production in America of dyes needed but not at present manufactured in this country. A circular letter was addressed to the members of the Society and there was found to be much interest, a considerable number of members volunteering to help in the work. The matter has also been discussed with certain producers and distributors of biological stains.

There is plainly a demand for work of this sort, and the committee is willing to undertake it if it can be properly organized.

Certain difficulties are in the way, in establishing satisfactory relations with commercial firms, and in securing the time and labor necessary to organize the work; but it is felt that these difficulties can be overcome. Further announcements will be made if the present plans develop.

## REFERENCES

- BREED, R. S., AND STOCKING, W. A., Jr. 1920 The accuracy of bacterial counts from milk samples. N. Y. Agr. Exp. Sta., Tech. Bul. 75, 1-97.
- CONN, H. J., AND HUCKER, G. J. 1920 The use of agar slants in detecting fermentation. J. Bact., 5, 433-435.
- CONN, H. J., ET AL. 1918 Methods of pure culture study. Preliminary report of the committee on the chart for identification of bacterial species. J. Bact., 3, 115-128.
- CONN, H. J., ET AL. 1919 Methods of pure culture study. Progress report for 1918 of the committee on the descriptive chart of the Society of American Bacteriologists. J. Bact., 4, 107-132.
- CONN, H. J., ET AL. 1920 Report of the committee on the descriptive chart for 1919. Part I. Methods of pure culture study. J. Bact., 5, 127-143.



## A STUDY OF THE VARIATIONS IN HYDROGEN-ION CONCENTRATION OF BROTH MEDIA

LAURENCE F. FOSTER AND SAMUEL B. RANDALL

*From the Department of Pathology and Bacteriology, University of California*

Received for publication August 15, 1920

At the present time it would seem scarcely necessary to lay emphasis upon the importance to bacterial growth and metabolism of the reaction of the environmental culture medium. That different degrees of acidity and alkalinity in media may profoundly influence the morphology, rate of fermentation, pigment production, growth, or viability of bacteria has been so thoroughly recognized that in the routine preparation of culture media as carried on in every bacteriological laboratory, the proper adjustment of reaction is carefully regulated. The use of scales of reaction such as that of Fuller, based upon adjustment to a definite "degree" of titratable acidity, has permitted a certain amount of uniformity, and in general, it may be said that these old titrimetric procedures have served a very useful purpose. But with the development, during the last few years, of the newer physico-chemical conception of hydrogen-ion concentration the theory of titration has undergone a fundamental change. As a consequence many of the data obtained in earlier investigations are of little value, having been based upon unsound premises.

An adequate conception of the far-reaching biological effects of hydrogen-ion concentration may best be gained through a study of the classic works of Michaelis (1914),<sup>1</sup> Sørensen (1912, 1909a, 1909b) and Clark and Lubs (1917a, 1917b, 1917c). The following statement from the works of the last-named investigators will serve to emphasize the importance to the science of bacteriology of this modern conception of acidity and alkalinity:

<sup>1</sup> Bibliography is found at the end of the third article, in this series, p. 231.

Hydrogen-ion concentration influences the condition in solution of every substance with acidic or basic properties—native proteins and their hydrolytic products, amines and amides, carboxyl, sulphonic, and phenolic compounds, even alcoholic compounds, as well as many inorganic compounds. It has a large effect on the effective solubilities and dispersion of colloids, upon determining tautomeric equilibria, and in one way or another in governing the activity of catalysts such as hydrolytic enzymes and oxidases. One or the other of these effects, induced directly or perhaps indirectly by the hydrogen-ion concentration must impress bacterial life.

That the expression of reaction in terms of titratable acid or alkali does not adequately define the true reaction of a solution has perhaps best been brought out by W. M. Clark (1915a) in his admirable paper, "The 'reaction' of bacteriologic culture media." The objections to the older procedure may be summarized in a quotation from Clark and Lubs (1917a):

The titrimetric method, designed originally for the quantitative estimation of strong acids and bases, cannot be applied to complex mixtures of very weak acidic and basic groups such as are found in the constituents of most culture media. In so far as the method is used to determine the "free acid" or to adjust to a certain degree of "free acid" it is an absolute failure when applied to culture media. There is however, an even more fundamental reason why the titrimetric method is inappropriate. Two media adjusted to the same degree of acidity may have widely divergent hydrogen-ion concentrations as shown by Clark (1915a).

With the development of the hydrogen electrode, making possible a direct measurement of hydrogen-ion concentration, some of the experimental and mathematical difficulties involved in the older methods were obviated, but there still remained to be elaborated some simpler and more rapid procedure that would be adapted to the adjustment of culture media and to the study of reaction changes in bacterial cultures. Guided by the earlier work of Friedenthal (1904), Salm (1904), Friedenthal and Salm (1907) who were the first to give a well worked-out series of indicators, Sørensen (1909a) in 1909 published his colorimetric method for determining hydrogen-ion concentrations. Since

this time a number of modified procedures have been suggested by Levy, Rowntree, and Marriott (1915), Hurwitz, Meyer and Ostenberg (1915, 1916); McLendon (1916); Barnett and Chapman (1918); Clark and Lubs (1916a, 1917a, 1917b, 1917c); Haas (1919); so that at the present time it is a relatively simple matter to prepare and have on hand in the ordinary bacteriological laboratory a suitable set of colorimetric standards for the measurement of the hydrogen-ion concentration of media and cultures. It is to Clark and Lubs (1917b, 1916b), Lubs and Clark (1915, 1916) that we are especially indebted for several new and valuable indicator substances as well as for a careful study of the ranges and usefulness of an entire set of indicators for the examination of biological fluids.

Deeleman (1897) in 1897, using the titration procedure, noted that media underwent certain changes in reaction during sterilization and sought to avoid such variation through the addition of proper amounts of sterile acid or alkali to the autoclaved material. Hesse (1904) used the same procedure in the adjustment of his media and further emphasized the fact that only that type of glassware which yields no alkali should be employed for containers, to prevent the increase in alkalinity that otherwise might occur. According to Sørensen (1909a) however, such factors as alkalinity from glassware and  $\text{CO}_2$  from the atmosphere exert only slight effects if the medium in question is properly buffered. Using the titration method, Anthony and Ekroth (1916) attempted to bring media to a stable reaction by repeatedly alkalizing and autoclaving, but were unable to produce such a stabilized condition even after many additions of alkali, supplemented by a total of fourteen hours autoclaving. They explain the change as due to the formation of acid principles through hydrolysis. In one case five times the quantity of base needed was added through an error, with the result that after several sterilizations the reaction of the broth fell to the required level. Wright (1917) has suggested that the amount of alkali indicated by titration is never sufficient to bring about a complete neutralization of the medium, it being always necessary to add a considerable excess over the amount indicated. On the other hand, Noyes

(1916) states that properly prepared media do not increase appreciably in acidity when the length of sterilization is increased or when repeated autoclavings are carried out. It is a known fact that many proteins may exist in solution only between certain limits of hydrogen-ion concentration and that slight changes, at or near the critical zones, cause the formation of precipitates. This phenomenon occurs in peptone solutions and as Kligler (1917) has shown it is possible to establish the limits of  $P_H$  which determine precipitation for each brand of peptone.<sup>2</sup> Cook and Lefevre (1918) showed that as much as 12 per cent of peptone may be lost through precipitation depending on whether this material were added previous to coagulation and filtration or subsequently. That a change in  $P_H$  accompanies such a precipitation in media has been found by Clark (1915a) who reported a fall in  $P_H$  of 0.80 (from 8.52 to 7.72) in an infusion broth containing 0.5 per cent  $K_2HPO_4$ . Itano (1916a) using the hydrogen electrode in his  $P_H$  measurements, was able to establish a rough correlation between the changes in  $P_H$  of an extract broth upon autoclaving and the increase in COOH groups as determined by the formol titration of Sørensen. Strangely enough the changes in  $P_H$  reported by Itano were always of the nature of an increase in alkalinity, and with this there appeared an increase in formol-titrating nitrogen, indicating that hydrolysis had occurred. As a result of boiling the broth for forty-five minutes this observer found that the material became stable as regards further changes in  $P_H$ . This last experiment, however, was tried only on media adjusted between  $P_H$  5.45 and 6.88. By sterilizing the constituents of his media separately it was possible to adjust to the desired  $P_H$  and obtain values which remained fairly constant throughout the entire experiment. Norton (1919) has reported that appreciable changes in the reaction of neutral and alkaline media, but little variation in the acid range, result from sterilization. Davis (1920), in recognition of the possibility of a change in the  $P_H$  of media adjusted in the alkaline range, has suggested that for the proper preparation of a glucose broth of  $P_H$  8.0–8.2 reaction it is well to

<sup>2</sup> The symbol  $P_H$  of Sørensen is used throughout to designate the hydrogen-ion concentration.



bring the material to an initial  $P_H$  of 8.6. Davis also emphasizes the superiority of the autoclave over the Arnold for media sterilization pointing out that prolonged heating is always to be avoided in order that the vitamine or hormone content may not undergo destruction. On the other hand, Fennel and Fisher (1919) report that in the preparation of over one hundred lots of beef infusion broth the initial  $P_H$  of 7.8 did not show variation as a result of autoclaving. In connection with his study of the effect of initial reaction of a medium upon *Corynebacterium diphtheriae*, Bunker (1919) noted certain reaction changes in his media upon sterilization. The variations appeared almost entirely on the alkaline side and were always noted as increases in acidity.<sup>3</sup> Very recently, Grace and Highberger (1920b) have carried out experiments with extract broth which seem to indicate that changes in reaction upon sterilization may not be of any greater order than are the changes which a medium may undergo simply upon standing, following autoclaving. The variations of greatest magnitude occurred in the alkaline range and all changes were toward a more acid reaction. No consistent tendencies could be detected, therefore it was not possible to come to definite conclusions as to the reasons for the observed changes. However, the possibilities of the influence of glass and atmospheric  $CO_2$ , as well as of slow hydrolysis, were suggested.

Early in the present investigation it was noted that culture media (broth) adjusted to definite  $P_H$  levels underwent changes in reaction upon autoclaving, thus rendering difficult the preparation of broth of desired reaction. Consequently it was considered important to investigate these changes with a hope of finding an explanation and perhaps of discovering some means of avoiding them.

#### METHODS AND TECHNIC

##### *Standard solutions*

All solutions were prepared according to the methods outlined by Clark and Lubs (1916a, 1917a) from boric acid and salts which

<sup>3</sup> The term acidity in the present paper signifies true acidity as expressed in terms of  $P_H$ .

had been recrystallized three to five times. Triple distilled water served as solvent. The stock solutions, as well as the standard buffer mixtures, were kept in heavily paraffined, glass-stoppered bottles. Check determinations on the mixtures at the outset and after a period of seven months showed that the standard buffers, from bottles in which the paraffin was not broken, had remained constant in  $P_H$  in spite of the fact that molds had developed in some of the liquids. Sørensen (1909a) reported a similar observation on solutions after nine months standing. The desired  $P_H$  ranges and the solutions used in their preparation are given below:

<i>Solutions</i>	$P_H$
M/5 Potassium acid phthalate, M/5 NaOH.....	4.0-5.8
M/5 $KH_2PO_4$ , M/5 NaOH.....	5.8-7.6
M/5 $H_3BO_3$ , M/5 KCl, M/5 NaOH.....	7.8-9.0

### *Indicators*

The indicator solutions were the following:

CHEMICAL NAME	COMMON NAME	CONCENTRATION IN 50 PER CENT $C_2H_5OH$	RANGE $P_H$
		<i>per cent</i>	
Ortho carboxy benzene azo di-methyl aniline.....	Methyl red	0.02	4.4-6.0
Di brom ortho cresol sulphon phthalein	Brom cresol purple	0.04	5.2-6.8
Phenol sulphon phthalein.....	Phenol red	0.02	6.8-8.4
Thymol sulphon phthalein (alkaline range).....	Thymol blue	0.04	8.0-9.6

### *Color standards*

Color standards were prepared by adding 0.3 cc. of the required indicator solution to 5 cc. of the buffer mixture. Tubes of colorless glass and uniform bore, 4 by  $\frac{3}{8}$  inches were used for the color standards as well as for the test liquids. Fresh standards were made up each week, as fading is apt to occur if the solutions are allowed to stand for a longer period. This is most pronounced in the methyl red series and least noticeable in the brom cresol purple series.

*Colorimetric determination of hydrogen-ion concentration*

In properly buffered solutions it is possible partially to eliminate such factors as color and turbidity by diluting the test fluid with water. Preliminary tests showed that with broth and cultures it was possible to dilute 1cc. of the material with 4 cc. of distilled water without altering the hydrogen-ion concentration. Accordingly this technic was employed in all the determinations. Freshly boiled and cooled distilled water was used for diluting as preliminary tests had shown that unboiled water gave slightly lower  $P_H$  readings. The  $P_H$  of the water itself was usually found to rise from 4.8 to 6.8 upon boiling, probably due to liberation of carbon dioxide. To eliminate factors of color and turbidity more completely Walpole's (1911) method of superposition was used by employing the comparator block described by Dernby and Avery (1918). All determinations were carried out at room temperature. The limit of error in the readings was 0.1  $P_H$ .

*The adjustment of broth media*

One cubic centimeter of the broth was diluted with distilled water (freshly boiled and cooled). Two acid solutions and two basic solutions were kept on hand. They were  $N/1$  HCl and an exact 1:10 dilution of the same;  $N/1$  NaOH and an exact 1:10 dilution. A specially made micro burette, of 1 cc. capacity and graduated to 0.01, contained the diluted acid or base. This was added to the tube containing the medium, water, and 0.3 cc. of the proper indicator solution until the color produced therein exactly matched that of the color standard of desired  $P_H$ . The reading on the micro burette was then taken and by calculation the amount of stock acid or base needed to adjust the total amount of broth was determined. Following the addition of the acid or base to the entire lot of medium a check determination was always carried out. The broth was autoclaved at 15 pounds for twenty minutes. In case this caused the formation of a precipitate the medium was filtered and subjected to a second autoclaving for twenty to thirty minutes at 10 pounds pressure. The low pressure prevents a second precipitation of the medium. The

$P_H$  should always be taken on the broth following the final autoclaving as well as at the outset of any given experiment. The reason for this will appear in the experiments about to be described.

In case the broth was to contain a sterile sugar this was added aseptically in 10 per cent solution to the sterile medium to avoid any possibility of splitting the sugar through heating. This procedure is especially important if the broth is adjusted in the acid or alkaline range as it is a known fact that glucose and other sugars are altered by heating with even small amounts of acid or base (Mathews, 1916). Furthermore, Mudge (1917) has observed an increased titratable acidity when sugars, at least disaccharides, are autoclaved with media. By adding the sugar aseptically in concentrated solution no change in reaction was ever noted.

*Experiment I. The extent of the changes in hydrogen-ion concentration which broth media adjusted to different initial  $P_H$  levels undergo upon autoclaving and standing*

The unadjusted broth was divided into portions of 75 cc. which were brought to values ranging from  $P_H$  5.0 to 9.0 at intervals of 0.4. Five cubic centimeter amounts were then tubed and autoclaved at 15 pounds for fifteen minutes after which they were allowed to cool and  $P_H$  readings taken. The tubes comprising each lot were divided into three sets, one of which was allowed to remain at room temperature, another was placed in the ice chest, while the third was incubated at 37°. After standing at these temperatures for intervals of two, seven, and fourteen days tubes were removed and  $P_H$  determinations made.

Five series were carried through and the data obtained are to be found in tables 1 to 5.

SERIES	COMPOSITION OF BROTH	RESULTS IN TABLE
I	Beef infusion	1
II	Beef extract	2
III	Bacto beef	3
IV	Beef infusion (repetition of I)	4
V	Beef extract (repetition of II)	5

Reference to tables 1 and 4, containing data for the two beef infusion series, reveals differences in  $P_H$  changes as a result of autoclaving. Whereas every tube of series I showed an increased acidity upon sterilization, the tubes of series IV from 5.0 to 5.8 inclusive exhibited a decrease in acidity; those of  $P_H$  6.1-7.3 suffered no alteration in reaction, while those lying in the 7.8-8.9 range showed a definite increase in acidity. Upon standing, the greatest changes in both series are manifest in the 8.6 and 9.0

TABLE 1

*Experiment I. Changes in reaction upon autoclaving and standing. (Beef infusion broth)*

Composition:

Distilled water.....	1000 cc.
Chopped lean beef.....	300 grams
Peptone (Parke, Davis & Co.).....	10 grams
NaCl.....	5 grams

BEFORE AUTO-CLAVING	AFTER AUTO-CLAVING	ROOM TEMPERATURE AFTER DAYS			ICE CHEST AFTER DAYS			INCUBATOR AFTER DAYS		
		2	7	14	2	7	14	2	7	14
5.0	4.8	4.8	4.4	4.7*	4.8	4.4	4.7*	4.8	4.4	4.7*
5.3	5.0	4.9	4.8	5.0*	4.9	4.8	5.0*	5.0	4.8	5.0*
5.8	5.6	5.5	5.4	5.3	5.5	5.4	5.3	5.5	5.4	5.3
6.2	5.9	5.8	6.0	5.8	5.8	6.0	5.9	5.8	6.0	5.9
6.5	6.2	6.2	6.4	6.2	6.1	6.3	6.2	6.2	6.4	6.2
7.1	6.9	6.8	7.0	7.0	6.8	6.8	7.0	6.7	6.9	7.0
7.3	7.1	7.1	7.2	7.3	7.1	7.2	7.3	7.1	7.3	
7.8	7.3	7.3	7.6	7.6	7.3	7.5	7.6	7.4	7.6	7.6
8.1	7.8	7.7	7.9	7.8	7.7	7.8	7.8	7.7	7.9	7.8
8.6	8.4	8.4	8.4	8.1	8.4	8.4	8.1	8.4	8.4	8.1
9.0	8.6	8.6	8.5	8.2	8.5	8.5	8.2	8.6	8.6	8.3

\* The unexpected increase in alkalinity may have been more apparent than real due to a fading of the standard buffer mixtures of the methyl red series.

tubes. These changes are in the nature of increases in acidity and are as great in magnitude as those produced by autoclaving. A possibility of this sort has apparently been overlooked by many observers. No differences worthy of mention appear as a result of storing the broth under different conditions of temperature.

Passing to the two beef extract series (tables 2 and 5) a remarkably small number of alterations are notable in one case (V). An increase in acidity of 0.2  $P_H$  occurred in the two lots of highest

$P_H$ , namely the 8.6 and 9.0 tubes. These two lots were practically the only ones to exhibit changes upon standing, the 9.0 registering an acidity change of 0.7  $P_H$  after fourteen days standing. In series II (table 2) decreases in acidity are noted in the acid and alkaline ranges upon autoclaving while within the range 6.6–7.3 the broth remained unchanged. In every lot of this series the acidity increased upon standing, the greatest changes occurring in the

TABLE 2

*Experiment I. Changes in reaction upon autoclaving and standing. (Beef extract broth)*

Composition:

Distilled water . . . . .	1000 cc.
Liebig's beef extract . . . . .	3 grams
Peptone (Parke, Davis & Co.) . . . . .	10 grams
NaCl . . . . .	5 grams

BEFORE AUTO- CLAVING	AFTER AUTO- CLAVING	ROOM TEMPERATURE AFTER DAYS			ICE CHEST AFTER DAYS			INCUBATOR AFTER DAYS		
		2	7	14	2	7	14	2	7	14
5.0*	5.2*	5.3	4.6	4.7	5.2	5.1	4.8	5.3	4.8	4.8
5.3*	5.4*	5.6	4.7	4.8	5.5	5.1	4.8	5.5	4.8	4.8
5.8	6.0	6.1	5.2	5.2	6.1	5.2	5.2	6.1	5.2	5.2
6.2	6.4	6.3	5.6	5.6	6.3	5.4	5.6	6.3	5.6	5.6
6.6	6.6	6.6	6.2	6.3	6.6	6.3	6.4	6.6	6.5	
7.0	7.0	7.0	6.8	6.8	7.0	6.8	6.8	7.0		
7.3	7.3	7.3	7.0	7.0	7.3	7.0	7.0	7.3	7.0	7.0
7.7	7.9	7.9	7.5	7.8	7.9	7.4	7.6	7.9	7.4	7.8
8.0	8.3	8.4	7.8	7.9	8.4	7.7	7.9	8.4	7.6	7.9
8.7*	8.9*	8.5	8.4	8.6†	8.6	8.4	8.6†	8.6	8.6	8.7†
9.0*	9.2*	8.8	8.6	8.8†	9.0	8.4	8.6†	9.0	8.6	9.0†

\* Precipitate.

† A slight fading of the standard buffer mixtures of the thymol blue series may have occurred thus accounting for the apparent increase in alkalinity.

more acid and alkaline ranges. Here, as previously mentioned in the case of beef infusion broth, the changes on standing seem to be independent of the environmental temperature.

The results in the bacto-beef series (table 3) are similar to those noted in the case of beef infusion. A decreased acidity in general appears in the range, 5.0–6.2, the 6.6–8.2 tubes remain practically unchanged, while the most alkaline members, 8.6 and 9.0 show increases in acidity upon autoclaving. Upon standing at

the three different temperatures the same general tendencies as have been observed in series IV may be noted.

It appears that there is no marked consistency in the variations which a given type of broth medium may exhibit as a result of autoclaving and standing. The same conclusions have been reached by Grace and Highberger (1920b) working with beef extract broth. Itano (1916a) however, reported only decreases in acidity in lots of extract broth adjusted throughout a wide range

TABLE 3

*Experiment I. Changes in reaction upon autoclaving and standing. (Bacto-beef broth)*

Composition:

Distilled water . . . . .	1000 cc.
Bacto-beef . . . . .	50 grams
Peptone (Parke, Davis & Co.) . . . . .	10 grams
NaCl . . . . .	5 grams

BEFORE AUTO- CLAVING	AFTER AUTO- CLAVING	ROOM TEMPERATURE AFTER DAYS			ICE CHEST AFTER DAYS			INCUBATOR AFTER DAYS		
		2	7	14	2	7	14	2	7	14
5.0*	5.4*	5.5	5.4	5.6	5.5	5.4	5.7	5.4	5.5	5.7
5.4*	5.2*	5.7	5.8	5.6	5.7	5.7	5.5	5.8	5.7	5.7
5.8*	6.3*	6.1	6.0	5.9	6.3	6.0	5.9	6.1	5.9	5.8
6.2	6.6	6.6	6.3	6.2	6.6	6.5	6.4	6.4	6.3	6.2
6.6	6.6	6.6	6.5	6.4	6.6	6.5	6.4	6.6	6.5	6.5
6.9	7.0	7.0	6.9	6.8	7.0	6.9	6.8	7.0	7.0	6.8
7.3	7.5	7.4	7.4	7.3	7.5	7.1	7.5	7.4	7.4	7.5
7.8	7.8	8.0	7.9	7.8	7.9	7.8	7.7	7.9	7.9	7.8
8.2	8.2*	8.2	8.1	7.9	8.2	8.0	7.9	8.2	8.1	7.9
8.6	8.4*	8.3	8.3	8.2	8.4	8.2	8.2	8.4	8.4	8.3
8.9*	8.6*	8.5	8.2	8.3	8.5	8.2	8.2	8.6	8.3	8.6

\* Precipitate.

of P<sub>H</sub>. His medium contained 2 per cent peptone which, as is well known, acts as a strong buffer. By sterilizing the components separately he was able to avoid anything more than slight alterations in reaction. No data were collected relative to the possibility of changes upon standing. The discrepancies appearing in the present beef infusion series were not so unexpected when it is considered that two different lots of beef were employed in their preparation, but the lack of uniformity in the changes

registered by the two beef extract series is not explainable upon such a basis for the same components were used in the preparation of each.

The remainder of the work has consisted of attempts to determine the causative factors in these reaction changes in order that some procedure might be devised to obviate the effects produced.

Although certain investigators have pointed out that the glassware employed may exert an effect upon the reaction of the con-

TABLE 4

*Experiment I. Changes in reaction upon autoclaving and standing. (Beef infusion broth)*

Composition:

Distilled water . . . . .	1000 cc.
Chopped lean beef . . . . .	300 grams
Peptone (Parke, Davis & Co.) . . . . .	10 grams
NaCl . . . . .	5 grams

BEFORE AUTO- CLAVING	AFTER AUTO- CLAVING	ROOM TEMPERATURE AFTER DAYS			ICE CHEST AFTER DAYS			INCUBATOR AFTER DAYS		
		2	7	14	2	7	14	2	7	14
5.0*	5.3*	5.2	5.3	5.3	5.2	5.3	5.3	5.2	5.3	5.3
5.4*	5.6*	5.5	5.6	5.5	5.5	5.6	5.4	5.4	5.5	5.4
5.6	5.8	5.6	5.8	5.8	5.6	5.8	5.8	5.6	5.8	5.8
5.8	5.9	5.9	6.0	6.0	5.9	6.0	6.0	5.9	6.0	6.0
6.1	6.1	6.1	6.2	6.2	6.1	6.2	6.2	6.1	6.2	6.2
6.5	6.5	6.5	6.5	6.5	6.5	6.5	6.5	6.5	6.5	6.5
7.0	7.0	6.9	7.1	7.1	6.9	7.0	7.1	6.9	7.0	7.1
7.3	7.3*	7.2	7.4	7.3	7.2	7.3	7.3	7.2	7.3	7.3
7.8	7.6*	7.5	7.6	7.6	7.4	7.5	7.6	7.4	7.5	7.6
8.0	7.9*	7.8	7.9	7.9	7.7	7.9	7.9	7.8	7.9	7.9
8.6*	8.5*	8.3	8.3	8.3	8.3	8.3	8.3	8.3	8.3	8.3
8.9*	8.6*	8.4	8.4	8.3	8.4	8.4	8.3	8.4	8.4	8.3

\* Precipitate.

tained media, experience in this laboratory has not borne out these contentions. In the course of the present work it has almost invariably been found that  $P_H$  determinations on a given medium distributed in different tubes check closely. Consequently this factor has at no time been seriously considered as even partially contributory to the reaction changes encountered.

It has been emphasized that in the very large majority of cases the reaction change was in the direction of an acidity increase



and further that the degree of variation upon standing was usually as great as upon autoclaving. In view of those findings the possibility of an absorption of sufficient CO<sub>2</sub> from the atmosphere to account for the changes noted was considered. Experiments II and III were carried out to decide this point.

TABLE 5

*Experiment I. Changes in reaction upon autoclaving and standing. (Beef extract broth)*

Composition:

Distilled water . . . . .	1000 cc.
Liebig's beef extract . . . . .	3 grams
Peptone (Parke, Davis & Co.) . . . . .	10 grams
NaCl . . . . .	5 grams

BEFORE AUTO-CLAVING	AFTER AUTO-CLAVING	ROOM TEMPERATURE AFTER DAYS			ICE CHEST AFTER DAYS			INCUBATOR AFTER DAYS		
		2	7	14	2	7	14	2	7	14
4.8*	4.8*	4.8	4.8	5.0	4.8	4.8	5.0	4.8	4.8	4.9
5.0*	5.0*	5.1	5.2	5.1	5.1	5.2	5.1	5.1	5.2	5.2
5.6	5.6	5.6	5.6	5.5	5.6	5.6	5.5	5.6	5.5	5.5
5.8	5.9	5.9	5.8	5.8	5.9	5.8	5.8			
6.1	6.2	6.1	6.0	6.4	6.1	6.0	6.0			
6.5	6.5	6.5	6.3	6.4	6.5	6.3	6.4	6.5		
6.9	7.0	7.0	7.0	6.9	7.0	7.0	6.9	7.0	6.9	
7.3	7.3	7.2	7.2	7.2	7.2	7.2	7.2	7.3	7.2	7.2
7.8	7.8	7.6	7.4	7.4	7.6	7.4	7.4	7.6	7.5	7.4
8.1	8.0	8.0	7.9	7.8	8.0	7.9	7.8	7.9	7.9	7.9
8.6	8.4*	8.2	8.2	8.0	8.2	8.1	8.0	8.2	8.0	
9.0	8.8*	8.3	8.2	8.1	8.3	8.2	8.2	8.4	8.3	

\* Precipitate.

*Experiment II. The effect of exposure in an atmosphere of CO<sub>2</sub> upon the reaction of broth*

Beef infusion broth, prepared and adjusted as outlined in the preceding experiment, was tubed, autoclaved, and treated as follows: (1) Control-beginning. (2) Exposed twenty-four hours in plugged tubes to an atmosphere of CO<sub>2</sub>. (3) Control after twenty-four hours.

The results shown in table 6 indicate that direct exposure of broth to CO<sub>2</sub> causes very decided increases in acidity, the amount of increase becoming greater as the alkalinity of the broth

increases. That such a condition is abnormal is, of course, quite obvious, but the experiment serves to indicate that  $\text{CO}_2$  may not be ruled out as a factor in causing acidity increases in media upon standing.

TABLE 6  
*Experiment II*

$P_{\text{H}}$ after autoclaving . . . . .	5.3	5.6	5.8	6.06	26.5	7.1	7.4	7.6	7.9	8.3	8.4
$P_{\text{H}}$ after exposure to $\text{CO}_2$ for 24 hours	5.3	5.4	5.5	5.65	75.8	5.9	6.1	6.2	6.26	36.4	
$P_{\text{H}}$ (control) after 24 hours . . . . .	5.3	5.6	5.8	6.06	26.5	7.1	7.4	7.6	7.9	8.3	8.4

*Experiment III. The effect of exposure of sterilized broth to an atmosphere free from  $\text{CO}_2$*

Tubes of the medium prepared in the preceding experiment were autoclaved and treated as follows: (1) Control, allowed to stand at room temperature. (2) Placed in a  $\text{CO}_2$ -free atmosphere.  $P_{\text{H}}$  readings were made at the outset, after seven days, and after fourteen days. To obtain atmosphere free from  $\text{CO}_2$  air was drawn through a train of Woulff bottles containing concentrated  $\text{NaOH}$ , 20 per cent  $\text{Ba}(\text{OH})_2$ , and  $\text{CaCl}_2$  into a large Navy jar containing the tubes of media.

By inspecting table 7, it will be noted at once that practically the same changes in  $P_{\text{H}}$  occurred in both sets of tubes. This would seem to dispose of atmospheric  $\text{CO}_2$  as a factor operative in causing the increases in acidity so frequently noted in the previous experiments.

TABLE 7  
*Experiment III*

$P_{\text{H}}$ after autoclaving . . . . .	5.1	5.3	5.8	6.16	36.6	7.07	27.6	8.08	58.7
$P_{\text{H}}$ after 7 days in atmosphere . . . . .	5.2	5.5	5.8	6.16	46.6	7.17	47.8	8.08	38.6
$P_{\text{H}}$ after 7 days in $\text{CO}_2$ -free air . . . . .	5.1	5.4	5.8	6.06	46.6	7.17	47.8	8.08	38.6
$P_{\text{H}}$ after 14 days in atmosphere . . . . .	5.0	5.4	5.8	6.16	46.6	7.07	37.8	8.08	48.6
$P_{\text{H}}$ after 14 days in $\text{CO}_2$ -free air . . . . .	5.0	5.4	5.7	6.06	36.6	6.97	7.3	7.9	38.4

Assuming that the external factors of glassware and atmospheric  $\text{CO}_2$  are not sources of change in reaction of broth media it will be necessary next to examine the internal factors, namely, the possibility of chemical changes in the medium itself. The organic

components of broth media are in themselves complex compounds, which in some cases, are relatively unstable and reactive. It has long been noted that in the preparation of media precipitates occur when certain amounts of acid or base are added. In some cases precipitation occurs as soon as the acid or base is added, in other cases autoclaving seems to be required to bring down the material. Kligler (1917) has established certain zones of hydrogen-ion concentration for aqueous solutions of peptone within which precipitation occurs, and has investigated the nature of the precipitates themselves. In the acid range he believes that the material arises largely from protein substances as upon redissolving it gives reactions of proteoses and peptones, whereas in the alkaline range it is made up largely of phosphates. It is rather significant that the ranges of  $P_H$  in which we find the greatest change in reaction upon sterilization and standing are those within which precipitation is apt to occur during adjustment of the media.

The rôle of peptone in media is two-fold. It furnishes nitrogenous food in the form of protein split products (peptones, proteoses, peptides, amino acids) and through its property of combining with acids and bases acts as a buffer. According to Rettger, Berman, and Sturges (1916) and Davis (1917) American peptones are lower in albumoses and higher in amino acids than Witte's, some of those examined by the latter having two or three times the content of amino acids.

It seems quite certain that during autoclaving of culture media the higher nitrogenous complexes are hydrolyzed to lower split products. This would be particularly true in media adjusted in the acid or alkaline ranges, inasmuch as acids and bases act as positive catalyzers of a protein hydrolysis. During the splitting of a protein by hydrolysis there occur marked changes in the acidity or alkalinity of the solution in which the change takes place. Sørensen (1912) has reported an experiment in which the digestion of peptone by trypsin was carried out, measurements of hydrogen-ion concentration and determinations of the increase in formol-titrating material being made at intervals. The increase in hydrogen-ion concentration did not stand in relation to

the increase in COOH groups and Sørensen concluded that the increased base-binding power was due to the formation of peptides. T. B. Robertson (1918) has studied rather intensively the changes in hydrogen-ion concentration which take place during the hydrolysis of certain proteins and concludes that the power to bind acids and bases resides in the  $-\text{COHN}-$  groups, inasmuch as the protein molecule does not contain a sufficient number of terminal  $-\text{COOH}$  and  $-\text{NH}_2$  groups to account for its high combining capacity for acids and alkalies. While bound up in the protein molecule these groups do not assist in the neutralization of acids and bases but during hydrolysis the bonds are opened and the binding capacity is increased.

Itano (1916a) has reported an increase in formol-titrating nitrogen in media upon sterilization and has apparently shown that at least a rough proportionality exists between the change in  $P_{\text{H}}$  (increase) and the increase in amino acids as measured by the method of Sørensen.

With the view to ascertaining whether or not the changes in  $P_{\text{H}}$  found in the experiments described could be correlated with an increase in COOH groups produced through hydrolysis of the peptone or protein of the broth the following experiments were carried out:

*Experiment IV. The relationship between  $P_{\text{H}}$  changes in media and changes in formol-titrating nitrogen*

Five lots of beef infusion broth were adjusted to  $P_{\text{H}}$  values ranging from 5.2 to 9.2 and each lot distributed in three 30 cc. portions. The  $P_{\text{H}}$  and formol number were determined: (1) before autoclaving; (2) after autoclaving; (3) after seven days standing at room temperature.

*Technic of formol titration*, Kendall, Day, and Walker (1913): Five cubic centimeters of the broth was diluted with 50 cc. of distilled water and 1 cc. of phenolphthalein (1 per cent alcoholic solution) was added. The material was titrated to a faint pink with  $N/20$  NaOH or  $N/20$  HCl. Five cubic centimeters of neutral formalin were then added and the mixture allowed to stand for thirty minutes after which it was again titrated with

N/20 NaOH. From the last figure, the formol number was obtained.

*Formol number (F. N.):* Milligrams of formol-titrating N per 100 cc. of culture.

The results of the experiment are contained in the following table:

TABLE 8  
*Experiment IV*

BEFORE AUTOCLAVING		AFTER AUTOCLAVING		AFTER SEVEN DAYS	
P <sub>H</sub>	F.N.	P <sub>H</sub>	F.N.	P <sub>H</sub>	F.N.
5.2	40.4	5.3	44.8	5.3	44.8
6.2	42.0	6.3	47.6	6.3	47.6
7.2	42.0	7.2	47.6	7.2	47.6
8.2	43.4	8.0	44.8	8.0	44.8
9.2	43.4	8.8	43.4	8.8	47.6

As a result of autoclaving, slight increases in formol-titrating nitrogen are manifest in every lot of broth excepting that adjusted to P<sub>H</sub> 9.2 which was the only flask to show any appreciable change in P<sub>H</sub>. The greatest increases in formol number are seen in the lots which showed little or no reaction change. No change in formol-titrating nitrogen occurs during the first seven days following autoclaving except in the 9.2 lot. Here a small increase occurred. From the results of this one experiment it must be concluded that changes in the P<sub>H</sub> of broth as a result of autoclaving and standing bear no relationship to changes in formol-titrating nitrogen. The results are at variance with those reported by Itano (1916a) in which decreases in the hydrogen-ion concentration of broth upon autoclaving appeared to be roughly correlated with increases in formol-titrating nitrogen. It perhaps should be noted that fewer changes in P<sub>H</sub> were recorded in experiment IV than were apparent in the earlier experiments.

At present, the most logical explanation of acidity increase noted in the various experiments would rest upon the observation of Robertson that as the hydrolysis of a protein proceeds the base-binding capacity of the material increases through the opening up of the -COHN- group of the protein molecule.

## SUMMARY AND CONCLUSIONS

1. Broth (beef infusion, beef extract, "bacto-beef") adjusted to  $P_H$  values ranging from 5.0 to 9.0 undergoes a change in hydrogen-ion concentration upon autoclaving. This change is most marked in media adjusted in the alkaline range (7.8–9.0), less great in the acid range (5.0–6.2), and is usually inappreciable in the neutral range (6.6–7.4). The maximum change is about 0.4  $P_H$  and in the majority of cases is not over 0.2  $P_H$ .

2. The change is usually an increased acidity (decrease in  $P_H$ ). Decreases in acidity have been observed in a few instances but these are exceptional.

3. In media of the same composition the reaction changes are not necessarily uniform in different experiments.

4. Autoclaved broth undergoes changes in hydrogen-ion concentration upon standing; the degree of change is not influenced by the environmental temperature within the limits, 10°C. (ice chest) and 37°C. (incubator).

5. The reaction changes upon standing, as in the case of autoclaving, are most noticeable in the alkaline range, less marked in the acid range, and least in the neutral range. Neutral media usually do not change at all upon standing.

6. The change upon standing is almost invariably in the direction of an increase in acidity.

7. Broth adjusted to various  $P_H$  levels ranging from 5.0 to 9.0 and exposed in tubes plugged with cotton to an atmosphere of  $CO_2$  for twenty-four hours shows marked alterations in reaction. The change is always an increase in acidity, as would be expected. The greatest change occurs in the alkaline range.

8. Upon allowing broth adjusted to various  $P_H$  levels to stand in a  $CO_2$ -free atmosphere the same reaction changes were noted as in duplicate lots of broth allowed to stand in the air of the laboratory. The increases in acidity exhibited by broth upon standing do not seem to be due to an absorption of atmospheric  $CO_2$ .

9. Reaction changes in media of  $P_H$  5.2 to 9.2 do not appear to stand in relation to changes in formol-titrating nitrogen.

10. The possibility of an increase in acidity of broth through the opening up of  $-COHN-$  groups during hydrolysis of the protein constituents suggested by Robertson remains a plausible one.

# THE RELATION OF HYDROGEN-ION CONCENTRATION TO THE GROWTH, VIABILITY, AND FERMENTATIVE ACTIVITY OF STREPTOCOCCUS HEMOLYTICUS

LAURENCE F. FOSTER

*From the Department of Pathology and Bacteriology, University of California*

Received for publication August 15, 1920

## I. THE FINAL HYDROGEN-ION CONCENTRATION PRODUCED BY STREPTOCOCCUS HEMOLYTICUS IN BROTH CONTAINING VARIOUS FERMENTABLE SUBSTANCES

In 1912, Michaelis and Marcora (1912) working with a culture of *Bact. coli* in lactose broth were able to show by means of accurate electrometric measurements, that this organism carries its fermentation of the sugar to a definite level of hydrogen-ion concentration and then ceases its activity. This point is reached regardless of the initial reaction of the medium and can be described as a physiological constant for the particular organism used. This finding was confirmed three years later by W. M. Clark (1915b)<sup>1</sup> who pointed out that the final hydrogen-ion concentration established as a physiological constant by Michaelis and Marcora for a single strain of *Bact. coli* applied to other strains as well. That the hydrogen-ion concentration of the culture, rather than the total acid produced, is the factor limiting activity of the organism seemed evident from the work of Clark. The usefulness of this so-called physiological constant appeared later as the result of the researches of Clark and Lubs (1915) who suggested a method of differentiating the bacteria of the colon-aerogenes group by means of a correlation with gas formation of the final hydrogen-ion concentration produced in glucose broth. In this work was laid the experimental foundation of the methyl

<sup>1</sup> Bibliography is found at the end of the third article in this series, p. 231.

red test in use at the present time. Ayers (1916) in an investigation of the final hydrogen-ion concentration in some 200 cultures of streptococci was able to demonstrate a somewhat higher acidity<sup>2</sup> in cultures of the non-pathogenic than in those of pathogenic species grown upon glucose broth. Later work by Ayers, Johnson, and Davis (1918), as well as by Avery and Cullen (1919a), has led to the suggestion of a rapid presumptive test for the differentiation of bovine and human streptococci based upon differences in the final hydrogen-ion concentration produced in glucose broth. However, as Brown (1920) has pointed out, no single procedure can perhaps serve to differentiate the two varieties absolutely inasmuch as atypical strains are somewhat frequent. Cullen and Chesney (1918), Jones (1920, 1920a), Avery and Cullen (1919b), and Lord and Nye (1919), working with pneumococci of the various types in glucose broth, have found a final hydrogen-ion concentration that is in close agreement with the constant established for the streptococci. This value appears to be the same in all types irrespective of immunological character. The works of Fred and Loomis (1917) upon alfalfa bacteria, of Bunker (1916-1917, 1919) and Davis (1918) upon *Corynebact. diphtheriae*, of Itano (1916a, 1916b) upon *B. subtilis* and certain streptococci, of Cole and Onslow (1916) upon the typhoid group, of Clark (1917) upon *Lactobacillus bulgaricus*, of Waksman and Joffe (1920) upon Actinomycetes, of Ayers and Rupp (1918) upon members of the alkali-forming group, of Wolf and Harris (1917a, 1917b) upon *Clostridium welchii* and *C. sporogenes*, of Gillespie (1916, 1918) on soil organisms, and of Cohen and Clark (1918) upon various organisms are indicative of an attempt on the part of present-day workers to gain a more accurate knowledge of the metabolic activities of micro-organisms through the measurement of changes in the hydrogen-ion concentration brought about in culture media. Determinations of titratable acidity and ammonia, according to Kligler (1916), give an indication of the extent of carbohydrate

<sup>2</sup> The terms *acid* and *acidity* in the present paper refer to true acidity as expressed in terms of  $P_H$ , except when the reference is specifically to *titratable acid* or *acidity*.



and protein splitting by bacteria, whereas measurement of the hydrogen-ion concentration in cultures measures the resultant of both these actions.

It seemed advisable at the beginning of the present phase of the investigation to obtain information as to the level of final acidity produced by *Streptococcus hemolyticus* in broth media containing a number of the common fermentable substances employed in the bacteriological laboratory. Accordingly experiment I was carried out.

#### *Methods and technic*

*Culture.* All of the work to be described in the present paper was carried out on one pure strain of *Streptococcus hemolyticus*. This strain, designated as the "H," was originally isolated from the lung in a fatal case of bronchopneumonia complicated by endocarditis, and corresponds to culture number 136 in the series obtained during the investigation of pneumonia in military camps by the Rockefeller Commission. The "H" strain was of high virulence, owing to repeated passage through rabbits in an investigation of experimental streptococcus empyema, and the pleural fluids of such animals, taken at autopsy with sterile precautions (Gay and Stone, 1920), were found to serve as an excellent source of culture material. All pleural fluids were stored in the ice chest as the contained organisms have been found to remain viable under such conditions for a number of weeks. A transplant of 0.2 cc. of the pleuritic exudate was made into 5 cc. of 1 per cent glucose broth and the tube incubated for eighteen hours. As this first generation culture invariably contained a considerable amount of cellular débris, a second sub-culture was prepared in a similar manner. This second generation served as a source of inoculum in practically all of the experiments to be described. The eighteen-hour incubation period was chosen inasmuch as preliminary tests had shown that rapid growth nearly always obtained in sub-cultures prepared from a parent culture of this age.

*Culture media.* Beef infusion broth served as the basis of the media employed throughout the work as it is a generally

recognized fact that the pathogenic streptococci develop more luxuriant growth upon this medium than upon broth prepared from beef extract. In some of the experiments "Bacto-beef" (Digestive Ferments Company) was employed instead of beef juice as a base. Growth upon this medium was found to be as luxuriant as upon the usual beef infusion broth. The broth contained 1 per cent peptone (Difco or Parke, Davis, and Company), and 0.5 per cent NaCl. Adjustment to the desired  $P_H$  was made according to the method previously described. The limits of  $P_H$ , 7.0-7.6, were found to favor luxuriant growth of the organism. The prepared broth was always incubated for twenty-four hours previous to inoculation to insure its sterility.

*$P_H$  determinations.*<sup>3</sup> These were made by the method described in a former paper using 1 cc. of culture plus 4 cc. of freshly boiled and cooled distilled water. A tube containing the same materials without indicator was always used by the method of superposition to eliminate as far as possible factors of color and turbidity. Determinations carried out in this way permitted readings to within 0.05  $P_H$  in nearly all cases.

*Experiment I. The final hydrogen-ion concentration of Streptococcus hemolyticus in broth containing various fermentable substances commonly employed in the bacteriological laboratory; also an attempt to investigate the possibility of an experimental adaptation to a given sugar medium, through repeated transplantation.*

Inoculation of 0.4 cc. of an eighteen-hour, second-generation culture was made into 10 cc. lots of beef infusion broth containing the given fermentable material in 1 per cent concentration. Transplants from each tube were made, into sterile lots of media of corresponding composition after twenty-four hours incubation. In this manner five generations were carried. Although the "H" strain had previously been found to produce the characteristic final hydrogen-ion concentration quite con-

<sup>3</sup> The symbol  $P_H$  of Sørensen is used throughout to designate the hydrogen ion concentration.

sistently within the first twenty-four hours following incubation, nevertheless in this experiment it was decided to allow a forty-eight-hour incubation period before making  $P_H$  determinations to insure the completion of the fermentation.

Reference to table 1 shows that of the several groups of substances tried only the hexoses and disaccharides were fermented by the streptococcus. A wide variation in final  $P_H$  is noted. No explanation of these differences is attempted at the present time. Clark (1915b) working with *Bact. coli*, reports lower  $P_H$  levels in glucose broth than in lactose broth, while Jones (1920) has described a similar phenomenon in cultures of *Streptococcus hemolyticus* and pneumococci. Similar results are evident in the present experiment. An interesting fact brought out is that plain broth shows an increase in hydrogen-ion concentration. It is also to be noted that in no case in which fermentation did occur was the characteristic final  $P_H$  reached in the first generation. This would seem to indicate that in procedures for differentiation based upon final  $P_H$  levels, several transfers of the cultures should be made upon the same medium before conclusions as to the final hydrogen-ion concentration are drawn. In nearly all cases the characteristic final value was reached after one transfer.

The fact that plain broth shows an increase in hydrogen-ion concentration when inoculated with the streptococcus would seem to indicate that sufficient muscle sugar is present to permit fermentation to the  $P_H$  level indicated. To decide this point, a lot of infusion broth was inoculated with *Bact. coli* to ferment out any free sugar, after which it was filtered, adjusted, and sterilized. Upon inoculation with a culture of *Streptococcus hemolyticus* it was found that the final  $P_H$  was the same as that noted in the experiment just described. In this case the initial  $P_H$  of the broth was slightly lower, namely, 7.35. A similar result was experienced when sugar-free, bacto-beef broth was tried. In their studies of the metabolism of *Streptococcus pyogenes* and other organisms Kendall and his associates (1912c, 1912a) found increases in titratable acidity in plain broth cultures but carried out no determinations of hydrogen-ion concen-

tration. According to these investigators, the phenomenon may be explained on the basis of a selective action of the organism in question upon that portion of Witte's peptone which Pick (1898) has shown contains a relatively large fraction of a sub-

TABLE I  
*Experiment I*

NUMBER	CARBOHYDRATE	PH (INITIAL)	GENERATION				
			1	2	3	4	5
1	None	7.50	{ +++ 6.70	{ ++ 6.70	{ ++ 6.70	{ ++ 6.70	
2	Glucose	7.50	{	{	{ +++ 5.10	{ +++ 4.80	{ +++ 4.85
3	Fructose	7.50	{ +++ 5.30	{ +++ 5.10	{ +++ 5.10	{ +++ 5.10	{ +++ 5.05
4	Mannose	7.50	{ +++ 5.40	{ +++ 5.20	{ +++ 5.25	{ +++ 5.20	{ +++ 5.20
5	Galactose	7.50	{ +++ 5.50	{ +++ 5.40	{ +++ 5.40	{ +++ 5.40	{ +++ 5.30
6	Xylose	7.50	{ ++ 6.60	{ ++ 6.70	{ ++ 6.70	{ ++ 6.70	
7	Sucrose	7.50	{ +++ 5.35	{ +++ 5.20	{ +++ 5.10	{ +++ 5.15	{ +++ 5.10
8	Lactose	7.50	{ +++ 5.50	{ +++ 5.50	{ +++ 5.40	{ +++ 5.40	{ +++ 5.40
9	Maltose	7.50	{ +++ 5.40	{ +++ 5.30	{ +++ 5.15	{ +++ 5.10	{ +++ 5.15
10	Inulin	7.50	{ ++ 6.60	{ ++ 6.60	{ ++ 6.70	{ ++ 6.70	{ ++ 6.70
11	Glycerol	7.50	{ ++ 6.60	{ ++ 6.70	{ ++ 6.70	{ ++ 6.70	{ ++ 6.50
12	Mannite	7.50	{ ++ 6.60	{ ++ 6.60	{ ++ 6.70	{ ++ 6.70	{ ++ 6.70

stance reacting typically like a carbohydrate. Although the peptone used in the present experiments was not Witte's it seems entirely possible that American peptones such as the one used here (Parke, Davis and Company) might contain a similar carbohydrate substance. The fact that a definite increase in hydrogen-ion concentration has always been observed in the sugar-free broth employed surely would lend support to such a supposition.

## II. THE INFLUENCE OF VARYING AMOUNTS OF GLUCOSE AND BUFFER SALTS UPON THE FINAL HYDROGEN-ION CONCENTRATION OF STREPTOCOCCUS HEMOLYTICUS

It has long been recognized that the acidity produced by certain organisms in culture media results from the elaboration of acid substances through a fermentation of material, mainly of carbohydrate nature. With the introduction of accurate methods of evaluating the acidity produced in bacterial fermentations through a determination of the concentration of the hydrogenions, it became necessary to investigate the factors which may be operative in the production of a limiting or final hydrogen-ion concentration. Thus, Clark and Lubs (1915) in their work on the differentiation of the bacteria of the colon-aerogenes family, used media containing amounts of glucose varying from 0 to 0.5 per cent and demonstrated that by increasing the concentration of the sugar up to a certain point a greater final acidity resulted. If sufficient sugar was present for the limiting acidity to be produced, no alkaline reversion occurred in their cultures. Browne (1914), using cultures of *Bact. coli* in lactose-broth, found that acid production was less marked in media containing under 1 per cent sugar but that the use of amounts over 1 per cent resulted in no increase. Browne titrated his cultures with  $N/20$  NaOH but failed to make determinations of the final hydrogen-ion concentration. Avery and Cullen (1919b) found that pneumococci were able to reduce the  $P_H$  of glucose-broth from 7.50 to 5.10 provided 0.4 per cent of the sugar was present. Increasing concentrations of glucose up to 4 per cent showed no change in

final  $P_H$ . In the work of the same investigators (1919a) upon Streptococci of human and bovine origin it was shown that the same final  $P_H$  is reached in broth containing 0.5, 1, or 1.5 per cent of glucose. Sekiguchi (1917) found the highest production of acid by streptococci with 0.5 to 2 per cent of glucose. Amounts of sugar over 5 per cent caused reduction in acid formation though growth was not hindered. H. Jones (1920) has recently found that a number of organisms are able to produce their characteristic final hydrogen-ion concentration provided 0.2 per cent or more glucose be present in the medium. He failed to state the initial  $P_H$  of the medium which factor has an important bearing on the minimum concentration of a sugar needed for production of the final acidity by any given organism. The effect of varying amounts of xylose upon the production of volatile acid by xylose fermenting organisms has been studied by Fred, Peterson, and Davenport (1919) who found that 2 per cent of the sugar gave the maximum production of acid. The presence in the culture medium of substances which through their buffer effect have the power of neutralizing some of the acid as it is produced is of interest and importance in this connection.

Henderson and Webster (1907) in 1907 suggested the use of phosphates to preserve neutrality in media during the growth of acid- or alkali-forming organisms, and Clark (1915a) has more recently pointed out in considerable detail the great importance of properly buffered media in bacteriological work. Using lots of broth containing different buffers, Clark (1915b) showed that *Bact. coli* produces somewhat lower levels of  $P_H$  in the more highly buffered media.

Kligler (1916) working with cultures of *Bact. cloacae*, *Bact. aerogenes*, and *Bact. coli* studied the final  $P_H$  as influenced by different concentrations of peptone,  $Na_2HPO_4$ , and glucose. The concentration of peptone was found to influence the utilization of glucose by the organisms in such a way as to result in a lower final  $P_H$  with a low peptone concentration in the medium. In some cases the presence of buffer allowed all of the sugar to be used up with a subsequent rise of  $P_H$  thus indicating that an

alkaline phase had been initiated through the splitting of peptone. The presence of buffer, according to Kligler, keeps the hydrogen-ion concentration below the lethal point and thus allows the organism to continue its activity over a longer period. As a result of this regulatory power the amount of glucose which may be used will vary, within limits, with the relative amount of buffer material present. Bronfenbrenner and Schlesinger (1918) working with *Bact. coli* have tried similar experiments by noting the effects of varying amounts of lactose, peptone, and buffer salts upon gas formation and final  $P_H$ . After trying some 294 combinations, these investigators concluded that with any given concentration of carbohydrate the amount of free acid depends upon the concentration of buffer in the medium. As the amount of peptone increases, the per cent of sugar attacked is smaller and lower hydrogen-ion concentrations result. The necessity of carefully controlling the composition of media employed in fermentation experiments is emphasized.

From the foregoing review the following facts seem to have been well established:

1. In any given medium a definite concentration of sugar must be present if the organism in question is to produce its characteristic final hydrogen-ion concentration.

2. This minimum concentration of sugar will depend upon the concentration of buffer salts present, as well as upon the concentration of peptone in the medium.

3. In making estimations of this minimum concentration of sugar required for the production of the final hydrogen-ion concentration the quantity of buffer should be known as well as the initial  $P_H$  of the culture medium.

4. With increasing concentrations of buffer salts there is an increased neutralizing power which delays the production of the final acidity level, thus allowing the organism more time for fermentation.

*Experiment II. The effect of varying concentrations of glucose upon the final hydrogen-ion concentration of Streptococcus hemolyticus*

Ten cubic centimeter amounts of beef infusion broth containing concentrations of glucose varying from 0.10 to 1 per cent were inoculated with 0.4 cc. of an eighteen-hour culture of *Streptococcus hemolyticus* in 1 per cent glucose broth and incubated for three days to insure the completion of the fermentation.  $P_H$  readings were then made. The results are shown in table 2.

TABLE 2  
*Experiment II*

NUMBER	MEDIUM	$P_H$ (INITIAL)	$P_H$ (FINAL) IN GLUCOSE (PER CENT)					
			0	0.1	0.2	0.3	0.5	1.0
1	Beef infusion broth	6.90		5.60	5.00	5.10	5.05	5.10
2	Beef infusion broth (sugar free)	7.35	6.70	6.05	5.60	5.10	5.15	5.00

In (1) which was adjusted to an initial  $P_H$  of 6.9 the final  $P_H$  was attained in a glucose concentration of 0.2 per cent, whereas in (2) which was adjusted to an initial  $P_H$  of 7.35 the final value was not shown in the 0.2 per cent glucose but did appear in the 0.3 per cent tube. As would be expected the minimum concentration of glucose needed to give the characteristic final  $P_H$  is dependent upon the initial  $P_H$  of the broth. Amounts of glucose over this minimum concentration have no further effect upon the level of the final hydrogen-ion concentration.

*Experiment III. The influence of a buffer salt upon the final hydrogen-ion concentration of Streptococcus hemolyticus in broth containing varying concentrations of glucose*

Bacto beef broth was adjusted and distributed in twelve lots in flasks. After autoclaving, the requisite amounts of glucose and di-potassium phosphate,  $K_2HPO_4$ , were added in the form of sterile 10 per cent solutions bringing the total volume of material in each flask to 25 cc. Following twenty-four



hours incubation to insure sterility each flask was inoculated with 1.25 cc. of an active twenty-two-hour culture. Determinations of  $P_H$  and "reaction" were made after an incubation period of four days. The "reaction" was determined by titrating 5 cc. of culture with  $N/50$  NaOH, using neutral red as an indicator and calculating the number of cubic centimeters of  $N/1$  NaOH needed to neutralize the acid in 100 cc. of culture. Table 3 contains the results of the experiment.

TABLE 3  
*Experiment III*

NUMBER	GLUCOSE	$K_2HPO_4$	$P_H$ (INITIAL)	$P_H$ (FINAL)	"REACTION"*
	<i>per cent</i>	<i>per cent</i>			
1	0.3	0	6.90	5.10	0.72
2	0.3	0.2	6.90	5.05	1.41
3	0.3	0.5	7.20	5.20	2.13
4	0.3	1.0	7.20	6.30	2.43
5	0.5	0	6.75	5.20	0.70
6	0.5	0.2	6.70	5.00	1.54
7	0.5	0.5	7.20	5.05	2.18
8	0.5	1.0	7.20	6.20	2.16
9	1.0	0	6.90	5.15	0.81
10	1.0	0.2	6.90	5.00	1.56
11	1.0	0.5	7.20	4.90	3.36
12	1.0	1.0	7.20	5.20	4.73

\* Cubic centimeters of  $N/1$  NaOH required to neutralize 100 cc. of culture.

As will be seen by referring to table 3 the final  $P_H$  characteristic of the streptococcus is not reached in the media containing 0.3 per cent and 0.5 per cent glucose plus 1 per cent phosphate (numbers 4 and 8 in table). These concentrations of glucose are apparently not sufficiently great to allow the formation of enough acid to bring the culture to the characteristic level, whereas in the case of the 1 per cent glucose plus 1 per cent phosphate a characteristic final  $P_H$  is reached. Correlated with these facts are the differences in titratable acid as shown in the last column of the above table. It is an interesting fact that virtually the same final  $P_H$  is shown in the greater number of the

above cases and yet the total quantities of actual acid, as shown by titration, are widely different. No better illustration of the efficiency of a buffer could be offered. Very obviously the utilization of glucose is here closely related to the concentration of buffer present. A further fact, of interest and importance, is that the final hydrogen-ion concentration rather than the total acid produced is the factor which limits the fermentative activities of the organism.

*Experiment IV. The influence of horse serum in glucose broth upon the final P<sub>H</sub> of Streptococcus hemolyticus*

Ten cubic centimeter lots of beef infusion broth (sugar-free) containing varying amounts of glucose and horse serum were prepared and inoculated with 0.4 cc. of an eighteen-hour culture. After an incubation of three days P<sub>H</sub> determinations were made. The results of (2) in experiment II are inserted in table 4 for purposes of comparison.

TABLE 4  
*Experiment IV*

NUMBER	HORSE-SERUM	P <sub>H</sub> (INITIAL)	P <sub>H</sub> (FINAL) IN GLUCOSE (PER CENT)					
			0	0.1	0.2	0.3	0.5	1.0
	<i>per cent</i>							
1	5.0	7.40	6.80	6.70	6.10	5.05	5.00	5.00
2	10.0	7.60	6.80	6.60	5.90	5.15	5.00	5.10
2 (exp. II)	None	7.35	6.70	6.05	5.60	5.10	5.15	5.00

As in experiment II it is to be noted that 0.3 per cent glucose is the minimum concentration which will permit the attainment of the characteristic final P<sub>H</sub>. The greatest differences in P<sub>H</sub> between the media containing horse serum and (2) of experiment II are seen in the tubes containing 0.1 per cent and 0.2 per cent glucose. It seems possible that in these cases the horse serum prevents the increase in acidity of the medium to a small extent through its action as a buffer. In those tubes containing sufficient glucose for the production of the final P<sub>H</sub> characteristic of the organism no differences in the level of this final value are seen. That we do have a decided difference in the rates of acid production will be shown in a later experiment.

*Experiment V. The buffer action of horse serum in broth*

To investigate further the buffer effect of horse serum titration curves of broth containing 1 per cent glucose, 1 per cent glucose plus 5 per cent horse serum, and 1 per cent glucose plus

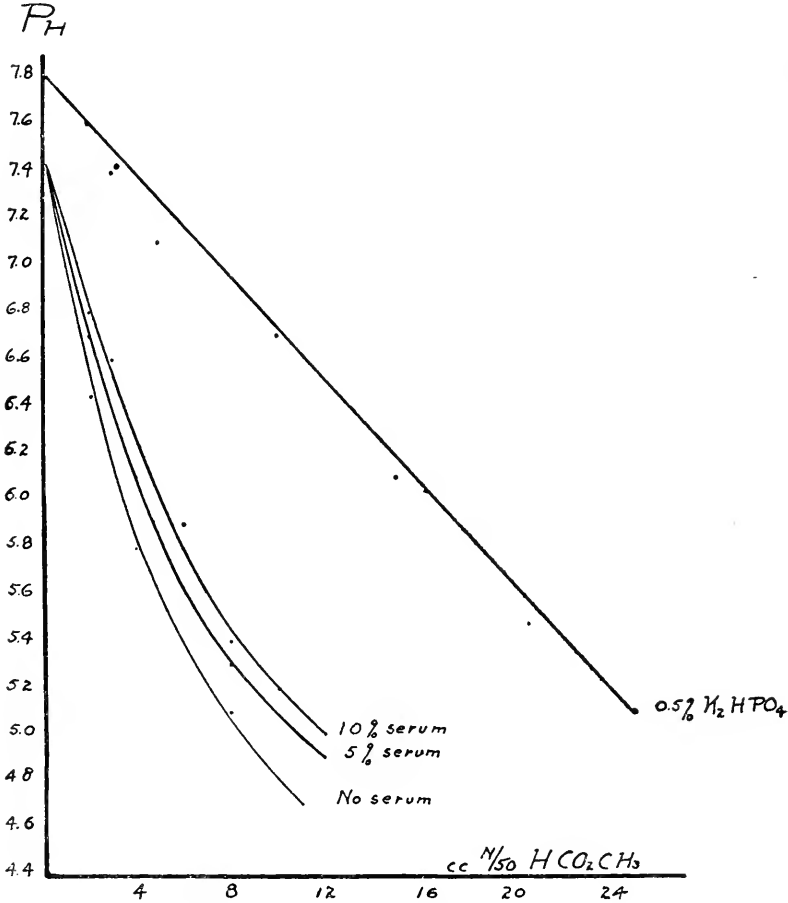

FIG. 1. EXPERIMENT V

10 per cent horse serum were plotted after the following procedure had been carried out: To 10 cc. portions of the three types of broth mentioned above, amounts of N/50 acetic acid varying from 1 to 12 cc. were added and the P<sub>H</sub> taken. The curves were

plotted using the cubic centimeter of acid as abscissae and the  $P_{\text{H}}$  readings as ordinates. Reference to the curves (fig. 1) will show that horse serum in these concentrations exerts a slight but distinct buffer effect. The 10 per cent series does not show a much greater buffer action than the 5 per cent series however, and the effect in no case is anything like that noted in the case of  $K_2HPO_4$  (experiment III).

### III. THE RATE OF ACIDITY FORMATION IN CULTURES OF STREPTOCOCCUS HEMOLYTICUS

Considerable work by a number of investigators has demonstrated that the life cycle of a given organism, as measured by the number of viable cells present at various intervals following inoculation, may be separated into very definite periods. Thus, Chesney (1916) has suggested a division into four phases: (1) latent period or lag, (2) maximum growth period, (3) stationary period, (4) period of decline.

No sharp dividing lines may be drawn between the periods, and their duration will vary in the case of the same organism with such factors as the amount of inoculum, age of parent culture, and initial reaction of the medium. Buchanan (1918) described seven periods in the life of an organism: (1) initial stationary phase; (2) lag phase when growth proceeds at a slowly accelerating rate; (3) maximum or logarithmic period in which the rate of increase in numbers is constant; (4) period of negative growth acceleration, the organisms are increasing at a decreasing rate; (5) maximum stationary period; no increase in numbers; (6) period of accelerated death, decrease in taking place at an increasing rate; (7) logarithmic death phase; death is occurring at a constant rate.

With the development of procedures for the mathematical analysis of the several phases (Buchner, Longard, and Riedlin (1887), Buchanan (1918), Slator (1917), Ledingham and Penfold (1914) has come the possibility of more definite knowledge concerning the growth activities of organisms.

A search through the literature reveals the fact that the latent period or lag phase has received the bulk of the attention of workers in this field. Müller (1896) perhaps was the first to recognize the phenomenon while working with cultures of *Bact. typhosum* at temperatures simulating febrile conditions. The duration of lag was found by him to vary with the age of the culture used for seeding, being shorter for young than for older cultures. He believed the phenomenon to be the result of an alteration of the cells sustained upon transplantation to a new medium, the duration of lag representing the time required for the organisms to recover from the injury. Rahn (1906), working with *Ps. fluorescens*, studied the influence upon lag of the amount of inoculum and concluded that the larger the number of organisms used for seeding, the shorter the lag. Penfold (1914) later demonstrated that this effect held, up to a certain limit, beyond which an increase in the amount of inoculum exerted no influence upon the duration of the lag period. In case of small inocula, however, Penfold showed that a diminution in amount of seed invariably caused a lengthening of lag. He found that older cultures caused lengthening of lag only up to a certain point, for example, a four-day culture gave the same duration of lag as a twelve-day culture in the case of *Bact. coli*. Barber (1908) working with single cells (*Bact. coli*) was the first to show that under proper conditions lag may be eliminated. He used rapidly dividing cells which were accustomed to the medium employed and was able to find no evidence of inhibition upon transplantation. This observation has received substantiation at the hands of Penfold (1914), Chesney (1916), and Salter (1919), all of whom worked with *Bact. coli*. Coplans (1909) also states that with *Bact. coli*, there is ordinarily no absolute lag upon transplantation to a favorable medium. New milk ordinarily possesses inhibitory properties but this investigator found that heating momentarily to 100°C. caused a disappearance of this special inhibitory quality. Salter (1919) found also that the age of the parent culture exerted a considerable influence upon the duration of lag, thus confirming the observations of previous investigators. Lane-Claypon (1909) has studied the

rate of growth of organisms as affected by different temperatures and has demonstrated a conformity of her curves with the Van't Hoff-Arrhenius law within certain limits.

The various other phases in the life of a culture have been investigated to a less extent but from the work of Buchanan (1918) and Ledingham and Penfold (1914) it seems probable that growth is a discontinuous process in the sense that development of a given organism is dependent upon different laws in the successive phases of the life of the culture.

An illustrative curve follows:

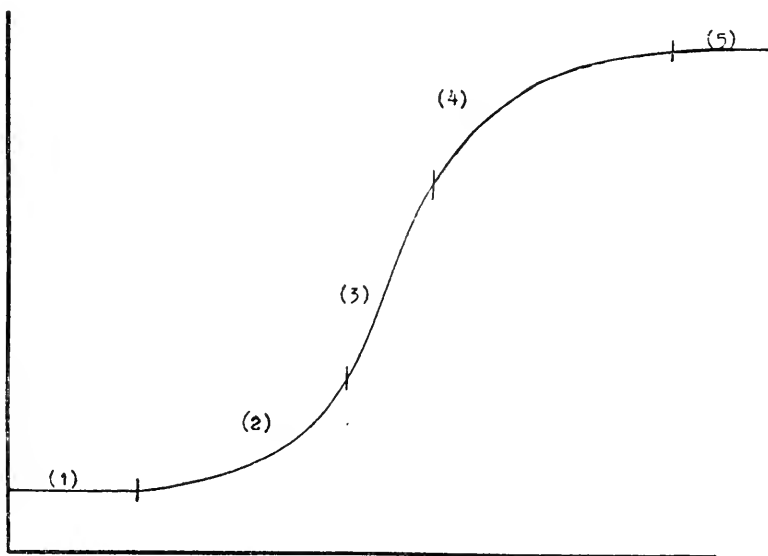

FIG. 2. ILLUSTRATIVE CURVE OF ACID FORMATION BY *STREPTOCOCCUS HEMOLYTICUS* IN GLUCOSE BROTH

- (1) Initial stationary period.
- (2) Lag period. Acid formed at a slowly increasing rate.
- (3) Maximum period. Acid formed at a constant, maximum rate; curve is an oblique, straight line.
- (4) Period of negative acceleration. Acid formed at a decreasing rate.
- (5) Maximum stationary period. Final  $P_H$  has been attained; curve is a straight line parallel to the abscissa.

If broth containing glucose be inoculated with an actively growing culture of *Streptococcus hemolyticus* and incubated, there ensue changes in the hydrogen-ion concentration of the medium culminating in the establishment of a limiting or final reaction. A study of these changes, as measured at regular intervals, indicates that the course is a perfectly definite one capable of being separated into the following characteristic phases: (1) Initial stationary period, no change in reaction; (2) latent or lag period, acid formation at a slowly increasing rate; (3) maximum period, acid formation at a constant rate; curve an oblique straight line; (4) period of negative acceleration, acid formation at a decreasing rate; (5) maximum stationary period, final  $P_H$  reached, curve a straight line parallel to the abscissa.

It will be noted that this sub-division of the course of reaction change corresponds with Buchanan's life phases of a bacterial culture based upon numerical determinations of viable organisms, with the exception that his two final periods, representing a decrease in number, cannot, of necessity, apply to an acid curve such as is characteristic for the streptococcus. The work of Cullen and Chesney (1918) on pneumococci has shown a close relationship between growth-rate and speed of acid production in plain broth, and accordingly these observers have concluded that acid formation is to be considered as an active metabolic process, closely associated with the growth activities of the organism. In examining the curves of Cullen and Chesney one is struck by the close parallelism that exists between the various phases in the life of the pneumococcus, as measured by numbers of viable cells on the one hand, and by acid formation on the other hand. As might be expected, a rise in the growth curve always preceded slightly a rise in acidity. Lord and Nye (1919) have reported results of similar nature on pneumococci grown in glucose broth. During the first 12 hours of their experiment the medium was found to change in reaction from  $P_H$  7.65 to 5.25. Up to this point, a rapid increase in the number of cells was evident, but during the subsequent acidification to the final  $P_H$ , 5.15, a rapid decrease in viable organisms was apparent.

In both of these investigations it is evident that the maximum changes in acid formation take place simultaneously with a rapid development and multiplication of the bacteria and thus show a conformity with the conception of Slator (1916) that "Chemical reactions brought about by microorganisms usually proceed under conditions where development of the organism and changes in the composition of the nutrient medium take place simultaneously." H. M. Jones (1920a) however, has recently obtained results which contradict the work of Cullen and Chesney, and Lord and Nye. Using cultures of pneumococci in glucose broth this investigator has shown that the growth curve rises sharply at the fourth to fifth hour while the onset of the maximum period of acid formation is delayed until the twelfth hour. Examination of the curves of this experiment shows the maximum period of growth to be associated with but a slight alteration in the reaction of the medium (7.4-7.0), whereas, the interval of acid formation at a maximum rate corresponds with the period of growth at a decreasing rate. This finding corresponds more or less closely to the observations of Cohen and Clark (1918) upon *Bact. coli* in glucose broth cultures. The growth curve was found to rise five hours previous to the onset of the maximum period of acid production, and, as in the experiments of Jones, the maximum period of acid formation was found to be coincident with the period of growth at a decreasing rate. At the point where strong symptoms of growth inhibition appeared, the  $P_H$  was found to correspond to the region at which acetic acid had been previously shown to check growth (5.5-5.7). The fermentative activity, however, was not seriously checked until the culture approached the region in which HCl had been found to inhibit growth (4.6-5.0). From a consideration of these findings it will appear, in the cases of *Bact. coli* and the pneumococcus at least, that the hydrogen-ion concentration may exert independent effects upon growth, on the one hand, and upon acid formation on the other, so that in experiments designed to follow the acid production of organisms in carbohydrate media it will be unsafe to assume that maximum changes in reaction parallel maximum rates of multiplication of bacterial cells.



Clark (1915b), working with *Bact. coli*, was perhaps the first to follow reaction changes in bacterial cultures by means of determinations of hydrogen-ion concentration. No change in  $P_H$  was noted under a period of ten hours in his experiment. Itano (1916a) followed the changes in acidity in cultures of *B. subtilis* and noted in certain media of unfavorable initial  $P_H$  that an "automatic adjustment" toward a more favorable reaction occurred during incubation. Working with *Clostridium perfringens* (*C. welchii*) and *C. sporogenes* (Metchnikoff), Wolf and Harris (1917b) found that curves of acidity change followed closely those of amino acid formation and gas production. Avery and Cullen (1919b) used media of different initial  $P_H$  with pneumococci and demonstrated that after completion of lag, growth, as evidenced by the rate of reaction change, proceeded at about equal speeds. Neither the final  $P_H$  nor the rate of acid formation was affected by the use of various available mono- or di-saccharides. The maximum period was found to lie between the fourth and eighth hours following seeding. Bunker (1919) noted an initial acidity rise followed by alkaline reversion in cultures of *Corynebact. diphtheriae* and apparently has shown that toxin production is closely associated with this phenomenon, as no toxin could be demonstrated in cultures which failed to exhibit an alkaline reversion. In a study of the logarithmic or maximum period in cultures of several organisms by Cohen and Clark (1918) it was observed that bacteria may multiply rapidly for a time in media varying considerably in initial reaction. The maximum period of growth in the case of *Bact. coli* fell between the fifth and tenth hours. Schoenholz and Meyer (1919), in their work on *Bact. typhosum*, have reported changes in the growth curve through the influence of hydrogen-ion concentration. Thus they found that growth at a maximum rate set in five hours following incubation, if the initial  $P_H$  of the medium was 7.0. At lower and higher levels lag was of longer duration.

Avery and Cullen (1919a), using streptococci of human and bovine origin, found the greatest increase in acidity between the seventh and twelfth hours, using eighteen-hour cultures as

sources of inocula. H. Jones (1920) has recently observed that in the case of pathogenic streptococci the age of the parent culture employed may exert a considerable influence upon the abundance of growth in sub-cultures which may, in turn, be reflected in the final  $P_H$  values. He also observed that cultures which were placed under conditions which tended to delay growth failed to show the characteristic final  $P_H$ . The statement frequently made that the final  $P_H$  of an organism is eventually reached, provided the culture exhibits growth, obviously can not apply to a delicate organism such as the streptococcus. Thro (1915) called attention to the same fact in his observation that with streptococci variations in luxuriance of growth were associated with differences in the quantities of acid substances produced.

Slator (1916) has devised an ingenious method for measuring the rate of growth of a lactic acid-forming organism through an indirect application of the titration values obtained at definite intervals throughout the course of the experiment. Using the formula suggested in a previous work (1917) he was able to show close agreement in the values of the constant,  $k$ , in different determinations. The possibility of simultaneous acid and alkaline fermentations in cultures of certain organisms has been emphasized by Ayers and Rupp (1918) who state that such actions may complicate and decrease the value of acidity determinations in certain cases. Methods of measuring both fermentations have been suggested by these investigators.

From the foregoing review it would appear that a study of the progress of reaction changes in cultures of *Streptococcus hemolyticus*, in order to furnish data of value, must of necessity entail an investigation of a number of interacting factors. Accordingly, experiments were planned to study the rate of acid formation as influenced by the following: (1) Amount of inoculum; (2) age of parent culture; (3) presence of a body fluid, horse serum, (4) initial reaction of medium.

*Experiment VI. The influence of the amount of inoculum upon the rate of acid formation in glucose broth*

Twenty cubic centimeters of 1 per cent glucose broth,  $P_H$  7.10, were inoculated with varying amounts of an active, eighteen hour culture of *Streptococcus hemolyticus* in 1 per cent glucose broth and incubated. At two-hour intervals  $P_H$  determinations were made on 1 cc. samples removed from the cultures with aseptic precautions. All cultures remained uncontaminated throughout the entire period of the experiment. The results of the experiment are to be found in table 5 and figure 3.

TABLE 5  
(*Experiment VI*)

NUMBER	INOCULUM	DURATION STATIONARY PERIOD	DURATION LAG PERIOD	ONSET OF MAXIMUM PERIOD	DURATION MAXIMUM PERIOD	PH LOWERING (MAXIMUM PERIOD)	
						Total	Per hour
	cc.	hours	hours				
1	0.2	8	6+				
2	0.4	2	8	10	2	0.8	0.4
3	0.8	None	8	8	4	1.35	0.34
4	2.0	None	6	6	2	1.40	0.70
5	4.0	None	4	4	6	1.45	0.24

Reference to the curves (fig. 3) shows that the rates of acid formation are at least roughly proportional to the quantities of inoculum used. It is interesting to find that the hourly rate (table 5) during the maximum period is least in the case of (5) notwithstanding the fact that this contained the largest inoculum. In other words, cultures (4), (3), and (2) though showing more prolonged lag periods than (5), are able to proceed with acid formation at more rapid rates, once the maximum period is initiated. No  $P_H$  determinations were made within the initial two-hour interval, hence it is not possible to assume that any of the cultures showed an entire absence of the stationary period. In (4) and (5), however, the stationary period, if present, was probably of very short duration.

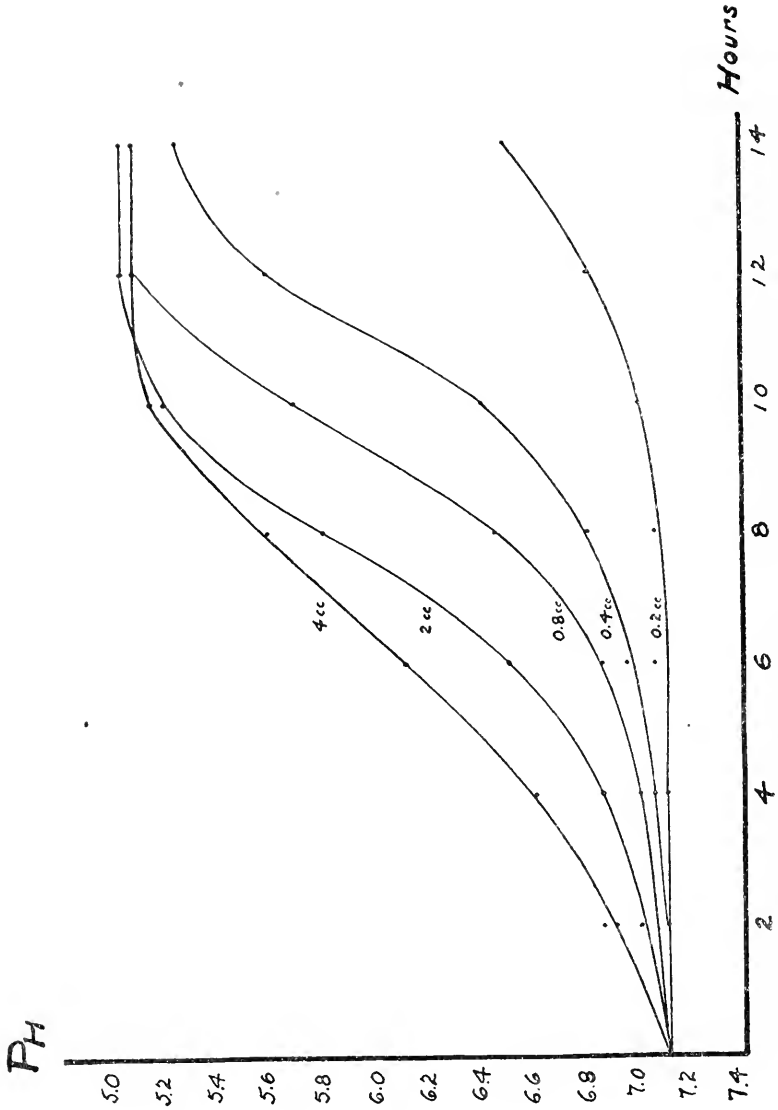

FIG. 3. EXPERIMENT VI. THE INFLUENCE OF THE AMOUNT OF INOCULUM UPON THE RATE OF ACIDITY FORMATION

*Experiment VII. The relation of the age of parent culture to the rate of acid formation in glucose broth*

Four cultures of *Streptococcus hemolyticus* were made in the usual manner at intervals of six hours. After eighteen hours incubation sub-cultures were made and these second-generation cultures incubated. The schedule was so arranged that at the time of the final inoculation into the medium of the experiment (20 cc. portions of 1 per cent glucose broth) organisms would be taken from parent cultures of six, twelve, eighteen and twenty-four-hours age. One hour previous to the final seeding counts of each parent culture were made by the method of Wright in order that each tube of broth to be used in the experiment might receive approximately the same number of organisms. The inoculum was based upon the proportion, 0.8 cc. of a twenty-four-hour culture per 20 cc. of broth.

*Bacterial counts*

NUMBER	AGE	ORGANISMS	INOCULUM
	<i>hours</i>	<i>millions per cu. mm.</i>	<i>cc.</i>
1	6	248	7.40
2	12	1088	1.68
3	18	1548	1.48
4	24	2282	0.80 (basis)

Examination of the curves (fig. 4) shows that (2) (from twelve hour culture) reaches the characteristic final  $P_H$  earliest, then come in order the tubes from the six-, eighteen- and twenty-four-hour parent cultures. The onset of the maximum period is seen to follow the same order. As might be expected, the differences are shown almost entirely in the duration of the lag and stationary periods of the four cultures. It is a fact of interest and importance that the rates of acid formation during the maximum period (table 6) were practically equal in the four cases.

From a consideration of the work of various investigators upon the life phases of an organism the results obtained here are not unexpected. It has been repeatedly demonstrated that the maximum rate of acid formation in glucose broth occurs between

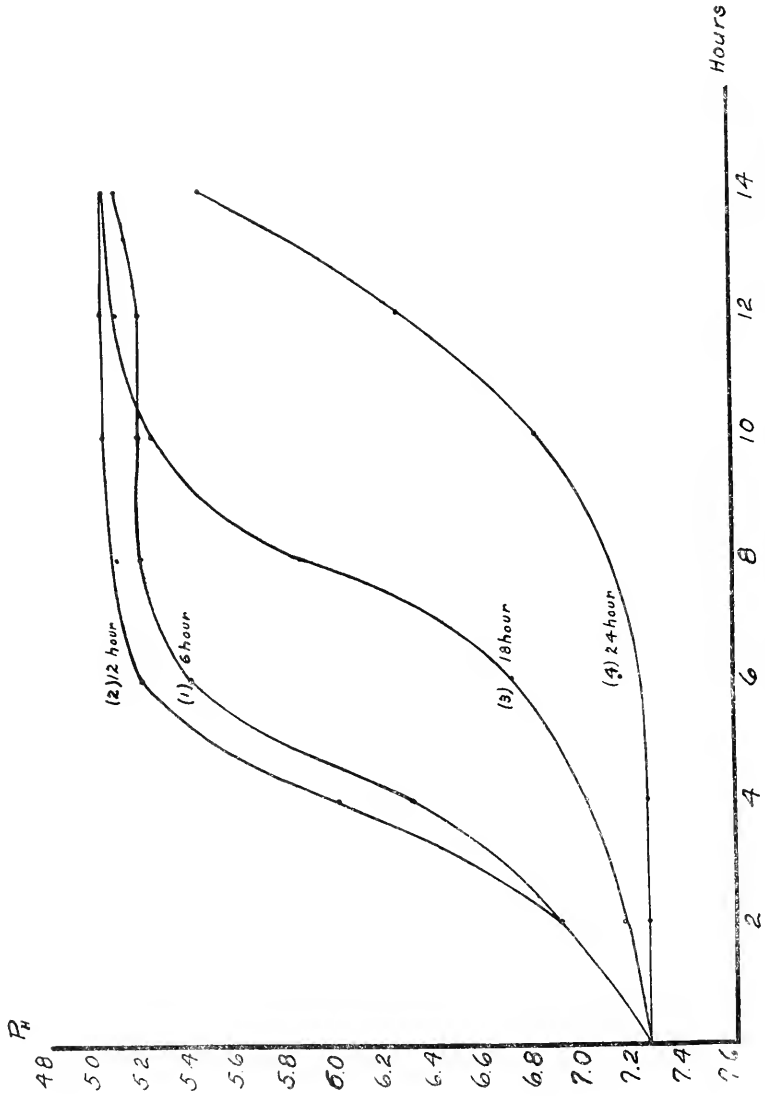

FIG. 4. EXPERIMENT VII. THE INFLUENCE OF THE AGE OF PARENT CULTURE UPON THE RATE OF ACIDITY FORMATION IN SUBCULTURES

the sixth and twelfth hours of incubation, provided the inoculum be taken from an eighteen-hour parent culture. If it be assumed that during this interval the organisms are growing rapidly and that their metabolic activities are at a maximum it would be anticipated that transplantation of organisms during this period to a favorable medium would result in resumption of growth and metabolism with a minimum of lag. The close parallelism in the curves of (1) and (2) bears out this supposition. That the organisms decrease progressively in vitality with the lengthening of their period of contact with the products of their own metabolism is brought out in the curves of (3) and (4).

TABLE 6  
*Experiment VII*

NUMBER	AGE OF PARENT CULTURE	DURATION STATIONARY PERIOD	DURATION LAG PERIOD	ONSET OF MAXIMUM PERIOD	DURATION MAXIMUM PERIOD	PH LOWERING (MAXIMUM PERIOD)	
						Total	Per hour
	<i>hours</i>	<i>hours</i>	<i>hours</i>		<i>hours</i>		
1	6	0	4	4	2	0.90	0.45
2	12	0	2	2	2	0.90	0.45
3	18	0	6	6	2	0.85	0.425
4	24	4	8	12	2 (?)	0.80	0.40

Here are seen more prolonged lag periods, indicating that the organisms required more time to recover from the injury sustained in the previous environment. The injury, however, appears to be only temporary for in all cases acid production is seen to proceed at practically the same rate following the onset of the maximum period. The entire absence of lag in acid production has never been observed with the streptococcus.

*Experiment VIII. The rates of acid formation of Streptococcus hemolyticus in glucose broth and in glucose-serum broth*

Forty cubic centimeter portions of infusion broth (initial  $P_{H}$  7.20) containing (1) 1 per cent glucose, and (2) 1 per cent glucose plus 5 per cent horse serum were inoculated with 1.6 cc. of an eighteen-hour glucose broth culture and incubated at 37°. Determinations of hydrogen-ion concentration were made at

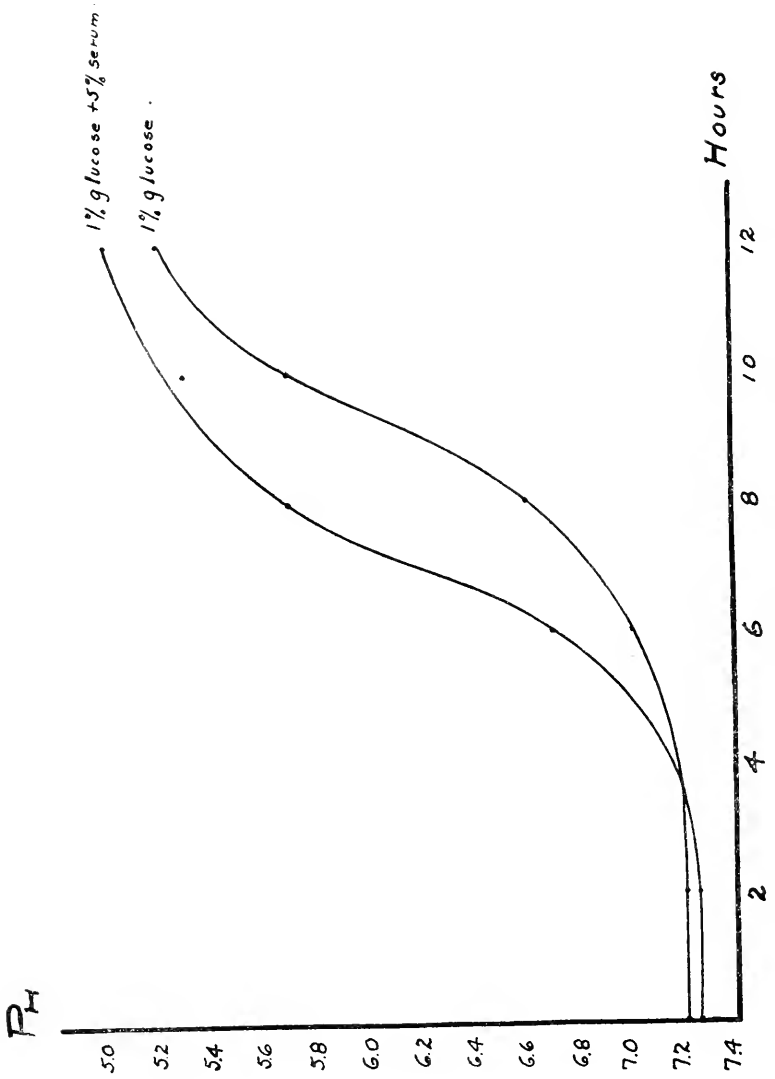

FIG. 5. EXPERIMENT VIII. THE RATE OF ACIDITY FORMATION IN GLUCOSE BROTH AND GLUCOSE-SERUM BROTH



the outset and at two-hour intervals by removing aseptically 2 cc. of material from the flasks. The experiment continued through twelve hours, at the conclusion of which period both cultures had reached their characteristic final level of  $P_H$ .

The outstanding fact here, as may readily be seen by reference to the curves (fig. 5), is a more rapid attainment of high levels of acidity on the part of the culture containing horse serum. Though a stationary period of two hours is noted in each, the lag in the glucose culture is of two hours longer duration than in the glucose-serum culture. A close parallelism in rates is seen during the maximum period.

It would seem logical to expect that the differences manifest in the above experiment would be closely correlated with the rates of increase in numbers of cells in the two cultures; in other words, multiplication at a maximum rate would be initiated earlier in the serum-glucose medium. It is a well recognized fact that we have at our disposal no very satisfactory method of enumerating viable streptococci. The method of Wright, though useful in the standardization of bacterial vaccines, gives only approximate results, and moreover, furnishes values which represent the total organisms, viable and nonviable, present in a culture. On the other hand, the method of plating dilutions of a culture which is recognized as valuable in numerical determinations of such organisms as *Bact. coli* and *Bact. typhosum*, is not adequate for enumerations of streptococci owing to the fact that single colonies upon the plate almost invariably represent streptococcal chains of varying length. Moreover, there arises a possibility of the breaking up of coccal chains through the mechanical disturbance occasioned in preparing dilutions of the culture.

Though the inadequacies of these two procedures were recognized it was nevertheless considered advisable to repeat experiment VIII supplementing the  $P_H$  determinations at two-hour intervals with estimations of the number of viable organisms through the medium of plate counts.

*Experiment IX. The relationship between the rates of acid formation and growth of Streptococcus hemolyticus in glucose broth and in glucose-serum broth*

Forty cubic centimeter portions of 1 per cent glucose broth and 1 per cent glucose-5 per cent horse-serum broth were prepared and incubated to insure sterility. Inoculations were made from an eighteen-hour, second-generation culture in 1 per cent glucose broth into the two lots of media. P<sub>H</sub> determinations and plating of dilutions were carried out every two hours. The experiment continued through twelve hours.

*Technic of plating.* 1.8 cc. of plain broth were used as diluting fluid throughout. 0.2 cc. of culture was transferred into this amount of broth and the fluids mixed by carefully drawing up and down in the pipette, after which 0.2 cc. of this dilution were added to 1.8 cc. of broth, etc. until all the dilutions required had been made. Especial care was taken to avoid agitation of the material during the preparation of the dilutions. Nutrient agar containing 10 per cent of defibrinated rabbit's blood was used as a plating medium.

Table 7 contains the results of the experiment.

TABLE 7  
*Experiment IX*

HOURS	GLUCOSE		GLUCOSE SERUM	
	P <sub>H</sub>	Counts*	P <sub>H</sub>	Counts*
0	7.65	1.68	7.65	1.68
2	7.65	0.38	7.65	40.30
4	7.60	158.00	7.20	140.00
6	7.50	1,498.00	5.90	76,000.00
8	6.80	3,243.00	5.15	713,600.00
10	5.90	250,000.00	5.05	Infinite
12	5.50	Infinite	4.90	1,040,000.00

\* Counts are expressed in millions per cubic millimeter.

Attempts to construct growth curves by plotting the logarithms of counts against time brought out certain irregularities which made impossible the formation of smooth curves. Con-

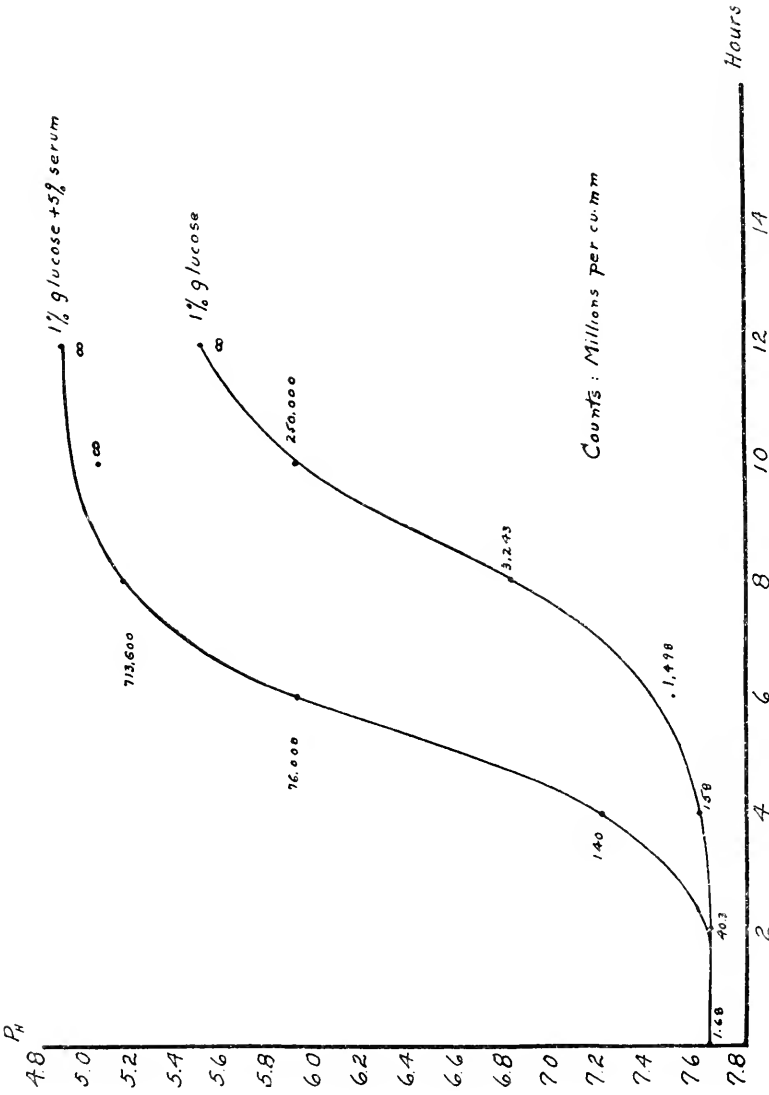

FIG. 6. EXPERIMENT IX. THE RATE OF GROWTH AND ACIDITY FORMATION IN GLUCOSE BROTH AND GLUCOSE-SERUM BROTH

sequently this procedure was abandoned. Curves of acid formation are shown in figure 6. At each point on the curves the number of organisms, expressed as millions per cubic millimeter, is shown. Examination of figure 6 shows that the two curves are analogous to those of experiment VIII (fig. 5), though the lag registered by the glucose-serum culture is of less duration. The numbers of viable organisms as shown by plate counts bear out the assumption that the earlier rise in acidity in a glucose-serum broth is associated with a corresponding period of multiplication at a rapid rate.

*Experiment X. The relation of the initial  $P_H$  of glucose-broth to the rate of acid formation by Streptococcus hemolyticus*

Beef infusion broth was adjusted to various  $P_H$  levels, divided into six portions, and sterilized in the usual manner. After adding the proper amount of glucose, the tubes, containing 20

TABLE 8  
*Experiment X*

NUMBER	$P_H$ (INITIAL)	DURA- TION OF STATION- ARY PERIOD	DURA- TION OF LAG PERIOD	ONSET OF MAXIMUM PERIOD	DURA- TION OF MAXI- MUM PERIOD	$P_H$ LOWERING (MAXIMUM PERIOD)	
						Total	Per hour
1	5.20			No growth			
2	6.20	10		Not reached in 14 hours			
3	7.00	2	4	6th hour	2	0.85	0.425
4	7.50	2	2	4th hour	4	1.70	0.425
5	8.10	2	4	6th hour	2	1.25	0.625
6	8.65	2	?	Not reached	?		

cc. of medium each, were incubated to insure sterility. The inoculum consisted of 1.33 cc. of an eighteen-hour second-generation culture in 1 per cent glucose broth. A massive inoculum was employed to complete the experiment within the fourteen hours. The results are found in table 8.

Reference to figure 7 reveals an interesting point, namely, that the cultures of initial  $P_H$  7.0, 7.5, 8.1 reached practically the same level of hydrogen-ion concentration after eight hours

incubation. To attain this result the cultures of necessity must have produced acid at varying rates. That this was true is brought out by the curves which show a tendency toward convergence after the second hour. From the data in table 8 it

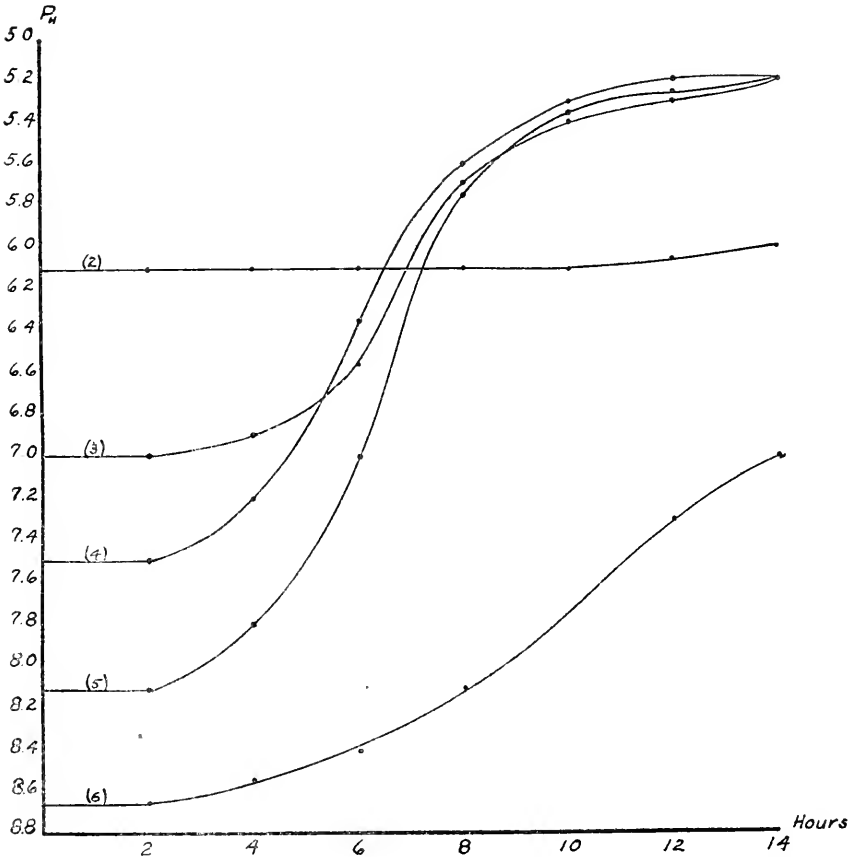

FIG. 7. EXPERIMENT X. THE INFLUENCE OF INITIAL  $P_H$  OF BROTH UPON THE RATE OF ACIDITY FORMATION

appears that culture (4) exhibited the shortest lag (two hours) though culture (5) showed the most rapid rate of acid formation during the maximum period, namely, a lowering of 0.625  $P_H$  against a lowering of 0.425  $P_H$  in the cases of (4) and (3). Culture

(6) began its acid formation after two hours at a slow, rather constant rate but at the close of the experiment had only reached a  $P_H$  of 7.0. After thirty hours its  $P_H$  was 6.0. It was not known whether this culture ever reached the final characteristic hydrogen-ion concentration. Culture (1) showed no growth while (2) was found to grow very poorly, the  $P_H$  after thirty hours being at the same level as at the fourteen-hour period.

TABLE 9  
*Summa p*

EXPERIMENT	AGE OF PLEURAL FLUID	DURATION STATIONARY PERIOD	DURATION LAG PERIOD	ONSET MAXIMUM PERIOD	$P_H$ (INITIAL)	$P_H$ CHANGE MAXIMUM PERIOD	DURATION MAXIMUM PERIOD	$P_H$ LOWERING	
								Total	Per hour
Medium: 1 per cent glucose broth									
	<i>days</i>	<i>hours</i>	<i>hours</i>				<i>hours</i>		
VI	18	4	4	8	7.10	6.45-5.70	4	1.35	0.34
VII	19	Under 2	6	6	7.25	6.70-5.85	2	0.85	0.425
VIII	18	3	5	8	7.20	6.60-5.70	2	0.90	0.45
IX	24	2	6	8	7.65	6.80-5.90	2	0.90	0.45
Medium: 1 per cent glucose, 5 per cent horse serum broth									
VIII	18	2	4	6	7.25	6.70-5.70	2	1.00	0.50
IX	24	2	2	4	7.65	7.20-5.90	2	1.30	0.65

From the foregoing data the following conclusions regarding the rate of acid formation in cultures of *Streptococcus hemolyticus* may be drawn:

1. The curves of acid formation with time may be separated into five characteristic periods: (1) Stationary period, (2) lag period, (3) maximum period, (4) period of negative acceleration, (5) maximum stationary period.

2. It is possible to reduce the duration of the stationary and lag periods to a minimum through increasing the quantity of inoculum. Whether this holds beyond a certain point is not known.

3. The age of the culture that is serving as a source of inoculum may exert a decided effect upon the duration of the stationary and lag periods in the sub-culture. If the inoculum be taken from a culture during its maximum period, lag is reduced to a

minimum in the sub-culture and growth and acid production at a maximum rate are initiated early. This point is of considerable importance, though seemingly it has been overlooked by many workers.

4. The presence of 5 per cent horse serum reduces lag by from two to four hours. This is correlated with an earlier period of multiplication of organisms at a maximum rate. Two possible explanations of this phenomenon present themselves: (1) Nutritive materials in some easily available form may be furnished by the serum or, (2) growth-accessory substances (vitamines) may be present in the enriching fluid. The second possibility would be in accord with Kligler's finding (1919) that the presence of tissue extracts shortened lag in the growth of *Streptococcus hemolyticus* and other organisms. Ordinarily these accessory substances are furnished by disintegrating cells which accounts for the fact that massive inocula give better cultures than light inocula.

5. Entire absence of lag in acid formation has never been noted. One case has been reported above in which a two-hour lag was apparent in glucose-serum broth.

6. In glucose broth the maximum period is initiated between the sixth and eighth hour and is usually maintained for two hours after which the period of negative acceleration sets in. The  $P_H$  decrease per hour in this medium is 0.42 (average of four<sup>†</sup> experiments). In glucose-serum broth the maximum periods sets in two to four hours earlier and proceeds for two hours. The  $P_H$  decrease per hour during this period is 0.50.

Recent work in this laboratory by Dr. Marjorie W. Cook has demonstrated that hemotoxin production by the "H" strain of *Streptococcus hemolyticus* occurs nearly always between the sixth and eighth hours. It is a fact of interest that this property appears during the interval which is most frequently associated with maximum acid formation.

7. In glucose broth of initial  $P_H$  ranging from 7.10 to 7.65 the maximum period sets in when the  $P_H$  of the culture has been brought to 6.45-6.80. The relation of this level of acidity to the optimum  $P_H$  of the enzymes associated with acid production might be suggested as a possible explanation of this phenomenon.

8. The initial  $P_H$  of broth exerts an effect upon the rate of acid formation. A medium of  $P_H$  7.5 was found to show a minimum of lag, while the most rapid acid formation occurred in broth of  $P_H$  8.1. The optimum  $P_H$  of broth for growth and acid production of the "H" strain of *Streptococcus hemolyticus* apparently lies between these two points,  $P_H$  7.5–8.1. Other observers have fixed the optimum  $P_H$  of the streptococcus at 7.8.

#### IV. THE INFLUENCE OF THE INITIAL $P_H$ OF BROTH UPON GROWTH AND ACID FORMATION OF STREPTOCOCCUS HEMOLYTICUS

Before the elaboration of accurate methods for determining the true reaction of a medium much attention was given to the study of the influence of acidity and alkalinity upon the physiological activities of organisms. Unfortunately much of the data obtained in these earlier investigations is of little value owing to the fact that determinations of titratable acidity rather than of true acidity were carried out. The fallacy of titrating media by the older method has been established by Clark (1915a) beyond question and if we are to accept the classic works of Sørensen and Michaelis, as supplemented by a constantly increasing mass of data by other investigators, it must be supposed that the hydrogen-ion concentration rather than the titratable acidity of the environmental medium is the determining factor in regulating the metabolic activities of bacteria and related organisms.

Though it is true that media adjusted by the old titration method may vary considerably in their hydrogen-ion concentrations yet it has been possible in the past to cultivate bacteria with a considerable degree of success. No doubt this has been due rather to the fact that many bacteria are able to develop within a fairly wide range of reaction than to the accuracy of adjustment of the media. The effect of variations in initial  $P_H$  would be demonstrable rather in altered rates of growth and fermentation. In the case of some of the more delicate pathogenic bacteria, small variations in reaction may induce very decided effects and it is here particularly that the true reaction



must be carefully controlled. One example may serve to illustrate this point: H. M. Jones (1920) working with the various types of pneumococci found that in a medium of  $P_H$  7.0 no strain was able to develop greater acidity than  $P_H$  5.6, whereas if the initial reaction was  $P_H$  7.6 all strains gave a final hydrogen-ion concentration ranging from 5.0 to 5.4. If the final  $P_H$  produced by certain organisms is to serve a useful purpose in differential procedures, the level of the initial hydrogen-ion concentration of the medium must obviously be controlled so as to permit the optimum development of the organism in question, in order that it may carry its fermentation to a maximum.

That there are levels of hydrogen-ion concentration which have the effect of limiting the activities of certain organisms was perhaps first recognized by Lazarus (1908) in 1908, who roughly adjusted her media to various hydrogen-ion concentrations with litmus, phenolphthalein, and methyl orange after which the reactions limiting growth were studied. The influence of reaction was considered a modification of the conditions of assimilation in that it exerted a definite effect upon the state of dissociation of the materials which the organism in question could take up or could alter.

With the recognition by investigators of the growing importance of the relationships of hydrogen-ion concentration to biological process in general, have come attempts to determine the limits of reaction within which bacteria may develop. The most complete single effort to establish such minimum, maximum, and optimum limits of  $P_H$  for a number of pathogenic organisms seems to have been that of Fennel and Fisher (1919). In the course of the present investigation it has been possible to collect from a number of sources data bearing on this point and in recognition of the value of a compilation such as this to workers in the field of bacteriology this information has been appended to the present section of the paper.

*Experiment XI. The relation of initial hydrogen-ion concentration of broth to the growth of Streptococcus hemolyticus.*

Portions of infusion broth were adjusted to values ranging from  $P_H$  5.0 to 9.0 and after the addition of proper amounts of glucose and horse serum, were incubated for twenty-four hours to insure sterility. Each tube contained 5 cc. of medium. The following series were used: (1) Plain broth, (2) 1 per cent glucose broth, (3) 1 per cent glucose-5 per cent horse serum broth. The inoculum consisted of 0.2 cc. of an eighteen-hour culture in 1 per cent glucose broth. Duplicate uninoculated tubes were carried as controls. The results are found in table 10.

The following summary will perhaps serve better to express the outstanding points of this experiment:

	PLAIN BROTH	1 PERCENT GLUCOSE- BROTH	1 PERCENT GLUCOSE, 5 PERCENT SERUM- BROTH
Minimum $P_H$ permitting growth . . . . .	6.35	6.35	5.70
Maximum $P_H$ permitting growth . . . . .	8.50+	8.50+	9.25+
$P_H$ limits within which luxuriant growth occurs . . . . .	6.60	6.35	5.90
	8.50	8.50	9.25

Whereas the limits of reaction which permit growth appear to be the same in plain and in 1 per cent glucose broth, the presence of horse serum in addition to the glucose enables the organisms to tolerate greater degrees of acidity and alkalinity. Hence it is to be emphasized that in expressing the levels of hydrogen-ion concentration which limit the growth of organisms the exact composition of the experimental media must be mentioned. It has been noted previously that horse serum exerts a strong stimulatory effect upon the growth and fermentative activities of the streptococcus. Here we find additional evidence of such an action in an increased tolerance of the organisms for acidity and alkalinity, manifested by growth throughout a wider range of hydrogen-ion concentration.

From the results of experiment VIII it must be concluded that the optimum  $P_H$ , based upon the rate of acid formation in 1

per cent glucose broth, lies between  $P_H$  7.5 and 8.1. If the mean of these two exponents be taken, the value,  $P_H$  7.8, represents the optimum hydrogen-ion concentration for growth and acid production. This corresponds to the optimum found by Fennel and Fisher (1919) for *Streptococcus hemolyticus*. It is interesting to note that this point corresponds exactly to the optimum established for the pneumococcus (see chart) and other pathogenic cocci, and that it is only slightly different from the  $P_H$  of human blood.

TABLE 10  
Experiment XI

NUMBER	PLAIN BROTH $P_H$			1 PER CENT GLUCOSE BROTH $P_H$			1 PER CENT GLUCOSE, 5 PER CENT HORSE SERUM BROTH $P_H$		
	Initial	48 hours	Control	Initial	48 hours	Control	Initial	48 hours	Control
1	5.00	—	5.0	5.0	—	5.0	5.0		5.0
2	5.30	—	5.4	5.3	—	5.4	5.5	5.4±	5.7
3	5.50	—	5.55	5.5	—	5.55	5.7	5.1+	5.7
4	5.70	—	5.60	5.7	—	5.6	5.9	5.05+++	5.9
5	6.05	—	6.00	6.05	5.95±	6.0	6.3	5.00+++	6.3
6	6.35	5.5+++	6.35	6.35	5.20+++	6.35	6.4	5.00+++	6.4
7	6.60	6.0+++	6.70	6.60	5.15+++	6.70	6.80	5.00+++	6.80
8	7.00	6.15+++	6.95	7.00	5.25+++	6.95	7.00	5.00+++	7.05
9	7.15	6.40+++	—	7.15	5.20+++	—	7.20	5.00+++	7.20
10	7.45	6.60+++	7.30	7.45	5.1+++	7.30	7.50	5.00+++	7.40
11	7.85	6.80+++	7.50	7.85	5.25+++	7.50	7.70	4.90+++	7.65
12	8.10	7.00+++	—	8.10	5.20+++	—	8.10	5.00+++	8.10
13	8.35	6.90+++	8.25	8.35	5.20+++	8.25	8.30	5.00+++	8.30
14	8.70	8.10++	8.50	8.70	5.20+++	8.50	8.7	5.10+++	8.50
15	9.40	—	8.95	9.40	—	8.95	9.25	5.20++	8.90

— No growth; ± growth doubtful; + fair growth; ++ good growth; +++ excellent growth.

Wolf and Harris (1917a) working with *Clostridium welchii* and *C. sporogenes* have found that the final hydrogen-ion concentration produced by these organisms in media adjusted to different levels is by no means a constant. By constructing curves to show what they term "reaction resultants" an orderly relationship between the point of initial and final  $P_H$  was noted. Moreover, in media adjusted within the acid range the character of the "reaction resultant" curve was dependent upon the type of

acid employed in fixing the initial reaction of the medium. Further doubt has been thrown upon the "physiological constant" theory by the work of Wyeth (1918) on *Bact. coli*. By constructing "reaction resultants" such as those suggested by Wolf and Harris (1917a) he was able to show a definite relationship between the initial and final  $P_H$  levels. The type of acid employed in adjusting the medium was also found to bear a definite relationship to the final  $P_H$  produced by the organisms. From the foregoing results these investigators concluded that no method of clinical differentiation based upon the production of a characteristic level of hydrogen-ion concentration may safely be applied, unless such factors as the initial  $P_H$  of the culture medium as well as its composition be very carefully controlled in every test.

Wolf and Harris (ibid.) have directed attention to the fact that fermentations characterized by a slowly decreasing production of acid in the period of depressed acceleration give rise to a final  $P_H$  which is a constant regardless of the initial reaction, provided the activities of the organism cease as soon as a definite level of  $P_H$  is attained. Expressed differently, the "reaction resultant" appears as a straight line parallel to the abscissa. Seemingly this condition prevails in streptococcus fermentations as table 10 reveals a marked constancy in the levels of final  $P_H$  produced in glucose and in glucose-serum media. So far as the initial reaction is concerned it must be concluded that this factor is without influence upon the production of a characteristic hydrogen-ion concentration but that levels of initial  $P_H$  which allow growth to occur satisfactorily will also conduce to the attainment of the  $P_H$  level established as a "physiological constant" of *Streptococcus hemolyticus*. That the composition of the medium may exert an effect upon the final  $P_H$  however, is illustrated in the values obtained with the glucose-serum series (table 10). Here there is a tendency toward the production of slightly higher points of hydrogen-ion concentration, that is, lower  $P_H$  levels.

*Limits of hydrogen-ion concentration which permit growth of organisms*

ORGANISM	REFERENCE	MEDIUM	MINIMUM	MAXIMUM	OPTIMUM
Pneumococcus	Dernby and Avery (1918)	Infusion broth	7.0	8.3	7.8
	Fennel and Fisher (1919)	Infusion broth	7.2	8.2	7.8
	Avery and Cullen (1919b)	Infusion broth	7.0	8.3	7.8
<i>Streptococcus hemolyticus</i>	Fennel and Fisher (1919)	Infusion broth	4.5	8.0	7.6-7.8
	Foster	Infusion broth (1 per cent glucose)	6.35	8.5+	7.8
		Infusion broth (1 per cent glucose, 5 per cent horse serum)	5.7	9.25+	
		Infusion broth	6.35	8.5+	
<i>Streptococcus viridans</i>	Grace and Highberger (1920a)	Ascites broth	6.40	8.00	6.8
	Fennel and Fisher (1919)		4.50	8.00	7.6-7.8
<i>Streptococcus erysipelatis</i>	Itano (1916b)				2.24×10 <sup>-8</sup>
Meningococcus	Fennel and Fisher (1919)	Glucose-agar	7.40	7.80	7.6
	Gates	Serum-glucose broth	6.10	7.80	7.4
Gonococcus	Cole and Lloyd (1917)	"Tryptamine B. E."	6.50	9.10	7.6
	Fennel and Fisher (1919)	Starch-agar (Vedder)	7.0	8.00	7.6
<i>Bact. coli</i>	Michaelis and Marcora (1912)	Lactose broth	5.0		
	Shohl and Janney (1917)	Urine	4.6-5.0	9.2-9.6	6.0-7.0
	Wyeth (1918)	Infusion broth	4.30		
	Wyeth (1918)	Infusion broth	4.52		
	Wyeth (1918)	Infusion broth	4.77		

*Limits of hydrogen-ion concentration which permit growth of organisms—continued*

ORGANISM	REFERENCE	MEDIUM	MINIMUM	MAXIMUM	OPTIMUM
<i>Bact. typhosum</i>	Fennel and Fisher (1919)	Nutrient agar	4.00	9.60	6.2-7.2
	Schoenholz and Meyer (1919)		5.00	8.60	6.8-7.0
<i>Bact. paratyphosum</i> (A)	Fennel and Fisher (1919)	Nutrient agar	4.00	9.60	6.2-7.2
<i>Bact. paratyphosum</i> (B)	Fennel and Fisher (1919)	Nutrient agar	4.00	9.60	6.2-7.2
<i>Bact. dysenteriae</i> (Flexner)	Fennel and Fisher (1919)	Nutrient agar	4.80	9.60	6.2-8.4
<i>Bact. dysenteriae</i> (Shiga)	Fennel and Fisher (1919)	Nutrient agar	4.80	9.60	6.2-8.4
<i>C. welchii</i>	Wolf and Harris (1917a)	Glucose-peptone (2 per cent) water	4.8		
<i>C. metchnikoff</i>	Wolf and Harris (1917a)	Glucose-peptone (2 per cent) water	4.94		
<i>Hemophilus influenzae</i>	Fennel and Fisher (1917a)	Chocolate medium			7.8-8.0
<i>Corynebact. diphtheriae</i>	Bunker (1916-17)		6.30	8.20	6.5-7.5
<i>V. cholerae</i>	Fennel and Fisher (1919)	Extract agar or broth	5.60	9.60	6.2-8.0
<i>B. melitensis</i>	Fennel and Fisher (1919)	Nutrient agar	6.30	8.40	6.6-8.2

*Reaction of differential media*

OBSERVER	MEDIUM	P <sub>H</sub> (MINIMUM)	P <sub>H</sub> (MAXIMUM)	P <sub>H</sub> (OPTIMUM)
Fennel and Fisher (1919) Kligler (1918)	Endo			7.8-8.0 7.8-8.0
Fennel and Fisher (1919) Kligler (1918) Meyer and Stickel (1918)	Brilliant green	6.40	7.20	6.8-7.0 7.0-7.2 6.4-7.0
Fennel and Fisher (1919) Kligler (1918)	Russel's double su- gar	7.0	7.8	7.4-7.6 7.4

## V. THE RELATION OF HYDROGEN-ION CONCENTRATION TO INHIBITION AND DEATH OF STREPTOCOCCUS HEMOLYTICUS

It has long been noted that the growth of a microörganism beyond a certain point exhibits symptoms of inhibition, manifest first in a decreasing growth rate, second by complete cessation of growth, third by a definite decrease in numbers, and finally by death, at which point the culture becomes entirely sterile. Inhibition, representing as it does an almost universal bacteriological phenomenon, ensues from the toxic action of the products of its own metabolism upon the organism itself. Through the continuous accumulation of these waste products in the encompassing medium and through the inability of the organism to escape their contact inhibition becomes more and more pronounced and eventually death supervenes. If the metabolic products are largely of acid nature these substances will exert a harmful effect and if in greater concentrations, a fatal influence. This fact has been well illustrated in the curves of acid formation previously discussed.

Recognizing this principle, Kitasato (1888) in 1888 added various acids to neutral media and then determined the minimum dose required to kill *Bact. typhosum* and *V. cholerae*, and the maximum dose which would still permit their growth. As the results of these experiments were expressed only in terms of percentage concentration they have for us now only historical interest.

Paul and Krönig (1896, 1897) in 1896 pointed out that the toxicity of metallic salts for anthrax spores and for cells of *Staphylococcus aureus* is dependent chiefly upon the effect of the cation but that the anions and undissociated molecules as well may exert a certain influence. Strong acids were found to act in accordance with their concentration of hydrogen ions and to depend to a small extent upon the specific action of the particular anion or undissociated molecules. Winslow and Lockridge (1906) in an extensive study of the toxic effects of certain acids upon colon and typhoid bacilli found that strong acids such as HCl and H<sub>2</sub>SO<sub>4</sub> proved fatal in concentrations at which they were highly ionized, whereas weak acids such as acetic and benzoic, proved fatal at concentrations where they were but slightly ionized. In the latter the effect appeared to be due rather to the whole molecules than to the actual concentration of hydrogen-ions.

Paul, Birstein, and Reuss (1910a) attributed a considerable toxic influence to the acid anion present as well as to the undissociated molecules. The toxic action of hydrogen-ions upon the cell appeared to be catalyzed by anions. This was found to be especially true of the weak organic acids. This finding has been supported by Norton and Hsu (1916) who added that the undissociated molecules act as negative catalyzers of the action of the hydrogen-ions. Addition of a salt having the same anion as the acid in question was found to decrease the disinfecting power through depression of the hydrogen-ion concentration (common ion effect), though the retarding influence appeared to be greater than would be expected from the decreased hydrogen-ion concentration alone. Salts not appreciably affecting the ionization of the acid brought about an increase in disinfecting power. These conclusions are not in accord with other results reported by Paul, Birstein, and Reuss (1910b). These observers showed that salts which exercised no disinfecting power in themselves were capable of increasing the toxicity of inorganic acids having the same or different anions.

A direct relationship between the degree of ionization of acids and their toxicity for yeast cells was reported by Bial (1902)



who accordingly divided the acids used into three classes based upon their ionization constants and similarity in toxicity. Surprising differences in the toxicity of various acids for molds were found by J. F. Clark (1899) in 1899. The degree of dissociation seemingly stood in no relation to the toxicity and this observer was forced to the conclusion that the inhibitory property, for molds at least, resided largely in the undissociated molecules.

The approximate concentrations of a number of common inorganic and organic acids required to inhibit growth of *Streptococcus pyogenes* have been determined by Taylor (1917) in the course of studies on the disinfection of war wounds. Considerable variation in potency was apparent with the organic acids investigated though apparently no account was taken of their degrees of ionization.

Wolf and Harris (1917a) in their study of the effect of acids upon the fermentations of *Clostridium welchii* and *C. sporogenes* point out that the influence is two-fold; first, that exerted by the hydrogen-ions, and second, that due to the anions and undissociated molecules. Lactic acid was found to have about the same toxicity as hydrochloric, whereas acetic, succinic, and butyric inhibited growth at lower hydrogen-ion concentrations (higher  $P_H$ ). Wyeth (1918) reported similar results with *Bact. coli*. He points out that if the actual mass of acid be considered hydrochloric was more inhibitory than lactic or acetic acids but that the lethal points of such organic acids, in terms of hydrogen-ion concentrations, were lower than that of hydrochloric. In equivalent quantities the highly ionized acids proved more effective in inhibiting growth.

Lord (1919), has obtained data which lead him to believe that acidity is the principal inhibitory factor in glucose broth cultures of pneumococcus, though H. M. Jones (1920) very recently has succeeded in demonstrating that in the presence of body fluid such as blood serum or ascitic fluid the tolerance of this organism for hydrogen ions is considerably increased. This same phenomenon had been noted previous to the appearance of Jones' article during the course of the present investigation upon *Streptococcus hemolyticus* and the facts have proved so

interesting that they will be presented in this section of the paper.

In numerous experiments it has been observed that a glucose broth culture of *Streptococcus hemolyticus*, after reaching a stationary level of hydrogen-ion concentration during the first twenty-four hours, remains viable for a period varying from two to five days. Subcultures made on each succeeding day during this period of death show stationary and lag periods of increasing duration. To gain some idea of the factors contributing to this inhibition the following experiments were carried out:

*Experiment XII. The growth and acid production of Streptococcus hemolyticus in neutralized filtrates*

A transplant of the usual quantity of an eighteen-hour culture was made into 1 per cent glucose broth,  $P_H$  7.5, and the material incubated until sterile (five days). The culture was then filtered through a sterile Berkefeld candle, after which the filtrate was brought back to the original reaction with sterile NaOH and re-inoculated with a fresh, actively growing culture. This procedure was repeated until no further growth resulted upon inoculation. The results are found in table 11.

TABLE 11  
*Experiment XII*

FILTRATE	FINAL $P_H$	GROWTH	BROUGHT TO $P_H$
1	5.10	+++	7.60
2	5.00	+++	7.50
3	5.30	+++	7.80
4		-	

From the data shown in table 11, it would appear that acidity is the chief factor causing inhibition and death of the streptococcus in glucose broth cultures. The inhibition which finally appears may be due to two factors; first, to an exhaustion of nutrient materials in the medium, and second to the accumulation of toxic products other than acid which check metabolism and growth.

Chesney (1916) in a rather extensive investigation of the latent period of bacteria noted variations in the toxicity of filtrates, taken at intervals following the maximum period from plain broth cultures. Inhibition appeared strongest at the time when the culture had attained the summit of its growth and became progressively less as the period of incubation increased. At the point where the culture became sterile a minimum of inhibition was shown. Filtrates taken early in the maximum period of growth showed no inhibitory property while those taken near the end of the same period proved to be somewhat toxic. According to Chesney the inhibitory substances represent waste products of the bacterial cells or unused portions of food molecules, and the alteration of the cells occasioned by their exposure to these toxic materials is concerned with that structure or function which is essential to metabolism and hence to growth. It must be emphasized that in Chesney's experiments plain broth cultures were studied and that consequently the factor of acidity was absent. In fact no determinations of hydrogen-ion concentration were carried out.

It is a well recognized fact that plain broth cultures of the streptococcus remain viable throughout much longer periods than do glucose-broth cultures of the organism. This would tend to substantiate the conclusion drawn from experiment XII that acidity is the chief single factor causing inhibition and death of the streptococcus. Natvig (1909) in an investigation of acid production by the streptococcus arrived at the same conclusion.

Refrigeration of streptococcus cultures is known to be one of the best means of maintaining the viability of the organisms and it has been observed in this laboratory that such a procedure is especially useful in preserving the pleuritic exudates employed as a source of culture material in the present investigation. It would be expected that the decrease in temperature occasioned in transferring a culture from the incubator to the ice chest would reduce the rates of metabolism and growth to a low level. As a consequence the toxic products of bacterial metabolism would increase in the medium at a much slower rate than if the culture were incubated. Obviously this condition would tend to preserve the viability of a culture for long periods.

*Experiment XIII. The inhibitory action of acids upon a culture of Streptococcus hemolyticus*

One per cent glucose broth was inoculated as usual with an eighteen-hour actively growing culture and permitted to incubate for eighteen hours. At the end of this interval a portion was filtered with sterile precautions through a Berkefeld candle and another portion was centrifugalized.  $P_H$  determinations were then made upon the supernatant and the filtrate. Portions of beef infusion broth containing 0.5 per cent  $KH_2PO_4$  (to aid in maintaining the reaction) and 0.5 per cent glucose were next adjusted to the  $P_H$  levels of the cultures, using the acids indicated in table 12. The supernatant fluid, Berkefeld filtrate, and tubes containing the broth adjusted with acids were inoculated with equal amounts of an eighteen-hour culture in 1 per cent glucose broth. Tests of viability were carried out by streaking one loopful of material on the surface of blood-agar plates at hourly intervals. As will be seen by reference to table 12 some of the tubes contained 5 per cent horse serum.

In the cases of (2) and (4) the addition of 5 per cent horse serum caused a change in  $P_H$  toward the alkaline side and consequently the results in these tubes are not comparable with the others. The rather close agreement in toxicity between lactic (1) and acetic (2) acids at the same  $P_H$  is of interest. The mixture of the two acids in molecular proportions killed in twelve hours, but inasmuch as the  $P_H$  of this tube was 5.15 as against 5.25 in (1) and (3) the result cannot be considered as evidence of increased toxicity. By comparing (6) with (1), (3), and (5) the protective action of horse serum is strikingly illustrated. Tube (6) contained viable cells after fifty-four hours contact with an acidity of 5.20; in other words, the streptococci were able to tolerate the same degree of acidity for a period nearly four times longer when in contact with 5 per cent horse-serum. Close agreement between the toxicities of the supernatant and filtrate are apparent ((7) and (8)) though neither proved as toxic as lactic or acetic acids of the same hydrogen-ion concentration.

TABLE 12  
 Experiment XIII

VIABILITY AFTER HOURS	ACID								
	(1)	(2)	(3)	(4)	(5)	(6)	(7)	(8)	(9)
	Lactic, P <sub>H</sub> 5.25	Lactic, 5 per cent horse serum, P <sub>H</sub> 5.40	Acetic, P <sub>H</sub> 5.25	Acetic, 5 per cent horse serum, P <sub>H</sub> 5.40	Lactic, acetic, P <sub>H</sub> 5.15	Lactic and acetic, 5 per cent horse serum, P <sub>H</sub> 5.20	Supernatant, P <sub>H</sub> 5.20	Filtrate, P <sub>H</sub> 5.30	Lactic, P <sub>H</sub> 4.95
6	+++	+++	+++	+++	++	+++	+++	+++	+
7	+++	+++	+++	+++	++	+++	+++	+++	#
8	+++	+++	+++	+++	60++	+++	+++	+++	-
9	+++	+++	+++	+++	10+	+++	+++	+++	-
10	++	+++	+++	+++	6+	+++	+++	+++	-
11	+	+++	+++	+++	1-	+++	+++	+++	-
12	+	+++	+	+++	-	+++	+++	+++	-
13	#	+++	35++	+++	-	+++	+++	+++	-
14	-	+++	21++	+++	-	+++	+++	+++	-
15	-	+++	6+	+++	-	+++	+++	+++	-
16	-	+++	-	+++	-	+++	+++	+++	-
17	-	++	-	+++	-	+++	++	++	-
19	-	60++	-	++	-	+++	14+	13+	-
21	-	10+	-	60++	-	++	5+	12+	-
32	-	5+	-	24+	-	35+	-	-	-
36	-	4+	-	4+	-	23+	-	-	-
54	-	-	-	2#	-	7+	-	-	-

Numbers represent colonies developing from one loopful of culture.

+++ Profuse growth; ++ good growth; + growth sparse (less than 50 colonies); # growth very doubtful (one or two colonies); - no growth after twenty-four hours incubation.

#### SUMMARY

1. *Streptococcus hemolyticus* is able to ferment the common hexoses and disaccharides but not the polysaccharides. The final hydrogen-ion concentration produced in broth containing different sugars varies between the limits P<sub>H</sub> 4.85-5.40. The lowest P<sub>H</sub> is registered in broth containing glucose; the highest P<sub>H</sub> in broth containing lactose. The characteristic final P<sub>H</sub> is seldom reached in the first generation but is usually attained by

the second generation culture. Subsequent transplants do not show lower levels of  $P_H$ .

2. Plain broth cultures of *Streptococcus hemolyticus* show a decrease in  $P_H$  which is practically the same as that exhibited by cultures of the organism in sugar-free broth. This is believed to be due to a selective action upon that portion of the peptone molecule which Pick has shown reacts typically like a carbohydrate.

3. *Streptococcus hemolyticus* is able to produce its characteristic final  $P_H$  in neutral broth containing 0.2 per cent glucose. Concentrations of glucose up to 1 per cent have no further effect upon the level of the final  $P_H$ .

4. The final hydrogen-ion concentration of the streptococcus is not influenced by the presence of  $K_2HPO_4$  in concentrations up to 1 per cent providing sufficient glucose is present.

5. Titration curves show that horse serum in broth exerts a slight but distinct buffer effect.

6. The curves of acid formation with time may be separated into five characteristic periods; (1) stationary period, (2) lag period, (3) maximum period, (4) period of negative acceleration, and (5) maximum stationary period.

7. Through an increase in the amount of inoculum or by employing a parent culture of suitable age as a source of inoculum it is possible to reduce the stationary and lag periods to a minimum.

8. The presence of 5 per cent horse serum in glucose broth reduces lag in acid formation by two to four hours. This may be due to, (1) the presence of growth-accessory substances, or (2) the presence of easily available nutritive materials.

9. In glucose broth the maximum period of acid formation is initiated usually between the sixth and the eighth hours and is maintained for two hours. Maximum production of hemotoxin has been found to occur between the sixth and the eighth hours.

10. The most rapid formation of acid takes place in broth adjusted to a  $P_H$  of 8.1, while a minimum of lag is shown in broth of  $P_H$  7.6. The optimum  $P_H$  for acid formation is believed to lie between these two levels, or at 7.8.

11. The limits of hydrogen-ion concentration which support growth of *Streptococcus hemolyticus* are as follows:

$P_H$	PLAIN BROTH	1 PER CENT GLUCOSE BROTH	1 PER CENT GLUCOSE, 5 PER CENT SERUM BROTH
Minimum permitting growth.....	6.35	6.35	5.70
Maximum permitting growth.....	8.50+	8.50+	9.25+
Limits permitting luxuriant growth... }	6.60-	6.35-	5.90-
	8.50	8.50	9.25

12. Acidity is the chief factor contributing to inhibition and death of the streptococcus in glucose broth cultures. This is evidenced by the fact that growth proceeds luxuriantly in filtrates from active cultures the acidity of which has been neutralized by a base.

13. At a  $P_H$  of 5.25 lactic and acetic acids appear to have about equal disinfecting powers for *Streptococcus hemolyticus*. Organisms live for longer periods in filtrates from active cultures than in broth brought to the same  $P_H$  with either lactic or acetic acids.

14. A marked increase in tolerance for acid is shown by streptococci in the presence of horse serum. In one test it was found that viability persisted for a period nearly four times as long in serum-glucose broth of  $P_H$  5.20 as was evident in glucose broth adjusted to the same  $P_H$ .





# THE BIOCHEMISTRY OF STREPTOCOCCUS HEMOLYTICUS

LAURENCE F. FOSTER

*From the Department of Pathology and Bacteriology, University of California*

Received for publication August 15, 1920

## I. THE ACIDS PRODUCED BY STREPTOCOCCUS HEMOLYTICUS<sup>1</sup>

The cessation of activity in a glucose broth culture of *Streptococcus hemolyticus* comes when a fairly constant point of hydrogen-ion concentration is reached. This change is caused by a fermentation of the medium with a resultant formation of acid substances. The present section of this paper has to do with the chemical nature of these acid products.

A review of the literature reveals the fact that scant attention has been paid to the biochemistry of bacterial fermentations. Emmerling (1896), in 1896, carried out determinations of acids obtained from the putrefaction of certain proteins through the action of *Proteus* and *Staphylococcus pyogenes*. Tissier and Martelly (1902) in a study of the putrefaction of meat found that *Streptococcus pyogenes* could only split natural proteins after the latter had been peptonized. The same organism rapidly attacked glucose forming, chiefly, lactic acid. *Clostridium welchii* and *C. sporogenes* were found to produce acid and alkaline substances simultaneously. Later work by Wolf and Telfer (1917) upon these last-mentioned organisms has shown that a large proportion of the acid formed in their fermentations is volatile in character. The method of Dyer (1916) was employed by these investigators in determining the volatile acids. Forty per cent of the total acid produced by the organisms mentioned proved to be non-volatile. The exact chemical nature of this fraction was not determined.

<sup>1</sup> Miss Bernice Rhodes rendered valuable assistance in carrying out the experimental work described in this section of the paper.

In a study of the acid fermentation of xylose by Fred, Peterson, and Davenport (1919) the main products were found to be acetic acid and lactic acid. The proportion of volatile acid to non-volatile acid proved to be the same throughout the entire ten to twelve days of fermentation; namely, 40 per cent of acetic to 60 per cent of lactic acid. The two acids represented about 90 per cent of the sugar consumed.

Speakman (1920) investigated the biochemistry of acetone and butyl alcohol fermentation of starch and showed that acetic and butyric acids are formed as intermediate products. A reduction of these acids to the corresponding alcohol subsequently sets in.

### *Methods*

*Volatile acids.* Volatile acids were determined by the steam distillation method of Duclaux (1900) as modified by Dyer (1916). This procedure is one in which the acid solution is distilled with steam at a constant volume. The distillate is collected in 10cc. fractions until 100 cc. have passed over, after which the remainder is taken off in 100 cc. portions. These fractions are then titrated with  $N/50$  alkali, using phenolphthalein as indicator, and the percentage of acid is calculated. The amount of acid in a given fraction, the "distilling constant" for the fraction, is plotted against the corresponding portion of distillate on logarithmic coordinate paper. Pure acids are graphically represented as straight lines and arrange themselves consecutively from the lower to the higher members of the series. With a mixture of two volatile acids the first part of the curve occupies a position intermediate to the lines representing the distilling rates of the higher and lower boiling acids. As the higher boiling acid is removed, the curve gradually becomes parallel with the line representing the lower boiling acid.

It follows that the distillate from an unknown acid mixture may be approximately determined by plotting a curve from the distilling constants and comparing this with the curves established for known acids.

The apparatus employed differed from that of Dyer (1916) in that the heating of the flasks was done with gas instead of electricity. By thoroughly insulating the flasks and connecting tubes with asbestos it was possible to maintain a constant volume throughout a long distillation.

To test the accuracy of the method several preliminary determinations of pure acids were first carried out. The results obtained for formic, acetic, and caproic acids are to be found in

TABLE I  
*Distilling constants (pure acids)*

FRACTION	FORMIC ACID	ACETIC ACID	CAPROIC ACID
cc.			
10	2.0	4.66	24.55
10	3.8	9.45	43.85
10	5.5	14.17	58.83
10	7.5	18.93	70.25
10	9.8	23.57	78.30
10	12.0	28.16	83.90
10	14.0	32.59	88.16
10	16.4	36.91	91.46
10	19.0	41.19	93.90
10	21.2	45.24	95.74
100	35.6	71.89	99.22
100	52.4	89.60	99.95
100	63.5	99.49	

table 1. Graphical representation of the distilling rates has been made on logarithmic coordinate paper (see fig. 1). The curves were found to fall between those of Dyer and those of Wolf and Telfer. Attempts to use the color tests suggested by Dyer did not meet with success and accordingly they were abandoned.

*Lactic acid.* It was presumed that the non-volatile portion of the cultures consisted mainly of lactic acid; therefore the following quantitative method suggested by Fred, Peterson, and Davenport (1919) was employed for its determinations:

The residue from the distillation flask was carefully evaporated on a hot plate to a volume of about 40 cc. This was placed in a Soxhlet extractor and extracted with ether for fifty to sixty hours

to remove the lactic acid. About 30 cc. of water were added to the ether extract and the ether removed by distillation. The water extract remaining was then titrated with  $N/10$   $Ba(OH)_2$  adding a 5 cc. excess of the base. The material was boiled for fifteen minutes to convert all of the lactic acid to the barium salt, after which the excess of  $Ba(OH)_2$  was removed by neutralization with  $H_2SO_4$ . This mixture was allowed to stand for several hours on a steam bath, filtered, and the filtrate and

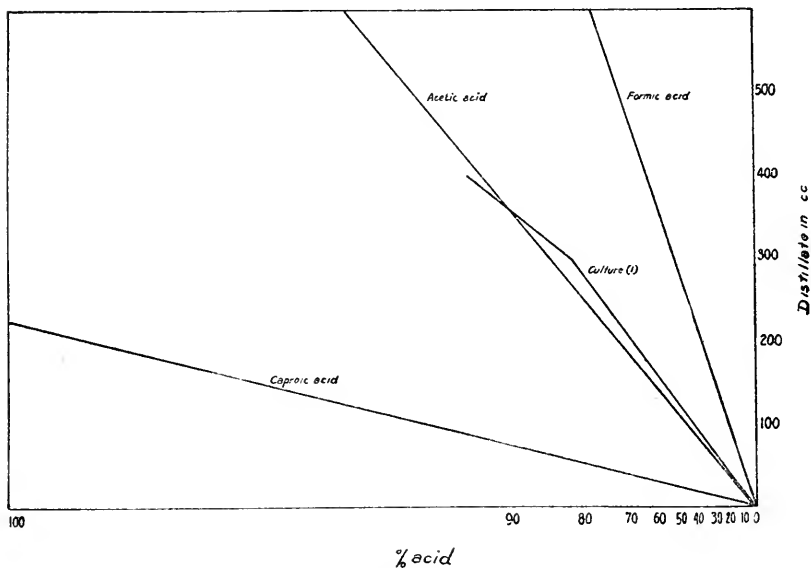

FIG. 1

washings evaporated to dryness. After taking up the residue with water the material was again filtered to remove traces of organic matter or carbonates. The filtrate was then made up to a definite volume (50 or 100 cc.) and a 10 or 20 cc. aliquot taken for analysis. A test for succinic acid was made at this point by adding to the aliquot sufficient 95 per cent alcohol to bring the volume to 100 cc. Succinic acid, if present, gives a precipitate, and the material must be filtered. The filtrate was again evaporated to dryness and the residue taken up in 60 per

cent alcohol. This alcoholic solution was carefully evaporated to dryness in a tared dish and dried at 130°C. to a constant weight. An excess of H<sub>2</sub>SO<sub>4</sub> was next added and the material converted to BaSO<sub>4</sub> by ignition. From the weight of BaSO<sub>4</sub> obtained, the corresponding weight of lactic acid was readily calculated. In case lactic is the only acid present the theoretical yield of BaSO<sub>4</sub> may be estimated from the weight of dried barium salt previously found.

*Experiment I. The volatile and non-volatile acids produced in streptococcus fermentations*

One hundred and fifty cubic centimeters of broth were inoculated with 6 cc. of a first-generation, glucose broth culture of *Streptococcus hemolyticus* and incubated for eighteen to twenty-four hours. Determinations of the volatile and non-volatile acids were made upon 100 cc. of this culture in the manner described. Control determinations were carried out upon a sample of uninoculated broth. The following results were obtained:

<i>Acids</i>	<i>Broth</i>
Volatile (as cc. of N/10 acid per 100 cc. broth).....	4.42
Lactic acid (as grams per 100 cc. broth).....	0.031

The values shown in the table were applied as corrections in the analyses of cultures.

Of the numerous estimations which have been made the results of but three will be presented: Culture (1), 1 per cent glucose broth; culture (2), 1 per cent glucose broth; culture (3), 1 per cent glucose, 5 per cent horse serum broth.

The curves plotted from the "distilling constants" (shown in table 2) proved to be so closely analogous that only one result will be shown. From the position of the line (fig. 1) representing the distilling rate of culture (1) it would appear that acetic acid, chiefly, is elaborated by the streptococcus during its growth in broth media containing either glucose or glucose plus horse serum. A trace of formic acid may also be present. This conclusion is the only one that may be drawn at present even though the

curve is not typical of a mixture of two volatile acids. No attempt has been made to re-fractionate the distillates, consequently the percentage of each acid in the volatile portion is not known. Reference to table 3 indicates that no close agreement exists between the per cents of volatile acid from culture (1) and culture (2) though the same lot of broth was used in each and the fermentation apparently progressed to the same point as the final  $P_H$  of the cultures was practically equal. Culture (3) gave a fraction of volatile acid still smaller than was noted in the other cases.

TABLE 2  
*Experiment I*

FRACTION	CULTURE (1)	CULTURE (2)	CULTURE (3)
cc.			
10	4.50	5.32	3.45
10	9.00	9.06	7.13
10	13.81	12.07	10.58
10	18.68	15.71	13.32
10	23.83	18.50	16.01
10	28.08	21.82	18.69
10	32.63	24.61	21.8
10	35.84	27.62	24.07
10	39.26	30.10	27.05
10	42.14	32.36	30.26
100	61.19	59.40	60.06
100	77.32	77.52	76.56
100	93.45	91.17	88.26
100	99.89	100.90	99.96

The lactic acid estimations in the two glucose broth cultures do not correspond especially well and the value obtained in culture (3) is smaller than would be expected.

Through a lack of time it has been impossible to carry the present phase of the investigation to a logical completion. As a consequence it will be inadvisable to draw other than very general conclusions from the data presented.

It may be concluded from results that are to be presented later that in a 1 per cent glucose broth culture of the streptococcus some 156 mgm. of glucose are utilized in the first twelve to eighteen hours. From the data shown in table 3 it is possible

to calculate the amount of glucose destroyed in the formation of the acids. Assuming for the moment that the volatile fraction consists entirely of acetic acid and the non-volatile fraction of lactic acid, a calculation indicates that the total acidity of this culture accounts for only 50 per cent of the glucose utilized. Fred, Peterson, and Davenport (1919) were able in this way to account for 90 per cent of the sugar utilized in their xylose fermentations. The large discrepancy in the present experiment may possibly be due to two factors, first to experimental error, and second to the fact that another unknown non-volatile acid is present in the fermentation mixtures.

TABLE 3  
*Experiment I*

NUMBER	CULTURE	PH		VOLA- TILE ACID (N/10 ACID PER 100 cc.)	LACTIC ACID		VOLA- TILE ACID	LACTIC ACID
		Initial	Final		Per 100 cc.	N/10 acid per 100 cc.		
1	Glucose broth	7.4	5.3 (18 hrs.)	1.196	0.061	6.78	15.0	85.0
2	Glucose broth	7.4	5.4 (18 hrs.)	2.98	0.0725	8.05	27.1	72.9
3	Glucose serum broth	7.4	4.9 (24 hrs.)	2.68	0.0534	5.25	33.8	66.2

## II. THE METABOLISM OF STREPTOCOCCUS HEMOLYTICUS

Within the past few years evidence has been increasing which indicates that bacterial metabolism and human cellular metabolism have certain fundamental characteristics in common. We are indebted principally to Kendall and his collaborators for our more definite knowledge of the chemical activities of unicellular organisms. Cellular metabolism consists of two distinct phases—(1) the anabolic or structural phase, (2) the katabolic, destructive or “fuel” phase. As in the case of man, bacteria obtain structural material from nitrogenous nutrients while the energy requirements are best satisfied by carbohydrate substances. The analogy may be extended farther to the well known physiological principle that “Carbohydrates spare body nitrogen.” In other words, those bacteria which are capable of utilizing both carbo-

hydrate and protein for katabolic purposes will attack the former in preference to the latter (Kendall and Farmer, 1912a, 1912b). This phenomenon, which has been established by Kendall and his associates as a fundamental principle of bacterial metabolism, may be expressed concisely, according to Kendall and Farmer (1912d) in the statement that, "Fermentation takes precedence over putrefaction." These authors define fermentation as, "The action of microorganisms upon carbohydrates, putrefaction as the action of microorganisms upon nitrogenous substances." They state further that "The products of proteolytic activity, which are only formed when bacteria are utilizing protein for fuel are alkaline nitrogenous substances; the products of fermentation, on the contrary, which are formed when bacteria are utilizing carbohydrates for fuel, are non-nitrogenous, acid products."

Inasmuch as nitrogen is the most important structural element entering into the composition of the cell, a quantitative measure of nitrogen degradation must form a very important step in the study of cellular metabolism. In man, nitrogenous waste is excreted from the body mainly as urea, but with bacteria, which are known to excrete nitrogen principally as ammonia, urea, if formed at all, would represent a product of intermediary metabolism. This theory is borne out by the fact that certain bacteria are able actually to utilize urea.

Kendall and his associates (1913) have concluded after many studies upon a variety of organisms that ammonia formation, representing the final step in the degradation of proteins and protein derivatives, is the best available index of proteolysis by bacteria. Ammonia formation is considered by Kendall and Walker (1915) to result from intracellular deamination of assimilated protein derivatives, incidental to their transformation into energy.

Kendall, Day, and Walker (1913a) have estimated that the amount of protein needed for structural purposes by the bacterial cell is in all probability exceeded by the amount wasted through excretion. The combined structural needs and structural waste are much less than the fuel needs and the fuel waste. Further, the fuel requirements only cease upon the death of the organism,



whereas the structural needs are practically complete when the cell attains its morphological maturity. Consequently the fuel requirement is one of comparatively long duration. According to the same authors, a rapid disintegration of fuel materials occurs in the case of saprophytic bacteria. In other words, such microorganisms must, in general, be considered more active chemically than are pathogenic bacteria.

In the experiments conducted with the streptococcus it has been noted that growth *in vitro* is always accompanied by elaboration of acid products through the fermentation of materials of carbohydrate nature. No medium has ever been used which does not respond to the fermentative activities of this organism. Kendall, Day, and Walker (1913b) state that when bacteria are metabolizing carbohydrate the nitrogen requirement is minimal, so that in glucose broth cultures of *Streptococcus hemolyticus* we would expect the katabolic or "fuel" phase to predominate over the anabolic or structural phase of metabolism.

Moreover, the presence of horse serum in broth was found to exercise a decided stimulatory effect upon growth rate and acid formation, and also proved effective in permitting growth throughout a wider range of hydrogen-ion concentration. From a consideration of the fundamental features of bacterial metabolism as outlined in the foregoing discussion, it would seem obvious that these phenomena represent a stimulated metabolism of the organisms brought about through some property of the serum. It was suggested previously that structural or growth-accessory substances are perhaps furnished by this material thus permitting the organisms to inaugurate their metabolic activities earlier with consequent reduction of lag. This theory would be in accord with the statement of Kendall, Day, and Walker (1913b) that the structural function always precedes the vegetative or fuel function chronologically, inasmuch as the cell must be formed before it can carry on its appropriate activities.

The following experiments represent an attempt to study the metabolism of the streptococcus in various culture media with an especial effort to determine whether correlation exists between the rates of acid formation and the rates of other metabolic processes in (1) glucose broth, and in (2) glucose-serum broth.

*Methods*

Ammonia was determined by the Folin air current method (1912) using 2 cc. of culture and collecting the gas in  $N/50$  acid after which the residual acid was determined by back titration with  $N/50$  base. Results are expressed as milligrams per 100 cc. of culture.

Amino acids were determined by the formol titration method of Sørensen previously described (see section I).

Glucose was determined by the method of Bertrand (Hawk, 1918). As the presence of peptone and protein material in the medium rendered the application of the method impossible, the following procedure, devised by Dr. Marjorie W. Cook, was employed to free the cultures from interfering substances:

Twenty cubic centimeters of culture was diluted to 100 cc. with distilled water and precipitated with 10 to 15 cc. of saturated tannic acid solution. After filtering, 5 to 7 grams of lead acetate were added to the filtrate to remove excess of tannic acid and this mixture was filtered. If the filtrate was turbid more lead acetate was added. To the filtrate from this treatment was added 2 to 3 grams of sodium oxalate. This removed the lead as  $Pb(C_2O_4)$ . The filtrate from this last treatment should be perfectly clear and colorless. It is important throughout the whole procedure to keep the containers and funnels covered thus minimizing evaporation and reducing the error from this source. Two 10 cc. portions of this liquid were now used for determinations of glucose.

Bacterial counts were made by the method of Wright and logarithms of the values so obtained were employed in plotting growth curves. It must be borne in mind that the method of Wright gives only approximate results and that the values represent the total number of organisms rather than the number of viable cells.

Titration of hemotoxin were made with sterile tubes, pipettes, etc., to maintain the purity of the streptococcus cultures. Rabbit corpuscles which had been washed three times in 0.85 per cent NaCl and made up in a 1 per cent suspension in beef infusion

broth were used in the tests. To 0.5 cc. of the corpuscular suspension were added amounts of culture varying from 0.005 cc. to 0.5 cc. The volume was then made up to a total of 1 cc. with broth, after which the mixture was incubated at 37° for two hours. During the first hour of incubation the tubes were frequently shaken to insure thorough mixing. At the end of the incubation period the degree of hemolysis was observed, and expressed as follows:

100 per cent of corpuscles hemolyzed	++++
90 per cent of corpuscles hemolyzed	+++±
75 per cent of corpuscles hemolyzed	+++
50 per cent of corpuscles hemolyzed	++
25 per cent of corpuscles hemolyzed	+
0 per cent of corpuscles hemolyzed	-

*Experiment II. The "protein sparing" action of Streptococcus hemolyticus*

Bacto beef broth, P<sub>H</sub> 7.2, served as the basis of the combinations used in the experiment. The inoculum for each 10 cc. of broth consisted of 0.4 cc. of an eighteen-hour, glucose broth culture. The ammonia determinations were made after seventy hours incubation. The results are incorporated in table 4.

TABLE 4  
*Experiment II*

NUMBER	SERUM	GLUCOSE	FREE NH <sub>3</sub> AS MGM. N PER 100 CC. (CULTURE)	FREE NH <sub>3</sub> AS MGM. N PER 100 CC. (CONTROL)
	<i>per cent</i>	<i>per cent</i>		
1	—	—	9.80	9.73
2	5	—	13.02	8.55
3	—	1.0	9.25	7.85
4	—	0.1	10.22	7.00
5	—	0.3	9.95	8.00
6	5	1.0	9.95	8.68

The results show that in the presence of little or no free carbohydrate, as in (2) and (4) of the table, the ammonia output is slightly increased over that found in the presence of 1 per cent glucose. If protein material in the form of horse serum be present the ammonia output is distinctly higher. This is shown

in (2). When the 5 per cent horse serum is in the presence of 1 per cent glucose, however, no increase in  $\text{NH}_3$  is manifest ((6) in the table) showing that the sugar shields the protein from attack in this instance.

*Experiment III. The protein and carbohydrate metabolism of Streptococcus hemolyticus in broth containing (1) glucose and (2) glucose plus horse-serum<sup>2</sup>*

Three hundred cubic centimeter lots of media of the following composition were prepared from beef infusion broth,  $\text{P}_H$  7.3: (1) 1 per cent glucose broth; (2) 1 per cent glucose, 5 per cent horse serum broth; (3) same as (2).

(1) and (2) were inoculated with 12 cc. of an eighteen-hour, second-generation culture from pleural fluid no. 198 in 1 per cent glucose-broth. (3) was inoculated with an equal amount of an eighteen-hour, first generation culture of the so-called laboratory strain. This culture differs from the pleural fluid culture in that it has been repeatedly transplanted upon artificial culture media since the original isolation, whereas the latter has been passed many times through rabbits. Both cultures were carried in this experiment in order to determine if repeated transplantation upon artificial culture media had brought about changes in the strain which might appear as an alteration of some phase of its metabolism.

The following determinations were carried out upon samples removed with aseptic precautions at intervals of three hours: (1) Bacterial counts; (2)  $\text{P}_H$ ; (3) glucose; (4) ammonia; (5) amino acids; (6) hemotoxin.

The experiment extended through a period of twelve hours. Table 5 contains the experimental data.

The curves of growth, acid<sup>3</sup> formation and glucose utilization in the three cultures are found in figures 2, 3, and 4. It will be

<sup>2</sup> The writer desires to express his appreciation for the assistance rendered by Dr. Marjorie W. Cook and Miss Bernice Rhodes in carrying out this experiment.

<sup>3</sup> The term acid is used to express true acidity in terms of  $\text{P}_H$ .

noted that although a rough parallelism between these factors is shown in the three curves of each culture it is most striking in the pleural fluid culture (fig. 3). Here, particularly in the maximum period, may be seen a close relationship between the curves of growth, acid formation, and glucose utilization. A correspondence of the three factors in the maximum period

TABLE 5  
*Experiment III*

TIME	BACTERIAL COUNT		PH	GLUCOSE		NH <sub>3</sub> , MGM. N PER 100 cc.	AMINO ACIDS, MGM. N PER 100 cc.	HEMOLYSIS
	Per cu. mm.	Log		Per 100 cc.	Utilized			
(1) 1 per cent glucose broth (pleural fluid no. 198)								
0	16,400	4.21	7.30	<i>grams</i> 1.09	<i>mgm.</i> 0	6.01	18.87	0
3	50,700	4.71	7.20	1.172	0	5.73	19.07	0
6	960,000	5.98	6.40	1.007	89	6.57	17.73	purple
9	1,140,000	6.06	5.75	0.955	141	9.93	17.57	+++
12	1,700,000	6.23	5.55	0.935	161	9.79	19.51	0
(2) 1 per cent glucose, 5 per cent horse-serum broth (pleural fluid no. 198)								
0	23,800	4.38	7.35	1.096	0	5.03	19.77	0
3	90,200	4.96	7.20	1.068	28	6.29	18.21	0
6	2,000,000	6.30	5.80	0.941	155	9.93	16.87	++++
9	3,500,000	6.54	5.10	0.877	219	10.49	19.41	++++
12	4,560,000	6.65	4.90	0.847	249	10.07	20.73	0
(3) 1 per cent glucose 5 per cent horse-serum (Laboratory strain)								
0	40,000	4.60	7.35	0.992	0	6.43	19.17	0
3	90,400	4.96	7.20	1.001	0	5.45	20.95	0
6	1,456,090	6.16	5.90	0.862	130	8.67	18.03	++++
9	2,860,000	6.46	4.95	0.722	270	8.25	20.55	++++
12	4,700,000	6.67	4.90	0.728	270	7.69	20.61	0

appears in the other two cultures as well, though it is less striking. In each case it will be observed that a rise in the acidity curve is preceded by a rise in the growth curve. Attention should be directed to the fact that while acid production proceeds most rapidly during the time when the organisms are multiplying at a maximum rate, nevertheless, a considerable lowering of

$P_H$  occurs during the succeeding period when the cells are increasing at a diminishing rate. Stated differently, the curves of growth in each culture depress more sharply from the maximum period than do the curves of glucose utilization and acid formation. Reference to table 5 shows that hemotoxin production commenced in the serum cultures by the sixth hour and persisted

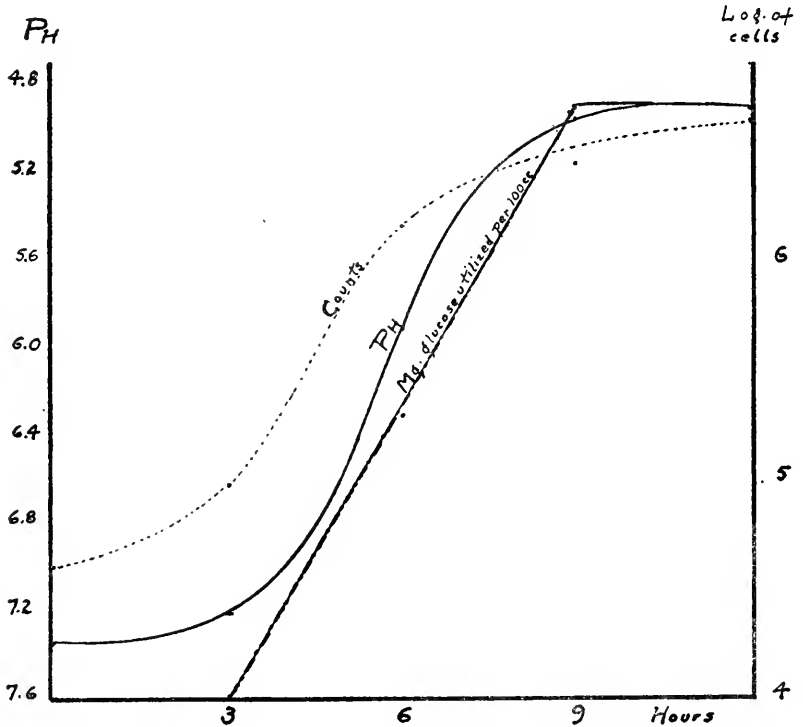

FIG. 2. EXPERIMENT III. CULTURE (1); 1 PER CENT GLUCOSE BROTH

for at least three hours. In the glucose culture however, no definite appearance of hemotoxin was evident until the ninth hour. In each case hemotoxin appears in the period characterized by growth and acid formation at decreasing rates.

Reference to figures 5, 6, and 7 indicates that ammonia production was undergoing a definite increase by the third hour in each of the cultures. This increase in the serum cultures (figs.

6 and 7) was greatest between the third and the sixth hours while in the glucose culture (fig. 5) it was largest between the sixth and the ninth hours. The increase in ammonia output in a general way parallels growth and acid formation during the maximum period in each case. Associated with this increase

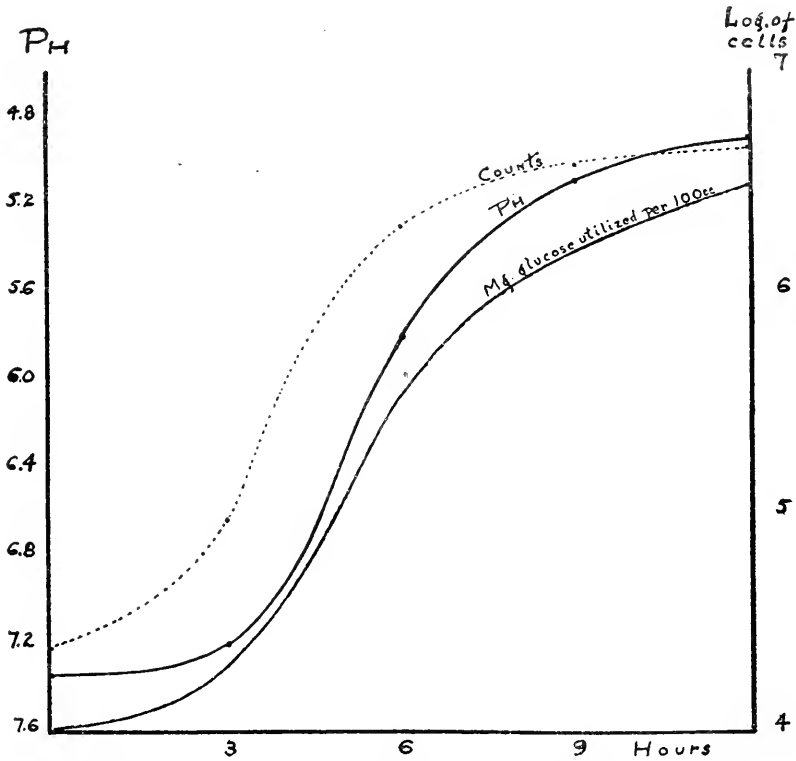

FIG. 3. EXPERIMENT III. CULTURE (2); 1 PER CENT GLUCOSE, 5 PER CENT HORSE SERUM BROTH (PLEURAL FLUID STRAIN)

in the output of ammonia a coincident decrease in amino acid production is evident. In the serum cultures the curves of amino acid output rise sharply at the sixth hour while in the glucose culture the rise is delayed until the ninth hour. The initiation of this rise appears to be in direct correlation with a high point of the ammonia curve.

From the results of this experiment it seems evident that acid formation is closely associated chronologically with growth and active metabolism of the streptococcus. In each of the three cultures we find the maximum period of acid production correlated with maximum rates of growth, and of glucose utilization. These results are not in accordance with the findings on pneu-

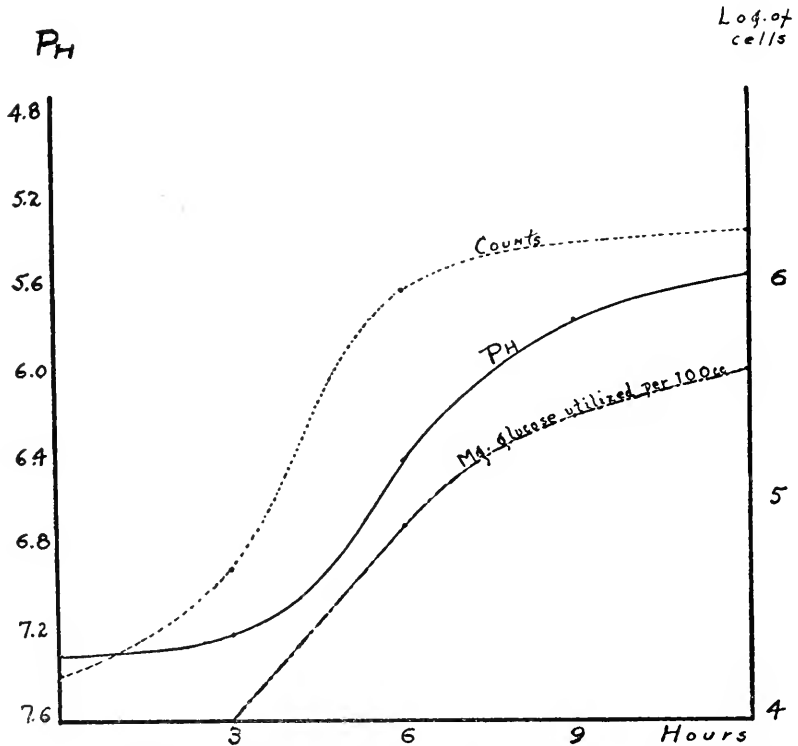

FIG. 4. EXPERIMENT III. CULTURE (3); 1 PER CENT GLUCOSE, 5 PER CENT HORSE SERUM BROTH (LABORATORY STRAIN)

mococci by H. M. Jones (1920) who reported a maximum period of growth correlated with slow acid formation, whereas the maximum period of acid production occurred during the time when the organisms were multiplying at a diminishing rate.

In a study of the nitrogen metabolism of actinomyces, Waksman (1920) concluded that the production of amino acids



is not a waste process resulting from growth but that it represents a definite step in the metabolism of the organisms. In his experiments amino acids did not accumulate in the medium until after the organism had made its growth. In explanation Waksman suggests two possibilities; either (1) the growing cells utilized the amino acids as rapidly as the latter were formed,

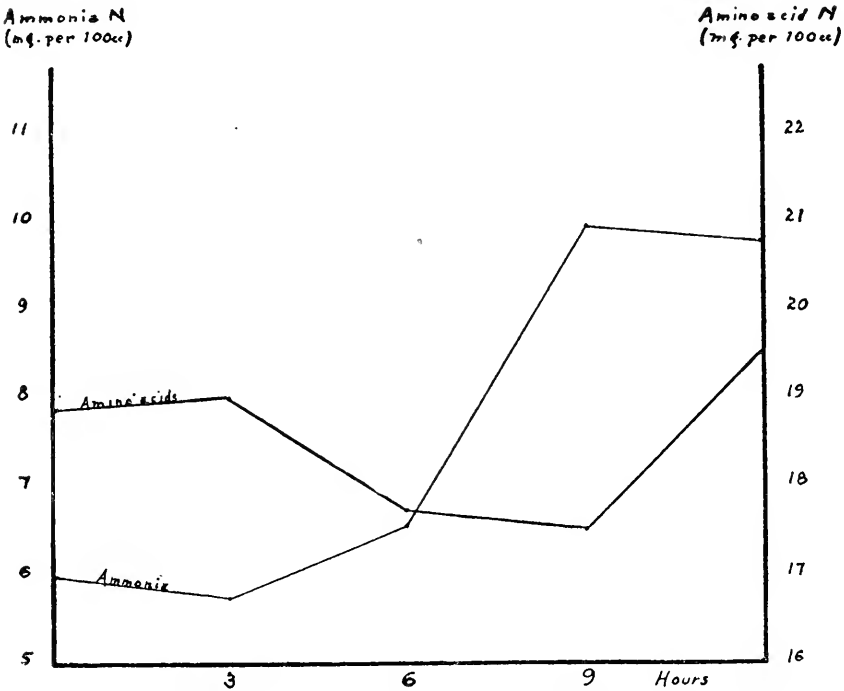

FIG. 5. EXPERIMENT III; CULTURE (1); 1 PER CENT GLUCOSE BROTH

or (2) the proteolytic enzyme necessary for their elaboration appeared only in the later stages of growth. Attention has been called to the fact that the curves of amino acid formation in experiment III exhibit a rise at the sixth or the ninth hour which would correspond to the findings of Waksman on the actinomycetes. Examination of the growth curves (figs. 2, 3, 4) at this point shows that the maximum period has just been passed and that the organisms are now multiplying at a diminishing

rate. As a consequence the amino acid intake of the cells is reduced to a low level. This would account for the increased output in the medium. It has been pointed out that the rise in ammonia production in each culture, starting at the third hour, is correlated with a drop in the amino acid curve (figs. 5, 6, 7). The most probable explanation of this finding rests

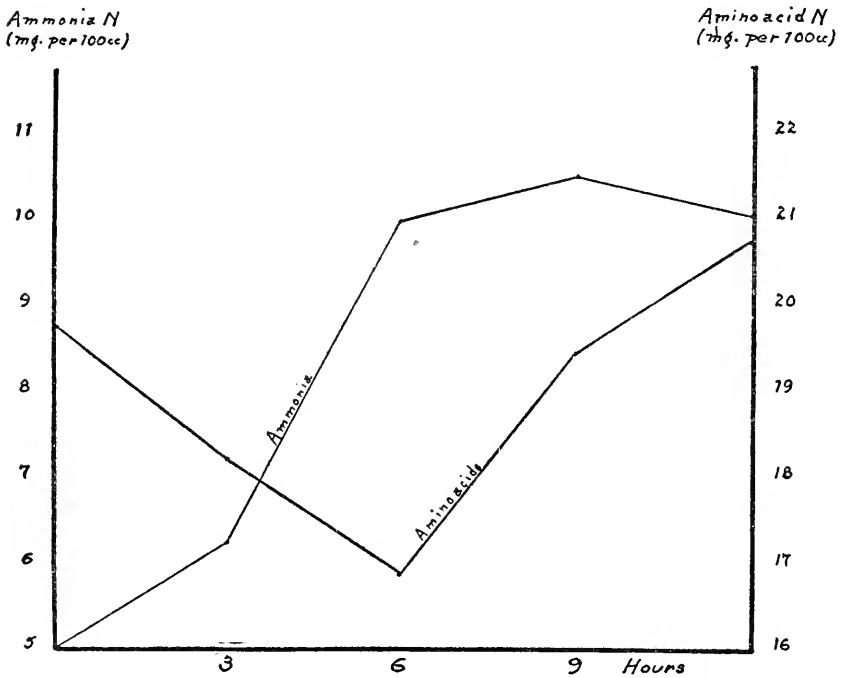

FIG. 6. EXPERIMENT III. CULTURE (2); 1 PER CENT GLUCOSE, 5 PER CENT HORSE SERUM BROTH (PLEURAL FLUID STRAIN)

upon the supposition that during the early life of the culture amino acids are utilized by the cells for structural purposes thus reducing their concentration in the medium. As more amino acid nitrogen is assimilated, a larger amount of ammonia is split off intracellularly. This is evidenced by a rise in the curves of ammonia production during this period. Such an hypothesis is in accord with the theory of Kendall and Walker (1915) that

ammonia formation is the result of intracellular deamination of assimilated protein material.

Wolf and Harris (1917b) in their study of the biochemistry of *Clostridium welchii* and *C. sporogenes* noted in cultures grown in a medium of high amino acid content that at the close of the experiment the concentration of amino acids was less than at the begin-

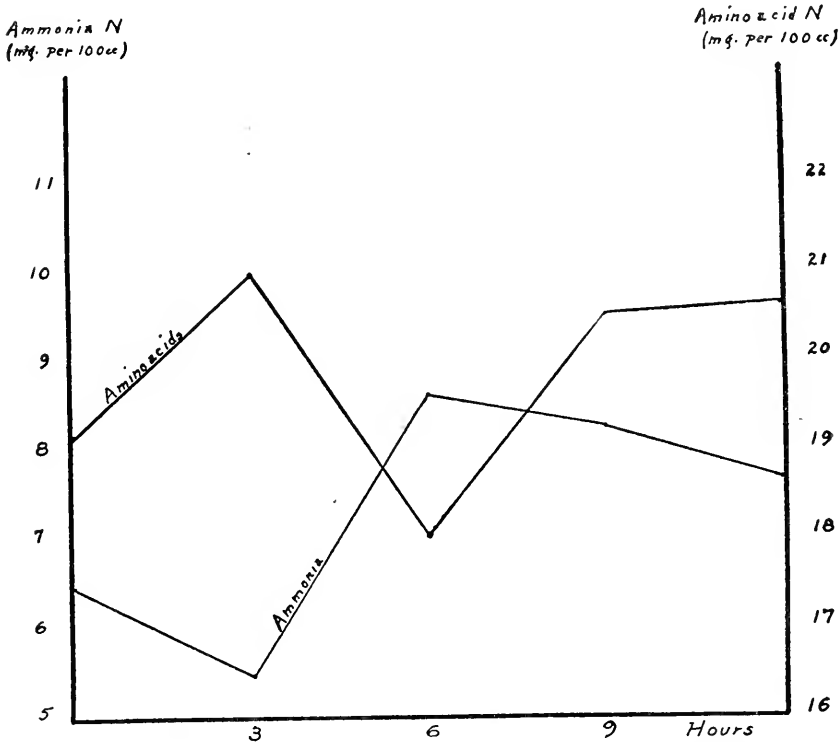

FIG. 7. EXPERIMENT III. CULTURE (3); 1 PER CENT GLUCOSE, 5 PER CENT HORSE SERUM BROTH (LABORATORY STRAIN)

ning. This indicates that these substances were assimilated by the growing organisms and destroyed through deamination.

Reference to figures 6 and 7 reveals a very decided difference in nitrogen metabolism in the two serum cultures during the initial three-hour period. The pleural fluid culture exhibited a definite decrease in amino acid output correlated with an increased

ammonia formation, whereas the laboratory culture showed a decided increase in amino acid output coupled with a slight decrease in ammonia excretion. Whether or not this deviation represents a permanently altered aspect of metabolism on the part of the laboratory strain must for the present remain undecided. It may be that through continued cultivation upon artificial media the organism has gained the ability to inaugurate proteolysis earlier. Such a conclusion would be opposed to the finding of Rosenthal and Patai (1914) that avirulent streptococci were less strongly proteolytic than cultures of the same strain the virulence of which had been increased by animal passage. In the present experiment the curves of nitrogen metabolism (figs. 6 and 7) show the same general features from the third hour to the end of the period of observation. No differences in the growth, acid formation, or glucose utilization were evident in the two cultures throughout the entire period of the experiment.

#### SUMMARY AND CONCLUSIONS

1. Lactic acid appears to be the principal acid formed by *Streptococcus hemolyticus* in its fermentation of glucose broth. A smaller proportion of volatile acids is formed. This fraction is made up chiefly of acetic, with perhaps a trace of formic acid.
2. A quantitative study of the ammonia excretion of the streptococcus indicates that a "protein sparing" action occurs in media containing available sugar to meet the energy requirement of the developing cells.
3. The maximum periods of glucose utilization and acid formation in glucose and in glucose-serum broth are correlated with growth at a maximum rate, though a considerable lowering of  $P_{H}$  occurs during the period when growth proceeds at a diminishing rate.
4. The greatest increase in output of ammonia is correlated in a general way with the maximum periods of growth, glucose utilization, and acid formation. Associated with this increased output of ammonia a corresponding decrease in amino acids is evident. This condition seems to be associated with the interval

in which the organisms are making their growth. During this period, in which it may be presumed that anabolic processes are actively under way, the organisms are utilizing amino acids for structural purposes. This would cause the latter to decrease in concentration in the medium and furthermore would produce an increased excretion of ammonia through the katabolism of a part of the absorbed amino acids.

5. Subsequent to the period in which the organisms have made their growth a rise in the curves of amino acid formation is manifest. In the cultures containing horse serum this rise is initiated by the sixth hour; in the glucose culture it appears by the ninth hour. A decrease in ammonia output, in general, accompanies the rise in amino acid formation. These findings indicate that a decreased utilization of nitrogenous materials ensues after the organism has passed its maximum period of growth, despite the fact that proteolysis continues.

6. A marked difference in nitrogen metabolism between a passage strain and a laboratory strain of *Streptococcus hemolyticus* is noted during the first three hours of incubation in glucose serum broth. Whereas the passage strain shows a definite decrease in amino acid output coupled with an increased ammonia excretion, the laboratory strain exhibits a decided increase in amino acid output coincident with a slight decrease in ammonia formation. Whether or not this represents a permanent deviation in metabolism resulting from continued transplantation upon artificial culture media is a question that for the present must remain undecided.

#### REFERENCES

- ANTHONY, B. V. A., AND EKROTH, C. V. 1916 Practical observations on titration and adjustment of culture media. *J. Bact.*, **1**, 209.
- AVERY, O. T., AND CULLEN, G. E. 1919a The use of final hydrogen-ion concentration in differentiation of *Streptococcus hemolyticus* of human and bovine types. *J. Exper. M.*, **29**, 215.
- AVERY, O. T., AND CULLEN, G. E. 1919b Hydrogen-ion concentration of cultures of pneumococci of the different types in carbohydrate media. *J. Exper. M.*, **30**, 359.
- AYERS, S. H. 1916 Hydrogen-ion concentration in cultures of streptococci. *J. Bact.*, **1**, 84.

- AYERS, S. H., JOHNSON, W. T., AND DAVIS, B. J. 1918 The thermal death point and limiting hydrogen-ion concentration of pathogenic streptococci. *J. Infect. Dis.*, **23**, 290.
- AYERS, S. H., AND RUPP, P. 1918 Simultaneous acid and alkaline bacterial fermentations from dextrose and the salts of organic acids respectively. *J. Infect. Dis.*, **23**, 188.
- BARBER, M. A. 1908 The rate of multiplication of *B. coli* at different temperatures. *J. Infect. Dis.*, **5**, 379.
- BARNETT, G. D., AND CHAPMAN, H. S. 1918 Colorimetric determination of the reaction of bacteriological mediums and other fluids. *J. Am. M. Ass.*, **70**, 1062.
- BIAL, M. 1902 Ueber die antiseptische Funktion des H Ions verdünnter Säuren. *Ztschr. f. physik. Chem.*, **40**, 513.
- BRONFENBRENNER, J., AND SCHLESINGER, M. J. 1918 Carbohydrate fermentation by bacteria as influenced by the composition of the medium. *Proc. Soc. Exper. Biol. and Med.*, **16**, 44.
- BROWN, J. H. 1920 Cultural differentiation of beta hemolytic streptococci of human and bovine origin. *J. Exper. M.*, **31**, 35.
- BROWNE, WM. W. 1914 The production of acid by the *Bacillus coli* group. *J. Infect. Dis.*, **15**, 580.
- BUCHANAN, R. E. 1918 Life phases in a bacterial culture. *J. Infect. Dis.*, **23**, 109.
- BUCHNER, H., LONGARD, K., AND RIEDLIN, G. 1887 Ueber die Vermehrungsgeschwindigkeit der Bacterien. *Centralbl. f. Bakteriol.*, **ii**, 1 (ref.).
- BUNKER, J. W. M. 1916-17 Some effects of hydrogen-ion concentration of media on the behavior of the diphtheria bacillus in culture. *Abstracts of Bact.*, **1**, 31.
- BUNKER, J. W. M. 1919 Studies of the diphtheria bacillus in culture. *J. Bact.*, **4**, 379.
- CHESNEY, A. M. 1916 The latent period in growth of bacteria. *J. Exper. M.*, **24**, 387.
- CLARK, J. F. 1899 On the toxic effect of deleterious agents on the germination and development of certain filamentous fungi. *Bot. Gaz.*, **28**, 289, also 378.
- CLARK, W. M. 1915a The "reaction" of bacteriologic culture media. *J. Infect. Dis.*, **17**, 109.
- CLARK, W. M. 1915b The final hydrogen-ion concentration of cultures of *B. coli*. *J. Biol. Chem.*, **22**, 87.
- CLARK, W. M. 1917 The acid production of *B. bulgaricus*. *Proc. Soc. Am. Bact.*, *Abst. Bact.*, **1**, 59.
- CLARK, W. M., AND COHEN, B. 1918 The influence of the hydrogen-ion concentration of media upon reproduction of some common bacteria. *Soc. Am. Bact. Proc.*
- CLARK, W. M., AND COHEN, B. 1919 The growth of certain bacteria in media of different hydrogen-ion concentration. *J. Bact.*, **4**, 409.
- CLARK, W. M., AND LUBS, H. 1915 The differentiation of bacteria of the colon-aerogenes family by means of indicators. *J. Infect. Dis.*, **17**, 160.

- CLARK, W. M., AND LUBS, H. 1916a Buffer mixtures and methods used in determining PH values. *J. Biol. Chem.*, **25**, 479.
- CLARK, W. M., AND LUBS, H. 1916b The colorimetric determination of the hydrogen-ion concentration of bacteriologic culture media. *J. Wash. Acad. Sc.*, **6**, 483.
- CLARK, W. M., AND LUBS, H. 1917a The colorimetric determination of hydrogen-ion concentration and its applications in bacteriology. (I.) *J. Bact.*, **2**, 1.
- CLARK, W. M., AND LUBS, H. 1917b The colorimetric determination of hydrogen-ion concentration and its applications in bacteriology. (II.) *J. Bact.*, **2**, 10.
- CLARK, W. M., AND LUBS, H. 1917c The colorimetric determination of hydrogen-ion concentration and its applications in bacteriology. (III.) *J. Bact.*, **2**, 191.
- COLE, S. W., AND LLOYD, D. J. 1917 The preparation of solid and liquid media for the cultivation of the gonococcus. *J. Path. and Bacteriol.*, **21**, 267.
- COLE, S. W., AND ONSLOW, H. 1916 On a rapid method for the cultural differentiation of the typhoid and paratyphoid bacilli A and B. *Lancet*, **191**, 1011.
- COOK, F. C., AND LEFEVRE, E. 1918 Chemical analyses of bacteriological bouillons. *Am. J. Pub. Health*, **8**, 587.
- COPLANS, M. 1909 Influences affecting growth of microorganisms—latency: inhibition; mass action. *J. Path. and Bacteriol.*, **14**, 1.
- CULLEN, G. E., AND CHESNEY, A. M. 1918 A note on the production of acid by pneumococci. *J. Exper. M.*, **28**, 289.
- DAVIS, L. 1917 An investigation of the chemical composition and biologic availability of peptone. *J. Lab. and Clin. M.*, **3**, 75.
- DAVIS, L. 1918 Studies on diphtheria toxin. *J. Lab. and Clin. M.*, **3**, 358.
- DAVIS, L. 1920 Some important factors in the preparation of culture media. *Am. J. Pub. Health*, **10**, 250.
- DEELEMAN, M. 1897 Der Einfluss der Reaktion des Nährbodens auf das Bakterienwachstum. *Arb. a. d. k. Gsndtsamte*, **13**, 374.
- DERNBY, K. G., AND AVERY, O. T. 1918 Optimum hydrogen-ion concentration for growth of pneumococcus. *J. Exper. M.*, **28**, 345.
- DUCLAUX, E. 1900 *Traité de microbiologie*. Tome III, Chapitre XX.
- DYER, D. C. 1916 A new method of steam distillation for the determination of the volatile fatty acids, including a series of colorimetric qualitative reactions for their identification. *J. Biol. Chem.*, **28**, 445.
- EMMERLING, O. 1896 Beitrag zur Kenntniss der Eiweissfaulniss. *Ber. d. deutsch. Chem. Gesellsch.*, **29**, 3, 2721.
- FENNEL, E. A., AND FISHER, M. B. 1919 Adjustment of reaction of culture mediums. *J. Infect. Dis.*, **25**, 444.
- FOLIN, O., AND FARMER, C. J. 1912 A new method for the determination of total nitrogen in urine. *J. Biol. Chem.*, **11**, 493.
- FOLIN, O., AND MACALLUM, A. B. 1912 On the determination of ammonia in urine. *J. Biol. Chem.*, **11**, 523.

- FRED, E. B., AND LOOMIS, N. E. 1917 The influence of hydrogen-ion concentration of the medium on reproduction of alfalfa bacteria. *J. Bact.*, **2**, 629.
- FRED, E. B., PETERSON, W. H., AND DAVENPORT, A. 1919 Acid fermentation of xylose. *J. Biol. Chem.*, **39**, 347.
- FRIEDENTHAL, H. 1904 Die Bestimmung der Reaktion einer Flüssigkeit mit Hilfe von Indikatoren. *Ztschr. f. Elektrochem.*, **10**, 113.
- GAY, F. P., AND STONE, R. L. 1920 Experimental streptococcus empyema. *J. Infect. Dis.*, **26**, 265.
- GILLESPIE, L. J. 1916 The reaction of soil and measurements of hydrogen-ion concentration. *J. Wash. Acad. Sc.*, **6**, 7.
- GILLESPIE, L. J. 1918 The growth of the potato scab organism at various hydrogen-ion concentrations as related to the comparative freedom of acid soils from the potato scab. *Phytopathology*, **8**, 257.
- GRACE, L. G., AND HIGHBERGER, F. 1920a Acid production by *Streptococcus viridans* in mediums of different hydrogen-ion concentration. *J. Infect. Dis.*, **26**, 451.
- GRACE, L. G., AND HIGHBERGER, F. 1920b Variations in the hydrogen-ion concentration in uninoculated culture media. *J. Infect. Dis.*, **26**, 457.
- HAAS, A. R. C. 1919 Colorimetric determination of the hydrogen-ion concentration in small quantities of solution. *J. Biol. Chem.*, **38**, 49.
- HAWK, P. B. 1918 Practical Physiological Chemistry, 6th edition, p. 550.
- HENDERSON, L. J., AND WEBSTER, H. B. 1907 Preservation of neutrality in culture media with the aid of phosphates. *J. Med. Research*, **16**, 1.
- HESSE, GUST. 1904 Beiträge zur Herstellung von Nährböden und zur Bakterienzüchtung. *Ztschr. f. Hyg. u. Infektionskrankh.*, **46**, 1.
- HURWITZ, S. H., MEYER, K. F., AND OSTENBERG, Z. 1915 On a colorimetric method of adjusting bacteriological culture media to any optimum hydrogen-ion concentration. *Proc. Soc. Exper. Biol. and Med.*, **13**, 24.
- HURWITZ, S. H., MEYER, K. F., AND OSTENBERG, Z. 1916 A colorimetric method for the determination of the hydrogen-ion concentration of biological fluids with special reference to adjustment of bacteriological culture media. *Johns Hopkins Hosp. Bull.*, **27**, 16.
- ITANO, ARAO 1916a I. The relation of hydrogen-ion concentration of media to the proteolytic activity of *Bacillus subtilis*. *Mass. Agr. Exp. Station Bull.*, 167.
- ITANO, ARAO 1916b II. Effect of hydrogen-ion concentration of media upon the proteoclastic activity in *Streptococcus lacticus*, *Streptococcus erysipelatos*. *Mass. Agr. Exp. Station Bull.*, 167.
- JONES, H. 1920 Some factors influencing the final hydrogen-ion concentration in bacterial cultures with special reference to streptococci. *J. Infect. Dis.*, **26**, 160.
- JONES, H. M. 1920 The limiting hydrogen-ion concentration of various types of pneumococci. *J. Infect. Dis.*, **26**, 435.
- KENDALL, A. I. 1916 Bacteriology: General, Pathological, Intestinal.
- KENDALL, A. I., DAY, A. A., AND WALKER, A. W. 1913a Studies in bacterial metabolism XIII-XXX. *J. Am. Chem. Soc.*, **35**, 1201.



- KENDALL, A. I., DAY, A. A., AND WALKER, A. W. 1913b Studies in bacterial metabolism X. *J. Infect. Dis.*, **13**, 425.
- KENDALL, A. I., AND FARMER, C. J. 1912a Studies in bacterial metabolism I. *J. Biol. Chem.*, **12**, 13.
- KENDALL, A. I., AND FARMER, C. J. 1912b Studies in bacterial metabolism II. *J. Biol. Chem.*, **12**, 19.
- KENDALL, A. I., AND FARMER, C. J. 1912c Studies in bacterial metabolism III. *J. Biol. Chem.*, **12**, 215.
- KENDALL, A. I., AND FARMER, C. J. 1912d Studies in bacterial metabolism VII. *J. Biol. Chem.*, **13**, 63.
- KENDALL, A. I., FARMER, C. J., BAGG, E. P., AND DAY, A. A. 1912 Studies in bacterial metabolism IV. *J. Biol. Chem.*, **12**, 219.
- KENDALL, A. I., AND WALKER, A. W. 1913 Studies in bacterial metabolism XI. *J. Biol. Chem.*, **15**, 277.
- KENDALL, A. I., AND WALKER, A. W. 1915 Studies in bacterial metabolism XL. *J. Infect. Dis.*, **17**, 442.
- KITASATO, S. 1888 Über das Verhalten der Typhus u. Cholera bacillen zu säure oder alkalihaltigen Nährböden. *Ztschr. f. Hyg.*, **3**, 404.
- KLIGLER, I. J. 1916 Some regulating factors in bacterial metabolism. *J. Bact.*, **1**, 663.
- KLIGLER, I. J. 1917 Effect of hydrogen-ion concentration on the production of precipitates in a solution of peptone and its relation to nutritive value of media. *J. Bact.*, **2**, 351.
- KLIGLER, I. J. 1918 Modifications of culture media used in the isolation and differentiation of typhoid, dysentery, and allied bacilli. *J. Exper. M.*, **28**, 319.
- KLIGLER, I. J. 1919 Growth accessory substances for pathogenic bacteria in animal tissues. *J. Exper. M.*, **30**, 31.
- KRÖNIG, B., AND PAUL, T. 1897 Die chemischen Grundlagen der Lehre von der Giftwirkung and Desinfection. *Ztschr. f. Hyg. u. Infektionskrankh.*, **25**, 1.
- LANE-CLAYTON, J. E. 1909 Multiplication of bacteria and the influence of temperature and some other conditions thereon. *J. Hyg.*, **9**, 239.
- LAZARUS, E. 1908 Sur la reaction des milieux pour la bacterie de davaine. *Compt. rend. Soc. de Biol.*, **65**, 730.
- LEDINGHAM, J. C. G., AND PENFOLD, W. J. 1914 Mathematical analysis of the lag phase in bacterial growth. *J. Hyg.*, **14**, 242.
- LEVY, R. L., ROWNTREE, L. C., AND MARIOTT, W. McK. 1915 A simple method for determining variations in the hydrogen-ion concentration of the blood. *Arch. Int. Med.*, **16**, 389.
- LORD, F. T. 1919 The relation of the pneumococcus to the production of acid in fluid culture mediums and the reaction of the pneumonic lung. *J. Am. M. Ass.*, **72**, 2, 1364.
- LORD, F. T., AND NYE, R. N. 1919 The relation of the pneumococcus to hydrogen-ion concentration, acid death point, and dissolution of the organism. *J. Exper. M.*, **30**, 389.
- LUBS, H., AND CLARK, Wm. M. 1915 On some new indicators for the colorimetric determination of hydrogen-ion concentration. *J. Wash. Acad. Sci.*, **5**, 609.

- LUBS, H., AND CLARK, WM. M. 1916 A note on the sulphone-phthaleins as indicators for the colorimetric determination of hydrogen-ion concentration. *J. Wash. Acad. Sci.*, **6**, 481.
- MATHEWS, A. 1916 *Physiological Chemistry*. 2nd edition, Chapter II.
- McLENDON, J. F. 1916 Buffer mixtures, standard tubes, and colorimeter for hydrogen-ion determination in sea water. *J. Biol. Chem.*, **23**, XXX.
- MEYER, K. F., AND STICHEL, J. E. 1918 A comparative study of the efficacy of the various agar-dye-mediums recommended for the isolation of typhoid and dysentery bacilli from feces. *J. Infect. Dis.*, **23**, 53.
- MICHAELIS, L. 1914 *Die Wasserstoffionenkonzentration*. Berlin.
- MICHAELIS, L., AND MARCORA, F. 1912 Die Säure produktivität des *Bacterium coli*. *Ztschr. f. Immunitätsforsch. u. exper. Therap.*, **14**, 170.
- MUDGE, C. 1917 Effect of sterilization upon sugars in culture media. *J. Bact.*, **2**, 403.
- MÜLLER, MAX 1896 Ueber den Einfluss von Fiebertemperaturen auf die Wachstumsgeschwindigkeit und die Virulenz des Typhusbacillus. *Ztschr. f. Hyg. u. Infektionskrankh.*, **20**, 245.
- NATVIG, A. 1909 Cited by E. Sachs in *Ztschr. f. Hyg. u. Infektionskrankh.*, **63**, 463.
- NORTON, J. F. 1919 Notes on the reactions of bacteriologic media. *Am. J. Pub. Health*, **9**, 190.
- NORTON, J. F., AND HSU, P. H. 1916 The physical chemistry of disinfection. *J. Infect. Dis.*, **18**, 180.
- NOYES, H. A. 1916 Acidity of media. *J. Bact.*, **1**, 87.
- PAUL, T., BIRSTEIN, G., AND REUSS, A. 1910a Beiträge zur Kinetik der Giftwirkung von gelösten Stoffen. *Biochem. Ztschr.*, **29**, 202.
- PAUL, T., BIRSTEIN, G., AND REUSS, A. 1910b Einfluss der Neutralsalze und der Temperatur auf die Desinfektionsgeschwindigkeit von Säuren. *Biochem. Ztschr.*, **29**, 249.
- PAUL, T., AND KRÖNIG, B. 1896 Ueber das Verhalten der Bakterien zu chemischen Reagentien. *Ztschr. f. physik. Chem.*, **21**, 414.
- PENFOLD, W. J. 1914 On the nature of bacterial lag. *J. Hyg.*, **14**, 215.
- PICK, E. P. 1898 Untersuchungen neues Verfahren zur Trennung von Albumosen und Peptones. *Ztschr. f. physiol. Chem.*, **24**, 246.
- RAHN, O. 1906 Ueber den Einfluss von Stoffwechselproducte auf das Wachstum der Bakterien. *Centralbl. f. Bakteriol.*, **II**, 16, 417.
- RETTGER, L. F., BERMAN, N., AND STURGES, W. S. 1916 Utilization of protein and non-protein nitrogen by bacteria. *J. Bact.*, **1**, 15.
- ROBERTSON, T. B. 1918 *The Physical Chemistry of the Proteins*.
- ROSENTHAL, E., AND PATAI, J. A. 1914 Ueber die proteolytische Aktivität von Streptokokken, Staphylokokken und *Coli* Kulturen. *Centralbl. f. Bakteriol. (Orig.)*, **73**, 406.
- SALM, E. 1904 Die Bestimmung des H- Gehaltes einer Lösung mit Hilfe von Indikatoren. *Ztschr. f. Elektrochem.*, **10**, 341.
- SALM, E., AND FRIEDENTHAL, H. 1907 Zur kenntnis der acidimetrischen und alkalimetrischen Indikatoren. *Ztschr. f. Elektrochem.*, **13**, 125.
- SALTER, R. 1919 The rate of growth of *B. coli*. *J. Infect. Dis.*, **24**, 260.

- SCHOENHOLZ, P., AND MEYER, K. F. 1919 The optimum hydrogen-ion concentration for the growth of *B. typhosus* and the effect of changes in hydrogen-ion concentration on the generation time. Proc. Soc. for Exper. Biol. and Med., **16**, 151.
- SEKIGUCHI, S. 1917 Some observations on hemolysin and acid produced by streptococci. J. Infect. Dis., **21**, 475.
- SHOHL, A. T., AND JANNEY, J. H. 1917 The growth of *B. coli* in urine at varying hydrogen-ion concentrations. J. Urology, **1**, 211.
- SLATOR, A. 1916 The rate of growth of bacteria. Trans. Chem. Soc., **109**, 1, 2.
- SLATOR, A. 1917 A note on the lag phase in growth of microorganisms. J. Hyg., **16**, 100.
- SÖRENSEN, S. P. L. 1912 Über die Messung und Bedeutung der Wasserstoffionenkonzentration bei biologischen Prozessen. Ergebn. Physiol., **12**, 393.
- SÖRENSEN, S. P. L. 1909a Etudes enzymatiques II. Sur la mesure et l'importance de la concentration des ions hydrogène dans les reactions enzymatiques. Compt. rendu Lab. Carlsberg, **8**, 1 and 396.
- SÖRENSEN, S. P. L. 1909b Ueber die Messung und die Bedeutung der Wasserstoffionenkonzentration bei enzymatischen Prozessen. Biochem. Ztschr., **21**, 131 and 201.
- SPEAKMAN, H. B. 1920 Biochemistry of the acetone and butyl alcohol fermentation of starch by *B. granulobacter pectinovorum*. J. Biol. Chem., **41**, 319.
- TAYLOR, K. 1917 Specificity in antiseptics. Lancet, **2**, 192, 294.
- THRO, W. C. 1915 Further experiments on variability of the fermentative reaction of bacteria, especially the streptococci. J. Infect. Dis., **17**, 228.
- TISSIER, H., AND MARTELLY 1902 Recherches sur la putrefaction de la viande de boucherie. Ann. de l'Inst. Pasteur, **16**, 865.
- WAKSMAN, S. A. 1920 Studies in the metabolism of actinomycetes. J. Bact., **5**, 1.
- WAKSMAN, S. A., AND JOFFE, J. S. 1920 Changes in reaction as a result of the growth of actinomycetes upon culture media. J. Bact., **5**, 31.
- WALPOLE, G. S. 1911 Chart presentation on recent work on indicators. Bio-Chem. J., **5**, 207.
- WINSLOW, C.-E. A., AND LOCKRIDGE, E. E. 1906 The toxic effect of certain acids upon typhoid and colon bacilli in relation to the degree of their dissociation. J. Infect. Dis., **3**, 547.
- WOLF, C. G. L., AND HARRIS, J. E. G. 1917a The effect of acids upon the growth of *B. welchii* (*B. perfringens*) and *B. sporogenes* (Metchnikoff). Biochem. J., **11**, 213.
- WOLF, C. G. L., AND HARRIS, J. E. G. 1917b The biochemistry of *B. welchii* and *B. sporogenes*. J. Path. and Bacteriol., **21**, 386.
- WOLF, C. G. L., AND TELFER, S. V. 1917 The acid production of *B. welchii* and *B. sporogenes*. Bio-Chem. J., **11**, 197.
- WRIGHT, J. H. 1917 Importance of uniform culture media in bacteriological examination of disinfectants. J. Bact., **2**, 315.
- WYETH, F. J. S. 1918 The effect of acids on the growth of *B. coli*. Bio-Chem. J., **12**, 382.



# NOTES ON THE FLAGELLATION OF THE NODULE BACTERIA OF LEGUMINOSAE

IVAN V. SHUNK

*Department of Botany, North Carolina State College*

Received for publication August 29, 1920

For many years it has been known that the nodule bacteria of Leguminosae are motile. Some early reports give the number of flagella as one, other reports describe several. From time to time some addition has been made to our knowledge of the flagellation of these organisms. Since the information on this point has been rather fragmentary and somewhat uncertain, the writer began the study of the flagellation of the nodule bacteria from a considerable number of host plants in the spring of 1920.

Different workers, using bacteria from different host plants, have found in some cases a single flagellum and in other cases several peritrichic flagella, and in a number of instances it has been assumed because the ones under observation were of a certain type, that therefore all nodule bacteria were similar to the ones studied. This point together with the general paucity of information on the flagellation of legume bacteria is well brought out by the following brief historical review of all available published reports.

Smith (1900) reported a single terminal flagellum about two  $\mu$  long bearing at the end a tuft like the lash of a whip. He does not state the source of his organism.

DeRossi (1907) found a single flagellum on organisms from *Vicia faba*. He later (1920) reported the organism to be a true Bacillus with several flagella, but it is not clear from his account what host plants furnished the bacteria except that *Trifolium repens* was one of those used.

Harrison and Barlow (1907) reported a single polar flagellum on the organisms from *Lathyrus sativus* and *Vicia villosa* but their method of staining was such that only the slime and mucilage around the bacteria were stained, leaving the bacteria themselves unstained.

Zipfel (1912) reported numerous peritrichic flagella, but did not state the source of his organisms.

Kellerman (1912) reported numerous peritrichic flagella on the organisms from *Phaseolus lunatus*, *Medicago sativa* and *Pisum sativum*.

Burrill and Hansen (1917) have given us the most extensive information on the question of the flagellation of this group. They reported a single flagellum on organisms from *Vigna sinensis*, *Glycine hispida*, *Acacia floribunda*, *Arachis hypogaea*, *Baptisia tinctoria*, *Genista tinctoria*, *Cassia chaemacrista*, *Amphicarpa monoica*, *Lespedeza striata*, *Desmodium canescens*, and *Mucuna utilis*.

Fred (1918) has found on the alfalfa organism several peritrichic flagella and on the lupine organism one or rarely two.

Prucha (1915) has found several flagella on the organism from the Canada field pea.

Wilson (1917) reported as many as four flagella on the soy bean organism.

Hansen (1919) has found peritrichic flagella on the organisms from *Trifolium pratense*, *Vicia villosa*, and *Mehilotus alba*.

Much of the difficulty in staining the flagella of these bacteria has been and still is due to the amount of slime that is produced by these organisms. Some produce slime more abundantly than others, and in some cases the mass of bacteria is so viscid that it may be drawn out in a string in making transfers.

#### METHOD OF ISOLATION

The roots of various leguminous plants were dug and carefully washed in running tap water. Small pieces of roots bearing nodules were then removed leaving enough root attached to aid in handling. These nodules were allowed to stand in tap water

for a few minutes after washing. With a pair of forceps a nodule was then placed in a disinfecting solution prepared by adding 2.5 cc. of concentrated hydrochloric acid to 500 cc. of a 1:500 corrosive sublimate solution and allowed to remain in this solution for one and a half to two minutes. It was then removed with a pair of flamed forceps, rinsed in sterile tap water, and placed in a drop or two of sterile tap water in the center of a sterile Petri dish. The nodule was crushed by using a flamed and cooled glass rod, after which a tube of sucrose agar which had been melted and properly cooled was added, and thoroughly mixed. The sucrose medium just referred to was made as follows:

Monobasic potassium phosphate . . . . .	1.0 gram
Magnesium sulphate . . . . .	0.5 gram
Sucrose . . . . .	10.0 grams
Tapwater . . . . .	1000.0 cc.
Agar . . . . .	10.0 or 15.0 grams

At first no attempt was made to adjust reaction, but as the growth on this medium was so slow most of the media used were adjusted to pH 7.0-7.4 using the colorimetric method.

Several plates were made at each time, thus insuring good distribution of colonies in at least one of the plates. All plates were kept at room temperatures. After the colonies developed transfers were made either to the same sucrose medium or to a similar medium, containing 10 grams of mannitol in place of the sucrose. The mannitol media were used almost exclusively for maintaining the organisms after transfer from the isolation plates.

#### METHOD OF STAINING FLAGELLA

The staining method used was a modification of Loeffler's flagella stain suggested by the writer in a previous paper (1920). Bacteria from a slant on mannitol or sucrose agar were removed and placed in a small quantity of sterile tap water in a test tube. Several small droplets of this suspension were, after a few minutes, placed on a well cleaned cover glass and allowed to air dry. About five drops of Mordant solution A were placed on the cover glass as soon as the droplets had dried, and this was followed

immediately by one or two drops of solution B. The combination was allowed to act at room temperature for two minutes, washed in distilled water and the stain applied for two minutes. The excess stain was washed off with water and the cover glass preparation dried and mounted in balsam.

#### RESULTS OF STAINING

The age of cultures of the organism from different legume host plants made a considerable difference in the staining reaction. It was sometimes necessary on this account to try cultures of varying ages before successfully staining the flagella. The following table contains the data bearing on the source of the cultures, their age at time of staining, and the number of flagella.

#### DISCUSSION

Manifestly the flagellation of the legume nodule bacteria is of two types, the single flagellate type and the peritrichic. In every case in which the organisms possessed more than one flagellum the arrangement was peritrichic and in the case of those with a single flagellum it was usually attached at the corner rather than exactly at the end. This corner arrangement seems to characterize the single flagellate type. In the case of organisms of this type, more than one flagellum was never found, and enough organisms were observed in each case so that there is no doubt that one is the correct number, and that it is an entirely different organism from the peritrichic type. Due to the breaking off of flagella in handling, bacteria of the peritrichic type showed an occasional organism with only one flagellum. For the most part the peritrichic flagella were longer than the single flagella and there was a tendency for the single flagella to be of greater diameter than those of the other type.

The present findings are in accord with those of Hansen (1919) who has suggested that since the organisms from different legumes have in some cases one flagellum, and in others several flagella, we have really two groups of organisms based on these differences of flagellation. Conn (1920) is of the opinion that the



TABLE I  
Flagellation of legume nodule bacteria

HOST PLANT	AGE OF CULTURE	NUMBER OF FLAGELLA
	<i>days</i>	
<i>Vicia angustifolia</i> (smaller common vetch) . . . . .	2	3 to 4
<i>Vicia dasycarpa</i> (vetch) . . . . .	4	3 to 4
<i>Vicia hirsuta</i> (tinweed or vetch) . . . . .	4	2 to 4
<i>Vicia alba</i> (vetch) . . . . .	1	3 to 5
<i>Vicia sativa</i> (common vetch) . . . . .	3	1 to 6
<i>Vicia villosa</i> (hairy vetch) . . . . .	4	1 to 4
<i>Vicia caroliniana</i> (Carolina vetch) . . . . .	4	2 to 3
<i>Trifolium pratense</i> (red clover) . . . . .	3	3 to 5
<i>Trifolium procumbens</i> (low hop clover) . . . . .	5	2 to 6
<i>Trifolium incarnatum</i> (crimson clover) . . . . .	2	2 to 6
<i>Trifolium repens</i> (white clover) . . . . .	3	2 to 5
<i>Trifolium dubium</i> (least hop clover) . . . . .	2	1 to 5
<i>Trifolium arvense</i> (rabbit-foot clover) . . . . .	4	1 to 4
<i>Trifolium hybridum</i> (alsike clover) . . . . .	2	2 to 4
<i>Medicago arabica</i> (bur-clover) . . . . .	2	7 to 14
<i>Medicago sativa</i> (alfalfa) . . . . .	4	1 to 4
<i>Melilotus alba</i> (white sweet clover) . . . . .	3	5 to 8
<i>Robinia pseudo acacia</i> (locust tree) . . . . .	3	2 to 4
<i>Albizia julibrissin</i> (silk tree) . . . . .	7	1
<i>Cassia nictitans</i> (sensitive pea) . . . . .	5, 6	1
<i>Falcata comosa</i> (hog peanut) . . . . .	5	1
<i>Baptisia tinctoria</i> (wild indigo) . . . . .	5	1
<i>Cracca virginiana</i> (wild sweet pea) . . . . .	2	1
<i>Cracca spicata</i> (loose flowered goat's rue) . . . . .	4	1
<i>Pisum sativum</i> (garden pea) . . . . .	2	4 to 9
<i>Phaseolus vulgaris</i> (garden bean) . . . . .	2	2 to 6
<i>Phaseolus lunatus</i> (lima bean) . . . . .	2	1 to 4
<i>Soja max</i> (soy bean) . . . . .	5, 6, 10	1
<i>Meibomia laevigata</i> (smooth tick trefoil) . . . . .	4	1
<i>Meibomia viridiflora</i> (velvet-leaved tick trefoil) . . . . .	4	1
<i>Meibomia obtusa</i> (hairy tick trefoil) . . . . .	4	1
<i>Meibomia paniculata</i> (panicked tick trefoil) . . . . .	6	1
<i>Vigna sinensis</i> (cow pea) . . . . .	14	1
<i>Arachis hypogoca</i> (peanut) . . . . .	6	1
<i>Stylosanthes biflora</i> (pencil flower) . . . . .	5	1
<i>Clitoria mariana</i> (butterfly pea) . . . . .	4	1
<i>Pueraria thunbergiana</i> (kudzu vine) . . . . .	5	1
<i>Dolicholus erectus</i> (erect rhynchosia) . . . . .	2	1
<i>Lathyrus odoratus</i> (sweet pea) . . . . .	5	2 to 4
<i>Lepedeza striata</i> (Japan clover) . . . . .	6	1
<i>Stizolobium deeringianum</i> (velvet bean) . . . . .	5	1

different results obtained by Wilson (1917) who found peritrichic flagella on the soy bean organism, and Hansen (1919) who found the single flagella on organisms from the same host, are due to the age of the cultures at time of staining. From inquiry Conn learned that Wilson's cultures were sometimes as old as twenty-eight days, whereas Hansen used two to three day old cultures. Conn suggests therefore, that the organism may be of the single flagellate type when two or three days old and becomes peritrichic when older. However, Wilson's paper (1917) states that the flagella were stained from one to seven day old cultures so the peritrichic flagella must have been present in seven days or less, and he furthermore makes no reference to finding single flagella in the younger cultures.

While the writer has been unable to stain flagella on the soy bean organism from very old cultures, yet he has found that up to ten days old the cultures still show the single flagellate type, with no indication that they will ever be anything else.

Wilson demonstrated that his peritrichic organism was able to form nodules on soy beans, and the strain of the single flagellate soy bean organism used by the writer has also been shown to be able to produce nodules when grown according to the method of Garman and Didlake (1914). This brings the writer to the conclusion that in different sections of the country, there is a different adaptation of nodule bacteria to the soy bean, and that Wilson and Hansen were working with the two different types.

Although a similar adaptation might be expected in the case of other legume host plants, yet it is interesting to note by referring to the groups of nodule bacteria found by Burrill and Hansen (1917) that if one host plant in a group has single flagella, all other host plants of that group which were investigated gave single flagella, and similar results were obtained in those groups having peritrichic flagella.

#### SUMMARY

1. The flagellation of the organisms from nodules of 41 species of leguminous plants has been studied.
2. Two distinct types of flagellation have been found, the single flagellate type and the peritrichic.

3. As suggested by Hansen (1919) the writer believes that the nodule bacteria of the Leguminosae are of two groups and if we follow Migula's classification they belong to two genera, *Pseudomonas* and *Bacillus*.

4. From 15 genera the flagella were of the single flagellate type. From 8 genera the flagella were of the peritrichic type.

5. In no case has any difference been found in the type of flagellation on organisms from plants of different species of a genus.

6. The single flagellate type is not strictly polar as the flagellum is usually attached at the corner rather than exactly at the end.

#### ACKNOWLEDGMENTS

The writer desires to express his thanks and appreciation to Dr. F. A. Wolf for kindly advice and assistance throughout the work.

#### REFERENCES

- BURRIL, T. J., AND HANSEN, R. 1917 Is symbiosis possible between legume bacteria and non-legume plants? Ill. Agr. Exp. Sta. Bul. 202, 122-123, 136-137, plates III, IV, V.
- CONN, H. J., AND BREED, R. S. 1920 A suggestion as to the flagellation of the organisms causing legume nodules. Sci. N. S., **51**, 391-392.
- DE ROSSI, GINO 1907 Ueber die Mikroorganismen, welche die Wurzelknöllchen der Leguminosen erzeugen. Centralb. f. Bakt., 2 Abt., **18**, 304.
- DE ROSSI, GINO 1920 Studien über den knöllchenerzeugenden Mikroorganismus der Leguminosen. I. Isolierung, bakteriologische Diagnose, Anwendbarkeit der Kulturen in der landwirtschaftlichen Praxis. Centralb. f. Bakt., 2 Abt., **26**, 267.
- FRED, E. B., AND DAVENPORT, A. 1918 Influence of reaction on nitrogen assimilating bacteria. Jour. Agr. Res., **14**, 320-321.
- GARMAN, H., AND DIDLAKE, MARY 1914 Six different species of nodule bacteria. Ky. Agr. Exp. Sta. Bul. 184, 343-344.
- HANSEN, R. 1919 Note on the flagellation of the nodule organisms of the Leguminosae. Sci. N. S., **50**, 568-569.
- HARRISON, F. C., AND BARLOW, E. 1907 The nodule organism of the Leguminosae—its isolation, cultivation, identification, and commercial application. Centralb. f. Bakt., 2 Abt., **19**, 427-428, Taf. II, 9, III, 14.
- KELLERMAN, K. F. 1912 The present status of soil inoculation. Centralb. f. Bakt., 2 Abt., **34**, 42-46, Taf. II.
- PRUCHA, M. J. 1915 Physiological studies of *Bacillus radicolica* of Canada field pea. Cornell Agr. Exp. Sta. Mem. 5, 16-18.
- SHUNK, I. V. 1920 A modification of Loeffler's flagella stain. Jour. Bact., **5**, 181-187.

- SMITH, R. G. 1900 The nodule organism of the Leguminosae. *Centralb. f. Bakt.*, 2 Abt., **6**, 371-372.
- WILSON, J. K. 1917 Physiological studies of *Bacillus radicola* of soy bean (*Soja max.*, Piper) and of factors influencing nodule production. *Cornell Agr. Exp. Sta. Bul.* 386.
- ZIPFEL, H. 1912 Beitrage zur Morphologie und Biologie der Knöllchenbakterien der Leguminosen. *Centralb. f. Bakt.*, 2 Abt., **32**, 109-110.

## PLATE 1

- FIG. 1. *Phaseolus vulgaris* (common bean)  
 FIG. 2. *Cracca virginiana* (wild sweet pea)  
 FIG. 3. *Vicia villosa* (hairy vetch)  
 FIG. 4. *Vicia caroliniana* (Carolina vetch)  
 FIG. 5. *Caßsia nictitans* (sensitive pea)  
 FIG. 6. *Trifolium hybridum* (alsike clover)  
 FIG. 7. *Meibomia viridiflora* (velvet-leaved Tick Trefoil)  
 FIG. 8. *Trifolium dubium* (least hop clover)  
 FIG. 9. *Albizia julibrissin* (silk tree)  
 FIG. 10. *Robinia pseudo acacia* (locust tree)  
 FIG. 11. *Stylosanthes biflora* (pencil flower)  
 FIG. 12. *Medicago sativa* (alfalfa)  
 FIG. 13. *Vicia sativa* (common vetch)  
 FIG. 14. *Pisum sativum* (garden pea)  
 FIG. 15. *Trifolium repens* (white clover)  
 FIG. 16. *Melilotus alba* (white sweet clover)  
 FIG. 17. *Trifolium arvense* (rabbit-foot clover)  
 FIG. 18. *Baptisia tinctoria* (wild indigo)  
 FIG. 19. *Vicia alba* (vetch)  
 FIG. 20. *Cracca spicata* (loose flowered Goat's Rue)  
 FIG. 21. *Vicia hirsuta* (tineweed or vetch)  
 FIG. 22. *Arachis hypogoea* (peanut)  
 FIG. 23. *Medicago arabica* (bur-clover)  
 FIG. 24. *Pueraria thunbergiana* (kudzu vine)  
 FIG. 25. *Vicia dasycarpa* (vetch)  
 FIG. 26. *Falcata comosa* (hog peanut)  
 FIG. 27. *Trifolium procumbens* (low hop clover)  
 FIG. 28. *Trifolium incarnatum* (crimson clover)  
 FIG. 29. *Lathyrus odoratus* (sweet pea)  
 FIG. 30. *Clitoria mariana* (butterfly pea)  
 FIG. 31. *Vicia angustifolia* (smaller common vetch)  
 FIG. 32. *Trifolium pratense* (red clover)  
 FIG. 33. *Meibomia lacvigata* (smooth tick trefoil)  
 FIG. 34. *Meibomia paniculata* (panicked tick trefoil)  
 FIG. 35. *Dolicholus erectus* (erect rhynchosia)  
 FIG. 36. *Phaseolus lunatus* (lima bean)  
 FIG. 37. *Soja max* (soy bean)  
 FIG. 38. *Meibomia obtusa* (hairy tick trefoil)  
 FIG. 39. *Vigna sinensis* (cow pea)  
 FIG. 40. *Stizolobium deeringianum* (velvet bean)  
 FIG. 41. *Lespedeza striata* (Japan clover)

All drawings were made to the same scale and with the aid of a camera lucida.

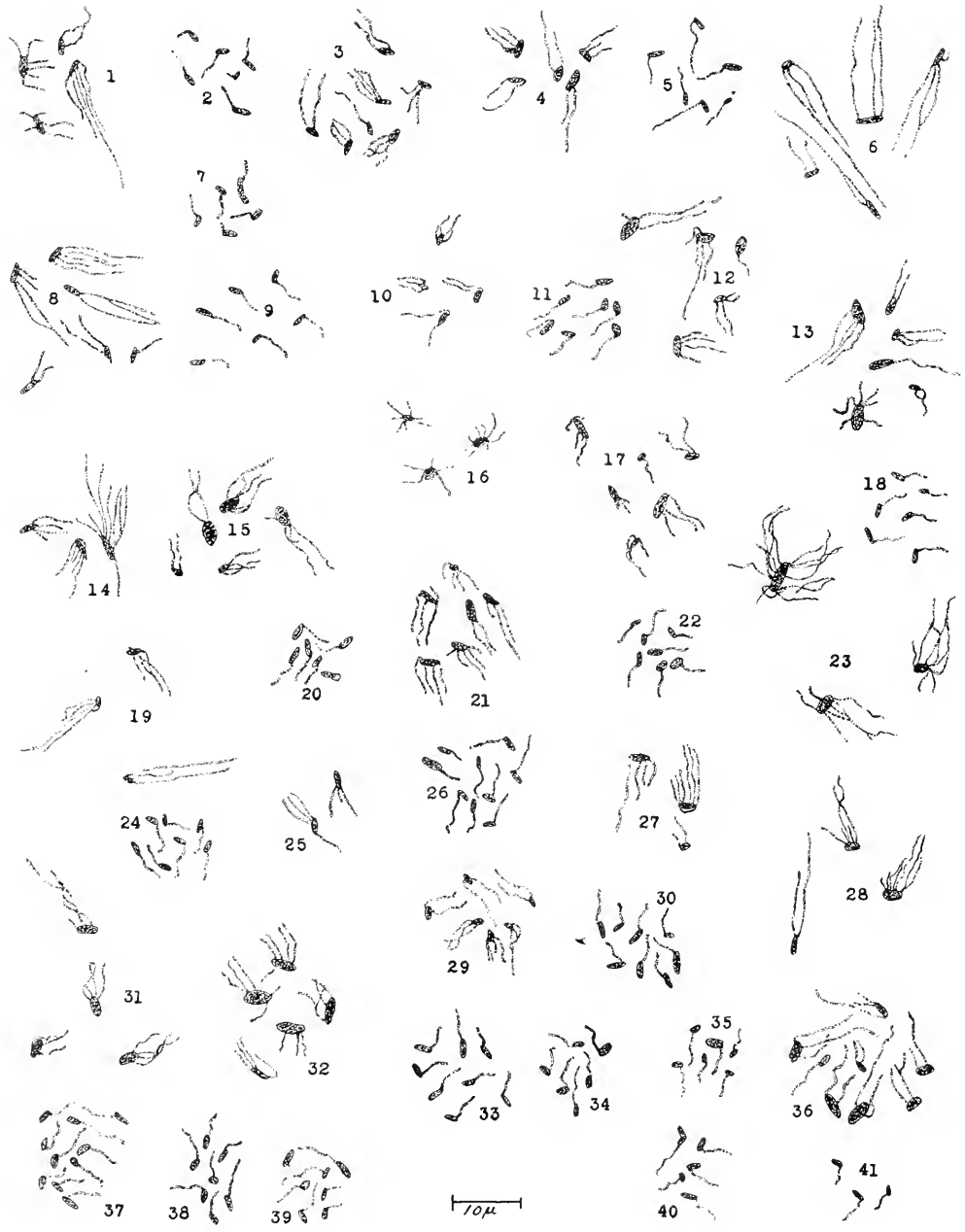

(Shunk: Flagellation of Bacteria of Leguminosae)



## METHOD FOR THE INTRAVENOUS INJECTION OF GUINEA-PIGS

GEORGE B. ROTH

*Hygienic Laboratory, United States Public Health Service, Washington, D. C.*

Received for publication September 15, 1920

Up to the present time two well-known methods have been employed for the intravenous injection of substances into guinea-pigs, namely the jugular vein and the ear vein methods.

By certain investigators the first method is considered objectionable by reason of the fact that when the jugular vein is used it is exceedingly difficult to control the head of the animal without interfering with the operator's movements when making the injections. The marginal vein of the ear which is advocated by Rous<sup>1</sup> can be employed only in selected animals and therefore is not especially adapted for routine use.

A method for routine work, which seems to have a distinct advantage over the preceding methods has been elaborated recently. This makes use of the comparatively large superficial vein lying on the dorsal and inner aspect of the hind leg of the animal. This vein nearly always runs diagonally<sup>2</sup> across the leg from the dorsal aspect below to the inner aspect above.

To use the above vessel for intravenous administration an operating board (fig. 1) has been devised which permits the operator to manipulate the hind legs of the animal freely and at the same time does not prevent the legs from being securely tied. The board proper is made from a flat piece of wood and is 16 inches long, 8 inches wide and  $\frac{3}{4}$  inch in thickness. It is similar to an ordinary animal board except that the end to which

<sup>1</sup>Rous, Peyton. Method for Intravenous Injection of Guinea-Pigs. Jour. Exper. Med., 1918, **27**, 459.

<sup>2</sup>Occasionally, the vessel may run anteriorly.

the hind legs are tied has a U-shaped piece cut from it, as shown in the illustration. The board is mounted near its center on an extension shaft, which is fitted with two joints, the one at the end to which the board is attached being a ball and socket joint and the other an adjustable swivel joint. The shaft is screwed into a metal base which has sufficient weight to hold the board steadily when placed in any position.

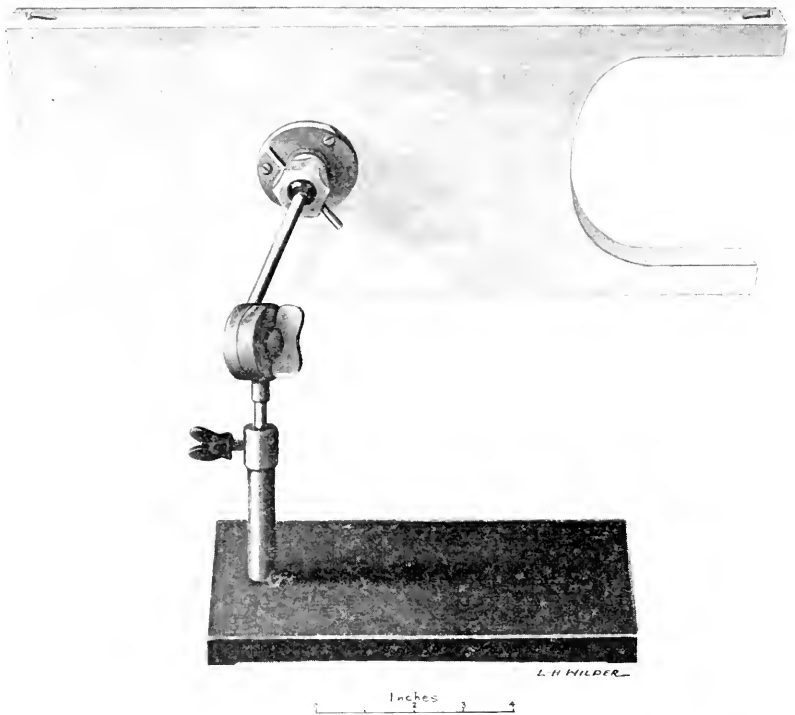

FIG. 1

The procedure for making the injection is as follows: With the board proper placed in a horizontal position, the animal is tied to it securely, abdomen downward, by means of strings. While the animal is being anesthetized, the board is placed in a vertical position and rotated on its vertical axis slightly so as to bring



the dorsal aspect of the right hind leg into view (fig. 2). After clipping the hair from the leg and shaving it, the leg is lifted up slightly by the first, or first and second fingers and lightly compressed by the thumb of the left hand. A small incision, usually about  $\frac{1}{4}$  inch long is made diagonally across the leg from the

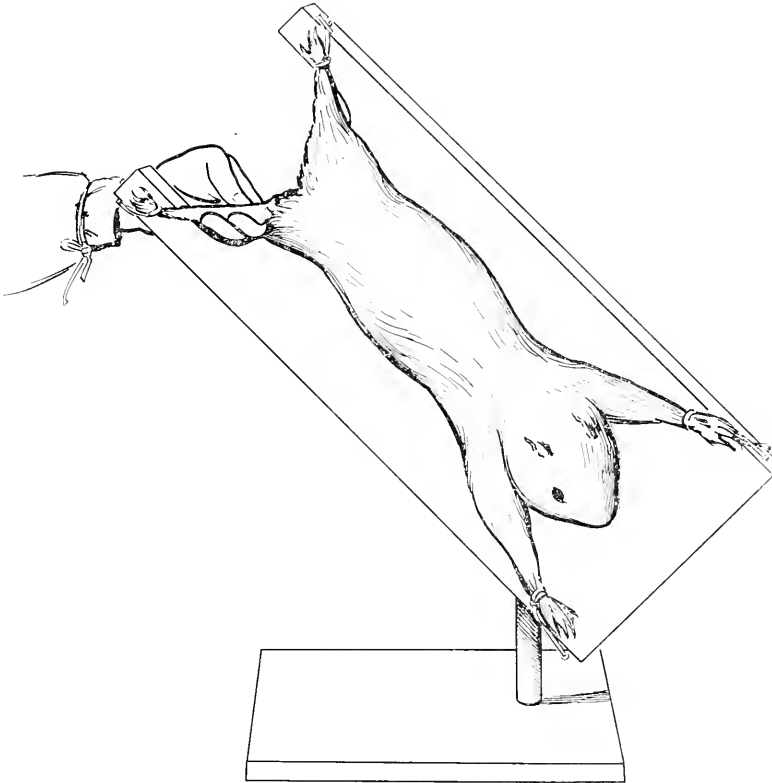

FIG. 2

outer, lower to the upper and inner aspect (fig. 3). The subcutaneous tissue is then pushed aside with a fine pointed forceps thereby permitting the vessel to come into view. The vessel when dilated by suitable compression permits the ready entrance of a number 23 B. & S. gauge needle, although a number 26 B. & S.,  $\frac{5}{8}$  inch needle is usually employed. The needle is always

introduced well into the lumen of the vein so that if there is any escape of fluid backward it can be prevented by pressure on the

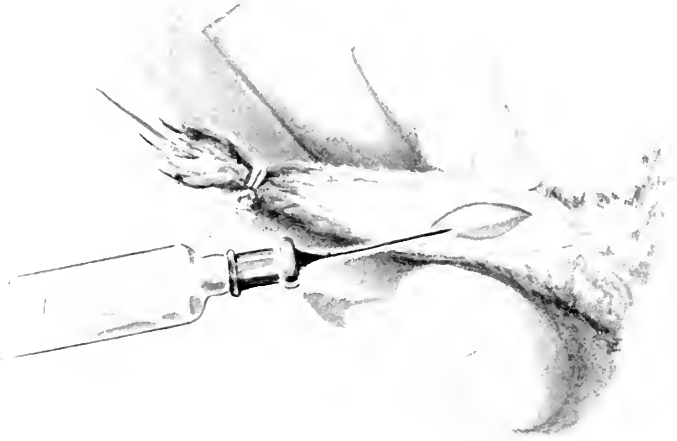

FIG. 3

vessel between the point of the needle and the opening in the vessel. Bleeding from the cut vessel can be readily controlled by pinching it with small forceps.

## ROSE BENGAL AS A GENERAL BACTERIAL STAIN

H. J. CONN

*New York Agricultural Experiment Station*

Received for publication October 2, 1920

Recently the use of rose bengal was mentioned (Conn, 1918) as a stain for detecting microorganisms in the soil. It has subsequently been found to be especially useful in staining two soil organisms, *B. radicola* and *Ps. caudatus*, both of which are hard to stain by ordinary methods on account of the slime they produce. Its use with these two species proved so successful that it is now one of the bacterial stains most commonly used in this laboratory, and it almost always gives satisfaction.

Rose bengal is a stain little known among bacteriologists, but deserves wider use. It belongs to the phthalein series of dyes, being closely related chemically to eosin. It differs from the latter stain in that the four atoms of bromine in eosine are replaced by four atoms of iodine with the addition of two atoms of chlorine. The dye as formerly made in Germany was apparently quite reliable, but it has scarcely ever been manufactured in America and it has proved difficult to get a satisfactory product of domestic manufacture. Some of the imported material is still available, and after investigation an American-made product has been found, sold by the Will Corporation as their "bioloid" grade, which gives as good results as that of German manufacture. The formula which has proved satisfactory is: Rose bengal, 1 gram; 5 per cent phenol, 100 cc. This solution remains in good condition for several months.

The chief value of this stain to the bacteriologist is that it has a great affinity for bacterial protoplasm but not for the slime or debris with which the cells are surrounded. It is therefore especially to be recommended for slime-formers. *B. radicola*, for instance, does not take the ordinary bacterial stains

unless it has been carefully separated from its slime, the organisms remaining unstained in a completely stained field. With rose bengal, on the other hand, the organisms stain deeply, showing their characteristic granules, and the field is practically unstained even though the organisms have been growing on a medium specially adapted to the production of slime. *Ps. caudatus*, which is only about 0.2 micron in diameter (see Conn and Bright, 1919), shows a peculiar and typical granulation with this stain that had not been suspected after considerable study with other dyes. Rose bengal, indeed, seems to be unusually well adapted for revealing structure in small bacterial cells. The very satisfactory results obtained with it in this laboratory make it seem worth recommending to bacteriologists in general. Although more expensive than the more commonly used dyes, its price is not prohibitive unless an unusual amount of staining is to be done.

## REFERENCES

- CONN, H. J. 1918 The microscopic study of bacteria and fungi in soil. N. Y. Agr. Exp. Sta., Tech. Bul. 64.
- CONN, H. J., AND BRIGHT, J. W. 1919 Ammonification of manure in soil. J. Agr. Res., **16**, 313-350. Also in N. Y. Agr. Exp. Sta., Tech. Bul. 67.

## INFORMATION FOR CONTRIBUTORS

Although there are numerous journals in the United States that deal with various special phases of bacteriology (as applied to Medicine, Sanitary Science, Agriculture and the like), there has been no journal in the English language to represent the science as a whole.

The Society of American Bacteriologists has established the **JOURNAL OF BACTERIOLOGY** as its official organ and as a medium for the discussion of the more general problems of the science—the structure and physiology of the microbes, the inter-relationships of microbic types, the effects of physical and chemical agents upon microbic life, the mutual interactions of microbes growing together in various media, the nutritional needs and products of metabolic activity of various microbes, and new methods of laboratory technique—and similar advances in knowledge which are so fundamental as to be of vital interest to workers in all parts of this great field. The **JOURNAL OF BACTERIOLOGY** includes in its scope not only the bacteria but other related micro-organisms, yeasts, molds, protozoa, etc. While it is planned to make the **JOURNAL** in particular an organ for the more fundamental and general aspects of bacteriology, it will necessarily include many papers whose interest is mainly technical, particularly in those fields of bacteriology which have now no satisfactory organ of publication at their disposal.

Manuscripts should be sent to Prof. C.-E. A. Winslow, Yale Medical School, New Haven, Conn.

All other communications pertaining to editorial work should be addressed to Major A. Parker Hitchens, M. C., Army Medical School, Washington, D. C.

Twenty-five reprints, without covers, of articles will be furnished gratis to contributors when ordered in advance. A table showing cost, with an order slip, is sent with proof.

## INFORMATION FOR SUBSCRIBERS

THE **JOURNAL OF BACTERIOLOGY** is issued bi-monthly, in January, March, May, July, September, and November. A volume consists of approximately 600 pages. Subscriptions to the **Journal** are taken for the volume only. Under the present plans, one volume is issued a year.

Subscription Price: 1921 volume, Vol. VI, \$5.00, United States, Mexico, Cuba; \$5.25, Canada; \$5.50, elsewhere, net postpaid.

Back Volumes are supplied on orders for Vols. I to V, inclusive. Price, \$30.00, United States, Mexico, Cuba; \$31.25, Canada; \$32.50, elsewhere. Extra single volumes will be supplied on request when in stock at \$5.00, United States, Mexico, Cuba; \$5.25, Canada; \$5.50, elsewhere. Prices are net postpaid. Single numbers can be furnished, in many instances, at \$1.00 a copy.

Correspondence concerning business matters should be addressed to the Williams & Wilkins Company, Mount Royal and Guilford Avenues, Baltimore, U. S. A.

Subscriptions are received:

For Argentina and Uruguay: Beutelspacher & Cia., Sarmiento 815, Buenos Aires, Argentina.

For Australia: Stirling & Co., 317 Collins Street, Melbourne.

For Belgium: Henri Lamertin, 58 Rue Coudenberg, Bruxelles.

For the British Empire, except Australia and Canada: Address any British bookseller or send your orders direct to the publishers.

For Canada: Wm. Dawson & Sons, Ltd., 87 Queen Street East, Toronto, Canada.

For Denmark: H. Hagerup's Boghandel, Gothersgade 30, Kobenhavn.

For France: Emile Bougault, 48 Rue des Ecoles, Paris.

For Germany: R. Friedländer & Sohn, Buchhandlung, Carlstrasse 11, Berlin NW. 6.

For Holland: Scheltema & Holkema, Boekhandel, Rokin 74-76, Amsterdam

For Italy: Ulrico Hoepli, Milan, Italy.

For Japan and Korea: Maruzen Company, Ltd. (Maruzen-Kabushiki-Kaisha), 11 to 15 Nihonbashi Tori-Sanchome, Tokyo; Fukuoka, Osaka, Kyoto, and Sendai, Japan.

For Spain: Ruiz Hermanos, Plaza de Santa Ana, 13, Madrid.

For Switzerland: George & Cie, Freiestrasse 10, Basel, Switzerland.

For the United States and other countries except as above: **WILLIAMS & WILKINS COMPANY, MOUNT ROYAL AND GUILFORD AVENUES, BALTIMORE, U. S. A.**

Claims for copies lost in the mails will not be allowed unless such claims are received within 30 days (90 days, foreign) of the date of issue. Claimants must state that the publication was not delivered at their recorded address. The publishers will not be responsible for loss due to change of address unless notification is received at least two weeks in advance of issue.



**RARE SUGARS**  
and  
**OTHER FINE CHEMICALS**  
"DIFCO" STANDARDIZED

*Being the first manufacturing firm in the United States to make and advertise extensively rare sugars, we have steadily added to the line, and our list now comprises the following:*

RARE SUGARS

Arabinose  
Dextrose (Glucose)  
Galactose  
Invert Sugar

Lactose  
Levulose (Fructose)  
Maltose  
Mannose  
Melezitose

Raffinose  
Rhamnose  
Saccharose (Sucrose)  
Trehalose  
Xylose

OTHER CHEMICALS

Inulin  
Mannite  
Dextrin  
Acid Potassium Phthalate  
Blood Serum, Dry

Beef Extract  
Fibrin  
Gelatin  
Invertase

Decolorizing Carbon  
Bacto-Peptone  
Proteose Peptone  
Tyrosine

*Carried in stock by the principal dealers in  
Scientific Supplies.*

---

Specify "DIFCO"  
WE INVITE COMPARISON

**DIGESTIVE FERMENTS COMPANY**  
Detroit, Michigan, U. S. A.

VOLUME VI

NUMBER 3

# JOURNAL OF BACTERIOLOGY

OFFICIAL ORGAN OF THE SOCIETY OF AMERICAN  
BACTERIOLOGISTS

MAY, 1921

EDITOR-IN-CHIEF

C.-E. A. WINSLOW



*It is characteristic of Science and Progress that they continually  
open new fields to our vision.—PASTEUR.*

PUBLISHED BI-MONTHLY  
WILLIAMS & WILKINS COMPANY  
BALTIMORE, U. S. A.

Entered as second-class matter April 17, 1916, at the postoffice at Baltimore, Maryland, under the act of March 3, 1879. Acceptance for mailing at special rate of postage provided for in Section 1103, Act of October 3, 1917. Authorized on July 16, 1918.

Copyright 1921, Williams and Wilkins Company

Price, net { \$5.00 per volume, United States, Mexico, Cuba  
postpaid { \$5.25 per volume, Canada  
          { \$5.50 per volume, other countries

# Holadin and Bile Salts

Holadin - - 2½ grs.

Bile Salts - - ½ gr.

(enteric capsules)

"Investigations begun originally by Professor Nencki in his Berne laboratory and carried on by Heidehain, Rachford, Williams and Martin, have shown that the bile has a favouring action on the ferments of the pancreatic juice.

"The Bile, indeed, proved itself to be a constant and powerful auxiliary of the pancreatic juice, a fluid which is of such importance for digestion and in itself already so complicated."

—Prof. J. P. Pawlow.

"Holadin and Bile Salts", a combination of the most potent pancreas extract with the isolated glycocholate and taurocholate of sodium, in their native association—

is a therapeutic resource of distinct service in pancreatic (intestinal) disorders dependent upon, or associated with, deficient bile action.

FAIRCHILD BROS. & FOSTER  
New York

## LaMotte Standards

GUARANTEED

Section 1.—Standardized Indicator dyes. Covering a wide range of H-ion concentration. Supplied in dry form and in sterile stock solutions. Each indicator is standardized in strict accordance with the specifications of Clark & Lubs. (Jr. Bact., Vol. II, Nos. 1, 2, 3, 1917.)

Common Name	Color Change	pH Value
Thymol Blue (acid range)	red-yellow	1.2-2.8
Methyl Orange	red-yellow	2.9-4.0
Bromphenol Blue	yellow-blue	3.0-4.6
Resorcin Blue	pink-blue	4.0-7.2
Methyl Red	red-yellow	4.4-6.0
Bromcresol Purple	yellow-purple	5.2-6.8
Litmus (special)	red-blue	5.5-8.9
Bromthymol Blue	yellow-blue	6.0-7.6
Phenol-Red	yellow-red	6.8-8.4
Cresol Red	yellow-red	7.2-8.8
Thymol Blue (alkaline range)	yellow-blue	8.0-9.8
Cresol-phthalein	colorless-red	8.2-9.8
Phenol-phthalein	colorless-red	8.4-9.2

Section 2-B.—Specially prepared and standardized Buffer salts and solutions. Buffer mixtures may be obtained in series covering any particular range of H-ion concentration from p<sub>H</sub> 1.0 to 10.0.

### Standardized Buffer Solutions (M/5)

Potassium Phosphate	Potassium Phthalate	Sodium Hydroxide (CO <sub>2</sub> free)
Potassium Chloride	Hydrochloric Acid	Di-Sodium Phosphate, 2H <sub>2</sub> O

A large number of general synthetic and purified compounds are manufactured by us and information concerning them may be obtained by addressing

**LA MOTTE CHEMICAL PRODUCTS CO.**  
"Standards Department"

13 W. Saratoga St.

Baltimore, Md.



# JOURNAL OF BACTERIOLOGY

OFFICIAL ORGAN OF THE SOCIETY OF AMERICAN BACTERIOLOGISTS

DEVOTED TO THE ADVANCEMENT AND DISSEMINATION OF KNOWLEDGE IN REGARD TO THE BACTERIA AND OTHER MICRO-ORGANISMS

## *Editorial Board*

### *Editor-in-Chief*

C.-E. A. WINSLOW

Yale Medical School, New Haven, Conn.

A. PARKER HITCHENS

DR. CHARLES KRUMWIEDE, JR., *Ex officio*

## *Advisory Editors*

C. C. BASS  
R. E. BUCHANAN  
P. F. CLARK  
F. P. GAY  
F. P. GORHAM  
P. C. HARRISON

H. W. HILL  
E. O. JORDAN  
A. I. KENDALL  
C. B. LIPMAN  
C. E. MARSHALL

V. A. MOORE  
M. E. PENINGTON  
F. B. PHELPS  
L. F. RETTGER  
L. A. ROGERS

M. J. ROSENAU  
W. T. SEDGWICK  
F. L. STEVENS  
A. W. WILLIAMS  
H. ZINSSER

## CONTENTS

WILLIAM THOMPSON SEDGWICK, 1855-1921.....	255
S. ORLA-JENSEN. The Main Lines of the Natural Bacterial System.....	263
KAN-ICHIRO MORISHIMA. Variations in Typhoid Bacilli.....	275
FREDERICK A. WOLF and I. V. SHUNK. Solid Culture Media with a Wide Range of Hydrogen or Hydroxyl Ion Concentration.....	325
AUGUSTO BONAZZI. Studies on <i>Azotobacter Chroococcum</i> Beijerinck.....	331

Abstracts of American and foreign bacteriological literature appear in a separate journal, *Abstracts of Bacteriology*, published bi-monthly by the Williams & Wilkins Company, under the editorial direction of the Society of American Bacteriologists. Back volumes can be furnished in sets consisting of Volumes I, II and III. Price per set, net, postpaid, \$18.00, United States, Mexico, Cuba; \$18.75, Canada; \$19.50, other countries. Subscriptions are in order for Volume IV, 1920. Price, per volume, \$5.00, United States, Mexico, Cuba; \$5.25, Canada; \$5.50, other countries.

# COLOR CHART OF INDICATORS

REPRINTED FROM

## The Determination of Hydrogen Ions

by

WM. MANSFIELD CLARK, Ph.D.

Are Now Available as a Separate

### EXPLANATION

The colors shown upon the chart were reproduced from tubes 16 mm. internal diameter containing 10 cc. standard buffer solution. The quantities of indicator solution added in each case were as follows:

Thymol blue, acid range (T.B. acid range).....	1 cc. 0.04
per cent solution	
Brom phenol blue (B.P.B.).....	0.5 cc. 0.04
per cent solution	
Methyl red (M.R.).....	0.3 cc. 0.02
per cent solution	
Brom cresol purple (B.C.P.).....	0.5 cc. 0.04
per cent solution	
Brom thymol blue (B.T.B.).....	0.5 cc. 0.04
per cent solution	
Phenol red (P.R.).....	0.5 cc. 0.02
per cent solution	
Cresol red (C.R.).....	0.5 cc. 0.02
per cent solution	
Thymol blue (T.B.).....	0.5 cc. 0.04
per cent solution	

It must be remembered that the light absorptions in the case of the standard solutions and in the case of the printed colors are quantitatively very different in the two cases. Therefore, the user of the chart will have to use discretion and should consider the printed colors to be only rough standards.

.....  
WILLIAMS & WILKINS COMPANY  
Publishers of Scientific Journals and Books  
BALTIMORE, MD., U. S. A.

Gentlemen: I or We enclose \$..... for:

One copy of the Chart .....	\$1.00 a copy
Three copies of the Chart.....	.90 a copy
Five copies of the Chart.....	.75 a copy
Ten copies of the Chart.....	.65 a copy
Fifteen copies of the Chart.....	.60 a copy
Twenty-five copies of the Chart, or over.....	.50 a copy

of the Color Chart of Indicators reprinted from Clark's "The Determination of Hydrogen Ions."

Signed.....

Address.....





WILLIAM THOMPSON SEDGWICK

WILLIAM THOMPSON SEDGWICK  
1855-1921

LIBRARY  
NEW YORK  
BOTANICAL  
GARDEN

William Thompson Sedgwick, the father of the modern public health movement in America, was born at West Hartford, Connecticut, December 29, 1855. He graduated from the Sheffield Scientific School of Yale University in 1877, his first contribution to scientific literature being a study of the local flora, in collaboration with his college chum and life-long friend, E. B. Wilson. He began the study of medicine, but, dissatisfied with the haphazard medical education of the time, discontinued his course a short time before he would have received his degree. He taught physiological chemistry under Chittenden at the Sheffield Scientific School in 1878-1879, and in 1879 accepted a fellowship in biology at Johns Hopkins where he came under the influence of Martin, to receive from him the vision of biology as a broad and liberal science, a vision which Martin brought over from the England of Huxley and transmitted through Sedgwick and Sedgwick's pupils to thousands of students in this country.

Sedgwick was made assistant in biology at Baltimore and received the degree of Ph.D. in 1881. In the winter following the reception of his doctorate and on the anniversary of his birth, December 29, 1881, he was married to Mary Catherine Rice of New Haven, the beginning of thirty-nine years of a relationship as complete and as beautiful as ever existed between man and wife. Mrs. Sedgwick not only gave to her husband a rare personal devotion which made his health and his comfort and the success of his career a constantly controlling motive, but her artistic tastes and rich temperament kept a warmth and color in his life which made it impossible for Sedgwick ever to feel those limitations which sometimes accompany a life of intellectual concentration, limitations which Charles Darwin, for example, felt so pathetically in his later years.

Sedgwick found his career in 1879, his wife in 1881, and the institution to which he and his wife devoted their lives with a rare ardor in 1883. Francis Walker, who was at this time beginning his brilliant service as president of the Massachusetts Institute of Technology, had known Sedgwick as a student at Yale, and with a characteristically broad view of technological education, called him to the Institute in 1883 as Assistant Professor of Biology. He became Associate Professor in 1884, and Professor in 1891 and was head of the department (later known as the Department of Biology and Public Health) until his death.

In the present prosperous state of scientific education, it is a little difficult to realize what the Institute of Technology meant to its protagonists. In those early days of doubt and difficulty the Institute became a symbol, an Ark of scientific education to Walker and the little band who fought for it at his side. Sedgwick was one of Walker's closest friends and, like Walker and so many of his faculty, was inspired by a devotion to the ideals of the Institute which is bestowed upon church and nation more often than upon an educational institution.

Sedgwick's original bent was toward physiology and his first important scientific contribution at the Institute was a study of the dangers of gas poisoning, conducted in collaboration with William Ripley Nichols. These were the golden days of the birth of bacteriology, however, and when Nichols died while on a visit to the European universities some tubes of Koch's strange new gelatin medium were brought back to the Institute with his personal effects. Sedgwick was quick to realize the possibilities of the new science and from that time on his own investigations and the energies of his department were focused more and more on bacteriology. The medical applications of the subject were being developed by Welch at Baltimore and by Prudden and Biggs and Park in New York, but Sedgwick's training and natural aptitudes made him the pioneer in the broader biological aspects of the new subject. When the Massachusetts State Board of Health was reorganized and the Lawrence Experiment Station was established in 1888, he was appointed biologist to the Board and with Mills, Drown and

Mrs. Richards and their pupils, Hazen, Whipple, Fuller and Jordan, he laid the foundation of modern sanitary science in its bacteriological and engineering aspects, as distinct from those which deal with the problems of the pathology and diagnosis of disease. His contributions to epidemiology in the study of water and milk-borne epidemics, conducted at this time, were of the highest scientific importance. The growth of the whole public health movement in America was, from 1890, connected in an intimate fashion with the development of the Department of Biology and Public Health at the Institute and of the School for Health Officers conducted in cooperation with Harvard University during recent years. It would be difficult to name any important health activity, investigative, administrative or educational, to which Sedgwick's pupils have not contributed in an important degree. It may be fairly said that he created the new field of non-medical sanitary science. Public health began as a branch of medicine but Sedgwick has taught America, and, through his pupils, is now teaching Europe that the two fields are intersecting but distinct, and that sanitary engineers, bacteriologists and even health administrators may be trained for the highest type of public service without passing through the established course which leads to the medical degree. The last important idea, which he put forward only a few months before his death, was the suggestion of a bifurcated course, based on the same two years of pre-clinical work, but leading in the last two years to the alternative degrees of Doctor of Medicine or Doctor of Public Health; and this suggestion was the logical development of his life work.

Aside from a multitude of important technical papers and addresses, Sedgwick was the author, or joint author, of five books which admirably express the more important interests of his professional life. "General Biology," published with E. B. Wilson in 1886 crystallized in effective form the viewpoint derived, through Martin, from Huxley of biology as a broad and fundamental discipline dealing with the underlying phenomena of protoplasmic action; and no single work has perhaps had so large an influence upon the teaching of the biological sciences

in the United States. The "Life and Letters of William Barton Rogers" (1896), in the preparation of which Sedgwick assisted President Roger's widow, was a labor of love which expressed all the loyalty of the Technology faculty and alumni to the great founder of the Institute. "Principles of Sanitary Science and the Public Health" (1902) was Sedgwick's most important literary production, a book which is still the best existing epitome of the principles of sanitary science and which many academic generations have found "as interesting as a novel." "The Human Mechanism," a textbook for schools and colleges, published with Theodore Hough in 1906, marked Sedgwick's return to his earlier interest in physiology and personal hygiene; and "A Short History of Science," published with H. W. Tyler in 1917, placed in permanent form the broad historical sense and the keen love of origins which were always among the greatest charms of Sedgwick's courses.

Sedgwick's scientific attainments received recognition in the conferring of the honorary degrees of Sc.D. by Yale in 1909, and LL.D. by the University of Cincinnati in 1920, as well as in election to the American Academy of Arts and Sciences and the American Philosophical Society. He was appointed a member of the Advisory Board of the United States Hygienic Laboratory in 1902, and later received a commission as Assistant Surgeon General in the United States Public Health Service. He was a member of the International Health Board of the Rockefeller Foundation. He was a founder and first president of the Society of American Bacteriologists and our organization owes its establishment and its broad charter more perhaps to him than to any other individual. He served also as president of the American Society of Naturalists, the American Public Health Association, and the New England Water Works Association.

Sedgwick's interests were, however, never narrowly bounded by his own technical field. Wherever educational or civic problems were to be solved he was ready to serve. A score of progressive movements in Massachusetts numbered him among their leaders. He was president of the board of trustees of Sharon Sanatorium from 1902 and a member of the Public Health



Council of Massachusetts from its inception. He was a trustee of Simmons College from its foundation in 1899. He was chairman of the Pauper Institutions' Trustees of the city of Boston in 1897-1899. He was a leading figure in the fight for Civil Service Reform, president of the Boston Civil Service Reform Association in 1900, and of the State Association in 1901. Finally, as curator of the Lowell Institute since 1897 he became perhaps more widely known to the citizens of Boston than in any other capacity. He did not confine himself to the abstract task of securing for Boston contracts with the most brilliant teachers of American and European thought; he was almost nightly on hand to act as a personal host and to give the problems of heating and lighting and ventilation an individual attention which made Huntington Hall famous throughout the country.

In all these works of public service Sedgwick was unwearied, until the very day and hour of his death (January 25, 1921). On Saturday he gave a dinner to some thirty of his colleagues and pupils in honor of a former student who was going abroad on a public health mission, and never was he more at his best in wisdom and courage and enthusiasm. On Monday he was at his office as usual; the writer will always cherish as one of his most precious possessions a long letter written on this day, about a projected journey, full of the sound counsel and the detailed practical advice which "The Chief" always found time to give to his old students. On Tuesday evening he attended a meeting in the interest of a plan for the formation of a state university, walked home enjoying the keen, frosty air of the Boston winter and on his arrival, after a word of cheer to Mrs. Sedgwick, succumbed in a moment to an attack of an affection of the heart which had for years threatened but never shadowed his life. He died without regaining consciousness, a "Happy Warrior" in the fight against ignorance and suffering and disease.

Sedgwick was a pioneer in American science and a zealous public servant; but it was as a teacher that he stood supreme. On the lecture platform, as in the intimacy of his laboratory, he had the gift, as rare as it is beneficent, of seizing the imagination,

kindling the enthusiasm, inspiring the will. He was no orator, but he compelled by the force of a ripe intellect, a genial philosophy and an unswerving ideal. He had the instinct for the vital point; and in the midst of all his busy life he never failed to gauge the strength and the weakness of each individual student. He was pitiless to the specious and the slipshod, and if his students did not learn to think honestly and clearly they had only themselves to blame.

Sedgwick's most notable intellectual quality was breadth of vision. He saw every fact in relation to a hundred other phenomena and he was at his very best with a small group of students, following out in the experimental vein a line of thought which might lead from the structure of plant tissue to the domestic life of ancient Rome, and then to some fundamental problem in philosophy or ethics. The Bible, the Greek classics and the poets and essayists of England were always fresh in his mind to furnish an allusion. He and Mrs. Sedgwick had travelled in Europe, widely and in unusual by-paths; and he travelled with eyes so wide open and interest so keen that he saw more and enjoyed more in a month than many a self-centered tourist can compass in a year. (One of the things his friends love best to remember is the satisfaction he derived from his trip to Europe last summer as exchange professor at Leeds and Cambridge.) The whole world, past and present, was in the background of his thoughts. He would take a simple fact and turn it this way and that, and play with it, and toss it in the air, so that it caught the light from a hundred different sources. No one who has ever heard him discuss with a class by the Socratic method the question, "What is truth, and why do we value it so highly?" can ever forget that lesson in clear and straightforward and constructive reasoning. The Institute is a busy place and no man on its faculty was more active than Sedgwick in multifarious lines of public service, yet he was always calm, serene and unhurried. If it could ever be said of any man, it was true of him that he saw life steadily and saw it whole.

Sedgwick had knowledge and wisdom, but, when all is said and done, it is moral qualities which mark the great teacher.

“Faith, Hope and Charity” are the things that count in the long run; and these virtues were his in bountiful degree.

He had an abiding faith in the general scheme of things, a faith based firmly on the biologists’ knowledge of the great underlying forces which have brought us up from the slime of the rockpools and which will yet carry us to heights undreamed of. He “Accepted the Universe,” he trusted “that power not ourselves that makes for righteousness.” His courage was absolute and instinctive. When he saw the truth he followed it. In times of doubt and and hesitation, one turned to him as to a well of clear water in the wilderness.

His optimism was no less notable a characteristic. He believed in his students and gave them responsibilities that seemed far beyond their powers, but almost always they “made good.” Scores of young men who bore every sign of mediocrity were re-made and launched on successful careers by the sheer power of his confidence. In his public life Sedgwick saw much of the seamy side of American politics, yet he would approach a case-hardened politician with the assumption that they shared the same high ideals of social responsibility, and here too his optimism often bore surprising fruit.

Finally, Sedgwick loved not only mankind but he loved his fellowmen, which is a rarer and more precious gift. He established human relations with extraordinary facility. He knew his choreman and his elevator boy and the janitors at the Institute as human beings. One of the most characteristic things he ever did was the giving of a dinner, when his summer home at Seal Harbor was completed, to all the carpenters and masons, his friends and fellow townsmen of the Maine village who had labored honestly to build it. Above all, it was to his students that he gave of this power of warm personal sympathy and comprehension. One thinks always of “Rugby Chapel” as the ultimate tribute to a great teacher. About Sedgwick, however, there was something so much closer and more intimate that the quotation dies on one’s lips. The master of Rugby was far off on the snowy heights. Sedgwick was in the midst of the rush of life and he held us by the hand. Arnold thought of his father

as a teacher. We who were Sedgwick's "boys" will think of our Chief as of a second father.

Yet he led us to the heights no less surely, if he led us always in warm and human fashion. It was not necessary for him, like the eastern sages, to go into the wilderness to learn the secret of selflessness. He knew it always. After a long and intimate talk with a student, he ended with the words "I think you can be a very useful man." Not a rich man, not a successful man, not an influential man; a useful man. That was his secret. I believe that never in his life, in matters great or small, did he say to himself, "Is it pleasant to do this?" "Is it to my interest to do this?" but only "Will this be useful?"

So, in this time, when the world seems very barren without his personal presence, his pupils and his colleagues and his friends can have but one thought—to labor more diligently and untiringly, that Sedgwick's spirit of service through knowledge may still bear fruit throughout the coming years.

C.-E. A. WINSLOW.

# THE MAIN LINES OF THE NATURAL BACTERIAL SYSTEM

S. ORLA-JENSEN

*Den polytekniske Laeranstalts bioteknisk-kemiske Laboratorium, Copenhagen*

Received for publication September 3, 1920

I am happy to see how very intelligently and thoroughly my proposition for a natural bacterial system has been discussed by the Committee appointed by the Society of American Bacteriologists (1917). This warrants the hope that some day, when the single groups of bacteria have been sufficiently studied, the bacteriologists of the different countries may fortunately come to an agreement about a fully satisfactory bacterial classification. On the other hand, the Committee does not let me hope that we might agree also upon a more practical system of nomenclature than that employed at present in bacteriology, and I therefore feel impelled to object against the rather severe criticism that the Committee has passed on my efforts in this direction.

The basis of every science is, next to exact investigations, to throw the greatest possible clearness in the terms to be used. But science does not consist in pedantically following old-established rules. On the contrary, hardly any important progress is ever accomplished without disregarding some of them. Let us therefore, as we are now building up a new science, try to avoid the monstrous mistake committed by zoölogists and botanists in coining rather unmeaning terms which are apt to cause the greatest difficulties for the memory. Out of regard for posterity, who probably will find themselves confronted by thousands of bacterial species, we have to provide for a certain intrinsic logic in the nomenclature. No human being would now-a-days be able to recollect chemistry, were it not that in due time there had been prepared such an excellent nomenclature that the

name of a chemical compound can be derived directly from the formula. Even if the principles of chemical nomenclature cannot be applied to bacteriology, there is no reason here to form the names servilely upon the principles of Linnæus, and it is so much the more meaningless to do so as the Committee has already in its classification of bacteria discarded these principles on the most important point, in giving the biological qualities precedence over the morphological.

In bacteriology as soon as the purely morphological principle of classification is abandoned, the relatively few purely morphological generic names do not suffice, but we must necessarily form a whole series of new generic names. Precisely in this connection I think I have displayed a great deal of conservatism by simply adding to the old designations a prefix which characterizes the genus more closely. From the generic name we then are still able to conclude as to the appearance of the bacteria in question. In my later work on the lactic acid bacteria I have given nearly related cocci and rod-forms the same prefix (for instance, *Streptococcus* and *Streptobacterium*, *Betacoccus* and *Betabacterium*), which I think is also a practical arrangement. The prefix of the generic name ought no more than the specific name to allude to a person, not even to the person who first described the bacteria concerned; for this question is only of interest in the history of our science, but absolutely not from a natural-history point of view, and we ought not to encumber the bacteriologists of the future, who will have to handle thousands of bacterial species, with the history of each. The name of an organism ought to seem so natural to any one who is thoroughly acquainted with the organism and knows where it is to be found, that it will be nothing new to be remembered, but will serve on the contrary to associate his conception of the particular organism.

As to the family names of the bacteria, it will be convenient to let all of them end in *-Bacteriaceae*, by which it will be seen directly what is in question. If there are to be formed families of the cocci and spirilla, they must consequently be termed *Coccobacteriaceae* and *Spirillobacteriaceae* (or by the older name

of Zopf, *Spirobacteriaceae*). The reason why I have made an exception from this rule with the family *Actinomycetes* is because by the suffix -mycetes I wish to indicate that we have here the transition to the *Eumycetes*; but, in deference to the proposal of the Committee, I am willing to change the name to *Mycobacteriaceae*. On the other hand, I cannot agree with the Committee in following the old rule, that "a family name must be formed from one of its component genera with the suffix *aceae*;" for, if so, there would most frequently be no sense in the family name except in regard to this single genus. There cannot be any doubt but that we ought to form the family name in such a way that it denotes a property—and preferably the most characteristic one—common to all the bacteria which belong to the family in question. Accordingly, it is no improvement on the name, when for the family of oxidizing bacteria set up by me, the *Oxydobacteriaceae*, the Committee proposes the name *Nitrobacteriaceae*, which is quite misleading in respect to its first four genera.

The main objection of the Committee to my system is, that I do not pay due regard to priority. But what does that really mean? In old sciences such as zoölogy and botany we meet with really time-honored names, the legitimacy of which is quite indisputable; but in a new science like bacteriology we cannot consider the older names as anything more than provisional labels. Indeed, we have not advanced farther than to find a number of species, wherever we make a thorough-going study of a so-called bacterial species, and in by far the largest number of cases it is quite impossible to guess which of the new species is meant by the original author.

The Committee itself holds that we ought not to take into consideration the names dating from the time when micro-organisms were not yet studied in pure culture—or rather the names proposed prior to 1885, when the system of Zopf appeared, the system which has formed the basis of the morphological classifications hitherto used. The Committee does not wish, however, to build up once more an exclusively morphological system, but a system based essentially on the far more important

biological properties, and as the researches initiated to that end are only in an embryonic state, it does not seem necessary to me that the bacteriologists out of regard for priority should relinquish all hope of establishing a practical nomenclature.

Although it is well-known that the red as well as the colorless sulphur bacteria may appear in all the forms known in the world of bacteria, and that even a single species of bacteria (for instance, *Crenothrix* and *Azotobacter*) in the first state of development may only divide in one plane but later in more planes, yet the Committee cannot admit that in case of other bacteria there may be a near relationship between sphere-, rod- and screw-forms. Still I entertain a perhaps not unwarranted hope, that my recently published monograph of the lactic acid bacteria may be able to change the opinion of the Committee. Here we have to do with a large group of bacteria consisting of sphere- as well as rod-forms, nevertheless forming a natural family which we could call *Lactobacteriaceae*. This family I have founded, of course, not only on the specially developed power of forming lactic acid (since there exist many different organisms which are able to form, at any rate, small quantities of lactic acid); but I base it upon the fact that the bacteria which we call true lactic acid bacteria have so many other properties in common that there cannot be any doubt about their close relationship. Thus, they are Gram-positive, facultatively anaerobic (without surface growth in stab culture), they make excessively great demands as to nitrogenous nutriment, and, most remarkably, in contradistinction to most other bacteria, they are unable to liberate oxygen from peroxide of hydrogen.

The sphere-forms belonging to the lactic acid bacteria ordinarily divide only in one plane, and, according as they form dextro- or laevo-lactic acid, they belong to the genera *Streptococcus* or *Betacoccus*. The acid-forming micrococci and sarcinae, on the contrary, differ in so many respects from the true lactic acid bacteria, that they can hardly be placed here. Thus, my researches lead to the result that it is not the shape that makes the difference between sphere- and rod-formed bacteria, but, if anything, the division in one or more planes. The rod-forms



(the genera *Thermobacterium*, *Streptobacterium* and *Betabacterium*) belonging to the lactic acid bacteria are by no means always straight. They can be screw-formed and (especially *Bacterium bifidum*) bifurcated. Among the propionic acid bacteria, which also form a natural family, we once more meet with both sphere and rod forms, and among the latter very often club-shaped and forked forms.

I am glad to see that Breed, Conn and Baker (1918) in their critique of the report of the Committee agree with me in the view that "the shape of cell or form of body is not a fundamental character." It is so much the more strange that these investigators nevertheless finish by setting up a purely morphological system.

There is one further particular in which I must dissent from the Committee, and that is in setting up new genera of pathogenic bacteria (some of these being moreover named after persons), and in this particular too Breed, Conn and Baker agree with me. The pathogenic characters are not always so constant that they can be used as specific characters; they are often difficult to maintain when the bacteria are cultivated on artificial media. Non-pathogenic species can become pathogenic (for instance, certain streptococci and micrococci) through animal passages or through mixed infections, or (in the case of certain coli bacteria) simply by living in the intestinal canal. What is true of the parasites of animals, will certainly also apply to those of plants, and we thus know of moulds sometimes appearing as saprophytes, sometimes as parasites. Many so-called pathogenic species of bacteria ought more correctly to be considered as saprophytes from which more or less virulent varieties are readily developed, and although such species are more often met with in one genus than in another, we must be very cautious in setting up pathogenic genera. The interest which has been awakened in the pathogenic bacteria described in medical literature has hitherto left its trace in bacteriology to such an extent that it has been attempted to group all known bacteria around these. This is a step which must necessarily lead to the establishment of systems as artificial as if in the animal and vegetable kingdoms

we knew only the few parasitic species and tried to group all other animals and plants with them. The pathogenic bacteria are, fortunately, in the minority; the bulk of bacteria are leading a saprophytic existence and like the plants have their natural habitats in the soil. We therefore first have to put in order the saprophytes; then we can begin to mediate about where we have to place the parasites.

From the point of view here maintained I cannot follow Winslow in distributing the cocci firstly under the two groups parasites and saprophytes, and it seems to me that he is going rather too far when he uses the chromogenic property of the cocci to divide them into several genera. The formation of coloring matter can on an extreme estimate, and only when taken together with other characters, be adopted as a specific character; it is too variable to be used as a generic character. We must at times submit to being in doubt about what we are to call a species and what we are to regard as a variety; but the generic characters should be in some measure fixed, even though we must admit that the many transitional forms between the genera make it impossible to draw quite well-defined lines.

On the other hand, I have confirmed the correctness of the observation of Winslow that acid-forming cocci are always Gram-positive, whilst the non-acid-forming are, as a rule, Gram-negative, and consequently it is doubtless right on that basis to set up two groups of cocci, which—I suppose—belong in quite different places in the bacterial system. However, my two groups of cocci do not cover those of Winslow, as I believe I am warranted in separating the lactic acid-forming streptococci, and grouping them together with the rod-formed lactic acid bacteria. The acid-forming micrococci and sarcinæ I have brought together in the genus *Tetracoccus*, as I believe it to be quite as wrong to draw a limit between the micrococci and the sarcinæ as between the short- and long-chained streptococci. The property of cohering after division, though in a certain measure characteristic of the bacteria, is to a great extent influenced by the temperature and the composition of the nutritive matter. For the Gram-negative, non-acid-forming or, at most,

very slightly acid-forming cocci (among which must probably be reckoned the gonococci and the meningococci too, as well as Gram-negative streptococci, if such exist) we might simply use the generic name *Coccus*, or, if they should turn out to have *terminal* flagella, *Coccomonas*.

Even as unjustifiable as it would be to unite all the spherical bacteria into a great family, *Coccaceae*, would it be to set up the family *Spirillaceae*. The rule is indubitably that in every bacterial family we may meet with both sphere, rod and screw forms. Certainly the lophotrichic spirilla, both in regard to their morphological and to their biological properties, form a natural group. This thoroughly justifies the setting up of a genus, *Spirillum*, or better *Spiromonas*, a new designation, which would also make it possible to incorporate nearly related monotrichic species in this group. We should surely be warranted in doing so, since in other genera of cephalotrichic rods we meet with both monotrichic and lophotrichic species. The genus *Vibrio*, which the bacteriologists, one and all, reckon among the family *Spirillaceae*, can on the contrary scarcely be maintained, since these organisms pass gradually through the phosphorescent bacteria into the cephalotrichic rods.

The only morphological property of the bacteria which can perhaps be taken into account as a family character, is spore formation. Yet this property as such is not used in the case of the sarcinæ nor of the spirilla, and it is not always quite constant, even in the true bacilli. In cheese I have frequently met with aerobic, gelatin-liquefying, gas-producing plectridia which comparatively easily lost the ability to form spores and thus were not distinguishable from the *Proteus* bacteria. Thus, these interesting forms not only form the transition between the spore-forming and the non-spore-forming rods, but, as aerobic plectridia, between aerobic and anaerobic bacilli. In my opinion, we generally know too little as yet about the bacteria to be warranted in definitely setting up families, and I therefore consider we may safely put that off to the time when all the groups of bacteria have been as thoroughly studied as the lactic acid bacteria have recently been.

Buchanan (1917) sets up six orders of bacteria. I shall not undertake to discuss whether he is right or not, but only point out that if we follow him consistently the order *Eubacteriales* is necessarily to be divided into two orders, which we may call *Pseudomonadales* and *Peritrichinales*, as these two groups are by no means more closely related than *Pseudomonadales* and *Thiobacteriales* (the sulphur bacteria), forming together the cephalotrichic bacteria. Again to reduce the seven orders thus established to the corresponding families would perhaps not be a quite unsatisfactory solution of the family problem.

If we class together the genera which I have set up—with the amendments occasioned by my experience and that acquired by other researchers—into the above-mentioned two orders, we arrive at the following general synopsis:

*Order 1: Pseudomonadales*

- 1 Methanomonas
- 2 Carboxydomonas
- 3 Hydrogenomonas
- 4 Nitrosomonas
- 5 Nitromonas
- 6 Azotomonas
- 7 Rhizomonas
- 8 Acetimonas
- 9 Fluormonas
- 10 Photomonas
- 11 Spiromonas

*Order 2: Peritrichinales*

- 1 Thermobacterium
- 2 Streptobacterium
- 3 Streptococcus
- 4 Betabacterium
- 5 Betacoccus
- 6 Propionibacterium\*
- 7 Microbacterium\*
- 8 Tetracoccus
- 9 Coccus
- 10 Bacterium\*
- 11 Bacillus\*
- 12 Clostridium\*

As for the position of *Rhizomonas* (*Rhizobium*) in the system, I accept the proposal of the Committee, to place it next to *Azotomonas* (*Azotobacter*). I have myself really met with forked cells in different genera of bacteria and thus cannot attach a decisive, systematic importance to the furcation. After the researches of Barthel (1917) and those of Burrill and Hansen (1917) it must now be considered as certain that *Rhizomonas* is lophotrichic, and as a Gram-negative, lophotrichic nitrogen gatherer it ranks naturally with *Azotomonas*.

On the other hand, I cannot accept the proposition of the Committee to give the acetic acid bacteria the generic name

*Mycoderma*, since—apart from the circumstance that this name does not fit in with my nomenclature—it is already generally used as a generic name of certain pellicle-forming yeasts. Moreover, the designation *Mycoderma* (*Mycoderma vini* and *Mycoderma aceti*) dates from a far more ancient time than that cited by the Committee.

Although the property of setting free nitrogen from nitrates and nitrites is not of so general occurrence among the bacteria as is the property of reducing nitrate to nitrite or ammonia, we meet with the property of denitrification in different bacterial genera, and hence it would be unwarrantable to maintain the genera *Denitromonas* and *Denitrobacterium*, set up by me. As the property of liquefying gelatin also cannot be adopted as a generic character but only as a species character, I think it would be best to group together my earlier genera *Denitromonas* and *Liquidomonas* in a single genus, which can be conveniently termed *Fluormonas*, as the bacteria of this group are ordinarily fluorescent. I cannot agree to call this genus *Pseudomonas* merely out of regard for so-called priority, as each and all of the bacteria which belong to the order under consideration are really Pseudomonades as well.

As the phosphorescent bacteria form, biologically, a connected whole, I deem it correct to unite them so as to form one genus, for which a better name than *Photomonas* can hardly be found.

According to the experience we have acquired in regard to the nitrate-reducing bacteria there will scarcely be any reason to create a special genus for sulphate-reducing bacteria; but we naturally include the vibrios belonging here in the genus *Spiromonas*. The reason why I prefer this designation over the generic name *Spirillum*, has been mentioned above.

As for the second order of bacteria, I provisionally follow the proposition of the Committee with the differences justified by my researches on the lactic acid bacteria. I have no doubt that the genera marked with an asterisk (\*), when studied more closely, will dissolve into two or more genera, some of which will cover some of those proposed in my natural bacterial system.

Whereas the shape of cells was formerly used as a family character, I have adopted it only as a generic one, and if we do not want to further confine its signification and only consider it as a specific character, we shall doubtless have to set up the genus *Propionicoccus* besides the genus *Propionibacterium*.

*Microbacterium* is to be understood as merely a provisional collective name for Gram-positive rods of size a little smaller than the ordinary bacteria. In biological respects some of these rods (*Bacillus acidophilus*) are closely related to the true lactic acid bacteria, whereas others approach the Tetracocci or the aerobic bacilli.

The genus *Tetracoccus*, including strictly aerobic as well as strictly anaerobic-species, is probably of as polygenetic a nature as is the genus *Microbacterium*, and the genus *Coccus* perhaps does not belong at all in the order of bacteria in question. In biological respects the Gram-negative, strictly aerobic, chromogenic cocci certainly appear to attach themselves rather closely to the genus *Fluoromonas*; yet their place in the system cannot be determined with certainty until the arrangement of the flagella of the motile species has been studied.

The genus *Bacterium* will undoubtedly dissolve into several genera, of which I may especially mention the *Colibacterium* and *Aerogenesbacterium*. The reason why I am now inclined, in contrast to my earlier opinion, to consider the coli- and aerogenesbacteria as two different genera, is because they differ not only in morphological, but, as later researches have shown, also in biological respects. I have myself proved (1914), that the Aerogenesbacteria completely oxidize the carbohydrates when the nutrient matter offers a sufficient buffer effect, and they thus correspond with their name in forming more gas than do other bacteria, and Rogers, Clark and Davis (1914) have shown that in the gas developed by the Colibacteria there is proportionately more hydrogen than in that developed by the Aerogenesbacteria. Perhaps the Committee is right in not regarding the Proteus-bacteria (my genus *Liquidomonas*) as a separate genus, as their whole metabolism indicates that they are to be looked upon as gelatin-liquefying Coli- and Aerogenesbacteria.

Just as the behavior towards the different sugars is one of the most valuable characteristics of the acid-forming bacteria, so the relation to the different amino-acids can be used to divide the ammonia-forming bacteria, and this probably is the way to arrive at a closer division of the genus *Bacillus*.

The use of the term *Clostridium* as a generic name presents the inconvenience that under the same we must group together not only the clostridia but also the plectridia. The division into true butyric acid bacteria (*Butyriclostridium*), the requirements of which in regard to nitrogenous nutriment are very moderate (they are able to assimilate even the nitrogen of the air) and anaerobic, putrefying bacteria (*Putriclostridium*) seems natural to me.

As all Pseudomonades—so far as I know—are completely or partially decolorized by Gram, it is reasonable to seek a connection with the peritrichic bacteria among the Gram-negative representatives of the latter group, and it ranges naturally from the denitrificating species of the genus *Fluormonas* to the denitrificating species of the genus *Bacterium*. The development then from here has gone farther in one direction to the putrefying bacteria, characterized by breaking down amino-acids, and in the other direction to the lactic acid bacteria, which are not able to attack amino-acids, but demand the most complex nitrogenous nutriment.

## REFERENCES

- BARTHEL, C. 1917 Zeitschrift für Gärungsphysiologie, **6**, 13-17.  
BREED, R. S., CONN, H. J., AND BAKER, J. C. 1918 Jour. Bact., **3**, 445-459.  
BUCHANAN, R. E. 1917 Jour. Bact., **2**, 155-164, 347-350.  
BURRILL, T. J. AND HANSEN, R. 1917 Ill. Agr. Exp. Stat. Bull. 202.  
ORLA-JENSEN, S. 1907 Det kgl. danske Videnskabernes Selskabs Oversigter, No. 5.  
ORLA-JENSEN, S. 1909 Centralblatt f. Bacteriologie, 2 Abt., **22**, 305-346.  
ORLA-JENSEN, S. 1914 International Dairy Congress at Bern.  
ROGERS, L. A., CLARK, W. M., AND DAVIS, B. J. 1914 Jour. Infect. Dis., **14**, 411-475.  
WINSLOW, C.-E. A., AND OTHERS 1917 Jour. Bact., **2**, 505-566.





# VARIATIONS IN TYPHOID BACILLI<sup>1</sup>

KAN-ICHIRO MORISHIMA

*Department of Bacteriology, College of Physicians and Surgeons, Columbia University, New York City*

Received for publication September 10, 1920

## INTRODUCTION

Just as there is often great difficulty in diagnosing atypical clinical conditions, so great difficulty may be experienced in identifying bacteria which develop abnormal characteristics. The acquisition, by individual strains of many species of bacteria, of morphological and cultural characteristics which differ from the usual type has been noted by many observers and has been referred to more or less loosely by several different terms. Thus, Neisser (1906) and Massini (1907) used the word "mutation" to designate atypical forms of *Bact. coli*, Pringsheim (1911) speaks of an "adaptation" of bacteria, and Gurney-Dixon (1919) uses the term "transmutation."

We can sometimes follow such variations by gradual changes, from one stage to another, during which the bacteria pass through a process of evolution, adapting themselves to their surroundings.

Such variations may consist in the acquisition of new morphological, biochemical, or serological characters, in the loss of similar properties, or the two processes may occur at one and the same time. The change may be sudden or gradual, and is generally retained by the offspring.

The study of such variations is of fundamental importance to an understanding of the bacteria and may have considerable botanical importance since it would seem that processes of evolution or adaptation could be most easily investigated with

<sup>1</sup> Submitted in partial fulfillment of the requirements for the degree of Doctor of Philosophy, in the Faculty of Pure Science, Columbia University, May, 1920.

forms whose characteristics are easily studied and in which generation follows generation with such speed that observation over the period of a year or longer might correspond to ages of development among the higher species. Moreover, from a purely practical point of view it is necessary to know to some extent just how much and how permanent a degree of variation is to be expected when well-known species are subjected to alteration between the conditions prevalent in artificial media and those existing in the human and animal bodies.

In the following studies the writer has occupied himself exclusively with the changes observed in the typhoid bacillus.

### *Strains*

The cultures employed in this study were 138 in number and had been carried on artificial mediums since their isolation from patients. They were divided into three groups, as follows:

1. The stock cultures of the United States Army Medical School . . . 116
2. Cultures collected by Dr. Oscar Teague . . . . . 10
3. Cultures collected by Lieut. R. C. Colwell in France, and given  
us by courtesy of Lieutenant-Colonel Nichols . . . . . 12

The sources of these cultures were as follows:

	<i>strains</i>
Blood cultures . . . . .	55
Stool cultures . . . . .	15
Urine cultures . . . . .	11
Bile cultures . . . . .	1
Sources unknown . . . . .	56

Duration of cultivation on artificial media:

Over two years . . . . .	15
One to two years . . . . .	25
Six to twelve months . . . . .	42
Less than six months . . . . .	32
Recent isolation . . . . .	11
Age unknown . . . . .	13

*Media and technique*

In our experiments the media used and technique employed were as follows:

(a) Meat infusion broth. Meat infusion inoculated with *Bact. coli*, incubated about twenty-four hours at 37°C., autoclaved and filtered. To this was added 1 per cent pepton and 0.5 per cent sodium chloride.

(b) Nutrose broth. Instead of meat infusion 0.25 per cent nutrose was used. Both broth media were autoclaved for fifteen minutes at 15 pounds' pressure, and the reaction was adjusted to pH 7.0 or pH 7.1.

(c) Media containing sugars. In order to diminish the risk of decomposing the sugars during sterilization, they were dissolved in sterile distilled water, and heated in the autoclave for ten minutes at 10 pounds' pressure.

The sterilized sugar solution was added in the proportion of 1 per cent to the sterile broth together with 5 cc. of sterilized litmus or 5 cc. of 2 per cent phenol red and 1.2 cc. of decolorized 1 per cent aqueous solution of china blue (Morishima, 1917) per 100 cc. of the broth. Then the medium was transferred to small test tubes, and allowed to stand at least twenty-four hours at 37°C. in an incubator and for twenty-four hours at room temperature before being used.

For plates meat infusion agar (2 per cent) containing 1 per cent of the sugar was used. Decolorized china blue was then added in the proportion given above for the fluid medium. The reaction of all media mentioned above was adjusted to pH = 7.0 or pH = 7.1 by means of phenol red.

The stock cultures were transferred to agar slopes and incubated over night. Then pepton water tubes (1 per cent pepton 0.5 per cent salt solution, reaction pH 7.0) were inoculated from the slant cultures. After the latter had been incubated over night, one loopful of the pepton water growth was transferred to each tube of sugar medium; agglutination tests with the pepton cultures were also carried out.

In plating cultures on Endo or any other plates, one or two loopfuls of bacterial suspensions were usually streaked close to the margin of the Petri dish. The plate was divided into five parts by lines drawn on its bottom. From the first streak made with the loop, the suspension was spread over one-fifth of the surface; from the border of this area over the next third, and then from the last border over the remaining surface. By this method the distribution of bacteria was found to be satisfactory (Morishima, 1917). They were then kept in the incuba-

tor until the end of the experiment. Endo plates were occasionally inoculated from the sugar media in order to control possible contamination of the latter.

### I. VARIATIONS IN THE UTILIZATION OF CARBOHYDRATES

Variations in the biological behavior of the typhoid bacillus have been the subject of a great deal of investigation but, in the earlier work, especially, the identification of the races under observation was often incomplete (at least as far as one can judge from the publications) and all the reported results cannot be accepted without analysis.

Some of the earliest work was done on indol formation and on the fermentation of lactose.

Miss Peckham (1897) induced indol formation in a number of strains of *Bact. typhosum*.

Wilson (1902) isolated a strain from a typhoid carrier which produced acidity in lactose media at 22°C. while it did not produce it at 37°C. and the strain agglutinated only in 1:50 dilution of a typhoid serum of high titre. In other respects it resembled typical typhoid strains.

Klotz (1904) isolated from the St. Lawrence River water, a typhoid-like organism which he called *B. perturbans*. It fermented lactose and sucrose, formed indol, produced acidity in milk without coagulation and agglutinated with 1:2480 dilution of anti-typhoid serum.

McNaught (1905) isolated two organisms which he named *B. typhosus similans*, one of them from harbor water, the other from a well. The former did not produce indol and the latter did. Neither agglutinated in anti-typhoid serum. Both were motile when isolated but after some days of cultivation lost their motility.

Klotz's strain isolated from the water of the St. Lawrence River; McNaught's *B. typhosus similans*; and Wilson's strain isolated from a typhoid carrier's stool cannot be definitely accepted as real typhoid bacilli, because they were not sufficiently investigated to determine this fact positively.

Mandelbaum (1912) obtained a bacillus from the blood or feces of more than fifty patients with clinical typhoid fever in Munich, which he named *B. metatyphi*. This bacillus resembled *Bact. typhosum* in all respects except that it produced alkali instead of acid in media con-

taining glycerol. He showed that these cases were infected, in all probability from the same typhoid carrier, a woman who served as a milker in a dairy near Munich. This woman harbored both typical and atypical bacilli. The *B. metatyphi* retained the property of producing alkali in glycerol medium for five and one-half years when transplanted on plain nutrient agar. Russowici (1908) reported one case of *B. metatyphi*, and Ditthorn and Luerssen (1912) reported two similar cases.

Jacobsen obtained (1910) a bacillus which he described as *B. typhi mutabile* from a small epidemic of clinical typhoid fever in an insane asylum in Denmark. It resembled *Bact. typhosum* in all respects except the following:

1. It fermented mannitol after fifty hours.
2. Its growth was strongly inhibited on Conradi-Drigalski agar or plain agar which had been autoclaved.
3. Cultures from the plates showing retarded growth did not agglutinate in typhoid immune serum, but cultures of the same strain on media yielding good growth gave typical agglutination with typhoid immune serum and resembled *Bact. typhosum* in all other respects. *B. typhi mutabile* gave good specific agglutination five months after its isolation. There was normal growth on the Endo plates which removed the inhibitory action exerted on this strain by other media.

Fromme (1911) reports a bacillus, the growth of which was retarded on nutrient agar but which grew in ascitic fluid, human blood, guinea pig's blood, rabbit's blood and egg-yolk or on agar to which sodium sulphite had been added. His bacillus differed from Jacobsen's in that it agglutinated with typhoid immune serum from the start.

The variants of typhoid bacilli—*B. metatyphid* (Mandelbaum), *B. typhi mutabile* (Jacobsen) and the xylose non-fermenter of Weiss are unquestionably true *Bact. typhosum*.

Twort (1907) after growing a strain of *Bact. typhosum* for two years in lactose media succeeded in producing a strain that fermented lactose. He also conducted special experiments with a typhoid bacillus which had acquired the power of fermenting dulcitol. When such a culture was plated out on agar, subcultures from single colonies retained the dulcitol splitting powers, although they were still capable of being agglutinated by a typhoid immune serum, thus proving that the fermentation was not due to any contaminating microbe. On inoculating the dulcitol-fermenting typhoid culture into a guinea pig, subcultures were obtained showing the same reactions and these reactions were also maintained, even when the organism was grown for several

generations on ordinary pepton agar. His conclusions were that the sugar fermenting powers of an organism may be artificially changed by growing the said organism for a succession of generations in media containing a sugar which at the commencement of the experiment it was unable to ferment.

Kuwabara (1907, 1909) under the direction of Dr. Shiga isolated an atypical typhoid in addition to a typical one from a typhoid patient's stool. It fermented lactose, sucrose, and milk-whey as *Bact. coli* does and produced reddish color on Endo and Conradi-Drigalski plates but agglutinated in antityphoid rabbit serum in high dilutions just as a normal culture of typhoid bacilli did. After twelve to fifteen passages through plain laboratory nutrient media these atypical characters all disappeared.

The results of Twort and Kuwabara amount practically to a complete alteration of the identification characteristics of the typhoid bacillus. These observations are of the greatest theoretical importance but fortunately strains of this nature have been produced or observed so rarely that they cannot be regarded as a practically important factor of confusion in identification. This is apparent from Penfold's work cited below.

Penfold (1910a, 1910b, 1911, 1914) as cited by Dixon, working with twenty strains and carrying many of them for more than a year in a lactose medium, obtained only negative results; he showed that the Twort lactose fermenting strain gave rise to daughter colonies on lactose agar. This Twort culture fermented sorbitol in broth only after a number of days and Penfold found that it also gave rise to daughter colonies on sorbitol agar. He observed with some of his cultures late acid production in rhamnose broth and on transplanting from rhamnose broth to rhamnose broth after several weeks of incubation, he was able to obtain subcultures which fermented in one, two or three days. He also made a very careful study of the behavior of *Bact. typhosum* in dulcitol broth and on neutral red dulcitol agar. In one of his experiments in which fourteen strains were inoculated into dulcitol broth the first signs of acidity occurred in from five to fifteen days. If, after one month, subcultures were made in new dulcitol broth, an acid reaction was produced in from one to four days. Subcultures, which had been trained to ferment dulcitol rapidly showed great permanency; one such culture transplanted twenty-five times in pepton water during a period

of five months and then plated on neutral red dulcitol agar yielded only fermenting colonies. Twenty colonies from a MacConkey plate of pure typhoid were inoculated into dulcitol broth; the time required for acidity to appear varied from eleven to thirty-two days. Slow fermenters of dulcitol died in dulcitol broth in two months while quick fermenters remained alive longer. He found one strain which did not ferment arabinose, but which after three months' subculturings became a quick fermenter. Three strains that did not ferment glycerol became after eight months' subcultivation quick fermenters, but never in less time than three to four days. In plating out on glycerol media he found a mixture of quick and slow fermenters.

Reiner Müller (1908, 1911) did not observe acid production in rhamnose by any of his typhoid cultures and noticed that the colonies on the rhamnose plates remained small and delicate but that 5 per cent rhamnose produced no more inhibition than 0.5 per cent. He showed, further, that other bacteria of the typhoid-colon group are not inhibited by rhamnose. He observed no production of acidity by typhoid bacilli on litmus agar containing arabinose, dulcitol or raffinose, but he observed acidity on rhamnose Endo agar.

Bull and Pritchett (1916) found an atypical typhoid strain showing irregularity in fermentation, glucose, levulose, and dextrin being all positive and the other sugars negative; indol being positive as in the case of *Bact. coli*, but the organism agglutinated in 1:20,000 dilution.

Krumwiede, Kohn and Valentine (1918) inoculated thirty-seven strains of *Bact. typhosum* into xylose broth and found that twenty-nine produced acid in twenty-four hours while eight of the strains required from five to thirteen days for this result.

Winslow, Kligler, and Rothberg (1919) recently reported the results of similar investigations of various bacteria. They describe the typical typhoid bacillus as a Gram-negative, non-spore-forming rod, actively motile. It forms translucent irregular colonies on gelatin media and faint, nearly colorless growths on potato. It produces strong and prompt acid but no gas in media containing the hexoses, maltose, mannitol, sorbitol, xylose and dextrin; it does not attack arabinose, rhamnose, or lactose; produces a slight initial reddening of litmus milk, which after two weeks reverts to a neutral or slightly alkaline reaction. It

fails to form indol or liquefy gelatin, will not grow in asparagin-mannitol medium, does not reduce neutral red and causes browning of lead acetate media. It has low tolerance for acid, but rather high tolerance for brilliant green dyes and alkali. It has characteristic serum agglutination reactions and is found in human stools and urines as an actual or potential cause of typhoid fever.

OUR OWN WORK ON VARIATION IN THE UTILIZATION OF  
CARBOHYDRATES

Some of this work has already been reported in the *Journal of Infectious Diseases*, 1920, 26, 52-76. The following table represents a condensed summary of previous work, together with new experiments performed since then:

*Sugar fermentation*

Arabinose broth

	<i>Number of strains</i>
First series. Meat infusion broth (litmus indicator) . . . . .	114
Second series. Nutrose broth (phenol red, china blue, indicators). . . . .	117
Third series. The same medium . . . . .	21
Fourth series. Meat infusion broth (phenol red, china blue, indicators) . . . . .	24
Results were as follows:	
Positive on the second day . . . . .	2
Positive on the third day . . . . .	1
Positive on the fourth day . . . . .	2
Positive on the sixth day . . . . .	6
Positive on the seventh day . . . . .	4
Positive on the ninth day . . . . .	1
Positive on the tenth day . . . . .	2
Positive on the eleventh day . . . . .	1
Positive on the fourteenth day . . . . .	1
Positive on the twenty-third day . . . . .	1
Positive on the twenty-fourth day . . . . .	1
Positive on the twenty-eighth day . . . . .	1
Positive (total) . . . . .	23
Negative on the 30th day . . . . .	279

The proportion of positives is 8.24 per cent against 91.76 per cent of negatives.



*Dulcitol*

We could not obtain uniform fermentation results with this sugar, despite many attempts. Some strains gave rise to acid at one time and failed to do so at others. On the other hand certain strains gave rise to alkalinity at the first test and in later tests gave an acid reaction. Usually they produced acid in from one to three weeks.

	<i>Number of strains</i>
First series. Meat infusion broth (litmus) . . . . .	115
Second series. Meat infusion broth (litmus) . . . . .	57
Third series. Nutrose broth (phenol red, china blue) . . . . .	21
Fourth series. Meat infusion broth (phenol red, china blue) . . . . .	29
Fifth series. Meat infusion broth (phenol red, china blue) . . . . .	139
The results were as below:	
Positive on the fourth day . . . . .	1
Positive on the sixth day . . . . .	26
Positive on the seventh day . . . . .	15
Positive on the ninth day . . . . .	31
Positive on the tenth day . . . . .	2
Positive on the eleventh day . . . . .	7
Positive on the twelfth day . . . . .	11
Positive on the thirteenth day . . . . .	9
Positive on the fourteenth day . . . . .	11
Positive on the fifteenth day . . . . .	11
Positive on the sixteenth day . . . . .	3
Positive on the seventeenth day . . . . .	3
Positive on the nineteenth day . . . . .	1
Positive on the twenty-third day . . . . .	12
Positive on the twenty-sixth day . . . . .	3
Positive on the thirtieth day . . . . .	9
Positive on the thirty-first day . . . . .	1
Total positive on or before the thirty-first day . . . . .	186
Negative on thirty-first day . . . . .	175

The proportion of positives is 51.51 per cent against 48.49 per cent of negatives.

In all of these tests there was a greater tendency for the indicators (litmus, or china blue-phenol red) to become reduced than was evident in arabinose or xylose broth cultures. For this reason it is possible that the percentage of positives may be too low, as all tubes showing reduction were recorded as negative.

*Glycerol*

## Glycerol broth

We prepared 1 per cent glycerol meat infusion broth, using china blue-phenol red indicator.

First series . . . . .	<i>strains</i> 123
Second series . . . . .	10
Third series . . . . .	10
Fourth series . . . . .	10
Total . . . . .	<hr/> 153

All of the cultures produced acidity.

Recently we studied these phenomena with 257 freshly isolated typhoid cultures from typhoid carriers' stools, using two different percentages of glycerol, namely 2 per cent and 6 per cent. We never found any alkali production in the early stage of incubation, but observed acid production between the third and eighth day; later some of the cultures showed reduction of color.

*Inosite*

Inosite is not a true sugar, but its character is similar to that of sugar and therefore it deserves discussion here.

## Inosite broth

One hundred and forty-two strains were inoculated in 1 per cent inosite meat infusion broth, using china blue, phenol red indicator. No fermentation or gas production resulted after thirty days' incubation. Nine subcultures were transferred from inosite broth to inosite broth with the same result.

*Raffinose*

## Raffinose broth

We used 1 per cent raffinose meat infusion broth, with china blue-phenol red indicator. In the first and fourth series, typhoid bacilli did not grow. The media showed slight acidity before

inoculation, but not sufficient to account for the inhibition of growth of typhoid bacilli. We do not know what substance caused this inhibitory action.

In the second series 60 strains and in the third series 21 strains were inoculated; all tubes became alkaline on the second day and showed no fermentation after thirty days' incubation. Of course both sets of media showed a neutral reaction before inoculation. Subcultures from a few of these raffinose broth cultures in raffinose broth again failed to produce fermentation.

### *Rhamnose*

#### Rhamnose broth

One per cent rhamnose meat infusion broth, with china blue and phenol red as indicators was used for this experiment. One set of tubes was inoculated with 144 strains of typhoid, and another with 19 strains. Both produced alkalinity after twenty-four to forty-eight hours' incubation.

### *Salicin*

#### Salicin broth

One per cent salicin meat infusion broth, containing china blue and phenol red indicator, was used. Two series of experiments, with 144 strains and with 21 strains were carried out, but no fermentation resulted during thirty days' incubation.

### *Xylose*

We used for the most part 1 per cent xylose meat infusion broth, with china blue and phenol red indicator. During the course of this study we carried on many fermentation experiments, in which we found 8 per cent of 126 strains to be xylose non-fermenters, while the remaining strains all fermented xylose in twenty-four hours. Apparently these 10 negative strains, and in addition 12 strains brought from France by Lieutenant Colwell were found to be slow xylose fermenters. On carrying

subcultures of these strains from xylose broth to xylose broth ten strains (not Lieutenant Colwell's strains) became xylose fermenters in twenty-four hours (or somewhat later) after a few transfers.

#### CROSS FERMENTATION OF BACTERIA IN DIFFERENT SUGARS

It might be supposed that a single enzyme produced by bacteria when cultivated in sugar media, especially those closely related, such as xylose and arabinose, might ferment more than one sugar. To test this supposition, 6 xylose fermenters, 7 arabinose fermenters, 9 dulcitol fermenters (all fermenting in twenty-four hours) and 6 xylose slow fermenters, 6 arabinose slow fermenters and 7 dulcitol fermenters were inoculated into three sets of sugar media. We could not find any evidence of cross fermentation. After thirty-five days' incubation the fermenter of a given sugar still continued to ferment the same sugar, and no other. Therefore, the enzymes produced by bacteria are, as assumed by many workers, specific for each sugar.

#### DURATION OF THE FERMENTING POWER

Some strains, which had been artificially induced to ferment certain sugars, maintained their fermenting power after three or four months, or even half a year, although few transplantations were made from one fresh medium to another, this being done in some cases to media containing no sugar. Other strains, however, lost their fermenting power quickly, after only one or two transplantations. Dulcitol fermenters especially are apt to be changeable. Our records show two strains which at first fermented dulcitol in twenty-four hours. Later one of them fermented dulcitol only after four days and the other after twenty-one days. Similarly a strain which at first fermented arabinose in twenty-four hours, later required six days for the fermentation of this sugar.

## FERMENTATION REACTIONS UNDER ANAEROBIC CONDITIONS

In the preceding experiments our cultures were grown under aerobic conditions. The following experiments were carried out anaerobically:

Two methods were used in these experiments. One was a combination of exhaustion and absorption with pyrogallol as used in this laboratory for routine work; and the other was the one devised by McIntosh and Fildes.

For the latter method we used a glass jar, connected by means of tubing with a tank of compressed hydrogen, which was inverted in a larger jar filled with water to a level of two or three inches above the inverted jar. The latter is held down by weights when its contents are displaced by hydrogen. Another tube fitted with a clamp connects this jar with the jar containing cultures. When everything is prepared in the culture jar a copper gauze package containing platinum asbestos is heated to redness and placed in the culture jar. The jar is sealed and the clamp released gradually thus allowing the hydrogen to enter the culture jar. The platinum asbestos will act as a catalyser to cause combination of oxygen and hydrogen.

When the oxygen in the jar is exhausted no more hydrogen will enter the jar. Then we seal the glass tubing to prevent the entry of air.

On account of its greater convenience we used the latter method more frequently.

Typhoid bacilli did not grow well under anaerobic conditions; consequently all reactions in sugar media were somewhat slower than under aerobic conditions.

*A. Sugar broth cultures*

We tried six strains in 0.01 per cent glucose, 1 per cent raffinose, 1 per cent arabinose, 1 per cent dulcitol, 1 and 2 per cent rhamnose, 1 per cent xylose and 2 per cent xylose. The results were as follows:

*(a) Glucose*

**Aerobic:** On twenty-four hours' incubation media distinctly showed alkalinity.

**Anaerobic:** Very slightly alkaline, even after ten days' incubation.

(b) *Dulcitol*

Aerobic: On tenth day, two cultures showed good acidity and on twentieth day four of them showed good acidity.

Anaerobic: Did not show acidity on tenth day; on twentieth day three of them showed slight acidity.

(c) *Rhamnose*

Aerobic: On the fourth day showed good alkalinity.

Anaerobic: On fifteenth day began to show alkalinity.

(d) *Xylose*.

True xylose fermenters ferment in twenty-four hours, under both conditions. The results with four slow fermenters follow: Aerobic: On sixth day one of them and on the eighth day two strains began to ferment.

Anaerobic: Up to the twentieth day no change in reaction appeared, then the same strains that fermented xylose under aerobic conditions produced very slight acidity.

(e) *Arabinose*

Aerobic: On the third day, they showed alkalinity and on the fifth day one strain showed slight acidity.

Anaerobic: Slight alkalinity persisted until the twenty-first day.

(f) *Raffinose*

Aerobic: On second day showed alkalinity.

Anaerobic: On the eighteenth day showed slight alkalinity. In second series, we tested four strains, and in a third series, four strains on xylose broth but they did not show sufficiently definite changes to be described here.

It will be seen from the above that our own work does not in every way agree with the work of others cited at the beginning of this section. As stated above, we believe that the strains of Klotz, McNaught and Wilson cannot be definitely accepted as having been true typhoid bacilli.

In regard to Mandelbaum's *Bacillus metatypfi* we feel that our results seem to indicate that Mandelbaum was dealing with slow glycerol fermenters rather than with known fermenting strains. We should add, however, that we ourselves never encountered any strains which exhibited the characteristics described by Mandelbaum.

As for the strains of Jacobsen none of our cultures corresponded to these.

As to the results of Penfold and Reiner-Müller, our results agree pretty definitely with those reported by these workers.

No strains corresponding to those described by Bull and Pritchett were met with by us and we were able to find no similar ones described in the literature.

We have confirmed the observations of Krumwiede, Kohn and Valentine, and in addition have shown in this work, as well as in a previous publication with Dr. Teague, that rapid xylose fermenters can be produced from slow fermenters with considerable ease.

Although in almost every respect our work corresponds with that of Winslow, Kligler and Rothberg, they do not entirely correspond with the results of these workers in regard to the action of the typhoid bacillus upon arabinose. Subcultures that ferment arabinose rapidly still retain this characteristic after having been kept on plain nutrient agar for one or two months.

The enzyme produced by a typhoid bacillus from one of the sugars, xylose, arabinose, or dulcitol, may be greatly increased without affecting the production of ferments for the other two sugars. In anaerobic cultures of typhoid bacilli the lack of oxygen supply causes a partial inhibition of growth.

#### DAUGHTER COLONIES<sup>2</sup>

Reiner Müller (1908, 1911) first showed that *Bact. typhosum* produced daughter colonies on rhamnose agar. He examined a large number of cultures in this regard and found that they all gave rise to daughter colonies and further that *Bact. typhosum* produced daughter colonies in eight days on agar containing as little as 0.025 per cent of rhamnose and in fourteen days on agar containing only 0.01 per cent. He suggests that the development of daughter colonies on rhamnose agar might be utilized in the identification of *Bact. typhosum*; the results

<sup>2</sup> The term "daughter colony" is used throughout as signifying the type of secondary colonies arising spontaneously within the substance of the parent colony. The formation of these daughter colonies seems to signify that certain individual cells within the colony acquire the property of utilizing the sugar and therefore growing with much greater speed than the remaining bacteria making up the mother colony.

obtained by Penfold, Saisawa, and by us as far as they go, indicate that he was right in concluding that all typhoid cultures exhibit the phenomenon. Muller and Saisawa found that some other bacteria besides *Bact. typhosum* also give rise to daughter colonies on rhamnose agar.

Penfold (1911) found that the twenty strains of *Bact. typhosum* investigated by him all gave daughter colonies on rhamnose neutral red agar and he noticed acid production in none of the daughter colonies. But after a number of subcultures in rhamnose broth, he obtained a strain which fermented rhamnose. Such a rapid fermenter no longer produced daughter colonies on rhamnose agar and even when it was passed through thirteen generations of pepton water and plated on rhamnose agar it still did not give rise to daughter colonies. He found that the Twort lactose fermenting *Bact. typhosum* and a typhoid culture which had been trained to ferment dulcitol rapidly both produced daughter colonies on rhamnose agar. Three strains inoculated on neutral red dulcitol agar yielded daughter colonies as early as the third day and some of the latter were acid by the fifth day. Some plates showed as low as 2 per cent of colonies with daughter colonies, some as high as 50 per cent. Different plates inoculated with the same culture also showed variations within these limits.

Mandelbaum (1912) observed the production of daughter colonies from *B. metatyphi* on glycerol agar; from daughter colonies were obtained organisms which behaved in all respects like *Bact. typhosum*.

Bernhardt and Ornstein (1913) found colonies on dried agar with irregular outlines, and nucleus forms like anthrax colonies besides the normal typhoid colonies. On cultivating in bouillon this organism produced a film on the surface and was only slightly motile. They did not observe any phenomena of hypo- or in-agglutinability. These types we too have seen on dried plates but they are not real daughter colonies.

Gildermeister's (1913) typhoid strains produced daughter colonies on rhamnose agar except in one strain which had been isolated from a stool. The dysentery bacillus, Shiga-Kruse type and Strong type, *Bact. coli*, *Bact. alkaligenes*, paratyphoid bacilli, Gaertner bacilli, and cholera vibrios did not produce daughter colonies, but *Bact. dysenteriae*, Flexner type, and six out of fourteen strains of the "Y" type produced them. Six passages on ascitic agar or transplants over two weeks in rhamnose bouillon caused typhoid bacilli to grow colonies without daughter colonies on rhamnose agar.



Saisawa (1913) observed daughter colonies of *Bact. typhosum* when plated on rhamnose, dulcitol, arabinose (small ones) or erythrite agar after one week. Also he found daughter colonies on plating on rhamnose agar all of twenty-five strains of typhoid, three strains of Shiga type of dysentery, three strains of Flexner type, thirteen strains of Y-type, two strains of Strong type, two out of three strains of Pseudodysenteriae and none of ten strains of Paratyphoid B, five strains of Paratyphoid A, ten strains of Gaertner's bacillus, three strains of mouse-typhoid and six strains of *Bact. coli*. He could not obtain any variation of typhoid bacilli in culture media containing phenol or malachite green or caffen or by heating at 50°C. for one hour.

Daughter colonies have been observed and studied in connection with cultures of *B. anthracis*, *V. cholerae*, *Bact. coli*, *Bact. dysenteriae*, and other organisms, but they were either caused by sugars not considered in this paper or were not due to sugars at all.

OUR OWN WORK WITH DAUGHTER COLONIES

A. On sugar media without indicator<sup>3</sup>

On the second day or a little later, in an isolated thin colony, one or more very small heaped-up yellow or slightly brownish

<sup>3</sup> The sugars which we used for our work were analyzed at the Bureau of Standards, Department of Commerce, at Washington, D. C. The results were as follows:

	<i>per cent</i>	
<i>Arabinose</i> .....	94.1	
Moisture . . . . .	1.1	Audubon Sugar School, Baton Rouge,
Insoluble matter . . . . .	1.4	La., 62 grams arabinose
Undetermined . . . . .	3.4	
Total impurity . . . . .	4.8	
<i>Rhamnose</i> .....	89.6	
Moisture . . . . .	9.9	Army Medical Museum, Rhamnose, AMS
Undetermined . . . . .	0.5	
<i>Xylose</i> . . . . .	100.6	
Moisture . . . . .	0.2	257378, xylose, Difco Standard, Digestive Ferment Co., Detroit, Mich., U. S. A.
<i>Raffinose</i> . . . . .	82.5	
Moisture . . . . .	15.1	Raffinose—no label to show where from
Total impurity . . . . .	2.4	
<i>Dulcitol</i> .....		
Polarization . . . . .	0	Dulcitol 10 grams Special Chemicals Co., Not inc., Highland Park, Ill.
Polarization in presence of borax . . . . .	0	
Melting point . . . . .	188	

yellow granules appear on the surface. Their borders can be distinctly seen by means of a hand lens or a low power microscope. Day by day they increase in thickness, in size, and in number, as the mother colonies enlarge. Later a confluent growth of the daughter colonies may entirely overgrow the mother colonies.

*B. On sugar plates containing indicators*

On plates which contain decolorized china blue the daughter colonies appear, blue in color and inside the mother colony. After a few days they increase in size, color, and number. The blue color doubtless is due to the production of acid by daughter colonies. Ten days or two weeks later, owing to a reduction of the dye, some of the fully grown colonies may have a brownish yellow color. The number of large blue daughter colonies that develop on the plate varies greatly according to the strains of typhoid bacilli employed, there being in some cases only 1 or 2, and in other cases 50 or 100 colonies.

Agglutination tests made with cultures of daughter colonies also showed no differences from those done with the original strain. When we used methylene blue eosin xylose plates (Holt-Harris and Teague, 1916) the mother colonies showed a pinkish color, but the daughter colonies appeared as white dots by transmitted light, some of which soon became black. These colonies exhibited the same rapidity of growth in the succeeding days that was described in the case of the blue daughter colonies on the china blue plates.

When we fished daughter colonies from the above plates and inoculated into the corresponding sugar broth, the latter showed acid production in twenty-four hours. We plated ten typhoid strains on eleven different 1 per cent sugar plates. On arabinose, dulcitol, raffinose, xylose and rhamnose plates from twenty to fifty strains were planted. The cultures were observed for about three weeks.

Below are described the variations in growth exhibited on each sugar medium:

1. *Arabinose*. Thirty-three strains plated on this medium. The daughter colonies appear in two to ten days, each colony usually containing many daughter colonies; a few of the daughter colonies frequently developed into large flat, deep blue colonies; all of the strains tested gave rise to daughter colonies.

2. *Dextrin*. No daughter colonies appeared.

3. *Glucose*. Colonies were smaller and denser than on other plates or control plates and no daughter colonies appeared.

4. *Dulcitol*. We plated forty cultures and daughter colonies appeared within two to five days. One or two opaque brownish yellow daughter colonies in a mother colony in succeeding days would grow so rapidly in size that sometimes the mother colony would be entirely covered. Furthermore, there is a tendency toward color reduction as the growth increases.

5. *Galactose*. Colonies were smaller than on control plain plates and no daughter colonies were produced.

6. *Glycerol*. We used 3 per cent glycerol plates for this purpose and obtained colonies which were very thick, opaque and yellowish brown in color. Plates containing China blue produced pale colonies on the first day, which became deep blue later. The color was reduced by the thick growth. No daughter colonies developed.

7. *Inosite*. No daughter colonies.

8. *Lactose*. No daughter colonies were seen.

9. *Mannitol*. No daughter colonies developed.

10. *Maltose*. There was good growth in point of size and thickness, but no daughter colonies were visible. Twenty strains were plated.

11. *Raffinose*. No daughter colonies developed, but ten days later, they showed papilliform colonies which did not increase in size nor in thickness on further incubation.

12. *Rhamnose*. All thirty typhoid strains which we tested on 1/10 per cent rhamnose plates gave rise to daughter colonies as well as on 1 per cent rhamnose plates. On the latter and on 2 per cent and 3 per cent plates, we could see many large opaque brownish yellow colonies scattered here and there with small daughter colonies and 1 per cent rhamnose Endo plates showed the same appearance.

The best method thus far developed for isolating typhoid bacilli from stools consists in plating upon a lactose medium containing brilliant green and an indicator for acid production. It seemed that a further improvement would be introduced by supplying a positive characteristic to the typhoid colonies instead of relying solely on the absence

of acid production. We attempted to accomplish this result by adding rhamnose (0.1 to 0.25 per cent) to brilliant green lactose agar, in the expectation that the daughter colonies within the typhoid colonies would furnish such a positive characteristic; however, we soon persuaded ourselves that this method has no practical value.

13. *Salicin*. No daughter colonies developed.

14. *Sucrose*. No daughter colonies developed.

15. *Xylose*. Fifty strains were planted. All xylose slow fermenters, thirteen in number, gave rise to daughter colonies on plates containing from 2 per cent to 0.04 per cent of xylose. The rapidly fermenting strains did not give rise to daughter colonies.

Sometimes xylose plates which contain 0.25 per cent glucose or which contained brilliant green eosin (Teague and Clurman) were used without interfering with the growth of the daughter colonies.

16. *Control plain plates*.

Some typhoid bacilli produced papillae-like forms on plain plates two or three weeks later when the plates were nearly dried up; such papillae sometimes occur also on plain plates inoculated with paratyphoid bacilli or *Bact. coli*. They never increase in size or in thickness. Therefore, we could not consider them true daughter colonies.

Under anaerobic conditions, we tested four strains, xylose slow fermenters (Rawling's, C-59, 57 and C-188) on 1 per cent xylose china blue plates; only two strains (C-59 and 57) produced daughter colonies on the eighth day; while under aerobic conditions, all four strains produced daughter colonies within three to five days.

#### RELATIONSHIP BETWEEN RAPID AND SLOW XYLOSE FERMENTERS

Kowalenko (1910, 1911) obtained *Bact. coli* cultures from Neisser, Massini (1907) and Burk, and tried to separate fermenters and non-fermenters from them after plating on Endo plates, and also from cultures which he isolated from a fever patient's stool on the Endo plate. He always obtained red-colored colonies after plating on Endo plates from a red-colored colony on the Endo plate, but he obtained white colonies and red colonies from a white colony on replating just as we observed above. He reached the conclusion after more study that mutation of bacteria could not be effected by influences from without,

by cultivation at various degrees of temperature, by long cultivation, by the addition of chemical substances, or by passing through the animal body. Saisawa (1913) tried in the same way to separate daughter colonies and mother colonies on plating typhoid bacilli but in vain.

It seemed to us that similar studies made with typhoid bacilli in regard to the separation of rapid and slow xylose fermenters from a single original strain might prove of great interest. Accordingly we made subcultures of two xylose slow fermenters two or three times on plain plates, each time fishing a single colony and planting from the single colony in 1 per cent pepton water. Then from the last suspension of a single colony we plated on 1 per cent xylose plates containing china blue or methylene blue-eosin. At the same time, a loopful of suspension was inoculated to 1 per cent xylose broth containing china blue indicator as a control. Repeated subcultures were made by this method in the hope that after some generations we might get a strain of non-xylose fermenters. We did not obtain such results, however. Charts of the subcultures obtained from the two strains follow:

*Strain 57*

This strain was always plated on 1 per cent xylose containing methylene blue and eosin.

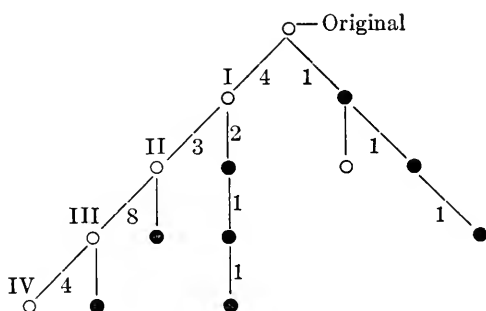

- = quick xylose fermenter in twenty-four hours.
- = slow fermenter.

*Day on which acidity appeared in xylose broth*

Original—fifth day  
 I—fourth day  
 II—fifth day  
 III—third day  
 IV—third day

Arabic numerals = interval in days between the appearance of a colony and subculture from it on 1 per cent xylose media containing indicator.

Roman numerals = number of generations.

We obtained only once a few pink colonies from a xylose fermenter. Thereafter we obtained only black colonies from xylose fermenter plates.

*Rawling's*

This strain was planted on 1 per cent xylose plates containing decolorized china blue.

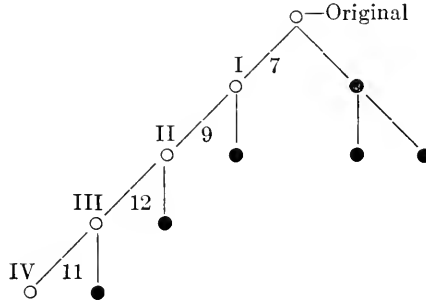
*Production of acidity*

Original—seventh day  
 I—sixth day  
 II—fifth day  
 III—ninth day  
 IV—seventh day

We could not obtain any nonfermenter from the cultivation on xylose plates.

From quick fermenters which we had isolated slow and rapid types were readily obtained.

## II. VARIATIONS IN REACTION TO SERUM

## INAGGLUTINABILITY AND AGGLUTINABILITY OF TYPHOID BACILLI

Agglutinability of typhoid bacilli isolated from specimens (blood, feces, urine, or bile) from the patient may vary greatly, depending to some extent on the number of culture generations for which they have been carried on artificial media. This has been reported by many workers (Förster (1897), Johnson and MacTaggart (1897), Müller, Eisenberg (1903), Sawyer (1912) and others). Thus, lack of agglutinability of the isolated bacilli in early culture generations is sometimes misleading in regard to diagnosis.

Schmidt (1903), for instance, erroneously reported typhoid bacilli as paratyphoid, owing to their inagglutinability. This inagglutinable state, acquired by the bacilli in the human body, can be easily produced by artificial means, such as cultivation on antityphoid serum broth. Such observations were first reported by Ransom and Kitashima, and by Müller. The former observed, in 1898, that the cholera spirillum lost its agglutinability when they cultivated it in anticholera serum, and the latter observed the same phenomenon in typhoid bacilli in 1903. The literature upon this subject is extensive and has been compiled in the articles of Eisenberg, Müller, and others.

As early as 1896 Metchnikoff and Bordet showed that cholera spirilla could partially lose their agglutinability under certain circumstances. Bail (1901) made similar observations with the typhoid bacillus, and Kirstein (1904) showed that cultivation at various temperatures could diminish the agglutinability of bacteria. It has been found, indeed, that organisms isolated from different cases of the same disease often varied considerably in their agglutinability in one and the same immune serum. This was noted by Grassberger and Schattentfroh (1900) in their studies upon anthrax. Bordet and Sleswyk (1910) studying the whooping cough bacillus showed that when a horse is immunized with a whooping cough bacillus which has been grown upon blood media, the serum of this animal will powerfully agglutinate this strain, but possesses little or no agglutinating activity against the same strain habituated to growth on plain agar, an observation which they

interpret as meaning that the agar strain has lost its receptors for the absorption of the specific agglutinin and this inability to absorb agglutinin they, indeed, demonstrated by experiment. Park and his collaborators have studied these relationships particularly with the dysentery bacilli, and Park and Williams (1917) make the following statement:

“The maltose fermenting paradysentery bacillus of Flexner was grown on each of eleven consecutive days in fresh bouillon solutions of the serum from a horse immunized through repeated injections of the bacillus. The solutions used were 15, 4 and 1.5 per cent. The serum agglutinated the culture before its treatment in dilutions up to 1 to 800, and was strongly bactericidal in animals. After the eleven transfers the culture grown in the 15 per cent solution ceased to be agglutinated by the serum and ceased to absorb its specific agglutinins. The cultures grown in the 15 and 4 per cent dilutions of serum agglutinated well in dilutions up to 1 to 60 and 1 to 100, and continued to absorb agglutinins. The recovery of the capacity to be agglutinated was very slow, the cultures being transplanted from time to time on nutrient agar; after growth for sixteen weeks, during which it was transplanted forty-three times, it agglutinated in dilutions of 1 to 200. The culture grown in 4 per cent agglutinated in 1 to 500 dilution, and the one in 1.5 per cent in 1 to 800.”

And in their new edition (seventh edition, (1920)) they say:

“The agglutinogenic power, or power to stimulate the production of other antibodies, is not lowered when bacteria become less agglutinable.”

The presence of a capsule may interfere with or prevent agglutination. The capsule, developing best in body-fluid or tissues is probably a protective substance. Porges (1905a,b) has outlined a method for the removal of the capsule as a preliminary to agglutination.

Eisenberg (1913) studying a typhoid strain carried along in blood bouillon for a considerable period, found similar development of inagglutinability. And Schmidt (1903) has cited a case of a typhoid bacillus isolated from human disease in which inagglutinability led to prolonged error of diagnosis. Bail working with typhoid bacilli cultivated from the peritoneal exudate of infected guinea pigs showed that under such conditions the organism loses a considerable degree of its agglutinability and attributes this to the development of a capsule-like substance which insulates the bacteria against the antibodies.

A definite loss of agglutinability under similar circumstances was noted by Zinsser and Dwyer (1918) in connection with experiments



upon proteotoxin, but without their finding anything in the nature of a capsule which could explain the phenomenon. Ransom and Kitashima, Müller (1911), Hamburger, Walker (1904) and several other workers have also produced inagglutinability by cultivating on sera containing agglutinin. Porges and Prantschoff (1906) used this method, obtaining irregular results, and attribute this to individual variations in the strains used.

Moon (1911) produced two substrains of a single typhoid bacillus culture by the Barber method, one of which agglutinated with anti-typhoid serum and the other did not. A few generations later both bacilli showed equal agglutinability.

In Zinsser's book (1918) *Infection and Resistance*, he states: "This lessened susceptibility to antibodies is noticeable not only in strains cultivated from the body in disease, but can be produced artificially by cultivating the bacteria on inactivated, homologous immune serum. Such strains may not only increase in virulence, but lose in both agglutinability and susceptibility to bactericidal effects."

Sacquepee (1901) obtained similar variations by keeping the organisms in collodion sacs in the peritoneal cavity. Sawyer (1912) isolated a strain from a typhoid carrier's stool which did not agglutinate with a serum dilution of 1 to 50, but after 11 transplants within two weeks the culture became agglutinable. The same phenomenon has been observed by Scheller (1908).

Recently Gay and Claypole (1913) studying the typhoid bacillus, found that when they produced the carrier state in rabbits the organisms isolated from such rabbits (culturally true typhoid bacilli) failed completely to agglutinate in serum produced with a stock culture and which agglutinated such stock cultures in dilutions as high as 1:20,000. The blood and bile cultures which were inagglutinable by means of the ordinary antiserum, were readily clumped by means of a serum produced by immunizing rabbits with cultures grown on a blood agar medium. If confirmed, these observations, like those of Bordet and Sleswyk, would indicate a complete alteration of antigenic properties by means of cultivation on blood media, and prolonged residence in the animal body; for the serum produced with the cultures upon blood, not only agglutinated these cultures, but also the plain agar growths, and if the cultures on blood were carried along for some generations on plain agar, they again became agglutinable by the serum produced with the plain agar culture. Gay (1914-15) uses this observation to explain the occasional inagglutinability in ordinary sera, of typhoid bacilli recently

isolated from human cases, and emphasizes the diagnostic difficulties which this may occasion. Bull and Pritchett (1916), however, repeating the work of Gay and Claypole found that 25 generations of cultivation in separate series upon plain agar and upon blood agar did not produce appreciable agglutination differences in a typhoid strain. They carried this out with 57 different strains of typhoid bacilli. Nichols too has contradicted the claim of Gay and Claypole that gall bladder infections could be regularly produced in rabbits by injection of typhoid strains grown on blood agar, an observation which would further strengthen the opinion of a fundamental change in reaction to the animal body and its fluids produced by cultivation upon blood constituents. Our own observations (in which we cultivate the typhoid strains upon normal rabbit's serum) also indicate that such a procedure does not exert any appreciable effect upon their agglutinability. Thus the results of Gay and Claypole concerning the inagglutinability of cultures obtained from infected human beings and rabbits would correspond in principle with the investigations of other workers. But the alterations obtained by them by simple growth upon normal blood agar cannot be accepted as conclusive in the light of contradictory results of Bull and Pritchett and of Nichols, and also in the light of our own failure to obtain appreciable changes in strains carried for many generations on normal rabbit serum broth.

It appears from these researches (and many others which might be cited) that the problem has not yet been solved in all particulars. But the general weight of evidence indicates that cultivation in the presence of specific serum antibodies alters the strains in the direction of lessened agglutinability.

The following experiments upon this phenomenon were carried out by us:

*Materials used in agglutination tests*

1. Broth. This consisted of 0.1 per cent Liebig's meat extract; 1 per cent pepton (Difco ); and 0.5 per cent sodium chloride per liter; its reaction was adjusted to pH 7.0. It was sterilized in the autoclave at 15 pounds pressure for fifteen minutes.

2. Antityphoid serum from rabbits immunized against monovalent strain of typhoid bacilli (Rawlings, C-51, no. 3, Cohen, C-188). Each serum titre was 1:10,000 or 1:20,000 for our standard laboratory strains.

3. Normal rabbit serum. Serum obtained from normal rabbits and inactivated at 56°C. for half an hour. About 1 cc. of each medium was placed in small test tubes used for Wassermann work under strictly aseptic precautions, and kept in an ice-chest.

4. The strains used were plated on plain plates three times, and each time one single colony fished to 0.85 per cent sterile salt solution and from this plated on another new plate.

### *Technique*

Stock cultures or newly isolated cultures as described above were suspended in 1 per cent pepton water, and transferred to serum broth or broth; thence retransferred from serum broth to new serum broth or from plain broth to new plain broth, by using a small platinum loop; then incubated at 37°C. Usually after twenty-four hours' growth the culture was plated on plain agar or implanted on slant, using a platinum needle or a very small platinum loop (in the use of the loop we took great precautions against including any serum broth); after standing overnight in the incubator at 37°C. the growth was evenly emulsified in 0.85 per cent salt solution (the bacterial growth always covered the entire surface of the slant). Special care was taken to have the emulsions of the cultures of as uniform a thickness as possible and for this purpose a tube of typhoid bacterial emulsion was kept for comparison.

Graded dilutions of the serum were made with 0.85 per cent sodium chloride solution and ranged from 1:50 to 1:24,300. Half a cubic centimeter of each dilution was transferred to small agglutination tubes and an equal amount of bacillary emulsion was added to each tube and also to a salt solution control.

The results were recorded after two hours' incubation at 37°C. and again after standing overnight in the ice-chest. The controls never showed agglutination. By this method cultures which had been grown on serum were allowed to develop for one generation on agar without serum before their agglutinability was tested. Controls were treated in the same way.

The serum media were occasionally tested for loss of agglutinating power, and were controlled for contamination by plating on plain plates or Endo plates or by inoculation in sugar media, but results were always negative. Such control cultures were made in sugar media (namely, xylose, arabinose, glucose, maltose, mannitol, lactose, sucrose,

rhamnose, raffinose, dulcitol) in broth, in litmus milk, and in 2 per cent glycerol; or plated on Endo plate; always, as stated above, with negative results.

#### STRAINS MADE INAGGLUTINABLE BY ARTIFICIAL MEANS

I. Antityphoid rabbit serum (Rawling's strain), with a titre of 1:10,000 for the homologous and for other laboratory strains, was mixed in proportions of one part of the serum to four parts of the broth in small test tubes. In the course of the experiments, this serum being exhausted, another antityphoid serum (made with strain C-51) with a titre of about 1:10,000 was substituted.

The same lot of broth was used in the controls.

The stock strains used were "Rawling's," "C-188," and "Cohen." These were prepared in the manner described above and inoculated into the media.

1. Rawling's strain. Within thirty-eight days this strain was retransplanted twenty-four times from one tube to another, in two parallel series, one upon antityphoid serum broth, the other on plain broth. During the first ten days, it was transplanted every day and later at intervals of several days. Agglutinability was tested eight times during this period with the same serum. Chart 1 shows the results.

As is shown by chart 1, the power of agglutinability in dilution of 1:8000 fell to 1:300 after three days, and twenty-four days later, after fifteen transplants in fresh serum media, the agglutinability was recovered. After that there was no remarkable difference between control and serum cultures, although the culture in serum broth was always somewhat lower in agglutinability than the control. The first readings of the serum broth culture after two hours' incubation always showed much lower agglutinability than the control cultures until the expiration of thirty-five days. The astonishing feature of this experiment was the fact that the serum strain seemed to recover its agglutinability after prolonged cultivation on serum, though at first it had lost it. For this reason, on and after the twenty-third day, we used

the other sera "C-51" and "3," for agglutination tests, but did not observe any striking difference between Rawling's serum and the other two sera in agglutinating Rawling's strain.

2. "C-188" strain was tested in the same way as the Rawling's strain.

Chart I

Rawling strain against Rawling's serum antityphoid

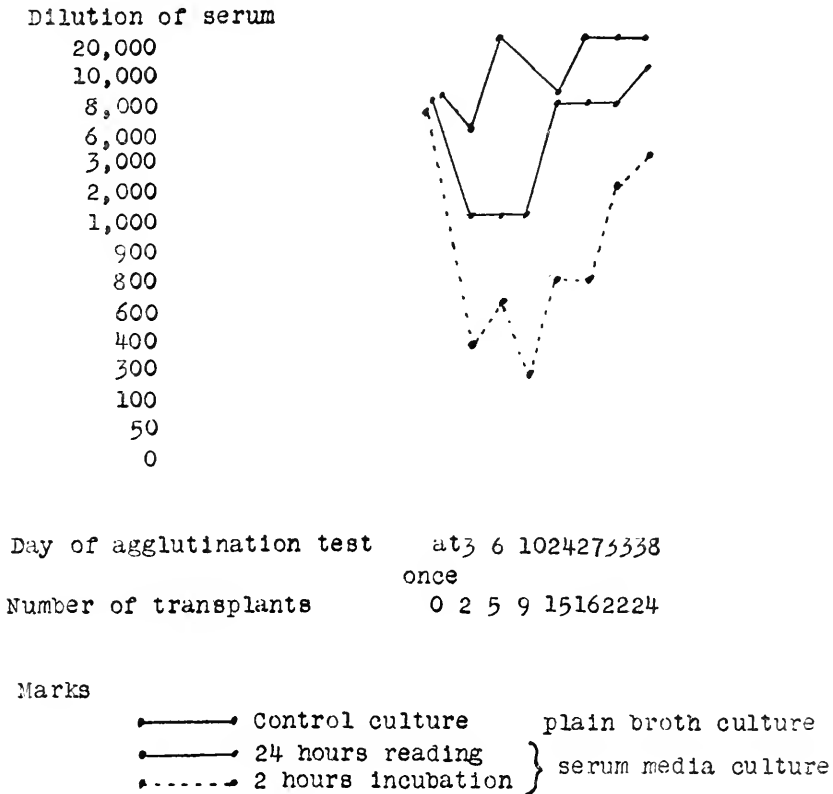

In this case, we made agglutination tests eleven times within sixty-three days. Its agglutinability fell from 1:8000 to 1:3000 after one day's cultivation in serum media. Three days later agglutination occurred only in dilution of 1:100. Six days later,

it was below 1:50. On the twenty-seventh day it rose to 1:300 and after the thirty-fifth day to 1:20,000. Thereafter, from the thirty-fifth to the sixty-third day, which was the last day of this experiment, the serum strain and the broth control remained entirely parallel. Other sera, C-51 and 3, were frequently used after the twenty-third day but no differences were seen between Rawling's serum and the other two sera.

Chart II

Cohen strain agglutination against Rawling's antityphoid serum

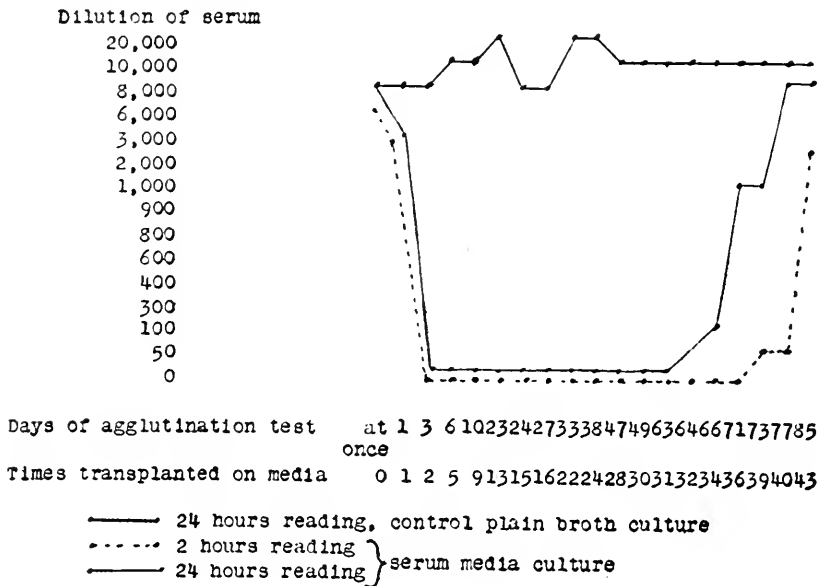

3. Cohen strain was tested in the same manner. We tested its agglutinability twenty-three times within eighty-five days, within which period we made forty-three transplantations. The results are shown on the next chart.

After seventy-one days this strain recovered its agglutinability gradually and at seventy-seven days it had almost completely recovered this property. But readings two hours after incubation were always slightly lower than the twenty-four hours' readings. On the fourth day very slight agglutination in dilu-

tions of 1:50 and 1:100 occurred, visible only with a lens. After that not the slightest agglutination could be seen in any dilution up to 1:50 until the forty-ninth day. On the forty-ninth day slight agglutination was visible by lens up to 1:300 dilution, and on the sixty-fourth day, we could recognize good agglutination in 1:50 dilution of serum. Then within about two weeks it reached almost the highest dilution of the serum attained by the control culture. Nine tests were made with the Rawlings serum. On and after the twenty-third day, we tested its agglutinability five times with C-51 serum as well as with the Rawling's serum. Readings at the end of two hours showed no agglutination for the first four times but agglutination appeared in 1:100 dilution of the serum after the forty-fifth day. In twenty-four hours' readings no agglutination appeared in 1:50 dilution of serum until the twenty-seventh day while on the thirty-third day, and after, it occurred in a serum dilution of 1:900.

During the same period we tested the strain seven times with antityphoid serum (no. 3). Two hour readings showed that no agglutination appeared in 1:50 dilution of serum until the forty-ninth day. On the sixty-fourth day good agglutination appeared in 1:100 dilution. In twenty-four hours' readings until the thirty-third day no agglutination was seen in 1:50 dilution. From the thirty-seventh to the sixty-fourth day it always showed agglutination up to 1:300 dilution of serum.

Agglutinations of control cultures by each serum ranged from 1:8000 to 1:10,000.

In all experiments done with different sera (Rawling's, C-188, and Cohen) when we changed the serum media there was a slight tendency toward agglutination in the first generation on the new serum. After two or three generations in the new serum media this tendency disappeared.

II. We controlled our experiments with normal rabbit serum broth in place of antityphoid serum broth media. Four parts of broth and one part of normal rabbit serum (inactivated by heating at 56°C. for half an hour) were used for this purpose and a series of agglutination tests carried out with the same strains and in the same manner as before.

Agglutination tests of each culture were carried out five times within forty-three days, using Rawling's serum for the tests. Twenty-eight transplants were made during this period.

III. Since the experiments done so far seemed to show a delicate difference between the reactions of individual strains with different antityphoid sera, we decided to repeat them carrying a single typhoid strain both on an homologous serum and on an antityphoid serum produced with another stock strain. For this purpose we immunized two rabbits, in one case using no. 3 culture and in the other C-51. The former is a rapid xylose fermenter and the latter a slow xylose fermenter. We obtained sera which agglutinated our laboratory strains and their own specific strains in dilution of 1:15,000. Cultivation in normal serum in no case changed the agglutinability of the bacilli, which remained parallel in every way to that of the cultures carried on plain broth. Serum media was again prepared (one part serum to four parts broth) and tubed in small tubes. Experiments as described above were then carried out.

(1) Strain C-51. After two days' cultivation both in its own serum broth and in no. 3 serum broth, this strain slightly lost in agglutinability (1:8000). This continued for twelve days, but on the fifteenth day both series recovered agglutinability equal to that shown by the control cultures.

In no. 3 serum broth its agglutinability was lowered slightly more than by growth in the homologous C-51 serum broth, but there was no very considerable difference between them.

(2) Strain no. 3. This strain was tested in the same way as C-51, by cultivation in its own serum broth and in C-51 serum broth. On the third and seventh days inagglutinability on serum no. 3 was most marked (1:100) both for the culture carried on no. 3 serum and for the one carried on C-51 serum. Both gradually recovered agglutinability and reached normal agglutinability on the thirty-sixth day.

When we used C-51 serum for agglutination tests similar results were obtained. On the third day both series reached the maximum point (1:2000) of inagglutinability. Then they gradually recovered, although in this case recovery to normal agglutinability was delayed for twenty-two days.



This experiment showed that typhoid strains lose agglutinability in the same degree, whether cultivated in a serum broth of their own specific immune serum or on a serum immunized against other strains. No difference was observed between rapid xylose fermenters and slow xylose fermenters.

IV. The above experiments were performed with old stock cultures. We next repeated these tests using freshly isolated strains. Two strains (Owen and Boyle) which were obtained from typhoid carriers' stools were used after three generations on artificial media.

The media consisted of four parts of broth and one part of Rawling's or C-51 serum, the agglutinating titre being 1:15,000.

The Owen strain was cultivated in Rawling's serum and C-51 serum broth and transplanted into fresh media six times in seven days. It reached its maximum inagglutinability (1:900) in seven days with the same serum in which it was grown. When tested with the other serum its loss of agglutinability was not so great. A few days later both cultures in Rawling's serum broth and in C-51 serum broth recovered their agglutinability.

Observations were made with the Boyle strain in the same manner as with the Owen strain. In this case the maximum point of inagglutinability in Rawling's serum broth and in C-51 serum broth was reached on the fourth day.

On carrying out agglutination tests with Rawling's serum one strain (Rawling's serum culture) continued its inagglutinability (1:300) at least ten days, while the other culture in C-51 serum broth regained its agglutinability on the seventh day. The other tests with C-51 serum ran almost parallel. The maximum point of inagglutinability (1:900) was reached on the fourth day and agglutinability was recovered on the seventh day.

In the foregoing experiments observations were made concerning the character of the growth of typhoid bacilli in serum broth *in vitro*. During the first few days the bacteria grew like a mass of cotton at the bottom of the tubes; later when the bacteria had partly recovered agglutinability some organisms grew on the surface of the media, forming a film, as well as at the bottom. Up to this point the mass of bacteria is not easily broken up by shaking, but after recovery of agglutinability it becomes very

easy to break up the spongelike growth. A few days later the broth becomes turbid, at first, with a few clumps of agglutinated bacteria, and later only a uniform turbidity is present; in the last stage, at least one month later, the cultures grow slightly more turbid in the tubes, and about two months later, the general turbidity of the cultures is only slightly less marked than that of control cultures in broth.

The experiments just described were carried out in concentrated antityphoid serum media. It seemed important to observe what influence would be exerted on typhoid bacilli by cultivation in broth which contained a very low percentage of antityphoid serum. This might perhaps tell us what influence would be exerted upon the bacilli in the early stages of typhoid fever.

We prepared a number of broth tubes containing Rawling's serum in a proportion of 1:10,000. The titre of this serum against Rawling's culture was 1:10,000. We used two strains for these observations, one the Rawling's strain, the other a culture designated as Sanguist, which had been freshly isolated from a patient's blood.

We carried out agglutination tests eight times within thirty-three days during which we made twenty-two transplants. Rawling's strain showed practically no change, a result distinctly in contrast with its loss of agglutinability when grown in concentrated serum broth. The Sanguist strain diminished in agglutinability after three days although the difference between the serum culture and the control broth culture was not great. After thirty-two transplants thirty-three days later, it regained agglutinability completely. In short, in this experiment a small amount of antityphoid serum in media did not produce any marked change in agglutinability of typhoid bacilli.

When the serum contained blood cells the typhoid bacilli acted haemolytically and reduced the medium from a reddish color to yellow in twenty-four hours.

Several varieties of sugar media and litmus milk were inoculated from the cultures described above and no differences appeared between control cultures and serum broth cultures within three weeks.

AGGLUTININ ABSORPTION TESTS OF XYLOSE QUICK FERMENTER  
AND XYLOSE SLOW FERMENTER

The next experiments were undertaken to determine whether xylose quick fermenters and xylose slow fermenters differed in regard to serum reactions.

We immunized rabbits against the xylose fermenting strains "Cohen" and "no. 3," and against the xylose slow fermenters, C-51, Rawling, and C-188. The serum titre of each strain was between 1:10,000 and 1:15,000 for each strain. Three agar slants of xylose quick fermenter twenty-four hours old were prepared and a suspension in 5 cc. of 0.85 per cent salt solution made. To each suspension was added 5 cc. of each corresponding serum in dilution of 1:50. The tubes were then incubated for three hours at 37°C. After that, we centrifuged them for half an hour at high speed, and pipetted off the supernatant fluid. This was then made up with 0.85 per cent salt solution into a series of dilutions ranging from 1:100 to 1:16,200. To 0.5 cc. of each dilution was added 0.5 cc. of the suspension of a xylose quick fermenter, and similarly to another series of dilution, 0.5 cc. of a suspension of a xylose slow fermenter was added. The two series were incubated for two hours at 37°C., and allowed to stand overnight in the ice-chest. The results were read before placing in the ice-chest and again the next morning. As controls, agglutination tests were carried out using the original strains and fresh unabsorbed serums.

After absorption of both sera by slow xylose fermenters we found that practically all agglutinin had been removed. The only exception to this was a slight persistence of agglutinin in the tube containing the 1:200 dilution. Vice versa we absorbed the serum produced with xylose quick fermenters by means of a xylose slow fermenting organism and then looked for traces of agglutinin by adding suspensions of both xylose rapid fermenting and xylose slow fermenting strains. The results were the same as those obtained above.

Control tests gave negative results.

Xylose slow fermenters and xylose quick fermenters are therefore not serologically different.

It is worth noting in this connection that Lieut.-Col. H. J. Nichols tells us that he has found no difference between rapid and slow xylose fermenters in regard to their virulence for rabbits.

Having determined the peculiar conditions under which typhoid bacilli become inagglutinable and subsequently regain their agglutinability, without removal from the specific immune serum, it seemed important to determine whether this was due to inability to absorb the agglutinins or possibly whether it had some relationship to a changed reaction to electrolytes in solution. Also it seemed important to determine whether or not something analogous to an insulating capsule as described by Bail, Kuhnemann and others was responsible for the phenomenon.

Accordingly we first proceeded to carry out agglutinin absorption tests as follows:

*a. Agglutinin absorption test*

This test was carried out several times using the Cohen strain culture in serum broth for sixty-six days with 49 transplants in serum broth (see chart 2). As controls Cohen and C-188 strains were cultures in plain broth. The serum used was usually Rawling's, sometimes others. The technique employed was that described in the section on agglutinin absorption tests of xylose quick fermenter and xylose slow fermenter. The results follow:

TYPHOID STRAINS BEFORE TREATMENT BY THE SERUM	DILUTION OF RAWLING'S ANTITYPHOID SERUM								SALINE CON- TROL
	100	200	400	800	1,600	4,800	14,150	43,200	
Cohen serum broth culture . . . . .	-	-	-	-	-	-	-	-	-
Cohen broth cul- ture (control) . . . .	+++	+++	+++	+++	+++	+++	++	-	-
C-188 broth culture (control) . . . . .	+++	++	++	+++	+++	+++	+	-	-

+++ = complete agglutination.

++ = good agglutination.

+ = good agglutination but still cloudy.

- = negative. No agglutination.

Results are recorded after two hours incubation at 37°C. and standing in an ice chest over night. Hereafter we shall use the following abbreviations:

- Cohen S = Cohen strain cultivated in serum broth
- Cohen B = Cohen strain cultivated in broth (control)
- C-188 B = C-188 strain cultivated in broth (control).

Tests done in Rawlings serum after absorption of this serum in dilution of 1:100 at 37°C. for three hours with the "serum" and the "broth" strains respectively:

(a)

BACTERIAL SUSPENSION	DILUTION OF RAWLING'S SERUM PREVIOUSLY TREATED BY COHEN S							SALINE CONTROL
	200	400	800	1,600	3,200	9,600	28,800	
Cohen S . . . . .	-	-	-	-	-	-	-	-
Cohen B . . . . .	+++	+++	+++	+++	+++	++	-	-
C-188 B . . . . .	+++	+++	+++	+++	+++	+	-	-

(b)

BACTERIAL SUSPENSION	DILUTION OF RAWLING'S SERUM PREVIOUSLY TREATED BY COHEN B							SALINE CONTROL
	200	400	800	1,600	3,200	9,600	28,800	
Cohen S . . . . .	-	-	-	-	-	-	-	-
Cohen B . . . . .	+	-	-	-	-	-	-	-
C-188B . . . . .	+	-	-	-	-	-	-	-

*Tests with C-188 serum*

Before absorption

BACTERIAL SUSPENSION	DILUTION OF C-188 ANTITYPHOID SERUM								SALINE CONTROL
	100	200	400	800	1,600	4,800	14,400	43,300	
Cohen S . . . . .	-	-	-	-	-	-	-	-	-
Cohen B . . . . .	+++	+++	+++	+++	+++	+++	+++	+	-
C-188 B . . . . .	+++	+++	+++	+++	+++	+++	++	-	-

After absorption of C-188 serum in dilution of 1:100 at 37°C. for three hours.

(a)

BACTERIAL SUSPENSION	DILUTION OF C-188 SERUM PREVIOUSLY ABSORBED WITH COHEN S							SALINE CON- TROL
	200	400	800	1,600	3,200	9,600	28,800	
Cohen S . . . . .	—	—	—	—	—	—	—	—
Cohen B . . . . .	+++	+++	+++	+++	+++	+++	+	—
C-188 B . . . . .	+++	+++	+++	+++	+++	++	—	—

(b)

BACTERIAL SUSPENSION	DILUTION OF C-188 SERUM PREVIOUSLY ABSORBED WITH COHEN B							SALINE CON- TROL
	200	400	800	1,600	3,200	9,600	28,800	
Cohen S . . . . .	—	—	—	—	—	—	—	—
Cohen B . . . . .	+	—	—	—	—	—	—	—
C-188 B . . . . .	+	—	—	—	—	—	—	—

*Tests with "Cohen" serum*  
Before absorption of serum

BACTERIAL SUSPENSION	DILUTION OF "COHEN" ANTITYPHOID SERUM								SALINE CON- TROL
	200	400	800	1,600	3,200	6,400	12,800	23,600	
Cohen S . . . . .	—	—	—	—	—	—	—	—	—
Cohen B . . . . .	+++	+++	+++	+++	+++	+++	+++	+	—
C-188 B . . . . .	+++	+++	+++	+++	+++	+++	++	+	—

After absorption of "Cohen" serum, diluted to 1:200 at 37°C. for three hours

(a)

BACTERIAL SUSPENSION	DILUTION OF "COHEN" SERUM WITH COHEN S							SALINE CON- TROL
	400	800	1,600	3,200	6,400	12,800	25,600	
Cohen S . . . . .	—	—	—	—	—	—	—	—
Cohen B . . . . .	+++	+++	+++	+++	+++	+++	—	—
C-188 B . . . . .	+++	+++	+++	+++	++	+	—	—

(b)

BACTERIAL SUSPENSION	DILUTION OF "COHEN" SERUM WITH COHEN B							SALINE CON- TROL
	400	800	1,600	3,200	6,400	12,800	25,600	
Cohen S . . . . .	—	—	—	—	—	—	—	—
Cohen B . . . . .	—	—	—	—	—	—	—	—
C-188 B . . . . .	+*	—	—	—	—	—	—	—

\* Slight.

These experiments showed that Cohen S cultures did not absorb the agglutinin of any of the three antityphoid sera.

The work of Bordet has demonstrated the essential importance of electrolytes in agglutination, and the studies of Neisser and Friedemann, Friedberger and others have shown that whereas small traces of salts will flocculate bacteria that have absorbed agglutinin, it requires very large amounts of the same electrolytes to flake out normal (insensitized) organisms. Since the researches of Neisser and Friedemann especially have shown that to a certain extent there is a relationship between the degree of sensitization and the amounts of salt necessary to bring about agglutination, we considered it of interest to determine by comparative tests the differences in sodium chloride concentration necessary to flake out, on the one hand, the Cohen serum strain, and on the other, the Cohen broth strain after both had been treated with homologous serum. This would show whether or not any trace of agglutinin had been absorbed by the Cohen S strain in the process.

Typhoid bacterial suspensions in Rawling's serum were centrifuged for thirty minutes and all the supernatant fluid decanted off for another agglutination test; the residue in both centrifuge tubes, one of them containing Cohen S and the other Cohen B strains was poured into a few centimeters of 0.85 per cent salt solution and without centrifuging but after slight shaking, all the fluid was decanted from the tubes, leaving a mass of bacteria. This was worked into an emulsion by means of a glass rod, and distilled water added drop by drop. The graded dilutions of the 20 per cent sodium chloride were prepared, to range from 20 per cent to 0.025 per cent. A half cubic centimeter of each dilution was transferred to small tubes and a half cubic centimeter of the above bacillary emulsion in distilled water was added to each tube and also to a distilled water control. The results were as follows:

The percentage shown below is the actual percentage after mixing salt solution and watery bacterial suspension:

	10	9	8	7	6	5	4	3	2	1	0.9	0.8	0.7	0.6	0.5	0.4	0.3	0.2	0.1	0.05	0.025	NO SALT	
Cohen S emulsion	-	-	-	-	-	-	-	-	-	-	-	-	-	-	-	-	-	-	-	-	-	-	-
Cohen B emulsion	+	+	+	+	+	+	+	+	+	+	+	+	+	+	+	+	+	+	+	+	+	+	-

This experiment shows that the Cohen S strain absorbed either no agglutinin at all or so little that it could not be demonstrated by strong solutions of sodium chloride.

We have now shown that the typhoid bacillus, which loses agglutinability after prolonged cultivation on immune serum, becomes inagglutinable because of its failure to absorb agglutinin. It was next desirable to determine, if possible, whether this inability to absorb antibody was due to an ectoplasmic insulation substance identical with or analogous to a capsule, since capsule formation in other bacteria has been shown to protect against serum effects. In spite of repeated attempts we never succeeded in demonstrating a capsule in our serum strains by staining methods. However, Bail and others have suggested that such capsular materials might be present in bacteria without showing demonstrable morphological change, except perhaps in the form of increased size of the bacterial cell as a whole. For this reason it seemed advisable to investigate this question by the method of Porges, who rendered the heavily capsulated and inagglutinable *Friendländer* bacilli agglutinable by dissolving off the capsule with weak acid and moderate heat.

If it be true that the inagglutinability of Cohen S is due to the formation of a capsule or something similar, then hydrolysis of protein of that capsule by Porges' (1905a, 1905b) method should restore the agglutinability. With this idea in mind, we tried the next experiment, using Rawling's serum, and carrying out the method of Porges exactly as described by him. The following tubes were prepared:

I. 3 cc. of each bacterial suspension plus 2 cc. of salt solution.

II. 3 cc. of each bacterial suspension plus 1 cc. of N/4 HCl plus 1 cc. of salt solution.



III. 3 cc. of each bacterial suspension plus 1 cc. of N/4 HCl plus 1 cc. of N/4 NaOH.

To 0.5 cc. of each of these mixtures graded serum dilutions from 1:100 to 1:25,800 were added; also to a salt solution control.

Results were as follows:

SOLUTION	BACTERIAL SUSPENSION	DILUTION OF RAWLING'S SERUM									SALT CONTROL
		100	200	400	800	1,600	3,200	6,400	12,800	25,600	
I	Cohen B	+++	+++	+++	+++	+++	+++	+++	+	-	-
	Cohen S	-	-	-	-	-	-	-	+S	-	-
II	Cohen B	-	-	-	-	-	-	-	-	-	-
	Cohen S	-	-	-	-	-	-	-	-	-	-
III	Cohen B	+S	+S	-	-	-	-	-	-	-	-
	Cohen S	-	-	-	+S	+	+	++	++	+++	+++

+S = slight agglutination.

In another experiment suspension I, II (without the addition of 1 cc. of salt solution) and III (without the addition of 1 cc. of N/4 NaOH solution) were made up. They were heated at 80°C. in a water bath for fifteen minutes, and then cooled in cold water. To no. II, 1 cc. of salt solution and to no. III, 1 cc. of N/4 NaOH solution were added respectively. After being shaken well, 0.5 cc. of each suspension was added to each of the serum dilutions described above.

The results were as follows:

SOLUTION	BACTERIAL SUSPENSION	DILUTION OF RAWLING'S SERUM									CONTROL
		100	200	400	800	1,600	3,200	6,400	12,800	25,600	
I	Cohen B	+	+	+	+	+	+S	-	-	-	-
	Cohen S	-	-	-	-	-	-	-	-	-	-
II	Cohen B	-	-	-	-	-	-	-	-	-	-
	Cohen S	-	-	-	-	-	-	-	-	-	-
III	Cohen B	+	-	-	-	-	-	-	-	-	-
	Cohen S	-	-	-	+S	+	++	++	+++	+++	+++

From these experiments it becomes apparent that the inagglutinability of our serum strains is not analogous to the similar inagglutinability of the Friedländer bacilli used by Porges in his experiments. At any rate our experiments do not permit us to conclude that the acquired inagglutinability of our strains is due to a capsule or to any analogous substance.

*Acid agglutination*

In 1911 Michaelis (1911) investigated the flocculation of bacteria by acids. His experiments were based upon the fact that serum globulins, casein, the so-called nucleoproteins and other forms of protein could be shown to precipitate at very definite optimum H-ion concentrations. Since Kraus (1897) and Neisser and Friedemann (1904) had claimed that the agglutination of bacteria depended upon the precipitation of a protein constituent of their cell bodies, Michaelis believed that for each species of bacteria an optimum H-ion concentration could be found which would agglutinate them. This he indeed demonstrated, and claimed that the typhoid bacillus especially could be shown to agglutinate at a definite H-ion concentration sufficiently characteristic to aid in the diagnosis of this organism. A number of investigators have confirmed this. For this reason we carried out the Michaelis technique with our broth and serum strains, to determine whether the H-ion optimum for agglutination had been altered by growth in serum.

The solutions were made as follows:

NUMBER	NORMAL SODIUM HYDRATE	NORMAL ACETIC ACID	STERILE WATER
	<i>cc.</i>	<i>cc.</i>	<i>cc.</i>
I	0.5	0.75	8.75
II	0.5	1.0	8.5
III	0.5	1.5	8.0
IV	0.5	2.5	7.0
V	0.5	4.5	5.0
VI	0.5	8.5	1.0
VII			10.0
VII	10 cc. of 0.85 per cent salt solution		

Both Cohen S and Cohen B cultures were suspended in sterile distilled water. Then 0.5 cc. of each of the above solutions and 0.5 cc. of bacterial suspension were put in small test tubes and the results recorded after two hours incubation at 37°C.

	I	II	III	IV	V	VI	VII	VIII
Cohen S.....	-	-	-	-	-	-	-	-
Cohen B.....	-	+S	++	++	+	+S	-	-
C-188 B.....	-	-	+	++	++	+S	-	-
Michaelis results of typhoid bacilli.....	-	+	++	++	+	-	-	-
Bact. coli by Michaelis results.....	-	-	-	-	-	-	-	-

This experiment shows that cultivation in serum has rendered the Cohen strain inagglutinable in an H-ion concentration which agglutinates the normal strain. In this test Cohen S resembles *Bact. coli*, but other tests (sugar fermentation) showed it to be an absolutely typical typhoid bacillus.

Similar tests were made with an inorganic acid, as follows:

*HCl agglutination*

Suspensions of both strains (Cohen S and Cohen B) were made in sterile water. From normal hydrochloric acid solutions in the following table were prepared by adding sterile water, 0.5 cc. of bacterial suspension, and 0.5 cc. of each acid solution were mixed in small test tubes and incubated at 37° for two hours, then stood in the ice chest overnight. The results were then noted.

The table below shows the final dilution of hydrochloric acid in the combination of acid and bacterial suspension:

	PROPORTION OF ACID											WATER CONTROL
	10	25	50	100	200	400	800	1,600	3,200	6,400	12,800	
Cohen S.....	-	-	+	++	+++	+++	+++	+++	+	-	-	-
Cohen B.....	-	-	-	-	-	+	++	+	-	-	-	-

Here Cohen S is very agglutinable in the presence of hydrochloric acid, although it is not so in the presence of acetic acid, as we have seen in Michaelis' test. Michaelis himself used only acetic acid.

#### SUMMARY AND CONCLUSIONS

In the study described above we have endeavored to investigate the variations which may occur in the characteristics of typical typhoid bacilli in regard to their abilities to utilize carbohydrates, and their behavior to serum antibodies under various conditions of cultivation. Underlying our plan of experimentation was the purpose of determining whether variations noted by others and described in many published accounts could properly be regarded as mutations in the botanical sense, and, secondarily, to contribute to the comprehension of the nature and the permanence of variations from type so often noticed in freshly isolated cultures, incidentally thereby shedding some light upon the practically difficult problems so often encountered by the bacteriologist in the identification of strains isolated from the human and animal body.

In order to obtain a true picture of the fermentative characteristics of a given species of bacterium it is clear from the foregoing study that the inoculation of a rather small number of strains into fluid media containing the various sugars and the recording of acid and gas production after a few days' incubation is entirely inadequate. A large number of strains must be investigated and the period of observation extended to thirty days, if necessary. Furthermore, it seems advisable to regard "fermentation" not as the production of gas and acid or even as the production of acid from the sugar by the bacterium, but simply as the utilization of the sugar as a food by the bacterium. Fermentation in this sense is demonstrated quite conclusively on agar plates if characteristic daughter colonies appear on the agar containing the sugar and no daughter colonies appear on control plates of the same agar without the sugar; precisely those cultures that yield unsatisfactory results in broth containing the sugar are apt to give rise to a well marked development of

daughter colonies. The writer believes that this method deserves a much more extended use in bacteriology than it has hitherto received. It seems likely that one could employ it to determine whether other substances besides sugars, for example, certain amino-acids, are utilized by the bacterium in question as a food, and in this way obtain a more accurate knowledge of the metabolism of the organism and possibly important diagnostic distinctions also.

By investigating a large number of strains of *Bact. typhosum*, using broth fluid and solid media and extending the period of observation over several weeks time it was observed that the behavior of many strains toward certain sugars varied widely from that of other strains. The slow fermenters of xylose resemble the mutations of the higher plants first described by de Vries, more closely than some of the other variants considered in this paper because they retain their characteristics quite constantly (for several years at least), so long as they are not grown in media containing xylose; all such strains investigated by us, with one exception, could be trained by long continued cultivation in xylose-media to produce acid in xylose broth in twenty-four hours like the typical *Bact. typhosum*. Furthermore, all of these slow fermenters, including the one that never produced acid in xylose-broth for us, showed daughter colonies on xylose agar; hence we were aware of the fact that these strains could utilize xylose as a food-stuff long before this had become evident from the observation of the xylose-broth tubes.

These observations would seem to indicate that even in the slowest xylose fermenters the xylose utilizing power is potentially retained as a latent characteristic. This would prevent our correctly applying to such cultures the term "mutation" in the sense of de Vries. Working with bacteria we are enabled to observe in a short time a sequence of generations far beyond anything that can be observed with higher plants and our work suggests, though of course in an entirely inconclusive way, that at least some of the "mutations" described by botanists may represent, in fact, a suppression of characteristics which remain latent and might easily become apparent again could a sufficient

number of generations be subjected to an environment in which this characteristic could again become useful.

The inoculation of solid media proved that all of our strains of *Bact. typhosum* utilize both arabinose and dulcitol for their nutrition. In fluid medium nearly half of the strains produced acid in dulcitol in from five to twenty days while only a small percentage showed acid production from arabinose. In striking contrast to the behavior of the typhoid strains in xylose broth, the strains that produced acid in arabinose or dulcitol in one test often failed to produce acid when the test was repeated under similar conditions.

All of our typhoid strains gave rise to daughter colonies on rhamnose agar, but none were observed to produce acid in rhamnose broth.

Our cultures showed no daughter colonies on raffinose agar and did not produce acid in raffinose broth. It is thus apparent that instead of stating that a given species of bacterium ferments such and such sugars, it should be said; that the organism in question can utilize such and such sugars as a food; that the organism produces acid in twenty-four hours in certain of these sugars; that a majority of the strains produce acid after several days in such and such sugars; etc., etc. Having obtained this information concerning certain related species of bacteria it should usually be easy to select those sugars which would yield the most reliable information for the differentiation of the species. Thus, Krumwiede (1918), and quite recently Jordan also, have recommended acid production in rhamnose broth as the most fundamental method of differentiating the paratyphoids from *Bact. typhosum*. We agree that this is a good practical medium for the differentiation of these species but we should bear in mind that *Bact. typhosum*, although it does not show acid production in rhamnose broth, is nevertheless able to utilize this sugar as a food.

Considerable discussion has arisen concerning the question whether certain of the variations from the normal type mentioned in this paper represent true mutations in the sense of de Vries. The writer believes that this term, which defined changes of a

definite character occurring in higher plants should not be introduced into bacteriology; for the bacteriologist, who studies his species not only from the morphological point of view, but also with regard to biochemical and immunological reactions, and who observes not a few generations only, but hundreds and thousands of generations, would almost surely have to modify the conception of the term in such a manner as to cause confusion to the botanist. It, therefore, seems advisable to leave the term mutation to the botanists and, for the present at least, to speak of atypical varieties of bacteria or simply of variants.

Typhoid bacilli grown upon normal serum do not become inagglutinable. Cultivated continuously upon specific immune serum they at first become inagglutinable, but if such cultivation is persisted in for two weeks longer, eventually these strains again become agglutinable. In some cases this return to normal agglutinability does not occur until the seventy-second day. This, however, is exceptional. It is important to notice that, whereas in other experiments the normal characteristics had developed, in this case a return to normal reaction with serum was brought about in spite of a continuous subjection to the unusual environment.

Inagglutinability of the typhoid bacillus is accompanied by inability to absorb agglutinin. There is no difference whatever in these relations between the xylose slow and xylose rapid fermenters. Our experiments do not indicate that capsular material is concerned in the inagglutinability. Treatment by the Porges method does not render the inagglutinable strains agglutinable.

Acid agglutination experiments by the method of Michaelis showed that the inagglutinable serum strain reacted negatively in the increasing concentrations of acetic acid, being in this way similar to colon bacilli, whereas the same strain cultivated in broth reacted with the acid typically as did Michaelis typhoid cultures. In other words, the inagglutinable strains showed a changed reaction in regard to hydrogen ion concentration of the environment.

Finally, we believe that since all the alterations brought about by artificial environment in the typhoid bacillus were rapidly lost when the organisms were returned to the environments prevailing under the usual cultural conditions and in the case of the inagglutinable strains, even in the course of persistent abnormal environment, the changes observed by others as well as by us should properly be regarded as variants and cannot be spoken of with accuracy as mutations in the sense of de Vries.

## REFERENCES

- BAIL 1901 Prager Med. Woch., Nr. 7.  
 BERNHARDT AND ORNSTEIN 1913 Berl. klin. Woch., Nr. I, 1519.  
 BORDET AND SLEEWIJK 1910 Ann. de l'Inst. Pasteur, **24**, 476.  
 BULL AND PRITCHETT 1916 Jour. of Exp. Med., **24**, 55  
 EISENBERG, P. 1903 Cent. f. Bakt., **34**.  
 EISENBERG, P. 1913 Ergeb. der Immunitäts. Exper. Ther. Bakt. u. Hyg., **73**.  
 FORSTER 1897 Zeitsch. f. Hyg., Bd. 24.  
 FROMME 1911 Cent. f. Bakt. 1 Abt. Orig., **58**, 445.  
 GAY, FREDERICK P. 1914-15 The Harvey Lectures, p. 49.  
 GAY AND CLAYPOLE 1913 Arch. of Intern. Med., **12**, 614.  
 GILDERMEISTER, E. 1913 Arbeit a. d. k. Gesundh. Amte, **45**, 226.  
 GURNEY-DIXON S. 1919 The Transmutation of Bacteria  
 HOLT-HARRIS AND TEAGUE 1916 Jour. of Infec. Dis., **18**, 596.  
 JACOBSEN, K. A. 1910 Cent. f. Bakt. Orig., **56**, 208.  
 JOHNSTON AND McTAGGART 1897 Montreal Med. Jour.  
 KIRSTEIN 1904 Zeit. f. Hyg., **46**, 229.  
 KLOTZ, OSCAR 1904 Jour. of Med. Res., **11**, 475.  
 KOWALENKO, A. 1910 Zeitsch. f. Hyg. u. Infekt., **66**, 277.  
 KOWALENKO, A. 1911 Cent. f. Bakt., 1 Abt. Ref. **48**, 658.  
 KRAUS, R. 1897 Wien, klin. Woch., Nr. 32.  
 KRUMWIEDE, COHN AND VALENTINE 1918 Jour. of Med. Res., **38**, 89.  
 KUWABARA, CH. 1907 Saikingakuzassi, No. 143.  
 KUWABARA, CH. 1909 Cent. f. Bakt. Ref. 1 Abt. **42**, 135.  
 LUERSSEN AND DITTHORN 1912 Cent. f. Bakt., 1 Abt. **58**, 47.  
 MANDELBAUM, M. 1912 Cent. f. Bakt. 1 Abt. Orig. **63**, 46.  
 MASSINI 1907 Arch. f. Hyg. **61**, 251.  
 McNAUGHT, J. G. 1905 Jour. of Path. and Bact., **10**, 380.  
 MICHAELIS, LEONOR 1911 Deut. med. Woch., 969.  
 MOON, V. H. 1911 Jour. of Inf. Dis., **8**, 463.  
 MORISHIMA, K., AND TEAGUE, OSCAR 1917 Jour. of Inf. Dis., **21**, 145.  
 MÜLLER, REINER 1908 Deut. Med. Woch., 1961.  
 MÜLLER, REINER 1911 Cent. f. Bakt. 1 Abt. Orig. **58**, 97.  
 MÜLLER, PAUL TH. 1903 Münch. med. Woch, **1**, 56.  
 NEISSER, I. M. 1906 Cent. f. Bakt. 1 Abt. Ref. **38**, 98.



- NEISSER AND FRIEDEMANN 1904 Münch. med. Woch., **51**, 465 and 827.
- PARK AND WILLIAMS 1917 Pathogenic Microorganisms, 6th Ed., 208.
- PARK AND WILLIAMS 1920 Pathogenic Microorganisms, 7th Ed., 55.
- PECKHAM, A. W. 1897 Jour. of Exper. Med., **2**, 549.
- PENFOLD, W. J. 1910 a Brit. Med. Jour., **2**, 1672.
- PENFOLD, W. J. 1910 b Jour. of Path. and Bact., **14**, 406.
- PENFOLD, W. J. 1911 Jour. of Hyg., **11**, 329.
- PENFOLD, W. J. 1914 Brit. Med. Jour., **2**, 710.
- PORGES, OTTO 1905 a Wien. klin. Woch., 691.
- PORGES, OTTO 1905 b Zeit. f. Exp. Path. u. Ther.
- PORGES AND PRANTSCHOFF 1906 Cent. f. Bakt., **41**.
- PRINGSHEIM, HANS 1911 Med. Klinik, **1**, 144
- RUSSOWICI 1908 Münch. med. Woch., **55**, 2507.
- SACQUEPEE 1901 Ann. de l'Inst. Pasteur, **15**, 261.
- SAISAWA, KOHZOH 1913 Zeit. f. Hyg., **74**, 61.
- SAWYER, WILBUR A. 1912 Jour. A. M. A., **58**, 1336.
- SCHATTENFROH, A., AND GRASSBERGER, R. 1900 Arch. f. Hyg.
- SHELLER, ROBERT 1908 Cent. f. Bakt. **46**, 385.
- SCHMIDT 1903 Wien. klin. Woch., 873.
- TWORT, F. W. 1907 Proc. of Royal Soc. of London, Ser. B., **79**, 329.
- WALKER, AINLEY AND MURRAY 1904 Brit. Med. Jour., **2**, 16.
- WILSON, W. JAMES 1902 Brit. Med. Jour., **12**, 1910.
- WINSLOW, KLIGLER AND ROTHBERG 1919 Jour. Bact., **4**, 428.
- ZINSSER, HANS 1918 Infection and Resistance, 2 Ed., Chap. 9.



# SOLID CULTURE MEDIA WITH A WIDE RANGE OF HYDROGEN OR HYDROXYL ION CONCENTRATION

FREDERICK A. WOLF AND I. V. SHUNK

*From the Botanical Laboratory, North Carolina Experiment Station, West Raleigh,  
North Carolina*

Received for publication October 11, 1920

A considerable number of investigations, made during the past few years, have extended our knowledge of the profound influence exerted by acids and alkalis upon the growth of micro-organisms. This is especially true in the case of such fungi and bacteria as lend themselves readily to cultivation on artificial media. Investigations have also clarified many problems related to these media themselves, such as the influence of acids and alkalis on colloidal hydration and jellification, the buffer action of proteins and salts, the devising of improved colorimetric and electrometric technic for the measurement of hydrogen and hydroxyl ion concentration, etc. The point covered in the present study, which grew out of an attempt to determine the limit of tolerance of certain organisms to acid and alkali on solid media, does not appear to have been brought out in any foregoing investigation. In previous studies use has been made of liquid media for very tolerant organisms, even for forms which are known to thrive best on solid media, since it has been impossible to make agar or gelatin with high pH values solid. It is the present purpose, therefore, to show that acids and alkalis need not materially modify the physical properties of agar and gelatin media within, and even far beyond, the limits of tolerance of any living organism.

## METHODS

The media were prepared by adding either 1 or 2 per cent commercial agar or 10 or 15 per cent bacto-gelatin to a bouillon consisting of 0.3 per cent Liebig's beef extract, 1 per cent Armour's

peptone and 0.5 per cent sodium chlorid. They were then heated in an autoclave, flaked, and sterilized, for fifteen minutes at 15 pounds pressure in the case of agar, and 10 pounds pressure in the case of gelatin. No attempt was made to adjust the reaction of the media to neutrality prior to sterilization. The acid used was hydrochloric, with a specific gravity of 1.20 or it possessed an HCl concentration of 39.11 per cent. The sodium hydroxid had a specific gravity of 1.226 or an NaOH concentration of approximately 20 per cent. Strong acid and alkali were employed to eliminate the factor of dilution of the media. Upon removal from the autoclave the agar was cooled to about 50°C. and the gelatin to about 40°C. before the addition of appropriate quantities of acid or alkali, and were maintained at these temperatures while 10 cc. portions were withdrawn with a pipette and put into test tubes. The acid or alkali was added to these 10 cc. portions with a 1 cc. pipette graduated in tenths. After the addition of the acid or alkali the tubes were well agitated and were further cooled with the results indicated in the tabulations which follow.

#### EXPERIMENTAL

Only those proportions of agar or gelatin which are commonly employed in making culture media were used in this study but they indicate, as would be anticipated, that the jellifying power is modified by the proportion of colloidal material added. The results with 1 and 2 per cent agar are shown in table 1.

It will be noted that the limits of solidification of 1 per cent agar are approximately 5.11 per cent acid and 0.39 per cent alkali whereas 2 per cent agar does not lose its jellifying power until 6.51 per cent acid or 0.58 per cent alkali has been added. A better appreciation of the degree of acidity and alkalinity of these limits can be gained when they are compared with pH values determined by the colorimetric method of Clark and Lubs (1917). It was found that the addition of 0.1 cc. of HCl to 10 cc. of agar gave a concentration of about pH 1.4 and 0.03 cc. NaOH a concentration of about pH 9.2. In reaching the limits

in 2 per cent agar it will be seen that 20 times this volume of acid and 9 times this volume of alkali were employed. Manifestly these limits are only approximate and could be more accurately determined by improved technic. They are, however, far beyond the limits of tolerance of microorganisms and are intended only to show that hydrogen or hydroxyl ion concentration need not be limiting factors in the preparation of solid agar media.

TABLE 1  
*Effect of acid and alkali on solidification of agar*

1 PER CENT AGAR					2 PER CENT AGAR						
Agar	HCl		NaOH		Physical state, 20°C.	Agar	HCl		NaOH		Physical state, 20°C.
cc.	cc.	per cent	cc.	per cent		cc.	cc.	per cent	cc.	per cent	
						10	2.0	6.51			Semisolid
						10	1.7	5.68			Solid
10	1.5	5.11			Semisolid	10	1.5	5.11			Solid
10	1.2	4.19			Solid	10	1.2	4.19			Solid
10	1.0	3.55			Solid	10	1.0	3.55			Solid
10	0.7	2.55			Solid	10	0.7	2.55			Solid
10	0.5	1.86			Solid	10	0.5	1.86			Solid
10	0.3	1.14			Solid	10	0.3	1.14			Solid
10	0.1	0.38			Solid	10	0.1	0.38			Solid
10			0.1	0.19	Solid	10			0.1	0.19	Solid
10			0.2	0.39	Semisolid	10			0.2	0.39	Solid
10			0.3	0.58	Liquid	10			0.3	0.58	Semisolid

All of the agar media in these series appear to be able to remain solid for an indefinite period when they are maintained at room temperature. If, however, they are autoclaved and then cooled all of the acid media were found to remain liquid, whereas the tubes of 1 per cent agar with 0.1 cc. NaOH and 2 per cent agar with 0.1 and 0.2 cc. NaOH became solid again.

Considerably larger amounts of acid or alkali must be added to 10 and 15 per cent gelatin to destroy the jellifying power as shown in table 2.

In the case of 10 per cent gelatin the limits are seen to be about 9.02 per cent HCl and between 3.33 and 4 per cent NaOH, and of 15 per cent gelatin between 9.02 and 10.15 per cent HCl

and about 4 per cent NaOH. When these media were examined after having been maintained in an ice chest at about 10°C. for twelve hours, all of those to which more than 1 cc. of NaOH had been added were found to have become liquid, and a heavy whitish precipitate had formed. All of the tubes to which HCl had been added were still solid, however. All of the tubes containing media which had remained solid were placed in boiling water until the media had liquified whereupon they

TABLE 2  
*Effect of acid and alkali on solidification of gelatin*

10 PER CENT GELATIN					15 PER CENT GELATIN						
Gela- tin	HCl		NaOH		Physical state 7.5°C.	Gela- tin	HCl		NaOH		Physical state 7.5°C.
	cc.	cc.	per cent	cc.			per cent	cc.	cc.	per cent	
						10	3.5	10.15			Liquid
10	3.0	9.02			Semisolid	10	3.0	9.02			Semisolid
10	2.5	7.82			Solid	10	2.5	7.82			Solid
10	2.0	6.51			Solid	10	2.0	6.51			Solid
10	1.7	5.68			Solid	10	1.7	5.68			Solid
10	1.5	5.11			Solid	10	1.5	5.11			Solid
10	1.2	4.19			Solid	10	1.2	4.19			Solid
10	1.0	3.55			Solid	10	1.0	3.55			Solid
10	0.5	1.86			Solid	10	0.5	1.86			Solid
10			0.5	0.95	Solid	10			0.5	0.95	Solid
10			1.0	1.82	Solid	10			1.0	1.82	Solid
10			1.2	2.14	Solid	10			1.2	2.14	Solid
10			1.5	2.61	Solid	10			1.5	2.61	Solid
10			1.7	2.90	Solid	10			1.7	2.90	Solid
10			2.0	3.33	Solid	10			2.0	3.33	Solid
10			2.5	4.00	Liquid	10			2.5	4.00	Semisolid

were again cooled to 7.5°C. The alkaline gelatin again solidified, but 1.5 cc. of HCl in 10 per cent gelatin and 1.7 cc. in 15 per cent gelatin were now the limits of the jellifying power.

#### DISCUSSION

Manifestly, in the case of both agar and gelatin, strong acid or alkali in the presence of high temperatures is capable of destroying the jellifying power. Everyone who has made culture

media according to accepted methods, i.e., sterilized them after the adjustment of reaction, has found that an acidity of 2 to 2.5 per cent normal HCl or a pH concentration of approximately 4 to 3.5 is the limit of solidification of agar. Alkalis in related proportions in the presence of heat have been found to exert a similar action on the jellifying power of agar. Fellers (1917), however, found that this range of jellifying power for 2 per cent agar could be extended to 5 per cent normal HCl or 5 per cent KOH if the acid or alkali were added while the agar was boiling hot and it was not subsequently sterilized. These highly acid or alkaline media were furthermore employed by him (1916) in studies on soil flora, since appropriate quantities could be transferred by means of a sterile pipette to sterile Petri dishes. When one permits the media to cool before adding the acid or alkali as was done in our studies, and as is indicated in Fellers' work, the range of solidification may be extended very much farther. The application of the principles involved herein are believed to make it possible both to simplify the making of media and to improve methods for investigation on the influence of hydrogen ion concentration on microorganisms. Reference to two recent papers one by Webb (1919) on the influence of reaction on the germination of fungous spores and the other by Fred and Davenport (1918) on the growth of nitrogen assimilating bacteria, will illustrate the possibilities which may come in similar studies from the use of very acid or very alkaline solid media.

In routine work it will be found to be advantageous to flask and sterilize the media in 200 cc. quantities for the reason that the addition of 1 or 2 drops of strong acid or alkali to this quantity will bring about a change in concentration of about pH 0.2. When acid is added to agar in flasks at 50° to 60°C. it may be thoroughly agitated by whirling, 10 cc. portions may be removed for comparison in reaction with the color standards of Clark and Lubs (1917), and when the usual precautions against contamination are observed the material in the flasks may be kept sterile, while the adjustment to the desired pH concentration is being made. The agar may then, before it has had time to solidify, be poured into sterile test tubes or sterile Petri dishes, where-

upon it is ready for use. The danger of contamination from this procedure, as judged by experience in making several thousand tubes of media, is no greater than when the tubes are sterilized after the media has been placed in them, as is usually done. In summary, this procedure removes the necessity of sterilization after adjustment of reaction, eliminates the chances of change of reaction or of other chemical changes which may be hastened by a rise in temperature, and does not, within a wide range, destroy the jellifying powers of the agar or gelatin.

#### CONCLUSION

Agar or gelatin media, if cooled before being made acid or alkaline, will jellify at limits far beyond pH concentrations tolerated by microorganisms. They may be manipulated so as to avoid contamination during adjustment of reaction and need not be subsequently sterilized.

#### REFERENCES

- CLARK, W. M., AND LUBS, H. A. 1917 The colorimetric determination of hydrogen ion concentration and its applications in bacteriology. *Jour. Bact.*, **2**, 1-34, 109-136, 191-236, f. 1-8.
- FELLERS, C. D. 1916 Some bacteriological studies on agar. *Soil Sci.*, **2**, 255-290.
- FELLERS, C. D. 1917 The analysis, purification, and some chemical properties of agar-agar. *Jour. Indus. Eng. Chem.*, **8**, 1128-1132.
- FRED, E. B., AND DAVENPORT, AUDREY 1918 Influence of reaction on nitrogen assimilating bacteria. *Jour. Agr. Res.*, **14**, 317-336.
- WEBB, R. W. 1919 Germination of the spores of certain fungi in relation to hydrogen ion concentration. *Ann. Mo. Bot. Garden*, **6**, 201-222.



# STUDIES ON AZOTOBACTER CHROOCOCCUM BEIJ.

AUGUSTO BONAZZI

*Contribution from the Ohio Agricultural Experiment Station, Wooster, Ohio,  
Laboratory of Soil Biology*

Received for publication October 15, 1920

## I. GENERAL

### *Introduction*

The study of the metabolism of *Azotobacter* has been generally approached from the standpoint of the rôle of this organism in the nitrogen cycle in Nature, but the fact that the ability to fix free nitrogen is regulated by the presence or absence of combined nitrogen in the medium has not been given serious attention although it is made plain in the works to be cited.

Bejierink and Van Delden (1902) have shown that *Azotobacter chroococcum* possesses the power to transform nitrates directly into ammonia and Lipman (1903), Stoklasa (1908), Stranak (1909) and Heinze (1906) found that small quantities of nitrates "stimulated" nitrogen fixation by this organism. If the property of nitrogen fixation were a function of the normal life cycle, it seems strange that, although of vital importance, it should be overcome with such facility. In this connection the data presented by Hills (1918) are most instructive. The accompanying table is a recalculation of the data given by him on pages 200-203 of his contribution, and is chosen as it is the only one given which was obtained by the use of a synthetic medium.

From this compilation we see that in presence of abundant stores of nitric nitrogen *Azotobacter* does not fix atmospheric nitrogen but assimilates the nitrogen of the nitrates. A close study of the original data shows that in the presence of ammonium nitrate the organism has a preference for the nitrate radicle leaving the ammonium radicle untouched.

The most important feature of the recalculated data, and one that the author apparently overlooked, is the one presented in the last column of table 1. A very appreciable "loss" of nitrogen takes place from the cultures, either as free nitrogen or as a volatile nitrogenous compound. It is assumed that the cultures used by Hills were pure.

Greaves (1918) in his recent review of this work seems not to consider this important phase of the metabolism of *Azotobacter*.

TABLE 1  
*Nitrogen balances in the cultures of Hills*

TYPE OF ORGANISM	TREATMENT OF SOLUTION	TOTAL NITROGEN		NITROGEN UNACCOUNTED FOR, PROBABLY LOST BY BACTERIAL ACTION
		Inoculated	Check	
A	NaNO <sub>3</sub>	105.20	164.95	59.75
	NH <sub>4</sub> NO <sub>3</sub>	162.12	206.75	44.63
B	NaNO <sub>3</sub>	135.60	164.95	29.35
	NH <sub>4</sub> NO <sub>3</sub>	192.85	206.75	13.90

After this very brief survey of the data in question it may be well to recall a statement which appeared in a previous communication from this laboratory (1915) to the effect that *A. chroococcum* may be a fixer of atmospheric nitrogen only under such conditions as we call "normal," i.e., in absence of fixed nitrogen and a denitrifier when such conditions are changed, i.e., when there is a possibility for it to consume nitrate under naturally normal conditions. In our present study of the literature we have excluded purely agronomic investigations and have considered only studies which have been made under conditions of control such as to give results of fundamental importance.

### *Historical*

A simple study of the relation of the carbon consumed to the nitrogen fixed has only a limited value, and this is especially true when we consider the great variations in the nitrogen fixing power of the same organism under different conditions. The quality of the carbohydrate utilized in the experiment and its

relation to the fixation of nitrogen have received considerable attention but it should be stated nevertheless that the ratio C:N, as often reported in the literature, has no absolute value since the determination of the carbon actually utilized has not been attempted, a complete consumption of all the carbohydrate originally present having been assumed.

Furthermore it must be stated that by following the practice of allowing all the carbohydrate to disappear from a solution the cultures are submitted to a negative phase, one of actual starvation which, as will be seen later vitiates the results of the experiments.

The excellent work of Koch and Seydel (1912) on the influence of the concentration of carbohydrate is typical of the results to be obtained when the concentration of sugar and time of incubation are made elements in an experiment. In fact from their work it is evident that each period of incubation has an optimum concentration of sugar a finding that makes it impossible to draw definite conclusions from data obtained with a given sugar concentration and an arbitrary number of days of incubation.

Stoklasa (1908), using glucose as a source of carbon, concludes that the products of carbohydrate attack by *Azotobacter* are: ethyl alcohol, formic acid, acetic acid, butyric acid (only once in anaerobic conditions), lactic acid, carbon dioxide and hydrogen. From his data it would appear as if the glucose actually incorporated by the cells during the period of his experiments should be represented by

	<i>grams</i>
Glucose actually consumed . . . . .	15.8900
Glucose found in byproducts . . . . .	9.3790
	<hr/>
Glucose theoretically in cells . . . . .	6.5110

But Stoklasa sums up his observations by stating that he cannot account for this quantity of 6.5110 grams of glucose and that probably not all the by-products were determined. A second possible reason for such unaccounted for glucose he assumes to be found in the inaccuracy of the methods for the determination of the by-products (volatile and non-volatile acids).

To reconcile this work with the statements of Omeliansky and Sewerowa (1911) is impossible if we assume both groups of workers to be working with pure cultures of the organism in question. Although statements as to the purity of his cultures were made by Stoklasa, the fact that hydrogen in the free state was found to be generated in appreciable quantities, as well as butyric acid, in some cases, would tend to make this purity questionable.

If now we consider in this connection the work of Krzmieniewsky (1908) we have a series of most interesting data that bring out two very striking features: 1, complete lack of hydrogen production and, 2, striking difference in the  $\text{CO}_2:\text{O}_2$  ratios resulting from the utilization of glucose and mannitol. One feature of this work which deserves special attention is that the ratio of  $\text{CO}_2$  formed to nitrogen fixed is not constant. Expressed in other words there does not exist a constant C:N ratio for *Azotobacter*. The nitrogen fixation from the atmosphere is such that it cannot be considered as a normal and essential function, necessary to the cell economy of the organism, but rather as an incidental or secondary factor in the cell metabolism. As an addendum to the main bulk of his work Krzmieniewsky mentions a series of experiments which fail to corroborate the findings of Stoklasa, with regard to the formation of by-products, and cast thereby additional doubt on the purity of the cultures of the latter investigator. That this difference in the metabolism (production of organic acids and alcohols) may not be due to differences in the organisms studied or, necessarily, to impurities is shown by some of the data presented by Mazé (1902).

That an organism such as *Eurotiopsis gayonii* is capable of changing its physiology and the nature of the by-products of its life activities (under anaerobic conditions performing only the process of intramolecular respiration) would tend to convince us that Stoklasa might not have been working with impure cultures but may rather have been growing his cultures under conditions of anaerobiosis. That such a process of anaerobiosis is possible in *Azotobacter* may be postulated when we consider the work of Mazé on the assimilation of glycerol, lactic acid and aldehyde by *Eurotiopsis*.

Nevertheless, although lactic acid and alcohol could be assumed as by-products of an abnormal physiology of *Azotobacter*, the production of hydrogen and butyric acid suggests a contaminating form.<sup>1</sup>

The fact that *Azotobacter* gave a ratio  $\text{CO}_2:\text{O}_2$  of about unity in Krzmieniewsky's work does not in itself indicate that all the carbohydrate consumed is utilized in a process of combustion. In fact, it is unfortunate that with such a careful study of the gaseous exchange in their cultures these authors were not in a position to present data showing the actual disappearance of the carbon source from the solutions.

If we consider the carbon balances in the mathematical terms introduced by Duclaux (1900) we obtain the following equation.

$$S = m.L + n.l.t \quad (1)$$

where  $S$  is the quantity of sugar consumed,  $L$  the weight of the cells at the end of the incubation period,  $l$  that quantity of cellular substance that constitutes the average throughout the period of experiment,  $m$  the quantity of sugar actually to be found in the mass of one unit of cellular substance,  $n$  that quantity of sugar necessary for the maintenance of one unit of cellular substance during the unit of time  $t$ .

Omeliansky and Sieber after a study of the composition of the cells of *Azotobacter* (1913) grown on agar concluded that cells of *Azotobacter* contained a relatively small quantity of protein (about 13 per cent), their greater mass being made up of nitrogen-free substances. It is possible that the heavy "schlimeschicht" that surrounds the cells during the early stages of development should not be forgotten in this connection as also the peculiar granulations to be found in the cells of this organism (Bonazzi, 1915) and which play a rôle in their life cycle that is not as yet completely understood. It is possible that such structures are largely made up of that sugar carbon which has been denominated  $m$  in the above equation. But as will be

<sup>1</sup> Krzmieniewsky admits of the possibility that the organism which Stoklasa was studying was not *Azotobacter*.

seen later these same structures are utilized in future life and should therefore be considered again in the calculation of  $n$ , that quantity of sugar which goes to the maintenance of the cell.<sup>2</sup>

The above analysis of the literature leads us to the following considerations: a) the C:N ratio of *Azotobacter* is an inconstant value, b) the metabolism of this organism is not as yet well understood, c) the nitrogen fixing capacity of this organism seems to be a function of secondary importance in the cell economy.

## II. EXPERIMENTAL

### *Carbon relations*

#### CO<sub>2</sub>:O<sub>2</sub> ratio and sugar consumption

*Experiment 44.* A large flat-bottomed Fernbach flask was fitted with the attachment shown in figure 1.

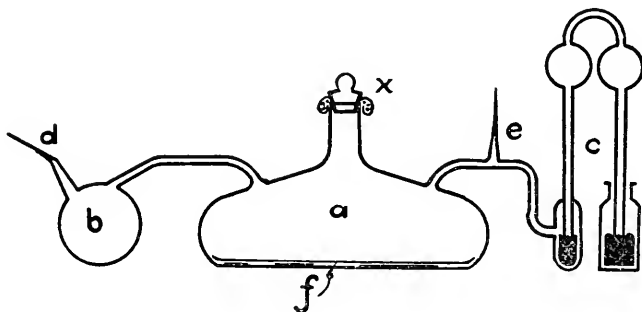

FIG. 1. *a*, culture flask; *b, d, c*, gas collecting chain; *c*, mercury valve; *f*, culture solution; *x*, paraffin and plaster of paris seal fitted over the ground glass stoppers to avoid possible gas leaks.

The total volume of the apparatus was 3290 cc. and since 100 cc. of solution were used, the total volume of air over the solution was 3190 cc. The solution used was of the following composition:

Deep well water . . . . .	500.00 cc.
K <sub>2</sub> HPO <sub>4</sub> . . . . .	0.10 gram
Glucose . . . . .	10.00 grams

<sup>2</sup> Krainsky obtains curves on the CO<sub>2</sub> production of cultures of *Azotobacter* but unfortunately gives no data on the actual sugar consumption.

One hundred cubic centimeters of this solution were placed in the flask together with 0.50 gram of precipitated  $\text{CaCO}_3$ . After sterilization and inoculation with a pure culture of *Azotobacter chroococcum* the whole apparatus was sealed and incubated at  $25^\circ\text{C}$ . for forty-eight days. A gas analysis at the start of the incubation period and at the end gave the results shown in table 2.

TABLE 2  
*Gas changes in culture of Azotobacter chroococcum*

GAS	COMPOSITION OF AIR				TOTAL GAS BALANCES
	At start		At the end		
	Per cent	Actual	Per cent	Actual	
		cc.		cc.	cc.
$\text{CO}_2$ . . . . .	0.00	0.00	9.70	309.40	+309.4
$\text{O}_2$ . . . . .	20.30	647.60	11.33	361.40	-286.2
$\text{H}_2$ . . . . .	0.00	0.00	0.00	0.00	0.0

Calculating the ratio  $\text{CO}_2:\text{O}_2$  we obtain the value 1.08 which closely approximates the value 1.02 obtained by Krzymieniewsky in his work with glucose. But under such high partial pressure of  $\text{CO}_2$  the solution in the flask can contain appreciable quantities of this gas in solution. In fact by titration of the solution with  $\text{Na}_2\text{CO}_3$  and  $\text{H}_2\text{SO}_4$  it was found to contain 50.70 mgm. of carbon dioxid. Gravimetrically then, the quantity of  $\text{CO}_2$  in the air would be 607.80 mgm., and that in solution 50.70 mgm., giving a total quantity of 658.50 mgm. of carbon dioxid in the system. The oxygen consumption was of 286.20 cc. corresponding to 408.80 mgm. of  $\text{O}_2$ . A sugar analysis showed the following changes in the solution:

Uninoculated . . . . . 1840.0 mgm.  $\text{C}_6\text{H}_{12}\text{O}_6$   
 Inoculated . . . . . 41.2 mgm.  $\text{C}_6\text{H}_{12}\text{O}_6$

Total sugar consumed . . . . . 1798.8 mgm.

Assuming the oxygen to be utilized in the combustion of the sugar according to the following equation (equation 2) which

represents only the final changes, we are in a position to estimate the quantity of  $\text{CO}_2$  which should have been formed in the process (table 3).

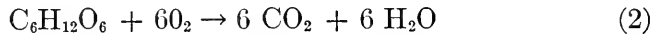

The final result of this experiment is therefore to show that more carbon dioxide is formed and more sugar consumed than can be accounted for by the amount of oxygen consumed.

The solution in the particular flask was the seat of vigorous development, beginning with the formation of a ring at the point of air-glass-solution contact, slowly clouding the whole solution and later sinking to the bottom of the flask in the form of a heavy deposit exhibiting the gray-brown pigmentation characteristic of *Azotobacter*.

TABLE 3  
*Gas balances in cultures of Azotobacter*

	$\text{C}_6\text{H}_{12}\text{O}_6$ CONSUMED	$\text{O}_2$ UTILIZED	$\text{CO}_2$ FORMED
	<i>mgm.</i>	<i>mgm.</i>	<i>mgm.</i>
Actual.....	1798.8	408.8	658.5
Calculated.....	383.2	408.8	562.1
Differences.....	+1415.6	0.0	+96.4

The quantity of sugar unaccounted for may well have been found in the cell body and secretions had an effort been made to account for the whole. Since this was not done we are only justified in assuming such a possibility. That some secondary actions do take place in a culture of *Azotobacter* is shown by the presence of 96.4 mgm.  $\text{CO}_2$  in excess of the theoretical amount. We may safely assume at present that this quantity of carbon dioxide is derived from a process of intramolecular respiration. A proof of this may be found in a later part of this paper, under the heading of Autophagy. This assumption is also in agreement with the equation of Duclaux for aerobic organisms, and is substantiated by the following experiment.

*Experiment 46.* A large Fernbach flask fitted with the attachments shown in figure 2, received 100 cc. of a solution of the composition shown below:



Deep well water . . . . .	250.00 cc.
K <sub>2</sub> HPO <sub>4</sub> . . . . .	0.05 gram
Glucose . . . . .	5.00 grams
Ca(NO <sub>3</sub> ) <sub>2</sub> + 4H <sub>2</sub> O . . . . .	0.316 gram

Calcium carbonate was added in the quantity of 0.5 gram.

The total volume of the apparatus was of 2666 cc. and the addition of the solution left 2566 cc. of air space. After sterilization and inoculation with a pure culture of *Azotobacter chro-*

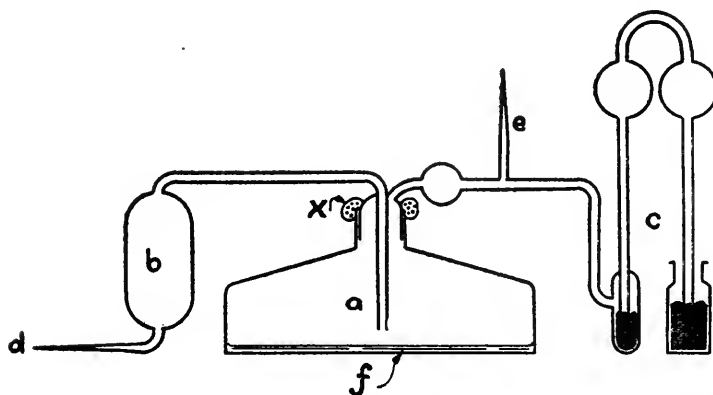

FIG. 2. *a*, culture flask; *b*, *d*, *e*, gas collecting chain; *c*, mercury valve; *x*, paraffin and plaster of paris seals over ground glass joints.

TABLE 4  
*Gas changes in culture of Azotobacter chroococcum*

GAS	COMPOSITION OF AIR				CHANGES IN TOTAL GAS
	Before		After		
	Per cent	Actual	Per cent	Actual	
		cc.		cc.	cc.
CO <sub>2</sub> . . . . .	0.13	3.33	20.70	531.20	+527.87
O <sub>2</sub> . . . . .	20.21	518.50	1.02	26.17	-492.33
H <sub>2</sub> . . . . .					

*ococcum* the apparatus was incubated at about 25°C. for fifty-two days, after which period a gas analysis was made. Comparing the results obtained at the end to the values at the start of the experiment we may calculate the gas exchanges in the culture as shown in table 4.

Calculating the  $\text{CO}_2:\text{O}_2$  ratio we obtain the value 1.07. Here again a very close approach is seen to the value obtained by Krzmieniewsky when glucose was used as a source of carbon. Again here as in the previous experiment the carbon dioxide dissolved in solution was determined and found to be 44.36 mgm. and the quantity of this gas in the atmosphere 1037.0 mgm. The total weight of the gas formed then would be 1081.4 mgm. while a total quantity of 703.3 mgm. of oxygen was consumed. A determination of the sugar concerned in the action follows:

Uninoculated . . . . .	1701.0 mgm. $\text{C}_6\text{H}_{12}\text{O}_6$
Inoculated . . . . .	572.8 mgm. $\text{C}_6\text{H}_{12}\text{O}_6$
	—————
Total sugar consumed . . . . .	1128.2 mgm.

If we assume that the consumed oxygen was utilized wholly in the process of sugar combustion we obtain the balances shown in table 5.

TABLE 5  
*Gas balances in cultures of Azotobacter*

	$\text{C}_6\text{H}_{12}\text{O}_6$ CONSUMED	$\text{O}_2$ UTILIZED	$\text{CO}_2$ FORMED
	mgm.	mgm.	mgm.
Actual . . . . .	1128.2	703.3	1081.4
Calculated . . . . .	659.4	703.3	967.2
Differences . . . . .	+468.8	0.00	+114.2

Here again we see indications of an intramolecular respiration taking place with a consumption of sugar above the theoretical.<sup>3</sup>

Comparing now the data from the two experiments mentioned above we have table 6.

It seems evident therefore that the cells of *Azotobacter* besides retaining abundant stores of the carbohydrate with which they

<sup>3</sup> A third experiment of the series, in which the  $\text{CO}_2:\text{O}_2$  ratio has been determined, gave a value of 1.09 for the respiratory exchange, a value in very close agreement to the others here reported. A summary of the  $\text{CO}_2:\text{O}_2$  ratios follows:

Experiment 44 . . . . .	1.08
Experiment 46 . . . . .	1.07
Experiment 78 . . . . .	1.09
Value of Krzmieniewsky . . . . .	1.02

are placed in contact secrete or produce in the surrounding medium compounds, the nature of which has not been determined. Before attempting to study these compounds we shall enter into a closer analysis of the above experiments. Expressing the quantity of unaccounted for sugar in terms of percentage of the amount of sugar actually disappeared from solution we obtain table 7.

TABLE 6  
*Summary of tables 3 and 5; values obtained in excess of theoretical*

TREATMENT	C <sub>6</sub> H <sub>12</sub> O <sub>6</sub>	CO <sub>2</sub>
	<i>mgm.</i>	<i>mgm.</i>
None.....	+1415.6	+96.4
Nitrate.....	+468.8	+114.2

TABLE 7  
*Sugar unaccounted for as per cent of the sugar which disappeared*

TREATMENT	VALUE
None.....	78.71
Nitrate.....	41.56

It is obvious that no relation whatever exists between the sugar unaccounted for and the CO<sub>2</sub> formed in excess of the theoretical, and from table 7 we gather that the addition of nitrogen in the form of Ca (NO<sub>3</sub>)<sub>2</sub> has induced a profound change in the physiology of Azotobacter. That the nitrogen is actually consumed during the process of growth could be assumed from the published works of other authors, but to obtain more specific results we may summarize the data obtained on the above mentioned cultures (table 8).

The transformation of nearly 10 mgm. of nitric nitrogen into organic nitrogen (which was probably in part organized) is directly connected with the carbohydrate consumption and with the stores of carbon in the cell body and by-products. If such soluble and insoluble material were actually formed it should be possible, by stopping fermentation in its early stages or by an oxygen hunger, to obtain a carbon balance showing a greater

disappearance of sugar than can be accounted for by the actual oxygen consumption; and the carbon dioxide production should be correspondingly diminished. That this is what actually happens is shown by the following experiment.

TABLE 8  
*Nitrogen balances of Azotobacter*

	CULTURE							
	No nitrate				Nitrate			
	NH <sub>3</sub>	N <sub>2</sub> O <sub>5</sub>	Organic	Total	NH <sub>3</sub>	N <sub>2</sub> O <sub>5</sub>	Organic	Total
	<i>mgm. N</i>	<i>mgm. N</i>	<i>mgm. N</i>	<i>mgm. N</i>	<i>mgm. N</i>	<i>mgm. N</i>	<i>mgm. N</i>	<i>mgm. N</i>
At start . . . . .				0.69		17.14	0.88	18.02
At end . . . . .				3.86		7.28	10.65	17.93
Balances . . . . .				+3.17		-9.86	+9.77	-0.09

*Experiment 79.* A number of heavy walled Erlenmeyer flasks of 300 cc. capacity received 50 cc. of a solution of the following composition:

Deep well water . . . . .	500.00 cc.
K <sub>2</sub> HPO <sub>4</sub> . . . . .	0.25 gram
NaCl . . . . .	0.25 gram
FeSO <sub>4</sub> + 7H <sub>2</sub> O . . . . .	0.025 gram
Glucose . . . . .	5.00 grams

Another set of flasks received 50 cc. of this same solution to which had been added 0.115 per cent of KNO<sub>3</sub>. The flasks were all fitted as is shown in the accompanying figure 3 with manometer tubes.

They had all received in addition to the solution 0.25 gram of precipitated CaCO<sub>3</sub>. One flask in each series (nos. 1 and 5) was left uninoculated to serve as control while the others were inoculated with a pure culture of *Azotobacter chroococcum*. After varying periods of incubation at 27°C. the gas was pumped out of the flasks by means of a mercury pump until the solution boiled at about 30°C.; then boiling was continued for a few minutes, and the gas mixture thus obtained was analyzed. The

solution was then used for the determination of the residual sugar. The results are presented in tables 9 and 10.

Expressing these values in terms of cubic centimeters of gas in the total volume of the flasks at 0°C. and 760 mm. we have the result shown in table 10.

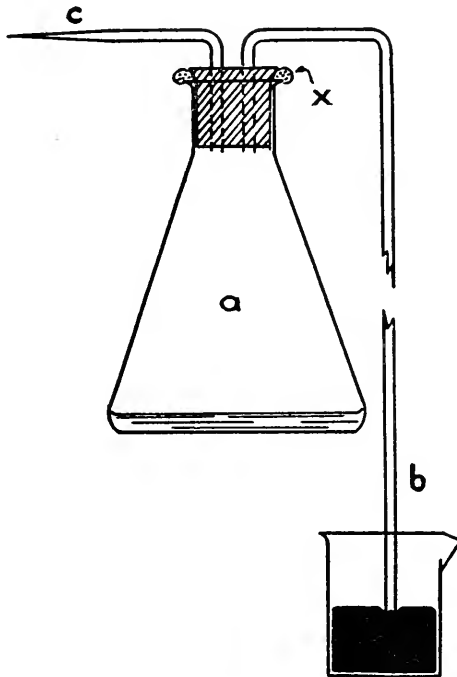

FIG. 3. *a*, culture flask; *b*, manometer tube (Hg rose to atmospheric pressure when evacuated); *c*, evacuation tube and gas collector connection; *x*, paraffin coating on rubber stopper.

If now we consider all the oxygen disappeared to be used in a process of combustion such as is expressed in equation 2 on page 338, we have the data given in table 11.

In the above data we find confirmation of the hypothesis expressed above. *Azotobacter* utilizes the sugar first in the building up of its cell substance and the preparation of non-reducing substances; and slowly digests these "stores" of carbonaceous material in the process of later development in the

presence of oxygen. It is also reasonable to assume that the energy resulting from this oxidation is utilized in further growth. If this were actually the case, it should be possible to follow these various steps and the coincident disappearance of sugar at close intervals of time, in a solution undergoing active fermentation.

TABLE 9

*Results of gas analyses of cultures of Azotobacter under oxygen starvation expressed in percentage of the gas mixture*

GAS	NO NITRATE				WITH NITRATE			
	Number of flask				Number of flask			
	1	2	3	4	5	6	7	8
CO <sub>2</sub> .....	0.00	17.51	17.64		0.00	17.96	19.87	
O <sub>2</sub> .....	20.32	0.49	1.94		20.27	0.80	0.97	

TABLE 10

*Gas and sugar changes in cultures of Azotobacter*

TREATMENT	NUMBER	DAYS OF INCUBATION	OXYGEN CONSUMED		CARBON DIOXID FORMED		SUGAR CONSUMED	CO <sub>2</sub> /O <sub>2</sub>
			cc.	mgm.	cc.	mgm.		
None.....	2	3	45.84	65.49	40.48	79.51	86.20	0.88
	3	4	42.93	61.33	42.16	82.82	76.80	0.98
Nitrate.....	6	3	45.79	65.41	42.24	82.97	70.00	0.92
	7	4	47.67	68.10	49.08	96.41	72.80	1.03

TABLE 11

*Gas balances in cultures of Azotobacter chroococcum*

TREATMENT	NUMBER	DAYS OF INCUBATION	C <sub>6</sub> H <sub>12</sub> O <sub>6</sub> CONSUMED ABOVE THEORY	CO <sub>2</sub> FORMED ABOVE OR BELOW THEORY
None.....	2	3	+24.80	-10.49
	3	4	+19.30	+1.51
Nitrate.....	6	3	+8.68	-6.97
	7	4	+8.55	+2.77

This method of study has been followed by Allen (1920) with the results diagrammatically shown in the figure 4.

The sharp fall of the sugar contents during the period *O-X'* from the quantity *Y* to *Y'* shows without doubt that the sugar

is worked over by the cells during the early stages of cultivation and is then slowly utilized by the cells in their later development, during that period when the sugar curve runs about parallel to the asymptote (to the axis  $X$ ).

In another experiment the following data were obtained, corroborating the above statement.

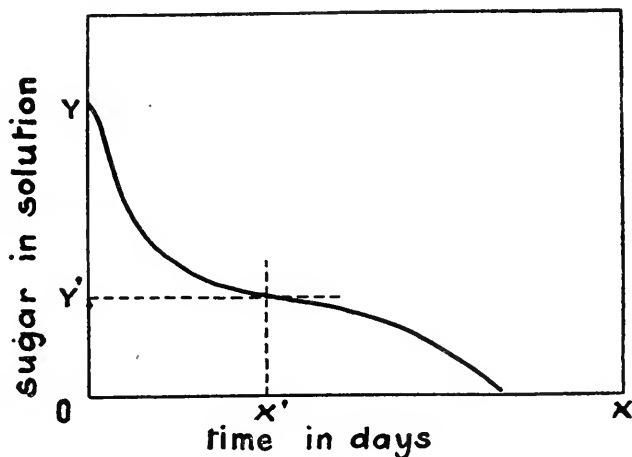

FIG. 4

*Experiment 51.* Sugar consumption in large petri dishes of 20 cm. diameter:

	FIRST 5 DAYS	NEXT 3 DAYS	NEXT 5 DAYS
	<i>mgm.</i>	<i>mgm.</i>	<i>mgm.</i>
Sugar consumed . . . . .	316.7	160.0	0.0
Consumed per day during periods . . . . .	63.0	53.0	0.0

Keeping in mind the fact that there are very few cells active during the first five days, the number in fact being negligible during the very first day or two, we can see that the first value is much more than 63 mgm. of sugar consumed per day.<sup>4</sup>

<sup>4</sup> Here it may be well to keep in mind the mathematical interpretation of bacterial growth presented by Duclaux and discussed by him in volumes 1 and 2. This interpretation was later included by Rahn in his treatment of the fermentive capacity of a single cell. Mich. Res. Bul. 10.

It is unnecessary to present more data on this point since it would all corroborate the above statements without adding new facts of importance. It is nevertheless important to obtain a crucial test of the actual storing and utilization of the stores of the sugar carbon; such evidence follows.

*Autophagy of Azotobacter*

That some of the sugar which disappears from solution during the first few days or hours of growth is actually stored in the cells is obvious in view of the fact that the carbon of the sugar contributes to the synthesis of the compounds of the cell substance, but in addition as will be seen, *Azotobacter* presents an interesting case of what Duclaux designates with the term "phénomène de vie continuée." This phase is one in which the organism is really living on its own reserves and the by-products of its previous life activities, just as yeast will continue to live in a fermented mixture at the expense of the glycogen, glycerol and succinic acid which it formed during its early stages of development and active fermentation.

*Experiment 19.* Pure cultures of *Azotobacter chroococcum* were made on Ashby's mannitol-washed-agar plates and allowed to incubate for twenty-four hours.

The growths thus obtained were emulsified in 0.75 per cent NaCl solution and aseptically placed in sterile test tubes. Slides of this bacterial suspension were prepared immediately and after forty-two and one hundred and fourteen hours' standing in the incubator. They were stained by means of the Giemsa solution which stains well the peculiar granulations studied in a previous communication (Bonazzi, 1915). Examining fifty microscopic fields at random on each of the slides so prepared, and counting the number of cells containing granules (granulated), those free of granules and those in which the granules have partially disappeared (transitional) the following data were obtained.

The cells here classed as transitional are those in which the granules had nearly disappeared or were greatly diminished in size and could well be classed among the ungranulated. If this were done the following table would be obtained.



From these data it seems evident that the stores which were accumulated by the cells during the first twenty-four hours of development on a complete medium were subsequently attacked when no more sugar was at their disposal. Nevertheless it must be stated that the granules may not be the only stores of the Azotobacter cell, and it is very probable that the heavy gelatinous capsule described by various authors is also a storing as well as a protecting organ.

TABLE 12  
*Autophagy of Azotobacter*

HOURS OF INCUBATION	PER CENT OF TOTAL NUMBER OF CELLS AS		
	Granulated	Transitional	Free of granulations
0	84.62	6.15	9.23
42	8.52	19.28	72.20
114	9.02	28.18	62.80

TABLE 13  
*Autophagy of Azotobacter*

HOURS OF INCUBATION	NORMAL CELLS	AUTOFRAGED CELLS
0	84.62	15.38
42	8.52	91.48
114	9.02	90.98

*Sugar: cells ratio*

Among the assimilation products of Azotobacter we should also consider such compounds as play only a transitory rôle in the cell metabolism and are later secreted in the surrounding medium. Stoklasa believes these to be ethyl alcohol, lactic, acetic and butyric acids, but we have seen that we should question his results since we have reason to accept Krzmieniewsky's data and Omeliansky's statements with regard to these formations. That no fixed acids are present has not as yet been shown with certainty (although Omeliansky points to their absence) while no volatile acids have been found in an Azotobacter culture by Krzmieniewsky. Repeated trials made in this laboratory in the hope of finding whether the unaccounted for sugar could be

found in the form of volatile acids, failed to reveal their presence when the cultures were distilled in presence of tartaric acid. Nevertheless, whatever these compounds are they do not seem capable of stopping the development of *Azotobacter* as is shown in the following experiment.

*Experiment 71.* A series of flasks containing each 25 cc. of a glucose solution,  $\text{Ca}(\text{NO}_3)_2$  and  $\text{CaCO}_3$  was inoculated with a pure culture of *Azotobacter chroococcum* and incubated at  $30^\circ\text{C}$ . One flask was left uninoculated as a control. After the necessary period of incubation had elapsed the solutions were acidified until complete solution of the carbonate, allowed to stand in this acidified condition for a short time and then filtered with suction, through a crucible filter prepared according to the accompanying illustration (fig. 5).

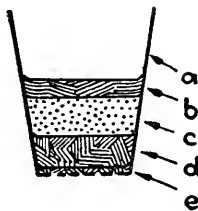

FIG. 5. *a*, perforated glazed crucible; *b*, glass wool; *c*, washed, digested, ignited quartz sand; *d*, asbestos; *e*, packed and burnished platinum sponge.

The solutions passing through the filter were perfectly clear showing that the cells were completely retained by the filter. Careful washing with water, in small quantities at a time, insured complete removal of the retained sugar. By this procedure it was possible to separate the cells from the surrounding medium so as to form a conception of the ratio  $S:c$  where  $S$  is the sugar consumed and  $c$  the weight of the cells produced, reckoned in terms of cellular substance dried at  $110^\circ\text{C}$ . in vacuum, over  $\text{P}_2\text{O}_5$ .

One of the above mentioned cultures, no. 5, was not filtered but received instead the addition of 2 cc. of a 12.5 per cent glucose solution under aseptic conditions; allowed to incubate for a longer period of time it was then subjected to the same

treatment as the others. The results of this experiment are tabulated in table 14.

TABLE 14

*Effect on the growth of Azotobacter chroococcum of its own by-products*

NUMBER OF CULTURE	C <sub>6</sub> H <sub>12</sub> O <sub>6</sub> FOUND				DAYS OF INCUBATION	DRY MATTER		S:c IN EACH PERIOD
	At start	At end	Consumed	Consumed in second period		Actual	Increase in second period	
	<i>mgm.</i>	<i>mgm.</i>	<i>mgm.</i>	<i>mgm.</i>				
1	162.0	162.0	0.0		0			
2	162.0	7.1	154.9		30	18.2		8.51
3	162.0	9.7	152.3		30	Lost		
4*	162+214.7 =376.7	376.7	0.0					
5	376.7	6.2	370.5	216.9	38	27.3	9.1	23.84

\* Total quantity of sugar at the beginning of second period.

Addition of carbohydrate to a culture that has come to a standstill will result in a new utilization of the carbon source with further growth. The first compounds resulting from the first utilization of the sugar had probably all been utilized during the first thirty days of incubation and only such by-products as the cells could not well utilize were to be found when the culture received the fresh supply of sugar; that these were not inhibitive is shown by the utilization of the sugar in the second period as well as by the additional growth. Their nature will be studied elsewhere, and at present it is sufficient to state that they are formed through the cell activity.

#### *Ferment powers of Azotobacter*

From table 14 we may see that the conception S:c is erroneous with regard to the data for culture 5. In fact while it is true that there was a renewal of growth in the second period with a corresponding increase in dry matter, we are not justified in considering that it was only the 9.1 mgm. additional growth that consumed the additional sugar, but we should deem it possible that the 18.2 mgm. of the cells already present in the culture used the new source of carbon for their maintenance. In other

words, referring to equation 1 set forth on page 335 of this memoir we may well express our hypothesis as follows: during the first period of incubation there was a balance between the two functions represented by the equation, while in the second period of incubation the addition of sugar disturbed the balance in such a way that although the first member of the second term was active on 9.1 mgm. of new cellular substance, the second member of this term was active on a total of  $9.1 + 18.3 = 27.4$  mgm. This leads us to the conclusion that the conception of "ferment power" in an organism such as *Azotobacter* should be carefully studied. The following series of experiments was therefore designed to study this phase.

*Experiment 69.* Some 250 cc. Erlenmeyer flasks received 50 cc. of the following solution together with 0.5 gram of precipitated calcium carbonate.

Deep well water . . . . .	500.00 cc.
K <sub>2</sub> HPO <sub>4</sub> . . . . .	0.25 gram
NaCl . . . . .	0.25 gram
FeSO <sub>4</sub> + 7H <sub>2</sub> O . . . . .	0.02 gram
Glucose . . . . .	5.00 grams
Ca(NO <sub>3</sub> ) <sub>2</sub> + 4H <sub>2</sub> O . . . . .	0.632 gram

TABLE 15  
*Sugar consumed per unit of dry matter in cultures of Azotobacter*

NUMBER OF CULTURE	DAYS OF INCUBATION	SUGAR CONSUMED	DRY MATTER OF CELLS AND SLIME	S:c	
				Actual	By periods
		<i>mgm.</i>	<i>mgm.</i>		
5	0	0	0.0	0.00	0.00
6	3	65	Lost		
7	5	109.8	12	9.15	9.15
8	23	411.5	62	6.63	6.03

After inoculation with equal quantities of a pure culture of *Azotobacter chroococcum* the flasks were incubated at 30°C. for varying periods of time. One of the flasks was left uninoculated to serve as control. The dry matter in the cultures was determined by acidifying, filtering in the manner referred to above, washing and drying at 110°C. in vacuum over P<sub>2</sub>O<sub>5</sub>, while the sugar was determined in the filtrate. The results are set forth in table 15.

Before entering into a discussion of the above data other experiments will be related.

*Experiment 81.* Twenty-five cubic centimeters of the solution mentioned in the previous experiment were placed into 1500 cc. Erlenmeyer flasks together with 0.25 gram of CaCO<sub>3</sub> and sterilized, inoculated with equal and very small quantities of

TABLE 16

*Sugar consumed per unit of dry matter in cultures of Azotobacter—experiment 81*

NUMBER OF CULTURE	DAYS OF INCUBATION	SUGAR CONSUMED	DRY MATTER OF CELLS AND SLIME	S:c	
				Actual	By periods
		<i>mgm.</i>	<i>mgm.</i>		
6	0	0.0	0.0	0.0	0.0
7	1	1.4	0.0		
8	2	4.4	0.0*		
9	4	69.2	6.3	10.9	10.3
10	9	184.8	24.8	7.4	6.2

\* Pronounced opalescence of solution too little to be weighed.

TABLE 17

*"Ferment power" of Azotobacter chroococcum*

DAYS OF INCUBATION	FERMENT POWER S:c.t*
30	0.28
23	0.29
9	0.82
5	1.83
4	2.74†

\* S:c.t, where *S* sugar consumed, *c* cellular dry matter and *t* time in days.

† This value is in reality calculated differently from the others. But since on the second day of incubation no appreciable amount of cell substance was formed (experiment S1, no. 8) we should be justified in calculating this value just as the others, i.e., on the base of a two days' growth; thus a "ferment power" = 5.45.

*Azotobacter chroococcum* and incubated at 30°C. for varying periods of time. The same analytical technique was used in the analysis of these as in the cultures of the previous experiment.

Comparing now the data presented in tables 14, 15 and 16 we see that the culture incubated thirty days gave a S:c ratio of

8.51 while the culture incubated twenty-three days gave a value 6.63—of approximately equal magnitude. From these data we can draw a very interesting set of figures if we consider the actual “ferment power” per day. The term “ferment power”

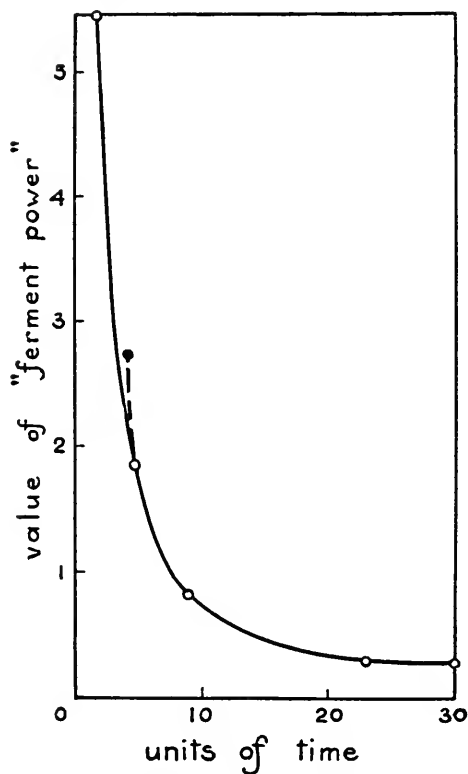

FIG. 6. ● = value of 4 day period on 4 day basis; ○ = value of 4 day period on 2 day basis (see text).

as used by Pasteur and modified by Duclaux to include the time element gives valuable indications as to the physiology of *Azotobacter* (see table 17 and fig. 6).

The term “ferment power” is here used to designate that quantity of sugar consumed by the unit of dry cell substance in the unit of time under the conditions of the experiments. This concept leads us to the conclusion that during the early stages of

development in a culture there is a greater transformation of the crude food substances than during the later stages, a conclusion that is corroborated by the opinion expressed in the previous pages.

We see thus: 1, that the term "*ferment power*" should not be considered as a function, constant throughout the life cycle of *Azotobacter* and, 2, that an organism such as this is capable of utilizing the carbohydrate of a culture in a process of "storage" or transformation without a corresponding cellular development.

#### *General considerations on carbon relations*

In the preceding pages we have assumed that that quantity of sugar carbon as such which disappears from the solution is to be found in the cells and their by-products. That it is not to be found in the cells themselves is shown by the high coefficient of "*ferment power*" in a young culture of the organism in question, since this value is based on that quantity of sugar that is "consumed" by the unit of cell substance in the unit of time.

Objection could be raised to the conception "unit of cell substance" only on the basis of numbers of active cells since the law of multiplication, when all factors remain equal during the duration of the experiment, makes the number of cells found at the end of an incubation period equal to the number that has been active throughout this period, provided the number of cells at the beginning is considered as unity.<sup>5</sup>

Nevertheless the final weight of cellular dry matter in a culture represents the algebraic summation of the two opposite phenomena of anabolism and catabolism, a value related not only to the size of the inoculum itself, but also to the activity of the organism concerned.

In other words, it furnishes an index both of the "growth capacity" of the organism and its ability to build living bacterial substance, as well as of its actual capacity as a ferment.

<sup>5</sup> Expressed in terms of equation:  $N = n - 1$  where  $N$  is the number of units at the end and  $n$  is the number of units actually active during the whole period of incubation, each unit of the same number of cells as the original inoculum which has multiplied in geometrical proportion on incubation.

We thus see that the sugar lost from a culture in the early stages of development passes through the cells in large quantities and is transformed into compounds which do not form integral part of the cells themselves but are dissolved in the medium. The curves of CO<sub>2</sub> production given by Krainsky (1908, 1910) might indicate the close relation between this function and growth, which is pointed to by the values of the ferment power here obtained.

This conception constitutes the conclusion to be drawn from the discussion and closes, temporarily, the chapter on carbon relations of *Azotobacter*. That it appears contrary to the conclusions of Krzymieniewsky and Omeliansky and Prazmowsky is evident, but it should be remembered that their search for soluble by-products was performed ten days after the start of the experiments,—probably when they had been already utilized. This is significant in view of the fact that we failed to find volatile acids in our cultures in conformity with the findings of the above mentioned investigators.

*Nitrogen relations—Attack on nitrates by Azotobacter*

The organism with which these investigations were undertaken was an organism from the Wooster soils that when grown in twenty-five cubic centimeters of Ashby solution (1 per cent mannitol) in 150 cc. Erlenmeyer flasks and incubated for fifty-nine days at a temperature of 28°C. possessed a low nitrogen fixing capacity.

*Experiment 15.*

B-1 check uninoculated (mgm. N <sub>2</sub> found) . . . . .	0.65
B-3 inoculated culture (mgm. N <sub>2</sub> found) . . . . .	2.78
	2.13
Nitrogen fixed (mgm.) . . . . .	2.13

Thus fixation calculated to the basis of 1 liter of solution would give 85.2 mgm. fixed nitrogen; a quantity that represents a fixation of 8.5 mgm. of nitrogen per gram of mannitol if we assume all the mannitol to be utilized during the experiment.



When this same organism was grown in 100 cc. of a 2 per cent mannitol solution in large Fernbach flasks it fixed the following quantities of nitrogen:

*Experiment 29-31.*

	Incubation in days	
	8	17
Check uninoculated (mgm. N <sub>2</sub> found).....	0.66	0.97
Inoculated (mgm. N <sub>2</sub> found).....	3.61	7.47
	2.95	6.50
Nitrogen fixed (mgm.).....	2.95	6.50

Incubation was done on a klinostat where the solution was kept in continual movement and the layer of solution was never above 0.5 cm. deep. (Bonazzi, 1919.) The organism proved itself to be a nitrogen fixer in the ordinary sense of the term, as it was found capable of utilizing the atmospheric nitrogen. The mannitol in these cultures was not all consumed and it was impossible to study the nitrogen fixation per gram of mannitol consumed.

From the work of the various investigators quoted in the first part of this memoir, it can be seen that *Azotobacter chroococcum* may utilize nitrates when grown in their presence. From the data reproduced as table 1 of this contribution Hills draws the following conclusion: "In regard to the fixation of nitrogen by these strains of *Azotobacter* it was found that nitrogen was assimilated both in presence and absence of nitrates. It seems evident that sodium and ammonium nitrate in the amounts studied did not prevent the fixation of the atmospheric nitrogen. In fact the presence of these salts seemed to stimulate the process." Again emphasis is placed on this interpretation when the author states: "However in contrast to the work of Stoklasa, both strains of *Azotobacter* assimilated more atmospheric nitrogen in presence than in absence of these salts."

From table 1 of the present memoir, where Hills' data are recalculated we see that such conclusions are wholly unjustified. Especially is this true when we consider that the analytical method used for the determination of nitrates includes the nitrite nitrogen as well. This speaks against the assumption that "the reduction of nitrates by *Azotobacter* takes place with

the formation of nitrites as is shown in table 14." By referring to table 14 of this author we find that 18.9 mgm. of nitrate nitrogen were lost with a resulting "slight" reaction for nitrites in the solution. A concentration of 18.9 mgm. of nitrites in 100 cc. of solution (for that matter even much less than this) gives more than a "slight" reaction with such a sensitive reagent as the Tromsdorff solution, and it is more than questionable if the totality of the nitrate lost is to be found in the form of nitrites. In addition the analytical data point to the incorrectness of this view.

It is a common experience to see a good development of *Azotobacter* in cultures containing nitrates while poor development takes place in cultures containing no nitrate. For the sake of argument we may assume that the nitrate acts solely in virtue of the stimulation it is supposed to exercise on the nitrogen fixing power of the organism. This increase in the nitrogen fixing power, if present at all, is relatively small and amounts to only 200 to 500 per cent of the original fixation; a stimulation that, when we consider the small original fixation, is relatively small. Although actual data are wanting, we may assume this stimulation to amount to 500 per cent (see the data of Hills on the influence of nitrates on the nitrogen fixation in sterilized soils). A relative increase of 500 per cent in nitrogen fixation brought about by an increase in the number of active cells of 3150 per cent represents an inconceivable stimulation in the fixation of nitrogen, every cell actually fixing less nitrogen in presence than in absence of the fixed nitrogen. It must furthermore be admitted that such a nitrate addition stimulates growth in a different measure than it does nitrogen fixation. Here again we obtain proof of the fact that the nitrogen fixing capacity of the cell is not intimately connected with the function of growth and reproduction.

If the stimulation hypothesis is to be accepted how are we to consider such a difference in these two powers? We are in reality more justified in considering the nitrates as stimulating (or better still aiding) growth in the first place. Basing our working hypothesis on the physiology of the organism we see

that the nitrates increase growth of the cells and their multiplication with a corresponding increase in sugar consumption, and in this process the nitrates disappear to be later found in the organic form, and only after such a phenomenon has taken place does the atmospheric nitrogen fixation really become active.

*Experiment 27.* Fifty cubic centimeter portions of a solution of the following composition were placed into 500 cc. Kjeldahl flasks together with 0.1 gram  $\text{CaCO}_3$ .

Mannitol . . . . .	20.0 grams
$\text{MgSO}_4 + 7\text{H}_2\text{O}$ . . . . .	0.408 gram
$\text{NaCl}$ . . . . .	0.200 gram
$\text{CaSO}_4 + 7\text{H}_2\text{O}$ . . . . .	0.127 gram
$\text{K}_2\text{HPO}_4$ . . . . .	0.200 gram
Tap water . . . . .	1000.00 cc.

TABLE 18

*Nitrogen fixation by Azotobacter in presence and absence of nitrates*

TREATMENT	NUMBER OF CULTURE	NITROGEN AS				AVERAGE OF TOTAL NITROGEN	NITROGEN FIXED
		$\text{NH}_3$	$\text{N}_2\text{O}_5$	Organic	Total		
		<i>mgm.</i>	<i>mgm.</i>	<i>mgm.</i>	<i>mgm.</i>	<i>mgm.</i>	<i>mgm.</i>
None:							
Check . . . . .	1			0		0	
Check . . . . .	2			0		0	
Inoculated . . . . .	3			*			
Inoculated . . . . .	4			0.81	0.81	0.81	+0.81
Nitrate:							
Check . . . . .	5	0.25	5.43	*			
Check . . . . .	6	0.21	5.30	1.76	7.35	7.35	
Inoculated . . . . .	7	0.19	4.37	1.98	6.54		
Inoculated . . . . .	8	0.18	3.79	1.98	5.96		
Inoculated . . . . .	9	0.17	4.50	1.89	6.56		
Inoculated . . . . .	10	0.13	4.54	1.96	6.62		
Inoculated . . . . .	11	0.15	4.10	*		6.38	-0.97

\* Determination lost.

Eleven flasks were prepared and numbered successively from 1 to 11. They were arranged as follows: Nos. 1-4 inclusive received in addition to the above solution 5 cc. of water and flasks 5-11 inclusive received 5 cc. of a 0.843 per cent solution of  $\text{Ca}(\text{NO}_3)_2 + 4\text{H}_2\text{O}$ . All the flasks except nos. 1, 2, 5, 6 were

inoculated with a pure culture of *Azotobacter chroococcum*. After an incubation of nineteen days at 30°C. the cultures were analyzed and found to give the values summarized in table 18. Reference to the cultural notes shows that by far the better growth was found in the nitrate cultures during the whole period of incubation.

An attack on the nitrate is here evident, without a quantitative corresponding increase in the organic nitrogen. Furthermore a certain amount of nitrogen (that quantity which failed to be organized) is actually lost from solution. Although the data are not quantitatively conclusive, their qualitative significance is paramount. They establish an actual loss from the solution in direct corroboration of the results of Hills. Since the depth of the solution layer may be responsible for the low nitrogen changes obtained, trials were made with extensive surfaces of exposure.

*Experiment 32.* Four large Fernbach flasks received 100 cc. of Ashby's solution together with 0.5 gram  $\text{CaCO}_3$ ; two of these

TABLE 19  
*Nitrogen fixed or lost by Azotobacter in absence or presence of nitrates*

TREATMENT	NUMBER OF CULTURE	NITROGEN AS			GAIN OR LOSS
		Organic and ammonia	Nitrous and nitric	Total	
		<i>mgm.</i>	<i>mgm.</i>	<i>mgm.</i>	<i>mgm.</i>
None:					
Control.....	2	0.66		0.66	
Inoculated.....	5	3.61		3.61	+2.95
Nitrate:					
Control.....	4	0.88	16.81	17.69	
Inoculated.....	6	15.84	1.38	17.22	-0.47

flasks received 5 cc. of water while the other two received 5 cc. of a 2.532 per cent solution of  $\text{Ca}(\text{NO}_3)_2 + 4\text{H}_2\text{O}$ . The flasks intended for inoculation were sterilized and all the flasks then received as infecting material equal amounts of a suspension of *Azotobacter chroococcum*. After this the controls were sterilized at the same temperature and pressure as the others.

After eight days' incubation at 25°C. the cultures were analyzed and found to give the values shown in table 19.

Here *Azotobacter* is found to break down the nitrate and actually change it into the organic form with a resultant loss from solution.

*Experiment 46.* When the mannitol is replaced by glucose in a solution of the following composition the nitrogen balances vary only with regard to the quantity of nitrogen lost from solution.

Glucose .....	5.00 grams
K <sub>2</sub> HPO <sub>4</sub> .....	0.05 gram
Ca(NO <sub>3</sub> ) <sub>2</sub> + 4H <sub>2</sub> O .....	0.316 gram
Deep well water .....	250.0 cc.

One hundred cubic centimeters of this solution pipetted into large Fernbach flasks received 0.5 gram CaCO<sub>3</sub>. After inoculation of one with a very small quantity of a pure culture of *Azotobacter chroococcum*, the flasks were incubated for fifty-two days at 25°C. Table 20 summarizes the results obtained.

TABLE 20  
*Attack of nitrates by Azotobacter chroococcum*

NUMBER OF CULTURE	TREATMENT	NITROGEN AS			SUGAR
		Organic and ammonia	Nitrous and nitric	Total	
		<i>mgm.</i>	<i>mgm.</i>	<i>mgm.</i>	<i>mgm.</i>
0	Check	0.88	17.14	18.02	1701.0
1	Inoculated	10.65	7.28	17.93	572.8
Differences .....		+9.77	-9.86	-0.09	-1128.2

Here again nearly the whole of the nitrate nitrogen reduced is to be found in the organic form. As the loss of nitrogen from solution is in this case negligible we may only draw attention to it now and reserve discussion to a later page.

To establish with certainty the fact of nitrate nitrogen attack and consumption another series of experiments may be cited which is typical of all the results obtained in this connection.

*Experiment 47.* A solution prepared according to Gerlach and Vogel constituted the basal medium.

Deep well water . . . . .	500.00 cc.
K <sub>2</sub> HPO <sub>4</sub> . . . . .	0.25 gram
NaCl . . . . .	0.25 gram
FeSO <sub>4</sub> + 7H <sub>2</sub> O . . . . .	0.01 gram
Glucose . . . . .	5.00 grams

To 250 cc. of this medium 0.316 gram Ca (NO<sub>3</sub>)<sub>2</sub> + 4H<sub>2</sub>O were added. Fifty cubic centimeters of the nitrate solution and of the nitrate-free solution were placed in very large petri

TABLE 21  
*Nitrate attack by Azotobacter chroococcum*

NUMBER OF CULTURE	TREATMENT	NITROGEN AS			GAIN OR LOSS OF NITROGEN
		Organic and ammonia	Nitrous and nitric	Total	
		<i>mgm.</i>	<i>mgm.</i>	<i>mgm.</i>	<i>mgm.</i>
A-0*	None				
	Control	0.76		0.76	
1	Inoculated	3.63		3.63	+2.87
2	Inoculated	4.43		4.43	+3.67
3	Inoculated	4.19		4.19	+3.43
4	Inoculated	4.50		4.50	+3.74
Average . . . . .					+3.43
B-0*	Nitrate				
	Control	0.76	8.55	9.31	
1	Inoculated	8.87	0.36	9.23	-0.08
2	Inoculated	8.64	0.43	9.07	-0.24
3	Inoculated	8.71	0.20	8.91	-0.40
4	Inoculated	8.84	0.25	9.09	-0.22
Average . . . . .					-0.24

\* Calculated from experiments 46 and 49 made with the same solutions.

dishes which had been sterilized with 0.5 gram CaCO<sub>3</sub>. Inoculation of some of the dishes with a pure culture of *Azotobacter chroococcum* was followed by incubation for twenty-four days at 25°C. The analytical results obtained are summarized in table 21.

The tabulated results require no further comment than has already been made. The nitric nitrogen is all, or nearly all, found in the form of organic or organized nitrogen.

The fact has thus been established that the nitrate nitrogen is organized by *Azotobacter* in its process of growth but no insight has been gained as to the *modus operandi* of this attack. A review of the reported data on nitrogen relations seems to point to the fact that the organism assimilates the nitrate in its early stages thus causing a loss of nitrogen from the solution, but later when the source of combined nitrogen is exhausted or nearly exhausted, a second physiological phase sets in, in which the cells assimilate atmospheric nitrogen, replacing thereby the losses which the solution underwent in its early stages. That this seems to be what actually takes place in the cultures of *Azotobacter* is evidenced by the accompanying experiments 51 and 55.

*Experiment 51.* Fifty cubic centimeters of a Vogel solution to which 0.126 per cent of  $\text{Ca}(\text{NO}_3)_2 + 4\text{H}_2\text{O}$  had been added were used; after inoculation and incubation at  $25^\circ\text{C}$ . for varying lengths of time the cultures were analyzed with the results given in table 22.

Before discussing the results presented in the above table, a new series of experiments aiming at the same end will be related. The earliest incubation period of five days seemed to be too long to allow a close study of the early assimilation of the nitrate to be made. Shorter incubation periods were therefore observed to obtain the required data.

*Experiment 55.* Fifty cubic centimeters of the same solution as was used in the previous experiment were pipetted into sterile petri dishes of 20 cm. diameters, containing 0.5 gram of  $\text{CaCO}_3$ . After inoculation and incubation for varying periods of time the cultures were analyzed with the results set forth in table 23.

Although the actual amount of nitrogen unaccounted for is in many cases small, yet indications are that the *modus operandi* of the nitrate attack by *Azotobacter chroococcum* may be stated to be as follows; the organism utilizes the combined nitrogen (in the form of nitrates) as soon as placed in contact with it and

TABLE 22  
*Nitrate attack by Azotobacter*

	DAYS OF INCUBATION	NITROGEN AS		SUGAR	NITROGEN UNAC-COUNTED FOR
		Nitric and nitrous	Organic and ammonia		
		<i>mgm.</i>	<i>mgm.</i>	<i>mgm.</i>	<i>mgm.</i>
Control.....	5	8.66	0.47	476.8	
Inoculated.....	5	1.12	6.53	160.1	
Balance.....		-7.54	+6.06	-316.7	-1.48
Control.....	8	8.66	0.47	476.8	
Inoculated.....	8	0.88	7.41	0.0	
Balance.....		-7.78	+6.94	-476.8	-0.84
Control.....	13	8.66	0.47	476.8	
Inoculated.....	13	0.72	8.59	0.0	
Balance.....		-7.94	+8.12	-476.8	+0.18

TABLE 23  
*Nitrate attack by Azotobacter*

	DAYS OF INCUBATION	NITROGEN AS		SUGAR	NITROGEN UNAC-COUNTED FOR
		Nitric and nitrous	Organic and ammonia		
		<i>mgm.</i>	<i>mgm.</i>	<i>mgm.</i>	<i>mgm.</i>
Control.....	2	9.34	0.13	511.6	
Inoculated.....	2	5.79	3.70	361.0	
Balance.....		-3.55	+3.57	-150.6	+0.02
Control.....	5	9.34	0.13	511.6	
Inoculated.....	5	1.82	7.29	103.0	
Balance.....		-7.52	+7.16	-408.6	-0.36
Control.....	7	9.34	0.13	511.6	
Inoculated.....	7	1.02	8.39	12.4	
Balance.....		-8.32	+8.26	-509.6	-0.06



causes a loss of this element under special conditions that are not as yet completely understood. This loss may later be replenished by this same organism in the process of "later life." Apparently this second phase, phase of replenishment of the lost nitrogen, is directly connected with the second phase of the carbon metabolism studied in the preceding pages, since it appears to take place after the reducing sugar has either disappeared from solution or has been transformed into a non-reducing substance. That this assumption is justified is shown by the fact that the nitrates have a special importance in the carbon metabolism as is also shown by the data in the chapters on the carbon relations.

*Nitrates and filtration of media*

From the work of Allen (1919) we gather that filtration of a culture solution, under the conditions designed to remove the phosphates quantitatively, makes it unsuited for the development of *Azotobacter chroococcum*. Although the addition of calcium carbonate to the filtered solutions acted as a slightly beneficial agent in bringing about nitrogen fixation, it was not until phosphate was added in the form of tricalcium phosphate that any appreciable nitrogen fixation took place. Unfortunately the criterion used by Allen in drawing his conclusions<sup>6</sup> is subject to objection in the light of the above results so that in the following study the sugar consumption and production of bacterial substance was used as a measure of growth rather than the fixation of atmospheric nitrogen. The phosphates were replaced by nitrates, since some traces of phosphorus in the soluble form were undoubtedly present in the solution.

*Experiment 69.* A solution of the following composition was prepared and filtered, after a short standing at room temperature, over a coarse filter paper.

Deep well water . . . . .	500.00 cc.
K <sub>2</sub> HPO <sub>4</sub> . . . . .	0.25 gram
NaCl . . . . .	0.25 gram
FeSO <sub>4</sub> + 7H <sub>2</sub> O . . . . .	0.02 gram
Glucose . . . . .	5.00 grams

---

<sup>6</sup> Fixation of atmospheric nitrogen.

To 250 cc. of the filtered solution were added 0.316 gram  $\text{Ca}(\text{NO}_3)_2 + 4\text{H}_2\text{O}$  and 50 cc. were pipetted into each of several 250 cc. Erlenmeyer flasks of Jena glass, containing 0.5000 gram of  $\text{CaCO}_3$  weighed on an analytical balance. After sterilization and inoculation with a pure culture of *Azotobacter chroococcum* the flasks were incubated at 30°C. for varying periods of time.

Sugar determinations were made as well as determinations of the dry matter in the cultures after acidifying with HCl; the dry matter reckoned on the basis of the substance at 110°C. in vacuum over  $\text{P}_2\text{O}_5$ .

TABLE 24

DAYS OF INCUBA- TION	NO NITRATE			NITRATE		
	Cultural characters	Sugar consumed	Cell substance	Cultural characters	Sugar consumed	Cell substance
		<i>mgm.</i>	<i>mgm.</i>		<i>mgm.</i>	<i>mgm.</i>
3	No growth	0	0	Distinct turbidity	65.0	
5	No growth	0	0	Good growth	169.8	12
23	No growth	0	0	Good growth and pigment	411.5	62

Although the evidence seems at first sight to throw a shadow of doubt on the theory of phosphorus hunger in the filtered cultures, closer analysis shows it to corroborate the conclusions of Allen.

The nitrate used was tested for phosphorus by means of the ammonium molybdate reagent and found to be phosphorus free. The attempt was also made to avoid secondary reactions on any phosphates which might have passed through the paper by using  $\text{Ca}(\text{NO}_3)_2$  instead of any other nitrate, but the aim might not have been fully reached. And this in spite of the work of Cameron and Hurst (1904) in which they found calcium nitrate to depress the concentration of the  $\text{PO}_4$  ions in a solution of  $\text{Ca}_3(\text{PO}_4)_2$  in presence of the solid phase.

### III. DISCUSSION AND CONCLUSIONS

*Azotobacter chroococcum* Beij. when grown in synthetic solutions presents a complicated physiology. Its carbon relations seem to vary with the age of the culture, and are deeply affected

by the presence or absence of combined nitrogen in the solution. These carbon relations are in reality so closely connected with the nitrogen relations that to treat them separately would make the discussion abstract and unsound.

The fact that the cells seem to attack the sugar with a respiratory quotient of  $\text{CO}_2:\text{O}_2 = \pm 1$  is apparently misleading and is not corroborated by a study of the sugar consumption. As we have seen we are forced to admit a first phase in the sugar metabolism, a phase that could well be named one of preparation, one in fact in which the sugar is worked up and changed into a compound or compounds of a non-reducing nature. From the study of the gas exchanges, it appears that the presence of nitrates aids in the better utilization of the sugar. (Tables 7 and 11.)

In this first stage, the "ferment power" of the organism is great and it is probably in this stage too, that the nitrates play an important rôle; in fact it is at this stage that the nitrate assimilation is at a maximum and evidence leads us to believe in a close relationship and interdependence of the two exalted functions, high "ferment power" and nitrate disappearance. Our filtration experiments before inoculation give us a proof of the paramount importance of nitrates in the process of sugar utilization, and, although the interpretation to be given to these facts is as yet unknown, evidence leads us to the belief that nitrates perform an intermediary function in the sugar fermentation and assimilation and it may well be that this preparation stage is directly dependent upon the formation of sugar-nitrate complexes analogous to the phosphate sugar complexes of Harden and Young.

In Allen's filtered solutions phosphates proved indispensable probably on account of their necessity in the formation of complexes of the hexose-phosphate type. The fact that nitrates proved to behave in a like manner leads us to the belief that *Azotobacter* cells may be capable of attacking complexes of the hexose-phosphate type as well as some homologues that involve the nitrate radicle.

The difference between the action of phosphates on zymase action and of the nitrates on cell metabolism lies in the fact that the nitrate proves to be actually organized by the cells whereas the phosphate in the work of Harden and Young is merely provisionally tied in an undisturbed form.

That this difference might be due to the fact that in the one case we are dealing with a "*figurated*" ferment while in the other we are only in presence of specific enzyme is not to be overlooked and investigation along this line may prove to us the possibility of this line of reasoning. In fact, the localization of the organized nitrogen in the *Azotobacter* cultures might be intracellular as well as extracellular and studies on this point would enhance our knowledge of the physiology of the organism concerned. Such studies are now under way in this laboratory.

In the second or maintenance phase, such complexes appear to be reworked, partially burned, partially utilized in the building of cellular substance and partially secreted in the surrounding medium in the form of soluble by-products. During this phase the nitrogen is actually assimilated, directly contrary to the belief of Hills.

A loss of nitrogen appears to take place during the first phase, a loss which, if slight, may be again made up in the second phase of development. The complication brought about by this first phase in the interpretation of the results does not render the term "ferment power" valueless or render useless the meaning adopted by Duclaux for this term but is only an example of what should be expected when studying the physiology of bacteria. Examples of a similar nature are not wanting in other branches of science and mention need only be made here of the limited value of the respiratory quotient in the study of the physiology of the *Crassulaceae* among plants and of *Ascaris* and *Lumbricus* among animals.

In concluding a word may be said of the practical interpretations of the above findings.

The activity of *Azotobacter* as a fixer of atmospheric nitrogen in the field is not easily demonstrated. Actual gains due to this organism in the nitrogen contents of a soil in the field are seldom

positively shown whereas it would be assumed that a nitrogen fixation from the atmosphere by the action of non-symbiotic nitrogen fixers should take place at an active rate to judge from laboratory experiments made in selective media and in absence of combined nitrogen. Yet a study of the subject will show that soils are only exceptionally free of nitrates and that these are easily washed away. It is therefore the belief of the present author that *Azotobacter* rather than serving as an active nitrogen (free) gatherer, may act to immobilize the nitrate nitrogen, taking the upper hand over the denitrifiers, and, to a considerable extent, stopping the mentioned percolation.

By this it should not be understood that the organism is hereby assumed to be lacking in all power of nitrogen fixation, but only that this function is not to be considered as an all-important phenomenon always active to the full benefit of man and to the detriment of the active organism itself, as it appears that "*all*" organisms choose the line of least resistance for obtaining and assimilating their food; and microorganisms are not an exception to the rule in spite of the arbitrary classification that is made of them into "*beneficial*" and "*non-beneficial*."

That these experiments were made in solution does not detract from the conclusions derived therefrom, since we have seen that an obligate aerobic function such as nitrite formation, when studied by the methods used in this memoir may be advantageously compared with this function in soils.

#### IV. METHODS

A word is probably necessary on the methods used in the analysis of the cultures. The procedure used for the determination of ammonia, nitric and organic nitrogen on the same sample has been outlined by Davisson elsewhere (1918). The ammonia determinations were done by aeration over 5 grams sodium carbonate and subsequent distillation into standard acid. Subsequent treatment of the material in the aeration flask with 2.5 cc. of concentrated sulphuric acid, to destroy the carbonate, followed by 2 cc. of 50 per cent sodium hydroxid

and distillation into diluted acid (30 cc.  $H_2SO_4$  in 30 cc.  $H_2O$ ) for thirty minutes served to collect any ammonia resulting from the hydrolysis of the organic substances in the alkaline liquid. The solution was then diluted back to approximately 250 cc. and the nitric nitrogen therein contained determined by reduction and distillation from the alkaline solution in presence of 2 grams of Devarda's alloy. The acid solution containing the ammonia resulting from the hydrolysis of the organic matter was then transferred to the Kjeldahl flask containing the residue from the nitrate determination and the solution digested for the determination of organic nitrogen. The solution was digested until excessive frothing had ceased, then 10 grams potassium sulphate were added and digestion continued for one hour after the solution had become bluish-green. It was then distilled through an all-glass apparatus.

When it was necessary to determine the total nitrogen including the nitric nitrogen, the procedure developed in this laboratory was adopted (1919).

The sugar was determined in the solutions by clearing with colloidal iron and the centrifuge, using the clear liquid for the reduction of the Fehling solution as recommended by Shaffer (1914) and titrating the cuprous oxid by means of 0.05 N. potassium permanganate after dissolving it in Bertrand's solution. This solution was previously made pink by the use of the permanganate solution to avoid errors in the determination.

Thanks are here due to Dr. E. R. Allen for making this work possible and to Mr. B. S. Davisson for his kind assistance in carrying through the numerous nitrogen determinations.

#### REFERENCES

- ALLEN 1915 *Jour. Ind. Eng. Chem.*, **7**, 521.  
ALLEN 1919 *Ann. Missouri Bot. Gardens*, **6**, 1-44.  
ALLEN 1920 *Ann. Missouri Bot. Gardens*, **7**, 75-79.  
BEIJERINK AND VANDERDEN 1902 *Centr. f. Bakt.* II., **9**, 3-43.  
BONAZZI 1915 *Jour. Agr. Res.*, **4**, 225-239.  
BONAZZI 1919 *Jour. Bact.*, **4**, 43-60.  
CAMERON AND HURST 1904 *Jour. Am. Chem. Soc.*, **26**.

- DAVISSON 1918 Jour. Ind. Eng. Chem., **10**, 600.  
DAVISSON AND PARSONS 1919 Jour. Ind. Eng. Chem., **11**, 306.  
DUCLAUX 1898-1900 Traité de microbiologie, **1** and **3**.  
GREAVES 1918 Soil Sci., **6**, 163-217.  
HEINZE 1906 Landw. Jahr., **36**, 888-910.  
HILLS 1918 Jour. Agr. Res., **12**, 183-230.  
KOCH U. SEYDEL 1912 Centr. f. Bakt. II., **31**, 570-577.  
KRAINSKY 1908 Centr. f. Bakt. II., **20**, 725-736.  
KRAINSKY 1910 Centr. f. Bakt. II., **26**, 231-235.  
KRZMIENIEWSKY 1908 Bull. Inter. Ac. Scie. Cracovie, Juillet, p. 929.  
LIPMAN 1903 N. J. Exp. Stat. Rept., **24**, 217-285.  
MAZÉ 1902 Ann. Inst. Pasteur, **16**, 195-346-433.  
OMELIANSKY U. SEWEROWA 1911 Centr. f. Bakt. II., **29**, 643-650.  
OMELIANSKY U. SIEBER 1913 Höpfe-Zeyler Zeitschr. Physiol. Chem., **88**, 445-459.  
SHAFFER 1914 Jour. Biol. Chem., **19**, 285.  
STOKLASA 1908 Centr. f. Bakt., II., **21**, 484-509; 620-632.  
STOKLASA 1908 Centr. f. Bakt., II., **21**, 620-632.  
STRANAK 1909 Zeitschr. f. Zuckerind. Bohmen. Jahr. **33**, 599.





# Announcement!

WE HAVE BEGUN THE MANUFACTURE  
OF THE APPARATUS REQUIRED FOR

## Frost's Little Plate Method

*for*

### Obtaining the Bacterial Count of Milk

as described in the

#### Methods of Milk Analysis

Recently published by

THE AMERICAN PUBLIC HEALTH ASSOCIATION

---

*For Dr. Frost's description of the method, see the Journal of Infectious  
Diseases for February*

---

In the July Number

### We Shall Illustrate the Complete Equipment

Required for this method

---

FOR INFORMATION WRITE FOR BULLETIN 97-B  
TO BE ISSUED SOON

**CENTRAL SCIENTIFIC COMPANY**

LABORATORY INCORPORATED CO SUPPLIES  
Apparatus **CNO** Chemicals  
CHICAGO, U.S.A.

460 E. Ohio St.,

Chicago.

U.S.A.



**RARE SUGARS**  
and  
**OTHER FINE CHEMICALS**  
"DIFCO" STANDARDIZED

*Being the first manufacturing firm in the United States to make and advertise extensively rare sugars, we have steadily added to the line, and our list now comprises the following:*

RARE SUGARS

Arabinose  
Dextrose (Glucose)  
Galactose  
Invert Sugar

Lactose  
Levulose (Fructose)  
Maltose  
Mannose  
Melezitose

Raffinose  
Rhamnose  
Saccharose (Sucrose)  
Trehalose  
Xylose

OTHER CHEMICALS

Inulin  
Mannite  
Dextrin  
Acid Potassium Phthalate  
Blood Serum, Dry

Beef Extract  
Fibrin  
Gelatin  
Invertase

Decolorizing Carbon  
Bacto-Peptone  
Proteose Peptone  
Tyrosine

*Carried in stock by the principal dealers in  
Scientific Supplies.*

---

Specify "DIFCO"  
WE INVITE COMPARISON

**DIGESTIVE FERMENTS COMPANY**  
Detroit, Michigan, U. S. A.

VOLUME VI

NUMBER 4

# JOURNAL OF BACTERIOLOGY

OFFICIAL ORGAN OF THE SOCIETY OF AMERICAN  
BACTERIOLOGISTS

JULY, 1921

EDITOR-IN-CHIEF

C.-E. A. WINSLOW



*It is characteristic of Science and Progress that they continually  
open new fields to our vision.—PASTEUR.*

PUBLISHED BI-MONTHLY  
WILLIAMS & WILKINS COMPANY  
BALTIMORE, U. S. A.

Entered as second-class matter April 17, 1916, at the postoffice at Baltimore, Maryland, under the act of March 3, 1879. Acceptance for mailing at special rate of postage provided for in Section 1103, Act of October 3, 1917. Authorized on July 16, 1918.

Copyright 1921, Williams and Wilkins Company

Price, net { \$5.00 per volume, United States, Mexico, Cuba  
postpaid { \$5.25 per volume, Canada  
          { \$5.50 per volume, other countries

# Holadin

and

# Bile Salts

Holadin - - 2½ grs.

Bile Salts - - ½ gr.

(enteric capsules)

“Investigations begun originally by Professor Nencki in his Berne laboratory and carried on by Heidehain, Rachford, Williams and Martin, have shown that the bile has a favouring action on the ferments of the pancreatic juice.

“The Bile, indeed, proved itself to be a constant and powerful auxiliary of the pancreatic juice, a fluid which is of such importance for digestion and in itself already so complicated.”

—Prof. J. P. Pawlow.

“Holadin and Bile Salts”, a combination of the most potent pancreas extract with the isolated glycocholate and taurocholate of sodium, in their native association—

is a therapeutic resource of distinct service in pancreatic (intestinal) disorders dependent upon, or associated with, deficient bile action.

FAIRCHILD BROS. & FOSTER  
New York

## LaMotte Standards

GUARANTEED

Section 1.—Standardized Indicator dyes. Covering a wide range of H-ion concentration. Supplied in dry form and in sterile stock solutions. Each indicator is standardized in strict accordance with the specifications of Clark & Lubs. (Jr. Bact., Vol. II, Nos. 1, 2, 3, 1917.)

Common Name	Color Change	P <sub>H</sub> Value
Thymol Blue (acid range)	red-yellow	1.2-2.8
Methyl Orange	red-yellow	2.9-4.0
Bromphenol Blue	yellow-blue	3.0-4.6
Resorcin Blue	pink-blue	4.0-7.2
Methyl Red	red-yellow	4.4-6.0
Bromcresol Purple	yellow-purple	5.2-6.8
Litmus (special)	red-blue	5.5-8.9
Bromthymol Blue	yellow-blue	6.0-7.6
Phenol-Red	yellow-red	6.8-8.4
Cresol Red	yellow-red	7.2-8.8
Thymol Blue (alkaline range)	yellow-blue	8.0-9.6
Cresol-phthalein	colorless-red	8.2-9.8
Phenol-phthalein	colorless-red	8.4-9.2

Section 2-B.—Specially prepared and standardized Buffer salts and solutions. Buffer mixtures may be obtained in series covering any particular range of H-ion concentration from P<sub>H</sub> 1.0 to 10.0.

### Standardized Buffer Solutions (M/5)

Potassium Phosphate	Potassium Phthalate	Sodium Hydroxide (CO <sub>2</sub> free)
Potassium Chloride	Hydrochloric Acid	Di-Sodium Phosphate, 2H <sub>2</sub> O

A large number of general synthetic and purified compounds are manufactured by us and information concerning them may be obtained by addressing

**LA MOTTE CHEMICAL PRODUCTS CO.**  
“Standards Department”

13 W. Saratoga St.

Baltimore, Md.

# JOURNAL OF BACTERIOLOGY

OFFICIAL ORGAN OF THE SOCIETY OF AMERICAN BACTERIOLOGISTS

DEVOTED TO THE ADVANCEMENT AND DISSEMINATION OF KNOWLEDGE IN REGARD TO THE BACTERIA AND OTHER MICRO-ORGANISMS

## *Editorial Board*

### *Editor-in-Chief*

C.-E. A. WINSLOW

Yale Medical School, New Haven, Conn.

A. PARKER HITCHENS

F. C. HARRISON, *Ex officio*

Principal, MacDonald College,

P. Q., Canada

## *Advisory Editors*

C. C. BASS  
R. E. BUCHANAN  
P. F. CLARK  
F. P. GAY  
F. P. GORHAM  
F. C. HARRISON

H. W. HILL  
E. O. JORDAN  
A. I. KENDALL  
C. B. LIPMAN  
C. E. MARSHALL

V. A. MOORE  
M. E. PENINGTON  
F. B. PHELPS  
L. F. RETTGER  
L. A. ROGERS

M. J. ROSENAU  
W. T. SEDGWICK  
F. L. STEVENS  
A. W. WILLIAMS  
H. ZINSSER

## CONTENTS

LAURA FLORENCE. Spiral Bodies in Bacterial Cultures.....	371
JAMES M. SHERMAN. The Cause of Eyes and Characteristic Flavor in Emmental or Swiss Cheese.....	379
G. J. HUCKER. A New Modification and Application of the Gram Stain.....	395
LOUIS J. GILLESPIE. Color Standards for the Colorimetric Measurement of H-Ion Concentration.....	399
HARRIET LESLIE WILCOX. The Effect of Pepton upon the Production of Tetanus Toxin.....	407
K. G. DERNBY AND J. BLANC. On the Growth and the Proteolytic Enzymes of Certain Anaerobes.....	419

Abstracts of American and foreign bacteriological literature appear in a separate journal, *Abstracts of Bacteriology*, published monthly by the Williams & Wilkins Company, under the editorial direction of the Society of American Bacteriologists. Back volumes can be furnished in sets consisting of Volumes I, II, III and IV. Price per set, net, postpaid, \$24.00, United States, Mexico, Cuba; \$25.00, Canada; \$26.00, other countries. Subscriptions are in order for Volume V, 1921. Price, per volume, \$5.00, United States, Mexico, Cuba; \$5.25, Canada; \$5.50, other countries.

# AMERICAN STANDARD HOT AIR STERILIZERS

THE TEST  
IN OUR STOCK FOR IMMEDIATE SHIPMENT  
OF SERVICE

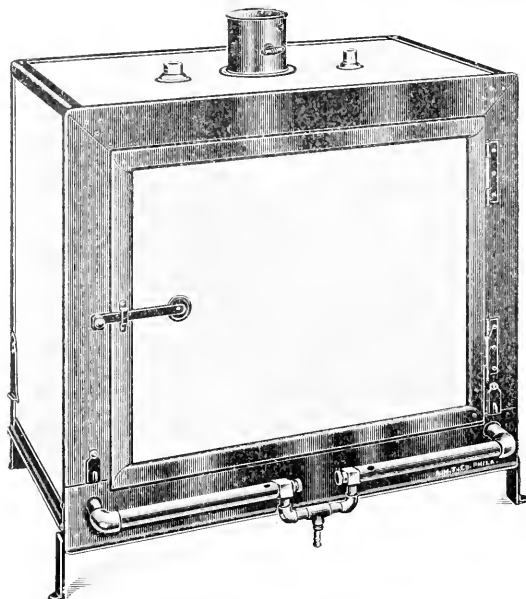

No. 20945. American Standard Hot Air Sterilizer

AMERICAN STANDARD HOT AIR STERILIZERS are of triple wall construction with the regenerative (so-called "Lautenschlaeger") heating arrangement which affords a uniform distribution of temperature throughout the inner compartment attained by no other method.

These Sterilizers are now provided with adjustable valve gas burners which operate with equal efficiency on gasoline, natural or ordinary illuminating gas. The three smaller sizes are furnished on short feet as shown in above illustration, while the largest size, i.e. No. 20949, is furnished on angle iron support 24 inches high.

20941.	American Standard Hot Air Sterilizer, as above described, with inside dimensions 12 x 18 x 9 inches.....	55.35
20942.	ditto, with inside dimensions 18 x 24 x 14 inches.....	71.50
20945.	" " " " 24 x 30 x 18 ".....	122.85
20949.	" " " " 30 x 36 x 20 ".....	195.00

*Prices subject to change without notice.*

## ARTHUR H. THOMAS COMPANY

WHOLESALE, RETAIL AND EXPORT MERCHANTS

### LABORATORY APPARATUS AND REAGENTS

WEST WASHINGTON SQUARE

PHILADELPHIA, U. S. A.

# Members

of the

## Society of American Bacteriologists

There is no reason why 100 per cent of our members should not obtain at least one new member for the Society. Failure to do this, it is felt, will not be due to lack of interest but to a failure to realize how many people of diversified interests will appreciate the journals and service of the Society.

In this connection a suggestion may be permitted. *ABSTRACTS OF BACTERIOLOGY* furnishes a strong appeal, not only to professional bacteriologists, but to those working in allied fields.

Those engaged in medicine and veterinary science in all their phases, in public health and its many branches, in plant pathology and mycology, in agricultural and industrial enterprises will be vitally interested in the subject matter covered in our abstract journal.

In order to obtain a new member something more than a mere invitation to join is necessary in most cases. The prospective member should be shown that value is to be received for his dues.

Why not think over your acquaintances and decide just how the Journals will be of benefit to them? If they are close at hand talk the matter over but don't confine your efforts to your local friends. Your activity is not limited and many can be reached by letters which point out how our journals bring information of vital importance to them. This plan has been followed in a number of cases with good results.

In order to derive the benefits of a successful campaign won't you help to make the members 100 per cent active by placing your name on the "Rolls?"

You will be interested in knowing that the offers of back volumes of the Journals has been extended, through the courtesy of the publishers, until November 15, 1921. Please keep this date in mind.

S. H. AYERS,  
*Chairman, Membership Campaign Committee for 1921.*

# MEMBERSHIP CAMPAIGN

TO JUNE 22, 1921

## HONOR ROLL

J. M. SHERMAN	12*	A. J. PACINI	4	PAUL EATON	2
F. C. HARRISON	8	ELSA T. SCHUFEREN	4	H. A. HOFF	2
C. S. MUDGE	8	N. P. SHERWOOD	4	NICHOLAS KOPELOFF	2
S. H. AYERS	5	G. W. STUPPY	4	ARTHUR LEDERER	2
C. A. BEHRENS	5	P. A. TETRAULT	4	H. F. LIENHARDT	2
P. F. CLARK	5	W. H. WRIGHT	4	C. E. MARSHALL	2
T. G. HULL	5	W. H. BARNES	3	M. H. NEIL	2
P. D. MEADER	5	JEAN V. COOKE	3	M. STARR NICHOLS	2
H. J. SEARS	5	M. S. FOREMAN	3	EDWARD RECORDS	2
I. L. BALDWIN	4	A. T. HENRIEL	3	NEVA RITTER	2
CORA M. DOWNS	4	EDWARD REDOWITZ	3	R. C. SALTER	2
I. C. HALL	4	L. D. BUSHNELL	2	M. J. SCHLESINGER	2
J. B. MCNAUGHT	4	C. T. BUTTERFIELD	2	F. CONSTANCE STEWART	2
A. W. NELSON	4	HENRIETTA CALHOUN	2	E. LEE TREECE	2
		E. C. DICKSON	2	S. A. WAKSMAN	2

\*Number of members introduced.

## DUTY ROLL

### ONE MEMBER INTRODUCED

C. L. BARTLETT	RUTH GILBERT	H. G. PARKER
J. R. BEACH	E. J. GRIMES	H. N. PARKER
RUTH BIGELOW	P. G. HEINEMANN	E. M. PICKENS
SARA E. BRANIAM	JULIA A. W. HEWITT	E. W. PRICE
C. P. BROWN	A. E. HITCHENS	JOHN REICHEL
GEORGIANA S. BURKE	DOROTHY F. HOLLAND	L. A. ROGERS
VICTOR BURKE	ARAO ITANO	THEOBALD SMITH
C. E. CLEMENT	P. H. JONES	FRANK SMITHIES
MARJORIE W. COOK	RUTH KANTSKY	P. R. STAFFORD
C. A. DARLING	WANN LANGSTON	G. I. STEFFEN
H. A. DAVIS	L. T. LEONARD	G. C. SUPPLEE
LEWIS DAVIS	W. L. LONG	H. B. SWITZER
H. R. EGGLESTON	M. L. MALLMANN	ROY L. VOLLUM
F. W. FABIAN	H. G. MAY	ANNA WILLIAMS
F. N. GALLIVAN	R. R. MELLON	H. F. ZOLLER
	RUTH NORMINGTON	

## MEMBERSHIP CAMPAIGN COMMITTEE FOR 1921

S. H. AYERS, *Chairman*

C. S. MUDGE

J. M. SHERMAN

*Is your name on the List of*

## ACTIVE MEMBERS?

This Campaign will continue so you still have a chance

WATCH FOR THE NEXT LIST



## SPIRAL BODIES IN BACTERIAL CULTURES

LAURA FLORENCE

*From the Department of Animal Pathology of The Rockefeller Institute for Medical Research, Princeton, New Jersey*

Received for publication November 12, 1920

During the winter of 1918–1919, in the course of some work with spore-bearing bacteria, spiral bodies resembling spirochetes were frequently found in cultures. When these were shown to Dr. Theobald Smith, he suggested that they were clusters of detached flagella such as had been seen by him at different times in cultures of anaerobes. Two interesting coincidences occurred at this time. The first was the receipt from an Institution of photographs of similar spiral bodies with the suggestion that they might be *Vibrio fetus* of infectious abortion in cattle, and the second was the publication of an investigation into spiral bodies in bacterial cultures by Koga and Otsubo (1919a). Since these authors have discussed the phenomenon as one hitherto undescribed and since their publication has more recently (1919b) appeared in Japan, it seems appropriate to call attention to earlier references and describe briefly the conditions under which these spiral bodies have now been found.

Loeffler (1889) first saw these spiral bodies when staining the flagella of the typhoid bacillus and the potato bacillus, but did not recognize their true nature until a year later (1890), when he found them in three different blood serum cultures of the bacillus of black leg. The latter were much larger than those seen in the typhoid cultures and he published, along with the description, a photograph of the preparation. At the same time he referred to a microphotograph, published by Fränkel and Pfeiffer, of the bacillus of malignant oedema in which spiral threads passed out from the organism just as he had found them in the typhoid bacillus. Three years later Sakharoff (1893) described and photo-

graphed spiral bodies found in cultures of an anaerobe, *Bacillus asiaticus*, isolated by him from stools of cholera patients and grown in gelatin stab cultures. He agreed with the hypothesis of Loeffler that these were made up of clusters of detached flagella, since they could not be gotten rid of in long series of transfers and varied considerably in length and thickness. Also they could not be evolution forms of the bacteria, as dead spirals were numerous in twenty-four hour cultures. In the same year Moore (1893) wrote,

In the microscopical examination of well-executed preparations for exhibiting the flagella three conditions have been universally observed: (1) . . . . ; (2) there were a considerable number of detached or free flagella lying between the bacteria; and (3) the numbers of flagella on the different bacilli were not constant.

A more detailed account of these spiral bodies, also illustrated by photographs, was published by Novy (1894), when he described a new anaerobic bacillus of malignant oedema. He first found them unstained in smears stained with Gentian violet of the peritoneal fluid of guinea pigs and rabbits dead from inoculation, and then well stained in smears prepared after Loeffler's method. He found identical spirals in pure cultures of the organism and thought the nature of the media to be in some way connected with their formation. They occurred rarely in bouillon cultures. They were more numerous in gelatin cultures, most plentiful in agar cultures, and in the two last cases they were found in the condensation water. Loeffler's work, but not that of Sakharoff, was known to Novy and he confirmed the presence of these spirals in cultures of the bacillus of black leg and found them also in cultures of the bacillus of malignant oedema and of tetanus. He was not, however, like Loeffler convinced that they were clusters of flagella and he suggested the possibility of their being single deformed flagella, analogous to the involution forms found among bacteria, and named them "Riesengeisseln."

When studying the morphology of the tetanus bacillus Kanthack and Connell (1897) found two types of flagella which they named primary and secondary. Photographs of the latter show them

to be similar to the spiral bodies under discussion, but the authors found them always attached to the organisms.

Malvoz (1902) working with Wathelet found spiral bodies in a culture of *Bacterium coli* isolated from the stools of a typhoid patient. Preparations stained after Loeffler's method were shown by them to Nuel (1893) who considered them identical with spirals which he had found almost ten years earlier in cultures made from a bacterial disease of the cornea. Like Novy he regarded them as individual flagella calling them "cils géants." Malvoz, however, inclined to Loeffler's view and referred to Migula's description of their formation as the best. He called them "cils composées," following the terminology of Sakharoff in preference to that of Nuel.

That these spirals were known to bacteriologists at the end of the last century is proved not only by Flügge's (1896) brief reference to them and Migula's (1897) account of their formation, but by the remark of Zettnow (1899), "Geisselzöpfe habe ich in den jungen anaëroben Culturen nicht beobachtet." In the atlas accompanying the first edition of Kolle and Wassermann (1902) were published Zettnow's photographs of small tufts of flagella from a pure culture of an unknown bacterium and of a very large tuft of flagella from *Sarcina agilis*. More recent references may be found in the texts of von Hibler (1908), of Kolle and Wassermann (1912), and of Friedberger and Pfeiffer (1919).

Koga and Otsubo (1919) while attempting to get pure cultures of smegma spirochetes, found spirochete-like spiral bodies in cultures of saprophytic bacilli. The occurrence of such forms in bacterial cultures was evidently unknown to them and the result of their investigation led them to conclude that they were "nothing more than an unusual development of the flagella or parts of the bacterial bodies." They worked chiefly with *Bacillus subtilis* but gave a list of other organisms, in cultures of which spiral bodies were also found.

For a number of years it has been the custom in this laboratory to keep certain cultures in tubes closed with sealing wax. In order to find out the general effect on culture growth of such a method a series of experiments with a number of spore-bearers was begun

during the winter of 1918-1919. In the cultures of motile forms, viz., *Bacillus cereus*, *Bacillus mesentericus-fuscus*, *Bacillus mesentericus-vulgatus* (2 strains), and a bacillus isolated from the lung of a calf and designated "Organism A," non-motile spiral bodies resembling spirochetes were frequently seen. None such were found in the cultures of non-motile forms being studied. All the cultures were grown on plain agar slants and the tubes were closed immediately after inoculation with paraffin-dipped cotton stoppers cut off level with the top of the tube and then pushed down approximately  $\frac{1}{8}$  inch below the top. The mouth of the tube was flamed until thoroughly hot, when a small amount of sealing wax was placed over the stopper. This was absorbed by stopper and, when the tube had cooled, the space above the stopper was filled with sealing wax care being taken to leave no air bubbles. Several series of cultures were also grown in bouillon sealed in the same way as the agar.

Spiral bodies were found in cultures of all five organisms, but they appeared with greatest regularity in the two strains of *Bacillus mesentericus-vulgatus*, in cultures of which Loeffler (1889) had also found them. At first it was thought that they were to be found only in sealed tubes, but later it was discovered that they were always present in the condensation water of twenty to twenty-four hour unsealed cultures of *Bacillus mesentericus-vulgatus*. They were also found in unsealed cultures of *Bacillus mesentericus-fuscus* and *Bacillus cereus* after the third day. They were seen first in hanging drops made from the condensation water, but were not found in smears made from the same and stained with methylene blue or carbol fuchsin. However, in smears stained after Loeffler's method they were always found well stained; but, if Johnston and Mack's modified method was followed they were not found, doubtless because they had disintegrated during the prolonged incubation in sterile water. Even in young cultures spirals of different sizes were seen, but very large ones, similar to those of the bacillus of black leg photographed by Loeffler, were found only in sealed cultures after an incubation period of fourteen to twenty days. In these large spirals striations parallel to their longitudinal axis were frequently seen. Their

non-motility and reaction towards stains differentiated them definitely from true spirochetes and their presence, in cultures of motile organisms only, suggested a relationship with the flagella. Further, their regular absence from preparations stained after Johnston and Mack would seem to prove that they were lifeless.

#### DISCUSSION

Since this phenomenon has been most frequently seen during the investigation of anaerobes, it has been thought that anaerobiosis and the formation of spiral bodies were in some way connected. It is now evident, however, that they are formed in aerobic cultures. We have found them exclusively in the condensation water of such cultures and in its rapid drying out may rest the explanation of their having been so frequently missed. Sakharoff (1893) when studying an aerobe, found them in hanging drops of the liquefied gelatin and there as in *Bacillus mesentericus-vulgatus* a stout pellicle had grown over the surface of the liquid. It may be said that under such a pellicle anaerobic conditions exist, but spiral bodies were found in the condensation water of *Bacillus cereus* and *Bacillus mesentericus-fuscus* after the third day, when no pellicles had formed. Also, both Loeffler (1890) and Moore (1893) found them in stained preparations of the typhoid bacillus made from cultures which they do not say were grown anaerobically. Koga and Otsubo (1919) found them in cultures of a number of bacilli but all were cultivated anaerobically. They further claim to have found flagella on *Pfeifferella mallei* and spiral bodies in their anaerobic cultures of this form.

In the earliest references no emphasis was laid on the nature of the media on which the organisms were cultivated. Novy (1894) was the first to suggest a relationship between the media and the formation of spiral bodies. Our findings agree with his in that spiral bodies were most abundant in the condensation water of cultures grown on agar slants and were very rare or entirely absent in bouillon cultures. We have not used gelatin. Koga and Otsubo (1919) state that spiral bodies did not develop at all in media lacking fresh protein and were never found, when

the organisms were cultivated on agar. In explanation of these opposite findings it may be suggested that the Japanese workers studied only the colonies on the agar slants, in which we have never found spiral bodies, and did not examine the contents of the condensation water, where we have repeatedly found them. These authors did not specify in what part of the cultures grown on media containing fresh protein the spiral bodies were found, but Loeffler (1890) described those found in the cultures of the black leg bacillus as lying on the surface layer of the blood serum.

To Migula's (1897) description of their formation as a mechanical process resulting from the collision of motile bacteria and the intertwining of their flagella in a circumscribed space nothing definite can be added. It is possible, however, that the nature of the media on which an organism is grown may exert a secondary influence on their formation and may explain the variation in their time of appearance in cultures of different organisms. It was thought that the viscosity of the condensation water might influence the formation of spirals, but this proved not to be the case.

#### SUMMARY

Spiral bodies resembling spirochetes were found in cultures of bacterial organisms grown aerobically, as well as in those grown in a limited amount of oxygen. They were regularly present in the condensation of water of such cultures.

As has been pointed out by other workers, such spiral bodies are to be distinguished from spirochetes (1) by their lack of motility, (2) by their reaction towards stains, and (3) by the impossibility of obtaining them in pure culture.

Their relationship with flagella is further proved by their presence in cultures of motile organisms only.

Their disintegration when incubated for two to three days in sterile water is evidence of their lifelessness.

## REFERENCES

- FLÜGGE, C. 1896 Die Mikroorganismen. 3te Auflage.
- FRIEDBERGER, E., AND PFEIFFER, R. 1919 Lehrbuch der Mikrobiologie.
- KANTHACK, A. A., AND CONNELL, T. W. 1897 Journ. Path. and Bact., **4**, 452.
- KOGA, G., AND OTSUBO 1919a Journ. Infect. Diseases, **24**, 56.
- KOGA, G., AND OTSUBO 1919b Kitasato Arch. Exper. Med., **3**, 207.
- KOLLE AND WASSERMANN 1902 Handbuch der pathogenen Mikroorganismen, Atlas, erste Auflage.
- KOLLE AND WASSERMANN 1912 Handbuch der pathogenen Mikroorganismen, Atlas, 2te Auflage.
- LOEFFLER, F. 1889 Centrbl. f. Bakt., **6**, 207.
- LOEFFLER, F. 1890 Centrbl. f. Bakt., **7**, 625.
- MALVOZ, E. 1902 Ann. Inst. Pasteur, **16**, 686.
- MIGULA, W. 1897 System der Bakterien.
- MOORE, V. A. 1893 The Wilder Quarter-Century Book, 339.
- NOVY, F. G. 1894 Zeit. f. Hyg., **17**, 209.
- NUEL 1893 Bull. Acad. med. Belgique.
- SAKHAROFF, M. N. 1893 Ann. Inst. Pasteur, **7**, 550.
- VON HIBLER, E. 1908 Untersuchungen über die pathogenen Anaeroben.
- ZETTNOW, E. 1899 Zeit. f. Hyg., **30**, 95.





# THE CAUSE OF EYES AND CHARACTERISTIC FLAVOR IN EMMENTAL OR SWISS CHEESE<sup>1</sup>

JAMES M. SHERMAN

*From the Research Laboratories of the Dairy Division, United States Department of Agriculture, Washington, D. C.*

Received for publication November 22, 1920

## INTRODUCTION

Due to a lack of the proper natural inoculation in the milk, the Swiss or Emmental cheese industry in the United States has had only a limited success. The peculiar sweetish flavor which is characteristic of the best cheese of this type is very commonly lacking in our American-made cheese. It is also frequently deficient in eye development, and in fact in some cases the cheeses are entirely "blind." Swiss cheese is made only during certain seasons in America, because of the uncertainty of obtaining the proper development of eyes and flavor. It would seem that this industry could be put on a sounder as well as a more scientific basis by the use of cultures which would cause proper ripening in the cheese. With such cultures at hand it should be possible to make Swiss cheese of a uniform and high-grade quality throughout the year; such practice should result in raising very materially the quality, as well as the quantity, of our American-made Swiss cheese.

Von Freudenrich and Orla-Jensen (1906) in their work in Switzerland have isolated propionic acid-producing bacteria which they consider the cause of eyes in Emmental cheese. The essential organism, called by them *Bact. acidi-propionici* (*a*), was found to ferment lactates with the production of propionic acid, acetic acid, and carbon dioxide. Other varieties of propionic

<sup>1</sup> Published with the permission of the Secretary of Agriculture.

bacteria were found but they did not appear to have much influence on the ripening of cheese.

In the early experiments conducted by the Department of Agriculture on Swiss cheese, some cultures of propionic acid bacteria were obtained from Professor Burri of Berne in the hope that these could be introduced and used in the manufacture of Swiss cheese in this country. The experiments conducted with these cultures, however, were not encouraging; in fact it was not established experimentally that they were able to cause the development of eyes when used for starters in the manufacture of Swiss cheese. Following the methods of Von Freudenrich and Orla-Jensen, cultures were isolated which corresponded to their published descriptions of the propionic-acid bacteria. These were also used in the manufacture of experimental Swiss cheese with negative results. These findings do not discredit the work of Von Freudenrich and Orla-Jensen, since it is entirely possible that the cultures used belonged to varieties which do not play important rôles in the ripening of Emmental cheese. The experiments referred to were carried on a few years after the death of Professor von Freudenrich; Professor Orla-Jensen at that time was not able to furnish cultures of these organisms.

#### I. CONCERNING THE OCCURRENCE AND NUMBERS OF LACTATE-FERMENTING BACTERIA IN EMMENTAL CHEESE

That there exist in Emmental or Swiss cheese bacteria which ferment lactates with the production of volatile acids has been shown by Von Freudenrich and Orla-Jensen (1906), who succeeded in isolating such organisms in pure culture; and the theory was advanced that the production of eyes is due to the carbon dioxide liberated by these bacteria in the transformation of lactic acid to propionic and acetic acids, according to the formula:

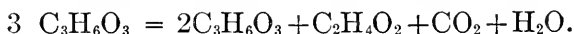

They also determined the approximate number of lactate-fermenting organisms in Emmental cheese by means of dilution cultures in a calcium lactate broth. By such methods they were

able to demonstrate that these bacteria occur in numbers from 10,000 to 200,000 per gram of cheese.

Troili-Petersson (1909) using the same methods found approximately the same numbers of lactate-fermenting bacteria as did Von Freudenrich and Orla-Jensen. In a previous report from these laboratories, Eldredge and Rogers (1914), who worked with American cheese of the Emmental type, found this type of organism present in somewhat smaller numbers than was reported by the European workers, and in fact apparently entirely lacking in some cheese.

*Modification of the lactate broth of Von Freudenrich and Orla-Jensen*

For the growth and isolation of lactate-fermenting bacteria from Emmental cheese, Von Freudenrich and Orla-Jensen (1906) used a calcium lactate broth of the following composition:

	<i>per cent</i>
Pepton (Witte).....	2.0
Sodium chloride.....	0.5
Dipotassium phosphate.....	0.2
Calcium lactate.....	2.0

Although such a mixture is obviously faulty, due to the incompatibility of the calcium and phosphate ingredients, resulting in a heavy precipitate of an insoluble calcium phosphate upon sterilization, the broth as used by Von Freudenrich and Orla-Jensen, so far as we are aware, has not been modified by subsequent workers who have used it extensively for studies of the propionic and butyric acid-forming groups of bacteria. Only recently Boekhout and De Vries (1917) have employed it in an extensive study of the bacteria responsible for gas formation in cheese.

It need hardly be mentioned, assuming that the several components of the broth are in fact of value, that the ingredients added should not be rendered inert by precipitation. This may be obviated by the use of another salt of lactic acid, such as sodium lactate, in place of the calcium. The commercial sodium lactate syrup may be used if desired, but we have found it convenient to prepare the sodium lactate just before use by neutralizing the desired amount of lactic acid with sodium hydroxide. The sodium lactate broth has been found to be in all respects as good

as that made with the calcium salt, and in one very important respect to be superior.

In the preparation of the calcium lactate broth no attention, so far as the published papers indicate, has been paid to its reaction; and considering the reactions of the individual ingredients employed there would seem offhand to be little need for concern about this point. It was noted, however, when broth was tested for its hydrogen-ion concentration, by means of the colorimetric method of Clark and Lubs, (1917) that a value of about  $\text{pH} = 5.2$  was always obtained. This result (from  $\text{pH} = 5.1$  to  $\text{pH} = 5.3$ ) was found with Witte pepton as well as with a variety of American brands.

An inquiry was therefore made into the reactions of the individual components and of combinations of the several components. Calcium lactate broth was made and at the same time solutions of the various ingredients were prepared separately in the same concentrations as they occur in the broth. These were all sterilized in the autoclave for twenty minutes at 15 pounds pressure. After cooling, the following results were obtained:

	<i>pH</i>
2.0 per cent pepton.....	6.8
0.5 per cent sodium chloride.....	7.3
0.2 per cent dipotassium phosphate.....	8.2
2.0 per cent calcium lactate.....	7.3
Von Freudenrich and Orla-Jensen broth.....	5.2

As is shown by these data, the reaction of the finished broth is much more acid than is any one of its several components. Another lot of broth made with the same ingredients, with the exception that sodium lactate was substituted for the calcium salt, gave a reaction of  $\text{pH} = 7.2$ .

It would appear then that the explanation is to be found in the reaction between the phosphate and the calcium lactate; and such it seems is the case, as is indicated by the result given below. These solutions were sterilized as were those reported above.

	<i>pH</i>
0.2 per cent dipotassium phosphate.....	8.2
2.0 per cent calcium lactate.....	7.3
0.2 per cent dipotassium phosphate + 2 per cent calcium lactate..	4.8

The marked acidity of the lactate-phosphate mixture is probably explained by the formation of acid phosphates and lactic acid along with the insoluble calcium phosphate.

Aside from the case of this particular broth, the principle here illustrated should be given more general consideration in the formulation of culture media. It would seem, *à priori*, that there is danger of such a shift in the hydrogen-ion concentration upon sterilization of any medium which contains calcium or magnesium and a phosphate, if the calcium-magnesium portion is in excess of the phosphate. This principle is violated in many of the synthetic media which are recorded in bacteriological literature. It is obvious also that the buffering effect of the phosphate is lost in such a combination.

In the recommendation that sodium lactate be used in the place of the calcium salt, it has been assumed that the dibasic phosphate employed in this medium serves some useful purpose. As a matter of fact, in pure culture, the lactate-fermenting bacteria of Swiss cheese grow very well in broth containing only pepton and either calcium or sodium lactate. This does not prove that the simplified medium would be just as good for quantitative estimations in which the seedings are very light.

In the work here reported quantitative determinations were made in a broth containing 1 per cent pepton, 1 per cent dried yeast and 1 per cent lactic acid (as sodium lactate). This broth supports a very active growth of the lactate-fermenters and is an excellent one for quantitative purposes.

#### *Approximate numbers found*

Quantitative dilutions of cheese were planted in broth composed of 1 per cent each of pepton, dried yeast, and lactic acid (in the form of sodium lactate). Dilutions of from 0.01 to 0.000,001 gram of cheese were tested. After incubation for four weeks at 30°C. the cultures were acidulated and subjected to steam distillation to determine the formation of volatile acids. Control flasks containing pepton-yeast broth without the lactate, inoculated with the same dilutions, were run in order to avoid any possible error through the measurement of the relatively small amounts of vola-

tile acids derived from the nitrogenous constituents of the medium.

Without going into details, it may be stated that of 16 samples of American-made Swiss cheese purchased on the open market all contained lactate-fermenting organisms in sufficient numbers to be revealed in 0.000,001 gram, the highest dilution used. These samples were representative of about the average run of domestic Swiss cheese; only samples which had sufficient eye development were taken, but the flavor varied from excellent to very poor.

Thus it will be seen that we have succeeded in demonstrating the presence of lactate-fermenting organisms in numbers considerably greater than has been reported by other investigators. Also, as will be shown later on, these bacteria have been isolated directly from cheese without previous enrichment in some selective broth.

#### *Relation to previous work*

Concerning the discrepancies between the results of various workers on this subject, we feel that these inconsistencies may well be reconciled through the observations made in connection with the work here reported. As has been noted, the reaction of the lactate broth, as employed by Von Freudenrich and Orla-Jensen and subsequent workers, is too acid for the best results. The error which may be introduced by this factor is well illustrated by the following test made on a pure culture of a lactate-fermenting organism from Swiss cheese: A broth culture one week old as tested by the dilution method, using the regular Von Freudenrich and Orla-Jensen broth (pH = 5.2), and another broth of the same composition except that sodium lactate was substituted for the calcium salt. This broth had a reaction of pH = 6.8. The result of this test showed that, whereas the sodium lactate broth gave a count of over 100,000,000 organisms per cubic centimeter the number as indicated by the calcium lactate broth was less than 1,000,000.

Aside from the error introduced through the unfavorable reaction of the calcium lactate broth, as it has been previously used, there are apparently other factors which make the dilution method

a rather uncertain one for the quantitative estimation of the lactate-fermenting bacteria of cheese. It has been noted on several occasions that the distillation for volatile acids gave negative results whereas further propagations from the culture used showed that lactate-fermenting bacteria were present. This phenomenon is probably to be explained by the presence in the culture of other organisms which consume the volatile acids. That this may sometimes be the case was indicated by the results obtained on certain samples of cheese in which volatile acids were produced from the high dilutions of cheese in lactate broth whereas the low dilutions, which contained a much heavier inoculation and a greater variety of organisms, gave negative results. In this work we have checked ourselves quite thoroughly against such errors by running all of our dilution cultures in triplicate, and also by making further examinations and propagations from dilution cultures which gave negative results. Thus we have on several occasions demonstrated the presence of the lactate-fermenting bacteria from cultures which gave negative results on the original test.

## II. THE CAUSE OF EYES AND FLAVOR

In our work on Swiss cheese during the past few years the identity of the organism responsible for the development of the characteristic flavor, as well as the eyes, of Emmental cheese has been quite clearly established. The ability of this organism to play these rôles in the ripening of cheese has not only been established by carefully controlled laboratory experiments, but also under practical commercial conditions in factories located in widely separated areas of the country.

### GENERAL CHARACTERISTICS

Morphologically the organism is a minute rod about twice as long as it is broad. It makes little or no growth on agar slope cultures; in agar stabs growth takes place throughout the length of the puncture but not on the surface. In agar shake cultures there is likewise no growth on the surface whereas good growth takes place throughout the medium; as incubation continues over

an extended period the growth is seen to become very heavy, barely below the surface of the agar. In a suitable nutrient broth a heavy slimy growth occurs at the bottom and the whole broth becomes turbid, with the usual exception of a narrow clear zone at the surface. Milk is rendered slowly acid and is usually curdled in from one to two weeks at 30°C. Growth in pepton milk is much better, curdling taking place in from four days to one week at 30°C. Small bubbles of gas may sometimes be seen in the curd. Gelatin is not liquefied. Glucose, lactose, maltose, sucrose, glycerol and salicin are fermented; raffinose, inulin, and mannitol are not.

One of the outstanding characteristics of this organism is the production of a large amount of catalase. Attention has previously been called to the relatively large amount of catalase which is found in Swiss cheese (Sherman 1919). The group of organisms herein described is the one which was shown to give this characteristic to cheese of the Emmental type.

Reference to the products produced by this bacterium indicates that it belongs to the group of proprionic acid bacteria which was described by Von Freudenrich and Orla-Jensen. Lactates are fermented with the production of volatile acids, including propionic and acetic, and carbon dioxide. Also in the fermentation of lactose, volatile acids and carbon dioxide are produced.

#### *Relation to previously described types*

Whether this organism is identical with any of the types isolated by Von Freudenrich and Orla-Jensen cannot be definitely stated at this time. In general it appears to agree quite closely with their description of *Bact. acidi-propionici* (*a*) which they considered to be the true cause of the development of eyes in cheese. A few points, however, in their description do not agree with the characteristics which we have observed in our organism; they state that it causes no visible change in milk, whereas our organism in litmus milk develops an acid reaction after several days and causes coagulation on longer incubation. Further, from their results on the production of volatile acids it was noted that only a small amount of these substances was produced from glycerol,



while our organism causes an active fermentation of glycerol with the production of a considerable quantity of volatile acids. Finally, it may be stated that the organism with which we have been working causes the typical sweetish flavor in Emmental cheese, whereas the experiments of Von Freudenrich and Orla-Jensen did not give definite results on this point. Orla-Jensen (1912) has since stated more conclusively that the sweetish flavor is due to a factor other than the propionic acid bacteria.

It is of course recognized that an accurate comparison can not be made from published descriptions. It is hoped, therefore, that we may obtain from European workers cultures of the various types of propionic acid-forming bacteria so as to determine more definitely whether this organism is identical with any of the previously described types or whether it is a new variety. In this connection it may be noted that we have also isolated a variety of these lactate-fermenting bacteria, among which have been found quite distinct types. Although the characteristics of all of these varieties have not been studied in detail, they appear to agree in a general way with the types which have been isolated by European workers. It is hoped that further studies on these organisms, in comparison with types obtained from Europe, may be made in the future.

In keeping with the nomenclature used by the European workers for the group of propionic acid-producing bacteria, this organism will be tentatively designated as *Bact. acidi-propionici* (d).

#### *The isolation of cultures*

The direct isolation of this organism from cheese is difficult for various reasons, particularly because of its slow growth and its oxygen requirements. Though not a strict anaerobe it requires a considerably reduced oxygen tension. Although in pure culture this organism grows in all ordinary culture media, including even 1 per cent pepton solution, it is apparently not so easy to obtain growths from it when taken directly from cheese. On a few occasions colonies have been isolated

from agar plates made directly from cheese, but success by this method is rare.

On a number of occasions this organism has been isolated, directly from the cheese, by sealing agar dilutions in glass tubing of about 0.5 cm. diameter. With this method it is very easy to isolate the individual colonies by cutting the tube at the desired points. By sterilization of the outsides of these tubes by immersion in a strong disinfectant solution, and then rinsing with sterile water, there has been no difficulty in making isolations by this method without contamination. The medium which we have found very satisfactory for this purpose is one consisting of 2 per cent pepton, 1 per cent yeast, 1 per cent lactic acid (as sodium lactate) and 1.5 per cent agar. Although we have had fairly good success in making isolations by this method, it has by no means always proven successful.

By making enrichment cultures of the cheese in lactate pepton broth, as was done by Von Freudenrich and Orla-Jensen, the isolation of lactate-fermenting bacteria is much easier. We have isolated a variety of organisms belonging to this group from such enrichment cultures.

Our interest thus far has been more in the practical application of these bacteria in the cheese industry than in making a thorough study of their physiological characteristics. There is little doubt however, that by taking advantage of their known properties, a simple differential method could be developed which would be satisfactory for the direct isolation of this group of organisms from cheese.

#### *Rôle in cheese*

For studying the effect of this organism in cheese we have had at our disposal a supply of milk, obtained from the experimental herd of the Dairy Division, which was entirely lacking in the bacteria necessary for the development of the desired characteristics of Emmental or Swiss cheese. Cheese made from this milk by the Swiss method is always entirely lacking in the characteristic sweetish flavor, and is also frequently "blind." When the natural inoculation in this milk is such as

to cause a development of eyes in the cheese the resulting flavor is in no way similar to that characteristic of the typical Swiss cheese. This fact is important, since it shows that the formation of eyes may be due to bacteria other than the one herein described; it probably explains also the fact that American Swiss cheese is so frequently deficient in flavor even when abundant eye formation takes place.

In our laboratory work small cheeses of the Emmental type are made from about 200 pounds of milk. These cheeses are then handled in exactly the same way as are the large Swiss cheeses made under factory conditions, and they ripen in an entirely normal manner. From such experiments it has been demonstrated time and again that the organism described in this paper is responsible for the characteristic sweetish flavor of Swiss cheese and that it also causes the development of eyes. Its relation to the eye formation is shown in the photograph reproduced at the end of this paper; its relation to flavor production has been demonstrated in over 100 laboratory experiments in which one cheese in each experiment was inoculated while another cheese made from the same milk was left uninoculated.

That the use of this bacterium as a "starter" is practicable under commercial conditions has been demonstrated in a number of different factories. In all cases these factory experiments have shown a marked influence on the ripening of the cheese with respect to both eyes and flavor. The application of these results in cheese-factory practice will be treated more in detail in a future publication.

#### ACKNOWLEDGMENT

Should the work herein reported prove of value to the cheese industry, major credit therefor is due Mr. L. A. Rogers, in charge of the Research Laboratories of the Dairy Division, who recognized the possibilities of pure cultures in the manufacture of Swiss cheese and initiated work toward that end over ten years ago, and who has fostered and directed the work through

a period of many discouragements due to lack of facilities and frequent changes in the experimenting staff.

Acknowledgment is also due to Mr. K. J. Matheson, and his several collaborators, whose cordial coöperation in conducting the cheese-manufacturing tests has made this work possible.

#### SUMMARY

1. Bacteria capable of fermenting lactates with the production of volatile acids have been found to be constantly present in normal cheese of the Swiss or Emmental type in numbers exceeding 1,000,000 per gram.

The discrepancies in the results of previous workers on this subject are probably explained by a faulty combination of salts contained in the medium used, resulting in the production of a reaction too acid for the optimum development of the organisms concerned.

2. The essential organism for the production of eyes and the characteristic sweetish flavor of Swiss cheese has been isolated and studied.

The organism concerned belongs to the group of propionic acid-producing bacteria, but appears to differ slightly in some of its characters from the several varieties of propionic bacteria which have been described in the literature.

Factory experiments have shown that pure cultures of the organism may be used successfully in practice to insure the proper ripening of Emmental cheese.

## REFERENCES

- BOEKHOUT, F. W., AND DEVRIES, J. J. O. 1917 Study on the normal production of gas in cheese. (Abstract) *Abs. Bact.*, **2**, 278.
- CLARK, W. M., AND LUBS, H. A. 1917 The colorimetric determination of hydrogen ion concentration and its applications in bacteriology. *Jour. Bact.*, **2**, 1-34, 109-136, 191-236.
- ELDRIDGE, E. E., AND ROGERS, L. A. 1914 The bacteriology of cheese of the Emmental type. *Centbl. Bakt. (etc.)*, Abt. 2, **40**, 5-21.
- ORLA-JENSEN, S. 1912 Der jetzige Stand der Käsureifungsfrage. *Centbl. Bakt. (etc.)*, Abt. 2, **32**, 202-209.
- SHERMAN, J. M. 1919 The catalase content of cheese. *Jour. Dairy Sci.*, **2**, 453-459.
- TROILI-PETERSSON, GERDA 1909 Studien über in Käse gefundene glyzerinvergärende und laktatvergärende Bakterien. *Centbl. Bakt. (etc.)*, Abt. 2, **24**, 333-342.
- VON FREUDENRICH, E., AND ORLA-JENSEN, S. 1906 Ueber die in Emmentalerkäse stattfindende Propionsäuregärung. *Landw. Jahrbuch d. Schweiz*, 320-338.

#### PLATE 1

The lower row of cheeses were made from milk lacking in the bacteria essential for the proper ripening of Swiss cheese.

The cheeses in the upper row were made from the same milk as their respective "blind" controls, with the addition of a pure culture of the eye and flavor producing organism.

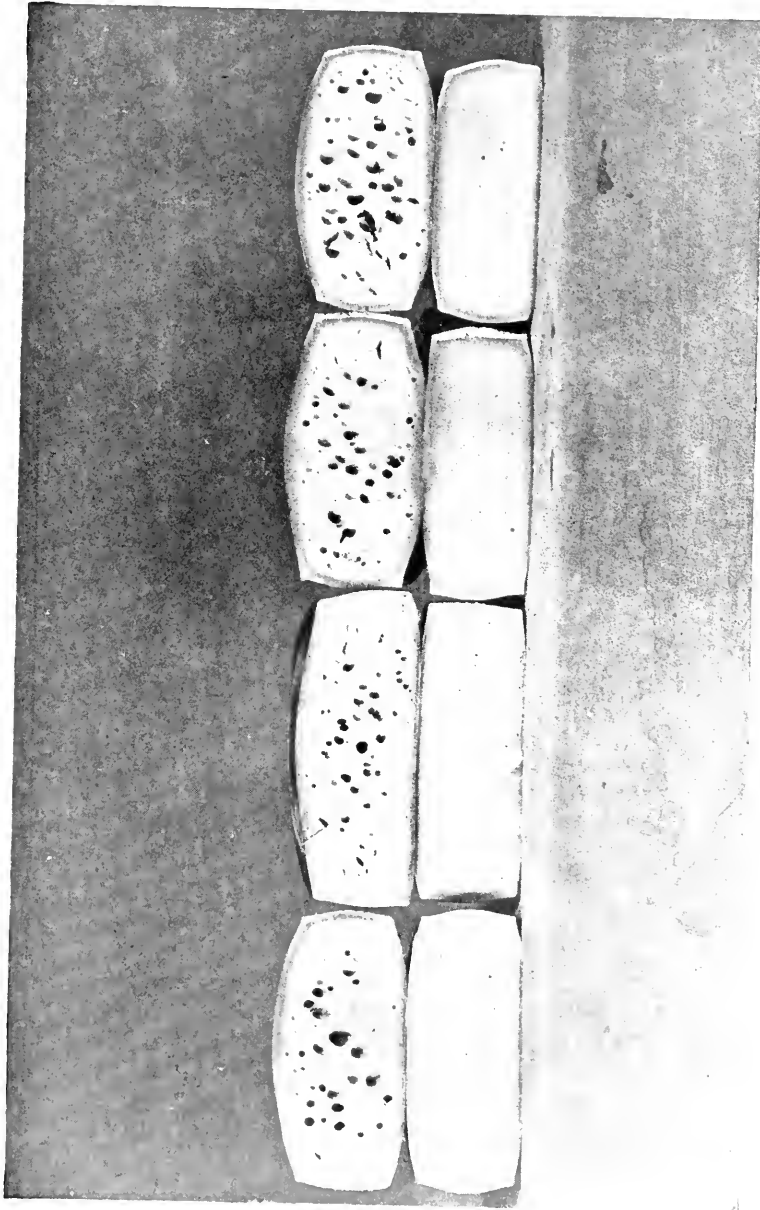





# A NEW MODIFICATION AND APPLICATION OF THE GRAM STAIN

G. J. HUCKER

*New York Agricultural Experiment Station, Geneva, New York*

Received for publication December 12, 1920

In making microscopical examinations of the quality of milk received at New York state cheese factories a need arose for a stain which would have a greater differential value than methylene blue, and which would be applicable for quantitative as well as qualitative results. The thought of the Gram stain at once suggested itself. While organisms can be classified only into general groups in methylene blue preparations, and no differentiation can be made between desirable and undesirable types for cheese making, the gas forming groups can be readily distinguished from the desirable lactic acid organisms in slides stained by the Gram method.

In developing a modification of the Gram stain which could be used in staining milk smears, the difficulty has been to secure a decolorizing solution which would allow the Gram positive organisms to retain the stain and still remove the color from the milk and the Gram negative types. The following method has proved satisfactory in our work, and is presented with the hope that it will help solve similar difficulties for other investigators.

The stain is as follows:

### *Gentian violet solution*

Anilin oil .....	3.0 cc.
Alcohol (absolute).....	7.0 cc.
Water.....	90.0 cc.
Shake; filter	
Gentian violet (Grübler).....	2.0 grams

### *Iodine solution*

Iodine.....	1.0 gram
Potassium iodide.....	2.0 grams
Water.....	300.0 cc.

*Decolorizing solution*

Anilin oil (2 parts)	} mixture.....	5 parts
Xylol (1 part)		
Alcohol (95 per cent).....		95 parts

*Counter stain*

Bismarek brown.....	4.5 grams
Water (boiling).....	50.0 cc.
Filter	
Alcohol (95 per cent).....	30.0 cc.

The milk smears were prepared by the usual Breed method (Breed and Brew, 1916); i.e., depositing 0.01 cc. of milk on a clean glass slide and spreading with a needle over an area of 1 sq. cm. The smears were dried and placed in xylol until the fat was dissolved, removed, drained, and immersed in 95 per cent alcohol for two minutes for fixing. The slides before being allowed to dry were placed in the gentian violet for forty-five seconds, blotted or allowed to drain after removing from the stain, and immersed in Gram's iodine solution for one minute, destained in the anilin-xylol-alcohol solution until no more stain could be removed; and then counterstained in Bismarck brown for forty-five seconds.

Several formulas of gentian violet solution were used but the particular concentration given has yielded the most consistent and satisfactory results. Satisfactory preparations could not be obtained with "Method 1" (commonly known as Stirling modification) of the Report of the Committee on the Descriptive Chart of the Society of American Bacteriologists (Conn et al., 1919) as light blue and green areas were deposited on the slide when such concentrated gentian violet was used. This was especially true of smears prepared from milk which had developed any degree of acidity. This reaction was probably due to the conversion of the gentian violet into closely related dyes in the presence of the acid and the alcohol of the destaining solution. No definite data are available at present on this point. The stains used in all cases were Grüber's.

The addition of the anilin oil and xylol to the destaining alcohol resulted in retarding the action of the solution sufficiently

to allow the Gram positive organisms to retain the stain while the color was removed from the Gram negative bacteria and the background of milk. Hastings, Evans and Hart (1912), in their cheese work used a decolorizing solution of anilin oil one part and xylol two parts. This solution although removing the stain from the Gram negative organisms and the milk, was slow in action and caused the organisms to appear distended and less brilliant in the final preparation. Consistent results could not be obtained using alcohol as a decolorizer as the stain was removed from the Gram positive bacteria before the milk was sufficiently destained. The results obtained with acetone, as a decolorizer, were similar to those where alcohol was used.

With exception of Bismarck brown,<sup>1</sup> no counterstain exhibited sufficient range of affinity between the nucleo-proteins of the cells and the casein of the milk to allow for different intensities of color even if destained. A few successful smears were made where an aqueous solution of safranin was used as a counterstain, provided the slides were well washed before the application of the safranin. A heavy precipitate will be deposited on the smear if the Bismarck brown is not frequently dissolved and filtered.

The above method has been used for the routine examination of milk samples for an entire season at a cheese factory where all grades of milk were being received, and it proved helpful in eliminating milk which would develop gassy curds. The smears were checked with duplicate samples stained with methylene blue and no appreciable difference in the count could be observed.

#### REFERENCES

- BREED, R. S., AND BREW, J. D. 1916 Counting bacteria by means of the microscope. N. Y. Agr. Exp. Sta. Tech. Bul. 49: (Condensed form) N. Y. Agr. Exp. Sta., Circ. 58.
- CONN, H. J., ET AL. 1919 Methods of pure culture study. Jour. Bact., **4**, 107-132.
- HASTINGS, E. G., EVANS, ALICE E., AND HART, E. B. 1912 The bacteriology of cheddar cheese. U. S. Dept. Agr. Bur. An. Ind. Bul. 150.

---

<sup>1</sup>If Bismarck brown stains the background of milk too deeply, slide may be immersed for a few seconds in a weak aqueous solution of acid fuchsin, after counter staining.



# COLOR STANDARDS FOR THE COLORIMETRIC MEASUREMENT OF H-ION CONCENTRATION

LOUIS J. GILLESPIE

*Contribution from the Research Laboratory of Physical Chemistry of the Massachusetts Institute of Technology, No. 135*

Received for publication December 18, 1920

In an article of the above title recently published in this journal, Medalia (1920) presents a system of color standards somewhat similar to one published by me a little before (Gillespie, 1920). The work is evidently independent of mine, but the proposed tables are in serious disagreement with the results of my work.

The cause of the disagreement apparently does not lie in a conflict of observations, but in the plan followed by Medalia in preparing the tables.

It is stated that a test of this plan with the indicator, bromthymol blue, "succeeded perfectly, i.e., the green color was found at (pair no. 4) pH 7; or slightly yellowish green at (pair no. 3) pH 6.8 according to this range. (The change of color of this indicator was found by the writer to start with pH 6.2 instead of pH 6 as given by Clark and Lubs.)"

Unfortunately, this test is not sufficient to afford evidence in favor of the plan as against the method used by me to "smooth out" experimental errors for the preparation of tables, because the mass action equation used for this smoothing requires that such a limited test of the plan shall succeed perfectly, the error involved being only 0.02 pH, well within the experimental error.

In fact, the mass action equation requires that, if one is able to determine both limits<sup>1</sup> equally distant from the half-transfor-

<sup>1</sup> Although there are practical limits to the useful range, there is of course no real point of pH where the indicator "starts in" to change color, but only a subjective point "over the threshold" where it may appear to do so.

mation point (at pair 4), then pairs 3, 4, and 5 will be substantially correct as calculated by the plan in question, but pairs 2 and 6 will be in error by nearly 0.10 pH, and pairs 1 and 7 by about 0.25. The mass action equation is, however, in accord over the useful interval of pH with the measurements of Tizard (1910) for methyl red, of Barnett and Chapman (1918) for phenol red,<sup>2</sup> and of the present writer for all indicators studied by Medalia, except the acid range of thymol blue, which was not studied.

We do not need to assume the applicability of the mass action equation in order to show that the proposed tables are in disagreement with these measurements. It is only necessary to plot the results to be compared on one diagram in any uniform manner,<sup>3</sup> and the discordance will be apparent. The proposed tables must therefore be considered incorrect, since the plan on which they are mainly based lacks a solid foundation, and is not supported by enough data to put into question the conflicting measurements.

In the article, mention is made of measurement of acid production of bacteria by means of pH determinations. A word of warning seems justified by the fact that the idea is apparent in the writings of others. The definition of acid production in terms of a difference between initial and final pH values is decidedly not superior to definition in terms of titration, but rather false, or at least of slender and involved significance. To measure *how much* acid is produced we must *titrate*.<sup>4</sup> If the composition of the culture medium makes impossible a true titration on the direct culture, then we may distil the volatile acids and titrate

<sup>2</sup> This has been shown by me (Gillespie, 1920).

<sup>3</sup> For instance, the percentage of indicator placed in the alkaline solution may be plotted against the pH pertaining to it, or better, the logarithm of the ratio between the quantities of indicator as distributed between the alkaline and the acid tubes of the color standards may be plotted against pH. By the second procedure a straight line is required by the mass action equation. Mathematically, the plan of Medalia consists of a pure guess as to the form of the curve obtained by such plotting of the data.

<sup>4</sup> Measurement of change of pH may, in some cases, give us the acid production, if we have already incorporated the results of titration in a titration curve.

them, or possibly change the composition of the culture medium ("standard methods" notwithstanding), or resort to even graver expedients, but the last expedient indeed should be the measurement of pH for the given purpose. Measurement of pH and titration furnish two distinct methods of attack, each with its own object and interpretation. The principles involved have been carefully discussed by Clark and Lubs (1917).

As to a statement to the effect that the electrometric method is more accurate than the colorimetric, but that the apparatus which it requires is beyond the possibilities of the average bacteriological laboratory; the writer can subscribe to neither part in the unqualified form, but would refer again to the article of Clark and Lubs (1917) for a discussion of the first part, and to the recent book of Clark (1920) for the second. The writings of Clark and Lubs also contain full discussions of other principal topics, such as titration of culture media, effect of bacterial growth and of sterilization upon the indicators, etc.

It is pleasing to note that Medalia was able to preserve his color standards. The standards prepared by me were not permanent, and the main difference seems to be in the means taken by Medalia to avoid microbial decomposition, this point having been neglected by me.

It seems well to describe in this article, otherwise not very constructive, an instrument for further study of the indicator constants and behavior, which was devised too late to be of service in the work published (Gillespie, 1920). The necessary improvements in method, for work substantially better than that already published, must include temperature control of the buffer solutions in which the indicator is placed, and more precise measurements of the percentage transformation. The apparatus shown schematically in figure 1 can easily be made to satisfy both requirements. The writer has not seen it described. It is a colorimeter for two-colored indicators, and by an obvious modification it can be used to determine, if desirable, both the percentages of the two colors present and the total concentration. A simple apparatus was improvised<sup>5</sup> with which the percentages

<sup>5</sup> In the Laboratories of Soil Fertility, Bureau of Plant Industry, Washington, D. C.

could be determined with far greater ease and precision than is possible with a one-colored indicator in the usual colorimeter, since the quality changes very rapidly with the adjustment. Plane polished surfaces are desirable in the optical system, but were not used.

The glass vessels *A* and *C* are fixed in position, and *B* can be moved up or down, the motion being measured by a pointer (not shown) fixed to *B* and moving upon a scale divided into 100 parts. The instrument is so made that the pointer moves from 0 to 100 when *B* moves from contact with *C* to contact with *A*. The acidified indicator solution of suitable strength may be placed in *B* and an alkaline indicator solution of the same strength

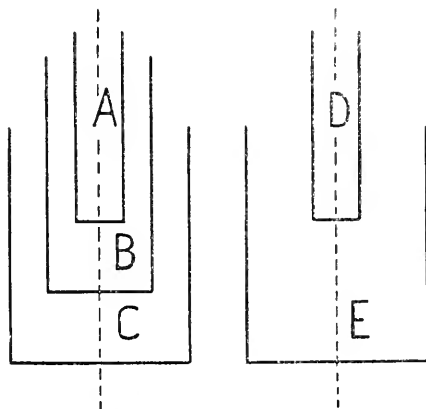

FIG. 1. COLORIMETER FOR TWO-COLORED INDICATORS

placed in *C*. *A* is left empty.<sup>6</sup> Then, if the scale reads 70, the path of light along the left-hand dotted line passes through the alkaline form during 70 per cent of its path in the indicator, and through the acid form during 30 per cent. The light along the right-hand dotted line traverses an indicator solution in tube *E*, again of the same strength, and over a path equal in length to the

<sup>6</sup> For use in the determination of pH, a tube containing unknown solution without indicator can be slipped into tube *A* in order to compensate for color or turbidity without lengthening the apparatus unduly. In this case, water would be introduced into *D* to equal height in order to equalize absorption and the meniscus effects.



total path on the left. The merit of the instrument consists in the fact that the length of this total path is not affected by the motion of tube *B*, though the percentages of the path lengths in the two solutions are varied directly thereby. The indicator solution in tube *E* consists of a buffer mixture (or solution, the pH of which is to be determined) to which the proper amount of indicator has been added. If conditions are such that 70 per cent of the molecules encountered along the path on the right are in the alkaline modification, and 30, in the acid, then the eye will perceive identical impressions upon looking through the two systems from above. This will be the case, even if each modification is not pure, but admixed with the other,<sup>7</sup> or if each modification absorbs to some extent like the other, or if the indicator exhibits dichromatism. Consequently the apparatus may be used to determine the apparent percentage transformation of the indicator at different hydrogen-ion exponents; the relation being studied at different temperatures and subsequently being used to determine unknown hydrogen-ion exponents.<sup>8</sup>

To control the temperature of the buffer solutions or of the unknown solution, water can be circulated in a jacket (not shown in the figure) about the tube *E*. The temperature should be controlled to about one degree, or possibly better.

It is evident that titrations can be carried out in the tube *E*, a proper quantity of strong indicator solution being added for every cubic centimeter, or smaller unit, of added reagent.

<sup>7</sup> It need not be the case if the indicator is grossly contaminated with another indicator of different apparent dissociation constant, or if the indicator behaves like a dibasic or polybasic acid. Wegscheider (1915) has made statements equivalent to those in the text above.

<sup>8</sup> The instrument can of course be used at once and dependence put for the time being on the apparent dissociation constants and tables published (Gillespie, 1920). If the indicator used, the temperature, and what information as may be available as to the salt content of the solution, be recorded, the corrections can be applied at any time when better values for the indicators and other data are obtained. Although the writer can not admit that the method previously published or the use of a double colorimeter is to be classed as approximate because of doubtful optical assumptions, it is of course only approximate until precise calibration of the standards is made. At present the instrument is capable of giving more precision than could be obtained in the calibration made without it, and it may possibly disclose some small deviations from the simple dissociation curve.

It is well known that the simple law used in ordinary colorimetry, namely—the thickness of the solution times the concentration equals a constant when the thickness and concentration are varied in such a way as to match a standard color—does not hold for solutions of potassium dichromate. Indeed, with a color standard of different composition from the solution itself, the colors shown by a solution of potassium dichromate, as it is progressively diluted, can not be matched either by dilution of the color standard or by changing the depth of the layers. On the other hand, the changing colors can be matched in the double colorimeter. For standards (in tubes *B* and *C*), may be used a highly acid solution of potassium dichromate, and a solution of potassium (yellow) chromate. As the solution in question is diluted, it becomes necessary to change the ratio of the path lengths through the red and the yellow “forms”, as well as to increase the path length through the solution (in tube *E*). It is generally assumed that a change of ionization occurs when potassium dichromate solution is diluted; and there seems to be no reason to doubt that the usual law of absorption holds for the *constituents* of the solution. There would appear to be no ground for a suspicion that the “dichromatism” of the sulphonephthalein indicators may interfere with their use in the double colorimeter.

In fact, to derive the law upon which ordinary colorimetry is based, we assume that light passing through a solution is affected independently by each particle of colored material, these particles usually being alike in kind. In order to apply the law to double colorimetry, we need only the further assumption that the same is true when the particles are not alike in kind, and it appears difficult to doubt this in the given case. Consideration of the expression for the intensity of the emergent light:  $Ia^{\epsilon c}$ , where *I* is the intensity of the entering light, *a* is the fraction absorbed by each particle,  $\epsilon$  is the thickness, and *c* is the concentration of particles, leads to the following conclusions.<sup>9</sup>

<sup>9</sup> The expression is applied to the different wave-lengths entering, the constant *a* being assumed different for each wave-length.

The variation of the constant  $a$  with wave-length, which leads to the dichromatism of the two-colored indicators, does not lead to any difficulty in the case of the double colorimeter. Dichromatism leads to the detection of errors made when turbidity of the solution to be measured is balanced optically in the usual manner. With a one-colored indicator the error made is no less because of the absence of dichromatism, but the error is not disclosed. In routine work, white light is advisable as a source for comparisons, when it can be used, so that such error may be made evident by dichromatism. When the subjective difficulties become too great for the use of white light, a screened light (Clark and Lubs, 1917) may be a valuable means of obtaining an approximate result.

#### SUMMARY

The recently published tables of Medalia are in disagreement with other published data and are not correct.

A colorimeter for two-colored indicators is described for use in accurate study of the indicators and for the measurement of hydrogen-ion exponent. The optical assumptions underlying its use are practically the same as those upon which ordinary colorimetry is based.

#### REFERENCES

- BARNETT, GEORGE D., AND CHAPMAN, HERBERT S. 1918 Colorimetric determination of reaction of bacteriologic mediums and other fluids. *Jour. Amer. Med. Assn.*, **70**, 1062.
- CLARK, W. MANSFIELD 1920 *The Determination of Hydrogen Ions*, 318 pp., Baltimore.
- CLARK, WILLIAM MANSFIELD, AND LUBS, HERBERT A. 1917 The colorimetric determination of hydrogen-ion concentration and its applications in bacteriology. *Jour. Bact.*, **2**, 1-34, 109-136, 191-236.
- GILLESPIE, LOUIS J. 1920 Colorimetric determination of hydrogen-ion concentration without buffer mixtures, with especial reference to soils. *Soil Science*, **9**, 115-136.
- MEDALIA, LEON S. 1920 "Color standards" for the colorimetric measurement of H-ion concentration pH 1.2 to pH 9.8. *Jour. Bact.*, **5**, 441-468.
- TIZARD, HENRY THOMAS 1910 The color changes of methyl orange and methyl red in acid solution. *Jour. Chem. Soc. (London) Trans.*, **97**, pt. 2, 2477-2490.
- WEGSCHEIDER, RUD. 1915 Theorie der azidimetrischen Indikatoren. *Ztschr. physik. Chem.*, **90**, 641-680. Especial reference to page 673.



# THE EFFECT OF PEPTON UPON THE PRODUCTION OF TETANUS TOXIN

HARRIET LESLIE WILCOX

*Research Laboratories, Department of Health, New York City*

Received for publication December 19, 1920

Not very long after the outbreak of the European War, laboratory workers realized that a substitute for Witte pepton in bacteriological work would have to be obtained. Many laboratories were sufficiently stocked with this pepton for the first twelve to eighteen months, but in the spring of 1915 it was evident that the supply of Witte pepton in the United States was fast dwindling and that it would soon be unobtainable.

## WITTE PEPTON

At the Bureau of Laboratories we had been using a Witte pepton glucose veal broth<sup>1</sup> with extremely satisfactory results. Those who have had experience in toxin production, particularly tetanus toxin, know that from time to time there will be marked variation in toxicity due to some unknown factor or factors. The same care may be used in the preparation of different lots of broth as well as in the filtration of the toxin, but the results may differ widely. In consideration of this fact it may be worth while to give the different potencies of the toxin made during the last three to four years when using Witte pepton glucose veal broth.

It is the opinion of some workers that the time of year has a definite influence upon the production of potent toxin. The results as given above show that the seasonal factor was of negative importance as far as toxicity was concerned. If we compare the quarterly results for the year 1915 we find that the averages did not vary greatly. The lowest average toxicity of 1:20,000

<sup>1</sup> Wilcox, Harriet Leslie, 1916, *Jour. of Bact.*, **1**, 333.

TABLE I  
*Witte peptone*

	1914	1915	1916	1917	1918
First quarter	None produced	7 lots 1:25,000 2 lots 1:15,000† 1 lot 1:10,000* 1 lot 1: 5,000	1 lot 1:35,000 2 lots 1:30,000 2 lots 1:25,000 1 lot 1:20,000 2 lots 1:15,000 1 lot 1:13,000 1 lot 1:10,000§ 1 lot Below 1:5,000** Average toxicity 1:20,000	None produced	1 lot 1:25,000 1 lot 1:15,000
		Average toxicity 1:20,000	Excluding** average toxicity 1:22,000		Average toxicity 1:35,000
		Excluding*† average toxicity 1:22,000	Excluding** average toxicity 1:22,000		None produced
		5 lots 1:30,000 4 lots 1:25,000 1 lot 1:20,000	4 lots 1:35,000 1 lot 1:10,000 1 lot 1: 5,000* Average toxicity 1:19,000	None produced	None produced
		Average toxicity 1:27,000	Excluding* average toxicity 1:22,000		
Second quarter					

Third quarter	2 lots 1:25,000	1 lot 1:40,000 2 lots 1:30,000 6 lots 1:25,000 3 lots 1:20,000 3 lots 1:15,000 2 lots 1:10,000 1 lot Below 1:5,000† Average toxicity 1:20,000	1 lot 1:30,000 3 lots 1:25,000 1 lot 1:20,000 2 lots 1:15,000	1 lot 1:100,000†† 1 lot 1: 60,000 1 lot 1: 25,000 2 lots 1: 20,000	None produced
	Average toxicity 1:25,000	Excluding† aver- age toxicity 1:22,000	Average toxicity 1:20,000	Average toxicity 1:45,000	
Fourth quarter	1 lot 1:40,000 5 lots 1:25,000	2 lots 1:35,000 5 lots 1:25,000 1 lot 1:15,000 2 lots 1:10,000 2 lots 1: 5,000 Average toxicity 1:20,000	1 lot 1:25,000 1 lot 1:25,000	1 lot 1:35,000 1 lot 1:20,000	None produced
	Average toxicity 1:27,000		Average toxicity 1:25,000	Average toxicity 1:27,000	

\* Flasks contaminated.

† Temperature of incubation down to 32°C.

‡ Broth very dark, due probably to over heating of glucose.

§ Broth very acid (2.2) after sterilization.

\*\* Two lots of toxin were interchanged through error when removed from the incubator. Lot inoculated 1-26-16 was mixed with that of 2-2-16.

†† This preparation is referred to in text as lot 127.

occurred in the first, third and fourth quarters, while the second quarter gave an average toxicity of 1:27,000.

The differences in the quarterly averages of the year 1916 were so slight that they were scarcely worth mentioning. The third quarter in this period showed the lowest average toxicity of 1:20,000 while the first, second and fourth quarters gave an average toxicity of 1:22,000.

Doubtless if Witte pepton veal broth had been used throughout the year 1917 we should have had a greater variation in the quarterly averages, due to the two extremely potent toxins produced in the third quarter. As far as was known no especial care was taken in the preparation of these two broths nor in the filtration of these toxins. In lot 127, the usual procedure of testing for 1:15,000 and 1:25,000 was carried out. When the pigs succumbed in less than forty-eight hours, higher tests, namely 1:40,000 and 1:60,000 were made with similar results. Dilutions of 1:80,000 and 1:100,000 were then injected into guinea pigs weighing 350 grams each. The pig receiving the 1:80,000 dilution died between the second and third day, while the pig which received the 1:100,000 dilution succumbed on the fourth day. Since this was the strongest toxin ever obtained at the Bureau of Laboratories, tests were made of the toxin filtrate to preclude any possibility of spores or bacilli having passed through the Berkefeld filter. These tests were negative.

#### DIFFERENT PEPTONS

In the spring of 1916, we anticipated the present shortage of Witte pepton and made comparative tests with some of the domestic peptons on the market. These results are to be regarded as comparative only, but in those that were controlled by the use of Witte pepton, the differences in the toxicity, with one or two exceptions, were very significant.

A subsequent test, made with another preparation of Fairchild pepton, gave a toxicity of only 1:8000. No control test was made as we were unable to obtain Witte pepton.



TABLE 2  
Comparative tests of different peptons

TEST	NAME OF PEPTON	TOXICITY
1	Witte (control)	1:25,000
	Leitz	1:5,000
	Eimer and Amend	1:1,000
2	Witte (control)	1:25,000
	Squibb	1:5,000
	Research no. 2	1:15,000
3	Witte (control)	1:25,000
	Fairchild	1:20,000
	Research no. 2	1:20,000
4	Witte (control)	1:30,000
	Parke, Davis and Company	1:8,000

#### MARTIN PEPTON

Sporadic attempts at using Martin pepton broth<sup>2</sup> were made early in the year 1916 with indifferent results. Nothing more was done until January, 1917, with regard to the adoption of Martin broth for tetanus toxin as used at the Pasteur Institute. The entire absence of Witte pepton at this time prevented us from making control tests with the usual Witte pepton glucose veal broth.

The highest average for this period, i.e., in the year 1917, occurred in the second quarter, when the average toxicity was 1:17,000. The first and third quarters gave respectively the average toxicity of 1:10,000 and 1:9,000 while the fourth quarter gave the lowest average toxicity of 1:5,000.

Three different strains of *Clostridium tetani* were used for a comparative test (table 4). The strain designated "Research" is the culture used in the routine production of tetanus toxin at the Bureau of Laboratories. This strain was obtained about ten years ago from the New York State Laboratory at Albany but its origin and date of isolation are not known. Unless otherwise

<sup>2</sup>Martin, Louis. Annales de l'Institut Pasteur, vol. 12, p. 26, 1897.

TABLE 3  
*Martin pepton veal broth*

	1917	1918
First quarter...	2 lots 1:15,000 1 lot Below 1:5,000 Average toxicity 1:10,000	2 lots below 1:5,000 Average toxicity below 1:5,000
Second quarter...	1 lot 1:25,000 1 lot 1:10,000 Average toxicity 1:17,000	1 lot below 1:5,000 Average toxicity below 1:5,000
Third quarter...	1 lot 1:15,000 2 lots 1:8,000 1 lot 1:5,000 Average toxicity 1:9,000	None produced
Fourth quarter...	1 lot 1:15,000 2 lots 1:8,000 3 lots 1:5,000 3 lots Below 1:5,000 Average toxicity 1:5,000	None produced

TABLE 4  
*Comparative tests of different strains in Martin pepton veal broth*

	STRAINS	TOXICITY
Experiment 1. December 23, 1916.....	Research	1:35,000
	Goadby	1:35,000
	Pasteur	1:25,000
Experiment 2. May 19, 1917.....	Research	1:10,000
	Goadby	1:15,000
Experiment 3. December 15, 1917.....	Research	1:8,000
	Pasteur	1:8,000
	Pasteur	1:8,000

stated this was the strain used in our tests. The Goadby strain was obtained from Dr. MacConkey, Lister Institute, England, in 1916, and had been isolated from a war case by Dr. Goadby in

1915. The Pasteur strain was the one formerly in use at the Pasteur Institute, Paris, for the production of tetanus toxin. That this strain did not produce so potent a toxin (1:25,000) as the Research and Goadby strains (1:35,000) was somewhat surprising as it had been kept on a medium made with Martin pepton for years, whereas the Goadby and Research strains had been accustomed to this medium for several months only.

That Martin pepton broth as made by us is capable occasionally of giving potent toxin, is evidenced by the results obtained in experiment 1 (table 4) and in experiment 4 (table 5.) The other preparations of toxin broth were made with the same precautions and care but, as is shown, with far different results. When it was apparent that equal parts of Martin pepton and veal infusion were not giving satisfactory toxin, tests were made with broth prepared by using more concentrated Martin pepton solution with ordinary veal infusion (experiment 4, table 5); also by using the usual amount of Martin pepton solution with a more highly concentrated veal infusion. In neither case was the result so satisfactory as with the usual preparation. Subsequent broths were prepared according to the original method, that is to say using equal parts of infusion and pepton, but the toxin was far too low in potency to be used.

Word was received in January, 1918, with regard to the modification of Martin pepton broth used with favorable results for tetanus toxin at the Pasteur Institute. The variation between this procedure and the one we were using lay in the concentration of the pepton solution, in the shortened incubation period and also in the absence of glucose. A preparation of toxin broth (see experiment 6, table 6), was made according to this modification, one-half of the broth having 1 per cent glucose added to it while the other half was prepared without any sugar. After seven days incubation instead of the usual period of fifteen days, the cultures were filtered and tested. The results of the animal tests were most disappointing as pigs inoculated with 1 cc. of a dilution of 1:5,000 from each preparation showed an absence of tetanic symptoms. In his article on the preparation of this pepton, Martin advises that not less than five stomachs should be used

TABLE 5

*Comparison of different methods for the preparation of Martin pepton veal broth*

	MEDIA	STRAIN	TOXICITY
Experiment 4. June 13, 1917...	<i>Control broth</i>		
	1 part Martin pepton solution (200 grams of minced stomach to 1000 cc. H <sub>2</sub> O)	Research	1:25,000
	1 part veal infusion (500 grams of veal to 1000 cc. H <sub>2</sub> O)		
	<i>Experimental broth</i>		
	1 part of Martin pepton solution	Research	1:8,000
	1 part of veal infusion (500 grams of veal to 500 cc. H <sub>2</sub> O)		
Experiment 5. October 10, 1917	<i>Experimental broth</i>		
	1 part of Martin pepton solution (400 grams of stomach to 1000 cc. H <sub>2</sub> O)	Research	Below 1:5,000
	1 part of veal infusion		
	<i>Control broth</i>		
	1 part Martin pepton	Research	1:5,000
	1 part of veal infusion		
Experiment 6. April 2, 1918....	<i>Experimental broth</i>		
	1 part of Martin pepton solution	Research	1:8,000
	2 parts of veal infusion		
	<i>Experimental broth</i>		
	1 part of Martin pepton solution (200 grams stomach to 1500 cc. H <sub>2</sub> O)	Research	1:5,000
	1 part of veal infusion		
Experiment 6. April 2, 1918....	1 part of Martin pepton solution (300 grams of stomach instead of usual 200 grams to 1000 cc. H <sub>2</sub> O)	Research	
	1 part of veal infusion	Research	Below 1:5,000
	To the above mixture of pepton and veal infusion 1 per cent glucose was added		
	1 part of Martin pepton (300 grams of stomach to 1000 cc. H <sub>2</sub> O)		
1 part of veal infusion. No glucose	Research	Below 1:5,000	

TABLE 6  
*Berna pepton*

	1918	1919	1920
First quarter...	None produced	1 lot 1:40,000 1 lot 1:35,000 1 lot 1:30,000 1 lot 1:25,000 1 lot 1:20,000 5 lots 1:15,000 4 lots 1:10,000 4 lots 1:8,000 1 lot 1:4,000 Average toxicity 1:15,000	1 lot 1:35,000 1 lot 1:30,000 1 lot 1:15,000 1 lot 1:10,000  Average toxicity 1:22,000
	1 lot 1:100,000 1 lot 1:45,000	1 lot 1:40,000 4 lots 1:35,000 1 lot 1:30,000 4 lots 1:25,000 2 lots 1:15,000 1 lot 1:10,000 3 lots 1:5,000* 1 lot 1:5,000 Average toxicity 1:21,000	1 lot 1:25,000 1 lot 1:20,000 1 lot 1:5,000  Average toxicity 1:16,000
	Average toxicity 1:72,000	Excluding* average toxicity 1:25,000	Average toxicity 1:16,000
	2 lots 1:8,000 2 lots 1:5,000 Average toxicity 1:6,500	2 lots 1:60,000  Average toxicity 1:60,000	1 lot 1:20,000 2 lots 1:12,000 Average toxicity 1:14,000
	1 lot 1:60,000 1 lot 1:45,000 1 lot 1:35,000 1 lot 1:25,000 1 lot 1:12,000 1 lot 1:7,000 Average toxicity 1:30,000	1 lot 1:30,000 1 lot 1:20,000 1 lot 1:15,000  Average toxicity 1:21,000	Production for this quarter not completed

\* These three lots were grown at too high temperature, i.e., 42°C.

owing to the great variation of the different stomachs. We are accustomed to make about fifteen liters of pepton solution for one preparation of toxin broth. This amount requires seven or eight stomachs according to the size. At the Pasteur Institute, marmites or large casseroles holding not less than 60 liters are employed for the digestion of the pigs' stomachs.

#### BERNA PEPTON

About this time our attention was called by Dr. Noble of the New York State Laboratory to a pepton put on the market by the Swiss Vaccine and Serum Company, of Berne, Switzerland. The statement that this pepton was made according to Witte's recipe was received with some skepticism but the thought did occur to us that this might be a means of getting Witte pepton into the Allied countries.

A small amount of broth (about 15 liters), was made up according to our usual method using the "Berna" pepton instead of the Witte. So interested were we in the result, that a small amount was withdrawn from one of the flasks, filtered and tested on the sixth day of growth. The minimum lethal dose was found to be over 1:10,000 after even this short incubation period. At the end of fifteen days the rest of the cultures were filtered and tested. The pig which received 1 cc. of a dilution of 1:45,000 died of tetanus on the fourth day. A second preparation of toxin broth made with this pepton yielded a toxin of 1:100,000 in potency.

Broth made with Berna pepton has been used at the Bureau of Laboratories since May, 1918, to the present time with favorable results for the production of tetanus toxin (see table 6). The variations in the quarterly averages were greater than when Witte pepton was employed.

The average toxicities as given in this table showed again that the seasonal factor was of no importance in the production of potent toxins. The second quarter in the years 1918, 1919 and 1920 gave averages of 1:72,000, 1:21,000 and 1:16,000 respectively. The third quarter of these same years showed still

greater differences. The average toxicity in this period of 1918 was 1:6,500. In the year 1919 this quarter gave a high average toxicity of 1:60,000 and the same period in the year 1910 showed an average toxicity of 1:14,000.

#### SUMMARY

In going over the above results, it will be seen that Witte pepton has been an important factor in the production of a fairly constant potent tetanus toxin. The indications are that the Berna pepton is a satisfactory substitute for Witte since the latter is no longer available.

It would seem either that the Swiss Serum and Vaccine Company was justified in its claim that Berna pepton was made according to Witte formula or that Berna pepton was in reality Witte pepton since only when using these two peptons did we obtain a toxicity of 1:100,000.

It was a great disappointment that Martin pepton broth as made by us proved so unreliable. It is just possible that one of the reasons for the better results with this broth at the Pasteur Institute, is due to the fact that a larger number of stomachs are used for the preparation of the pepton than we can handle at one time at the Bureau of Laboratories.





# ON THE GROWTH AND THE PROTEOLYTIC ENZYMES OF CERTAIN ANAEROBES

K. G. DERNBY AND J. BLANC

*From the Pasteur Institute, Paris*

Received for publication January 7, 1921

In a work that soon will be published one of us, Blanc has extensively studied the biochemistry of certain anaerobes, especially *Bacillus sporogenes* and *Bacillus histolyticus*. It seemed to be of interest also to introduce in that work the methods, especially worked out in America by Clark and Lubs (1917) and their followers, for studying the influence of hydrogen ion concentration in its relation to growth and proteolytic activity. The other of us, Dernby, has already in a series of papers used these methods (Dernby 1918, Dernby and Avery 1918 and Dernby and David 1920), and as we have limited this paper to as short a communication as possible, we may for the description of methods refer to these papers mentioned above. What will follow are merely the main results of our work with some anaerobic microorganisms.

Some time ago, Wolf and Harris and Wolf and Telfer (1917) studied the biochemistry of the anaerobes, *B. welchii* (*perfringens*) and *B. sporogenes* (Metchnikoff), taking into consideration the influence of hydrogen ion concentration. It seems, however, that they, like many other authors at that time, paid too much attention to what is called "the limiting hydrogen ion concentration" and the influence of organic acids on the growth of the microorganisms. In our opinion the first thing to do, when studying the biochemistry of a given microorganism, is to determine the limiting and the optimal pH values for the growth of this organism in a given medium. We by no means claim that either of these values should be used as a new basis of classifying

the microorganisms, and especially as to the "limiting pH value" we are very doubtful whether it bears any deciding significance. The essential thing is to determine the optimum, and, even if this should change a little under different conditions, to fix such an initial reaction of the medium as can easily be reproduced and allow a sufficient growth.

In the first part of this paper we have determined the relation between growth and hydrogen ion concentration for a certain number of anaerobes, and in the second part we have studied the proteolytic activity of filtrates from *Clostridium sporogenes* and *Clostridium histolyticum*.

#### I. THE OPTIMAL HYDROGEN ION CONCENTRATION FOR THE GROWTH OF SOME ANAEROBES

The following microorganisms have been studied:

*Clostridium sporogenes* A (Klein-Metchnikoff)

*Clostridium sporogenes* O, isolated from horse excrements

*Clostridium canadiense*, isolated by Blanc from a case of gangrene

*Clostridium histolyticum* (Weinberg-Seguín)

*Clostridium putrificum* (Bienstock)

*Clostridium perfringens* (Veillon-Zuber)

For all these microorganisms the same broth medium was used. This was made up in the following way: 1 kgm. finely chopped veal was immersed in 2 liters of tapwater and allowed to autolyze at 37° for twenty-four hours; thereafter boiled and filtered; 0.5 per cent NaCl and 1 per cent pepton added; then sterilized at 110° for twenty minutes. In preparing an experiment the same amount of broth was divided among nine flasks to which different amounts of HCl or NaOH were added, in order to obtain certain hydrogen ion concentrations. Table 1 shows the composition of our nine standard media.

The contents of the nine flasks were then divided up into test tubes, 10 cc. of the same standard in each, and the test tubes then sterilized as before. Thus we could always work in a uniform manner. The tubes were allowed to stand at least for a day at room temperature in order to obtain a stable hydrogen ion con-

centration. All sets of nine tubes, except one intended to serve as a control for the pH determination, were inoculated with the same amount of bacterial suspensions. Simultaneously there were added a few milligrams of solid calcium sulphide powder. The microorganisms were taken from a twenty-hour pepton-gelatin culture. Before inoculation all tubes were heated to about 37°.

TABLE 1  
*Composition of "Standard" broth media*  
30 cc. broth, HCl, NaOH, or H<sub>2</sub>O, 32 cc.

NUMBER	N. NaOH	N. HCl	H <sub>2</sub> O	pH 24 HOURS AFTER STERILIZATION
	cc.	cc.	cc.	
1		1.8	0.2	3.1
2		1.0	1.0	4.0
3			2.0	4.9
4	0.3		1.7	6.0
5	0.6		1.4	6.5
6	0.9		1.1	7.0
7	1.2		0.8	7.5
8	1.4		0.6	8.0
9	1.8		0.2	8.8

The tubes were placed in an incubator at 37° and after certain intervals growth was recorded. No microscopic count of the bacilli was made, the growth was merely estimated, and in order to be able to reproduce the results graphically we have indicated the amount of growth by numbers from 0 to 4. Preliminary experiments indicated that a time of incubation of from fifteen to twenty hours was the most favorable to determine the optimal growth.

The initial and the final pH values were determined according to Clark and Lubs, with the method described in the mentioned paper by Dernby and Avery. All our experiments showed that under the chosen conditions (see tables 2 and 3) these anaerobes did not (at least during the first days of incubation) change the hydrogen ion concentration of the medium to any appreciable extent. Therefore it was not necessary here as in the case with pneumococcus or diphtheria bacillus to add any buffers. From

many aspects this is undesirable. Already earlier authors have pointed out that these anaerobes do not change the acidity or alkalinity of the medium.

TABLE 2  
*Growth of Clostridium sporogenes O.*  
Time of incubation, sixteen hours. Temperature 37°

NUMBER	pH INITIAL	pH AFTER 16 HOURS	DEGREE OF GROWTH
1	3.1	3.3	Trace
2	4.0	4.0	Trace
3	4.9	5.0	1
4	6.0	6.0	3
5	6.5	6.5	4
6	7.0	7.0	4
7	7.5	7.5	3
8	8.0	7.9	2
9	8.8	8.5	0

TABLE 3  
*Growth of Clostridium histolyticum*  
Time of incubation, sixteen hours. Temperature, 37°

NUMBER	pH INITIAL	pH AFTER 16 HOURS	DEGREE OF GROWTH
1	3.1	3.1	0
2	4.0	4.0	0
3	4.9	5.0	0
4	6.0	6.0	2
5	6.5	6.5	3
6	7.0	7.0	4
7	7.5	7.5	4
8	8.0	7.8	3
9	8.8	8.6	0

In tables 2, 3 and 4 some of our experiments are recorded.

Our method, though apparently arbitrary, and giving no absolute basis for the calculation of the rate of growth, yet provides by the range of comparison which it affords, a quite adequate standard for all practical purposes.

In figure 1 the results from the tables 2, 3 and 4 are graphically represented. Even if the point for the optimum pH and the limits in the different cases change, we may as a whole state that

the curves of growth in relation to hydrogen ion concentration are almost identical for all the anaerobes studied. When comparing these curves with those given before for the pneumococcus and diphtheria bacillus (Dernby and Avery, 1918, Dernby and David, 1920), it is obvious that they are much broader, with limits from pH 5 to pH 9, whereas the limits for the pneumococcus are pH 7 to pH 8.3 and for the diphtheria bacillus pH 5.5 to pH 8. Obviously the hydrogen ion concentration has much

TABLE 4

*Growth of four types of anaerobes*

Strains used: 1. *Clostridium sporogenes* A. (Klein-Metchnikoff)

2. *Clostridium canadiense*

3. *Clostridium putrificum* (Bienstock)

4. *Clostridium perfringens* (Veillon and Zuber)

Time of incubation, seventeen hours. Temperature, 37°

NUMBER	pH INITIAL	DEGREE OF GROWTH			
		<i>Clostridium sporogenes</i> A	<i>Clostridium canadiense</i>	<i>Clostridium putrificum</i>	<i>Clostridium perfringens</i>
1	3.1	0	0	0	0
2	4.0	0	0	0	0
3	4.9	Trace	0	Trace	Trace
4	6.0	2	2	1	1
5	6.5	4	3	4	3
6	7.0	4	4	4	4
7	7.5	3	3	4	4
8	8.0	2	1	3	3½
9	8.8	0	0	1	1

less influence—within certain limits—on the growth of these anaerobes than on the growth of, e.g., the pneumococcus.

The optimum for all of the microorganisms studied here seems to fall between pH 6.5 and pH 7.5. If any distinction should be made it might be said that *Clostridium sporogenes* seems to have an optimum a little less than pH 7 and the others a little more than pH 7. That indicates that these microorganisms grow most favorably in media which have a neutral reaction, that is pH 7.

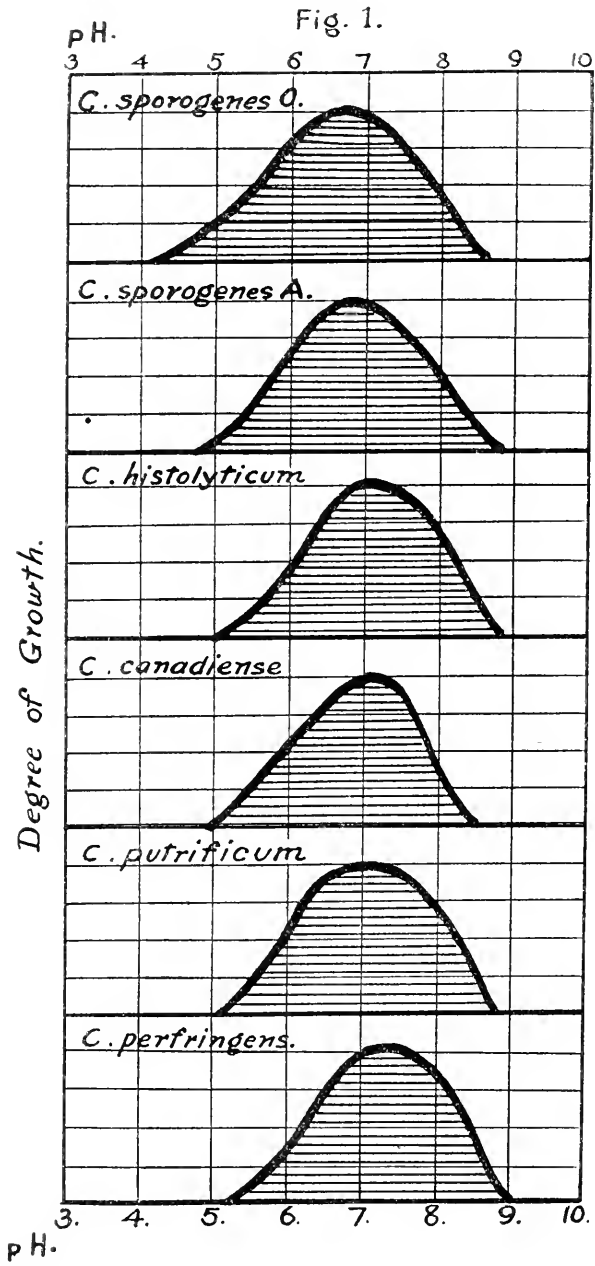

## II. THE PROTEOLYTIC ACTIVITY OF FILTRATES FROM CLOSTRIDIUM SPOROGENES AND CLOSTRIDIUM HISTOLYTICUM

It is well known that anaerobes of this type are strongly proteolytic, dissolve fibrin and casein, liquefy gelatin, disintegrate pepton, and so on. The present mode of classifying the proteolytic enzymes seems to be to determine (1) the substrates attacked, (2) the products of digestion and (3) the optimal hydrogen ion concentration for the action. The two best substrates, which can be used in solution, are gelatin and pepton. In the cited paper by Dernby (1918) the method for using these substrates is fully described. Below we have studied the proteolytic activity of *Clostridium sporogenes* and *Clostridium histolyticum*. As enzyme the broth culture after passing a Chamberland filter has been used. By this method, we of course get information only in regard to the "ekto" enzymes, whereas the "endo" enzymes will escape our attention. The ideal thing would be to obtain large quantities of the bacilli, let them autolyze and determine the proteolytic activity of the autolysate. It is possible that in that case we should obtain enzymes both of the pepsin and of the trypsin-erepsin group as has been found is the case of yeast (Dernby, 1917).

The filtrates were obtained in the following way: For each culture 500 cc. of an ordinary broth made from autolyzed veal was taken, 1 per cent glucose and enough NaOH to render the initial reaction almost neutral (pH 7) were added. The mixture was sterilized at 107° for an hour. After cooling to 37° the flasks were inoculated with the microorganism in question, and simultaneously a minimal dose of solid calcium sulphide was added. The flasks were allowed to stand in the incubator at 37° for seventy-two hours, and then 3 cc. of chloroform were added. The culture was first filtered through paper and thereafter passed through a Chamberland filter. The clear filtrate was kept sterile at room temperature, and exhibited strong proteolytic activity for several months.

*Gelatin tests*

In order to make all experiments in exactly the same manner standard mixtures of gelatin and HCl or NaOH were made beforehand, of which the hydrogen ion concentrations were known. Table 5 shows the composition of these mixtures.

As our aim was to study the optimum reaction, it was sufficient for us to study the first stages in the liquefaction process. During this early period the hydrogen ion concentration will not change much, and buffers could be omitted.

TABLE 5

*Composition of gelatin mixtures*

The gelatin solution contained 14 per cent gelatin and 0.4 per cent thymol. 10 cc. gelatin, HCl, NaOH or H<sub>2</sub>O, 12 cc.

NUMBER	N. HCl	N. NaOH	H <sub>2</sub> O	pH
	cc.	cc.	cc.	
1	1.0		1.0	3.0
2	0.2		1.8	4.0
3			2.0	4.8
4		0.04	1.96	5.5
5		0.1	1.9	6.3
6		0.2	1.8	7.0
7		0.3	1.7	8.3

In preliminary experiments it was determined how much of the enzyme had to be taken in order to liquefy the gelatin within 4 to 20 hours at the optimum pH value 6.5.

In all cases a set of seven tubes was used, covering a range in pH from 3.0 to 9.0. Ordinarily 5 cc. gelatin were used for each test. The tubes were warmed to 37° before the enzyme was added. The gelatin contained 0.5 per cent thymol and the enzyme solution was aseptic. Therefore hardly any proteolytic activity from other microorganisms need be taken into consideration during the short time of digestion. A blank experiment was always run at the same time. After certain intervals the tubes were taken from the incubator and put into an ice bath for exactly ten minutes; thereafter the degree of liquefaction was estimated by the method given in the paper by Dernby (1918).



In figure 2 the results are graphically represented. The results from the tables 6 and 7 are almost similar. In both cases there is a marked proteolytic activity between pH 4 and pH 8, and the optimum is in both cases near pH 6. When allowed

TABLE 6

*Clostridium sporogenes* on gelatin

Filtrate from *Clostridium sporogenes* A. Klein-Metchnikoff. Temperature, 37°. 6 cc. gelatin, 0.5 cc. filtrate

NUMBER	pH INITIAL	DEGREE OF LIQUEFACTION AFTER		
		3 hours	6 hours	20 hours
1	3.0	0	0	0
2	4.0	0	0	1
3	4.8	0	$\frac{1}{2}$	2
4	5.5	1	1	5
5	6.3	2	3	5
6	7.0	1	2	3
7	8.3	0	0	1

TABLE 7

*Clostridium histolyticum* on gelatin

Filtrate from *Clostridium histolyticum* Weinberg and Seguin. Temperature, 37°. 6 cc. gelatin, 0.5 cc. filtrate

NUMBER	pH INITIAL	DEGREE OF LIQUEFACTION AFTER		
		2 hours	4 hours	20 hours
1	3.0	0	0	0
2	4.0	0	0	0
3	4.8	1	$1\frac{1}{2}$	4
4	5.5	2	4	6
5	6.3	$1\frac{1}{2}$	$3\frac{1}{2}$	6
6	7.0	0	1	5
7	8.3	0	1	5

to digest for a long period of time all tubes except the most acid ones are liquefied.

We seem justified in stating that in the filtrates from these two microorganisms enzymes resembling trypsin are present.

*Pepton test*

Table 8 shows the composition of the pepton standard solutions. The rate of digestion was measured with the Sørensen formol method. Tables 9 and 10 give the results of experiments with *Clostridium sporogenes* and *Clostridium histolyticum*.

It may be objected that in this case the Van Slyke method might have given sharper values, but the only question we wanted to study was the optimum for the action of the enzymes on pepton, and for this purpose the formol method gives results which

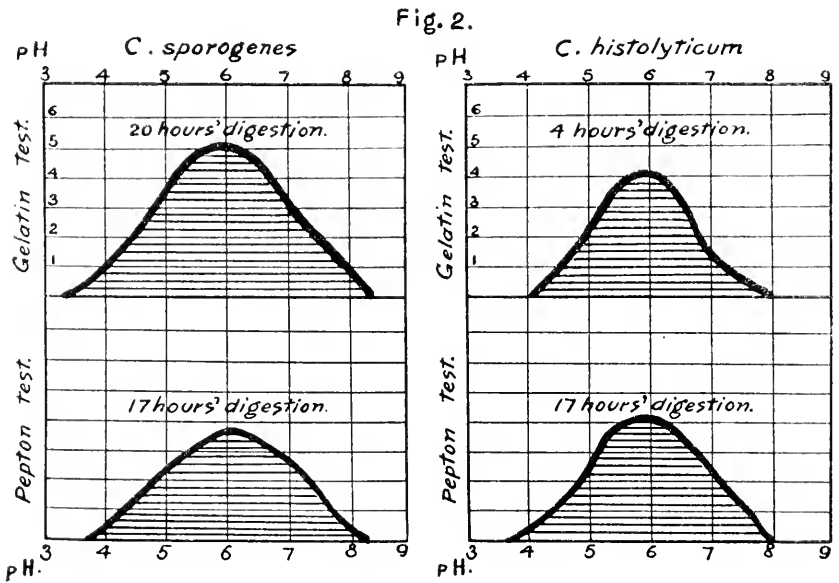

can not be misinterpreted. In figure 2 the results are graphically represented. It is evident that the enzymes from *Clostridium sporogenes* act in the same manner as to the pH optimum as those from *Clostridium histolyticum*. For both the optimum is at pH 6 and the range within which they act is pH 4 to pH 8. Also in this case the enzymes acting on pepton seem to be "tryptases."

From figure 2 it is evident that the action on gelatin and the action on pepton of the two anaerobes in relation to the hydrogen

TABLE 8

*Composition of pepton mixtures*

10 cc. 4 per cent pepton solution, NaOH, HCl or H<sub>2</sub>O, 40 cc. Chloroform and toluene added

NUMBER	N. NaOH	N. HCl	pH
	cc.	cc.	
1		0.6	3.0
2		0.1	4.0
3			4.7
4	0.04		5.5
5	0.08		6.2
6	0.2		7.1
7	0.3		7.7
8	0.5		8.5

TABLE 9

*Clostridium sporogencus A. on pepton*

10 cc. pepton, 0.5 cc. filtrate. Temperature, 37°. Time of digestion, seventeen hours

NUMBER	pH INITIAL	LIBERATED AMINO-N IN 10 CC. AFTER 17 HOURS
		mgm.
1	3.0	0
2	4.0	0.1
3	4.7	0.55
4	5.5	0.65
5	6.2	1.0
6	7.1	0.65
7	7.7	0.4
8	8.5	0

TABLE 10

*Clostridium histolyticum on pepton*

10 cc. pepton, 0.5 cc. filtrate. Temperature, 37°. Time of digestion, seventeen hours

NUMBER	pH INITIAL	LIBERATED AMINO-N IN 10 CC. AFTER 17 HOURS
		mgm.
1	3.0	0
2	4.0	0.2
3	4.7	0.7
4	5.5	1.95
5	6.2	1.95
6	7.1	1.1
7	7.7	0.3
8	8.5	0

ion concentration are almost identical. Whether it is the same tryptase that acts in both cases, or whether there are several is impossible to say.

The conclusion we have arrived at by these experiments is simply that the proteolytic enzymes in filtrates from *Clostridium sporogenes* and *Clostridium histolyticum* seem to be very much alike, and that the enzymes which can be detected belong to the tryptase group.

It must be remembered however that in the living or dead microorganisms there are also present proteolytic enzymes of other types.

#### SUMMARY

The optimal and limiting hydrogen ion concentrations for the growth of the anaerobes, *Clostridium sporogenes*, *Clostridium histolyticum*, *Clostridium canadiense*, *Clostridium putrificum* and *Clostridium perfringens* have been determined. The range in which all of these organisms live has the limits pH 5 to pH 9. The optimum range for all seems to be at or about the neutral point pH 7 and is apparently a rather broad one.

2. The proteolytic activity of filtrates from *Clostridium sporogenes* and *Clostridium histolyticum* has been studied. Gelatin is liquefied and pepton is disintegrated in the range pH 4 to pH 8, and the optimum for both these reactions seems to be about pH 6. The conclusion is that in the filtrates a *tryptase* is present.

#### REFERENCES

- CLARK, W. M., AND LUBS, H. A. 1917 Jour. Bact., **2**, 1.  
DERNBY, K. G. 1917 Biochem. Z., **81**, 109.  
DERNBY, K. G. 1918 Jour. Biol. Chem., **35**, 179.  
DERNBY, K. G., AND AVERY, O. T. 1918 Jour. Exp. Med., **28**, 345.  
DERNBY, K. G., AND DAVID, H.: 1920.  
WOLF, CH. G., AND HARRIS, J. 1917 Jour. Path. and Bact., **21**, 385, and Biochem. Jour., **11**, 213.  
WOLF, CH. G., AND TELFER, S. V. 1917 Biochem. Jour., **11**, 297.

# A RAPID METHOD

HAS BEEN DEvised FOR

## COUNTING BACTERIA IN MILK

BY

Prof. W. D. FROST, of the Bacteriology Laboratories of the Department of Agriculture, University of Wisconsin.

The two items illustrated here are the principal pieces of apparatus required.

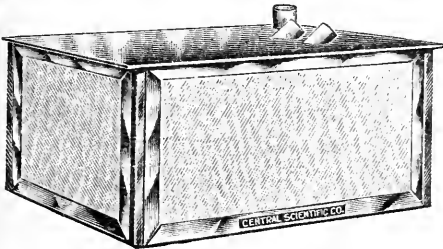

Warming Table

### DESCRIPTION OF TECHNIQUE:

For complete description of the methods and apparatus required, see the following: *Journal of Infectious Diseases*, Vol. XXVIII, No. 2, February, 1921, pages 176-184, "Improved Technique for the Micro or Little Plate Method of Counting Bacteria in Milk," by Dr. W. D. Frost.

Standard Methods for the Bacteriological Examination of Milk, Third Edition, page 18, "Microscopic Colony Count (Frost Method)," published by the American Public Health Association.

### ADVANTAGES OVER STANDARD PLATE METHOD

1. Rapidity of method, requiring only from 1/12 to 1/4 of the time required with the standard plate method.
2. Simplicity of technique.
3. Economy, due to small amount of materials required, both apparatus and media.
4. Special adaptability for field work, because of the light and compact equipment. The carrying case may serve as an incubator.
5. Feasibility of determining total number of bacteria by making single cells visible through proper staining.
6. Possibility of identifying, by means of the higher powers of the microscope, the different organisms present through their individual peculiarities as shown on the little plate.
7. Ability to distinguish dead from living bacteria, in connection with the study of pasteurization.
8. Ability to keep a faithful permanent record for future use by filing the dry slides.
9. Reliability of the method, since the little plates can all be counted due to (1) the relatively large amount of milk used, (2) smaller dilution required and (3) lack of interference from spreaders.

### ACCURACY

Numerous tests made by Frost and others show that the results secured by this method compare reasonably well with those obtained by the standard plate method. Variations between the two methods are no greater than between duplicate determinations by the standard plate method.

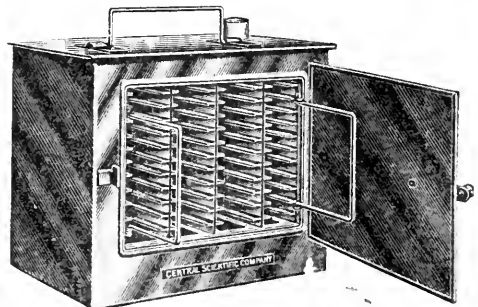

Moist Chamber Cabinet

For Complete Descriptions and Directions for Use, send for Bulletin 97B.

## CENTRAL SCIENTIFIC COMPANY

LABORATORY (INCORPORATED) SUPPLIES  
 Apparatus **CNO** Chemicals  
CHICAGO, U.S.A.  
 Chicago.

460 E. Ohio St.,

U.S.A.



## BACTO-PEPTONE

has stood the test of six years of use in laboratories all over the world.

### DEHYDRATED CULTURE MEDIA

are a signal advance in the science and art of bacteriology.

### RARE SUGARS "DIFCO"

are of the highest standard of purity, especially suitable for bacteriological work.

### OTHER FINE CHEMICALS

are gradually being added to our line, such as

*Acid Potassium Phthalate, Decolorizing Carbon, Tyrosine, Invertase.*

---

*Send for descriptive bulletins and price list. "DIFCO" products are carried in stock by the principal dealers in Scientific Supplies.*

---

## DIGESTIVE FERMENTS COMPANY

Detroit, Michigan, U. S. A.

VOLUME VI

NUMBER 5

# JOURNAL OF BACTERIOLOGY

OFFICIAL ORGAN OF THE SOCIETY OF AMERICAN  
BACTERIOLOGISTS

SEPTEMBER, 1921

EDITOR-IN-CHIEF

C.-E. A. WINSLOW



*It is characteristic of Science and Progress that they continually  
open new fields to our vision.—PASTEUR.*

PUBLISHED BI-MONTHLY  
WILLIAMS & WILKINS COMPANY  
BALTIMORE, U. S. A.

Entered as second-class matter April 17, 1916, at the postoffice at Baltimore, Maryland, under the act of March 3, 1879. Acceptance for mailing at special rate of postage provided for in Section 1103, Act of October 3, 1917. Authorized on July 16, 1918.

Copyright 1921, Williams and Wilkins Company

Price, net { \$5.00 per volume, United States, Mexico, Cuba  
postpaid { \$5.25 per volume, Canada  
          { \$5.50 per volume, other countries

# Holadin and Bile Salts

Holadin - - 2½ grs.

Bile Salts - - ½ gr.

(enteric capsules)

“Investigations begun originally by Professor ‘Nencki in his Berne laboratory and carried ‘on by Heidehain, Rachford, Williams and ‘Martin, have shown that the bile has a ‘favouring action on the ferments of the pan- ‘creatic juice.

“The Bile, indeed, proved itself to be a ‘constant and powerful auxiliary of the pan- ‘creatic juice, a fluid which is of such impor- ‘tance for digestion and in itself already so ‘complicated.”

—Prof. J. P. Pawlow.

“*Holadin and Bile Salts*”, a combination of the most potent pancreas extract with the isolated glycocholate and taurocholate of sodium, in their native association—

is a therapeutic resource of distinct service in pancreatic (intestinal) disorders dependent upon, or associated with, deficient bile action.

FAIRCHILD BROS. & FOSTER  
New York

## LaMotte Standards GUARANTEED

Section 1.—Standardized Indicator dyes. Covering a wide range of H-ion concentration. Supplied in dry form and in sterile stock solutions. Each indicator is standardized in strict accordance with the specifications of Clark & Lubs. (Jr. Bact., Vol. II, Nos. 1, 2, 3, 1917.)

Common Name	Color Change	pH Value
Thymol Blue (acid range)	red-yellow	1.2-2.8
Methyl Orange	red-yellow	2.9-4.0
Bromphenol Blue	yellow-blue	3.0-4.6
Resorcin Blue	pink-blue	4.0-7.2
Methyl Red	red-yellow	4.4-6.0
Bromcresol Purple	yellow-purple	5.2-6.8
Litmus (special)	red-blue	5.5-8.9
Bromthymol Blue	yellow-blue	6.0-7.6
Phenol-Red	yellow-red	6.8-8.4
Cresol Red	yellow-red	7.2-8.8
Thymol Blue (alkaline range)	yellow-blue	8.0-9.6
Cresol-phthalain	colorless-red	8.2-9.8
Phenol-phthalein	colorless-red	8.4-9.2

Section 2-B.—Specially prepared and standardized Buffer salts and solutions. Buffer mixtures may be obtained in series covering any particular range of H-ion concentration from  $P_H$  1.0 to 10.0.

### Standardized Buffer Solutions (M/5)

Potassium Phosphate	Potassium Phthalate	Sodium Hydroxide (CO <sub>2</sub> free)
Potassium Chloride	Hydrochloric Acid	Di-Sodium Phosphate, 2H <sub>2</sub> O

A large number of general synthetic and purified compounds are manufactured by us and information concerning them may be obtained by addressing

**LA MOTTE CHEMICAL PRODUCTS CO.**  
“Standards Department”

13 W. Saratoga St.

Baltimore, Md.



## INFORMATION FOR CONTRIBUTORS

Although there are numerous journals in the United States that deal with various special phases of bacteriology (as applied to Medicine, Sanitary Science, Agriculture and the like), there has been no journal in the English language to represent the science as a whole.

The Society of American Bacteriologists has established the **JOURNAL OF BACTERIOLOGY** as its official organ and as a medium for the discussion of the more general problems of the science—the structure and physiology of the microbes, the inter-relationships of microbial types, the effects of physical and chemical agents upon microbial life, the mutual interactions of microbes growing together in various media, the nutritional needs and products of metabolic activity of various microbes, and new methods of laboratory technique—and similar advances in knowledge which are so fundamental as to be of vital interest to workers in all parts of this great field. The **JOURNAL OF BACTERIOLOGY** includes in its scope not only the bacteria but other related micro-organisms, yeasts, molds, protozoa, etc. While it is planned to make the **JOURNAL** in particular an organ for the more fundamental and general aspects of bacteriology, it will necessarily include many papers whose interest is mainly technical, particularly in those fields of bacteriology which have now no satisfactory organ of publication at their disposal.

Manuscripts should be sent to Prof. C.-E. A. Winslow, Yale Medical School, New Haven, Conn.

All other communications pertaining to editorial work should be addressed to Major A. Parker Hitchens, M. C., Army Medical School, Washington, D. C.

Twenty-five reprints, without covers, of articles will be furnished gratis to contributors when ordered in advance. A table showing cost, with an order slip, is sent with proof.

## INFORMATION FOR SUBSCRIBERS

THE **JOURNAL OF BACTERIOLOGY** is issued bi-monthly, in January, March, May, July, September, and November. A volume consists of approximately 600 pages. Subscriptions to the **Journal** are taken for the volume only. Under the present plans, one volume is issued a year.

**Subscription Price:** 1921 volume, Vol. VI, \$5.00, United States, Mexico, Cuba; \$5.25, Canada; \$5.50, elsewhere, net postpaid.

**Back Volumes** are supplied on orders for Vols. I to V, inclusive. Price, \$30.00, United States, Mexico, Cuba; \$31.25, Canada; \$32.50, elsewhere. Extra single volumes will be supplied on request when in stock at \$5.00, United States, Mexico, Cuba; \$5.25, Canada; \$5.50, elsewhere. Prices are net postpaid. Single numbers can be furnished, in many instances, at \$1.00 a copy.

Correspondence concerning business matters should be addressed to the Williams & Wilkins Company, Mount Royal and Guilford Avenues, Baltimore, U. S. A.

Subscriptions are received:

For Argentina and Uruguay: Beutelspacher & Cia., Sarmiento 815, Buenos Aires, Argentina

For Australia: Stirling & Co., 317 Collins Street, Melbourne.

For Belgium: Henri Lamertin, 58 Rue Coudenberg, Bruxelles.

For the British Empire, except Australia and Canada: Address any British bookseller or send your orders direct to the publishers.

For Canada: Wm. Dawson & Sons, Ltd., 87 Queen Street East, Toronto, Canada.

For Denmark: H. Hagerup's Boghandel, Gothersgade 30, Kobenhavn.

For France: Emile Bougault, 48 Rue des Ecoles, Paris.

For Germany: R. Friedländer & Sohn, Buchhandlung, Carlstrasse 11, Berlin NW. 6.

For Holland: Scheltema & Holkema, Boekhandel, Rokin 74-76, Amsterdam

For Japan and Korea: Maruzen Company, Ltd. (Maruzen-Kabushiki-Kaisha), 11 to 15 Nihonbashi Tori-Sancho, Tokyo; Fukuoka, Osaka, Kyoto, and Sendai, Japan.

For Spain: Ruiz Hermanos, Plaza de Santa Ana, 13, Madrid.

For the United States and other countries except as above: **WILLIAMS & WILKINS COMPANY, MOUNT ROYAL AND GUILFORD AVENUES, BALTIMORE, U. S. A.**

Claims for copies lost in the mails will not be allowed unless such claims are received within 30 days (90 days, foreign) of the date of issue. Claimants must state that the publication was not delivered at their recorded address. The publishers will not be responsible for loss due to change of address unless notification is received at least two weeks in advance of issue.

Subscription in India Rs. 6 per annum. Foreign Rs. 7-8. Payable in advance.

# THE INDIAN JOURNAL OF MEDICAL RESEARCH

EDITED BY

THE DIRECTOR-GENERAL, INDIAN MEDICAL SERVICE,  
THE PUBLIC HEALTH COMMISSIONER WITH THE GOVT. OF INDIA  
AND

THE DIRECTOR OF MEDICAL RESEARCH

IN COLLABORATION WITH

SIR RONALD ROSS, K.C.B., K.C.M.G., F.R.S., N.L., D.Sc., LL.D., M.D., F.R.C.S., Colonel, A.M.S.

C. DONOVAN, M.D., Lieut.-Colonel, I.M.S. (Retd.)  
SIR L. ROGERS, Kt., C.I.E., M.D., F.R.C.P., F.R.S.,  
Lieut.-Colonel, I.M.S. (Retd.)

R. ROW, M.D., D.Sc., Temy. Lieut.-Colonel, I.M.S.  
E. D. W. GREIG, C.I.E., M.D., D.Sc., Lieut.-Colonel,  
I.M.S.

CLAYTON LANE, M.D., Lieut.-Colonel, I.M.S. (Retd.)

F. NORMAN WHITE, C.I.E., M.D., Major, I.M.S. (Retd.)  
R. A. NEEDHAM, C.I.E., D.S.O., M.D., D.P.H., Lieut.-  
Colonel, I.M.S.

H. J. WALTON, M.D., F.R.C.S., Lieut.-Colonel, I.M.S.

A. G. MCKENDRICK, M.B., Lieut.-Colonel, I.M.S.

W. GLEN LISTON, C.I.E., M.D., D.P.H., Lieut.-Col.,  
I.M.S.

W. D. H. STEVENSON, C.I.E., M.D., D.P.H., Lieut.-  
Colonel, I.M.S.

W. C. H. FORSTER, M.B., D.P.H., Lieut.-Col., I.M.S.

W. F. HARVEY, C.I.E., M.B., D.P.H., Lieut.-Colonel,  
I.M.S.

S. R. CHRISTOPHERS, C.I.E., O.B.E., M.B., Major, I.M.S.

The *Indian Journal of Medical Research* is published quarterly. Each number contains at least 150 pages and is illustrated with plates in colour and half-tone and with diagrams and charts, and is the only medium publishing the results of all the best medical research work being carried on by leading scientific medical men in India and the East.

Papers for Publication should be sent to the Secretary, Scientific Advisory Board, Indian Research Fund Association, Simla, from whom all information regarding the journal may be obtained. Purely business communications and applications for copies of the journal should be addressed to Messrs. Thacker, Spink & Co., P. O. Box 54, Calcutta, to whom also subscriptions should be paid.

Contributors will receive 50 reprints of their papers free and additional copies at cost price up to a limit of 100. Applications for reprints should be made at the time of returning the final proof.

The Terms of subscriptions are six rupees per annum, payable in advance; foreign subscribers seven rupees eight annas, including postage; single issues are two rupees, each.

**THACKER, SPINK & CO.,** P. O. Box 54, CALCUTTA,  
and Regent House, SIMLA.

# JOURNAL OF IMMUNOLOGY

OFFICIAL PUBLICATION OF

THE SOCIETY FOR SEROLOGY AND HEMATOLOGY AND  
THE AMERICAN ASSOCIATION OF IMMUNOLOGISTS

Edited by ARTHUR F. COCA

Vol. VI, No. 3

CONTENTS

MAY, 1921

CHARLES KRUMWIEDE AND W. CAREY NOBLE. A Note on the Claim that Agglutinins are Lipoidal Nature.....	201
ROKURO UMEMURA. The Relation between the Absorption of Antibodies and the Isolated Protein Bodies.....	205
MOYER S. FLEISCHER AND NATALIE ARNSTEIN. Specificity of Anti-organ Sera.....	223
F. M. HUNTON AND S. H. CRAIG. Polyvalent Antibody Response to Multiple Antigens.....	235

Current Volume: Vol. VI, 1921—Price, \$5.00 Domestic; \$5.50 Foreign

Back volumes can be furnished; Vols. I-V incl. Price per set: \$24.00, United States, Mexico, Cuba; \$25.00, Canada; \$26.00, other countries. Prices are net postpaid

## Subscription Order for the Journal of Immunology

WILLIAMS & WILKINS COMPANY, MOUNT ROYAL AND GULFORD AVENUES, BALTIMORE, MD., U. S. A.

I } enclose { \$ \_\_\_\_\_ } for subscription to the current volume of JOURNAL OF IMMUNOLOGY.  
We }

Please send Back Volumes

Name.....  
(Please state whether Dr., Prof., etc.)

Address.....

# THE MANNITOL-PRODUCING ORGANISMS IN SILAGE

G. P. PLAISANCE AND B. W. HAMMER

*From the Bacteriology and Dairy Sections of the Iowa Agricultural Experiment Station*

Received for publication December 27, 1920

## INTRODUCTION

The chemistry section of the Iowa agricultural experiment station has shown (Dox and Plaisance, 1917 a and b) that mannitol is a normal constituent of silage and has reported experiments indicating that "it is formed in silage fermentation by bacterial reduction of the fructose-half of the sucrose molecule." In silage, the mannitol is produced in considerable amounts, simultaneously with the acids, the carbon dioxide and the alcohol and "its presence accounts in large measure for the deficit noted when the sum of these products is balanced with the fermented sugar."

The results reported in the present paper<sup>1</sup> deal with the isolation from silage of organisms capable of producing mannitol when grown in pure cultures in corn, corn juice, and various other materials.

## HISTORICAL

The presence of mannitol in the higher plants, in both the higher and lower fungi, and in various fermented materials such as wine, vinegar and sauerkraut, as well as its production by organisms, has already been dealt with in some little detail in the publications of the Iowa station. It is evident that mannitol fermentation has long been known and that it is more or less common.

<sup>1</sup> The work herein dealt with was carried out in 1917 and was to have been reported at the meeting of the American Society of Bacteriologists in that year. The National Research Council, however, requested that the report be delayed because of the possible use of mannitol in the manufacture of explosives.

## METHODS USED

In order to prevent repetition, some of the materials used are here described. The corn juice was secured by pressing green corn, while the stover juice was obtained by soaking corn stover in water for twelve hours and then pressing. The corn silos were made by packing chopped green corn, and the stover silos by packing chopped stover, and adding a calculated amount of water and usually about 5 per cent sucrose, calculated on a dry basis. For most of the silos, the material was packed in quart Mason jars but in a few instances bottles or flasks holding from 1 to 2 liters were used.

Corn juice agar was made by adding 1.5 per cent agar and 1 per cent pepton to the corn juice while the stover juice agar was made by adding 1.5 per cent agar, 1 per cent pepton and 5 per cent sucrose to the stover juice; the stover juice agar was commonly cleared with an egg when it was wanted for plating but this was not necessary with the corn juice agar. The corn juice agar was more satisfactory than the stover juice agar because it was lighter in color and apparently gave a more satisfactory growth.

The method of isolating and determining mannitol in silage was that used in the former work at the Iowa station which has already been referred to. Mannitol was determined in liquid cultures by evaporating 100 cc. aliquot to dryness on a steam box; the residue was then extracted five times with boiling 95 per cent alcohol (about 15 cc. of alcohol in each portion) and the combined extracts filtered as soon as cold. After standing over night the mannitol had crystallized; the crystals were sucked dry, recrystallized from water and alcohol, dried and then weighed.

## RESULTS SECURED

*The rôle of microorganisms in mannitol production*

Although in the previous work at the Iowa station the production of mannitol was secured by inoculating sterilized stover (plus sucrose and water) with a decoction of a leaf of corn silage

and was not secured in "antiseptic" silage made by adding ether to corn, it seemed desirable to repeat and extend these experiments in order to confirm the relationship of organisms to mannitol production. The inoculation of sterilized corn or stover silos with a bit of normal silage gave mannitol production regularly. The lack of mannitol in corn silos treated with various chemicals and held at room temperature for periods that gave mannitol with the untreated corn is shown in table 1.

When silage from the silos to which the various chemicals had been added was examined under the microscope a very few lightly stained bacteria were the only microorganisms observed and these, in all probability, represented organisms that were

TABLE 1

*The influence of various chemicals on mannitol production, room temperature incubation*

ADDED TO THE CORN	PERIOD OF HOLDING	MANNITOL
	<i>days</i>	
Nothing added, normal fermentation.....	14	Present
Ether.....	14	None
Chloroform.....	14	None
Chloroform and toluol.....	14	None
Formaldehyde.....	14	None

present on the corn at the time the silos were filled. The normal silage on the other hand showed very large numbers of well stained bacterial and yeast cells and thus presented a very different picture than the treated silage. When these statements are compared with table 1 it is evident that when microorganisms developed normally mannitol was produced, while when the growth of microorganisms was prevented by various chemicals no mannitol was formed.

#### *The isolation of mannitol-producing organisms*

The isolation of organisms capable of producing mannitol was attempted by plating out samples of silage on corn juice or stover juice agar. Representative organisms developing on the plates were grown on agar slopes (usually the same agar as

that used for plating) and were then tested for mannitol-producing power by inoculating into sterile corn juice, sterile stover juice, a sterile corn silo or a sterile stover silo, allowing growth to go on for a period varying from a few days to several weeks, and then examining the material for mannitol.

Attempts were made to isolate mannitol-producing organisms from a number of samples of silage that had been ensiled several months but only negative results were secured. Yeast<sup>2</sup> colonies were commonly present on the plates in considerable numbers and often made up the greater part of the developing flora; many of these were tried out for mannitol-producing power but when the yeasts were in pure culture mannitol was never found. Other types of silage were then studied and the first mannitol-producing organism isolated —M39— was secured from silage fourteen days old that was made by ensiling green corn from the greenhouse; the silage contained 1.09 per cent mannitol at the time it was plated out. The colony from which M39 was secured was very small and comparatively few of its kind were present; the organism was found capable of producing mannitol in sterile corn juice, in sterile stover juice, in sterile corn silos, and in sterile stover sucrose silos and has consistently given mannitol in a large number of trials.

Mannitol-producing organisms were readily isolated from a sample of corn juice that was covered with oil (to keep down mold growth) and allowed to ferment spontaneously and that showed, after a short period, considerable quantities of mannitol. A direct microscopic examination showed many yeast cells and still larger numbers of bacteria. On plating out, on corn juice agar, material from both the upper and lower layers of this fermenting juice, colonies similar to those of M39 were found in large numbers, together with many yeast colonies. When the colonies similar to those of M39 were streaked on agar slopes and then inoculated into either sterile corn juice or a sterile silo, mannitol was found in considerable amounts after the usual holding period.

<sup>2</sup> The term yeast is used to indicate organisms reproducing by budding.

Evidence that organisms of the type of M39 are concerned in the production of mannitol was furnished unexpectedly in two instances as follows:

1. A control stover silo, which had been opened after sterilization only for the purpose of adding sterile water, contained considerable mannitol when it was examined after a period of about two weeks. Microscopic examination showed many organisms morphologically resembling M39 and corn juice agar plates inoculated with the material yielded colonies like those of M39; transfers were made to corn juice agar and when the organisms were inoculated back into the usual test materials mannitol was found in considerable quantities after a holding period of from ten to twenty days. It seems that the presence of the mannitol-producing organisms in the silo was due to accidental inoculation since the organism is not exceptionally heat resistant and accordingly would not be expected to survive the heating during sterilization; moreover the other control showed neither organisms nor mannitol.

2. One of the yeasts isolated from silage was inoculated into a sterile stover silo and after the usual holding period an examination showed the presence of mannitol. When the silage was examined microscopically, in addition to the yeast, an organism morphologically similar to M39 was found in large numbers; this organism was isolated by plating on corn juice agar and proved capable of producing mannitol when inoculated into the usual test materials. Although a microscopic examination of the original yeast culture had shown no bacteria, it is entirely possible that a very small number of organisms of the M39 type may have been present in the culture and had thus been inoculated into the silo along with the yeast. Contamination of the silo, either at the time of inoculation or later when the silo was opened to release pressure, is another means of explaining the results secured.

#### *Influence of oil at the surface of the liquid on mannitol production*

Since the formation of mannitol is to be looked upon as a reducing process, it was thought that the addition of sterilized

oil to the flasks of liquids to be fermented might materially modify the results obtained. A number of comparisons of oiled and unoiled material were made at room temperature, using a juice expressed from cane and to which 2 per cent sucrose had been added before sterilization; the results secured are presented in table 2. From the data given it is evident that under the conditions employed, a larger percentage of mannitol was secured with oil than without it. Because of the gas liberated, which probably drives off much of the unconsumed oxygen, the conditions in the unoiled flasks must be, to a certain extent, anaerobic and this, in all probability, explains the formation of mannitol in the absence of oil. Whether the presence of air results in a smaller production of mannitol or in a destruction

TABLE 2

*The influence of oil on mannitol production, room temperature incubation*

ORGANISM	PERIOD OF INCUBATION <i>days</i>	PER CENT OF MANNITOL	
		Without oil	With oil
M39	12	1.58	1.75
M363	12	0.60	0.83
M308	12	Trace	1.79
M439	12	0.44	1.60
M283	12	0.46	0.71

of a portion of that produced is impossible to determine from the data available.

In general, during the fermentation of the juices used there was a pronounced change in color; in the unoiled flasks the lighter portion involved mainly the lower depths, due presumably to the air above, while in the oiled flasks practically the entire liquid was involved. It seems probable that the change in color involved a reduction of some indicator present in the fermenting juice, the process being essentially similar to the reduction of litmus by many organisms, although it is possible that the change in color was due to the production of acid; the latter explanation is less acceptable than the former since the change in color in general agrees with the state of anaerobiosis.



*Materials yielding mannitol*

The organisms that were found capable of producing mannitol in the usual test preparations were studied as to their ability to produce it in a number of other materials. Two cultures from different samples of silage were inoculated into sterilized carrot juice<sup>3</sup> but no mannitol was secured. Both table and sugar beet juices were tried, two cultures on the former and four on the latter, but with negative results. Cabbage juice gave considerable quantities of mannitol with each of the three organisms inoculated into it and in general there was abundant gas formation. With the juices of the carrot, beet and cabbage there was a change in color similar to that secured with the corn and stover juices and in all cases the turbidity which developed indicated that the organisms were growing well. The failure to secure the production of appreciable amounts of mannitol with carrot and beet juice was undoubtedly due to the lack of the proper carbohydrate materials in them. A considerable number of flasks of apple juice were sterilized and inoculated with different cultures but there was no evidence of growth in any of them and the few flasks examined showed no mannitol; the same results were secured when the apple juice was neutralized before sterilization. Considerable quantities of mannitol were secured when sunflower stalks, leaves and blossoms were chopped, packed in jars, sterilized and inoculated with pure cultures of different mannitol-producing organisms, or when the sunflower material was packed in jars and allowed to ferment spontaneously. Cane yielded considerable quantities of mannitol when treated similarly to the sunflowers, as did also mixtures of stems, leaves and blossoms of dandelions.

One lot of stover juice (juice x) was found to contain only very small amounts of hexose sugars and accordingly it was used as a basis for testing out various materials. When 5 per cent cane sugar was added to this juice and the material sterilized, tests showed no appreciable inversion of the sugar; on inoculation with some of the mannitol-producing organisms

<sup>3</sup> The various juices were secured with a powerful press.

only traces of mannitol were found and it seems probable that this came from the small amounts of hexose sugars present in the juice. In the light of these tests it seems difficult to explain the value of the cane sugar in the stover juice, stover silos, etc.; it is entirely possible, however, that inversion might have occurred in some cases, even if not with juice x. By the addition of 5 per cent invert sugar to juice x, sterilization, and the inoculation of mannitol-producing organisms considerable quantities of mannitol were secured; growth was apparently very rapid and there was usually a pronounced change in color and the evolution of considerable gas. When honey (usually 8 per cent was used) was added to juice x, there was

TABLE 3  
*Mannitol in silage made from stover plus various substances, room temperature incubation*

MATERIAL ADDED TO STOVER	MANNITOL <i>per cent</i>
Glycerol.....	0
Galactose.....	0
Glucose.....	0
Fructose.....	3.71
Maltose.....	0
Lactose.....	0
Inulin.....	0.40
Starch.....	0

an exceptionally heavy gas production, a pronounced change in color and the formation of considerable quantities of mannitol.

A series of silos was made by cutting up corn stover (containing practically no sugars) adding various substances, packing in Mason jars and then sterilizing, after which organism M39 was inoculated. The results of mannitol determinations made on the silage after a suitable holding period at room temperature are shown in table 3. From the data presented it is evident that fructose and inulin yielded mannitol while glycerol, galactose, glucose, maltose, lactose and starch did not. Many lots of silage made by inoculating various organisms into sterilized stover plus sucrose have, as already stated, yielded mannitol.

It seems then that only fructose, or materials giving fructose on hydrolysis were capable of yielding mannitol when acted on by the mannitol-producing organisms studied. The small amount of mannitol produced in the inulin stover silo, as well as in many of the sucrose stover silos, was undoubtedly due to the inability of the organisms to hydrolyze these materials and to the small amount of hydrolysis which occurred during the process of sterilization. The variations in the amounts of mannitol produced in the sucrose stover silos were very likely due to differences in the amount of hydrolysis, and this was materially influenced by the amount of acid present and by the extent of the heating. Gayon and Dubourg (1894; 1901) found that only fructose or its moiety yielded mannitol and Brown has shown how the configuration of fructose is such that it alone can be changed to mannitol by organisms.

It is entirely possible that certain organisms may be able to produce mannitol from such materials as sucrose and some results have been secured which indicate that one of the cultures isolated is able to do this. It seems quite certain, however, from results secured with the use of bouillon to which sucrose was added, that most of the cultures isolated are unable to change sucrose to mannitol.

#### *Distribution of the mannitol-producing organisms*

Since mannitol is a normal silage constituent and is produced by the action of microorganisms, it would be expected that mannitol-producing organisms would be rather widely distributed about barns where silage is used, due to the scattering of silage and of manure from animals consuming silage. A number of materials have been tested for mannitol-producing organisms by inoculating them into sterile corn juice, flooding the juice with sterile oil in order to keep down the growth of molds and then determining the presence or absence of mannitol after a suitable incubation period at room temperature. The production of mannitol has been secured with soil from a farm yard and also with milk, but the trials made are too few in number to allow of any conclusions regarding the extent of the contamination of these materials.

*The per cent of mannitol produced in various materials*

The per cent of mannitol produced in different materials varied widely. While this was due to a large extent to variations in the per cent of total sugar, as well as to variations in the make-up of the sugar in the original materials, differences in the efficiency of the different organisms tried undoubtedly played a very large part. Table 4 presents data, other than those already presented, showing the per cent of mannitol produced under different conditions and in various materials. Many other determinations were made only to find out whether mannitol was present in traces or in considerable quantities and the results are of course omitted.

TABLE 4

*The per cent of mannitol produced under different conditions, room temperature incubation*

MATERIAL	INOCULATION	PERIOD OF HOLDING	MANNITOL
		<i>days</i>	<i>per cent</i>
Cane juice plus 2 per cent sucrose.....	M283 plus yeast	12	1.85
Cane juice plus 2 per cent sucrose.....	M283 plus yeast	12	1.05
Cane juice plus 2 per cent sucrose.....	M308 plus yeast	12	1.65
Cane juice plus 2 per cent sucrose.....	M308 plus yeast	12	1.00
Cane juice plus 2 per cent sucrose.....	M439	12	0.49
Cane juice plus 2 per cent sucrose.....	M308	12	0.52
Green corn silage.....	M39	18	0.59
Corn juice.....	M393	12	0.60
Corn juice.....	M393	20	0.92

*The destruction of mannitol*

The data already reported by the Iowa station show that, in a silo, part of the mannitol produced is destroyed. Table 5 shows the per cent of mannitol present at various times in stover silage containing sucrose inoculated with organism M39 and held at room temperature. A series of silos were prepared and a different one used for each determination.

From table 5 it seems that, at least with the organism used, the production of mannitol was accompanied or followed by its partial destruction.

*Organisms having mannitol-producing powers*

A considerable number of organisms capable of producing mannitol were isolated from various samples of silage and studied morphologically, culturally, and biochemically. The results showed that the organisms cannot be considered to be of one type. Most of the cultures isolated produced no appreciable change in milk and undoubtedly should be classed as *Bacillus manniticus* of Gayon and Dubourg, but one of the cultures in particular produced a coagulation in litmus milk with an extensive reduction of the litmus and its general characteristics indicated that it should be classed as *Bact. casei*. Certain of the rod-shaped (Kruse 1910; Orla-Jensen 1919) lactic acid

TABLE 5

*The per cent of mannitol at various times in stover silage containing sucrose and inoculated with organism M39, room temperature incubation*

PERIOD OF HOLDING	MANNITOL
<i>days</i>	<i>per cent</i>
6	1.41
8	2.41
10	2.63
12	1.60
14	1.54
20	1.38

organisms have been shown by a number of investigators to produce mannitol. With this group of organisms, however, mannitol production is not a general characteristic since a considerable number of cultures from sources such as milk, silage and cow feces were examined for mannitol production by inoculating into satisfactory media but only with negative results.

From the findings reported it seems that the production of mannitol in silage is not the result of the action of organisms present in silage alone but is brought about by the activity of organisms that have been shown to produce mannitol in other materials such as wines, etc. The conditions, such as a lack of oxygen and the presence of sugar, existing in silage during the period of active fermentation are undoubtedly very favorable

to the type of change resulting in the formation of mannitol from fructose. The rod-shaped lactic acid organisms constitute a group that is present in silage in enormous numbers (Hunter and Bushnell, 1916; Sherman, 1916) and while many of these do not produce mannitol it seems probable that mannitol-producing forms may be expected among them.

#### CONCLUSIONS

1. The production of mannitol in silage is very evidently due to bacterial action.

2. Mannitol-producing organisms were readily isolated from silage, provided it had been ensiled recently. They were also secured from a sample of fermenting corn juice.

3. In liquids, more mannitol was produced when they were flooded with oil than when they were not.

4. Mannitol was produced, by the organisms isolated, in the juice of cabbage and in silage made from corn, sunflowers, cane or dandelions, but not in the juice of carrots, beets, or apples. Fructose, or materials giving fructose on hydrolysis, such as sucrose or inulin, also yielded mannitol when added to stover before sterilization; it is probable that the hydrolysis was due to the heating and the acid present and cannot be accomplished by the organisms although there may be variations among the organisms in this respect. Glycerol, galactose, glucose, maltose, lactose and starch did not yield mannitol when added to stover before sterilization while honey gave large amounts.

5. The mannitol-producing organisms were found to be present in soil from a farm yard and in milk.

6. The per cent of mannitol produced in different materials varied widely, due undoubtedly to a large extent to variations in the types and amounts of sugar present.

7. With the only organism that was tried, the production of mannitol was accompanied or followed by its partial destruction.

8. The organisms producing the mannitol in silage cannot be considered to be of one type.

## REFERENCES

- DOX, ARTHUR W., AND PLAISANCE, G. P. 1917a The occurrence and significance of mannitol in silage. Jour. Am. Chem. Soc., **39**, 2078.
- DOX, ARTHUR W., AND PLAISANCE, G. P. 1917b The occurrence and significance of mannitol in silage. Ia. Agr. Exper. Sta. Res. Bul. 42.
- GAYON, U., AND DUBOURG, E. 1894 and 1901 Sur les Vins Mannités. Ann. Inst. Pasteur., **8**, 108; and Nouvelles Recherches sur le Ferment Mannitique. Ann. Inst. Pasteur., **15**, 527.
- HUNTER, O. W., AND BUSHNELL, L. D. 1916 The importance of *Bacterium bulgaricus* group in ensilage. Science, n.s., **43**, 318.
- KRUSE, W. 1910 Allgemeine Mikrobiologie, p. 401.
- ORLA-JENSEN, S. 1919 The lactic acid bacteria. Mémoires de l'Académie Royale des Sciences et des Lettres de Danemark. Section des Sciences, 8<sup>me</sup> série, **5**, no. 2.
- SHERMAN, JAMES M. 1916 A contribution to the bacteriology of silage. Jour. Bact., **1**, 445.





# PRINCIPLES CONCERNING THE ISOLATION OF ANAEROBES

## STUDIES IN PATHOGENIC ANAEROBES. II

HILDA HEMPL HELLER

*From the George Williams Hooper Foundation for Medical Research, University of California Medical School, San Francisco*

Received for publication December 30, 1920

The subject of the isolation of anaerobes is one which the worker is inclined to approach with apologies. Every month or so a paper appears in some journal in which a new and expeditious procedure for the separation of anaerobes is described. There are many successful ways of isolating anaerobes and it is unwise to recommend any one method above all others. I have succeeded with various arrangements; and wish in this paper to analyze some of the principles governing the isolation of these organisms and to explain a few of the pitfalls which have caused many workers to believe that the securing of "absolutely pure" anaerobic cultures is a difficult matter. With a little practice and with the exercise of much discrimination, anaerobes may be isolated as quickly, or nearly as quickly, as aerobes.

Contamination occurs somewhat more frequently in anaerobic cultures than in those of aerobes. Contamination of originally pure cultures may be attributed to the following causes: (1) Insufficiently sterilized media; anaerobe media are usually pasty and require more careful sterilization than others. (2) Inoculation transfer involving the exposure of the cotton plug and of the inoculum to the air. I have noted in working in London and near the sea in San Francisco, that the more dusty the air, the more frequent are contaminations, and the contamination flora may vary according to location. (3) During incubation in closed jars the cotton plugs may become sufficiently moist for

molds to grow through them; where a mold can grow a bacillus can follow. (4) During prolonged incubation water of condensation may even run into the tubes from the top of the jar. (5) If stored in closed cans molds may grow through the plugs. Workers should take these points into consideration in planning their work. Anaerobic jars are exceedingly convenient and practical for periods of incubation under four or five days, and for much anaerobic study twenty-four to forty-eight hours incubation is sufficient. Prolonged incubation should be made under vase-line or in the case of sugar-free media in exhausted sealed tubes. Sealing of tubes is inadvisable where carbon-dioxide may be so confined that it produces an acid end-point. Re-incubation of cultures in exhaust jars should be cautiously undertaken so that the medium may not boil up to the cotton plugs. Anaerobic jars which do not require exhaustion are preferable for re-incubation of cultures.

The commonest contaminators of my cultures have been cocci and molds, not anaerobes. The reason that anaerobic contamination of anaerobe cultures is so very common probably lies principally in the uncritical handling of such cultures. If a coccus or mold contaminates a culture the worker immediately kills such an organism, but if an anaerobe enters the tube it proceeds to multiply unmolested. Daily watchful observation of the cultures studied is absolutely necessary for successful anaerobic work. I have not found indications of any so-called symbiotic tendency that makes anaerobes more difficult to isolate than aerobes.

Anaerobes vary greatly in their behavior and requirements, and the method of isolation must be adapted to the problem in hand as it turns up. Each combination of two or more species of organisms presents different elements for consideration and for adaptation of technique. There is no one method that is always best, and it is only after a worker knows something about the nature of the particular organisms that he is dealing with, their cultural behavior, and their morphology in the medium in which he regularly grows them, that he is able quickly and surely to isolate numbers of strains.

It is, of course, desirable to make use of methods that may be applied to the largest possible number of species, that are easy of manipulation, and moderate as to cost of time and material.

The organisms present in material to be investigated may belong in any one of four large groups, which may be described as follows:

ORGANISMS	UNDESIRABLE	DESIRABLE
<i>Easily killed by heat</i>	Non-sporulating aerobes, common, many species	Non-sporulating anaerobes: Welch bacillus is, in most media, the chief consideration
<i>Not easily killed by heat</i>	Sporulating aerobes, not common in pathological material; species numerous, however	Sporulating anaerobes, species legion in number

Whatever be the material that is to be investigated, a microscopic examination of a Gram stain is first in order. Practice only will enable the worker to form judgments which will be of value to him. As hints to the beginner, one may suggest that there are an endless number of species of anaerobes and that specific diagnosis by microscopic examination is futile. There are frequently many species of anaerobes in the material that finds its way to a laboratory, and, unless a study of many strains is intended, the isolation or demonstration of a single species, whose nature is guessed at, must be attempted. If the microscope shows the probability of the presence of that species, matters are simplified. To seek a certain organism one should familiarize himself with a pure strain of that type of organism, or study photographs or drawings of it; verbal descriptions are not of much value. He should also learn the colony form of *several strains* of the type he desires to obtain. The employment of a medium in which the morphology of the organisms is varied and characteristic is imperative. This laboratory uses chopped meat medium containing 5 per cent peptic digest broth (pH 7.2) for routine cultivation and this medium excels all other autoclaved media in the above respect. The use of oil over the medium to

produce anaerobiosis should be avoided whenever possible for routine work, as it interferes with the making of satisfactory smears; for long incubation and under certain circumstances demanded by technical considerations, vaseline will be found very useful. Ghon and Sachs recommend the use of agar for stratification; liquid media should be frozen before the agar is poured.

*Heating.* To free sporulating organisms from non-sporulating organisms heating is always resorted to. Heating of inoculum may be performed in one of two ways. Heavily inoculated media may be heated to 80° in a water bath for fifteen to thirty minutes. This method is highly inaccurate, especially in case pasty media are used, but it serves on occasion. Or the material to be inoculated may be heated in a Pasteur pipette after the following fashion:

Sera, exudates, and muscle extracts should be diluted with sterile saline. Cut the end of a Pasteur pipette off square with a file, flame it, then draw up the inoculum for about two inches by capillary attraction, and seal the pipette with less than a quarter of an inch of air space between the tip and the liquid. To kill non-sporulating organisms heat in a waterbath for ten minutes at 70° to 72°. Then flame the pipette above the inoculum to kill organisms that may have been above the water-line, mark the tip in several places with the file or diamond, slowly flame the tip, insert it in the tube of fresh medium, flame a pair of light forceps and with them break the tip of the pipette against the inner wall of the tube and expel the material.

If a worker is certain that the type of sporulating anaerobe desired is always highly resistant to heat, he may use higher temperatures, in the neighborhood of 100°C. for heating his cultures. Dr. K. F. Meyer informs me that he has repeatedly employed this method with success in the isolation of *Bacillus botulinus*. Von Hibler sowed mixtures containing such organisms, and even less resistant ones, directly into hot agar. Some strains of *B. botulinus* and of Novy's bacillus are highly resistant to heat.

*1. To separate non-sporulating anaerobes from aerobes*

1. Heat to 56°-58° for five or ten minutes. This occasionally serves the purpose.

2. Try to induce sporulation by growing the mixture on alkaline sugar-free medium, such as alkaline egg, or serum medium (von Hibler, 1908, p. 189). When the anaerobes form spores, heat. This procedure is a sure method of freeing *B. Welchii* from ordinary aerobes: incubate for four days. This organism is found in a sporulating condition in soil and in fecal material.

3. Try a pathogenicity test. If the organism sought is pathogenic it may be recovered in pure culture from the animal tissues. Use this method for *B. Welchii*, *B. egens*, *B. fallax*.

4. Use selective media. For the Welch bacillus use milk or 1 per cent glucose broth. Inoculate it with a pipette, a fresh tube of medium every twelve hours if possible.

5. Use good anaerobic methods. Cultivate the material on meat medium in strict anaerobiosis, inoculate in agar dilution tubes that have been thoroughly boiled, and fish the colonies. This technique is described on page 461.

6. Northrup suggests the use of a 25-cc. burette, in which the organisms of an inoculated mixture will, on short incubation, sort themselves out, the aerobes growing above, the anaerobes below, where they may be drawn off through a stopcock.

*II. To separate non-sporulating anaerobes or reluctantly sporulating anaerobes from other sporulating anaerobes*

1. Use selective media, milk, with short incubation periods, for *B. Welchii*.

2. Use animal inoculation.

3. Use shake cultures.

4. Use semi-anaerobiosis: The non-sporulating anaerobes are naturally more resistant to oxygen than the sporulating ones.

Aside from *B. Welchii* this sort of organism is rarely sought after or noticed. Few non-sporulating anaerobes are described, and the group has been generally neglected, but careful methods show that non-sporulating anaerobic rods and cocci are not uncommon.

III. To separate either variety of anaerobes from sporulating aerobes

Sporulating aerobes are rather infrequently found in pathological material. One meets them frequently, however, in a medium that has been insufficiently sterilized. My encounters with sporulating aerobes have been so rare that it would be wise to recommend that a worker always go back to the original material and test it for the presence of any sporulating aerobe that he finds in a culture with which he is working. Avoid sporulating aerobes, do not contaminate cultures with them, and isolate the anaerobes from the original material again.

1. Sporulating aerobes are of two classes: strict aerobes (any good anaerobic technique followed by a colony method will free a culture of these) and facultative anaerobes. I have never encountered a sporulating facultatively-anaerobic aerobe that grew better under strictly anaerobic conditions than its accompanying anaerobes. Any strictly anaerobic colony method that will separate anaerobes from each other will separate them from aerobes. In my experience trouble with abundantly growing aerobic organisms denotes faulty anaerobiosis: the presence of a small amount of oxygen that permits the undue multiplication of the aerobes. My experience has, however, been almost entirely with pathological material and I may have failed to meet with the most troublesome aerobic organisms.

2. Kitasato and Weyl found that anaerobes were less sensitive to pyrocatechin, chinon, sodium formate, and sodium sulphindigotate than were the aerobes causative of cholera, typhoid and anthrax. Rivas continued this type of investigation.

3. Churchman has investigated the inhibitive effect of gentian violet on aerobic growth. Hall recommends the use of gentian violet in a dilution of 1:100,000 to separate sporulating aerobes from anaerobes. This, I should think, would work very well for the heavy Gram positive organisms of the *B. subtilis* group, provided the desired anaerobe is not of the same nature.

4. The spores of aerobes may sometimes be satisfactorily germinated in broth in a Petri dish, the broth being then heated and inoculated into agar.

IV. To separate sporulating anaerobes from non-sporulating anaerobes and aerobes

Heat as described on page 448.

V. To separate sporulating anaerobes from other sporulating anaerobes by cultural methods

I. *Heating.* The following diagram shows how heating may be employed:

ANAEROBIC BACTERIA	PROTEOLYTIC GROUP	NON-PROTEOLYTIC GROUP
<i>Early sporulating species</i> (18-24 hours)	Bifermentans group <i>et alii</i> . Do not occur very frequently	Nearly all sporulating organisms
<i>Later sporulating species</i> (24-48 hours)	Sporogenes group <i>et alii</i>	
<i>Late sporulating species</i> (48 hours on)	Tetanus group, botulinus group, <i>et alii</i>	

This diagram shows that if proteolytic early-sporulating organisms are absent, as is frequently the case, a saccharolytic form may be isolated or be rendered relatively far more abundant by heating eighteen to twenty-four-hour cultures successively. I have had mixtures of *B. sporogenes* and organisms of the blackleg group that were not pathogenic for guinea-pigs because of the scarcity of *B. Chauvoei*. Two successive heatings and inoculations made blackleg the predominant organism and the culture was highly pathogenic. This method is also excellent for organisms of the vibron-septique group and for many non-pathogenic saccharolytic bacteria, as well as the early-sporulating proteolytic ones.

II. *Selective media.* Isolation methods usually depend on securing a predominance of the organism sought. To increase the relative numbers of an organism with whose nature one is familiar, a medium should be selected on which the organism grows best. For saccharolytic species mixed with proteolytic ones, use sugar-containing media. Meat medium plus 1 per cent glucose is

good, meat medium not neutralized in the making is also good. Ordinary meat medium, the culture being taken early in its development, is usually sufficiently selective. Sugar media selective for certain groups may be used, if the number of cultures to be isolated warrants the investigation of the sugars split by that group. I have found that culture in casein-digest liver-broth renders black-leg the most able guinea-pig invader in a blackleg-vibrion-septique mixture. To increase the percentage of proteolytic organisms use meat medium or brain medium in a culture two to four days old, or even older; or employ the medium of Achalme-Passini, salt solution or broth containing cubes of egg-white; or use serum medium or other sugar-free media; or a medium made up at pH 8.0 or above. For an organism whose morphology interests one and whose nature is not known, experiments should be tried with various media, and the behavior of the mixture should be studied. Under laboratory conditions certain types always tend to disappear from mixed cultures. It must be kept in mind that conditions must exist in nature which favor the multiplication of such species or they would have died out long ago. For such organisms try media of vegetable origin.

In taking samples of pathological material enrichment with the tissue in which the organisms are found is advisable. Schottmüller isolated septicemic streptococci in blood-glucose agar shakes. The many tissue-containing media favor the growth of pathogens. (Media summarized by Pfuhl.) Tunnicliffe used serum and ascites agar for the anaerobic coccus found by her in measles cases. Plotz and his co-workers added ascites or hydrocele fluid to glucose agar for blood cultures from their typhus patients. Dick and Henry employed blood-glucose agar for the various anaerobes found in the blood of scarlet fever patients. Leucowicz used serum-sugar agar for *Fusiformis*.

Digest media are excellent for anaerobes. A number of such media are discussed by Stickel and Meyer.

Serious problems sometimes arise. Thus, *B. tetani* is particularly difficult to isolate from gross mixtures, as it is not a tissue invader, and because it sporulates later than the organisms that usually accompany it. In case an organism like *B. tetani* grows



excellently on a given medium but its accompanying organisms grow better than it does, try similar selective media of modified reaction, or make use of exhaust media of the type recommended by Tulloch. One may always grow the objectionable species or several species in a medium till growth ceases, filter the medium and then grow the mixed culture in the filtrate. In case this fails one may add a minute quantity of some solid protein for a starter. Tulloch added a bit of rabbit kidney to an exhaust filtrate and found it highly selective for *B. tetani*. Von Hibler grew mixtures containing *B. tetani* on clotted rabbits' blood and stated it to be selective for that organism. But his photographs of the organism show his cultures to have been so badly contaminated that he may have been mistaken.

I have found a modification of a medium of Beijerinck's excellent for the enrichment of soil anaerobes (sodium phosphate 0.05 per cent, ammonium sulphate 0.05 per cent, soluble starch 1 per cent, calcium carbonate 0.5 per cent). The anaerobic flora obtained in such a medium after heating a soil emulsion is very different from that obtained in meat or other media of complex composition. By fishing large lenticular or modified lenticular colonies from 2 per cent agar shakes of this medium which have been incubated for four days, the large butyric acid bacteria of the genus *Clostridium* may be isolated with comparative ease. Winogradsky (1902) recommends the use of media free of fixed nitrogen for the isolation of nitrogen fixing anaerobes (*Clostridium Pastorianum*); this medium is described by Fred (1916) and Bredemann used it for the isolation of his *Bacillus amylobacter* which he considers to be the same organism as Winogradsky's. Milk may also be used as an enrichment medium for many organisms of this genus.

Omeliansky (1904) describes the following method for enriching cellulose fermenters: Place in a long-necked flask any cellulose substance, paper, cotton, flax; add chalk, and fill to the top with water which contains 0.1 per cent ammonium phosphate, 0.1 per cent calcium phosphate, 0.05 per cent magnesium sulphate, and a little sodium chloride. Inoculate with slime or horse manure, cover, and set in the dark. In other publications (1895;

1902) he gives other formulae; several are given by Fred. Ankerschmitt used physiological salt solution containing cubes of potato to enrich splitters of hemicellulose. Choukevitch employed 1 per cent pepton broth with 5 per cent starch for starch splitting organisms. Silicate jelly as a substrate for such of these organisms as will not grow on agar is described by Omeliansky (1899) and formulae for similar jellies are given by Fred and by Küster.

III. *Symbionts* have been used to enrich certain types of anaerobes. Sturges and Rettger found that *B. putrificus* flourished best in the presence of *Bact. coli*, and used the latter as a symbiont for the former. Rhein used *Bact. faecalis-alcaligenes* as a symbiont for anaerobes, cultivating them in the presence of air: this organism has several advantages. Wilson and Stere describe a cocco-bacillus which is an excellent anaerobe symbiont.

IV. Another resource is to test the *resistance* of the desired species to *unfavorable circumstances*. Thus McCoy and Bengtson of United States Public Health Laboratory isolated many strains of tetanus with great ease by heating toxic strains at 70° for a half hour and inoculating the spores in veal agar dilution shakes. This technique is adverse for an anaerobe, but *B. tetani* appears to be hardy enough to withstand it. Modified highly acid or alkaline media, or media poor in protein may be used for such purposes. A pure strain of the desired organism is invaluable in testing out media of this sort.

V. *Aniline dyes* may be used to eliminate certain species of organisms and the possibilities which they offer are almost unlimited.

VI. *Selective temperatures* may be employed for enrichment of various organisms. *B. botulinus* was long thought to produce toxin at low temperatures only, because the contaminating organisms in the cultures outgrew it at 37°. Thermophilic organisms are of various types, and are discussed by Bergey. Major W. J. Tulloch tells me that the flora obtained by incubating a mixture of anaerobes in meat medium at 42° is quite different from that obtained at 37°, slender, oval end-sporing organisms predominating. It is probable that anaerobic organisms will be found that grow at much higher temperatures than at 42°.

VII. *Separation of organisms before sowing* was suggested by Stoddard, who shook his material with sea sand to separate encapsulated or autoagglutinated organisms. Dr. K. F. Meyer tells me that he has found such technique useful in isolating anaerobes from soil and from old meat cultures which had sporulated heavily. Such separation is not necessary when fresh cultures are used.

VIII. *Isolation by various colony methods.* Because of the confusion that exists as to the purity of cultures of anaerobes, it will be well to study the biological factors involved in the genesis of bacterial colonies. A colony is an aggregation of organisms that are prevented from mixing with other organisms by a physical obstruction. A colony may be defined as follows:

*a.* From one single organism—the ideal colony for isolation purposes.

*b.* From two or more organisms descended directly or indirectly from one organism—a satisfactory colony for isolation purposes.

*c.* From two or more organisms of closely related strains—the most undesirable type of colony for isolation purposes.

*d.* Or from two or more organisms of unrelated strains—an undesirable type of colony for isolation purposes. This type or a contaminated pure colony is sometimes useful in procuring a new proportional mixture of strains.

Broadly speaking a colony may consist of any number of organisms from one to infinity. Technically speaking a colony consists of the organisms confined within a certain radius inside of or on the surface of the mass of colloid gel. For purposes of discussion, let us define a bacterial colony as the uncontaminated descendants of a very small number of organisms, irrespective of the medium in which they are found. It will be realized that this definition covers perfectly the biological factors involved in the derivation of any ordinary agar or gelatin colony.

Colony methods available for the isolation of anaerobes are the following:

- I. Agar colonies—von Hibler and older workers used also gelatin.
  - A. Surface colonies.
    1. On plates.
    2. On tube slants.
  - B. Deep colonies.
    1. In Petri dishes.
    2. In deep agar tubes.
- II. Colonies in liquid media.
  - A. Isolation of a single bacillus by the India-ink method.
  - B. Isolation of a single bacillus or of a small number of organisms by the technique of Barber.
  - C. Isolation of a single bacillus by the technique of Schouten, of Hecker, of Holker, or that of Malone.

*Isolation from surface colonies* has been employed by many workers with anaerobes. Veillon and Zuber list a large number of types of anaerobic apparatus, von Hibler (1908) gives a bibliography of various plates and apparatus for purposes of anaerobic culture, Besson's textbook figures a number of arrangements, and Fildes describes various methods at the end of McIntosh's report.

Henry uses plates of agar which he streaks with egg-albumen and incubates in hydrogen. Stoddard uses slants made of the modified egg medium of Stitt, made with tryptic broth and 1 per cent glucose. Zeissler, who at first used glucose agar plates containing human blood for the isolation of anaerobes, later employed horse blood and sheep blood agar plates. Many laboratories now make use of large slants of blood agar, kept under anaerobic conditions for the isolation of anaerobes. Isolation of nitrogen fixing organisms was accomplished by Winogradsky by inoculating cultures on pieces of carrot which he placed in vacuo, and Fribes isolated pectin fermenters on potato slants rubbed with chalk. McIntosh prefers agar slants to plates for isolation procedure. He reiterates: "It cannot here be impressed too strongly on the worker that the purity of a culture can only be tested and controlled by repeated surface cultivation," and he speaks of the Veillon-tube method of continental workers as giving impure cultures. I have used plating occasionally and am familiar with technique necessary to make anaerobes grow on plates. In fact

it was the first method for the isolation of anaerobes that I learned to use. It is a perfectly feasible method, but I find it to be less satisfactory than others for various reasons.

The difficulty of regulating the amount of moisture on the surface of the plate or slant is the primary drawback to the use of surface methods. Aerobic cultures differ fundamentally from anaerobic ones in this respect. They are, so to speak, self-regulating in their moisture content. When a plate is poured, the surface of the agar is exceedingly moist, and the organisms planted in it grow rapidly till their growth is inhibited by the drying atmosphere of the incubator. Moisture conditions are fairly uniform in ordinary bacteriological technique; colonies of most species are discrete and characteristic. The colonies, when few, are usually pure; the viable aerobes usually all form colonies, and the method as a whole is easy and practical. But with anaerobes the moisture content of the medium and the moisture on its surface become of great importance. I have known agar in deep tubes of medium, which had given perfect results with blackleg colonies, to refuse to give a growth of blackleg when it was somewhat old and dried out, though the agar had nowhere, as yet, separated from the side of the tube. The addition of sterile distilled water made the medium as fertile a soil as fresh agar. I have encountered aerobes which grow to the surface of the agar of a shake, but not in colonies upon its surface. How much more would dryness affect the growth of the more delicate anaerobic organisms on the surface of a plate! Even the hardy tetanus organisms, which grow well in dry deep agar, often refuse to grow on its surface. In order to produce discrete anaerobic colonies plates must be dried after pouring. They must be dried just long enough and not too long. This period varies with the composition, age and thickness of the agar, with the humidity of the atmosphere, and with the moisture present in the anaerobic jar. It takes time and patience to learn to adjust the period for drying the plates. Then when the culture is sown and the plates are ready to incubate, what have we for anaerobic methods? A variety of available atmospheres for the growth of the organisms almost as great as is the number of workers in the anaerobic field: Hydrogen, carbon-

dioxide, nitrogen, illuminating gas, nitrogen-hydrogen-carbon-dioxide and vacuum with varying degrees of moisture, pressure and oxygen present. How can one hope to standardize type colonies under such conditions? And what, may we ask, is the proper moisture for the surface of a plate? There is no universal proper moisture. Agar moist enough to grow tetanus will allow the spread of *B. sporogenes* till the *B. sporogenes* has increased a million times more than the tetanus has. Some mixtures of organisms allow isolation of their components by surface methods, and some do not. When discouraged with plates that have dried too long, the worker dries them less, and finds to his joy beautiful discrete colonies, some round and some lobed. He must fish them immediately onto plates or into a deep medium or they may die. But let him beware of a pitfall. Let him hold them to the light without a cover and look between the colonies. A slight film of moisture there may represent a spread of growth which contaminates all his colonies. But such a spread may be difficult or impossible of detection. A fragment of coverslip dropped between colonies may show bacilli. I venture to suggest that it is almost impossible to determine in an agar slant the non-existence of such a thin spread, and such a thin spreading film is far more likely to occur in the confines of a tube than on a plate.

Methods of spreading a culture on a surface do not separate the individual organisms from one another so well as does a shaking in liquid agar—in properly made shakes the colonies are beautifully distributed.

Other minor disadvantages of a surface method are that the plates must be incubated immediately after sowing and be fished immediately after opening; they are usually valueless when reincubated after opening for inspection because of too much drying, and they require the use of more glassware than do deep-tube methods, and also the use of an anaerobic jar or other anaerobic apparatus.

The method of Marino should be recommended for organisms which form minute colonies, and for demonstration plates. Marino poured inoculated agar in the upper half of a Petri dish, and covered it directly with the inverted lower half, and covered the whole with a larger Petri dish. This method is convenient but

not necessary for photographic work, as sections for that purpose may be cut from tubes of agar and may then be mounted between cover and slide. Fehrs and Sachs-Mücke used a similar method, covering the agar with a photographic plate. Krumwiede and Pratt used Marino's method satisfactorily for the isolation of fusiform bacilli, sealing the open crack with wax. Rhein used it with satisfaction for general anaerobic work, pouring a sterile agar layer on either side of the inoculated one. Dick used the method of Rhein, replacing the top dish by a layer of paraffin. All these methods are probably preferable to surface plating for isolation purposes, but are somewhat cumbersome.

Foth complains that the invention of new anaerobic methods has become a sort of sport. Many procedures are too complicated to use, though most methods will serve well for the cultivation of anaerobes. It would seem as though any method employing sticky black pyrogallic acid and alkali should be avoided, or at least only chosen in the modification of Lentz.

Certain workers with surface methods have charged that deep colony procedures do not give pure cultures. Either type of procedure will give pure cultures in the hands of the critical worker and impure ones in the hands of the uncritical one. But I have found in making a large collection of anaerobes that the cultures from laboratories whose isolation procedure was a deep colony method were more often pure than those from laboratories where surface methods were preferred, and I believe that, with the same amount of labor, the same expenditure of time and material, and the same degree of critique, the deep-colony methods are more successful than are surface ones.

Deep-colony methods have been described by the Hesses, by Liborius, and by Veillon and Zuber, and they have been used extensively by von Hibler, Burri, and by French workers. Von Hibler (1908) preferred deep colony isolation to plate methods because of the fact that water of condensation was likely to render plates worthless.

The selection of a suitable medium for deep-colony isolation is an essential to its success. For general work the primary requirement is that the nutriment in the medium allow every anaerobe

present to grow and form a colony. Otherwise colonies may be fished through agar that contains living invisible organisms of other species, and the most deceptive sort of contamination will take place. The medium should be clear and transparent. Our standard agar medium for routine work is made of beef liver. The usual proportion of one part of meat to two of water gave too active a growth and too much gas. The medium is made as follows:

One part of ground beef liver and four parts of distilled water are infused over night, boiled, and strained. To the broth add 1.5 per cent peptone, 0.5 per cent salt, and for ordinary purposes make up with 2 per cent agar pH 7.2 (faintly alkaline to litmus).

When unusually active gas-producers are present, high dilutions and short (twelve hours) incubation periods are resorted to. Such methods always suffice when rapidly growing species are the ones to be isolated. But when slowly growing species are sought in the presence of actively growing ones, other methods are available. To absorb hydrogen, 1 per cent potassium nitrate may be added to the agar (Veillon and Mazé). To prevent the colonies of the rapidly growing types from outrunning the others, use 3 per cent agar or old agar that has partially dried out, or pay particular attention to enrichment of the desired species in the inoculum and employ abundant dilution tubes. Do not depend upon any colony method for the isolation of badly contaminated slowly growing tissue invaders, but resort directly to guinea-pig inoculation. For slowly growing non-pathogenic organisms mixed with rankly growing gas-producers, try a sugar-free agar (von Hibler, 1908).

There is an essential point in the employment of deep colony tubes which must be observed. Otherwise the method is of no more use than any other. Actively growing anaerobes frequently leave their colonies and grow in the agar as though it were a broth.

This happens more readily with some types of organisms than with others. *B. Welchii* is the chief offender and should be avoided by heating whenever possible. A tube in which this phenomenon has occurred is readily identified by holding it to the



light with a control. Such tubes are to be regarded as "enrichment cultures." Thus their colonies may be of great use when directly inoculated onto another agar series. They are of no use when inoculated into a liquid medium. The close observation of this phenomenon of "permeating growth" cannot be too earnestly insisted upon.

The deep colonies of anaerobes are highly characteristic. Surface colonies are quite characteristic but are obviously subject to many more outside influences than are deep ones. Often colonies of different strains in the same species are different and sometimes colonies of one type of anaerobe resemble those of an entirely different type. But carefully made agar shakes often give a beautiful picture of the flora of a wound or of a culture. They are very easily observed with a hand lens and may be as closely approached as may surface colonies. Aerobic growth is easily distinguished from anaerobic growth. My routine method of testing for impurity of culture has been to make three dilution shakes on liver agar. The first and second tubes tell whether or not the culture is pure. The third usually furnishes colonies suitable for fishing. I was able to isolate, in two series of three agar tubes each, a strain of *oedematiens* type that had been overgrown 1:500 by a vibriion septique.

*Technique of sowing and fishing.* Boil the tubes of agar for a minute or two, remove them from the water, shake them, boil them a little longer, shake them again to remove the air, then cool them to 45°. Do not boil them for ten or fifteen minutes or the cotton will become saturated with moisture. For ordinary purposes use three tubes to each culture. For new and important material of doubtful nature or for shyly growing organisms among rankly growing ones, use more tubes. Inoculate tube 1 with one loopful of culture and roll it, tip it, and roll it four or five times. Take a Pasteur pipette<sup>1</sup> of large bore, flame it, draw up agar of tube

<sup>1</sup> It is to be noted that few laboratory workers today understand the making of strong and serviceable Pasteur pipettes, and I hope to be pardoned for describing so simple an operation. Meeker burners are best for this purpose. Heat the glass in the portion of the flame where the heat is nearly uniform for a considerable distance. In a blowpipe or Bunsen flame this is above the cone; in the flame of the Meeker burner it is half an inch above the base. Turn the glass

1, expel it, draw up fresh agar and expel it into tube 2. For cultures containing abundant organisms, give tube 2 2 inches of agar measured in the capillary portion of the tube. For ordinary cultures give 5 inches, for *B. Novyi*, etc., give about two capillaries full. Place the inoculum throughout the length of the agar while withdrawing the pipette, but do not blow air into the agar of tube 2. Roll tube 2. Flame the Pasteur pipette. By means of it place agar from tube 2 in tube 3 to the amount of 0.5 to 1 inch on the upper or thick portion of the Pasteur pipette. Roll the tube. Incubate aerobically at 37°. If actively growing species are present, incubate twelve hours. Otherwise incubate eighteen to twenty-four hours. For blackleg, clostridia, and unknown shy types, incubate four days. Examine the colonies with a hand lens. Look for permeating growth. It is better, in fishing from a tube containing more than one type of colony, to fish once more onto a series of agar tubes. Final isolation should be made from colonies of mixed cultures. Study the tubes carefully with a hand lens, noting minute colonies and aerobic growth. Select the tube to be fished, and, if possible, select the colonies desired. Take a well-made, strong Pasteur pipette of fairly large bore, bend it at right angles where the capillary begins, break the tip, flame the whole capillary. Remove the plug from the tube and loose fibers of cotton from its opening, insert the Pasteur pipette along the side to the bottom, remove and empty it of agar; re-insert it, and blow the whole column of agar into a sterile Petri dish. The large Pasteur pipette may be used many times. One-half Petri dish serves for each tube. Take a short-stemmed Pasteur pipette, hold it in the flame, draw the capillary out to a hair-like tube, and break it off fairly short. Suck up the desired colony and expel it into a tube of meat medium or tube 1 of another agar series. Draw out the

constantly but slowly in the *same* direction, *not* forwards and backwards. Continue till the hot portion softens and contracts to about four-fifths of its former diameter. Never pull the glass while it is in the flame. Remove the rod from the flame and *wait* a second, then pull *slowly*. If the glass is pulled too soon or too quickly the fine bore is formed from the hottest portion only, and not from all the heated glass, the bore is small, and its walls are thin and weak. An hour's continuous practice is necessary to begin with; the art, once learned, is extremely useful and is not forgotten.

pipette again, flaming it well, and use it to isolate two or three more colonies. Other workers employ other methods, which are probably as good. Burri (1902) recommends the use of tubes open at both ends with an autoclaved rubber stopper placed in the lower end. Some use the loop only for purposes of dilution. Some heat the end of the test tube and expel the agar column by force of the steam thus generated. It is necessary to break the tube at the bottom only when an aerobe is present. Burke used a dissecting lens with stand for fishing colonies; Dr. Meyer finds a binocular a great help in some cases. He sections the agar with a sterile blade when researching for minute colonies that are rare. Some workers prefer to attach a rubber tube or a teat to the pipette used in fishing. It is theoretically wrong to fish the colonies from the top of the column of agar without removing it from the tube, because the capillary may pass ungerminated organisms, but such a method might prove practical when used with discretion. Some workers fish the colonies with a platinum needle, but this would hardly prove as satisfactory as a pipette method.

*Methods of single-bacillus isolation.* Isolation of a single bacillus has been resorted to for the separation of anaerobes. Miss Robertson found that the India-ink method of Burri (Besson 1913) exposed the organisms too much and they failed to germinate. I used the Barber method for some time for blackleg and vibrioseptique organisms, and found that the exposure killed vegetative forms and that spores were necessary to give a growth. I fished from apparently pure cultures various numbers of organisms, from one to ten, into meat tubes and used for a type strain the tube that grew and had received the fewest bacilli. I found the method wasteful of time, material, eyesight, and nervous energy, and have abandoned it. My employment of the apparatus was, however, far from being as skillful as that of Dr. Barber. I explained my difficulties to Dr. Barber and he (1920) has made a careful statistical study of the behavior of various anaerobes when isolated by his technique. He was successful when inoculating various media with different anaerobes in securing 62 growths from 400 single bacilli, and 93 growths from 211 single spores. Vegetative rods

of vibrion-septique were particularly sensitive to the air. Barber found the semi-solid medium of Lignières excellent for securing growth of single anaerobes. Colonies could be secured from spores in a chamber containing a *Pseudomonas pyocyanea* culture.

Malone and Holker have devised pipette methods for single bacillus isolation with which I have no personal experience. It may be that they protect the organisms from air better than does the Barber method. Hecker makes interesting technical suggestions. Hort objects to all methods of single bacillus isolation from liquids and he objects to capillary methods on account of optical difficulties. The method preferred by Hort, the perforated plate method, is too aerobic for our purposes.

IX. *Animal inoculation* is frequently resorted to for the isolation of anaerobes. The guinea-pig is the best animal for this purpose. It is highly susceptible to infections and also develops very characteristic lesions, of diagnostic value. Animal inoculation is of prime value for recovering pathogens that have been badly overgrown. It is the only way I know of to recover blackleg organisms that have been grossly contaminated. A drop of lactic acid may be used for a second trial, if the first fails. Inoculation of mixtures from the involved tissues of gas-gangrene cases is of course necessary, but it is likely to give misleading ideas as to the flora of those tissues. It is advisable to run deep-colony cultures from various portions of an amputated limb or of material derived from tissue-puncture or from a blood culture, and to inspect the flora of the limb carefully. A culture or smear from the wound itself may give very misleading data as to the etiology of a gangrenous process. I believe that the rôle played by *B. Welchii* in gas-gangrene infections has been grossly exaggerated because of the failure of many workers to study carefully the flora from various portions of infected muscle. When the colony method has given pure or apparently pure cultures, inoculate them into guinea-pigs and record results. When immediate identification of pathogens is urgent, examine smears made by puncture from affected tissue *remote* from the wound. Conjecture the possible types there

represented, inoculate a series of guinea-pigs with antitoxic or antibacterial sera of the groups probably represented on the smears, in such a manner that for each type of organism there is a guinea-pig immunized against the other types only. Then inoculate the mixed material into all the guinea-pigs. This method was found successful by the Committee. In large war hospitals collections of guinea-pigs immunized by bacterial inoculation have been kept for diagnostic purposes.

It is best to inoculate guinea-pigs in the thigh muscles. Take cultures from various points in the body. The heart-blood culture is usually the most valuable. *Oedematiens*-group organisms and some other pathogens do not always become septicemic, however. Bifermentans-group organisms and other proteolytic types may become septicemic. Inoculate into another guinea-pig a culture from the heart-blood in smaller quantity than was used before. If this fails, isolate the proteolytic organism, immunize a guinea-pig with it, then inoculate the mixture. For all animal work keep a careful record of the cultures inoculated, incubation periods, lesions in the animals, and, above all, make constant use of the microscope.

Anaerobic organisms should be sought in the following pathological conditions:

Infected wounds (rods or cocci).

Gangrene.

Oedema.

Emphysema of muscles, connective-tissue, liver or other organs.

Haemorrhagic condition of muscles.

Pneumonic processes where anaerobic infection is suspected, pulmonary gangrene.

Necrosis of muscle or connective tissue (*B. necrophorus et alii*).

Injection of serous surfaces, especially in ruminants.

Abortion in animals (search foetus for *Bact. abortum*).

Endometritis, post abortum or post partum (*Streptococcus*).

Appendicitis and various ulcerative and suppurative conditions.

Tetanus (in absence of wounds and uterine infection, search for peridental infection).

Botulism, intestinal content and wall, liver, spleen, stools from patients.

Obscure fevers, measles, scarlet fever. Blood cultures, look for various invaders.

Rhinitis, Vincent's angina; mucous surfaces.

Make smears of affected tissue, make meat or brain cultures and make at the same time numerous shakes in deep liver-agar. Examine shakes twelve hours after incubation if possible, and examine meat cultures twenty to twenty-four hours after incubation. Blood cultures in broth, meat or agar should always be made, if possible, *ante mortem* and *post mortem*.

I wish to express my thanks to Dr. Karl F. Meyer for his active interest and coöperation in this work.

#### SUMMARY

As an aid to the isolation of anaerobes the following notes may be observed:

1. Success in the isolation of anaerobes depends more on the critical sense of the worker than on the method he employs.

2. Microscopic observation should be made of incoming material and of cultures after twenty-four and forty-eight hours' incubation, and the development of a critical eye for the morphology and staining reactions of anaerobes is imperative.

3. Heating of material should be executed according to the logical requirements for that material. Heating at 70° in pipettes is to be recommended for routine work.

4. A routine medium should be employed which will favor as many diverse forms as possible. Chopped beef heart, preferably containing a little peptic digest broth, the reaction at about pH 7.2, presents numerous advantages as a routine medium, for most of the anaerobes studied in a pathological laboratory. If freshly boiled it is usually quite unnecessary to incubate it anaerobically.

5. Selective media may be employed for special purposes, and they offer many possibilities.

6. Isolation by means of guinea-pig inoculation, securing the organism from the heart's blood or from the affected tissues remote from the site of inoculation, is preferable for invading patho-

gens, but may not be depended upon to give a true picture of the pathogenic flora of the material injected.

7. The making of dilution shakes in deep agar (method of Liborius and of Veillon) is to be preferred to other colony methods; care must be taken to isolate for a type a colony from an apparently pure culture.

8. A medium for dilution shakes should afford an opportunity for growth to just as many species as possible. Such a medium is pepton-liver agar, as described in the text.

9. When once pure, a culture should be carefully kept pure. Re-incubation, prolonged incubation in closed jars, storing in closed cans or in dusty places, are to be avoided. Autoclaved media only should be employed for the preservation of type cultures; one cannot be too careful as to routine technique.

## REFERENCES

- ACHALME-PASSINI See Choukevitch (1911).
- ANKERSCHMITT, P. 1905 Untersuchungen über die Bakterien im Verdauungskanal des Rindes. *Centralbl. f. Bakteriol., O.*, **39**, 359, 574, 687; *Ibid.*, **40**, 100.
- BARBER, M. A. 1914 The pipette method in the isolation of single microorganisms and in the inoculation of substances into living cells. *Philippine Jour. of Science*, **19**, 307.
- BARBER, M. A. 1920 The use of the single cell method in obtaining pure cultures of anaerobes. *Jour. Exper. Med.*, **32**, 295.
- BERGEY, D. H. 1919 Thermophilic bacteria. *Jour. Bacteriol.*, **4**, 301.
- BESSON, A. 1913 *Practical bacteriology, microbiology and serumtherapy.* London.
- BREDEMANN, G. 1909 *Bacillus amylobacter* A. M. et Bredemann, in morphologischer, physiologischer und systematischer Beziehung. *Centralbl. f. Bakt. II. Abt.*, **23**, 385.
- BURKE, G. S. 1919 Notes on *Bacillus botulinus*. *Jour. Bact.*, **4**, 555.
- BURRI, R. See Besson 1913.
- BURRI, R. 1902 Zur Isolierung der Anaëroben. *Centralbl. f. Bakteriol. Abt. II.*, **8**, 533.
- CHOUKEVITCH, J. 1911 Étude de la flore bactérienne du gros intestin du cheval. *Ann. de l'Inst. Past.*, **25**, 247.
- CHURCHMAN 1912 The selective bactericidal action of gentian violet. *Jour. Exper. Med.*, **16**, 221.
- COMMITTEE on Anaerobic Infections: Medical Research Committee, Reports of the Committee upon Anaerobic Bacteria and Infections. Report on the anaerobic infections of wounds and the bacteriological and serological problems arising therefrom. 1919. Special Report Series, No. 39, London.

- DICK, G. F. 1918 A plate method for isolating anaerobes. *Jour. Inf. Dis.*, **23**, 578.
- DICK, G. F., AND HENRY, G. R. 1914 Anaerobic cultures in scarlet fever. *Jour. Inf. Dis.*, **15**, 85.
- FEHRS, AND SACHS-MÜCKE 1908 Beitrag zur Züchtung und Isolierung von Anaerobiern. *Centralbl. f. Bakteriol. I. O.*, **48**, 122.
- FOTH 1909 Die Diagnose des Rauschbrandes. *Zeitschr. f. Infekth. d. Haustierre.* **6**, 201.
- FRED, E. B. 1916 A laboratory manual of soil bacteriology. Philadelphia and London.
- FRIBES See Winogradsky (1895).
- GHON, A., AND SACHS, M. 1902 Beiträge zur Kenntnis der anaeroben Bakterien des Menschen. Ueber die anaerobe Züchtung. *Centralbl. f. Bakteriol.*, **32**, 403.
- HALL, I. C. 1919 Selective elimination of hay bacillus from cultures of obligative anaerobes. *Jour. Am. Med. Assoc.*, **72**, 274.
- HALL, I. C. 1920 Method for purification of obligate anaerobes. *J. Inf. Dis.*, **27**, 576.
- HECKER, F. 1916 A new model of double pipette holder and the technic for the isolation of living organisms. *J. Inf. Dis.*, **19**, 306.
- HENRY, H. 1917 A simple device for the growth of anaerobes on plates. *Brit. Med. J.*, **1**, 762.
- HESSE, W., AND HESSE, R. 1885 Ueber Züchtung der Bazillen des malignen Oedems. *Deutsche med. Wehnschr.*, **11**, 214.
- VON HIBLER, E. 1908 Untersuchungen über die pathogenen Anaeroben. Jena.
- HOLKER, J. 1919 Micro-and macro-methods of cultivating anaerobic organisms. *J. Path. and Bacteriol.*, **22**, 28.
- HORT, E. C. 1920 The cultivation of anaerobic bacteria from single cells. *J. Hyg.*, **18**, 361.
- KITASATO, S., UND WEYL, TH. 1890 Zur Kenntniss der Anaeroben. *Zeitschr. f. Hyg.*, **8**, 41.
- KRUMWIEDE, C., AND PRATT, J. 1913 Isolation and cultivation of fusiform bacilli. *J. Inf. Dis.*, **12**, 199.
- KÜSTER, E. 1913 Kultur der Mikroorganismen. Leipzig and Berlin.
- LENTZ, O. 1910 Ein neues Verfahren für die Anaerobenzüchtung. *Centralbl. f. Bakteriol. I. O.*, 1910, **53**, 358.
- LENTZ, O. 1919 Friedberger und Pfeiffer. *Lehrbuch der Mikrobiologie.* Jena. p. 370.
- LEWKOWICZ, X. 1906 Ueber die Reinkulturen des fusiformen Bacillus. *Centralbl. f. Bakteriol. I.*, **41**, 153.
- LIBORIUS, P. 1886 Beiträge zur Kenntnis des Sauerstoffbedürfnisses der Bakterien. *Zeitschr. f. Hyg. u. Infekth.*, **1**, 115.
- LIGNIÈRES, J. 1919a Nouvelle méthode pour la recherche et la culture des anaerobies pouvant servir au diagnostic des affections causees par les microbes. *Bull. Acad. Med.*, 3, s., **82**, 181.
- LIGNIÈRES, J. 1919b Nouvelle méthode très simple pour cultiver facilement les microbes anaerobies. Les milieux semi-liquides en bactériologie. *Compt. rend. Soc. Biol.*, **82**, 1091.
- MALONE, R. H. 1918-1919 A simple apparatus for isolating single microorganisms. *J. Path. and Bacteriol.*, **22**, 222.



- MARINO, F. 1907 Methode pour isoler les anaérobies. Ann. de l'Inst. Past., **21**, 1005.
- MCCOY, G. W., AND BENGTON, I. A. 1919 Enrichment described. Am. J. Public Health, **9**, 427.
- MCINTOSH, J., AND FILDES, P. 1917 The classification and study of the anaerobic bacteria of war wounds. Med. Res. Comm. Special Report Series No. 12, London.
- NORTHROP, Z. 1916 A simple apparatus for isolating anaerobes. J. Bact., **1**, 90.
- OMELIANSKY, W. L. 1895 Sur la fermentation de la cellulose. Compt. rend. Soc. Biol., **121**, 653.
- OMELIANSKY, W. L. 1899 Ueber die Isolierung der Nitrifikations-mikroben aus dem Erdboden. Centralbl. f. Bakteriologie. Abt. II., **5**, 537.
- OMELIANSKY, W. L. 1902 Ueber die Gärung der Cellulose. Ibid., **81**, 226.
- OMELIANSKY, W. L. 1904 Ueber die Trennung der Wasserstoff und Methan-gärung der Cellulose. Ibid. **11**, 369, 703.
- PFUHL, E. 1907 Die Züchtung anaérober Bakterien in Leberbouillon, sowie in Zuckerbouillon, etc. Centralbl. f. Bakteriologie. I. O., **44**, 378.
- PLOTZ, OLITZKY, AND BAEHR 1915 The etiology of typhus exanthematicus. J. Inf. Dis., **17**, 1.
- RHEIN, M. 1919 La culture et l'isolement des anaérobies sans appareillage spécial. Le Presse Med., **27**, 504.
- RIVAS, D. 1902 Ein Beitrag zur Anaërobenzüchtung. Centralbl. f. Bakteriologie, **32**, 831.
- SCHOTTMÜLLER, H. 1910 Zur Bedeutung einiger Anaeroben. Mitt. a.d. Grenzgebiete d. Med. u. Chir., **21**, 450.
- SHOUTEN, S. L. 1905; 1907 Reinkulturen aus einen unter dem Mikroskop isolierten Zelle. Zeitschr. f. wiss. Mikr., **22**, 10; **24**, 258. See also Küster, 57. 1913.
- STICKEL, J., AND MEYER, K. F. 1918 Inexpensive culture mediums. J. Inf. Dis., **23**, 68.
- STODDARD, J. L. 1918 Points in the technic of separating anaerobes. J. Am. Med. Assn., **79**, 906.
- STURGES, W. S., AND RETTGER, L. F. 1919 Isolation and cultivation of *B. putrificus*. J. Bact., **4**, 171.
- TULLOCH, W. J. 1917 On the bacteriology of wound infections in cases of tetanus and the identification of *B. tetani* by serological reactions. J. Roy. Army Med. Corps. **29**, 631.
- TULLOCH, W. J. 1919 The isolation and seriological differentiation of *B. tetani*. Proc. Roy. Soc., B **90**, 145.
- TUNNICLIFFE, R. 1913 An anaerobic organism associated with acute rhinitis. J. Inf. Dis., **13**, 283.
- TUNNICLIFFE, R. 1917 The cultivation of micrococcus from blood in pre-eruptive and eruptive stages of measles. J. Am. Med. Assn., **68**, 1029.
- VEILLON, A., AND MAZÉ, P. 1910 De l'emploi des nitrates pour la culture et l'isolement des microbes anaérobies. Compt. rend. Soc. Biol., **68**, 112.
- VEILLON, A. AND ZUBER 1898 Recherches sur quelques microbes strictement anaérobies et leur role en pathologie. Arch. de Med. Exper., 1st, ser. **10**, 516.

- WILSON, J., AND STEER, P. 1918 Points in the technivue employed in the isolation and cultivation of anaerobic bacteria. *Brit. Med. J.*, **2**, 568.
- WINOGRADSKY, S. 1893; 1894 Sur l'assimilation de l'azote gazeux de l'atmosphère par les microbes. *Compt. Rend. Acad. Sciences*, **66**, 1385; **68**, 353. 1894 *Centralbl. f. Bakteriol.*, **16**, 129.
- WINOGRADSKY, S. 1895 Sur le rouissage du lin et son agent microbien. *Compt. Rend. Acad. Sciences*, **71**, 742.
- WINOGRADSKY, S. 1902 *Clostridium Pastorianum*, seine Morphologie, und seine Eigenschaften als Buttersäureferment. *Centralbl. f. Bakteriol.* II, **9**, 49.
- ZEISSLER, J. 1918 Die Pferdeblut-oder Schafblut-Traubenzuckeragarplatte als Ersatz für die Menschenbluttraubenzuckeragarplatte zur Züchtung der pathogenen anaerobier. *Deutsche. med. Wehnschr.*, **64**, 942.

## INDOL PRODUCTION BY BACTERIA

JOHN F. NORTON AND MARY V. SAWYER

*From the Department of Hygiene and Bacteriology, The University of Chicago*

Received for publication January 11, 1921

The formation of indol in certain culture media has long been considered an important differential characteristic for the identification of bacteria. Special interest in the test has been recently aroused in connection with investigations on respiratory diseases because Pfeiffer's bacillus appears to be practically the only mouth organism producing indol (Jordan, 1919, Malone, 1920); in consequence of which Malone has suggested that the test be used as an index of the presence of this organism without actually isolating it. Rivers (1920) has made a similar suggestion for diagnosis of influenzal meningitis. For this paper we have attempted to collect from the literature the more recent information, both positive and negative, concerning indol production by bacteria. On account of the uncertainty of indol tests much of the older work is unreliable. This information has been supplemented by tests on over 180 strains of bacteria, most of which are being carried as stock cultures in this laboratory and have been collected from a great variety of sources. Incidentally we have made a comprehensive comparison of three recommended media and also determined the effect of the incubation period on indol production.

### MEDIA

Indol is a disintegration product of proteins containing the tryptophane group. The ideal medium would therefore be one to which pure tryptophane had been added but on account of the difficulty of obtaining the material it is impractical, although Zipfel (1913) used such a medium. Dunham's pepton is the easiest medium to prepare and has been most frequently used.

Siere (1909) and Porcher (1911) have studied the use of various peptons finding that some already contain indol and that with others indol is never produced by bacteria, so that it is necessary not only to make blank tests on any chosen medium but also to control experiments with a known indol-producing organism. In each instance our tests were controlled by inoculating one tube of medium with *Bact. coli*, an indol-forming organism, and another with *Bact. typhosum*, a non-indol-former, and we regarded such controls as essential. For media, besides Dunham's pepton and the tryptophane medium of Zipfel, Rivas has suggested trypsinized pepton (Rivas, 1912) and Cannon (1916), instead of preparing pure tryptophane from casein as was done by Zipfel, used hydrolyzed casein as the basis for his medium.

Homer (1916) believes that tryptophane is necessary for bacterial life and if not present will be synthesized by the organisms. Logie (1920) has used synthetic media containing ammonium lactate with asparagin or sodium asparaginate and claims that indol producing organisms possess an enzyme which enables them to split off and utilize part of the tryptophane molecule. It is possible that many organisms may be capable of synthesizing indol but make use of it in their metabolism.

For the hemophilic group a heated blood broth has been used (Jordan, 1919).

It is well known that the addition of glucose to a medium interferes with the indol test. Fischer (1915) reports that lactose, galactose, maltose or fructose are without effect. He believes that this action of glucose is due not to acid production, as had been supposed, but to the inactivation of the proteolytic enzyme concerned in splitting the tryptophane. Logie (1920) found that if glucose was added to a living culture of *Bact. coli* in which indol had already been produced the latter rapidly disappeared. From this he concluded that glucose caused an increased demand in the organism for indol. Homer (1916) explains the effect of the presence of glucose either on the basis of the preference of the organism for glucose over tryptophane or by assuming the formation of a chemical compound between glucose and tryptophane which is relatively stable.

We have used three media. (1) Dunham's pepton solution. One per cent of pepton (Armour's) and 0.5 per cent sodium chloride were dissolved in distilled water and the reaction adjusted to +1 to phenolphthalein. (2) Rivas' trypsinized pepton (Rivas 1912). Ten grams of pepton (Armour's) were dissolved in 200 cc. distilled water. To this was added a solution of 0.5 gram trypsin in 10 cc. of water (trypsin dissolved by shaking and gentle heating not over 40°C.) and digestion allowed to continue for three hours at 37°C., with frequent stirring. The solution was then made up to 1 liter and reaction adjusted to + 1 to phenolphthalein. (3) Cannon's casein medium (Cannon, 1916). Twenty grams of chemically pure casein were added to 250 cc. distilled water and the whole made alkaline to phenolphthalein with sodium carbonate. One-half gram of trypsin was added and the casein allowed to digest for six hours. The medium was then autoclaved and 5 grams each of asparagin and ammonium lactate, 2 grams of dipotassium phosphate and 0.2 gram magnesium sulphate were added. The solution was made up to 1 liter and reaction adjusted to +1 to phenolphthalein.

A large number of comparative tests were made on these three media. In no case did the final indol test vary but a positive reaction was obtained more quickly, and the color tests were stronger, with the trypsinized casein or pepton than with Dunham's pepton solution. Positive tests with the trypsinized pepton were noted after six hours incubation with *Bact. coli* and color production with Ehrlich's reagent was at its maximum at the end of twenty-four hours. With Dunham's solution the maximum was obtained only after four days. After six days the indol began to disappear. As most of our tests were made simultaneously on all three media we used the four day period, although forty-eight hours is sufficient for the trypsinized media.

The influence of oxygen supply on indol formation has been studied by Porcher and Panisset (1911). They found that growing cultures of the colon bacillus and of proteus anaerobically decreased the amount of indol formed, while if a current of oxygen was kept going through the flask, the amount was increased. However, they were unable to provoke the formation

of indol by *Bact. typhosum* by an oxygen current. Our cultures were incubated aerobically, except in the case of the strict anaerobes.

#### INDOL REAGENTS

Numerous tests for indol have been suggested and used. Nelson (1916) gives four: (1) dimethylamine, glycolic acid, glyceric aldehyde and sulphuric acid, giving a pink color; (2) peruvic aldehyde, sulphuric acid and ferric sulphate, giving a violet color; (3) vanillin and an acid, giving an orange color; (4) Salkowski test—sulphuric acid and potassium nitrite, giving a pink to red ring. Escallon (1908) recommends furfural. This, in the presence of hydrochloric acid, gives an orange yellow color. It is claimed that this test is sensitive to 1 part in 800,000. Baudisch (1915) describes a reaction using nitromethane. By far the most satisfactory test is that suggested by Ehrlich (1901). The reagent is prepared by dissolving 4 grams of paradimethyl-amido-benzaldehyde in 380 cc. of alcohol and adding 80 cc. of concentrated hydrochloric acid. A red color is formed in the presence of indol at the junction of the reagent and the liquid to be tested if the former is added so that it forms a layer on top. A solution of potassium persulphate is sometimes added to bring out the color more clearly but we have found the reagent quite satisfactory without this. In making our tests, if a red color appeared on adding the Ehrlich reagent, 1 cc. of amyl alcohol was added and the tube shaken. The red coloring matter, if due to indol, is soluble in amyl alcohol.

#### SUMMARY

In the following table we have summarized the results of our tests together with those we have been able to find in the literature. Owing to the uncertainty of results obtained by use of the older methods of testing for indol, only relatively recent work has been included. The organisms are divided into two groups: (I) those which may pretty definitely be regarded as giving negative tests and (II) those for which positive results have been reported. It should be noted that in every instance where

any considerable number of strains of an organism in group II have been examined, negative as well as positive results have been reported, with the exception of the cholera vibrio.

From this summary we must conclude that whereas the indol test may serve as a valuable aid in differentiating bacteria, it cannot be regarded as an absolute criterion. A positive test may give definite information but a negative test must be interpreted with caution.

We should also like to emphasize the necessity for a standard reagent for the indol test and suggest the use of Ehrlich's dimethylamidobenzaldehyde solution for this purpose.

In this table we have used the classification adopted by the Society of American Bacteriologists (Winslow, 1920).

*Group I. Indol negative*

- Beaillus anthracis\* (Zipfel)
- subtilis\*
- Actinomyces asteroides\*
- bovis\*
- graminaris\*
- Bacterium abortum (Weeter)
- cloacae (5 strains\*, Kligler)
- enteritidis (3 strains\*, Crossonini, Porcher and Panisset, Zipfel, Nonnotte and Demanche)
- fecalis-ascaligenes (3 strains\*)
- icteroides (Crossonini)
- mucosum-capsulatum\* (Hiss and Zinsser)
- paratyphosum A (2 strains\*, Zipfel, Jordan, Nonnotte and Demanche)
- paratyphosum B (13 strains\*, Zipfel, Jordan, Nonnotte and Demanche)
- pullorum (5 strains\*, Mulsow)
- rhinoscleromatis\*
- sanguinarium (Mulsow)
- suipestifer (4 strains\*, Zipfel, Crossonini)
- typhosum (15 strains\*, all investigators)
- typhi-murium (Nonnotte and Demanche)
- Clostridium botulinum (6 strains\*)
- chauvei\*
- Welchii\*
- Corynebacterium Hoffmannii (3 stains\*)
- pseudodiphtheriae (4 strains\*)
- xerosis (2 strains\*)

---

\* Our tests.

- Diphtheroids (Malone)  
 Diplococcus pneumoniae (Jordan, Malone)  
 Erythrobacillus miniaceus\*  
     mycoides-roseus\*  
     mycoides-corallinus\*  
     prodigiosus (4 strains\*, Crossonini, Zipfel)  
 Myobacterium leprae\*  
     Moelleri (2 strains\*)  
     tuberculosis (4 strains\*, Zipfel)  
 Neisseria meningitidis (Jordan)  
     catarrhalis (Malone)  
 Pseudomonas cyanea\*  
     cyanogenes\*  
     violacea\*  
 Pasteurella pestis\* (Zipfel)  
 Staphylococcus albus (8 strains\*, Zipfel)  
     aureus (4 strains\*, Zipfel)  
     citreus (Zipfel)  
     not specified (Jordan, Malone)  
 Streptococcus viridans (13 strains\*, Jordan, Malone)  
     hemolyticus (2 strains\*, Zipfel)  
     rheumaticus\*  
 Sarcina lutea\*  
     rosea\*  
 Vibrio tyrogenus (Deneke)\* (Zipfel, Tobey)  
 Zopfius zopfii (3 strains\*)  
 Sporothrix schenkkii\*  
 Blastomycetes dermatitidis\*  
 Sac. pastorianus\*

*Group II. Indol positive or negative*

- Bacterium aerogenes\* (Kligler, Chen and Rettger)†  
     coli\* (Kligler, Chen and Rettger)‡  
     dysenteriae\* (Zipfel, Kolle and Wassermann)§  
 Clostridium sporogenes (edematis)\* (Bertrand)  
     tetani (Hall)  
 Corynebacterium diphtheriae (Escallon, Zipfel)  
 Hemophilus influenzae (Rhein, Jordan, Malone)±

---

\* Our tests.

† Chen and Rettger found 141 strains +, 306 -.

‡ Chen and Rettger found from feces 173 strains +, 0 -; from soil 15 strains + 5 -.

§ We found as + Flexner, Hiss-Russel, Shiga, 110, 12 U. S., as - Hoffmanni, 177. Zipfel found Flexner and Y +, Shiga -. Kolle and Wassermann give Strong -.

± Rhein found 7 strains +, 1 -; Jordan 18 +, 7 -; Malone found 92 per cent +, 8 per cent -.



*Pasteurella aviseptica* (Mulsow, Kolle and Wassermann)  
*Proteus* group (Bengston, Horowitz, Kligler, Larson and Bell, Rhein, Sicre)  
*Pseudomonas pyocyanea*\* (Jordan)¶  
*Vibrio cholerae* (2 strains\*, Crossonini, Baudisch, Zipfel, Tobey)  
     *finklerei* (Crossonini, Tobey, Zipfel)  
     *metschnikovi*\* (Crossonini, Steensma, Tobey)  
     *protea*\*

---

\* Our tests.

¶ We found 13 strains —, 6 of them freshly isolated; Jordan reported both + and —; see also Lartigau (1898)

#### REFERENCES

- BAUDISCH 1915 Über eine neue Indolreaktion, *Zeitschr. Physiol. Chem.*, **94**, 132.  
 BENGSTON 1919 The proteus group. *Jour. Infect. Dis.*, **24**, 445.  
 BERTRAND 1913 Influence des régime alimentaire sur la formation de l'indol dans l'organisme. *Ann. Inst. Pasteur*, **27**, 76.  
 CANNON 1916 A simple and rapid indol test. *Jour. Bact.*, **1**, 535.  
 CHEN AND RETTGER 1920 A correlation study of the colon-aerogenes group of bacteria, with special reference to the organisms occurring in the soil. *Jour. Bact.*, **5**, 253.  
 CROSSONINI 1910 Über den Nachweis von Indol. *Arch. Hyg.*, **72**, 161.  
 EHRLICH 1901 Über die Dimethyl-Amidobenzaldehyde Reaction. *Berl. Med. Wochenschr.*, **1**, 151.  
 ESCALLON 1908 Reserche de l'indol dans les cultures microbiennes a l'aide du furfural. *Compt. rend. soc. biol.*, **65**, 507.  
 FISCHER 1915 Hemmung der Indolbildung bei *Bact. coli* in Kulturen mit Zuckerzusatz. *Biochem. Zeitschr.*, **70**, 105.  
 HALL 1920 Unpublished communication.  
 HISS AND ZINSSER 1917 Textbook of Bacteriology.  
 HOMER 1916 A suggestion as to the cause of lessened production of indol in media containing glucose. *Jour. Hygiene*, **15**, 401.  
 HOROWITZ 1916 Contribution a l'étude du genre *Proteus* Vulgaris. *Ann. Inst. Pasteur*, **30**, 307.  
 JORDAN 1899 Bacillus pyocyaneus and its pigments. *Jour. Exp. Med.*, **4**, 627.  
 JORDAN 1917 Differentiation of the paratyphoid-enteriditis group I. *Jour. Infect. Dis.*, **20**, 7.  
 JORDAN 1919 Production of indol by strains of Pfeiffer's bacilli. *Jour. Am. Med. Assn.*, **72**, 1542.  
 JORDAN 1920 Biology of the Pfeiffer bacillus. *Am. Jour. Pub. Health*, **10**, 648.  
 KLIGLER 1914 Observation on indol production in the Colon-typhoid group. *Jour. Infect. Dis.*, **14**, 81.  
 KOLLE AND WASSERMANN 1913 *Handb. d. pathogen. Mikroorganismen.*

- LARSON AND BELL 1913 A study of the lesions produced by *Bacillus proteus*. Jour. Infect. Dis., **13**, 510.
- LARTIGAU 1898 Epidemic dysentery caused by *Bacillus pyocyaneus*. Jour. Exp. Med., **3**, 604.
- LOGHEM AND LOGHEM-POUW. 1912 Beiträge zur Differenzierung des *Proteus* Gruppe. Centrabl. Bakt., Orig., I. Abt., **66**, 19.
- LOGIE 1920 Synthesis of tryptophane by certain bacteria and the nature of indol formation. Jour. Path. and Bact., **23**, 224.
- MALONE 1920 The production of indol by Pfeiffer's bacillus. Indian Jour. Med. Res., **7**, 519.
- MULSOW 1919 Avian paratyphoid bacilli. Jour. Infect. Dis., **25**, 135.
- NELSON 1916 Some color reactions for indole and scatole. Jour. Biol. Chem., **24**, 527.
- NONNOTTE AND DEMANCHE 1908 Sur la recherche de l'indol dans les cultures microbiennes. Compt. rend. soc. biol., **64**, 658.
- PORCHER 1911 Les diverses peptone et la formation de l'indol. Compt. rend. soc. biol., **70**, 464.
- PORCHER AND PANISSET 1909 Indol dans les bouillons microbiens. La présence dans las cultures du cholera des poules. Compt. rend. soc. biol., **66**, 624.
- PORCHER AND PANISSET 1911 La formation de l'indol dans les cultures en milieu aerobes et en milieu anaerobes. Compt. rend. soc. biol., **70**, 436.
- RHEIN 1919 Sur la production d'indol per le bacille de Pfeiffer. Compt. rend. soc. biol., **82**, 138.
- RIVAS 1912 Studies on indol. Centralbl. Bakt., Orig., I. Abt., **63**, 547.
- RIVERS 1920 Indol test on the spinal fluid for rapid diagnosis of influenzal meningitis. J. Am. Med. Assn., **75**, 1495.
- SICRE 1909 Sur la reserche de l'indol dans les cultures microbiennes a l'aide des nouveaux réactife. Compt. rend. soc. biol., **67**, 76.
- STEENSMA 1906 Über den Nachweis von Indol und die Bildung von Indol vortausehenden Soffen in Bakterien Kulturen. Centralbl. Bakt., Orig., I. Abt., **41**, 295.
- TOBEY 1906 Cholera red and indol reaction. Jour. Med. Res., **15**, 305.
- WEETER 1920 Unpublished communication.
- ZIFFEL 1913 Weitere Beiträge zur Kenntniss der Indolreaktion. Centralbl. Bakt., Orig., I. Abt., **67**, 583.
- WINSLOW AND OTHERS 1920 The Families and Genera of the Bacteria. Jour. Bact., **5**, 191.

## ON NITRIFICATION

### IV. THE CARBON AND NITROGEN RELATIONS OF THE NITRITE FERMENT

AUGUSTO BONAZZI

*Contribution from the Laboratory of Soil Biology of the Ohio Agricultural Experiment Station, Wooster, Ohio*

Received for publication, January 21, 1921

Winogradsky (1890) showed that the organism of nitrosofermentation is capable of growing in a medium completely void of fixed organic matter when in presence of ordinary air. He proved, thereby, that the organism must derive its carbon from one or all of the following sources; the mineral carbonates, the free carbon dioxide, or the volatile organic compounds of the atmosphere.

That a source of carbon is found and utilized by the organism is supported by the fact that analysis of the culture liquid after nitrosofermentation has taken place shows it to contain an appreciably greater quantity of carbon than it did before the fermentation was activated by inoculation.

Godlewsky (1892, 1895) as well as Winogradsky and Omeliansky (1899), found that cultures of nitrite and nitrate-forming organisms lacking free or combined carbon dioxide could not develop. In discussing the experiments of Winogradsky, above referred to, Beijerinck (1903), points to the possibility that the carbon was not fixed by the cells but by the magnesium oxide present in the basic carbonate used by this investigator. If this criticism were true it is hard to understand why the ratio of "nitrogen nitrified" to "carbon assimilated" should be a constant value. It might be assumed that the results of Ashby (1907-8), (soon to be related) could support Beijerinck's hypothesis, but close scrutiny shows them to bear a different significance.

It appears, therefore, that the function of nitrosofermentation is closely and intimately connected with the function of carbon assimilation by the bacterial cells. In fact, from the data at our disposal it appears as if their separation were impossible. Loew (1891) as early as 1891, soon after the classical researches of Winogradsky, advanced the view that the process of nitrosofermentation does not take place according to the path described in the accompanying equation:

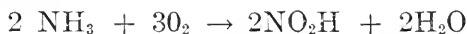

but rather by the path symbolized as follows:



The hydrogen liberated during the reaction is not found free in the medium but is momentarily formed in the cells and utilized in a synthetic process according to the following equation:

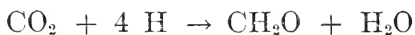

The resulting formaldehyde is not condensed into carbohydrate but directly into protein substances. The fact that nitrates are not utilized by the organism is cited by Loew in support of the above view.

From a physiological standpoint the question is an important one, and a full understanding of its "*modus operandi*" will lead to an understanding of the formation of the oxidized nitrogenous compounds in nature and of the early phases of the accumulation of the carbon supplies on the earth.

#### EXPERIMENTAL

It was at first necessary to establish whether the organism from American soils behaved towards carbon dioxide in a manner similar to that of the organisms from Europe and Asia, since the differences in form and life-cycle shown by these different organisms could well be accompanied by differences in physiological characteristics. With this aim in view, in 1914 a soil which had received the application of 9000 pounds of calcium carbonate

per acre was used. Three 100 gram lots in the air-dry condition were each moistened with 20 cc. of a 0.5 per cent solution of ammonium sulphate and incubated at room temperature under the following conditions: no. 1, together with a beaker of water, under a bell-jar sealed with vaseline to a glass plate; no. 2, under a bell-jar together with a beaker of soda-lime; no. 3, in the open laboratory air. After thirty days the soils were extracted with water, and the nitrates determined in the extract by means of the phenoldisulphonic acid method. The results obtained are summarized in table 1.

TABLE 1

NUM- BER	CONDITION OF ATMOSPHERE	NITROGEN AS NITRATES PER KILO OF SOIL		
		At the start	At the end	Formed
		<i>mgm.</i>	<i>mgm.</i>	<i>mgm.</i>
1	Natural but limited.....	15	168	153
2	Carbon dioxide removed.....	15	58	43
3	Natural open.....	15	125	110

It thus appears that the process of nitrification in American soils is appreciably hindered by the removal of the free carbon dioxide. At first it would seem as if these results were contrary to those given by Godlewsky, since even in presence of soda lime a certain amount of nitrification did take place. Nevertheless, the arrangement of the experiment may account for this. The soil was in Erlenmeyer flasks and the bell-jars used were of 5000 cc. capacity. Had the soda-lime been in the immediate vicinity of the soil, the carbon dioxide removal would have been more complete. Furthermore, in a soil containing organic matter, decompositions are always taking place, and by virtue of the great surface and high retentive power of soils for gases, enough carbon dioxide may easily have been retained to furnish a source of this gas in the immediate vicinity of the bacterial cells. Using the ratio  $N/C = 36$  established by Winogradsky, the quantity of carbon fixed in the nitrification of 4.3 mgm. of nitrogen, would be 0.1 mgm. a quantity easily retained by the soil.

Indications are, therefore, that the organism of nitrosofermentation acting in the soils with which the present work was undertaken, behaves towards free carbon dioxide in a manner similar to the organisms with which Winogradsky and Godlewsky were working. Additional proof on this point is furnished by experiments in solutions in which the above disturbing factors were eliminated.

*Experiment 244*

In each of two large flat bottomed Fernbach flasks were placed 50 cc. of the ordinary Omeliansky solution, and both were inoculated with an active culture of *Nitrosococcus* from Wooster soil, in equal amounts. One was incubated with no additional treatment while a small container of concentrated potassium hydroxide was placed in the neck of the other and the flask sealed with a manometer tube so as to avoid negative pressures in the system. After incubation at 25°C. for fifteen days the following results were obtained.

TABLE 2

NUMBER	TREATMENT	NITRITE NITROGEN FORMED
1	Normal air.....	<i>mgm.</i> 16.98
2	Air minus CO <sub>2</sub> .....	0.41

There is evidently no doubt that the organisms acting in Wooster soil are physiologically similar to those acting in European soils.

A system containing the ordinary Omeliansky solution for nitrite formation from ammonium sulphate, and magnesium carbonate as a base, derives its free carbon dioxide from various sources.

The interaction of the nitrogen and carbon sources, as they are added, leads according to equation I, to the formation of CO<sub>2</sub>. By the process of nitrification itself, according to equation II, more free CO<sub>2</sub> is formed, while the atmospheric carbon dioxide

constitutes a source that for convenience shall be here named III. It is then, possible that, like all other organisms, the Nitrosococcus undergoes processes of anabolism and catabolism, in the latter probably giving off carbon dioxide by respiration: this source shall be here named IV.

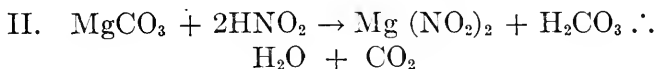
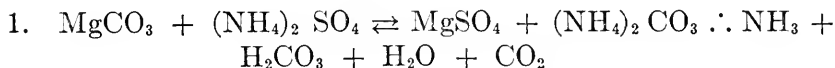

Duclaux (1896) expressed the opinion, based upon the results of the work of Winogradsky and of Godlewsky, that if the organisms were not capable of utilizing the carbon of the carbonate this could be due to the fact that some difference might exist between the carbon dioxide of the atmosphere and that arising from equations I and II above. One point should nevertheless be mentioned as a criticism of this view i. e., that by allowing the carbon dioxide absorbant to be continually present in the system (as was done by Godlewsky and in the above experiments duplicating his work), the action of the bacteria will be dependent not on the quality of the gas but on the velocity of distillation of the latter from solution. With very large surfaces of the culture solutions and relatively large surfaces of the absorbent, the  $\text{CO}_2$  tension in the gaseous phase of the system will be so slight that the organisms will not be in position to utilize the very slight traces temporarily to be found in the solution, before they are removed from contact with them.

The question therefore becomes a twofold one: the organism of nitrofermentation apparently cannot develop in the absence of all traces of gaseous carbon dioxide, yet is able to develop in media free of all traces of fixed organic carbon as was shown by Winogradsky (unless the traces carried in the inoculum may be considered as sufficient to vitiate the results, a conclusion hardly justified in view of the care with which the author attempted to avoid this a priori objection).

But the question of the growth of the nitrosoferment in an environment only initially free of carbon dioxide is as yet an open one. In order to answer the theoretical question advanced by Duclaux, cultures in full nitrification are best adapted, since in these the  $\text{CO}_2$ -production from equations I and II is considerable.

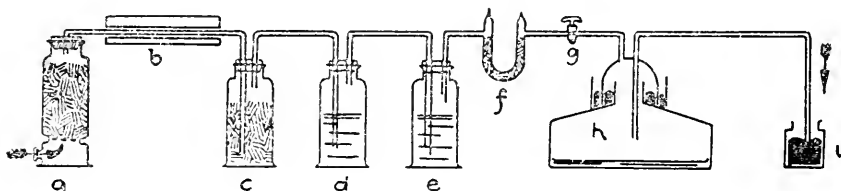

FIG. 1

*a*, Soda lime; *b*, furnace at 900-1000°C.; *c*, soda lime; *d-e*, concentrated KOH; *f*, soda lime; *g*, stop-cock; *h*, culture chamber; *i*, Hg. manometer.

### Experiment 200

An apparatus prepared as is shown in figure 1.

The culture was in full nitrification when used and the experiment was started by aerating the flask for two and one-half hours, with air freed of  $\text{CO}_2$  by passing through the train shown above. After aeration stopcock *g* was closed and the flask was incubated on a clinostat (Bonazzi, 1919 b). The quantities of nitrite formed before and after the treatment are given in table 3.

TABLE 3

	NITRITE NITROGEN FORMED IN 100 CC. OF SOLUTION DURING THE		
	Five days of preparation	Two days previous to treatment	Three days of treatment
Total.....	47.79	32.50	9.20
Formed per day.....	11.94	16.25	3.07

### Experiment 229 and 229a

The apparatus used in these experiments were such that no negative pressures could obtain in the culture systems; the aeration train was similar to the one used in experiment 200,



with the omission of the furnace. The manometer of the previous experiment was also replaced by a paraffin-oil manometer guarded from the external carbon dioxide by a soda lime tube. A barium hydroxide bulb was placed between the culture flask and the suction pump to allow the detection of even small traces of  $\text{CO}_2$ . Aeration was carried out for two hours during which time the flasks were often shaken. After aeration, the bulb of  $\text{Ba}(\text{OH})_2$  was inserted and aeration continued for one half hour more during which time the hydroxide showed no turbidity. The results of these experiments are given in table 4 in which is also given the activity of the cultures in the period of preparation.

TABLE 4

	EXPERIMENT 229		EXPERIMENT 229 A	
	Nitrogen transformed to nitrite during			
	Two days previous to treatment	Seven days of treatment	Two days previous to treatment	Five days of treatment
	<i>mgm.</i>	<i>mgm.</i>	<i>mgm.</i>	<i>n.gm.</i>
Total.....	8.44	18.66	11.33	19.72
Formed per day.....	4.22	2.67	5.56	3.94

It appears therefore that nitrification takes place normally at the expense of the carbon dioxide formed by the reactions in the culture medium and that therefore it must be assumed that the suggestion of Duclaux was based upon facts which could not well be utilized in the formulation of the hypothesis.

As may be seen, the cultures here used were in full and intensive nitrosofermentation and the carbon sources varied. Yet owing to the specific arrangement of the experiments, there should be a possibility of separating the supplies at their point of formation. In fact, if a very small inoculum were used in place of the very great ones used in the previous experiments, it should be possible to diminish appreciably if not to stop completely the formation of the supplies due to equation II. This was done in experiment 227-a.

*Experiment 227-a*

The apparatus used were made up according to figure 2.

Aeration was carried on for about one hour and the complete absence of  $\text{CO}_2$  ascertained by means of the barium hydroxide bulb. The medium used was ignited and sterilized compost, moistened with sterile Omeliansky solution in the proportion of 40 cc. for each 100 gram of soil. One gram of basic  $\text{MgCO}_3$  had been placed in each flask, while dry, before sterilization.

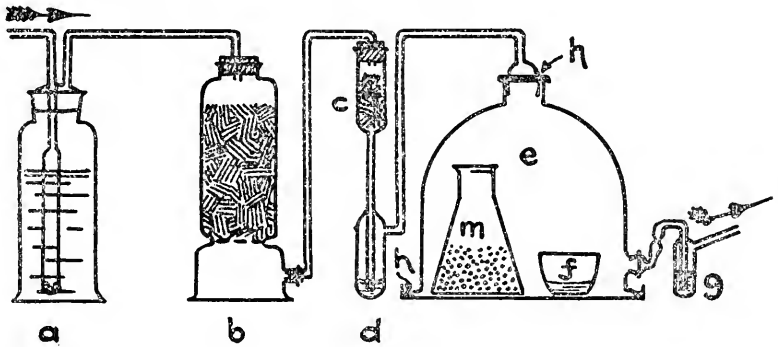

FIG. 2

*a*, Concentrated  $\text{NaOH}$ ; *b*, soda lime; *c*, soda lime; *d*, paraffin oil seal; *e*, culture chamber with culture in *m*; *f*, crucible with appropriate solution; *g*,  $\text{Ba}(\text{OH})_2$  guard for detecting  $\text{CO}_2$ ; *h*, paraffin seals.

All flasks were inoculated with a soil suspension which contained negligible amounts of nitric or nitrous nitrogen. After inoculation, the cotton plugs were removed, the flasks placed under the bell jars, the seal made by pouring melted paraffin at the contact of jar and plate and aeration started. The arrangement of the flasks was the following:

No. 1. Check uninoculated.

No. 2. Air in system freed only of the initial  $\text{CO}_2$ .

No. 3. Air freed of  $\text{CO}_2$  throughout, containing  $\text{NaOH}$  50 per cent.

No. 4. Air containing only the  $\text{CO}_2$  developing from the reaction of 5 mgm.  $\text{Na}_2\text{CO}_3$  and an excess of  $\text{H}_2\text{SO}_4$  taking place in *f*.

No. 5. Air with no change in composition (natural).

After thirty days incubation at 25°C. the nitrates were extracted, and determined by reduction and distillation. The results are given in table 5.

TABLE 5

NUMBER	TREATMENT	NH <sub>3</sub> - N <sub>2</sub> AT THE END	N <sub>2</sub> NITRIFIED
		<i>mgm.</i>	<i>mgm.</i>
1	Check.....	....	....
2	No CO <sub>2</sub> at start.....	8.77	1.28
3	No CO <sub>2</sub> throughout.....	9.75	0.44
4	CO <sub>2</sub> added.....	0.00	8.26
5	Natural air.....	0.07	14.57

System no. 4 requires a little discussion. Sulphuric acid was added in excess of the quantity needed for the neutralization of the Na<sub>2</sub>CO<sub>3</sub>, and apparently its action has been to absorb the ammonia which was distilling from the culture itself; the final nitrite content could be but low. It should also be stated that no attempt was made to recover all the residual ammonia in the soil. The quantity of nitrate formed in no. 3, if not accountable by an experimental error in analysis, would require, according to the ratio established by Winogradsky, a quantity of 0.01 mgm. of carbon as CO<sub>2</sub>, a quantity which could easily have escaped immediate absorption by the alkali used.

The conclusions to be drawn from these experiments are, then: (a) that nitrification is completely checked by the complete absence of carbon dioxide in the system throughout the experimental period (when a concentrated alkali is present therein); (b) that when a small inoculum is used, in spite of the fact that ignited soil holds carbon dioxide by absorption, and when the supply of this gas is nil at the start, the phenomenon of nitroso-fermentation is practically inhibited.

In direct consequence of these facts stands the conclusion that, since the inoculum was small and nitrification in no. 2 was negligible, contrary to the results of experiments 229 and 229a, and since in this case there was not an active production of carbon

dioxide by virtue of equation II, the latter source of the gas appears to be the one most active in furthering nitrification. This is probably attributable to the fact that it is directly connected with the life activities of the organism concerned.

The supply due to reaction I is, therefore, slowly utilized, probably because very rapidly distilled from the immediate surroundings of the cells; or a molecular rearrangement of the basic carbonate used may take place. These considerations would then place the process of nitrification dependent upon and secondary to the process of carbon assimilation. We shall have occasion to return to this point later in this paper.

According to Warington, nitrification of ammonia can take place only with ammonium carbonate, and the function of the carbonated base is to furnish that compound by reaction with other ammonium salts. Ashby found nitrification to take place in presence of ferric hydrate to a considerable extent, and also some nitrification of the ammonia absorbed by modeling clay alone (1907-1908).

Hopkins and Whiting (1916) also claim that nitrification will take place in presence of tri-calcium phosphate as a neutralizing substance. It is evident that in the experiments of the last named investigators ammonium carbonate could not be formed by reaction between the neutralizing base and the source of nitrogen, a fact that throws a doubt on Warington's assumption. The reaction leading to the formation of ammonium carbonate should then be directly connected with the nitrogen nutrition of the organism of nitrosofermentation rather than with the carbon nutrition. The question of the autotrophy and heterotrophy of the organisms is also intimately connected with these observations.

If it were possible to avoid, in a culture, reactions I and II, a step would be taken towards the understanding of the phenomenon that Winogradsky named, "chlorophyllic action without chlorophyll". The aim could be approached either by the use of a non-carbonated base or by allowing nitrification of the ammoniacal nitrogen in the form of hydroxide. Experiments in the hope that the second of these two assumptions might prove

practical failed to give satisfaction. In presence of  $MgCO_3$ .  $Mg(OH)_2$  as a neutralizing base, ammonium hydroxide added in small amounts at a time was easily volatilized and removed from the nitrifying system: only 7 mgm. of nitrogen were transformed to nitrite in eleven days although 30 mgm. of nitrogen as ammonium hydroxide were added during this period, in small amounts ranging from 2 to 9.4 mgm. at one time. This source of ammonia even though undergoing slow nitrification did not seem to hinder the action of the organisms, since the same culture which had received the hydroxide additions was capable, after this treatment, of nitrifying in three days 2 cc. of a 10 per cent solution of ammonium sulphate for every 100 cc. of culture solution:

Although the results obtained pointed to the possibility of nitrification of ammonium hydroxide, it was thought that a study of a non-carbonated base to be used in the cultures would prove more satisfactory. Magnesium oxide was chosen since it has a lower solubility of the carbonate and would give results directly comparable to the conditions existing in the ordinary culture solution as used in the present paper. Calcium oxide and hydroxides as well as the oxides and hydroxides of the other metals were discarded *a priori* on account of their greater solubility and greater alkalinity. The aim was to use a base that would serve to neutralize the acids arising from the reactions taking place during nitrification rather than to exert its physiologically alkaline properties. That the oxide chosen is not toxic is to be assumed from the fact that the carbonate, used in all the previous experiments, contained one molecule of the oxide for every molecule of the carbonate.

#### *Experiment 234*

Six flasks with very large flat bottoms received 50 cc. of the ordinary Omeliansky solution made up with tap water. After sterilizing and cooling, flasks 1, 2 and 3 received the addition of a sterile suspension of  $MgCO_3$ .  $Mg(OH)_2$ , while flasks 4, 5 and 6 received a sterile suspension of  $MgO$ . All except nos.

TABLE 6

NUM- BER	TREATMENT		REACTION AFTER			
			Nine days		Thirteen days	
	Base	Inoculation	NH <sub>3</sub>	N <sub>2</sub> O <sub>3</sub>	NH <sub>3</sub>	N <sub>2</sub> O <sub>3</sub>
1	MgCO <sub>3</sub>	Check uninoculated.....	※	0		
2	MgCO <sub>3</sub>	Inoculated.....	0	※		
3	MgCO <sub>3</sub>	Inoculated.....	0	※		
4	MgO	Check uninoculated.....	※	0	※	0
5	MgO	Inoculated.....	※	1	※	1
6	MgO	Inoculated.....	※	+	※	+

1 and 4 were inoculated with an active culture of the nitrite ferment and incubated at 25°C. Tests made at various intervals yielded the results given in table 6 where 0 signifies a negative result and 1, +, ※ positive results of increasing intensity.

On a short period of incubation, although free atmospheric carbon dioxide was in contact with the solutions no appreciable nitrification took place, when magnesium oxide was used, while nitrification was active in the presence of the carbonate.

#### Experiment 240

The above cultures in which no appreciable nitrification took place (nos. 4, 5, 6) were each divided into two equal portions by means of sterile pipettes and placed, without reinoculation, in sterile flasks of equal diameter. One portion, left as control, received no addition whereas the other portions received various treatments, as is shown in table 7.

TABLE 7

NUMBER	TREATMENT	NITROGEN AS NITRITE AFTER SECOND PERIOD OF INCUBATION	FINAL AMMONIA REACTION
		<i>mgm.</i>	
4	Check uninoculated.....	0.77	※
5	(NH <sub>4</sub> ) <sub>2</sub> SO <sub>4</sub> and MgO.....	6.22	?
51	(NH <sub>4</sub> ) <sub>2</sub> SO <sub>4</sub> and MgO and MgCO <sub>3</sub> .....	4.85	?
6	(NH <sub>4</sub> ) <sub>2</sub> SO <sub>4</sub> and MgO and (NH <sub>4</sub> ) <sub>2</sub> CO <sub>3</sub> .....	2.50	+
61	(NH <sub>4</sub> ) <sub>2</sub> SO <sub>4</sub> and MgO, (NH <sub>4</sub> ) <sub>2</sub> CO <sub>3</sub> and MgCO <sub>3</sub>	2.35	※

The results obtained in this, the second, period of incubation are striking. Ammonium sulphate will be nitrified, although slowly, in the presence of a non-carbonated base, the difference in the results of experiments 234 and 240 being due to the *time* factor. The lag in nitrite formation in cultures 51, 6 and 61 may be explained in either of two ways: (a) distillation of the ammonium carbonate, and (b) retarding effect of this compound with subsequent volatilization of considerable quantities of ammonia. In fact in the cultures 6 and 61 a concentration of ammonium carbonate was used such as to give 28 mgm. of nitrogen in 25 cc. of solution, a quantity twice as great as that of the ordinary Omeliansky solution.

The results relating to the nitrification in the presence of a non-carbonated base are then in accord with the findings of Ashby and of Hopkins and Whiting and it is possible that the atmospheric carbon dioxide, here, played an important rôle in the process of nitrification. That ammonium carbonate is nitrifiable as such should be assumed from the work of Warington, but additional proof is furnished by experiments here to be related.

#### *Experiment 241*

Fifty cubic centimeters of Omeliansky solution from which the ammonia source was omitted, were sterilized in 750 cc. Erlenmeyer flasks. After cooling they received sterile magnesium carbonate suspension or magnesium oxide and either 1 cc. of a sterile 10 per cent ammonium sulphate solution or 0.5 cc. of a 17.2 per cent ammonium carbonate<sup>1</sup> solution pasteurized at 60°C.

The arrangement of the experiments<sup>2</sup> and the results obtained are given in table 8.

<sup>1</sup> The carbonate used in all these experiments was a mixture of the normal carbonate and the carbamate of the following empirical formula:  $(\text{NH}_4)_2\text{CO}_3 \cdot \text{NH}_4\text{CO}_2\text{NH}_2$ .

<sup>2</sup> The term *capped* in this and other experiments refers to the mercury or paraffin oil seals used in order to avoid the escape of volatile substances from the nitrifying systems. Their efficiency may be noticed by a comparison of the results obtained in nos. 3 and 4 of table 8.

TABLE 8

NUM- BER	TREATMENT	REACTION AFTER		NITRITE NITROGEN FOUND AFTER 31 DAYS
		10 days	19 days	
1	(NH <sub>4</sub> ) <sub>2</sub> SO <sub>4</sub> and MgCO <sub>3</sub> open.....	1	✗	12.25
2	(NH <sub>4</sub> ) <sub>2</sub> SO <sub>4</sub> and MgCO <sub>3</sub> capped.....	0	0	4.44
3	(NH <sub>4</sub> ) <sub>2</sub> CO <sub>3</sub> open.....	+	✗	6.47
4	(NH <sub>4</sub> ) <sub>2</sub> CO <sub>3</sub> capped.....	1	✗	20.62
5	(NH <sub>4</sub> ) <sub>2</sub> CO <sub>3</sub> and MgCO <sub>3</sub> capped.....	0	1	13.12
6	(NH <sub>4</sub> ) <sub>2</sub> CO <sub>3</sub> and MgO capped.....	0	0	0.75
7	(NH <sub>4</sub> ) <sub>2</sub> CO <sub>3</sub> and MgO capped.....	0	0	0.78

In no. 2 nitrification was, for some unknown reason, retarded, for, even after nineteen days no nitrite formation had taken place, so that the quantity found after thirty-one days was formed during the last twelve days of incubation. The action of the magnesium oxide on the nitrification of ammonium carbonate is a retarding one and this may be due to physical reasons. Distillation of the ammonia from the neutral or slightly acid solution takes place at a relatively fast rate, as is shown in no. 3 and in a solution made alkaline by the addition of MgO the distillation is too fast to allow any competition by the bacterial cells.

Since it is evident from these experiments that the ammonium carbonate can be utilized by the nitrosoferment even in the absence of a base, a study of the nitrification of this substance in the presence or absence of atmospheric carbon dioxide will lead to a better understanding of the function of the magnesium carbonate in the cultures undergoing nitrification. Besides, if ammonium carbonate were nitrified in the absence of atmospheric carbon dioxide it would be evident that this nitrogenous carbonated substance could furnish the carbon necessary for the life of the organism. The latter condition would also indicate the mode of action of the compound.



*Experiment 244*

A solution prepared as follows: sodium chloride 1 gram; dipotassium phosphate 0.5 gram; hydrated magnesium sulphate 0.51 gram; hydrated ferrous sulphate 0.364 gram; distilled water 500 cc. Fifty cubic centimeter portions pipetted into six large flat-bottomed Fernbach flasks fitted with paraffin oil seals.

After sterilization flasks 1, 2 and 3 received sterile  $\text{MgCO}_3$ ,  $\text{Mg}(\text{OH})_2$  and 1 cc. of a sterile 10 per cent  $(\text{NH}_4)_2\text{SO}_4$  solution, while nos. 4, 5 and 6 received only 1.5 cc. of a 6.75 per cent pasteurized solution of ammonium carbonate. Subsequently all were inoculated. Flasks 2 and 5 received a small container of concentrated KOH in the neck while flasks 3 and 6 were washed free of all carbon dioxide by aeration for one hour, the air issuing from the flasks at the end of this time causing no turbidity in  $\text{Ba}(\text{OH})_2$  when passed through it. Inoculation was made with an active culture of *Nitrosococcus*, and incubation was at  $25^\circ\text{C}$ . for fifteen days. Analysis of the cultures after this period gave the results presented in table 9.

TABLE 9

NUMBER	TREATMENT	NITRITE NITROGEN FOUND AT THE END OF INCUBATION PERIOD
	$\text{MgCO}_3$ and $(\text{NH}_4)_2\text{SO}_4$	
		<i>mgm.</i>
1	Normal air.....	16.98
2	$\text{CO}_2$ removed throughout experiment.....	0.41
3	Only the initial $\text{CO}_2$ removed.....	8.76
	$(\text{NH}_4)_2\text{CO}_3 \cdot \text{NH}_4\text{CO}_2\text{NH}_2$	
4	Normal air.....	7.17
5	$\text{CO}_2$ removed throughout experiment.....	0.47
6	Only initial $\text{CO}_2$ removed.....	8.59

*Experiment 246*

Erlenmeyer flasks of 750 cc. capacity were used with mercury seals, and 50 cc. of the solution used in the previous experiment. After sterilization, 1 cc. of the pasteurized solution of ammonium

carbonate used in experiment 244 was pipetted in each flask and, after inoculation, a container with concentrated KOH was placed in the necks of nos. 1 and 2. After incubation at 25°C. the solutions submitted to analysis gave the following results (table 10).

TABLE 10

NUMBER	TREATMENT	NITRITE NITROGEN FOUND AT THE END OF INCUBATION PERIOD
		<i>mgm.</i>
1	All CO <sub>2</sub> removed throughout experiment.....	0.13
2	All CO <sub>2</sub> removed throughout experiment.....	0.38
3	Natural stagnant air.....	7.52
4	Natural stagnant air.....	6.24

Repetition of this experiment (experiment 249) yielded the results given in table 11.

TABLE 11

NUMBER	TREATMENT	NITRITE NITROGEN FOUND AT THE END OF INCUBATION PERIOD
		<i>mgm.</i>
1	All CO <sub>2</sub> removed throughout experiment.....	0.35
2	Natural stagnant air.....	16.63

## DISCUSSION AND CONCLUSIONS

From the foregoing experiments the following considerations seem justified.

In the solution containing ammonium sulphate and magnesium carbonate removal of all traces of carbon dioxide causes nitrosofermentation to come to a standstill, whereas if only the carbon dioxide present at the start be removed but that developing through reactions I and II (given on page 483) be allowed to accumulate in the systems nitrosofermentation could continue in a ratio roughly proportional to the size of the inoculum. In fact, even with a very small inoculum some nitrification could be detected.

It should be assumed, therefore, that the carbon dioxide formed through these reactions can go to replace that removed at the start; the  $\text{CO}_2$  tension in the liquid and gaseous phase soon approaching that state of equilibrium which is favorable to the action of the nitrite-forming bacteria. In the presence of  $\text{KOH}$ , or other  $\text{CO}_2$  absorbent, these reactions are taking place, but the gaseous products formed in relatively small quantities are soon removed by the absorbent, the resulting  $\text{CO}_2$  tension in the culture solution reaching the point where the normal activity of the organism is impossible. Under such conditions it is even to be doubted whether ammonium carbonate is formed as such and not immediately hydrolyzed and the products of hydrolysis distilled from reach of the cells before completion of the synthetic step in the reaction. This is evidenced by the fact that when Omeliansky solution containing ammonium carbonate as the source of nitrogen is exposed to a concentrated alkali in a closed system it rapidly changes from an acid reaction, to phenolphthalein, to a strongly alkaline reaction. If ammonium sulphate be the source of nitrogen and magnesium carbonate be added to the solution, the final result is the same, a very strong alkalinity being developed where at first only a weak one could be detected.

In the tables reported above it is evident that such conditions lead to a check on the process of nitrification. The carbonate-carbamate used in view of the hypothesis of Chodat under the above conditions of  $\text{CO}_2$  removal did not lead to a nitrogen hunger. This is proved by the fact that a solution containing this compound, and incubated in a system in which  $\text{KOH}$  was present, contained after the incubation considerable quantities of ammonia as determined by the Nessler reagent, while a heavy precipitate was obtained by allowing a drop or two of the culture solution thus incubated to react with  $\text{Ba}(\text{OH})_2$ . Some carbonate as such was therefore still in solution.

These last considerations lead to the conclusion that it is the carbon dioxide as such that is necessary to the organisms of nitrosofermentation and that it can be utilized only when the tension of this gas is above a minimum limit. Thus the nitrogen nutrition of the organism is closely related and in fact completely

dependent upon its carbon nutrition. The free carbon dioxide is not only necessary for growth but is also necessary for the performance of the normal oxidative functions peculiar to the cells. Therefore nitrosofermentation which is supposed to furnish the energy for the carbon assimilation can not even be established in the absence of free carbon dioxide. The small quantity of nitrite formation in the presence of KOH, if positive at all, must be considered as the result of an autooxidation of the cells themselves and a utilization of the energy thus liberated, for the process of nitrite formation, a process which soon comes to a standstill because of the strong negative pressure of the  $\text{CO}_2$  outside the cell and of the subsequent diffusion of the intracellular material towards the outside, and also because of the strong alkalinity developed in the medium.

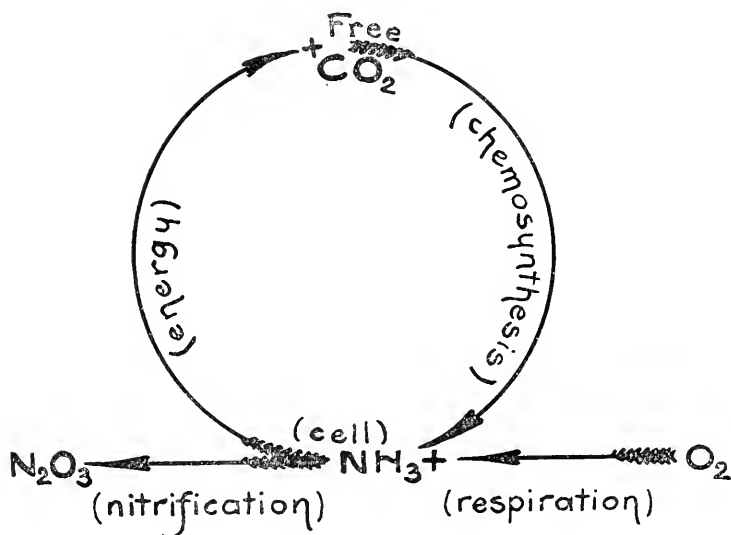

FIG. 3

This interpretation leads to a special conception of the life of the organisms of nitrosofermentation. When the optimum carbon dioxide tension is existent, the cells, during their life cycle, perform two synchronous functions; one of cellular respiration and one of carbon assimilation, the former serving for the initiation of the process of nitrosofermentation and subsequent

carbon assimilation by the second. Expressing these functions by means of a diagrammatic representation, figure 3 is obtained.

According to the above diagram, when the cell carbon is sufficiently large the process of chemosynthesis is endless, unless one of the end products is removed. Thus in the case of narcosis of the cell, respiration continues with degeneration and complete consumption of the available cell carbon, and when all such were consumed death of the cell would result. This condition of narcosis may be brought about by an excessive concentration of food substances or of cellular byproducts, with the cellular breakdown demonstrated by Bonazzi (1919-a) and by Gibbs (1919) and physiological inertia as has been shown by Boullanger and Massol (1903, 1904):

When the supply of free carbon dioxide is nil throughout the experiment the respiration process regulates chemosynthesis and the products of nitrosofermentation are in immediate relation to the quantity of cell substance respired and, since no carbon assimilation can follow, death of the cells results.

When ammonium carbonate is used as a source of carbon and the free carbon dioxide is continually removed by means of an absorbent there is a slow accumulation of the carbamate and fast removal of the ionized  $\text{CO}_2$  (Macleod and Haskins 1906). Together with this there is a depletion of all the respirable stores in the cell, so that in the system the following substances will be found:  $(\text{NH}_4)_2\text{CO}_3$ ,  $\text{NH}_4\text{CO}_2\text{NH}_2$ , cells, traces of respired C compounds, and  $\text{NH}_3$ . Since it has been experimentally proved that the cells cannot, under these conditions, assimilate this nitrogen (experiment 244, 246 and 249) the interpretation to be given to these facts is that the free carbon dioxide is closely tied up with the nitrogen nutrition of the organism and that in this condition it distills too fast for the cells to utilize it. It follows that if this distillation is prevented by mechanical means, there should then be possible some nitrification and chemosynthesis: this is what actually takes place in experiments fulfilling the required conditions.<sup>3</sup>

<sup>3</sup> Meyerhoff in Pflüger's Archiv f. Ges. Physiol. 1917. 166, 240-280, found nitrification to proceed in the presence of 10 per cent NaOH solution, and the

The results obtained by the use of ammonium carbonate as a source of nitrogen and carbon, as well as those obtained with a non-carbonated base emphasize the fact that it is the free  $\text{CO}_2$  that is utilized by the cells, a view substantially corroborated by the findings of Ashby and of Hopkins and Whiting reported above.

This free carbon dioxide is not necessary for the formation of ammonium carbonate, but for another purpose: chemosynthesis.

The oxidation of ammonia is to be considered as taking place in two steps: (a) one of respiration with resultant gain in energy and synchronous nitrogen absorption, (b) the other of nitrogen assimilation (nitrification proper) whereby oxidation of the absorbed nitrogen takes place, the utilized portion going to make up the following cell generations, nitrous acid is split off and excreted as a non-utilizable product, and energy is liberated. Therefore, if the free carbon dioxide were removed from a culture containing both ammonium carbonate, as a nitrogenous source, and large numbers of bacterial cells, respiration should be great enough to allow some nitrification to take place. If, on the other hand, the number of active cells were limited, nitrification would come to a standstill before a quantity of nitrites were formed detectable by the ordinary chemical means. Experimental evidence bears proof of the correctness of the above hypothesis.

#### SUMMARY

This paper reports a study of the functions of autotrophic carbon assimilation and nitrogen nutrition of the nitrosoferment. These functions are found to be intimately connected and mutually interdependent, the bacterial cell being unable to assimilate the abundant stores of nitrogen in a nutritive solution in the absence of "free" carbon dioxide, even though a carbonate as such, be present, in the medium. Consequently on the presence of this "free" carbon dioxide is dependent the process

present author found nitrification to proceed when the tube containing concentrated KOH was placed very near the mouth of the flask so that free circulation of the air was interfered with.

of nitrogen oxidation which follows the absorption and leads to the formation of nitrous acid and its salts.

## REFERENCES

- ASHBY 1907-1908 *Jour. Agric. Sci. (Cambridge)* **2**, 52-67.  
BIEJERINCK AND VAN DELDEN 1903 *Centr. f. Bakter., 2 Abt.*, **10**, 33-67.  
BONAZZI 1919a *Botan. Gazette*, **68**, 194-207.  
BONAZZI 1919b *Jour. Bact.*, **4**, 43-59.  
BOULLANGER AND MASSOL 1903 *Annales d. l'Institut Pasteur*, **17**, 492-515.  
BOULLANGER AND MASSOL 1904 *Annales d. l'Institut Pasteur*, **18**, 181-196.  
DUCLAUX 1896 *Annales de l'Institut Pasteur*, **10**, 414-416.  
GIBBS 1919 *Soil Science*, **8**, 427-471.  
GODLEWSKY 1892 *Bull. Intern. Acad. Scie. Cracovie*, 408-417.  
GODLEWSKY 1895 *Bull. Intern. Acad. Scie. Cracovie*, 178-192.  
HOPKINS AND WHITING 1916 *Bull. 190, Illinois Agric. Exper. Stat.*, 395-406.  
LOEW 1891 *Botan. Central.*, **46**, 222-223.  
MACLEOD AND HASKINS 1906 *Jour. Biol. Chem.*, **1**, 319-334.  
WINOGRADSKY 1890 *Annales de l'Institut Pasteur*, **4**, 257-275.  
WINOGRADSKY AND OMELIANSKY 1899 *Centr. f. Bakter., 2 Abt.*, **5**, 329, 377, and 429.





## TOXINS OF BACT. DYSENTERIAE, GROUP III

TH. THJØTTA AND ODD FALSEN SUNDT

*From the Bacteriological Laboratory of the Norwegian Medical Corps, Kristiania, Norway*

Received for publication, February 10, 1921

It was Shiga (1898) who first demonstrated the toxicity of cultures of the dysentery bacillus isolated by him in 1898. Later this toxin production has been studied by several investigators among whom are Neisser and Shiga (1903), Conradi (1903), Vaillard and Dopter (1903), Flexner and Sweet (1906) and Kraus and Doerr (1905). Recently Olitsky and Kligler (1920) have published a very interesting paper on this subject, showing that the dysentery bacillus of group I of Thjøtta's (1919) classification (the bacillus of Shiga) produces a soluble toxin (exotoxin) as well as an endotoxin, and that these two toxins act differently in rabbits. The former was shown to be a neurotoxin having no intestinal action, while the latter is an enterotoxin having no effect on the nervous system.

In the past the dysentery bacilli of group I were considered the only toxic forms of this bacillus, while those of the other groups (group II of Thjøtta's classification, i.e., the types of Flexner and Strong and the Hiss Y bacillus) were held to be atoxic.

In the following we will show that *Bact. dysenteriae* of group III as well as of group I produces toxins thus showing the relation of this group to the toxic strains of the *Bact. dysenteriae*.

Before going into the details of our experiments we will present the main characters of the bacillus of group III. It is, as in the case of other *Bact. dysenteriae* a Gram negative, non-motile non-gas producing microbe, that forms acid in mannitol, maltose, glucose, and as a rule in sucrose. It does not produce indol and it grows in peculiar colonies having an irregular, crenated edge. It is toxic to a milder degree for rabbits and monkeys (Sonne).

This microorganism was evidently seen by Kruse in 1907 and called by him type E (Kruse, 1907): but it was first regarded as a definite type by Sonne in 1914 (Sonne, 1915) and classed by him in group III. Since then it has been described in France by d'Herelle (1916), in Norway by Thjotta (1919) and in Sweden by Ohnell (1918).

#### EXPERIMENTAL

As a control on our technique, and as a confirmation of the results obtained by Olitsky and Kligler a strain of Shiga bacilli, the first of this form of dysentery bacilli to be isolated in Norway (by the authors) was examined.

The Shiga strain was grown in plain broth for eight days, then filtered, and the filtrate (Berkefeld) injected intravenously in the following rabbits with these results:

#### *Experiment I. Exotoxin*

RABBIT NUM- BER	WEIGHT		AMOUNT INJECTED	FIRST DAY	SECOND DAY	THIRD DAY	FOURTH DAY
	grams	cc.					
1	3250	1.0		Very sick	Dead		
2	4000	0.5		Sick	Lies on side, does not move	Dead	
3	3600	0.25		Well	Quiet	Paresis of forelegs	Complete paralysis of anterior part of body
4	3250	0.125		Well	Well	Well	Well
5	3600	0.063		Well	Well	Well	Well

Thus it is proved that the filtrate acts as a neurotoxin, producing distinct paralysis: that a period of incubation precedes the development of these symptoms; and that the effect is dependent upon the amount of the filtrate employed. In none of these rabbits were intestinal lesions found.

The Shiga strain was grown on agar surface for twenty-four hours, washed off in saline solution, heated for 1 hour at 60°C., and finally

warmed at 37°C. for forty-eight hours. The suspensions were then filtered and injected into rabbits with the following results:

*Endotoxin*

RABBIT NUMBER	WEIGHT	AMOUNT INJECTED	FIRST DAY	SECOND DAY	THIRD DAY	FOURTH DAY
	<i>grams</i>	<i>cc.</i>				
1	2900	1.0	Dead			
2	3600	0.25—	Sick	Diarrhea	Very sick, diarrhea	Dead
3	3000	0.125—	Sick	Dead		
4	2800	0.063—	Sick	Diarrhea	Dead	

From these experiments it is to be noted that the prominent symptoms were intestinal in origin. At autopsy a marked hemorrhagic colitis was found, similar to that observed in dysentery in man in the stage prior to the development of necrosis. None of these rabbits showed nervous symptoms.

Thus the results were in accordance with the findings of Olitsky and Kligler, and we concluded that the conditions for obtaining a good yield of exotoxin and endotoxin were met by our technique.

We then proceeded with the study of the *Bact. dysenteriae*, group III. The reaction of the medium during the growth varied as follows:

TABLE 1

DAYS INCUBATION	pH
1	7.2*
2	7.3
3	7.5
4	8.0
5	8.0
6	8.0

\*Medium before inoculation pH 7.6.

We thus find an initial acid production that is followed by a period of alkalinity. In the end the reaction is more alkaline than at the beginning of the experiment. This confirms the observations of Olitsky and Kligler who also found that the toxin production did not begin until the alkaline period had

set in. Following the technique of Olitsky and Kligler we collected our toxin after seven days' growth since too prolonged growth tends to yield mixed exotoxin and endotoxin. The broth was now filtered through a Berkefeld filter, the filtrate tested for sterility and the toxin thus prepared was injected into rabbits and white mice.

*Experiment II. Injections into rabbits*

RABBIT NUMBER	WEIGHT	AMOUNT OF EXOTOXIN INJECTED INTRAVENOUSLY
	<i>grams</i>	<i>cc.</i>
1	2500	3.0
2	2700	2.0
3	2600	1.0
4	1250	0.5

The results were as follows:

Four hours after the injection the animals became ill. All lay quiet without trying to move. Rabbits 1 and 2 also had quick labored respiration and appeared to be moribund. After this immediate and probably non-specific effect the animals returned to normal as to appearance. If they were disturbed, however, they did not jump about as normal rabbits do, but dragged themselves along with a distinct weakness of the hind legs.

The weakness of the hind legs was most distinct in the second and third day of the experiment; thereafter it gradually disappeared.

The loss of weight was as much as 500 grams (rabbit 1).

A control rabbit injected with 3 cc. of sterile broth did not show any symptoms.

Additional experiments were made but as the results were similar the protocols are not given. The injection of filtered broth cultures of dysentery bacilli of group III thus causes an effect in the rabbits characterized mainly by distinct paresis of the extremities. No diarrhea was observed and no deaths occurred.

*Endotoxins of Bact. dysenteriae, group III.* The endotoxin was prepared as follows:

Large flasks of agar (diameter 18 by 10.5 cm.) were incubated after inoculation with the strains used in the experiments on exotoxin. A

twenty-four hours' growth of the bacilli was emulsified in normal saline, and the emulsion placed in the incubator for autolysis for two days. It was then filtered through Berkefeld candles, tested for sterility and injected into rabbits.

*Experiment III. Injections into rabbits*

RABBIT NUMBER	WEIGHT	AMOUNT INJECTED	FIRST DAY	SECOND DAY	FOURTH DAY
	<i>grams</i>	<i>cc.</i>			
1	750	3	Dead		
2	700	2	Very ill, diarrhoea	Improved	Well, weight 550 grams
3	800	1	Slight diarrhoea	Well	Well, weight 850 grams
4	2850	3	Very ill, diarrhoea	Improved	Well, weight 2650 grams
5	2250	2	Normal stool	Well	Well, weight 2100 grams

Thus, the rabbits after being injected with the endotoxins of the dysentery bacillus of group III showed intestinal disturbances as indicated by the diarrhoea. One animal died following a large dose (3 cc.) after having shown a profuse blood-stained discharge from the intestines. One animal did not show any sign of diarrhoea. In no case was there paresis, and recovery followed promptly.

*Experiments on mice*

Kraus and Doerr studied the effects of the toxins of the Shiga bacillus on hens and pigeons and found they were refractory. Doerr likewise found that guinea-pigs were not affected. We undertook the study of the effects of both the exo- and endotoxin on mice with the following results:

*Experiment IV. Exotoxin*

MOUSE NUMBER	AMOUNT OF EXOTOXIN INJECTED
	<i>cc.</i>
1	1.0
2	0.5
3	0.25
4	0.10
5	0.05
6	1.0*

\* Sterile broth.

Four hours after the injection mice 1 to 5 had a profuse bloody and slimy discharge from the anus, the stool hanging in drops from the anal opening. All the mice were sick, huddling together and showing raised hair. Thirty-six hour after the injection the animals were all right. Mouse 6 did not show any symptoms at all.

*Experiment V. Endotoxin*

MOUSE NUMBER	AMOUNT OF ENDO- TOXIN INJECTED	FIRST DAY	SECOND DAY	THIRD DAY
	<i>cc.</i>			
1	2.0	Dead		
2	1.0	Dead		
3	0.5	Very sick	Sick	Well
4	0.25	Very sick	Sick	Well
5	0.10	Very sick	Dead	
6	0.05	Sick	Sick	Well

All the sick mice had a diarrhea of blood-stained mucus after the injection, developing very soon (one and a half hours after injection). At autopsy there was enterocolitis and the lumina of the intestine contained blood-stained mucus.

Considering the rapid development of the symptoms in mice and the uniformity of the latter in both experiments it is probable that the symptoms were non-specific, at least where the exotoxin is concerned. As to the endotoxin, this certainly made the mice very sick and even killed them, the toxicity of the filtered broth thus being certain. However whether this toxic action was only due to the non-specific bacterial protein toxicity or indicated the specific action of a dysentery toxin we cannot state with certainty.

*Antitoxins*

Our next step was to study the production of antitoxins in the blood of immunized animals and to determine whether these antitoxins were capable of neutralizing the action of both the exotoxin and the endotoxin. For this purpose strong full-grown rabbits were used. The first rabbit receiving exotoxin died from a fulminating intoxication after three injections. The next animal bore the injections well and was given 10 doses of 1 cc.

each before the serum was drawn. An endotoxin animal also received 10 injections of 1 cc. each before the serum was used; and after these injections both these animals were apparently immune against the corresponding toxin.

Owing to a shortage of animals we have made only one experiment with rabbits. We chose to try endotoxin as this toxin showed more distinct symptoms of poisoning than the exotoxin.

ENDOTOXIN	ANTIEN-DOTOXIN	RESULTS
cc.	cc.	
3	1.0	Well, no diarrhea, loss of weight in 2 days, 50 grams.
3	0.1	Slight diarrhea, loss of weight in 2 days, 200 grams.
ENDOTOXIN	ANTIEXO-TOXIN	RESULTS
cc.	cc.	
3	1.0	Very sick, diarrhea
3	0.5	Very sick, diarrhea.
3	0.1	Very sick, diarrhea, died in 26 hours after injection.
3	0	Very sick, diarrhea, lived

In this experiment the sick animals and the one death occurred in the tests made with heterologous toxin and antitoxin, while the animals that were injected with the mixture of homologous toxin and antitoxin were fairly well.

We are quite aware that our doses were large and our animals few. But we cannot free ourselves of the opinion that there was a distinct antitoxic action exercised by the sera from the animals immunized against the homologous toxins. The titration of this action in exact doses was hardly possible because of the mild action.

We now turned our attention to the effect of neutralizing sera on mice, which, as noted previously, acted in a non-specific manner to the action of exotoxin, and possibly in a specific manner to that of the endotoxin.

ENDOTOXIN	ANTIENDO- TOXIN	RESULTS
cc.	cc.	
2	0.5	All animals well
2	0.1	All animals well
2	0.01	All animals well
ENDOTOXIN	ANTIEXO- TOXIN	RESULTS
cc.	cc.	
2	0.5	Sick with diarrhea, lived
2	0.1	Sick with diarrhea, died within 24 hours
ENDOTOXIN	NORMAL SERUM	RESULTS
cc.	cc.	
2	0.5	Sick, diarrhea, lived
EXOTOXIN	ANTIEXO- TOXIN	RESULTS
cc.	cc.	
2	1.0	Slight diarrhea, lived
2	0.5	Well
2	0.1	Died in 24 hours
2	0.05	Well
EXOTOXIN	ANTIENDO- TOXIN	RESULTS
cc.	cc.	
2	1.0	Died in 24 hours
2	0.5	Sick without diarrhea
2	0.1	Sick without diarrhea
2	0.05	Sick without diarrhea
2	0.005	Died in 24 hours

The experiment seems to show a distinct protective action of the antiendotoxin serum against its homologous toxin, while the control tests with endotoxin and antiexotoxin serum did not show protection. It seems therefore justifiable to consider the toxic effect of the extract of the dysentery bacilli (the "endotoxin") as a specific action due to the endotoxins of the dysentery bacillus rather than to a non-specific protein toxicity.

In the tests with exotoxin we did not find any distinct neutralization of the toxic effect of the broth injected. This fact might be due to the short period of immunization of our serum



yielding animals. In comparison however with the non-specific appearance of the symptoms of the exotoxin injection we find that this lack of neutralizing effect of the antiexotoxin serum makes it still more probable that the reaction of the mice after injection of exotoxin must be characterized as a non-specific reaction.

#### CONCLUSIONS

1. *Bact. dysenteriae* of group III produces both exotoxin and endotoxin.

2. The endotoxin is the most marked in effect and produces intestinal symptoms in rabbits and mice, while the exotoxin of this group is milder in action, producing pareses in rabbits, while mice react non-specifically to it.

3. The repeated injections of these toxins over a relatively short period of time render rabbits immune. The sera of these animals show a weak protective action against the homologous toxins.

#### REFERENCES

- CONRADI, H. 1903 Deut. med. Woch., **29**, 26.  
D'HERELLE, H. 1916 Ann de l'Inst. Pasteur, **30**, 145  
FLEXNER, S., AND SWEET, J. E. 1906 Jour. Exp. Med., **8**, 514.  
KRAUS, R., AND DOERR, R. 1905 Weiner Klin. Woch., **18**, 514.  
KRUSE, 1907 Deut. Med. Woch., **33**, Nos. 8 and 9.  
NEISSER M., AND SHIGA, K. 1903 Deut. med. Woch., **29**, 61.  
ØHNELL, H. 1918 Kliniska och bakteriologiska bidrag till kännedomen om dysenterien i Sverige, Stockholm.  
OLITSKY, PETER K., AND KLIGLER, I. J. 1920 Jour. Exp. Med., **31**, 19.  
SHIGA, K. 1898 Centr. f. Bakt., **23**, 599.  
SONNE, C. 1915 Centralbl. f. Bakt., **75**, 408.  
THJÓTTA, TH. 1919 Jour. Bact., **4**, 355.  
VAILLARD, L., AND DOPTER, C. 1903 Ann. de l'Inst. Pasteur, **17**, 486.



# A RAPID METHOD

HAS BEEN DEvised FOR

## COUNTING BACTERIA IN MILK

BY

Prof. W. D. FROST, of the Bacteriology Laboratories of the Department of Agriculture, University of Wisconsin.

The two items illustrated here are the principal pieces of apparatus required.

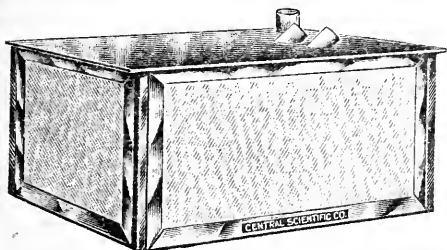

Warming Table

### DESCRIPTION OF TECHNIQUE:

For complete description of the methods and apparatus required, see the following: *Journal of Infectious Diseases*, Vol. XXVIII, No. 2, February, 1921, pages 176-184, "Improved Technique for the Micro or Little Plate Method of Counting Bacteria in Milk," by Dr. W. D. Frost.

Standard Methods for the Bacteriological Examination of Milk. Third Edition, page 18, "Microscopic Colony Count (Frost Method)," published by the American Public Health Association.

### ADVANTAGES OVER STANDARD PLATE METHOD

1. Rapidity of method, requiring only from 1/12 to 1/4 of the time required with the standard plate method.
2. Simplicity of technique.
3. Economy, due to small amount of materials required, both apparatus and media.
4. Special adaptability for field work, because of the light and compact equipment. The carrying case may serve as an incubator.
5. Feasibility of determining total number of bacteria by making single cells visible through proper staining.
6. Possibility of identifying, by means of the higher powers of the microscope, the different organisms present through their individual peculiarities as shown on the little plate.
7. Ability to distinguish dead from living bacteria, in connection with the study of pasteurization.
8. Ability to keep a faithful permanent record for future use by filing the dry slides.
9. Reliability of the method, since the little plates can all be counted due to (1) the relatively large amount of milk used, (2) smaller dilution required and (3) lack of interference from spreaders.

### ACCURACY

Numerous tests made by Frost and others show that the results secured by this method compare reasonably well with those obtained by the standard plate method. Variations between the two methods are no greater than between duplicate determinations by the standard plate method.

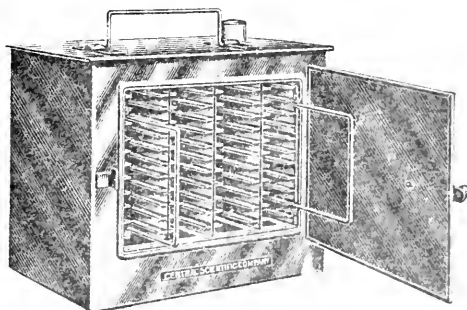

Moist Chamber Cabinet

For Complete Descriptions and Directions for Use, send for Bulletin 97B.

## CENTRAL SCIENTIFIC COMPANY

LABORATORY SUPPLIES  
Apparatus CHEMICALS

460 E. Ohio St.,

CHICAGO, U.S.A.  
Chicago

U.S.A.



## BACTO-PEPTONE

has stood the test of six years of use in laboratories all over the world.

### DEHYDRATED CULTURE MEDIA

are a signal advance in the science and art of bacteriology.

### RARE SUGARS "DIFCO"

are of the highest standard of purity, especially suitable for bacteriological work.

### OTHER FINE CHEMICALS

are gradually being added to our line, such as

*Acid Potassium Phthalate, Decolorizing Carbon, Tyrosine, Invertase.*

---

*Send for descriptive bulletins and price list. "DIFCO" products are carried in stock by the principal dealers in Scientific Supplies.*

---

## DIGESTIVE FERMENTS COMPANY

Detroit, Michigan, U. S. A.

THIS NUMBER COMPLETES VOLUME VI

VOLUME VI

NUMBER 6

# JOURNAL OF BACTERIOLOGY

OFFICIAL ORGAN OF THE SOCIETY OF AMERICAN  
BACTERIOLOGISTS

NOVEMBER, 1921

EDITOR-IN-CHIEF

C.-E. A. WINSLOW



*It is characteristic of Science and Progress that they continually  
open new fields to our visions.—PASTEUR.*

PUBLISHED BI-MONTHLY  
WILLIAMS & WILKINS COMPANY  
BALTIMORE, U. S. A.

Entered as second-class matter April 17, 1916, at the postoffice at Baltimore, Maryland, under the act of March 3, 1879. Acceptance for mailing at special rate of postage provided for in Section 1103, Act of October 3, 1917. Authorized on July 16, 1918.

Copyright 1921, Williams and Wilkins Company

Price, net { \$5.00 per volume, United States, Mexico, Cuba  
postpaid { \$5.25 per volume, Canada  
          { \$5.50 per volume. other countries

# Holadin and Bile Salts

Holadin - - 2½ grs.

Bile Salts - - ½ gr.

(enteric capsules)

“Investigations begun originally by Professor “Nencki in his Berne laboratory and carried “on by Heidehain, Rachford, Williams and “Martin, have shown that the bile has a “favouring action on the ferments of the pan- “creatic juice.

“The Bile, indeed, proved itself to be a “constant and powerful auxiliary of the pan- “creatic juice, a fluid which is of such impor- “tance for digestion and in itself already so “complicated.”

—Prof. J. P. Pawlow.

“*Holadin and Bile Salts*”, a combination of the most potent pancreas extract with the isolated glycocholate and taurocholate of sodium, in their native association—

is a therapeutic resource of distinct service in pancreatic (intestinal) disorders dependent upon, or associated with, deficient bile action.

FAIRCHILD BROS. & FOSTER  
New York

# HENRY HEIL CHEMICAL CO.

210-214 South 4th Street

St. Louis, Mo.

IMPORTERS AND MANUFACTURERS OF

## Chemical Apparatus, Chemicals, Laboratory and Assay Supplies Generally

*We have the stock and can make prompt delivery*

### SPECIALTIES:

Best Grade of American Glassware, “Non-Sol,” “Perfection,” “Pyrex” and “Fry” Munktell, Whatman and H. H. C. Co.’s. crimped white Filtering Paper, low in ash and filtering rapidly, especially manufactured for us in America

Coors Best American Porcelain Ware

Troemner & Becker Balances and Weights, Platinum, Wire, Foil and Ware

Fused Silica Laboratory Utensils “Vitrosil”

Hanovia Pure Transparent Quartz Glass, Alundum Ware

Hoskins’ Electric Furnaces, Chatelier’s Pyrometers, Bausch and Lomb Microscopes and Accessories

Hydrometers and Thermometers of every description

Chemically Pure Acids and Ammonia, Molybdic Acid and Molybdate of Ammonia

Merck’s, Baker & Adamson’s and J. T. Baker Chemical Co.’s Chemicals and Reagents

Caustic Potash and Soda, purified in sticks and pure by alcohol, Acetate of Lead, Cyanide Mixture,

Soda Ash and Commercial Caustic Soda

We carry a very large and complete stock of everything used in the laboratory and solicit your orders or inquiries. There is nothing in the chemical line which we cannot furnish. You will find us prompt, courteous and reliable.

*In our Glassblowing Establishment we can produce any Apparatus, no matter how complicated*

# JOURNAL OF BACTERIOLOGY

OFFICIAL ORGAN OF THE SOCIETY OF AMERICAN BACTERIOLOGISTS

DEVOTED TO THE ADVANCEMENT AND DISSEMINATION OF KNOWLEDGE IN REGARD TO THE BACTERIA AND OTHER MICRO-ORGANISMS

## *Editorial Board*

### *Editor-in-Chief*

C.-E. A. WINSLOW  
Yale Medical School, New Haven, Conn.

A. PARKER HITCHENS

F. C. HARRISON, *Ex officio*  
Principal, MacDonald College,  
P. Q., Canada

## *Advisory Editors*

C. C. BASS  
R. E. BUCHANAN  
P. F. CLARK  
F. P. GAY  
F. P. GORHAM  
F. C. HARRISON

H. W. HILL  
E. O. JORDAN  
A. I. KENDALL  
C. B. LIPMAN  
C. E. MARSHALL

V. A. MOORE  
M. E. PENINGTON  
F. B. PHELPS  
L. F. RETTGER  
L. A. ROGERS

M. J. ROSENAU  
W. T. SEDGWICK  
F. L. STEVENS  
A. W. WILLIAMS  
H. ZINSSER

## CONTENTS

GEORGE E. HOLM AND JAMES M. SHERMAN. Salt Effects in Bacterial Growth. I. Preliminary Paper .....	511
HILDA HEMPL HELLER. Suggestions Concerning a Rational Basis for the Classification of the Anaerobic Bacteria. Studies in Pathogenic Anaerobes. IV. I. Preliminary Paper.....	521
J. HOWARD BROWN. Hydrogen Ions, Titration and the Buffer Index of Bacteriological Media .....	555
J. E. RUSH AND G. A. PALMER. On Decreasing the Exposure Necessary for the Gelatin Determination.....	571
HAROLD MACY. Chart of the Families and Genera of the Bacteria.....	575
Index to Volume VI .....	577

Abstracts of American and foreign bacteriological literature appear in a separate journal, *Abstracts of Bacteriology*, published monthly by the Williams & Wilkins Company, under the editorial direction of the Society of American Bacteriologists. Back volumes can be furnished in sets consisting of Volumes I, II, III and IV. Price per set, net, postpaid, \$24.00, United States, Mexico, Cuba; \$25.00, Canada; \$26.00, other countries. Subscriptions are in order for Volume V, 1921. Price, per volume, \$5.00, United States, Mexico, Cuba; \$5.25, Canada; \$5.50, other countries.

# PETRI DISHES

The Petri Dishes now in our stock are of a quality and finish superior to any dishes we have had to offer since 1914.

The 100 x 10 mm is the standard size for bacteriological use throughout the U. S., but as there is an increasing demand for a deeper dish, we also supply 100 x 15 mm dishes.

The bottoms are exactly 95 mm outside diameter and can be used with Clay Covers 97 mm inside diameter, and the tops can be used with Clay Covers 103 mm inside diameter. The tops and bottoms are also sold separately.

Size	100 x 10 mm	100 x 15 mm
Per pair .....	.25	.25

*10% discount in cartons containing 1 dozen pairs*  
*20% " " cases " 1 gross "*  
*25% " " lots of 10 gross pairs*

---

*Prices subject to change without notice*

---

**ARTHUR H. THOMAS COMPANY**

WHOLESALE, RETAIL AND EXPORT MERCHANTS

**LABORATORY APPARATUS AND REAGENTS**

WEST WASHINGTON SQUARE

PHILADELPHIA, U. S. A.



# SALT EFFECTS IN BACTERIAL GROWTH<sup>1</sup>

## I. PRELIMINARY PAPER

GEORGE E. HOLM AND JAMES M. SHERMAN

*From the Research Laboratories of the Dairy Division, United States Department of Agriculture, Washington, D. C.*

Received for publication February 28, 1921

The Hofmeister series shows the effects of ions of neutral salts upon the coagulation of colloids and upon the swelling and other physical properties of proteins. Our knowledge of these ion effects in solution has been greatly extended by Freundlich and his students. They noted that the ions could be arranged in a definite order with respect to their effects upon compressibility, surface tension, solubility, viscosity, absorption, ratio of reaction, etc. Freundlich seems to favor the hydration theory of salts as an explanation of this neutral salt action, and since the properties affected are so closely related and bound up with one another, and the ions so consistent in their order of effect, he calls these effects "lyotropic" effects. The lyotropic explanation does not lay claim to being a full explanation of neutral salt action, but it does lay claim to correctness in that it systematically treats complicated phenomena.

In most cases the influence of the anion far outweighs that of the cation and the order of anion effects usually reads as follows,  $F > SO_4 > PO_4 > Cl > NO_3 > Br > I > CNS$ ; while the order of arrangement for the cation is usually  $Ca > Sr > Mg > Cs > Rb > K > Na > Li$ . The same sequence is obtained in the widely differing changes mentioned above and does not seem to follow any recognizable order with respect to valency, atomic weight, etc. Certain reagents may promote or hinder the salt effects as compared with those in pure solution. In some cases the

<sup>1</sup> Published with the permission of the Secretary of Agriculture.

LIBRARY  
NEW YORK  
BOTANICAL  
GARDEN

order of effects may be reversed when changes take place in acid or in alkaline solutions, but the sequence usually remains the same.

The lyotropic effects of salts upon compressibility, surface tension, solubility, etc., of organic and inorganic substances in solution is not great in most cases. It is in the field of colloid chemistry that these effects attain a magnitude of great significance. A review of the literature covering this field is out of the question here, but a few citations from the biochemical field will serve to show the reasons for extending the work to the field of bacteriology.

In view of the recent and extensive investigations of Loeb (1918-1921) upon the physical and chemical properties of proteins it will probably be necessary to modify certain conceptions now held concerning the relative magnitude of various ionic effects in protein solutions. As to whether the Hofmeister series of ions will be shown to be entirely a delusion, as is believed by Loeb, we do not care to express an opinion, and it is not the purpose of the present paper to take sides on that controversial question.

Whatever may be the status of ion effects in protein chemistry, specific ionic effects in biological phenomena have been well established by the work of Loeb and many others. It is our purpose to study systematically salt effects, especially the qualitative and quantitative relationships of radicals (anions and cations), as related to bacterial growth, and to correlate these findings with other effects which have been noted in pure chemistry as well as in biology.

Closely related to the phenomena of hydration and coagulation is that of permeability and diffusion. On the basis of the view of Bechhold and Ziegler (1919) that membranes do not act like sieves, but as though they were a network of arranged ions, it is easy to conceive of enormous salt effects upon permeability, both by influence upon ions which are to diffuse and by effects upon ions forming the membrane network.

Bacteria perhaps represent matter in a state as near the state of colloids and also as near the state of living protoplasm as

any organism does. The effects of salts should therefore not only be very marked but might reach magnitudes that ought to be taken into account in the culture of bacteria.

Brooks (1919) found that NaCl and KCl in concentrations of 0.15 to 0.20M increased the rate of respiration of *B. subtilis*, while in higher concentrations they decreased the rate. CaCl<sub>2</sub> increased the rate in a concentration of 0.05M and decreased the rate in higher concentrations. Dealing with the respiration of *Aspergillus niger*, Gustafson (1919) likewise found a stimulation by NaCl in concentrations of 0.25 to 0.5M and by 0.5M CaCl<sub>2</sub>.

The work of Winslow and Falk (1919) shows that NaCl and CaCl<sub>2</sub> both increase the mortality of *Bact. coli* in water. In the case of NaCl 5 isotonic was distinctly lethal, while in the case of CaCl<sub>2</sub> 0.1 isotonic was injurious.

Greaves (1916) found the toxicity of anions as measured by ammonification in soils to be in the following order: Cl > NO<sub>3</sub> > SO<sub>4</sub> > CO<sub>3</sub>. He also noted that the toxicity of some salts increases more rapidly with increased concentration than does that of others. This action he ascribes to the physiological factor of the organism rather than to the osmotic pressure or salt action of the solution.

The influence of alkaline salts upon phagocytosis was found by Radsma (1920) to depend mainly upon the anions but also somewhat upon the cations. Radsma explains the effect as surface action and considers it an indication of colloidal chemical structure of protein substances at the surface.

Mathews (1906) pointed out that the action of salts upon the protoplasmic system is due chiefly to the ions of the salts and he considers the physiological action dependent upon the available potential energy.

Whether or not the salt action upon bacteria is due to the available potential energy of the ions we shall not attempt to decide. We merely wish to point out in this paper that salts do affect bacterial growth much in the same manner as they affect chemical reactions, coagulation, permeability, etc.; that

this effect is modified by the hydrogen ion concentration of the medium, and that such effects are probably great enough to be given consideration in bacterial culture.

#### EXPERIMENTAL

The organism used was *Bact. coli*, and the basic medium chosen was a 1 per cent pepton solution to which was added the crystalline salts in amounts necessary to give the desired concentrations. The media were autoclaved and filtered in case of the formation of a slight precipitate. At this point the pH was adjusted if necessary with HCl or NaOH, and the media tubed and sterilized. These tubes containing 10 cc. were in each case inoculated with a loopful of a young culture and incubated at 37°C.

There was some question as what should constitute a measure of bacterial growth and what factor would be constant enough for comparative purposes. The reduction of methylene blue was first tried. In this case a layer of paraffin oil was used to prevent oxidation by the air. Although it worked quite satisfactorily, it was found that reoxidation occurred in the cases where bacterial action was slow, and thus, instead of giving a sharp end point, really increased the time for reduction. The rapidly growing cultures gave a sharp end point. It was noticed, however, that a slight turbidity was apparent in most cases before reduction could be detected. It was decided, therefore, to use the first sign of turbidity as an indication of the rapidity of bacterial growth.

A few trial experiments indicated that the two methods of detecting growth checked very well, except for the fact that turbidity was first detected and proved a sharper measure than reduction. The first sign of turbidity when the tubes were held against a strong artificial light was therefore used to measure rapidity of growth. This method was further verified by growing the same organism in a medium of 1 per cent pepton containing 1 per cent lactose and adjusted to a pH of 7.0. The production of acidity paralleled the results obtained by reduction and visible turbidity.

Inasmuch as the anionic effects seem to be predominant in chemical reactions it was decided to try the effects of salts having a common cation (sodium). The salt concentration chosen to be used was 0.20 molar, which was low enough to give the ionic effects and not too pronounced osmotic effects of the salts. To eliminate as nearly as possible H-ion effects the pH was adjusted to 7.0, colorimetrically, before final sterilization.

TABLE I

*Showing the effect of various sodium salts upon the rate of growth of Bact. coli*

MEDIUM	pH	TIME REQUIRED TO SHOW TURBIDITY
		<i>hours</i>
1 per cent pepton.....	7.2	4½
1 per cent pepton 0.20 M NaCl.....	7.3	3½
1 per cent pepton 0.20 M NaI.....	7.3	3½
1 per cent pepton 0.20 M NaNO <sub>3</sub> .....	7.3	3½
1 per cent pepton 0.20 M Na <sub>2</sub> SO <sub>4</sub> .....	7.0	4
1 per cent pepton* 0.20 M Na H PO <sub>4</sub> .....	7.3	4½
1 per cent pepton† 0.20 M Na lactate.....	7.0	4½
1 per cent pepton 0.20 M Na oxalate.....	7.0	9½
1 per cent pepton 0.20 M Na acetate.....	7.0	10½
1 per cent pepton 0.20 M Na citrate.....	7.3	10½
1 per cent pepton 0.20 M Na fluoride.....	7.4	48

\* Mono- and di-sodium phosphate were mixed in proper proportions to give a pH of approximately 7.0.

† The sodium lactate used was prepared by adding NaOH to lactic acid until a pH of 7.0 was reached.

Table I shows the effects of various sodium salts upon the growth of *Bact. coli*. The table indicates that the Cl, I, NO<sub>3</sub>, SO<sub>4</sub>, PO<sub>4</sub>, and lactate ions accelerate growth of *Bact. coli*, while the other ions tried inhibit to a greater or less extent. Using the Cl, I, SO<sub>4</sub>, and lactate ions in the same concentrations, the series was repeated with the following results:

<i>Medium</i>	<i>Time</i> <i>hours</i>
1 per cent pepton.....	4½
1 per cent pepton 0.20 M NaCl.....	3½
1 per cent pepton 0.20 M NaI.....	3½
1 per cent pepton 0.20 M Na lactate.....	3½
1 per cent pepton 0.20 M Na <sub>2</sub> SO <sub>4</sub> .....	4½

Table 1 indicates that there is a marked effect of salts upon the growth of *Bact. coli*, and it would seem that it is largely due to the anion.

To find out to what extent the cation affects such growth the effect of the following salts were tried: KCl, NaCl,  $\text{NH}_4\text{Cl}$ ,  $\text{MgCl}_2$ ,  $\text{CaCl}_2$ , and  $\text{FeCl}_3$ . Table 2 gives the effects of 0.20 molar concentrations of these salts upon growth. Table 2 seems to indicate that there is little difference between the effects of the Na, K, and  $\text{NH}_4$  ions. Since in the case of  $\text{MgCl}_2$  we have twice the concentration of Cl ions which we have in the former, a true comparison cannot be made if the anionic effects predominate. To make our experiments comparable we compared growth in a 0.20 molar NaCl pepton medium with growth in

TABLE 2  
*Showing the effect of various cations upon the rate of growth of Bact. coli*

MEDIUM	pH	TIME REQUIRED TO SHOW TURBIDITY
		<i>hours</i>
1 per cent pepton.....	Approx. 7.0	5
1 per cent pepton 0.20 M NaCl.....	" 7.0	$3\frac{1}{2}$
1 per cent pepton 0.20 M KCl.....	" 7.0	$3\frac{3}{4}$
1 per cent pepton 0.20 M $\text{NH}_4\text{Cl}$ .....	" 7.0	$3\frac{3}{4}$
1 per cent pepton 0.20 M $\text{MgCl}_2$ .....	" 7.0	8
1 per cent pepton 0.20 M $\text{CaCl}_2$ .....	" 7.0	120
1 per cent pepton 0.20 M $\text{FeCl}_3$ .....	" 7.0	No growth

0.10 molar  $\text{MgCl}_2$  pepton medium. The effects of 0.40 molar NaCl and 0.20 molar  $\text{MgCl}_2$  were also tried.

The results are shown in table 3.  $\text{MgCl}_2$  and NaCl, therefore, in concentrations where the number of Cl ions is the same, are comparable in effect. That there is a cation effect in greater concentrations, however, is shown by the fact that the time for 0.20 molar  $\text{MgCl}_2$  is 12 hours, while that for 0.40 molar NaCl is but  $4\frac{3}{4}$ . Doubling the NaCl concentration changes the time rate very little, while doubling the  $\text{MgCl}_2$  concentration more than triples the time. This is strong evidence that there is a cation effect, though it may not be so marked as the anion effects.  $\text{CaCl}_2$  has a much stronger inhibiting effect while  $\text{FeCl}_3$  entirely inhibited growth in the concentration used.

Our results so far have been obtained upon media adjusted to a pH of approximately 7.0. Since we know that the H-ion concentration materially affects growth of bacteria, it is of both interest and value to know to what extent the salts modify the time element at pH values on either side of neutrality. Table 4 shows these effects with the salts given and at the H-ion concentrations stated. The results indicate that the different salts

TABLE 3

Showing the effects of various concentrations of NaCl and of MgCl<sub>2</sub> upon the rate of growth of *Bact. coli*

MEDIUM	pH	TIME REQUIRED TO SHOW TURBIDITY
		hours
1 per cent pepton 0.20 M NaCl.....	7.0	3 $\frac{1}{4}$
1 per cent pepton 0.40 M NaCl.....	7.0	4 $\frac{3}{4}$
1 per cent pepton 0.10 M MgCl <sub>2</sub> .....	7.0	3 $\frac{1}{4}$
1 per cent pepton 0.20 M MgCl <sub>2</sub> .....	7.0	12

TABLE 4

Showing the effects of various salts upon the growth of *Bact. coli* at different H-ion concentrations

MEDIUM	TIME OF VISIBLE GROWTH AT pH VALUES OF				
	5.2	6.2	7.6	8.2	9.2
	hours	hours	hours	hours	hours
1 per cent pepton.....	17 $\frac{1}{4}$	5 $\frac{3}{4}$	6 $\frac{1}{2}$	8	32
1 per cent pepton 0.20 M NaCl.....	5 $\frac{1}{2}$	4 $\frac{1}{2}$	3 $\frac{1}{2}$	3	14
1 per cent pepton 0.20 M Na <sub>2</sub> SO <sub>4</sub> .....	6 $\frac{1}{2}$	4 $\frac{1}{2}$	4 $\frac{1}{2}$	3 $\frac{1}{2}$	
1 per cent pepton 0.20 M Na citrate.....	26	8 $\frac{1}{2}$	7 $\frac{1}{2}$	22	

have marked changes of effect with changes in pH. In general we may say that NaCl and Na<sub>2</sub>SO<sub>4</sub> widen the optimum range of growth, while Na citrate narrows this pH range.

## DISCUSSION

The data presented show in a general way some correlation between the so-called lyotropic series and the order of effect upon the growth of *Bact. coli*. There are, however, ions which

are exceptions and which, in concentrations thus far tried, have proved highly retarding in their action. These ions are the sulphocyanate and fluoride. Whether in lower concentrations they might not prove but slightly retarding or even beneficial to growth remains to be ascertained. The position of the  $\text{SO}_4$  radical with regard to effect upon bacterial growth is also somewhat at variance with its usual position in the lyotropic series. Instead of being found opposite the iodine end of the series it is found next to the Cl and I radicals.

While these are deviations from the usual order, it is not surprising since in many of the phenomena in biochemistry the lyotropic order does not strictly compare with the usual order as determined by effects upon surface tension, viscosity, etc., especially at different concentrations and temperatures. We must also remember that here we are dealing with an added factor which is not present with proteins in solution or with colloids in general; that is, the life of an organism. Since this is our measure of effects it must be taken into account. We do not know what properties affect viability most, and consequently we have no means of knowing what mechanism causes retarding and inhibitory effects. There seems to be, as might be expected, an order of specificity which must be taken into account.

The general order of the lyotropic series, however, holds at pH 7.0 Cl and I are found at one end of the series aiding or accelerating action, while the citrate, acetate, and oxalate at the other end retard growth.

Considering the effect of cations, we have a close analogy between action here and action of salts in the animal body. As might be expected, there is little difference between the Na, K, and  $\text{NH}_4$  ions. With Mg the action begins to manifest itself, although it is greatly modified by the anion effect. The calcium ion produces its characteristic strong effect.

It is in media of different H-ion concentrations that these effects become significant. In the region of optimum growth the influences are not exceedingly marked, but as we near the H-ion concentrations which mark the limits for growth of *Bact. coli*



the differences in the rate of growth are greatly increased. In other words the H-ion range for optimum growth is widened or narrowed as shown in the table given.

This factor becomes of practical value in adjusting media for optimum bacterial growth. The figures show that certain ions are of value in pepton media for accelerating the growth of *Bact. coli* and also for widening the range for optimum growth, while certain other ions narrow the H-ion range and decrease the rate of growth. This would perhaps explain the findings of Cohen and Clark (1919) that culture media adjusted with HCl had a higher limit of growth on the acid side than media adjusted with acetic acid.

#### SUMMARY.

It has been shown that the growth of *Bact. coli* in 1 per cent pepton medium is accelerated or retarded by different salts in low molecular concentrations.

The salt effects at various H-ion concentrations vary greatly. Those salts which accelerate growth seem to widen the H-ion range for optimum growth, while those which retard growth seem to narrow the limits for optimum activity.

Cations and anions are both effective.

#### REFERENCES

- BECHHOLD, H., AND ZIEGLER, J. 1919 *In* Colloids in biology and medicine, by H. Bechhold and J. G. M. Bullock, p. 55.
- BROOKS, M. M. 1919 *Jour. Gen. Physiol.*, **2**, 5.
- COHEN, B., AND CLARK, W. M. 1919 *Jour. Bact.*, **4**, 409.
- GREAVES, J. E. 1916 *Soil Science*, **2**, 443.
- GUSTAFSON, F. G. 1919 *Jour. Gen. Physiol.*, **2**, 17.
- LOEB, J. 1918-1921 *Jour. Gen. Physiol.*, 1918-19, **1**, 39, 237, 363, 483, 559; 1919-20, **2**, 87, 273; 1920-21, **3**, 85, 247, 391.
- MATHEWS, A. P. 1906 *Jour. Infect. Dis.*, **3**, 572.
- WINSLOW, C.-E. A., AND FALK, I. S. 1919 *Abs. Bact.*, **3**, 5.



SUGGESTIONS CONCERNING A RATIONAL BASIS FOR  
THE CLASSIFICATION OF THE ANAEROBIC  
BACTERIA<sup>1</sup>

STUDIES IN PATHOGENIC ANAEROBES. IV

I. PRELIMINARY PAPER

HILDA HEMPL HELLER

*From the George Williams Hooper Foundation for Medical Research, University  
of California Medical School, San Francisco*

Received for publication March 1, 1921

During the past three or four years I have made a study of a carefully controlled series of certain groups of anaerobic strains secured from pathological material. Attention was directed almost entirely to such strains as were found to be capable of penetrating living guinea-pig muscle in doses of 1 cc. or less of young ground beef-heart culture. *B. Welchii* was not considered, and this organism is not included in the following list. Though I was forced for want of time to neglect non-pathogenic forms, such organisms are so frequently encountered in a study of pathological material that one who has collected anaerobes of one group must necessarily observe those of other sorts and learn something of their ways. The pathogenic tissue-invading strains included in my collection are 80 in number: 23 from human wound infections, 32 from cases of so-called "blackleg" of cattle, 10 from cases of braxy and of blackleg of sheep, and 15 from other animals. The collection includes 30 odd strains of tetanus and other proteolytic organisms of various sorts.

<sup>1</sup> This work and that described in the following papers was commenced during the author's tenure of the Alice Freeman Palmer Fellowship of Wellesley College.

All strains were carefully isolated and the cultures were continually observed in order to detect contaminations.<sup>2</sup>

The samples collected, though they do not exhaust the pathological material from anaerobic infections, are very widely representative, and the collection of much more material and the isolation from it of many more pathogenic strains would be an exceedingly arduous task. It must also be borne in mind that in greatly increasing the number of strains under observation one must necessarily relax the vigilance with which he criticises the purity of those strains which are studied. The examination of any considerable number of anaerobes is a comparatively new task, and any proposal for classification which is made at the present period is bound to be a temporary one. The time is unquestionably not ripe for an elaborate study of several hundred strains of any particular type of anaerobe because the material for such a study has never been collected, and such a collection would represent several years' work and a considerable outlay for experimental animals. But the cultures that I have been able to isolate during the past few years have furnished so much material for investigation, and the information gained from them has so radically altered my attitude toward the anaerobic group, that I feel that the time has arrived to state my results, to organize them as consistently as may be, and to propose a system for their classification. In other words I feel that the status of the classification of the anaerobes is today so chaotic and unsatisfactory that a pioneer effort at a logical grouping according to our present knowledge is very much needed. If we consider the fact that the investigated material, when compared with the vast amount of uninvestigated material, is exceedingly scanty, we shall not expect such a classification to be final. We have today, however, a fairly definite conception of the pathogenic anaerobes, and by analyzing the

<sup>2</sup> An account of the affinities of the animal strains studied will be found in part in *The Journal of Infectious Diseases* for November, 1920, Vol. 27, and in full in the *Collected Reprints of the Hooper Foundation* for 1921, Vol. VI, under the title "Etiology of Acute Gangrenous Infections of Animals." This paper contains a description of the methods employed in the isolation of my cultures.

groups thus studied we shall be enabled so to orient our classification of the whole anaerobic group that some conception of its size and general relationships will be presented for the use of future investigators.

The uncertainties prevailing in the classification of the anaerobes, apparent to anyone who has tried to identify an isolated anaerobic strain, become more glaring as one proceeds to study several strains that were handed to him under the same name, but which display great differences in their behavior. Later, on continuous study of anaerobes of various types, and of the literature of anaerobic infections, the worker comes to the realization that identifications by means of descriptions found in the existing literature can at best be only tentative and approximate, and that the majority of those type strains on which were based the descriptions to which we are compelled to refer for priority are now lost or badly contaminated. Thus a large number of the older descriptions are potentially invalidated, or orphaned, so to speak, and cannot, today, be used for any definite systematic purpose, and the names proposed in those descriptions are now *nomina nuda*. This situation must be deliberately faced. What we need is an elastic, adaptable system of classification in which the old descriptions can find a place as well as the new: a system consistent, also, with the Rules of Botanical Nomenclature, whose adoption has been proposed by the Committee of the Society of American Bacteriologists.

#### FORMER CLASSIFICATIONS

It is necessary to consider what have been the methods of classifying our group that have been proposed by other workers.

Zopf defined the genus *Bacillus* as including: "Cocci and rods with spores" and the genus *Clostridium* as: "Like *Bacillus* but spores in spindle-shaped elements."

Kruse (1896, pp. 67 and 185) included in his family of *Bacillaceae* three groups which comprise the anaerobes. They are:

6. The malignant oedema group: large spore-bearing anaerobic bacilli. Saprophytic or parasitic. Colonies on agar usually stellate.

No change in form of mother cell on spore formation. Less easily stained by Gram method than preceding group (anthrax group). Usually liquefy gelatin and produce foul odors.

7. The symptomatic anthrax and butyric acid group. Large bacilli that swell to form clostridia on sporulation, saprophytic and parasitic, mostly anaerobes.

8. Tetanus group. Fairly large bacilli with drumstick (Knöpfchen) spores. Mostly anaerobic parasites and saprophytes.

Migula (1900) included in his family *Bacteriaceae* the peritrichially flagellate rods in one enormous genus, *Bacillus*; the non-flagellate rods in another, *Bacterium*.

Fischer (1903) in his second classification divided the *Bacillaceae* into: Sporulating and non-sporulating rods, sporangia unchanged in shape, *Bacillieae*; and spore-bearing rods modified in shape: spindle-shaped, *Clostridieae*, and drumstick shaped, *Plectridieae*.

Lehmann and Neumann (1904) divide the *Bacteriaceae* into the genera: "*Bacterium*, without endogenous spores, rods usually under 0.8 to 1 $\mu$  in diameter," and "*Bacillus*, with endogenous spores, rods often more than 1 $\mu$  in diameter."

Orla-Jensen (1909) in his comprehensive reorganization of systematic bacteriology according to the chemical behavior of the organisms, proposed for the higher bacteria the order *Peritrichinae*, to include rods and spherical forms which show a marked tendency to split carbohydrates and amino-acids. In this order he proposed four families, two aerobic and two anaerobic, two producing acid and two producing alkali. The anaerobic families he called *Butyribacteriaceae* and *Putribacteriaceae*. He would place with these, I presume, the anaerobic cocci, and spore-formation is evidently not a requisite criterion for admission to the anaerobic groups. In the *Butyribacteriaceae* he proposed three genera: *Butyribacillus* (to include *B. Welchii* and *B. Chauvoei*), *Pectobacillus*, and *Cellulobacillus*. In the *Putribacteriaceae* he proposed the genera *Putribacillus* and *Botulobacillus*, the latter to include *B. botulinus* and *B. tetani* on account of their toxin production.

The Committee of the Society of American Bacteriologists (1920, classification first formulated in 1917) places in the family (no. VII) *Bacillaceae*, sporulating rods, two divisions which are ranked as genera. These are: 1. The genus "*Bacillus* Cohn 1872 Aerobic forms. Mostly saprophytes. Liquefy gelatin. Often occur in long threads and form rhizoid colonies. Form of rod usually not greatly changed at sporulation. The type species is *Bacillus subtilis* Cohn:" and genus 2: "*Clostridium* Prazmowski 1880 Anaerobes or micro-aerophiles. Often parasitic. Rods frequently enlarged at sporulation, producing clostridium or plectridium forms. The type species is *Clostridium butyricum* Prazmowski."

Breed, Conn and Baker (1908) commented at length on the major divisions proposed by the Committee: "This family, for the spore forming rods, has very good justification. The two genera, *Bacillus* and *Clostridium* can probably be separated, but whether on the basis of relation to oxygen or of shape of the sporangium, the future must decide. Although relation to oxygen is a very important physiological distinction, it must be admitted that the selection of a physiological basis for the separation of these two genera is rather unsatisfactory. It places some of the polar-spored organisms in one genus, some in another, and raises the question where to place facultative anaerobes like *B. mycoides* and *B. cereus*." These authors proposed a family (5): "*Bacillaceae*, rods producing endospores, usually Gram-positive. Flagella, when present, peritrichous. Primarily saprophytes secreting proteolytic enzymes. A few parasites." This family would include the majority of the anaerobes and many aerobes.

Buchanan (1918, a and b) reclassified the bacteria, using physiological characters far less than did the Committee. His classification of the non-acid-fast members of the family *Bacteriaceae*, sporeogenous rods, is as follows: Tribe 1. *Bacilleae*, endosporogenous rods, with four genera: 1. *Bacillus*, Aerobic rods, usually Gram-positive, as a rule liquefying gelatin, spores usually not distorting rods when formed. 2 and 3. Anaerobic or micro-aerophilic usually: 2. *Plectridium*, spores produced at

extreme tip of cells, forming typical drumsticks. 3. *Clostridium*, spores not produced at extreme tip of cells, at least not forming drumsticks. Cells usually somewhat swollen when spores are formed. 4. *Metabacterium*, with usually a number of spores within a swollen cell. Tribe 2. *Bacteriaceae*, not producing endospores.

Rahn (1920) defines the anaerobes as sporulating rods that store up Iogen (granulose) with or without glycogen. He believes that further research would show the possibility of changing any spore-forming anaerobe into another.

#### THE CHARACTERS USED FOR CLASSIFICATION

Let us consider the value in classification of the characters whose use has been proposed in the above arrangements.

*Morphology of the vegetative cell.* Most of the authors define the *Bacillaceae* as rods. Exceptions to this rule are the arrangements of Zopf (1885) who believed in the transformation of bacterial species, and of Jensen (1909), who used physiological characters for his classification. Both Zopf and Jensen state that spherical forms may be included in such a family. Apparently the unity of origin of the cocci has never been settled by systematists. Winslow and Winslow say (1908): "Yet a consideration of the properties of the members of the group makes it clear that they are mutually interrelated and all sharply separated from the rod-shaped bacteria, except perhaps at one end of the series which they form." Breed, Conn, and Baker do not consider the question of the unity of the origin of all spherical bacteria as settled. The series of strains which Winslow and Winslow used for their study did not, I believe, include any strict anaerobes. Many cocci are facultatively anaerobic. Strict anaerobes of this group are only occasionally met with, but it does not follow that their occurrence is very rare, because the usual technique for the isolation of anaerobes involves some heating process that eliminates the non-sporulating organisms. Anaerobic cocci have been described by a number of authors. Ozaki reviewed the subject (1915<sup>b</sup>). There are, in his list, four



diplococci, three micrococci, and four staphylococci, one of these latter appearing at times as a streptococcus or as a micrococcus. Anaerobic streptococci are, according to Hüssy and Bondy, normally human saprophytes which may become parasitic. They are commonly found in cases of puerperal endometritis, according to these authors and according to Schottmüller. Adamson isolated anaerobic diplococci from eighteen out of fifty-one wounds. Sternberg has described an anaerobic streptococcus. Anaerobic cocci have been found in the blood of scarlet-fever patients by Dick and Henry and in that of measles patients by Tunnicliff. Beijerinck (1906) finds a sarcina in soil that is a fermenting anaerobe. Winslow and Winslow did not find the arrangement of the cells of the cocci a good basis for classification. About half the anaerobic cocci produce gas in sugar media. Probably nothing can be decided as to the real affinities of these anaerobic cocci until the chemical behavior of some of them has been studied by one worker and has been compared with that of the anaerobic rods. A morphological basis, when one considers the varied types of anaerobic cocci, would certainly lead one to conclude that anaerobiosis had been independently acquired by certain strains of the various types. Here, as in many cases, morphological and chemical criteria flatly contradict each other. But form of cell (sphere, rod, or spiral) is certainly to be recognized as a much more fundamental character than is the arrangement of cells. Nevertheless, Almquist found that bacilli may grow as spheres at low temperatures. Yet it would seem that the anaerobic cocci do resemble other cocci in their chemical behavior more than they do the anaerobic rods (see Adamson, 1918-19, p. 394). So for the present it is advisable to exclude them from an anaerobic group which contains rods. The chemical study of the anaerobic cocci should be more extensive before they can be placed anywhere.

*Motility.* The possession of flagella was used as a primary character for classification by Migula, spore-formation being given a secondary place. Chester followed Migula in crediting importance to this character; but other workers have not done so. The Committee (1920, p. 516) state: "The prominent place

given to motility seems to us to constitute a peculiar infelicity in these schemes." And Winslow and Winslow (1908, p. 52) do not find motility correlated with other characters in the group of the *Coccaceae*. It would seem that for our purposes the character of motility was entirely unsuited for the making of major divisions. Thus organisms in general so similar as *B. Welchii* and *B. Chauvoei* were placed by Migula's system in entirely different groups because one was flagellate and the other was not. And aerobes of many sorts and proteolytic anaerobes dwell in his work peacefully side by side with *B. Chauvoei* in the enormous and unwieldy genus *Bacillus*; while *B. Welchii* on account of its nudity is relegated to the genus *Bacterium* along with *Bacterium tuberculosis* and other strangers.

*Spore formation* has been turned to by many classifiers as an important character for the subdivision of the rod-like forms. Zopf, Kruse, Fischer, Lehmann and Neumann, the Committee, and Breed, Conn, and Baker have used it as a basis for making their primary division. It is probable that this is a character of far more value than is motility. It is, however, true that, though there are many similarities between the sporulating rods, we have no proof that they are more closely related to each other than they are to some of the non-sporulating rods, or that the formation of spores originated with any one type. Should we accept such a hypothesis, we should still be unable to show that certain sporulating rods had not lost their power of spore-formation. This power is certainly an advantage to a species, and on that account anaerobic forms losing it are not so likely to persist as are others. But that does not mean that such a phenomenon may not occur.

Kruse strenuously protests (1896, p. 81) the use of spore-formation as a primary character. Moreover the adoption of spore-formation as a character for the subdivision of the rods would make us exclude from the anaerobic group such organisms as *B. egypticus*, *B. necrophorus*, *Bacillus D* of Adamson, *B. fragilis* of Veillon and Zuber, and probably a goodly number of undescribed organisms which in their behavior closely resemble the sporulating anaerobes. I find that *B. egypticus* and another Gram-

positive pathogen are so similar in many respects to *B. Welchii* that they might easily be identified as one species by many workers, and it is evident that only an artificial classification would separate them, yet *B. egens* and the other pathogens have not been shown to produce spores. *Asporogenous* anaerobic rods have not been frequently reported, but when one remembers that the preliminary step in isolating anaerobes is usually a heating process, it will be clear that the proportion of anaerobes that do not sporulate may be considerably greater than one would estimate on the basis of published descriptions. The soil mixtures from which Weinberg's organisms, *B. egens* of Stoddard, and my above-mentioned pathogen were isolated had all been subjected to a physiological weeding out in human tissue before they were inoculated into media, and a colony method without heating was thus practicable for isolation purposes.

The matter of a primary division of the rod-shaped bacteria then simmers down to a question of whether an anaerobic habit or a spore-forming habit is the more fundamental one. It is perfectly evident that certain asporogenous anaerobes have closer physiological affinities with certain sporulating anaerobes than the latter have with the sporulating aerobes or even with most other anaerobes. We may have in the power of sporulation such a phenomenon as that noted among the insects: there are primitively wingless insects, the *Thysanura*, and there are various types of insects, such as the *Siphonaptera*, and the *Mallophaga*, which have lost their wings, and there are insects that have no wings at the time or in the form that we happen to observe them—larvae and pupae and worker ants and apterous mutants of winged forms. Therefore the possession of wings, conspicuous insect characteristic that it is, has been discarded as a character for the separation of insects from other forms. The whole question is reduced to the much agitated one: Are we going to give precedence to physiological or to morphological characters in the classification of the bacteria?

*Morphology of the sporangium* has been used as a character by a long succession of workers. Its use may be more vigorously attacked than that of the other characters. It was introduced

by strict morphologists (Zopf, Fischer) entirely independently of any physiological criteria, and in this way was quite justifiable because by its use a superficially consistent division could be made. The rods which did not swell at sporulation formed one group, those which did swell formed another. But Kruse and the Committee have superimposed upon this type of classification a physiological one, and the result is a division that it is impossible to carry out. Probably more aerobic rods fail to swell at sporulation than do anaerobic rods, but the exceptions to this rule are so numerous on both sides as to render worse than useless the employment of the morphological character in connection with the physiological one. The reader is referred to the illustrations given by Ford and his co-workers and by von Hibler (1908) and by the Medical Research Committee.

*The position of the spore* has been used by several authors in subdividing the anaerobes. Species of anaerobes have very characteristic ways of sporulating. But the position of the spore may vary in one species within limits wide enough to render its use exceedingly inadvisable as a character for the grouping of genera. One may take as a single illustration the behavior of a pure strain of vibriion septique. Vegetative forms are fairly uniform on most media. Sporangia, however, show in their variations all the characteristic forms described by Fischer, by the Committee, and by Buchanan. They are, on meat medium (forty hours' culture), usually thickened in the center with the typical form of clostridia. But some rods may contain spores and still have parallel sides, and forms with sub-terminal and terminal spores are nearly always to be found. On serum media the vegetative rods may vary greatly in their proportions, the sporangia assume many fantastic shapes, and "drumstick" forms are common. On the liver of animals the vegetative rods form enormous thick filaments: some strains may sporulate without at all changing their outline or may form clostridia, and some, identical with the first in morphology on ordinary media, may, on the liver of animals, show club-shapes that resemble the clubs formed by the actinomycetes, while others form great globoid masses, terminally or mesially placed in the rods. Rarely

three or four spores may occur in a rod which has remained undivided. In fact the only fixed morphological character to be noted is the shape of the spores, which, so far as I know, in this species everywhere remains oval. This is the sole morphological character that was noted in my anaerobic studies that cannot be assailed as inconstant, yet the shape of the spore is a character that has been consistently overlooked by classifying morphologists, who have chosen instead the extremely variable one of spore-position.

*The size of the rod* has not been mentioned by most classifiers. In general the sporulating rods are larger than the non-sporulating rods. But to reduce this generalization to definite measurements as Lehmann and Neumann have done is not a practical procedure.

*The arrangement of the bacilli in chains* is not significant. Probably the aerobes form chains more frequently than do the anaerobes, but filament formation cannot logically be used as a character for their differentiation. Winslow and Winslow found chain formation a character of minor value in the classification of the streptococci. Certain organisms, e.g., *B. Novyi*, regularly form filaments on certain media, but the character is of specific, not of generic, value.

*Morphology of colonies* would be mercilessly discarded by experimental workers as a means of subdividing a large group like that of the *Bacillaceae*. It has more value for lower subdivisions.

*The Gram-stain* is an impossible character to use in dividing the *Bacillaceae*. It fits neither with the morphological characters nor with the physiological. There are numerous Gram-positive anaerobes and aerobes, and numerous Gram-negative anaerobes and aerobes. (See Heller, 1920.)

*Granulose* (Iogen) content of the bacterial cells cannot be seriously considered as a general character of anaerobic rods.

*Habitat.* Winslow and Winslow found that the *Coccaceae* could logically be divided according to habitat. The parasitic forms constituted one group and the saprophytic ones another. Certain anaerobes are frequently inhabitants of the intestines

of animals. But this type of character has not been worked out for the anaerobic organisms and should evidently not be used in classification until it has been investigated thoroughly. In view of the fact that a large variety of anaerobes are to be found in soil it is not advisable to state that anaerobes are "often parasitic." Habitat might be used conservatively as a descriptive character.

*The formation of toxin and the pathogenicity for animals*—the most interesting of characters to the majority of us—cannot logically find a place in the higher divisions of our group. They become of more systematic value in classifying genera and species, but they should always be used in connection with other characters. Jensen's grouping of *B. tetani* and *B. botulinus* in the genus *Botulobacillus* because both produce toxin is not advisable. The toxins produced by these organisms are diametrically opposite in their effect on nerve tissue and that of *B. botulinus* and probably that of *B. tetani* are entirely adventitious so far as a parasitic mode of life is concerned. Other anaerobes of different affinities form toxins that produce still other and different effects.

We have seen with what ease objections may be made to almost any morphological character used for the division of the rods of higher metabolism, in case any physiological character is allowed to enter into the classification. We have stated also that some of the proposed morphological characters are not sound for single species or even for a given culture of a single strain. As Breed, Conn, and Baker say, the future must decide what type of character, physiological or morphological, will predominate in the classification of the bacteria. The two systems are so often contradictory that they can never exist side by side. One must always be used as the chief deciding factor, the other as an auxiliary which may, at any time, give precedence to the former.

Experience with a single group may be misleading. The higher plants, and even the fungi, may be satisfactorily classified on a purely morphological basis. At present the systematics of bacteriology are so tentative that the matter must be left to

the judgment, or shall we say to the taste, of those who have themselves worked with the groups that they discuss. I am totally unable to see how morphological criteria can possibly be used to any logical end in the classification of the rods of higher metabolism, or even of the main groups of anaerobes. In 1902 Achalme found morphology of absolutely no use for the differentiation of anaerobes. In 1905 von Hibler energetically decried the use of morphology in anaerobic classification. In analysis of the anaerobic group morphology has its place, and can logically be used to distinguish types that are otherwise similar. It can *not*, in my opinion, be used to unite groups that are otherwise dissimilar. In the anaerobic group morphological criteria alone would hopelessly bewilder the student and lead him to the correlation of fundamentally different types and to the separation of sister rods of the same strain. Morphology need, however, never be entirely discarded from classification. The morphology of the anaerobes is, for a given species, so characteristic, that if it be observed conscientiously, and if the worker does not generalize too freely in formulating his description, it may well be used as a valuable descriptive character for species, and as an auxiliary character for the description of genera. It is in organizing the major groups of anaerobes that morphology fails us. Professor Harvey M. Hall of the Botany Department of this university suggests that after a logical and fundamentally historical chemical classification has been made, morphological characteristics will be found which will be consistent with it. One must distinguish between different types of morphological criteria. Gross form of rod and position of spore are not fundamental morphological characters: they vary greatly within the species. But a highly refined cytological technique such as has never been generally applied to our organisms might reveal consistent morphological characters.

#### THE ANAEROBIC RODS

In my opinion the most logical division of the bacterial rods—the rods which split higher compounds and are not acid-fast—is the physiological one of susceptibility to free oxygen. Ability

to live in the absence of free oxygen has been developed by too many types to make it a character of value. But fewer types have developed a susceptibility to free oxygen. The classification proposed by the Committee (1920) places certain anaerobic forms such as the anaerobic leptotrichia with aerobic forms that are patently their relatives. The Committee justly assigns generic rank to the obligately parasitic, non-sporulating, shyly growing, fusiform anaerobes. They do not mention the anaerobic cocci, which should probably be included with the *Coccaceae*. The Committee does not mention any anaerobic non-sporulating, non-fusiform rods. In my collection there are two such strains (*B. egens* and one of my own isolation) which do not readily attack milk, and these organisms do not fall into any of the groups designated in the key, which follows the Committee's classification. *B. necrophorus*, again, of whose phylogenetic position I am in doubt, does not sporulate.

Fusiform bacilli have probably recently acquired an anaerobic habit through parasitism. Thus Larson and Barron describe a strain of these organisms which became adapted to growth under aerobic conditions. Analogous is the behavior of *B. abortus-bovis*, which frequently refuses to grow aerobically when first isolated but later accustoms itself to living in the presence of oxygen. The anaerobic habit may, in some cases, be due to a sensitiveness to carbon dioxide instead of oxygen. Curtis has described a motile curved anaerobic rod which he isolated from uterine discharges. The phylogenetic position of this organism is in doubt. So also is the position of the branching anaerobes *B. ramosus* and *B. furcosus* of Veillon and Zuber, and the influenza-bacillus-like rod isolated from an abscess by Russ. Tunnicliff reports anaerobic rods from rhinitis and from bronchitis patients; and Tunnicliff, Plotz and his co-workers, and Dick and Henry, report anaerobic organisms in the blood of fever patients. But these organisms grow slowly and do not resemble the chemically active anaerobic rods. We are justified in concluding that an organism which has lived as a saprophyte or parasite in the tissues or in the uterus may owe its anaerobic habit to such residence. There are several reasons why we should



hesitate to attribute to a parasitic or intestinal saprophytic history the anaerobic habit of the rods found commonly in soil. These rods are abundant in unmanured soil, their species are very numerous, their metabolic processes exceedingly varied. They may grow under aerobic conditions in company with aerobes and may grow in the presence of oxygen in pasty or solid material or in liquids containing soap or other substances which alter surface tension. But they retain their anaerobic habit on clear liquid or agar media. The commonest intestinal organisms, those of the colon group, have not assumed a sensitiveness to oxygen. Many of the anaerobes, such as those of putrificus, sporogenes, and bifermentans affinities, are the common agents of putrefaction outside the animal body, while others described by Omeliansky are the common cause of the decay of cellulose. When parasitic outside the intestine, these organisms usually show little of the character of true parasites, but cause fulminating fermentative processes which do not pass from affected individuals to healthy ones. *B. abortus*, the anaerobic streptococci, fusiform bacilli, and certain types of *B. coli*, when they invade the tissue may establish chronic infections, characteristic of highly developed parasites, but the anaerobic rods common in soil do not, so far as we know, behave in this manner. They are apparently unable to establish themselves as chronic parasites in tissues which are well vascularized. Had they a history of intestinal saprophytism, we should probably find highly adapted parasites among them, and should find it easy to educate them to an aerobic habit.

No one has, of course, suggested that the nitrogen-fixing anaerobes described by Winogradsky developed their anaerobic habit through parasitism. These organisms are active splitters of carbohydrates. They are usually regarded as primitive. It is more probable that the anaerobes of higher metabolism had an evolution of the following type rather than one from the sporulating aerobes or from intestinal saprophytes of large animals which appeared at a comparatively late geological period.

Nitrogen-fixing anaerobes that split carbohydrates. E.g. *Clostridium Pastorianum* Winogradsky, a large anaerobic rod that forms oval spores.

Carbohydrate-splitting anaerobes that can utilize fixed nitrogen but not free nitrogen. They do not produce gross proteolysis. E.g. *vibrion septique*.

Anaerobes that split proteins very actively. Some but not all have lost the power of splitting carbohydrates. E.g. the sporogenes type.

Geologically this sequence would be the most natural. But we know so little about bacteria and their evolution that any evolutionary arrangement is little more than guess-work at the present time.

It is my intention to propose a division which seems more logical than "the *Bacillaceae*, spore-bearing rods," as distinguished from the "*Bacteriaceae*, non-sporulating rods of higher metabolism." This division implies the creation of a family: "The *Clostridiaceae*, rod-like forms, not spiral, which will not grow within seven millimeters of the surface of a shaft of clear tissue-free agar medium contained in a tube 12 millimeters or more in diameter, incubated in air, in which they are able to grow in the depths. They may or may not possess peritrichial flagella; they may or may not form spores. Most members of the group are characterized by their energetic action on proteins or on carbohydrates or on both of these types of substances." It would be unwise to claim that we have evidence to show that these organisms are descended from a single type—in other words that this is a perfectly logical classification. Bacteriologists have no characters available for purposes of classification whose nature is sufficiently understood to grant us the liberty to make such assumptions. But I believe that this primary division will separate fewer types that are physiologically alike than any other thus far proposed. The energetic action of the anaerobic non-fusiform rods upon carbohydrates and proteins is characteristic and separates them from most other groups. In the present state of our knowledge it is only the separation of types that have several characters in common that is care-

fully to be avoided. The bacterial characters understood by us are so elementary that we can, as yet, have no assurance that we are not at times uniting types that have not the same ancestry.

It will be noted that the Committee has arranged the bacteria into orders, families, and genera. Most families have also been divided into tribes. The genera of the *Actinomycetales* have not thus been arranged in tribes, because their relationships are avowedly obscure. But the sporulating rods have been given the very inferior position of two genera and the tribal relationships are not expressed. This is because these organisms have been so slightly studied. As Ford says in his introduction, our knowledge of the spore-bearing bacteria is still in a state of chaos. The sporulating organisms, at least the anaerobes, are legion in species, and form a group that is to be divided and subdivided.

Whether or not the aerobic spore-bearers (genus *Bacillus* of the Committee) form a homologous family, I am unable to say. Compared with the anaerobic rods they are apparently very few in number of species. Ford and his co-workers list twenty-eight species which they place, on the basis of morphological and gross cultural characters in nine "groups." These groups would probably form as logical genera as some of the others which have been recognized.

It may be asked why tribal rank should not be assigned to the anaerobic and aerobic rods instead of family rank. It would seem that the group of anaerobic rods is sufficiently large, peculiar, and important, to warrant its being given family rank. Probably none of the botanical or zoological families contain nearly as many species as may be found among the anaerobic rods. On strict analogy with botanical and zoological classifications the anaerobes should command an order at least, but being unfortunately dogmatically confined in our classification to a single class which must include all one-celled cellulose- and chlorophyll-free plants that divide by simple fission, we must be modest in our demands.

In order to ensure a natural classification, characters must be worked out for each group, characters that will to some extent correspond, and show by such correspondence or by the lack of it where lie the historical divisions and where the parallel developments that have taken place independently. This alone is a great labor. For the group of the anaerobic rods and for many other groups nothing of the sort has as yet been seriously attempted. The Winslows' classification of the *Coccaceae*, a pioneer work in this direction, has applied several principles, which may well be heeded in making future classifications. These authors applied to 500 strains of cocci from various sources the biometric principles in use by students of heredity, by anthropologists, and to some extent by botanists and zoologists. Upon a study of the tabulated figures based on the behavior of these organisms they formulated their determination of what to call a species and of how to group species into genera. They found, in common with botanists and zoologists, that when abundant material is at hand it is quite impossible to define as a species one single type. If our methods were sufficiently refined we could probably distinguish every bacterial strain from every other, just as we can distinguish every human being from every other. A species is finally to be determined by comparing the characters of aggregates of individuals (higher plants and animals) or of strains (bacteria), and by selecting the types which occur most frequently as the standard upon which to base specific descriptions. The conclusions arrived at by Winslow and Winslow as to analysis of their data are as follows:

First, each center of numerical frequency, marking a group of organisms varying about a distinct type in regard to a single definite property, may be recognised as a species. Second, those species which are bound together by the possession of a number of similar properties may be constituted as genera, and larger groups of genera, still characterized by some characters in common, may receive the rank of families or subfamilies.

This method of working is evidently very different from the old method whereby one man described one strain and another

man another, and a third decided some ten years later from their descriptions whether they were working with the same or with different species. The biometric method is evidently true biology, while the other is a process of cataloging. The principles of the biometric method are those that one would choose to follow, even though one were unable to make a study of so extensive a series as did Winslow and Winslow. But it is upon the first method, that of collation of descriptions from the literature, that our comprehensive classifications have so far been made. This has led to a complete misunderstanding of the nature of the anaerobic group. A few anaerobes have been described, most of the descriptions being wholly inadequate for purposes of specific determination. This fact has in no way deterred workers from making identifications. Some of these mistaken identifications are now thoroughly ingrained in the literature, for example the use of the name *putrificus* in Germany for the *sporogenes* type of organism, when there is a different definite type existent which corresponds far more closely to Bienstock's description of *B. putrificus*. The names of some of the described anaerobes have been accepted, and if these types are pathogenic or very common they find their way into the textbooks. Textbooks mention usually five anaerobic organisms: *B. tetani*, *B. botulinus*, *B. oedematis-maligni*, *B. Welchii*, and *B. Chauvoei*. So far as I can see the classifications are largely based on a conception of the anaerobic world which knows few forms but these. But the worker with "wild" material can easily pick up and isolate two or three new species of anaerobes a day for an almost indefinite period. Few workers now pay any attention to non-pathogenic anaerobes, knowing that their path would be crossed by so many new species that no end but the mere description of new species would be attained. But these undescribed forms are just as important, theoretically, to the systematist, as are the pathogenic ones.

The ideal way of classifying anaerobes would be a biometric one carried out on a scientifically adequate number of strains. But it will be years before sufficient interest in the anaerobes exists to warrant the collection of any such material. The labor

of making such collections and of keeping close watch on all strains to insure their purity is tremendous. The bacteriologist is not the only systematist who has to do with such a problem as ours. The classifier of the *Coccaceae* is in the position of the curator of a museum who has before him the skins of a hundred or two of squirrels or other rodents, their measurements and habitat given, their skulls freed of muscle reposing in tiny bottles by their sides. The classifier of the anaerobes is today in the position of the exploring zoologist who sets his traps at night on his journey and catches one or two or three new rats or mice that do not resemble any thus far met by him. Both men describe new species and both serve science in so doing. But the museum worker may use as his type-species the animal whose characters are an average of those of all the rest, while the exploring zoologist must call the "type" one of his chance catches which may be a freak in one or more ways. And yet we would not have the explorer place his mice from a far country nameless in a museum for a future zoologist to describe some seventy-five years hence when the far country has been settled and the mice have been caught by the hundred.

The problems presented in the classification of the *Coccaceae* and of the *Clostridiaceae* are quite different in other ways. The anaerobes form a group of far more diverse types of organisms, both from the morphological and from the physiological standpoint, than do the cocci. One may say that their characters are more salient, more easily perceived, or more definite in their nature, than are those of the cocci. Or one may state with equal truth that the anaerobic group is a less homogeneous one than that of the cocci. One would also be justified in stating that the anaerobic species and genera are far more numerous than are those of the *Coccaceae*. Therefore a representative and adequate collection of anaerobic strains for statistical study would have to contain not hundreds but thousands of strains. But this element of distinctive characters places in our hands a means for the determination of genera before we are familiar with many strains of each genus.

## SPECIFIC AND GENERIC CHARACTERS

No one will dispute that the decision as to the line between specific characters and generic characters lies with the systematist who, though he have a previous knowledge of many other groups, has confined his attention to one group, and not with the systematist who organizes the published work of others. In different groups these boundaries vary somewhat. But in general the following definition will probably be accepted for such types of material as we are *unable* to examine thoroughly by a biometric method. *Strains of bacteria that regularly and consistently differ from each other in certain characters that we have come to recognize as significant may be assigned to different species. These characters may be quantitative in their nature. It lies in the hands of each worker to decide what the value of these characters is.* An arrangement made without reference to biometric data is in any case bound to be tentative. *Generic characters are based on qualitative properties.* As a working system the following classification of specific and generic characters for organisms of the anaerobic group is suggested:

*Generic characters, qualitative:*

Qualitative chemical action: behavior on usual laboratory media (excepting the fermentation of milk).

Staining reaction and general morphology of individuals.

General habits of colony formation.

Pathogenic action.

*Specific characters, quantitative:*

Quantitative chemical action: behavior on carefully standardized media; hydrogen-ion end point attained as a result of specific enzyme action.

Sugar fermentations if not subject to active mutation.

Peculiar habits of the morphology of individuals.

Exact behavior of colony formation on a standard medium.

Details as to pathogenic action.

In studying my material, I find abundant justification for the application of properties of this sort. With such characters to build upon, a more detailed structure, more exactly expressing

relationships, can later be erected. We are not yet ready to declare where the limits of variation for the organisms of our group may lie. But I am decidedly of the opinion that in general the old conception of species as accepted for the anaerobic group must in future be taken as the conception of genera, and that we must be more exact in our examination and analysis of these organisms. To do otherwise, and classify as the same species organisms which regularly and consistently show marked quantitative differences in their behavior, would be to distinguish our system of classification sharply from those of the botanists and zoologists and to set up our own meanings of "species" and "genus." The application and use of the characters here suggested will be described more fully in a future paper.

Perhaps the first-noted definite "character," splitting up a so-called species into a number of groups, is the agglutination reaction. Thus Tulloch by this method demonstrated the existence of four types of the group recognized under the name of *B. tetani*. Robertson thus subdivided her vibriion septique strains into four groups, and Henry divided the species of *B. sporogenes* into two groups on the basis of the agglutination reaction. It has been found by various workers that agglutinating anti-sera formed against various strains of *B. Welchii* do not agglutinate heterologous strains of the same organism, though Werner found a serum that agglutinated one out of several heterologous strains. When one thinks, however, of the comparatively numerous cases of cross agglutination recognized in other groups, some of which may, and some of which may not be modified in their importance by absorption-of-agglutinin tests, and when one considers the Weil-Felix reaction, one is ready to look for a more highly specific character than that of the agglutination reaction by which to analyze his strains. The Medical Research Committee term the agglutination reaction "ultra specific" (1919). I personally regard this reaction as of sub-generic rank, and not as of sub-specific rank in the anaerobic group. The agglutination reaction has not yet been investigated thoroughly enough to determine its value as a systematic character for anaerobic bacteria.



## NOMENCLATURE OF LOWER GROUPS

Our next concern relates to the nomenclature of our genera and species. We are peculiarly hampered in bacteriological work, when we try to base our names for organisms upon their behavior or characters. Morphology is a notoriously bad bacterial character for generic names, though it has long been used as a generic character for our primary divisions of the bacteria (*Coccus*, *Bacillus*, *Spirillum*) and apparently has a sound basis in this case. Pathogenic action is an equally misleading character upon which to base generic names: most anaerobes are not pathogenic and of those that are, various groups produce gas, oedema, haemorrhagia, etc. Chemical action would be the best type of character for descriptive purposes. But how often might we not, in a group that is so enormous as that of the bacteria, inappropriately name a new genus for a chemical character that was possessed in a greater degree by other genera, or was not possessed by all the members of the genus? There is also a prejudice among botanists against the formation of generic names from specific names, though such forms are not unusual in zoological nomenclature.

Dr. Karl F. Meyer has suggested to me the use, for purposes of generic nomenclature, of patronymics, preferably of the name of the author first describing the original species of a genus. This seems to me the most fitting and logical procedure. It has ample precedent in botanical nomenclature, and has been used in bacteriological nomenclature for years: e.g., *Pasteurella*, *Eberthella*.

Recommendation V.e. (International Rules for Botanical Nomenclature, Chap. III, Sec. 3, No. 3) will, if heeded in the formation of generic names, aid greatly in overcoming conservative objections to the new system of classification. This recommendation reads: "To recall, if possible, by the formation or ending of the name, the affinities or the analogies of the genus." Thus in the group of the cocci, *-coccus* has been accepted as the usual termination of the generic appellations; *-bacillus* has never been popular for such formations, probably on account of its

length. I had considered the ending *-ella* as used in 1900 by Lignières for *Pasteurella*, and by Buchanan for *Pfeifferella*. But *-ella*, like *-ia*, is a common ending for generic names among the higher plants. Would it not, in view of the existence of this recommendation, be appropriate to terminate the generic names of bacillary forms with the ending *-illus* (from *Bac-illus*)? (Patronymics ending in vowels may drop the final vowel before adding *-illus*.) Perhaps the ending *-erium* may also be found appropriate for names created in subdividing the old genus *Bacterium*. Specific names should be adapted from the original specific name, if such is valid, and new species can, of course, be named according to the will of the author describing them.

#### TYPE STRAINS

Because of the factor of variation in the habits of cultures, because many species of organisms must be frequently transplanted to keep them alive, and because of the important rôle played by contaminations, the custom, so long accepted by the botanists and zoologists, of preserving in museums type-specimens of newly-described species, has never been popular with bacteriologists. The facts as related to the anaerobic group are as follows: No experienced investigator of anaerobes would care unreservedly to turn over to anyone else his type-strains for general distribution, because of the ease with which they may become contaminated, and because of the difficulty that the ordinary worker has in recognizing contaminations. The rather generally disseminated view of Grassberger and Schattentfro (see Heller, (1920)) that the characters of anaerobes are highly variable is one to which I cannot subscribe. This view, which has cast a blight on modern German anaerobic studies and caused grave misinterpretations (see Rahn), has also deterred workers from the use of type-strains to make their descriptions definite. The anaerobic bacteria are fairly stable types (when in pure culture) and they have, in common with all other organisms, that degree of variability which permits them to adapt themselves somewhat to changing conditions and they

may, occasionally, show mutations as do all living organisms. The problem of their variability is essentially no different from the problem of the variability of other bacteria. Their behavior toward proteins is remarkably constant, while their action on carbohydrates is somewhat variable.

#### THE SUBDIVISION OF THE CLOSTRIDIACEAE

We have now outlined the status of the anaerobes in bacterial classification, and the position to be held by genera and species. It remains to organize the structure between the generic rank and the family rank. It is here that we have the most need of allowing room or elasticity for the convenience of future systematists whose information will be greater than ours is today. With our present knowledge I do not think that we are entitled to make more than one main subdivision of the *Clostridiaceae*. This division should follow that made by von Hibler in 1899, in 1905, and in 1908. Von Hibler showed that some anaerobes produce more acid than alkali on certain media, while others produce more alkali than acid. On the basis of this observation he classified the fifteen species studied by himself into two groups. He titrated brain cultures and milk cultures against  $\frac{N}{100}$  HCl and KOH, and found that on both media the organisms of the first group produced an acid reaction, while on brain medium, which is poor in sugar, the organisms of the second group invariably produced an alkaline reaction, and on milk, though some of them at first produced an acid reaction, they all finally gave an alkaline end point. The production of an alkaline reaction was always associated with peptonization of milk and was usually associated with a blackening of brain medium and with the production of hydrogen sulfide. The organisms that produced and maintained an acid reaction in milk and brain never peptonized casein or blackened the brain particles.

The division thus made by von Hibler has been accepted and followed by Jensen and by various anaerobic workers. The alkali-producing group is termed *proteolytic* or *putrefactive*, the

acid-producing group *non-proteolytic* or *saccharolytic*. The organisms studied by von Hibler were all energetic in their reactions. *B. Novyi* and organisms related to it, such as *B. oedematiens*, form hydrogen sulfide in blood media and do not produce much acid in milk. They do not peptonize casein or blacken or putrefy meat. They and the *Bifermentans* type and certain other organisms that I have encountered do not fit so nicely into von Hibler's scheme that we can safely place them in either group without drawing a dogmatic line and measuring their activities accurately. Douglas, Fleming, and Colebrook describe a sporulating anaerobe, *B. cochlearius*, which shows no marked properties that unite it with either of von Hibler's groups. It therefore seems advisable to define conditions under which anaerobes may be tested to determine their affinities with these two groups. Objection may be made to such a separation of the anaerobes on the grounds that when borderline organisms are in question it is but a cataloging process to separate them. Perhaps so, but when a classification is developing as is this one and when so very few borderline forms are known, a cataloging classification is better than none; later a group containing these organisms may be formed if necessary. Moreover the vast majority of anaerobes do fall definitely into one or the other of these two groups and can be placed where they belong on the basis of their behavior on ordinary media.

The requisites governing the selection of a medium for such a purpose are definite. In the first place all anaerobes must grow upon it. Blackleg organisms usually refuse to grow on simple sugar media. In order to give the organisms a good start, and to furnish material for the formation of acid, our medium should contain a little sugar, of the sort available to the greatest possible number of anaerobes: glucose is probably the sugar which best fulfills this requirement. But this sugar should be little in amount, and sufficient protein should be present, so that the acid formed from the sugar may not inhibit the growth of the organisms and prevent them from carrying the reaction back to an alkaline end point if they are capable of so splitting protein that they produce such an end point in the absence of acid.

Probably tissue-containing media best fulfill the above requirements. They need no more glucose than that which they derive from the tissue contained in them. Brain medium as used by von Hibler would be excellent were it made up with sufficient liquid for titration purposes. Von Hibler titrated liquid from his brain medium with litmus against potassium hydrate or hydrochloric acid. Today workers would prefer to use a hydrogen-ion determination, for which a fairly clear liquid is necessary in case the simple colorimetric method is employed. Bromthymol-blue is a suitable indicator for making this separation. At present most laboratories use the beef-heart medium introduced by Robertson and Martin for anaerobic study because it has many technical advantages over brain medium. It should preferably contain about 5 per cent of peptic digest broth and should be made with twice its weight of distilled water and tubed in large tubes in order that enough liquid may be present for hydrogen-ion determinations on several occasions.

Ten days' incubation at 37° will be found quite sufficient in most cases for such a determination as we wish to make. Von Hibler found the reaction decidedly acid or alkaline in brain medium after five days. But to allow time for weakly proteolytic organisms which form acid from glucose, to carry the reaction over to the alkaline side, we should incubate the cultures for twenty days at least. Such organisms do not at first produce gross signs of putrefaction, but their proteolytic tendencies may be tested for by the lead acetate test for hydrogen sulfide. There may be soil anaerobes which do not grow at 37°. Time and temperature for incubation will have to be decided upon for such organisms separately in case they are found.

Von Hibler (1908, p. 88) found that with his pasty brain medium the mode of incubation, aerobic, or anaerobic in hydrogen or in carbon dioxide, made no difference in the reaction. But if we are to use a medium with a considerable amount of liquid on the surface it would probably be unwise, even though anaerobes grow in the medium with the surface open to the air, thus to incubate our organisms for twenty days. An anaerobic method should be employed. The simplest method available

to most laboratories is stratification with vaseline. After incubation the culture should always be boiled to expel carbon dioxide.

For pure culture study the exact point of the reaction of the medium at the time of inoculation is not important. It is important only that the reaction should be well within the limits for growth of the organism studied, and not very far from neutrality. A reaction of pH 7.2 (neutral to litmus) has been used in this laboratory for most anaerobe media. The selection of a reaction point for the dividing of the two types of anaerobes is more difficult. Von Hibler (1908, pp. 89, 104) used the neutral point of litmus. The selection of a dividing point in meat medium is frankly an arbitrary affair. I suggest pH 7.0, the neutral point of hydrogen-ion concentration, for the dividing line between the alkali-producing and the acid-producing anaerobes.

It is unlikely that any other division of the *Clostridiaceae* will be made which would be placed above the division into the two groups just described. But I am certain that various arrangements of the genera which compose these groups will in time be made. There are many anaerobes that behave quite alike in one way and entirely differently in other ways. If this were to be a final classification of the group, or if one wished to outline a temporary classification, one would give the division into putrefactive and non-proteolytic anaerobes a tribal rank. But I am quite certain that the makers of future arrangements will want very much to utilize tribal and subtribal ranks for other purposes. I had myself thought of dividing the non-proteolytic anaerobes into two tribes or subtribes on the basis of presence or absence of flagella, but Dr. M. Christiansen has repeatedly been unable to demonstrate flagella on his whale-septicaemia bacillus which so closely resembles the vibrioseptique type of organism that they should probably be placed in the same genus. But tribal and sub-tribal classifications are sure to be made by someone before long and it will be a better provision for the future to give the proteolytic-non-proteolytic division sub-family rank.

I propose, therefore, the two subfamilies, *Clostridioideae* and *Putrificoideae*.

*Clostridioideae: Clostridiaceae* which on meat medium produce after twenty days' incubation under oil at 37° a reaction of pH 7.0 or a more acid reaction, the reaction being read after the culture has been boiled.

*Putrificoideae: Clostridiaceae* which on meat medium produce after twenty days' incubation under oil at 37° a reaction of pH 7.1 or a more alkaline reaction, the reaction being read after the culture has been boiled. \*

The name *Clostridioideae* is derived from Prazmowski's generic name *Clostridium*. The name *Putrificoideae* is formed from the specific name *putrificus* (Bienstock 1884). (*Putribacillus vulgaris* of Jensen.) We are hard put to it to find sufficient generic names upon which to form appellations for higher groups in the anaerobic field because *Bacillus* was the generic name applied to any and almost every rod described. But I think that bacteriologists will be justified in using ancient specific names for the formation of the names of tribes and families. Such a proceeding would have a basis in logic if not in precedent. The name *Putrificus* has probably been used for various organisms of the same genus (as well as for those of other genera) and is as much a generic name in sense as though it had been originally designated as such. I should, for example, on finding a slender proteolytic rod that formed terminal oval spores and did not split glucose or other sugars, term it *putrificus type*, knowing that more organisms might be found that corresponded to such a description but that would probably not be specifically identical (see Rodella). Bienstock himself refers to his organism as *B. putrificus* and as *Putrificus* (1899).

#### A SUGGESTED CLASSIFICATION OF THE ANAEROBIC BACTERIA

- PHYLUM 1. *Bacteria* (Nov. phyl.): Simple one-celled plants that multiply typically by binary fission and occasionally by budding. They show no form of sexual multiplication. They rarely contain cellulose and do not contain chlorophyll or phycoeyanin.
- CLASS 1. *Eubacterieae*.
- CLASS 2. (*Mycobacterieae*, *Bacteria* which join to form a complex fruiting body (see Vahle, p. 196)).

- CLASS 1. *Eubacteriaceae*: *Bacteria* which do not form a complex fruiting body.
- ORDER 1. *Eubacteriales*.
- ORDER 2. (*Thiobacteriales*, sulphur bacteria.)
- ORDER 3. (*Chlamydobacteriales*, iron and manganese bacteria.)
- ORDER 1. *Eubacteriales*: *Eubacteriaceae* whose cells are never in sheathed filaments. Conidia not observed. Free iron, sulphur, or bacteriopurpurin never present. Multiplication always occurs by transverse fission. (Committee)
- FAMILY 6 (?) *Clostridiaceae* (nov. fam.): *Eubacteriales* that are rod-like, not spiral, that will not grow within 7 mm. of the surface of a shaft of clear tissue-free agar medium contained in a tube 12 millimeters or more in diameter, incubated in air, in which they are able to grow in the depths. They may or may not possess peritrichial flagella, they may or may not form endospores. Most members of the group are characterized by their energetic catalytic action on proteins or on carbohydrates or on both of these types of substances.
- SUBFAMILY 1. *Clostridioideae* (nov. subfam.): *Clostridiaceae* which on meat medium produce after twenty days' incubation under vaseline at 37° a reaction of pH 7.0 or a more acid reaction, the reaction being read after the culture has been boiled.  
Type genus *Rivoltillus* (nov. gen.), the vibrion septique type as described by Heller.
- SUBFAMILY 2. *Putrificoideae* (nov. subfam.): *Clostridiaceae* which on meat medium produce after twenty days' incubation at 37° under vaseline a reaction of pH 7.1 or a more alkaline reaction, the reaction being read after the culture has been boiled.  
Type genus *Metchnikovillus* (nov. gen.), the sporogenes types as defined in the description of *Bacillus sporogenes*, described by the Medical Research Committee as Metchnikoff's type A.

## SUMMARY

1. Morphological criteria cannot be used in classifying the higher groups of anaerobes.
2. The anaerobic rods may logically be placed in a common family on the basis of the physiological character of sensitivity to free oxygen.
3. This family may be subdivided into two sub-families on the basis of chemical action on carbohydrates and proteins.
4. The divisions "tribe" and "sub-tribe" may well be left open for future organization.



5. The old conception of species in the anaerobic group corresponds to the general systematists' conception of genera. Generic characters may be based chiefly on qualitative behavior on ordinary media. Pathogenesis and general morphology may be used as auxilliary generic characters.

6. Specific characters may be based on sugar fermentations, on quantitative chemical action, on the morphology of colonies and to some extent on the morphology of individuals.

7. We are not as yet ready for extensive biometric determinations in studying many of the anaerobic groups and must temporarily adopt a more easily performed technique for the distinction of these organisms.

8. A classification of the anaerobic group is proposed whose details are to be elaborated in a following paper.

I wish to extend my hearty thanks to Dr. K. F. Meyer and to Dr. Harvey M. Hall for reading the manuscript of this paper and for making many wise and helpful suggestions which have been followed in its compilation.

#### REFERENCES

- ACHALME, P. 1902 Recherches sur quelques bacilles anaérobies et leur différentiation. Ann. de l'Inst. Past., **16**, 641.
- ADAMSON, R. S. 1918-19 On the cultural characters of certain anaerobic bacteria isolated from war wounds. Jour. Path. and Bacteriol., **22**, 345.
- ALMQUIST. 1908 Verhalten einiger pathogenen Mikroorganismen bei niedriger Temperatur. Centralbl. f. Bakteriol. I. O. **48**, 175.
- BEIJERINCK, M. W. 1906 Een obligat anaerobe gistningssarcine. Ref. Centralbl. f. Bakteriol. Abt. II., **15**, 473.
- BIENSTOCK, B. 1884 Über Bakterien der Fäces. Zeitschr. f. klin. Med., **8**, 1.
- BIENSTOCK, B. 1906 *Bacillus putrificus*. Ann. de l'Inst. Past., **20**, 407.
- BONDY, O. 1911 Über puerperale Infektion durch anaerobe Streptokokken. Monatsschr. f. Geburtsh. u. Gyn., **34**, 536.
- BREED, CONN, AND BAKER 1918 Comments on the evolution and classification of the bacteria. Jour. Bacteriol., **3**, 445.
- BUCHANAN, R. E. 1917 Studies in the nomenclature and classification of the bacteria. II. Jour. Bacteriol., **2**, 155.
- BUCHANAN, R. E. 1918 a (Report of Committee.) Some possible additions to the genera of bacteria recognized by the Committee. Abstr. of Bacteriol., **2**, 8.
- BUCHANAN, R. E. 1918 b Subgroups and genera of the *Bacteriaceae*. J. of Bacteriol., **3**, 27.
- CHESTER. 1901 A manual of determinative bacteriology. New York.

- CHRISTIANSEN, M. 1919 Hvalseptikæmiebacillen. Norsk Mag. for Laegevidenskab, No. 10.
- The Committee on Classification. See Winslow, C.-E. A., and others.
- CURTIS, A. H. 1913 A motile curved anaerobic bacillus in uterine discharges. Jour. Infec. Diseases, **12**, 165.
- DICK, A. F. AND HENRY, A. R. 1914 Anaerobic cultures in scarlet fever. Jour. Infec. Dis., **15**, 85.
- DOUGLAS, FLEMMING AND COLEBROOK. Unpublished work quoted by the Med. Res. Committee.
- FISCHER, A. 1895 Untersuchungen über Bakterien. Pringsheim's Jahrbücher für Wissenschaftliche Botanik, **27**, No. 1. Quoted from Migula.
- FISCHER, A. 1903 Vorlesungen über Bakterien, Ed. 2, Jena.
- FORD, W. W. AND HIS CO-WORKERS, J. S. LAWRENCE AND OTHERS. 1916 Studies on aerobic spore-bearing non-pathogenic bacteria. Jour. Bacteriol., **1**, 273, 493.
- HELLER, H. H. 1920 The etiology of acute gangrenous infections of animals. Jour. Infec. Diseases, **27**, 385.
- HENRY, H. Quoted by Med. Res. Comm., p. 54.
- VON HIBLER, E. 1899 Beiträge zur Kenntnis der durch anaeroben Spaltpilze erzeugte Infektionskrankheiten. Zentralbl. f. Bakteriologie, **25**, 593.
- VON HIBLER, E. 1905 Über die Differentialdiagnose der pathogenen Anaeroben. Verh. d. deutschen path. Gesellschaft., **9**, 118.
- VON HIBLER, E. 1908 Die pathogenen Anaeroben. Jena.
- HUSSY, P. 1915 Die Bedeutung der anaeroben Bakterien für die Puerperalinfektion. Monatsschr. f. Geburtsh. u. Gyn., **41**, 299.
- KLIGLER, I. J. 1917 The evolution and relationship of the great groups of bacteria. Jour. Bacteriol., **2**, 165.
- KRUSE. 1896 a Einleitende Bemerkungen zur Klassifikation. Flügge's die Mikroorganismen II, Ed. 3, Leipzig, p. 67.
- KRUSE. 1896 b Bacillen. Ibid. p. 185.
- LARSON, W. P. AND BARRON, M. 1913 Fusiform bacillus isolated from blood stream. Jour. Infec. Diseases, **3**, 429.
- LEHMANN UND NEUMANN. 1904 Atlas und Grundriss der Bakteriologie. II. Ed. 3. Munich.
- LIGNIÈRES. 1900, 1902 Contribution a l'étude des septicémies hémorrhagiques. Buenos Ayres, 1900, 212, and Rec. de Med. Veter., 1902, 444.
- MEDICAL RESEARCH COMMITTEE 1919 Reports of the Committee upon Anaerobic Bacteria and Infections. Medical Research Committee, Special Report Series No. 39. London. (Excellent bibliography.)
- METCHNIKOFF, E. 1908 Études sur la flore intestinale. Ann. de l'Inst. Past., **22**, 929.
- MIGULA, W. 1900 System der Bakterien, Jena, II.
- ORLA-JENSEN, S. 1909 Die Hauptlinien des natürlichen Bakteriensystems. Zentralbl. f. Bakteriologie. Abt. II., **22**, 305.
- OZAKI. 1915 Zur Kenntnis der anaeroben Bakterien der Mundhöhle. Zentralbl. f. Bakteriologie. I. O., **76**, 118.
- PLOTZ, H. OLITZKY, P. K. AND BAEHR, A. 1915 The etiology of typhus-exanthematicus. Jour. Infec. Dis., **17**, 1.

- PRAZMOWSKI, A. 1880 Untersuchungen über die Entwicklungsgeschichte und Fermentwirkung einiger Bakterienarten. Leipzig. Quoted from the Committee.
- ROBERTSON, M. 1915-16 Notes upon certain anaerobes isolated from wounds. *Jour. Pathol. and Bacteriol.*, **20**, 327.
- ROBERTSON AND MARTIN. See Robertson.
- RODELLA, A. 1905 Sur la differentiation du "Bacillus putrificus" (Bienstock) et des bacilles anaérobies tryptobutyriques (Achalmé). *Ann. de l'Inst. Past.*, **19**, 804.
- RUSS, V. K. 1905 Ueber ein Influenzabacillen ähnliches anaerobes stäbchen. *Centralbl. f. Bakteriol. I*, **39**, 357.
- SCHOTTMÜLLER, H. 1909-10 Zur Bedeutung einiger Anaeroben in der Pathologie, insbesondere bei puerperalen Erkrankungen. *Mitt. aus den Grenzgebieten der Med. u. Chir.*, **21**, 450.
- STERNBERG. 1919 Quoted from Gerard and Rouant. *C. R. Soc. Biol.*, **82**.
- TIEGHEM, P. E. L., VAN 1877 Sur le Bacillus Amylobacter et son rôle dans le putréfaction des tissus végétaux. *Bull. de la Soc. Bot. de France*, **24**.
- TUNNICLIFF, R. 1913 An anaerobic organism associated with acute rhinitis. *Jour. Infec. Dis.*, **13**, 282.
- TUNNICLIFF, R. 1913 An anaerobic bacillus isolated from a case of chronic bronchitis. *Ibid.*, 289.
- TUNNICLIFF, R. 1917 The cultivation of a micrococcus from the blood in pre-eruptive and eruptive stages of measles. *Jour. Am. Med. Ass.*, **68**, 1029.
- TULLOCH, W. J. 1919 The distribution of the serological types of *B. tetani*. *Jour. Hyg.*, **18**, 103.
- VAHLE, C. 1910 Vergleichende Untersuchungen über die myxobakteriazeen und Bakteriazeen. *Centralbl. f. Bakteriol. II.*, **25**, 178.
- VEILLON AND ZUBER 1898 Recherches sur quelques microbes strictement anaérobies. *Archives de Méd. Experimentale. 1 ser.*, **10**, 517.
- VIENNA RULES. Transactions of the International Botanical Congress in Vienna in 1905.
- WERNER, G. 1905 Die Agglutination bei Gasphegmonebacillen. *Arch. f. Hyg.*, **53**, 128.
- WINOGRADSKY, S. 1893, 1894 Sur l'assimilation de l'azote gazeux de l'atmosphère par les microbes. *C. R. de l'Acad. de Sciences*, **116**, 1385; **118**, 353.
- WINSLOW, C.-E. A., AND OTHERS: 1920 Final report of the Committee of the Society of American Bacteriologists on characterization and classification of bacterial types. "The families and genera of the bacteria." *Jour. Bacteriol.*, **5**, 191. Preliminary Report, *ibid.*, 1917, **2**, 505.
- WINSLOW AND WINSLOW. 1908 Systematic Relationships of the Coccaceae. New York.
- ZOPF 1883, 1885 Die Spaltpilze. 1-3 Ed., Breslau. Quoted from Migula.



# HYDROGEN IONS, TITRATION AND THE BUFFER INDEX OF BACTERIOLOGICAL MEDIA

J. HOWARD BROWN

*From the Department of Animal Pathology of The Rockefeller Institute for Medical Research, Princeton, New Jersey*

Received for publication April 19, 1921

Of recent years bacteriologists have become familiar with the determination of hydrogen ion concentration as applied to the problems of bacteriology. In many if not most laboratories media are properly adjusted to certain hydrogen ion concentrations, and the changes in reaction produced by the growth of organisms in these media are likewise determined in terms of hydrogen ion concentration. It has been repeatedly pointed out that media of the same titratable acidity or alkalinity may differ widely in their actual or true acidity or alkalinity. It is known that an acid-forming organism growing well in the presence of an excess of fermentable sugar in different bouillons may arrive at approximately the same final hydrogen ion concentration in each medium, whereas the titratable acidities of the cultures may differ widely. Who of us has not been confronted repeatedly by such questions as—Why do you titrate your cultures? Is not the *true* acidity found by the determination of hydrogen ion concentration and is it not much simpler? Why bother with titration? To which the answer is—Yes, but titration and hydrogen ion determination tell entirely different stories: they are not simply two methods, one more accurate than the other, of determining the same thing.

The committee on the Descriptive Chart of the Society of American Bacteriologists (1919) has published the statement that “the titration method (is) entirely illogical for adjusting the reaction of media or for determining the amount of acid produced by an organism.” To both parts of this statement

exception must be taken. The inaccuracies of the titration of media, as it has been commonly practiced in the past, are well known and it is agreed that the reaction of media should be adjusted to certain hydrogen ion concentrations. Nevertheless the committee's condemnation of titration seems entirely too sweeping and therefore misleading.

When one takes a sample of medium and determines how much acid or alkali must be added to bring it to a certain hydrogen ion concentration he performs a titration, though he may choose a better indicator than phenolphthalein and may determine the end point by comparison with a color standard in a comparator block, or may determine the end point electrometrically. If one wishes to determine the reaction of a culture, he must make a hydrogen ion determination, but if he wishes to determine "the amount of acid produced by an organism" he must titrate the culture with a strong alkali, precisely because in a well buffered medium much of the acid formed enters into combination with buffer substances and is not revealed by a hydrogen ion determination.

It has been claimed by H. M. Jones (1920b) that various factors may influence the final hydrogen ion concentration of a culture. Similar conclusions were reached by F. S. Jones (1920) who regards titration under well controlled conditions as quite as satisfactory as the method of determination of hydrogen ion concentration for the study of the fermentative activity of streptococci. The first mentioned author states that "the amount of glucose which a given organism can consume is influenced by the buffer content of the medium . . . which aids in holding the concentration of hydrogen ion from the toxic limit, thus permitting a larger amount of sugar to be decomposed." It follows that in a poorly buffered medium the fermentation of very little glucose is required to raise the acidity to the toxic limit and that therefore in such a medium the presence of a small amount of glucose, as an impurity in a test substance may be a very disturbing factor. The possibility is illustrated by the following experiment.

A culture of *Bact. coli* in Bacto bouillon (poorly buffered) plus 0.1 per cent glucose reached a hydrogen ion concentration of pH 4.8 in 24 hours and remained at this acidity during incubation for 5 days. On the other hand a similar culture in a highly buffered fermented veal infusion bouillon plus 0.1 per cent glucose showed a slight increase in acidity up to 48 hours and then became progressively alkaline reaching a hydrogen ion concentration of pH 8.5 in five days.

It is conceivable that there may be encountered an organism of very low acid tolerance (e.g., pH 6.0 or 6.5) but which may be an active fermenter of various carbohydrates so long as the hydrogen ion concentration is kept down by a well buffered medium. In such a case titration would reveal a considerable amount of acid formed whereas the final hydrogen ion concentration would lead one to believe that little or no fermentation had occurred *unless the buffer content of the medium was well known.*

To be impressed by the importance of a knowledge of the buffer content of media one needs only to note the frequent references to it in the literature, notably the papers by Kligler (1916), Berman and Rettger (1918), Bronfenbrenner and Schlesinger (1918), H. Jones (1920a) and Wolf (1920). Most of the discussion between the protagonists of titration and those of hydrogen ion determination centers about the question of buffer substances. By the use of a color standard of known hydrogen ion concentration and a comparator block the titrationist need no longer be embarrassed by the variable personal equation in judging a poor end point, but to both the titrationist and the hydrogen ion determinist the presence of variable and unknown amounts of buffer substances in media constitutes a real difficulty.

A complete analysis of the reaction between buffer content and growing culture would require a detailed knowledge of the metabolism of the particular organism being cultivated, taking into consideration the fact that the buffer content itself may be modified by the culture. Nevertheless an index of the buffer content at the beginning or at any time during the growth of the culture is readily obtained by titrating the medium with

standard acid or alkali from one known hydrogen ion concentration to another. In the determination of such an index two factors must be more or less arbitrarily selected, the limits of hydrogen ion concentration between which titration is to be performed, and the acid or alkali to be used.

Clark (1915b), Bovie (1915), and Clark and Lubs (1917) have published titration curves of bacteriological media. From these curves it is seen that if one starts with a medium of pH 8.0 or a little more alkaline and titrates with hydrochloric acid to pH 5.0 the curve is practically a straight line. If a weak acid such as lactic or acetic acid is used the curve begins to flatten out slightly between pH 6.0 and pH 5.0, and markedly after leaving pH 5.0 because of the lower dissociation constant of the weak acids. The greater part of the range of hydrogen ion concentration of bacteria of interest to the pathologist and sanitarian lies between pH 8.0 and pH 5.0. This is also the range of  $\text{Na}_2\text{HPO}_4 \rightleftharpoons \text{NaH}_2\text{PO}_4$ . The acids formed in cultures are mixtures of weak acids but within the range mentioned the curves of acetic and lactic acid are almost identical with that of hydrochloric acid. It would seem therefore that for the general purpose of determining the relative buffer values of media hydrochloric acid may well be employed.

The "buffer indices" of a number of samples of bouillon from various laboratories have been titrated. The method has been (1) to determine the hydrogen ion concentration of the medium, which usually lies between pH 7.0 and pH 8.0, (2) to add sufficient N/20 NaOH from a burette to reduce the reaction of the sample to pH 8.0, and then (3) to the same or another sample sufficient N/20 HCl to raise the hydrogen ion concentration to pH 5.0. The amount of alkali required to reduce the hydrogen ion concentration of a medium from its initial reaction to a stated lower hydrogen ion concentration, say pH 8.0, may be called the "reserve acidity" (Washburn 1910) of the medium<sup>1</sup>

<sup>1</sup> It is to be noted that the terms "reserve acidity," "reserve alkalinity" and "buffer index" are qualified by the pH values between which the titrations are made. While the determinations here reported are for BI (pH 8-5), for certain problems it may be advisable to adopt other limits of hydrogen ion concentration, as for instance BI (pH 9-5) or BI (pH 5-3).



indicated by the symbols  $R_H(pH n - 8)$  in which  $n =$  the initial pH. The amount of acid required to raise the hydrogen ion

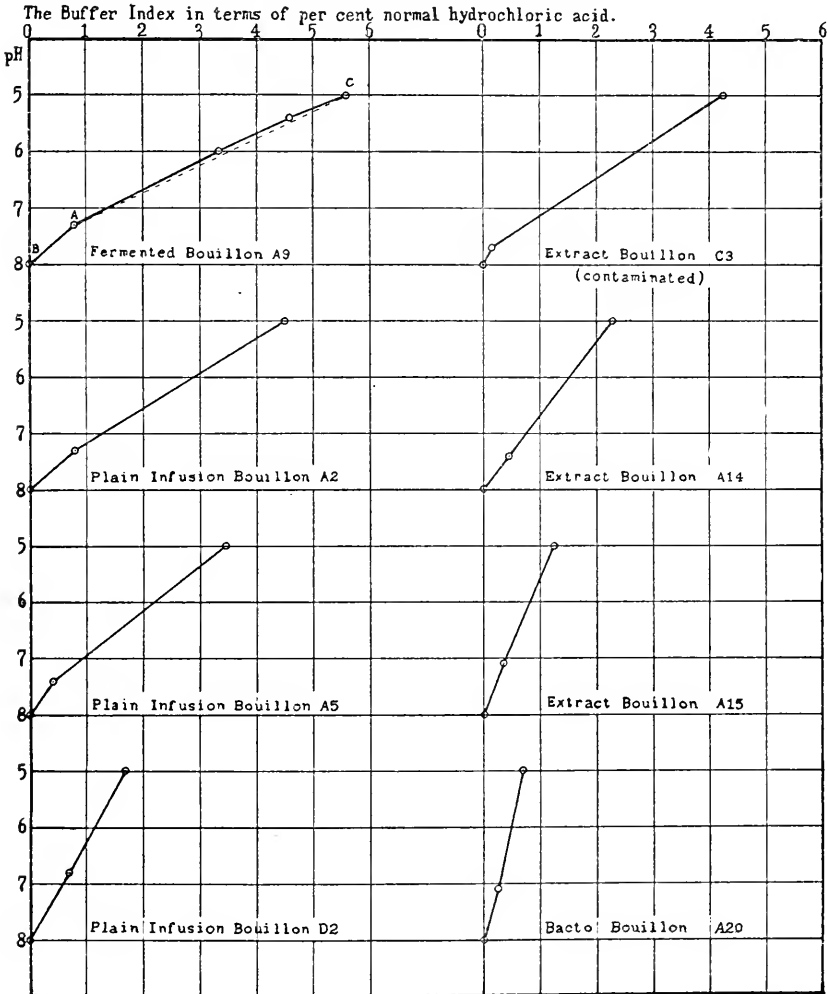

TEXT-FIG. 1. GRAPHIC REPRESENTATION OF THE BUFFER INDICES OF A NUMBER OF SAMPLES OF BOUILLON

concentration from pH  $n$  to pH 5.0 may be called the "reserve alkalinity" (Washburn 1910) of the medium indicated by the symbols  $R_{OH}(pH n - 5)$ . The "buffer index" indicated by

the symbols  $BI(pH\ 8 - 5)$  is the sum of the reserve acidity plus the reserve alkalinity, each value being expressed in terms of per cent normal acid or alkali, i.e., the number of cubic centimeters of  $N/1$  acid or alkali required to change the hydrogen ion concentration of 100 cc. of medium from one stated hydrogen ion concentration to the other. In figure 1 the reserve acidity is represented on the abscissa by the distance A to B, the reserve alkalinity by A to C, and the buffer index by B to C.<sup>2</sup>

The values referred to may be determined by at least three methods which are as follows. 1. The reserve acidity may be titrated with alkali from pH  $n$  to pH 8.0 and then using the same sample the buffer index may be titrated with acid from pH 8.0 to pH 5.0. The reserve alkalinity is calculated by subtracting the former from the latter. 2. The reserve alkalinity may be titrated with acid from pH  $n$  to pH 5.0 and then using the same sample the buffer index may be titrated with alkali from pH to 8.0. The reserve acidity is calculated by subtracting the former from the latter. 3. The reserve acidity may be titrated with alkali from pH  $n$  to pH 8.0 in one sample and the reserve alkalinity titrated with acid from pH  $n$  to pH 5.0 in another sample, the buffer index then being calculated by addition of the other two values. Identical results may be obtained by all three methods if the dilution of the color of the medium and of the indicator is carefully controlled. Many of the results here reported were obtained by the first method. However, the third method is the simplest and is described in detail in the appendix to this paper. It is hardly necessary to point out that the titrations may be controlled electrometrically quite as well as by the colorimetric method, the potentiometer merely taking the place of the color indicators.

Samples of bouillon from five different laboratories, indicated by the letters A, B, C, D, and E, have been titrated and the

<sup>2</sup> Whereas the reserve acidity and reserve alkalinity change with each change in the reaction of the medium, the buffer index may remain constant.

The prevalent method of titrating media against sodium hydrate with phenolphthalein as an indicator is actually a titration of the reserve acidity to an end point of about pH 8.5.

TABLE 1  
*The buffer index of various bouillons*

BOUILLON NUMBER	DESCRIPTION	INITIAL pH	BUFFER INDEX pH 8-5	RE-SERVE ACIDITY pH n-8	RE-SERVE ALKALINITY pH n-5
A1	Plain veal infusion, 1 per cent Fairchild pepton	7.2	5.25	1.25	4.0
A2	Plain veal infusion, 1 per cent Fairchild pepton	7.3	4.5	0.8	3.7
A3	Plain veal infusion, 1 per cent Fairchild pepton	7.3	4.0	0.75	3.25
A4	Plain veal infusion, 1 per cent Fairchild pepton	7.4	4.0	0.5	3.5
A5	Plain veal infusion, 1 per cent Fairchild pepton	7.4	3.45	0.4	3.05
A6	Plain veal infusion, 1 per cent Fairchild pepton	7.3	3.9	0.75	3.15
A7	Plain veal infusion, 1 per cent Fairchild pepton	7.3	3.85	0.8	3.05
ASa	Plain veal infusion, 1 per cent Fairchild pepton	7.1	3.75	0.95	2.8
ASb	Plain veal infusion, 0.5 per cent aminoids	7.3	3.35	0.55	2.8
ASc	Plain veal infusion, 1 per cent Witte pepton	7.2	3.5	0.6	2.9
ASd	Plain veal infusion, 1 per cent Bacto pepton	7.3	3.45	0.5	2.95
B1	Plain beef infusion bouillon	7.4	5.65	0.75	4.9
B2	Plain beef infusion bouillon	7.6	5.95	0.2	5.75
C1	Plain meat infusion bouillon	7.4	3.6	0.6	3.0
D1	Plain meat infusion bouillon	6.7	3.5	1.7	1.8
D2	Plain meat infusion bouillon	6.8	1.7	0.7	1.0
E1	Plain horse infusion bouillon	6.8	3.5	1.2	2.3
E2	Plain veal infusion bouillon	6.9	3.15	1.2	1.95
A9	Fermented veal infusion bouillon	7.3	5.6	0.75	4.85
A10	Fermented veal infusion bouillon	7.6	5.3	0.6	4.7
A11	Fermented veal infusion bouillon	7.2	5.35	1.0	4.35
A12	Fermented veal infusion bouillon	7.7	5.0	0.15	4.85
C2	Fermented meat infusion bouillon	7.2	4.05	0.75	3.3
D3	Fermented meat infusion bouillon	6.8	3.2	1.1	2.1
E3	Fermented beef infusion bouillon	7.3	3.5	0.5	3.0
A13	0.3 per cent Liebig extract, 1.0 per cent Fairchild pepton	7.4	1.8	0.4	1.4
A14	0.3 per cent Liebig extract, 2.0 per cent Fairchild pepton	7.4	2.3	0.45	1.85
A15	0.3 per cent Liebig extract, 1.0 per cent Witte pepton	7.1	1.25	0.35	0.9

TABLE 1—Continued

BOUILLON NUMBER	DESCRIPTION	INITIAL pH	BUFFER INDEX pH 8-5	RE-SERVE ACIDITY pH n-8	RE-SERVE ALKALINITY pH n-5
A16	0.3 per cent Liebig extract, 1.0 per cent Bacto pepton	7.3	1.25	0.3	.95
A17	0.3 per cent Liebig extract, 1.0 per cent Fairchild pepton	8.1	2.0	-0.15	2.15
A18	0.5 per cent Liebig extract, 1.0 per cent Fairchild pepton	8.0	2.5	0.0	2.5
A19	0.5 per cent Liebig extract, 2.0 per cent Fairchild pepton	8.0	2.9	0.0	2.9
C3	0.5 per cent Liebig extract, 1.0 per cent Bacto pepton (contaminated)	7.7	4.25	0.15	4.1
A20	Bacto bouillon (dehydrated), 0.8 per cent	7.1	0.7	0.25	0.45

The buffer index, reserve acidity and reserve alkalinity are expressed in terms of per cent normal alkali or acid. Note that the buffer index equals the reserve acidity plus the reserve alkalinity.

results tabulated in table 1. Each sample represents a different lot of bouillon. The buffer indices of the samples of plain meat infusion bouillon varied from 1.7 to 5.95. Samples from our own laboratory (A), made at different times but under supposedly uniform conditions, varied from BI 3.45 to 5.25. Of the two samples from laboratory D one had a buffer index of 1.7 and the other 3.5. Four lots of bouillon, A8a, A8b, A8c and A8d were made from the same veal infusion but with different brands of pepton. Their buffer indices were fairly uniform but not very high. Somewhat less variation was shown by the samples of fermented bouillon titrated. Samples of bouillon made from Liebig's beef extract had low buffer indices except sample C3 which titrated BI (pH 8 - 5) = 4.25. This sample was found contaminated by a mixed culture when received. The lowest index was that of sample A20, made of Bacto Nutrient Broth (dehydrated) according to the manufacturer's directions printed on the bottle.

The association of contamination with the high buffer index of extract bouillon C3 suggested that the growth of the culture might have altered the buffer index. Two samples of bouillon

of low buffer index, Bacto bouillon and Liebig extract bouillon, were inoculated with the mixed culture from bouillon C3, incubated forty-eight hours with sterile controls of the same media, and the buffer indices titrated. The results, tabulated in table 2, show that in Bacto bouillon the index was doubled and in extract bouillon was increased slightly. Cultures of *Bact. coli* in the same media showed small increases in the indices of both. A clear centrifugate of the mixed culture in Bacto bouillon had

TABLE 2  
The effect of cultures on the buffer index

MEDIUM	CULTURE INCUBATED 48 HOURS	FINAL PH	BUFFER INDEX pH 8-5
Bacto nutrient bouillon	Sterile control	7.2	0.8
	<i>Bact. coli</i>	7.3	0.9
	Mixed culture from extract bouillon C3 (clouded whole culture)	6.8	1.6
	Clear centrifugate from the above	6.9	1.5
Beef extract bouillon....	Sterile control	7.4	1.55
	<i>Bact. coli</i>	7.5	2.05
	Mixed culture from extract bouillon C3	7.4	1.6
Fermented bouillon.....	Sterile control	7.6	4.25
	<i>Bact. alkaligenes</i>	8.4	5.1
Plain veal bouillon.....	Sterile control	7.4	4.0
	<i>Bact. alkaligenes</i>	8.1	4.2

practically the same buffer index as the clouded culture, showing that the increase was not due to the presence of bacterial bodies but to substances in solution. A similar experiment was conducted with *Bact. alkaligenes* using fermented bouillon and plain unfermented veal infusion bouillon. There was an appreciable increase in the buffer index of the culture in fermented bouillon but only a slight increase in that of the plain bouillon. In other experiments the buffer indices of cultures of *Bact. coli* in plain veal bouillon increased markedly, but when an excess of glucose was added little or no change in the buffer index

occurred. A hemolytic streptococcus produced no change in the buffer index of glucose bouillon though the hydrogen ion concentration increased from pH 7.1 to pH 4.7 during incubation for eight days. The results of these experiments suggest that in the cases mentioned the increase in buffer index was the result of protein metabolism. It is suggested that the ability or failure of a culture to produce changes in the buffer indices of media may be of differential value.

TABLE 3

*Influence of the reserve alkalinity and the amount of fermentable sugar on the final hydrogen ion concentration*

MEDIUM: VEAL INFUSION BOUILLON				CULTURE OF BACT. COLI		
Dextrose per cent	Initial pH	BI (pH 8-5)	ROI (pH 8-5)	48 hours pH	96 hours pH	144 hours pH
0.5	6.2	4.45	1.95	5.1	5.8	7.5
0.5	7.5	4.1	3.6	5.5	6.5	7.8
0.75	6.2	4.4	2.0	5.1	5.1	5.4
0.75	7.5	4.2	3.6	5.2	5.5	7.0
1.0	6.2	4.3	1.9	5.1	5.0	4.9
1.0	7.4	4.2	3.5	5.1	5.2	5.3
1.25	6.1	4.2	1.65	5.1	5.0	4.9
1.25	7.4	4.4	3.7	5.1	5.1	5.1

In figure 1 are plotted the buffer indices of a number of bouillons. The pH values are located along the ordinate axis and the percentage of normal acid or alkali used on the abscissa. By the simple methods of titration described above three points are located, the initial pH at A (as shown on the curve of fermented bouillon A9), pH 8.0 at B, and pH 5.0 at C. If other points between A and C are determined they are found to lie very close to the straight line from A to C. The true form of the curve for fermented bouillon A9 is shown. A comparison of the curves shown in figure 1 shows that the smaller the buffer index the more nearly does the curve approach a straight line.

In a certain lot of bouillon containing 1 per cent of glucose *Bact. coli* produced an alkaline reaction after incubation for four days. This bouillon had a high buffer index and reserve alkalinity. The experiment recorded in table 3 was designed to explain this phenomenon and shows that the reserve alkalinity of a medium may be of diagnostic importance. It is seen that in a bouillon with a reserve alkalinity (pH n - 5) of 3.5 per cent normal, 1 per cent of glucose was hardly sufficient to insure continued acidity. The culture in the same medium containing 0.75 per cent of glucose actually became alkaline to brom cresol purple (pH 7.0) in one hundred forty-four hours. On

TABLE 4  
*Acid production by Bacterium coli*

MEDIUM			CHANGES DURING INCUBATION				
Composition	pH	BI (pH 8-5)	6 hours		25 hours		
			Turbidity	pH	Turbidity	pH	Titration to pH 8
Bacto bouillon + 1 per cent glucose.....	7.0	0.7	++	5.0	++	4.8	1.25
Veal bouillon + 1 per cent glucose.....	6.9	5.2	+++	6.1	++++	5.5	4.85

The titration is expressed in terms of per cent normal acid or cubic centimeters of N/20 NaOH required to reduce the acidity of 5 cc. of culture to pH 8.0.

the other hand if the reserve alkalinity was reduced to about 2.0, less than 1 per cent of glucose was sufficient to maintain the acidity of the culture.

Of what value would the buffer indices illustrated in figure 1 be to the bacteriologist in selecting his medium? To mention only one or two illustrations; if he were working with a member of the *Bacterium coli* group and wished to determine in a few hours whether the organism would ferment sucrose, he might select a bouillon with a low buffer index, i.e., one in which the formation of a small amount of acid would be revealed by a rapidly rising hydrogen ion concentration. If, on the other hand, he desired abundant growth and the production of a

large amount of acid he would do well to select a medium with a high buffer index and high reserve alkalinity. This is illustrated in the experiment recorded in table 4, in which *Bact. coli* was grown in glucose bouillons of low and high buffer indices. The *degree* of acidity rose much more quickly and the final hydrogen ion concentration was higher in the bouillon of low buffer index but the *amount* of acid produced was much greater in the bouillon of high buffer index. The experiments recorded in tables 4 and 5 also illustrate the statement of Clark (1915a) that "unless the media employed by different laboratories are identical, at least in their buffer effect, the titratable acidity

TABLE 5  
*Acid production by a streptococcus*

MEDIUM			CULTURES INCUBATED 8 DAYS	
Composition	pH	BI (pH 8-5)	Final pH	Titra- tion to pH 8.0
Veal bouillon + 1.0 per cent glucose, Lot 1 . . . . .	7.1	3.75	4.7	3.9
Veal bouillon + 1.0 per cent glucose, Lot 2 . . . . .	6.9	5.2	4.9	5.3

The titration is expressed in terms of per cent normal acid or cubic centimeters of N/20 NaOH required to reduce 5 cc. of culture to pH 8.0.

produced by the same organism may be found to be very different." They also confirm his observation that "the greater the buffer effect of the medium, the lower the final hydrogen ion concentration attained." It may be added, therefore, that if it is desired to compare the final hydrogen ion concentrations or the titratable acidities of similar cultures in different media, at least the buffer indices of the media should be known. It is not claimed that the titratable acidity is always a measure of the amount of acid produced, nor that the buffer content is the only factor which determines the amount of acid which may be produced or the amount of growth which a medium can support. There may be simultaneous production of acid and alkali by some organisms. It has been shown above that the buffer content may be altered by the growth of the culture.



Many organisms grow less abundantly in fermented bouillon plus glucose than in unfermented bouillon plus glucose although the two media have equally high buffer indices. Nevertheless, the buffer index is one of the most important factors and one which should be determined.<sup>3</sup>

#### CONCLUSIONS

The titration of media is not to be regarded as a crude method of determining the reaction of media but a process which reveals facts not disclosed by a simple hydrogen ion determination.

For many common purposes a knowledge of the buffer content of media is quite as important as the hydrogen ion concentration.

The buffer content between stated limits of hydrogen ion concentration is easily defined as the *buffer index* which is the sum of the *reserve acidity* and *reserve alkalinity* between those limits.

A simple colorimetric method of determining these values is described, a method which need not consume more than five minutes time. The determination can be made by any laboratory helper who can make a titration or a hydrogen ion determination and should be recorded for each lot of medium made.

There is appended a copy of instructions for laboratory helpers and a convenient form of record on which is recorded a sample titration.

The author wishes to acknowledge his indebtedness to Dr. P. E. Howe of this department for valuable suggestions and criticisms.

<sup>3</sup> Since this paper has been written there has appeared the paper on The Relation of Hydrogen-ion Concentration to the Growth, Viability, and Fermentative Activity of *Streptococcus hemolyticus* by L. F. Foster (Jour. Bact., March, 1921, 6, 161). The author illustrates admirably some of the points brought out in the present paper. He emphasizes the necessity of knowing the buffer content of a medium.

## REFERENCES

- BERMAN, N., AND RETTGER, L. F. 1918 The influence of carbohydrate on the nitrogen metabolism of bacteria. *Jour. Bact.*, **5**, 389.
- BOVIE, W. T. 1915 A direct reading potentiometer for measuring and recording both the actual and total reaction of solutions. *Jour. Med. Res.*, **33**, 295.
- BRONFENBRENNER, J., AND SCHLESINGER, M. J. 1918 Carbohydrate fermentation by bacteria as influenced by the composition of the medium. *Proc. Soc. Exp. Biol. and Med.*, **16**, 44.
- CLARK, W. M. 1915a The final hydrogen ion concentrations of cultures of *Bacillus coli*. *Jour. Biol. Chem.*, **22**, 87.
- CLARK, W. M. 1915b The reaction of bacteriologic culture media. *Jour. Inf. Dis.*, **17**, 109.
- CLARK, W. M., AND LUBS, H. A. 1917 The colorimetric determination of hydrogen ion concentration and its applications in bacteriology. *Jour. Bact.*, **2**, 1.
- CONN, H. J., HARDING, H. A., KLIGLER, I. J., FROST, W. D., PRUCHA, H. J., AND ATKINS K. N. 1919 Methods of pure culture study. Progress report for 1918 of the committee on the descriptive chart of the Society of American Bacteriologists. *Jour. Bact.*, **4**, 128-129.
- HURWITZ, S. H., MEYER, K. F., AND OSTENBERG, Z. 1915 On a colorimetric method of adjusting bacteriological culture media to any optimum hydrogen ion concentration. *Proc. Soc. Exp. Biol. and Med.*, **13**, 24.
- JONES, F. S. 1920 Influence of variations of media on acid production by streptococci. *Jour. Exp. Med.*, **32**, 273.
- JONES, H. M. 1920a Effect of carbohydrate on amino acid utilization of certain bacteria. *Jour. Inf. Dis.*, **27**, 169.
- JONES, H. M. 1920b Factors influencing final hydrogen ion concentration in bacterial cultures with special reference to streptococci. *Jour. Inf. Dis.*, **26**, 160.
- KLIGLER, I. J. 1916 Some regulating factors in bacterial metabolism. *Jour. Bact.*, **1**, 663.
- WASHBURN, E. W. 1910 The significance of the term alkalinity in water analysis and the determination of alkalinity by means of indicators. *Proc. Second Meeting Illinois Water Supply Assn.*, p. 93.
- WOLF, C. G. L. 1920 The influence of the reaction of media and of the presence of buffer salts on the metabolism of bacteria. *Brit. Jour. Exp. Path.* **1**, 288.

## APPENDIX

## METHOD FOR THE TITRATION OF MEDIA

*Equipment*

A set of colorimetric hydrogen ion standards of the following ranges and containing the indicators mentioned.

pH 5.0 – 5.8 (methyl red)

pH 5.8 – 6.8 (brom cresol purple)

pH 6.8 – 8.0 (phenol red)

A comparator block.

Drop bottles or pipette bottles containing the indicators mentioned.

Solutions of N/20 NaOH and N/20 HCl.

Two finely graduated burettes.

A very accurate 1 cc. or graduated 2 cc. pipette.

Tubes of uniform internal diameter similar to those containing the standards. Ordinary potato tubes of NONSOL glass are satisfactory.

Distilled water.

*Method*

1. Into each of 3 clean tubes place 9 cc. of distilled water and 1 cc. (very accurately measured) of the medium to be titrated.

2. Make the hydrogen ion determination in the usual manner, using one of the tubes (*tube I*) as a color screen and adding phenol red to another (*tube II*). (If the hydrogen ion concentration of the medium lies outside the color range of phenol red but inside the range of brom cresol purple (pH 5.8 to 6.8) the pH determination had better be made in a separate sample which is then discarded.)

*Record the hydrogen ion concentration on the record sheet.*

3. Place the pH 8.0 standard in the comparator block behind the color screen (*tube I*). From the burette cautiously add N/20 NaOH to *tube II* (containing phenol red) until its hydrogen ion concentration becomes pH 8.0 as determined by viewing it in the comparator block beside *tube I*.

*Record figures in spaces a, b, and c of the record sheet.*

4. Place the pH 5.0 standard in the comparator block behind *tube I*. Discard *tube II* and to a third tube of the diluted medium (*tube III*) add methyl red. From a burette cautiously add N/20 HCl to *tube III* until its hydrogen ion concentration becomes pH 5.0.

*Record figures in spaces e, f, and g of the record sheet.*

5. Calculate the reserve acidity and reserve alkalinity as indicated on the record sheet. The buffer index is the sum of the reserve acidity plus the reserve alkalinity.

*Record these values on the record sheet.*

### Notes

Greater accuracy is attained by using N/20 NaOH and N/20 HCl containing phenol red and methyl red respectively in the same concentration as is present in the color standards, as suggested by Hurowitz, Meyer and Ostenberg (1915).

If sufficient volumes of N/20 NaOH or HCl are added to tubes II or III to change the volume of the contents appreciably, the volume of the contents of the color screen, tube I, should be increased equally by the addition of distilled water or of N/20 alkali or acid without indicator.

Determinations should be made in duplicate, at least until the technician has perfect confidence in his results.

### Record of titration of medium

Medium *Fermented Veal Infusion Bouillon No. A9*

Sample (x) = 1 cc. of medium in each tube.

Initial hydrogen ion concentration (n) = pH 7.3.

Titration of reserve acidity with N/20 NaOH from initial pH 7.3 to pH 8.0

		Sample I	Sample II
Burette reading.....	(a)	0.00	0.15
Burette reading.....	(b)	0.15	0.3
		<hr/>	<hr/>
Difference.....	(c)	0.15	0.15
Average.....	(d)	0.15	

$$\text{Reserve acidity} = d \times 5 \div x = 0.75$$

Titration of reserve alkalinity with N/20 HCl from initial pH 7.3 to pH 5.0

		Sample I	Sample II
Burette reading.....	(e)	1.32	2.28
Burette reading.....	(f)	2.28	3.26
		<hr/>	<hr/>
Difference.....	(g)	0.96	0.98
Average.....	(h)	0.97	

$$\text{Reserve alkalinity} = h \times 5 \div x = 4.85$$

Calculation of buffer index;

$$\text{Reserve acidity, } R_H (\text{pH } n - 8) = 0.75$$

$$\text{Reserve alkalinity, } R_{OH} (\text{pH } n - 5) = 4.85$$

$$\text{Buffer index, BI (pH } 8 - 5) = 5.60$$

# ON DECREASING THE EXPOSURE NECESSARY FOR THE GELATIN DETERMINATION

J. E. RUSH AND G. A. PALMER

*Sanitary Engineering Department, Carnegie Institute of Technology, Pittsburgh,  
Pennsylvania*

Received for publication March 8, 1921

Some time ago, one of us (J. E. R.) was advised of the fact that there was a more rapid method for determining the ability of organisms to liquefy gelatin than the routine one, in use in most laboratories, namely, subjecting the gelatin stab to a temperature of 20°C. for ten or fourteen days after inoculation and then noting the results. Search of the literature failed to reveal any description of the more rapid method which was described as incubation at 37°C. for four days followed by twenty-four hours incubation at 20°C. after which the results were recorded.

Many reasons recommend the latter procedure providing the results obtained are identical with those recorded by the present recognized procedure. Among such reasons we might enumerate:

1. The saving of time (five days requirement as contrasted with fourteen days).
2. Earlier liberation of test tubes from the incubator (which in a busy laboratory is an important factor).
3. Necessity of less incubator space to meet the requirements of any laboratory (in some cases dispensing altogether with the use of a 20°C. incubator).

As search of the literature failed to reveal any information on this point it was determined to test out the two methods simultaneously on the next set of cultures which came into the laboratory and upon which confirmatory work (including the gelatin reaction) was to be done. This opportunity came when

it was desired to examine several organisms isolated from a water supply and upon which confirmatory work for *Bact. coli* was necessary.

Inoculations of the same batch of gelatin were made in duplicate and controls from the same batch of media were used. In the making of the media the standard procedure<sup>1</sup> was used, i.e., 10 per cent gelatin was made and the final reaction was adjusted to +1 on the phenolphthalein scale. As above stated inoculations were made in duplicate of the cultures to be examined—one set was placed in the 20°C. incubator, following the generally accepted method of procedure and observations were made after ten and fourteen days (as recorded below). The other set was placed at 37°C. for four days and then transferred to the 20°C. incubator for twenty-four hours after which the results were recorded.

It is a well recognized fact, that in a number of gelatin stabs exposed to 20°C. the longer the time of exposure, the greater will be the percentage showing liquefaction. This has been definitely shown by Gage and Phelps<sup>2</sup> but so far as we are aware the relation between a certain time (ten to fourteen days) at 20°C. and the combination incubation, first at 37°C. and later at 20°C. has not been determined. Prolonged high temperature will keep gelatin from solidifying again but this did not obtain here with exposure of the gelatin to 37°C. for four days, as evidenced by the fact that the controls on the media, while liquid after removal from the 37°C. incubator were again solid when removed from the 20°C. incubator after a further exposure of twenty-four hours.

This gelatin inoculation is made, as is well recognized, for the simple purpose of determining the presence or absence of certain proteolytic enzymes, namely, gelatinases. As in other biochemical reactions, the rate of reaction is influenced by certain factors in the environment and one of the most important factors is that of temperature. The cultures experimented

<sup>1</sup> Standard Methods for Examination of Water and Sewage, 1920.

<sup>2</sup> Gage and Phelps. Quoted by Prescott and Winslow. Elements of Water Bacteriology. John Wiley and Sons. 1915.

with, probably represent an average population of those organisms found in water supplies and giving a positive presumptive test for *Bact. coli*, because they are from many sources and sampled under a variety of conditions.

It should be further recalled that the optimum temperature of these organisms, undoubtedly varied considerably and that they probably exhibited varying degrees of adaptation. In addition, it may well be assumed that the difference between exposure at 37°C. and 20°C. even for a short time would be sufficient to stimulate a gelatinase production in certain forms while inhibiting it in others. That we are probably not dealing with a single enzyme which has the power of gelatin liquefaction, and that our problem is thus complicated is evident from certain work on zymology.<sup>3</sup>

The general results of our tests are shown in the table below:

LIQUEFACTION AFTER		NUMBER STRAINS
Four days at 37° and one day at 20°	Fourteen days at 20°	
None	None	97
None	Slight	78
None	Marked	17
Slight	Slight	8
Marked	Slight	4
Complete	None	1
Complete	Slight	8
Complete	Marked	8

"Slight" signifies 20 per cent liquefaction or less; "Marked" signifies 25 per cent liquefaction or more.

#### CONCLUSIONS

From the table it will be seen that no very definite statements can be made except that if we desire to get the results (as ordinarily done now) by exposure to 20°C. for ten or fourteen days—these same results cannot be realized by exposure to 37°C. for four days and then to 20°C. for one day.

<sup>3</sup> Biochemical Catalysts in Life and Industry. Effront and Prescott. John Wiley and Sons. 1917.

It was naturally noted (as previously reported) that a greater number of inoculations show liquefaction at 20°C. as time progresses (comparing results at 20°C. for ten days with those at the same temperature for fourteen days). It should also be noted that certain cases show a definite increase in percentage liquefaction from the ten to the fourteen day period. The number of tubes which show liquefaction at fourteen days and none at ten days is however less than one-half of one per cent of the total cultures examined.

As a general thing more cultures show liquefaction, or there is an increased amount of liquefaction, at 20°C. for fourteen days than by the method of exposure to 37°C. for four days and to 20°C. for one day.

In those inoculations in which a greater liquefaction by the more rapid method was noted, it may be pointed out that in practically every case total liquefaction occurred. Whether or not this has any significance we are unable to say.



# CHART OF THE FAMILIES AND GENERA OF THE BACTERIA

HAROLD MACY

*From the Dairy Bacteriology Laboratory, University of Minnesota*

Received for publication May 19, 1921

The final report<sup>1</sup> of the Committee of the Society of American Bacteriologists on Characterization and Classification of Bacterial Types offers a suggestive and tentative outline of bacterial classification.

The idea of preparing a chart which would illustrate graphically the position of the orders, families, tribes and genera presented itself to the writer, with the result that the accompanying chart was prepared. It is realized that the classification is not, in any way, final but it is thought that the chart may prove useful to bacteriologists who wish to have a convenient guide to the arrangement of the Schizomycetes under the proposed classification.

<sup>1</sup> C.-E. A. Winslow, Chairman, Jean Broadhurst, R. E. Buchanan, Charles Krumwiede, Jr., L. A. Rogers, and G. H. Smith. The Families and Genera of the Bacteria. Jour. Bact., vol. V, no. 3, May, 1920, pp. 191-215.

# CLASS SCHIZOMYCETES

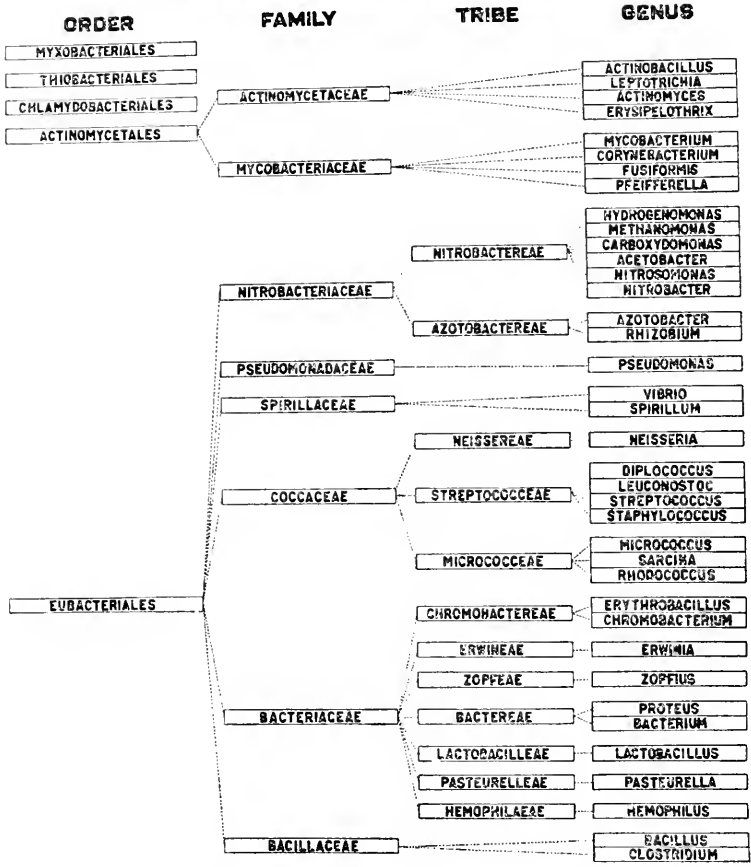

## INDEX TO VOLUME VI

Anaerobes, On the growth and the proteolytic enzymes of certain.....	419
—, Pathogenic, Studies in, II. Principles concerning the isolation of anaerobes.....	445
—, Pathogenic, Studies in, IV. Suggestions concerning a rational basis for the classification of the anaerobic bacteria.....	521
—, Principles concerning the isolation of. Studies in pathogenic anaerobes II. ....	445
Anaerobic bacteria, Suggestions concerning a rational basis for the classification of the. Studies in pathogenic anaerobes IV.....	521
Anaerobiosis, Chemical criteria of, with special reference to methylene blue	1
Atkins, K. N., Conn, H. J., Chairman. Kligler, I. J., Norton, J. F., and Harmon, G. E. Progress report for 1920 committee on bacteriological technic.....	135
<i>Azotobacter chroococcum</i> <i>Beij</i> , Studies on.....	331
Bacilli, typhoid, Variations in.....	275
Bacillus megatherium, The antigens of <i>Corynebacterium diphtheriae</i> and, and their relation to toxin. The nature of toxin.....	103
<i>Bact. dysenteriae</i> , group III, Toxins of.....	501
Bacteria, anaerobic, Suggestions concerning a rational basis for the classification of the. Studies in pathogenic anaerobes IV.....	521
—, Chart of the families and genera of the.....	575
—, concerned in the ripening of corn silage.....	45
—, The importance of preserving the original types of newly described species of.....	133
—, Indol production by.....	471
—, nodule, of Leguminosae, Notes on the flagellation of the .....	239
Bacterial cultures, Spiral bodies in.....	371
— growth, Salt effects in. I. Preliminary paper.....	511
— system, The main lines of the natural.....	263
Bacteriological media, Hydrogen ions, titration and the buffer index of....	555
Bacteriological technic, Progress report for 1920 committee on.....	135
Barthel, Chr. Note on the indol test in tryptophane solution.....	85
Biochemistry, The, of <i>Streptococcus hemolyticus</i> .....	211
Blanc, J., and Dernby, K. G. On the growth and the proteolytic enzymes of certain anaerobes.....	419
Bonazzi, Augusto. On Nitrification. IV. The carbon and nitrogen relations of the nitrite ferment.....	479
—, Studies on <i>Azotobacter Chroococcum</i> <i>Beij</i> .....	331
Botulism in cattle.....	69
Broth media, A study of the variations in hydrogen-ion concentration of..	143

- Brown, J. Howard. Hydrogen ions, titration and the buffer index of bacteriological media..... 555  
 Buffer index of bacteriological media, Hydrogen ions, titration and the.... 555
- Cattle, Botulism in..... 69  
 Cause, The, of eyes and characteristic flavor in Emmental or Swiss cheese.. 379  
 Chart of the families and genera of the bacteria..... 575  
 Cheese, The cause of eyes and characteristic flavor in Emmental or Swiss.. 379  
 Chemical criteria of anaerobiosis with special reference to methylene blue. 1  
 Classification of the anaerobic bacteria, Suggestions concerning a rational basis for the. Studies in pathogenic anaerobes IV..... 521  
 Colon-aerogenes forms isolated from natural waters, Some atypical..... 53  
 Color standards for the colorimetric measurement of H-ion concentration.. 399  
 Colorimetric measurement of H-ion concentration, Color standards for the.. 399  
 Committee on bacteriological technic, Progress report for 1920..... 135  
 Conn, H. J. Rose bengal as a general bacterial stain..... 253  
 —, Chairman, Atkins, K. N., Kligler, I. J., Norton, J. F., and Harmon, G. E. Progress report for 1920 committee on bacteriological technic... 135  
 Connell, J. T., and Holly, L. E. The nature of hemolysins..... 89  
 —, Warden, C. C., and Holly, L. E. The nature of toxin. The antigens of *Corynebacterium diphtheriae* and *Bacillus mcgatheryium* and their relation to toxin..... 103  
*Corynebacterium diphtheriae* and *Bacillus mcgatheryium* and their relation to toxin, The antigens of. The nature of toxin..... 103  
 Culture media, Solid, with a wide range of hydrogen or hydroxyl ion concentration..... 325
- Dernby, K. G., and Blanc, J. On the growth and the proteolytic enzymes of certain anaerobes..... 419
- Effect, The, of pepton upon the production of tetanus toxin..... 407  
 Emmental or Swiss cheese, The cause of eyes and characteristic flavor in.. 379  
 Enzymes, proteolytic, On the growth and the, of certain anaerobes..... 419  
 Eyes, The cause of, and characteristic flavor in Emmental or Swiss cheese.. 379
- Families and genera of the bacteria, Chart of the..... 575  
 Flagellation, Notes on the, of the nodule bacteria of Leguminosae..... 239  
 Flavor, The cause of eyes and characteristic, in Emmental or Swiss cheese.. 379  
 Florence, Laura. Spiral bodies in bacterial cultures..... 371  
 Foster, Laurence F. The biochemistry of *Streptococcus hemolyticus*..... 211  
 —. The relation of hydrogen-ion concentration to the growth, viability, and fermentative activity of *Streptococcus hemolyticus*..... 161  
 —, and Randall, Samuel B. A study of the variations in hydrogen-ion concentration of broth media..... 143
- Gas production, The, of *Streptococcus kefir*..... 127  
 Gelatin determination, On decreasing the exposure necessary for the..... 571

Gillespie, Louis J. Color standards for the colorimetric measurement of H-ion concentration.....	399
Graham, Robert, and Schwarze, Herman R. Botulism in cattle.....	69
Gram stain, A new modification and application of the.....	395
Growth, bacterial, Salt effects in. I. Preliminary paper.....	511
—, On the, and the proteolytic enzymes of certain anaerobes.....	419
Guinea-pigs, Method for the intravenous injection of.....	249
H-ion concentration, Color standards for the colorimetric measurement of.....	399
Hall, Ivan C. Chemical criteria of anaerobiosis with special reference to methylene blue.....	1
Hamilton, Herbert W. Powdered litmus milk. A product of constant quality and color which can be made in any laboratory.....	43
Hammer, B. W., and Plaisance, G. P. The mannitol-producing organisms in silage.....	431
Harmon, G. E., Conn, H. J., Chairman, Atkins, K. N., Kligler, I. J., Norton, J. F. Progress report for 1920 committee on bacteriological technic....	135
Heineman, P. G., and Hixson, Charles R. Bacteria concerned in the ripening of corn silage.....	45
Heller, Hilda Hempl. Principles concerning the isolation of anaerobes. Studies in pathogenic anaerobes II.....	445
—, Suggestions concerning a rational basis for the classification of the anaerobic bacteria. Studies in pathogenic anaerobes IV.....	521
Hemolysins, The nature of.....	89
Hixson, Charles, and Heineman, P. G. Bacteria concerned in the ripening of corn silage.....	45
Holly, L. E., and Connell, J. T. The nature of hemolysins.....	89
—, Warden, C. C., and Connell, J. T. The nature of toxin. The antigens of <i>Corynebacterium diphtheriae</i> and <i>Bacillus megatherium</i> and their relation to toxin.....	103
Holm, George E., and Sherman, James M. Salt effects in bacterial growth. I. Preliminary paper.....	511
Hucker, G. J. A new modification and application of the Gram stain.....	395
Hydrogen or hydroxyl ion concentration, Solid culture media with a wide range of.....	325
Hydrogen-ion concentration of broth media, A study of the variations in..	143
— concentration, The relation of, to the growth, viability, and fermentative activity of <i>Streptococcus hemolyticus</i> .....	555
Hydrogen ions, titration and the buffer index of bacteriological media....	161
Importance, The, of preserving the original types of newly described species of bacteria.....	133
Indol production by bacteria.....	471
— test, Note on the, in tryptophane solution.....	85
Intravenous injection of guinea-pigs, Method for the.....	249
Isolation of anaerobes, Principles concerning the. Studies in pathogenic anaerobes II.....	445

Kligler, I. J., Conn, H. J., Chairman, Atkins, K. N., Norton, J. F., and Harmon, G. E. Progress report for 1920 committee on bacteriological technic.....	135
Leguminosae, Notes on the flagellation of the nodule bacteria of.....	239
Macy, Harold. Chart of the families and genera of the bacteria.....	575
Main lines, The, of the natural bacterial system.....	263
Mannitol-producing, The, organisms in silage.....	431
Method for the intravenous injection of guinea-pigs.....	249
Methylene blue, Chemical criteria of anaerobiosis with special reference to..	1
Milk, Powdered litmus. A product of constant quality and color which can be made in any laboratory.....	43
Monfort, W. F., and Perry, Margaret C. Some atypical colon-aerogenes forms isolated from natural waters.....	53
Morishima, Kan-Ichiro. Variations in typhoid bacilli.....	275
Nature, The, of hemolysins.....	89
—, The, of toxin. The antigens of <i>Corynebacterium diphtheriae</i> and <i>Bacillus megatherium</i> and their relation to toxin.....	103
New, A, modification and application of the Gram stain.....	395
Nitrite ferment, On nitrification. IV. The carbon and nitrogen relations of the.....	479
Nitrification, On. IV. The carbon and nitrogen relations of the nitrite ferment.....	479
Nodule bacteria of Leguminosae, Notes on the flagellation of the.....	239
Norton, J. F., Conn, H. J., Chairman, Atkins, K. N., Kligler, I. J., and Harmon, G. E. Progress report for 1920 committee on bacteriological technic.....	135
—, and Sawyer, Mary V. Indol production by bacteria.....	471
Note on the indol test in tryptophane solution.....	85
Notes on the flagellation of the nodule bacteria of Leguminosae.....	239
On decreasing the exposure necessary for the gelatin determination.....	571
— nitrification. IV. The carbon and nitrogen relations of the nitrite ferment.....	479
— the growth and the proteolytic enzymes of certain anaerobes.....	419
Organisms, The mannitol-producing, in silage.....	431
Orla-Jensen, S. The main lines of the natural bacterial system.....	263
Palmer, G. A., and Rush, J. E. On decreasing the exposure necessary for the gelatin determination.....	571
Pathogenic anaerobes, Studies in, II. Principles concerning the isolation of anaerobes.....	445
— —, Studies in, IV. Suggestions concerning a rational basis for the classification of the anaerobic bacteria.....	521
Pepton, The effect of, upon the production of tetanus toxin.....	407

Perry, Margaret C., and Monfort, W. F. Some atypical colon-aerogenes forms isolated from natural waters.....	53
Plaisance, G. P., and Hammer, B. W. The mannitol-producing organisms in silage.....	431
Powdered litmus milk. A product of constant quality and color which can be made in any laboratory.....	43
Principles concerning the isolation of anaerobes. Studies in pathogenic anaerobes II.....	445
Progress report for 1920 committee on bacteriological technic.....	135
Proteolytic enzymes, On the growth and the, of certain anaerobes.....	419
Randall, Samuel B., and Foster, Laurence F. A study of the variations in hydrogen-ion concentration of broth media.....	143
Relation, The, of hydrogen-ion concentration to the growth, viability and fermentative activity of <i>Streptococcus hemolyticus</i> .....	161
Ripening of corn silage. Bacteria concerned in the.....	45
Rose bengal as a general bacterial stain.....	253
Roth, George B. Method for the intravenous injection of guinea-pigs.....	249
Rush, J. E., and Palmer, G. A. On decreasing the exposure necessary for the gelatin determination.....	571
Salt effects in bacterial growth. I. Preliminary paper.....	511
Sawyer, Mary V., and Norton, John F. Indol production by bacteria.....	471
Schwarze, Herman R., and Graham, Robert. Botulism in cattle.....	69
Sedgwick, William Thompson, 1855-1921.....	255
Sherman, James M. The cause of eyes and characteristic flavor in Emmental or Swiss cheese.....	379
—, The gas production of <i>Streptococcus kefir</i> .....	127
Shunk, Ivan V. Notes on the flagellation of the nodule bacteria of Leguminosae.....	239
— and Wolf, Frederick A. Solid culture media with a wide range of hydrogen or hydroxyl ion concentration.....	325
Silage, corn, Bacteria concerned in the ripening of.....	45
—, The mannitol-producing organisms in.....	431
Solid culture media with a wide range of hydrogen or hydroxyl ion concentration.....	325
Some atypical colon-aerogenes forms isolated from natural waters.....	53
Spiral bodies in bacterial cultures.....	371
Stain, A new modification and application of the Gram.....	395
—, Rose bengal as a general bacterial.....	253
<i>Streptococcus hemolyticus</i> , The biochemistry of.....	211
— —, The relation of hydrogen-ion concentration to the growth, viability, and fermentative activity of.....	161
— <i>kefir</i> , The gas production of.....	127
Studies in pathogenic anaerobes II. Principles concerning the isolation of anaerobes.....	445
— — — — IV. Suggestions concerning a rational basis for the classification of the anaerobic bacteria.....	521

Studies on <i>Azotobacter Chroococcum Beij.</i> .....	331
Study, A, of the variations in hydrogen-ion concentration of broth media..	143
Suggestions concerning a rational basis for the classification of the anaerobic bacteria. Studies in pathogenic anaerobes IV.....	521
Swiss cheese, The cause of eyes and characteristic flavor in Emmental or...	379
Tetanus toxin, The effect of pepton upon the production of.....	407
Thjøtta, Th. Toxins of <i>Bact. dysenteriae</i> , Group III.....	501
Titration and the buffer index of bacteriological media, Hydrogen-ions,....	555
Toxin, The nature of. The antigens of <i>Corynebacterium diphtheriae</i> and <i>Bacillus megatherium</i> and their relation to toxin.....	103
Toxins of <i>Bact. dysenteriae</i> , Group III.....	501
Tryptophane solution, Note on the indol test in.....	85
Typhoid bacilli, Variations in.....	275
Variations, A study of the, in hydrogen-ion concentration of broth media	143
— in typhoid bacilli.....	275
Warden, C. C., Connell, J. T., and Holly, L. E. The nature of toxin. The antigens of <i>Corynebacterium diphtheriae</i> and <i>Bacillus megatherium</i> and their relation to toxin.....	103
Wilcox, Harriet Leslie. The effect of pepton upon the production of tetanus toxin.....	407
William Thompson Sedgwick, 1855-1921.....	255
Winslow, C.-E. A. The importance of preserving the original types of newly described species of bacteria.....	133
— William Thompson Sedgwick, 1855-1921.....	255
Wolf, Frederick A., and Shunk, I. V. Solid culture media with a wide range of hydrogen or hydroxyl ion concentration.....	325



## *Announcement*

### **THE NATIONAL STAIN & REAGENT COMPANY**

announces a change in name to

### **THE COLEMAN & BELL COMPANY, Inc.**

No change has been made in the personnel of the company, nor in its business policies. The Biological Stains, Chemical Indicators and C. P. Organic Chemicals sold formerly under the "National" label will hereafter appear under the name of The Coleman & Bell Co., Norwood, O., U. S. A.

By specifying Coleman & Bell Stains and Indicators, you are assured of receiving dyestuffs manufactured under expert supervision and subjected, prior to sale, to the most rigid chemical and biological tests known. Coleman & Bell products may be secured from laboratory supply houses throughout the United States and Canada, or may be ordered direct. Catalogue upon request.

### **THE COLEMAN & BELL COMPANY**

NORWOOD, OHIO

Chemical Indicators and C. P. Organic Chemicals  
Biological Stains and Reagents of Highest Quality

.....Made in U. S. A.....

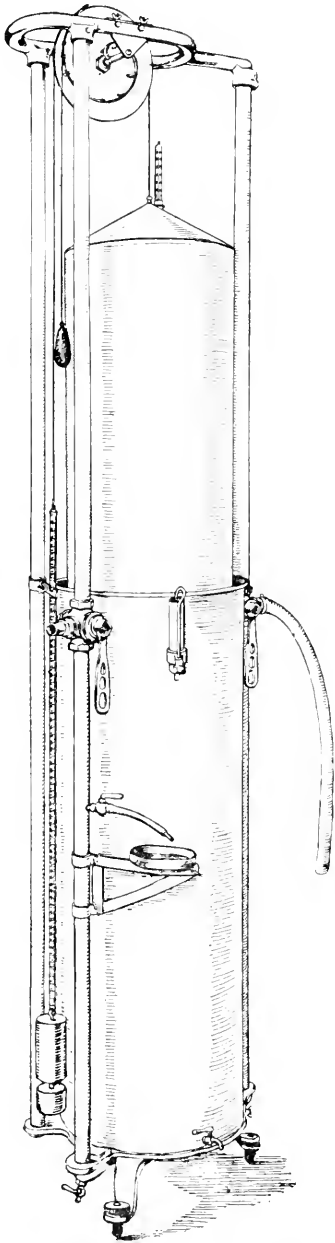

# AN OUTFIT

FOR

## Basal Metabolism Estimations

AS DESIGNED BY

Dr. Cameron Vernon Bailey of the  
Laboratory of Pathological Chemistry  
New York Post Graduate Medical  
School and Hospital

For detailed description see September issue  
*Journal of Laboratory and Clinical Medicine*



AMERICAN MADE PRODUCTS

REPRESENT QUALITY OF HIGHEST STANDARD

---

MANUFACTURED BY

**C. M. SORENSEN CO., Inc.**

DEPT. K

177 East 87th Street

New York

# INTERNATIONAL CENTRIFUGES

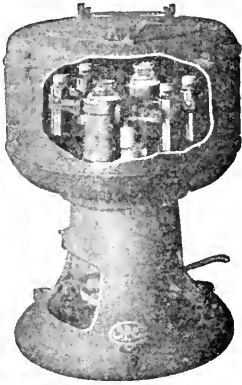

Latest model, self-balancing centrifuge with brake and brush release, and removable top adapted to use with perforated basket.

**International Equipment Co.**

352 Western Avenue (Brighton)  
Boston 35, Mass.

*Catalogue Cy sent on Request*

# ZEISS

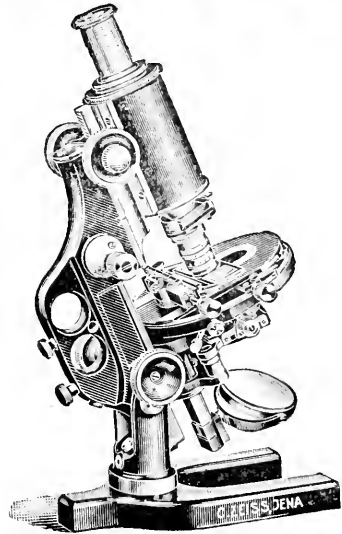

Microscopes  
Photo-Micrographic and  
Projection Apparatus  
Refractometers  
Interferometers  
Spectroscopes  
Opto Medical Apparatus  
Haemacytometers  
Photo Lenses  
Field Glasses  
Surveying Instruments  
Telescopes

Immediate delivery from stock.  
Catalogs for any of the instruments  
enumerated, supplied upon request.



**HAROLD M. BENNETT**  
U. S. AGENT  
153 West 23d St. New York City

## THE JOURNAL OF CANCER RESEARCH

The official organ of the  
American Association for Cancer Research

**WILLIAM H. WOGLOM**  
Editor

The Journal is of interest from the practical and theoretical standpoints.

Five dollars a volume—United States and Canada. Five dollars and fifty cents elsewhere.

Order from  
**WILLIAMS & WILKINS CO.**  
Baltimore, U. S. A.

# HEYL STAINS

The time has passed when the bacteriologist will buy stains on the mere assurance of the advertiser that his stains are biologically controlled by expert supervision.

The past five years have demonstrated *who is who* in the production of reliable microscopic stains—the kind the bacteriologist was accustomed to, before the war shut off importation. The secret of HEYL STAINS may be found in the long technical and practical experience of the bacteriological chemist who prepares and adjusts their mixtures.

## HEYL STAIN SPECIALTIES

METHYLENE

(25% polychrome)

METHYL GREEN

(Indicator)

GENTIAN VIOLET No. 2

(Kolle-Hetsch)

NEW WRIGHT STAIN

ISAMINE BLUE

MAY-GRÜNWALD STAIN

TOLUIDINE BLUE

(Cinna)

PYRONIN G

(Pappenheim)

METHYLENE VIOLET

DAHLIA VIOLET

PYRROL BLUE

(Cassella)

EHRlich's VITAL RED

TRYPAN BLUE C

(Veterinary Antiseptic)

FUCHSINE (NEW)

(for Endo)

LAUTH'S VIOLET

THIONINE (LV)

TRYPAN RED

ANILIN-BLUE-BLACK

(Grübler)

(Sold in 1, 5 and 10 Gm. vials and 1 pound original bottles)

HEYL STAINS are obtainable thru most of the principal dealers at a price commensurate with their quality and reliability.

*When ordering stains specify: HEYL*

**HEYL LABORATORIES, INC., NEW YORK CITY, U. S. A.**

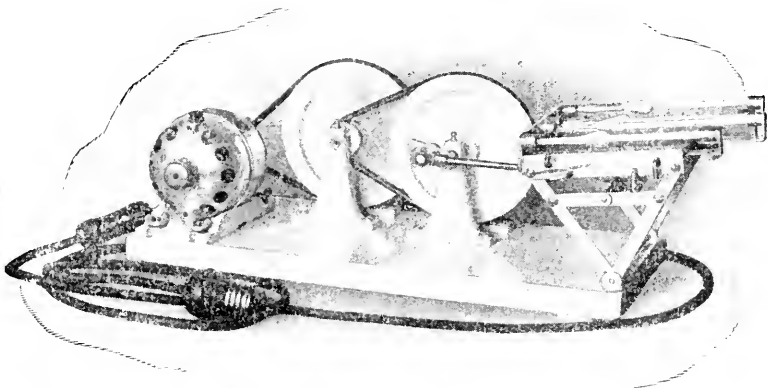

## Will Shaking Machine

Designed for the agitation of

Haemocytometer Pipettes, Test Tubes, Flasks, Bottles.

Especially valuable in diagnostic and clinical laboratories for such operations as the emulsification of sputum, estimating urobilin, determination of lactic acid in gastric contents, preparation of vaccine and bacterial extracts, in sero-diagnostic work, and many other operations where shaking is essential.

**Mechanical shaking is exact, time-saving and superior to hand manipulation in every way.**

*A splendid adjunct to the modern clinical laboratory.*

### WILL CORPORATION

Products for Every Laboratory  
Guaranteed Without Reservation  
ROCHESTER, N. Y.

# LaMotte Standards

GUARANTEED

Section 1.—Standardized Indicator dyes. Covering a wide range of H-ion concentration. Supplied in dry form and in sterile stock solutions. Each indicator is standardized in strict accordance with the specifications of Clark & Lubs. (Jr. Bact., Vol. II, Nos. 1, 2, 3, 1917.)

Common Name	Color Change	pH Value
Thymol Blue (acid range)	red-yellow	1.2-2.8
Methyl Orange	red-yellow	2.9-4.0
Bromphenol Blue	yellow-blue	3.0-4.6
Resorcin Blue	pink-blue	4.0-7.2
Methyl Red	red-yellow	4.4-6.0
Bromeresol Purple	yellow-purple	5.2-6.8
Litmus (special)	red-blue	5.5-8.9
Bromthymol Blue	yellow-blue	6.0-7.6
Phenol-Red	yellow-red	6.8-8.4
Cresol Red	yellow-red	7.2-8.8
Thymol Blue (alkaline range)	yellow-blue	8.0-9.6
Cresol-phthalein	colorless-red	8.2-9.8
Phenol-phthalein	colorless-red	8.4-9.2

Section 2-B.—Specially prepared and standardized Buffer salts and solutions. Buffer mixtures may be obtained in series covering any particular range of H-ion concentration from  $p_{\text{H}}$  1.0 to 10.0.

## Standardized Buffer Solutions (M/5)

Potassium Phosphate	Potassium Phthalate	Sodium Hydroxide (CO <sub>2</sub> free)
Potassium Chloride	Hydrochloric Acid	Di-Sodium Phosphate, 2H <sub>2</sub> O

A large number of general synthetic and purified compounds are manufactured by us and information concerning them may be obtained by addressing

**LA MOTTE CHEMICAL PRODUCTS CO.**

“Standards Department”

13 W. Saratoga St.

Baltimore, Md.

## Summarized Proceedings and Membership List

OF THE

### AMERICAN ASSOCIATION

FOR THE

### ADVANCEMENT OF SCIENCE

This volume contains the constitution of the Association, and the summarized reports of seven annual meetings—from 1914 to 1920—with lists of officers, etc., for each of the years, together with references to SCIENCE for presidential and vice-presidential addresses and other official communications for those years.

The MEMBERSHIP LIST, contained in the volume, forms one of the most useful directories of its kind, as an address list of American scientific workers and friends of science. The list, corrected to June 15, 1921, contains about 12,000 names and addresses, together with specific scientific, professional, or industrial connections. It constitutes an invaluable reference volume at a very low cost.

This volume may be purchased from the office of the Permanent Secretary of the Association, in the Smithsonian Institution, Washington, D. C.; or from the Williams & Wilkins Company, Mt. Royal and Guilford Aves., Baltimore, Md.

Price: \$2.00 to members of the Association, \$2.50 to non-members, payable when the order is placed. Prices are net, postpaid.

# PATHOLOGICA

Ogni quindici giorni

Fondata 1908

Annue \$6

**PATHOLOGICA** è un vecchio ed influente periodico che si dirama in tutti i centri internazionali di cultura, diffondendo con tenace ardore la produzione scientifica italiana, esso deve la sua attuale posizione di primo ordine alla collaborazione dei migliori autori nostrani, alla varietà delle rubriche, alla obbiettività dei giudizi, alla ricchezza delle informazioni.

**Riassume la produzione mondiale di patologia collazionando criticamente oltre seicento periodici di ogni continente. Pubblica il fiore della produzione scientifica italiana.**

La collezione di **PATHOLOGICA** contiene novecento lavori originali e oltre trentamila lavori riassunti.

Collezione completa 1908-1920 elegantemente rilegata in tela

Fcs. 480 - a mezzo chèque bancario

Abbonamento annuo \$ 6 : £ 1.8.0 - a mezzo chèque bancario.

Via XX Settembre, 11-1

GENOVA

Casella Postale 884

*Subscription in India Rs. 6 per annum. Foreign Rs. 7-8. Payable in advance.*

## THE INDIAN JOURNAL OF MEDICAL RESEARCH

EDITED BY

THE DIRECTOR-GENERAL, INDIAN MEDICAL SERVICE,  
THE PUBLIC HEALTH COMMISSIONER WITH THE GOVT. OF INDIA  
AND

THE DIRECTOR OF MEDICAL RESEARCH

IN COLLABORATION WITH

SIR RONALD ROSS, K.C.B., K.C.M.G., F.R.S., N.L., D.Sc., LL.D., M.D., F.R.C.S., Colonel, A.M.S.  
C. DONOVAN, M.D., Lieut.-Colonel, I.M.S. (Retd.)  
SIR L. ROGERS, Kt., C.I.E., M.D., F.R.C.P., F.R.S.,  
Lieut.-Colonel, I.M.S. (Retd.)  
CLAYTON LANE, M.D., Lieut.-Colonel, I.M.S. (Retd.)  
H. J. WALTON, M.D., F.R.C.S., Lieut.-Colonel, I.M.S.  
W. GLEN LISTON, C.I.E., M.D., D.P.H., Lieut.-Col.,  
I.M.S.  
W. C. H. FORSTER, M.B., D.P.H., Lieut.-Col., I.M.S.  
W. F. HARVEY, C.I.E., M.B., D.P.H., Lieut.-Colonel,  
I.M.S.  
S. R. CHRISTOPHERS, C.I.E., O.B.E., M.B., Major, I.M.S.  
R. ROW, M.D., D.Sc., Temy, Lieut.-Colonel, I.M.S.  
E. D. W. GREIG, C.I.E., M.D., D.Sc., Lieut.-Colonel,  
I.M.S.  
F. NORMAN WHITE, C.I.E., M.D., Major, I.M.S. (Retd.)  
R. A. NEEDHAM, C.I.E., D.S.O., M.D., D.P.H., Lieut.-  
Colonel, I.M.S.  
A. G. MCKENDRICK, M.B., Lieut.-Colonel, I.M.S.  
W. D. H. STEVENSON, C.I.E., M.D., D.P.H., Lieut.-  
Colonel, I.M.S.  
F. P. MACKIE, O.B.E., M.D., F.R.C.P., F.R.C.S., Major,  
I.M.S.

The **Indian Journal of Medical Research** is published quarterly. Each number contains at least 150 pages and is illustrated with plates in colour and half-tone and with diagrams and charts, and is the only medium publishing the results of all the best medical research work being carried on by leading scientific medical men in India and the East.

**Papers for Publication** should be sent to the Secretary, Scientific Advisory Board, Indian Research Fund Association, Simla. From whom all information regarding the journal may be obtained. Purely business communications and applications for copies of the journal should be addressed to Messrs. Thacker, Spink & Co., P. O. Box 54, Calcutta, to whom also subscriptions should be paid.

**Contributors** will receive 50 reprints of their papers free and additional copies at cost price up to a limit of 100. Applications for reprints should be made at the time of returning the final proof.

The **Terms of subscriptions** are six rupees per annum, payable in advance; foreign subscribers seven rupees eight annas, including postage; single issues are two rupees, each.

**THACKER, SPINK & CO.,** P. O. Box 54, CALCUTTA,  
and Regent House, SIMLA.

## INFORMATION FOR CONTRIBUTORS

Although there are numerous journals in the United States that deal with various special phases of bacteriology (as applied to Medicine, Sanitary Science, Agriculture and the like), THE JOURNAL OF BACTERIOLOGY is the only journal in the English language to represent the science as a whole.

The Society of American Bacteriologists has established the JOURNAL OF BACTERIOLOGY as its official organ and as a medium for the discussion of the more general problems of the science—the structure and physiology of the microbes, the inter-relationships of microbial types, the effects of physical and chemical agents upon microbial life, the mutual interactions of microbes growing together in various media, the nutritional needs and products of metabolic activity of various microbes, and new methods of laboratory technique—and similar advances in knowledge which are so fundamental as to be of vital interest to workers in all parts of this great field. The JOURNAL OF BACTERIOLOGY includes in its scope not only the bacteria but other related micro-organisms, yeasts, molds, protozoa, etc. While it is planned to make the JOURNAL in particular an organ for the more fundamental and general aspects of bacteriology, it will necessarily include many papers whose interest is mainly technical, particularly in those fields of bacteriology which have now no satisfactory organ of publication at their disposal.

**Manuscripts** should be sent to Prof. C.-E. A. Winslow, Yale Medical School, New Haven, Conn.

All other communications pertaining to editorial work should be addressed to Major A. Parker Hitchens, M. C., Army Medical School, Washington, D. C.

**Twenty-five reprints**, without covers, of articles will be furnished gratis to contributors when ordered in advance. A table showing cost, with an order slip, is sent with proof.

## INFORMATION FOR SUBSCRIBERS

THE JOURNAL OF BACTERIOLOGY is issued bi-monthly, in January, March, May, July, September, and November. A volume consists of approximately 600 pages. Subscriptions to the Journal are taken for the volume only. Under the present plans, one volume is issued a year.

**Subscription Price:** 1922 volume, Vol. VII, \$5.00, United States, Mexico, Cuba; \$5.25, Canada; \$5.50, elsewhere, net postpaid. *Foreign subscriptions to the current volume accepted at par of exchange.*

**Back Volumes** are supplied on orders for Vols. I to VI, inclusive. Price, \$36.00, United States, Mexico, Cuba; \$37.50, Canada; \$39.00, elsewhere. Extra single volumes will be supplied on request when in stock at \$5.00, United States, Mexico, Cuba; \$5.25, Canada; \$5.50, elsewhere. Prices are net postpaid. Single numbers can be furnished, in many instances, at \$1.00 a copy. *Foreign subscriptions to the back volumes accepted at the current rate of exchange.*

**Correspondence concerning business matters** should be addressed to the Williams & Wilkins Company, Publishers of Scientific Journals and Books, Mount Royal and Guilford Avenues, Baltimore, U. S. A.

Subscriptions are received:

**For Argentina and Uruguay:** Beutelspacher & Cia., Sarmiento 815, Buenos Aires, Argentina.

**For Australia:** Stirling & Co., 317 Collins Street, Melbourne.

**For Belgium:** Henri Lamertin, 58 Rue Coudenberg, Bruxelles.

**For the British Empire, except Australia and Canada:** Address any British bookseller or send your orders direct to the publishers.

**For Canada:** Wm. Dawson & Sons, Ltd., 87 Queen Street East, Toronto, Canada.

**For Denmark:** H. Hagerup's Boghandel, Gothersgade 30, Kobenhavn.

**For France:** Emile Bougault, 48 Rue des Ecoles, Paris.

**For Germany:** R. Friedländer & Sohn, Buchhandlung, Carlstrasse 11, Berlin NW. 6.

**For Holland:** Scheltema & Holkema, Boekhandel, Rokin 74-76, Amsterdam

**For Japan and Korea:** Maruzen Company, Ltd. (Maruzen-Kabushiki-Kaisha), 11 to 15 Nihonbashi Tori-Sanchome, Tokyo; Fukuoka, Osaka, Kyoto, and Sendai, Japan.

**For Spain:** Ruiz Hermanos, Plaza de Santa Ana, 13, Madrid.

**For the United States and other countries except as above:** WILLIAMS & WILKINS COMPANY, MOUNT ROYAL AND GUILFORD AVENUES, BALTIMORE, U. S. A.

Claims for copies lost in the mails will not be allowed unless such claims are received within 30 days (90 days, foreign) of the date of issue. Claimants must state that the publication was not delivered at their recorded address. The publishers will not be responsible for loss due to change of address unless notification is received at least two weeks in advance of issue.

**T**HE PRESENTATION of essential data concerning vitamins to succeeding groups of students has become increasingly difficult with the development of research in this field. The literature itself has assumed a bulk that precludes sending the student to original sources except in those instances when they are themselves to become investigators. The demand on the part of the layman for concise information about the new food factors is increasing and worthy of attention. For all of these reasons it has seemed worth while to collate the existing data and put it in a form which would be available for both student and layman. Such is the purpose of *The Vitamine Manual*.

**I**T HAS been called a manual since the arrangement aims to provide the student with working material and suggestions for investigation as well as information. The bibliography, the data in the chapter on vitamin testing, the tables and the subdivision of subject matter have all been arranged to aid the laboratory workers and it is the hope that this plan may make the manual of especial value to the student investigator. The details necessary to laboratory investigation are separated from the more purely historical aspects of the subject, an arrangement that will be appreciated by the lay reader as well as the student.

**N**O APOLOGIES are made for data which on publication shall be found obsolete. The whole subject is in too active a state of investigation to permit of more than a record of events and their apparent bearing.

*(From the preface of THE VITAMINE MANUAL)*

## *A Timely New Book*

that answers the demand  
for concise information  
about the new  
food factors

# THE VITAMINE MANUAL

BY

WALTER H. EDDY

ASSOCIATE PROFESSOR PHYSIOLOGICAL CHEMISTRY

*Teachers College, Columbia University*

*The Vitamine Manual* will prove useful to Medical Men, Public Health Officers, Dietitians, Nutrition Experts, Chemists, and to all individuals interested in promoting correct habits of living and correct habits of diet.

*The Vitamine Manual* will serve as a valuable text for classroom purposes.

WILLIAMS & WILKINS COMPANY

*Publishers of Scientific Journals and Books*

WILLIAMS & WILKINS COMPANY,  
Publishers of Scientific Journals and Books,  
Baltimore, Maryland, U. S. A.

I (or) We enclose \$.....for.....copy (copies) of THE VITAMINE MANUAL.

Price, \$2.50 a copy, net postpaid

5 Copies - - - -	10% discount	25 Copies - - - -	15% discount
10 Copies - - - -	12% discount	50 Copies - - - -	20% discount

(Signed) .....

Address .....

.....



# Exceptional Values in HIGH GRADE RUBBER GOODS

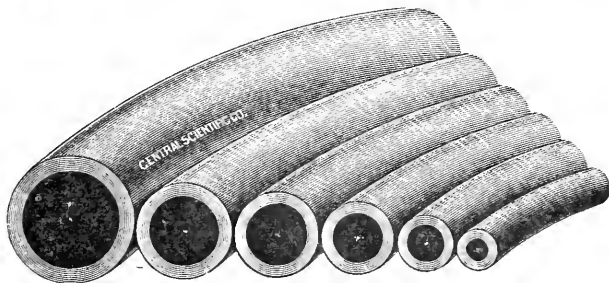

11580. **RUBBER TUBING**, White, light wall, hand made, cloth impression. This tubing is recommended for general laboratory use where an inexpensive tubing is desired.
- |                                    |                |                |                |                |                |                |
|------------------------------------|----------------|----------------|----------------|----------------|----------------|----------------|
| Diameter inside, inches.....       | $\frac{1}{8}$  | $\frac{3}{16}$ | $\frac{1}{4}$  | $\frac{5}{16}$ | $\frac{3}{8}$  | $\frac{1}{2}$  |
| Thickness of wall, inches.....     | $\frac{3}{64}$ | $\frac{5}{64}$ | $\frac{1}{16}$ | $\frac{1}{16}$ | $\frac{1}{16}$ | $\frac{1}{16}$ |
| Approximate no. feet per box.....  | 192            | 192            | 192            | 196            | 196            | 196            |
| Per foot (see Special Notice)..... | .05            | .08            | .10            | .12            | .14            | .26            |
11582. **RUBBER TUBING**, White, heavy wall, same quality as No. 11580. The  $\frac{1}{4}$  inch size is the standard size and quality for Bunsen burner connections.
- |                                    |                |                |                |                |               |
|------------------------------------|----------------|----------------|----------------|----------------|---------------|
| Diameter inside, inches.....       | $\frac{3}{16}$ | $\frac{1}{4}$  | $\frac{5}{16}$ | $\frac{3}{8}$  | $\frac{1}{2}$ |
| Thickness of wall, inches.....     | $\frac{5}{64}$ | $\frac{3}{32}$ | $\frac{5}{32}$ | $\frac{3}{16}$ | $\frac{1}{8}$ |
| Approximate no. feet per box.....  | 192            | 192            | 196            | 196            | 196           |
| Per foot (see Special Notice)..... | .12            | .17            | .20            | .26            | .39           |
11588. **RUBBER TUBING**, Red, Antimony, light wall, hand made, cloth impression. Retains its elasticity longer than No. 11580 and is preferred by many users for this reason.
- |                                    |                |                |                |                |                |                |
|------------------------------------|----------------|----------------|----------------|----------------|----------------|----------------|
| Diameter inside, inches.....       | $\frac{1}{8}$  | $\frac{3}{16}$ | $\frac{1}{4}$  | $\frac{5}{16}$ | $\frac{3}{8}$  | $\frac{1}{2}$  |
| Thickness of wall, inches.....     | $\frac{3}{64}$ | $\frac{5}{64}$ | $\frac{1}{16}$ | $\frac{1}{16}$ | $\frac{1}{16}$ | $\frac{1}{16}$ |
| Approximate no. feet per box.....  | 192            | 192            | 192            | 196            | 196            | 196            |
| Per foot (see Special Notice)..... | .06            | .09            | .13            | .15            | .24            | .39            |
11590. **RUBBER TUBING**, Red, Antimony, heavy wall, same quality as No. 11588. Preferred by many users for Bunsen burner tubing in place of No. 11582.
- |                                    |                |                |                |                |               |
|------------------------------------|----------------|----------------|----------------|----------------|---------------|
| Diameter inside, inches.....       | $\frac{3}{16}$ | $\frac{1}{4}$  | $\frac{5}{16}$ | $\frac{3}{8}$  | $\frac{1}{2}$ |
| Thickness of wall, inches.....     | $\frac{5}{64}$ | $\frac{3}{32}$ | $\frac{5}{32}$ | $\frac{3}{16}$ | $\frac{1}{8}$ |
| Approximate no. feet per box.....  | 192            | 192            | 196            | 196            | 196           |
| Per foot (see Special Notice)..... | .15            | .22            | .27            | .36            | .55           |

**Special Notice.** Rubber Tubing of the various kinds listed comes from the manufacturer in original 12 foot lengths or in boxes of the quantity indicated under each size. In small quantities rubber tubing is sold only in lengths of 3 feet or multiples of 3. We will allow a discount of 15% on orders for 12 ft. lengths and a 30% discount on orders for original boxes.

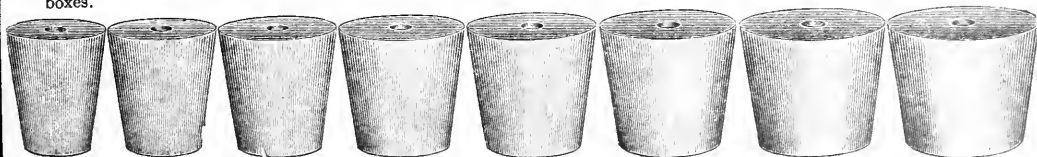

No. 11572.

11572. **RUBBER STOPPERS**, made from best quality of rubber especially for laboratory use; will not harden from age. Each size furnished in three styles—solid, one hole or two holes.....Per pound \$1.40

**Table Showing Approximate Number of Rubber Stoppers in One Pound**

Number.....	00	0	1	2	3	4	5	6	7	8	9	10	11	12	13	
Diameter large end, mm.....	14	17	18	20	23	25	27	32	37	41	45	50	56	63	68	
Diameter small end, mm.....	9	12	15	16	18	20	23	26	30	33	37	42	48	53	61	
Approximate	Solid.....															
Number in	1 hole.....															
One pound	130	90	65	60	45	35	30	21	16	13	11	8	6	5	4	
Number in	2 hole.....															
One pound	138	94	70	64	47	38	32	22	17	14	12	8	6	5	4	

Note: We will allow a discount of 15% on orders for rubber stoppers of 10 pounds or more and a 25% discount on orders of 25 pounds or more.

7240. **GLOVES**, Rubber, black, medium weight. Sizes 6 to 10. per pair .70  
 7242. **GLOVES**, Rubber, tight fitting, made of thinnest pure gum, as used by surgeons in operating. Sizes 6 to 10..... per pair .75  
 7246. **GLOVES**, Rubber, Acid Gloves, loose fitting, heavy, gauntleted.  
 Light weight. Sizes 6 to 9..... per pair \$2.70  
 Heavy weight. Sizes 10 to 12..... per pair \$4.00  
 Kindly give size of usual kid glove in ordering.



No. 7242

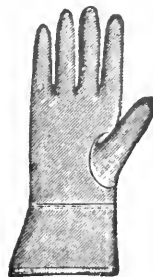

No. 7246

## CENTRAL SCIENTIFIC COMPANY

LABORATORY (INCORPORATED) SUPPLIES  
 Apparatus **CENCO** Chemicals.  
CHICAGO - U.S.A.

460 E. Ohio St.,

Chicago.

U.S.A.

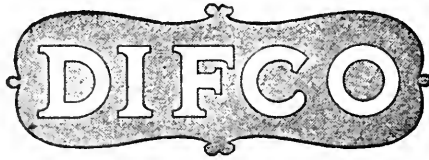

# RARE SUGARS

and

## OTHER FINE CHEMICALS

"DIFCO" STANDARDIZED

*Being the first manufacturing firm in the United States to make and extensively advertise rare sugars, we have steadily added to our line, and our list now comprises the following:*

### RARE SUGARS

Arabinose  
Dextrose (Glucose)  
Galactose  
Invert Sugar  
Lactose

Levulose (Fructose)  
Maltose  
Mannose  
Melezitose  
Melibiose

Raffinose  
Rhamnose  
Saccharose (Sucrose)  
Trehalose  
Xylose

### OTHER CARBOHYDRATES

Dextrin      Mannite      Inulin      Salicin

### LABORATORY REAGENTS

Invertase for Analytical Use

Acid Potassium Phthalate  
Fibrin

Blood Serum, Desiccated  
Gelatin  
Tyrosine

Beef Extract  
Decolorizing Carbon

---

### DEHYDRATED CULTURE MEDIA

Bacto-Peptone      Proteose Peptone

*Carried in stock by the principal dealers in  
Scientific Supplies*

---

Specify "DIFCO"  
WE INVITE COMPARISON

# DIGESTIVE FERMENTS COMPANY

Detroit, Michigan, U. S. A.





3 5185 00263 9662

