

Instructions to build the Tubes4HiFi /VTA M-125 as an *Ultralinear ONLY* device.

See http://ielogical.com/Audio/VTA_M-125.php for more information.
*Be certain of all modifications **before** implementation!*

NOTE: Chassis is Earth Safety ONLY **0vA [Zero volts Audio] does not connect to directly Earth Safety**

Version 16-February-2024

*Derived from VTA M-125 v16 Driver Assembly manual 120 volt
Driver board is v19 as of April 2020. Circuit is same as v15, possibly earlier.*

Tubes4HiFi v19 changes in August 2021

- *c6/8 PIO cap value changed to 0.33 μ F - slightly lower HP filter to power tubes*
- *r20/22 changed to 27k Ω - slightly better phase splitter match, reduced gain*
- *r8 changed to 6.8k - increased feedback, lower gain*
- *c12 changed to 680pF - bandwidth reduction to 31kHz*

Larger Images current version of this doc available at <http://ielogical.com/assets/M-125/Build>

Italics indicate comments on Tubes4HiFi /VTA claims.

1. A 16 gauge STAINLESS STEEL chassis. This chassis is NON-MAGNETIC and removes any magnetic interference effects of a steel chassis on the audio circuitry. *Magnetic permeability depends on the steel type. LF effectiveness is suspect.*
2. A USA made A-125 custom wound output transformer which is interleaved/layer-wound and incorporates high quality M-6 grain oriented silicon steel laminations.
3. A USA made PA-125 power transformer rated at 120 volts, having 410-0-410 secondaries and a 450mA current transfer capability. **WARNING: If the Power Transformer is dual voltage, be sure to insulate the unused connection. Depending on mains connection, the unused lead could be 5 or 115 VAC!**
4. All stainless steel screws with zinc plated KEP nuts
5. Heat resistant Celanex™ octal tube sockets. *Marginal quality. Socket quality depends on the pin clamp more than body material. They are OK, provided you solder quickly. Update: After three years and about 6 tube removals, some pins are pulling out of the sockets.*
6. ***An 80, 40, 30, 20 main electrolytic cap with a 550VDC continuous use rating. *Better performance can be realized with individual caps. The only quad cap benefit is caché. 525VDC rating on driver 30 μ F section. 30 μ F section and driver 100 μ F/400vDC caps driven over-voltage without driver tubes v6 & v7. **DO NOT run the amp at mains voltage without tubes for an extended time.***
7. An all triode VTA driver board made of mil-spec epoxy fiberglass. **The board is pretty poor. 1oz copper will not support much rework, so be very careful and ensure correct parts BEFORE soldering. We've received a few damaged boards from users.** This board also contains an on board bias supply for the output tubes, power supply upgrade caps and Russian PIO main coupling caps. **Bias supply can be improved by changing r39 to 1k and inserting 1k between D1 anode and its pad. This creates a filter to reduce the half-wave noise. We use the original Audioamp Auto Bias Modules without issue. They hold bias absolutely rock solid.**

8. Gold plated input and output terminals. *Input terminals are internally fragile. Output terminals are junk. The output cable side nuts are not sufficiently robust to tighten heavy cables securely. If planning anything but banana connectors, **replace them!***

9. A dual choke system rated at 480mA. *-20%/+50% Voltage & ripple not specified. **Mount with wires facing to counter phase them thus reducing magnetic radiation into OPT directly above and excess wire radiation length.***

10. A triode/pentode Ultralinear switch to allow the amp to run in two modes of operation. *Discarded in this Ultralinear build.*

11. A 75 μ F supplementary cap module (SCM) and a 1 μ F MPP ESL reduction capacitor. *75 μ F is too small and affects low end distortion. 1 μ F ESL is purely arbitrary as impedance control is more complex than hanging a film cap across the DC buss. Rudimentary testing found no benefit with a properly sized, low impedance capacitor bank.*

Seller supplied parts

- 1 - 16 gauge brushed stainless steel chassis frame with bottom cover and 4 chassis supports
- 1 - VTA CCS driver board with parts set with capacitor upgrades and Russian PIO coupling capacitors
- 5 - Celanex™ octal tube sockets
- 4 - 5 lug terminals strips (in with tube sockets)
- 1 - USA made PA-125 power transformer
- 4 - hard rubber isolation washers for the power transformer
- 1 - USA made A-125 custom interleave/layer wound output transformer
- 2 - Triad C24-X chokes - *wire anti-phase to reduce field into output transformer*
- 1 - multi section (80, 40, 30, 20) quadruple capacitor KTL25 (35mm diam) ***
- 1 - 3 lug terminal strip
- 1 - 2 lug terminal strip
- 1 - ring lug
- 3 - bias test jacks
- 1 - gold plated RCA input jack - **suspect quality. Several have reported short lifetime.**
- 1 - gold plated output binding posts with mounting board
- 1 - IEC AC connector
- 1 - fuse post with 5 amp SLO-BLO fuse (inside the fuse holder)
- 1 - 10 amp rated SPST *toggle* switch
- 1 - 10 amp rated DPDT triode/pentode *toggle* switch
- 1 - 15 amp rated IEC AC power cord
- 2 - 22nF/100vdc capacitors
- 4 - 1k Ω /1w resistors
- 4 - 100 Ω /1w resistors - **not used in Ultralinear circuit**
- 2 - 10 Ω /5w bias resistors
- 1 - 7k5 Ω /3w resistor for quad cap ***
- 1 - Supplementary Cap Module (SCM)
- 1 - 1.0 μ F/630vdc ESL reduction capacitor
- 1 - 20 foot coil of 20 gauge tinned solid core copper wire + 18 inches of #16 wire - **silicone wire preferred ****
- 1 - hardware kit for amp

NOTE: parts may not be exactly as pictured in the pictorial. ALWAYS double verify you have the correct part **BEFORE** installation.

** 20ga solid silicone covered wire can be difficult to source. 20ga wire has an 11 amp chassis maximum. 22ga silicone wire is easier to find, but only has a 7 amp chassis rating. This is fine for everything but the power tube heaters which can be fed with a four wire loom of 22ga. Using separate colors and adding adding a wire color notes to these instructions during assembly makes troubleshooting a breeze.

Polarity Adapter - to reduce line voltage to inexpensive scope input limits

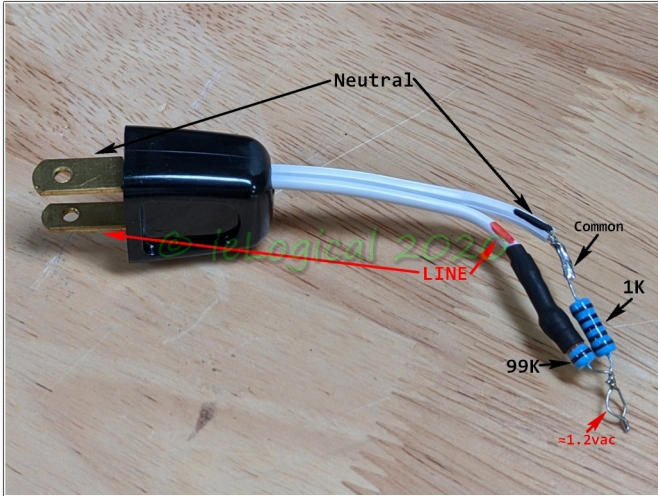

- | | | |
|----|-------------------------|---------------------------------|
| 1x | 1k resistor | Digikey 1kΩ 1w |
| 1x | 100k resistor | Digikey 100k 1w |
| 1x | polarized line plugging | Hardware store |
| 1x | zip cord | Hardware store |
| 1x | heat shrink | Hardware store |

Quad Capacitor Markings

* The quad capacitor should have each terminal marked with a symbol:
80 μ F ◐ / 40 μ F ◑ / 30 μ F ◒ / 20 μ F ◓
Ensure that all symbols are legible.
Mark any that are missing.

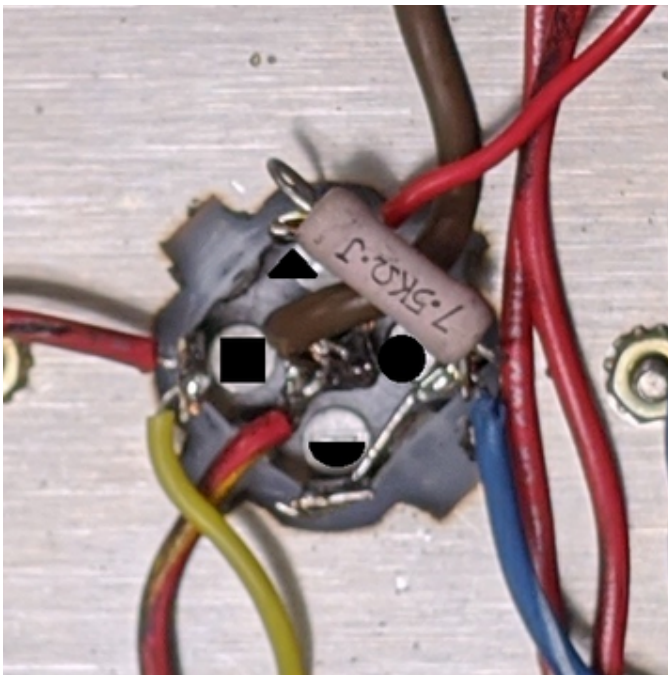

Viewed from rear power connector side of amp

!! DANGER - LETHAL VOLTAGE !!

POWER Transformer Polarity Matching w/o a scope

!! Variac recommended !! Power OFF when making all connections !!

Newer US power transformers have two primary taps to allow 115 or 120 volt operation so should not require input polarity matching. Heater supplies should still be matched to the line phase.

Input polarity matching is easily performed before the power transformers are inserted in the chassis. A variac will allow using a low input voltage considerably reducing the output voltages and consequently, the danger.

NOTE: This is predicated on the transformers being wired identically.

The BIAS winding is internally connected to 0vA allowing its use as a reference for matching transformer polarities.

Insulate all output leads on the two power transformers except 0vA [RED-YELLOW] and —BIAS [RED-BLACK]

Connect the two transformer secondary 0vA leads together.

Connect the primary transformers in parallel and apply a low voltage. Measure the —BIAS voltage to 0vA on each transformer. It should be about $\frac{1}{2}$ the applied input voltage.

Measure AC voltage between the two —BIAS leads.

If the voltage is near zero, the transformer primaries are in phase. If it is near the applied input voltage, the transformers are out of phase. Swap primary polarity on one transformer and retest.

Heater Polarity Testing - !! HEATER WINDINGS MUST BE UNCONNECTED !!

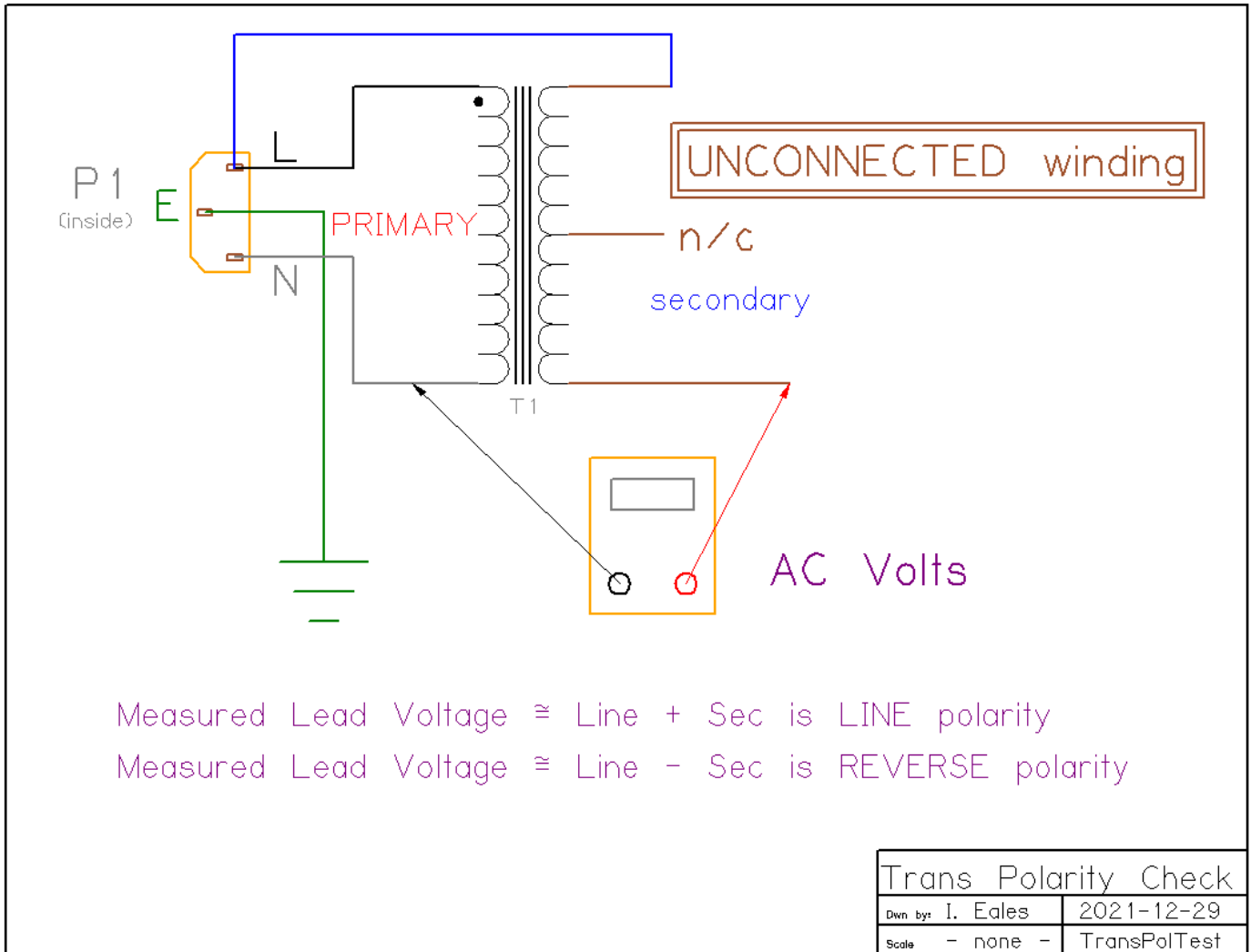

Either leg of the secondary is tied to LINE.

With a **measured** line voltage of 120:

If the unconnected leg reads greater than 120, ≈ 128 , that's the same polarity as the line.
 P in the Heater connections table.

If the unconnected leg reads less, ≈ 112 , it's the opposite polarity.
 N in the heater connections table.

Be EXTREMELY CAREFUL when working with the 415VAC output. Keep one hand in your pocket and use clip leads so as to not probe live LETHAL VOLTAGES!

Internal Bucker - courtesy of WP

If using solid state rectification with old single voltage primary US transformers, using the method above, the 5vac rectifier heater winding can be wired as an internal bucker to drop the mains by 5v which drops the heater and B+ voltages by about 4%.

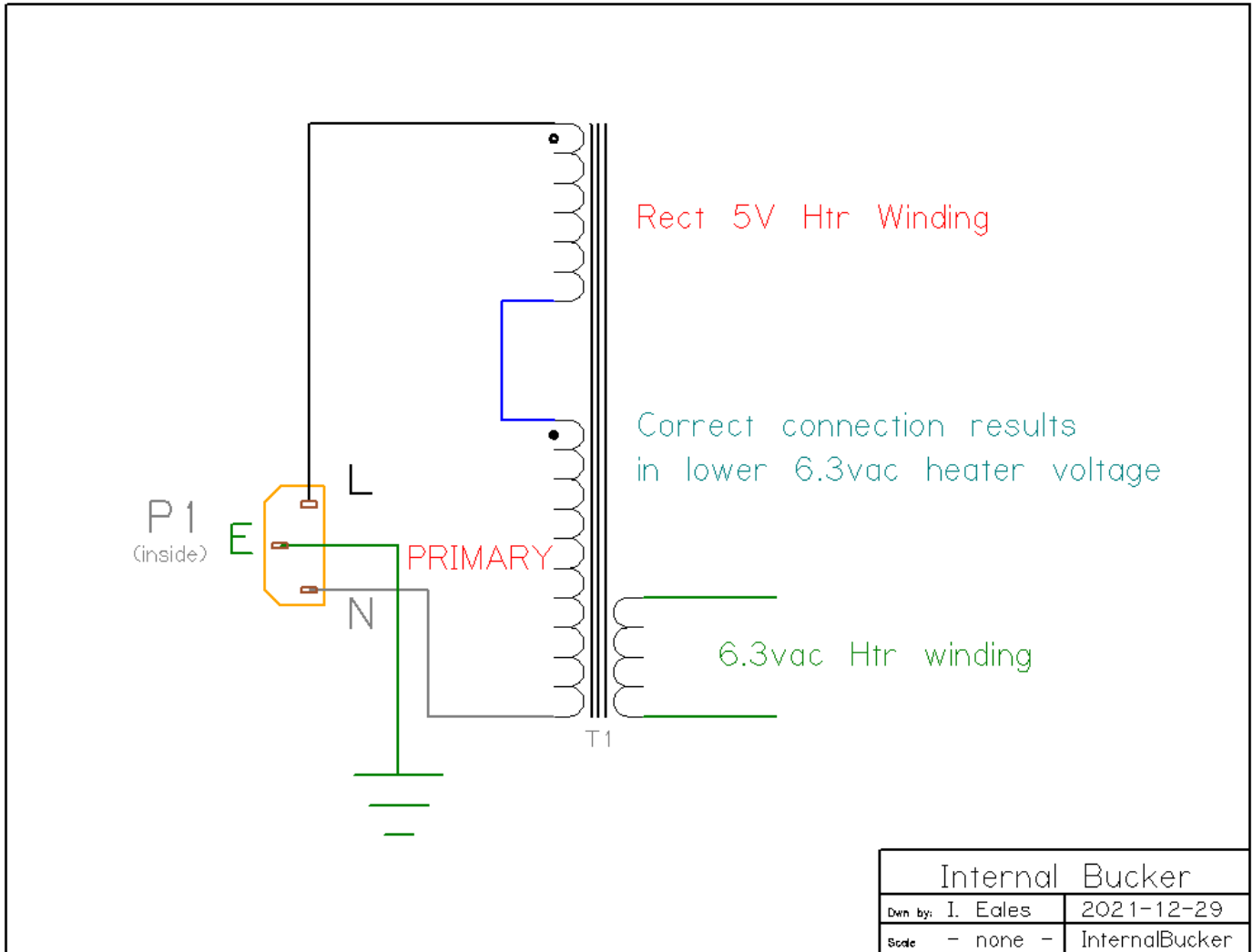

Child Safe

The amps can be made Child and Pet safe by mounting components on the under side of the driver and installing a plex cover. - courtesy WP

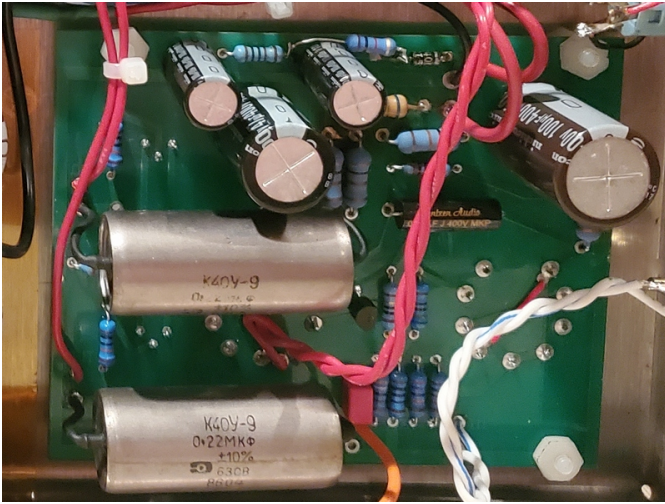

Driver Modifications

Recommend building the driver board first.
Red lines - Solder side. Orange - bias, Green - 0vA

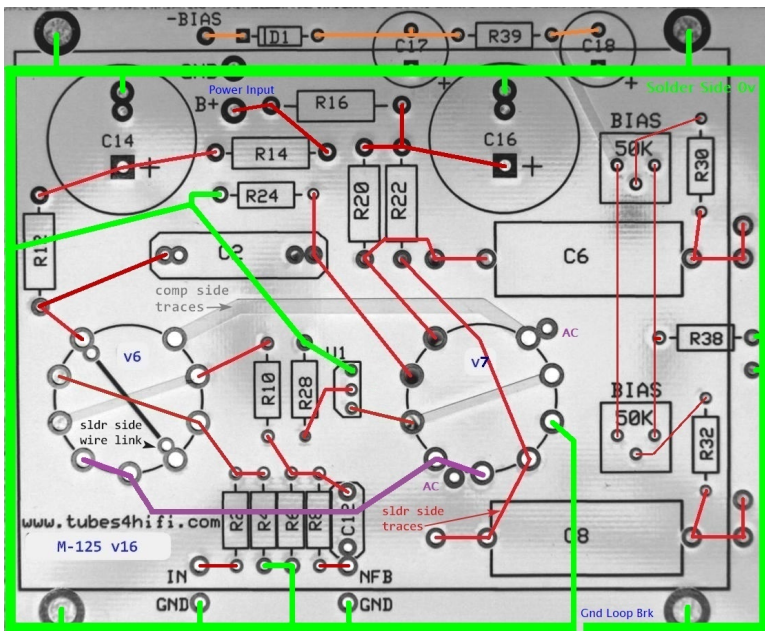

A) Break 0vA loop by cutting the trace at the point shown on the back of the board near C8

B) Input Filter

Add 220pF across R4 to roll off input about 75kHz

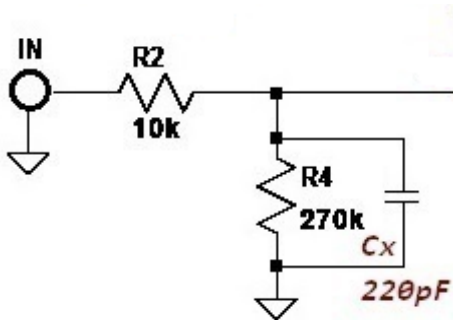

C) Feedback adjustment for 4Ω or 8Ω output terminal

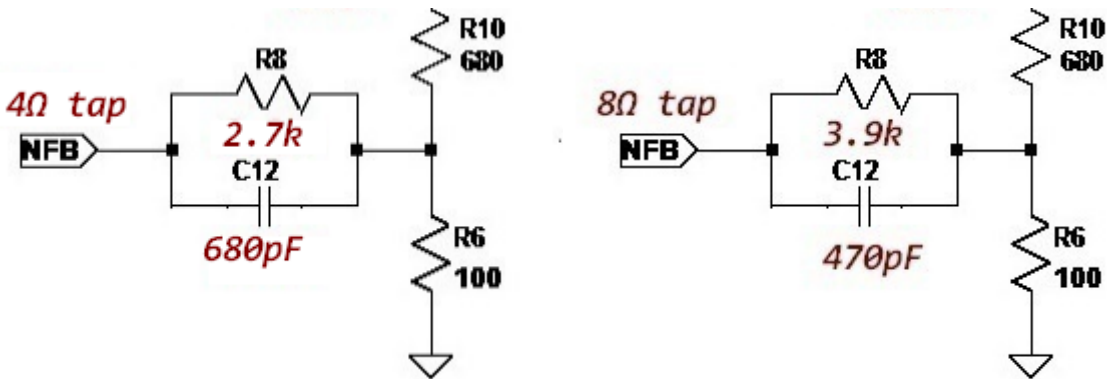

4Ω - Change R8 to 2k7Ω and C12 to 680pF / **8Ω** - Change R8 to 3k9Ω and C12 to 470pF.
Type is critical. Polystyrene, mica or polypropylene.

Obtain feedback from 8Ω output terminal

D) Output Transformer open circuit protection

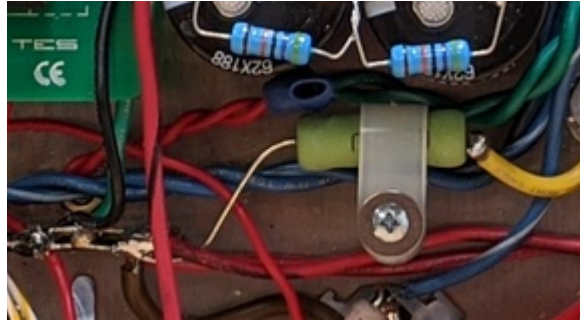
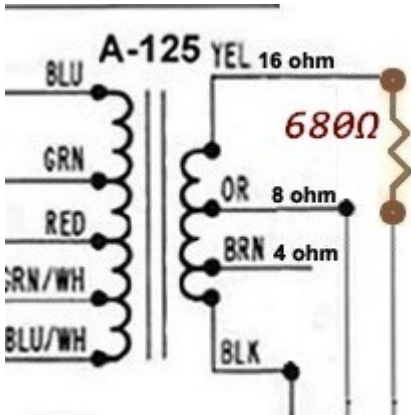

Add $\approx 600\Omega/5w$ resistor between 16 Ω output transformer lead and 0vA.

E) Bias filter to reduce mains frequency ripple.

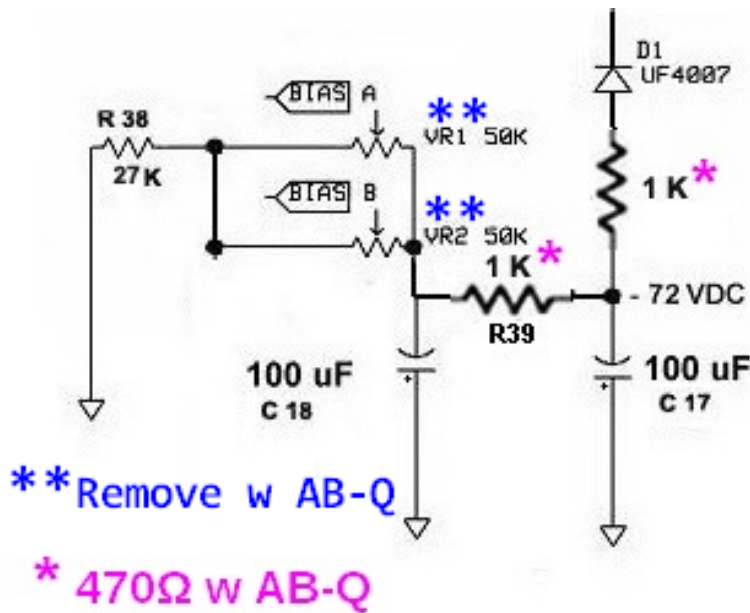

Stock Hum Injection

Modified Filter

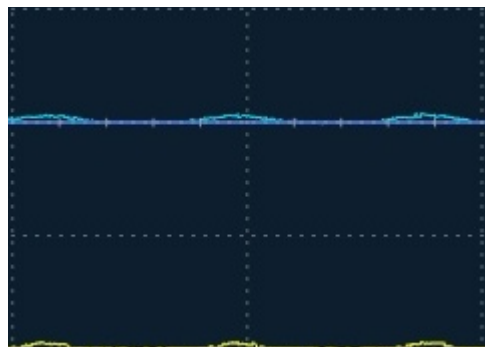

See http://ielogical.com/Audio/VTA_M-125.php#RegBias for regulated DC bias. Note that AudioAmp makes [AutoBias versions with DC Bias built in.](#)

F) LM334 Temperature compensation

Components may be mounted on board reverse side as shown here for increased temperature stability.

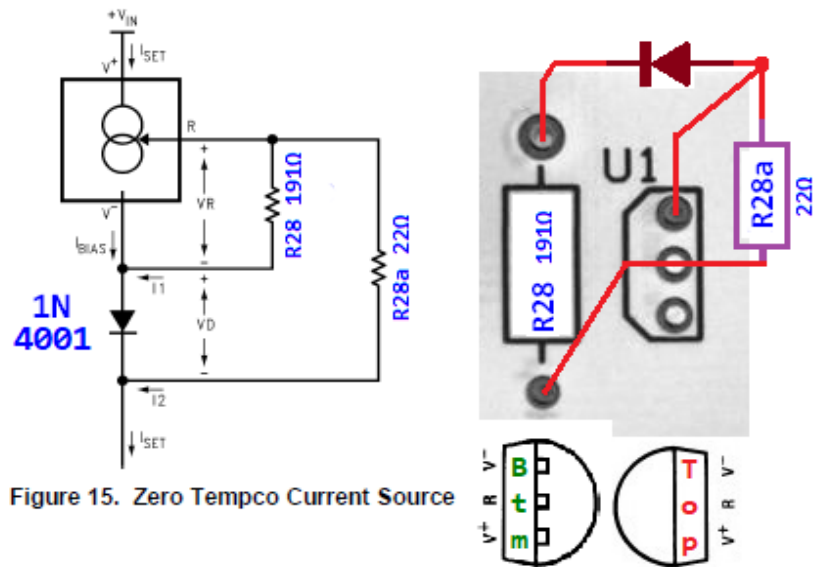
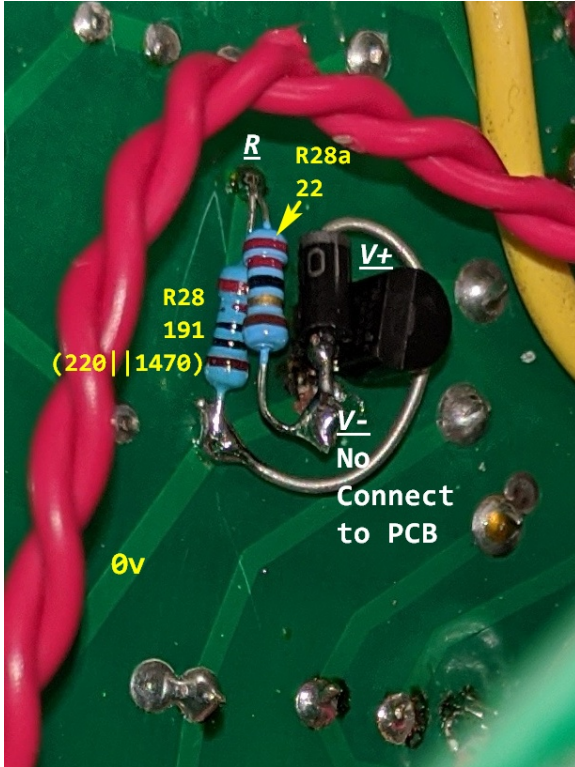

LM334 pin V- **does not connect to the PCB!** U1 in the schematic above is the LM334, not the footprint

R28 / 191Ω [220||1470] and is fit in R28 on the PCB

R28a / 22Ω connects between LM334 terminals R & V-

1n4001 diode connects between LM334 V- [anode / unmarked end] and 0vA [cathode / banded end]

Additional parts required: [per amp] Links are to parts used. Similar should work as well.

● **Snubbers - not optional**

- 8x 47Ω /2W resistor – pref carbon film [Part Connexion Kiwame 47Ω 1% 2W](#)
- 15ft 28ga magnet wire. Send street address to ieales@ielogical.com for 12 foot length

● **Driver Board Hardware** – to insulate from chassis

- 4x #6-32 x 0.625 nylon screws <https://www.mcmaster.com/94735A732/>
- 4x #6-32 x 0.187 nylon standoff <https://www.mcmaster.com/92319A610/>

With AB-Q add:

- 4x #6-32 x 0.375 nylon screws <https://www.mcmaster.com/94735A729/>
- 4x #6-32 x 0.750 nylon standoff <https://www.mcmaster.com/92319A658/>

● **Driver Board Filter Caps**

- 2x 100μF **500V** low ESR capacitors [DIGIKEY 500VDC CAPS](#)

● **Earth Safety [Ground] Loop Break**

- 1x 10Ω 5w flame-proof resistor [Digikey Ohmite 10Ω 5W](#)
- 1x 100nF/400V poly film capacitor [Digikey 100nF 630vdc / 250vac PP cap](#)
- 1x 50A diode bridge [Amazon 2x 50A 1000V Diode Bridge](#)
- 1x #10 x 1 [3.5mm x 25mm] machine screw [Hardware store](#)
- 1x #10 [3.5mm] KEP nut [Hardware store](#)
- 1x #14ga x #8 solder ring terminal. [Optionally, expand provided ring terminal to accept Loop Break and Earth Safety wires] [Hardware store](#)

See Rod Elliott's [Use Of Loop Breaker Circuits](#)

● **AuthentiCap Isolation**

- 1x 1.39" [35mm] clamp for High Voltage capacitor <https://www.parts-express.com/Mounting-Bracket-Clamp-020-615>
- Insulating material – HDPE from a milk jug works great [The Bin](#)
- 2x #6-32 x 1/2 in SS bolts [Hardware store](#)
- 2x #6-32 KEP nuts [Hardware store](#)
- 2x #6x3/8 SS washers [Hardware store](#)

● **AuthentiCap Replacement - OPTIONAL on new builds, suggested on old**

- 1x 100μF 630vdc cap [Digikey KEMET 100UF 20% 630V SNAP](#)
- 1x 47μF 550vdc cap [Digikey EPCOS 47UF 20% 550V SNAP](#)

● **Simple Bias Filter**

- 2x 1kΩ/0.5w resistors [Digikey 1kΩ ½w](#)

● **Regulated DC Bias**

- see http://ielogical.com/Audio/VTA_M-125.php#Bias for better filtering and DC bias options
- 1x 1n5266B 68v Zener. Send street address to ieales@ielogical.com address for free one
- 5x 100μF 100v Caps [Digikey 100μF 100v Nichicon](#)
[bias caps from kit can be used. Fewer input filter caps save a cupla bux]
- 1x 2SB1109 PNP or equiv [Futurelec 2SB1109](#)
- 1x 2k7 ½w resistor [Digikey 2k7 ½w](#)
- 1x 1n4007 diode [Digikey OnSemi 1n4007 1A/1000VDC diode](#)
[D1 from driver board]
- 1x small piece of perf board for assembly [Digikey PTH proto perf 3.5 x 2 inches](#)

● Individual Tube Bias Checking

- 1x small DPDT On-Off-On switch [Amazon 10ea DPDT on-off-on switch](#)
- 2x 10Ω/5W flame-proof resistor [Digikey Ohmite 10Ω 5W](#)
 - resistors not required with Auto-Bias
 - resistors could be 10Ω/½w metal film. In the event of a tube failure, the resistor should open. Auto-Bias is a better solution.

● Improved Yellow Sheet mod [not required w SS rectifier]

- 1x 1n5407 diode [Mouser OnSemi 1n5407 3A/800VDC diode](#)

● Big C capacitance [see [ieLogical VTA M-125 Final Thoughts](#) for construction details]

- 6x 330μF/400V caps [25.4mm diameter x 35mm length] [Mouser United Chemi-Con](#)
- 6x 470kΩ /1w resistors [Digikey 470k 2w](#)
- 2x 1/4-20 or 6mm bolts to fit Hardware store
 - Insulate bolt inside chassis where it passes between caps as +ve cap case is B+/2. Insulate the chassis top below the capacitor bank.** If the cap insulation should become damaged, B+/2 could be on the chassis, which should blow the fuse.
- 2x 1/4-20 or 6mm acorn nuts Hardware store
- 2x 1/4 x 1in SS fender washer [1in diameter w 1/4 hole flat washer] Hardware store

● LM334 Temperature Compensation

- 1x 1n4001 diode - ONLY for temp co [Digikey 1n4001 1A](#)
- 1x 22.1Ω/0.25w 1% resistor [Digikey 22r1 ¼w](#)
- 1x 191Ω/0.25w 1% resistor [Digikey 191Ω ¼w](#)

● Secure Octal Socket Mount

- 10x #4-40 x ¼" flat head Phillips SS screws Hardware store

● OPT Safety

- 1x 560Ω - 680Ω 5W resistor [Digikey 560Ω 5w](#)

● Output Terminals

- 3x Vampire BP-HEX or similar non-rotating terminal. Lateral space is limited w/o machining chassis [Part Connexion Vampire BP-HEX](#)
- 1x mounting block for replacement binding posts. Mill or 3d print mount

● 8Ω Feedback

- 1x 3k9Ω/1w resistor [Digikey 3k9 1w](#)
- 1x 470pF polypropylene capacitor [Digikey WIMA 470pF 400vdc 5%](#)

● 4Ω Feedback

- 1x 2k7Ω/1w resistor [Digikey 2k7 1w](#)
- 1x 680pF polypropylene capacitor [Digikey WIMA 680pF 400vdc 5%](#)

● Input LP Filter

- 1x 220pF - 270pF mica or polypropylene capacitor [original FB cap used here] [Digikey WIMA 220pF 5%](#)

-
- **Input RCA**

- supplied parts are internally fragile and may not stand repeated plugging. Be sure to get a part with an external nut so the jack can be properly snugged to the chassis
[Parts Connexion Tiffany RCA](#)
- [Zerone @ Amazon](#) are the ones I installed. The cost a bit more, but have a large inside boss that makes mounting easier. Outside panel tightening.

- **Unused Valve Rectifier Heater - can be used as a Bucker winding for 115v transformer**

- 1x 5100Ω/1w metal film resistor [Digikey 5.1kΩ / 1w metal film](#)
- 1x cable clamp [Hardware store](#)
- 1x mounting hardware [Hardware store](#)

- **Soft Start**

- 1x [Rubli HTR214 Soft Start](#) if using SS rectifiers. Tubes4HiFi TDR not recommended as delay is too short and it applies full power through a relay contact rather than ramping. Relay contacts degrade from first use. Note the *additional* 750kΩ/2w bleed resistor.

- **Rubli Soft Start Bleed Resistor**

- 1x 750kΩ/1w metal film resistor [Digikey 750kΩ / 1w metal film](#)

- **Chassis Spacers** - to improve cooling and damping

- 6x 0.25 x 0.125 rubber bumpers [Hardware store](#)

- **Misc heat shrink**

- as needed [Hardware store](#)

- **8Ω / 100w Power Resistor**

- for testing. All serious audiophools should have at least one wired up with banana plugs. They will get **VERY HOT very quickly** at high power, so plan accordingly. [eBay](#) or [Amazon](#)

[Amplified Parts Terminal strips](#) similar to included @ [Amazon](#)



Center Terminal is bent down & around to back to keep clear of chassis connection and provide additional mounting strength. Two required.

Chassis Modifications



Recommend countersinking the octal tube socket mounting holes and using flat Phillips head screws to better and more deeply seat the power tubes and regulator. Large base tubes like the KT-88 do not seat properly.

Optionally use top mount sockets or sockets with more protrusion and slightly better cooling



[Socket 8 Pin Ceramic Chassis Mount Gold Tube Socket \(partsconnexion.com\)](http://partsconnexion.com)



[Socket 8 Pin Ceramic Chassis Mount GZC8-Y-1-Gold Tube Socket \(partsconnexion.com\)](http://partsconnexion.com)

Earth Safety Loop Break Mounting Hole

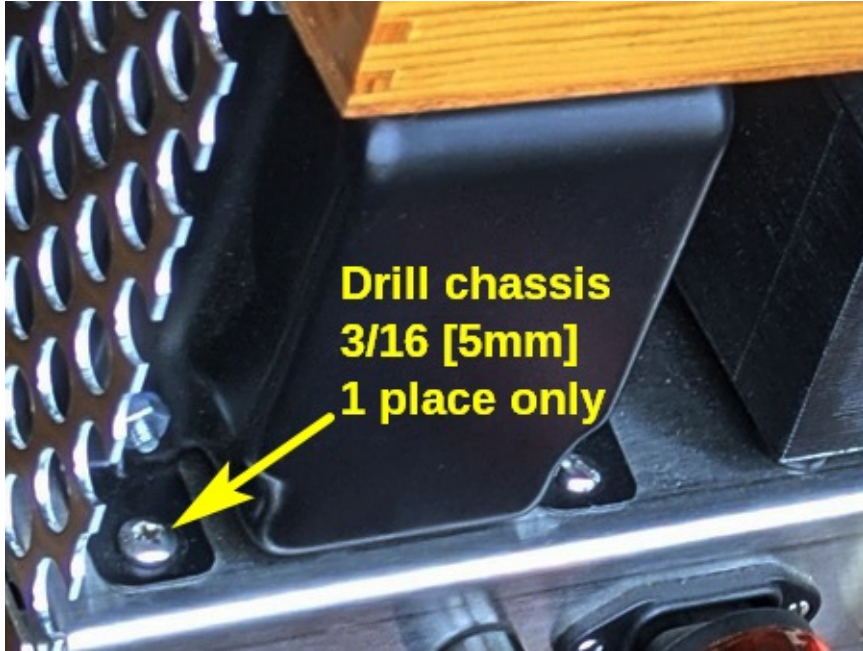

4x Tube Bias Check switch and Isolated Driver Board Mount [If isolated mount is used, Auto-Bias AB-Q board also needs drilling]

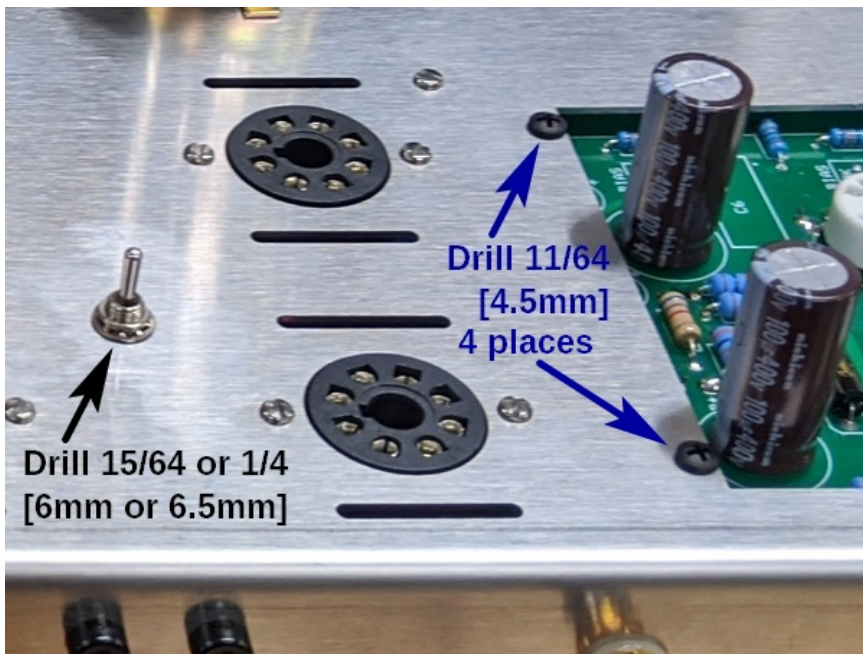

AuthentiCap Replacement [OPTIONAL]

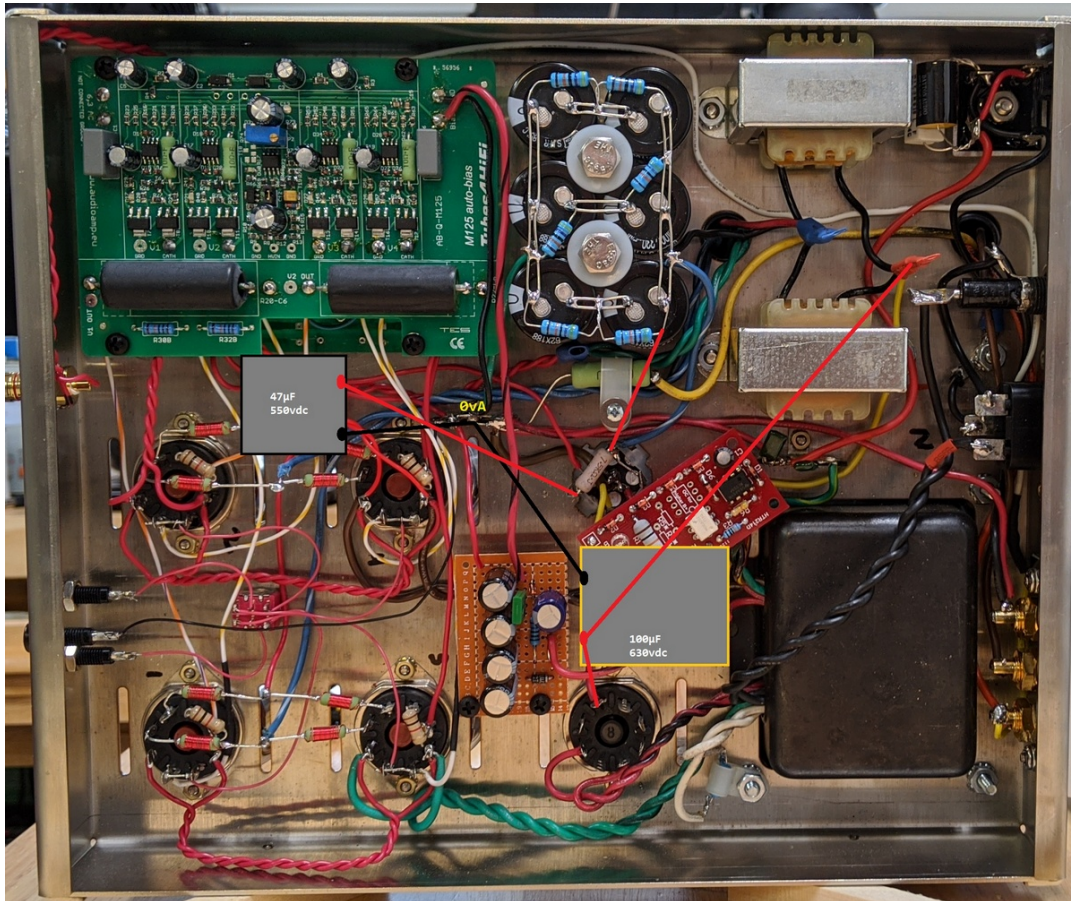
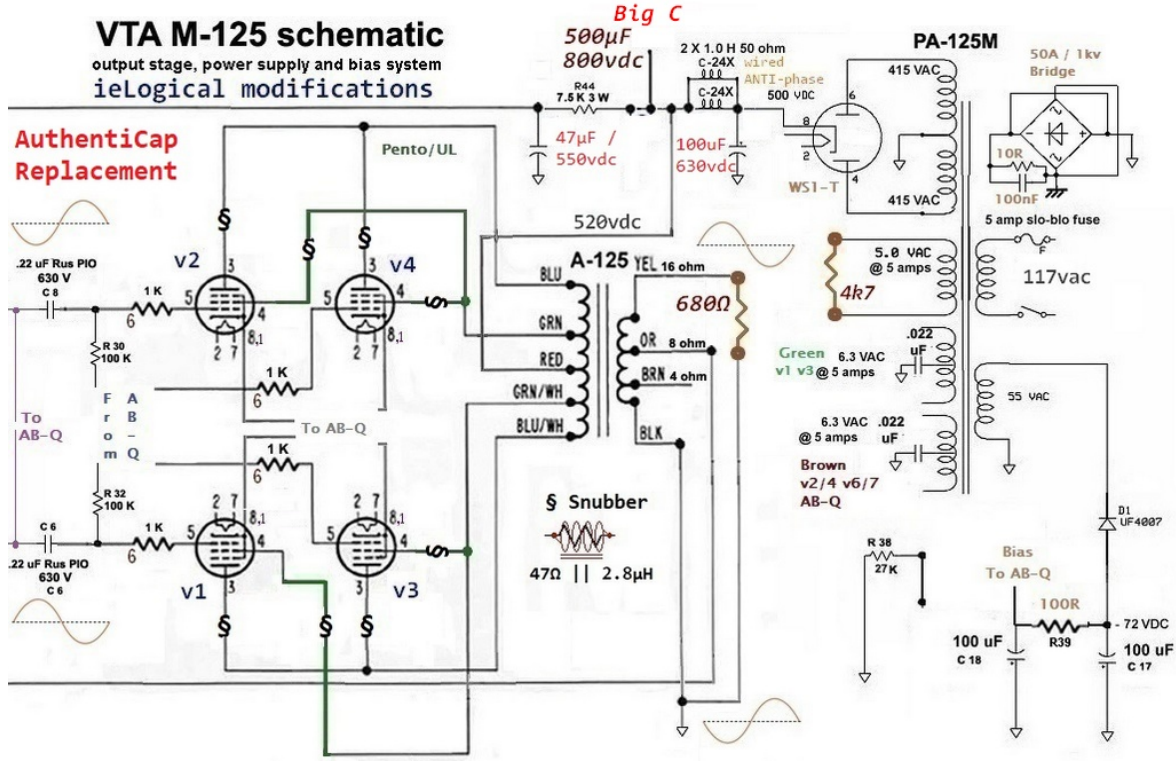

******* Triple **RED** asterisks in the instructions mark changes to implement AuthentiCap replacement.

AuthentiCap sections: 80 μ F ◐ / 40 μ F ■ / 30 μ F ▲ / 20 μ F ●

- I.** The 100 μ F 630vdc cap replaces the 40 μ F ■ section between the rectifier and the chokes. The negative terminal of the 630vdc cap is connected to 0vA, the positive to the rectifier output and the choke input.
- II.** Choke output is wired to Big C input, replacing the 80 μ F ◐ & 20 μ F ● sections
- III.** The 47 μ F 550vdc cap replaces the 30 μ F ▲ section with the 7k5 resistor between the Big C / choke connection and the +ve terminal. The negative terminal is connected to 0vA

AuthentiCap Cutout [NOT required with AuthentiCap replacement above]

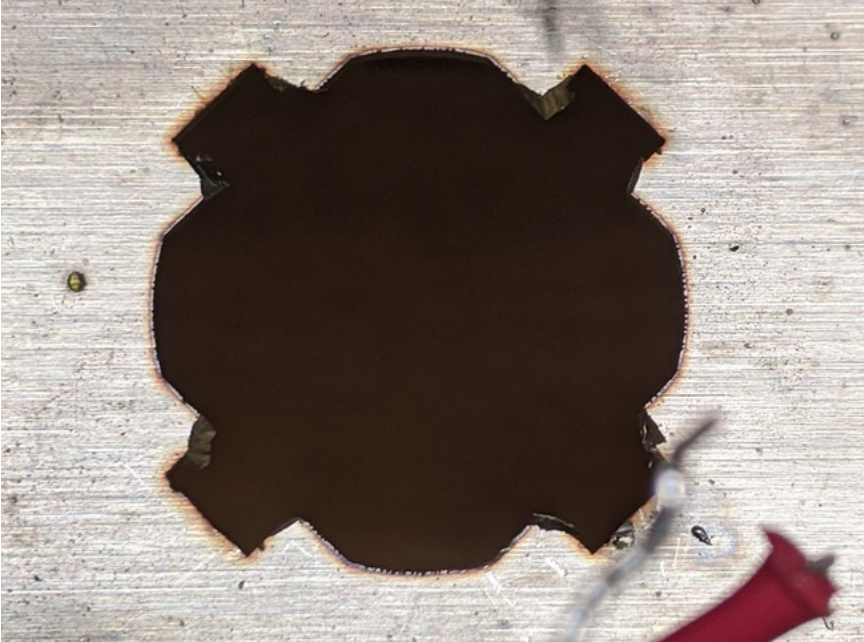

Mount ear holes cut with a Dremel tool.
Ensure there is MORE THAN ADEQUATE clearance to all terminals.

AuthentiCap Mount

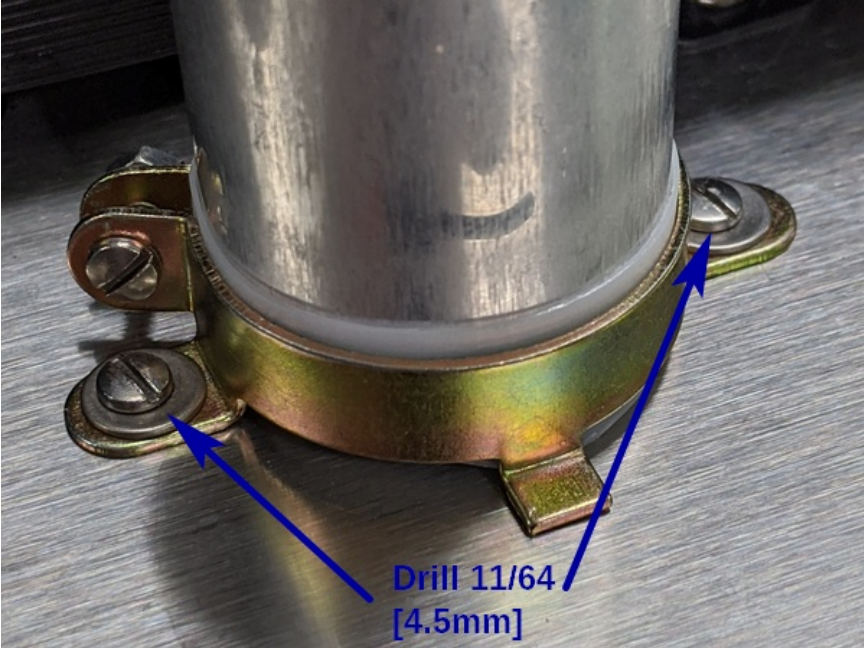

Big C Mount

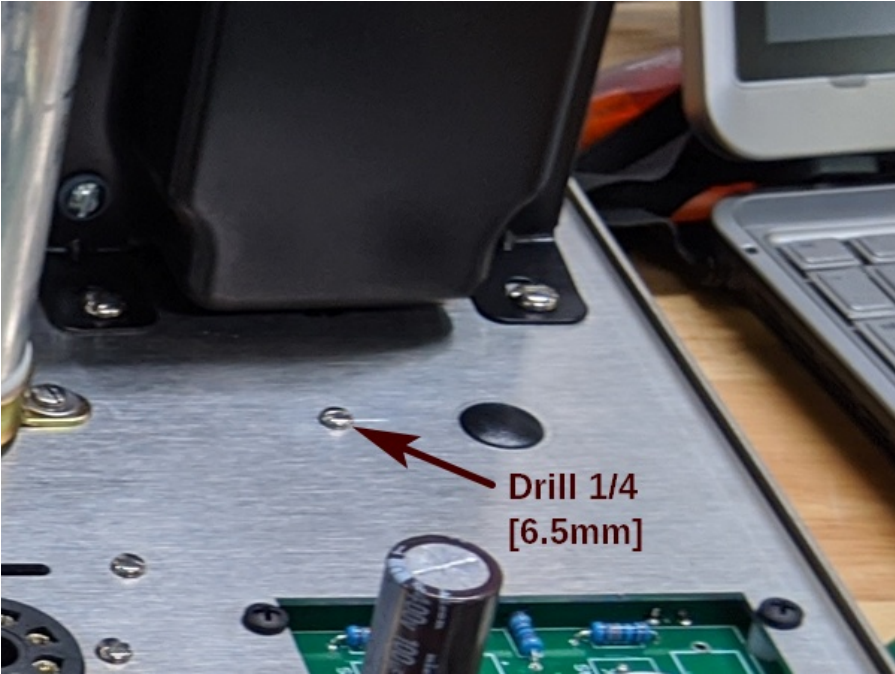

Snubbers

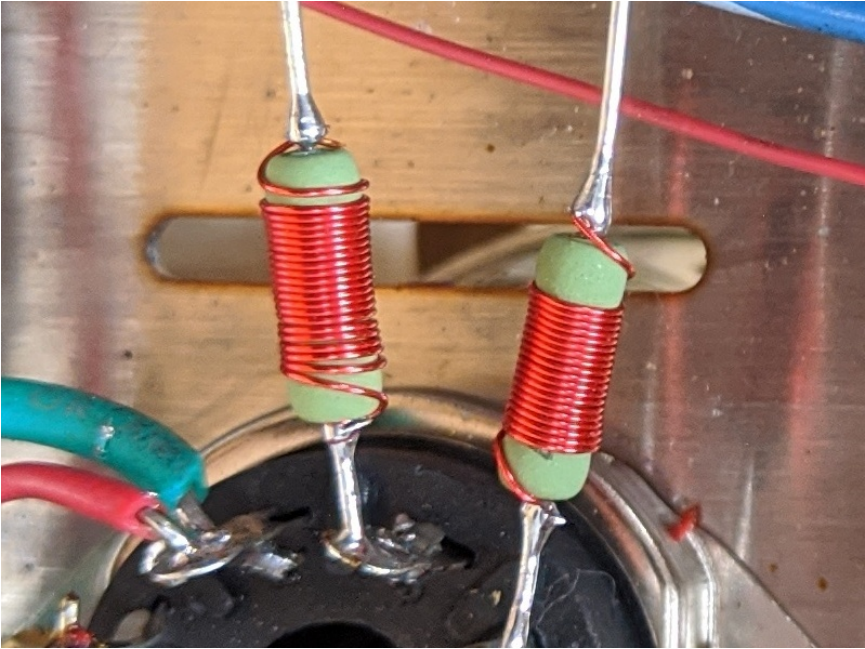

About 20 turns of 28ga magnet wire wrapped around 47Ω/2w CF resistors

Apparently Tubes4HiFi/VTA had a falling out with Audioamp over the [AutoBias](#) boards, so no longer sell direct. AutoBias boards have been 100% reliable here. Highly recommended. Sold in the U.S. by [Erhard Audio](#)

Rubli Soft Start Connections

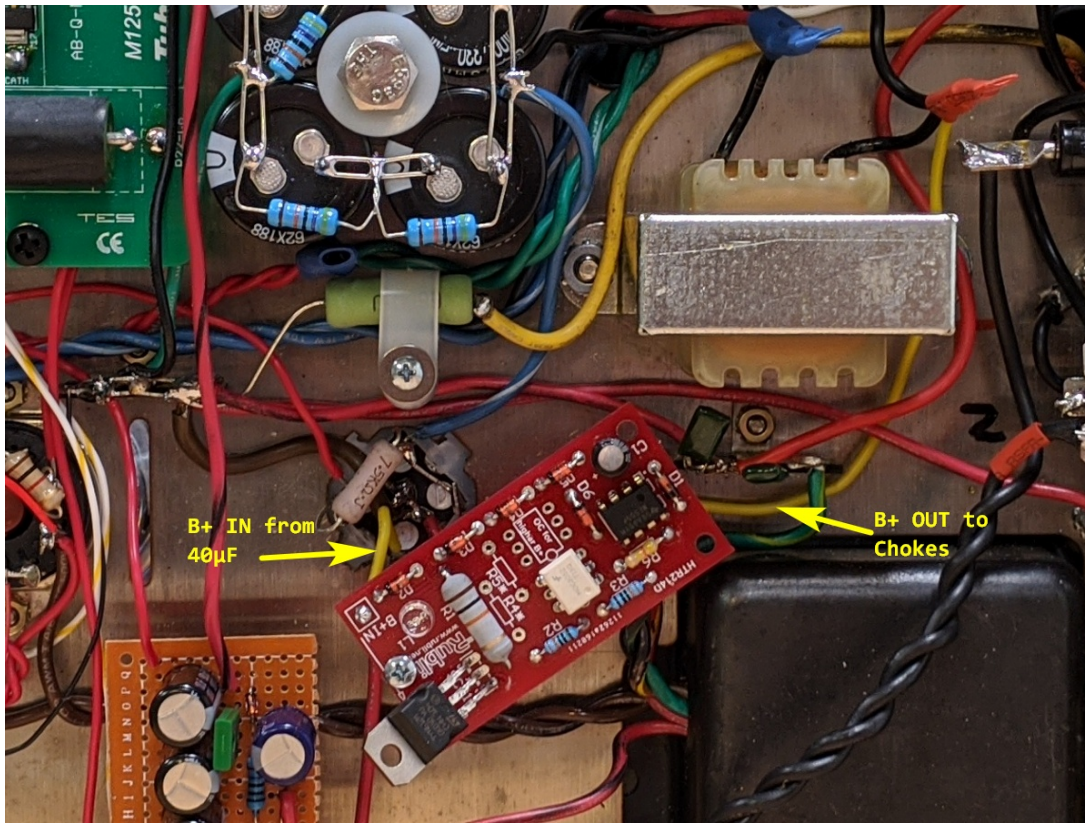

Add Soft Start Bleed Resistor if not fit

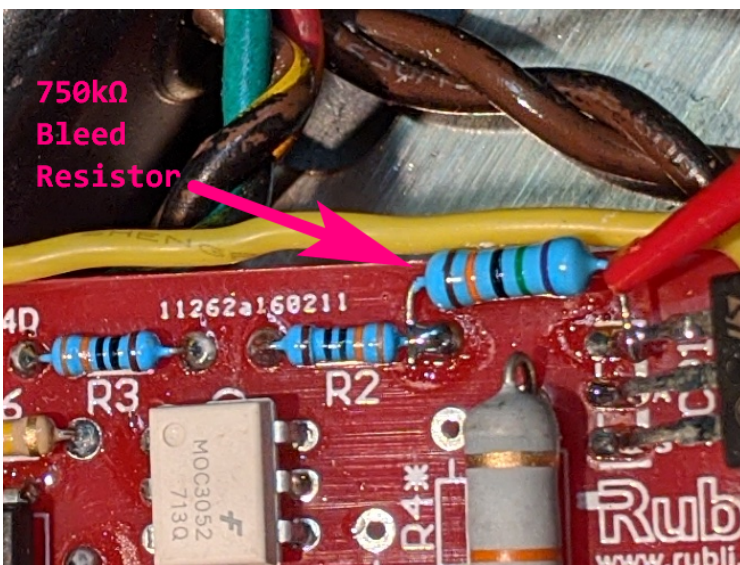

INSTRUCTIONS

There are some modifications to the Driver board. Identify those you intend to use and mark the appropriate sections in the driver board build instructions.

There is only ONE assembly manual included if you are building a PAIR of M-125 monoblocks. In order to keep your place during assembly, circle each number after completing that instruction number when you build the FIRST amp of the pair. When you build the SECOND amp of the pair place a check beside the circled number after completing each assembly instruction. Check each step TWICE.

Recommended build mode is step by step on both amps. It's easier to see a mistake if each step is double checked as completed.

Build a pair of stands and build both amps at the same time. Measure TWICE and cut once.
<http://ielogical.com/assets/M-125/BuildStand.jpg> Stands will be useful for modifications, repairs and updates.

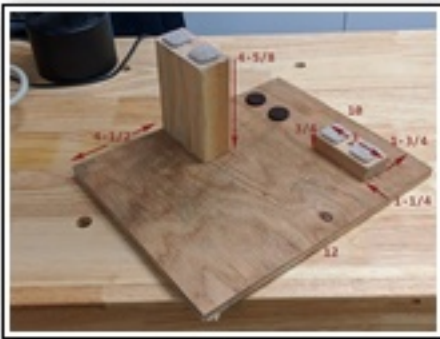

Remove the four stainless steel 6 X 32 screws and separate the bottom cover from the chassis. Taped inside the bottom cover are 4 black rubber chassis supports. Remove each rubber support from the backing and stick one over each of the four holes on the OUTSIDE of the bottom cover. Orient the chassis with the power transformer cutout facing you and mark "v1", "v2", "v3", "v4" and "v5" with a felt tip marker on the inside of the chassis next to the appropriate tube socket as marked on the pictorial photograph.

The symbol "(S)" means to solder that connection at that time. If you don't see the symbol DO NOT solder that connection at that time.

After completing each assembly instruction, check what you just did against the pictorial photograph. If what you just did looks OK, then proceed to the next instruction number.

Use 20ga solid silicone wire. Multiple colors simplify error trapping and troubleshooting.

Recommended colors

Black	0vA
Red	B+
Blue	Bias
Yellow	Signal

Note: Images included here do not exactly follow these instructions as model amps were poorly built by Tubes4HiFi.

1. Mount the FIVE octal sockets that fit on the chassis from the bottom of the chassis with $\frac{1}{4}$ inch long 4-40 stainless steel screws and 4-40 KEP nuts. *v1-4 keyway faces away from the center of the amp, towards the left when viewed from the transformer end. v5 keyway faces toward chassis center.*
2. Remove all binding posts from the backing board. Mount the backing board on the outside of the amp with two 4-40 screws and nuts. Center the backing board on the chassis opening and then tighten the nuts securely. Place the two RED posts with the spacer in the two holes of the backing board closest to the outside of the chassis. Place the BLACK post with the spacer in the remaining hole closest to the center of the chassis. Place the (red or black) plastic spacer on the inside of the chassis and then the flat washer, star washer and two lock nuts. (NOTE - The inside spacer will lock up against the metal of the chassis.) Loosen the (red or black) plastic nut on the outside of the chassis until you can see the hole in each binding post. Rotate each binding post until the hole in the metal post faces UP and DOWN. Tighten the two nuts on the inside of the chassis. You can use a small screwdriver or a thin nail through the hole in the post to keep the hole lined up as you tighten the two nuts.
3. Mount the IEC connector on the rear of the chassis with two 4-40 screws and KEP nuts. Orient the connector with the two leads toward the chassis bottom. The center Earth Safety connection pin should be close to the underside of the chassis top.
4. Mount the fuse holder in the "D" shaped hole in the chassis back. The slim black washer goes on the outside of the chassis. Tighten the large nut on the inside of the chassis. Do not over tighten as this may strip the plastic threads. Check that the 5 amp SLO-BLO fuse is inside the fuse holder.
5. Verify one input jack has a RED band and one has a BLACK band to differentiate the amps after assembly. Mount the RCA input jack on the chassis front. Make sure that one of the two white shoulder washers is on the INSIDE of the chassis and the other is on the OUTSIDE of the chassis. Place the 0vA lug over the inside white washer. Tighten the nut on the inside of the chassis keeping the 0vA lug to the left. Bend the 0vA lug out at a 45 degree angle from the chassis. The two washers are there to insulate the body of the RCA jack from the chassis. Verify the lug does not connect to the chassis with an ohmmeter. After the jack is installed, the metal of the jack should not touch the chassis but should be insulated by the two plastic washers. Verify connectivity to both 0vA and signal with an RCA cable. Wiggle it about. Might save tracking down an intermittent later.
6. Power Switch removed
7. Install the three test jacks in the three small holes on the left front of the chassis. Tighten them in place with the metal nut on the inside of the chassis. Do not over tighten.
8. Triode Switch removed
9. Install the 3 lug terminal strip in the small hole between the power transformer cut out and where the left choke will go with a 4-40 screw and KEP nut. Face the strip towards the power transformer cut out hole. Tighten the nut securely.
10. Prepare a 5 lug terminal strip by bending down the center tab around the phenolic strip. Install terminal strip in the hole near the driver board corner and v4 with a 4-40 screw and nut. Face the terminal side inboard. Connect the 4 terminals with buss wire fed through the holes. This is the 0vA start point. This point will have several connections, so a robust iron and tip are required. Make good mechanical connections, but not so robust that rework becomes difficult.

11. Instruction for Triode mode removed

Recommend much higher capacitance. Significant reduction in 60 & 120Hz noise with more C.
Assembly instructions for Big C here http://ielogical.com/Audio/VTA_M-125.php#FinalThoughts
If installing Big C, go to skip Step 12.

NOTE: Ensure that the marked side of the capacitors connect to 0vA.

12. Assemble and mount the Supplementary Cap Module (SCM)

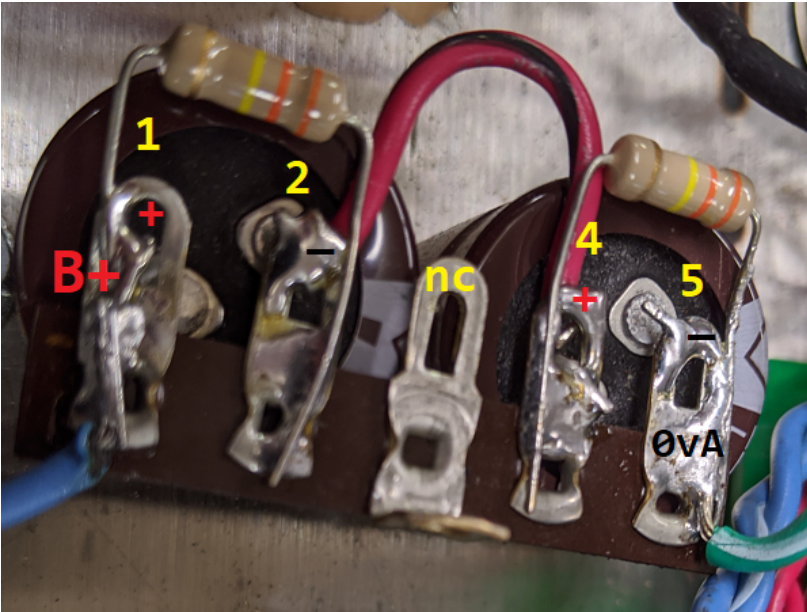

- A. Obtain the 5 lug terminal strip from the SCM kit. Inspect for any damage to plastic cover.
- B. Hold the strip with the lug that attaches to the chassis towards your RIGHT - The lug closest to you is lug 1 and the next four lugs are lugs 2, 3, 4 and 5.
- C. Connect one 330k Ω /1w resistor between lugs 1 and 2 - have the resistor straight in line with the terminal strip and not on the side of the lug.
- D. Connect a jumper wire between lugs 2 and 4 - have the jumper straight in line with the terminal strip and not on the side of the lug. Arch the jumper over the top of lug 3.
- E. Connect one 330k Ω /1w resistor between lugs 4 and 5 - have the resistor straight in line with the terminal strip and not on the side of the lug.
- F. Connect a 5 inch and a 3½ inch RED wire wire to lug 1 [B+] on the side of lug 1 which faces the strip's chassis attachment hole.
- G. Connect a 3 1/2 inch GREEN wire to lug 5 [0vA] on the side of lug 5 which faces the strip's chassis attachment hole.
- H. Obtain one of the two supplementary caps and connect the NEGATIVE terminal of this cap (the terminal with the GRAY STRIPE next to it) to lug 2 of the terminal strip. Connect it on the side OPPOSITE the chassis attachment hole. Keep both cap terminals close to the UPPER SIDE of the solder lug. (**S**) Fit the other lug of this cap into lug 1 of the terminal strip (**S**). You may have to bend the cap leads slightly to fit the holes in the terminal strip.
- I. Fit the OTHER supplementary cap with the NEGATIVE terminal (the terminal with the GRAY STRIPE next to it) in lug 5 (**S**) and the POSITIVE terminal in lug 4 (**S**). Connect it on the side OPPOSITE the chassis attachment hole. Keep both cap terminals close to the UPPER SIDE of the solder lug. You may have to bend the cap leads slightly to fit the holes in the terminal strip.

- J. Mount the SCM in the small hole just to left of the large hole with a 4-40 screw and KEP nut.
NOTE - The two caps should not touch the chassis when mounted.

Newer US transformers may have dual power input leads which should facilitate uniform polarity. With transformers with only a pair of input leads, polarity should be determined. A useful tool for DIYers is a variac. The line voltage can be reduced to only a few volts for determining winding polarities. **CAUTION: Even with reduced input voltages lethal voltages may be present on the outputs. Insulate all outputs except the winding being identified**

The easiest way to determine polarities is with an oscilloscope and choke comparing the generated field. Once the input polarity is identified, the output windings must also be identified. See http://ielogical.com/Audio/VTA_M-125.php#HowBad

Correct Polarity for the heaters can reduce common mode noise.

The bias winding does not need identification as it is common to the 0vA B+ center tap.

IF a valve rectifier is employed, the 5vac tube diode and the B+ windings should be identified and both amps wired identically. It should not matter, but the truly neurotic may want to test. Please advise if it does, *with measurements and documentation*.

6.3V polarities must be determined and both amps wired with same phase so there is no potential difference between the two amps from power line A/C polarity. P indicates the 6.3v lead with the same polarity as the power line. Mark the P lines for easy identification later. An easy way to mark is to run a Sharpie down the lead.

13. Place the 4 rubber isolation washers on the ends of each of the four bolts of the PA-125 power transformer. Mount the PA-125 power transformer in the special power transformer cut out. The wires should face the FRONT of the chassis. Fasten the power transformer securely to the chassis with four 8-32 KEP nuts.

Assemble the Earth Safety Loop Break. The Loop Break bolts to the outboard rear Output Transformer bolt so leave adequate room for the nut. Link the two ~ terminals and add a 2nd link between + and - terminals. Parallel 10Ω/5w and 100nF capacitor and connect between ± and ≈. Add a 6in BLACK lead to the ± (S). Add a 4in GREEN lead to ≈ (S). Solder any open connections.

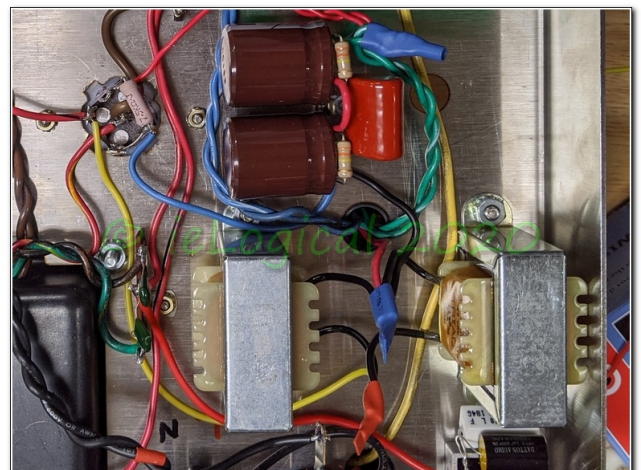
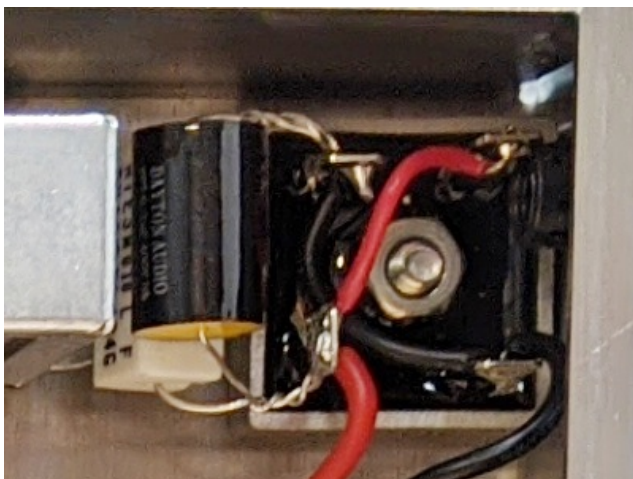

14. The side of the Output transformer with the YELLOW-ORANGE-BROWN-BLACK leads must face the power connector side of the amp. First mount the chokes on the inside of the chassis with just the one 8-32 screw and nut for the choke that is closer to the back of the chassis. (see pictorial) The other choke mount screw for each choke is a front mount screw of the output transformer. Have the two leads face between the chokes. Tighten the one nut for each choke but keep the other hole for each choke lined up with front transformer mount hole. Mount the output transformer on the chassis top with the 3 remaining 8-32 and 1 #10 screws and KEP nuts. The two front transformer mounting screws and KEP nuts will also secure each choke from the front. **Ensure that none of the Loop Break terminals is common with the chassis!!**

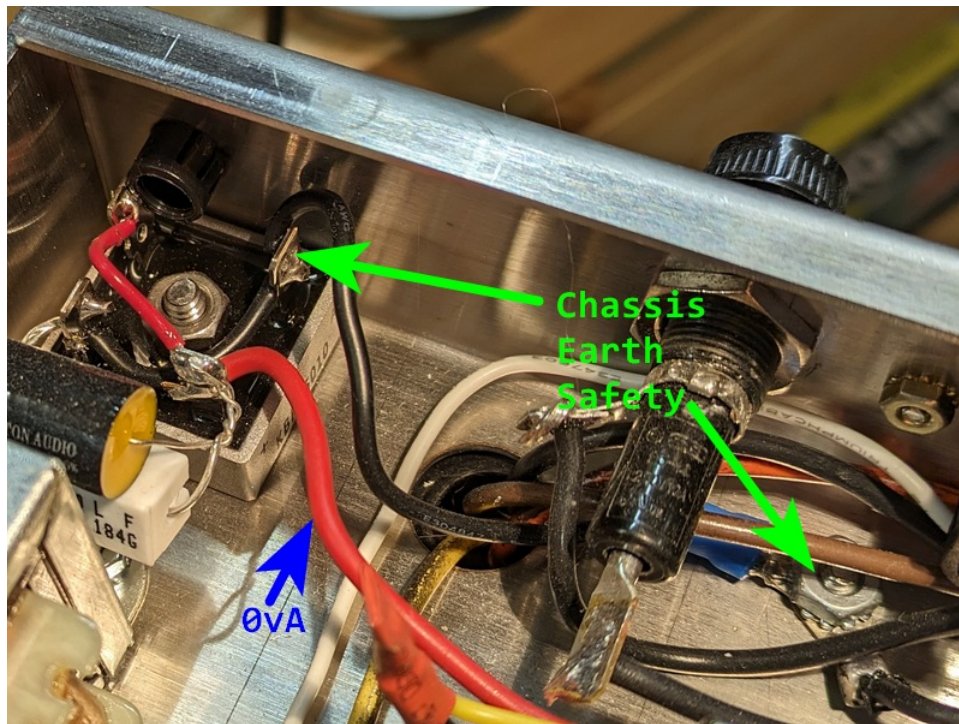

Go to WIRING on next page if replacing the AuthentiCap

Increase the size of the AuthentiCap mounting hole so the can clears all chassis metal. Use an insulated clamp mount for the QUAD capacitor. Bend the 4 can terminals inward and link the 4 can terminals with buss wire. This is power transformer 415VAC center tap and link to 0vA buss. Ensure there is no contact with any of the capacitor terminals.

15. Mount the quadruple section filter capacitor (quad cap) in the clamp with insulating material. HDPE from a milk jug works a charm. The can **must not** connect to the chassis. It is imperative that the quad cap be properly oriented. The 80 μ F section with \blacktriangleright on the terminal must face the power connector side of the amp.

Heater Connection Polarity Chart

Amp	Modified			
	Left		Right	
Valve	Pin	Pin	Pin	Pin
	<u>2</u>	<u>7</u>	<u>2</u>	<u>7</u>
3	P	N	P	N
1	N	P	N	P
4	P	N	P	N
2	N	P	N	P
	<u>4/5</u>	<u>9</u>	<u>4/5</u>	<u>9</u>
7	N	P	N	P
AB-Q	<u>6.3</u>	<u>Gnd</u>	<u>6.3</u>	<u>Gnd</u>
	P	N	P	N

- Twist the pair of green leads from the power transformer together and extend to socket v3. Connect green lead P to v3/2 and green lead N to v3/7.
- Twist the pair of brown leads from the power transformer together and extend to socket v4. Connect brown lead P to v4/2 and the brown lead N to v4/7.
- Twist the brown/yellow and green/yellow wires from the power transformer and extend to the 3 lug terminal strip next to the power transformer. Connect the brown/yellow lead to lug # 3 closest to the amp front. Connect the green/yellow wire to lug # 1 closest to the amp rear.
- ***Connect the Power transformer red/yellow lead to 0vA in the quad cap filter capacitor.
- Extend the RED lead from the output transformer to the rearmost lug (#1) on the SCM.
- ***Connect the 5 inch red wire from lug 1 B+ of the Supplementary Cap Module (SCM) to the 80µF terminal on the quad cap. Connect the green wire from lug 5 of the SCM to the 0vA buss near the center of the amp.
- ***Cut choke leads to approximately 2½ inches. Connect rear leads together and connect approx 6" wire. **(S) If installing a Rubli Soft Start**, connect to Soft Start B+ OUT. **(S)** Connect 3" wire from B+ IN to 40µF quad cap terminal [closest to v5]. **Otherwise** connect 6" wire to 40µF quad cap terminal [closest to v5]. Route wire between 3 lug terminal and power transformer.

Connect SCM 3½" red lead, red Output transformer B+ and front choke leads. **(S)** Insulate choke lead junctions.

See <http://ielogical.com/assets/M-125/DCwiringMod.jpg>

- Connect previously determined Line black lead of the power transformer to lug "A" of the fuse post. Make a good mechanical connection. **(S)** Connect previously determined power transformer Neutral black lead to left terminal of IEC connector as you face the rear of the amp. Make a good mechanical connection. **(S)** Link the Right IEC terminal to the "B" terminal of the fuse post.

Solder a 3 inch #16 wire and the free end of the Loop Break GREEN wire to a ring terminal. Solder free end of #16 wire end to Earth Safety, the center pin closest to chassis on the IEC

connector. Remove the #8-32 KEP nut on the power transformer that is closest to the IEC connector. Place the ring of the ring lug over the bolt and re-tighten the nut.

11. Connect the black lead from the output transformer to the notch at the end of the black speaker terminal inside the amp. Connect one end of a wire to the notch at the end of the black speaker terminal inside the amp (S). Connect the other end of this wire to one of the 0vA buss. Connect the brown (4Ω) wire to the middle red binding post notch closest to the black post (S) and connect the orange (8 Ω) wire to the red binding post notch furthest away from the black post (S).

NOTE > The remaining YELLOW wire from the output transformer will be connected at a later step in construction.

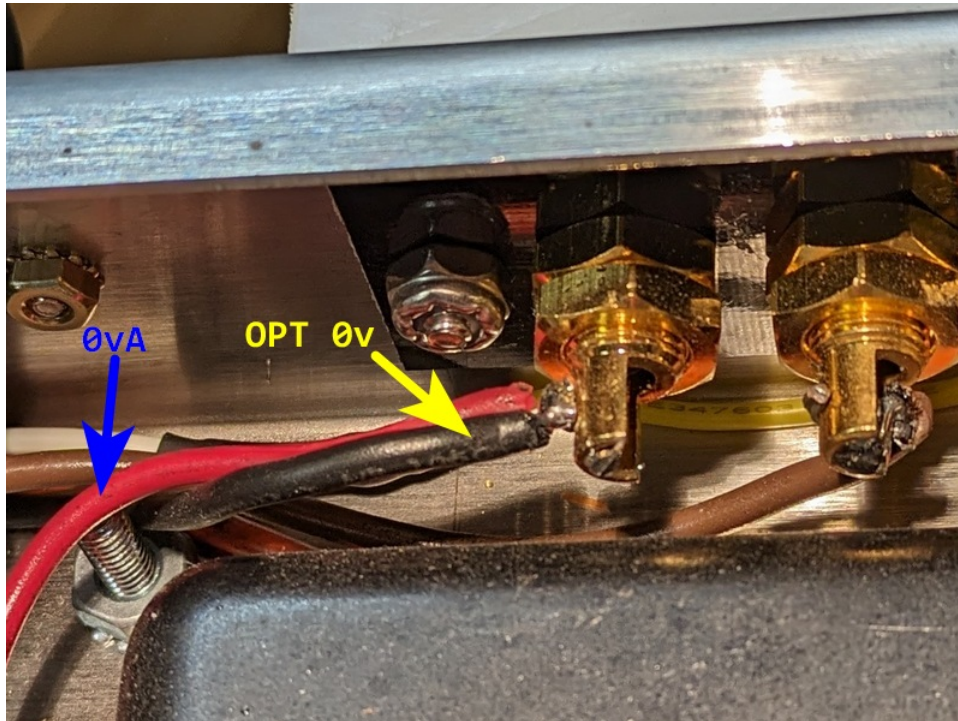

12.

Snubber Connections

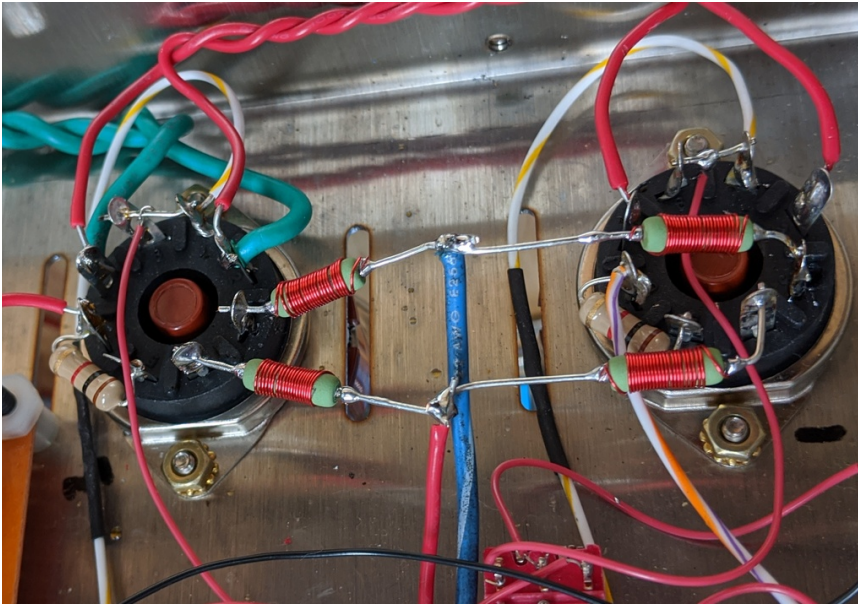

Fit snubbers between v1/3 & v3/3, v1/4 & v3/4 and v2/3 & v4/3, v2/4 & v4/4. Ensure snubbers are well clear of other pins. Note that additional connections will be made later to v1-4.

13. Connect the blue wire from the output transformer to snubber junction on pin #3 of v2 & v4. **(S)**
Connect the blue/white wire from the output transformer to snubber junction of pin #3 of v1 & v3. **(S)**
14. Triode mode removed.
15. Triode mode removed.
16. Connect the green wire from the output transformer to snubber junction on pin #4 of v2 & v4. **(S)**
Connect the green/white wire from the output transformer to snubber junction of pin #4 of v1 & v3. **(S)**
17. Triode mode removed.

18. Connect one end of a 22nF /100v capacitor to lug #1 of the 3 lug terminal strip (S). Connect the other end of this capacitor to lug #2 of this terminal strip. Connect one end of another 22nF capacitor to lug #3 of the 3 lug terminal strip (S) and the other end of this capacitor to center lug #2. Connect one end of a wire from lug # 2 of this terminal strip (S). Connect the other end of this wire to one of the two main 0vA buss near v4.

Heater polarity must be maintained. Either use different colors or mark one wire at both ends to ensure wire to correct pin on each socket pair. Create two twisted pairs of 6½ inch wires.

Heater 22nF caps must be isolated from Chassis and connected to 0vA ONLY

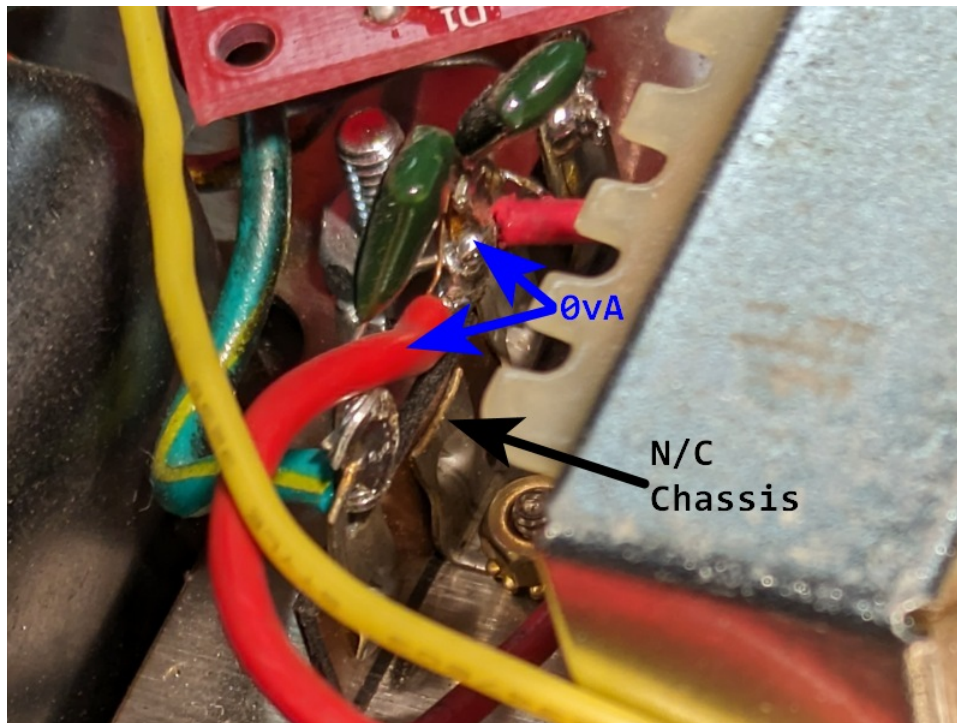

19. OPTIONAL:

Heater voltage tend to run a bit high on the M-125. See [Heater Over Voltage](#) in the Heaters section on the web page for more information.

20. Connect one end of one wire to v3/2 (S). Connect the other end of the same wire to v1/7 (S). Connect the other wire to v3/7. (S) Connect the other end to v1/2. (S)
21. Connect one end of one wire to v4/2 (S). Connect the other end of the same wire to v2/7 (S). Connect the other wire v4/7. (S) Connect the other end to v2/2. (S)

22. OPTIONAL:

*******Valve Rectifier Improved Yellow Sheet Mod - to prevent the filter bank discharging into the rectifier. Connect 1n5407 diode anode [unmarked] to v5/8. **(S)** Connect cathode [marked] end to v5/7. Connect 3" wire from v5/7 **(S)** to the quad cap filter capacitor 40 μ F ■. **(S)** Bypass step 20 below.

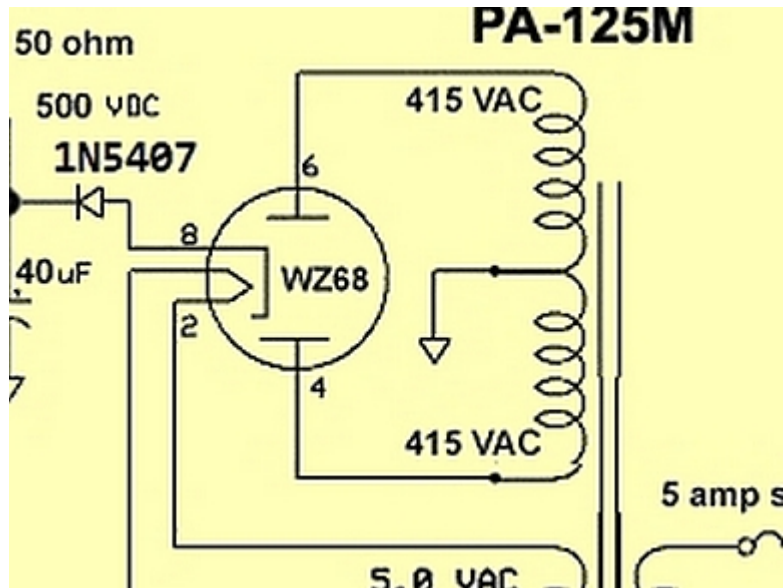

23. *******Connect one end of a 3 inch wire from v5/8 **(S)**. Connect the other end of this wire to the quad cap filter capacitor 40 μ F ■ **(S)**
24. *******Connect one end of a 1½ inch jumper wire from the 80 μ F ▸ lug on the quad cap filter capacitor **(S)**. Connect the other end of this jumper wire to the 20 μ F ● filter capacitor terminal furthest to the right.
25. *******Connect one end of the 7k5 Ω /3w resistor from the 20 μ F ● lug. Connect the other end of this resistor to the remaining 30 μ F ▲ lug on the quad cap filter capacitor.
26. *******Installation optional. Impedance control is more than just hanging a film cap across electrolytics. Connect one end of the 1 μ F/630vdc ESL reduction capacitor to the 20 μ F ● quad cap terminal. **(S)** Connect the other end of this capacitor to the main 0vA buss.
27. *******Fabricate an 8 inch twisted pair of red and black wire. Connect one end of the red wire to the quad cap filter capacitor 30 μ F ▲ lug . **(S)** Connect the black lead to the 0vA buss. The free end of this wire will be connected at a later step.
28. Connect one end of a short 3 or 4 inch wire to the quad cap 0vA. **(S)** Connect the other end to the 0vA buss next to the quad cap.
29. Solder all connections to the 0vA buss. **(S)** When you solder these connections, count to make sure that you have SEVEN wires connected to the buss:
 - A. The RED-YELLOW wire from the power transformer
 - B. A wire from the BLACK speaker terminal
 - C. A wire from one end of the ESL capacitor, if installed
 - D. A wire coming from center lug #2 of the 3 lug terminal strip near the power transformer
 - E. A wire connected to the 0vA of the quad cap

F. A wire coming from lug 5 of the SCM

G. A black wire with one end free (which will be connected in a later step).

It is important that the 0vA buss is soldered properly as this is the main 0vA point for the entire amp.

30. Keep the leads to resistors in this step at 3/8 inch [10mm] or less. Connect one end of a 1k Ω /1w resistor to v3/5 (S). Connect the other end to v3/6. Connect one end of a 1k Ω /1w resistor to v1/5 (S). Connect the other end to v1/6. Connect one end of a 1k Ω /1w resistor to v4/5 (S). Connect the other end to v4/6. Connect one end of a 1k Ω /1w resistor to v2/5 (S). Connect the other end to v2/6. Connect a wire between v1/6 (S) to pin 6 of v3/6. Connect a wire between v2/6 (S) to v4/6. NOTE: If installing the AB-Q, the wires to v1/6 and v3/6 will be replaced
31. Link pin 1 & 8 on v1-4 with a short piece of bare wire. Bend the ends around as this is a permanent connection. If planning to install Auto-Bias AB-Q, the resistors will be removed, so connect appropriately. Connect 2x 10 Ω /5w resistors end to end by twisting the leads together, with about 3/4 inch [19mm] between them. Make another identical assembly. Connect free end of one resistor to v1/8 (S) and the other free end to v3/1. (S) Repeat for v2/8 & v4/1.

Connect a wire from the middle of each added resistor pair (S) to 0vA buss. (S) Ensure the connections are well clear of chassis metal. This wire will be removed if installing Auto-Bias AB-Q.

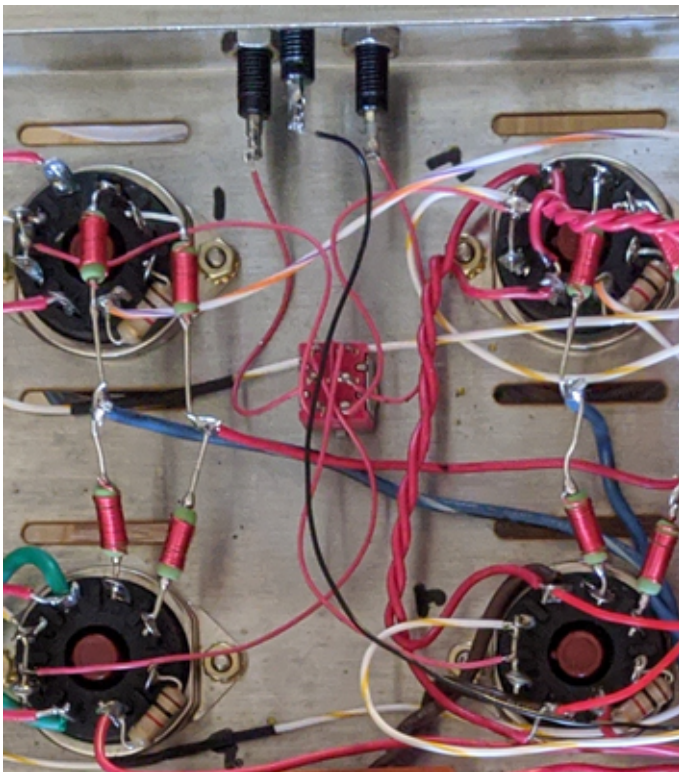

Install DPDT On/Off/On switch in hole between the power tubes. Fore & aft paddle orientation is preferred to indicate tubes being measured. (A Popsicle stick with a 1/8 inch [3.5mm] hole in the end makes a great toggle tool between hot tubes.) Connect a wire from left middle switch terminal (S) to left bias check pin (S). Repeat for right side.

Connect a wire from v1/8 to the **rear left** switch terminal. (S) Connect a wire from v3/1 to the **front left** switch terminal. (S) Repeat connections for v2 & 4.

32. Step 29 covered in 28 above.

Installation of the VTA driver board

If you have not as yet built the M-125 VTA driver board please do so now and when completed come back to this point in this instruction manual. The instructions for building the VTA driver board are with the board. It would be well to review BIAS modifications prior to assembly. If the board was built first, review the suggested mods above.

1. Place the four #6-32 x 5/8 nylon screws in from the TOP of the chassis. Install a #6-32 x 1/4 stand-off from the inside of the chassis. Do not fully tighten. Place the Driver board on the screws. Tighten the screw firmly, but don't over do it as it will deform the nylon. Ensure the 2 outboard 100k Ω resistors do not touch the chassis. Secure the board in place with #6-32 x 3/4 stand-offs. Make a final test fit and then remove the board. Slide the Driver board onto the 4 screws until it bottoms out on the stand-offs. Make sure that the "INPUT" eyelets and "NFB" eyelet are towards the RIGHT side of the amp. Tighten down the board this time with four 4-40 KEP nuts.

Connections to the VTA driver board

1. Cut two 8 inches wires, one red, one black. Twist the wires together except for 1/2 inch on both ends. Connect the black wire to the input "GND" eyelet on the RIGHT SIDE of the driver board next to the "IN" eyelet. **(S)** Connect the red to the driver board "IN" eyelet. **(S)** Run the wires toward the front along the right side of the chassis to the input jack. Connect the black wire to in RCA input 0vA TAB. **(S)** Connect the red wire to the center pin of the RCA input jack. **(S)**

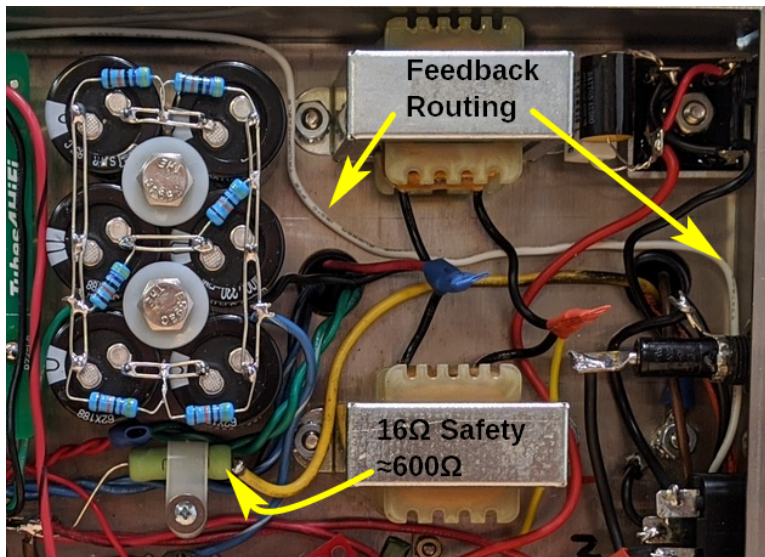

2. To minimize distortion, connect intended load speaker terminal to NFB. Driver board Gain R8 and FB capacitor C9 values require change.

8 Ω - R8 - 3k9 Ω , C12 - 470pF.

4 Ω - R8 - 2k7 Ω , C12 - 680pF.

Connect 16Ω YELLOW lead to 0vA with $\approx 600\Omega/5w$ to help prevent Output transformer damage from disconnected load.

Run feedback wire from speaker terminal along the amp rear under the power connector and fuse, midway between the chokes, angling over to the chassis along the side of driver board. Connect the feedback wire from the output (S) to the "NFB" eyelet on the right side of the driver board. (S)

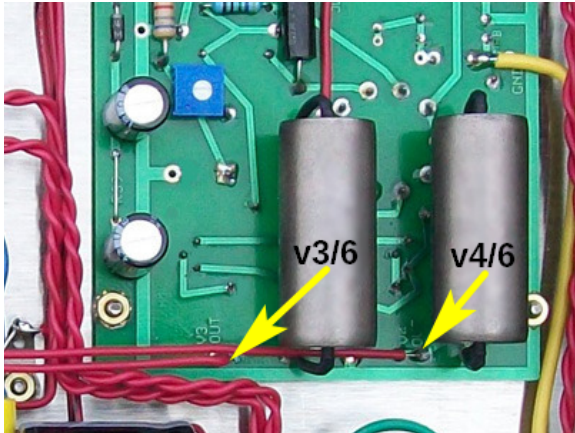

3. Connect a wire to the eyelet on the back edge of the driver board. (S) Connect the other end of this wire to v4/6. (S) Connect a wire to the eyelet on the back edge of the driver board. (S) Connect the other end of this wire v3/6. (S)
4. Twist one red, one black 8 inch wires except for 3/4 inch on each end. Connect one end of the red wire to v2/2. (S) Connect the black wire to v2/7. (S) Connect the red wire to the "FIL" eyelet on the driver board on v7/9. (S) Connect the black wire to the "FIL" eyelet on the driver board on v7/4&5. (S)
5. Connect the free end of the red wire coming from the 30μF ▲ terminal on the quad cap to the "B+" eyelet on the bottom of the driver board. (S) Connect the black wire to the "GND" eyelet close to the B+. (S)
6. Route the RED-BLACK power transformer lead to the driver board, routed midway between v3&4, turning to run between v2&4 and over to the —BIAS eyelet. Trim to length. Ensure the wire does not contact the chassis. (S)
7. 0vA lead soldered in 5. above
8. Earth Safety attached earlier
9. Power Switch not installed

<< **Before ANY Power Applied !!!** >>

0vA Check

Attach negative ohm meter lead to 0vA buss and verify 0vA connectivity to driver board, SCM 0vA and no where else:

- $\approx 10\Omega$ to chassis with Loop Break installed.
- OPT Speaker: BLACK 0Ω , 16 Ω yellow lead $> 500\Omega$, 8 Ω tap $\approx 0.4\Omega$, 4 Ω tap $\approx 0.3\Omega$
- Input +ve, $\approx 280k$. Input -ve, 0Ω .
- Input -ve to Output black, 0Ω
- IEC socket L & N, open or O/L
- IEC socket E, $\approx 10\Omega$ to 0vA & 0Ω to chassis

Initial Startup

ALWAYS wait several minutes after power down to allow capacitor discharge.

Use a S E C U R E Clip lead for the 0vA connection.

KEEP ONE HAND in your Pocket when probing a live amp. Rubber sole shoes may help.

Wear cotton inspection gloves w beaded palms when working with warm tubes.

<https://www.mccormicksnet.com/Beaded-Gloves-p/6033550cb.htm> or similar

If at any time a fuse blows IMMEDIATELY when you turn the amp ON, check carefully all the power transformer wiring for an error. Check all wiring against the pictorial. If a fuse blows AFTER A FEW SECONDS and/or the rectifier tube shows arcing after a few seconds check carefully all of the QUAD CAP, SCM and ESL capacitor connections against the pictorial. With a solid state rectifier, a "no bias" situation usually indicates a bad rectifier.

1. Make sure that the 5 amp SLO-BLO fuse is in the fuse holder. Place the two 12BH7 (or 12AU7) driver tubes in the sockets on the top of the driver board. DO NOT PLUG IN THE RECTIFIER OR THE KT88 OUTPUT TUBES at this time. Connect power to the amp. Wait about 10 seconds to see if the two driver tubes light up. If they do and they stay on for a minute then unplug the amp and proceed to step 2.

If the driver tubes don't light up or if the fuse blows check the wiring below and measure the AC voltage where both pair of twisted wires connect to the driver board. Check to see that you get about 6.1 - 6.8 volts AC between v6/4 v6/9. If not, check the wiring back to the power transformer for an error. Unplug the amp.

2. Set VOM range to 2 volts DC. Insert a shorting plug in the input and **CONNECT 100W 8 Ω power resistor to the 8 Ω terminal.** Insert rectifier into v5 and one power tube into v3 & v4 sockets. Turn the two bias adjusters on the driver board fully to the left to set bias its lowest value. Turn on the amp. Allow the amp to warm up for at least one full minute and check to see that the two power tubes light up. *Move the bias selector switch toward the transformers.* Measure the bias on the output tubes by placing the black negative probe into the black center test socket and the red positive probe into the left test pin. The left bias potentiometer biases the left tubes as viewed from the front. Similarly the right bias potentiometer biases the right tubes. With an insulated pot tweaker, slowly adjust the bias adjuster on the driver board to read 500mV DC for a bias current of 50mA. Repeat for v4 with the +test lead in the right test socket. Wait 2 minutes

and recheck. $\pm 10\text{mV}$ is fine. $1\text{mV} = 0.1\text{mA}$ bias, too little to worry about. Verify there is 0VDC and less than 10mVAC across the output power resistor.

3. Two tube operation not recommended. Excessive Heater voltages may result. Buy a Stereo 120

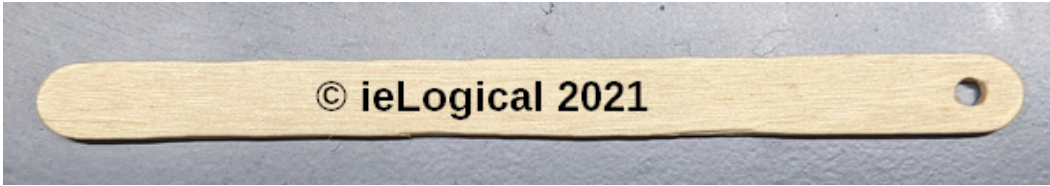

4. Power off the amp and **wait TWO FULL MINUTES**. Insert v 1 & v2. Turn the amp on. Move the bias check toggle switch forward and verify that v1 & v2 also read very close to 500mV . Repeat output check at 0VDC and $< 10\text{mVAC}$. Let the amp idle for a few minutes and recheck the bias values. They should remain nearly constant.

Subsequent bias checks should retain setting and a very close match between tubes. Repeated tweaking is discouraged as it is a sure way to wear out the trimmers. If bias balance between v1/v3 or v2/v4 changes markedly, the out of band tube is failing. Replace the quad. Auto-Bias sets each tube individually and keeps them balanced.

It is possible *but not easy* to add additional circuitry to bias each tube individually as in the Stereo series, but many aspects of the M-125 were somewhat poorly conceived.

5. Blown fuse warning moved to top of initial test

Complete both amplifiers **before** connecting to system and loudspeakers. A monitored burn in of a few [≈ 5] hours should weed out any component infant mortality.

In the last century, had a saying that if it lasts 20 seconds it should last 20 minutes and if it lasted 20 minutes it should last 20 years. With good tubes, should still hold true for the M-125.

Basic tube troubleshooting is to swap tubes between amps. [Recommend marking tubes on their base with a black Sharpie for Left and Red for Right]

A defective input tube may cause hum. Gently tapping a tube with the eraser end of a wooden pencil can help detect a microphonic tube.

DO NOT try "floating the ground connection" on the amp with a 3 to 2 "cheater plug" which effectively lifts the chassis Earth Safety connection for the IEC connector.

Solve the problem. The earth safety is to protect your life. If you lift the earth safety and there is a wiring fault, Y O U may become the path.

6. ALWAYS BE CAREFUL WORKING ON THE AMP with the power on. This amp has more than 500 volts in certain areas. **KEEP ONE HAND IN YOUR POCKET AND MAKE SURE YOU ARE NOT EARTHED. DRY, RUBBER SOLE SHOES ARE A GOOD IDEA.**
7. Triode mode not implemented

Always adjust bias with no signal going through the amplifier and a speaker or load resistor connected to the amp. Without a load, bias may jump around because of circuit instability. Bias will vary with line voltage and tube changes. *Don't try to be a fanatic about getting the bias "perfect"* - Expect bias to go up and down as your line voltage goes up and go down. Subtle changes in bias have no effect on sound. Checking the bias about once a month is fine. As the tubes wear a little bias will change slightly.

If one of v1/v3 or v2/v4 pairs vary radically in bias, it could be new tube time.

If you cannot bias ONE output tube or ONE PAIR of output tubes properly then one tube (or one of a pair) may be defective. REPLACE that tube or tubes. If ALL tubes will not bias properly try replacing the GZ34 rectifier tube or the solid state rectifier. A common symptom of a weak or bad rectifier is LOW bias or NO BIAS on all or multiple tubes with the bias control turned all the way clockwise. Using a solid state rectifier gives a slightly higher B+ voltage and require a different bias adjustment than a tube rectifier. Always use either KT88, 6550, KT90, KT100 or KT120 output tubes in this amp. Do not use EL34, 6L6, KT66 or KT77 output tubes in this amp. Always use a MATCHED QUAD of output tubes in the four output tube mode or a MATCHED PAIR of output tubes in the two output tube mode. NOTE: The Celanex octal tube sockets have "floating pins" for easier insertion of the tube. When you remove a tube sometimes a pin will "rise" with the tube. This is normal. The pin will never come all the way up. Just push it down. You can also bend all the socket pins inside the amp at a 45 degree angle away from the tube socket center to prevent this "pin rise" if it bothers you. [This is next impossible once wired.] The fuse is a 5 amp SLO-BLO fuse. Do not use a FAST-BLO fuse with this amp. Tube equipment needs a SLO-BLO fuse. If you have a problem with the amp

For Factory Service email Bob01605@aol.com or phone 1-508-347-9120 from 9 AM to 9 PM Eastern

Search the WWW for answers to your problem. Advice on DTAF from Messrs. Latino and Mottram sometimes ranges from dubious to flat out incorrect. Caveat emptor.

NOTE: *Bob may not take your call or answer your email if you are building the ieLogical revision.*
Email: ieales@ielogical.com

Document Revisions:

- 16-Feb-2024 - Add Yellow Sheet Improved dwg, change diode to 1N5407
- 03-Dec-2023 - Add 0vA clarification images
- 12-Mar-2023 - Add Heater voltage reduction note to web page
- 05-Feb-2023 - Add AuthentiCap replacement parts and placement information
- 14-Jan-2023 - Add Internal Bucker diagram
- 20-Dec-2022 - Add note regarding use of silicone 22ga wire
- 17-Sep-2022 - Add transformer polarity matching method
- 24-Aug-2022 - Add link to Rod Elliott's "Use of Loop Break Circuits"
- 19-Jul-2022 - Add 4Ω feed back part links, mini-schematic
- 06-Jun-2022 - Add Kid Safe build and internal bucker mods
- 27-Apr-2022 - Fix R8 error in section "Connections to the VTA driver board"
- 04-Apr-2022 - Add note about correct supplementary cap installation
- 30-Mar-2022 - Add Rubli Soft Start connection image
- 27-Mar-2022 - Add note about AB-Q board with onboard DC Bias, remove Bias VR w AB-Q
- 08-Feb-2022 - Add pre power 0vA checking
- 05-Jan-2022 - 4 tube bias check clarification, add 5k1 for unused tube rectifier heater load
- 29-Dec-2021 - add Heater Polarity checking diagram
- 28-Dec-2021 - add perf board for DC bias
- 26-Dec-2021 - add LM334 temp compensation instructions
- 25-Dec-2021 - add warning about multi-voltage transformer wiring
- 23-Dec-2021 - add vendor links to additional parts
- 28-Nov-2021 - correct v5 orientation error. 01-Dec-2021 - add RCA jack comments.

Tubes4HiFi Claimed Specifications for the VTA M-125 amp
removed as ieLogical could not validate most of them

M-125 voltage readings

All tubes should be plugged in, the input shorted, a *load resistor connected* and no signal should be running through the amplifier.

Note 1: - Make sure meter set to AC or DC as mentioned below. 0vA is the central star point. Clip the BLACK or negative probe on the star and probe with the RED or positive probe on the point mentioned.

All DIYers should have a pair of *insulated* clip to banana leads for working on hardware. With a clip lead on one probe there is no excuse for violation of the **one hand in pocket** rule.

Another smoke keeping trick is to shield all but the very tip of the test probe with tubing or shrink which will dramatically reduce the chance of shorting pins.

*Be careful not to cross two pins with the positive probe !
Once you let the smoke out, nothing works*

Note 2: - Readings $\pm 5\%$ below the range are not normally a sign of a problem. Line voltages vary considerably throughout the country. When a solid state rectifier is used some voltages (marked with an asterisk) will be at the high end of the voltage range.

At v5 rectifier

Pin 4 to 0vA - 400 - 425 VAC

Pin 6 to 0vA - 400 - 425 VAC

Pin 2 to 0vA - 490 - 530 VDC * [0v w SS rectifier and 5VAC not connected]

Pin 8 to 0vA - 490 - 530 VDC *

Any output tube

Pin 1 to 0vA - approx 500mV DC

Across pins 2 and 7 - 6.0 - 6.8 volts AC

Pin 3 to 0vA - 470 - 520 volts DC *

Pin 4 to 0vA - 470 - 520 volts DC *

Pin 5 to 0vA - *minus* 45 to *minus* 65 volts DC (actual value depends on bias pot setting)

Pin 6 to 0vA - *minus* 45 to *minus* 65 volts DC (actual value depends on bias pot setting)

Pin 8 to 0vA - approx 500mV DC

Be careful probing the quad cap ! Chassis terminals are very near!

Quad cap - Section # 1 (SQUARE symbol) ----- 480 - 530 volts DC *

Section # 2 (HALF CIRCLE symbol) --- 470 - 525 volts DC *

Section # 3 (NO or CIRCLE symbol) --- 470 - 525 volts DC *

Section # 4 (TRIANGLE symbol) ----- 380 - 420 volts DC *

"B+" on driver board > 380 - 420 volts DC *

**NOTE: Following schematics are for Auto-Bias AB-Q board.
Power schematic includes bias supply. Actual amps have regulated DC Bias**

See http://ielogical.com/Audio/VTA_M-125.php#RegBias

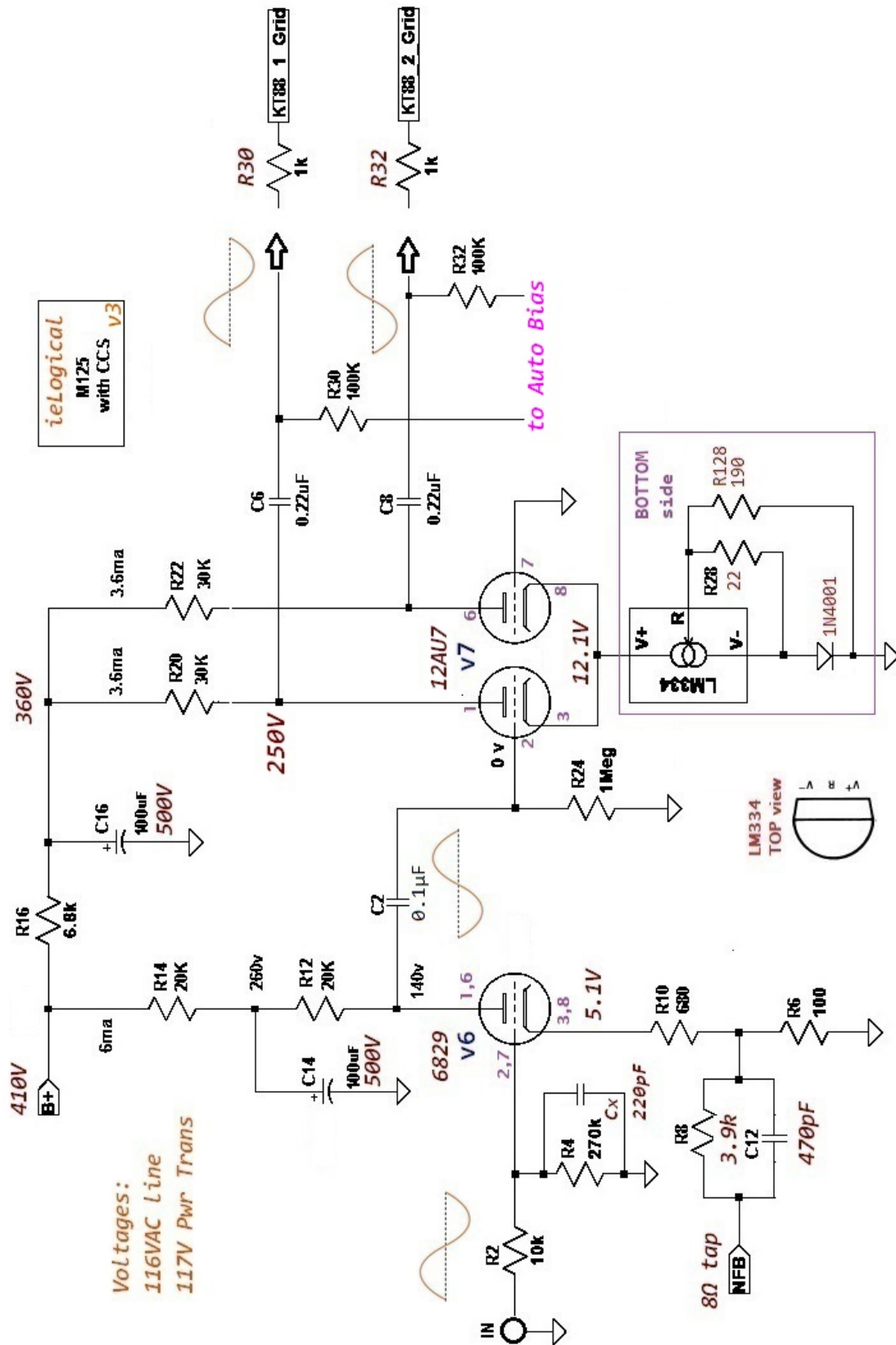

ieLogical Driver Modifications

VTA M-125 schematic output stage, power supply and bias system ieLogical modifications

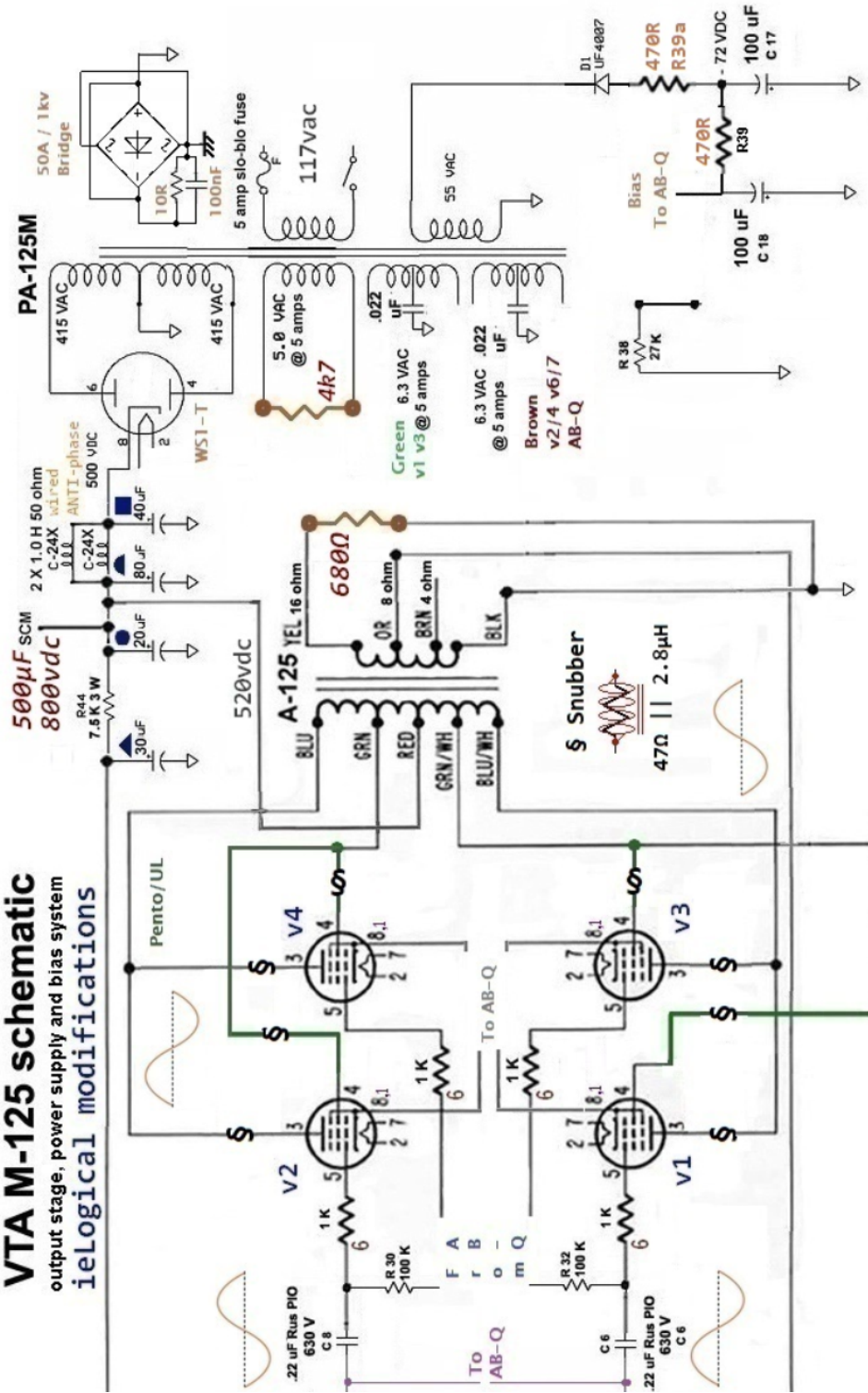

Original M-125 wire routing
 - for reference only -

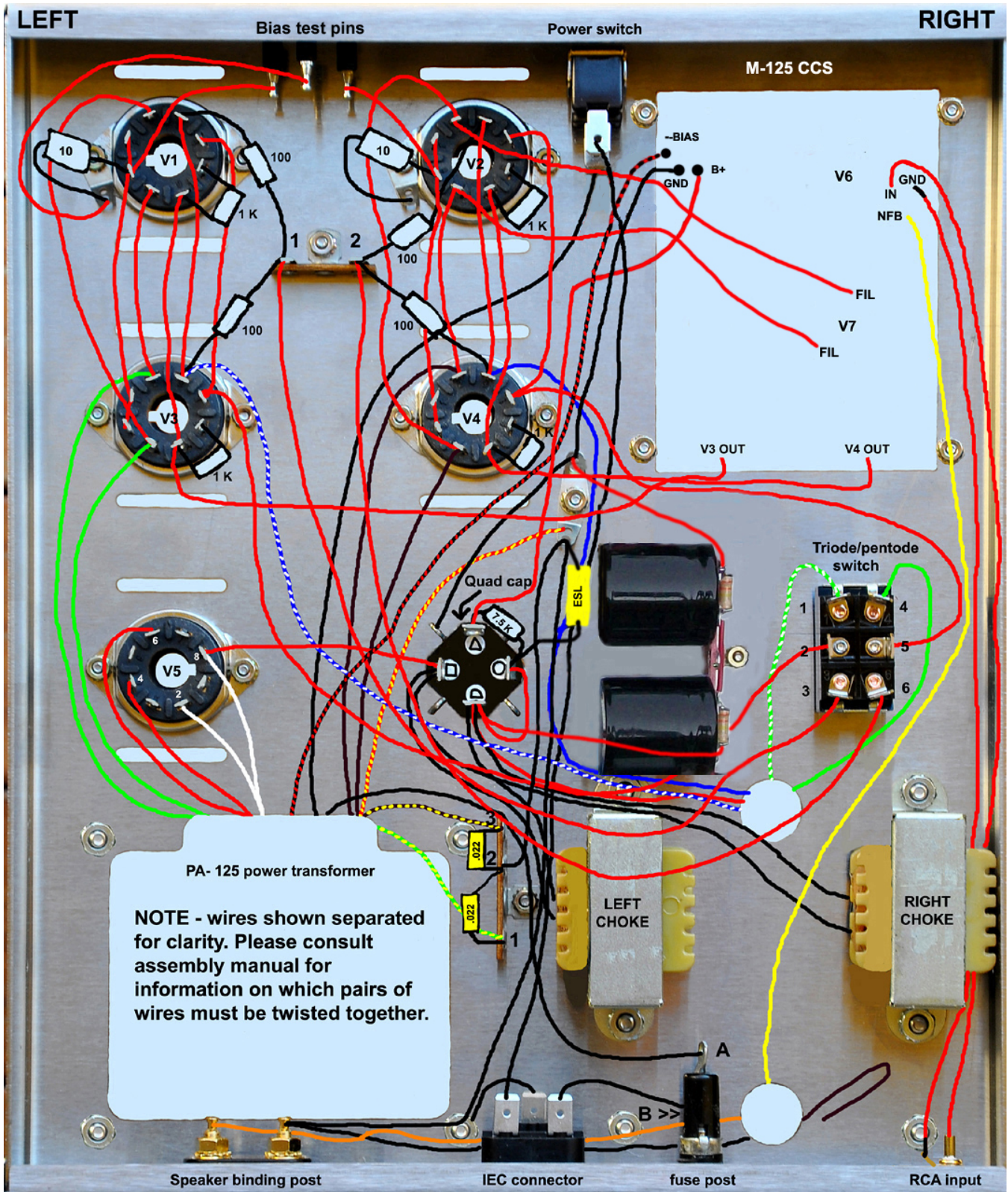

Original M-125 wiring
- for reference only -

