

The Sharp SX™ & The Sharp SX™ with Printer *Service & Maintenance Manual*

Models 1075, 1084, 1097, 1099, 1108, 1109, and 1121



www.sharppackaging.com

Parts: (800) 634-6359 ext. 571
parts@sharppackaging.com

Service: (800) 634-6359 ext. 572
service@sharppackaging.com

PN: 960714-02B

Printed In USA 0924
Copyright © 2007

The safety information presented is a guideline that should be followed by all personnel. Anyone operating or maintaining the equipment should read and follow all the information in this manual, without exception.

DEFINITION OF TERMS



Throughout this manual, you will find the following safety notices with this accompanying symbol. This symbol signifies important safety issues regarding the operation and maintenance of the Sharp SX™.

 WARNING
GENERAL WARNING. Indicates information important to the proper operation of the equipment. Failure to observe may result in damage to the equipment and severe bodily injury or death.

 CAUTION
GENERAL CAUTION. Indicates information important to the proper operation of the equipment. Failure to observe may result in damage to the equipment.

EQUIPMENT SAFETY FEATURES

The Sharp SX™ is equipped with a polycarbonate shield covering the pressure and heated seal bars. **DO NOT** operate the unit with the shield removed.

 WARNING
Operating the unit without the safety guards in place may result in serious bodily injury or death.

SAFETY RULES AND PROCEDURES

The machine requires regular, periodic maintenance to ensure reliable service. No maintenance should be performed unless the safety precautions for maintenance are thoroughly understood.

- Follow all instructions in this manual for safe operation.
- Follow all company and industry standard safety policies regarding this kind of machinery that may exceed those listed in this manual.
- Keep all safety features, guards, interlocks and sensors in good working order.
- ALWAYS turn off machine power, ensure that all mechanical motion has stopped and allow any heated components to cool down before removing any machine parts.

 WARNING
Operating machine without safety guards in place may result in serious bodily injury or death.

 WARNING
Always remove electrical power from the SX™ prior to performing any maintenance on the machine.

 WARNING
Prior to operating or servicing the SX™, remove any loose jewelry, make certain clothing and hair are not loose to interfere with or become tangled with the machine. Failure to do so could result in severe bodily injury or death.

SAFETY LABELS

The following label is placed on the Sharp SX™ wherever a removable shield or panel guards the heated sealing area. Always disconnect electrical power from the machine prior to removing any guards and/or panels.



The following label is located in the proximity of a fused circuit. Be certain to replace blown fuses **ONLY** with fuses with the same electrical rating. Always disconnect electrical power before removing any guards and/or panels or servicing the Sharp SX™.

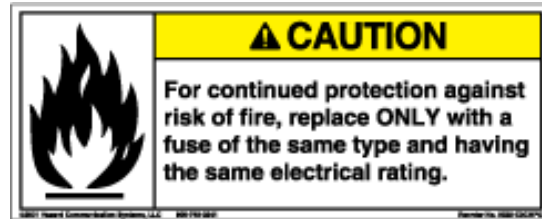

The following label is used where there is the potential of your hands, long hair, jewelry, etc. becoming entangled between two rotating parts. Be sure to secure loose items before approaching and operating the machine.



The label shown on the right is placed on the Sharp SX™ wherever a removable shield or panel guards electrical components. Always disconnect electrical power from the machine prior to removing any guards and/or panels.



The following label on the Sharp SX™ is located where there is the potential of injury due to pinch points or moving parts. Make certain electrical power is disconnected before removing any guards and/or panels or servicing the machine.



Section 1- Introduction

General Information 1-1
 About This Manual 1-1
 Model Variations 1-2
 Technical Assistance 1-2
Theory of Operation 1-3
 General 1-3
 Faults 1-4
 EZ-Bags® and Film Materials 1-5
 Thermal Transfer Ribbon 1-5
Specifications 1-6
 Machine Specifications 1-6
 Packaging Specifications 1-6
 Machine Dimensions 1-6

Section 2 – Maintenance & Adjustments

Maintenance Schedule 2-1
 Daily Maintenance 2-1
 Annual Maintenance 2-1
Cleaning 2-2
 General 2-2
 Cleaning the Printhead and Film Feed Rollers 2-3
Machine Adjustments 2-5
 Adjusting the Pinch Roller 2-5
 Checking Belt Tension 2-6
 Checking Belt Tension 2-7
 Sharp SX™ with Printer 2-8

Section 3 – Component Repair

Electrical Assembly 3-1
 Pressure Jaw and Film Feed Motor Controllers 3-1
 Fuses 3-6
 24VDC Power Supply 3-8
 Line Filter 3-16
 Main Power Switch (RED) 3-20
 Transformers 3-22
 Aromat PLC 3-27
 Aromat PLC Battery 3-28
 Color Touch Screen 3-30
 Cooling Fan 3-33

Solid State Relay 3-35
 Grey Relay 24V 3-39
 Red Relay 24V 3-41
 Printer GPIO Board 3-44
 Printer Performance Logic Board 3-45
 Printer Power Supply Board 3-46
 24 VDC Fan Assembly 3-48
 Laminated White Ribbon Cable 3-49
 Datamax LCD Module 3-51
 Printhead Stepper Drive 3-53
Film Feed Assembly 3-56
 Photoelectric Sensor 3-56
 Film Feed Motor Drive Belt 3-60
 Film Feed Roller Drive Belt 3-61
 Platen Roller Drive Belt 3-63
 Film Feed Roller 3-67
 Platen Roller 3-69
 Film Feed Drive Motor 3-72
 Cradle Lock Cams 3-74
Printhead Cradle Assembly 3-76
 Ribbon Rewind Assembly 3-76
 Ribbon Rewind Motor 3-76
 Primary Ribbon Drive Belt 3-79
 DC Roller Clutch 3-81
 Secondary Ribbon Drive Belt 3-83
 Adjustable Slip Clutch 3-87
Printhead Position Assembly 3-89
 Printhead Position Motor 3-89
 Printhead Position Drive Belt 3-92
 Printhead Pressure Cams 3-94
 Printhead Position Sensor 3-100
 Thermal Printhead 3-102
Ribbon Supply Assembly 3-103
 Slip Clutch Spring 3-103
 Ribbon Motion Sensor 3-104
 Ribbon Clips 3-106
 Gas Springs 3-107
 Cross Flow Fan 3-108

Cradle Latch Lever..... 3-110
Cradle Latch..... 3-111
Sealer Assembly 3-113
 Pressure Bar Drive Motor..... 3-113
 Pressure Bar Gearbox 3-116
 Pressure Bar Belt..... 3-118
 Linear Bearings..... 3-120
 Stripper Plate Assembly..... 3-122
 Sealpoint Components..... 3-129
 Seal Wire Tension Springs..... 3-132
 Stripper Plate Sensors 3-135
 Jaw Position Sensors..... 3-140
Unwind Assembly 3-145
 Unwind Spring..... 3-145

Appendix

Replacement Parts Order Form..... A-1
Warranty A-2
Protecting Your Printhead..... A-3
Printer Menu Structure..... A-6

Wiring Diagram – Located in the back of this binder or [Click Here](#)

Section 4 – Troubleshooting

Troubleshooting Chart 4-1

Section 5 – Parts Lists

Electrical Assembly..... 5-1
Film Feed Assembly 5-3
Frame Assembly 5-4
Printhead Cradle Assembly (Model 1108)..... 5-5
Cradle Assembly (Model 1097)..... 5-9
Sealer Assembly 5-10
Unwind Assembly 5-12

Section 6 – Assembly Drawings

Electrical Assembly..... 6-1
Film Feed Assembly 6-5
Frame Assembly 6-6
Printhead Cradle Assembly (Model 1108)..... 6-9
Cradle Assembly (Model 1097)..... 6-14
Sealer Assembly 6-17
Unwind Assembly 6-20

GENERAL INFORMATION

ABOUT THIS MANUAL

This manual has been prepared for your use in servicing the Sharp SX™ Packaging Machine and the Sharp SX™ Packaging Machine with Printer. Included in the procedures are helpful facts on service, troubleshooting, specifications and parts information.

All procedures should be performed by a qualified service technician.

It is important that you familiarize yourself with the product as much as possible before initiating any maintenance, troubleshooting or repairs.

Make sure you read through the *IMPORTANT SAFETY INFORMATION* and *INTRODUCTION* sections of this manual before attempting any service procedures.

As you disassemble your machine to service and replace parts, keep the following points in mind:

- Do not remove or loosen more parts than needed. Use common sense to keep your work to a minimum.
- Mark any wires before disconnecting to make reassembly easier.
- Use Loctite® Blue or equivalent on all threaded fasteners without lock washers.

Within the *Component Repair* section of this manual, each repair procedure is broken down into three main categories for each component. These categories are *Testing*, *Adjustment*, and *Replacement* and are identified by the following symbols:

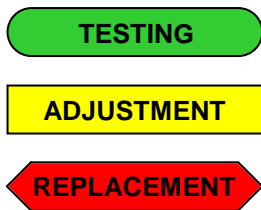

Accompanying this manual, attached to the inside front cover, is a Compact Disc containing an electronic color version of this manual in Acrobat .pdf format along with other useful digital content. For more information view the README.TXT file located on the CD.

Adobe Reader is required to view .pdf files and can be downloaded free of charge from the following website:

<http://www.adobe.com/products/acrobat/alternate.html#50>

The digital color version of the manual is also interactive, allowing the user to simply click onto a subject within the *Table of Contents* to take them to the specified page.



This manual is designed to be used by Authorized Service Personnel only. Sharp Packaging Systems, Inc. assumes no responsibility for any repairs made on Sharp Packaging units by anyone other than Authorized Service Technicians.

GENERAL INFORMATION

MODEL VARIATION

This manual has been developed to assist in servicing and maintaining the Sharp SX™ with Printer model 1108 and the Sharp SX™ model 1109. Although this manual has been written for this specific model, the procedures and techniques for replacing components and troubleshooting can generally be applied to all models of the SX™. Major differences in machine maintenance or component repair will be noted on a case by case basis. The parts lists and assembly drawings located in sections 5 and 6 of this manual are specifically for these two models. If a replacement part is needed for an older model of machine, please refer to the CD located in the front of this manual. This CD contains the parts lists and assembly drawings for all previous models of the Sharp SX™ and the Sharp SX™ with Printer.

The replacement parts lists located on the CD have been separated by model number for ease of identifying the parts that are needed. Simply locate the section of the manual that coincides with the SX™ model you have and proceed from there.

To determine which model of the Sharp SX™ you have, refer to Figure 1-1. The serial number is located on a placard or sticker directly below the roll unwind shaft. The highlighted numbers in Figures 1-2 and 1-3 coincide with the model of the machine.

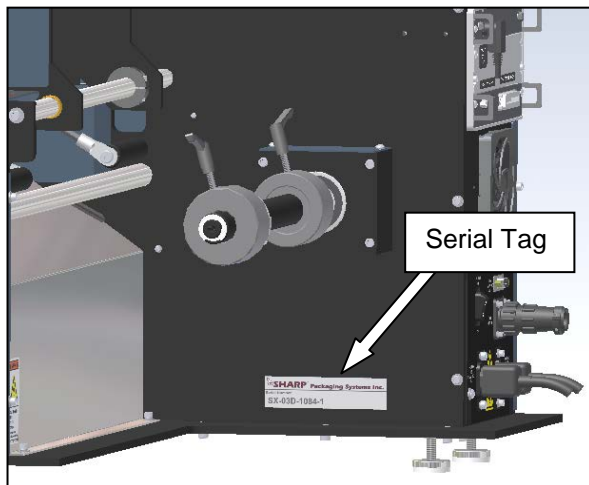

Figure 1-1. Serial Tag Location

TECHINCAL ASSISTANCE

Assistance with the SX™ can be obtained by notifying Sharp Packaging Systems at:

Sharp Packaging Systems
PO Box 124
Sussex, WI 53089, USA

Service: 800-634-6359 (ext. 572)
service@sharppackaging.com

Parts: 800-634-6359 (ext. 571)
parts@sharppackaging.com

Fax: 262-246-3387

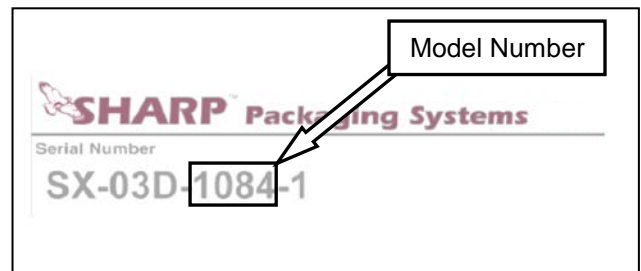

Figure 1-2. Model 1075 and 1084 Serial Tag

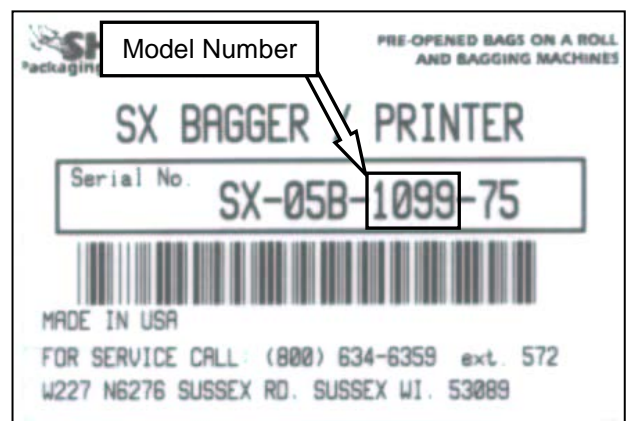

Figure 1-3. Model 1097, 1099, 1108, and 1109 Serial Tag

THEORY OF OPERATION

GENERAL

The Sharp SX™ is controlled by a PLC (Programmable Logic Controller). The PLC receives input from the operator touchscreen to control a stepper drive motor and an electric eye sensor on the bag feeder output end.

The Sharp SX™ is equipped with a sensor on the pressure jaw which can detect an obstruction. If an object triggers the sensor, the pressure jaw motor will reverse, and place the bagger into a fault. A message appears on the control panel displaying the jaw fault, allowing the operator to clear the seal area and restart the bagging cycle.

Note: the Sharp SX™ is not designed to interface with automatic infeed units such as counters, scales, or infeed conveyors.

**WARNING**

The Sharp SX™ is equipped with a jaw obstruction detection sensor. This sensor is not designed, nor intended, to be a safety sensor.

- The Sharp SX™ uses pre-opened Sharp EZ-Bags®. The bags are dispensed through the powered drive rollers.
- A constant stream of air opens (inflates) the bag, preparing the bag to be loaded.
- Product is loaded into the bag.
- Once the bag is loaded, the operator cycles the machine (either by foot control, optional dual optical palm buttons, from the Touchscreen or the machine can be set on automatic cycle) to seal the bag.
- The pressure jaw closes and grips the bag. The impulse sealer heats up and seals the bag while the power drive rollers reverse to separate the bag at the perforation.
- An electric eye is used to sense the trailing edge of the bag. Hang holes, vent holes, etc. must be prevented from passing over the electric eye as this will send a false signal to the PLC. To prevent this, the electric eye has been designed to be off center of the bag, however, in some cases the bags may have to be repositioned when larger hang holes, vent holes, etc. are present (see *Loading Bag Film*).
- When the bag is sealed and seal dwell is complete, the pressure jaw opens.
- The Printhead is lowered and the bag is indexed forward at printing speed until the label is completed. The Printhead is raised and the balance of the bag length is indexed forward at full index speed (bagger speed). (*Note: This step occurs only if model is equipped with an imprinter*)
- As the bags are indexed, the Material Unwind Shaft will spin allowing the bags to be pulled from the roll. The Material Unwind Shaft is comprised of a Roll Tensioner with compression spring, Core Chuck, and a torsion spring. When the roll of bags is loaded onto the machine, pressure is applied to the Roll Tensioner which in turn applies pressure to the roll side plate creating a kind of slip clutch. The pressure that is applied to the Roll Tensioner is directly proportional to the type and thickness of the material being used. As this pressure increases the amount of tension on the web also increases. The appropriate amount of pressure that should be applied to the Roll Tensioner can be found using trial and error.
- The constant stream of air inflates the bag, preparing the bag to be loaded.



Figure 1-4. Sharp SX™

THEORY OF OPERATION

FAULTS

The Sharp SX™ has been designed to alert the operator, via the Touchscreen, to a situation (fault) that requires immediate attention. These faults may indicate a serious condition where, if not corrected, damage to the unit may occur or the fault may simply alert the operator that the unit has run out of film. The following is a list of possible faults that may occur during operation. A detailed list of faults, causes and solutions can be found in the *Troubleshooting* section of this manual.

- **WEB DID NOT BACK UP**

The machine reverses the drive rollers to separate the web of bags at the perforation. The bagger has a photo eye that it uses to detect the trailing edge of the bag. When the photo eye does not detect this trailing edge within the allowed time, this fault is triggered.

- **JAW FAULT**

The Obstruction Sensing Jaw has detected an object in the sealing area during the sealing operation.

- **OBSTRUCTION SENSING JAW TIMER FAULT**

The Obstruction Sensing Jaw did not close within the preset time, but there was no obstruction sensed.

- **THERE ARE NO BAGS COVERING THE EYE**

This fault is triggered when the machine cycle is initiated and the photo eye is not activated.

- **BATCH IS COMPLETE**

This message is activated when the bagger has cycled the specified number of times set by the operator under Batch Target.

Batch Target – A predetermined number of cycles that will be completed before the machine will automatically stop.

- **WAITING FOR PRINTER SIGNAL***

The bagger has sent a print signal to the printer and is waiting for a return signal.

**Note: This fault will only occur if the Sharp SX™ is equipped with an imprinter.*

THEORY OF OPERATION

**SHARP EZ-BAGS®
AND FILM MATERIALS**

The Sharp SX™ is designed to use a wide variety of bag sizes and materials. Sharp EZ-Bags® are recommended for optimum operating performance, efficiency and safety. System performance specifications are based on utilizing consistent, high quality, pre-opened bags. Any bag used must meet Sharp Packaging Systems' manufacturing tolerances. The following list shows some of the Sharp EZ-Bags® films available through Sharp Packaging Systems, Inc.

- Low Density Polyethylene (LDPE)
- Linear Low Density Polyethylene (LLDPE)
- High Molecular Weight, High Density Polyethylene (HMWHDPE)
- Laminated Oriented Polypropylene (Laminate/OPP)
- Polypropylene
- Metallic Films (including conductive films)
- Co-Extruded Films (combination films)
- Other Laminates (any other laminates laminated with polyethylene)
- Anti-static and Triboelectric films
- VCI corrosion inhibiting films
- Opaque films

Contact Sharp Customer Service (800-634-6359) or www.customerserviceteam@sharppackaging.com to order Sharp EZ-Bags® and for information regarding film and bag specifications.

THERMAL TRANSFER RIBBON*

The Sharp SX™ uses thermal transfer ribbon to print variable information onto the bags as they pass through the machine. The following is a list of ribbon that is available through Sharp Packaging Systems, Inc. For ordering information refer to the *Replacement Parts Order Form* in the Appendix on page [A-1](#).

- Standard Direct Wax Ribbon
- Premium Wax Resin Ribbon

**Note: Used only if the Sharp SX™ is equipped with an imprinter.*

SUPPLIES

Thermal Transfer Ribbons

Sharp thermal transfer ribbons are selected specifically for use with our printer. Use of ribbons other than those supplied by Sharp, may result in a poor quality printing, especially bar-codes and their ability to be successfully scanned. This may also void the print head warranty.

Recommended Sharp ribbons are:

- Black ink, scratch and smudge resistant
- 2000' (609 meters), 3.5 to 4.5 microns thick
- 1" core, no notch required
- Ink side in
- Back coated ribbons only

Special purpose thermal transfer ribbons, sizes other than those listed above, such as colored ribbons, or low temperature release ribbons are available.

SPECIFICATIONS

PACKAGING SPECIFICATIONS

	Bag Width	Bag Length	Film Gauge
Minimum	2" (5.08 cm)	4" (10.16 cm)	.001" (1 mil) 25 microns
Maximum	9" (22.86 cm)	32" (81 cm)	.004" (4 mil) 100 microns

MACHINE SPECIFICATIONS

Width	Height	Depth	Weight	Power Req.	Rate	Operating Temp	Humidity Range
26.75" (67.9 cm)	19" (48.3 cm)	35.25" (89.5 cm)	200 lbs. (91 kg)	115 VAC 50/60 Hz 15 Amps	35** bags per minute	0°-40°C 32°-140°F	10%-90%RH Non- Condensing

** Size of package along with weight and size of product will cause rate to vary.

DIMENSIONS

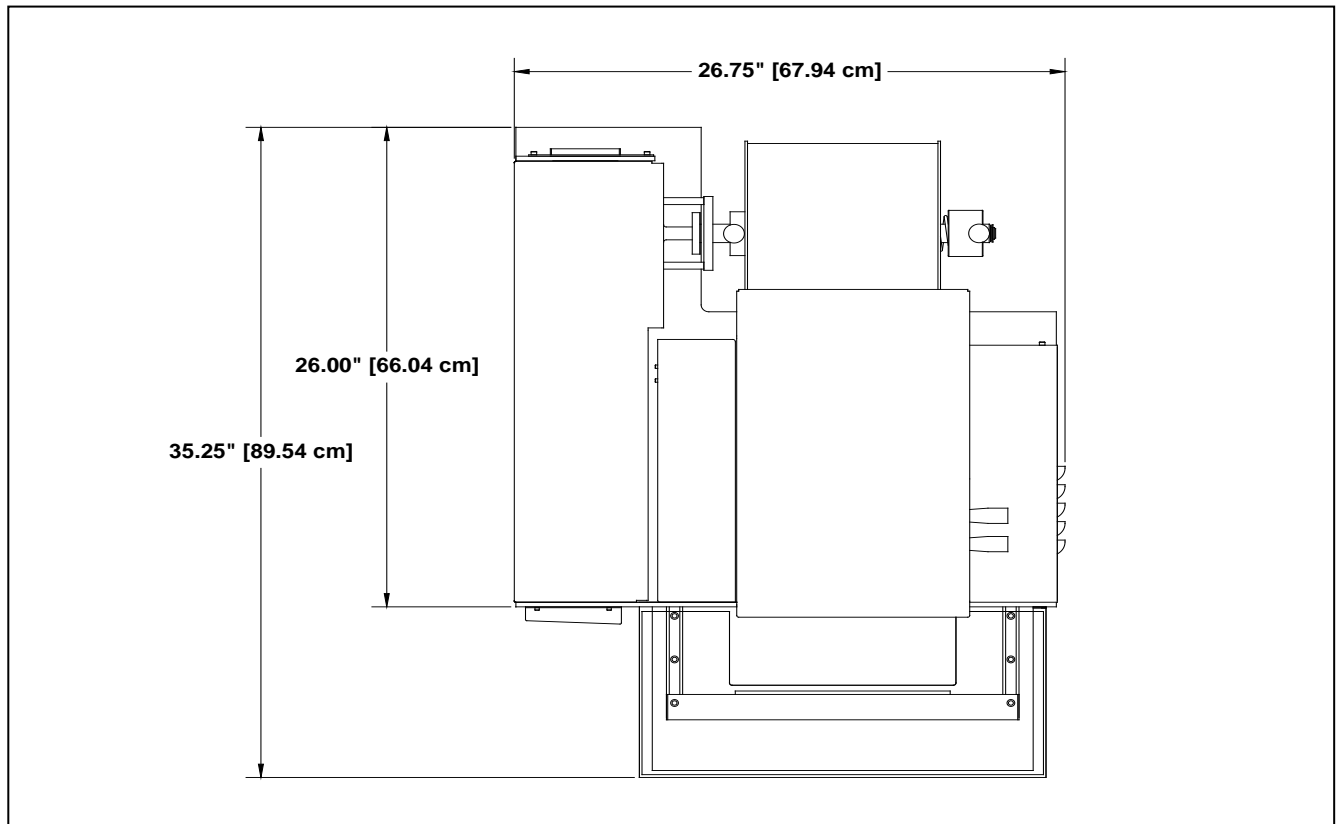

MAINTENANCE SCHEDULE



WARNING

Always remove electrical power from the SX™ prior to performing any maintenance on the machine.

DAILY MAINTENANCE

- Inspect the electric eye. Clean with a cotton swab if dirty. Do not use any solvents or cleaning solutions on the sensing portions of the electric eye.
- Clean any excess material from the drive roller and platen roller on the film feed assembly. Plastic compounds tend to build-up on the rollers. Clean regularly with a soft, lint-free cloth using a rubber platen roller conditioner/cleaner or isopropyl alcohol.
- Inspect Teflon tape on the seal wire and replace if damaged or worn.
- Inspect the anvil rubber on the pressure bar assembly and replace if damaged or worn.
- Inspect all electrical lines for any sign of wear or damage. Replace any lines that appear worn or unsafe.
- If the Sharp SX™ is equipped with a printer, the printhead needs to be cleaned with a soft, lint-free cloth and isopropyl alcohol. This will be explained further on page 2-3 in the section entitled “Cleaning the Printhead and Film Feed Rollers.”

ANNUAL MAINTENANCE

- Check all electrical connections.
- Check entire machine for loose bolts or nuts.
- Inspect all drive belts for excessive wear and slack.
- Grease the four pressure bar linear guide bearings using lithium grease (JIS Type 2).*
- Apply a light film of grease to the pressure bar rack and pinion gearing using lithium grease (JIS Type 2).*

** Note: The recommended lubrication interval for the linear guide bearings based on total travel is approximately 500,000 cycles. Sharp Packaging Systems suggests greasing the bearings at this frequency or once a year, whichever comes first. Both the linear guide bearings and the pressure bar gear rack and pinion gear can be lubricated with the same frequency.*

MONTHLY MAINTENANCE

- Clean the foam element located on the cooling fan on the rear of the machine with water, wring out, and reinstall.

CLEANING

GENERAL

This machine requires regular, periodic cleaning to ensure reliable service. Shift and daily cleaning can be performed by the operator with a minimum of training.

Regular cleaning is important for the proper operation and performance of the machine. During operation there will be a normal buildup of dirt, dust, and lubricants on various parts of the machine. If using the Sharp SX™ with Printer, ink rubbed off of printed film can also build up.

The machine and areas directly adjacent to it should be kept clean of debris as these can create safety hazards for the operator and the machine.

No cleaning should be performed unless these safety precautions are thoroughly understood and are adhered to without exception.

Clean machine surfaces during each pause in production – NEVER while the machine is running. Remove contaminants and debris, and use a clean, soft lint-free cloth to wipe down the machine.

- Inspect the machine to determine if there has been an accumulation of dust or other contamination. Clean if necessary.
- ALWAYS SHUT OFF AND UNPLUG machine power cord before cleaning or removing any guards.
- NEVER defeat any safety device or interlock on the machine.
- DO NOT use steel wool on machine surfaces. Particles of steel wool may break off and cause rusting or contaminate lubricated surfaces.
- DO NOT allow wrenches, fittings or other metallic objects to lie on machine surfaces during production.
- DO NOT use chlorine, ammonia, alkalis, acids, or cleaning solutions that will damage metallic machine surfaces, cause corrosion or contaminate containers.

 WARNING
Disconnect electrical power cords from the machine prior to performing any maintenance on machine.

 WARNING
Do not spray the electrical components of the machine with any liquid while power is applied. Liquids on electrical components can cause shorts, damaging the components and causing personal injury or death.

 WARNING
Avoid hot surfaces. Do not service the machine until the heated surfaces have cooled after disconnecting power.

 WARNING
Do not attempt to clean the machine while it is running. Cleaning the machine while it is running can damage the machine and cause severe personal injury or death.

CLEANING

CLEANING THE PRINTHEAD & FILM FEED ROLLERS

**Note: This section is specifically for the Model SX™ with Printer. If your model does not have a printer, only follow steps 5 and 6 for cleaning the film feed drive roller.*

**WARNING**

Always remove electrical power from the SX™ prior to performing any maintenance on the machine.

1. With power removed from the machine, release the cradle latch to grant access to the printhead and the rubber rollers on the film feed assembly. Also, open the printhead cradle cover (Figure 2-1).
2. Gently slide the ribbon to the side to expose the printhead.
3. Moisten a soft, lint-free cloth with isopropyl alcohol and gently wipe the surface of the printhead to clean dust and residue from the surface, as shown in Figure 2-2.

**CAUTION**

Do not pour isopropyl alcohol or any cleaning solution directly onto the printhead or rollers. Liquids may short electrical components, causing damage to the machine.

4. Slide the ribbon into its original position. Make approximately ten turns on the ribbon rewind hub to take up slack and wrinkles, ensuring it is completely flat over the ribbon rollers and printhead.

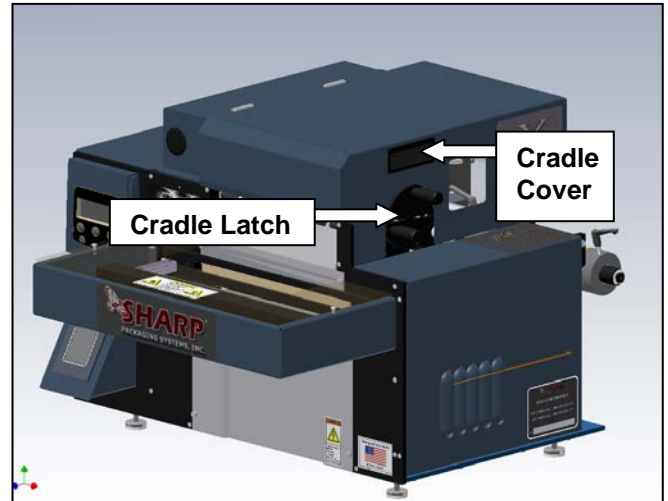

Figure 2-1. Opening the Printhead Cradle

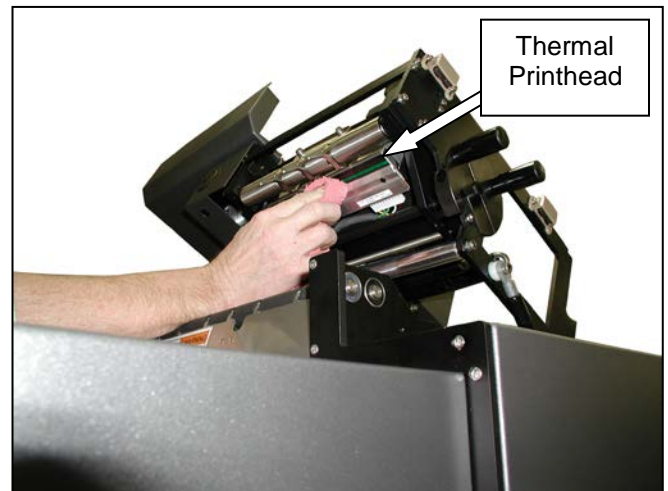

Figure 2-2. Cleaning the Printhead

CLEANING

CLEANING THE PRINTHEAD & FILM FEED ROLLERS (cont.)

5. Remoisten the lint-free cloth with isopropyl alcohol and rub back and forth along film feed drive roller as shown in Figure 2-3. Clean roller until residue is removed. Be careful not to damage rubber coating on roller, as this will affect machine performance.
6. Manually rotate film feed drive roller, and repeat procedure in step 5. Continue wiping and rotating until the entire surface of the drive roller is clean.
7. Repeat steps 5 and 6 on the platen roller, again being careful to not damage the rubber surface.
8. When both rollers are clean, thread bag film through the machine, and close the printhead cradle cover. Turn the cradle latch to the locked position.

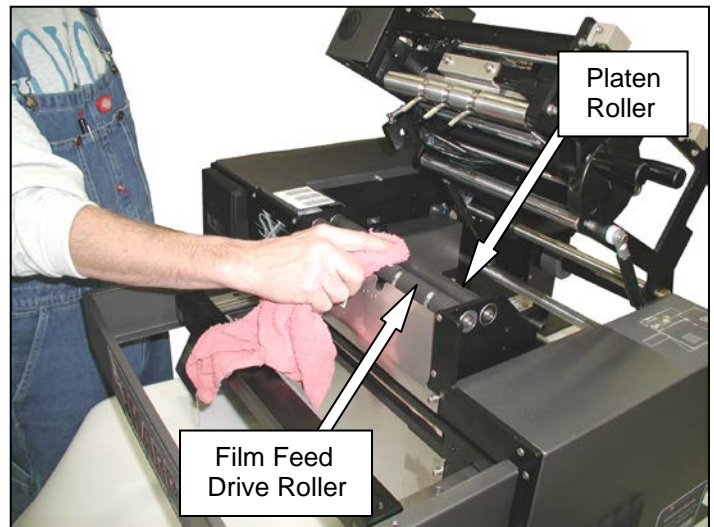

Figure 2-3. Cleaning the Film Feed Drive Roller

MACHINE ADJUSTMENTS

ADJUSTING THE PINCH ROLLER

The pinch roller adjustment is used to control excess “traveling” of the film to either side of the pinch roller. This traveling is due to uneven pressure distributed by the pinch roller onto the drive roller. This pressure is created by slide-spring mechanisms on each end of the pinch roller. Under normal usage, the pinch roller should not come out of adjustment. Before changing the factory settings on the pinch roller, be sure to check the unwind for proper web tension and alignment. If changing the roll setting does not prevent traveling, follow these steps to adjust the pinch roller tension.

1. Open the printhead cradle cover to expose the printhead components and pinch roller.
2. Confirm the preset adjustment of the pinch roller. The top of the set screw should be flush with the top of the hex jam nut. If either side is not flush, turn the jam nut counter-clockwise to unlock the set screw. Adjust the set screw to the proper height, and retighten the jam nut to lock into place. Close cradle cover, and cycle machine to check for traveling issues.
3. If the pinch roller adjustment springs are set correctly and the film still travels, release the jam nut and turn the set screw opposite the side the media is pulling towards down in 1/4 turn increments. Lock the jam nut, and check for traveling. Continue this process until the bag film feeds out evenly and does not walk to either side.

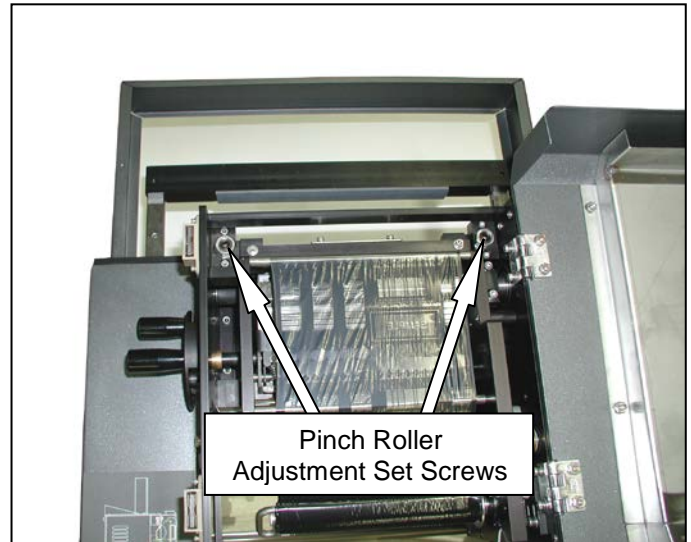

Figure 2-4. Pinch Roller Adjustment Screws

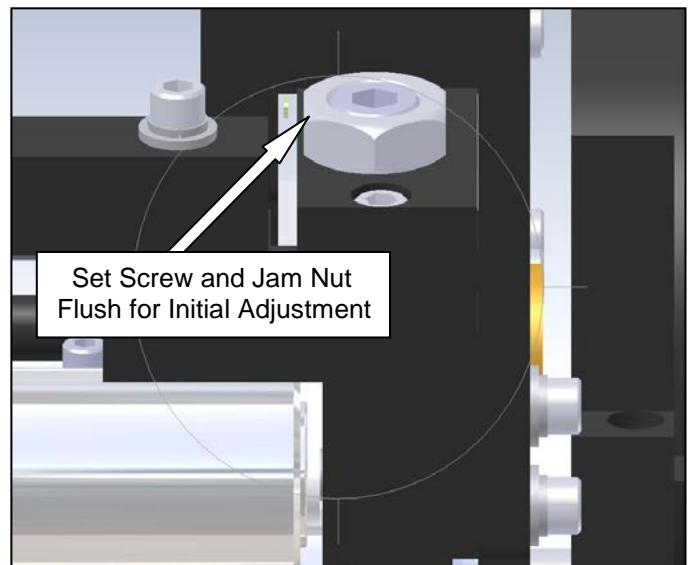

Figure 2-5. Jam Nut and Set Screw

MACHINE ADJUSTMENTS

CHECKING BELT TENSION

Sharp SX™

The Sharp SX™ has three belts, one which drives the pressure jaw and two that drive the film feed drive roller. To ensure proper operation of the machine, these belts need to be checked for proper tension to avoid slip.

**WARNING**

Always remove electrical power from the SX™ prior to performing any maintenance on the machine.

1. With machine power disconnected, remove the left side frame guard. Remove the two screws on the rear face plate, the two screws on the front face plate, and the two screws on the middle unwind plate (Figure 2-6).

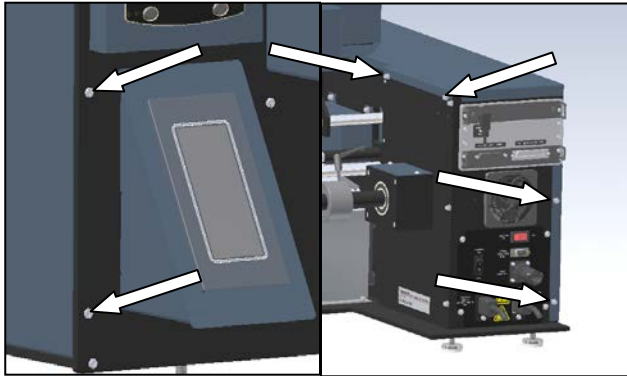

Figure 2-6. Frame Cover Screws

2. Locate the pressure jaw drive belt (Figure 2-7). Depress the center of the belt to determine if the tension is appropriate. The belt should deflect approximately 1/8" when depressed with one finger at the center of the longest belt span.*

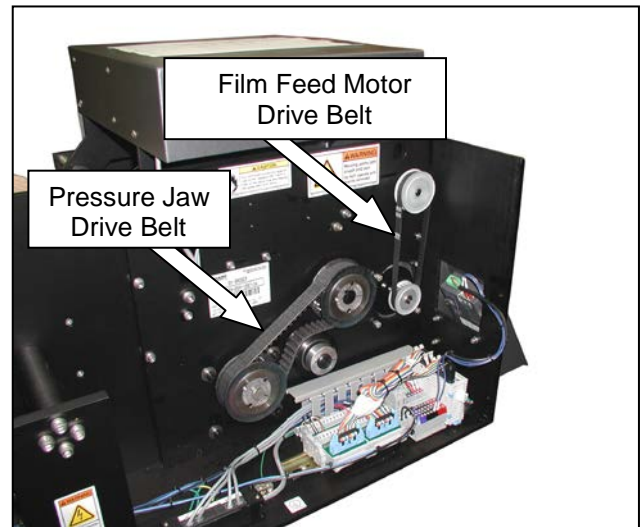

Figure 2-7. Pressure Bar and Film Feed Belts

3. If the belt deflects more than 1/8 loosen the four motor mounting screws and apply downward pressure to the pressure bar drive motor. When motor is in desired position for proper belt tension, tighten four screws and verify the belt deflects the recommended amount. Repeat until belt is correctly tensioned.
4. Locate the film feed motor drive belt (Figure 2-7). Repeat the process in step two to check for correct tension. This belt should deflect approximately 3/32" at proper tension. If too tight or too loose, repeat step three on the film feed drive motor.

**Note: Belt tension should be just enough to ensure a positive interference between belt and sprocket teeth without allowing them to jump. If too tight, the load may cause undue stress on the shafts and shorten belt life. If too loose, the belt will not engage the sprocket properly and the drive will slip under normal loads. For a more detailed method of determining proper belt tension, contact Sharp Packaging Systems customer service or consult the belt manufacturer.*

MACHINE ADJUSTMENTS

Sharp SX™ (con't)

5. Release the cradle latch and open the cradle. Remove the pulley cover to expose the drive roller belt.
6. Check the film feed drive roller belt for tension (Figure 2-9). This belt should deflect approximately 1/16" using one finger to push on the center of the belt span. If adjustment is needed, loosen the idler screw and slide to increase tension. Retighten screw and check tension.
7. Reinstall frame guard and pulley guard that were removed earlier. Close cradle and lock into position.

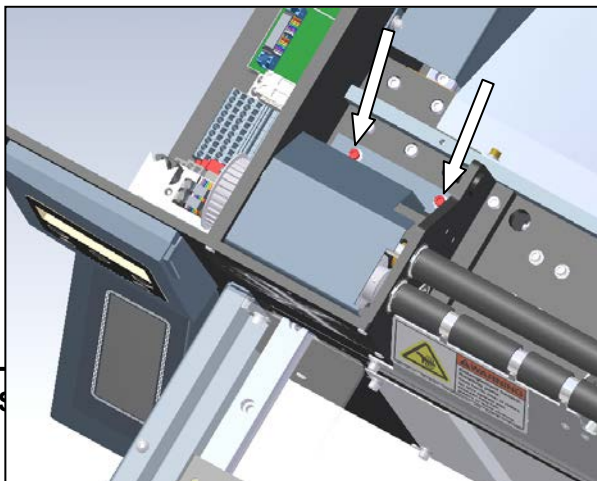

Figure 2-8 Pulley Guard Screws
Note: Cradle Removed for Clarity

MACHINE ADJUSTMENTS

Sharp SX™ with Printer

The Sharp SX™ with Printer utilizes seven drive belts during operation: one to drive the pressure jaw, two to drive film feed rollers, one for the platen roller, one for the printhead lift cams, and two to drive the printer ribbon rewind hub.



WARNING
Always remove electrical power from the SX™ prior to performing any maintenance on the machine.

1. Follow steps 1 through 6 on pages 2-6 and 2-7 to check for proper tension of the pressure bar drive belt and the two film feed drive belts.
2. Check the platen roller drive belt for tension (Figure 2-10). This belt should deflect approximately 1/16" using one finger to push on the center of the belt span.

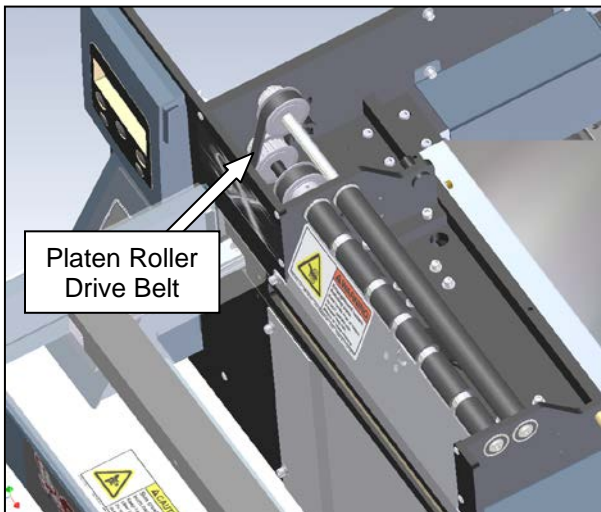

Figure 2-10 Platen Roller Drive Belt
Note: Cradle Removed for Clarity

3. If belt tension is incorrect, loosen the idler screw and slide idler to add or remove tension. Tighten screw and check belt. Repeat as necessary.
4. Replace the pulley guard by reinstalling the two mounting screws.
5. Remove the four screws that hold the outside cradle cover (Figure 2-11). Slide the cover off to expose the ribbon rewind hub drive and the printhead lift drive.

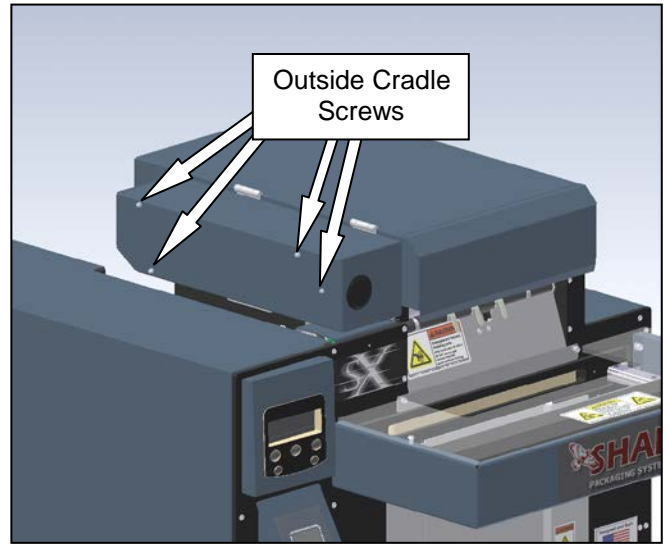

Figure 2-11. Removing the Outside Cradle Cover

6. Check the tension on the ribbon rewind motor drive belt (Figure 2-12) using the same procedure for the film feed drive belt. This belt should deflect about 1/16".

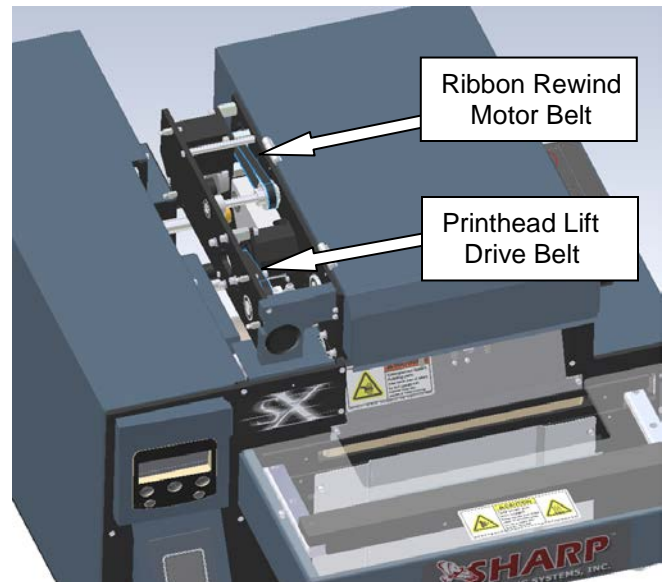

Figure 2-12. Ribbon Rewind Motor Belt and Printhead Lift Drive Belt

7. If belt does not have proper tension, loosen four motor mounting screws and apply pressure to motor towards the rear of the machine. Retighten motor screws and check for tension. Repeat as necessary.

MACHINE ADJUSTMENTS

Sharp SX™ with Printer (con't)

8. Check the tension on the printhead lift drive belt (Figure 2-12). This belt should deflect 1/16". If incorrect, follow method in step seven to achieve proper tension.
9. Replace outside cradle cover, and reinstall four screws removed in step 5.
10. Close the printhead cradle and turn the latch counter-clockwise to lock into position.
11. Open the top cradle cover by lifting on the recessed plastic handle.
12. Locate the slip clutch belt between the left printhead plate and the outer plate on the hinged side of the cradle (Figure 2-13). At proper tension, this belt should deflect about 1/16".

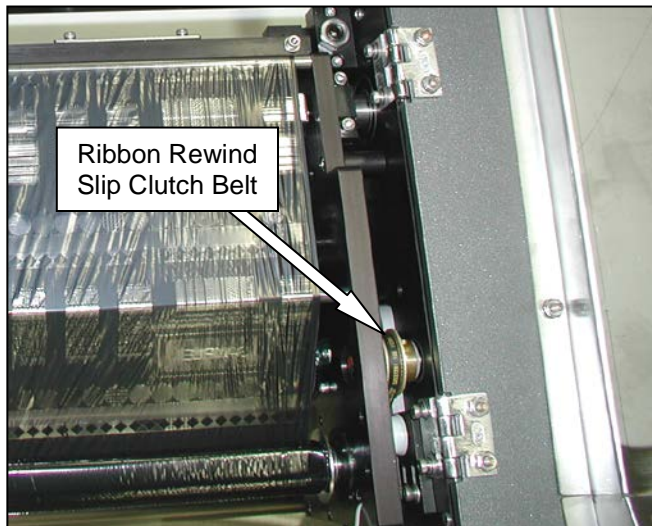

Figure 2-13. Ribbon Rewind Slip Clutch Belt

13. To add or remove tension to this belt, loosen the two screws on the idler plate and slide it forward or backward to add or remove tension. Tighten the screws, and recheck belt. Repeat as necessary.
14. Once all belt tensions have been checked and properly set, replace the side frame guard.

ELECTRICAL COMPONENTS

PRESSURE JAW AND FILM FEED MOTOR CONTROLLERS

The Sharp SX™ bagger uses stepper drive technology to precisely control the movement of various mechanical systems. This section will describe how to service the two TM4500 stepper drive units. These units control the Pressure Jaw and Film Feed motors.

TESTING



WARNING

Always remove electrical power from the SX™ prior to performing any maintenance on the machine.

1. Remove the four screws holding the Load Plate, set screws and Load Plate aside (Figure 3-1).
2. Locate the two identical stepper drives inside the Sharp SX™ Bagger. The Pressure Jaw drive is on the left and the Film Feed drive is on the right (Figure 3-2).
3. Locate the fuse on the defective unit (Figure 3-3).
4. Set your Digital Volt/Ohm Meter (DVOM) to test for continuity.
5. With the red probe, make contact with the metal on one side of the fuse and with the black probe make contact with the other side of the fuse (Figure 3-3).
6. If your DVOM indicates that there is no continuity, replace the fuse.

Note: A blown fuse can be an indication of a larger problem. If you continue to blow fuses, test the stepper motors and power connections.



Figure 3-1. Load Plate Screws

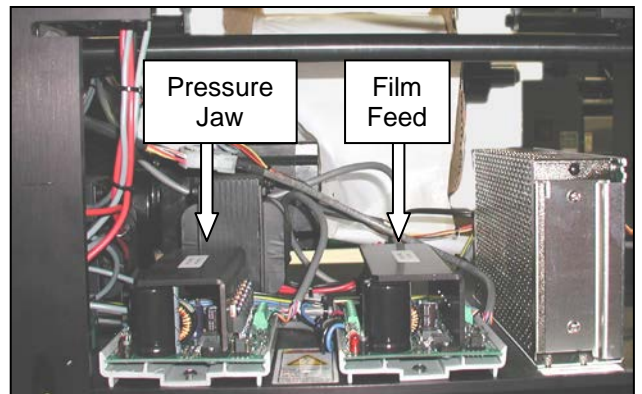

Figure 3-2. TM4500 Drive locations

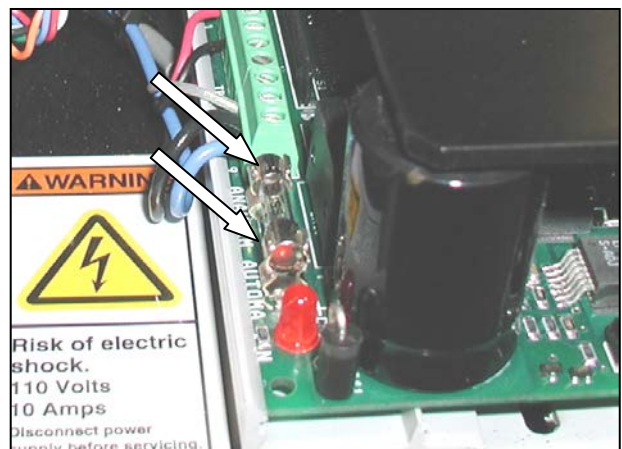



Figure 3-3. Fuse Probe Locations

ELECTRICAL COMPONENTS

PRESSURE JAW AND FILM FEED MOTOR CONTROLLERS (con't)

7. If the fuse is OK, check the wiring of TB1 and TB2. Reconnect any loose wires. (Figure 3-5).
8. Connect power cords to the Sharp SX™ Bagger and turn the bagger on.

	WARNING
USE EXTREME CAUTION WHILE SERVICING A MACHINE WHILE POWER IS APPLIED. UNEXPECTED MACHINE STARTUP CAN CAUSE SERIOUS INJURY.	

	WARNING
DO NOT ATTEMPT TO SERVICE THE MACHINE DURING NORMAL OPERATION. KEEP HANDS AND ARMS CLEAR OF MOVING PARTS.	

	WARNING
WHEN TESTING ELECTRICAL COMPONENTS WHILE POWER IS APPLIED TO THE MACHINE, USE PROPER TROUBLESHOOTING TECHNIQUES TO AVOID ELECTRICAL SHOCK.	

9. Locate Red LED on the defective drive (Figure 3-4).

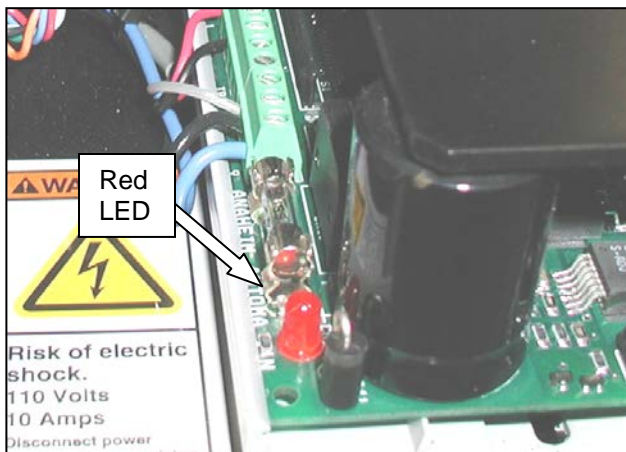

Figure 3-4. Status LED Location

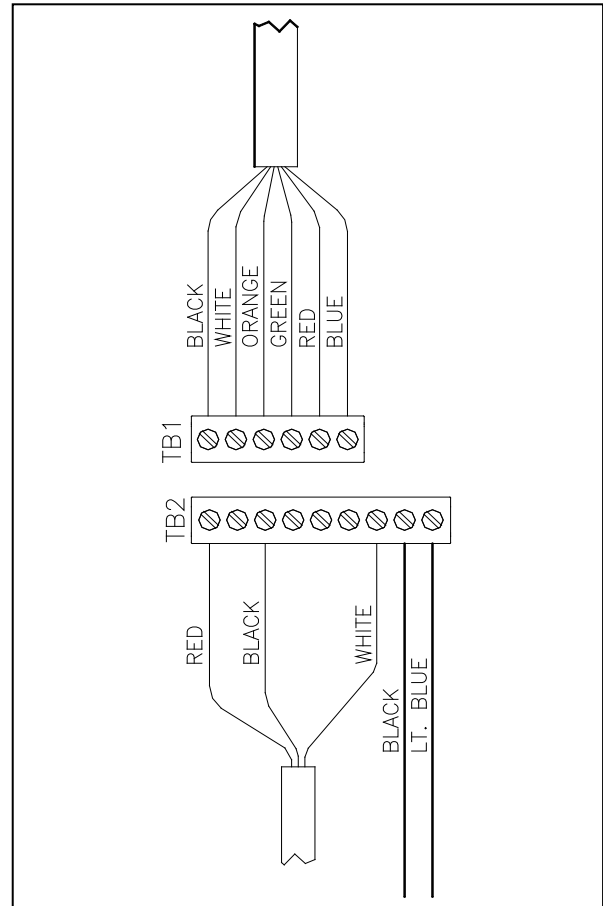

Figure 3-5. TM4500 Wiring Configuration

10. If the LED is blinking, use the following information to diagnose the problem.
 - Is the LED blinking once? This error code indicates that there is an open or sporadic connection in one of the motor wires. Check the wiring and ensure that the connector screws are tight.
 - Is the LED blinking twice? This error code indicates that there is a short in one of the motor lines. This can either occur in the windings of the motor or be caused by loose wiring.
 1. Disconnect the motor from the drive at the white 2x3 pin plug.
 2. Check the motor and wiring for shorts.

ELECTRICAL COMPONENTS

PRESSURE JAW AND FILM FEED MOTOR CONTROLLERS (con't)

11. Refer to section on testing transformers to test incoming voltage.

ADJUSTMENT

The TM4500 Stepper Drives are controlled by the Aromat PLC and should be left at the factory default settings. The following steps will guide you through resetting the drives to factory defaults.

1. Remove the four screws from the Load Plate and set aside (Figure 3-6).

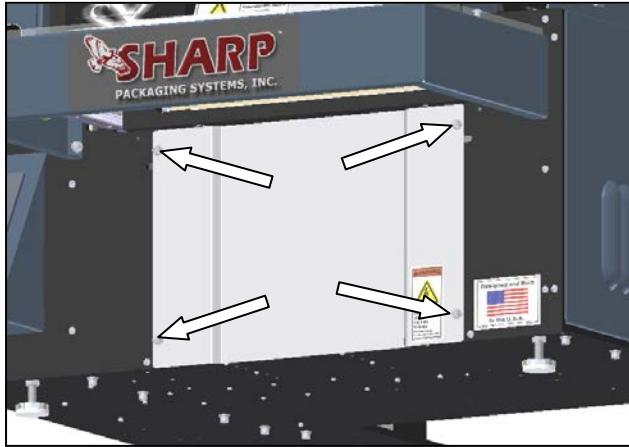

Figure 3-6. Load Plate Screws

2. There are two identical TM4500 drives, the Pressure Jaw motor controller is on the left and the Film Feed motor controller is on the right (Figure 3-7).

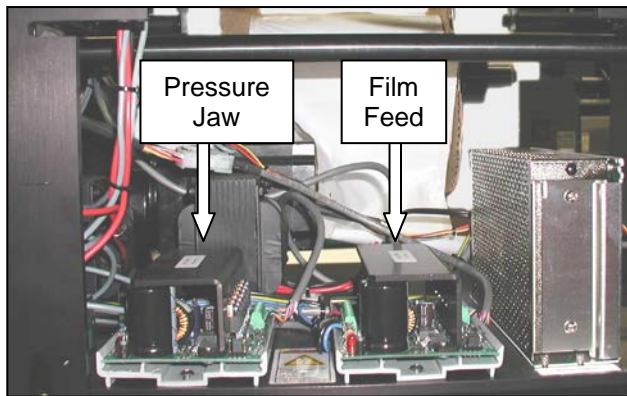

Figure 3-7. TM4500 Drive locations

3. Set Jumpers JP1, JP2 and JP3 so that the jumpers covers pins 1 and 2 (Figure 3-8 A)

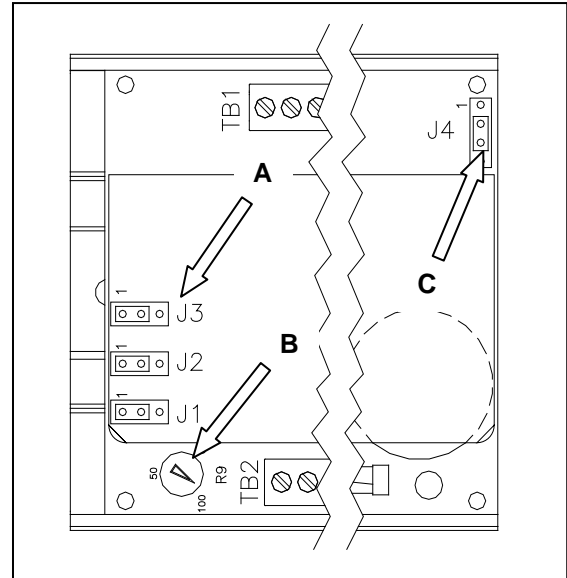

Figure 3-8. TM4500 Configuration

4. Adjust Kick Current POT (potentiometer) so that arrow points to 100 (Figure 3-8 B).

5. Set jumper JP4 so that the jumper covers pins 2 and 3 (Figure 3-8 C).

6. Reattach Load Plate to front of machine with screws and locking washers.

ELECTRICAL COMPONENTS

PRESSURE JAW AND FILM FEED
MOTOR CONTROLLERS (con't)

REPLACEMENT



WARNING

Always remove electrical power from the SX™ prior to performing any maintenance on the machine.

1. Remove the four screws holding the Load Plate, set screws and Load Plate aside (Figure 3-9).
2. Locate the TM4500 Stepper Drive that requires replacement. The Pressure Jaw motor controller is on the left and the Film Feed motor controller is on the right (Figure 3-10).
3. Unscrew all connections from the green connection blocks TB1 and TB2 (Figure 3-11).
4. Slide drive out of grey DIN rail holder. The drive is held in the DIN rail holder by friction and requires considerable force to remove. Brace the machine with one hand while firmly pulling the drive toward you with the other hand.
5. Remove new drive from static bag.



Figure 3-9. Load Plate Screws

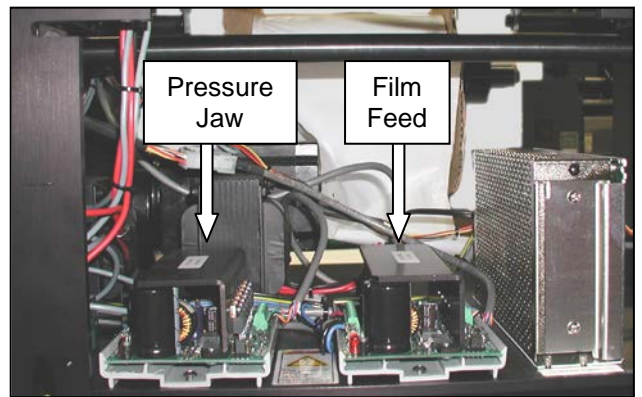

Figure 3-10. TM4500 Drive locations

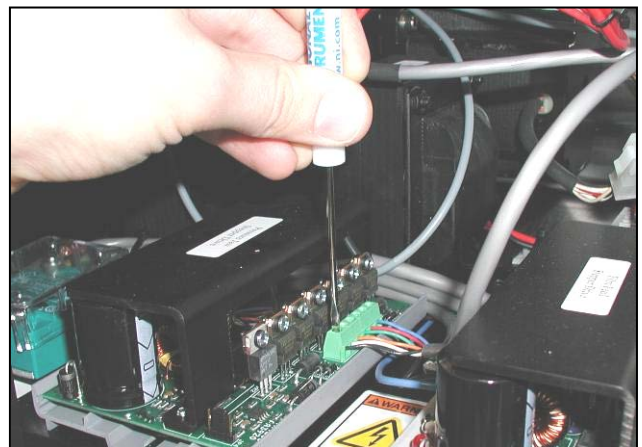

Figure 3-11 Green Connector Block

ELECTRICAL COMPONENTS

PRESSURE JAW AND FILM FEED
MOTOR CONTROLLERS (con't)

6. Set jumpers JP1, JP2 and JP3 so that the jumper covers pins 1 and 2 (Figure 3-12 A).
7. Set the POT so that the arrow points to 100 (Figure 3-12 B).
8. Set jumper JP4 so that the jumper covers pins 2 and 3 (Figure 3-12 C).
9. Orientate drive so TB2 is on your left and slide new drive into DIN rail holder. This will take considerable force. Brace the machine with one hand while firmly pushing the new drive into the DIN rail holder.
10. Reconnect all wires as they were connected to the previous drive (Figure 3-13).
11. Reattach Load Plate to front of machine using screws and locking washers.

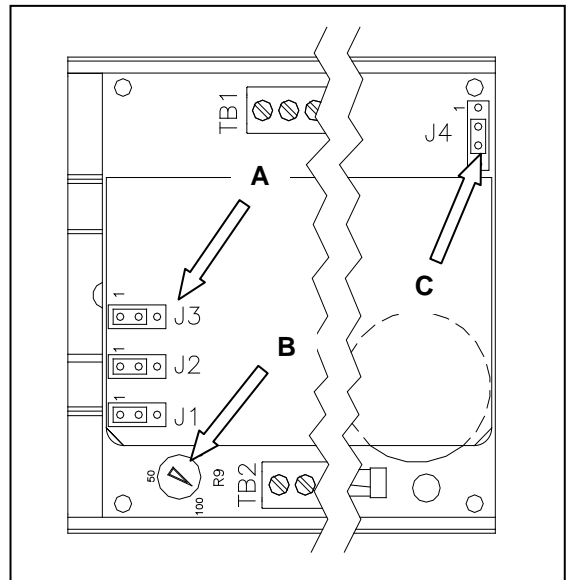

Figure 3-12. TM4500 Configuration

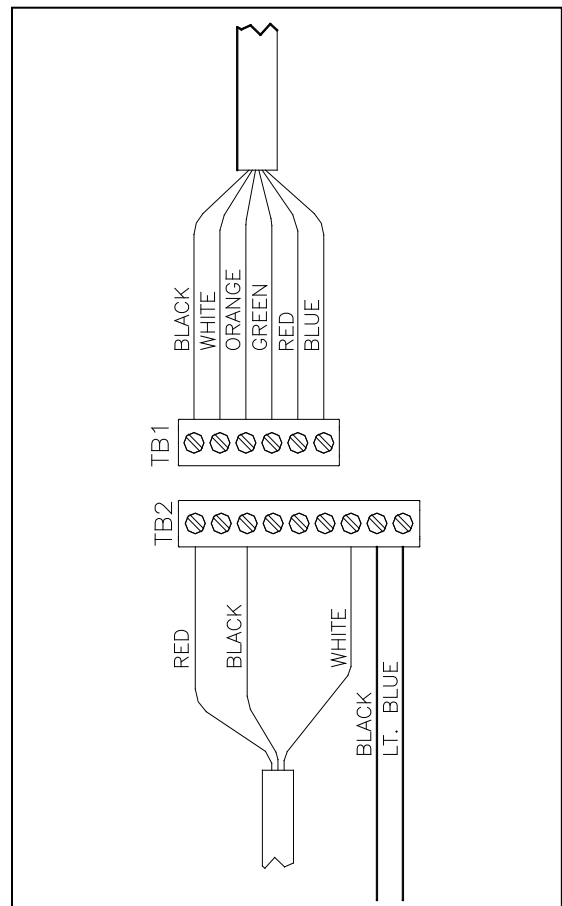

Figure 3-13. TM4500 Wiring Configuration

ELECTRICAL COMPONENTS

FUSES

The Sharp SX™ Bagger uses a series of fuses to protect the machinery from overloads. Fuses are NOT intended to protect against electrocution and are not considered a safety device.

TESTING

WARNING

Always remove electrical power from the SX™ prior to performing any maintenance on the machine.

1. Remove Frame Cover Screws. There are six screws to remove (Figure 3-14).

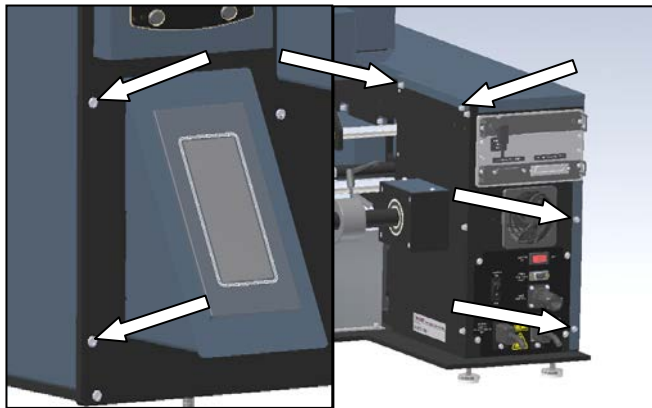

Figure 3-14. Frame Cover Screws

2. Remove Frame Cover and set aside.
3. Locate the two Fuses. (Figure 3-15)

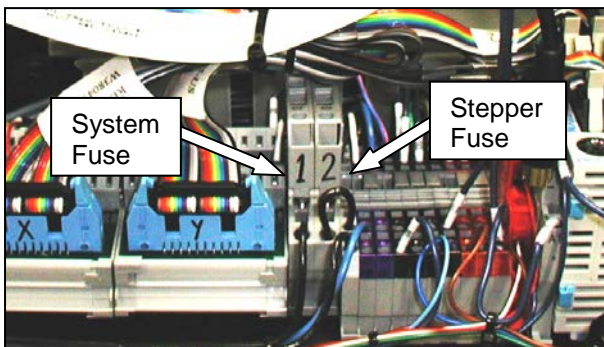

Figure 3-15. Fuse Locations

4. Pivot fuse holder to gain access to the Fuse Access Door on the defective fuse.

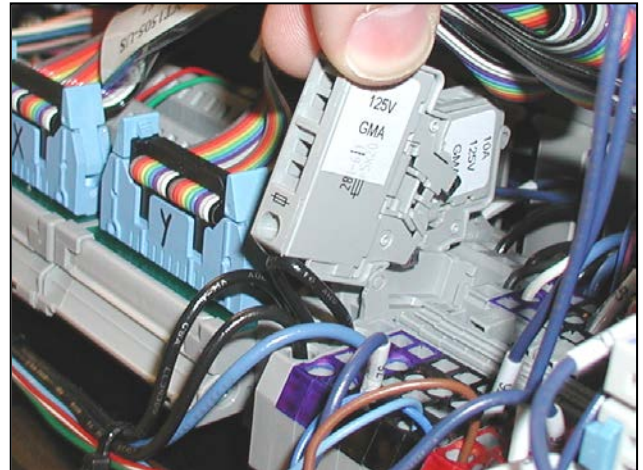

Figure 3-16. Pivot Fuse Holder

5. Open Fuse Access Door and remove fuse (Figure 3-17)

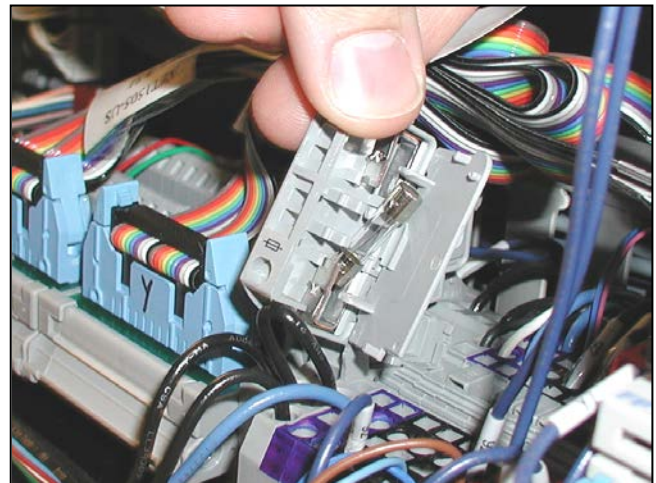

Figure 3-17. Fuse Access Door

6. With a DVOM set to test for continuity, touch the black probe to one side of the fuse and the red probe to the other side of the fuse. If the DVOM does not indicate continuity, replace fuse.

ELECTRICAL COMPONENTS

FUSES (con't)

ADJUSTMENT

There are no adjustments necessary on fuses.

REPLACEMENT

A blown fuse can be an indication of a larger issue with the electronics in the Sharp SX™ Bagger. DO NOT REPLACE A BLOWN FUSE WITH A LARGER AMPERAGE FUSE. If you continue to blow fuses, troubleshoot other components to discover problem.



WARNING

Always remove electrical power from the SX™ prior to performing any maintenance on the machine.

1. Remove Frame Cover Screws; there are six screws to remove (Figure 3-18).
2. Locate the defective fuse. The 10 Amp system fuse is on the left and the 5 amp stepper drive fuse is on the right.
3. Pivot fuse holder to gain access to the Fuse Access Door (Figure 3-19).
4. Open Fuse Access Door and remove fuse (Figure 3-20).
5. Replace with a 5x20mm fuse of the same amperage.
6. Close access door and pivot fuse holder back into its home position.
7. Replace Frame Cover with screws and locking washers.

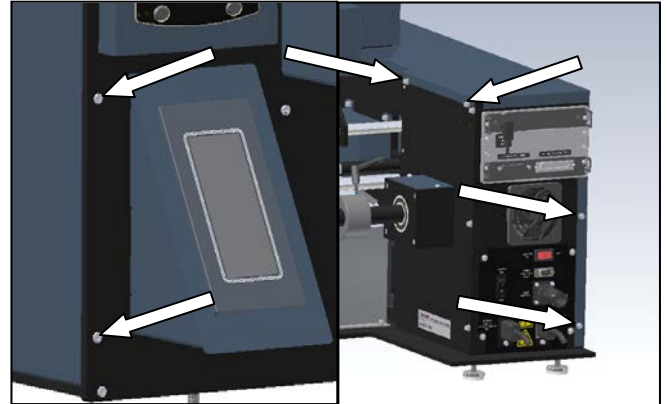

Figure 3-18. Frame Cover Screws

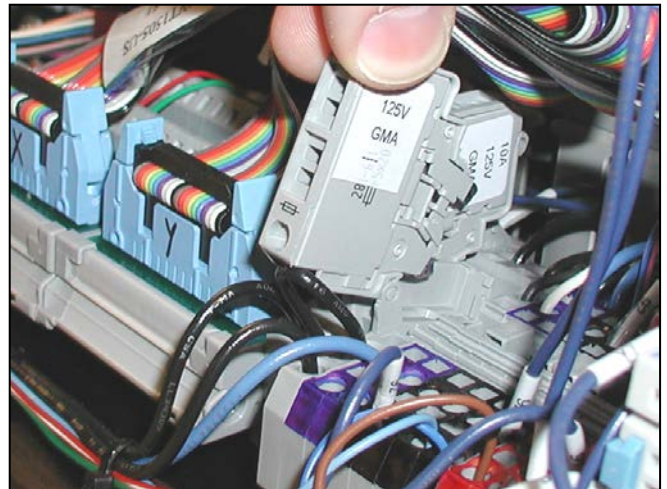

Figure 3-19. Pivot Fuse Holder



Figure 3-20. Fuse Access Door

ELECTRICAL COMPONENTS

24 VDC POWER SUPPLY

The Sharp SX™ bagger uses a single 24 VDC power supply for all sensors, relays and control components. This section will explain how to troubleshoot and if necessary, replace the power supply.

TESTING

The symptoms of a non-functioning Power Supply are easy to spot. The “Bag Open Cage Fan” and “Cabinet Cooling Fan” are not powered by the 24 VDC power supply. If when powering up a machine, the fans can be heard running, but the rest of the system is unresponsive, The Power Supply is most likely defective. If a machine is completely unresponsive, refer to the section on checking and replacing fuses.

1. Plug machine in but do not turn on.
2. Remove any bags in the machine web path and remove bag roll.
3. Remove the two rear screws and the two front screws from the Motor Cover (Figure 3-21 and Figure 3-22).
4. Remove Motor Cover and set aside.
5. Locate the 24 VDC Power Supply.

Note: The Power Supply location changes depending on your version of the Sharp SX™ Bagger. The wiring however is exactly the same.

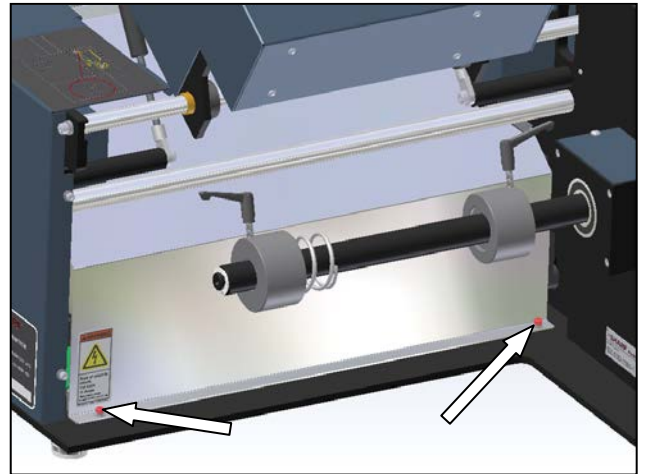

Figure 3-21. Motor Cover Rear Screws

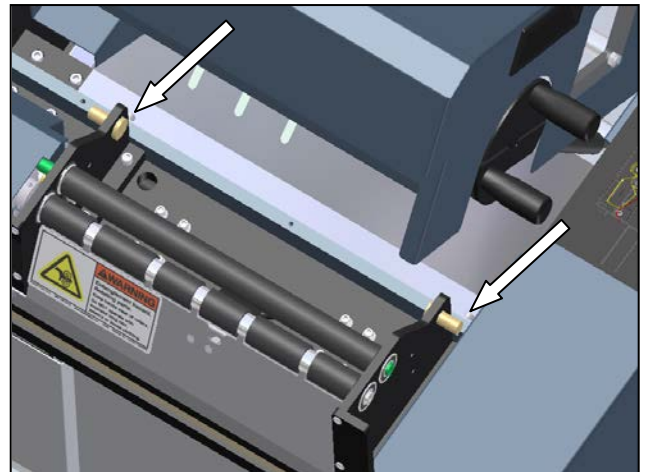

Figure 3-22. Motor Cover Front Screws

ELECTRICAL COMPONENTS

24 VDC POWER SUPPLY (con't)

6. Visually check wiring on Power Supply. (Figure 3-23)

Note: The “V-“connection on the Power Supply is connected to “Earth Ground” by a short wire. Also, lines labeled with “Printer” are only present on baggers with a printer.

7. If there is a noticeable problem with the wiring of the Power Supply, refer to the replacement section for directions to rewire power supply.
8. Turn ON device using the power switch in the back of the machine.
9. Check that the Green Status LED is illuminated. (Figure 3-24) If it is, you may proceed to step 13.
10. Set your DVOM to a range capable of testing 120 Volts AC.

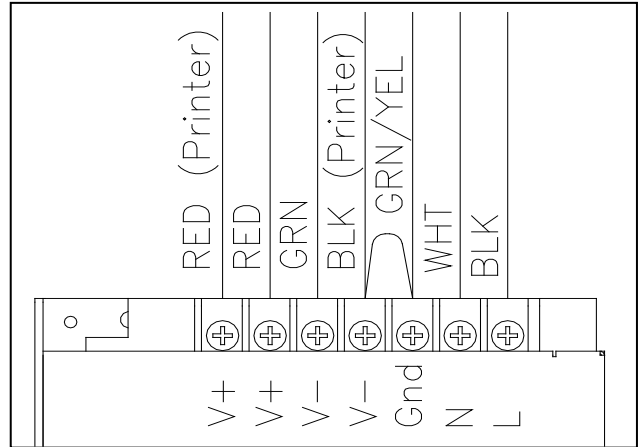





Figure 3-23. 24 VDC Power Supply

 **WARNING**

USE EXTREME CAUTION WHILE SERVICING A MACHINE WHILE POWER IS APPLIED. UNEXPECTED MACHINE STARTUP CAN CAUSE SERIOUS INJURY.

 **WARNING**

DO NOT ATTEMPT TO SERVICE THE MACHINE DURING NORMAL OPERATION. KEEP HANDS AND ARMS CLEAR OF MOVING PARTS.

 **WARNING**

WHEN TESTING ELECTRICAL COMPONENTS WHILE POWER IS APPLIED TO THE MACHINE, USE PROPER TROUBLESHOOTING TECHNIQUES TO AVOID ELECTRICAL SHOCK.

11. Probe the L and N contacts on the Power Supply with a DVOM; it should display approximately 120 VAC (Figure 3-25).

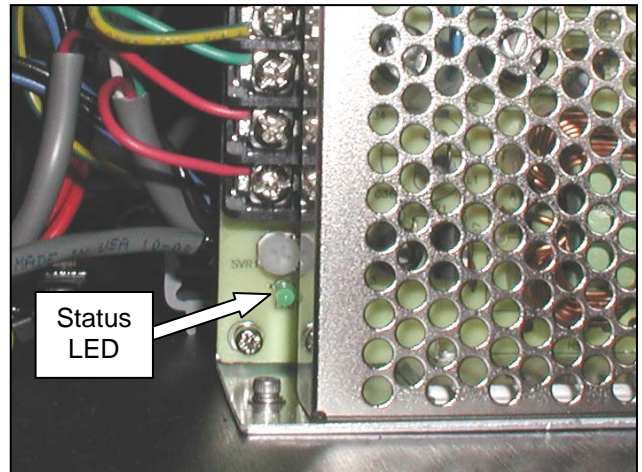

Figure 3-24. Power Supply Status LED

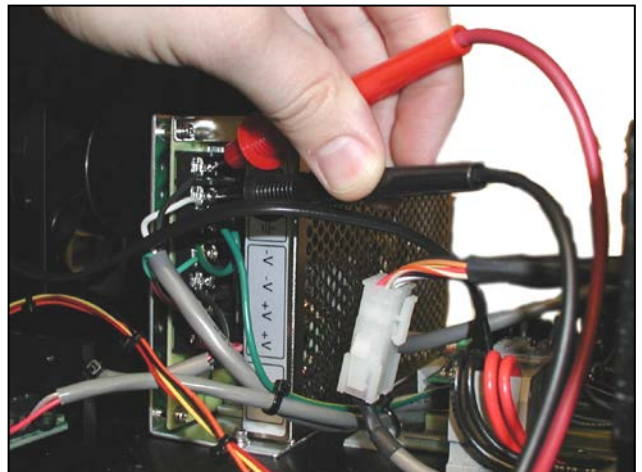

Figure 3-25. Probing 120 VAC on Power Supply

ELECTRICAL COMPONENTS

24 VDC POWER SUPPLY (con't)

12. If 0 VAC is displayed, there is no power reaching the Power Supply. Check the 10 amp system fuse and ensure there are no loose wires.
13. Set your DVOM to a range capable of measuring 24 VDC. Probe between the “V-“and “V+” contacts on the Power Supply (Figure 3-26).
14. If 0 Volts DC is displayed, then the Power Supply is defective. Refer to the Replacement section.

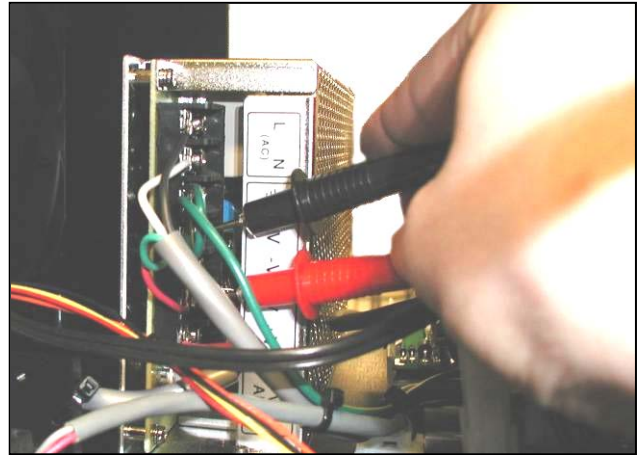

Figure 3-26. Probing “V-“ and “V+”

ELECTRICAL COMPONENTS

24 VDC POWER SUPPLY (con't)

ADJUSTMENT

The Sharp SX™ Bagger's Power Supply has two user adjustable settings. These settings are set at the factory and do not require regular adjustment. The following steps will guide you through setting the Power Supply to the factory defaults.

1. Remove the two rear screws and the two front screws from the Motor Cover (Figure 3-27 and Figure 3-28).

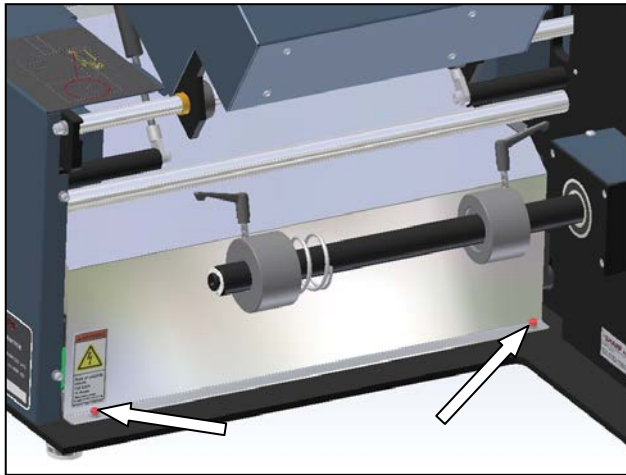

Figure 3-27. Motor Cover Rear Screws

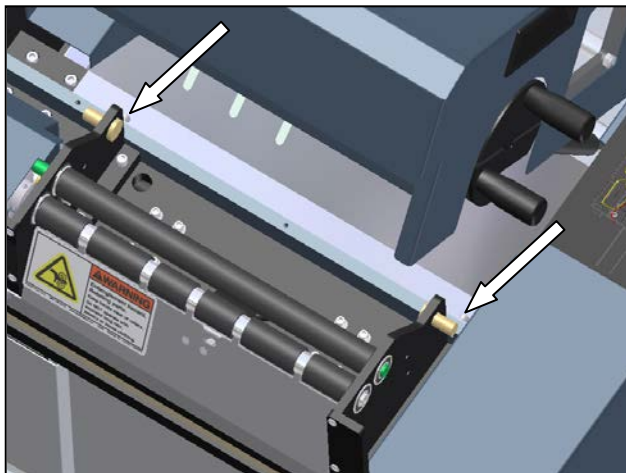

Figure 3-28. Motor Cover Front Screws

2. Locate the 24 VDC Power Supply.

Note: The power supply location changes depending on your version of the Sharp SX™ Bagger. The wiring however is exactly the same

3. Locate the red Switch on the side of the Power Supply. (Figure 3-29).

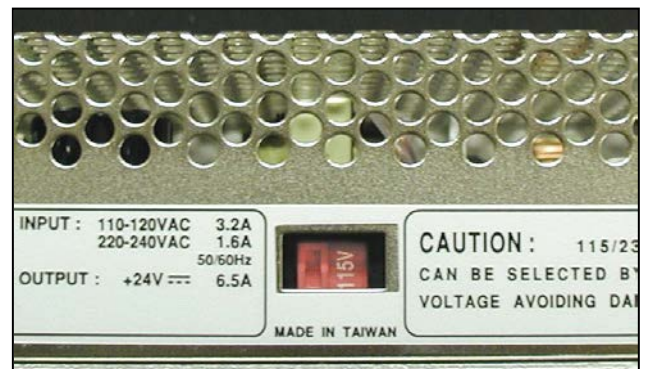

Figure 3-29. Voltage Selector Switch

4. Set the Voltage Selector Switch to 115V.

Note: If your region uses 230 VAC as the standard voltage, a step-down transformer is required. This will lower the voltage entering the machine to 115 VAC. Set the Voltage Selector Switch to 115V regardless of your region.

ELECTRICAL COMPONENTS

24 VDC POWER SUPPLY (con't)

- Plug the Sharp SX™ Bagger in and turn the machine on.

**WARNING**

USE EXTREME CAUTION WHILE SERVICING A MACHINE WHILE POWER IS APPLIED. UNEXPECTED MACHINE STARTUP CAN CAUSE SERIOUS INJURY.

**WARNING**

DO NOT ATTEMPT TO SERVICE THE MACHINE DURING NORMAL OPERATION. KEEP HANDS AND ARMS CLEAR OF MOVING PARTS.

**WARNING**

WHEN TESTING ELECTRICAL COMPONENTS WHILE POWER IS APPLIED TO THE MACHINE, USE PROPER TROUBLESHOOTING TECHNIQUES TO AVOID ELECTRICAL SHOCK.

- Set your DVOM to a range capable of measuring 24 VDC.
- With one hand, position a small screwdriver on the voltage adjustment POT (Figure 3-30).
- Place the black probe on the “V-“contact and the red probe on the “V+” contact (Figure 3-31).
- Adjust the POT until your DVOM reads 24.0 VDC +/- .5.

Note: Depending on your version of the Sharp SX™ Bagger, the Power Supply POT may be difficult to reach. If this is the case, measure the voltage, then set the probes aside and adjust the voltage with a small screwdriver. Repeat until DVOM indicates 24.0 VDC.

- Replace Motor Cover using screws and locking washers.

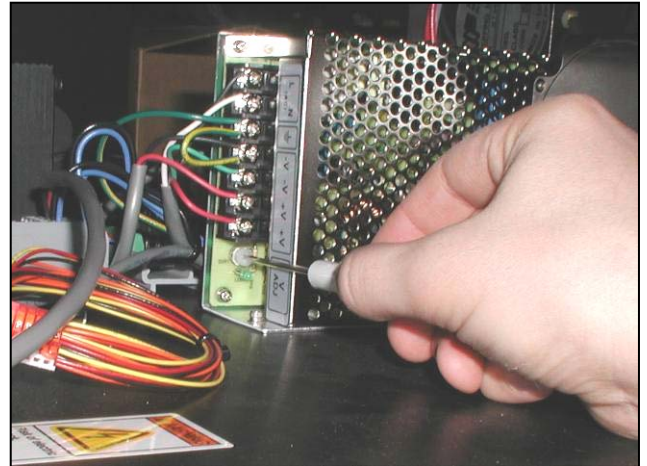

Figure 3-30. Adjusting Power Supply Voltage

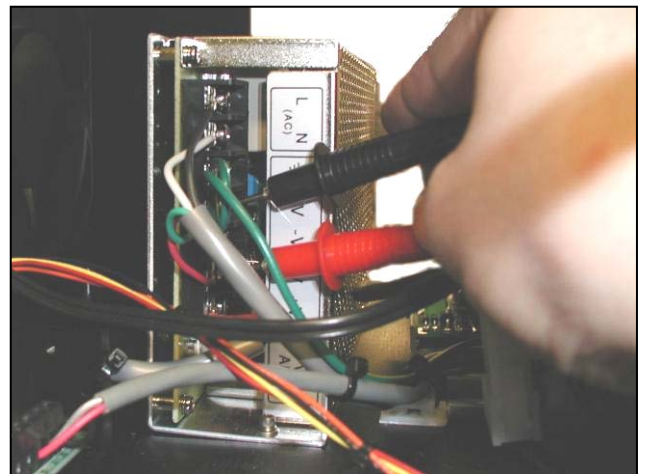

Figure 3-31. Testing 24 VDC on Power Supply

ELECTRICAL COMPONENTS

24 VDC POWER SUPPLY (con't)

REPLACEMENT

1. Turn off the Sharp SX™ Bagger and disconnect all power cords.

WARNING

Always remove electrical power from the SX™ prior to performing any maintenance on the machine.

2. Remove the two rear screws and the two front screws from the Motor Cover (Figure 3-32 and Figure 3-33).

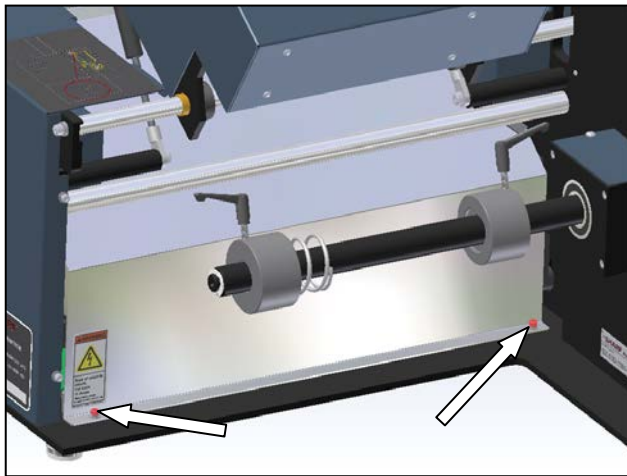

Figure 3-32. Motor Cover Rear Screws

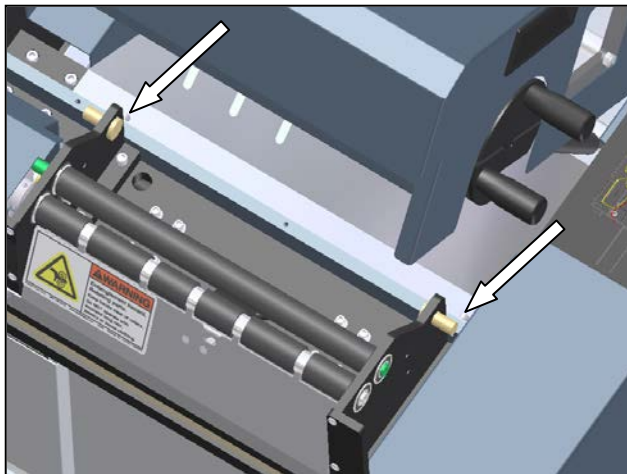

Figure 3-33. Motor Cover Front Screws

3. Disconnect all wires from the Power Supply.
4. Remove the three screws holding the Power Supply to the frame. (Figure 3-34).

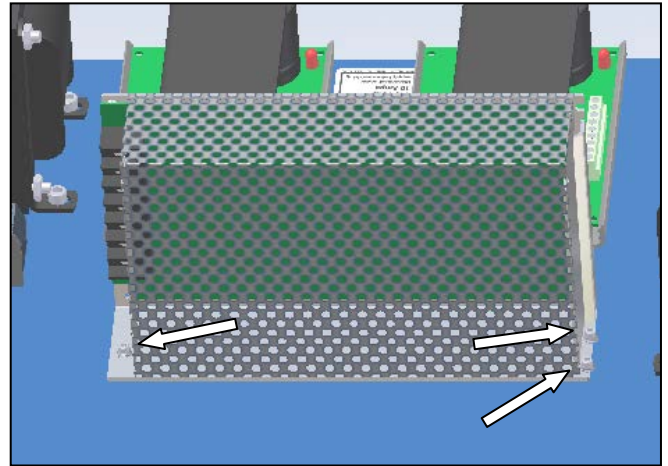

Figure 3-34. Power Supply screw locations

5. Remove the defective Power Supply and set aside.
6. With new power supply, check that the Voltage Selector Switch is set to 115 VAC (Figure 3-35).

Note: If your region uses 230 VAC as the standard voltage, a step-down transformer is required. This will lower the voltage entering the machine to 115 VAC. Set the Voltage Selector Switch to 115V regardless of your region.

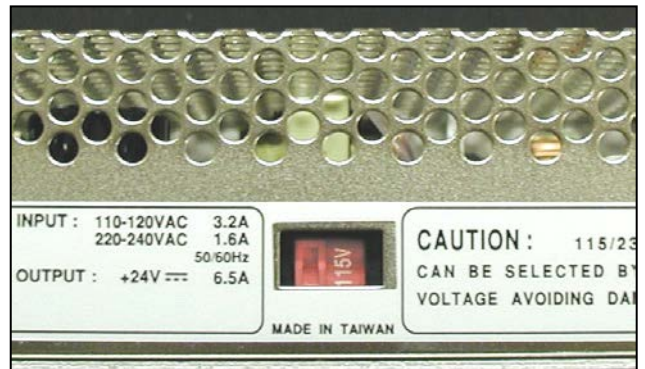

Figure 3-35. Voltage Selector Switch

ELECTRICAL COMPONENTS

24 VDC POWER SUPPLY (con't)

7. Reconnect all wires to the Power Supply (Figure 3-36).
8. Place new Power Supply in the Sharp SX™ Bagger in the same location and orientation as the old power supply.
9. Use screws from old Power Supply and secure new Power Supply to the frame.
10. Reconnect power cord to the Sharp SX™ Bagger and turn machine on.
11. Set your DVOM to a range capable of measuring 24 VDC.

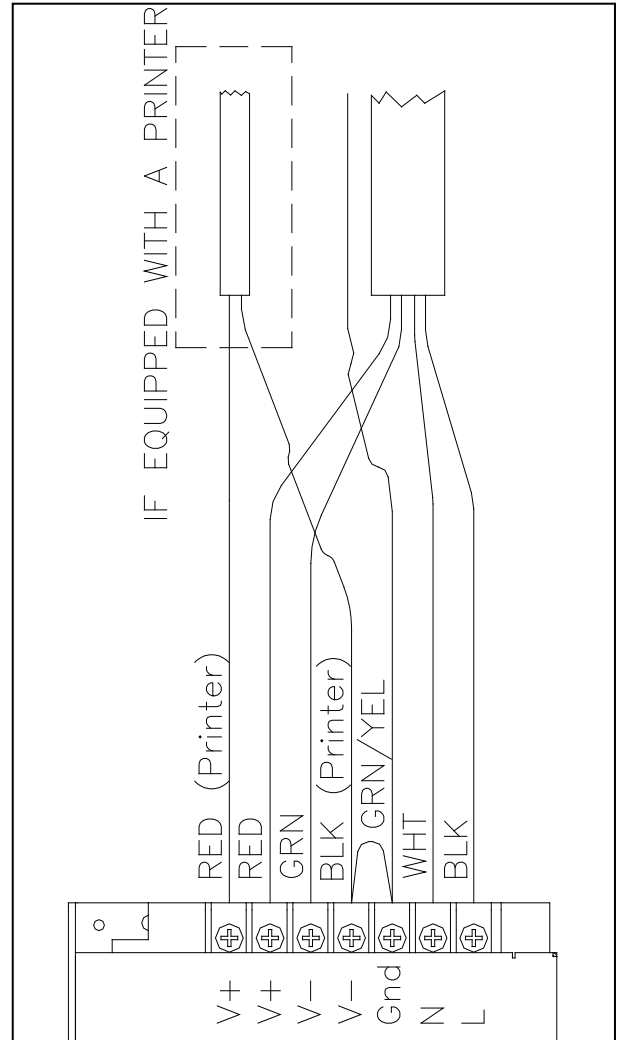

Figure 3-36. 24 VDC Power Supply

ELECTRICAL COMPONENTS

24 VDC POWER SUPPLY (con't)

12. With one hand, position a small screwdriver on the voltage adjustment POT (Figure 3-37).
13. Place the black probe on the “V-“contact and the red probe on the “V+” contact (Figure 3-38).
14. Adjust the POT until your DVOM reads 24.0 VDC.

Note: Depending on your version of the Sharp SX™ Bagger, the Power Supply POT may be difficult to reach. If this is the case, measure the voltage, then set the probes aside and adjust the voltage with a small screwdriver. Repeat until DVOM indicates 24.0 VDC.

15. Replace Motor Cover.

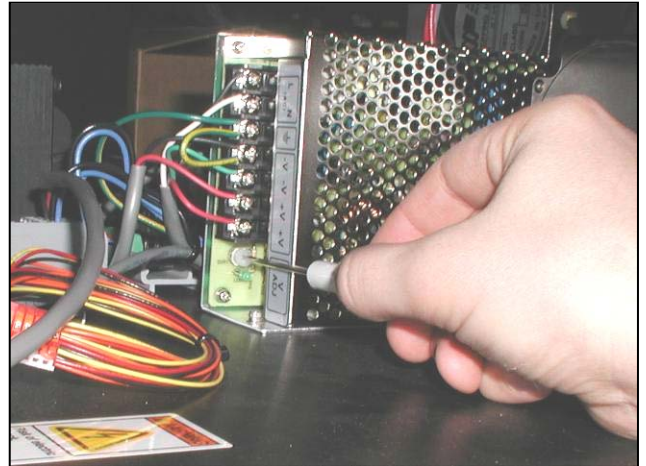

Figure 3-37. Adjusting Power Supply Voltage

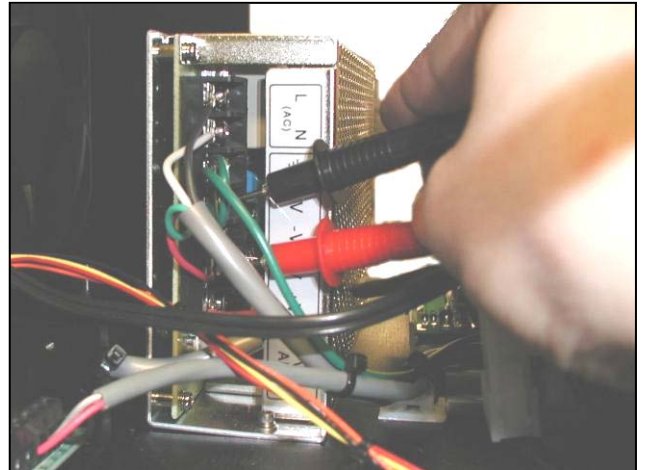

Figure 3-38. Testing 24 VDC on Power Supply

ELECTRICAL COMPONENTS

LINE FILTER

TESTING

This procedure requires working with exposed high voltages. Only qualified personnel familiar with electrical safety should perform this procedure.

1. Remove all power to the machine.
2. Remove the six screws holding the Frame Cover. Set screws and Frame Cover aside (Figure 3-39).

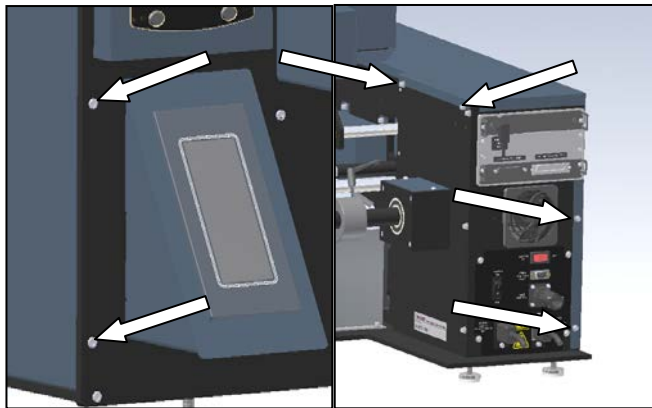

Figure 3-39. Frame Cover Screws

3. Remove any bags on a roll from machine.
4. Remove the seven screws holding the Mandrel Support Plate, set screws and plate aside (Figure 3-40 & Figure 3-41).

Note: There are seven screws holding the Mandrel Support Plate. Use care when removing bottom screws and never work on an unstable platform.

5. Detach the three spade connectors from the Line Filter (Figure 3-42).

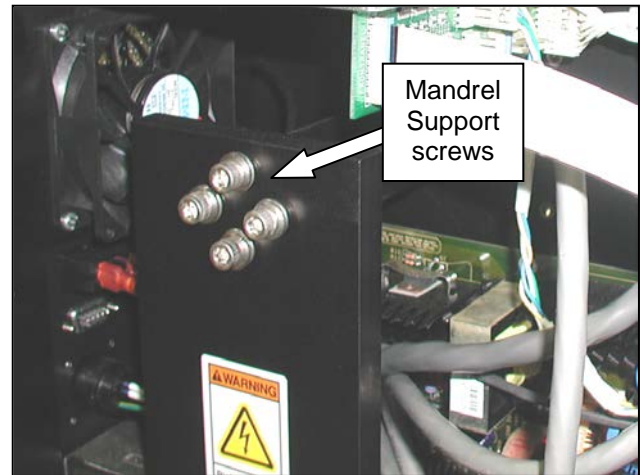

Figure 3-40. Mandrel Support Screws

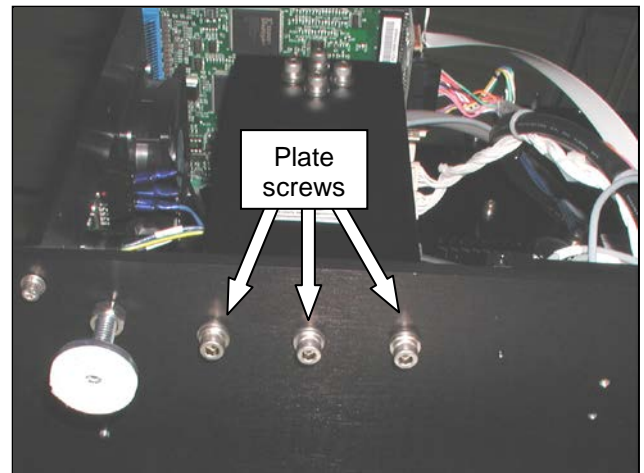

Figure 3-41. Mandrel Support Plate Bottom Screws

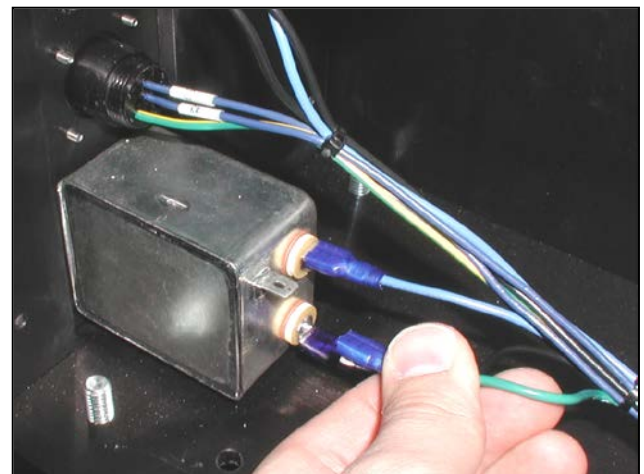

Figure 3-42. Remove three spade connectors

ELECTRICAL COMPONENTS

LINE FILTER (con't)

6. Reconnect the power cord to the machine.

Note: There will be exposed 120 VAC. Use extreme caution when working with exposed wires.

	WARNING
USE EXTREME CAUTION WHILE SERVICING A MACHINE WHILE POWER IS APPLIED. UNEXPECTED MACHINE STARTUP CAN CAUSE SERIOUS INJURY.	

	WARNING
DO NOT ATTEMPT TO SERVICE THE MACHINE DURING NORMAL OPERATION. KEEP HANDS AND ARMS CLEAR OF MOVING PARTS.	

	WARNING
WHEN TESTING ELECTRICAL COMPONENTS WHILE POWER IS APPLIED TO THE MACHINE, USE PROPER TROUBLESHOOTING TECHNIQUES TO AVOID ELECTRICAL SHOCK.	

7. With a DVOM configured to measure 120 VAC, contact the red probe to the L pin and the Black probe to the N pin. If 120 VAC is not indicated, the Line Filter is defective or no power is reaching the machine.
8. Unplug machine from any power sources.

	WARNING
Always remove electrical power from the SX™ prior to performing any maintenance on the machine.	

9. Reconnect spade connectors to the Line Filter (Figure 3-43).
10. Replace the seven screws for the Mandrel Support Plate but do not tighten down.

11. Hand tighten the four top screws, ensuring that the end of the Material Roll Mandrel is sitting inside the recessed circle of the Mandrel Support Plate (Figure 3-44).
12. Tighten all screws with an Allen Wrench.

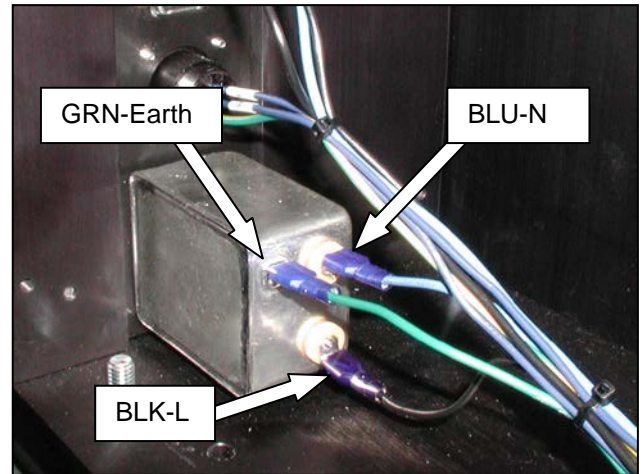

Figure 3-43. Wire colors and locations

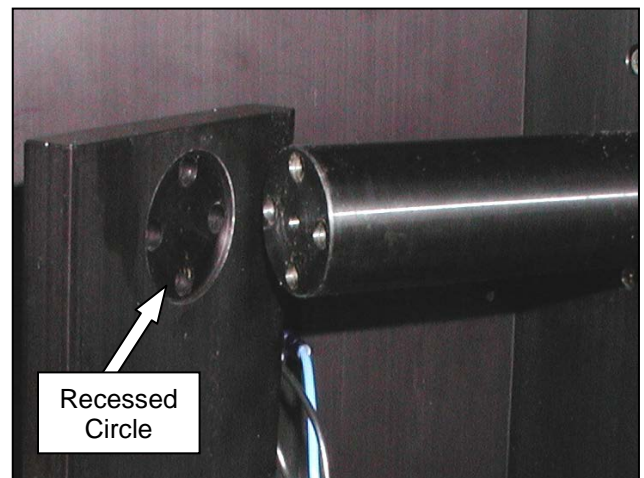

Figure 3-44. Mandrel Support Plate alignment

ELECTRICAL COMPONENTS

LINE FILTER (con't)

ADJUSTMENT

There are no adjustments necessary on the Line Filter.

REPLACEMENT



WARNING

Always remove electrical power from the SX™ prior to performing any maintenance on the machine.

1. Remove the six screws holding the Frame Cover, set screws and Frame Cover aside (Figure 3-45).

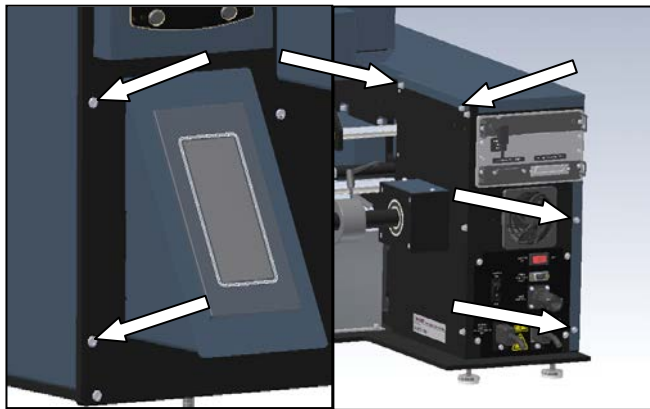

Figure 3-45. Frame Cover Screws

2. Remove the seven screws holding the Mandrel Support Plate, set screws and plate aside (Figure 3-46 & 3-47).

Note: There are seven screws holding the Mandrel Support Plate. Use care when removing bottom screws and never work on an unstable platform.

3. Remove the three spade connectors from the Line Filter (Figure 3-48).

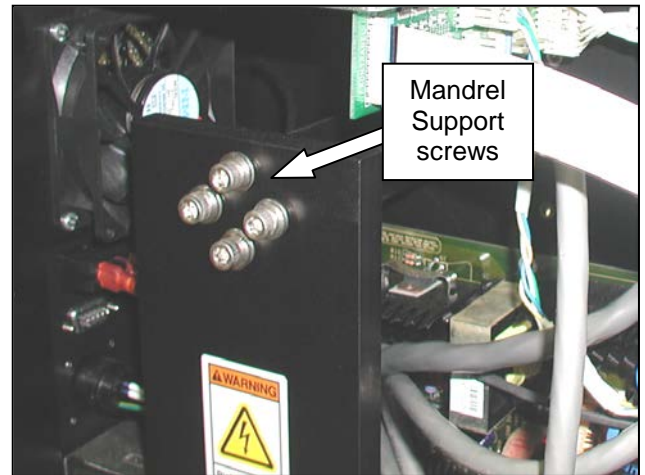

Figure 3-46. Mandrel Support screws

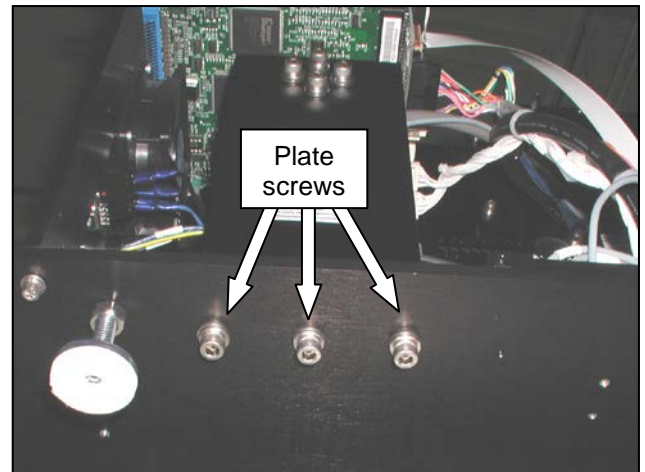

Figure 3-47. Mandrel Support Plate Bottom Screws

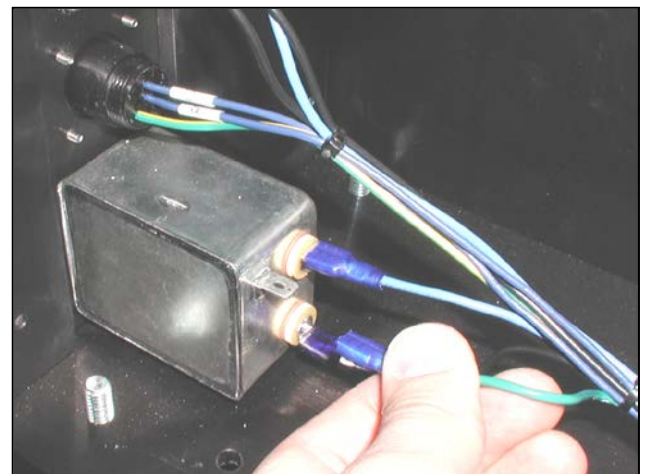

Figure 3-48. Remove three spade connectors

ELECTRICAL COMPONENTS

LINE FILTER (con't)

4. Remove the two screws holding the Line Filter to the Rear Face Plate (Figure 3-49).
5. Remove Line Filter.
6. Orientate new module so the two spade connectors are towards the top.
7. Refasten new module to frame with screws from defective module.
8. Reattach the three connector wires, Earth (Green) on the left, Neutral (Blue) on the top right, and Live (Black) on the bottom (Figure 3-50).
9. Replace the seven screws for the Mandrel Support Plate but do not tighten down.
10. Hand-tighten the four top screws, ensuring that the end of the Material Roll Mandrel is sitting inside the recessed circle of the Mandrel Support Plate (Figure 3-50).
11. Tighten all screws with an Allen wrench.
12. Replace Frame Cover with screws and lock washers.

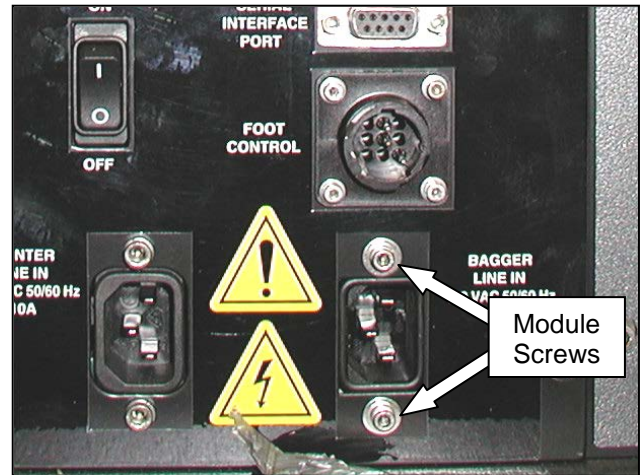

Figure 3-49. Line Filter Screws

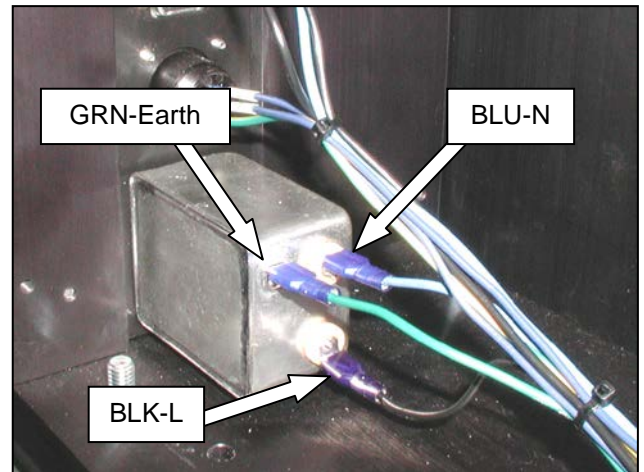

Figure 3-50. Wire colors and locations

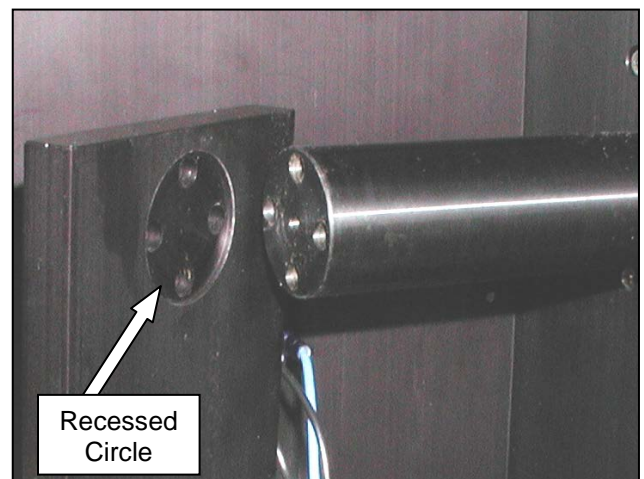



Figure 3-51. Mandrel Support Plate alignment

ELECTRICAL COMPONENTS

MAIN POWER SWITCH (RED)

TESTING

 WARNING
<p>Always remove electrical power from the SX™ prior to performing any maintenance on the machine.</p>

1. Remove the six screws holding the Frame Cover, set screws and Frame Cover aside (Figure 3-52).
2. Turn the switch to the OFF position (Figure 3-53).
3. Configure your DVOM to test for continuity, contact one probe to the 5A Fuse and the other probe to the 10A Fuse (Figure 3-54) It should NOT read continuity.
4. Turn the switch to the ON position.
5. Configure your DVOM to test for continuity, contact one probe to the 5A Fuse and the other probe to the 10A Fuse (Figure 3-54). It should read continuity. If it does not, ensure there are no loose wires. If the wiring is not defective, replace the Main Power Switch.
6. If the Main Power Switch is not found to be defective, troubleshoot the Line Filter and fuses if you haven't already done so.

ADJUSTMENT

There are no adjustments necessary on the Main Power Switch.

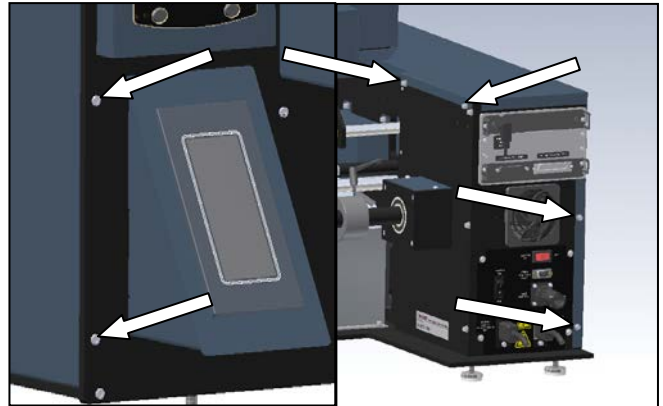

Figure 3-52. Frame Cover Screws



Figure 3-53. Main Red Switch location

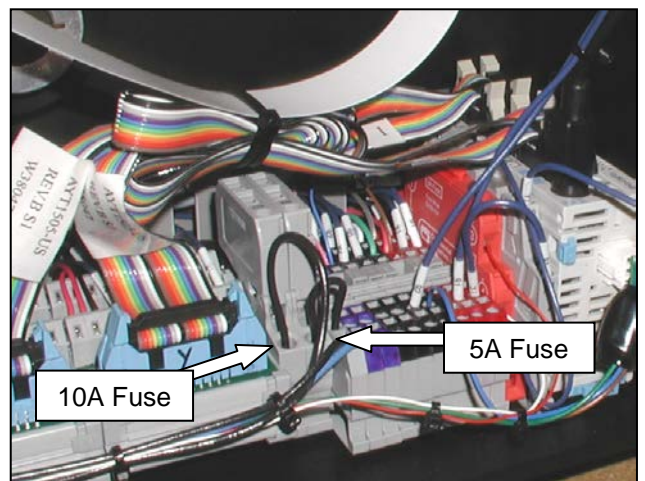

Figure 3-54. Fuse Locations

ELECTRICAL COMPONENTS

MAIN POWER SWITCH (RED) (con't)

REPLACEMENT



WARNING

Always remove electrical power from the SX™ prior to performing any maintenance on the machine.

1. Remove the six screws holding the Frame Cover. Set screws and Frame Cover aside (Figure 3-55).
2. Remove the seven screws holding the Mandrel Support Plate, set screws and plate aside.
3. Remove the three spade connectors from the back of the Main Power Switch (Figure 3-56).
4. The switch is held in place by four retaining clips, squeeze clips on either side of the switch while firmly pushing switch out of Rear Face Plate (Figure 3-57).
5. Orientate switch so the plastic divider is on the left side as you are looking at the back of the switch as you snap it into the Rear Face Plate. Snap replacement switch into Rear Face Plate.
6. Reconnect the three spade connectors. The Light Blue wire is attached to the contact furthest from you; the two Black wires are attached to the remaining contacts.

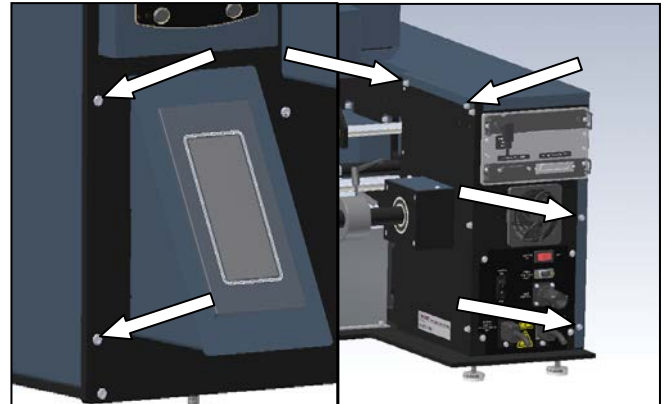

Figure 3-55. Frame Cover Screws

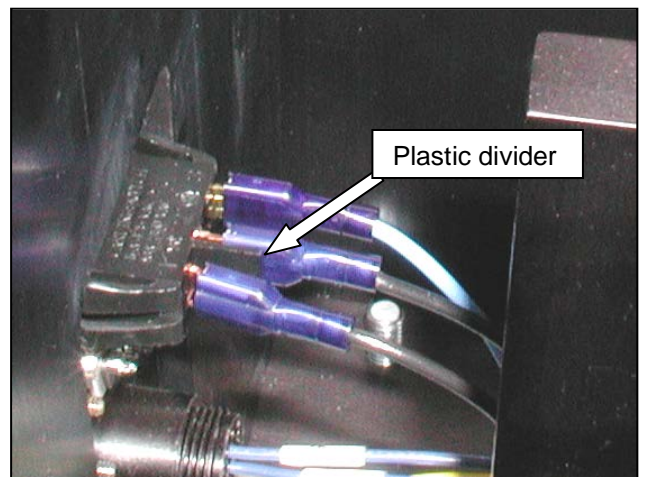

Figure 3-56. Plastic divider location

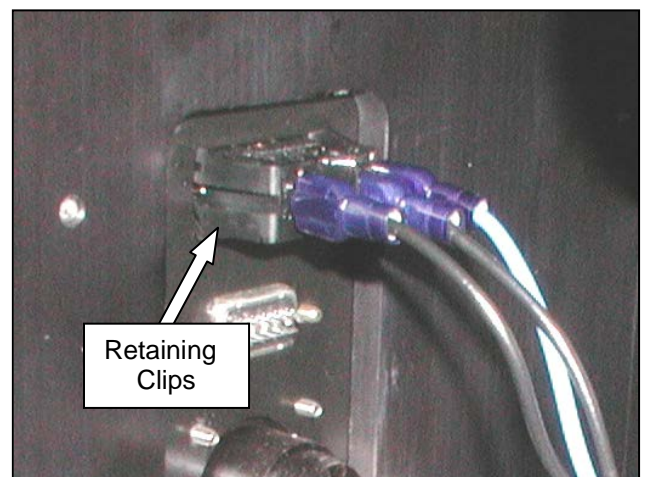

Figure 3-57. Back of Main Power Switch

ELECTRICAL COMPONENTS

TRANSFORMERS

The Sharp SX™ Bagger uses two “Step-Down” transformers. One is used for the Seal Wire and the other is used for the two TM4500 stepper drives. They are each 0.365 KVA transformers with a 120(P):28(S) voltage ratio. Only replace with equal or greater KVA rating and same voltage ratio.

TESTING

⚠ WARNING

Always remove electrical power from the SX™ prior to performing any maintenance on the machine.

1. Remove the two rear screws and the two front screws holding the Motor Cover. (Figure 3-58 and Figure 3-59)

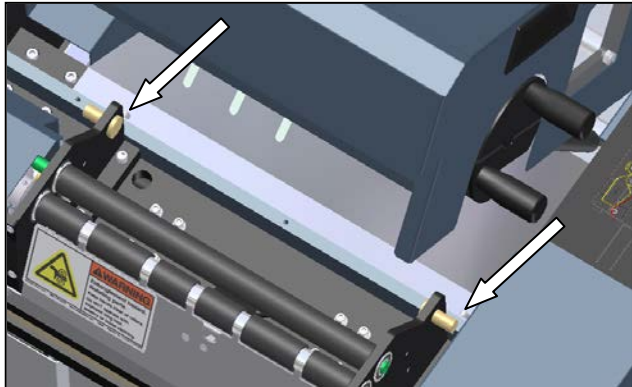

Figure 3-58. Motor Cover Front Screws

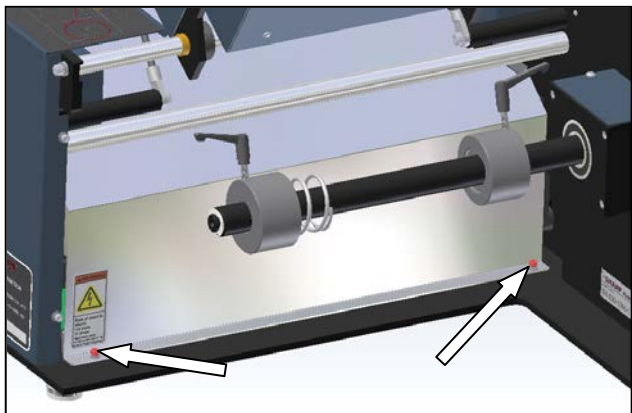

Figure 3-59. Motor Cover Rear Screws

2. Remove Motor Cover and set aside.
3. Remove the four screws holding the Load Plate, set screws and Load Plate aside (Figure 3-60.)

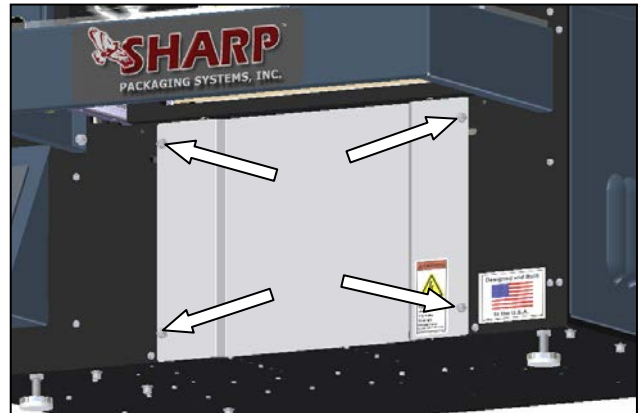

Figure 3-60. Load Plate Screws

4. Locate the transformer you wish to troubleshoot and proceed to that section (Figure 3-61).

Note: Transformer locations will change depending on your version of the SX. The Stepper Drive transformer's wires terminate in a terminal block. The Seal Wire transformer is connected to the Solid State Relay and Seal Wire.

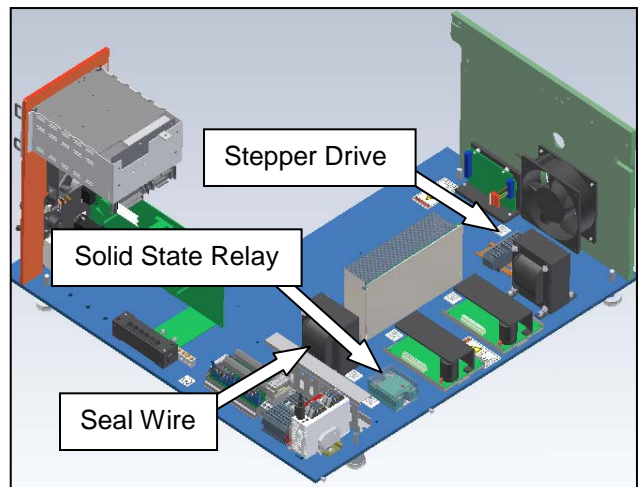

Figure 3-61. Transformer locations for the SX 1108 and 1109

ELECTRICAL COMPONENTS

TRANSFORMERS (con't)

Seal Wire Transformer

1. Remove clear plastic covering over Solid State Relay.
2. Set your DVOM to test for continuity. With the Black probe, contact the Blue terminal block in the electrical area, with the Red probe, contact pin 2 of the Solid State Relay. (Figure 3-62) Your DVOM should indicate continuity. If it does not, check the transformer wiring. If the wiring is correct, the transformer is defective and will require replacement.
3. Remove the Left screw holding the Red wire to the Seal Wire. Pull wire away from contact (Figure 3-63).
4. With a DVOM set to test for continuity, contact one probe to the loose Red wire you just disconnected, and contact the other probe to the right screw holding the other Red wire to the Seal Wire (Figure 3-64).
5. The DVOM will indicate continuity, if it does not the Seal Wire Transformer is defective and must be replaced.
6. If the transformer is not defective, troubleshoot the Solid State Relay and the Seal Wire.

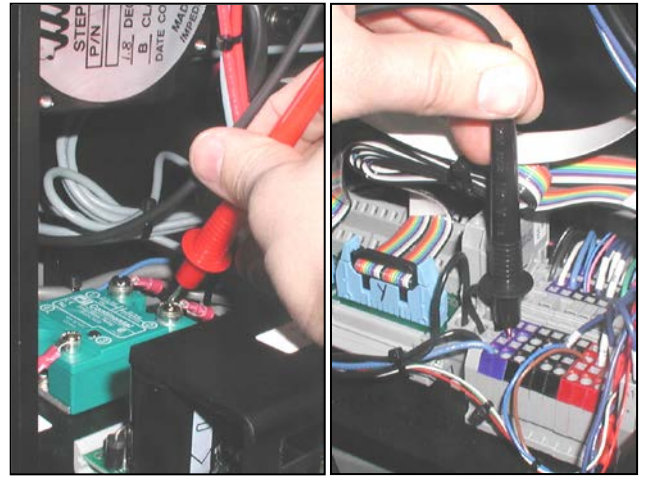

Figure 3-62. Testing pin 2 of Solid State Relay

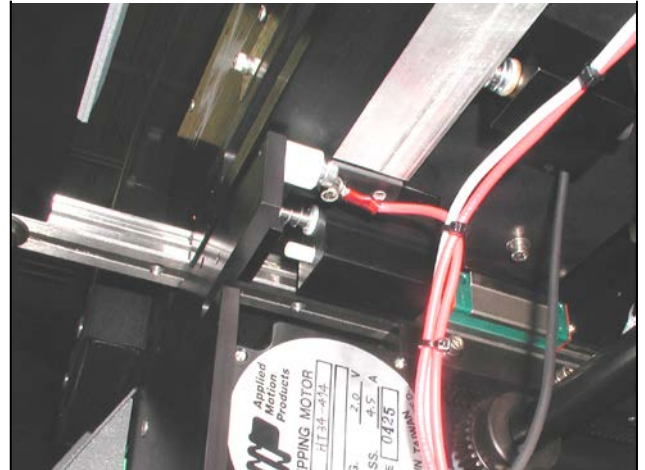

Figure 3-63. Left side Seal Bar connection

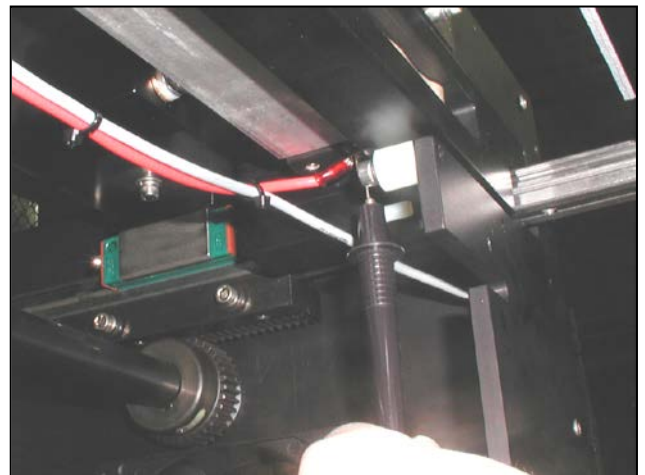

Figure 3-64. Probing right side of Seal Wire

ELECTRICAL COMPONENTS

TRANSFORMERS (con't)

ADJUSTMENT

Stepper Drive Transformer

There are no adjustments necessary on transformers.

1. Locate the two terminal blocks with the Red wires connected to the transformer (Figure 3-65).

Note: Location and orientation will vary depending on model.

2. With a DVOM set to test for continuity, probe the two front terminal blocks and the two rear terminal blocks. Both should indicate continuity. (Figure 3-66).
3. Reconnect machine to power and turn machine on.

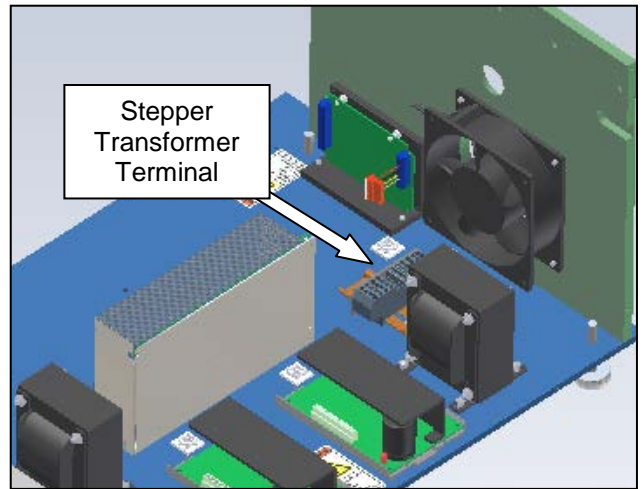





Figure 3-65 Print Head Stepper Drive
Note: Electrical assembly isolated for clarity

	WARNING
USE EXTREME CAUTION WHILE SERVICING A MACHINE WHILE POWER IS APPLIED. UNEXPECTED MACHINE STARTUP CAN CAUSE SERIOUS INJURY.	

	WARNING
DO NOT ATTEMPT TO SERVICE THE MACHINE DURING NORMAL OPERATION. KEEP HANDS AND ARMS CLEAR OF MOVING PARTS.	

	WARNING
WHEN TESTING ELECTRICAL COMPONENTS WHILE POWER IS APPLIED TO THE MACHINE, USE PROPER TROUBLESHOOTING TECHNIQUES TO AVOID ELECTRICAL SHOCK.	

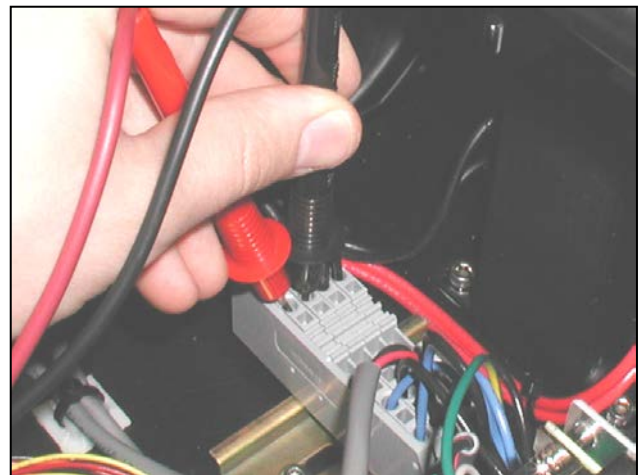

Figure 3-66 Testing two front terminal blocks

4. Set your DVOM measure 120 VAC. Probe the two terminal blocks connected to the Black wires from the transformer. The DVOM should indicate 120 VAC. If it does not, troubleshoot the wiring from the main DIN Rail (located under the frame guard behind the display, where terminals, PLC, and fuse blocks are snapped onto).

ELECTRICAL COMPONENTS

TRANSFORMERS (con't)

REPLACEMENT

WARNING

Always remove electrical power from the SX™ prior to performing any maintenance on the machine.

1. Remove the two rear and two front screws holding the Motor Cover on. Set screws and Motor Cover aside (Figures 3-67 & 3-68)...

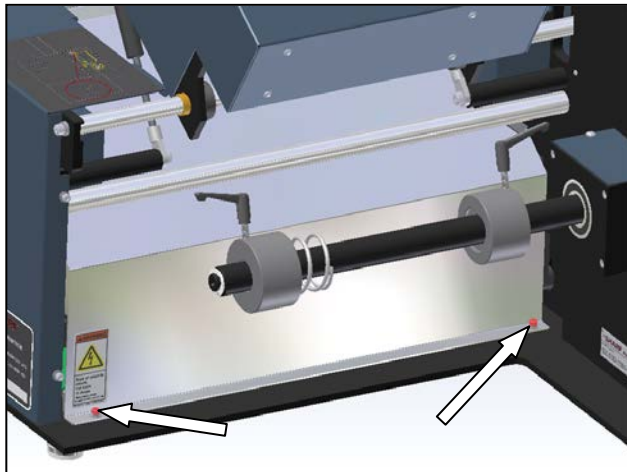

Figure 3-67. Motor Cover Rear Screws

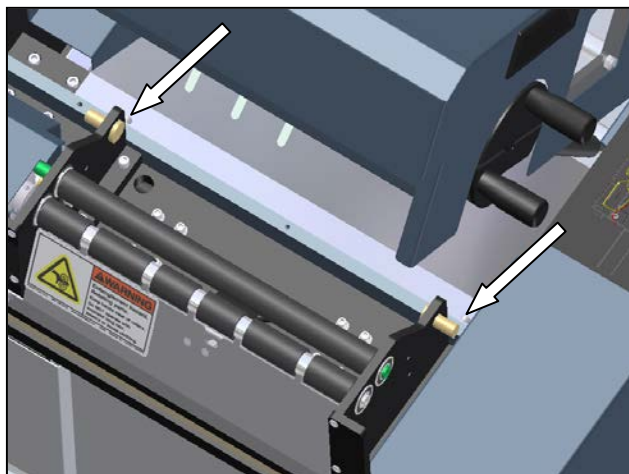

Figure 3-68. Motor Cover Front Screws

2. Locate transformer that requires replacement (Figure 3-70).

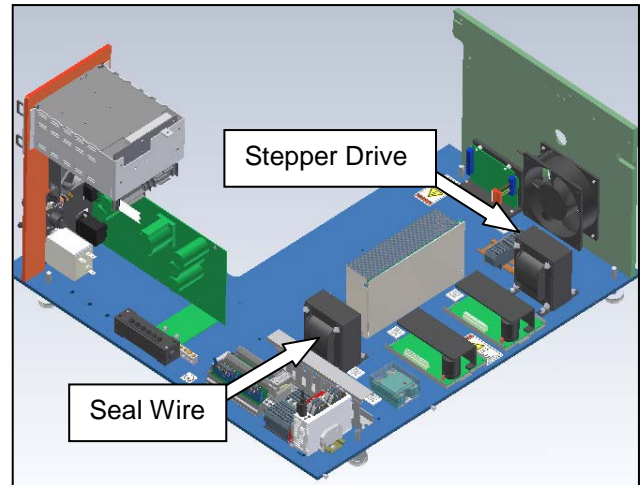

Figure 3-69. Transformer locations on an 1108 or 1109

3. If you are replacing the Seal Wire Transformer Remove the six screws holding the Frame Cover, set screws and Frame Cover aside (Figure 3-70).

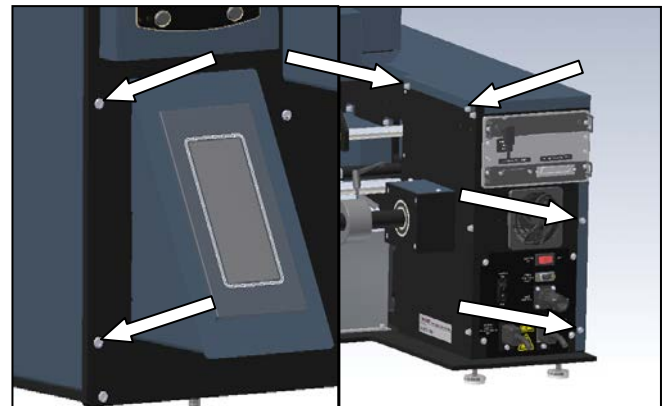

Figure 3-70. Frame Cover Screws

ELECTRICAL COMPONENTS

TRANSFORMERS (con't)

4. If you are replacing the Stepper Drive Transformer, remove the four screws holding the Load Plate, set screws and Load Plate aside (Figure 3-71).
5. Follow each of the four wires coming out of the Transformer and note their locations and color. You may want to write this information down.

Note: The wiring diagram in this manual can be used to determine transformer connections; however it is easier to write this information down.

6. Disconnect the ends of each wire and feed them back through any Wire Troughs or Wire Ties. You will probably have to cut a few Wire Ties to do this.
7. Remove the four screws holding the Transformer to the Base Plate (Figure 3-72).
8. Note the orientation of the Red and Black wires. Remove transformer.
9. With the replacement Transformer, orientate Red and Black wires so that they are facing the same direction as the old Transformer.
10. Fasten Transformer to Base Plate with the four screws from the old Transformer.
11. Reconnect the two Red and two Black wires to their previous locations.

Note: If replacing the Seal Wire Transformer, you will have to terminate the Red wires with a Ring Terminal of similar size.

12. Replace Frame Cover and Motor Cover using screws and locking washers.



Figure 3-71. Load Plate Screws

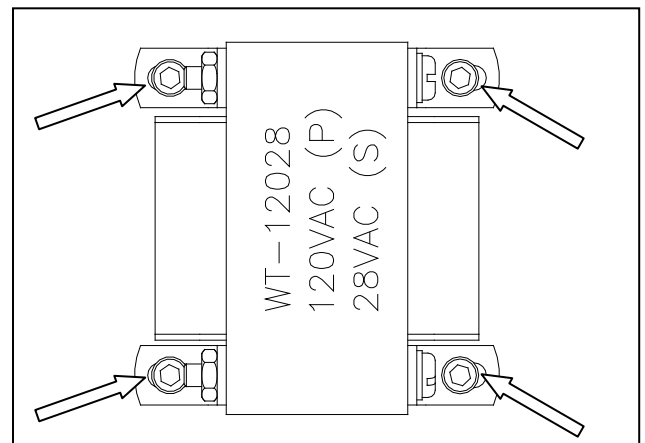

Figure 3-72 Transformer Bolt Locations

ELECTRICAL COMPONENTS

AROMAT PLC

The Sharp SX™ Bagger is controlled by an Aromat FPΣ PLC. This is an NPN (sinking outputs) device with 16 inputs and 16 outputs.

TESTING

Check that there is power reaching the PLC by checking for green lights on top of the PLC. If there are no lights, check the PLC Power connector, or troubleshoot the 24VDC Power Supply. If there is a red blinking light on the PLC, the PLC has faulted, contact Sharp Packaging.

ADJUSTMENT

There are no adjustments necessary on the Aromat PLC

REPLACEMENT



WARNING

Always remove electrical power from the SX™ prior to performing any maintenance on the machine.

1. Remove the six screws holding the Frame Cover. Set screws and Frame Cover aside (Figure 3-73).
2. Remove all connections from the Aromat PLC. There are six connections: Power, Display and four ribbon cables. Note where the ribbon cables are connected to the PLC (Figure 3-74).
3. Using a small flat screwdriver, pull the blue DIN rail release tab toward you and pivot the PLC up and back (Figure 3-75).
4. Remove old Aromat PLC and set aside.
5. Place new Aromat PLC onto DIN rail with the circular plug closest to you.
6. Reconnect all wires (Figure 3-74).

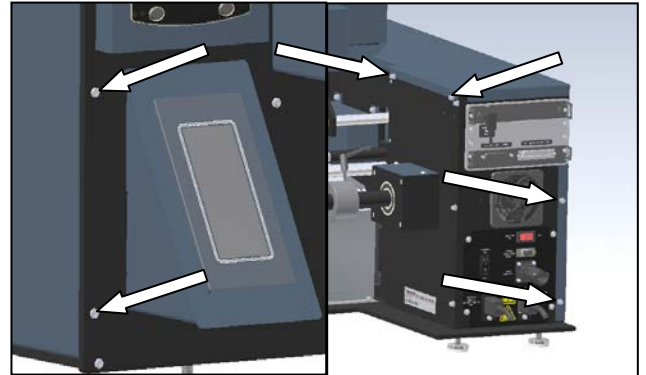

Figure 3-73. Frame Cover Screws

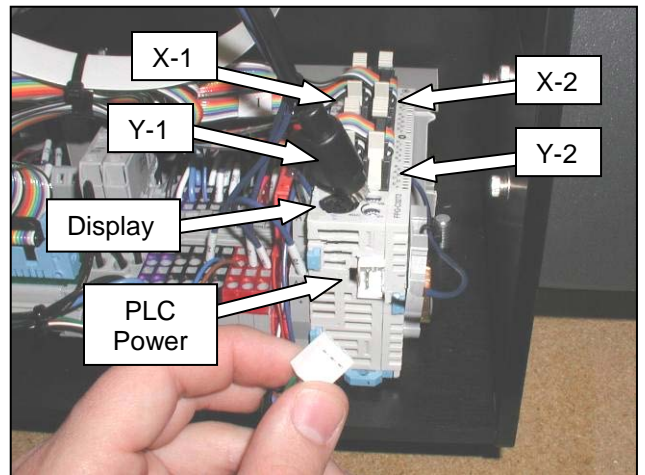

Figure 3-74 PLC Connections

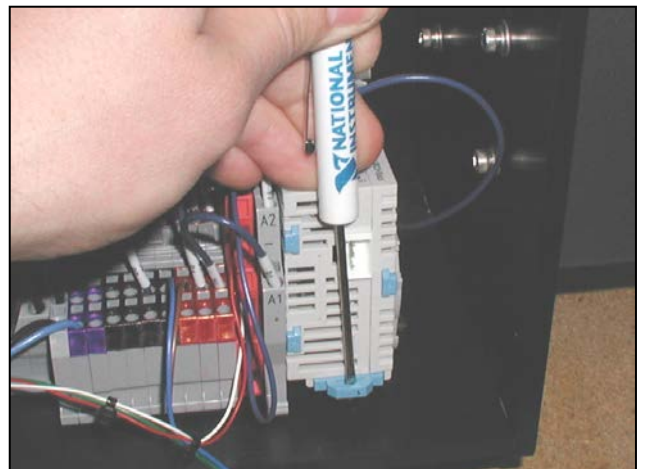

Figure 3-75 Removing PLC

ELECTRICAL COMPONENTS

AROMAT PLC BATTERY

The Aromat PLC battery is a 1.5 VDC “Button” battery. It is used by the PLC to retain user settings. The average lifetime of the PLC battery is two years. It is suggested that you replace the battery annually.

Note: Not all machines are equipped with a PLC Battery. If no battery is present in your PLC, you do not have to install one.

TESTING

There are no testing procedures to be performed on the Aromat PLC battery.

ADJUSTMENT

There are no adjustments necessary on the Aromat PLC battery.

REPLACEMENT



WARNING

Always remove electrical power from the SX™ prior to performing any maintenance on the machine.

1. Remove the six Frame Cover screws (Figure 3-76).
2. Remove Frame Cover and set aside.
3. Disconnect the touch screen communications cable and the power wiring connector (Figure 3-77).
4. Using a small flat screwdriver, pull the blue DIN rail release tab toward you and pivot the PLC up and back (Figure 3-78).
5. Remove the PLC from the DIN Rail.

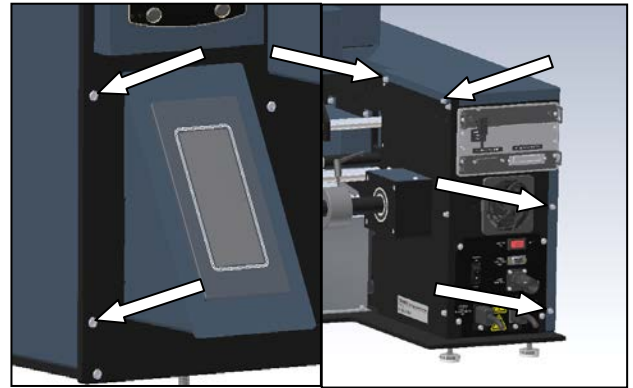

Figure 3-76. Frame Cover Screws

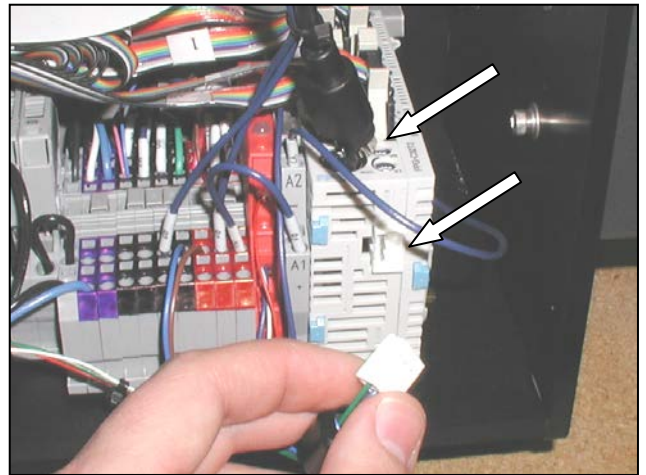

Figure 3-77. PLC Connections

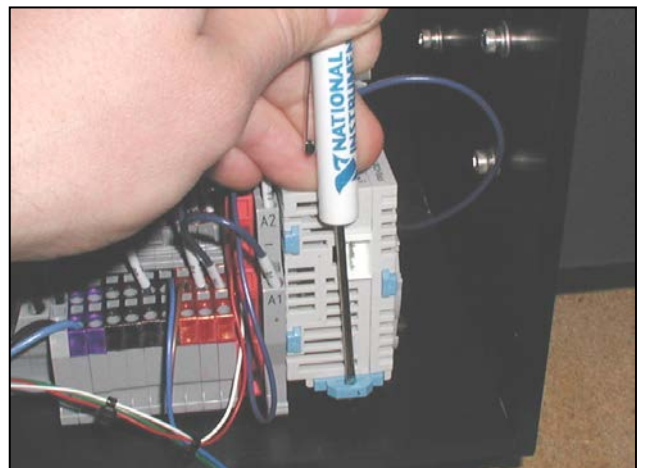

Figure 3-78. Removing PLC

ELECTRICAL COMPONENTS

AROMAT PLC BATTERY (con't)

6. Remove the battery cover by lifting the edge of the cover and remove the cover (Figure 3-79).
7. Remove replacement battery from any packaging.

Note: To avoid losing any data, connect the new battery to the PLC within 30 seconds of disconnecting the old one.

8. Disconnect old PLC battery wiring plug (Figure 3-80).
9. Install the new battery and connect the wiring plug.

Note: the plug is keyed and can only be installed in the correct orientation.

10. Snap the battery cover back into place.
11. Install the PLC onto the din rail.
12. Reconnect the touch screen communications cable and the power wiring (Figure 3-81).
13. Replace Frame Cover; there are six screws with locking washers to replace.

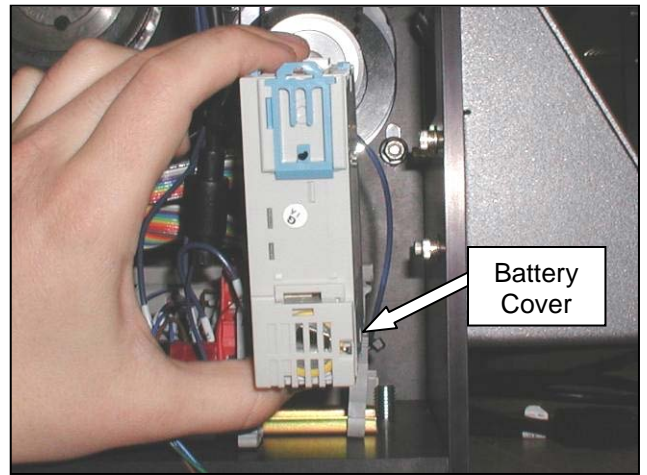

Figure 3-79. PLC Battery Location

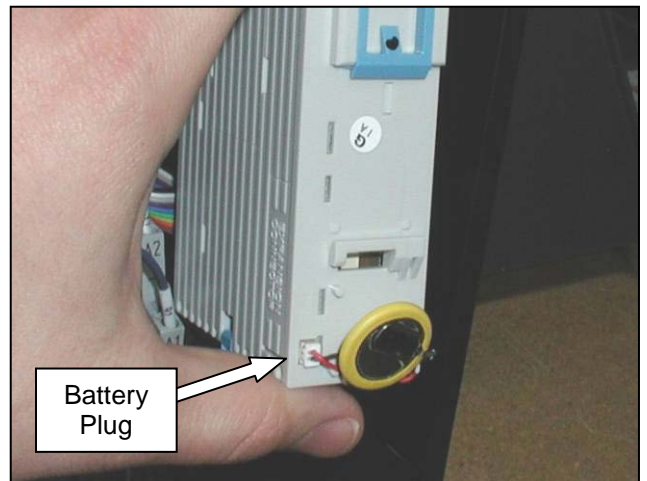

Figure 3-80. PLC Battery Connector

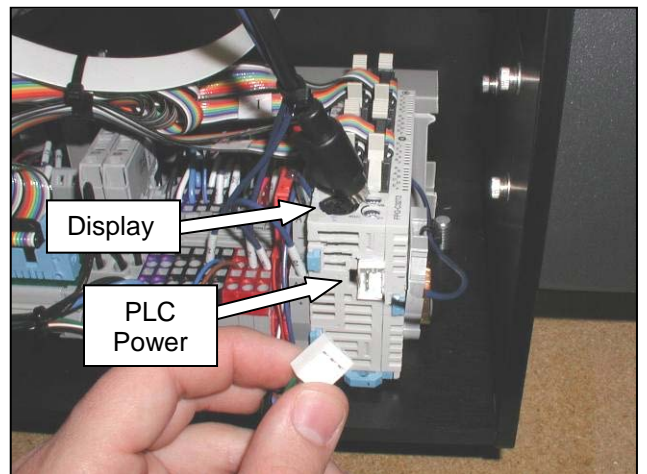

Figure 3-81. PLC Connections

ELECTRICAL COMPONENTS

COLOR TOUCH SCREEN

The Sharp SX™ bagger includes a three color, touch sensitive user interface. The screen interfaces with the Aromat PLC to provide the user with setup functions and status information.

TESTING

1. If the display does not turn on with the machine or it turns on but nothing is displayed, proceed to the “Power Problem” section on the next page. If “ERRF” is displayed in the corner, proceed to the “Communication Problem” section on the next page. If “Screen No. Error” is displayed proceed to the “Program Problem” on the next page.

1. Remove the six screws holding the Frame Cover, set screws and Frame Cover aside (Figure 3-82).

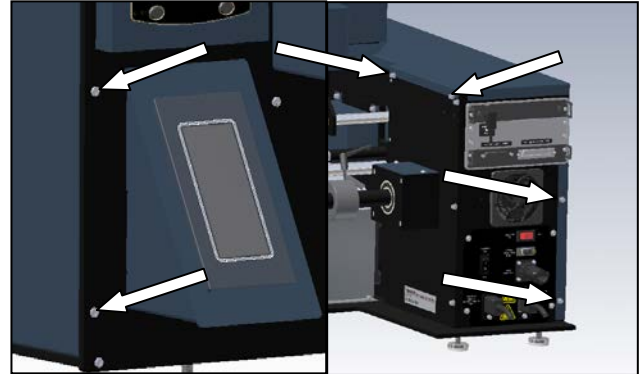

Figure 3-82. Frame Cover Screws

⚠ WARNING
USE EXTREME CAUTION WHILE SERVICING A MACHINE WHILE POWER IS APPLIED. UNEXPECTED MACHINE STARTUP CAN CAUSE SERIOUS INJURY.

2. With a Digital Volt/Ohm Meter (DVOM) set to a range capable of measuring 24VDC, contact the red probe to the 92 connection and the black probe to the 91 connection (Figure 3-83).

⚠ WARNING
DO NOT ATTEMPT TO SERVICE THE MACHINE DURING NORMAL OPERATION. KEEP HANDS AND ARMS CLEAR OF MOVING PARTS.

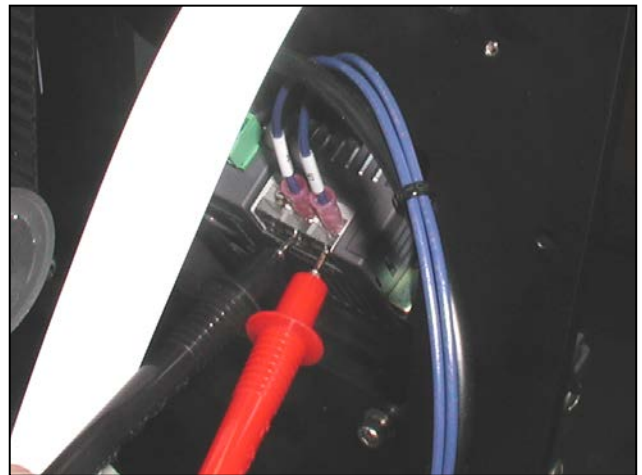

Figure 3-83. Measuring 24 VDC on Display

⚠ WARNING
WHEN TESTING ELECTRICAL COMPONENTS WHILE POWER IS APPLIED TO THE MACHINE, USE PROPER TROUBLESHOOTING TECHNIQUES TO AVOID ELECTRICAL SHOCK.

3. If 24 VDC is not displayed, troubleshoot the wiring between the power terminal blocks and the display. If 24VDC is displayed, the display is defective and will require replacement.

ELECTRICAL COMPONENTS

COLOR TOUCH SCREEN (con't)

Communications Problem

1. Inspect Data Cable connection with PLC. Ensure that the cable is pushed all the way into the socket on the PLC
2. Check that the wiring in the Display Plug is correct and securely screwed down (Figure 3-84).
3. Check that the PLC has power by looking for any illuminated lights on top of the PLC. If the PLC is not receiving power, refer to the Aromat PLC Section.
4. Display is defective.

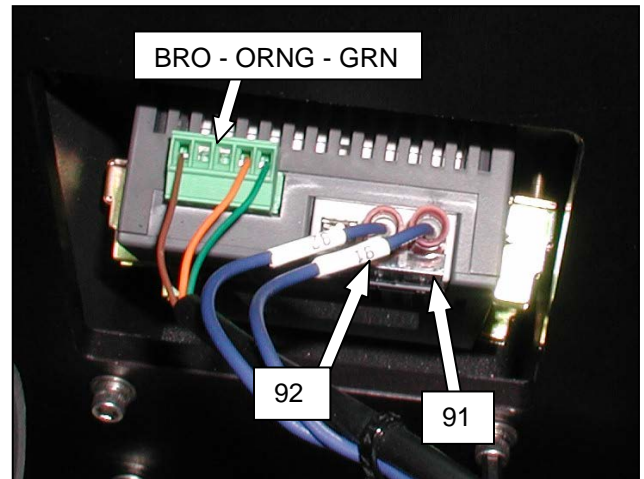

Figure 3-84. Display Connections

Program Problem

A Screen No. Error occurs when the PLC requests a screen number that is not programmed into the display. This typically occurs when the PLC Battery loses its charge. In this case, the PLC will require reprogramming.

ADJUSTMENT

There are no adjustments necessary on the Color Touch Screen.

REPLACEMENT

Note: The replacement Color Touch Screen will require reprogramming if not obtained from Sharp Packaging.

 WARNING
<p>Always remove electrical power from the SX™ prior to performing any maintenance on the machine.</p>

1. Remove the six screws holding the Frame Cover, set screws and Frame Cover aside (Figure 3-85).

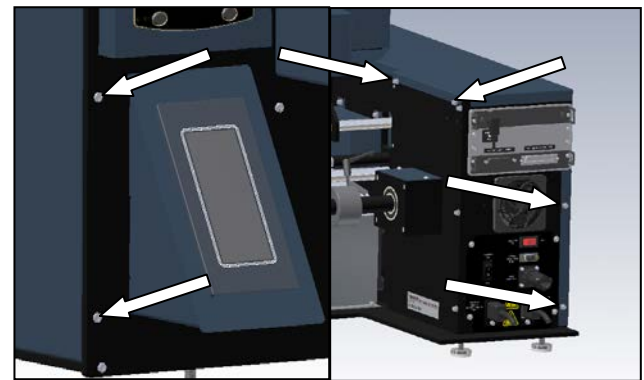

Figure 3-85. Frame Cover Screws

ELECTRICAL COMPONENTS

COLOR TOUCH SCREEN (con't)

- Unplug communications cable from display and unscrew the power connections (Figure 3-86).

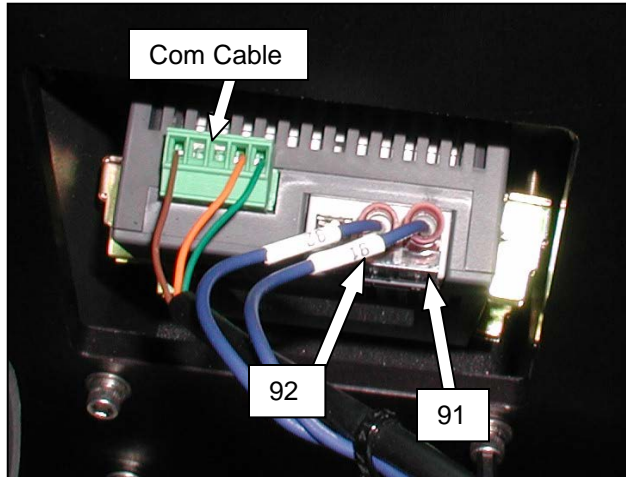

Figure 3-86. Display Connections

- Remove the four screws holding the Touch Screen Housing (Figure 3-87).

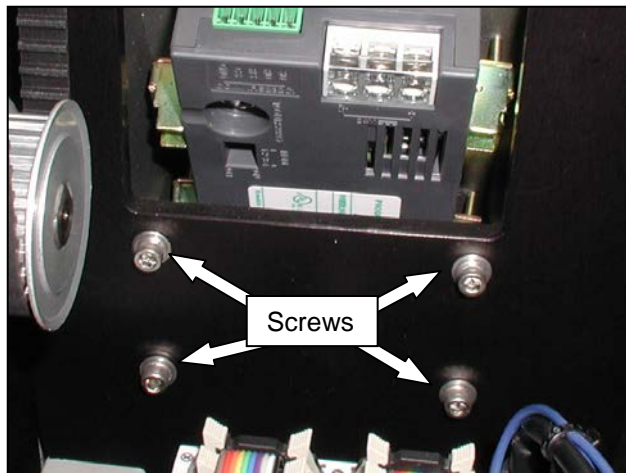

Figure 3-87. Touch Screen Housing Screws

- Pull Touch Screen Housing off Front Plate and place on a table, Touch Screen side down.

Note: Do not place display on any harsh surfaces as this will scratch the screen.

- Loosen the screws on the four clips holding the Touch Screen. Remove clips from Touch Screen (Figure 3-88).

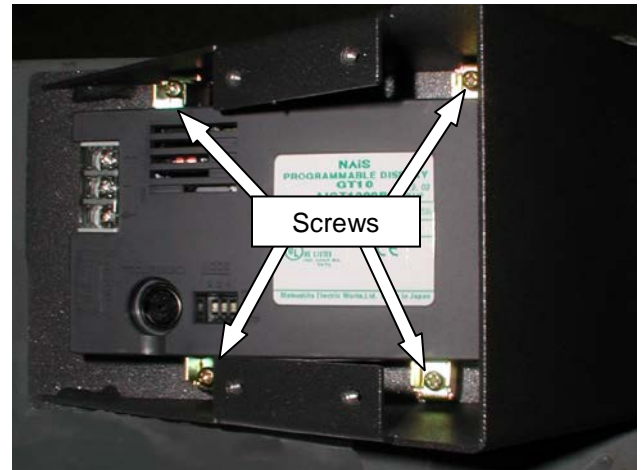

Figure 3-88. Display Screws

- Remove the Touch Screen from the housing.
- Insert new Touch Screen into housing; position Touch Screen so that the connections will be on top when reinserted into Front Plate.
- Reattach retaining clips to Touch Screen (Figure 3-89).

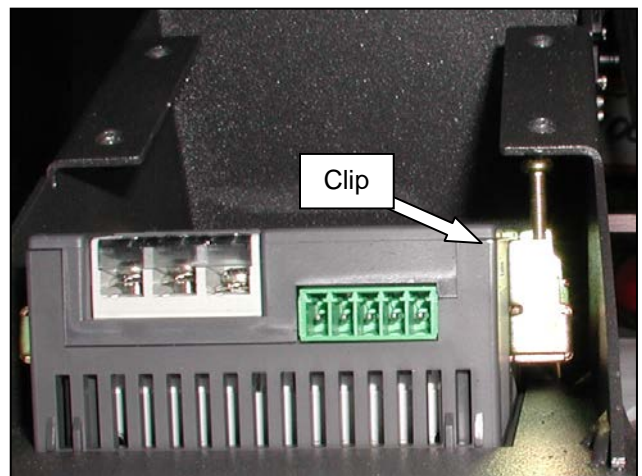

Figure 3-89. Reattach Retaining Clips

- Tighten the screws on the four retaining clips.
- Reattach Touch Screen Housing to Front Plate with the four screws.
- Reconnect Power and Communications Cable.
- Replace Frame Cover.

ELECTRICAL COMPONENTS

COOLING FAN

TESTING

Check that all connections to the fan are connected and secure.

ADJUSTMENT

There are no adjustments necessary on the Cooling Fan.

REPLACEMENT



WARNING

Always remove electrical power from the SX™ prior to performing any maintenance on the machine.

1. Remove the two rear screws and the two front screws from the Motor Cover (Figure 3-90 and Figure 3-91).
2. Remove Motor Cover and set aside.
3. Remove the Outside Cover – Right (Figure 3-92).

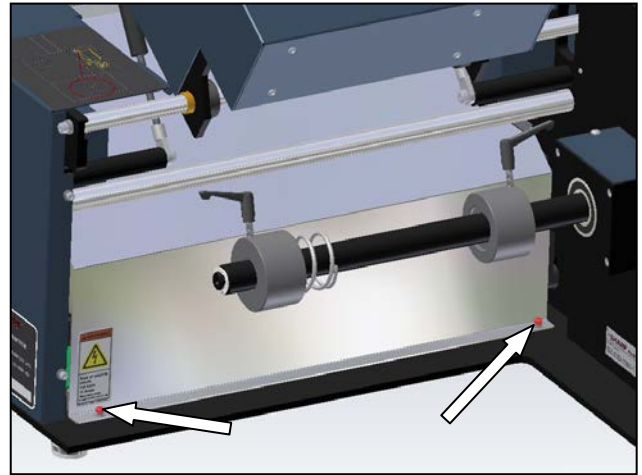

Figure 3-90. Motor Cover Rear Screws

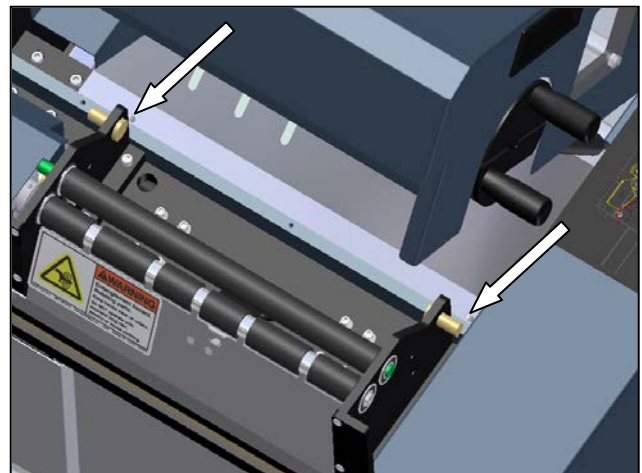

Figure 3-91. Motor Cover Front Screws

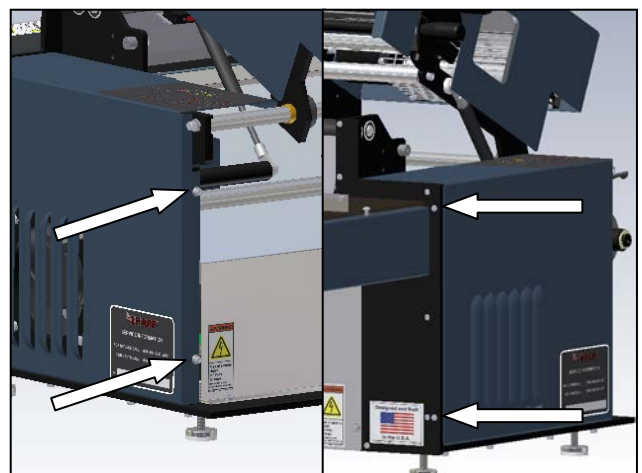

Figure 3-92. Outside Cover - Right Screws

ELECTRICAL COMPONENTS**COOLING FAN (con't)**

4. Unplug power connection from Cooling Fan (Figure 3-93).
5. Remove the four screws holding the Cooling Fan to the Outside Plate (Figure 3-94).
6. Remove the old Cooling Fan.
7. With replacement fan, orientate so that the airflow direction indicator points towards the outside of the frame and so that the Cooler Fan plug is at the top facing you (Figure 3-95).
8. Line up the screw holes in the Outside Plate with those on the Cooler Fan.
9. With the screws from the old Cooler Fan, reattach the new Cooler Fan to the Outside Plate.
10. Reattach Cooler Fan plug.
11. Replace Motor Cover and Outside Cover.

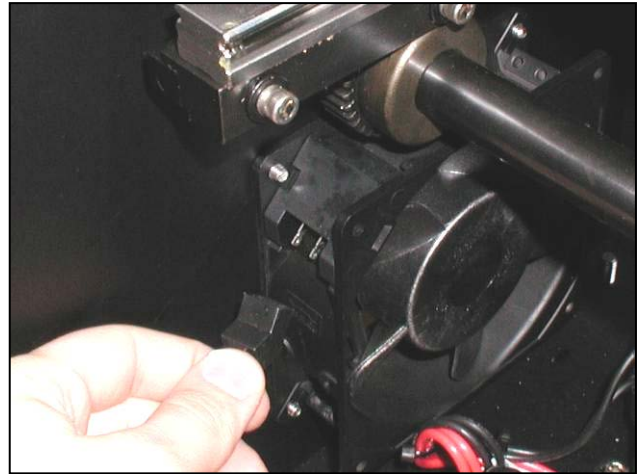

Figure 3-93. Remove Cooling Fan plug



Figure 3-94. Cooling Fan screws



Figure 3-95. Airflow direction indicator

ELECTRICAL COMPONENTS

SOLID STATE RELAY

The Sharp SX™ Bagger uses a Solid State Relay to provide power to the heating element.

TESTING

There are two sets of connections to check on the Solid State Relay. One is the incoming control signal from the PLC, pins 3 and 4. The other connection is the incoming power, pins 1 and 2.

Control Signal

1. Remove the four screws holding the Load Plate, set Load Plate aside (Figure 3-96).

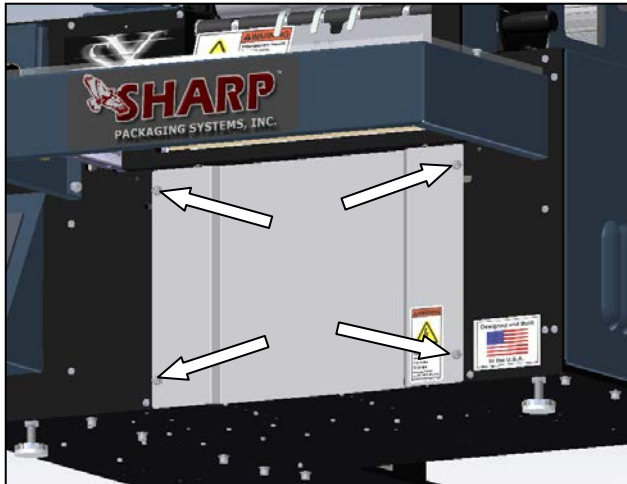

Figure 3-96. Load Plate Screws

2. Remove the six screws holding the Frame Cover, set Frame Cover aside (Figure 3-97).

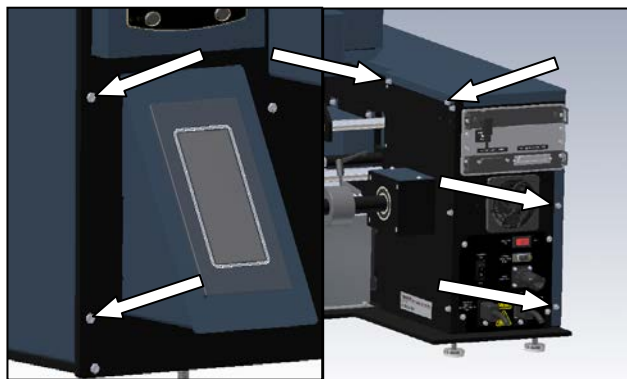





Figure 3-97. Frame Cover Screws

 **WARNING**

USE EXTREME CAUTION WHILE SERVICING A MACHINE WHILE POWER IS APPLIED. UNEXPECTED MACHINE STARTUP CAN CAUSE SERIOUS INJURY.

 **WARNING**

DO NOT ATTEMPT TO SERVICE THE MACHINE DURING NORMAL OPERATION. KEEP HANDS AND ARMS CLEAR OF MOVING PARTS.

 **WARNING**

WHEN TESTING ELECTRICAL COMPONENTS WHILE POWER IS APPLIED TO THE MACHINE, USE PROPER TROUBLESHOOTING TECHNIQUES TO AVOID ELECTRICAL SHOCK.

3. Locate Solid State Relay and remove clear plastic cover (Figure 3-98).



Figure 3-98. Solid State Relay with cover

4. Power up machine and cycle. If the LED momentarily lights, proceed to Incoming Power section.

ELECTRICAL COMPONENTS

SOLID STATE RELAY (con't)

5. Set your DVOM to a range capable of measuring continuity. Contact the black probe to the red colored terminal block in the electrical area and the red probe to the number 3 contact on the Solid State Relay as shown in (Figure 3-99). The DVOM should indicate continuity.

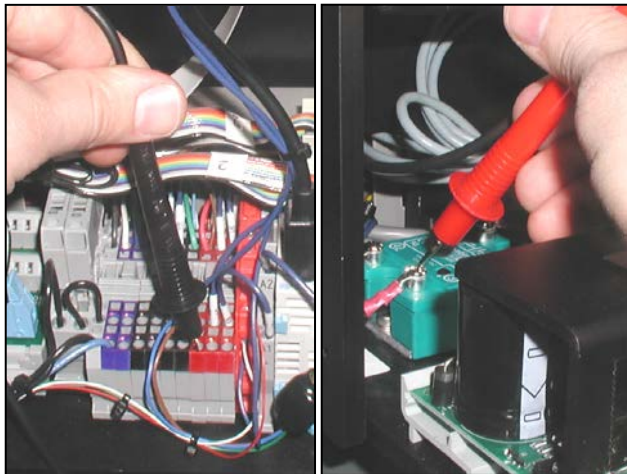

Figure 3-99. Pin 3 on Solid State Relay

6. With your DVOM set to test for continuity, contact the black probe to pin 14 on the Y Breakout Module in the electrical area, and the red probe to pin 4 of the Solid State Relay as shown in (Figure 3-100). The DVOM should indicate continuity, if it does proceed to the Incoming Power section.

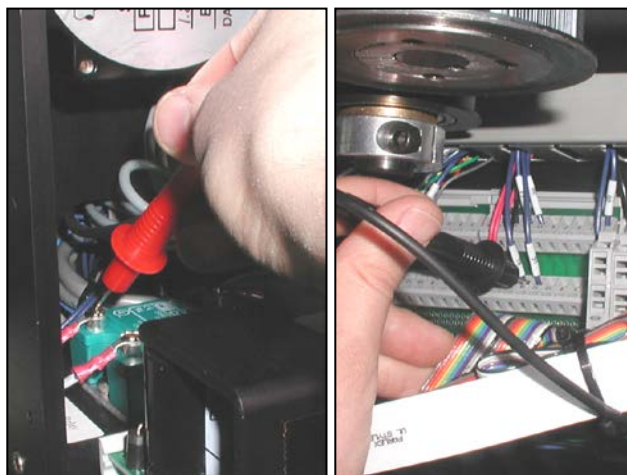



Figure 3-100. Solid State Relay Control

7. If the tests in steps 5 and 6 show in continuity, there is a loose connection between the Solid State Relay and a terminal block. Troubleshoot the number 3 and 4 connections looking for shorts, disconnects or frayed wires.

Incoming Power

1. Reconnect all power to the machine and turn on.

Note: This procedure involves testing high voltages. Only qualified personnel familiar with testing electronics should perform this procedure.

 WARNING
USE EXTREME CAUTION WHILE SERVICING A MACHINE WHILE POWER IS APPLIED. UNEXPECTED MACHINE STARTUP CAN CAUSE SERIOUS INJURY OR DEATH.

 WARNING
DO NOT ATTEMPT TO SERVICE THE MACHINE DURING NORMAL OPERATION. KEEP HANDS AND ARMS CLEAR OF MOVING PARTS.

 WARNING
WHEN TESTING ELECTRICAL COMPONENTS WHILE POWER IS APPLIED TO THE MACHINE, USE PROPER TROUBLESHOOTING TECHNIQUES TO AVOID ELECTRICAL SHOCK.

ELECTRICAL COMPONENTS

SOLID STATE RELAY (con't)

2. Set your DVOM to a range capable of measuring 120 VAC. With one probe, contact pin number 1, with the other probe, contact pin number 2 (Figure 3-101). 120 VAC should be shown. If 0 VAC is shown, refer to the section on testing the Seal Wire Transformer.
3. If nothing is found wrong with the Seal Wire Transformer, the relay is defective and will require replacement.

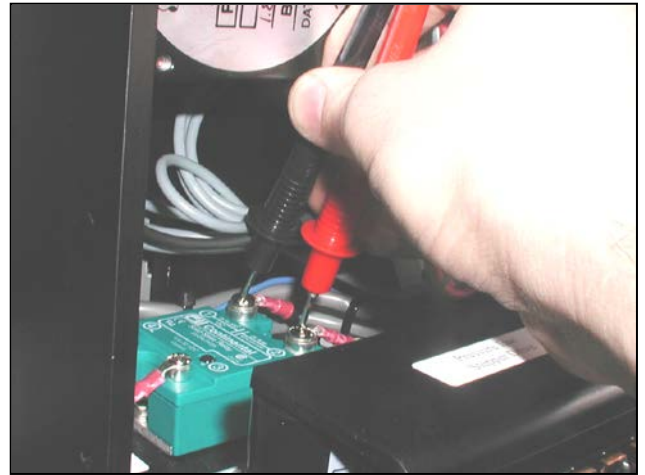

Figure 3-101. Testing 120VAC on Solid State Relay

ELECTRICAL COMPONENTS

SOLID STATE RELAY (con't)

ADJUSTMENT

There are no adjustments necessary on the Solid State Relay.

REPLACEMENT



WARNING

Always remove electrical power from the SX™ prior to performing any maintenance on the machine.

1. Remove the four screws holding the Load Plate, set Load Plate aside (Figure 3-102).
2. Locate Solid State Relay; remove clear plastic cover (Figure 3-103).
3. Remove the four wire screws.
4. Remove the two screws holding the Solid State Relay to the Base Plate and set aside.
5. Remove defective relay.
6. Orientate replacement Solid State Relay so that connections 3 and 4 are towards the front of the machine.
7. Screw Solid State Relay down onto Base Plate.
8. Reconnect the four wires and tighten holding screws (Table 3-1).
9. Snap clear plastic cover over Solid State Relay.
10. Reattach Load Plate using screws and locking washers.



Figure 3-102. Load Plate Screws



Figure 3-103. Solid State Relay with cover

Wire Label	Wire Color	Terminal Number
-	Black	1
-	Black	2
91	Dark Blue	3
Y6	Dark Blue	4

Table 3-1. Solid State Relay connections

ELECTRICAL COMPONENTS

GREY RELAY 24V

The Grey Wago relay is only present in Sharp SX™ Baggers that are equipped with a printer. It is used to trigger the start print signal to the imprinter.

TESTING

1. Remove the six screws holding the Frame Cover, set screws and Frame Cover aside (Figure 3-104).
2. Plug machine in and turn on.



WARNING

USE EXTREME CAUTION WHILE SERVICING A MACHINE WHILE POWER IS APPLIED. UNEXPECTED MACHINE STARTUP CAN CAUSE SERIOUS INJURY.



WARNING

DO NOT ATTEMPT TO SERVICE THE MACHINE DURING NORMAL OPERATION. KEEP HANDS AND ARMS CLEAR OF MOVING PARTS.



WARNING

WHEN TESTING ELECTRICAL COMPONENTS WHILE POWER IS APPLIED TO THE MACHINE, USE PROPER TROUBLESHOOTING TECHNIQUES TO AVOID ELECTRICAL SHOCK.

3. Locate Relay, 24V SPDT (Single Pole Double Throw) (Figure 3-105).
4. With a DVOM (Digital Volt/Ohm Meter) set to test for continuity, probe pins 11 and 14 of the Grey Relay. There should be no continuity.
5. Insert a piece of jumper wire into the 92 (Black) Terminal block. Contact the other end to A2- (Figure 3-106). If red LED does not illuminate check the wiring of A1+
6. With the jumper wire installed and a DVOM (Digital Volt/Ohm Meter) set to test for

continuity, probe pins 11 and 14 of the Grey Relay. There should be continuity.

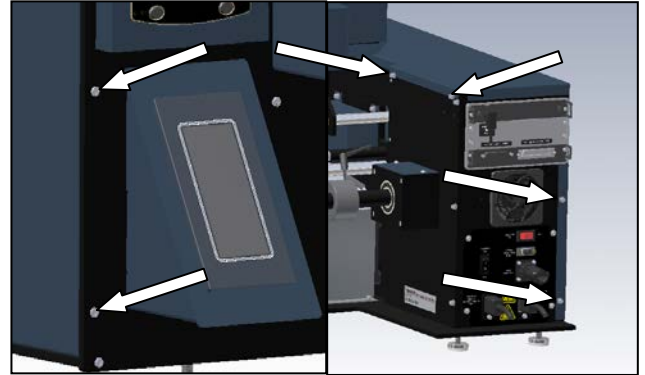

Figure 3-104. Frame Cover Screws

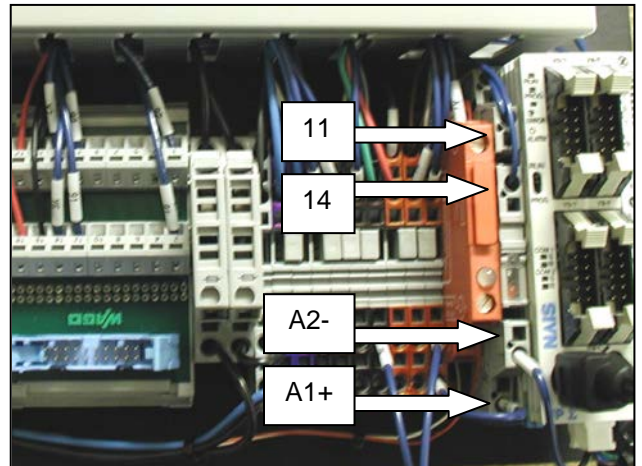

Figure 3-105. Grey Relay location

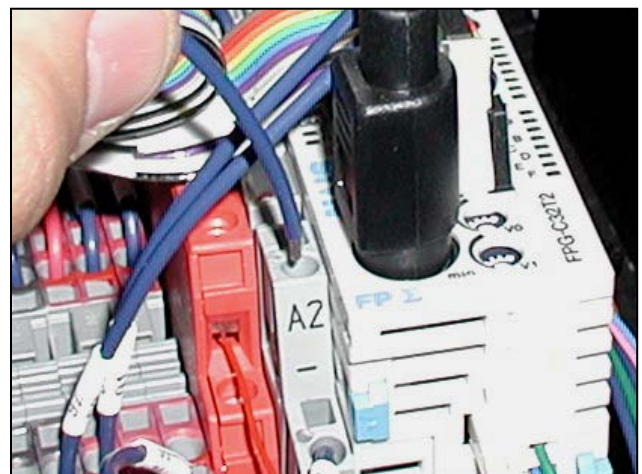

Figure 3-106. Using a jumper on A2-

ELECTRICAL COMPONENTS

GREY RELAY 24V (con't)

ADJUSTMENT

There are no adjustments necessary on the grey Relay.

REPLACEMENT

WARNING

Always remove electrical power from the SX™ prior to performing any maintenance on the machine.

1. Remove the six screws holding the Frame Cover, set screws and Frame Cover aside (Figure 3-107).
2. Locate Grey Relay (Figure 3-108).
3. Using a small screwdriver, remove all wires from Relay.
4. Remove Relay from DIN rail by taking a small screwdriver and pulling tab out while pivoting Relay back (Figure 3-109).
5. Remove Relay from DIN Rail.
6. Snap replacement Relay onto DIN rail, red LED should be towards the outside.
7. Reconnect all wires (Table 3-2).

Wire Label	Wire Color	Terminal Number
-	Dark Blue	11
-	Dark Blue	14
Y7	Dark Blue	A2
91	Dark Blue	A1

Table 3-2. Relay wire locations (Note: Lines in 11 and 14 are interchangeable).

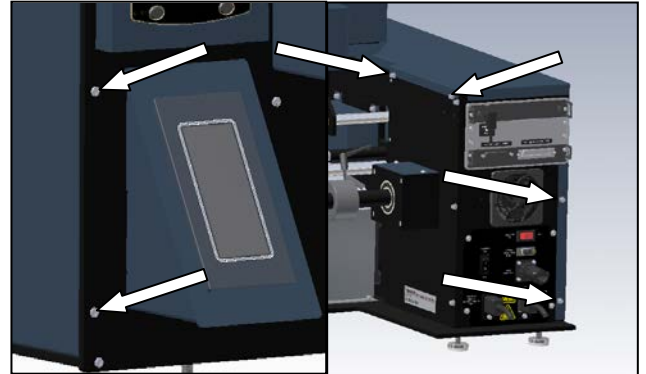

Figure 3-107. Frame Cover Screws

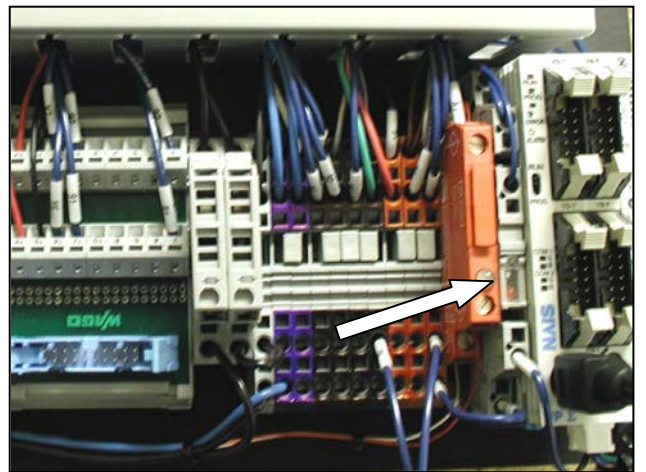

Figure 3-108. Relay location

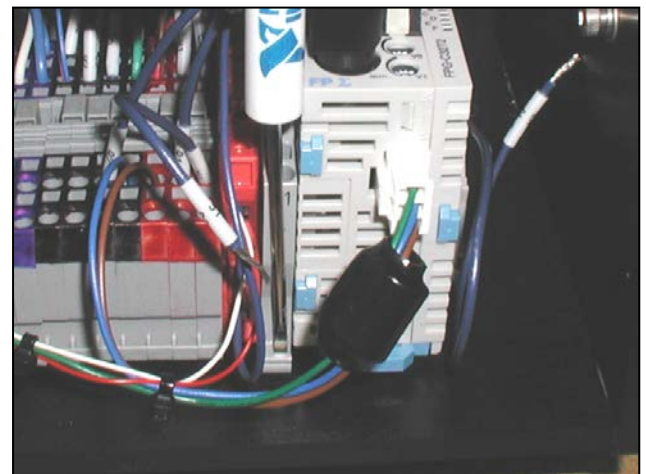

Figure 3-109. Removing Relay

ELECTRICAL COMPONENTS

RED RELAY 24V

The red 24V Relay is only present in Sharp SX™ Baggers that are equipped with a printer. This relay receives an end of print signal from the printer and communicates that to the PLC.

TESTING



WARNING

Always remove electrical power from the SX™ prior to performing any maintenance on the machine.

1. Remove the six screws holding the Frame Cover. Set screws and Frame Cover aside (Figure 3-110).
2. Remove fuse drawer from top of Relay (Figure 3-111).
3. With a DVOM set to test for continuity, contact one probe to each side of the fuse. If the DVOM does not indicate continuity, replace fuse.

Note: A blown fuse can be an indication of a larger issue. If you continue to blow fuses inspect the wiring for shorts or frays.

4. Push the fuse back into position.

Note: Occasionally this fuse will not make a good contact with the fuse holder. Reseating the fuse may resolve the issue.

5. With a DVOM (Digital Volt/Ohm Meter) set to test continuity, probe between pins 1 and 2 of the relay. The DVOM should not indicate continuity.

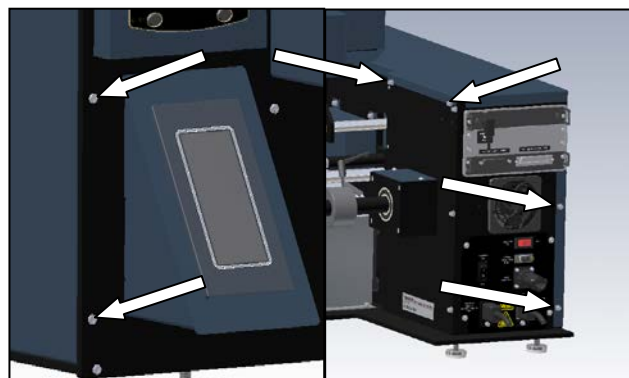

Figure 3-110. Frame Cover Screws

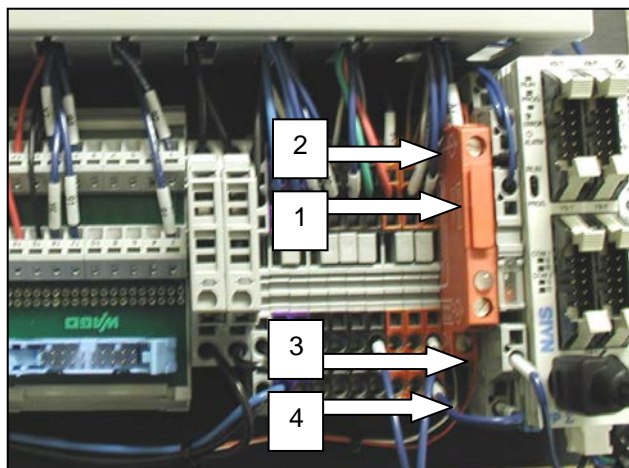

Figure 3-111. Grey Relay location

ELECTRICAL COMPONENTS

RED RELAY 24V (con't)

6. Plug machine in and turn on.

**WARNING**

USE EXTREME CAUTION WHILE SERVICING A MACHINE WHILE POWER IS APPLIED. UNEXPECTED MACHINE STARTUP CAN CAUSE SERIOUS INJURY.

**WARNING**

DO NOT ATTEMPT TO SERVICE THE MACHINE DURING NORMAL OPERATION. KEEP HANDS AND ARMS CLEAR OF MOVING PARTS.

**WARNING**

WHEN TESTING ELECTRICAL COMPONENTS WHILE POWER IS APPLIED TO THE MACHINE, USE PROPER TROUBLESHOOTING TECHNIQUES TO AVOID ELECTRICAL SHOCK.

7. Cycle the machine with the printer enabled. Observe the LED on top of the Relay. If the LED does not momentarily illuminate, check the wiring on pins 3 and 4. If wiring is OK, inspect GPIO connector for damage (Figure 3-112).
8. Cycle machine with printer enabled again. Observed input LED X7 on the PLC. If LED does not momentarily illuminate, check wiring of pin 2.
9. If all wiring is functional, relay is defective.

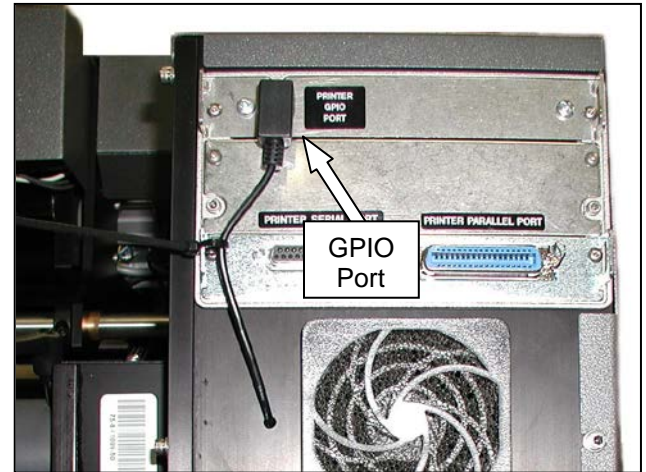

Figure 3-112. GPIO Location

ELECTRICAL COMPONENTS

RED RELAY 24V (con't)

ADJUSTMENT

There are no adjustments necessary on the Red Relay.

REPLACEMENT

1. Remove the six screws holding the Frame Cover, Set screws and Frame Cover aside (Figure 3-113).
2. With a small screwdriver, remove all connections from Red Relay.
3. Using the same screwdriver, pull the DIN release tab out and pivot Relay up and towards you (Figure 3-114).
4. Remove Relay.
5. Snap replacement Relay onto DIN rail with the Red LED closest to you.
6. Reconnect all wires (Table 3-3).

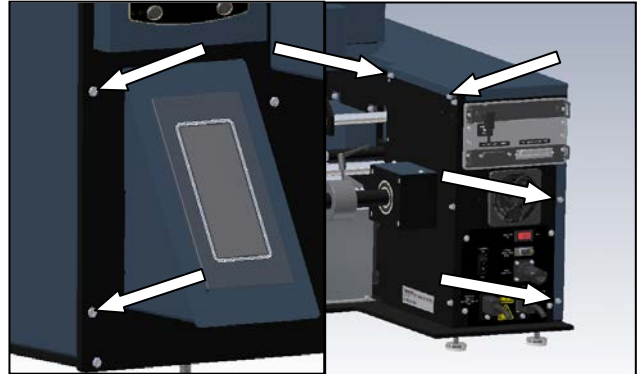

Figure 3-113. Frame Cover Screws

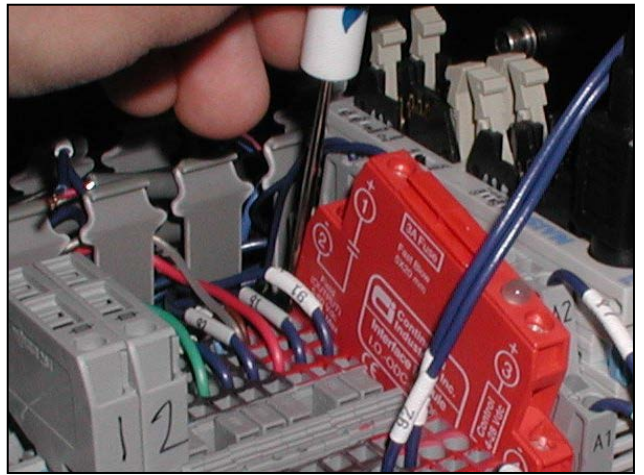

Figure 3-114. Remove Red Relay

Wire Label	Wire Color	Terminal Number
X7	Dark Blue	1
92	Dark Blue	2
-	Red	3
-	White & Blue	4

Table 3-3. Red Relay connections

ELECTRICAL COMPONENTS

PRINTER GPIO BOARD

The Printer GPIO Board is only present in Sharp SX™ Baggers that are equipped with a printer. It is used for communications between the PLC and the Datamax Printer. A defective GPIO board will typically result in the printer running continuously without the bagger running. A non-functioning printer is usually caused by faulty relays. Refer to the Grey and Red Relay sections to troubleshoot a non responsive printer.

TESTING

There are no testing procedures for the Printer GPIO Board.

ADJUSTMENT

There are no adjustments necessary on the GPIO Board.

REPLACEMENT

 WARNING
<p>Always remove electrical power from the SX™ prior to performing any maintenance on the machine.</p>

1. Unplug the GPIO cable from the GPIO Board (Figure 3-115).

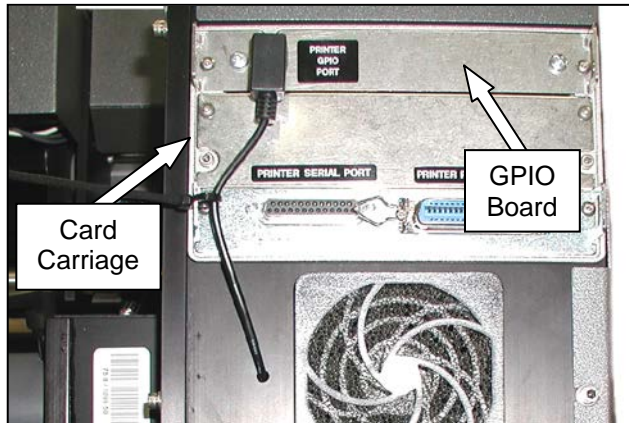



Figure 3-115. GPIO and Card Carriage Locations.

2. Remove the two screws holding the GPIO Board to the Card Carriage.

 WARNING
<p>This procedure deals with handling parts susceptible to damage from electrostatic discharge (ESD). Use static control precautions while servicing this equipment.</p>

3. Pull the board straight out towards you and set aside.
4. Line up new board with the card track inside the Card Carriage (Figure 3-116).

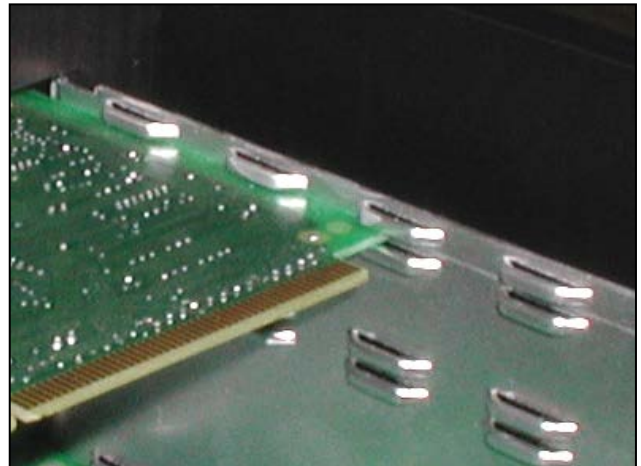

Figure 3-116. Card Track
 Note: Frame Cover Removed for Clarity

5. Slide new board all the way into Carriage. Resistance will increase in the last inch as the board slides into the connector.
6. Screw new GPIO Board to Card Carriage.
7. Reattach GPIO cable.

ELECTRICAL COMPONENTS

PRINTER PERFORMANCE LOGIC BOARD

The Printer Performance Logic Board is only present in Sharp SX™ Baggers that are equipped with a printer. The symptoms of a defective board will be a nonfunctioning Printer LCD Display and an unresponsive printer.

TESTING

There is no testing procedure for the Printer Performance Logic Board.

ADJUSTMENT

There are no adjustments necessary on the Printer Performance Logic Board.

REPLACEMENT

 WARNING
<p>Always remove electrical power from the SX™ prior to performing any maintenance on the machine.</p>

1. Snip the cable tie holding the GPIO cable to the Printer Performance Logic Board (Figure 3-117).

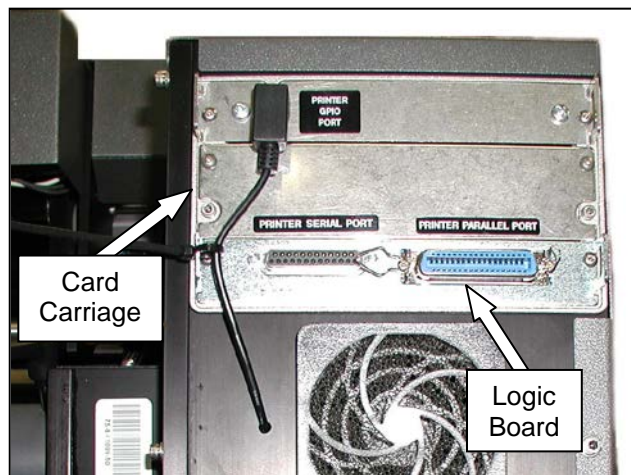

Figure 3-117. Printer Performance Logic Board and Card Carriage Locations.

2. Remove the two screws holding the board to the Card Carriage

 WARNING
<p>This procedure deals with handling parts susceptible to damage from electrostatic discharge (ESD). Use static control precautions while servicing this equipment.</p>

3. Pull the board out of the Card Carriage.
4. Remove new board from static bag.
5. Line up new board with the card track inside the Card Carriage (Figure 3-118).

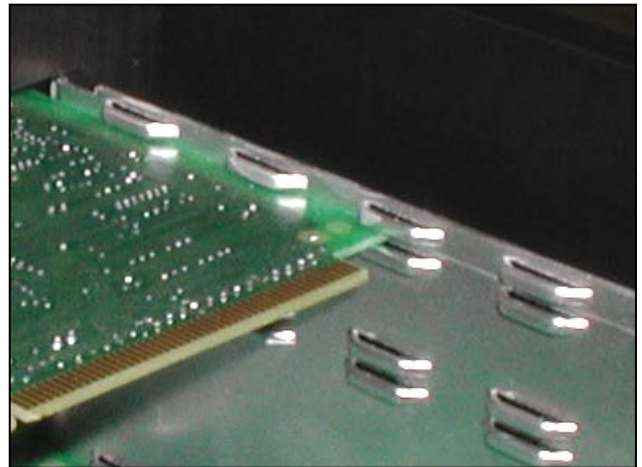

Figure 3-118. Card Track
Note: Frame Cover Removed for Clarity

6. Slide new board all the way into Carriage. Resistance will increase in the last inch as the board slides into the connector.
7. Screw new board to Card Carriage.
8. Reconnect any cables that may have been connected to Printer Performance Logic Board.

ELECTRICAL COMPONENTS (1099 & 1108)

PRINTER POWER SUPPLY BOARD

TESTING

There are no testing procedures for the Printer Power Supply Board.

ADJUSTMENT

There are no adjustments necessary on the Printer Power Supply Board.

REPLACEMENT

WARNING

Always remove electrical power from the SX™ prior to performing any maintenance on the machine.

1. Remove the six screws holding the Frame Cover, set screws and Frame Cover aside (Figure 3-119).
2. Remove any bags on a roll from the machine.
3. Remove the seven screws from the Mandrel Support Plate (Figure 3-120 & 3-121).

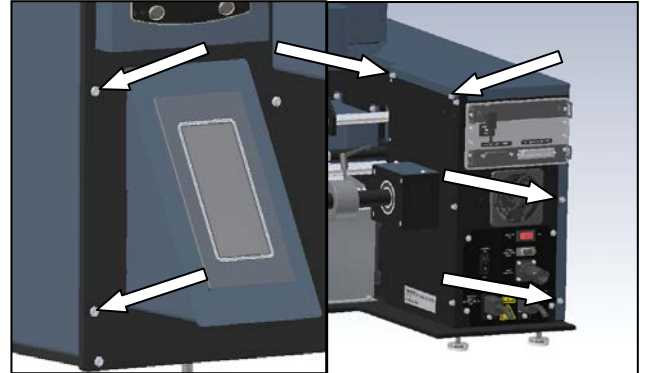

Figure 3-119. Frame Cover Screws

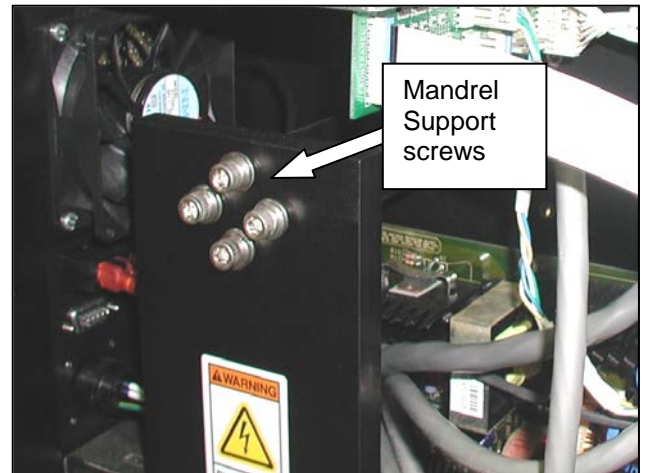

Figure 3-120. Mandrel Support Screws

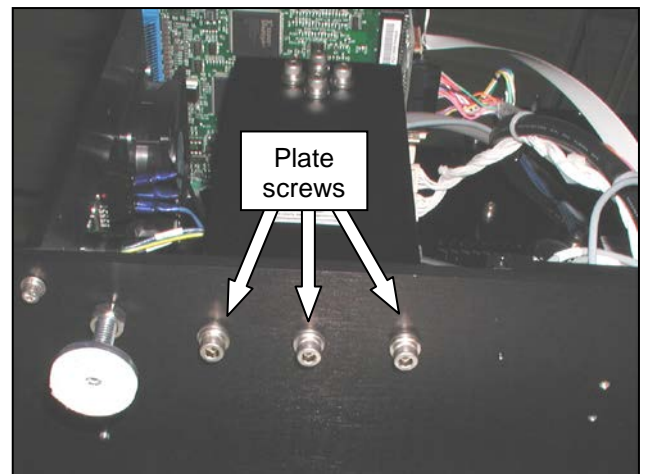

Figure 3-121. Mandrel Support Plate Bottom Screws

ELECTRICAL COMPONENTS (1099 & 1108)

**PRINTER POWER SUPPLY BOARD
(con't)**

4. Remove the two screws holding the Power Supply Board to the Base Plate and the one additional screw securing it to the upright frame plate (Figure 3-122).
5. Remove the two screws holding the Power Supply Board to the Rear Face Plate (Figure 3-123).
6. Disconnect the five cables from the board (Figure 3-124). There also will be a short ground wire by the rear plate that will need to be removed from the base plate.
7. Remove defective Power Supply Board from machine.
8. Remove new Power Supply Board from packaging.
9. Place new board in machine, position so that the power switch and plug receptacle are aligned with their cutouts in the Rear Face Plate.
10. Screw the Power Supply onto the case using the five screws from the old Power Supply.
11. Reconnect the five cables to the board; the plugs will only fit in their respective connectors.
12. Replace Frame Cover.

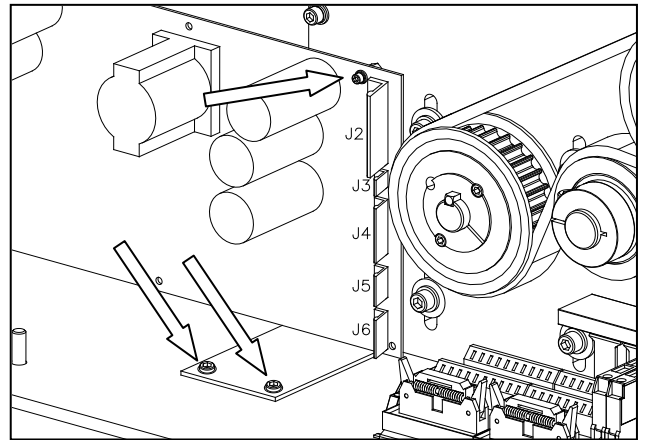

Figure 3-122. Printer Power Supply Board Screws



Figure 3-123. Printer Power Supply Screws

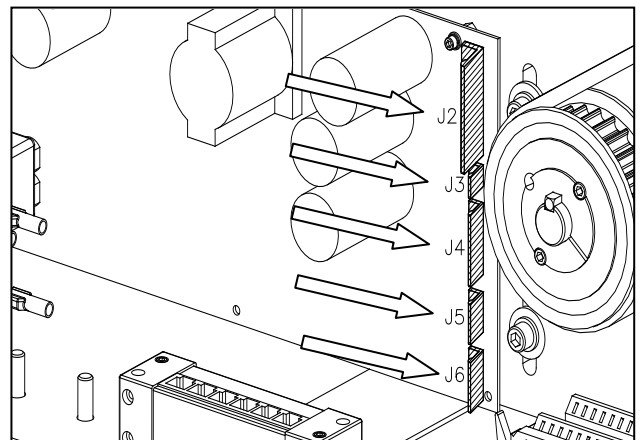

Figure 3-124. Printer Power Supply Board Connections

ELECTRICAL COMPONENTS (1099 & 1108)

24 VDC FAN ASSEMBLY

The 24 VDC Fan Assembly is only present in Sharp SX™ Baggers that are equipped with a printer.

TESTING

There are no testing procedures for the 24 VDC Fan Assembly. If the fan is not receiving power, the printer will not turn on, as they both use the same power source.

ADJUSTMENT

There are no adjustments necessary on the 24 VDC Fan Assembly

REPLACEMENT



WARNING

Always remove electrical power from the SX™ prior to performing any maintenance on the machine.

1. Remove six screws holding Frame Guard, set screws and Frame Guard aside (Figure 3-125).
2. Snap off Air Filter Holder (Figure 3-126).
3. Remove Filter (clean if necessary).
4. Remove four screws holding 24 VDC Fan to Rear Face Plate. When removing last screw, hold fan so it doesn't fall (Figure 3-127).
5. Unplug and remove fan.
6. Using the screws from the old fan, screw the replacement fan to the Rear Face Plate.
7. Snap Air Filter Holder and Air Filter onto Fan Guard.
8. Reconnect power cord to Power Supply Board.
9. Replace Frame Cover.

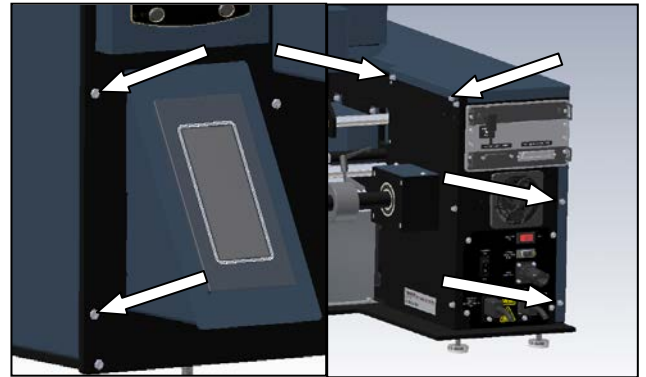

Figure 3-125. Frame Cover Screws

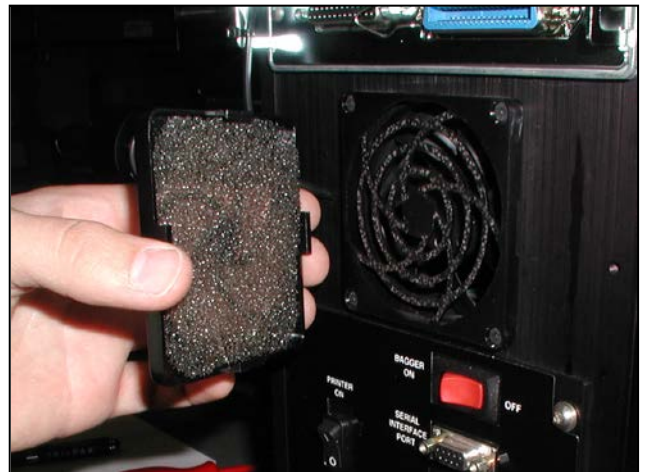

Figure 3-126. Fan Cover



Figure 3-127. Remove Fan Guard

ELECTRICAL COMPONENTS (1099 & 1108)

LAMINATED WHITE RIBBON CABLE

The Ribbon Cable is only present in Sharp SX™ Baggers that are equipped with a printer. The Ribbon Cable is the data connection between the Datamax Logic Board and the LCD Module. If this cable becomes damaged or dislodged, the printer's LCD Display will malfunction. Use the following procedures to remedy the problem.

TESTING

1. Remove the six screws holding the Frame Cover, set screws and Frame Cover aside (Figure 3-128).
2. Inspect both sides of the Ribbon Cable and the Cable itself; look for exposed metal contacts, cuts or sharp bends (Figure 3-129). Also ensure both ends of the cable are completely seating in the cable receptacles.
3. If the Cable does not appear damaged, troubleshoot the Printer LCD Module and the Printer Performance Logic Board.

ADJUSTMENT

There are no adjustments necessary on the White Ribbon Cable.

REPLACEMENT



WARNING

Always remove electrical power from the SX™ prior to performing any maintenance on the machine.

1. Remove the six screws holding the Frame Cover, set screws and Frame Cover aside.
2. Snip any cable ties holding the Cable.
3. Unlock both sides of the cable from their connectors by pulling the sides of the connectors out (Figure 3-130).

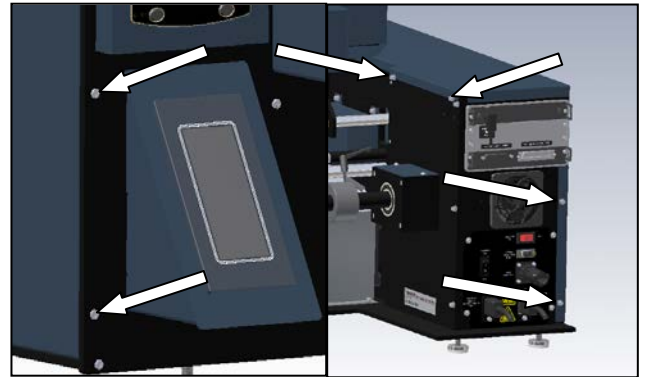

Figure 3-128. Frame Cover Screws

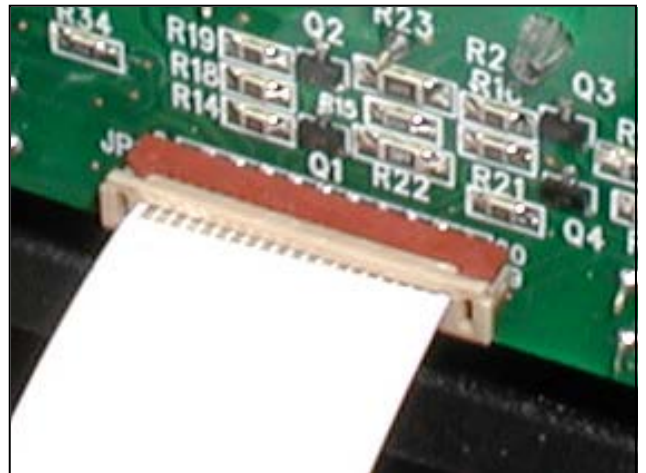

Figure 3-129. Loose ribbon cable example

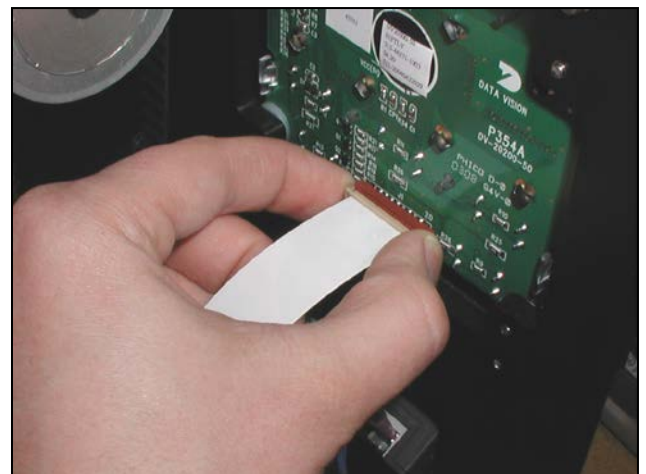

Figure 3-130. White Ribbon Cable Lock

ELECTRICAL COMPONENTS (1099 & 1108)

**LAMINATED WHITE RIBBON CABLE
(con't)**

4. Remove Cable.
5. Insert one side of the replacement cable in Position 1 with exposed metal contacts facing up and lock down (Figure 3-131).
6. Follow the LEFT edge of the cable (Pin 1) and insert cable into Position 2 with that edge on TOP.
7. Lock down the other end of cable.
8. Secure cable into position with cable ties.
9. Replace Frame Cover.

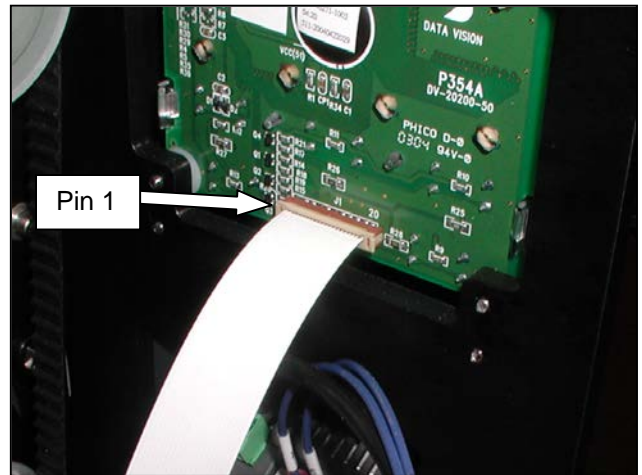

Figure 3-131. White Ribbon Cable Position 1

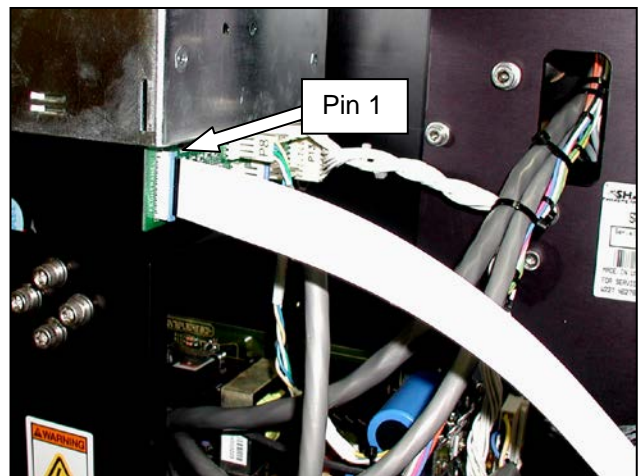

Figure 3-132. White Ribbon Cable Position 2

ELECTRICAL COMPONENTS (1099 & 1108)

DATAMAX LCD MODULE

The Datamax LCD Module is only present in Sharp SX™ Baggers that are equipped with a printer.

TESTING

There are no testing procedures for the Datamax LCD Module.

ADJUSTMENT

There are no adjustments necessary on the Datamax LCD Module.

REPLACEMENT



WARNING

Always remove electrical power from the SX™ prior to performing any maintenance on the machine.

1. Remove the six screws holding the Frame Cover, set screws and Frame Cover aside (Figure 3-133).
2. Remove the White Ribbon Cable from the back of the Display (Figure 3-134).
3. Remove the two screws holding the Printer Front Panel (Figure 3-135). Remove panel and set aside.

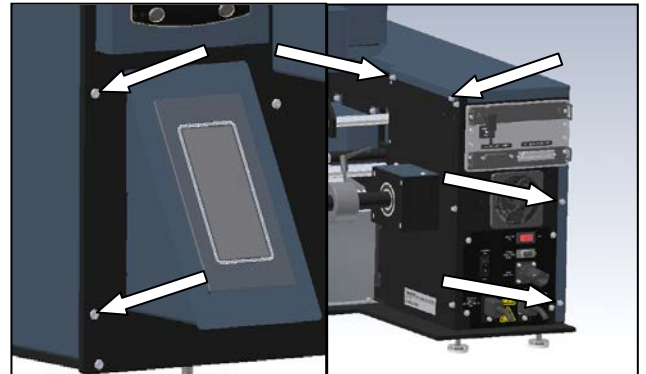

Figure 3-133. Frame Cover Screws

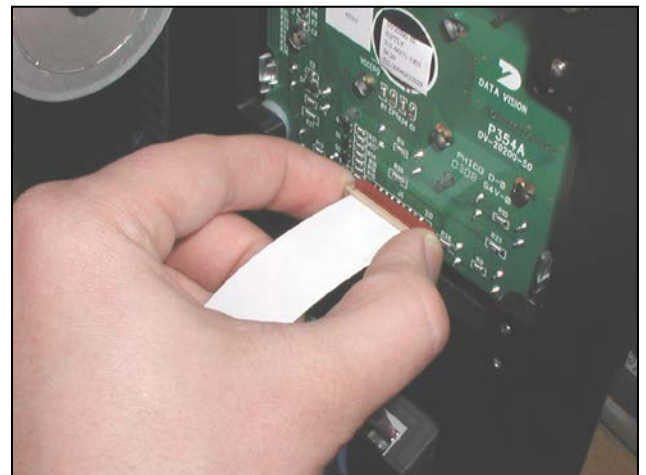

Figure 3-134. White Ribbon Cable Lock

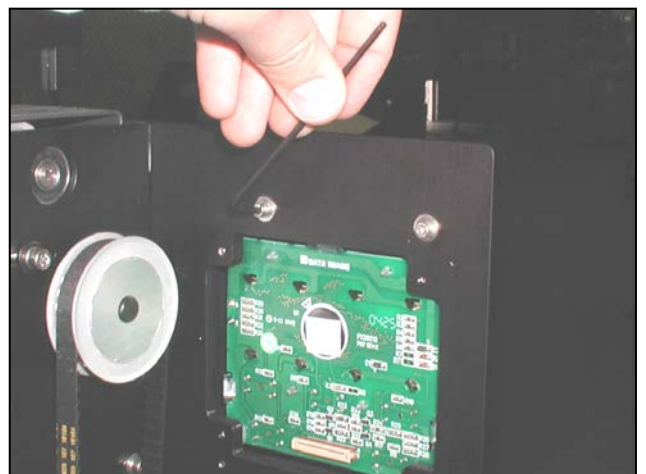

Figure 3-135. Remove LCD Module Cover Screws

ELECTRICAL COMPONENTS (1099 & 1108)

DATAMAX LCD MODULE (con't)

4. Release the two lower Face Plate tabs (Figure 3-136).
5. Remove Face Plate (Figure 3-137).
6. Unscrew the two screws holding the LCD Module to the Front Plate (Figure 3-138).
7. Remove LCD Module from Front Plate.
8. Replace LCD Module with new Module.
9. Screw LCD Module to Front Plate with screws from old Module; be sure to include the two spacers.
10. Snap Font Bezel onto LCD Module.
11. Reattach Printer Front Panel to Machine Front Panel.
12. Reattach White Ribbon Cable to back of LCD Module (Refer to Laminated White Ribbon Cable section on page 3-49 for assistance).
13. Replace Frame Cover using screws and locking washers.

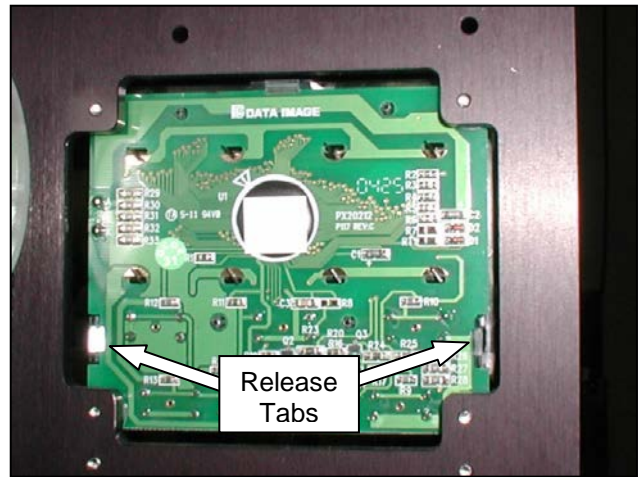

Figure 3-136. Release tabs

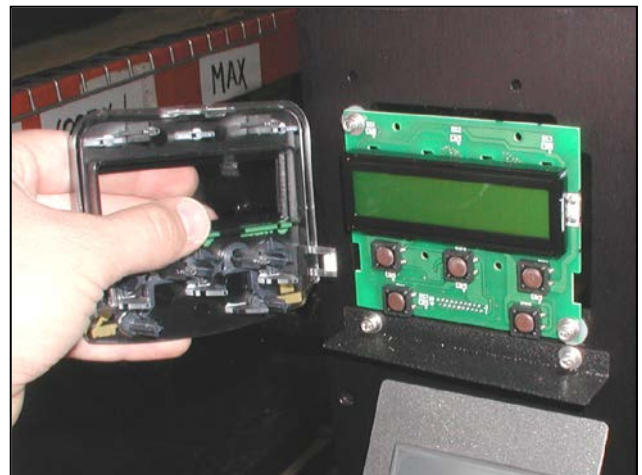

Figure 3-137. Remove Face Plate

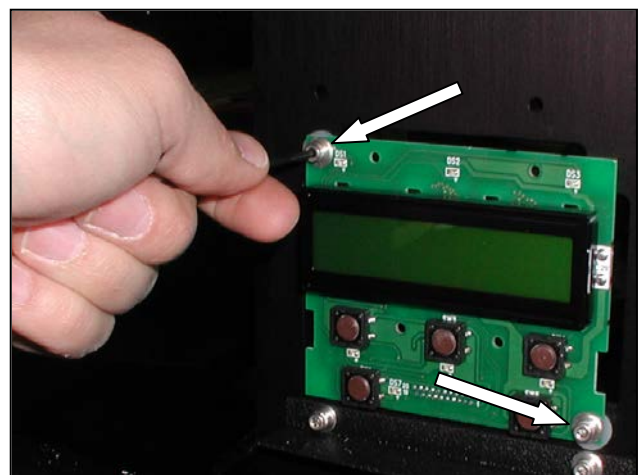

Figure 3-138. Remove Display Screws

ELECTRICAL COMPONENTS (1099 & 1108)

PRINT HEAD STEPPER DRIVE

If your Sharp SX™ Bagger is equipped with a printer, there will be an additional Stepper Drive to control the Print Head. This drive controls the motor that drops the print head onto the platen roller.

TESTING

1. Check that the Stepper Drive is receiving power by looking for the RED Status LED (Figure 3-139).
2. Visually inspect all electrical components looking for burn marks or deformed casings.
3. Make sure all wires are securely tightened in their screw terminals.

ADJUSTMENT

There are no adjustments necessary on the Print Head Stepper Drive.

REPLACEMENT

	WARNING
<p>Disconnect electrical power cords from the SX™ prior to performing any maintenance on machine. Unexpected machine startup can cause serious injury or death.</p>	

	WARNING
<p>This procedure deals with handling parts susceptible to damage from electrostatic discharge (ESD). Use static control precautions while servicing this equipment.</p>	

1. Remove the two rear screws and the two front screws from the Motor Cover (Figure 3-140).
2. Remove the Motor Cover and set aside.

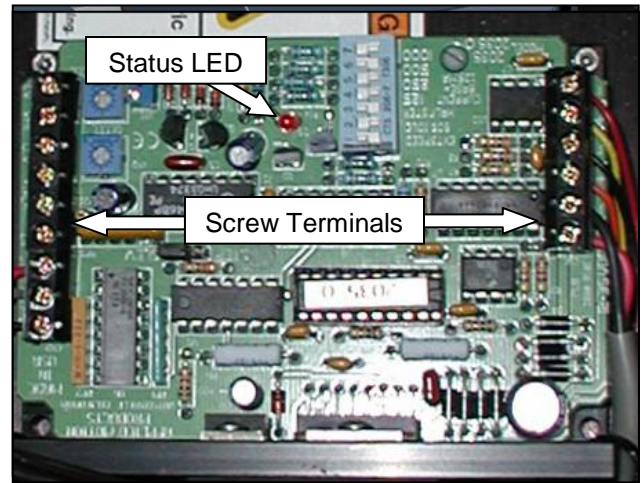

Figure 3-139. Print Head Stepper Drive

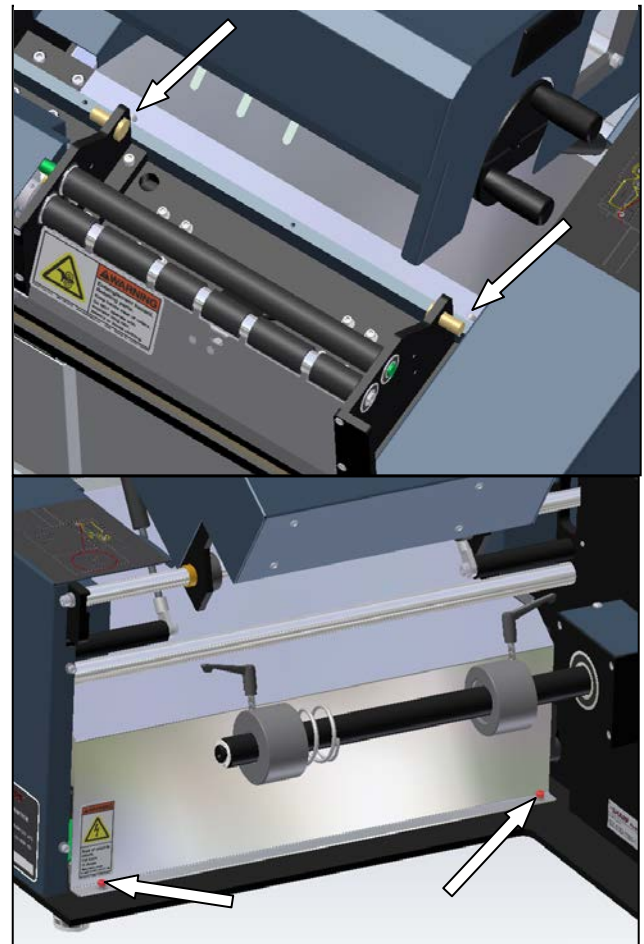

Figure 3-140. Motor Cover Screws

ELECTRICAL COMPONENTS (1099 & 1108)

PRINT HEAD STEPPER DRIVE (con't)

3. Locate the Print Head Stepper Drive (Figure 3-141).

Note: Depending on your version of the Sharp SX™ Bagger, the orientation of the stepper drive will vary; the wiring however is exactly the same.

4. Remove all connections from the Stepper Drive
5. Remove the screws holding the stepper drive to the Base Plate and remove drive.
6. Position replacement Stepper Drive in the same orientation as the old drive.
7. Screw new Stepper Drive to Base Plate.
8. Reconnect all wires; there are nine lines (Figure 3-143).
9. If you ordered a replacement Stepper Drive from Sharp Packaging, it will be pre configured, proceed to step 17.
10. Set the POTs to their maximum value (Figure 3-143).
11. Set the configuration DIP Switches (Figure 3-143).
12. The Speed POT controls the speed of the Print Head and requires fine tuning. Using a small screwdriver, turn the brass adjusting knob counterclockwise as far as it will go.
13. Turn the Speed POT five full rotations clockwise. This will get the speed close to its correct value.
14. Set Jumper to "SLEW" (Figure 3-142).

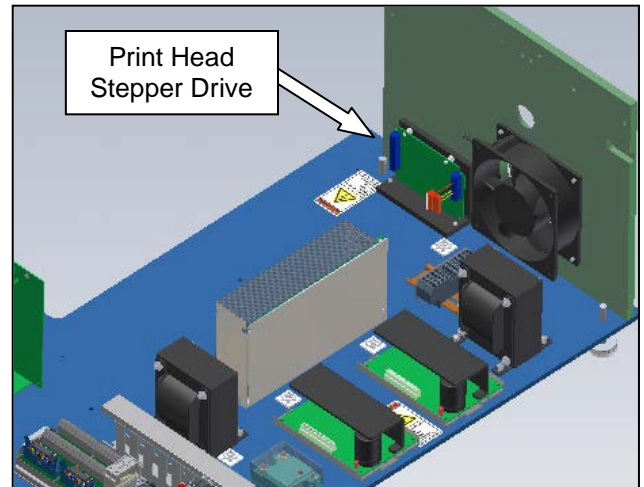

Figure 3-141. Print Head Stepper Drive (Electrical assembly isolated for clarity)

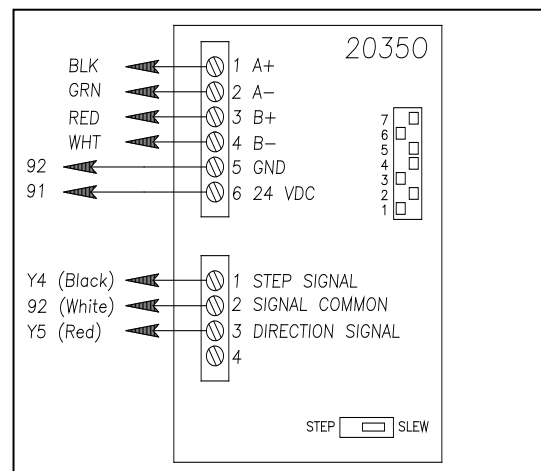

Figure 3-142. Print Head Stepper Drive

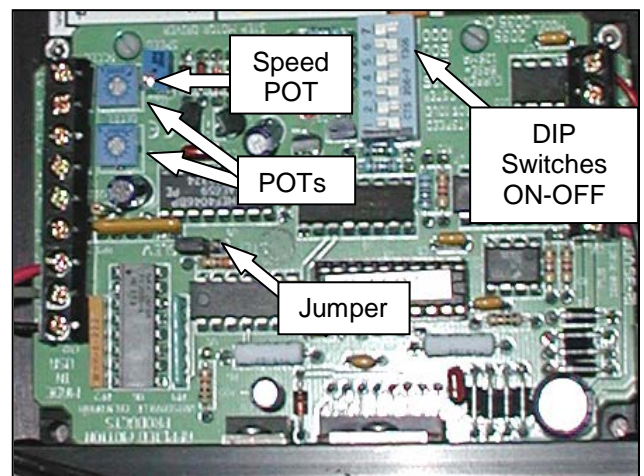



Figure 3-143. Print Head Stepper Drive

ELECTRICAL COMPONENTS (1099 & 1108)

PRINT HEAD STEPPER DRIVE (con't)

15. Further adjustment of the Speed POT requires that the machine be operating. Load bags into machine and setup to print.

 WARNING
USE EXTREME CAUTION WHILE SERVICING A MACHINE WHILE POWER IS APPLIED. UNEXPECTED MACHINE STARTUP CAN CAUSE SERIOUS INJURY.

 WARNING
DO NOT ATTEMPT TO SERVICE THE MACHINE DURING NORMAL OPERATION. KEEP HANDS AND ARMS CLEAR OF MOVING PARTS.

 WARNING
WHEN TESTING ELECTRICAL COMPONENTS WHILE POWER IS APPLIED TO THE MACHINE, USE PROPER TROUBLESHOOTING TECHNIQUES TO AVOID ELECTRICAL SHOCK.

16. Adjust the Speed POT, counterclockwise if the Print Head comes down too fast and the print is distorted, and clockwise if the Print Head comes down too slow and the machine faults. Repeat this step until the machine is printing satisfactorily
17. Replace Motor Cover with screws and locking washers

FILM FEED ASSEMBLY

PHOTOELECTRIC SENSOR

Some of the procedures in this section require that the electrical power to the machine remain ON.

 WARNING
<p>USE EXTREME CAUTION WHILE SERVICING A MACHINE WHILE POWER IS APPLIED. UNEXPECTED MACHINE STARTUP CAN CAUSE SERIOUS INJURY.</p>

 WARNING
<p>DO NOT ATTEMPT TO SERVICE THE MACHINE DURING NORMAL OPERATION. KEEP HANDS AND ARMS CLEAR OF MOVING PARTS.</p>

 WARNING
<p>WHILE TESTING ELECTRICAL COMPONENTS WITH POWER APPLIED TO THE MACHINE, USE PROPER TROUBLESHOOTING TECHNIQUES TO AVOID ELECTRICAL SHOCK.</p>

TESTING

The photoelectric sensor is located behind the front finger plate below the film feed drive roller. This sensor detects the edge of the bag when the film feed drive roller is reversed, thus stopping the reverse motion of the film. There are three steps involved in testing the photoelectric sensor.

- Ensure machine power is on.

1. Check the photo sensing eye to ensure the sensing beam is illuminated. The sensing beam is the red light visible from the front of the machine. If the red sensor beam is not on, either the sensor is faulty or there is no power to the electric eye. Remove the frame guard (see Figure 3-144) and follow the wires from the sensor to the terminal block/breakout module and ensure the wires are making a positive connection with the terminals. If the connections are good, the sensor is faulty and needs replacement.

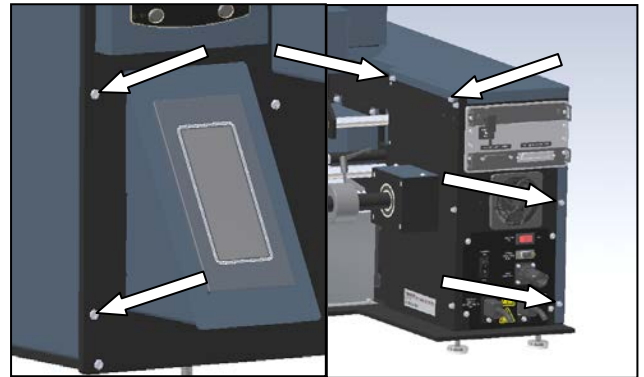

Figure 3-144. Frame Cover Screws

2. With the cradle cover open, locate the two indicator lights on the left-hand side of the sensor. The lower light should be illuminated green. Pass your hand in front of the eye (within 1 inch of the front finger plate) while watching the indicator lights. The upper light should illuminate orange when the sensor is activated. If it does not, the sensor is faulty and needs replacement.
3. Remove the frame guard by removing the six screws shown in (figure 3-144). Locate the PLC. Watch the indicator light on the PLC labeled “X2” and watch to see if it turns on when the sensor is activated. If it does not, the sensor wires are faulty and the sensor needs replacement.

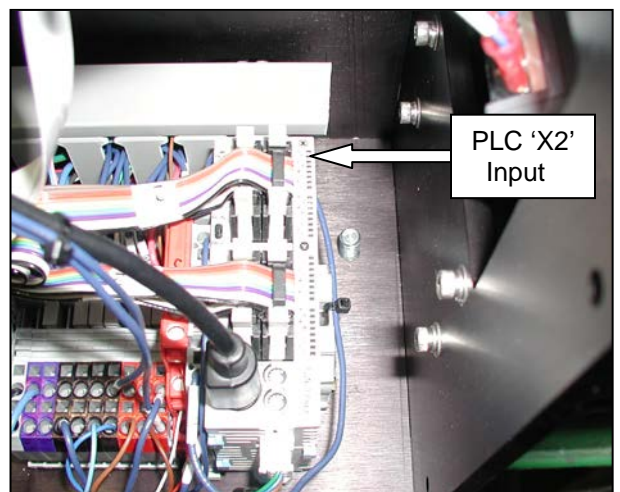

Figure 3-145. The PLC

FILM FEED ASSEMBLY

PHOTOELECTRIC SENSOR (con't)

Adjustment of the photoelectric sensor involves calibrating the sensor's range to approximately 2" from the front of the finger plate. This range has been determined to be effective for hand loading applications to prevent accidental triggering of the sensor with one's hand or the product itself. Setting the sensor includes the following steps.

- Ensure machine power is on.

1. Place a solid object 2" from the front finger plate of the machine, being careful to keep it parallel to the plate. The object should be located such that the sensor beam hits the object. (See Figure 3-146).
2. On the rear of the sensor, there is a digital display which will show a number. Record the number, as it will be needed in the following step.
3. Remove the object used in step 1 from the front of the machine. Using the "up" and "down" arrows on either side of the display, adjust the preset value until it matches the number recorded in step two above. This will set the sensing range to approximately 2".

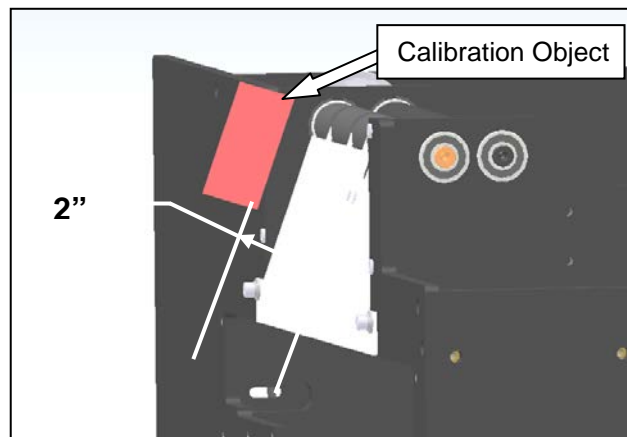



Figure 3-146. Calibrating the Photoelectric Sensor

FILM FEED ASSEMBLY

PHOTOELECTRIC SENSOR (con't)

Use the following steps to replace the photoelectric sensor.

 WARNING
<p>Always remove electrical power from the SX™ prior to performing any maintenance on the machine.</p>

1. Remove the frame guard, the load plate, and the motor cover (Figure 3-147).

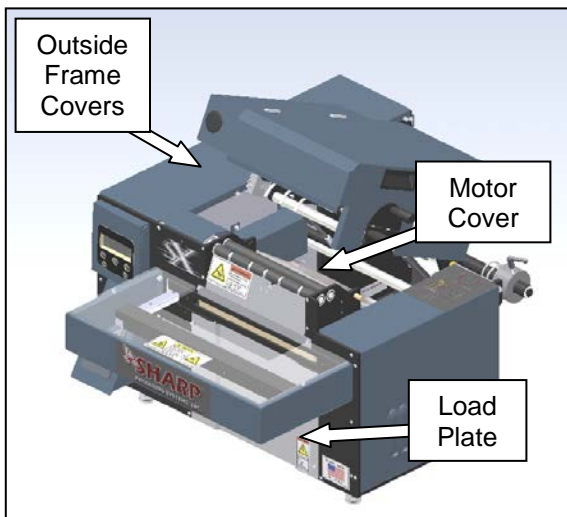

Figure 3-147. Guard Identification

2. Remove the two screws that hold the front finger plate onto the machine (Figure 3-148). Be careful not to pull this plate away from the machine too briskly, as the sensor is affixed to it.

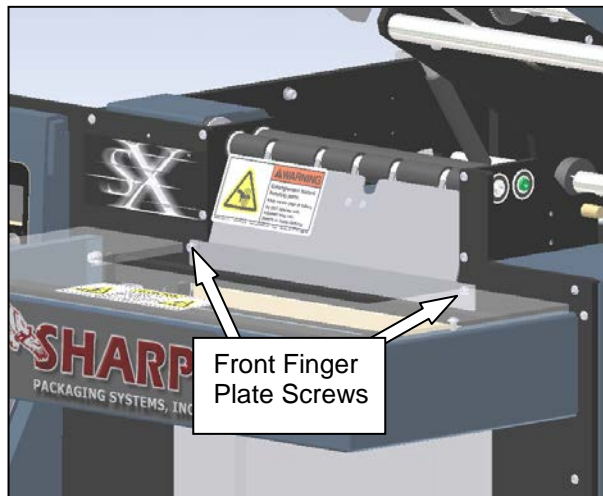

Figure 3-148. Front Finger Plate

3. Remove the photoelectric sensor from the front finger plate. This is done by removing two screws from the bottom of the sensor.
4. Follow the photoelectric sensor wires back through the machine and remove any cable ties attached to the sensor wire as necessary.
5. Once the cable has been followed to the electrical area, remove the wire duct cover and gently remove the sensor wire.
6. Disconnect the wires from the terminals. Wiring is as follows:

Wire Color	Terminal
Brown	91 (Red Terminals)
Blue	92 (Black Terminals)
Pink	92 (Black Terminals)
Black	X18 (Breakout Module)

Table 3-4. Photoelectric Sensor Wiring

FILM FEED ASSEMBLY

PHOTOELECTRIC SENSOR (con't)

Note: On older models of the SX™, the photoelectric sensor may be wired to the machine using an RJ11 'modular connector' (the same plugs used on telephone jacks). Simply remove this plug to disconnect the sensor from the machine on these models. The replacement sensor will be from the current model, which will need to be hard wired using the following steps.

7. Gently remove the sensor from the machine. Pull the wire out of the machine, being **extremely** careful to not pull any other wires in the machine that may become free.
8. Thread the new sensor wire through the machine following the same wire routing the old wire followed. **Be sure to keep the wire away from any moving parts inside of the machine.**
9. Rewire the sensor to the terminal blocks and breakout module following the wiring list in Table 3-4 of the previous page.

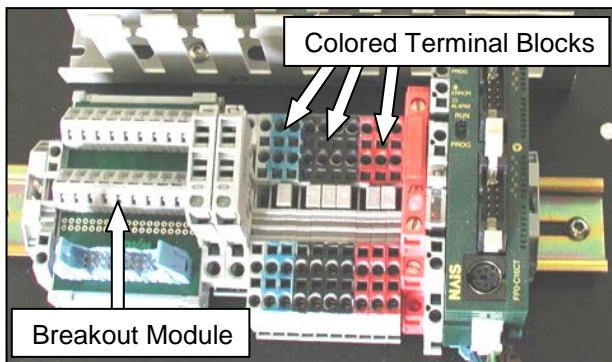

Figure 3-149. Electrical Components

10. Mount new sensor to the sensor bracket on the front finger plate. To achieve proper alignment of the sensor, position the sensor as shown in (figure 3-150). The left screw should be completely to the front of the slot, while the right screw should be completely to the rear of the slot. This will position the sensor correctly to "see" the bag film.

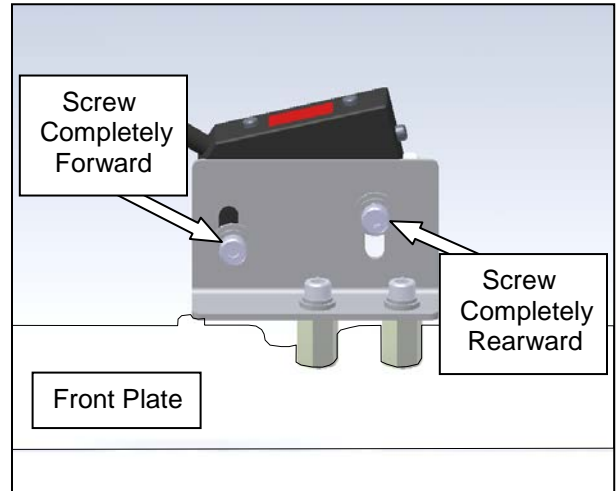

Figure 3-150. Photoelectric Sensor Positioning

11. Mount the front finger plate to the machine. Ensure the fingers are centered in the grooves on the film feed drive roller.
12. Power now needs to be applied to the machine to calibrate and test the sensor.

**WARNING**

USE EXTREME CAUTION WHILE SERVICING A MACHINE WHILE POWER IS APPLIED. UNEXPECTED MACHINE STARTUP CAN CAUSE SERIOUS INJURY.

**WARNING**

WHILE TESTING ELECTRICAL COMPONENTS WITH POWER APPLIED TO THE MACHINE, USE PROPER TROUBLESHOOTING TECHNIQUES TO AVOID ELECTRICAL SHOCK.

13. Follow the procedures in the **Testing** section (page 3-56) to ensure the new sensor has power and is communicating with the PLC. If the sensor passes all three tests, calibrate the sensor using the steps in the **Adjustment** section (page 3-57).

FILM FEED ASSEMBLY

PHOTOELECTRIC SENSOR (con't)

14. Follow the cable through the machine and wire tie it to the cable bundle.
15. Reinstall all guards removed in step 1, and close the cradle cover.

FILM FEED MOTOR DRIVE BELT



WARNING

Always remove electrical power from the SX™ prior to performing any maintenance on the machine.

TESTING

1. Ensure the film feed motor drive belt has the proper tension. Refer to **Machine Adjustments: Checking Belt Tension** section to determine the correct tension.
2. Perform a visual inspection of the belt. If it is showing signs of wear, such as cracking or fraying, it needs to be replaced.

ADJUSTMENT

Refer to the **Machine Adjustments: Checking Belt Tension** section.

REPLACEMENT

Perform the following steps to replace the film feed drive motor belt.

1. Remove the outside frame guard and the front load plate (Figure 3-151).

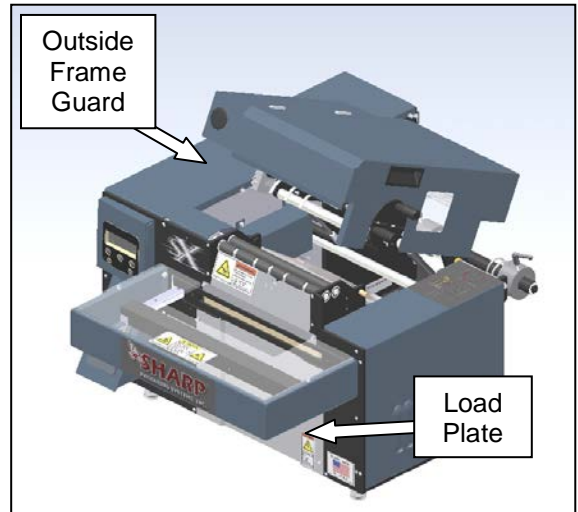

Figure 3-151. Guard Identification

2. Loosen the four motor mounting screws. The head of the screws can be accessed through the opening exposed by removing the load plate (Figure 3-152).

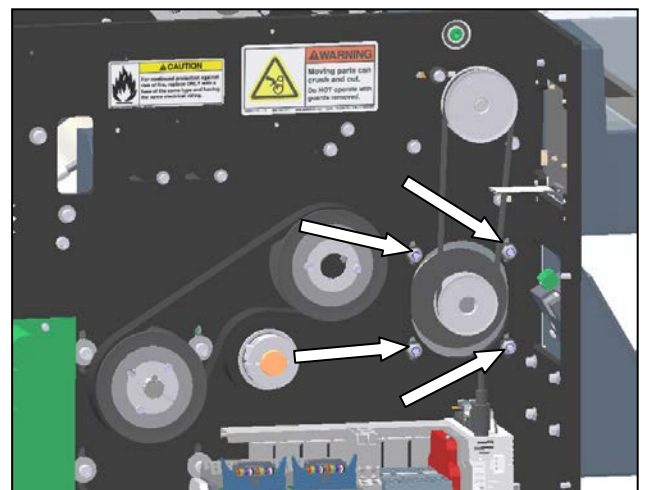

Figure 3-152. File Feed Drive Motor Mounting

3. Once loosened, slide the motor up to create slack in the belt. Remove the belt from the motor pulley and release the motor. The belt can then be removed from the machine and replaced.

FILM FEED ASSEMBLY

FILM FEED MOTOR DRIVE BELT (con't)

4. Lift the motor up to allow room for the new belt to be installed. Once the belt is over the pulley, apply downward pressure on the motor to tension the belt, following the tensioning guidelines outlined in Section 2, Maintenance and Adjustments.
5. Replace the load plate and the frame cover to complete belt replacement.

FILM FEED ROLLER DRIVE BELT

 WARNING
<p>Always remove electrical power from the SX™ prior to performing any maintenance on the machine.</p>

TESTING

1. Ensure the film feed roller drive belt has the proper tension. Refer to **Machine Adjustments: Checking Belt Tension** section to determine the correct tension.
2. Perform a visual inspection of the belt. If it is showing signs of wear, such as cracking or fraying, it needs to be replaced.

ADJUSTMENT

3. Refer to the **Machine Adjustments: Checking Belt Tension** section to determine the correct tension.

REPLACEMENT

1. Remove the outside frame guard and the pulley guard (Figure 3-153).

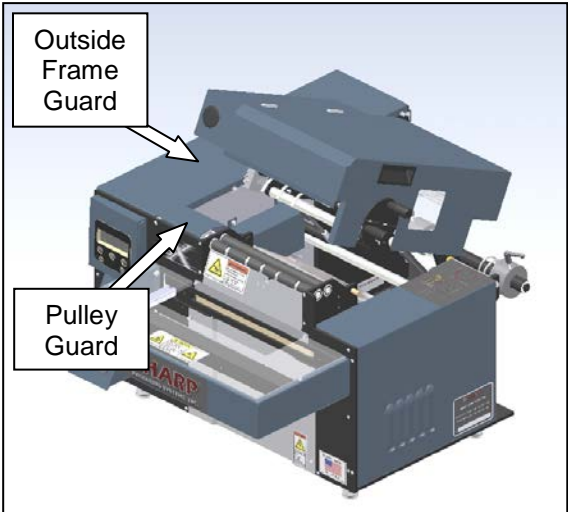

Figure 3-153. Guard Identification

2. Loosen the belt take-up shaft to create slack in the belt (Figure 3-154). (Note: if the model SX™ is equipped with a printer, the platen roller belt take-up shaft must also be loosened to give the platen roller drive belt slack.)

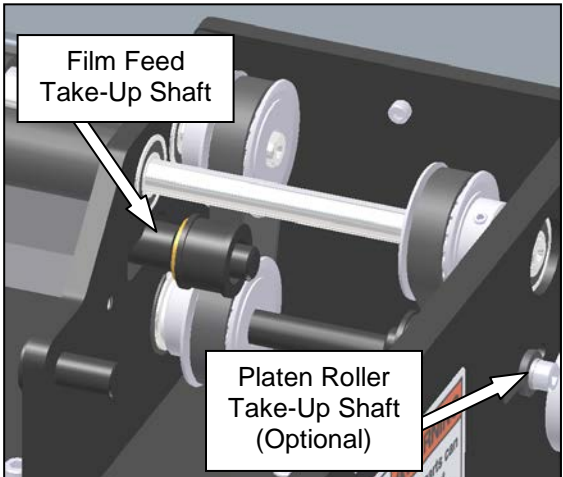

Figure 3-154. Film Feed Belt Take-Up Shaft

3. Loosen the four screws that mount the film feed drive motor and remove the belt. (See section entitled **Film Feed Motor Drive Belt** for a more detailed description of how to remove this belt.)

FILM FEED ASSEMBLY

FILM FEED ROLLER DRIVE BELT (con't)

- Loosen the two set screws on the pulley on the transfer shaft (Figure 3-155). This will allow the pulley to slide on the transfer shaft. Also loosen the clamping collar located next to the middle frame plate. (Note: if the model SX™ is equipped with a printer, the platen roller drive pulley set screws will also need to be loosened to allow the transfer shaft to slide. This pulley is the substitute for the clamping collar. Refer to Figure 3-155 for details.)

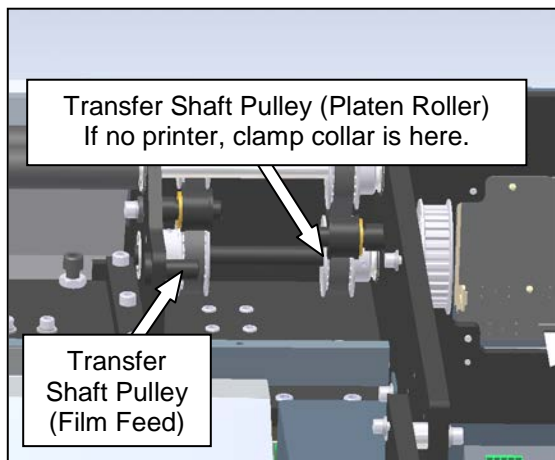

Figure 3-155 Pulley Identification

- Remove the transfer shaft by pulling outward on the driven motor pulley. While removing the transfer shaft, be careful not to misplace the two nylon washers on the transfer shaft: one between the film feed drive pulley and the left bearing plate and one between the collar clamp and middle frame plate. These washers act as spacers for proper belt alignment. (Note: if the model SX™ is equipped with a printer, the collar clamp will be substituted with the platen roller drive pulley on the transfer shaft. It will also have a nylon washer located between the pulley and the middle frame plate.)

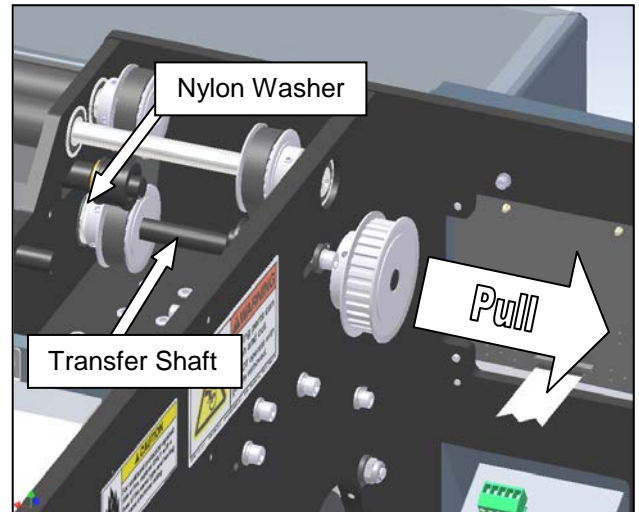

Figure 3-156. Removing the Transfer Shaft

- Replace the belt, putting it on the roller pulley first. Place the transfer shaft pulley inside the belt, and reinstall the transfer shaft. **Do not forget to reinstall the nylon washer.** (Note: if the model SX™ is equipped with a printer, also align the transfer shaft with the platen roller drive pulley and the second nylon washer.)
- Press the transfer shaft pulley tight to the nylon washer. Perform a quick visual inspection to ensure the pulleys are aligned.
- Once pulleys are aligned, tighten the set screws to locate the pulley(s) on the transfer shaft. The shaft has 2 flat areas 90° apart for the set screws to seat on. **Be sure the set screws are tightened onto the flat areas of the transfer shaft** (Figure 3-157). Also tighten the clamping collar once it is moved tight to the nylon washer by the middle frame plate. This will capture the transfer shaft to prevent movement during operation.

FILM FEED ASSEMBLY

FILM FEED ROLLER DRIVE BELT (con't)

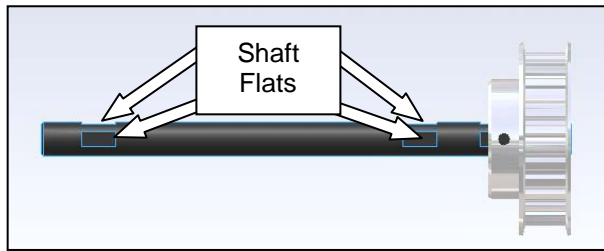

Figure 3-157. Transfer Shaft

9. Slide the film feed belt take-up shaft to the belt to put tension on the belt. This belt should deflect approximately 1/16" at the center of belt span for proper tension. (Note: Repeat this procedure on the platen roller belt take-up shaft if the SX™ is equipped with a printer.)
10. Reinstall the drive motor belt and adjust the belt to proper tension. This belt should deflect about 3/32" when tightened correctly.
11. Replace the pulley guard and the outside frame guard removed in step 1, and close the cradle cover.

PLATEN ROLLER DRIVE BELT (optional)

This section only applies to the Sharp SX™ with Printer.

**WARNING**

Always remove electrical power from the SX™ prior to performing any maintenance on the machine.

TESTING

1. Ensure the platen roller drive belt has the proper tension. Refer to **Machine Adjustments: Checking Belt Tension** section

on pages 2-6 to 2-9 to determine the correct tension.

2. Perform a visual inspection of the belt. If it is showing signs of wear, such as cracking or fraying, it needs to be replaced.

ADJUSTMENT

Refer to the **Machine Adjustments: Checking Belt Tension** section on pages 2-6 to 2-9.

REPLACEMENT

1. Remove the outside frame guard and the pulley guard (Figure 3-158).

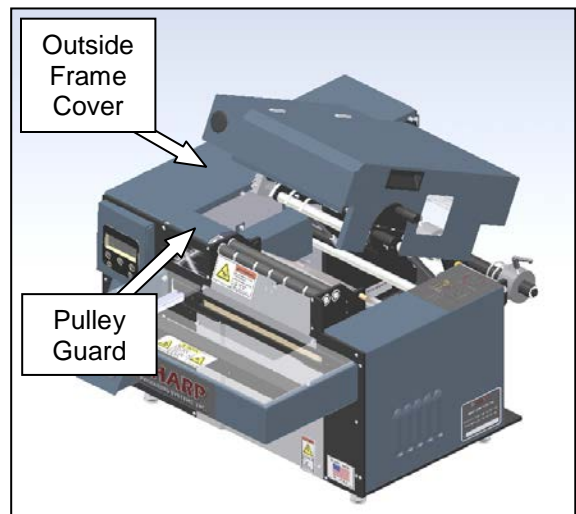

Figure 3-158. Guard Identification

2. Loosen the film feed belt take-up shaft and the platen roller belt take-up shaft to create slack in these two belts (Figure 3-159).

FILM FEED ASSEMBLY

PLATEN ROLLER DRIVE BELT (con't)

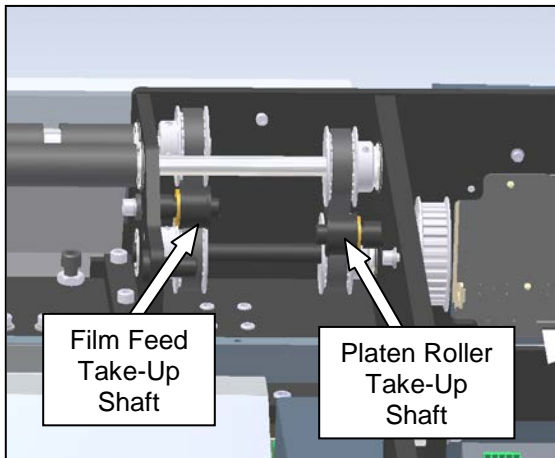

Figure 3-159. Belt Take-Up Shafts
 Note: Viewed from Rear; Cradle Removed for Clarity

3. Loosen the four screws that mount the film feed drive motor and remove the belt. (See section entitled **Film Feed Motor Drive Belt** for a more detailed description of how to remove this belt.)
4. Loosen the set screws on the three pulleys identified in Figure 3-160.

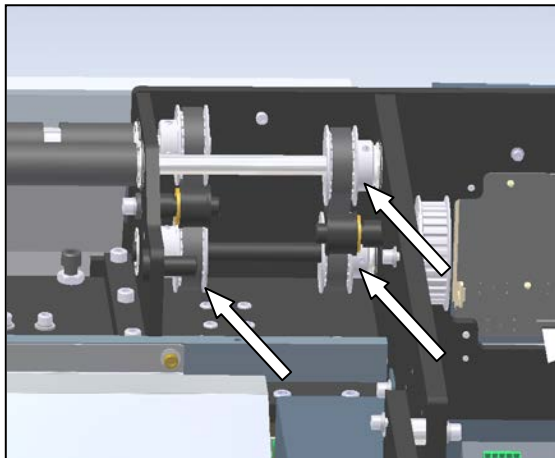

Figure 3-160. Drive Pulleys
 Note: Viewed from Rear; Cradle Removed for Clarity

5. Remove the transfer shaft by pulling outward on the driven motor pulley. While removing the transfer shaft, be careful not to misplace the nylon washer between the film feed drive pulley and the left bearing plate and the nylon washer between the middle frame plate and the platen roller drive pulley. These washers act as spacers for proper belt alignment (Figure 3-161).

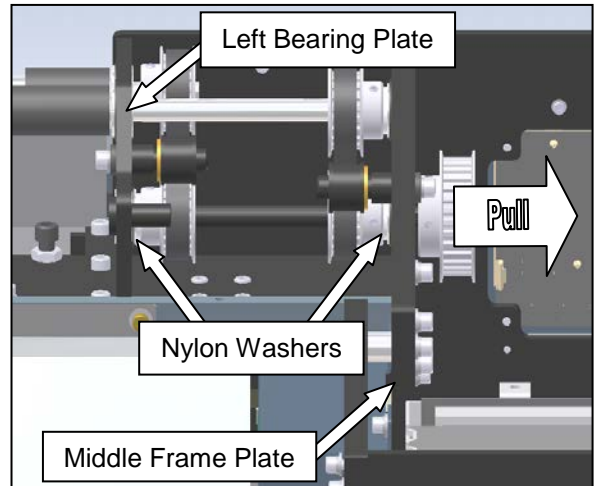

Figure 3-161. Removing the Transfer Shaft
 Note: Viewed from Rear; Cradle Removed for Clarity

6. Remove the front finger plate from the machine. **Do not pull the plate away from the machine too quickly, as the photoelectric eye is attached to the plate and wired to the machine.** Gently place the plate under the rollers, ensuring the sensor wire is not excessively pulled (Figure 3-162).

FILM FEED ASSEMBLY

PLATEN ROLLER DRIVE BELT (con't)

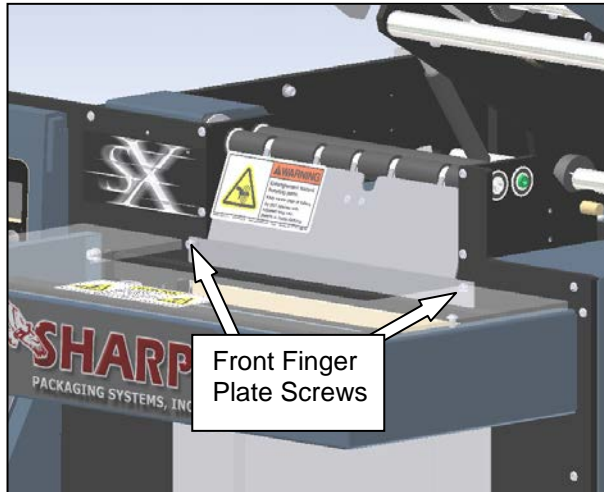

Figure 3-162. Front Finger Plate

7. Remove the right bearing plate by removing three screws from the base and two screws from the face plate (Figure 3-163). Slide the plate to the right to release the rollers from the bearing plate. (Note: the film feed roller will be free to dip on the right side.)

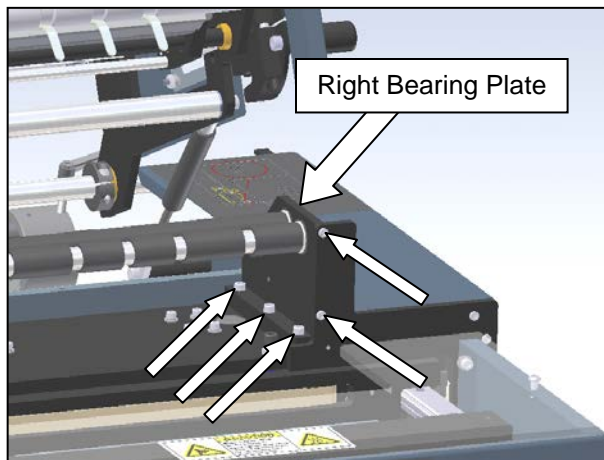
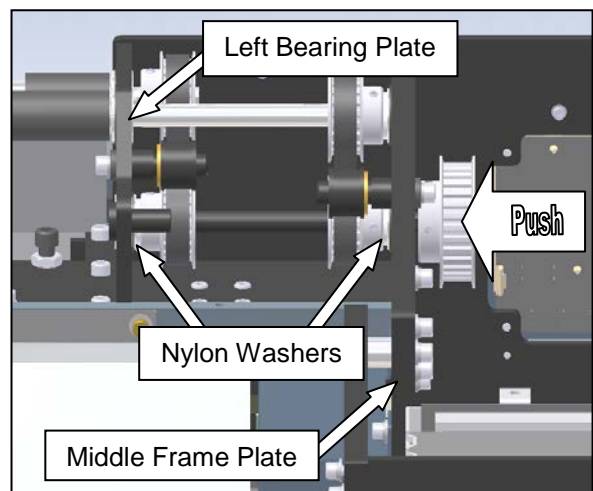

Figure 3-163. Right Bearing Plate and Screws

8. Gently pull the platen roller out of the middle frame plate to create a small gap. This gap needs to be just large enough to slide the belt through. Between the plate and the pulley there will be a nylon washer. **Do not misplace this washer, as it is needed for proper belt alignment.**

9. Install the new belt by sliding it through the gap created in step 8. Once the new belt is in place, the platen roller can be reinserted into the bearing in the middle frame plate. **Be sure to reinstall the nylon washer between the bearing and the pulley.**
10. Reinstall the right bearing plate. Align the platen roller and the film feed roller with the two bearings on the plate. Once in position, replace the five screws removed in step 7 to secure the plate.
11. Mount the front finger plate to the machine. Before tightening the screws, perform a quick visual inspection to ensure the fingers are not rubbing on the film feed roller.
12. Insert the transfer shaft through the bearing in the middle frame plate. Slide one nylon washer onto the shaft. Place the platen roller pulley and film feed pulley inside their respective belts, and carefully push the transfer shaft through the pulleys. Slide the remaining nylon washer onto the shaft, and put the shaft into the left bearing plate (Figure 3-164).

Figure 3-164. Reinstalling the Transfer Shaft
Note: Viewed from Rear; Cradle Removed for Clarity

FILM FEED ASSEMBLY

PLATEN ROLLER DRIVE BELT (con't)

13. Press the transfer shaft pulley for the platen roller tight to the nylon washer. Perform a quick visual inspection to ensure the pulleys are aligned.
14. Once pulleys are aligned, tighten the set screws to locate the pulley(s) on the transfer shaft. The shaft has 2 flat areas 90° apart for the set screws to seat on. **Be sure the set screws are tightened onto the flat areas of the transfer shaft** (Figure 3-165).

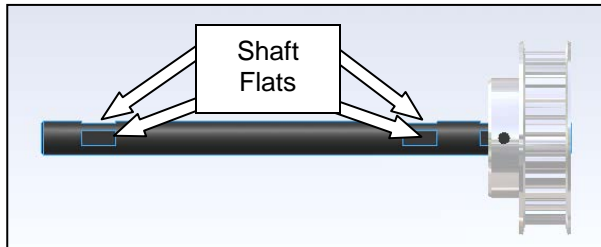

Figure 3-165. Transfer Shaft

15. Slide the transfer shaft pulley for the film feed roller tight to the nylon washer between it and the left bearing plate. Visually check pulley alignment.
16. Tighten the set screws on the film feed roller drive pulley. **Again, be sure the set screws are tightened onto the flat areas of the transfer shaft.**
17. Reinstall the film feed motor drive belt. (See section entitled **Film Feed Motor Drive Belt** for a more detailed description of how to reinstall this belt.)

18. Slide the film feed belt take-up shaft to the belt to put tension on the belt. This belt should deflect approximately 1/16" at the center of belt span for proper tension. Repeat on the platen roller take-up shaft. As shown in (Figure 3-166.)

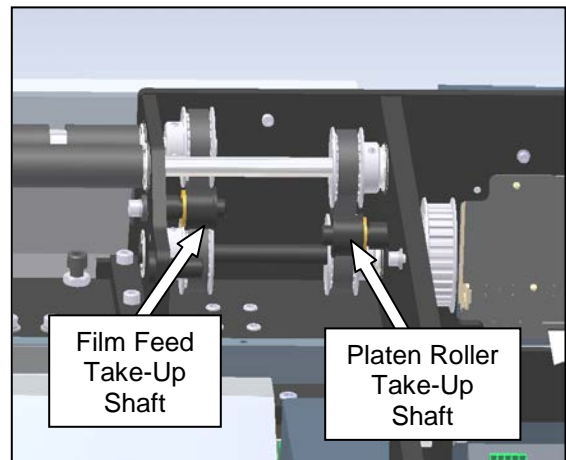

Figure 3-166. Belt Take-Up Shafts

Note: Viewed from Rear; Cradle Removed for Clarity

19. Replace the pulley guard and the outside frame guard removed in step 1, and close the cradle cover.

FILM FEED ASSEMBLY

FILM FEED ROLLER

⚠ WARNING

Always remove electrical power from the SX™ prior to performing any maintenance on the machine.

TESTING

1. Testing of the film feed roller consists of a visual inspection to determine the wear level of the rubber surface. This surface should be free of pitting, grooves, or other defects to ensure the best machine performance. If the roller shows severe wear, it needs to be replaced.

ADJUSTMENT

No adjustments are necessary on the film feed roller.

REPLACEMENT

1. Remove the pulley guard and the outside cover-right (Figure 3-167).

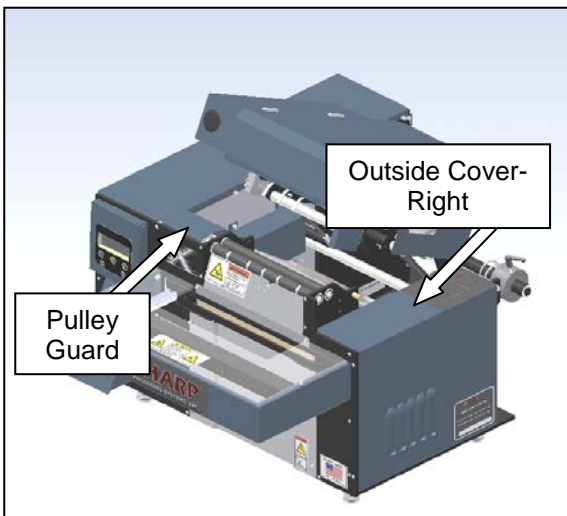

Figure 3-167. Guard Identification

2. Loosen the belt take-up shaft to create slack in the belt (Figure 3-168).

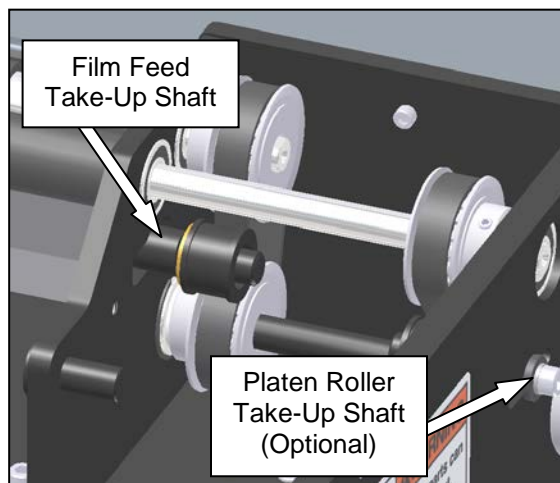

Figure 3-168. Film Feed Belt Take-Up Shaft

3. Loosen the four set screws on the two pulleys shown in Figure 3-169. Slide the pulleys to the left until the top pulley on the film feed drive roller is completely removed.

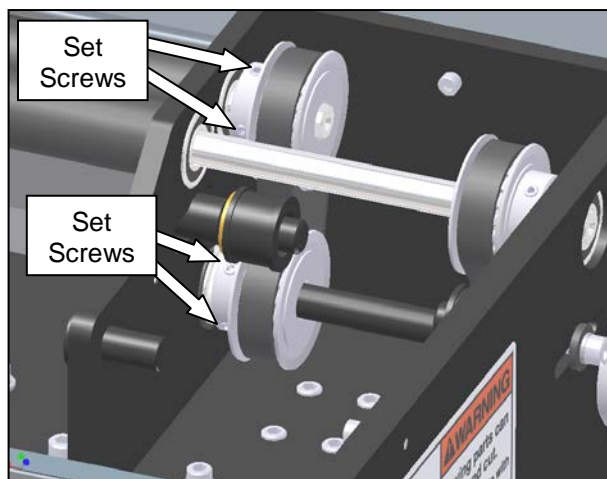

Figure 3-169. Film Feed Pulley Set Screws

FILM FEED ASSEMBLY

FILM FEED ROLLER (con't)

- Remove the front finger plate from the machine. **Do not pull the plate away from the machine too quickly, as the photoelectric eye is attached to the plate and wired to the machine.** Gently place the plate under the rollers, ensuring the sensor wire is not excessively pulled (Figure 3-170).

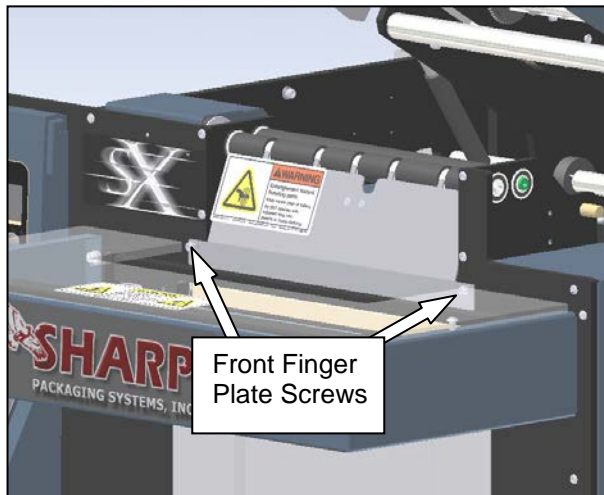

Figure 3-170. Front Finger Plate

- Remove the right bearing plate by removing three screws from the base and two screws from the face plate (Figure 3-171). Slide the plate to the right to release the rollers from the bearing plate. (Note: the film feed roller will be free to dip on the right side if your model is equipped with an imprinter.)

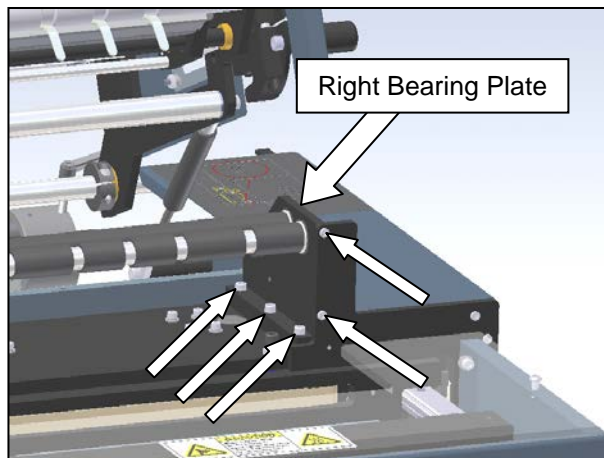

Figure 3-171. Right Bearing Plate and Screws

- Remove the film feed roller (shown in Figure 3-172) by sliding it to the right, freeing it from the left bearing plate.

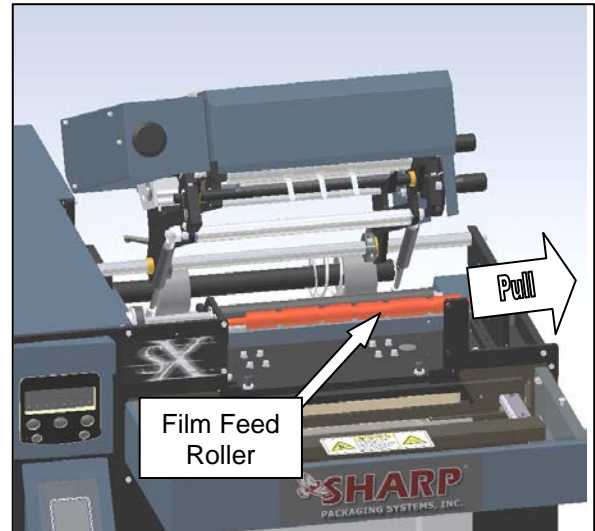

Figure 3-172. Removing the Film Feed Roller

- Install the new film feed roller by sliding the longer end with the two machined flats into the left bearing plate.
- Reinstall the right bearing plate. Align the film feed roller with the bearing and slide plate into roller. (Note: if the model SX™ is equipped with a printer, the platen roller shaft also needs to be aligned with the right bearing plate rear bearing before mounting the plate to the machine.) Replace the five screws removed in step 5 (Refer to Figure 3-171).
- Mount the front finger plate to the machine. Before tightening the screws, perform a quick visual inspection to ensure the fingers are not rubbing on the film feed roller.

FILM FEED ASSEMBLY

FILM FEED ROLLER (con't)

- Reinstall the film feed roller pulley, remembering to first place the pulley inside of the belt. Slide the transfer shaft pulley and the roller pulley in unison to ensure the belt stays on the pulleys. Move the pulleys until the pulley on the transfer shaft is tight to the nylon washer.
- Align the transfer shaft pulley set screws with the two flats on the transfer shaft and tighten set screws.

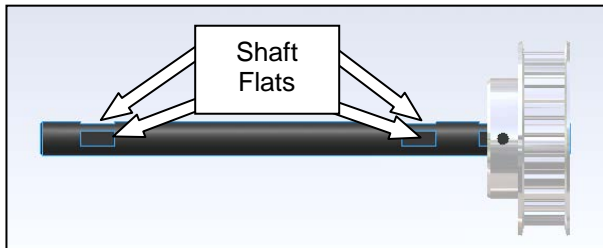

Figure 3-173. Transfer Shaft

- Using a straightedge, align the film feed roller pulley with the transfer shaft pulley. Once the pulleys are in-line, rotate the film feed roller until the two machined flats are aligned with the set screws and tighten them.
- Slide the film feed belt take-up shaft to the belt to put tension on the belt. This belt should deflect approximately 1/16" at the center of belt span for proper tension.
- Reinstall the guards removed in step 1, and close the cradle cover.

PLATEN ROLLER

This section only applies to the Sharp SX™ with Printer.

**WARNING**

Always remove electrical power from the SX™ prior to performing any maintenance on the machine.

TESTING

- Testing of the film feed roller consists of a visual inspection to determine the wear level of the rubber surface. This surface should be free of pitting, grooves, or other defects to ensure the best machine performance. If the roller shows severe wear, it needs to be replaced.

ADJUSTMENT

No adjustments are necessary on the platen roller.

REPLACEMENT

- Remove the pulley guard and the outside cover-right (Figure 3-174).

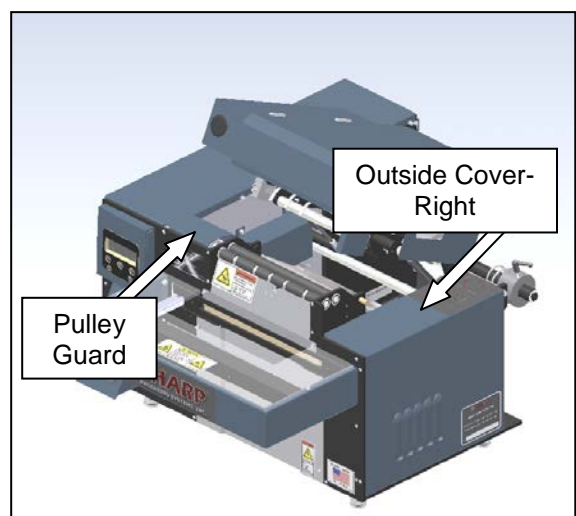

Figure 3-174. Guard Identification

FILM FEED ASSEMBLY

PLATEN ROLLER (con't)

- Loosen the film feed belt take-up shaft and the platen roller belt take-up shaft to create slack in these two belts (Figure 3-175).

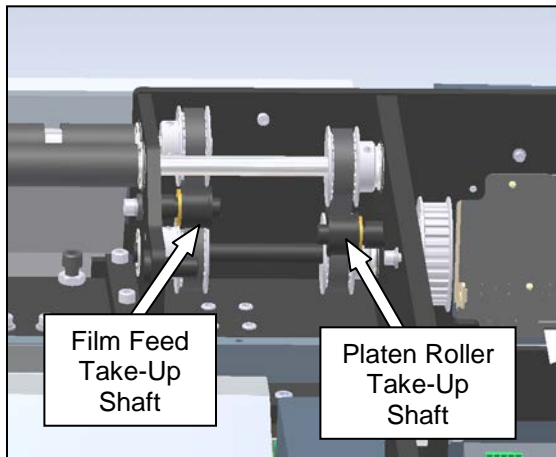

Figure 3-175. Belt Take-Up Shafts
Note: Viewed from Rear; Cradle Removed for Clarity

- Loosen the four set screws on the two pulleys shown in Figure 3-176 until they are free to slide.

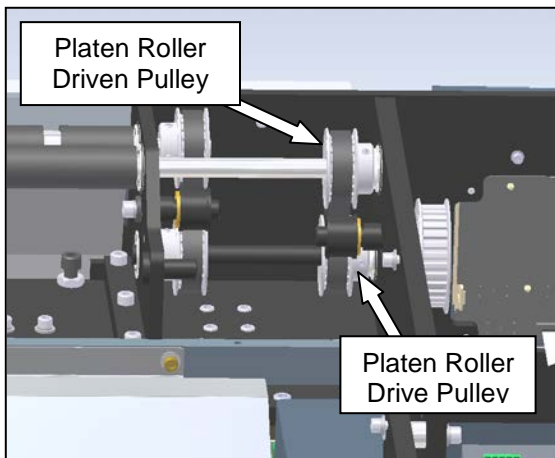

Figure 3-176. Belt Take-Up Shafts
Note: Viewed from Rear; Cradle Removed for Clarity

- Remove the front finger plate from the machine. **Do not pull the plate away from the machine too quickly, as the photoelectric eye is attached to the plate and wired to the machine.** Gently place the plate under the rollers, ensuring the sensor wire is not excessively pulled (Figure 3-177).

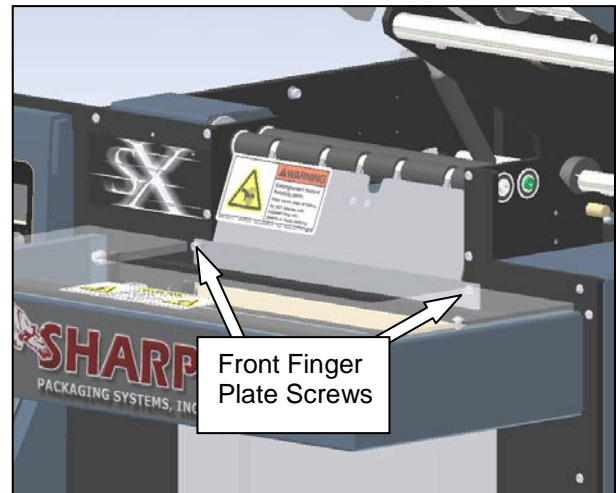

Figure 3-177. Front Finger Plate

- Remove the right bearing plate by removing three screws from the base and two screws from the face plate (Figure 3-178). Slide the plate to the right to release the rollers from the bearing plate. Note: the platen roller will be free to dip on the right side if your model is equipped with an imprinter.

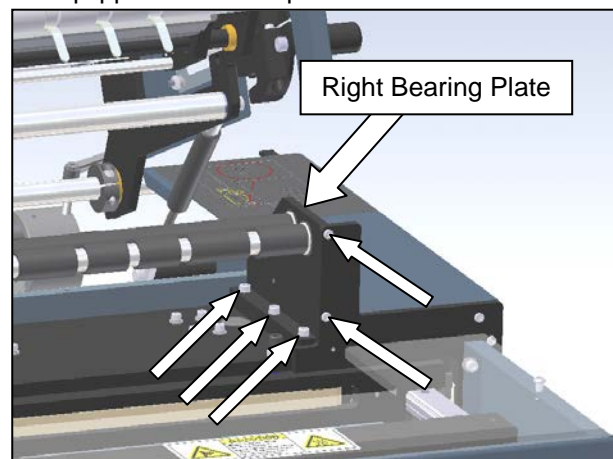

Figure 3-178. Right Bearing Plate and Screws

FILM FEED ASSEMBLY

PLATEN ROLLER (con't)

6. Slide the platen roller (shown in Figure 3-179) out of the machine to the right, freeing it from the left bearing plate. While pulling the roller, place one hand on the roller pulley, as this pulley will be free to fall once the platen roller shaft is removed. Between the pulley and the middle frame plate is a nylon washer. **Be careful not to misplace this washer, as it is needed for proper belt alignment.**

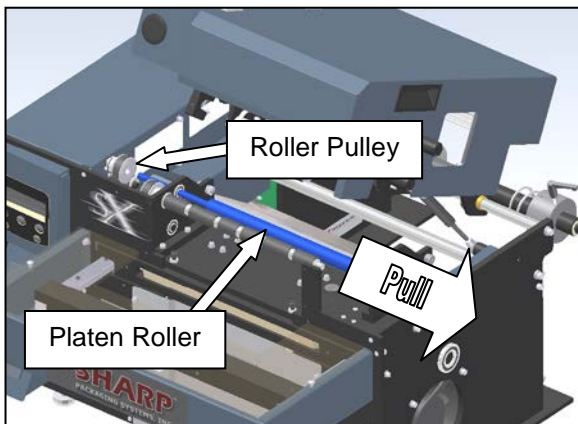

Figure 3-179. Removing the Platen Roller

7. Install the new platen roller. First, slide the long end of the shaft into the left bearing plate. Once the shaft is about halfway in, slide the two platen roller pulleys in tandem over until the roller pulley is fully engaged on the roller shaft. Also, place the nylon washer removed in step 6 onto the shaft after the pulley (Figure 3-180).

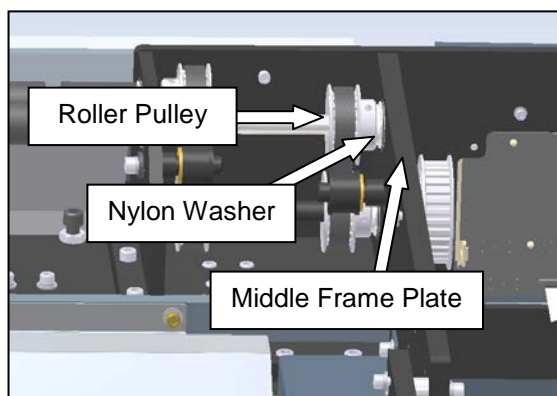

Figure 3-180. Reinstalling the Platen Roller

8. Continue sliding the platen roller into the machine until the shaft is tight to the rear bearing on the left bearing plate. The end of the shaft will need to be aligned with a second bearing in the middle frame plate.
9. Reinstall the right bearing plate. Align the film feed roller and the platen roller with their respective bearings, and slide the plate over until both shafts are completely inserted. Replace the five screws removed in step 5.
10. Slide the platen roller pulleys in tandem tight to the middle frame plate. Once in position, tighten the four set screws on the pulleys.
11. Mount the front finger plate to the machine. Before tightening the screws, perform a quick visual inspection to ensure the fingers are not rubbing on the film feed roller.
12. Slide the film feed belt take-up shaft to the belt to put tension on the belt. This belt should deflect approximately 1/16" at the center of belt span for proper tension.
13. Reinstall the guards removed in step 1, and close the cradle cover.

FILM FEED ASSEMBLY

FILM FEED DRIVE MOTOR

WARNING

Always remove electrical power from the SX™ prior to performing any maintenance on the machine.

TESTING

1. The wire for the film feed motor has a quick disconnect plug about 5 inches from the motor. Ensure the plug is completely inserted into the receptacle.
2. Using a Digital Volt/Ohm Meter (DVOM), first check continuity on the motor at the film feed stepper drive. Use the following step to do this.
 - a. Remove the four screws shown in Figure 3-181 to remove front load plate.



Figure 3-181. Load Plate Screws

- b. Locate the film feed stepper drive (Figure 3-182)

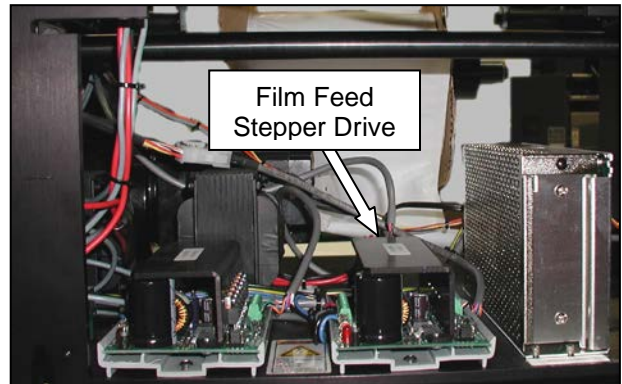

Figure 3-182. Film Feed Drive Location

- c. On the right-rear corner of the drive are the motor cable terminals. Check continuity between terminals 1 and 2, 1 and 3, and 2 and 3. Also check continuity between terminals 4 and 5, 4 and 6, and 5 and 6 (refer to Figure 3-183 for terminal identification). If all six tests for continuity pass, the motor is not faulty and other troubleshooting techniques need to be followed. (Refer to **Pressure Jaw and Film Feed Motor Controllers** on Page 3-1 for information on how to check the stepper drive).

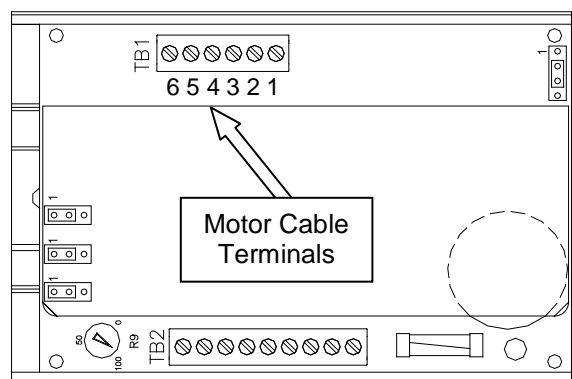

Figure 3-183. TM4500 Configuration

FILM FEED ASSEMBLY

FILM FEED DRIVE MOTOR (con't)

3. If there is no continuity at the stepper drive, the quick disconnect cable may be faulty. Follow these steps to check the motor at the plug.
 - a. Unplug the quick disconnect located near the motor.
 - b. Using a DVOM, check the continuity on the motor end of the plug. First, check between pins 1 and 3, 1 and 6, and 3 and 6. Then check for continuity between 2 and 4, 2 and 5, and 4 and 5 (see figure 3-184 for pin locations). If all six checks pass, the motor is not faulty, and there is a problem with the motor cable. Check the cable and connections to make sure the wires are not broken or pinched, and check pins to ensure they are still connected.

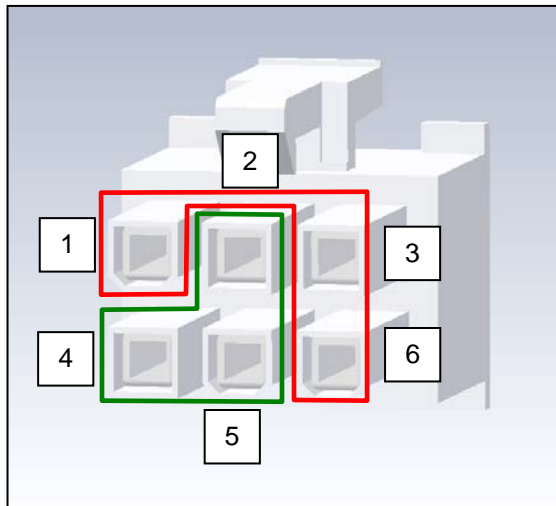

Figure 3-184. Motor Plug

ADJUSTMENT

The film feed drive motor is adjustment free.

REPLACEMENT

1. Remove the outside frame guard and the load plate. (See Figure 3-185.)

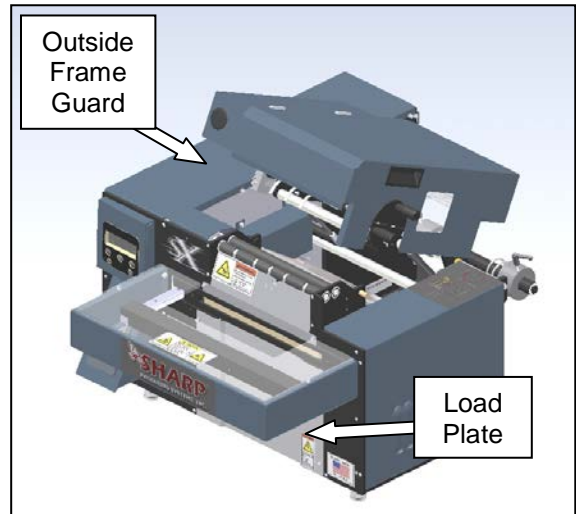

Figure 3-185. Guard Identification

2. Unplug the quick disconnect on the motor cable, and remove the four motor mounting screws. The head of the screws can be accessed through the opening exposed by removing the load plate (Figure 3-186).

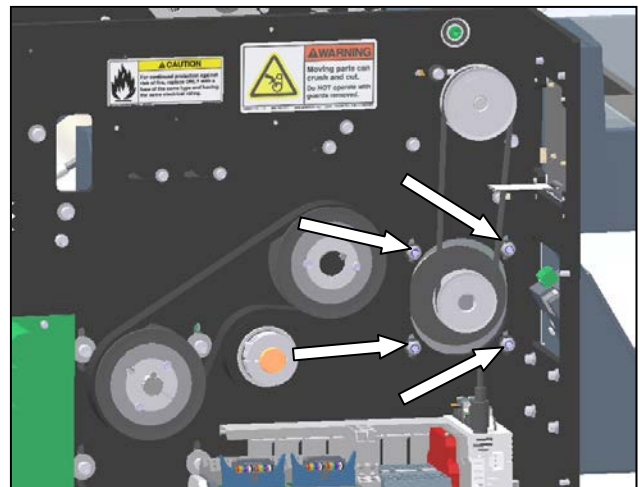

Figure 3-186. File Feed Drive Motor Mounting

FILM FEED ASSEMBLY

FILM FEED DRIVE MOTOR (con't)

3. Lift the motor upwards to remove the pulley from the belt. Carefully slide the motor out of the machine through the opening exposed by the load plate.
4. Remove the pulley from the old motor and reinstall on the new motor. **Note location and orientation of pulley on motor shaft, and duplicate when installing on new motor.** Be sure to tighten the pulley set screws on the machined flat areas of the motor shaft.
5. Install the motor into the machine. The motor should be oriented such that the plug and wire pigtail are to the back of the machine. Do not tighten the screws at this time, as the film feed belt needs to be tensioned.
6. Plug the motor cable into the quick disconnect harness.
7. Apply downward pressure on the motor to tension the belt. At proper tension, the belt should deflect about 3/32" at the center of belt span using one finger to push the belt. When proper tension is achieved, tighten the four motor mounting screws.
8. Reinstall guards removed in step 1.

CRADLE LOCK CAMS

Note: Earlier models of the Sharp SX™ are equipped with latch pins in the place of cam followers. If the latch pins need replacing, the latch mechanism needs to be upgraded to the cam followers. This procedure is best completed at Sharp Packaging Systems' facility by our service personnel because substantial machine disassembly is required.



WARNING

Always remove electrical power from the SX™ prior to performing any maintenance on the machine.

TESTING

1. Turn the cam follower (shown in Figure 3-187) by hand, ensuring it spins smoothly with no spots that stick. Also check that it is free of lateral movement.

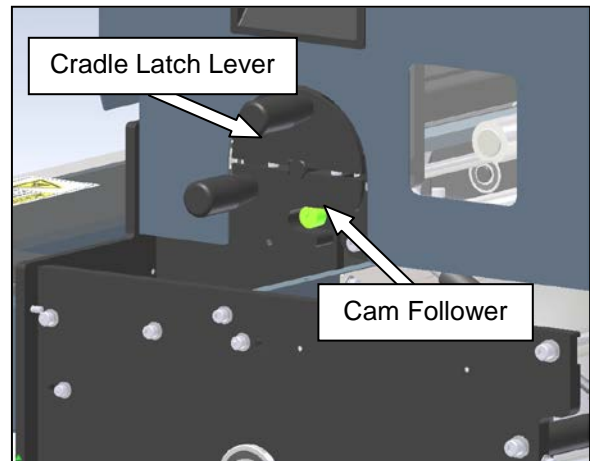

Figure 3-187. Cradle Latch

FILM FEED ASSEMBLY

CRADLE LOCK CAMS (con't)

REPLACEMENT

2. Inspect the cradle latch (shown in Figure 3-188) and the cradle latch lever to ensure the surfaces that the cams ride on show minimal wear.

1. With the cradle open, loosen the jam nut on the interior of the bearing plate (Figure 3-189) while holding the shaft of the cam with a 1/8" hex wrench.

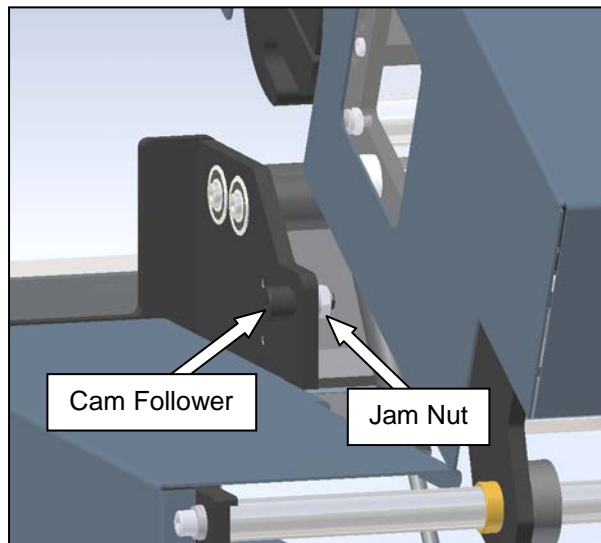

Figure 3-188. Cradle Latch

Figure 3-189. Cradle Locking Cams

ADJUSTMENT

The cradle lock cams on the Sharp SX™ are adjustment free.

2. Remove the cam follower from the plate, and place new cam into bearing plate hole.
3. Reinstall hex jam nut, using Loctite® 242.

PRINthead CRADLE ASSEMBLY

RIBBON REWIND ASSEMBLY

RIBBON REWIND MOTOR

Some of the procedures in this section require that the electrical power to the machine remain ON.

⚠ WARNING

USE EXTREME CAUTION WHILE SERVICING A MACHINE WHILE POWER IS APPLIED. UNEXPECTED MACHINE STARTUP CAN CAUSE SERIOUS INJURY.

⚠ WARNING

DO NOT ATTEMPT TO SERVICE THE MACHINE DURING NORMAL OPERATION. KEEP HANDS AND ARMS CLEAR OF MOVING PARTS.

⚠ WARNING

WHILE TESTING ELECTRICAL COMPONENTS WITH POWER APPLIED TO THE MACHINE, USE PROPER TROUBLESHOOTING TECHNIQUES TO AVOID ELECTRICAL SHOCK.

TESTING

1. Remove the outside cradle cover.

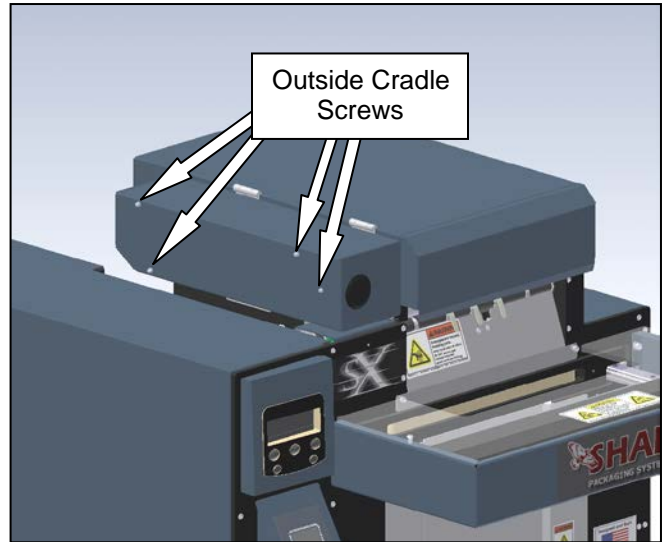

Figure 3-190. Removing the Outside Cradle Cover

2. Press the “Feed” button on the printer control panel, and watch the ribbon rewind motor. If the motor spins and the rewind hub does not, the ribbon motor is working properly and further troubleshooting of the ribbon rewind assembly is required.

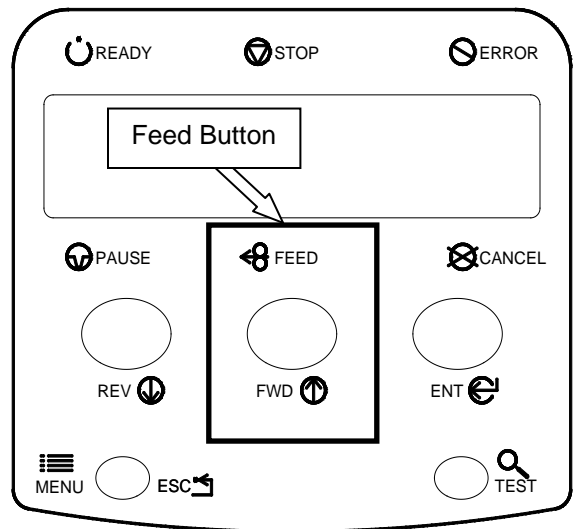

Figure 3-191. Printer Control Panel

PRINTHEAD CRADLE ASSEMBLY

RIBBON REWIND MOTOR (con't)

3. If the motor is not turning, unplug the motor cable and check for continuity. Using a Digital Volt/Ohm Meter (DVOM) set to test for continuity, probe between pins 1 & 2, 1 & 3, and 2 & 3. Repeat continuity check between pins 4 & 5, 4 & 6, and 5 & 6. If the motor passes all continuity checks, the motor is functioning properly.

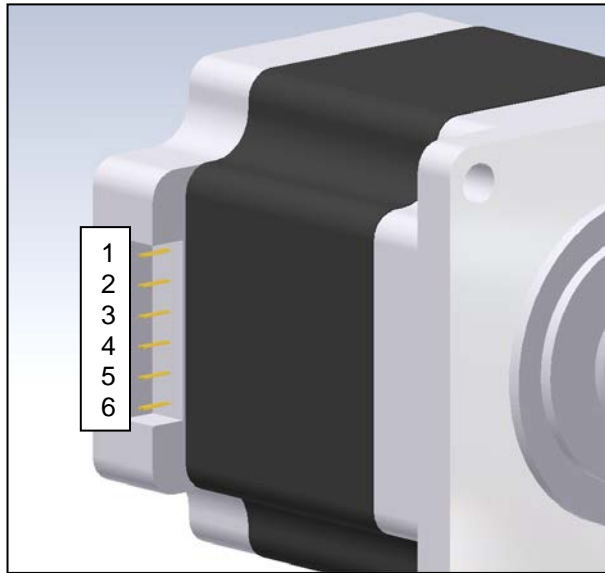

Figure 3-192. Ribbon Rewind Motor Pin ID

5. Locate the printer power supply board in the lower rear corner of the electrical area. Unplug the motor cable plugged into "J6". Using the DVOM, check continuity between pins 1 and 2, 1 and 3, and 2 and 3 on the cable. Also check continuity between pins 4 and 5, 4 and 6, and 5 and 6. Since the pins may be smaller than the probes on the DVOM, wire leads may need to be inserted into the plug for testing. If the motor has continuity and the cable does not, the cable needs replacement. If both the motor and cable are continuous, troubleshoot the printer power supply board (page 3-46). If no component replacement or further testing is to be done, reinstall the outside cradle cover and outside frame guard.

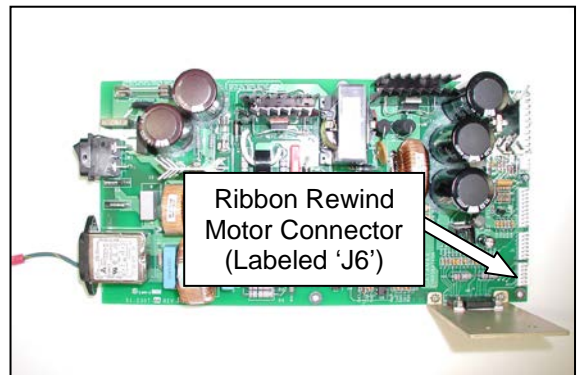

Figure 3-194. Ribbon Rewind Cable Connector

4. Remove the outer frame guard.

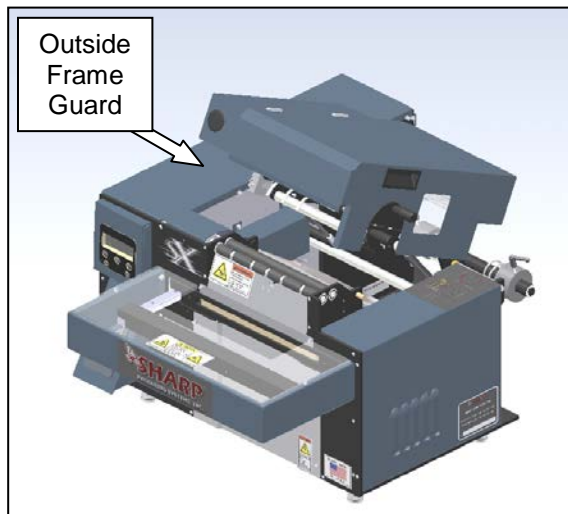

Figure 3-193. Guard Identification

ADJUSTMENT

The ribbon rewind motor is adjustment free.

PRINthead CRADLE ASSEMBLY

RIBBON REWIND MOTOR (con't)

REPLACEMENT



WARNING

Always remove electrical power from the SX™ prior to performing any maintenance on the machine.

1. Remove the outside cradle cover.

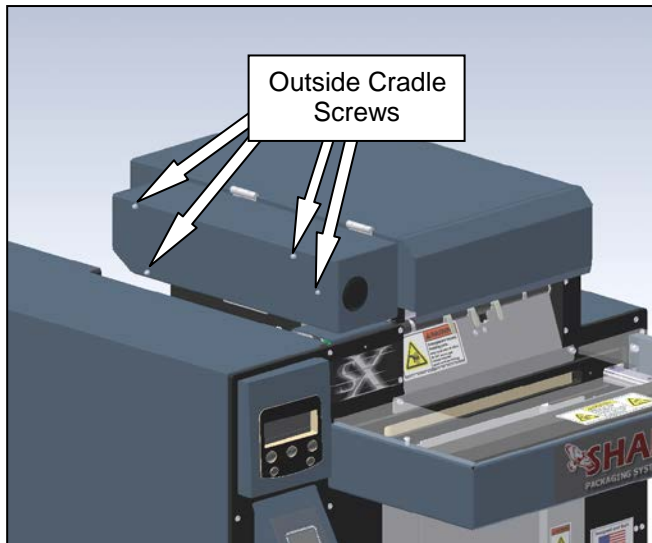

Figure 3-195. Removing the Outside Cradle Cover

2. Unplug the cable from the motor.
3. Open the cradle cover, and remove the four motor mounting screws from the cradle plate. This will free the motor from the machine. Be careful of the drive belt when taking the motor out of its position.

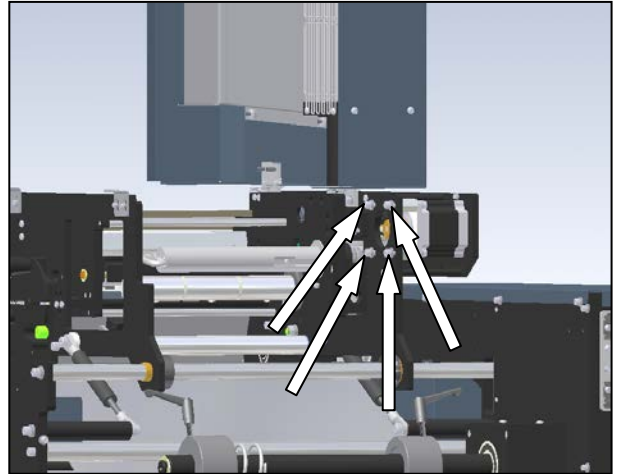

Figure 3-196. Ribbon Motor Mounting Screws

4. Remove the pulley and four standoffs from the old motor, and install on the new motor.
5. Place the new motor into the machine, being sure to orientate the cable receptacle to the inside of the machine. Also be sure the belt is over the pulley.
6. Reinstall the screws into the motor standoffs through the slots in the cradle side plate. Before tightening into position, be sure to set the belt tension to a satisfactory level. The center of belt span should displace about 1/16th of an inch when pressed with one finger perpendicular to the belt travel (Refer to "Checking Belt Tension" in Section 2 Machine Adjustments for a more detailed explanation).
7. Replace all guards removed in the previous steps.

PRINthead CRADLE ASSEMBLY

PRIMARY RIBBON DRIVE BELT

This belt runs between the ribbon rewind drive motor and the ribbon transfer shaft.

TESTING



WARNING

Always remove electrical power from the SX™ prior to performing any maintenance on the machine.

1. Ensure the primary ribbon drive belt has the proper tension. Refer to **Machine Adjustments: Checking Belt Tension** section to determine the correct tension.
2. Perform a visual inspection of the belt. If it is showing signs of wear, such as cracking or fraying, it needs to be replaced.

ADJUSTMENT

Refer to the **Machine Adjustments: Checking Belt Tension** section for a more detailed explanation.

REPLACEMENT

1. Remove the outside cradle cover.

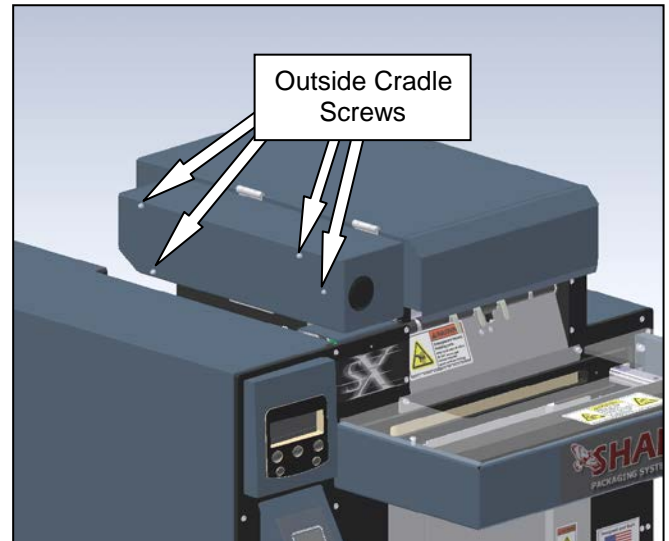

Figure 3-197. Removing the Outside Cradle Cover

2. Unplug the ribbon drive motor cable, and remove the drive motor.

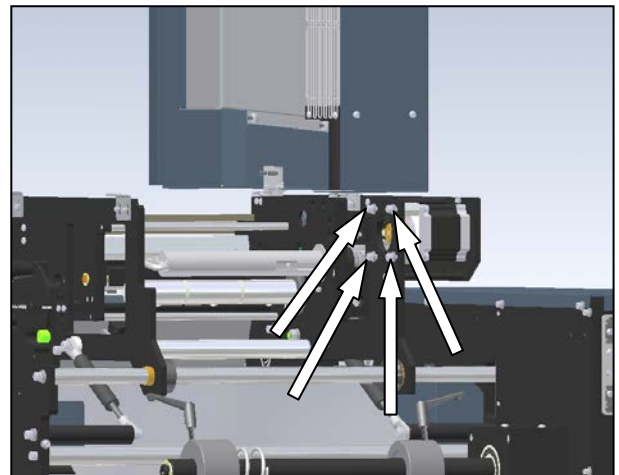

Figure 3-198. Ribbon Motor Mounting Screws

PRINTHEAD CRADLE ASSEMBLY

PRIMARY RIBBON DRIVE BELT (con't)

- Loosen the set screws on the transfer shaft pulley. This will allow the pulley to slide freely, and also allow the transfer shaft to move side to side in the bearings.

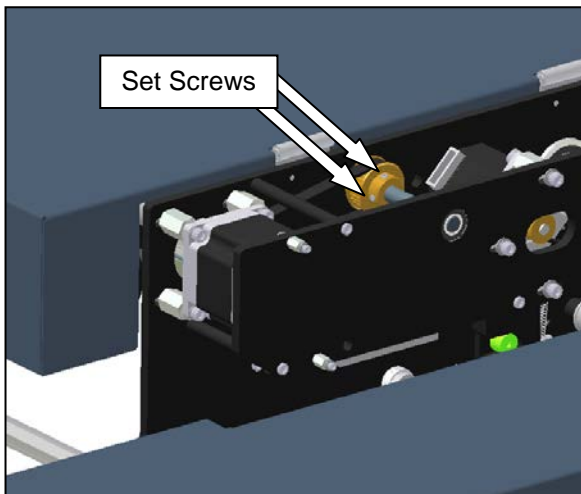

Figure 3-199. Transfer Shaft Pulley

- Slide the shaft into the bearing towards the center of the machine until the belt can be removed from the outer end of the shaft. When sliding the shaft, there will be a nylon washer that will be free to be removed from between the clamp collar and the outer cradle plate bearing. Do not misplace this washer, as it is needed for proper machine operation.

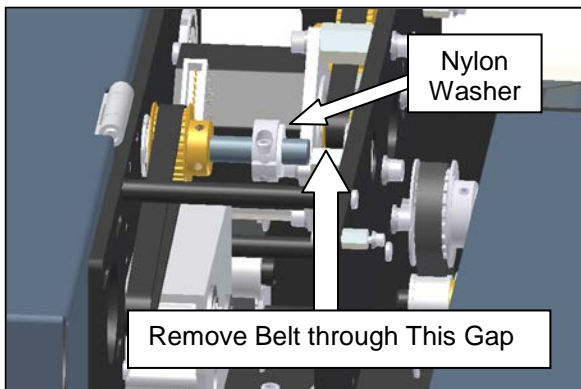

Figure 3-200. Removing the Belt

- Insert the new belt onto the shaft through the gap created in step 4.
- Slide the transfer shaft into the outer cradle plate until the clamp collar and nylon washer are tight against the bearing. Also, slide the pulley tight to the inner cradle plate. Once in position, tighten the pulley set screws on the flat areas of the transfer shaft.
- Reinstall the ribbon rewind drive motor. Be sure to properly tension the new belt. The center of belt span should displace about 1/16th of an inch when pressed with one finger perpendicular to the belt travel (Refer **Machine Adjustments: Checking Belt Tension** section for a more detailed explanation).
- Reinstall the outer cradle cover.

PRINthead CRADLE ASSEMBLY

DC ROLLER CLUTCH

The DC roller clutch is pressed into a timing pulley on the printer side of the main cradle plate. The clutch cannot be seen without some disassembly of the machine.

TESTING

⚠ WARNING

Always remove electrical power from the SX™ prior to performing any maintenance on the machine.

1. With the cradle cover open, spin the rewind hub. Watch the roller clutch pulley located between the two inner cradle plates. When winding the ribbon onto the hub (counter-clockwise), the DC clutch will spin freely on the transfer shaft. When unwinding the ribbon (clockwise), the DC roller clutch will turn the transfer shaft. If either of these conditions is not met, the clutch needs replacement.

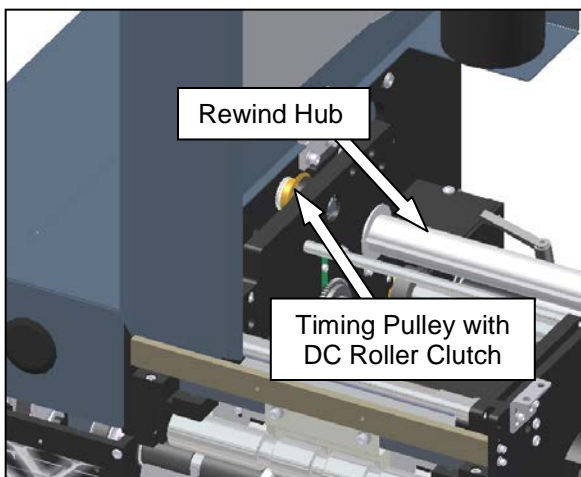

Figure 3-201. Locating the DC Roller Clutch

ADJUSTMENT

The DC roller clutch is adjustment free.

REPLACEMENT

1. Remove the outside cradle cover.

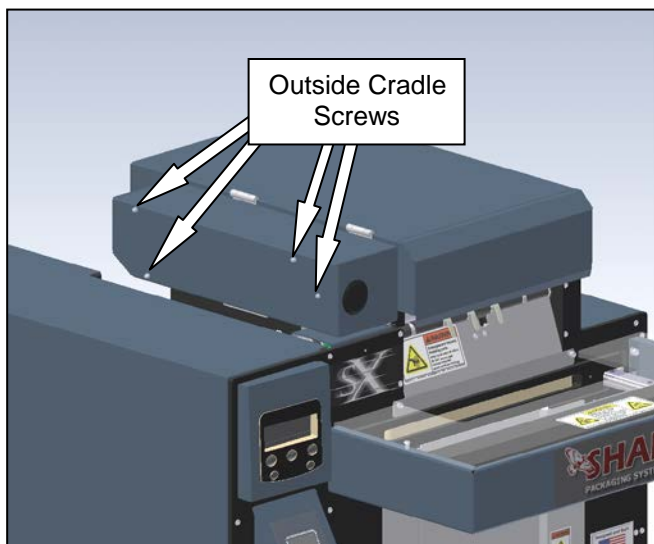

Figure 3-202. Removing the Outside Cradle Cover

2. Loosen the clamp collar and the set screws on the transfer shaft pulley.

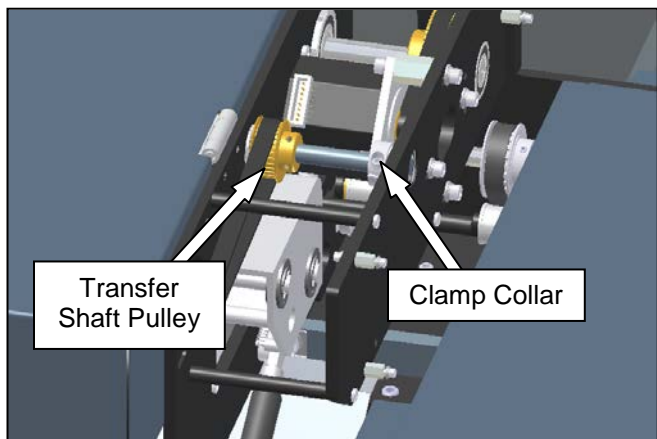

Figure 3-203. Transfer Shaft Components

PRINTHEAD CRADLE ASSEMBLY

DC ROLLER CLUTCH (con't)

- Open the cradle cover, and locate the belt tensioner for the secondary ribbon rewind drive belt (this belt is located between the two cradle plates). Loosen this belt tensioner, accessing the two mounting screws through the clearance holes in the inner plate. (Note: depending on the model of Sharp SX™ you have, there may be a cable tie through one of the clearance holes. If the hex wrench will not fit through the hole and properly seat in the screw, the cable tie will need to be removed and replaced at the end of this repair.) The hinge screws fastening the hinge to the cradle plate also need to be removed to allow clearance for the pulley to slide out of the machine.

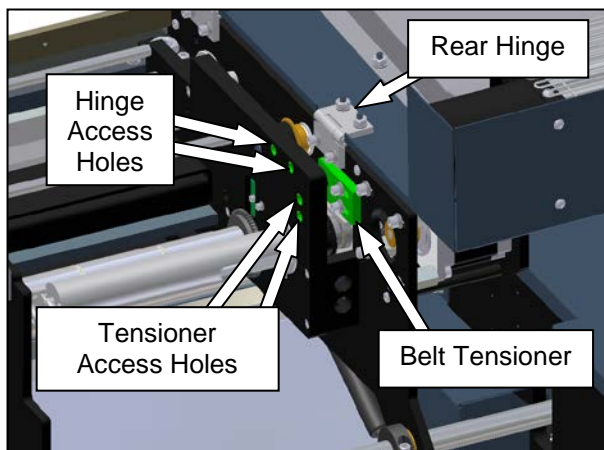
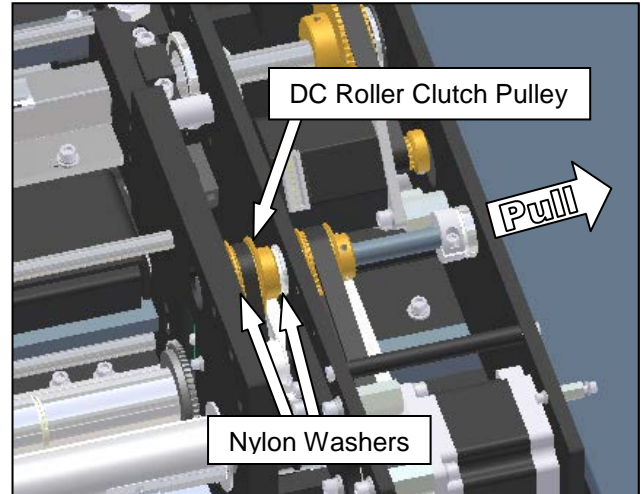

Figure 3-204. Secondary Ribbon Drive Belt

- The transfer shaft will now be free to slide. Move the transfer shaft to the outside of the machine to remove the DC roller clutch pulley. There is one nylon washer located on each side of this pulley. When sliding the transfer shaft, be sure to catch the pulley and the two nylon washers as the shaft is withdrawn from them. Do not misplace these washers, as they are needed for proper machine operation. Once the shaft is free of the interior components, lift the pulley up from the machine. Remove the belt from the teeth of the pulley and onto the hub. Rotate the pulley to free it from the belt.

Figure 3-205. Interior Transfer Shaft Components
Note: Cradle Cover Removed for Clarity

- The DC roller clutch now needs to be pressed out of the pulley. Once removed, insert the new clutch into the pulley, oriented such that the writing on the end of the bearing is visible when looking into the hub side of the pulley. The roller should be flush with the opposite (flange) side of the pulley to ensure proper operation. (As shown in Figure 3-206)

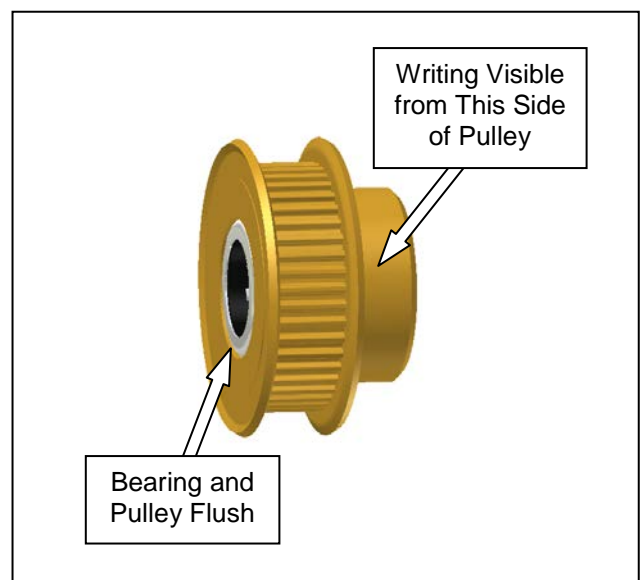

Figure 3-206. DC Roller Clutch Orientation

PRINthead CRADLE ASSEMBLY

DC ROLLER CLUTCH (con't)

- Reinstall the DC roller clutch pulley into the machine. When pushing the transfer shaft back into position, remember the two nylon washers (one on each side) of the pulley. Be sure the belt is fully engaged in the pulley teeth.
- Once each end of the transfer shaft is flush with the outer and inner plates, slide the clamp collar and nylon washer to the outside plate and tighten into position. Slide the transfer shaft drive pulley tight to the nylon washer and bearing on the inner plate and tighten the two set screws on the two flat areas of the shaft.

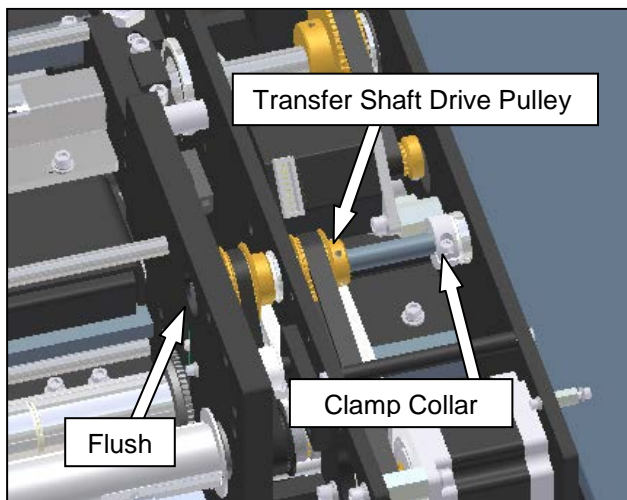

Figure 3-207. Positioning the Transfer Shaft
Note: Cradle Cover Removed for Clarity

- Slide the belt tensioner towards the belt until the belt is properly tensioned. When tightened correctly, the belt should deflect about 1/8th inch when depressed with one finger at the center of belt span. Once in position, tighten the two mounting screws.
- Reinstall the rear cover hinge by tightening the two screws that hold it into position.

- Reinstall the outside cradle cover.

SECONDARY RIBBON DRIVE BELT

This belt runs between the DC roller clutch pulley on the transfer shaft and the adjustable slip clutch on the ribbon rewind hub shaft.

TESTING



WARNING

Always remove electrical power from the SX™ prior to performing any maintenance on the machine.

- Ensure the secondary ribbon drive belt has the proper tension. Refer to **Machine Adjustments: Checking Belt Tension** section to determine the correct tension.
- Perform a visual inspection of the belt. If it is showing signs of wear, such as cracking or fraying, it needs to be replaced.

ADJUSTMENT

Refer to the **Machine Adjustments: Checking Belt Tension** section.

PRINthead CRADLE ASSEMBLY

SECONDARY RIBBON DRIVE BELT (con't)

REPLACEMENT

1. Remove any ribbon from both the supply and take-up hubs.
2. Remove the outside cradle cover.

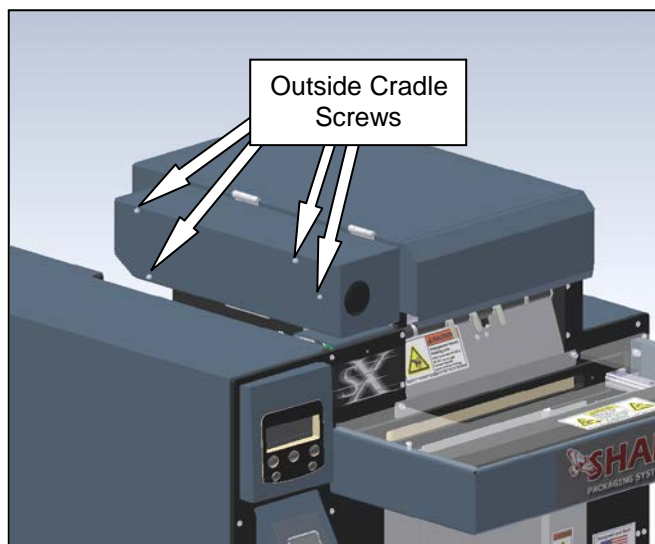

Figure 3-208. Removing the Outside Cradle Cover

3. Loosen the clamp collar and the set screws on the transfer shaft pulley.

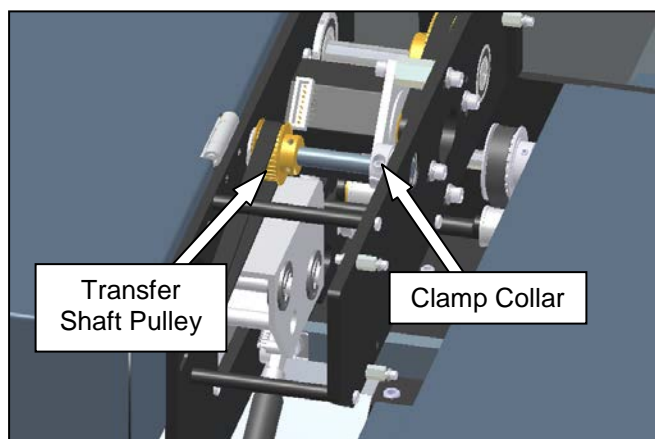

Figure 3-209. Transfer Shaft Components

4. Open the cradle cover and locate the belt tensioner for the secondary ribbon rewind drive belt. Loosen this belt tensioner, accessing the two mounting screws through the clearance holes in the inner plate. (Note: depending on the model of Sharp SX™ you have, there may be a cable tie through one of the clearance holes. If the hex wrench will not fit through the hole and properly seat in the screw, the cable tie will need to be removed and replaced at the end of this repair.) The hinge screws fastening the hinge to the cradle plate also need to be removed to allow clearance for the pulley to slide out of the machine.

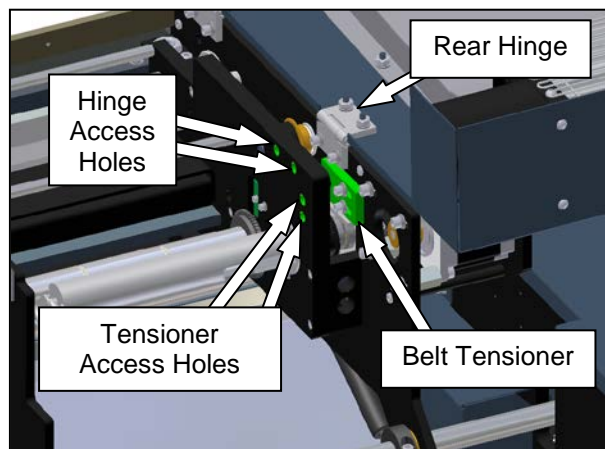

Figure 3-210. Secondary Ribbon Drive Belt Tensioner

5. The transfer shaft will now be free to slide. Move the transfer shaft to the outside of the machine to remove the DC roller clutch pulley. There is one nylon washer located on each side of this pulley. When sliding the transfer shaft, be sure to catch the pulley and the two nylon washers as the shaft is withdrawn from them. Do not misplace these washers, as they are needed for proper machine operation. Once the shaft is free of the interior components, lift the pulley up from the machine. Remove the belt from the teeth of the pulley and onto the hub. Rotate the pulley to free it from the belt.

PRINTHEAD CRADLE ASSEMBLY

SECONDARY RIBBON DRIVE BELT
(con't)

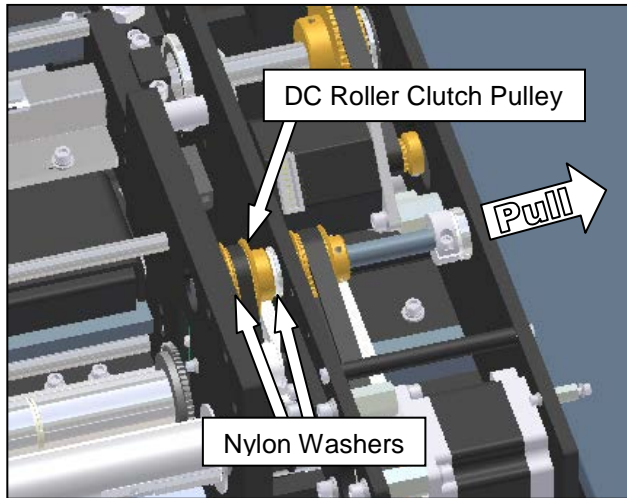

Figure 3-211. Interior Transfer Shaft Components
Note: Cradle Cover Removed for Clarity

- Loosen the two set screws on the adjustable slip clutch.

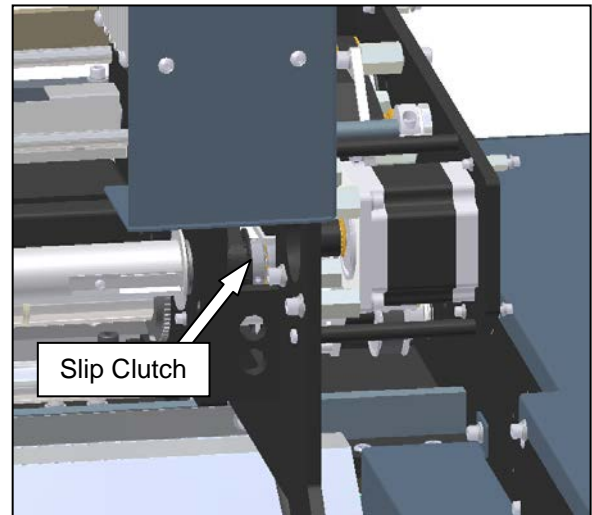

Figure 3-213. Adjustable Slip Clutch

- Remove the E-Clip from the ribbon take-up shaft. This clip is located between the outside cradle plate and the main cradle plate, outside of the gray housing located in the lower-rear section of the area exposed by the outside cradle cover.

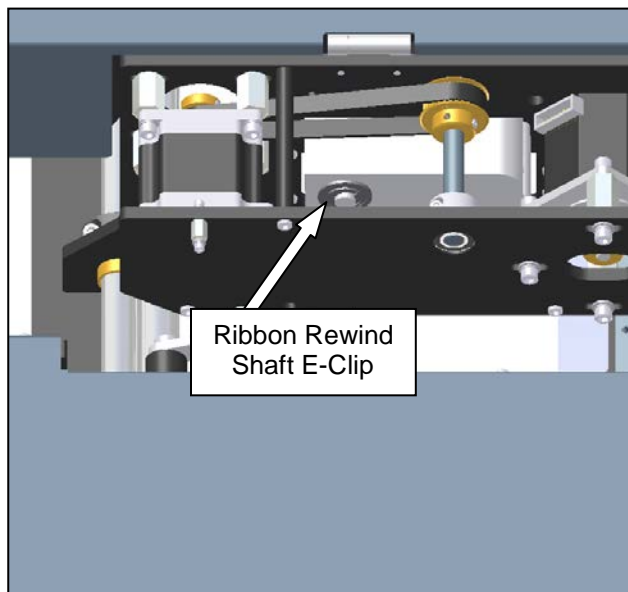

Figure 3-212. Ribbon Rewind Shaft E-Clip

- Remove the ribbon take-up hub from the machine by pulling it through the opening in the latch-side plate. When removing the hub, the slip clutch, a nylon washer, a nylon spacer, a flange bearing on the gray housing, and the belt will all be free from the machine. Do not misplace these parts, as they are needed for reinstalling the ribbon hub.

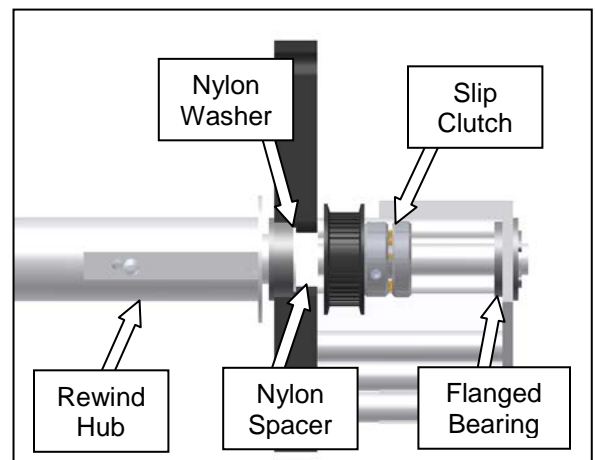

Figure 3-214. Rewind Hub Shaft Components
Note: Plate Cut Away for Clarity

PRINTHEAD CRADLE ASSEMBLY**SECONDARY RIBBON DRIVE BELT
(con't)**

9. Reinstall the ribbon hub shaft components with the new belt on the slip clutch. Be sure to include all the parts shown in figure 3-214 during installation. Once all components are in place, reinstall the E-Clip on the end of the shaft on the outer side of the bearing.
10. Tighten the slip clutch set screws onto the flat areas of the ribbon rewind hub shaft.
11. Reinstall the DC roller clutch pulley into the machine. When pushing the transfer shaft back into position, remember the two nylon washers (one on each side) of the pulley. Be sure the belt is fully engaged in the pulley teeth.
12. Once each end of the transfer shaft is flush with the outer and inner plates, slide the clamp collar and nylon washer to the outside plate and tighten into position. Slide the transfer shaft drive pulley tight to the nylon washer and bearing on the inner plate and tighten the two set screws on the two flat areas of the shaft.
13. Slide the belt tensioner towards the belt until the belt is properly tensioned. When tightened correctly, the belt should deflect about 1/8th inch when depressed with one finger at the center of belt span. Once in position, tighten the two mounting screws.
14. Reinstall the rear cover hinge by tightening the two screws that hold it into position.
15. Reinstall the outside cradle cover.

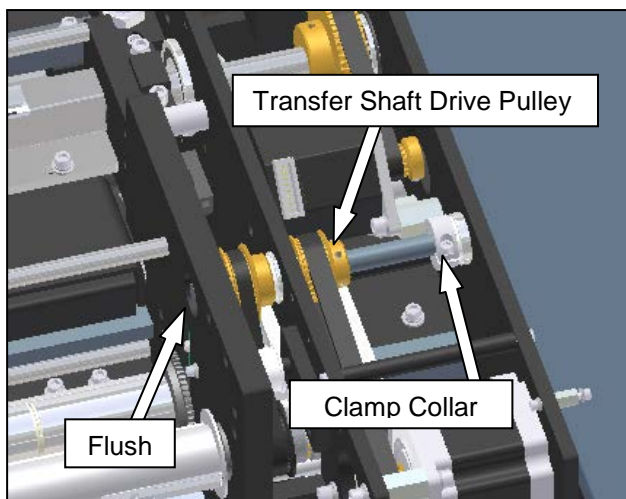

Figure 3-215. Positioning the Transfer Shaft
Note: Cradle Cover Removed for Clarity

PRINthead CRADLE ASSEMBLY

ADJUSTABLE SLIP CLUTCH

The adjustable slip clutch is contained in the pulley that directly drives the ribbon rewind hub.

Some of the procedures in this section require that the electrical power to the machine remain ON.

TESTING

 WARNING
USE EXTREME CAUTION WHILE SERVICING A MACHINE WHILE POWER IS APPLIED. UNEXPECTED MACHINE STARTUP CAN CAUSE SERIOUS INJURY.

 WARNING
DO NOT ATTEMPT TO SERVICE THE MACHINE DURING NORMAL OPERATION. KEEP HANDS AND ARMS CLEAR OF MOVING PARTS.

 WARNING
WHILE TESTING ELECTRICAL COMPONENTS WITH POWER APPLIED TO THE MACHINE, USE PROPER TROUBLESHOOTING TECHNIQUES TO AVOID ELECTRICAL SHOCK.

1. Open the cradle cover, and locate the ribbon rewind hub. Press the “Feed” button on the printer control panel and watch the slip clutch. If the secondary drive belt is turning and the ribbon rewind hub is not, the slip clutch is either out of adjustment or needs replacement.

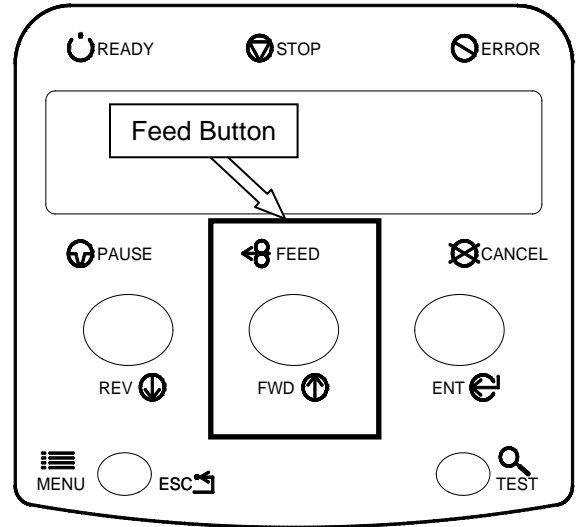

Figure 3-216. Printer Control Panel

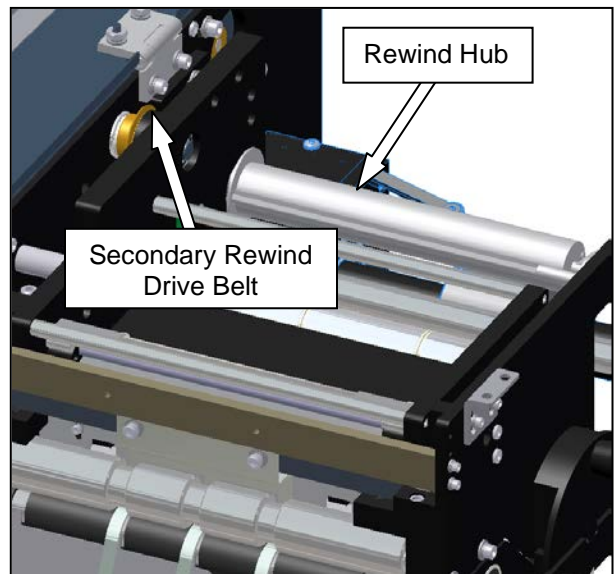

Figure 3-217. Slip Clutch Testing

PRINthead CRADLE ASSEMBLY

ADJUSTABLE SLIP CLUTCH (con't)

ADJUSTMENT

REPLACEMENT



WARNING

Always remove electrical power from the SX™ prior to performing any maintenance on the machine.

Substantial machine disassembly is required to replace the adjustable slip clutch. This procedure is best performed by Sharp Packaging Systems Inc. trained service personnel.

1. If the slip clutch is out of adjustment, it can be tightened by turning the outer hub towards the pulley. This can be done while installed in the machine by using a flat-blade screwdriver to hold the knurled ring and turning the rewind hub in the direction of unwinding the ribbon. Turn in 1/8th turn increments clockwise, and check function. If the clutch is over-tightened, ribbon usage will increase and the print will appear stretched-out and lighter than normal.

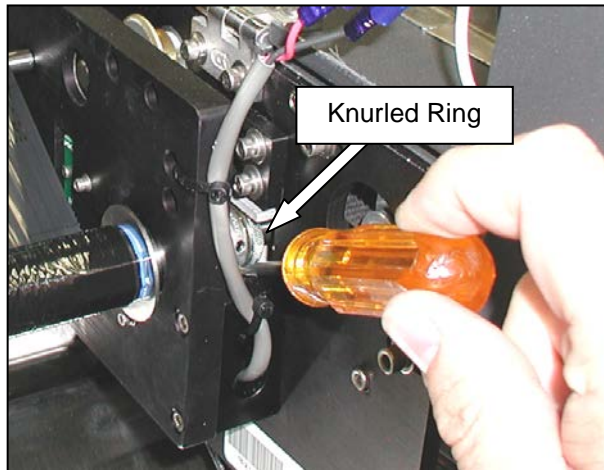

Figure 3-218. Adjusting the Slip Clutch

PRINthead CRADLE ASSEMBLY

PRINthead POSITION ASSEMBLY

PRINthead POSITION MOTOR

This is the motor that drives the cam shaft to control the up and down motion of the printhead.

Some of the procedures in this section require that the electrical power to the machine remain ON.

TESTING

 WARNING
USE EXTREME CAUTION WHILE SERVICING A MACHINE WHILE POWER IS APPLIED. UNEXPECTED MACHINE STARTUP CAN CAUSE SERIOUS INJURY.

 WARNING
DO NOT ATTEMPT TO SERVICE THE MACHINE DURING NORMAL OPERATION. KEEP HANDS AND ARMS CLEAR OF MOVING PARTS.

 WARNING
WHILE TESTING ELECTRICAL COMPONENTS WITH POWER APPLIED TO THE MACHINE, USE PROPER TROUBLESHOOTING TECHNIQUES TO AVOID ELECTRICAL SHOCK.

1. Remove the outside cradle cover.

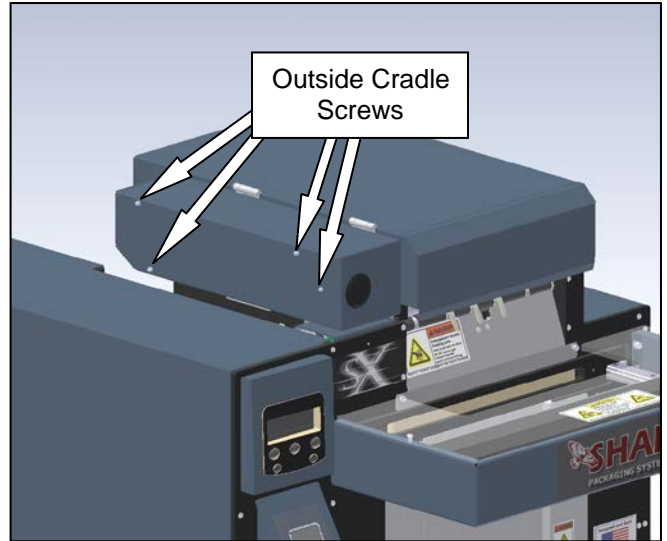



Figure 2-219. Removing the Outside Cradle Cover

2. Cycle the machine. Watch the printhead position motor to ensure it rotates. If it does, the printhead position motor is working properly and troubleshooting of the printhead stepper drive (page 3-53) is required.

3. Remove power from the machine.

 WARNING
Always remove electrical power from the SX™ prior to performing any maintenance on the machine.

PRINthead CRADLE ASSEMBLY

PRINthead POSITION MOTOR (con't)

4. If the motor is not turning, unplug the motor cable and check for continuity. Using a Digital Volt/Ohm Meter (DVOM) set to test for continuity, probe between pins 1 & 5, 2 & 6, 3 & 7, and 4 & 8. If the motor passes all continuity checks, the motor is functioning properly.

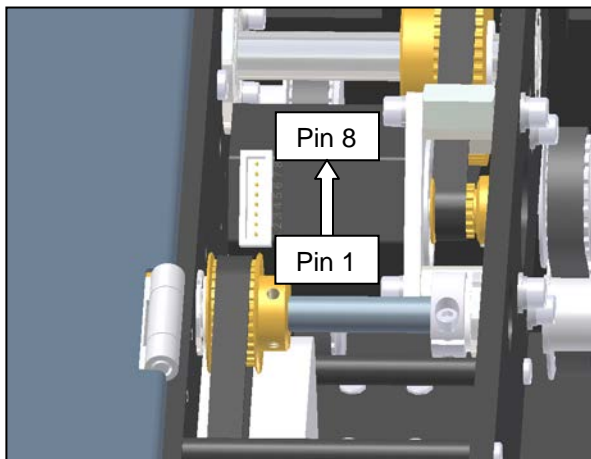

Figure 3-220. Printhead Position Motor Pins

5. Remove the rear motor cover.

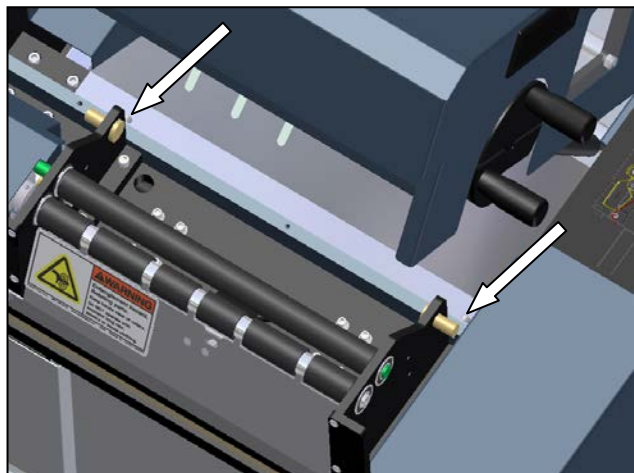

Figure 3-221. Motor Cover Front Screws

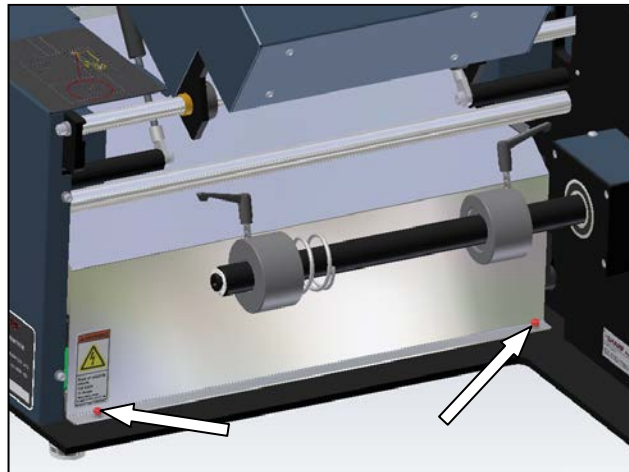

Figure 3-222. Motor Cover Rear Screws

6. Locate the printhead position stepper drive.

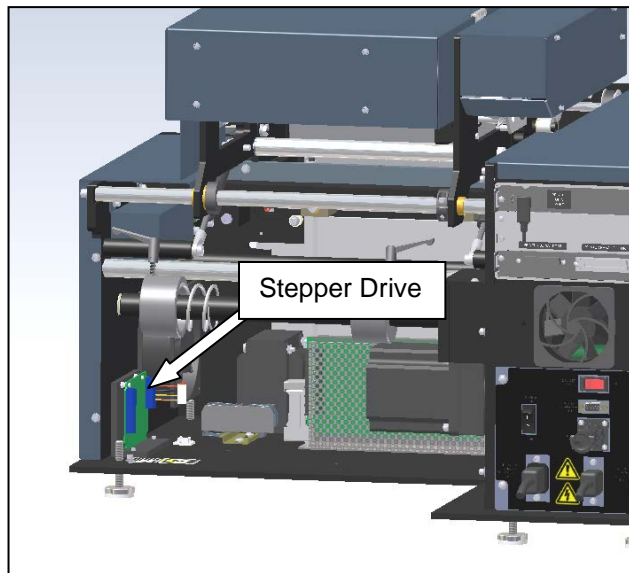

Figure 3-223 Printhead Position Stepper Drive

PRINthead CRADLE ASSEMBLY

PRINthead POSITION MOTOR (con't)

7. Test the motor cable. Using a Digital Volt/Ohm Meter (DVOM) set to test for continuity, probe between pins A+ & A- and B+ & B-. If the cable passes all continuity checks, it is functioning properly and further troubleshooting is required (Refer **Section 3 Component Repair: Printhead Stepper Drive** section for a more detailed explanation).

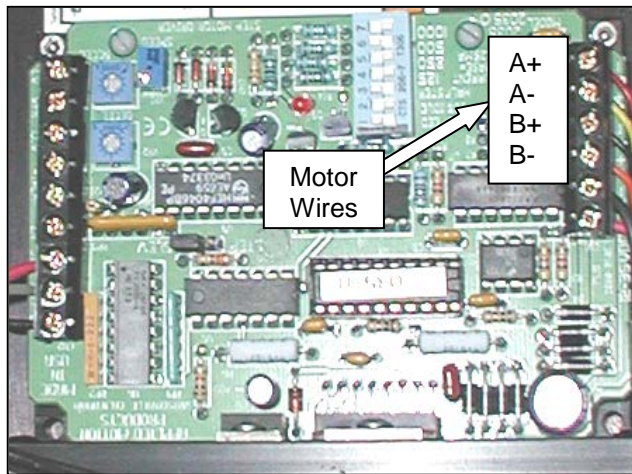

Figure 3-224 Print Head Stepper Drive

ADJUSTMENT

The printhead position motor is adjustment-free.

REPLACEMENT

1. Remove the outside cradle cover.

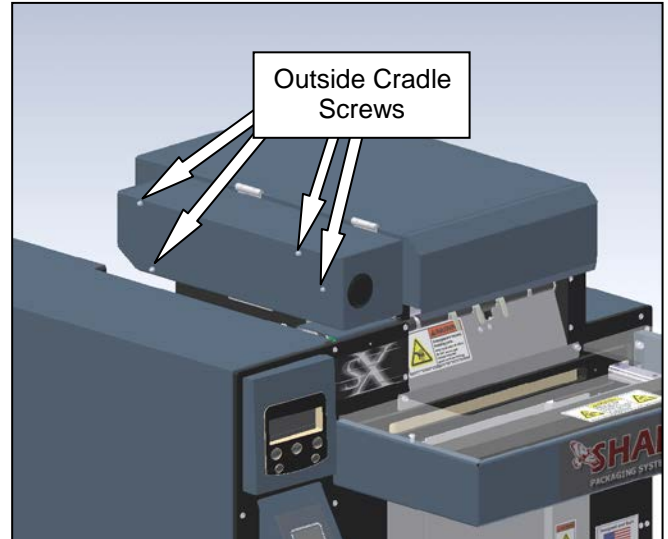

Figure 3-225. Removing the Outside Cradle Cover

2. Unplug the motor cable.
3. Remove the four bolts that mount the printhead position motor to the outside cradle plate. Slide the motor to the front of the machine to release the belt from the motor pulley. Once the belt is free, slide the motor up to remove from the machine.

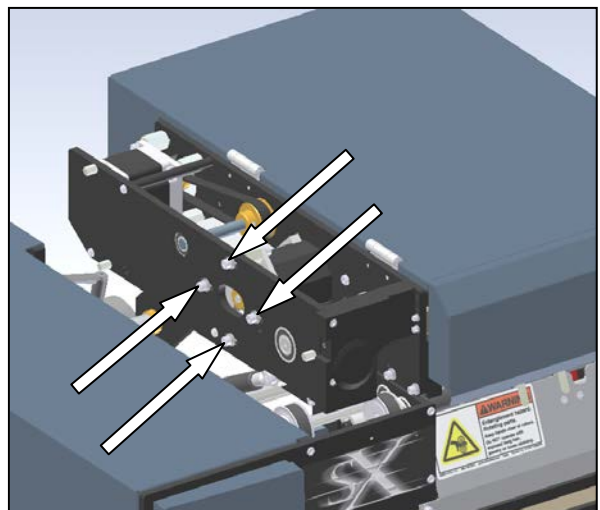

Figure 3-226. Printhead Position Motor Screws

PRINthead CRADLE ASSEMBLY

PRINthead POSITION MOTOR (con't)

- Remove the pulley and four standoffs from the old motor, and reinstall on the new motor.
- Place the new motor into the machine, being sure to orientate the cable receptacle to the top-rear of the machine. Also be sure the belt is over the pulley.

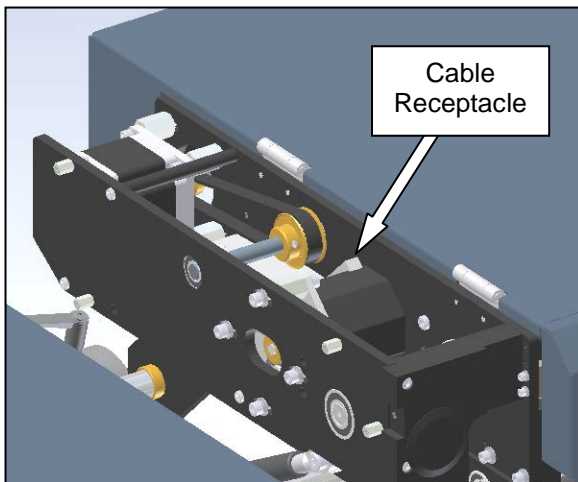

Figure 3-227. Printhead Position Motor Orientation

- Reinstall the screws into the motor standoffs through the slots in the outside cradle plate. Before tightening into position, be sure to set the belt tension to a satisfactory level. The center of belt span should displace about 1/16th of an inch when pressed with one finger perpendicular to the belt travel (Refer to **Machine Adjustments: Checking Belt Tension** for a more detailed explanation).
- Reinstall the motor cable.
- Replace all guards removed in the previous steps.

PRINthead POSITION DRIVE BELT

This belt drives the printhead cam transfer shaft, which controls the up-and-down motion of the printhead.

TESTING



WARNING

Always remove electrical power from the SX™ prior to performing any maintenance on the machine.

- Ensure the printhead position drive belt has the proper tension. Refer to **Machine Adjustments: Checking Belt Tension** section to determine the correct tension.
- Perform a visual inspection of the belt. If it is showing signs of wear, such as cracking or fraying, it needs to be replaced.

ADJUSTMENT

Refer to the **Machine Adjustments: Checking Belt Tension** section.

PRINthead CRADLE ASSEMBLY

PRINthead POSITION DRIVE BELT (con't)

REPLACEMENT

1. Remove the outside cradle cover.

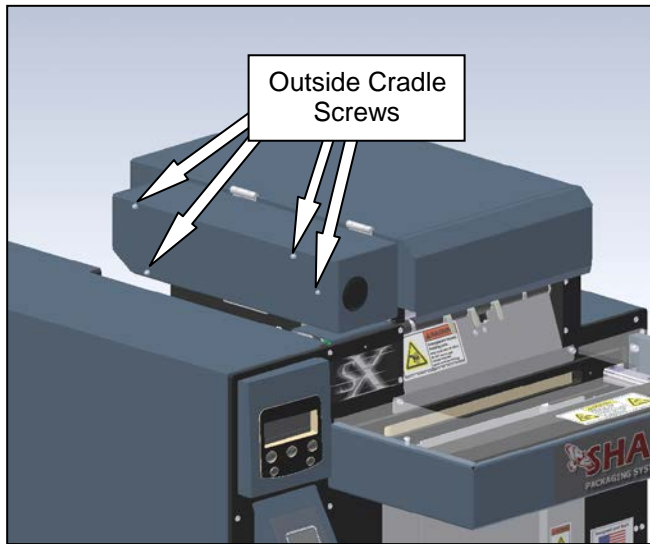

Figure 3-228. Removing the Outside Cradle Cover

2. Unplug the motor cable.
3. Remove the four bolts that mount the printhead position motor to the outside cradle plate. Slide the motor to the front of the machine to release the belt from the motor pulley. Once the belt is free, slide the motor up to remove from the machine.

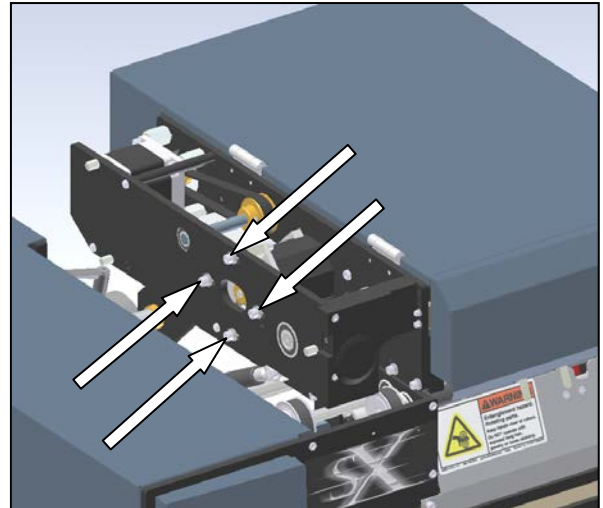

Figure 3-229. Printhead Position Motor Screws

4. Remove the outside cradle plate from the machine. This is done by removing three screws from the side of the plate and two screws from the front edge. Once the plate is free, gently slide it off the transfer shaft and remove from the machine.

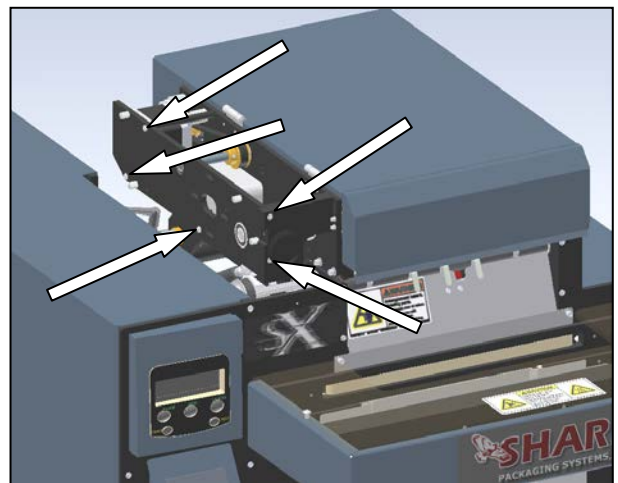

Figure 3-230. Outside Cradle Plate Screws

PRINthead CRADLE ASSEMBLY

PRINthead POSITION DRIVE BELT (con't)

5. Slide the belt off the transfer shaft pulley, and replace with the new belt.
6. Reinstall the outside cradle plate, and reinstall the five screws that hold it in place.
7. Place the motor into the machine, being sure to orientate the cable receptacle to the top-rear of the machine. Also be sure the belt is over the pulley.

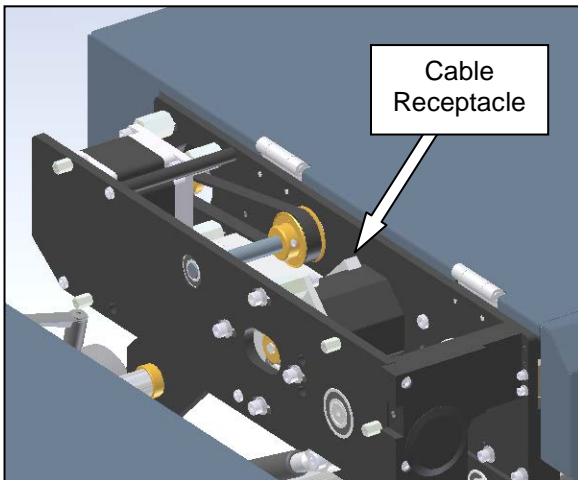

Figure 3-231. Printhead Position Motor Orientation

8. Reinstall the screws into the motor standoffs through the slots in the outside cradle plate. Before tightening into position, be sure to set the belt tension to a satisfactory level. The center of belt span should displace about 1/16th of an inch when pressed with one finger perpendicular to the belt travel (Refer to **Machine Adjustments: Checking Belt Tension** for a more detailed explanation).
9. Reinstall the motor cable.
10. Replace all guards removed in the previous steps.

PRINthead PRESSURE CAMS

The printhead cams press on the top of the printhead pressure assembly while imprinting on the film during operation of the Sharp SX™. The cams also lift the printhead off the film while feeding and not printing.

TESTING



WARNING

Always remove electrical power from the SX™ prior to performing any maintenance on the machine.

1. Symptoms of cam shaft wear include light print, higher ribbon usage, and misfeeds with the ribbon. Visually inspect the cam shafts for unevenness in the bearing surfaces. The profile of the cam should be smooth and round. Flats spots in the cam indicate wear, and require replacement of the plastic cams.

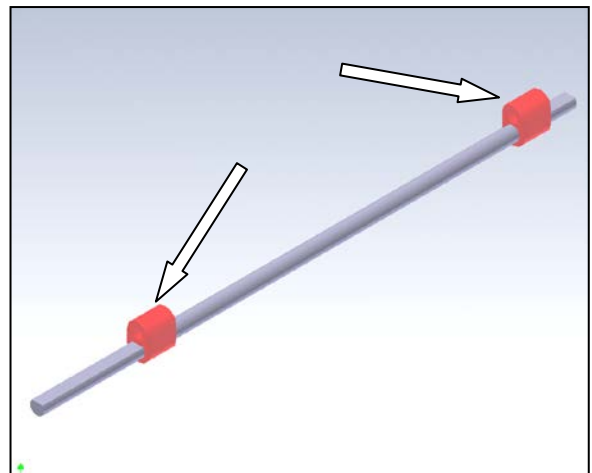

Figure 3-232. Cam Bearing Surfaces

ADJUSTMENT

The printhead pressure cams are adjustment free.

PRINTHEAD CRADLE ASSEMBLY

PRINTHEAD PRESSURE CAMS (con't)

REPLACEMENT

1. Remove the outside cradle cover.(Figure 3-233)

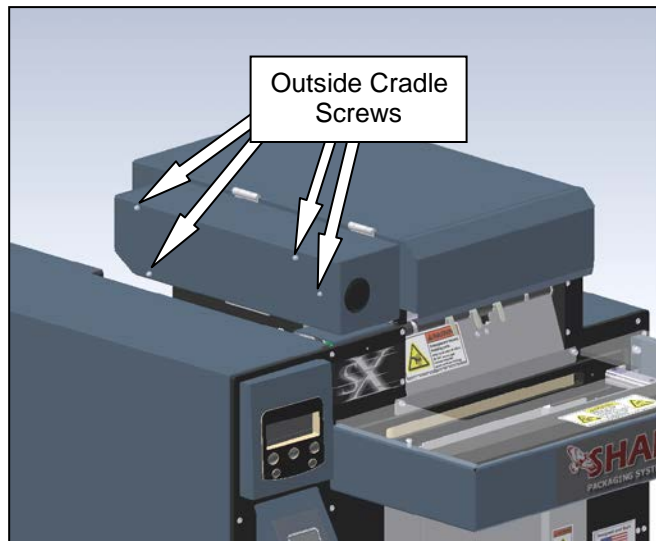
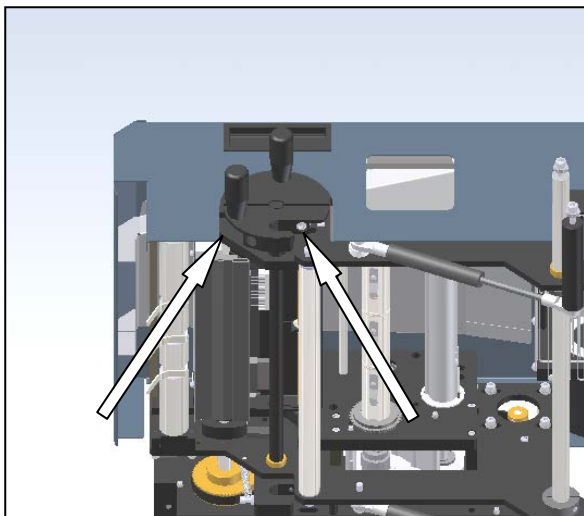

Figure 3-233. Removing the Outside Cradle Cover

2. Release the cradle latch to expose the printhead and drive rollers, and remove the cradle latch by loosening the two countersunk screws from the bottom (Figure 3-234). Slide the latch from the machine, being sure to catch the nylon washer on the shaft between the latch and side plate. Slide the latch shaft in to clear the plate.

Figure 3-234. Cradle Latch Lever Screws
Note: Printhead Cradle Isolated for Clarity

3. Open the cradle cover. Mark the sensor flag position on the transfer shaft (Figure 3-236). Make a reference point on the flag and corresponding line on the shaft, being sure to identify both rotation angle and distance from the bearing. This reference point will be needed for reassembly.

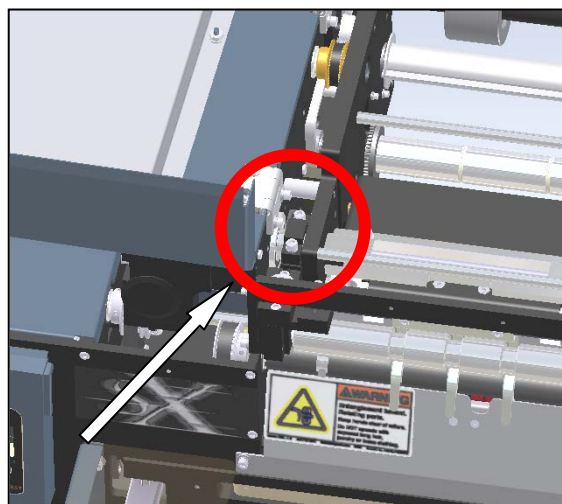

Figure 3-235. Locating the Sensor Flag

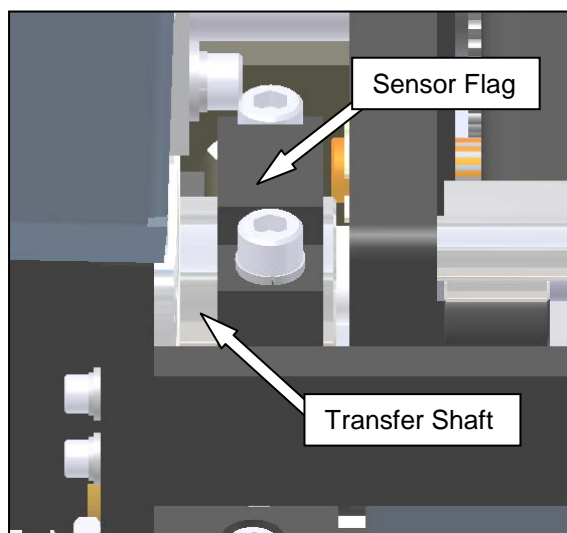

Figure 3-236. Transfer Shaft and Sensor Flag

PRINthead CRADLE ASSEMBLY

PRINthead PRESSURE CAMS (con't)

4. Remove the top shoulder bolt from the gas spring on the right side of the machine. Be sure to catch the four nylon washers that are between the plate and the spring.

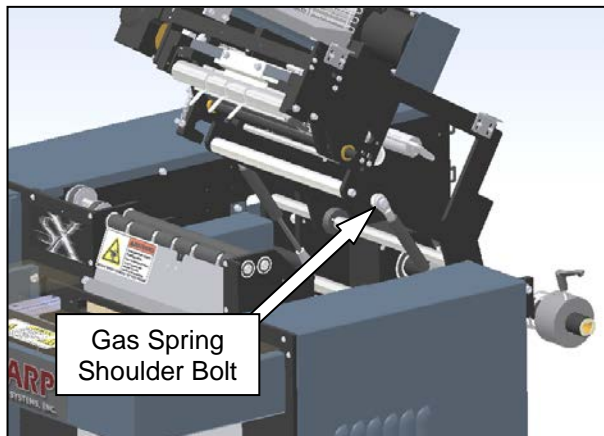

Figure 3-237. Removing the Gas Spring

5. Remove the eight screws identified in Figure 3-238. This will allow the right side cradle plate to rotate on the back flanged bushing. Gently slide the plate away from the machine, and turn the plate towards the rear so it is out of the way. This will also allow the roller identified to be removed.

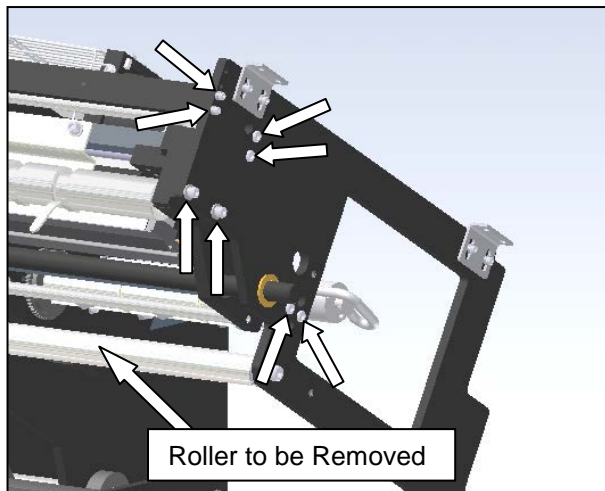

Figure 3-238. Screw Identification for Right Side Plate

6. Remove the E-Clip from the printhead pivot shaft.

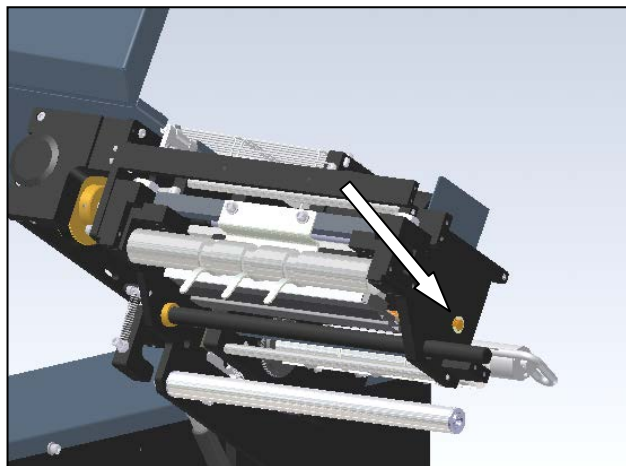

Figure 3-239. Removing the E-Clip

7. Remove the five screws identified in Figure 3-240. This will allow the right inner plate to be removed.

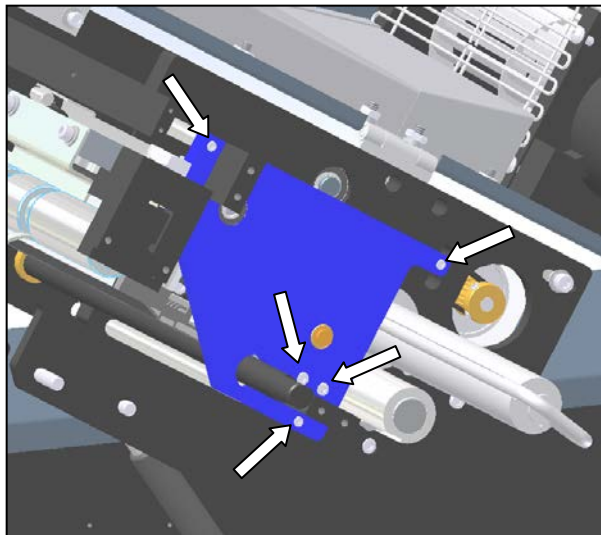

Figure 3-240. Screw Identification for Right Inner Plate.

PRINthead CRADLE ASSEMBLY

PRINthead CRADLE ASSEMBLY

PRINthead PRESSURE CAMS (con't)

- Remove the front cross member bar by removing two screws shown in Figure 3-241.

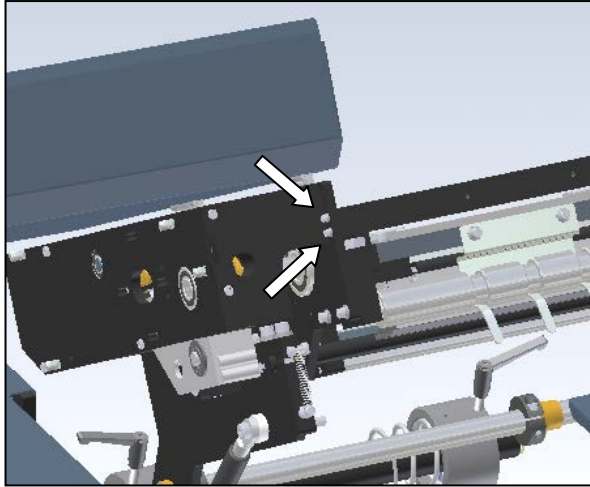

Figure 3-241. Front Cross member Screws

- Loosen the two screws on the sensor flag (which was previously marked in step 3). Once loose, slide completely to the left to expose the transfer shaft set screw.

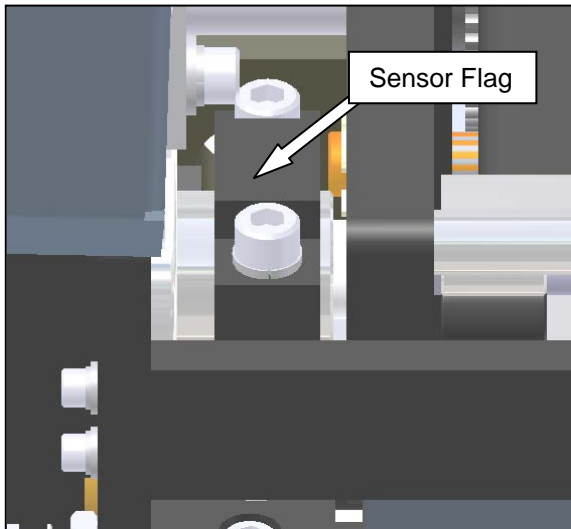

Figure 3-242. Sensor Flag

- Once the sensor flag is slid to the right, a set screw on the transfer shaft will be exposed. Loosen this set screw about 1 turn; this will free the cam shaft and allow it to be removed from the machine. When removing the cam shaft, there will be a nylon washer between the transfer shaft and left inner plate. Be careful not to misplace this washer, as it is needed for reassembly.

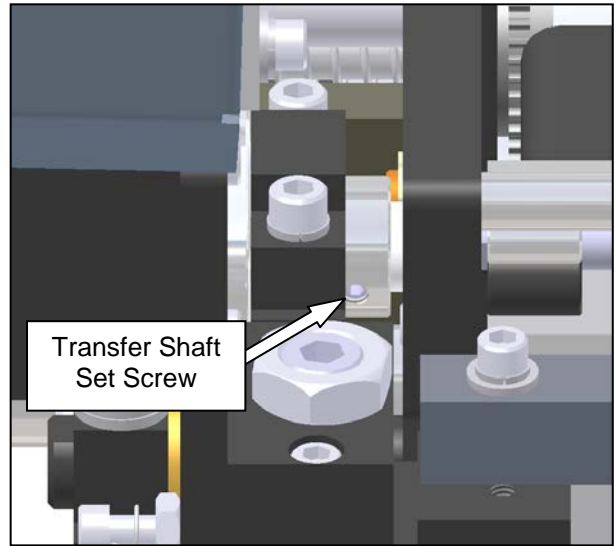

Figure 3-243. Transfer Shaft Set Screw

- Remove the worn cams from the cam shaft by sliding them off each end. Slide the new cams onto the shaft.

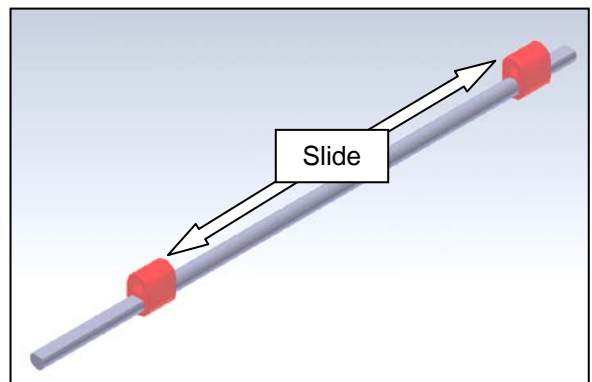

Figure 3-244. Cams and Cam Shaft

PRINthead CRADLE ASSEMBLY

PRINthead PRESSURE CAMS (con't)

12. Reinsert the cam shaft into the machine through the printhead lift bracket and into the left inner plate. Slide the nylon washer into position next to the bearing, and continue to slide the cam shaft into the transfer shaft. Be sure the cam shaft is completely pressed into the transfer shaft.

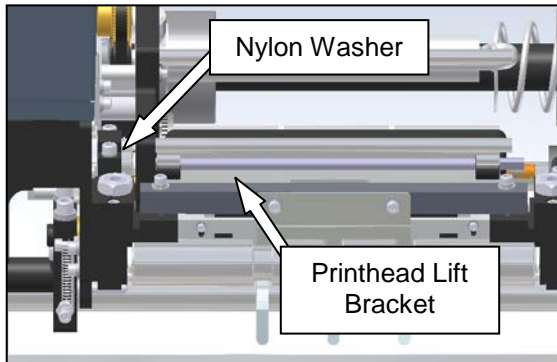

Figure 3-245. Reinstalling the Cam Shaft

13. Tighten the set screw in the transfer shaft onto the flat area of the cam shaft, making sure the cam shaft is fully inserted.
14. Reposition the sensor flag according to the marks made in step 3. It is crucial the sensor flag is positioned in the correct spot for proper machine operation. However, adjustments can be made when reassembly is completed.

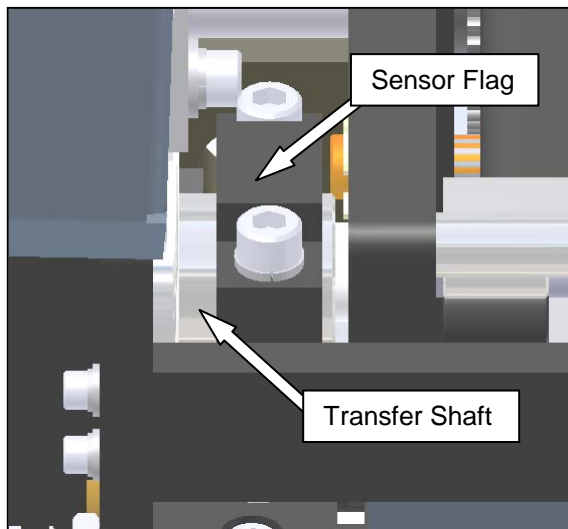

Figure 3-246. Transfer Shaft and Sensor Flag

15. Reinstall the two left screws on the front cross member bar.



Figure 3-247. Front Cross member Screws

16. Mount the right inner plate with the five screws removed in step 7, and reinstall the E-Clip on the printhead pivot shaft removed in step 6.
17. Rotate the right side cradle plate up into position. Reinstall the roller removed in step 5, and move plate into position to align screw holes. Reinstall eight screws.

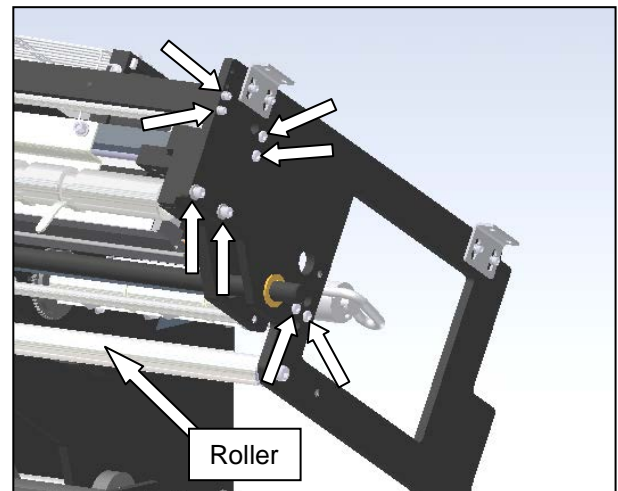

Figure 3-248. Screw Identification for Right Side Plate

PRINTHEAD CRADLE ASSEMBLY

PRINTHEAD PRESSURE CAMS (con't)

18. Return the gas spring into position. Insert shoulder bolt through clevis end on spring, and slide the four nylon washers over the shoulder bolt. Tighten into plate.

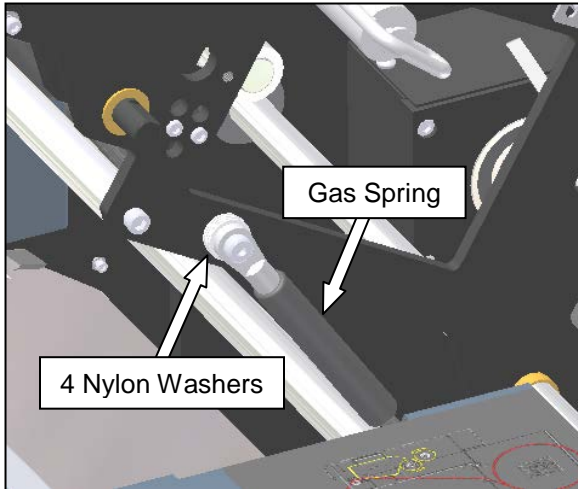

Figure 3-249. Gas Spring and Nylon Washers

19. Reinstall the cradle latch lever. Be sure to replace the nylon washer between the bushing and the latch. When tightening the latch into position, make sure the shaft is completely moved over to the right. Hold the opposite end of the shaft tight to the left plate.

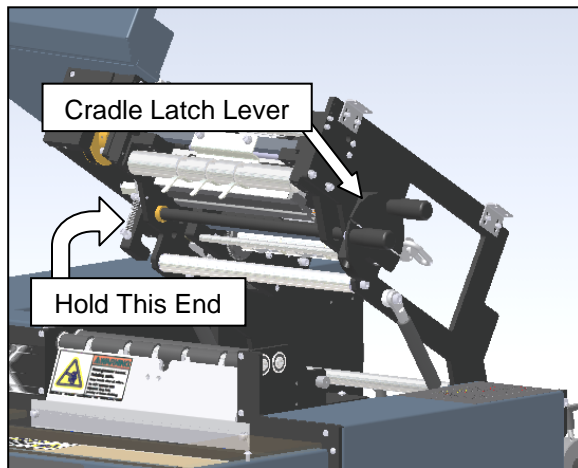

Figure 3-250. Reinstalling the Cradle Latch

20. Check the position of the sensor flag manually. Turn the transfer shaft pulley back and forth to ensure the flag will not hit the front or rear plate support. If severe interference is indicated, adjust the sensor flag by turning the pulley counterclockwise to position the printhead at its highest position (Fig. 3-251). The sensor flag should be parallel to the pinch roller brackets in this position (Fig. 3-252).

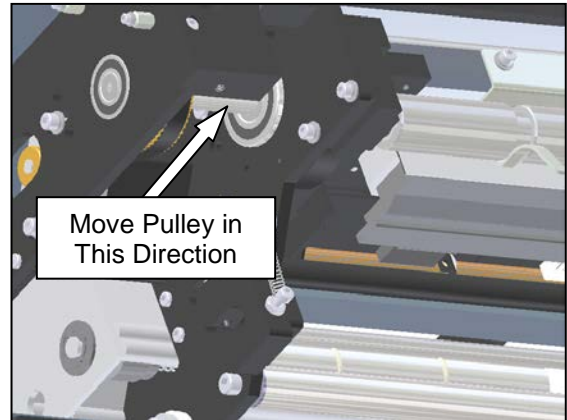

Figure 3-251. Transfer Shaft Pulley

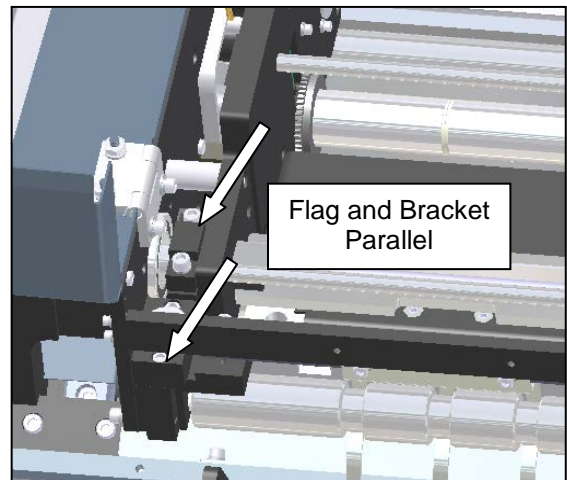

Figure 3-252. Sensor Flag Position

21. Replace the outside cradle cover.

PRINthead CRADLE ASSEMBLY

PRINthead POSITION SENSOR

The printhead position sensor communicates to the PLC the location of the printhead. If the sensor does not indicate the printhead is in the “down” position, the machine will not print.

TESTING

Parts of this procedure require that power is applied to the machine.

⚠ WARNING

USE EXTREME CAUTION WHILE SERVICING A MACHINE WHILE POWER IS APPLIED. UNEXPECTED MACHINE STARTUP CAN CAUSE SERIOUS INJURY.

⚠ WARNING

DO NOT ATTEMPT TO SERVICE THE MACHINE DURING NORMAL OPERATION. KEEP HANDS AND ARMS CLEAR OF MOVING PARTS.

⚠ WARNING

WHILE TESTING ELECTRICAL COMPONENTS WITH POWER APPLIED TO THE MACHINE, USE PROPER TROUBLESHOOTING TECHNIQUES TO AVOID ELECTRICAL SHOCK.

- Open the cradle cover, and check sensor function. Take any small metal object (such as a hex wrench) and pass in front of the sensor (within 1/8”). While moving the object back and forth, watch the PLC indicator lights. The light for Input “X4” should illuminate when the sensor is activated. If it does not, the sensor is faulty and needs replacement.

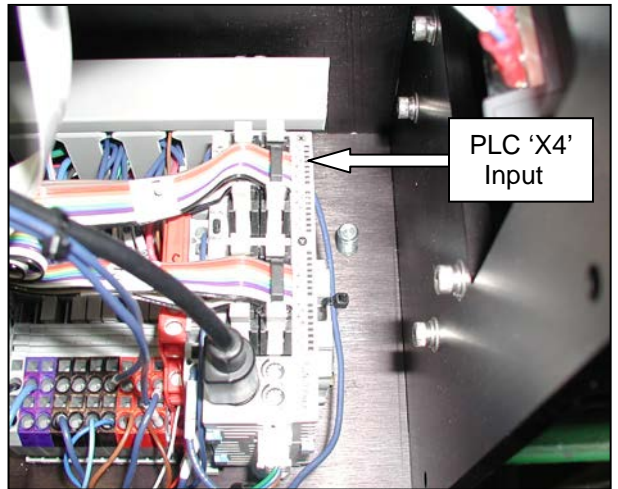

Figure 3-254. The PLC

ADJUSTMENT

The printhead position sensor is adjustment free.

REPLACEMENT

⚠ WARNING

Always remove electrical power from the SX™ prior to performing any maintenance on the machine.

- Remove the outside frame cover.

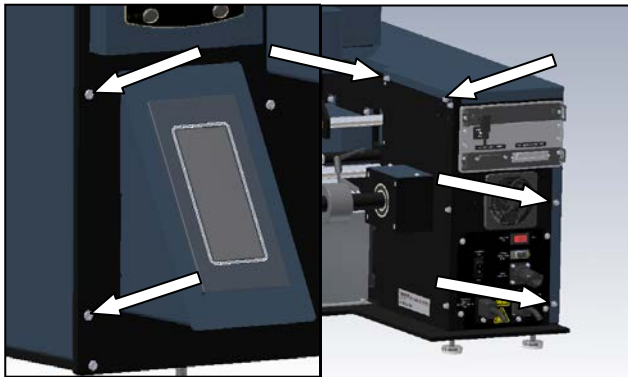

Figure 3-253. Frame Cover Screws

PRINthead POSITION SENSOR (con't)

1. Open the cradle, and remove the outside cradle cover. (Figure 3-255).

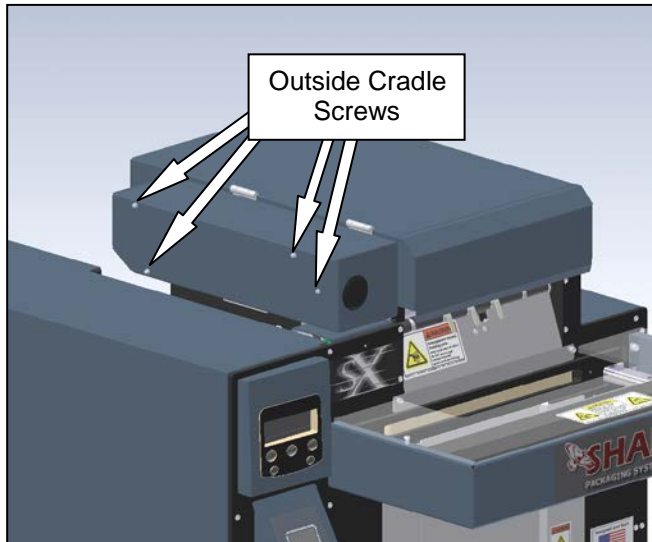

Figure 3-255. Removing the Outside Cradle Cover

2. Locate the printhead position sensor. Remove the flat head screw that holds the sensor in place. (Figure 3-256).

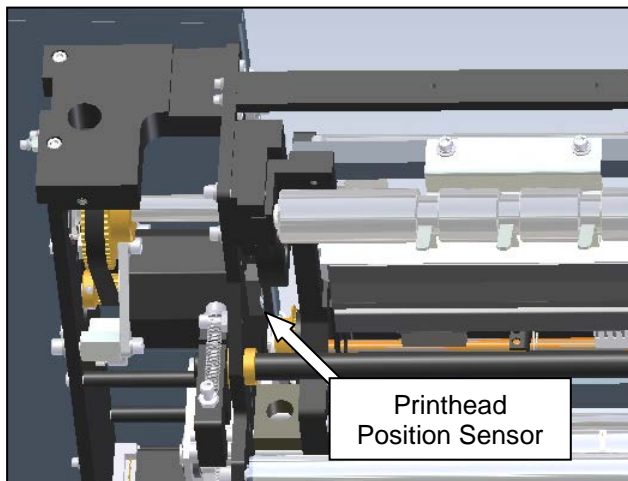

Figure 3-256. Locating the Printhead Position Sensor.

3. Follow the sensor cable back through the machine, cutting any cable ties that secure the cable to the bundle. Once the cable is free, unplug the connector from the Printhead position sensor receptacle on the base of the machine (Figure 3-257).

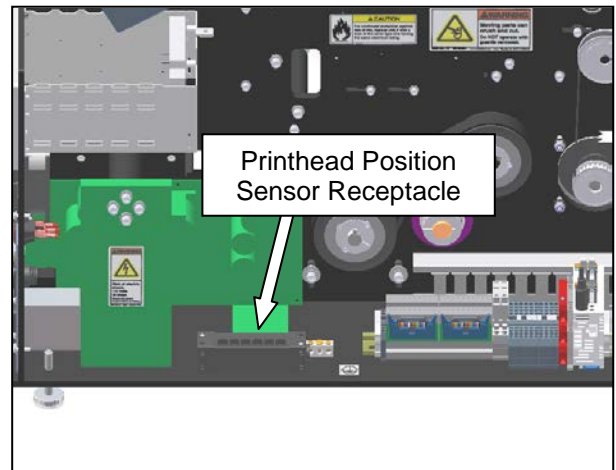

Figure 3-257. Sensor Connector Block

4. Unthread the sensor from the machine, removing it from the cradle. Rethread the new sensor cable, following the same route of the old sensor cable. Secure in place with cable ties, and trim the excess from the ends of the ties.
5. Reinstall the sensor screw. The alignment pin on the sensor should be to the front of the machine, seated in a locating hole on the cradle plate.
6. Replace all guards removed in the previous steps.

PRINthead CRADLE ASSEMBLY

THERMAL PRINthead

TESTING



WARNING

Always remove electrical power from the SX™ prior to performing any maintenance on the machine.

1. Problems with the printhead are indicated by poor image quality, unreadable bar codes, or voids in the print (repeated areas unprinted on the bag). Visually inspect the printhead for scratches or buildup of ribbon or film materials. Clean the printhead and platen roller thoroughly using a soft, lint-free cloth and isopropyl alcohol. If cleaning does not produce desired results, the printhead needs replacement. (Note: Refer to Appendix 1, "Protecting Your Printhead" located in the back of this manual for tips on getting the longest life out of a thermal printhead.)

ADJUSTMENT

Small adjustments can be made to fine-tune the print quality by moving the printhead adjustment screws slightly (Figure 3-258). This moves the print contact area on the platen roller to optimize the print quality. Make small adjustments, and cycle machine to test results. Continue until print quality is best.

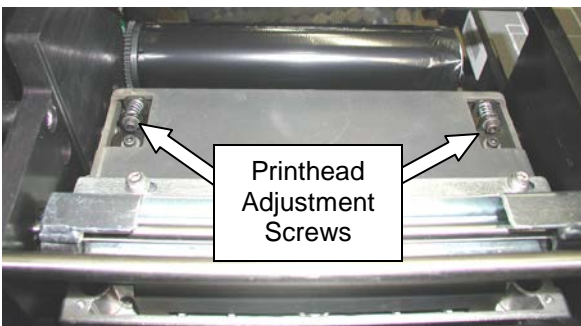

Figure 3-258. Printhead Adjustment Screws

REPLACEMENT

1. With power removed, open the cradle cover and release the cradle latch to expose the printhead. Remove any ribbon from the print area.
2. Locate the two screws shown in (Figure 3-259). Remove these two screws to free the printhead. Note: Once these screws are removed, the printhead will only be held by the cables.

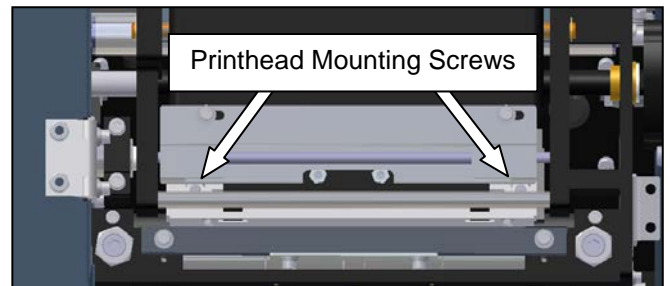

Figure 3-259. Printhead Mounting Screws

3. Unplug the power and data cables from the back of the printhead.



WARNING

This procedure deals with handling parts susceptible to damage from electrostatic discharge (ESD). Use static control precautions while servicing this equipment.

4. Install the cables into the new printhead, making certain the cable ends are fully inserted into the receptacles.
5. Install the new printhead onto the printhead pressure assembly. The printhead will align with locating pins on the pressure assembly to fully seat the printhead into the correct position. Once in position, insert the two screws and secure.
6. Rethread the ribbon according to the threading diagram located on the top panel of the side guard.

PRINTHEAD CRADLE ASSEMBLY

RIBBON SUPPLY ASSEMBLY

SLIP CLUTCH SPRING

The ribbon supply hub slip clutch spring is attached to the center plate and the slip clutch on the printhead cradle.

TESTING



WARNING

Always remove electrical power from the SX™ prior to performing any maintenance on the machine.

1. Spin the ribbon supply hub by hand. If the hub turns freely, the spring is either broken or disconnected.
2. Open the cradle cover, and locate the supply hub slip clutch spring. Check to ensure both ends of the spring are attached; one end on the center plate peg and one on the slip clutch. (as Shown in Figure 3-260).

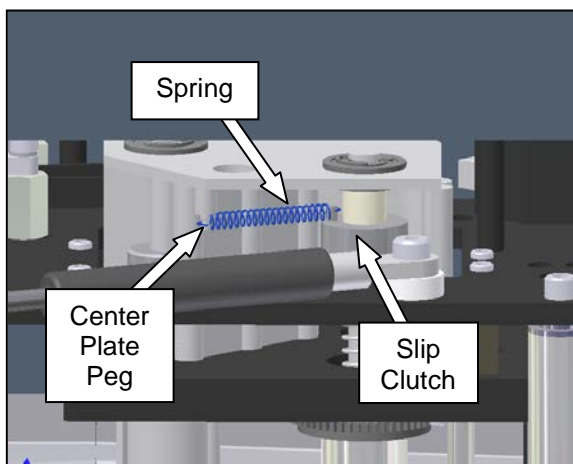

Figure 3-260. Supply Hub Slip Clutch Spring

Note: Cradle Isolated for Clarity

ADJUSTMENT

There are no adjustments to be made on the slip clutch spring.

REPLACEMENT

The slip clutch spring can be replaced without any machine disassembly. Open the cradle, and locate the spring. Place the loops of the spring over the pegs on the slip clutch and center plate.

PRINthead CRADLE ASSEMBLY

RIBBON MOTION SENSOR

This sensor communicates to the machine the motion of the ribbon supply hub. If the ribbon is not unwinding during a machine cycle, the machine will go into a “Ribbon Fault.”

TESTING

Some parts of testing the ribbon motion sensor require that power be applied to the machine.

WARNING

USE EXTREME CAUTION WHILE SERVICING A MACHINE WHILE POWER IS APPLIED. UNEXPECTED MACHINE STARTUP CAN CAUSE SERIOUS INJURY OR DEATH.

WARNING

DO NOT ATTEMPT TO SERVICE THE MACHINE DURING NORMAL OPERATION. KEEP HANDS AND ARMS CLEAR OF MOVING PARTS.

WARNING

WHILE TESTING ELECTRICAL COMPONENTS WITH POWER APPLIED TO THE MACHINE, USE PROPER TROUBLESHOOTING TECHNIQUES TO AVOID ELECTRICAL SHOCK.

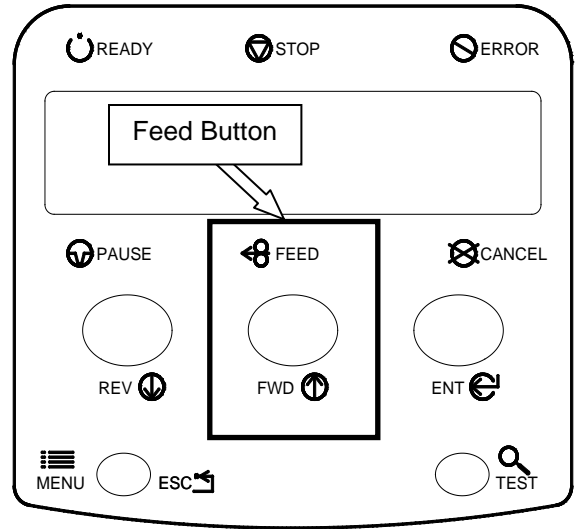

Figure 3-261. Printer Control Panel

- Remove power from the machine, and remove the outside frame cover (Figure 3-262).

WARNING

Always remove electrical power from the SX™ prior to performing any maintenance on the machine.

- If the machine goes into a “Ribbon Fault,” check to make sure there is ribbon left on the supply roll and that it is properly threaded through the machine. If the ribbon is completely used, install a new roll of ribbon and check machine operation.
- After the machine passes a visual check, press the “Feed” button on the printer control panel (Figure 3-261). This will pull the ribbon through the machine. If this does not clear the ribbon fault, move to step 3.

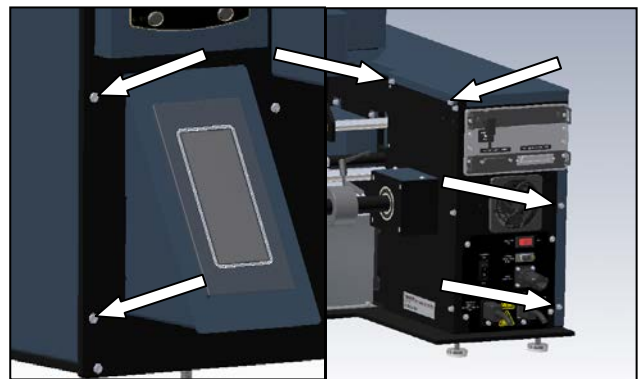

Figure 3-262. Frame Cover Screws

PRINTHEAD CRADLE ASSEMBLY

REPLACEMENT

RIBBON MOTION SENSOR (con't)

4. Check to ensure the sensor cable is plugged into the rear of the card cage (Figure 3-263). The plug (labeled "P8") should be fully inserted over the pins (labeled "Ribbon Motion") on the board. If the cable is fully engaged on the receptacle on the board, and all other testing has passed, the ribbon sensor is faulty and needs replacement.

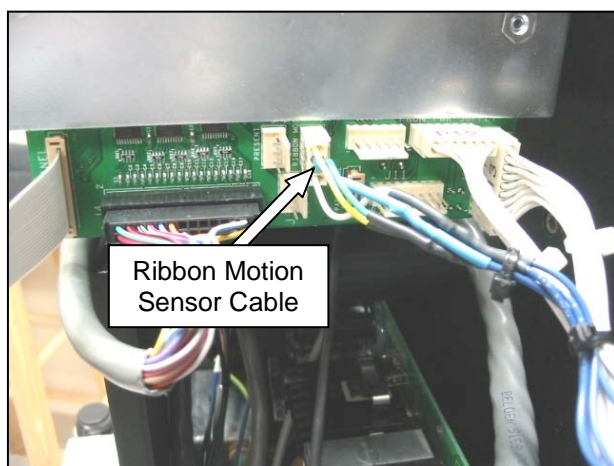

Figure 3-263. Ribbon Motion Sensor Cable Plug

ADJUSTMENT

The ribbon motion sensor is adjustment free.

1. Open the cradle cover, and locate the ribbon motion sensor (Figure 3-264). Remove the mounting screw.

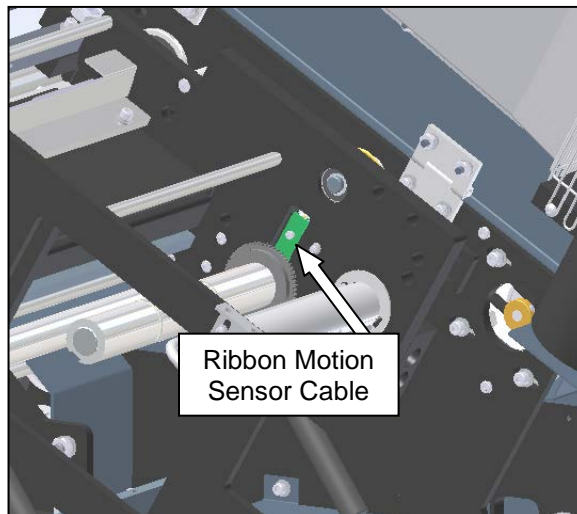

Figure 3-264. Ribbon Motion Sensor

2. Lift the sensor out of the recessed mounting pocket. Once the sensor is clear of the supply hub, slide it through the clearance hole in the center plate. Follow the cable through the machine, cutting any cable ties holding the cable to the bundle. Once the complete cable is free, unplug the sensor from the board.
3. Route the new cable through the machine, following the same path as the old cable. Once in position, plug the sensor into the card cage board, and reinstall the sensor screw on the cradle.
4. Replace all guards removed in the previous steps.

PRINthead CRADLE ASSEMBLY

RIBBON CLIPS

The ribbon clips are used to hold the core of the ribbon to the ribbon supply hub assembly (Figure 3-265).

TESTING



WARNING

Always remove electrical power from the SX™ prior to performing any maintenance on the machine.

1. Open the cradle cover, and spin the roll of ribbon. Watch the supply hub assembly. The supply hub should spin in unison with the roll of ribbon. If the ribbon roll spins independently, the ribbon clips need replacement.

ADJUSTMENT

The ribbon clips are adjustment free.

REPLACEMENT

1. Open the cradle cover, and remove the ribbon core from the ribbon supply hub assembly.
2. Remove the button head cap screws from whichever clip(s) need replacement. Install the new ribbon clips onto the individual hubs as needed.

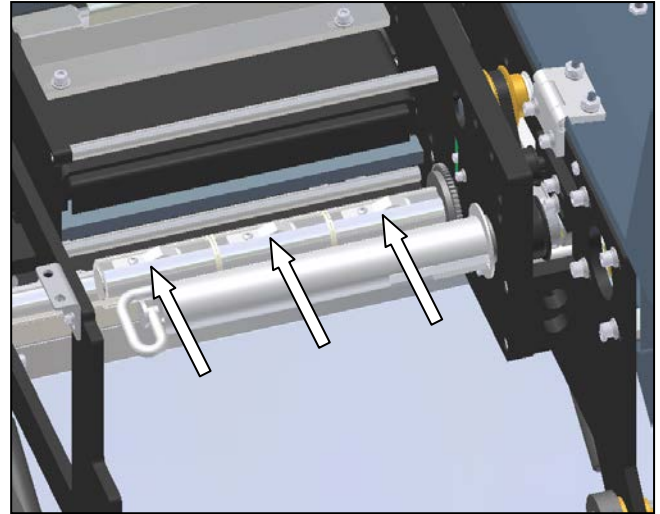

Figure 3-265. Ribbon Clips

PRINthead CRADLE ASSEMBLY

GAS SPRINGS

TESTING



WARNING

Always remove electrical power from the SX™ prior to performing any maintenance on the machine.

If the cradle does not hold itself up when opened, the gas springs are worn and need replacement. Sharp Packaging Systems Inc. recommends replacing the gas springs in pairs.

ADJUSTMENT

The gas springs are adjustment free.

REPLACEMENT

1. Open the cradle cover, and open the cradle by releasing the latch lever on the right side of the machine.



Figure 3-266. Cradle Latch

2. Remove the top shoulder bolt of the right gas spring from the cradle plate. Once the screw is free of the plate, be sure to catch the four nylon washers used as spacers between the plate and the gas spring clevis. Note that the cradle will not support itself, and will be free to fall. **Be sure to support the cradle and lower it gently to avoid pinching and crushing of arms or fingers.**

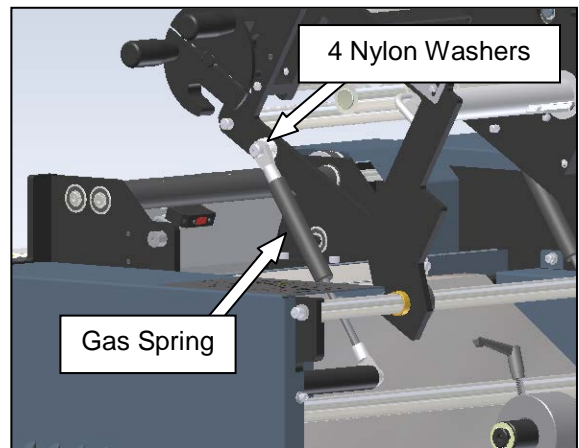

Figure 3-267. Gas Spring Mounting

3. Remove the right gas spring from the standoff on the frame.

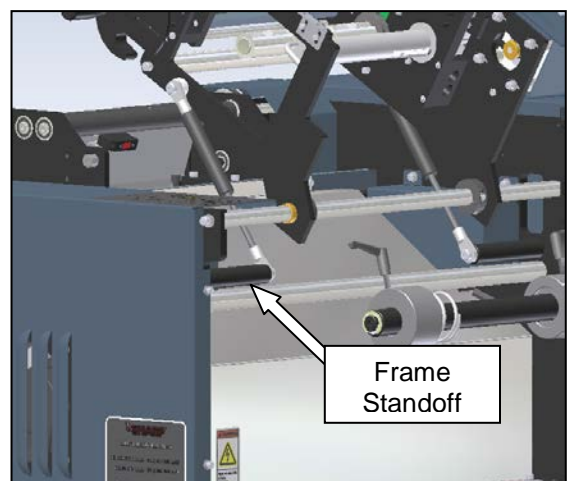

Figure 3-268. Frame Standoffs

PRINTHEAD CRADLE ASSEMBLY

GAS SPRINGS (con't)

- Remove the rod end clevis from each end of the gas spring, and install on the new spring (Figure 3-268).

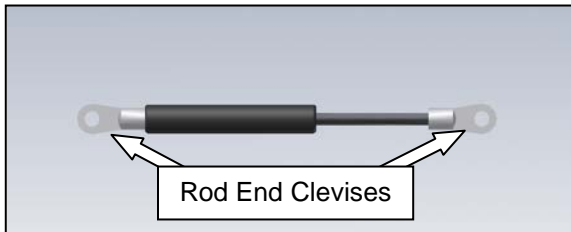

Figure 3-269. Removing the Rod End Clevises

- Install the new gas spring on the machine. Be sure to replace the four nylon washers between the clevis and the cradle plate.
- Repeat the replacement procedure for the left gas spring. Again, the cradle will be free to close when the gas spring is removed. **Be sure to support the cradle and lower it gently to avoid pinching and crushing of arms or fingers.**

CROSS FLOW FAN

The cross flow fan is mounted in the cradle cover, and is used for opening bag film before filling.

TESTING



WARNING

USE EXTREME CAUTION WHILE SERVICING A MACHINE WHILE POWER IS APPLIED. UNEXPECTED MACHINE STARTUP CAN CAUSE SERIOUS INJURY.



WARNING

DO NOT ATTEMPT TO SERVICE THE MACHINE DURING NORMAL OPERATION. KEEP HANDS AND ARMS CLEAR OF MOVING PARTS.



WARNING

WHILE TESTING ELECTRICAL COMPONENTS WITH POWER APPLIED TO THE MACHINE, USE PROPER TROUBLESHOOTING TECHNIQUES TO AVOID ELECTRICAL SHOCK.

- Open the cradle cover, and locate the cross flow fan. Cut the cable ties holding the connectors together, and unplug the fan. Using a Digital Volt/Ohm Meter (DVOM) set to check for AC Voltage, probe between the two wires unplugged from the fan. The voltage should read 110 Volts. If power is being supplied to the fan and it is not working, the cross flow fan is faulty and needs replacement.

PRINthead CRADLE ASSEMBLY

CROSS FLOW FAN (con't)

ADJUSTMENT

The cross flow fan is adjustment free.

REPLACEMENT



WARNING

Always remove electrical power from the SX™ prior to performing any maintenance on the machine.

1. If not previously done in the “Testing” section, open the cradle cover and unplug the two connectors which power the cross flow fan.
2. Remove the four mounting screws from the back of the cradle cover (Figure 3-270).

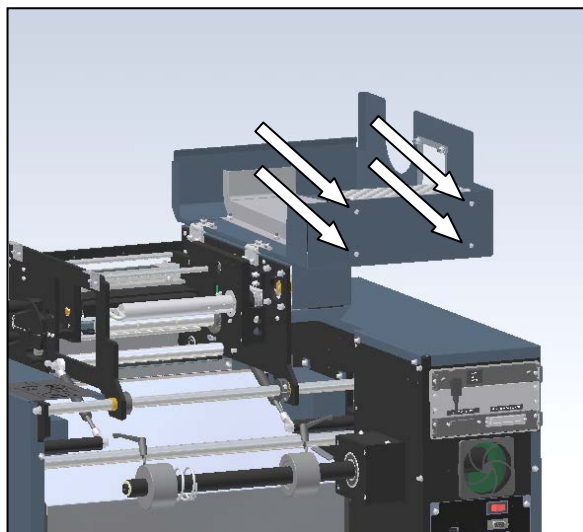

Figure 3-270. Cross Flow Fan Screws

3. Remove the fan from the cradle by lifting straight up from the machine. Be sure the finger guards clear the duct inside of the cover. Note: if the Sharp SX™ is not equipped with a printer, the cradle cover cannot be hinged open, and the fan will drop out below the cover.
4. Remove the two finger guards from the fan, and reinstall on the new fan (Figure 3-271).

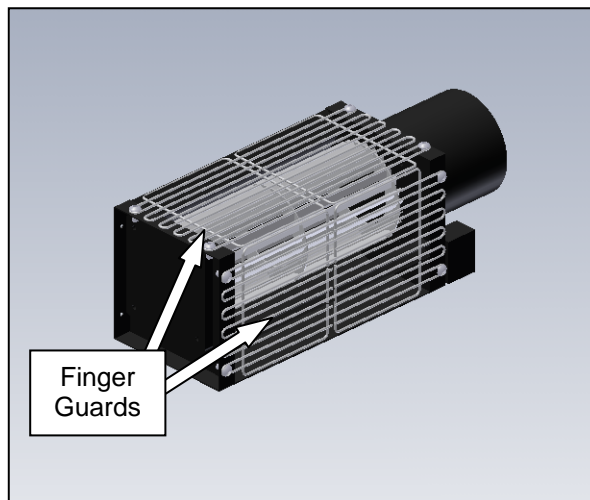

Figure 3-271. Cross Flow Fan Finger Guards

5. Install the fan in the cradle cover. Once in position, tighten the four mounting screws on the rear of the cover. Connect the two power wires, and coil the excess cable together with cable ties.

Note: the wiring is interchangeable, so either wire from the machine can connect to either wire from the fan.

PRINthead CRADLE ASSEMBLY

CRADLE LATCH LEVER

Note: Earlier models of the Sharp SX™ are equipped with latch pins in the place of cam followers. If the latch pins need replacing, the latch mechanism needs to be upgraded to the cam followers. This procedure is best completed at Sharp Packaging Systems' facility by our service personnel because substantial machine disassembly is required.

The cradle latch lever holds the cradle into position, compressing the pinch roller onto the film feed roller to ensure the bag film is fed through the machine. This works in tandem with the cradle latch, located on the opposite side of the cradle. Sharp Packaging Systems Inc. recommends replacing the cradle latch lever and the cradle latch together for best results.

TESTING



WARNING

Always remove electrical power from the SX™ prior to performing any maintenance on the machine.

1. If the cradle latch is worn, the film may track to either side of the roller, or the cradle may unexpectedly open or open easily. Also, it will not "snap" into position when the cradle is to be locked closed. If this is the case, the cradle latch lever needs replacement.

ADJUSTMENT

The cradle latch lever is adjustment free.

REPLACEMENT

1. Release the cradle latch to expose the printhead and drive rollers. Remove the cradle latch by loosening the two countersunk screws

from the bottom (Figure 3-272). Slide the latch from the machine, being sure to catch the nylon washer on the shaft between the latch and side plate.

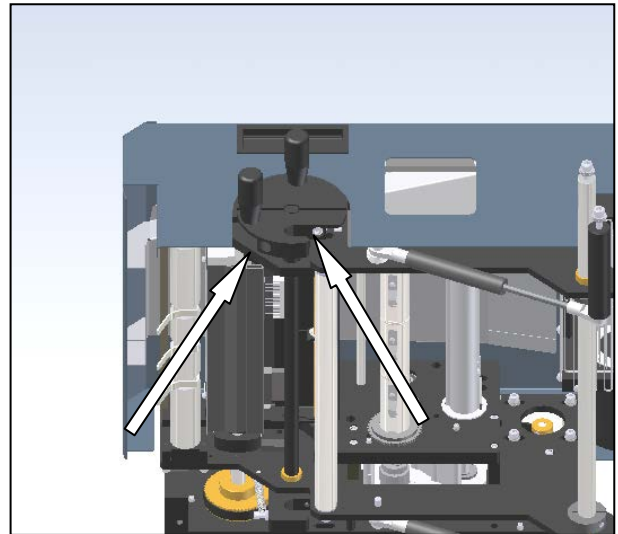

Figure 3-272. Cradle Latch Lever Screws

Note: Printhead Cradle Isolated for Clarity

2. Once the cradle latch lever is free of the machine, remove the two handles by unthreading the two screws shown (Figure 3-273).

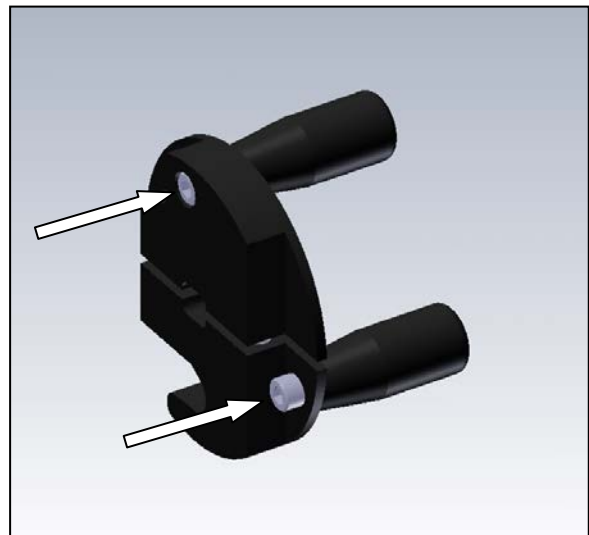

Figure 3-273. Cradle Latch Lever

PRINthead CRADLE ASSEMBLY

CRADLE LATCH

CRADLE LATCH LEVER (con't)

3. Reinstall the handles on the new latch.
4. Place the new cradle latch lever on the latch shaft, remembering to replace the nylon washer between the plate and the latch. Hold the opposite side of the latch shaft tight to the left plate, and tighten the latch lever into position (Figure 3-274).

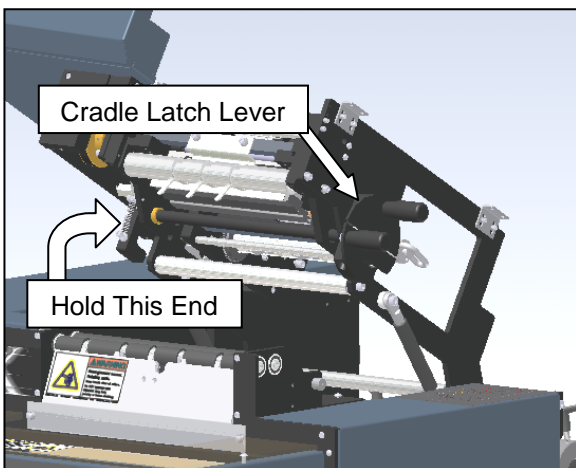

Figure 3-274. Reinstalling the Cradle Latch

The cradle latch lever holds the cradle into position, compressing the pinch roller onto the film feed roller to ensure the bag film is fed through the machine. This works in tandem with the cradle latch lever, located on the opposite side of the cradle. The cradle latch also contains a spring to hold the latch points clear when closing the cradle.

TESTING



WARNING

Always remove electrical power from the SX™ prior to performing any maintenance on the machine.

1. If the cradle latch is worn, the film may track to either side of the roller, or the cradle may unexpectedly open or open easily. Also, it will not “snap” into position when the cradle is to be locked closed. If this is the case, the cradle latch needs replacement.

ADJUSTMENT

The cradle latch lever is adjustment free.

REPLACEMENT

1. Release the cradle latch lever to expose the printhead and drive rollers.

PRINthead CRADLE ASSEMBLY

CRADLE LATCH (con't)

- Remove the top screw holding the spring into position. Unlock the hex nut, and remove screw from the cradle plate (Figure 3-275).

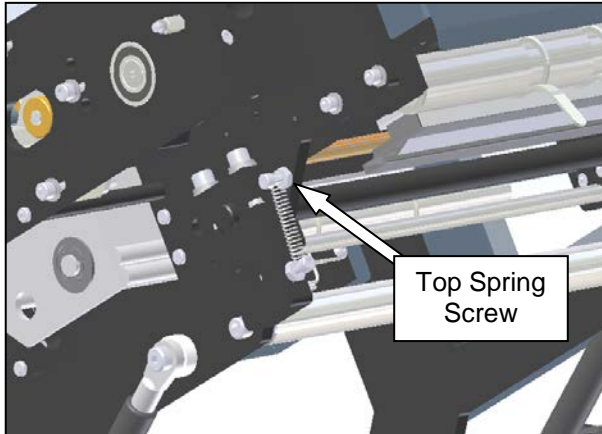

Figure 3-275. Cradle Latch Spring

- Once the top spring screw is removed, the latch can be rotated 180 degrees to access the latch screws. Loosen the two screws on the top of the cradle latch. Once loose, the cradle latch can be removed from the machine (Figure 3-276).

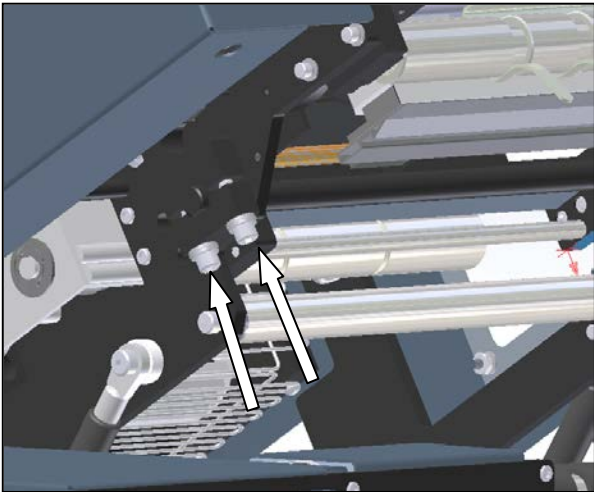

Figure 3-276. Cradle Latch Screws

- Remove the spring from the latch, and reinstall on the new part.

- Install the new latch onto the machine. Be sure to hold the right side of the latch lever tight to the plate. Once in position, tighten the latch screws (Figure 3-277).

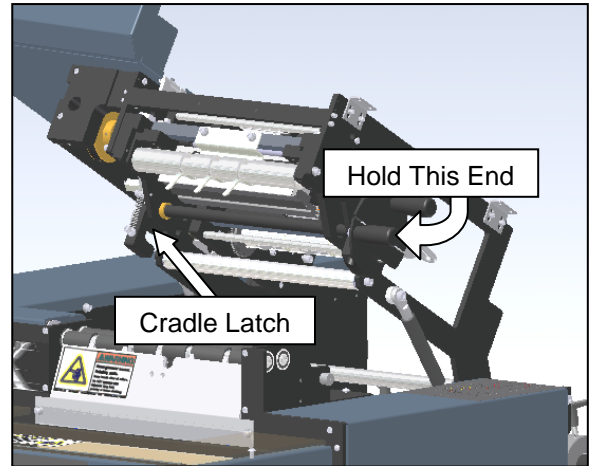

Figure 3-277. Reinstalling the Cradle Latch

- Reinstall the top spring screw into the cradle plate.

SEALER ASSEMBLY

PRESSURE BAR DRIVE MOTOR

TESTING

WARNING

Always remove electrical power from the SX™ prior to performing any maintenance on the machine.

1. The wire for the pressure bar motor has a quick disconnect plug about 5 inches from the motor. Ensure the plug is completely inserted into the receptacle.
2. Using a Digital Volt/Ohm Meter (DVOM), first check continuity on the motor at the pressure bar stepper drive. Use the following step to do this.
 - a. Remove the four screws shown in Figure 3-278 to remove front load plate.



Figure 3-278. Load Plate Screws

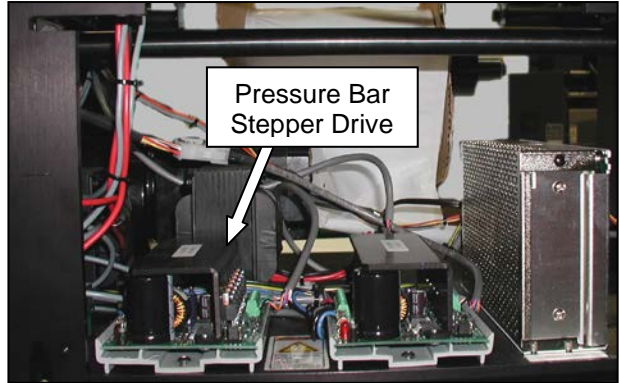

Figure 3-279. Pressure Bar Drive Location

- c. On the right-rear corner of the drive are the motor cable terminals. Check continuity between terminals 1 and 2, 1 and 3, and 2 and 3. Also check continuity between terminals 4 and 5, 4 and 6, and 5 and 6 (refer to figure 3-280 for terminal identification). If all six tests for continuity pass, the motor is not faulty and other troubleshooting techniques need to be followed. (Refer to **(Pressure Jaw and Film Feed Motor Controllers** for information on how to check the stepper drive).

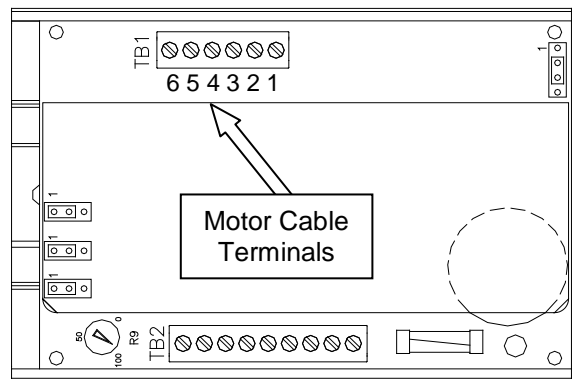

Figure 3-280. TM4500 Configuration

SEALER ASSEMBLY

PRESSURE BAR DRIVE MOTOR (con't)

3. If there is no continuity at the stepper drive, the quick disconnect cable may be faulty. Follow these steps to check the motor at the plug.
 - a. Unplug the quick disconnect located near the motor.
 - b. Using a DVOM, check the continuity on the motor end of the plug. First, check between pins 1 and 3, 1 and 6, and 3 and 6. Then check for continuity between 2 and 4, 2 and 5, and 4 and 5 (see **figure 3-281** for pin locations). If all six checks pass, the motor is not faulty, and there is a problem with the motor cable. Check the cable and connections to make sure the wires are not broken or pinched, and check pins to ensure they are still connected.

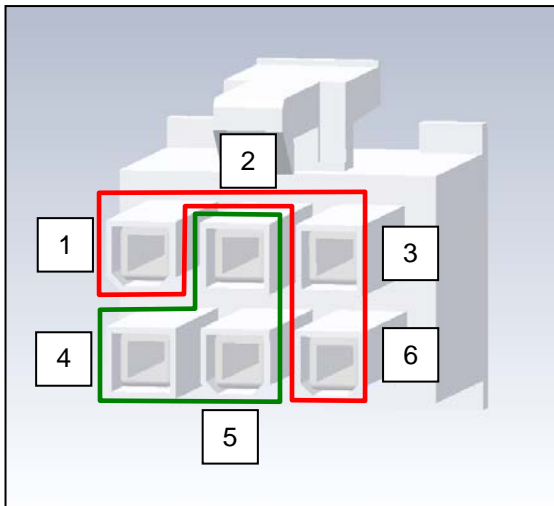

Figure 3-281. Motor Plug

ADJUSTMENT

The film feed drive motor is adjustment free.

REPLACEMENT

1. Remove the motor covers and the load plate (see Figures 3-282, 283 and 284).

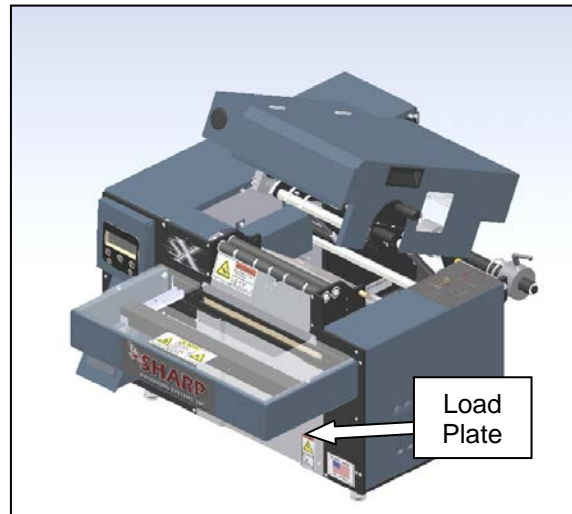

Figure 3-282. Guard Identification

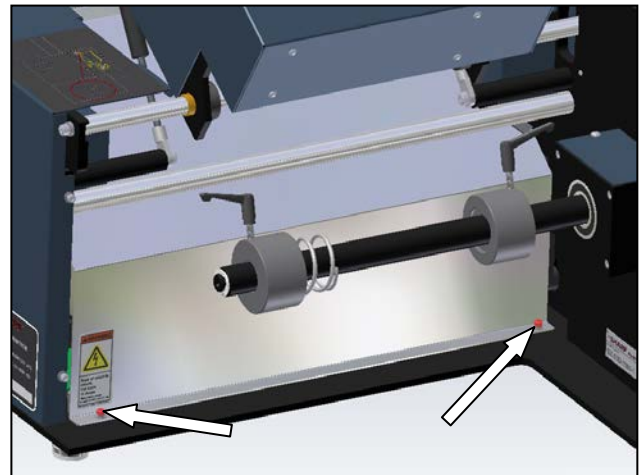

Figure 3-283. Motor Cover Rear Screws

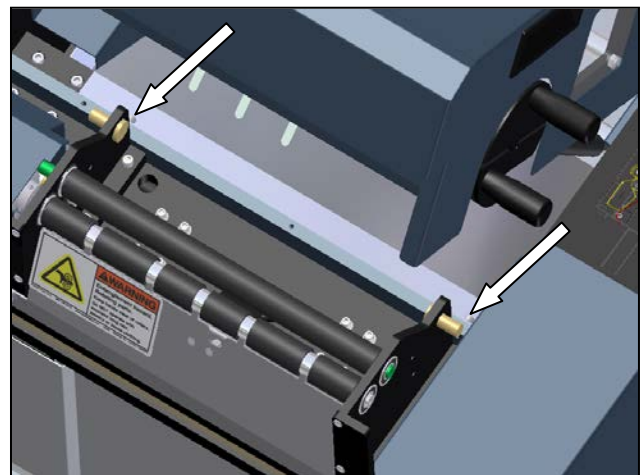

Figure 3-284. Motor Cover Front Screws

SEALER ASSEMBLY

PRESSURE BAR DRIVE MOTOR (con't)

1 Unplug the quick disconnect on the Pressure Bar Drive Motor (Figure 3-385), and remove the four motor mounting screws.

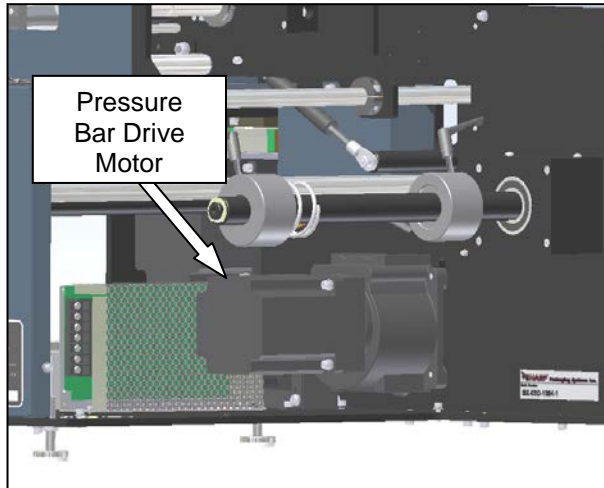

Figure 3-285. Pressure Bar Drive Motor

2 Take the new motor, and verify the length of the output shaft. The correct length should be 1.1" (Figure 3-287). If it is longer (stock length is 1.4"), the motor shaft needs to be cut down to the proper length. Be sure to deburr the cut end of the shaft, and clean all shavings from the face of the motor.

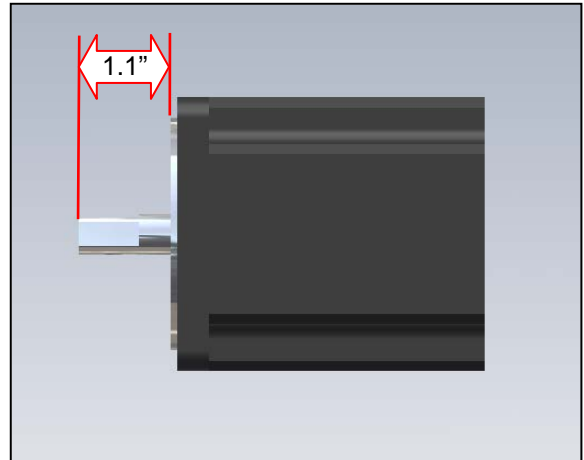

Figure 3-287. Pressure Bar Motor Shaft

1. Gently slide the motor out of the gearbox. Once removed, loosen the screw on the gearbox pinion, and remove (Figure 3-286).

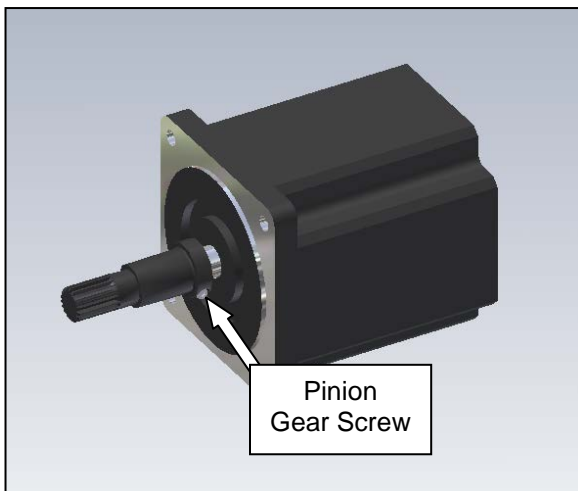

Figure 3-286. Pressure Bar Motor and Pinion

2. Reinstall the pinion on the motor shaft.
3. Slide the motor into the gearbox, with the plug and pigtail oriented to the top. The motor shaft may need to be turned to get the pinion to fully engage the gear in the gearbox.
4. Reinstall the four motor screws, and tighten into position.
5. Plug the motor cable into the quick disconnect harness.
6. Reinstall guards removed in step 1.

SEALER ASSEMBLY

PRESSURE BAR GEARBOX

TESTING



WARNING

Always remove electrical power from the SX™ prior to performing any maintenance on the machine.

1. Remove the rear motor cover (Figure 3-288 and 3-289).

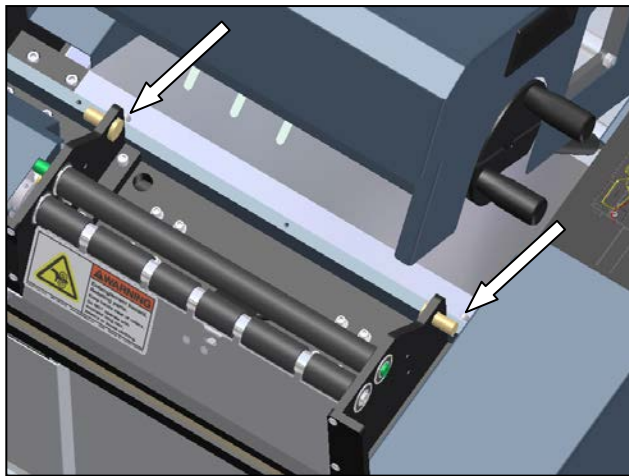

Figure 3-288. Motor Cover Front Screws

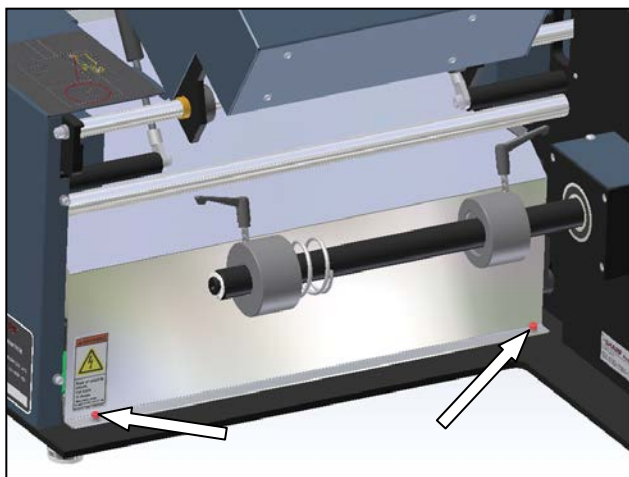

Figure 3-289. Motor Cover Rear Screws

2. Locate the pressure bar gearbox and motor. Examine the base plate underneath the assembly (see Figure 3-285). The plate should be clean and dry. If oil is present, the gearbox is leaking and needs repair or replacement.

3. Remove the outside frame guard (Figure 3-290).

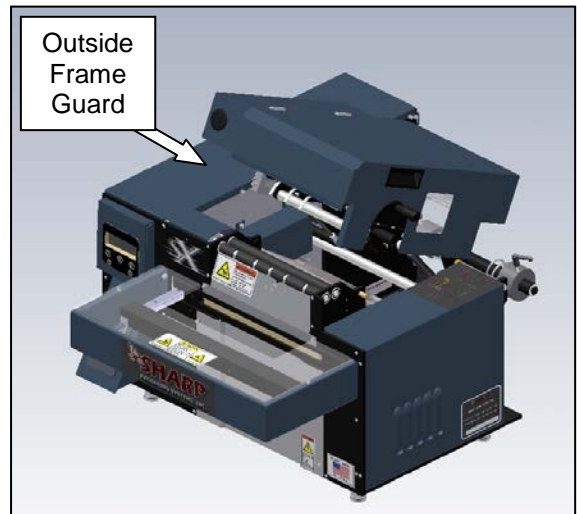

Figure 3-290. Guard Identification

4. Spin the output shaft and pulley on the gearbox by hand (Figure 3-291). If the shaft is able to be turned, it is functioning properly. Note: the pulley on the gearbox will be difficult to turn with the belt for the pressure bar still attached, but will move with an adequate amount of force.

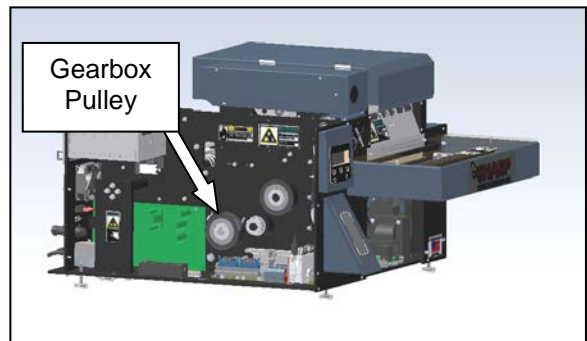

Figure 3-291. Gearbox Pulley

SEALER ASSEMBLY

PRESSURE BAR GEARBOX (con't)

ADJUSTMENT

The pressure bar gearbox is adjustment free.

REPLACEMENT

1. Remove the rear motor cover and the outside frame guard (see Figures 3-288 thru 3-290).
2. Loosen the four gearbox mounting screws. Once the gearbox is able to slide in the adjustment slots, lift the motor up to remove the belt (Figure 3-292).

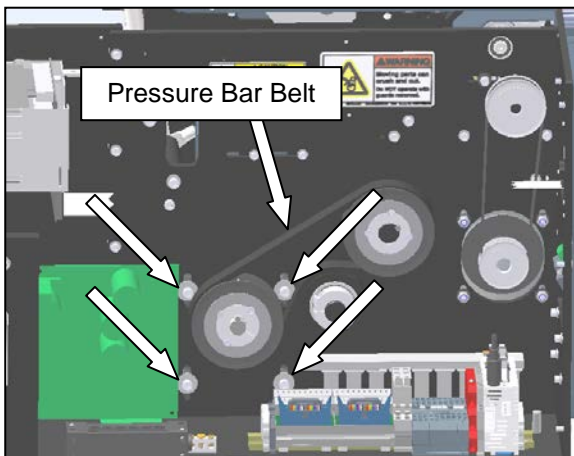

Figure 3-292. Gearbox Mounting Screws

3. Remove the two set screws from the taper-lock bushing on the gearbox pulley. Using one of these set screws, thread into the middle hole (identified in Figure 3-293). This will remove the bushing from the pulley, thus removing the pulley and bushing from the gearbox. Note: The gearbox shaft and the bushing are coupled to spin together with a square key. This will also be free once the bushing is removed.

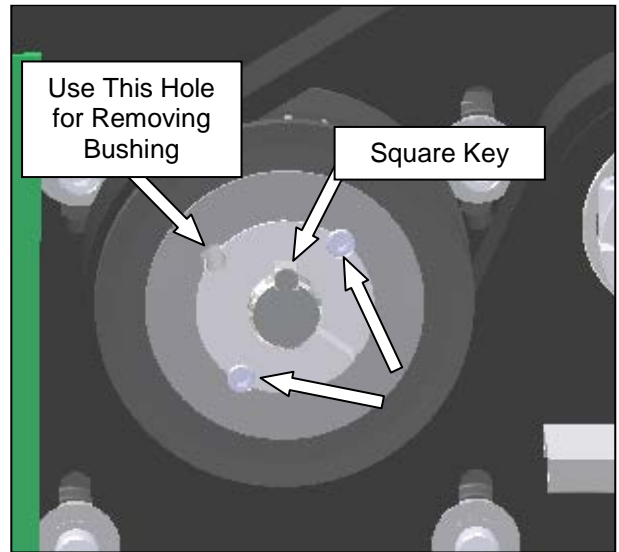

Figure 3-293. Gearbox Mounting Screws

4. Completely remove the gearbox mounting screws.
5. Unplug the pressure bar motor, allowing the gearbox and motor to be removed from the machine.
6. Once free of the machine, remove the motor from the gearbox, and replace onto the new gearbox. Note: the motor shaft may need to be turned to get the pinion gear to fully engage the gearbox. Also be certain the motor is oriented in the correct position, such that the plug will be to the inside of the machine when installed.



Figure 3-294 Gearbox and Motor

SEALER ASSEMBLY

PRESSURE BAR GEARBOX (con't)

7. Replace the gearbox into the machine from the rear. Reinstall the mounting screws into the machine, but do not tighten them into position.
8. Reinstall the pulley, taper-lock bushing, and the square key onto the gearbox shaft. Be sure to tighten the pulley such that it is aligned with the jaw shaft pulley and idler to ensure proper belt alignment.
9. Reinstall the belt over the gearbox pulley. Once engaged, press down on the gearbox and motor to tension the belt. At proper tension, the belt should deflect about 3/32" using two fingers and depressing perpendicular to the belt span. Once at proper tension, tighten the four mounting screws (Figure 3-295).

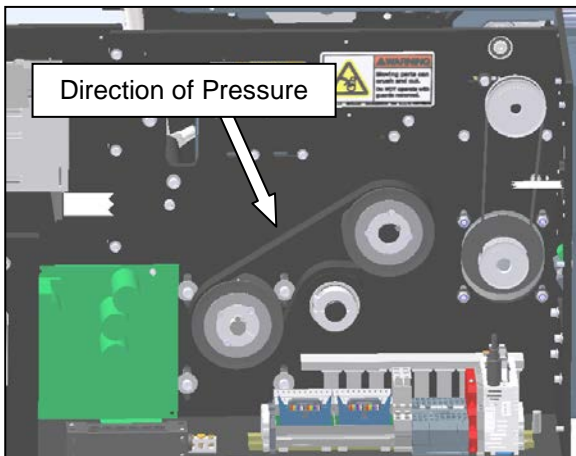

Figure 3-295. Pressure Bar Belt Tensioning

10. Plug the motor into the receptacle from the machine.
11. Replace any guards removed in the previous steps.

PRESSURE BAR BELT

TESTING



WARNING

Always remove electrical power from the SX™ prior to performing any maintenance on the machine.

1. Remove the outside frame guard (Figure 3-296).

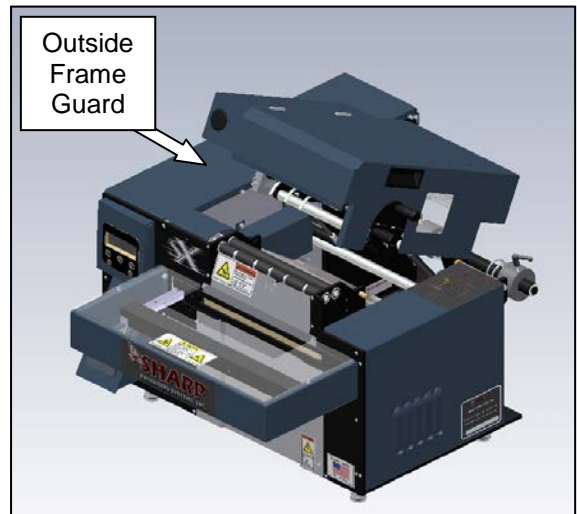

Figure 3-296. Guard Identification

2. Ensure the pressure bar drive belt has the proper tension. Refer to **Machine Adjustments: Checking Belt Tension** section to determine the correct tension.

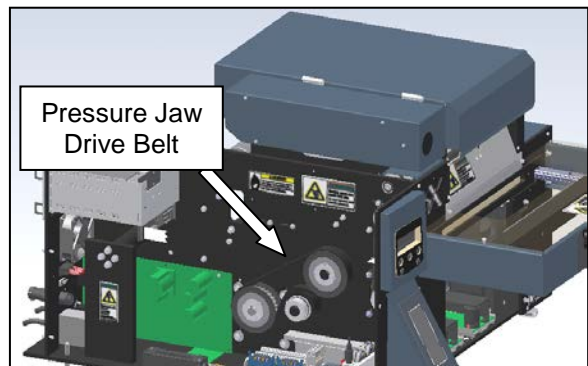

Figure 3-297. Pressure Jaw Drive Belt

SEALER ASSEMBLY

PRESSURE BAR BELT (con't)

3. Perform a visual inspection of the belt. If it is showing signs of wear, such as cracking or fraying, it needs to be replaced.

ADJUSTMENT

Refer to the **Machine Adjustments: Checking Belt Tension** section.

REPLACEMENT

1. Remove the outside frame guard and motor cover (Figure 3-298 and 3-299).

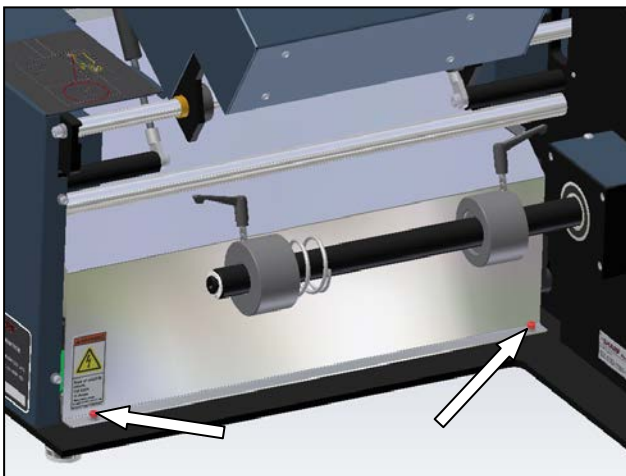

Figure 3-298. Motor Cover Rear Screws

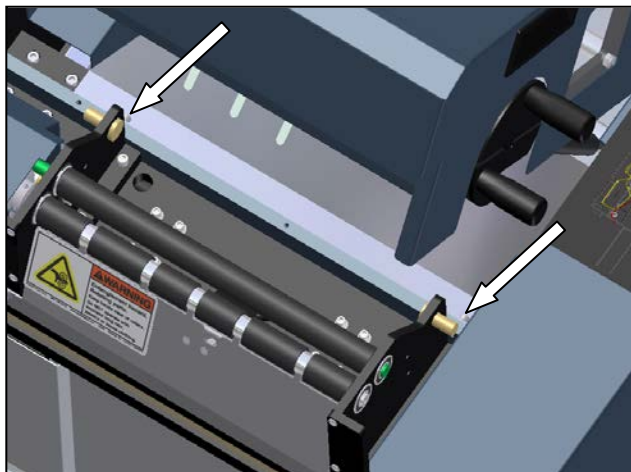

Figure 3-299. Motor Cover Front Screws

2. Loosen the four gearbox mounting screws.

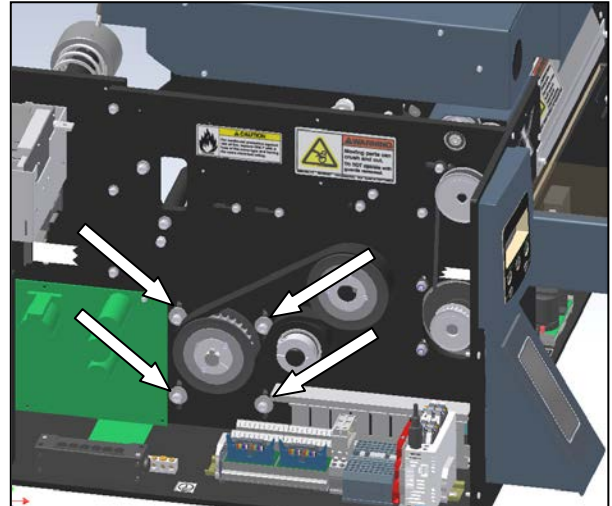

Figure 3-300. Gearbox Mounting Screws

3. Remove the idler pulley by loosening the socket head cap screw indicated in Figure 3-301

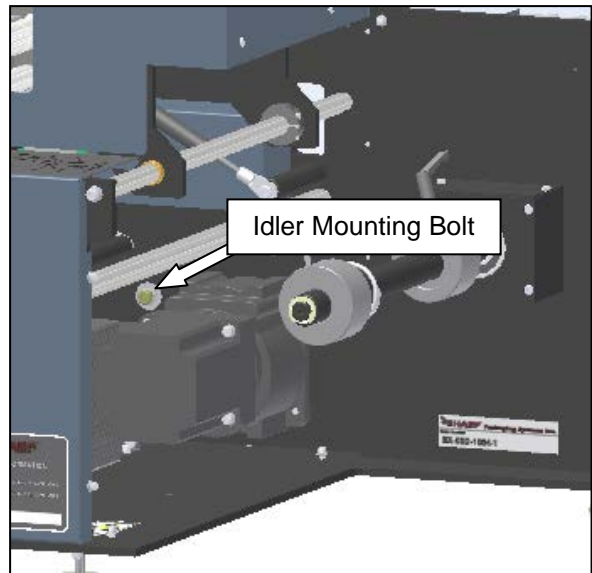

Figure 3-301. Pressure Bar Belt Idler

SEALER ASSEMBLY

PRESSURE BAR BELT (con't)

4. Slide the belt over the drive and drive pulleys to remove from the machine. Replace with the new belt.
5. Reinstall the idler pulley.
6. Slide the gearbox and motor down until the belt is properly tensioned. When tightened correctly, the belt should deflect about 1/8th inch when depressed with one finger at the center of belt span. Once in position, tighten the four gearbox mounting screws.
7. Replace any guards removed in the previous steps.

LINEAR BEARINGS

TESTING



WARNING

Always remove electrical power from the SX™ prior to performing any maintenance on the machine.

If the pressure bar has substantial play or slop in it while moving it up and down, the linear bearings are worn and need replacement. Also, inspect the rails to ensure the bearing surface is smooth and free of wear. Surface imperfections indicate bearing wear.

ADJUSTMENT

The linear guide bearings are adjustment free.

REPLACEMENT

Note: Sharp Packaging Systems recommends changing the linear guide bearings in pairs for best results.

1. Remove the rear motor cover and the right outside cover (Figure 3-302).

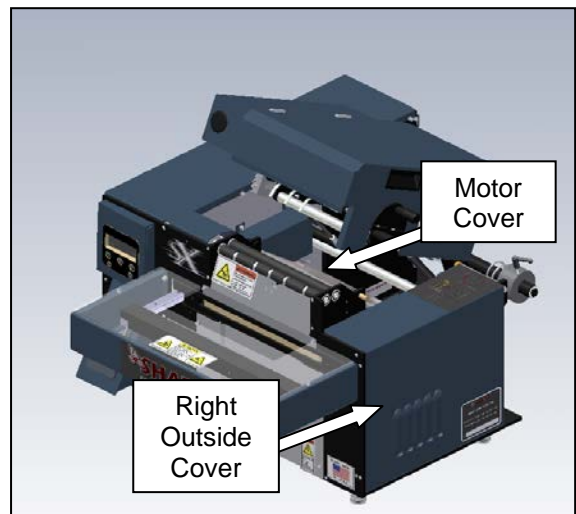

Figure 3-302. Guard Identification

SEALER ASSEMBLY

LINEAR BEARINGS (con't)

- Remove the left and right sealer guide guards identified in Figure 3-303.

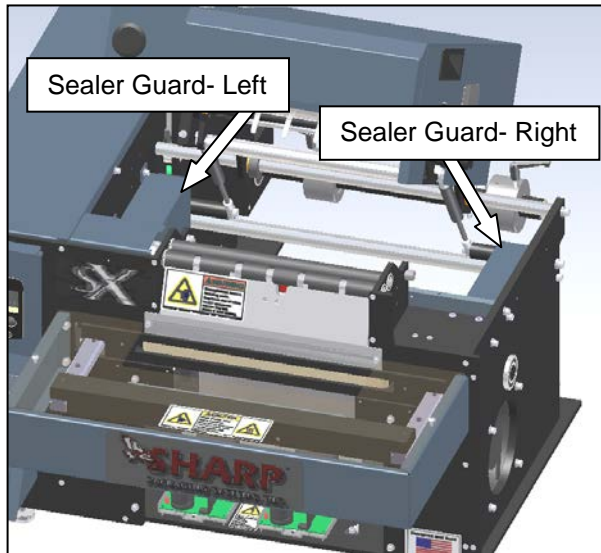

Figure 3-303. Left and Right Sealer Guards

- Move the pressure jaw to its completely extended position by pulling it out by hand.
- Locate the right linear bearing mounting screws and remove (Figure 3-304). Take the spacer from the top of the linear bearing, and slide out of the machine. The linear bearing can now be slid off the guide rail and out of the machine to the rear.

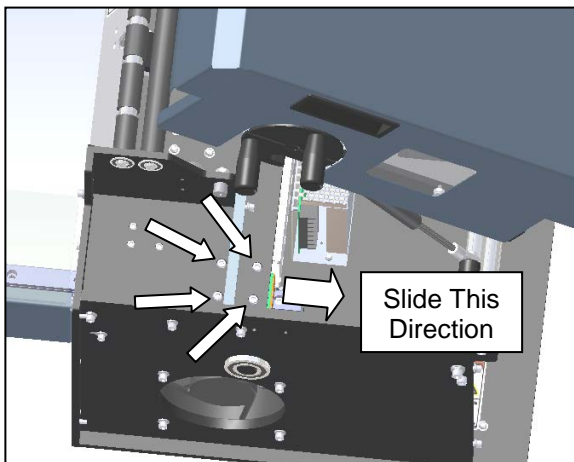

Figure 3-304. Right Linear Bearing

- Install the new linear bearing by sliding on the end of the guide rail, replacing the spacer, and reinstalling the four mounting screws.
- Remove the four mounting screws for the left linear bearing. Take the spacer from above the bearing. Slide to the rear of the machine along the rail to free the linear bearing from the machine (Figures 3-305 and 3-306).

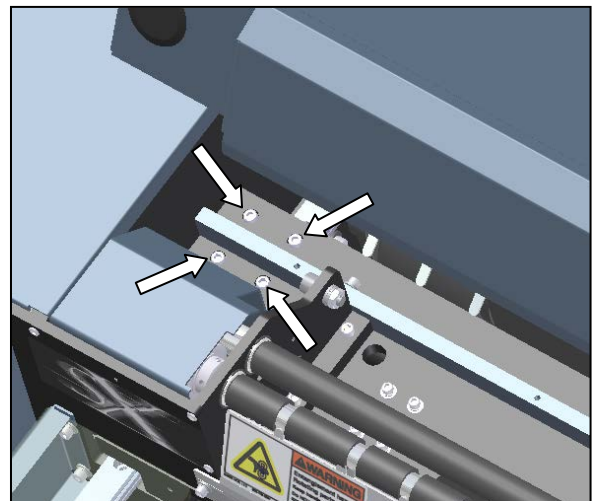

Figure 3-305. Left Linear Bearing Screws

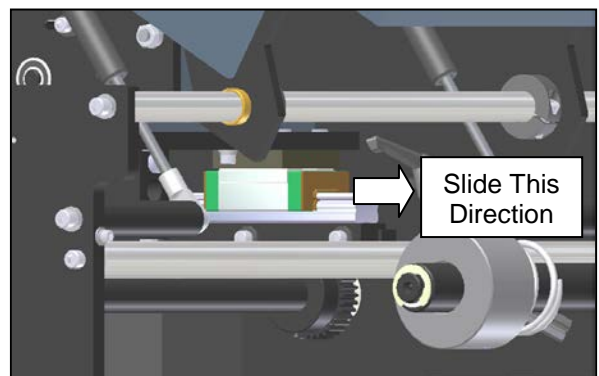

Figure 3-306. Left Linear Bearing Removal

SEALER ASSEMBLY

STRIPPER PLATE ASSEMBLY

LINEAR BEARINGS (con't)

7. Install the new linear bearing into machine by sliding it onto the rail from the rear of the machine. Replace the spacer above the bearing, and insert the four mounting screws.
8. Manually slide the pressure jaw in and out a few times to test the movement. The jaw will be relatively difficult to move due to the drive linkages still being connected, but should move smoothly over the fully range of motion.
9. Reinstall all guards removed in the previous steps.

The stripper plate assembly consists of the stripper plate, mounting blocks, the springs and shoulder bolts that hold the stripper plate into position for product loading, and the gripper buttons and springs which apply force to the pressure jaw to pinch the bag film for sealing and separating the sealed bag from the roll of film yet to be used. If any of the components in this assembly fail, Sharp Packaging Systems recommends changing all springs and wear items associated with the stripper plate, since somewhat substantial machine disassembly is required to access the springs, etc. Replaceable items are available as a stripper plate maintenance kit (part number 960881-01), which can be purchased from Sharp Packaging Systems Inc.

TESTING



WARNING

Always remove electrical power from the SX™ prior to performing any maintenance on the machine.

1. Depress the stripper plate by hand to check the springs. The stripper plate should smoothly slide in and out, and the spring force should be enough to keep the plate slightly beyond flush with the front of the machine with no pressure applied. Once fully depressed, the stripper plate should sit parallel to the front plate of the machine.

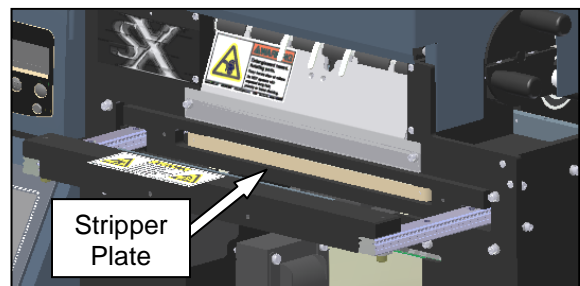

Figure 3-307. Stripper Plate

SEALER ASSEMBLY

STRIPPER PLATE ASSEMBLY (con't)

- To test the gripper buttons and springs, fully depress the stripper plate, and continue pressing on each corner to collapse the gripper button springs. These springs are stronger than the plate springs, and will take a considerable amount of force to compress. If the plate moves easily in, either the spring is broken or the set screw is out of adjustment (checking the adjustment of the gripper button set screws will be covered in the adjustment section).

ADJUSTMENT

- Remove the load plate, the motor cover, and the right outside cover.

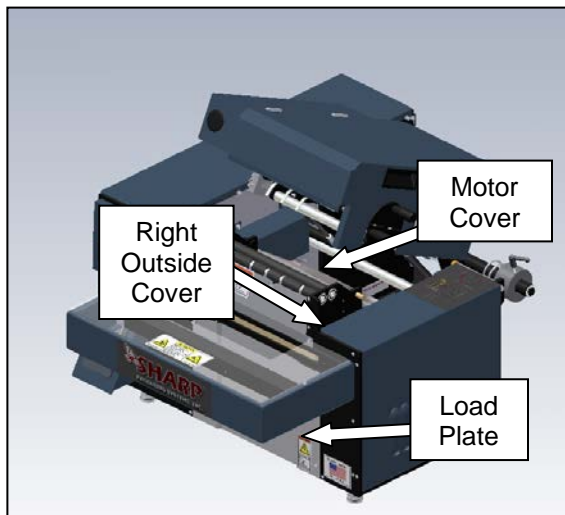

Figure 3-308. Guard Identification

- Locate the spring blocks, which mount the stripper plate to the machine (these can be accessed through the rear of the machine). The set screws for the gripper buttons on the back of the spring blocks should protrude 1/8" from the back of the block (Figure 3-309).

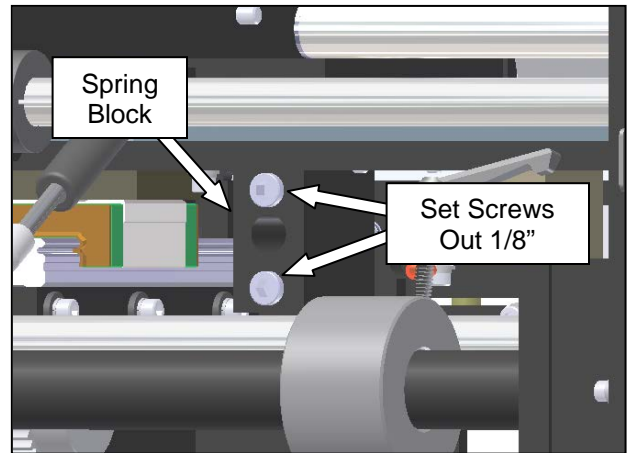

Figure 3-309. Stripper Plate Spring Block

REPLACEMENT

- Remove the six guards identified in (Figure 3-310) if not done in the testing section.

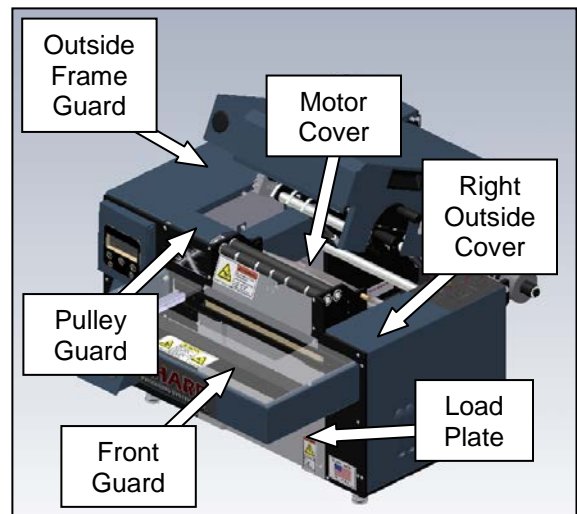

Figure 3-310. Guard Identification

SEALER ASSEMBLY

STRIPPER PLATE ASSEMBLY (con't)

- Loosen the four film feed motor mounting screws. Slide the motor upward and remove the belt (Figure 3-311).

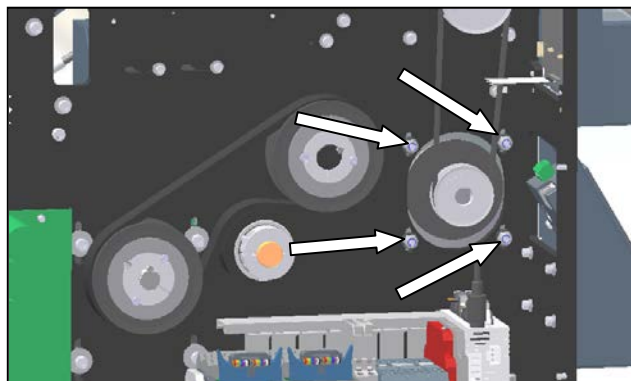

Figure 3-311. File Feed Drive Motor Mounting

- Remove the take-up shaft for the film feed roller drive belt. Note: if the Sharp SX™ is equipped with a printer, also remove the take-up shaft for the platen roller drive belt (Figure 3-12).

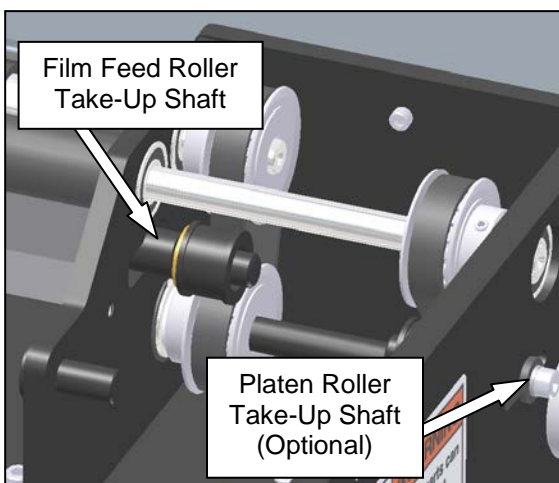

Figure 3-312. Film Feed Belt Take-Up Shaft

- Loosen the set screws on the film feed drive pulley on the transfer shaft, and the film feed driven pulley on the roller shaft. Note: if the Sharp SX™ is equipped with a printer, also loosen the set screws on the platen roller drive pulley (Figure 3-313).

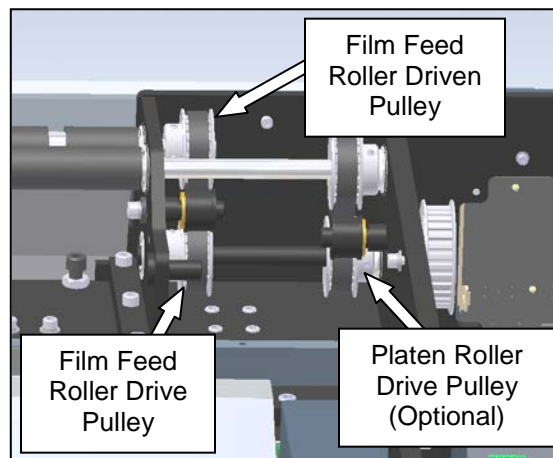

Figure 3-313. Pulleys

Note: Viewed from Rear; Cradle Removed for Clarity

- Pull the transfer shaft out of the machine, sliding the film feed driven pulley with it in unison until the roller pulley is clear of the roller shaft. The transfer shaft does not need to be removed, only slid back until access to the spring block mounting screws is obtained. Note: there is a nylon washer between the left bearing plate and the film feed drive pulley. Do not misplace this washer, as it is needed for proper machine operation (Figure 3-314).

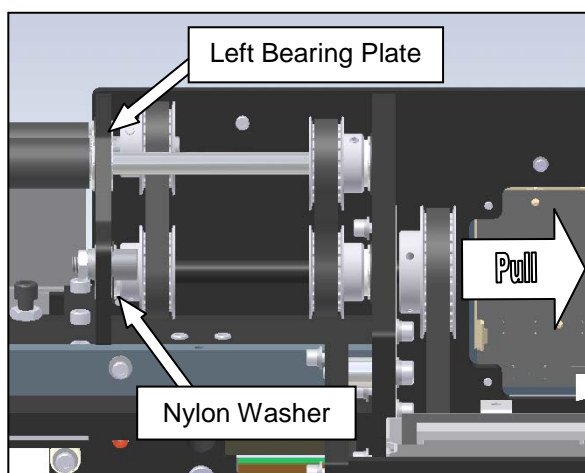

Figure 3-314. Clearing the Transfer Shaft

Note: Viewed from Rear; Cradle Removed for Clarity

SEALER ASSEMBLY

STRIPPER PLATE ASSEMBLY (con't)

6. Remove the front finger plate from the machine. **Do not pull the plate away from the machine too quickly, as the photoelectric eye is attached to the plate and wired to the machine.** Gently place the plate under the rollers, ensuring the sensor wire is not excessively pulled (Figure 3-315).

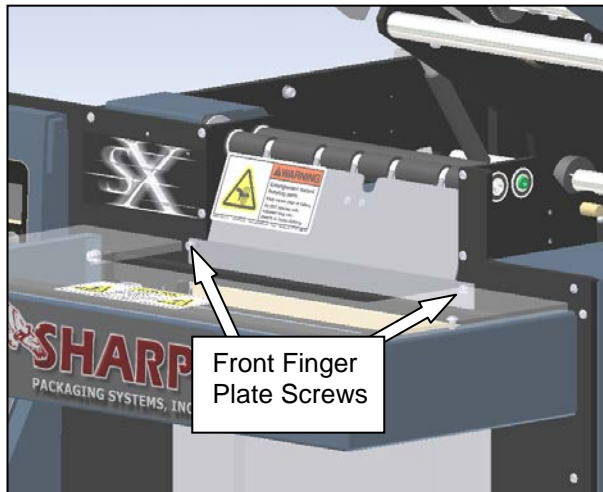
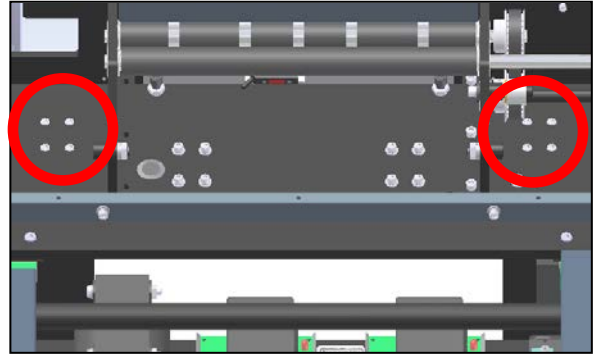

Figure 3-315. Front Finger Plate

7. Remove the eight bolts identified in figure 3-316 to unfasten the heater block from the middle horizontal plate. Once the screws are removed, the heater block will be free to hang loose inside of the machine, but cannot be removed as it will still be held by wires. Gently let the heater block hang inside of the machine.

Figure 3-316. Heater Block Mounting Screws
Note: Viewed from Rear; Cradle Removed for Clarity

8. Remove the eight spring block mounting screws.

Figure 3-317. Spring Block Mounting Screws
Note: Viewed from Rear; Cradle Removed for Clarity

9. Remove the stripper plate assembly from the machine. Being sure the pressure jaw is completely open, slowly slide the stripper plate to the front of the machine until the spring blocks hit the front plate. Through the opening created by removing the front guard, reach in and turn the spring blocks 90°. This will allow the complete stripper plate assembly to be removed from the machine by continuing to slide it forward (Figure 3-318).

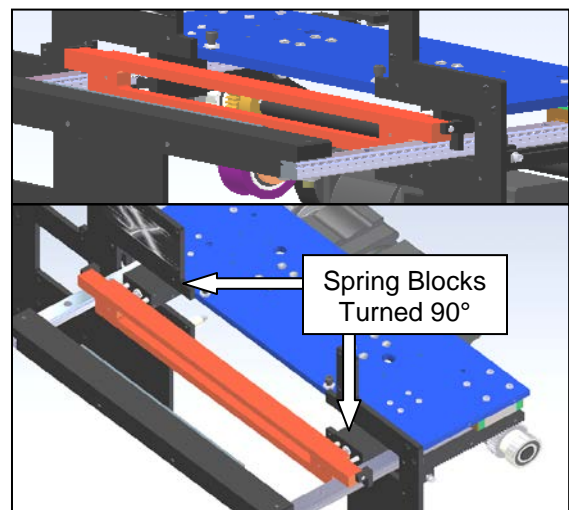
Figure 3-318. Removing the Stripper Plate
Note: Sealer Assembly Isolated for Clarity; Stripper Plate shown in Red, Horizontal Mounting Plate Shown in Blue

SEALER ASSEMBLY

STRIPPER PLATE ASSEMBLY (con't)

10. With the stripper plate assembly completely free of the machine, remove the two shoulder bolts that hold the stripper plate to the spring blocks. Each bolt has a nylon washer between the spring and the block. Do not misplace these washers, as they are needed during reinstallation (Figure 3-319).

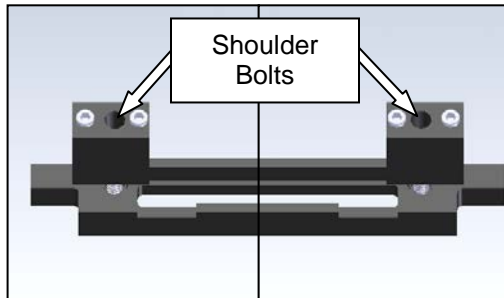

Figure 3-319. Stripper Plate Mounting

11. Take one spring block, and remove one of the set screws. Remove the spring and gripper button from the block, and replace with the new components. Reinstall the set screw with Loctite® Blue, and turn until the screw is protruding 1/8". This will give the gripper button springs the proper preload. Repeat this procedure for the other spring and gripper button, and for the other block (Figure 3-320).

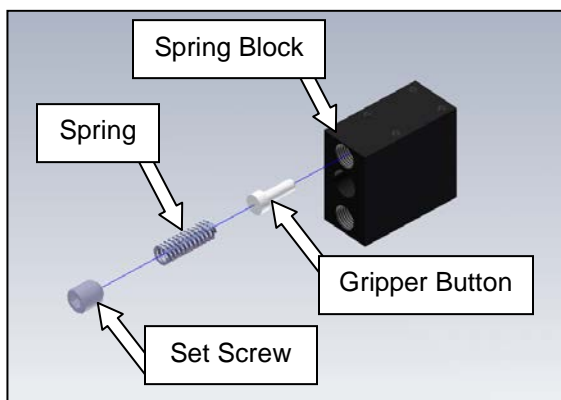

Figure 3-320. Gripper Button Components

12. Reinstall the shoulder bolts through the spring blocks and into the stripper plate according to Figure 3-321. Remember to install the two nylon washers removed in step 10.

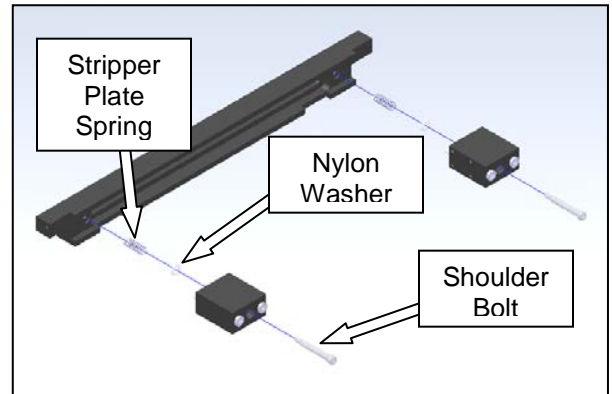

Figure 3-321. Mounting the Stripper Plate

13. Reinstall the stripper plate assembly into the machine. Place on top of the jaw guide rails with the spring blocks turned 90° from their mounting position, and slide through the plate. Once the stripper plate is completely into the machine, turn the spring blocks to their mounting positions, and insert the eight mounting screws through the horizontal plate (Figure 3-322).

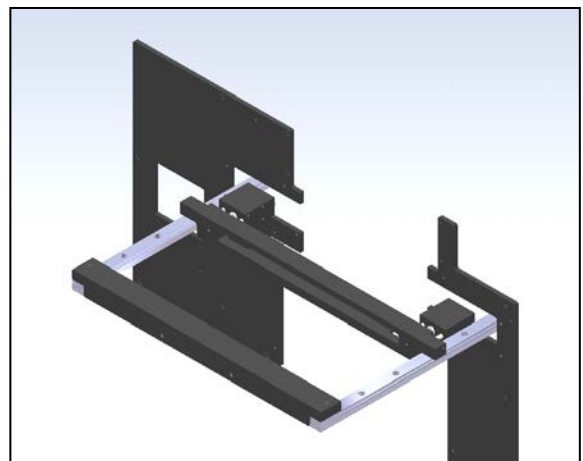

Figure 3-322. Reinstalling the Stripper Plate Assembly
 Note: Stripper Plate Assembly and Selected Components Isolated for Clarity

SEALER ASSEMBLY

STRIPPER PLATE ASSEMBLY (con't)

14. Lift the heater block into position, and install the eight mounting screws with lock and flat washers through the holes in the horizontal mounting plate (Figure 3-323). The Teflon tape and heater band should be aligned with the opening in the stripper plate at proper orientation.

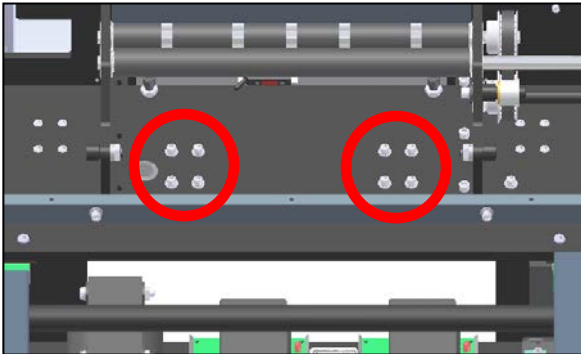

Figure 3-323. Heater Block Mounting Screws
Note: Viewed from Rear; Cradle Removed for Clarity

15. Reinstall the front finger plate, visually aligning the “fingers” with the grooves in the film feed roller. Ensure the fingers do not rub on the roller, but are as close as possible to ensure the bags feed through the machine correctly. Be cautious of the photoelectric eye wires, being sure to not excessively pull on them.

16. Place the film feed roller belt over the film feed drive pulley on the transfer shaft (if removed) and ensure the nylon washer is still in position on the shaft. Slide the transfer shaft into the machine until the shaft is fully seated in the inside bearing on the left bearing plate. The outer transfer shaft pulley should be aligned with the film feed drive motor pulley when the transfer shaft is in its correct position. Once in position, insert the film feed drive pulley into the belt, and slide pulleys in unison until they are in position (Figures 3-324 and 3-325).

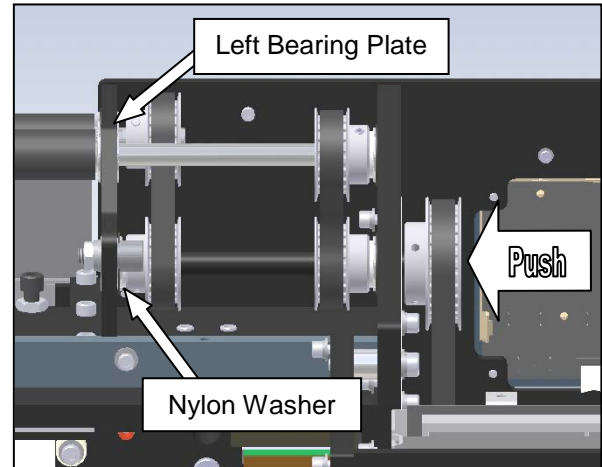

Figure 3-324. Reinserting the Transfer Shaft
Note: Viewed from Rear; Cradle Removed for Clarity

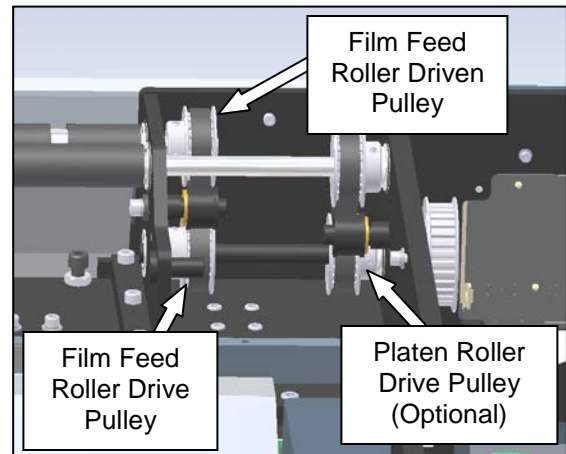

Figure 3-325. Pulleys
Note: Viewed from Rear; Cradle Removed for Clarity

17. Align the flat areas of the shaft with the set screws on the pulleys loosened in step 4 above. Slide the film feed roller drive pulley tight to the nylon washer, and tighten set screws to secure in place. Align the film feed roller driven pulley with the drive pulley, and tighten into position. If equipped with a printer, also tighten the set screws on the platen roller drive pulley.

SEALER ASSEMBLY

STRIPPER PLATE ASSEMBLY (con't)

18. Reinstall the film feed take-up shaft and the platen roller take-up shaft (if equipped with a printer) (Figure 3-326).

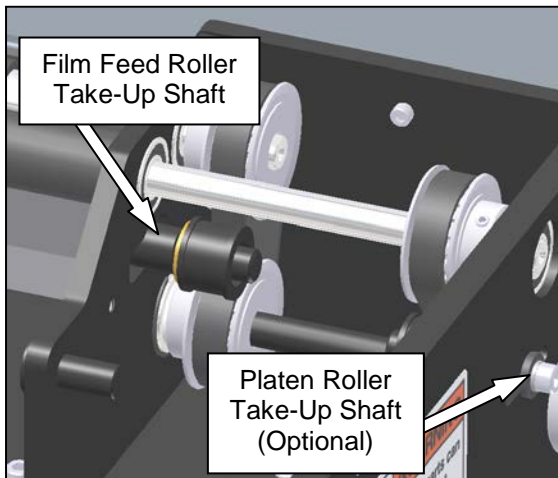

Figure 3-326. Film Feed Belt Take-Up Shaft

20. Reinstall all guards removed in step 1 above.

19. Reinstall the film feed motor drive belt. Apply downward pressure on the motor to tension the belt. At proper tension, the belt should deflect about $3/32$ " at the center of belt span using one finger to push the belt. When proper tension is achieved, tighten the four motor mounting screws (Figure 3-327).

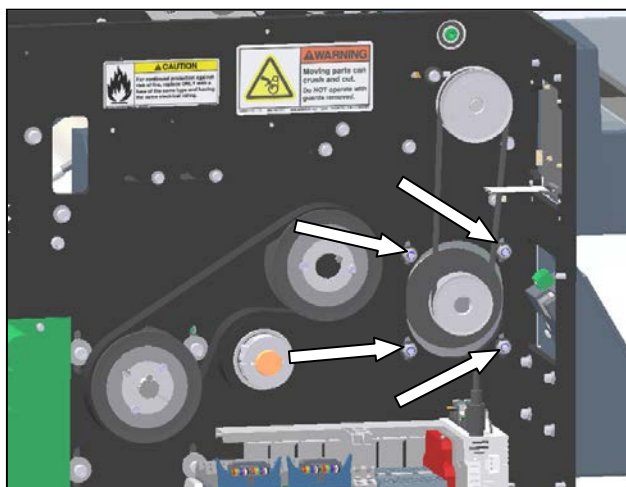

Figure 3-327. Film Feed Drive Motor Mounting

SEALER ASSEMBLY

SEALPOINT COMPONENTS

Seal wires, Teflon tape, and anvil rubber are available together in the Sealer Maintenance Kit (P/N 960552-01), which is available from Sharp Packaging Systems Inc. These wear items are inexpensive and easy to replace, yet provide great improvement to the overall quality of the seals when replaced at regular intervals.

Seal Wire

TESTING

 WARNING
<p>Always remove electrical power from the SX™ prior to performing any maintenance on the machine.</p>

If the Sharp SX™ will not seal bags, remove the Teflon tape to expose the seal wire. If the seal wire is not broken, further troubleshooting is required (See the **Electrical Assembly: Transformers** section to troubleshoot the seal wire circuitry).

ADJUSTMENT

The seal wire is adjustment free.

REPLACEMENT

1. Remove the front lexan guard (Figure 3-328).

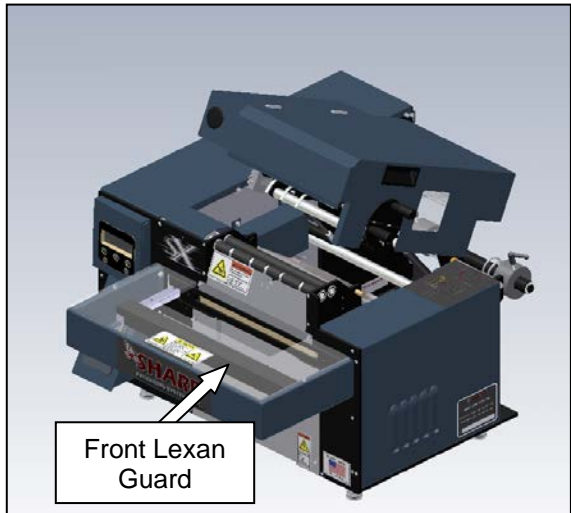

Figure 3-328. Guard Identification

2. Completely remove the Teflon tape from the seal wire area (Figure 3-329).



Figure 3-329. Removing the Teflon Tape

SEALER ASSEMBLY

SEALPOINT COMPONENTS (con't)

3. Manually open the pressure jaw to its completely open position. Insert the seal wire changing tools (shipped with the accessories for your Sharp SX™ in the accompanying box) into the stripper plate as shown in Figure 3-330.

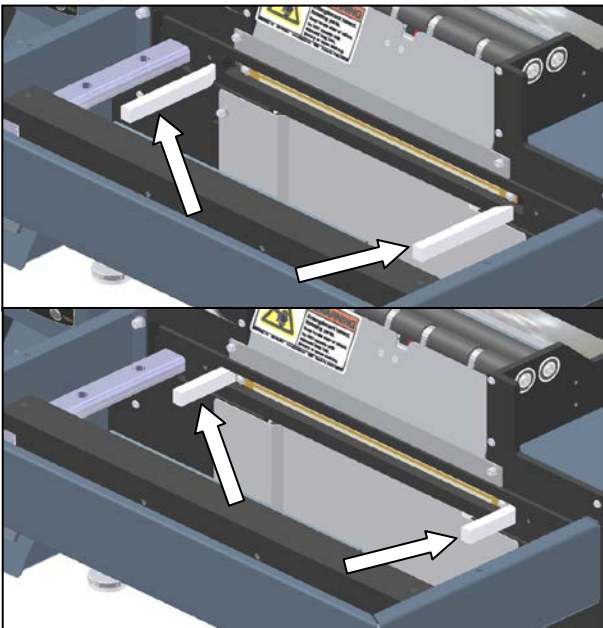

Figure 3-330. Inserting the Seal Wire Changing Tools

4. Remove the two mounting screws for the seal wire. Install the new seal wire as shown, with the open ends of the hooks to the bottom of the machine. **The tapered, profile side of the seal wire is to be exposed, to the outside of the machine (Figure 3-331).**

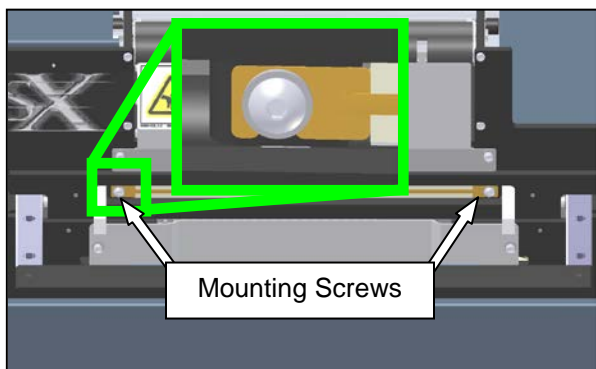

Figure 3-331. Seal Wire Mounting Screws

5. Remove the seal wire changing tools from the stripper plate.
6. Remove the adhesive backing from a new strip of Teflon tape, and place over the seal wire, ensuring it is completely covering the wire.
7. Reinstall the front lexan guard.

Teflon Tape

The Teflon tape covers the seal wire and does not allow the seal wire to contact the bag while sealing. Periodic replacement of the seal wire produces better seals and allows the bag to release from the sealpoint during operation. To replace the Teflon tape, simply peel the old strip from the front of the machine, remove the adhesive backing from the new strip, and place over the seal wire, being sure to completely cover the metal element (Figure 3-332).

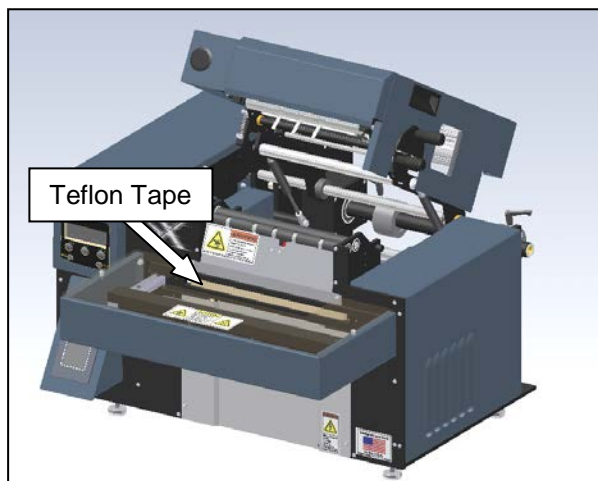

Figure 3-332. Teflon Tape

SEALER ASSEMBLY

SEALPOINT COMPONENTS (con't)

Anvil Rubber

The anvil rubber is located on the pressure jaw, and aids in gripping the bag during film separation while also providing a non-stick surface to allow the completed bag to fall from the sealing area. To replace the anvil rubber, remove the old strip from the face plate, clean the adhesive from the jaw with isopropyl alcohol, remove the adhesive backing from the new piece of rubber, and install on the pressure jaw in the same location as the previous strip. The rubber should completely cover the machined step on the pressure bar (Figure 3-333).

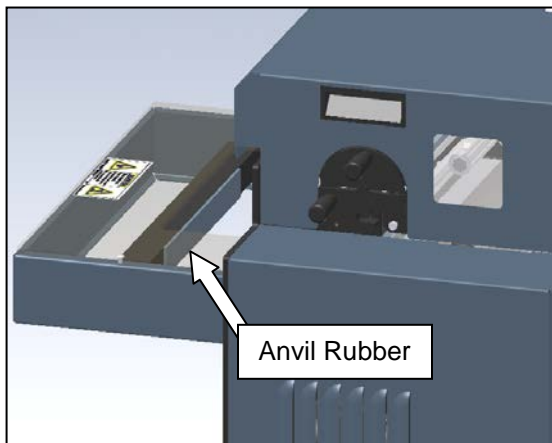



Figure 3-333. Anvil Rubber

SEALER ASSEMBLY

SEAL WIRE TENSION SPRINGS

The seal wire tension springs apply the proper tension to the seal wire while mounted to the impulse seal bar. They are located inside the bar, and can only be seen with disassembly.

TESTING

 WARNING
<p>Always remove electrical power from the SX™ prior to performing any maintenance on the machine.</p>

1. Peel back the Teflon tape on the seal wire. Inspect the seal wire to ensure it is taught and lying flat against the phenolic insulating strip. Also, using a seal wire changing tool, press each end of the seal wire heater block towards the center of the machine and ensure there is resistance. If it appears loose or does not lie flat against the back strip, the springs are faulty and need replacement. Note: Sharp Packaging Systems recommends replacing the tension springs in pairs to ensure even tensioning.

ADJUSTMENT

The seal wire tension springs are adjustment free.

REPLACEMENT

1. Remove the front lexan guard (Figure 3-334).

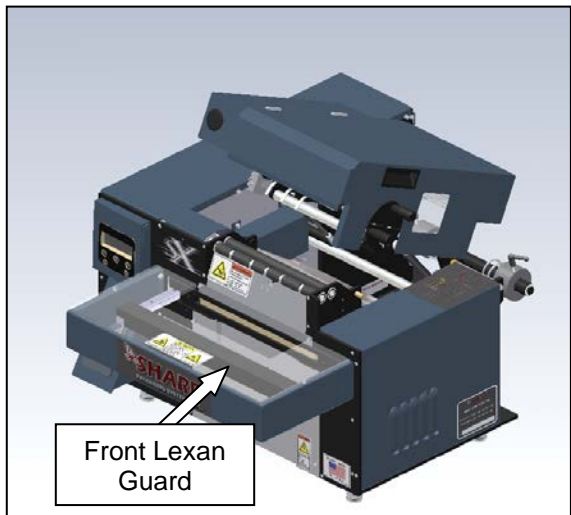

Figure 3-334. Guard Identification

2. Completely remove the Teflon tape from the seal wire area (Figure 3-335).

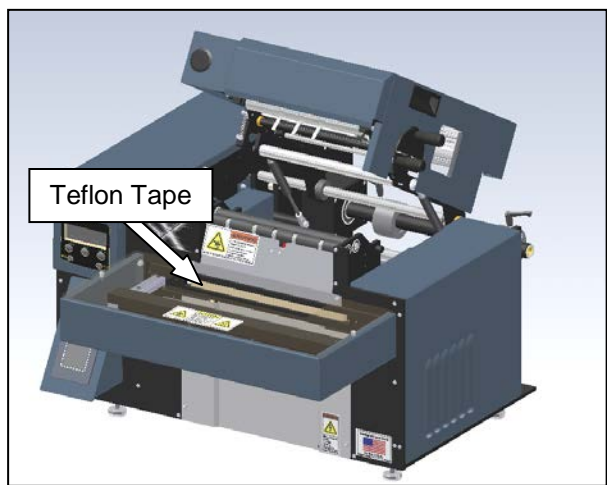

Figure 3-335. Removing the Teflon Tape

SEALER ASSEMBLY

SEAL WIRE TENSION SPRINGS (con't)

3. Manually open the pressure jaw to its completely open position. Insert the seal wire changing tools (shipped with the accessories for your Sharp SX™ in the accompanying box) into the stripper plate as shown in Figure 3-336.

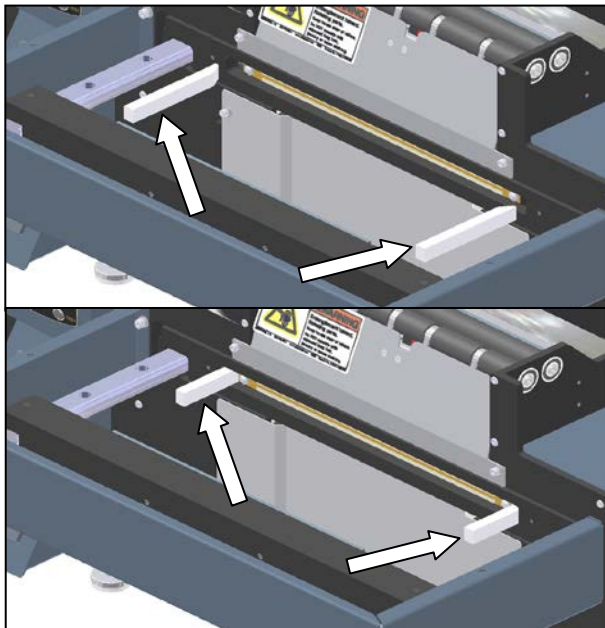

Figure 3-336. Inserting the Seal Wire Changing Tools

4. Remove the two mounting screws for the seal wire. Once the seal wire is free of the machine, remove the seal wire changing tools (Figure 3-337).

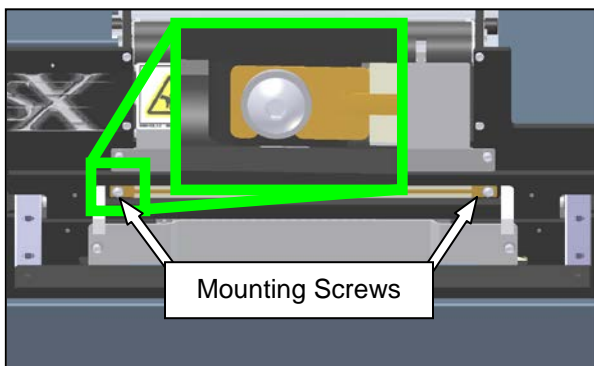

Figure 3-337. Seal Wire Mounting Screws

5. Locate the eight heater block mounting screws and remove. Once the screws are out, the heater block will fall down until the wires attached to it are tight. Catch the heater block, and slowly move down until the wires are holding it (Figure 3-338).

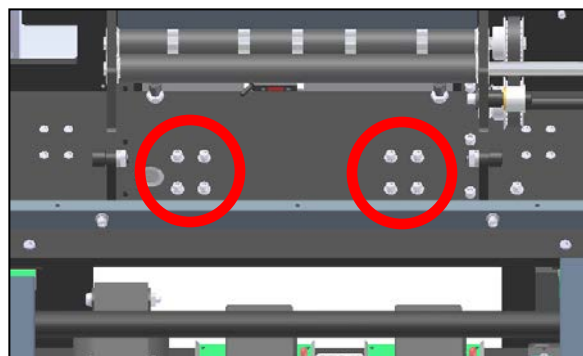

Figure 3-338. Heater Block Mounting Screws
Note: Viewed from Rear; Cradle Removed for Clarity

6. With the heater block hanging loose from the horizontal plate, rotate one end of the jaw end block outwards, exposing the tension plunger. Remove the plunger and plunger spring, and replace. Repeat on the other jaw end block (Figure 3-339).

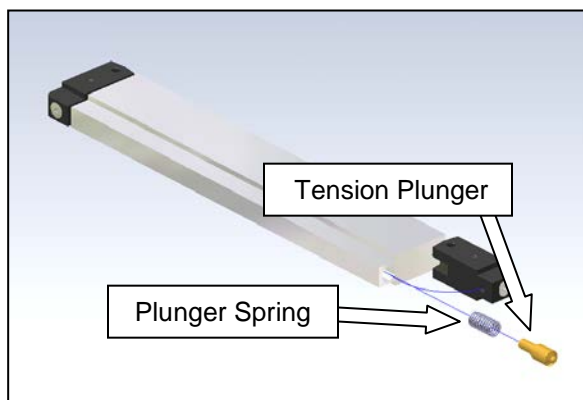

Figure 3-339. Removing the Plunger Spring

SEALER ASSEMBLY

SEAL WIRE TENSION SPRINGS (con't)

- Lift the heater block back into position, and reinstall the eight mounting screws (Figure 3-340).



Figure 3-340. Heater Block Mounting Screws
Note: Viewed from Rear; Cradle Removed for Clarity

- Reinstall the seal wire changing tools to compress the tension springs, and reinstall the seal wire. Be sure the orientation is such that the open ends of the seal wire are to the bottom of the machine (Figure 3-341).

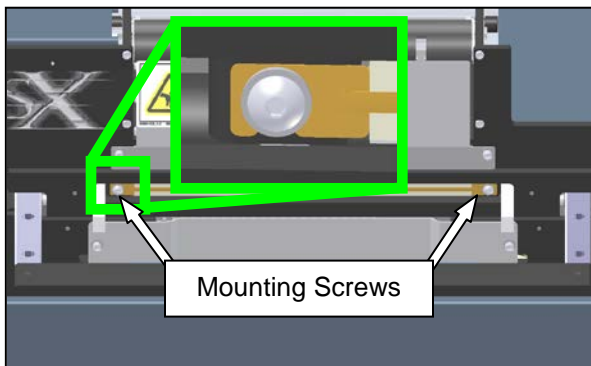

Figure 3-341. Seal Wire Mounting Screws

- Remove the adhesive backing from a new strip of Teflon tape, and place over the seal wire, ensuring it is completely covering the wire.
- Reinstall the front guard.

SEALER ASSEMBLY

STRIPPER PLATE SENSORS

The stripper plate sensors are part of the Obstruction Sensing Jaw. The two sensors are located inside the machine on each end of the stripper plate, and are activated by flags on the plate. If they are not working, the machine will go into a jaw fault and will not cycle.

Some of the procedures in this section require that the electrical power to the machine remain ON.

⚠ WARNING

USE EXTREME CAUTION WHILE SERVICING A MACHINE WHILE POWER IS APPLIED. UNEXPECTED MACHINE STARTUP CAN CAUSE SERIOUS INJURY OR DEATH.

⚠ WARNING

DO NOT ATTEMPT TO SERVICE THE MACHINE DURING NORMAL OPERATION. KEEP HANDS AND ARMS CLEAR OF MOVING PARTS.

⚠ WARNING

WHILE TESTING ELECTRICAL COMPONENTS WITH POWER APPLIED TO THE MACHINE, USE PROPER TROUBLESHOOTING TECHNIQUES TO AVOID ELECTRICAL SHOCK.

TESTING

1. Remove the outside frame guard (Figure 3-342).

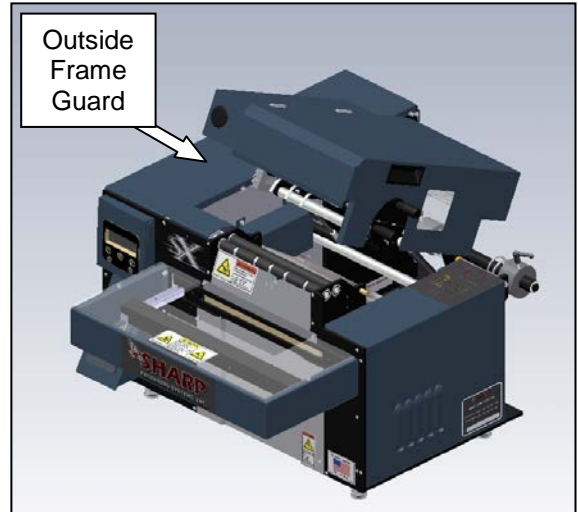

Figure 3-342. Guard Identification

2. Locate the 6-position junction box. Ensure the plugs are fully inserted into the ports. The left stripper plate sensor will be in the receptacle numbered '5' and the right sensor will be in receptacle '6' (Figure 3-343).

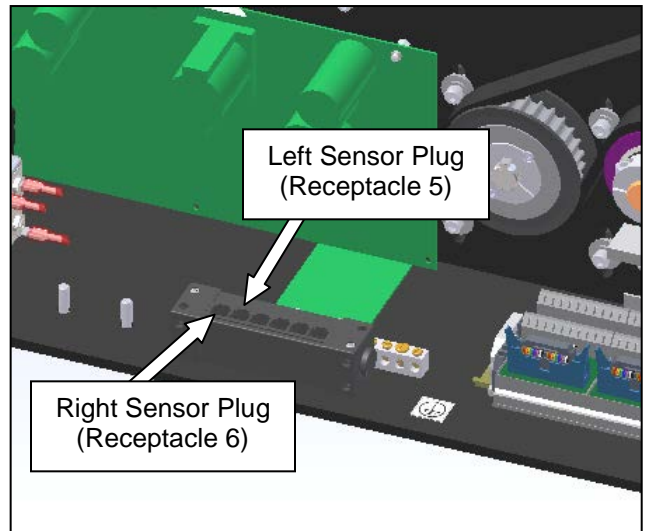

Figure 3-343. Stripper Plate Sensor Plugs

SEALER ASSEMBLY

TRIPPER PLATE SENSORS (con't)

3. Locate the PLC. While watching the inputs labeled 'X1' and 'X6', depress each side of the stripper plate. When pressing the left side of the stripper plate, the input light for 'X1' should turn on. When pressing the right side of the plate, the input light for 'X6' should light up. If the PLC does not illuminate when either sensor is activated, the sensor is faulty and needs replacement (Figure 3-344).

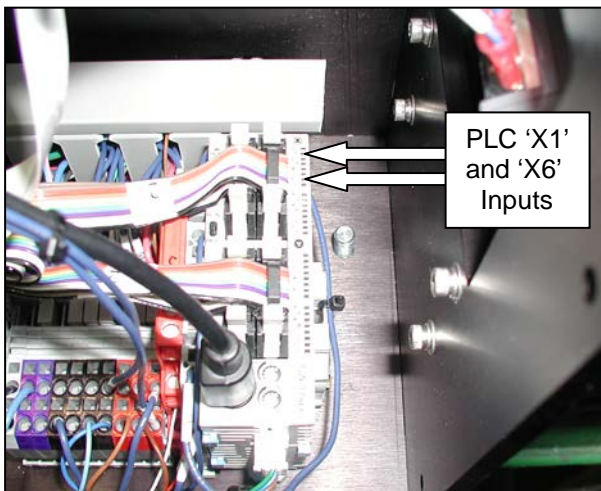

Figure 3-344. The PLC

ADJUSTMENT

1. Move the pressure bar inward, and place the two seal wire changing tools between the face plate and the pressure bar approximately 2" from each end (Figure 3-345).



Figure 3-345. Stripper Plate Positioning for Jaw Sensors

2. Move the left and right sensors all the way towards the front of the machine.
3. Slide left sensor bracket back until light X1 on the PLC turns on, and secure in place
4. Slide the right sensor bracket back until light X6 on the PLC turns on, and secure in place.

REPLACEMENT



WARNING

Always remove electrical power from the SX™ prior to performing any maintenance on the machine.

SEALER ASSEMBLY

STRIPPER PLATE SENSORS (con't)

1. Remove the four guards identified in Figure 3-346.

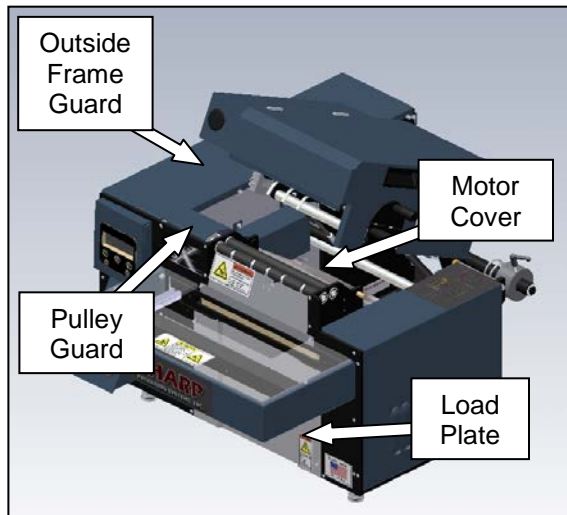

Figure 3-346. Guard Identification

To replace the right stripper plate sensor, follow steps 2 through 6:

2. Remove the mounting screw identified in Figure 3-347. Once free, access the sensor through the rear of the machine. Follow the wire routing through the machine, and remove any wire ties as necessary.

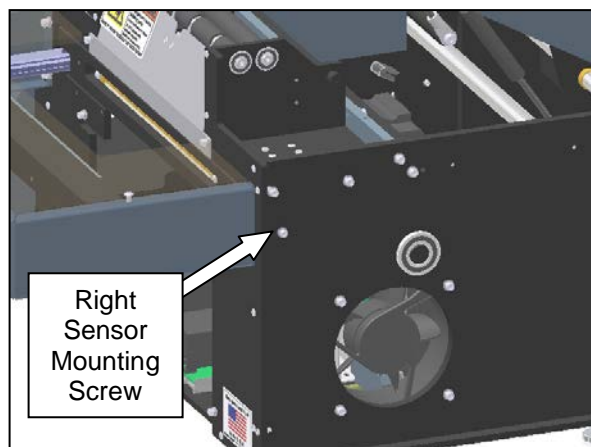

Figure 3-347. Right Sensor Mounting Screw

3. Locate the 6-position junction box, and unplug the connector in port 6. This should free the sensor completely from the machine. Gently pull the wire, being careful of other wires still in the machine (Figure 3-348).

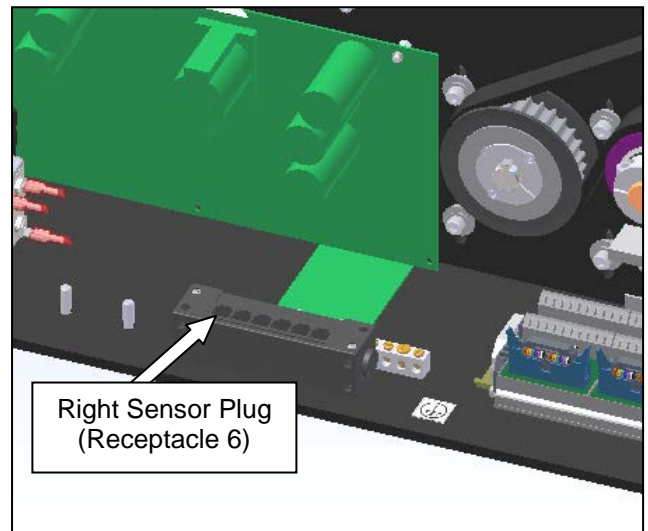

Figure 3-348. Stripper Plate Sensor Plugs

4. Remove the sensor from the mounting block, and install the new sensor (Figure 3-349).

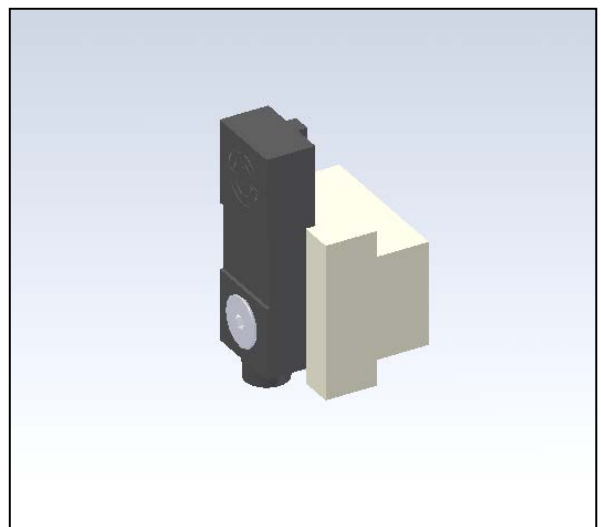

Figure 3-349. Sensor Mounting Block

SEALER ASSEMBLY

STRIPPER PLATE SENSORS (con't)

5. Reinstall the sensor and mounting block into the machine. The sensing area of the sensor is to be oriented to the top of the machine (Figure 3-350).

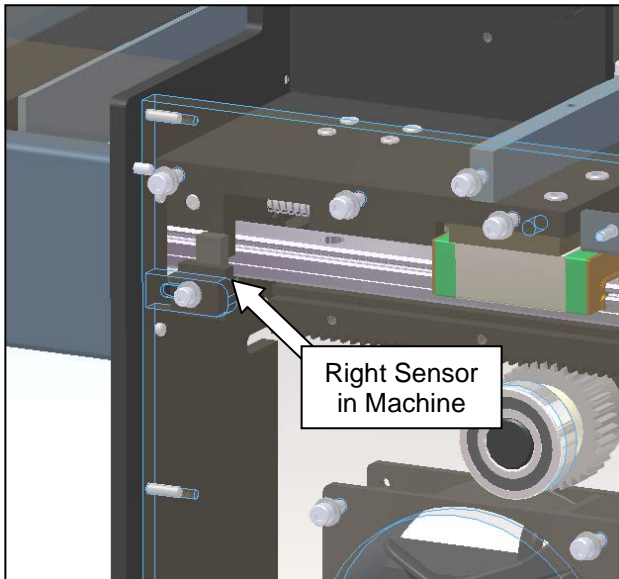

Figure 3-350. Installing the Right Plate Sensor
Note: Side Plate Shown Clear for Clarity

6. Route the sensor cable through the machine, following the same path the previous cable took. Plug the sensor into receptacle 6 on the 6-position junction box. Secure sensor cables to bundles inside the machine to keep wires free of moving parts.

To replace the left stripper plate sensor, follow steps 7 through 12:

7. Remove the film feed drive motor from the machine. Unplug the cable, and remove the four mounting screws (Figure 3-351).

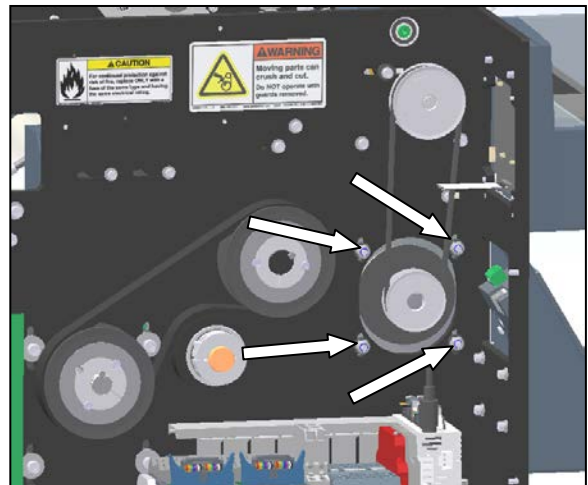

Figure 3-351. File Feed Drive Motor Mounting

8. Remove the sensor mounting screw, identified in Figure 3-352.

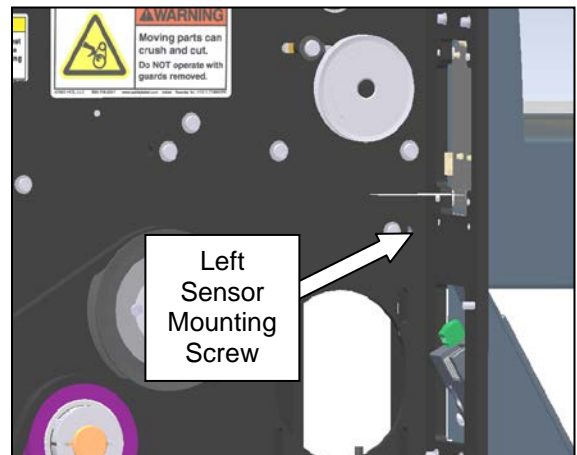

Figure 3-352. Left Sensor Mounting Screw

SEALER ASSEMBLY

STRIPPER PLATE SENSORS (con't)

9. Follow the sensor cable back through the machine, removing wire ties as necessary to free the sensor from the machine. Unplug the sensor from the 6-position junction box. The left stripper plate sensor is plugged into receptacle 5 (Figure 3-364).

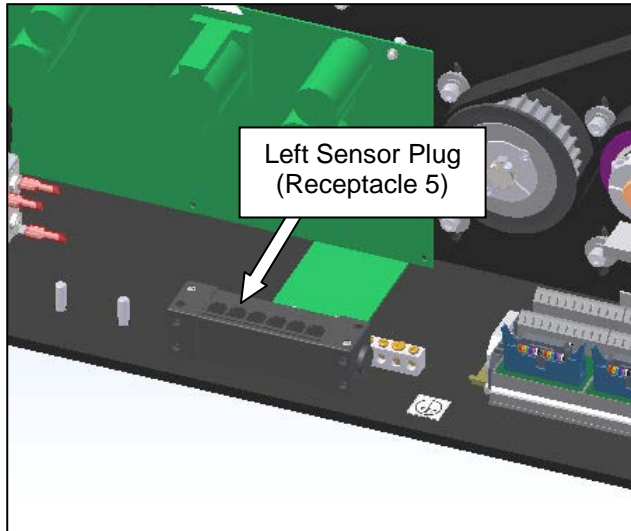

Figure 3-353. Stripper Plate Sensor Plugs

10. Remove the sensor from the mounting block, and install the new sensor (Figure 3-354).

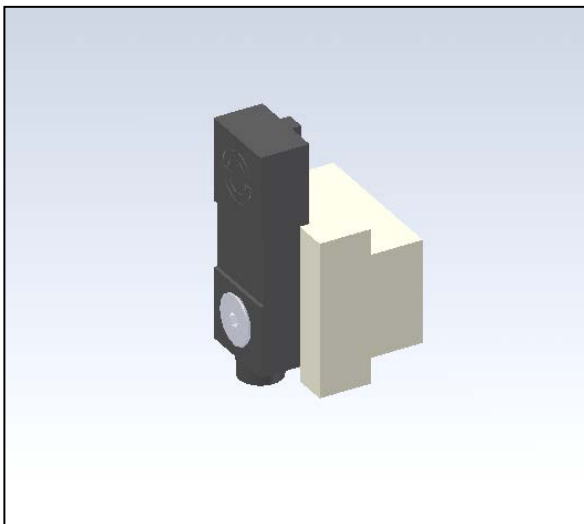

Figure 3-354. Sensor Mounting Block

11. Reinstall the left sensor and mounting block into the machine (Figure 3-355).

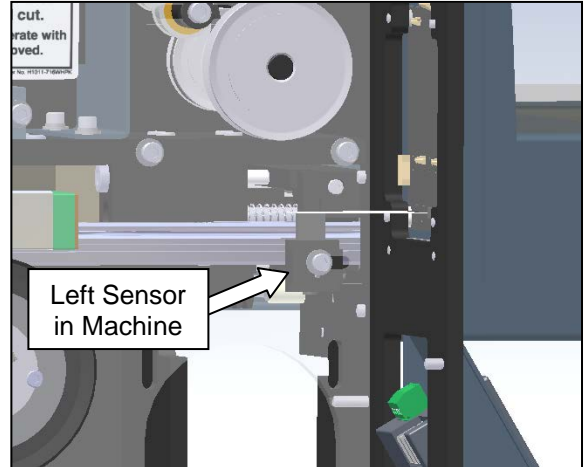

Figure 3-355. Installing the Left Plate Sensor
 Note: Side Plate Shown Clear for Clarity

12. Route the sensor cable through the machine, following the same path the previous cable took. Plug the sensor into receptacle 5 on the 6-position junction box. Secure sensor cables to bundles inside the machine to keep wires free of moving parts.

Setting Sensor Position (Both Sides)

13. Follow the steps outlined in the “Adjustment” section to position the sensors in the correct location.
14. Reinstall all guards removed in the previous steps.

SEALER ASSEMBLY

JAW POSITION SENSORS

The jaw position sensors communicate to the machine the location of the pressure jaw, determining the speed at which the jaw is closing. Jaw position is determined by two sensors, the first called “near-home” and the second called “home.”

Some of the procedures in this section require that the electrical power to the machine remain ON.

 WARNING
<p>USE EXTREME CAUTION WHILE SERVICING A MACHINE WHILE POWER IS APPLIED. UNEXPECTED MACHINE STARTUP CAN CAUSE SERIOUS INJURY.</p>

 WARNING
<p>DO NOT ATTEMPT TO SERVICE THE MACHINE DURING NORMAL OPERATION. KEEP HANDS AND ARMS CLEAR OF MOVING PARTS.</p>

 WARNING
<p>WHILE TESTING ELECTRICAL COMPONENTS WITH POWER APPLIED TO THE MACHINE, USE PROPER TROUBLESHOOTING TECHNIQUES TO AVOID ELECTRICAL SHOCK.</p>

TESTING

1. Remove the outside frame guard (Figure 3-356).

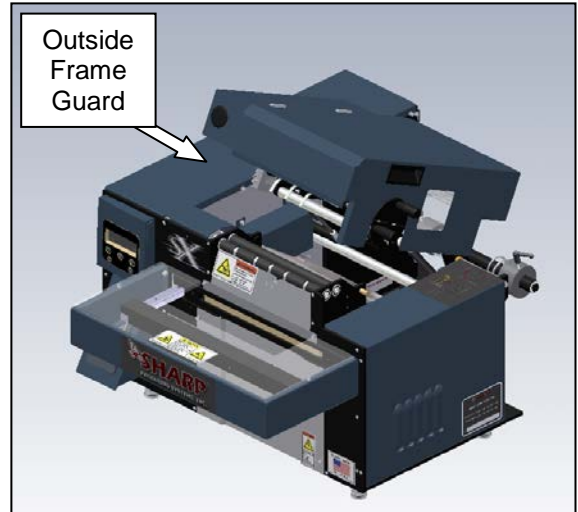

Figure 3-356. Guard Identification

2. Locate the 6-position junction box. Ensure the plugs are fully inserted into the ports. The “near home” sensor will be in the receptacle numbered ‘1’ and the “home” sensor will be in receptacle ‘2’ (Figure 3-357).

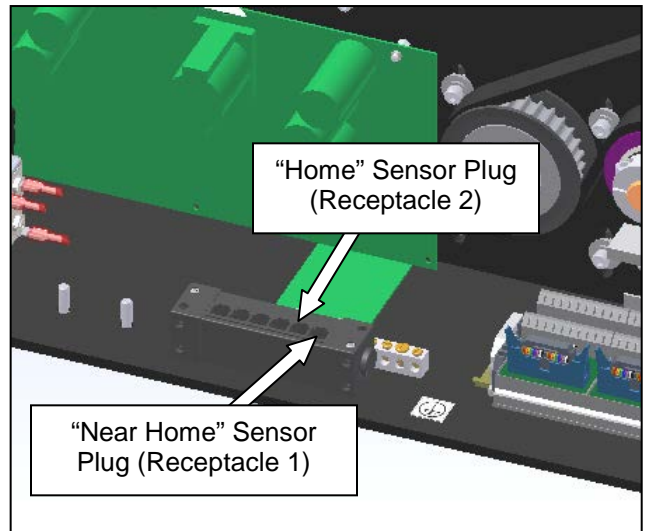

Figure 3-357. Jaw Position Sensor Plugs

SEALER ASSEMBLY

JAW POSITION SENSORS (con't)

4. Locate the PLC. While watching the inputs labeled 'X0' and 'X5', pass a metal object within .125" of the sensors. When activating the forward (near home) sensor, the indicator light labeled 'X0' on the PLC should illuminate. Activating the rear (home) sensor should illuminate the 'X5' indicator light. If the PLC does not illuminate when either sensor is activated, that sensor is faulty and needs replacement.

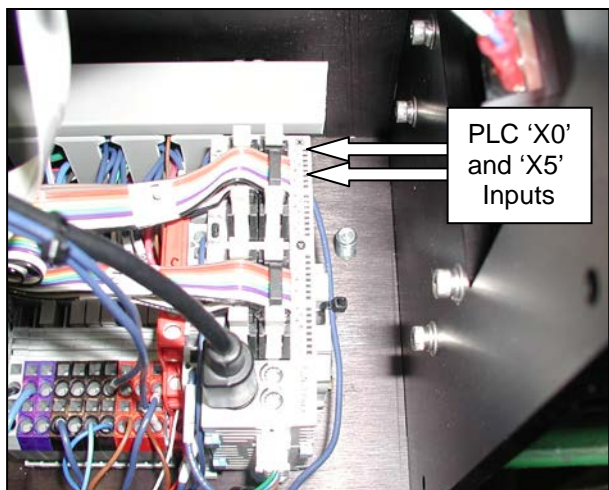

Figure 3-358. The PLC

ADJUSTMENT



WARNING

Always remove electrical power from the SX™ prior to performing any maintenance on the machine.

Setting the pressure bar sensors to the proper position requires the use of a setup jig, which can be ordered from Sharp Packaging Systems Inc. (Part Number 708709-01)

1. Remove the guards identified in Figure 3-371.

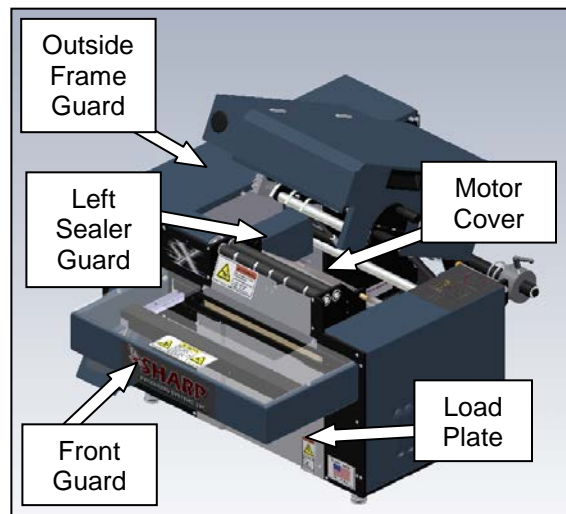

Figure 3-359. Guard Identification

2. Fully slide the pressure bar in, and apply a clamp between the pressure bar and rear surface of the horizontal mounting plate. The clamp should go underneath the horizontal mounting plate as shown in Figure 3-360. This will position the jaw in its sealing location.

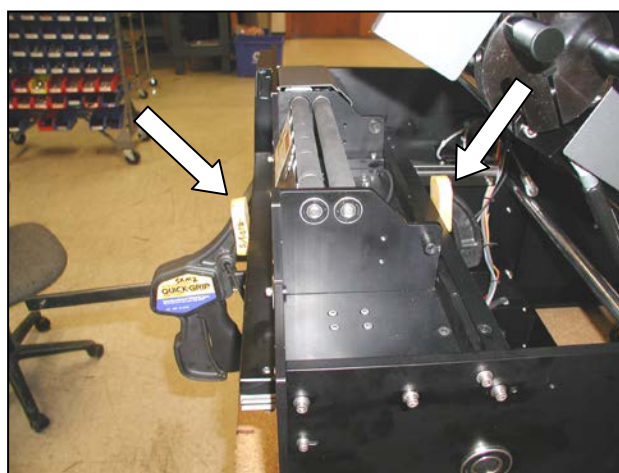

Figure 3-360. Clamping the Pressure Jaw for Setting Sensors

SEALER ASSEMBLY

JAW POSITION SENSORS (con't)

3. Position the setup jig against the back of left guide rail so that the jig sits squarely against the rear surface of the rail (surface 1 in Figure 3-361). Slide rear sensor bracket back until it touches the jig (surface 2 in figure). **Be sure the jig is only against the mounting bracket, not the sensor itself.** When in position, tighten the mounting screw identified in Figure 3-361.
4. Move jig into position shown in Figure 3-363, ensuring that it squarely touches the front surface of the rear sensor (surface 3 in figure). Slide front sensor back until it touches the front surface of the jig (surface 4 in figure). **Again, ensure that the jig is touching only the mounting bracket, not the sensor.** Once in position, tighten the mounting screw.

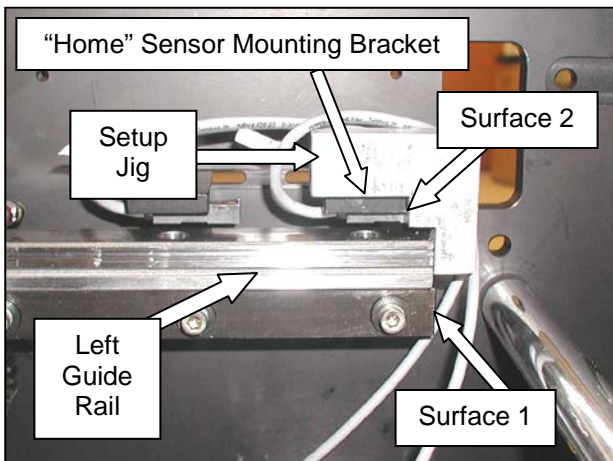

Figure 3-361. Setting the "Home" Jaw Position Sensor

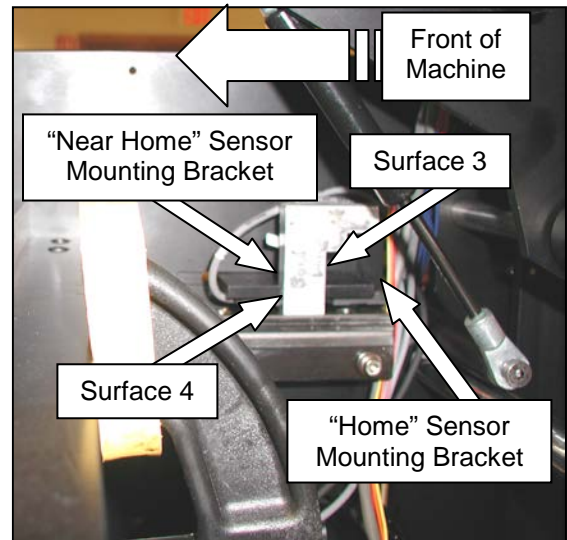

Figure 3-363. Setting the "Near Home" Sensor

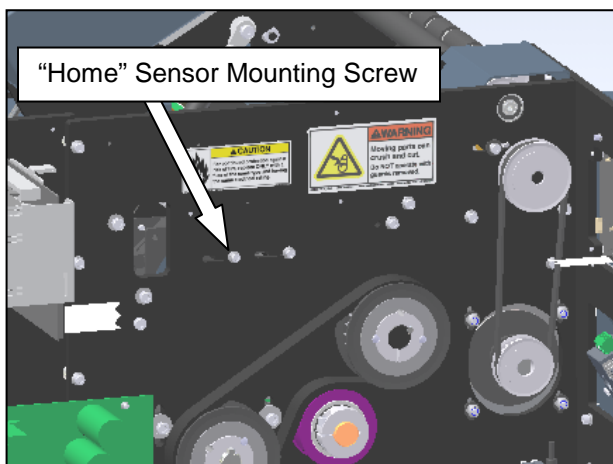

Figure 3-362. "Home" Sensor Mounting Screw

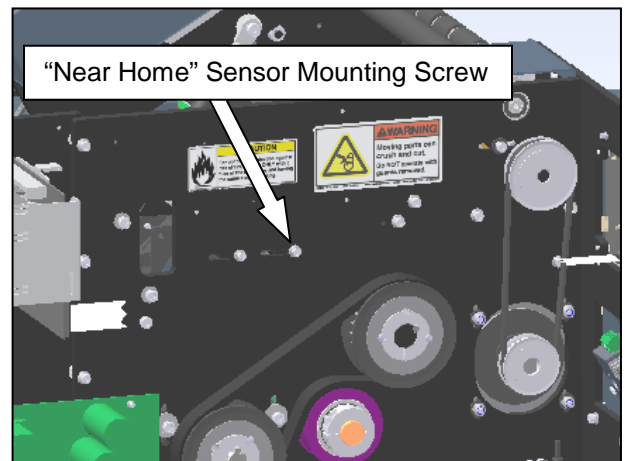

Figure 3-364. "Near Home" Sensor Mounting Screw

SEALER ASSEMBLY

JAW POSITION SENSORS (con't)

REPLACEMENT

1. Remove the guards identified in Figure 3-365.

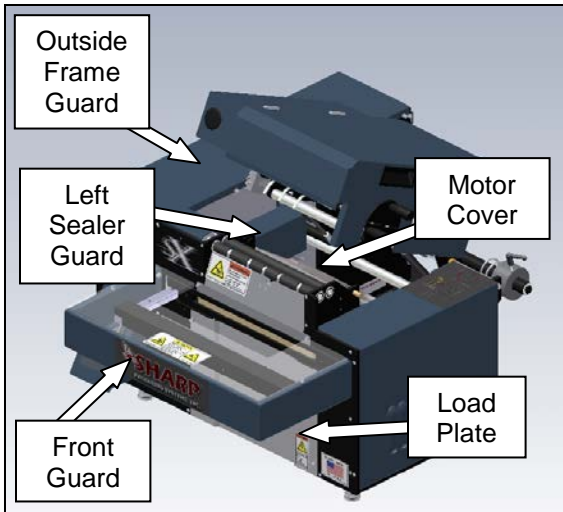

Figure 3-365. Guard Identification

2. Remove the mounting screws for the sensor bracket that needs replacement. Once free, access the sensor through the rear of the machine. Follow the wire routing through the machine, and remove any wire ties as necessary.

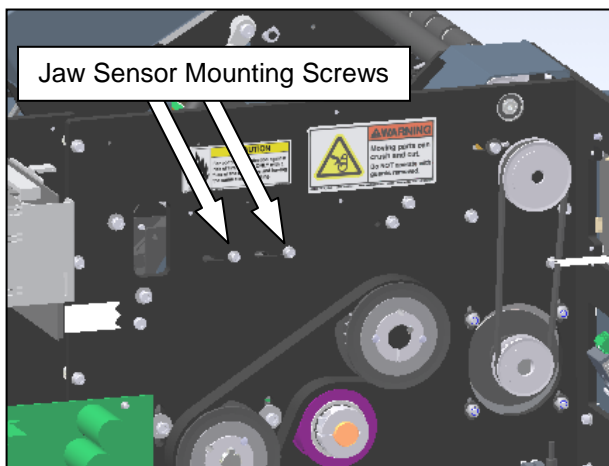

Figure 3-366. "Near Home" Sensor Mounting Screw

3. Locate the 6-position junction box, and unplug the connector in port 1 for the "Near Home" Sensor and/or port 2 for the "Home Sensor". This should free the sensor completely from the machine. Gently pull the wire, being careful of other wires still in the machine (Figure 3-367).

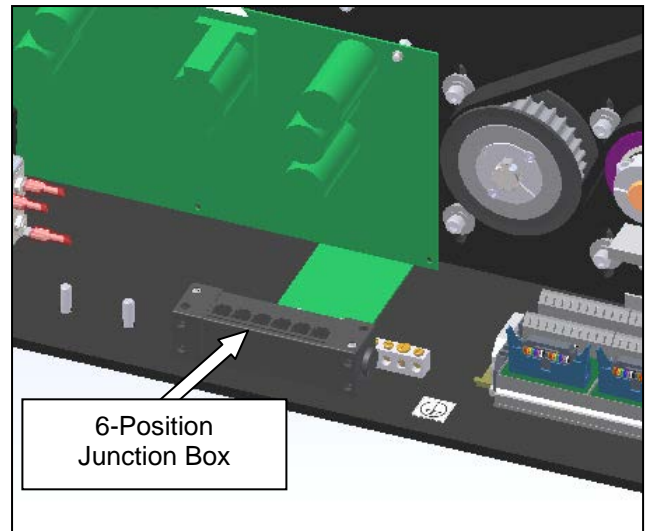

Figure 3-367. Stripper Plate Sensor Plugs

4. Remove the sensor mounting screw from the block, and install the new sensor in the orientation shown in Figure 3-368.

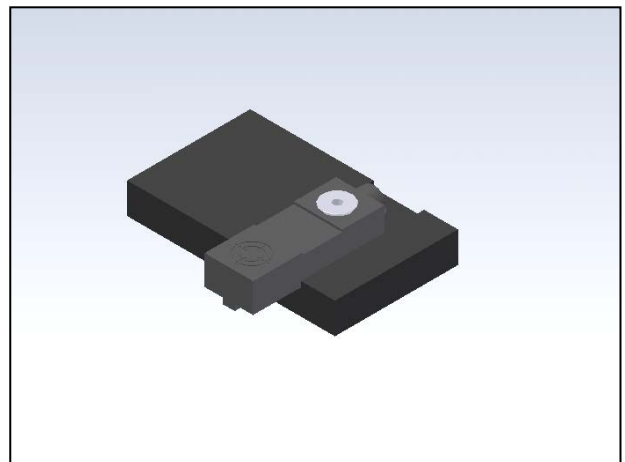

Figure 3-368. Sensor Mounting Block

UNWIND ASSEMBLY

JAW POSITION SENSORS (con't)

5. Route the new sensor cable through the machine, following the path taken by the old cable. Be sure to secure the cable to existing wire bundles or frame members to keep clear of moving parts.
6. Follow the steps outlined in the “Adjustments” section on page 3-141 to secure the sensor(s) in place.
7. Replace any guards removed in the previous steps.

UNWIND ASSEMBLY

UNWIND SPRING

The unwind spring supplies the tension to the web during machine operation.

TESTING



WARNING

Always remove electrical power from the SX™ prior to performing any maintenance on the machine.

Turn the unwind shaft by hand, and release. The shaft should come back to its pre-turned position. If it does not, the unwind spring is broken and needs replacement.

ADJUSTMENT

The unwind spring is adjustment free.

REPLACEMENT

1. Remove the E-clip and nylon washer from the end of the unwind shaft (Figure 3-369).

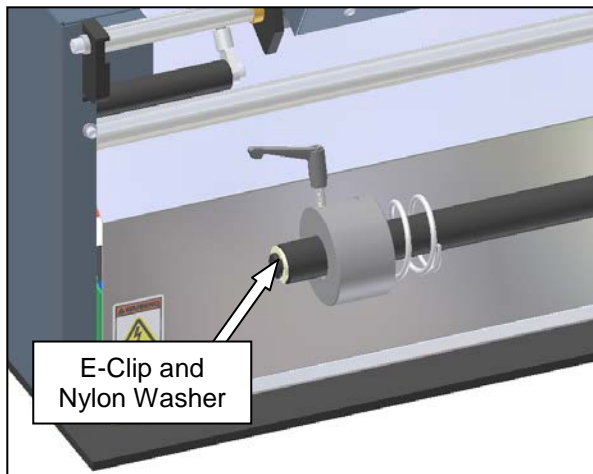

Figure 3-369. Unwind Shaft Components

2. Remove the four unwind bearing plate mounting screws shown in Figure 3-370.

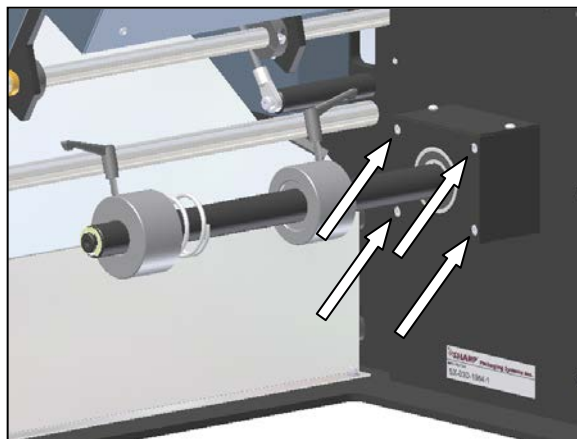

Figure 3-370. Unwind Plate Mounting Screws

3. With the unwind bearing plate loose, slide the unwind shaft off of the machine. This will expose the unwind spring which should now be removed (Figure 3-371).

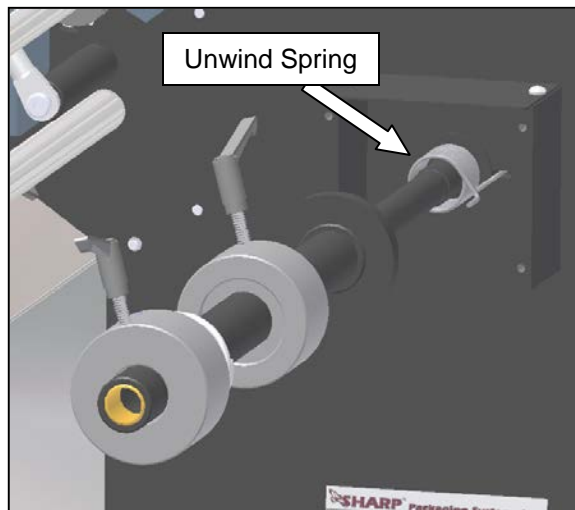

Figure 3-371. Removing the Unwind Spring

UNWIND ASSEMBLY

UNWIND SPRING (con't)

- Slide the new spring onto the shaft. The end of the spring is to be inserted into the slot on the rear side of the hole in the middle unwind plate (Figure 3-372).

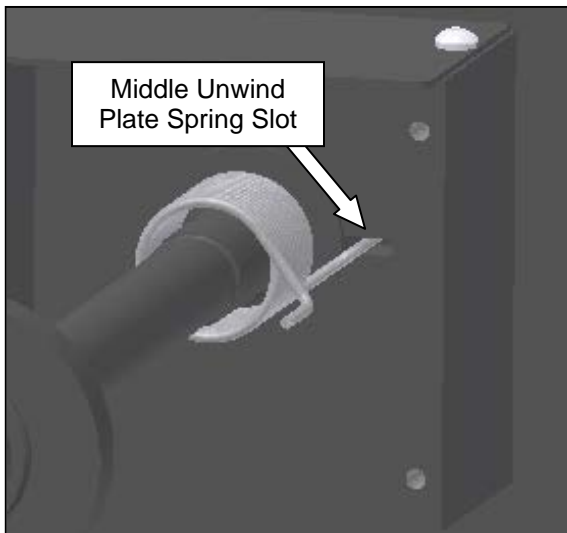

Figure 3-372. Inserting the Unwind Spring

- Slide the unwind shaft into position. The exposed end of the spring is to be inserted into the machined slot on the back side of the unwind shaft flange (Figure 3-373).

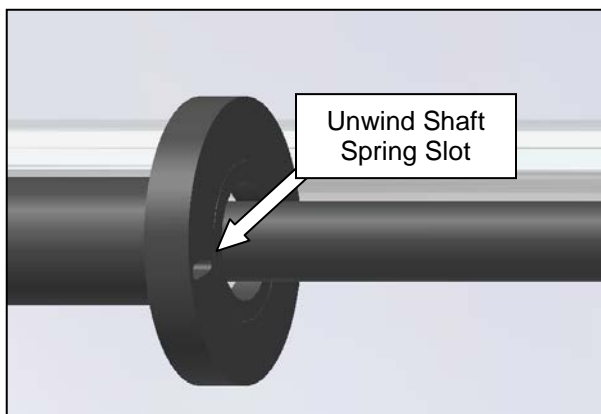

Figure 3-373. Inserting the Unwind Spring

- With the shaft completely slid onto the machine, reinsert the four mounting screws for the unwind bearing plate (Figure 3-374).

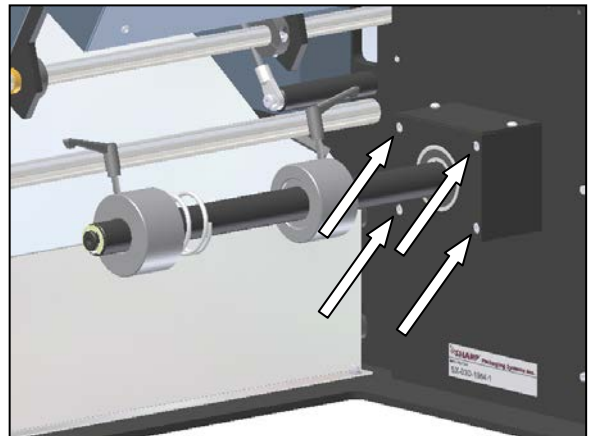

Figure 3-374. Unwind Plate Mounting Screws

- Reinstall the nylon washer and the E-Clip on the end of the unwind shaft.

PROBLEM	CAUSE	SOLUTION
Machine will not power up.	<ol style="list-style-type: none"> 1. Power cord is unplugged. 2. Power switch is turned on, but machine will not power up. 3. System fuse blown. 4. Wiring issue. 	<ol style="list-style-type: none"> 1. Plug power cord into a working power outlet. 2. Refer to the Main Red Power Switch Section (page 3-20). 3. Refer to the Fuses Section (page 3-6). 4. Use the electrical schematics to troubleshoot the machine wiring.
When turning the machine on, the case fan runs but the display does not illuminate.	<ol style="list-style-type: none"> 1. Faulty power supply. 2. Wiring issue. 	<ol style="list-style-type: none"> 1. Refer to the Power Supply section (page 3-8). 2. Use the electrical schematics to troubleshoot the machine wiring.
Machine turns on, but will not cycle.	<ol style="list-style-type: none"> 1. No bags. 2. Foot switch not plugged in. 3. Machine is faulted. 4. Stepper drive is faulted. 	<ol style="list-style-type: none"> 1. Ensure there are bags on the roll, and they are properly installed on the unwind shaft. 2. Ensure the foot switch plug is making a solid connection with the receptacle on the machine. 3. Check the fault condition on the display and troubleshoot accordingly. 4. Refer to the Pressure Bar and Film Feed Motor Controllers Section (page 3-1).
Bag film will not advance.	<ol style="list-style-type: none"> 1. Cradle not properly latched. 2. Jaw “Home” sensor is out of position. 3. Loose pulley or drive belt. 4. Broken drive belt. 5. Motor is not plugged in. 6. Blown system or drive fuse. 	<ol style="list-style-type: none"> 1. Ensure the cradle is completely closed and securely latched. 2. Refer to the Jaw Position Sensors Section (page 3-146) to verify sensor alignment. 3. Check drive pulleys for tight fit on shafts, and drive belts for proper tension (see Checking Belt Tension on Page 2-6). 4. Check the Film Feed Motor Drive Belt (page 3-60) and the Film Feed Roller Drive Belt (page 3-61). 5. Check motor plug for proper connection. 6. Refer to Fuses (page3-6) and Film Feed Stepper Drive (page3-1) sections.

PROBLEM	CAUSE	SOLUTION
Seal wire will not heat up.	<ol style="list-style-type: none"> 1. Seal time set too low. 2. Loose or broken seal wire. 3. Faulty solid state relay. 4. Faulty transformer. 5. "Home" position sensor out of adjustment. 	<ol style="list-style-type: none"> 1. Increase "Seal Time" on the "Settings" menu in .1 second increments and check the bag seals after cycling. 2. Refer to Sealpoint Components Section (page 3-135). 3. Refer to Solid State Relay Section (page 3-35). 4. Refer to Transformers Section (page 3-22). 5. Refer to Jaw Position Sensors Section (page 3-146) to set correct position.
Bag does not open.	<ol style="list-style-type: none"> 1. Bag film is incorrectly threaded into the machine. 2. Bags are not centered on the drive roller. 3. Bag openings are not registered below air flow (incorrect bag length). 4. Obstructed or no air flow. 5. Excessive static. 	<ol style="list-style-type: none"> 1. Ensure the bags are on the unwind shaft such that the bags come off the bottom of the roll and up to the drive roller. 2. Adjust roll of bags on unwind shaft to the center of machine. Open cradle and adjust web path. 3. Adjust bag length to allow perforations to be between drive rollers and pressure bar. 4. Check the Cross Flow Fan (page 3-108) and cradle duct for obstructions. 5. Try a different roll of bags to see if problems persist. If bags are still causing problems, contact the Sharp Packaging Systems Inc. service line.
Bags do not separate.	<ol style="list-style-type: none"> 1. Incorrect bag length setting 2. Cradle not properly latched. 3. Cradle latch is worn. 4. Film feed roller is dirty. 	<ol style="list-style-type: none"> 1. Adjust bag length to allow perforations to be between drive rollers and pressure bar. 2. Ensure the cradle is completely closed and securely latched. 3. Replace or upgrade to Cradle Lock Cams (page 3-74). 4. Clean the film feed roller following the Cleaning procedure on page 2-3.
<i>Continued on next page</i>	<i>Continued on next page</i>	<i>Continued on next page</i>

PROBLEM	CAUSE	SOLUTION
Bags do not separate (con't).	5. "Home" position sensor out of adjustment. 6. Loose pulley or drive belt. 7. The pinch roller springs are loose. 8. Stripper plate is not properly gripping the bag.	5. Refer to Jaw Position Sensors Section (page 3-146) to set correct position. 6. Check drive pulleys for tight fit on shafts, and drive belts for proper tension (see Checking Belt Tension on Page 2-6). 7. Refer to the Adjusting Pinch Roller Section (page 2-5) to verify settings. 8. Refer to the Stripper Plate Assembly Section (page 3-128) to adjust and replace the stripper plate springs.
"Object in Sealing Area" Fault	1. Obstruction in the seal area. 2. Stripper plate is wedged in. 3. Stripper plate sensors or jaw position sensors out of adjustment. 4. Stripper plate sensors are faulty.	1. Remove any obstruction from between the pressure jaw and stripper plate. 2. Press the stripper plate to check the springs that return it to its home position. If springs do not push plate out, refer to the Stripper Plate Assembly Section (page 3-128) to replace the springs. 3. Refer to the Stripper Plate Sensors Section (page 3-141) and the Jaw Position Sensors Section (page 3-146) to check adjustment. 4. Refer to the Stripper Plate Sensors Section (page 3-141) to replace the sensors.
"No Bags" Fault	1. Roll of bags is empty. 2. Web has broken. 3. Bags are present, but machine does not detect them. 4. Photoelectric sensor is faulty.	1. Install and properly thread a new roll of bags. 2. Adjust the roll tensioner pressure and rethread machine. 3. Ensure bags are centered in the machine and they cover the photoelectric eye. Also check that any hangholes in the bags are not directly centered on the machine so the eye sees them. 4. Refer to the Photoelectric Sensor Section (page 3-56) for adjustment and replacement instructions.

PROBLEM	CAUSE	SOLUTION
<p>“Reverse” Fault (See also ‘Bags do not separate’ Section).</p>	<ol style="list-style-type: none"> 1. Bag openings are not registered below air flow (incorrect bag length). 2. Photoelectric eye was falsely triggered. 3. Photoelectric eye is faulty. 	<ol style="list-style-type: none"> 1. Adjust bag length to allow perforations to be between drive rollers and pressure bar. 2. Recalibrate the photoelectric sensor using the procedure in the Photoelectric Sensor Section (page3-56). 3. Refer to the Photoelectric Sensor Section (page 3-56) for replacement instructions.
<p>“Printer Not Ready” Fault</p>	<ol style="list-style-type: none"> 1. Printer power is not on. 2. Printer not initialized. 3. Machine/printer communication issue. 	<ol style="list-style-type: none"> 1. Turn on printer power switch on the rear of the machine. 2. Press the “Feed” button on the printer display to initialize the printer. 3. Troubleshoot the Red Relay (page 3-41).
<p>“No Labels or Ribbon” Fault</p>	<ol style="list-style-type: none"> 1. Printer is out of ribbon. 2. Printer ribbon is broken. 3. Ribbon is threaded incorrectly. 4. Printer is out of labels. 5. Machine is not properly rewinding the ribbon. 	<ol style="list-style-type: none"> 1. Install and properly thread a new roll of ribbon. 2. Rethread the ribbon according to the web threading diagram on the outer guard of the machine. 3. Rethread the ribbon according to the web threading diagram on the outer guard of the machine. 4. Download a label to the printer. 5. Troubleshoot the Ribbon Rewind Assembly Components on page 3-76.
<p>Machine will not print.</p> <p><i>Continued on next page</i></p>	<ol style="list-style-type: none"> 1. Printer power not connected or not turned on. 2. Printer option is turned off. 3. Printer not initialized. 4. No label loaded into the printer. <p><i>Continued on next page</i></p>	<ol style="list-style-type: none"> 1. Ensure power cord is fully plugged into machine and into a working outlet. 2. Enable printer in the “Options” menu. 3. Press the “Feed” button on the printer display to initialize the printer. 4. Download a label to the printer. <p><i>Continued on next page</i></p>

PROBLEM	CAUSE	SOLUTION
Machine will not print (con't).	<p>5. Ribbon is threaded incorrectly.</p> <p>6. Printhead cables are loose or disconnected.</p> <p>7. Printhead is severely out of adjustment.</p> <p>8. Printhead pressure is incorrect.</p> <p>9. Machine/printer communication issue.</p> <p>10. Printhead position assembly is not functioning properly.</p> <p>11. Machine is not properly rewinding the ribbon.</p>	<p>5. Rethread the ribbon according to the web threading diagram on the outer guard of the machine.</p> <p>6. Ensure the cables on the printhead are fully engaged.</p> <p>7. Adjust the printhead screws in and/or out and cycle machine to check for print on bag film.</p> <p>8. Refer to the Printhead Stepper Drive Section (page 3-53) to adjust the drive.</p> <p>9. Troubleshoot the Red Relay (page 3-41) and the Grey Relay (page 3-39).</p> <p>10. Refer to the Printhead Position Assembly Section (page 3-89).</p> <p>11. Troubleshoot the Ribbon Rewind Assembly Components on page 3-76.</p>
Print appears light and/or uneven.	<p>1. Printing temperature is too low.</p> <p>2. Printhead is out of adjustment.</p> <p>3. Printhead pressure is incorrect.</p>	<p>1. Increase the temperature setting in the label setup area of the label creation/printing software.</p> <p>2. Adjust the printhead screws in and/or out and cycle machine to check the print on bag film.</p> <p>3. Refer to the Printhead Stepper Drive Section (page 3-53) to adjust the drive.</p>
Print has vertical lines through the entire length of print.	<p>1. The printhead is dirty.</p> <p>2. Worn printhead.</p>	<p>1. Clean printhead following the Cleaning procedure on page 2-3.</p> <p>2. Refer to the Thermal Printhead Section (page 3-102) to replace the printhead.</p>
Print location is drifting.	<p>1. Unwind spring tension is improperly set.</p>	<p>1. Change the roll tension on the core chuck spring to allow bags to feed evenly.</p>

PROBLEM	CAUSE	SOLUTION
<p>Print appears smaller and shrunk together or larger and stretched out.</p>	<ol style="list-style-type: none"> 1. Print speeds in machine and downloaded label are mismatched. 2. Platen roller is dirty. 3. Loose pulley or drive belt. 4. Machine is not properly rewinding the ribbon. 	<ol style="list-style-type: none"> 1. Verify the value for print speed in the label setup and the print speed in the printer options menu on the machine match. 2. Clean the platen roller following the Cleaning procedure on page 2-3. 3. Check drive pulleys for tight fit on shafts, and drive belts for proper tension (see Checking Belt Tension on Page 2-6). 3. Troubleshoot the Ribbon Rewind Assembly Components on page 3-76.
<p>Printhead does not lift.</p>	<ol style="list-style-type: none"> 1. Sensor flag is out of adjustment. 2. Printhead position sensor is faulty. 3. Printhead position motor is not working. 	<ol style="list-style-type: none"> 1. Refer to the Printhead Pressure Cams Section (page 3-94) for aligning the sensor flag. 2. Refer to the Printhead Position Sensor Section (page 3-100) to replace the sensor. 3. Ensure the motor cable is completely plugged in, and troubleshoot the Printhead Position Motor (page 3-89) as necessary.
<p>The printer display shows "Top of Form" fault.</p>	<ol style="list-style-type: none"> 1. Incorrect label settings 	<ol style="list-style-type: none"> 1. Reset the setting to the following: <ul style="list-style-type: none"> • SENSOR TYPE– Continuous • BACKFEED– 0 <p>Refer to the Printer Flowchart on Page A-5 in the appendix for menu paths.</p>
<p>Printer prints entire quantity of labels.</p>	<ol style="list-style-type: none"> 1. GPIO connection is faulty. 	<ol style="list-style-type: none"> 1. Check the GPIO cable on the back of the machine to ensure it is completely plugged in and the pins and sockets are not bent.

SECTION 5- PARTS LISTS

ELECTRICAL ASSEMBLY					
ITEM	CONTROL #	DESCRIPTION	PART NUMBER	VENDOR	QTY
1	706557-01	Stepper Drive	TM4500	Anaheim Auto.	2
2	706554-01	Stepper Drive, 2A, 35 VDC	2035-O	Applied Motion	1
3	706839-01	PLC, Sigma	FPG-C32T2	Aromat	1
4	707927-01	Power Supply, 24 VDC, 6.5A	S-150-24	Mean Well	1
5	706768-01	Cable, P21NRXD-LNF-NS-00	GW0000F	Minarik	1
10	707286-01	Power Cord, Y-Style w/ Twin End	17274A BLACK	Volex	1
11	832039-01	Switch, Main Red	1A824	Grainger	1
12	706315-01	DIN Rail (252 Mm)	B0006375	Triphase Auto.	1
13	705841-01	End Barrier	280-314	WAGO	1
14	705457-01	End Anchor	249-116	WAGO	2
15	705456-01	Terminal Jumper	280-402	WAGO	6
16	705455-01	Terminal - 4 Connect	280-833	WAGO	14
17	704757-01	Cable, Flat, 0.5 Meter	AYT1505-US	Innovative Auto	2
18	704755-01	Breakout Module	289-504	WAGO	2
20	704664-01	Socket, 9 Pin, Standard Sex	512-1155	Amp	1
22	706196-01	Terminal, Disconnect W/ Fuse	281-611	WAGO	2
24	700058-01	Fuse, 10A, 250 VAC, 5 X 20 mm	740-9575	Bussman	1
26	706597-01	Fuse, 5 A, 250 VAC, 5 X 20 mm	740-3014	Bussman	1
27	706559-01	Fan Cooling, 115 VAC, 105 CFM	A47-B15A-A5T3-100	Minarik	1
29	704790-01	Transformer	WT-12028	Watertown Trans.	2
34	100362	Touchscreen Housing	C0007341	SMSsharp	1
35	706598-01	GT-10 Color Touchscreen	AGT1000B	Aromat	1
36	706236-01	Cable GT-30 Communication	GC98830440	Go Cable	1
37	706560-01	Power cord, Fan	FPC24	Minarik	1
38	707727-01	Rear Face Plate	C0007355	MPSsharp	1
39	700056-01	Relay, Solid State, 25 Amp	S505-OSJ625-000	Continental Ind.	1
40	700163-01	Line Filter, W/Plug	F1250CA10	Curtis	1
41	706558-01	Track Mount, 5" For TM4500	AA3963	Minarik	2
42	880090-01	Connector 9 Pin Cable	A-2047-ND	Amp	1
43	705030-01	Relay Module	OI-ODC-RO-060	Continental Ind.	1
44	706317-01	DIN Rail (72 mm)	A0006377	Sharp	1
45	706695-01	Relay 24V, 1 Pole	859-304	Amp	1

ELECTRICAL ASSEMBLY

ITEM	CONTROL #	DESCRIPTION	PART NUMBER	VENDOR	QTY
46	708052-01	Base Plate	D0007571	MPSHarp	1
47	100206	Rear Connector Plate	C0006143	SMSHarp	1
49	707001-01	Leveling Mt, 5/16-18, Zinc Plated	62805K33	McMaster Carr	5
50	700078-01	Foot Switch Cover	522-B14	Line Master	1
51	700077-01	Foot Switch, Linemaster	971-SC26	Line Master	1
52	704662-01	Back Shell	206966-1	Amp	1
53	704665-01	Plug, 9 Pin, Standard Sex	206708-1	Amp	1
54	706897-01	Resistor, 2.2K, 1/4 Watt	296-6318	Allied Electronics	1
55	705454-01	Block, Terminal, 2 Pos. Wago	280-901	Wago	1
61	706678-01	Junction Box, Multi-Port	M6P	Powermation	1
62	715324-01	Jack Screw Kit, Steel	SDG450XS		1
63	707875-01	Connector, GPIO 90 Degree	GC98840310-1	Cable Sys.	1
64	707569-01	Cable, White Laminated Ribbon	100-20-610BO		1
67	706840-01	Battery for PLC	AFPG804	Tri-Phase	1
68	706639-01	Decal, Printer GPIO Board	A0006524	MPSHarp	1
69	706641-01	Decal, SX Serial Port	A0006522	MPSHarp	1
70	706640-01	Decal, SX Parallel Port	A0006523	MPSHarp	1
71	710280-01	Decal, SX Connections	C0008822	MPSHarp	1
72	708264-01	Plate, Mounting Rear	12-3342-01	Datamax-O'Neil	1
73	706823-01	Board, Logic, Performance, CCA	51-2301-03	Datamax-O'Neil	1
74	713722-01	Fan, Axial	3110KL-05W-B50-D00	NMB Tech	1
75	706812-01	Board, Back Plane, CCA, 6"	24-2568-01	Datamax-O'Neil	1
76	706824-01	Guard, Fan	17-2432-01	Datamax-O'Neil	1
77	706788-01	Board, GPIO	DPO78-2256-02	Datamax-O'Neil	1
78	706792-01	Plate, Cover, Read	11-5279-01	Datamax-O'Neil	1
79	710284-01	Label, Warning General Electric	710284-01	Clarion	2
80	706797-01	Board, Power Supply, CCA	51-2307-00	Datamax-O'Neil	1
81	707757-01	Plate, Front	D0007405	MPSHarp	
82	100208	Cover, Touch Pad Bottom	B0006434	MPSHarp	
83	706818-01	Panel, Front	P74-2379-01	Datamax-O'Neil	1
84	706819-01	Bezel, Front	16-2578-01	Datamax-O'Neil	1
85	706820-01	Buttons, Control Panel	16-2579-01	Datamax-O'Neil	1
86	706821-01	Module, LCD	45-2013-01	Datamax-O'Neil	1

FILM FEED ASSEMBLY

ITEM	CONTROL #	DESCRIPTION	PART NUMBER	VENDOR	QTY
1	706571-01	Stepper Motor, NEMA 34, 1 Stack	HT34-474-FLAT-CON	Applied Motion	1
2	706550-01	Timing Pulley, Flanged, 1/2" Bore	24XL0376FA x 1/2 BORE	Neuman	1
3	706551-01	Timing Pulley, 3/8" Bore, 2 SS	30XL0376FA	Neuman	1
4	706447-01	Timing Pulley, 3/8" Bore, 2 SS	20XL0376FA	Neuman	4
5	706655-01	Snap Ring Bearing, 3/8" Bore	S21406-88	GBC	7
6	700198-01	Timing Belt	170XL037	Browning	1
7	706446-01	Timing Belt	80XL037	Browning	2
8	706594-01	Thrust Bushing, 3/8" I.D. X 1/2" Lg	BSF-1216-8	Symmco	2
9	706982-01	Flat Washer, #10 X 3/32" Thk	98029A011	McMaster Carr	2
10	707743-01	Film Feed Drive Roller	C0007400	Metal Rubber Co.	1
11	706455-01	Printer Platen Roller	C0006008	Metal Rubber Co.	1
12	706498-01	Belt Take-Up Shaft	A0006039	MPSHarp	2
13	706499-01	Take-Up Pulley	A0006040	MPSHarp	2
14	706500-01	Transfer Shaft	A0006276	MPSHarp	1
15	707744-01	Front Finger Plate	C0007399	SMSHarp	1
16	706506-01	Idler Roller W/ Bearings	B0006467	Perkins	1
18	708044-01	Left Bearing Plate	C0007756	MPSHarp	1
19	708045-01	Right Bearing Plate	C0007757	MPSHarp	1
20	707772-01	Sensor Mounting Angle	A0007427	MPSHarp	1
21	707730-01	Photoelectric Sensor, Reflective	PZ-V11	Keyence	1
24	707931-01	Cam Follower, 1/2" Dia, Heavy Stud	CFH-1/2-SB	McGill	2

FRAME ASSEMBLY

ITEM	CONTROL #	DESCRIPTION	PART NUMBER	VENDOR	QTY
3	707659-01	Horizontal Mounting Plate	C0007325	MPSHarp	1
4	707731-01	Middle Support Bar	B0007403	MPSHarp	1
6	706985-01	Outside Plate - Right	C0006842	MPSHarp	1
7	707732-01	Middle Frame Plate	D0007396	MPSHarp	1
9	706611-01	Zinc-Plated Steel Spacer #10 Screw	92415A844	McMaster Carr	3
10	707634-01	Front Plate - Left	D0007298	MPSHarp	1
15	707733-01	Motor Cover	C0007404	SMSHarp	1
16	100276	Sealer Guide Guard - Left	C0006851	SMSHarp	1
17	100277	Sealer Guide Guard - Right	C0006852	SMSHarp	1
19	100351	Frame Cover	D0007354	SMSHarp	1
21	706491-01	Middle Unwind Plate	D0006145	SMSHarp	1
22	100385	Outside Cover - Right	C0007755	MPSHarp	1
25	100217	Bag Deflator Jaw Guard	C0006484	SMSHarp	1
27	706685-01	Bag Deflator Jaw Top Guard	C0006485	SMSHarp	1
31	707770-01	Recessed Load Plate	D0007366	Gemini Plastics	1
40	100209	Pulley Cover	B0006285	SMSHarp	1
42	706425-01	SX Logo Decal	B0006516	Rallye	1
43	706424-01	Sharp Logo Decal	B0006515	Holland Engrave	1
45	706649-01	Service Information Decal	B0006519	Holland Engrave	1
48	706647-01	SX Web And Ribbon Threading Decal	B0006525	Holland Engrave	1
63	700573-01	Caution Label, Burn Hazard	H1073/6043-714CHPH	Holland Engrave	1
64	706878-01	Caution Label, Entanglement Hazard	H1018-715WHPK	HCS	1
65	706879-01	Warning Label, Moving Parts	H1011-716WHPK	HCS	1
66	706880-01	Warning Label, Electrical Shock	H6010-717WVPL	HCS	3
67	706894-01	Label, USA	9251	HCS	1
68	707564-01	Caution Label, Risk Of Fire Hazard	6020-C3CHPI	HCS	1
69	707807-01	Cap Plug	PIP 9/16	AJ Ellis	1

SECTION 5- PARTS LIST

PRINthead CRADLE ASSEMBLY (MODEL 1108)

ITEM	CONTROL #	DESCRIPTION	PART NUMBER	VENDOR	QTY
1	706584-01	Radial Bearing, 1/4 Bore	21104-88	GBC	4
2	705522-01	Compression Spring, 1" Long	LHL-375AB-01	Lee Spring	2
4	706390-01	Power Cable, Printhead	GC98830123-1	Go Cable	1
5	706389-01	Datamax Data Cable	GC98830123	Go Cable	1
6	706556-01	Stepper Motor, 23 Frame	P21NRXD-LNF-NS-00	Pacific Scientific	1
9	707738-01	Upper Guide Finger Plate	C0007401	SMSharp	1
10	707126-01	Spring Bracket Cross member	B0006999	MPSharp	1
11	707323-01	Adjustment Cap	A0007091	MPSharp	2
12	707123-01	Pinch Spring Bracket	B0006997	MPSharp	2
13	707124-01	Pinch Stationary Bracket	B0006998	MPSharp	2
14	707739-01	Pinch Roller	B0007402	MPSharp	1
15	706421-01	Slip Clutch, 0-25 Oz.-In. Torque	XSH-2414	Polyclutch	1
16	706593-01	DC Roller Clutch, 3/8 Bore	RC-061008	Torrington	1
17	706449-01	Mod. Timing Pulley 44MP-0256FA	A0006035	MPSharp	1
18	706450-01	Mod. Timing Pulley 30M3-L09M6FA	A0006036	MPSharp	1
19	706448-01	Mod. Timing Pulley 16M3-L09M6FCA	A0006037	MPSharp	2
20	706451-01	Mod. Timing Pulley 60M3-L09M6A	A0006438	MPSharp	1
21	812072-30	Proximity Switch, 4 mm Range	NBN4-F29-EO	Peperell & Fuchs	1
24	706515-01	Pinch Roller Shaft	B0006286	MPSharp	1
25	700192-01	Clamp Collar, One Pc., 3/8" Bore,	1C-037-A	Climax	1
27	706547-01	Timing Belt, HTD	300-3M-09	Gates	1
28	706548-01	Timing Belt, HTD	267-3M-09	Gates	1
29	706549-01	Timing Belt	88MXL025	Gates	1
30	706991-01	Cradle Drive Side Plate	D0006866	MPSharp	1
31	708046-01	Cradle Side Plate	D0007759	MPSharp	1
32	706518-01	Latch Pivot Shaft	B0006443	MPSharp	1
33	706519-01	Cradle Pivot Shaft	B0006289	MPSharp	1
34	706520-01	Ribbon Roller	B0006049	MPSharp	1
35	706521-01	Ribbon Roller - Short	B0006050	MPSharp	2
36	706522-01	Printhead Pivot Shaft	B0006051	MPSharp	1
37	706523-01	Printhead Transfer Shaft	A0006052	MPSharp	1
38	706524-01	Cradle Outside Drive Plate	C0006462	MPSharp	1
39	706993-01	Printhead Side Plate - Right	B0006867	MPSharp	1

PRINthead CRADLE ASSEMBLY (MODEL 1108)

ITEM	CONTROL #	DESCRIPTION	PART NUMBER	VENDOR	QTY
40	706994-01	Printhead Side Plate - Left	C0006865	MPSharp	1
41	706995-01	Printhead Lift Bracket	C0006845	SMSharp	1
42	707928-01	Cradle Latch Lever	C0007629	MPSharp	1
43	707929-01	Cradle Latch	B0007630	MPSharp	1
44	706996-01	Right Plate Mounting Block	A0006864	MPSharp	2
45	706997-01	Printhead Support	B0006869	MPSharp	1
46	707740-01	Left Plate Mounting Block	B0007407	MPSharp	1
47	706533-01	Center Mounting Block	A0006061	MPSharp	1
48	706534-01	End Mounting Block	A0006062	MPSharp	1
49	706535-01	Left Plate Stand-Off	A0006064	MPSharp	3
50	707752-01	Print Head Sensor Actuator	B0007418	MPSharp	1
51	706537-01	Printhead Cam Shaft	B0006066	MPSharp	1
52	706538-01	Printhead Cam Transfer Shaft	B0006439	MPSharp	1
54	706540-01	Idler Mounting Plate	A0005921	MPSharp	1
55	706541-01	Idler Shaft	A0005922	MPSharp	1
56	706998-01	Idler Pulley	A0006863	MPSharp	1
57	707753-01	Side Plate Mounting Post	A0007419	MPSharp	1
62	706585-01	Radial Bearing, 3/8 Bore	21462-88	GBC	3
63	706672-01	Snap Ring Bearing, 1/2 Bore	S21808-88	GBC	1
64	702633-01	Radial Bearing, 3/4 Bore	22612-88	GBC	1
65	706589-01	Flanged Bearing, 5/8 ID X 5/8 Lg	SF-2024-10	Symmco	2
66	706590-01	Flange Bushing, 1/2 ID X 1/2 Lg	FF-609-3	Symmco	2
67	706591-01	Bushing, 5/16 ID X 7/16 OD X 3/8 Lg	SS-1014-6	Symmco	2
68	706592-01	Clamp Collar, One Pc., 5/8" Bore	1C-062	Climax	2
83	705803-01	Steel Eyelet 6mm	9416K84	McMaster Carr	4
84	706619-01	Fixed Force Gas Spring, 50 lb	9416K11-50	McMaster Carr	2
85	706543-01	Gas Shock Mounting Post	A0006290	MPSharp	2
89	100353	Outside Cradle Cover	C0007406	SMSharp	1
90	100354	Printhead Top Cradle Cover	D0007408	SMSharp	1
91	707754-01	Printhead Cradle Cover Duct	D0007409	SMSharp	1
95	706545-01	Shield Mounting Bar	B0006219	MPSharp	1
102	706575-01	Cross Flow Fan	MF915B-BC	Oriental Motor	1
103	706576-01	Finger Guard	FG915D	Oriental Motor	2

SECTION 5- PARTS LIST

PRINthead CRADLE ASSEMBLY (MODEL 1108)

ITEM	CONTROL #	DESCRIPTION	PART NUMBER	VENDOR	QTY
104	708176-01	Stem Bumper, SBR Rubber 70A	9544K16	McMaster Carr	4
105	706622-01	Extension Spring, 1.05" Long	9433K44	McMaster Carr	1
106	708047-01	Bumper Mount	B0007758	SMSsharp	2
107	706595-01	Conical Handle, 1.97 Long	6136012	J.W. Winco	2
109	706624-01	Flush Surface Mount Pull	1098A91	McMaster Carr	1
110	706563-01	Lexan Window	B0006298	Gemini Plastics	1
111	706384-01	Stainless Steel Hinge, Polished	1488A12	McMaster Carr	2
112	707829-01	Plug, Finishing	9750K55	McMaster Carr	1
115	706505-01	Idler Roller W/ Bearings	B0006466	Perkins	1
121	704946-01	Shaft, Cam For Prodigy Max	DPO899680	Datamax	1
123	706786-01	Nylon Spacer, .380" X .5" X 27/64"	17-2749-01	Datamax	1
124	706344-01	E-Ring 3/8" Truarc	10-0563-01	Datamax	3
125	706789-01	Spring, Comp., .480" X .045" X 1.75"	17-2763-01	Datamax	1
126	706790-01	Pin, Straight, .094" Dia. X .437" Long	17-2426-01	Datamax	1
127	706791-01	Shaft, Ribbon Rewind	12-2528-01	Datamax	1
128	706343-01	Bearing, Flanged .375" I.D. X .875"	17-2310-01	Datamax	4
129	706793-01	Assembly, Ribbon Rewind Hub, 6"	15-2486-01	Datamax	1
130	706794-01	Spring Clamp	899144	Datamax	1
131	706795-01	Button Head Cap Screw 4-40 X 1/8"	10-2571-01	Datamax	1
132	706796-01	J-Hook, Ribbon Rewind, 6" Printer	12-2530-01	Datamax	1
133	706345-01	Screw M3 X .5 Long	10-2856-01	Datamax	3
134	706798-01	Ribbon Clip	11-5007-01	Datamax	3
135	706799-01	Plug, Button 1/2"	17-2750-01	Datamax	1
136	706800-01	Screw, Socket Set M4 X 6	10-2378-02	Datamax	2
137	706801-01	Disk, Friction	16-2754-01	Datamax	2
138	706802-01	Disk, Friction	16-2754-02	Datamax	1
139	706803-01	Disk, Friction	16-2754-03	Datamax	1
140	706804-01	Ribbon Hub	12-2795-01	Datamax	3
141	706805-01	Flanged Gear	16-2751-01	Datamax	1
142	706806-01	Ribbon Sensor Label	14-2726-01	Datamax	1
143	706807-01	Ribbon Supply Hub Shaft	12-2788-01	Datamax	1
144	706808-01	Spacer	10-2565-01	Datamax	1
145	706809-01	Flat Nylon Washer	10-2560-01	Datamax	2

SECTION 5- PARTS LIST**PRINthead CRADLE ASSEMBLY (MODEL 1108)**

ITEM	CONTROL #	DESCRIPTION	PART NUMBER	VENDOR	QTY
146	706810-01	Spring, Ext, .180" X .024" X 1.25"	17-2748-04	Datamax	1
147	706811-01	Slip Clutch Assembly	17-2470-01	Datamax	1
148	706342-01	Sleeve Bushing, .377" X .592" X 1/4"	17-2753-01	Datamax	6
149	706813-01	Drive Motor Assembly, 203 DPI	24-2521-01	Datamax	1
150	706814-01	Printhead Assembly	15-2915-01	Datamax	1
151	706815-01	Spring Wave Washer	17-2317-08	Datamax	1
152	706785-01	Thermal Printhead, 203 Dpi, 6"	20-2164-01	Datamax	1
153	706816-01	Metric S.H.C.S. M3x0.5 X 10	10-2512-03	Datamax	2
154	706817-01	Center Plate	12-2734-01	Datamax	1

CRADLE ASSEMBLY (MODEL 1097)

ITEM	CONTROL #	DESCRIPTION	PART NUMBER	VENDOR	QTY
1	706584-01	Radial Bearing, 1/4 Bore	21104-88	GBC	2
2	705522-01	Compression Spring, .055" X 1" Long	LHL-375AB-01	Lee Spring	2
9	707738-01	Upper Guide Finger Plate	C0007401	SMSsharp	1
10	707126-01	Spring Bracket Cross member	B0006999	MPSsharp	1
11	707323-01	Adjustment Cap	A0007091	MPSsharp	2
12	707123-01	Pinch Spring Bracket	B0006997	MPSsharp	2
13	707124-01	Pinch Stationary Bracket	B0006998	MPSsharp	2
14	707739-01	Pinch Roller	B0007402	MPSsharp	1
24	706515-01	Pinch Roller Shaft	B0006286	MPSsharp	1
30	707631-01	Cradle Drive Side Plate	D0007303	MPSsharp	1
31	707632-01	Cradle Side Plate	D0007304	MPSsharp	1
32	706518-01	Latch Pivot Shaft	B0006443	MPSsharp	1
33	706519-01	Cradle Pivot Shaft	B0006289	MPSsharp	1
42	706528-01	Cradle Latch Lever	C0006444	MPSsharp	1
43	706529-01	Cradle Latch	B0006288	MPSsharp	1
46	707740-01	Left Plate Mounting Block	B0007407	MPSsharp	1
65	706589-01	Flanged Bearing, 5/8 I.D. X 5/8	SF-2024-10	Symmco	2
66	706590-01	Flange Bushing, 1/2 I.D. X 1/2 Long	FF-609-3	Symmco	2
68	706592-01	Clamp Collar, One Pc, 5/8" Steel	1C-062	Climax	2
83	705803-01	Steel Eyelet 6mm	9416K84	McMaster Carr	4
84	706619-01	Fixed Force Gas Spring, 50 Lb	9416K11-50	McMaster Carr	2
85	706543-01	Gas Shock Mounting Post	A0006290	MPSsharp	2
89	707722-01	Cradle Cover Duct	D0007337	SMSsharp	1
90	707649-01	Top Cradle Cover	D0007292	SMSsharp	1
95	706545-01	Shield Mounting Bar	B0006219	MPSsharp	1
102	706575-01	Cross Flow Fan	MF915B-BC	Oriental Motor	1
103	706576-01	Finger Guard	FG915D	Oriental Motor	2
105	706622-01	Extension Spring, 1/4" OD X 1.05"	9433K44	McMaster Carr	1
107	706595-01	Conical Handle, 1.97 Long	6136012	J.W. Winco	2
112	707829-01	Plug, Finishing	9750K55	McMaster Carr	1
115	706505-01	Idler Roller W/ Bearings	B0006466	Perkins	1

SEALER ASSEMBLY

ITEM	CONTROL #	DESCRIPTION	PART NUMBER	VENDOR	QTY
1	706552-01	Gear Reducer	509-01-508	Bison	1
2	706553-01	Stepper Motor, Nema 34, 2 Stack	HT34-476-FLAT-CON	Applied Motion	1
3	707686-01	Linear Guide Block	AGH20-CA-ZO-C	Hiwin	2
5	706566-01	Comp. Spring, 1.25" Lg.	LC-067G-6M	Lee Spring	2
6	706587-01	Flange Bushing, 1/4" I.D.	FF-310-2	Symmco	4
8	706086-01	O-Ring #9 (As 568-09)	AS 568-009	Fastenal	4
10	812072-30	Prox. Switch, 4 mm Sense Range	NBN4-F29-EO	Peperell & Fuchs	4
11	706608-01	Nylon Tip SHCS, 1/4-20	9030A130	McMaster Carr	2
12	707657-01	Linear Guide Spacer	B0007324	MPSHarp	2
13	707784-01	Spring Pin, 3/16" X 3/4" LG	90692A723	McMaster Carr	2
14	707785-01	Rod End, 1/4-20 Thd, 3/16" ID	6066K31	McMaster Carr	2
15	707786-01	Comp. Spring, 1.125" Lg.	LC-049E-10-M	Lee Spring	2
16	707787-01	Tension Block	B0007440	MPSHarp	2
17	707788-01	Tension Plunger	A0007441	MPSHarp	2
19	706565-01	Comp. Spring, 1.25" Lg.	LC-032E-11M	Lee Spring	2
20	707004-01	Sealing Jaw	C0006855	MPSHarp	1
21	707789-01	Sealing Jaw Rubber	B0007442	Kuehn Rubber	1
26	706466-01	Spur Gear YSS2035 - Right	A0006341	Applied Ind. Tech.	1
27	706467-01	Spur Gear YSS2035 - Left	A0006342	Applied Ind. Tech.	1
28	707003-01	Sealer Gear Rack YSR20x1/2	A0006856	MPSHarp	2
30	707005-01	Sealing Stripper Plate	C0006860	MPSHarp	1
32	707006-01	Modified Guide Rail	B0006853	Triphase Auto.	2
33	706472-01	Sealer Jaw Drive Shaft	B0006260	MPSHarp	1
34	707007-01	Gear Rack Mounting Block - Right	B0006858	MPSHarp	1
35	707008-01	Gear Rack Mounting Block - Left	B0006857	MPSHarp	1
36	707782-01	Impulse Seal Bar	B0007367	MPSHarp	1
38	706746-01	Seal Bar Guide Block	A0006261	MPSHarp	2
39	702633-01	Radial Bearing, 3/4 Bore	22612-88	GBC	2
40	706588-01	Thrustwasher, 3/4" ID	ST-2440-4	Symmco	1
41	707010-01	Thrust Sleeve	A0006843	MPSHarp	2
42	704107-01	Clamp Collar, One Pc., 3/4"	1C-075-A	Climax	1
43	706583-01	Radial Bearing, 3/4" Bore	22812-88	GBC	2
45	707011-02	Sealing Wire Assembly	A0007411	SMSHarp	1

SEALER ASSEMBLY

ITEM	CONTROL #	DESCRIPTION	PART NUMBER	VENDOR	QTY
46	707783-01	Insulating Strip	B0007410	Toss	1
51	706319-01	Take-Up Shaft	A0006033	MPSharp	1
52	706477-01	Take-Up Pulley	A0006034	MPSharp	1
61	706510-01	Taper-Lock Bushing	1008 x 5/8 Bore	Gates	1
62	706508-01	Timing Pulley, Taper Lock	P28-8MGT-20	Gates	2
63	707734-01	Timing Belt, 8mm Pitch	ASSY0942 560-8MGT-20	Gates	1
65	706511-01	Taper-Lock Bushing	1108 x 3/4 Bore	Gates	1
66	706439-01	Spring Block	B0006459	MPSharp	2
67	706481-01	Sensor Mounting Bracket	B0006429	MPSharp	2
68	707012-01	Sealer Sensor Bracket	A0006861	MPSharp	2
70	706483-01	Seal Wire Changing Tool	A0006401	MPSharp	1
72	706907-01	Sensor Actuator - Right	A0006824	MPSharp	1
73	706908-01	Sensor Actuator - Left	A0006825	MPSharp	1
74	706392-01	Nylon Spacer, 1/2" LG X 1/2" OD	94639A554	McMaster Carr	2
77	706440-01	Gripper Button	A0006460	MPSharp	4
79	706435-01	Comp. Spring, 1.25" Lg.	LC-055E-11M	Lee Spring	4
84	706437-01	Sealing Wire Teflon Tape	B0006424	Sharp	1

SECTION 5- PARTS LIST**UNWIND ASSEMBLY**

ITEM	CONTROL #	DESCRIPTION	PART NUMBER	VENDOR	QTY
1	706493-01	Material Roll Outer Tube	C0006280	MPSHarp	1
2	706492-01	Material Roll Mandrel	C0006279	MPSHarp	1
4	706669-01	Retaining Ring, E-Style, 5/8 Shaft	98407A140	McMaster Carr	1
5	706586-01	Bushing, 5/8 ID X 3/4 OD X 7/8 LG	SS-2024-14	Symmco	2
6	706582-01	Snap Ring Bearing, 1" ID	S23216-88	GBC	1
13	706494-01	Bearing Mount Mandrel	B0006209	Century Spring	1
14	706495-01	Mandrel Support Plate	B0006283	MPSHarp	1
17	706496-01	Core Chuck	B0006253	MPSHarp	1
21	706306-01	Support Spacer	A0006210	MPSHarp	2
22	706572-01	Torsion Spring	TO-5223L	Century Spring	1
23	706610-01	Nylon Washer, 5/8 ID X 0.812 OD	95606A220	McMaster Carr	2
24	706968-01	Comp. Spring - Left Hand Wound	B0006837	Lee Spring	1
26	704109-01	Hand Lever, 1/4-20 X 1-1/4 Black	6305K55	McMaster Carr	2
27	706497-01	Tension Core Chuck	B0006282	MPSHarp	1
28	706462-01	Torsion Spring Cover	A0006441	SMSHarp	1
29	706880-01	Warning Label, Electrical Shock	H6010-717WVPL	HCS	1

ELECTRICAL ASSEMBLY

NOTE: Reference numbers correspond to Parts List on pages 5-1 to 5-2.

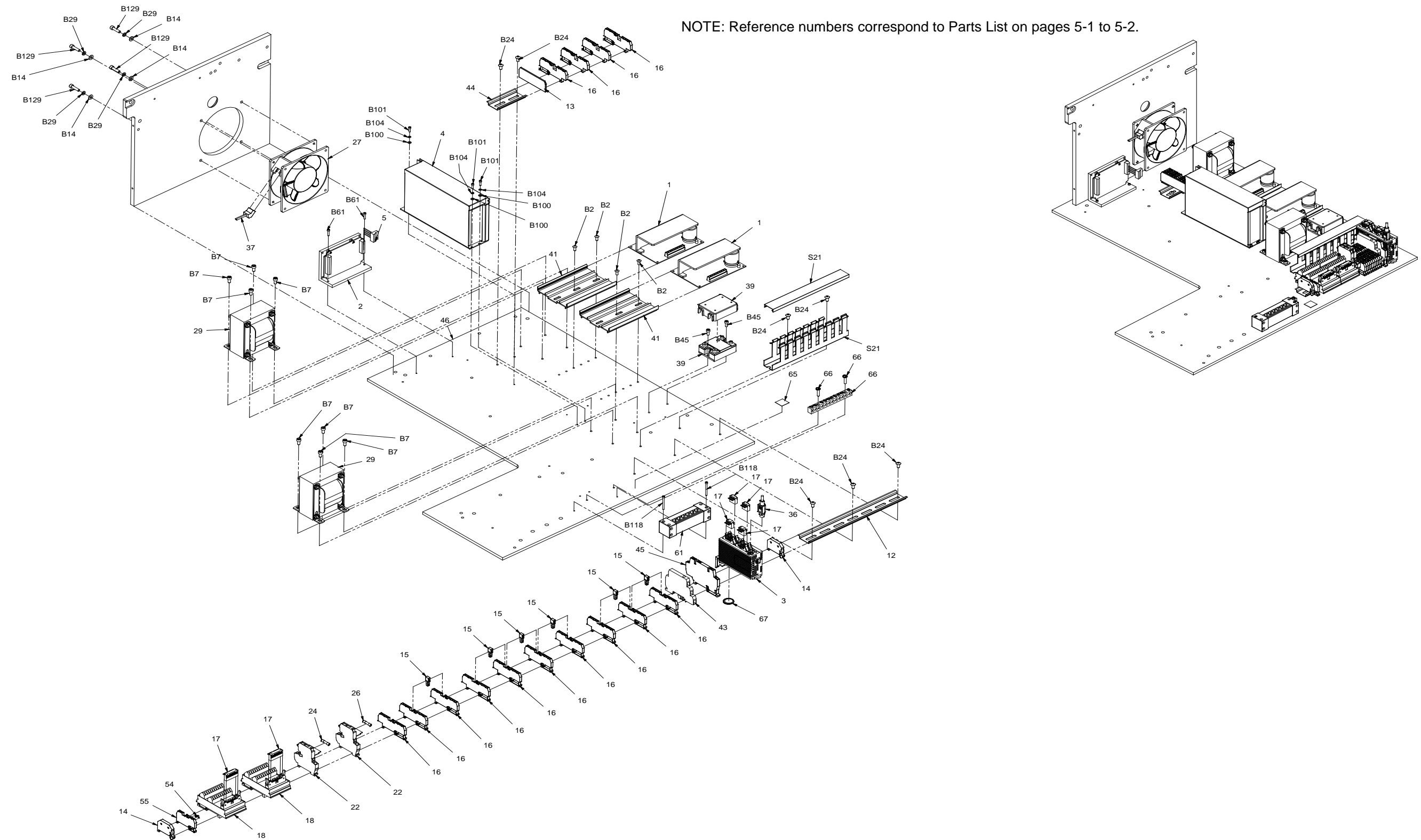

ELECTRICAL ASSEMBLY

NOTE: Reference numbers correspond to Parts List on pages 5-1 to 5-2.

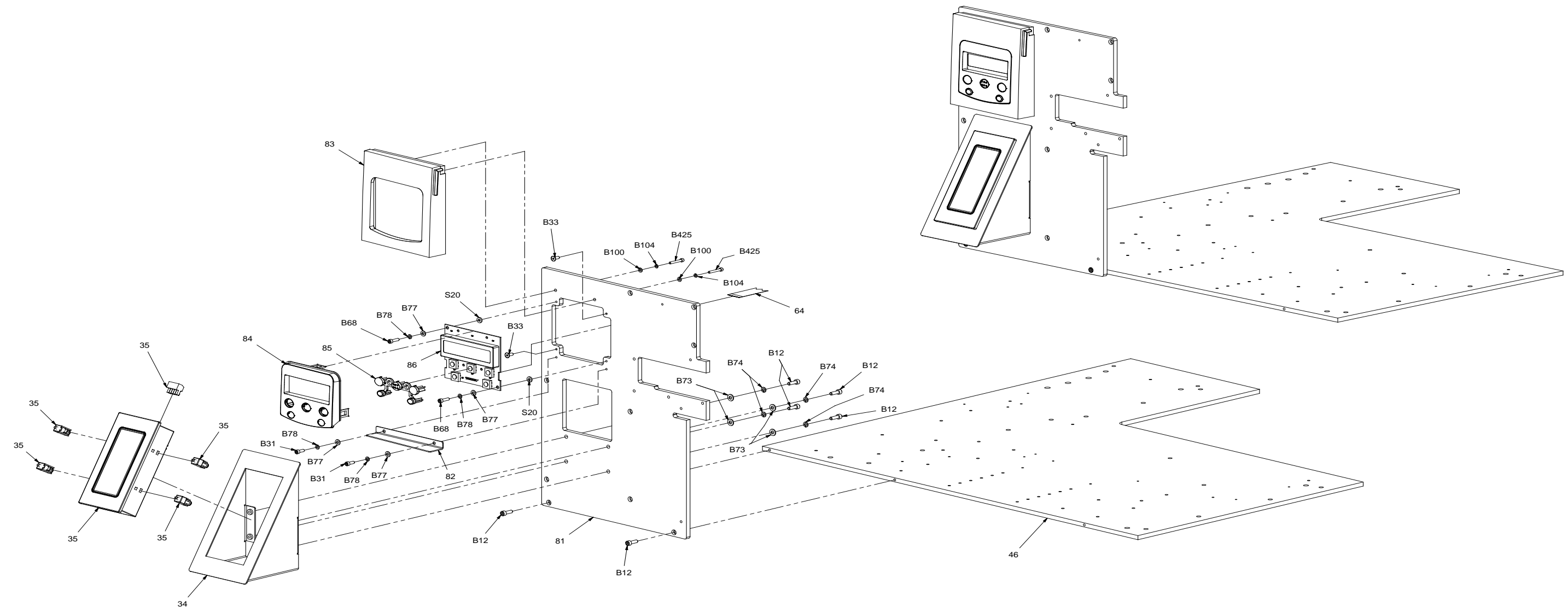

ELECTRICAL ASSEMBLY

NOTE: Reference numbers correspond to Parts List on pages 5-1 to 5-2.

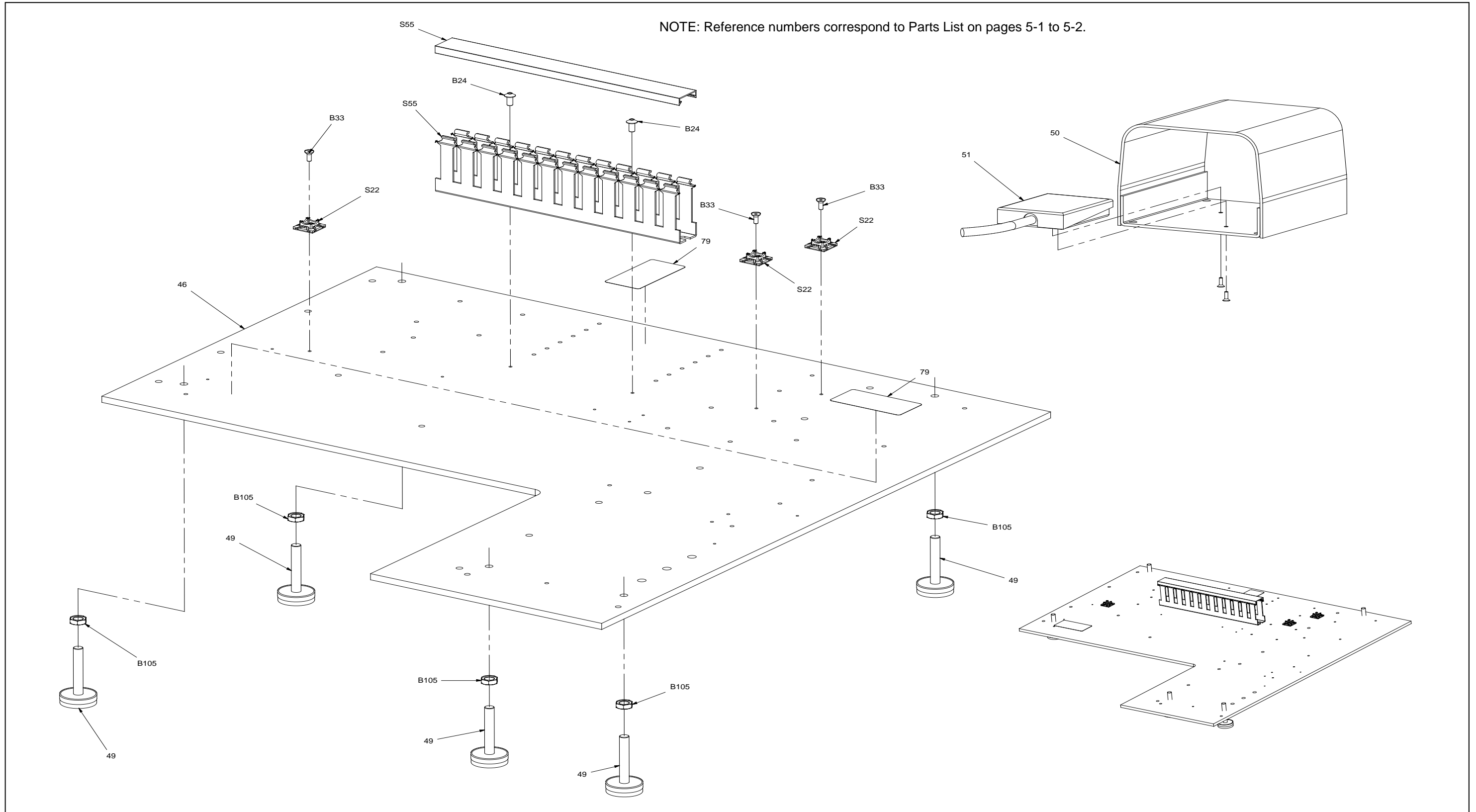

FRAME ASSEMBLY

NOTE: Reference numbers correspond to Parts List on page 5-4.

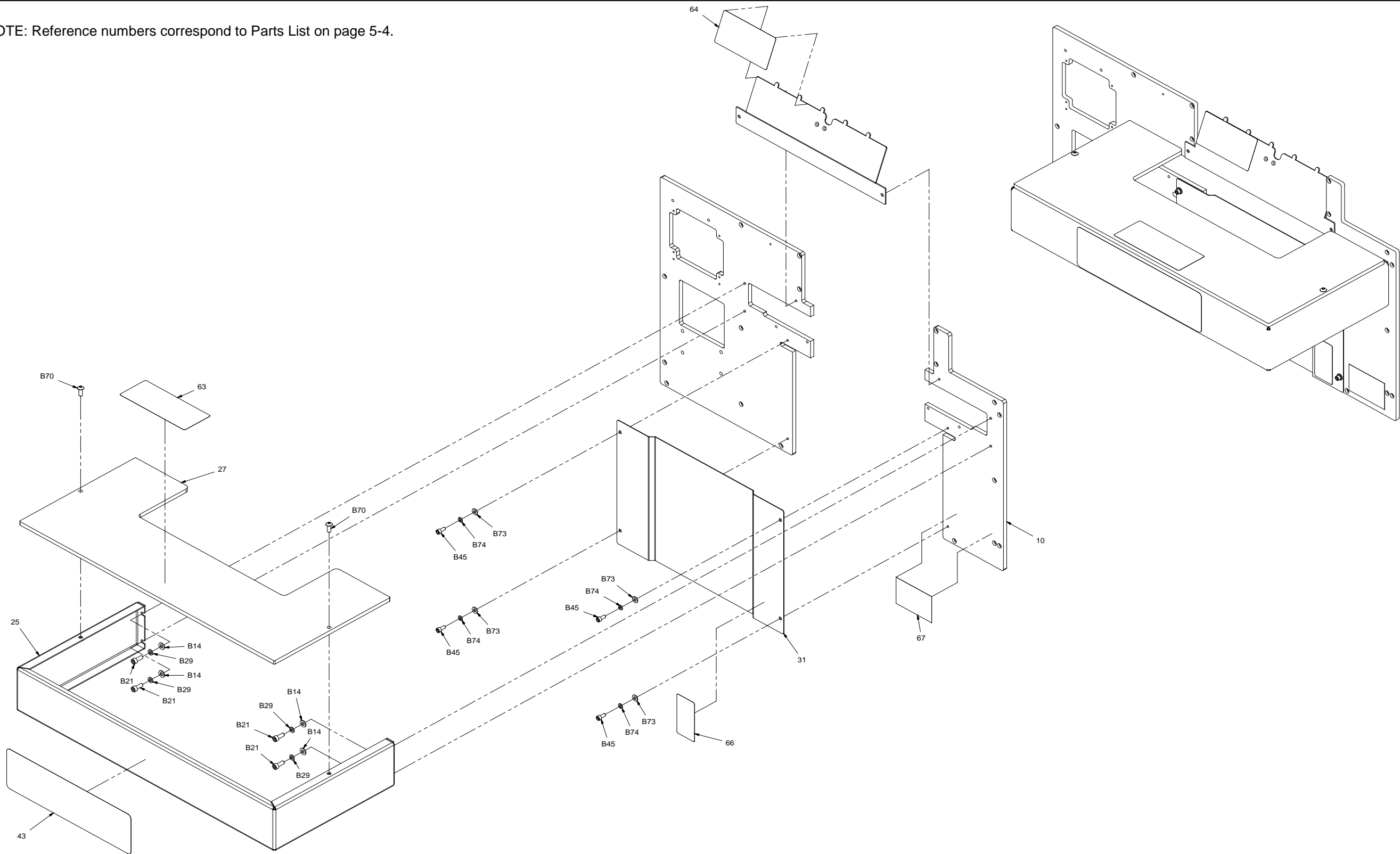

FRAME ASSEMBLY

NOTE: Reference numbers correspond to Parts List on page 5-4.

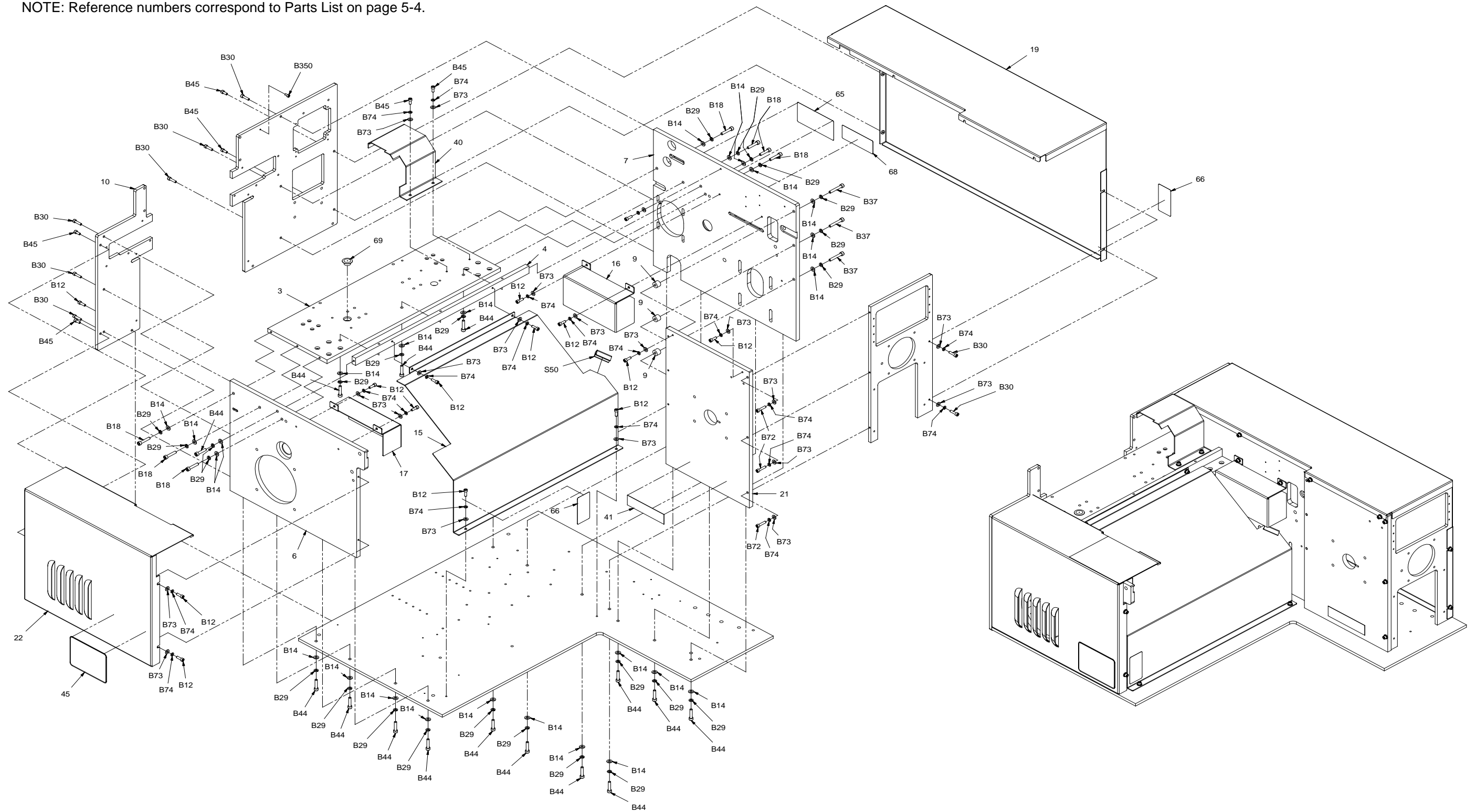

FRAME ASSEMBLY

NOTE: Reference numbers correspond to Parts List on page 5-4.

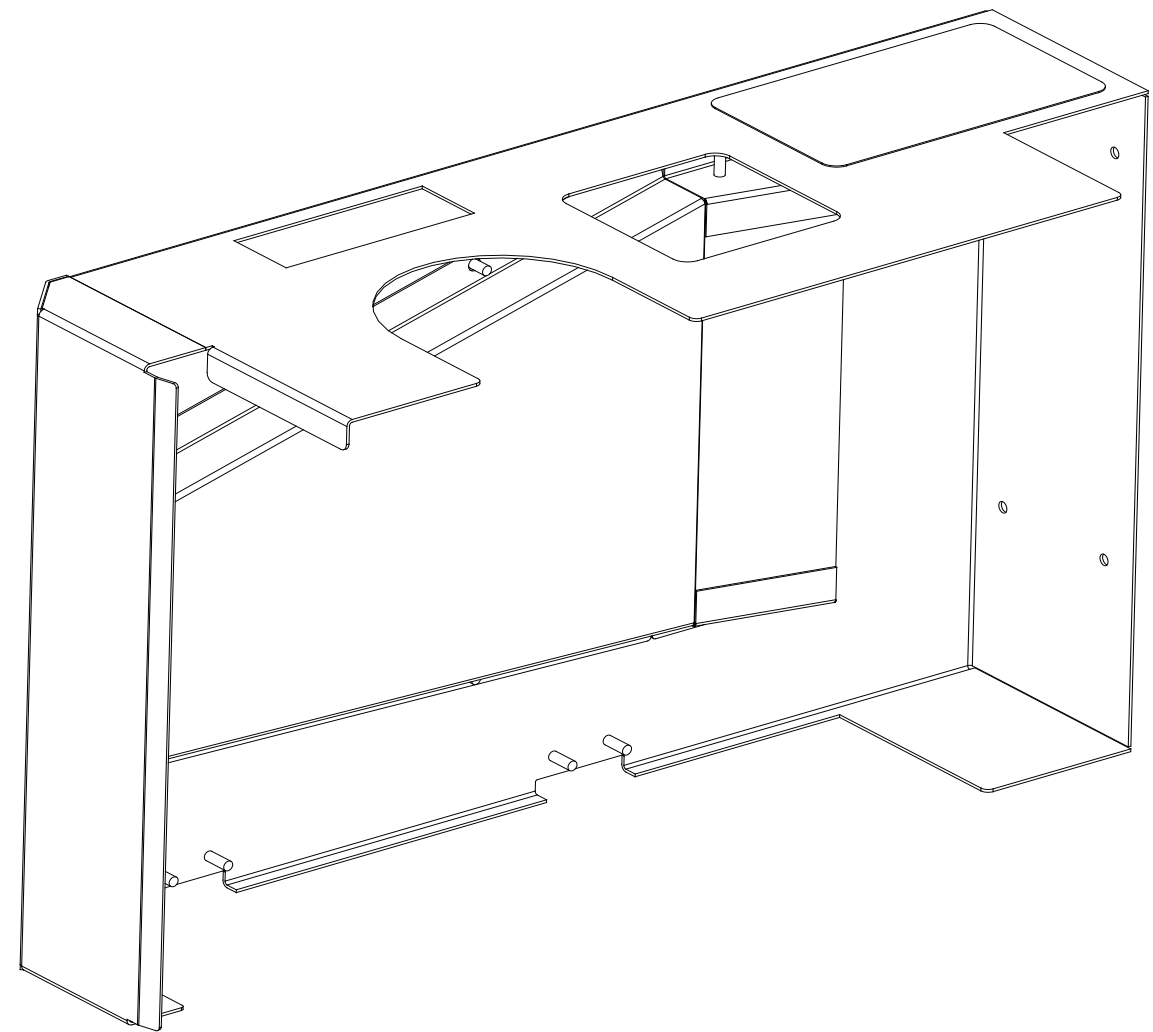
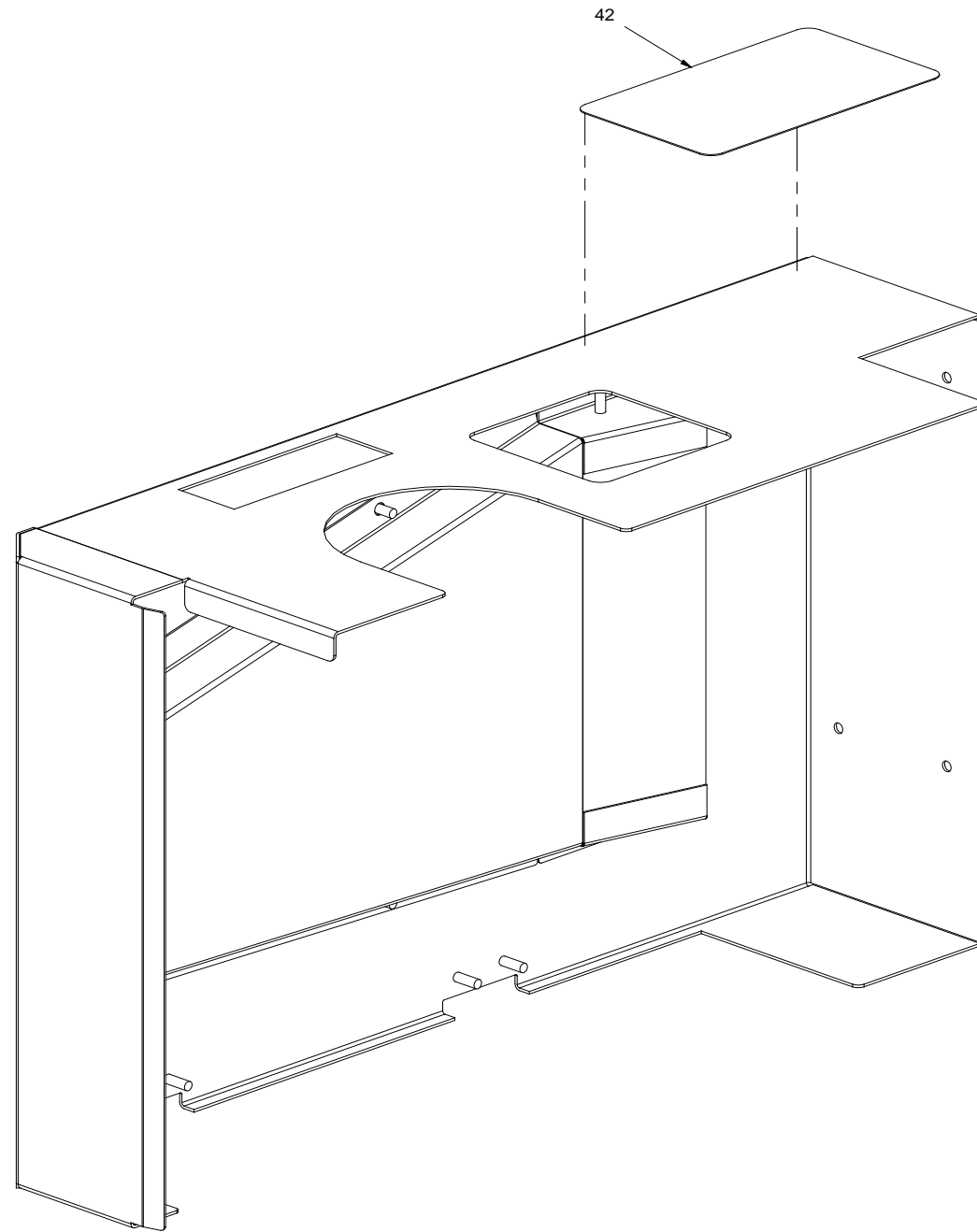

PRINthead CRADLE ASSEMBLY

NOTE: Reference numbers correspond to Parts List on pages 5-5 to 5-8.

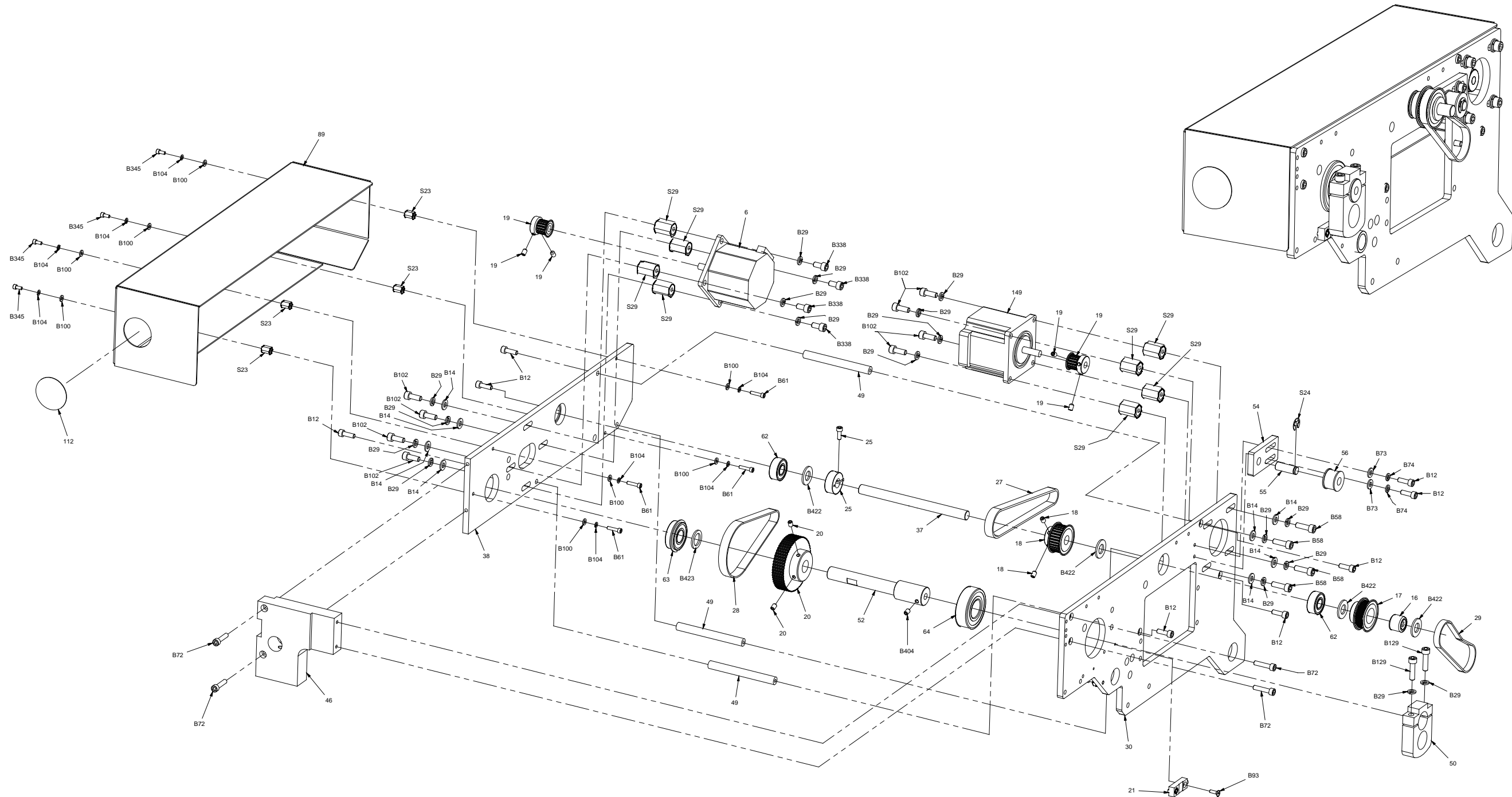

PRINthead CRADLE ASSEMBLY

NOTE: Reference numbers correspond to Parts List on pages 5-5 to 5-8.

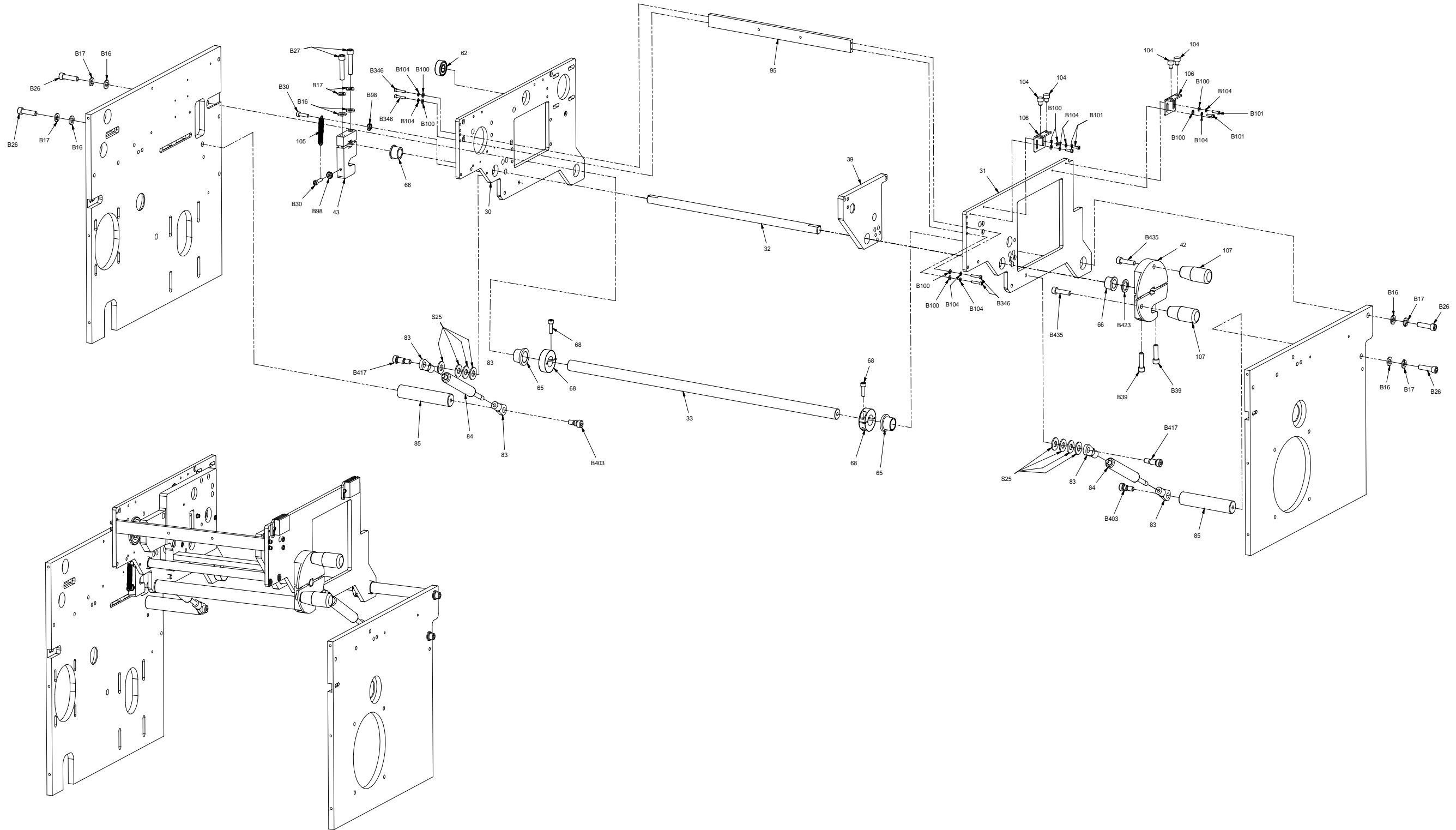

PRINthead CRADLE ASSEMBLY

NOTE: Reference numbers correspond to Parts List on pages 5-5 to 5-8.

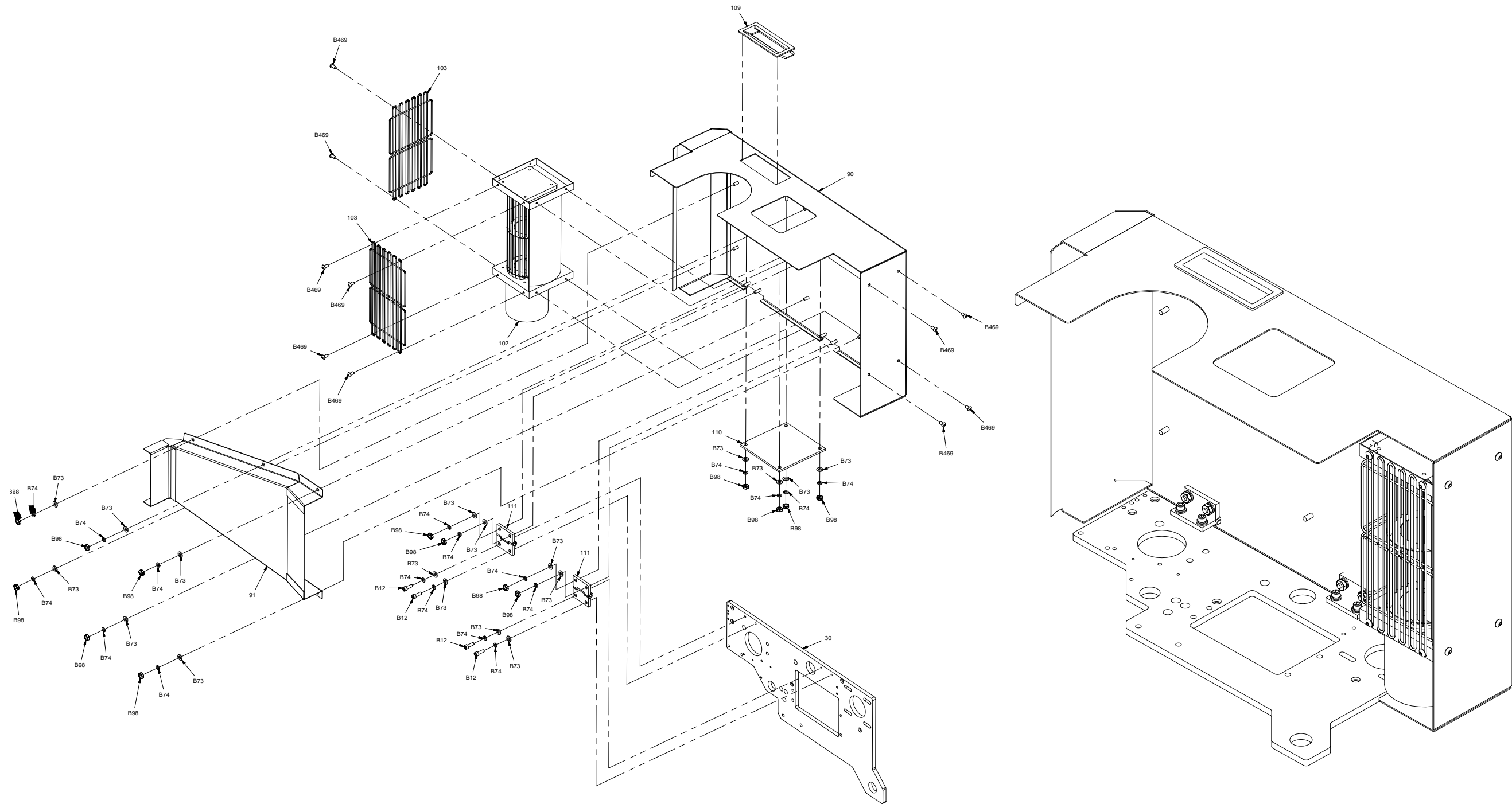

CRADLE ASSEMBLY (MODEL 1097)

NOTE: Reference numbers correspond to Parts List on page 5-9.

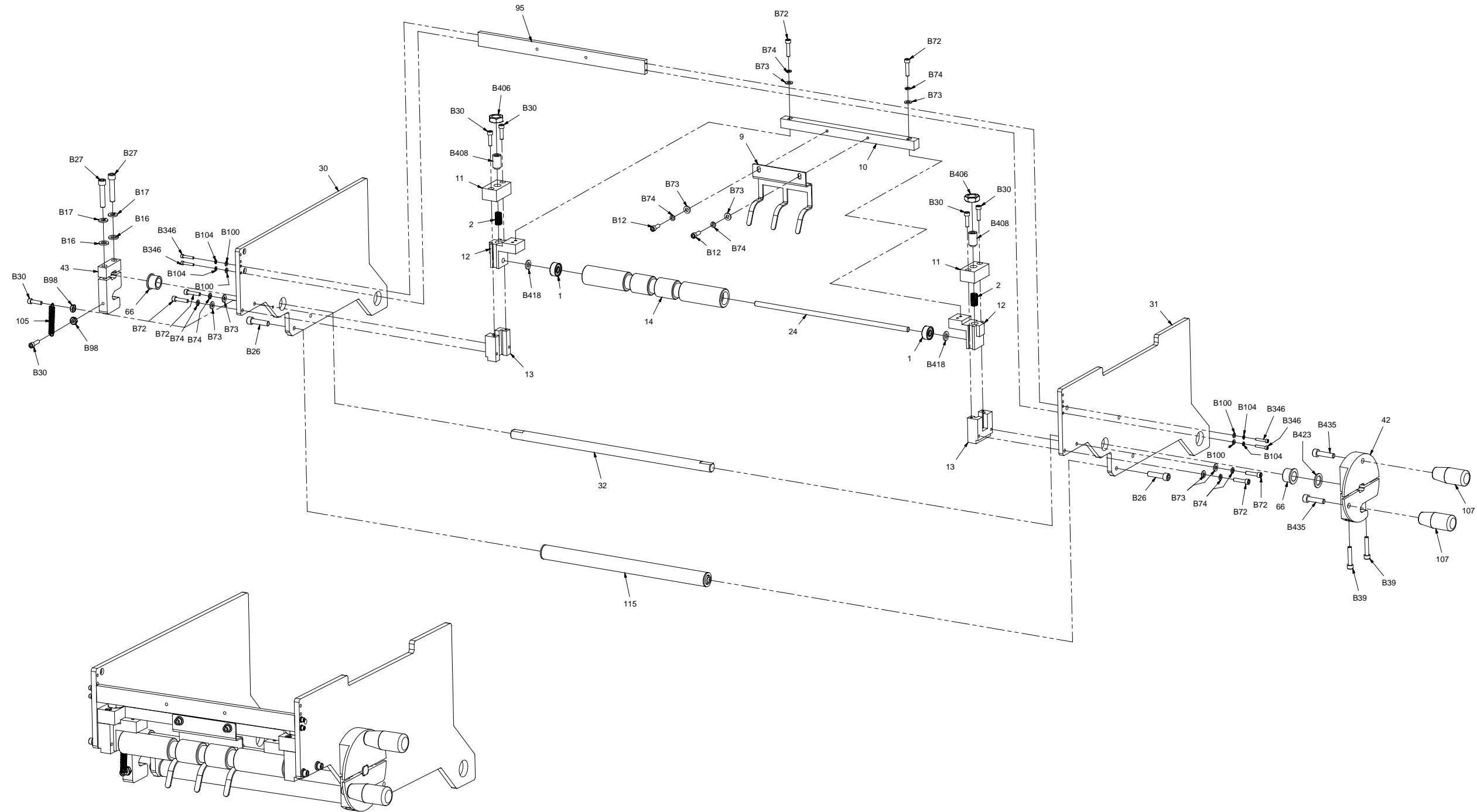

CRADLE ASSEMBLY (MODEL 1097)

NOTE: Reference numbers correspond to Parts List on page 5-9.

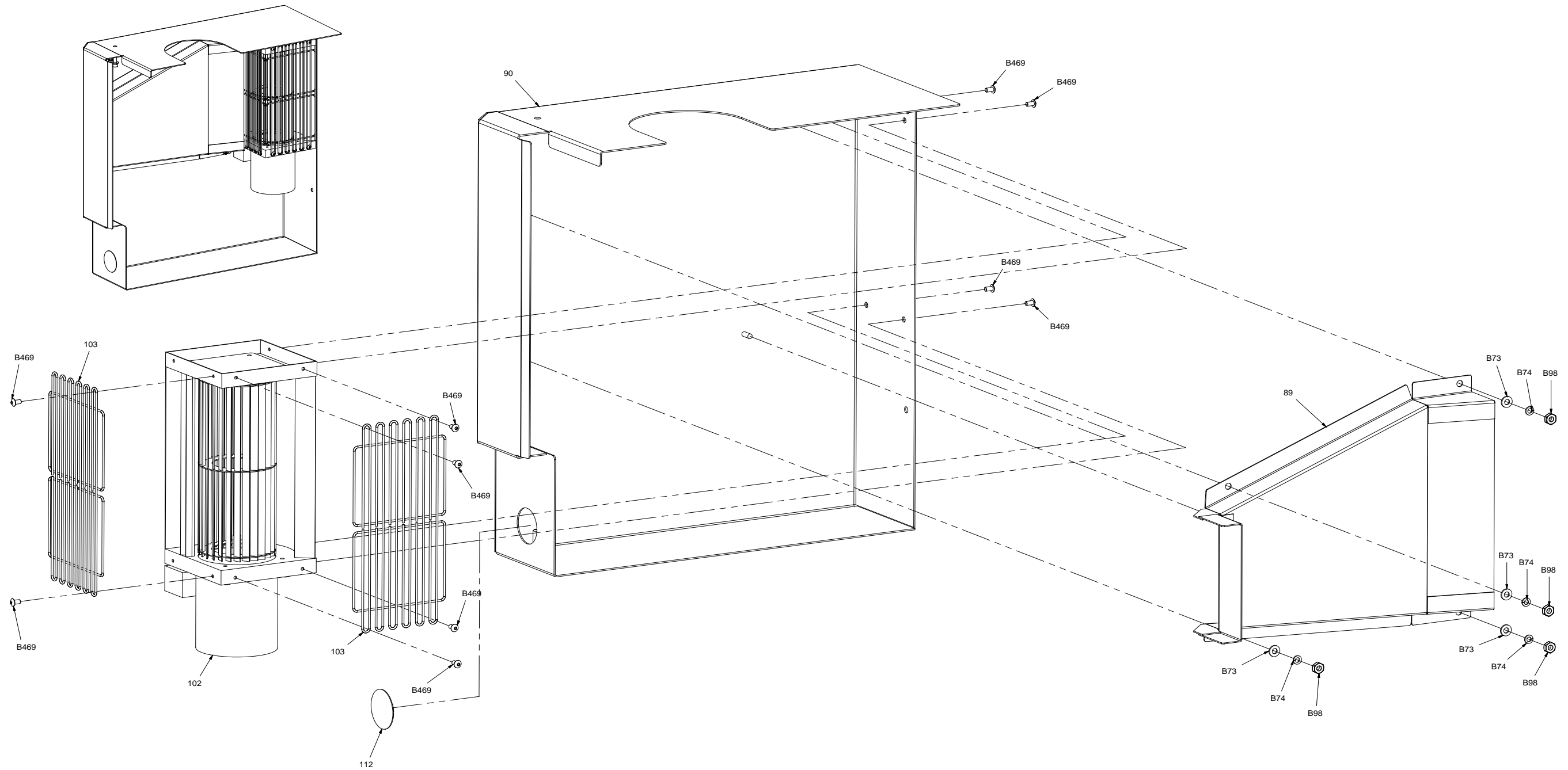

SEALER ASSEMBLY

NOTE: Reference numbers correspond to Parts List on pages 5-10 to 5-11.

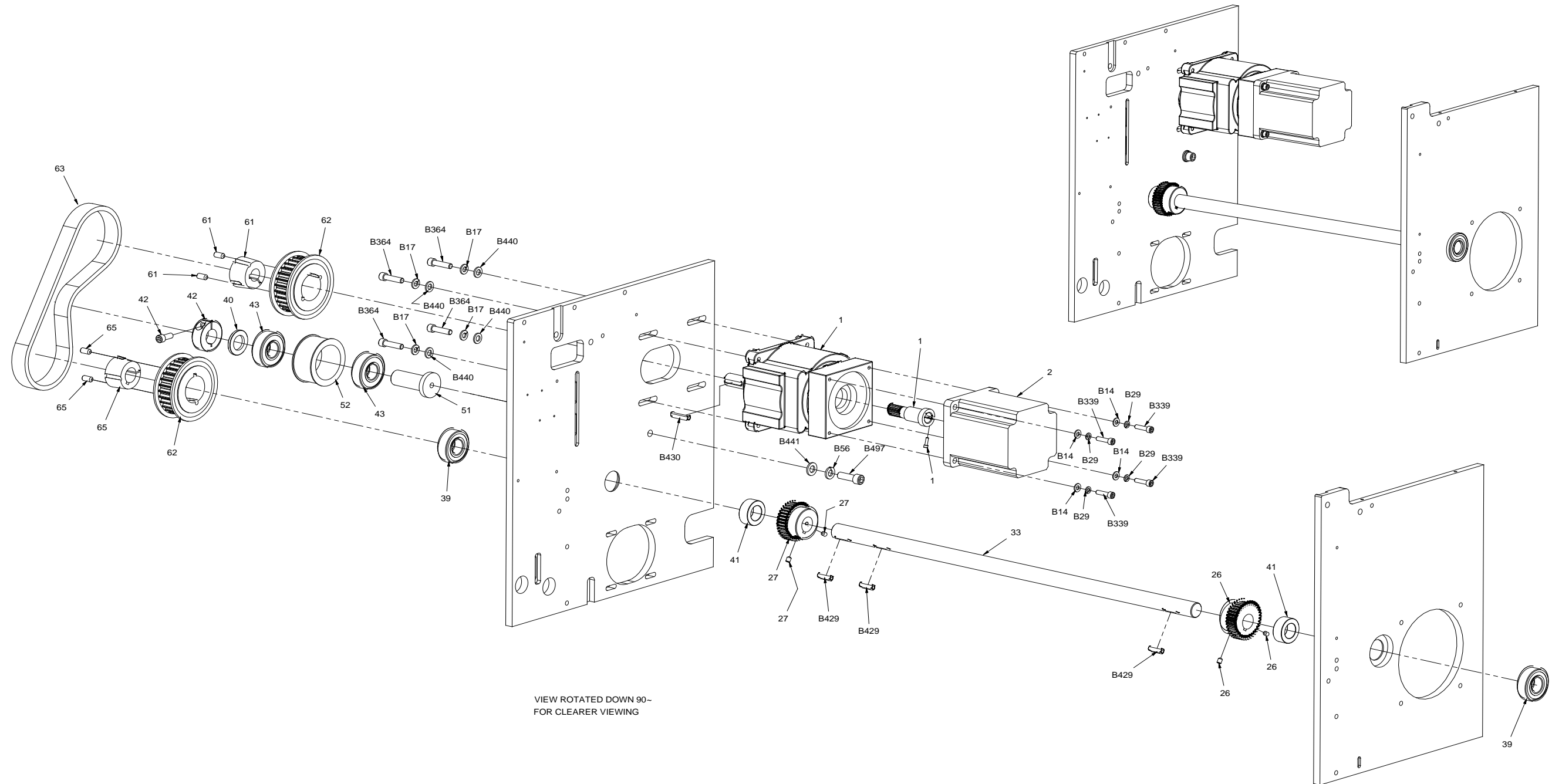

VIEW ROTATED DOWN 90-
FOR CLEARER VIEWING

UNIWND ASSEMBLY

NOTE: Reference numbers correspond to Parts List on page 5-12.

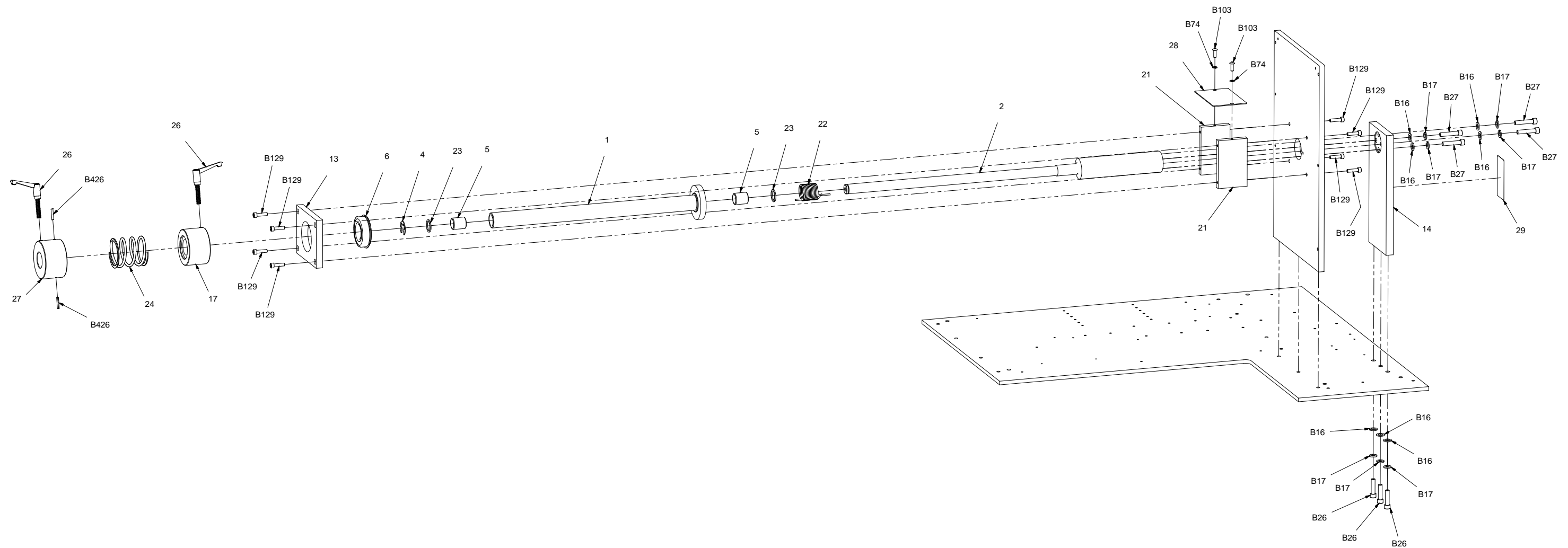

REPLACEMENT PARTS ORDER FORM

Spare or replacement parts can be purchased directly through Sharp Packaging or your local distributor. If faxing or mailing in an order it must be accompanied by a hard copy purchase order. Please follow up with a confirming telephone call. Cut off time for next day air shipments is 2:30 p.m. CST.

Sharp Packaging Systems P.O. Box 124 Sussex, WI 53089 parts@sharppackaging.com Parts: 800-634-6359 (Ext. 571) Fax: 262-246-3387 (Please Fill in Boxes Below)	<p>RECOMMENDED SPARE PARTS</p> <p>Check <input checked="" type="checkbox"/> to Order</p> <table border="1" style="width: 100%; border-collapse: collapse;"> <thead> <tr> <th style="width: 5%;"></th> <th style="width: 20%;"><u>PART NO.</u></th> <th style="width: 5%;"><u>QTY.</u></th> <th style="width: 70%;"><u>DESCRIPTION</u></th> </tr> </thead> <tbody> <tr><td><input type="checkbox"/></td><td>706597-01</td><td>___</td><td>Fuse, 5A, 250V, 5 x 20mm</td></tr> <tr><td><input type="checkbox"/></td><td>700058-01</td><td>___</td><td>Fuse, 10A, 250V, 5 x 20mm</td></tr> <tr><td><input type="checkbox"/></td><td>706785-01</td><td>___</td><td>Printhead, Thermal, 6" 203 dpi</td></tr> <tr><td><input type="checkbox"/></td><td>869129-01</td><td>___</td><td>Ribbon, Standard, 6.5" x 1181'</td></tr> <tr><td><input type="checkbox"/></td><td>869130-01</td><td>___</td><td>Ribbon, Premium, 6.7" x 1181'</td></tr> <tr><td><input type="checkbox"/></td><td>706455-01</td><td>___</td><td>Roller, Printer Platen</td></tr> <tr><td><input type="checkbox"/></td><td>960551-01</td><td>___</td><td>Sealer Maintenance Kit</td></tr> <tr><td><input type="checkbox"/></td><td>960552-01</td><td>___</td><td>Seal Wire Kit</td></tr> <tr><td><input type="checkbox"/></td><td>960881-01</td><td>___</td><td>Stripper Plate Maintenance Kit</td></tr> <tr><td><input type="checkbox"/></td><td>705522-01</td><td>___</td><td>Spring, Compression, Nip Roller</td></tr> <tr><td><input type="checkbox"/></td><td>706566-01</td><td>___</td><td>Spring, Compression, Sealer</td></tr> <tr><td><input type="checkbox"/></td><td>706622-01</td><td>___</td><td>Spring, Printhead Cradle Latch</td></tr> <tr><td><input type="checkbox"/></td><td>706572-01</td><td>___</td><td>Spring, Unwind</td></tr> <tr><td><input type="checkbox"/></td><td>812072-01</td><td>___</td><td>Switch, Proximity</td></tr> <tr><td><input type="checkbox"/></td><td>700198-01</td><td>___</td><td>Timing Belt, Motor (170XL037)</td></tr> <tr><td><input type="checkbox"/></td><td>706509-01</td><td>___</td><td>Timing Belt, Pressure Jaw (640-8MGT-20)</td></tr> <tr><td><input type="checkbox"/></td><td>706548-01</td><td>___</td><td>Timing Belt, Printhead up/down (267-3M-09)</td></tr> <tr><td><input type="checkbox"/></td><td>706446-01</td><td>___</td><td>Timing Belt, Platen and Drive Roller (80XL037)</td></tr> <tr><td><input type="checkbox"/></td><td>706547-01</td><td>___</td><td>Timing Belt, Ribbon Rewind, Motor Side (300-3M-09)</td></tr> <tr><td><input type="checkbox"/></td><td>706549-01</td><td>___</td><td>Timing Belt, Ribbon Rewind, Rewind Shaft Side (88MXL025)</td></tr> </tbody> </table>		<u>PART NO.</u>	<u>QTY.</u>	<u>DESCRIPTION</u>	<input type="checkbox"/>	706597-01	___	Fuse, 5A, 250V, 5 x 20mm	<input type="checkbox"/>	700058-01	___	Fuse, 10A, 250V, 5 x 20mm	<input type="checkbox"/>	706785-01	___	Printhead, Thermal, 6" 203 dpi	<input type="checkbox"/>	869129-01	___	Ribbon, Standard, 6.5" x 1181'	<input type="checkbox"/>	869130-01	___	Ribbon, Premium, 6.7" x 1181'	<input type="checkbox"/>	706455-01	___	Roller, Printer Platen	<input type="checkbox"/>	960551-01	___	Sealer Maintenance Kit	<input type="checkbox"/>	960552-01	___	Seal Wire Kit	<input type="checkbox"/>	960881-01	___	Stripper Plate Maintenance Kit	<input type="checkbox"/>	705522-01	___	Spring, Compression, Nip Roller	<input type="checkbox"/>	706566-01	___	Spring, Compression, Sealer	<input type="checkbox"/>	706622-01	___	Spring, Printhead Cradle Latch	<input type="checkbox"/>	706572-01	___	Spring, Unwind	<input type="checkbox"/>	812072-01	___	Switch, Proximity	<input type="checkbox"/>	700198-01	___	Timing Belt, Motor (170XL037)	<input type="checkbox"/>	706509-01	___	Timing Belt, Pressure Jaw (640-8MGT-20)	<input type="checkbox"/>	706548-01	___	Timing Belt, Printhead up/down (267-3M-09)	<input type="checkbox"/>	706446-01	___	Timing Belt, Platen and Drive Roller (80XL037)	<input type="checkbox"/>	706547-01	___	Timing Belt, Ribbon Rewind, Motor Side (300-3M-09)	<input type="checkbox"/>	706549-01	___	Timing Belt, Ribbon Rewind, Rewind Shaft Side (88MXL025)
	<u>PART NO.</u>	<u>QTY.</u>	<u>DESCRIPTION</u>																																																																																		
<input type="checkbox"/>	706597-01	___	Fuse, 5A, 250V, 5 x 20mm																																																																																		
<input type="checkbox"/>	700058-01	___	Fuse, 10A, 250V, 5 x 20mm																																																																																		
<input type="checkbox"/>	706785-01	___	Printhead, Thermal, 6" 203 dpi																																																																																		
<input type="checkbox"/>	869129-01	___	Ribbon, Standard, 6.5" x 1181'																																																																																		
<input type="checkbox"/>	869130-01	___	Ribbon, Premium, 6.7" x 1181'																																																																																		
<input type="checkbox"/>	706455-01	___	Roller, Printer Platen																																																																																		
<input type="checkbox"/>	960551-01	___	Sealer Maintenance Kit																																																																																		
<input type="checkbox"/>	960552-01	___	Seal Wire Kit																																																																																		
<input type="checkbox"/>	960881-01	___	Stripper Plate Maintenance Kit																																																																																		
<input type="checkbox"/>	705522-01	___	Spring, Compression, Nip Roller																																																																																		
<input type="checkbox"/>	706566-01	___	Spring, Compression, Sealer																																																																																		
<input type="checkbox"/>	706622-01	___	Spring, Printhead Cradle Latch																																																																																		
<input type="checkbox"/>	706572-01	___	Spring, Unwind																																																																																		
<input type="checkbox"/>	812072-01	___	Switch, Proximity																																																																																		
<input type="checkbox"/>	700198-01	___	Timing Belt, Motor (170XL037)																																																																																		
<input type="checkbox"/>	706509-01	___	Timing Belt, Pressure Jaw (640-8MGT-20)																																																																																		
<input type="checkbox"/>	706548-01	___	Timing Belt, Printhead up/down (267-3M-09)																																																																																		
<input type="checkbox"/>	706446-01	___	Timing Belt, Platen and Drive Roller (80XL037)																																																																																		
<input type="checkbox"/>	706547-01	___	Timing Belt, Ribbon Rewind, Motor Side (300-3M-09)																																																																																		
<input type="checkbox"/>	706549-01	___	Timing Belt, Ribbon Rewind, Rewind Shaft Side (88MXL025)																																																																																		
Customer Name:																																																																																					
Shipping Address:																																																																																					
Sharp Account Number:																																																																																					
Model and Serial Number:																																																																																					
Shipping Method:																																																																																					
Purchase Order Number:																																																																																					
Other Information:																																																																																					

Copy this form, and then fax it to Sharp Packaging at the number listed above.

SHARP PACKAGING SYSTEMS ("SHARP") STANDARD TERMS AND CONDITIONS FOR PACKAGING MACHINERY

By placing an order, Buyer agrees to the following terms and conditions:

1. **TERMS OF PAYMENT:** Cash in lawful U.S. currency payable as follows: For base machinery w/o automatic in-feed devices, (2/3) of net price with the order and the final (1/3) of net price within thirty (30) days after shipment. For all custom systems and systems with automatic in-feed devices, (50%) of net price with the order, (40%) of net price prior to shipment and (10%) of net price within thirty (30) days after shipment. In addition to any other remedy of Sharp hereunder, if the final payment is not received by Sharp within thirty (30) days after shipment, Buyer shall pay interest thereafter at the rate of eighteen (18) percent per year or the maximum rate permitted by law, whichever is less.
2. **SHIPMENT:** All prices are f.o.b. Sharp's plant in Sussex, Wisconsin. Method and route of shipment are at Sharp's discretion and freight is prepaid and added to Buyer's invoice unless Buyer supplies to Sharp explicit written instructions as to method and route of shipment in which case freight is billed collect. All shipments are insured at Buyer's expense and made at Buyer's risk.
3. **DELIVERY:** Shipping promises are made in good faith. Shipping dates appearing on acknowledgments or orders, or given Buyer in any other manner, are approximate. When Buyer delays in supplying information necessary to proceed with the order, the date of shipment may be extended accordingly and determined by the conditions of Sharp's factory at the time specifications are completed. Sharp shall not be liable for any failure or delay of delivery or performance of this order due to causes beyond its reasonable control. The existence of such causes of delay shall extend the time for delivery or performance of this order by the period of time lost for such reasons unless Sharp and Buyer shall have otherwise expressly agreed in writing.
4. **QUOTATIONS AND PRICES:** Sharp's written quotations of prices automatically expire thirty (30) calendar days from the date issued and are subject to change or to termination by notice within the period. Clerical errors are subject to correction.
5. **TITLE: RIGHTS RESERVED UNTIL PAYMENT:** Until payment of the entire purchase price of the machine purchased: (a) ownership title shall remain in Sharp; (b) Buyer shall not sell, pledge, mortgage or otherwise encumber the machine or permit the machine to be encumbered, shall not remove the machine from its premises, shall protect and keep insured the machine at Buyer's expense (with proceeds payable to Sharp as its interest appears) against injury, loss or destruction, and shall execute and file such Financing Statement as to the property under the Uniform Commercial Code as Sharp shall reasonably request. No injury, loss or destruction of the machine after delivery to Buyer shall release Buyer from its obligation to pay Sharp the entire purchase price. Upon receipt by Sharp of payment of the entire purchase price for the machine, title shall automatically vest in Buyer and Sharp will execute releases or other documents as Buyer may request to confirm that fact.
6. **DEFAULT:** On cancellation of the order by Buyer or default by Buyer in any payment of the price or in the performance of any terms or conditions imposed on Buyer herein, Sharp, without notice, may (a) take immediate possession of the machine as Sharp's own individual and sole property, free and clear of any claim by Buyer, and retain any and all payments made as liquidated damages for Sharp's lost profits, any use of the machine by Buyer, any depreciation of the machine, and any expense to Sharp of taking possession of the machine; or (b) take immediate possession of the machine and sell the machine, without notice, in which case the proceeds of sale shall be applied on the unpaid balance of the price and expenses to Sharp of taking possession, storage and resale. If the proceeds of the resale do not equal the portion of the price remaining unpaid and the expenses to Sharp of taking possession, storage and resale, Buyer agrees to promptly pay to Sharp any deficiency. Buyer hereby irrevocably grants to Sharp, or Sharp's agents or servants, the right to enter at any time, with or without force, any premises in which the machine may be located, and the right to examine or take possession of the machine. Buyer waives any right of action, which might accrue by reason of the entry, or the taking of possession of the machine.
7. **TAXES:** Sharp's prices do not include sale, use, excise or similar taxes or charges now or hereafter imposed. The amount of any such taxes or charges shall be paid by Buyer, or in lieu thereof, Buyer shall provide Sharp with a tax exemption certificate acceptable to the taxing authorities.
8. **LIMITED WARRANTY:** Sharp warrants to the original Buyer only that each new machine will be free from defects in material and workmanship, when properly maintained and under normal use and service, subject to the terms of this warranty. Buyer's sole and exclusive remedy under this warranty shall be limited to repair or replacement, at Sharp's option, of any defective part of the machine which is returned, transportation prepaid, to Sharp's authorized service center within the warranty period. The warranty starts on the date the machine is delivered to the original Buyer and expires one (1) year for parts, and ninety (90) days for labor, after that date. Buyer, at Sharp's request, shall provide documents establishing the delivery date. Exclusions: This warranty shall not apply to: (a) any machine subjected to misuse, abuse, or accident; (b) damage in transit or from external sources; (c) overloading of machine capacity; (d) failures which are due to a lack of proper maintenance or care as prescribed in the operating and maintenance instructions; (e) normal wear and tear or relatively minor adjustments; (f) replacement of consumable items (including, but not limited to, heating elements, silicon pads and Teflon cloth/tape); (g) repairs or alterations performed by any organization other than Sharp or Sharp's authorized service centers and (h) parts, accessories, or other items manufactured by others which are in any way used and/or installed in or on the machine; such machine components may be covered under their own manufacturer's warranties. THIS WARRANTY IS EXCLUSIVE AND IN LIEU OF ANY AND ALL OTHER EXPRESS OR IMPLIED WARRANTIES, WHETHER WRITTEN, ORAL OR IMPLIED, INCLUDING ANY IMPLIED WARRANTY OF MERCHANTABILITY OR FITNESS FOR A PARTICULAR PURPOSE. THIS WARRANTY SHALL CONSTITUTE THE SOLE REMEDY OF BUYER AND THE SOLE LIABILITY OF SHARP, WHETHER IN CONTRACT, TORT OR STRICT LIABILITY. IN NO EVENT SHALL SHARP BE LIABLE FOR ANY LOSS PROFITS OR OTHER INCIDENTAL, CONSEQUENTIAL, OR PUNITIVE DAMAGES ARISING OUT OF, RELATED TO, OR CONNECTED WITH THE FURNISHING, PERFORMANCE, USE OF OR INABILITY TO USE THE MACHINE, EVEN IF SHARP HAS BEEN ADVISED OF THE POSSIBILITY OF SUCH DAMAGES, OR FOR ANY CLAIM AGAINST BUYER BY ANY OTHER PARTY. Buyer shall give written notice to Sharp of any alleged failure or refusal of Sharp to repair or replace as promised by this warranty within fifteen (15) days after Buyer learns of the alleged failure or refusal. If Buyer fails to do so, this warranty shall be void as to the alleged failure or refusal. No action for breach of this warranty shall be commenced more than one year after the cause of action accrues. No modification of this warranty or waiver of its terms shall be binding on Sharp unless approved in writing by an authorized corporate officer of Sharp. This warranty is the entire warranty given by Sharp on the machine and supersedes any prior statements or representations.
9. **INDEMNIFICATION:** Buyer agrees to indemnify and hold Sharp harmless from all claims, demands, losses, damages, costs and expenses, including legal fees, arising out of: (a) any machine subjected to misuse, abuse, or accident; (b) damage in transit or from external sources; (c) overloading of machine capacity; (d) failures which are due to a lack of proper maintenance or care as prescribed in the operating and maintenance instructions; (e) normal wear and tear or relatively minor adjustments; (f) replacement of consumable items (including, but not limited to, heating elements, silicon pads and teflon cloth/tape); (g) repairs or alterations performed by any organization other than Sharp or Sharp's authorized service centers and (h) parts, accessories, or other items manufactured by others which are in any way used and/or installed in or on the machine.
10. **COLLECTION:** If Sharp commences any action against buyer to collect any amount due from Buyer to Sharp in connection with the order, Buyer shall pay Sharp's costs of collection, including reasonable attorneys' fees, whether incurred before or after judgment.
11. **GENERAL:** The "Agreement" means only the provisions of these Standard Terms and Conditions. Acceptance of Buyer's order is expressly made conditional on Buyer's assent to these Standard Terms and Conditions. The Agreement states the entire agreement of the parties concerning the order. The Agreement supersedes all prior agreements, communications, and representations between Buyer and Sharp concerning the order, including any provisions in any order or other form initiated by Buyer which are not expressly accepted by Sharp in writing. The Agreement may be modified or amended except by written agreement of Sharp signed by an authorized corporate officer of Sharp. Sharp's remedies under the Agreement shall be cumulative. Sharp's election of one remedy shall not preclude pursuit of other remedies. Sharp's waiver of any right shall not prevent Sharp from exercising that right subsequently. Any notice to Buyer shall be deemed given when (a) mailed to Buyer by first class mail at its last known address, or (b) transmitted to Buyer by facsimile at its last known facsimile number, or (c) received by Buyer, whichever is first. If any part of the Agreement is invalid, the rest of the Agreement shall remain in effect.
12. **GOVERNING LAW AND FORUM:** The Agreement shall be interpreted under and governed by the laws of the United States and the State of Wisconsin. Any action arising out of, related to, or connected with the Agreement or machines sold under the Agreement shall be commenced only in the United States District Court for the Eastern District of Wisconsin or the Circuit Court for Waukesha County, Wisconsin. Buyer consents to personal jurisdiction and venue in such courts.

Revised: November 27, 2006 Supersedes: July 19, 2006

Sharp Packaging Systems P.O. Box 124 Sussex, WI 53089, USA 1-800-634-6359 FAX (262) 246-8885

PROTECTING YOUR PRINTHEAD

PROTECTING YOUR PRINTHEAD

How Thermal Transfer Ribbons Affect Printhead Life and Performance

Reprinted with permission from Sony Chemicals Corporation of America

For many years now, thermal printer users have selected ribbons based on image quality and price. Recently, manufacturers of ribbons have been calling users' attention to a third consideration - printhead life.

The printhead is, figuratively speaking, "where the rubber meets the road," in terms of getting a quality thermal transfer image. So, it is worthwhile to consider how to optimize printhead performance over extended periods of time.

The short course on this subject is:

1. Select a good printer.
2. Use it according to the OEM's recommended operating conditions and maintenance schedule.
3. Select a compatible ribbon and substrate combination.

What follows is a somewhat longer Q&A discussion on the role ribbons play in optimizing printhead longevity and performance.

Frequently Asked Questions

Q: Why worry about printhead life? Why not buy the cheapest ribbon and replace the printhead whenever it wears out?

A: Print heads are expensive, ranging from several hundred dollars to several thousand dollars each. For this reason alone, you want them to last as long as possible. However, there is an even more important reason. When print heads wear out before their time, there usually is a period during which poor print quality and marginally scanable and unscanable bar codes are generated. The longer the printhead lasts, the less chance of generating non-readable bar codes. Therefore, it is essential to protect the printhead with proper maintenance and use of a quality ribbon.

Q: What does the printhead need to be protected from?

A: Friction and prolonged use at unnecessarily high printhead energies (i.e., heat). In addition, excessive build-up or residue on the printhead, misuse and abuse by the operator, and improper cleaning can also damage the printhead.

Q: How does a thermal transfer printhead work?

A: A thermal printhead has a hard surface in which dot-shaped resistors are embedded. Resistance to electrical current in selected dots generates a thermal energy pulse that melts or softens waxes and resins in the ribbon, resulting in the transfer of an image in the shape of the heated dots onto the label substrate. The faster the printhead can pulse and recover, the higher the potential speed of the printer.

Q: What are the sources of abrasive damage to my printhead?

A: A quality printhead will see at least one million or more inches of paper and ribbon pass across its surface at high speeds before a change is necessary. If the printhead were not protected from abrasion, its useful life would be far shorter. Ribbons have a lubricated backcoat designed to protect the printhead

PROTECTING YOUR PRINTHEAD

from abrasive wear. However, abrasive damage can arise when a label or tag stock is wider than the ribbon so that the media on either side of the ribbon's edges passes directly over the printhead. Using a ribbon with a less effective backcoat, using inappropriate media for thermal transfer and improper cleaning of the printhead are additional causes of printhead failure. Ironically, unlike Sony ribbons, some ribbons with backcoats specially formulated to clean the printhead may also cause abrasive damage.

Q: How can I recognize abrasive damage?

A: The first sign of abrasive damage to a printhead is likely to be a decrease in image quality. In the extreme, abrasive wear can result in failure of one or more heater elements in the print head. This leads to a "white line" through the printed image where the printhead no longer has the ability to transfer ink.

Q: What protects the printhead from abrasion?

A: Print heads have a thin, hard coating over the heating elements that protect them from abrasion while providing efficient heat transfer. The ribbon also protects the printhead from abrasive damage. First, the ribbon separates the printhead from the printing substrate to shield it from abrasive movements. This is why the ribbon must be at least as wide as the printing substrate. The ribbon also has a lubricated backcoat that allows it to flow smoothly over the printhead with minimal abrasiveness. (Note: Many thermal transfer printers can be run in either the Thermal Transfer or the Direct Thermal mode. In the Direct Thermal mode, heat energy is delivered directly to thermal paper and no ribbon is used. Print heads wear out faster in this mode, not only because of the additional temperature requirements, but also because there is no ribbon in place to prevent abrasive wear caused by the substrate).

Q: What is the printhead energy setting used for?

A: The printhead energy setting has a direct bearing on the darkness of the image. Generally speaking, the higher the energy, the more ink that is transferred from a given ribbon. It is important to run the printer at its optimum energy setting. The optimum setting is the lowest energy required to deliver acceptable print quality with the media used and the selected print speed.

Q: Why do operators frequently feel the need to turn the energy settings up?

A: There are a number of factors that can make it difficult to print good quality labels without turning the energy setting up. These include the use of low sensitivity substrates that require a blast of thermal energy to ensure ink adhesion, build-up of particulates and ink residue on the heater elements that present a barrier to efficient energy transfer, high printing speeds, and insufficient or improper maintenance of the printer. Operators try to overcome these factors by increasing the printhead energy setting.

Q: Are there other factors that impact the printer's energy output?

A: Yes. Coverage of ink on the label also affects the overall energy output of the printhead. A typical label has about 30% coverage. When a label with 70% coverage is run, more than twice as many heating elements in the printhead are activated during every printing cycle. Unfortunately, running a thermal transfer printer at the resulting higher temperatures may shorten the print head's life. In addition, if the printer is accidentally set for the Direct Thermal mode for a thermal transfer application, an unnecessary amount of heat will be generated by the printhead, ultimately contributing to premature printhead failure.

Q: Will a quality ribbon help me run at a lower energy setting?

A: Yes. Choosing a ribbon and substrate combination that is matched for optimum print quality at the lowest energy settings can extend printhead life. In addition, quality ribbons are coated with a high-

PROTECTING YOUR PRINthead

performance backcoat designed to protect the printhead from abrasion, prevent hard residue deposits from building up on the printhead surface, and provide intimate contact with the printhead to improve heat transfer efficiency (see Graph 1).

Q: What is printhead "build-up?"

A: Build-up of deposits on print heads over time is a normal occurrence and is not a cause for concern. Build-up may be caused by several sources including small amounts of ink and backcoat from the ribbon, dust and dirt from the near-by environment, paper dust and particles on the media created during the label conversion and slitting process, and/or excessive adhesive applied during the laminating process.

Q: When does printhead build-up become a problem?

A: Build-up becomes a problem when maintenance guidelines are not followed. Any deposit on the printhead, if not removed regularly, can insulate the heating elements from the ribbon and lead to having to print at higher energy settings. Using a "bargain" ribbon that can leave build-up on the printhead, which is virtually impossible to remove even with alcohol cleaning pads, increases the problem. To compensate for the resulting deterioration of the image, operators gradually increase energy settings on the printer, which can ultimately shorten printhead life. Burned out pixels in the printhead result in unscannable images and returned merchandise. Some retailers, such as K-Mart and Wal-Mart, will even fine companies who provide merchandise with unscannable tags and labels.

Q: How do I prevent build-up from becoming a problem?

A: Purchase a good quality ribbon and printing substrate. Minimize the accumulation of dust by keeping the printer cover closed. Follow the OEM's recommended operating, maintenance and printhead cleaning schedule.

Q: Is it a good idea to use a ribbon that will clean the printhead?

A: No. This type of backcoat formulation is not needed when good quality ribbons are used and the printer manufacturer's operating and maintenance schedules are followed. In fact, test results indicate that use of this type of ribbon may actually cause abrasive wear and premature failure of the printhead. (Note: Ribbons with backcoats formulated to clean the printhead should not be confused with ribbons that have a leader to clean the head.)

Q: Do I have to sacrifice printer performance or print quality to optimize printhead life?

A: No. Quality printers, ribbons and substrates are designed to provide a million or more linear inches of printhead usage without damaging the printhead due to build-up or abrasive wear.

Q: How long will a printhead last if I use the best possible ribbon?

A: Actually, that depends on the printhead design and such additional factors as printer speed, energy settings, static, substrate and ribbon quality. A good ribbon should be guaranteed not to cause significant degradation due to build-up or abrasion throughout the print head's rated life. Generally, the industry standard is that the printhead should last for one million linear inches of use. Sony's TR4085plus™ resin/enhanced wax thermal transfer ribbon is guaranteed to permit normal printhead functioning for up to three million linear inches. Print heads will eventually degrade from normal wear and tear, but they should not fail prematurely due to the adverse effects of inappropriate ribbon selection.

SX TABLETOP BAGGER
PRINTER MENU STRUCTURE
FIRMWARE VERSION SHARP.ZS

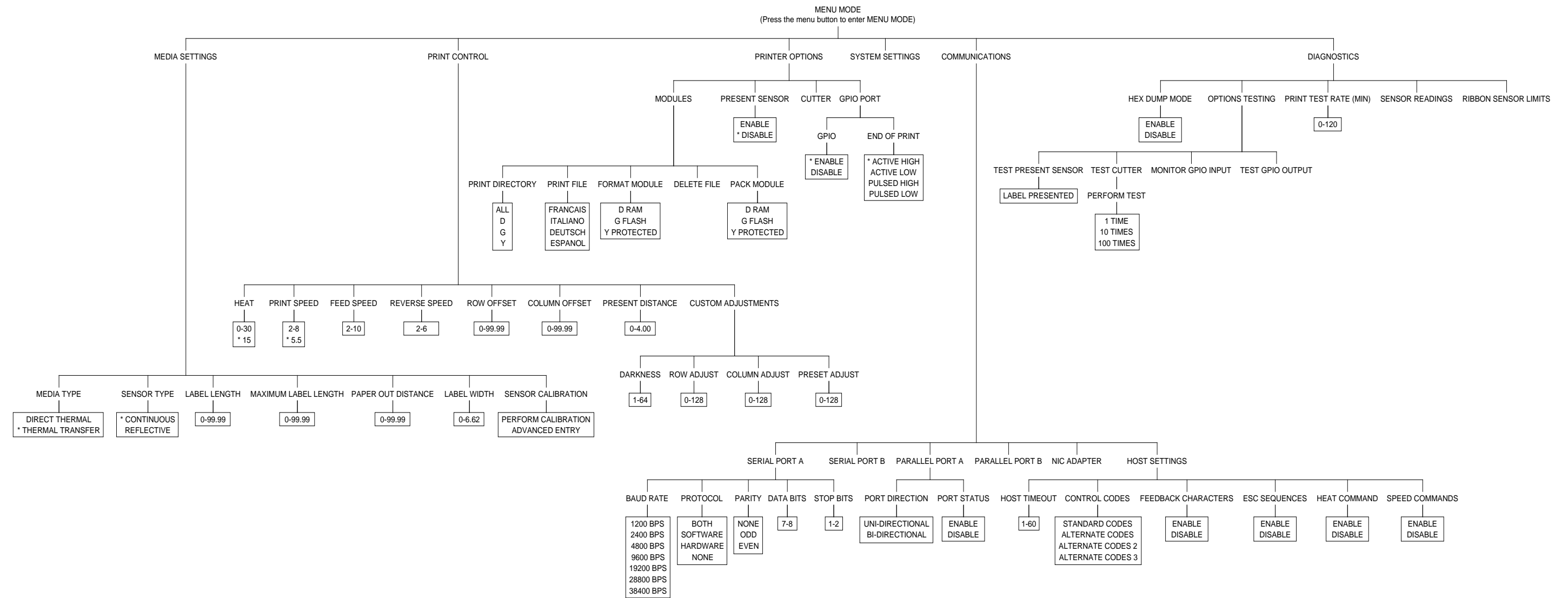
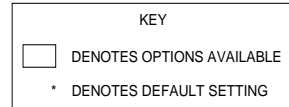

Figure A-1. SX™ Printer Menu Flowchart